



CITY COUNCIL & URBAN RENEWAL AGENCY

AGENDA

MONDAY, FEBRUARY 12, 2024

Where Life is Sweet

COUNCIL CHAMBERS - 180 NE 2ND ST.

*Other ways of viewing or participating in live meetings are available through:
YouTube at: <https://bit.ly/HermistonYoutube>*

*Zoom with Meeting ID: 841 0675 8958 Passcode: 075556 Telephone number to join is: 1 253
215 8782; or submitting comments to meetings@hermiston.or.us*

1. CALL REGULAR MEETING TO ORDER – 7:00 PM

2. DECLARATION OF QUORUM

3. FLAG SALUTE

4. PRESENTATIONS

- A. Hermiston School District Updates
- B. Umatilla County Housing Authority Updates

5. CITIZEN INPUT ON NON-AGENDA ITEMS

Anyone wishing to bring anything before the council that is not on the agenda is asked to please do the following: 1. Please limit comments to not more than FIVE minutes; 2. State your name and address; 3. Direct your comments to the Chair.

6. CONSENT AGENDA

- A. Confirmation to reappoint Position 4 on the Recreation Projects Fund Advisory Committee (representing Hoteliers) ending 12/31/2026 to James Whalley
- B. Confirmation to appoint Position 3 on the Parks and Recreation Advisory Committee term ending 12/31/2024 to Hunter Tibbals
- C. Recommendation to reappoint Position 1 on the Faith-Based Advisory Committee term ending 12/31/2026 to James Lafolette

- D. Recommendation to reappoint Position 2 on the Faith-Based Advisory Committee term ending 12/31/2026 to Terry Cummings
- E. Recommendation to appoint Position 4 on the Budget Committee term ending 12/31/2026 to Ed Brookshier
- F. Recommendation to reappoint Position 5 on the Budget Committee term ending 12/31/2026 to Lori Davis
- G. Recommendation to reappoint Position 6 on the Budget Committee term ending 12/31/2026 to Paul Magana
- H. Committee Vacancy Announcements
- I. Minutes of the January 22nd City Council Work Session and Regular Meeting
- J. Minutes of the January 25th & 26th City Council Goal Setting Session

7. ITEMS REMOVED FROM CONSENT AGENDA

8. ORDINANCES AND RESOLUTIONS

- A. Resolution No. 2307 – A Resolution To Consent For Inclusion Of Territory In Umatilla County Road District
- B. Resolution No. 2308 – A Resolution To Authorize Bonds for Various City Projects
- C. Resolution No. 2309 – Designate No Parking W Dogwood Ave from NW Spruce St to NW 2nd St
- D. Resolution No. 2310- Adopting the Revised City Design Standards and Specifications Manual
- E. Resolution No. 2311 - Adopting the Immunity from Liability for use of Trails or Structures in Public Easement or Unimproved Right of Way Provided in ORS 105.668
- F. Ordinance No. 2355 – An Ordinance Amending Chapters 51 and 52 of the Hermiston Municipal Code by Increasing the Due and Payable Date for Sewer, Water, and Solid Waste Bills from within Ten Days to Twenty Days

9. COMMITTEE REPORTS

A. City Committee and Liaison:

Airport Advisory, Budget, Hispanic Advisory, Library Board, Parks and Recreation, Planning Commission, Recreation Projects Fund, Faith-Based Advisory, Community Enhancement, Community Accountability, Public Safety, Public Infrastructure, Transit Planning, EOTEC, Stepping Stones Alliance (not a City Committee)

B. Mayor's Report

C. Council Report

D. Youth Advisory Report

E. Manager's Report

10. ADJOURN CITY COUNCIL MEETING AND CONVENE URBAN RENEWAL AGENCY MEETING

11. CALL TO ORDER

12. NEW BUSINESS

A. HURA Resolution No. 20 - Award a Contract to Reconstruct the SE 2nd Street/Highway 395 S intersection

B. Resolution No. 21 - Bond Authorization for North Hermiston Urban Renewal Area Infrastructure Project

13. ADJOURN URBAN RENEWAL AGENCY MEETING

**** AMERICANS WITH DISABILITIES ACT NOTICE****

Please contact Hermiston City Hall, 180 NE 2nd Street, Hermiston, OR 97838 (Phone No. 541-567-5521) at least 48 hours prior to the scheduled meeting time if you need an accommodation. TTY and TDD users please call Oregon Telecommunications Relay Service at 1-800-735-2900 or 711.



PUBLIC ANNOUNCEMENT

The City is accepting applications for the following Committees:

1) Planning Commission

- Positions 7, 8, and 9: 3-year term ending March 31, 2027 (Advertised as of 02/01/2024)

Deadline to apply for all Committees: Open Until Filled

Interested persons are asked to submit an application to City Hall, 180 NE 2nd Street, Hermiston, or at lalarcon-strong@hermiston.or.us. Application forms are available at City Hall or on the City's website at <https://hermiston.or.us/volunteer>. If you have questions, please call Lilly Alarcon-Strong at 541-567-5521.

Proposed appointment and confirmation of these positions are made by the City Council. All appointments to city boards and commissions shall be made in accordance with the ordinances and city charter. Appointees shall not be full-time employees of the city, shall not be elected officials of the city, shall not be appointed to more than two boards or commissions at a time, and shall not sell to the city or its boards and commissions over which the council has appointive powers and budget control either directly as a prime contractor or supplier, or indirectly as a first-tier subcontractor or supplier. Sales shall be construed to mean sales, services or fees aggregating \$7,500 or more in any one calendar year. Preference for appointees shall be given to city residents.



Where Life is Sweet

CITY COUNCIL

Work Session Meeting Minutes January 22, 2024

Mayor Drotzmann called the work session meeting to order at 6:00pm. Present were Councilors Hardin, Primmer, Barron (arrived at 6:01pm), Duron, Linton, McCarthy, and Myers. Councilor Peterson was excused. Staff in attendance included: City Manager Byron Smith, Assistant City Manager Mark Morgan, City Attorney Rich Tovey, Chief Edmiston, Parks and Recreation Director Brandon Artz, Court Administrator Jillian Viles (arrived at 6:07pm), and City Recorder Lilly Alarcon-Strong.

City Project Updates

City Manager Smith gave information (PowerPoint Presentation attached) regarding building project updates at the:

- Harkenrider Senior Center, specific to developing the basement area
- City Hall, specific to developing the remaining space in the basement area
- The Library
- Public Safety Center
- The Arc Building, and
- Carnegie Library

City Manager Smith gave information regarding each building's history, why improvements are needed, estimated costs associated to complete each project, and possible renderings of the spaces once construction has been completed.

Adjournment

Mayor Drotzmann adjourned the work session meeting at 6:57pm and stated the Council will take a short recess before starting the regular council meeting.



Overview

- Many Council Goals Related to Various Buildings
 - Civic Projects (Construction Manager/General Contractor (CMGC) Hacker/CB Construction)
 - Harkenrider Center
 - City Hall – IT Space
 - Library
 - Public Safety Center
 - The Arc Building (aka USO Building)
 - Carnegie Building



Harkenrider Center

- History/Situation
 - Completed in September 2018
 - Replaced Senior Center Building (5,500ft²) on former Fairgrounds
 - Base Building (7,200ft²) Funded with CDBG (\$2 million)
 - Added 3,800ft² in walkout basement at City's sole expense (\$750,000)
 - Senior Center Board Operates with Help



Harkenrider Center

- History/Situation
 - Dedicated Senior Time is 8am to 3pm Monday-Friday
 - Parks and Rec Utilizes a Shared Calendar
 - Adopted Fee Schedule
 - Revenue Shared 60/40
 - Current Estimate - ~\$600,000
- Project – Finish Basement Space (3,800ft²)



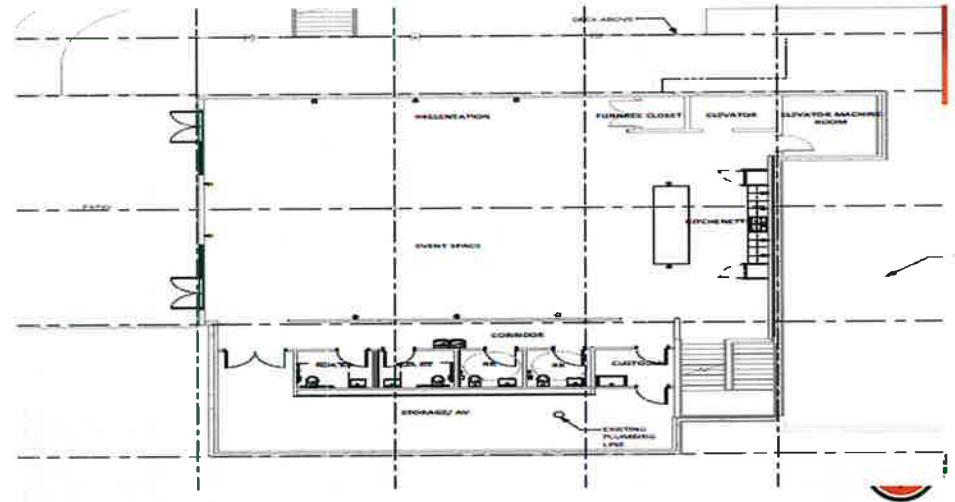

City Hall – IT Space

- History/Situation
 - Space in City Hall Basement for Future Growth
 - During City Hall Design/Construction IT Department was Established
 - Currently IT Staff in Carnegie Building
 - Current Estimate - ~\$300,000
- Project – Finish Future Growth Space (1,500ft²)

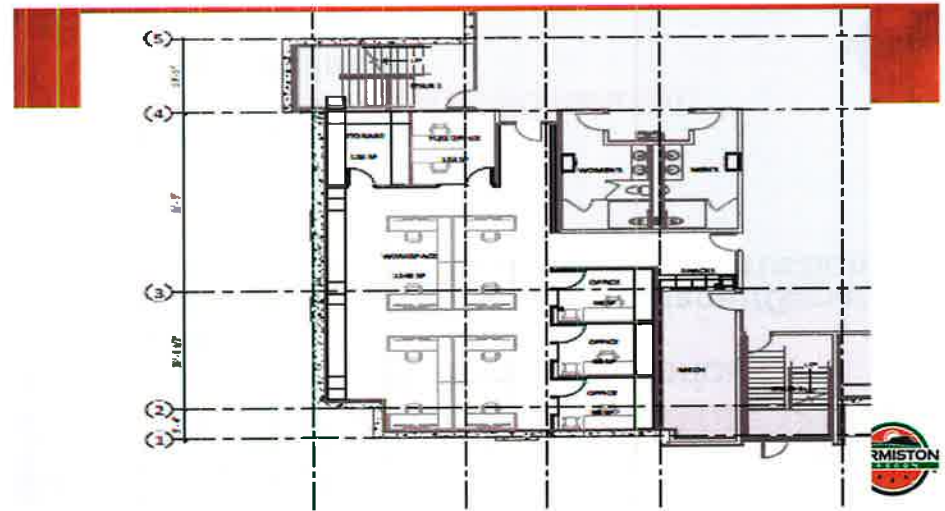

Library

- History/Situation
 - Building Originally Occupied in 1989
 - Basement Built-out Over Time
 - Original Basement Design Not Functional, Inviting, etc.
 - Phase I Remodel Completed in 2021 as Interim City Hall
 - Phase II Proposed as Multi-Cultural Resource Center



Library

- History/Situation
 - Umatilla County Dedicated \$2.5 million to Multi-Cultural Resource Center (Potential for More)
 - Current Estimate – ~\$4.5 million
- Project – Phase II Remodel: Upstairs and Finish Downstairs

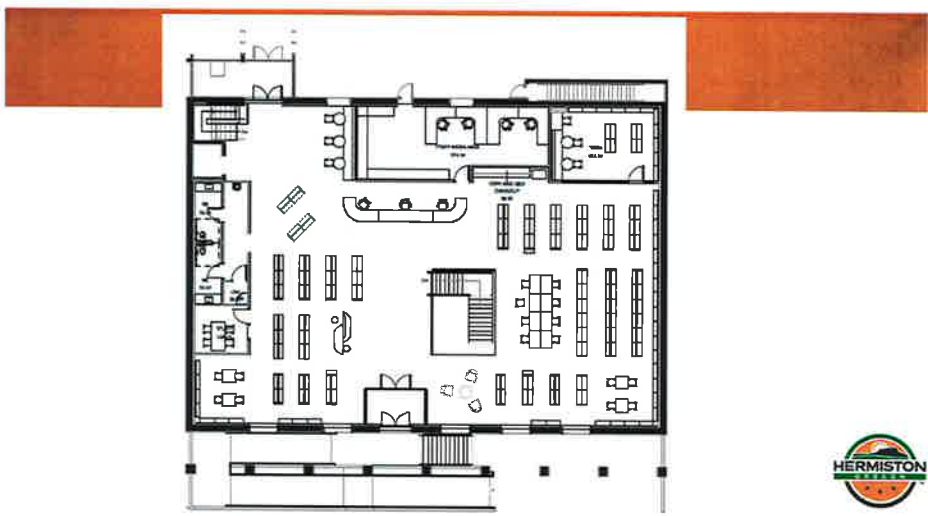
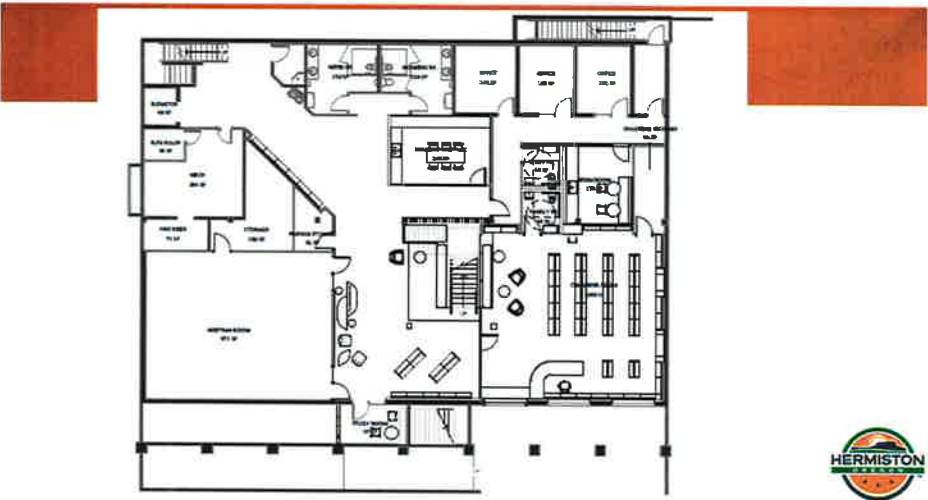



Public Safety Center

- History/Situation
 - Originally Occupied in ~1972
 - CSEPP/Fire Addition Completed in 2004
 - Early City Hall Designs Attempted to Include Police Department
 - Current Police Department Space Inadequate
 - Detectives in a separate building
 - Very “creative” use of space
 - Inadequate evidence storage
 - Inadequate/unsafe arrest processing space



Public Safety Center

- History/Situation
 - UCFD#1 Undergoing Station Upgrades Funded by their Bond
 - Utilizing UCFD#1's CMGC Team (Schlager Zimmerman Architects/McCormack Construction)
 - Acquired ~\$2.5 million Seismic Upgrade Grant
 - Need Temporary Space
 - Current Estimate ~\$11.5 million
- Project – Remodel Public Safety Center mostly on the Police side



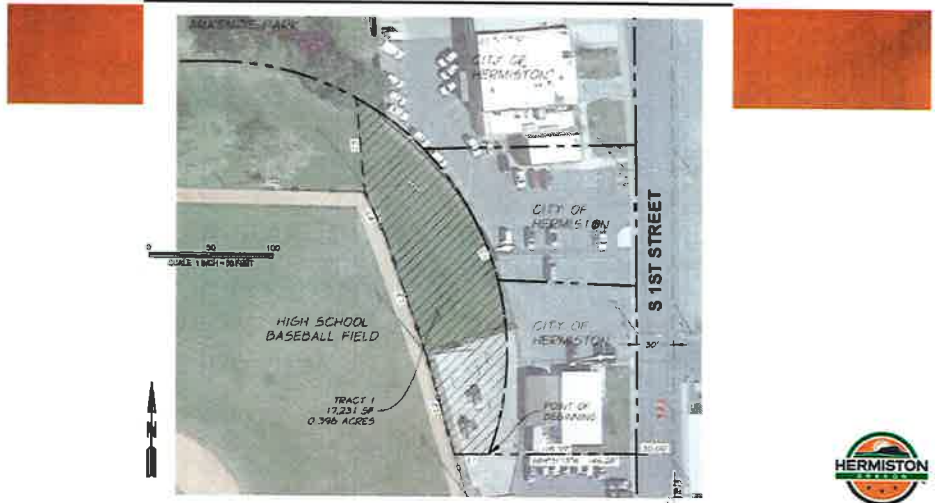
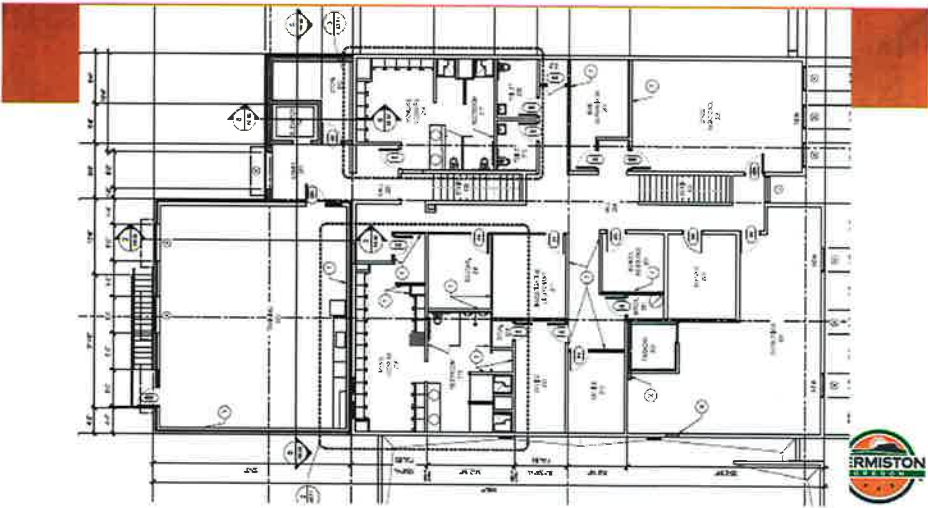
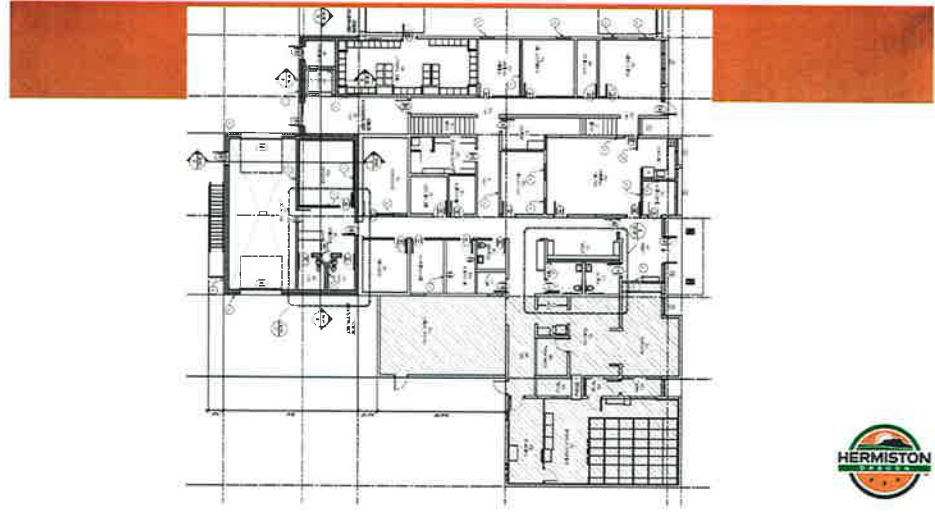

10-11



The Arc Building (USO)

- History/Situation
 - City leased to the Arc of Umatilla County in 1996
 - In 2015 or 2016 the City assisted in getting a new heating system installed (technically the Arc responsibility)
 - Thought of as temporary police station
 - City could invest in the building and help the Arc in the long-term
 - Short-term inconvenience of moving to a temporary location
- Potential Projects
 - Replace roof
 - Update/add electrical
 - Repair foundation in the rear of the building
 - Rebuild Front Entry Ramp
 - Reside and/or paint exterior
 - Replace windows



Carnegie Building

- History/Situation
 - Current offices for IT
 - Possible interim library space
 - Possible community museum



**Comments/
Questions?**

Where Life is Sweet™



Where Life is Sweet

CITY COUNCIL

Regular Meeting Minutes January 22, 2024

Mayor Drotzmann called the regular meeting to order at 7:00pm. Present were Councilors McCarthy, Barron, Linton, Primmer, Hardin, Duron, and Myers. Councilor Peterson was excused. City Staff in attendance included: City Manager Byron Smith, Assistant City Manager Mark Morgan, City Attorney Rich Tovey, Chief Edmiston, Planning Director Clint Spencer, Parks and Recreation Director Brandon Artz, Court Administrator Jillian Villes, and City Recorder Lilly Alarcon-Strong. The pledge of allegiance was given.

Presentation- Greater Hermiston Chamber of Commerce Updates

Greater Hermiston Chamber of Commerce Executive Director Val Hoxie gave information regarding: the Board's decision to sell their property on Evelyn Street, Open Rewards Program, upcoming events hosted by the Chamber to include: the Candidate Forum, Chamber Luncheon on March 27th from 11:00am to 1:00pm at the Community Center which will host Representative Greg Smith speaking about the Short Session, and the Hermiston Distinguished Citizens Awards Banquet held this year in March at the Community Center which will be hosted by the Good Shepherd Community Health Foundation going forward.

Citizen Input on Non-Agenda Items

None given.

Consent Agenda Items

Councilor Primmer moved and Councilor McCarthy seconded to approve Consent Agenda items A-E to include:

- A. Major Partition - 4N2823 Tax Lot 200 Amazon Data Services Inc 908 E Penney Ave
- B. Airport Ground Lease- Stratton
- C. Recommendation to appoint Position 4 on the Recreation Projects Fund Advisory Committee (representing Hoteliers) ending 12/31/2026 to James Whalley
- D. Recommendation to appoint Position 3 on the Parks and Recreation Advisory Committee term ending 12/31/2024 to Hunter Tibbals
- E. Minutes of the January 8th City Council Meeting

Councilors McCarthy, Barron, Primmer, Myers, Hardin, and Duron voted in favor; Councilor Linton voted against. Motion carried 6-1.

Ordinance No. 2352 – Adopting a Business License Fee

City Manager Smith gave information (PowerPoint Presentation attached) regarding possibly adopting a Business License Fee with an effective date of January 1, 2025 as presented and discussed during City Council meetings since shortly after the adoption of the 2023-24 Budget which went into effective July 1, 2024, during the budget Town Hall Meeting, and the Budget Overview and Outreach Report given at the last meeting.

Public Comment

Kristi Kopacz (371 E. Hurlburt Ave)- Stated the City should be doing more to notify business owners as many do not know. Ms. Kopacz stated she has been a business owner for 33 years and already pays a business license fee through the State. She is opposed to this fee as she knows that if approved the fee will increase each year.

Kena West (690 W. Sandpiper Ave)- Stated \$85.00 per year is too expensive for a small business and \$1,000.00 is not enough for large businesses like Wal-Mart. Asked that the Council consider this thoroughly as no services are being provided for this fee and the proposed amounts do not make sense.



CITY COUNCIL

Regular Meeting Minutes January 22, 2024

Nick Ridling (1003 SW Olive Court)- Asked if those working remotely would be required to pay this fee, stated the violation fee is notorious, and asked that the Council think about how this will impact small businesses.

After some discussion, Mayor Drotzmann requested that the first reading be by title only. Hearing no opposition, City Attorney Tovey read the ordinance by title only. Mayor Drotzmann requested the ordinance be put on for final adoption at this meeting and that the second reading be by title only. After City Attorney Tovey read the ordinance by title only, Councilor Linton moved to table the decision. Hearing no second the motion died. Councilor McCarthy moved and Councilor Myers seconded that Ordinance No. 2352 be adopted and become effective 30 days after adoption by the City Council. Councilors McCarthy, Barron, Primmer, Myers, Hardin, and Duron voted in favor; Councilor Linton voted against. Motion carried 6-1.

Resolution No. 2305 – Updating the Master Fee Schedule for Business License and Sewer Fees

City Manager Smith and Assistant City Manager Mark Morgan gave information (PowerPoint Presentations attached) regarding updating the Master Fee schedule to include a Business License Fee and updating the annual sewer fees.

After further discussion, Councilor Linton moved and Councilor Primmer seconded to approve Resolution No. 2305 with the exception of approval of the proposed Business License fees, which would come before the Council for further discussion at a following meeting and lay upon the record. Motion carried unanimously.

Ordinance No. 2353 – Amending Chapter 70 and Chapter 72 of the Hermiston Municipal Code

City Manager Smith gave information (PowerPoint Presentation attached) regarding possibly adopting changes to traffic and parking penalties.

After some discussion, Mayor Drotzmann requested that the first reading be by title only. Hearing no opposition, City Attorney Tovey read the ordinance by title only. Mayor Drotzmann requested the ordinance be put on for final adoption at this meeting and that the second reading be by title only. After City Attorney Tovey read the ordinance by title only, Councilor Linton moved, and Councilor Myers seconded that Ordinance No. 2353 be adopted and become effective 30 days after adoption by the City Council. Motion carried unanimously.

Ordinance No. 2354 – Amending Chapter 96 of the Hermiston Municipal Code

City Manager Smith gave information (PowerPoint Presentation attached) regarding possibly adopting changes to the Rules of Conduct for City Properties.

After some discussion, Mayor Drotzmann requested that the first reading be by title only. Hearing no opposition, City Attorney Tovey read the ordinance by title only. Mayor Drotzmann requested the ordinance be put on for final adoption at this meeting and that the second reading be by title only. After City Attorney Tovey read the ordinance by title only, Councilor Primmer moved and Councilor Hardin seconded that Ordinance No. 2354 be adopted and become effective 30 days after adoption by the City Council. Motion carried unanimously.



CITY COUNCIL

Regular Meeting Minutes January 22, 2024

Resolution No. 2306 – Planning Services Contract with Winterbrook Planning for Urban Growth Boundary Expansion Services- City Manager Smith and Planning Director Clint Spencer gave information (PowerPoint Presentations attached) regarding awarding the planning services contract to Winterbrook Planning to assist the City in potentially expanding the southern urban growth boundary.

After further discussion, Councilor McCarthy moved and Councilor Primmer seconded to approve Resolution No. 2306 and lay upon the record. Motion carried unanimously.

December 2023 Financial Report

Councilor Linton moved, and Councilor McCarthy seconded to accept the December 2023 Financial Report as presented (PowerPoint Presentation attached) by City Manager Smith. Motion carried unanimously.

Council Goal Setting Update

City Manager Smith reviewed updates of the 2023 Council Goals as established and included in the agenda packet.

Mayor Drotzmann stated Goals are established each year by a lengthy and in-depth discussion that takes place over a two-day period between Council and staff members.

Councilor Barron asked if the Goal Setting Session could be scheduled Friday and Saturday next year instead of Thursday and Friday as he will be unable to attend the Friday session due to work.

City Manager Smith and Mayor Drotzmann stated next year's scheduling will be discussed on Thursday as it is very important that each Councilor is able to attend both days of the session if possible.

Committee Reports

Parks and Recreation Advisory Committee- Councilor Myers stated the meeting was cancelled due to weather. **Hispanic Advisory Committee-** Councilor Barron stated the meeting was postponed to February. The Committee has all positions filled with great diverse members who are eager to support the Latino community.

Mayor Drotzmann stated almost all open City Committee positions have been filled.

Mayor's Report

Mayor Drotzmann spoke regarding:

- Attended the Small Cities LOC Meeting in Irrigon
- Reminded the Council there is an upcoming LOC Spring Conference

Council Reports

Councilor Duron clarified the Hermiston Distinguished Citizens Awards Banquet will be held March 20th at the Community Center.

Councilor McCarthy thanked all city staff who helped remove snow from the roadways and clarified that the City does own and operate snow plows.



Where Life is Sweet

CITY COUNCIL

Regular Meeting Minutes January 22, 2024

Councilor Barron stated he added the MLK event last week. Each year the event gets better and better with great speakers both from adults and youth.

Mayor Drotzmann agreed with Councilor Barron stating the event brings great cultural awareness to the community and acknowledged High School Senior Aaron Thacker for doing an amazing job stepping in at the last minute to sing America the Beautiful as the person scheduled was unable to make it to the event due to the weather.

Youth Advisory Report

None present.

City Manager's Report

City Manager Smith spoke regarding:

- Roger Condie the Executive Director of the Umatilla County Housing Authority will be attending the next meeting to discuss the Veteran's Housing Project
- The Fair Appreciation Dinner will be this Saturday at EOTEC
- A Finance Director candidate has been offered employment and the City should know by the end of this week if they have accepted the offer.

Adjournment

Mayor Drotzmann adjourned the City Council meeting at 8:35pm as there was no other City business.

SIGNED:

Dr. David Drotzmann, Mayor

ATTEST:

Lilly Alarcon-Strong, CMC, City Recorder

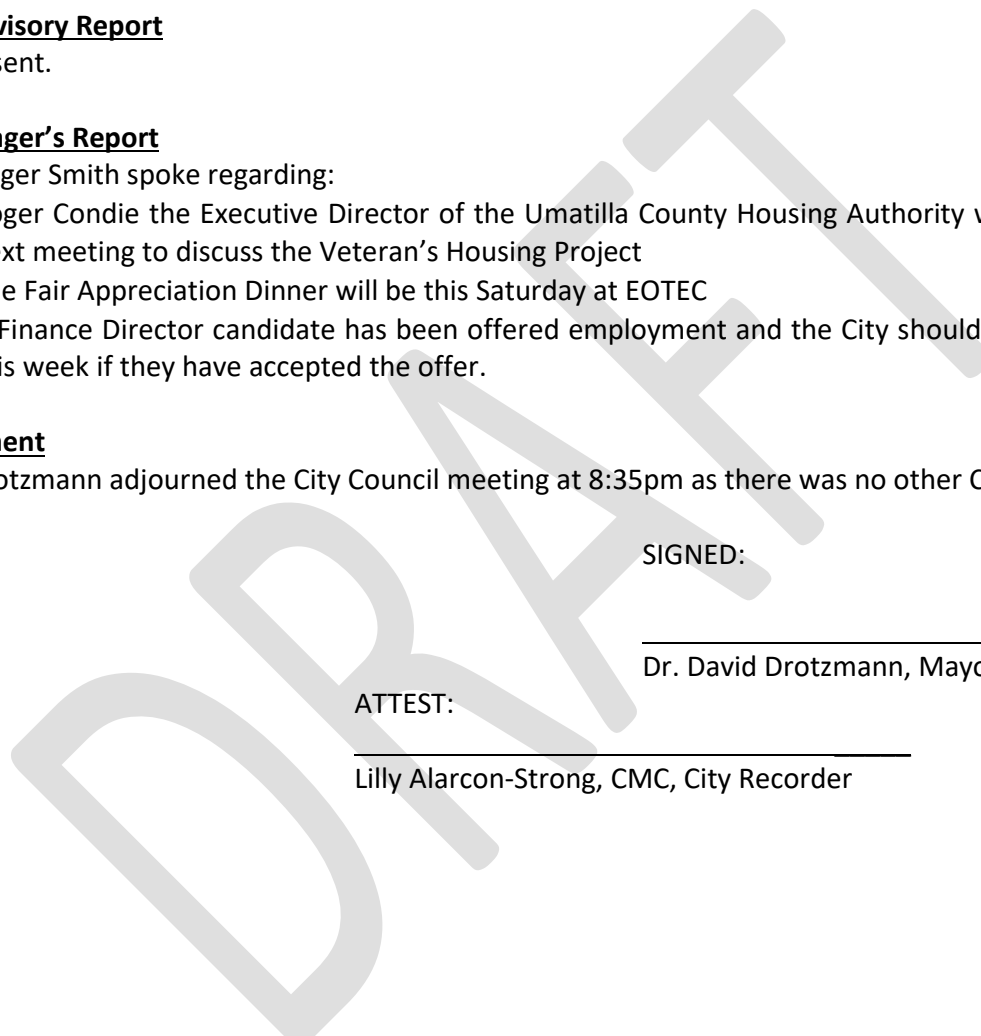

January 22, 2024 Agenda Items

January 22, 2024

Business License Fee

- Ord. 2352 - Institute a Business License Fee
- Employee includes owner and her/his spouse
- FTE is all hours worked divided by 2080

Businesses WITH a Permanent Location WITHIN City Limits	
1. Base Fee – Includes 0-5 Full-Time Equivalent (FTE) Employees	1. \$85.00
2. 6-49 FTE Employees	2. Base + \$15.00 per Employee over 5
3. 50+ FTE Employees	3. \$1,000.00
Businesses WITHOUT a Permanent Location WITHIN City Limits	
1. Base Fee- Includes 0-5 Hermiston FTE	1. \$100.00
2. 6-49 FTE Hermiston Employees	2. Base + \$20.00 per Employee over 5
3. 50+ FTE Hermiston Employees	3. \$1,200.00

Business License Fee

- Institute a Business License Fee
- Effective January 1, 2025
- Annually - \$100,000



Master Fee Schedule

- Res. 2305
- **Establish Business License Fee Amounts (pg. 16 of 41)**

Businesses WITH a Permanent Location WITHIN City Limits	
1. Base Fee – Includes 0-5 Full-Time Equivalent (FTE) Employees	1. \$85.00
2. 6-49 FTE Employees	2. Base + \$15.00 per Employee over
3. 50+ FTE Employees	3. \$1,000.00
Businesses WITHOUT a Permanent Location WITHIN City Limits	
1. Base Fee- Includes 0-5 Hermiston FTE	1. \$100.00
2. 6-49 FTE Hermiston Employees	2. Base + \$20.00 per Employee over 5
3. 50+ FTE Hermiston Employees	3. \$1,200.00

Master Fee Schedule

- Res. 2305
 - Update Sewer Rates by 2.58% (Page 35 of 41)



HERMISTON OREGON

Comments/
Questions?

Where Life is Sweet

Resolution 2305 Sewer Fees

City Council: January 22, 2024

HERMISTON OREGON

HERMISTON OREGON

Inflation Adjustments

- Predictability/Stability for Customers
- Annual Adjustments
- 3-Year Average to Moderate 2021/2022 Spikes
- 3-Year Average: 5.77%

HERMISTON Resolution 2305

- 2023 Actual 1-Year Inflation: 2.58%
- Sewer Monthly Base Rate: \$40.67 (+2.58%)
- Sewer Usage Rate (per 1kg):\$3.49 (+2.58%)
- Median Residential User Monthly Increase: \$1.37



HERMISTON Revenue Purchasing Power

	Purchase Power	Real \$ Increase
3-Yr Avg (5.77%)	Even	\$284,000
1-Yr (2.58%)	-\$157,000	\$127,000
Commercial Only (2.58%)	-\$257,000	\$27,000



HERMISTON 2.58% Increase Revenue Impact

USER TYPE	USER #	ANNUAL REVENUE	2.58% INCREASE
RESIDENTIAL	5,625	\$3,867,308	\$99,776
COMMERCIAL	411	\$1,049,211	\$27,069
LOW-INCOME	8	\$3,927	\$101
TOTAL	6,044	\$4,920,446	\$126,946



HERMISTON 2.58% INCREASE ONLY ON COMM

USER TYPE	USER #	ANNUAL REVENUE	2.58% INCREASE
RESIDENTIAL	5,625	\$3,867,308	\$0
COMMERCIAL	411	\$1,049,211	\$27,069
LOW-INCOME	8	\$3,927	\$0
TOTAL	6,044	\$4,920,446	\$27,069

- Effective Department Revenue Increase: 0.5%
- 2023 Inflation: 2.58%



HERMISTON \$127K Increase Only on Commercial

USER TYPE	USER #	ANNUAL REVENUE	INCREASE
RESIDENTIAL	5,625	\$3,867,308	\$0
COMMERCIAL	411	\$1,049,211	\$126,946
LOW-INCOME	8	\$3,927	\$0
TOTAL	6,044	\$4,920,446	\$0

- Commercial Increase: **+12.1%**
- Sm Commercial (bookstore): **+\$6.28/mo**
- Lg Commercial (fast food): **+\$43.46/mo**



HERMISTON Impact Summary

- Small Commercial (i.e bookstore): **\$1.08**
- Median Residential: **\$1.37**
- Large Commercial (i.e. Fast Food): **\$7.62**





QUESTIONS?

Where Life is Sweet

Parking Ordinance Changes

- Ord. 2353
 - Amends the penalty of most traffic violations to a D violation
 - Adds a parking violation for parking on a street that has been closed by the City or by a permit issued by the City
 - Clarifies language regarding the United States Postal Service vehicles
 - Clarifies towing language
 - Amends the parking citation procedure by having all traffic tickets filed with the municipal court





Comments/ Questions?

Where Life is Sweet

Conduct on City Property

- Ord. 2354
- This Chapter added in April 2023
- Amendments to Streamline Administration
 - **Allows police officers to issue exclusion notices effective for 30 days with repeat notices possible for 90 and 180 days. Mirrors exclusion from city parks.**
 - **Amends the ordinance to add the penalty of a Class "A" violation for violating an exclusion notice.**



Comments/ Questions?

Where Life is Sweet

Planning Services Contract

- Res. 2306
 - **February 2023 Industrial Lands Analysis**
 - **Need large parcels at least 100 acres**
 - **RFQ Process**
 - **Winterbrook Planning**
 - **\$233,000**
 - **All paid for by an interested landowner**





**Comments/
Questions?**

Where Life is Sweet™

Monthly Financial Report

- Property Taxes coming in a little ahead of normal
 - 95% of projected
- General Fund Expenses are on a good track
 - This month about 5% below projections
 - YTD 4.4% below projections



Monthly Financial Report

- Capital Projects
 - Phase II RWS Improvements Pre-construction this month
 - Lead and Copper program started well
 - (Snow has slowed them down)
 - Well #5 Improvements nearly complete
 - Hermiston Drain Burying Complete
 - Gladys & Main Waterline Replacement
 - Anticipate contract award in February
 - McDonalds/395 Sewer Main Replacement
 - Anticipate contract award in February
 - Teen Adventure Park
 - Anticipate ribbon cutting in May



**Comments/
Questions?**

Where Life is Sweet™



CITY COUNCIL

Goal Setting Meeting Minutes January 25th & 26th, 2024

Mayor Drotzmann called the Goal Setting Meeting for Thursday, January 25, 2024 to order at 5:37pm. Present were Councilors Duron, Primmer, Hardin, Myers, Linton, McCarthy, Peterson, and Barron. Staff members in attendance were City Manager Byron Smith, Assistant City Manager Mark Morgan, City Attorney Rich Tovey, Library Director Mark Rose, Parks and Recreation Director Brandon Artz, Chief Edmiston, Planning Director Clint Spencer, Court Administrator Jillian Viles, Hermiston Energy Services General Manager Nate Rivera, Human Resources Specialist Crystal Inners, IT Director Jordan Standley, and City Recorder Lilly Alarcon-Strong.

Sara Singer Wilson, Ashley Sonoff, and Sasha Konell from SSW Consulting, LLC outlined the agenda, council and staff gave information regarding Hermiston’s history related to growth and city projects from 1990 through 2023 and discussed progress, accomplishments, and challenges of projects from the 2023 established goals.

After Council and staff discussion, Sara Singer Wilson discussed next year’s Goal Setting Scheduling and preferences the Council may have regarding during the week and/or weekend scheduling. Councilor Barron stated he would prefer a Friday/Saturday schedule; Councilors Duron and McCarthy stated they would prefer weekday scheduling; and Councilors Peterson, Linton, Hardin, and Primmer stated they did not have a preference. After additional discussion, the meeting adjourned for the evening at 8:25pm.

Mayor Drotzmann called the Goal Setting Meeting for Friday, January 26, 2024 to order at 8:30am. Present were Councilors Duron, Primmer, Hardin, Myers, Linton, McCarthy, Peterson, and Barron. Staff members in attendance were City Manager Byron Smith, Assistant City Manager Mark Morgan, City Attorney Rich Tovey, Library Director Mark Rose, Parks and Recreation Director Brandon Artz, Chief Edmiston, Planning Director Clint Spencer, Court Administrator Jillian Viles, Hermiston Energy Services General Manager Nate Rivera, Human Resources Specialist Crystal Inners, IT Director Jordan Standley, EOTEC General Manager Al Davis, and City Recorder Lilly Alarcon-Strong.

Ashley Sonoff reviewed the 2023 goals as discussed the day prior. There was consensus that due to recent budget issues, the 2023 established goals that are still in progress, should be refined to identify and prioritize only the most pressing issues facing Hermiston and only those items should be put forth as the 2024 Council Goals. After Council and staff worked on this effort, Ashley stated the 2024 goals will be refined by SSW Consulting, LLC and presented for adoption at a City Council Meeting in the near future.

The meeting was adjourned at 3:00pm.

SIGNED:

Dr. David Drotzmann, MAYOR

ATTEST:

Lilly Alarcon-Strong, CMC, CITY RECORDER



Where Life is Sweet

Mayor and Members of the City Council
STAFF REPORT
For the Meeting of February 12, 2024

Title/Subject

Resolution No. 2307 – A Resolution To Consent For Inclusion Of Territory In Umatilla County Road District

Summary and Background

Historically Umatilla County has received funding from the federal government for roads within the Umatilla County road system. More recently it has had to elect to receive funding either from a percentage of the timber sale receipts in the county, or from the Secure Rural Schools (SRS) program. In addition, any funding under the SRS program reduces payments made by the federal government in lieu of tax.

The Oregon legislature revised the law, allowing SRS payments to go to a county road district, rather than the county, and not have the county pass up this additional revenue. Payments made to the county road district would then be paid to the county to maintain County Roads. The county road district, however, is to include all areas of the county, including any incorporated cities.

The Board of Commissioners is initiating the formation of the Umatilla County Road District to take advantage of the change in law and obtain the additional funding for Umatilla County Roads. The district is proposed to include the city limits of Hermiston. To do so, the consent of the city is necessary.

The Board is requesting the City to consent to the inclusion.

Tie-In to Council Goals

N/A

Fiscal Information

No financial impact to the city.

Current estimates for additional revenue to Umatilla County is ~\$100,000 per year.

Alternatives and Recommendation

Alternatives

- 1. Adopt Resolution No. 2307 without modification.
- 2. Adopt Resolution No. 2307 with specific modifications.
- 3. Direct staff to make major changes to Resolution No. 2307 and bring back at a later date.

Recommended Action/Motion

Adopt Resolution No. 2307 without modification.

Submitted By: Byron D. Smith

RESOLUTION NO. 2307

A RESOLUTION TO CONSENT FOR INCLUSION OF TERRITORY IN UMATILLA COUNTY ROAD DISTRICT

WHEREAS, the Umatilla County Board of Commissioners is initiating the formation of the Umatilla County Road District, which will include all areas of the county, including those within incorporated cities; and

WHEREAS, the purpose of the district is to allow for additional federal funding for roads within the jurisdiction of Umatilla County and its road maintenance system; and

WHEREAS, the formation of the district will not include any request for a permanent tax rate and will not result in the addition to or increase in the rate of property taxes for property owners; and

WHEREAS, the district will not result in any impacts on cities, including any funding increases or decreases; and

WHEREAS, the Board of Commissioners will consider partnering with the City of Hermiston on roads within the City’s Urban Growth Boundary using these or other funds as appropriate; and

WHEREAS, the Board of Commissioners is requesting the consent of the City of Hermiston for inclusion of the property within its city limits to be part of the proposed district.

NOW, THEREFORE, THE CITY OF HERMISTON RESOLVES AS FOLLOWS:

1. That the City of Hermiston consents to the territory within the City of Hermiston to be included within the boundaries of the Umatilla County Road District.
2. That this resolution is effective immediately upon its passage.

PASSED by the Common Council this 12th day of February 2024.

SIGNED by the Mayor this 12th day of February 2024.

Dr. David Drotzmann, MAYOR

ATTEST:

Lilly Alarcon-Strong, CMC, CITY RECORDER



Where Life is Sweet

Mayor and Members of the City Council
STAFF REPORT
For the Meeting of February 12, 2024

Title/Subject

Resolution No. 2308 – A Resolution To Authorize Bonds for Various City Projects

Summary and Background

As described in detail during the council work session on January 22, 2024, there are five current building projects that are in various stages of development. In addition to those there is a building project at the Eastern Oregon Trade and Event Center (EOTEC) and one infrastructure project in the North Hermiston Urban Renewal Area. All seven of these projects need some level of financing to complete them. Below I will briefly summarize each of these projects and then talk in more detail about the proposed method to pay for these projects.

Civic Projects (Hacker Architects/CB Construction)

- Harkenrider Center
 - Build out the basement of the Harkenrider Center
 - Current Estimate - ~\$600,000
- City Hall – IT Space
 - Finish the “growth” space in the basement of City Hall
 - Current Estimate - ~\$300,000
- Library Phase II – Multi-Cultural Resource Center
 - Reconfigure Upstairs; Finish Downstairs
 - Current Estimate - ~\$4.5 million

Public Safety Center

- Police/Court/Fire Remodel (Schlager Zimmerman Architects/McCormack Construction)
 - Renovate Police Side; Incorporate former Court space
 - Add Space for Fire
 - Current Estimate - ~\$11.5 million
- Arc Remodel
 - Secure the outside of building
 - Provide additional electrical/internet
 - Current Estimate - ~\$650,000

EOTEC Barns Project (Knerr Construction)

- State Funding for fairgrounds (\$1.3 million)
- Extend two of three barns (beef and swine)
- Current Estimate - ~\$1.6 million

North Hermiston Urban Renewal Area (NHURA)

- Plan dictates road and water construction project including ROW acquisition and 395 Signalization
- Current Estimate - \$5 million

Tie-In to Council Goals

2023 Goal 3 Sustainable; Focus Area City Facilities

3.1, 3.2, 3.3 are all related to these facilities

Fiscal Information

Total Borrowing is \$20,000,000. That is more than just adding up the current estimates. Will allow early repayment.

See Attached Spreadsheet.

Alternatives and Recommendation

Alternatives

1. Adopt Resolution No. 2308 without modification.
2. Adopt Resolution No. 2308 with specific modifications.
3. Direct staff to make major changes to Resolution No. 2308 and bring back at a later date.

Recommended Action/Motion

Adopt Resolution No. 2308 without modification.

Submitted By: Byron D. Smith

	1	2	3	4	5	6	7	8	9
Revenues	FY2020	FY2021	FY2022	FY2023	FY2024	FY2025	FY2026	FY2027	FY2028
Umatilla County	\$ 500,000	\$ 500,000	\$ 500,000	\$ 500,000	\$ 500,000	\$ 400,000	\$ 400,000	\$ 400,000	\$ 400,000
Lamb Weston	\$ 500,000	\$ 500,000	\$ 500,000	\$ 500,000	\$ 500,000	\$ 500,000	\$ 500,000	\$ 500,000	\$ 500,000
PDX 138							\$ 1,000,000	\$ 1,000,000	\$ 1,500,000
PDX 245					\$ 2,500,000			\$ 1,000,000	\$ 1,000,000
PDX 146								\$ 2,500,000	
Gross Revenue	\$ 1,000,000	\$ 1,000,000	\$ 1,000,000	\$ 1,000,000	\$ 3,500,000	\$ 900,000	\$ 1,900,000	\$ 5,400,000	\$ 3,400,000
Liabilities									
IFA (Water Tower)	\$ (162,784)	\$ (377,484)	\$ (377,484)	\$ (377,484)	\$ (377,484)	\$ (377,484)	\$ (377,484)	\$ (377,484)	\$ (377,484)
Recreation Projects Fund	\$ (50,000)	\$ (50,000)	\$ (50,000)	\$ (50,000)	\$ (50,000)	\$ (50,000)	\$ (50,000)	\$ (50,000)	\$ (50,000)
City Hall Debt		\$ (460,825)	\$ (460,825)	\$ (460,825)	\$ (460,825)	\$ (460,825)	\$ (460,825)	\$ (460,825)	\$ (460,825)
Civic Project Debt						\$ (1,100,000)	\$ (1,100,000)	\$ (1,100,000)	\$ (1,100,000)
Gross Liabilities	\$ (212,784)	\$ (888,309)	\$ (888,309)	\$ (888,309)	\$ (888,309)	\$ (1,988,309)	\$ (1,988,309)	\$ (1,988,309)	\$ (1,988,309)
Annual Net Revenue	\$ 787,216	\$ 111,691	\$ 111,691	\$ 111,691	\$ 2,611,691	\$ (1,088,309)	\$ (88,309)	\$ 3,411,691	\$ 1,411,691
Cumulative Revenue	\$ 787,216	\$ 898,907	\$ 1,010,598	\$ 1,122,289	\$ 3,733,980	\$ 2,645,671	\$ 2,557,362	\$ 5,969,053	\$ 7,380,744

	10	11	12	13	14	15	16	17	18
Revenues	FY2029	FY2030	FY2031	FY2032	FY2033	FY2034	FY2035	FY2036	FY2037
Umatilla County	\$ 400,000	\$ 400,000	\$ 500,000	\$ 500,000	\$ 500,000	\$ 500,000			
Lamb Weston	\$ 500,000	\$ 500,000	\$ 500,000	\$ 500,000	\$ 500,000	\$ 500,000			
PDX 138	\$ 2,000,000	\$ 2,000,000	\$ 2,000,000	\$ 2,000,000	\$ 2,000,000	\$ 2,000,000	\$ 2,000,000	\$ 2,000,000	\$ 2,000,000
PDX 245	\$ 1,500,000	\$ 2,000,000	\$ 2,000,000	\$ 2,000,000	\$ 2,000,000	\$ 2,000,000	\$ 2,000,000	\$ 2,000,000	\$ 2,000,000
PDX 146	\$ 1,000,000	\$ 2,000,000	\$ 2,000,000	\$ 2,000,000	\$ 2,000,000	\$ 2,000,000	\$ 2,000,000	\$ 2,000,000	\$ 2,000,000
Gross Revenue	\$ 5,400,000	\$ 6,900,000	\$ 7,000,000	\$ 7,000,000	\$ 7,000,000	\$ 7,000,000	\$ 6,000,000	\$ 6,000,000	\$ 6,000,000
Liabilities									
IFA (Water Tower)	\$ (377,484)	\$ (377,484)	\$ (377,484)	\$ (377,484)	\$ (377,484)	\$ (377,484)	\$ (377,484)		
Recreation Projects Fund	\$ (50,000)	\$ (50,000)	\$ (50,000)	\$ (50,000)	\$ (50,000)	\$ (50,000)	\$ -	\$ -	\$ -
City Hall Debt	\$ (460,825)	\$ (460,825)	\$ (460,825)	\$ (460,825)	\$ (460,825)	\$ (460,825)	\$ (460,825)	\$ (460,825)	\$ (460,825)
Civic Project Debt	\$ (1,100,000)	\$ (1,100,000)	\$ (1,100,000)	\$ (1,100,000)	\$ (1,100,000)	\$ (1,100,000)	\$ (1,100,000)	\$ (1,100,000)	\$ (1,100,000)
Gross Liabilities	\$ (1,988,309)	\$ (1,988,309)	\$ (1,988,309)	\$ (1,988,309)	\$ (1,988,309)	\$ (1,988,309)	\$ (1,938,309)	\$ (1,560,825)	\$ (1,560,825)
Annual Net Revenue	\$ 3,411,691	\$ 4,911,691	\$ 5,011,691	\$ 5,011,691	\$ 5,011,691	\$ 5,011,691	\$ 4,061,691	\$ 4,439,175	\$ 4,439,175
Cumulative Revenue	\$ 10,792,435	\$ 15,704,126	\$ 20,715,817	\$ 25,727,508	\$ 30,739,199	\$ 35,750,890	\$ 39,812,581	\$ 44,251,756	\$ 48,690,931

	19	20	21	22	23	24	25	26	27	28
Revenues	FY2038	FY2039	FY2040	FY2041	FY2042	FY2043	FY2044	FY2045	FY2046	FY2047
Umatilla County										
Lamb Weston										
PDX 138	\$ 2,000,000	\$ 2,000,000	\$ 2,000,000							
PDX 245	\$ 2,000,000	\$ 2,000,000	\$ 2,000,000	\$ 2,000,000						
PDX 146	\$ 2,000,000	\$ 2,000,000	\$ 2,000,000	\$ 2,000,000	\$ 2,000,000	\$ 2,000,000				
Gross Revenue	\$ 6,000,000	\$ 6,000,000	\$ 6,000,000	\$ 4,000,000	\$ 2,000,000	\$ 2,000,000	\$ -	\$ -	\$ -	\$ -
Liabilities										
IFA (Water Tower)										
Recreation Projects Fund	\$ -	\$ -	\$ -	\$ -	\$ -	\$ -	\$ -	\$ -	\$ -	\$ -
City Hall Debt	\$ (460,825)	\$ (460,825)	\$ (460,825)	\$ (460,825)	\$ (460,825)	\$ (460,825)	\$ (460,825)	\$ (460,825)	\$ (460,825)	\$ (460,825)
Civic Project Debt	\$ (1,100,000)	\$ (1,100,000)	\$ (1,100,000)	\$ (1,100,000)	\$ (1,100,000)	\$ (1,100,000)	\$ (1,100,000)	\$ (1,100,000)	\$ (1,100,000)	\$ (1,100,000)
Gross Liabilities	\$ (1,560,825)	\$ (1,560,825)	\$ (1,560,825)	\$ (1,560,825)	\$ (1,560,825)	\$ (1,560,825)	\$ (1,560,825)	\$ (1,560,825)	\$ (1,560,825)	\$ (1,560,825)
Annual Net Revenue	\$ 4,439,175	\$ 4,439,175	\$ 4,439,175	\$ 2,439,175	\$ 439,175	\$ 439,175	\$ (1,560,825)	\$ (1,560,825)	\$ (1,560,825)	\$ (1,560,825)
Cumulative Revenue	\$ 53,130,106	\$ 57,569,281	\$ 62,008,456	\$ 64,447,631	\$ 64,886,806	\$ 65,325,981	\$ 63,765,156	\$ 62,204,331	\$ 60,643,506	\$ 59,082,681

	29	30	31	32	33	34	35	36
Revenues	FY2048	FY2049	FY2050	FY2051	FY2052	FY2053	FY2054	FY2055
Umatilla County								
Lamb Weston								
PDX 138								
PDX 245								
PDX 146								
Gross Revenue	\$ -	\$ -	\$ -	\$ -	\$ -	\$ -	\$ -	\$ -
Liabilities								
IFA (Water Tower)								
Recreation Projects Fund	\$ -	\$ -	\$ -	\$ -	\$ -			
City Hall Debt	\$ (460,825)	\$ (460,825)	\$ (460,825)					
Civic Project Debt	\$ (1,100,000)	\$ (1,100,000)	\$ (1,100,000)	\$ (1,100,000)	\$ (1,100,000)	\$ (1,100,000)	\$ (1,100,000)	\$ (1,100,000)
Gross Liabilities	\$ (1,560,825)	\$ (1,560,825)	\$ (1,560,825)	\$ (1,100,000)	\$ (1,100,000)	\$ (1,100,000)	\$ (1,100,000)	\$ (1,100,000)
Annual Net Revenue	\$ (1,560,825)	\$ (1,560,825)	\$ (1,560,825)	\$ (1,100,000)	\$ (1,100,000)	\$ (1,100,000)	\$ (1,100,000)	\$ (1,100,000)
Cumulative Revenue	\$ 57,521,856	\$ 55,961,031	\$ 54,400,206	\$ 53,300,206	\$ 52,200,206	\$ 51,100,206	\$ 50,000,206	\$ 48,900,206

RESOLUTION NO. 2308

A RESOLUTION AUTHORIZING THE EXECUTION AND DELIVERY OF FULL FAITH AND CREDIT OBLIGATIONS TO FINANCE CAPITAL PROJECTS; AUTHORIZING AN INTERGOVERNMENTAL AGREEMENT WITH THE AGENCY; DESIGNATING AN AUTHORIZED REPRESENTATIVE; AND RELATED MATTERS.

RECITALS:

- A. City of Hermiston, Umatilla County, Oregon (the “**City**”), is authorized by Oregon Revised Statutes (“**ORS**”) Sections 271.390 and 287A.315 to (i) enter into financing agreements to finance and refinance real and personal property that the City determines is needed, (ii) pledge its full faith and credit, and (iii) pay the costs of issuance of such financing agreements; and
- B. The Charter of the City does not (1) prohibit the City from entering into a financing agreement and pledging its full faith and credit as security for a financing agreement, nor (2) require a non-appropriation clause to be included in a financing agreement; and
- C. The City has determined that capital projects are needed including improving, constructing, and equipping the Library, City Hall, Public Safety Center, park and recreation buildings, Eastern Oregon Trade and Event Center, streets, water system and related improvements (collectively, the “**Projects**”); and
- D. Street and water improvement projects are included in the North Hermiston Urban Renewal Plan and Report (the “**North Plan**”) of the Urban Renewal Agency of the City of Hermiston (the “**Agency**”).
- E. The City anticipates incurring expenditures (the “**Expenditures**”) to finance the costs of the Projects and wishes to declare its official intent to reimburse itself for any Expenditures it may make from City funds on the Projects from the proceeds of a financing agreement, the interest on which may be excluded from gross income under Section 103 of the Internal Revenue Code of 1986, as amended (the “**Code**”); and
- F. The City desires to authorize the execution and delivery of a financing agreement(s) to finance the Projects and related matters.
- G. The City further desires to enter into an intergovernmental agreement(s) (the “**2024 IGA**”) with the Agency to receive funds from the Agency to repay the portion of the Agreement allocable to projects in the North Plan including the street and water projects and costs incidental thereto (the “**Agency Projects**”).

- H. The estimated weighted average life of the financing agreement will not exceed the estimated dollar weighted average life of the Projects; and
- I. The Agreement will be issued as a full faith and credit obligation of the City, secured by the general, non-restricted revenues of the City and other funds that may be available for that purpose, including taxes levied within the restrictions of Sections 11 and 11b, Article XI of the Constitution of the State of Oregon.

NOW, THEREFORE, THE CITY OF HERMISTON RESOLVES AS FOLLOWS:

Section 1. Authorization. The Council of the City hereby authorizes:

A. Financing Agreement. The City authorizes the execution and delivery of one or more full faith and credit financing agreements (the “**Financing Agreement**”) in a form satisfactory to the Authorized Representative (defined herein). The aggregate principal amount of the Financing Agreement may not exceed \$20,000,000 and the proceeds shall be used to finance the Projects. The Financing Agreement may consist of one or more financing agreements and may be issued as taxable and/or tax-exempt obligations at true effective rates as determined by the Authorized Representative and shall mature on date(s) set by the Authorized Representative.

B. Method of Sale. As determined by the Authorized Representative, the Financing Agreement may be entered into directly with a lender (a “**Private Placement**”) and obligations representing the principal amount payable under the Financing Agreement may be sold to an underwriter by negotiated or competitive sale (a “**Public Offering**”).

C. Private Placement. The Financing Agreement may be evidenced by a note and may be entered into with a lender(s) as determined by the Authorized Representative.

D. Public Offering. The Financing Agreement may be issued through a Public Offering. If the Financing Agreement is issued through a Public Offering, the City authorizes the issuance and sale of Full Faith and Credit Obligations, Series 2024 (the “**Series 2024 Obligations**”) which shall be issued by the escrow agent (the “**Escrow Agent**”), for and on behalf of the City, representing the principal amount payable under the Financing Agreement. The Series 2024 Obligations may be issued in one or more series, shall be issued at a true effective rate as determined by the Authorized Representative and shall mature on dates set by the Authorized Representative. The City authorizes the execution and delivery of one or more escrow agreements between the City and the Escrow Agent (the “**Escrow Agreement**”), in a form satisfactory to the Authorized Representative, pursuant to which the Escrow Agent shall execute the Series 2024 Obligations representing the principal amount payable under the Financing Agreement, and evidencing the right of the Escrow Agent to receive the City’s financing payments under the Financing Agreement (the “**Financing Payments**”).

E. Intergovernmental Agreement. The City Council authorizes the 2024 IGA with the Agency for the Agency Projects and to receive funds from the Agency to repay the portion of the Financing Agreement allocable to the Agency Projects.

Section 2. Security.

The Financing Agreement shall be payable from the lawfully available, non-restricted funds of the City, including the unspent proceeds of the Financing Agreement, and other funds which may be available for that purpose, including taxes levied within the restrictions of Sections 11 and 11b, Article XI of the Constitution of the State of Oregon. The obligation of the City to make payments under the Financing Agreement shall be a full faith and credit obligation of the City, not subject to annual appropriation. The Financing Agreement shall not be secured by any real or personal property of the City. The City may issue additional agreements on parity with the Financing Agreement.

Section 3. Designation of Authorized Representative.

The City Council of the City hereby authorizes the City Manager or the Assistant City Manager (the “**Authorized Representative**”) to act as the authorized representative on behalf of the City and determine the remaining terms of the Financing Agreement as delegated herein.

Section 4. Delegation of Final Terms of the Financing Agreement and Additional Documents.

The Authorized Representative is authorized, on behalf of the City, to:

A. determine the method of sale, determine the provisions of the notice of sale if sold at a competitive sale, act upon bids received, negotiate the terms of, and execute and deliver a purchase agreement if sold at a negotiated sale, and negotiate the terms of, and execute and deliver documents if privately placed with a lender.

B. establish the maturity and interest payment dates, dated dates, principal amounts, capitalized interest (if any), optional and/or mandatory redemption provisions, interest rates, draw-down provisions, amortization schedules, covenants, fees, denominations, and all other terms under which the Financing Agreement and Series 2024 Obligations shall be issued, sold, executed, and delivered;

C. negotiate the terms and approve of the Financing Agreement and the Escrow Agreement, if applicable, as the Authorized Representative determines to be in the best interest of the City, and to execute and deliver the Financing Agreement and the Escrow Agreement;

D. deem final, approve of and authorize the distribution of any preliminary and final Official Statements to prospective purchasers of the Series 2024 Obligations;

E. determine whether the Series 2024 Obligations shall be Book-Entry certificates and to take such actions as are necessary to qualify the Series 2024 Obligations for the Book-Entry System of DTC, including the execution of a Blanket Issuer Letter of Representations;

F. apply for ratings for the Series 2024 Obligations and determine whether to purchase municipal bond insurance or other credit enhancement, negotiate and enter into agreements with providers of credit enhancers, and expend proceeds to pay credit enhancement fees;

G. determine if the Financing Agreement will be issued on a tax-exempt basis and/or a taxable basis; and all other terms of the Financing Agreement and approve, execute and deliver the Financing Agreement;

H. designate the Financing Agreement and the Series 2024 Obligations as a “qualified tax-exempt obligation” pursuant to Section 265(b)(3) of the Internal Revenue Code of 1986, as amended (the “Code”) if they qualify for such designation;

I. approve, execute and deliver a Tax Certificate for that portion of the Financing Agreement issued on a tax-exempt basis;

J. approve, execute and deliver a continuing disclosure certificate pursuant to SEC Rule 15c2-12, as amended (17 CFR Part 240, §240.15c2-12) for each series of Series 2024 Obligations;

K. engage the services of any professionals whose services the Authorized Representative determines are necessary or desirable for the Series 2024 Obligations;

L. determine which fund or funds are available to pay the Financing Agreement;

M. negotiate the terms of and enter into the 2024 IGA with the Agency;

N. execute and deliver a certificate specifying the action taken pursuant to this Resolution, and any other documents, agreements or certificates that the Authorized Representative determines are necessary and desirable to issue, sell and deliver the Financing Agreement and Series 2024 Obligations in accordance with this Resolution; and

O. take any other actions which the Authorized Representative determines are necessary or desirable to finance the Project in accordance with this Resolution.

Section 5. Maintenance of Tax-Exempt Status.

The City hereby covenants for the benefit of the Owners of the Financing Agreement issued on a tax-exempt basis to use the Financing Agreement proceeds and the Projects financed with such proceeds in the manner required, and to otherwise comply with

all provisions of the Code, which are required so that interest paid on the Financing Agreement will not be includable in gross income of the Owners of such Financing Agreement for federal income tax purposes. The City makes the following specific covenants with respect to the Code:

- A. The City will not take any action or omit any action if it would cause the Financing Agreement to become “arbitrage bonds” under Section 148 of the Code.
- B. The City shall operate the Projects financed with a tax-exempt Financing Agreement so that the Financing Agreement does not become a “private activity bond” within the meaning of Section 141 of the Code.
- C. The City shall comply with appropriate Code reporting requirements.
- D. The City shall pay, when due, all rebates and penalties with respect to the Financing Agreement which are required by Section 148(f) of the Code.

The covenants contained in this Section 5 and any covenants in the closing documents for the Financing Agreement shall constitute contracts with the owners of the Financing Agreement, and shall be enforceable by them. The Authorized Representative may enter into covenants on behalf of the City to protect the tax-exempt status of the Financing Agreement.

Section 6. Conditional Notice of Optional Redemption.

Any notice of optional redemption to the Paying Agent or to the Owners may state that the optional redemption is conditional upon receipt by the Paying Agent of moneys sufficient to pay the redemption price of such Series 2024 Obligations or upon the satisfaction of any other condition, and/or that such notice may be rescinded upon the occurrence of any other event, and any conditional notice so given may be rescinded at any time before payment of such redemption price if any such condition so specified is not satisfied or if any such other event occurs. Notice of such rescission or of the failure of any such condition shall be given by the Paying Agent to affected Series 2024 Owners of Obligations as promptly as practicable upon the failure of such condition or the occurrence of such other event.

Section 7. Appointment of Placement Agent/Underwriter.

The City appoints Piper Sandler & Co. as placement agent/underwriter for the issuance of the Financing Agreement and the Series 2024 Obligations.

Section 8. Continuing Disclosure.

The City covenants and agrees to comply with and carry out all of the provisions of any Continuing Disclosure Agreement which may be negotiated with the underwriter. Notwithstanding any other provision of this Resolution, failure by the City to comply with

the Continuing Disclosure Agreement will not constitute an event of default; however, owners may take such actions as may be necessary and appropriate, including seeking mandate or specific performance by court order, to cause the City to comply with its obligations under this Section and the Continuing Disclosure Certificate.

Section 9. Preliminary and Final Official Statement.

The City may prepare or cause to be prepared a preliminary official statement for the Series 2024 Obligations which shall be available for distribution to prospective purchasers. In addition, an official statement may be prepared and shall be ready for delivery to the purchasers of the Series 2024 Obligations no later than the seventh (7th) business day after the sale of the Series 2024 Obligations. When the City determines that the final official statement does not contain any untrue statement of a material fact or omit to state any material fact necessary to make the statements contained in the official statement not misleading in the light of the circumstances under which they are made, the Authorized Representative is authorized to certify the accuracy of the official statement on behalf of the City.

Section 10. Closing of the Financing Agreement.

The Authorized Representative is authorized to negotiate the terms and conditions of a term sheet or commitment letter in the case of a Private Placement or a purchase agreement in the case of a Public Offering. The Authorized Representative is authorized to execute the commitment letter or the purchase agreement, as the case may be, for and on behalf of the City and to execute such additional documents, including a Tax Certificate, and to perform any and all other things or acts necessary for the sale and delivery of the Financing Agreement or Series 2024 Obligations as herein authorized. Such acts of the Authorized Representative are for and on behalf of and are authorized by the Council of the City of the City.

Section 11. Resolution to Constitute Contract.

In consideration of the purchase and acceptance of any or all of the Financing Agreement or Series 2024 Obligations by those who shall own the same from time to time (the “Owners”), the provisions of this Resolution shall be part of the contract of the City with the Owners and shall be deemed to be and shall constitute a contract between the City and the Owners. The covenants, pledges, representations and warranties contained in this Resolution or in the closing documents executed in connection with the Financing Agreement or Series 2024 Obligations and the other covenants and agreements herein set forth to be performed by or on behalf of the City shall be contracts for the equal benefit, protection and security of the Owners, all of which shall be of equal rank without preference, priority or distinction of any of such Financing Agreement and Series 2024 Obligations over any other thereof, except as expressly provided in or pursuant to this Resolution.

Section 12. Bank Designation.

For purposes of paragraph (3) of Section 265(b) of the Code, the Authorized Representative is authorized to designate the Financing Agreement as a “qualified tax-exempt obligation” provided the Financing Agreement does not constitute a private activity bond as defined in Section 141 of the Code and not more than \$10,000,000 aggregate principal amount of obligations, the interest on which is excludable under Section 103(a) of the Code from gross income for federal income tax purposes (excluding, however, private activity bonds other than qualified 501(c)(3) bonds) including the Financing Agreement have been or reasonably expects to be issued by the City, including all subordinate entities of the City, if any, during the current calendar year in which the Financing Agreement is entered into.

Section 13. Defeasance.

A. If the Financing Agreement is issued through a Public Offering, the City may defease the Series 2024 Obligations by irrevocably depositing with the Escrow Agent or an independent escrow agent, Defeasance Obligations in such amount which will, together with the interest to accrue thereon, be sufficient to pay all Financing Payments attributable to such Obligations, as and when the same become due and payable, as evidenced by a verification report. Obligations which have been defeased shall cease and terminate, except for the obligation of the City to pay the Additional Charges specified in the Financing Agreement and to pay Financing Payments from the amount so deposited, and of the Escrow Agent to apply amounts on deposit to the payment of the Financing Payments. For the purposes of this section, “Defeasance Obligations” means non-callable direct obligations of the United States of America or obligations the principal of and interest on which are unconditionally guaranteed by the United States of America.

B. If the Financing Agreement is entered into directly with a lender in a Private Placement, paragraph A above does not apply and the Authorized Representative shall determine the requirements for defeasance.

Section 14. Post Issuance Compliance Procedures.

The Authorized Representative is authorized to adopt, or modify existing, procedures regarding post issuance compliance related to tax-exempt and taxable obligations of the City.

Section 15. Reimbursement.

The City hereby declares its official intent to reimburse itself with the proceeds of the Financing Agreement for any of Expenditures incurred by it prior to the issuance of the Financing Agreement.

Section 16. Effective Date.

This resolution shall take effect on the date of its adoption.

PASSED by the Common Council this 12th day of February 2024.

SIGNED by the Mayor this 12th day of February 2024.

Dr. David Drotzmann, MAYOR

ATTEST:

Lilly Alarcon-Strong, CMC, CITY RECORDER



Where Life is Sweet

Mayor and Members of the City Council
STAFF REPORT
For the Meeting of February 12, 2024

Title/Subject

Resolution 2309 – Designate No Parking W Dogwood Ave from NW Spruce St to NW 2nd St

Summary and Background

This resolution will designate both sides of W Dogwood Ave between NW Spruce Street and NW 2nd Street as “No Parking” zones. The designation is intended to assist in abating ongoing nuisance parking in this area. This portion of W Dogwood Avenue is a gravel street with no curbs, sidewalk, or other improvements. The wide right-of-way, lack of curb and gutter to establish firm travel lanes, industrial nature of the street, and isolated nature of this block all contribute to creating an attractive area for large vehicle parking, even leading to long-term on-street parking.

The no parking designation is recommended at this time to assist in moving vehicles off the road and discouraging using the road for long-term storage. The attached aerial photo and street view maps both show that the street is being used for storage with two detached trailers sitting on the street in the aerial photo and a parked truck in the street view. The use of the street for long-term parking has resulted in a significant volume of citizen complaints and use of staff time both at the code enforcement and police level to make contact with vehicle owners or occupants and move them along. The city has also incurred code enforcement expenses in having illegally parked trucks towed from the site. Designation as a no parking zone will make it easier to cite vehicles without requiring the 72-hour waiting period. Since no parking is designated by resolution, the council may remove the designation and allow on-street parking again in the future as the area develops and urban street improvements are installed.

Tie-In to Council Goals

The designation of this street as no parking ties into the council’s focus area for public safety.

Fiscal Information

There is no fiscal impact beyond the cost of sign installation.

Alternatives and Recommendation

Alternatives

The council may choose to:

- Adopt Resolution 2309 and designate this portion of W Dogwood Ave as “No Parking”
- Reject Resolution 2309 and continue to allow parking on W Dogwood Ave

Recommended Action/Motion

Motion to adopt Resolution 2309

Submitted By:

Clinton Spencer, Planning Director

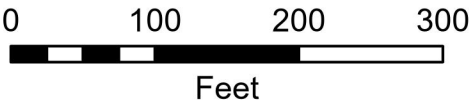
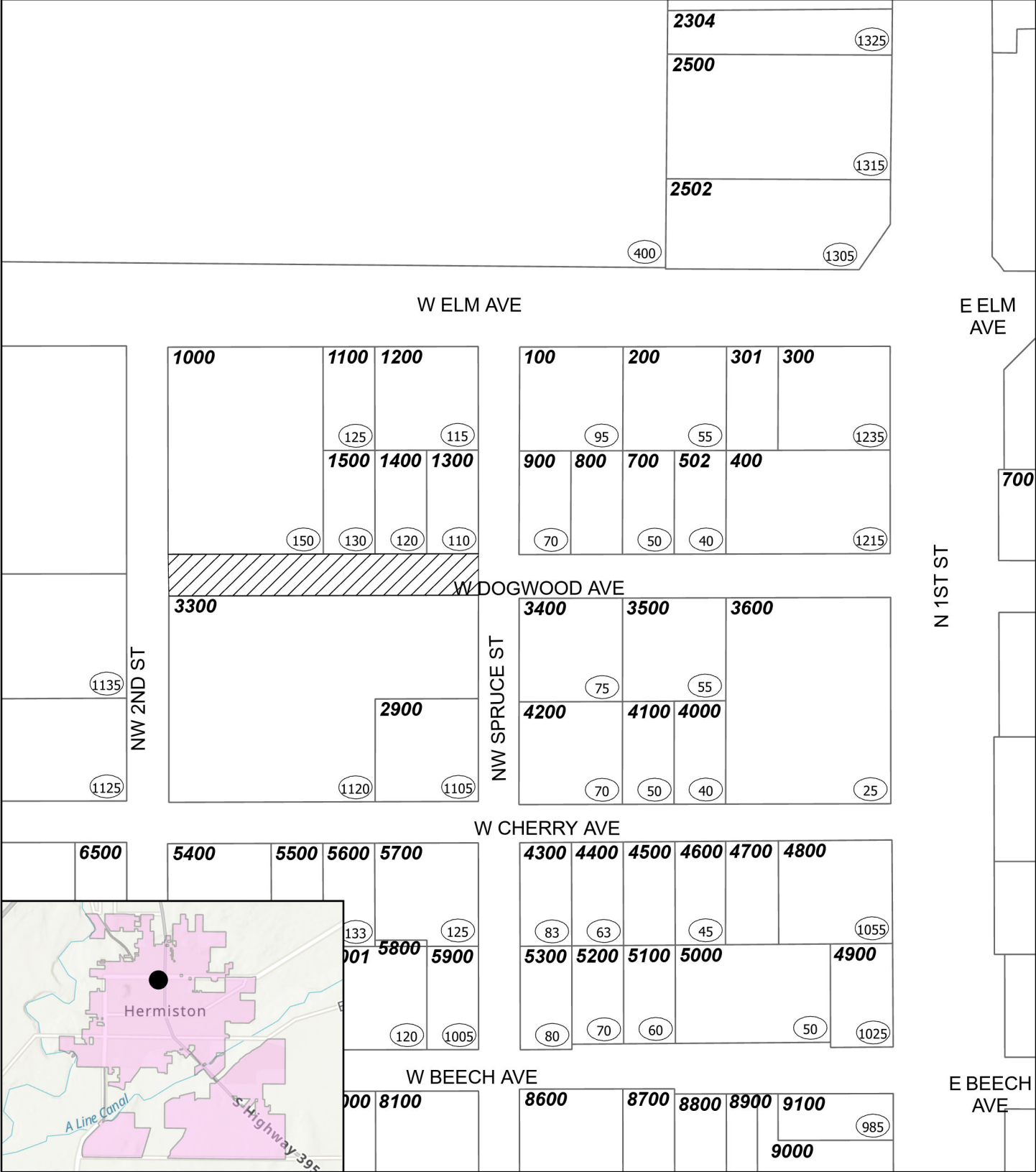

Legend
 No Parking Area
 Property Line



Aerial Photo
W Dogwood Ave No Parking



Street View
W Dogwood Ave No Parking



RESOLUTION NO. 2309

A RESOLUTION TO ESTABLISH A NO PARKING ZONE ON W DOGWOOD AVENUE

WHEREAS, pursuant to HMC §70.03, the City Council for the City of Hermiston shall exercise all local traffic authority to regulating the parking and standing of vehicles; and

WHEREAS, the area of W Dogwood Avenue between NW 2nd Street and NW Spruce Street has seen ongoing issues with illegal parking of vehicles and equipment; and

WHEREAS, it has been requested by City staff that “No Parking Zones” be established on W Dogwood Avenue between NW 2nd Street and NW Spruce Street to assist in abating ongoing nuisance parking.

NOW, THEREFORE, THE CITY OF HERMISTON RESOLVES AS FOLLOWS:

1. That it is expedient and necessary to establish “No Parking Zones” on both north and south sides of W Dogwood Avenue between NW 2nd Street and NW Spruce Street for vehicular traffic regulation in accordance with the provisions outlined in Section 70.03 of the Hermiston Municipal Code.
2. That this resolution is effective immediately upon its passage.

PASSED by the Common Council this 12th day of February 2024.

SIGNED by the Mayor this 12th day of February 2024.

Dr. David Drotzmann, MAYOR

ATTEST:

Lilly Alarcon-Strong, CMC, CITY RECORDER



Where Life is Sweet

Mayor and Members of the City Council
STAFF REPORT
For the Meeting of February 12, 2024

Title/Subject

Resolution #2310- Adopting the Revised City Design Standards and Specifications Manual

Summary and Background

The Design Standards and Specifications Manual establishes uniform standards for installation of utility and street infrastructure throughout the City. These standards are used by the City during system expansion or replacement projects, but also are used by private parties when a development occurs and needs connection to the street or utility networks.

City staff worked extensively with Anderson Perry & Associates to update this manual and specifications, which were adopted in 2022. The intent at the time was to begin updating this manual annually moving forward so that future updates aren't as large. Council adopted minor updates/revisions to the manual in 2023. This year's updates also mainly include a handful of small changes which were either recommended by city staff, or members of the development community, over the past year. Each update was reviewed by Anderson Perry and discussed internally with staff, and are now recommended for approval.

Tie-In to Council Goals

Day to Day Administration.

Fiscal Information

Adoption of this resolution is not anticipated to have any fiscal impact on the City.

Alternatives and Recommendation

Alternatives

1. Adoption of this resolution
2. Rejection of this resolution
3. Table this resolution

Recommended Action/Motion

Motion to approve Resolution 2310 as presented.

Submitted By:

Mark Morgan

RESOLUTION NO. 2310

A RESOLUTION ADOPTING THE REVISED CITY’S PUBLIC WORK STANDARDS, TECHNICAL SPECIFICATIONS, AND STANDARD DRAWINGS MANUAL

WHEREAS, it is necessary for the health and safety of the residents of the city that all public improvements be built to a uniform standard design in accordance with the best practices of engineering; and

WHEREAS, the engineering firm of Anderson Perry & Associates, Inc. have reviewed the existing standard plans and specifications and determined that revisions to the city’s Public Works Standards, Technical Specifications, and Standard Drawings manual are necessary to accommodate the changing patterns of development in the city; and

WHEREAS, the revised Public Works Standards, Technical Specifications, and Standard Drawings manual is attached hereto.

NOW, THEREFORE, THE CITY OF HERMISTON RESOLVES AS FOLLOWS:

- 1. That the attached revised Public Works Standards, Technical Specifications, and Standard Drawings manual is approved and adopted.
- 2. That this resolution is effective immediately upon its passage.

PASSED by the Common Council this 12th day of February 2024.

SIGNED by the Mayor this 12th day of February 2024.

Dr. David Drotzmann, MAYOR

ATTEST:

Lilly Alarcon-Strong, CMC, CITY RECORDER

CITY OF HERMISTON, OREGON

PUBLIC WORKS STANDARDS, TECHNICAL SPECIFICATIONS, AND STANDARD DRAWINGS

FEBRUARY 2024



180 N.E. 2nd Street
Hermiston, OR 97838

CITY OF HERMISTON, OREGON

**PUBLIC WORKS STANDARDS
TECHNICAL SPECIFICATIONS
AND STANDARD DRAWINGS**

FEBRUARY 2024



ANDERSON PERRY & ASSOCIATES, INC.

La Grande, Redmond, Hermiston, and Enterprise, Oregon
Walla Walla, Washington

TABLE OF CONTENTS
DESIGN STANDARDS AND SPECIFICATIONS

TITLE PAGE

RESPONSIBILITY STATEMENT FOR USE OF STANDARDS

STATEMENT OF UNDERSTANDING AND RULES FOR USE OF STANDARDS

SPECIFICATIONS

- General Requirements
- Technical Specifications
 - Section 1 Excavation and Grading
 - Section 2 Storm Drainage
 - Section 3 Sanitary Sewers
 - Section 4 Water Mains
 - Section 5 Streets

STANDARD DRAWINGS

- G01 General Notes and Index

- ST01 Curb and Gutter
- ST02 Cross Gutter Type I
- ST03 Cross Gutter Type II
- ST04 Sidewalk
- ST05 Driveway and Alley Ramps
- ST06 Curb Ramps
- ST07 Urban Major Arterial
- ST08 Urban Minor Arterial
- ST09 Urban Major Collector
- ST10 Urban Minor Collector
- ST11 Urban Local Street
- ST12 Urban Local Street with Swale
- ST13 Rural Arterial, Collector, and Local Roads
- ST14 Fire Apparatus Turnaround
- ST15 Alley
- ST16 Cul-de-Sac
- ST17 Pavement Striping and Markings
- ST18 Monument Box
- ST19 Signs
- ST20 Trench Bedding, Backfill, and Surface Restoration
- ST21 Erosion and Sediment Control

TABLE OF CONTENTS
DESIGN STANDARDS AND SPECIFICATIONS

- SD01 Storm Drain Catch Basin
- SD02 Storm Drain Manhole
- SD03 Sedimentation Chamber and Drywell

- SS01 Sanitary Sewer Manhole
- SS02 Pipe to Manhole Connections
- SS03 Outside Drop Manholes
- SS04 Sewer Cleanouts
- SS05 Sewer Service Connection
- SS06 Water-Sewer Crossing
- SS07 Water-Sewer Line Separation
- SS08 Sewer Service Curb Stamp

- W01 3/4" or 1" Water Service
- W02 1-1/2" or 2" Water Service
- W03 3" or Larger Water Service
- W04 Valve Box and Water Utility Marker
- W05 Water Main and Service Line Stubs
- W06 Water Main Tie-In
- W07 Fire Hydrant Assembly
- W08 Main Dead-End Blowoff Assembly
- W09 Combination Air Valve Assembly
- W10 Water Main Casing
- W11 Thrust Blocks
- W12 Pipe Slope Anchors
- W13 Water Service Curb Stamp
- W14 Chlorination and Bacteria Testing

**CITY OF HERMISTON, OREGON
PUBLIC WORKS STANDARDS
2024**

RESPONSIBILITY STATEMENT FOR USE OF STANDARDS

These City of Hermiston Public Works Standards, Technical Specifications, and Standard Drawings have been prepared by Anderson Perry & Associates, Inc., for exclusive use by the City of Hermiston, Oregon (City) on public works infrastructure projects within the City’s urban growth boundary that the City will own, operate, and maintain, and for any other project where conformance to these Public Works Standards, Technical Specifications, and Standard Drawings, in the opinion of the City, is essential for the protection of public safety and health. The Standards are intended to be general in nature and set minimum guidance for projects within the City. Use of these Standards, Technical Specifications, and Standard Drawings or any portion thereof on projects outside of the City is strictly prohibited without written approval of the City and Anderson Perry & Associates, Inc.

All users of these documents on projects within the City shall adapt these documents as needed to the specific project for which they will be used. The use of the City of Hermiston's Public Works Standards, Technical Specifications, and Standard Drawings, or modifications thereto, shall be stamped and signed by the responsible engineer and shall be submitted to the City for review prior to their use on a project within the City. When documents are submitted, the locations of proposed adaptations and/or deviations shall be clearly marked and/or noted in writing to expedite the review process.

All third-party users agree to indemnify, defend, and hold the City, and Anderson Perry & Associates, Inc., its partners, agents, and employees harmless from and against any and all claims, suits, demands, losses, and expenses including attorneys’ fees accruing or resulting from any and all persons, firms, or any other legal entity on account of any damage or loss to property or persons, including death, arising out of the result of utilizing these Standards, Technical Specifications, and Standard Drawings.

**CITY OF HERMISTON, OREGON
PUBLIC WORKS STANDARDS
2024**

STATEMENT OF UNDERSTANDING AND RULES FOR USE OF STANDARDS

This document is intended to set minimum standards for public work improvements within the urban growth boundary of the City of Hermiston, Oregon. These standards are not a substitution for professional experience. Sound engineering judgement must be exercised in the application to specific conditions. The City may vary or modify any of the City's Public Works Standards, on a case-by-case basis, if it is found that the strict application of the City's Public Works Standards is impractical or if it would result in hardship. Deviations from these specifications are subject to approval of the City.

The City of Hermiston Public Works Standards, Technical Specifications, and Standard Drawings will be incorporated in and made a part of any contract for the design and construction of a municipal project. The portions of this specification relating to design, easements, materials, and workmanship shall be adhered to for private developments where improvements will become part of municipally owned and operated systems. These Standards and Specifications will be updated periodically and, as such, all persons should ensure they are working with the most current set of Standards and Specifications.

Minimum general standards shall be as set forth in the current City of Hermiston Public Works Standards, Technical Specifications, and Standard Drawings.

No project or construction work that requires City inspection shall commence until the appropriate agreements have been signed, performance bonds submitted for work in a public right of way, final construction plans approved, preconstruction meeting held, all associated fees and deposits have been paid and 'Notice to Proceed' issued.

The Owner/Developer, or agent, will be responsible for any faulty material and workmanship for one year from the date of the formal acceptance of the sewer, street, water, storm drainage or other public facility installation. Final Acceptance of a project, or any portion of a project, shall be in writing from the City, and shall state any special conditions required for acceptance by the City.

The Owner/Developer, or agent, shall comply with all terms and conditions of applicable governmental rules and regulations pertaining to the work. The design and construction of all proposed facilities shall be in conformance with the City of Hermiston Public Works Standards, Technical Specifications, and Standard Drawings, and all standards and specifications referenced therein.

Workmanship and materials not conforming to these Standards and Specifications will be deemed a violation of City code and any associated agreement and may result in an immediate suspension of the Contractor's activities. When an authorized representative of the City suspends the Contractor's activities, all work shall cease on the subject project until the violation is corrected to the satisfaction of the City.

SPECIFICATIONS

GENERAL REQUIREMENTS

GENERAL REQUIREMENTS

TABLE OF CONTENTS

	Page GR-
A. General Standards.....	1
B. Project Work Meetings	27
C. Environmental and Other Special Requirements	27
D. Project Safety	27
E. Quality Control.....	28
F. Review of Work.....	34
G. Cooperation with Others	34
H. Existing Survey Monumentation.....	34
I. Existing Utilities.....	35
J. Progress of the Work - Cleanup	37
K. Permits	38

A. GENERAL STANDARDS

1.1 Authority and Purpose

Title V, IX, and XV of the Hermiston Code of Ordinances (Code) regulate construction and development. These Public Works Standards, Technical Specifications, and Standard Drawings implement the rules and policies contained in the Code.

The purpose of these Public Works Standards, Technical Specifications, and Standard Drawings is to provide a consistent policy under which certain physical aspects of public facility design and construction shall be implemented. Most of the elements contained in the Public Works Standards, Technical Specifications, and Standard Drawings are Public Works oriented and intended to be applied to both public improvements under City contract and public improvements under private contract designated herein.

These Public Works Standards, Technical Specifications, and Standard Drawings cannot provide for all situations. They are intended to assist but not to substitute for competent work by design professionals and experienced Contractors. It is expected that engineers and Contractors will bring to each project the best of skills from their respective disciplines.

These Public Works Standards, Technical Specifications, and Standard Drawings are not intended to unreasonably limit any innovative or creative effort that could result in better quality, better cost savings, or both. Any proposed departure from the Public Works Standards, Technical Specifications, and Standard Drawings will be judged, however, on the likelihood that such variances will produce a compensating or comparable result, in every way adequate for the user and City residents.

Alternate materials and methods will be considered for approval by the City as the need arises and conditions warrant modification. This consideration will be on a case-by-case basis and will require sufficient justification prior to approval (see subsection 1.5 below).

1.2 Engineering Policy

It shall be the policy of the City of Hermiston to require compliance with Oregon Revised Statutes, Chapter 672 for professional engineers.

All engineering plans, reports, or documents shall be prepared by a registered professional engineer (design engineer), or by a subordinate employee under the design engineer's direction, and shall be signed by the design engineer and stamped with the design engineer's seal to indicate the design engineer's responsibility for them. It shall be the design engineer's responsibility to review any proposed public facility extension, modification or other change with the City, prior to engineering or proposed design work, to determine any special requirements or whether the proposal is permissible. A

"Preliminary Review" and/or a "Plans Approved for Construction" stamp of the City, on the Plans, etc., for any job, does not in any way relieve the design engineer of responsibility to meet all requirements of the City or obligation to protect life, health, and property of the public. The Plan for any project shall be revised or supplemented at any time it is determined that the full requirements of the City have not been met.

1.3 Applicability

The Public Works Standards, Technical Specifications, and Standard Drawings contained herein shall govern all construction and upgrading of all public and privately financed public facilities in the City of Hermiston and applicable work within its service areas.

1.4 Standard Specifications

Except as otherwise provided by these Public Works Standards, Technical Specifications, and Standard Drawings, all construction, design, craftsmanship, materials, equipment, and details shall be in accordance with the current Oregon Standard Specifications for Construction and Standard Drawings as published by the Oregon Department of Transportation (ODOT) and American Public Works Association (APWA), Oregon Chapter.

1.5 Approval of Alternate Materials or Methods

Any alternate method or material not explicitly approved herein will be considered for approval as set forth in Section 1.1 of this section. Persons seeking such approvals shall make application in writing. Approval of any deviation from these Public Works Standards, Technical Specifications, and Standard Drawings shall be in written form. Approval of alternate methods and/or materials will be made in writing.

Alternates must meet or exceed the minimum requirements as set forth in these Public Works Standards, Technical Specifications, and Standard Drawings.

The written application is to include, but is not limited to, the manufacturer's specifications and testing results, design drawings, calculations, reason, justification, and other pertinent information.

Any deviations or special issues shall be reviewed on a case-by-case basis and approved by the City. When requested by the City, full design calculations shall be submitted for review with the request for approval.

1.6 Special Design Problems

Special applications not covered in these Public Works Standards, Technical Specifications, and Standard Drawings require review and approval by the City.

Submittal of full design calculations, supplemental drawings, and information will be required prior to any approval.

Applications requiring special review and approval may include, but are not limited to, the following:

- Sewer Force mains
- Relining of Existing Sewers
- Internal Sealing of Existing Sewers
- Sewage Pump Stations
- Sewer Siphons
- Sewage Treatment Plants
- Sewer Flow Measurement/Monitoring Devices
- Water Distribution Pump Stations
- Relining of Existing Water Mains
- Water Pressure Regulating Devices
- Energy Dissipaters
- Water Reservoirs
- Water Treatment Plants
- Water Flow Measurement/Monitoring
- Bridges
- Stormwater Pump Stations

1.7 Revisions to Public Works Standards, Technical Specifications, and Standard Drawings

Revisions to these Public Works Standards, Technical Specifications, and Standard Drawings are anticipated to be made from time to time. The date appearing on the bottom of each page is the date of the latest revision. Users should apply the latest published issue to the work contemplated.

Some sections may be changed more than once and it shall be the user's responsibility to maintain his/her copy of these Public Works Standards, Technical Specifications, and Standard Drawings with the latest changes.

1.8 Definitions

Alley - A public access easement or right-of-way (ROW) not more than 20 feet and not less than 12 feet in width, which intersects with a public street.

Approval - The proposed work or completed work conforms to these Public Works Standards, Technical Specifications, and Standard Drawings in the opinion of the City. Approvals shall not be considered valid unless given in writing by the appropriate City Representative.

Approved Back Flow Prevention Device - A device that has been investigated and approved by the Oregon Health Authority - Drinking Water Services.

Arterial Street - A street intended to carry large volumes of traffic at steady speeds with minimum interruptions to traffic flow.

As-Graded - The extent of the surface conditions on completion of grading.

Backflow - The flow of water or other liquids, mixtures, or substances into the distributing pipes of a potable supply of water from any sources other than its intended source.

Backflow Preventer - A device or means to prevent backflow into the potable water system.

Back Siphonage - The flowing back of used, contaminated, or polluted water from a plumbing fixture or vessel into a water supply pipe due to a negative pressure in such pipes.

Bedrock - In-place solid rock typically underlying soil layers.

Bench - A relatively level step excavated into earth material where fill is to be placed.

Bike Lanes - A designated travel-way for bicyclists that is located within the roadway directly adjacent to the outside vehicular lane or on the shoulder.

Bike Path - A designated travel-way for bicycling that is completely separated from the vehicular travel lanes and is within independent ROWs.

Bike Route - A designated travel-way for bicyclist that is shared with vehicular traffic. The roadway is designated with signs for bicycling (no pavement markings for the bike route or delineation of parking spaces are used).

Borrow - Earth material acquired from an off-site location for use in grading on a site.

City - The City of Hermiston, Oregon, and/or City Representatives from the City of Hermiston, Oregon.

City Representative - The City Manager and the Assistant City Manager are the primary City Representatives. All department heads are also City Representatives in matters relating to their department by delegated authority from the City Manager and Assistant City Manager. Department heads may assign City Representative responsibilities to qualified individuals within their respective departments as needed.

Collection Systems - Facilities maintained by the City and connected thereto for collecting, pumping, conveying, and controlling the sewer.

Collector Sewer - The portion of the public sewerage system that is primarily installed to receive sewer water directly from individual residences and other individual public or private structures.

Collector Street - Street which forms the boundary of major blocks of land and is intended primarily for inter-neighborhood traffic; can function as a road to service areas from the arterial system.

Compaction - The densification of earth material by mechanical means.

Core - To cut and remove a circular portion of concrete, pavement, pipe, or soil.

Cross Connection - Any connection or arrangement, physical or otherwise, between a potable water supply system and any plumbing fixture or any tank, receptacle, equipment or device, through which it may be possible for non-potable, used, unclean, polluted and contaminated water, or other substances, to enter into any part of such potable water system under any condition.

Cul-de-sac - A dead-end street having a turnaround area at the end.

Curb - The line indicating the edge of the vehicular roadway within the overall ROW.

Cut Sheets - Sheets of tabulated data indicating stationing, structures, fittings, angle points, beginning of curve, points on curve, end of curves, storm drain slope, staking offset, various elevations, offset cuts, and storm drain depths for streets, water lines, sanitary sewers, and storm drains.

Datum - The vertical elevation control for the City of Hermiston is "The North American Vertical Datum of 1988." The horizontal datum is State Plane Oregon North NAD83 expressed in international feet.

Dead-end Street - A street or series of streets that can be accessed from only one point. Dead-end streets can be either temporary (intended for future extension as part of a future street plan) or permanent.

Definition of Words - Whenever the words "directed," "required," "permitted," "ordered," "designated," or words of like importance are used in these Public Works Standards, Technical Specifications, and Standard Drawings, they shall be understood to mean the direction, requirement, permission, or order of designation of the City. Similarly, the words "approved," "acceptable," or "satisfactory," shall mean approved

by, acceptable to, or satisfactory to the City. All "approvals" shall be in writing or they shall not be considered approved.

Design Engineer - The engineer, licensed by the State of Oregon as a Professional Engineer, under whose direction the Plans for the work are prepared and submitted to the City for review and approval.

Designated Arterial or Collector Street - A street designated as an arterial or collector in the Comprehensive Plan.

Detention - The holding of runoff for a short period of time and then releasing it to the natural water course where it returns to the hydrologic cycle.

Domestic Sewage - The liquid and waterborne waste derived from the ordinary living processes, free from industrial wastes, and of such character to permit satisfactory disposal, without special treatment into the public sewer or by means of private sewage disposal system.

Double Check Detector Assembly (DCDA) - See Double Detector Check Valve Assembly (DDCVA).

Double Check Valve Assembly (DCVA) - An assembly composed of two single, independently acting, approved check valves, including tightly closing shut-off valves located at each end of the assembly and fitted with properly located test cocks.

Double Detector Check Valve Assembly (DDCVA) - A line-sized approved double check valve assembly with a parallel meter and meter-sized approved double check valve assembly. The purpose of this assembly is to provide backflow protection for the distribution system and at the same time provide metering of the fire system showing any system leakage or unauthorized use of water.

Drainage Facilities - Pipes, ditches, detention basins, creeks, culvert bridges, etc., used singularly or in combination with each other for the purpose of conveying or storing stormwater runoff.

Earth Material - Any rock, natural soil, or fill or any combination thereof.

Easement - Areas located outside of dedicated ROWs that are granted to the City for special uses.

Engineering Geologist - A geologist experienced and knowledgeable in engineering geology.

Engineering Geology - The application of geologic knowledge and principles in the investigation and evaluation of naturally occurring rock and soil for use in the design of civil works.

Erosion - The wearing away of the ground surface as result of the movement of wind, water, or ice.

Excavation - The mechanical removal of earth material.

Existing Grade - The grade prior to grading.

Expansion Joint - A joint to control cracking in the concrete surface structure and filled with preformed expansion joint filler.

Fill - The deposit of earth material placed by artificial means.

Finish Grade - The final grade of the site, which conforms to the approved plan.

Fire Hydrant Assembly - The fire hydrant, attached auxiliary valve, and associated piping and fittings.

Fire Protection System - Water line(s) with attached fire suppression infrastructure connected to a water fire service line and intended only for the extinguishing of fires and the necessary flushing for its proper maintenance.

Geotechnical Engineer - An engineer experienced and knowledgeable in the practice of geotechnical engineering.

Geotechnical Engineering - The application of the principles of soil mechanics in the investigation, evaluation, and design of civil works involving the use of earth materials and the inspection or testing of the construction thereof.

Grade - The degree of inclination of a road or slope, or the vertical location of the ground surface or the degree of inclination of a road or slope.

Grading - Any excavating or filling or combination thereof.

Groundwater - Water that exists underground in the cracks and voids of subsurface soil and rock.

Hydrant Lead - The water line connecting the fire hydrant to the auxiliary valve on the City distribution main.

Impervious Areas - Those hard surface areas located upon real property that either prevent or retard saturation of water into the land surface and cause water to run off

the land surface in greater quantities or at an increased rate of flow from that present under natural conditions preexisting to development.

Industrial Waste - Solid, liquid, or gaseous waste resulting from any industrial, manufacturing, trade, or business process or from development, recovery, or processing of natural resource.

Irrigation Service - A metered connection intended for seasonal use and delivering water not discharged to the sanitary sewer.

Local or Residential Street - A street designated to provide vehicular access to abutting properties and discourage through traffic.

Longitudinal Joint - A joint that follows a course approximately parallel to the centerline of the roadway.

Major Partition - A partition that includes the creation of a road or street.

Major Trees - Trees within the ROW that have a caliper of 4 inches or larger measured 18 inches above the existing ground. Street improvement plans will identify major trees by location, caliper, and species.

Major tree species are those that contribute to the landscape character of the area to include: Douglas Fir, cedar, redwood, sequoia, oak, ash, birch, walnut, and maple. The identification of major trees should distinguish species generally suitable for retention adjacent to streets and those species with growth habits that create nuisances, unusual maintenance problems, or hazards to the public.

Manufacturer's Name - Any manufacturer's name, specification, catalog, number, or type used herein is specified by make and order to establish the standard requirements of the City. Other equivalent makes will be considered for approval, providing they are comparable with this established standard.

Minor Partition - A partition that does not include the creation of a road or a street.

Natural Grade - The grade of the land in an undisturbed state.

On-Site Detention - The storage of excess runoff on the development site prior to its entry into a public storm drain system and gradual release of the stored runoff after the peak of the runoff has passed.

Oregon Plumbing Specialty Code - The Uniform Plumbing Code adopted by the current edition of the International Association of Plumbing and Mechanical Officials, as revised by the State of Oregon.

Owner - The owner of record of real property as shown on the latest tax rolls or deed records of the County, and includes a person who furnishes evidence that he/she is purchasing a parcel of property under a written recorded land sale contract.

Partition - To divide an area or tract of land into two or three parcels within a calendar year when such area or tract of land exists as a unit or contiguous units of land under single ownership at the beginning of such year.

Peak Runoff - The maximum water runoff rate in cubic feet per second (cfs) determined for the design storm.

Person - Individual, firm, corporation, association, agency, or other entity.

Plans - Construction plans, including system plans, sewer plans and profiles, cross sections, detailed drawings, specifications, etc., or reproductions thereof, approved or to be approved by the City, which show the location, character, dimensions, and details for the work to be performed, in which constitute a supplement to these Public Works Standards, Technical Specifications, and Standard Drawings.

Potable Water - Water that is satisfactory for drinking, culinary, and domestic purposes and meets the requirement of the health authority having jurisdiction.

Private Collection System - A privately owned and maintained sewer system installed to serve multi-unit structures on single ownership properties, which cannot legally be further divided.

Private Storm Drain - A storm drain located on private property serving more than one structure on the same premises or parking lot catch basins.

Professional Inspection - The inspection required to be performed by the design engineer, geotechnical engineer, or engineering geologist. Such inspections include that performed by persons supervised by such engineers or geologists and shall be sufficient to form an opinion relating to the conduct of the work.

Public Sanitary Sewer - Any sewer located in a public ROW or easement and operated and maintained by the City for carrying sewage and/or industrial waste.

Public Storm Drain - Any storm sewer located in a public ROW or easement and operated and maintained by the City.

Record Drawings - Plans signed and dated by the design engineer indicating that the Plans have been reviewed and revised, if necessary, to accurately show all as-built construction details and changes.

Reduced Pressure Backflow Assembly (RPBA) - A mechanical backflow preventer that consists of two independently acting, spring-loaded check valves with a hydraulically operating, mechanically independent, spring-loaded pressure differential relief valve between the check valves and below the first check valve. It includes shutoff valves at each end of the assembly and is equipped with test cocks. It is always installed above grade. Annual testing is required by the state and must be performed by a state-certified tester.

Release Rate - The controlled rate of release of drainage, storm, and runoff water from property, storage pond, runoff detention pond, or other facility during and following a storm event.

Right-of-Way - All land or interest therein which by deed, conveyance, agreement, easement, dedication, usage, or process of law is reserved for or dedicated to the use of the public for sidewalk, utility, and/or roadway/transportation purposes.

Roadway - All of that portion of the ROW used or to be used for vehicle movement, which exists between the curbs or proposed curb lines.

Rough Grade - The stage at which the grade approximately conforms to the approved plan.

Sedimentation - Disposition of erosional debris, soil sediment transported by water from a higher elevation to an area of lower gradient where sediments are deposited as a result of slack water.

Sewage - A combination of the water-carried wastes from residences, business buildings, institutions, and industrial establishments, except industrial wastes.

Sewer Line, Building - A private sanitary sewer line beginning 5 feet outside the building and extending to the property line or public easement line, connecting to the sewer service lateral.

Sewer Main - Any public pipe that conveys sewage and/or industrial waste toward the treatment plant.

Sewer Service Lateral - A private sanitary sewer line beginning at the property line or public easement line and extending to the sanitary sewer main. Also referred to as "sewer lateral."

Sewer Service Line - See Sewer Service Lateral.

Sidewalk - A walk or path along the side of a road for pedestrians. A ROW deeded, dedicated, and designated for the use of non-motorized vehicles and pedestrians.

GENERAL REQUIREMENTS

Silt - Fine textured soil particles including clay and sand as differentiated from coarse particles of sand and gravel.

Siltation - Deposition of (silt) waterborne sediments.

Slope -An inclined ground surface the inclination of which is expressed as a ratio of horizontal distance to vertical distance.

Soil - Naturally occurring superficial deposits overlying bedrock.

Standard Drawings - The drawings of structures or devices commonly used on public improvements and referred to on construction Plans.

Stormwater - Any water generated from a precipitation/storm event that has not yet infiltrated into the subsurface or run off into a body of surface water.

Streets or Roads - Any public highway, road, street, avenue, alleyway, easement, or ROW used or to be used for vehicle movement.

Structures - Those structures designated on the Plans such as catch basins, manholes, etc.

Subdivide - To divide an area or tract of land into four or more lots when such area or tract of land previously existed as a unit or contiguous units of land under a single ownership.

Subdivision - An area or tract of land that has been subdivided.

Super Elevation - The vertical distance between the heights of the inner and outer edges of a highway pavement with the cross slope of the highway being continuous across the entire width of the paved roadway.

Surface Water - Any permanent, semipermanent, or seasonal body of water found on the Earth's surface including rivers, streams, and lakes.

Terrace - A relatively level step constructed in the face of a graded slope surface for drainage and maintenance purposes.

Transverse Joint - A joint that follows a course approximately perpendicular to the centerline of the roadway.

Traveled Way - That portion of the roadway for the movement of vehicles, exclusive of shoulder and auxiliary lanes.

Trunk Sewer - The primary public sanitary sewer that conveys wastewater to the wastewater treatment plant and is primarily intended to receive wastewater from a collector sewer, another trunk sewer, an existing major discharger of raw or inadequately treated wastewater, or water pollution control facility.

Turnaround Area - An area of sufficient size and configuration that a motor vehicle may maneuver so as to travel in the opposite direction.

Underground Injection Control (UIC) System - A system that places fluids (mainly stormwater) below the ground and meets all requirements of the U.S. Environmental Protection Agency and the Oregon Department of Environmental Quality.

Wastewater - The total fluid flow in the sanitary sewerage system, which includes industrial waste-sewage or any other waste including that which may be combined with any groundwater, surface water, or stormwater that may be discharged into the sanitary sewerage system.

Water Distribution System - Water distribution pipelines, pumping stations, valves, and ancillary equipment used to transmit water from the supply source to the service line.

Water Fire Service Line - A water line connecting the public water main to a fire protection system. The line generally terminates or connects to a fire protection system at or near the property line or easement boundary.

Water Main - The water supply pipes for public or community use.

Water Main, Transmission - A water main whose primary purpose is to convey water from one location to another. Transmission water mains generally do not have water service lines connected to them.

Water Service Line - The pipe connection from the City water main to the user's water meter.

Water Supply Line - The pipe carrying potable water from the water meter or other source of water supply to a building or other point of use or distribution on the lot.

Wetlands - Those lands adjacent to watercourses or isolated therefrom which may normally or periodically be inundated by the waters from the watercourse or the drainage waters from the drainage basin in which it is located. These include swamps, bogs, sinks, marshes and lakes, all of which are considered to be part of the watercourse and drainage system of the City and shall include the headwater areas where the watercourse first surfaces. They may be, but are not necessarily, characterized by special vegetation or soils such as peat, muck, and mud. Wetlands shall include all areas identified by the National Wetlands Inventory. Any areas not included in the National

Wetlands Inventory and which, in the City's opinion, could be considered a wetland shall be identified and delineated by the developer.

1.9 Construction Plans

a. Plan Preparation

Construction Plans and specifications shall be prepared as specified in Sections b through i below by a professional engineer licensed in the State of Oregon.

b. General Information

Prior to any construction work and plan approval, complete construction Plans, specifications, stormwater calculations, and all other necessary submittals shall be submitted to the City for review.

c. Sheet Size

All construction Plans shall be clearly and legibly drawn in ink on Mylar sheets measuring 22 x 34 inches or other permanent paper stock that is approved by the City. Sheets shall have 1-1/2 inches of clear margin on the left edge and a 1/2-inch margin on all other edges.

d. Sets of Plans

When Plans are prepared for developer financed projects, the following scale of drawings is suggested.

Plan/Scale	Horizontal*	Vertical
Street	1 inch = 20 feet	1 inch = 5 feet
Sewer	1 inch = 20 feet	1 inch = 5 feet
Storm	1 inch = 20 feet	1 inch = 5 feet
Water	1 inch = 20 feet	1 inch = 5 feet

**When a scale is used that is smaller than 1 inch = 20 feet (i.e., 1 inch = 40 feet) intersection details showing fittings and valving shall be provided at a larger scale.*

Architectural scales (i.e., 1/4 inch = 1 foot, 0 inches) are not permitted unless otherwise approved.

GENERAL REQUIREMENTS

e. Required Sheets

Construction plan submittals shall contain the following minimum sheets: title sheet, plan and profile sheets, detail sheets, and inspection sheets.

f. Title Sheet

All subdivision projects and multiple street improvements projects shall have a title sheet as the first page of the construction Plans. This sheet shall contain the following minimum information.

- 1) Site Plans of the entire project with street ROW and/or subdivision layout at a 1 inch = 100 feet scale. A 1 inch = 200 feet scale may be used if project size is too large. The site plan shall also be a composite utility plan showing all properties served by proposed sewer, water, and storm facilities, in addition to the proposed facility and all easements. The site plan shall also include all adjacent public facilities within 100 feet of the proposed project.
- 2) Vicinity map at a 1 inch = 1,000 feet scale, or greater.
- 3) Index of sheets.
- 4) Complete legend of symbols, line types, and hatches used. Legend items shall clearly differentiate between existing and proposed improvements with proposed improvements being more prominent than existing improvements. All legend items shall be unique.
- 5) General and construction notes pertinent to project.
- 6) Temporary and/or permanent benchmarks used along with their descriptions, elevations of benchmark, and datum.
- 7) Horizontal and Vertical Coordinate Systems

The City requires the use of the Oregon State Plan North and the National American Vertical Datum of 1988.
- 8) Design engineer's name, address, phone number, and seal.
- 9) Developer's/owner's name, address, and phone number for public improvements with private financing.
- 10) Statement referencing City of Hermiston Public Works Standards, Technical Specifications, and Standard Drawings and the current Oregon Standard Specifications for Construction and Standard Drawings.

GENERAL REQUIREMENTS

- 11) Provide contact phone numbers for all affected utility companies.
- 12) Show tax lot numbers or lot and block designations.
- 13) A City Standard Drawing index for all referenced Standard Drawings.
- 14) A signature block for the design engineer's signature with the statement "I am certifying that I have contacted all of the impacted outside utility providers associated with this project. Furthermore, I will work with those utilities to ensure that their infrastructure will be addressed prior to the start of construction." The Developer is responsible for coordinating with each utility and meeting their established system requirements and review/approval processes separate from the City plan submission requirements. If utility information other than City-owned utilities are included on the design Drawings, the City will not review or otherwise be responsible for approval of outside utilities. For reference, the outside utilities, at a minimum, that this certification of acknowledgement covers are:
 - a) Hermiston Irrigation District
 - b) Hermiston Energy Services
 - c) Umatilla Electric Cooperative
 - d) Pacific Power
 - e) Cascade Natural Gas
 - f) Spectrum
 - g) CenturyLink/Lumen
 - h) Ziplly Fiber
 - i) Eastern Oregon Telecom
 - j) Blue Mountain Networks
 - k) Uni-Tech Communications
 - l) Windwave Communications

g. Plan Sheet

The plan view of each sheet shall be drawn at the appropriate scale showing the following minimum information:

- 1) Adjacent street curbs, property lines, ROW lines, utility easements referenced to property lines, street centerlines and intersections. Show property corner and curb elevations to determine water service level, serviceability of lot/property and sanitary sewer, points of disposal for building storm drains, and how new curbs will join to existing curbs.
- 2) Location of all underground utilities within 100 feet of the project (if they are affected by the project), existing power/telephone poles and guy anchors, valves, manholes, catch basins, fire hydrants, meter boxes, vaults, signs, etc.
- 3) Location of all watercourses, railroad crossings, culverts, bridges, major trees, water lines, sewer lines, and/or storm drain lines within 200 feet of proposed sewer and storm drain extensions if they affect the design of the project. All watercourses shall show the 100-year floodplain as indicated on the U.S. Army Corps of Engineers and Federal Emergency Management Agency (FEMA) maps.
- 4) On sewer and storm drain Plans, each manhole, catch basin, and cleanout shall be numbered and stationed. Stationing shall tie to existing street monuments, unless the City approves the use of property corners or manholes. Each line shall be stationed continuously upgrade from left to right on the plan sheet. Each separate line shall be individually designated (e.g., sewer line 'A', storm line 'A', etc.)
- 5) On street Plans, horizontal stationing shall show points of tangent and curvature for centerline curve data and shall show tangent length, radius distance, centerline curve length, and delta angle. Centerline intersection stationing, in both directions, shall be shown.
- 6) Where streets are being widened, edge of pavement elevations shall be shown to determine pavement cross-slope to new curb or pavement edge.
- 7) On water Plans, all fittings shall be shown and identified by type (i.e., MJ x MJ, FLG X MJ, etc.). Fire hydrants and intersection details for valves and fittings are required when scale of Plans is smaller than 1 inch = 20 feet (i.e., 1 inch = 40 feet). All valves, fittings, and pipe conditions shall be indicated.

GENERAL REQUIREMENTS

- 8) On erosion control Plans, the location of silt fences, inlet barriers, gravel entryways, temporary ditches and detention ponds, and surface preparation shall be shown. The plan shall show the entire development. Details of erosion control devices can be shown on this sheet.
- 9) All notes and keynotes shall reference appropriate City Standards and/or Drawings when applicable.

h. Profile Sheet

Profiles for construction Plans shall be the same horizontal scale as the plan sheet. Where profiles are drawn on the same sheet as the plan view, the profile shall be immediately below the plan view. Stationing shall be continuously upgrade from left to right with lower stations to the left. The following minimum information shall be shown:

- 1) For sewers and storm drains, show locations of manholes, catch basins, and cleanouts with each numbered and stationed as indicated in General Requirements, A. General Public Works Standards, Technical Specifications, and Standard Drawings, 1.9 Construction Plans, g. Plan Sheet, 4) above.
- 2) Existing profile at centerline of proposed utility or street.
- 3) Proposed profile grade, as appropriate, for all sewers, storm drains and water lines giving pipe size, length between structures, slope, surface restoration type, pipe materials, sewer inverts, rim elevations, etc.
- 4) Existing underground utilities that cross the alignment of the proposed facility.
- 5) Beginning of all vertical curves, points of vertical intersection, end of vertical curve, low point of sag curve and length of vertical curve. Profiles of existing centerline grade shall extend a minimum of 250 feet beyond the end of the improvement.
- 6) Clearly show all potential utility conflicts with appropriate pipes, conduits, vaults, etc., that affect the proposed design.
- 7) All notes and keynotes shall reference appropriate City Standards and/or Drawings when applicable.

Note: City Record Drawings are only to be used as an aid to the design engineer. When a potential conflict may occur, the design engineer shall field locate, or

GENERAL REQUIREMENTS

cause to be located, and verify the alignment, depth, and inverts of all existing facilities shown on the Plans that will be crossed by the proposed facility.

i. Detail Sheets

Detailed drawings shall be included with all construction Plans where Oregon or City Standard Drawings do not exist or apply. If a standard drawing must be modified to fit existing or unique conditions, the modified drawing shall be shown on the Plans. When appropriate, due to required detail complexity, a separate detail sheet shall be drawn. When Oregon or City Standard Drawings are used, they must be included with the Plan set. In lieu of including the actual Standard Drawings with the design documents, an index referencing all pertinent Standard Drawings with their specific drawing number(s) may be included on the title sheet.

j. Inspection Sheet

The inspection sheet shall have a list of all applicable inspections that will be performed by a City Representative or the design engineer. A general table of inspections is included below as a starting point. See General Requirements, Section K for more detail. This table shall be modified as needed to fit the scope of the project. The City may elect to waive this requirement when utilizing a project representative to oversee the project.

City Of Hermiston Public Improvements Inspection Checklist - 2024				
Project Name:				
Streets				
No.	Date	Inspection	Description	City Initials
1		Geotechnical Report	Geotechnical Report and special details review	
2		Trench and/or Fill Material Compaction	See City Standard Drawing ST20	
3		Subgrade	Load test with minimum 10-yard loaded dump truck	
4		Curb and Gutter Aggregate Base	See City Standard Drawing ST01	
5		Curb and Gutter Installation	Meeting with foreman prior to installation, observe process	
6		Curb and Gutter	See City Standard Drawing ST01	
7		Americans with Disabilities Act (ADA) Ramp Forms	Check slopes and layout	
8		ADA Ramps	Must meet ADA slope specifications (see City Standard Drawing ST06)	
9		Street Aggregate Base	Size, depth, 100 percent fractured face, compaction test results, 2.5 percent cross slope. See City Standard Drawings ST07 to ST13.	

GENERAL REQUIREMENTS

10		Sidewalk Forms	3/4"-0 at 4 inches deep, 100 percent fractured face, compaction test results, 1.5 percent cross slope	
11		Driveway Forms	3/4"-0 at 4 inches deep, 100 perfect fractured face, compaction test results, 6 inches thick	
12		Asphalt Concrete Pavement	Meet with crew prior to installation to review curb joint, roller pattern, and roller speed requirements, check mix temperature, no bones left on mat, 2.5 percent cross slope	
13		Sidewalk Completion	Two percent maximum cross slope, joint spacing, broomed finish, visual	
14		Driveway Completion	Sloped toward the right-of-way; width does not exceed maximum permitted width	
15		Substantial Completion	Create Punch List	
16		Final Completion	Punch List items completed	
Storm Drain				
No.	Date	Inspection	Description	City Initials
17		Erosion Control	Installed per Plans before construction begins	
18		Pipe Material	See City Technical Specifications	
19		Manhole Materials	Concentric cone, correct rim and cover, resilient connectors (see City Standard Drawing SD02)	
20		Catch Basin Materials	Correct size, correct casings (see City Standard Drawing SD01)	
21		Initial Pipe Install	Bedding, haunches, setting pipe, pipe zone, locating wire, backfill, compaction tests, and laser for grade (see City Standard Drawing ST20)	
22		First Manhole	Aggregate base, resilient connectors, channel, backfill, and compaction (see City Standard Drawing SD02)	
23		First Catch Basin	Aggregate base, location relative to top back of curb (see City Standard Drawing SD01)	
24		Swale Rough In	See City Standard Drawing ST12	
25		Swale Completion	1- to 1.5-inch clean basalt, 6 inches to fabric, correct fabric type (see City Standard Drawing ST12)	
26		Drywell	Holes, filter fabric, rock (see City Standard Drawing SD03)	
27		Manhole Test	See City Technical Specifications	
28		Pipe Pressure Test	See City Technical Specifications	
29		Pipe Mandrel Test	See City Technical Specifications	
30		Pipe Television (TV) Inspection	See City Technical Specifications	
31		Substantial Completion	Create Punch List	
32		Final Completion	Punch List items completed	
Sanitary Sewer				
No.	Date	Inspection	Description	City Initials
33		Geotechnical Report	Geotechnical Report and special details review	
34		Pipe Material	See City Technical Specifications	
35		Manhole Materials	Concentric cone, correct rim and cover, resilient	

GENERAL REQUIREMENTS

			connectors (see City Standard Drawing SS01)	
36		Initial Pipe Install	Bedding, haunches, setting pipe, pipe zone, locating wire, backfill, compaction tests, and laser for grade (see City Standard Drawing ST20)	
37		First Manhole	Aggregate base, resilient connectors, channel, backfill, and compaction (see City Standard Drawing SD02)	
38		First Service Lateral	Bedding and backfill, wye, service line marker, grade, tracer wire (see City Standard Drawing SS06)	
39		Manhole Test	See City Technical Specifications	
40		Pipe Pressure Test	See City Technical Specifications	
41		Pipe Mandrel Test	See City Technical Specifications	
42		Pipe TV Inspection	See City Technical Specifications	
43		Substantial Completion	Create Punch List	
44		Final Completion	Punch List items completed	
Water				
No.	Date	Inspection	Description	City Initials
45		Geotechnical Report	Geotechnical Report and special details review	
46		Pipe Material	Ductile iron (see City Technical Specifications)	
47		Valves, Fittings, and Other Materials	Compact fittings, valve type and product number, hydrant product, hydrant color (see City Technical Specifications)	
48		Water Main Tie-in	See City Standard Drawing W06	
49		Initial Pipe Install	Bedding, haunches, setting pipe, pipe zone, locating wire, backfill, compaction tests, and laser for grade (see City Standard Drawing ST20)	
50		First Valve/Fitting Install	See City Technical Specifications and City Standard Drawing W04	
51		First Service Line	See City Standard Drawings W01 to W03	
52		First Hydrant Install	See City Standard Drawing W07	
53		Pipe Pressure Test	See City Technical Specifications	
54		Disinfection and Bacteria Testing	See City Technical Specifications	
55		Substantial Completion	Create Punch List	
56		Final Completion	Punch List items completed	

Note: Inspections by City representatives are intended to be general in nature only and do not relieve the Contractor of their responsibility to complete the work in accordance with City Standards and Specifications and the design Drawings.

1.10 Supporting Information

The design engineer shall submit sufficient supporting information to justify the proposed design. Such information shall include, but not be limited to, the following:

- a. Design calculations.

- b. Hydrology and hydraulic calculations with basin maps. This includes storm drainage calculations.
- c. Alternate materials specifications including manufacturers' design application recommendations.
- d. Plan support information to include as required:
 - 1) Geotechnical Report
 - 2) Hydrology, hydraulic, and stormwater calculations
 - 3) Engineering Geology Report
 - 4) Traffic Impact Analysis

1.11 Utility Plan

When designing sanitary or storm sewer facilities, a utility plan shall be submitted with the construction Plans when required by the City. The utility plan shall be used to identify and analyze the extension of the proposed facilities and shall include a topographic plan. The topographic plan shall show all upstream and tributary areas within no less than 200 feet of the proposed development.

The utility plan shall include existing contours at 1 foot intervals, or as approved by the City. Include locations of existing structures and public and private utilities.

1.12 Plan Submittal

Plans for all privately financed Public Works facility improvements shall be submitted to the City. The City will coordinate the plan review and approval of all construction Plans, which will include reviews for compliance with all City Codes, Ordinances, Public Works Standards, Technical Specifications, and Standard Drawings, Oregon Standard Drawings, and utility master plans.

All Plan submittals shall include information required in General Requirements, 1.9 Construction Plans, along with all other information requested by the City. This information shall include, but is not limited to, construction cost estimates, easement documents, ROW dedications, and executed agreements. All submittals shall be reviewed by the design engineer for completeness and the City notified if required information is missing. Submittals should be made in a timely manner as lack of information to the City may impede the review process.

1.13 Public Improvement Procedure

The developers/Contractors of all major developments and subdivisions within the City are responsible for installation of public improvements within all newly proposed streets, all existing adjacent unimproved streets and off-site improvements determined by the City to be necessary for the functionality of the development and/or to mitigate development impacts. Public improvements shall include, but are not limited to:

- Street paving
- Storm drainage
- Curbs
- Sidewalks
- Gutters
- ADA ramps
- Bike paths
- Public water lines
- Public sewer lines
- Street lights
- Fire hydrants

In addition to the above listed improvements, it may be necessary to construct or contribute to the future construction of traffic signals, water or sewer pump stations, or future infrastructure upgrades such as pipe oversizing.

All applicants for development shall attend a pre-application meeting with City development staff. This meeting is intended to familiarize applicants with the development process and the City's Standard Drawings and specifications. All applications for development shall be accompanied by preliminary drawings for installation of public improvements. Drawings shall be prepared by an Oregon registered professional engineer and shall be in compliance with the current Public Works Standards, Technical Specifications, and Standard Drawings. Following approval of the proposed development by planning staff and/or the planning commission, public improvement plans shall be revised and receive final approval from development staff.

In most cases, the applicant will be required to enter into an improvement agreement with the City of Hermiston, agreeing to install all required improvements, specifying time frames for installation, and agreeing to future maintenance of said improvements. The improvement agreement must be completed prior to initiating construction within the development.

In lieu of installation of improvements in new subdivisions, an applicant may provide a letter of credit for 110 percent of the total cost of all improvements. After receipt of a letter of credit, the City will release the subdivision plat and construction of homes may

GENERAL REQUIREMENTS

begin and lots may be sold. However, the applicant must still work towards completion of all improvements and no Certificates of Occupancy will be released until all improvements are completed. Commercial and multi-family developments may construct buildings and public improvements concurrently, but also may not receive any Certificates of Occupancy until all public improvements are completed and accepted by the City.

All drainage improvements must be completed at the time any street is constructed, and sidewalk must be completed prior to any occupancy for which sidewalk is required.

Following completion of improvement installation, City Public Works staff will inspect all improvements. The City will generate a punch list of corrections needed and submit said list to the applicant. Following completion of all punch list items, the applicant may request re-inspection. Once the improvements are accepted by the City, the applicant must provide Record Drawings of all public improvements, prepared by the design engineer. The applicant must also provide a one-year maintenance bond for 25 percent of the cost of the installed improvements.

CHECKLIST FOR DESIGN DRAWING SUBMISSION, REVIEW, AND CONSTRUCTION

Action	Date
Attend Pre-Application Meeting	
Obtain Standard Plans and Specifications	
Submit Proposed Design Drawings with Erosion Control Plan	
Revised Design Drawings per City Comments*	
Resubmit Design Drawings as Required	
City Approves Design Drawings	
Sign Improvement Agreement	
Developer Schedules and Attends Pre-Construction Meeting with Selected Contractor	
Begin Construction of Improvements	
Submit Letter of Credit (if desired)	
Complete Testing of Improvements as Required	
Complete Construction of Improvements	
Call for Substantial Completion Inspection of Improvements	
City Issues Substantial Completion Punch List of Corrections	
Call for Reinspection	
City Approves Improvements	
Submit Record Drawings (see subsection 1.14 below)	

GENERAL REQUIREMENTS

Action	Date
Submit Maintenance Bond	
City Releases Certificate of Occupancy	

**All revised design drawings shall include revision numbers and dates, and all revisions shall be clouded. A document shall be provided with a specific written response to each review comment.*

1.14 Record Drawings

For all Public Works facility improvements, the design engineer shall submit certified Record Drawings for all Plans approved for construction. Record Drawings shall meet the requirements of Sections a through e of this section and shall be of archival quality. The Record Drawings shall be 4 mil Mylar with silver halide emulsion. Original inked Mylars may also be submitted in lieu of photographic Mylars on Mylar sheets. The design engineer may submit Record Drawings on another permanent paper as approved by the City.

The design engineer shall submit a signed statement certifying that all work for which Plans were approved has been completed in accordance with the Public Works Standards, Technical Specifications, Standard Drawings, and design documents. This statement shall be included directly on the Record Drawings. An example of an acceptable statement is shown below.

ENGINEER'S RECORD DRAWING CERTIFICATE
<p>Affidavit certifying Engineer's inspection of project to certify compliance with approved project Plans and Specifications.</p> <p>Engineering Firm:</p> <p>I, _____, an Oregon licensed Engineer, P.E. No. _____, do hereby certify that I possess the engineering qualification required by Oregon law and that all work performed relating to the provided professional services were performed by me or under my direct supervision.</p> <p>That to the best of my knowledge the project complies with the approved project Plans and Specifications.</p> <p>Dated _____</p> <p>_____</p> <p>Licensed Engineer</p>
ENGINEER'S NOTE
<p>The use of the word "certify" or "certification" within this certification only constitutes an expression of professional opinion regarding those facts and findings shown on this Drawing and does not constitute a warranty or guarantee, either implied or expressed.</p>

The words "Record Drawing" shall appear as the last entry in the revision block along with the month, day, and year the Record Drawing was prepared.

Note: Actual location and depth from finish grade of any other utilities encountered during construction shall be noted on the Record Drawings.

a. Sheets

The following minimum information shall be noted on the street Record Drawings:

- 1) Change in horizontal alignment, curve data, and stationing of primary control points (e.g., PC, PI, PT, PRC).
- 2) Vertical curve or grade changes; change in location of low point in sag vertical curve.
- 3) Change to approved thickness for street pavement section components. Show station limits where changes in structural section have occurred.
- 4) Change to driveway locations or widths.
- 5) Other change(s) altering the approved Plans including, but not limited to, curbs, sidewalks, street monuments, ADA ramps, and lighting.

b. Storm Drains

The following minimum information shall be noted on storm drain Record Drawings:

- 1) Station of drainage structures such as manholes and catch basins. Tie each drainage structure to nearest property corner ROW line, and distance back from the top back of curb.
- 2) Show alignment changes, grade changes, and changes in construction materials. If alignment changes result in station changes, a station equation shall be shown as appropriate at a manhole.
- 3) Other change(s) altering the approved Plans including, but not limited to, catch basin location, manhole location, pipe size, dry well location, etc.

c. Sanitary Sewers

The following minimum information shall be noted on sanitary sewer Record Drawings:

- 1) Station of manhole, wye, or tee into main line. Tie each to nearest property corner at ROW line, and distance back from the top back of curb.
- 2) Depth at the end of service lateral measured from existing ground to invert of pipe. When required by the City, invert elevations shall be noted.
- 3) Length of service lateral measured from centerline of sewer main to end of pipe.
- 4) Changes in alignment, grade, pipe size and construction materials. If such changes in alignment and/or grade result in station changes, the stationing and offsets shall be changed for the manholes and other structures affected by the changes.
- 5) Other change altering the approved Plans.
- 6) Type of pipe, backfill material, and location.

d. Water Mains

The following minimum information shall be noted on water main Record Drawings:

- 1) Station and/or property line/corner to valves (not at standard location), all fittings, blowoffs and dead-end lines.
- 2) All changes from standard 36-inch depth cover. Limits shall be shown on all Plans with annotated reason for change. Actual pipe elevation (top of pipe) will be taken at each fitting.
- 3) Changes in alignment, grade, pipe size, and construction materials. If such changes in alignment and/or grade result in station changes, the stationing and offsets shall be changed for the valves and other fittings affected by the changes.
- 4) Provide manufacturer of all valves identify types of fittings (i.e., MJ X MJ, FLG x MJ, etc.) if there are deviations from the Plans. Provide information in the form of an inventory list on construction drawings.

- 5) Other changes altering the approved Plans.
 - 6) Provide photographs of all installed valves and fittings in place before backfilling if required by the City.
- e. Inspection and Testing Results

The Contractor/developer shall submit all inspection and testing results to the City as part of the Record Drawings submittal. This shall include all compaction density testing for aggregate base and asphalt concrete pavement, concrete cylinder test results (i.e., slump, air, break result, etc.), bacteria testing, air test documentation, hydrostatic test results, etc. The Record Drawings shall not be deemed complete until this information is provided.

B. PROJECT WORK MEETINGS

The Contractor and/or their superintendent shall meet with the City on a regular basis to review the progress of the Work, Work schedule, Project concerns, etc., as may be appropriate. The intent of this meeting will be to keep communication channels open and to keep all parties informed as to the status of the Work. Generally, the meeting shall be held bi-weekly; however, it may be scheduled at other times if needed. This meeting will be used to review Record Drawings being kept on the Project by the Contractor.

C. ENVIRONMENTAL AND OTHER SPECIAL REQUIREMENTS

The Contractor shall be responsible for obtaining a National Pollutant Discharge Elimination System Permit 1200-C for erosion and sedimentation control during construction if this permit is required. A copy of the permit shall be provided to the City prior to the start of construction. See Technical Specifications - "Storm Drainage," Part 1 - General, 1.5 Erosion Control for additional requirements.

If a cultural resource study, wetland delineation, Conditional Letter of Map Revision, Letter of Map Revision, or other items are required, they shall be the responsibility of the developer.

D. PROJECT SAFETY

- 1.1 The Contractor shall be solely responsible for initiating, maintaining, and supervising all safety precautions and programs in connection with the Work, including excavation safety. The Contractor shall comply with all applicable Laws and Regulations, ordinances, rules, and orders of any public body having jurisdiction as it relates to Project and Work safety.
- 1.2 The Contractor shall maintain local access to area residents and emergency traffic throughout the life of the Project and coordinate construction activities closely with

area residents to keep them informed of operations that may impact their use of any streets or roadways.

- 1.3 All signs, barricades, barriers, lights, cones, trench boxes, shoring/bracing, and other such "devices" required to warn, protect, or direct the public and workmen during the life of the Contract shall be furnished, installed, moved, and removed by the Contractor. When conditions warrant their use, flagpersons shall also be provided by the Contractor. The determination of what measures are required, in addition to those specifically called for by the Public Works Standards, Technical Specifications, and Standard Drawings, shall be solely the responsibility of the Contractor.
- 1.4 All construction Work shall be performed in accordance with the provisions of the Occupational Safety and Health Regulations of the Oregon Occupational Safety and Health Division, and other applicable regulations. It shall be the Contractor's responsibility to meet all requirements of Chapter 437 of the State of Oregon Administrative Rules. In addition, Oregon Revised Statutes (ORS) 757.542 through 757.562 and Oregon Administrative Rules (OAR) 860-024-0007 administered by the Oregon Public Utilities Commission shall apply.
- 1.5 The materials used for and the installation of all warning and traffic control devices shall be in like-new condition and shall conform to the applicable provisions of the Oregon Standard Specifications for Construction - current edition, Sections 00220 and 00228, and the Manual on Uniform Traffic Control Devices, U.S. Department of Transportation, Federal Highway Administration, current edition.

E. QUALITY CONTROL

- 1.1 The Contractor shall be responsible for providing their own construction monitoring and quality control program to ensure the materials used on the Project and in the Contractor's operations are in compliance with the Public Works Standards, Technical Specifications, and Standard Drawings. A written quality control program shall be provided to the City for their review prior to any Work being performed. The plan shall describe how the Contractor will monitor and ensure quality control throughout the Work. Materials, equipment, or Work that fails to meet the Contract requirements shall not be used in the Work.
- 1.2 Special inspections and testing shall be performed in accordance with the latest edition of the Oregon Structural Specialty Code (OSSC). As required by the OSSC, any special inspections or tests performed on a project shall be completed by a qualified firm normally engaged in the business of providing said special inspections and tests. The special inspection and testing services shall be performed and paid for by the Contractor. All other testing and inspections required that are not deemed special inspections and testing as defined in the OSSC shall also be performed and paid for by

the Contractor, unless at the City's discretion they elect to contract the testing and/or inspection services. The Contractor or developer shall be responsible for reimbursement to the City for all special inspection and testing costs.

- 1.3 The City and their representatives will at all times have access to the Work. In addition, authorized representatives and agents of any participating federal or state agency shall be permitted to review all Work, materials, invoices of materials, and other relevant data and records. The Contractor will provide proper facilities for such access and observation of the Work and also for any review or testing thereof. The Contractor shall notify testing personnel, including testing personnel provided by the City, at least three business days in advance of operations to allow for personnel assignments and test scheduling. All materials to be tested shall be provided by the Contractor at their expense. After tests are completed, the Contractor shall be responsible for repairing test areas to match original conditions. The Contractor shall pay for all additional reviews and retesting required because of defective Work or ill-timed notices.
- 1.4 Tests or reviews by the City or others shall not relieve the Contractor from their obligations to perform the Work in accordance with the requirements of the Public Works Standards, Technical Specifications, and Standard Drawings and does not make the City, or others, an insurer of the Contractor's Work.
- 1.5 When tests are required, the technician or technicians performing any testing shall possess valid Western Alliance for Quality Transportation Construction (WAQTC) recognized certifications, ODOT recognized certifications, or American Concrete Institute (ACI) recognized certifications in the following disciplines:
 - Aggregate Testing Technician (AgTT)
 - Asphalt Testing Technician (AsTT)
 - Concrete Testing Technician (CTT)
 - Embankment and Base Testing Technician (EBTT)
 - Density Testing Technician (DTT)
 - ACI Concrete Strength Testing Technician (CSTT)
 - ACI Concrete Field Testing Technician (CTT)
 - Certified Aggregate Technician (CAgT) (WAQTC = AgTT)
 - Certified Embankment and Base Technician (CEBT) (WAQTC = EBTT)
 - Certified Density Technician (CDT) (WAQTC = DTT)
 - Certified Asphalt Technician I (CAT-I) (WAQTC = AsTT)
 - Certified Asphalt Technician II (CAT-II)
 - Certified Mix Design Technician (CMDT)
 - Quality Control Technician (QCT)
 - Concrete Control Technician (CCT)

- Concrete Strength Technician (CST)
- Concrete Laboratory Testing Technician (CLTT)

1.6 Following are the minimum required tests and testing frequency that shall be included in the Contractor’s quality control program for the materials listed. See other sections of these Public Works Standards for other testing and quality control requirements. If the Contractor fails to provide all or any part of the required quality control testing and corresponding reports for the Project after the City has requested the Contractor to do so in writing, the City may elect to have the quality control work performed by others and charge the Contractor the actual cost of quality work plus \$100 for each test performed.

a. Trench Backfill Materials

A minimum of one ASTM D1557 laboratory density test will be performed for each testable material used as trench backfill, providing the maximum theoretical density and optimum moisture content of the material. Nuclear gauge density tests (ASTM D6938) shall be performed in accordance with the Standard Drawings.

b. Earthwork

A minimum of one AASHTO T 180 laboratory density test will be performed for each testable material used as embankment material, providing the maximum theoretical density and optimum moisture content of the material can be determined. A minimum of one nuclear gauge density test (ASTM D6938) will be performed every 800 square yards on each lift of material to show required density is being achieved. Once an acceptable compaction method is established and verified with field density tests, the testing interval can be reduced to one test each 1,600 square yards on each lift. If backfill material or compaction equipment changes, compaction testing shall immediately be performed to verify that density is being achieved and shall continue at 800 square yard intervals until a new compaction method is verified.

c. Aggregate Base

- 1) Testing required to qualify material source prior to production as outlined in Technical Specifications - "Streets."
- 2) Quality control testing required during production consists of the following:

Gradation	AASHTO T 27	Start of production and one test every 1,000 tons (three tests)
-----------	-------------	---

GENERAL REQUIREMENTS

		minimum)
Fracture Face	AASHTO T 335	Start of production and one test every 3,000 tons (three tests minimum)
Sand Equivalent	AASHTO T 176	Start of production and one test every 3,000 tons (three tests minimum)

3) Compliance of aggregate base produced and stockpiled before the Award Date or Notice to Proceed of this Contract will be determined by the following:

- a) Provide all production records for testing that was performed during production.
- b) If production records are not available, provide post testing of the stockpile per AASHTO T 2 as follows:

Gradation	AASHTO T 27	One test every 1,000 tons in stockpile (three tests minimum)
Fracture Face	AASHTO T 335	One test every 3,000 tons in stockpile (three tests minimum)
Sand Equivalent	AASHTO T 176	One test every 3,000 tons in stockpile (three tests minimum)

4) Compliance of aggregate base delivered to the Project Site will be determined by the following:

Gradation	AASHTO T 27	One test every 1,000 tons (three tests minimum)
Fracture Face	AASHTO T 335	One test every 3,000 tons (three tests minimum)
Sand Equivalent	AASHTO T 176	One test every 3,000 tons (three tests minimum)

5) A minimum of one AASHTO T 180 laboratory density test will be performed on aggregate base material, providing the maximum theoretical density and optimum moisture content of the material can be determined. A minimum of one nuclear gauge density test (ASTM D6938 or AASHTO T 310) will be performed every 800 square yards on each lift of aggregate

GENERAL REQUIREMENTS

base to show required density is being achieved. Once an acceptable compaction method is established and verified with field density tests, the testing interval can be reduced to one test each 1,600 square yards on each lift. If aggregate base material or compaction equipment changes, compaction testing shall immediately be performed to verify that density is being achieved and shall continue at 800 square yard intervals until a new compaction method is verified.

d. Asphalt Concrete Pavement (ACP)

- 1) Testing required to qualify ACP aggregate material source prior to production consists of the following (current ODOT certification of the material source can be substituted for this testing):

Soundness	AASHTO T 104
Abrasion	AASHTO T 96
Degradation	ODOT TM T-208
Lightweight Pieces	AASHTO T 113
Plastic Index	AASHTO T 103
Friable Particles	AASHTO T 112

- 2) Quality control testing required on ACP aggregate during production consists of the following:

Gradation	AASHTO T 27	Start of production and one test every 1,000 tons (three tests minimum)
Sand Equivalent	AASHTO T 176	Start of production and one test every 3,000 tons (three tests minimum)
Fracture Face	AASHTO T 335	Start of production and one test every 3,000 tons (three tests minimum)
Wood Particles	ODOT TM T-225	Start of production and one test every 3,000 tons (three tests minimum)
Elongated Pieces	ODOT TM T-229	Start of production and one test every 3,000 tons (three tests minimum)
Dust or Clay Coating	ODOT TM T-226	Start of production and one test every 3,000 tons (three tests minimum)

GENERAL REQUIREMENTS

3) Compliance of ACP aggregates produced and stockpiled before the Award Date or Notice to Proceed of this Contract will be determined by the following:

- a) Provide all production records for testing that was performed during production.
- b) If production records are not available, provide post testing of the stockpile per AASHTO T 2 as follows:

Gradation	AASHTO T 27	One test every 1,000 tons in stockpile (three tests minimum)
Sand Equivalent	AASHTO T 176	One test every 3,000 tons in stockpile (three tests minimum)
Fracture Face	AASHTO T 335	One test every 3,000 tons in stockpile (three tests minimum)
Wood Particles	ODOT TM T-225	One test every 3,000 tons in stockpile (three tests minimum)
Elongated Pieces	ODOT TM T-229	One test every 3,000 tons in stockpile (three tests minimum)
Dust or Clay Coating	ODOT TM T-226	One test every 3,000 tons in stockpile (three tests minimum)

4) Quality control testing of ACP mixture required during placement is as follows:

Asphalt Content	AASHTO T 308	One test every 1,000 tons, one test per day minimum
Gradation	AASHTO T 30	One test every 1,000 tons, one test per day minimum
Maximum Specific Gravity	AASHTO T 209	One test every 1,000 tons, one test per day minimum
Compaction	WAQTC TM 8	5 tests every 1,000 tons
Percent Hydrated Lime	ODOT TM T-321	One test every 1,000 tons

Asphalt content, gradation, and maximum specific gravity testing will be performed at the start of production to verify the hot-mix asphalt mix design.

e. Portland Cement Concrete (PCC)

Aggregate testing is required to be completed with the mix design. Should additional testing of aggregate for PCC be deemed necessary by the City, testing shall be performed by the Contractor as specified by ASTM C33. Samples shall be selected at random from the stockpile and tested for conformance with the Specifications. The decision to perform aggregate testing and testing frequencies shall be left to the City.

Quality control testing of PCC during and following placement is as follows:

Air Content	AASHTO T 152	One test per each set of cylinders One test per each truck
Slump	AASHTO T 119	One test per each set of cylinders One test per each truck
Concrete Temperature	AASHTO T 309 ASTM C1064	One test per each set of cylinders One test per each set of cylinders
Strength	AASHTO T 22, AASHTO T 23, ASTM C31, and ASTM C39	One set of three cylinders per 25 cubic yards (minimum one set per day)

F. REVIEW OF WORK

It is not the intent of the City to provide continuous or full-time observation of all Work. When required by the City, the Contractor shall provide the City a weekly report of their Work progress and proposed Work schedule for the next week. This weekly communication shall be a requirement.

G. COOPERATION WITH OTHERS

The Contractor shall cooperate with the residents and business owners in the area to provide good access to private property whenever possible. Sidewalks shall be kept clear at all times of any construction materials. Barricades, traffic cones, blinkers, and signing shall be used to direct the public through the Work area safely.

H. EXISTING SURVEY MONUMENTATION

1.1 The Contractor shall be responsible for the protection and perpetuation of existing land survey, property, or construction monuments shown on the Drawings, which are marked or are clearly visible on the ground.

- 1.2 The Contractor shall give the City a minimum of three business days' notice prior to working in the vicinity of any such monument that the Contractor may disturb so the City can arrange for such monuments to be referenced. When proper notice is provided, the City shall have any disturbed monuments restored following construction. Should the Contractor fail to provide adequate notice to the City, the Contractor shall be responsible for the expense of having the disturbed monument restored by a qualified surveyor.

I. EXISTING UTILITIES

- 1.1 The Contractor shall notify by the one call number 1-800-332-2344, at least three business days in advance, all utility offices affected by the construction operations. The Contractor shall not expose any marked out underground utility without first notifying the affected agency and being granted permission to do so. The Contractor is responsible for locating and exposing, if necessary, all existing underground utilities in advance of the trenching operation.

The Contractor is responsible for protecting all power and telephone poles and overhead cables from damage. If interfering power poles, telephone poles, guy wires, or anchors are encountered, the Contractor shall notify the utility owner at least three business days in advance of construction operations to permit the necessary arrangements with the affected utility company for protection or relocation of the interfering structure. The Contractor shall be solely and directly responsible to the owner and operators of such utilities/properties for any damage, injury, expense, loss or inconvenience, delay, suits, actions, or claims of any kind brought because of injuries or damage that result from performing the contract work.

The Contractor shall immediately notify the proper authority in the event of interruption to domestic water, sanitary sewer, storm sewer, or other utility service resulting from accidental breakage, or as a result of being exposed or unsupported. All repair or replacement of existing water or sewer pipe must conform to the City's Public Works Standards. If an existing water or sewer pipe is damaged to any extent, the City's Water and/or Recycled Water departments must be notified immediately. The damaged pipe must remain exposed until inspected by a City Representative. Repairs will be made upon approval by the City. All repairs or replacements will be inspected by the City prior to backfill. Repaired or replaced sewer lines will be inspected by closed circuit TV in accordance with the Technical Specifications. The Contractor shall cooperate with the affected agency to restore services as promptly as possible and shall bear all costs of repair for the utility. In no case shall interruption of any water, sanitary sewer, or utility service be allowed outside normal working hours unless prior approval is granted by the City.

Neither the City, the utility owner, nor its officers or agents shall be responsible to the Contractor for damages resulting from the location of any underground utilities being other than that shown on the Plans, or for the existence of underground utilities not shown on the Plans or properly marked out on the site.

Should the Contractor encounter any utility service lines that interfere with trenching or conflict with the proposed work, the Contractor may obtain prior approval of the utility owner and governing authority to cut the service, dig through, and cause the service to be restored or relocated with similar and equal materials at the Contractor's expense.

The Contractor shall make any advance exploration necessary to protect all existing utilities and to properly plan the installation of pipelines or other work to the design line and grade. The Work shall include all labor, equipment, etc., necessary to perform the location work.

ATTENTION: Oregon law requires you to follow rules adopted by the Oregon Utility Notification Center. Those rules are set forth in OAR 952-001-0001 through 952-001-0100. You may obtain copies of the rules by calling the center.

NOTE: The telephone number for the Oregon Utility Notification Center is 503-232-1987.

- 1.2 The Contractor shall receive prior approval from the appropriate authority or utility owner before any public or private utility service is interrupted.

The Contractor shall give a minimum of three business days' notice to all utility customers who will be affected by the Contractor's operations. No utility service shall be disconnected or interrupted for more than nine hours or as required by the utility owner, whichever is less, in any 24-hour period. When disruption of service will be longer than nine hours in any one day, the Contractor shall provide safe and appropriate temporary service. All temporary service shall be coordinated with the utility owner.

When regular utility service interruption is required during the course of the Work, the Contractor shall submit a written plan to the City and utility owner which details proposed Work plan notification procedures, and estimated extent of service interruption. The Contractor must obtain written approval of their plan from the utility owner prior to interrupting the utility service. As a minimum, notification shall include door hangers and public notification in the newspaper and radio, as appropriate. Personal contact shall be made where practical.

The Contractor shall make every effort possible to provide continuous utility service to all utility customers. When special conditions exist where an interruption of utility service would create an extra hardship on the utility customer or create a hazardous condition, the Contractor shall provide continuous service. Particular care and planning

must be arranged to provide continuous service of existing services or temporary services as approved by the utility owner and the City.

If the Contractor inadvertently damages or interrupts an existing utility, the Contractor shall immediately notify the affected utility company, City, and utility users and make arrangements to provide temporary service to the parties affected.

- 1.3 The Contractor shall support and otherwise protect all pipes, conduits, cables, poles, and other existing services where they cross the trench or are otherwise undermined or affected by their Work. The Contractor shall restore the support of an undermined existing utility using select backfill compacted to 95 percent maximum density as determined by ASTM D698.

J. PROGRESS OF THE WORK - CLEANUP

- 1.1 The Contractor shall arrange their work schedule such that all phases of Work, once started, shall be diligently pursued until completed. The intent is that the work area shall not be disturbed for undue periods of time. Work shall not be left uncompleted. If the City determines that Work is not being diligently completed, the City shall request the Contractor to complete said Work.
- 1.2 Cleaning up shall be a continuing process from the start of the Work to final acceptance of the Project. The Contractor shall, at all times, at their own expense and without further order, keep property on which Work is in progress free from accumulations of waste material or rubbish caused by employees or by the Work, and at all times during the construction period shall maintain structure sites, rights-of-way, easements, adjacent property, and the surfaces of streets and roads on which Work is being done in a safe condition for the Contractor's workers and the public.
 - a. Accumulations of waste materials that might constitute a fire hazard will not be permitted.
 - b. Spillage from the Contractor's hauling vehicles on traveled public or private roads shall be promptly cleaned up. The Contractor shall take appropriate action to control dust caused by their operations. This shall include, but not be limited to, watering of exposed areas, cleaning of roadways, etc. This is considered a normal part of the construction Project.
 - c. Upon completion of the Work, the Contractor shall, at their own expense, remove all temporary structures, rubbish, waste material, equipment, and supplies resulting from their operations. They shall leave such lands in a neat and orderly condition that is at least as good as the condition in which they found them prior to their operations.

- d. Should the Contractor fail to provide said cleanup upon 24-hour written notice, the City shall have the right to perform such Work at the expense of the Contractor/developer.

1.3 The Contractor shall replace or restore, equivalent to their original condition, all surfaces or existing facilities disturbed by their Work, whether within or outside of the Work areas. Restoration work will include, but is not limited to, roadways, utilities, structures, landscaping, etc.

K. PERMITS

All permits shall be obtained before beginning construction, alteration or repairs, other than ordinary repairs, using application forms furnished by the City.

1.1 Application

To obtain a permit, the applicant shall first file an application in writing on a form furnished by the City for that purpose. Every such applicant shall:

- a. Identify and describe the work to be covered by the permit for which application is made.
- b. Describe the land on which the proposed work is to be performed by legal description, street address, or similar description that will readily identify and definitely locate the proposed building.
- c. Indicate the use or occupancy for which the proposed work is intended.
- d. Be accompanied by Plans, diagrams, computations, specifications, and other data as required.
- e. State the valuation of any new building or structure or any addition, remodeling or alteration to an existing building.
- f. Be signed by the applicant, or his/her authorized agent.
- g. Give such other data and information as may be required by the building official.

1.2 Permit Fees

Permit fees are established by the State of Oregon and/or the City.

1.3 Expiration

Every permit issued by the City under the provisions of the Codes and/or Ordinances of the City shall expire by limitation and become null and void if the building or work

authorized by such permit is not commenced within six months from the issue date of the permit, or if the building or work authorized by such permit is suspended or abandoned at any time after work is commenced for a period of six months. Before work can be resumed, a new permit shall be obtained to do so, and the fee shall be one-half the amount required for a new permit for such work, provided no changes have been made in the original Plans and specifications for such work; and provided further that such suspensions or abandonment has not exceeded six months.

A permittee holding an unexpired permit may apply for a one-time extension, provided he/she can show good and satisfactory reasons, and beyond his/her control the work cannot be commenced within the six-month period from the issue date. To renew work on a permit after it has expired, the permittee shall pay a new full permit fee.

1.4 Penalty

Any person, firm, or corporation violating any of the provisions of the Codes and/or Ordinances of the City, shall be guilty of a misdemeanor and each such person shall be deemed guilty of a separate offense for each and every day or portion thereof during which any violation of any of the provisions of the Codes and/or Ordinances is committed, continued or permitted, and upon conviction of any such violation such person shall be punishable by a fine, or by imprisonment, or by both with such fine and imprisonment as established by local applicable laws.

1.5 Right of Appeal

All persons shall have the right to appeal the City official's decision through a body appointed by the City and qualified by the experience and training to pass upon matters pertaining to building construction.

1.6 Plans

When required by the City, Plans shall be drawn to scale and shall be of sufficient clarity to indicate the nature and extent of the work proposed and shall show in detail that the project will conform to the provisions of City Standard Drawings and all relevant laws, ordinances, rules and regulations. Plans shall include a plot plan drawn to scale showing the locations of all easements, drainage facilities, adjacent grades, property lines, the proposed building, and of every existing building on the property. Two sets of Plans are required. One additional complete set of Plans shall be kept on the job site at all times and made readily accessible to the inspector.

1.7 Inspections

a. General

All construction of public improvements and work for which a permit is required shall be subject to inspection by the City and all such construction or work shall remain accessible and exposed for inspection purposes until approved by the City. In addition, certain types of construction shall have continuous inspection.

Approval as a result of an inspection shall not be construed to be an approval of a violation of the provisions of the Codes and/or Ordinances of the City. Inspections presuming to give authority to violate or cancel the provisions of the Codes and/or Ordinances of the City shall not be valid.

It shall be the duty of the permit applicant to cause the work to remain accessible and exposed for inspection purposes. Neither the City Representative nor the City shall be liable for expense entailed in the removal or replacement of any material required to allow inspection.

A survey of the lot may be required by the City to verify that the structure is located in accordance with the approved Plans.

b. Inspections for Right-of-Way Improvements

If the construction of sidewalk, curb and gutter, or asphalt concrete pavement improvements, is not included in a performance bond of an approved subdivision or the performance bond has lapsed, then every person, firm, or corporation desiring to construct sidewalks as provided by these Public Works Standards, before commencing the work or improvement, shall comply with the following:

- 1) An occupancy permit shall not be issued for a development until provisions of these Public Works Standards are satisfied.
- 2) The City may allow temporary noncompliance with the provisions of these Public Works Standards to the landowner, builder or Contractor when, in the City's opinion, the construction of the ROW improvements is impractical for one or more of the following reasons:
 - a) Sidewalk grades have not and cannot be established for the property in question within a reasonable length of time;
 - b) Forthcoming installation of public utilities or street paving would be likely to cause severe damage to the new sidewalk;

GENERAL REQUIREMENTS

- c) Street ROW is insufficient to accommodate a sidewalk on one or both sides of the street; or
- d) Topography or elevation of the sidewalk base area makes construction of a sidewalk impractical or economically feasible.

c. Inspection Record Card

Work requiring a permit shall not commence until the permit holder or his/her agent have posted or otherwise made available an inspection record card such as to allow the City to conveniently make the required entries thereon regarding inspection of the work. This card shall be maintained available by the permit holder until final approval has been granted by the City.

d. Inspection Requests

It shall be the duty of the person doing the work authorized by a permit to notify the City that such work is ready for inspection. Requests for inspection shall be made at least three business days before such inspection is desired. Such request shall be in writing or by telephone at the option of the City.

It shall be the duty of the person requesting any inspections required to provide access to and means for inspection of such work.

e. Required Inspections

Reinforcing steel or structural framework of any part of any building or structure shall not be covered or concealed without first obtaining the approval of the City.

The City, upon notification, shall make the following inspections and shall either approve that portion of the construction as completed or shall notify the permit holder or his/her agent wherein the same fails to comply with Public Works Standards.

f. Inspections by City Representatives

A City Representative shall be notified and/or present for the following work items when applicable.

1) Grading - Streets

- a) Geotechnical Report: all recommendations and requirements of the Geotechnical Report shall be followed unless City requirements are more conservative.

GENERAL REQUIREMENTS

- b) Trench and/or fill material compaction: trench compaction shall be in accordance with the City Standard Drawings. Fill shall be compacted in accordance with the Technical Specifications.
- c) Subgrade: subgrade shall be load tested in accordance with the Technical Specifications.
- d) Curb and gutter aggregate base: see City Standard Drawings for requirements. Compaction tests are required.
- e) Curb and gutter installation: foreman shall meet with the City prior to installation, and the City shall observe the installation process.
- f) ADA ramp forms: slopes and aggregate base requirements of the City Standard Drawings shall be met. Regardless of the outcome of this inspection, the Contractor shall be responsible for meeting all ADA laws, codes, and requirements of the City Standards.
- g) ADA ramps: all ramps must meet all applicable ADA laws/codes and requirements of the City Standard Drawings.
- h) Street aggregate base: aggregate base shall conform to all the requirements of the City Standard Drawings. Compaction tests are required.
- i) Sidewalk forms: sidewalk forms shall be inspected by the City prior to the pouring of concrete. Compaction tests are required. Regardless of the outcome of this inspection, the Contractor shall be responsible for meeting all requirements of the City Standards.
- j) Driveway forms: driveway forms shall be inspected by the City prior to the pouring of concrete. Compaction tests are required. Regardless of the outcome of this inspection, the Contractor shall be responsible for meeting all requirements of the City Standards.
- k) Asphalt concrete pavement: a pre-paving conference shall be held between the City and the paving Contractor and crew to review curb joint, roller pattern, and roller speed requirements. Cross slope shall meet City Standard Drawing requirements. No bones shall be left on the mat. Asphalt temperature shall be checked, and density test(s) shall be performed. All quality control shall meet City Standards.

GENERAL REQUIREMENTS

- l) Sidewalk completion: sidewalk shall meet all the requirements of the City Standards.
 - m) Driveway completion: driveway shall be sloped toward the right-of-way and shall have a width not exceeding the maximum permitted width as set forth in the City Standard Drawings.
 - n) Substantial completion: see General Requirements, K. Permits, 5. Substantial and Final Completion, page GR-46.
 - o) Final completion: see General Requirements, K. Permits, 5. Substantial and Final Completion, page GR-46.
- 2) Storm Drain
- a) Erosion control: must be installed per the design Drawings, City Standard Drawings, and City Technical Specifications prior to construction beginning.
 - b) Geotechnical Report: all recommendations and requirements of the Geotechnical Report shall be followed unless City requirements are more conservative.
 - c) Pipe material: pipe material must be per the City Standards.
 - d) Manhole material: manholes, including cones, castings, resilient connectors, etc., shall meet the requirements of the City Standard Drawings and Technical Specifications.
 - e) Catch basin material: Catch basins, including, precast boxes and castings shall be per the City Standard Drawings and Technical Specifications.
 - f) Initial pipe install: pipe installation including bedding, backfill, locating wire, haunches, pipe zone location, and compaction tests shall be per the City Standard Drawings and Technical Specifications. The use of a laser for grade shall be confirmed.
 - g) First manhole: manholes shall be installed per City Standards including aggregate base, attachment of resilient connectors, backfill, and compaction.

GENERAL REQUIREMENTS

- h) First catch basin/inlet install: catch basins shall be installed per City Standards including aggregate base, backfill, compaction, and location.
 - i) Swale rough in: swale shall be roughed in prior to the placement of drain rock, if any, in accordance with the City Standard Drawings and Technical Specifications.
 - j) Swale completion: swales shall be in accordance with all City Standard Drawings and Technical Specifications.
 - k) Drywell: drywells shall be constructed in accordance with City Standard Drawings and Technical Specifications.
 - l) Manhole test: see City Technical Specifications.
 - m) Pipe pressure test: see City Technical Specifications.
 - n) Pipe mandrel test: see City Technical Specifications.
 - o) Pipe TV inspection: see City Technical Specifications.
 - p) Substantial completion: see General Requirements, K. Permits, 5. Substantial and Final Completion, page GR-46.
 - q) Final completion: see General Requirements, K. Permits, 5. Substantial and Final Completion, page GR-46.
- 3) Sanitary Sewer
- a) Geotechnical report: all recommendations and requirements of the Geotechnical Report shall be followed unless City requirements are more conservative.
 - b) Pipe material: pipe material must be per the City Standards.
 - c) Manhole material: manholes including cones, castings, resilient connectors, etc., shall meet the requirements of the City Standard Drawings and Technical Specifications.
 - d) Initial pipe install: pipe installation including bedding, backfill, locating wire, haunches, pipe zone location, and compaction tests shall be City Standard Drawings and Technical Specifications. The use of a laser for grade shall be confirmed.

GENERAL REQUIREMENTS

- e) First manhole: manholes shall be installed per City Standards including aggregate base, attachment of resilient connectors, backfill, and compaction.
 - f) First service lateral: service laterals shall meet all City Standards including appropriate bedding and backfill, wye connections, service line markers, cleanouts, grades, and tracer wire.
 - g) Manhole test: see City Technical Specifications.
 - h) Pipe pressure test: see City Technical Specifications.
 - i) Pipe mandrel test: see City Technical Specifications.
 - j) Pipe TV inspection: see City Technical Specifications.
 - k) Substantial completion: see General Requirements, K. Permits, 5. Substantial and Final Completion, page GR-46.
 - l) Final completion: see General Requirements, K. Permits, 5. Substantial and Final Completion, page GR-46.
- 4) Water
- a) Geotechnical report: all recommendations and requirements of the Geotechnical Report shall be followed unless City requirements are more conservative.
 - b) Pipe material: pipe material must be per the City Standards.
 - c) Valves, fittings and other materials: all valves, fittings, and other materials including hydrants must be per the City Standards.
 - d) Initial pipe install: same as above. Pipe installation including bedding, backfill, locating wire, haunches, pipe zone location, and compaction tests shall be per City Standard Drawings and Technical Specifications.
 - e) First valve/fitting install: see City Standard Drawings and Technical Specifications.
 - f) First service line install: see City Standard Drawings and Technical Specifications.
 - g) Pressure test: see City Technical Specifications.

GENERAL REQUIREMENTS

Section 8, Item D.

- h) Disinfection and bacteria testing: see City Standard Drawings and Technical Specifications.
- 5) Substantial and Final Completion
- a) After improvements are substantially complete, a City Representative from each relevant department shall perform a walkthrough and create a punch list of outstanding items or items in need of correction. Approved Plans are required to be on site for use by the City Representative(s) performing the walkthrough.
 - b) Punch list should include unfinished items (such as grading of the lots), damage done by construction (chipped curbs, etc.), items that do not meet plans or City Standards, restoration, clean-up, maintenance bond, and/or Record Drawings.
 - c) Record Drawings with design engineer certification shall be provided to the City along with all required test results.
 - d) Final acceptance of construction improvements shall only be after all punch list items are completed.

END OF SECTION

TECHNICAL SPECIFICATIONS

TABLE OF CONTENTS
SECTION 1
EXCAVATION AND GRADING

PART 1 - General 1-1
1.1 Purpose 1-1
1.2 Scope 1-1
1.3 Hazards 1-1
1.4 Grading Plan Requirements 1-2
1.5 Fees 1-6
1.6 Cuts 1-6
1.7 Fill 1-7
1.8 Drainage and Terracing 1-8
1.9 Erosion Control 1-9
1.10 Grading Inspection 1-10
1.11 Completion of Work 1-12
1.12 Safety 1-13
1.13 Existing Utilities 1-13
1.14 Dust and Mud Control 1-13
1.15 Restoration of Disturbed Areas 1-13
PART 2 - Materials 1-13
2.1 Earthwork 1-13
2.2 Geotextile Fabric 1-14
2.3 Aggregate Materials 1-14
2.4 Select Backfill 1-15
2.5 General Backfill 1-15
2.6 Controlled Density Fill (CDF) 1-16
2.7 Seed 1-16
2.8 Topsoil 1-16
2.9 Mulch 1-17
2.10 Sod 1-17
2.11 Erosion Control Matting 1-17
2.12 Hydroseed 1-17
2.13 Slope Stabilization Rock 1-18
PART 3 - Execution 1-18
3.1 Earthwork 1-18
3.2 Geotextile Fabric Installation 1-20
3.3 Placement of Aggregate Materials 1-21
3.4 Site Cleanup 1-22
3.5 Dewatering Excavated Areas 1-22
3.6 Location of Imported Material 1-22
3.7 Location of Excavated Materials 1-22
3.8 Disposal of Excavated Materials 1-22

TABLE OF CONTENTS
SECTION 1
EXCAVATION AND GRADING

3.9 Execution of Dust and Mud Control..... 1-23
3.10 General Surface Restoration 1-23
3.11 Lawn Sod Restoration 1-24
3.12 Hydroseeding 1-26
3.13 Erosion Control Matting..... 1-27
3.14 Mulch..... 1-27
3.15 Cleanup..... 1-28

TECHNICAL SPECIFICATIONS
SECTION 1
EXCAVATION AND GRADING

PART 1 - GENERAL

1.1 Purpose

The purpose of these Public Works Standards, Technical Specifications, and Standard Drawings is to safeguard life, limb, property and the public welfare by regulating grading on private property.

1.2 Scope

These Public Works Standards, Technical Specifications, and Standard Drawings set forth rules and regulations to control excavation, grading, and earthwork construction, including fills and embankments, and provide for the approval of plans and the inspection of grading construction.

The standards listed below are guideline standards.

A. Testing

1. ASTM D1557, Moisture-density Relations of Soils and Soil Aggregate Mixtures
2. ASTM D1556, In-Place Density of Soils by the Sand-Cone Method
3. ASTM D2167, In-Place Density of Soils by the Rubber-Balloon Method
4. ASTM D2937, In-Place Density of Soils by the Drive-Cylinder Method
5. ASTM D2922 and ASTM D3017, In-Place Moisture Content and Density of Soils by Nuclear Methods.

1.3 Hazards

Whenever the City determines that any existing excavation, embankment, or fill on private property has become a hazard to life and limb; endangers property; or adversely affects the safety, use, or stability of a public way or drainage channel the owner of the property upon which the excavation or fill is located or other person or agent in control of said property, upon receipt of notice in writing from the City, shall within the period specified therein repair or eliminate such excavation, embankment, or fill so as to eliminate the hazard and be in conformance with the requirements of these Public Works Standards, Technical Specifications, and Standard Drawings.

TECHNICAL SPECIFICATIONS
SECTION 1
EXCAVATION AND GRADING

1.4 Grading Plan Requirements

A. Grading Designation

- 1. Unless grading is considered exempt grading, grading in excess of 5,000 CY shall be designated as "engineered grading." Grading involving less than 5,000 CY shall be designated "regular grading," unless the owner/developer chooses to have the grading performed as engineered grading or the City determines that special conditions or unusual hazards exist, in which case grading shall conform to the requirements for engineered grading. Regardless of the grading volume, engineered grading shall be required on all proposed developments other than individual lots permitted for single-family or two-family dwellings.

- 2. Grading is considered to be exempt grading in the following scenarios:
 - a. Grading in an isolated, self-contained area where there is no danger to private or public property, only when approved by the City.

 - b. An excavation below finished grade for basements and footings of a building, retaining wall, or other structure authorized by a valid building permit. This shall not exempt any fill made with the material from such excavation or exempt any excavation having an unsupported height greater than 5 feet after the completion of such structure.

 - c. Cemetery graves.

 - d. Refuse disposal sites controlled by other regulations.

 - e. Mining, quarrying, excavating, processing, stockpiling of rock, sand, gravel, aggregate or clay where established and provided for by law, provided such operations do not affect the lateral support or increase the stresses in or pressure upon any adjacent or contiguous property.

 - f. Exploratory excavations under the direction of geotechnical engineers or engineering geologists.

 - g. An excavation that:
 - 1) is less than 2 feet in depth,

 - 2) does not create a cut slope greater than 5 feet in height,

TECHNICAL SPECIFICATIONS
SECTION 1
EXCAVATION AND GRADING

- 3) does not create a slope steeper than 2H:1V, and
- 4) is less than 50 cubic yards (CY).
- h. Fill that:
 - 1) is less than 1 foot in depth,
 - 2) is placed on natural terrain with a maximum slope of 5H:1V,
 - 3) is not intended to support structures,
 - 4) does not exceed 50 CY, and
 - 5) does not obstruct a drainage course.
- B. Exempt Grading Requirements
 - 1. Grading plans, Geotechnical Reports, and Engineering Geology Reports are not required to be submitted to the City for review or approval. Exempt grading is not required to conform to the requirements of Technical Specifications - "Excavation and Grading."
 - 2. Exemptions from the excavation and grading requirements of this section shall not be deemed to grant authorization for any work to be performed in any manner in violation of the provisions of this section or any other laws or ordinances of the City.
- C. Engineered Grading Requirements
 - 1. No person shall perform any grading without first having submitted a grading plan to the City and received approval of said grading plan. An approval of a separate grading plan shall be obtained for each site and may cover both excavation and fill. Grading shall be performed in accordance with approved grading plans.
 - 2. Grading plans shall be accompanied with supporting data consisting of a Geotechnical Report and/or, as deemed necessary by the City, an Engineering Geology Report. The plans and specifications shall be prepared, stamped, and signed by a professional engineer licensed in the State of Oregon who specializes in geotechnical engineering. The City may require professional inspection and testing by a geotechnical engineer and/or an engineering geologist.

TECHNICAL SPECIFICATIONS
SECTION 1
EXCAVATION AND GRADING

3. Specifications

Specifications shall contain information covering construction and material requirements.

4. Plans

a. Plans shall be prepared in accordance with the General Requirements and this section, shall clearly indicate the nature and extent of the work proposed, and shall be shown in detail that they will conform to the provisions of these Public Works Standards, Technical Specifications, and Standard Drawings and all relevant laws, ordinances, rules, and regulations. The first sheet of each set of plans shall identify the location of the work, the names and addresses of the owner/ developer, and the person by whom they were prepared.

b. The plans shall include the following information:

- 1) General vicinity of the proposed site.
- 2) Property limits and accurate contours of existing ground and details of terrain and area drainage.
- 3) Limiting dimensions, elevations, and finish contours to be achieved by the grading, proposed drainage channels, and related construction.
- 4) Detailed plans of all surface and subsurface drainage devices, walls, cribbing, dams and other protective devices to be constructed with, or as a part of, the proposed work, together with a map showing the drainage area and the estimated runoff of the area served by any drain.
- 5) Locations of any buildings or structures on the property where the work is to be performed and the location of any buildings or structures on adjacent land within 15 feet of the property or which may be affected by the proposed grading operations.
- 6) Recommendations included in the Geotechnical Report and the Engineering Geology Report shall be incorporated in the grading plans or specifications. When approved by the City, specific recommendations contained in the Geotechnical Report and the

TECHNICAL SPECIFICATIONS

SECTION 1

EXCAVATION AND GRADING

Engineering Geology Report, which are applicable to grading, may be included by reference.

- 7) The dates of the Geotechnical and Engineering Geology Reports, together with the names, addresses, and phone numbers of the firms or individuals who prepared the reports.
- 8) The estimated quantity of both cut and fill.

D. Regular Grading Requirements

- 1. No person shall perform any grading without first having submitted a grading plan to the City and received approval of said grading plan. An approval of a separate grading plan shall be obtained for each site and may cover both excavation and fill. A Geotechnical Report and/or an Engineering Geology Report may be required by the City depending on site conditions such as steep slopes, evidence of slippage or slides, high groundwater, location of improvements, geologic conditions, etc.
- 2. Each grading plan shall clearly indicate the nature and extent of the work. The City may require professional inspection and testing by a geotechnical engineer and/or an engineering geologist. When the City has cause to believe that geologic factors may be involved, the City may require regular grading to meet the requirements of engineered grading.
- 3. Plans

The plans shall include the following information:

- a. Name of the person who prepared the plan and the name of the owner/ developer
- b. General vicinity of the proposed site.
- c. Location and extents of the area to be graded.
- d. Limiting dimensions and depth of cut and fill.
- e. Location of any buildings or structures where work is to be performed, and the location of any buildings or structures within 15 feet of the proposed grading.

TECHNICAL SPECIFICATIONS
SECTION 1
EXCAVATION AND GRADING

E. Grading Modifications

The City may require that grading operations and project designs be modified if delays occur that incur weather-generated problems not considered at the time the grading plan was approved.

F. Geotechnical Report

Geotechnical Reports shall include data regarding the water table; the nature, distribution, and strength of existing soils; conclusions and recommendations for grading procedures; design criteria for corrective measures, including buttress fills, when necessary; and an opinion on adequacy for the intended use of sites to be developed by the proposed grading as affected by geotechnical engineering factors, including the stability of slopes.

G. Engineering Geology Report

Engineering Geology Reports shall include an adequate description of the geology of the site, conclusions and recommendations regarding the effect of geologic conditions on the proposed development, and an opinion on the adequacy for the intended use of sites to be developed by the proposed grading, as affected by geologic factors.

Note: The City may require professional inspection and testing by the geotechnical engineer. When the City has cause to believe that geologic factors may be involved, the grading shall conform to engineered grading.

1.5 Fees

Fees, including plan review fees, shall be assessed in accordance with City codes, ordinances, and/or resolutions approved by the City.

1.6 Cuts

A. General

1. Unless otherwise recommended in the approved Geotechnical Report or an Engineering Geology Report, cuts shall conform to the provisions of these Public Works Standards, Technical Specifications, and Standard Drawings.
2. In the absence of an approved Geotechnical Report, these provisions may be waived for minor cuts not intended to support structures.

TECHNICAL SPECIFICATIONS
SECTION 1
EXCAVATION AND GRADING

B. Slope

The slope of cut surfaces shall be no steeper than is safe for the intended use and shall be no steeper than 3H:1V, unless the owner/developer furnishes a Geotechnical Report or an Engineering Geology Report, or both, stating the site has been investigated and an opinion that a cut at a steeper slope will be stable and not create a hazard to public or private property is given.

1.7 Fill

A. General

1. Unless otherwise recommended in the approved Geotechnical Report, fill shall conform to the provisions of these Public Works Standards, Technical Specifications, and Standard Drawings.
2. In the absence of an approved Geotechnical Report, these provisions may be waived for minor fill not intended to support structures.

B. Preparation of Ground

Fill slopes shall not be constructed on natural slopes steeper than 3H:1V. The ground surface shall be prepared to receive fill by removing vegetation, noncomplying fill, topsoil, and other unsuitable material to provide a bond with the new fill and, where slopes are steeper than 5H:1V and the height is greater than 5 feet, by benching into sound bedrock or other competent material as determined by the geotechnical engineer. The bench under the toe of a fill on a slope steeper than 5H:1V vertical shall be at least 10 feet wide. The area beyond the toe of fill shall be sloped for sheet overflow or a paved drain shall be provided. When fill is to be placed over a cut, the bench under the toe of fill shall be at least 10 feet wide but the cut shall be made before placing the fill and acceptance by the geotechnical engineer or engineering geologist or both as a suitable foundation for fill.

C. Fill Material

Organic material shall not be permitted in fills. Except as permitted by the City, no rock or other material with a dimension greater than 8 inches shall be buried or placed in fills.

Exception: The City may permit placement of larger rock when the geotechnical engineer properly devises a method of placement, and continuously inspects its placement and approves the fill stability. The following conditions shall also apply:

TECHNICAL SPECIFICATIONS

SECTION 1

EXCAVATION AND GRADING

- 1. Prior to issuance of the grading permit, potential rock disposal areas shall be delineated on the grading plan.
- 2. Rock sizes greater than 8 inches in dimension shall be at least 10 feet below finish grade.
- 3. Rocks shall be placed so as to ensure filling of all voids with well-graded soil.

D. Compaction

All fill shall be compacted to a minimum of 90 percent of maximum density per ASTM D1557, unless the Geotechnical Report and/or the Engineering Geology Report suggests a denser compaction.

E. Slope

The slope of fill surfaces shall be no steeper than is safe for the intended use. Fill slopes shall be no steeper than 3H:1V unless the owner/developer furnishes a Geotechnical Report or an Engineering Geology Report, or both, stating the site has been investigated and an opinion is given that a fill at a steeper slope will be stable and not create a hazard to public or private property.

1.8 Drainage and Terracing

A. General

Unless otherwise indicated on the approved grading plan, drainage facilities and terracing shall conform to the provisions of these Public Works Standards, Technical Specifications, and Standard Drawings for cut or fill slopes steeper than 3H:1V.

B. Terrace

- 1. Terraces shall be designed and constructed in accordance with the Oregon Department of Transportation Geotechnical Design Manual (current edition).
- 2. Swales or ditches on terraces shall have a minimum gradient of 5 percent and must be paved with reinforced concrete not less than 3 inches in thickness or an approved equal paving. They shall have a minimum depth at the deepest point of 1 foot and a minimum paved width of 5 feet.
- 3. A single run of swale or ditch shall not collect runoff from a tributary area exceeding 13,500 square feet (projected) without discharging into a down drain.

TECHNICAL SPECIFICATIONS
SECTION 1
EXCAVATION AND GRADING

C. Subsurface Drainage

Cut and fill slopes shall be provided with subsurface drainage as necessary for stability.

D. Disposal

1. All drainage facilities shall be designed to carry waters to the nearest practicable drainage way approved by the City or other appropriate jurisdiction as a safe place to deposit such water, erosion of ground in the area of discharge shall be prevented by installation of non-corrosive down drains or other devices.
2. Building pads shall have a drainage gradient of 2 percent toward approved drainage facilities, unless waived by the City.

Exception: The gradient for the building pad may be reduced to 1 percent if all of the following conditions exist throughout the area:

- a. No proposed fills are greater than 10 feet in maximum depth.
- b. No proposed finish cut or fill slope faces have a vertical height in excess of 10 feet.
- c. No existing slope faces, which have a slope face steeper than 10H:1V, have a vertical height in excess of 10 feet.

E. Interceptor Drains

Paved interceptor drains shall be installed along the top of all cut slopes where the tributary drainage area above slopes toward the cut and has a drainage path greater than 40 feet measured horizontally. Interceptor drains shall be paved with a minimum of 3 inches of concrete or gunite and be reinforced. They shall have a minimum depth of 12 inches and minimum paved width of 30 inches measured horizontally across the drain. Drain slope shall be approved by the City.

1.9 Erosion Control

A. Slopes

The faces of cut and fill slopes shall be prepared and maintained to control against erosion. This control may consist of effective planting, matting or covering. The protection for the slopes shall be installed as soon as practicable and prior to calling for

TECHNICAL SPECIFICATIONS
SECTION 1
EXCAVATION AND GRADING

final approval. Where cut slopes are not subject to erosion due to the erosion-resistant character of the materials, such protection may be omitted.

B. Other Devices

Where necessary, check dams, cribbing, riprap, or other devices or methods shall be employed to control erosion and provide safety.

C. Construction

Temporary erosion control facilities shall be used to protect against erosion during construction. See Technical Specifications - "Storm Drainage," Part 1 - General, 1.5 Erosion Control for additional requirements.

1.10 Grading Inspection

A. General

Grading operations for which a grading plan is required shall be subject to inspection by the City. Professional inspection of grading operations shall be provided by the design engineer, geotechnical engineer, and/or the engineering geologist retained to provide such services for engineered grading and as required by the City for regular grading.

B. Design Engineer

The design engineer shall provide professional inspection within such engineer's area of technical specialty, which shall consist of observation and review as to the establishment of line, grade and surface drainage of the development area. If revised plans are required during the course of the work they shall be prepared by the design engineer.

C. Geotechnical Engineer

The geotechnical engineer shall provide professional inspection within such engineer's area of technical specialty, which shall include observation during grading and testing for required compaction. The geotechnical engineer shall provide sufficient observation during the preparation of the natural ground and placement and compaction of the fill to verify that such work is being performed in accordance with the conditions of the approved plan and the appropriate requirements of this section of these Public Works Standards, Technical Specifications, and Standard Drawings. Revised recommendations relating to conditions differing from the approved Geotechnical and Engineering

TECHNICAL SPECIFICATIONS

SECTION 1

EXCAVATION AND GRADING

Geology Reports shall be submitted to the owner/developer, the appropriate City Representative, and the design engineer.

D. Engineering Geologist

The engineering geologist shall provide professional inspection within their area of technical specialty, which shall include professional inspection of the bedrock excavation to determine if conditions encountered are in conformance with the approved report, revised recommendations relating to conditions differing from the approved Engineering Geology Report shall be submitted to the geotechnical engineer.

E. Owner/Developer

The owner/developer shall be responsible for the work to be performed in accordance with the approved plans and specifications and in conformance with the provisions of this section, and the owner/developer shall engage consultants, if required, to provide professional inspections on a timely basis. The owner/developer shall act as a coordinator between the consultants, the Contractor and the City. In the event of changed conditions, the owner/developer shall be responsible for informing the City of such change and shall provide revised plans for approval.

F. City Representative

The appropriate City Representative(s) shall inspect the project at the various stages of work requiring approval to determine that adequate control is being exercised by the professional consultants.

G. Notification of Noncompliance

If, in the course of fulfilling their respective duties under this section of these Public Works Standards, Technical Specifications, and Standard Drawings, the design engineer, geotechnical engineer, or engineering geologist find that the work is not being performed in conformance with this section or the approved grading plans, the discrepancies shall be reported immediately in writing to the owner/developer and to the City.

H. Transfer of Responsibility

1. If the design engineer, the geotechnical engineer, or the engineering geologist of record is changed during grading, the work shall be stopped until the replacement has agreed in writing to accept their responsibility within the area of technical competence for approval upon completion of the work.

TECHNICAL SPECIFICATIONS
SECTION 1
EXCAVATION AND GRADING

- 2. It shall be the duty of the owner/developer to notify the City in writing of such change prior to the recommencement of such grading.

1.11 Completion of Work

A. Final Reports

Upon completion of the rough grading work and at the final completion of the work, the following reports, drawings, and supplements thereto are required for engineered grading or when professional inspection is performed for regular grading, as applicable.

- 1. A Record Drawing grading plan prepared by the design engineer retained to provide such service in accordance with Section 1.6.F showing original ground surface elevations, as-graded ground surface elevations, lot drainage patterns, and the locations and elevations of surface drainage facilities and of the outlets of subsurface drains. As-constructed locations, elevations, and details of subsurface drains shall be shown as reported by the geotechnical engineer.

Grading Record Drawings shall meet all Record Drawings requirements set forth in the General Requirements section of these Public Works Standards, Technical Specifications, and Standard Drawings.

- 2. A report prepared by the geotechnical engineer retained to provide such services in accordance with Section 1.6.G, including locations and elevations of field density tests, summaries of field and laboratory tests, other substantiating data, and comments on any changes made during grading and their effect on the recommendations made in the approved Geotechnical Report. Geotechnical engineers shall submit a statement that, to the best of their knowledge, the work within their area of responsibilities is in accordance with the approved Geotechnical Report and applicable provisions of this chapter.
- 3. A report prepared by the engineering geologist retained to provide such services in accordance with Section 1.6.H, including a final description of the geology of the site and any new information disclosed during the grading and the effect of same on recommendations incorporated in the approved grading plan. Engineering geologists shall submit a statement that, to the best of their knowledge, the work within their area or responsibility is in accordance with the approved Engineering Geology Report and applicable provisions of this section of these Public Works Standards, Technical Specifications, and Standard Drawings.

TECHNICAL SPECIFICATIONS

SECTION 1

EXCAVATION AND GRADING

- 4. The grading Contractor shall submit, in a form approved by the City, a statement of conformance to said Record Drawings and the specifications.

B. Notification of Completion

The owner/developer shall notify the City when the grading operation is ready for final inspection. Final approval shall not be given until all work, including installation of all drainage facilities and their protective devices, and all erosion-control measures have been completed in accordance with the approved grading plan, and the required reports have been submitted.

1.12 Safety

See requirements for Project safety in the General Requirements

1.13 Existing Utilities

See the General Requirements for Contract requirements for existing utilities and for preservation of survey monumentation.

1.14 Dust and Mud Control

The Contractor shall take appropriate action to control dust and mud caused by their operations. This shall include, but not be limited to, watering of exposed areas, cleaning of roadways, etc. This is considered a normal part of the construction Project.

1.15 Restoration of Disturbed Areas

The Contractor shall perform all Work and furnish all materials to restore the work area or adjacent other disturbed areas including any gravel, asphalt, concrete, lawn, fences, or any other surfaces or items damaged or disturbed by their construction operation. Surface restoration shall follow as closely as possible the backfill and compaction of excavations.

PART 2 - MATERIALS

2.1 Earthwork

A. Embankment Material

The embankment material shall be native or import free of vegetative or organic matter, boulders 8 inches or larger in diameter, or frozen material and shall be at or below optimum moisture content at the time of placement.

TECHNICAL SPECIFICATIONS

SECTION 1

EXCAVATION AND GRADING

B. Backfill Material

Suitable backfill material, unless shown otherwise on the City Standard Drawings, shall be the material excavated at the Site or aggregate base as approved by the City. Backfill material shall be free from sod, roots, trash, large cobbles, or other debris, etc., and shall be at a proper moisture content to achieve compaction.

C. Borrow Material

Borrow material shall be equal to or better than the on-site embankment material.

2.2 Geotextile Fabric

Geotextile fabric shall be Mirafi 500X or approved equal.

2.3 Aggregate Materials

A. General

All aggregate materials for aggregate base or surface rock, unless called for otherwise, shall meet the following requirements:

Percent Wear (AASHTO T 96)	40% Maximum
Durability Index Coarse and Fine	35% Maximum

B. Aggregate Base

Aggregate base shall substantially conform to current Oregon "Standard Specifications for Construction" for base aggregate materials, Section 02630, or as otherwise approved by the City. The Contractor shall use the size of aggregate base as called for on the City Standard Drawings. Aggregate base shall be 100 percent fractured face basalt.

C. Surface Rock

1. The surface rock shall be crushed stone or gravel meeting the following requirements:

Liquid Limit (AASHTO T 89)	35 Maximum
Plasticity Index (AASHTO T 90)	2-9 Maximum
Dust Ratio	<u>% Passing No. 200</u> 2/3 Maximum
	% Passing No. 30

TECHNICAL SPECIFICATIONS
SECTION 1
EXCAVATION AND GRADING

2. Grading Requirements (AASHTO T 11 and T 27)

Sieve	Percent Passing
1"	100
3/4"	70-98
#4	36-60
#8	25-47
#30	12-31
#200	8-15

3. Surface rock shall have at least 70 percent by weight of the particles retained on the #4 sieve and shall have at least two fractured faces.

2.4 Select Backfill

When native materials are not suitable, select backfill shall be well-graded 3/4"-0 or 1"-0 aggregate base or approved equal. All select backfill materials shall be subject to the approval of the City. In general, the native soils may be used for select backfill provided they are at or below optimum moisture at the time of placement/compaction and are free of vegetative matter, frozen material, trash, cobbles or boulders (greater than 8 inches), and other unsuitable material and debris. Where the City determines that the native soils excavated from the trench are not acceptable as select backfill, the Contractor shall import aggregate base. Placement of select backfill, whether native soils or imported aggregate base, shall be as required and as shown on the City Standard Drawings.

2.5 General Backfill

- A. General backfill will consist of material excavated from the trench, or material imported by the Contractor. General backfill material shall be free of vegetative matter, boulders (8-inch plus), frozen material and any other unsuitable material, and shall have a moisture content that will allow for the required compaction of the general backfill material unless approved otherwise by the City. Use of backfill material containing consolidated masses 6-inch in diameter or greater is prohibited.
- B. When the City determines that the native material excavated from the trench is unsuitable or unacceptable for use as general backfill, the City may require the Contractor to remove the unsuitable material from the Project Site and import suitable general backfill material. Suitable material shall be similar in nature to native soils as approved by the City. When imported general backfill must be placed in or below the groundwater, the imported general backfill shall be free draining granular material with

TECHNICAL SPECIFICATIONS
SECTION 1
EXCAVATION AND GRADING

less than 20 percent passing a No. 4 sieve and less than 3 percent passing a No. 200 sieve.

2.6 Controlled Density Fill (CDF)

- A. CDF material shall be a flowable cement, sand or pea gravel, and Fly Ash Pozzolanic, or other approved materials, mixture that contains 75 to 120 pounds of Type II cement per cubic yard.
- B. The sand and other aggregates shall generally conform with the requirements of ASTM C33.
- C. Air-entraining agent shall be added at the rate of 3 to 5 oz. per cubic yard.
- D. The material shall have a 28-day compressive strength of 100 to 200 psi and have a slump of 7 inches plus or minus 1-1/2 inches at the time of placement. The Contractor shall provide a mix design and data on the CDF material they propose to use along with typical compression test results.

2.7 Seed

- A. Lawn Seed

Lawn seed shall be a blend typically used in the area and of the type to match existing lawn areas, and must be approved by the property owner, if any, prior to use.

- B. Pasture Seed

Pasture seed shall be a mixture of orchard grass, rye grass, and fescue, native to the area and must be approved by the property owner, if any, prior to use.

2.8 Topsoil

Topsoil shall be native to the area and shall be approved by the City prior to use.

Furnish topsoil containing no substance detrimental to the growth of plants, that is free of plants designated by the Oregon Department of Agriculture as Type "A" or Type "B" weeds, and that is free of quack grass or crabgrass species.

Furnish topsoil that is from the fertile part of a soil profile, commonly referred to as the "A" horizon, typically ranging in depth from 3 inches to 12 inches below original ground surface. Do not take material for topsoil from a depth greater than 12 inches below original ground surface.

TECHNICAL SPECIFICATIONS
SECTION 1
EXCAVATION AND GRADING

2.9 Mulch

All mulch shall be straw that has been air dried and seasoned before baling or loading. It shall be free of noxious weeds and other materials detrimental to grass growth.

2.10 Sod

- A. Sod shall be 100 percent Kentucky Blue Grass or other types as approved by the City.
- B. The sod shall be grown on agricultural land that is cultivated specifically for turf sod. The sod shall be free of weeds, diseases, nematodes, and insects. All sod shall be mature and not less than 10 months old. All sod shall be machine cut to a uniform thickness of 5/8-inch or more, excluding top growth and thatch.

2.11 Erosion Control Matting

Erosion control matting shall be seed and curlex blanket as supplied by American Excelsior Co., of Yakima, Washington, or approved equal.

2.12 Hydroseed

- A. The hydroseed shall be a specifically designed hydromulch consisting of cellulose fiber, fertilizers, seed, tackifier, etc.
- B. The hydromulch shall be specifically processed cellulose fiber containing no growth or germination inhibiting factors. It shall be manufactured in such a manner that, after addition and agitation in slurry tanks with water, the fibers in the material become uniformly suspended to form a homogenous slurry. When sprayed on the ground, the material shall allow absorption and percolation of moisture. Each package of cellulose fiber shall be marked by the manufacturer to show the air dry weight and content.
- C. The fertilizer shall be a complete plant food containing slow release nitrogen, phosphoric acid, and potash in the amounts of 16-16-16+1.5 FE. It shall be delivered in uniform composition and be dry and free flowing and delivered in the original unopened containers bearing the manufacturer's guaranteed analysis.
- D. The grass seed shall be certified, blue tagged, cleaned, and delivered in original unopened packages bearing an analysis of the contents. It shall be guaranteed 95 percent pure and have a minimum germination rate of 85 percent within 1 year of test. The seed shall be as agreed upon by the City. The seed shall be applied at a minimum rate of 4 pounds per 1,000 square feet.

TECHNICAL SPECIFICATIONS
SECTION 1
EXCAVATION AND GRADING

2.13 Slope Stabilization Rock

A. Slope stabilization rock shall be pit run, a well-graded 4"-0 material with the approximate gradation:

Sieve	Percent Passing
4"	100
2"	35-50
1/2"	10-20
Less 1/4"	0-5

B. The 4"-0 slope stabilization rock shall be hard, durable, and resistant to weathering. The rock shall be angular in shape with an apparent specific gravity of 2.5 minimum. The Contractor shall develop a test pile of 4"-0 slope stabilization rock for approval by the City. Once the test pile has been approved by the City, all other 4"-0 rock shall be visually the same as the test pile.

PART 3 - EXECUTION

3.1 Earthwork

A. Clearing and Grubbing

1. All vegetation, rubbish, and debris shall be removed and disposed of by the Contractor in conformance with the requirements of local authorities controlling air pollution and solid waste disposal.
2. When topsoil at the Site is to be saved and reused, it shall be stripped and stored clear of the construction area. Take reasonable care to prevent the topsoil from becoming mixed with subsoil and other debris, etc.
3. The Contractor shall exercise care to minimize disturbing the natural ground or vegetation outside the limits of the construction area.

B. Excavation

1. Prior to any excavation, the area to be excavated shall be cleared and grubbed.
2. Allow for forms, working space, granular base, and finish topsoil as shown or required. Do not carry excavation for footings and slabs deeper than the elevation shown. All over-excavated areas shall be corrected at the Contractor's expense and to the satisfaction of the City.

TECHNICAL SPECIFICATIONS
SECTION 1
EXCAVATION AND GRADING

C. Embankments

1. Prior to construction of any embankment on the Site, the area beneath the embankment and the areas from which embankment material will be obtained shall be cleared and grubbed. The existing soil beneath the embankment shall then be compacted to 90 percent of maximum density as determined by ASTM D1557 for a minimum of 6 inches below ground surface. Any unsuitable soils or material shall be removed prior to placement of any embankment.
2. Upon completion of the embankment foundation, embankment material shall be placed in horizontal lifts and compacted. Compaction of embankments supporting footings and structures shall be compacted to 95 percent of ASTM D1557 laboratory density. All other embankments, unless otherwise noted on the Drawings, shall be compacted to 90 percent of ASTM D1557 laboratory density. Embankment lift depth shall not exceed the capability of compaction equipment being used to achieve the required compaction for the full depth of each lift.
3. The embankment shall be brought to the lines and grade required on the Design Drawings. Any unsuitable material which may have been used in constructing the embankment shall be removed and replaced with suitable material and compacted.

D. Backfilling

The Contractor shall exercise care during backfilling operations to prevent damage to footings, pipes, manholes, or other structural elements. The Contractor shall also pay particular attention to compaction around footings to avoid settlement of floor slabs or steel floors at the footing-floor connection points. All fill material shall be compacted to 95 percent of ASTM D1557 laboratory density.

E. Subgrade Cut Areas

In subgrade cut areas, the subgrade material shall be compacted to 90 percent of maximum density as determined by ASTM D1557 for a minimum of 6 inches below the top of the subgrade. Depending on the type of material encountered, the Contractor may have to scarify, aerate or add water, over-excavate, or take other actions as necessary to achieve the required compaction.

TECHNICAL SPECIFICATIONS
SECTION 1
EXCAVATION AND GRADING

F. Roadway and Site Subgrades

1. All grading and subgrade preparation and other excavations and embankments shall be trimmed accurately to the lines, grades and cross sections as shown on the Design Drawings and established by the design engineer and shall be finished in a thoroughly workmanlike manner to within plus or minus 0.05 foot of the required grade.
2. The grade shall be in a neat and well-finished condition at the time the project is completed. The entire right-of-way area shall be cleaned up and made free of debris and foreign matter of all kinds. Accumulations of dirt and/or other materials shall be disposed of in a manner satisfactory to the City.
3. Upon completion of the subgrade and prior to placement of any geotextile fabric, if required, and aggregate materials, the Contractor shall load test the finished subgrade surface. The load test shall consist of slowly driving a loaded dump truck over the subgrade surface. The dump truck shall have a minimum capacity of 10 cubic yards. The City Representative and Contractor shall note any soft areas.
4. The Contractor shall excavate and either replace unsuitable material or properly compact all soft areas in order to provide a firm base that conforms to the Specifications. Any soft areas that occur as part of the project because of overwatering, improper compaction, weather, etc., shall be replaced.

G. Water for Compaction

The Contractor shall be responsible for obtaining, transporting and the application of the water.

H. Shoring, Sheeting, Bracing, and Sloping

Install and maintain shoring, sheeting, bracing, and sloping necessary to support the sides of the excavation, to keep and to prevent any movement which may damage adjacent pavements, utilities, or structures, damage or delay the Work, or endanger life and health. Install and maintain shoring, sheeting, bracing, and sloping as required by OSHA, and other applicable governmental regulations and agencies.

3.2 Geotextile Fabric Installation

Geotextile fabric shall be installed as shown on the Design Drawings or as directed by the design engineer. Fabric placed for subgrade stabilization under embankments or over roadbed

TECHNICAL SPECIFICATIONS
SECTION 1
EXCAVATION AND GRADING

subgrade shall be placed parallel to the centerline of the roadway, with placement starting at the low side of the super elevation or crown. The fabric shall either be sewn together at all longitudinal and transverse edges or overlapped a minimum of two feet at all edges. Transverse overlaps shall be made in the direction of base material placement.

3.3 Placement of Aggregate Materials

- A. The construction procedure described herein shall be understood to apply to each of the courses and/or layers of aggregate materials of which the Site is to be constructed.
 - 1. After the subgrade is brought to the proper line, cross section and compaction, the aggregate materials shall be spread and shaped as required.
 - 2. The spreading and shaping of the aggregate materials shall be so performed as to prevent separation of the coarser material from the finer materials including the use of adequate water.
 - 3. The aggregate materials shall be brought to proper moisture content as required for compaction and compacted to 95 percent of maximum density as determined by ASTM D1557.
 - 4. The finished surface when tested with a 10-foot straightedge shall not vary from the testing edge by more than 0.05 foot at any point.
 - 5. Following construction of each lift, the Contractor shall do such blading, brooming, watering and other work as necessary to prevent raveling and rutting.
 - 6. These operations are to be continued as required until the lift is covered by a following lift or until all Work to be done under the Contract is completed.
 - 7. If the required compacted depth of any lift exceeds 6 inches, it shall be constructed in two or more lifts, each lift not exceeding 6 inches in depth.
- B. Upon completion of the aggregate materials placement, the Contractor shall load test the finished surface. The load test shall consist of slowly driving a loaded minimum 10 yard dump truck over the road surface.
- C. All soft areas shall be noted. The Contractor shall excavate and/or compact all soft areas in order to provide a firm base that conforms to the requirements of these Public Works Standards, Technical Specifications, and Standard Drawings.

TECHNICAL SPECIFICATIONS
SECTION 1
EXCAVATION AND GRADING

3.4 Site Cleanup

The Site shall be left in a clean, neat, and presentable condition. All debris, construction materials, unsightly rocks, tree roots, or other material which detracts from the appearance of the Site shall be disposed of in a satisfactory manner.

3.5 Dewatering Excavated Areas

- A. All groundwater, seepage, or stormwater that may occur or accumulate in the excavation during the progress of the Work shall be removed. In areas where the nature of soil and hydrostatic pressures are of such a character as to develop a quick condition in the earth mass of the trench, the dewatering operation shall be conducted so that the hydrostatic pressure will be reduced to or near zero in the immediate vicinity of the trench.
- B. All excavations shall be kept free of standing water during the construction or until otherwise requested by the design engineer.

3.6 Location of Imported Material

Imported material shall not be stockpiled on paved surfaces unless approved by the City. Any damage to paved surfaces resulting from stockpiled imported material on said surfaces shall be repaired at the Contractor's expense.

3.7 Location of Excavated Materials

- A. During trench excavation, the excavated material shall be located within the construction easement or right-of-way so that the excavated material will not obstruct any private or public traveled roadways or streets, or cause undue damage to the streets.
- B. Contractor shall provide means of containing overly saturated soils, i.e., muck, or remove the muck from the Work area as it is excavated, if such soils are encountered in the excavation.

3.8 Disposal of Excavated Materials

Contractor shall dispose of all excavated material, which is not required for, or is unsuitable for, backfill. The Contractor's method of disposal shall comply with regulations of the governing body having jurisdiction.

TECHNICAL SPECIFICATIONS
SECTION 1
EXCAVATION AND GRADING

3.9 Execution of Dust and Mud Control

If the Contractor fails to properly control the dust and mud, the City may request them to do so in writing. If, after 24 hours from this request, the Contractor has not corrected the dust or mud problem, the City may elect to have the corrective work performed and withhold the cost from the Contractor's payments.

3.10 General Surface Restoration

A. General

1. The Contractor shall replace or restore, equivalent to their original condition, all surfaces, trees and shrubbery, lawns, agricultural areas, pastures and fences, or other existing facilities disturbed by their Work unless otherwise specified. Restoration and cleanup shall be a continuing operation and shall be diligently pursued until completed. Surface restoration shall be completed as soon as possible after the underground work is complete.
2. All surplus material, rock and debris, and temporary structures, as well as excess excavation, shall be removed by the Contractor and the entire Site of Contractor's operations shall be left in a neat and clean condition.
3. Lawns and pastures in private easements shall be restored to a smooth condition and reseeded with a like mixture of grass unless specified otherwise on the Design Drawings. When backfilling trenches in private easements, unless otherwise specified, Contractor shall replace topsoil to minimum 1-foot depth or to a depth equal to the original depth, whichever is less. Lawn sod shall be utilized where called for on the Design Drawings or where required by the design engineer.

B. Agricultural Areas

1. Where called for on the Drawings, the existing top soils in the excavation area shall be removed and stockpiled at a separate location from the general trench excavation material. This topsoil shall not be mixed or contaminated with any other materials.
2. Upon completion of the trench backfill and after all rocks and unsuitable material have been removed from the work area, the stockpiled topsoil shall be replaced and graded to match the existing ground. The depth of topsoil restoration shall be as shown on the Design Drawings.

TECHNICAL SPECIFICATIONS

SECTION 1

EXCAVATION AND GRADING

C. Seeding

1. All areas to be seeded shall have a minimum of 6 inches of topsoil.
2. After the backfilling and compaction have been completed, the top 2 inches of the topsoil shall be scarified to provide a good seed bed and the area seeded, fertilized, compacted with a weighted roller, a straw mulch or approved equal applied, and the initial watering completed.
3. All additional watering of the grass seed shall be the responsibility of the property owners.
4. Unless required otherwise, the seed shall be applied at a minimum rate of 4 pounds per 1,000 square feet, the fertilizer at 1 pound per 100 square feet, and the mulch at a rate needed to provide a minimum mulch thickness of 1 inch.

3.11 Lawn Sod Restoration

A. Preparation of Areas

1. Cultivate the existing ground or new topsoil so the soil is loose and friable for at least a 6 inch depth and suitable for fine grading. Remove vegetative matter, rocks, clods, roots, sticks, debris, and other matter detrimental to the germination and growth of sod from the areas to be sodded.
2. Apply herbicide to kill existing weeds and grasses.
3. Spread soil amendments and fertilizers evenly over the sod bed at the rates specified below, then thoroughly till into the upper 4 inches of the soil.
4. After tilling, fine-grade and roll the area to provide a fine-textured, smooth, firm surface, free of any undulations or irregularities.
5. The finish grade of the sod bed shall be 1 inch below the finish grade of the walks. Rates of applications shall be as follows:

Material	Rate Per 1,000 Sq. Ft.
Soil Conditioner	6 Cu. Yds. (2" Depth)
Fertilizer: 22-16-8	10 Lbs.

TECHNICAL SPECIFICATIONS
SECTION 1
EXCAVATION AND GRADING

B. Planting Season

Perform the Work only when local weather and other conditions are favorable to bed preparation and placing of sod. Do not place sod before March 15 or after September 30, unless approved otherwise.

C. Placing Sod

1. Do not place sod until the sod bed has been approved. Immediately before placing sod, water the bed to prevent drying of grass roots.
2. Lay the first row in a straight line and place subsequent rows parallel to and tightly against each other. Stagger lateral joints. Do not stretch or overlap the sod. Tightly butt all joints. Do not use sod segments containing less than 2 square feet of surface area, broken, torn, or uneven pieces.
3. After placing sod, diagonally roll and thoroughly water. Apply a second application of fertilizer (22-16-8) at the rate specified for preparation of areas and thoroughly water.

D. Sod Lawn Establishment

1. The establishment period for sod lawn begins after placing of sod in an area is completed. The establishment period will be at least two weeks and ends when accepted by the City. During the established period, the Contractor shall adequately water the sod to keep the new sod green. Keep mowed to a height of 1-1/2 to 2 inches.
2. Do not attempt the first mowing until the sod is firmly rooted and secure in place. Remove no more than 1/3 of the grass leaf during initial or subsequent cuttings.
3. Control all weeds, foreign grasses, etc., that grow in or through the sod for up to 45 days after the sod is placed.
4. Acceptance of sod lawn will be contingent on the grass being uniform in color, density, and height, and being weed-free. All dead or brown sod shall be replaced at no cost to the City.

TECHNICAL SPECIFICATIONS
SECTION 1
EXCAVATION AND GRADING

3.12 Hydroseeding

A. Application Rates

Hydroseeding shall be placed at the following application rates unless otherwise shown on the Design Drawings or approved by the City.

Material	Application Rate
Mulch	2,000 pounds per acre
Fertilizer	Lawn 430 pounds per acre Dryland Grass 50 pounds per acre
Tackifier	20 pounds per acre
Seed	4 pounds per 1,000 square feet
Wood Cellulose Fiber Tracer	< 250 pounds per acre

B. Seeding shall not be done during windy weather or when the ground is excessively wet or otherwise un-tillable. Seed shall be placed at the rate and mix specified below. Seed will be placed with an approved hydroseeder which utilizes water as the carrying agent, and maintains continuous agitation through paddle blades.

C. Hydroseeder

1. Hydroseeder shall have an operating capacity sufficient to agitate, suspend and mix into a homogenous slurry, and the specified amount of seed and water or other material.
2. Distribution and discharge lines shall be large enough to prevent stoppage and shall be equipped with a set of hydraulic spray nozzles which will provide a uniform distribution of the slurry.

D. Seed and fertilizer may be applied in one application provided the fertilizer is placed in the hydroseeder tank no more than 30 minutes prior to application. The seed shall have a tracer added to aid uniform application. This tracer shall not be harmful to plant and animal life.

E. The Contractor shall remove mulch material which falls on plants, roadways, gravel shoulders, structures, areas where mulching is not specified, or which collects at the ends of culverts or accumulates to excessive depths, as directed.

TECHNICAL SPECIFICATIONS
SECTION 1
EXCAVATION AND GRADING

3.13 Erosion Control Matting

- A. Place matting as called for on the Design Drawings or as required by the design engineer. Prepare Site as specified for permanent seeding area preparation.
- B. Immediately following the establishment of the finished grade, matting shall be placed parallel to the flow of water. Where more than one strip of matting is required to cover the given area, it shall overlap the adjacent mat a minimum of 4 inches.
- C. The ends of the matting shall overlap at least 6 inches with the upgrade section on top. The upslope end of matting shall be staked and buried in a 6-inch deep trench with the soil firmly tamped against the mat. Three stakes per width of matting (one stake at each overlap) shall be driven below the finish ground line prior to backfilling of the trench. The City may require that any other edge exposed to more than normal flow of water or strong prevailing winds be staked and buried in a similar manner.
- D. The edges of matting shall be buried around the edges of catch basins and other structures. Matting must be spread evenly and smoothly and in contact with the soil at all points.
- E. Matting shall be held in place by approved wire staples, pins, spikes, or wooden stakes driven vertically into the soil. The matting shall be fastened at intervals not more than 3 feet apart in three rows for each strip of the matting, with one row along each edge and one row alternately spaced in the middle. All ends of the matting and check slots shall be fastened at 6-inch intervals across their width. Length of fastening devices shall be sufficient to securely anchor the matting against the soil and driven flush with the finished grade.

3.14 Mulch

- A. Place mulch approximately 1-1/2 inches deep in a loose condition at a rate of 2 to 2.5 tons/acre. Place grass straw mulch so that it is loose enough for sunlight to penetrate and air to circulate; but dense enough to shade the ground, reduce water evaporation, and materially reduce soil erosion.
- B. Anchor using a crimping disc, an approved tackifier, or approved modified sheepsfoot roller, or another method approved by the City.

TECHNICAL SPECIFICATIONS
SECTION 1
EXCAVATION AND GRADING

3.15 Cleanup

- A. Cleaning up shall be a continuing process from the start of the work to final acceptance of the Project. The Contractor shall, at all times, keep the area on which work is in progress free from accumulations of waste material or rubbish.

- B. Spillage from the Contractor's hauling vehicles on traveled public or private roads shall be promptly cleaned up. Upon completion of the work the Contractor shall remove all temporary structures, rubbish, and waste material, equipment and supplies, resulting from the Contractor's operations. The Contractor shall leave such lands in a neat and orderly condition which is at least as good as the condition in which the Contractor found them prior to the Contractor's operations.

- C. In roadways and traffic areas, the Contractor shall be responsible for maintaining a road surface suitable for travel by the public from the time of excavation until the road surface has been restored. Such work includes dust control, temporary patching, signing, grading, and filling of potholes on temporary street surfaces, etc. The Contractor shall be responsible for all Claims and damages resulting from their failure to maintain a suitable surface.

END OF SECTION

TABLE OF CONTENTS

SECTION 2

STORM DRAINAGE

PART 1 - General2-1

1.1 General Design Requirements2-1

1.2 Alignment and Cover2-7

1.3 Structure Location2-9

1.4 Storm Detention2-10

1.5 Erosion Control2-11

1.6 Private Drainage Systems2-13

1.7 Specification References.....2-13

1.8 Care and Handling of Materials2-13

PART 2 - Materials.....2-14

2.1 Bedding, Select Backfill, and General Backfill2-14

2.2 General Backfill.....2-14

2.3 Gravity Storm Drain Pipe2-14

2.4 Manholes.....2-15

2.5 Catch Basins.....2-17

2.6 Culverts.....2-19

2.7 Sedimentation Chamber/Drywell Combo.....2-19

2.8 Drain Rock2-19

2.9 Filter Fabric.....2-19

2.10 Hydroseed2-20

2.11 Mulch2-20

PART 3 - Execution2-20

3.1 Trench Excavation2-20

3.2 Shoring, Sheeting, and Bracing of Trenches.....2-21

3.3 Dewatering Excavated Areas2-21

3.4 Location of Excavated Materials.....2-21

3.5 Disposal of Excavated Materials2-22

3.6 Trench Backfill2-22

3.7 Execution of Dust and Mud Control2-24

3.8 Restoration, Finishing, and Cleanup2-24

3.9 Existing Utilities2-24

3.10 Installation of Pipe.....2-24

3.11 Manhole Installation and Connections2-26

3.12 Catch Basins.....2-27

3.13 Culverts.....2-27

3.14 Cleaning and Flushing of Completed and Tested Storm Drains2-28

3.15 Environmental Protection of Catch Basins.....2-28

TECHNICAL SPECIFICATIONS

SECTION 2

STORM DRAINAGE

PART 1 - GENERAL

1.1 General Design Requirements

A. Performance Standards

- 1. Storm drainage design within a development area shall include provisions to adequately control runoff from all public and private streets, roofs of buildings, landscaped areas, paved areas, and any other impervious or pervious surface. The design engineer must ensure storm drain system improvements are designed to account for the entire drainage basin taking into consideration future improvements. All surface water, groundwater, and stormwater shall be handled in conformance with these Public Works Standards, Technical Specifications, and Standard Drawings. These provisions include:
 - a. All stormwater generated on site shall be collected, treated, and disposed of on site as applicable unless otherwise approved by the City. Where the site abuts the public right-of-way, a maximum 10-foot transition area at driveways, as measured from the back of the sidewalk, is permitted to drain to the public right-of-way. Residential driveways are permitted to drain a maximum of 20 feet from the property line.
 - b. Surface water or groundwater, and the drainage thereof, caused or effected by the changing of the natural grade of the existing ground, the removal of natural ground cover, or the placement of impervious surfaces, shall not be allowed to flow over, under, or through adjacent public or private property in a volume or location materially different from that which existed before development occurred. Any necessary drainage of surface water or groundwater shall be collected and conveyed in an approved manner to an approved point of disposal.
 - c. Surface water entering the subject property shall be received at the naturally occurring locations and surface water exiting the subject property shall be discharged at the natural locations with adequate energy dissipaters within the subject property to minimize downstream damage with no diversion at any of these points.
 - d. Potential approved points of disposal for stormwater, surface water, or groundwater include, but are not limited to, storm drain systems; underground injection control (UIC) systems (typically drywells), infiltration swales, infiltration or retention ponds, creeks, rivers, ditches,

TECHNICAL SPECIFICATIONS

SECTION 2

STORM DRAINAGE

open channels, etc., approved by the City. Acceptance of suggested systems will depend upon the prevailing site conditions, capacity of existing downstream facilities, and feasibility of the design.

- e. When private property must be crossed to reach an approved point of disposal, it shall be the developer's responsibility to acquire a recorded drainage easement (of dimensions in accordance with Section 1.2 D of this section. The drainage facility shall be a closed conduit system. Temporary drainage ditch facilities, when approved, shall be engineered to contain the stormwater without causing erosion or other adverse effects.
 - f. The design peak discharge from the subject property shall not be increased from conditions existing prior to the proposed development, except where it can be satisfactorily demonstrated by the owner/ developer that there is no adverse impact.
 - g. Retention/detention facilities will be required when necessary to maintain stormwater and/or surface water discharge rates at or below the existing design storm peak discharge, except when it can be demonstrated that no adverse impact will result from said facilities not being provided.
 - h. Minimum width of an access easement from an existing public road to a drainage facility shall be 15 feet.
 - i. Vegetation shall be established on areas disturbed by/or on areas of construction as necessary to minimize erosion, in accordance with Section 1.5 of this section.
2. All storm drain system designs shall make adequate provisions for collecting all stormwater runoff. The system shall accommodate all runoff from upstream tributary areas whether or not such areas are within the proposed development. The amount of runoff to be accommodated shall be based upon ultimate development of all upstream tributary areas.
3. Where storm drains are constructed on slopes greater than 20 percent; in areas designated as hazardous; where site conditions may cause damage to improvements, slippage, or slides; or as determined by the City; a Geotechnical Report and/or an Engineering Geology Report may be required.

TECHNICAL SPECIFICATIONS

SECTION 2

STORM DRAINAGE

- 4. For erosion control requirements, refer to Technical Specifications - "Excavation and Grading," Part 1 - General, 1.9 Erosion Control.
- 5. Where the finished graded surface has a greater than 20 percent slope, or as required, soil stabilization fabric shall be placed over the entire disturbed area.
- 6. Proposed storm drain systems shall not discharge flows into inadequate downstream systems unless approved by the City.
- 7. Public storm lines shall be located within the public right-of-way (ROW) per 1.2 Alignment and Cover, A. Right-of-Way Location below.
- 8. Drawings relevant to this section are included in the Standard Drawings.

B. Site Drainage Plans

- 1. Existing Drainage Plan
 - a. A topographical contour map defining existing conditions shall be provided and include the following minimum information:
 - 1) One-foot contour intervals; slopes over 10 percent may use 2-foot intervals. Extend the contours a minimum of 50 feet beyond the property boundary.
 - 2) All structures, buildings, parking lots, and utilities on the property.
 - 3) Isolation of all existing drainage facilities and watercourses, including wetlands and floodplain areas.
 - b. Locations of all subsurface water outlets (e.g., springs.) Show arrows to indicate direction of flow for all drainage information.
 - c. Floodplain information, delineating all floodplain limits, shall be shown where it occurs within the development. Floodplain limits shall be based on maps prepared by the U.S. Army Corps of Engineers and the Federal Emergency Management Agency (FEMA). Where better information is available, it shall be used by the design engineer.

TECHNICAL SPECIFICATIONS

SECTION 2

STORM DRAINAGE

2. Proposed Drainage Plan

Show proposed site grading and drainage facilities on a topographical contour map. Unless the detail for proposed improvements will obscure the conditions shown on the existing drainage plan, proposed site grading and drainage may be shown on the existing drainage plan. The following minimum information shall also be shown.

- a. Finished contours of the property after development shall be at 1-foot contour intervals; slopes over 10 percent may use 2-foot intervals. Extend the contours to daylight into existing contours at or before project extents.
- b. Percent grade elevations, dimensions, and locations for all graded slopes.
- c. Cut/fill areas, structural fill placement areas, and erosion/sedimentation control methods including reseeding areas.
- d. All proposed drainage facilities including public and private systems, drainage ditches, culverts, surface detention or infiltration infrastructure, UIC infrastructure, etc.
- e. All proposed changes to floodplain boundaries must meet the requirements of FEMA.

C. Drainage Calculations

Furnish such supporting information as required per General Requirements, A. General Public Works Standards, Technical Specifications, and Standard Drawings, 1.10 Supporting Information, and 1.1 General Design Requirements, E. Performance Standards, below.

D. Detention Requirements

All proposed development is required to use adequate drainage management practices. Developments located within a master planned drainage basin will follow the recommendations adopted to that plan. Developments not located within master planned drainage basins shall minimize the rate and amount of runoff to receiving systems and streams.

TECHNICAL SPECIFICATIONS

SECTION 2

STORM DRAINAGE

E. Minimum Design Criteria

1. Design Storm

The Type II storm with a duration of 24 hours shall be used.

2. Storm Frequency

All storm drain systems shall be designed for the design minimum storm recurrence interval in the following table:

DRAINAGE SYSTEM DESIGN CAPACITY

Drainage System Element	Minimum Design Storm Recurrence Interval (Years)
Streets, curbs, gutters, inlets, catch basins, and connector drains	10
Lateral/collectors (less than 250 tributary acres)	10
Trunklines (greater than 250 tributary acres)	50*
Arterial streets and the drainage system in or under arterial streets	50*
Watercourses	
Without designated floodplain	50
With designated floodplain	100
Bridges	100
Detention Facilities	
Storage volume (on site)	25
Storage volume	100
Private storm drainage systems	25

**Surcharging contained within pipe system will be allowed.*

3. Precipitation

Precipitation depths shall be determined using the *Oregon Department of Transportation Hydraulics Design Manual*, current edition, but shall in no case be taken less than the following:

Recurrence Interval (Years)	24-hour Precipitation (inches)
10	1.4
25	1.5
50	1.8

TECHNICAL SPECIFICATIONS

SECTION 2

STORM DRAINAGE

Recurrence Interval (Years)	24-hour Precipitation (inches)
100	1.9

4. Infiltration Rate

The design infiltration rate shall be as required by the Geotechnical Report or Engineering Geology Report. When a range of acceptable infiltration rates is given in the report, the lowest value shall be conservatively used. When a Geotechnical Report and/or Engineering Geology Report is not required, the infiltration rate shall be determined in accordance with the requirements of the Stormwater Management Manual for Eastern Washington (SMMEW), current edition. For convenience, at the time these standards were developed, Section 6.3.3 of the SMMEW provides requirements for infiltration rate determination. When presumptive infiltration rates are used in accordance with the SMMEW, testing shall be performed to verify the soil type prior to approval of the design drawings.

5. Time of Concentration

Overland flow of runoff to the initial catchment point into the storm drain system shall be calculated in accordance with the *Oregon Department of Transportation Hydraulic Design Manual*, current edition. The minimum time of concentration shall be 5 minutes.

6. Velocity and Slope

All storm drains shall be on a grade that produces a mean velocity, when flowing full, of at least 3 feet per second.

7. Manning's Equation

When calculating minimum pipe slopes and velocities, the design engineer shall use the Manning pipe friction equation.

8. Pipe Coefficient

The storm drain pipe roughness coefficient to be used in the Manning's equation shall be not less than 0.013.

TECHNICAL SPECIFICATIONS

SECTION 2

STORM DRAINAGE

- 9. Design Methods
 - a. Several methods are available to design engineers for estimating peak runoff. For areas under 200 acres, the Rational Method can be used. Regression equations can only be used as a check on other methods. For areas larger than 200 acres, a hydrographic-based formula shall be used.
 - b. When used, the Rational Method shall be per the *Oregon Department of Transportation Hydraulics Design Manual*, current edition. The runoff coefficient "C" for impervious surfaces shall be taken as 0.9. The rainfall intensity shall be calculated based on the time of concentration, with iterative calculations used as necessary.

10. Void Ratio

When designing drywells or other rock pockets to store and infiltrate stormwater, the design void ratio shall not exceed 35 percent. When permitted by the City, the design void ratio may be increased above 35 percent when a specific, locally available rock type/gradation is specified and the rock is tested in accordance with ASTM C29 prior to construction.

1.2 Alignment and Cover

A. Right-of-Way Location

Storm drain lines shall generally be located at centerline. All changes in direction of pipe shall be made at an approved structure, except as provided in B. Curvature below.

B. Curvature

Storm drain lines shall not be curved between structures. If unusual circumstances are present, as determined by the City, small diameter storm drains may be curved. Such curves shall conform to the street curvature.

C. Minimum Cover

- 1. All storm drains shall be laid at a depth sufficient to protect against damage by traffic and to drain building footings where practical. Sufficient depth shall mean the minimum cover from the top of the pipe to finish grade at the storm drain alignment.

TECHNICAL SPECIFICATIONS

SECTION 2

STORM DRAINAGE

- 2. Minimum cover shall be 18 inches above the top of the pipe. Less than minimum cover may be allowed if unusual circumstances are present and appropriate measures are taken to protect the pipe integrity, as determined by the City.
- 3. The design engineer must show that sufficient depth is provided at the boundary of the development to properly drain the remainder of the upstream basin area tributary to the site.

D. Easements

- 1. When it is necessary to locate storm drains in easements, the storm drain shall be centered in the easement. All storm drain easements shall be exclusive and shall not be used for any purpose that would interfere with the unrestricted use of the storm drain line. Exceptions to this requirement will be reviewed on a case-by-case basis (e.g., a utility corridor in a new subdivision).
- 2. Easements for storm drain lines 36 inches or less in diameter shall have a minimum width of 15 feet. Easements for storm drain lines greater than 36 inches in diameter, shall have a minimum width of 20 feet. Wider easement widths may be required for special circumstances.
- 3. Open channel easement widths shall be 20 feet from the waterway centerline, or 15 feet from the top of the recognized bank, whichever is greater.
- 4. Easement locations for public storm drains serving a Public Utility District, apartment complex, or commercial/industrial development shall be in parking lots, private drives, or similar open areas, which will permit unobstructed vehicle access for maintenance.
- 5. Structures shall not be built over the easements, nor shall trees or large bushes be planted in the easement.
- 6. Easements shall be furnished to the City for review and approval prior to recording.

E. Relation to Watercourses

Storm drain lines discharging to a creek or drainage channel shall be preapproved by the Oregon Department of Environmental Quality (DEQ).

TECHNICAL SPECIFICATIONS

SECTION 2

STORM DRAINAGE

1.3 Structure Location

A. Manholes

1. Manholes shall be included at all changes in slope, alignment, pipe size, and pipe junctions with present or future storm drains. Manhole spacing shall not be greater than 400 feet.
2. Standard manholes are required when rim to crown of pipe elevations exceed 4 feet at pipe junctions. Flat-top manholes shall be used when rim to crown of pipe elevations are less than 4 feet.
3. When the downstream pipe size increases, the crown of all upstream pipes shall not be lower than the crown of the larger downstream pipe.

B. Catch Basins

1. Catch basins shall be located in streets at the curb line to receive stormwater runoff and convey it to the main storm drain system, UIC system, or other approved discharge point.
2. Catch basins shall be located at the following locations but shall, in no case, be spaced farther than 500 feet apart:
 - a. Curb returns on the upstream side of an intersection.
 - b. Dead-end streets with a descending grade.
 - c. At intermediate locations so storm flow widths at the curb line do not encroach on the traveled way or exceed 3 inches in depth (measured at the curb face), whichever is less. For roads classified as local streets and when approved by the City, storm flow widths at the curb line may encroach a maximum of half a lane width into the traveled right-of-way but shall in no case exceed 3 inches in depth.
 - d. Upstream of driveways where design gutter flows would otherwise overtop the back of the sidewalk.
 - e. At the low points of vertical curves.

TECHNICAL SPECIFICATIONS

SECTION 2

STORM DRAINAGE

f. For grades greater than 8 percent, the design engineer shall provide calculations considering catch basin inlet capacity and shall decrease catch basin spacing where required.

3. Catch basins shall be capable of intercepting design storm flows at the curb.

C. Drywells

Where there are no natural or constructed drain ways, or an existing stormwater system, drywells can be used as a discharge point providing they are installed in accordance with DEQ regulations and are approved by the City and are in conformance with the City’s current Underground Injection Control System Management Plan.

D. Anchor Blocks

For storm drain pipes greater than 4 inches in diameter, concrete anchor blocks shall be required if the slopes are greater than 20 percent. Anchor blocks shall key into trench sides. Spacing for anchor blocks is as follows:

SPACING FOR ANCHOR BLOCK FOR ALL SIZE PIPE

Slope (Percent)	Minimum Spacing (Feet)
0 to 19.99	No Anchor Required
20 to 34.99	35
35 to 50.99	25
51 or more	15 or Special Design

E. Water Bars

Where the finished graded surface has a slope greater than or equal to 3H:1V or as required, water bars shall be installed. The water bars shall be sloped slightly to drain runoff water away from the pipe line alignment. Water bars shall have a maximum spacing of 40 feet.

1.4 Storm Detention

A. Development Not Requiring Detention

All developments should retain all stormwater on site unless otherwise approved by the City. When permitted to discharge stormwater off site, developments meeting the following criteria will not be required to provide detention:

TECHNICAL SPECIFICATIONS

SECTION 2

STORM DRAINAGE

- 1. Land divisions of less than four lots.
- 2. Multi-family developments of less than four units.
- 3. Commercial and industrial development where the construction of a new or the expansion of an existing facility will not increase the impervious area by more than 5,000 square feet.

B. Detention Volume

When detention is permitted or required, the volume to be detained shall be based on the following:

- 1. The rate of runoff from a developed site during a 25-year recurrence interval storm which shall not exceed the pre-development rate of runoff released based on a 10-year recurrence interval storm.

C. Emergency Overflow

- 1. The design engineer shall assess the impacts of system failure for on-site detention. Overflows may occur due to rainfall intensity that exceeds the design storm, debris blockage of storm drain system, or some other reason.
- 2. If a system overflows, it shall not cause inundation of neighboring properties. Potential overflow routes shall be protected from erosion by adequate means.

D. Detention Facilities

Detention volume storage methods in order of preference are the following:

- 1. Surface storage
- 2. Underground storage

1.5 Erosion Control

Developments shall provide erosion control methods to limit the removal of soil materials caused by storm runoff during the construction phase of a project. Developers shall obtain a DEQ 1200-C Permit if required by the DEQ. It shall be the responsibility of the developer to determine if a 1200-C Permit is required. See General Requirements, C. Environmental and Other Special Requirements for additional requirements.

TECHNICAL SPECIFICATIONS

SECTION 2

STORM DRAINAGE

A. Erosion Control - Application

1. For subdivision plats, temporary erosion control measures shall be utilized by the applicant during installation of plat improvements and by subsequent builders during construction of dwellings and other lot improvements.
2. Prior to the initial clearing and grading of any land development, provisions shall be made for the interception of all potential silt-laden runoff that could result from said clearing and grading. Said interception shall preclude any silt-laden runoff from discharging from the proposed land development to downstream properties, unless previously approved by the City. Said interception shall cause all silt-laden runoff to be conveyed by open ditch or other means to a temporary facility designed by the design engineer to remove silt prior to discharge to downstream properties.
3. Prior to initial clearing and grading of the construction site, an evaluation of the following factors must be carried out:
 - a. Soil Erodibility

Soil erodibility should be identified using Natural Resources Conservation Service erodibility ratings. Erosion control techniques shall be designed accordingly.
 - b. Slope and Runoff

Cleared areas will require protection from erosion.
 - c. Cover

Erosion protection will be required for all disturbed areas.
4. Temporary facilities may include silt fences, drain barriers, gravel entries, ditches, surface stabilization, or other methods and devices as necessary.
5. Temporary/permanent hydroseeding or acceptable seeding and mulching must be provided whenever perennial cover cannot be established on sites that will be exposed after September 1 or prior to June 1.

TECHNICAL SPECIFICATIONS

SECTION 2

STORM DRAINAGE

1.6 Private Drainage Systems

Private drainage systems shall not enter the public ROW and shall be in accordance with DEQ requirements.

A. Subdivisions

When subdivision lots drain to the rear, it may be necessary to provide a private drainage system in private easements. This system shall be for collection of roof drains, footing drains, and surface runoff. This system shall be designed to meet the Oregon Plumbing Specialty Code, current edition.

B. Subsurface Drainage

Subsurface drains (under drains) shall be provided at the following locations:

1. For all existing springs and field tile intercepted during construction activity for other facilities, i.e., sewer, water, mains, street excavations, foundations, etc. Subsurface drains are not needed if the tile is removed.
2. Where high groundwater exists or when it is necessary to reduce the piezometric surface to an acceptable level to prevent land slippage or under floor flooding of buildings.
3. The drainage line installed shall begin at a cleanout and terminate at an approved point of disposal. Open jointed storm drain lines will not be considered as an acceptable solution.

1.7 Specification References

Specification references made herein for manufactured materials such as pipe, fittings, and manhole rings and covers refer to designations for the American Water Works Association (AWWA), ASTM International (ASTM), or the American Association of State Highway and Transportation Officials (AASHTO) as they are effective on the date of submission to the City.

1.8 Care and Handling of Materials

- A.** Adequate precautions shall be taken to prevent damage to pipes, fittings, manhole components, and all other materials used in construction of the storm drainage system. Pipe and other materials during transport shall be secured individually by use of wood spacer blocks or wood crates, or otherwise protected to prevent collision of individual pieces and possible subsequent damage.

TECHNICAL SPECIFICATIONS

SECTION 2

STORM DRAINAGE

- B. All pipe, fittings, and manhole components shall be loaded and unloaded in a manner to prevent shock or damage. Under no circumstances shall such material be dropped. All materials on the ground shall be protected from damage. All pipes, fittings, manhole components, and all other materials used in the construction of the drainage system shall be carefully inspected by the Contractor prior to installation. All defective materials shall be rejected. All materials that are delivered considerably in advance of their installation shall be stored in a satisfactory manner.

- C. Proper materials, tools, and equipment shall be used by the Contractor for safe and convenient prosecution of the Work. All pipes, fittings, etc., shall be carefully lowered into the trench piece by piece in such a manner to prevent any damage to the materials. Under no circumstances shall materials be dropped or dumped into the trenches.

PART 2 - MATERIALS

2.1 Bedding, Select Backfill, and General Backfill

Bedding, select backfill, and general backfill for storm drain pipelines shall be as required on the City Standard Drawings and Technical Specifications - "Excavation and Grading," Part 2 - Materials, 2.4 Select Backfill and 2.5 General Backfill.

2.2 General Backfill

See Technical Specifications - "Excavation and Grading," Part 2 - Materials, 2.5 General Backfill.

2.3 Gravity Storm Drain Pipe

- A. General
 - 1. Public storm drain pipe shall be constructed of solid wall polyvinyl chloride (PVC) except where pipe has less than the required minimum cover. Where minimum cover cannot be achieved, the pipe material shall be ductile iron.

 - 2. Solid wall PVC pipe may be used in lieu of ductile iron pipe if alternative methods (e.g., controlled density fill) are utilized to protect the pipe and are approved by the City. The City may require calculations or other documentation from the design engineer.

 - 3. Public storm drain pipe shall meet DEQ requirements and shall be in accordance with the City of Hermiston Stormwater System Plan.

 - 4. All public storm drain lines shall be a minimum of 12 inches in diameter.

TECHNICAL SPECIFICATIONS

SECTION 2

STORM DRAINAGE

B. Ductile Iron Pipe

Ductile iron pipe and fittings shall conform to AWWA C150, AWWA C115, AWWA C151, and AWWA C110 and shall be minimum pressure Class 150 unless specified otherwise. All ductile iron pipe shall have a bituminous sealed cement mortar lining conforming to AWWA C104. All joints, unless otherwise specified, shall be push-on rubber gasket joints conforming to AWWA C111.

C. PVC Pipe

1. Solid Wall PVC Pipe

Solid wall PVC pipe shall be solid wall construction and shall conform to the requirements of ASTM D3034, SDR 35 for pipe up to 15-inch diameter and ASTM F679, Type 1 only, for pipe sizes 18- to 27-inch diameter. Joints for solid wall PVC pipe shall conform to ASTM D3212 using elastomeric gaskets conforming to ASTM F477.

2. Profile Wall PVC Pipe

Profile wall PVC culvert pipe and profile wall PVC storm drain pipe shall be Johns-Manville "Perma-Loc," or equal, meeting the requirements of AASHTO M 304 or ASTM F794 Series 46. Joints for profile wall PVC pipe shall conform to ASTM D3212 using elastomeric gaskets conforming to ASTM F477.

2.4 Manholes

A. Cast-in-place Base Sections

1. Cast-in-place base sections for manhole construction shall have a minimum 28 day strength of 4,000 psi, unless approved otherwise by the City, and shall not be less than 5 inches in thickness in any section. All shelf area shall be uniformly shaped, have a rough float finish, and slightly slope towards the channel. The shelf shall be above the top of the storm drain pipe.
2. The Contractor shall be responsible for the determination of pipe hole orientation and grade.
3. After placement of the concrete for the base, the bottom manhole ring shall be set level into the wet concrete to form a tight seal. The base concrete shall then be properly cured for a minimum of 24 hours before placing the remaining rings and cone.

TECHNICAL SPECIFICATIONS

SECTION 2

STORM DRAINAGE

4. Cast-in-place base sections will be used only when specifically approved by the City.
- B. Precast Base Sections
1. Precast base sections shall conform to ASTM C479. Concrete shall be consolidated by mechanical vibration. Reinforcing shall be provided in the base and walls. Minimum concrete thickness shall be 5 inches.
 2. All shelf area shall be uniformly shaped, have a rough float finish, and slightly slope towards the channel. The shelf shall be above the top of the storm drain pipe.
 3. The Contractor shall be responsible for the determination of pipe hole orientation and grade.
 4. Precast base sections shall be used unless otherwise specifically approved by the City.
- C. Precast Manhole Sections
1. Precast manhole sections shall conform to ASTM C478 and consist of circular sections in the standard 48-inch diameter.
 2. No more than two lift holes shall be cast into each section. Holes shall be located as to not damage reinforcing or expose it to corrosion. At the manufacturer's option, steel loops may be provided for handling in lieu of lift holes. All lift holes shall be patched after installation.
 3. Precast manhole cones shall be concentric, unless otherwise specified, and shall meet ASTM C478.
 4. Flat slab covers for Type "B" manholes shall conform to ASTM C478.
 5. Slabs, cones, and ring sections shall be free from fractures, cracks, rock pockets, or exposed reinforcement.
- D. Pipe Connections to Manholes
1. All pipe connections to manholes shall be constructed as shown on the City Standard Drawings. All pipe-to-manhole connections shall be watertight.

TECHNICAL SPECIFICATIONS

SECTION 2

STORM DRAINAGE

- 2. For solid wall PVC and ductile iron pipe, sewer couplings with an appropriate adaptor gasket by Romac Industries, or approved equal, may be used for cast-in-place manhole bases OR an A-Lok pipe connector as manufactured by A-Lok Products, Inc., PSC Flexible Connector as manufactured by Press Seal Gasket Corporation, Kor-N-Seal as manufactured by Core and Seal Company, or approved equal shall be used when precast base sections are used, OR a 1/2-inch pipe gasket stretched over the pipe shall be used in combination with a non-shrink grout to provide a watertight seal.
- 3. Profile wall PVC and HDPE pipe to manhole connections shall utilize gaskets or fittings in combination with a non-shrink grout to provide a watertight seal.
- 4. All connections shall match the grade and alignment of the pipe entering and exiting each manhole. Manhole pipe connections shall be constructed so flow through the manhole is not restricted in any way.

E. Manhole Rings and Covers

- 1. Manhole rings and covers shall as called for on the City Standard Drawings, or approved equal.
- 2. Castings shall be tough, close-grained, gray iron free from blow holes, shrinkage, and cold sheets. They shall conform to ASTM A48 and shall be smooth, sound, clean, and free from blisters and defects.
- 3. Castings and covers shall be planed and ground when necessary to ensure flat and true surfaces.
- 4. Covers shall be true and shall seat within the ring at all points.

2.5 Catch Basins

A. Catch Basins

- 1. Catch basins shall be precast units manufactured in accordance with ASTM C139 and C913. Basin type shall be as called for on the City Standard Drawings, or approved equal.
- 2. Concrete shall have a compressive strength of 4,000 psi.
- 3. Reinforcement in precast structures shall be rebar meeting ASTM A615 Grade 60 or welded wire meeting ASTM A497.

TECHNICAL SPECIFICATIONS

SECTION 2

STORM DRAINAGE

4. Precast bases shall be furnished with cutouts or knockouts. Knockouts for pipes shall have a wall thickness of 2 inches minimum and may be located on all four sides.
- B. Frames and Grates
1. Catch basin grates shall be metal castings conforming to the requirements of ASTM A48, Class 30. Castings shall be tough, close-grained, gray iron free from blow holes, shrinkage, and cold sheets. They shall be smooth, sound, clean, and free from blisters and defects. Castings shall be planed and ground when necessary to ensure flat and true surfaces.
 2. Catch basin frame, hood, and grate shall be as called for on the City Standard Drawings, or approved equal.
 3. Field inlet frames, hoods, and grates shall be hot dip galvanized flat bar A36 steel as shown on the City Standard Drawings, or approved equal.
- C. Oil-Water Separators
1. Oil-water separators shall be The Snout by Best Management Products, Inc. (800-504-8008), or approved equal.
 2. Oil-water separators shall be constructed of a corrosion resistant material and be equipped with a watertight access port, a mounting flange, and a means to prevent siphons.
 3. The size and position of the oil-water separator shall accommodate the outlet pipe size and allow the bottom of the device to be located 6 inches below the pipe invert elevation. The oil-water separator shall be securely attached to the structure wall with an oil-resistant gasket, corrosion resistant hardware, couplings, etc., for a complete installation.
- D. Pipe Connection to Catch Basins
1. All pipe connections to precast units shall be watertight.
 2. For solid wall PVC and ductile iron pipe, a 1/2-inch pipe gasket stretched over the pipe shall be used in combination with a non-shrink grout to provide a watertight seal.

TECHNICAL SPECIFICATIONS

SECTION 2

STORM DRAINAGE

- 3. The profile wall PVC and HDPE pipe connection shall utilize gaskets or fittings in combination with a non-shrink grout to provide a watertight seal and shall be approved by the City.

2.6 Culverts

A. Corrugated Steel

Culverts shall be Type 2 corrugated steel pipe and shall be a minimum 14-gauge with 2-2/3-inch x 1/2-inch corrugations. Fabrication of pipe shall conform to AASHTO M 274 and AASHTO M 36 specifications. Joints shall be made with corrugated steel culvert bands over 3/8-inch neoprene gaskets. Culvert bands shall be 12 inches wide.

B. Reinforced Concrete Culvert Pipe

- 1. Reinforced concrete culvert pipe shall be round and conform to the requirements of AASHTO M 170 except as modified below. Pipes shall be within the maximum and minimum diameters set forth in AASHTO M 170. The wall thickness and steel area for all classes of pipe that are not described in AASHTO M 170 shall be determined by interpolation from data given in the tables for pipes of diameters next smaller and next larger, respectively.
- 2. For all classes of pipe, except Class I, which are smaller than the minimum size set forth in AASHTO M 170 for the particular class, the minimum wall thickness shall be 1-3/4-inch and the steel area shall not be less than 0.06 square inch per linear foot of pipe barrel length.
- 3. All bell and spigot concrete culvert pipe shall be joined with rubber gaskets conforming to AASHTO M 198.

2.7 Sedimentation Chamber/Drywell Combo

Sedimentation chambers/drywell combo shall be as shown on the City Standard Drawings.

2.8 Drain Rock

Drain rock shall be as called for on the City Standard Drawings.

2.9 Filter Fabric

Filter fabric shall be as called for on the City Standard Drawings.

TECHNICAL SPECIFICATIONS

SECTION 2

STORM DRAINAGE

2.10 Hydroseed

See Technical Specifications - "Excavation and Grading," Part 2 - Materials, 2.10 Hydroseed.

2.11 Mulch

See Technical Specifications - "Excavation and Grading," Part 2 - Materials, 2.11 Mulch.

PART 3 - EXECUTION

3.1 Trench Excavation

A. General

When solid rock is encountered in trench excavation, the City shall be notified.

B. Trench Width

1. The maximum trench width in the pipe zone shall be 2 feet plus the O.D. of the pipe and the minimum trench width in the pipe zone shall be 1 foot plus the O.D. of the pipe. This width shall be maintained to the top of the pipe.
2. The maximum clear width above the top of the pipe will not be limited except in cases where excess width of excavation would cause damage to adjacent structures or utilities.

C. Unsuitable Material

1. When natural soil conditions exist in the bottom of the trench that are unsuitable for proper pipe installation, the Contractor shall immediately notify the design engineer. The Contractor shall then over-excavate the trench below the design grade to a depth specified by the design engineer. Such over-excavation shall be to provide for foundation material.
2. Foundation material or stabilization fabric, as shown on the City Standard Drawings, shall be provided by the Contractor only when specifically called for on the City Standard Drawings or when required by the City.
3. As an alternative to over-excavation and placement of foundation material, a geotextile fabric may be used if field use proves acceptable. The fabric material shall be placed on the bottom of the trench and the bedding material placed

TECHNICAL SPECIFICATIONS

SECTION 2

STORM DRAINAGE

over the fabric to proper pipe grade. The fabric width shall be one foot wider than the trench bottom.

D. Exploratory Work

Contractor shall perform appropriate exploratory work to locate utilities when they are known to exist but the specific location is unknown or not marked accurately. Appropriate exploratory work shall be performed in these situations.

3.2 Shoring, Sheeting, and Bracing of Trenches

- A. The Contractor shall adequately sheet and brace the trench during excavation whenever necessary to satisfy trench safety standards, prevent cave-ins, or to protect adjacent structures or property. Where sheeting and bracing are used, the Contractor shall increase trench widths for the bracing material accordingly.
- B. The sheeting must be kept in place until the pipe has been placed, backfilled at the pipe zone, tested for defects, and repaired if necessary. All sheeting, shoring, and bracing of trenches shall conform to the requirements of the public agency having jurisdiction.

3.3 Dewatering Excavated Areas

- A. All groundwater, seepage, or stormwater that may occur or accumulate in the excavation during the progress of the Work shall be removed. In areas where the nature of soil and hydrostatic pressures are of such a character as to develop a quick condition in the earth mass of the trench, the dewatering operation shall be conducted so that the hydrostatic pressure will be reduced to or near zero in the immediate vicinity of the trench.
- B. All excavations shall be kept free of water during the construction or until otherwise requested by the City.
- C. Contractor shall dispose of all waste and water removed from the trench. Disposal shall be in accordance with all state and local regulations.

3.4 Location of Excavated Materials

- A. During trench excavation, the excavated material shall be located within the construction easement or right-of-way so that the excavated material will not obstruct any private or public traveled roadways or streets, or cause undue damage to the streets.

TECHNICAL SPECIFICATIONS

SECTION 2

STORM DRAINAGE

- B. Contractor shall provide means of containing overly saturated soils, i.e., muck, or remove the muck from the Work area as it is excavated, if such soils are encountered in the excavation. The intent is to prevent excessive damage or disruption to street rights-of-way or easement beyond what would normally occur during such Work. Pile and maintain material from trenches so that the toe of the slope of the material excavated is at least two feet from the edge of the trench. It shall be the Contractor's responsibility, however, to determine the safe loading of all trenches.

3.5 Disposal of Excavated Materials

Contractor shall dispose of all excavated material, which is not required for, or is unsuitable for, backfill. The Contractor's method of disposal shall comply with regulations of the governing body having jurisdiction.

3.6 Trench Backfill

- A. All backfill material shall be placed into the trench so that free fall of the materials into the trench is prevented until at least two feet of cover is provided over the pipe. Under no circumstances shall sharp or heavy pieces of material be allowed to drop directly onto the pipe. Methods of backfilling, other than as specified herein, shall be used only upon the approval of the City.
- B. Bedding and Select Backfill
 - 1. A minimum 6-inch depth of bedding shall be placed on the trench bottom, in accordance with the City Standard Drawings, as applicable, and smoothed to provide uniform bedding so the pipe is supported along its full length and not by the bells. Bell holes at each joint shall be provided to ensure support along the entire pipe length.
 - 2. It shall be understood that the 6-inch depth is a minimum depth only, not an average depth, and does not preclude the Contractor at their option from placing additional depth of bedding to facilitate their Work. Care shall be used to ensure that the bedding material is properly worked under the haunch of the pipe for its full length.
 - 3. Select backfill shall then be brought up from the spring line to the minimum distance above the top of the pipe shown on the City Standard Drawings, leveled and compacted. Compaction of the bedding and select backfill by hand tamping will be allowed if the required compaction density is achieved; otherwise, mechanical tamping will be required.

TECHNICAL SPECIFICATIONS

SECTION 2

STORM DRAINAGE

- 4. When an open-graded material is used for bedding or foundation material to facilitate trench dewatering, the open graded material shall be placed to the spring line of the pipe. The Contractor shall make provisions to ensure that fines from the select backfill do not migrate into the open graded bedding or foundation material. To prevent soil migration the Contractor may use any of the following:
 - a. Provide an approved fiber/fabric between the open graded bedding material and select backfill.
 - b. Provide an alternative approved by the City.

- C. All general backfill material shall be pushed first onto the slope of the backfill previously placed and allowed to roll down into the trench. The Contractor shall not push the backfill material directly into the trench until at least two feet of cover is provided over the pipe.

- D. CDF Placement
 - 1. When called for on the Design Drawings, Contractor shall backfill trenches with CDF.
 - 2. CDF shall be placed in the trench in such a manner to ensure the trench is completely filled to the lines and grades called for on the Design Drawings.
 - 3. CDF shall be protected from traffic loads for a three-hour period, after which required surface restoration work may be performed.

- E. Canal or Irrigation Ditch Crossing
 - 1. Where the trench crosses a canal, irrigation ditch or culvert, the backfill shall be compacted the entire trench depth with mechanical tampers to 90 percent of the laboratory density as determined by ASTM D1557.
 - 2. All backfill material in the canal or ditch liner and in the trench cut-off wall shall be imported clay or a soil/bentonite mixture as approved by the City. Unless required otherwise, the soil/bentonite mixture shall be 1 part bentonite to 10 parts soil by weight. A high grade bentonite material shall be used.
 - 3. The ditch lining, conduit or pipe shall be restored to its original condition. The crossing shall be water tight and free of any leakage or seepage. The Contractor

TECHNICAL SPECIFICATIONS

SECTION 2

STORM DRAINAGE

shall be fully responsible for repairing canal or ditch banks should leakage occur at the crossing.

F. Anti-Flotation Fabric Placement

- 1. When called for on the Design Drawings or called for by the design engineer, the Contractor shall place geotextile fabric over the select backfill material prior to placing general backfill. This fabric will help reduce the exposure to pipeline flotation.
- 2. The fabric shall be placed in accordance with the requirements shown on the City Standard Drawings.

3.7 Execution of Dust and Mud Control

If the Contractor fails to properly control the dust and mud, the City may request them to do so in writing. If, after 24 hours from this request, the Contractor has not corrected the dust or mud problem, the City may elect to have the corrective work performed and charge the Contractor/ developer for said work.

3.8 Restoration, Finishing, and Cleanup

- A. The Contractor shall restore or replace all paved surfaces, graveled surfaces, curbing, sidewalks, trees and shrubbery, lawns, pastures and fences, or other existing facilities disturbed by their Work unless otherwise specified. Restoration and cleanup shall be a continuing operation and shall be diligently pursued until completed.
- B. All surplus material and temporary structures as well as excess excavation shall be removed by the Contractor and the entire Site of Contractor operations shall be left in a neat and clean condition.

3.9 Existing Utilities

The Contractor shall be responsible for the actual locating and protecting of existing utilities. If a conflict develops between the design line and grade of a pipeline and an existing utility, the City may require adjustment to the pipeline grade or relocation of the existing utility.

3.10 Installation of Pipe

- A. Gravity storm drain pipe shall be installed in accordance with the best current practices and as required by the manufacturer. Gravity storm drain pipe, unless otherwise approved by the City, shall be laid by progressing upgrade from the existing or newly

TECHNICAL SPECIFICATIONS

SECTION 2

STORM DRAINAGE

constructed storm drain; the pipe shall be installed with bell ends laid upgrade unless otherwise approved. Each pipe shall be properly bedded so as to be supported along the full length of the pipe. A suitable foundation shall be achieved by a slight excavation for the bell at each joint.

- B. All joints shall be properly lubricated, where required, and installed in accordance with the installation instructions of the pipe manufacturer, taking particular care to avoid pinching or otherwise causing damage to pipe gaskets. All joints shall be free of dirt and other foreign matter prior to the joining of the next pipe. All joints shall be restrained to prevent creep and misalignment of joints. All pipe shall have a ring painted around the spigot ends in such a manner as to allow field checking of setting depth of pipe in socket.
- C. Gravity storm drain main lines shall be installed with the use of a laser beam and target. The design engineer shall provide slopes for each line. Careful attention shall be given to the setting up of the laser and the periodic checking of its aim, etc. All grade checking of the laser shall be the responsibility of the Contractor.
- D. All pipe shall be installed true to line except when approved otherwise by the City. A tolerance of $\pm 1/4$ -inch deviation from true grade at each joint will be allowed. Extra care shall be given to the installation of storm drain lines at minimum slopes to avoid flat slopes in the line.
- E. All foreign matter and gravel shall be removed from the inside of the pipe and fittings before being installed, and the pipe and fittings shall be kept clean during placement. No pipe shall be laid when conditions exist that, in the opinion of the City, are unsuitable for the placing of pipe. All pipe and manholes shall be covered or plugged at night.

F. Line and Grade

Do not vary from established line and grade by more than 1/32 inch per inch of pipe diameter. Variance shall not exceed 1/2 inch and shall not result in a level or reverse sloping invert.

G. Testing

1. Required Tests

A deflection test is required on all storm drain lines. When the bottom of the storm drain pipe is within 5 feet of the maximum groundwater surface elevation,

TECHNICAL SPECIFICATIONS

SECTION 2

STORM DRAINAGE

a low pressure air test is required, and the pipe must meet the same infiltration requirements as sanitary sewer lines. All storm drain line testing procedures shall be as specified in the Technical Specifications - "Sanitary Sewers."

2. Equipment

The Contractor shall perform all Work and furnish all materials and equipment as required to perform all required tests.

3.11 Manhole Installation and Connections

A. Construction

1. Manholes shall be constructed to the line, grade, and detail as shown on the Design Drawings and as approved by the design engineer.
2. Backfill of the manhole shall be brought up evenly on all sides of the manhole.
3. The "U" shaped channels in the manhole bases shall be constructed by the use of properly shaped forms.
4. Intersecting flow channels shall have uniform transitions. All channels inside the manhole shall have smooth troweled finishes.
5. Manhole testing shall be required when the bottom of the manhole is within 5 feet of the maximum groundwater surface elevation. All testing for storm drain manholes shall conform to the testing for sewer manholes as specified in the Technical Specifications - "Sanitary Sewers."

B. Connection to Existing Manhole

1. Connections to existing manholes, when required on the Design Drawings, shall be made by the Contractor.
2. All flow lines shall be properly shaped, and all new concrete shall be placed against a clean and sound surface.
3. An approved epoxy bonding agent shall be used on all existing surfaces to be bonded to new concrete or mortar.
4. All applicable conditions for new manholes described previously shall apply.

TECHNICAL SPECIFICATIONS

SECTION 2

STORM DRAINAGE

3.12 Catch Basins

- A. Catch basins shall be constructed to the line, grade, and detail as shown on the Design Drawings and as approved by the City.
- B. Backfill shall be brought up evenly on all sides of the catch basin.
- C. All catch basins are to be watertight, including all connections and joints, and any leakage shall be corrected in an approved manner.
- D. New Connections
 - 1. All connections shall match the grade and alignment of the pipe entering and exiting each unit. Pipe connections shall be constructed so flow is not restricted in any way.
 - 2. All holes shall be located to provide the design flow line and direction of any pipe entering the catch basin. After the pipe connection is made and set to grade, the annular space between the pre-cast unit and the pipe shall be cement grouted to permanently set the flow line of the pipe. Non-shrink cement grout shall be used.
- E. Connection to Existing Catch Basins
 - 1. Connections to existing catch basins, when required on the Design Drawings, shall be made by the Contractor.
 - 2. All connections shall be made in such a manner as to leave the existing catch basin watertight. All new concrete shall be placed against a clean and sound surface.
 - 3. An approved epoxy bonding agent shall be used on all existing surfaces to be bonded to new concrete or mortar.
 - 4. All applicable conditions for new catch basins described previously shall apply.

3.13 Culverts

- A. Culverts shall be installed in the location and at the grade shown on the Design Drawings and specified herein.

TECHNICAL SPECIFICATIONS

SECTION 2

STORM DRAINAGE

- B. Culverts shall be bedded and backfilled uniformly on both sides of the pipe at the same time to prevent displacement or buckling of the pipe. Bedding material shall be worked carefully under the pipe haunches and then compacted. Bedding and backfill material shall consist of select native material free of particle sizes greater than 1-1/2-inch in diameter unless otherwise approved by the City.

3.14 Cleaning and Flushing of Completed and Tested Storm Drains

- A. Prior to final inspection of the storm drain system by a City Representative, the Contractor shall flush and clean all parts of the system. All accumulated construction debris, rocks, gravel, sand, silt, and other foreign material shall be removed from the system at or near the closest downstream manhole.
- B. All storm drain pipes, manholes, and catch basins installed shall be flushed as thoroughly as possible. It must be understood that flushing removes only the lighter solids and cannot be relied upon to remove heavy material allowed to get into the pipes during construction. The Contractor shall provide sufficient water and appropriately sized taps to develop a velocity in the pipes during flushing of at least 2.5 fps. Check local rules for discharges to natural waterways.

3.15 Environmental Protection of Catch Basins

The Contractor shall provide biofilter bags, or approved equal, at each catch basin, field inlet, or area drain installed by the Contractor on the project. The biofilter bags shall be in place during the Contractor's Work to prevent sediment from entering the catch basins and shall be maintained until the risk of sediment entering the catch basin from construction activities on the Site no longer exists. When all Work is complete, the biofilter bags shall be removed by the Contractor.

END OF SECTION

CITY OF HERMISTON, OREGON
MANDREL TEST RECORD

Witnessed for the City of Hermiston, Oregon, by:

Witness _____ Date _____

Project _____

1. Manhole/Catch Basin No. _____ Station No. _____ To Manhole No. _____ Station No. _____
Length _____ Diameter _____ Comments _____

2. Manhole/Catch Basin No. _____ Station No. _____ To Manhole No. _____ Station No. _____
Length _____ Diameter _____ Comments _____

3. Manhole/Catch Basin No. _____ Station No. _____ To Manhole No. _____ Station No. _____
Length _____ Diameter _____ Comments _____

4. Manhole/Catch Basin No. _____ Station No. _____ To Manhole No. _____ Station No. _____
Length _____ Diameter _____ Comments _____

5. Manhole/Catch Basin No. _____ Station No. _____ To Manhole No. _____ Station No. _____
Length _____ Diameter _____ Comments _____

6. Manhole/Catch Basin No. _____ Station No. _____ To Manhole No. _____ Station No. _____
Length _____ Diameter _____ Comments _____

7. Manhole/Catch Basin No. _____ Station No. _____ To Manhole No. _____ Station No. _____
Length _____ Diameter _____ Comments _____

8. Manhole/Catch Basin No. _____ Station No. _____ To Manhole No. _____ Station No. _____
Length _____ Diameter _____ Comments _____

TABLE OF CONTENTS

SECTION 3

SANITARY SEWERS

PART 1 - General 3-1

1.1 General Design Requirements 3-1

1.2 Specifications References..... 3-15

1.3 Submittals..... 3-15

1.4 Care and Handling of Materials..... 3-16

1.5 Materials Furnished by City..... 3-16

1.6 Restoration, Finishing, and Cleanup 3-16

PART 2 - Materials..... 3-17

2.1 Bedding, Select Backfill, and General Backfill 3-17

2.2 Pipe..... 3-17

2.3 Fittings 3-18

2.4 Valves and Appurtenances..... 3-19

2.5 Thrust and Anchor Blocks..... 3-20

2.6 Manholes..... 3-20

2.7 Cleanouts..... 3-23

2.8 Frost-free Sanitary Yard Hydrant 3-23

2.9 Sewage Lift Station Valve Vault..... 3-23

2.10 Sewage Lift Station Pumps and Appurtenances 3-24

2.11 Sewage Lift Station Controls 3-27

2.12 Sewage Lift Station Control Operation 3-28

2.13 Sewage Lift Station Control Panel..... 3-28

2.14 Sewage Lift Station Electrical Requirements 3-29

PART 3 - Execution 3-29

3.1 Trench Excavation and Backfill..... 3-29

3.2 Existing Utilities 3-29

3.3 Installation of Pipe 3-29

3.4 Gravity Service Lines 3-30

3.5 Gravity Sewer Testing..... 3-31

3.6 Pressure Sewer Construction - Pipeline..... 3-34

3.7 Pressure Sewer Testing 3-35

3.8 Manhole Construction 3-36

3.9 Cleanout Construction 3-37

3.10 Water-Sewer Crossing..... 3-37

3.11 Locating Wire 3-38

3.12 Cleaning and Flushing of Completed and Tested Sewers 3-39

3.13 Sewer Line Cleaning and Inspection 3-39

Attachments - Worksheets

TECHNICAL SPECIFICATIONS

SECTION 3

SANITARY SEWERS

PART 1 - GENERAL

1.1 General Design Requirements

A. Performance Standards

1. Sanitary sewer system design shall meet the policies and guidelines of the current Oregon Administrative Rules (OAR) and the Oregon Department of Environmental Quality (DEQ) guidelines.
2. Sanitary sewer systems shall be designed to provide gravity service to all areas of developments. Pump stations are acceptable only if it is not possible to provide gravity service.
3. Sanitary sewer system capacity shall be designed for ultimate development density of the tributary area. The system shall allow for future system extension and development.
4. Sanitary sewers shall be designed to remove the domestic sewage and industrial wastes from basements of residences, commercial or industrial buildings, and all public and private establishments where practical.
5. Stormwater, including street, roof, or footing drainage, shall not be discharged into the sanitary sewer system, but shall be removed by a system of storm drains or by some other method. See Technical Specifications - "Storm Drainage."
6. Unpolluted or non-contact cooling waters shall not be discharged into sanitary sewers. The overflow drains and filter backwash lines of swimming pools and hot tubs shall not drain into a sanitary sewer.
7. As a condition of sewer service, all developments will be required to provide public sewers to adjacent upstream parcels to provide for an orderly development of the drainage area. This includes the extension of sewer mains in easements across the property to adjoining properties and across the street frontage of the property to adjoining properties when the main is located in the street right-of-way (ROW) and trunk sewers that are oversized to provide capacity for upstream development.
8. All sewer main lines shall be extended to the end of the farthest development site.

TECHNICAL SPECIFICATIONS

SECTION 3

SANITARY SEWERS

9. All sewer lines shall be located within the public ROW as directed by the City. These lines are placed in the public ROW for ease of maintenance, access, control of the facility operation, and to provide required replacement and/or repair.
10. Where sewers are constructed on slopes greater than 20 percent; in areas designated as hazardous; where site conditions may cause damage to improvements, slippage, or slides; or as determined by the City, a Geotechnical and/or Engineering Geology Report may be required.
11. Where the finished graded surface is greater than 20 percent, or as required by the City, soil stabilization fabric shall be placed over the entire disturbed area.
12. Notify the City's recycled water personnel 72 hours prior to the installation of any sanitary sewer main.
13. All trench construction shall be per City of Hermiston Standard Drawings.
14. Manhole adjustment grade rings shall conform to City Standard Drawings.
15. The Contractor shall field-verify the depth and location of all existing sewer lines to be connected to prior to beginning construction. The Contractor shall inform the City of any discrepancies with the information found in the field compared with that given on the Plans.
16. Where conditions make compliance with these rules impractical, exceptions may be permitted. However, it will be necessary for the design engineer to provide a complete analysis of the need for such exceptions.
17. The Contractor shall not make any connections to new service stubs until sewer lines have been tested and approved.

Drawings relevant to this section are included in the Standard Drawings.

B. Pipe Size

Private sanitary sewers shall meet the appropriate sections of the Oregon Plumbing Specialty Code, current edition. All sanitary sewer main lines shall be a minimum diameter of 8 inches; 6-inch diameter sewer for non-extendible sewers of up to 250 feet in length serving eight lots or less may be permitted with approval.

TECHNICAL SPECIFICATIONS

SECTION 3

SANITARY SEWERS

C. Minimum Design Criteria

1. Velocity

All sanitary sewers shall be designed and constructed to give mean velocities, when flowing full, of not less than 2.0 feet per second (fps). Self-cleaning velocity shall be provided and demonstrated by the design engineer to the City, to prevent the problem caused by a lack of sufficient flow.

2. Pipe Slope

All sanitary sewer pipe slopes shall be designed and constructed with minimum slopes tabulated below. Installed pipe not meeting minimum grade requirements shall be removed and replaced at the Contractor's expense. Design grades exceeding minimum values should be considered to allow for realistic installation precision.

Nominal Pipe Size (inches)	Minimum Slope (feet/100 foot)
6	1.00
8	0.40
10	0.28
12	0.22
15	0.15
18	0.12

3. Manning's Equation

When calculating minimum pipe slopes and velocities, the design engineer shall use the Manning's pipe friction equation.

4. Pipe Coefficient

The minimum pipe roughness coefficient for sanitary sewers shall be 0.013.

D. Alignment and Cover

1. Right-of-Way Location

a. Sanitary sewer lines shall be located 5 feet north and west from the ROW centerline. All changes in direction of pipe shall be made at a manhole.

TECHNICAL SPECIFICATIONS

SECTION 3

SANITARY SEWERS

- b. Sewers shall be located in the street ROW. If streets have curved alignments, the center of the manhole shall not be less than 6 feet from the curb face on the outside of the curve nor the sewer centerline less than 6 feet from the curb face on the inside of the curve.
 - c. Curved alignments in sanitary sewers are not permitted.
2. Minimum Cover
- a. Sanitary sewers shall be laid at a depth sufficient to drain building and basement sewers, and to protect against damage by frost or traffic. In new residential hillside subdivisions, main and lateral sewers shall be placed at a depth sufficient to drain structures on the low side of the street.
 - b. Sanitary sewers in residential areas shall be placed in the street with the following minimum cover:
 - 1) Building Service Lateral - 6 feet
 - 2) Trunk and Collector Sewer - 8 feet
 - 3) In Easements - 8 feet
 - c. Where pipes cross under ditches or streams and the cover is less than 3 feet, extra protection is required in accordance with Section 1.1.D.5 of this section.
 - d. Where existing sewers are shallow (5 feet or less), the cover shall be a minimum of 3 feet. Deviation from the above standards will be considered on a case-by-case basis when one of the following circumstances exist:
 - 1) Underlying Rock Strata

Requires a written request to the City containing a Geotechnical Report and a plan and profile certifying bedrock exists 3 feet below the undisturbed ground surface at all investigated alignments.

TECHNICAL SPECIFICATIONS

SECTION 3

SANITARY SEWERS

2) Crossing a Ditch or Stream

Requires a written request to the City containing a plan and profile with a horizontal scale of 1 inch = 20 feet and a vertical scale of 1 inch = 2 feet.

3) Cover Depth Less than 3 feet

Requires a written request to the City allowing the use of ductile iron pipe, pipe encasement, or other methods be used.

3. Separation with Water Lines

a. Mains shall be installed in accordance with OAR Division 52 a minimum clear distance of 10 feet horizontally and 1-1/2 feet vertically from water lines. Exceptions to these requirements shall be submitted to the City for approval prior to construction.

b. The minimum spacing between water mains, storm drains, gas lines, and other underground utilities shall be 3 feet horizontally when the standard utility location cannot be maintained.

4. Easements

a. Easements will only be allowed when no other alternative for sewer service is available.

b. Sewers placed in easements along a property line shall have the easement centered on the property line and the sewer shall be offset 18 inches from the property lines. For sewers placed in an easement located other than along a property line, the sewer shall be placed in the center of the easement. The conditions of the easement shall be such that the easement shall not be used for any purpose that would interfere with the unrestricted use for sewer main purposes. Under no circumstances shall a building or structure be placed over a sanitary sewer easement. This includes overhanging structures with footings located outside the easement. Further, no trees or large bushes shall be planted in the easement.

c. Easements for sewers less than 12 inches in diameter shall have a minimum width of 15 feet. Sewers greater than 12 inches in diameter shall have a minimum easement width of 20 feet.

TECHNICAL SPECIFICATIONS

SECTION 3

SANITARY SEWERS

- d. Sewers with more than 8 feet of cover and/or inside diameters 24 inches or greater will require wider easements. A slope of 1H:1V from the sewer invert to ground surface will be used to determine easement width. Easement widths shall increase from the 15 foot minimum by 5-foot increments, e.g., 15, 20, 25 feet.
 - e. Easement locations for public sewer mains serving a Public Utility District, apartment complex, or commercial/industrial development shall be in parking lots, private drives, or similar open areas, which will permit unobstructed vehicle access for maintenance by City personnel. Full vehicle access shall be provided to all sewer easements, pipelines, cleanouts, and manholes outside of public ROW.
 - f. All easements shall be submitted to the City for review and approval prior to recording.
5. Relation to Watercourses
- a. Generally, the top of all sanitary sewers entering, crossing, or adjacent to streams, irrigation ditches, or drainage ways shall be at a sufficient depth below the natural bottom of the waterway to protect the sewer line. Three feet of cover is required.
 - b. Sewers located along streams shall be located outside of the streambed and sufficiently removed to provide for future possible stream channel widening. All manhole covers shall be watertight and at or above the 100-year flood elevation.
 - c. Sewers crossing streams or drainage channels shall be designed to cross the stream as nearly perpendicular to the stream channel as possible and shall be free from change in grade. The minimum cover shall be 36 inches from the bottom of the streambed or drainage channel.
 - d. Pipe material shall be ductile iron with an 18 foot length of pipe centered on the stream or drainage channel centerline. The ductile iron pipe shall extend to a point where a 1:1 slope, which begins at the top of the bank and slopes down from the bank away from the channel centerline, intersects the top of the pipe.
 - e. A scour pad centered on the sewer line will be required when the top of the pipe to the bottom of the stream or drainage channel is 30 inches or

TECHNICAL SPECIFICATIONS

SECTION 3

SANITARY SEWERS

less. The scour pad shall be concrete, 6 inches thick and 6 feet wide, reinforced with #4 rebar spaced 12 inches on center both ways, and shall extend to a point where a 1:1 slope, that begins at the top of the bank and slopes down from the bank away from channel centerline, intersects the top of the pipe. Deviations from the above requirements shall require review and approval on a case-by-case basis.

E. Structures

1. Manholes

- a. Manholes shall be located at changes in slope, alignment, pipe size, and at all pipe junctions with present or future sanitary sewers.
- b. Manhole spacing shall not exceed 500 feet, unless approved by the City.
- c. The angle between incoming and outgoing sewer lines shall be greater than 80 degrees. Manholes are shown in the City Standard Drawings and are suitable for most conditions. New designs or revisions should not be shown on the design drawings, unless the City Standard Drawings are not suitable. New or revised designs may be necessary if:
 - 1) One or more of the sewers to be connected to the manhole is over 36 inches in diameter. Smaller diameters may require a special design if the manhole is at an alignment change.
 - 2) Several sewers will be connected to the manhole.
 - 3) There is less than 80 degrees between the incoming and outgoing sewer.
 - 4) The manhole will be subject to unusual structural loads.
 - 5) Diversion or other flow control measures are required.
- d. Where one or more of conditions 1), 2), or 3) above are encountered, a drawing of the manhole base should be made to determine if it is feasible to use designs shown in the City Standard Drawings. It may be necessary to restrict the options to a specific City Standard Drawing specified by a note on the construction drawings. If a special design is required for any reason, it will be necessary to show the details on the design drawings and to provide structural calculations as needed.

TECHNICAL SPECIFICATIONS

SECTION 3

SANITARY SEWERS

- e. Some alternate manhole features are shown on the City Standard Drawings. Where these features are required, they must be specified by a note on the design drawings. Some examples are:
 - 1) Type A manholes are required unless shallow manhole depths require the use of Type B manholes, as determined by the City Standard Drawings.
 - 2) Watertight manhole frames and covers are to be used if floodwaters are expected to cover the manhole top or if the manhole must be located in the street gutter. Such conditions should be avoided wherever feasible.
 - 3) Tamper-proof manhole frames and covers are required in areas subject to vandalism, such as areas that are not readily visible to the general public or the property occupants.

- f. Design standards for elevation differences at manholes have been established to compensate for normal energy losses and to prevent surcharging of a sewer by a larger sewer. For purposes of slope calculation and for establishing elevation differences, the elevations are given at the intersection of the sewer centerline (usually the center of the manhole). The rules for elevation differences at manholes are:
 - 1) The crowns of incoming sewers shall be at least as high as the crown of the outgoing sewer.
 - 2) The invert elevation difference shall be at least 0.10 foot for 0 to 45 degrees of horizontal deflection angle and 0.20 foot for more than 45 degrees of horizontal deflection angle.
 - 3) The slope of a sewer within a manhole shall be no less than the slope of the same sewer outside of the manhole. Where the difference between the slope of the incoming and outgoing pipe is greater than 6 percent, the slope across the manhole shall be the average of the incoming and outgoing pipes.
 - 4) Drop connections are required when the vertical distance between flow lines exceeds 2 feet. The diameter of the drop connection must be specified on the construction drawings. The diameter of the drop connection shall not be more than one pipe

TECHNICAL SPECIFICATIONS

SECTION 3

SANITARY SEWERS

size smaller than the diameter of the incoming sewer. Smooth flow lines with vertical distances of less than 1 foot must be provided wherever feasible. Drop connections shall be outside drops.

- 5) All connections must enter the manhole through a channel in the base. This includes drop connections and connections to existing manholes.
 - g. Where conditions make compliance with these rules impractical, exceptions may be permitted. However, it will be necessary for the design engineer to provide a complete analysis of the need for such designs.
2. Cleanouts
- a. Cleanouts will not be approved as substitutes for manholes on public sewer lines. Cleanouts are permitted at the upper end of a sewer that will be extended during a future construction phase. When the sewer is extended, the clean out will be removed and a manhole shall be installed in the appropriate location. If future extension requires a change in sewer alignment or grade, a manhole will be required at the cleanout location.
 - b. Cleanouts are permitted at the end of a non-extendable sewer line that does not exceed 250 feet in length nor serve more than eight lots.
 - c. Cleanouts are permitted only in paved asphalt areas within the public ROW. Cleanouts shall in no case be installed in unpaved areas even when future asphalt pavement is planned as part of another phase or project.
3. Anchor Blocks

For sewer pipes greater than 4 inches in diameter, concrete anchor blocks shall be required if the slopes are greater than 20 percent. Anchor blocks shall key into trench sides. Spacing for anchor blocks is as follows:

TECHNICAL SPECIFICATIONS

SECTION 3

SANITARY SEWERS

SPACING FOR ANCHOR BLOCK FOR ALL SIZE PIPE

Slope (Percent)	Minimum Spacing (Feet)
0 to 19.99	No Anchor Required
20 to 34.99	35
35 to 50.99	25
51 or more	15 or Special Design

F. Service Lateral

1. See the General Requirements for the definition.
2. A minimum of one service lateral is required per property. For multi-family dwellings with two units, and for all accessory dwelling units, a separate service lateral is required for each unit. A single service lateral shall not provide service to multiple properties. Any deviations from these requirements must be approved by the City.
3. The minimum inside diameter of a sewer service lateral shall be 4 inches and shall be equal to or greater than the building sewer diameter. Service laterals are to be built to the same construction standards and of the same materials as the sewer main line. Service laterals in general shall be placed at 90 degrees to the main sewer line to avoid excessive exposure to other utilities during excavation for construction or maintenance of the service lines. Angles other than 90 degrees may be approved for special conditions such as cul-de-sac lots. In no case shall the angle between the main and the service be less than 90 degrees. Service line connections shall not be made at manholes except at cul-de-sacs.
4. The minimum slope of sewer service lines shall be 2 percent except that for unusual conditions, a slope of 1 percent may be approved. However, it will be necessary for the designer to provide a complete analysis of the need for any sewer service lateral slope less than 2 percent. The maximum slope shall be 100 percent (45 degrees or 1 foot per foot). Deep connection risers (see the City Standard Drawing for service lateral to deep sewers) or drop connections to manholes must be used where service line slopes would exceed 100 percent.
5. Tees for service laterals shall be installed at 100 percent slope, and one-sixteenth or one-eighth bends shall be installed to provide proper grade for service lateral. Service laterals shall be extended to the end at the street ROW line or easement line, when a sewer is installed in the easement. A water tight plug shall be installed in the end of the lateral and a 2" x 4" wood marker shall be placed at

TECHNICAL SPECIFICATIONS

SECTION 3

SANITARY SEWERS

the lateral end from the pipe invert to 2 feet above the ground. The 2" x 4" top shall be painted green and marked with the depth of the lateral measured from ground to invert of the pipe. A green tracer wire shall also be installed on the service line. The curb shall have an "S" stamped on the curb at lateral crossing.

6. The Contractor shall not make any connections to new service stubs until sewer lines have been tested and approved.
- G. Connection to Existing Sewers
1. Connections to, and extensions of, existing sewers will occur to facilitate new development. Connections to existing manholes shall be made with the following guidelines:
 - a. Where the invert of the connecting pipe is 2 feet or less above the manhole shelf, a beaver slide will be constructed utilizing Portland Cement concrete. The sewage entering the manhole will follow a smooth concrete channel transitioning evenly from the invert of the inlet pipe to the main channel. Sewage will not be allowed to fall freely to the manhole base.
 - b. Where the invert of the connecting pipe is more than 2 feet above the manhole shelf, the Contractor will be required to construct an outside drop with the inlet pipe invert being located at the manhole shelf. The sewage entering the manhole will follow a smooth concrete channel transition from the inlet pipe to the main channel.
 - c. Where the invert is required to enter below the shelf of the manhole, the inlet pipe will not enter below a point where the crown of the new inlet pipe is below the crown of the outlet pipe. The base of the manhole will be rebuilt if damaged in this process. The sewage will enter the main flow by way of a smooth channel transitioning from the inlet pipe to the main channel.
 - d. In manholes, the minimum angle between all incoming pipe/flows and the outgoing pipe/flow shall be 90 degrees.
 2. When sewers are extended from cleanouts, the entire cleanout assembly, including the wye, shall be removed.
 3. New building service laterals will be made at existing wyes/tees where possible.

TECHNICAL SPECIFICATIONS

SECTION 3

SANITARY SEWERS

- 4. When wyes/tees do not exist on the Public Sanitary Sewer System, the new lateral sewer will enter the collection system through a "cored" opening with an approved connector.

H. Private Sewer Lines

Private sewer systems shall be constructed in accordance with the Oregon Plumbing Specialty Code, current edition.

I. Sewage Lift Station Design Standards

1. General

The pump station shall be a duplex submersible pumping system designed by an engineer registered in the State of Oregon and experienced in the design of such facilities. Service area peak flows, pump station cycle, and hydrogen sulfide calculations shall be submitted to the City for review and approval.

2. Construction

Pump station construction shall include a wetwell, pump enclosure, associated piping and valves, electrical controls, automatic dialer, alarm system compatible with the City's current alarm system, emergency power transfer switch and connection receptacle, lighting, heater, ventilating fan, instrumentation, access road, fencing, landscaping, and potable water supply, and shall conform to DEQ standards and OAR Chapter 340, Division 52.

3. Capacities

Pump station shall be designed to pump the peak wastewater flow from the service area. When the service area is not built out, staging of pump station capacity will be allowed. The wetwell shall be sized to allow for a maximum number of ten starts per hour. Inlet piping shall not be used as a portion of the wetwell.

4. Hydrogen Sulfide

Calculations for hydrogen sulfide production shall be performed. Hydrogen sulfide control equipment shall be installed as required. The method used (flow back, air injection, chemical injection) shall be reviewed and approved by the City.

TECHNICAL SPECIFICATIONS

SECTION 3

SANITARY SEWERS

- 5. Electrical and Controls
 - a. Electrical
 - 1) Pump station and related facilities will be constructed to electrical and building codes.
 - 2) Electrical controls shall be located aboveground and mounted in a waterproof enclosure. Electrical panels shall be UL listed. The pump station wetwell shall be considered a hazardous location. Level controls in the wetwell shall be intrinsically safe.
 - b. Controls
 - 1) Controls shall be mechanical relays or programmable logic-controllers. Pumps shall automatically alternate lead-lag position with each pumping cycle.
 - 2) Wetwell liquid surface elevation sensors shall be pressure transducers. When required by the City, radar or other level sensing technologies shall be used.
 - c. Power
 - 1) An auxiliary power connector shall be mounted on the exterior of the station with a manual transfer switch mounted in the interior.
 - 2) At a minimum, a receptacle enabling the use of a portable generator must be provided. Where the flow is substantial or where environmental damage may occur due to power failure, the City may require permanent standby power. Backup power shall meet all DEQ requirements.
 - d. Alarms
 - Alarms shall include:
 - 1) Power failure
 - 2) Telemetry failure
 - 3) High water level

TECHNICAL SPECIFICATIONS

SECTION 3

SANITARY SEWERS

6. Materials

a. Pumps

A minimum of two pumps shall be supplied. Each pump shall be capable of pumping the peak wastewater flow. When more than two pumps are used, the station shall be able to pump peak wastewater flow when the largest pump is out of service. See Part 2 - Materials, 2.10 Sewage Lift Station Pumps and Appurtenances for more information regarding pumps.

b. Piping and Valves

- 1) Piping outside the wetwell shall be ductile iron to a point at least 1 foot outside the wetwell. Valves shall be AWWA-rated metal, suitable for wastewater use. Pressure gauges with isolation and purge valves on pump suction and discharge piping shall be provided.
- 2) All piping inside the wetwell and to a point at least 1 foot outside the wetwell shall be 316L stainless steel with wall thickness no less than Schedule 10.
- 3) TNEMEC MC Polyurethane and Polyurethane Protective Coating paint is required on all exposed ductile iron valves, piping, and pipe fittings. Prime coat shall be TNEMEC Series 1 Omnithane, and finish coat shall be TNEMEC Series 73 Endura-Shield. Paint thickness shall be per manufacturer requirements.
- 4) Forcemain shall be designed for nominal flow velocity in the range of 3 to 5 fps. Forcemains shall not be less than 4 inches in diameter for raw sewage unless otherwise approved by the City.

c. Spare Parts

Supply two sets each of all gaskets, bearings, V-belts, and mechanical seals for rotation equipment.

7. Additional Features

- a. Provide a 1-inch anti-freeze hose bib. Potable water shall be provided by an aboveground, reduced pressure backflow preventer.

TECHNICAL SPECIFICATIONS

SECTION 3

SANITARY SEWERS

- b. Provide positive ventilation in the enclosure. Provide odor control as required.
 - c. A 6-foot high chain link fence shall surround the pump station.
8. Operating and Maintenance Data
- a. Compile product data and related information appropriate for City's maintenance and operation of products furnished under the contract.
 - b. Prepare an Operations and Maintenance Manual.
 - c. Instruct City personnel in the maintenance of products and in the operation of equipment and systems.
9. Erosion Control
- a. Erosion control shall be required for all areas disturbed during construction and following construction until permanent protection is established.
 - b. Temporary facilities may include silt fences, drain barriers, gravel entries, ditches, surface stabilization, or other devices, as necessary.
 - c. Temporary/permanent hydroseeding or acceptable seeding and mulching must be provided whenever perennial cover cannot be established on sites that will be exposed after September 1 or prior to June 1.

1.2 Specifications References

Specification references made herein for manufactured materials such as pipe, fittings, and manhole rings and covers refer to designations for the American Public Works Association (APWA), the American Water Works Association (AWWA), or the ASTM International (ASTM) as they are effective on the date of submission to the City.

1.3 Submittals

Catalog information on all materials and/or equipment to be installed shall be submitted to the City for review prior to installation.

TECHNICAL SPECIFICATIONS

SECTION 3

SANITARY SEWERS

1.4 Care and Handling of Materials

- A. Adequate precautions shall be taken to prevent damage to pipes, fittings, manhole components, and all other materials used in construction of a sewerage system. Pipe and other materials during transport shall be secured individually by use of wood spacer blocks or wood crates, or otherwise protected to prevent collision of individual pieces and the possible subsequent damage.
- B. All pipe, fittings, manhole components, and valves shall be loaded and unloaded in a manner to prevent shock or damage. Under no circumstances shall such material be dropped. All materials on the ground shall be protected from damage. All pipes, fittings, manhole components, valves, and all other materials used in the construction of the sewerage system shall be carefully inspected by the Contractor prior to installation. All defective materials shall be rejected. All materials which are delivered considerably in advance of their installation shall be stored in a satisfactory manner.
- C. Proper materials, tools and equipment shall be used by the Contractor for safe and convenient prosecution of the Work. All pipes, fittings, etc., shall be carefully lowered into the trench piece by piece in such a manner to prevent any damage to the materials. Under no circumstances shall sewage system materials be dropped or dumped into the trenches.

1.5 Materials Furnished by City

The Contractor's responsibility for material furnished by the City shall begin at the point of delivery to the Contractor. Materials already on the Site shall become the Contractor's responsibility on the start work date of the Contract. The Contractor shall examine all material furnished by the City at the time and place of delivery and shall reject all defective material. Any material furnished by the City that becomes damaged by the Contractor shall be replaced by the Contractor at their own expense. The Contractor shall assume full responsibility for materials furnished by the City once they are received by the Contractor.

1.6 Restoration, Finishing, and Cleanup

The Contractor shall restore or replace all paved surfaces, graveled surfaces, curbing, sidewalks, trees and shrubbery, lawns, pastures, fences, and other existing facilities to their original condition.

TECHNICAL SPECIFICATIONS

SECTION 3

SANITARY SEWERS

PART 2 - MATERIALS

2.1 Bedding, Select Backfill, and General Backfill

Bedding, select backfill, and general backfill for storm drain pipelines shall be as required on the City Standard Drawings and the Technical Specifications - "Excavation and Grading," Part 2 - Materials, 2.4 Select Backfill and 2.5 General Backfill.

2.2 Pipe

A. General

All public sanitary sewer lines shall be constructed of polyvinyl chloride (PVC) pipe. When required for added strength, ductile iron pipe may be used.

B. PVC Gravity Pipe

PVC gravity sewer pipe and fittings 15-inch diameter and smaller shall conform to ASTM D3034, SDR 35 unless called for otherwise on the Drawings. Pipes 18-inch diameter to 24-inch diameter shall conform to ASTM F679 unless called for otherwise on the Drawings. The joints shall be flexible joint with rubber ring gasket.

C. PVC Pressure Pipe

PVC pipe for pressure sewer lines shall conform to AWWA C900-16, DR 18 (235 psi pipe), or as otherwise specified. The pipe shall have flexible rubber gasketed joints conforming to ASTM D3139 and ASTM F477. Pipe color shall be green.

D. Ductile Iron Pipe

1. Ductile iron pipe and fittings shall conform to AWWA C150, AWWA C115, AWWA C151, AWWA C153, and AWWA C110 and shall be minimum pressure Class 350 unless specified otherwise. All ductile iron pipe shall have a bituminous sealed cement mortar lining conforming to AWWA C104. All joints, unless otherwise specified, shall be push-on rubber gasket joints conforming to AWWA C111.
2. When flanged pipe is required, the Contractor shall provide the D.I. pipe class required by the flange manufacturer to ensure the pipe and flange units are compatible. This data shall be provided to the City for review prior to ordering these materials. Flanges for couplings and fittings shall conform to ANSI 16.1, 125-pound bolt hole template.

TECHNICAL SPECIFICATIONS

SECTION 3

SANITARY SEWERS

2.3 Fittings

A. Fittings for Ductile Iron and PVC Pressure Pipe

Unless specified otherwise, all fittings such as elbows, tees, crosses, etc., shall be mechanical joint short-bodied compact ductile iron fittings conforming to AWWA C153, Class 350. When called for, flanged cast iron fittings shall conform to AWWA C110 with ANSI B16.1, 125-pound bolt hole template. All fittings shall be cement mortar lined in accordance with AWWA C104. Gaskets for flanges shall be either ring or full faced, 1/8 inch thick conforming to AWWA C111, Appendix B.

B. Fittings for Sewer Service Connection

Main line fittings for sewer service connections when installing new gravity sewer pipe shall be a gasketed tee suitable for ASTM D3034 or ASTM F679 sewer pipe. When service connections are required on existing sewer lines, a sewer tapping saddle shall be used, such as "Geneco Sealtite," of the type and model required to match the sewer main line and service line pipe materials, or approved equal.

C. Couplings

Couplings shall have stainless steel shear rings of the size and style required to match the pipe size and type being utilized. Couplings shall be manufactured by Fernco with stainless steel shear rings or approved equal.

D. Restrained Push-on Joint Pipe

When restrained joint ductile iron pipe is required, the pipe shall be the same class and type as the ductile iron pipe specified herein. Joints shall be Tyton Joint with Field Lok 350 gaskets, or approved equal. The restraint shall be boltless, integral restraining system, rated for 350 psi in accordance with the performance requirements of ANSI/AWWA C111/A21.11.

E. Restrained Fittings

All mechanical joint fittings called out to be restrained shall be equipped with a MEGALUG Series 1100 mechanical joint restraint system as manufactured by EBAA Iron, Inc., or approved equal.

TECHNICAL SPECIFICATIONS

SECTION 3

SANITARY SEWERS

2.4 Valves and Appurtenances

A. Plug Valves

1. All plug valves shall conform to AWWA C504. The valve body shall be constructed of cast iron (semi-steel) conforming to ASTM A126 Class B and shall be protected with a factory-applied fusion-bonded coating meeting AWWA C550. The shaft and plug shall be integrally constructed of cast iron (semi-steel) and shall be 100 percent encapsulated with Buna N rubber. The stem seals shall be Buna N multiple "V" ring stem packing seals. The valve seat surface shall be raised welded-in overlay of not less than 90 percent nickel.
2. Flange dimensions, facing, and drilling shall conform to ANSI B16.1, Class 125. Mechanical joints shall meet the requirements of AWWA C111/ANSI A21.11.
3. The valve shall have a 2-inch AWWA operator nut for buried services and hand wheel operator for non-buried services or as called for on the Drawings. Worm gear operators shall be furnished for all 4-inch or larger valves.
4. Valves shall be Dezurik eccentric plug valves, Pratt Ballcentric plug valves, or approved equal.

B. Valve Boxes

Each valve shall be equipped with an adjustable cast iron box of the sliding type with a base large enough to cover the top casting of the valve. The diameter of the valve box shall be not less than five (5) inches, and shall be of such length so as to provide the depth of cover over the pipe without full extension. Materials and installation workmanship for valve boxes shall be in accordance with AWWA C600, Section 10.3.

C. Sewage Air Release Valve

1. Air release valves where called for shall be Valve and Primer Corporation, #400 APCO Sewage Air Release Valve and/or #401 APCO Sewage Air and Vacuum Valve with 2-inch inlet or approved equal. An auxiliary 2-inch 125 psi bronze rising stem solid disc gate valve shall be installed with all sewage air release valves.
2. Air release valves shall also be furnished with accessory valves and connections (for flushing purposes) as shown on the City Standard Drawings.

TECHNICAL SPECIFICATIONS

SECTION 3

SANITARY SEWERS

- 3. The furnishing and installation of sewage air release valves shall include the construction of all associated structures and appurtenances as shown on the design drawings.

2.5 Thrust and Anchor Blocks

Thrust and anchor blocks shall be located and sized as shown on the City Standard Drawings, and at all changes in direction, or as required by the design engineer or City. Concrete used for the blocks shall be Portland Cement concrete with a minimum 28-day strength of 2,500 psi. All concrete shall be placed so that pipe joints and fittings will be accessible for repair. Concrete shall be placed against undisturbed material. Anchor rods shall be 3/4-inch diameter galvanized steel, embedded a minimum of 18 inches in concrete.

2.6 Manholes

A. Cast-in-place Concrete Base Sections

- 1. Cast-in-place concrete base sections for manhole construction shall have a minimum 28-day strength of 4,000 psi, unless approved otherwise by the City, and shall not be less than 6 inches in thickness in any section.
- 2. Required "U" shaped channels shall be constructed by the use of properly shaped forms. Intersecting flow channels shall have smooth uniform transitions. All channels shall have smooth troweled finishes. All shelf area shall be uniformly shaped, have a rough float finish and shall slightly slope towards the channel. The shelf shall be above the top of the sewer pipe.
- 3. The Contractor shall be responsible for the determination of pipe hole orientation and grade. Cast-in-place base sections will only be used where called for specifically on the Drawings or where required by the design engineer.

B. Precast Concrete Base Sections

- 1. Precast concrete base sections shall be approved by the design engineer and shall conform to ASTM C478. Concrete shall be consolidated by mechanical vibration. Reinforcing shall be provided in the base and walls. Minimum concrete thickness shall be 5 inches unless otherwise required for deep manholes.
- 2. Required "U" shaped channels shall be constructed by the use of properly shaped forms. Intersecting flow channels shall have smooth uniform transitions. All channels shall have smooth troweled finishes. All shelf area shall be uniformly

TECHNICAL SPECIFICATIONS

SECTION 3

SANITARY SEWERS

shaped, have a rough float finish and shall slightly slope towards the channel. The shelf shall be above the top of the sewer pipe.

3. The Contractor shall be responsible for the determination of pipe hole orientation and grade. Precast base sections shall be used unless specifically called for otherwise on the design drawings or by the design engineer.

C. Precast Concrete Manhole Sections

1. Precast concrete manhole sections shall conform to ASTM C478 and consist of circular sections in the standard 48-inch diameter, unless otherwise noted. No more than two lift holes shall be cast into each section. Holes shall be located as to not damage reinforcing or expose it to corrosion. All lift holes shall be patched to prevent water seepage into the manhole, utilizing an approved, non-shrink grout.
2. Precast manhole cones shall be concentric unless otherwise specified and shall meet ASTM C478.
3. Flat slab covers for manholes shall conform to ASTM C478. Slabs, cones and ring sections shall be free from fractures, cracks, rock pockets, or exposed reinforcement. Joint seal material shall be "Kent seal" mastic acrylic polymeric sealant, or approved equal.

D. Pipe Connection to Manholes

1. All pipe connections to manholes shall be constructed as shown on the Drawings, shall be flexible, and shall allow movement of the sewer pipe in all directions. Manhole pipe couplings shall be suitable for the sewer pipe type connecting to the manhole.
2. A-Lok field sleeve, or approved equal, may be used for cast-in-place manhole bases.
3. When precast base sections are used, an A-Lok pipe connector as manufactured by A-Lok Products, Inc., PSX Flexible Connector as manufactured by Press Seal Gasket Corporation, Kor-N-Seal as manufactured by Core and Seal Company, or approved equal shall be used.
4. Fittings for drop manholes shall be of the same material as the attached sewer pipe.

TECHNICAL SPECIFICATIONS

SECTION 3

SANITARY SEWERS

E. Manhole Rings and Covers

1. Castings shall be tough, close-grained, gray iron free from blow holes, shrinkage and cold sheets.
2. Manhole rings and covers shall conform to ASTM A48 and shall be smooth, sound, clean and free from blisters and defects. Castings and covers shall be planed and ground when necessary to insure flat and true surfaces. Covers shall be true and shall seat within the ring at all points. Manhole rings shall have a maximum height as shown on the City Standard Drawings.
3. Manhole rings and covers shall be as called for on the City Standard Drawings.

F. Manhole Inflow Protectors

1. The watertight manhole inflow protectors shall be manufactured of a plastic polymer that will not corrode, cannot be damaged by sewer gases or road oils, and will not become brittle in subfreezing temperatures. They shall have a spring loaded gas relief valve automatically activated at approximately 1/2 psi and a vacuum relief valve automatically activated when the differential pressure reaches approximately 2-1/4 psi.
2. The bowl shall be deep enough that the valves or the protector are not damaged during the removal of the lid. The gasket shall be a heat welded type that conforms to the irregularities in the frame.
3. The watertight manhole insert shall be Sewer Guard by Fosroc-Preco Industries, Ltd., or approved equal.
4. The Contractor shall be responsible for measurement of manhole openings, the dimension of which is required for ordering of watertight manhole inserts. New covers to have manhole inserts shall be factory-machined to accept the insert.

G. Manhole Stubouts

1. Manhole stubouts shall be constructed as called for on the Drawings or as directed by the City. The stubouts shall have the appropriate flexible connection at the manhole.
2. The outside end of the stubout shall be secured, sealed watertight with a block and plug with rubber ring seal.

TECHNICAL SPECIFICATIONS

SECTION 3

SANITARY SEWERS

3. All stubouts shall be 8-inch minimum, unless otherwise approved or shown.

H. Pressure Sewer Discharge Manholes

The Contractor shall construct the Pressure Sewer Discharge Manholes as shown on the Drawings and also in accordance with the Specifications herein for standard manholes.

2.7 Cleanouts

A. Cast Iron Rings and Covers

Cleanouts shall have cast iron rings and covers as called for on the City Standard Drawings, or approved equal.

B. Pipe

Pipe used in the construction of cleanouts shall be consistent with type of sewer pipe to which it is connected.

2.8 Frost-free Sanitary Yard Hydrant

Frost-free sanitary yard hydrant shall be Hoeptner FreezeFlow, or approved equal, with a PK1400 self-draining vacuum breaker as manufactured by Arrowhead Brass and Plumbing, LLC, or approved equal.

2.9 Sewage Lift Station Valve Vault

A. General

The valve vault shall be a 72-inch precast manhole or an approved precast valve vault. The valve vault shall be watertight and set plumb and to grade.

B. Precast Manhole Sections

Precast manhole base, wall, and top slab sections shall conform to ASTM C478. Steel loops shall be provided for handling. Lift holes shall not be used. All sections shall be free from fractures, cracks, rock pockets, or exposed reinforcement. Joint seal material shall be "Kent seal" mastic acrylic polymeric sealant, O-ring rubber gasket, or approved equal.

TECHNICAL SPECIFICATIONS

SECTION 3

SANITARY SEWERS

C. Pipe Connection to Valve Vault

1. An A-Lok pipe connector as manufactured by A-Lok Products, Inc., PSX Flexible Connector as manufactured by Press Seal Gasket Corporation, or approved equal shall be used.
2. Rubber boot pipe-to-manhole connections, such as Kor-N-Seal as manufactured by Core and Seal Company or equal may also be used. The rubber-booted connection of sewer pipe to manholes shall be performed as per manufacturer instructions and as required to make long lasting flexible watertight connections. The rubber-booted connection shall be used in conjunction with precast manhole bases with core-drilled holes. All holes shall be located so as to provide the design flow line and direction of all pipe entering each manhole. After the pipe-to-manhole connection is made and set to grade, the annular space between the rubber boot and the pipe shall be cement grouted in order to permanently set the flow line of the pipe, as recommended by the manufacturer.
3. All pipe connections shall be constructed as shown on the Drawings and shall be flexible and watertight.

2.10 Sewage Lift Station Pumps and Appurtenances

A. General

1. The Contractor shall furnish and install a complete duplex submersible non-clog pumping system in the wetwell including two submersible wastewater non-clog pumps, rail guides, float switches, etc.
2. A duplex pump control panel shall be installed in an above-ground Contractor-furnished enclosure.
3. In addition, the Contractor shall furnish one identical spare submersible wastewater grinder pump, complete with motor.

B. Performance

Motor shall be sized to be non-overloading on any part of the curve. Service factor shall not be used in this determination.

TECHNICAL SPECIFICATIONS**SECTION 3****SANITARY SEWERS****C. Pump Design**

1. The pump(s) shall be capable of handling raw, unscreened wastewater.
2. The discharge connection elbow shall be permanently installed in the pump well along with the discharge piping. The pump shall be automatically connected to the discharge connection elbow when lowered into place, and shall be easily removed for inspection or service.
3. There shall be no need for personnel to enter the pump well to remove a pump. Sealing of the pumping unit to the discharge connection elbow shall be accomplished by a simple linear downward motion of the pump. A sliding guide bracket shall be an integral part of the pump unit. The entire weight of the pumping unit shall be guided by one or two guide bars and pressed tightly against the discharge connection elbow with a watertight seal. No portion of the pump shall bear directly on the floor of the sump.
4. The pump, with its appurtenances and cable, shall be capable of continuous submergence under water without loss of watertight integrity to a depth of 65 feet.
5. Pumps to be used shall be as manufactured by Flygt, or approved equal.

D. Pump and Motor Construction

1. Major pump components shall be of gray cast iron, Class 30B, with smooth surfaces devoid of blow holes and other irregularities. Where watertight sealing is required, O-rings made of nitrile rubber 70° IRH shall be used. All exposed nuts and bolts shall be of AISI Type 304 stainless steel or brass construction. All surfaces, other than stainless steel or brass, coming into contact with wastewater, shall be protected by an approved wastewater resistant coating.
2. All mating surfaces where watertight sealing is required shall be machined and fitted with nitrile rubber O-rings. Fitting shall be such that sealing is accomplished by metal-to-metal contact between machined surfaces. This will result in controlled compression of nitrile rubber O-rings without the requirement of a specific torque limit. No secondary sealing compounds, rectangular gaskets, elliptical O-rings, grease, or other devices shall be used.
3. The cable entry water seal design shall preclude specific torque requirements to ensure a watertight and submersible seal. The cable entry shall be comprised of

TECHNICAL SPECIFICATIONS

SECTION 3

SANITARY SEWERS

a single cylindrical elastomer grommet, flanked by stainless steel washers, all having a close tolerance fit against the cable outside diameter and the entry inside diameter and compressed by the entry body containing a strain relief function, separate from the function of sealing the cable. The assembly shall bear against a shoulder in the pump top. The cable entry junction chamber and motor shall be separated by a stator lead sealing gland or terminal board, which shall isolate the motor interior from foreign material gaining access through the pump top.

4. **The pump motor shall be an explosion proof FM approved, squirrel cage, induction shell type design, housed in an air-filled, watertight chamber and suitable for operation in a Class 1, Division 1, Group C and D, hazardous location.** The stator winding shall be insulated with moisture resistant Class F insulation which will resist a temperature of 155°C (311°F). The stator shall be dipped and baked three times in Class F varnish and shall be heat-shrink fitted into the stator housing. The use of bolts, pins or other fastening devices requiring penetration of the stator housing shall be rejected. The motor shall be designed for continuous duty, capable of sustaining a minimum of ten (10) starts per hour. The rotor bars and short circuit rings shall be of aluminum. Bimetallic thermal switches shall be imbedded in each phase of the winding to sense high temperature. These sensors shall be wired to the control panel for use in conjunction with the external motor overload protection.
5. The pump motor cable, installed, shall be suitable for submersible pump application with P122-MSHA approval and this shall be indicated by a code or legend permanently embossed on the cable. Cable sizing shall conform to NEC and ICEA specifications for pump motors. A ground check conductor shall be provided.
6. At the maximum rated power of this unit, thermal radiators (cooling fins) integral to the stator housing, shall be adequate to provide the cooling required by the motor. Water jacket or other device shall not be necessary for continuous pumping at sump liquid levels down to the midpoint of stator housing.
7. The junction chamber, containing the terminal board, shall be sealed from the motor by an elastomer compression seal (grommet).
8. The pump shaft shall be of AISI Type 420 stainless steel. This is a nickel bearing chromium steel designed for heat treatment to high mechanical properties providing superior corrosion resistant characteristics.

TECHNICAL SPECIFICATIONS

SECTION 3

SANITARY SEWERS

9. Each pump shall be provided with a tandem mechanical shaft seal system. The lower seal (pump side) shall be of the mechanical type with silicon or tungsten carbide faces. The upper seal shall be a lip-type seal or silicon or tungsten carbide seals.
10. Each pump shall be provided with an oil chamber for the shaft sealing system. The drain and inspection plug, with positive anti-leak seal, shall be easily accessible from the outside. The oil chamber shall include an air pressure reserve for oil pressure compensation. An electronic probe connected to the control panel shall be provided in the oil chamber to detect the leakage of water into the chamber. If water enters the oil chamber, the probe shall activate a seal failure warning light in the control panel.
11. The pump shaft shall rotate on two permanently-lubricated bearings. The upper bearing shall be a single-row ball bearing and the lower bearing a two-row angular contact ball bearing.
12. The volute shall be of a single piece, non-concentric design and shall have smooth fluid passage large enough to pass any size solids which can pass through the impeller.

E. Guide Rails

Two-inch diameter Type 304 or 316 stainless steel pipe guide rail(s) shall be installed. Intermediate supports shall be provided as recommended by the pump Supplier to ensure necessary rigidity. Lifting chains shall be provided for each pump. Chain shall be 3/8-inch stainless steel and be securely attached both to the pump lifting bracket and the access frame.

2.11 Sewage Lift Station Controls

- A. Pump motor circuits provided must be adequate to meet all the requirements of the system.
- B. Pump motor starters shall be rated and properly sized to ensure proper operation of the pump motors.
- C. Pump motor circuit breakers shall be rated properly to ensure proper operation of the pump motors.
- D. All applications that are single- or 3-phase require surge and lightning protection.

TECHNICAL SPECIFICATIONS

SECTION 3

SANITARY SEWERS

- E. Transformers shall be fused on the primary and secondary side of the windings.
- F. Transformers shall be sized properly to accommodate all controls functions.
- G. The controls shall include Hand-Off-Auto selector switches for operation of the pump station in conjunction with liquid level controls.
- H. Pump alternating circuit to equalize pump motor run time shall be included.
- I. Dry alarm contacts shall be provided.
- J. The controls shall include an intrinsically safe barrier for connection to level sensing devices.
- K. Pump run and fail indicator lights shall be provided.
- L. Controls shall be by relays only. Programmable logic controller controls will not be allowed.
- M. All fail alarms shall be sent to an automatic dialer.

2.12 Sewage Lift Station Control Operation

Primary level control operation shall be:

- A. Stop level - All pumps stop
- B. Lead pump start level - Lead pump starts
- C. Lag pump start level - Lag pump starts
- D. High level alarm level - High level beacon and alarm activated

2.13 Sewage Lift Station Control Panel

A control panel and associated field devices shall be provided. The control panel shall be prewired and factory tested and shall meet UL508A standard for industrial control panels. The control panel shall be UL listed and labeled with intrinsically safe circuit extensions. The pump control panel shall fit inside the electrical service panel.

TECHNICAL SPECIFICATIONS

SECTION 3

SANITARY SEWERS

2.14 Sewage Lift Station Electrical Requirements

- A. Panel wiring to be numbered and labeled.
- B. Controls shall be assembled, prewired, and tested by a reputable UL508A-certified control manufacturing company with a minimum of ten (10) years of custom control fabrication.
- C. Control wiring schematics shall be located on the inner door front.
- D. Warning labels applied to outer door as per National Electric Code.

PART 3 - EXECUTION

3.1 Trench Excavation and Backfill

Trench excavation and backfill shall be performed as specified in Section 2 - "Storm Drainage," Part 3 - Execution, Sections 3.1 through 3.8.

3.2 Existing Utilities

Requirements for existing utilities shall be as specified in Section 2 - "Storm Drainage," Part 3 - Execution, 3.9 Existing Utilities.

3.3 Installation of Pipe

- A. Gravity sewer pipe shall be installed in accordance with the best current practices and as required by the manufacturer. Gravity sewer pipe, unless otherwise approved by the City, shall be laid by progressing up grade from the existing or newly constructed sewer; the sewer pipe shall be installed with bell ends laid up grade unless otherwise approved.
- B. All rubber ring joints shall be lubricated, except when using rolling rubber gaskets with concrete pipe, and installed in accordance with the installation instructions of the pipe manufacturer, taking particular care to avoid pinching or otherwise causing damage to the rubber ring. All joints shall be free of dirt and other foreign matter prior to the joining of the next pipe. All pipe shall be installed to prevent creep and misalignment of joints. All pipe shall have a ring painted around the spigot ends in such a manner as to allow field checking of setting depth of pipe in socket.
- C. Gravity sewer pipe shall be installed with the use of a laser beam and target. Unless the Work involves deep excavations, traffic problems, water problems, or approved by the City, the trench for the first 100 feet shall not be backfilled until the sewer grade has

TECHNICAL SPECIFICATIONS

SECTION 3

SANITARY SEWERS

been checked. The Contractor shall set and aim the laser as controlled by the "cuts" and "slopes." Careful attention shall be given to the setting up of the laser and the periodic checking of its aim, etc. All grade checking of laser shall be the responsibility of the Contractor. All pipe shall be installed true to line and grade. A tolerance of $\pm 1/8$ -inch deviation from true grade at each joint will be allowed. Extra care shall be given to the installation of sewer lines at minimum slopes to avoid flat slopes in the line. All pipe shall be installed true to line. Except when approved by the City, the Contractor may not install a pipeline on a curve.

- D. All foreign matter and gravel shall be removed from the inside of the pipe and fittings before being installed and the pipe and fittings shall be kept clean during placement. No pipe shall be laid in water or when conditions exist that in the opinion of the City are unsuitable for the placing of pipe. All pipe and manholes shall be covered or plugged at night and whenever the Work is not supervised.
- E. All pipe/manhole connections shall be watertight. The manhole pipe couplings shall be installed in accordance with all manufacturer instructions. All connections shall match the grade and alignment of the pipe entering and exiting each manhole. Manhole pipe connections shall be constructed so that the wastewater flow through the manhole is not restricted in any way.
- F. Do not vary from established line and grade by more than $1/32$ inch per inch of pipe diameter. Variance shall not exceed $1/2$ inch and shall not result in a level or reverse sloping invert.

3.4 Gravity Service Lines

- A. Gravity service lines shall be constructed in accordance with the Drawings, Specifications, and applicable provisions of the Oregon Plumbing Specialty Code, current edition. The pipe size of gravity service lines shall be a minimum 4-inch diameter unless otherwise specified. The Contractor shall end gravity service lines at the location as per the Drawings and at the invert elevation as shown on the Drawings or as set by the design engineer. Dead ends of service lines shall be marked with 2" x 4" pressure treated posts installed in the ground as shown on the City Standard Drawings.
- B. Connection of service lines to new or existing gravity sewer main lines shall be as per the Drawings and shall be inspected and accepted by the City prior to backfilling. All sewer service connections shall be watertight utilizing appropriate sewer service saddles or wyes. An approved wye fitting shall be used when new sewer mains are being installed. All holes and taps into an existing sewer main shall be cut using an approved tapping machine.

TECHNICAL SPECIFICATIONS

SECTION 3

SANITARY SEWERS

- C. In the construction of new sewage collection systems, connection of new services allowing sewage into the system shall not be made until approval for connections has been given by the City. No existing sewer service shall be interrupted without the approval of the City and service owner. Connections of new service lines to existing service lines shall be by the proper adaptor coupling.
- D. The Contractor shall obtain all necessary permits required to construct service lines on private property. The Contractor must utilize a licensed plumber for service line work on private property when required by state or local regulations.

3.5 Gravity Sewer Testing

A. General

The Contractor shall furnish all labor, necessary equipment, and other apparatus including, but not limited to, gauges, mechanical or pneumatic plugs, and air hoses, necessary to properly perform the testing of sewer lines as specified.

B. Acceptance of Tests

The Contractor shall perform all preliminary testing required to determine that the sewer infrastructure to be tested is acceptable and complies with the requirements of this section of the Specifications. The Contractor may preliminarily test sewer infrastructure before backfilling at their own option, but all acceptance tests shall be performed only after backfilling, cleaning, and flushing has been completed. After the Contractor has determined that the sewer infrastructure will pass the required tests, the Contractor shall arrange for acceptance tests to be witnessed by the City. The Contractor shall coordinate the timing of acceptance tests with the City. Sewer infrastructure will not be accepted until all acceptance tests have been witnessed and documented as passing.

C. Low-Pressure Air Test Procedure

The method of testing follows the procedures outlined in the Oregon Standard Specifications for Construction, Part 00400, Section 00445.72(c), current edition. All air testing shall be by the Time Pressure Drop Method. Specific questions concerning test procedures may be referred to this publication. To facilitate test verification by the City, all air used shall pass through a single, aboveground control panel. The pressure gauge used in air testing shall have minimum divisions of 0.10 psi and have an accuracy of 0.0625 psi (one ounce per square inch). The City shall have the option of requiring the use of their own gauge.

TECHNICAL SPECIFICATIONS

SECTION 3

SANITARY SEWERS

The Contractor may low pressure test sections of sewer lines before backfilling at their own option; but the acceptance test shall be performed only after backfilling, cleaning, and flushing has been completed.

Test procedures are summarized below:

1. Field Test
 - a. The Contractor may wet the lines prior to testing.
 - b. Determine the average height of the groundwater over the line. The test pressures required shall be increased 0.433 psi for each foot of average water depth over the exterior crown of the pipe, but no greater than 9.0 psig.
 - c. Add air slowly to the section of system being tested until the internal air pressure is raised to 4.0 psig greater than the average back pressure due to groundwater.
 - d. After the test pressure is reached, allow at least two minutes for the air temperature to stabilize adding only the amount of air required to maintain pressure.
 - e. After the temperature stabilization period, disconnect the air supply. Record the time in seconds that is required for the internal air pressure to drop from 3.5 psig to 2.5 psig greater than the average back pressure due to groundwater.
 - f. Compare the time recorded in the above step with the test time determined hereafter.

2. Acceptance
 - a. Record the diameter in inches and the length in feet of all pipe in the section to be tested, including the service connections on the worksheet found at the end of this section.
 - b. Using the nomograph (Figure No. 1) found at the end of this section, place a straightedge from the "d" column (diameter in inches) to the "L" column (length in feet). Read the corresponding "K" and "C" values for each of the pipes listed above, and record them on the worksheet.

TECHNICAL SPECIFICATIONS

SECTION 3

SANITARY SEWERS

- c. Add all values of "K" and all values of "C" for the section being tested.
- d. If the total of all the "C" values is less than one, the time shall be the total of all the "K" values.
- e. If the total of all the "C" values is greater than one, the time shall be found by dividing the total of all the "K" values by the total of all the "C" values. The result is the maximum test time. To make this division using the nomograph (Figure No. 1), use the total "C" and "K" values and read the time from the "t_q" scale.
- f. In the event that the "d" and "L" values for a particular section of the system do not fall within the limits of the nomograph, the values of "K" and "C" may be computed from the following equations: "K" = 0.011d²L; "C" = 0.0003882dL.
- g. If the "actual time" (field test) is equal to or greater than the "test time" required for the pipe section being tested, the pipe section will have passed the pressure test. (See worksheet.)

D. Infiltration Allowance

Groundwater infiltration to the collection system, including manholes, shall not exceed 50 gallons/inch diameter of pipe/mile/day. Any infiltration in excess of this amount shall be corrected at the Contractor's expense.

E. Deflection Test for PVC Pipe

- 1. All sanitary sewers constructed of PVC pipe shall be able to pass a deflection test. The test shall be conducted by pulling a go-nogo solid pointed mandrel or sewer ball through the completed pipeline. The diameter of the mandrel or ball shall not be less than 95 percent of the base inside pipe diameter as defined by ASTM D3034, SDR 35 and ASTM F679, T-1 pipe. The base inside pipe diameter and minimum mandrel diameter are as follows:

Nominal Pipe Size, In.	Minimum Mandrel Dia., In.	Base Inside Pipe Dia., In.
6	5.46	5.742
8	7.28	7.665
10	9.08	9.568
12	10.79	11.361
15	13.20	13.898

TECHNICAL SPECIFICATIONS

SECTION 3

SANITARY SEWERS

Nominal Pipe Size, In.	Minimum Mandrel Dia., In.	Base Inside Pipe Dia., In.
18	16.13	16.970
21	19.00	20.004
24	21.36	22.480
27	24.06	25.327

- 2. All lines shall be tested unless determined otherwise by the City based upon their observations during pipeline installation and visual inspection of the pipeline. Testing shall be conducted on a manhole to manhole basis and shall be done after the line has been completely cleaned and flushed with water. The Contractor shall, at their own expense, locate and repair any sections failing to pass the deflection test. All areas failing the deflection test shall be retested after corrective action has been taken. Results shall be recorded on the form "Mandrel Test Record" at the end of this section.

F. Equipment

The Contractor shall perform all Work and furnish all materials and equipment as required to perform all required tests.

3.6 Pressure Sewer Construction - Pipeline

- A. The Contractor shall construct pressure sewer lines of the size, type, and class specified on the Drawings. Pipe shall meet the material specifications contained herein. All Work performed in the installation of pressure sewer lines shall be performed as per the design drawings, the applicable portions of subsection "Gravity Sewer Construction" contained herein, and as required by the manufacturer. When it is necessary to deflect pipe joints to conform to the profile and alignment of the sewage forcemain, the amount of deflection per joint shall not exceed 70 percent of the deflection recommended by the Manufacturer. All pressure sewer lines shall be installed to grade as shown on the Drawings.
- B. Installation of service line pipe shall be in accordance with the applicable requirements contained herein. The Contractor shall end pressure service lines at the location as per the design drawings and at the invert elevation as shown on the design drawings. Dead ends of service lines shall be marked with 2" x 4" pressure treated posts installed in the ground as shown on the City Standard Drawings.
- C. In the construction of new sewage collection systems, connection of new services allowing sewage into the system shall not be made until approval for connections has

TECHNICAL SPECIFICATIONS

SECTION 3

SANITARY SEWERS

been given by the City. No existing sewer service shall be interrupted without the approval of the City and service owner.

- D. The Contractor shall obtain all necessary permits required to construct service lines on private property.

3.7 Pressure Sewer Testing

- A. General

The Contractor shall be responsible for determining the length of any given section of line to be tested. It is recommended that the length of line to be tested not be excessive so that the identification of any problem areas can be readily made. It is also recommended that testing follow closely after the pipe installation and backfill.

- B. Hydrostatic Testing of Pressure Sewer Lines

- 1. Before being placed into service, each section of the lines shall be isolated and slowly filled with water. Air should be expelled from the lines through taps made at the high points. The Contractor shall be responsible for making any necessary taps in addition to those shown on the design drawings.
- 2. All lines shall be pressure tested by the Contractor at 100 psi pressure, at the lowest pipe elevation, for one hour. Any cracked or defective pipe or fitting shall be removed and replaced.

- C. Leakage Test

- 1. Each section of the line before being placed into service shall be tested by the Contractor for leakage for a period of two hours at an average gage pressure of 60 psi. The pressure during the test shall not fall below 40 psi. The allowable leakage is defined by the following equation:

$$\text{PVC and DI Pipe: } Q = \frac{LD \sqrt{P}}{148,000}$$

In which:

- Q = Allowable Leakage Gal/Hr
- L = Length of Pipe Section being Tested in Ft.
- D = Pipe Nominal Diameter in Inches
- P = Gauge Pressure in psi

TECHNICAL SPECIFICATIONS

SECTION 3

SANITARY SEWERS

- 2. Leakage is defined as the quantity of water supplied into the section of line being tested, during and at the end of the test, that quantity being such that the pressure at the end of the test is equal to the pressure at the beginning of the test.
- 3. Should any test disclose leakage greater than that specified, the Contractor shall locate and repair the defective joints until the leakage is within the specified allowance.

D. Equipment

The Contractor shall perform and provide all equipment and materials necessary to perform the required test.

3.8 Manhole Construction

A. Installation

- 1. Manholes shall be constructed to the line, grade and detail as shown on the design drawings and as approved by the design engineer. Excavation and backfill of the manhole shall be performed in the same manner as specified in Technical Specifications - "Excavation and Grading," Part 3 - Execution, 3.1 Earthwork, D. Backfilling. Backfill shall be brought up evenly on all sides of the manhole.
- 2. The manhole base section shall be carefully placed on a prepared base of 6-inch minimum deep 3/4"-0 aggregate base and geotextile fabric so as to be fully and uniformly supported in true alignment, and making sure that all entering pipes can be inserted on proper grade.
- 3. All connections and joints made at manholes shall be watertight. All manholes are to be watertight and any leakage shall be corrected in an approved manner.

B. Testing

- 1. The Contractor shall be responsible for providing all equipment, labor, and materials necessary for performing manhole testing.
- 2. All manholes shall be individually tested to verify their watertightness. Each manhole shall be tested for acceptance after all Work has been completed, including restoration work. Testing shall be completed in accordance with Oregon Standard Specifications for Construction, Part 00400, Section 00470.71 (a) or (b), current edition. Results shall be recorded on the form "Manhole Test

TECHNICAL SPECIFICATIONS

SECTION 3

SANITARY SEWERS

Record" at the end of this section. Preliminary testing prior to final acceptance is advised.

- C. Connection to Existing Manhole
 - 1. Connections to existing manholes when required on the Drawings shall be made by the Contractor. All connections shall be made in such a manner as to leave the existing manhole watertight. Connections shall be as shown on the City Standard Drawings.
 - 2. All flow lines shall be properly shaped, and all new concrete shall be placed against a clean and sound surface.
 - 3. An approved bonding agent shall be used on all existing surfaces to be bonded to new concrete or mortar. All applicable conditions for new manholes described previously shall apply.

3.9 Cleanout Construction

A. Main Line Cleanouts

Main line cleanouts shall be constructed as shown on the City Standard Drawings. The select backfill shall be carefully compacted around the cleanout riser pipe to prevent damage or displacement of the pipe.

B. Service Line Cleanouts

Service line cleanouts in public ROWs shall be constructed as per the City Standard Drawings and approved by the City. Service line cleanouts on private property shall be constructed in accordance with the Oregon Plumbing Specialty Code, current edition.

C. Testing

Cleanouts shall be tested as a part of the lines to which they are connected.

3.10 Water-Sewer Crossing

- A. Wherever possible, the bottom of new or existing water lines shall be 1.5 feet or more above the top of the sanitary sewer line. Where the water line crosses over the sanitary sewer line but with a clearance of less than 1.5 feet, or where the water line crosses under the sanitary sewer line, the Contractor shall construct the water-sewer line crossing as shown on the City Standard Drawings.

TECHNICAL SPECIFICATIONS

SECTION 3

SANITARY SEWERS

- B. If the City determines that conditions are not favorable or finds evidence of poor water line condition, the existing water line shall be replaced with a full length of water pipe centered at the crossing point.
- C. When constructing sewer service lines, the Engineer may require the depth of the service lines to be revised in order to eliminate the need for a water-sewer line crossing.

3.11 Locating Wire

- A. A continuous solid copper tracer or locating wire shall be taped along the top of all pressure sewer lines, including service lines. This wire shall be secured to the top of the pipe at maximum 10-foot intervals using 6-inch strips of 2-inch wide duct tape. All splices shall be tied, electrically continuous, and made waterproof.
- B. The location wire shall be brought to the surface at all valve boxes, cleanouts, and terminal line marker posts. The wire shall be secured to valve boxes, cleanouts, and posts with stainless steel pipe clamps.
- C. Access to terminal ends of the locating wire shall be made at all manholes, cleanouts, valve boxes, terminal line marker posts, etc. The result of this installation shall be a continuous wire circuit electrically isolated from ground.
- D. The Contractor shall be responsible for testing continuity and for testing isolation from ground in the wire after all Work has been completed on the test section. The Contractor is advised to do intermediate testing on their own after backfilling operations and prior to surface restoration work to be sure continuity is maintained. If there is a break or defect in the wire, it shall be the Contractor's responsibility to locate and repair the defect.
- E. The continuity of the location wire shall be tested from one test load point to the next by use of a temporary wire laid between test points in-line with an ohmmeter. Resistance shall be measured with an approved ohmmeter that has been properly calibrated. The continuity of a test section will be accepted if the resistance of the test section does not exceed 5 ohms per 500 feet of location wire being tested. Isolation from ground shall be measured with a megohm meter and shall be a minimum of 20 megohms for any section of location wire tested.
- F. A City Representative shall witness the acceptance test.

TECHNICAL SPECIFICATIONS

SECTION 3

SANITARY SEWERS

3.12 Cleaning and Flushing of Completed and Tested Sewers

- A. Prior to closed-circuit television (TV) inspection and final inspection of the sewer system by the City, the Contractor shall flush and clean all parts of the system. All accumulated construction debris, rocks, gravel, sand, silt, and other foreign material shall be removed from the sewer system at or near the closest downstream manhole. If necessary, mechanical rodding or bucketing equipment shall be used.

- B. All sewer pipes including gravity sewers, pressure sewer lines, service lines, etc., installed shall be flushed, as thoroughly as possible with the water pressure and outlets available. Flushing shall be done after the pressure test has been completed. Flushing removes only the lighter solids and cannot be relied upon to remove heavy material allowed to get into the sewers during construction. The Contractor shall provide sufficient water and appropriately sized taps at either end of the line to develop a velocity in the sewers during flushing of at least 2.5 fps.

3.13 Sewer Line Cleaning and Inspection

- A. Television Inspection

All new and repaired gravity sewer lines shall be visually inspected by means of closed-circuit TV at the Contractor's expense. The purpose of the TV inspection is to inspect the interior of select runs of gravity sewer line to determine the general quality of pipeline installation and to provide a permanent visual and audio record of the pipe section inspected.

Prior to TV inspection, sewer lines shall be cleaned sufficiently to allow passage of TV equipment and so that cracked joints and breaks can best be observed. Cleaning shall be per Technical Specifications - "Sanitary Sewers," Part 3 - Execution, 3.12 Cleaning and Flushing of Completed and Tested Sewers. New sewer lines shall be flushed with water two hours prior to the TV inspection work. During the TV inspection, the Contractor shall maintain a small flow of water in the pipeline in order to observe high or low areas in the grade of the pipe.

The TV camera used for the inspection shall be one specifically designed and constructed for such inspections. The camera shall be self-propelled, with a remote control rotating head type capable of "looking up" service line connections and also capable of 360° scanning of pipeline joints. It shall be operative in 100 percent humidity conditions. Lighting and camera quality shall be suitable to allow a clear, in-focus picture of a minimum of 6 linear feet of the entire inside periphery of the sewer pipe. The camera shall be color with standard broadcast quality or better. The Contractor shall

TECHNICAL SPECIFICATIONS

SECTION 3

SANITARY SEWERS

submit a video recording on a USB drive that demonstrates the camera picture quality prior to performing the work. The camera picture quality shall be approved by the City prior to beginning TV inspection. To ensure peak picture quality throughout all conditions encountered during the survey, a variable intensity control of the camera lights and remote control adjustments for focus shall be located at the monitoring station. Focal distance shall be adjustable through a range of 6 inches to infinity. Camera monitors shall be located within a studio that will allow seating of two authorized viewing personnel in addition to the operating technician. There shall be available within the studio two or more viewing monitors operating simultaneously and of a proper size to allow all persons in the studio to have a satisfactory and comfortable view of the video presentation. Monitors shall have good quality resolution. Continuously displayed on the monitors as part of the video presentation shall be the date of the survey, number designation of the manhole section being surveyed, and a continuous forward and reverse readout of the camera distance in feet from the manhole of reference. The ability to change the location of this readout on the picture is a desirable feature.

The operating technician shall have control of the movement of the TV camera at all times. This may be accomplished by means of remote control winches or by telephone or other suitable means of communications between the winches at either end of the manhole section being surveyed. The travel speed of the camera shall be uniform and shall not exceed 30 feet per minute. Any means of propelling the camera through the sewer that would exceed this rate of speed or produce non-uniform or jerky movements shall not be acceptable. At the Contractor's discretion or at the direction of the City, the camera shall be stopped and backed up to view and analyze conditions that appear unusual or uncommon to a good, sound sewer. The operating technician shall, at all times, be able to move the camera through the line in either direction without loss of quality in the video presentation on the monitor. The picture, at all times, shall be free of electrical interference and provide a clear, stable image of the resolutions specified.

Video recording of all sewer line inspections shall be made on a USB drive. The composite video and audio recordings of the sewer line inspections shall be compatible for replay on standard Windows computers. The replay of the recorded video information, when reviewed on a monitor receiver, shall be free of electrical interference and provide a clear, stable image. The audio portion of the composite signal shall be sufficiently free from electrical interference and background noise to provide complete intelligibility of the oral report. Audio reports shall be recorded by the operating technician on the video as they are being produced and shall include the location of the sewer, the names or numbers of the manholes involved, a manhole-to-

TECHNICAL SPECIFICATIONS

SECTION 3

SANITARY SEWERS

manhole direction of travel, and a detailed description of the conditions in the sewer line as they are encountered.

B. Video Inspection Recording and Written Inspection Report

Furnish all preconstruction and post-construction inspection video and reports within 14 calendar days after completing the inspections, in such number and format as requested by the City. Reports shall be recorded by the operating technician on the video as they are being produced and shall include the location of the sewer, the names or numbers of the manholes involved, a manhole-to-manhole direction of travel, and a detailed description of the conditions in the sewer line as they are encountered. If inspection video or audio recording quality is poor, the City has the right to reject the recording and request new video inspection at no additional cost to the City.

1. Inspection Report

Provide an inspection report that includes each defect, deformity, and joint along with the distance from the inspection starting point. Provide still digital images in the report along with a reference and description of each defect, deformity, and joint.

2. Deflection Report

Provide an inspection report and include a report generated from the laser profiler software.

In no case will dubbing of the audio portion be allowed after the survey. The video recording and the monitoring equipment shall have the capability to instantly review both video and audio quality of the productions at all times during the TV survey. The recordings and reports shall become the property of the City upon completion of the project.

Detailed printed location records shall be made by the operating technician and shall clearly show the exact location in relation to the adjacent manholes of each infiltration point, building sewer connections, all joints that are infiltrating or exhibit other unusual conditions, roots, storm drain connections, collapsed sections of pipe, joints sealed, presence of scale or corrosion, and other discernible features. Handwritten reports are not permitted. The video shall be properly indexed to the written reports using real time, and an index to the written reports shall be provided that indexes each sewer line section (between manholes) to the reports. The intent is to enable a user of the report to easily find any given section of the sewer system in the reports and on the video.

TECHNICAL SPECIFICATIONS

SECTION 3

SANITARY SEWERS

Prior to commencing work, the Contractor shall provide the City a sample of the proposed report format to be used by the Contractor. The City and Contractor shall agree on the report format before work proceeds. All reports shall be complete and accurate.

C. Necessary Repairs

If in the opinion of the City, after TV inspection, the sewer lines in question require repair and/or replacement to meet the approved design drawings and/or City Standards, the Contractor shall be required to perform all necessary repairs and replacement at no cost to the City. It shall be understood that any necessary repairs required will have been the result of poor construction or defective materials. Video inspection and an updated written report for the entire section of pipe requiring repair shall be submitted to the City as prescribed in 3.11 Sewer Line Cleaning and Inspection, A. Television Inspection above.

D. Inspection of Lines by Excavation

Supplemental to TV inspection shall be the inspection of lines by excavation at suspected joints, etc. If, in the opinion of the City, a line is suspected to have excess infiltration, the City may require the Contractor to excavate down to the joint(s) in question. The Contractor is responsible only for those lines or parts thereof they actually constructed.

END OF SECTION

**WORKSHEET FOR THE
GRAVITY SEWER LINE LOW PRESSURE AIR TEST
BY THE TIME PRESSURE DROP METHOD**

Project Name _____

Date _____ Job No. _____

Location of Test/Stationing _____

1. Wetted Line: Yes _____ No _____
2. Average height of groundwater over crown of sewer line _____ ft.
3. Internal Air Pressure (P₁):
 $P_1 = 4.0 \text{ psig} + \text{Groundwater Ht.} \times 0.433 \text{ psi} = 4.0 + (\text{_____}' \times .433) = \text{_____} \text{ psig}$
4. Initial Starting Test Air Pressure (P₂):
 $P_2 = P_1 - 0.5 \text{ psig} = \text{_____} - 0.5 = \text{_____} \text{ psig}$
5. Ending Test Air Pressure (P₃):
 $P_3 = P_2 - 1.0 \text{ psig} = \text{_____} - 1.0 = \text{_____} \text{ psig}$
6. Time of test from P₂ to P₃ (in seconds)
 Start Time T₁ _____
 End Time T₂ _____

Actual Time = T₂ - T₁ _____ seconds

7. Test Time

Pipe Diameter (inches)	Length of Pipe	"C" Value*	"K" Value*
TOTAL			

*See Figure No. 1
for "C" & "K" Values

If Total "C" Value is <1.0, use Total "K" Value as Test Time in seconds.

If Total "C" Value is ≥1.0, use Total "K" Value ÷ Total "C" Value as Test Time in seconds.

Results of Test

Actual time = _____ seconds

Test time = _____ seconds

If Actual Time is equal to or greater than test time required for the pipe section being tested, the pipe section will have passed the Pressure Test.

Test Passed: _____ yes _____ no

Corrective Measures: _____

Contractor's Firm Name: _____

Contractor's Representative Signature: _____ Title: _____

Engineer's Representative Signature: _____ Title: _____

FIGURE NO. 1

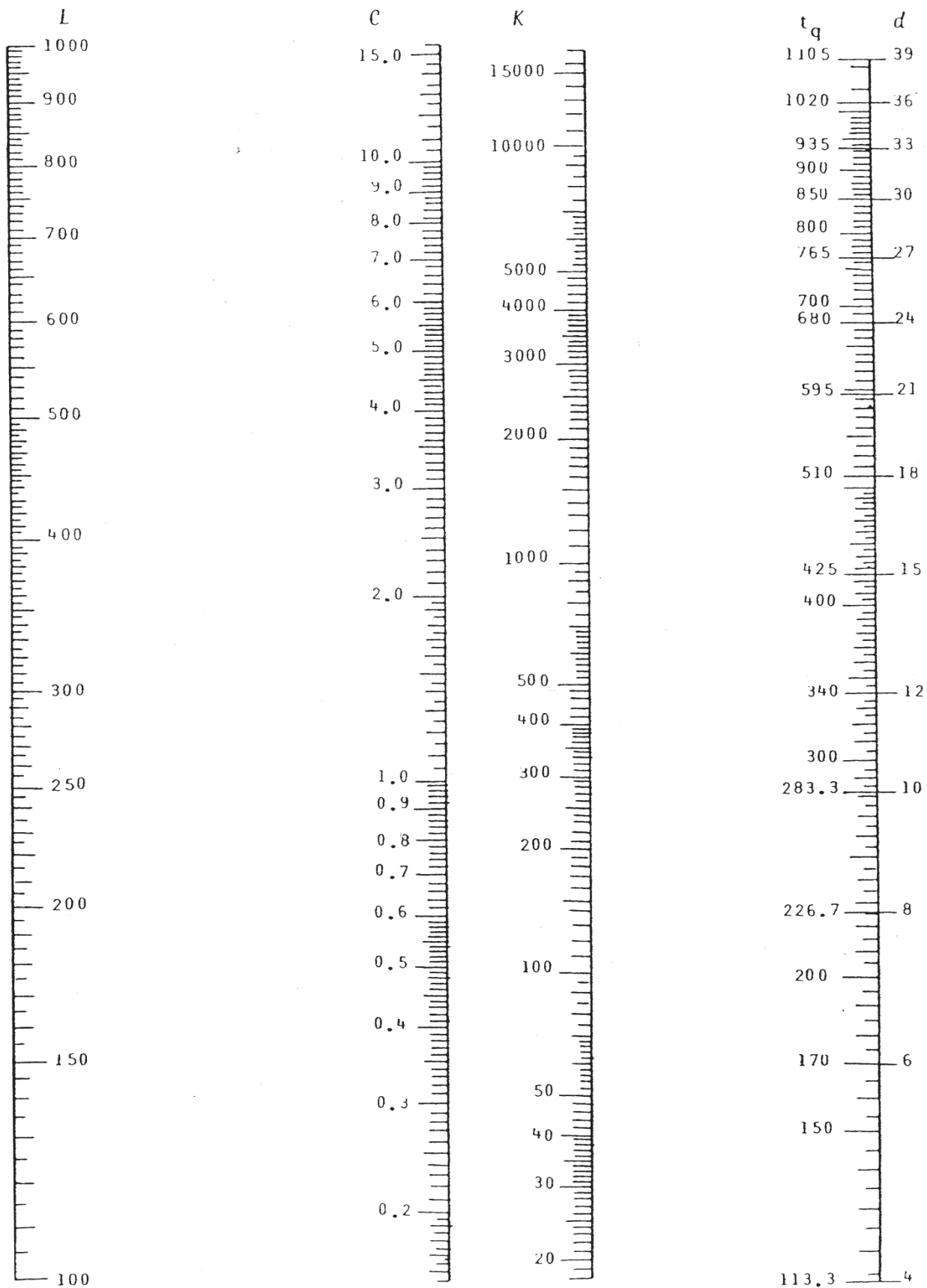

Nomograph for the solution of $K = .011d^2L$, $C = .0003882dL$, $t_q = K \div C$

CITY OF HERMISTON, OREGON
MANDREL TEST RECORD

Witnessed for the City of Hermiston, Oregon, by:

Witness _____ Date _____

Project _____

1. Manhole No. _____ Station No. _____ To Manhole No. _____ Station No. _____
Length _____ Diameter _____ Comments _____

2. Manhole No. _____ Station No. _____ To Manhole No. _____ Station No. _____
Length _____ Diameter _____ Comments _____

3. Manhole No. _____ Station No. _____ To Manhole No. _____ Station No. _____
Length _____ Diameter _____ Comments _____

4. Manhole No. _____ Station No. _____ To Manhole No. _____ Station No. _____
Length _____ Diameter _____ Comments _____

5. Manhole No. _____ Station No. _____ To Manhole No. _____ Station No. _____
Length _____ Diameter _____ Comments _____

6. Manhole No. _____ Station No. _____ To Manhole No. _____ Station No. _____
Length _____ Diameter _____ Comments _____

7. Manhole No. _____ Station No. _____ To Manhole No. _____ Station No. _____
Length _____ Diameter _____ Comments _____

8. Manhole No. _____ Station No. _____ To Manhole No. _____ Station No. _____
Length _____ Diameter _____ Comments _____

CITY OF HERMISTON, OREGON
MANHOLE TEST RECORD

Project Name _____

Contractor _____

Test Company _____

Witnessed By _____

Hydrostatic/Vacuum Test

Test Date	Manhole Station	Paved	Depth	Total Time	Volume Change	Pass	Fail

Witnessed for the City of Hermiston, Oregon, by:

Witness _____ Date _____

TABLE OF CONTENTS

SECTION 4

WATER MAINS

PART 1 - General4-1

1.1 General Design Requirements4-1

1.2 Specifications References4-13

1.3 Delivery, Storage, and Handling4-13

1.4 Materials Furnished by City4-14

PART 2 - Materials.....4-14

2.1 General4-14

2.2 Bedding, Select Backfill, and General Backfill4-15

2.3 Pipe.....4-15

2.4 Fittings for Iron and PVC Pipe4-16

2.5 Valves4-17

2.6 Fire Hydrants4-18

2.7 Combination Air Release Valves4-19

2.8 Service Saddles4-19

2.9 Corporation Stops.....4-19

2.10 Service Line Couplings4-19

2.11 Meter Setters4-20

2.12 Water Meters4-20

2.13 Water Meter Box and Cover4-20

2.14 Locating Wire.....4-20

2.15 Thrust and Anchor Blocks and Concrete Collars4-21

2.16 Water Line Blowoff.....4-21

2.17 Water Marker Post4-21

2.18 Water Utility Markers4-21

PART 3 - Execution4-21

3.1 Trench Excavation4-21

3.2 Existing Utilities4-21

3.3 Installation of Pipe.....4-21

3.4 Thrust and Anchor Blocks4-22

3.5 Locating Wire.....4-23

3.6 Service Connections4-24

3.7 Service Lines4-24

3.8 Service Lines by Boring and Open Trench Methods.....4-25

3.9 Valves and Valve Boxes4-25

3.10 Water Meters4-25

3.11 Fire Hydrants4-26

3.12 Removal of Existing Fire Hydrants4-26

3.13 Water Line Blowoffs4-26

3.14 Water-Sewer Line Crossings4-26

TABLE OF CONTENTS

SECTION 4

WATER MAINS

3.15 Abandoning Water Services.....4-27

3.16 Abandoned Water Lines4-27

3.17 Air Release Valves.....4-27

3.18 Removal and Salvage of Water Main Appurtenances, Fittings, and Other Items4-27

3.19 Testing and Disinfection4-28

3.20 Restoration, Finishing, and Cleanup4-33

Attachments:

Chlorination and Bacteria Testing

Test Worksheet for the Water Lines - Leakage Test

TECHNICAL SPECIFICATIONS

SECTION 4

WATER MAINS

PART 1 - GENERAL

1.1 General Design Requirements

A. Performance Standards

1. Water distribution systems shall be designed to meet Oregon Administrative Rules and guidelines of the Water System Master Plan (WSMP), American Water Works Association (AWWA), and their updates.
2. Water system design shall provide adequate flow for fire protection and maximum water usage and consumption. Required water system demands shall be met by maintaining the minimum operating pressures required by the City. For single-family residential areas the minimum static pressure shall be 50 pounds per square inch (psi), and the minimum fire flow shall be 1,000 gallons per minute (gpm). For all other developments, the required fire pressure flow shall be as determined by the fire chief.
3. Water system design shall meet distribution needs for maximum water usage and consumption within a given service area. New water systems shall be extended to the far side of the property to allow for future extensions beyond present development and to be consistent with the WSMP.
4. All water lines shall be located within the public right-of-way (ROW) or as directed by the City. The City, under special conditions, may allow a public water line to be located within a public water easement as referenced in E. Alignment and Cover, 4. Easements below.
5. Where water lines are constructed on slopes greater than 20 percent; in areas designated as hazardous; where site conditions may cause damage to improvements, slippage, or slides; or as determined by the City, a Geotechnical and/or Engineering Geology Report may be required.
6. Where the finished graded surface is greater than 20 percent, or as required by the City, soil stabilization fabric shall be placed over the entire disturbed area.
7. Drawings relevant to this section are included in the Standard Drawings.

TECHNICAL SPECIFICATIONS

SECTION 4

WATER MAINS

B. Pipe Size

- 1. All public water mains shall be constructed with 8-inch minimum diameter ductile iron pipe.

For more information regarding pipe, see Part 2 - Materials, 2.3 Pipe.

- 2. Service lines shall be as shown on the following table.

Service Line Pipe Size (inches)	Pipe Material
1-inch and Smaller	Type K Copper Tubing
1-1/2-inch and 2-inch	High Density Polyethylene (HDPE)
3-inch and Larger	Ductile Iron

- 3. Water distribution main sizes shall conform to the following:

- a. Four-inch (only with City approval)

- 1) A looped water main utilized on dead-end residential streets (cul-de-sac) with less than 450 feet measured from the center of the street intersection and the radius point of the cul-de-sac with no more than twelve 3/4-inch residential services. The actual number of services will be based on actual flow and pressure available. Fire hydrants are not permitted on 4-inch lines.
- 2) Non-looped water mains may only be used with City approval, when residential zones on dead-end streets are less than 250 feet measured from the center of the intersection street to the radius point of the cul-de-sac with service to no more than 12 residences, and shall be connected to a looped minimum 6-inch main. Fire hydrants are not permitted on 4-inch lines. Dead-end 4-inch lines shall terminate with a standard 2-inch blowoff.

- b. Six-inch (only with City approval)

Minimum size residential subdivision distribution water main for the grid (looped) system and for fire protection, not to exceed an unsupported length of 600 feet and shall not be a permanent dead-end. Looping of the distribution grid shall be at least every 600 feet.

TECHNICAL SPECIFICATIONS

SECTION 4

WATER MAINS

- c. Eight-inch

Minimum size for permanent dead-end mains supplying fire hydrants with a fire flow less than 1,500 gpm and for primary feeder mains in residential subdivisions.

- d. Ten-inch and greater

As required for primary feeder lines in subdivisions, industrial, and commercial areas.

- 4. Water service lines shall conform to the following:

- a. 3/4-inch for residential services.
- b. 1-inch and up for public, commercial, industrial, and other non-residential uses shall be sized per actual usage.

- 5. Velocity in distribution mains shall be designed not to exceed 5 feet per second. Velocity in service lines shall not exceed 10 fps in accordance with H. Water Service Lines below.

C. Grid System

The distribution system mains shall be looped at all possible locations. All developments will be required to extend mains across existing or proposed streets for future extensions by the City or other developments. All terminations shall be planned and located such that new or existing pavement shall not be cut in the future when the main is extended. The installation of dead-end water mains with a length greater than 250 feet, upon which fire protection is dependent, shall not be permitted.

D. Dead-end Mains

Temporary and permanent dead-end mains shall terminate with a standard fire hydrant assembly, unless otherwise approved by the City.

E. Alignment and Cover

- 1. Right-of-Way Location

Water systems shall be located 12 feet south and east from the ROW centerline, except as provided in 4. Easements below or as directed by the City. All abrupt

TECHNICAL SPECIFICATIONS

SECTION 4

WATER MAINS

changes in vertical or horizontal alignment shall be made with a concrete thrust block, a MEGALUG, MJ grip ring, or as required by the City. Curved alignment for water lines or mains is permitted and shall follow the street centerline when practical. The maximum amount of deflection for pipe shall not exceed 80 percent of the recommended maximum deflection specified in AWWA C600.

- 2. Minimum Cover
 - a. The bury depth of water mains within the street ROW or easements shall be 36 to 42 inches from finish grade.
 - b. Deviation from the above standards will be considered on a case-by-case basis when the following exists:
 - 1) When there is underlying rock strata that prohibits placement of the water main 36 inches below finish grade, a written request must be submitted to the City, together with submission of a Geotechnical Report with a plan and profile certifying that bedrock exists less than 3 feet below the undisturbed ground surface.

- 3. Separation with Sewer Lines and Other Utilities
 - a. Vertical and horizontal separation of water, sewer, and other utility lines shall meet all applicable Oregon Department of Environmental Quality requirements.
 - b. Horizontal and vertical separation of water and sanitary sewer lines shall be per the City Standard Drawings. Any exceptions shall be submitted to the City for approval. In all instances, the distances shall be measured edge to edge.
 - c. Water sewer crossings shall meet the requirements of the City Standard Drawings. Any exceptions shall be submitted to the City for approval.
 - d. The minimum spacing between water mains and storm drains, gas lines, and other underground utilities, except sanitary sewers, shall be 3 feet horizontally when the standard utility location cannot be maintained.
 - e. Where water lines are being designed for installation parallel with the other water mains, utility pipe, or conduit lines, the vertical separation

TECHNICAL SPECIFICATIONS

SECTION 4

WATER MAINS

shall be 12 inches below or in such a manner that will permit future side connections of mains, hydrants, or services and avoid conflicts with parallel utilities without abrupt changes in vertical grade of the abovementioned main, hydrant, or service. Where crossing of utilities other than sanitary sewer lines is required, the minimum vertical clearance shall be 6 inches.

- 4. Easements
 - a. Mains placed in easements along a property line shall have easements centered on the property line and shall be offset 3 feet from the property line. For mains placed in easements in locations other than along a property line, the main shall be placed in the center of the easement. Easements shall be exclusive and a minimum of 15 feet in width. The conditions of the easement shall be such that the easement shall not be used for any purpose that would interfere with the unrestricted use for water main purposes. Under no circumstances shall a building or structure be placed over a water main or water main easement. This includes overhanging structures with footings located outside the easement. Further, no trees or large bushes shall be planted in the easement.
 - b. Easement locations for public mains serving a Public Utility District, apartment complex, or commercial/industrial development shall be in parking lots, private drives, or similar open areas, which will permit unobstructed vehicle access for maintenance by City personnel.
 - c. Water mains located within a water main easement will be permanently marked per the City Standard Drawings at all angle points and no less than every 300 feet. In addition, such markers shall be placed where the water line intersects the public ROW at the easement location. A monument cap set in the pavement of a parking lot shall be an acceptable alternative to the marker.
 - d. Easements shall be furnished to the City for review and approval prior to recording.

TECHNICAL SPECIFICATIONS

SECTION 4

WATER MAINS

5. Relation to Watercourses

Pipe constructed per this section shall require the use of restrained pipe joints or approved equal. New water mains may cross over or under existing streams, ponds, rivers, or other waterbodies.

a. Above Water Crossings

The pipe shall be engineered to provide support, anchorage, and protection from freezing and damage, yet shall remain accessible for repair and maintenance. All above water crossings require review and approval by the City.

- 1) Valves shall be provided at each end.
- 2) Air/vacuum relief valves shall be provided.

b. Underwater Crossings

- 1) Mains that cross stream or drainage channels shall be designed to cross as near perpendicular to the channel as possible.
- 2) Valves shall be provided at both ends of the water crossing so that the section can be isolated for testing or repair. The valves shall be easily accessible and not subject to flooding. The valves shall be in valve boxes. Permanent taps shall be made on each side of the valve within the valve box to allow insertion of a small meter for testing to determine leakage and for sampling.
- 3) The minimum cover from the bottom of the streambed or drainage channel to the top of pipe shall be 36 inches.
- 4) A scour pad centered on the water line will be required if the top of the pipe to the bottom of the streambed or drainage channel is 30 inches or less. The scour pad shall be concrete, 6 inches thick and 6 feet wide, reinforced with #4 bars on 12 inch centers in both directions, and shall extend to a point where a 1H:1V slope, that begins at the top of the bank and slopes down from the bank away from channel centerline, intersects the top of the pipe.

TECHNICAL SPECIFICATIONS

SECTION 4

WATER MAINS

- c. The following surface water crossings will be treated on a case-by-case basis:
 - 1) Stream or drainage channel crossing for pipes 12 inches inside diameter and greater.
 - 2) River or creek crossings requiring special approval from the Oregon Department of State Lands.

F. Appurtenances

1. Valves

- a. Valves shall be the same size as the water main. Main line valves shall be resilient, seated gate valves meeting the requirements of AWWA C509. Valves 16 inches and larger shall be butterfly valves.
- b. Distribution system valves shall be located at tee or cross fittings. Valves shall be installed on all branches of a tee or cross fitting. Deviation of this standard will be considered by the City on a case-by-case basis. Spacing of valves shall not exceed 500 feet in commercial or industrial areas and shall not exceed 800 feet in other areas.
- c. Transmission water mains shall have valves at no more than 1,000-foot spacing. Hazardous crossings, such as creek, railroad, and highway crossings, shall be valved on each side.
- d. Distribution tees and crosses with valves for future branch lines on transmission mains may be required as directed by the City.

2. Valve Boxes

Valve boxes shall be as shown on the City Standard Drawings.

3. Blowoff Assemblies

Blowoff assemblies shall be as shown on the City Standard Drawings.

TECHNICAL SPECIFICATIONS

SECTION 4

WATER MAINS

- 4. Fire Hydrant Assemblies
 - a. Fire hydrant assemblies shall be as shown on the City Standard Drawings. See Part 2 - Materials, 2.6 Fire Hydrants below for more information regarding fire hydrant materials.
 - b. Hydrants shall be installed on minimum 8-inch diameter water mains. If the water system is a looped system, hydrants may be installed on minimum 6-inch diameter water mains. The hydrant lead pipe shall be a minimum of 6 inches in diameter.
 - c. All fire hydrants will be located 6 inches behind sidewalks and behind the existing or proposed curb. Hydrants that encroach on private property shall require an easement as directed by the City.
 - d. Hydrants shall not be installed within 5 feet of any existing aboveground utility nor shall any utility install facilities closer than 5 feet from an existing hydrant.
 - e. Full-depth hydrants will be required in all installations. Hydrant extensions require prior approval of the City.
 - f. Hydrants shall not be located within 20 feet of any building, nor will they be blocked by parking. The large hydrant port should face the road or travel way.
 - g. Hydrant guard posts a minimum of 3 feet high shall be required for protection from vehicles when necessary. Such protection shall consist of 4-inch diameter steel pipes 6 feet long filled with concrete and buried at a minimum of 3 feet deep in concrete and located at the corners of a 6 foot square with the hydrant located in the center. Use of posts other than at the four corners may be approved by the City.
 - h. Residential hydrants shall be located as near as possible to the corner of street intersections and not more than 500 feet from cul-de-sac radius points.
 - i. The distribution of hydrants shall be based upon the required average fire flow for the area served. Design coverage shall be as required by the Oregon Fire Code, current edition, and shall be reviewed and approved by the fire chief. Generally design coverage shall result in

TECHNICAL SPECIFICATIONS

SECTION 4

WATER MAINS

hydrant spacing of approximately 500 feet in residential areas, approximately 300 feet in commercial or industrial areas, or as approved by the fire chief and City. In addition, sufficient hydrants shall be available within 1,000 feet of a building in commercial/industrial areas to provide its required fire flow.

- j. The public fire hydrant system shall be designed to provide up to a maximum of 3,500 gpm. The distribution system shall be designed in commercial/industrial areas to accommodate fire flows up to 4,500 gpm or as required by the fire chief. Minimum fire flow in single-family residential areas shall be 1,500 gpm.

5. Fire Hydrant Meters

- a. Fire hydrant meters are required when utilizing fire hydrants as fill stations or when using hydrants as a water source for any other purpose unless otherwise approved by the City.
- b. Fire hydrant meters shall be provided by the City unless otherwise approved by the City. All fees shall be as required by City code and/or ordinance.
- c. The City may monitor all water fill stations to ensure compliance with City, state, and/or federal requirements.
- d. A backflow prevention device or an air gap must be installed on the truck, tank, or hose when filling at hydrant/standpipe locations.

1) Preferred Method

- a) Install a permanent plumbing fixture on the hauling vehicle that creates an air gap between the end of the fill pipe and the tank on the hauling vehicle.
- b) The air gap must be twice the diameter of the inlet pipe (i.e., if the diameter of the fill hose is 2 inches, the air gap must be 4 inches).
- c) Contractor must supply hose with a hydrant thread fitting to connect to the hydrant meter unless otherwise approved by the City.

TECHNICAL SPECIFICATIONS

SECTION 4

WATER MAINS

- 2) Alternate Method
 - a) Install a reduced pressure backflow assembly device either on the hauling vehicle or on the hose between the filling fitting and the tank.
 - b) Contractor must supply hose with a hydrant thread fitting to connect to the hydrant meter unless otherwise approved by the City.
 - c) Each year, arrange and pay for a licensed backflow prevention tester to test the backflow prevention device. City may require proof in the form of a valid test report that certifies that the device is in good working condition.
- e. See City Standard Drawings for additional requirements.
- 6. Pressure Reducing and Air Release Valves
 - a. The City's water distribution system is divided into several pressure zones. Where water systems cross these zone lines, a pressure reducing valve station will be required. The specific design and location for such valves require review and approval by the City.
 - b. Air release valves shall be installed as required per the City Standard Drawings.
- 7. Railroad or Highway Crossings

Such crossings defined above, or as determined by the City, shall be valved on both sides of the crossing. Casing of railroad or highway crossings, if required, shall be as noted in the permit from the respective agency.
- 8. Anchor Blocks

For water pipes greater than 4 inches in diameter, concrete anchor blocks shall be required if the slopes are greater than 20 percent. Anchor blocks shall key into trench sides. Spacing for anchor blocks is as follows:

TECHNICAL SPECIFICATIONS

SECTION 4

WATER MAINS

SPACING FOR ANCHOR BLOCK FOR ALL SIZE PIPE

Slope (Percent)	Minimum Spacing (Feet)
0 to 19.99	No Anchor Required
20 to 34.99	35
35 to 50.99	25
51 or more	15 or Special Design

G. Backflow Prevention

Backflow prevention shall be provided when required by OAR Chapter 333. Backflow prevention shall meet all the requirements of OAR Chapter 333. When backflow prevention is not required per OAR Chapter 333, backflow prevention shall be as shown on the City Standard Drawings for water services.

H. Water Service Lines

1. The sizes of water service lines that may be used are 3/4-, 1-, 1-1/2-, 2-, 4-, 6-, 8-, 10-, and 12-inch. Water service lines will be reviewed for effects on the distribution system and shall not be greater in size than the distribution main.
2. For services larger than 3 inches, a design detail must be submitted showing the vault and fitting requirements. For services 2 inches and larger, the expected flow (normal and maximum daily flow) requirements and proposed usage shall be included on the Plans.
3. Domestic service lines 3/4-inch through 2-inch shall normally extend from the main to behind the curb with a meter setter and meter box located at the termination of the service connection. Meters shall be provided and installed by the City at the cost of the developer. Meter boxes shall be provided by the developer. Individual service connections shall terminate in front of the property to be served and shall be located 2 feet on each side of a common property line.
4. A minimum of one service line and meter are required per property. For multi-family dwellings with two units and for all accessory dwelling units, a separate service line and meter are required for each unit. A single service line and meter shall not provide service to multiple properties. A single service line shall not feed multiple meters. Any deviations from these requirements must be approved by the City.

TECHNICAL SPECIFICATIONS

SECTION 4

WATER MAINS

- 5. Meter boxes and setters and water service lines shall be as shown on the City Standard Drawings.
- 6. Hot taps shall be permitted with prior authorization of the City. The City shall inspect the hot tap, and the coupon removed from the water main shall be relinquished to the City.
- 7. Direct taps are required for 3/4-inch and 1-inch service lines.
- 8. A marker post shall be installed for each service line per the City Standard Drawings.
- 9. All service lines shall be perpendicular to the water main for the entire length of the service line.
- 10. Water service lines from the main line up to and including the water meter are owned by the City.
- 11. Fire Service Lines
 - a. There are three categories of private fire protection systems:
 - 1) Hydrants
 - 2) Fire sprinkler lines
 - 3) Combination hydrant and fire sprinkler lines.
 - b. The water fire service line shall be perpendicular to the water main, shall include an operable valve as close to the water main as possible, and shall terminate with a double detector check valve assembly installed in a vault.
 - c. Where the fire protection system is privately owned, the owner shall own the water fire service line up to the City-owned water main including the valve located adjacent to the water main.
- 12. Fire Vaults

A vault will be required when a development provides fire sprinklers. The vault design drawing shall be included on construction drawings submitted to the City.

TECHNICAL SPECIFICATIONS

SECTION 4

WATER MAINS

The vault shall contain all valves, fittings, meters, and appurtenances required for fire service to the development.

I. System Testing

All new water systems (lines, valves, hydrants, and services) shall be individually pressure tested, chlorinated, and tested for bacteria as shown on the City Standard Drawings. Tests shall be performed in the presence of a City Representative. The City requires notification for scheduling of water main testing a minimum of 72 hours prior to the start of testing.

J. Erosion Control

1. Erosion control will be required for all areas disturbed during construction and following construction until permanent protection is established.
2. Temporary facilities may include silt fences, drain barriers, gravel entries, ditches, surface stabilization or other devices as necessary.
3. Temporary/permanent hydroseeding or acceptable seeding and mulching must be provided whenever perennial cover cannot be established on sites that will be exposed after September 1 or prior to June 1.

1.2 Specifications References

Specification references made herein for manufactured materials such as pipe, valves, and fittings refer to designations for the AWWA, American National Standards Institute, Inc. (ANSI) or to the American Society for Testing and Materials (ASTM) as they are effective on the date of call for Bids.

1.3 Delivery, Storage, and Handling

- A. Adequate precautions shall be taken to prevent damage to piping and protective coatings. During transporting, pipe and other materials shall be secured individually by use of wood spacer blocks, wood crates, or otherwise protected to prevent collision of individual pieces and accompanying damage.
- B. Where possible, all materials furnished by the Contractor shall be delivered and distributed at the Site by the Contractor so that each piece is unloaded opposite or near the place where it is to be placed in the trench.

TECHNICAL SPECIFICATIONS

SECTION 4

WATER MAINS

- C. All pipe, fittings, valves, hydrants, and accessories shall be loaded and unloaded by lifting with hoists or skidding so as to avoid shock or damage. During freezing weather, valves shall be stored to prevent accumulation of water in housing which could freeze and damage valves. Under no circumstances shall materials dropped during handling be installed or be used in the Work.
- D. All pipes, valves, fittings, and all other materials used in the construction of the water lines shall be carefully inspected by the Contractor prior to installation. All defective materials shall be rejected.
- E. Proper materials, tools, and equipment shall be used by the Contractor to provide safe and convenient prosecution of the Work.

1.4 Materials Furnished by City

- A. The Contractor's responsibility for material furnished by the City, if any, shall begin at the point of delivery to the Contractor. Materials already on the Site shall become the Contractor's responsibility on the day of the award of the Contract.
- B. The Contractor shall examine all material furnished by the City at the time and place of delivery and shall separate all defective material.
- C. Any material furnished by the City that becomes damaged by the Contractor shall be replaced by the Contractor at their own expense.
- D. The Contractor shall assume full responsibility for materials furnished by the City once they are received by the Contractor.

PART 2 - MATERIALS

2.1 General

- A. The Contractor shall furnish and install water lines and valves of the size, type, class, and material called for on the Drawings and as specified herein.
- B. Materials and products which come into contact with drinking water supplied by public water systems or which come into contact with drinking water treatment chemicals used by public water systems shall meet the requirements of National Sanitation Foundation Standard 61 Drinking Water System Components - Health Effects (latest version) or equivalent. These materials and products include, but are not limited to, process media, protective materials, joining and sealing materials, pipes and related

TECHNICAL SPECIFICATIONS

SECTION 4

WATER MAINS

products, and mechanical devices used in treatment, transmission, and distribution systems.

2.2 Bedding, Select Backfill, and General Backfill

Bedding, select backfill, and general backfill for storm drain pipelines shall be as required on the City Standard Drawings and Technical Specifications - "Excavation and Grading," Part 2 - Materials, 2.4 Select Backfill and 2.5 General Backfill.

2.3 Pipe

A. Ductile Iron Pipe

- 1. City water mains shall be ductile iron, unless otherwise approved by the City.
- 2. Ductile iron pipe and fittings shall conform to AWWA C150, AWWA C115, AWWA C151, AWWA C153, and AWWA C110 and shall be of the class shown on the following table unless otherwise approved by the City.

Pipe Size (inches)	Minimum Ductile Iron Thickness/Pressure Class
8 and smaller	52
10	51
12	50
14 to 18	Minimum 350
20 and larger	Requires professional engineer

- 3. All ductile iron pipe shall have a bituminous sealed cement mortar lining conforming to AWWA C104 on the interior.
- 4. All joints unless otherwise specified shall be Tyton push-on rubber gaskets or Fastite push-on rubber gaskets conforming to AWWA C111 and shall be furnished complete with all necessary accessories.
 - a. Flanges for couplings and fittings shall conform to ANSI B16.1, 125-pound bolt hole template.
 - b. Mechanical joints shall conform to AWWA C111.
- 5. Where called for on the design drawings, restrained pipe joints shall be per 2.3 Fittings for Iron and PVC Pipe, B. Restrained Pipe Joints and Fittings below.

TECHNICAL SPECIFICATIONS

SECTION 4

WATER MAINS

6. When flanged pipe is required, the Contractor shall provide the D.I. pipe class required by the flange manufacturer to ensure the pipe and flange units are compatible. These data shall be provided to the City for review prior to ordering these materials.

B. HDPE Tubing for Service Lines

HDPE tubing for service lines shall be CTS meeting the requirements of AWWA C901 and ASTM D2239, SDR 7 (PE 4710), rated for 200 psi working pressure. Stainless steel inserts shall be installed at all compression fittings.

C. Copper Pipe for Service Lines

All copper pipe, when required, shall be type K, seamless, soft, annealed conforming to ASTM B88.

2.4 Fittings for Iron and PVC Pipe

A. General

1. Unless specified otherwise, all fittings such as elbows, tees, crosses, valves, etc., shall have mechanical joints conforming to AWWA C111 and shall be short-bodied compact ductile iron fittings conforming to AWWA C153, Class 350.
2. When called for, flanged cast iron fittings shall conform to AWWA C110 with ANSI B16.1, 125-pound bolt hole template.
3. All fittings shall be cement mortar lined in accordance with AWWA C104.
4. Gaskets shall be either ring or full faced, 1/8-inch thick conforming to AWWA C111, Appendix B.

B. Restrained Pipe Joints and Fittings

1. Restrained Push-on Joint Pipe

When restrained joint ductile iron pipe is required, the pipe shall be the same class and type as the ductile iron pipe specified herein. Joints shall be Tyton Joint with Field Lok 350 gaskets or Fastite Joint with Fast-Grip gaskets. The restraint shall be boltless, integral restraining system, rated for 350 psi in accordance with the performance requirements of ANSI/AWWA C111/A21.11.

TECHNICAL SPECIFICATIONS

SECTION 4

WATER MAINS

2. Restrained Fittings

All mechanical joint fittings called out to be restrained shall be equipped with a MEGALUG Series 1100 mechanical joint restraint system as manufactured by EBAA Iron, Inc., or approved equal.

C. Water Main Couplings

1. Water main couplings shall be fabricated steel "Dresser" style couplings, or approved equal, conforming to AWWA C219.
2. The Contractor shall provide the appropriate coupling and gaskets as required to match the water line types and sizes being utilized.
3. Couplings shall be rated for the working pressure of the pipe main for which they will be utilized.

2.5 Valves

A. Gate Valves

1. Gate valves 1-1/2 inches and smaller shall be all bronze, non-rising stem, conforming to Manufacturers Standardization Society (MSS) SP-80, Class A rated for a minimum working pressure of 125 psi.
2. Gate valves 2-inch to 12-inch shall conform to AWWA C509 or C515. Valves shall be designed for 200 psi minimum working pressure and shall be of iron body, resilient wedge, non-rising stem construction. Valves shall be equipped with O-ring type packing. The valve shall have a 2-inch AWWA operating nut for buried service or as called for on the Drawings. The valve ends shall be of the type required to match the pipe to which they will be connected, or as shown on the Drawings. Valves shall have mechanical joint connections, unless called for otherwise on the Drawings. Valves shall be resilient wedge, Kennedy KSRW or KSFV, M&H Style 4067 or 7000, Clow, or equal.

B. Ball Valves

Ball valves 2 inches and smaller shall be three-piece, full port, ASTM A276 GR316 or ASTM A351/A351M GR CF8M stainless steel body and end pieces, Type 316 stainless steel ball, NPT threaded ends, reinforced PTFE seats, seals, and packing, adjustable packing gland, blowout-proof stainless steel stem, stainless steel level operator with

TECHNICAL SPECIFICATIONS

SECTION 4

WATER MAINS

vinyl grip, rated minimum 1,000 psig CWP, and comply with MSS SP-110. Manufacturers and products shall be as called for on the City Standard Drawings.

C. Butterfly Valves

1. All valves 14 inches and greater shall be butterfly valves, unless otherwise approved by the City.
2. All butterfly valves shall be of the rubber-seated tight-closing type that shall meet or exceed the requirements of AWWA C504. All valves shall be M&H 4500, Clow 4500, or approved equal.
3. The valve shall be for direct buried service with a sealed gear operator having 2-inch AWWA operating nut and shall open counter-clockwise.
4. The valve ends shall be of type required to match the pipe to which they will be connected as shown on the design drawings.

D. Cast Iron Valve Box

1. Each valve shall be equipped with an adjustable cast iron box of the sliding type as shown on the City Standard Drawings.
2. The diameter of the valve box shall be not less than 5 inches, and shall be of such length so as to provide the depth of cover over the pipe without full extension.

2.6 Fire Hydrants

- A. Fire hydrants shall conform to AWWA C502 and shall have 5-1/4-inch main valve opening, two 2-1/2-inch NST nozzles and one 4-1/2-inch NST pumper nozzle. Operating nut shall be 1-1/2-inch pentagon. Fire hydrants shall be per the City Standard Drawings.
- B. All hydrants shall have a bury depth of 36 to 42 inches. Where conditions require, hydrant extensions shall be provided and installed to provide the proper placement and installation of the hydrant.
- C. Hydrants shall receive factory coats of Benjamin Moore super spec HP urethane alkyd gloss enamel P22 paint, or approved equal, and shall also receive an additional field coat after installation. Colors shall be 21 Safety Red, 82 Safety Black, 15 Safety Yellow, 4B Safety Green IM-40 as tinted in store at Standard Paint & Flooring, LLC, located in Richland, Washington, or approved equal. The hydrant body shall be yellow. The caps

TECHNICAL SPECIFICATIONS

SECTION 4

WATER MAINS

and bonnet color are dependent upon the water main at the tee to the hydrant as follows:

- 4-inch main = red
- 6-inch main = black
- 8-inch main and larger = green

D. All hydrants shall be of the traffic model type.

2.7 Combination Air Release Valves

Air release valves shall be a combination air and vacuum type as shown on the City Standard Drawings, with an appropriately sized inlet and designed for 150 psi operating pressure. Gaskets shall be specified to accommodate the anticipated working pressure range.

2.8 Service Saddles

- A. Service saddles shall have a ductile iron body, wide stainless steel band, and stainless steel bolts and nuts. Service saddles shall be as shown on the City Standard Drawings.
- B. Saddle sizes and threads shall be AWWA iron pipe thread or compatible with the pipe type and sizes being utilized.
- C. Service saddles are not required for ductile iron pressure class pipe for taps 1-inch and less. Service saddles are required for ductile iron pressure class pipe for taps greater than 1-inch.

2.9 Corporation Stops

- A. Corporation stops shall be brass ball valve stops complying with AWWA C800. Corporation stops shall be Ford ball corp or approved equal.
- B. Inlet threads and outlet connections shall be as required for type and size of water service lines and service saddles being utilized.

2.10 Service Line Couplings

- A. Service line couplings, when approved by the City, shall be Ford Quick Joint couplings or approved equal.

TECHNICAL SPECIFICATIONS

SECTION 4

WATER MAINS

- B. Provide appropriate coupling as required to match water service line types and sizes being utilized. Appropriate stainless steel insert stiffeners shall be used for all PVC pipe and polyethylene tubing.
- C. Where metal pipe of dissimilar type are being connected, an insulating adaptor gasket such as Dresser Style 65, or approved equal, shall be utilized to prevent galvanic corrosion.

2.11 Meter Setters

- A. Meter setters shall be as shown on the City Standard Drawings.
- B. Provide appropriate meter setter heights, sizes, connections, etc., as required for the meter and water service line sizes and types being utilized.

2.12 Water Meters

- A. Water meters shall be manufactured by Badger Meter with ORION cellular endpoints compatible with the City's existing cellular read central system, or approved equal.
- B. Meters larger than 1-1/2 inches shall be compound meters unless shown otherwise on the design drawings.
- C. All meters shall read in gallons.
- D. For new development and redevelopment projects, the City shall purchase and install all meters where meter setters are utilized. When no meter setter is used for larger meters, the City shall purchase the meter and the Contractor shall install the meter. Meters will be installed by the City or provided to the Contractor only after all associated fees and/or charges required by City ordinance(s) have been paid in full.

2.13 Water Meter Box and Cover

Water meter boxes and covers shall be as shown on the City Standard Drawings.

2.14 Locating Wire

- A. Locating wire shall be a minimum of 12 awg UF solid copper with blue colored insulation. The use of THHN wire will not be acceptable. The silicone splice kit shall be King Technology Model 50-566 or approved equal.

TECHNICAL SPECIFICATIONS

SECTION 4

WATER MAINS

- B. Where location wire is to be secured to the exterior of fire hydrants, valve boxes, posts, etc., stainless steel pipe straps shall be used.

2.15 Thrust and Anchor Blocks and Concrete Collars

- A. Concrete used for thrust and anchor blocks, and concrete collars shall be Portland Cement concrete with a 28-day compressive strength of 2,500 psi. Concrete thrust blocks shall cure for 3 to 5 days before hydrostatic or leakage testing of pipelines unless otherwise approved by the City.
- B. Anchor rods shall be 3/4-inch diameter galvanized steel or epoxy coated reinforcement bar conforming to AASHTO M 284, embedded a minimum of 18 inches in the concrete.

2.16 Water Line Blowoff

Water line blowoff shall be as shown on the City Standard Drawings.

2.17 Water Marker Post

Water marker posts shall be as shown on the City Standard Drawings.

2.18 Water Utility Markers

Markers shall be as shown on the City Standard Drawings.

PART 3 - EXECUTION

3.1 Trench Excavation

Trench excavation and backfill shall be performed as specified in the Technical Specifications - "Storm Drainage," Part 3 - Execution, Sections 3.1 through 3.8.

3.2 Existing Utilities

Requirements for existing utilities shall be as specified in Technical Specifications - "Storm Drainage," Part 3 - Execution, 3.9 Existing Utilities.

3.3 Installation of Pipe

- A. Water pipe shall be installed in accordance with best current practices as required by the manufacturer and as specified herein. Ductile iron pipe installation shall conform to the requirements of AWWA C600.

TECHNICAL SPECIFICATIONS

SECTION 4

WATER MAINS

- B. Water pipe shall be installed with bell ends laid facing in the direction of laying unless directed otherwise by the City. Each pipe shall be properly bedded so as to be supported for the full length of the pipe. A suitable foundation shall be achieved by a slight excavation under the bell at each joint. All rubber ring joints shall be lubricated and installed in accordance with the installation instructions of the pipe manufacturer, taking particular care to avoid pinching or otherwise causing damage to the rubber ring. All joints shall be free of dirt and other foreign matter prior to the joining of the next pipe. All joints shall be restrained to prevent creep and misalignment of joints.

- C. Water lines shall be installed to the specified depths called for on the Drawings and to the lines and grades when shown.
 - 1. It shall be recognized that water line depths may vary from the specified depths shown when adjustment of grade is required to avoid conflict with existing utilities.
 - 2. Additional fittings may also be required when a grade adjustment is required.

- D. No pipe shall be installed in water or when conditions exist that, in the opinion of the, are unsuitable for the laying of the pipe.
 - 1. At times when pipe laying is not in progress, the open ends of pipe shall be closed by a watertight plug or other approved means. This provision applies during the noon hour as well as overnight.
 - 2. If there is water in the trench, the seal should remain in place until the trench is dewatered sufficiently to prevent groundwater from entering the pipe. Adequate provisions shall be made by the Contractor for final disposal of the groundwater pumped from trenches.

- E. All pipe shall be installed true to line. The Contractor may install a pipeline on a curve when called for on the Plans or when approved by the City. For rubber gasketed ductile iron pipe installed on a curve, the pipe shall be joined in a straight alignment, then deflected.

3.4 Thrust and Anchor Blocks

- A. Thrust and anchor blocks shall be constructed as shown on the City Standard Drawings and placed at all changes in direction, all changes in the diameter of the pipe, all dead-ends, as specifically shown on the and as required by the City.

TECHNICAL SPECIFICATIONS

SECTION 4

WATER MAINS

- B. All thrust blocks shall be placed between the undisturbed ground and the fitting to be anchored. Plastic sheeting shall be used to provide a bonding barrier between the fittings and the concrete. The quantity of concrete and the area of bearing on the soil shall be as shown on the City Standard Drawings or as approved by the City.
- C. All thrust blocks shall be placed so that the entire pipe and fitting joints will be accessible for repairs. Bolts for mechanical and flange fittings and fire hydrant weep holes shall not be covered with concrete. All bolts shall be accessible and removable without interference from the thrust block.
- D. Thrust blocks may not be required where approved restraint joint pipe and fittings are utilized.
- E. Concrete thrust blocks shall cure for 3 to 5 days before hydrostatic or leakage testing of pipelines unless otherwise approved by the City.
- F. No backfill of thrust blocks shall occur until the Work has been observed by the City Representative.

3.5 Locating Wire

- A. A continuous solid copper locating wire shall be placed along the top of all water pipe, including service lines. This wire shall be secured to the top of the pipe at maximum 10-foot intervals using 6-inch strips of 2-inch wide duct tape. All splices shall be electrically continuous. At all splices, the connecting ends of the wires shall be overlapped and tied. The ends shall be stripped and connected with a wire nut to ensure an electrical connection and made waterproof with an approved silicone splice kit. Access to terminal ends of the locating wire shall be made at all valve boxes, meter boxes, fire hydrants, vaults, etc. The result of this installation shall be a continuous wire circuit electrically isolated from ground.
- B. The Contractor shall be responsible for testing continuity and for testing isolation from ground in the wire after all Work has been completed on the test section. The Contractor is advised to do intermediate testing on their own after backfilling operations and prior to surface restoration work to be sure continuity is maintained. If there is a break or defect in the wire, it shall be the Contractor's responsibility to locate and repair the defect.
- C. The continuity of the location wire shall be tested from one test load point to the next by use of a temporary wire laid between test points in-line with an ohmmeter. Resistance shall be measured with an approved ohmmeter that has been properly

TECHNICAL SPECIFICATIONS

SECTION 4

WATER MAINS

calibrated. The continuity of a test section will be accepted if the resistance of the test section does not exceed 5 ohms per 500 feet of location wire being tested. Isolation from ground shall be measured with a megohmmeter and shall be a minimum of 20 megohms for any section of location wire tested. The City shall witness the acceptance test. The wire and installation shall be included in the water line bid item price. No separate payment shall be made.

3.6 Service Connections

The Contractor shall connect service lines to new or existing water mains as shown on the Plans. This Work includes the installation of a saddle and corporation stop, and making the connection. The Work will include potholing to locate any existing pipeline or service lines as required so the service connection can be performed.

3.7 Service Lines

- A. The installation of new service lines and the connecting of existing service lines shall be performed in accordance with the Plans, manufacturer requirements, and as specified herein. Water service lines shall be laid by placing the pipe on the trench bottom with sufficient slack to prevent pulling apart of the joints when the backfill is placed. Splices shall be kept to an absolute minimum. If required, they shall be made using, Ford Quick Joint couplings or approved equal.
- B. When constructing a new water line to replace an existing line, the existing water line shall remain in service until the new water line has been tested, disinfected, and approved by the City. When possible, the existing line and new line shall both be in operation during the transfer of service lines. The transfer shall be made so that the interruption of water service to the utility customer is held to a minimum. All service lines shall be thoroughly flushed before connecting to existing lines or meters.
- C. The Contractor shall pothole to locate any existing pipelines or service lines as may be required so the service lines can be installed. The Work also includes connecting to the existing service lines when required.
- D. When the Drawings indicate that existing service lines will be utilized, and if the Contractor encounters an existing service line which appears to be in poor or unserviceable condition, the Contractor shall promptly contact the City. If the City determines that a portion of the existing service line needs replacement, the Contractor shall install a new service line.

TECHNICAL SPECIFICATIONS

SECTION 4

WATER MAINS

3.8 Service Lines by Boring and Open Trench Methods

- A. It is the general intent to try to install service lines under paved streets by boring where practical. A pneumatic boring tool or other approved method will be used to install service lines under all paved streets. There may be areas where it is not possible to bore due to ground conditions which interfere in the operation.
 - 1. Where requested by the City, the Contractor shall attempt to bore under paved streets. In areas where it appears that boring will be difficult as determined by the City and the Contractor, the service lines shall be installed by the open trench method. The Contractor shall make two attempts, if required, to bore under paved streets. If the second attempt fails, the Contractor shall install the service line by the open trench method.
- B. The Contractor shall take care to not damage other utilities which might exist in the area. Prior to boring, the Contractor shall pothole to locate existing utilities. "Blind-boring" is not allowed. Repairs for damage to other utilities shall be the responsibility of the Contractor.
- C. Service lines to be installed in areas not under asphalt streets may be installed by either open trenching or boring as the Contractor may elect.

3.9 Valves and Valve Boxes

- A. Valves and valve boxes shall be installed as shown on the City Standard Drawings. All valves and valve boxes shall be set plumb. The valve box shall be centered over the valve operator and free of any obstruction which would prevent operation of the valve nut.
- B. If the bury depth of the valve is greater than 4-1/2 feet, a valve operator extension shall be provided to within 1 foot of finish grade. The extension shall not be permanently attached to the valve operator and a self-centering device shall be provided near the top of the valve operator extension. The box cover shall be flush with the finished grade. A concrete collar, where required, shall be installed.

3.10 Water Meters

Water meters shall be installed by City of Hermiston Water Department personnel.

TECHNICAL SPECIFICATIONS

SECTION 4

WATER MAINS

3.11 Fire Hydrants

- A. Hydrant installation shall conform with AWWA Manual M17 and AWWA C600, and as shown on the City Standard Drawings. Extensions required for hydrant adjustment shall be installed to the manufacturer's specifications.
- B. Hydrants may be installed on new water mains installed as part of the Work, or on existing mains. Special attention shall be given when installing hydrants on existing mains to ensure that adequate thrust restraint is being achieved as the hydrants can be placed in service before normal cast-in-place thrust blocks can achieve the required strength. The block and plug shall be held securely by temporary thrust block or other approved method, such as precast thrust blocks, restraining rods, etc.
- C. The newly installed hydrants shall be covered in a manner acceptable to the City until they are placed into permanent service.

3.12 Removal of Existing Fire Hydrants

- A. All hydrants removed shall remain the property of the City and shall be delivered and properly stacked at a site designated by the City.
- B. After the old hydrant is removed, the lead line, if it is to be abandoned, shall be plugged at the main line tee with a watertight plug and thrust block. When the lead pipe is connected to a water main which is being abandoned, it will not need to be plugged.
- C. The fire hydrant assembly valve and valve box shall be removed and delivered to a location designated by the City.

3.13 Water Line Blowoffs

The 2-inch water line blowoffs shall be constructed as shown on the City Standard Drawings. Unless noted by the City, a fire hydrant shall be installed in lieu of a water line blowoff.

3.14 Water-Sewer Line Crossings

- A. See Technical Specifications - "Sanitary Sewers," Part 3 - Execution, 3.10 Water-Sewer Crossings.
- B. When constructing water service lines, the City may require the depth of the service line to be revised in order to eliminate the need for a water-sewer line crossing.

TECHNICAL SPECIFICATIONS

SECTION 4

WATER MAINS

3.15 Abandoning Water Services

- A. When required, the Contractor shall remove the service line and install a plug in the existing water main when an existing service is to be taken out of service. All plugs are to be permanent and watertight. When required, thrust restraints shall be provided.
- B. Unless specified otherwise, the plugging of an abandoned service line shall be performed at the connection to the water main which is to remain in service. No stubbed service lines shall be left in the ground unless approved otherwise by the City. The Contractor shall excavate and expose the service line connection to be plugged, perform the Work, and backfill as required.

3.16 Abandoned Water Lines

- A. The existing water lines to be taken out of service are to remain in service until the new lines are properly installed and tested, and water services have been connected. Approval from the City shall be obtained before any line is abandoned.
- B. The existing lines shall then be abandoned and their actual location and abandoned designation recorded on all Record Drawings.
- C. Unless called for otherwise, the abandoned lines will remain in the ground. The ends of all pipes which are abandoned shall be plugged with concrete or other methods approved by the City.

3.17 Air Release Valves

Air release valves shall be installed as shown on the City Standard Drawings, and as required by the manufacturer.

3.18 Removal and Salvage of Water Main Appurtenances, Fittings, and Other Items

The Contractor shall remove all existing valves, hydrants, and fittings as required to properly perform the Work, or as shown on the Drawings. All such materials shall be transported to an area designated by the City and stockpiled. Materials shall be removed and handled in such a manner which will prevent damage.

TECHNICAL SPECIFICATIONS

SECTION 4

WATER MAINS

3.19 Testing and Disinfection

A. General

1. All testing and disinfection shall be scheduled 72 hours in advance with City Water Department staff. A City Representative shall observe all steps in the testing and disinfection process.
2. The Contractor shall furnish all necessary equipment and other apparatus, including gauges, necessary to properly perform the testing and disinfection of water lines as specified herein and as shown on the City Standard Drawings. Lines to be tested include mains and service lines. Each section of the lines, before being tested and placed into service, shall be isolated and slowly filled with water. Air should be expelled from the line through hydrants or taps made at the high points. The City shall have the option of requiring the use of their own gauges. Water mains shall be generally tested in sections between valves and as the Work progresses. The Contractor shall be responsible for determining the length, timing, and section of lines to be tested, unless otherwise noted. When appropriate, testing intermediate sections of long lines should be considered. The Contractor shall provide any temporary test heads, fittings, blocking, etc., as may be required to properly test any given water main section. The Contractor shall be responsible for locating and repairing any defects in the water mains that fail to pass the required test.
3. Standard process for fill, flush, disinfection, and pressure testing is four to five business days. This process shall start at the beginning of a typical work week.

B. Acceptance Test

The Contractor shall perform all preliminary testing required to determine that the lines to be tested are acceptable and comply with the requirements of these Technical Specifications. After the Contractor has determined that the lines will pass the required test, the Contractor shall arrange for an acceptance test to be witnessed by the City’s representative. The Contractor shall coordinate the timing of this acceptance test with the City’s representative. The lines will not be accepted until the acceptance test has been witnessed and documented as passing. Forms for performing the various tests are included at the end of this section for use and reference by the Contractor.

TECHNICAL SPECIFICATIONS

SECTION 4

WATER MAINS

C. Hydrostatic Testing of Water Lines

1. Pressure Requirements

The standard test pressure shall be 150 psi for pipes less than 12 inches in diameter and 200 psi for pipes 12 inches or larger in diameter provided that the following maximum and minimum pressure requirements are met. The minimum allowable test pressure shall be 1.5 times the actual work pressure at the lowest elevation along the test section. The maximum allowable pressure shall be the thrust restraint design pressure, or 1.5 times the pressure rating of the pipe or joints, whichever is less. Valves shall not be operated in either direction at a differential pressure exceeding the rated valve working pressure.

2. Test Procedure

Each section of the line, after all backfill and compaction work has been completed and before being placed into service, shall be tested at a minimum average gauge pressure meeting the requirements of this section. Each section of pipeline shall be slowly filled with water to prevent excessive surge pressures when the water reaches the air venting opening(s). All air shall then be expelled completely from the pipeline. If permanent air vents are not located at all high points, corporation stops rated for the specified test pressure shall be installed at these points to expel any air. After all air is vented, any corporation stops and other vents shall be closed. Working pressure shall then be applied using a suitable pump connected to the pipeline. Working pressure shall be maintained for a sufficient period of time for the pipe to stabilize with respect to line movement under pressure, water absorption by the lining, etc. This may require several cycles of pressurizing and bleeding trapped air prior to beginning the test. The specified test pressure shall then be applied and maintained for a minimum two-hour period. The test shall not vary by more than ± 5 psi for the duration of the test. The test pressure shall be maintained by adding makeup water through the pressure test pump into the pipeline. The amount of makeup water added shall be accurately measured in gallons per hour by suitable methods. The amount of makeup water added to maintain the test pressure is equal to the leakage in the test section. Leakage shall not exceed the applicable testing allowance specified in the equation below. Should any test disclose leakage greater than that specified, the Contractor shall locate and repair the defective joints until the leakage is within the specified allowance. Any cracked or defective pipe, joint, or fitting shall be removed and replaced. Any temporary

TECHNICAL SPECIFICATIONS

SECTION 4

WATER MAINS

corp stop used to facilitate the testing procedure shall be removed and the resulting opening plugged with a brass plug.

$$\text{DI Pipe: } L = \frac{SD\sqrt{P}}{148,000}$$

In which:

- L = Allowable Leakage Gal/Hr
- S = Length of Pipe Tested in Ft.
- D = Nominal Diameter in Inches
- P = Gauge Pressure in psi

D. Disinfection of Potable Water Mains

1. Each section of the line, before being placed into service, shall be thoroughly flushed and disinfected in accordance with current regulations of the Oregon Health Authority - Drinking Water Services (DWS), specifically Oregon Administrative Rule, Section 333-061-0050(10) Construction Standards, current edition. For convenience, DWS requirements at the time these Standards were compiled are summarized as follows:

"(10) Disinfection of facilities:

- (a) Following construction or installation of new facilities and repairs to existing facilities, those portions of the facilities which will be in contact with water delivered to users must be cleaned and flushed with potable water and disinfected according to AWWA Standards C651 through C654 before they are placed into service. Disinfection must be by chlorine unless another disinfectant can be demonstrated to be equally effective.
- (b) For construction of new distribution pipelines (with any associated service connections and other appurtenances installed at the time of construction), disinfection by chlorination must be conducted as specified in paragraphs (A) through (C) of this subsection unless another method from AWWA Standard C651 is used.
 - (A) A solution with a free chlorine residual of at least 25 mg/l must be introduced to the pipe such that the solution will contact all surfaces and trapped air will be eliminated. The solution must remain in place for at least 24 hours.

TECHNICAL SPECIFICATIONS

SECTION 4

WATER MAINS

- (B) After 24 hours, if the free chlorine residual is 10 mg/l or greater, the chlorine solution must be drained and the pipe flushed with potable water. If the free chlorine residual is less than 10 mg/l after 24-hours, the pipe must be flushed and rechlorinated until a free chlorine residual of 10 mg/l or more is present after a 24 hour period.

- (C) After the pipe is disinfected, flushed and filled with potable water, bacteriological samples must be collected to determine the procedures' effectiveness. At least two samples must be collected from the new pipe at least 16 hours apart and analyzed for coliform bacteria. If the pipe has held potable water for at least 16 hours before sample collection, two samples may be collected at least 15 minutes apart while the sample tap is left running. If the results of both analyses indicate the water is free of coliform bacteria, the pipe may be put into service. If either sample indicates the presence of coliform bacteria, the pipe may be re-flushed, filled with potable water and re-sampled. If this second set of samples is free of coliform bacteria, the pipe may be put into service, otherwise the disinfection and flushing process must be repeated until samples are free of coliform.

- (c) For repaired pipelines that were depressurized and wholly or partly dewatered during repair or that likely experienced contamination during repair, disinfection according to the procedure specified in paragraphs (10)(b)(A) through (C) of this rule must be followed except that bacteriological samples must be collected downstream of the repair site. If the direction of flow is unknown, samples must be collected on each side of the repair site.

- (d) A water line may be returned to service, following repairs or routine maintenance, prior to receiving a report on the bacteriological analysis if the following procedures have been completed:
 - (A) Customer meters were shut off prior to placing the water line out of service;

 - (B) The area below the water line to be repaired was excavated and dewatered;

TECHNICAL SPECIFICATIONS

SECTION 4

WATER MAINS

- (C) The exposed pipe was treated with a hypochlorite solution;
 - (D) The water line was flushed thoroughly, and a concentration of residual chlorine has been re-established that is comparable to the level normally maintained by the water system, if applicable; and
 - (E) Bacteriological analysis was conducted to verify repair effectiveness according to this section and samples were collected downstream of the repair site or on each side of the repair site if the direction of flow is unknown."
2. Disinfection must be by liquid chlorine unless another disinfectant can be demonstrated to be equally effective. The use of granular, powder, or other types of solid chlorine is not permitted.
 3. When fittings, service lines, or other components of the water system (i.e., fittings used to connect to an existing main) are not disinfected in conjunction with the water mains, the Contractor shall disinfect these items using a 300 mg/L minimum chlorine solution. These items shall be flushed or otherwise coated with the chlorine solution in such a manner that will result in thorough wetting of all surfaces on the inside of these items. These items shall have at least 15 minutes of contact time with the chlorine solution prior to flushing/rinsing and being put into service.
 4. After disinfection, the Contractor shall collect bacteriological samples for testing in the presence of the City. A minimum of two samples shall be taken every 800 feet of water line to be tested. The City may require additional samples to be taken if the section to be tested is complex and proper disinfection could be difficult. The analysis shall be performed by a laboratory certified by the DWS or the EPA. The cost of the bacteriological testing(s) is to be paid by the Contractor. If positive results are obtained, the system shall be disinfected again by the Contractor, at their own expense. Bacteriological samples will again be collected in the presence of the City and resubmitted for testing. This shall be repeated until negative results are obtained. The method of disinfecting and the chlorination materials used are subject to the approval of the City. Disinfection by introducing granular or tablet chlorine compounds in each pipe length is not an acceptable method of disinfection.

TECHNICAL SPECIFICATIONS

SECTION 4

WATER MAINS

- 5. The results of all bacteriological tests shall be submitted to the City and placed in the Operation and Maintenance Manual. No section of pipe shall be placed into service until acceptable bacteriological tests have been obtained.
- 6. Disposal of any water containing chlorine shall be performed in accordance with AWWA C651, Section 4.5.2, and any other local requirements. Disposal may be made into existing sanitary sewer systems providing approvals are obtained from the respective sewerage agency. Any chlorinated water discharged to open stream channels must be dechlorinated prior to discharge.
- 7. Bacteria testing shall conform to the requirements of the City Standard Drawings.

3.20 Restoration, Finishing, and Cleanup

- A. The Contractor shall restore or replace all paved surfaces, graveled surfaces, curbing, sidewalks, trees, shrubbery, lawns, pastures, fences, and other existing facilities equal to their original condition.
- B. All surplus material and temporary structures as well as excess excavation shall be removed and the entire Site of Contractor operations shall be left in a neat and clean condition as outlined in the General Conditions.

END OF SECTION

CHLORINATION AND BACTERIA TESTING

Project Name _____

Date _____ Job No. _____

NEW MAIN IF CONNECTED TO EXISTING MAIN

Day 1 -

- Flush Main
- Chlorine Inject to 50 ppm
- 24-hour Holding Time

Day 2 -

- Verify Chlorine Residual = 10 ppm minimum
- Flush Chlorine to Greater Than 1.0 ppm
- 16- to 24-hour Holding Time

Day 3 -

- City Provides Bac-T Bottles
- Pull Bac-T Samples (City to determine quantity)*
- 24-hour Sample Time

Day 4 -

- Bac-T Results - Positive - Start Over with Day 1 Steps
- Bac-T Results - Negative - Proceed to Pressure Test (see Water Line Leakage Test Form)

NEW MAIN NOT CONNECTED TO EXISTING MAIN

Day 1 -

- Flush Main
- Pressure Test (City to Witness)
- Chlorine Inject to 50 ppm (City to Verify)
- 24-hour Holding Time

Day 2 -

- Verify Chlorine Residual = 10 ppm minimum
- Flush Chlorine to Greater Than 1.0 ppm
- 16- to 24-hour Holding Time

Day 3 -

- Pull Bac-T Sample(s) (City to determine quantity)* (Bottles Provided)
- 24-hour Sample Time

Day 4 -

- Bac-T Results - Positive - Start Over with Day 1 Steps
- Bac-T Results - Negative

*BAC-T SAMPLES ARE NOT PERMITTED ON FRIDAY, SATURDAY, SUNDAY, OR HOLIDAYS

HYDROSTATIC TEST WORKSHEET FOR WATER LINES

Project Name _____

Date _____ Job No. _____

Test Pressure _____

Time Test Started _____

Time Test Completed _____

TOTAL TIME _____ minutes

Test Passed Yes No

$$\text{DI Pipe: } L = \frac{SD\sqrt{P}}{148,000}$$

In which:

- L = Allowable Leakage Gal/Hr
- S = Length of Pipe Tested in Ft.
- D = Nominal Diameter in Inches
- P = Gauge Pressure in psi

Allowable Leakage

<u>Pipe Section</u>	<u>Nominal Diameter</u>	<u>Number of Joints or Connections</u>	<u>Length of Pipe</u>	<u>Allowable Leakage</u>
_____	_____	_____	_____	_____
_____	_____	_____	_____	_____
_____	_____	_____	_____	_____
_____	_____	_____	_____	_____
_____	_____	_____	_____	_____
_____	_____	_____	_____	_____
_____	_____	_____	_____	_____
_____	_____	_____	_____	_____
_____	_____	_____	_____	_____
_____	_____	_____	_____	_____
_____	_____	_____	_____	_____

Total Allowable Leakage _____ gal/hr

Time Test Started _____

Total Leakage Measured _____ gal.

Time Test Completed _____

Total Leakage Measured/Gal= _____ gal/hr

TOTAL TIME _____ mins.

_____ Time (hr.)

Defects Observed: Yes No Test Passed: Yes No

Contractor's Firm Name: _____

Contractor's Representative Signature _____

City's Representative Signature _____

Hydrostatic Testing Allowance per 1,000 feet of Pipeline*, gallons per hour**

Average Test Pressure, psi	Nominal Pipe Diameter, inches																	
	3	4	6	8	10	12	14	16	18	20	24	30	36	42	48	54	60	64
450	0.43	0.57	0.86	1.15	1.43	1.72	2.01	2.29	2.58	2.87	3.44	4.30	5.16	6.02	6.88	7.74	8.60	9.17
400	0.41	0.54	0.81	1.08	1.35	1.62	1.89	2.16	2.43	2.70	3.24	4.05	4.86	5.68	6.49	7.30	8.11	8.65
350	0.38	0.51	0.76	1.01	1.26	1.52	1.77	2.02	2.28	2.53	3.03	3.79	4.55	5.31	6.07	6.83	7.58	8.09
300	0.35	0.47	0.70	0.94	1.17	1.40	1.64	1.87	2.11	2.34	2.81	3.51	4.21	4.92	5.62	6.32	7.02	7.49
275	0.34	0.45	0.67	0.90	1.12	1.34	1.57	1.79	2.02	2.24	2.69	3.36	4.03	4.71	5.38	6.05	6.72	7.17
250	0.32	0.43	0.64	0.85	1.07	1.28	1.50	1.71	1.92	2.14	2.56	3.21	3.85	4.49	5.13	5.77	6.41	6.84
225	0.30	0.41	0.61	0.81	1.01	1.22	1.42	1.62	1.82	2.03	2.43	3.04	3.65	4.26	4.86	5.47	6.08	6.49
200	0.29	0.38	0.57	0.76	0.96	1.15	1.34	1.53	1.72	1.91	2.29	2.87	3.44	4.01	4.59	5.16	5.73	6.12
175	0.27	0.36	0.54	0.72	0.89	1.07	1.25	1.43	1.61	1.79	2.15	2.68	3.22	3.75	4.29	4.83	5.36	5.72
150	0.25	0.33	0.50	0.66	0.83	0.99	1.16	1.32	1.49	1.66	1.99	2.48	2.98	3.48	3.97	4.47	4.97	5.30
125	0.23	0.30	0.45	0.60	0.76	0.91	1.06	1.21	1.36	1.51	1.81	2.27	2.72	3.17	3.63	4.08	4.53	4.83
100	0.20	0.27	0.41	0.54	0.68	0.81	0.95	1.08	1.22	1.35	1.62	2.03	2.43	2.84	3.24	3.65	4.05	4.32

*If the pipeline under test contains sections of various diameters, the testing allowance will be the sum of the testing allowance for each size.

**Evaluated on the basis of equation $L=(SDVP)/148,000$. Tabulated values must be multiplied by the test duration in hours to determine maximum allowable leakage volume in gallons.

psi = pounds per square inch

TABLE OF CONTENTS

SECTION 5

STREETS

PART 1 - General5-1

 1.1 General Design Requirements5-1

 1.2 Definitions5-19

PART 2 - Materials.....5-20

 2.1 Water for Compaction.....5-20

 2.2 Geotextile Fabric5-20

 2.3 Aggregate Base.....5-20

 2.4 Soil Sterilant5-21

 2.5 Paving Fabric5-21

 2.6 Asphalt Tack Coat5-21

 2.7 Asphalt Concrete Pavement5-22

 2.8 Asphalt Fog Seal5-23

 2.9 Street Monument Boxes.....5-23

 2.10 Concrete Characteristics.....5-23

 2.11 Portland Cement5-23

 2.12 Aggregates.....5-24

 2.13 Water5-25

 2.14 Admixtures5-25

 2.15 Pre-molded Joint Filler.....5-25

 2.16 Truncated Dome Detectable Warning Texture5-26

 2.17 Pavement Striping and Markings (General).....5-26

 2.18 Signs5-26

 2.19 Sign Posts.....5-26

PART 3 - Execution5-26

 3.1 Earthwork.....5-26

 3.2 Geotextile Fabric5-29

 3.3 Aggregate Base.....5-29

 3.4 Soil Sterilant5-30

 3.5 Pre-paving Conference5-30

 3.6 Overlay Preparation5-31

 3.7 Asphalt Concrete Pavement5-34

 3.8 Adjustment of Utility Covers to Grade.....5-36

 3.9 Asphalt Fog Seal5-36

 3.10 Street Monument Boxes.....5-37

 3.11 Restoration, Finishing, and Cleanup5-37

 3.12 Concrete Forms5-37

 3.13 Concrete General Placement and Finishing.....5-37

 3.14 Curing5-38

 3.15 Restrictions Due to Weather5-39

TABLE OF CONTENTS

SECTION 5

STREETS

3.16 Backfill5-40

3.17 Curb and Curb and Gutter5-40

3.18 Sidewalk, Driveway, and Alley Approaches5-42

3.19 Steps5-43

3.20 Reinforcing Bars.....5-44

3.21 Truncated Dome Detectable Warning Texture5-44

3.22 ADA Requirements5-44

3.23 Testing and Inspection.....5-44

3.24 Signs and Sign Posts.....5-45

3.25 Pavement Markings.....5-46

3.26 Pavement Striping5-48

3.27 Public Safety and Convenience5-49

3.28 Disposal of Waste5-50

3.29 Removal or Repair of Unacceptable Work.....5-50

3.30 Paint Markings and Striping Warranty.....5-50

TECHNICAL SPECIFICATIONS

SECTION 5

STREETS

PART 1 - GENERAL

1.1 General Design Requirements

A. Performance Standards

1. All street designs shall provide for the safe and efficient travel of the motoring public. Streets shall be designed to carry the recommended traffic volumes identified for each street classification.
2. Streets shall be designed to meet or exceed minimum guidelines in accordance with the current AASHTO, "Policy on Geometric Design of Highways and Streets." Traffic control and traffic control devices (TCD) shall conform with the current Federal Highway Administration "Manual on Uniform Traffic Control Devices for Streets and Highways," and Oregon Department of Transportation (ODOT)/ APWA supplements.
3. All vertical and horizontal curves shall meet AASHTO design speed and street classification guidelines. Where practical, the design engineer shall provide the desirable stopping sight distance set forth in AASHTO, but in no case shall it be less than the minimum stopping sight distance.
4. Drawings relevant to this section are included in the Standard Drawings.

B. Right-of-Way and Pavement Width

Right-of-way (ROW) and pavement widths for each street classification shall be as shown on the City Standard Drawings.

C. Access

All developments shall be provided public street access. Public and/or private access roads, approaches, and easements shall be as set forth in other sections of these Public Works Standards, Technical Specifications, and Standard Drawings.

D. Traffic Analysis

1. The City will require a Traffic Impact Analysis (TIA) as determined by the type of development and its potential impact to existing street systems. A TIA may be required for a development when:

TECHNICAL SPECIFICATIONS

SECTION 5

STREETS

- a. it will generate 1,000 vehicle trips per weekday or more, or
 - b. its location, proposed site plan, and traffic characteristics could affect traffic safety, access management, street capacity, or known traffic problems or deficiencies in a development's study area.
2. The TIA shall be prepared by a professional engineer licensed in the State of Oregon who specializes in traffic engineering. At a minimum, the TIA shall contain the following:
- a. Purpose of TIA and Study Objectives
 - 1) A discussion of key traffic issues to be addressed and the transportation system and development objectives related to a specific development.
 - 2) General transportation system objectives are:
 - a) to maintain safe and efficient traffic flow on surrounding street system;
 - b) to provide safe and effective transfer of vehicular traffic between the site and the street system, providing a convenient, safe, and efficient on-site and off-site movement of private, service, and delivery vehicles, pedestrians, transit and bicycles; and
 - c) to effectively mitigate adverse site-generated traffic impacts on affected streets and intersections. Site-specific objectives may be established by the City for each study and report.
 - b. Executive Summary

A concise summary of the study purpose/objectives, site location and study area, development description, key assumptions, findings, conclusions, and recommendations.
 - c. Description of Site and Study Area Roadways
 - 1) A description of the site, study area, existing traffic conditions in the study area, anticipated nearby development, and committed

TECHNICAL SPECIFICATIONS

SECTION 5

STREETS

roadway improvements that would affect future traffic in the study area.

- 2) The study area will be defined as all roads, ramps, and intersections through which peak hour site traffic composes at least 5 percent of the existing capacity of an intersection approach, or roadway sections on which accident character or residential traffic character is expected to be significantly impacted.

d. On-site Traffic Evaluation

An evaluation of the proposed (and alternative) site access locations, the adequacy of access depth, number of lanes, queuing storage, safety, and efficiency of proposed vehicular circulation, parking layout, pedestrians, service vehicle routes/facilities, together with recommendations for on-site traffic markings and controls.

e. Technical Appendix

A technical appendix including worksheets, charts, traffic count, and drawings to support findings as described in the body of the report.

f. Recommendations for Public Improvements

- 1) Recommendations should be made for external roadway improvements, such as additional through and turn lanes, and TCD necessitated as a result of the development. Recommended improvements to transit facilities, pedestrian, and bicycle circulation should also be reported.
- 2) The recommendations should specify the time period within which improvements should be made, particularly if improvements are associated with a phased development; the estimated cost of improvements; and any monitoring of operating conditions and improvements that may be needed. If needed street improvements, unrelated to the development, are identified during the analysis, such improvements shall be reported.

TECHNICAL SPECIFICATIONS

SECTION 5

STREETS

- g. Access Management
 - 1) On sites with arterial and collector street frontages, the report shall evaluate and recommend the use of access management plans or techniques:
 - 2) To separate basic conflict areas: Reduce the number of approaches or increase spacing between approaches and intersections.
 - 3) To remove turning vehicles or queues from the through lanes (reduce both the frequency and severity of conflicts by providing separate paths and storage areas for turning vehicles and queues): Techniques may include turn restrictions, striping, medians, frontage roads, channelizing of lanes or approaches, shared approaches, access between similar uses, access consolidation, lanes for left or right turns, and other transportation system management actions.
- h. A review of alternative access points for site access to highways, city streets, and county roads.
- i. The analysis of alternate access proposals should include:
 - 1) Existing daily and p.m. peak hour counts, by traffic movements, at intersections affected by generated traffic from the development. (Use traffic flow diagrams).
 - 2) Projected daily and p.m. peak hour volumes for the same intersections and proposed access points when the development is in full service. (Use traffic flow diagrams.)
 - 3) A determination of the existing levels of service and projected levels of service at each intersection and access points studied.
 - 4) A discussion of the need for traffic signals. This should include a traffic warrant computation based on the "Manual on Uniform Traffic Control Devices."
 - a) The recommendations made in the TIA should be specific and should be based on a minimum level of service when the development is in full service. As an example, if a

TECHNICAL SPECIFICATIONS

SECTION 5

STREETS

traffic signal is recommended, the recommendation should include the type of traffic signal control and what movements should be signalized. If a storage lane for right turn or left turn is needed, the recommendation should include the amount of storage needed. If several intersections are involved for signalization and an interconnect system is considered, specific analysis should be made concerning progression of traffic between intersections.

- b) The TIA should include a discussion of bicycle and pedestrian usage and the facilities provided along with the availability of mass transit to serve the development, if appropriate.

E. Intersections

1. Connecting Street Intersections

Connecting street intersections shall be located to provide for traffic flow, safety, and turning movements, as conditions warrant. Minimum flow line slope from tangent to tangent at all intersection corners shall not exceed 2 percent unless otherwise approved by the City.

2. Arterial Intersections

- a. Exclusive left and right turn lanes shall be provided.
- b. Bus turnouts shall be provided if traffic flow and safety conditions warrant.
- c. Designated crosswalks shall be provided at controlled locations.
- d. Street alignments across intersections shall be continuous.

3. Collector and Local Street Intersections

- a. Street and intersection alignments should facilitate local circulation but avoid alignments that encourage non-local through traffic.
- b. Streets shall be aligned to intersect at right angles, 90°. Angles of less than 75° will not be permitted.

TECHNICAL SPECIFICATIONS

SECTION 5

STREETS

- c. Intersection of more than two streets at one point will not be permitted.
- d. New streets shall intersect with existing street intersections so that centerlines are not offset, except as provided below. Where existing streets adjacent to a proposed development do not align properly, conditions may warrant the development to provide the proper alignment.
- e. For intersections that are not directly aligned, the minimum separation distance shall be as follows:

Street Class	Intersection Spacing (feet)
Arterial	500*
Collector	400*
Local	300*
Cul-de-sac	150

* The City may permit a minimum intersection spacing of not less than 300 feet for Arterial, and 200 feet for Collector/Local, when findings establish that:

- a. without the change, there could be no public street access from the parcel(s) to the existing street, and
- b. all other provisions of the street design requirements can be met.

F. Half-Street Construction

Half-street design is generally not acceptable. Where such a street is justified, the ROW and pavement width shall be approved by the City. In no case shall the pavement width required be less than that required to provide two lanes of traffic to pass at a safe distance. For a 36-foot local street, the half-street pavement width shall be 20 feet. Half-streets shall be approved only when the abutting or opposite frontage property is undeveloped and the full improvement will be provided with development of the abutting or opposite (upon ROW dedication) frontage property.

Half-street improvements shall include curb, sidewalk, and storm drainage on one side of the street. When a half-street improvement is required, the entire street shall be designed.

TECHNICAL SPECIFICATIONS

SECTION 5

STREETS

A development on an unimproved street shall be responsible for constructing a continuous City standard street to a connection with the nearest standard (publicly maintained) street.

G. Street Classification

1. All streets within the City shall be classified in accordance with the City of Hermiston Transportation System Plan, current edition.
2. Any street not classified in the Hermiston Transportation System Plan, current edition, shall be determined by the City.

H. Design Speed

Design speeds for classified streets shall be 25 miles per hour unless a speed study is performed by the developer and the City reviews the study and approves the change. The City may require the developer to perform a speed study when, in the opinion of the City, the speed limit should be greater than 25 miles per hour.

I. Horizontal Curves

Horizontal curve radius (on centerline) for each street classification shall be designed according to the roadway design speed. The radius shall not be less than the following:

Classification	Feet
Arterial	415 to 830
Collector	275 to 600
Local	165
Cul-de-sac	165

J. Vertical Curves

1. Vertical curve lengths shall be based on design criteria which includes:
 - a. design speed,
 - b. crest vertical curve, and
 - c. sag vertical curve.
2. Stopping sight distance for crest and sag vertical curves shall be based on sight distance and headlight sight distance, respectively.

TECHNICAL SPECIFICATIONS

SECTION 5

STREETS

- 3. All vertical curves shall be parabolic, and the length shall be computed for each location.

K. Grades

- 1. Maximum grades for each street classification shall be as follows:

Classification	Feet per Foot (ft/ft)*
Arterial	0.06
Collector	0.08
Local	0.08
Cul-de-sac	0.08

**All street grades shall not exceed 3 percent within 30 feet of the edge of an intersection.*

- 2. The City may approve a grade greater than those specified when all of the following conditions exist:
 - a. Topographic constraints do not allow the development to be served by a street with a maximum grade of 8 percent without causing destabilization of soils by excessive cuts and fills.
 - b. There is no access to the property being developed through adjacent properties at a maximum 8 percent grade.
 - c. The section of local street will not exceed a combination of length, horizontal alignment, and/or grades exceeding 8 percent that will create hazardous traffic conditions.
 - d. In no case shall the maximum street grade exceed 16 percent.
- 3. Minimum design grade for all streets shall be 0.007 ft/ft (0.70 percent). Minimum constructed grade for all streets shall be 0.005 ft/ft (0.50 percent); however, in all cases, street grades shall allow for proper and adequate drainage.
- 4. Design street cross slope shall per the City Standard Drawings.

L. Pavement Design

- 1. In general, all streets shall be constructed with asphalt concrete pavement (ACP) unless otherwise approved by the City.

TECHNICAL SPECIFICATIONS

SECTION 5

STREETS

- 2. Typical flexible pavement sections shall be as shown on the City Standard Drawings per street classification.
- 3. The design engineer will provide a street structural design section for all roadways classified collector and higher and local streets in Industrial zones. A pavement section structural number shall be provided to confirm or revise the pavement section when the Geotechnical Report indicates poor soil.

M. Concrete Curb

- 1. All development projects are required to construct street improvements with concrete curbs. Curb and gutter shall be used on streets classified Arterial, Collector, and Local. Joint spacing in curbs shall be in accordance with the City Standard Drawings. Ribbon concrete curb shall be used on all streets classified as Urban Local Street with Swale.
- 2. Curb Return Radius
 - a. Curb return radius at street intersections shall be designed to accommodate all expected traffic. Minimum curb radius required shall be as follows:

Intersection	Radius (feet)
Local/Cul-de-sac with Local/Cul-de-sac	25
Local/Cul-de-sac with Collector /Arterial	35
Collector/Arterial with Collector/Arterial	35

- b. A larger curb radius may be required on streets serving commercial/ industrial properties or anywhere where truck traffic should reasonably be expected. The design engineer shall determine if a larger curb radius is necessary and shall provide drawings with vehicle turning movements to the City that demonstrate the design truck can navigate the turn without leaving their lane.

TECHNICAL SPECIFICATIONS

SECTION 5

STREETS

N. Parking

1. For streets designated Collector and below, the City may consider design modifications to conserve major trees in the public ROW. Parking lanes may be removed on one or on both sides of a street subject to approval by the City.
2. All parking areas shall have durable, dust free surfacing of ACP, Portland cement concrete, or other approved materials.
3. The design pavement section shall conform to the use and the Geotechnical Report.
4. All parking areas, including those in conjunction with a single-family or two-family dwelling shall be graded so as not to drain stormwater over the public sidewalk or onto any abutting public or private property.
5. Parking space dimensions shall be a minimum of 9 feet wide by 20 feet deep unless otherwise approved by the City.
6. All required handicap parking spaces shall conform to Oregon Revised Statutes 447.210 to 447.310 and the current edition of the Standards for Accessible Parking Places as published by ODOT.

O. Sidewalks

1. In general, new sidewalks are required for all development requiring a development permit.
2. New sidewalks shall have a minimum width of 5 feet, not including the curb width. Sidewalks may be required to meander within the dedicated ROW and/or outside of the ROW within an easement.
3. For streets designated Collector and below, the City may consider design modifications to conserve major trees in the public ROW. Sidewalks may be omitted on one side of a street when approved by the City.
4. Americans with Disabilities Act (ADA) Requirements
 - a. At intersections, each corner radius shall include ADA ramps. ADA ramps shall also be included at marked crossings. ADA ramps shall be in accordance with the City Standard Drawings.

TECHNICAL SPECIFICATIONS

SECTION 5

STREETS

- b. Locations of sidewalk ramps shall be designed with regard to stormwater flows, street grades, and pole locations. Other factors may also dictate sidewalk ramp locations.
- c. When development triggering public improvements occurs, all existing sidewalk and/or ramps not complying with current ADA requirements shall be brought into compliance.

P. Bikeways

- 1. These design standards summarize the City's policy and implementation strategies for bikeways within the City and for connection with metropolitan bikeways. The City's plan has adopted both AASHTO and ODOT/APWA standards and criteria as the minimum guidelines for bikeway design and construction.
- 2. The City's adopted guidelines for bikeways consist of the following:
 - a. Guide for Development of New Bicycle Facilities, 1981.
 - b. AASHTO, Oregon Supplements and Exceptions to AASHTO Guide.
 - c. Manual on Uniform Traffic Control Devices with Oregon supplements by the Oregon Transportation Commission.
- 3. Location and Width
 - a. For on-street bike lanes, see the City Standard Drawings.
 - b. See the table below for off-street bike lanes.

Bikeway Location	Minimum Width (feet)	Comments
Off-Street Bicycle Path	5 *	One-Way Travel Off-Street
Bicycle Path	10 *	Two-Way Travel Off-Street

* Paths are constructed with 2-foot gravel shoulders on both sides unless otherwise approved by the City.

- 4. Design Criteria
 - a. All bikeways shall have a minimum cross slope 2.5 percent and a maximum cross slope of 5 percent. On curved alignments, the cross slope shall be to the inside of the curve.

TECHNICAL SPECIFICATIONS

SECTION 5

STREETS

- b. Bikeway curvature shall be based on a minimum design speed of 20 MPH. Bikeway grades shall be limited to a maximum of 5 percent. Where topography dictates, grades over 5 percent are acceptable when a higher design speed is used and additional width is provided.
 - c. Where bikeways are shared with pedestrians, all ADA design criteria shall apply.
5. Construction
- a. Off-street bikeways shall be constructed for two situations: where limited City maintenance vehicle use will occur, and where heavy City maintenance vehicle use will occur. In both cases, subgrade preparation will require removal of existing organic material and compaction.

Use	ACP	Aggregate Base
Limited	2.5 inches	6 inches
Heavy	3 inches	9 inches

- b. When drainage, such as side ditches, is required parallel with the bikeway, the ditch centerline shall be at least 5 feet from the edge of the pavement. Ditch side slope adjacent to a bikeway shall be no steeper than 2H:1V when measuring the horizontal distance to the vertical distance.
- c. When culverts cross bikeways, the ends of the pipe shall be no closer than 5 feet from the edge of the bikeway.

6. Lighting

Lighting should be included in the bikeway design when nighttime security could be a problem and a high nighttime use is expected (i.e., paths serving students, commuters). The horizontal illumination levels shall be 0.05 foot-candle (5 lux) to 2 foot-candles (22 lux) except when security problems exist; higher illumination levels should be considered in these locations. The placement of the light standards (poles) shall meet all vertical and horizontal clearances.

7. Deterring Motor Vehicle Use

- a. Bikeways intersecting with roadways require physical barriers to deter use by unauthorized motor vehicles. Lockable, removable posts may be used to discourage such use and still permit authorized vehicles to access

TECHNICAL SPECIFICATIONS

SECTION 5

STREETS

the bikeways. Posts shall be brilliantly colored and permanently reflectorized. If more than one post is required, the spacing shall not exceed a separation of more than 5 feet.

- b. An alternative to deterring motor vehicles is to design two 5-foot wide lanes separated by low landscaping at the intersection.

Q. Driveways

1. Access to private property shall be permitted with the use of approach curb cuts (driveways). The access points with the street shall be the minimum necessary to provide access while not inhibiting the safe circulation and carrying capacity of the street.
2. On Collector streets and above, one driveway per site frontage will be the normal maximum number. Double frontage lots and corner lots on these streets may be limited to access from a single street, usually the lower classification street. If additional driveways on a frontage are approved by the City, a finding shall be made that no eminent traffic hazard would result and impacts on through traffic would be minimal. Restrictions may be imposed on additional driveways, such as limited turn movements, shared access between uses, closure of existing driveways, or other access management actions.
3. Driveway types shall be per the City Standard Drawings.
4. The City Standard Drawings show permitted driveway widths. Minimum distances from a driveway to radius curb return and number allowed are shown below.

Street Classification	Minimum Distance from Approach to Radius Curb
Major and Minor Arterial ^a	250 ^b
Major Collector ^a	150
Minor Collector ^a	100
Local Street	50 ^c

Notes:

^aDirect access to this street will not be allowed if an alternative exists or is planned.

^bMinimum distance from curb return unless this prohibits access to the site.

^c25 feet will be allowed for corner lots with limited frontage where distance requirements cannot be met.

5. For classification of Collector and above, approaches adjacent to street intersections shall be located beyond the required queue length for traffic

TECHNICAL SPECIFICATIONS

SECTION 5

STREETS

movements at the intersection. If this requirement prohibits access to the site, an approach with restricted turn movements may be allowed.

- 6. Within commercial, industrial, and multi-family areas shared approaches and internal access between similar uses are encouraged to reduce the access points to the higher classified roadways, to improve internal site circulation, and to reduce local trips or movements on the street system. Shared approaches or internal access between uses will be established by means of common access easements at the time of development.
- 7. Approach grades shall not exceed 12 percent from the curb line to the property line.

R. Street Lighting, Names, and Signage

1. Street Lighting

- a. A complete streetlighting system shall be the responsibility of the development. All streets fronting the property shall be provided with adequate lighting. Developer is required to provide lighting for public convenience and safety. For lighting requirements, all developments will be required to submit three copies of the final plat (residential and major land partitions) to the City. Commercial and industrial developments, in addition to the above requirement, shall submit three copies of the site plan to the City.
- b. Streetlighting shall be provided as part of the street design process. Design illumination levels shall be in accordance with the recommendations of the "Illuminating Engineering Society" and are summarized on the following table.

**Recommendations for Roadway Average Maintained
Horizontal Illumination (Foot-Candles)**

Street Classification	Commercial	Urban Intermediate	Residential
Highway	1.4	1.2	1.0
Arterial	2.0	1.4	1.0
Collector	1.2	0.9	0.6
Local/Cul-de-sac	-	0.9	0.6

TECHNICAL SPECIFICATIONS

SECTION 5

STREETS

- c. The average-to-minimum uniformity ratios for roadways in commercial and intermediate areas shall be 4H:1V or better. In residential areas this uniformity ratio shall be 6H:1V or better.
- d. The streetlighting system shall be provided using high pressure sodium vapor luminaries. The design average horizontal illumination and uniformity ratio shall be obtained by considering together the factors of lamp wattage, pole support spacing, maintaining height and luminaire of the streetlights to locate poles at lot line extensions and not in the middle of a lot, and to locate poles at corners.

2. Street Names and Traffic Control

- a. Street names for all new developments will be approved by the City prior to recording of any maps or plats. The developments shall pay for all street name and traffic control signage prior to the signing of the final plat or map by the City. All new signage will be provided and installed by the developer.
- b. Street names shall conform with the established grid system(s) in the City and its urban growth boundary (UGB). No new street name shall be used that will duplicate or be confused with the name of existing streets in the UGB area.
- c. Building numbering will be issued by the City.

S. Mailboxes

- 1. Joint mailbox facilities shall be provided in all residential developments, with each joint mailbox serving at least two dwelling units.
- 2. Joint mailbox structures shall be placed adjacent to roadway curbs.
- 3. Proposed locations of joint mailboxes shall be designated as part of the development plan and shall be approved by the U.S. Postal Service.
- 4. Plans for the joint mailbox structure to be used shall be submitted as part of the development plan for approval by the U.S. Postal Service.

TECHNICAL SPECIFICATIONS

SECTION 5

STREETS

T. Street System Description and Function

1. General Guidelines

The UGB map, policies, and access requirements for various land uses, as adopted by the Comprehensive Plan and Zoning Ordinance, shall serve as guidelines for the functional classifications, definitions, and standards requirements and rules adopted under these Public Works Standards, Technical Specifications, and Standard Drawings.

2. Functional Classifications

a. Functional classifications categorize roads and streets by their operational purpose. Some of the key factors considered when adopting the functional classifications are the following:

- 1) Relation between street traffic and land use of the abutting properties.
- 2) Volume and kinds of traffic.
- 3) Relative origins and destinations of traffic and lengths of trips.

b. The basic hierarchy of functional classifications are Arterial, Collector, and Local/Cul-de-sac streets. These categories are defined as follows:

1) Arterial Streets

Arterial streets carry higher volumes of traffic, usually more than 4,000 vehicles per day, and generally consist of three or more lanes, with the third lane being a common turn lane. Their function is to serve intra-county trips, that is, trips that have at least one end trip within the county.

2) Collector Streets

Collector streets gather area traffic from local streets within a 1/2-mile radius and connect it to the arterial system. They are not intended to serve through traffic and are the lowest order of streets designed to carry transient vehicles. Collector streets generally have a traffic volume rate of 1,000 to 4,000 vehicles per day. Abutting land uses are generally residential.

TECHNICAL SPECIFICATIONS

SECTION 5

STREETS

3) Local Streets

Local streets provide access to abutting property and do not serve to move through traffic. Local street standards will be further categorized by adjacent land use into residential, commercial, and industrial local streets.

4) Local Streets (Commercial/Industrial)

Within the local street classification, there may be considerable difference between the kind of improvement specified where commercial or industrial land uses access a local street, as compared to the kind of improvement specified for residential access. Generally, a local street classification in commercial or industrial areas will require an improvement equal to that specified for a collector classification.

5) Cul-de-sac Streets

- a) Cul-de-sac streets provide access to abutting property only and will be as short as possible. In no event shall a cul-de-sac be more than 400 feet in length.
- b) The length of a cul-de-sac shall be measured along the centerline of the roadway from the near side of the intersecting street to the farthest point of the cul-de-sac.
- c) All cul-de-sac streets shall terminate in a circular turnaround.

U. Dead-End Streets

- 1. A standard cul-de-sac turnaround shall be provided at the end of a permanent dead-end street that does not provide looped circulation. Permanent dead-end streets shall not exceed 400 feet in length measured from the point of the nearest intersection centerline. All dead-end streets that exceed 150 feet in length shall be provided with an approved turnaround per the City Standard Drawings.
- 2. A permanent dead-end street is measured from the ROW line at the nearest intersecting street, which has at least two points of access, to the ROW line at the farthest end of the dead-end street.

TECHNICAL SPECIFICATIONS

SECTION 5

STREETS

- 3. An existing dead-end street system that is more than 600 feet long or that serves more than 25 dwelling units may be terminated in a cul-de-sac if no Future Street Plan has been adopted and the following criteria are met:
 - a. Alternative emergency vehicle access or fire protection is provided satisfactory to the local fire authority.
 - b. Neighborhood traffic circulation needs are not adversely impacted by the proposed cul-de-sac termination of the street.
 - 4. Temporary dead-end streets more than 150 feet in length shall be provided with an approved turnaround for emergency vehicles.
- V. Alleyways and Private Residential Streets/Access Ways
- 1. Alleyways
 - a. Alleyways may be provided in commercial and industrial developments with approval by the City. When approved, alleyways shall be dedicated to the City. The ROW width shall be 20 feet with a 20-foot surfacing width.
 - b. Design for alleyways shall be as shown on the City Standard Drawings. Generally, alleyways shall be designed for one-way operations.
 - 2. Private Residential Access Ways

In general, private residential streets and access ways shall be provided for multi-family developments such as condominiums and apartments. Interior design for private access ways in a manufactured home park shall meet standards for private residential access ways:

 - a. Dead-end access ways shall not exceed 400 feet in length. Dead-end access ways that exceed 150 feet in length shall be provided with an approved turnaround per the City Standard Drawings.
 - b. "Private street" signage and approaches shall be placed at the intersection with the public street to clearly identify the private access way.

TECHNICAL SPECIFICATIONS

SECTION 5

STREETS

- c. Private maintenance of the private streets/access ways shall be provided by a Homeowner’s Association or other appropriate entity. Maintenance shall ensure continual emergency access at all times.
- d. The location of private access ways shall meet the Uniform Fire Code and meet the minimum pavement section of local residential streets.
- e. Private residential access ways shall not be allowed in manufactured home parks or subdivisions.

3. Pavement Cuts

Where pavement is installed next to existing pavement and at all trench cuts, the existing pavement shall be saw cut. The face of the joint between the new and existing pavement shall be coated with asphalt emulsion and the surface of the joint shall be sand-sealed.

4. Shoulders

Where sidewalks and pavement end or where there is no curb and sidewalk (such as half-street improvements), shoulder aggregate base shall be provided to grade with the pavement. Shoulder aggregate base shall be a minimum of 6 inches in depth, 36 inches wide, and shall be 3/4"-0 crushed aggregate base.

1.2 Definitions

A. Painted Markings

Markings constructed of paint and traffic paint beads.

B. Type B - Preformed, Fused Thermoplastic Film Markings

Preformed, fused thermoplastic film with intermixed traffic paint beads, and with or without a separate application of additional traffic paint beads on the surface.

C. Pavement Striping

Lines of paint and glass beads applied to the pavement surface.

TECHNICAL SPECIFICATIONS

SECTION 5

STREETS

PART 2 - MATERIALS

2.1 Water for Compaction

The Contractor shall be responsible for obtaining, transporting and the application of the water.

2.2 Geotextile Fabric

Geotextile fabric shall be Mirafi 500X, Exxon GTF 200, or approved equal.

2.3 Aggregate Base

A. Aggregate Base

Aggregate base shall conform to the requirements of Section 02630 - Base Aggregate, Oregon Standard Specifications for Construction, current edition, for dense graded aggregate as modified hereafter. Acceptable gradation includes 1"-0 or 3/4"-0 as selected by the Contractor. Aggregate base shall be 100 percent fractured. No round faces shall be permitted. The Contractor shall submit to the City samples of the aggregate base for use on the Project.

B. Surface Rock

1. The surface rock shall be crushed stone, slag, or gravel meeting the following requirements:

- a. Liquid Limit (AASHTO T 89) 35 Maximum
- b. Plastic Index (AASHTO T 90) 2-9 Maximum
- c. Dust Ratio: $\frac{\% \text{ Passing No. 200}}{\% \text{ Passing No. 30}}$ 2/3 Maximum

Grading Requirements (AASHTO T 11 and T 27):

Sieve	Percent Passing
1"	100
3/4"	70-98
No. 4	36-60
No. 8	25-47
No. 30	12-31
No. 200	8-15

TECHNICAL SPECIFICATIONS

SECTION 5

STREETS

- 2. Surface rock shall have at least 70 percent by weight of the particles retained on the No. 4 sieve and shall have 100 percent fractured faces.

2.4 Soil Sterilant

The sterilant shall be Pramitol 5PS as manufactured by Makhteshim Agan of North America, Inc., Monobor-chlorate, or approved equal and shall be applied in accordance with the manufacturer's or Supplier's recommendations to adequately sterilize the base.

2.5 Paving Fabric

The paving fabric used shall be non-woven, fabricated from polypropylene resin, and shall have the following properties:

Weight, oz./sq.yd.	4.0 Minimum
Grab Tensile Strength, lbs.	90 Minimum
Elongation at Break, percent	55 Minimum
Asphalt Retention, gals/sq.yd.	0.20 Minimum

2.6 Asphalt Tack Coat

- A. The material is to be CRS-1 or CSS-1 emulsified asphalt unless otherwise approved.
- B. Furnish emulsified asphalt meeting the requirements of ODOT's publication "Standard Specifications for Asphalt Materials." Copies of the publication are available from the ODOT Pavement Services Engineer. The applicable Specifications are those contained in the current publication on the date the Project is advertised. The materials may be conditionally accepted at the source or point of loading for transport to the Project.
- C. Excessive delay in the use of the emulsified asphalt or excessive pumping of the emulsified asphalt may significantly reduce the viscosity and may make the material unsuitable for tack coat use. For this reason, limit pumping between the bulk storage tank, hauling transportation, field storage tanks, and distributors to an absolute minimum to maintain proper viscosity. Final acceptance of emulsified asphalt will be at the point of application.
- D. Dilution of the tack coat material may be allowed to a maximum 1:1 ratio. Determine the proportion of water to be added to the emulsified asphalt. Do not dilute the emulsified asphalt until the City approves the dilution ratio. Add the water to the emulsified asphalt and mix according to the asphalt Supplier.

TECHNICAL SPECIFICATIONS

SECTION 5

STREETS

- E. Obtain Samples according to AASHTO T 40 prior to dilution with water, if allowed. Samples will be tested at the ODOT Materials Laboratory or other laboratory as designated by the City. Emulsified asphalt will be tested within 30 calendar days from the date it is sampled.

2.7 Asphalt Concrete Pavement

- A. General

The asphalt concrete pavement (ACP) shall consist of a hot mixture of asphalt cement, well-graded high quality aggregate, mineral filler and adhesive as required. It shall be plant mixed into a uniformly coated mass, hot laid on a prepared foundation and compacted to the specified density.

- B. Asphalt Concrete Pavement

Materials shall be in accordance with "Section 00744 - Asphalt Concrete Pavement" and related sections of the Oregon Standard Specifications for Construction, current edition, supplemented and modified as follows:

- 1. Project Mix Requirements
 - a. Level 3 ACP
 - b. 1/2-inch Dense Graded
 - c. Asphalt Cement PG 64-28
- 2. Add the following to the end of subsection 00744.11:

Testing of asphalt cement will be at the expense of the Contractor.

- 3. Replace the first paragraph of subsection 00744.13 with the following:

00744.13 Job Mix Formula (JMF) Requirements - Previously prepared JMF will be allowed, provided adequate test data are available to document the suitability of the mix, the Contractor can document that the same materials are being used, the JMF was prepared within the last 12 months, and the JMF meets the requirements of these Public Works Standards, Technical Specifications, and Standard Drawings. Copies of the results of tests made on the mix during production on previous projects shall also be submitted if any are available.

Do not begin production on the Project until the JMF is reviewed by the City and written consent is provided to proceed. A new JMF is required if the asphalt

TECHNICAL SPECIFICATIONS

SECTION 5

STREETS

cement grade, any additives, or the source of the aggregate change during production. Provide a JMF for the Project meeting the following criteria:

2.8 Asphalt Fog Seal

Asphalt for the asphalt fog seal shall consist of CSS-1, CSS-1h, or HFRS-P1 emulsified asphalt mixed with water at a rate of 1 to 1.

2.9 Street Monument Boxes

The monument boxes shall be as shown on the City Standard Drawings.

2.10 Concrete Characteristics

- A. The Portland Cement concrete used for this Work shall be a commercial transit mix. The exact proportions of all the materials entering into the concrete shall be as established by an approved laboratory mix design and shall be changed only as directed by the City or Laboratory when necessary to obtain the specified strength, desired density, uniformity, or workability. Previously prepared mix designs will be allowed provided adequate test data is available to document the suitability of the mix and the Contractor can document that the same materials are being used. The mix design shall be provided to the City for review.
- B. The concrete shall have the following characteristics.

Parameter	Value
Min. 28-day Compressive Strength	4,000 psi
Min. Cement per Cubic Yard	564 lbs./yd.
Max. Water-Cement Ratio	0.45
Air Content (range)	5-7 percent
Max. Allowable Slump	4 inches

- C. In some localities, additional cement may be required to achieve the minimum 4,000 psi 28-day compressive strength. The use of additives will be allowed when designed into the mix. Mixes used with reinforcing steel shall have a maximum water soluble chlorine ion content of 0.06 percent of mix design concrete weight.

2.11 Portland Cement

- A. Portland cement shall conform to the requirements of ASTM C150, for Type I - II cement. The City may direct the use of Portland Cement of a type other than that

TECHNICAL SPECIFICATIONS

SECTION 5

STREETS

specified in the Contract Documents. In this case, the City will pay the additional cost, if any, for the cement required over the cost of that specified or shall receive appropriate credit for any cement required of a lesser cost than that specified.

- B. All cement shall be stored in a suitable weather-tight building in such a manner as to protect the cement from dampness and to permit easy access for proper inspection. Storage bins for bulk cement shall be weather-tight and constructed so there will be no dead storage.

2.12 Aggregates

- A. General

All aggregates for concrete shall conform to the requirements of ASTM C33. No aggregate shall be incorporated into the Work until and unless the aggregates are approved by the City. The decision to perform any or all tests on aggregates shall be left to the City. Should testing of the aggregates be deemed necessary, Samples shall be selected at random from the stockpile and tested for conformance with the Specifications. When the aggregates have been approved by the City, the source shall not be changed without written approval from the City.

Fine and coarse aggregates shall be stored and measured separately. Aggregates shall be protected from contamination with dust, dirt, or other foreign materials.

- B. Fine Aggregate

Fine aggregate shall consist of natural sand having hard, strong, and durable particles, which does not contain more than 2 percent by weight of such deleterious substances as clay lumps, shale, schist, alkali, mica coated grains, or soft and flaky particles. The grading of fine aggregate shall range uniformly from coarse to fine within the limits indicated in ASTM C33.

- C. Coarse Aggregate

- 1. Coarse aggregate shall consist of clean, hard, fine grained, sound crushed rock, or washed gravel that does not contain in excess of 5 percent by weight of flat, chip like, thin, elongated, friable, or laminated pieces, or more than 2 percent by weight of shale or cherty material.
- 2. Any piece having a major dimension in excess of 2-1/2 times the average thickness shall be considered to be flat and/or elongated.

TECHNICAL SPECIFICATIONS

SECTION 5

STREETS

- 3. The maximum size of coarse aggregate shall not exceed 1-1/2 inches or one-fifth of the narrowest dimension between the forms nor three-quarters of the clear spacing between reinforcing bars. The minimum size of coarse aggregate shall be 3/4-inch unless approved otherwise.
- 4. Coarse aggregate shall be uniformly graded from coarse to fine within the limits allowed in ASTM C33.

2.13 Water

Water for mixing shall be clean, fresh, and free from injurious amounts of oil, acid, chlorides, sulfates, alkali, organic matter, or other deleterious substances.

2.14 Admixtures

The use of admixtures will be allowed only when included in the mix design or as specified. Admixtures used will be considered a means of improving workability and/or placement of the concrete. Admixtures shall conform to requirements:

Parameter	Reference
Air-entraining	ASTM C260
Water Reducer	ASTM C494, Type A
Set Retarding	ASTM C494, Type B
Water Reducing/Set Retarding	ASTM C494, Type D
High Range Water Reducing (Superplasticizer)	ASTM C494, Type F and G
Pozzolanic	ASTM C618
Fly Ash	AASHTO M 295, Class C or F

2.15 Pre-molded Joint Filler

Pre-molded joint filler for use in expansion (through) joints shall be asphalt-impregnated cellular fiber, be a material listed on the ODOT Qualified Products List as approved by ODOT for the intended use, and shall conform to ASTM D1751. The thickness shall be 1/2-inch or match existing adjacent expansion joints.

TECHNICAL SPECIFICATIONS

SECTION 5

STREETS

2.16 Truncated Dome Detectable Warning Texture

Truncated dome detectable warning texture used on sidewalk ramps shall be a material listed on the ODOT Qualified Products List as approved by ODOT for the intended use. See Oregon Standard Drawings RD755, RD756, and RD757, current edition.

2.17 Pavement Striping and Markings (General)

Use materials conforming to the requirements of Section 00850 of the Oregon Standard Specifications for Construction, current edition. Materials and Suppliers for paint, traffic beads, and pavement marking legends shall be listed in the ODOT Qualified Products List as approved by ODOT for the intended use.

2.18 Signs

Use materials conforming to the requirements of Section 00940, current revision, and Special Provision SP2910 of the Oregon Standard Specifications for Construction, current edition. Materials and Suppliers for signs shall be listed in the ODOT Qualified Products List as approved by ODOT for the intended use.

All signs shall be constructed of sheet aluminum with type IX sheeting.

2.19 Sign Posts

Use materials conforming to the requirements of Section 00930 of the Oregon Standard Specifications for Construction, current edition. Sign posts shall be as shown on the City Standard Drawings.

PART 3 - EXECUTION

3.1 Earthwork

A. Clearing and Grubbing

1. Clearing and grubbing shall include the removal and disposal of any obstructions, such as existing curbs, sidewalks, pavement, culverts, fences, etc., and organic material such as trees, tree stumps, brush, hedges, vegetation, roots, rubbish, posts, fences, topsoil, and any other obstacles or materials in the construction area which would prevent completing the Project, and which are unsuitable for road work construction.

TECHNICAL SPECIFICATIONS

SECTION 5

STREETS

2. All vegetation and rubbish shall be removed and disposed of by the Contractor in conformance with the requirements of local authorities controlling air pollution and solid waste disposal.
- B. Roadway Excavation
1. Prior to any excavation, the area to be excavated shall be cleared and grubbed.
 2. Roadway excavation shall consist of the excavation, haul, and satisfactory disposal of all materials taken from within the right-of-way for the construction of embankments, subgrade, shoulders, intersections, ditches, waterways, entrances, approaches (including excavation at private entrances outside the right-of-way), curbs, sidewalks, and incidental work, in accordance with the lines, grades, and cross sections shown on the Plans, and as required by the design engineer.
- C. Embankments
1. Prior to construction of any embankment, the area beneath the embankment and the areas from which embankment material will be obtained shall be cleared and grubbed. The existing soil beneath the embankment shall then be compacted to 90 percent of maximum density as determined by ASTM D1557 for a minimum of 6 inches below ground surface. Any unsuitable material shall be removed prior to placement of any embankment.
 2. Upon completion of the embankment foundation, embankment material shall be placed in horizontal lifts and compacted to 90 percent of ASTM D1557. Embankment lift depth shall not exceed the capability of compaction equipment being used to achieve the required compaction for the full depth of each lift. The embankment material shall be native or import free of vegetative or organic matter, boulders 6 inches or larger in diameter, or frozen material and shall be at or below optimum moisture content at the time of placement. Depending on the type of embankment material, the Contractor may have to scarify, aerate, water, or take other actions as necessary to bring soils to proper moisture in order to achieve the required compaction.
 3. The embankment shall be brought to the lines and grade required on the Plans and as established by the design engineer. Any unsuitable material which may have been used in constructing the embankment shall be removed and replaced with suitable material and compacted at no cost to the City.

TECHNICAL SPECIFICATIONS

SECTION 5

STREETS

D. Roadbed Cuts

1. In roadbed cuts, the subgrade material shall be compacted to 90 percent of maximum density as determined by ASTM D1557 for a minimum of 6 inches below the top of the subgrade.
2. Depending on the type of material encountered, the Contractor may have to scarify, aerate or water, over-excavate, or take other actions as necessary to bring soils to proper moisture in order to achieve the required compaction.

E. Finishing of Subgrade

1. All roadbeds, ditches, and other excavations and embankments shall be trimmed accurately to the lines, grades and cross sections as shown on the Drawings and established by the design engineer and shall be finished in a thoroughly workmanlike manner to within plus or minus 0.05 foot of the required grade.
2. Upon completion of the subgrade and prior to placement of the geotextile fabric, if any, and aggregate base, the Contractor shall load test the finished subgrade surface. The load test shall consist of slowly driving a loaded dump truck over the road surface. The dump truck shall have a minimum capacity of 10 cubic yards. The City Representative and Contractor shall note and mark any soft areas. The Contractor shall excavate out and either replace unsuitable material or properly compact all soft areas in order to provide a firm base that conforms to Public Works Standards, Technical Specifications, and Standard Drawings. Any soft areas that occur as part of the Project because of over-watering, improper compaction, weather, etc., shall be replaced.

F. Dust and Mud Control

1. The Contractor shall be responsible for controlling dust and mud caused by their operations. This shall include, but not be limited to, street work, trench work, shoulder work, sidewalk work, driveways, connecting streets, etc. The Contractor shall be responsible for controlling dust on the roadway surface until the time asphalt pavement is placed.
2. Dust and mud control performed by the Contractor is considered a normal part of the construction Project. If the Contractor fails to properly control the dust and mud, the City may request the Contractor to do so in writing. If, after 24 hours from this request, the Contractor has not corrected the dust or mud

TECHNICAL SPECIFICATIONS

SECTION 5

STREETS

problem, the City may elect to have the corrective work performed and charge the Contractor/developer for said Work.

3.2 Geotextile Fabric

A. Scope

This Work consists of furnishing and placing geotextile fabrics in underdrains, under embankments, over roadbed subgrade, and at other locations as shown on the Plans or directed by the City.

B. Fabric

Fabric placed for subgrade stabilization under embankments or over roadbed subgrade shall be placed parallel to the centerline of the roadway, with placement starting at the low side of the super elevation or crown. The fabric shall either be sewn together at all longitudinal and transverse edges or overlapped a minimum of two feet at all edges. Transverse overlaps shall be made in the direction of base material placement.

3.3 Aggregate Base

A. Scope

Aggregate base shall be placed to the lines, depths, and grades shown on the City Standard Drawings. Prior to placement of the materials, each succeeding lift, i.e., subgrade, aggregate base, etc., shall be properly constructed and reviewed by the City.

B. Construction

1. The construction procedure here described shall be understood to apply to each of the courses and/or layers of which the road base is to be constructed. The construction of the road base shall not be limited to the construction of the main roadway to which the Contract applies, but shall include the construction of base on approach roads, driveways, connecting roads and connecting streets as shown on the Plans.
2. After the subgrade is brought to the proper line, cross section and compaction, the aggregate materials shall be spread and shaped as required. The spreading and shaping of the aggregate materials shall be so performed as to prevent separation of the coarser material from the finer materials including the use of adequate water.

TECHNICAL SPECIFICATIONS

SECTION 5

STREETS

- 3. The aggregate materials shall be brought to proper moisture content as required for compaction and compacted to 95 percent of maximum density as determined by ASTM D1557.
- 4. The finished surface when tested with a 10-foot straightedge shall not vary from the testing edge by more than 0.05 foot at any point.
- 5. Following construction of each lift, the Contractor shall do such blading, brooming, watering, and other work as necessary to prevent raveling and rutting. These operations are to be continued as required until the lift is covered by a following lift or until all Work to be done under the Contract is completed. If the required compacted depth of the aggregate base exceeds 6 inches, it shall be constructed in two or more lifts, each lift not exceeding 6 inches in depth.
- 6. Upon completion of the aggregate materials and prior to placement of asphalt concrete pavement, the Contractor shall load test the finished base surface. The load test shall consist of slowly driving a loaded minimum 10 yard dump truck over the road surface. All soft areas shall be noted. The Contractor shall excavate and/or compact all soft areas in order to provide a firm base that conforms to Public Works Standards, Technical Specifications, and Standard Drawings.
- 7. Gravel shoulders when required shall be constructed as a part of construction of the base and are not to be added on after completion of asphalt paving. The finished gravel shoulder shall be graded, trimmed and compacted to the required lines, grades and cross sections in a neat manner leaving the gravel shoulder flush with the edge of the asphalt pavement. Coarse segregated aggregate shall not be used in the construction of gravel shoulders. All such non-specification material shall be removed and replaced with specification material.

3.4 Soil Sterilant

- A. Upon completion of the base and prior to placement of asphalt concrete, the Contractor shall apply a soil sterilant to the surface of the base.
- B. The applicator shall be licensed by the State of Oregon for the class of herbicide utilized. Any damage to adjacent areas caused by the sterilant shall be repaired by the Contractor at no expense to the City.

3.5 Pre-paving Conference

At least one week before paving is scheduled to begin, the Contractor will set up a pre-paving meeting between the Contractor and the City. If a paving Subcontractor is being used they shall

TECHNICAL SPECIFICATIONS

SECTION 5

STREETS

also be present. The intent of the meeting is to allow the City and the Contractor to jointly review the proposed method of operation, equipment, personnel, mix, schedule, etc., along with the Public Works Standards, Technical Specifications, and Standard Drawings.

3.6 Overlay Preparation

A. Asphalt Concrete Patching

1. The City will mark all unstable or unsuitable areas. The Contractor shall then remove all material from the designated areas to a depth as detailed on the Plans or as required by the City.
2. The area shall then be backfilled as detailed on the Plans, or as required by the City. All materials shall be properly placed and compacted to Public Works Standards, Technical Specifications, and Standard Drawings.

B. Asphalt Crack Sealing

1. All cracks and joints shall be routed and cleaned of all loose material and vegetation. Cleaning shall be accomplished with using a hook or other similar device to loosen the material and either blowing, brooming or flushing the material from the crack. After all cracks are cleaned, the entire paved surface shall be cleaned of foreign material. Care shall be taken not to refill the cracks with foreign material.
2. Filling of cracks and voids shall not commence until they are clean and dry.
 - a. Voids in the base below the pavement shall be filled with clean sand and compacted. Cracks 1-inch and less in width shall be completely filled to the pavement surface with hot liquid rubberized asphalt conforming to ASTM D3405.
 - b. Cracks greater than 1-inch in width shall be filled with a mixture of 50 percent 1/4-0 aggregate and 50 percent CSS-1 asphalt emulsion or other approved mixture to within 1/4 inch of the pavement surface and topped off with hot liquid rubberized asphalt.
 - c. The following day, any cracks which are not completely full shall be topped off with additional rubberized asphalt. After sealing, the filler shall be broomed or squeegeed flush with the existing pavement surface and allowed to cure prior to constructing the asphalt concrete overlay.

TECHNICAL SPECIFICATIONS

SECTION 5

STREETS

- d. All sealed cracks shall be flush with the existing pavement after sealing is complete.

C. Cleaning

The existing surface of all areas to be overlaid shall be thoroughly cleaned of all loose material, dirt, debris, or other undesirable materials by brooming, flushing with water, or other methods acceptable to the City.

D. Asphalt Concrete Pre-leveling

- 1. All areas with irregular grades to be pre-leveled shall be marked by the design engineer and pre-leveled with 3/8-inch dense asphalt concrete.
- 2. The pre-leveling will be performed while the street is clean and thoroughly dry and will be accomplished by applying a tack coat of asphalt at a rate of 0.05 to 0.15 gallons per square yard and then placing and compacting the asphalt mix. The actual rate of tack coat application will be determined in the field by the design engineer.
- 3. The compaction of the asphalt concrete shall be accomplished with a pneumatic tired roller. The rolling shall follow directly behind the placement and be performed in such a manner that the entire surface receives at least four coverages of the roller. The pneumatic-tired roller shall be capable of exerting at least 80 pounds per square inch ground pressures and shall not be operated at speeds in excess of 5 mph. Finish rolling shall be accomplished with a steel wheeled roller and shall continue until all roller marks are eliminated.

E. Paving Fabric

Once the street is clean and all repair work is completed the paving fabric, if any, shall be installed where called for on the Plans. The following procedures and materials are to be used.

- 1. Tack Coat Application
 - a. Apply a tack coat of AR4000W graded asphalt cement at the rate of 0.15 to 0.25 gallons per square yard. This can only be done with the ambient temperatures above 60°F. The actual rate will be determined in the field by the design engineer to suit the existing surface.

TECHNICAL SPECIFICATIONS

SECTION 5

STREETS

- b. The tack material shall be between 275° and 325°F at the time of application and shall be applied with a single pass of distributor truck.
 - c. An accessory hand sprayer shall be used on patches, lap sections and areas where truck spraying is impractical. It is extremely important that the tack coat be uniformly applied. Application will not be allowed unless the distributor equipment is operating properly.
2. The paving fabric shall be placed directly behind the distributor with the use of equipment that will provide automatic tensioning capabilities to assure fast wrinkle-free unrolling.
- a. Any minor wrinkles or air bubbles shall be brushed out with a stiff-bristle push broom. Wrinkles that won't brush out shall be cut out and a patch of fabric layered at least 6 inches in all directions be installed.
 - b. The fabric shall be cut into sections to match curves and corners. Overlap these sections and the start of all new rolls at least 6 inches and apply approximately 0.20 gallons per square yard tack coat to the seams.
 - c. If any blistering of the fabric arises a 4-ton tandem roller shall be used to restore the fabric adhesion prior to the overlay application.
3. The overlay work shall begin as soon after lay-down of the paving fabric as practical.

F. Asphalt Tack Coat

- 1. An asphalt tack coat shall be applied to existing pavement surfaces to be overlaid with new asphalt concrete, except where paving fabric has been placed. All pavement repair work and surface cleaning shall be completed prior to application of tack coat.
- 2. Provide an asphalt distributor designed, equipped, maintained, and operated so the emulsified asphalt material may be applied uniformly at even heat. The distributor shall be capable of applying the asphalt on variable surface widths up to 16 feet, at readily determined and controlled rates from 0.05 to 2.0 gallons per square yard, and with uniform pressure. The variation allowed from any specified rate shall not exceed 0.02 gallons per square yard. Provide distributor equipment that includes a tachometer, pressure gauges, accurate volume measuring devices, and a thermometer for measuring temperature of tank contents. Provide distributors equipped with a positive power unit for the

TECHNICAL SPECIFICATIONS

SECTION 5

STREETS

asphalt pump, and full circulation spray bars adjustable both laterally and vertically. Set the bar height for triple lap coverage.

- 3. Apply the emulsified asphalt with a pressure distributor. Apply the emulsified asphalt to the prepared surface at a rate between 0.05 and 0.20 gallons per square yard as directed and with the emulsified asphalt temperature between 140°F and 185°F as recommended by the manufacturer. Application rates for tack coat diluted will be increased as necessary to provide the same amount of residual asphalt as the application rates specified above.

Do not place hot mixed asphalt concrete pavement or emulsified asphalt concrete pavement on the tack coat until the emulsified asphalt separates from the water (breaks), but before it loses its tackiness.

- 4. All surfaces must be clean and dry at the time of the tack coat application and at a temperature of at least 50°F. Remove all loose material from the surface. The tack coat shall only be constructed far enough in advance as is appropriate to ensure a tacky, sticky condition at the time the asphalt concrete is placed on it.
- 5. A tack coat will not be required between pavement lifts if paving of succeeding lifts occurs within 24 hours and the pavement surface is kept clean. If the pavement surface is not clean, as determined by the City, a tack coat will be required between lifts.

3.7 Asphalt Concrete Pavement

A. Scope

After completion of the base, the Contractor shall place and compact the ACP to the lines, grades, thicknesses, and cross-sections shown on the Drawings and as established by the City.

B. Construction

Construction shall be performed in accordance with applicable "Section 00744 - Asphalt Concrete Pavement" and related sections of the Oregon Standard Specifications for Construction, current edition, supplemented and modified as follows:

- 1. Delete subsection 00744.16 and 00744.17 and replace with the following:

00744.16 ACP Acceptance - Perform sampling and testing according to the "Quality Control" section of the General Requirements.

TECHNICAL SPECIFICATIONS

SECTION 5

STREETS

- 2. Replace subsection 00744.30 with the following:

00744.30 Paving Crew - Only trained and experienced personnel shall be used on the paving crew performing the Work. The Contractor shall submit to the City, prior to the pre-paving conference, job assignments, experience history, and training background for all members of the paving crew. Untrained and inexperienced personnel may not be used. The City may request personnel be replaced if it cannot be demonstrated that they have the proper training and experience to be a part of an experienced crew. The paving superintendent and paving machine operator shall have at least five years' experience, and the roller operators shall have at least two years' experience.

- 3. Replace Section 00744.40 with the following:

00744.40 Season and Temperature Limitations - Place ACP when the temperature of the surface that is to be paved is not less than the temperature indicated, unless approved by the City:

Nominal Compacted Thickness of Individual Lifts and Courses as shown on the typical section of the plans	All Levels
	Surface Temperature*
Dense Graded Mixes	
Less than 2 inches	60°F
2 inches - 2-1/2 inches	50°F
Greater than 2-1/2 inches	40°F
Temporary	40°F

* If placing MHMAC between March 15 and September 30, temperature requirement may be lowered 5°F.

- 4. Add the following paragraph to the end of subsection 00744.42:

All edges of manholes, valve boxes, curbs, existing pavement, etc., that are to be in contact with the new asphalt concrete shall be cleaned and painted or sprayed with a thin tack coat. This tack coat is to be applied only far enough in advance as is appropriate to ensure a tacky, sticky condition at the time the asphalt concrete comes in contact with the structure. The application of the tack coat shall be done in a neat, workmanlike fashion. Any material inadvertently applied

TECHNICAL SPECIFICATIONS

SECTION 5

STREETS

to surfaces outside the limits of the paving, such as on sidewalks, exposed sections of curbs, etc., shall be fully cleaned by the Contractor.

- 5. Delete the following subsections:
 - a. 00744.80
 - b. 00744.90

3.8 Adjustment of Utility Covers to Grade

The Contractor shall adjust the tops of all manholes, valve boxes, and other utility covers as required to bring the covers or gratings of the structures to the grade shown on the City Standard Drawings. The Contractor shall repair any of these structures which are damaged during performance of the Work.

3.9 Asphalt Fog Seal

- A. After the construction of the asphalt concrete, the City will evaluate the surface to determine whether a fog seal is required. When a seal is determined necessary by the design engineer, the Contractor shall apply an asphalt fog seal. It is anticipated that the application rate will be between 0.05 to 0.20 (0.03 to 0.10 residual) gallons per square yard. The application rate shall be determined by the design engineer.
- B. The areas to be sealed shall be dry and free of dirt, dust, leaves, or other foreign matter at the time of placement.
- C. Provide an asphalt distributor designed, equipped, maintained, and operated so the emulsified asphalt material is applied uniformly at even heat. The distributor shall be capable of applying the asphalt on variable surface widths up to 16 feet, at readily determined and controlled rates from 0.05 to 2.0 gallons per square yard, and with uniform pressure. The variation allowed from any specified rate shall not exceed 0.02 gallons per square yard. Provide distributor equipment that includes a tachometer, pressure gauges, accurate volume measuring devices and a thermometer for measuring temperature of tank contents. Provide distributors equipped with a positive power unit for the asphalt pump, and full circulation spray bars adjustable both laterally and vertically. Set the bar height for triple lap coverage.
- D. Discontinue application of the emulsified asphalt fog seal sufficiently early in the day to permit the termination of traffic control prior to sunset. Apply emulsified asphalt to only one designated traffic lane at a time.

TECHNICAL SPECIFICATIONS

SECTION 5

STREETS

- E. All of this Work, a portion of it, or none of it may be performed, depending on the evaluation made by the design engineer.

3.10 Street Monument Boxes

The Contractor shall provide and install cast iron street monument boxes at all points shown on the Plans. Monument boxes shall be installed during placement of the asphalt concrete pavement. The asphalt concrete shall be placed to leave a smooth ride. Monuments within the boxes shall be installed by the owner's/developer's surveyor.

3.11 Restoration, Finishing, and Cleanup

- A. Prior to the final inspection of the Work, the Contractor shall restore or replace all paved surfaces, graveled surfaces, curbing, sidewalks, trees and shrubbery, lawns, pastures and fences, or other existing facilities disturbed or damaged by their Work.
- B. The Contractor shall cleanup and leave in a neat, orderly condition the right of way, and other property occupied in connection with the Work.
- C. The Contractor shall reshape, clean out ditches, retrieve shoulders and slopes, and do all other work required to bring the Project to the final lines, grades, and condition called for. The finished Project shall be clean and neat in its final appearance.

3.12 Concrete Forms

Forms shall be wood or metal and shall extend for the full depth of the concrete. All forms shall be straight, free from ways, and of sufficient strength to resist the pressure of the concrete without springing. Bracing and staking of forms shall be such that the forms remain in both horizontal and vertical alignment until their removal.

3.13 Concrete General Placement and Finishing

- A. The foundation and forms shall be well wetted prior to placement of the concrete. Unless otherwise specified, all concrete shall be placed upon clean, damp surfaces free of running or standing water, and never upon soft mud, dry porous earth, or frozen subgrade.
- B. All concrete shall be placed before the initial set has occurred and unless otherwise authorized by the City. It shall be placed within 1-1/2 hours after water has been added to the mix. The temperature of the concrete at placement shall not be below 50°F or exceed 90°F unless approved otherwise by the City.

TECHNICAL SPECIFICATIONS

SECTION 5

STREETS

- C. The concrete shall be placed on a moist base and deposited as close as possible to its final location and to its required depth. Movement of the concrete horizontally with a vibrator will not be allowed.
- D. Once the concrete has been placed, it shall be struck off to the proper elevation using a straightedge and sawing motion. A smooth surface shall be provided after the concrete has been straight edged by the use of a bull float or Darbie. A wooden bull float shall be used unless the Contractor can show that a magnesium bull float does not seal in the bleed water.
- E. Bull floating shall occur immediately after striking off and before bleed water accumulates on the surface. Bull floating shall be done in such a manner that the surface is not sealed, so bleed water is not trapped below the surface. Care shall be taken not to overwork the surface. The use of a jitterbug or tamper will not be allowed unless approved by the City. Initial edging shall be performed with a wide edger, again in a manner that will avoid sealing the surface.
- F. Upon completion of the above floating, the concrete shall be allowed to sit until the bleeding has stopped, the bleed water has disappeared, and the concrete is firm enough to permit a man to walk on the surface leaving footprints no more than 1/4-inch deep. After the waiting period, the concrete may be floated and finished as required. Adding water to the surface or working bleed water to aid in finishing is not allowed.

3.14 Curing

- A. As soon as the concrete has been placed and finished, as specified, it shall be cured:
 - 1. By application of an approved Type 2, Class B white or gray pigmented or Type 1-D clear compound with fugitive dye liquid membrane-forming compound applied uniformly at a rate of at least 1 gallon per 200 square feet to the damp concrete by pressure spray methods; or
 - 2. By keeping the concrete continually damp for at least 120 hours. The actual curing method and materials shall meet the requirements of ACI 308 and ASTM C309.
- B. The Contractor shall submit a proposed method of curing to the design engineer prior to placement of any concrete.
- C. The Contractor shall protect the newly placed concrete from vandalism and any other damages. The exact method of protection shall be left up to the Contractor. Any

TECHNICAL SPECIFICATIONS

SECTION 5

STREETS

damages, regardless of the cause, shall be repaired or replaced to the satisfaction of the design engineer.

3.15 Restrictions Due to Weather

A. Cold Weather

1. Concrete placement in cold weather (50°F or less) will be permitted only under conditions that shall meet the approval of the City. In general, cold weather placing shall conform to "Recommended Practice for Cold Weather Concreting" (ACI 306).
2. Salts, chemicals, or other foreign materials shall not be mixed with the concrete to prevent freezing, unless such use is authorized by the design engineer in writing.
3. All concrete shall be effectively protected from frost action for a period of five days after placement. Upon written notice from the design engineer, all concrete that may have become damaged by frost action shall be replaced by the Contractor.

B. Hot Weather

1. For concrete placed during extremely hot weather (air temperature exceeding 95°F), the aggregate shall be cooled by frequent spraying in such a manner as to utilize the cooling effect of evaporation.
2. During such periods, the placement schedule shall be arranged, as approved, in such a manner as to provide time for the temperature of the previously placed concrete to begin to recede.
3. The mixing water shall be the coolest available at the Site insofar as is practical.

C. Low Humidity/Wind

1. Pouring of concrete during periods of low humidity (below 50 percent) and/or windy conditions should be avoided when feasible and economically possible, particularly when large surface areas need to be finished.
2. No concrete shall be placed if the rate of evaporation approaches 0.2 pounds per square foot per hour unless approved by the design engineer and precautions against plastic shrinkage cracking are taken.

TECHNICAL SPECIFICATIONS

SECTION 5

STREETS

- 3. In any event, surfaces exposed to the drying wind shall be covered up immediately after finishing with polyethylene sheets and be water cured continuously as soon as the concrete has set up. Curing compounds, in lieu of water, may not be used.

3.16 Backfill

- A. After the concrete has reached sufficient strength, the space in back of structures shall be backfilled to the required elevation with the proper material as shown on the Plans, which shall be compacted until firm and solid.
- B. When the entire Project has been finished, any damaged structure sections shall be repaired or replaced by the Contractor.

3.17 Curb and Curb and Gutter

- A. General
 - 1. Concrete curb and curb and gutter shall be constructed in accordance with Public Works Standards, Technical Specifications, and Standard Drawings and the lines, grades, and cross sections shown on the Plans. They can be constructed with forms or with a curbing machine meeting the Public Works Standards, Technical Specifications, and Standard Drawings.
 - 2. Curbs located on vertical or horizontal curves shall be constructed to result in a smooth curve.
- B. Curbing Machine
 - 1. The machine for extruding Portland Cement concrete curb shall be of the self-propelled type equipped with a material hopper, distributing screw, and adjustable curb forming devices capable of placing and compacting Portland Cement concrete to the lines, grades, and cross sections as shown in an even, homogeneous manner.
 - 2. A grade line gauge or pointer shall be attached to the machine in such a manner that a continual comparison can be made between the curb being placed and the established curb grade as indicated by the offset guideline.

TECHNICAL SPECIFICATIONS

SECTION 5

STREETS

C. Placement and Finishing

1. The top and face of finished curb and curb and gutter shall be true and straight, and the top surface of curb shall be of uniform width free from humps, sags, honeycombs, or other irregularities.
2. When the curbing machine is used, the Contractor shall feed the concrete into the extruding machine at a uniform rate and operate the machine under sufficient restraint in a forward motion to produce a well compacted mass of concrete.
3. All exposed surfaces of the curb or curb and gutter shall be floated, followed by a light brush finish.
4. If forms are used, they shall be removed after the concrete has taken its initial set and while the concrete is still green enough to finish.
5. Minor defects shall be repaired with mortar containing one part Portland Cement and two parts sand. Honeycombed, slumped, and other structurally defective concrete shall be removed and replaced at no expense to the City.
6. All exposed formed surfaces shall receive a rubbed finish utilizing a Carborundum brick or other abrasive until a uniform color and texture is produced.

D. Joints

1. Expansion Joints
 - a. Expansion joints shall be provided as required by the City Standard Drawings.
 - b. The width of joints and thicknesses of filler shall match those of the joints and abutting or underlying concrete; elsewhere the filler thickness shall be 1/2 inch.
 - c. Each expansion joint shall be at right angles to the structure alignment, vertical to the structure surface, placed full depth of the concrete section, and shall fully separate the concrete section.

TECHNICAL SPECIFICATIONS

SECTION 5

STREETS

- 2. Transverse Control Joints
 - a. Transverse control joints of the weakened plane shall be formed in the exposed surfaces opposite control joints in abutting concrete and at other locations in the new curb as required by the City Standard Drawings. The joints shall be formed by grooving, by insertion and removal of plates or other devices, or, when approved by the City, by sawing.
 - b. Control joints shall be 3/16-inch in width and a minimum depth of one-third of the thickness of the concrete. The edges of joints shall be tooled, unfilled grooves, and shall be clean and neat. Joint filler shall be even and flush with the surface of the concrete.
 - c. If permitted by the City, when the joints are constructed by sawing, the sawing shall be performed as soon as practical after pouring and prior to the occurrence of any shrinkage cracking.

3.18 Sidewalk, Driveway, and Alley Approaches

A. General

Concrete sidewalks shall be constructed in accordance with Public Works Standards, Technical Specifications, and Standard Drawings and the lines, grades, and cross sections shown on the Plans.

B. Placement and Finishing

- 1. Before the concrete is given the final finishing, the surface of the sidewalk shall be checked with a 10-foot straightedge; any irregularities of more than 1/4-inch in 10 feet shall be eliminated.
- 2. Edges, including those of expansion joints, shall be rounded with an approved finishing tool.
- 3. The final surface of the concrete shall receive a medium to coarse cross brooming finish so as to provide a granular or matte texture that will not be slick when wet.
- 4. Cross brooming shall be transverse to the length of the sidewalk and approaches.

TECHNICAL SPECIFICATIONS

SECTION 5

STREETS

C. Joints

1. Expansion Joints

- a. Expansion joints shall be provided opposite abutting expansion joints, at the end of curved sections, at all corners other than those 90 degrees, at connections to existing sidewalks, adjacent to any structure, and as shown on the City Standard Drawings.
- b. The width of the joints and thickness of the filler shall match those of the joints and abutting or underlying concrete; elsewhere, the thickness shall be 1/2 inch.
- c. Each expansion joint shall be at right angles to the structure alignment, vertical to the structure surface, placed full depth of the concrete section, and shall fully separate the concrete section.

2. Transverse Control Joints

- a. Transverse control joints are required to be spaced at a distance equal to the width of the sidewalk with a maximum spacing of 6 feet.
- b. The joints between sections shall be formed by steel templates 1/8-inch in thickness or sawn in with a concrete saw after initial set of the concrete to a minimum depth of 1/4 the thickness of the concrete. Joints shall be at right angles to the alignment.

3.19 Steps

A. General

Steps shall be constructed in accordance with Public Works Standards, Technical Specifications, and Standard Drawings and to the lines, grades, and cross sections shown on the Plans.

B. Placement and Finishing

- 1. All edges shall be rounded with an approved finishing tool. All horizontal surface of the step shall receive burlap or cross-brooming finish to provide a granular or matte texture which will not be slick when wet.

TECHNICAL SPECIFICATIONS

SECTION 5

STREETS

- 2. After the forms are removed and while the concrete is still green, the vertical surfaces shall be finished.
- 3. Minor defects shall be repaired with a mortar containing one part Portland Cement and two parts sand. Honeycombed, slumped, and other structurally defective concrete shall be removed and replaced at no expense to the City.
- 4. All vertical surfaces shall receive a rubbed finish utilizing a Carborundum brick or other abrasive until a uniform color and texture is produced.

3.20 Reinforcing Bars

- A. Mild steel reinforcing bars shall be furnished, cut, bent, and placed as indicated on the Drawings and to the latest methods of practice approved by the Concrete Reinforcing Steel Institute.
- B. At the time of placing concrete, all reinforcement shall be free from loose mill scale, rust, grease, or other coating that might destroy or reduce its bond with concrete. Steel reinforcement not placed in the Work shall be stored under cover to prevent rusting and shall be placed on blocking so no steel touches any ground surfaces.
- C. Reinforcing steel shall be in position before concrete placement is begun. All reinforcing steel shall be tied together and supported in such a manner that displacement during placing of concrete will not occur.

3.21 Truncated Dome Detectable Warning Texture

Truncated dome detectable warning texture shall be installed in accordance with the manufacturer's requirements and in accordance with current Oregon Standard Drawings.

3.22 ADA Requirements

All sidewalks, curb ramps, etc., shall be constructed in accordance with all ADA standards and requirements. The Contractor shall immediately notify the City if non-ADA work is being required or being performed.

3.23 Testing and Inspection

The Contractor shall provide and maintain a quality control program that will ensure the quality of the Work and materials incorporated into the Project. See the General Requirements, Quality Control.

TECHNICAL SPECIFICATIONS

SECTION 5

STREETS

A. Contractor's Responsibilities

1. The Contractor shall provide routine testing and inspection services on materials and Work incorporated on the Project for quality control purposes. These tests include, but are not limited to, spot gradation checks, slump, air content, and compressive strength.
 - a. Slump. Concrete shall be tested for slump in accordance with ASTM C143.
 - b. Air Content. Air content shall be tested in accordance with ASTM C231.
 - c. Compressive Strength. Sample concrete cylinders shall be taken from the Work by the Contractor or their representative. At least three identical cylinders may be taken not less than once a day, nor less than once for each 50 cubic yards of concrete placed. When the frequency of testing will provide less than five tests for a given class of concrete, tests may be made from at least five randomly selected batches or from each batch if fewer than five are used, or as required by the City.
2. All cylinders shall be prepared and cured in accordance with ASTM C31 and tested in accordance with ASTM C39. One cylinder shall be tested at the age of 7 days and two at the age of 28 days. Each strength test result shall be the average of the two cylinders from the same Sample tested at 28 days.
3. The results of all tests performed on materials to be used on the Project by the Contractor shall be submitted to the City.
4. The Contractor shall notify testing and inspection personnel at least 72 hours in advance of operations to allow for personnel assignments and test scheduling.
5. All materials to be tested shall be provided by the Contractor.
6. After tests are completed, the Contractor shall be responsible for repairing test areas to match original conditions. The Contractor shall remove all defective material from the Site.

3.24 Signs and Sign Posts

- A. All signs shall be constructed, laid out, and installed in accordance with Public Works Standards, Technical Specifications, and Standard Drawings, the Manual on Uniform Traffic Control Devices, and in accordance with applicable sections of the Oregon Standard Specifications for Construction, current edition, Sections 00900 and 00910.

TECHNICAL SPECIFICATIONS

SECTION 5

STREETS

Signs shall be provided and installed as called for on the Plans. Signs shall be securely set plumb and straight and in a workmanlike manner.

- B. Wood sign posts shall be sized according to the current Oregon Standard Drawing TM670.

3.25 Pavement Markings

A. General

- 1. The Contractor shall place pavement markings as shown on the City Standard Drawings, the ODOT Standard Drawings, according to the Manual on Uniform Traffic Control Devices, the current edition of ODOT's Traffic Line Manual, and as specified herein. Apply the markings according to the manufacturer's recommendations. Furnish a copy of the manufacturer's instructions to the City a minimum of seven days before placing markings. Unless otherwise specified, apply pavement markings before public traffic is allowed on the freshly paved surface.
- 2. The Contractor shall remove and replace markings not conforming to Public Works Standards, Technical Specifications, and Standard Drawings or not properly installed.
- 3. The Contractor shall install pavement markings so the completed markings have a uniform cross-section. Pre-formed markings 12 inches or wider may be fabricated from 12-inch or 6-inch wide material.

B. Substrate Materials

- 1. Materials shall be applied to a surface that is clean, dry, free of contaminants, and meets the following requirements:
 - a. New Asphalt Concrete

Materials shall be applied to new asphalt concrete that is sufficiently cured, normally prior to opening the road to vehicle traffic.
 - b. Existing Asphalt Concrete

Materials shall be applied to existing asphalt concrete free of surface oils and existing road marking materials.

TECHNICAL SPECIFICATIONS

SECTION 5

STREETS

c. Portland Cement Concrete

Materials shall be applied to concrete that has reached a minimum compressive strength of 3,000 psi and is free of curing agents, laitance, surface oils, and road marking materials, normally prior to opening the road to vehicle traffic.

C. Prepare and Prime Pavement

1. The Contractor shall completely remove, by approved methods, existing pavement markings (painted, thermoplastic, raised buttons, or other durable materials) that are being replaced with new pavement markings, unless otherwise approved.
2. The Contractor shall clean the pavement before application of the marking material and shall remove contaminants such as curing compounds and existing pavement markings by an approved mechanical means. The Contractor shall sweep and air blast the pavement, as necessary, with an acceptable high-pressure system to remove extraneous or loose material. After the pavement surface is clean and dry, a primer shall be applied, if recommended by the manufacturer, to the area receiving the pavement markings. Primer shall be applied in a continuous, solid film according to the recommendations of the primer manufacturer and the pavement markings manufacturer.

D. Application of Pavement Markings

The Contractor shall follow the manufacturer's recommendations for installing the marking materials and shall provide manual or automatic application equipment as necessary for the job requirements.

1. Type B-HS: Preformed, Fused Thermoplastic Film

All pavement markings, including crosswalks, railroad crossings, turnarounds, and parallel parking pavement markings, shall be Type B-HS. See ODOT Standard Specifications Section 00867 - "Transverse Pavement Markings - Legends and Bars."

TECHNICAL SPECIFICATIONS

SECTION 5

STREETS

3.26 Pavement Striping

A. Equipment

The Contractor shall use paint sprayers made specifically for the purpose of applying paint, containing traffic paint beads, to a uniform width, thickness, and alignment on the roadway surface, using a truck-mounted three-gun system.

B. General

1. Striping shall be applied to the lines and locations shown in the Drawings, in the ODOT Traffic Line Manual, or as directed. For overlays and shoulder widening projects, the Contractor shall replace striping to match existing striping unless otherwise directed. If the roadway has changed significantly or is a new roadway, the Contractor shall propose variations in standard layouts to handle unusual conditions, subject to approval.
2. The Contractor shall place permanent striping prior to traffic being allowed on the pavement or shall provide temporary lane markings such as temporary flexible reflective pavement markers or other approved method in accordance with the Manual of Uniform Traffic Control Devices.

C. Layout and Alignment

The Contractor shall lay out a spot alignment for the striping consisting of control points every 50 feet on tangent and every 25 feet on a curve, or as directed. The Contractor shall not proceed with striping prior to receiving approval of the layout by the design engineer.

D. Application

1. Two separate applications of painted longitudinal pavement markings shall be applied. The Contractor shall retrace the second application directly over the first application, within 1/16-inch as follows:
 - The second application shall be applied after 2 hours but within 48 hours of the first application.
 - For yellow colored markings, the second application shall be applied in the opposite direction of the first application. For white colored markings, the second application shall be applied in the same direction as the first application.

TECHNICAL SPECIFICATIONS

SECTION 5

STREETS

2. Each painted marking application shall be applied at a thickness of 15 mils wet, equivalent to 17 gallons per mile for a 4-inch wide solid stripe.
3. Reflective elements for each application shall be applied at a minimum rate of 5 pounds per gallon of paint. The Contractor shall embed, by means of paint wicking, a minimum of 80 percent of the reflective elements in the paint to a minimum depth of 50 percent of their diameter. Minimum initial retroreflectivity shall be the following:
 - White - 250 mcd/m²/lx
 - Yellow - 200 mcd/m²/lx
4. When striping over open-graded HMAC, two applications of pavement striping shall be applied, the second retracing the first. The second application shall be performed approximately three weeks to a month after the initial striping is complete. Each application shall be applied at a thickness of 15 mils (wet), and include traffic paint beads.
5. The Contractor shall immediately clean up paint dribbled beyond the cutoff to avoid tracking of new paint. All areas tracked through will be reviewed by the City for possible cleanup and retracing.

E. Placement Tolerance

The Contractor shall place striping parallel and true to line and shall make skip ends square and clean. Skip stripes shall be placed so they are in cycle with at least one end of any adjacent project. Allowable tolerances for installation are:

1. Side to side - 1/2-inch on tangents, 1-inch on curves.
2. Length of skips - 10 feet, ±2 inches.
3. End to end on skips - 30 feet, ±2 inches. Place skips on cycle to a tolerance of 2 inches. A tolerance of 12 inches will be allowed on the first skip of a run, but it shall be on cycle in one skip.
4. Double lines - Parallel, with a gap tolerance of 1/2-inch.

3.27 Public Safety and Convenience

- A. The Contractor shall provide for the safety and convenience of the public and shall protect applied markings from traffic until sufficiently dry so as not to be damaged or

TECHNICAL SPECIFICATIONS

SECTION 5

STREETS

tracked by normal traffic movements. At a minimum, tubular markers or conical markers shall be placed next to all markings, and barricades shall be placed by all areas where cross traffic is anticipated. Additional protection, as required by the City, may be necessary and will be considered incidental to the pavement markings.

- B. The Contractor shall immediately correct improper alignment, broken equipment, spilled product, or other striping problems that impair traffic, including appropriate traffic control. Documentation from the Oregon Department of Environmental Quality shall be provided indicating proper cleanup of spills. Blacking out or covering up the markings and/or lines will not be allowed, except in a short-term emergency, and when approved.
- C. The Contractor shall conduct Work at all times for the least possible interference with the traveling public.
- D. The Contractor shall not open any Work area to traffic that is not adequately striped and cured.
- E. The Contractor shall not perform any Work, or close any lane to traffic, until the area is adequately signed and protected according to the Traffic Control Plan.

3.28 Disposal of Waste

Waste material is the property of the Contractor. All waste materials, including grindings and old markings, shall be removed from the Project Site and disposed of by the Contractor according to applicable state, federal, and local regulations. The cost of disposal will be incidental to the Work under these Public Works Standards, Technical Specifications, and Standard Drawings.

3.29 Removal or Repair of Unacceptable Work

The Contractor shall remove or repair all unacceptable work and dispose of it and shall repair or replace unacceptable work immediately if it causes a safety problem. The removed material becomes the property of the Contractor.

3.30 Paint Markings and Striping Warranty

The Contractor shall guarantee the paint markings and paint striping for a period of one year from the date of application against deterioration and/or delamination beyond normal wear.

END OF SECTION

STANDARD DRAWINGS

GENERAL NOTES

- ALL WORK SHALL COMPLY WITH THE CITY DESIGN STANDARDS AND SPECIFICATIONS.
- THE CONTRACTOR SHALL MAINTAIN FULL COMPLIANCE WITH ALL SAFETY AND POLLUTION REGULATIONS AS APPLICABLE TO THIS PROJECT.
- THE CONTRACTOR SHALL STABILIZE ALL AREAS OF EXCAVATION AND FILL TO PREVENT THE EROSION OF SOILS CAUSED BY WIND AND/OR WATER.
- THE CONTRACTOR SHALL CONTACT ALL UNDERGROUND UTILITY COMPANIES FOR THEIR RESPECTIVE EXISTING UTILITY LOCATIONS TWO BUSINESS DAYS PRIOR TO THE COMMENCEMENT OF ANY CONSTRUCTION ON THIS PROJECT. CALL 1-800-424-5555 (OR 811).
- THE CONTRACTOR SHALL COMPACT ALL EMBANKMENTS OUTSIDE OF THE ROADWAY TO 92% OF THE MAXIMUM DRY DENSITY PER ASTM D1557, OR AS REQUIRED BY THE CITY.
- THE CONTRACTOR SHALL STRIP THE SITE OF ALL VEGETATION PRIOR TO THE PLACEMENT OF ANY STRUCTURAL FILL.
- THE CONTRACTOR SHALL COMPACT ALL UTILITY TRENCHING FILL MATERIAL WITHIN THE RIGHT-OF-WAY TO 95% MAXIMUM DRY DENSITY PER ASTM D1557. THE CONTRACTOR SHALL COMPACT ALL UTILITY TRENCHING OUTSIDE OF THE RIGHT-OF-WAY TO 90% MAXIMUM DRY DENSITY PER ASTM D1557.
- THE CONTRACTOR SHALL COORDINATE WITH HERMISTON ENERGY SERVICES AND ALL PRIVATE UTILITIES. WHERE CONDUIT CROSSES UNDER WATER LINES, THERE SHALL BE 6" CLEARANCE BETWEEN THE WATER LINE OUTSIDE INVERT AND THE OUTSIDE CROWN ON THE CONDUIT.
- THE CONTRACTOR IS RESPONSIBLE FOR ADHERING TO THE REQUIREMENTS AND SPECIFICATIONS OF ALL PERMITS NECESSARY FOR PROPER CONSTRUCTION OF THE PROJECT.
- THE CONTRACTOR SHALL INSTALL 4" SCHEDULE 80 PVC FOR ALL UNDERGROUND ELECTRICAL CROSSINGS IN CITY STREETS.
- THE CONTRACTOR SHALL PROVIDE TRENCHING AND BACKFILL FOR ALL UNDERGROUND ELECTRICAL SERVICES.
- THE CONTRACTOR SHALL INSTALL MAILBOX CLUSTERS AT LOCATIONS ESTABLISHED BY THE U.S. POSTAL SERVICE REGULATIONS AND REQUIREMENTS.
- THE CONTRACTOR SHALL STAMP ON THE TOP OF CURB ALL UTILITY CROSSINGS UNDER THE CURB WITH THE FOLLOWING CODE:
 - "S" - SANITARY SEWER
 - "W" - POTABLE WATER
 - "I" - IRRIGATION
 - "C" - CONDUIT (UTILITIES, ELECTRICAL, TELEPHONE, CABLE, GAS, ETC.).
 LETTERS NOT PLACED BY A CITY APPROVED STAMP WILL NOT BE ACCEPTED AND THAT SECTION OF CURB MUST BE REMOVED AND REPLACED.
- NOTIFY THE CITY TWO BUSINESS DAYS BEFORE COMMENCING WORK. THE DEVELOPER SHALL BE RESPONSIBLE FOR PROVIDING ALL MATERIAL TESTING ON THIS PROJECT. ALL RESULTS SHALL BE SENT ELECTRONICALLY TO THE CITY ENGINEER AND APPROPRIATE DEPARTMENT SUPERINTENDENT.
- THE CONTRACTOR SHALL STOCKPILE ALL SUITABLE TOPSOIL/STRIPPINGS AND SHALL, UPON COMPLETION OF THE FINAL GRADING, SPREAD EVENLY ACROSS SITE TO A DEPTH NOT GREATER THAN 6" ON THE INDIVIDUAL LOTS. SUITABLE TOPSOIL SHALL BE FREE OF VEGETATION, LARGE DIRT CLOUDS, AND TREE ROOTS. CONTRACTOR SHALL SMOOTH TOPSOIL TO FINISHED GRADE ON LOTS AND PROVIDE ADEQUATE EROSION CONTROL TO MINIMIZE BLOWING DUST AND ANY SEDIMENT RUNOFF ON THE SITE POST-CONSTRUCTION.
- THE CONTRACTOR SHALL AT ALL TIMES ABIDE BY APPLICABLE SAFETY RULES OF OSHA AND, IN PARTICULAR, THOSE PERTAINING TO ADEQUATE SHORING AND TRENCH PROTECTION OF WORKMEN.
- ANY REQUIRED REINFORCING SHALL BE GRADE 60 (ASTM A615).
- THE CONTRACTOR IS RESPONSIBLE FOR PROVIDING DUST CONTROL ON THIS PROJECT.
- THE CONTRACTOR SHALL PROVIDE RECORD DRAWINGS TO THE CITY AT THE END OF THE PROJECT.
- CONTRACTOR SHALL ABIDE BY ALL CURRENT OREGON REVISED STATUTES (ORS) AS APPLICABLE.
- THE CONTRACTOR SHALL FIELD-VERIFY THE DEPTH AND LOCATION OF ALL EXISTING SEWER, STORM DRAIN, AND WATER LINES TO BE CONNECTED TO PRIOR TO BEGINNING CONSTRUCTION. THE CONTRACTOR SHALL INFORM THE DESIGN ENGINEER OF ANY DISCREPANCIES WITH THE INFORMATION FOUND IN THE FIELD COMPARED WITH THAT GIVEN ON THE PLANS.
- THE CONTRACTOR SHALL BE RESPONSIBLE FOR ALL MATERIAL AND UTILITY TESTING FOR THE PROJECT. RECORDS OF ALL TESTING SHALL BE DOCUMENTED AND COPIES OF ALL TEST RESULTS SHALL BE SENT ELECTRONICALLY TO THE CITY. THE CONTRACTOR SHALL NOTIFY THE CITY 3 BUSINESS DAYS PRIOR TO TESTING, A CITY REPRESENTATIVE SHALL WITNESS THE TESTING UNLESS OTHERWISE APPROVED IN WRITING BY THE CITY.
- THE CONTRACTOR SHALL PROVIDE AND MAINTAIN ADEQUATE TRAFFIC CONTROL WITHIN AND ADJACENT TO THE PROJECT AS REQUIRED BY THE CITY. ALL TRAFFIC CONTROL SHALL COMPLY WITH THE REQUIREMENTS OF THE CURRENT VERSION OF THE MANUAL ON UNIFORM TRAFFIC CONTROL DEVICES (MUTCD).
- THE CONTRACTOR SHALL OBTAIN A RIGHT-OF-WAY PERMIT AND SUBMIT A TRAFFIC CONTROL PLAN TO THE CITY FOR REVIEW AND APPROVAL PRIOR TO BEGINNING WORK.
- ALL TRENCH CONSTRUCTION SHALL BE PER CITY STANDARD DRAWING ST20.
- ALL AGGREGATE BASE SHALL BE 100-PERCENT FRACTURED FACE BASALT.

SANITARY NOTES

- ALL SANITARY SEWER PIPE SHALL BE PVC CONFORMING TO CITY DESIGN STANDARDS.
- ALL SEWER PIPE SHALL HAVE A MINIMUM CLEARANCE OF 36" COVER FROM FINISHED GRADE.
- THE CONTRACTOR SHALL ADJUST ALL MANHOLE LIDS AND CLEANOUT BOXES TO FINISHED GRADE PER CITY STANDARD DRAWINGS SS01 AND SS04.
- THE CONTRACTOR SHALL NOTIFY THE CITY WASTEWATER DEPARTMENT 72 HOURS PRIOR TO TESTING OF SANITARY SEWER SYSTEM. TESTING SHALL BE PER CITY DESIGN STANDARDS.
- THE CONTRACTOR SHALL MAINTAIN THE FLOW IN EXISTING STORM AND SANITARY SEWER LINES AT ALL TIMES.
- THE CONTRACTOR SHALL NOT MAKE ANY CONNECTIONS TO NEW SERVICE STUBS UNTIL AFTER SANITARY SEWER LINES HAVE BEEN TESTED AND APPROVED BY THE CITY.

WATER NOTES

- ALL WATER MAINS SHALL BE DUCTILE IRON CONFORMING TO CITY DESIGN STANDARDS.
- WATER SYSTEM TO BE TESTED PER CITY DESIGN STANDARDS.
- THE CONTRACTOR SHALL NOT MAKE ANY CONNECTIONS TO NEW SERVICE STUBS UNTIL AFTER WATER LINES HAVE BEEN TESTED AND APPROVED BY THE CITY.
- THE CONTRACTOR SHALL BE RESPONSIBLE FOR INSTALLING THE METER BOXES AND WATER SERVICE LINES PER CITY STANDARDS.
- RSGV REFERS TO THE INSTALLATION OF A RESILIENT SEATED GATE VALVE ON THE WATER LINE PLANS.
- ALL WATER LINE PIPE SHALL HAVE A MINIMUM 36" OF COVER FROM FINISHED GRADE. MAXIMUM COVER IS 48" FROM FINISHED GRADE.
- MAXIMUM WATER LINE DEFLECTION AT THE JOINTS SHALL NOT EXCEED 80% OF AWWA STANDARDS.
- THE CONTRACTOR SHALL RESTRAIN ALL BENDS, TEES, CROSSES, FITTINGS, AND VALVES WITH THRUST BLOCKING OR APPROVED JOINT RESTRAINT PER CITY STANDARDS.
- THE CONTRACTOR SHALL CHLORINATE ALL WATER MAINS PRIOR TO PRESSURE TESTING PER CITY STANDARD DRAWING W14 AND TECHNICAL SPECIFICATIONS.
- ALL FIRE HYDRANTS MUST BE REVIEWED AND APPROVED BY THE CITY'S FIRE MARSHAL.
- THE CONTRACTOR SHALL ADJUST ALL VALVE BOXES TO FINISH GRADE PER CITY STANDARD DRAWING W04.

STREET NOTES

- ALL CURB RADII SHALL BE AS REQUIRED BY CITY DESIGN STANDARDS.
- THE CONTRACTOR SHALL SAW CUT STRAIGHT LINES TO MEET EXISTING PAVEMENT WITH NEW PAVEMENT.
- CONTRACTOR SHALL NOTIFY THE STREET DEPARTMENT 3 BUSINESS DAYS PRIOR TO ANY TESTING. ASPHALT PAVEMENT SHALL BE TESTED TO MEET 92% OF THE RICE THEORETICAL MAX DENSITY.
- RAMP CONSTRUCTION SHALL MEET ALL CURRENT ADA STANDARDS AND SPECIFICATIONS.
- THE CONTRACTOR IS TO CONTACT THE STREET SUPERINTENDENT PRIOR TO CONSTRUCTION OF ADA RAMPS. RAMP LOCATIONS SHALL BE LOCATED IN THE FIELD BY THE STREET SUPERINTENDENT.
- ALL FUTURE DRIVEWAYS AND SIDEWALKS NOT SHOWN ON THE PLANS SHALL BE CONSTRUCTED PER CITY DESIGN STANDARDS UNDER A SEPARATE PERMIT.
- THE CONTRACTOR SHALL PROVIDE AND INSTALL ALL MONUMENT BOXES. THE SURVEY MONUMENTS WITHIN THE BOXES WILL BE ESTABLISHED BY THE OWNER/DEVELOPERS SURVEYOR. SURVEY MONUMENT COORDINATES AND ELEVATION SHALL BE SHOWN ON THE RECORD DRAWINGS. BOXES TO BE INSTALLED PER CITY STANDARD DRAWING ST18.
- THE CONTRACTOR SHALL COMPACT ALL ROADWAY EMBANKMENTS TO 95% OF THE MAXIMUM DENSITY PER ASTM D1557, OR AS REQUIRED BY THE CITY.
- THE CONTRACTOR MAY BE REQUIRED TO TEST THE FINISHED SURFACE OF THE SUBGRADE AS DIRECTED BY THE CITY IN AREAS WHERE VISUAL OBSERVATION INDICATES THE POSSIBLE PRESENCE OF EXPANSIVE SOILS. THE CONTRACTOR SHALL PERFORM THE REQUIRED TESTS AND PROVIDE THE CITY WITH THE TEST RESULTS FOR THE DETERMINATION OF SUBGRADE TREATMENT. THE CONTRACTOR SHALL BE REQUIRED TO MAKE THE NECESSARY ADJUSTMENTS TO MEET THE MINIMUM SUBGRADE REQUIREMENTS AS DIRECTED BY THE CITY.
- ANY MATERIAL INCLUDING EXCAVATED, IMPORTED, OR CUT MATERIAL SHALL NOT BE STOCKPILED ON PAVED SURFACES WITHIN THE PUBLIC RIGHT-OF-WAY, UNLESS APPROVED BY THE CITY. ANY DAMAGE TO PAVED SURFACES RESULTING FROM STOCKPILED IMPORTED MATERIAL ON SAID SURFACES SHALL BE REPAIRED AT THE CONTRACTOR'S EXPENSE.

EROSION CONTROL NOTES

- APPROVAL OF AN EROSION/SEDIMENTATION CONTROL (ESC) PLAN DOES NOT CONSTITUTE AN APPROVAL OF PERMANENT ROAD OR DRAINAGE DESIGN (I.E., SIZE AND LOCATION OF ROADS, PIPES, CHANNELS, RETENTION FACILITIES, UTILITIES, ETC.).
- IMPLEMENTATION OF ESC PLANS AND THE CONSTRUCTION, MAINTENANCE, REPLACEMENT, AND UPGRADE OF ESC FACILITIES IS THE RESPONSIBILITY OF THE CONTRACTOR UNTIL ALL CONSTRUCTION IS COMPLETED AND APPROVED BY THE CITY AND VEGETATION/LANDSCAPING IS ESTABLISHED.
- THE ESC FACILITIES SHOWN ON THIS PLAN MUST BE INSTALLED IN CONJUNCTION WITH ALL CLEARING AND GRADING ACTIVITIES, AND IN SUCH A MANNER AS TO ENSURE THAT SEDIMENT AND SEDIMENT LADEN WATER DO NOT LEAVE THE SITE AND ENTER ADJACENT WATERCOURSES OR DRAINAGE WAYS.
- DURING CONSTRUCTION ESC FACILITIES SHALL BE UPGRADED AS NEEDED FOR UNEXPECTED STORM EVENTS TO ENSURE THAT SEDIMENT AND SEDIMENT LADEN WATER DO NOT LEAVE THE SITE.
- ESC FACILITIES SHALL BE INSPECTED DAILY BY THE CONTRACTOR AND MAINTAINED AS NECESSARY TO ENSURE THE CONTINUING FUNCTION OF THE FACILITIES.
- ESC FACILITIES ON INACTIVE SITES SHALL BE INSPECTED AND MAINTAINED A MINIMUM OF ONCE A MONTH OR WITHIN 48 HOURS FOLLOWING A STORM EVENT.
- AT NO TIME SHALL MORE THAN 1' OF SEDIMENT BE ALLOWED TO ACCUMULATE WITHIN A TRAPPED CATCH BASIN. ALL CATCH BASINS AND CONVEYANCE LINES SHALL BE CLEANED PRIOR TO PAVING. THE CLEANING OPERATION SHALL NOT FLUSH SEDIMENT LADEN WATER INTO THE DOWNSTREAM SYSTEM.
- CONSTRUCTION ENTRANCES PER CITY STANDARD DRAWING ST21 SHALL BE INSTALLED AT THE BEGINNING OF CONSTRUCTION AND MAINTAINED FOR THE DURATION OF THE PROJECT. ADDITIONAL MEASURES MAY BE REQUIRED TO ENSURE THAT ALL PAVED AREAS ARE KEPT CLEAN FOR THE DURATION OF THE PROJECT.
- SEDIMENT FENCES AND STRAW BALE BARRIERS SHALL BE REMOVED WHEN THEY HAVE SERVED THEIR USEFUL PURPOSE, BUT NOT BEFORE THE UPSLOPE AREAS HAVE BEEN PERMANENTLY STABILIZED.
- THE CONTRACTOR SHALL MAINTAIN A WATER TRUCK ON THE SITE AS NECESSARY TO PREVENT DUST AND SAND FROM BLOWING ONTO ADJACENT PROPERTIES.
- THE CONTRACTOR SHALL KEEP THE PAVED RIGHT-OF-WAY FREE OF DEBRIS, MUD, DIRT, AND OTHER POLLUTANTS. DAILY SWEEPING OR OTHER BEST MANAGEMENT PRACTICES SHALL BE EMPLOYED AS NEEDED.

COORDINATION WITH PRIVATE UTILITIES

- IT SHALL BE THE CONTRACTOR'S RESPONSIBILITY TO SET UP A PRE-CONSTRUCTION MEETING WITH ALL IMPACTED PRIVATE UTILITY COMPANIES (ELECTRICAL, TELEPHONE, CABLE, GAS, IRRIGATION), THE CITY, AND THE DESIGN ENGINEER TO DISCUSS THE INSTALLATION OF THE PRIVATE UTILITIES. AT THE TIME OF THE PRE-CONSTRUCTION MEETING WITH THE CITY, THE CONTRACTOR SHALL SUBMIT TO THE CITY DETAILED PLANS SHOWING THE LOCATION OF ALL TRENCHING, STREET CROSSINGS, VAULT LOCATIONS, AND PEDESTAL LOCATIONS FOR EACH UTILITY. THE CONTRACTOR WILL NOT BE ALLOWED TO EXCAVATE ANY PRIVATE UTILITY TRENCHES OR INSTALL ANY VAULTS, PEDESTALS, OR CONDUIT PRIOR TO THIS PRE-CONSTRUCTION MEETING. THE LOCATION OF ALL PEDESTALS, VAULTS, AND CONDUITS SHALL BE APPROVED BY THE CITY PRIOR TO COMMENCING WITH WORK.

STANDARD DRAWING INDEX

- G01 - GENERAL NOTES AND INDEX
- ST01 - CURB AND GUTTER
 ST02 - CROSS GUTTER TYPE I
 ST03 - CROSS GUTTER TYPE II
 ST04 - SIDEWALK
 ST05 - DRIVEWAY AND ALLEY RAMPS
 ST06 - CURB RAMPS
 ST07 - URBAN MAJOR ARTERIAL
 ST08 - URBAN MINOR ARTERIAL
 ST09 - URBAN MAJOR COLLECTOR
 ST10 - URBAN MINOR COLLECTOR
 ST11 - URBAN LOCAL STREET
 ST12 - URBAN LOCAL STREET WITH SWALE
 ST13 - RURAL ARTERIAL, COLLECTOR, AND LOCAL ROADS
 ST14 - FIRE APPARATUS TURNAROUND
 ST15 - ALLEY
 ST16 - CUL-DE-SAC
 ST17 - PAVEMENT STRIPING AND MARKINGS
 ST18 - MONUMENT BOX
 ST19 - SIGNS
 ST20 - TRENCH BEDDING, BACKFILL, AND SURFACE RESTORATION
 ST21 - EROSION AND SEDIMENT CONTROL
- SD01 - STORM DRAIN CATCH BASIN
 SD02 - STORM DRAIN MANHOLE
 SD03 - SEDIMENTATION CHAMBER AND DRYWELL
- SS01 - SANITARY SEWER MANHOLE
 SS02 - PIPE TO MANHOLE CONNECTIONS
 SS03 - OUTSIDE DROP MANHOLES
 SS04 - SEWER CLEANOUTS
 SS05 - SEWER SERVICE CONNECTION
 SS06 - WATER-SEWER CROSSING
 SS07 - WATER - SEWER LINE SEPARATION
 SS08 - SEWER SERVICE CURB STAMP
- W01 3/4" OR 1" WATER SERVICE
 W02 1-1/2" OR 2" WATER SERVICE
 W03 3" OR LARGER WATER SERVICE
 W04 - VALVE BOX AND WATER UTILITY MARKER
 W05 - WATER MAIN AND SERVICE LINE STUBS
 W06 - WATER MAIN TIE-IN
 W07 - FIRE HYDRANT ASSEMBLY
 W08 - MAIN DEAD-END BLOWOFF ASSEMBLY
 W09 - COMBINATION AIR VALVE ASSEMBLY
 W10 - WATER MAIN CASING
 W11 - THRUST BLOCKS
 W12 - PIPE SLOPE ANCHORS
 W13 - WATER SERVICE CURB STAMP
 W14 - CHLORINATION AND BACTERIA TESTING

x:\Clients\hermiston_01_citystandarddrawings\HermStdDwg_G01_Gen_Notes_Index.dwg, G01, 1/29/2024 2:50 PM, lwilhlite



CITY OF
HERMISTON, OREGON
STANDARD DRAWINGS

GENERAL NOTES AND INDEX

FIGURE
G01

NOTES

1. GUTTER CROSS SLOPE SHALL BE MINIMUM 2% AND MAXIMUM 3% UNLESS OTHERWISE APPROVED BY THE CITY.
2. ALL CONCRETE SHALL BE COMMERCIAL GRADE 4,000 PSI CONCRETE.
3. COMPACT AGGREGATE BASE TO 95% MAXIMUM DRY DENSITY PER ASTM D1557.
4. AGGREGATE BASE THICKNESS BELOW CURB AND GUTTER SHALL BE 6" THICK OR CONFORM TO CITY STD DWG ST07-ST11, WHICHEVER IS GREATER.
5. SEE CITY STD DWG ST04 FOR CURB AND GUTTER JOINT REQUIREMENTS.
6. CONCRETE SHALL BE TROWELED SMOOTH PRIOR TO APPLYING BROOM FINISH.
7. INSPECTION CRITERIA:
 - 7.1. COMPLETED CURB AND GUTTER SHALL NOT CAUSE PUDDLING ISSUES. PUDDLE WIDTH SHALL NOT EXCEED 75% OF THE GUTTER WIDTH AND PUDDLE LENGTH SHALL NOT EXCEED 2'.
 - 7.2. CROSS SLOPE OF THE GUTTER SHALL BE A MINIMUM OF 1.5% AND A MAXIMUM OF 3.5% AS MEASURED BY A 2' ELECTRONIC LEVEL.
 - 7.3. THERE SHALL BE NO BREAK POINTS OR REVERSE SLOPE IN THE GUTTER CROSS SLOPE AS MEASURED BY A 2' ELECTRONIC LEVEL. THE MAXIMUM ALLOWABLE GAP BETWEEN THE LEVEL AND THE GUTTER SURFACE SHALL BE 1/8".
 - 7.4. WHEN A 6 FOOT LONG STRAIGHTEDGE IS LAID ON THE TOP FACE OF THE CURB OR ON THE SURFACE OF THE GUTTER, THE SURFACE SHALL NOT VARY MORE THAN 0.02 FEET FROM THE EDGE OF THE STRAIGHTEDGE EXCEPT AT GRADE CHANGES OR VERTICAL CURVES.
 - 7.5. THE CONTRACTOR SHALL CONSTRUCT ALL CURB AND GUTTER WITHIN 0.02 FEET OF TRUE LINE, WITHIN 0.02 FEET OF ESTABLISHED SURFACE GRADE, CROSS SECTION, AND SLOPE, AND WITHIN 0.02 FEET OF SPECIFIED THICKNESS.
8. WHEN INSTALLING NEW CURB AND GUTTER ON AN EXISTING PAVED STREET, THE ASPHALT SHALL BE CUT A MINIMUM OF 2 FEET FROM THE EDGE OF THE GUTTER OR AS NEEDED TO ACHIEVE COMPACTION OF THE AGGREGATE BASE BY MECHANICAL MEANS.

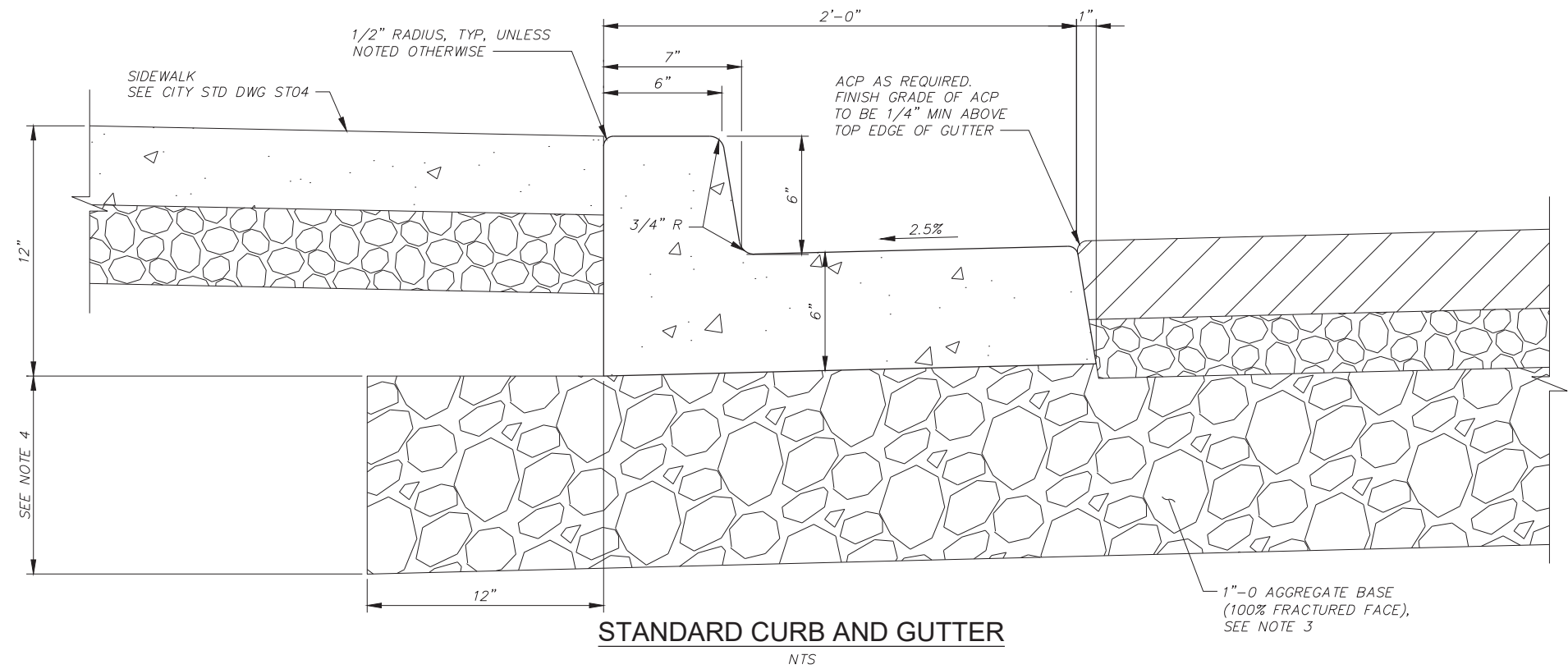

STANDARD CURB AND GUTTER
NTS

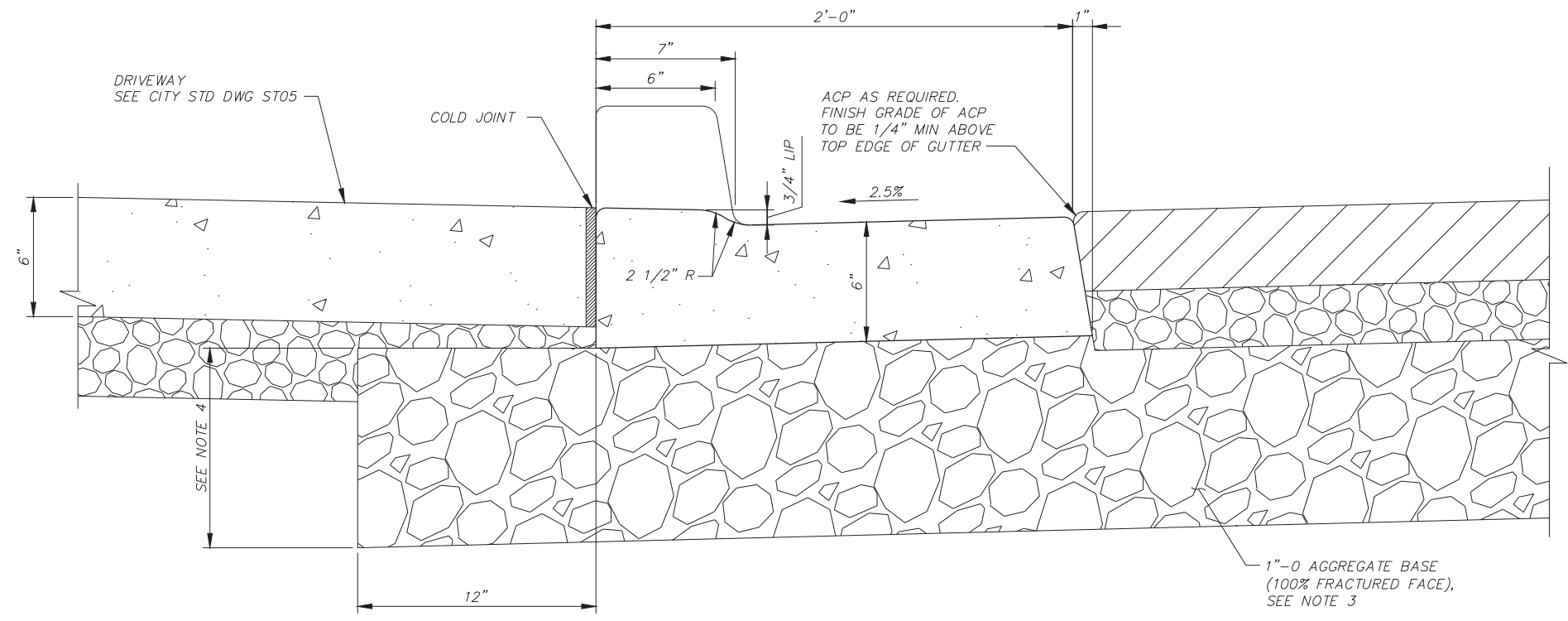

CURB AND GUTTER AT DRIVEWAY
NTS

x:\Clients\hermiston_01_citystandarddrawings\HermStdDwg_ST01_Curb_Gutter.dwg_ST01_1/29/2024 2:51 PM.lwilhite

	<p>CITY OF HERMISTON, OREGON STANDARD DRAWINGS</p>	<p>FIGURE ST01</p>
<p>CURB AND GUTTER</p>		
<p>305</p>		

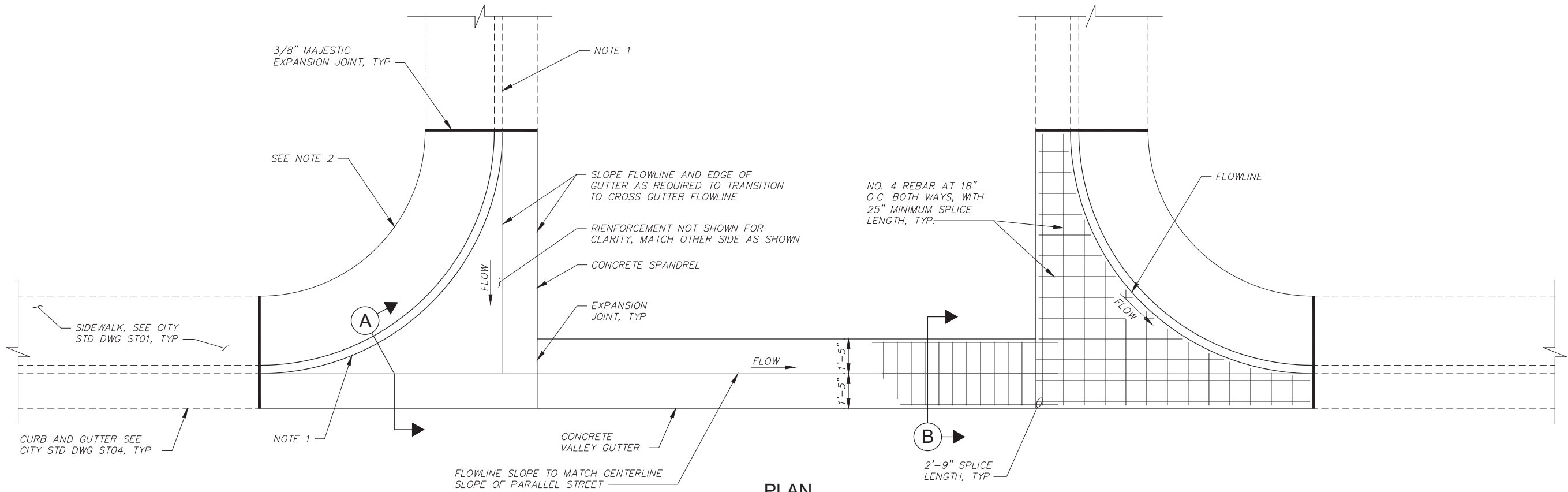

PLAN
NTS

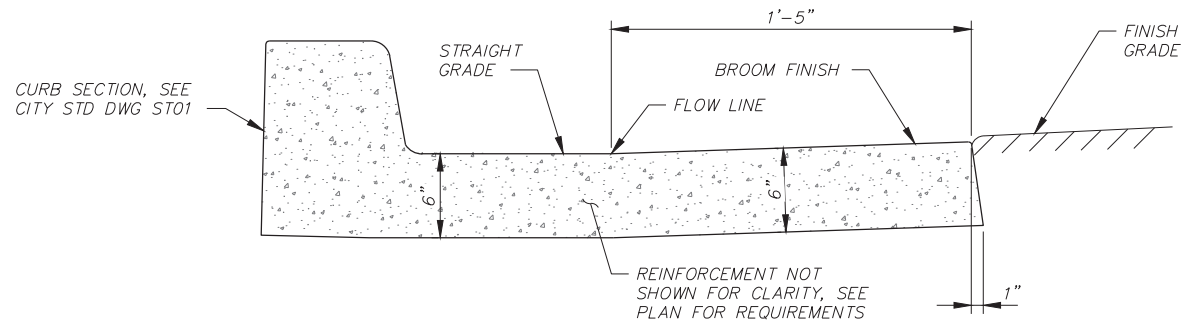

SECTION A
NTS

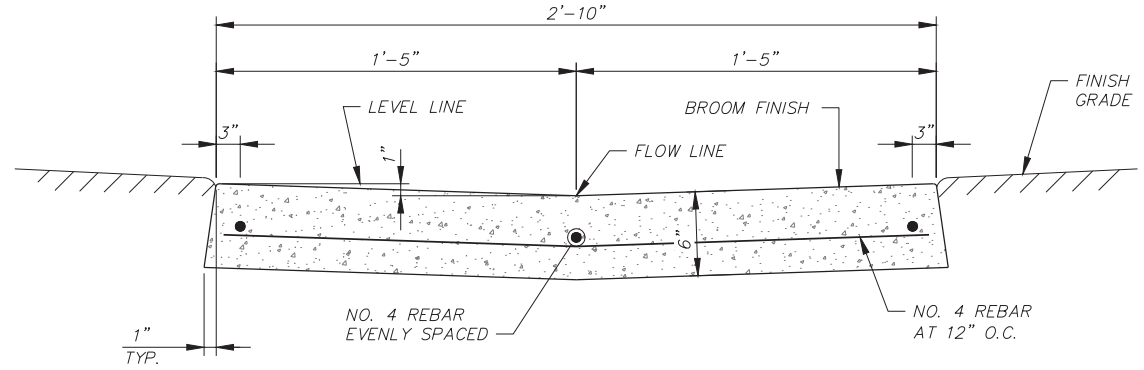

SECTION B
NTS

NOTES

1. SEE CITY STD DWG ST06 FOR CURB RAMP DETAILS. SLOPE THROUGH THE FLOW LINE RADIUS SHALL NOT EXCEED 1.5% FOR DESIGN AND 2% FOR CONSTRUCTION.
2. SEE DESIGN DRAWINGS FOR LENGTH OF RADIUS OR AS APPROVED BY THE CITY ENGINEER.
3. ALL CONCRETE SHALL BE COMMERCIAL GRADE 4,000 PSI CONCRETE.
4. FLOWLINE MINIMUM SLOPE IS 0.5%.
5. SPANDREL CURB SHALL BE POURED MONOLITHICALLY.

x:\Clients\hermiston or_ city standard drawings\HermStdDwg_ST02_CROSS_GUTTER_1.dwg, ST02, 1/29/2024 2:51 PM, lwillhite

	<p>CITY OF HERMISTON, OREGON STANDARD DRAWINGS</p> <p>CROSS GUTTER TYPE I</p>	<p>FIGURE ST02</p>
---	---	-------------------------------

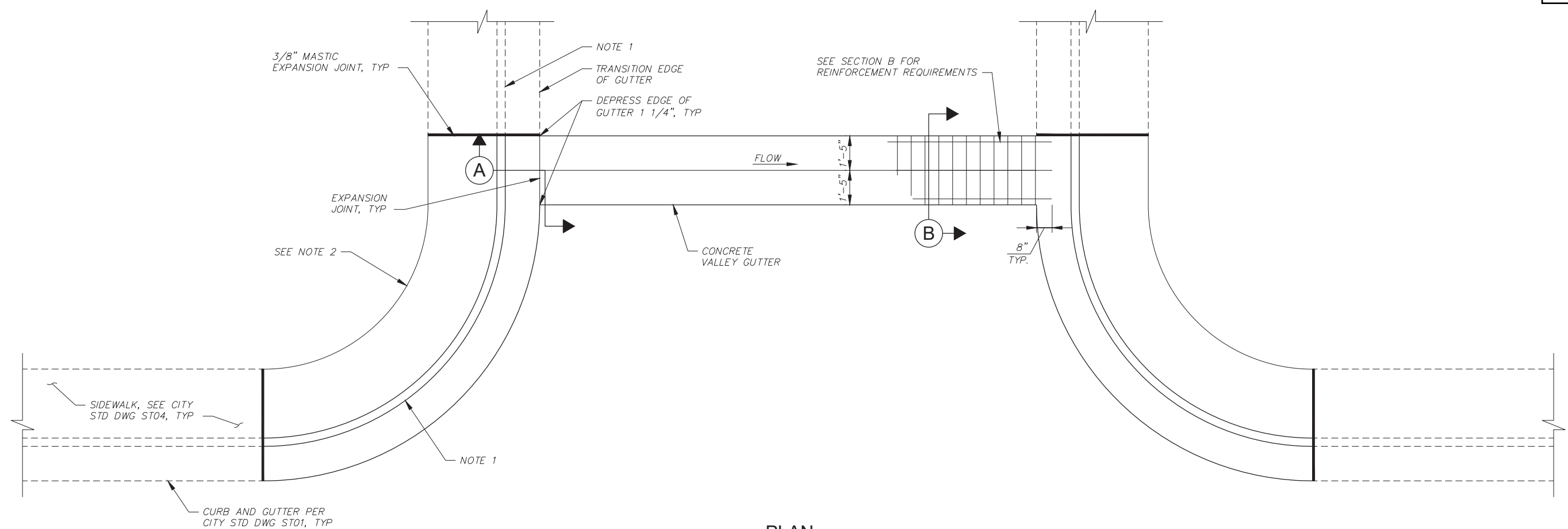

PLAN
NTS

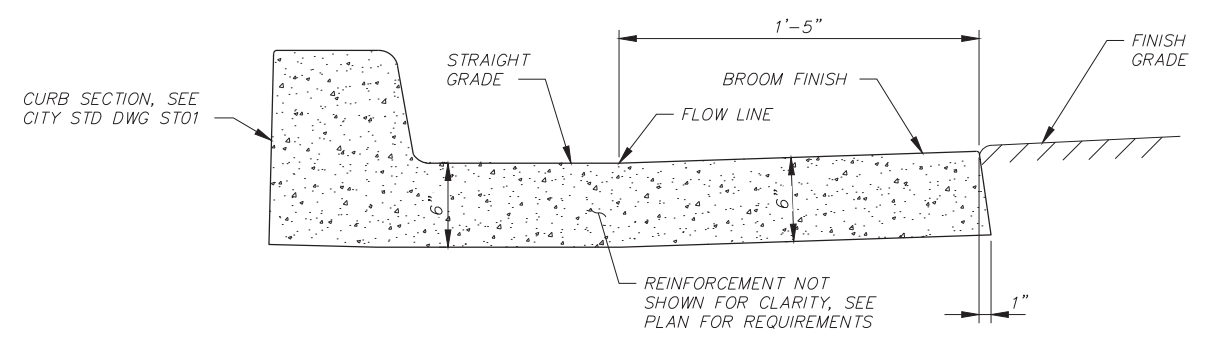

SECTION A
NTS

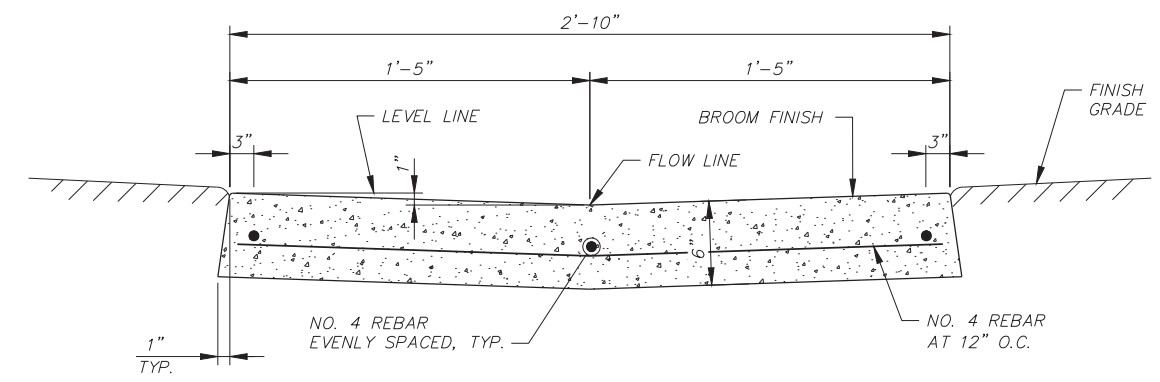

SECTION B
NTS

NOTES

1. SEE CITY STD DWG ST06 FOR CURB RAMP DETAILS. SLOPE THROUGH THE FLOW LINE RADIUS SHALL NOT EXCEED 2% IN EITHER DIRECTION.
2. SEE DESIGN DRAWINGS FOR LENGTH OF RADIUS OR AS APPROVED BY THE CITY ENGINEER.
3. ALL CONCRETE SHALL BE COMMERCIAL GRADE 4,000 PSI CONCRETE.
4. FLOWLINE MINIMUM DESIGN SLOPE IS 0.7%; MINIMUM CONSTRUCTED SLOPE IS 0.5%.
5. THE USE OF TYPE II CROSS GUTTERS MUST BE APPROVED BY THE CITY AND SHOULD ONLY BE USED WHEN A TYPE I CROSS GUTTER IS NOT PRACTICAL.

x:\Clients\hermiston or_ city standard drawings\HermStdDwg_ST03_CROSS_GUTTER_2.dwg, ST03, 1/29/2024 2:51 PM, lwillhite

	<p>CITY OF HERMISTON, OREGON STANDARD DRAWINGS</p> <p>CROSS GUTTER TYPE II</p>	<p>FIGURE ST03</p>
---	--	-------------------------------

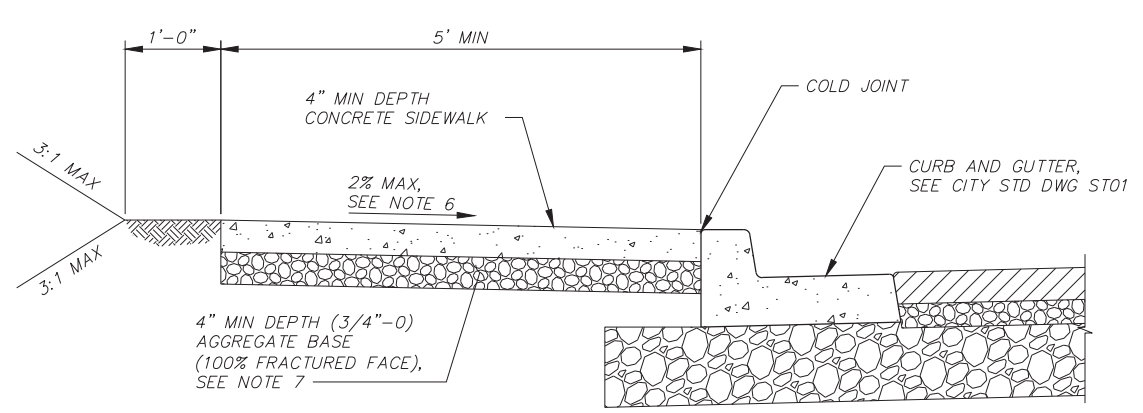

SIDEWALK SECTION
NTS

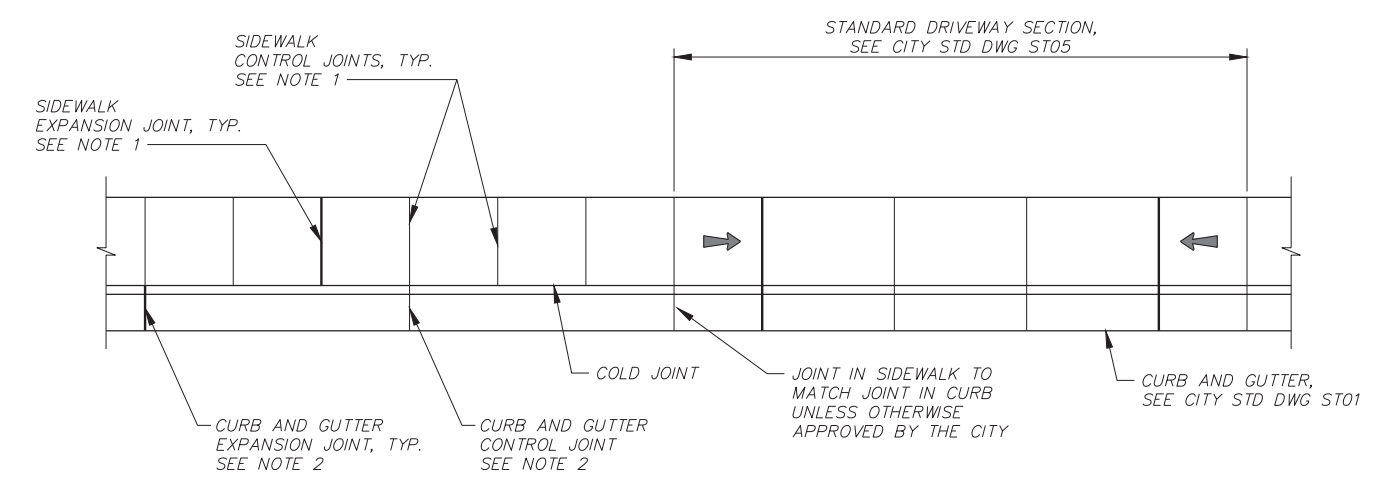

TYPICAL PLAN VIEW
NTS

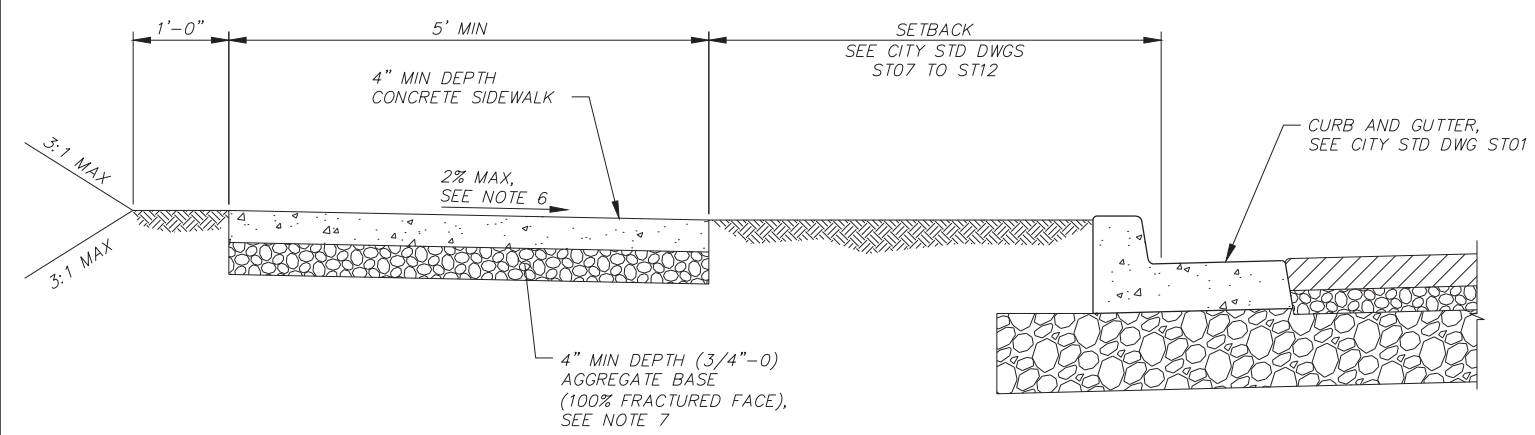

SIDEWALK SECTION WITH SETBACK
NTS

NOTES

1. SIDEWALK JOINT REQUIREMENTS:
 - EXPANSION JOINT SPACING SHALL BE 45' ON CENTER MAXIMUM, AND SHALL BE PROVIDED AROUND POLES, BOXES, AND ANY FIXTURES WHICH PROTRUDE THROUGH THE SIDEWALK, BETWEEN ANY STRUCTURE IMMEDIATELY ADJACENT TO THE SIDEWALK, AND AT THE ENDS OF EACH DRIVEWAY (AS DETERMINED BY DRIVEWAY WIDTH).
 - FOR SIDEWALKS LESS THAN 8' WIDE, TRANSVERSE CONTROL JOINT SPACING SHALL BE EQUAL TO THE WIDTH OF THE SIDEWALK EXCLUDING THE CURB. FOR SIDEWALKS 8' OR GREATER IN WIDTH TRANSVERSE CONTROL JOINT SPACING SHALL BE EQUAL TO HALF THE WIDTH OF THE SIDEWALK AND A LONGITUDINAL CONTROL JOINT SHALL BE CONSTRUCTED AT THE CENTER OF THE SIDEWALK.
2. CURB AND GUTTER JOINT REQUIREMENTS:
 - EXPANSION JOINTS ARE OPTIONAL WHEN USED. SPACING SHALL BE 200' ON CENTER MAXIMUM AND SHALL BE PLACED AT POINTS OF TANGENCY, AT BOTH ENDS OF EACH DRIVEWAY, AT CONNECTION TO EXISTING CURB/GUTTER, AND ADJACENT TO ANY STRUCTURE.
 - CONTROL JOINT SPACING SHALL BE 15' ON CENTER MAXIMUM, AND SHALL BE PLACED AT THE ENDS OF EACH STORMWATER INLET AND CURB RAMP.
3. CONCRETE DEPTH FOR SIDEWALKS SHALL BE 4" MIN, SEE ST05 FOR DRIVEWAY THICKNESS.
4. BROOM FINISH ALL SIDEWALKS AND DRIVEWAYS.
5. WHERE NEW SIDEWALK CONSTRUCTION ABUTS AN EXISTING SIDEWALK NOT MEETING CITY STANDARDS, NEW SIDEWALK CONSTRUCTION MUST TRANSITION TO MEET CITY STANDARDS WITHIN A MAXIMUM DISTANCE EQUAL TO THE WIDTH OF THE SIDEWALK EXCLUDING THE CURB.
6. TO ENSURE SLOPES DO NOT EXCEED MAXIMUM ALLOWABLE SLOPES, IT IS RECOMMENDED TO SET SLOPES LOWER THAN MAXIMUM ALLOWABLE SLOPES AS FOLLOWS:
 - FOR 2% MAX, SET SLOPE AT 1.5%
 - FOR 8.33% MAX, SET SLOPE AT 7.5%
 SIDEWALK WITH SLOPES EXCEEDING MAXIMUM ALLOWABLE VALUES SHALL BE REMOVED AND REPLACED AT THE CONTRACTORS EXPENSE.
7. COMPACT AGGREGATE BASE (100% FRACTURED FACE) TO 95% MAXIMUM DRY DENSITY PER ASTM D1557.
8. ALL CONCRETE SHALL BE COMMERCIAL GRADE 4,000 PSI CONCRETE.

x:\Clients\hermiston_or_citystandarddrawings\HermStdDwg_ST04_SIDEWALK.dwg, ST04, 1/29/2024 2:51 PM, lwillwhite

	<p>CITY OF HERMISTON, OREGON STANDARD DRAWINGS</p>	<p>FIGURE ST04</p>
<p>SIDEWALK</p>		
<p>308</p>		

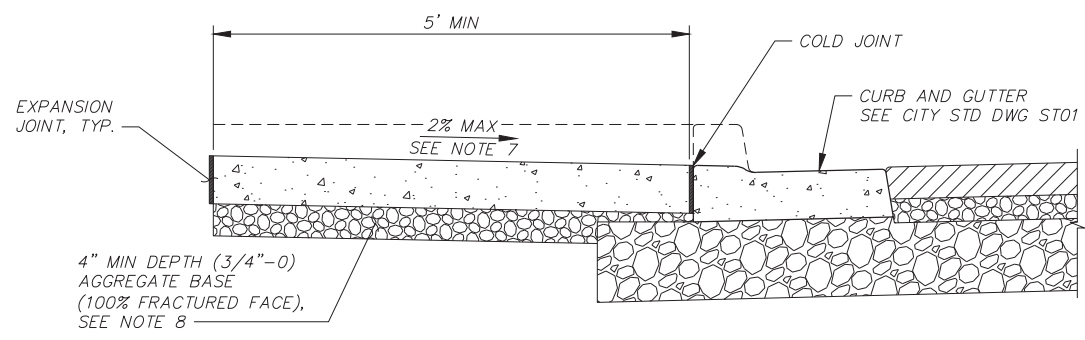

SECTION VIEW

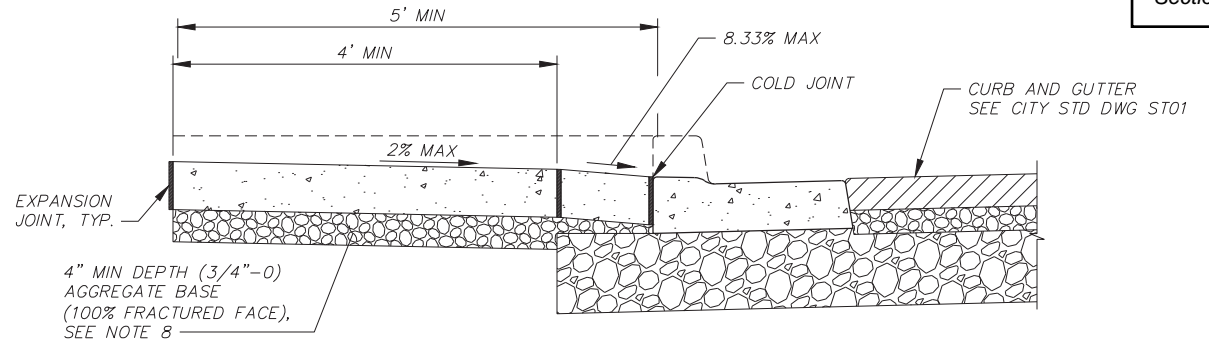

SECTION VIEW

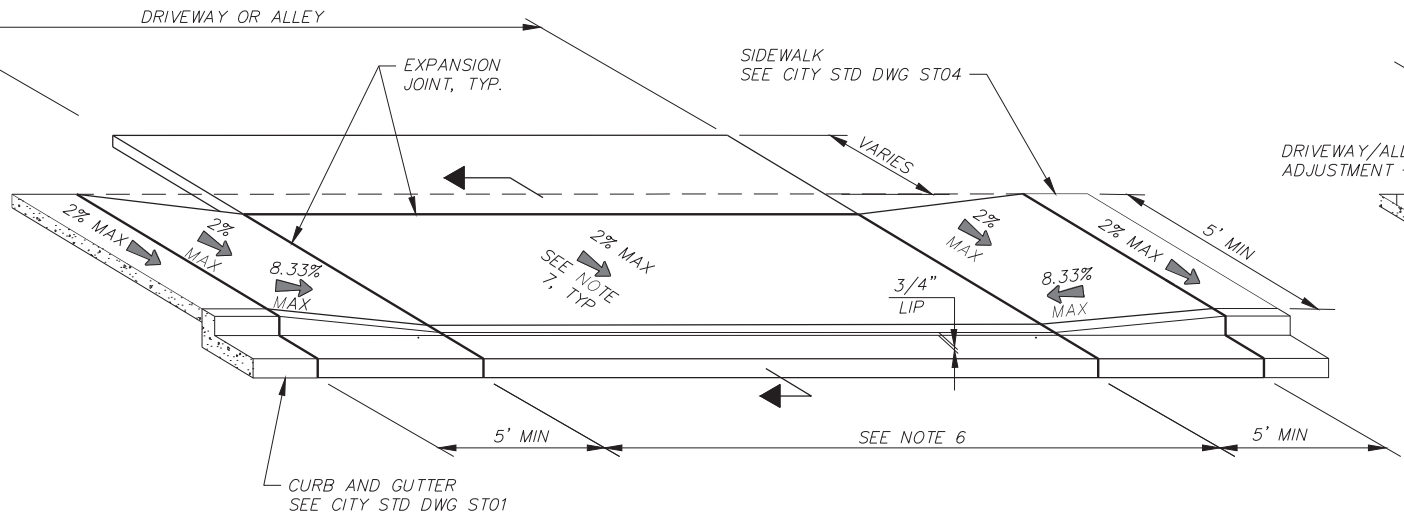

ISOMETRIC VIEW

DRIVEWAY/ALLEY RAMP (OPTION 1)

NTS

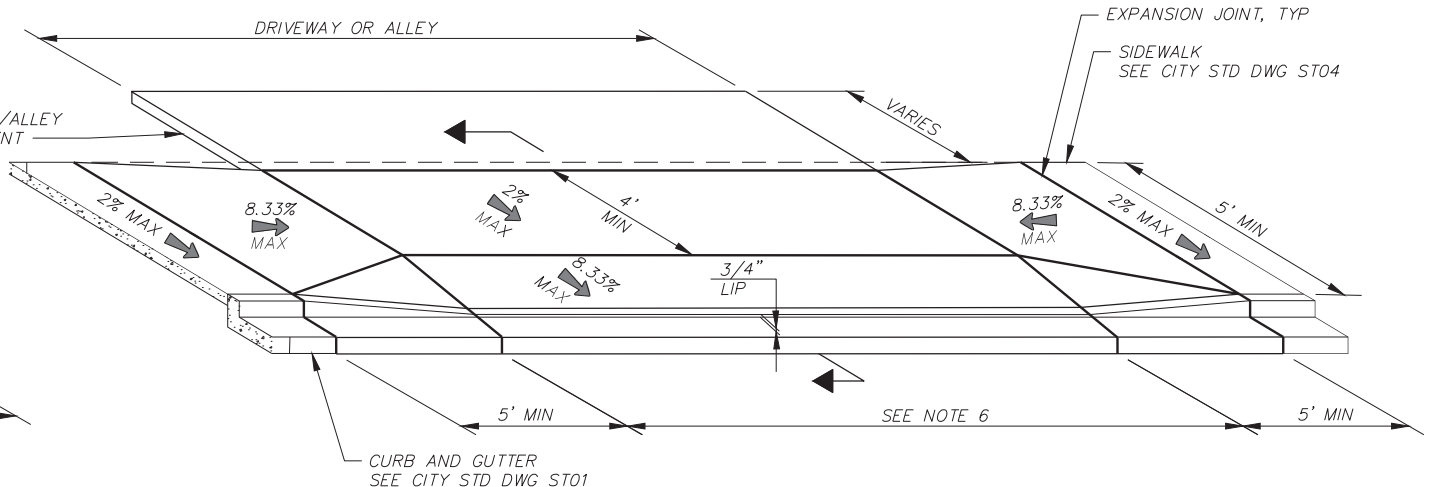

ISOMETRIC VIEW

DRIVEWAY/ALLEY RAMP (OPTION 2)

NTS

NOTES

1. RESIDENTIAL DRIVEWAYS AND SIDEWALK SECTIONS THROUGH DRIVEWAYS SHALL HAVE A MINIMUM NOMINAL THICKNESS OF 6".
2. CONCRETE FOR COMMERCIAL USE AND ALLEY APPROACHES SHALL HAVE A MINIMUM NOMINAL THICKNESS OF 8". ALL CONCRETE SHALL BE COMMERCIAL GRADE 4,000 PSI CONCRETE.
3. THE 2% CROSS-SLOPE OF SIDEWALK IS MEASURED FROM HORIZONTAL. THE 12:1 SLOPE OF SIDEWALK TRANSITION TO DRIVEWAY/ALLEY IS RELATIVE TO THE RUNNING SLOPE OF THE SIDEWALK. THE SLOPE OF THE APRON IS MEASURED RELATIVE TO HORIZONTAL, SEE NOTE 7.
4. THE DRIVEWAY SHALL NOT BE PLACED INTEGRAL WITH THE SIDEWALK, CURB, OR ANY DRIVEWAY TRANSITION SLAB AND SHALL BE ISOLATED WITH FULL DEPTH EXPANSION JOINTS.
5. DRIVEWAY CONTROL JOINTS (NOT SHOWN) SHALL BE SPACED AT A MAXIMUM ON CENTER SPACING EQUAL TO THE SIDEWALK WIDTH OR TO MATCH EXISTING SIDEWALK CONTROL JOINT SPACING, WHICHEVER IS LESS.
6. DRIVEWAY WIDTH SHALL CONFORM TO THE FOLLOWING REQUIREMENTS:
 - 6.1. DRIVEWAYS SHALL NOT BE LOCATED CLOSER THAN 5 FEET TO SIDE PROPERTY LINES.
 - 6.2. DRIVEWAYS SHALL BE LOCATED A MINIMUM DISTANCE FROM CURB RETURNS AS REQUIRED BY TECHNICAL SPECIFICATIONS SECTION 5 STREETS SECTION 1.1.Q.5.
 - 6.3. MAXIMUM DRIVEWAY WIDTH SHALL BE 50% OF THE PROPERTY FRONTAGE OR 50 FEET WHICHEVER IS LESS. ADDITIONAL, WHERE ROADSIDE SWALES ARE PRESENT THE DRIVEWAY WIDTH SHALL IN NO CASE LIMIT THE SWALE CUMULATIVE LENGTH TO LESS THAN 50% OF THE PROPERTY FRONTAGE.
7. TO ENSURE SLOPES DO NOT EXCEED MAXIMUM ALLOWABLE SLOPES, IT IS RECOMMENDED TO SET SLOPES LOWER THAN MAXIMUM ALLOWABLE SLOPES AS FOLLOWS:
 - FOR 2% MAX, SET SLOPE AT 1.5%
 - FOR 8.33% MAX, SET SLOPE AT 7.5%
 DRIVEWAYS WITH SLOPES EXCEEDING MAXIMUM ALLOWABLE VALUES SHALL BE REMOVED AND REPLACED AT THE CONTRACTORS EXPENSE.
8. COMPACT AGGREGATE BASE (100% FRACTURED FACE) TO 95% MAXIMUM DRY DENSITY PER ASTM D1557.

x:\clients\hermiston\01_citystandarddrawings\HermStdDwg_ST05_Driveway_Ramp.dwg_ST05_1/29/2024 2:51 PM.lwillhite



CITY OF
HERMISTON, OREGON
STANDARD DRAWINGS

DRIVEWAY AND ALLEY RAMPS

FIGURE
ST05

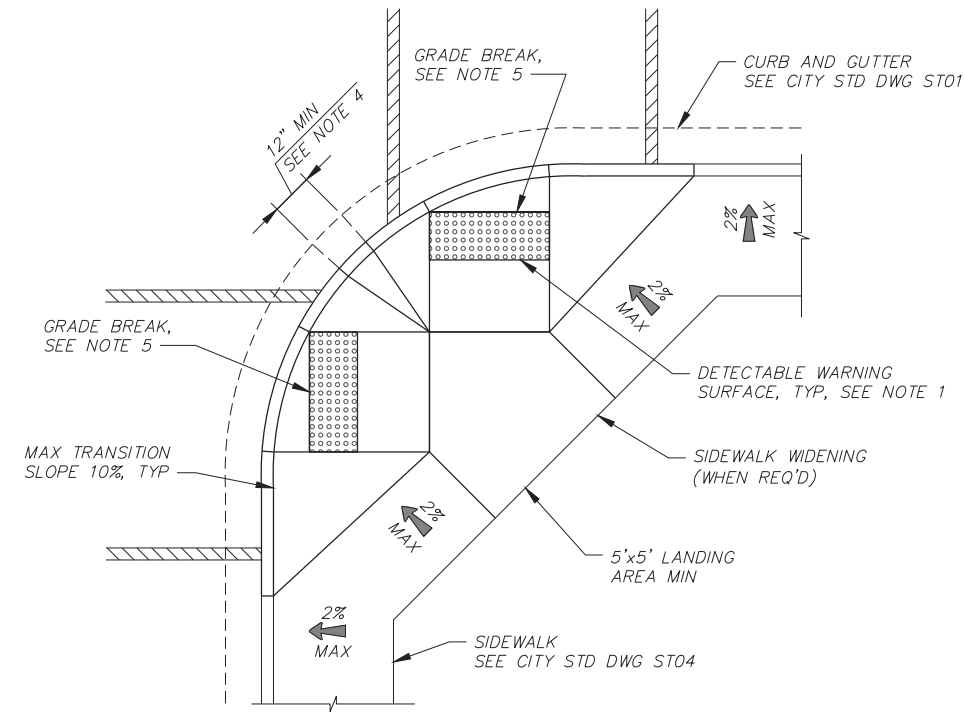

CURB RAMP (OPTION 1)
NTS

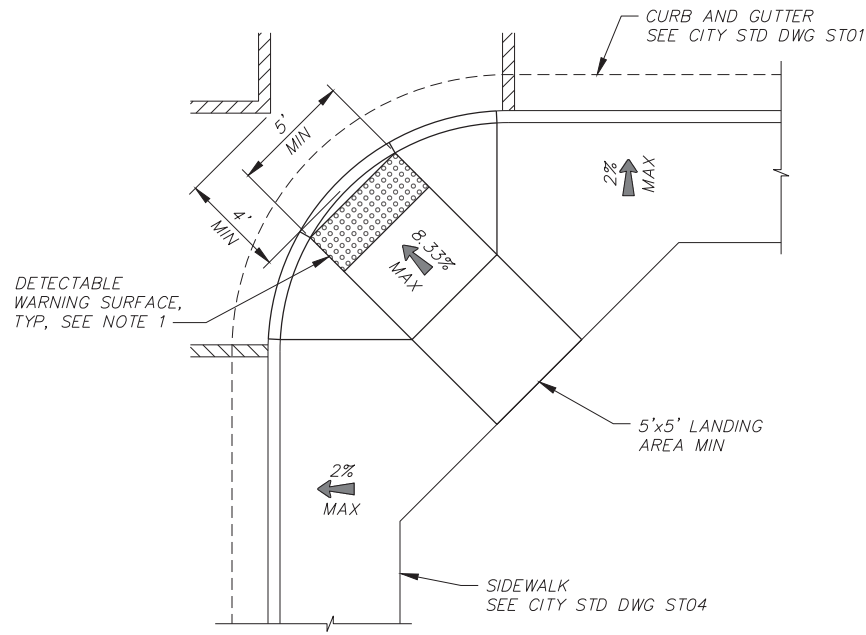

CURB RAMP (OPTION 2)
NTS

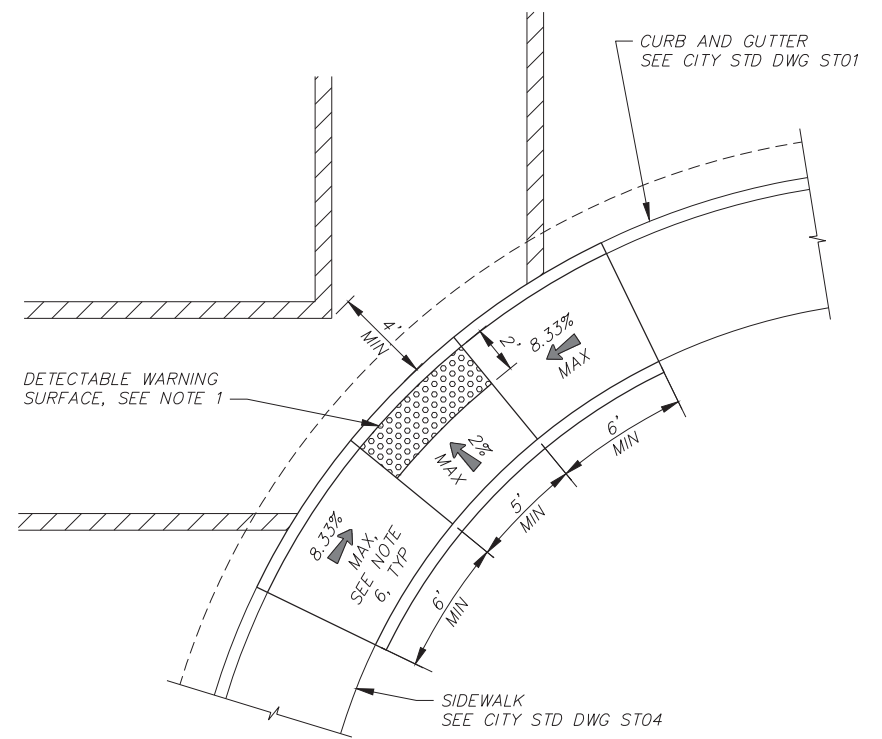

CURB RAMP (OPTION 3)
NTS

NOTES

1. DETECTABLE WARNING SURFACE SHALL BE 2' MINIMUM IN DEPTH AND THE GREATER OF 5' OR THE WIDTH OF THE RAMP IN LENGTH. A 2" GAP BETWEEN THE EDGE OF THE RAMP AND THE DETECTABLE WARNING SURFACE IS PERMISSIBLE AND MAY DECREASE THE REQUIRED MINIMUM LENGTH BY 4". DETECTABLE WARNING SURFACE SHALL MEET THE ODOT TRUNCATED DOME PATTERN REQUIREMENTS AND SHALL BE SAFETY YELLOW IN COLOR. DETECTABLE WARNING SURFACE SHALL NOT BE CUT OR SPLICED UNLESS OTHERWISE APPROVED BY THE CITY. DETECTABLE WARNING SURFACE SHALL BE REPLACEABLE.
2. ALL WALKING SURFACES SHALL HAVE A MAXIMUM CROSS SLOPE OF 2% AND A MAXIMUM OF 12:1 SLOPE IN THE DIRECTION OF TRAVEL.
3. CONTROL JOINTS ARE REQUIRED AT ALL CURB RAMP GRADE BREAK LINES.
4. WHEN TWO CURB RAMP ARE IMMEDIATELY ADJACENT, THE CURB EXPOSURE BETWEEN ADJACENT CURB TRANSITIONS MAY RANGE BETWEEN 3" AND FULL DESIGN EXPOSURE.
5. GRADE BREAKS AT THE TOP AND BOTTOM OF CURB RAMP RUNS SHALL BE PERPENDICULAR TO THE DIRECTION OF THE RAMP RUN. GRADE BREAKS SHALL NOT BE PERMITTED ON THE SURFACE OF RAMP RUNS AND TURNING SPACES. SURFACE SLOPES THAT MEET AT GRADE BREAKS SHALL BE FLUSH. GRADE BREAK AT BOTTOM OF RAMP MUST BE WITHIN 5' OF BACK OF CURB.
6. TO ENSURE SLOPES DO NOT EXCEED MAXIMUM ALLOWABLE SLOPES, IT IS RECOMMENDED TO SET SLOPES LOWER THAN MAXIMUM ALLOWABLE SLOPES AS FOLLOWS:
 -FOR 2% MAX, SET SLOPE AT 1.5%
 -FOR 8.33% MAX, SET SLOPE AT 7.5%
 RAMP WITH SLOPES EXCEEDING MAXIMUM ALLOWABLE VALUES SHALL BE REMOVED AND REPLACED TO MEET MAXIMUM SLOPES AT THE CONTRACTORS EXPENSE.
7. ALL CONCRETE SHALL BE COMMERCIAL GRADE 4,000 PSI CONCRETE.
8. DISTANCE BETWEEN EDGE OF DETECTABLE WARNING SURFACE AND SIDE EDGE OF CURB RAMP SHALL BE 2" UNLESS OTHERWISE APPROVED. CURB RAMP NOT MEETING THIS REQUIREMENT SHALL BE REMOVED AND REPLACED AT THE CONTRACTOR'S EXPENSE.

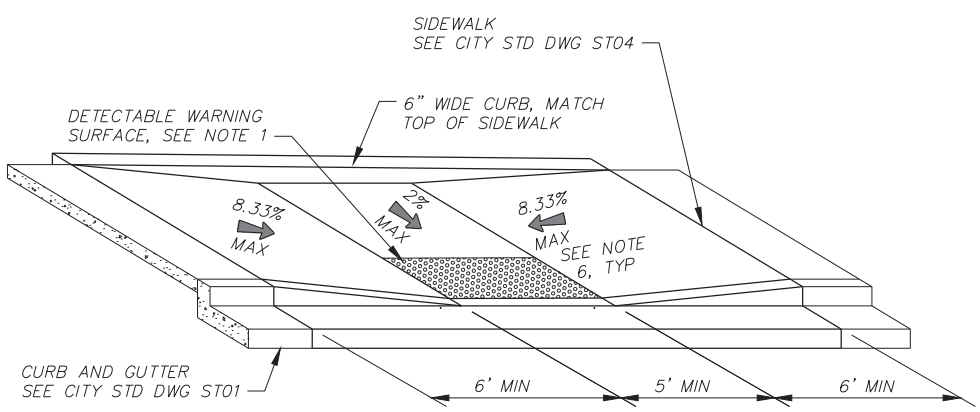

PARALLEL CURB RAMP
NTS

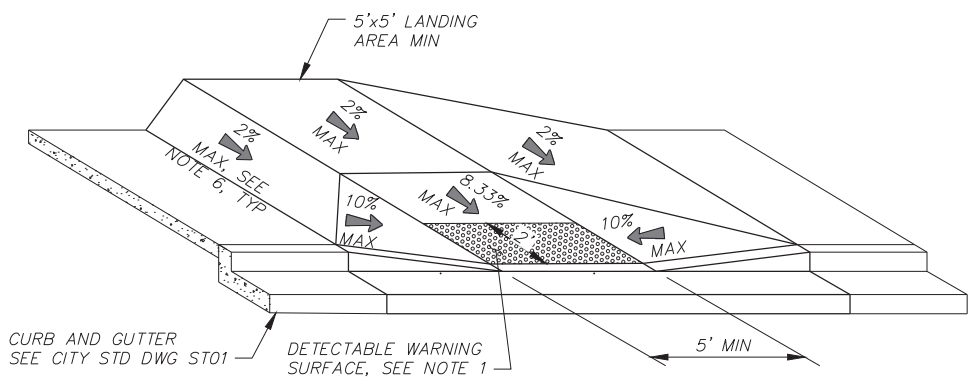

PERPENDICULAR CURB RAMP
NTS

x:\clients\hermiston\on_citystandarddrawings\HermStdDwg_ST06_Curb_Ramp.dwg, ST06, 1/29/2024 2:51 PM, lwilwhite



**CITY OF
HERMISTON, OREGON
STANDARD DRAWINGS**

CURB RAMPS

**FIGURE
ST06**

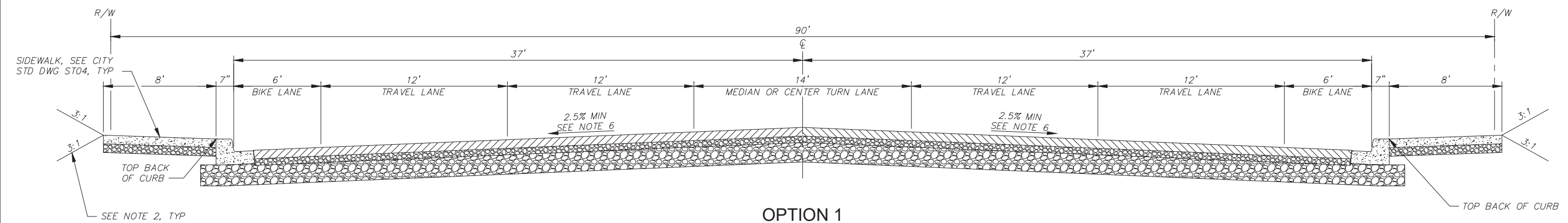

OPTION 1
(IN CENTRAL BUSINESS DISTRICT)
NTS

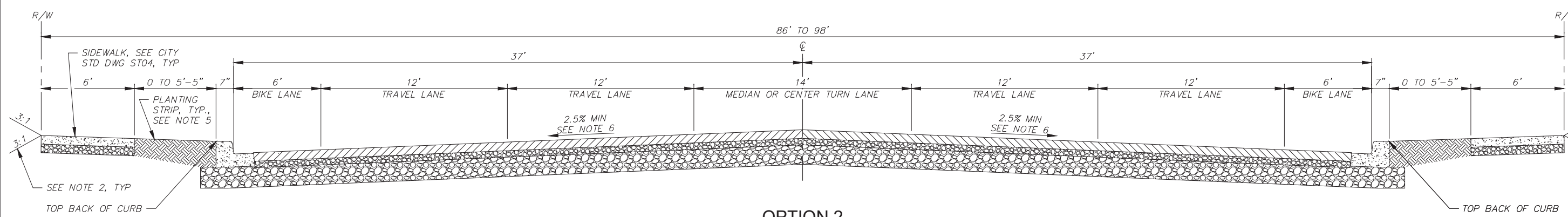

OPTION 2
(OUTSIDE CENTRAL BUSINESS DISTRICT)
NTS

NOTES

1. ASPHALT CONCRETE PAVEMENT SHALL BE CONSTRUCTED IN 2 EQUAL 2" LIFTS.
2. SLOPES SHALL NOT EXCEED 3:1 UNLESS APPROVED BY THE CITY.
3. COMPACT AGGREGATE BASE (100% FRACTURED FACE) AND SUBGRADE TO 95% MAXIMUM DRY DENSITY PER ASTM D1557.
4. THE DISTANCE BETWEEN TOP BACK OF CURBS IS A CRITICAL DIMENSION. CURBS POURED IN AN INCORRECT LOCATION SHALL BE REMOVED AND REPLACED BY THE CONTRACTOR.
5. TREES ARE PROHIBITED IN THE PLANTING STRIP.
6. DESIGN STREET CROSS SLOPE SHALL BE 2.5%. CONSTRUCTED STREET CROSS SLOPE SHALL BE MINIMUM 2% AND MAXIMUM 3%. WHERE NEWLY INSTALLED CURB AND GUTTER ELEVATIONS DEVIATE FROM THE APPROVED PLANS, THE FINISH GRADE OF CENTERLINE SHALL BE BASED ON THE ACTUAL EDGE OF GUTTER ELEVATIONS TO ENSURE STREET CROSS SLOPE REQUIREMENTS ARE MET.

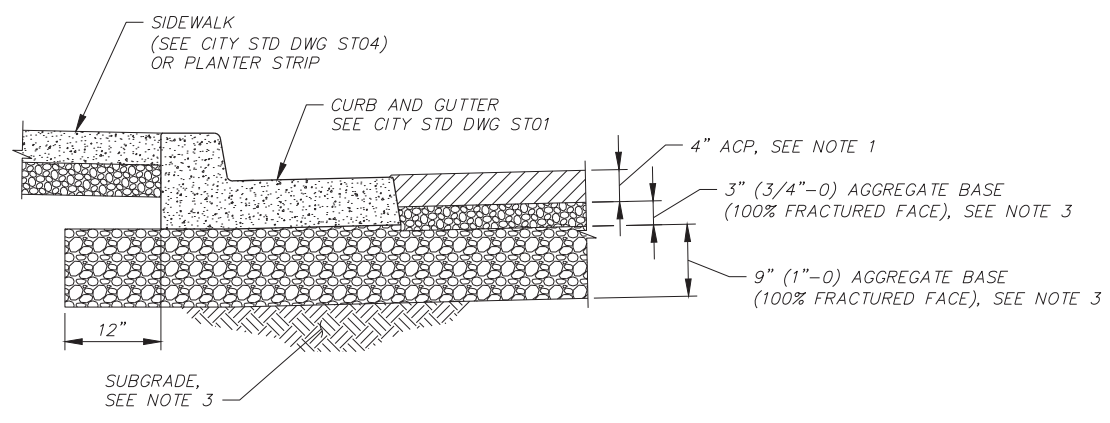

PAVEMENT SECTION
NTS

x:\Clients\hermiston_01_citystandarddrawings\HermStdDwg_ST07_Maj_Ar_Cross_Sec.dwg, ST07, 1/29/2024 2:51 PM, lwillhite



**CITY OF
HERMISTON, OREGON
STANDARD DRAWINGS**

URBAN MAJOR ARTERIAL

**FIGURE
ST07**

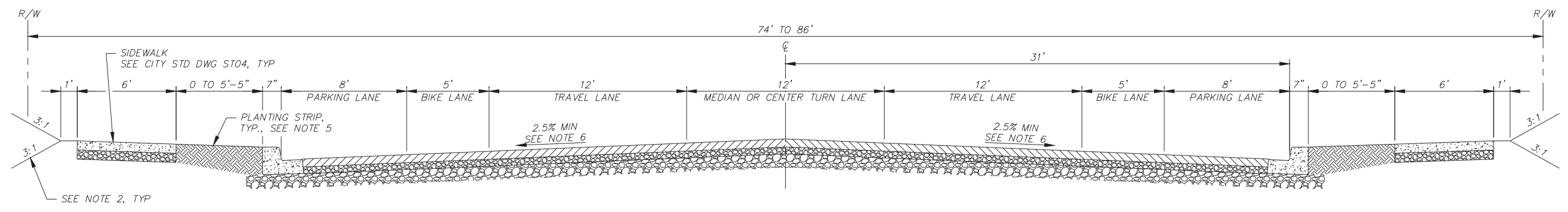

OPTION 1
(WITH PARKING)
NTS

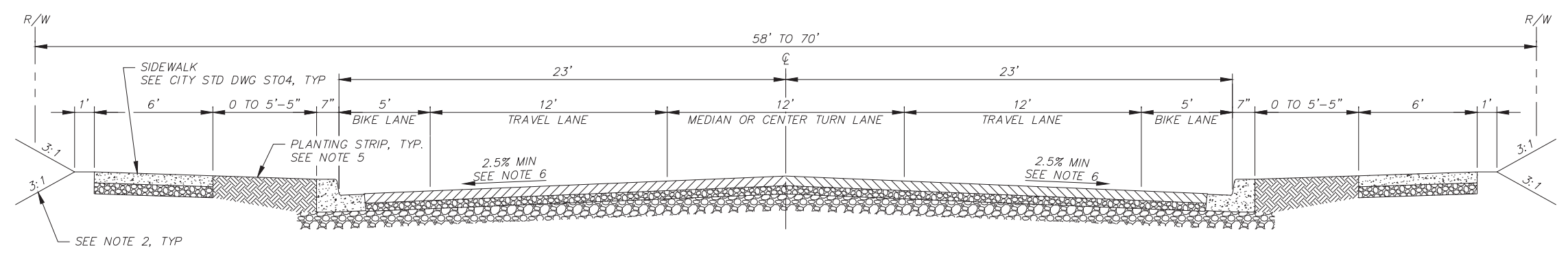

OPTION 2
(NO PARKING)
NTS

NOTES

1. ASPHALT CONCRETE PAVEMENT SHALL BE CONSTRUCTED IN 2 EQUAL 2" LIFTS.
2. SLOPES SHALL NOT EXCEED 3:1 UNLESS APPROVED BY THE CITY.
3. COMPACT AGGREGATE BASE (100% FRACTURED FACE) AND SUBGRADE TO 95% MAXIMUM DRY DENSITY PER ASTM D1557.
4. THE DISTANCE BETWEEN TOP BACK OF CURBS IS A CRITICAL DIMENSION. CURBS POURED IN AN INCORRECT LOCATION SHALL BE REMOVED AND REPLACED BY THE CONTRACTOR.
5. TREES ARE PROHIBITED IN THE PLANTING STRIP.
6. DESIGN STREET CROSS SLOPE SHALL BE 2.5%. CONSTRUCTED STREET CROSS SLOPE SHALL BE MINIMUM 2% AND MAXIMUM 3%. WHERE NEWLY INSTALLED CURB AND GUTTER ELEVATIONS DEVIATE FROM THE APPROVED PLANS, THE FINISH GRADE OF CENTERLINE SHALL BE BASED ON THE ACTUAL EDGE OF GUTTER ELEVATIONS TO ENSURE STREET CROSS SLOPE REQUIREMENTS ARE MET.

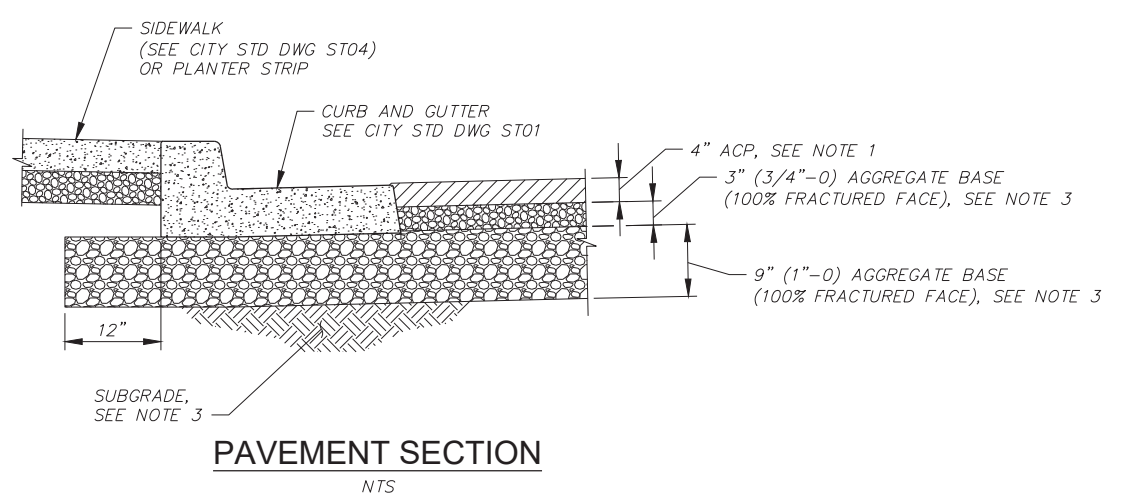

PAVEMENT SECTION
NTS

x:\Clients\hermiston_01_citystandarddrawings\HermStdDwg_ST08_Mnr_Atr_Cross_Sec.dwg, ST08, 1/29/2024 2:52 PM, lwillhite



**CITY OF
HERMISTON, OREGON**
STANDARD DRAWINGS

URBAN MINOR ARTERIAL

**FIGURE
ST08**

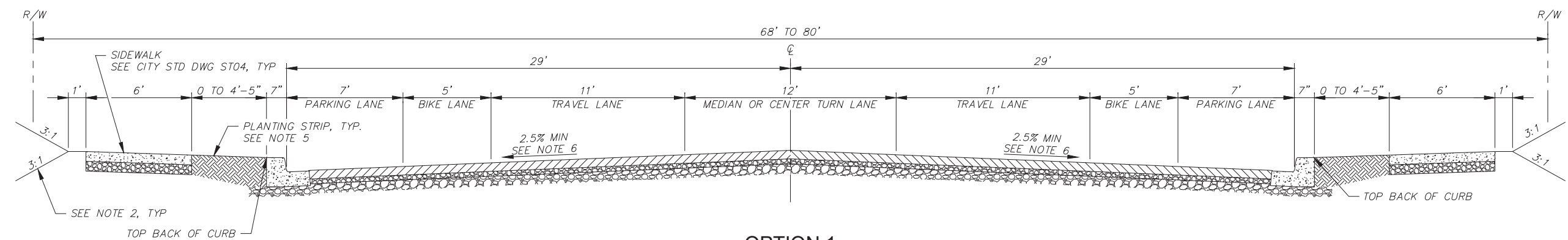

**OPTION 1
(WITH PARKING)**
NTS

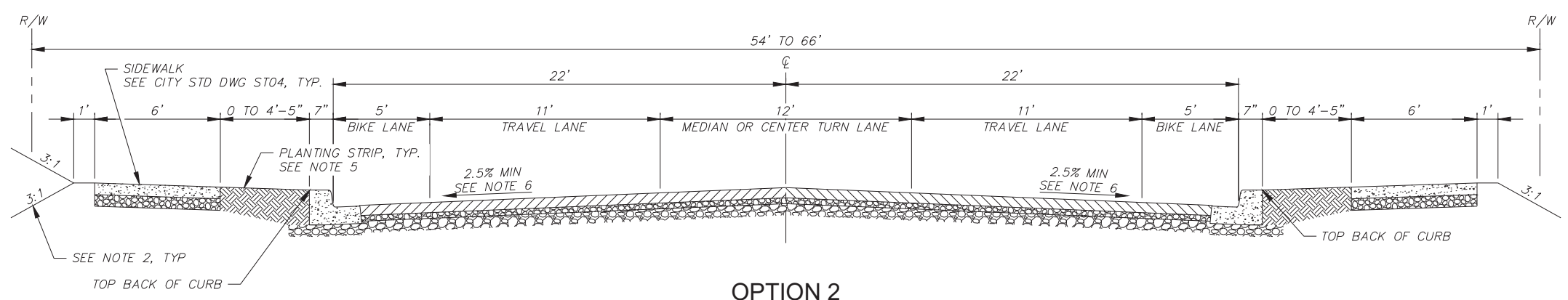

**OPTION 2
(NO PARKING)**
NTS

NOTES

1. ASPHALT CONCRETE PAVEMENT SHALL BE CONSTRUCTED IN 2 EQUAL 2" LIFTS.
2. SLOPES SHALL NOT EXCEED 3:1 UNLESS APPROVED BY THE CITY.
3. COMPACT AGGREGATE BASE (100% FRACTURED FACE) AND SUBGRADE TO 95% MAXIMUM DRY DENSITY PER ASTM D1557.
4. THE DISTANCE BETWEEN TOP BACK OF CURBS IS A CRITICAL DIMENSION. CURBS POURED IN AN INCORRECT LOCATION SHALL BE REMOVED AND REPLACED BY THE CONTRACTOR.
5. TREES ARE PROHIBITED IN THE PLANTING STRIP.
6. DESIGN STREET CROSS SLOPE SHALL BE 2.5%. CONSTRUCTED STREET CROSS SLOPE SHALL BE MINIMUM 2% AND MAXIMUM 3% WHERE NEWLY INSTALLED CURB AND GUTTER ELEVATIONS DEVIATE FROM THE APPROVED PLANS, THE FINISH GRADE OF CENTERLINE SHALL BE BASED ON THE ACTUAL EDGE OF GUTTER ELEVATIONS TO ENSURE STREET CROSS SLOPE REQUIREMENTS ARE MET.

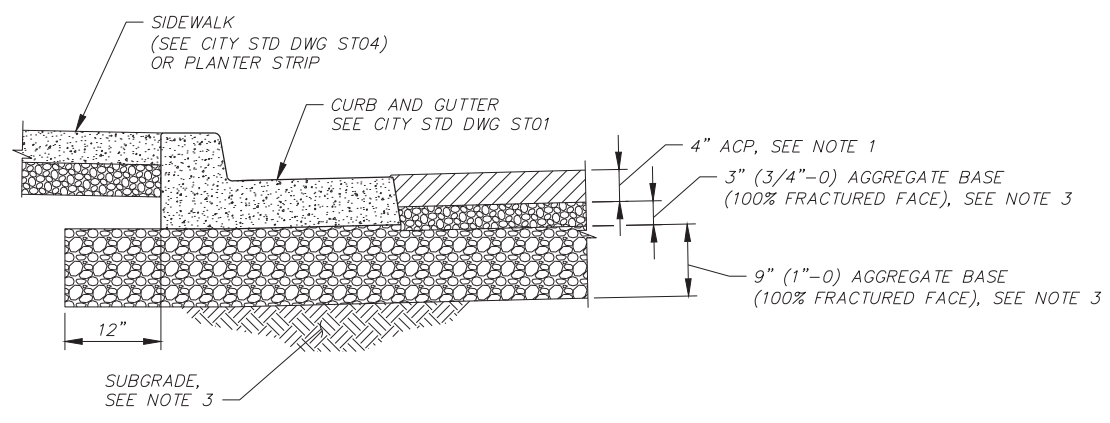

PAVEMENT SECTION
NTS

x:\Clients\hermiston_01_citystandarddrawings\HermStdDwg_ST09_Maj_Collectr_Cross_Sec.dwg, ST09, 1/29/2024 2:52 PM, lwillite



**CITY OF
HERMISTON, OREGON
STANDARD DRAWINGS**

URBAN MAJOR COLLECTOR

**FIGURE
ST09**

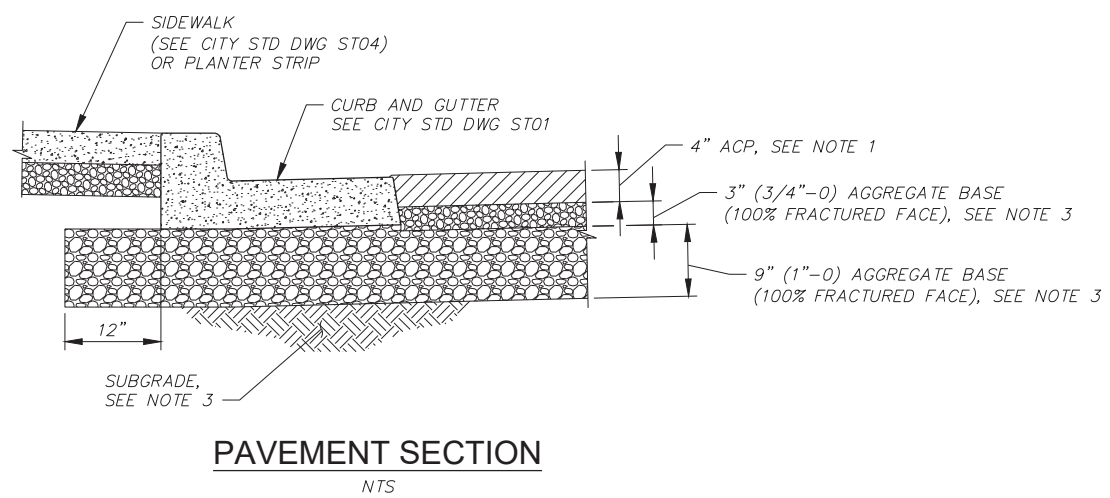
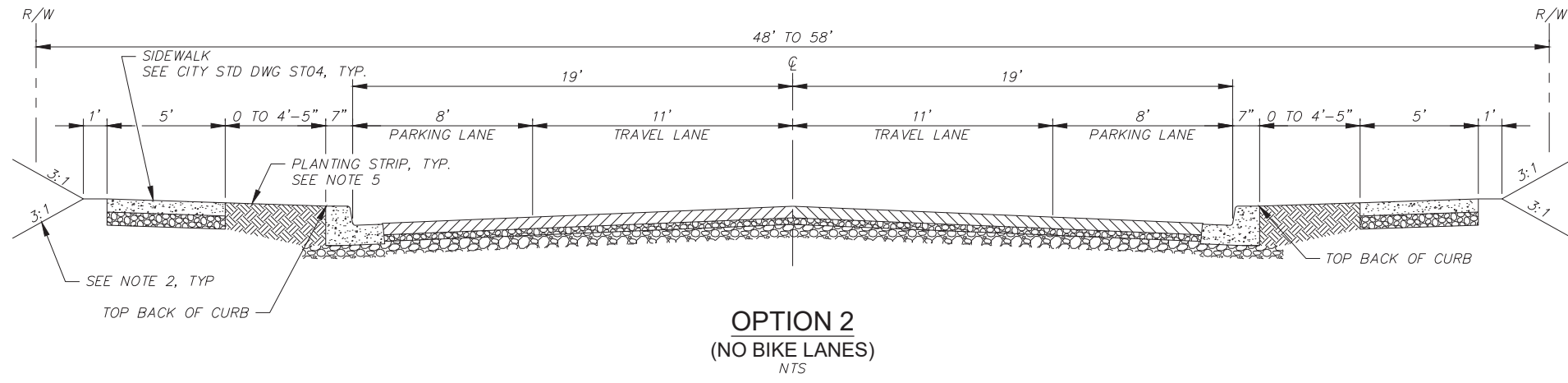
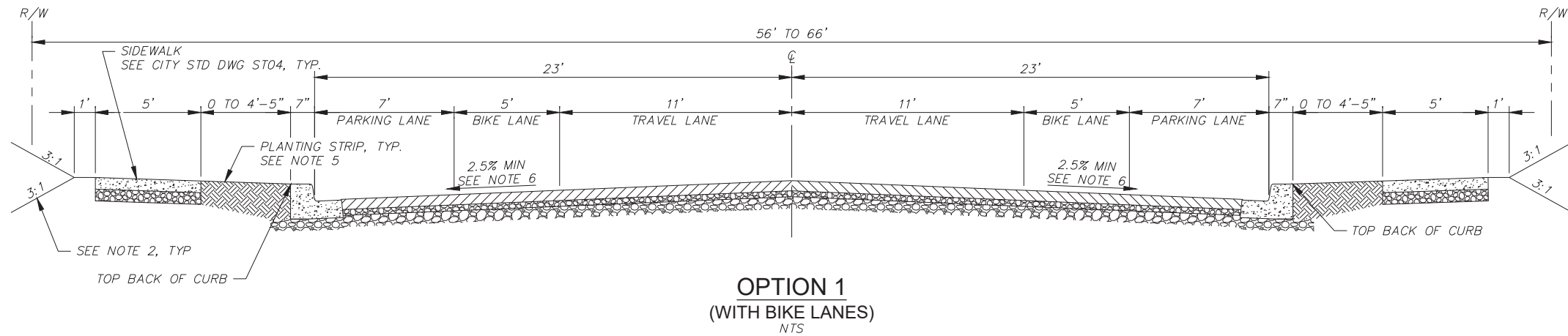

NOTES

1. ASPHALT CONCRETE PAVEMENT SHALL BE CONSTRUCTED IN 2 EQUAL 2" LIFTS.
2. SLOPES SHALL NOT EXCEED 3:1 UNLESS APPROVED BY THE CITY.
3. COMPACT AGGREGATE BASE (100% FRACTURED FACE) AND SUBGRADE TO 95% MAXIMUM DRY DENSITY PER ASTM D1557.
4. THE DISTANCE BETWEEN TOP BACK OF CURBS IS A CRITICAL DIMENSION. CURBS POURED IN AN INCORRECT LOCATION SHALL BE REMOVED AND REPLACED BY THE CONTRACTOR.
5. TREES ARE PROHIBITED IN THE PLANTING STRIP.
6. DESIGN STREET CROSS SLOPE SHALL BE 2.5%. CONSTRUCTED STREET CROSS SLOPE SHALL BE MINIMUM 2% AND MAXIMUM 3% WHERE NEWLY INSTALLED CURB AND GUTTER ELEVATIONS DEVIATE FROM THE APPROVED PLANS, THE FINISH GRADE OF CENTERLINE SHALL BE BASED ON THE ACTUAL EDGE OF GUTTER ELEVATIONS TO ENSURE STREET CROSS SLOPE REQUIREMENTS ARE MET.

x:\Clients\hermiston_01_citystandarddrawings\HermStdDwg_ST10_Mnr_Collectr_Cross_Sec.dwg, ST10, 1/29/2024 2:52 PM, lwillite



**CITY OF
HERMISTON, OREGON
STANDARD DRAWINGS**

URBAN MINOR COLLECTOR

**FIGURE
ST10**

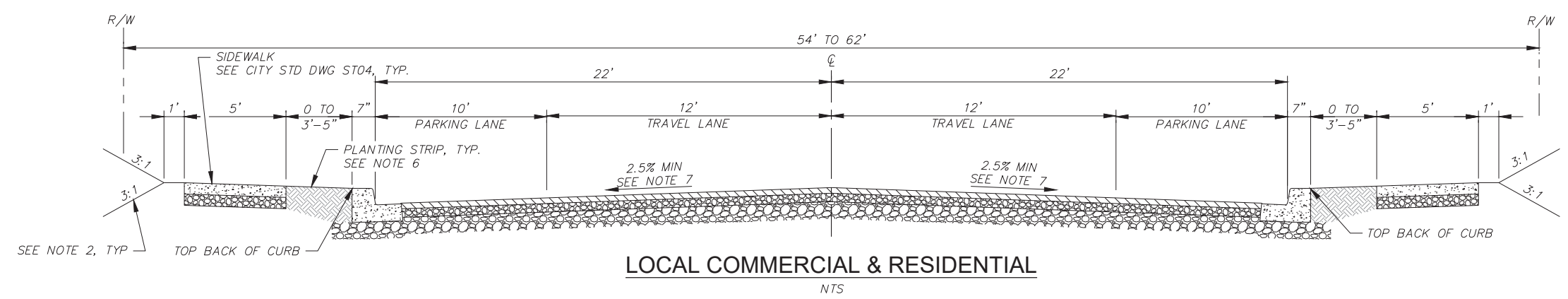

LOCAL COMMERCIAL & RESIDENTIAL
NTS

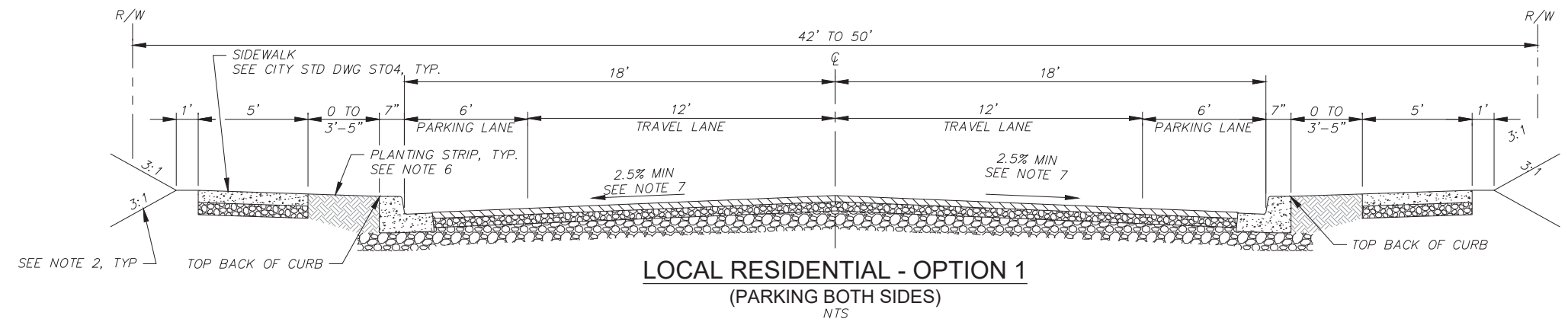

LOCAL RESIDENTIAL - OPTION 1
(PARKING BOTH SIDES)
NTS

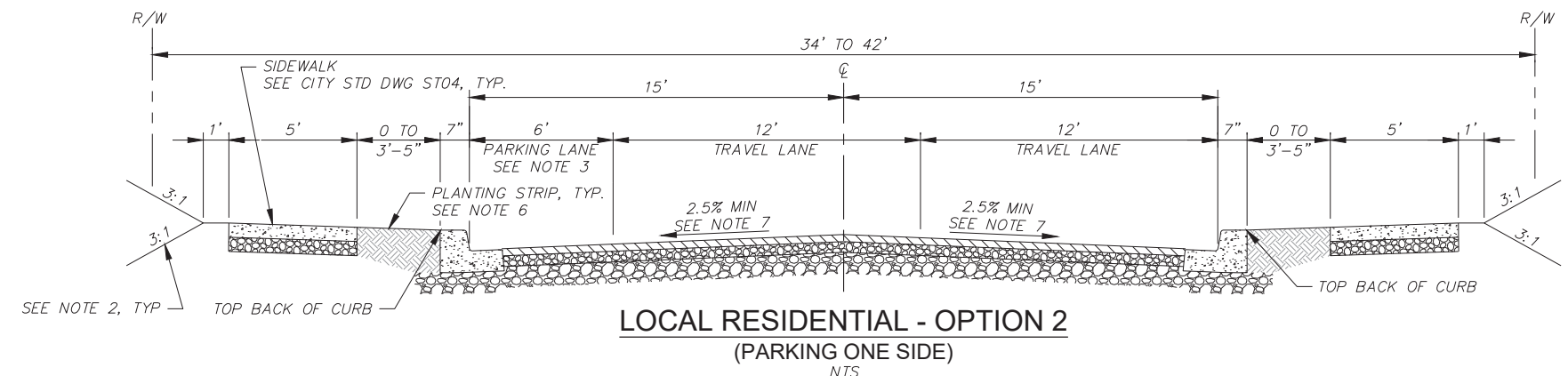

LOCAL RESIDENTIAL - OPTION 2
(PARKING ONE SIDE)
NTS

NOTES

1. ASPHALT CONCRETE PAVEMENT SHALL BE CONSTRUCTED IN 2 EQUAL 2" LIFTS.
2. SLOPES SHALL NOT EXCEED 3:1 UNLESS APPROVED BY THE CITY.
3. PARKING LANE MAY BE LOCATED ON EITHER SIDE OF STREET.
4. COMPACT AGGREGATE BASE (100% FRACTURED FACE) AND SUBGRADE TO 95% MAXIMUM DRY DENSITY PER ASTM D1557.
5. THE DISTANCE BETWEEN TOP BACK OF CURBS IS A CRITICAL DIMENSION. CURBS POURED IN AN INCORRECT LOCATION SHALL BE REMOVED AND REPLACED BY THE CONTRACTOR.
6. TREES ARE PROHIBITED IN THE PLANTING STRIP.
7. DESIGN STREET CROSS SLOPE SHALL BE 2.5%. CONSTRUCTED STREET CROSS SLOPE SHALL BE MINIMUM 2% AND MAXIMUM 3%. WHERE NEWLY INSTALLED CURB AND GUTTER ELEVATIONS DEVIATE FROM THE APPROVED PLANS, THE FINISH GRADE OF CENTERLINE SHALL BE BASED ON THE ACTUAL EDGE OF GUTTER ELEVATIONS TO ENSURE STREET CROSS SLOPE REQUIREMENTS ARE MET.

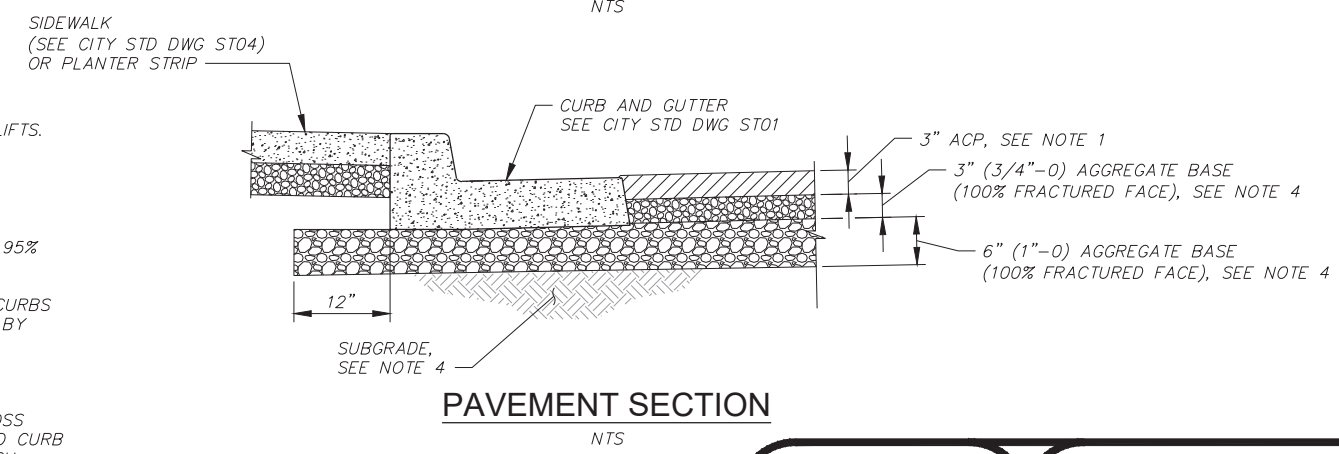

PAVEMENT SECTION
NTS

x:\Clients\hermiston_01_citystandarddrawings\HermStdDwg_ST11_Loc_Cross_Sec_Curb.dwg, ST11, 1/29/2024 2:52 PM, twillite



**CITY OF
HERMISTON, OREGON
STANDARD DRAWINGS**

URBAN LOCAL STREET

**FIGURE
ST11**

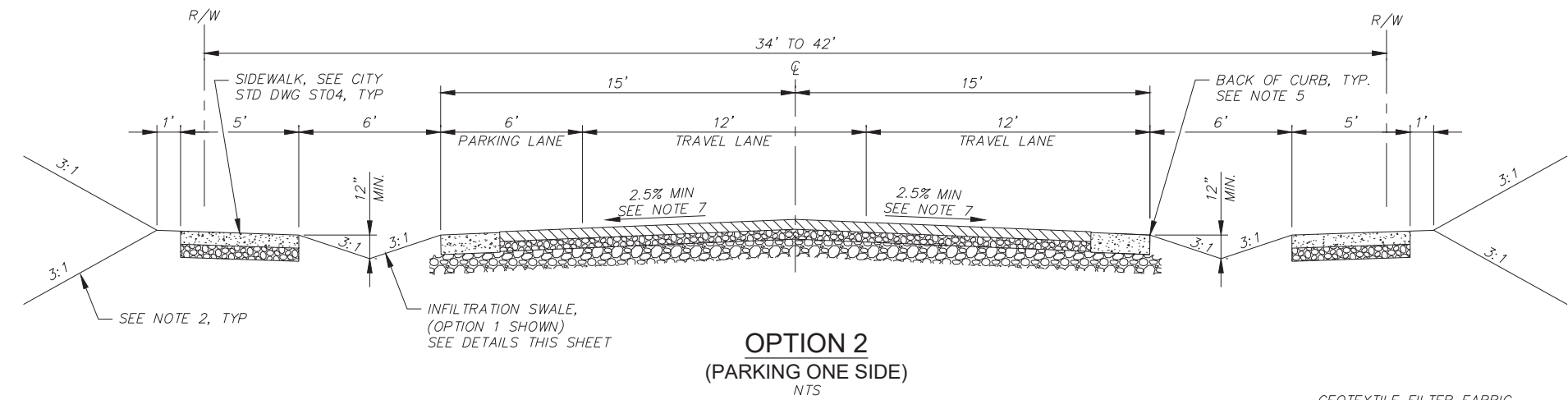
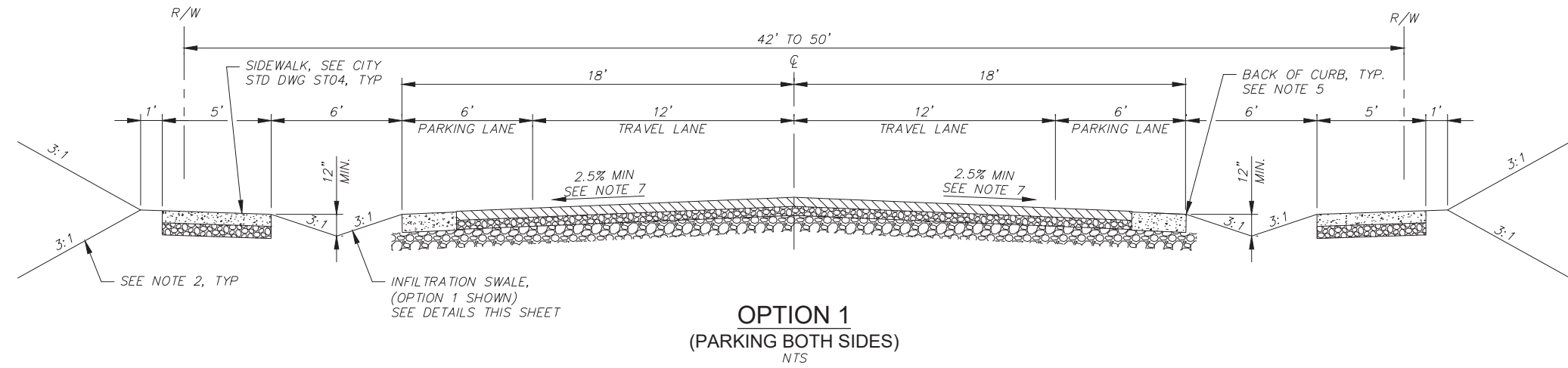

NOTES

1. ASPHALT CONCRETE PAVEMENT SHALL BE CONSTRUCTED IN ONE LIFT.
2. SLOPES SHALL NOT EXCEED 3:1 UNLESS OTHERWISE APPROVED BY THE CITY.
3. PARKING LANE MAY BE LOCATED ON EITHER SIDE OF STREET.
4. COMPACT AGGREGATE BASE (100% FRACTURED FACE) AND SUBGRADE TO 95% MAXIMUM DRY DENSITY PER ASTM D1557.
5. THE DISTANCE BETWEEN TOP BACK OF CURBS IS A CRITICAL DIMENSION. CURBS POURED IN AN INCORRECT LOCATION SHALL BE REMOVED AND REPLACED BY THE CONTRACTOR.
6. INFILTRATION SWALE OPTION 2 ASSUMES POORLY GRADED SAND WITH SILT WITH A DESIGN INFILTRATION RATE OF 3" PER HOUR. SHOULD SOIL CONDITIONS SUCH AS CALICHE, HARD PAN, CLAY, SILT, ETC. BE ENCOUNTERED, THE CONTRACTOR SHALL NOTIFY THE CITY IMMEDIATELY. THE CROSS SECTIONAL AREA MAY BE ADJUSTED TO ACCOMMODATE DIFFERENT SOIL TYPES WHEN APPROVED BY THE CITY.
7. DESIGN STREET CROSS SLOPE SHALL BE 2.5%. CONSTRUCTED STREET CROSS SLOPE SHALL BE MINIMUM 2% AND MAXIMUM 3% WHERE NEWLY INSTALLED CURB AND GUTTER ELEVATIONS DEVIATE FROM THE APPROVED PLANS, THE FINISH GRADE OF CENTERLINE SHALL BE BASED ON THE ACTUAL EDGE OF GUTTER ELEVATIONS TO ENSURE STREET CROSS SLOPE REQUIREMENTS ARE MET.
8. THE MINIMUM INFILTRATION SWALE LENGTH SHALL BE 50% OF THE LENGTH OF THE PROPERTY FRONTAGE UNLESS OTHERWISE APPROVED BY THE CITY.

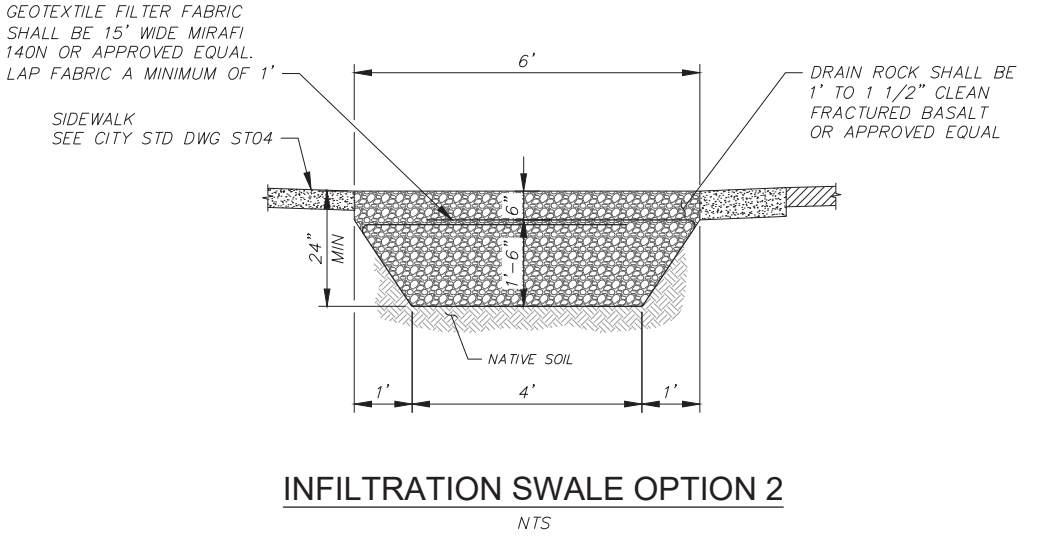
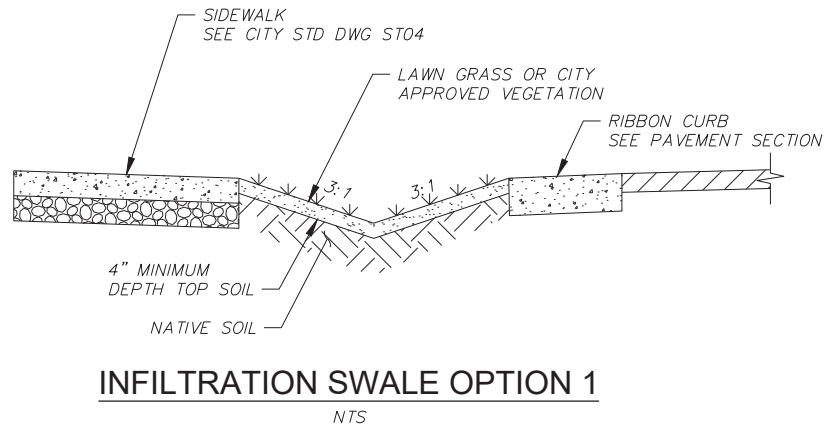
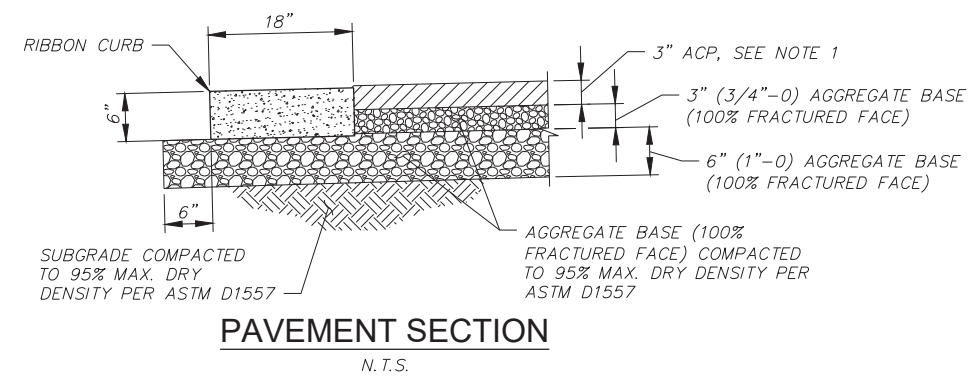

**CITY OF
HERMISTON, OREGON
STANDARD DRAWINGS**

**FIGURE
ST12**

URBAN LOCAL STREET WITH SWALE

316

x:\clients\hermiston\on_citystandarddrawings\HermStdDwg_ST12_Loc_Cross_Sec_Swale.dwg, ST12, 1/29/2024 2:52 PM, lwillite

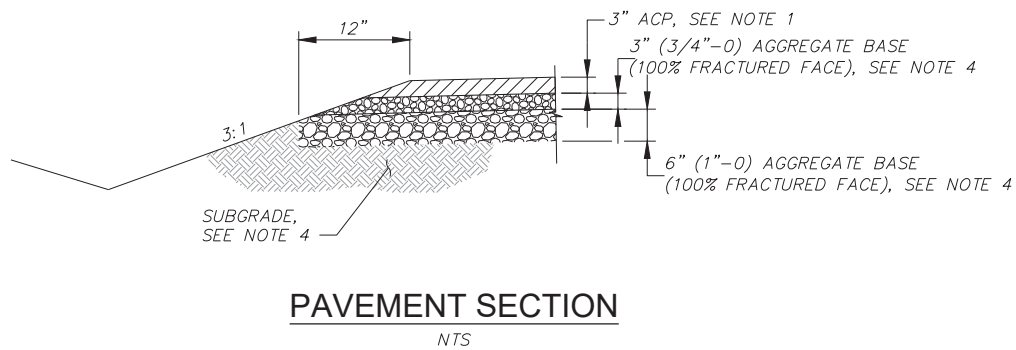
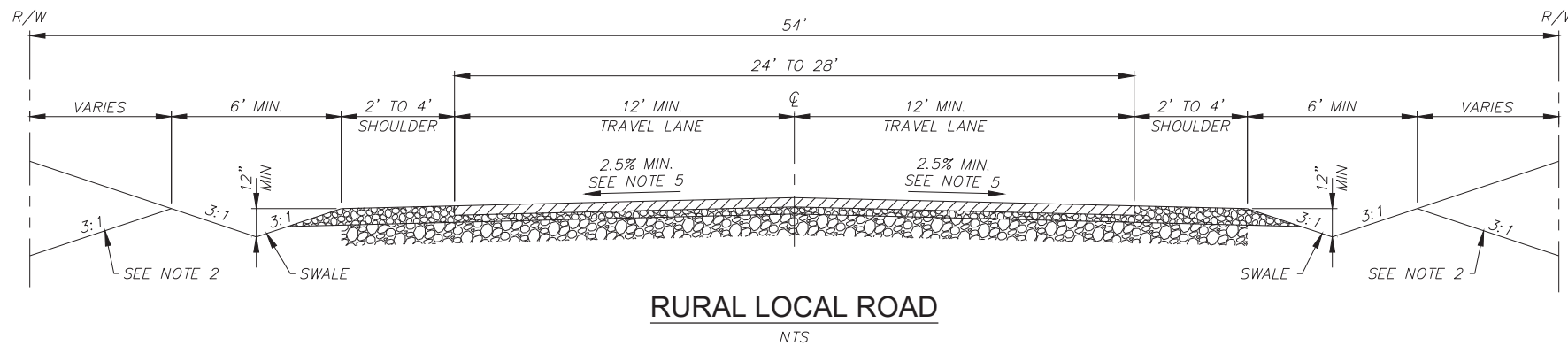
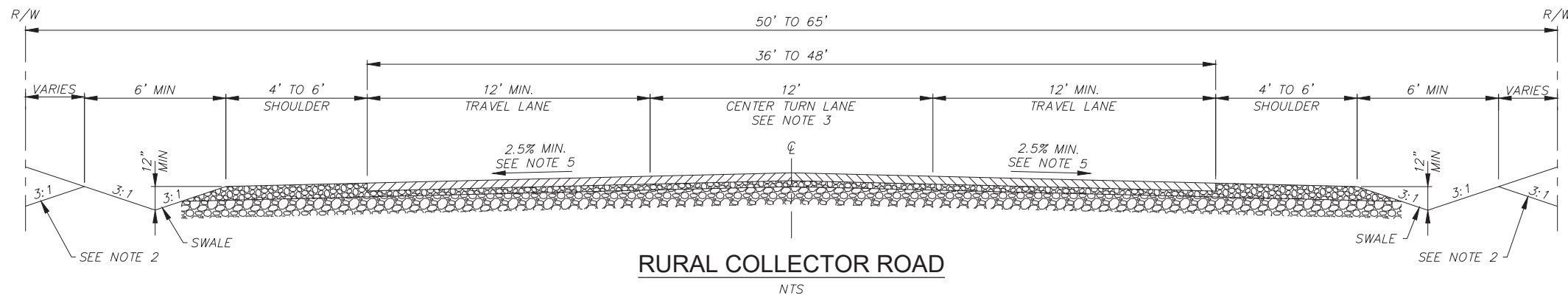
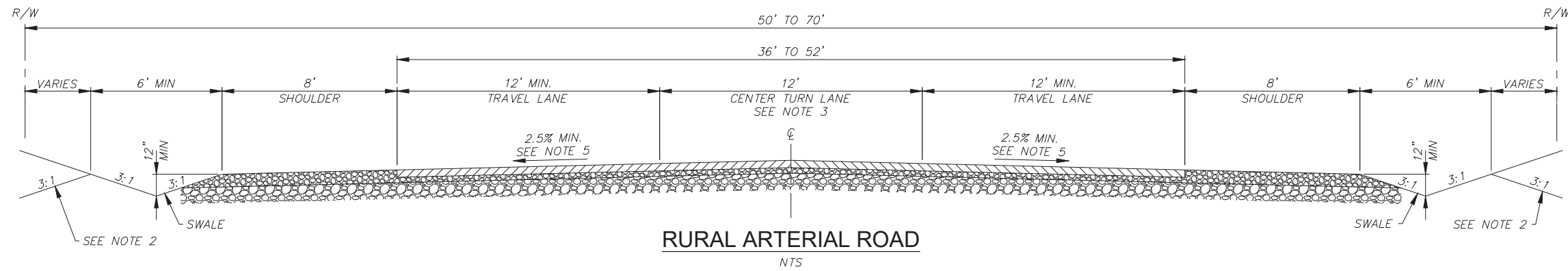

NOTES

1. ASPHALT CONCRETE PAVEMENT SHALL BE CONSTRUCTED IN ONE LIFT.
2. SLOPES SHALL NOT EXCEED 3:1 UNLESS APPROVED BY THE CITY.
3. CENTER TURN LANE NOT REQUIRED, UNLESS OTHERWISE NOTED ON PLAN SHEETS.
4. COMPACT AGGREGATE BASE (100% FRACTURED FACE) AND SUBGRADE TO 95% MAXIMUM DRY DENSITY PER ASTM D1557.
5. DESIGN STREET CROSS SLOPE SHALL BE 2.5%. CONSTRUCTED STREET CROSS SLOPE SHALL BE MINIMUM 2% AND MAXIMUM 3%.

x:\Clients\hermiston or_ citystandarddrawings\HermStdDwg_ST13_1/29/2024 2:52 PM_1\white



**CITY OF
HERMISTON, OREGON
STANDARD DRAWINGS**

**RURAL ARTERIAL, COLLECTOR,
AND LOCAL ROADS**

**FIGURE
ST13**

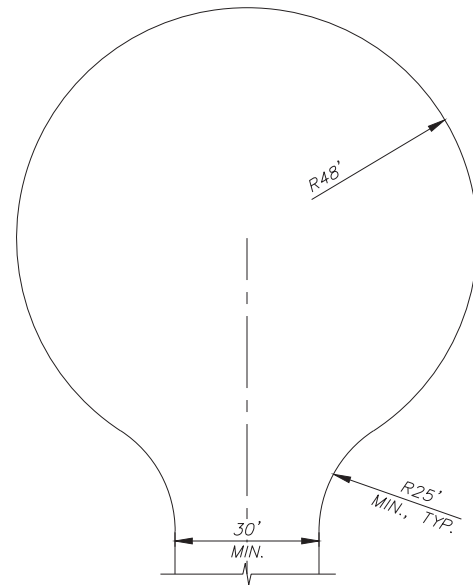

CUL-DE-SAC
NTS

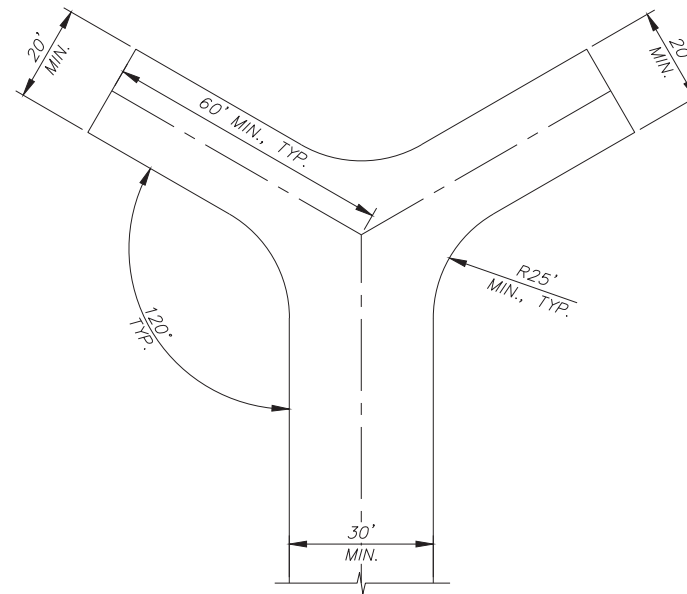

60-FOOT-'Y'
NTS

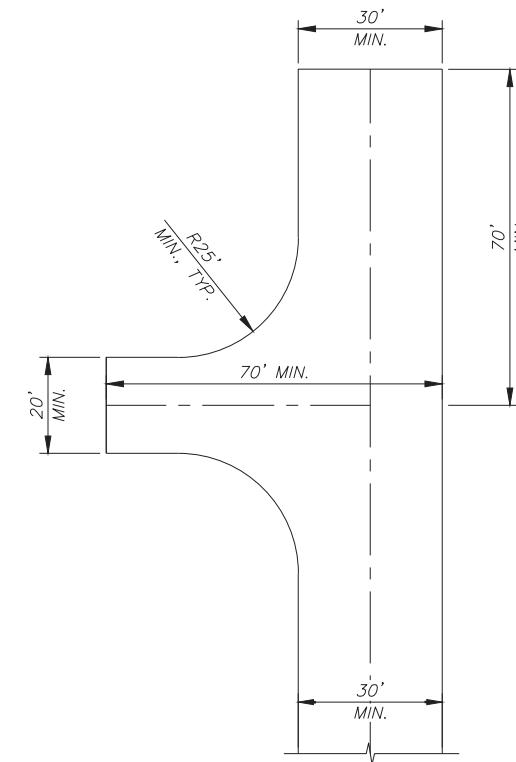

ALTERNATIVE HAMMERHEAD
NTS

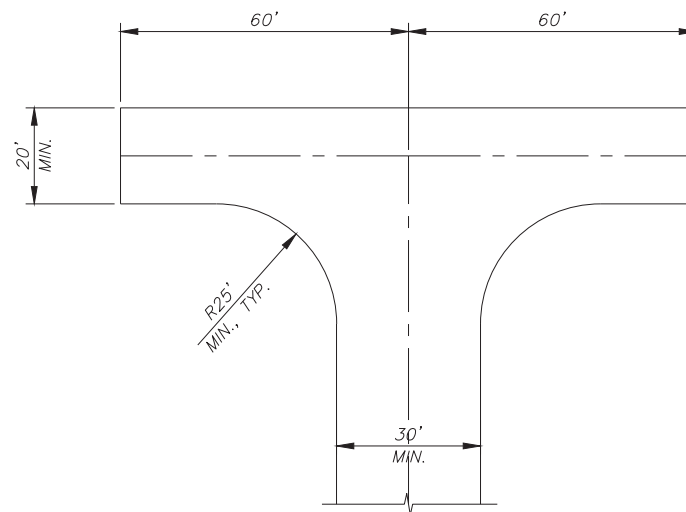

HAMMERHEAD
NTS

NOTES

1. ALL TURNAROUNDS SHALL MEET ALL REQUIREMENTS OF THE OREGON FIRE CODE CURRENT ADDITION.
2. ALL TURNAROUNDS SHALL BE PAVED. WHEN TURNAROUNDS ARE INTENDED TO BE TEMPORARY, THE CITY AND FIRE CHIEF MAY APPROVE THE USE OF AGGREGATE BASE OR GRAVEL COMPACTED TO 95% MAXIMUM DRY DENSITY PER ASTM D1557.

x:\Clients\hermiston or\citystandarddrawings\HermStdDwg_ST14_S_Indust_St_Stand.dwg_ST14_S_Indust_St_Stand.dwg_ST14_S_Indust_St_Stand.dwg

	<p>CITY OF HERMISTON, OREGON STANDARD DRAWINGS</p> <p>FIRE APPARATUS TURNAROUND</p>	<p>FIGURE ST14</p>
---	---	-------------------------------

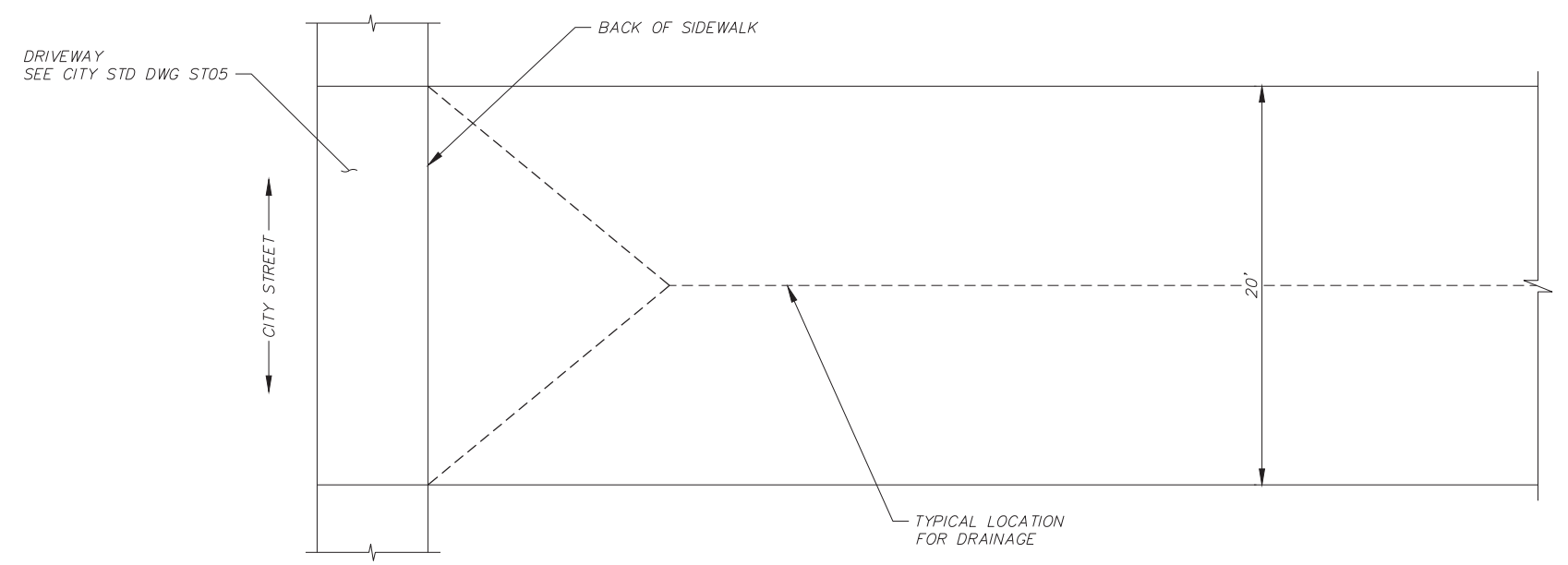

PLAN
NTS

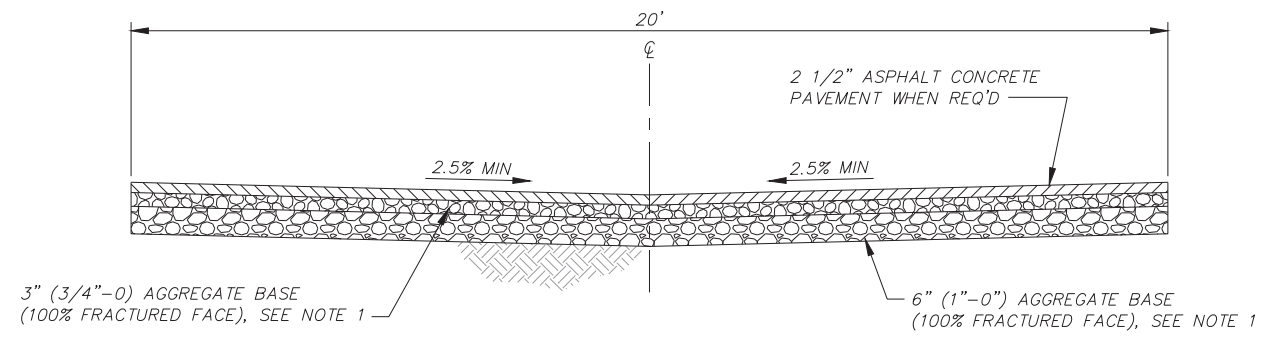

SECTION
NTS

NOTE

- 1. COMPACT AGGREGATE BASE (100% FRACTURED FACE) AND SUBGRADE TO 95% MAXIMUM DRY DENSITY PER ASTM D1557.

x:\Clients\hermiston or\citystandarddrawings\HermStdDwg_ST15_Alley.dwg_ST15_1/29/2024 2:53 PM, lwillhite



CITY OF
HERMISTON, OREGON
STANDARD DRAWINGS

ALLEY

FIGURE
ST15

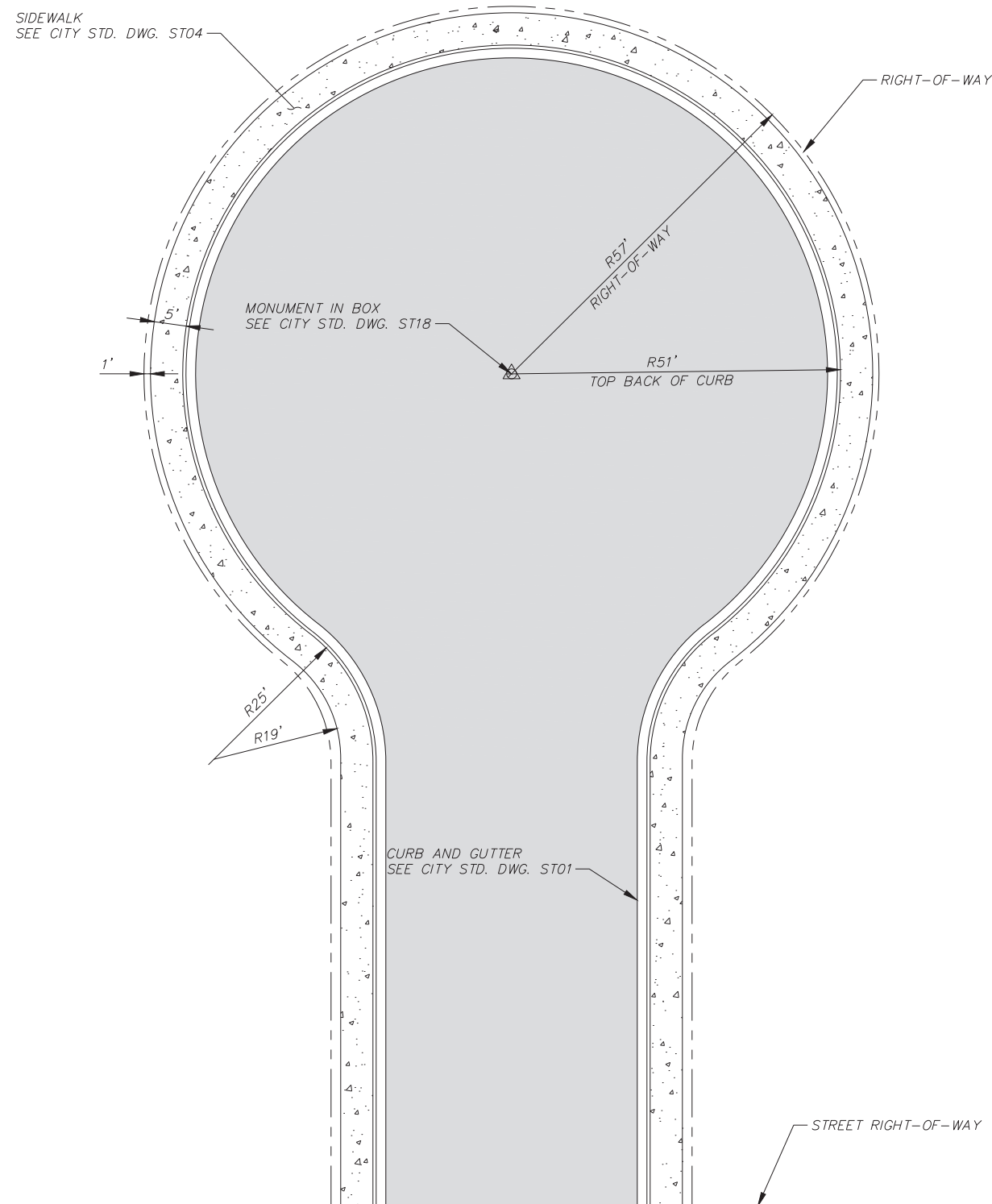

STANDARD CUL-DE-SAC WITHOUT SWALE

NTS

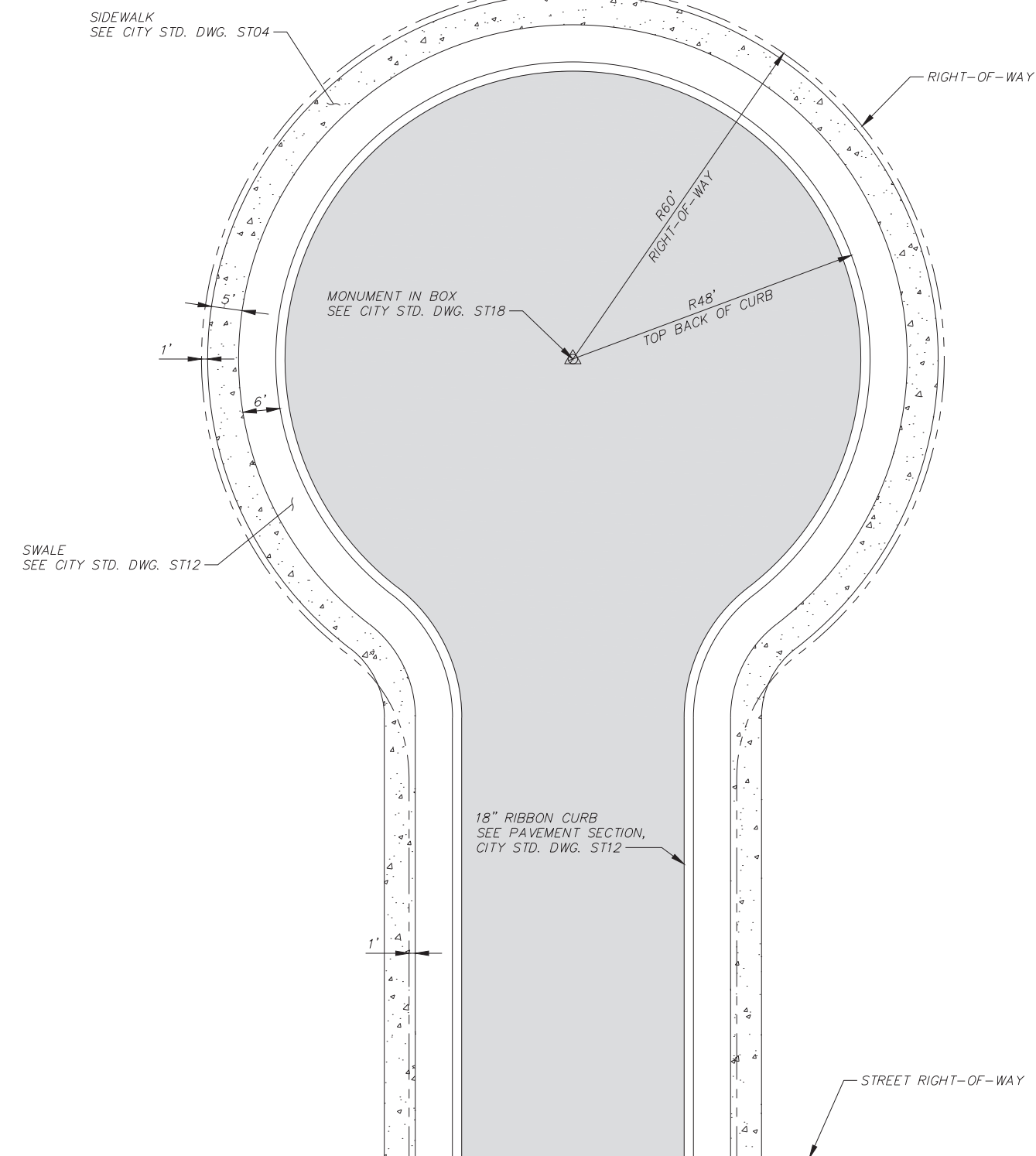

STANDARD CUL-DE-SAC WITH SWALE

(CAN ONLY BE USED WHEN APPROVED BY THE CITY DUE TO DRIVEWAY WIDTH LIMITATIONS)

NTS

NOTE

- 1. FOR COMMERCIAL AND INDUSTRIAL AREAS, THE DESIGN ENGINEER MUST SHOW CUL-DE-SAC CAN ACCOMMODATE WB-67 TRUCK TURNING MOVEMENTS. CUL-DE-SAC AND ASSOCIATED RIGHT-OF-WAY RADII MAY NEED TO BE INCREASED TO ACCOMMODATE TURNING MOVEMENTS.

x:\Clients\hermiston\01_citystandarddrawings\HermStdDwg_ST16_CulDeSac.dwg_ST16_1/29/2024 2:53 PM.lwilhite



CITY OF
HERMISTON, OREGON
STANDARD DRAWINGS

CUL-DE-SAC

FIGURE
ST16

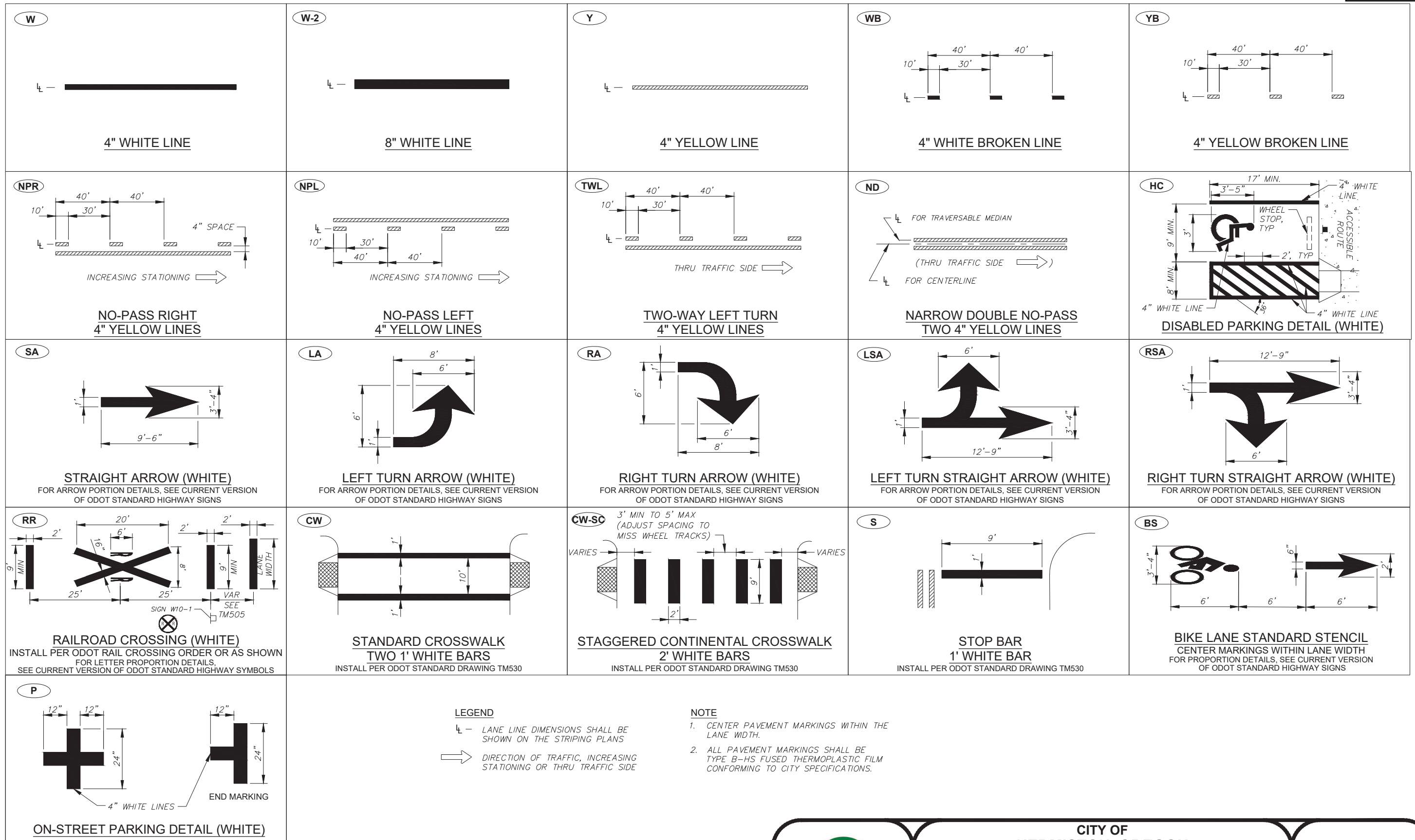

x:\Clients\hermiston_or_citystandarddrawings\HermStdDwg_ST17_1/29/2024 2:53 PM.twhlwhite



Where Life is Sweet

CITY OF
HERMISTON, OREGON
STANDARD DRAWINGS

PAVEMENT STRIPING AND MARKINGS

FIGURE
ST17

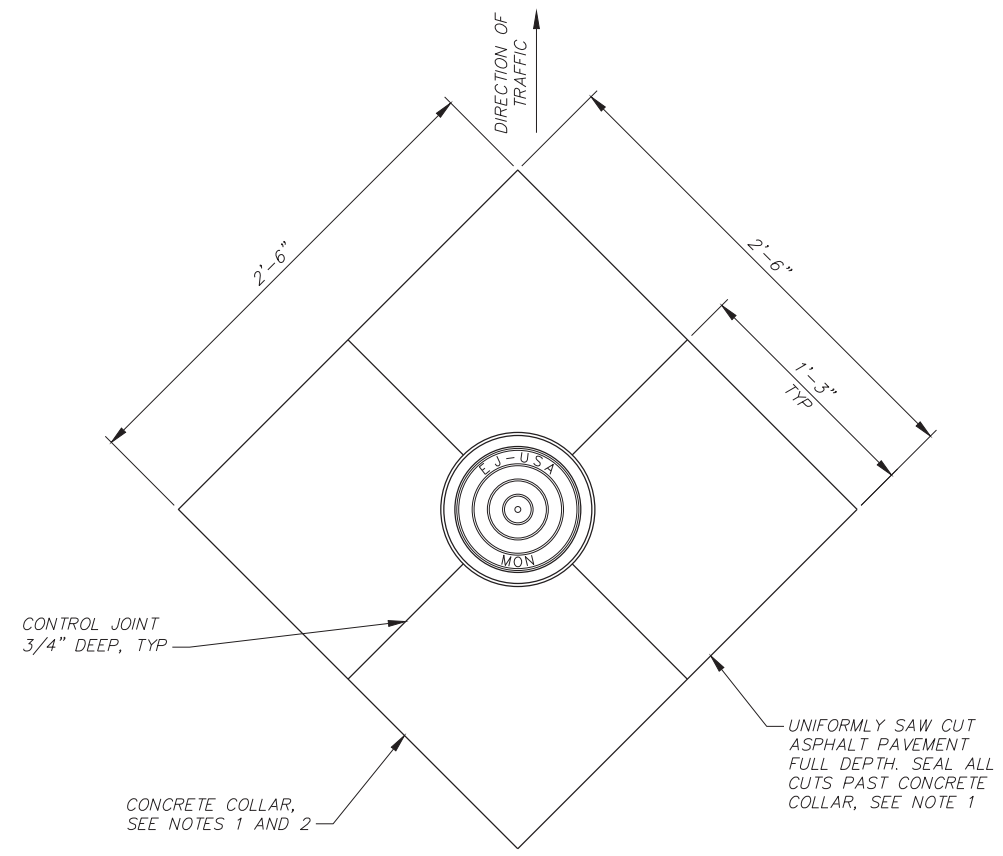

PLAN

REQUIREMENTS FOR CONCRETE COLLARS

1. ALL CONCRETE SHALL BE COMMERCIAL GRADE 4000 PSI CONCRETE.
2. COLLAR TO BE FORMED SQUARE.
3. SMOOTH BROOMED FINISH REQUIRED.
4. APPLY CONCRETE CURING COMPOUND.
5. PROTECT FROM TRAFFIC FOR 4 DAYS MINIMUM.

CONCRETE COLLAR

NTS

NOTES

1. CONCRETE COLLAR REQUIRED IF MONUMENT BOX GRADE IS ADJUSTED AFTER PAVEMENT WORK IS PERFORMED. IF GRADE ADJUSTMENT OCCURS PRIOR TO PAVEMENT WORK THEN CONCRETE COLLAR IS NOT REQUIRED.
2. ALL MONUMENTS SHALL HAVE A CONCRETE COLLAR IF INSTALLED ON GRAVEL STREETS, ROAD SHOULDER, OR NATURAL GROUND.
3. CASTING SHALL MEET AASHTO H20 REQUIREMENT.
4. COMPACT ALL AGGREGATE BASE (100% FRACTURED FACE) TO 95% MAXIMUM DRY DENSITY PER ASTM D1557.
5. MONUMENTS AND BOXES SHALL BE INSTALLED ON ROADWAY CENTERLINES, AT EACH ROADWAY INTERSECTION, CUL-DE-SAC CENTER, DEAD END, POINT OF CURVE (PC), POINT OF TANGENCY (PT), AND AT ANY OTHER CHANGE IN CENTERLINE DIRECTION.
6. CONTRACTOR AND SURVEYOR SHALL COORDINATE TO ENSURE BOX LOCATION MATCHES REQUIRED MONUMENT LOCATION (SEE NOTE 5).
7. OREGON LICENSED PROFESSIONAL LAND SURVEYOR OR PARTY UNDER THE LICENSED LAND SURVEYOR'S DIRECT SUPERVISION TO REFERENCE MONUMENT LOCATION FOR INSTALLATION AND PUNCH CAP AFTER INSTALLATION.
8. ALL MONUMENTS SHALL BE SET IN ACCORDANCE WITH THE CURRENT OREGON REVISED STATUTES AND OREGON ADMINISTRATIVE RULES.

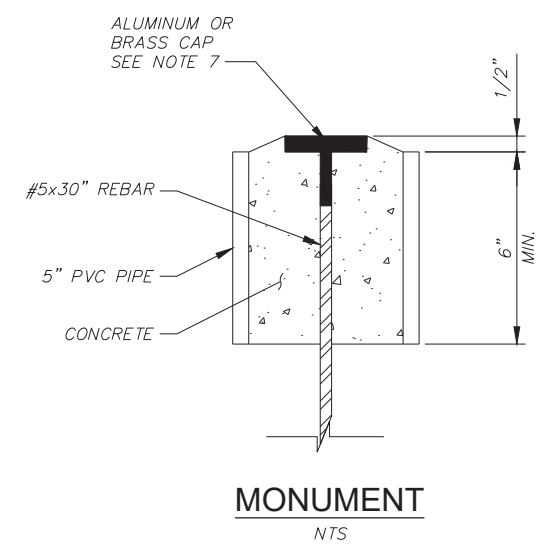
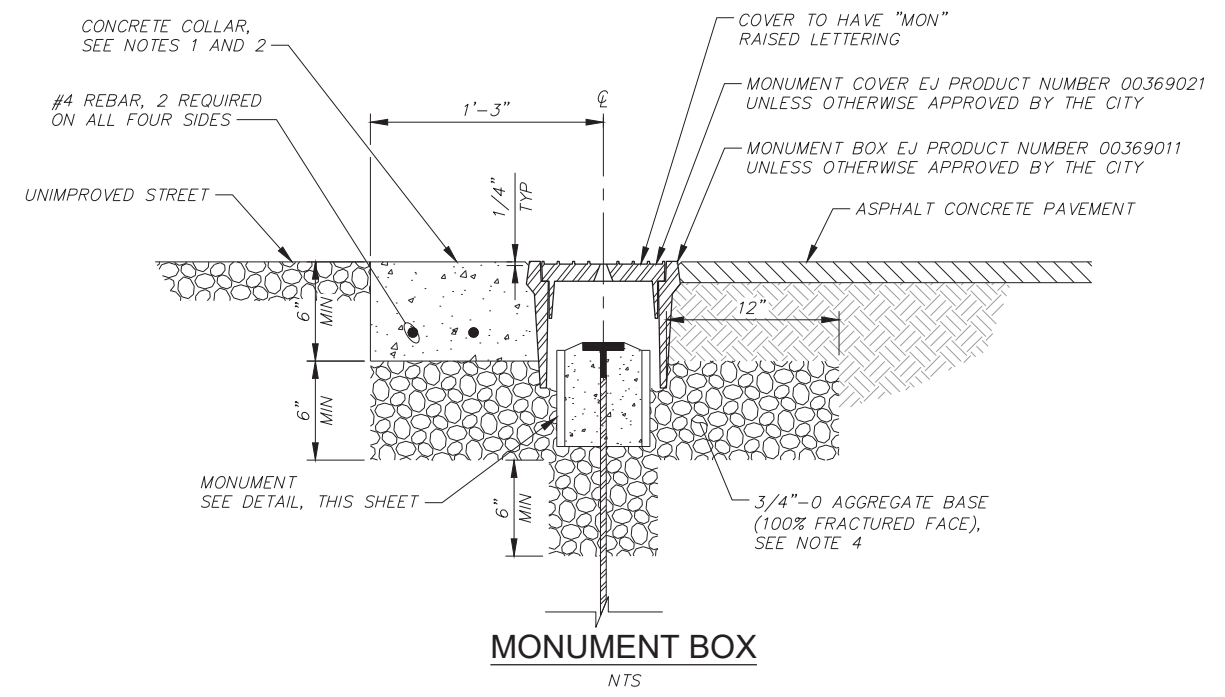

	<p>CITY OF HERMISTON, OREGON STANDARD DRAWINGS</p> <p>MONUMENT BOX</p>	<p>FIGURE ST18</p>
---	--	-------------------------------

x:\Clients\hermiston_or_citystandarddrawings\HermStdDwg_ST18_Mon_Box.dwg, ST18, 1/29/2024 2:53 PM, lwillhite

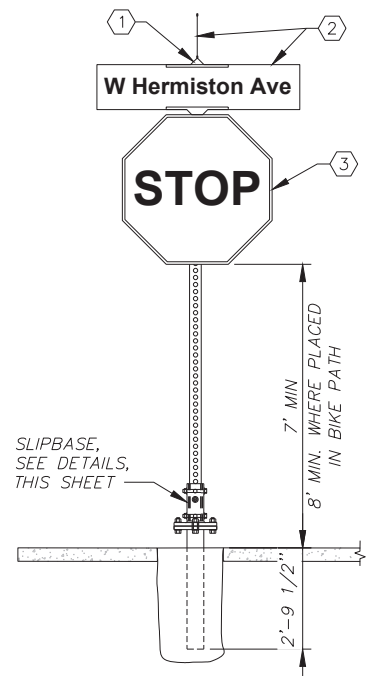

KEY NOTES

- ① STREET NAME SIGN BRACKET SHALL BE ZUMAR 90° CROSS BRACKET FOR EXTRUDED BLADE, OR APPROVED EQUAL.
- ② STREET NAME SIGNS SHALL BE MUTCD SIGN NO. D3-1, OR APPROVED EQUAL (VARIES X 6" MIN). CAPITAL LETTERS SHALL BE 4" IN HEIGHT AND LOWER CASE LETTERS SHALL BE 3" IN HEIGHT.
- ③ STOP SIGN SHALL BE MUTCD SIGN NO. R1-1 (30"X30"), OR APPROVED EQUAL

NOTES

- 1. STOP SIGN SHALL BE PLACED ON THE RIGHT SIDE OF THE ROADWAY, 4- FEET IN ADVANCE OF THE PROPOSED OR EXISTING CROSSWALK OR AS DIRECTED BY ENGINEER.
- 2. ORIENT SIGNS TO BEST FIT FIELD CONDITIONS.
- 3. SIGN SUPPORT SHALL BE PERFORATED STEEL SQUARE TUBE.
- 4. NO PERIODS SHALL FOLLOW ABBREVIATIONS ON STREET SIGNS.

TYPICAL TRAFFIC SIGN
NTS

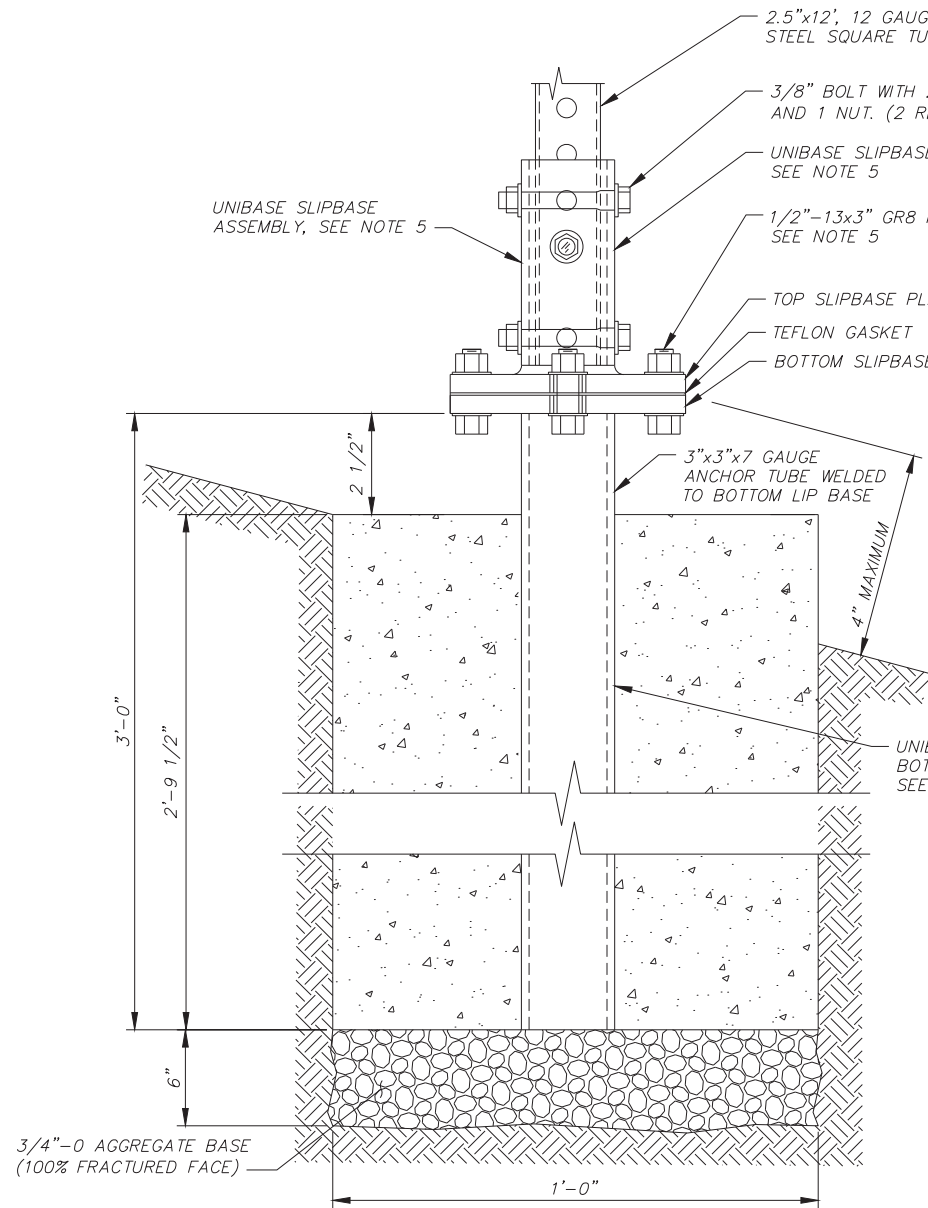

SLIPBASE ELEVATION
NTS

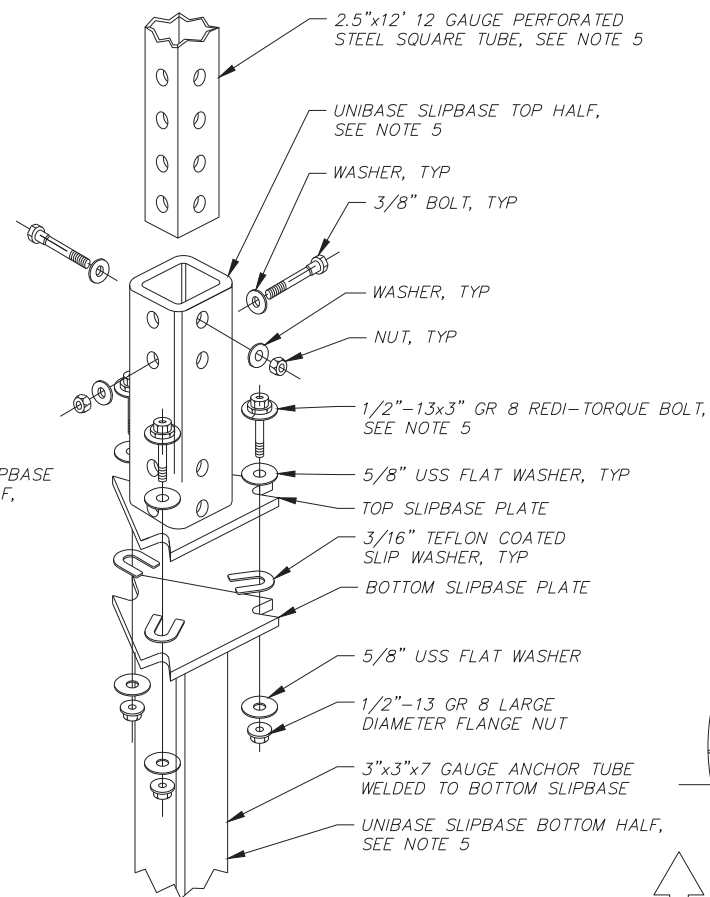

SLIPBASE EXPLODED VIEW
NTS

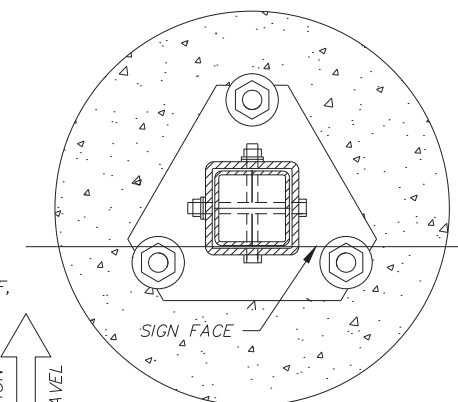

SLIPBASE PLAN
NTS

NOTES

- 1. MATERIAL GRADE FOR BASE HARDWARE CONNECTION SHALL BE ACCORDING TO THE MANUFACTURER'S RECOMMENDATION AND BASED ON CRASH TESTING.
- 2. SLIPBASE STEEL SHALL BE HOT DIPPED GALVANIZED OR APPROVED EQUAL.
- 3. FOOTING CONCRETE SHALL BE COMMERCIAL GRADE 3,000 PSI CONCRETE.
- 4. ALL SLIPBASES SHALL BE PRE-ASSEMBLED BY THE MANUFACTURER AND SHALL BE INSTALLED ACCORDING TO THE MANUFACTURER'S INSTRUCTIONS.
- 5. TRAFFIC SAFETY PART NUMBERS:
 -UNIBASE SLIPBASE ASSEMBLY - KIT-SLIPBASEODOT36
 -UNIBASE SLIPBASE TOP HALF - DP00384
 -UNIBASE SLIPBASE BOTTOM HALF - DP00385
 -2.5"x12', 12 GAUGE POST - DP00313
 -UNIBASE SLIPBASE REDI-TORQUE MATCH PLATE HARDWARE KIT - DP00387

x:\Clients\hermiston_01_citystandarddrawings\HermStdDwg_ST19_Sign.dwg, ST19_Sign.dwg, ST19, 1/29/2024 2:53 PM, lwillhite



**CITY OF
HERMISTON, OREGON
STANDARD DRAWINGS**

SIGNS

**FIGURE
ST19**

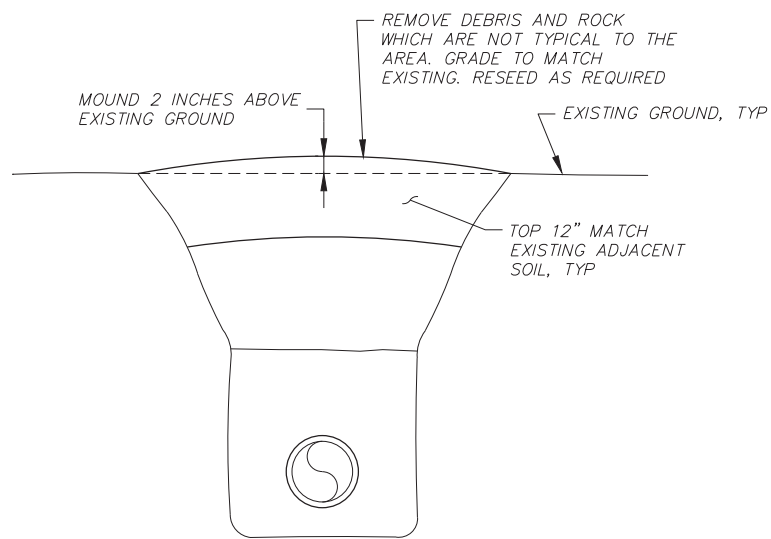

SURFACE RESTORATION
NATURAL SURFACES
NTS

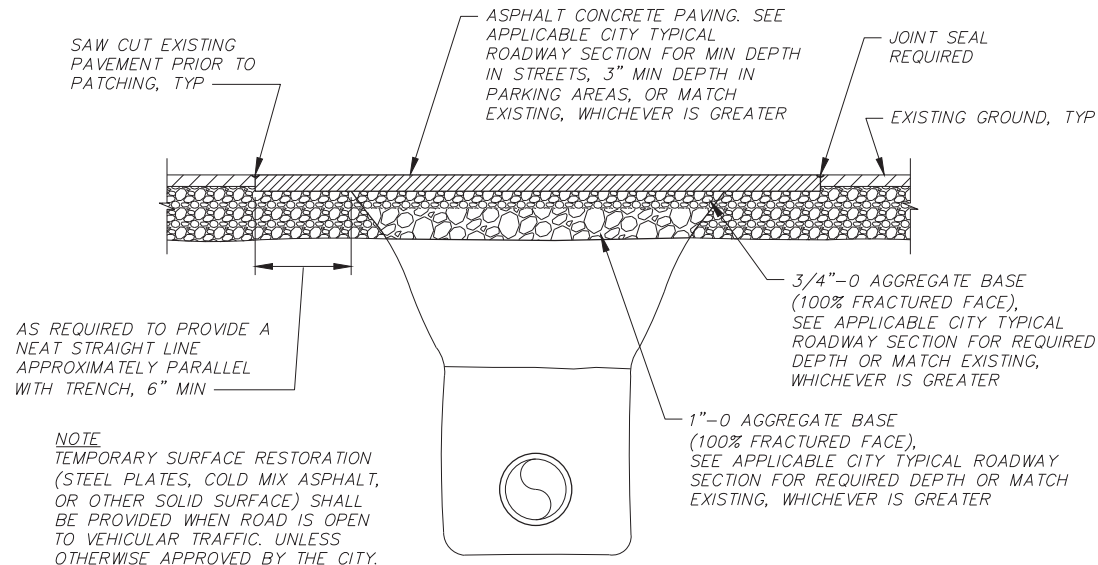

SURFACE RESTORATION
PAVED SURFACES
NTS

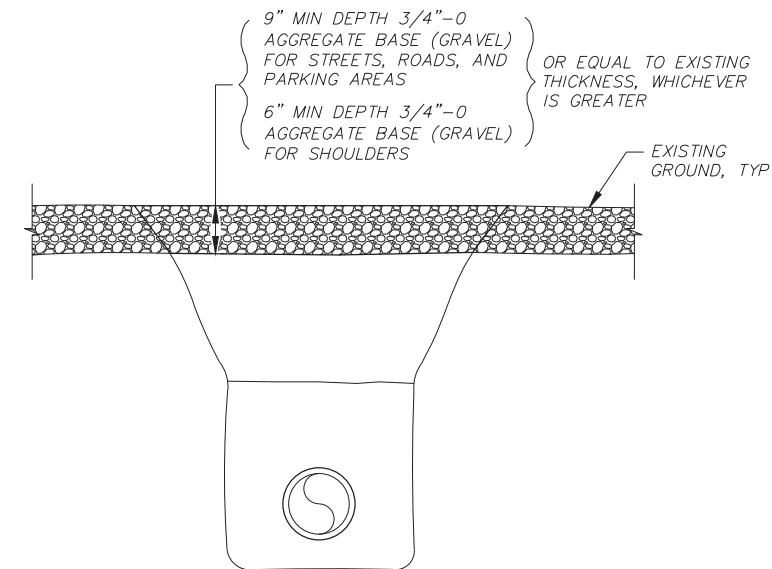

SURFACE RESTORATION
GRAVEL SURFACES
NTS

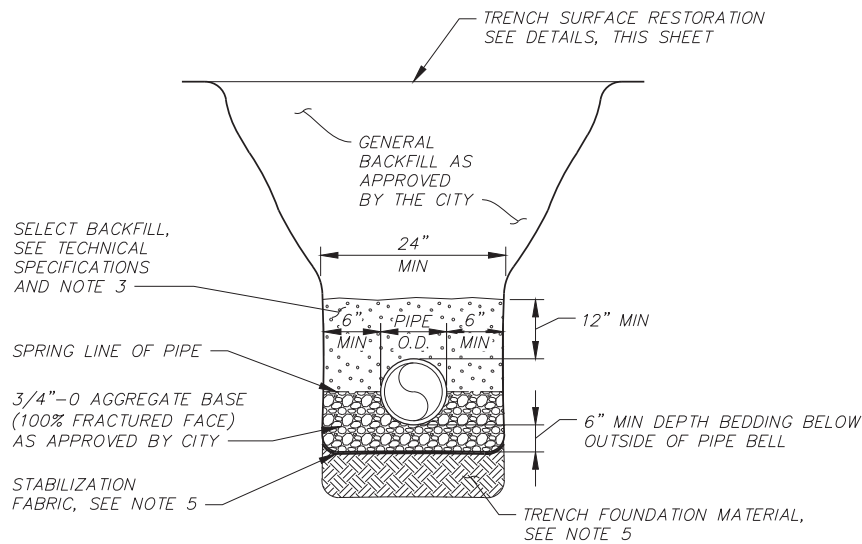

SEWER AND STORM DRAIN LINE
TRENCH BEDDING AND BACKFILL
NTS

TRENCH BEDDING AND BACKFILL NOTES

1. SURFACING OF PAVED AREAS SHALL COMPLY WITH CITY STANDARD STREET DRAWINGS.
2. ALL BACKFILL MATERIAL SHALL BE COMPACTED TO 95% MAXIMUM DRY DENSITY PER ASTM D1557 AND SHALL BE PLACED AND COMPACTED IN 6" LIFTS, UNLESS NOTED OTHERWISE.
3. BACKFILL FROM PIPE BOTTOM TO 12-INCHES ABOVE PIPE SHALL BE COMPACTED TO 85% MAXIMUM DRY DENSITY PER ASTM D1557. COMPACTION BY HAND TAMPING WILL BE ALLOWED IF 85% DENSITY IS ACHIEVED. OTHERWISE MECHANICAL TAMPING WILL BE REQUIRED.
4. BACKFILL INSPECTION/TESTING
 - TRENCH DEPTH OF LESS THAN 1 FT VISUAL INSPECTION BY CITY.
 - TRENCH DEPTH GREATER THAN 1 FT:
 - BELOW FINISH AGGREGATE BASE (100% FRACTURED FACE) GRADE: 1 TEST PER 300 FT OF TRENCH AND EVERY 1.5 FT OF FILL.
 - AT FINISH AGGREGATE BASE (100% FRACTURED FACE) GRADE: 1 TEST PER 300 FT OF TRENCH OR 2 TESTS PER STREET CROSSING.
 - IF BACKFILL MATERIAL OR COMPACTION EQUIPMENT CHANGES, COMPACTION TESTING SHALL IMMEDIATELY BE PERFORMED TO VERIFY THAT DENSITY IS BEING ACHIEVED.
5. STABILIZATION FABRIC AND IMPORTED FOUNDATION MATERIAL SHALL BE REQUIRED WHERE NATURAL SOIL CONDITIONS IN THE BOTTOM OF THE TRENCH ARE UNSUITABLE FOR PROPER PIPE INSTALLATION.

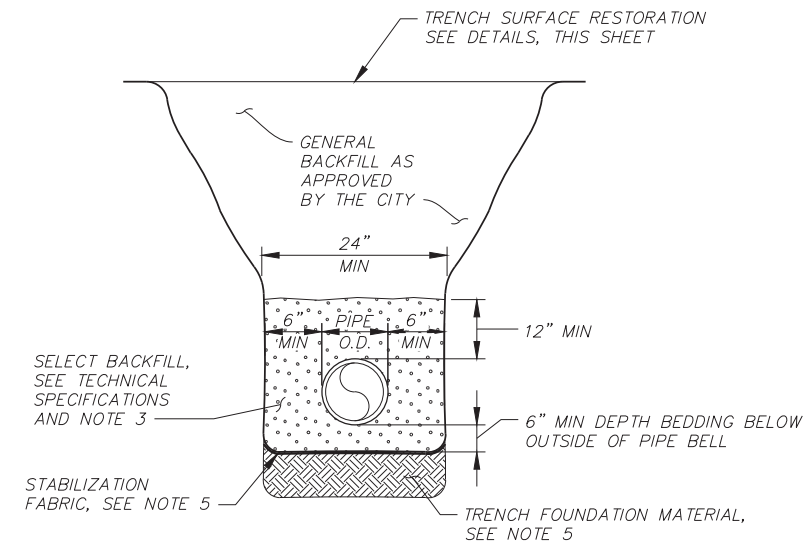

WATER LINE TRENCH BEDDING AND BACKFILL
NTS

x:\Clients\hermiston\on_citystandarddrawings\HermStdDwg_ST20_Trench_Bed_Pipe.dwg, ST20_Trench_Bed_Pipe.dwg, ST20_Trench_Bed_Pipe.dwg, 1/29/2024 2:53 PM, twillhie



CITY OF
HERMISTON, OREGON
STANDARD DRAWINGS
**TRENCH BEDDING, BACKFILL,
AND SURFACE RESTORATION**

FIGURE
ST20

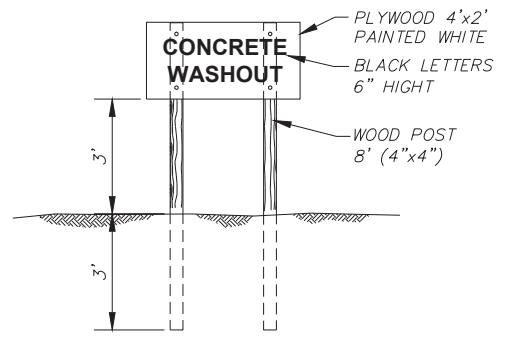

CONCRETE WASHOUT SIGN DETAIL

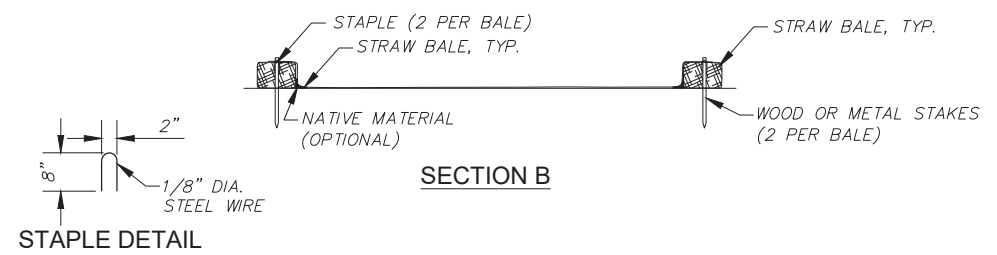

STAPLE DETAIL

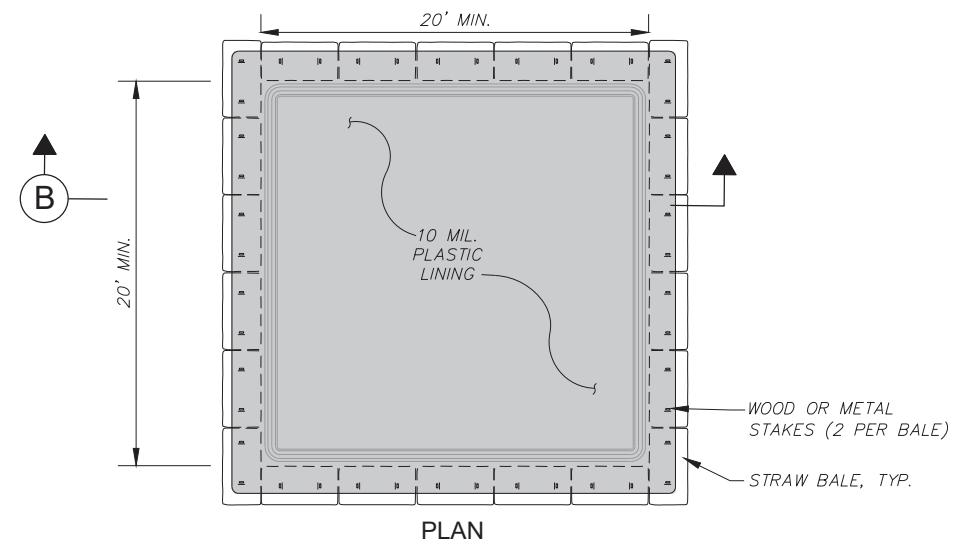

CONCRETE WASHOUT AREA DETAILS
(NUMBER AS REQUIRED)
N.T.S.

WORK ITEM

- 1 PLACE CONSTRUCTION GEOTEXTILE FOR SOIL STABILIZATION AND A MINIMUM OF 2" OF 3/4"-0 AGGREGATE BASE (100% FRACTURED FACE) UNDER THE SPALLS FROM THE EDGE OF THE EXISTING ROADWAY TO THE RADIUS RETURNS, OR AS DIRECTED BY CITY.

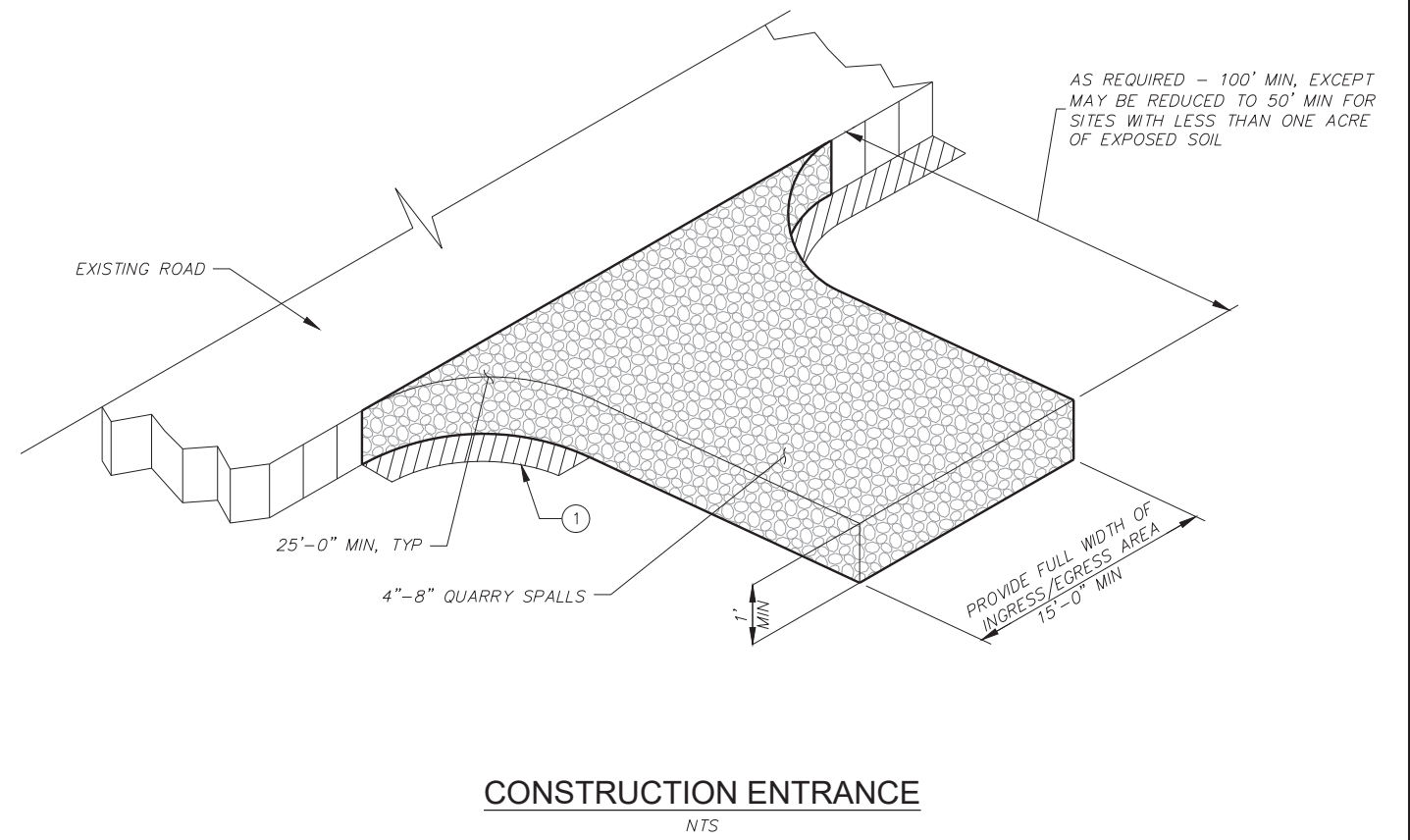

CONSTRUCTION ENTRANCE
NTS

x:\Clients\hermiston or\citystandard\drawings\HermStdDwg_ST21_Erosion_Sedi_Contrl.dwg, ST21, 1/29/2024 2:53 PM, lwilhlite

 <p>HERMISTON OREGON Where Life is Sweet</p>	<p>CITY OF HERMISTON, OREGON STANDARD DRAWINGS</p> <p>EROSION AND SEDIMENT CONTROL</p>	<p>FIGURE ST21</p>
---	--	------------------------

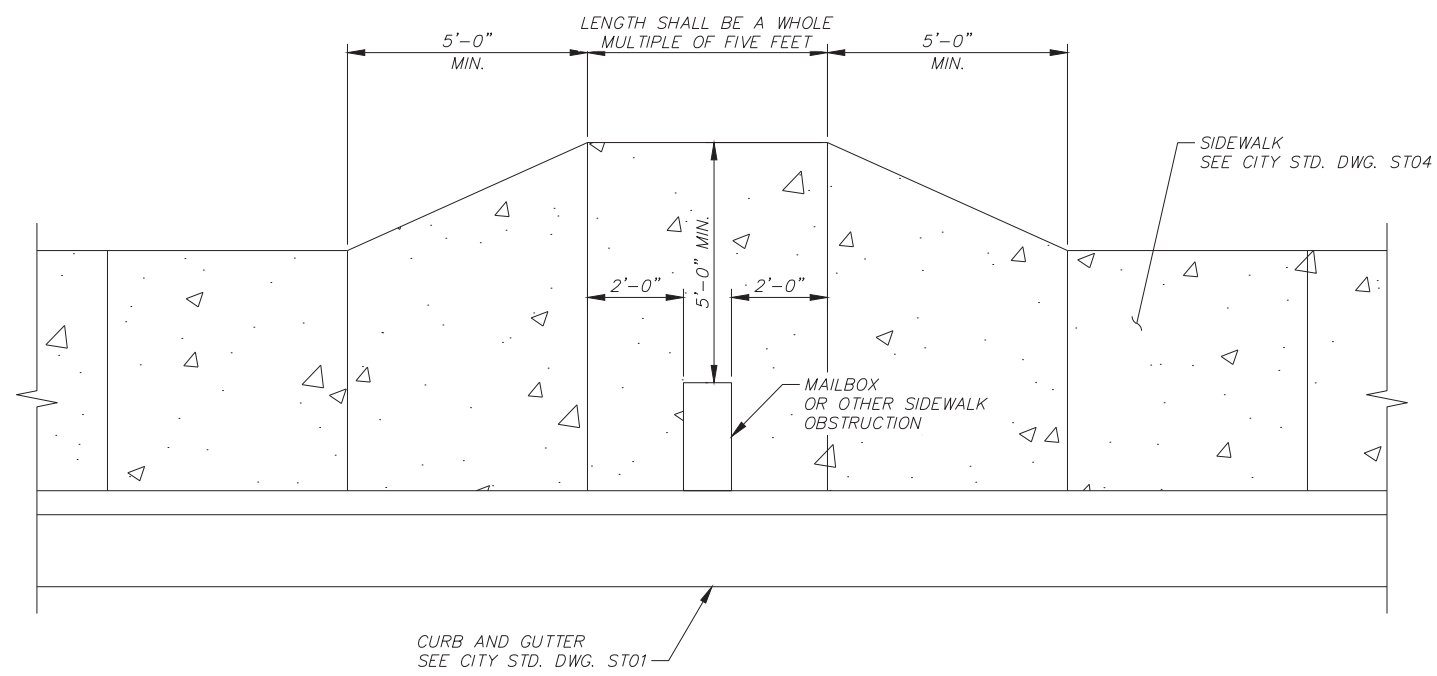

SIDEWALK WIDENING AROUND OBSTRUCTIONS
NTS

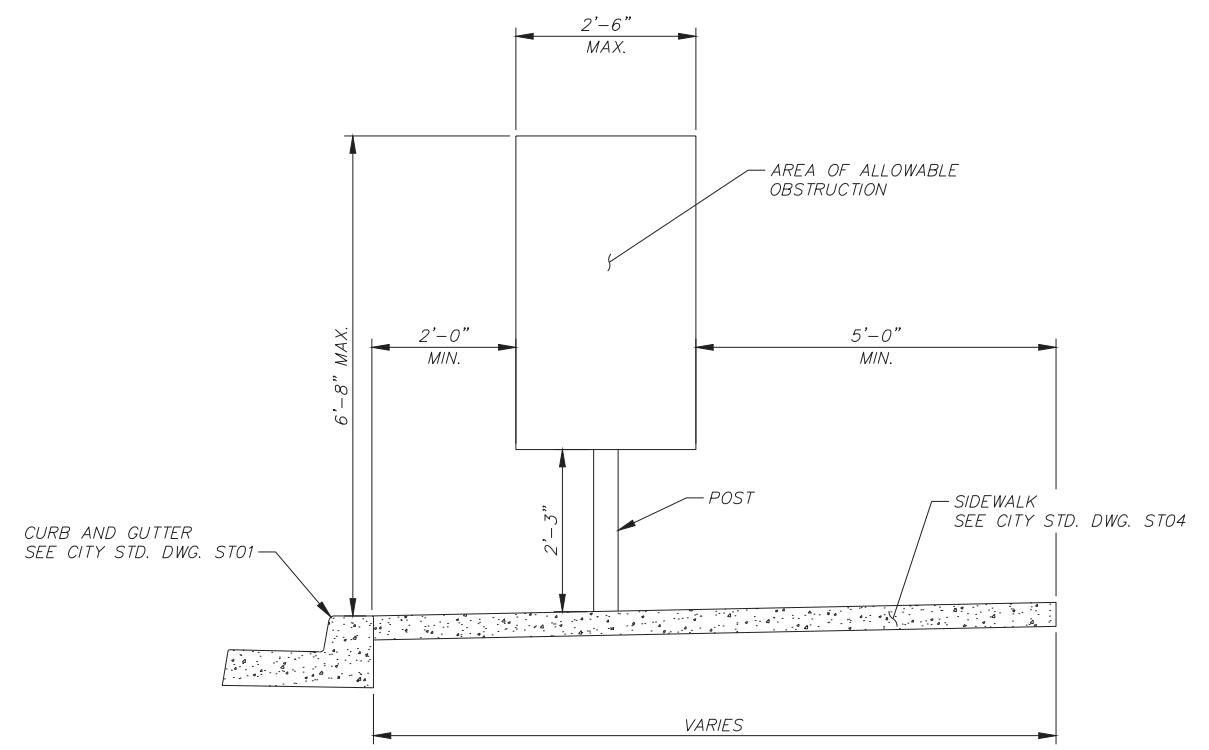

POST MOUNTED OBSTRUCTION WITHIN SIDEWALK
NTS

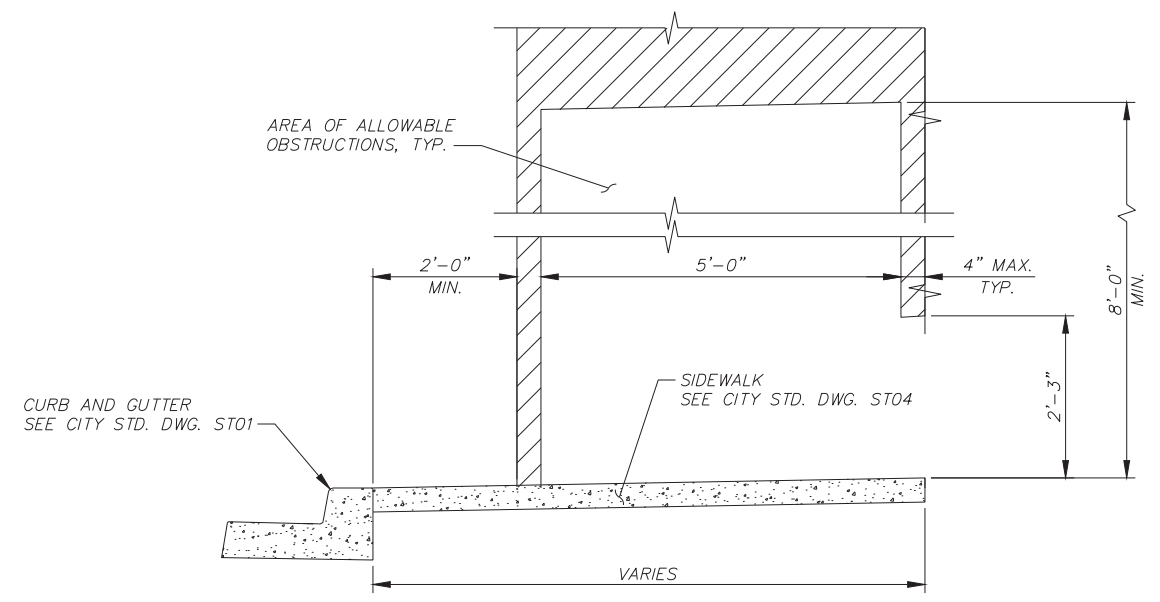

PROTRUDING OBJECTS AND OTHER OBSTRUCTIONS
NTS

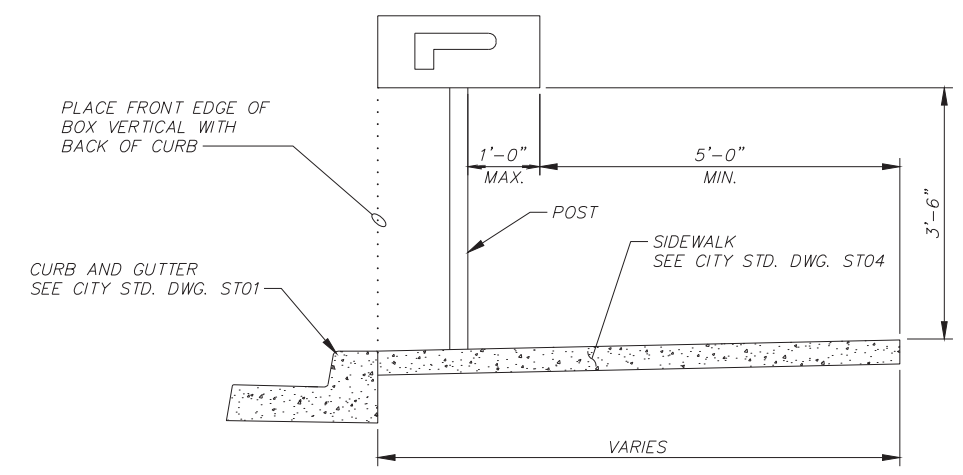

TYPICAL MAILBOX INSTALLATION
NTS

NOTES

1. INSTALL FULL DEPTH EXPANSION JOINT AROUND ALL OBSTRUCTIONS PENETRATING SIDEWALK SURFACE.
2. EXCEPTIONS TO THE REQUIREMENTS IN THIS DRAWING MUST BE APPROVED BY THE CITY AND MUST COMPLY WITH THE CURRENT PUBLIC RIGHT-OF-WAY ACCESSIBILITY GUIDELINES.

x:\Clients\hermiston\01_citystandard\drawings\HermStdDwg_ST22_SWLK Obstruct & Protud.dwg, ST22, 1/29/2024 2:54 PM, lwillhite



**CITY OF
HERMISTON, OREGON
STANDARD DRAWINGS**

SIDEWALK OBSTRUCTIONS

**FIGURE
ST22**

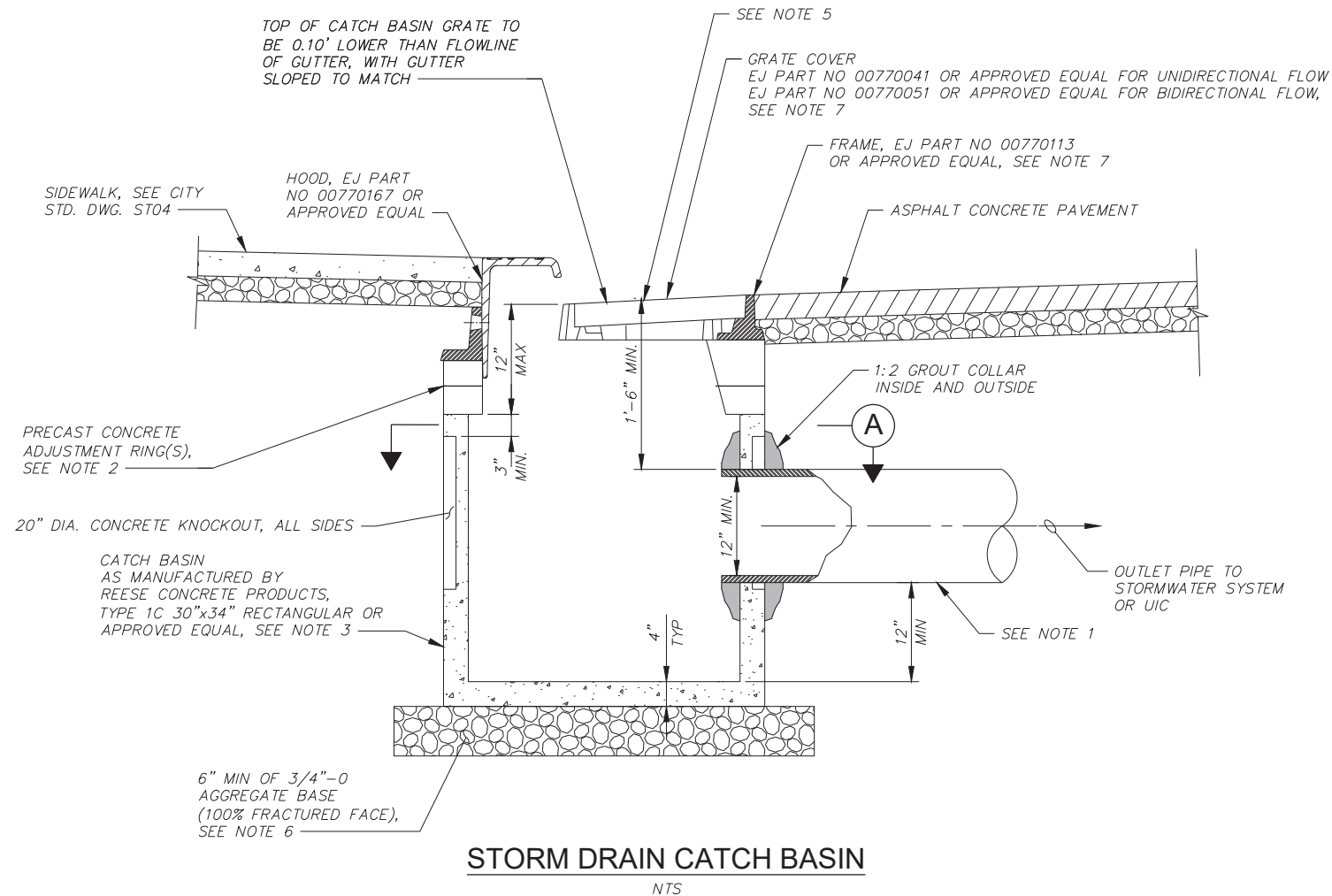

NOTES:

1. MINIMUM PIPE BURY TO BE 30" UNLESS OTHERWISE APPROVED BY CITY. NUMBER OF PIPES CONNECTING TO CATCH BASIN SHALL NOT EXCEED 3. MINIMUM PIPE SIZE SHALL BE 12".
2. FOR ADJUSTMENTS LESS THAN 2" GROUT BETWEEN FRAME AND TOP OF CONCRETE OR ADJUSTMENT RINGS. ADJUSTMENTS 2" AND GREATER SHALL BE MADE WITH PRECAST CONCRETE RINGS.
3. WIRE REINFORCED PRECAST CATCH BASIN SHALL BE REQUIRED WHEN 3-12" PIPES ARE TO BE CONNECTED AND SHALL CONFORM TO ASTM C913.
4. CONTRACTOR TO INSTALL EROSION AND SEDIMENT CONTROL PROTECTION DURING CONSTRUCTION PER CURRENT DEQ STANDARDS.
5. CATCH BASIN GRATES AND FRAMES NOT LOCATED IN CURB AND GUTTER REQUIRE CITY APPROVAL.
6. COMPACT ALL AGGREGATE BASE TO 95% MAXIMUM DRY DENSITY PER ASTM D1557.
7. AREA DRAIN CATCH BASINS LOCATED IN PAVED AREAS SHALL BE INSTALLED WITH A RECTANGULAR ADA GRATE (EJ PART NO 00775036) AND A NON SLOPING FRAME (EJ PART NO 00777011)
8. INSPECTION REQUIREMENTS: CONTRACTOR SHALL SET A STRING LINE FOR THE TOP BACK OF CURB. CITY REPRESENTATIVE SHALL WITNESS THAT THE STRING LINE IS DIRECTLY ABOVE INSIDE FACE OF THE CONCRETE RISER RING.

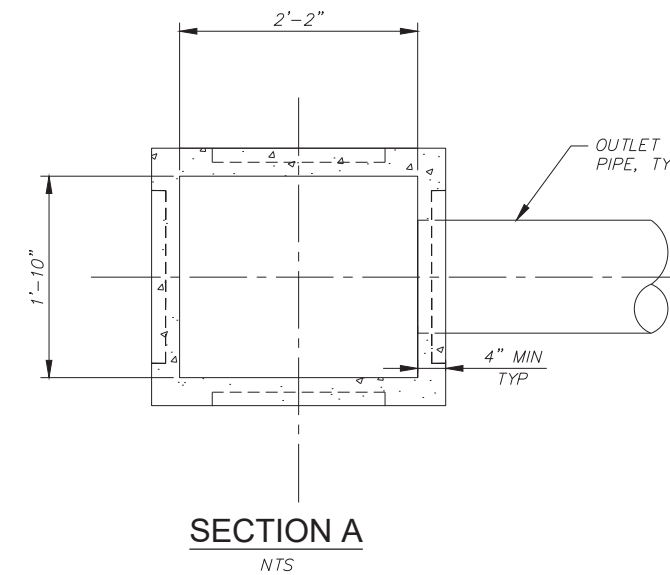

x:\Clients\hermiston_or_citystandarddrawings\HermStdDwg_SD01_Type_1_SD_CB.dwg_SD01_Type_1_1/29/2024 2:54 PM: lw\lwhite



CITY OF
HERMISTON, OREGON
STANDARD DRAWINGS

STORM DRAIN CATCH BASIN

FIGURE
SD01

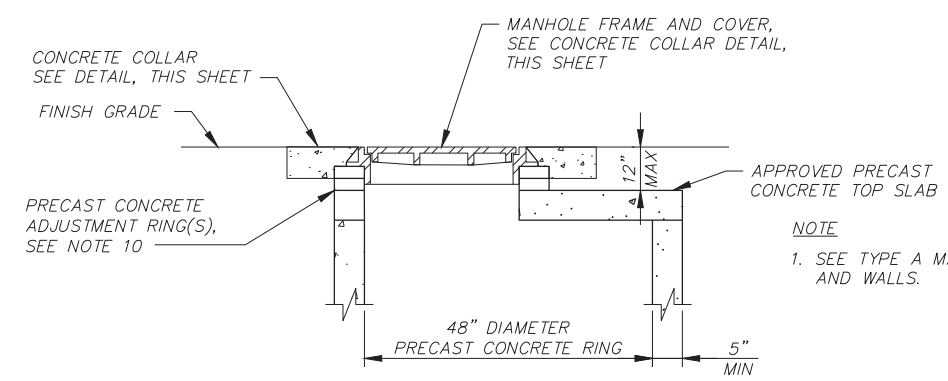

STORM DRAIN TOP SLAB MANHOLE
TYPE B
NTS

NOTE
1. SEE TYPE A MANHOLE FOR BASE AND WALLS.

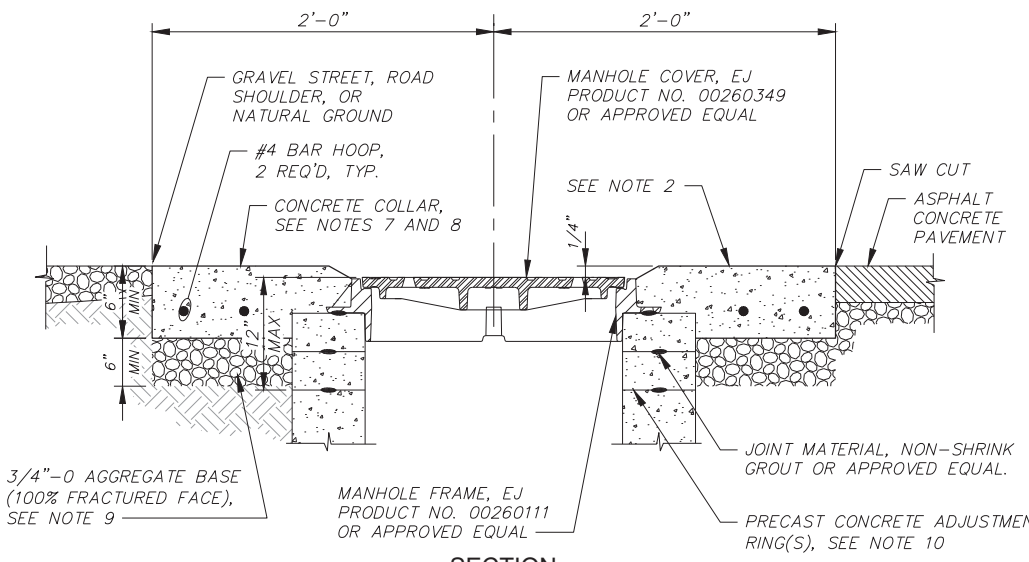

CONCRETE COLLAR DETAIL
(IN GRAVEL STREETS, NATURAL GROUND OR ASPHALT PAVEMENT)
NTS

REQUIREMENTS FOR CONCRETE COLLARS:
1. ALL CONCRETE SHALL BE COMMERCIAL GRADE 4000 PSI CONCRETE.
2. COLLAR TO BE FORMED SQUARE.
3. SMOOTH BROOMED FINISH REQUIRED.
4. APPLY CONCRETE CURING COMPOUND.
5. PROTECT FROM TRAFFIC FOR 4 DAYS MINIMUM.

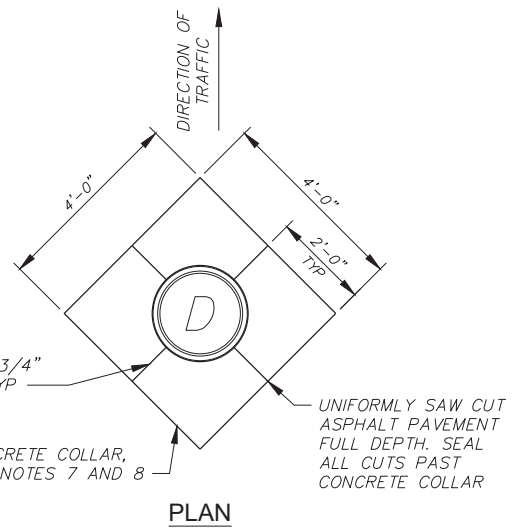

PLAN

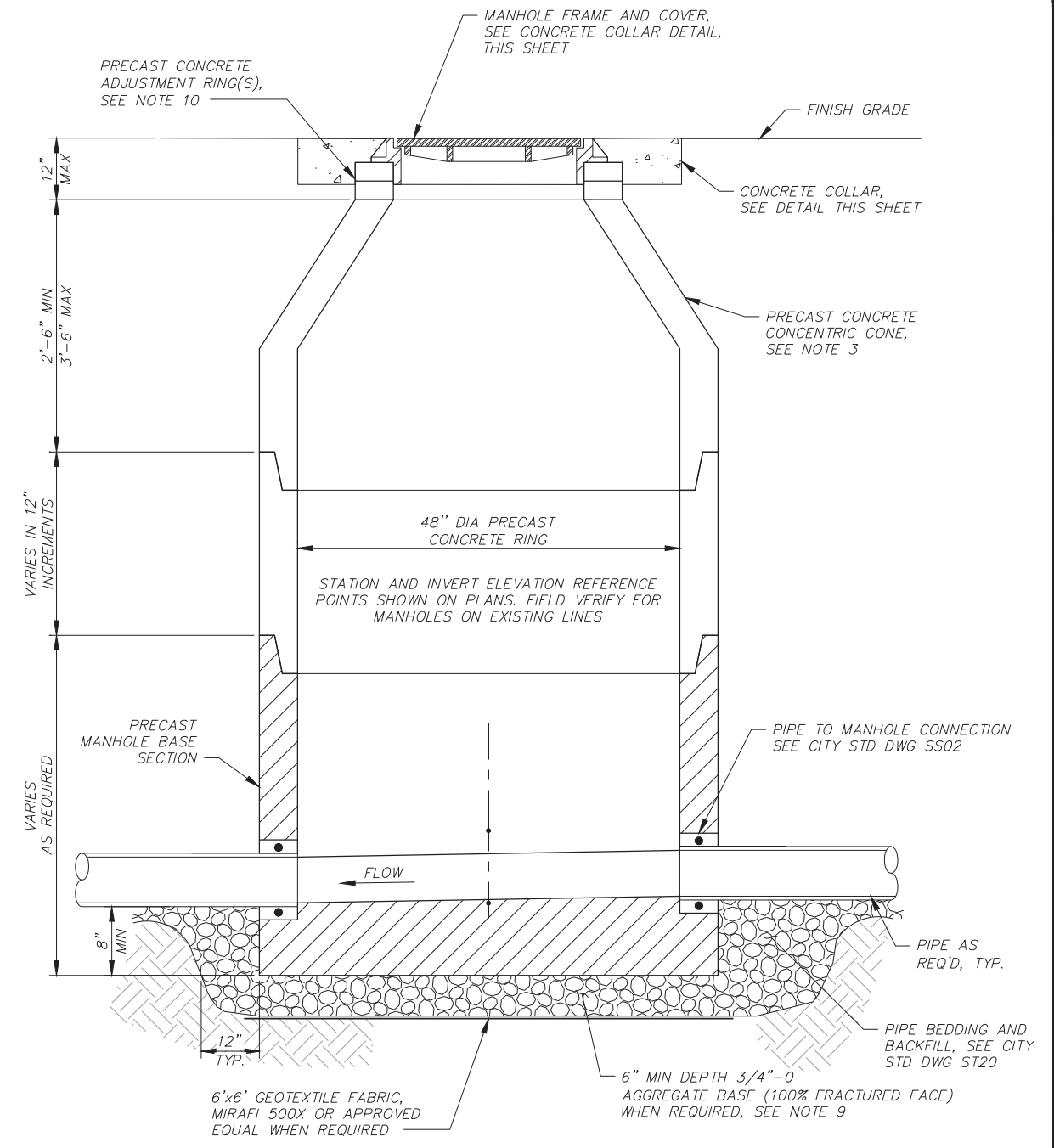

STANDARD STORM DRAIN MANHOLE
TYPE A
NTS

NOTES

1. ALL MANHOLES SHALL BE PRECAST MANHOLE UNITS CONFORMING TO ASTM C478.
2. ANY GAPS, HOLES, ROUGH SPOTS, ETC, IN THE INVERT CHANNELS SHALL BE FILLED OR REPAIRED IN THE FIELD.
3. CONE SECTION SHALL BE TYPE A UNLESS MANHOLE DEPTH IS 5.5 FEET OR LESS. MANHOLES 5.5 FEET OR LESS IN DEPTH SHALL BE TYPE B UNLESS OTHERWISE CALLED FOR ON THE DESIGN DRAWINGS.
4. PRIOR TO MANUFACTURING MANHOLES THE CONTRACTOR SHALL VERIFY FIELD CONDITIONS, PIPE INVERT ELEVATIONS, PIPE ORIENTATION, AND MANHOLE DEPTH. CONTRACTOR SHOULD ALSO NOTE THAT PIPE SLOPES ARE CALCULATED TO CENTER OF THE MANHOLE.
5. ALL PRECAST MANHOLE BASE SECTIONS SHALL HAVE FACTORY CAST FLOW CHANNELS UNLESS OTHERWISE APPROVED BY THE CITY.
6. MANHOLE STEPS NOT PERMITTED.
7. CONCRETE COLLAR REQUIRED AFTER PLACEMENT OF ACP.
8. ALL MANHOLES SHALL HAVE A CONCRETE COLLAR REGARDLESS OF BEING INSTALLED ON PAVED OR GRAVEL STREET, ROAD SHOULDER, OR NATURAL GROUND.
9. COMPACT ALL AGGREGATE BASE (100% FRACTURED FACE) TO 95% MAXIMUM DRY DENSITY PER ASTM D1557.
10. FOR ADJUSTMENTS LESS THAN 2" GROUT BETWEEN FRAME AND TOP OF CONCRETE OR ADJUSTMENT RINGS. ADJUSTMENTS 2" AND GREATER SHALL BE MADE WITH PRECAST CONCRETE RINGS.

x:\Clients\hermiston or_ citystandarddrawings\HermStdDwg_SD02_SD_Manhole_Type_A.dwg_SD02_1/29/2024 2:54 PM.twillhite



**CITY OF
HERMISTON, OREGON
STANDARD DRAWINGS**

STORM DRAIN MANHOLE

**FIGURE
SD02**

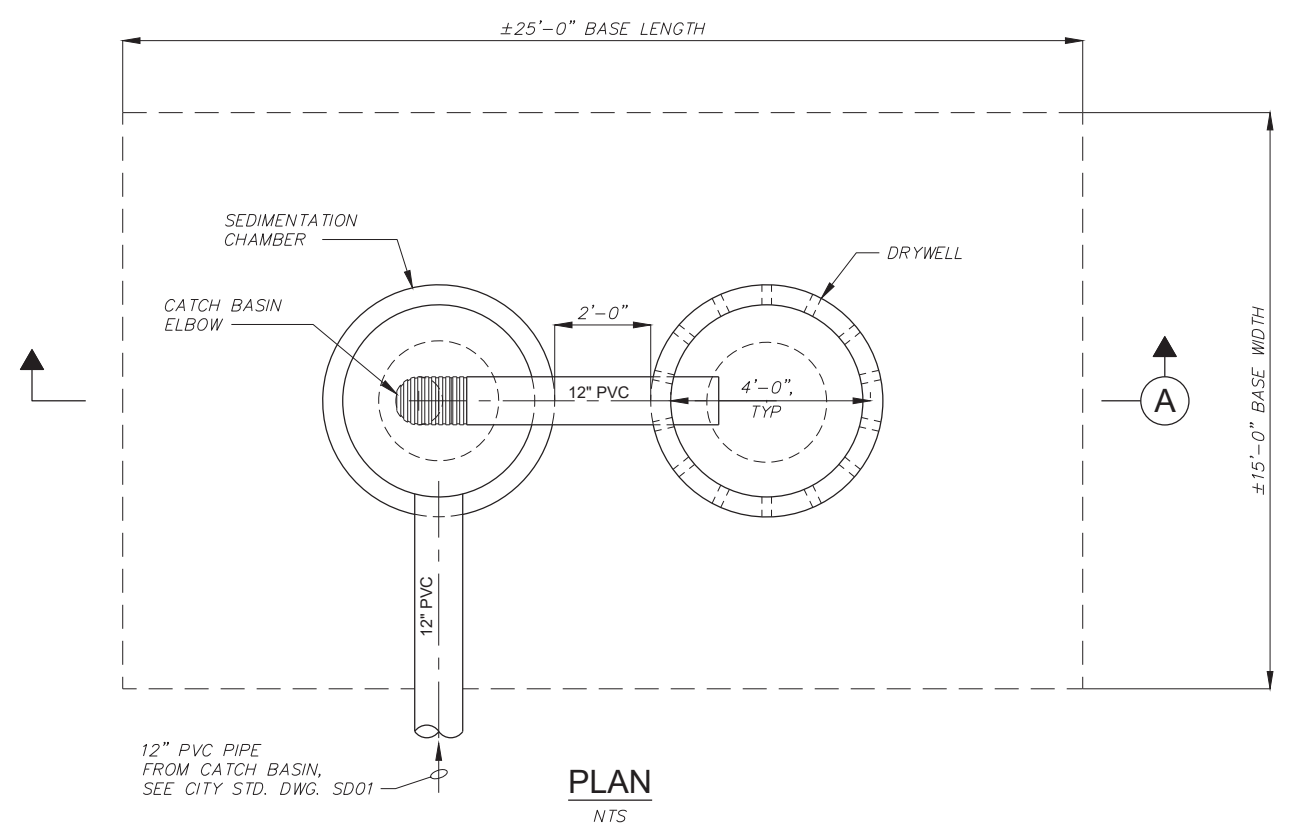

DESIGN NOTES

1. DRYWELL DRAINAGE AREA DESIGNED FOR 25 YEAR EVENT USING TYPE II STORM EVENT WITH A TIME OF CONCENTRATION OF 5 MIN.
2. DRYWELL DESIGNED TO DRAIN 12,600 SQUARE FEET OF STREET AREA.
3. MINIMUM BASE AREA OF 12'x20'.
4. ASSUMES POORLY GRADED SAND WITH SILT WITH A DESIGN INFILTRATION RATE OF 5" PER HOUR. SHOULD SOIL CONDITIONS SUCH AS CALICHE, HARD PAN, CLAY, SILT, ECT. BE ENCOUNTERED, THE CONTRACTOR SHALL NOTIFY THE CITY IMMEDIATELY. THE ACTUAL SIZE OF THE EXCAVATED AREA MAY BE ADJUSTED TO ACCOMMODATE DIFFERENT SOIL TYPES.
5. GROUNDWATER MUST BE A MINIMUM 5' BELOW BASE OF DRYWELL.
6. DRYWELLS SHALL NOT BE INSTALLED WITHIN THE 2-YEAR TIME OF TRAVEL OF AN EXISTING IRRIGATION OR DRINKING WELL. WHERE A 2-YEAR TIME OF TRAVEL HAS NOT BEEN IDENTIFIED, DRYWELLS SHALL NOT BE INSTALLED WITHIN 500' OF THE WELL.

CONSTRUCTION NOTES

1. SOIL STABILITY WILL DETERMINE THE PLACEMENT OF SEDIMENTATION CHAMBER AND DRYWELL. EXCAVATION SHALL NOT RESULT IN CURB, SIDEWALK, OR OTHER STRUCTURES TO BE UNDERMINED.
2. PRECAST SECTIONS SHALL CONFORM TO THE REQUIREMENTS OF ASTM C478.
3. ACTUAL LOCATION OF DRYWELL TO BE APPROVED BY CITY PRIOR TO CONSTRUCTION.
4. SEAL ALL PIPE PENETRATIONS WATERTIGHT WITH NONSHRINK GROUT.
5. PRECAST SECTIONS TO BE PLACED ON NATIVE UNDISTURBED SOIL.
6. ALL AGGREGATE BASE AND BACKFILL SHALL BE COMPACTED TO 95% MAXIMUM DRY DENSITY PER ASTM D1557.

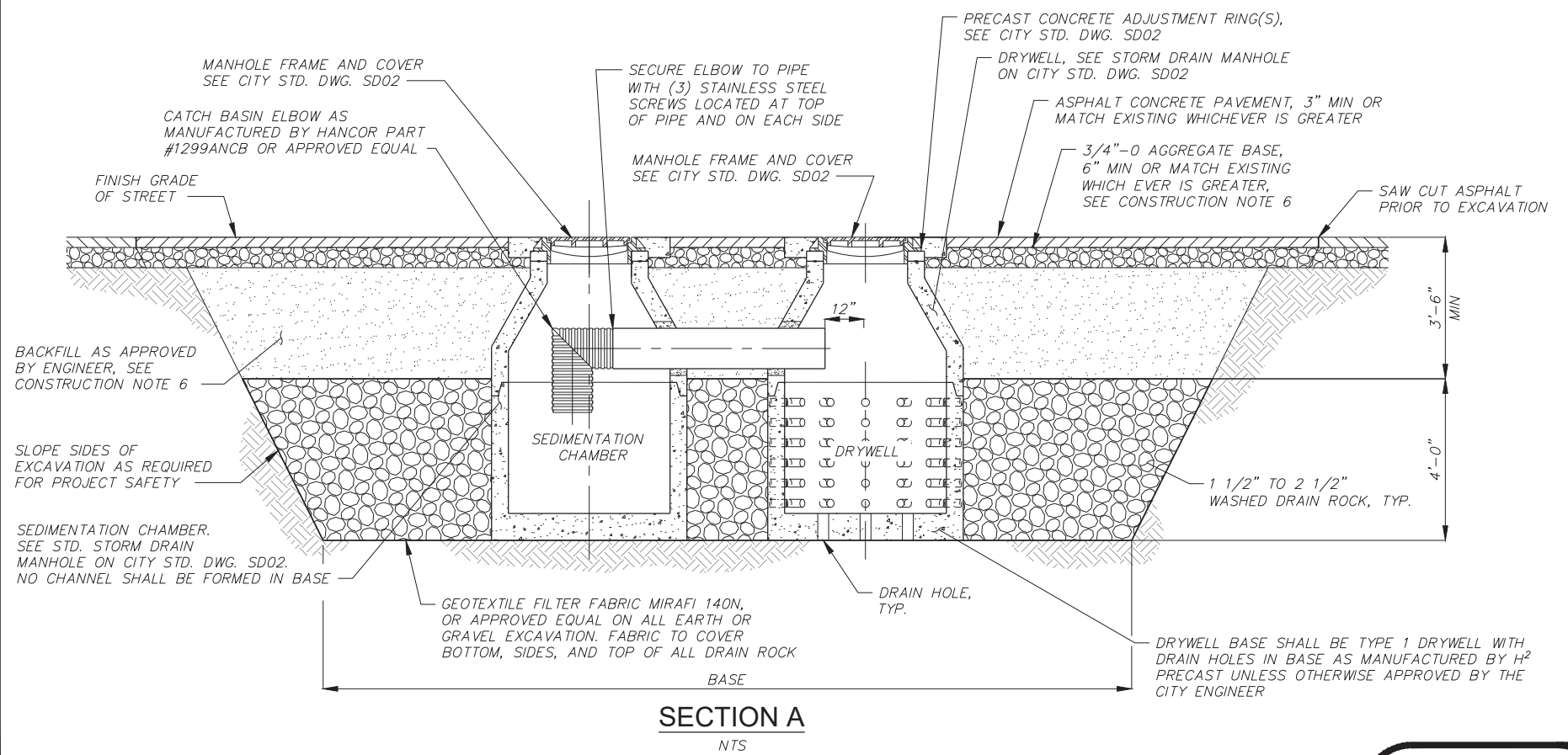

x:\Clients\hermiston_01_citystandarddrawings\HermStdDwg_SD03_SDMT_DW_Combo.dwg_SD03_1/29/2024 2:54 PM.lwl\lwhite



CITY OF
HERMISTON, OREGON
STANDARD DRAWINGS

**SEDIMENTATION CHAMBER
AND DRYWELL**

FIGURE
SD03

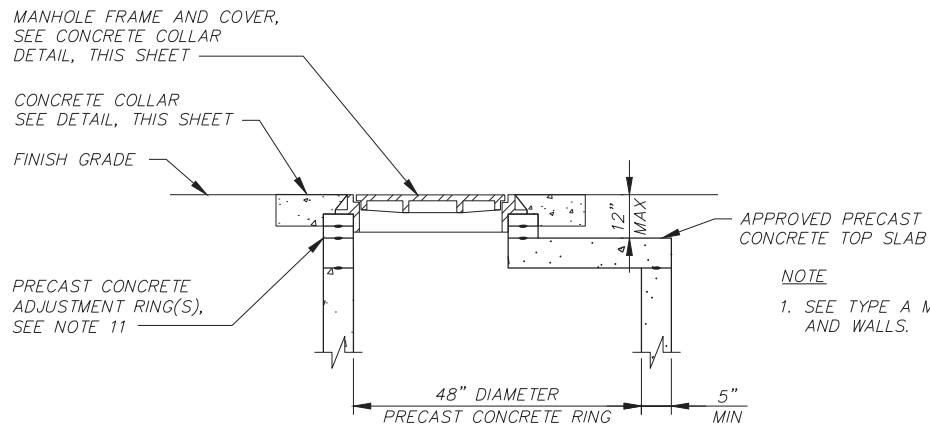

SANITARY SEWER TOP SLAB MANHOLE

TYPE B
NTS

NOTE
1. SEE TYPE A MANHOLE FOR BASE AND WALLS.

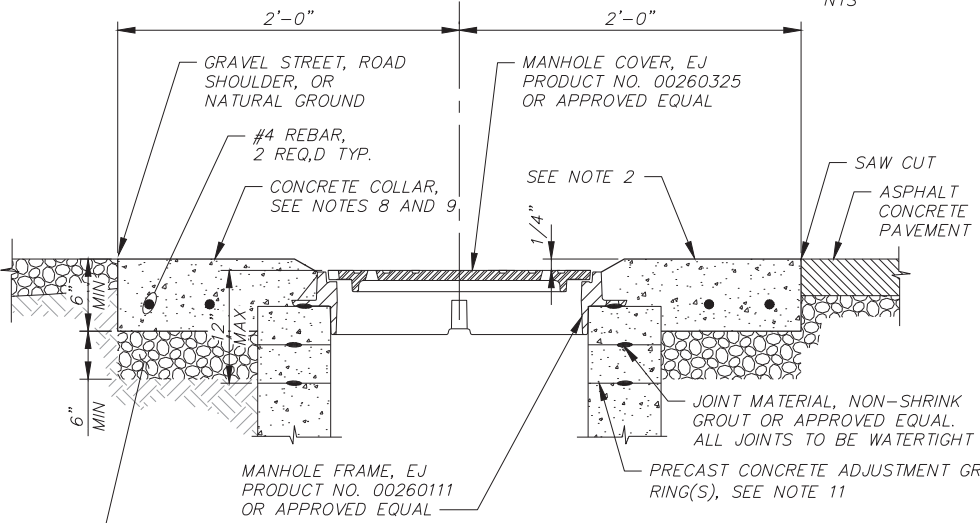

REQUIREMENTS FOR CONCRETE COLLARS

1. ALL CONCRETE SHALL BE COMMERCIAL GRADE 4000 PSI CONCRETE.
2. COLLAR TO BE FORMED SQUARE.
3. SMOOTH BROOMED FINISH REQUIRED.
4. APPLY CONCRETE CURING COMPOUND.
5. PROTECT FROM TRAFFIC FOR 4 DAYS MINIMUM.

CONCRETE COLLAR DETAIL
(IN GRAVEL STREETS, NATURAL GROUND OR ASPHALT PAVEMENT)
NTS

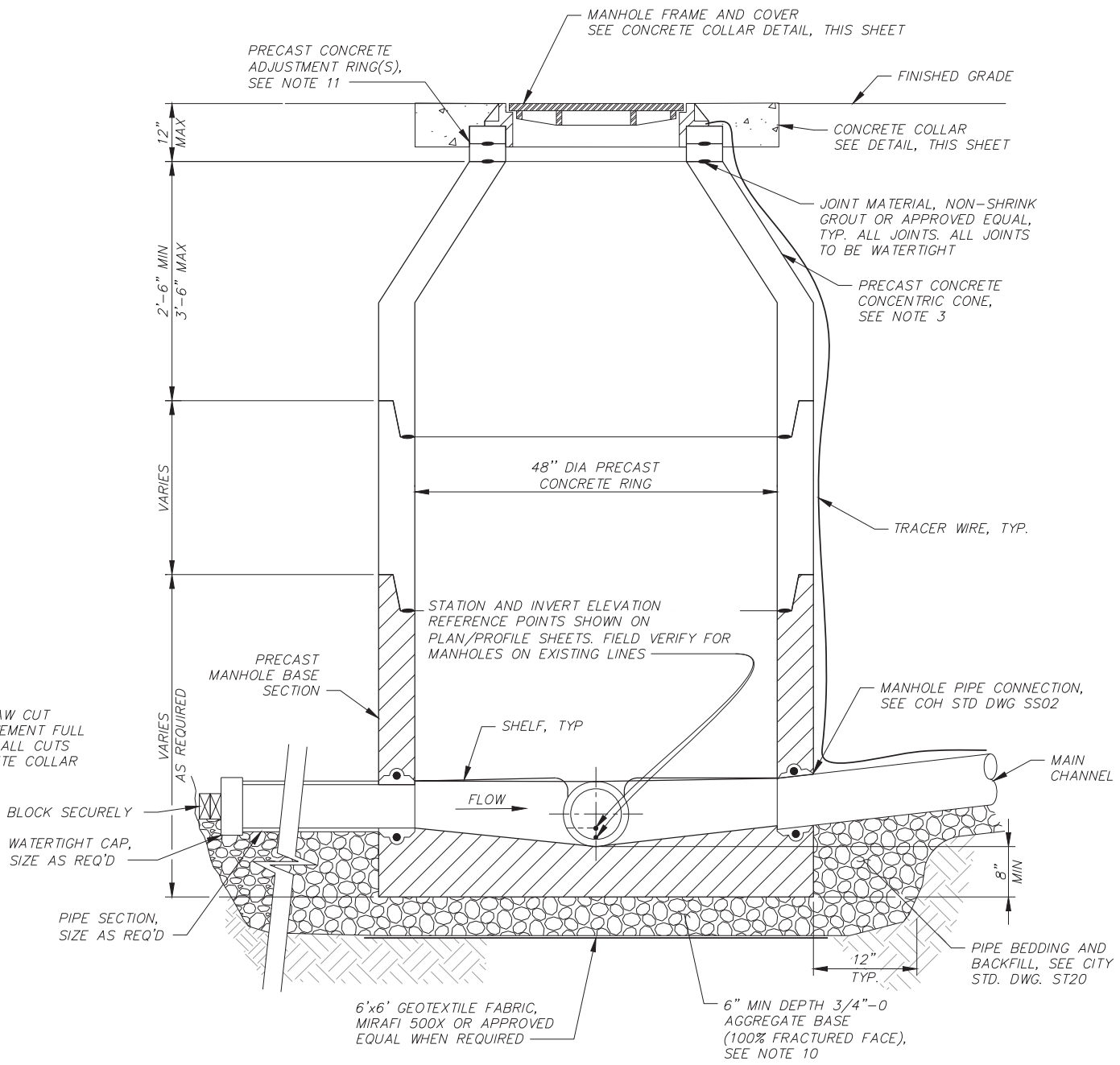
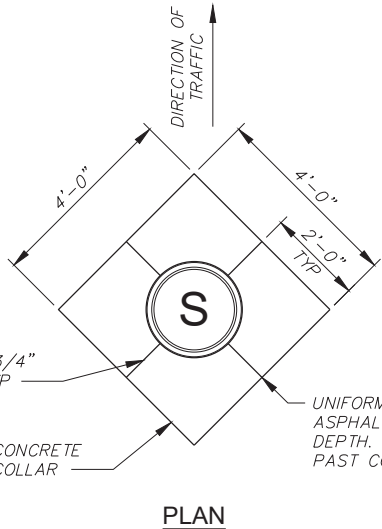

STANDARD SANITARY SEWER MANHOLE

TYPE A
NTS

NOTES

1. ALL MANHOLES SHALL BE PRECAST MANHOLE UNITS CONFORMING TO ASTM C478.
2. ANY GAPS, HOLES, ROUGH SPOTS, ETC, IN THE CHANNELS SHALL BE FILLED OR REPAIRED IN THE FIELD.
3. MANHOLES SHALL BE TYPE A UNLESS MANHOLE DEPTH IS LESS THAN 5 FEET. MANHOLES LESS THAN 5 FEET IN DEPTH SHALL BE TYPE B UNLESS OTHERWISE CALLED FOR ON THE DESIGN DRAWINGS. MANHOLE DEPTH SHALL BE AS MEASURED FROM FINISHED GRADE TO INVERT OF PIPE.
4. PRIOR TO MANUFACTURING MANHOLES, THE CONTRACTOR SHALL VERIFY FIELD CONDITIONS, PIPE INVERT ELEVATIONS, PIPE ORIENTATION, AND MANHOLE DEPTH. CONTRACTOR SHOULD ALSO NOTE THAT PIPE SLOPES ARE CALCULATED TO CENTER OF THE MANHOLE.
5. WHERE THE DISTANCE BETWEEN INLET PIPE INVERT AND MANHOLE CHANNEL INVERT IS GREATER THAN 2 FEET A DROP MANHOLE SHALL BE USED.
6. ALL PRECAST MANHOLE BASE SECTIONS SHALL HAVE FACTORY CAST FLOW CHANNELS UNLESS OTHERWISE APPROVED BY THE CITY ENGINEER.
7. MANHOLE STEPS NOT PERMITTED.
8. CONCRETE COLLAR REQUIRED AFTER PLACEMENT OF ACP.
9. ALL MANHOLES SHALL HAVE A CONCRETE COLLAR REGARDLESS OF BEING INSTALLED ON PAVED OR GRAVEL STREETS, ROAD SHOULDER, OR NATURAL GROUND.
10. COMPACT ALL AGGREGATE BASE (100% FRACTURED FACE) TO 95% MAXIMUM DRY DENSITY PER ASTM D1557.
11. FOR ADJUSTMENTS LESS THAN 2" GROUT BETWEEN FRAME AND TOP OF CONCRETE OR ADJUSTMENT RINGS. ADJUSTMENTS 2" AND GREATER SHALL BE MADE WITH PRECAST CONCRETE RINGS.



CITY OF HERMISTON, OREGON
STANDARD DRAWINGS

SANITARY SEWER MANHOLE

FIGURE
SS01

x:\clients\hermiston_or_city\standarddrawings\HermStdDwg.SS01_SS.Manhole_Type_A.dwg.SS01_1/29/2024 2:54 PM.lwlwhite

NOTES

1. ALL PRECAST SECTIONS SHALL CONFORM TO REQUIREMENTS OF ASTM C478.
2. MANHOLE BASE SECTIONS SHALL BE PRECAST UNLESS OTHERWISE APPROVED BY CITY.
3. ALL CONCRETE SHALL BE COMMERCIAL GRADE, 4000 PSI CONCRETE.
4. LOCATION, ELEVATION, DIAMETER, SLOPE, AND NUMBER OF PIPE(S) VARIES, SEE DESIGN DRAWINGS.
5. MAXIMUM PIPE DIAMETER VARIES WITH PIPE MATERIAL.
6. INVERT CHANNELS SHALL BE CONSTRUCTED TO PROVIDE SMOOTH SLOPES AND RADII TO OUTLET PIPE.
7. RESILIENT CONNECTOR SHALL BE THE X-CEL CONNECTOR AS MANUFACTURED BY A•LOK PRODUCTS, INC. OR APPROVED EQUAL. IN ADDITION, THE FIELD SLEEVE AS MANUFACTURED BY A•LOK PRODUCTS, INC. OR APPROVED EQUAL SHALL BE USED WHEN CONNECTING TO AN EXISTING MANHOLE. ALL CONNECTORS AND FIELD SLEEVES, INCLUDING GROUT IF ANY, SHALL BE INSTALLED PER THE CONNECTOR MANUFACTURERS RECOMMENDATIONS TO ENSURE A FLEXIBLE CONNECTION IS MAINTAINED.

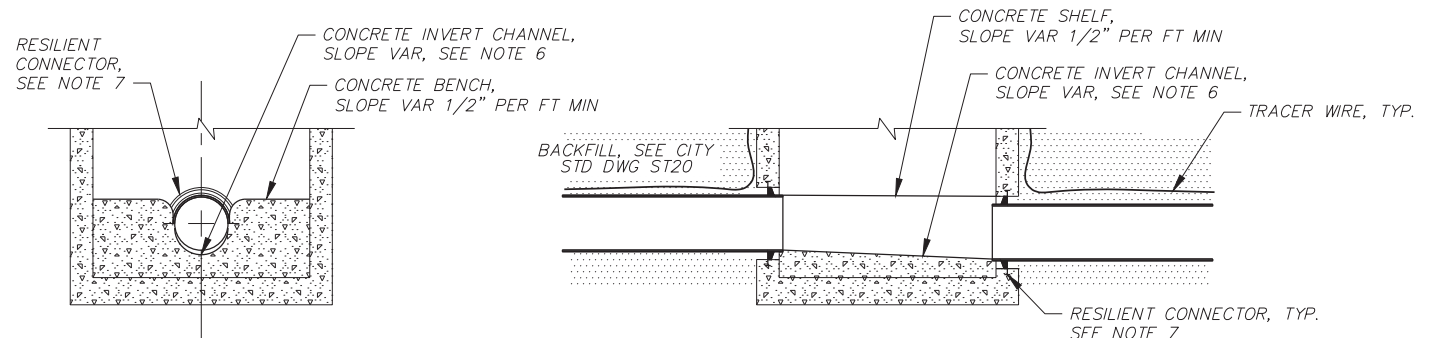

SECTION A

SECTION B

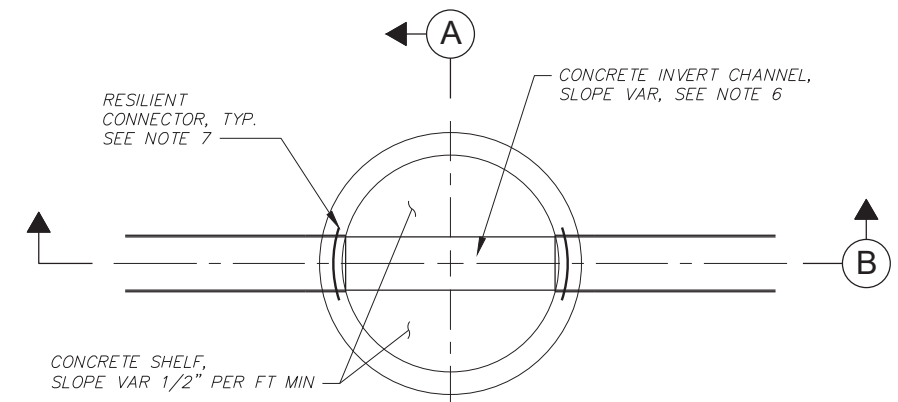

PLAN

FLEXIBLE PIPE TO MANHOLE CONNECTION

NTS

x:\Clients\hermiston or\citystandarddrawings\HermStdDwg_SS02_Pipe_To_MH_Comm.dwg_SS02_1/29/2024 2:54 PM_lwillhite

	<p>CITY OF HERMISTON, OREGON STANDARD DRAWINGS</p> <p>PIPE TO MANHOLE CONNECTIONS</p>	<p>FIGURE SS02</p>
---	--	-------------------------------

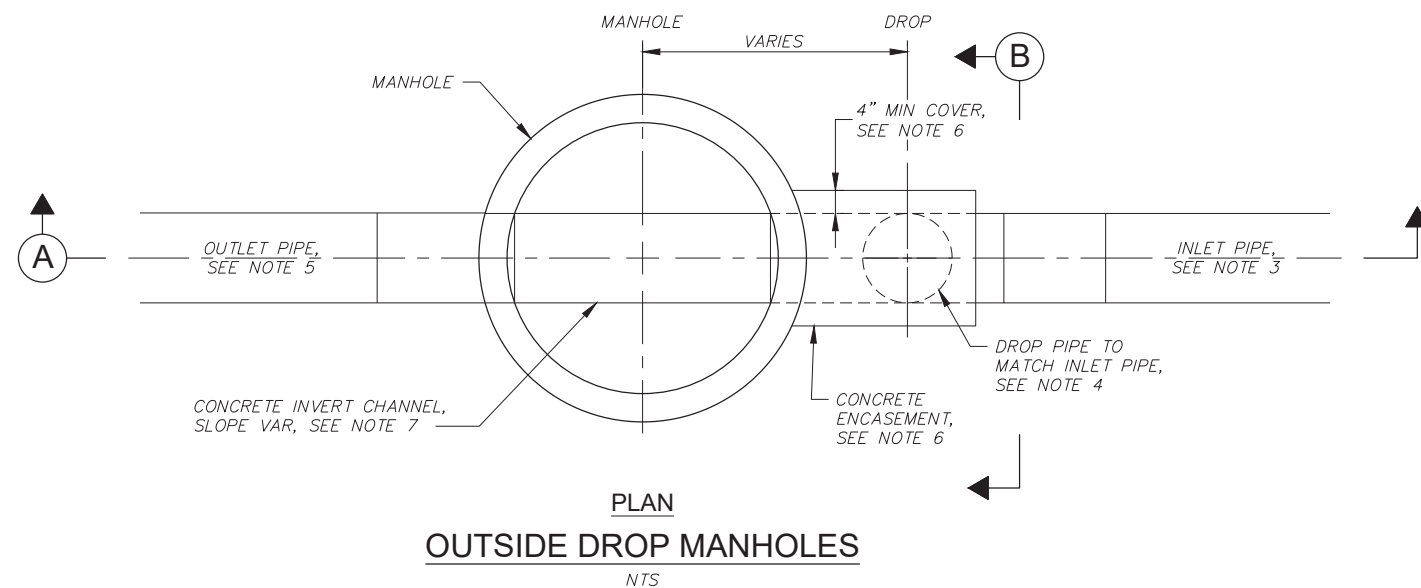
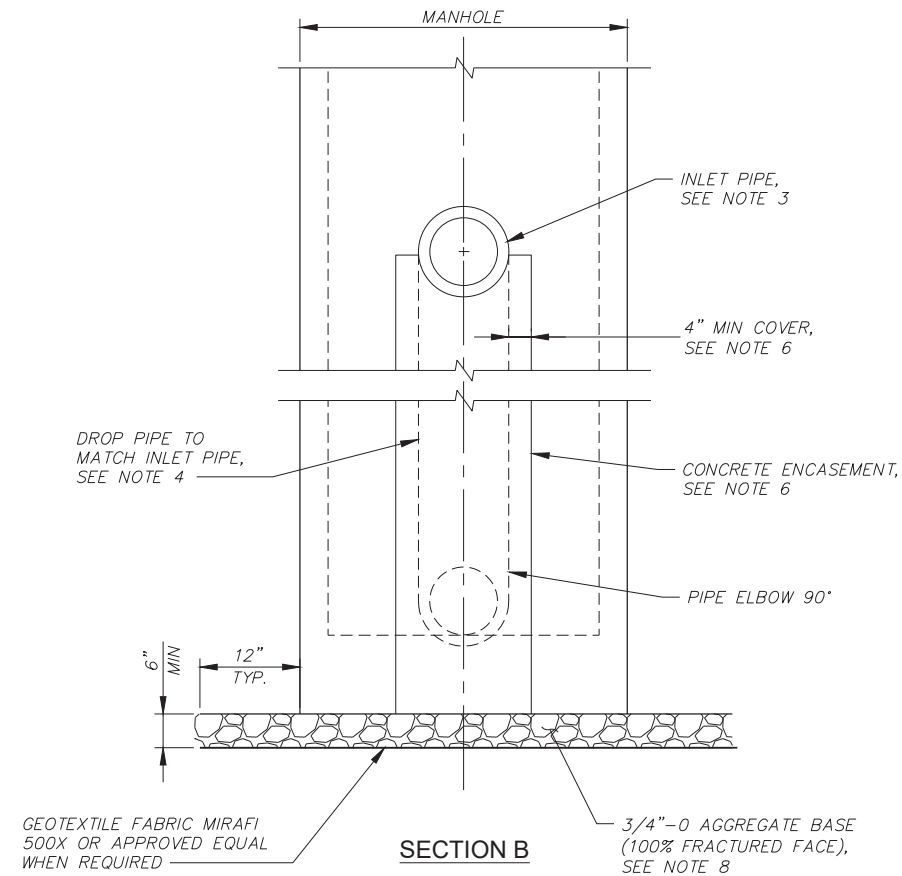
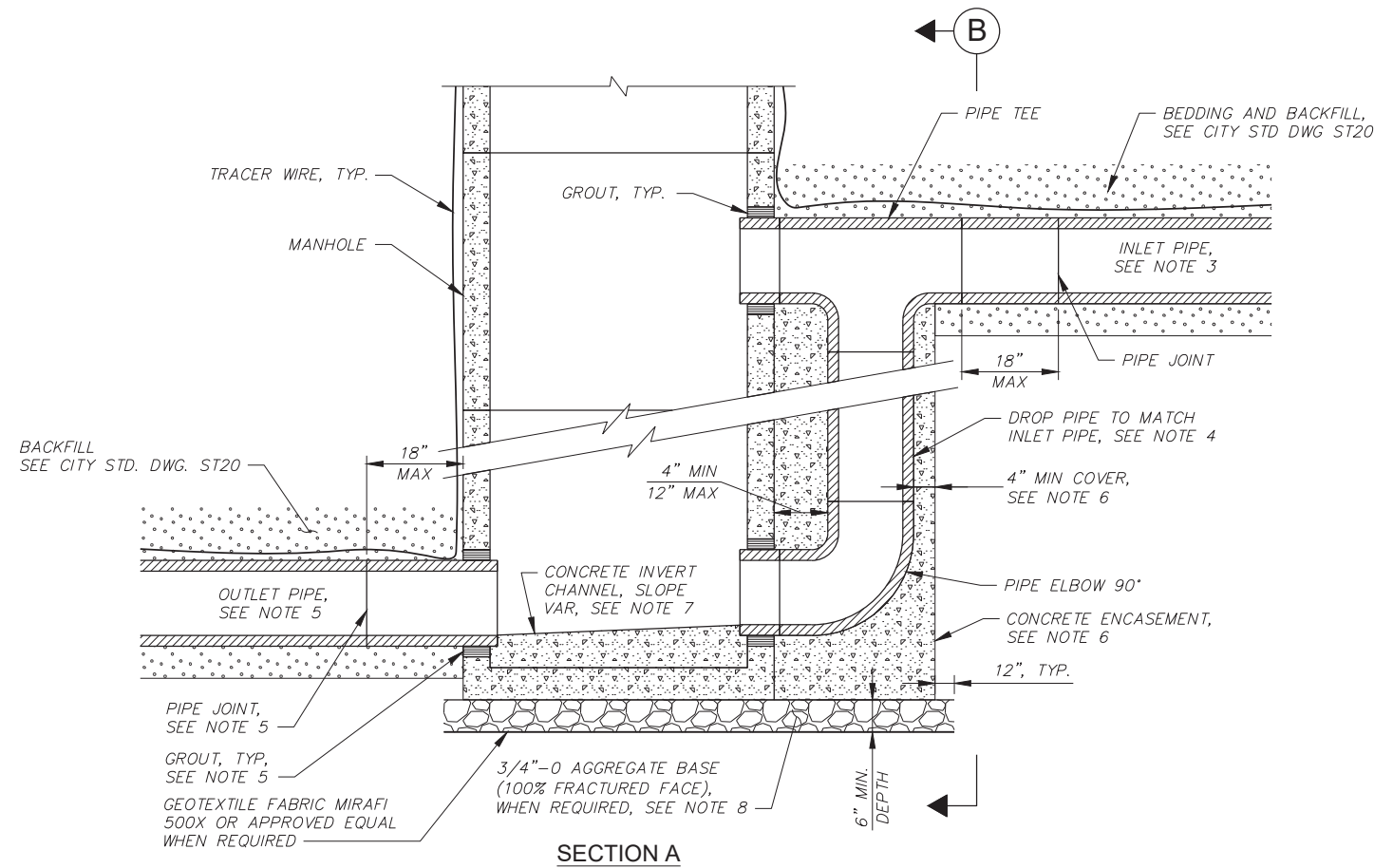

NOTES

1. SEE CITY STD. DWGS. SS01 AND SS02 FOR DETAILS NOT SHOWN.
2. LOCATION, ELEVATION, DIAMETER, SLOPE, AND NUMBER OF PIPE(S) VARIES, SEE DESIGN DRAWINGS.
3. INLET PIPE MAY BE RIGID OR FLEXIBLE, MAXIMUM DIAMETER 18". THE CONNECTING PIPE SHALL HAVE A FLEXIBLE, GASKETED AND UNRESTRAINED JOINT WITHIN 18" OF PIPE TEE, AS SHOWN. JOINT TYPE VARIES WITH MANUFACTURER.
4. DROP PIPE, TEE, AND ELBOW TO MATCH INLET PIPE.
5. RIGID PIPE CONNECTION SHOWN. OUTLET PIPE(S) MAY BE RIGID OR FLEXIBLE, SEE PROJECT PLANS. MAX OUTLET PIPE DIAMETER VARIES WITH PIPE MATERIAL. SEE CITY STD. DWG. SS02 FOR PIPE TO MANHOLE CONNECTIONS.
6. CONCRETE ENCASEMENT SHALL BE COMMERCIAL GRADE, 4000 PSI CONCRETE. PROVIDE 4" MINIMUM COVER OVER OUTER MOST PARTS OF PIPE AND FITTINGS.
7. INVERT CHANNELS SHALL BE CONSTRUCTED TO PROVIDE SMOOTH SLOPES AND RADIUS TO OUTLET PIPE.
8. COMPACT ALL AGGREGATE BASE (100% FRACTURED FACE) TO 95% MAXIMUM DRY DENSITY PER ASTM D1557.
9. INSIDE DROP MANHOLES MAY BE ALLOWED ONLY IF APPROVED BY THE CITY. A DETAIL MUST BE PROVIDED WHEN INSIDE DROP IS USED. A BOWL SHALL BE REQUIRED ON ALL INSIDE DROP MANHOLES.

x:\Clients\hermiston_or\citystandarddrawings\HermStdDwg. SS03_1/29/2024 2:54 PM. lwillhite



**CITY OF
HERMISTON, OREGON
STANDARD DRAWINGS**

OUTSIDE DROP MANHOLES

**FIGURE
SS03**

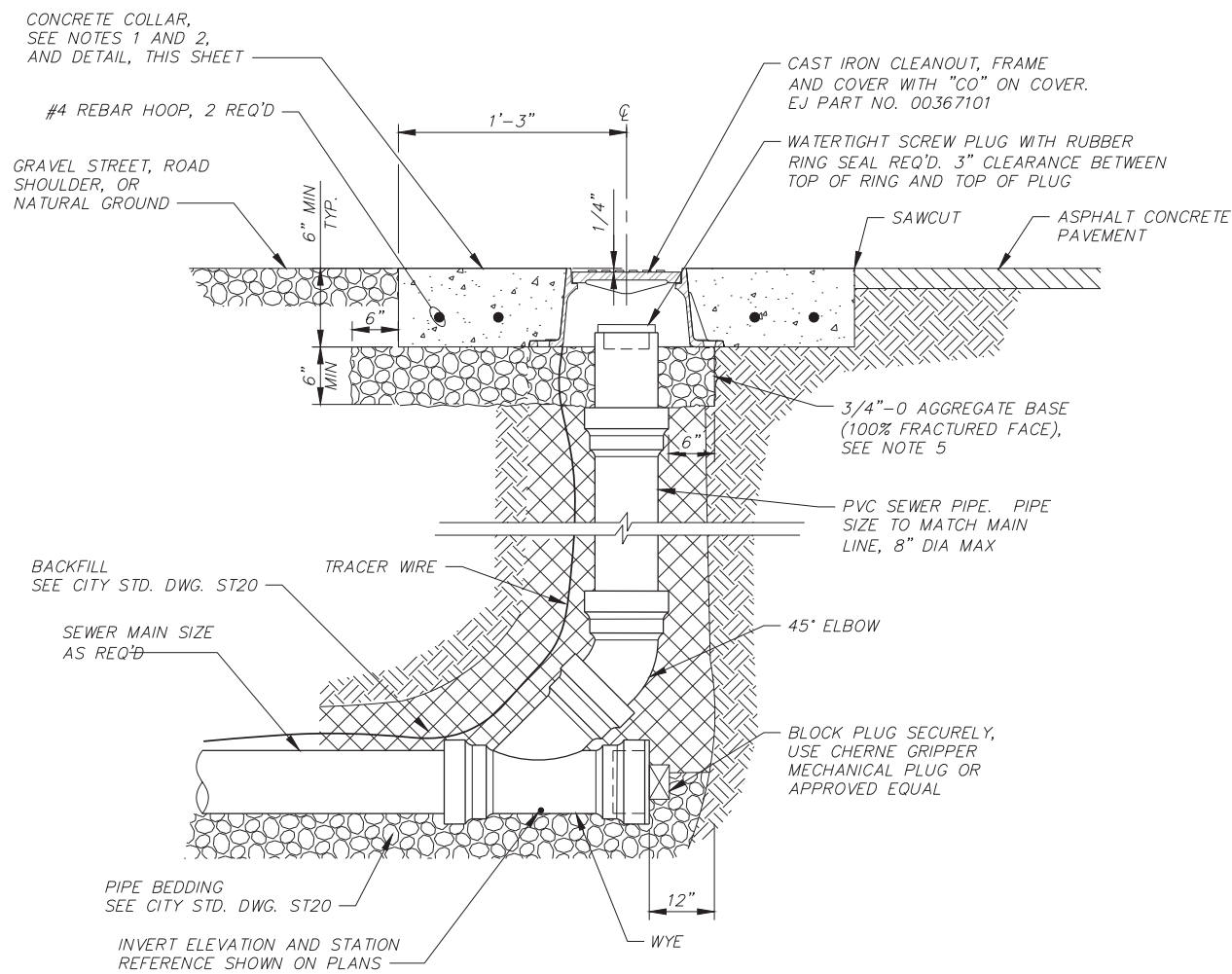

GRAVITY SEWER MAIN LINE CLEANOUT
NTS

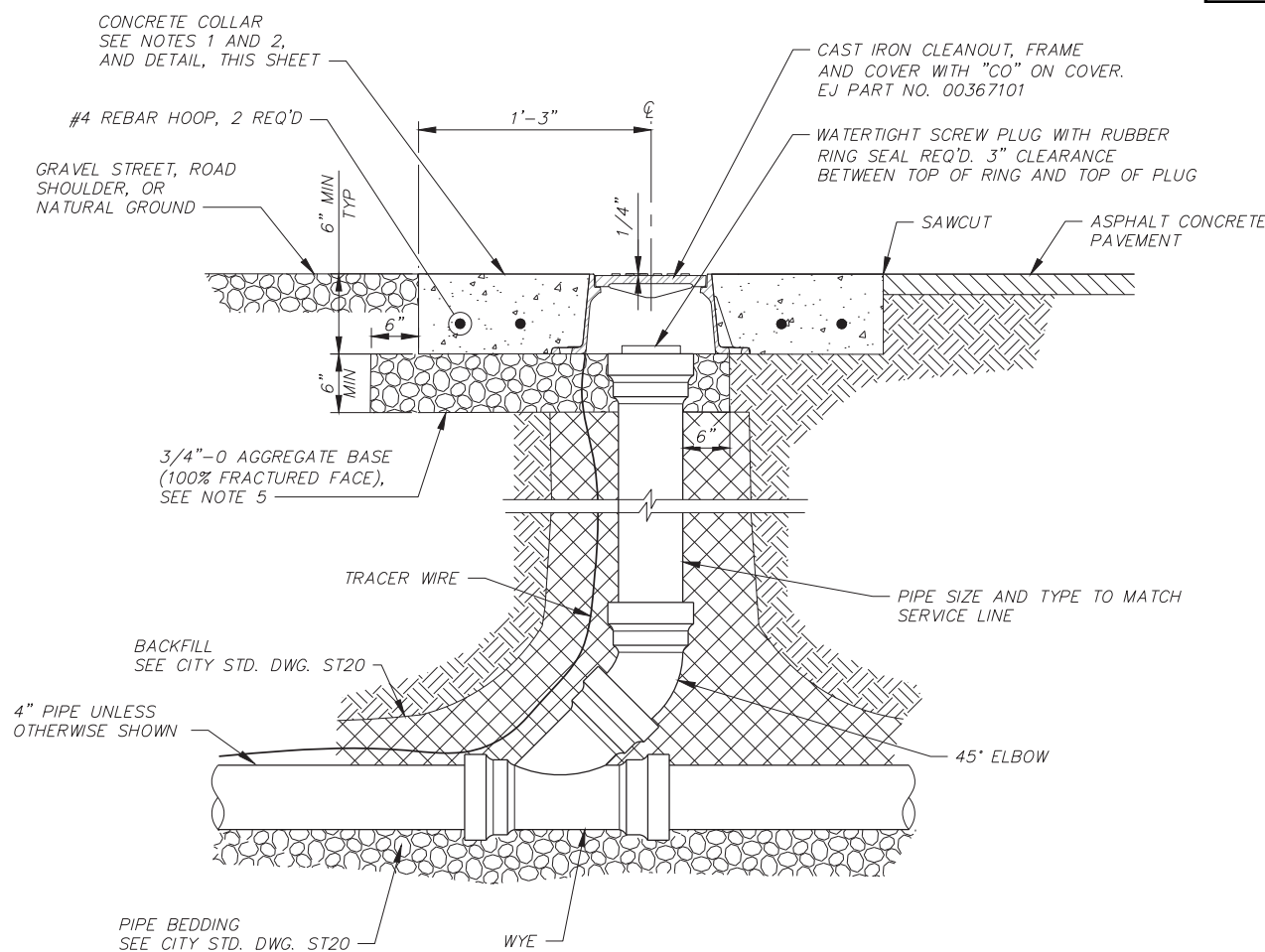

SEWER SERVICE LINE CLEANOUT
NTS

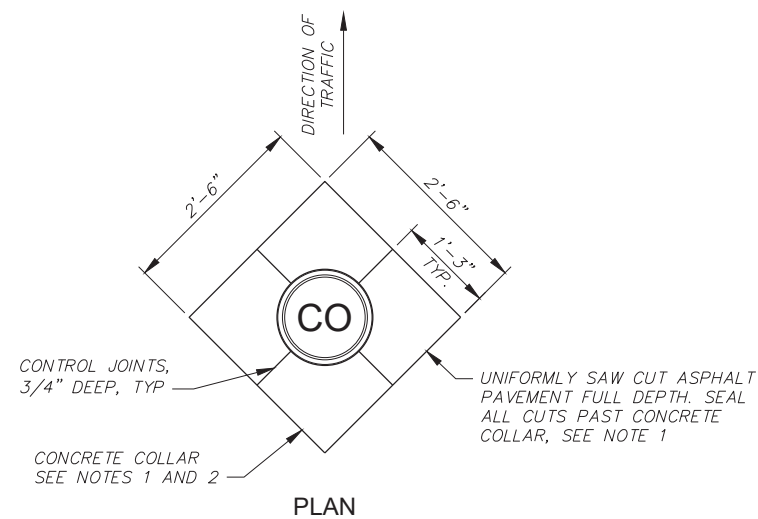

REQUIREMENTS FOR CONCRETE COLLARS

1. ALL CONCRETE SHALL BE COMMERCIAL GRADE 4000 PSI CONCRETE.
2. COLLAR TO BE FORMED SQUARE.
3. SMOOTH BROOMED FINISH REQUIRED.
4. APPLY CONCRETE CURING COMPOUND.
5. PROTECT FROM TRAFFIC FOR 4 DAYS MINIMUM.

CONCRETE COLLAR DETAIL
NTS

NOTES

1. CONCRETE COLLAR REQUIRED AFTER PLACEMENT OF ACP. WHERE A SERVICE LINE CLEANOUT IS INSTALLED OUTSIDE OF ASPHALT CONCRETE PAVING AT THE EDGE OF THE RIGHT-OF-WAY AS REQUIRED BY CITY STD. DWG. SS05. A CONCRETE COLLAR IS NOT REQUIRED.
2. ALL CLEANOUTS SHALL HAVE A CONCRETE COLLAR IF INSTALLED ON GRAVEL STREET, ROAD, ON SHOULDER, OR NATURAL GROUND.
-EXCEPTION FOR RESIDENTIAL CONSTRUCTION: IF CLEANOUT IS INSTALLED ON PRIVATE PROPERTY, CONCRETE COLLAR REQUIREMENTS MAY BE WAIVED BY OWNER.
3. SEWER CLEANOUT RISER SIZE AND MATERIAL TO MATCH CARRIER PIPE.
4. CASTING SHALL MEET AASHTO H20 REQUIREMENT.
5. COMPACT ALL AGGREGATE BASE (100% FRACTURED FACE) TO 95% MAXIMUM DRY DENSITY PER ASTM D1557.
6. MANHOLES SHALL BE INSTALLED WHEREVER POSSIBLE. CLEANOUTS SHALL ONLY BE INSTALLED WHEN APPROVED BY THE CITY.



**CITY OF
HERMISTON, OREGON
STANDARD DRAWINGS**

SEWER CLEANOUTS

**FIGURE
SS04**

x:\Clients\hermiston_01_citystandarddrawings\HermStdDwg_SS04_Sewer_Cleanouts.dwg, SS04, 1/29/2024 2:55 PM, twillhie

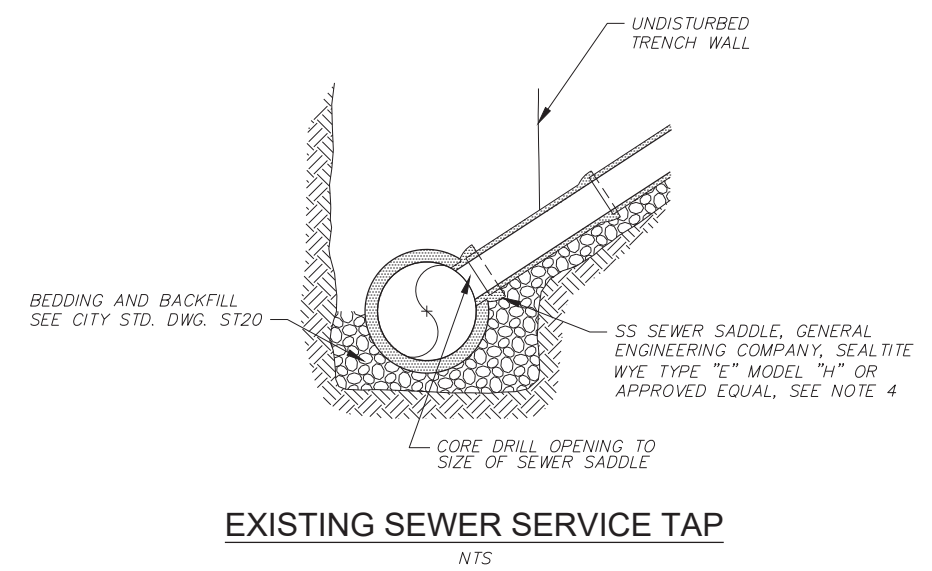
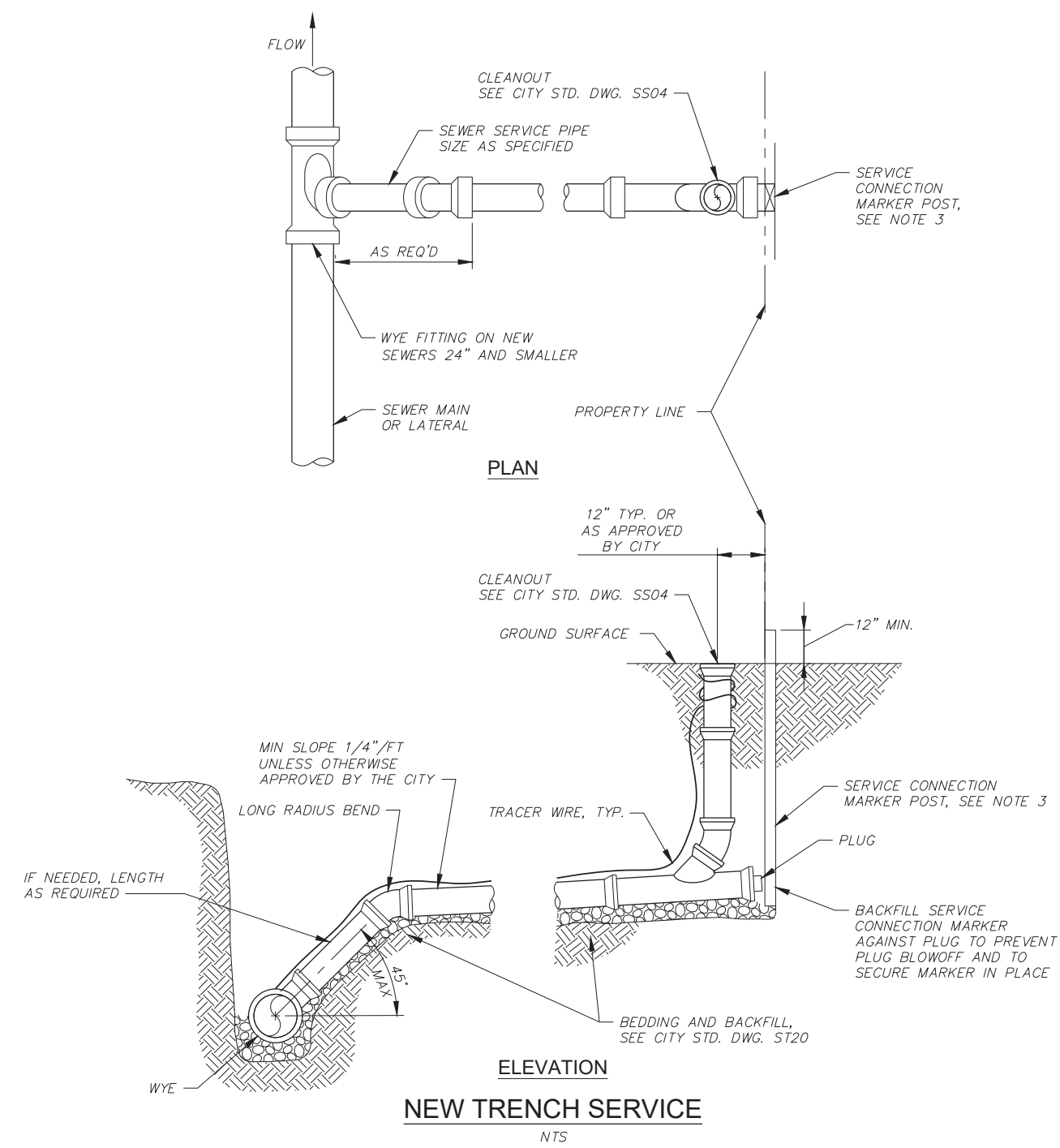

- NOTES**
1. PIPE AND FITTINGS SHALL BE COMPATIBLE. ONLY MANUFACTURED FITTINGS SHALL BE USED.
 2. CONTRACTOR SHALL MAXIMIZE DEPTH OF THE SEWER SERVICE LATERAL AT THE PROPERTY LINE. SEWER SERVICE INVERT DEPTHS AT THE RIGHT-OF-WAY OR EASEMENT LINE SHALL BE SUFFICIENTLY DEEP SUCH THAT ALL POINTS ON THE PROPERTY CAN BE SERVICED BY SEWER PIPE HAVING A MINIMUM SLOPE OF 1/4" PER FOOT AND MEETING ALL REQUIREMENTS OF THE OREGON PLUMBING SPECIALTY CODE CURRENT EDITION INCLUDING MINIMUM COVER REQUIREMENTS. IN NO CASE SHALL THE SEWER SERVICE LATERAL HAVE LESS THAN 4 FEET OF COVER AT RIGHT OF WAY OR EASEMENT LINE, UNLESS OTHERWISE APPROVED BY THE CITY.
 3. SERVICE CONNECTION MARKER POST SHALL BE 2"x4" (10' LONG) PRESSURE TREATED FIR. EXPOSED AREA SHALL BE PAINTED GREEN. THE DEPTH FROM THE FINISHED GRADE TO THE INVERT OF THE LATERAL SHALL BE CLEARLY MARKED IN WEATHER RESISTANT, FADE RESISTANT INK. BURIED END SHALL BE SET AT INVERT OF THE SERVICE LATERAL.
 4. SEWER SADDLE:
 - 4.1. SEAT SADDLE IN PLACE TO FIT OUTSIDE SURFACE OF CARRIER PIPE AND TO FORM WATERTIGHT SEAL.
 - 4.2. SEWER SADDLE AND SERVICE LATERAL TEE SHALL NOT PROTRUDE INTO PIPE.
 5. SERVICE LATERALS 8" AND LARGER SHALL BE CONNECTED TO THE SEWER MAIN LINE AT A MANHOLE UNLESS OTHERWISE APPROVED BY THE CITY.

x:\Clients\hermiston or_ city standard drawings\HermStdDwg_SS05_Trench_Serv_Conn.dwg_SS05_1/29/2024 2:55 PM, lwillhite

	<p>CITY OF HERMISTON, OREGON STANDARD DRAWINGS</p> <p>SEWER SERVICE CONNECTION</p>	<p>FIGURE SS05</p>
---	--	-------------------------------

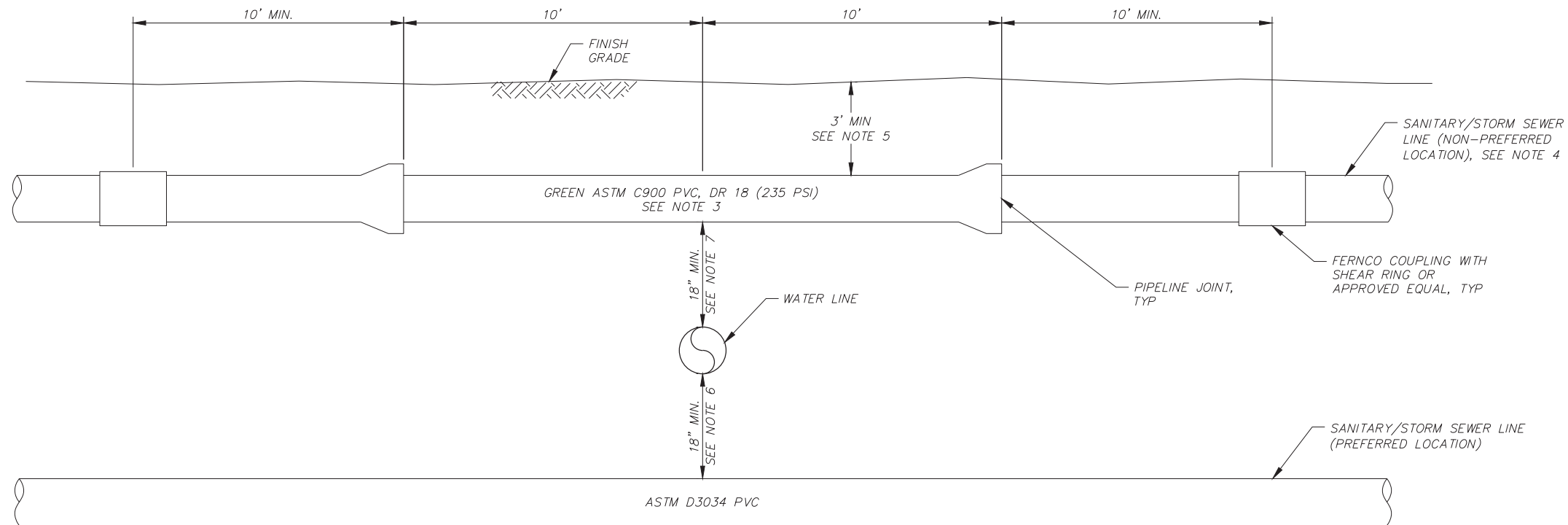

WATER-SEWER CROSSING
NTS

NOTES



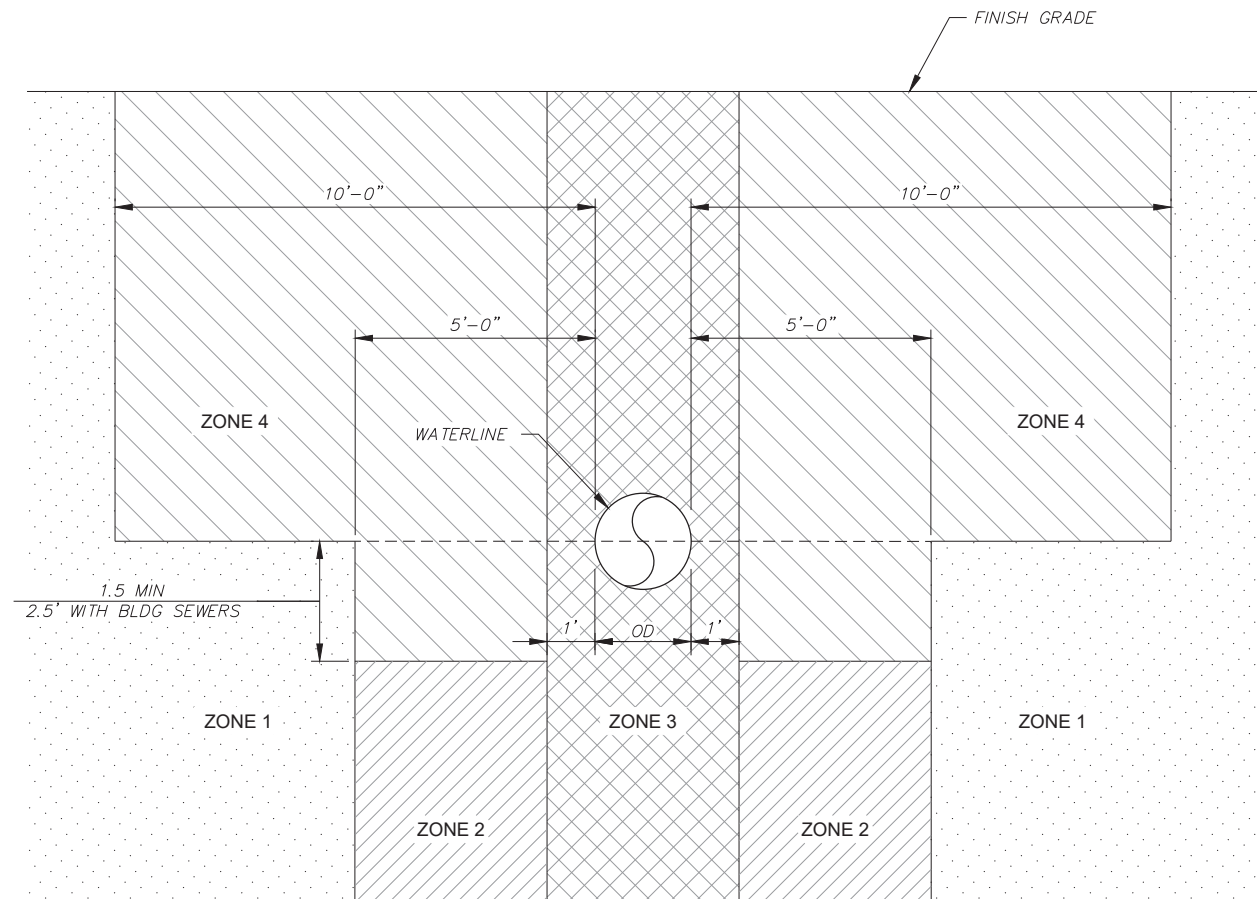

1. PROVIDE SUPPORT BEAM DETAIL WHEN REQUIRED.
2. ALL BACKFILL IN AREA OF WATER-SEWER CROSSING SHALL BE COMPACTED PER CITY STD. DWG. ST20.
3. BLUE AND PURPLE PIPE IS NOT PERMITTED. WHITE PIPE WITH MINIMUM 22" WIDE NON-DETECTABLE SEWER MARKING TAPE MEETING THE REQUIREMENTS OF THE APWA COLOR CODE MAY BE USED WHEN APPROVED BY THE CITY. WHEN APPROVED, MARKING TAPE SHALL BE INSTALLED 24"-36" ABOVE THE SEWER LINE CROWN BUT SHALL IN NO CASE BE INSTALLED WITH LESS THAN 12" OF COVER.
4. WHEN SANITARY/STORM SEWER LINE CROSSES OVER EXISTING WATER LINE, A FULL LENGTH OF PRESSURE SEWER PIPE SHALL BE CENTERED OVER THE WATERLINE CROSSING POINT. PRESSURE PIPE SHALL EXTEND 20 FEET MINIMUM EACH SIDE OF CROSSING (40 FEET MINIMUM TOTAL).
5. MINIMUM DEPTH FOR STORM SEWER LINES MAY BE REDUCED TO 30" IN PAVED AREAS.
6. WHEN CONDITIONS PREVENT THE MINIMUM VERTICAL SEPARATION FOR THE PREFERRED SANITARY/STORM SEWER LOCATION SCENARIO, THE FOLLOWING ADDITIONAL REQUIREMENTS SHALL APPLY:
 - 6.1. PIPE SHALL BE GREEN ASTM C900 PVC, DR 18 (235 PSI).
 - 6.2. ONE FULL 20 FOOT SEGMENT OF SEWER PIPE SHALL BE CENTERED UNDER THE WATERLINE.
 - 6.3. 50 PSI (100 PSI MAXIMUM) CONTROLLED DENSITY FILL SHALL BE PLACED AT A MINIMUM FROM THE SPRING LINE OF THE SANITARY/STORM SEWER LINE TO THE SPRING LINE OF THE WATER LINE AND SHALL EXTEND 10 FEET ON EACH SIDE OF THE CROSSING.
 - 6.4. UNDER NO CIRCUMSTANCES SHALL THE VERTICAL SEPARATION BE LESS THAN 6 INCHES.
7. WHEN CONDITIONS PREVENT THE MINIMUM VERTICAL SEPARATION FOR THE NON-PREFERRED SANITARY/STORM SEWER LOCATION SCENARIO, THE FOLLOWING ADDITIONAL REQUIREMENTS SHALL APPLY:
 - 7.1. 50 PSI (100 PSI MAXIMUM) CONTROLLED DENSITY FILL SHALL BE PLACED AT A MINIMUM FROM THE TRENCH BOTTOM TO THE SPRING LINE OF THE SANITARY/STORM SEWER LINE AND SHALL EXTEND 10 FEET ON EACH SIDE OF THE CROSSING.
 - 7.2. UNDER NO CIRCUMSTANCES SHALL THE MINIMUM VERTICAL SEPARATION BE LESS THAN 6 INCHES.

x:\Clients\hermiston or\citystandarddrawings\HermStdDwg_SS06_Swr_Wtr_Crossing.dwg_SS06_1/29/2024 2:55 PM:lwllwhite

	<p>CITY OF HERMISTON, OREGON STANDARD DRAWINGS</p> <p>WATER-SEWER CROSSING</p>	<p>FIGURE SS06</p>
---	--	-------------------------------



SEWER LINE ZONES

- 
ZONE 1 SEWER LINE CAN BE LAID IN THIS AREA WITH NO SPECIAL REQUIREMENTS OF EITHER CONSTRUCTION OR MATERIALS.
- 
ZONE 2 INSTALLING A SEWER LINE IN THIS ZONE IS NOT ADVISABLE AND MUST BE JUSTIFIED IN EACH CASE. WATER LINE SHOULD BE LOCATED ON A BENCH OF UNDISTURBED EARTH WHEN CONSTRUCTED CONCURRENTLY IN A COMMON TRENCH WITH SEWER LINE.
- 
ZONE 3 INSTALLING A SEWER MAIN DIRECTLY OVER A WATER MAIN OR DIRECTLY UNDER A WATER MAIN IN THIS ZONE IS PROHIBITED SINCE TAPPING, OPERATION, AND MAINTENANCE OF EACH LINE WOULD BE IMPAIRED.
- 
ZONE 4 SEWER LINE CONSTRUCTION IN THIS ZONE WOULD GENERALLY NOT BE PERMITTED. EACH INSTALLATION MUST BE JUSTIFIED. IF CONSTRUCTION WAS PERMITTED, PRESSURE PIPE MATERIALS FOR THIS SEWER LINE WOULD BE REQUIRED.

NOTE
THE CONTRACTOR SHALL MEET ALL THE REQUIREMENTS OF THE DEQ, INCLUDING OAR 340 DIVISION 52.

WATER - SEWER LINE SEPARATION

NTS

x:\Clients\hermiston_01_citystandarddrawings\HermStdDwg_SS07_Swr_Line_Zon.dwg, SS07, 1/29/2024 2:55 PM, lwillhite

	<p align="center">CITY OF HERMISTON, OREGON STANDARD DRAWINGS</p> <p align="center">WATER - SEWER LINE SEPARATION</p>	<p align="center">FIGURE SS07</p>
---	--	--

NOTES

- 1. ALL NEW AND EXISTING SANITARY SEWER SERVICE LOCATIONS SHALL BE MARKED IN CURB AS SHOWN. STAMPING OF SERVICE LOCATIONS SHALL BE CONSIDERED INCIDENTAL TO THE PRICE OF THE CURB.
- 2. STAMPS MAY BE PURCHASED FROM THE CITY.
- 3. S's NOT PLACED BY SPECIFIC STAMP WILL NOT BE ACCEPTED AND THAT SECTION OF CURB SHALL BE REMOVED AND REPLACED.
- 4. SEE CITY STD. DWG. W13 FOR WATER SERVICE LOCATION CURB STAMP.

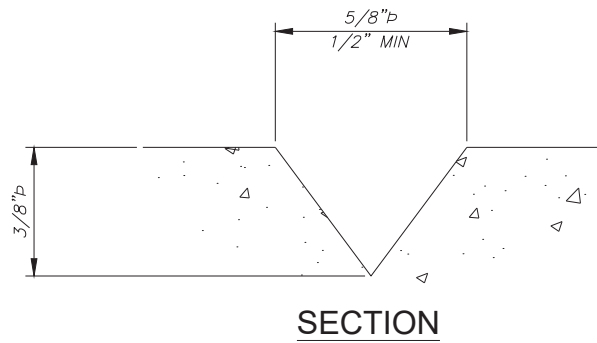
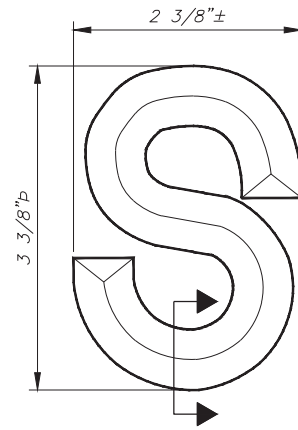

STAMP "S" IN FACE OF CURB IN LINE WITH CLEANOUT LOCATION, PERPENDICULAR TO CURB LINE

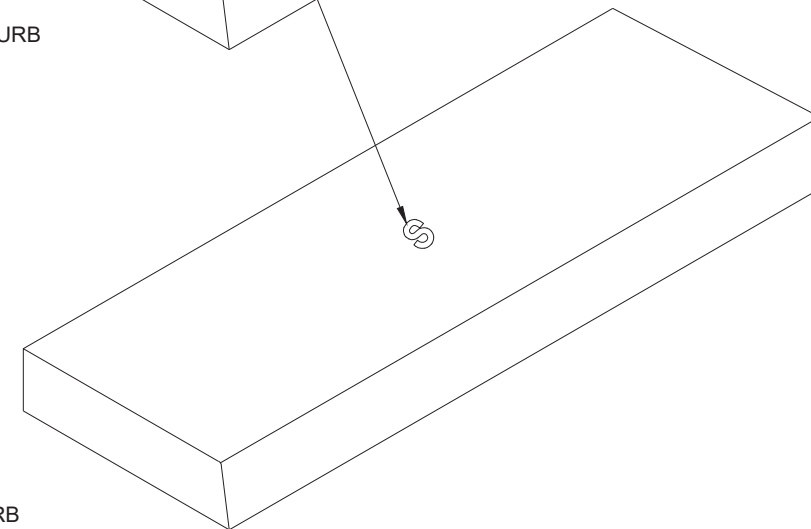
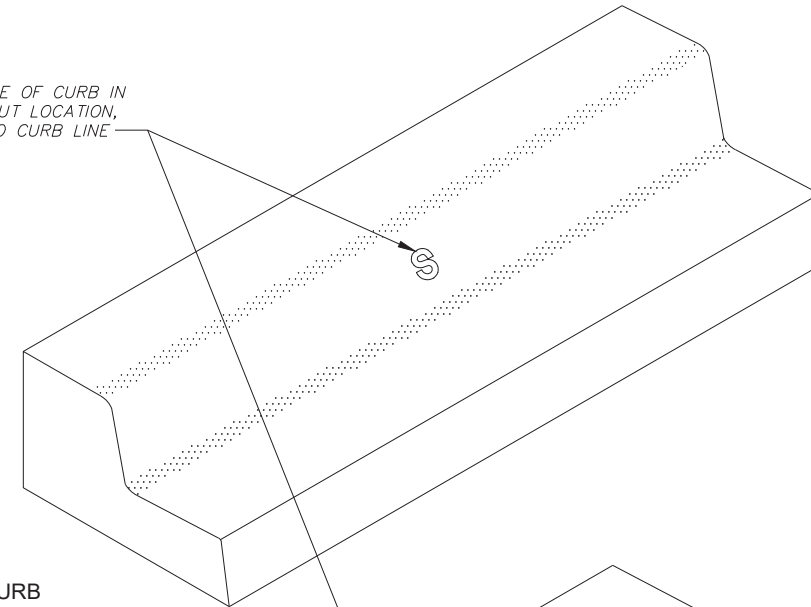

x:\Clients\hermiston or\citystandarddrawings\HermStdDwg_SS08_Curb_Stamp.dwg, SS08, 1/29/2024 2:55 PM, lwillhite



CITY OF
HERMISTON, OREGON
STANDARD DRAWINGS

SEWER SERVICE CURB STAMP

FIGURE
SS08

NOTES

1. METER BOX SHALL BE SET WITHIN 6" OF BACK OF WALK AND A MINIMUM 5' FROM BACK OF CURB.
2. ALL BACKFILL AND AGGREGATE BASE SHALL BE COMPACTED TO 95% MAX DRY DENSITY PER ASTM D1557. SEE CITY STD. DWG. ST20.
3. METER BOX SHALL BE CENTERED OVER THE COMPLETED METER SETTER ASSEMBLY.
4. METER SETTER SHALL BE PERPENDICULAR TO CURB LINE
5. TRAFFIC BEARING METER BOXES AND LIDS SHALL BE USED WHERE METERS ARE LOCATED WITHIN ANY PORTION OF DRIVEWAYS OR APRON AND OTHER TRAFFIC AREAS.
6. ONLY CITY APPROVED BIT AND TAPPING MACHINE ALLOWED FOR INSTALLATION OF TAP.
7. WATER SERVICE SHALL BE INSTALLED IN A DIRECT LINE BETWEEN TAP AND METER.
8. DO NOT INSTALL MORE THAN ONE METER PER SERVICE LINE.
9. WHEN REPLACING OR RECONFIGURING AN EXISTING WATER SERVICE LINE AND/OR WATER SUPPLY LINE, IF EXISTING WATER SERVICE LINE IS NOT COPPER, IT SHALL BE COMPLETELY REMOVED AND REPLACED WITH COPPER. ABANDONING SERVICE LINES IS NOT PERMITTED. A COPPER WATER SUPPLY LINE EXTENSION SHALL BE INSTALLED PER CITY STANDARDS IF ONE DOES NOT EXIST.

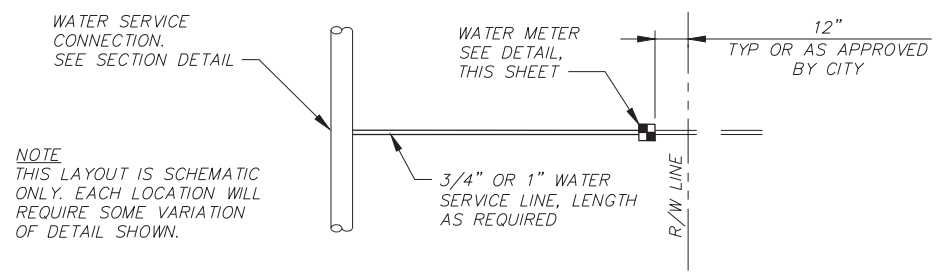

NOTE
THIS LAYOUT IS SCHEMATIC ONLY. EACH LOCATION WILL REQUIRE SOME VARIATION OF DETAIL SHOWN.

PLAN

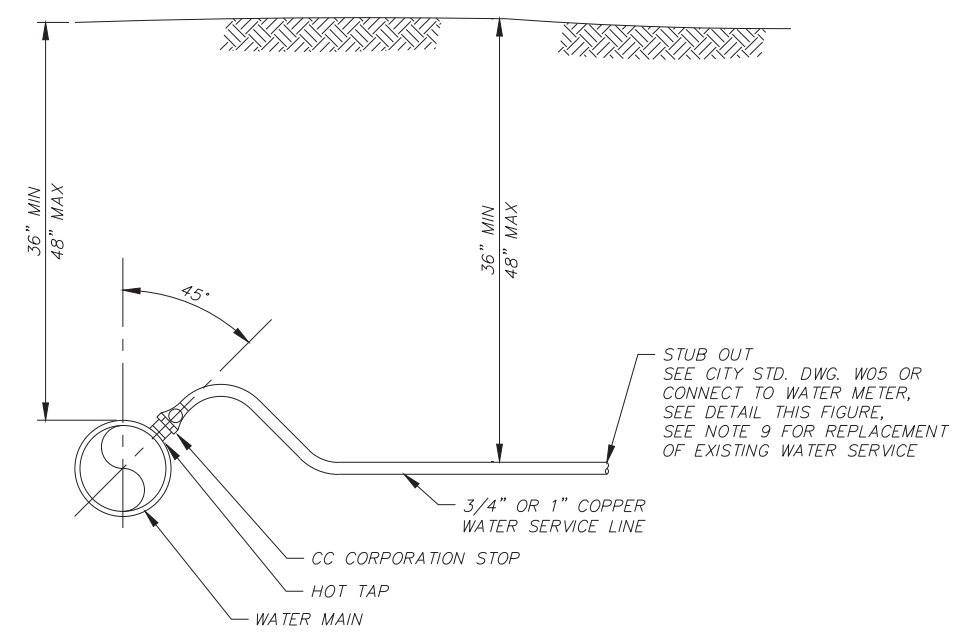

SECTION

TYPICAL 3/4" OR 1" WATER SERVICE LINE

NTS

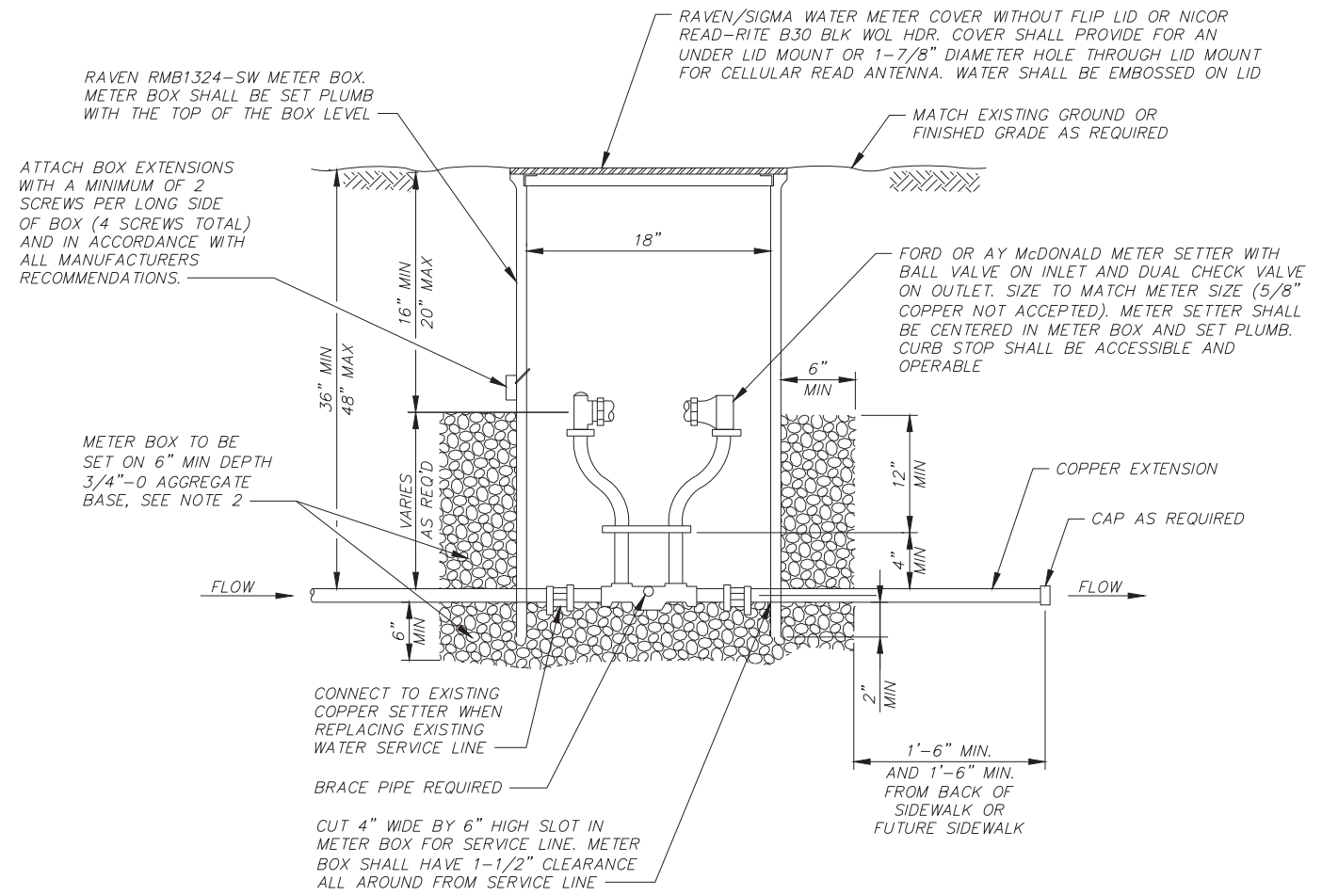

TYPICAL 3/4" OR 1" WATER METER INSTALLATION

NTS

x:\Clients\hermiston or_ citystandarddrawings\HermStdDwg_W01_Wtr_Srv_Sec_Plan_I.dwg_W01_1/29/2024 2:55 PM. l.wilfite



Where Life is Sweet

**CITY OF
HERMISTON, OREGON
STANDARD DRAWINGS**

WATER SERVICE LINE - .75" OR 1"

**FIGURE
W01**

CONSTRUCTION NOTES

- EDGE OF METER BOX SHALL BE SET WITHIN 6" OF BACK OF WALK AND A MINIMUM OF 5' FROM BACK OF CURB.
- ALL BACKFILL AND AGGREGATE BASE SHALL BE COMPACTED TO 95% MAX DRY DENSITY PER ASTM D1557. SEE CITY STD DWG ST20.
- METER BOX SHALL BE CENTERED OVER THE COMPLETED METER SETTER ASSEMBLY.
- METER SETTER SHALL BE PERPENDICULAR TO CURB LINE.
- SET SADDLE AT 3 OR 9 O'CLOCK ON WATER MAIN.
- TRAFFIC BEARING METER BOX LIDS SHALL BE USED WHERE METERS ARE LOCATED WITHIN ANY PORTION OF DRIVEWAY OR APRON AND OTHER TRAFFIC AREAS.
- WATER SERVICE SHALL BE INSTALLED IN A DIRECT LINE BETWEEN TAP AND METER.
- DO NOT INSTALL MORE THAN ONE METER PER SERVICE LINE.
- FIRE LINES SHALL HAVE A DOUBLE CHECK DETECTOR ASSEMBLY INSTALLED UPSTREAM FROM THE WATER METER WHEN WATER METER IS REQUIRED.
- INSTALL TRACER WIRE ALONG TOP OF ALL NON-METALLIC WATER SERVICE LINES. TRACER WIRE SHALL BE MIN 12 AWG UF WITH BLUE (WATER) INSULATION. HOLD TRACER WIRE IN POSITION ON TOP OF PIPE WITH 6" MIN. LENGTHS OF DUCT TAPE PLACED AT A MAXIMUM OF 10 FT. ON CENTER. AT ALL SPLICES, CONNECTING ENDS OF WIRE SHALL BE STRIPPED AND JOINED WITH A WIRE NUT TO ENSURE ELECTRICAL CONNECTION AND MADE WATERPROOF WITH AN APPROVED SILICON SPLICE KIT. PROVIDE SUFFICIENT LENGTH OF WIRE LOOP INSIDE METER BOX TO EXTEND A MINIMUM OF 24" ABOVE THE GROUND SURFACE.
- METER BOX AND COVER ARE NOT TRAFFIC RATED. INSTALL ONLY IN AREAS NOT ACCESSIBLE TO VEHICULAR TRAFFIC. IF SITE CONDITIONS PRECLUDE INSTALLATION IN AN AREA NOT ACCESSIBLE TO VEHICULAR TRAFFIC, THEN AN HS20 RATED METER BOX AND LID SHALL BE SUBMITTED TO THE CITY FOR THEIR REVIEW AND APPROVAL.

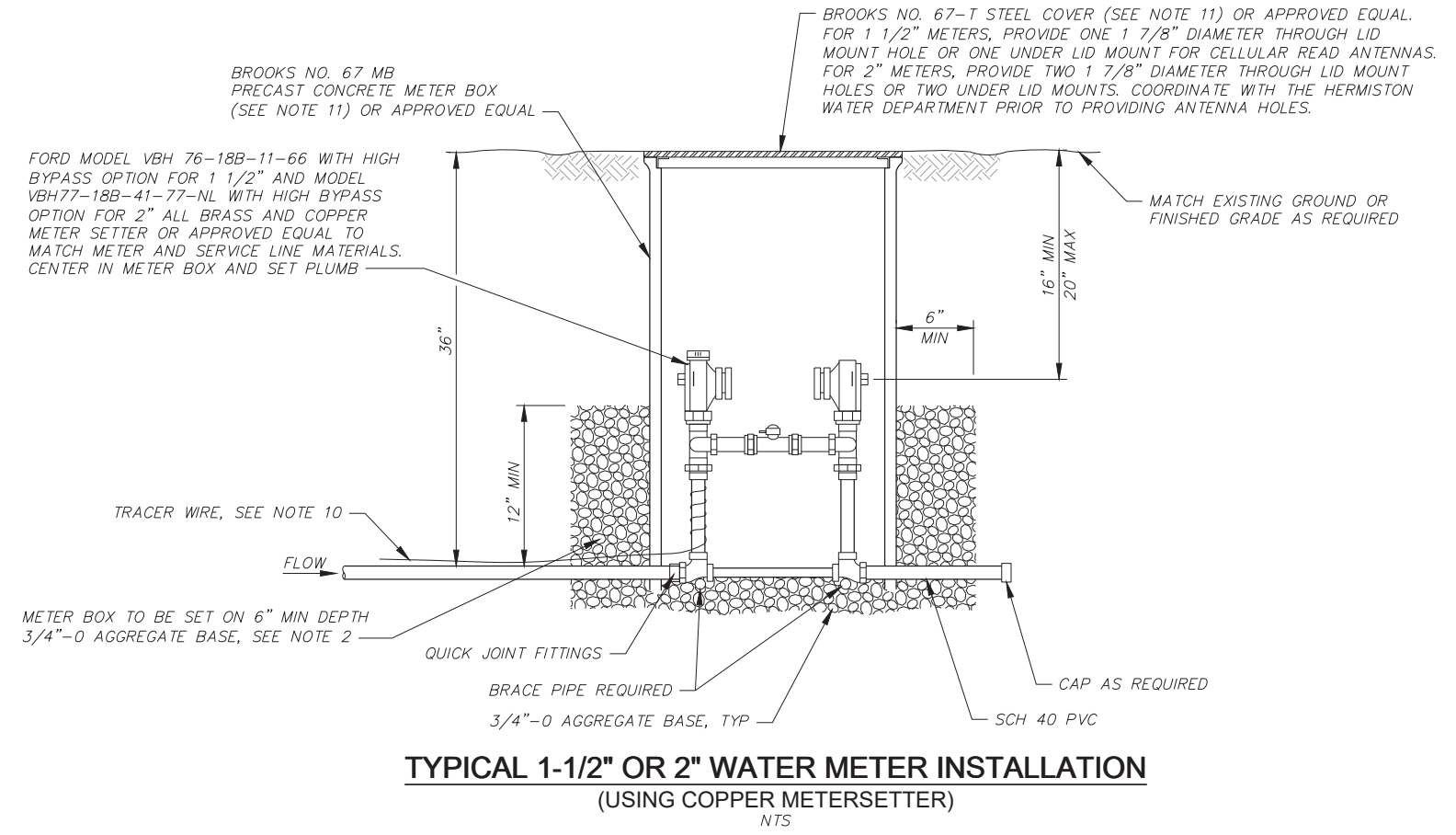
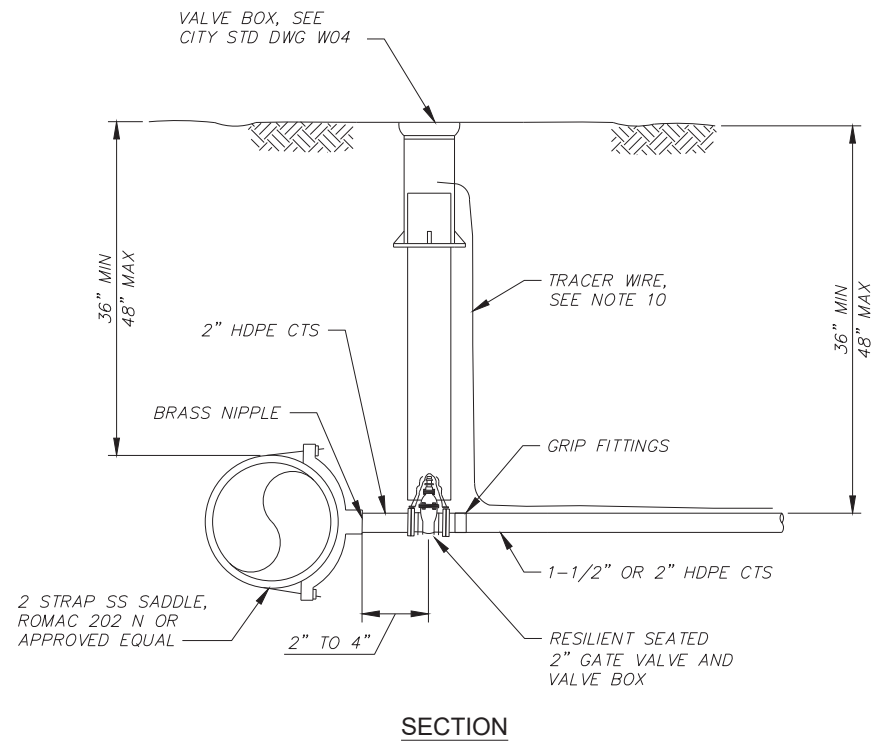
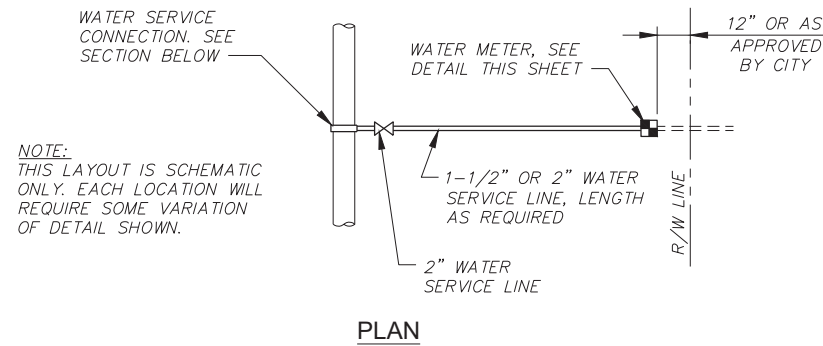

x:\Clients\hermiston or_1_citystandarddrawings\HermStdDwg_W02_Wtr_Sv_Sec_Plann_II.dwg_W02_Wtr_Sv_Sec_Plann_II.dwg 1/29/2024 2:55 PM lwilwhite



**CITY OF
HERMISTON, OREGON
STANDARD DRAWINGS**

**FIGURE
W02**

WATER SERVICE LINES - .5" OR 2"

339

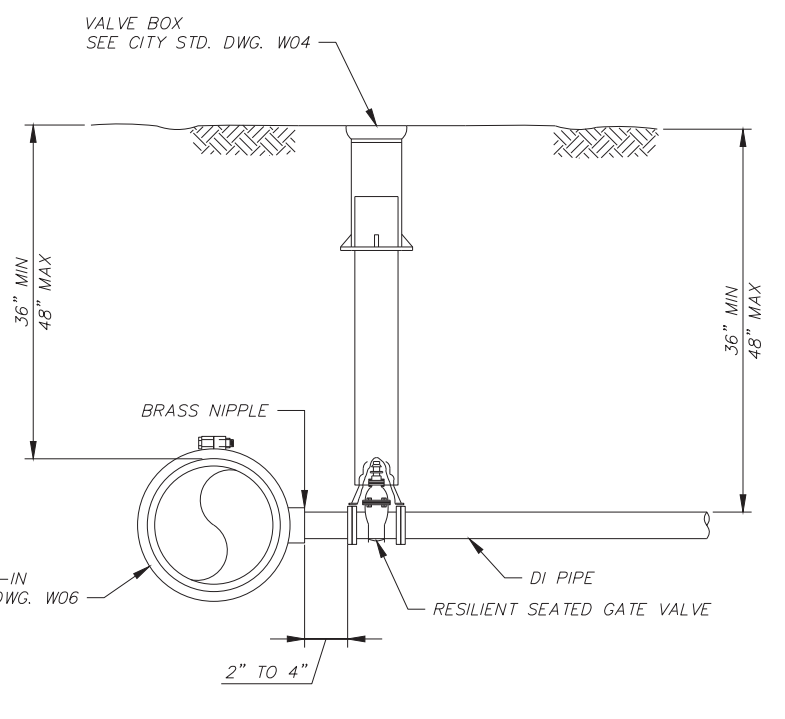
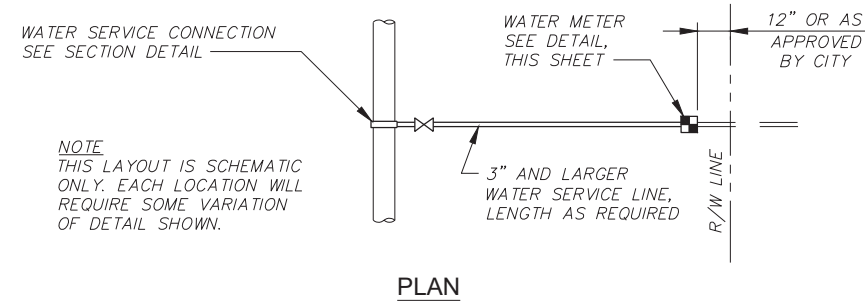

TYPICAL WATER SERVICE LINE 3" AND LARGER
NTS

NOTES

1. VAULTS SHALL BE SET PLUMB WITH TOP LEVEL.
2. PROVIDE LADDER IN VAULT. LADDER TO BE APPROVED BY CITY PRIOR TO INSTALLATION. LADDER IS NOT SHOWN FOR CLARITY.
3. GATE VALVES SHALL HAVE HAND WHEEL OPERATORS.
4. SIZE VAULT TO ACCOMMODATE INTERNAL PIPING.
5. COMPONENT SIZE AS REQUIRED.
6. FIRE LINE SHALL HAVE A DOUBLE CHECK ASSEMBLY INSTALLED UPSTREAM FROM THE WATER METER.
7. ALL BACKFILL AND AGGREGATE SHALL BE COMPACTED TO 95% MAXIMUM DRY DENSITY PER ASTM D1557, SEE CITY STD DWG S120.
8. METER VAULT SHALL BE CENTERED OVER THE COMPLETED METER ASSEMBLY.
9. METERSETTER SHALL BE PERPENDICULAR TO CURB LINE.
10. TRAFFIC BEARING METER VAULT LIDS SHALL BE USED WHERE METERS ARE LOCATED WITHIN ANY PORTION OF DRIVEWAYS OR APRON AND OTHER TRAFFIC AREAS.
11. WATER SERVICE SHALL BE INSTALLED IN A DIRECT LINE BETWEEN TAP AND METER.
12. DO NOT INSTALL MORE THAN ONE METER PER SERVICE LINE.
13. FOR METERS 4-INCHES AND LARGER, VAULTS AND VAULT LIDS SHALL BE SUBMITTED TO THE CITY FOR THEIR REVIEW AND APPROVAL.

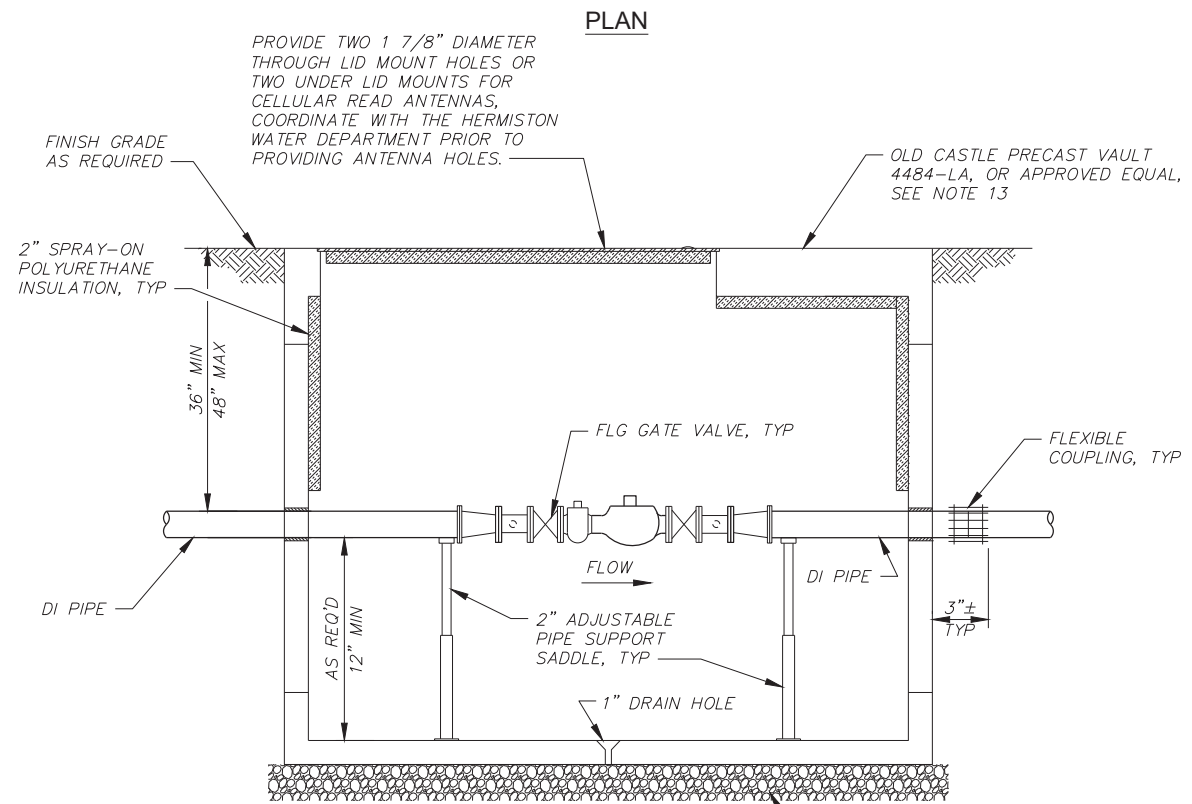
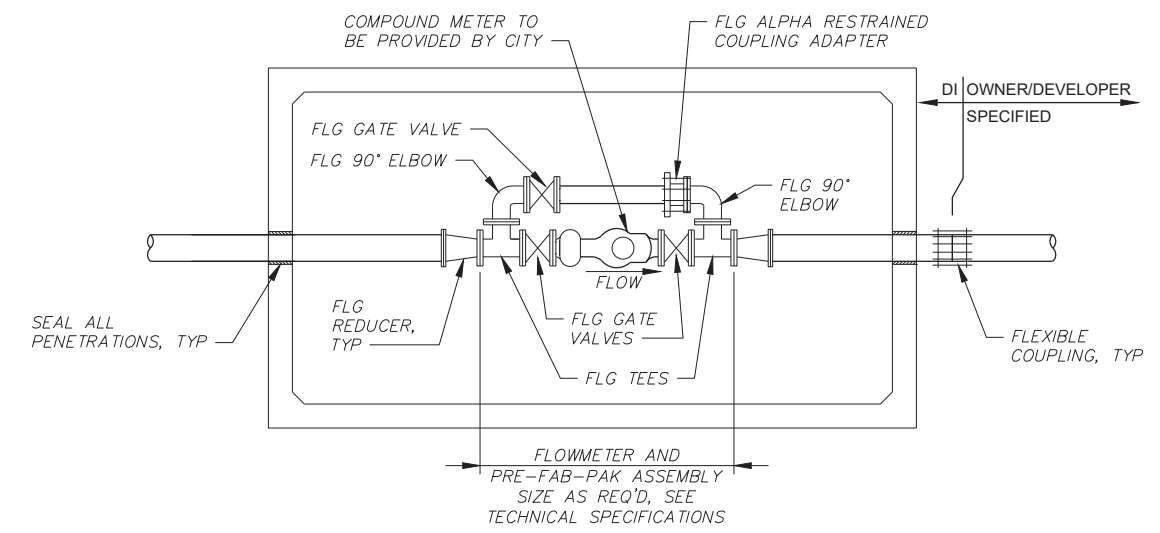

WATER METER 3" AND LARGER
NTS

x:\Clients\hermiston_or\citystandarddrawings\HermStdDwg_W03_Wtr_Srv_Sec_Plan_III.dwg_W03_Wtr_Srv_Sec_Plan_III.dwg_1/29/2024 2:56 PM, lwillhite

**CITY OF
HERMISTON, OREGON
STANDARD DRAWINGS**

**FIGURE
W03**

3-INCH AND LARGER WATER SERVICE

340

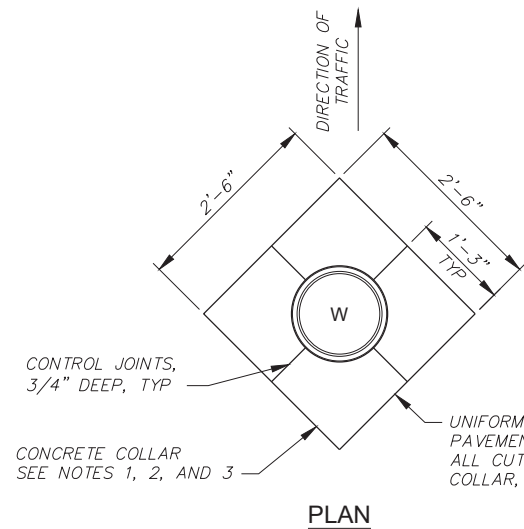

REQUIREMENTS FOR CONCRETE COLLARS

1. ALL CONCRETE SHALL BE COMMERCIAL GRADE, 4000 PSI CONCRETE.
2. COLLAR TO BE FORMED SQUARE.
3. SMOOTH BROOMED FINISH REQUIRED.
4. APPLY CONCRETE CURING COMPOUND.
5. PROTECT FROM TRAFFIC FOR 4 DAYS MINIMUM.

CONCRETE COLLAR DETAIL

NTS

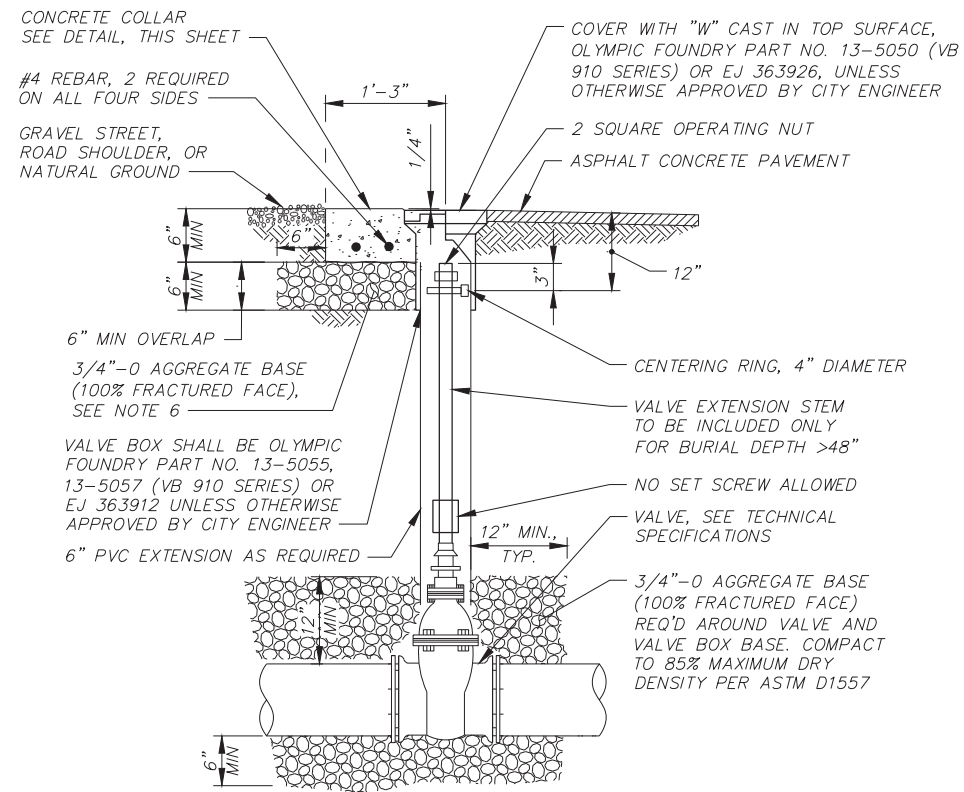
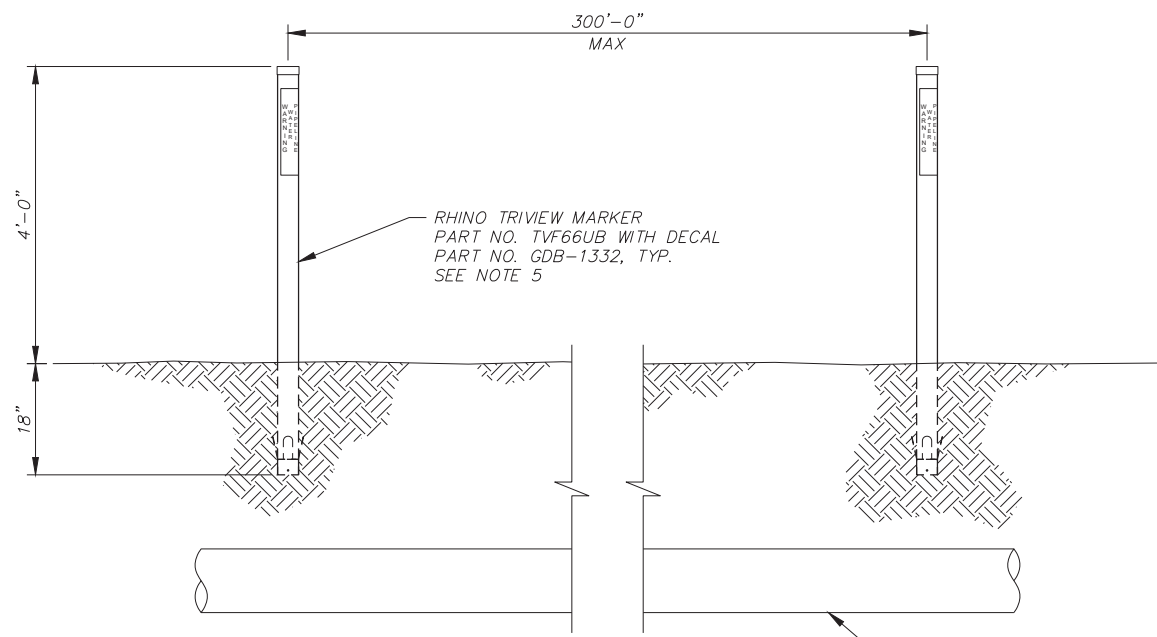

VALVE BOX DETAIL

NTS

NOTES

1. CONCRETE COLLAR REQUIRED IF VALVE BOX GRADE IS ADJUSTED AFTER PAVEMENT WORK IS PERFORMED. IF GRADE ADJUSTMENT OCCURS PRIOR TO PAVEMENT WORK, THEN CONCRETE COLLAR IS NOT REQUIRED.
2. ALL VALVE BOXES SHALL HAVE A CONCRETE COLLAR IF INSTALLED ON GRAVEL, ROAD SHOULDER, OR NATURAL GROUND.
3. CONCRETE COLLARS REQUIRED ON ALL ARTERIAL AND COLLECTOR STREETS.
4. CASTING SHALL MEET AASHTO H20 REQUIREMENT.
5. MARKERS REQUIRED WHEN SURFACE IS UNPAVED UNLESS OTHERWISE APPROVED BY THE CITY.
6. COMPACT ALL AGGREGATE BASE (100% FRACTURED FACE) TO 95% MAXIMUM DRY DENSITY PER ASTM D1557 UNLESS NOTED OTHERWISE.
7. TOP OF BOX SHALL BE FLUSH WITH FINISH GRADE. BOX SHALL NOT EXTEND ABOVE FINISH GRADE OR BE BELOW FINISH GRADE BY MORE THAN 1/4".



CITY OF
HERMISTON, OREGON
STANDARD DRAWINGS

VALVE BOX AND WATER UTILITY MARKER

FIGURE
W04

x:\Clients\hermiston or_\citystandard\drawings\HermStdDwg_W04_Valve_Box_Wire_Collar.dwg_W04_1/29/2024 2:56 PM_lwillhite

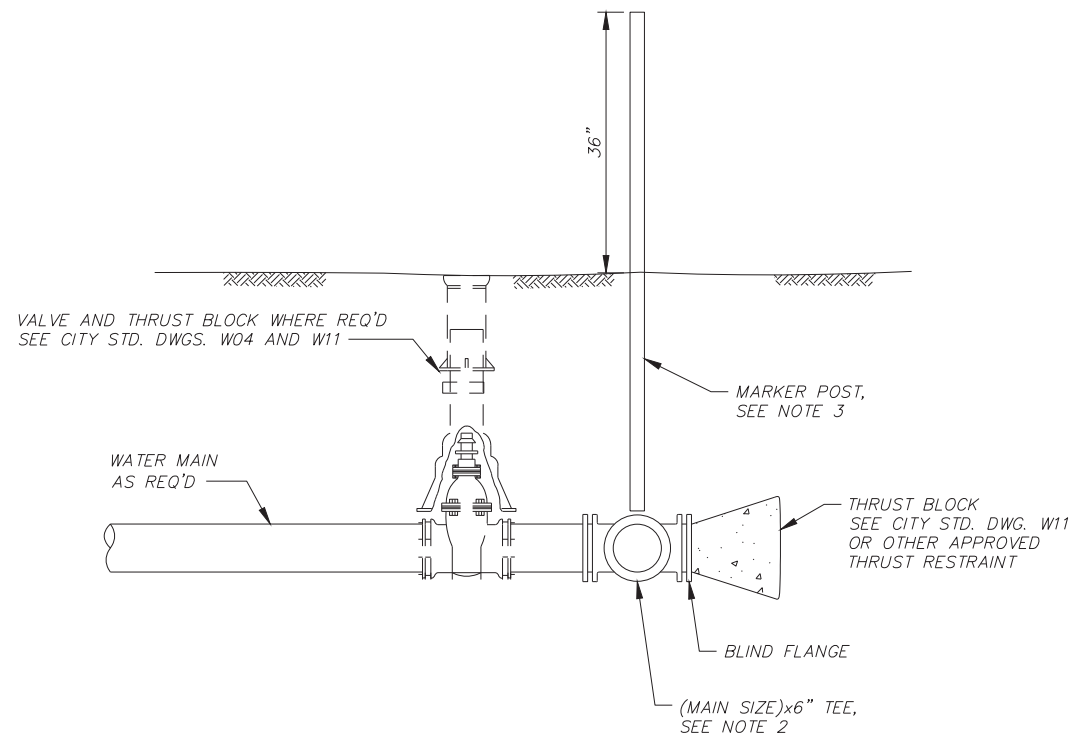

TYPICAL WATER MAIN STUB
SECTION
NTS

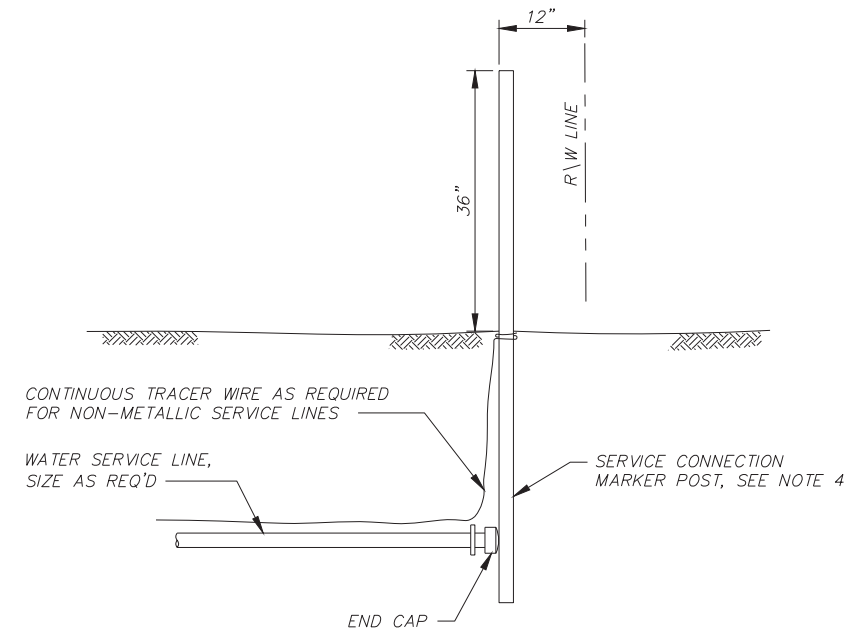

TYPICAL WATER SERVICE LINE STUB
SECTION
NTS

NOTES

1. THE CONTRACTOR SHALL PROVIDE TWO REFERENCES FROM PERMANENT OBJECTS TO THE END OF WATER SERVICE LINE. THESE TIES SHALL BE SHOWN AND DIMENSIONED ON THE "RECORD DRAWINGS" PREPARED BY THE CONTRACTOR.
2. FIRE HYDRANT ASSEMBLIES SHALL BE INSTALLED AT THE END OF DEAD-END MAIN LINE STUBS. SEE CITY STD. DWG. W07. BLOWOFF ASSEMBLIES ARE NOT PERMITTED UNLESS APPROVED BY THE CITY.
3. WATER MAIN MARKER POST SHALL BE BULLET STYLE OR TRIVIEW STYLE POST TO 360° VIEW AND SHALL BE BLUE IN COLOR. MARKER POST TO BE RHINO TRIVIEW MARKER, RHINO DOME MARKER OR APPROVED EQUAL. SEE CITY STD. DWG. W04.
4. SERVICE CONNECTION MARKER POST SHALL BE 2"x4" (10' LONG) PRESSURE TREATED FIR. EXPOSED AREA SHALL BE PAINTED BLUE.

x:\Clients\hermiston or\citystandarddrawings\HermStdDwg_W05_Wtr_Main_Srv_Stubs.dwg_W05_1/29/2024 2:56 PM, lwillite



**CITY OF
HERMISTON, OREGON
STANDARD DRAWINGS**

WATER MAIN AND SERVICE LINE STUBS

**FIGURE
W05**

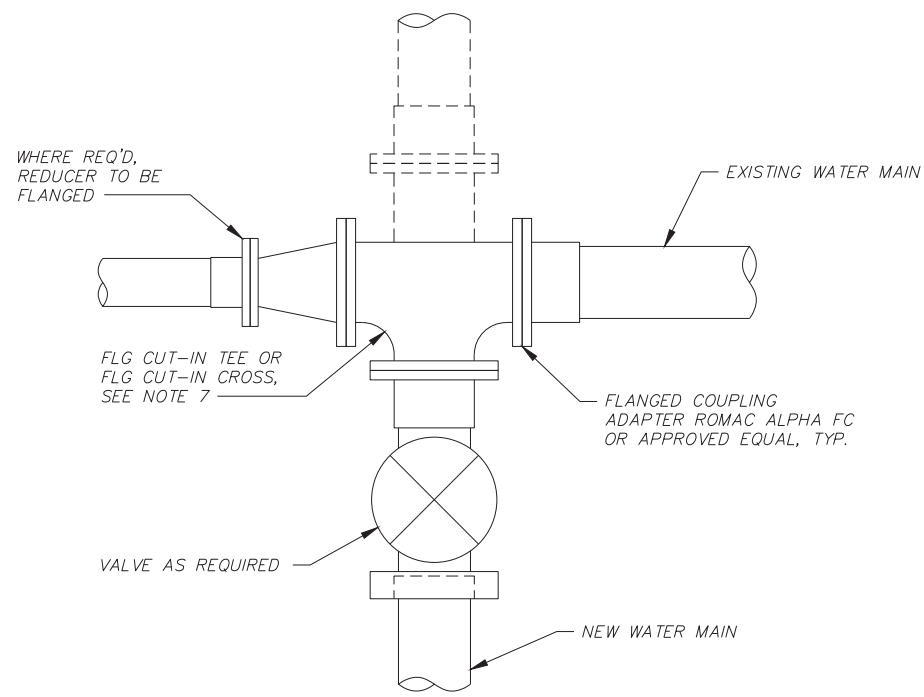

CUT-IN TEE
NTS

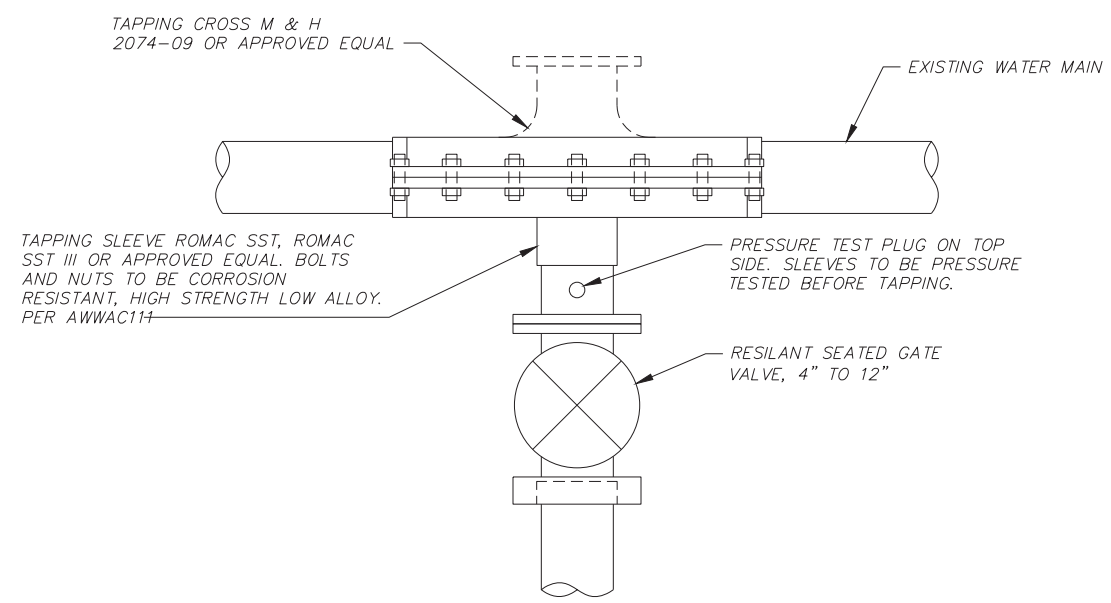

TAPPING SADDLE AND VALVE
NTS

NOTES

1. CONTRACTOR TO DIG AND VERIFY MAIN SIZE AND PIPE PRIOR TO ORDERING MATERIALS.
2. MATERIALS TO BE ON THE JOB PRIOR TO SCHEDULING SHUTDOWNS OR TAPS.
3. MAXIMUM SADDLE TAP TO EXISTING LINE NOT TO EXCEED 50% OF MAIN DIAMETER ON ASBESTOS CEMENT OR PVC PIPE, OR MORE THAN 75% OF THE MAIN DIAMETER FOR STEEL OR DUCTILE IRON PIPE. MAXIMUM SADDLE TAP FOR CROSS NOT TO EXCEED 50% OF MAIN.
4. FOR NEW WATER LINES WITH DIAMETER LESS THAN 1 1/2", HOT TAP IS ACCEPTABLE. SEE CITY STD DWG W01.
5. INSTALL THRUST BLOCKS, SEE CITY STD. DWG. W11.
6. ON STEEL PIPE, CONTRACTOR TO RESTORE ALL DISTURBED COAL, TAR, AND WRAPPING.
7. WHEN EXISTING WATERLINE REQUIRES THE IN-LINE INSTALLATION OF A VALVE, REDUCER, OR FLANGE ADAPTER, ALL CONNECTIONS TO THE TEE OR VALVE SHALL BE FLANGED.

x:\Clients\hermiston or\citystandarddrawings\HermStdDwg_W06_Wtr_Main_Tap.dwg, W06, 1/29/2024 2:56 PM, twillite

	<p>CITY OF HERMISTON, OREGON STANDARD DRAWINGS</p> <p>WATER MAIN TIE-IN</p>	<p>FIGURE W06</p>
---	---	------------------------------

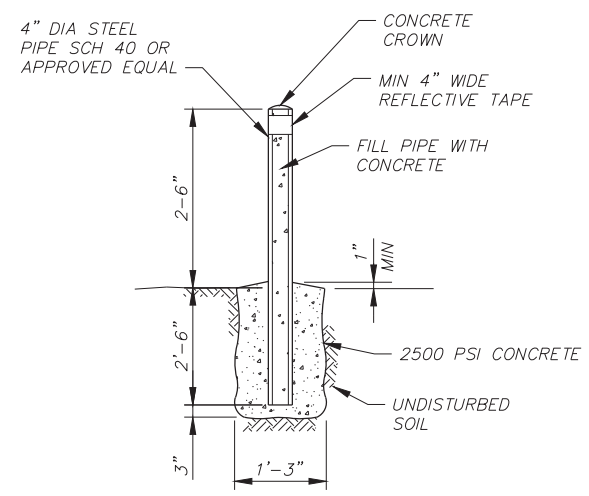

SECTION A

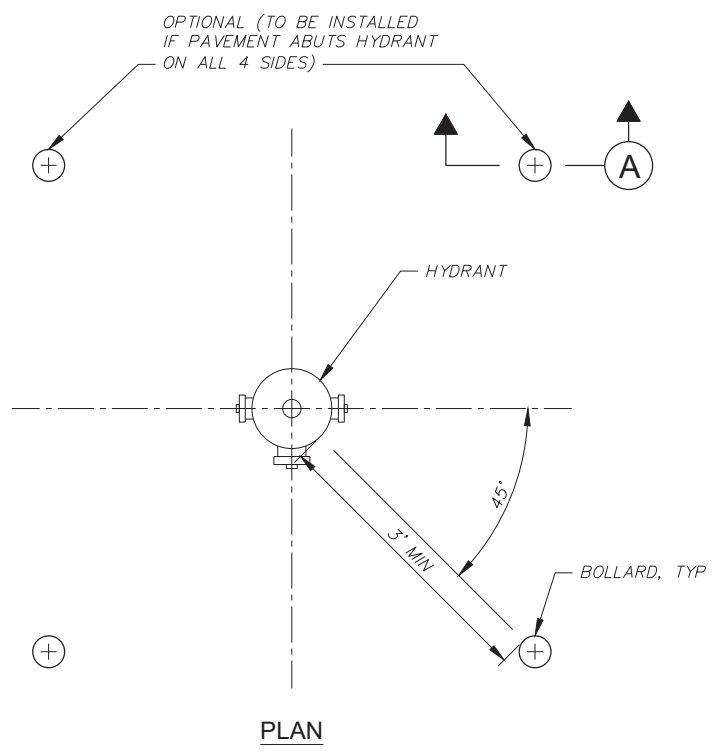

PLAN

BOLLARD NOTES

1. WHERE CONCRETE CURBING IS NOT INSTALLED, BOLLARDS (2 EA MIN) SHALL BE INSTALLED ON SIDE FACING PAVED SURFACE.
2. BOLLARDS SHALL BE PLUMB.
3. PAINT ONLY AFTER SURFACE IS FREE OF RUST, OIL, AND GREASE. PRIMER AND TWO SAFETY YELLOW (BENJAMIN MOORE OR APPROVED EQUAL) FINISH COATS SHALL BE APPLIED TO METAL PIPE FOLLOWED BY THE REFLECTION TAPE AS SHOWN.

BOLLARD DETAIL
NTS

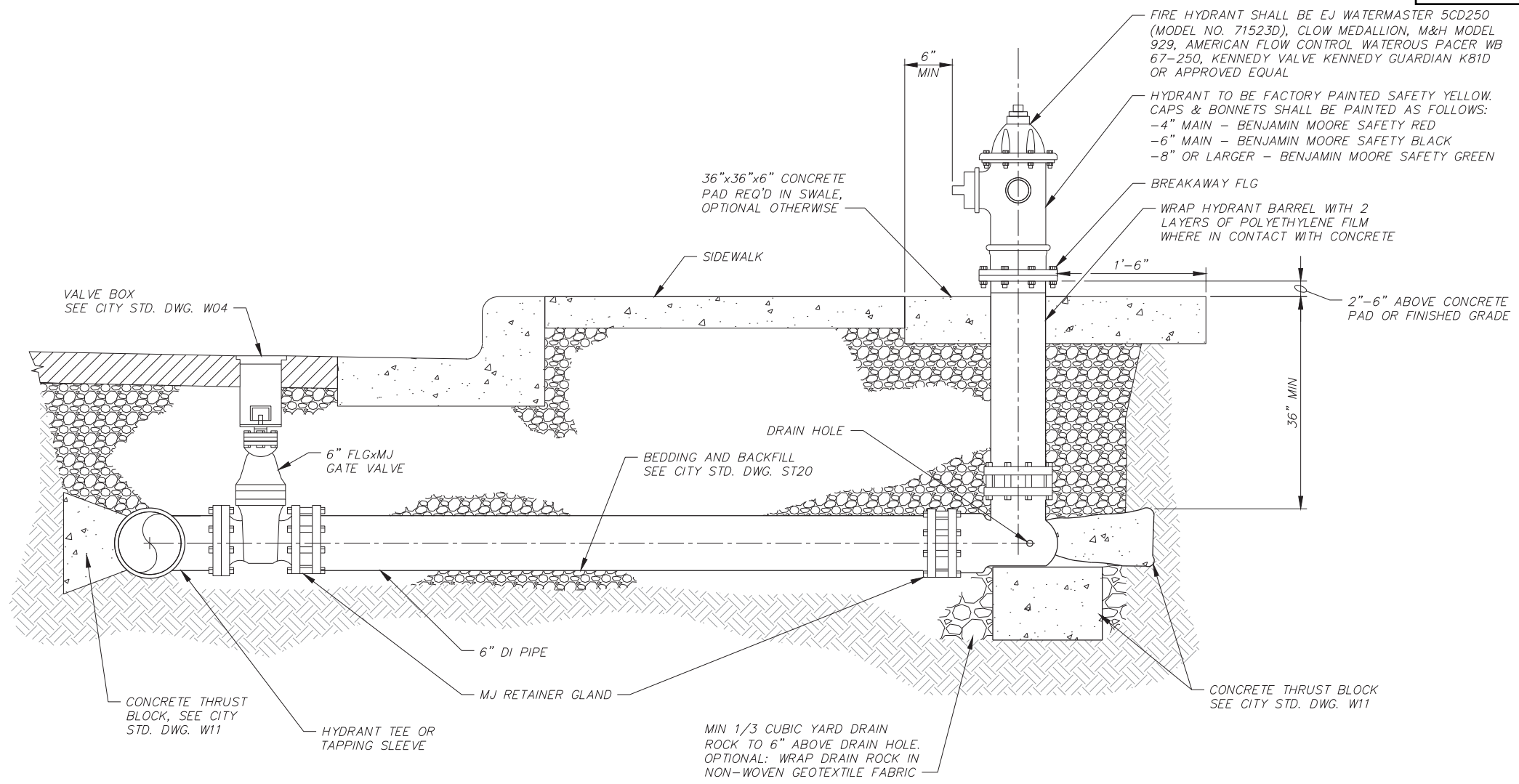

HYDRANT ASSEMBLY
NTS

NOTES

1. WHEN PIPE IS SHORTER THAN 18', NO JOINTS ALLOWED. USE MECHANICAL JOINT RETAINER GLANDS. TWO 3/4" GALVANIZED TIE RODS MAY BE USED IN LIEU OF THRUST BLOCKS FOR INSTALLATION LESS THAN 18' LONG. COAT TIE RODS WITH 2 COATS OF COAL TAR EPOXY.
2. WHEN PIPE IS LONGER THAN 18' RETAINER GLANDS NOT REQUIRED.
3. THERE SHALL BE A MINIMUM OF 3' HORIZONTAL CLEARANCE AROUND HYDRANT.
4. WHEN PLACED ADJACENT TO CURB, HYDRANT PORT SHALL BE 24" FROM FACE OF CURB.
5. CONCRETE THRUST BLOCKS SHALL BE CONSTRUCTED PER CITY STD. DWG. W11. DO NOT BLOCK DRAIN HOLES.
6. EXTENSIONS REQUIRED FOR HYDRANT SYSTEMS SHALL BE INSTALLED TO THE MANUFACTURER'S SPECIFICATIONS.
7. HYDRANT PUMPER PORT SHALL FACE DIRECTION OF ACCESS.
8. SET HYDRANT PLUMB IN ALL DIRECTIONS.

x:\Clients\hermiston\01_citystandarddrawings\HermStdDwg_W07_Hydrant_Inst.dwg_W07_1/29/2024 2:56 PM, lwillhite



**CITY OF
HERMISTON, OREGON
STANDARD DRAWINGS**

**FIGURE
W07**

FIRE HYDRANT ASSEMBLY

344

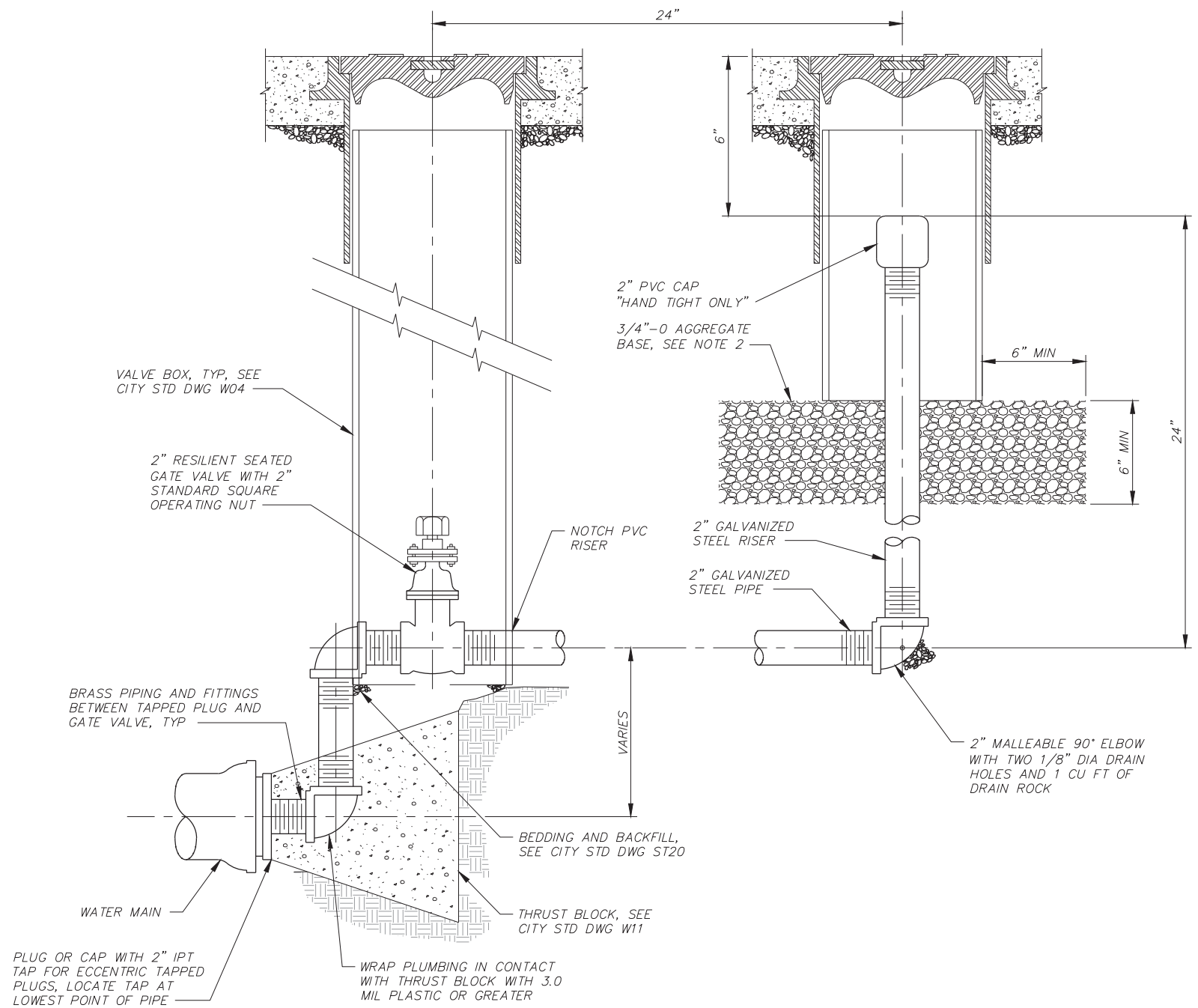

NOTES

1. BLOW-OFF ASSEMBLIES ARE GENERALLY NOT TO BE USED BUT MAY BE APPROVED IN SPECIAL CIRCUMSTANCES AS DETERMINED BY THE CITY.
2. ALL AGGREGATE BASE SHALL BE COMPACTED TO 95% MAXIMUM DRY DENSITY PER ASTM D1557.

MAIN DEAD-END BLOWOFF ASSEMBLY
NTS

x:\Clients\hermiston or\citystandarddrawings\HermStdDwg_W08_Main_Deadend_Blowoff.dwg, W08, 1/29/2024 2:56 PM, lwillite

	<p>CITY OF HERMISTON, OREGON STANDARD DRAWINGS</p> <p>MAIN DEAD-END BLOWOFF ASSEMBLY</p>	<p>FIGURE W08</p>
---	--	------------------------------

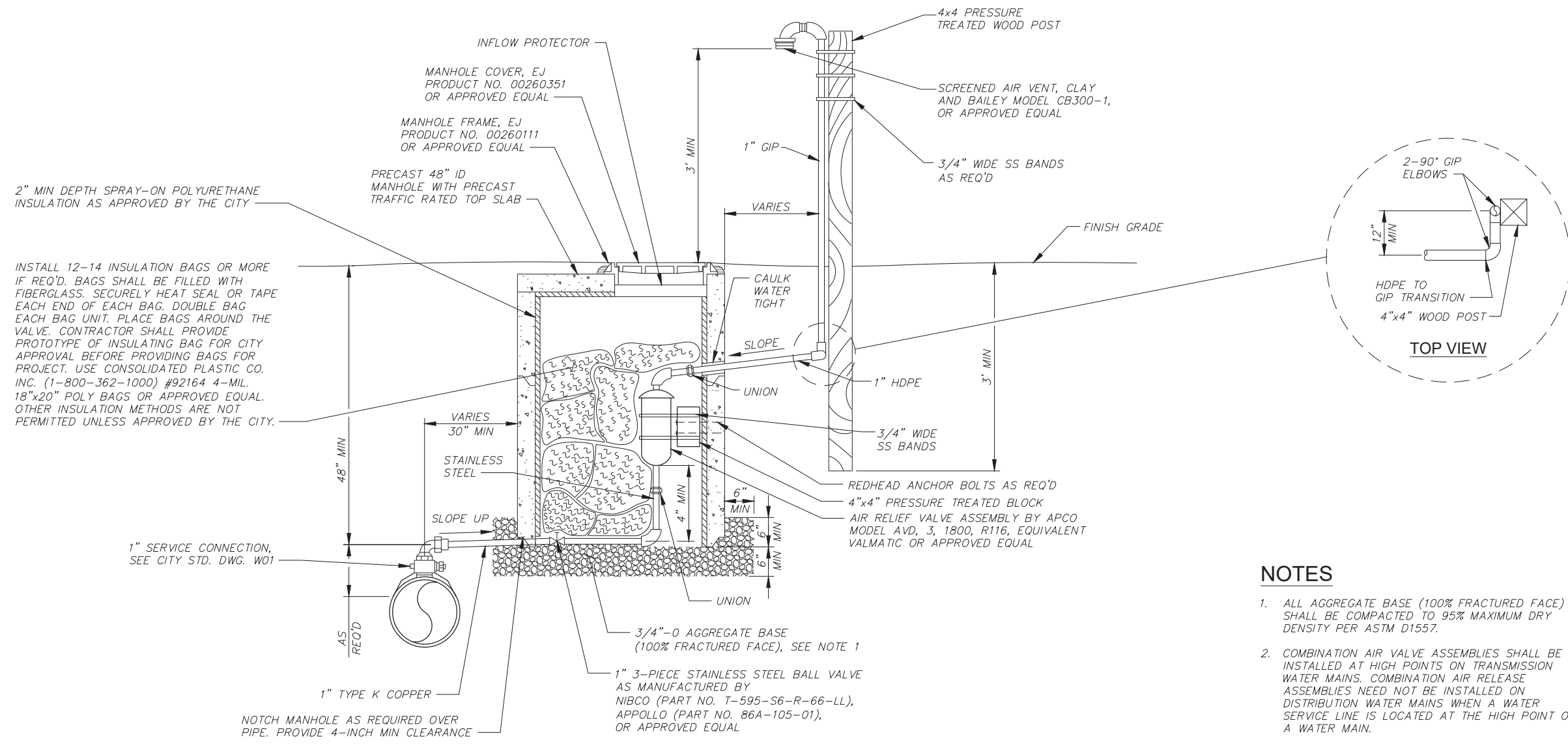

COMBINATION AIR VALVE ASSEMBLY
NTS

- NOTES**
1. ALL AGGREGATE BASE (100% FRACTURED FACE) SHALL BE COMPACTED TO 95% MAXIMUM DRY DENSITY PER ASTM D1557.
 2. COMBINATION AIR VALVE ASSEMBLIES SHALL BE INSTALLED AT HIGH POINTS ON TRANSMISSION WATER MAINS. COMBINATION AIR RELEASE ASSEMBLIES NEED NOT BE INSTALLED ON DISTRIBUTION WATER MAINS WHEN A WATER SERVICE LINE IS LOCATED AT THE HIGH POINT ON A WATER MAIN.

x:\Clients\hermiston_or_citystandarddrawings\HermStdDwg_W09_Air_Rls.dwg_W09_Air_Rls.dwg, W09_Air_Rls.dwg, 11/29/2024 2:56 PM, lwillhite

	<p>CITY OF HERMISTON, OREGON STANDARD DRAWINGS</p> <p>COMBINATION AIR VALVE ASSEMBLY</p>	<p>FIGURE W09</p>
---	--	------------------------------

NOTE

1. PROVIDE 3-INCH MINIMUM CLEARANCE BETWEEN ID OF CASING AND OD OF CARRIER PIPE JOINT.

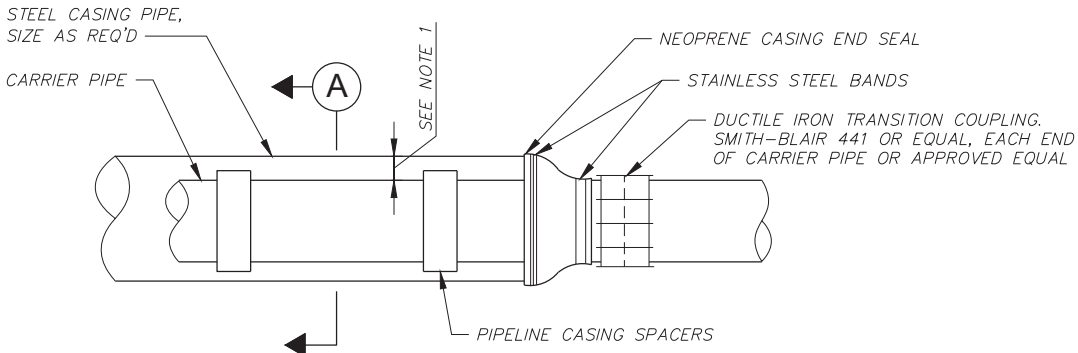

ELEVATION

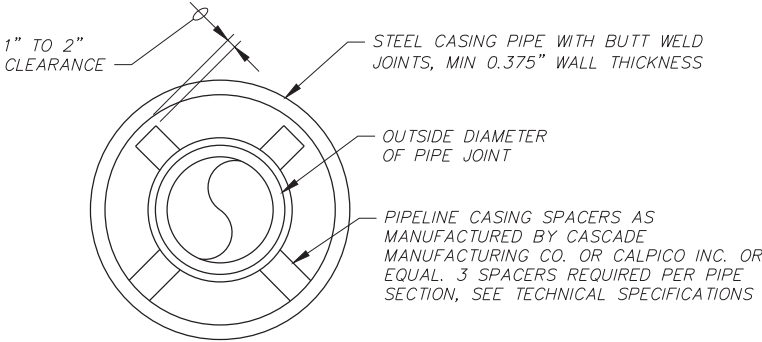

SECTION A

WATER MAIN CASING DETAIL

NTS

x:\Clients\hermiston or\citystandarddrawings\HermStdDwg_W10_Bore_Casing.dwg, W10, 1/29/2024 2:57 PM, lwilHITE



CITY OF
HERMISTON, OREGON
 STANDARD DRAWINGS

WATER MAIN CASING

FIGURE
W10

THRUST BLOCK NOTES

1. THRUST BLOCKS SHALL BE REQUIRED AT THE FOLLOWING LOCATIONS:
 - A. ALL CHANGES IN DIRECTION.
 - B. ALL DEAD-ENDS.
 - C. WHEN REDUCERS ARE INSTALLED.
 - D. ALL VALVES 8-INCHES AND LARGER SHALL BE SIZED FOR CLOSED CONDITION EXCEPTIONS:
 - (1) WHEN RESTRAINED JOINT PIPE IS USED ON BOTH SIDES OF VALVE.
 - (2) WHEN VALVE IS RESTRAINED JOINT CONNECTED TO A FITTING WHICH HAS APPROPRIATE THRUST BLOCKING.
 - E. AT LOCATIONS SPECIFICALLY CALLED OUT ON THE DRAWINGS.
 - F. AT TEMPORARY DEAD ENDS DURING PIPE INSTALLATION AS REQUIRED FOR TEMPORARY PRESSURE TESTING.
 - G. AT OTHER LOCATIONS REQUIRED BY THE ENGINEER.
2. THRUST BLOCKS SHALL BE SIZED AS REQUIRED BY SOIL CONDITIONS, DESIGN PRESSURE, AND PRESSURE INDUCED DURING THE HYDROSTATIC PRESSURE TEST.
3. PLACE CONCRETE AGAINST UNDISTURBED TRENCH WALL.
4. CONCRETE SHALL BE 2,500 PSI MINIMUM.
5. ALL CONCRETE SHALL BE PLACED SO THAT PIPE, FITTING JOINTS, BOLTS AND NUTS, ETC., WILL BE ACCESSIBLE FOR REPAIRS.
6. PLACE ONE LAYER OF VISQUEEN BETWEEN FITTING AND CONCRETE TO FACILITATE FUTURE REMOVAL OF THRUST BLOCK IF REQUIRED.
7. ANCHOR RODS SHALL BE 3/4" DIAMETER GALVANIZED STEEL RODS OR #6 EPOXY COATED REINFORCEMENT BAR, AASHTO M284, HAVING AN 18" MINIMUM EMBEDMENT IN CONCRETE.
8. IF THE REQUIRED BEARING AREA IS LESS THAN 1 SQUARE FOOT, A THRUST BLOCK SHALL NOT BE REQUIRED.
9. THRUST BLOCK BEARING AREA SHALL BE SHOWN ON PLANS.

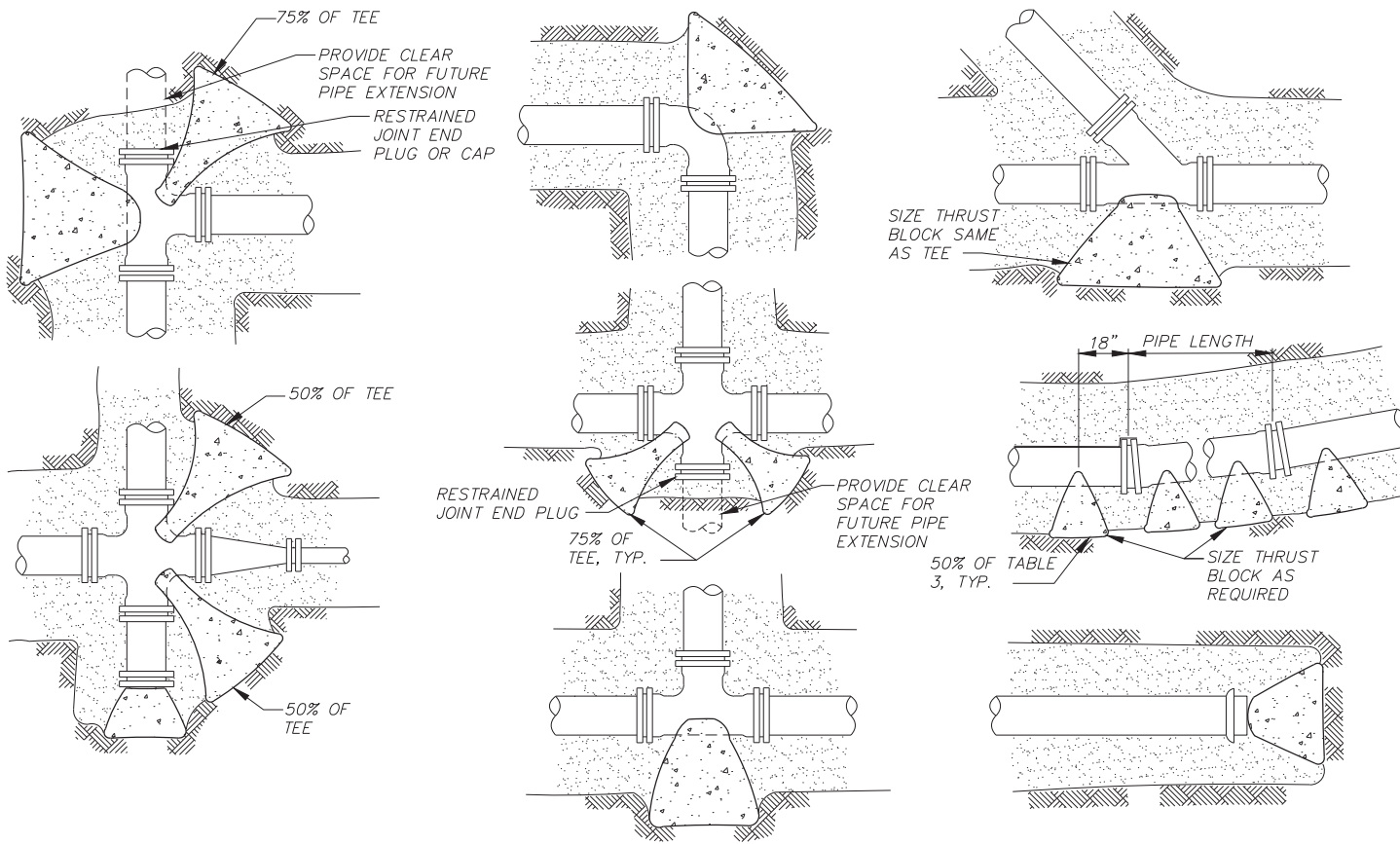

TYPICAL THRUST BLOCK LOCATIONS

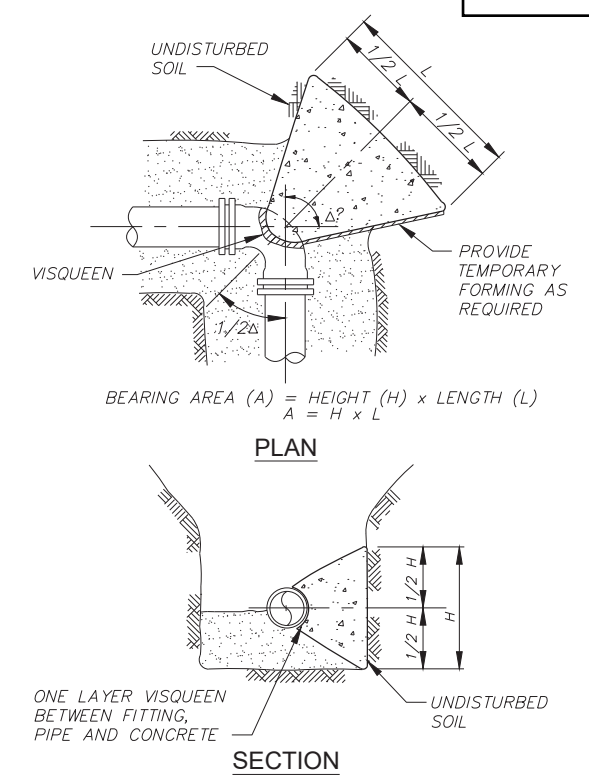

TYPICAL THRUST BLOCK DETAILS

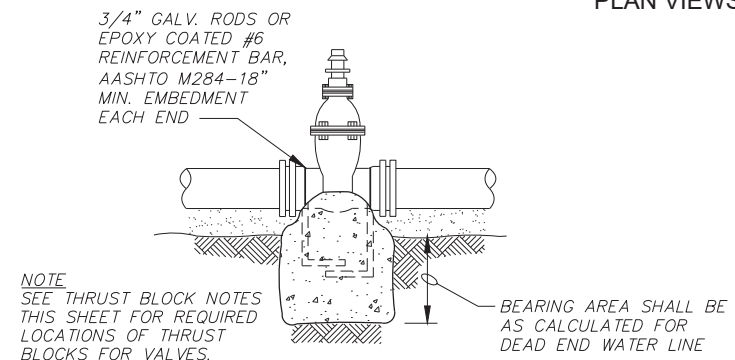

TYPICAL VALVE THRUST BLOCK

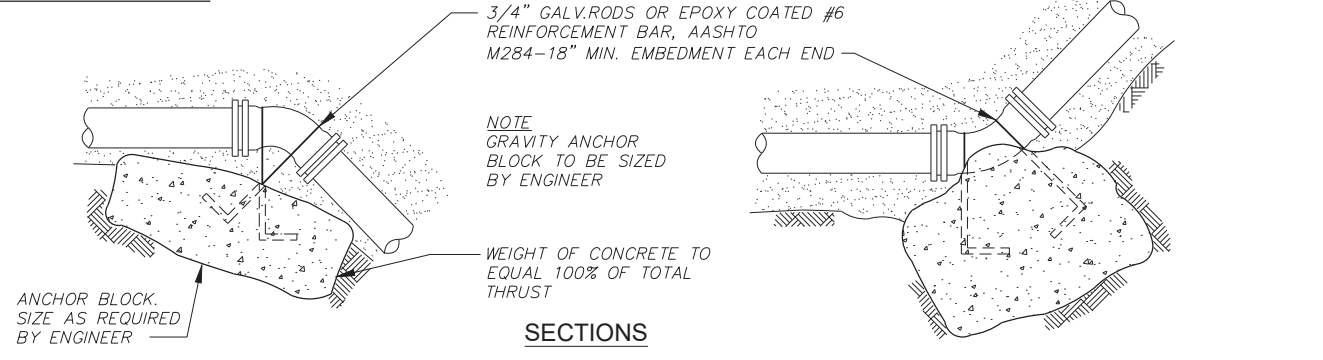

TYPICAL ANCHOR BLOCKS

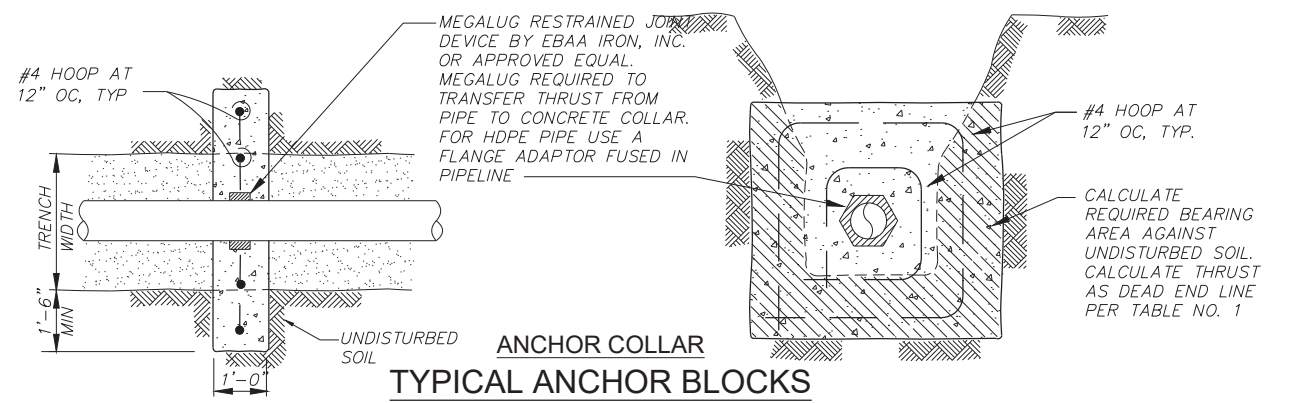

TYPICAL ANCHOR COLLAR

x:\Clients\hermiston_01_citystandarddrawings\HermStdDwg_W11_Trust_Blk.dwg_W11_1/29/2024 2:57 PM.lwl\white



Where Life is Sweet

**CITY OF
HERMISTON, OREGON
STANDARD DRAWINGS**

THRUST BLOCKS

**FIGURE
W11**

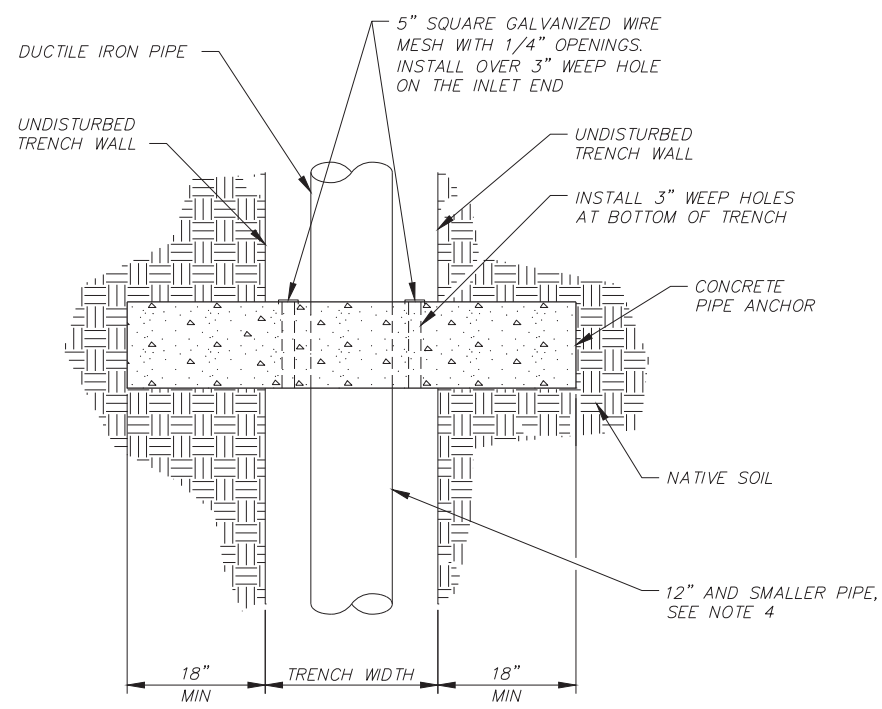

NOTE
 METAL PIPE REQUIRES POLYMERIC COATING WHEN USING SLOPE ANCHORS MADE WITH CONCRETE.

PLAN

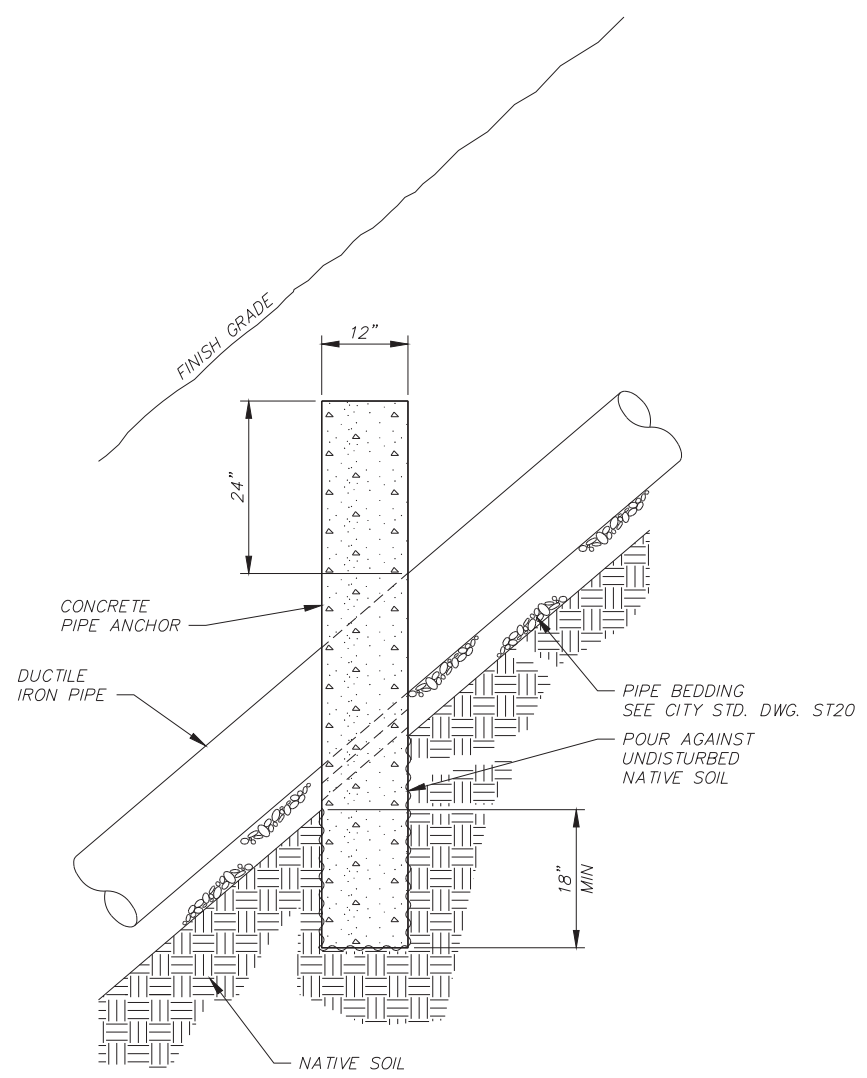

ELEVATION

PIPE SLOPE ANCHORS

NTS

NOTES

1. CONCRETE PIPE ANCHORS SHALL BE CONSTRUCTED USING FORMS WHEN SEWERS, STORM DRAINS AND OTHER PIPELINES ARE CONSTRUCTED WITH SLOPES 20% OR GREATER. REMOVE FORMS PRIOR TO BACKFILLING TRENCH.
2. ALL CONCRETE SHALL BE COMMERCIAL GRADE 2,500 PSI CONCRETE.
3. CENTER TO CENTER MAX. SPACING OF CONCRETE PIPE ANCHORS SHALL BE:

SLOPE	SPACING (ON SLOPE)
20-34%	35'
35-50%	25'
50+ %	15' OR CONCRETE ENCASEMENT
4. DIMENSIONS FOR EMBEDMENT FOR PIPES LARGER THAN 12" SHALL BE APPROVED BY THE ENGINEER.

x:\Clients\hermiston or\citystandarddrawings\HermStdDwg_W12_Pipe_Slope_Conc_Anchr.dwg, W12, 1/29/2024 2:57 PM, lwillhite



**CITY OF
 HERMISTON, OREGON
 STANDARD DRAWINGS**

PIPE SLOPE ANCHORS

**FIGURE
 W12**

NOTES

- 1. ALL NEW AND EXISTING WATER SERVICE LOCATIONS SHALL BE MARKED IN CURB AS SHOWN OR AS APPROVED BY THE CITY ENGINEER. STAMPING OF SERVICE LOCATIONS SHALL BE CONSIDERED INCIDENTAL TO THE PRICE OF THE CURB.
- 2. STAMPS MAY BE PURCHASED FROM THE CITY.
- 3. W's NOT PLACED BY SPECIFIC STAMP WILL NOT BE ACCEPTED AND THAT SECTION OF CURB SHALL BE REMOVED AND REPLACED.
- 4. SEE CITY STD DWG SS08 FOR SEWER SERVICE LOCATION CURB STAMP.

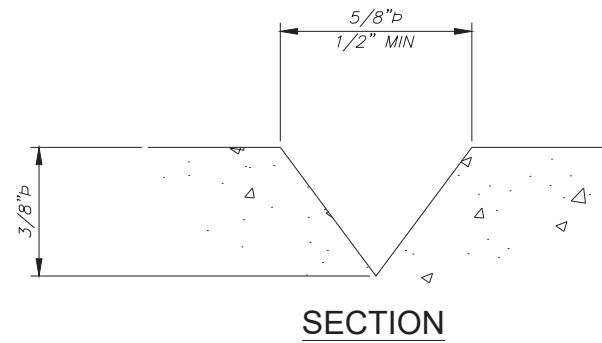
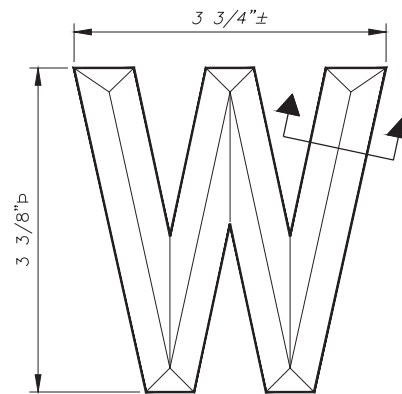

STAMP "W" IN FACE OF CURB IN LINE WITH CLEANOUT LOCATION, PERPENDICULAR TO CURB LINE

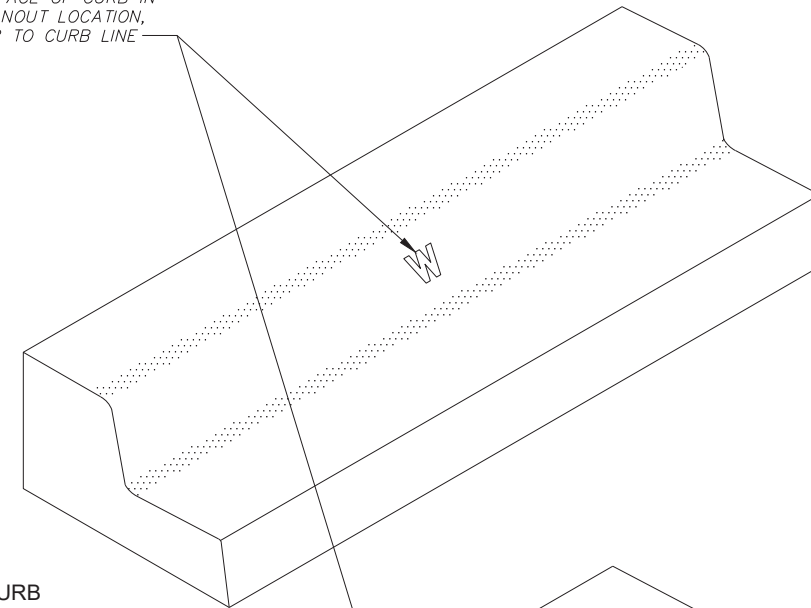

STANDARD CURB

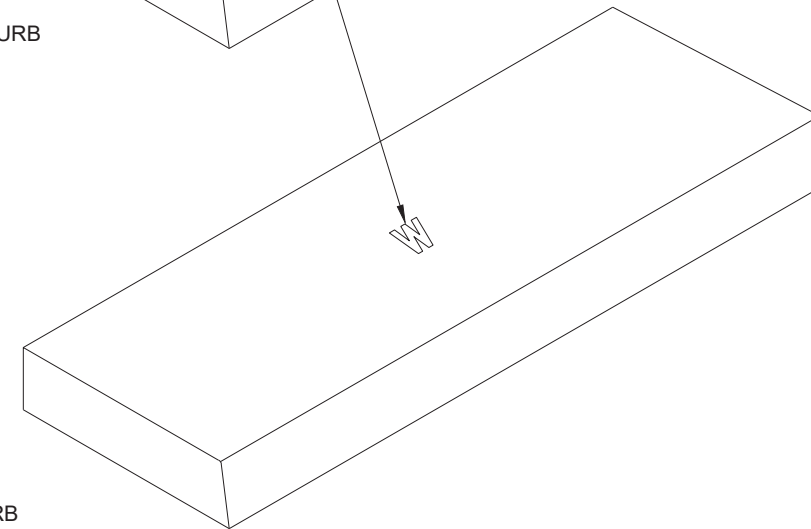

RIBBON CURB

x:\Clients\hermiston or\citystandarddrawings\HermStdDwg_W13_Curb_Stamp.dwg_W13_1/29/2024 2:57 PM_lwilhite



CITY OF
HERMISTON, OREGON
STANDARD DRAWINGS
WATER SERVICE CURB STAMP

FIGURE
W13

CHLORINATION AND BACTERIA TESTING PROCEDURES

NEW MAIN TESTING IF CONNECTED TO EXISTING

- DAY 1
 - 1. FLUSH MAIN
 - 2. INJECT Cl_2 TO 25 MG/L MINIMUM (CITY VERIFY)
 - 2A. 24HR HOLDING TIME
- DAY 2
 - 3. Cl_2 RESIDUAL ≥ 10 MG/L MIN (IF NO-RESTART STEP 1-CITY VERIFY)
 - 3A. FLUSH Cl_2 TO ≤ 1.0 MG/L
 - 3B. 16-24HR HOLDING TIME
- DAY 3
 - *4. PULL BAC-T SAMPLE(S) CITY DETERMINES QUANTITY (CITY PROVIDES BAC-T BOTTLES)
 - 4A. 24HR SAMPLE TIME
- DAY 4
 - 5. IF BAC-T RESULTS ARE POSITIVE
 - 5A. START BACK @ STEP 1
 - 5B. OR OPTIONALLY ONLY AFTER FIRST POSITIVE RESULTS, START BACK AT STEP 3A
 - 6. IF BAC-T RESULTS ARE NEGATIVE:
 - 6A. BAC-T TEST COMPLETE. READY FOR PRESSURE TEST (CITY WITNESS)

*BAC-T SAMPLES NOT PERMITTED ON: FRI, SAT, SUN, OR HOLIDAYS

NEW MAIN TESTING IF NOT CONNECTED TO EXISTING

- DAY 1
 - 1. FLUSH
 - 2. PRESSURE TEST (CITY WITNESS)
 - 3. INJECT Cl_2 TO 25 MG/L MINIMUM (CITY VERIFY)
 - 3A. 24HR HOLDING TIME
- DAY 2
 - 4. Cl_2 RESIDUAL ≥ 10 MG/L MIN (IF NO-RESTART STEP 3 - CITY VERIFY)
 - 4A. FLUSH Cl_2 TO ≤ 1.0 MG/L
 - 4B. 16-24HR HOLDING TIME
- DAY 3
 - *5. PULL BAC-T SAMPLE(S)-CITY DETERMINES QUANTITY (CITY PROVIDES BAC-T BOTTLES)
 - 5A. 24HR SAMPLE TIME
- DAY 4
 - 6. IF BAC-T RESULTS ARE POSITIVE
 - 6A. START BACK @ STEP 3
 - 6B. OR OPTIONALLY ONLY AFTER FIRST POSITIVE RESULTS, START BACK AT STEP 4A
 - 7. IF BAC-T RESULTS ARE NEGATIVE
 - 7A. BAC-T TESTING IS COMPLETE

*BAC-T SAMPLES NOT PERMITTED ON: FRI, SAT, SUN, OR HOLIDAYS

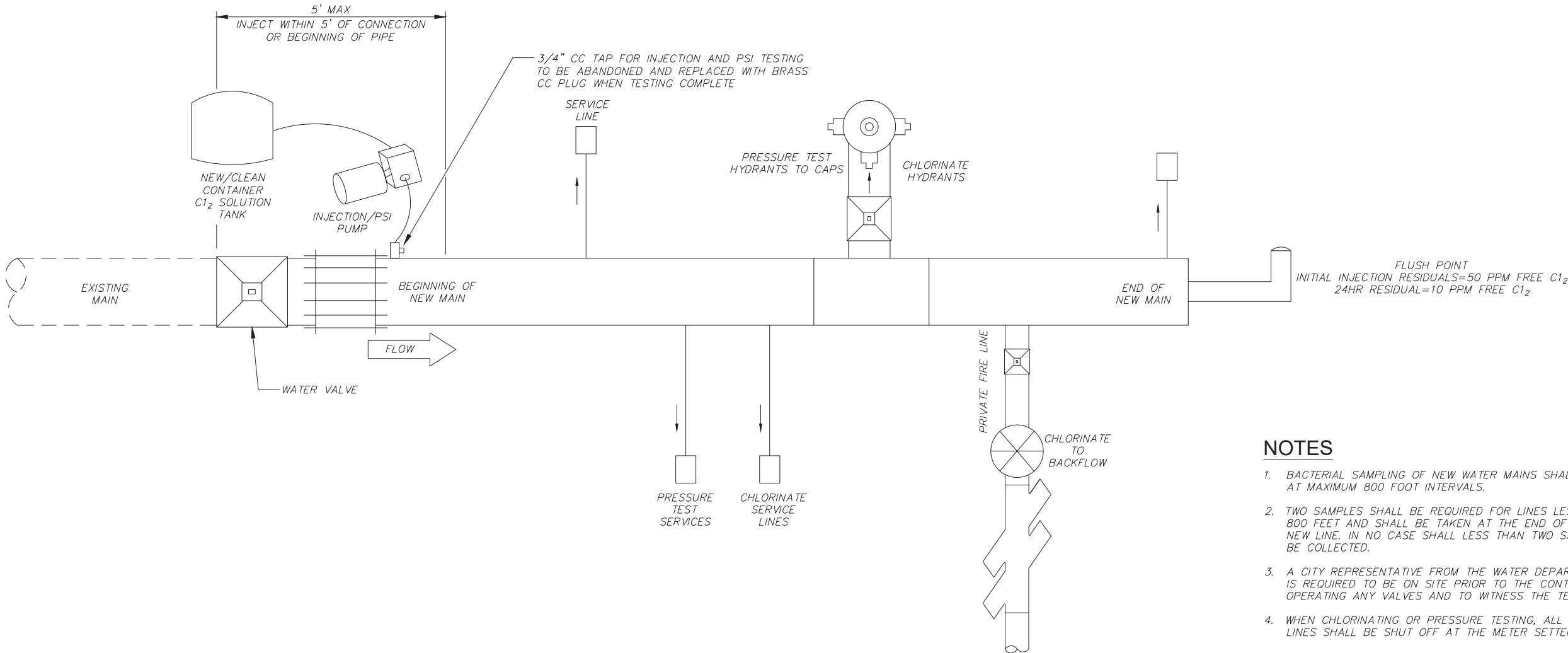

NOTES

- 1. BACTERIAL SAMPLING OF NEW WATER MAINS SHALL OCCUR AT MAXIMUM 800 FOOT INTERVALS.
- 2. TWO SAMPLES SHALL BE REQUIRED FOR LINES LESS THAN 800 FEET AND SHALL BE TAKEN AT THE END OF THE NEW LINE. IN NO CASE SHALL LESS THAN TWO SAMPLES BE COLLECTED.
- 3. A CITY REPRESENTATIVE FROM THE WATER DEPARTMENT IS REQUIRED TO BE ON SITE PRIOR TO THE CONTRACTOR OPERATING ANY VALVES AND TO WITNESS THE TEST.
- 4. WHEN CHLORINATING OR PRESSURE TESTING, ALL SERVICE LINES SHALL BE SHUT OFF AT THE METER SETTER.

x:\Clients\hermiston_or_citystandarddrawings\HermStdDwg_W14_Chlor_Bac_Test.dwg, W14, 1/29/2024 2:57 PM, lwillite



**CITY OF
HERMISTON, OREGON
STANDARD DRAWINGS**

**FIGURE
W14**

CHLORINATION AND BACTERIA TESTING

351

PREFERRED METHOD (AIR GAP)

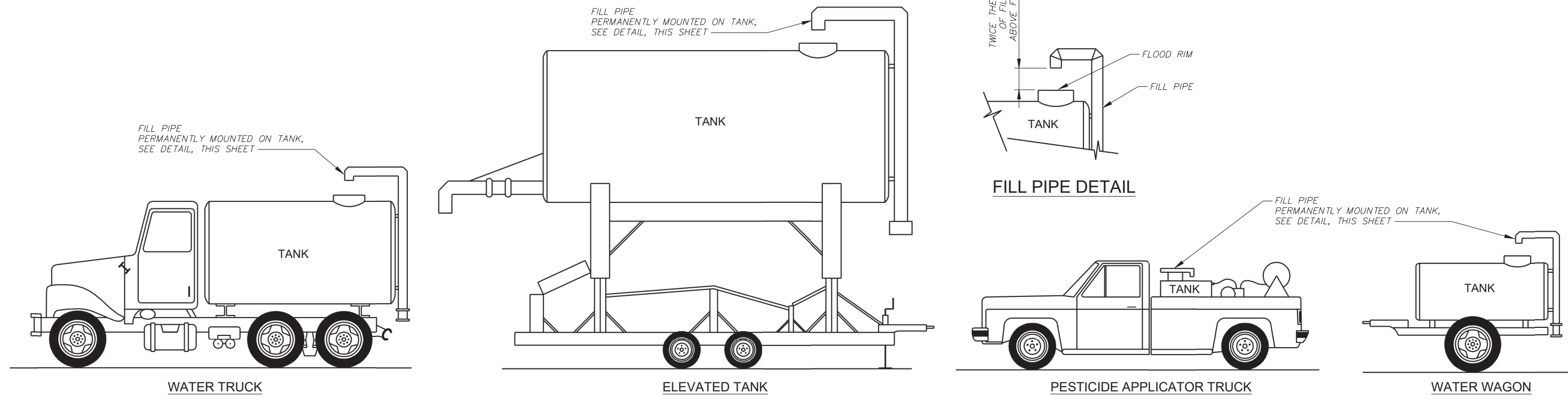

ALTERNATIVE METHOD (RPBA)

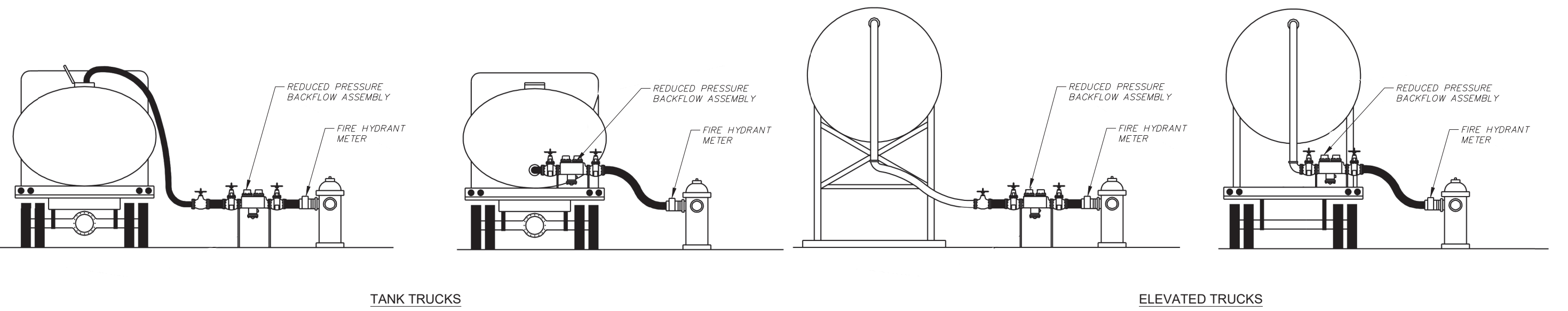

NOTE

1. SEE FIRE HYDRANT METER TECHNICAL SPECIFICATIONS FOR ADDITIONAL REQUIREMENTS.

HERMISTON
OREGON
Where Life is Sweet

CITY OF
HERMISTON, OREGON
STANDARD DRAWINGS

FIRE HYDRANT METER USE

FIGURE
W15

x:\Clients\hermiston_or\citystandarddrawings\HermStdDwg_W15_FireHyd Mtr Use.dwg, W14_1/29/2024 2:57 PM, lwillite



Where Life is Sweet

Mayor and Members of the City Council
STAFF REPORT
For the Meeting of February 12, 2024

Title/Subject

Resolution No. 2311 - Adopting the Immunity from Liability for use of Trails or Structures in Public Easement or Unimproved Right of Way Provided in ORS 105.668

Summary and Background

On July 6, 2023, the Oregon Court of Appeals issued an opinion effectively ending recreational immunity for improved trails. Public and private landowners of improved trails are no longer protected from lawsuits. (Fields v. City of Newport). In Fields v. Newport a woman was walking with her friend and their dogs on the beach. She walked away from the beach on an improved trail which was owned and maintained by the city of Newport. The woman came to a wooden footbridge that was wet. She slipped and fell, then filed a lawsuit against the City. Ms. Fields' suit alleged the City was negligent in maintaining the bridge and not putting up warning signs. Newport responded that it was immune from suit because Fields was using the Ocean to Bay Trail for a recreational purpose, walking with a friend and their dogs while they talked and socialized.

The trial court agreed with the City, ruling that recreational immunity protects landowners from a lawsuit when they open their property to the public for recreational purposes without a fee. Because of recreational immunity the trial court granted summary judgment, which ended the case early in favor of Newport. The trial court determined "there are no genuine issues of material fact in dispute" and that under state law, the plaintiff was "using the trail for recreational purposes" by "walking her dog on a trail to the beach with a friend," and thus the City was entitled to recreational immunity from any liability.

Plaintiff Fields appealed the trial court's ruling, arguing that the trial court could not conclude that her "principal purpose" (as required under state law) in walking on the trail was recreational as long as she claimed that the subjective intent in her mind was something else.

The Oregon Court of Appeals decided that there is a factual dispute between Plaintiff Fields and the City as to whether her use of the trail was recreational, or whether her primary purpose was instead for "accessing the beach." In other words, the Court of Appeals held that the trial court needed to hold a jury trial to determine whether the plaintiff's principal purpose on the trail was accessing the beach, or to recreate while using the trail with a friend and their dogs while they "socialized." Either way, recreational immunity no longer stops a case at the beginning (an "immunity" from suit), because any plaintiff can claim their "principal purpose" was not to recreate.

This particular case is not the first one that has reduced the scope of recreational immunity. Once again, the League of Oregon Cities and the Association of Oregon Counties are bringing a bill to the Legislature in 2024 to restore recreational immunity. Along with that effort, City/County Insurance (CCI) is recommending to their members that they adopt the provisions of ORS 105.668 and improve signage along our trails to reduce exposure and improve the defense of claims.

With those recommendations, CCI also offered \$5,000 grants to help their members accomplish these goals. We received one of these grants and are working to implement the new signage as well as bringing the resolution for adoption.

Tie-In to Council Goals

N/A

Fiscal Information

Maintenance of signs in the future.

Alternatives and Recommendation

Alternatives

1. Adopt Resolution No. 2311 without modification.
2. Adopt Resolution No. 2311 with specific modifications.
3. Direct staff to make major changes to Resolution No. 2311 and bring back at a later date.

Recommended Action/Motion

Adopt Resolution No. 2311 without modification.

Submitted By: Byron D. Smith

RESOLUTION NO. 2311

A RESOLUTION ADOPTING THE IMMUNITY FROM LIABILITY FOR USE OF TRAILS OR STRUCTURES IN PUBLIC EASEMENT OR UNIMPROVED RIGHT OF WAY PROVIDED IN ORS 105.668

WHEREAS, ORS 105.668(2) provides to cities with a population of 500,000 or more immunity from liability for injury or property damage against cities including their officers, employees, or agents, adjacent property owners, and certain nonprofit groups and their volunteers that arise from the use of trails or structures located on public easements or unimproved right of way; and

WHEREAS, ORS 105.668(3) authorizes cities with populations of less than 500,000 to opt into the immunities provided in ORS 105.668(2) by adoption of an ordinance or resolution; and

WHEREAS, the City desires to opt into the immunities provided by ORS 105.668 to further the public interest by protecting and supporting efforts and activities of the City.

NOW, THEREFORE, THE CITY OF HERMISTON RESOLVES AS FOLLOWS:

1. The Hermiston City Council hereby opts into the immunity from liability for injury or property damage arising from the use of trails or structures in public easement or unimproved right of way provided by ORS 105.668.
2. That this resolution is effective immediately upon its passage.

PASSED by the Common Council this 12th day of February 2024.

SIGNED by the Mayor this 12th day of February 2024.

Dr. David Drotzmann, MAYOR

ATTEST:

Lilly Alarcon-Strong, CMC, CITY RECORDER



Where Life is Sweet

Mayor and Members of the City Council
STAFF REPORT
For the Meeting of February 12, 2024

Title/Subject

Ordinance No. 2355 – An Ordinance Amending Chapters 51 and 52 of the Hermiston Municipal Code by Increasing the Due and Payable Date for Sewer, Water, and Solid Waste Bills from within Ten Days to Twenty Days

Summary and Background

Currently under Chapters 51 and 52 of the Hermiston Municipal Code, bills for water, sewage, and solid waste services are due and payable within ten days of issuance and all bills that are not paid within ten days of issuance are considered delinquent and an additional charge imposed. Delays in mail service have increased the time it takes for bills to reach customers and has cut down on the amount of time customers have to return payment before becoming delinquent. To assist city customers, the Finance Department has requested an amendment to the Municipal Code to extending the due and payable date of sewer, water, and solid waste bills from ten days to twenty days.

Tie-In to Council Goals

N/A

Fiscal Information

N/A

Alternatives and Recommendation

Alternatives

1. Adopt Ordinance No. 2355
2. Amend Ordinance No. 2355
3. Reject Ordinance No. 2355
4. Table and request more information

Recommended Action/Motion

Motion to adopt Ordinance No 2355 as proposed.

Submitted By:

Richard Tovey

ORDINANCE NO. 2355

AN ORDINANCE AMENDING CHAPTERS 51 AND 52 OF THE HERMISTON MUNICIPAL CODE BY INCREASING THE DUE AND PAYABLE DATE FOR SEWER, WATER, AND SOLID WASTE BILLS FROM WITHIN TEN DAYS TO TWENTY DAYS

WHEREAS, the City of Hermiston under §51.072, §51.073, and §52.09 require bills for sewer and water to be due and payable within ten days of issuance; and

WHEREAS, bills that are unpaid after ten days of issuance shall be considered delinquent and an additional charge imposed; and

WHEREAS, the delivery of bills for sewer, water, and solid waste services issued by the City through the United States Postal Service is taking longer for the bills to reach City customers and has thereby decreased the amount of time customers have to be able to return payment; and

WHEREAS, to assist City customers, it is proposed that §51.072, §51.073, and §52.09 be amended to make bills be due and payable within twenty days of issuance.

THE CITY OF HERMISTON ORDAINS AS FOLLOWS:

(New language is in red and underlined and repealed language has ~~a line through it.~~)

Section 1. Subsection 51.072(D) of the Hermiston Municipal Code is amended as follows:

51.072 BILLING PROCEDURES.

- (A) The users of the sewerage system shall be billed on a monthly basis for services after rendered in accordance with the rate schedule. The city may issue a combined bill for sewer, water, and solid waste management services.
- (B) The date of the billing shall be in accordance with the monthly cycle billing.
- (C) Notice of billing, delinquencies, and all other required information shall be deemed to have been given when notices are placed in the United States mail with postage prepaid and addressed as shown in the utility records. Failure to provide address change information will not cause notice to be defective. Notice of termination of sewer service may also be made by hand delivery or posting at the consumer’s place of use.
- (D) Sewer user charges shall be due and payable to the city no later than twenty ~~ten~~ days after the date of billing.

Section 2. Section 51.073(B) and (C) of the Hermiston Municipal Code is amended as follows:

51.073 DELINQUENCIES AND SERVICE SHUTOFF.

(A) All bills for sewer service shall be rendered monthly at the same time that bills for water services and solid waste services are rendered and may be collected as a combined bill for water, sewage and solid waste services furnished to the consumer.

(B) All bills for water, sewage and solid waste services are due and payable within ~~ten~~ twenty days of issuance. All water, sewage, and solid waste bills unpaid, ~~ten~~ twenty days after the date of issuance, shall be considered delinquent and an additional charge shall be imposed on the gross amount of the billing.

(C) All other charges arising under this chapter and not required to be paid in advance shall be due ~~ten~~ twenty days from the date of issuance of a statement of the amount owed. All such amounts unpaid, ~~ten~~ twenty days after date of issuance, shall be considered delinquent and an additional charge imposed.

(D) The city shall send the initial notice of delinquency to the user. If the account remains delinquent, the city, prior to terminating service, shall provide a second notice of delinquency by first class mail or personal service to the user and to the property owner if the owner has provided to the city a mailing address for notification. It shall be the responsibility of the owner to ensure that the city has a current address. The notice shall state that failure to pay the amount due may result in one or all such services being discontinued on the date specified in the notice which shall not be less than ten days from issuance and that the city may impose a shutoff/reinstatement fee. It shall summarize the right to appeal provided in subsection (H) of this section.

(E) Unless other arrangements have been made, satisfactory to the city, discontinued services shall not be restored until all charges including but not limited to the delinquency and any shutoff/reinstatement fee have been paid.

(F) Sewer service, including water provision, may also be shut off if the consumer tampers or in any way interferes with any meter, connections, service pipes, valves or other appurtenances belonging to the city or for any violation by a consumer of the terms of this or any other applicable ordinance of the city or the statutes of the state relating to the sewer system. Notice and opportunity to appeal shall be provided in the same manner as a delinquency.

(G) Notwithstanding any other provision of this chapter, the city may immediately shut off services, remove or close a sewer connection if there is an immediate threat of substantial harm to public health or safety. Notice shall be provided as reasonably practicable. The consumer or property owner may appeal the shutoff within ten days of notice or shutoff as provided in subsection (H) of this section, which appeal shall be expedited.

(H) A person notified of a delinquency may appeal the determination, in writing, stating the reasons therefor as provided in Chapter [136](#). Except in case of an immediate threat of substantial harm to public health or safety, service will not be shut off pending the outcome of the appeal provided the appeal is received by the city prior to the discontinuance. The appeal authority may grant the appeal, deny the appeal or adjust the delinquency, as appropriate, including providing for a payment plan. If the appeal is denied or adjusted and the amount

established to be due is not paid within ten days of notice of the decision or as otherwise provided in the decision, service may be discontinued.

Section 3. Section 52.09(B) and (C) of the Hermiston Municipal Code is amended as follows:

52.09 BILLING; DELINQUENCY; SHUTOFF.

(A) All bills for water service shall be rendered monthly at the same time as bills for sewage services and solid waste services and may be collected as a combined bill for water, sewage and solid waste services furnished to the consumer.

(B) All bills for water, sewage and solid waste services are due and payable within ~~ten~~ **twenty** days of issuance. All water, sewage and solid waste bills unpaid ~~ten~~ **twenty** days after the date of issuance shall be considered delinquent and an additional charge shall be imposed on the gross amount of the billing.

(C) All other charges arising under this chapter, and not required to be paid in advance, shall be due ~~ten~~ **twenty** days from the date of issuance of a statement of the amount owed. All such amounts unpaid, ~~ten~~ **twenty** days after date of issuance, shall be considered delinquent and an additional charge imposed.

(D) The city shall send the initial notice of delinquency to the consumer. If the account remains delinquent prior to terminating service, the city shall provide notice of delinquency by first class mail or personal service to the consumer and to the property owner if the property owner has provided to the city a mailing address for notification. It shall be the responsibility of the owner to ensure that the city has a current address. The notice shall state that failure to pay the amount due may result in one or all such services being discontinued on the date specified in the notice which shall not be less than ten days from issuance and that the city may impose a shutoff/reinstatement fee. It shall summarize the right to appeal provided in subsection (H) of this section.

(E) Unless other arrangements have been made satisfactory to the city, discontinued services shall not be restored until all charges, including but not limited to the delinquency and any shutoff/reinstatement fee have been paid.

(F) Water service may also be shut off if the consumer tampers or in any way interferes with any meter, connections, service pipes, valves or other appurtenances belonging to the city or for any violation by a consumer of the terms of this or any other applicable ordinance of the city or the statutes of the state relating to the waterworks system. Notice and opportunity to appeal shall be provided in the same manner as a delinquency.

(G) Notwithstanding any other provision of this chapter, the city may immediately shut off services if there is an immediate threat of substantial harm to public health or safety. Notice shall be provided as reasonably practicable. The consumer or property owner may appeal the shut-off within ten days of notice or shutoff as provided in subsection (H) of this section, which appeal shall be expedited to the extent reasonably practicable.

(H) A person notified of a delinquency may appeal the determination in writing, stating the reasons therefor as provided in Chapter 136. Except in case of an immediate threat of substantial harm to public health or safety, service will not be shut off pending the outcome of the appeal provided the appeal is received by the city prior to the discontinuance. If the water has been shut off, the appeal shall be expedited to the extent reasonably practicable. The appeal authority may grant the appeal, deny the appeal or adjust the delinquency as appropriate, including providing for a payment plan. If the appeal is denied or adjusted and the amount established to be due is not paid within ten days of notice of the decision or as otherwise provided in the decision, service may be discontinued.

(I) No user may receive water service at any location if the user has outstanding unpaid water bills at any other location until all outstanding amounts owed by the user are paid in full.

(J) The city does not guarantee to maintain any specific water pressure for its service and no complaint concerning the pressure shall give any right of claim against the city, its officers, employees or agents.

Section 4. All other provisions of the Hermiston Municipal Code remain unchanged and in full effect.

Section 5. The City Recorder is hereby authorized to correct any scrivener’s errors and to conform the revisions to the Hermiston Municipal Code with appropriate numbering.

Section 6. Effective Date. This ordinance shall take effect on the 30th day after its adoption.

ADOPTED by the Common Council this 12th day of February 2024.

SIGNED by the Mayor this 12th day of February 2024.

Dr. David Drotzmann, Mayor

ATTEST:

Lilly Alarcon-Strong, CMC City Recorder



Where Life is Sweet

Mayor and Members of the Urban Renewal Board
STAFF REPORT
 For the Meeting of February 12, 2024

Title/Subject

Resolution No. 20 - Award a contract to reconstruct the SE 2nd Street/Highway 395 S intersection

Summary and Background

This resolution awards a contract to reconstruct the SE 2nd Street/Highway 395 S intersection in accordance with the Downtown Urban Renewal Plan adopted in 2013. The city council approved the design for the intersection in April of 2023. Staff also held a neighborhood meeting in March of 2023 to gather feedback on the proposed design. The project was bid in March of 2023 and only two bids were received. Both bids exceeded the project budget of \$360,000. The urban renewal agency therefore rejected all bids and chose to remove some project components and rebid in a more favorable bidding climate in the winter. To save money, landscape elements and seat walls were removed, and one of the two columns was moved to a bid alternative to be constructed only if funds allow.

The revised project was re-bid in January of 2024. Four bids were received and are shown in the table below.

Bidder	Bid	Bid Options	Bid Total
Odyssey Contracting LLC	\$274,372.50	\$40,375.00	\$314,747.50
Nelson Construction Corp	\$328,130.00	\$68,150.00	\$396,280.00
Silver Creek Contracting LLC	\$432,389.70	\$60,150.30	\$492,539.70
Cascade Civil Corp	\$598,329.00	\$115,000.00	\$713,329.00

The engineer’s estimate for the project is \$329,000 for the main project and an additional \$70,000 for construction alternatives of irrigation and a second gateway column. Therefore, the total estimate for the project is \$399,000 and the low bid is \$314,747.50 from Odyssey Contracting LLC.

Tie-In to Council Goals

Administration of the Downtown Urban Renewal Area remains a council priority.

Fiscal Information

\$360,000 is budgeted in the HURA budget for the 23/24 fiscal year for this project. In addition to the \$315,000 for construction costs, an additional fee will be required for construction engineering and oversight from the city’s engineers with Anderson Perry. Construction oversight is estimated to be between \$20,000 and \$30,000 bringing the project total to \$345,000. This conservative budget is under the cash on hand within the Downtown Urban Renewal Area’s budget.

Alternatives and Recommendation

Alternatives

- Award the contract to Odyssey Contracting LLC
- Reject all bids

Recommended Action/Motion

Motion to approve Resolution No. 20 and award the construction contract to Odyssey Contracting LLC.

Submitted By:

Clinton Spencer, Urban Renewal Director

RESOLUTION NO. 20

A RESOLUTION AWARDED A CONTRACT FOR CONSTRUCTION OF THE SE 2nd STREET/HIGHWAY 395 S REALIGNMENT PROJECT AND AUTHORIZING THE CITY MANAGER TO SIGN ALL NECESSARY DOCUMENTS ON BEHALF OF THE CITY

WHEREAS, the Hermiston Urban Renewal Agency (“Agency”) has determined the need for realignment of the SE 2nd Street/Highway 395 S intersection to create a gateway to the downtown and enhance safety; and

WHEREAS, the SE 2nd Street project (“project”) will include the removal of existing street improvements, realignment of the intersection and installation of new curb, gutter, and sidewalk as well as gateway columns; and

WHEREAS, notice was published, and bids were received, with Odyssey Contracting, LLC. being the lowest responsive and responsible bidder with a bid of an amount of \$314,747.50; and

WHEREAS, the Agency has funds available for this project.

NOW, THEREFORE, THE CITY OF HERMISTON RESOLVES AS FOLLOWS:

1. That Odyssey Contracting, LLC. is awarded the contract for the SE 2nd Street Project.
2. That the City Manager be, and is, hereby authorized to execute and deliver the contract to Odyssey Contracting, LLC. with such changes, additions, deletions, and modifications as the City Manager may approve.
3. That this resolution is effective immediately upon its passage.

PASSED by the Common Council this 12th day of February 2024.

SIGNED by the Mayor this 12th day of February 2024.

Dr. David Drotzmann, CHAIR

ATTEST:

Lilly Alarcon-Strong, CMC, CITY RECORDER



Where Life is Sweet

Mayor and Members of the Urban Renewal Board
STAFF REPORT
For the Meeting of February 12, 2024

Title/Subject

Resolution No. 21 - Bond Authorization for North Hermiston Urban Renewal Area Infrastructure Project

Summary and Background

As discussed in previous council meetings, the formation of the North Hermiston Urban Renewal Area (NHURA) is key to the development of some of the only vacant land available along the N. Highway 395 corridor. Since the formation of the NHURA, developers are interested in what the project will ultimately look like so they can make their plans related to possible projects.

Staff is proposing to borrow the funding necessary to build the connection between N. Hwy 395 and NE 4th Street including a traffic signal and a waterline. These projects will give some certainty to the developers.

Tie-In to Council Goals

Enhancing the economic opportunities remains a council priority.

Fiscal Information

The recently adopted NHURA plan estimates these projects to cost \$5 million. The plan also shows that the \$5 million costs can be paid with purely on the 3% increase in revenue on the existing properties. With construction, the timeline to pay off the bonds would move even faster.

Coupling this borrowing with the other projects the city is doing helps gain efficiencies in the borrowing costs.

Alternatives and Recommendation

Alternatives

1. Adopt Resolution No. 21 without modification.
2. Adopt Resolution No. 21 with specific modifications.
3. Direct staff to make major changes to Resolution No. 21 and bring back at a later date.

Recommended Action/Motion

Motion to approve Resolution No. 21 and authorize the bonding for the NHURA Infrastructure Project.

Submitted By:

Byron D. Smith

RESOLUTION NO. 21

URBAN RENEWAL AGENCY OF THE CITY OF HERMISTON

A RESOLUTION AUTHORIZING AN INTERGOVERNMENTAL AGREEMENT WITH THE CITY OF HERMISTON TO FINANCE CAPITAL PROJECTS AND TRANSFER TAX INCREMENT REVENUES FOR THE PURPOSE OF PAYING FINANCING PAYMENTS OF THE CITY; DESIGNATING AN AUTHORIZED REPRESENTATIVE; AND RELATED MATTERS.

RECITALS:

- A. The North Hermiston Urban Renewal Plan (the “**Plan**”) of the Urban Renewal Agency of the City of Hermiston, Oregon (the “**Agency**”), was formed by the City of Hermiston (the “**City**”) City Council in July 2023 for the purpose of addressing infrastructure deficiencies and parcel patterns that are limiting the development potential in the Plan Area (the “**Area**”). The Agency established a maximum indebtedness for Plan in the amount of \$5,000,000 (the “**Maximum Indebtedness Limit**”).
- B. Projects in the Plan, including street and water improvements, are needed (the “**Projects**”).
- C. The City is planning to enter into one or more tax-exempt and/or taxable obligations (the “**City Obligations**”) to finance the Project; and
- D. The Agency anticipates incurring expenditures (the “**Expenditures**”) to finance the costs of the Projects and wishes to declare its official intent to reimburse itself for any Expenditures it may make from Agency funds on the Projects from the proceeds of obligations the interest on which may be excluded from gross income under Section 103 of the Internal Revenue Code of 1986, as amended (the “**Code**”).
- E. The Agency and the City wish to enter into an intergovernmental agreement (the “**IGA**”) whereby the Agency shall transfer tax increment revenues and proceeds accumulated by the Agency for the payment of the portion of the City Obligations allocable to Projects at the times, in amounts and under the terms determined by the City.

THE BOARD OF DIRECTORS OF THE URBAN RENEWAL AGENCY OF THE CITY OF HERMISTON RESOLVES AS FOLLOWS:

- 1. Authorization. Pursuant to the authority of ORS Chapter 457, the Agency is hereby authorized to enter into an IGA to repay the City Obligations allocated to the Project in an amount not to exceed \$5,000,000 and within the Maximum Indebtedness Limit from the tax increment revenues of the Area. The Agency authorizes and directs the City Manager or the Assistant City Manager of the City acting on behalf of the Agency or any of their designees (each an “**Authorized**

Representative”) to approve the final form of the IGA and execute the IGA on behalf of the Agency. The Authorized Representative is authorized, on behalf of the Agency, to:

- A. establish the terms of the IGA, including the maturity and interest payment dates, dated dates, principal amounts, prepayment provisions, capitalized interest (if any), tax-exempt and/or taxable interest rates, draw-down provisions, amortization schedules, covenants, fees, financial reporting requirements, term, denominations, and all other terms under which the IGA shall be executed and delivered; and
 - B. engage the services of any professionals whose services the Authorized Representative determines are necessary or desirable;
 - C. execute and deliver and any other documents, agreements or certificates that the Authorized Representative determines are necessary or desirable, including a tax certificate of the Agency, and take any other actions that the Authorized Representative determines are necessary or desirable in furtherance of the IGA.
2. Reimbursement. It is the reasonable official intent of the Agency to reimburse itself for the capital expenditures associated with the Project with the proceeds of the City Obligation and IGA in the principal amount not to exceed \$5,000,000. This declaration of official intent is given pursuant to United States Treasury Regulations Section 1.150-2.

This resolution shall take effect on the date of its adoption. This resolution is adopted by the Board of Directors of the City of Hermiston Urban Renewal Agency this 12th day of February 2024.

URBAN RENWAL AGENCY OF THE CITY OF HERMISTON
UMATILLA COUNTY, OREGON

By _____
Chair

ATTEST:

Lilly Alarcon-Strong, CMC City Recorder