

MEETING AGENDA



Planning and Zoning Commission

Village of Homewood

May 28, 2026

Meeting Start Time: 7:00 PM

Village Hall Board Room

2020 Chestnut Road, Homewood, IL

Commission Meetings will be held as in-person meetings. In addition to in-person public comment during the meeting, members of the public may submit written comments by email to pzc@homewoodil.gov or by placing written comments in the drop box outside Village Hall. Comments submitted before 4:00 p.m. on the meeting date will be distributed to all Commission members prior to the meeting.

Please see last page of agenda for virtual meeting information.

1. Call to Order
2. Roll Call
3. Minutes:
 - [Approve](#) minutes from the April 9, 2026 meeting of the Planning and Zoning Commission.
 - [Approve](#) minutes from the May 14, 2026 meeting of the Planning and Zoning Commission.
4. Public Comments
5. Regular Business:
 - A. **Public Meeting** for Case 26-08: Site Plan Review for 7Brew Coffee Shop at 17855 Halsted Street
 - B. **Public Hearing** for Case 26-33: Special Use Permit for Drive-Through Facility at 17855 Halsted Street
 - C. **Public Hearing** at Case 26-37: Variance for Perimeter Landscape Area Requirements (7Brew Coffee Shop) at 17855 Halsted Street
6. Old Business:
 - A. **Pre-Meeting for Planned Development** for two mixed-use development projects proposed at 2024 Chestnut Road and 2066 Ridge Road (continued from April 9, 2026).
7. New Business:
8. Adjourn

The public is invited to the meeting using the link below to join Webinar:
<https://us06web.zoom.us/j/99184811606?pwd=UkU5TjBQc0Y0QXkxektpaGRYdz09>

To listen to the Meeting via phone: Dial: 1-312-626-6799
Webinar ID: 991 8481 1606 Passcode: 573812

VILLAGE OF HOMEWOOD



MEETING MINUTES

DATE OF MEETING:

April 9, 2026

PLANNING AND ZONING COMMISSION

7:00 pm

Village Hall Board Room
2020 Chestnut Street
Homewood, IL 60430

CALL TO ORDER:

Chair Sierzega called the meeting to order at 7:01 pm. Chair Sierzega stated as there are only 4 members in attendance and 4 votes are need to approve, he would ask for each case if they wished to proceed or continue.

ROLL CALL:

Roll call was performed by Chair Sierzega. Present from the Village were Director Angela Mesaros, Director of Economic & Community Development and serving as Staff Liaison; Assistant Director of Economic & Community Development; and Darlene Leonard, Building Department Secretary. There were 18 members of the public in attendance, and there were 2 members of the public on Zoom webinar.

AYES: 4 (Members Alfonso, Bransky, O'Brien, Chair Sierzega)
NAYES (ABSENT): 3 (Members Cap, Johnson, and Castaneda)

APPROVAL OF MEETING MINUTES:

Chair Sierzega asked for any changes to the minutes from the February 26, 2026 meeting.

Member O'Brien stated that the comment at the bottom of page 4 regarding the population of the pod should be struck. In the middle of page 5 in his question, "amiable" should changed to "allowed". On the top of page 6, "Martin" should be struck.

Member Bransky asked if information had been received from the Police and Fire Departments regarding accident counts.

Staff Liaison Mesaros stated no, and she would follow up on it.

A motion to approve the minutes as amended by Member O'Brien; seconded by Member Alfonso.

AYES: 4 (Members Alfonso, Bransky, O'Brien, and Chair Sierzega)
NAYES: 0 (None)
ABSTENTIONS: 0 (None)
ABSENT: 3 (Member Cap, Johnson, Castaneda)

PUBLIC COMMENT:

Chair Sierzega asked if there were any public comments not related to the items on the agenda.

- **There were no public comments.**

Meeting Minutes | April 14, 2026

NEW BUSINESS:

Pre-Meeting for Planned Development for two mixed-use development projects proposed at 2024 Chestnut Road and 2066 Ridge Road.

Chair Sierzega swore in Drew Mitchell, Christopher Walsh, Mike O'Connor, and Laurie Kappell.

Mr. Mitchell stated they like to get feedback on their projects. They like getting feedback from residents from the pre-meeting.

Mr. O'Connor stated their goal is to fulfill the vision of the RFP and master plan and stated the plans are conceptual.

Mr. Walsh stated the building on Chestnut would be a 5-story building with 2 levels of parking and retail on the bottom. The building would be in a u-shape with an atrium area for residents on the second floor. They created a plaza on the south side after Village feedback. And the building would be continually staffed. The building would have 118 units with a 1.2 parking ratio. The building on Ridge Road would have 28 units and be just under a 1.2 parking ratio.

Mr. Mitchell stated the two projects will be separate from each other. They have been in contact with property owners to the north and east about acquiring their property, but the land would not delay the project.

Ms. Kappell spoke about the elements on the atrium deck at the Chestnut property. There would be a fountain, multi-surfaced areas, and a dog run.

The Commission members asked about the size of the retail spaces, access to the atrium area, on site-parking, traffic, and concerns about noise from the trains to the west.

Mr. Mitchell, Mr. O'Connor, and Mr. Walsh responded by saying the parking at the location would not include Village employees or the public. They use windows with a soundproofing of 45 which they used at a building near O'Hare. The concern for noise is internal not external.

Assistant Director Schumerth stated that both the Police and Fire Departments desire secure parking and some of the spaces in the lot have to be kept for short-term and ADA parking for the Village Hall and Police Department.

Chair Sierzega asked about the angled parking on Chestnut and the traffic direction.

Assistant Direst Schumerth stated it is in discussion. It came from a 2019 traffic study where 1-way traffic was recommended on Elm & Chestnut. It would be 1-way southbound on Harwood to Ridge, Chestnut would be 1-way eastbound on Chestnut, and 1-way westbound on Elm.

Staff Liaison Mesaros stated the jurisdictional transfer of Harwood only goes to Ridge.

Chair Sierzega asked if there were any comments or questions from the audience.

Amy Crump stated she enjoyed hearing the details of the project as some of them wasn't communicated at the Village meetings and it was nice to hear the details.

REGULAR BUSINESS:

Case 26-02, Variance for Bulk and Dimension Standards at 17863 Golfview Avenue:

Chair Sierzega introduced the case and asked if any comments had been received.

- **Assistant Director Schumerth stated no, there was one call was received asking what it was about.**

Chair Sierzega swore in the petitioner, Steven Scott from Chicago and asked if would like to postpone or continue.

- **Mr. Scott stated he would like to continue and that he can make changes if it's not approved.**
- **Mr. Scott stated it is a 2-story house an interior ADU on the second floor. The property was a challenge and he wanted to be in compliance with the setbacks. There will not be a front facing garage. The lot itself is not in compliance with R-1 zoning, there is a fire hydrant at the southwest corner, and there are berms in the rear. The berms can't be moved which it a challenge, but he loves the lot. Currently the engineer is developing a plan for the drainage to go east and south to the berm and golf course and west to an inlet. Everything possible was done to get the house into the space.**

Chair Sierzega asked of there was a view of the house.

- **Assistant Director Schumerth stated no, only the site plan.**
- **Mr. Scott stated it's just the elevation plan, the design isn't done yet.**

Member O'Brien asked about the 2 garages and asked where the attached one is located.

- **Assistant Director Schumerth stated it is on the back of the house and is shown with the dashed line.**

Member O'Brien asked the square footage of the ADU.

- **Mr. Scott said 520 square feet.**
- **Assistant Director Schumerth stated 540 square feet.**

Member O'Brien asked about the square footage of the house being 1,554 square feet.

- **Mr. Scott stated the square footage is the primary house, but does not include the second floor.**

Member O'Brien asked how the 4,258 square feet of impervious surface was reached.

- **Mr. Scott stated it includes the house without the ADU, the attached garage, the detached garage, and the driveway.**

Member Bransky stated it is an ambitious project and he has no questions without the engineering plan for the drainage.

- **Member Alfonso stated as long as the drainage is being taken care of she has no issues with it.**

Chair Sierzega stated there was a lot of effort done to get a house onto the lot with all the restrictions.

Chair Sierzega asked if there were any public comments.

There were no public comments.

Motion by Member Bransky to approve Case 26-02, Variance for Bulk and Dimensional Standards at 17863 Golfview Avenue, to permit the construction of a single-family dwelling residence which exceeds the maximum building coverage and impervious service coverage requirements which apply to the property, subject to the following condition: The applicant shall provide a copy of flow diagrams of other grading and drainage plans as requested by the Village Engineer to demonstrate drainage from the rear 15' of the property. The drawings shall be reviewed and approved by the Village Engineer prior to issuance of building permits. And Incorporate the Findings of Facts into the record; Motion seconded by Member O'Brien.

AYES: 6 (Members Alfonso, Bransky, Castaneda, Johnson, O'Brien, and Chair Sierzega)

NAYES: 0 (None)

ABSTENTIONS: 0 (None)

ABSENT: 1 (Member Cap)

Case 26-21, Special Use Permit for Professional Office at 18219 Dixie Highway:

Chair Sierzega introduced the case and asked if any comments had been received.

- **Assistant Director Schumerth stated none.**

Chair Sierzega swore in the applicant, Carmela Wallace and asked if she was the owner of the brewery also.

- **Ms. Wallace stated yes. She started the foundation, Live Free 999, in honor of her son for mental health. The business is growing and she wants to give it a home and the proceeds go to the foundation. The goal is to have more boots on the ground and have space to work more effectively.**

Chair Sierzega asked what is being done with the building.

- **Ms. Wallace stated there will be offices, a podcast area, and a merchandise area for shipping.**

Chair Sierzega said the building is going to be painted and asked what was being done with the mural.

- **Ms. Wallace stated they proposed a different mural to be installed.**
- **Assistant Director Schumerth stated the existing mural needs approval by the Village Board to be relocated it and they have been looking for a new location.**

- **Staff Liaison Mesaros stated the mural is owned by the Village. The building owner has an agreement with the Village to find a new location.**

Chair Sierzega asked if the original artist is still around.

- **Staff Liaison Mesaros stated yes the artist is, but that isn't who painted it.**

Chair Sierzega asked Ms. Wallace is she is okay with having the mural removed and incurring the cost.

- **Ms. Wallace stated yes.**

Member Alfonso asked why the case is a special use.

- **Staff Liaison Mesaros stated the new code established a specific square footage for offices over a certain size because of parking issues and traffic.**

Member Alfonso asked if there would be handicap parking space in the rear.

- **Ms. Wallace stated yes.**

Member Bransky asked if there is any part of the business that would have the public on site or is it strictly to run the foundation.

- **Ms. Wallace stated it's just the foundation office.**

Member O'Brien stated he like the plan as it is what is needed to consolidate and help the foundation grow. The problem is with the access on the south side of the property when the brewery was built because it's just an access not a road. In one area it's less than 20-feet wide in one spot because of the utility meters on the side of the building. Member O'Brien suggested adding a stop sign at the front corner of the building. Because it's not a street there is no requirement for it.

- **Staff Liaison Mesaros asked Ms. Wallace if she would be willing to add a stop sign.**
- **Ms. Wallace stated yes.**

Chair Sierzega asked if there were any public comments or questions.

There were none.

Chair Sierzega stated he thinks the stop sign would be helpful.

- **Assistant Director Schumerth stated it could be installed using a side mounted bracket.**

Chair Sierzega asked about the planters in the front and is merchandise would be available in the location.

- **Ms. Wallace stated she wanted something beautiful and the nothing would be available at the location; it is all online.**

Member Bransky stated that there should be coordination with the Village Engineer for the installation of the stop sign.

- **Assistant Director Schumerth said they wants it to be approved by the engineer.**

Member Bransky asked if the wording was needed now.

- **Staff Liaison Mesaros stated it can be put into the ordinance.**

Motion by Member Bransky to approved Case 26-21; Special Use Permit for Professional Office at 18219 Dixie Highway, to allow the operation of the foundation office of Live Free 999 Foundation, subject to the following conditions: 1. Revise the side plan drawings to indicate the location of one (1) ADA-accessible parking space adjacent to the rear entrance of the building, as required in the 2018 Illinois Accessibility Code. 2. The applicant must receive approval for an administrative variance to reduce the on-site parking requirement by one (1) space. 3. Recommend consideration of placing a stop sign on the access road to the south of the building to protect pedestrians on the sidewalk, subject to approval by the Village Engineer; and Incorporate the Findings of fact into the record; Motion seconded by Member O’Brien.

AYES: 5 (Members Alfonso, Bransky, O’Brien, and Chair Sierzega)

NAYES: 0 (None)

ABSTENTIONS: None

ABSENT: 3 (Members Cap, Johnson, and Castaneda)

Member O’Brien stated in the rear lot in the front row of spaces there is a spot that is 4” above grade and is a tripping hazard and should be looked into.

- **Assistant Director Schumerth stated it would be looked at during the construction process.**

Case 26-18, Special Use Permit for Medical Office Expansion at 18114 Gottschalk Avenue and Case 26-19, Site Plan Review for Medical Office Expansion at 18114 Gottschalk Avenue:

Chair Sierzega introduced the case and asked if any questions or concerns had been received.

- **Assistant Director Schumerth stated 1 call was received and the person just had general questions about how it was classified in the code.**

Chair Sierzega swore in Massimo Fozio from Homer Glen.

- **Mr. Fazio stated the addition would be 1,300 square feet added to the north side of the building. It would not cover the entire the vacant space. It would match the existing exterior and update and modernize it and blend together. The landscaping plan was turned in and it follows the plan suggestions and requirements.**

Chair Sierzega asked if there would still be 4 spaces in the back of the building.

- **Mr. Fazio stated there will be 5 spaces with 1 being a handicap space and they have a license agreement with the dance studio for spaces.**
- **Assistant Director Schumerth stated it is across the alley to the north for 10 additional spaces.**

Chair Sierzega asked how long to start and complete the project.

- **Mr. Fazio stated typically about 6 months.**

Member O'Brien stated it's a wonderful addition and plan and asked if the sign is still there. Member O'Brien stated he is not a fan of the stark black and white.

Member Bransky stated the current entry at the corner is kind of art deco and said they should try to keep it to maintain the character of the building. Member Bransky added it was wide to get the parking agreement.

- **Mr. Fazio stated they will match the stone around the door and keep the look around it.**

Member Alfonso stated she was happy to see the agreement and that they came prepared, and asked the busiest time of day.

- **Mr. Fazio stated he isn't the doctor, but the hours are from 9-3 and there may be a few later appointments.**

Member Alfonso asked if opatones would be used.

- **Mr. Fazio stated there would be dental chairs and exam rooms.**

Member Bransky asked if there would be a meter service change with the permit.

- **Assistant Director Schumerth stated the lead service line replacement.**

Mr. Fazio stated it might need to get changed out.

- **Assistant Director Schumerth stated it is wide spread to replace the lead water service line, but would need the schedule to see how it applies.**

Mr. Fazio stated they can updated and come back if needed.

- **Assistant Director Schumerth said it can be checked for incentives or reimbursement, but it has to be replaced during construction.**
- **Staff Liaison Mesaros stated all commercial business have to replace the lead service line when doing this kind of work.**

Member Bransky asked if it can be done together with the second condition.

- **Assistant Director Schumerth stated it is related to Thorn Creek and they have already gotten the repost that a permit is not required so it can be struck.**

Member O’Brien asked where Domani Builders is located.

- **Mr. Fazio stated Homer Glen.**

A motion by Member Bransky to approve Case 26-18, Special Use Permit for Medical Office Expansion at 18114 Gottschalk Avenue, to allow for the expansion of an existing dental practice at the location; AND approve Case 26-19, Site Plan review for Medical Office Expansion at 18114 Gottschalk Avenue, to allow for the construction of a 1,347 square foot expansion to the medical office at this location, subject to the following conditions; 1. Provide utility plans indicating the location and specifications for a new Type K copper water service line extending from the Village water main (at a location no less than two (2) feet from the current main connection point) to the existing water meter, prior to issuance of building permit. 2. Has been struck. 3. Revise the site plan drawings to include bicycle parking for at least two bicycles (one rack) on a paved surface in conformance with standards for off-street parking in the Village Zoning Ordinance (Section 44-05-02(n)). 4. Director of Economic and Community development shall provide a waiver of the transparency requirements for the building to meet Appearance Plan standards and ensure consistency with current lighting requirements of the Village Zoning Ordinance. 6. Add an additional shielded security lighting fixture at the northwest corner of the building on the west façade, matching the existing security lighting fixture at the southwest corner of the building on the west façade, to ensure sufficient security lighting on this side of the building.; and Incorporate the Findings of Fact into the record.; seconded by Member Alfonso.

AYES: 4 (Members Alfonso, Bransky, O’Brien, Chair Sierzega)

NAYES: None

ABSTENTIONS: None

ABSENT: 3 (Members Cap, Johnson, and Castaneda)

NEW BUSINESS:

Chair Sierzega asked staff how the first case came to them.

- **Staff Liaison Mesaros stated it was not an official item, nothing has to be done. It was just an introduction and the first project is the Chestnut site.**

Chair Sierzega asked if there was a time limit for them to come back.

- **Staff Liaison Mesaros stated no, it was just to introduce the project.**

Member Bransky stated the agenda was stacked and that it’s possible some of them items didn’t get the attention needed. Maybe it should be after the residents and businesses.

- **Staff Liaison Mesaros stated the next couple of agendas are stacked too. It would be best to be by itself.**
- **Assistant Director Schumerth said a free agendas may be hard to come by the way the year is coming.**

Member O’Brien asked how many discussion were done and asked about the 3 alternative proposals.

- **Staff Liaison Mesaros stated they asked for a community meeting separate from the Village.**
- **Assistant Director Schumerth stated of all the proposals, Holiday’s was selected. The 3 alternatives were removed from consideration and they submitted revised submittals not new submittals.**

OLD BUSINESS:

None.

ADJOURN:

Member O’Brien made a motion to adjourn; seconded by Member Alfonso. The meeting adjourned at 9:10 pm.

AYES: 4 (Members Alfonso, Bransky, O’Brien, and Chair Sierzega)

NAYES: None

ABSTENTIONS: None

ABSENT: 3 (Members Cap, Johnson, and Castaneda)

Respectfully submitted,

Darlene Leonard

**Darlene Leonard
Building Department Secretary**

VILLAGE OF HOMEWOOD



MEETING MINUTES

DATE OF MEETING:

May 14, 2026

PLANNING AND ZONING COMMISSION

7:00 pm

Village Hall Board Room
2020 Chestnut Street
Homewood, IL 60430

CALL TO ORDER:

Chair Pro Tem Bransky called the meeting to order at 7:01 pm.

ROLL CALL:

Roll call was performed by Chair Pro Tem Bransky. Present from the Village were Noah Schumerth Interim Director of Economic & Community Development acting as Staff Liaison, Darlene Leonard, Building Department Secretary, Assistant Village Manager Terence Acquah, and Village Manager Napoleon Haney. There were 2 members of the public in attendance, and there were no members of the public on Zoom webinar.

AYES: 6 (Members Alfonso, Cap, O'Brien, Johnson, Sierzega, and Chair Bransky)
NAYES (ABSENT): 1 (Member Castaneda)

Staff Liaison Schumerth stated that Member Bransky would now be Chair of the Commission and thanked Chair Sierzega for his 49 years of service as Chair and that he would continue as a Member on the Commission. It will be formalized at the Village Board Meeting on May 26 where he will be recognized for his contributions to the Village.

APPROVAL OF MEETING MINUTES:

Chair Bransky stated there was a technical snafu that prevented the minutes from going out with the packet so they were sent out in the last 48 hours. And asked if the Commission was comfortable with voting on the minutes, if not it can be done at another meeting.

Chair Bransky asked for any changes to the minutes from the April 23, 2026 meeting.

Member O'Brien stated there were no page numbers, but on page 3 in Cases 25-13, 25-15, and 25-16 he questioned the description of the CN tower as abandoned which implies a state of disrepair. The term should probably be inactive if CN's intent is to maintain the tower, which should be confirmed. And in Case 25-45 a hypothetical question was asked if a developer today proposed a 5-story building similar to Holladay Properties and not be required to provide any parking. The answer was yes, hypothetically.

Chair Bransky stated on page 2, the project is Van Buren and Millennial not Van Drunen. In the Vote on page 7, the count for the Ayes should be 5 as he abstained.

A motion to approve the minutes as amended by Member O'Brien; seconded by Member Cap.

AYES: 5 (Members Alfonso, Cap, O'Brien, Johnson, and Chair Bransky)
NAYES: 0 (None)

Meeting Minutes | May 14, 2026

ABSTENTIONS: 1 (Member Sierzega)
ABSENT: 1 (Member Castaneda)

PUBLIC COMMENT:

Chair Pro Tem Bransky asked if there were any public comments not related to the items on the agenda.

- **There were no public comments.**

REGULAR BUSINESS:

Case 26-32: Special Use Permit for Salon/Spa Establishment at 18332 Kedzie Avenue:

Chair Bransky introduced the case and asked if any feedback had been received.

- **Staff Liaison Schumerth stated no comments were received.**

Chair Bransky swore in the petitioner, Stanley Nevels of Park Forest.

- **Mr. Nevels stated he wants to move from Chicago Heights, has 8 barbers, and runs a full service shop.**

Chair Bransky asked how long he has been in business.

- **Mr. Nevels stated 2 years.**

Member Johnson asked if anything other than barber services would be offered and asked if the hours would be 8-8 all days, with Sunday and Monday being by appointment.

- **Mr. Nevels stated no other services would be offered and confirmed the hours. Mr. Nevels stated that the appointments would be available from 8-8.**

Member Johnson stated there are two other salons in the strip plaza and asked if there would be any similar services.

- **Mr. Nevels stated one does braiding and the other nails and that he would not offer any similar services.**

Member Johnson asked if Mr. Nevels was concerned about the parking lot.

- **Mr. Nevels stated no.**

Member O'Brien asked the suite number.

- **Mr. Nevels stated there isn't a suite number, it's located in the plaza next to the vacant paint store.**

Member O’Brien stated to Staff in the Findings of Fact and on page 6 the ownership information doesn’t match.

- **Staff Liaison Schumerth stated it would have to be looked up and would have the information by the end of the meeting.**

Member Cap asked Staff if the location on Kedzie is subject to the state parking pre-emption, the “People over Parking Act.”

- **Staff Liaison Schumerth stated it does not apply as it the location is outside of the ½ mile buffer. Full parking requirements in the code would apply.**

Member Sierzega asked if the 8 workers will be independent contractors, and if everyone would be working at the same time.

- **Mr. Nevels stated the workers are independent contractors and not everyone would be working at the same time. Working hours would be based off client schedule. Saturday would be the busiest and most barbers will be working, and walk-ins would be accepted on Saturdays.**

Member Alfonso stated it seems like a perfect spot and there would be minimal buildout and asked who would be there to open and close.

- **Mr. Nevels stated he would be there for the most part or his wife, but there would be a key holder.**

Chair Bransky stated he had no questions and thinks it’s a good spot.

Motion by Member Alfonso to approve Case 26-32: Special Use Permit for salon/spa establishment at 18332 Kedzie Avenue, and incorporate the Findings of Fact into the record with the company name verified ; seconded by Member O’Brien.

AYES: 6 (Members Alfonso, Sierzega, Cap, O’Brien, Johnson, and Chair Bransky)
 NAYES: 0 (None)
 ABSTENTIONS: 0 (None)
 ABSENT: 1 (Member Castaneda)

Member Sierzega stated the property owner is Intercontinental Homewood and believes the other name is the leasing agent.

Assistant Director Schumerth stated that the name in the Findings of Fact is what is on the County record for the property.

Case 26-35, Special Use Permit for Indoor Commercial Place of Assembly at 1820 Ridge Road:

Chair Bransky introduced the case and asked if any comments had been received.

- **Staff Liaison Schumerth stated no comments were received.**

Chair Bransky swore in the applicant Kasey Reed.

- **Ms. Reed stated she would be offering a CNA program. She has gotten approval from the Illinois Board of Higher Education to teach the program. She has been in the medical field for over 20 years and it has been a dream to open a CNA/phlebotomy school.**

Member Alfonso asked what her background is and what qualifies her to teach.

- **Ms. Reed stated she has been in nursing for over 20 years and is working towards a doctorate degree. She believes in “old-fashioned” nursing that is about care. She wants the program to be a small school. The students can work in the community for home health practitioners. It’s good for high school students or people that want to be in the medical field.**

Member Alfonso asked how long a session was.

- **Ms. Reed stated 8 weeks; most schools are 4 or 6 weeks. Classes would be Monday, Wednesday, and Thursday evenings. Eventually there would be another teacher, but for now it’s just her. And, eventually she will have online courses.**

Member Alfonso asked the number of students.

- **Ms. Reed stated that she plans on 10 students per session.**

Member Sierzega asked the difference between a CNA and a regular nurse.

- **Ms. Reed stated RNs have more functions like dispersing medications and doing assessments. CNAs are more focused on managing care in activities and daily living.**

Member Sierzega asked what education is needed before starting.

- **Ms. Reed stated be at least 16 years old and in line for graduation. She also does an interview.**

Member Cap asked if classes will be in the evenings.

- **Ms. Reed stated yes, for now.**

Member Cap stated evening classes would enable everyone for parking onsite.

Member O’Brien asked staff about the discrepancy in the materials regarding the age of the property.

- **Staff Liaison Schumerth stated the materials were based off County records which say 1970. 1970 could be the start of construction. The other date was what was provided by the realtor.**

Chair Bransky stated it is good to have something like the proposed business coming in.

Chair Bransky asked staff if it expands to AM classes would the special use need to come back.

- **Staff Liaison Schumerth stated it depends on the expansion of services. Minor amendments don’t have to come back, they can be handled by staff.**

Meeting Minutes | May 14, 2026

Member Johnson asked why there were no hours in the Findings of Fact.

- **Staff Liaison Schumerth stated the entire application is reviewed and there is no condition to specify hours for approval.**

Motion by Member Johnson to approve Case 26-35: Special Use Permit for indoor commercial place of assembly at 1820 Ride Road; and Incorporate the Findings of Fact into the Record; Seconded by Member O’Brien.

AYES: 6 (Members Alfonso, Sierzega, Cap, O’Brien, Johnson, and Chair Bransky)

NAYES: 0 (none)

ABSTENTIONS: 0 (None)

ABSENT: 1 (Member Castaneda)

Cases 26-33: Special Use Permit for Drive-Through Facility at 17855 Halsted Street, Case 26-37: Variance for Front Perimeter Landscape Buffer at 17855 Halsted Street, and Case 26-08 Site Plan Review for 7 Brew Drive-Through Coffee Shop at 17855 Halsted Street:

Chair Bransky stated the cases will be continued to a later date.

Assistant Director Schumerth stated one motion can be made for the three related cases, and all three need to be approved together.

Motion to continue Case 26-33, Case 26-37, and Case 26-08 to the meeting on May 28; seconded by Member Cap

AYES: 6 (Members Alfonso, Sierzega, Cap, O’Brien, Johnson, and Chair Bransky)

NAYES: 0 (None)

ABSTENTIONS: 0 (none)

ABSENT: 1 (Member Castaneda)

OLD BUSINESS:

Staff Liaison Schumerth stated special use cases have specific definitions for major and minor; it’s not arbitrary by staff.

Chair Bransky stated special use is specific and wanted to clarify.

Building Department Secretary Leonard stated the Donut and Hot Dog restaurants were approved to open.

Member Alfonso asked about the Mediterranean restaurant on Maple.

Building Department Secretary Leonard stated the Building Inspector is scheduled to go by and check on it.

Staff Liaison Schumerth stated Holladay Properties is scheduled for May 28.

Meeting Minutes | May 14, 2026

Chair Bransky stated, as a courtesy, the residents should go first so they do not have to sit through the presentation.

Member Johnson asked how many cases are on the agenda for May 28.

Staff Liaison Schumerth stated the 3 that were continued and Holladay and there may be a site plan on the agenda. It just came in.

ADJOURN:

Member Alfonso made a motion to adjourn; seconded by Member O’Brien. The meeting adjourned at 7:40 pm.

AYES: 6 (Members Alfonso, Sierzega, Cap, O’Brien, Johnson, and Chair Tem Bransky)

NAYES: None

ABSTENTIONS: None

ABSENT: 1 (Member Castaneda)

Respectfully submitted,

Darlene Leonard

Darlene Leonard
Building Department Secretary

VILLAGE OF HOMEWOOD



MEMORANDUM

DATE OF MEETING: May 14, 2026

To: Planning and Zoning Commission

From: Noah Schumerth, Assistant Director of Economic and Community Development

Topic: Cases 26-08, 26-33 and 26-37: Special Use Permit, Variance and Site Plan Review for 7Brew Drive-Through Coffee Shop at 17855 Halsted Street

APPLICATION INFORMATION

APPLICANT	Laura Pacino/Matthew Nyweide
ACTION REQUESTED	Special Use Permit, Variance and Site Plan Review
ADDRESS	17855 Halsted Street, Homewood, IL 60430
PIN	29-33-100-063

ZONING & LAND USE

SUBJECT PROPERTY	ZONING	LAND USE
CURRENT	B-4 Shopping Center	Vacant (former Boston Market)
SURROUNDING	N: B-4 Shopping Center	Restaurant (Krispy Kreme)
	E: B-4 Shopping Center	Retail (Home Depot)
	S: B-4 Shopping Center	Retail (various)
	W: B-4 Shopping Center	Retail (various)

LEGAL NOTICE Legal notice was published in *Daily Southtown* on April 22, 2026. Mailed notice was sent to property owners and residents within 250’ on May 8, 2026.

DOCUMENTS FOR REVIEW

Title	Pages	Prepared by	Date
Application	3	Matthew Nyweide, WhoBrew LLC	04/15/2026
Narrative	2	Matthew Nyweide, WhoBrew LLC	04/13/2026
Special Use Standards	3	Matthew Nyweide, WhoBrew LLC	04/13/2026
Variance Standards	2	Matthew Nyweide, WhoBrew LLC	05/19/2026
Site Plan	1	DVG Team Inc., Architect/ Engineer	04/13/2026
Landscape Plan	1	DVG Team Inc., Architect/ Engineer	05/19/2026
Floor Plan	1	Veritas Architecture and Design, Architect	04/13/2026
Roof Plan	1	Veritas Architecture and Design, Architect	04/13/2026

Elevations	5	Veritas Architecture and Design, Architect	04/13/2026
Additional Site Details	1	Veritas Architecture and Design, Architect	04/13/2026
Colors and Materials	1	WhoBrew LLC, Applicant	05/18/2026
Renderings	1	WhoBrew LLC, Applicant	04/13/2026
Engineering Plans	2	DVG Team Inc., Architect/Engineer	05/21/2026
Staff Exhibits	2	Noah Schumerth, Int. Dir. ECD	05/22/2026

BACKGROUND

The applicant has proposed the construction of a drive-through coffee shop restaurant at 17855 Halsted Street. The applicant has proposed the demolition of an existing vacant restaurant building (formerly occupied by Boston Market) to allow for the construction of the coffee shop restaurant. The proposed coffee shop will be operated by national chain brand 7Brew Coffee. The coffee shop will only serve drive-through customers, and will not have interior customer service or a walk-up window for ordering.

The applicant will require three approvals from the Planning and Zoning Commission:

- **Special Use Permit:** For drive-through facility associated with new development
- **Variance:** For reduction of front perimeter landscape buffer width from 15’ to 12’
- **Site Plan Review:** For all improvements associated with new restaurant use

HISTORY

The property was constructed as a Sizzler Steakhouse in 1975. The restaurant was remodeled into a Boston Market in 1993-1994. The restaurant closed in 2024.

DISCUSSION

Site Layout

The applicant has proposed to demolish the current 4,800 square-foot restaurant building formerly occupied by Boston Market, as well as many of the parking areas on the site.

The applicant will construct a 1,031 square foot building to support a drive-through coffee shop business. The building will be served by two drive-through lanes bringing traffic from the north up to the building. Customers in the drive-through lanes will be served from two large sliding doors in the building where employees can enter and exit the building and walk to customers in vehicles. A pass-through lane will be provided to the west of the drive-through lanes to provide access to parking for employees. Additional parking will be provided on the north side of the site where existing parking is currently located. A large landscape median will be provided between the new aisles and the private drive located to the east of the site.

Drive-Through Facility Details

The 7Brew business model focuses on serving drive-through customers and does not provide any walk-up customer traffic or interior customer service. The company does not use any apps or menu boards for ordering. Drivers provide orders at the pick-up window of the building, and products are “made to order” at the window.

The dual-lane drive-through must meet the following requirements from the Village Zoning Ordinance:

- **Design and Layout:**
 - Provide minimum 6” curbs **(met)**
 - All curb cuts and drive aisles shall be approved by the Village Engineer **(met)**
- **Stacking**
 - Minimum 6 spaces of stacking per order box – **12 required (met)**
 - Minimum 10’ stacking lane width **(met)**
- **Menu Boards**
 - No menu boards proposed
- **Overhead Canopy**
 - No greater than 20’ canopy height **(met)**
 - Canopy shall be uniform in height and maintain consistent roofline with building **(met)**
 - Exterior cladding shall be consistent with the primary building **(met)**
- **Screening from residential use**
 - No residential use
 - Village Engineer or Economic and Community Development may recommend additional screening based on impacts on public streets or access drives **(no additional concerns)**

Landscaping

The applicant has proposed landscaping along the front of the site, in addition to accent landscaping in the rear and near the side of the building.

The following requirements for landscaping for this development are set forth in the Village Zoning Ordinance (Section 44-05-06):

- Parking lot perimeter landscaping area (along Halsted Street)
- Building foundation landscaping area

The landscape plan must also meet the standards of the 2015 Halsted Street Corridor Landscape Plan. No mature trees are proposed to be removed, and the Village’s tree preservation ordinance does not apply (Section 44-05-07 of the Village Zoning Ordinance).

Foundation Landscaping

The applicant must provide a building foundation landscaping area on the front (Halsted) side of the building with a minimum width of seven feet. This area shall extend along at least 80% of the length of the façade.

The building is not proposed to provide this foundation landscaping, as the drive-through lane will directly abut the front (Halsted) façade of the building. The Village Zoning Ordinance authorizes the director of economic and community development to approve other alternatives as outlined in the

Village Zoning Ordinance, including the use of stormwater detention planters or tree plantings elsewhere on the site in lieu of the foundation landscaping.

The applicant may provide one (1) additional canopy tree planting for each 50’ of required building foundation landscaping to be removed. One (1) additional canopy tree must be provided for the 69’ of building foundation landscaping to be waived. The applicant has proposed 16 trees along the front and side of the subject site in the perimeter landscape zone along Halsted Street, where 14 canopy trees are required. **The applicant provides an approved alternative to building foundation landscaping and is not required to provide building foundation landscaping.**

Parking Lot Perimeter Landscaping

The applicant is required to provide a minimum 15’ wide landscape area along Halsted Street as a parking lot perimeter landscape area. This area shall be located between parking spaces and the property line adjacent to the right-of-way of Halsted Street. The frontage of perimeter landscaping required is 210’ (existing parking areas remaining after construction are not required to add new perimeter landscaping). This landscape area shall meet the following requirements:

- For every three feet, one shrub or native grass shall be provided – **met required, 57 shrubs and additional native grass areas provided.**
- For every 25’ of landscape area length, one understory/evergreen tree shall be provided – **met, 9 provided, 8 required**
- For every 25’ of landscape area length, one canopy tree shall be provided – **not met, 7 provided, 8 required**
- The remainder of landscaped area outside of shrubs/plantings shall be planted with live groundcover – **met, multiple groundcovers provided**

The applicant has also provided a perimeter landscaping area which is narrower than the required width for the landscaping area (11’ 7” vs. 15’). The applicant has submitted a variance for this reduction in required width, which is reviewed in detail in this memo. The proposed perimeter landscape area meets Village standards, provided the following conditions are met:

1. **The Planning and Zoning Commission and Village Board approve a request for a variance to reduce the required width for the perimeter landscape area from 15’ to 11’ 7”**
2. **The applicant submits a revised landscape plan which incorporates preferred species from the Village Arborist and replaces one (1) understory/evergreen tree with one (1) canopy tree.**
3. **The applicant submits a revised landscape plan with a full plant list pursuant recommendations of the Village Arborist, including native grasses and groundcovers.**

Halsted Street Landscape Plan

The applicant must also meet the minimum requirements of the 2015 Halsted Street Corridor Landscape Plan. This site would be subject to the planting prototype for a parking lot with a buffer, as found in Exhibit 2 of the landscape plan (shown below).

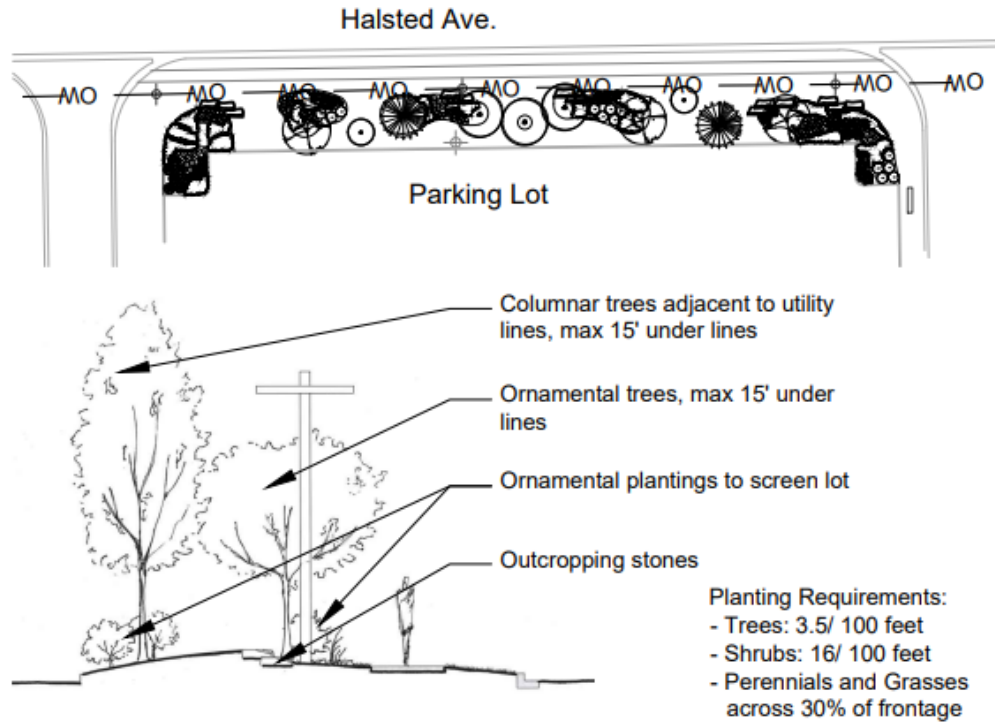

2 **Planting Prototype, Parking Lot with Buffer**

This plan recommends the following landscaping improvements with new development:

- Tree plantings (minimum 3.5' per 100' frontage) – 13 trees minimum **(met)**
- Shrubs – 57 shrubs minimum **(met)**
- Perennials or native grasses – across 30% of the frontage **(met)**

The proposed landscape plan meets the requirements of the Halsted Street Corridor Landscape Plan.

Site Engineering

The applicant proposes the following utility improvements to support the use:

Storm Sewer/Site Drainage: The applicant will construct a new 6" storm sewer line to an existing 10" storm sewer main on the northwest corner of the site, which drains to a larger storm sewer main along Halsted Street. The applicant will construct downspouts from the new building and canopy to this storm sewer. The northern portion of the site will not be altered and will utilize existing storm sewer connections.

Sanitary Sewer: A new 6" sanitary service line will connect to an existing 8" sanitary sewer main on the southeastern corner of the site.

Electrical: The applicant will construct a new transformer on the south side of the site. The transformer will be screened from Halsted Street with landscaping. The building will be connected with new service from this transformer.

Water: The applicant will connect a new 1.5” Type K water line from the existing capped 6” main which terminates on the southern boundary of the site. A new water connection and meter will be added on the southwestern corner of the building. A new Buffalo Box will be installed on the southern end of the site near the connection to the existing Village main.

Grease Trap: A new 277-gallon Schier GB-250 grease interceptor will be constructed on the southeastern corner of the building.

Elevations

The proposed 1,031 square-foot restaurant building will be constructed as a modular building. Modular components are constructed off-site and assembled at the restaurant location.

All new development must meet the requirements of the Village Zoning Ordinance, including requirements for building materials, transparency and façade articulation. Staff has provided a review of this development against these standards in this memo.

Materials

The building will be clad in full-depth smooth-face brick on all sides. The brick cladding will be comprised of panels of smooth-face brick material. Brick will be used on all four elevations of the building, in accordance with recommendations provided by the Village’s Appearance Commission.

The building will also feature a series of canopies clad in aluminum paneling. These panels will be colored blue to match the brand colors of 7Brew. The largest canopy will cover the drive-through lanes of the building, while additional smaller canopies will be installed over service doors.

The roof will be designed with a curved, concave shape sloping toward the southern end of the building. The roof structure will be constructed of aluminum panels with seams running lengthwise along the roof. The roof structure will also be colored blue to match the brand colors of 7Brew.

The following requirements for materials are set forth in the Village Zoning Ordinance (Table 44-05-11.(b)):

Table 44-05-11(b): Allowed Exterior Building Cladding Materials			
Building Facade Elevation	Tier I	Tier II	Tier III
Front and Exterior Side	Minimum 50%	Maximum 50%	Maximum 25%
Interior Side and Rear	Minimum 25%	Maximum 75%	Maximum 25%

The building will be fully clad in Tier I materials. **The applicants meets requirements for material selection for this development.**

Façade Articulation

The proposed building will be approximately 69’ x 15.5’. Façade articulation is required on the front (Halsted) and rear (private drive aisle) elevations of the building which will be greater than 60’ in length. Façade articulation may be achieved through a variety of architectural features or design methods, including the addition of:

- Changes of depth of the facade such as projections and recesses
- Architectural features such as pilasters, cornices or other ornament
- Change in materials
- Windows and doors
- Awnings and canopies
- Public art



Both facades include several changes in the depth of the façade. The front (Halsted) elevation includes opaque glass panels to simulate windows (example from Florida location, left) and projections in the façade. The rear façade includes two canopies and several changes in materials.

The applicant meets requirements for façade articulation for this development.

Building Transparency

The building is required to meet transparency requirements “to the extent possible within existing conditions, unless otherwise approved by the director of economic and community development.” This requirement requires that a minimum of 60% of the front (Halsted) elevation include transparency.

The applicant has provided a front elevation with approximately 8% of the façade as transparent area. The building is not proposed to be a building which services customers outside of their vehicles, and the entire floor area of the proposed building will be occupied by kitchen areas or interior cooler space. To account for this proposed layout, the applicant has provided spandrel glass (faux windows) across the entire front façade. With these areas considered as transparent area, approximately 40% of the façade area would be considered as transparent area.

Staff has recommended a waiver of transparency requirements as permitted with approval by the economic and community development director. See Recommended Planning and Zoning Commission Action.

SPECIAL USE PERMIT REVIEW

Drive-through facilities require a *special use* in any zoning district where such a facility is permitted. Any special use must be reviewed against the Special Use Standards found in Section 44-07-11 of the Village Zoning Ordinance.

Staff has reviewed the application utilizing the Special Use Standards. The full responses to the Special Use Standards, completed by the applicant, are attached with this application.

- 1) Is the special use deemed necessary for the public convenience at that location? The 7Brew drive-through is focused primarily on serving drive-through customers. The restaurant’s business locations are selected to capture traffic along commercial corridors with high volumes of regional vehicle traffic, such as Halsted Street. The drive-through facility is designed with two lanes to accommodate the uniquely high traffic load created by the lack of interior service.

- 2) Will the special use be detrimental to the economic welfare of the community? The proposed 7Brew location will replace a restaurant space which has been vacant since 2024. The special use will generate sales tax and places of eating taxes for the Village and provide additional employment opportunities in the Halsted corridor.
- 3) Will the special use be consistent with the goals and policies of the comprehensive plan and other adopted plans of the village? The Halsted Street corridor is designated for regional commercial uses in the 1999 Comprehensive Plan. The Comprehensive Plan encourages the expansion of commercial activity within the Halsted Street corridor. The arrangement of the site is consistent with the Village's adopted Halsted Street Corridor Landscape Plan.

The use is not consistent with the land use and transportation goals of the Far South Halsted TOD Plan, a regional plan which is designed to shape future land use and transportation decisions along the Halsted Street corridor between Chicago to the north and Chicago Heights to the south. However, transit service and transportation investments to support future transit-oriented development in this corridor is not yet implemented.

The Village participated in the development of this regional plan but has not yet implemented zoning or land use policies considered by this plan. The site is not currently zoned or surrounded by compatible land uses to support this type of development. The use is appropriately in alignment with current adopted plans and land use policies of the Village.

- 4) Is the special use at the subject property so designed, located, and proposed to be operated, that the public health, safety, and welfare will be protected? The site is designed to hold at least 22 vehicles on-site for queueing purposes (minimum of 12 required). Additional overflow capacity is planned to flow into the private access aisle of the larger shopping development, which may cause temporary impacts on overall circulation within the larger development. Pedestrian routes have been provided within the site to ensure safe access for employees, customers, and those requiring ADA parking access. The design of the drive-through has been arranged in a manner which minimizes potential health and safety hazards.
- 5) Is the special use a suitable use of the property and, without the special use, could the property will be substantially diminished in value? The Halsted Street corridor is a suitable location for drive-through businesses which require access to corridors with high levels of vehicle traffic. The property has diminished in value due to the aging existing development on the site and may face further property value decline without redevelopment.
- 6) Will the special use cause substantial injury to the value of other property in the neighborhood in which it is located? Drive-through queueing overflow has been designed to minimize potential direct impacts on private property, such as overflow into neighboring properties. However, overflow in the private access drive adjacent to the development may cause minor impacts to circulation within the larger development. The applicant has maximized queueing on-site to minimize potential impacts on surrounding development to the maximum extent possible given the size and dimensions of the site.
- 7) Will the special use be consistent with the uses and community character of the neighborhood surrounding the subject property? There are six (6) other drive-through facilities within ¼ mile of

the proposed business for other restaurants or financial institutions. The surrounding area is primarily occupied by regional commercial uses which require access by vehicle. The use is consistent with the surrounding area.

- 8) Will the special use be injurious to the use or enjoyment of other property in the neighborhood for the purposes permitted in the zoning district? The impact of traffic on the private drive aisle may cause minor impacts on surrounding development. However, impacts are not anticipated to impact the full enjoyment and use of other property, including the ability to access these properties for the purposes permitted in the B-4 Shopping Center zoning district.
- 9) Will the special use impede the normal and orderly development and improvement of surrounding properties for uses permitted in the zoning district? The use is not anticipated to impact the development of surrounding properties. The applicant has planned the site to minimize disruption to surrounding private property which may be improved or redeveloped in the future. The use will not impacts utilities or other facilities necessary to support surrounding land uses in a manner which will disrupt future development.
- 10) Does the proposed special use at the subject property provides adequate measures of ingress and egress in a manner that minimizes traffic congestion in the public streets? The site has adequate ingress and egress for vehicles accessing the site. The site does not have interior customer access nor walk-up service, and minimal customer ingress/egress is required to support the use. The proposed drive-through facility is designed to minimize any impacts of queueing or congestion on local streets. The driveway to the south of the site will likely serve as the primary point of access to the use from Halsted Street. The driveway provides full access for traffic arriving or departing in either direction on Halsted Street. The existing driveway has sufficient capacity for handling traffic entering and exiting the use without causing congestion or vehicle hazards on Halsted Street.
- 11) Is the subject property adequately served by utilities, drainage, road access, public safety and other necessary facilities to support the special use? The site is proposed in a manner which meets Village requirements for utility access, drainage, road access, safety infrastructure and other facilities. The drive-through facility is designed in a manner which does not impact the site's ability to meet these requirements.
- 12) Will the special use have a substantial adverse effect on one or more historical, archeological, cultural, natural or scenic resources located on the parcel or surrounding properties? No impacts are anticipated.

VARIANCE REVIEW

The proposed development requires a "parking area perimeter landscape zone," which buffers and screens parking areas from public right-of-way. The applicant has requested a variance to reduce the required width of this landscape area from 15' to 11' 7".

The variance must be reviewed against the two sets of Variance Standards found in the Village Zoning Ordinance – one set of required minimum standards for a variance, and an additional set of standards evaluating the degree of hardship and impacts on neighboring property. Staff has reviewed the proposed

variance with these standards. The full responses to the Variance Standards, completed by the applicant, are attached with this application.

(1) The Planning and Zoning Commission shall use the following standards when considering this variance request, as set forth in Section 44-07-12 of the Village Zoning Ordinance. No variance shall be granted unless findings of fact for each specific application demonstrate a suitable degree of hardship outside of the control of the property owner, and the minimal deviation from this chapter necessary, as provided in the applicant's response to each of the following standards:

a. Can the property in question yield a reasonable return if permitted to be used only under the conditions allowed by the regulations governing the district in which it is located?

The proposed 7Brew coffee shop restaurant is designed to exclusively serve drive-through customers. To accommodate peak levels of traffic for the restaurant development, the applicant has proposed two drive-through lanes. These two lanes will provide space for queueing on-site for up to 22 vehicles and is designed to maximize queueing on-site and minimize off-site overflow queueing. The development is required to maintain an additional passing lane to provide emergency vehicle access or egress for vehicles leaving the drive-through facility. The site also requires five parking spaces, including one (1) ADA-accessible space which is located near the building. The applicant has attempted to fit these improvements on a site that is approximately 89' wide.

The minimum width of all required areas (drive-aisle, two drive-through lanes, and required landscape buffers) is 68'. The requirements are as follows (from front of proposed development to rear):

- **Perimeter Landscape Area: 16'**
- **Minimum 60-degree parking stall depth: 17'**
- **One-way drive-aisle width: 16'**
- **Minimum drive-through aisle width (2 aisles): 10'**

These requirements for this drive-through business limit space for the commercial building and other improvements on the site as required by the zoning ordinance. The design of this use on the proposed site in a manner which meets all requirements of the Zoning Ordinance would be exceedingly difficult and may limit the ability for the business to be constructed and operated on the site. **The ability for the site to be developed and yield a reasonable return would be significantly impacted under the conditions allowed by the regulations otherwise governing this development in the B-4 zoning district.**

b. Is the plight of the owner due to unique circumstances?

The subject site has a depth of 89', which is narrower than all other commercial properties in the vicinity, including nearby outlots (which range from 103' to 154' in depth). Many of these sites were also developed prior to the adoption of additional landscape buffering requirements as established in the current Zoning Ordinance.

The site is also adjacent to an additional 25' parkway along Halsted Street, which is controlled by the Illinois Department of Transportation (IDOT), which creates an additional setback between the public street and any improvements on the subject property.

The subject site has unique constraints and circumstances which were not created by the property owner which impact the ability of the property to be developed under the regulations otherwise governing this site.

c. If granted, will the variance alter the essential character of the locality?

The site is adjacent to a large 25' parkway along Halsted Street, controlled by IDOT, which further sets the property back from Halsted Street. This parkway creates an additional setback and buffer between the public street and required parking areas, and further reduces the visual impact of parking and drive-through facilities from the public street.

Though the applicant has proposed a parking lot perimeter landscape zone which is narrower than the Zoning Ordinance allows, the applicant has also proposed landscape materials which fully meet the requirements of the Village Zoning Ordinance, as well as the standards set forth in the Halsted Street Corridor Landscape Plan.

The reduction in the width of the required parking lot perimeter landscape zone is not expected to alter the essential character of the surrounding commercial area, and the proposed landscaping within the zone meets the requirements and recommended standards of the Village's Zoning Ordinance and adopted plans.

(2) Supplemental to the above standards, the decision-making authority shall also consider findings on the character of the alleged hardship and the potential impacts to neighboring properties of granting the variance, as provided in the applicant's response to each of the following standards. Not one of the standards is controlling.

d. Do the particular physical surroundings, shape, or topographical conditions of the subject property pose a particular hardship upon the owner, as distinguished from a mere inconvenience, under the strict application of these regulations?

The subject site has a depth of 89', which is narrower than all other commercial properties in the vicinity, including nearby outlots (which range from 103' to 154' in depth). Many of these sites were also developed prior to the adoption of additional landscape buffering requirements as established in the current Zoning Ordinance. This narrow lot creates additional constraints on the development, the primary use being permitted by-right and the accessory drive-through facility use being designed in a manner to minimize impacts on surrounding development. **The narrow lot shape creates additional constraints on the development and pose a unique hardship to develop the site as proposed.**

e. Would the conditions upon which the petition for variance is based be generally applicable to other properties within the same zoning classification?

Most other existing commercial developments on outlots in the immediate vicinity of the proposed development would not meet the current requirements for perimeter landscaping along Halsted Street. Of the six nearest outlot developments (Krispy Kreme, Huntington Bank, Chili's, Panda Express, and two multi-tenant strip centers), four developments have perimeter landscaping along Halsted Street which would not meet the requirements for width of the perimeter landscape area, nor the materials required

within the landscape area. The lot on which the proposed 7Brew development is to be located is significantly narrower than any of these lots.

Additionally, the new development has been reviewed by the Village Engineer who has strongly discouraged a site design which places the drive-through on the east side of the lot (away from Halsted Street) in a manner which may increase the likelihood of meeting the perimeter landscaping requirements of the Zoning Ordinance by placing parking areas away from the street. This orientation of the site would require additional left turns to enter the development which may more severely impact circulation in the surrounding shopping center, and would place the building in a manner which would not utilize existing utility connections on the site and would cause challenges for utility placement on the site.

The condition of the property (including the narrow width of the lot and the placement of existing utilities) are unique to the site and would not apply to other nearby properties in the B-4 zoning district. Most other similar developments in the vicinity (built prior to the adoption of current zoning requirements) would not meet current zoning requirements.

f. Has the alleged practical difficulty or particular hardship been created by any person presently having an interest in the property?

The owner purchased the property in 2026. **The lot has not been modified in any manner by the applicant or any other person having a current interest in the property.**

g. If granted, will the variance be detrimental to the public welfare or injurious to other neighboring property?

The applicant has proposed a landscape plan which otherwise meets the requirements for perimeter landscape zone placement and the number of trees, shrubs, and groundcover plantings within the perimeter landscape zone. The property is also setback from Halsted Street by an additional 25' parkway controlled by IDOT. **The variance is unlikely to be detrimental to the public welfare or injurious to other neighboring property.**

e. If granted, will the variance: impair an adequate supply of light and air to adjacent property; or substantially increase the danger of fire or otherwise endanger the public safety; or substantially diminish or impair values of neighboring property?

The variance is unlikely to impair the adequate supply of light and air to adjacent property, substantially increase the danger of fire, endanger the public safety, or substantially diminish or impair the value of neighboring property.

APPEARANCE COMMISSION

On May 7, 2026, the Appearance Commission conditionally approved an Appearance Review for the proposed development. The approval was conditioned on the following, which are incorporated into comments and recommended actions for this Site Plan Review application:

1. Submit a revised landscape plan to provide shrubs/grasses and understory/evergreen trees as required by the Village Zoning Ordinance and the Halsted Street Corridor Landscape Plan, subject to review by Village planning staff and Village Arborist;
2. Director of economic and community development shall provide a waiver of the transparency requirements for the building as permitted in Section 44-05-11.(d) of the Village Zoning Ordinance;
3. Submit a revised material board and elevation drawings to replace proposed fiber cement cladding with brick or similar material, subject to review by Village planning staff and Village Arborist.

FINDINGS OF FACT

Staff has prepared the draft findings of fact following the standards outlined in Sections 44-07-11 and 44-07-12 of the Village Zoning Ordinance for special use permit and variance applications. The findings of fact, as proposed or as amended, may be entered into the record upon a recommendation of approval:

1. The subject property is located at 17855 Halsted Street and is located within the B-4 Shopping Center, with Cook County PIN # 29-33-100-063-0000;
2. The subject property is currently owned by BSG Homewood LLC;
3. The proposed use of the property is a restaurant use, which is a permitted use in the B-4 Shopping Center zoning district;
4. The proposed use includes an accessory drive-through facility use, which is a special use in any zoning district where such a facility is allowed as an accessory use;
5. The applicant has requested a variance from requirements for the parking area perimeter landscape zone, reducing the required width of the zone from 15' to 11' 7";
6. The subject site meets the use-specific standards for restaurants in Section 44-04-04 of the Village Zoning Ordinance;
7. The subject site meets applicable development standards in Section 44-05 of the Village Zoning Ordinance;
8. The proposed special use is consistent with the applicable standards for special use permit approval as set forth in Section 44-07-11;
9. The proposed variance meets the applicable standards for variance approval as set forth in Section 44-07-12.

RECOMMENDED PLANNING & ZONING COMMISSION ACTION

The Planning and Zoning Commission may wish to consider the following motion:

- Recommend approval** of Case 26-33: Special Use Permit for drive-through facility associated with a proposed restaurant use at 17855 Halsted Street;
- AND
- Recommend approval** of Case 26-37: Variance for reduction of required width of perimeter parking lot landscape buffer associated with a proposed restaurant use at 17855 Halsted Street;
- AND

Approve Case 26-08: Site Plan Review for proposed restaurant development at 17855 Halsted Street, subject to the following conditions:

1. The applicant submits a revised landscape plan which incorporates preferred species from the Village Arborist and replaces one (1) understory/evergreen tree with one (1) canopy tree.
2. The applicant submits a revised landscape plan with a full plant list pursuant recommendations of the Village Arborist, including native grasses and groundcovers.

AND

Incorporate the draft Findings of Fact into the record.

NON-RESIDENTIAL ZONING REVIEW PROCESS AND REQUIREMENTS

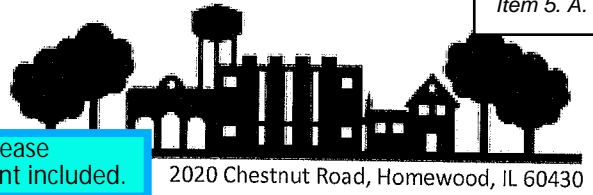

Ground Lease Agreement included.

APPLICATION CHECKLIST

For all applications, provide the following:

- | | | |
|---|---|--|
| <input checked="" type="checkbox"/> Completed application form | <input checked="" type="checkbox"/> Floor of ownership, or Letter of authorization by the owner | <input checked="" type="checkbox"/> Materials, as listed below |
| <input checked="" type="checkbox"/> Plat of survey with legal description | | <input type="checkbox"/> Payment of fee |

Based on each action(s) requested, provide the required materials listed below. Staff reserves the right to request additional materials, as required by the scope of the request, to make an informed decision.

Special Use, Limited Use, Temporary Use

- Site plan
- Conceptual floor plan
- Completed worksheet responding to applicable standards or review criteria
- Narrative describing the proposed use, including:
 - services provided
 - hours of operations
 - anticipated average and peak capacity

Site Plan Review

- Site plan or survey of existing conditions
- Site plan of proposed development
- Conceptual floor plan(s)
- Landscape plan, existing and proposed, if impacted by changes

Planned Development

- Proposed plat of record for lot consolidation or subdivision
- Directory of all development team members/consultants with contact information
- Site plan or survey of existing conditions
- Site plan of proposed development
- Conceptual floor plan(s)
- Transportation Impact Study
- Village Impact Study
- Studies or reports by outside agencies

Text or Map Amendment

- Site plan
- Conceptual floor plan
- Narrative describing the proposed land use requiring the amendment to the zoning text or map
- Completed worksheet responding to applicable standards

Variance

- Site plan
- Conceptual floor plan
- Completed worksheet responding to standards
- Letters of support from neighbors, optional

APPEARANCE REVIEW

For applications requiring Appearance Review, submit the following materials:

- Completed Appearance Commission application form
- Narrative describing the proposed new or changed to elevations, landscaping, lighting, and/or signage
- Elevation and/or plan drawings showing the existing and proposed conditions
- Photometric plan for new or changes to exterior lighting
- Material palette board (digital), showing, as applicable:
 - building materials
 - plants and landscape materials
 - cut sheets for lighting fixture
 - cut sheets for site furnishings



VILLAGE OF HOMEWOOD

APPL **Item 5. A.**

NON-RESIDENTIAL ZONING REVIEW

2020 Chestnut Road, Homewood, IL 60430

PROPERTY INFORMATION

Street Address: 17855 S Halsted St Homewood, IL 60430

Property Index Number(s): 29-33-100-063-0000

Lot Size: 32208 sq. ft. 0.74 acres
If the subject property is multiple lots, provide the combined area.

Zoning District:
 R-1 R-2 R-3 R-4 B-1 B-2 B-3 B-4 M-1 M-2 PL-1 PL-2

Complete this section to determine your required review(s):

Is the subject property more than one lot held in common ownership?

yes no

→ *If yes, lots held in common ownership should be consolidated*

A Planned Development is required for development of lots >25,000 sf or located in the B-1 or B-2 Zoning Districts.

REQUESTED USE

Requested Use: Coffee Stand - Drive-thru service only

Gross Floor Area: 500 sq. ft. **Parking Provided:** 17

Existing Use: Restaurant

The requested use is:

- Permitted
- Limited
- Special
- Other:

SITE OR BUILDING CHANGES

Existing Development: Boston Market Restaurant

Proposed Development *Check all that apply. Provide a description and metrics below.*
 New Construction Addition Site Alterations Exterior Building Alterations

The existing Boston Market building and signage will be demolished and replaced with a new 7 Brew building and cooler with a reduced building footprint. The site will be reconfigured with reconstructed curb and pavement, resulting in a net reduction in impervious area. New landscaping, photometrics, and signage are proposed.

Development Metrics	Existing	Proposed
Gross Floor Area (sq. ft):	<u>4300</u>	<u>500</u>
Parking Spaces	<u>45</u>	<u>17</u>
Lot Coverage		
Impervious Area (sq. ft.)	<u>24161</u>	<u>20040</u>
Impervious Coverage (%)	<u>.75</u>	<u>.62</u>

New construction?

yes no

→ *If yes, requires Site Plan Review*

Floor area increase is 20% or more?

yes no

→ *If yes, requires Site Plan Review*

Does the applicant elect to proceed as a Planned Development?

yes no

Is site circulation or parking impacted?

yes no

→ *If yes, requires Site Plan Review*

Is site landscaping impacted?

yes no

→ *If yes, requires Site Plan Review*

Exterior building alterations?

yes no

→ *If yes, requires Appearance Review*

ZONING RELIEF OR CHANGES

Zoning Variance or Amendment *Describe any requested zoning relief or changes below.*

Variance requested for parking lot perimeter landscaping along Halsted St to be reduced from 15ft to 12 ft.

The applicant requests:

- Variance
- Administrative Exception
- Zoning Text Amendment
- Zoning Map Amendment

APPLICANT

Name Who Brew LLC
 Company Who Brew LLC
 Address 100 Powell Place #1230
Nashville, TN 37204
 Phone 847-342-2586
 Email chrisgeorge@whobrewllc.com
 Role _____

PROPERTY OWNER

Name BSG Homewood LLC
 Company BSG Homewood LLC
 Address 3201 Old Glenview 235
Wilmette, IL 60091
 Phone _____
 Email _____
 Check box if the applicant is the property owner

I acknowledge and attest that:

- » All the information and exhibits submitted with this application are true and accurate to the best of my knowledge;
- » Village representatives are permitted to make reasonable inspections of the subject property necessary to process this application;
- » I agree to pay all required fees;
- » No work may be done without first obtaining a Building Permit. All work shall be completed in accordance with Village Codes and Ordinances.

Matthew Nyweide
 Applicant Name

 Applicant Signature

4/15/2026
 Date

Staff Notes

Do not write below this line.

Fee: _____ <input type="checkbox"/> Paid	Date Received: _____
CASE NO: _____ REQUEST: _____	
Comments/ Conditions:	<input type="checkbox"/> Approved <input type="checkbox"/> Approved with Conditions <input type="checkbox"/> Denied Date: _____
CASE NO: _____ REQUEST: _____	
Comments/ Conditions:	<input type="checkbox"/> Approved <input type="checkbox"/> Approved with Conditions <input type="checkbox"/> Denied Date: _____
CASE NO: _____ REQUEST: _____	
Comments/ Conditions:	<input type="checkbox"/> Approved <input type="checkbox"/> Approved with Conditions <input type="checkbox"/> Denied Date: _____
This application has zoning approvals and may proceed to obtain Building Permits or a Certificate of Occupancy.	
Name: _____	Signature: _____ Date: _____



Project Narrative	7 Brew Homewood	Date: 2026.04.13
-------------------	-----------------	------------------

Who Brew LLC is proposing to redevelop the existing Boston Market site at 17855 S Halsted St, Homewood, IL into a 7 Brew drive-thru coffee stand. The existing building and signage will be removed and replaced with a new building and associated cooler. The buildings will have a combined footprint smaller than the existing building. The site will be reconfigured to accommodate a dual drive-thru layout, including reconstructed pavement and curbing, resulting in improved circulation and a reduction in overall impervious area.

7 Brew operates as a drive-thru-focused coffee concept, serving beverages such as coffee, teas, and energy drinks. The business model emphasizes efficient service, with staff taking orders directly from vehicles and delivering completed orders at the pick-up window. This approach minimizes wait times and allows for a high volume of customers to be served efficiently without the need for indoor seating. The stand operates from 5:30 AM to 10:00 PM daily, with extended hours until 11:00 PM on Fridays and Saturdays. The proposed use will provide a convenient service option for residents and commuters while reinvesting in an existing commercial property.

Traffic circulation has been designed to function efficiently within the site. Vehicles will enter via the existing driveway and proceed through dual drive-thru lanes with significant on-site stacking capacity before exiting through a proposed exit driveway. Based on the Institute of Transportation Engineers (ITE) Trip Generation Manual, 11th Edition, a coffee shop with dual drive-thru lanes and no indoor seating is expected to generate approximately 50 customers during the peak morning hour. The site layout is designed to accommodate this demand while maintaining on-site circulation. The layout allows for internal vehicle movement without impacting adjacent roadways, and staff are trained to manage traffic during peak periods.

Stormwater management will utilize the existing on-site infrastructure, which previously served the entire property and will remain in place. The proposed design includes a new curb inlet structure and downspout connections that tie into the existing system. A portion of the reconstructed lot will continue to drain to existing inlets, while the southern half of the site will be redirected to a new catch basin that conveys to the existing system. As the redevelopment reduces overall impervious area, the impact to the storm sewer system is positive, with no increase in runoff demand.

Sanitary service will be provided by connecting to the existing sanitary sewer system, with the addition of a new grease interceptor to support the proposed use. Domestic water service will be extended from the existing water line that previously served the site. No significant modifications to off-site utility infrastructure are required.



Project Narrative	7 Brew Homewood	Date: 2026.04.13
-------------------	-----------------	------------------

The site will include a new, code-compliant landscaping plan designed to enhance the appearance of the property and provide additional screening along Halsted Street, with all existing trees preserved. A new monument sign is proposed to be located at the southwest corner of the lot. A code-compliant photometric plan will be provided to ensure adequate lighting while minimizing impacts to surrounding properties.

Overall, the proposed redevelopment represents a reinvestment in an existing commercial site, improving site functionality, reducing impervious coverage, and providing a service that is compatible with the surrounding area.



STANDARDS FOR: SPECIAL USE

2020 Chestnut Road, Homewood, IL 60430

Street Address: 17855 S Halsted St	Homewood, IL 60430
Requested Use: Coffee Stand - Drive-thru service only	Area: 32208 sq. ft.
Business Name: 7 Brew Drive-thru Coffee	
Applicant Name: Who Brew LLC	Date: 04/13/2026

Provide responses to each question below using complete sentences and specific to the proposed business and selected location.

The Planning and Zoning Commission and Village Board shall consider the following responses to the Standards for a Special Use in evaluating the application. No one is controlling.

1. Is the special use deemed necessary for the public convenience at this location?

Describe why this location is best-suited for your business to serve the community.

This location is well-suited due to its position along Halsted Street within an existing commercial corridor. The drive-thru model provides a convenient, quick-service option for residents and commuters. The site layout supports adequate vehicle stacking and circulation.

2. Is the special use detrimental to the economic welfare of the community?

Will the business have a negative impact on other businesses?

The proposed use will not negatively impact the local economy. It will reinvest in an underutilized site, create jobs, and increase commercial activity. The business complements existing restaurants by offering a different, convenience-based service.

3. Will the special use be consistent with the goals and policies of the Comprehensive Plan?

Describe how your business fits with the goals and policies summarized on the attached sheet.

The project supports reinvestment in existing commercial property and aligns with goals to promote appropriate retail development and strengthen the Village's economic base.

4. Is the special use so designed, located, and proposed to be operated, that the public health, safety, and welfare will be protected?

Describe any negative impacts, external to your business, that may result from it operating at this location.

The site is designed for safe and efficient operation, with dual drive-thru lanes and approximately 26 vehicles of on-site stacking. During occasional peak or promotional events, limited overflow may extend into the internal shopping center drive aisles, but will not impact public roadways. Traffic control is utilized during these rare events. No significant off-site impacts are anticipated.

5. Is the special use a suitable use of the property, and will the property will be substantially diminished in value without the special use?

Describe why your business is best-suited for your this property.

The property is appropriate for this use given its commercial zoning and prior restaurant use. The layout accommodates drive-thru circulation, and redevelopment prevents underutilization.

6. Will the special use cause substantial injury to the value of other property in the neighborhood in which it is located?

Will your business decrease the value of other properties?

The development is not expected to reduce nearby property values. Site improvements, including landscaping and reduced impervious area, will enhance the property and likely bring business to the surrounding commercial properties.

7. Will the special use be consistent with the uses and community character of the neighborhood surrounding the property?

Describe how your business is compatible with its neighbors.

The use is consistent with the surrounding commercial area. It complements nearby businesses and will include extra screening along Halsted Street to beautify the development.

8. Will the special use be injurious to the use or enjoyment of other property in the neighborhood for the purposes permitted in the zoning district?

Describe any negative impacts, external to your business, that may result from it operating at this location.

No significant negative impacts are expected. Operations are typical for commercial uses, and traffic and activity are managed on-site.

9. Will the special use impede the normal and orderly development and improvement of surrounding properties for uses permitted in the zoning district?

Describe any negative impacts, external to your business, that may result from it operating at this location.

The project will not impede surrounding development. It supports continued commercial investment in the area.

10. Does the special use provide adequate measures of ingress and egress in a manner that minimizes traffic congestion in the public streets?

Describe how will customers get to and from your business.

Access will be provided via one existing driveway for entry and a proposed driveway for exit. The site layout is designed to support efficient drive-thru circulation, with dual lanes and on-site stacking to minimize impacts to surrounding roadways.

11. Is the special use served by adequate utilities, drainage, road access, public safety and other necessary facilities?

A new business going into an existing development, may answer 'no.'

The site is served by existing utilities and infrastructure, which are adequate for the proposed use.

12. Will the special use substantially adversely affect one or more historical, archaeological, cultural, natural or scenic resources located on the parcel or surrounding properties?

A new business going into an existing development, may answer 'no.'

No impacts to historical, cultural, or natural resources are anticipated, as the site is already developed.

1999 COMPREHENSIVE PLAN

Below is an excerpt of the 1999 Comprehensive Plan containing those goals and objectives related to land use and community economic development which may be informative in the evaluation of special use permits.

Goal 1 - Land Use and Community Economic Development

Promote development of all remaining undeveloped property within the Village of Homewood for sound and orderly residential, commercial, and industrial development consistent with the Comprehensive Plan and the Future Land Use Map.

Objectives

- 1.1 - Recruit additional appropriate retail and industrial development for designated vacant commercial and industrial areas shown on the Future Land Use Map [current zoning map].
- 1.2 - Prepare a streetscape right-of-way plan for 183rd Street from the intersection of Dixie Highway to Governor's Highway to establish commercial "entryways" into the downtown central business district.
- 1.3 - Complete a plan to assess the potential for the Downtown to serve as a regional entertainment and "upscale" shopping district, serving residents within a 10-mile radius.
- 1.4 - Establish a transition zone surrounding the current downtown where, depending on market timing, changes in zoning from residential to commercial or mixed-uses would be favorably considered depending on specifics of the proposal.
- 1.5 - Complete an assessment of the success of the recent parking improvement actions to provide additional parking in the downtown and, if warranted, study the need and location of additional parking- both surface and elevated.
- 1.6 - Establish guidelines for appropriate mixed-use downtown development, including parking requirements, acceptable uses, and Village financing assistance (if deemed appropriate).
- 1.7 - Implement municipal utility improvements, especially storm water improvements, sidewalk construction/ replacement, streetscape, street tree plantings, and signage improvements.

2009 DOWNTOWN MASTER PLAN

Below is an excerpt of the 2009 Downtown Master Plan containing the objectives of the Master Plan. The Downtown Master Plan generally encompasses those areas zoned B-1 and B-2.

Master Plan Objectives

- » Sustain and enhance Downtown Homewood as a regional draw for the South Suburbs.
- » Encourage mixed-use development of key opportunity sites to create a more active "18-hour" downtown.
- » Increase commercial development to provide more goods and services for residents and visitors.
- » Increase commercial development to enhance the economic base of the Village.
- » Increase residential densities throughout Downtown to support transit use and new commercial activity.
- » Increase use of the Amtrak and Metra stations.
- » Encourage new residential development that provides a wider range of housing products in the Village, including apartments, condominiums, townhomes, and senior housing.
- » Enhance and increase open space within Downtown.
- » Significantly improve physical conditions by expanding streetscape improvements to all Downtown blocks, upgrading street furniture, and improving the pedestrian tunnel and viaducts under the tracks.
- » Improve pedestrian and vehicular access and circulation.



1155 Troutwine Road
Crown Point, IN 46307
P: (219) 662-7710
F: (219) 662-2740
www.dvgteam.com

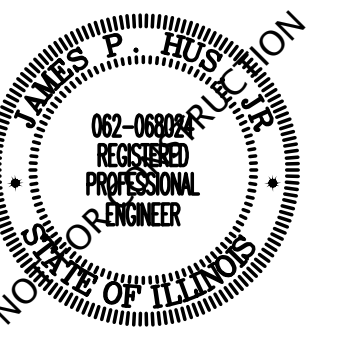

04/15/26

WHO BREW LLC
100 Powell Place #1230
Nashville, TN 37204

DATE:	REVISIONS AND NOTES:

7 BREW HOMEWOOD
Site Plan

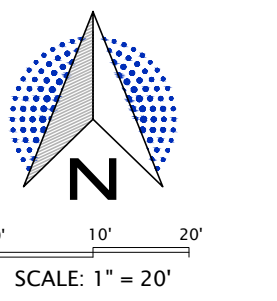

© COPYRIGHT 2017 DVG TEAM, INC
DESIGN BY: JWP DATE: 04/15/26
PROJECT NO.: 26-0021

C103

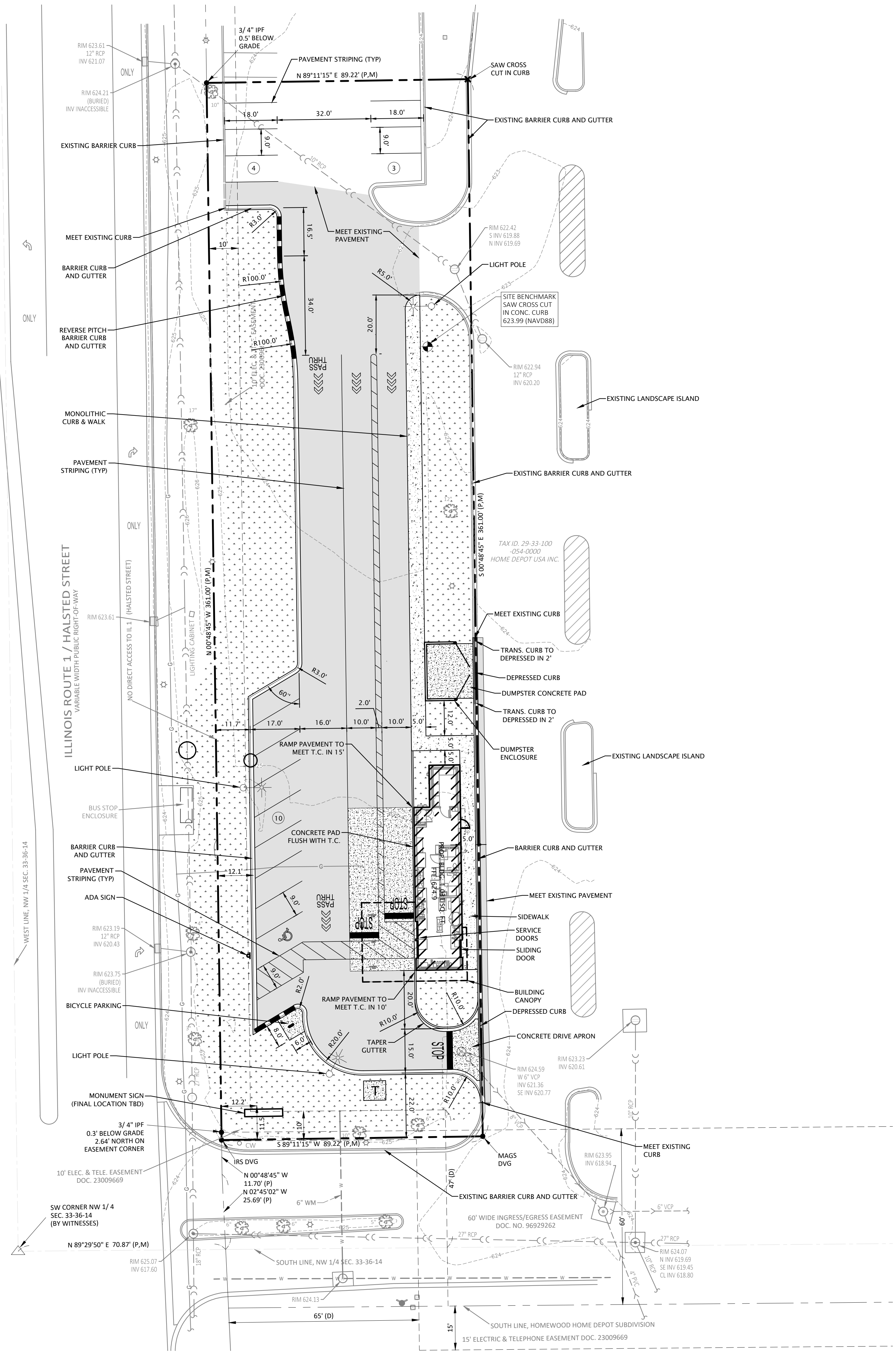

SITE DATA	
ZONING:	B-4 SHOPPING CENTER
LOT AREA:	32,208 SQ. FT.
IMPERVIOUS AREA:	20,317 SQ. FT. (63% OF LOT)
BUILDING AREA:	1,031 SQ. FT.
PARKING REQUIRED:	5 SPACES (1 SPACE PER 200 SQ FT)
PARKING PROVIDED:	17 SPACES

LEGEND	
	CONCRETE SIDEWALK
	ASPHALT PAVEMENT
	CONCRETE PAD
	4" (MIN) TOPSOIL & SEEDING/LANDSCAPING (SEE LANDSCAPE PLAN)
	STRIPING (PAINT, 4" WIDE)
	BARRIER CURB & GUTTER
	REVERSE PITCH CURB AND GUTTER

NOTES

- DIMENSIONING SHALL BE TO FACE OF CURB UNLESS OTHERWISE SHOWN.

NOT FOR CONSTRUCTION

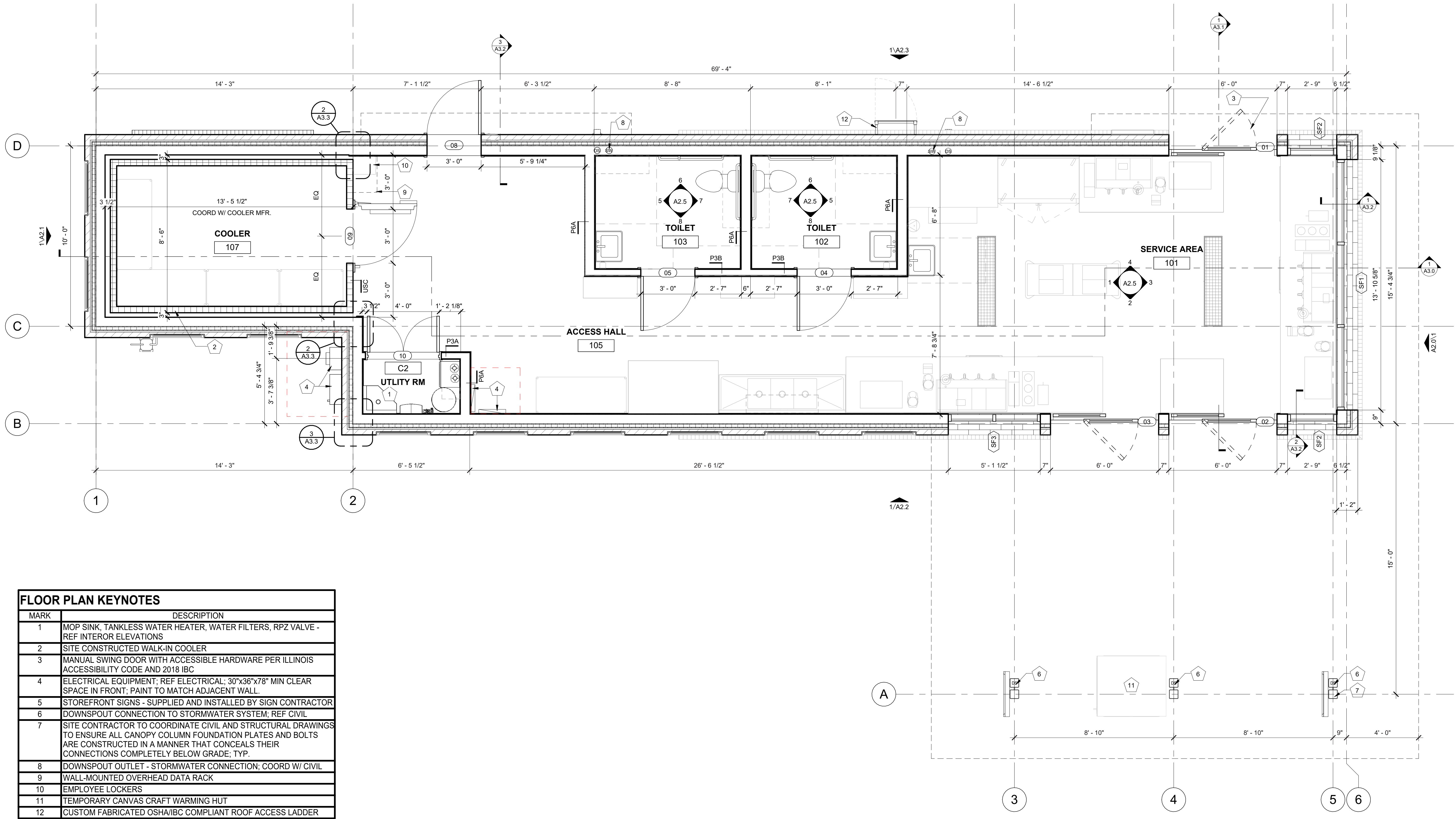

FLOOR PLAN KEYNOTES	
MARK	DESCRIPTION
1	MOP SINK, TANKLESS WATER HEATER, WATER FILTERS, RPZ VALVE - REF INTERIOR ELEVATIONS
2	SITE CONSTRUCTED WALK-IN COOLER
3	MANUAL SWING DOOR WITH ACCESSIBLE HARDWARE PER ILLINOIS ACCESSIBILITY CODE AND 2018 IBC
4	ELECTRICAL EQUIPMENT; REF ELECTRICAL; 30"x36"x78" MIN CLEAR SPACE IN FRONT; PAINT TO MATCH ADJACENT WALL.
5	STOREFRONT SIGNS - SUPPLIED AND INSTALLED BY SIGN CONTRACTOR
6	DOWNSPOUT CONNECTION TO STORMWATER SYSTEM; REF CIVIL
7	SITE CONTRACTOR TO COORDINATE CIVIL AND STRUCTURAL DRAWINGS TO ENSURE ALL CANOPY COLUMN FOUNDATION PLATES AND BOLTS ARE CONSTRUCTED IN A MANNER THAT CONCEALS THEIR CONNECTIONS COMPLETELY BELOW GRADE; TYP.
8	DOWNSPOUT OUTLET - STORMWATER CONNECTION; COORD W/ CIVIL
9	WALL-MOUNTED OVERHEAD DATA RACK
10	EMPLOYEE LOCKERS
11	TEMPORARY CANVAS CRAFT WARMING HUT
12	CUSTOM FABRICATED OSHA/IBC COMPLIANT ROOF ACCESS LADDER

1 FLOOR PLAN
 3/8" = 1'-0"

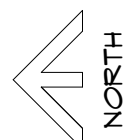

5/20/2026 5:14:32 PM C:\Users\sam\Documents\23.43.61_Homewood IL - Halsted_Entitlement_R24_sam6QWCY.rvt
 7 Brew Template V3.0
 2022-11-20_LAYOUT V04
 This drawing is an instrument of service and, as such, shall remain the property of Veritas Architecture and Design LLC. Unauthorised use or reproduction without permission is prohibited. This document is for use in connection with the specified project and shall not be used for other locations. © 2023

No.	Description	Date

sheet issue date:
 4/13/26
 project no.:
 23.43.61

sheet contents:
 ROOF PLAN

sheet no.:
A1.6

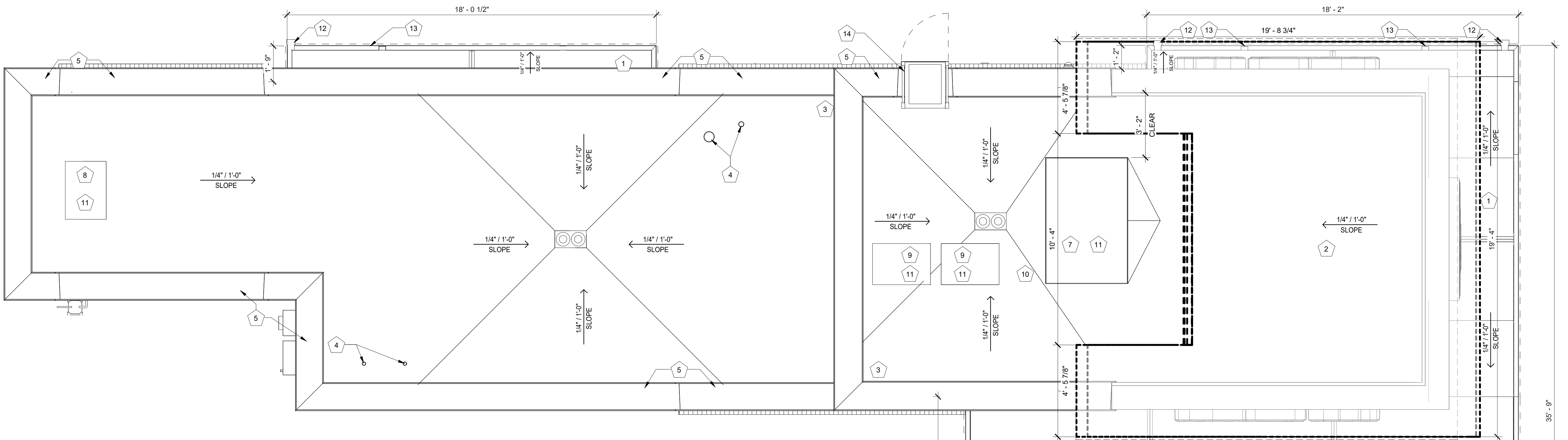

1 ROOF PLAN
 3/8" = 1'-0"

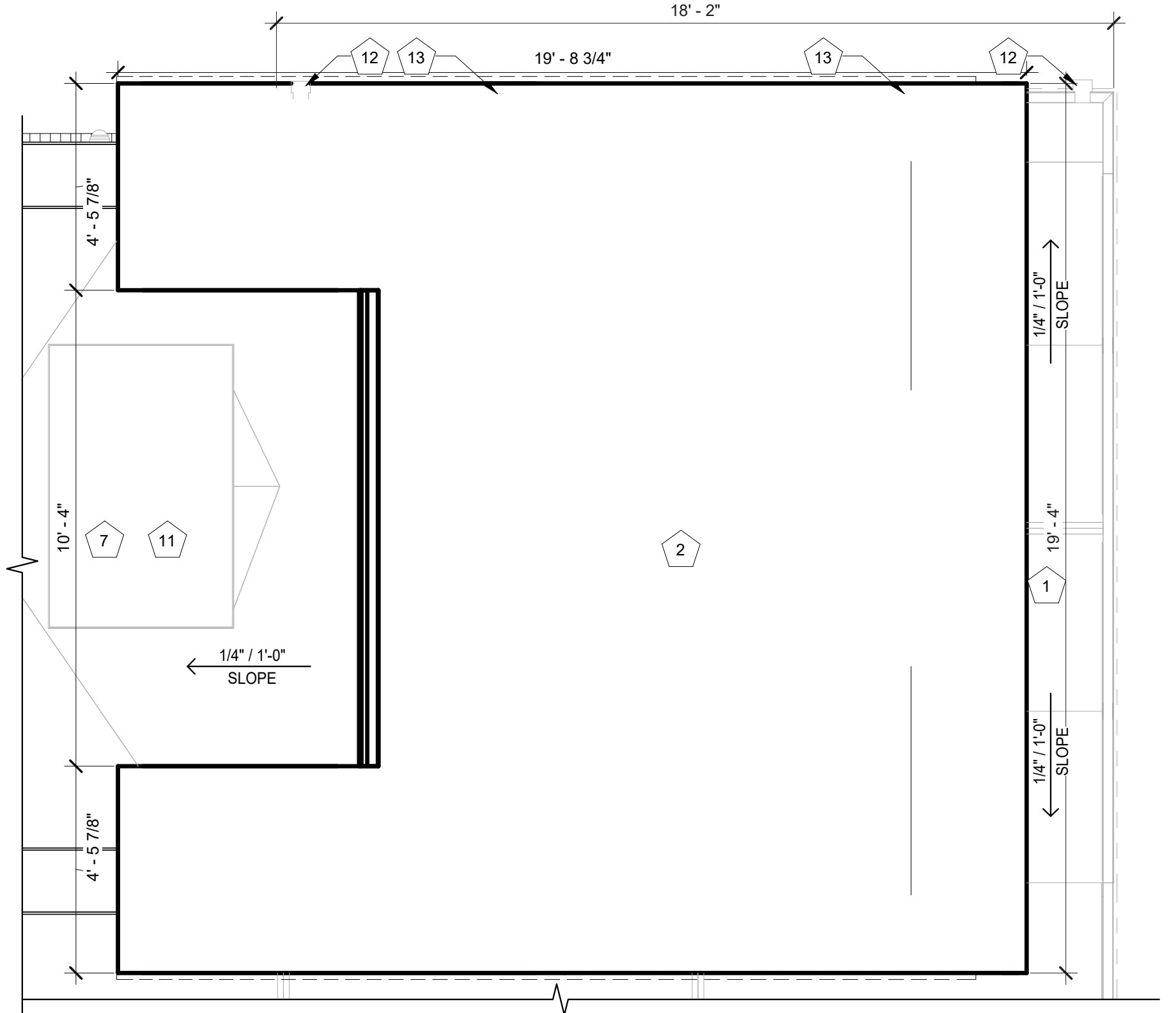

2 MUFFIN TOP ROOF PLAN
 3/8" = 1'-0"

MARK	DESCRIPTION
1	CANOPY W/ TPO ROOFING ON ROOF SHEATHING PER STRUCT ON BUILT-UP 2x CRICKET FRAMING; REF CANOPY SHOP DRAWINGS
2	STANDING SEAM CURVED METAL ROOF ON #15 FELT ON PLYWOOD ROOF SHEATHING
3	30 YEAR WARRENTY TPO ROOFING ON ROOF SHEATHING (PER STRUCT) ON BUILT-UP 2x CRICKET FRAMING
4	VARIOUS ROOF PENETRATIONS REQUIRED FOR VENTING AND MISC. REF MEP FOR REQUIRED ROOF PENETRATIONS AND LOCATIONS
5	BRAKE METAL CAP; REF ELEVATIONS
6	ROOF DRAIN WITHIN STRUCTURAL COLUMN; CONNECT TO STORMWATER COLLECTION SYSTEM; REF CIVIL
7	HVAC EQUIPMENT
8	WALK-IN COOLER CONDENSER; COORD W/ MANUF
9	ICE MACHINE CONDENSERS; SITE CONTRACTOR TO DETERMINE FINAL LOCATION
10	WALKING PADS PER IBC
11	CONTRACTOR TO PROVIDE CRICKETS AS REQ. AROUND MECHANICAL UNITS
12	OPEN TOP SCUPPER PER TPO MANUF INSTALLATION INSTRUCT; 4" MIN WIDTH & PROVIDE MIN 3" OVERHANG W/ SHARP EDGE
13	LOCATION OF OVERFLOW CUTOUT; COPING DROPPED 1.5" LOWER FOR 4" AT THIS LOCATION FOR OVERFLOW
14	CUSTOM FABRICATED OSHA/IBC COMPLIANT ROOF ACCESS LADDER

This drawing is an instrument of service and, as such, shall remain the property of Veritas Architecture and Design LLC. Unauthorised use or reproduction without permission is prohibited. This document is for use in connection with the specified project and shall not be used for other locations. © 2023

REVISIONS

No.	Description	Date

sheet issue date:
4/13/26

project no.:
23.43.61

sheet contents:
EXTERIOR ELEVATIONS

sheet no.:

A2.0

EXTERIOR ELEVATION MATERIALS LEGEND	
MARK	DESCRIPTION
A	ARCHITECTURAL CEMENT BOARD SIDING (BRK-2)
B	ARCHITECTURAL CEMENT BOARD SIDING (BRK-1)
C	BRAKE METAL FASCIA (MP-2)
D	SOFFIT PANELS (MP-2)
E	STANDING SEAM ROOF PANELS (MP-2)
F	METAL BRAKE CAP (MP-3)
G	VERTICAL METAL SIDING (MP-1)
H	SPANDREL GLAZING

EXTERIOR ELEVATION KEYNOTES	
MARK	DESCRIPTION
1	SITE BUILT CANOPY; REF STRUCTURAL
2	SURFACE-MOUNTED SHIELDED LED NEON FLEX LIGHTING AS INDICATED (SHOWN DASHED), TYP: REF ELECTRICAL
3	MOUNTED SPEAKER SYSTEM; REF SYSTEMS PLAN
4	CANOPY HEATER
5	ADDRESS NUMBERS TO BE 8" TALL x 2" BRUSH STROKE
6	FROST-PROOF FLUSH HOSE BIB
7	EXTERIOR WEATHER-PROOF OUTLET; REF ELECTRICAL
8	KNOX BOX
9	OUTLINE OF MECHANICAL UNIT BEYOND
10	DISPLAYS2GO MODEL: LEDOD2436 SILVER FRAME SURFACE-MOUNTED LIGHTED SIGN BOX
11	ROUND STOREFRONT SIGN; SUPPLIED AND INSTALLED BY SIGN CONTRACTOR
12	1/4" THICK ACRYLIC SIGNAGE APPLIED TO SIDING WITH VH DOUBLE SIDE TAPE
13	ILLUMINATED STOREFRONT SIGNAGE BY SIGN CONTRACTOR
14	EXTERIOR SECURITY LIGHT
15	PAINTED STRUCTURAL CANOPY COLUMN; REF CIVIL
16	GAS METER, PAINTED TO MATCH BUILDING; REF PLUMBING
17	PAINTED STRUCTURAL CANOPY COLUMN; RAINWATER DOWNSPOUT WITHIN; CONNECT BASE OF CANOPY COLUMN DOWNSPOUT TO STORMWATER MANAGEMENT SYSTEM; REF CIVIL
19	DOWNSPOUT OUTLET; CONNECT TO SUBGRADE STORMWATER CONNECTION; REF CIVIL
20	TEMPORARY CANVAS CRAFT WARMING HUT
21	CUSTOM FABRICATED OSHA/IBC COMPLIANT ROOF ACCESS LADDER
22	GUTTER AND DOWNSPOUT
23	DAYLIGHT ROOF OVERFLOW DRAIN; TRIM WITH BRASS LAMBS TONGUE

EXTERIOR ELEVATION COOLER GLAZING SUMMARY		
SOUTH ELEVATION - 715F TOTAL MAIN LEVEL FACADE AREA BETWEEN 2'-6" AND 7'-0" (100%)		
MATERIAL	MAX % / SF	PROPOSED % / SF
GLASS	MIN 30 % / 215F	PROPOSED 88 % / 635F



1 EXTERIOR ELEVATION - SOUTH
 3/8" = 1'-0"

EXTERIOR ELEVATION MATERIALS LEGEND	
MARK	DESCRIPTION
A	ARCHITECTURAL CEMENT BOARD SIDING (BRK-2)
B	ARCHITECTURAL CEMENT BOARD SIDING (BRK-1)
C	BRAKE METAL FASCIA (MP-2)
D	SOFFIT PANELS (MP-2)
E	STANDING SEAM ROOF PANELS (MP-2)
F	METAL BRAKE CAP (MP-3)
G	VERTICAL METAL SIDING (MP-1)
H	SPANDREL GLAZING

EXTERIOR ELEVATION KEYNOTES	
MARK	DESCRIPTION
1	SITE BUILT CANOPY; REF STRUCTURAL
2	SURFACE-MOUNTED SHIELDED LED NEON FLEX LIGHTING AS INDICATED (SHOWN DASHED), TYP; REF ELECTRICAL
3	MOUNTED SPEAKER SYSTEM; REF SYSTEMS PLAN
4	CANOPY HEATER
5	ADDRESS NUMBERS TO BE 8" TALL x 2" BRUSH STROKE
6	FROST-PROOF FLUSH HOSE BIB
7	EXTERIOR WEATHER-PROOF OUTLET; REF ELECTRICAL
8	KNOX BOX
9	OUTLINE OF MECHANICAL UNIT BEYOND
10	DISPLAYS2GO MODEL: LEDOD2436 SILVER FRAME SURFACE-MOUNTED LIGHTED SIGN BOX
11	ROUND STOREFRONT SIGN; SUPPLIED AND INSTALLED BY SIGN CONTRACTOR
12	1/4" THICK ACRYLIC SIGNAGE APPLIED TO SIDING WITH VH DOUBLE SIDE TAPE
13	ILLUMINATED STOREFRONT SIGNAGE BY SIGN CONTRACTOR
14	EXTERIOR SECURITY LIGHT
15	PAINTED STRUCTURAL CANOPY COLUMN; REF CIVIL
16	GAS METER, PAINTED TO MATCH BUILDING; REF PLUMBING
17	PAINTED STRUCTURAL CANOPY COLUMN; RAINWATER DOWNSPOUT WITHIN; CONNECT BASE OF CANOPY COLUMN DOWNSPOUT TO STORMWATER MANAGEMENT SYSTEM; REF CIVIL
19	DOWNSPOUT OUTLET; CONNECT TO SUBGRADE STORMWATER CONNECTION; REF CIVIL
20	TEMPORARY CANVAS CRAFT WARMING HUT
21	CUSTOM FABRICATED OSHA/IBC COMPLIANT ROOF ACCESS LADDER
22	GUTTER AND DOWNSPOUT
23	DAYLIGHT ROOF OVERFLOW DRAIN; TRIM WITH BRASS LAMBS TONGUE

EXTERIOR ELEVATION COOLER GLAZING SUMMARY		
NORTH ELEVATION - 715F TOTAL MAIN LEVEL FAÇADE AREA BETWEEN 2'-6" AND 7'-0" (100%)		
MATERIAL	MAX % / SF	PROPOSED % / SF
GLASS	MIN 30 % / 215F	PROPOSED 42 % / 305F

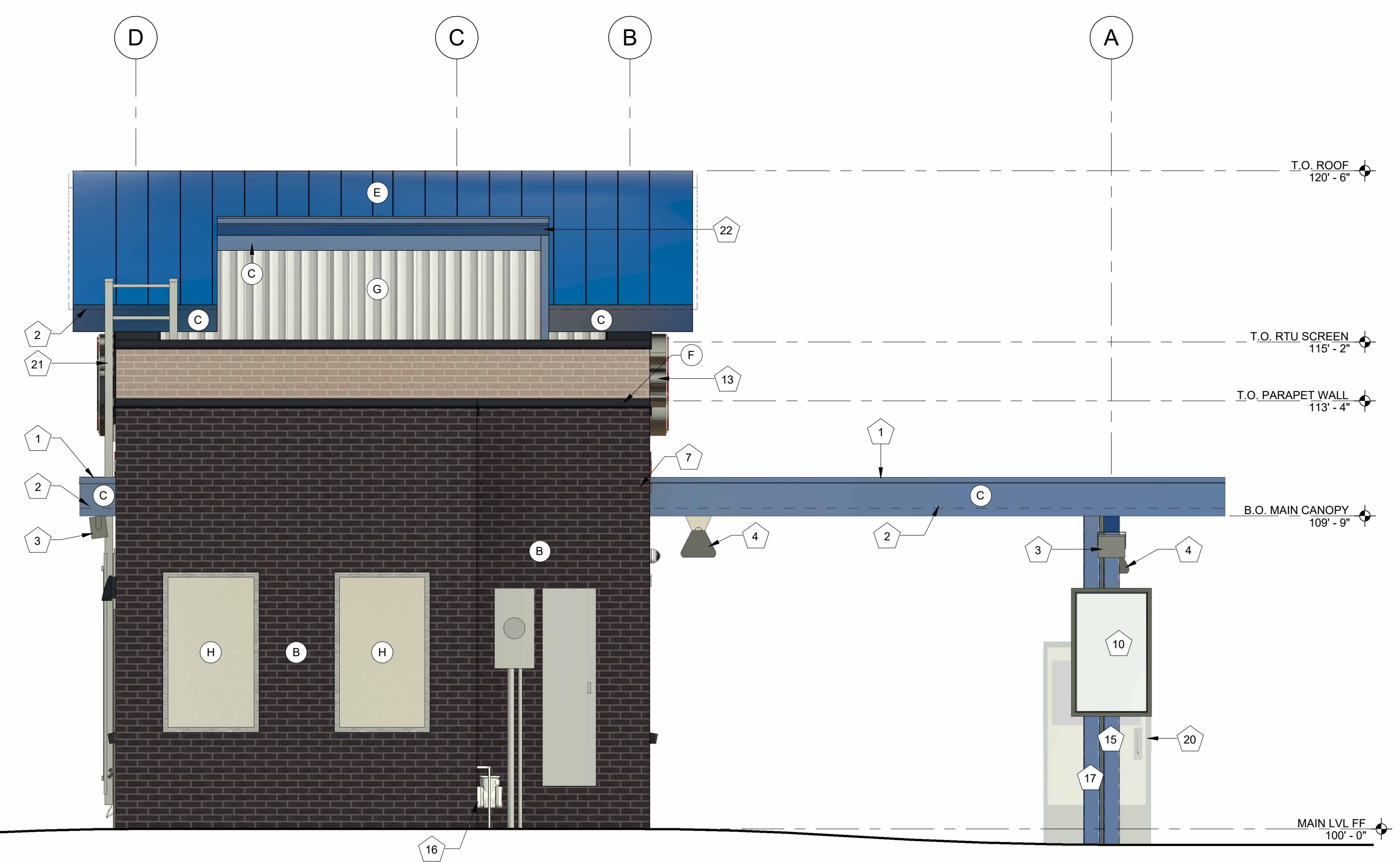

1 EXTERIOR ELEVATION - NORTH
 3/8" = 1'-0"

7 BREW DRIVE THRU - HOMEWOOD - HALSTED

WHO BREW, LLC
 17855 South Halsted Street, Homewood, Illinois 60430

REVISIONS
 No. Description Date

sheet issue date:
 4/13/26

project no.:
 23.43.61

sheet contents:
 EXTERIOR ELEVATIONS

sheet no.:
A2.1

EXTERIOR ELEVATION MATERIALS LEGEND	
MARK	DESCRIPTION
A	ARCHITECTURAL CEMENT BOARD SIDING (BRK-2)
B	ARCHITECTURAL CEMENT BOARD SIDING (BRK-1)
C	BRAKE METAL FASCIA (MP-2)
D	SOFFIT PANELS (MP-2)
E	STANDING SEAM ROOF PANELS (MP-2)
F	METAL BRAKE CAP (MP-3)
G	VERTICAL METAL SIDING (MP-1)
H	SPANDREL GLAZING

EXTERIOR ELEVATION KEYNOTES	
MARK	DESCRIPTION
1	SITE BUILT CANOPY; REF STRUCTURAL
2	SURFACE-MOUNTED SHIELDED LED NEON FLEX LIGHTING AS INDICATED (SHOWN DASHED), TYP; REF ELECTRICAL
3	MOUNTED SPEAKER SYSTEM; REF SYSTEMS PLAN
4	CANOPY HEATER
5	ADDRESS NUMBERS TO BE 8" TALL x 2" BRUSH STROKE
6	FROST-PROOF FLUSH HOSE BIB
7	EXTERIOR WEATHER-PROOF OUTLET; REF ELECTRICAL
8	KNOX BOX
9	OUTLINE OF MECHANICAL UNIT BEYOND
10	DISPLAYS2GO MODEL: LEDOD2436 SILVER FRAME SURFACE-MOUNTED LIGHTED SIGN BOX
11	ROUND STOREFRONT SIGN; SUPPLIED AND INSTALLED BY SIGN CONTRACTOR
12	1/4" THICK ACRYLIC SIGNAGE APPLIED TO SIDING WITH VH DOUBLE SIDE TAPE
13	ILLUMINATED STOREFRONT SIGNAGE BY SIGN CONTRACTOR
14	EXTERIOR SECURITY LIGHT
15	PAINTED STRUCTURAL CANOPY COLUMN; REF CIVIL
16	GAS METER, PAINTED TO MATCH BUILDING; REF PLUMBING
17	PAINTED STRUCTURAL CANOPY COLUMN; RAINWATER DOWNSPOUT WITHIN; CONNECT BASE OF CANOPY COLUMN DOWNSPOUT TO STORMWATER MANAGEMENT SYSTEM; REF CIVIL
19	DOWNSPOUT OUTLET; CONNECT TO SUBGRADE STORMWATER CONNECTION; REF CIVIL
20	TEMPORARY CANVAS CRAFT WARMING HUT
21	CUSTOM FABRICATED OSHA/IBC COMPLIANT ROOF ACCESS LADDER
22	GUTTER AND DOWNSPOUT
23	DAYLIGHT ROOF OVERFLOW DRAIN; TRIM WITH BRASS LAMBS TONGUE

EXTERIOR ELEVATION COOLER GLAZING SUMMARY		
WEST ELEVATION - 3145F TOTAL MAIN LEVEL FACADE AREA BETWEEN 2'-6" AND 7'-0" (100%)		
MATERIAL	MAX % / SF	PROPOSED % / SF
GLASS	MIN 60 % / 188SF	PROPOSED 64 % / 2045F

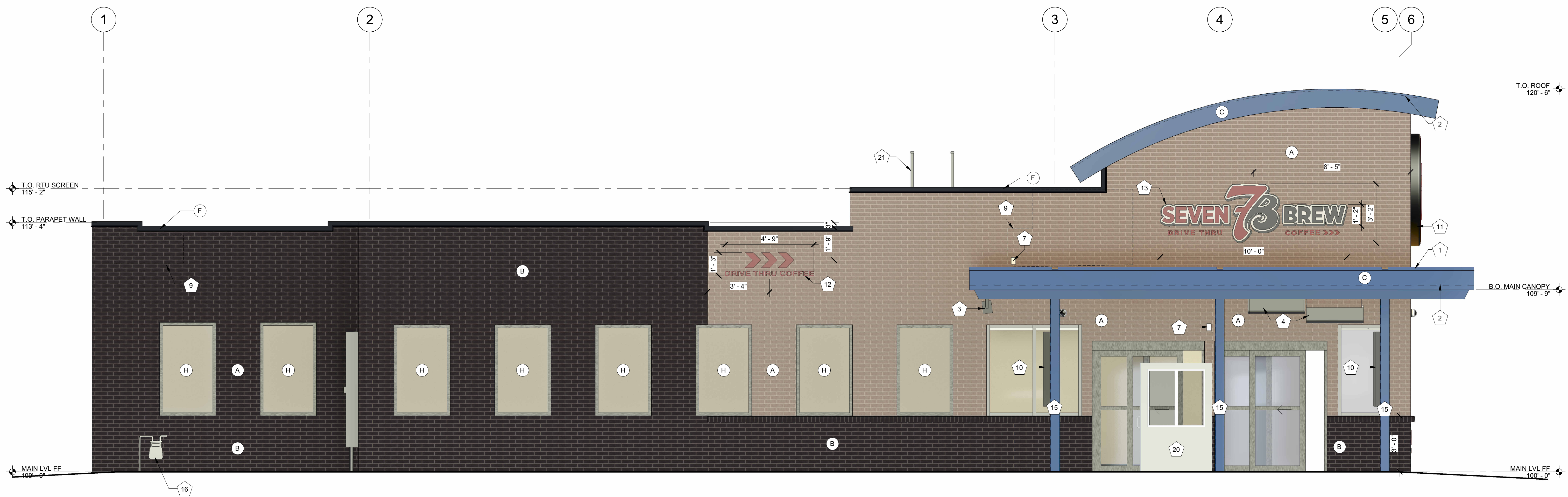

1 EXTERIOR ELEVATION - WEST
 3/8" = 1'-0"

7 BREW DRIVE THRU - HOMEWOOD - HALSTED

WHO BREW, LLC
 17855 South Halsted Street, Homewood, Illinois 60430

REVISIONS		
No.	Description	Date

sheet issue date: 4/13/26
 project no.: 23.43.61
 sheet contents: EXTERIOR ELEVATIONS
 sheet no.:

A2.2

EXTERIOR ELEVATION MATERIALS LEGEND	
MARK	DESCRIPTION
A	ARCHITECTURAL CEMENT BOARD SIDING (BRK-2)
B	ARCHITECTURAL CEMENT BOARD SIDING (BRK-1)
C	BRAKE METAL FASCIA (MP-2)
D	SOFFIT PANELS (MP-2)
E	STANDING SEAM ROOF PANELS (MP-2)
F	METAL BRAKE CAP (MP-3)
G	VERTICAL METAL SIDING (MP-1)
H	SPANDREL GLAZING

EXTERIOR ELEVATION KEYNOTES	
MARK	DESCRIPTION
1	SITE BUILT CANOPY; REF STRUCTURAL
2	SURFACE-MOUNTED SHIELDED LED NEON FLEX LIGHTING AS INDICATED (SHOWN DASHED), TYP: REF ELECTRICAL
3	MOUNTED SPEAKER SYSTEM; REF SYSTEMS PLAN
4	CANOPY HEATER
5	ADDRESS NUMBERS TO BE 8" TALL x 2" BRUSH STROKE
6	FROST-PROOF FLUSH HOSE BIB
7	EXTERIOR WEATHER-PROOF OUTLET; REF ELECTRICAL
8	KNOX BOX
9	OUTLINE OF MECHANICAL UNIT BEYOND
10	DISPLAYS2GO MODEL: LEDOD2436 SILVER FRAME SURFACE-MOUNTED LIGHTED SIGN BOX
11	ROUND STOREFRONT SIGN; SUPPLIED AND INSTALLED BY SIGN CONTRACTOR
12	1/4" THICK ACRYLIC SIGNAGE APPLIED TO SIDING WITH VH DOUBLE SIDE TAPE
13	ILLUMINATED STOREFRONT SIGNAGE BY SIGN CONTRACTOR
14	EXTERIOR SECURITY LIGHT
15	PAINTED STRUCTURAL CANOPY COLUMN; REF CIVIL
16	GAS METER, PAINTED TO MATCH BUILDING; REF PLUMBING
17	PAINTED STRUCTURAL CANOPY COLUMN; RAINWATER DOWNSPOUT WITHIN; CONNECT BASE OF CANOPY COLUMN DOWNSPOUT TO STORMWATER MANAGEMENT SYSTEM; REF CIVIL
19	DOWNSPOUT OUTLET; CONNECT TO SUBGRADE STORMWATER CONNECTION; REF CIVIL
20	TEMPORARY CANVAS CRAFT WARMING HUT
21	CUSTOM FABRICATED OSHA/IBC COMPLIANT ROOF ACCESS LADDER
22	GUTTER AND DOWNSPOUT
23	DAYLIGHT ROOF OVERFLOW DRAIN; TRIM WITH BRASS LAMBS TONGUE

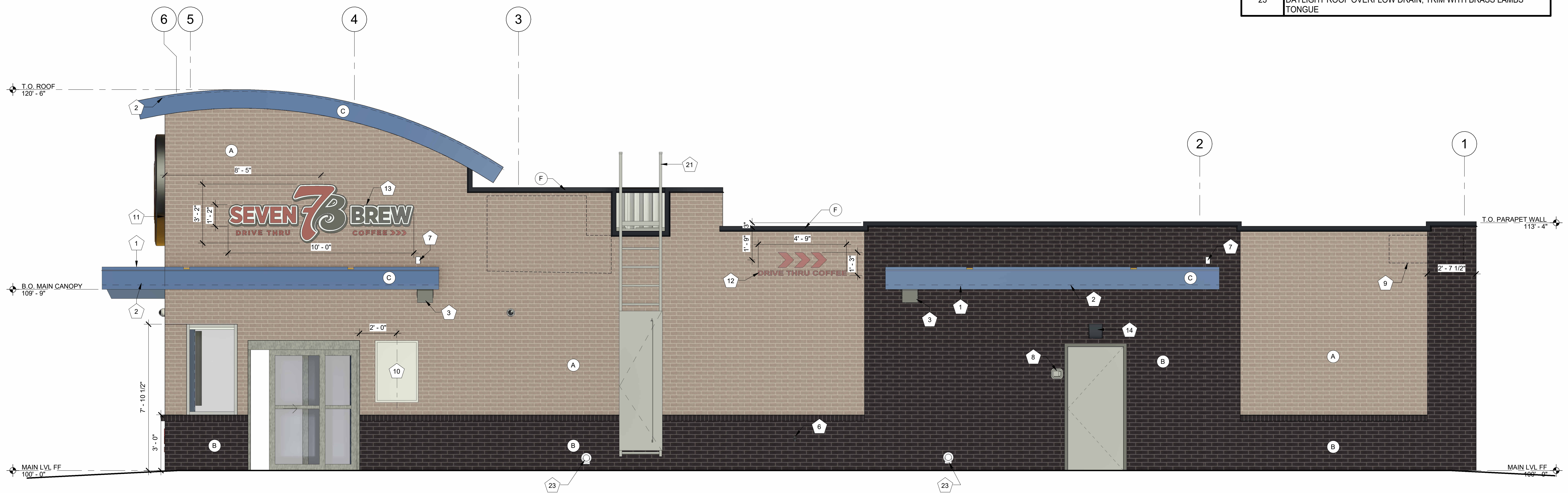

1 EXTERIOR ELEVATION - EAST
 3/8" = 1'-0"

7 BREW DRIVE THRU - HOMEWOOD - HALSTED

WHO BREW, LLC
 17855 South Halsted Street, Homewood, Illinois 60430

REVISIONS		
No.	Description	Date

sheet issue date:
 4/13/26
 project no.:
 23.43.61
 sheet contents:
 EXTERIOR ELEVATIONS

sheet no.:
A2.3

7 BREW DRIVE THRU - HOMEWOOD - HALSTED

WHO BREW, LLC
 17855 South Halsted Street, Homewood, Illinois 60430

REVISIONS
 No. Description Date

sheet issue date:
 4/13/26
 project no.:
 23.43.61

sheet contents:
 BUILDING SECTION

sheet no.:
A3.0

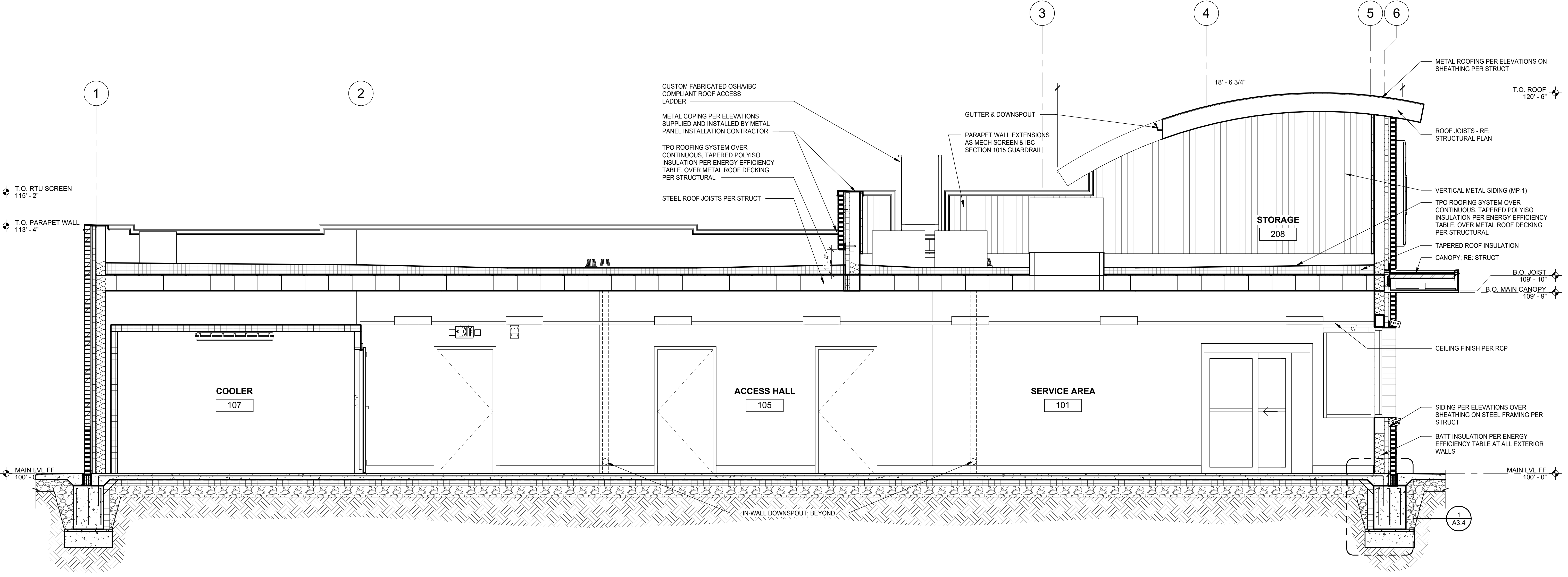

1 BUILDING SECTION
 3/8" = 1'-0"

REVISIONS

No.	Description	Date

sheet issue date:
4/13/26
 project no.:
23.43.61
 sheet contents:
TRASH ENCLOSURE

ENCLOSURE KEYNOTES	
Note Number	Note Text
1	MP-3 METAL WALL CAP
2	BRK-1 OVER 8" CMU
3	1X6 VERTICAL CLEAR SEALED CEDAR PLANKS
4	ALL METAL FRAMING, POST AND HARDWARE 1 COAT POR-15 PRIMER AND 2 COATS FINISH. PAINT TO BE OIL BASED; COLOR TO MATCH ROYAL BLUE MP-2

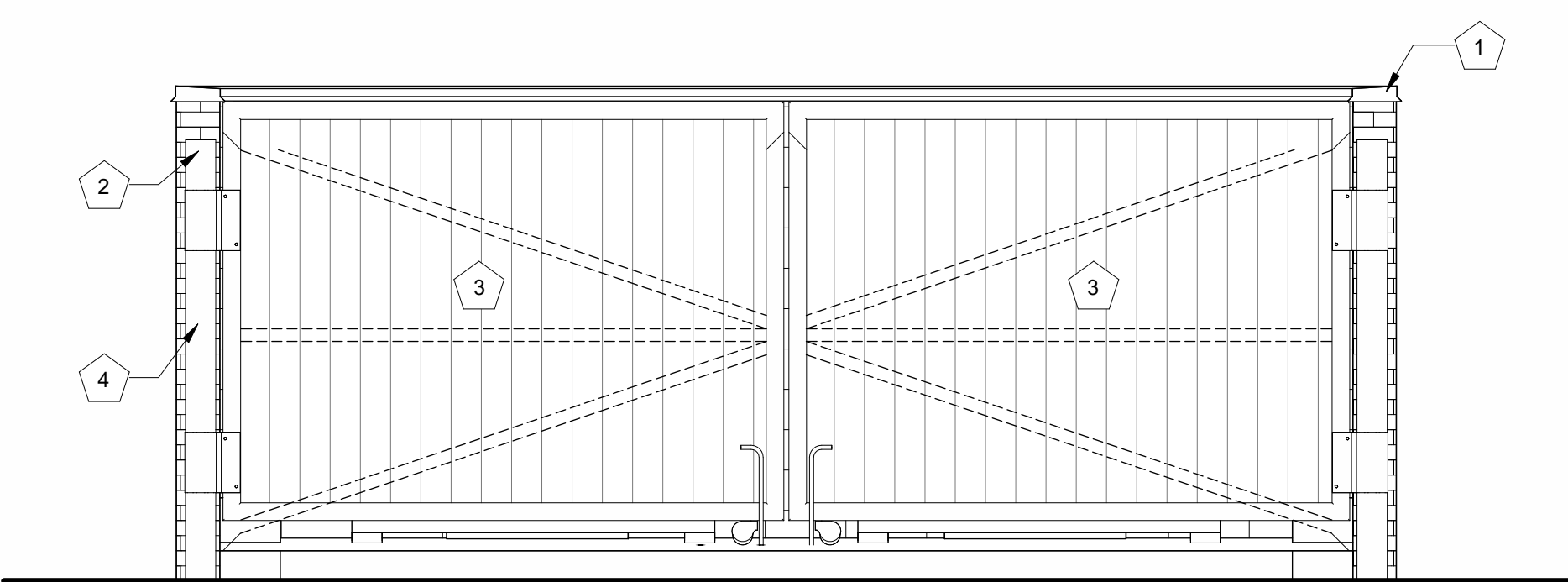

1 TRASH ENCLOSURE ELEVATION
 3/8" = 1'-0"

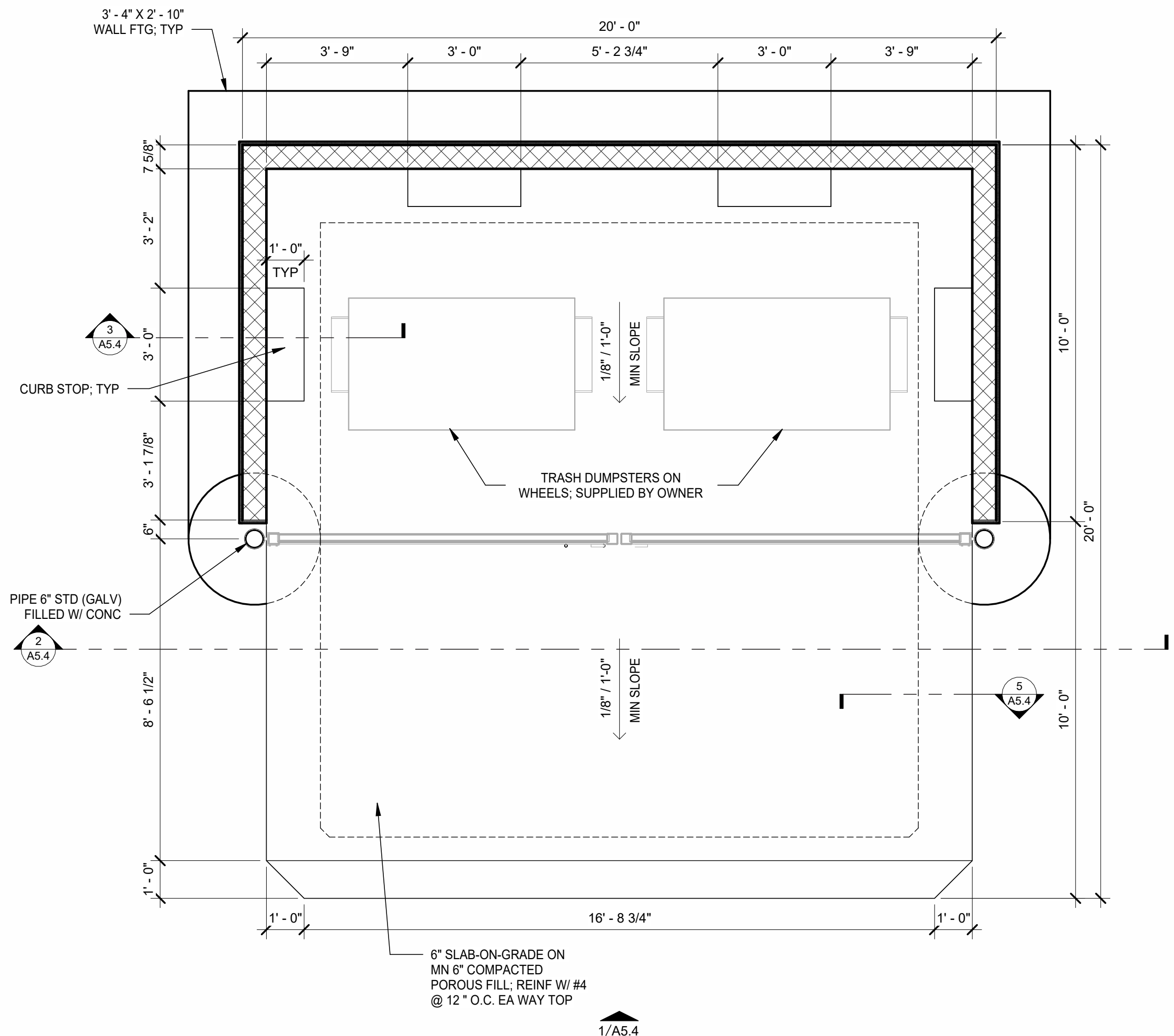

4 TRASH ENCLOSURE PLAN
 3/8" = 1'-0"

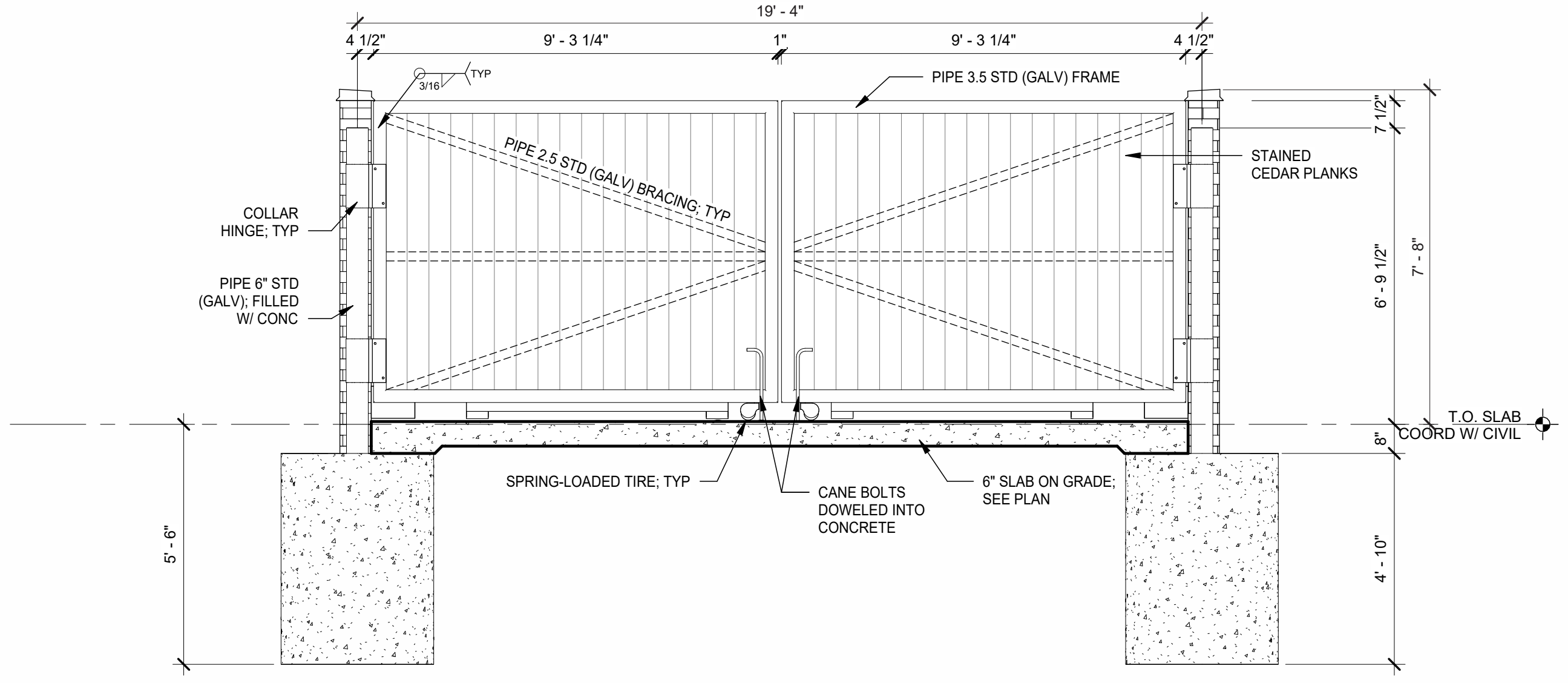

2 TRASH ENCLOSURE SECTION
 3/8" = 1'-0"

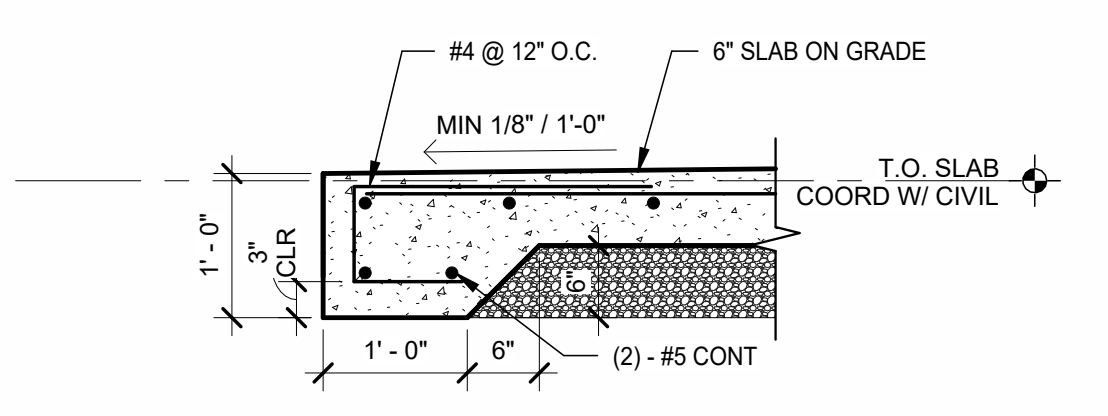

5 TRASH ENCLOSURE APRON DETAIL
 3/4" = 1'-0"

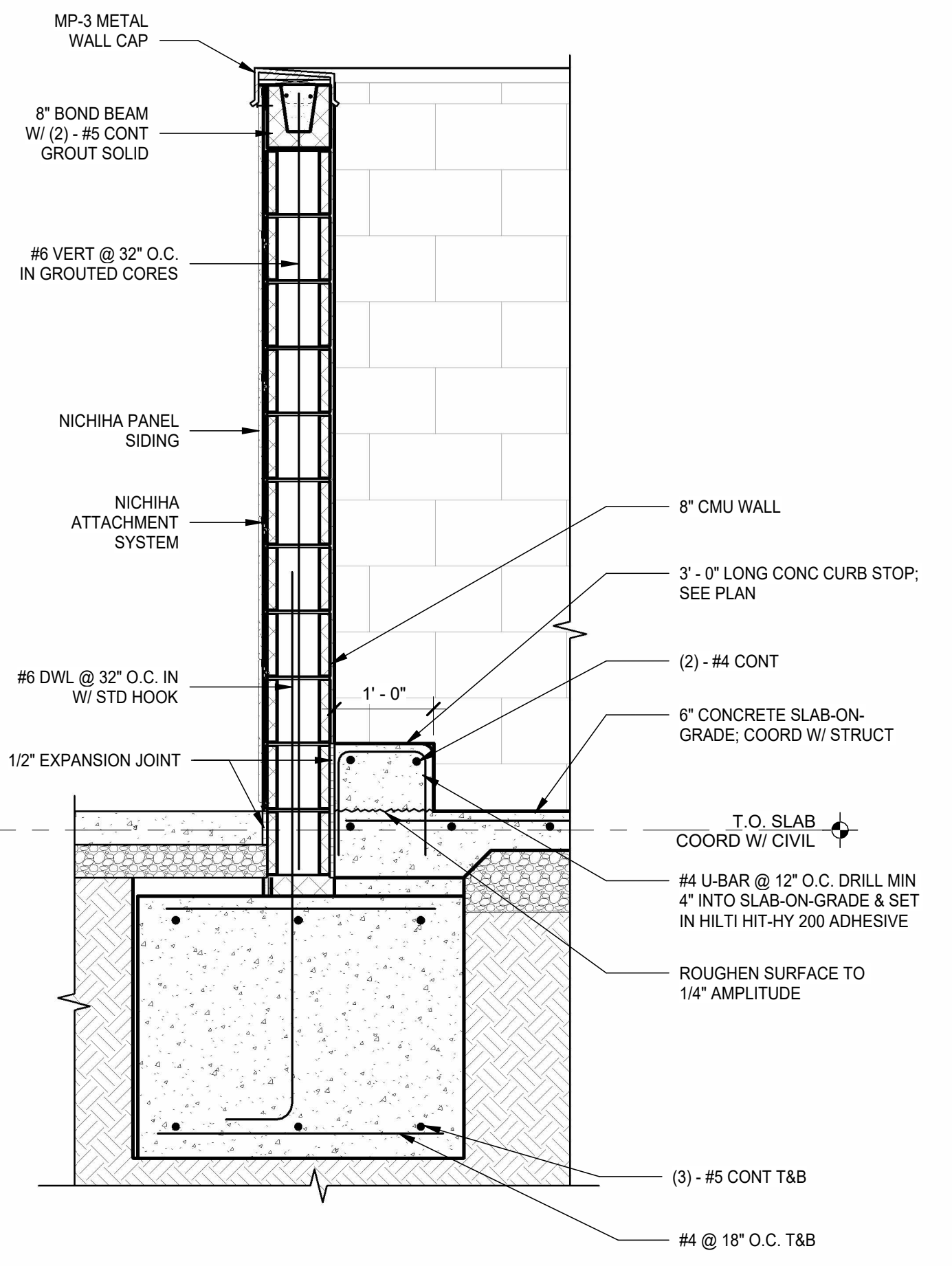

3 TRASH ENCLOSURE WALL SECTION
 3/4" = 1'-0"

5/20/2026 5:15:34 PM C:\Users\sam\Documents\23.43.61_Homewood IL- Halsted_Entitlement_R24_sam6QWCY.rvt
 This drawing is an instrument of service and, as such, shall remain the property of Veritas Architecture and Design LLC. Unauthorised use or reproduction without permission is prohibited. This document is for use in connection with the specified project and shall not be used for other locations. © 2023
 7 Brew Template V2.0

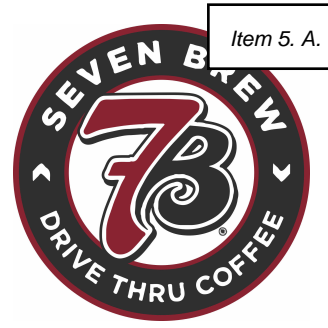

Item 5. A.

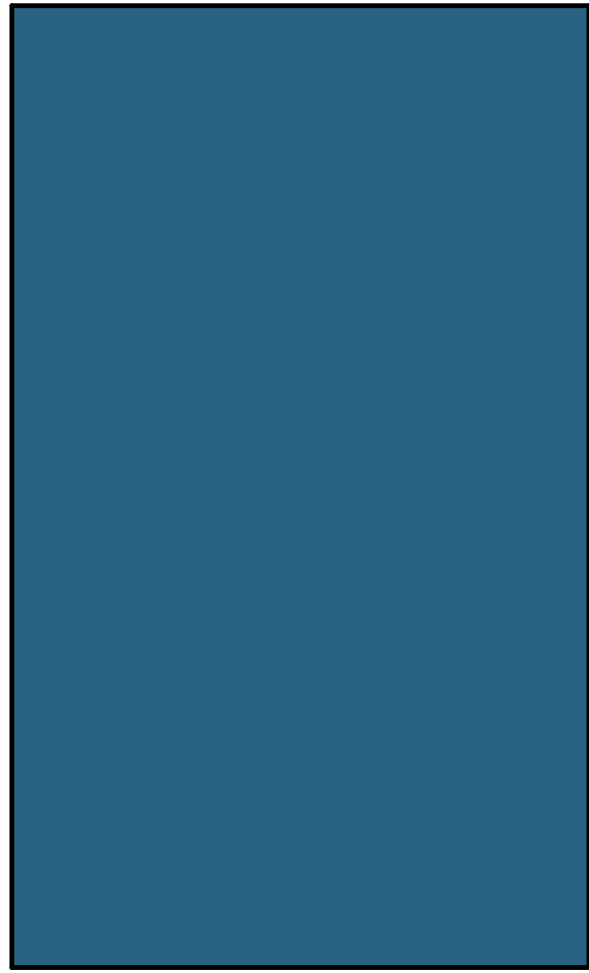

BLUE METAL PANEL MP-2
BRAND: BERRIDGE
COLOR: ROYAL BLUE
FINISH: LOW SHEEN SMOOTH - REFLECTIVITY .26

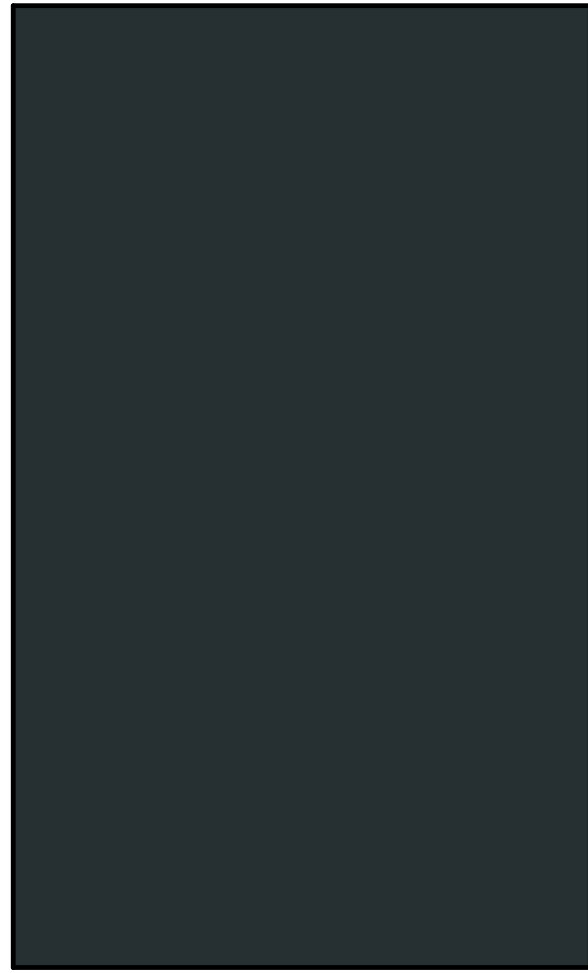

COPING TRIM METAL MP-3
BRAND: BERRIDGE
COLOR: MATTE BLACK
FINISH: LOW SHEEN SMOOTH - REFLECTIVITY .39

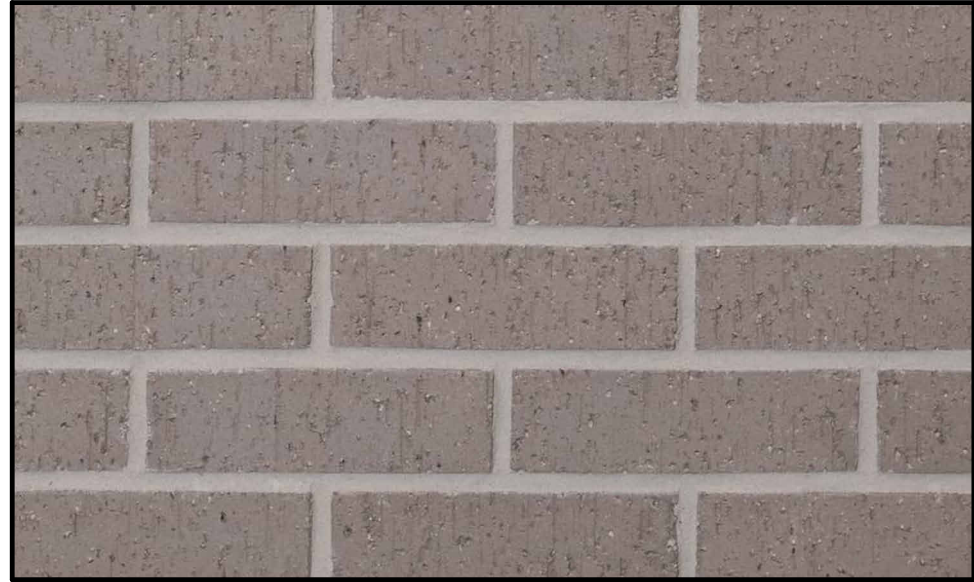

FULL DEPTH BRICK - BRK-2
BRAND: HEBRON
COLOR: SILVERADO
FINISH: VELOUR



FULL DEPTH BRICK - BRK-1
BRAND: HEBRON
COLOR: ONYX IRONSPOT
FINISH: RUSTIC

23.43.61
7 BREW DRIVE THRU -
HOMEWOOD -
HALSTED
4/13/26

MATERIAL COLOR
BOARD

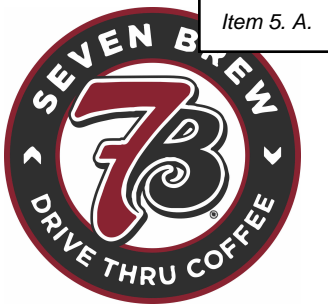

23.43.61
7 BREW DRIVE THRU -
HOMEWOOD -
HALSTED
4/13/26

RENDERINGS

Item 5. A.

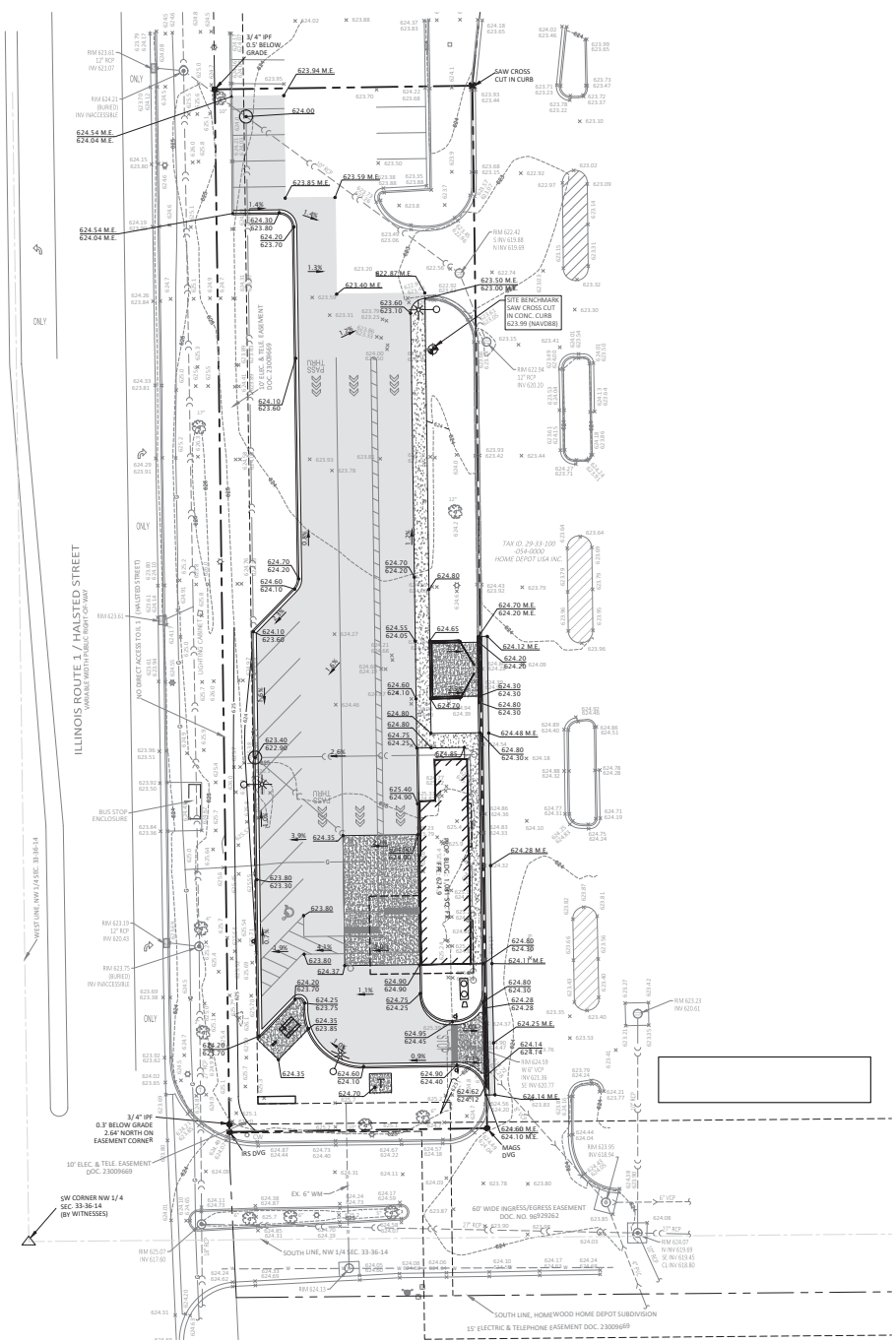

NOT FOR CONSTRUCTION

DVG TEAM INC
 1155 Troutwine Road
 Crown Point, IN 46307
 P: (219) 662-7710
 F: (219) 662-2740
 www.dvgteam.com

JAMES P. HUBBARD
 REGISTERED PROFESSIONAL ENGINEER
 STATE OF ILLINOIS
 01/21/26

WHO BREW LLC
 100 Powell Place #1230
 Nashville, TN 37204

DATE: REVISIONS AND NOTES:

7 BREW HOMEWOOD
 Grading Plan

NOT FOR CONSTRUCTION

7 BREW HOMEWOOD
 Grading Plan

© COPYRIGHT 2017 DVG TEAM, INC.
 DESIGN BY: JWP DATE: 05/21/26
 PROJECT NO. 26-0021
C104





2024 CHESTNUT ROAD



A Transit-Oriented Development By:



HOLLADAY
PROPERTIES

2024 CHESTNUT ROAD: CONCEPTUAL PLANS

2024 CHESTNUT RD. - DATA OVERVIEW

ITEM	UNIT SF
Site (1.03 acres)	45,000
Public Plaza	4,170
Public Garden Area	3,000
Total Dwelling Units	118
Main Building Height	5 Stories
Main Parking Level (SF)	28,434
Lower Parking Level (SF)	27,457
Total Parking Area SF	55,891
Main Level Utilities (Trash, Elec, Pump Rm) (SF)	873
Main Level Garage Stair & Elevator (SF)	585
Lower Level Garage Stairs & Elevators (SF)	1,101
Total Utility Areas, Garage Stair & Elevator	2,559
Second Level Courtyard Open Area (SF)	6,520
Level 1 Leasing, Offices & Lobby (SF)	3,740
Retail Space (SF)	2,000
Main Level (sf)	35,650
Level 2 (SF)	27,426
Level 3 (SF)	27,426
Level 4 (SF)	27,426
Total Building SF	145,354
Total Building SF (incl. Courtyrd & parking levels)	209,544
Indoor Parking Spaces - non-handicapped	127
Indoor Parking Spaces - handicapped	6
Total Site Parking Spaces (Ratio 1.13)	133

UNIT SUMMARY

	2nd Floor	3rd Floor	4th Floor	5th Floor	TOTAL	Percentage
Studio	5	5	5	5	20	16.95%
1 Bedroom	17	18	18	18	71	60.17%
2 Bedroom	5	6	6	6	23	19.49%
3 Bedroom	1	1	1	1	4	3.39%
Total Per Floor	28	30	30	30	118	100%

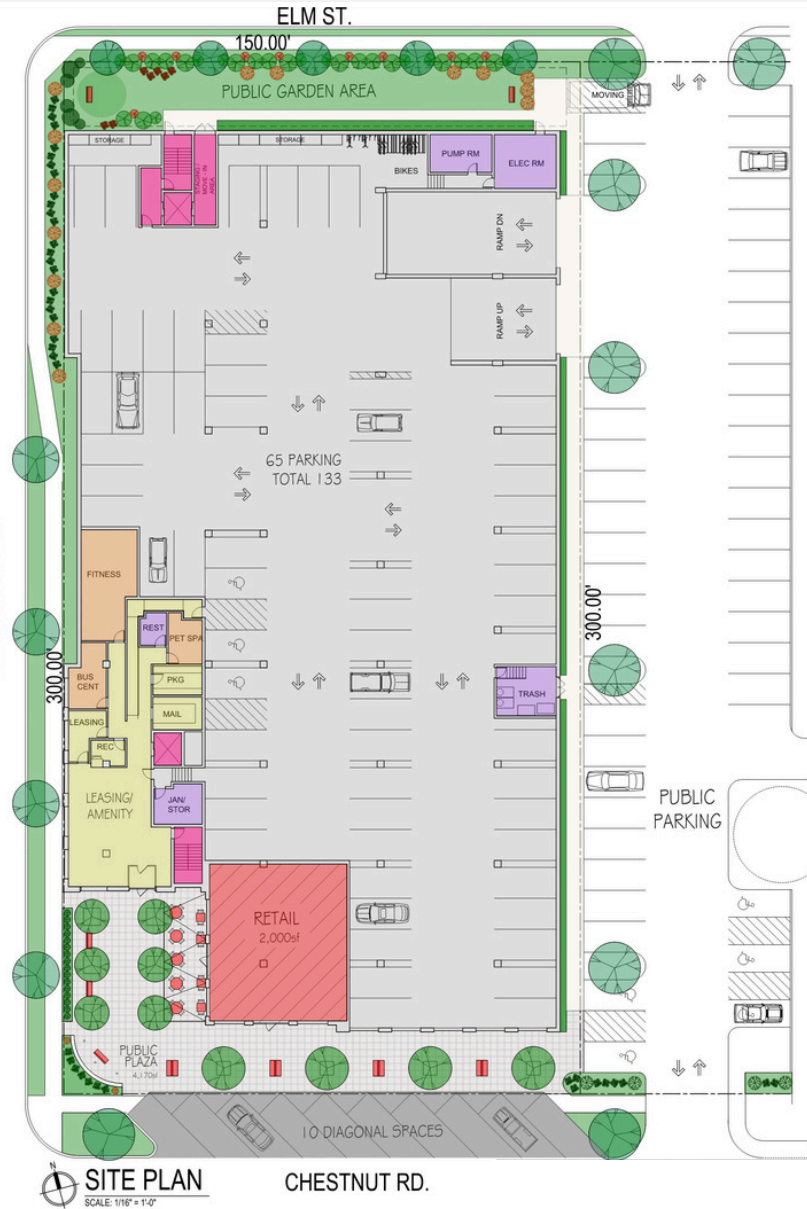
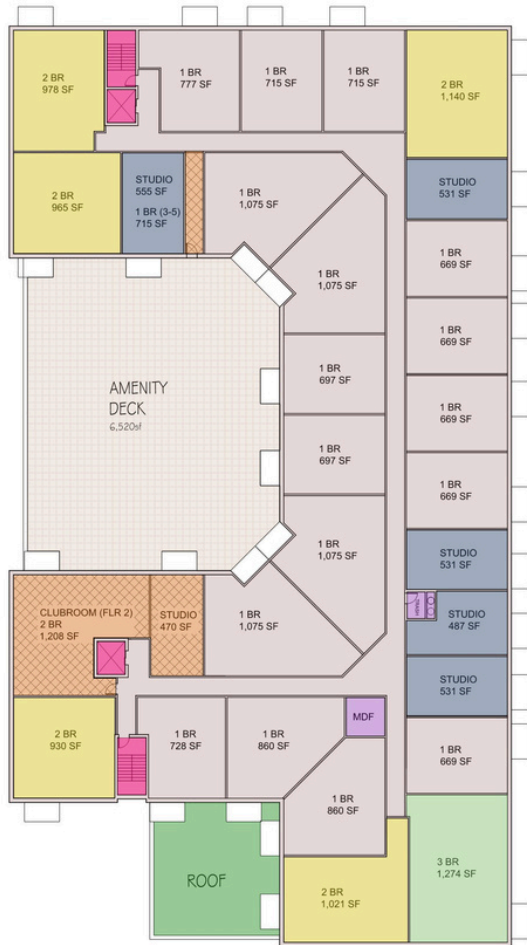

2066 RIDGE ROAD



A Transit-Oriented Development By:



HOLLADAY
PROPERTIES

2066 RIDGE ROAD: CONCEPTUAL PLANS

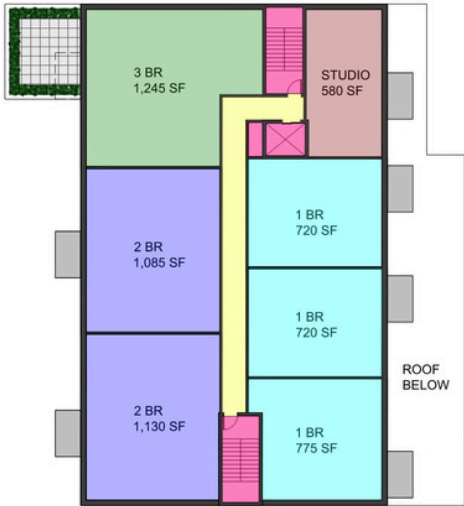

TYP 2nd - 5th FLOOR PLAN



SITE PLAN

2066 RIDGE RD. - DATA OVERVIEW	
ITEM	UNIT SF
Site (0.46 acres)	19,750
Total Dwelling Units	28
Main Building Height	5 Stories
Garages	1,515
Lobby, Mail, Elev Stair & Storage (SF)	1,256
Retail Space (SF)	5,925
Main Level (sf)	8,883
Level 2 (SF)	7,128
Level 3 (SF)	7,128
Level 4 (SF)	7,128
Level 5 (SF)	7,128
Total Building SF	37,395
Indoor Parking Spaces - non-handicapped	8
Indoor Parking Spaces - handicapped	23
Total Site Parking Spaces	31
Resident Parking Spaces (1.11 ratio)	31

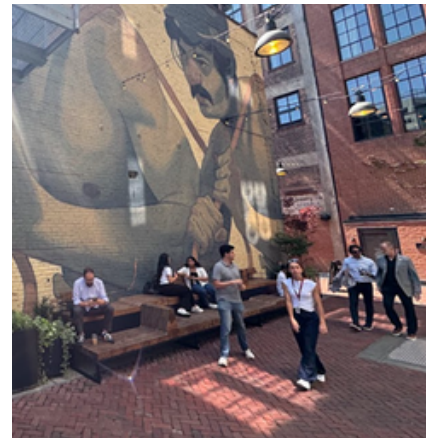

2024 CHESTNUT ROAD: OUTDOOR AMENITY DECK PROGRAMING

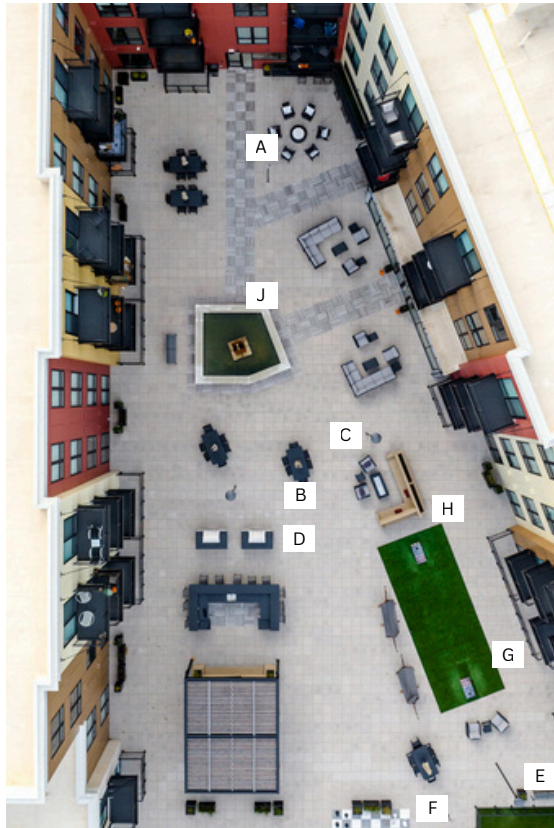

2024 CHESTNUT ROAD: OUTDOOR AMENITY DECK PROGRAMING



LILAC STATION - LOMBARD, IL

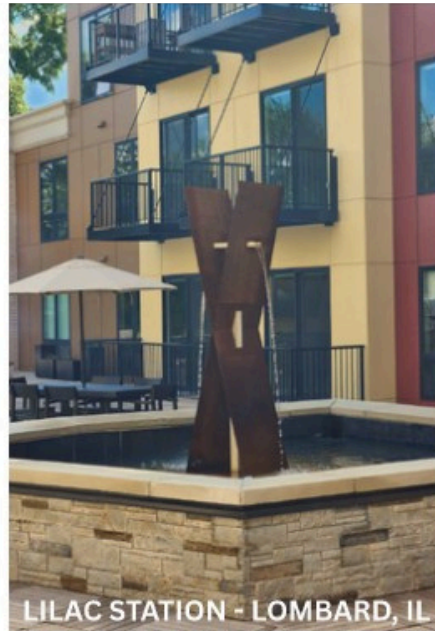

LILAC STATION - LOMBARD, IL



QUINCY STATION - WESTMONT, IL



GLENWOOD STATION -
GLEN ELLYN, IL



BURLINGTON STATION - DOWNERS GROVE, IL

2024 CHESTNUT ROAD: OUTDOOR AMENITY DECK PROGRAMING

WIND FEATURE

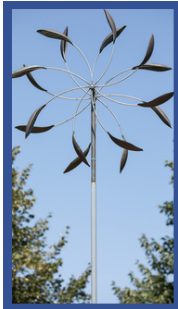

MULTIPURPOSE TURF



OUTDOOR KITCHEN

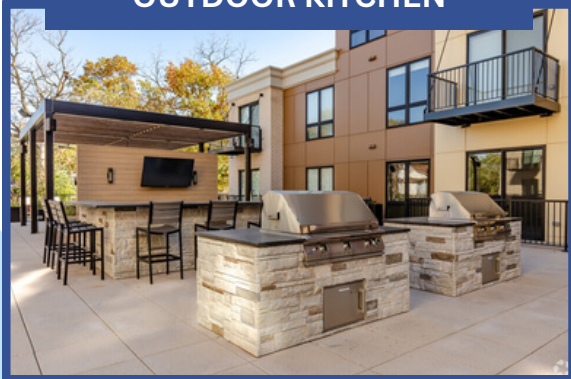

FIRE FEATURE



PERGOLA WITH SEATING

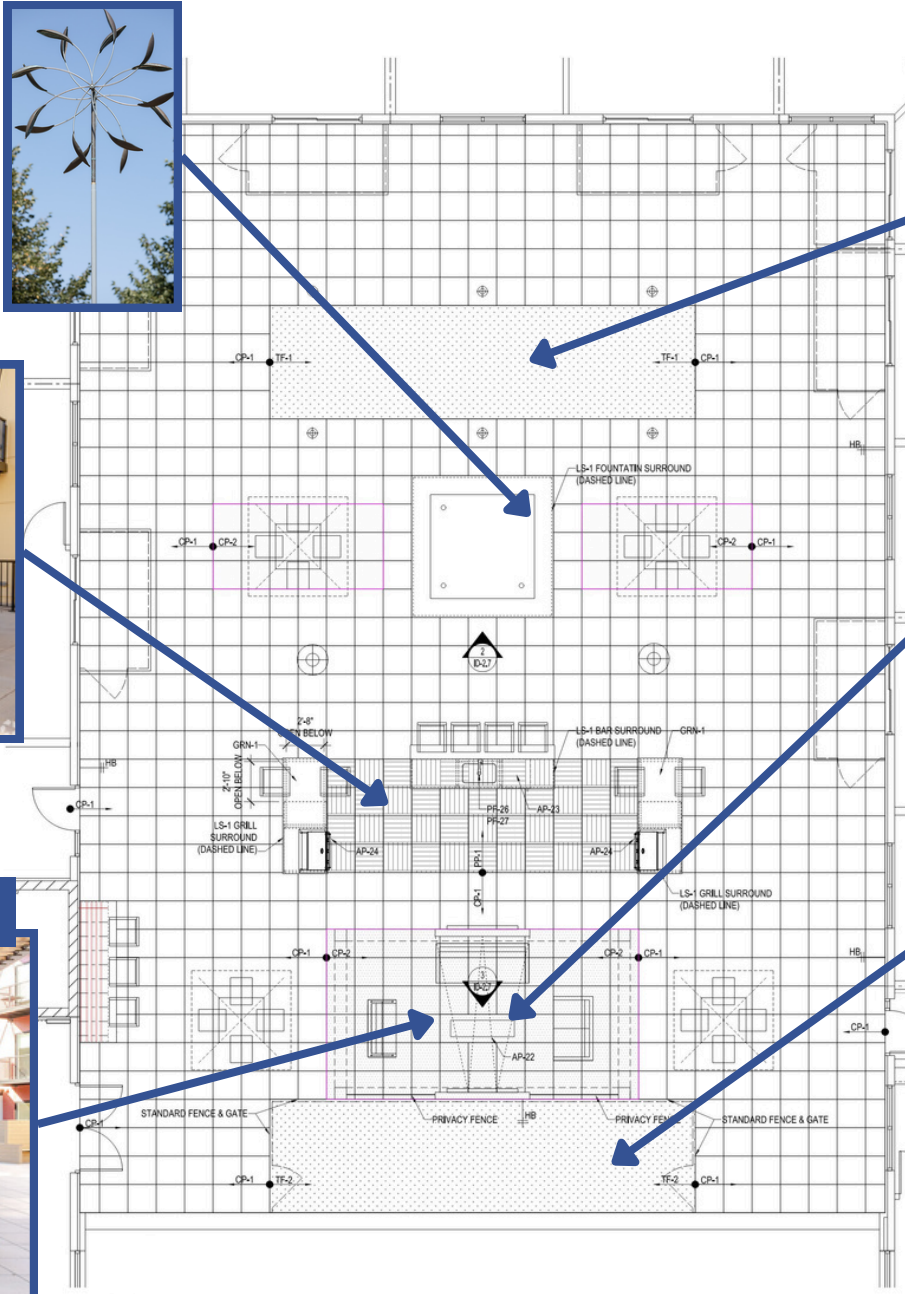
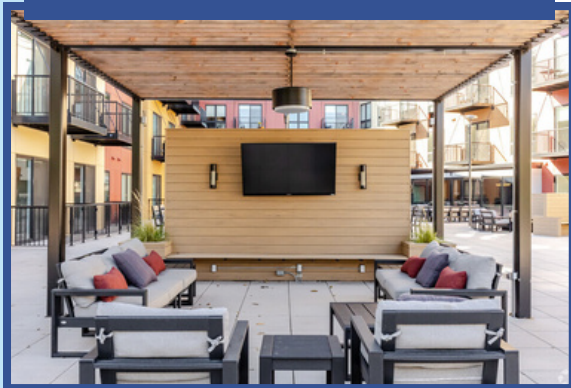

DOG RUN



2024 CHESTNUT ROAD: INDOOR AMENITY SPACE PROGRAMMING

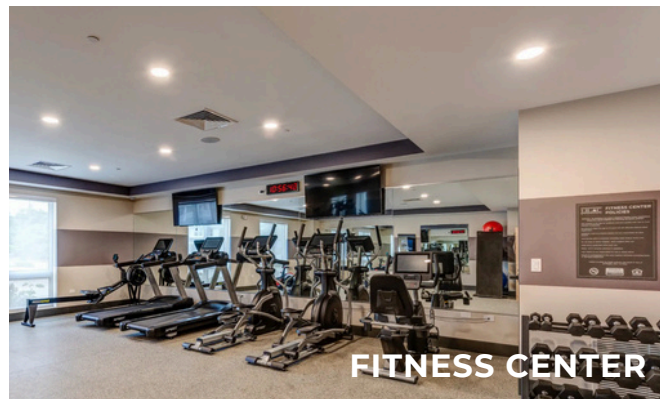
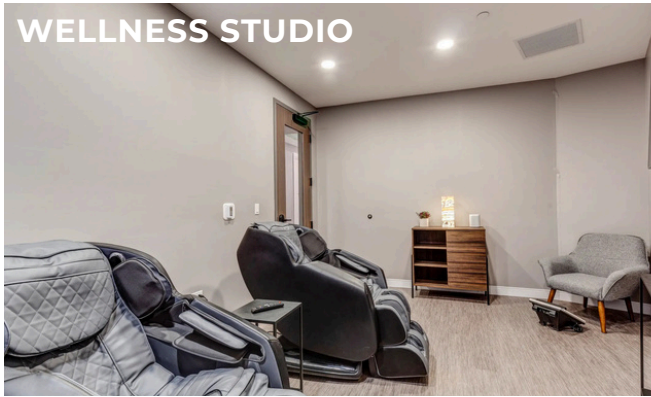

UNIT LAYOUT EXAMPLES



2024 CHESTNUT UNIT SUMMARY						
UNIT STYLE	2 ND FLOOR	3 RD FLOOR	4 TH FLOOR	5 TH FLOOR	TOTAL	PERCENTAGE
STUDIO	5	5	5	5	20	16.95%
1 BED	17	18	18	18	71	60.17%
2 BED	5	6	6	6	23	19.4%
3 BED	1	1	1	1	4	3.39%
TOTAL PER FLOOR	28	30	30	30	118	

2066 RIDGE ROAD UNIT SUMMARY						
UNIT STYLE	2 ND FLOOR	3 RD FLOOR	4 TH FLOOR	5 TH FLOOR	TOTAL	PERCENTAGE
STUDIO	1	1	1	1	4	14.29%
1 BED	3	3	3	3	12	42.86%
2 BED	2	2	2	2	8	28.58%
3 BED	1	1	1	1	4	14.29%
TOTAL PER FLOOR	7	7	7	7	28	

