

# MEETING AGENDA



## Board of Trustees Meeting

Village of Homewood

July 23, 2024

Meeting Start Time: 7:00 PM

Village Hall Board Room

2020 Chestnut Road, Homewood, IL

Board Meetings will be held as in-person meetings. In addition to in-person public comment during the meeting, members of the public may submit written comments by email to [comments@homewoodil.gov](mailto:comments@homewoodil.gov) or by placing written comments in the drop box outside Village Hall. Comments submitted before 4:00 p.m. on the meeting date will be distributed to all Village Board members prior to the meeting.

Please see last page of agenda for virtual meeting information.

1. Call to Order
2. Pledge of Allegiance
3. Roll Call
4. Introduction of Staff
5. Minutes:
  - Consider a motion to approve the minutes from the regular meeting of the Board of Trustees held on July 9, 2024.
6. Claims List:
  - Consider a motion to approve the Claims List of Tuesday, July 23, 2024 in the amount of \$413,558.64.
7. Hear from the Audience
8. Meet Your Merchants
9. Presentation(s):
  - Assistant Village Manager Terence Acquah will give a presentation of the RAVE Communications Software.
10. Oaths of Office: The Village Clerk will administer the oath of office to:
  - A. Valerie Spada for the position of Finance Clerk.
  - B. Joshua Burman for the position of Director of Public Works.
11. Omnibus Vote: Consider a motion to pass, approve, authorize, accept, or award the following item(s):
  - A. Reappointments/Appearance Commission/Economic Development Committee: Approve the reappointments of Jack Hrymak and Kalinda Preston to the Appearance Commission for a three-year term ending on July 23, 2027; and Terry Keigher and Craig Schmidt to the Economic Development Committee for a two-year term ending on July 23, 2026.
  - B. Bid Award/HVAC Replacement/Jones Environmental Control, Inc.: Award a bid to Jones Environmental Control, Inc. of Mokena, IL, the lowest responsible bidder, in the amount of

\$41,878. to replace the HVAC rooftop unit located at the Village of Homewood Auditorium, 2010 Chestnut Road.

- C. Bid Award/Street Sweeping Services/ Advance Sweeping Services: Authorize the Village Manager to engage the services of Advance Sweeping Services of Rockford, IL for contract sweeping services for five residential and 15 commercial sweeps in an amount not to exceed \$8,366.66 per residential sweep, and \$833.33 per commercial sweep.
- D. Purchase/Passageway Lighting/Chicago Lightworks: Authorize the purchase of ten (10) Color Kinetics Red, Green, Blue, White (RGBW) lights and one (1) Pharos controller from Chicago Lightworks, of Lisle, IL, for an amount not to exceed \$27,228.
- E. Waive Competitive Bidding/Contract Approval/Tivoli Lighting/F.H. Paschen: Waive competitive bidding due to utilizing a professional company that has previous experience with this project in Homewood; and, approve a contract with F.H. Paschen, of Chicago, IL for the purchase and installation of Tivoli lights along both sides of Martin Avenue, from Chestnut Road to Martin Square, in the amount of \$170,978.94 with a contingency amount of \$8,000 to cover the costs for any unforeseen and/or underground construction issues for a total amount of \$178,978.94.
- F. Agreement/Public Parking Lot Signage/ROEDA Signs: Authorize the Village President to enter into an agreement with ROEDA Signs of Lynwood, IL for illuminated public parking lot entry signs and parking directional signs in the amount of \$64,463.
- G. Redevelopment Agreement Amendment/Wind Creek IL LLC: Authorize the Village President to enter into an amendment to the redevelopment agreement with Wind Creek IL LLC.

12. New Business:

Discussion/Liquor License/Mitchell and Michaels Plat Du Jour/18031 Dixie Highway: Discuss a liquor license request from Mitchell and Michaels Plat Du Jour. After discussion, and if the Board is in favor of granting the request for a liquor license, staff should be directed to prepare an ordinance to increase the allowed number of Class 4A liquor licenses for the proposed Mitchell and Michaels Plat Du Jour location at 18031 Dixie Highway. The ordinance will be agendized at a future Board meeting, once the petitioner successfully completes the application requirements for a Village of Homewood liquor license.

13. General Board Discussion

14. Adjourn

---

Zoom Link: <https://zoom.us/>

- To View the Meeting via Computer or Smartphone - Type in: Zoom.us into any internet browser.

Select: JOIN A MEETING from menu at top right of page. Meeting I.D.: 980 4907 6232

Meeting Password: 830183. Enter an email address (required), or

- To Listen to the Meeting via Phone - Dial: (312) 626-6799

Enter above "Meeting I.D. and Meeting Password" followed by "#" sign

---

VILLAGE OF HOMEWOOD  
BOARD OF TRUSTEES MEETING  
TUESDAY, JULY 9, 2024  
VILLAGE HALL BOARD ROOM

CALL TO ORDER: President Hofeld called the meeting of the Board of Trustees to order at 7 p.m.

PLEDGE OF ALLEGIANCE: President Hofeld led trustees in the Pledge of Allegiance.

ROLL CALL: Clerk Marilyn Thomas called the roll. Those present were Village President Richard Hofeld, Trustee Julie Willis, Trustee Vivian Harris-Jones, Trustee Jay Heiferman, Trustee Phillip Mason, and Trustee Lauren Roman. Trustee Allisa Opyd was absent.

President Hofeld introduced staff present: Village Manager Napoleon Haney, Village Attorney Chris Cummings, Director of Economic and Community Development Angela Mesaros, Fire Chief Bob Grabowski, Police Chief Denise McGrath and Assistant Village Manager Terence Acquah.

MINUTES: The minutes of the June 25, 2024, regular Village Board meeting were presented. There were no comments or corrections.

A motion was made by Trustee Mason and seconded by Trustee Harris-Jones to approve the minutes as presented.

***Roll Call: AYES --Trustees Willis, Harris-Jones, Heiferman, Mason, and Roman. NAYS –None. Motion carried.***

CLAIMS LIST: The Claims List in the amount of \$812,497.20 was presented. There were no questions from the Trustees.

A motion was made by Trustee Willis and seconded by Trustee Mason to approve the Claims List as presented.

***Roll Call: AYES --Trustees Willis, Harris-Jones, Heiferman, Mason, and Roman. NAYS –None. Motion carried.***

President Hofeld said the \$254,575.66 payment for employee health insurance for July and the \$314,516.05 payment to Chicago Heights for water totaled 70% of the total Claims List.

HEAR FROM THE AUDIENCE: President Hofeld invited any audience member to address the board on any subject not on the agenda. No comments were offered.

MEET THE MERCHANTS: Director Mesaros welcomed Keith Stoffle, director of golf at Ravisloe Country Club. What once was a private club, from 1901 through 2008, was sold to Claude Gendreau in 2009 and he opened it as a public course. The facility also has a putting green and golf simulator. The restaurant serves in the dining room or outside on the patio. Ravisloe Country Club is open seven days a week. The website is ravisloe.com.

APPOINTMENT: A motion was made by Trustee Mason and seconded by Trustee Roman to approve the appointment of Naomi Perkins to the Events Committee.

**Roll Call: AYES --Trustees Willis, Harris-Jones, Heiferman, Mason, and Roman. NAYS –None. Motion carried.**

Clerk Thomas administered the oath of office to Ms. Perkins.

**PRESENTATION:** Antonia Steinmiller, the village’s Communications & Engagement Specialist, said she was tasked with ways to help residents prepare for the invasion of the cicadas this spring. She plotted out a poster following an example from Taylor Swift, and it went viral through social media. The design was put on T-shirts for sale online, through a pop-up shop and at the Art & Garden Fair, and the sale raised \$3,486 for Anew: Building Beyond Violence and Abuse. President Hofeld presented a check to volunteers and staff with the organization.

**OATH OF OFFICE:** Chief Grabowski introduced Andrew Sline as the newest firefighter/paramedic. He represents the third generation in his family to be a member of the Homewood Fire Department. His grandfather and uncle and great uncle all served before him. Andrew is a Homewood resident and graduate of Homewood-Flossmoor High School. He was a volunteer firefighter in Glenwood since age 16 and got hired on as a part-time firefighter in Homewood serving from 2021-2023. Chief Grabowski said Sline tested and was on the Homewood firefighter list. He officially joined the Homewood Fire Department June 3, 2024.

**NEW BUSINESS:** Director Mesaros asked Trustees to consider the proposal to hire a consultant for work on a proposed Tax Increment Financing District south of 175th Street and the west side of Halsted Street. The Board would be approving a contract with Ryan LLC of Chicago to initiate a TIF designation for certain properties, including the former Walmart property that has been vacant since March 2023.

The firm would be preparing a TIF eligibility analysis; preparing a redevelopment plan; preparing the required notices and mailing lists and completing the public approval process. The contract is for \$23,500 with a 15 percent cost contingency in the amount of \$3,525. The total cost of the contract is \$27,025.

A motion was made by Trustee Heiferman and seconded by Trustee Roman to approve the consultant agreement with Ryan LLC of Chicago.

**Roll Call: AYES --Trustees Willis, Harris-Jones, Heiferman, Mason, and Roman. NAYS –None. Motion carried.**

**OLD BUSINESS:** The Board was asked to accept staff’s recommendation to negotiate a purchase and sale agreement and a redevelopment agreement with Grace Yan Cui of CIG (Chicago Investment Group) 2018 Homewood LLC for the property at 2018-2020 Ridge Road. The building is owned by the Village. It previously housed Karate Kids. When it was donated to the Village it was leased to the Homewood Science Center for its use, but the HSC staff said it did not need the space. The Village solicited alternate proposals as required by the TIF Act and received two proposals in addition to the plan submitted by the Chicago Investment Group. After reviewing all proposals, staff recommended selecting the Chicago Investment Group plan.

President Hofeld asked for comments from the Trustees. Trustees Willis and Harris-Jones said they were satisfied with the analysis by staff that supported the recommendation. Trustees Heiferman and Mason said they were excited for the Mongolian BBQ restaurant planned for the space. Trustee

Roman said the delay (by two weeks) in approving the CIG proposal was meant to be due diligence for the project. She too welcomed CIG to the Village.

A motion was made by Trustee Willis and seconded by Trustee Mason to negotiate a purchase sale agreement and redevelopment agreement with Grace Yan Cui and CIG 2018 Homewood LLC.

***Roll Call: AYES --Trustees Willis, Harris-Jones, Heiferman, Mason, and Roman. NAYS –None. Motion carried.***

GENERAL BOARD DISCUSSION: Trustees Willis and Harris-Jones said the 4th of July parade was outstanding. Trustee Heiferman commented on the restorations being done to the Gottschalk House.

President Hofeld announced a public meeting with Cook County Assessor Fritz Kaegi to hear from him about the jump in taxes after the south suburbs were reassessed. The meeting will be at 9:30 a.m. on Saturday, July 20, at the Homewood Auditorium. It will be a question/answer session.

ADJOURN: A motion was made by Trustee Roman and seconded by Trustee Harris-Jones to adjourn the regular meeting of the Board of Trustees.

***Roll Call: AYES --Trustees Willis, Harris-Jones, Heiferman, Mason, and Roman. NAYS –None. Motion carried.***

The meeting adjourned at 7:22 p.m.

Respectfully submitted,

Marilyn Thomas



## Public Comments for the July 9, 2024 Board Meeting

---

**From:** Kris Condon  
**Sent:** Sunday, July 7, 2024 7:39 PM  
**To:** PublicComments  
**Subject:** (Thank you) For Public Comment, July 9, 2024

Good Evening, President Hofeld and Members of the Board of Trustees:

As you are by now aware, I am not reluctant to bring issues of personal concern to this body, as evidenced by my message of June 25, 2024, regarding consistent enforcement of the Village fireworks ordinance. At the same time, I am equally compelled to share my thanks and appreciation to Chief McGrath, Deputy Chief Johnson, and Officer Dean for their assistance over the July 4 holiday.

At the June 25 meeting, you heard my neighbor express concern about neighbors (and I use that term loosely, as the behavior was not remotely neighborly) firing Roman candles and bottle rockets at her wooden deck and my frame garage. Mrs. Townsend's concerns were well-founded this past week. We had a repeat performance from another neighbor who was shooting fireworks into a 70-foot tall tree; attempting to shoot bottle rockets between transformer lines; and aiming for her deck, another neighbor's backyard, and over my frame garage roof onto my patio. My call to 911 was handled quickly and professionally by Officer Dean, who called me after the fireworks confiscation occurred. Officer Dean was forthcoming about what he could and could not tell me and further understood my fear of retaliation given this person's history of verbally abusive interactions with other neighbors. While there was admittedly activity in the rest of the neighborhood over the July 4 holiday, the situation was infinitely improved over last year, and I attribute that in great part to the assurances the Chief offered the Board on June 25.

Homewood did not need home rule on July 4 to have a safer holiday. This was all about choices and consequences, with the individual in question understanding that the act of thumbing his nose at neighbors and the Village would be addressed accordingly, irrespective of home rule. What we needed this past week was enhanced communication, enforcement of existing ordinances, and Village leadership's support of those law enforcement officers who had a completely thankless job that evening. That's what I witnessed. For my part, I thank Homewood Police Department for delivering as promised. I am a grateful resident.

Sincerely, Kris Condon

**Dr. Kristine M. (Kris) Condon**  
Homewood, IL 60430

Name	Description	DEPARTMENT	Net Invoice Amount
911 TECH INC	COPFTO SOFTWARE ANNUAL FEE	POLICE DEPARTMENT	2,472.00
Total 911 TECH INC:			2,472.00
ADRIAN ESPARZA	ROCK THE BLOCK ENTERTAINMENT	MANAGER'S OFFICE	500.00
Total ADRIAN ESPARZA:			500.00
ADVANCED AUTO PARTS	OPERATING SUPPLIES PW	PUBLIC WORKS	8.27
Total ADVANCED AUTO PARTS:			8.27
AMAZON CAPITAL SERVICES IN	OFFICE SUPPLIES	MANAGER'S OFFICE	63.98
AMAZON CAPITAL SERVICES IN	BEAUTIFIATION COMMITTEE	EXPENSES	349.00
AMAZON CAPITAL SERVICES IN	GOTTSCHALK THE WALK MATERIALS	MANAGER'S OFFICE	90.67
AMAZON CAPITAL SERVICES IN	OFFICE SUPPLIES	MANAGER'S OFFICE	19.99
AMAZON CAPITAL SERVICES IN	GOTTSCHALK THE WALK MATERIALS	MANAGER'S OFFICE	167.04
AMAZON CAPITAL SERVICES IN	OFFICE SUPPLIES	MANAGER'S OFFICE	8.50
AMAZON CAPITAL SERVICES IN	GOTTSCHALK THE WALK MATERIALS	MANAGER'S OFFICE	174.50
AMAZON CAPITAL SERVICES IN	BUILDING MAINTENANCE SUPPLIES	PUBLIC WORKS	78.24
Total AMAZON CAPITAL SERVICES INC:			951.92
AMERICAN LAWN LLC	SHOPPING CARTS	FIRE DEPARTMENT	150.00
AMERICAN LAWN LLC	SHOPPING CARTS	FIRE DEPARTMENT	50.00
AMERICAN LAWN LLC	SHOPPING CARTS	FIRE DEPARTMENT	125.00
Total AMERICAN LAWN LLC:			325.00
B ALLAN GRAPHICS	BUSINESS CARDS	MANAGER'S OFFICE	65.00
Total B ALLAN GRAPHICS:			65.00
BARTELSON MICHAEL	80% MEDICARE SUPPLEMENT REIMBURSEMENT	MANAGER'S OFFICE	424.83
Total BARTELSON MICHAEL:			424.83
BURNS & MCDONNELL ENGINE	LEAD SERVICE PLAN	PUBLIC WORKS	6,000.00
Total BURNS & MCDONNELL ENGINEERING CO., INC.:			6,000.00
BURRIS EQUIPMENT CO	L&M DEPT REPAIR PARTS	PUBLIC WORKS	1,110.60
Total BURRIS EQUIPMENT CO:			1,110.60
C & M PIPE SUPPLY	REARYARD DRAINAGE MATERIALS	PUBLIC WORKS	1,102.00
Total C & M PIPE SUPPLY:			1,102.00
C & T LAWN AND LANDSCAPE	VACANT PROPERTY MOWING	PUBLIC WORKS	1,168.00
Total C & T LAWN AND LANDSCAPE:			1,168.00
CDW GOVERNMENT INC	CRADLEPOINT FOR NEW AMBULANCE	MANAGER'S OFFICE	1,243.69
Total CDW GOVERNMENT INC:			1,243.69

Name	Description	DEPARTMENT	Net Invoice Amount
CIVIC SYSTEMS LLC	ADDITIONAL HOSTED USERS FOR CASELLE	MANAGER'S OFFICE	360.00
CIVIC SYSTEMS LLC	ADDITIONAL HOSTED USERS FOR CASELLE	PUBLIC WORKS	360.00
Total CIVIC SYSTEMS LLC:			720.00
COMMUNITY FIREFIGHTERS	MABAS FEES - FD	FIRE DEPARTMENT	235.00
Total COMMUNITY FIREFIGHTERS:			235.00
CURRIE MOTORS (PARTS)	POLICE DEPT REPAIR PARTS	PUBLIC WORKS	118.76
CURRIE MOTORS (PARTS)	POLICE DEPT REPAIR PARTS	PUBLIC WORKS	85.91
Total CURRIE MOTORS (PARTS):			204.67
DACRA ADJUDICATION LLC	MOS/MOVE/ABC MONTHLY FEE	POLICE DEPARTMENT	1,632.00
Total DACRA ADJUDICATION LLC:			1,632.00
DANA ROBINSON	80% MEDICARE SUPPLEMENT REIMBURSEMENT	MANAGER'S OFFICE	119.20
Total DANA ROBINSON:			119.20
DANIEL ROSSI	80% MEDICARE SUPPLEMENT REIMBURSEMENT	MANAGER'S OFFICE	516.13
Total DANIEL ROSSI:			516.13
DELTA SONIC CAR WASH	VEHICLE WASHES	PUBLIC WORKS	40.50
Total DELTA SONIC CAR WASH:			40.50
DENISE MCGRATH	IACP CONFERENCE AIRFARE	POLICE DEPARTMENT	327.96
Total DENISE MCGRATH:			327.96
DENNIS GIOMETTI	80% MEDICARE SUPPLEMENT REIMBURSEMENT	MANAGER'S OFFICE	323.20
Total DENNIS GIOMETTI:			323.20
DIKA HOMEWOOD LLC	BURLINGTON SALES TAX SHARING	MANAGER'S OFFICE	4,641.65
Total DIKA HOMEWOOD LLC:			4,641.65
DIRECTION PROMO INC	TOD PLAN ACTION KIT	MANAGER'S OFFICE	137.43
Total DIRECTION PROMO INC:			137.43
E-COM	FY 2024-2025 Q2 OPERATING	POLICE DEPARTMENT	96,290.32
Total E-COM:			96,290.32
EMPERIAL	COMMERCIAL CUTS	FIRE DEPARTMENT	616.24
Total EMPERIAL:			616.24
EXPERT CHEMICAL	OPERATING SUPPLIES	FIRE DEPARTMENT	1,041.37



Name	Description	DEPARTMENT	Net Invoice Amount
Total EXPERT CHEMICAL:			1,041.37
FAIRVIEW REALTY GROUP	POLICE APPLICANT BACKGROUND CHECK	MANAGER'S OFFICE	50.00
FAIRVIEW REALTY GROUP	POLICE APPLICANT BACKGROUND CHECK	MANAGER'S OFFICE	100.00
Total FAIRVIEW REALTY GROUP:			150.00
FESSCO FIRE EQUIP SALES &	FIRE EXTINGUISHER SERVICE	PUBLIC WORKS	223.20
Total FESSCO FIRE EQUIP SALES & SVC:			223.20
FIRST EAGLE BANK	EMERGENCY WARNING SIRENS LEASE PYMT #3	FIRE DEPARTMENT	18,070.82
Total FIRST EAGLE BANK:			18,070.82
FORD OF HOMEWOOD	POLICE DEPT REPAIR PARTS	PUBLIC WORKS	15.63
FORD OF HOMEWOOD	POLICE DEPT REPAIR PARTS	PUBLIC WORKS	15.84
FORD OF HOMEWOOD	POLICE DEPT REPAIR PARTS	PUBLIC WORKS	83.40
FORD OF HOMEWOOD	POLICE DEPT REPAIR PARTS	PUBLIC WORKS	63.06
FORD OF HOMEWOOD	VEHICLE PARTS - FD	FIRE DEPARTMENT	79.96
FORD OF HOMEWOOD	FIRE VEHICLE MAINTENANCE	FIRE DEPARTMENT	26.00
Total FORD OF HOMEWOOD:			283.89
FRIEDMAN & HUEY ASSOC LLC	EXCESS PROPERTY TAX CREDIT-1313 175TH	PUBLIC WORKS	39,056.66
Total FRIEDMAN & HUEY ASSOC LLC:			39,056.66
GALLAGHER MATERIALS	ASPHALT	PUBLIC WORKS	138.00
Total GALLAGHER MATERIALS:			138.00
GFC LEASING	COPIER METERS	MANAGER'S OFFICE	97.00
GFC LEASING	COPIER/PRINTER SUPPLIES	MANAGER'S OFFICE	883.50
Total GFC LEASING:			980.50
GRAINGER INC	VEHICLE MAINT DEPT TOOLS	PUBLIC WORKS	222.16
GRAINGER INC	BUILDING MAINTENANCE SUPPLIES	PUBLIC WORKS	14.40
Total GRAINGER INC:			236.56
GW BERKHEIMER CO INC	HVAC REPAIRS - PW	PUBLIC WORKS	170.09
Total GW BERKHEIMER CO INC:			170.09
HISKES, DILLNER, O'DONNELL	CONTRACT/CONSULTING SERVICE	MANAGER'S OFFICE	1,387.00
Total HISKES, DILLNER, O'DONNELL:			1,387.00
HOMEWOOD DISPOSAL	DUMP CHARGES	PUBLIC WORKS	624.47
HOMEWOOD DISPOSAL	DUMP CHARGES	PUBLIC WORKS	88.00
Total HOMEWOOD DISPOSAL:			712.47
ILCMA	RECRUITMENT	MANAGER'S OFFICE	50.00

Name	Description	DEPARTMENT	Net Invoice Amount
Total ILCMA:			50.00
ILLINOIS TOLLWAY	OPERATING SUPPLIES - PW	PUBLIC WORKS	257.20
Total ILLINOIS TOLLWAY:			257.20
INTERSTATE BATTERY	POLICE DEPT REPAIR PARTS	PUBLIC WORKS	372.90
Total INTERSTATE BATTERY:			372.90
IRMA	JUNE DEDUCTIBLE	MANAGER'S OFFICE	3,517.94
IRMA	JUNE DEDUCTIBLE	POLICE DEPARTMENT	30.00
IRMA	JUNE DEDUCTIBLE	FIRE DEPARTMENT	6,722.15
IRMA	JUNE DEDUCTIBLE	PUBLIC WORKS	4,396.43
IRMA	JUNE DEDUCTIBLE	PUBLIC WORKS	2,090.99
Total IRMA:			16,757.51
JODY APPELATE	80% MEDICARE SUPPLEMENT REIMBURSEMENT	MANAGER'S OFFICE	111.23
Total JODY APPELATE:			111.23
JOHN M ELLSWORTH CO INC	WATER DEPT REPAIR PARTS	PUBLIC WORKS	179.74
JOHN M ELLSWORTH CO INC	WATER DEPT REPAIR PARTS	PUBLIC WORKS	163.12
Total JOHN M ELLSWORTH CO INC:			342.86
JOHN SATHER	FARMERS MARKET ENTERTAINMENT	MANAGER'S OFFICE	300.00
JOHN SATHER	FARMERS MARKET ENTERTAINMENT	MANAGER'S OFFICE	300.00
Total JOHN SATHER:			600.00
JONES PARTS & SERVICE INC	WATER DEPT REPAIR PARTS	PUBLIC WORKS	92.37
Total JONES PARTS & SERVICE INC:			92.37
KELLY STRAYER	IACP CONFERENCE AIRFARE	POLICE DEPARTMENT	327.96
Total KELLY STRAYER:			327.96
KENNETH REUSNOW	80% MEDICARE SUPPLEMENT REIMBURSEMENT	MANAGER'S OFFICE	1,406.40
Total KENNETH REUSNOW:			1,406.40
LANER MUCHIN LTD	RETAINER/LABOR RELATIONS	MANAGER'S OFFICE	3,846.67
Total LANER MUCHIN LTD:			3,846.67
LexisNexis RISK DATA MANAGE	BACKGROUND CHECKS	POLICE DEPARTMENT	200.00
Total LexisNexis RISK DATA MANAGEMENT:			200.00
LOGSDON CONSULTATION SER	CONTRACTUAL SERVICES - FD	FIRE DEPARTMENT	375.00
Total LOGSDON CONSULTATION SERVICES:			375.00

Name	Description	DEPARTMENT	Net Invoice Amount
LOTT #1 INC	PRISONER MEALS	POLICE DEPARTMENT	42.12
Total LOTT #1 INC:			42.12
LOUISE WOLF	80% MEDICARE SUPPLEMENT REIMBURSEMENT	MANAGER'S OFFICE	483.20
Total LOUISE WOLF:			483.20
MACDONALD MICHAEL	80% MEDICARE SUPPLEMENT REIMBURSEMENT	MANAGER'S OFFICE	558.27
Total MACDONALD MICHAEL:			558.27
MARIAN KIEPURA	80% MEDICARE SUPPLEMENT REIMBURSEMENT	MANAGER'S OFFICE	338.06
Total MARIAN KIEPURA:			338.06
MARY ANN MURPHY	80% MEDICARE SUPPLEMENT REIMBURSEMENT	MANAGER'S OFFICE	2,038.40
Total MARY ANN MURPHY:			2,038.40
MENARDS INC	OPERATING SUPPLIES	PUBLIC WORKS	39.96
MENARDS INC	OPERATING SUPPLIES	FIRE DEPARTMENT	268.48
Total MENARDS INC:			308.44
MICHAEL NICKOLAOU	80% MEDICARE SUPPLEMENT REIMBURSEMENT	MANAGER'S OFFICE	188.06
Total MICHAEL NICKOLAOU:			188.06
MONARCH AUTO SUPPLY INC	ADMIN REPAIR PARTS	PUBLIC WORKS	41.65
MONARCH AUTO SUPPLY INC	VEHICLE MAINT TOOLS	PUBLIC WORKS	486.99
MONARCH AUTO SUPPLY INC	VEHICLE MAINT OPERATING SUPPLIES	PUBLIC WORKS	107.88
MONARCH AUTO SUPPLY INC	POLICE DEPT REPAIR PARTS	PUBLIC WORKS	102.44
MONARCH AUTO SUPPLY INC	VEHICLE MAINT OPERATING SUPPLIES	PUBLIC WORKS	202.81
MONARCH AUTO SUPPLY INC	VEHICLE MAINT OPERATING SUPPLIES	PUBLIC WORKS	10.18
MONARCH AUTO SUPPLY INC	VEHICLE MAINT OPERATING SUPPLIES	PUBLIC WORKS	10.18
Total MONARCH AUTO SUPPLY INC:			962.13
MUNICIPAL COLLECTION SERVI	MCSI COLLECTION FEES -- ABC	POLICE DEPARTMENT	212.87
MUNICIPAL COLLECTION SERVI	MCSI COLLECTION FEES -- MOVE	POLICE DEPARTMENT	327.22
MUNICIPAL COLLECTION SERVI	MCSI COLLECTION FEES -- P/C TICKETS	POLICE DEPARTMENT	277.05
Total MUNICIPAL COLLECTION SERVICES:			817.14
MUNICIPAL EMERGENCY SERV	TURN OUT GEAR - FD	FIRE DEPARTMENT	7,861.03
Total MUNICIPAL EMERGENCY SERVICES INC:			7,861.03
NIX NAX	UNIFORM EMBROIDERY	PUBLIC WORKS	12.50
Total NIX NAX:			12.50
OLD NATIONAL BANK/FD	PARAMEDICAL RENEWAL	FIRE DEPARTMENT	41.00
OLD NATIONAL BANK/FD	MEMBERSHIP	FIRE DEPARTMENT	115.00
OLD NATIONAL BANK/FD	FD SHIELDS	FIRE DEPARTMENT	149.32
OLD NATIONAL BANK/FD	BANNER	FIRE DEPARTMENT	120.00

Name	Description	DEPARTMENT	Net Invoice Amount
Total OLD NATIONAL BANK/FD:			425.32
OLD NATIONAL BANK/FIN	FINANCE LUNCHEON	MANAGER'S OFFICE	79.08
Total OLD NATIONAL BANK/FIN:			79.08
OLD NATIONAL BANK/MO	AMTRAK TICKETS - MESAROS&HOFELD	MANAGER'S OFFICE	68.40-
OLD NATIONAL BANK/MO	SUNGLASSES FOR BOOTH GIVEAWAY 2024	MANAGER'S OFFICE	722.53
OLD NATIONAL BANK/MO	AMTRAK TICKETS - MESAROS&HOFELD	MANAGER'S OFFICE	68.40
OLD NATIONAL BANK/MO	APPLE MUSIC JUNE	MANAGER'S OFFICE	10.99
OLD NATIONAL BANK/MO	ASST PW DIRECTOR RECRUITMENT AD	MANAGER'S OFFICE	375.00
OLD NATIONAL BANK/MO	RECRUITMENT	MANAGER'S OFFICE	25.00
OLD NATIONAL BANK/MO	COMCAST CONSOLIDATED BILL	MANAGER'S OFFICE	1,493.15
OLD NATIONAL BANK/MO	COMCAST CONSOLIDATED BILL	MANAGER'S OFFICE	21.00
OLD NATIONAL BANK/MO	CONSTANT CONTACT	MANAGER'S OFFICE	145.00
OLD NATIONAL BANK/MO	AGENDA HOLDERS	MANAGER'S OFFICE	44.93
OLD NATIONAL BANK/MO	TRAVEL INSURANCE FOR AMTRAK SAULUKI	MANAGER'S OFFICE	18.00
OLD NATIONAL BANK/MO	BACK TO SCHOOL ENTERTAINMENT DEPOSIT	MANAGER'S OFFICE	365.00
OLD NATIONAL BANK/MO	FOURTH OF JULY PARADE ENTERTAINMENT	MANAGER'S OFFICE	4,032.45
OLD NATIONAL BANK/MO	GIFT AND SUBSCRIPTION	MANAGER'S OFFICE	85.43
OLD NATIONAL BANK/MO	NEWSPAPER SUBSCRIPTION	MANAGER'S OFFICE	79.00
OLD NATIONAL BANK/MO	IML CONFERENCE - TRUSTEE	MANAGER'S OFFICE	325.00
OLD NATIONAL BANK/MO	DECOR	MANAGER'S OFFICE	139.80
OLD NATIONAL BANK/MO	AD POSTING FOR PW POSITION	MANAGER'S OFFICE	200.00
OLD NATIONAL BANK/MO	APPLICATION FEE - TOD PLAN	MANAGER'S OFFICE	75.00
OLD NATIONAL BANK/MO	FOURTH OF JULY SUPPLIES	MANAGER'S OFFICE	5.29
OLD NATIONAL BANK/MO	BLOCK PARTY RENTALS	MANAGER'S OFFICE	1,309.05
OLD NATIONAL BANK/MO	ROCK THE BLOCK ENTERTAINMENT	MANAGER'S OFFICE	600.00
OLD NATIONAL BANK/MO	ZOOM MONTHLY	MANAGER'S OFFICE	40.00
Total OLD NATIONAL BANK/MO:			10,111.62
OLD NATIONAL BANK/PD	NOTARY APPLICATION & BOND	POLICE DEPARTMENT	107.29
OLD NATIONAL BANK/PD	NOTARY APPLICATION & BOND	POLICE DEPARTMENT	107.29
OLD NATIONAL BANK/PD	OFFICE SUPPLIES	POLICE DEPARTMENT	46.93
OLD NATIONAL BANK/PD	OFFICE SUPPLIES	POLICE DEPARTMENT	23.70
OLD NATIONAL BANK/PD	OFFICE SUPPLIES	POLICE DEPARTMENT	36.73
OLD NATIONAL BANK/PD	OFFICE SUPPLIES	POLICE DEPARTMENT	29.94
OLD NATIONAL BANK/PD	OFFICE SUPPLIES	POLICE DEPARTMENT	13.48
OLD NATIONAL BANK/PD	RETURN	POLICE DEPARTMENT	16.99-
OLD NATIONAL BANK/PD	OFFICE SUPPLIES	POLICE DEPARTMENT	23.70-
OLD NATIONAL BANK/PD	OFFICE SUPPLIES	POLICE DEPARTMENT	19.99
OLD NATIONAL BANK/PD	ENVELOPES	POLICE DEPARTMENT	953.60
OLD NATIONAL BANK/PD	RETIREMENT LUNCH	POLICE DEPARTMENT	280.83
OLD NATIONAL BANK/PD	ANNUAL MEMBERSHIP FEE	POLICE DEPARTMENT	190.00
OLD NATIONAL BANK/PD	OFFICE SUPPLIES	POLICE DEPARTMENT	60.77
OLD NATIONAL BANK/PD	OFFICE SUPPLIES	POLICE DEPARTMENT	51.29
OLD NATIONAL BANK/PD	ENTRY LEVEL ORAL INTERVIEWS	MANAGER'S OFFICE	65.86
OLD NATIONAL BANK/PD	REFUND FOR CHAIRS	POLICE DEPARTMENT	1,399.93-
OLD NATIONAL BANK/PD	BUSINESS CARDS	POLICE DEPARTMENT	237.95
OLD NATIONAL BANK/PD	RETIREMENT EXPENSES	POLICE DEPARTMENT	56.56
Total OLD NATIONAL BANK/PD:			841.59
OLD NATIONAL BANK/PW	TRAINING	PUBLIC WORKS	569.00
OLD NATIONAL BANK/PW	CHAINSAW EQUIPMENT	PUBLIC WORKS	280.00

Name	Description	DEPARTMENT	Net Invoice Amount
OLD NATIONAL BANK/PW	BUILDING MAINTENANCE	PUBLIC WORKS	148.97
OLD NATIONAL BANK/PW	BUILDING MAINTENANCE	PUBLIC WORKS	196.03
OLD NATIONAL BANK/PW	BUILDING MAINTENANCE	PUBLIC WORKS	966.00
OLD NATIONAL BANK/PW	ADMIN REPAIR PARTS	PUBLIC WORKS	90.36
OLD NATIONAL BANK/PW	TRAINING	PUBLIC WORKS	207.96
OLD NATIONAL BANK/PW	RETIREMENT LUNCHEON	PUBLIC WORKS	408.91
Total OLD NATIONAL BANK/PW:			2,867.23
OVERDOORS OF ILLINOIS INC	GARAGE BAY DOORS PW	PUBLIC WORKS	3,480.00
Total OVERDOORS OF ILLINOIS INC:			3,480.00
P F PETTIBONE CO	PARKING/COMPLIANCE TICKETS	POLICE DEPARTMENT	2,224.68
Total P F PETTIBONE CO:			2,224.68
PHILLIP B ARVIA	FARMERS MARKET ENTERTAINMENT	MANAGER'S OFFICE	350.00
Total PHILLIP B ARVIA:			350.00
PHILLIPS CHEVROLET	VEHICLE MAINTENANCE	FIRE DEPARTMENT	751.70
Total PHILLIPS CHEVROLET:			751.70
RED WING BUSINESS ADVANT	WORK BOOTS	PUBLIC WORKS	258.98
RED WING BUSINESS ADVANT	WORK BOOTS	PUBLIC WORKS	207.23
RED WING BUSINESS ADVANT	WORK BOOTS	PUBLIC WORKS	256.98
Total RED WING BUSINESS ADVANTAGE:			723.19
RELIANCE SAFETY LANE & SE	VEHICLE SAFETY INSPECTION - FD	FIRE DEPARTMENT	114.50
RELIANCE SAFETY LANE & SE	VEHICLE SAFETY INSPECTION - PW	PUBLIC WORKS	32.50
Total RELIANCE SAFETY LANE & SERVICE:			147.00
RICHARD PRALLE	INSURANCE PREMIUM REIMBURSEMENT	ASSETS	405.28
Total RICHARD PRALLE:			405.28
SAMUEL PEREZ	QUARTERMASTER-UNIFORMS-PD	POLICE DEPARTMENT	300.38
Total SAMUEL PEREZ:			300.38
SEBIS - POSTAGE	SEBIS POSTAGE	PUBLIC WORKS	2,971.24
Total SEBIS - POSTAGE:			2,971.24
SEBIS DIRECT INC	SEBIS DIRECT	PUBLIC WORKS	681.25
Total SEBIS DIRECT INC:			681.25
SEECO CONSULTANTS INC	PATCHING MATERIALS TEST	PUBLIC WORKS	1,486.00
SEECO CONSULTANTS INC	PATCHING MATERIALS TEST	PUBLIC WORKS	888.00
Total SEECO CONSULTANTS INC:			2,374.00

Name	Description	DEPARTMENT	Net Invoice Amount
SHARK SHREDDING INC	MONTHLY SHREDDING	FIRE DEPARTMENT	67.20
Total SHARK SHREDDING INC:			67.20
SHOREWOOD HOME AND AUT	L&M DEPT REPAIR PARTS	PUBLIC WORKS	84.72
Total SHOREWOOD HOME AND AUTO INC:			84.72
SOUND INCORPORATED	MONTHLY HOSTED SERVICES FEE	MANAGER'S OFFICE	495.00
SOUND INCORPORATED	50% ANNUAL MAINT - SECURITY CAMERAS	MANAGER'S OFFICE	2,956.50
Total SOUND INCORPORATED:			3,451.50
SOUTH SIDE CONTROL SUPPL	HVAC REPAIRS - PW	PUBLIC WORKS	64.58
Total SOUTH SIDE CONTROL SUPPLY CO:			64.58
SOUTH SUBURBAN PADS	PADS CONTRIBUTION	ASSETS	245.00
Total SOUTH SUBURBAN PADS:			245.00
TALLGRASS RESTORATION LL	WETLAND RESTORATION PROJECT	PUBLIC WORKS	1,800.00
TALLGRASS RESTORATION LL	WETLAND RESTORATION PROJECT	PUBLIC WORKS	1,800.00
Total TALLGRASS RESTORATION LLC:			3,600.00
TELCOM INNOVATIONS GROUP	HEARTBEAT SERVICE FOR RECORDER	MANAGER'S OFFICE	181.25
Total TELCOM INNOVATIONS GROUP LLC:			181.25
TERMINIX PROCESSING CNTR	PEST CONTROL SERVICE	PUBLIC WORKS	200.00
TERMINIX PROCESSING CNTR	PEST CONTROL SERVICE	PUBLIC WORKS	125.00
TERMINIX PROCESSING CNTR	PEST CONTROL SERVICE	PUBLIC WORKS	126.00
Total TERMINIX PROCESSING CNTR:			451.00
THE CARROLL-KELLER GROUP	CUSTOMER SERVICE TRAINING	MANAGER'S OFFICE	255.00
THE CARROLL-KELLER GROUP	CUSTOMER SERVICE TRAINING	FIRE DEPARTMENT	255.00
Total THE CARROLL-KELLER GROUP:			510.00
THE EAGLE UNIFORM CO INC	QUARTERMASTER - FD	FIRE DEPARTMENT	70.00
Total THE EAGLE UNIFORM CO INC:			70.00
THIRD DISTRIC FIRE CHIEF AS	QUARTERLY MABAS DUES	FIRE DEPARTMENT	1,818.00
Total THIRD DISTRIC FIRE CHIEF ASSOCIATION:			1,818.00
THOMPSON ELEVATOR INSPEC	ELEVATOR INSPECTIONS	FIRE DEPARTMENT	50.00
THOMPSON ELEVATOR INSPEC	ELEVATOR INSPECTIONS	FIRE DEPARTMENT	100.00
Total THOMPSON ELEVATOR INSPECTION:			150.00
THORN CREEK BASIN SAN DIS	TCBSD REVENUE PAYOUT	ASSETS	87,441.80
THORN CREEK BASIN SAN DIS	LATE PMT PENALTIES CHARGED TO CUSTOMERS	ASSETS	1,179.77

Name	Description	DEPARTMENT	Net Invoice Amount
Total THORN CREEK BASIN SAN DISTRICT:			88,621.57
TPI BUILDING CODE CONSULT	PLAN REVIEWS JUNE 2024	FIRE DEPARTMENT	2,703.50
Total TPI BUILDING CODE CONSULTANTS:			2,703.50
TRAINING CONCEPTS INC	AFFILIATION FEE	PUBLIC WORKS	120.00
Total TRAINING CONCEPTS INC:			120.00
TRL TIRE SERVICE	PUBLIC WORKS TIRES	PUBLIC WORKS	508.50
TRL TIRE SERVICE	PUBLIC WORKS TIRES	PUBLIC WORKS	137.50
TRL TIRE SERVICE	PUBLIC WORKS TIRES	PUBLIC WORKS	277.50
Total TRL TIRE SERVICE:			923.50
UNIVERSAL CONCRETE GRIND	SIDEWALK GRINDING - TRIP HAZARDS	PUBLIC WORKS	55,732.04
Total UNIVERSAL CONCRETE GRINDING:			55,732.04
UTERMARK & SONS QUALITY L	GRASS CUTTING	FIRE DEPARTMENT	293.97
UTERMARK & SONS QUALITY L	GRASS CUTTING	FIRE DEPARTMENT	216.72
Total UTERMARK & SONS QUALITY LAWN CARE CO:			510.69
VERIZON WIRELESS SVCS LLC	MOBILE PHONE SERVICE-ALL DEPTS	MANAGER'S OFFICE	587.06
Total VERIZON WIRELESS SVCS LLC:			587.06
WAREHOUSE DIRECT OFFICE	OFFICE/BREAK ROOM SUPPLIES	MANAGER'S OFFICE	651.75
WAREHOUSE DIRECT OFFICE	OFFICE SUPPLIES	MANAGER'S OFFICE	161.02
Total WAREHOUSE DIRECT OFFICE PDTS:			812.77
WEST SIDE TRACTOR SALES	STREET DEPT REPAIR PARTS	PUBLIC WORKS	912.53
WEST SIDE TRACTOR SALES	WATER DEPT REPAIR PARTS	PUBLIC WORKS	731.25
Total WEST SIDE TRACTOR SALES:			1,643.78
WISCO	OXYGEN - FD	FIRE DEPARTMENT	256.30
Total WISCO:			256.30
WORKING WELL	PRE EMPLOYMENT PHYSICAL	MANAGER'S OFFICE	245.00
Total WORKING WELL:			245.00
Grand Totals:			413,558.64

---

Name	Description	DEPARTMENT	Net Invoice Amount
------	-------------	------------	-----------------------

---

Dated: \_\_\_\_\_

Village Clerk: \_\_\_\_\_





## BOARD AGENDA MEMORANDUM

DATE OF MEETING: July 23, 2024

---

**To:** Village President and Board of Trustees

**Through:** Napoleon Haney, Village Manager

**From:** Amy Zukowski, Director of Finance

**Topic:** Oath of Office – Valerie Spada – Full-Time Finance Clerk

### PURPOSE

Administer the oath of office to Valerie Spada for the position of full-time Finance Clerk in the Finance Department.

### PROCESS

Valerie was hired as a part-time Finance Clerk with the Village on February 27, 2023. Valerie adapted to the part-time position very quickly. Her customer service skills and willingness to assist in all areas in have made her a critical asset to the Finance Department and Village.

Recently, Valerie took on the financial portion of the Business License and Business Operation Certificate process. These added responsibilities, along with the tasks associated with the lead service line replacement project, and the overall value that Valerie adds to the Village, were factors in determining to change her position to full time. Valerie's first day in her full-time position was July 1, 2024.

### OUTCOME

This transition from part-time to full-time Finance Clerk will be a significant assist to the Finance Department.

### FINANCIAL IMPACT

- **Funding Source:** N/A
- **Budgeted Amount:** N/A
- **Cost:** N/A

### LEGAL REVIEW

Not required

### RECOMMENDED BOARD ACTION

Request the Village Clerk to administer the Oath of Office to Valerie Spada for the position of full-time Finance Clerk in the Finance Department.

# VILLAGE OF HOMEWOOD

Item 10. A.



## ATTACHMENT(S)

None



## BOARD AGENDA MEMORANDUM

DATE OF MEETING: July 23, 2024

---

**To:** Village President and Board of Trustees

**From:** Napoleon Haney, Village Manager

**Topic:** Oath of Office – Joshua Burman

### PURPOSE

Administer the oath of office to Joshua Burman for the position of Director of Public Works.

### PROCESS

With the retirement of John Schaefer, the Director of Public Works position became vacant. After talking extensively with John, both he and I agreed that Joshua would be the perfect person for this promotional opportunity. Prior to coming to Homewood as the Assistant Public Works Director, Joshua enjoyed over nine years of experience in the Public Works environment, and was previously employed by the Village of Orland Park as Utilities Operations Supervisor.

### OUTCOME

Joshua Burman was promoted to the position of Public Works Director on June 28, 2024. We welcome Joshua to the Village of Homewood and look forward to his career here.

### FINANCIAL IMPACT

- **Funding Source:** N/A
- **Budgeted Amount:** N/A
- **Cost:** N/A

### LEGAL REVIEW

Not Required

### RECOMMENDED BOARD ACTION

Administer the oath of office to Joshua Burman for the position of Director for the Department of Public Works.

### ATTACHMENT(S)

None



**BOARD AGENDA MEMORANDUM**

**DATE OF MEETING: July 23, 2024**

**To:** Village President and Board of Trustees

**Through:** Napoleon Haney, Village Manager

**From:** Joshua Burman, Director of Public Works

**Topic:** HVAC Replacement at 2010 Chestnut Rd (Auditorium)

**PURPOSE**

To award a bid for replacement of the HVAC rooftop unit at the Village of Homewood Auditorium located at 2010 Chestnut Road.

**PROCESS**

On July 9, 2024, proposals were opened for qualified contractors to remove and replace the HVAC rooftop unit at the Village of Homewood Auditorium. Submittals were to include removal of the current unit, placement of new unit, cost of new roof curb (if needed), connections to existing ductwork, recapture of old Freon gas, proper disposal, new thermostat (if needed), and unit startup. The following is the tabulation of proposals that were received:

Vendor	Total
<b>OGNI Group, Wood Dale, IL</b>	\$44,540.
<b>Green Light National, Chicago, IL</b>	\$101,217.
<b>Jones Environmental, Mokena, IL</b>	\$41,878.
<b>Premistar, Deerfield, IL</b>	\$51,450.
<b>McDonough Mechanical, Waukegan, IL</b>	\$45,532.
<b>Hoekstra, Homewood, IL</b>	No Bid (Residential Contractor)
<b>Midwest Mechanical, Lombard, IL</b>	No Bid

**OUTCOME**

Four out of the five bids came in under the budgeted amount of \$52,000. Staff recommends awarding the contract to Jones Environmental Control, Inc of Mokena, IL, the lowest responsible bidder, in the amount of \$41,878.

**FINANCIAL IMPACT**

- **Funding Source:** General Capital
- **Budgeted Amount:** \$52,000.
- **Cost:** \$41,878.

# VILLAGE OF HOMEWOOD

Item 11. B.



## **LEGAL REVIEW**

Not Required

## **RECOMMENDED BOARD ACTION**

Award a bid to Jones Environmental Control, Inc. of Mokena, IL, the lowest responsible bidder, in the amount of \$41,878. To replace the HVAC rooftop unit located at the Village of Homewood Auditorium, 2010 Chestnut Road.

## **ATTACHMENT(S):**

None

# Village of Homewood - Bid Tabulation Sheet

Project: HVAC - AUDITORIUM  
Bid Number: RFP  
Bid Opening Date: JULY 9, 2024  
Bid Opening Time: 10AM  
Persons Attending Bid Opening: BURMAN, CABAAY, SCHAEFER, J.ALWIN w/ OGNI

Bidders Name	Total Amount of Bid	Notes
1 OGNI GROUP	\$44,540.00	
2 GREEN LIGHT NATIONAL	\$101,217.00	
3 JONES ENVIRONMENTAL	\$41,878.00	
4 PERMISTAR	\$51,450.00	
5 MCDONOUGH MECHANICAL	\$45,532.00	
6 HOEKSTRA		EMAILED NO BID (RESIDENTIAL)
7 MIDWEST MECHANICAL		EMAILED NO BIID



**BOARD AGENDA MEMORANDUM**

**DATE OF MEETING: July 23, 2024**

**To:** Village President and Board of Trustees

**Through:** Napoleon Haney, Village Manager

**From:** Joshua Burman, Director of Public Works

**Topic:** Bid Award – Street Sweeping Services

**PURPOSE**

To award the bid for street sweeping services for the 2024-2025 season.

**PROCESS**

On July 2, 2024 bids were opened for contract street sweeping services for the 2024-2025 fiscal year. Bid specifications were advertised, requesting proposals for five residential sweeps and 15 commercial sweeps of the Village of Homewood’s 126 miles of curb. Subject to Village Board approval, the contract is renewable for two successive years for a term of one year at each renewal, with unit price adjustments based on the consumer price index.

Bid Tabulations Received:

<b>Vendor</b>	<b>Total</b>
<b>Advance Sweeping Services</b>	\$54,333.28
<b>Central Sweeping Services</b>	No Bid
<b>Dejana Industries</b>	No Bid
<b>American Sweeping</b>	No Bid
<b>Homewood Disposal Service</b>	No Bid
<b>Waste Management</b>	No Bid
<b>Diamond Sweeping Co., Inc.</b>	No Bid
<b>Flood Brothers</b>	No Bid

**OUTCOME**

Advance Sweeping Services, Inc of Rockford, IL is the lowest responsible bidder. Advance Sweeping has been working for organizations such as Village of Downers Grove, Village of Oak Park, Chicago Parks District, and Metropolitan Water Reclamation District (MWRD), and we are confident that they will perform the contract work in a manner consistent with our specifications.



The street sweeping contract has three goals:

### **To Improve Water Quality by Reducing Pollutants in Stormwater Runoff**

Street sweeping is a key activity of the operation and maintenance of the Village’s stormwater system. This activity is recognized as a Best Management Practice (BMP) as part of the National Pollutant Discharge Elimination System (NPDES) requirements that are applicable to the Village with respect to stormwater. Streets and parking lots within the Village accumulate significant amounts of pollutants that contribute to stormwater pollutant runoff to surface waters. Pollutants, including sediment, debris, trash, road salt, and trace metals are minimized by street sweeping. Street sweeping also improves the aesthetics of municipal roadways, controls dust, and decreases the accumulation of pollutants in catch basins.

### **To Remove Leaves and Tree Debris from the Public Right-of-Way**

The fall sweeping occurs from mid-October through early December on Village streets. Street sweeping performed under this contract will be performed with regenerative air sweepers that are capable of removing particles, leaving the pavement clean and minimizing dust. The sweepers have a large carrying capacity that allow for the efficient transfer of leaves to the transfer site.

### **Improve the Appearance of Village Streets and Parking Lots**

Village streets, public parking lots, and streets within the downtown are swept on a regular cycle to remove litter and other debris. Under the terms of this contract, the contractor will be responsible for the liability and the cost of the disposal of the material collected during street sweeping. The street sweepers will also be equipped with GPS units that will provide the Village with real-time information about areas of the Village as they are completed.

## **FINANCIAL IMPACT**

- **Funding Source:** General Fund
- **Budgeted Amount:** \$80,000.00
- **Cost:** \$54,333.28

## **LEGAL REVIEW**

Not Required

## **RECOMMENDED BOARD ACTION**

Authorize the Village Manager to engage the services of Advance Sweeping Services of Rockford, IL for contract sweeping services for five residential and 15 commercial sweeps in an amount not to exceed \$8,366.66 per residential sweep, and \$833.33 per commercial sweep.

## **ATTACHMENT(S)**

None



# Village of Homewood - Bid Tabulation Sheet

Project:	Street Sweeping
Bid Number:	23-17aPW
Bid Opening Date:	July 2, 2024
Bid Opening Time:	10:00 am
Bid Award:	3/26/2024
Persons Attending Bid Opening:	Hankey, Cabay, Burman

Bidders Name	Total Amount of Bid	Notes
1 Advanced Sweeping	\$54,333.28	
2 Central Sweeping Services	No Bid	
3 DeJana Industries, Inc.	No Bid	
4 American Sweeping	No Bid	
5 Homewood Disposal Service, Inc.	No Bid	
6 Waste Management	No Bid	
7 Diamond Sweeping Co., Inc.	No Bid	
8 Flood Brothers	No Bid	
9		



## BOARD AGENDA MEMORANDUM

DATE OF MEETING: July 23, 2024

---

**To:** Village President and Board of Trustees

**Through:** Napoleon Haney, Village Manager

**From:** Terence Acquah, Assistant Village Manager

**Topic:** Hartford Building Light Installation Project

### PURPOSE

Staff is seeking approval from the Village Board to purchase and install lighting materials that will transform an ordinary alley way into a downtown focal point and destination. The construction of the Hartford Building created an alley way in the downtown that connects a parking lot to the sidewalks along Ridge Road. The goal is to lighting the alleyway providing entertaining and colorful lighting while accentuating a proposed mural that will be installed in the alley way. To accomplish this, the Village would need to acquire ten (10) Color Kinetics Red, Green, Blue, White (RGBW) lights and one (1) Pharos controller from Chicago Lightworks, of Lisle, IL, for a total amount not to exceed \$27,228. Public Works staff will install the lights resulting in a cost savings to the Village. The Village budgeted \$40,000 for this work through American Rescue Plan Act (ARPA) funds. The lights will be installed on the wall of the recently completed Hartford Building at 2033 Ridge Road. This purchase requires Board approval.

### PROCESS

In September 2023, Flaherty and Collins Properties completed construction of the Hartford Building at 2033 Ridge Road, formerly the site of the Triumph Building. Upon completion, a passageway was established between 2033 Ridge Road (Hartford Building) and 2049 Ridge Road (Loulou Belle) to improve access from Ridge Road to the parking lot at the back of the buildings. This created an empty space, which raised concerns about potential loitering. Suggestions were made to enhance the passageway's appeal and align it with the Downtown area's characteristics, thus birthing the idea for an artistic installation.

In order to move forward with the idea, the Village engaged in discussions with the property owners of both buildings, Tim Flanagan of 2033 Ridge Road and Danijela Savic of 2049 Ridge Road, seeking permission to create an interactive art installation in the passageway. It was agreed by both property owners that permission will be given to install a mural and interactive lighting system in the alleyway.

Prior to commencing the mural portion of the project, the property owner of 2049 Ridge Road will have to perform repairs on the downspouts on the side of the building where the mural is to



be placed. A redevelopment agreement (RDA) is currently being drafted to utilize Tax Increment Financing (TIF) funds to reimburse the owner for these repairs. The repairs are estimated to cost around \$500.00.

### *Artistic Lighting*

Staff received a quote from Chicago Lightworks for the passageway lighting in the amount of \$27,228, and received an additional quote from Helsel-Jepperson Electrical Inc. of Chicago Heights, IL in the amount of \$31,459. Staff made the decision to recommend Chicago Lightworks for this project due to the lower price as well as the technical assistance that they will provide to assist Village staff with installation of the lights and programming the controller. Helsel-Jepperson would only provide the fixtures. Also, the Village may be responsible for the freight cost under Helsel-Jepperson, while freight will be covered under Chicago Lightworks.

Village staff will be responsible for the installation of the ten (10) RGBW lights, however, a Chicago Lightworks technician will provide guidance throughout the process, especially in setting up the control systems. The lights are Blast Powercore gen5 high-performance LED luminaires that combine white lights with rich, saturated color and color-changing effects. Blast Powercore gen5 offers a range of accessories that allow customizable beam angles for floodlighting, spotlighting, wall washing, and grazing, along with the efficiency and cost-effectiveness of Powercore technology in a rugged die-cast aluminum housing. The lighting system has a simplified installation process and will be managed through a wireless Pharos cloud-based controller, enabling operators to control the lights via mobile application. The cloud-based controller requires a yearly subscription fee of \$544.

Concurrently, while the lights are being procured and installed, Village staff is preparing to present a few mural proposals from artist Nate Otto to the Appearance Commission in the coming weeks. Once a mural is selected, staff will collaborate with Mr. Otto to determine a commencement date for the painting. It is hoped that the integration of both the lights and mural will transform the passageway, echoing the ambiance of renowned art installations in cities like Milwaukee, WI (Black Cat Alley), Wichita, KS (Gallery Alley), and Downtown Iowa City, IA (Fall Gallery Walk).

### **OUTCOME**

The dynamic color-changing lights will illuminate the alleyway at 2049 Ridge Road, enhancing the area to provide an interactive and captivating experience for patrons while enriching the overall charm of downtown Homewood.

The project will make the Hartford Building passageway an interactive space where patrons can admire the art, and will also be a tourist attraction for individuals visiting the Village. It will serve as beacon of light along the Downtown Ridge Road area.



## FINANCIAL IMPACT

- **Funding Source:** American Rescue Plan Act (ARPA) Funds
- **Budgeted Amount:** \$40,000.
- **Cost:** \$27,228.

## LEGAL REVIEW

Completed

## RECOMMENDED BOARD ACTION

Authorize the purchase of ten (10) Color Kinetics Red, Green, Blue, White (RGBW) lights and one (1) Pharos controller from Chicago Lightworks, of Lisle, IL, for an amount not to exceed \$27,228.

## ATTACHMENT(S)

- Quote from Chicago Lightworks
- Photometric
- Color Kinetics light fixture specifications
- Pharos Controller specifications
- Quote from Helsel-Jepperson



**Project** HARTFORD BUILDING ALLEY  
ILLUMINATION HOMEWOOD - BUDGET  
1 - REQUESTED DB 6.25.24  
**Location** HOMEWOOD IL  
**Quote** CLW24-28280-2

Phone:  
Fax:  
**From: Rob Robinson**  
**Quoter Ph:**  
Email: rrobinson@chicagolightworks.com

**To:** Terence Acquah  
Homewood  
EMail: tacquah@homewoodil.gov

**For**  
**Bid Date** Jul 5, 2024  
**Expires** Aug 4, 2024

QTY	Type	MFG	Part	Price	UQ	ExtPrice
<b>FIXTURES</b>						
10		COLOR KINETI	423-000027-01   COLORBLAST GEN5 POWERCORE, RGBW, CLEAR LENS, BLACKHOUSING, UL/CE	\$1,415.00		\$14,150.00
10		COLOR KINETI	120-000185-10 ACCESSORY, BLAST GEN4 POWERCORE, DIFFUSER, 60 DEGREE WIDEFLOOD (WFL)	\$67.00		\$670.00
10		COLOR KINETI	120-000185-01 ACCESSORY, BLAST GEN4 POWERCORE, DIFFUSER TRIM RING, BLACK	\$67.00		\$670.00
1		COLOR KINETI	106-000004-00 DATA ENABLER PRO, UL	\$718.00		\$718.00
<b>Total for: FIXTURES</b>						<b>\$16,208.00</b>
<b>CONTROLS - RECOMMENDED</b>						
Note	<i>BUDGETARY ONLY, REQUIRED QUANTITY OF OPTOS DEPENDENT ON CIRCUITING AND WIRING DETAIL.</i>					
Note	<i>IT IS RECOMMENDED THAT FIXTURE POWER BE ON TIMECLOCK CONTROL. IF NOT EXISTING IN BUILDING CAN BE ADDED TO QUOTE.</i>					
1	CTRL	SSL	PHAROS XPC2 Expert Controller; 1024 channels of eDMX/DMX	\$1,657.00		\$1,657.00
1	POE	SSL	PHAROS XPS Expert switch, 4 port POE	\$634.00		\$634.00
1	CLOUD	SSL	PHAROS CLOUD 1 YEAR SUBSCRIPTION TO PHAROS CLOUD SOFTWARE	\$544.00		\$544.00
<b>Line Note:</b> COST ESTIMATED, DEPENDENT ON CONFIRMED # OF DEVICES.						
1		TMB	ENCLOSURE BUDGET budget only, sizing dependent on optos required.	\$3,837.00		\$3,837.00
2	PROG	ARCHETYPE	FULL DAY 8 hours tech on site	\$2,174.00		\$4,348.00
<b>Total for: CONTROLS - RECOMMENDED</b>						<b>\$11,020.00</b>
<b>Total:</b>						<b>\$27,228.00</b>

**Mfg Terms:**

Archetype Services Freight allowed on orders over \$5,000 per published list price.

Freight Allowance  
Total

\$4,348.00



**Project** HARTFORD BUILDING ALLEY  
ILLUMINATION HOMEWOOD - BUDGET  
1 - REQUESTED DB 6.25.24  
**Location** HOMEWOOD IL  
**Quote** CLW24-28280-2

Phone:  
Fax:  
**From: Rob Robinson**  
**Quoter Ph:**  
Email: rrobinson@chicagolightworks.com

Late Delivery. Any time quoted by Archetype for delivery is an estimate only. Archetype is not liable for any loss or damage arising from any delay in filling any order, failure to deliver or delay in delivery. However, if Seller delays shipment of all or any Goods for more than 30 days after the estimated delivery date (the "Delayed Shipment Date"), then Buyer may, as its sole remedy, cancel the related Purchase Order with respect to the delayed Goods by giving Archetype Notice within 10 days of the Delayed Shipment Date. No delay in the shipment or delivery of any Goods relieves Buyer of its obligations under this Agreement, including without limitation accepting delivery of any remaining installment(s) of Goods.

Signify	<p>Freight Allowed \$3,000. Orders under \$3,000 are subject to a \$200 shipping/handling charge. To avoid \$200 shipping/handling charge, supply freight carrier and account number on PO. A \$75 surcharge will be added to the following regardless of whether you provide your own freight account info: *Expedited Orders (same day shipments) *Change Order Fee (any order changes requested after 24 hours of original submission) *Small Order Handling Fee (any orders below \$200)</p> <p>A \$300 surcharge will be added to orders of 5 poles or less regardless of whether you provide your own freight account information.</p>	<table border="0"> <tr> <td>Freight Allowance</td> <td></td> </tr> <tr> <td>Total</td> <td>\$16,208.00</td> </tr> </table>	Freight Allowance		Total	\$16,208.00
Freight Allowance						
Total	\$16,208.00					

SOLID STATE LUMINAIRE	<p>TERMS: FC Lighting, Inc., Solid State Luminaires and Paramount Industries (FC, SSL &amp; Paramount ) standard product purchase invoices are net 30 days for approved customers. All orders are subject to approval by our credit department. The 30 day term begin from the time purchased product is dispatched from our manufacturing facility. After 30 days, a 1.5% late charge will be applied to any remaining balance All orders are subject to approval by our credit department. Minimum order amount is \$500.00. Orders purchased using a credit card are subject to fees incurred by FC &amp; SSL from the</p>	<table border="0"> <tr> <td>Freight Allowance</td> <td></td> </tr> <tr> <td>Total</td> <td>\$2,835.00</td> </tr> </table>	Freight Allowance		Total	\$2,835.00
Freight Allowance						
Total	\$2,835.00					



**Project** HARTFORD BUILDING ALLEY  
ILLUMINATION HOMEWOOD - BUDGET  
1 - REQUESTED DB 6.25.24  
**Location** HOMEWOOD IL  
**Quote** CLW24-28280-2

Phone:  
Fax:  
**From: Rob Robinson**  
**Quoter Ph:**  
Email: rrobinson@chicagolightworks.com

originating credit card company. All shipments at or over \$3500.00 are freight allowed except for shipments outside the 48 contiguous states. Shipments to Canada at or over \$5000.00 are freight allowed - taxes and other charges will be added to the invoice. Charges for partial shipments, requested by the purchaser, will be the purchaser's responsibility.

PAINT FEES: A lot charge of \$500.00 for RAL colors and \$700.00 for all non-standard color options will be applied. Additional per unit costs and lead times on specialty colors may vary. Standard colors not incurring a lot set up fee include FC's standard Black, White, Silver, and Bronze.

TMB	Freight - PPD and ADD. Pre-Paid Proforma required for ALL orders.	Freight Allowance	
		Total	\$3,837.00



- Products ▾
- Showcase ▾
- Solutions ▾
- Learn ▾
- Contact ▾
- Support ▾
- About ▾



[< Return to category page](#)

# Blast Powercore gen5, RGBW

**Exterior versatile and customizable luminaire with intelligent RGBW light**

Blast Powercore gen5 high-performance LED luminaires combine white and rich, saturated, color and color-changing effects with simplified installation. Blast Powercore gen5 offers a range of accessories that allow customizable beam angles for floodlighting, spotlighting, wall washing, and grazing, along with the efficiency and cost-effectiveness of Powercore technology in a rugged die-cast aluminium housing.

Toggle view







## Product Summary and Specification Sheets

[Download Product Summary](#)

<b>Beam Angles</b>	10° (Native), 20°, 40°, 60°, 80°, 10° x 40°	<b>Input Voltage</b>	100 to 277 VAC, auto-ranging, 50/60 Hz via Data Enabler Pro
<b>Lumens All Channels Full On</b>	1,733 to 2,547	<b>Power Consumption</b>	46.4 W
<b>Efficacy (lm/W) All Channels Full On</b>	36.7 to 54.0	<b>Weight</b>	3.9 kg (8.2 lb)
<b>LED Channels</b>	Red/Green/Blue/White	<b>Housing Material</b>	Die-cast aluminium, powder-coated finish
<b>Applications</b>	Flood Lighting, Spot Lighting, Wall Washing	<b>Approbations</b>	UL/cUL, FCC Class A, CE, PSE, CQC, RCM
<b>Warranty</b>	<a href="#">Limited 5 year warranty</a>	<b>Technologies</b>	<a href="#">Chromacore</a> <a href="#">Chromasync</a> <a href="#">Optibin</a> <a href="#">Powercore</a>
		<b>Environment</b>	Dry/Damp/Wet Location, IP66

## Luminaire Specification Sheets

In addition to the standard Blast luminaires shown below numerous custom configurations are available. These include single color LEDs, single white CCTs with CRI up to 90, and custom LED mixes, a full range of RAL housing colors (with matching accessories), internal and external diffusers, and custom leader cable lengths. Please contact your [Color Kinetics Lighting sales rep.](#)

Specification Sheet	Item Number	Item Number 2	12NC	12NC 2	Availability
<a href="#">100 – 277 VAC, 10° Native (no spread lens), White Housing, UL/CE/CQC</a>	423-000027-00		912400137697		<a href="#">Ships within 48 hours in US</a>
<a href="#">100 – 277 VAC, 20° Spread Lens, White Housing, UL/CE/CQC</a>	423-000027-00	120-000185-08	912400137697	912400130344	
<a href="#">100 – 277 VAC, 40° Spread Lens, White Housing, UL/CE/CQC</a>	423-000027-00	120-000185-09	912400137697	912400130345	
<a href="#">100 – 277 VAC, 60° Spread Lens, White Housing, UL/CE/CQC</a>	423-000027-00	120-000185-10	912400137697	912400130346	
<a href="#">100 – 277 VAC, 80° Spread Lens, White Housing, UL/CE/CQC</a>	423-000027-00	120-000185-11	912400137697	912400130347	

<a href="#">100 – 277 VAC, 10° x 40° Asymmetric Spread Lens, White Housing, UL/CE/CQC</a>	423-000027-00	120-000185-12	912400137697	912400130348	
<a href="#">100 – 277 VAC, 10° Native (no spread lens), Black Housing, UL/CE/CQC</a>	423-000027-01		912400137698		<a href="#">Ships within 48 hours in US</a>
<a href="#">100 – 277 VAC, 20° Spread Lens, Black Housing, UL/CE/CQC</a>	423-000027-01	120-000185-08	912400137698	912400130344	
<a href="#">100 – 277 VAC, 40° Spread Lens, Black Housing, UL/CE/CQC</a>	423-000027-01	120-000185-09	912400137698	912400130345	
<a href="#">100 – 277 VAC, 60° Spread Lens, Black Housing, UL/CE/CQC</a>	423-000027-01	120-000185-10	912400137698	912400130346	
<a href="#">100 – 277 VAC, 80° Spread Lens, Black Housing, UL/CE/CQC</a>	423-000027-01	120-000185-11	912400137698	912400130347	
<a href="#">100 – 277 VAC, 10° x 40° Asymmetric Spread Lens, Black Housing, UL/CE/CQC</a>	423-000027-01	120-000185-12	912400137698	912400130348	
<a href="#">100 – 277 VAC, 10° Native (no spread lens), Gray Housing, UL/CE/CQC</a>	423-000027-04		912400137699		
<a href="#">100 – 277 VAC, 20° Spread Lens, Gray Housing, UL/CE/CQC</a>	423-000027-04	120-000185-08	912400137699	912400130344	
<a href="#">100 – 277 VAC, 40° Spread Lens, Gray Housing, UL/CE/CQC</a>	423-000027-04	120-000185-09	912400137699	912400130345	
<a href="#">100 – 277 VAC, 60° Spread Lens, Gray Housing, UL/CE/CQC</a>	423-000027-04	120-000185-10	912400137699	912400130346	
<a href="#">100 – 277 VAC, 80° Spread Lens, Gray Housing, UL/CE/CQC</a>	423-000027-04	120-000185-11	912400137699	912400130347	
<a href="#">100 – 277 VAC, 10° x 40° Asymmetric Spread Lens, Gray Housing, UL/CE/CQC</a>	423-000027-04	120-000185-12	912400137699	912400130348	

\* Trim Ring required for mounting spread lens. Must be ordered separately.

## Easy Accessory options

Choose from a full line of field-installed accessories, from spread lenses, louvers, full and half glare shields, rock guards, mounting arms, and wiring compartments for all Blast luminaires. Color Kinetics high-quality accessories make project customization simple. And these optional secondary accessories—combined with precise (and simple) aiming—let you get the look and performance necessary for any project.





## Accessory Specification Sheets

PDF Download	Item Number	12NC	Availability
<a href="#">Data Enabler Pro, 3/4 in / 1/2 in NPT (US trade size conduit), UL</a>	106-000004-00	910503701210	<a href="#">Ships within 48 hours in US</a>
<a href="#">Data Enabler Pro, PG21/PG13 (metric size conduit), 100-277 VAC</a>	106-000004-01	910503701211	
<a href="#">Wiring Compartment, 4 in Diameter, Black Housing (CE)</a>	106-000011-40	910503703275	
<a href="#">Wiring Compartment, 4 in Diameter, Silver/Gray Housing (CE)</a>	106-000011-42	910503703277	
<a href="#">Wiring Compartment, 4 in Diameter, White Housing (CE)</a>	106-000011-41	910503703276	
<a href="#">Wiring Compartment, 4 in Diameter, Black Housing (UL/cUL)</a>	106-000011-30	910503704147	
<a href="#">Wiring Compartment, 4 in Diameter, Silver/Gray Housing (UL/cUL)</a>	106-000011-32	910503704149	
<a href="#">Wiring Compartment, 4 in Diameter, White Housing (UL/cUL)</a>	106-000011-31	910503704148	

## Downloads

Documentation			
<a href="#">Product Guide</a>	<a href="#">Product Summary</a>	<ul style="list-style-type: none"> <li>• <a href="#">Blast Powercore Accessories, Installation Instructions</a></li> <li>• <a href="#">ColorBlast Powercore gen4/gen5 Installation Instructions</a></li> <li>• <a href="#">Mounting Arm Accessory Installation Instructions</a></li> </ul>	<a href="#">QuickPlay Pro 2 Commissioning Guide</a> <ul style="list-style-type: none"> <li>• <a href="#">Color Kinetics Installation Checklist</a></li> <li>• <a href="#">Config Calc - Run length and power calculation tool</a></li> <li>• <a href="#">IP ratings for LED Lighting Systems</a></li> <li>• <a href="#">LED mix descriptions</a></li> <li>• <a href="#">Thermal protection and Color Kinetics luminaires</a></li> <li>• <a href="#">Understanding Corrosion Resistance</a></li> <li>• <a href="#">Understanding Surge Protection For LED Lighting Systems</a></li> </ul>

IES Files	Full On
Blast Powercore gen5, RGBW 10° Native (no spread lens)	<a href="#">10° native (no spread lens)</a>
Blast Powercore gen5, RGBW 10° x 40° Asymmetric Spread Lens	<a href="#">10° x 40° asymmetric spread lens</a>
Blast Powercore gen5, RGBW 20° Spread Lens	<a href="#">20° spread lens</a>

Blast Powercore gen5, RGBW 40° Spread Lens	<a href="#">40° spread lens</a>
Blast Powercore gen5, RGBW 60° Spread Lens	<a href="#">60° spread lens</a>
Blast Powercore gen5, RGBW 80° Spread Lens	<a href="#">80° spread lens</a>

**Wiring Diagrams**

Blast Powercore : Data Enabler Pro : Antumbra iColor Keypad	<a href="#">PDF</a>
Blast Powercore : Data Enabler Pro : ColorDial Pro	<a href="#">PDF</a>
Blast Powercore : Data Enabler Pro : iPlayer 3	<a href="#">PDF</a>
Blast Powercore : Data Enabler Pro : iPlayer 4	<a href="#">PDF</a>

**Revit Files**[Blast Powercore gen5, RGBW Revit File](#)**Drawings**

Blast gen4/gen5 Luminaire and Accessories - Full Set	<a href="#">PDF</a>
--	---------------------

*Item 11. D.*

# Features

- Expands customization with a wide range of new accessory options. In addition to the native 10° lens, five different spread lenses can customize the luminaire to produce 20°, 40°, 60°, 80°, and 10° x 40° (asymmetric) beam angles. Three housing color choices (black, gray, and white) – plus the option to add or combine a louver, rock guard, full glare shield, and half glare shield – create new aesthetic possibilities for designers and architects.
- Meets ASTM B117 standard for > 1,500 hours of corrosion resistance and ANSI C136.31-2010 standard with a 3G vibration rating.
- Improves durability with new flat lens that prevents water from pooling into the luminaire, keeping the LEDs protected and secure over the course of a luminaire's lifetime.
- Universal power input range of 100 to 277 VAC.
- Works seamlessly with the complete Color Kinetics line of controllers, including ColorDial Pro, iPlayer 3, and Light System Manager – as well as third-party controllers.
- Improves color consistency between all LED luminaires in a family with Chromasync technology. During the manufacturing process a calibrated light measurement device creates an algorithm to define a common color gamut for an entire family of LED luminaires. When Chromasync is enabled, color consistency between luminaires is achieved without having to manually adjust color points on each luminaire.
- Features an innovative optical system that improves the quality of light from each LED, enhancing the color uniformity and color mixing capabilities of each Blast Powercore gen5 luminaire.
- Integrates patented Powercore technology that controls power output to luminaires directly from line voltage – rapidly, efficiently, and accurately. The Color Kinetics Data Enabler Pro merges line voltage with control data and delivers them to luminaires over a single standard cable, dramatically simplifying installation and lowering total system cost.



## Related Products



**Blast Powercore gen5, IntelliHue**

Item 11. D.



## Related cases



Michigan Lottery Falls Hotel and Casino



Denon Vain

# How can we help you?

Free Ground Shipping --- Express Shipping Available --- Call Us (281) 324-0908



- Brands ▾
- LED Lighting ▾
- LED Drivers ▾
- DMX Control ▾
- Accessories ▾
- Apparel ▾
- Open Box



0.0 ★★★★★  
No rating available

Item 11. D.



Item 11. D.



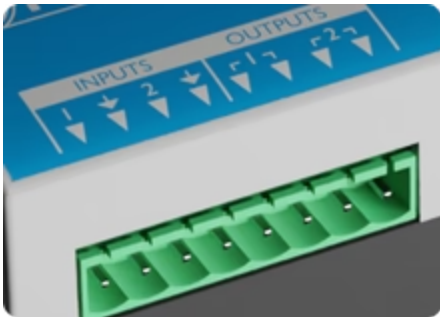
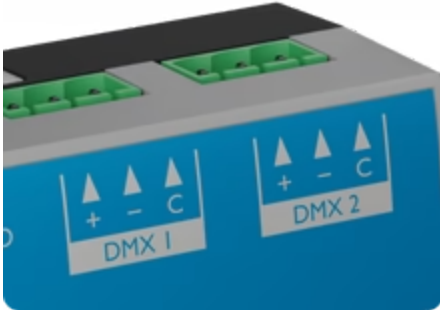

# Pharos XPC 2 Expert Control 2 - 1024 Channels eDMX/DMX, Dali, IO, Stand Alone Ethernet Controller

Expert Control XPC 2

PHAROS

\$1,295.00

Shipping calculated at checkout.

Stock: 2

Quantity

**ADD TO CART**

Buy with

[More payment options](#)

✓ Pickup available at **3307 West Street**  
Usually ready in 2 hours

[View store information](#)

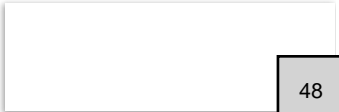



Benefit from the Pharos' expertise in dynamic architectural lighting with an all-new, practical, straightforward control solution centered around a single, reliable Set-and forgets controller. With DMX, DALI, and a couple of convenient contact closures and relays all on board, Expert Control 2 provides up to 1024 channels and is just the job for architectural lighting that requires the benefits of dynamic movement and color in a cost-effective and user-friendly package.

Expert Software helps and guides you through programming the controller. Also available are a companion 5" touchscreen; the elegant Expert Touch, and completing the range is two accessories: Expert Repeat, which is a convenient DMX splitter for output distribution and Expert Switch for PoE networking.

With the reliability you expect from Pharos and our expertise in dynamic lighting in architecture and entertainment: an easy-to-install, easy-to-use control solution.

## Main Features

### Supported Fixtures:

- LEDs: LEDs in any color configuration (RGB, RGBW, RGBA, 8-bit, 16-bit, tunable white)
- Generic: Downlights, spotlights, Uplights, etc. via controllable dimmers and relays
- DALI: Ballasts are supported, such as single channel, RGBWAF, Tc, and XY

## Output:

- Output: 1024 DMX Channels (2 ports)
- RDM: Supports discovery and addressing via Designer Software
- sACN: USITT E1.31 (with per fixture priority) standard
- Art-Net: ArtNet, ArtNet II, and ArtNet III (configurable broadcast overrides)
- KiNET: KiNET V1 (DMX out) and V2 (Port out); PDS/Data Enabler discovery
- DALI: Support for a single channel, Tc, XY and RGBWAF
- Simultaneous: Multiple protocols can be in operation simultaneously. Limited by patched channels, not universes used

## Interfaces:

- Rotary Dial: A rotating dial for switching to customizable preprogrammed states or test setups
- Ethernet: RJ45 socket for 10/100Base-TX Ethernet Link/Data LEDs; Static IP or DHCP; Dual IP address for eDMX
- DMX512: Two isolated DMX ports, RDM compatible
- Inputs: Two inputs, individually selectable operating mode for contact closure, digital or analog input
- Relay Outs: Two individually isolated (1KV) relay outputs (48V 250mA)

## Specifications:

- Power: 9V to 48V DC \* or PoE (IEEE802.3af, Class 2) 4W typical
- Data Storage: Removable MicroSD card (provided)
- Temperature: 0°C to 50°C (32°F to 122°F)
- IP Rating: IP40
- Warranty: 5 years
- Certifications: CE compliant, ETL/cETL listed, UKCA compliant

## Documents

- [Datasheet](#)

Item 11. D.



Item 11. D.



## Pharos XPC 2 Expert Control 2 - 1024 Channels eDMX/DMX, Dali, IO, Stand Alone Ethernet Controller

Benefit from the Pharos' expertise in dynamic architectural lighting with an all-new, practical, straightforward control solution centered around a single, reliable Set-and forgets controller. With DMX, DALI, and a couple of convenient contact closures and relays all on board, Expert Control 2 provides up to 1024 channels and is just the job for architectural lighting that requires the benefits of dynamic movement and color in a cost-effective and user-friendly package.



Expert Software helps and guides you through programming the controller. Also available are a companion 5" touchscreen; the elegant Expert Touch, and completing the range is two accessories: Expert Repeat, which is a convenient DMX splitter for output distribution and Expert Switch for PoE networking.

With the reliability you expect from Pharos and our expertise in dynamic lighting in architecture and entertainment: an easy-to-install, easy-to-use control solution.

Supported Fixtures:

- LEDs: LEDs in any color configuration (RGB, RGBW, RGBA, 8-bit, 16-bit, tunable white)
- Generic: Downlights, spotlights, Uplights, etc. via controllable dimmers and relays
- DALI: Ballasts are supported, such as single channel, RGBWAF, Tc, and XY

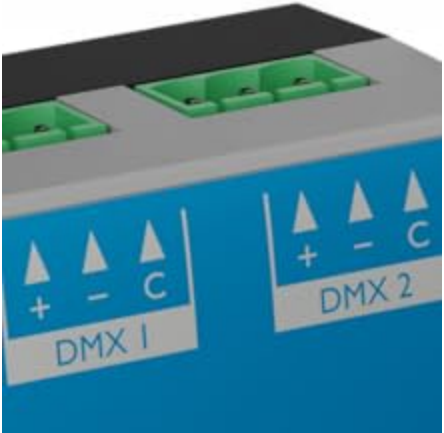
Item 11. D.

		
<p><b>DMX512</b></p> <p>Two isolated DMX ports, RDM compatible</p>	<p><b>Ethernet</b></p> <p>RJ45 socket for 10/100Base-TX Ethernet Link/Data LEDs; Static IP or DHCP; Dual IP address for eDMX</p>	<p><b>Inputs</b></p> <p>Two inputs, individual operating mode: digital or analog</p>



## Output

Output	1024 DMX Channels (2 ports)
RDM	Supports discovery and addressing via Designer Software

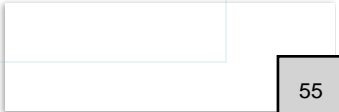

sACN	USITT E1.31 (with per fixture priority) standard
Art-Net	ArtNet, ArtNet II, and ArtNet III (configurable broadcast overrides)
KiNET	KiNET V1 (DMX out) and V2 (Port out); PDS/Data Enable discovery
DALI	Support for a single channel, Tc, XY and RGBWAF
Simultaneous	Multiple protocols can be in operation simultaneously. Limited by patched channels, not universes used

## Specifications

Power	9V to 48V DC * or PoE (IEEE802.3af, Class 2) 4W typical
Data Storage	Removable MicroSD card (provided)
Temperature	0°C to 50°C (32°F to 122°F)
IP Rating	IP40



Certifications

CE compliant, ETL/cETL listed, UKCA compliant

## YOU MAY ALSO LIKE



### **Pharos XPC 1 Expert Control 1 - 512 Channels eDMX/DMX, Dali, IO, Stand Alone Ethernet Controller**

Expert Control XPC 1

\$895.00



### Chromateq CQSA-E 1024 USB DMX Ethernet Stand Alone Multiprotocol Interface & Software (Download Only)

CQSA-E 1024

**\$559.00** ~~\$671.00~~

SALE



## Chromateq CQSA 1024 USB DMX Stand Alone Interface & Software (Download Only)

CQSA 1024

**\$499.00** ~~\$599.00~~

SALE



## Pharos XPS Expert Switch / DIN rail Ethernet switch with 4 Port, Class 2 PoE, 24V DC

Expert Switch XPS

\$495.00

SIRS-E {semiconductor • illumination • research • solutions} - The core of our business is the manufacturing of LED linear lighting and DMX decoders, [read more](#)

Refunds

Shipping

Support

Privacy

Terms

Enttec

eldoLED (OSRAM)

SIRS-E

Madrix

Swisson

### Be the first to know about exclusive discounts and offers

SUBSCRIBE

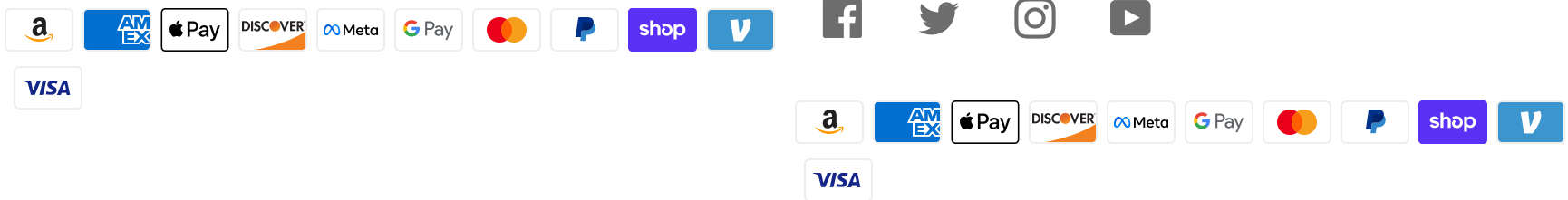

© 2024, SIRS Electronics, Inc.

# Village of Homewood

## Ally

### Blast

# Photometric Rendering

Pseudo Color

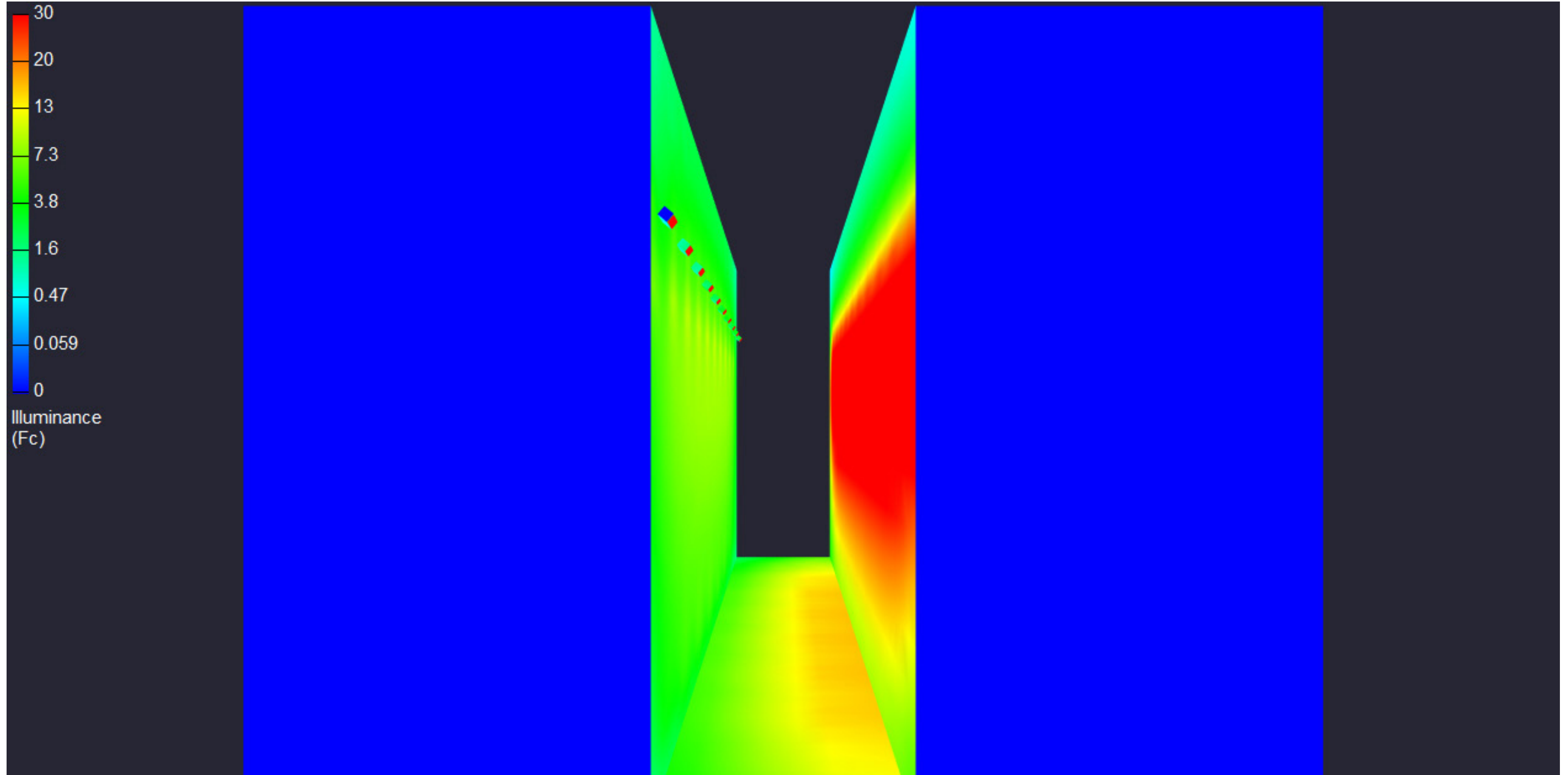

Notes:

- Renderings are for conceptual purposes only.
- Mockup is recommended to ensure design intent is met.

# Photometric Rendering

Black and White

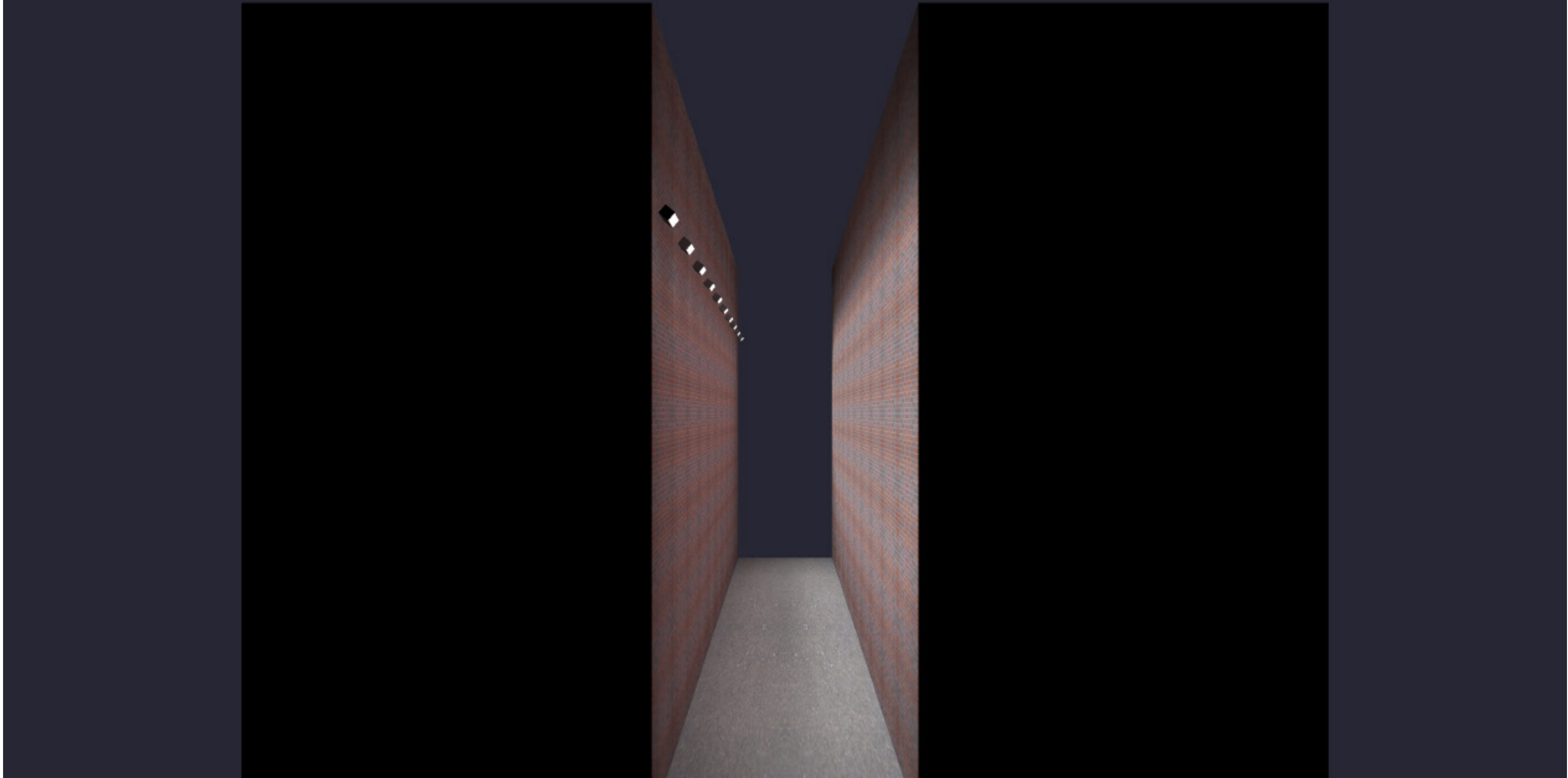

- Notes:
- Renderings are for conceptual purposes only.
  - Mockup is recommended to ensure design intent is met.



# Fixture Placement

Top View

KEY	QTY	FIXTURE DESCRIPTION	BEAM ANGLE
	10	Blast Powercore gen5, IntelliHue	60°

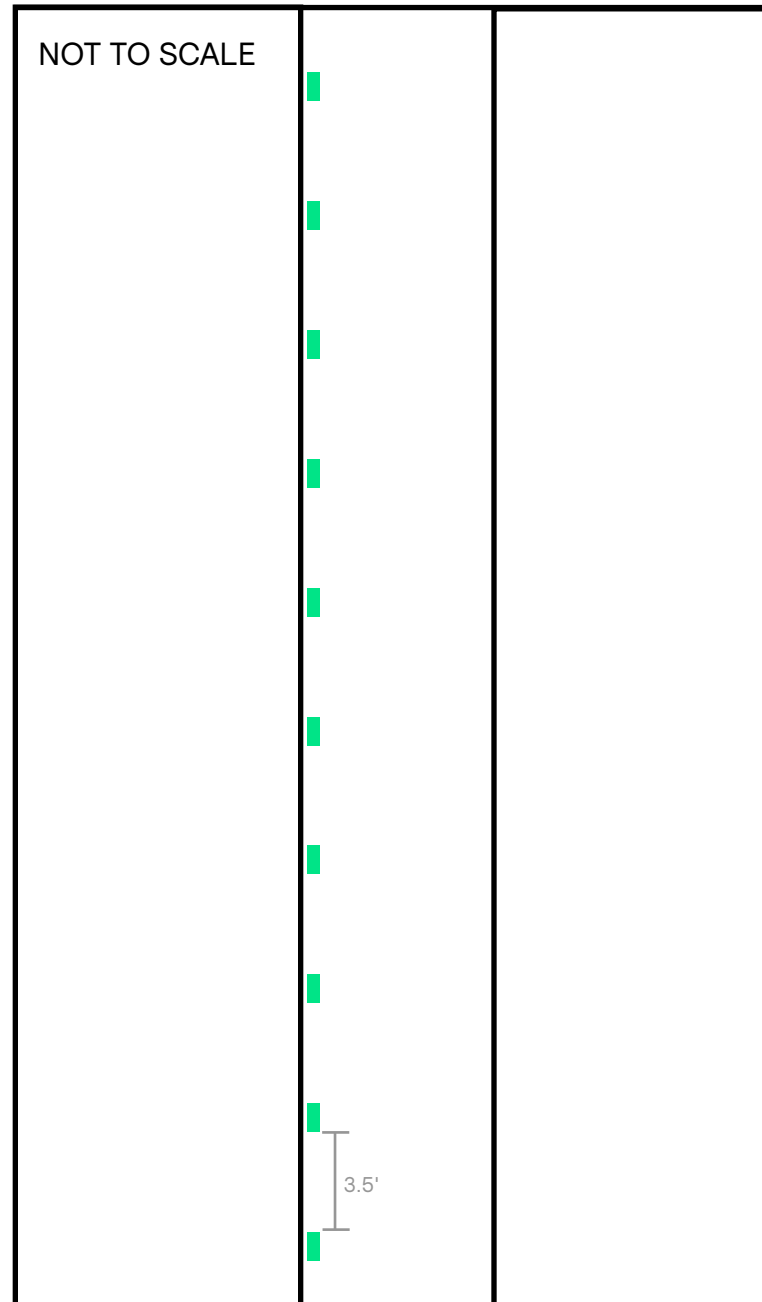

Notes:

- Renderings are for conceptual purposes only.
- Mockup is recommended to ensure design intent is met.

**QUOTE**  
 Hesel-Jepperson Electrical, Inc.  
 103 N. Halsted Street  
 Chicago Heights, IL 60411  
 708-756-5600

Item 11. D.

**PROJECT NAME:** HARTFORD ALLEY

**LOCATION:** HOMEWOOD, IL

**SPECIFIER:**

**DATE:** JULY 19, 2024

**\*TAX IS NOT INCLUDED ON THIS QUOTATION**

**\*CUSTOMER IS RESPONSIBLE FOR INCOMING FREIGHT - CHARGED PER VENDOR'S FREIGHT TERMS**

**\*IT IS THE CUSTOMER'S RESPONSIBILITY TO REVIEW THIS BOM FOR ACCURACY**

**\*PRICES ARE VALID PER VENDORS APPROVAL - AFTER WHICH WILL REQUIRE A REQUOTE**

TYPE	QTY	CATALOG NUMBER	MFR	PRICE	EXT PRICE	REP
		<b>BOM NEEDS TO BE REVIEWED ONCE LAYOUT IS AVAILABLE</b>				
	10	LFM CR UL 120_277 48 22W MRGBW40K 60X60 FR NF LT NVR WMC1 XD BK NA	LUMENPULSE	\$1,700.00	\$17,000.00	KSA
	1	LFLC CR/CH UL 120_277 150FT XC3P3D 180D BK	LUMENPULSE	\$263.00	\$263.00	KSA
	9	LFJC UL 120_277 5FT XC3P3D 180D BK	LUMENPULSE	\$85.00	\$765.00	KSA
	1	LTL 100/277 DMX BK UL	LUMENPULSE	\$374.00	\$374.00	KSA
	1	PHAROS U1 BB SBB	LUMENPULSE	\$3,438.00	\$3,438.00	KSA
	1	LMS ONSS COMM	LUMENPULSE	\$3,484.00	\$3,484.00	KSA
	1	LMC P 324	LUMENPULSE	\$6,135.00	\$6,135.00	KSA
				<b>TOTAL</b>	<b>\$31,459.00</b>	



## BOARD AGENDA MEMORANDUM

DATE OF MEETING: July 23, 2024

---

**To:** Village President and Board of Trustees

**Through:** Napoleon Haney, Village Manager

**From:** Joshua Burman, Director of Public Works

**Topic:** Tivoli Light Expansion

### PURPOSE:

Staff is requesting that the Village Board accept a proposal from F.H. Paschen of Chicago, IL to furnish and install Tivoli lights along both sides of Martin Avenue, from Chestnut Road to Martin Square; a distance of approximately 160 feet. As part of this project, F.H. Paschen will install ten (10) 20-foot-high aluminum black flag poles that will have a dual function: (1) to hoist a 4 x 6 flag, and (2) to support LED Tivoli lights between them. Upon completion of the project, the Tivoli lights will illuminate Martin Avenue all the way from Chestnut Road to Kroner Avenue, completing the final stage of a downtown project that was initiated in 2019.

### PROCESS

In 2015 the construction company, F.H. Paschen of Chicago, IL began construction of the Martin Avenue Open Space project. Martin Square has become a vibrant location and focal point for community events with overhead Tivoli lights creating a stunning evening ambiance. It has always been the Village's intent to extend the Martin Avenue event space to Chestnut Road because of its natural proximity to the Science Center and Village Hall. To create this continued downtown event space, Tivoli lights would need to be extended south along Martin Avenue to Chestnut Road, completing the downtown event footprint.

In 2019, as part of the initial Martin Avenue Open Space project, Lyons Electric Company, Inc. of LaGrange, IL was awarded the bid to furnish and install Tivoli lights along Martin Avenue between Kroner Lane and Ridge Road. The scope of work included installing 20 black aluminum flag poles on both sides of Martin Avenue from which 4'x6' flags could be hung, followed by the installation of LED Tivoli lights. Specifications were sent to six vendors, but Lyons Electric Company, Inc. was the **only** company to submit a bid.

On April 4, 2024, the bid to complete and extend the Tivoli lights from Martin Square (Ridge Road) to Chestnut Road was shared with vendors and formally advertised. At the end of the bid deadline, the Village had not received **any** responses to the bid, which was consistent with our 2019 bid experience for this unique type of project. Surprisingly, our 2019 Tivoli light contractor (Lyons Electric Company) did not submit a bid. Staff then reached out to F.H Paschen of Chicago,



IL to request that they submit a proposal to facilitate this work. F.H. Paschen was contacted not only because of their familiarity with the Martin Avenue Open Space project, but also because of their use of Job Order Contracting (JOC). JOC is an efficient procurement strategy employed by agencies and organizations primarily for minor construction, repair, and renovation projects. F.H. Paschen as a general contractor uses pre-approved contractors selected through a competitive bidding process. These contractors are awarded a blanket contract for a specific period, often lasting several years. The contracts also include a Unit Price Book (UPB), which is a catalog of pre-priced tasks or units of work that have a set price, simplifying the estimation and invoicing processes for projects. F.H. Paschen is intimately familiar with prevailing wage laws and costs which are reflected in all of their municipal proposals and bids.

Staff is comfortable recommending and requesting that the Village Board waive competitive bidding based on F.H. Paschen's history with this specific project area and their use of Job Order Contracting for their subcontractors.

## OUTCOME

The Village budgeted \$200,000 for this work through American Rescue Plan Act (ARPA) funds. The completion of the Tivoli Lighting project from Martin Square to Chestnut Road will extend the downtown event footprint to this popular area of Downtown Homewood. Because there will be extensive underground work required to run conduit and install flag pole bases in an established downtown right of way, staff is requesting a contingency amount of \$8,000. This contingency funding will not be used or be available to the contractor unless staff absolutely agrees and deems that there are critical and unforeseeable circumstances that require the contractor to go above and beyond the initial scope of work.

## FINANCIAL IMPACT

- **Funding Source:** American Rescue Plan Act (ARPA) Funds
- **Budgeted Amount:** \$200,000
- **Proposal Amount:** \$170,978.94
- **Contingency:** \$8,000
- **Total Potential Cost:** \$178,978.94

## LEGAL REVIEW

Completed

## RECOMMENDED BOARD ACTION

Waive competitive bidding due to utilizing a professional company that has previous experience with this project in Homewood, and authorize the purchase and installation of Tivoli Lights from F.H. Paschen, of Chicago, IL to install Tivoli lights along both sides of Martin Avenue, from Chestnut Road to Martin Square, in the amount of \$170,978.94 with a contingency amount of

## VILLAGE OF HOMEWOOD

Item 11. E.



\$8,000 to cover the costs for any unforeseen and/or underground construction issues for a total amount of \$178,978.94 .

### **ATTACHMENT(S)**

- Contract
- Map

## Work Order Signature Document

**Contract No.:IL-R2-GC-122122-FHP**

**New Work Order**

**Modify an Existing Work Order**

Work Order #: 129681.00 Work Order Date: \_\_\_\_\_

Owner PO No: \_\_\_\_\_

Title: Village of Homewood - Tivoli Lighting Project

Owner Name: SOURCEWELL - ILLINOIS - Village of Homewood Contractor Name: F.H. Paschen

Contact: \_\_\_\_\_ Contact: Contractor Project Manager

Phone: \_\_\_\_\_ Phone: \_\_\_\_\_

### Work to be Performed

Work to be performed as per the Final Detailed Scope of Work Attached and as per the terms and conditions of EZIQC Contract No IL-R2-GC-122122-FHP.

Brief Work Order Description:

Provide exterior improvements on Martin Avenue. Improvements include but are not limited to electrical, concrete, and brick work.

□

**Work Order Firm Fixed Price: \$170,978.94**

Owner Purchase Order Number:

### Approvals

\_\_\_\_\_  
Owner

\_\_\_\_\_  
Date

\_\_\_\_\_  
Contractor

\_\_\_\_\_  
Date

## Detailed Scope of Work

---

**Date:** 7/9/2024  
**Work Order #:** 129681.00  
**Title:** Village of Homewood - Tivoli Lighting Project  
**Contractor:** F.H. Paschen  
**Contractor Number:** IL-R2-GC-122122-FHP  
**Job Order Value:** \$170,978.94

---

**Location:** Village of Homewood - Tivoli Lighting Project

**Brief Scope:**

Provide exterior improvements on Martin Avenue. Improvements include but are not limited to electrical, concrete, and brick work.

---

Dear John Schaefer,

The following items detail the scope of work as discussed at the site. All requirements necessary to accomplish the items set forth below shall be considered part of this scope of work:

**Detailed Scope:**

Please see detailed scope of work attached below.

**Requirements:**

Should you have any questions, please do not hesitate to contact me at 815.355.3314.

**SCOPE OF WORK:**

FH Paschen will perform the following scope of work:

- Mobilize and prepare area for new work.
- Provide portable toilets.
- Provide temporary fence around the entire work area.
- Remove and salvage existing sidewalk pavers on the east and west sides of the work area.
- Remove and store existing sidewalk pavers to be reinstalled.
- Sawcut concrete walkway, curbs and etc. as needed for demolition.
- Break up and remove existing concrete sidewalks as needed on both east and west sides.
- Trench for new UG electrical conduit ¾" & 6" sizes.
- Remove and haul all existing spoils from excavation.
- Auger and install (10) new 24" x 48" concrete flagpole bases.
- Install (10) 20 LF tall flag poles provided by Concord American Flagpole. Model number: ESS20C51-BLK
- Backfill and provide aggregate for all excavations and trenches.
- Provide aggregate base course for all sidewalks.
- Compact all base courses.
- Form and pour new curb and gutter where existing was removed.
- Form and pour new 5" thick sidewalks where removed.
- Provide leveling and sand leveling for areas in which pavers will be re-installed.
- Provide and install stainless steel cable between light poles.
- Provide and install new Tivoli lighting to new flag poles.
- Install (6) new Quazite handhole boxes along east side.
- Install all new wiring and connections to flagpoles from electrical junction.
- Pressure wash all new concrete and existing concrete and pavers.
- Clean up work area.
- Take down all temporary fencing.
- Final walk through
- Demobilize
- Turnover to village.

**Clarifications**

- This proposal **excludes** any unforeseen conditions that may arise.
- This proposal **excludes** the removal and disposal of any hazardous material and/or Sub-Title D disposal. Any Sub- Title D disposal will be provided at an additional cost.
- This proposal **excludes** any permits, or fees.
- This proposal **includes** testing.
- This proposal **includes** any payment or performance bonds.
- This proposal **includes** only the items described in the above scope.
- This proposal **excludes** any overtime or premium time, proposal is based on normal work hours.
- This proposal **includes** locating of existing utilities.
- This proposal **includes** temporary fencing.
- This proposal **excludes** landscape restoration.



**Applicability:** All items contained in the instructions are applicable to this request for proposal.

**Questions Concerning Project:** Any questions by the contractor related to the specifications of this project must be submitted in writing.

Contact Person: John Schaefer  
Director of Public Works  
[jschaefer@homewoodil.gov](mailto:jschaefer@homewoodil.gov)  
708-206-2901 / 708-417-0861  
Monday through Friday [7:00 a.m. through 4:00 p.m.]

## Scope of Work

The Village of Homewood is seeking to install ten, 20-foot-high aluminum black flag poles along both sides of Martin Avenue from Chestnut Road south to Martin Square, which is approximately 160 feet. The flag poles will serve two purposes; as a pole to fly a 4 x 6 flag, and to hang LED Tivoli lights from pole to pole, but not at the same time when flags are flown. Power supply to the flag poles will be required, from two existing power cabinets that are located on each side of Martin Avenue.

- Remove and salvage existing sidewalk pavers on the West side and East of the work zone, and the existing sidewalk pavers in front of the existing electrical cabinet as necessary.
- Saw cut concrete walkway, curbs, etc. as needed for demolition.
- Break up and remove existing concrete sidewalk as needed on West and East side of Martin Avenue.
- Load and haul all demolition spoils off site and dispose of.
- Auger and install ten new 24" X 48" concrete light pole foundations with PVC pole sleeves.
- Install ten, 20-foot-high aluminum black flag poles manufactured by Concord American Flagpole Model # ESS20C51-BLK, PT# 79306 and distributed by Flag Desk, Inc.
- Provide and place compacted aggregate trench backfill at all excavations.
- Provide and place compacted aggregate base course at all curb and sidewalk locations.
- Form and pour new curb and gutter where existing was removed.
- Provide and install new sand leveling course and concrete unit pavers at West and East side of Martin along sidewalk as needed.
- Install new sand leveling course and reinstall all removed and salvaged pavers from West sidewalk and in front of electrical cabinet.
- Provide and install stainless steel cable between poles for Tivoli lights.
- Installation of owner supplied Tivoli strand lighting and cabling.
- Trench and install all new underground conduit as required.
- Install six Quazite handhole boxes on back side of curb along the East side of Martin Avenue with 6" underground conduit to all. Handhole type to match existing on West side of Martin Avenue.

**VILLAGE OF HOMEWOOD**  
**Street Poles & Lighting**

---

Item 11. E.

- Install all required conduit, electrical cable, electrical cabinet modifications and connections, etc.
- Remove, replace and modify underground electric at West sidewalk as required for new lighting layout.
- Provide project insurance, project management and site supervision.

**VILLAGE OF HOMEWOOD**  
**Street Poles & Lighting**

Item 11. E.

# Proposal

DESCRIPTION OF WORK	COST PER UNIT	UNIT TYPE	ESTIMATED QUANTITY	SCHEDULED VALUE
Remove and salvage existing sidewalk pavers on the West side and East of the work zone, and the existing sidewalk pavers in front of the existing electrical cabinet as necessary		Per Sq. Foot	790	
Saw cut concrete walkway, curbs, etc. as needed for demolition		Lump Sum	1	
Break up and remove existing concrete sidewalk as needed on East side of Martin Avenue		Per Sq. Foot	240	
Load and haul all demolition spoils off site and dispose of		Per Cubic Yard	60	
Auger and install ten new 24" X 48" concrete light pole foundations with PVC pole sleeves		Each	10	
Install 10, 20-foot-high aluminum black flag poles		Each	10	
Provide and place aggregate trench backfill at all excavations		Per Cubic Yard	60	
Provide and place compacted aggregate base course at all sidewalk locations (4" depth)		Per Sq. Yard	27	
Form and pour new curb and gutter where existing was removed. Includes 4" aggregate base		Per Lin Feet	40	
Form and pour new 5" thick sidewalk where removed		Per Sq. Foot	240	
Provide and install new sand leveling course and concrete unit pavers at West and East side of Martin along sidewalk as needed (2" sand depth)		Per Sq. Foot	300	
Install new sand leveling course and reinstall all removed and salvaged pavers from West sidewalk and in front of electrical cabinet (2" sand depth)		Per Sq. Foot	450	
Provide and install stainless steel cable between poles for Tivoli lights		Per Lin Feet	500	
Installation of owner supplied Tivoli strand lighting and cabling		Per Lin Feet	500	
Trench and install all new underground conduit as required		Per Lin Feet	30	
Install six Quazite handhole boxes on back side of curb along the East side of		Lump Sum	1	

**VILLAGE OF HOMEWOOD  
Street Poles & Lighting**

Item 11. E.

Martin Avenue with 6" empty PVC underground conduit to each				
Install all electrical cabling, electrical cabinet modifications and connections, etc.		Lump Sum	1	
Remove, replace and modify underground electric at West sidewalk as required for new lighting layout		Lump Sum	1	
Misc. Materials/Dumpsters/Porta Potties		Lump Sum	1	
Provide project insurance, project management and site supervision		Lump Sum	1	
Soil tests for CCDD Contaminants		Each	1	
Performance & Payment Bond		Lump Sum	1	

## Authorization

---

**Submitted by:** \_\_\_\_\_ **Name/Title:** \_\_\_\_\_  
*Company*

**Authorized Signature:** \_\_\_\_\_ **Date:** \_\_\_\_\_

**City/State/Zip:** \_\_\_\_\_

**Phone:** (\_\_\_\_) \_\_\_\_\_ **Email:** \_\_\_\_\_

# QUALIFICATION OF BIDDER

Bidder must demonstrate satisfactory performance on at least five (5) municipal contracts of similar nature and scope within the last three years in order to be considered a responsible bidder. These references must include the location of the work, the dollar value of the work, the owner or agency involved, and the name and phone number of the contact person.

Following is a list of three contracts of a similar nature and scope, which have been performed in the past three years:

1. \_\_\_\_\_  
Company Name Phone  
  
\_\_\_\_\_  
Location of Work Dollar Value Contract Date
  
2. \_\_\_\_\_  
Company Name Phone  
  
\_\_\_\_\_  
Location of Work Dollar Value Contract Date
  
3. \_\_\_\_\_  
Company Name Phone  
  
\_\_\_\_\_  
Location of Work Dollar Value Contract Date
  
4. \_\_\_\_\_  
Company Name Phone  
  
\_\_\_\_\_  
Location of Work Dollar Value Contract Date
  
5. \_\_\_\_\_  
Company Name Phone  
  
\_\_\_\_\_  
Location of Work Dollar Value Contract Date

**VILLAGE OF HOMEWOOD**  
**Street Poles & Lighting**

---

<b>ATTACHMENT FOR SIGN OFF BY BIDDER</b>	<b>REQUIRED</b>	<b>NOT REQUIRED</b>
W-9 Form	X	
Drug Free Workplace Certification	X	
Equal Employment Opportunity	X	
Hold Harmless Agreement	X	
Insurance Requirements	X	
Prevailing Wage Certification	X	
Compliance With Safety Standards	X	
Sexual Harassment Policy Certification	X	
Blood Borne Pathogens Compliance Certification		X
Authorization To Perform Background Checks	X	
Contact Information	X	
Certificate of Authorized Dealer		X
Performance/Payment Bond	X	

**VILLAGE OF HOMEWOOD**  
**Street Poles & Lighting**

---

Item 11. E.

**W-9 Form**

The bidder shall furnish a W-9 form with bid proposal.

**DRUG FREE WORKPLACE CERTIFICATION**

---

# Request for Taxpayer Identification Number and Certification

Give Form to the requester. Do not send to the IRS.

▶ Go to [www.irs.gov/FormW9](http://www.irs.gov/FormW9) for instructions and the latest information.

1 Name (as shown on your income tax return). Name is required on this line; do not leave this line blank.

**F.H. Paschen, S.N. Nielsen & Assoc. LLC**

2 Business name/disregarded entity name, if different from above

3 Check appropriate box for federal tax classification of the person whose name is entered on line 1. Check only one of the following seven boxes.

Individual/sole proprietor or single-member LLC

C Corporation

S Corporation

Partnership

Trust/estate

Limited liability company. Enter the tax classification (C=C corporation, S=S corporation, P=Partnership) ▶ **P**

Note: Check the appropriate box in the line above for the tax classification of the single-member owner. Do not check LLC if the LLC is classified as a single-member LLC that is disregarded from the owner unless the owner of the LLC is another LLC that is not disregarded from the owner for U.S. federal tax purposes. Otherwise, a single-member LLC that is disregarded from the owner should check the appropriate box for the tax classification of its owner.

Other (see instructions) ▶

4 Exemptions (codes apply only to certain entities, not individuals; see instructions on page 3):

Exempt payee code (if any) \_\_\_\_\_

Exemption from FATCA reporting code (if any) \_\_\_\_\_

(Applies to accounts maintained outside the U.S.)

5 Address (number, street, and apt. or suite no.) See instructions.

**5515 N. East River Road**

6 City, state, and ZIP code

**Chicago, IL. 60656**

Requester's name and address (optional)

7 List account number(s) here (optional)

Print or type.  
See Specific Instructions on page 3.

## Part I Taxpayer Identification Number (TIN)

Enter your TIN in the appropriate box. The TIN provided must match the name given on line 1 to avoid backup withholding. For individuals, this is generally your social security number (SSN). However, for a resident alien, sole proprietor, or disregarded entity, see the instructions for Part I, later. For other entities, it is your employer identification number (EIN). If you do not have a number, see *How to get a TIN*, later.

Note: If the account is in more than one name, see the instructions for line 1. Also see *What Name and Number To Give the Requester* for guidelines on whose number to enter.

Social security number								
			-			-		

or

Employer identification number								
3	6	-	4	5	1	8	4	3

## Part II Certification

Under penalties of perjury, I certify that:

- The number shown on this form is my correct taxpayer identification number (or I am waiting for a number to be issued to me); and
- I am not subject to backup withholding because: (a) I am exempt from backup withholding, or (b) I have not been notified by the Internal Revenue Service (IRS) that I am subject to backup withholding as a result of a failure to report all interest or dividends, or (c) the IRS has notified me that I am no longer subject to backup withholding; and
- I am a U.S. citizen or other U.S. person (defined below); and
- The FATCA code(s) entered on this form (if any) indicating that I am exempt from FATCA reporting is correct.

**Certification instructions.** You must cross out item 2 above if you have been notified by the IRS that you are currently subject to backup withholding because you have failed to report all interest and dividends on your tax return. For real estate transactions, item 2 does not apply. For mortgage interest paid, acquisition or abandonment of secured property, cancellation of debt, contributions to an individual retirement arrangement (IRA), and generally, payments other than interest and dividends, you are not required to sign the certification, but you must provide your correct TIN. See the instructions for Part II, later.

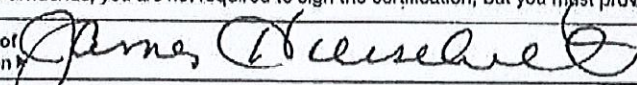
Sign Here Signature of U.S. person  Date ▶ **3/19/19**

## General Instructions

Section references are to the Internal Revenue Code unless otherwise noted.

**Future developments.** For the latest information about developments related to Form W-9 and its instructions, such as legislation enacted after they were published, go to [www.irs.gov/FormW9](http://www.irs.gov/FormW9).

## Purpose of Form

An individual or entity (Form W-9 requester) who is required to file an information return with the IRS must obtain your correct taxpayer identification number (TIN) which may be your social security number (SSN), individual taxpayer identification number (ITIN), adoption taxpayer identification number (ATIN), or employer identification number (EIN), to report on an information return the amount paid to you, or other amount reportable on an information return. Examples of information returns include, but are not limited to, the following.

- Form 1099-INT (interest earned or paid)

- Form 1099-DIV (dividends, including those from stocks or mutual funds)
  - Form 1099-MISC (various types of income, prizes, awards, or gross proceeds)
  - Form 1099-B (stock or mutual fund sales and certain other transactions by brokers)
  - Form 1099-S (proceeds from real estate transactions)
  - Form 1099-K (merchant card and third party network transactions)
  - Form 1098 (home mortgage interest), 1098-E (student loan interest), 1098-T (tuition)
  - Form 1099-C (canceled debt)
  - Form 1099-A (acquisition or abandonment of secured property)
- Use Form W-9 only if you are a U.S. person (including a resident alien), to provide your correct TIN.

If you do not return Form W-9 to the requester with a TIN, you might be subject to backup withholding. See *What is backup withholding*, later.



**VILLAGE OF HOMEWOOD**  
**Street Poles & Lighting**

---

The bidder shall certify that it will comply with all requirements of the Illinois Drug Free Workplace Act (30 ILCS 580/1 *et seq.*) including but not limited to:

1. Publishing a Statement:
  - A. Notifying the employees that the unlawful manufacture, distribution, dispensation, possession, or use of a controlled substance is prohibited in the bidder's workplace,
  - B. Specifying the actions that will be taken against employees for violations of such prohibition,
  - C. Notifying the employee that as a condition of employment on such contract or grant, the employee will; 1) abide by the terms of the statement and 2) notify the employer of any criminal drug statute conviction for a violation occurring in the workplace no later than 5 days after such conviction.
2. Establishing a drug free awareness program to inform employees about:
  - A. The dangers of drug abuse in the workplace;
  - B. The grantee's or bidder's policy of maintaining a drug free workplace;
  - C. Any available drug counseling, rehabilitation, and employee assistance programs; and
  - D. The penalties that may be imposed upon employees for drug violations.
3. Making it a requirement to give a copy of the statement required by subsection (1) to each employee engaged in the performance of the contract or grant and to post the statement in a prominent place in the workplace.
4. Notifying the Village of Homewood within 10 days after receiving notice under part (2) of paragraph (C) of subsection 14.1 from an employee or otherwise receiving actual notice of such conviction.
5. Imposing a sanction on, or requiring the satisfactory participation in a drug abuse assistance or rehabilitation program by an employee who is convicted, as required by Section 5 of the Illinois Drug Free Workplace Act.
6. Training of personnel to effectively assist employees in selecting a proper course of action in the event drug counseling, treatment, and rehabilitation is required and indicating an effectively trained counseling and referral team is in place.
7. Making a good faith effort to continue to maintain a drug free workplace through implementation of requirements of Section 15.3.

### EQUAL EMPLOYMENT OPPORTUNITY

In the event of the bidder's non-compliance with any provision of this equal employment opportunity clause, the Illinois Human Rights Act or the Illinois Department of Human Rights (IDHR) Rules and Regulations for Public Contracts, the bidder may be declared non-responsible, and therefore, ineligible for future contracts or sub-contracts with the State of Illinois or any of its political subdivisions or municipal corporations, and the contract may be canceled or voided in whole or in part, and other sanctions or penalties may be imposed or remedies provided by statute or regulations.

During the performance of this contract the bidder agrees as follows:

1. It will not discriminate against any employee or applicant for employment because of race, color, religion, sex, national origin, ancestry or other legally protected class; and further that it will examine all job classifications to determine if minority persons or women are underutilized and will take appropriate affirmative action to rectify any such under-utilization.
2. If it hires additional employees in order to perform this contract, or any portion hereof, it will determine the availability (in accordance with the IDHR's Rules and Regulations for Public Contracts) of minorities and women in the area(s) from which it may reasonable recruit, and it will hire from each job classification from which employees are hired in such a way that minorities and women are not underutilized.
3. In all solicitation or advertisements for employees placed by it or on its behalf, it will state that all applicants will be afforded equal opportunity without discrimination because of race, color, religion, sex, national origin, ancestry, or other legally protected class.
4. It will send to each labor organization or representative of workers with which it has or is bound by a collective bargaining or other agreement or understanding, a notice advising such labor organization or representative of the bidder's obligations under the Human Rights Act and IDHR's Rules and Regulations for Public Contracts. If any such labor organization or representative fails or refuses to cooperate with the bidder in its efforts to comply with such act and rules and regulations, the bidder will promptly so notify IDHR and the contracting agency and will recruit employees from other sources when necessary to fulfill its obligations there under.
5. It will submit reports as required by IDHR Rules and Regulations for Public Contracts, furnish all relevant information as may from time to time be requested by IDHR or the contracting agency and in all respects comply with the Illinois Human Rights Act and IDHR Rules and Regulations for Public Contracts.
6. It will permit access to all relevant books, records, accounts and work sites by personnel by the contracting agency and IDHR for the purposes of investigation to ascertain compliance.

**HOLD HARMLESS AGREEMENT**

The successful bidder shall agree to the fullest extent permitted by law to defend, indemnify and hold harmless the Village of Homewood, its elected and appointed officials, agents and employees, against all injuries, deaths, loss, damages, claims, patent claims, suits, liabilities, judgments, cost and expenses, including reasonable attorney fees, which in any way may accrue against the Village of Homewood, its elected and appointed officials, agents and employees, arising in whole, in part, or in consequence of the performance of this work by the Bidder or its employees or subcontractors, or which may in any way result therefrom, except for those injuries, deaths, loss, damages, claims, patent claims, suits, liabilities, judgments, cost and expenses caused solely by the acts of the Village of Homewood, its elected or appointed officials, agents or employees. The Bidder shall, at its own expense, appear, defend and pay all attorney fees, costs and other expenses arising therefore or incurred in connection with this hold harmless agreement. If any judgment is rendered against the Village of Homewood, its elected or appointed officials, agents or employees, the Bidder shall, at its own expense, satisfy and discharge the same.

Bidder expressly understands and agrees that any performance bond, payment bond or insurance policy required by this contract or state law shall not limit its responsibility to indemnify, keep and save harmless and defend the Village of Homewood, its elected and appointed officials, agents and employees as herein provided.

## INSURANCE REQUIREMENTS

Upon bid award, the bidder shall submit a Certificate of Insurance providing the following coverage:

- 1) Comprehensive General Liability and Excess Liability Insurance for Personal Injury, Property Damage, Contractual Liability, Product/Complete Operations, Premises Operations and Independent Contractor's coverage. Minimum coverage is \$1,000,000.00.
- 2) Workers' Compensation – coverages A and B.
- 3) Automobile Liability insurance including coverage of Uninsured Motorists and Hired/non-owned auto.

The certificate shall name the Village of Homewood and all its officials and employees, elected and appointed, as additional insured and shall include the policy's expiration date. In addition, as part of the contract, the Village of Homewood must receive a minimum of ten days notice upon cancellation of the company's insurance policy.

- 4) The bidder shall not commence work until it provides the certificate of insurance as described above. The bidder shall maintain all such insurance coverage for the term of the contract.

## PREVAILING WAGE CERTIFICATION

The bidder shall certify that it will comply with the Illinois Prevailing Wage Act. (830 ILCS 130/1 *et seq.*) This contract calls for the construction of a “public-work, within the meaning of the Illinois Prevailing Wage Act, 820 ILCS 130/.01 *et seq* (The “Act”). The Act requires contractors and subcontractors to pay laborers, workers and mechanics performing services on public works projects no less than the current “prevailing rate of wages” (hourly cash wages plus amount for fringe benefits) in the county where the work is performed. The Department publishes the prevailing wage rates on its website at <http://labor.illinois.gov/>. The Department revises the prevailing wage rates and the contractor/subcontractor has an obligation to check the Department’s website for revisions to prevailing wage rates. For information regarding current prevailing wage rates, please refer top the Illinois Department of Labor’s web site. All contractors and subcontractors rendering services under this contract must comply with all requirements of the Act, including but not limited to, all wage requirements and notice and record keeping duties.

**VILLAGE OF HOMEWOOD**  
**Street Poles & Lighting**

---

**COMPLIANCE WITH SAFETY STANDARDS**

The bidder shall certifies that it has a written safety policy and agrees to comply with all state and federal regulations pertaining to employee safety, including but not limited to the Federal Occupational Safety and Health Act, EPA and OSHA safety standards, and the Village of Homewood's Safety Policy Manual.

**SEXUAL HARASSMENT POLICY CERTIFICATION**

The bidder hereby certifies that it has a written sexual harassment policy in place in full compliance with 775 ILCS 5/2-105(A)(4).

**BLOOD BORNE PATHOGENS COMPLIANCE CERTIFICATION**

Bidder shall submit a BLOOD BORNE PATHOGEN COMPLIANCE CERTIFICATION statement, certifying that the Bidder is in compliance with OSHA standards for Occupational Exposure to Blood Borne Pathogens, 29 CFR, Part 1910.1030.



**VILLAGE OF HOMEWOOD**  
**Street Poles & Lighting**

---

**AUTHORIZATION TO PERFORM BACKGROUND CHECKS**

Personnel assigned by Bidder to perform work at the Village of Homewood shall pass a routine background check to be conducted by the Homewood Police Department prior to commencing work.

Bidder authorizes the Village of Homewood to perform a routine background check on personnel assigned to perform work.

VILLAGE OF HOMEWOOD  
Street Poles & Lighting

---

CONTACT INFORMATION

Bidder shall designate a point of contact responsible for day to day contract performance, including the following information:

Jim Lloyd  
Name

Project Manager  
Title

FH Paschen 5515 N. East River Rd. Chicago, IL 60654  
Organization Name/Address

\_\_\_\_\_  
Office Phone

815-355-3314  
Cell Phone

JLLOYD@FHPPASCHEN.COM  
Email Address

**VILLAGE OF HOMEWOOD**  
**Street Poles & Lighting**

---

**AUTHORIZED DEALER CERTIFICATION**

The bidder shall certify that it is an Authorized Dealer of the product for which a bid has been submitted, and will provide a bona fide manufacturer's warranty reflecting the Village of Homewood as the original purchaser.

**VILLAGE OF HOMEWOOD**  
**Street Poles & Lighting**

---

**PUBLIC CONSTRUCTION BOND ACT COMPLIANCE**

The bidder shall provide a performance/payment bond as required by the Public Construction Bond Act (30 ILCS 550/1 et seq.)

VILLAGE OF HOMEWOOD  
Street Poles & Lighting

ACKNOWLEDGEMENT OF TERMS

The undersigned, on behalf of the bidder, hereby agrees that all of the provisions marked "required" on page one of this addendum shall be incorporated into their bid as if fully restated therein.

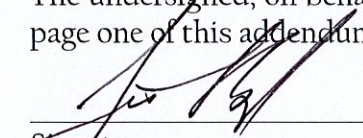
  
\_\_\_\_\_

Signature

Jim Lleye  
\_\_\_\_\_

Name (Print)

Project Manager  
\_\_\_\_\_

Title

FH Raschum  
\_\_\_\_\_

Organization

5515 N. East River Rd Chicago, IL 60656  
\_\_\_\_\_

Address

7/9/24  
\_\_\_\_\_

Date

WITNESS:

Antoine John Carver Tucker  
\_\_\_\_\_

Signature/Printed Name

7/9/24  
\_\_\_\_\_

Date



**Estate Series**

ESS - External Single Stationary  
Rope Halyard  
Ground Set Installation

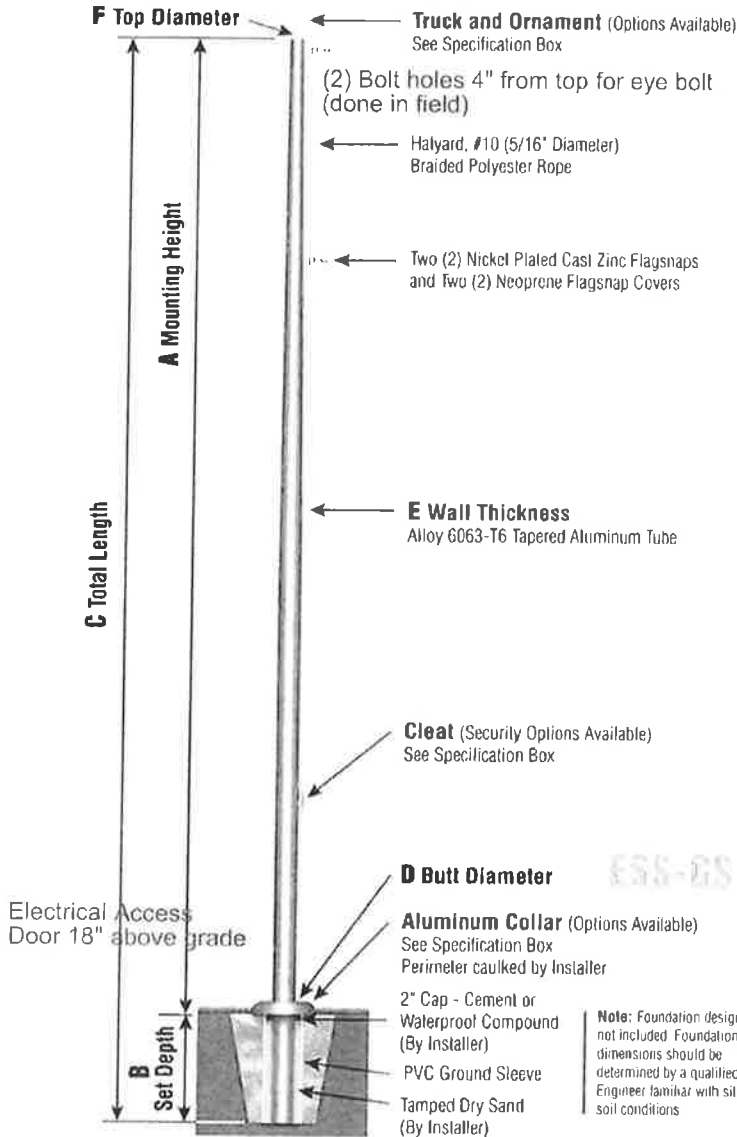

**ESS20C51 - BLK**



**TRK-9301-BLK**  
External Truck  
Single Stationary



**BAL-0512-BLK**  
HD Powder Coat  
Ball To Match Pole

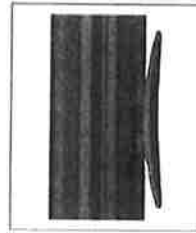

**CLA-9090-BLK |**  
**6.5' from bottom**  
Cleat Only



**COL1-A05S-BLK**  
FC-11 Spun Alum  
1-Piece



**BLK**  
Black  
Powder Coat

NOTE: Flagpole Components on Anodized and Powder Coat  
flagpoles (excluding specified Ornaments and Ball Trucks) will  
match flagpole color specified.

Specifications	
A Mounting Height:	20'
B. Set Depth:	2'-0"
C. Total Length:	22'-0"
D. Butt Diameter:	5"
E. Wall Thickness:	.156"
F. Top Diameter:	3"
Flagpole Sections:	1
Shaft Weight:	76 lbs
Hardware Weight:	9 lbs
Ground Sleeve Weight:	4 lbs.
* Max Flag Size:	4' x 6'
* Max Wind Speed w/Nylon Flag:	160 mph
* Max Wind Speed No Flag:	262 mph
* Wind Speed Specifications from ANSI/NAAMM FP 1001-07	

Customer Name: Village of Homewood	
Dealer: Flag Desk Inc	Qty: 10
Project: Village of Homewood	Location: Homewood, IL
Notes:	
1. Electrical Access door to be installed 18" above grade	
2. Two bolt holes tapped in field - 4" from top - (threaded with eyebolt) (to be done in field)	

ESS20C51G-T0C-Q0R-SK-C0L-BLK



Flag Desk, Inc.  
 512 Central Ave.  
 Wilmette, IL 60091  
 Phone: (800) 526-8183  
 Email: sales@flagdesk.com

**Flag Desk**

Item 11. E.

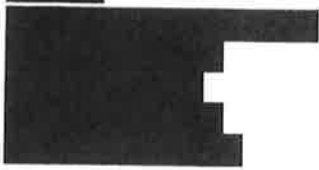
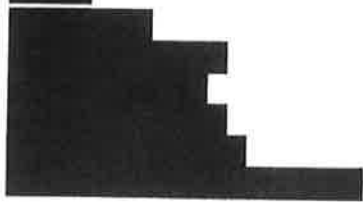

Item	Description	Price	Qty	Total
<del>ESS20C51-BLK</del>	ESS20C51 Estate Series Flagpole, Black Powder Coat External Single Stationary (ESS) - Rope Halyard ADD Hand Hole 18" above grade Technical Details: Brand: Concord American Mounting Height: 20' Butt Dia.: 5" Wall Thickness: .156" Pole Sections: 1 Set Depth: 2'-0" Ground Sleeve included Top Dia.: 3" Std. Flag Size: 4' x 6' Max Wind Speed w/Single Nylon Flag: 160 mph Max Wind Speed w/Single Polyester Flag: 142 mph Max Wind Speed w/Double Nylon Flags: 136 mph Max Wind Speed w/No Flag: 262 mph			
<del>BAL-0512-BLK</del>	BAL-0512 Heavy-Duty Aluminum Flagpole Ball, Black Powder Coat Industry Exclusive, Patented Ball Construction  Technical Details: Brand: Concord American Ball Diameter: 5" Rod Size: 1/2"-13NC			
<del>CCA-9030-BLK</del>	CCA-9030 Cleat Cover, Black Powder Coat Halyard Security  Technical Details: Brand: Concord American Use With Pole Diameters: 5" to 6" Description: Cleat Cover - Cylinder Lock Cleat Size: 9"			
<del>LNK-0300</del>	LNK-0300 Connecting Link, Stainless Steel 5/16" Thread-Lock Stainless Steel  Technical Details: Brand: Concord American Description: Connecting Link - Stainless Steel			

Item	Description	Price	Qty	Total
<del>PUL-1094</del>	PUL-1094 Pulleys / Eyebolt, Single Pulley - With Swivel and Eyebolt Single and Double Swivel  Technical Details: Brand: Concord American Description: Single Pulley - With Swivel and Eyebolt / Acorn Nut to cap 4" from top set bolt holes to be drilled in field			
EDS17-NQ112	Installation by others			

Notes

Lead time 3-4 weeks for fabrication & Powder Coat / Installation by others / Inclusions - Shop Drawings / Exclusions - No PE Stamp, No Tax, No Samples



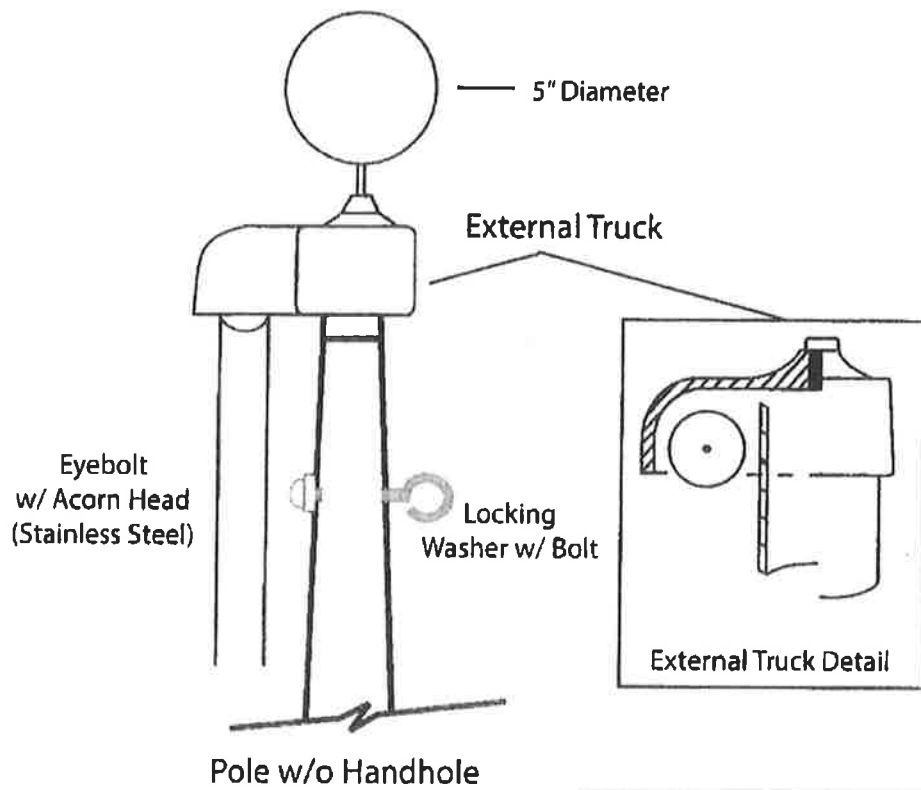

Notes:

- Quick-Link hooks into eye-bolt and acts as a connection between pole anchor, guideline and lighting cable
- Truck is secure via stainless steel set screws
- SYSTEM NOT DESIGNED TO FLY FLAGS AND LIGHTS AT SAME TIME.**

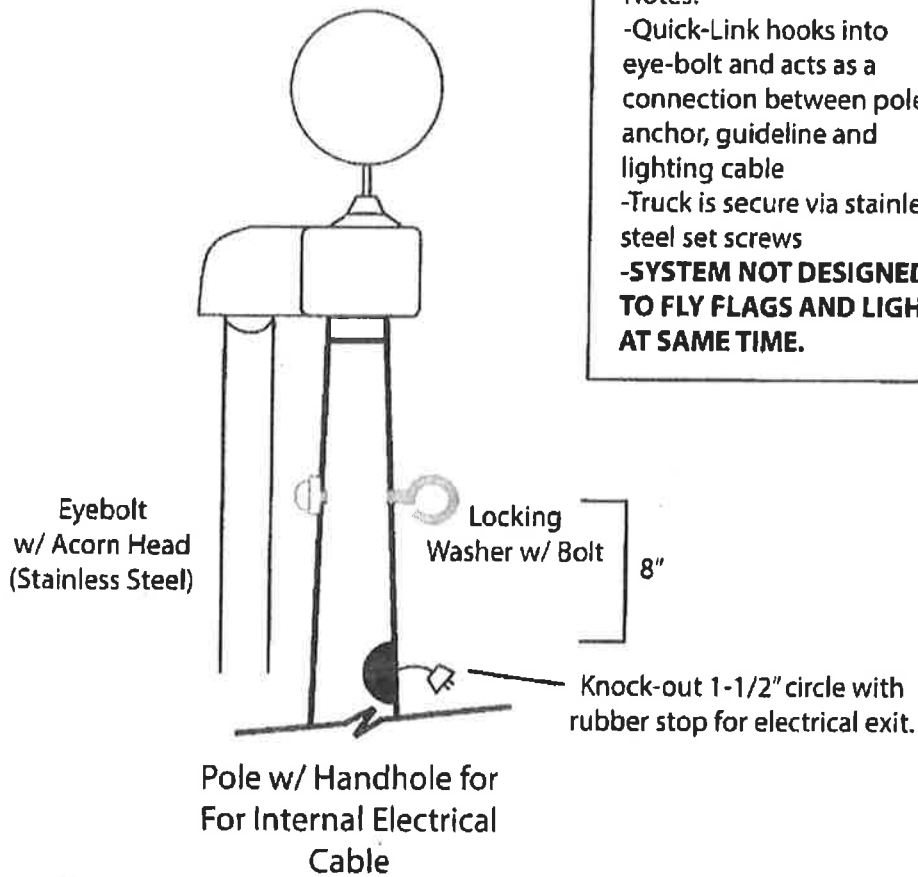

# SIDEWALK

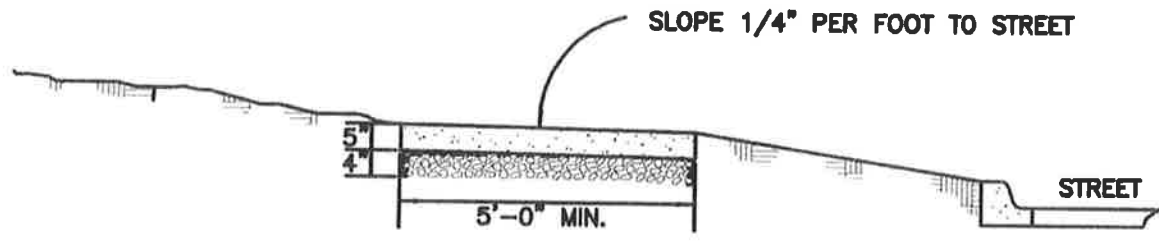

TYPICAL SIDEWALK SECTION

NOTE:

- ① CONCRETE SHALL BE CLASS SI
- ② SIDEWALK THICKNESS SHALL BE MINIMUM OF 5"
- ③ SIDEWALK THICKNESS ACROSS DRIVEWAYS SHALL BE MINIMUM OF 8"
- ④ THE BASE SHALL BE A MINIMUM OF 4" COMPACTED CRUSHED STONE, CA-11, 12, 13, 14, 15

## HOMEWOOD STANDARD

JANUARY, 1997

UNIT PAVER  
MANUFACTURED BY "PAVELOC INDUSTRIES, INC."  
NOMINAL 4"x8"x2.36" IN SIZE  
COMPRESSIVE STRENGTH 8,000 PSI  
ABSORPTION RATE OF LESS THAN 5%.  
PAVER COLOR RANGES SHALL MATCH ORIGINAL EXISTING COLORS AS  
MANUFACTURED AND FURNISHED BY PAVELOC IND.

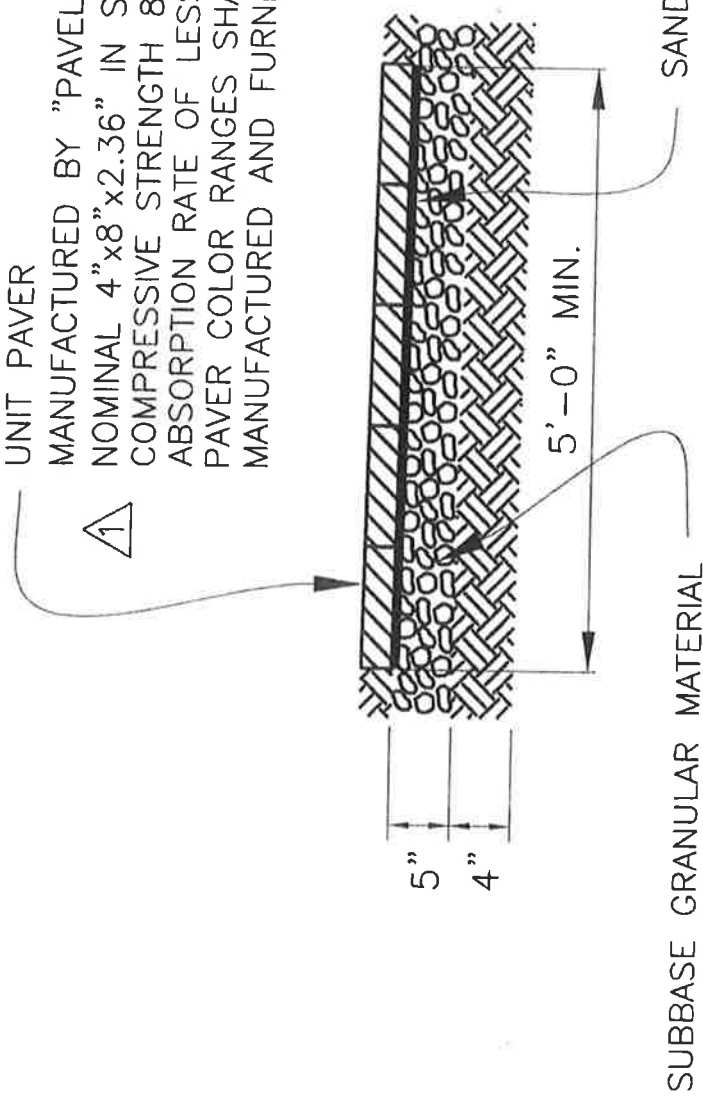

## SIDEWALK PAVERS

# TRENCH SECTION IN PAVED AREA FLEXIBLE PIPE

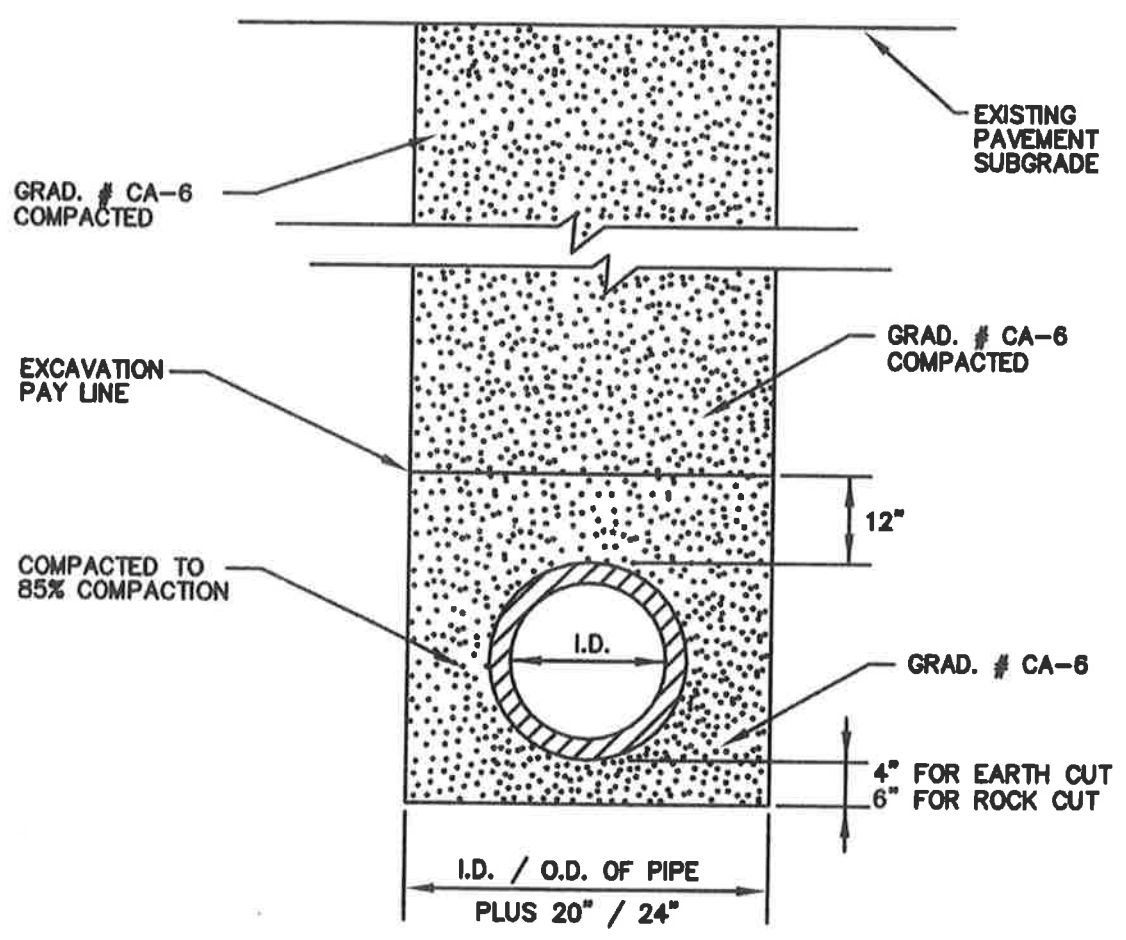

PAY LINE: PIPE SIZES UP TO 24", USE I.D. PLUS 20" &  
 PIPE SIZES OVER 24", USE O.D. PLUS 24"

**HOMEWOOD STANDARD**

**JANUARY, 1997**

Item: #LS15BKREEL

### C9 Commercial String Lights - Bulk Reel 330 ft, No Plug, Black

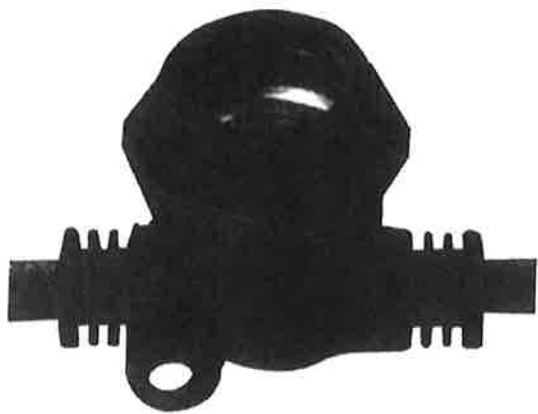

Availability: In Stock

\$594.00

Qty:

With your purchase, receive at no cost: **buy safe 3-in-1 GUARANTEE**

Add to Wishlist



**buy safe 3-in-1**  
Included with

- \$10,000 ID TI
- \$1,000 Purch
- \$100 Lowest

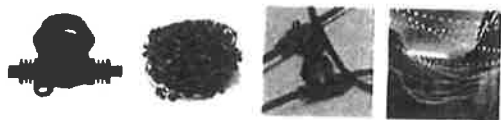

Allows you the flexibility to cut your own lengths! You save 10% by purchasing the bulk reels vs. custom-length strings. This commercial grade lighting is intended to be hard-wired directly to a power source and does not come finished with plugs. Perfect for permanent installation on outdoor exteriors to trim your home, patios, pool areas, etc.

Designed to be permanently mounted to a structure. If not mounting, must be supported by a guide wire. [sold separately](#)

Installation / Cut Sheet

Bulb / Socket Guide

Complete details below

#### Details

For use with [C9/intermediate-base bulbs](#) (sold separately).

One 330' reel = 264 sockets with 15' spacing between sockets.

Maximum run is 1200 watts. Max load for each socket is 10 watts. For 7 watt bulbs you can cut up to 171 sockets (213.75 ft). For 10 watt bulbs up to 120 sockets (150 ft). For our [LED bulbs](#), you can use the entire reel.

This reel **DOES NOT** come with plugs. It is intended to be hard-wired to a power source or you can attach your own plugs. If one bulb burns out, the rest stay lit.

Manufactured with 16-gauge wire and high-quality sockets.

PVC socket: forms a tight weatherproof seal around the bulb.

Indoor or outdoor use. Suitable for permanent, outdoor installation. You must keep a bulb in every socket to maintain weatherproof quality.

#### Related Products



G40 Bulb - Clear  
(C9/Intermediate base)  
\$0.90



G50 Bulb - Clear  
(C9/Intermediate base)  
\$1.00



10S11 Bulb - Frosted  
\$1.00



LED C9 Bulb - Warm White  
\$1.80



LED C9 Bulb - Cool White  
\$1.80

## Commercial Grade Light String

### Installation instructions for LC, LS15, M and MS light string product for permanent installation

**WARNING:** These products may represent a possible shock or fire hazard if improperly installed or attached in any way. Products should be installed in accordance with these instructions; and current electrical codes and/or the current National Electric Code (NEC).

#### **CAUTION – To reduce the risk of fire, electric shock or injury to persons:**

1. Commercial Grade Light String is intended for installation by trained, qualified electrical contractors.
2. Light string can be supported by steel guide cables, with zip ties and eyebolts. Proper diameter cabling must be used for the maximum span distance between supports according to local building codes. See chart on reverse side for maximum span distances between supports.
3. Suspend strings properly by attaching suspension cable (not provided) to solid support structures, such as joists, beams or wall studs.
4. Light sockets must be suspended so that bulbs are facing down ONLY.
5. Keep combustible material clear of bulbs. Do NOT allow lamps or sockets to come into contact with walls, ceilings, fabrics associated with shades, blinds or other materials. Lamps should hang freely in a downward direction with a minimum of 3" space from the nearest object.
6. Do not cluster the bulbs.
7. Not intended for installation in ceilings, soffits, cabinets or other enclosed spaces.
8. Not intended for lighting aquariums.
9. Do NOT secure light string to buildings or other structural supports using nails, staples or other sharp, conducting materials.
10. Avoid damage to the insulation during installation. Do NOT pierce or otherwise compromise wire's or socket's outer covering, jacket or sheathing.
11. Periodically inspect wire and sockets for degradation due to weather, UV light or other damage. Promptly replace worn out light string.
12. **DO NOT MOUNT THE LIGHT STRINGS WITH SOCKETS FACING UPWARD!**
13. **DO NOT OVERLOAD ANY SOCKET'S MAXIMUM WATTAGE RATING!**
14. **DO NOT OVERLOAD MAXIMUM WATTAGE CAPACITY IN ANY RUN!**

#### **WARNING – RISK OF ELECTRIC SHOCK!!**

Disconnect power at source prior to wiring, re-lamping or servicing in any way.

#### **LIGHT STRING SETS WITH POLARIZED PLUG**

1. Do not connect the light string to any other string.
2. The plug-in light string sets are supplied with an attached polarized plug that will only fit into a polarized outlet. If it does not fit, reverse the plug. If it still does not fit, contact a qualified electrician. Do not alter the plug.
3. **DO NOT EXCEED THE MAXIMUM WATTAGE FOR LIGHT STRING SETS WITH ATTACHED PLUG:**

LS Series: 1200 WATTS MAXIMUM FOR 25 FOOT PLUG-IN LIGHT STRING SETS!

LS Series: 1120 WATTS MAXIMUM FOR 100 FOOT PLUG-IN LIGHT STRING SETS!

M and MS Series: 600 WATTS MAXIMUM FOR 48 FOOT PLUG-IN LIGHT STRING SETS!

M and MS Series: 1250 WATTS MAXIMUM FOR 100 FOOT PLUG-IN LIGHT STRING SETS!

**PartyLights.com**

# Commercial Grade Light String

## Installation instructions for LC, LS15, M and MS light string product for permanent installation

### SUSPENDING LIGHT STRINGS

1. Light string must be securely attached to a support structure at each end of each span. See chart below for maximum span distances:

MODEL #	Max. span between supports
M and MS 24" spacing between sockets	10 sockets or 20'
LS15 with 15" spacing between sockets	15 sockets or 19'
LC with 12" spacing between bulbs	20 sockets or 20'

2. Secure light string to supporting hardware (eyebolts, brackets, etc., not provided) using cable ties (not included). See Figure 1.

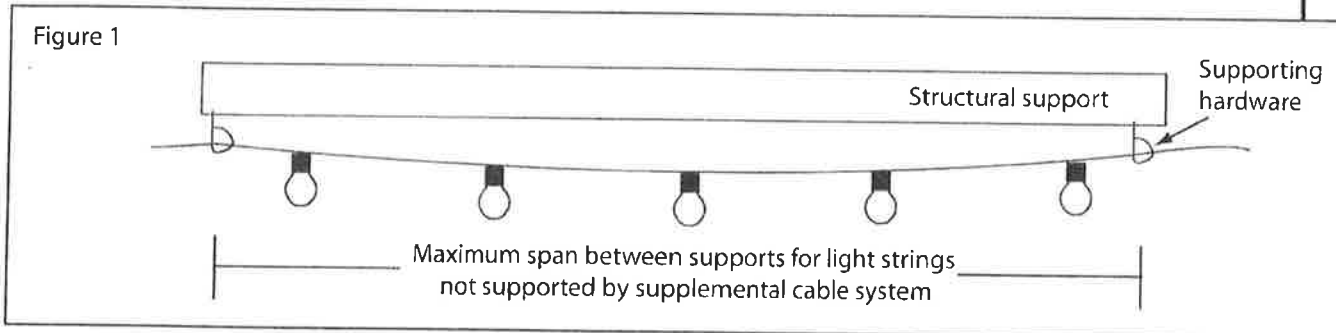

3. For spans exceeding the above, use properly rated cable support system and cable ties (both not provided) and follow local codes for suspended structures and loads.

### CONNECTING LIGHT STRINGS TO POWER SOURCE

**WARNING - RISK OF ELECTRIC SHOCK!!** Disconnect power at source prior to wiring and follow any required lock-out/tag-out procedures. Wiring instructions intended for use by qualified and licensed electrical contractors.

1. Located power source in properly rated junction box (not supplied) for indoor or outdoor application. See Figure 2.
2. Thread light string end through strain relief fitting (indoor installations) or water tight strain relief fitting (outdoor installations) and into junction box.
3. Connect light string to power source: smooth wire to black (hot) wire; ribbed wire to white (neutral) wire.
4. Ensure that no bare wires are exposed outside the electrical connections.
5. Power source may be switched with properly rated switch or dimmer control (not provided). For maximum run distances, see Table 1 on following page.

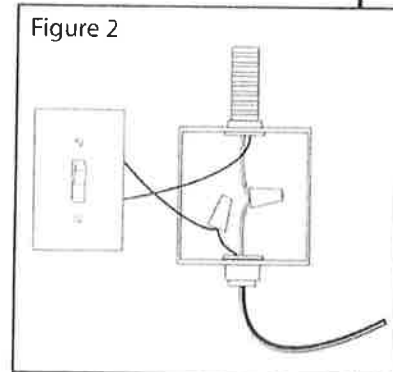

Note: Use 14AWG for connection to power source. Check local electrical codes for variations before installing or lamping light string.

# PartyLights.com

## Commercial Grade Light String

Installation instructions for LC, LS15, M and MS light string product for permanent installation

### RE-LAMPING LIGHT STRINGS

**WARNING – RISK OF ELECTRIC SHOCK!!** Disconnect power at source prior to re-lamping light strings. For outdoor light strings, do NOT re-lamp light strings during rain or other inclement weather conditions.

1. Re-lamp light strings only during dry and calm weather conditions.
2. Unscrew existing lamps by lightly holding the socket in one hand and twisting the lamp counter-clockwise. Lamps may be tight in the sockets. This is normal to prevent moisture from getting into the socket.
3. Replace with proper wattage and type lamps according to the following chart.

Table 1

MODEL #	Maximum Load in Watts per socket type	Maximum Load in Watts	
		Plug-in	Hardwire
M and MS	25 (medium base)	600/1250*	1800***
LS15	10 (intermediate base)	1200/1120**	1200***
LC	10 (candelabra base)	N/A	1200***

\*Maximum run for 48 foot plug-in sets is 600 watts, based on 24 sockets at 25 watts each maximum; maximum run for 100 foot plug-in sets is 1250 watts, based on 50 sockets at 25 watts each maximum.

\*\*Maximum run for 25 foot plug-in sets is 1200 watts, based on a total of 6 strands (120 sockets) at 10 watts each maximum; maximum run for 100 foot plug-in sets is 1120 watts, based on a total of 2 strands (160 sockets) at 7 watts each; If using 10 watt bulbs, maximum run is 800 watts (1 strand).

\*\*\*Use 14AWG for hardwire connection to 120V power source. Check local electrical codes for variations before installing or lamping light string.

### 4. DO NOT OVERLOAD SOCKETS OR LIGHT STRING!!

### COMMERCIAL GRADE LIGHT STRINGS SPECIFICATIONS

Specifications	LC Series	LS15 Series	M Series	MS Series
Socket Type	Candelabra Base	Intermediate Base	Medium Base	Medium Base
Max Bulb Wattage	10 watt	10 watt	25 watt	25 watt
Max Amperage Load	10 Amps	10 Amps	10 Amps	10 Amps
Lamp Spacing	12 inches	15 inches	24 inches	24 inches
Max Run - Watts	1200 watts <sup>†</sup>	1200 watts <sup>†</sup>	1800 watts <sup>†</sup>	1800 watts <sup>†</sup>

<sup>†</sup>Maximum run for LC and LS15 bulk reels is 1200 watts, based on 10 amps allowed on 16AWG wire; maximum run for M and MS bulk reels is 1800 watts, based on 15 amps allowed on 14AWG wire.

PartyLights.com



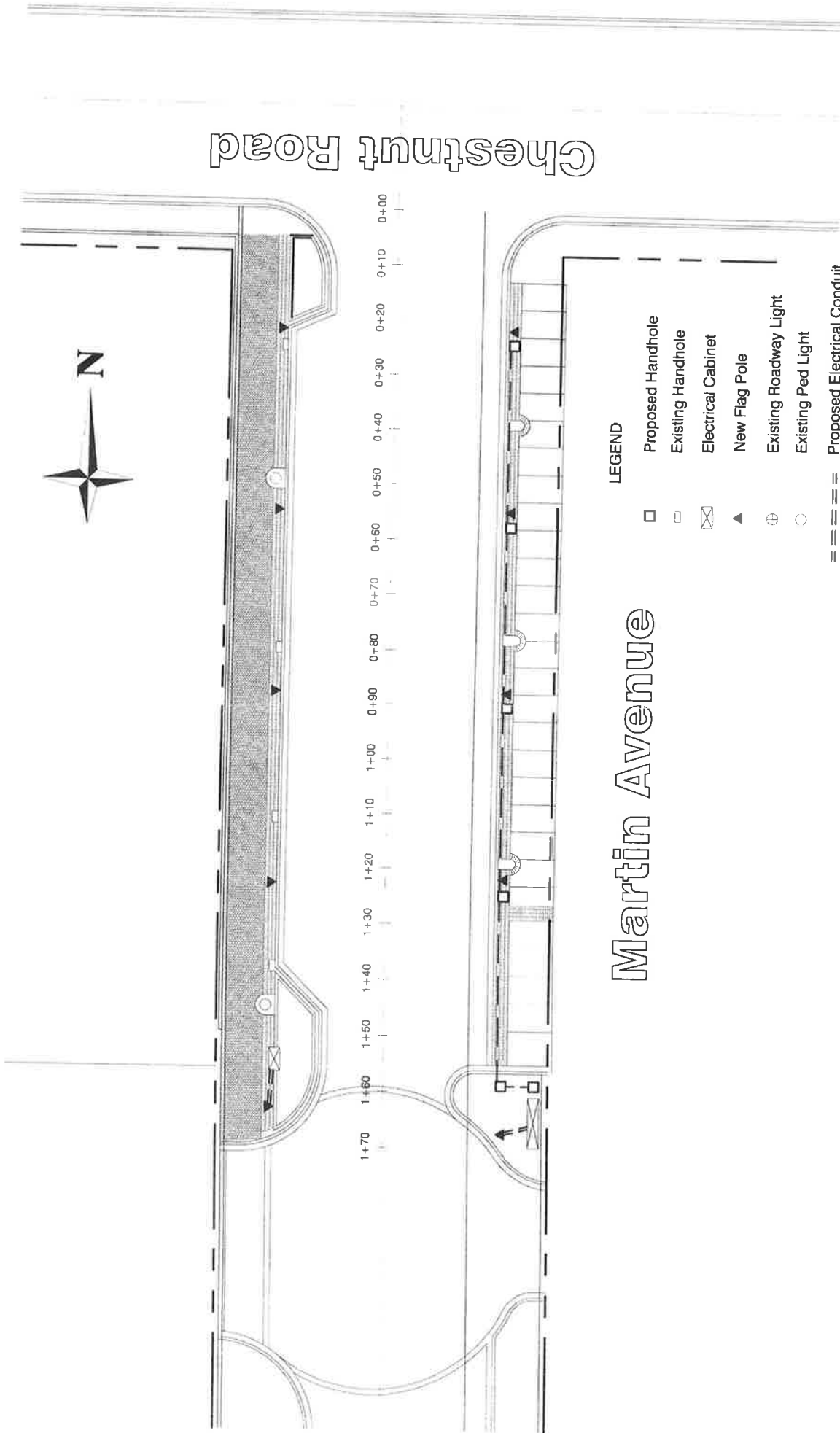

# Chestnut Road

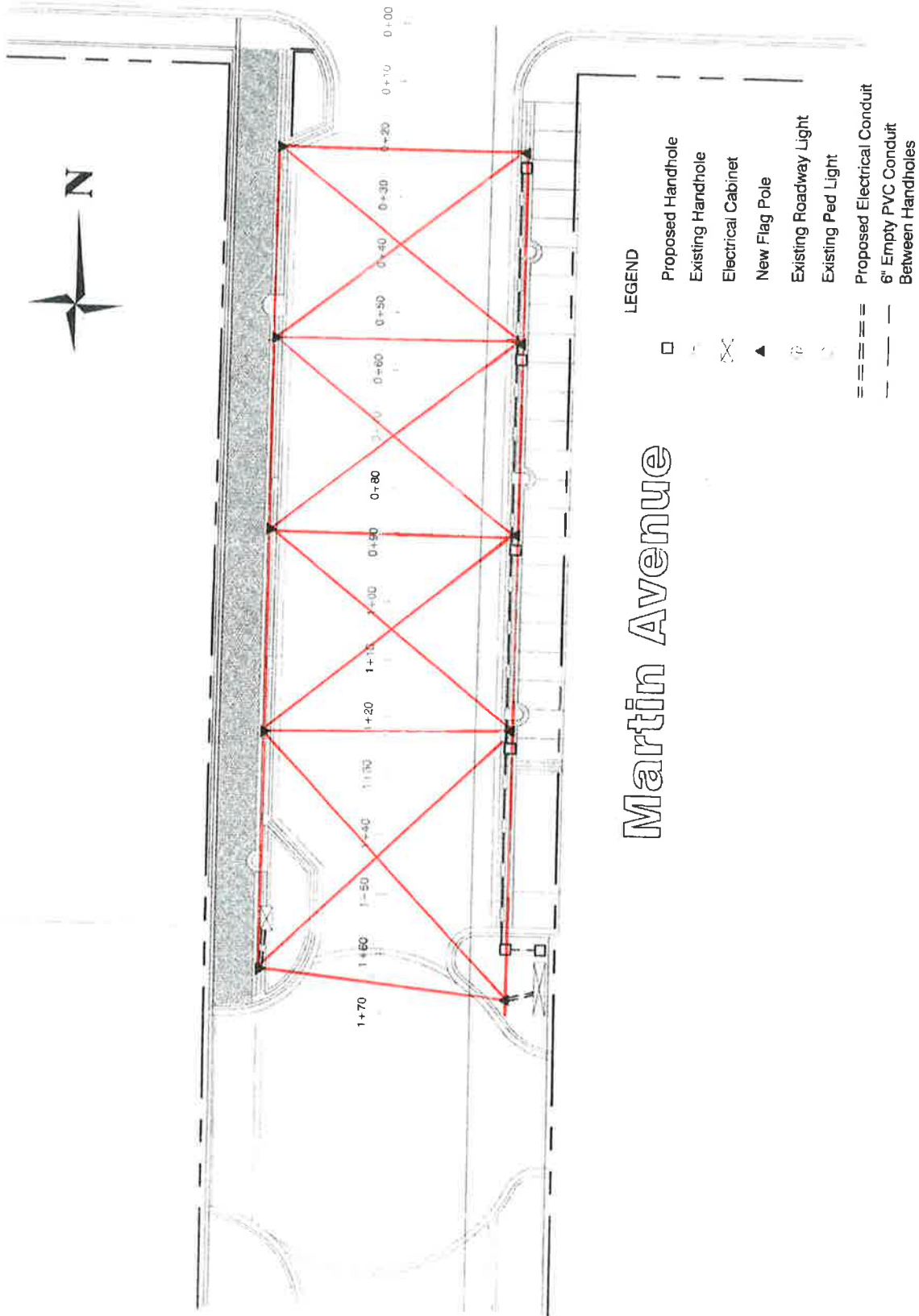

## Contractor Price Proposal Summaries - CSI

**Date:** 7/9/2024  
**Work Order #:** 129681.00  
**Title:** Village of Homewood - Tivoli Lighting Project  
**Contractor:** F.H. Paschen  
**Contractor Number:** IL-R2-GC-122122-FHP  
**Job Order Value:** \$170,978.94

**Proposal Name:** Village of Homewood - Tivoli Lighting Project  
**Proposal Value:** \$170,978.94

**To:** Project Manager **From:** Contractor Project Manager

CSI Section	LineTotal
<b>01 - General Requirements</b>	<b>\$31,147.23</b>
<b>02 - Existing Conditions</b>	<b>\$10,963.67</b>
<b>03 - Concrete</b>	<b>\$3,146.15</b>
<b>10 - Specialties</b>	<b>\$38,955.43</b>
<b>11 - Equipment</b>	<b>\$2,999.64</b>
<b>21 - Fire Suppression</b>	<b>\$859.67</b>
<b>23 - Heating, Ventilating, And Air-Conditioning (HVAC)</b>	<b>\$324.01</b>
<b>26 - Electrical</b>	<b>\$41,577.89</b>
<b>31 - Earthwork</b>	<b>\$7,920.73</b>
<b>32 - Exterior Improvements</b>	<b>\$23,158.73</b>
<b>33 - Utilities</b>	<b>\$9,925.79</b>
<b>Grand Total:</b>	<b>\$170,978.94</b>

This work order proposal total represents the correct total for the proposal. Any discrepancy between line totals, sub-totals and the proposal total is due to rounding of the line totals and sub-totals.

**The Percent of NPP on this Proposal: 0.00**

## Contractor Price Proposal Details - CSI

**Date:** 7/9/2024  
**Work Order #:** 129681.00  
**Title:** Village of Homewood - Tivoli Lighting Project  
**Contractor:** F.H. Paschen  
**Contractor Number:** IL-R2-GC-122122-FHP  
**Job Order Value:** \$170,978.94

**Proposal Name:** Village of Homewood - Tivoli Lighting Project  
**Proposal Value:** \$170,978.94

CSI Number	Mod	UOM	Description	LineTotal
<b>01 - General Requirements</b>				
1	01 22 16 00-0002	EA	Reimbursable Fees Reimbursable Fees will be paid to the contractor for eligible costs as directed by Owner. Insert the appropriate quantity to adjust the base cost to the actual Reimbursable Fee. If there are multiple Reimbursable Fees, list each one separately and add a comment in the "note" block to identify the Reimbursable Fee (e.g. sidewalk closure, road cut, various permits, extended warranty, expedited shipping costs, etc.). A copy of each receipt, invoice, or proof of payment shall be submitted with the Price Proposal.	\$4,237.80
			Qty      Unit Price      Factor      Total	
			<b>Installation</b> 3,500.00 X      \$1.00 X      1.2108      \$4,237.80	
			0	
			<b>Contractor Notes:</b> <i>P&amp;P Bond</i>	
2	01 22 23 00-0039	WK	30' Electric, Articulating (Up/Over) Boom Man Lift With Platform	\$2,445.53
			Qty      Unit Price      Factor      Total	
			<b>Installation</b> 2.000 X      \$1,009.88 X      1.2108      \$2,445.53	
			<b>Contractor Notes:</b> <i>Boom lift for installing poles and lighting</i>	
3	01 22 23 00-0281	WK	700 LB Capacity, 36" Wide, Skid-Steer Loader With Full-Time Operator	\$5,041.12
			Qty      Unit Price      Factor      Total	
			<b>Installation</b> 1.000 X      \$4,163.46 X      1.2108      \$5,041.12	
			<b>Contractor Notes:</b> <i>Move materials and debris</i>	
4	01 22 23 00-0305	WK	Broom Attachment For Skid-Steer Loaders	\$487.15
			Qty      Unit Price      Factor      Total	
			<b>Installation</b> 1.000 X      \$402.34 X      1.2108      \$487.15	
			<b>Contractor Notes:</b> <i>Site clean up on sidewalks and road</i>	
5	01 22 23 00-0346	WK	3/8 CY Hydraulic Excavator With Full-Time Operator	\$5,636.56
			Qty      Unit Price      Factor      Total	
			<b>Installation</b> 1.000 X      \$4,655.24 X      1.2108      \$5,636.56	
			<b>Contractor Notes:</b> <i>Excavate new trenches for electrical conduits</i>	

CSI Number	Mod	UOM	Description	LineTotal
<b>01 - General Requirements</b>				
6	01 22 23 00-0982	DAY	6 Ton Lift, Truck Mounted Hydraulic Crane With Full-Time Operator	\$2,787.07
			Qty Unit Price Factor Total	
			Installation 2.000 X \$1,150.92 X 1.2108 \$2,787.07	
			Contractor Notes: Lift flag poles in place	
7	01 22 23 00-1476	DAY	1,500 To 2,000 Gallon Vacuum Truck With Full-Time Truck Driver	\$2,499.26
			Qty Unit Price Factor Total	
			Installation 2.000 X \$1,032.07 X 1.2108 \$2,499.26	
8	01 45 23 00-0017	EA	Coarse Aggregate Sieve Analysis Test, ASTM C-136, CA 202	\$533.04
			Qty Unit Price Factor Total	
			Installation 4.000 X \$110.06 X 1.2108 \$533.04	
			Contractor Notes: Aggregate test for backfill to be used on site	
9	01 45 23 00-0061	EA	Concrete Mix Design Review	\$506.37
			Qty Unit Price Factor Total	
			Installation 1.000 X \$418.21 X 1.2108 \$506.37	
			Contractor Notes: Concrete mix review	
10	01 45 23 00-0068	EA	Cement Grab Sample (CCR Title 24)Includes sealing and storing 1 year.	\$133.26
			Qty Unit Price Factor Total	
			Installation 2.000 X \$55.03 X 1.2108 \$133.26	
			Contractor Notes: Concrete samples	
11	01 55 26 00-0054	MO	Type III Barricade, Up To 5' Wide With Three Reflective Rails	\$101.20
			Qty Unit Price Factor Total	
			Installation 2.000 X \$41.79 X 1.2108 \$101.20	
			Contractor Notes: Block off traffic from main road (2) barricades for (1) month.	
12	01 56 26 00-0005	LF	Temporary 6' High Chain Link Fence And Posts, Up To 6 Months	\$3,361.42
			Qty Unit Price Factor Total	
			Installation 420.000 X \$6.61 X 1.2108 \$3,361.42	
			Contractor Notes: Temporary fencing around work areas	
13	01 56 26 00-0005	0068 MOD	For >250 To 500, Deduct	(\$172.90)
			Qty Unit Price Factor Total	
			Installation 420.000 X (\$0.34) X 1.2108 (\$172.90)	
14	01 57 23 00-0002	EA	36" x 48" x 18" Non-Woven Polypropylene Trash and Debris Drain Guard (Ultra-Drain Guard® 9227)	\$493.57
			Qty Unit Price Factor Total	
			Installation 4.000 X \$101.91 X 1.2108 \$493.57	
			Contractor Notes: Protect existing sewer inlets	

CSI Number	Mod	UOM	Description	LineTotal
<b>01 - General Requirements</b>				
15	01 71 13 00-0003	EA	Equipment Delivery, Pickup, Mobilization And Demobilization Using A Tractor Trailer With Up To 53' BedIncludes loading, tie-down of equipment, delivery of equipment, off loading on site, rigging, dismantling, loading for return and transporting away. For equipment such as bulldozers, motor scrapers, hydraulic excavators, gradalls, road graders, loader-backhoes, heavy duty construction loaders, tractors, pavers, rollers, bridge finishers, straight mast construction forklifts, telescoping boom rough terrain construction forklifts, telescoping and articulating boom man lifts with >40' boom lengths, etc.	\$1,702.18
			Qty Unit Price Factor Total	
			Installation 1.000 X \$1,405.83 X 1.2108 \$1,702.18	
16	01 74 19 00-0014	EA	20 CY Dumpster (3 Ton) "Construction Debris"Includes delivery of dumpster, rental cost, pick-up cost, hauling, and disposal fee. Non-hazardous material.	\$728.05
			Qty Unit Price Factor Total	
			Installation 1.000 X \$601.30 X 1.2108 \$728.05	
			Contractor Notes: Construction debris	
17	01 74 19 00-0018	MO	Rampless Concrete Washout BinIncludes delivery.	\$626.55
			Qty Unit Price Factor Total	
			Installation 1.000 X \$517.47 X 1.2108 \$626.55	
			Contractor Notes: Concrete washout	
<b>Subtotal for 01 - General Requirements:</b>				<b>\$31,147.23</b>
<b>02 - Existing Conditions</b>				
18	02 41 19 13-0062	LF	Welded Wire Reinforced Concrete Slab Up To 4" Depth, Saw Cut	\$838.48
			Qty Unit Price Factor Total	
			Installation 250.000 X \$2.77 X 1.2108 \$838.48	
			Contractor Notes: Sawcut walkway and curbs for demo.	
19	02 41 19 13-0062	0030 MOD	For Each Additional Pass (Depth To 3"), Add	\$64.17
			Qty Unit Price Factor Total	
			Installation 50.000 X \$1.06 X 1.2108 \$64.17	
20	02 41 19 13-0285	IN	1" Diameter Drilling In Concrete Per Inch Of Depth	\$9,868.50
			Qty Unit Price Factor Total	
			Installation 2,880.00 X \$2.83 X 1.2108 \$9,868.50	
21	02 66 13 00-0002	CY	Excavate, Haul And Place Soil At Landfill	\$192.52
			Qty Unit Price Factor Total	
			Installation 60.000 X \$2.65 X 1.2108 \$192.52	
			Contractor Notes: removal of spoils	
<b>Subtotal for 02 - Existing Conditions:</b>				<b>\$10,963.67</b>

CSI Number	Mod	UOM	Description	LineTotal
<b>03 - Concrete</b>				
22	03 15 16 00-0002	LF	1/2" x 1" Plain Asphalt Expansion Joint, Poured	\$138.52
			Qty Unit Price Factor Total	
			Installation 40.000 X \$2.86 X 1.2108 \$138.52	
		Contractor Notes: <i>between curb and pavers/concrete</i>		
23	03 21 16 00-0175	EA	1" Diameter x 24" Long, Epoxy Coated Deformed Straight Dowel	\$3,007.63
			Qty Unit Price Factor Total	
			Installation 240.000 X \$10.35 X 1.2108 \$3,007.63	
<b>Subtotal for 03 - Concrete:</b>				<b>\$3,146.15</b>
<b>10 - Specialties</b>				
24	10 75 16 00-0002	EA	25' Exposed Height, Tapered White Fiberglass Flagpole6" butt diameter, 3" top diameter and 0.180" wall.	\$38,955.43
			Qty Unit Price Factor Total	
			Installation 10.000 X \$3,217.33 X 1.2108 \$38,955.43	
		Contractor Notes: <i>line item used to represent (10) new flag poles 20 L:F tall. Flag poles will be Concord American Flagpole States Series ESS20C51-BLK.</i>		
<b>Subtotal for 10 - Specialties:</b>				<b>\$38,955.43</b>
<b>11 - Equipment</b>				
25	11 68 23 33-0007	PR	Polyvinyl Chloride (PVC) Ground Sleeves For Tennis Court Net Posts	\$2,999.64
			Qty Unit Price Factor Total	
			Installation 10.000 X \$247.74 X 1.2108 \$2,999.64	
		Contractor Notes: <i>Sleeves for flag poles</i>		
<b>Subtotal for 11 - Equipment:</b>				<b>\$2,999.64</b>
<b>21 - Fire Suppression</b>				
26	21 24 16 00-0082	LF	1/16" Stainless Steel Cable	\$859.67
			Qty Unit Price Factor Total	
			Installation 1,000.00 X \$0.71 X 1.2108 \$859.67	
		Contractor Notes: <i>New lighting cable,, using line item to represent thicker cable</i>		
<b>Subtotal for 21 - Fire Suppression:</b>				<b>\$859.67</b>
<b>23 - Heating, Ventilating, And Air-Conditioning (HVAC)</b>				
27	23 31 16 23-0072	EA	Stainless Steel Cable Locks For Horizontal CablesRequires two (2) cable locks per support point or per stretcher.	\$324.01
			Qty Unit Price Factor Total	
			Installation 20.000 X \$13.38 X 1.2108 \$324.01	
<b>Subtotal for 23 - Heating, Ventilating, And Air-Conditioning (HVAC):</b>				<b>\$324.01</b>

CSI Number	Mod	UOM	Description	LineTotal
<b>26 - Electrical</b>				
28	26 01 20 91-0008	EA	Lighting, Existing Circuit Tracing Per Circuit	\$75.99
			Qty Unit Price Factor Total	
			Installation 4.000 X \$15.69 X 1.2108 \$75.99	
29	26 05 19 16-0003	LF	Pull String Installed To Remain In Place, In Existing Conduit	\$45.41
			Qty Unit Price Factor Total	
			Installation 150.000 X \$0.25 X 1.2108 \$45.41	
30	26 05 19 16-0056	MLF	3 Conductors, #12 AWG, 600 Volt, XLP (XHHW-2), Copper, Stranded, Power Cable, Installed In Conduit	\$4,916.06
			Qty Unit Price Factor Total	
			Installation 2.192 X \$1,852.27 X 1.2108 \$4,916.06	
			<b>Contractor Notes:</b> Wire for new poles from existing transformer.	
31	26 05 29 00-0245	EA	Snap On, Switch And Outlet Box Support (Caddy MSF)	\$39.59
			Qty Unit Price Factor Total	
			Installation 10.000 X \$3.27 X 1.2108 \$39.59	
32	26 05 33 13-0471	EA	3/4" Rigid Galvanized Steel (RGS) Sealing Locknut	\$84.03
			Qty Unit Price Factor Total	
			Installation 20.000 X \$3.47 X 1.2108 \$84.03	
33	26 05 33 13-0851	LF	3/4" Polyvinyl Chloride (PVC) Coated, Urethane Lined, Rigid Galvanized Steel (RGS) Conduit	\$4,764.28
			Qty Unit Price Factor Total	
			Installation 326.000 X \$12.07 X 1.2108 \$4,764.28	
34	26 05 33 13-0851	0007 MOD	For >250 To 500, Deduct	(\$185.52)
			Qty Unit Price Factor Total	
			Installation 326.000 X (\$0.47) X 1.2108 (\$185.52)	
35	26 05 33 13-0861	LF	6" Polyvinyl Chloride (PVC) Coated, Urethane Lined, Rigid Galvanized Steel (RGS) Conduit	\$28,276.42
			Qty Unit Price Factor Total	
			Installation 150.000 X \$155.69 X 1.2108 \$28,276.42	
36	26 05 33 13-1615	EA	6" Polyvinyl Chloride (PVC) Conduit Male Terminal Adapter	\$1,274.73
			Qty Unit Price Factor Total	
			Installation 10.000 X \$105.28 X 1.2108 \$1,274.73	
37	26 05 53 00-0019	EA	Labeling Existing Wire	\$17.14
			Qty Unit Price Factor Total	
			Installation 6.000 X \$2.36 X 1.2108 \$17.14	
38	26 27 26 00-0018	EA	20 Amperes, 125 Volt, 1 Phase, NEMA 5-20, Duplex Receptacle	\$461.07
			Qty Unit Price Factor Total	
			Installation 20.000 X \$19.04 X 1.2108 \$461.07	
39	26 27 26 00-0268	EA	1 Gang, 302 Stainless Steel With Satin Finish Switch Wall Plates	\$198.81
			Qty Unit Price Factor Total	
			Installation 20.000 X \$8.21 X 1.2108 \$198.81	



CSI Number	Mod	UOM	Description	LineTotal
<b>26 - Electrical</b>				
40	26 56 13 00-0292	EA	Extra Handhole For Steel Area Light Poles	\$1,609.88
			Qty Unit Price Factor Total	
			Installation 10.000 X \$132.96 X 1.2108 \$1,609.88	
<b>Subtotal for 26 - Electrical:</b>				<b>\$41,577.89</b>
<b>31 - Earthwork</b>				
41	31 05 13 00-0002	CY	Bank Run/Fill Sand	\$206.11
			Qty Unit Price Factor Total	
			Installation 4.970 X \$34.25 X 1.2108 \$206.11	
			Contractor Notes: $790 \text{ Sf} \times 2"(.17) = 134.3 / 27 = 4.97\text{CY}$	
42	31 05 13 00-0002	0053 MOD	For Up To 8, Add	\$40.39
			Qty Unit Price Factor Total	
			Installation 4.870 X \$6.85 X 1.2108 \$40.39	
43	31 05 16 00-0006	CY	#6 Stone Aggregate Fill (3/8" To 3/4" Clean)	\$1,941.55
			Qty Unit Price Factor Total	
			Installation 27.000 X \$59.39 X 1.2108 \$1,941.55	
44	31 23 16 13-0004	CY	12" Wide or Less, Excavation for Trenching by Machine in Loose Rock Includes compacted aggregate	\$931.71
			Qty Unit Price Factor Total	
			Installation 50.000 X \$15.39 X 1.2108 \$931.71	
45	31 23 16 13-0008	CY	Excavation For Trenching By Hand In Loose Rock Or Compacted Aggregate Includes stockpiling excess materials and trimming sides and bottom of trench.	\$2,287.32
			Qty Unit Price Factor Total	
			Installation 10.000 X \$188.91 X 1.2108 \$2,287.32	
46	31 23 16 13-0010	CY	Backfilling or Placing Subbase for Trenches with Imported or Stockpiled Materials by Machine	\$196.76
			Qty Unit Price Factor Total	
			Installation 50.000 X \$3.25 X 1.2108 \$196.76	
47	31 23 16 13-0011	CY	Backfilling or Placing Subbase for Trenches with Imported or Stockpiled Materials by Hand	\$370.38
			Qty Unit Price Factor Total	
			Installation 10.000 X \$30.59 X 1.2108 \$370.38	
48	31 23 16 13-0013	CY	Compaction of Fill or Subbase for Trenches by Vibratory Plate, Air Tamper, Etcetera	\$388.06
			Qty Unit Price Factor Total	
			Installation 50.000 X \$6.41 X 1.2108 \$388.06	
49	31 23 16 13-0014	CY	Compaction of Fill or Subbase for Trenches by Hand	\$417.85
			Qty Unit Price Factor Total	
			Installation 10.000 X \$34.51 X 1.2108 \$417.85	

CSI Number	Mod	UOM	Description	LineTotal
<b>31 - Earthwork</b>				
50	31 23 16 16-0010	VLF	12" Diameter Hole, Auger By Machine Post Hole In Soil	\$900.84
			Qty Unit Price Factor Total	
			Installation 40.000 X \$18.60 X 1.2108 \$900.84	
51	31 24 13 00-0007	SY	Shape Embankment/Slope By Hand Up To 1 On 4 Slope	\$182.13
			Qty Unit Price Factor Total	
			Installation 26.670 X \$5.64 X 1.2108 \$182.13	
			Contractor Notes: Grading for proper drainage on sand bedding.	
52	31 24 13 00-0020	LF	Finish Grade For Curb And Gutter	\$57.63
			Qty Unit Price Factor Total	
			Installation 40.000 X \$1.19 X 1.2108 \$57.63	
<b>Subtotal for 31 - Earthwork:</b>				<b>\$7,920.73</b>
<b>32 - Exterior Improvements</b>				
53	32 11 23 16-0004	SF	4" Crushed Aggregate Base Course For Sidewalks	\$354.52
			Qty Unit Price Factor Total	
			Installation 240.000 X \$1.22 X 1.2108 \$354.52	
54	32 14 11 00-0002	SF	1" To 2" Sand Bedding, Screeded	\$817.29
			Qty Unit Price Factor Total	
			Installation 750.000 X \$0.90 X 1.2108 \$817.29	
55	32 14 16 00-0003	SF	4" x 8" x 2-1/4" Brick, Laid On Edge	\$6,312.02
			Qty Unit Price Factor Total	
			Installation 450.000 X \$6.16 X 1.2108 \$3,356.34	
			Demolition 790.000 X 3.09 X 1.2108 \$2,955.68	
			Contractor Notes: storage and replace existing	
56	32 14 16 00-0003	SF	4" x 8" x 2-1/4" Brick, Laid On Edge	\$10,816.20
			Qty Unit Price Factor Total	
			Installation 300.000 X \$21.64 X 1.2108 \$7,860.51	
			Demolition 790.000 X 3.09 X 1.2108 \$2,955.68	
			Contractor Notes: 300 sf new brick, demo 790 sf	
57	32 16 13 13-0016	LF	6" x 12" Cast In Place Concrete Gutter With 6" Curb And Face - Straight	\$1,545.47
			Qty Unit Price Factor Total	
			Installation 40.000 X \$22.15 X 1.2108 \$1,072.77	
			Demolition 40.000 X 9.76 X 1.2108 \$472.70	
58	32 16 13 13-0016	0080 MOD	For >20 To 50, Add	\$404.41
			Qty Unit Price Factor Total	
			Installation 40.000 X \$8.35 X 1.2108 \$404.41	
59	32 16 23 00-0012	SF	5" Cast In Place Concrete Sidewalk With Fiber Mesh	\$2,603.70
			Qty Unit Price Factor Total	
			Installation 240.000 X \$8.96 X 1.2108 \$2,603.70	

CSI Number	Mod	UOM	Description	LineTotal
<b>32 - Exterior Improvements</b>				
60	32 16 23 00-0012	0097	MOD For >100 To 500, Add	\$305.12
			Qty Unit Price Factor Total	
			Installation 240.000 X \$1.05 X 1.2108 \$305.12	
<b>Subtotal for 32 - Exterior Improvements:</b>				<b>\$23,158.73</b>
<b>33 - Utilities</b>				
61	33 05 07 13-0036	EA	Up To 6" Horizontal Directional Boring Minimum Set-up ChargeFor projects where the total horizontal directional boring charge is less than the minimum set-up charge, use this task exclusively. This task should not be used in conjunction with any other tasks in this section.	\$3,590.74
			Qty Unit Price Factor Total	
			Installation 1.000 X \$2,965.59 X 1.2108 \$3,590.74	
62	33 05 63 00-0428	EA	12" x 12" x 12" Precast Concrete Handholes With Steel Cover8000 To 12000 pound traffic rated top.	\$6,335.05
			Qty Unit Price Factor Total	
			Installation 6.000 X \$872.02 X 1.2108 \$6,335.05	
			<b>Contractor Notes:</b> No line item for Quazite handholds.so we used this line item instead. These will be as specified with fiber composite cover.	
<b>Subtotal for 33 - Utilities:</b>				<b>\$9,925.79</b>
<b>Grand Total:</b>				<b>\$170,978.94</b>

This work order proposal total represents the correct total for the proposal. Any discrepancy between line totals, sub-totals and the proposal total is due to rounding of the line totals and sub-totals.

**The Percent of NPP on this Proposal: 0.00**



## BOARD AGENDA MEMORANDUM

DATE OF MEETING: July 23, 2024

**To:** Village President and Board of Trustees

**Through:** Napoleon Haney, Village Manager

**From:** Angela Mesaros, Director of Economic and Community Development

**Topic:** Signage for Public Parking Lots

### PURPOSE

Many of the Village's public parking lots have either no signage or inadequate-sized and inconsistent signage. To increase public parking visibility, staff proposes new parking lot identification signs at each of the Village-owned public parking lots and directional signs at key locations along main routes to assist drivers in finding public parking. The signage costs would be funded with American Rescue Plan Act (ARPA) funds to support local businesses.

### PROCESS

The current Village wayfinding and parking lot signage dates back to 2007. With the number of new businesses in downtown Homewood that rely on public parking for customers, staff recognizes a greater need for parking visibility. Many of the existing parking lot signs are small and not easily visible. Therefore, staff has designed new parking lot identification and directional signage for the public parking lots. The signs will be illuminated.

Staff issued a Request for Proposals (RFP) on May 24, 2024, for the design, fabrication, and installation of eleven (11) ground-mounted parking identification signs with external illumination and six (6) pole-mounted parking directional signs with internal illumination. The Request for Proposals (RFP) was open from May 24, 2024 to June 11, 2024. Seven (7) vendors responded to the RFP.

Staff from multiple Village disciplines including Economic and Community Development, Public Works, Communications, and Village Manager's Office evaluated the proposals. The proposals were narrowed down to two (2) leading vendors based on the overall "per unit" cost of each proposal, and whether each proposal included all project details specified by Village staff. The remaining two (2) proposals were evaluated through a scoring process, looking at proposals against the following weighted project criteria:

- Adherence to RFP Instructions (5%)
- Company/Vendor Experience and Background (20%)
- Project Design (35%)



- Project Cost and Financial Viability (35%)
- Additional Details (5%)

## OUTCOME

After completing the scoring, and making sure each vendor met Prevailing Wage requirements, Village staff selected ROEDA Signs of Lynwood, IL, as the preferred vendor. The following is staff's evaluation:

- **Design Quality/Clarity:** Roeda provided a high level of detail in sign design and services including product details for solar lighting fixtures and sign features. Roeda provided quality ornamental sign posts and finials capping each post of the ground-mounted signs. Roeda also provided an 8" cabinet sign for a similar cost to the 6" cabinet sign proposed by the other vendor.
- **Project Value:** While the proposal by Roeda was not the least expensive, staff found that their proposal provided the greatest project value of all the proposals received. Roeda adequately responded to all elements of the RFP with high-quality products and comprehensive installation services at a reasonable cost.
- **Customization:** Roeda provided opportunities for customization of signposts, finials, and final sign details with minimal changes to the proposed project cost, and allowed changes until the final fabrication of the signs.
- **Installation Details:** Roeda provided installation details common for this infrastructure project.
- **Past project experience:** Roeda has completed previous exterior sign projects for the Village with a high level of quality. Roeda has familiarity working with the Village electrical systems and parkway infrastructure.

## FINANCIAL IMPACT

- **Funding Source:** American Rescue Plan Act (ARPA) Funding
- **Budgeted Amount:** \$90,000 (Signage & Digital Kiosk)
- **Cost:** \$64,463

## LEGAL REVIEW

Completed



## **RECOMMENDED BOARD ACTION**

Authorize the Village President to enter an agreement with ROEDA for Illuminated public parking lot entry signs and parking directional signs.

## **ATTACHMENT(S)**

- Proposal
- Drawings



800.829.3021 • www.roeda.com  
 20530 Stoney Island Ave. Lynwood, IL 60411  
 Local: 708.333.3021 • info@roeda.com

PROPOSAL #: 13643 Item 11. F.

PROPOSAL DATE: 6/11/2024

CUSTOMER #: \_\_\_\_\_

PREPARED BY: Rod

ROEDA, INC. HEREBY PROPOSES TO FURNISH THE MATERIAL AND LABOR NECESSARY TO COMPLETE THE SIGN OR GRAPHIC PROJECT SPECIFIED BELOW FOR THE CUSTOMER LISTED AND AT THE LOCATION LISTED.

SOLD TO:	JOB LOCATION:
Village of Homewood 2020 Chestnut Rd Homewood IL 60430	Various Locations in Homewood

Qty	Item	Description	Unit Price	Total Price
		Contact: Noah Schumerth; Email: nschumerth@homewoodil.gov; Phone: 708-206-3380 Scope: Ornamental Double-Sided Post & Panel Systems For Parking Lot Entry's & Parking Directional Signs =====		
11	A-Signs	36" x 54" & 36" x 8" Double-Sided Lot Entry Signs; .080 Aluminum Slide-In Panels ---Includes - Series 300 - Ornamental Bases, 3" Smooth Round Posts & 3" - 3B - Finial Ball Caps ---Digitally Printed & Laminated Reflective Vinyl Graphics on Both Sides ---10' Long Posts for Direct Burial in Concrete ---Each Sign, Including Graphics on All Sides =====	2,598.00	28,578.00
11	A-Signs	Add Solar Powered Down Lighting on Both Sides ---24" Wide Solar LED Light Bars =====	610.00	6,710.00
11	Installation	Installation of 11 Lot Entry Signs ---Direct Burial, Including Concrete =====	1,425.00	15,675.00

**TOTAL PROPOSED AMOUNT:**

TERMS AND CONDITIONS • DETAILED ON SECOND PAGE

A 50% DEPOSIT IS REQUIRED TO PROCEED. BALANCE IS DUE AT COMPLETION UNLESS OTHERWISE STATED; PRICES ARE REASONABLE FOR 30 DAYS AFTER THE PROPOSAL DATE. IF APPLICABLE, PERMIT COSTS, RELATED FEES, SHIPPING, AND DELIVERY CHARGES WILL BE ADDED TO THE FINAL INVOICE.

Payment can be made by check ten days before the job starts or by credit card.  
 Due to increasing processing costs, electronic payments are subject to a minimum of 3% processing fees for credit cards.  
 All material is guaranteed to be as specified, and the above should be by drawings and specifications.  
 Due to volatility due to increases in raw material costs, pricing may be subject to change before the start of production.  
 If full payment or other acceptable arrangements have yet to be received for 15 days after installation,  
 ROEDA, Inc. reserves the right to repossess the product and levy interest at 1.5% per month on any unpaid balance.

THE ABOVE PRICING, SPECIFICATIONS, AND CONDITIONS ARE SATISFACTORY AND ACCEPTED. YOU ARE AUTHORIZED TO DO THE WORK AS SPECIFIED. PAYMENT WILL BE MADE AS OUTLINED. WORK WILL NOT BEGIN UNTIL THE SIGNED PROPOSAL AND DOWN PAYMENT ARE RECEIVED.

ACCEPTED BY: \_\_\_\_\_ DATE: \_\_\_\_\_

PRINT NAME: \_\_\_\_\_ DATE: \_\_\_\_\_

DOWN PAYMENT AMOUNT: \_\_\_\_\_

ROEDA INITIALS \_\_\_\_\_

*Thank You For The Opportunity To Quote!*

CUSTOMER INITIALS \_\_\_\_\_ 119



800.829.3021 • www.roeda.com  
 20530 Stoney Island Ave. Lynwood, IL 60411  
 Local: 708.333.3021 • info@roeda.com

PROPOSAL #: 13643 Item 11. F.

PROPOSAL DATE: 6/11/2024

CUSTOMER #: \_\_\_\_\_

PREPARED BY: Rod

ROEDA, INC. HEREBY PROPOSES TO FURNISH THE MATERIAL AND LABOR NECESSARY TO COMPLETE THE SIGN OR GRAPHIC PROJECT SPECIFIED BELOW FOR THE CUSTOMER LISTED AND AT THE LOCATION LISTED.

SOLD TO:	JOB LOCATION:
Village of Homewood 2020 Chestnut Rd Homewood IL 60430	Various Locations in Homewood

Qty	Item	Description	Unit Price	Total Price
6	A-Signs	LED Illuminated Directional Signs 18" x 30" x 8" D, Double-Sided Illuminated Signs w/ Pole Mount For Mounting on Existing Light Poles	1,365.00	8,190.00
6	Installation	Installation of Illuminated Directional Signs on Existing Light Poles w/ New Banding Brackets  ***Will Require The Villages Electrical Contractor to Coordinate ***Installation Labor is Based On Cook County, IL Prevailing Wages for 'Sign Hangers' - 5/20/24  Contractor shall not pay less than the prevailing rates of wages to all laborers, workmen, and mechanics performing work under this contract, and shall comply with the requirements of the Illinois Wages of Employees on Public Works Act (820 ILCS 130/1-12).	885.00	5,310.00

**TOTAL PROPOSED AMOUNT:** \$64,463.00

TERMS AND CONDITIONS • DETAILED ON SECOND PAGE

**A 50% DEPOSIT IS REQUIRED TO PROCEED. BALANCE IS DUE AT COMPLETION UNLESS OTHERWISE STATED; PRICES ARE REASONABLE FOR 30 DAYS AFTER THE PROPOSAL DATE. IF APPLICABLE, PERMIT COSTS, RELATED FEES, SHIPPING, AND DELIVERY CHARGES WILL BE ADDED TO THE FINAL INVOICE.**

Payment can be made by check ten days before the job starts or by credit card.  
 Due to increasing processing costs, electronic payments are subject to a minimum of 3% processing fees for credit cards.  
 All material is guaranteed to be as specified, and the above should be by drawings and specifications.  
 Due to volatility due to increases in raw material costs, pricing may be subject to change before the start of production.  
 If full payment or other acceptable arrangements have yet to be received for 15 days after installation,  
 ROEDA, Inc. reserves the right to repossess the product and levy interest at 1.5% per month on any unpaid balance.

**THE ABOVE PRICING, SPECIFICATIONS, AND CONDITIONS ARE SATISFACTORY AND ACCEPTED. YOU ARE AUTHORIZED TO DO THE WORK AS SPECIFIED. PAYMENT WILL BE MADE AS OUTLINED. WORK WILL NOT BEGIN UNTIL THE SIGNED PROPOSAL AND DOWN PAYMENT ARE RECEIVED.**

ACCEPTED BY: \_\_\_\_\_ DATE: \_\_\_\_\_

PRINT NAME: \_\_\_\_\_ DATE: \_\_\_\_\_

DOWN PAYMENT AMOUNT: \_\_\_\_\_

ROEDA INITIALS \_\_\_\_\_

*Thank You For The Opportunity To Quote!*

CUSTOMER INITIALS \_\_\_\_\_ 120



# Signage Location Specifications

**P** **Parking Lot Identification Signs:** Signs to be located adjacent to entrances for each public parking lot. The signs will be placed in Village grass parkway areas, or existing landscaping beds on public property within the lot area.

**P** **Parking Lot Wayfinding Signs:** Signs to be located on existing poles (pedestrian or street) within the Village right-of-way or IDOT-controlled roadway area as allowable by state law.

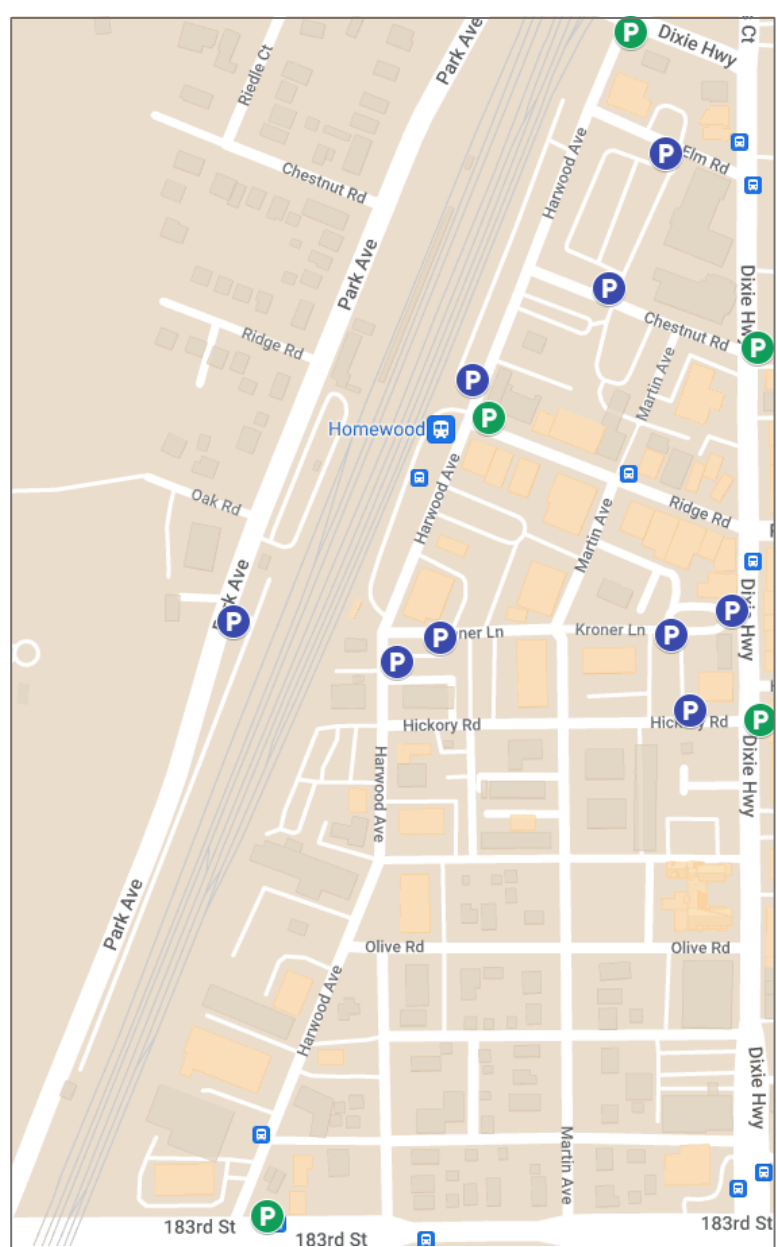

Downtown

**Figure A:** Map with locations for proposed signage. Full interactive map can be found at:

<https://www.google.com/maps/d/u/0/edit?mid=12VNU9KBYkgEmuMIE-shXVUv4Emg5All&usp=sharing>

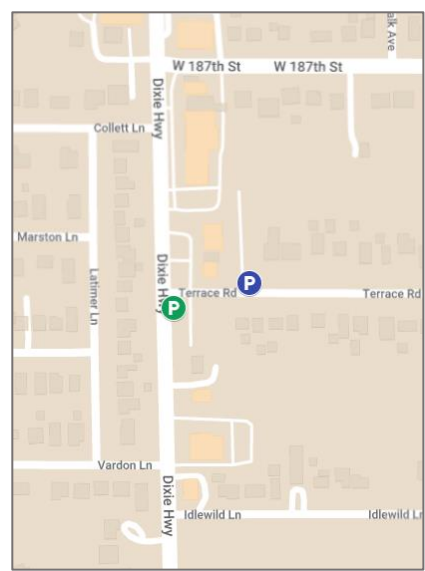

Southgate

**Project Description:** Custom Ornamental Post & Panel System W/ Reflective Vinyl graphics, Double Sided. 3" Diamter Smooth Round Poles, w/ Series 300 Base & 3B Ball Finial. 8" x 36" Lower Plate for Additional info.



**A SIGNED PROOF IS NECESSARY PRIOR TO ANY ORDER BEING PUT INTO PRODUCTION.**

**LOOK OVER CAREFULLY.**

The drawing(s) and/or design(s) contained in these pages are the property of Roeda, Inc. Any reproduction or use of these drawings without the exclusive consent of Roeda, Inc. is unlawful. Roeda, Inc. is not responsible for any errors in production if a proof has been approved and signed.

- Spelling and punctuation are correct
- Names, phone numbers, websites are correct
- Print size is correct (width" x height")
- Print color is correct

- Approved/Proceed
- OK with corrections. Revise as noted
- Revise as noted & submit a new proof

Notes/Revisions:

Signature: \_\_\_\_\_

Date: \_\_\_\_\_

**Project Description:** 8" deep Double Sided Illumated Pole Sign. 1" Retainer. Mounted w/ 3 Banded Brackets to Pole.



**A SIGNED PROOF IS NECESSARY PRIOR TO ANY ORDER BEING PUT INTO PRODUCTION.**

**LOOK OVER CAREFULLY.**

The drawing(s) and/or design(s) contained in these pages are the property of Roeda, Inc. Any reproduction or use of these drawings without the exclusive consent of Roeda, Inc. is unlawful. Roeda, Inc. is not responsible for any errors in production if a proof has been approved and signed.

- Spelling and punctuation are correct
- Names, phone numbers, websites are correct
- Print size is correct (width" x height")
- Print color is correct

- Approved/Proceed
- OK with corrections. Revise as noted
- Revise as noted & submit a new proof

Notes/Revisions:

Signature: \_\_\_\_\_

Date: \_\_\_\_\_

This document was prepared by:  
Paul W. Shadle  
DLA Piper LLP (US)  
444 W. Lake Street, Suite 900  
Chicago, IL 60606

**FIRST AMENDMENT TO REDEVELOPMENT AGREEMENT AMONG  
THE VILLAGE OF EAST HAZEL CREST,  
THE VILLAGE OF HOMEWOOD  
AND WIND CREEK IL LLC**

This First Amendment to Redevelopment Agreement (this “First Amendment”) is made and entered into this \_\_\_\_ day of \_\_\_\_\_, 2024 , by and among the Village of East Hazel Crest, an Illinois municipality located in Cook County, Illinois (“East Hazel Crest”), the Village of Homewood, an Illinois municipality located in Cook County, Illinois (“Homewood”) (collectively, the “Villages”) and Wind Creek IL LLC, an Illinois limited liability company (the “Developer”). The “Effective Date” of this Agreement shall be the date hereof.

**RECITALS**

WHEREAS, the Villages have undertaken a program for the redevelopment of certain property within the Villages, which property is hereinafter described, pursuant to 65 ILCS 5/11-74.4-1 et seq., as amended, the Tax Increment Allocation Redevelopment Act (the “Act”); and

WHEREAS, the Villages entered into a certain Intergovernmental Agreement to Jointly Develop Property within the Villages of East Hazel Crest and Homewood dated November 27, 2012 (the “IGA”) pursuant to which the Villages were authorized to enter, and the Villages did so enter, into that certain Redevelopment Agreement with Developer on June 27, 2023 (the “RDA”), and all terms not defined herein shall have the meanings ascribed to them in the RDA; and

WHEREAS, the RDA provides for, among other things, Developer’s redevelopment of the “Subject Property” which is legally described on Exhibit A attached hereto, and the Village’s reimbursement of certain redevelopment project costs related to the Project, as defined herein, with tax increment financing funds as provided in the Act, and support of Developer’s application to Cook County for Class 8 classification of the Subject Property; and

WHEREAS, the parties desire to amend the RDA as provided in this First Amendment; and

NOW, THEREFORE, it is hereby agreed by and between the Villages and Developer, as follows:

**Section 1. Preambles.**

The Recitals set forth hereinabove are incorporated as if fully set forth herein.

**Section 2. Project Definition and Construction.**

- A. The parties agree that the proposed development Project on the Subject Property shall be defined as set forth herein.

The "Project" will include the construction of a land-based casino and hotel complex in East Hazel Crest and an adjacent attendant garage and surface parking in Homewood (the "Casino"). Specifically, the Project will include a 10,200-square foot lobby / welcome center, an approximately 73,511-square foot gaming floor, a food court of approximately 18,000 square feet as well as approximately 19,482 square feet of office space, and an approximately 8,779-square foot employee operations area. In addition, the Project will include a 16 story, 255-room hotel and an approximately 15,000 square foot convention center with accessory retail and accessory parking (the "Hotel").

- B. Upon request from the Developer, the Villages shall support and cooperate with the Developer in obtaining from all governmental and other applicable regulatory authorities with jurisdiction, and the Villages themselves shall provide as necessary, all Project Approvals required (as Project Approvals generally are described in Section 3.H. of the RDA) to allow the Developer to expand the Project improvements located on the Subject Property to construct a second hotel tower including as many as 255 rooms and an entertainment venue, as well as to expand the then existing parking facilities, to be constructed as a part of a Phase 2 of the development of the Subject Property.

**Section 3. Additional Village Obligations.**

- A. **Support of Class 8 Renewal.**

Upon request from the Developer, and at such time as is necessary to enable the Developer to seek to renew the Class 8 classification of the Subject Property, the current Village Boards recommend to the Village Boards sitting at that time to each take all necessary steps to make all necessary findings, to issue resolutions required for, and to approve, consent to, and support the renewal of such Class 8 classification of the Subject Property as required, and for the longest period of time allowed, by Section 74-63 of the Cook County Real Property Assessment Classification Ordinance.

**B. Approval of Project Costs.**

The Developer may certify in writing to East Hazel Crest that the Developer has incurred Project Costs prior to each Village's issuance of its Certificate of Completion. Within thirty (30) days of the Developer's certification to East Hazel Crest of Project Costs incurred by the Developer, East Hazel Crest shall approve such Project Costs in writing, provided that each Village shall be obligated to issue its Certificate of Completion only at such time as the Casino opens for business and the Developer has commenced construction of the Hotel.

**Section 4. Miscellaneous Provisions.**

**A. Time of the Essence and Mutual Assistance.**

Time is of the essence of this Agreement. The Parties agree to take such actions, including the execution and delivery of such documents, instruments and certifications (and, in the case of the Villages, the adoption of such ordinances and resolutions), as may be necessary or appropriate from time to time to carry out the terms, provisions and intent of this Agreement and to aid and assist each other in carrying out such terms, provisions and intent.

**B. Entire Agreement.**

The RDA, as amended by this First Amendment (together with the exhibits attached hereto), is the entire contract between the Villages and the Developer relating to the subject matter thereof, and supersedes all prior and contemporaneous negotiations, understandings, and agreements, written or oral, between the Villages and the Developer, and may not be modified or amended except by a written instrument executed by the parties hereto. Except as modified by this First Amendment, the RDA remains in full force and effect.

**C. Governing Law.**

The validity, meaning and effect of this Agreement shall be determined in accordance with the laws of the State of Illinois.

**D. Severability.**

If any provision of this Agreement is held invalid by a court of competent jurisdiction or in the event such a court shall determine that the Villages do not have the power to perform any provisions hereunder, such provisions shall be deemed to be excised and shall not affect any of the other provisions contained herein, and such judgment shall relieve the Villages from performance only under such invalid provision of this Agreement; provided, however, if the judgment relieves the Villages of their

monetary obligations under this Agreement, then the Developer will be relieved of its obligations hereunder.

[Signature Page Follows]

IN WITNESS WHEREOF, the parties hereto have executed this Agreement as of the year and date first above written.

**WIND CREEK IL LLC**

By: \_\_\_\_\_  
Name: \_\_\_\_\_  
Title: \_\_\_\_\_

**VILLAGE OF HOMEWOOD**

By: \_\_\_\_\_  
Name: \_\_\_\_\_  
Title: \_\_\_\_\_

**VILLAGE OF EAST HAZEL CREST**

By: \_\_\_\_\_  
Name: \_\_\_\_\_  
Title: \_\_\_\_\_



## Exhibit A

### Legal Description of Subject Property

PARCEL 1:

LOT 3, 4, 5 AND THE EAST 74.24 FEET OF LOT 2 (AS MEASURED ALONG THE SOUTHERLY LINE THEREOF) IN EAST HAZEL CREST COMMERCIAL, BEING A SUBDIVISION OF THE SOUTH 28 ACRES OF THE NORTH 38 ACRES OF THE EAST 1/2 OF THE SOUTHEAST 1/4 OF SECTION 29 TOWNSHIP 36 NORTH, RANGE 14, EAST OF THE THIRD PRINCIPAL MERIDIAN, IN COOK COUNTY, ILLINOIS.

PARCEL 2:

THAT PART OF LOT 200 OF HOMEWOOD COURT SUBDIVISION, BEING A SUBDIVISION AND RESUBDIVISION OF PART, OF THE SOUTH 20 ACRES OF THE NORTH 58 ACRES OF THE EAST HALF OF THE SOUTHEAST QUARTER OF SECTION 29, TOWNSHIP 36 NORTH, RANGE 14 EAST OF THE THIRD PRINCIPAL MERIDIAN, ACCORDING TO THE PLAT THEREOF RECORDED AS DOCUMENT NUMBER 0934519091 IN COOK COUNTY, ILLINOIS, EXCEPTING THEREFROM THAT PART DESCRIBED AS FOLLOWS:

BEGINNING AT THE SOUTHEAST CORNER OF SAID LOT 200: THENCE SOUTH 89 DEGREES, 11 MINUTES 36 SECONDS WEST ALONG THE SOUTH LINE OF SAID LOT 200 A DISTANCE OF 210.82 FEET, TO A BEND; THENCE NORTH 75 DEGREES 13 MINUTES 51 SECONDS WEST ALONG THE SOUTHWESTERLY LINE OF LOT 200 A DISTANCE OF 76.61 FEET; THENCE NORTH 84 DEGREES 18 MINUTES 59 SECONDS EAST 285.90 FEET, TO THE EAST LINE OF SAID LOT 200: THENCE SOUTH 0 DEGREES 28 MINUTES 51 SECONDS EAST ALONG SAID EAST LINE OF LOT 200 A DISTANCE OF 44.88 FEET, TO THE POINT OF BEGINNING, IN COOK COUNTY, ILLINOIS.

PARCEL 3:

THAT PART OF THE EAST 1/2 OF THE SOUTHEAST 1/4 OF SECTION 29, TOWNSHIP 36 NORTH, RANGE 14, EAST OF THE THIRD PRINCIPAL MERIDIAN, BOUNDED AND DESCRIBED AS FOLLOWS: BEGINNING AT THE POINT OF INTERSECTION OF A LINE 1963.94 FEET SOUTH OF AND PARALLEL WITH THE NORTH LINE OF THE SOUTHEAST 1/4 OF SAID SECTION 29, WITH A LINE 83.00 FEET WEST OF AND PARALLEL WITH THE EAST LINE OF THE SOUTHEAST 1/4 OF SAID SECTION 29, AS MEASURED ON THE NORTH LINE THEREOF, (SAID POINT OF BEGINNING BEING ALSO THE POINT OF INTERSECTION OF A WEST LINE OF THE NORTHERN ILLINOIS STATE TOLL HIGHWAY PARCEL NO. T-FA\*-18.01 WITH THE SOUTH LINE OF THE NORTHERN ILLINOIS STATE TOLL HIGHWAY PARCEL NO. T-1W-502); THENCE (THE FOLLOWING THREE (3) COURSES BEING ON TWO (2) WEST LINES AND ON A NORTH LINE OF THE NORTHERN ILLINOIS STATE TOLLWAY PARCEL NO. T-1-'A'-18.1) SOUTH 00 DEGREE, 00 MINUTE, 00 SECOND EAST, A DISTANCE OF 4.62 FEET; THENCE SOUTH 90 DEGREES, 00 MINUTE, 00 SECOND EAST, A DISTANCE OF 33.00 FEET; THENCE SOUTH 00 DEGREE, 00 MINUTE, 00 SECOND WEST, A DISTANCE OF 425.38 FEET; THENCE NORTH 90 DEGREES, 00 MINUTE, 00 SECOND WEST ON A LINE PERPENDICULAR TO THE LAST DESCRIBED COURSE, A DISTANCE OF 617.08 FEET TO A POINT ON A LINE 667.08 FEET WEST OF AND PARALLEL WITH THE EAST LINE OF THE SOUTHEAST 1/4 OF

SAID SECTION 29; THENCE NORTH 00 DEGREE, 00 MINUTE, 00 SECOND EAST ON THE LAST DESCRIBED LINE, A DISTANCE OF 320.00 FEET; THENCE SOUTH 90 DEGREES, 00 MINUTE, 00 SECOND EAST, A DISTANCE OF 24.00 FEET TO A POINT ON A LINE 643.08 FEET WEST OF AND PARALLEL WITH THE EAST LINE OF THE SOUTHEAST 1/4 OF SAID SECTION 29; THENCE NORTH 00 DEGREE, 00 MINUTE, 00 SECOND EAST ON THE LAST DESCRIBED LINE, A DISTANCE OF 172.96 FEET TO A POINT ON THE SOUTH LINE OF THE NORTHERN ILLINOIS TOLL HIGHWAY PARCEL NO. T-I-A-501.2); THENCE NORTH 89 DEGREES, 41 MINUTES, 20 SECONDS EAST ON THE LAST DESCRIBED LINE, A DISTANCE OF 1.35 FEET TO THE MOST WESTERLY CORNER OF THE NORTHERN STATE TOLL HIGHWAY PARCEL NO. T-I-A'-502; THENCE (THE FOLLOWING TWO (2) COURSES BEING ON THE SOUTHWESTERLY AND SOUTH LINE OF SAID PARCEL NO. T-I-A'- 502) SOUTH 74 DEGREES, 44 MINUTES, 59 SECONDS EAST, A DISTANCE OF 246.02 FEET; THENCE NORTH 89 DEGREES, 41 MINUTES, 20 SECONDS EAST, A DISTANCE OF 321.38 FEET TO THE POINT OF BEGINNING, EXCEPTING THEREFROM THE EAST 25.00FEET THEREOF, ALL IN COOK COUNTY, ILLINOIS.

PARCEL 4:

THAT PART OF THE EAST 1/2 OF THE SOUTHEAST 1/4 OF SECTION 29, TOWNSHIP 36 NORTH, RANGE 14, EAST OF THE THIRD PRINCIPAL MERIDIAN,, BOUNDED AND DESCRIBED AS FOLLOWS: BEGINNING AT THE NORTHWEST CORNER OF LOT 1 IN M-R BANK SUBDIVISION AS RECORDED, THENCE NORTH 00 DEGREES 19 MINUTES 02 SECONDS EAST 99.55 FEET, MORE OR LESS, ALONG THE WEST LINE OF SAID LOT 1 EXTENDED NORTH TO A POINT ON THE NORTH LINE OF LOT 1 IN MATTESON RICHTON BANK SUBDIVISION, AS RECORDED, EXTENDED WESTERLY; THENCE SOUTH 89 DEGREES 40 MINUTES 58 SECONDS EAST ALONG SAID LINE AS EXTENDED 203.91 FEET, MORE OR LESS, TO THE NORTHWEST CORNER OF SAID LOT 1 IN MATTESON RICHTON BANK SUBDIVISION; THENCE SOUTH ALONG THE WEST LINE OF SAID LOT 1 IN MATTESON RICHTON BANK SUBDIVISION A DISTANCE OF 99.55 FEET, MORE OR LESS, TO THE NORTHEAST CORNER OF LOT 1 IN M-R BANK SUBDIVISION, AFORESAID; THENCE NORTH 89 DEGREES 40 MINUTES 58 SECONDS WEST ALONG THE NORTH LINE OF SAID LOT 1 IN M-R BANK SUBDIVISION 203.91 FEET, MORE OR LESS, TO THE POINT OF BEGINNING, IN COOK COUNTY, ILLINOIS.

PARCEL 5:

PARCEL T-1A-501:

THAT PART OF THE EAST ONE HALF OF THE SOUTHEAST QUARTER OF SECTION 29, TOWNSHIP 36 NORTH, RANGE 14 EAST OF THE THIRD PRINCIPAL MERIDIAN, COOK COUNTY, ILLINOIS, DESCRIBED AS FOLLOWS: COMMENCING AT THE NORTHEAST CORNER OF THE SOUTHEAST QUARTER OF SAID SECTION 29; THENCE SOUTH ALONG THE EAST LINE OF THE SOUTHEAST QUARTER FOR A DISTANCE OF 1243.16 FEET TO A POINT ON THE NORTH LINE OF THE SOUTH 20 ACRES OF THE NORTH 58 ACRES OF THE EAST ONE-HALF OF THE SAID SOUTHEAST QUARTER; THENCE WEST ALONG THE LAST DESCRIBED LINE A DISTANCE OF 83.00 FEET FOR A POINT OF BEGINNING; THENCE CONTINUING WESTERLY ALONG THE LAST DESCRIBED LINE, A DISTANCE OF 27.00 FEET TO A POINT; THEN SOUTHERLY ALONG A LINE FORMING AN ANGLE OF 89 DEGREES 40 MINUTES 20 SECONDS TO THE LEFT OF THE LAST DESCRIBED LINE, A DISTANCE OF 654.78 FEET TO A POINT ON THE SOUTH LINE OF THE NORTH 58 ACRES OF THE EAST ONE-HALF OF THE SAID SOUTHEAST QUARTER, SAID POINT BEING 110 FEET WEST OF THE EAST LINE OF THE SAID

SOUTHEAST QUARTER, THENCE EASTERLY ALONG SAID SOUTH LINE OF THE NORTH 58 ACRES OF THE EAST ONE-HALF OF THE SAID SOUTHWEST QUARTER, A DISTANCE OF 27.00 FEET TO A POINT; THENCE NORTHERLY ALONG A LINE FORMING AN ANGLE OF 89°40'20" TO THE LEFT OF THE LAST DESCRIBED LINE, A DISTANCE OF 654.78 FEET TO THE POINT OF BEGINNING.

AND

PARCEL T-1A-501.3:

THAT PART OF THE EAST ONE-HALF OF THE SOUTHEAST QUARTER OF SECTION 29, TOWNSHIP 36 NORTH, RANGE 14, EAST OF THE THIRD PRINCIPAL MERIDIAN, IN THE COUNTY OF COOK, STATE OF ILLINOIS, DESCRIBED AS FOLLOWS: COMMENCING AT THE NORTHEAST CORNER OF THE SOUTHEAST QUARTER OF SECTION 29; THENCE SOUTH ALONG THE EAST LINE OF THE SOUTHEAST QUARTER FOR A DISTANCE OF 1243.16 FEET TO A POINT ON THE NORTH LINE OF THE SOUTH 20 ACRES OF THE NORTH 58 ACRES OF THE EAST ONE-HALF OF THE SAID SOUTHEAST QUARTER; THENCE WEST ALONG THE LAST DESCRIBED LINE A DISTANCE OF 110 FEET FOR A POINT OF BEGINNING; THENCE CONTINUING WESTERLY ALONG SAID LINE FOR A DISTANCE OF 40 FEET TO A POINT; THENCE SOUTHEASTERLY TO A POINT ON THE WEST LINE OF THE EAST 110 FEET OF THE SOUTHEAST QUARTER, SAID POINT BEING 50 FEET SOUTH OF THE POINT OF BEGINNING AS MEASURED ALONG SAID WEST LINE; THENCE NORTHERLY 50 FEET ALONG SAID WEST LINE TO THE POINT OF BEGINNING.

174<sup>th</sup> Street Parcel

THAT PART OF THE EAST ONE HALF OF THE SOUTHEAST QUARTER OF SECTION 29, TOWNSHIP 36 NORTH, RANGE 14, EAST OF THE THIRD PRINCIPAL MERIDIAN, DESCRIBED AS FOLLOWS: COMMENCING AT THE NORTHEAST CORNER OF THE SOUTHEAST QUARTER OF THE SAID SECTION 29; THENCE SOUTH ALONG THE EAST LINE THEREOF, A DISTANCE OF 1897.94 FEET TO A POINT; THENCE WESTERLY ALONG A LINE FORMING AN ANGLE OF 89 DEGREES 40 MINUTES 20 SECONDS TO THE RIGHT OF THE LAST DESCRIBED LINE EXTENDED, A DISTANCE OF 83.0 FEET, FOR A POINT OF BEGINNING; THENCE CONTINUING WESTERLY ALONG THE LAST DESCRIBED LINE EXTENDED, A DISTANCE OF 558.74 FEET TO A POINT; THENCE SOUTHEASTERLY ALONG A LINE FORMING AN ANGLE OF 164 DEGREES 26 MINUTES 19 SECONDS TO THE LEFT OF THE LAST DESCRIBED LINE EXTENDED A DISTANCE OF 246.02 FEET TO A POINT; THENCE EASTERLY ALONG A LINE FORMING AN ANGLE OF 15 DEGREES 33 MINUTES 41 SECONDS TO THE LEFT OF THE LAST DESCRIBED LINE EXTENDED, A DISTANCE OF 321.38 FEET TO A POINT; THENCE NORTHERLY ALONG A LINE FORMING AN ANGLE OF 89 DEGREES 40 MINUTES 20 SECONDS TO THE LEFT OF THE LAST DESCRIBED LINE EXTENDED A DISTANCE OF 66.0 FEET TO THE POINT OF BEGINNING IN COOK COUNTY, ILLINOIS.

Property Index Number:  
29-29-409-0112-0000

Common address: 174<sup>th</sup> Street west of Halsted Street, Homewood, Illinois

# VILLAGE OF HOMEWOOD



**BOARD AGENDA MEMORANDUM**

**DATE OF MEETING: July 23, 2024**

---

**To:** Village President and Board of Trustees

**Through:** Napoleon Haney, Village Manager

**From:** Amy Zukowski, Director of Finance

**Topic:** Liquor license request

## **PURPOSE**

Mitchell and Michaels Plat Du Jour has requested a Class 4A 75/25 restaurant with bar liquor license for the former Culture location at 18031 Dixie Highway. Mitchell and Michaels Plat Du Jour will be a space that offers a combination of live performances and exceptional soul food cuisine.

A Class 4A liquor license allows the retail sale of any alcoholic liquor for on-premises consumption only and is available only to establishments primarily serving meals prepared in the establishment's kitchen, having a seating capacity for the service of meals at tables or counters for not less than 50 patrons. No more than 25% of sales can be from liquor. The Liquor Commissioner supports issuing the requested license.

## **PROCESS**

David Mitchell and Christopher Pegue have purchased the building at 18031 Dixie Highway and are preparing to open Mitchell & Michaels Plat Du Jour in September 2024. It will be a cultural destination where patrons can enjoy a diverse range of live performances, including Jazz, Comedy, Country, Blues, and more. This distinctive blend of culinary excellence and entertainment will create an immersive atmosphere that sets it apart from traditional dining establishments. The menu at Mitchell & Michaels has been curated to offer soulful delights that showcase the rich culinary heritage of the southern United States.

If the Board is in favor of this request, staff should be directed to begin the liquor license application process. After successfully completing all of the steps required for obtaining a Village of Homewood liquor license, an ordinance to increase the number of allowed Class 4A liquor licenses for Mitchell and Michaels Plat Du Jour will be presented at a Board meeting for approval.

## **OUTCOME**

Approval of this request will enable Mitchell and Michaels Plat Du Jour to offer more options to their dining patrons.

## VILLAGE OF HOMEWOOD



### FINANCIAL IMPACT

- **Funding Source:** N/A
- **Budgeted Amount:** N/A
- **Cost:** N/A

### LEGAL REVIEW

Not required

### RECOMMENDED BOARD ACTION

After discussion, and if the Board is in favor of granting the request for a liquor license, staff should be directed to prepare an ordinance to increase the allowed number of Class 4A liquor licenses for the proposed Mitchell and Michaels Plat Du Jour location at 18031 Dixie Highway. The ordinance will be agendized at a future Board meeting, once the petitioner successfully completes the application requirements for a Village of Homewood liquor license.

### ATTACHMENT(S)

Letter

**From:** Chris Pegue <cmpegue@gmail.com>  
**Date:** July 9, 2024 at 4:37:11 PM CDT  
**To:** [rhofeld@homesweethomewood.com](mailto:rhofeld@homesweethomewood.com)  
**Subject: Liquor License Request**

Good Afternoon Mayor Hofeld.

We would first like to thank you for welcoming and granting us the opportunity to bring our new restaurant Mitchell and Michaels Plat Du Jour to the Village of Homewood at 18031 Dixie Hwy. We had sought out quite a few locations in other cities for a while. However, we were always primarily drawn to Homewood for so many reasons, and to now have acquired the former Culture space we feel right at home and know this is truly the blessing we were hoping for. So thank you for allowing us to pursue this dream with your Village.

We would like to request both a liquor and gaming license for our restaurant. We will adhere to the guidelines of 75% food and 25% liquor sales and arrange our hours for normal business as well as special event hours. We anticipate a 6 day a week operation to start with, and normal business hours being 11am-9pm for kitchen operations. On special event nights with live entertainment, we anticipate a complete closing no later than 1am.

In the warmer months we would also like to ask for permission for outside seating on the front side of the building with the area being approved by the village.

Could you please advise us as to the next steps in completing the application for the liquor and gaming licenses.

Thank you again, and we look forward to your response.

David Mitchell & Chris Pegue