



Agenda

City Council Regular Meeting

Monday, November 27, 2023 at 6:00 PM

Cowles Council Chambers In-Person & Via Zoom Webinar

Homer City Hall

491 E. Pioneer Avenue
Homer, Alaska 99603
www.cityofhomer-ak.gov

Zoom Webinar ID: 205 093 973 Password: 610853

<https://cityofhomer.zoom.us>
Dial: 346-248-7799 or 669-900-6833;
(Toll Free) 888-788-0099 or 877-853-5247

CALL TO ORDER, PLEDGE OF ALLEGIANCE

AGENDA APPROVAL (Only those matters on the noticed agenda may be considered, pursuant to City Council's Operating Manual)

MAYORAL PROCLAMATIONS AND RECOGNITIONS

PUBLIC COMMENT ON MATTERS ALREADY ON THE AGENDA

RECONSIDERATION

CONSENT AGENDA (Items listed below will be enacted by one motion. If a separate discussion is desired on an item, that item may be removed from the Consent Agenda and placed on the Regular Meeting Agenda at the request of a Councilmember.)

- a. Homer City Council Unapproved Special and Regular Meeting Minutes of November 13, 2023. City Clerk. Recommend adoption.
- b. Memorandum CC-23-271 from Mayor Castner re: Appointment of Jessica Williams to the Parks Art Recreation & Culture Advisory Commission. Recommend approval.
- c. Memorandum CC-23-272 from City Clerk re: Marijuana Retail and Product Manufacturing License Renewals for Cosmic Cannabis Company and Cosmic SeaWeed LLC. Recommend approval.
- d. Ordinance 23-61, An Ordinance of the City Council of Homer, Alaska Amending the FY24 Capital Budget by Appropriating \$300,000 from the Water Capital Asset Repair and Maintenance Allowance (CARMA) Fund to Design and Rebuild the Ben Walters Pressure Reducing Station. City Manager/Public Works Director. Recommended dates Introduction November 27, 2023 Public Hearing and Second Reading January 8, 2024.

Memorandum CC-23-261 from Public Works Director as backup.

- e. Ordinance 23-62, An Ordinance of the City Council of Homer, Alaska Amending the FY24 Capital Budget by Appropriating an Additional \$25,000 from the Homer Accelerated Roads and Trails

(HART) Road Fund to Complete the Design of the Heath Street Pavement Restoration Project. City Manager/Public Works Director. Recommended dates Introduction November 27, 2023 Public Hearing and Second Reading January 8, 2024.

Memorandum CC-23-262 from Public Works Director as backup.

- f. Ordinance 23-63, An Ordinance of the City Council of Homer, Alaska Amending the FY24 Capital Budget by Renewing the Appropriation of Funds in the Amount of \$100,000 from the Port & Harbor Reserves for the Purpose of Replacing the Fish Grinding Building and Completing Drainage Improvements. City Manager/Port Director. Recommended dates Introduction November 27, 2023 Public Hearing and Second Reading January 8, 2024.

Memorandum CC-23-263 from Port Director as backup.

- g. Resolution 23-123, A Resolution of the City Council of Homer, Alaska Approving a Sole Source Contract to Zenon Environmental Corporation to Purchase Five Membrane Filter Trains for the Water Treatment Plant with the First Payment due in 2024 in the Amount of \$92,774 and Payments in Subsequent Years Subject to Inflation and Future Council Appropriations, and Authorizing the City Manager to Negotiate and Execute the Appropriate Documents. City Manager/Public Works Director. Recommend adoption.

Memorandum CC-23-264 from Public Works Director as backup.

- h. Resolution 23-124, A Resolution of the City Council of Homer, Alaska Approving the 2024 Regular Meeting Schedule for the City Council, Americans with Disabilities Act (ADA) Advisory Board, Economic Development Advisory Commission, Library Advisory Board, Parks Art Recreation and Culture Advisory Commission, Planning Commission, Port and Harbor Advisory Commission. City Clerk. Recommend adoption.

Memorandum CC-23-265 from City Clerk as backup.

- i. Resolution 23-125, A Resolution of the City Council of Homer, Alaska Approving a Task Order with RESPEC Engineering in the Amount of \$61,990 for the Construction Documents and Engineering Support for the Fish Grinding Building Replacement Project and Authorizing the City Manager to Negotiate and Execute the Appropriate Documents. City Manager. Recommend adoption.

Memorandum CC-23-266 from Port Director as backup.

- j. Resolution 23-126, A Resolution of the City Council of Homer, Alaska Agreeing to Participate in a Memorandum of Agreement for the Joint Exercise of a Tourism Promotion between the Kenai Peninsula Borough and the Cities of Kachemak, Kenai, Homer, Seldovia, Seward and Soldotna and Authorizing the City Manager to Negotiate and Execute the Appropriate Documents. Recommend adoption.

Memorandum CC-23-267 from City Manager as backup.

- k. Resolution 23-127, A Resolution of the City Council of Homer, Alaska Awarding the Contract for the Solid Waste Collection and Disposal Contract to Alaska Waste-Kenai Peninsula, LLC for a Three Year Term with Two One-Year Renewal Options in the amount of \$76,002 per year and Authorizing the City Manager to Negotiate and Execute the Appropriate Documents. City Manager/ Port Director. Recommend adoption.

Memorandum CC-23-268 from Port Director as backup.

- l. Resolution 23-128, A Resolution of the City Council of Homer, Alaska Supporting the Creation of a Sister City Donation Account to Support the 40th Anniversary of Homer's Relationship with Teshio, Hokkaido Japan. City Manager. Recommend adoption.

VISITORS

- a. South Peninsula Hospital Annual Report - Ryan Smith, CEO (10 minutes)
- b. Cook Inlet Regional Citizens Advisory Council - Shaylon Cochran and Sue Saupe (10 Minutes)
- c. Kenai Peninsula Economic Development District - Tim Dillon, Executive Director and Cassidi Cameron, Special Projects Manager (10 minutes)

ANNOUNCEMENTS / PRESENTATIONS / REPORTS (5 Minute limit per report)

- a. Worksession Report
- b. Committee of the Whole Report
- c. Mayor's Report
- d. Borough Report
- e. Economic Development Advisory Commission
- f. Parks Art Recreation and Culture Advisory Commission
- g. Library Advisory Board
- h. Conversations with a Council Member

PUBLIC HEARING(S)

- a. Ordinance 23-55, An Ordinance of the City Council of Homer, Alaska Accepting and Appropriating an FY 2023 State Homeland Security Program Grant in the Amount of \$88,196.56 from the Alaska Division of Homeland Security & Emergency Management (DHS&EM) to Upgrade Homer Volunteer Fire Department Portable Radios and Provide a Backup Repeater for the City's Public Safety Communications System, Authorizing a Sole Source Request to Contract with PROCOMM Alaska and Authorizing the City Manager to Negotiate and Execute the Appropriate Documents. City Manager. Introduction November 13, 2023 Public Hearing and Second Reading November 27, 2023.

Memorandum CC-23-255 from Police Chief as backup.

- [b.](#) Ordinance 23-56, An Ordinance of the City Council of Homer, Alaska Extending the Allocation for the Upgrade of the City's Microwave Wide Area Network through June 30, 2024. City Manager/Chief Technology Officer. Introduction November 13, 2023, Public Hearing and Second Reading November 27, 2023.

Memorandum CC-23-256 from Chief Technology Officer as backup.

- [c.](#) Ordinance 23-57, An Ordinance of the City Council of Homer, Alaska Amending the FY23 Capital Budget by Appropriating an Additional \$35,000 from the Water Capital Asset Repair and Maintenance Allowance Fund to Purchase One Membrane Filter Module for the Water Treatment Plant. City Manager/Public Works Director. Introduction November 13, 2023, Public Hearing and Second Reading November 27, 2023.

Memorandum CC-23-257 from Public Works Director as backup.

- [d.](#) Ordinance 23-58, An Ordinance of the City Council of Homer, Alaska Amending the FY24 Capital Budget by Accepting and Appropriating a Hazard Mitigation Grant Programming Award in the Amount of \$2,109,033 from the Alaska Division of Homeland Security & Emergency Management (DHS&EM) to Replace the City's Raw Water Transmission Mains and Authorizing the City Manager to Negotiate and Execute the Appropriate Documents. City Manager. Introduction November 13, 2023 Public Hearing and Second Reading November 27, 2023.

Memorandum CC-23-258 from Special Projects & Communications Coordinator as backup.

- [e.](#) Ordinance 23-59, An Ordinance of the City Council of Homer, Alaska Amending the FY24 Capital Budget by Accepting and Appropriating a Hazard Mitigation Grant Program Award in the Amount of \$105,452 from the Alaska Division of Homeland Security & Emergency Management (DHS&EM) to Reimburse City of Homer Costs Associated with Managing and Administering the DHS&EM Hazard Mitigation Grant 4413.001 1R and Authorizing the City Manager to Negotiate and Execute the Appropriate Documents. City Manager. Introduction November 13, 2023 Public Hearing and Second Reading November 27, 2023.

Memorandum CC-23-258 from Special Projects Coordinator & Communications Coordinator as backup.

- [f.](#) Ordinance 23-60, An Ordinance of the City Council of Homer, Alaska Amending Homer City Code Chapter 7.04 to add new Section 7.04.015 Local Traffic Provisions and Amend Section 7.04.030 Traffic Fine Schedules to Reduce Speed Limits on Cul-De-Sacs to 15 MPH. Lord. Introduction November 13, 2023, Public Hearing and Second Reading November 27, 2023.

ORDINANCE(S)

CITY MANAGER'S REPORT

- [a.](#) City Manager's Report

PENDING BUSINESS

NEW BUSINESS

RESOLUTIONS

- [a.](#) Resolution 23-129, A Resolution of the City Council of Homer, Alaska Creating a Steering Committee to Aid in the Development of a New Comprehensive Plan and Title 21 Zoning Code. City Manager/City Planner.

Memorandum CC-23-269 from City Planner as backup.

- [b.](#) Resolution 23-130, A Resolution of the City Council of Homer, Alaska Expressing Support for Continuation of the Homer Harbor Expansion General Investigation by Authorizing the City Manager to Sign an Updated Project Management Plan with the US Army Corps of Engineers, and Stating Intent to Fund 25% of the Updated General Investigation Cost. Lord/Hansen.

Memorandum CC-23-270 from Council Members as backup.

COMMENTS OF THE AUDIENCE

COMMENTS OF THE CITY ATTORNEY

COMMENTS OF THE CITY CLERK

COMMENTS OF THE CITY MANAGER

COMMENTS OF THE MAYOR

COMMENTS OF THE CITY COUNCIL

ADJOURNMENT

Next Regular Meeting is Monday, January 8, 2024 at 6:00 p.m. and Committee of the Whole at 5:00 p.m. All meetings are scheduled to be held in the City Hall Cowles Council Chambers located at 491 E. Pioneer Avenue, Homer, Alaska.

Session 23-22 a Special Meeting of the City Council of Homer, Alaska was called to order on November 13, 2023 by Mayor Ken Castner at 4:00 p.m. at the City Hall Cowles Council Chambers located at 491 E. Pioneer Avenue, Homer, Alaska, and opened with the Pledge of Allegiance.

PRESENT: COUNCILMEMBERS ADERHOLD, HANSEN, LORD, VENUTI

ABSENT: COUNCIL MEMBERS DAVIS AND ERICKSON (excused)

STAFF: CITY MANAGER DUMOUCHEL
CITY CLERK JACOBSEN
LIBRARY DIRECTOR BERRY
CHIEF TECHNOLOGY OFFICER JIRSA
CITY ATTORNEY GATTI

AGENDA APPROVAL (Only those matters on the noticed agenda may be considered, pursuant to City Council's Operating Manual)

LORD/VENUTI MOVED TO APPROVE THE AGENDA

There was no discussion.

VOTE: NON OBJECTION: UNANIMOUS CONSENT

Motion carried.

PUBLIC COMMENT ON MATTERS ALREADY ON THE AGENDA (3 minute time limit)

PENDING BUSINESS

NEW BUSINESS

- a. Memorandum CC-23-252 from City Clerk re: Request for Executive Session Pursuant to AS 44.62.310 (C)(1)& (3) Matters, the Immediate Knowledge of Which would Clearly have an Adverse Effect upon the Finances of the Government Unit and Attorney Client Privilege (IT Data Security Strategies and IT Data Security Pending Issue)

LORD/ADERHOLD MOVED TO GO INTO EXECUTIVE SESSION PURSUANT TO AS 44.62.310 (C)(1)& (3) MATTERS, THE IMMEDIATE KNOWLEDGE OF WHICH WOULD CLEARLY HAVE AN ADVERSE EFFECT UPON THE FINANCES OF THE GOVERNMENT UNIT AND ATTORNEY CLIENT PRIVILEGE (IT DATA SECURITY STRATEGIES AND IT DATA SECURITY PENDING ISSUE).

Mayor Castner noted for the record that City Attorney Gatti, Library Director Berry, and Chief Technology Officer Jirsa will participate in the executive session.

VOTE: YES: VENUTI, ADERHOLD, LORD, HANSEN

Motion carried.

Council recessed into executive session at 4:03 p.m. and returned to open session at 4:56 p.m.

COMMENTS OF THE AUDIENCE

ADJOURN

There being no further business to come before the Council Mayor Castner adjourned the meeting at 4:57 p.m. The next Regular Meeting is Monday, November 27, 2023 at 6:00 p.m., Work Session at 4:00 p.m. and Committee of the Whole at 5:00 p.m. All meetings are scheduled to be held in the City Hall Cowles Council Chambers located at 491 E. Pioneer Avenue, Homer, Alaska.

Melissa Jacobsen, MMC, City Clerk

Approved: _____

Session 23-23 a Regular Meeting of the City Council of Homer, Alaska was called to order on November 13, 2023 by Mayor Ken Castner at 6:00 p.m. at the City Hall Cowles Council Chambers located at 491 E. Pioneer Avenue, Homer, Alaska, and opened with the Pledge of Allegiance.

PRESENT: COUNCILMEMBERS ADERHOLD, DAVIS, ERICKSON, HANSEN, LORD, VENUTI

STAFF: CITY MANAGER DUMOUCHEL
CITY CLERK JACOBSEN
FINANCE DIRECTOR WALTON
PORT DIRECTOR HAWKINS
PUBLIC WORKS DIRECTOR KEISER
CHIEF TECHNOLOGY OFFICER JIRSA
CITY ATTORNEY GATTI

AGENDA APPROVAL (Only those matters on the noticed agenda may be considered, pursuant to City Council's Operating Manual)

LORD/VENUTI MOVED TO APPROVE THE AGENDA.

There was no discussion.

VOTE: NON OBJECTION: UNANIMOUS CONSENT

Motion carried.

MAYORAL PROCLAMATIONS AND RECOGNITIONS

PUBLIC COMMENT ON MATTERS ALREADY ON THE AGENDA

Marie MacDougall commented in support of Ordinance 23-61 and sensible regulation of short term rentals.

Scott Adams, city resident, commented regarding Ordinance 23-61. He questioned who would enforce the regulations and questioned the permit fees.

RECONSIDERATION

CONSENT AGENDA (Items listed below will be enacted by one motion. If a separate discussion is desired on an item, that item may be removed from the Consent Agenda and placed on the Regular Meeting Agenda at the request of a Councilmember.)

Council Member Aderhold noted a potential conflict of interest that Holly Brennan, who's being appointed to the Economic Development Advisory Commission, is her step-daughter.

Mayor Castner responded there isn't any financial implication to the appointment and ruled there is no conflict of interest. There was no objection from Council.

- a. Homer City Council Unapproved Regular Meeting Minutes of October 23, 2023. City Clerk. Recommend adoption.
- b. Memorandum CC-23-253 from Mayor Castner re: Appointment of Daniel Hasche and Holly Brennan to the Economic Development Advisory Commission. Recommend approval.
- c. Ordinance 23-55, An Ordinance of the City Council of Homer, Alaska Accepting and Appropriating an FY 2023 State Homeland Security Program Grant in the Amount of \$88,196.56 from the Alaska Division of Homeland Security & Emergency Management (DHS&EM) to Upgrade Homer Volunteer Fire Department Portable Radios and Provide a Backup Repeater for the City's Public Safety Communications System, Authorizing a Sole Source Request to Contract with PROCOMM Alaska and Authorizing the City Manager to Negotiate and Execute the Appropriate Documents. City Manager. Recommended dates Introduction November 13, 2023 Public Hearing and Second Reading November 27, 2023.

Memorandum CC-23-255 from Police Chief as backup.

- d. Ordinance 23-56, An Ordinance of the City Council of Homer, Alaska Extending the Allocation for the Upgrade of the City's Microwave Wide Area Network through June 30, 2024. City Manager/Chief Technology Officer. Recommended dates Introduction November 13, 2023, Public Hearing and Second Reading November 27, 2023.

Memorandum CC-23-256 from Chief Technology Officer as backup.

- e. Ordinance 23-57, An Ordinance of the City Council of Homer, Alaska Amending the FY23 Capital Budget by Appropriating an Additional \$35,000 from the Water Capital Asset Repair and Maintenance Allowance Fund to Purchase One Membrane Filter Module for the Water Treatment Plant. City Manager/Public Works Director. Recommended dates Introduction November 13, 2023, Public Hearing and Second Reading November 27, 2023.

Memorandum CC-23-257 from Public Works Director as backup.

- f. Ordinance 23-58, An Ordinance of the City Council of Homer, Alaska Amending the FY24 Capital Budget by Accepting and Appropriating a Hazard Mitigation Grant Program Award in the Amount of \$2,109,033 from the Alaska Division of Homeland Security & Emergency Management (DHS&EM) to Replace the City's Raw Water Transmission Mains and Authorizing the City Manager to Negotiate and Execute the Appropriate Documents. City Manager. Recommended dates Introduction November 13, 2023 Public Hearing and Second Reading November 27, 2023.

Memorandum CC-23-258 from Special Projects & Communications Coordinator as backup.

- g. Ordinance 23-59, An Ordinance of the City Council of Homer, Alaska Amending the FY24 Capital Budget by Accepting and Appropriating a Hazard Mitigation Grant Program Award in the Amount of \$105,452 from the Alaska Division of Homeland Security & Emergency Management

(DHS&EM) to Reimburse City of Homer Costs Associated with Managing and Administering the DHS&EM Hazard Mitigation Grant 4413.001 1R and Authorizing the City Manager to Negotiate and Execute the Appropriate Documents. City Manager. Recommended dates Introduction November 13, 2023 Public Hearing and Second Reading November 27, 2023.

Memorandum CC-23-258 from Special Projects & Communications Coordinator as backup.

- h. Ordinance 23-60, An Ordinance of the City Council of Homer, Alaska Amending Homer City Code Chapter 7.04 to add new Section 7.04.015 Local Traffic Provisions and Amend Section 7.04.030 Traffic Fine Schedules. Lord. Recommended dates Introduction November 13, 2023, Public Hearing and Second Reading November 27, 2023.
- i. Ordinance 23-61, An Ordinance of the City Council of Homer, Alaska Amending Homer City Code Title 5 to add Chapter 5.48 Short Term Rentals. Aderhold/Davis. Recommended dates Introduction November 13, 2023, Refer to Planning Commission and Economic Development Commission, Public Hearing and Second Reading February 26, 2024.

Memorandum CC-23-260 from City Manager as backup.

Moved to Ordinances item a. Aderhold.

- j. Resolution 23-121, A Resolution of the City Council of Homer, Alaska in Support of Full Funding of \$7,644,677 for the State of Alaska Municipal Harbor Facility Grant Program in the FY 2025 State Capital Budget. City Manager/Port Director. Recommend adoption.
- k. Resolution 23-122, A Resolution of the City Council of Homer, Alaska Awarding the Contract for the Homer Animal Shelter Operation and Management Services to the firm of Homer Animal Services, LLC in the Amount of \$330,000, Transferring \$15,000 of Unencumbered Operating Funds, and Authorizing the City Manager to Negotiate and Execute the Appropriate Documents. City Manager. Recommend adoption.

Memorandum CC-23-259 from City Clerk as backup.

Item i. moved to Ordinances item a. Aderhold.

LORD/ADERHOLD MOVED TO ADOPT THE RECOMMENDATIONS OF THE CONSENT AGENDA.

Council Member Lord noted a correction to Ordinance 23-60 that the title should include “to reduces speed limits on City cul-de-sacs to 15 mph”

VOTE: NON OBJECTION: UNANIMOUS CONSENT.

Motion carried.

VISITORS

- a. Chamber of Commerce Annual Report – Brad Anderson, Executive Director (10 minutes)

Brad Anderson, Executive Director, Mina Gherman, Marketing Director and Silas Firth, Membership Director presented regarding the Chambers upcoming community events and highlighted events for 2024, updates to the Homer Relocation Guide and Tourism Guide, social media statistics, marketing partners, tourism promotion, and the Chambers upcoming 75th anniversary.

ANNOUNCEMENTS / PRESENTATIONS / REPORTS (5 Minute limit per report)

- a. Special Meeting Report

City Manager Dumouchel reported that Council had an executive session on IT Data Security Strategies and Issues.

- b. Committee of the Whole Report

Council Member Lord reported Council heard a presentation about our Sister City relationship with Teshio, Hokkaido in Japan and the upcoming 40th anniversary celebration. Japanese Club students did a presentation to Council, led by Megumi Beams. Folks interested in being involved with the Sister City celebration can contact Library Director Dave Berry at the Homer Library, and the Japanese Club is looking for donations to purchase Taiko Drums for the students to play at the celebration.

- c. Mayor's Report

- i. Letter to Aaron Hunting, PE, AKDOT

Mayor Castner noted his letter in the packet and reported the Alaska Department of Transportation had reached out for additional information for the proposed underpass for the Diamond Creek Trail connection to other recreational land.

- d. Borough Report

- e. Planning Commission

- i. Planning Commission written report

Planning Commissioner David Schneider reported at their last meeting the Commission had a work session to discuss a Planning Commission Strategic Plan. At their regular meeting City Planner Foster reported on the status of Ordinance 23-21(S) and future work on the topic, and an upcoming Transportation Plan Steering Committee. They approved their 2024 meeting schedule.

- f. Port and Harbor Advisory Commission

PUBLIC HEARING(S)

- a. Ordinance 23-53, An Ordinance of the City Council of Homer, Alaska Amending the FY24 Capital Budget by Accepting \$66,650 from the State of Alaska Department of Corrections for

Reimbursement for the Purchase of the Jail Van. City Manager/Police Chief. Introduction October 23, 2023 Public Hearing and Second Reading November 13, 2023.

Memorandum CC-23-238 from Police Chief as backup.

Mayor Castner opened the public hearing. There were no comments and the hearing was closed.

LORD/ADERHOLD MOVED TO ADOPT ORDINANCE 23-53 BY READING OF TITLE ONLY FOR SECOND AND FINAL READING.

There were brief comments of appreciation for the States assistance with this matter.

VOTE: NON OBJECTION: UNANIMOUS CONSENT

Motion carried.

- b. Ordinance 23-54, An Ordinance of the City Council of Homer, Alaska Amending the FY24 Capital Budget by Appropriating \$15,000 from the Port Reserves Fund for Repair of the Deep Water Dock Sink Hole. City Manager/Port Director. Introduction October 23, 2023, Public Hearing and Second Reading November 13, 2023.

Memorandum CC-23-239 from Port Director as backup.

Mayor Castner opened the public hearing. There were no comments and the hearing was closed.

LORD/ADERHOLD MOVED TO ADOPT ORDINANCE 23-54 BY READING OF TITLE ONLY FOR SECOND AND FINAL READING.

There was no discussion.

VOTE: NON OBJECTION: UNANIMOUS CONSENT

Motion carried.

ORDINANCE(S)

- i. Ordinance 23-61, An Ordinance of the City Council of Homer, Alaska Amending Homer City Code Title 5 to add Chapter 5.48 Short Term Rentals. Aderhold/Davis. Recommended dates Introduction November 13, 2023, Refer to Planning Commission and Economic Development Commission, Public Hearing and Second Reading February 26, 2024.

Memorandum CC-23-260 from City Manager as backup.

ADERHOLD/VENUTI MOVED TO INTRODUCE ORDINANCE 23-61 AND REFER THE ORDINANCE TO THE PLANNING COMMISSION AND ECONOMIC DEVELOPMENT ADVISORY COMMISSION.

Council Member Aderhold shared that she pulled this from the consent agenda for discussion and so their comments can be sent on to the Commissions. She shared the background that they've been talking about short term rentals (STR) since their last visioning session in March of 2022. They attempted to work with a company that would help locate the STR's around town, but it wasn't successful. This ordinance is a first step opportunity to get a sense of who's out there and have them receive a permit to operate, similar to what the food trucks have, so we know where they are and that they are collecting taxes due to the city, and to establish a fine structure for non-compliance. There's potential for follow on ordinances in the future, but this is a starting point for next year.

Council Member Lord looks forward to feedback from the Planning Commission and Economic Development Commission to hear their perspectives and also feedback they have based on public comments they receive. She noted this is Title 5 and City Manager Dumouchel added that there will need to be an amendment to Title 21 in the future. Council Member Lord also noted that the \$100 per day fee that a couple members of the public have referenced is in the fine schedule and only a per day fee if they are in violation of this section of code.

Council Member Venuti commented regarding enforcement and potential staff impacts. City Manager Dumouchel responded general permitting will be a function of Administration and any serious health and safety violations will be handled by the Police Department. He also shared about efforts for rebuilding capacity for Planning.

Mayor Castner commented briefly how this relates to business licenses.

VOTE (introduction): NON OBJECTION: UNANIMOUS CONSENT

Motion carried.

CITY MANAGER'S REPORT

a. City Manager's Report

City Manager Dumouchel noted his report in the packet and highlighted upcoming tsunami siren testing, council champion updates, parking and camping reporting, and the upcoming work session about.

They discussed the campground operating report and the feeling there's more to consider there. The campground also operates as a large vessel haul out, and there's tension with the competing interests between the enterprise and general fund. Council values both the campground and the haul out, and recognizes it wouldn't be unreasonable for the enterprise to proposing that the campground go away. It's a Council role to make the decision whether it's a campground or a haul out, and this could be a good opportunity for a work session with Port and Harbor to have the conversation.

b. Roads and Trails Financial Plans

Public Works Director Keiser reviewed proposed projects in the roads financial plan and trails financial plan which are intended to be used as budget planning documents, and responded to questions from Mayor and Council.

PENDING BUSINESS

NEW BUSINESS

- a. Memorandum CC-23-254 from Council Members Lord and Hansen Re: Harbor Expansion General Investigation Continuation Resolution. (10 minutes)

There was brief discussion that this is provided as follow-up from discussion at their last meeting of the intent to bring back a resolution. The sponsors felt it would be most appropriate to bring it forward at the November 27th meeting when a full council is expected, and the intent of the resolution will be to support moving forward with funding and new development plan. The need for Council to work as a body and a team in conversations with federal and state partners and maintain positive relationships was also addressed.

This was provided as an informational item and no action was taken.

RESOLUTIONS

COMMENTS OF THE AUDIENCE

Scott Adams, city resident, recommended watching the video for the Port and Harbor Advisory Commission meeting regarding discussion on the campground and large vessel haul out. What they want is a budget to run things out there. He has concerns about eliminating camping. He commented about proposals for parking fees increasing to \$25 per day and eliminating the long term parking pass. He explained about his experience at a Florida beach where visitors could use a QR code displayed on signage instead of having to find a parking meter. He also commented about the continued lack of action for clean up at Mattox and East End Road.

COMMENTS OF THE CITY ATTORNEY

City Attorney Gatti had no comments.

COMMENTS OF THE CITY CLERK

City Clerk Jacobsen announced openings on the ADA Advisory Board and Parks Art Recreation and Culture Advisory Commission, and a Student Representative seat on the Port and Harbor Advisory Commission.

COMMENTS OF THE CITY MANAGER

City Manager Dumouchel commented the City is recruiting for Planning staff and Fire Fighters. Information is available on the City website.

COMMENTS OF THE MAYOR

Mayor Castner reiterated that 2024 is the 40th anniversary of the Sister City relationship between Teshio and Homer. He anticipates the Council will be making moves to make it a celebration. He also shared that he was called by a surveyor who's laying out the sewer line to Jack Gist Park, he's pleased that's happening before the ground freezes up.

COMMENTS OF THE CITY COUNCIL

Council Member Lord loved having the kids a Committee of the Whole and thanked Megumi Beams and all the families for helping get them here. She shared about her experience in Anchorage last week attending the Inter-Tribal Agriculture Council first Alaska Summit and the Alaska Food and Farm Festival. She noted Karen Sonnen, from Homer's Natural Resource Conservation Service office who's the only range land specialist in Alaska who presented on reindeer habitat at the summit, and the many Homer participants at the festival.

Council Member Venuti wished everyone happy Thanksgiving. She shared about the successful Empty Bowls fundraiser for the food pantry where they sold all of the 140 bowls donated by local potters and all the great soups that were donated.

Council Member Aderhold commented she was also in Anchorage last week but didn't bump into anyone from Homer, and she got the last bowl at the Empty Bowls event. She wished everyone happy Thanksgiving.

Council Member Hansen recalled the beginning of the Sister City relationship from when she was a kid, it was amazing. She announced the All Things Recovery bonfire planned at Bishops Beach and emphasized the importance of supporting our sober community and normalizing it.

ADJOURN

There being no further business to come before the Council Mayor Castner adjourned the meeting at 7:43 p.m. The next Regular Meeting is Monday, November 27, 2023 at 6:00 p.m., Work Session at 4:00 p.m. and Committee of the Whole at 5:00 p.m. All meetings are scheduled to be held in the City Hall Cowles Council Chambers located at 491 E. Pioneer Avenue, Homer, Alaska.

Melissa Jacobsen, MMC, City Clerk

Approved:_____



MEMORANDUM

Appointment of Jessica Williams to the Parks Art Recreation and Culture Advisory Commission.

Item Type: Action Memorandum
Prepared For: Homer City Council
Date: November 21, 2023
From: Mayor Castner

Jessica Williams is appointed to the Parks Art Recreation and Culture Advisory Commission to fill the seat vacated by Deb Lowney. The term expires October 31, 2026.

Recommendation

Confirm the appointments of Jessica Williams to the Parks Art Recreation and Culture Advisory Commission.

Attachments:

Janie Leisk application
Jessica Williams application

Published on *City of Homer Alaska Official Website* (<https://www.cityofhomer-ak.gov>)

[Home](#) > [Application for Appointment to an Advisory Body](#) > [Webform results](#) > Application for Appointment to an Advisory Body

Submission information

Form: [Application for Appointment to an Advisory Body](#) [1]

Submitted by Visitor (not verified)

Sun, 10/29/2023 - 4:20pm

65.74.105.243

Applicant Information

Full Name

Janie Leask

Physical Address Where you Claim Residency

233 Island View Court; Homer, AK 99603

Mailing Address

PO Box 522; Homer, AK 99603

Phone Number(s)

907.250.1944

Email

huntave@yahoo.com

Advisory Bodies

Parks, Art, Recreation & Culture Advisory Commission – Meetings held on the 3rd Thursday of February through June and August through November at 5:30 p.m.

Residency

Are you a City Resident? Yes

If yes, how long have you been a City Resident? 10 years

How long have you been a resident of the South Peninsula Area? 10 years

Background Information

Have you ever served on a similar advisory body?

If so please list when, where, and how long:

I've not served on a local advisory body, but did served on the South Peninsula Haven House

Board of Directors for 7 years. I lived in Anchorage for 40 years prior to moving to Homer and during those years I served both on Boards of Directors and as CEO's of nonprofits. I've also served on the Anchorage Parks Foundation Board as well as on the Alaska State Board of Education and on the Board of the Alaska Permanent Fund. I have experience both as a Committee/Board member as well as the head of an organization.

Other memberships

Please list any current memberships or organizations you belong to related to your selection(s):

Volunteer President of the Homer Pickleball Club

Special Training & Education

Please list any special training, education, or background you may have which is related to your selection(s):

I've played sports all my life - softball, racquetball, hockey, and pickleball. I've also hiked, camped, fished, and skied. I'm currently a volunteer for Community Recreation. I've been to numerous trainings over my career which have equipped me as board member, executive, community builder and team player.

Why are you interested in serving on the selected Advisory Body?

Please briefly state why you are interested in serving on the advisory body selected. This may include information on future goals or projects you wish to see accomplished or any additional information that may assist the Mayor in the decision making process.

I'm a huge believer in community involvement and recreation. I believe recreation is important to the well-being of a community. Homer residents of all ages need to stay active and engaged in organized physical activities as well as to stay connected through recreation, classes, or the arts. Our community - residents and visitors alike - benefits through the investment we make in the recreational infrastructure. PARCAC is an important voice. I would hope to add to that voice by being an advocate for recreation and community involvement. One of my personal priorities is the completion of a multi-purpose community center and what happens to the current site of the HERC.

Source URL: <https://www.cityofhomer-ak.gov/node/9051/submission/51369>

Links

[1] <https://www.cityofhomer-ak.gov/cityclerk/application-appointment-advisory-body>

Published on *City of Homer Alaska Official Website* (<https://www.cityofhomer-ak.gov>)

[Home](#) > [Application for Appointment to an Advisory Body](#) > [Webform results](#) > Application for Appointment to an Advisory Body

Submission information

Form: [Application for Appointment to an Advisory Body](#) ^[1]

Submitted by Visitor (not verified)

Mon, 11/13/2023 - 12:27pm

146.71.68.181

Applicant Information

Full Name

Jessica Williams

Physical Address Where you Claim Residency

357 E Fairview Ave Apt C, Homer, AK 99603

Mailing Address

PO Box 2713, Homer, AK 99603

Phone Number(s)

9072992279

Email

jessica.annewilliams@yahoo.com

Advisory Bodies

Parks, Art, Recreation & Culture Advisory Commission – Meetings held on the 3rd Thursday of February through June and August through November at 5:30 p.m.

Residency

Are you a City Resident? Yes

If yes, how long have you been a City Resident? 5 years

How long have you been a resident of the South Peninsula Area? 5 years

Background Information

Have you ever served on a similar advisory body?

N/A

Other memberships

Americans for the Arts and Society of Human Resources Management

Special Training & Education

Bachelor's in Musical Theatre, Master's in Arts Administration

Why are you interested in serving on the selected Advisory Body?

Change begins at home and it would be so rewarding to lead the change in Homer. I am a volunteer and supporter of the arts in Homer. It would be so rewarding to give back to the community that has given us so much.

Source URL:<https://www.cityofhomer-ak.gov/node/9051/submission/51399>

Links

[1] <https://www.cityofhomer-ak.gov/cityclerk/application-appointment-advisory-body>



Memorandum

Marijuana Retail and Product Manufacturing License Renewals for Cosmic Cannabis Company and Cosmic SeaWeed LLC

Item Type: Action Memorandum
Prepared For: Mayor & City Council
Meeting Date: November 22, 2023
From: Melissa Jacobsen, MMC, City Clerk

The City Clerk's Office has been notified by the Alcohol and Marijuana Control Office of Retail Marijuana Store and Marijuana Product Manufacturing Facility Applications within the City of Homer for the following businesses:

Lic #: 21417
DBA Name: Cosmic Cannabis Company
Service Location: 261 East Bunnell Avenue, Homer, AK 99603
Licensee: Cosmic SeaWeed, LLC
Designated Licensee: Christina Logan
Mailing Address: 261 E. Bunnell Ave., Charles Way, Homer, AK 99603

Type: Marijuana Manufacturing Facility
Lic#: 19728
DBA Name: Cosmic SeaWeed, LLC
Service Location: 262 Charles Way, Homer, AK 99603
Licensee: Cosmic SeaWeed, LLC
Designated Licensee: Christina Logan
Mailing Address: 261 E. Bunnell Ave., Homer, AK 99603

Staff Recommendation:

Voice non-objection and approval for the Retail Marijuana Store and Marijuana Product Manufacturing Facility Applications.



November 14, 2023

Licensee: **Cosmic SeaWeed, LLC**
DBA: Cosmic Seaweed, LLC
VIA email: cosmicseaweed@gmail.com
Local Government: Homer
Local Government 2: Kenai Peninsula Borough

Via Email: mjacobsen@ci.homer.ak.us ; rkrause@ci.homer.ak.us ; clerk@cityofhomer-ak.gov
micheletturner@kpb.us ; tward@kpb.us ; mjenkins@kpb.us ; nscarlett@kpb.us ; mboehmler@kpb.us ;
rraidmae@kpb.us ; slopez@kpb.us ; bcarter@kpb.us ; jbeauchamp@kpb.us

Re: Marijuana Product Manufacturing Facility #19728 Combined Renewal Notice

License Number:	#19728
License Type:	Marijuana Product Manufacturing Facility
Licensee:	Cosmic Seaweed, LLC
Doing Business As:	Cosmic Seaweed, LLC
Physical Address:	262 Charles Way Homer, AK 99603
Designated Licensee:	Chris Long
Phone Number:	907-982-0513
Email Address:	cosmicseaweed@gmail.com

License Renewal Application **Endorsement Renewal Application**

Dear Licensee:

After reviewing your renewal documents, AMCO staff has deemed the application complete for the purposes of 3 AAC 306.035(c).

Your application will now be sent electronically, in its entirety, to your local government, your community council (if your proposed premises is in Anchorage or certain locations in the Mat-Su Borough), and to any non-profit agencies who have requested notification of applications. The local government has 60 days to protest your application per 3 AAC 306.060.

At the May 15, 2017 Marijuana Control Board meeting, the board delegated to AMCO Director the authority to approve renewal applications. However, the board is required to consider this application independently if you have been issued any notices of violation for this license, if your local government

protests this application, or if a public objection to this application is received within 30 days of this notice under 3 AAC 306.065.

If AMCO staff determines that your application requires independent board consideration for any reason, you will be sent an email notification regarding your mandatory board appearance. Upon final approval, your 2023/2024 license will be provided to you during your annual inspection. If our office determines that an inspection is not necessary, the license will be mailed to you at the mailing address on file for your establishment.

Please feel free to contact us through the marijuana.licensing@alaska.gov email address if you have any questions.

Dear Local Government:

AMCO has received a complete renewal application and/or endorsement renewal application for a marijuana establishment within your jurisdiction. This notice is required under 3 AAC 306.035(c)(2). Application documents will be sent to you separately via ZendTo.

To protest the approval of this application pursuant to 3 AAC 306.060, you must furnish the director **and** the applicant with a clear and concise written statement of reasons for the protest within 60 days of the date of this notice, and provide AMCO proof of service of the protest upon the applicant.

3 AAC 306.060 states that the board will uphold a local government protest and deny an application for a marijuana establishment license unless the board finds that a protest by a local government is arbitrary, capricious, and unreasonable. If the protest is a “conditional protest” as defined in 3 AAC 306.060(d)(2) and the application otherwise meets all the criteria set forth by the regulations, the Marijuana Control Board may approve the license renewal, but require the applicant to show to the board’s satisfaction that the requirements of the local government have been met before the director issues the license.

At the May 15, 2017, Marijuana Control Board meeting, the board delegated to AMCO Director the authority to approve renewal applications with no protests, objections, or notices of violation. However, if a timely protest or objection is filed for this application, or if any notices of violation have been issued for this license, the board will consider the application. In those situations, a temporary license will be issued pending board consideration.

If you have any questions, please email amco.localgovernmentonly@alaska.gov.

Sincerely,



Joan M. Wilson, Director
907-269-0350

Alcohol & Marijuana Control Office

License Number: 19728

License Status: Active-Operating

License Type: Marijuana Product Manufacturing Facility

Doing Business As: COSMIC SEAWEED, LLC

Business License Number: 1088609

Designated Licensee: Chris Long

Email Address: cosmicseaweed@gmail.com

Local Government: Homer

Local Government 2: Kenai Peninsula Borough

Community Council:

Latitude, Longitude: 59.638874, -151.539705

Physical Address: 262 Charles Way
Homer, AK 99603
UNITED STATES

Licensee #1

Type: Entity

Alaska Entity Number: 10093588

Alaska Entity Name: Cosmic SeaWeed, LLC

Phone Number: 907-982-0513

Email Address: pyrofish13@gmail.com

Mailing Address: 879 Linda Ct
Homer, AK 99603
UNITED STATES

Entity Official #1

Type: Individual

Name: Christina Logan

[REDACTED]

[REDACTED]

Phone Number: 419-708-0174

Email Address: cosmicseaweed@gmail.com

Mailing Address: 261 East Bunnell
Homer, AK 99603
UNITED STATES

Entity Official #2

Type: Individual

Name: Chris Long

[REDACTED]

[REDACTED]

Phone Number: 419-708-0174

Email Address: cosmicseaweed@gmail.com

Mailing Address: 879 Linda Court
Homer, AK 99603
UNITED STATES

Note: No affiliates entered for this license.



Alaska Marijuana Control Board

Form MJ-20: 2023-2024 Renewal Application Certifications

Why is this form needed?

This renewal application certifications form is required for all marijuana establishment license renewal applications. Each person signing an application for a marijuana establishment license must declare that he/she has read and is familiar with AS 17.38 and 3 AAC 306. A person other than a licensee may not have direct or indirect financial interest (as defined in 3 AAC 306.015(e)(1)) in the business for which a marijuana establishment license is issued, per 3 AAC 306.015(a).

This form must be completed and submitted to AMCO's Anchorage office by each licensee (as defined in 3 AAC 306.020(b)(2)) before any license renewal application will be considered complete.

Section 1 – Establishment Information

Enter information for the licensed establishment, as identified on the license application.

Licensee:	Cosmic SeaWeed LLC	License Number:	19728		
License Type:	Marijuana Product Manufacturing Facility				
Doing Business As:	Cosmic SeaWeed LLC				
Premises Address:	262 Charles Way				
City:	Homer	State:	AK	ZIP:	99603

Section 2 – Individual Information

Enter information for the individual licensee who is completing this form.

Name:	Chris Long
Title:	Owner

Section 3 – Violations & Charges

Read each line below, and then sign your initials in the box to the right of any applicable statements:

Initials

I certify that I have not been convicted of any criminal charge in the previous two calendar years.

ce

I certify that I have not committed any civil violation of AS 04, AS 17.38, or 3 AAC 306 in the previous two calendar years.

ce

I certify that a notice of violation has not been issued for this license between July 1, 2022 and June 30, 2023.

ce

Sign your initials to the following statement only if you are unable to certify one or more of the above statements:

Initials

I have attached a written explanation for why I cannot certify one or more of the above statements, which includes the type of violation or offense, as required under 3 AAC 306.035(b)



Form MJ-20: 2023-2024 Renewal Application Certifications

Section 5 – Certifications

Read each line below, and then sign your initials in the box to the right of each statement:

Initials

I certify that no person other than a licensee listed on my marijuana establishment license renewal application has a direct or indirect financial interest, as defined in 3 AAC 306.015(e)(1), in the business for which the marijuana establishment license has been issued.

cl

I certify that I meet the residency requirement under AS 43.23 or I have submitted a residency exception affidavit (MJ-20a) along with this application.

cl

I certify that this establishment complies with any applicable health, fire, safety, or tax statute, ordinance, regulation, or other law in the state.

cl

I certify that the license is operated in accordance with the operating plan currently approved by the Marijuana Control Board.

cl

I certify that I am operating in compliance with the Alaska Department of Labor and Workforce Development's laws and requirements pertaining to employees.

cl

I certify that I have not violated any restrictions pertaining to this particular license type, and that this license has not been operated in violation of a condition or restriction imposed by the Marijuana Control Board.

cl

Initial this box if you are submitting an original fingerprint card and the applicable fees to AMCO for AMCO to obtain criminal justice information and a national criminal history record required by AS 17.38.200 and 3 AAC 306.035(d). If I have multiple marijuana licenses being renewed, I understand one fingerprint card and fee will suffice for all marijuana licenses being renewed.

If multiple licenses are held, list all license numbers below:

19728, 21417

I hereby certify that I am the person herein named and subscribing to this application and that I have read the complete application, and I know the full content thereof. I declare that all of the information contained herein, and evidence or other documents submitted are true and correct. I understand that any falsification or misrepresentation of any item or response in this application, or any attachment, or documents to support this application, is sufficient grounds for denying or revoking a license/permit. I further understand that it is a Class A misdemeanor under Alaska Statute 11.56.210 to falsify an application and commit the crime of unsworn falsification.

cl

Chris Long
Printed name of licensee

Chris Long
Signature of licensee



Alaska Marijuana Control Board

Form MJ-20: 2023-2024 Renewal Application Certifications

Why is this form needed?

This renewal application certifications form is required for all marijuana establishment license renewal applications. Each person signing an application for a marijuana establishment license must declare that he/she has read and is familiar with AS 17.38 and 3 AAC 306. A person other than a licensee may not have direct or indirect financial interest (as defined in 3 AAC 306.015(e)(1)) in the business for which a marijuana establishment license is issued, per 3 AAC 306.015(a).

This form must be completed and submitted to AMCO's Anchorage office by each licensee (as defined in 3 AAC 306.020(b)(2)) before any license renewal application will be considered complete.

Section 1 – Establishment Information

Enter information for the licensed establishment, as identified on the license application.

Licensee:	Cosmic SeaWeed LLC	License Number:	19728		
License Type:	Marijuana Product Manufacturing Facility				
Doing Business As:	Cosmic SeaWeed LLC				
Premises Address:	262 Charles Way				
City:	Homer	State:	AK	ZIP:	99603

Section 2 – Individual Information

Enter information for the individual licensee who is completing this form.

Name:	Chris Logan
Title:	Owner

Section 3 – Violations & Charges

Read each line below, and then sign your initials in the box to the right of any applicable statements:

Initials

I certify that I have **not** been convicted of any criminal charge in the previous two calendar years.

I certify that I have **not** committed any civil violation of AS 04, AS 17.38, or 3 AAC 306 in the previous two calendar years.

I certify that a notice of violation has **not** been issued for this license between July 1, 2022 and June 30, 2023.

Sign your initials to the following statement **only** if you are unable to certify one or more of the above statements:

Initials

I have attached a written explanation for why I cannot certify one or more of the above statements, which includes the type of violation or offense, as required under 3 AAC 306.035(b)



Section 5 - Certifications

Read each line below, and then sign your initials in the box to the right of each statement:

Initials

I certify that no person other than a licensee listed on my marijuana establishment license renewal application has a direct or indirect financial interest, as defined in 3 AAC 306.015(e)(1), in the business for which the marijuana establishment license has been issued.

Q

I certify that I meet the residency requirement under AS 43.23 or I have submitted a residency exception affidavit (MJ-20a) along with this application.

Q

I certify that this establishment complies with any applicable health, fire, safety, or tax statute, ordinance, regulation, or other law in the state.

Q

I certify that the license is operated in accordance with the operating plan currently approved by the Marijuana Control Board.

Q

I certify that I am operating in compliance with the Alaska Department of Labor and Workforce Development's laws and requirements pertaining to employees.

Q

I certify that I have not violated any restrictions pertaining to this particular license type, and that this license has not been operated in violation of a condition or restriction imposed by the Marijuana Control Board.

Q

Initial this box if you are submitting an original fingerprint card and the applicable fees to AMCO for AMCO to obtain criminal justice information and a national criminal history record required by AS 17.38.200 and 3 AAC 306.035(d). If I have multiple marijuana licenses being renewed, I understand one fingerprint card and fee will suffice for all marijuana licenses being renewed.

N/A

If multiple licenses are held, list all license numbers below:

19728, 21417

I hereby certify that I am the person herein named and subscribing to this application and that I have read the complete application, and I know the full content thereof. I declare that all of the information contained herein, and evidence or other documents submitted are true and correct. I understand that any falsification or misrepresentation of any item or response in this application, or any attachment, or documents to support this application, is sufficient grounds for denying or revoking a license/permit. I further understand that it is a Class A misdemeanor under Alaska Statute 11.56.210 to falsify an application and commit the crime of unsworn falsification.

Q

Christina Logan
Printed name of licensee

Signature of licensee



November 16, 2023

From: marijuana.licensing@alaska.gov ; amco.localgovernmentonly@alaska.gov

Licensee: **Cosmic SeaWeed, LLC**
DBA: Cosmic Cannabis Company
VIA email: cosmicseaweed@gmail.com
CC: n/a
Local Government1 : Homer
Local Government 2: Kenai Peninsula Borough

Via Email: micheletturner@kpb.us; tward@kpb.us; mjenkins@kpb.us; nscarlett@kpb.us;
mboehmler@kpb.us; rraidmae@kpb.us; slopez@kpb.us; bcarter@kpb.us; jbeauchamp@kpb.us;
mjacobsen@ci.homer.ak.us; rkrause@ci.homer.ak.us; clerk@cityofhomer-ak.gov

Community Council: n/a

Via Email:

CC: n/a

BCC: amco.admin@alaska.gov

Re: Retail Marijuana Store #21417 Combined Renewal Notice

License Number:	#21417
License Type:	Marijuana Retail Store
Licensee:	Cosmic SeaWeed, LLC
Doing Business As:	Cosmic Cannabis Company
Physical Address:	261 East Bunnell Ave Homer, AK 99603
Designated Licensee:	Cosmic SeaWeed, LLC
Phone Number:	907-982-0513
Email Address:	cosmicseaweed@gmail.com

License Renewal Application

Endorsement Renewal Application

Dear Licensee:

After reviewing your renewal documents, AMCO staff has deemed the application complete for the purposes of 3 AAC 306.035(c).

Your application will now be sent electronically, in its entirety, to your local government, your community council (if your proposed premises is in Anchorage or certain locations in the Mat-Su Borough), and to any non-profit agencies who have requested notification of applications. The local government has 60 days to protest your application per 3 AAC 306.060.

At the May 15, 2017 Marijuana Control Board meeting, the board delegated to AMCO Director the authority to approve renewal applications. However, the board is required to consider this application independently if you have been issued any notices of violation for this license, if your local government protests this application, or if a public objection to this application is received within 30 days of this notice under 3 AAC 306.065.

If AMCO staff determines that your application requires independent board consideration for any reason, you will be sent an email notification regarding your mandatory board appearance. Upon final approval, your 2023/2024 license will be provided to you during your annual inspection. If our office determines that an inspection is not necessary, the license will be mailed to you at the mailing address on file for your establishment.

Please feel free to contact us through the marijuana.licensing@alaska.gov email address if you have any questions.

Dear Local Government:

AMCO has received a complete renewal application and/or endorsement renewal application for a marijuana establishment within your jurisdiction. This notice is required under 3 AAC 306.035(c)(2). Application documents will be sent to you separately via ZendTo.

To protest the approval of this application pursuant to 3 AAC 306.060, you must furnish the director **and** the applicant with a clear and concise written statement of reasons for the protest within 60 days of the date of this notice, and provide AMCO proof of service of the protest upon the applicant.

3 AAC 306.060 states that the board will uphold a local government protest and deny an application for a marijuana establishment license unless the board finds that a protest by a local government is arbitrary, capricious, and unreasonable. If the protest is a “conditional protest” as defined in 3 AAC 306.060(d)(2) and the application otherwise meets all the criteria set forth by the regulations, the Marijuana Control Board may approve the license renewal, but require the applicant to show to the board’s satisfaction that the requirements of the local government have been met before the director issues the license.

At the May 15, 2017, Marijuana Control Board meeting, the board delegated to AMCO Director the authority to approve renewal applications with no protests, objections, or notices of violation. However, if a timely protest or objection is filed for this application, or if any notices of violation have been issued for this license, the board will consider the application. In those situations, a temporary license will be issued pending board consideration.

If you have any questions, please email amco.localgovernmentonly@alaska.gov.

Dear Community Council (Municipality of Anchorage and Mat-Su Borough only)

AMCO has received a complete renewal application for the above listed license within your jurisdiction. This notice is required under 3 AAC 306.035(c)(2). Application documents will be sent to you separately via ZendTo.

To object to the approval of this application pursuant to 3 AAC 306.065, you must furnish the director **and** the applicant with a clear and concise written statement of reasons for the objection within 30 days of the date of this notice. We recommend that you contact the local government with jurisdiction over the proposed premises to share objections you may have about the application.

At the May 15, 2017, Marijuana Control Board meeting, the board delegated to AMCO Director the authority to approve renewal applications with no protests, objections, or notices of violation. However, if a timely protest or objection is filed for this application, or if any notices of violation have been issued for this license, the board will consider the application independently. In those situations, a temporary license will be issued pending board consideration.

If you have any questions, please email marijuana.licensing@alaska.gov.

Sincerely,

A handwritten signature in blue ink that reads "Joan M. Wilson". The signature is written in a cursive style with a large initial "J".

Joan M. Wilson, Director
907-269-0350

Alcohol & Marijuana Control Office

License Number: 21417

License Status: Active-Operating

License Type: Retail Marijuana Store

Doing Business As: Cosmic Cannabis Company

Business License Number: 2111543

Designated Licensee: Chris Long

Email Address: cosmicseaweed@gmail.com

Local Government: Homer

Local Government 2: Kenai Peninsula Borough

Community Council:

Latitude, Longitude: 59.639667, -151.539490

Physical Address: 261 East Bunnell Ave
Homer, AK 99603
UNITED STATES

Licensee #1

Type: Entity

Alaska Entity Number: 10093588

Alaska Entity Name: Cosmic SeaWeed, LLC

Phone Number: 907-982-0513

Email Address: cosmicseaweed@gmail.com

Mailing Address: 261 East Bunnell Ave
Homer, AK 99603
UNITED STATES

Entity Official #1

Type: Individual

Name: Christina Logan

[REDACTED]

[REDACTED]

Phone Number: 907-982-0513

Email Address: cosmicseaweed@gmail.com

Mailing Address: 2303 Tulik Drive
Anchorage, AK 99517
UNITED STATES

Entity Official #2

Type: Individual

Name: Chris Long

[REDACTED]

[REDACTED]

Phone Number: 419-708-0174

Email Address: cosmicseaweed@gmail.com

Mailing Address: 879 Linda Court
Homer, AK 99603
UNITED STATES

Note: No affiliates entered for this license.



Alaska Marijuana Control Board

Form MJ-20: 2023-2024 Renewal Application Certifications

Why is this form needed?

This renewal application certifications form is required for all marijuana establishment license renewal applications. Each person signing an application for a marijuana establishment license must declare that he/she has read and is familiar with AS 17.38 and 3 AAC 306. A person other than a licensee may not have direct or indirect financial interest (as defined in 3 AAC 306.015(e)(1)) in the business for which a marijuana establishment license is issued, per 3 AAC 306.015(a).

This form must be completed and submitted to AMCO's Anchorage office by each licensee (as defined in 3 AAC 306.020(b)(2)) before any license renewal application will be considered complete.

Section 1 – Establishment Information

Enter information for the licensed establishment, as identified on the license application.

Licensee:	Cosmic SeaWeed LLC	License Number:	21417		
License Type:	Marijuana Retail Store				
Doing Business As:	Cosmic SeaWeed LLC				
Premises Address:	261 East Bunnell Ave				
City:	Homer	State:	AK	ZIP:	99603

Section 2 – Individual Information

Enter information for the individual licensee who is completing this form.

Name:	Chris Long
Title:	Owner

Section 3 – Violations & Charges

Read each line below, and then sign your initials in the box to the right of any applicable statements:

Initials

I certify that I have not been convicted of any criminal charge in the previous two calendar years.

I certify that I have not committed any civil violation of AS 04, AS 17.38, or 3 AAC 306 in the previous two calendar years.

I certify that a notice of violation has not been issued for this license between July 1, 2022 and June 30, 2023.

Sign your initials to the following statement only if you are unable to certify one or more of the above statements:

Initials

I have attached a written explanation for why I cannot certify one or more of the above statements, which includes the type of violation or offense, as required under 3 AAC 306.025(b)



Form MJ-20: 2023-2024 Renewal Application Certifications

Section 5 – Certifications

Read each line below, and then sign your initials in the box to the right of each statement:

Initials

I certify that no person other than a licensee listed on my marijuana establishment license renewal application has a direct or indirect financial interest, as defined in 3 AAC 306.015(e)(1), in the business for which the marijuana establishment license has been issued.

CL

I certify that I meet the residency requirement under AS 43.23 or I have submitted a residency exception affidavit (MJ-20a) along with this application.

CL

I certify that this establishment complies with any applicable health, fire, safety, or tax statute, ordinance, regulation, or other law in the state.

CL

I certify that the license is operated in accordance with the operating plan currently approved by the Marijuana Control Board.

CL

I certify that I am operating in compliance with the Alaska Department of Labor and Workforce Development's laws and requirements pertaining to employees.

CL

I certify that I have not violated any restrictions pertaining to this particular license type, and that this license has not been operated in violation of a condition or restriction imposed by the Marijuana Control Board.

CL

Initial this box if you are submitting an original fingerprint card and the applicable fees to AMCO for AMCO to obtain criminal justice information and a national criminal history record required by AS 17.38.200 and 3 AAC 306.035(d). If I have multiple marijuana licenses being renewed, I understand one fingerprint card and fee will suffice for all marijuana licenses being renewed.

If multiple licenses are held, list all license numbers below:

19728, 21417

I hereby certify that I am the person herein named and subscribing to this application and that I have read the complete application, and I know the full content thereof. I declare that all of the information contained herein, and evidence or other documents submitted are true and correct. I understand that any falsification or misrepresentation of any item or response in this application, or any attachment, or documents to support this application, is sufficient grounds for denying or revoking a license/permit. I further understand that it is a Class A misdemeanor under Alaska Statute 11.56.210 to falsify an application and commit the crime of unsworn falsification.

CL

Chris Long

Printed name of licensee

Chris Long

Signature of licensee



Alaska Marijuana Control Board

Form MJ-20: 2023-2024 Renewal Application Certifications

Why is this form needed?

This renewal application certifications form is required for all marijuana establishment license renewal applications. Each person signing an application for a marijuana establishment license must declare that he/she has read and is familiar with AS 17.38 and 3 AAC 306. A person other than a licensee may not have direct or indirect financial interest (as defined in 3 AAC 306.015(e)(1)) in the business for which a marijuana establishment license is issued, per 3 AAC 306.015(a).

This form must be completed and submitted to AMCO's Anchorage office by each licensee (as defined in 3 AAC 306.020(b)(2)) before any license renewal application will be considered complete.

Section 1 – Establishment Information

Enter information for the licensed establishment, as identified on the license application.

Licensee:	Cosmic SeaWeed LLC	License Number:	21417		
License Type:	Marijuana Retail Store				
Doing Business As:	Cosmic SeaWeed LLC				
Premises Address:	261 East Bunnell Ave				
City:	Homer	State:	AK	ZIP:	99603

Section 2 – Individual Information

Enter information for the individual licensee who is completing this form.

Name:	Chris Logan
Title:	Owner

Section 3 – Violations & Charges

Read each line below, and then sign your initials in the box to the right of any applicable statements:

Initials

I certify that I have **not** been convicted of any criminal charge in the previous two calendar years.

I certify that I have **not** committed any civil violation of AS 04, AS 17.38, or 3 AAC 306 in the previous two calendar years.

I certify that a notice of violation has **not** been issued for this license between July 1, 2022 and June 30, 2023.

Sign your initials to the following statement only if you are unable to certify one or more of the above statements:

Initials

I have attached a written explanation for why I cannot certify one or more of the above statements, which includes the type of violation or offense, as required under 3 AAC 306.035(b)



Form MJ-20: 2023-2024 Renewal Application Certifications

Section 5 – Certifications

Read each line below, and then sign your initials in the box to the right of each statement:

Initials

I certify that no person other than a licensee listed on my marijuana establishment license renewal application has a direct or indirect financial interest, as defined in 3 AAC 306.015(e)(1), in the business for which the marijuana establishment license has been issued.

I certify that I meet the residency requirement under AS 43.23 or I have submitted a residency exception affidavit (MJ-20a) along with this application.

I certify that this establishment complies with any applicable health, fire, safety, or tax statute, ordinance, regulation, or other law in the state.

I certify that the license is operated in accordance with the operating plan currently approved by the Marijuana Control Board.

I certify that I am operating in compliance with the Alaska Department of Labor and Workforce Development's laws and requirements pertaining to employees.

I certify that I have not violated any restrictions pertaining to this particular license type, and that this license has not been operated in violation of a condition or restriction imposed by the Marijuana Control Board.

Initial this box if you are submitting an original fingerprint card and the applicable fees to AMCO for AMCO to obtain criminal justice information and a national criminal history record required by AS 17.38.200 and 3 AAC 306.035(d). If I have multiple marijuana licenses being renewed, I understand one fingerprint card and fee will suffice for all marijuana licenses being renewed.

If multiple licenses are held, list all license numbers below:

19728, 21417

I hereby certify that I am the person herein named and subscribing to this application and that I have read the complete application, and I know the full content thereof. I declare that all of the information contained herein, and evidence or other documents submitted are true and correct. I understand that any falsification or misrepresentation of any item or response in this application, or any attachment, or documents to support this application, is sufficient grounds for denying or revoking a license/permit. I further understand that it is a Class A misdemeanor under Alaska Statute 11.56.210 to falsify an application and commit the crime of unsworn falsification.

Printed name of licensee

Signature of licensee



City of Homer

www.cityofhomer-ak.gov

Office of the City Clerk

491 East Pioneer Avenue
Homer, Alaska 99603

clerk@cityofhomer-ak.gov

(p) 907-235-3130

(f) 907-235-3143

Memorandum

TO: MARK ROBL, POLICE CHIEF

CC: LISA LINEGAR, COMMUNICATIONS SUPERVISOR

FROM: ZACH PETTIT, DEPUTY CITY CLERK

DATE: NOVEMBER 17, 2023

SUBJECT: MARIJUANA LICENSE RENEWAL FOR UNCLE HERB'S

The City Clerk's Office has been notified by the Alcohol and Marijuana Control Office of a Marijuana License Renewal within the City of Homer for the following businesses:

License Type: Marijuana Product Manufacturing Facility
License #: 19728
DBA Name: Cosmic SeaWeed, LLC
Service Location: 262 Charles Way, Homer, AK 99603
Licensee: Cosmic SeaWeed, LLC
Contact Person: Chris Long

License Type: Marijuana Retail Store
License #: 21417
DBA Name: Cosmic Cannabis Company
Service Location: 261 East Bunnell Ave, Homer, AK 99603
Licensee: Cosmic SeaWeed, LLC
Contact Person: Chris Long

This matter is scheduled for the November 27, 2023 City Council Regular Meeting. Please respond in a memorandum to the City Clerk's Office with objections/non-objections to this liquor license renewal no later than the afternoon on **Tuesday, November 21, 2023**.

Thank you for your assistance.



Office of the Borough Clerk

144 North Binkley Street, Soldotna, Alaska 99669 • (907) 714-2160 • (907) 714-2388 Fax

Michele Turner, CMC
Borough Clerk

Friday, November 17, 2023

Sent via email: clerk@ci.homer.ak.us

Melissa Jacobsen, City Clerk
City of Homer

RE: Renewal Application for Marijuana Product Manufacturing Facility

Business Name : Cosmic SeaWeed, LLC
License Location : Homer/262 Charles Way, Homer, AK 99603
License No. : 19728

Dear Ms. Jacobsen,

This serves to advise that the Kenai Peninsula Borough (KPB) has reviewed the above referenced application and has no objection to the issuance of the license.

Should you have any questions, or need additional information, please don't hesitate to let us know.

Sincerely,

Michele Turner, CMC
Borough Clerk

cc: cosmicseaweed@gmail.com

amco.localgovernmentonly@alaska.gov



MEMORANDUM

Ordinance 23-61, An Ordinance of the City Council of Homer, Alaska Amending the FY24 Capital Budget by Appropriating \$300,000 from the Water Capital Asset Repair and Maintenance Allowance (CARMA) Fund to Design and Rebuild the Ben Walters Pressure Reducing Station. City Manager/Public Works Director.

Item Type: Backup Memorandum
Prepared For: City Council
Date: November 14, 2023
From: Janette Keiser, PE, Public Works Director/City Engineer
Through: Rob Dumouchel, City Manager

I. Issue: The purpose of this Memorandum is to request an appropriation in the amount of \$300,000 from the Water CARMA to rebuild the pressure reducing station in Ben Walters Way.

II. Background:

There is a pressure reducing station in Ben Walters Way, directly under the alignment of the curb/gutter, which will be installed as part of the new sidewalk project. This station is old. It leaks, has outdated plumbing and obsolete electrical works. At first we thought we could abandon this station by demolishing it in place. We proceeded to design the Ben Walters sidewalk with this idea in mind. However, this past summer, we completed work to update Homer's Water Model. This work involved using a computer program to simulate water pressures/flows throughout Homer's water distribution system, augmented by field tests taken at fire hydrants around town. Results from the Water Model demonstrated that the Ben Walters Pressure Reducing Station is an important element of Homer's water distribution resilience; that is, this station allows us to adjust water pressures in multiple branches of the water distribution line, so we can provide continuous water flow to customers in the event an emergency cuts off flow in the immediate proximity. We concluded it is not in the best interests of the public to abandon this pressure reducing station after all.

Once we realized we needed to keep the pressure reducing station at this location, we took a closer look at what was required to bring it to a state of good repair. First, the access port for the station is directly within the alignment of the new sidewalk. As a minimum, we need to relocate the access port so that it doesn't create a conduit for inflow of storm water into the pressure reducing station or create a tripping hazard in the new sidewalk. Next, we need to

repair the plumbing and upgrade the electrical works. We also need to stop ground water from leaking into the station, which will require excavation to expose the concrete vault and applying water proofing. We concluded, with all this work, it would be more cost effective to build a new, above-ground pressure reducing facility, outside the footprint of the road and sidewalk. The estimated cost of doing this is \$300,000. This work needs to be done in conjunction with the sidewalk project, to minimize adverse impact to the water operations and protect the integrity of the new sidewalk. We don't want to have to tear up the new sidewalk to access the old pressure reducing facility.

We are requesting funds from the Water CARMA fund so we can design the rebuild as soon as possible so the work can be done as part of the sidewalk project. Construction of the sidewalk is slated for the summer 2024.

- III. RECOMMENDATION:** That the City Council appropriate \$300,000 from the Water CARMA fund to pay for design and construction of rebuilding a new Ben Walters Pressure Reducing Station as part of the Ben Walters Sidewalk Project.

CITY OF HOMER
FINANCIAL SUPPLEMENT

PROJECT NAME	<u>Ben Walters Pressure Reducing Station</u>	DATE	<u>11/22/2023</u>
DEPARTMENT	<u>Public Works</u>	SPONSOR	<u>PW Director</u>
REQUESTED AMOUNT	<u>\$ 300,000</u>		

DESCRIPTION	<p>The Ben Walters Pressure Reducing Station is an important element of Homer’s water distribution resilience. This station allows Public Works to adjust water pressures in multiple branches of the water distribution line, to provide continuous water flow to customers in the event an emergency cuts off flow in the immediate proximity. The pressure reducing station in Ben Walters Way leaks as well as has outdated plumbing and obsolete electrical works and the most cost effective way of addressing the issues is to build a new, above-ground station, out of the path of the sidewalk.</p> <p>Completing this work as part of the Ben Walters Sidewalk will alleviate the need to tear up a portion of the new sidewalk after its built. Appropriating funds for the design the repairs will allow for the inclusion of the repair work as part of the sidewalk project that is slated for construction in Summer 2024.</p>
-------------	--

FUNDING SOURCE(S)	OPERATING	GF CARMA	GF FLEET CARMA	PORT RESERVES	WATER CARMA
	0%	0%	0%	0%	100%
	HAWSP	HART-ROADS	HART-TRAILS	PORT FLEET RESERVES	SEWER CARMA
	0%	0%	0%	0%	0%

FUNDING SOURCE 1: WATER CARMA (256-0378)	FUNDING SOURCE 2:	FUNDING SOURCE 3:
Current Balance <u>\$ 2,115,991</u>	Current Balance _____	Current Balance _____
Encumbered <u>\$ 825,644</u>	Encumbered _____	Encumbered _____
Requested Amount <u>\$ 300,000</u>	Requested Amount _____	Requested Amount _____
Other Items on Current Agenda <u>\$ 35,000</u>	Other Items on Current Agenda _____	Other Items on Current Agenda _____
Remaining Balance <u>\$ 955,347</u>	Remaining Balance _____	Remaining Balance _____
FUNDING SOURCE 4:	FUNDING SOURCE 5:	FUNDING SOURCE 6:
Current Balance _____	Current Balance _____	Current Balance _____
Encumbered _____	Encumbered _____	Encumbered _____
Requested Amount _____	Requested Amount _____	Requested Amount _____
Remaining Balance _____	Remaining Balance _____	Remaining Balance _____

1 **CITY OF HOMER**
2 **HOMER, ALASKA**

3 City Manager
4 Public Works Director

5 **ORDINANCE 23-61**

6
7 AN ORDINANCE OF THE CITY COUNCIL OF HOMER, ALASKA
8 AMENDING THE FY24 CAPITAL BUDGET BY APPROPRIATING
9 \$300,000 FROM THE WATER CAPITAL ASSET REPAIR AND
10 MAINTENANCE (CARMA) FUND TO DESIGN AND REBUILD THE BEN
11 WALTERS PRESSURE REDUCING STATION.
12

13 WHEREAS, The Ben Walters Pressure Reducing Station is an important element of
14 Homer’s water distribution resilience; and
15

16 WHEREAS, This station allows Public Works to adjust water pressures in multiple
17 branches of the water distribution line, to provide continuous water flow to customers in the
18 event an emergency cuts off flow in the immediate proximity; and
19

20 WHEREAS, The pressure reducing station in Ben Walters Way leaks as well as has
21 outdated plumbing and obsolete electrical works and the most cost effective way of
22 addressing the issues is to build a new, above-ground station, out of the path of the sidewalk;
23 and
24

25 WHEREAS, Completing this work as part of the Ben Walters Sidewalk will alleviate the
26 need to tear up a portion of the new sidewalk after its built; and
27

28 WHEREAS, Appropriating funds for the design the repairs will allow for the inclusion of
29 the repair work as part of the sidewalk project that is slated for construction in Summer 2024.
30

31 NOW, THEREFORE, THE CITY OF HOMER ORDAINS:
32

33 Section 1. The Homer City Council hereby amends the FY24 Capital Budget by
34 appropriating \$300,000 to design and rebuild the Ben Walters Pressure Reducing Station as
35 follows:
36

<u>Fund</u>	<u>Description</u>	<u>Amount</u>
256-0378	Ben Walters Pressure Reducing Station	\$300,000

37
38
39

40 Section 2. This is a budget amendment ordinance, is temporary in nature, and shall
41 not be codified.
42

43 ENACTED BY THE CITY COUNCIL OF HOMER, ALASKA, this ___ day of ____, 2024.
44

45
46
47
48
49
50
51
52
53
54
55
56
57
58
59
60
61
62
63

CITY OF HOMER

KEN CASTNER, MAYOR

ATTEST:

MELISSA JACOBSEN, MMC, CITY CLERK

YES:

NO:

ABSENT:

ABSTAIN:

First Reading:

Public Hearing:

Second Reading:

Effective Date:



MEMORANDUM

Ordinance 23-62, An Ordinance of the City Council of Homer, Alaska Amending the FY24 Capital Budget by Appropriating an Additional \$25,000 from the Homer Accelerated Roads and Trails (HART) Road Fund to Complete the Design of the Heath Street Pavement Restoration Project. City Manager/Public Works Director.

Item Type: Backup Memorandum
Prepared For: City Council
Date: November 21, 2023
From: Janette Keiser, PE, Public Works Director/City Engineer
Through: Rob Dumouchel, City Manager

I. Issue: The purpose of this Memorandum is to request an additional appropriation in the amount of \$25,000 to complete the final design of the Heath Street Pavement Restoration Project.

II. Background:

Ordinance 22-26 appropriated \$500,000 from the HART Roads Fund to create the Pavement Restoration Program. Shortly thereafter, Resolution 22-073 was adopted, which authorized a Task Order, in the amount of \$140,472, to Kinney Engineering, LLC (“Kinney”) to design the Heath Street Pavement Restoration Project, one of the projects in that program. Kinney started work and the design work is now over 95% complete.

We asked Kinney to provide some out-of-scope work to evaluate and design a mid-block crossing at the intersection of Hazel Avenue and Heath Street as well as video camera the existing storm drain. The total cost of this out-of-scope work is \$16,181.25, about 11.5% of the original contract value. The Pavement Restoration Program was closed during the FY24/25 budget process. There is currently no appropriation from which we can pay for this out-of-scope work or provide for any other incidental services, which may be required before to progress the 95% design to a 100% complete Bid Package. Thus, we are seeking an appropriation to cover the \$16,181.25 as well as a small contingency, for a total of \$25,000.

III. RECOMMENDATION: That the City Council appropriate \$25,000 from the HART Road Fund to pay for completion of the design of the Heath Street Pavement Restoration Project.

DRAFTED BY: BILL PADDOCK
 SCALE: LAYOUT A1
 DATE TIME: 8/31/2023 8:09 AM
 Z:\PROJETS\00710.city of homer. term contract 2022\22-04 heath street\DWG\C\Sheets\00710_22-04_A1_Title

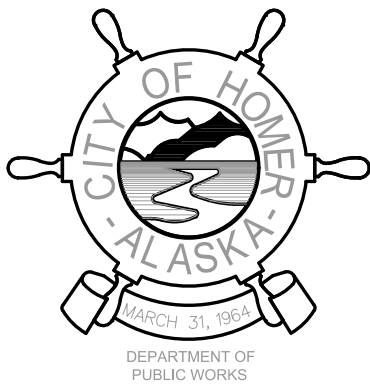

DEPARTMENT OF PUBLIC WORKS

CITY OF HOMER

PUBLIC WORKS DEPARTMENT

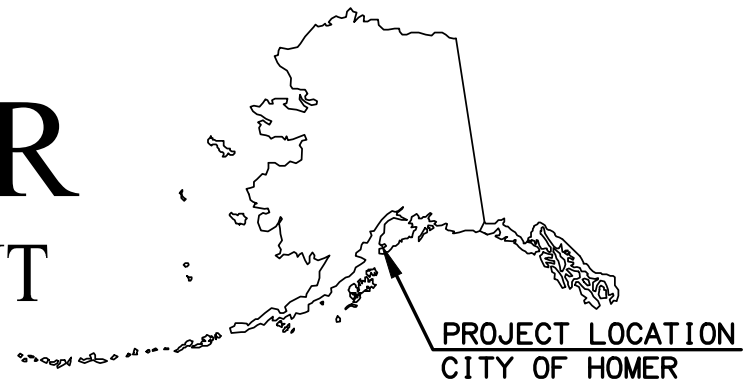

REVISIONS			YEAR	SHEET NO.	TOTAL 'A' SHEETS
NO.	DATE	DESCRIPTION			
			2023	A1	A4
				PLAN SET TOTAL	28

MAYOR
 KEN CASTNER

CITY MANAGER
 ROB DUMOUCHEL

PUBLIC WORKS DIRECTOR
 JANETTE KEISER, P.E.

CITY COUNCIL MEMBERS
 SHELLY ERIKSON
 DONNA ADERHOLD
 CAROLINE VENUPI
 JASON DAVIS
 RACHEL LORD
 STORM HANSEN

PAVEMENT RESTORATION

HEATH STREET

INDEX	
SHEET NO.	DESCRIPTION
A1	TITLE
A2	LEGEND
A3	SHEET LAYOUT AND GENERAL NOTES
A4	SURVEY CONTROL
B1	TYPICAL SECTIONS
C1	ESTIMATE OF QUANTITIES
D1	SUMMARY TABLES
E1-E4	DETAILS
F1-F4	PLAN AND PROFILE
G1-G3	GRADING PLANS
H1	TRAFFIC LEGEND AND NOTES
H2-H3	SIGNING, STRIPING AND SIGNAL PLANS
H4	SIGN SUMMARY
H5-H8	SIGNING, STRIPING AND SIGNAL DETAILS
J1	TRAFFIC CONTROL
J2	TRAFFIC CONTROL DEVICES

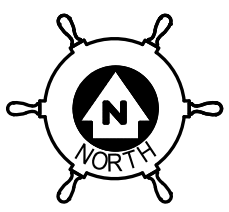
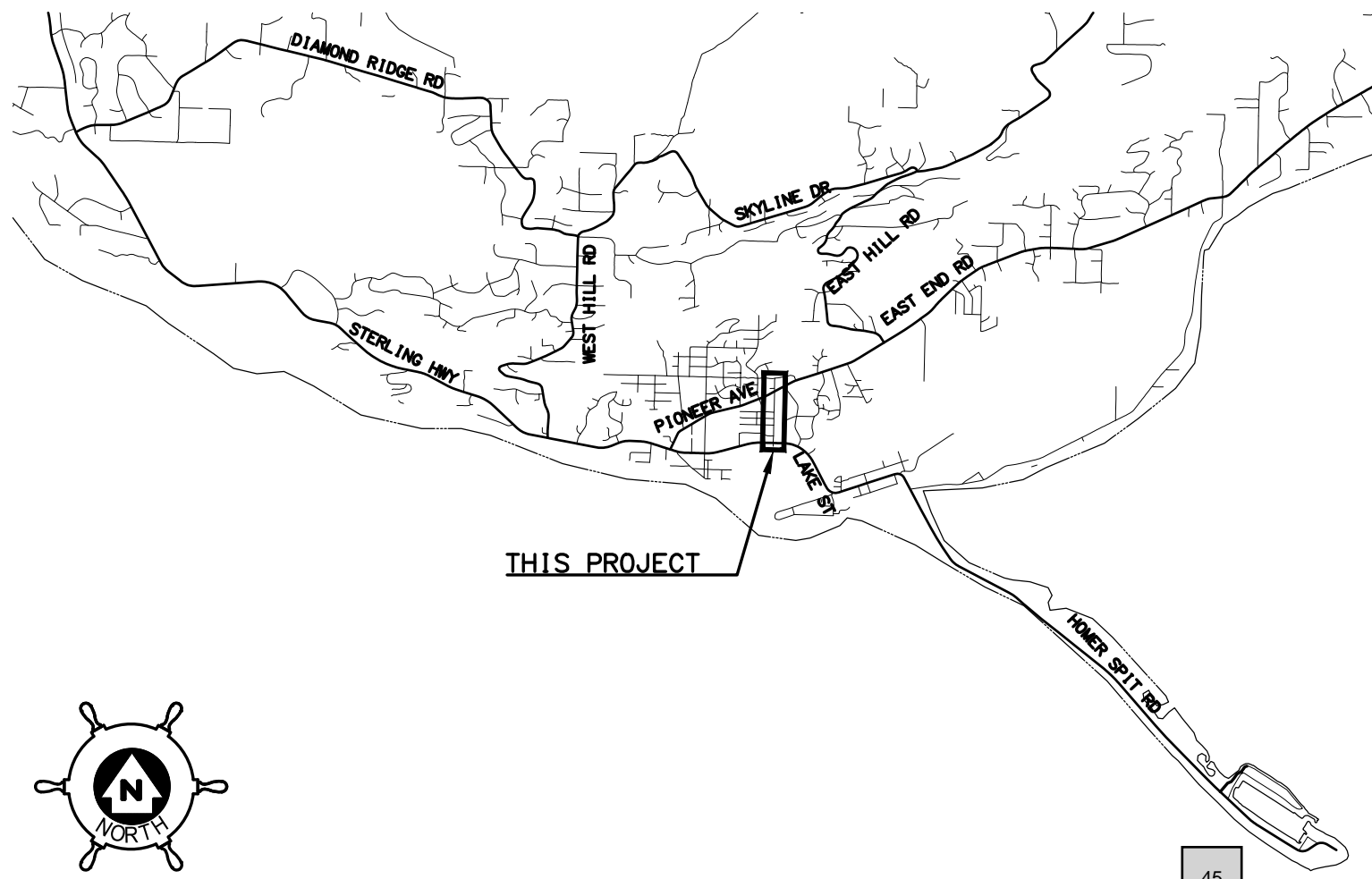

CITY OF HOMER, ALASKA
 PUBLIC WORKS DEPARTMENT
 3575 HEATH STREET
 HOMER, ALASKA 99603
 PHONE: (907) 235-3170
 FAX: (907) 235-3145

PLANS DEVELOPED BY: KINNEY ENGINEERING, LLC 3909 Arctic Blvd, Suite 400 Anchorage, Alaska 99503 (907) 346-2373 CERT. OF AUTH. NO. AECL 1102	
--	--

PLANS PREPARED BY: KINNEY ENGINEERING, LLC 3909 ARCTIC BLVD., SUITE 400 ANCHORAGE, AK 99503 : COA# AECL 1102 : PROJECT LOCATION: HOMER, AK
 DRAFTED BY: BILL PADDOCK
 SCALE: A2
 LAYOUT: A2
 DATE: 7/26/2023 3:28 PM
 FILE: Z:\PROJECTS\00710-city of homer term contract 2022\22-04 health street\DWG\00710_22-04_A2_LEGEND.dwg

UTILITIES

PIPELINES:

STORM DRAIN STRUCTURE AND PIPE NUMBERS, APPLICABLE IF SHOWN

STORM DRAIN

MANHOLE STORM DRAIN

CURB INLET CATCH BASIN

FIELD INLET CATCH BASIN

END CAP

PIPE CULVERT w/ END SECTION

SANITARY SEWER

SANITARY SEWER MANHOLE, CLEAN OUT

SEPTIC VENTS

SEWER SERVICE CONNECTION

WATER

FIRE HYDRANT

VALVE OR RISER

(OVERHEAD)
(UNDERGROUND)

ELECTRIC

UTILITY POLE

UTILITY POLE WITH LUMINAIRE

GUY WIRE

ELECTRICAL PEDESTAL, TRANSFORMER

TELEPHONE (UNDERGROUND)

TELEPHONE MANHOLE, PEDESTAL

NATURAL GAS

CABLE TV (UNDERGROUND)

FIBER OPTIC (UNDERGROUND)

FIBER OPTIC MANHOLE

EXISTING PROPOSED

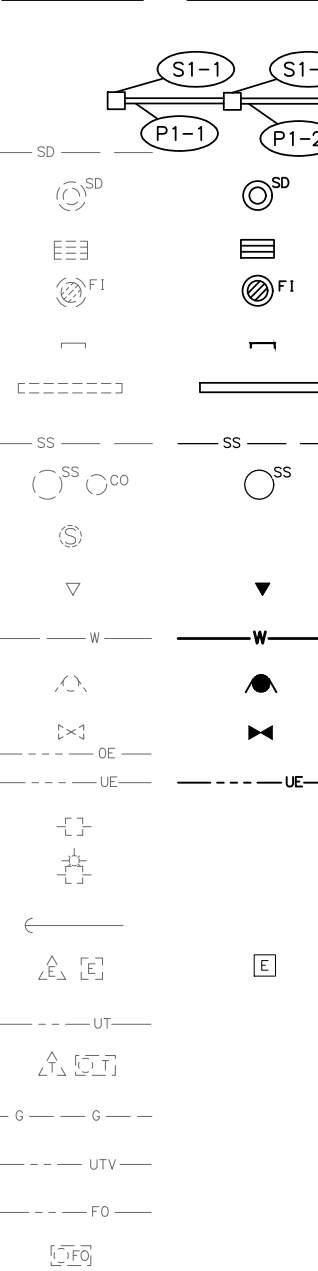

ABBREVIATIONS

- AC - ASPHALT CEMENT
- ASTM - AMERICAN SOCIETY FOR TESTING AND MATERIALS
- AWWA - AMERICAN WATER WORKS ASSOCIATION
- BF - BOARD FOOT
- B.O.P. - BOTTOM OF PIPE
- CB - CATCH BASIN AND CONSTRUCT CATCH BASIN
- CMP - CORRUGATED METAL PIPE
- C.O.H. - CITY OF HOMER
- CY - CUBIC YARD
- D.I.P. - DUCTILE IRON PIPE
- DOT - DEPARTMENT OF TRANSPORTATION
- E - EASTING
- EA - EACH
- ELEV - ELEVATION
- F&I - FURNISH AND INSTALL
- FT - FOOT OR FEET
- GRSC - GALVANIZED RIGID STEEL CONDUIT
- GB - GRADE BREAK
- GV - GATE VALVE
- H - HORIZONTAL

UTILITIES

ELECTROLIER

ILLUMINATION

TYPE IA JUNCTION BOX

TYPE II JUNCTION BOX

LOAD CENTER

RIGHT-OF-WAY

PROPERTY LINE

EASEMENT

TEMPORARY CONSTRUCTION EASEMENT/PERMIT

PROJECT CENTERLINE

EXISTING CENTERLINE

WETLANDS

CONTOURS - MAJOR

CONTOURS - MINOR

TREE (CONIFER/DECIDUOUS)
TREELINE (EDGE OF VEGETATION)

BOULDER OR BOULDERS

DRAINAGE FLOW

TRAFFIC SIGN

POST, BOLLARD

BUILDING

LANDSCAPE/GARDEN

CONTROL POINT

MAIL BOX

TEST HOLE

EXISTING PROPOSED

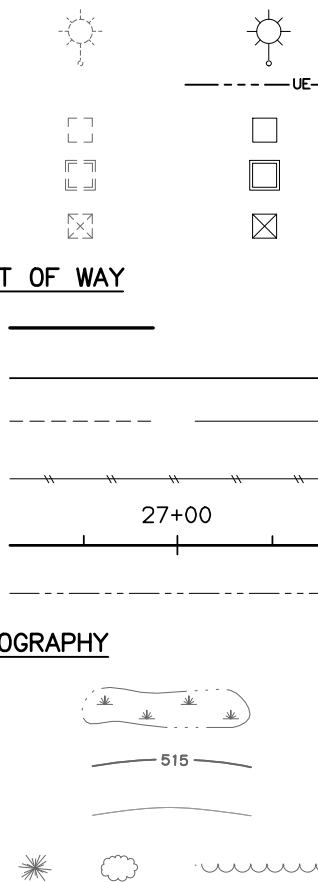

RIGHT OF WAY

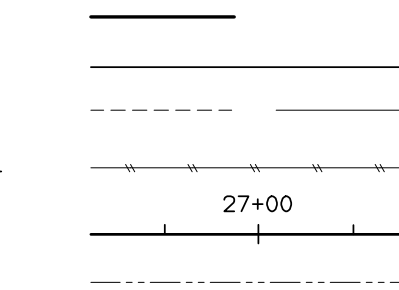

TOPOGRAPHY

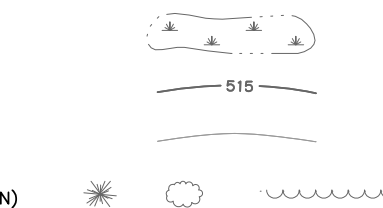

EXISTING PROPOSED



MISCELLANEOUS

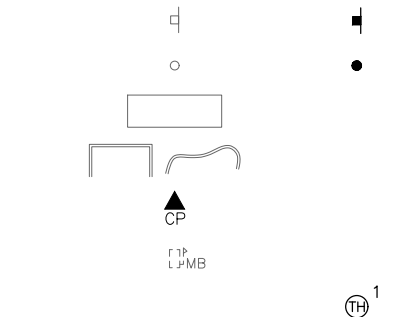

ROADWAY

EXISTING PROPOSED

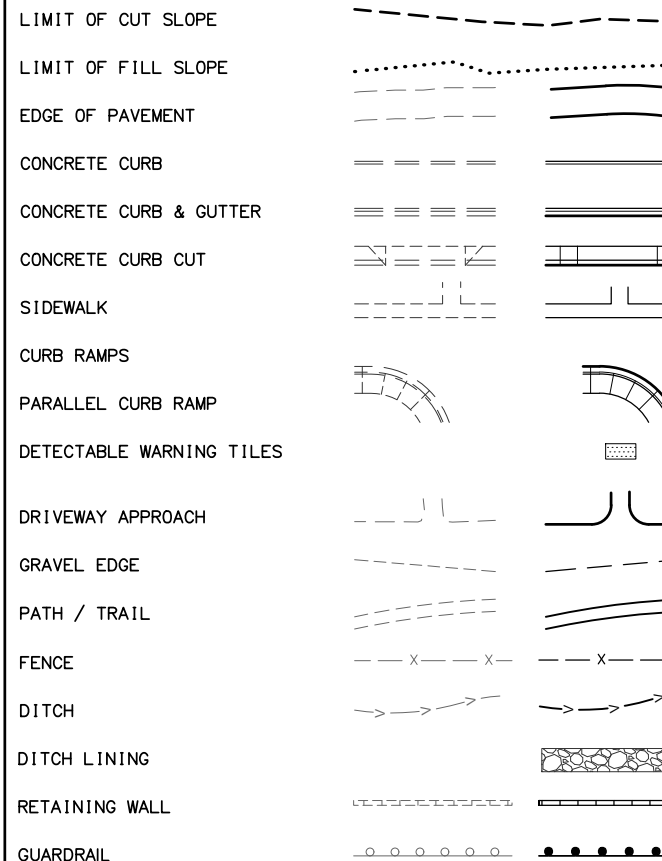

LEGEND - SOIL

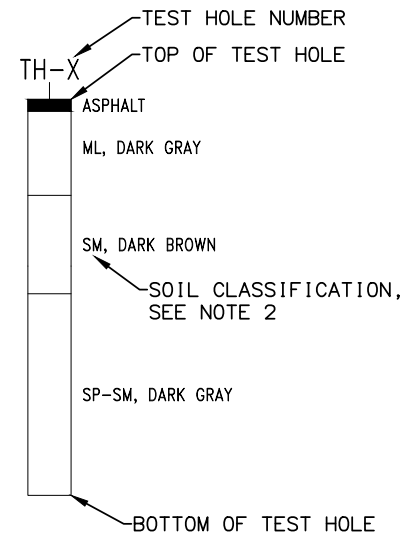

NOTES:

1. STANDARD LEGEND AND ABBREVIATIONS SHOWN. NOT ALL LEGEND ITEMS ARE PART OF THIS CONTRACT.
2. SOIL CLASSIFICATION IS BASED UPON UNIFIED SOIL CLASSIFICATION (ASTM D 2487-00), SEE GEOTECHNICAL REPORT FOR MORE INFORMATION.

SHEET NO. TOTAL SHEETS

A2 A4

ADDENDUM NO.

ATTACHMENT NO.

REVISIONS

NO.	DATE	DESCRIPTION

PLANS DEVELOPED BY:
KINNEY ENGINEERING, LLC
FOR
CITY OF HOMER, ALASKA
PUBLIC WORKS DEPARTMENT

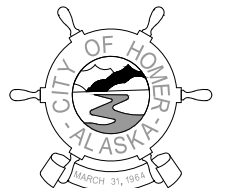

PHONE: (907) 235-3170
FAX: (907) 235-3145



CITY OF HOMER
PAVEMENT RESTORATION
HEATH STREET

LEGEND

PLANS PREPARED BY: KINNEY ENGINEERING, LLC 3909 ARCTIC BLVD., SUITE 400 ANCHORAGE, AK 99503 : COA# AECL 1102 : PROJECT LOCATION: HOMER, AK
 DRAFTING LOCATION
 Z:\PROJECTS\00710.ctb of homer. Term contract 2022\22-04 heath street\DWGS\C\Sheets\00710_22-04_A3_LAYOUT AND NOTES.dwg 8/30/2023 11:25 AM
 DRAWING LOCATION
 Z:\PROJECTS\00710.ctb of homer. Term contract 2022\22-04 heath street\DWGS\C\Sheets\00710_22-04_A3_LAYOUT AND NOTES.dwg 8/30/2023 11:25 AM
 DRAFTED BY: BILL PADDOCK
 SCALE
 LAYOUT A3

GENERAL NOTES:

- CONTRACTOR SHALL COMPLETE CONSTRUCTION IN ACCORDANCE WITH THE CITY OF HOMER STANDARD SPECIFICATIONS LATEST EDITION INCLUDING ITEMS, DRAWINGS, AND TECHNICAL SPECIFICATIONS. TECHNICAL SPECIFICATIONS TAKE PRECEDENCE OVER THE STANDARD SPECIFICATIONS.
- THE CITY SHALL OBTAIN ALL NECESSARY LOCAL, STATE AND FEDERAL PERMITS PRIOR TO BEGINNING CONSTRUCTION. THE PERMITS SHALL BE MAINTAINED AT THE JOB SITE.
- CONTRACTOR SHALL MAINTAIN "REDLINE" RECORD DRAWINGS ON A CLEAN SET OF CONSTRUCTION DRAWINGS. THE CONTRACTOR SHALL MAINTAIN THE "REDLINES" CURRENT ON A DAILY BASIS WHICH SHALL BE AVAILABLE TO THE ENGINEER FOR INSPECTION ON THE JOB SITE. CONTRACTOR SHALL RECORD SURVEY NOTES AND SUBMIT DAILY TO THE ENGINEER. CONTRACTOR SHALL RECORD SURVEY NOTES FOR SUBMITTAL WITH RECORD DRAWINGS, INCLUDING HORIZONTAL AND VERTICAL LOCATIONS OF ALL UTILITIES ENCOUNTERED IN THE FIELD. CONTRACTOR SHALL RECORD ALL DEVIATIONS FROM THE PLANS.
- CONSTRUCTION OPERATIONS REQUIRED FOR THIS PROJECT SHALL REMAIN WITHIN EXISTING CITY OF HOMER AND STATE OF ALASKA RIGHTS-OF-WAY AND EASEMENTS, UNLESS OTHERWISE APPROVED IN WRITING BY THE ENGINEER AND THE AFFECTED PROPERTY OWNER.
- LOCATIONS DEPICTED FOR THE UTILITIES AND OTHER EXISTING FEATURES ARE APPROXIMATE. SOME UTILITIES HAVE BEEN LOCATED FROM RECORD DRAWINGS AND UTILITY COMPANY LOCATES. CONTRACTOR SHALL LOCATE AND VERIFY ALL UTILITIES PRIOR TO CONSTRUCTION.
- UNDERGROUND ELECTRICAL AND TELECOMMUNICATION, WATER SEWER, AND NATURAL GAS, LINES OCCUR WITHIN THE PROJECT AREA; CONTRACTOR SHALL COORDINATE WORK ACCORDINGLY. ALL WORK IN CLOSE PROXIMITY TO EXISTING UNDER-GROUND LINES SHALL COMPLY WITH APPLICABLE FEDERAL, STATE, AND LOCAL STATUTES, CODES AND GUIDELINES, AND THE ELECTRICAL FACILITY CLEARANCE REQUIREMENTS OF THE GOVERNING UTILITY. CONTRACTOR SHALL HAND DIG WITHIN TWO FEET OF BURIED ELECTRICAL CABLE.
- CONTRACTOR SHALL SAWCUT EXISTING PAVEMENT (ROADS, PARKING AREAS, DRIVEWAYS, ETC.) TO A LINE 2 FEET BEYOND THE PROPOSED IMPROVEMENTS, DURING THE INITIAL EXCAVATION OPERATIONS. IF EXISTING PAVEMENT HAS BEEN LIFTED, IF EDGE DOES NOT OCCUR IN UNDISTURBED MATERIAL, OR IF EDGE IS LOCATED WITHIN A TRAVEL LANE, FURTHER REMOVAL MAY BE REQUIRED, AS DIRECTED BY THE ENGINEER, TO PROVIDE A PROPER TRANSITION BETWEEN NEW AND EXISTING PAVEMENT. SAW CUTTING OF EXISTING PAVEMENT IS INCIDENTAL TO THE BID ITEM "REMOVE PAVEMENT", AND NO SEPARATE PAYMENT SHALL BE MADE. SAWCUTS WITHIN THE ROADWAY SHALL BE SKEWED AT AN ANGLE OF 15 TO 25 DEGREES WHERE MATCHING EXISTING ASPHALT, OR AS SHOWN ON THE PLANS.
- CONTRACTOR SHALL APPLY TACK COAT TO THE SAW CUT ASPHALT FACE PRIOR TO PAVING. CONTRACTOR SHALL SAWCUT CURB & GUTTER AND SIDEWALK AT THE NEAREST JOINT & OR BEYOND REMOVAL LIMITS OR AS DIRECTED BY THE ENGINEER. TACK COAT IS INCIDENTAL TO THE RESPECTIVE BID ITEM.
- CONTRACTOR SHALL MAINTAIN STOP SIGNS AND STREET NAME SIGNS OPERATIONAL IN THE PROJECT AREA DURING CONSTRUCTION.
- LIMITS OF EXCAVATION AND BACKFILL SHALL BE AS SHOWN ON THE PLANS OR AS DIRECTED BY THE ENGINEER.
- CONTRACTOR SHALL REMOVE ORGANIC MATERIAL FROM THE SUBGRADE TO A DEPTH TO BE DETERMINED BY THE ENGINEER. CONTRACTOR SHALL NOT PLACE OR SHALL NOT OTHERWISE UTILIZE ORGANIC MATERIAL OR OTHER DELETERIOUS MATERIAL FOR BACKFILL, UNLESS OTHERWISE DIRECTED BY THE ENGINEER.
- WORK AND MATERIALS REQUIRED FOR REMOVING LITTER OR DEBRIS THAT EXIST WITHIN THE PROJECT LIMITS ARE INCIDENTAL TO THE PROJECT AND NO SEPARATE PAYMENT SHALL BE MADE.
- CONTRACTOR SHALL REPLACE ALL DISTURBED PROPERTY CORNERS. PAYMENT FOR REPLACING DISTURBED PROPERTY CORNERS IS INCIDENTAL TO THE CONTRACT AND NO SEPARATE PAYMENT SHALL BE MADE.
- CONTRACTOR SHALL TOPSOIL AND SEED ALL DISTURBED AREAS WHERE OTHER SURFACE IS NOT SPECIFIED.
- CONTRACTOR SHALL RESTORE DISTURBED PROPERTY TO PRECONSTRUCTION CONDITION(S), UNLESS OTHERWISE DIRECTED BY THE ENGINEER. PAYMENT FOR RESTORING DISTURBED PROPERTY IS INCIDENTAL TO THE CONTRACT AND NO SEPARATE PAYMENT SHALL BE MADE.
- DEWATERING MAY BE REQUIRED TO REMOVE SURFACE AND SUBSURFACE WATER FROM THE ROADWAY AND AND UTILITY EXCAVATION AND DEWATERING IS INCIDENTAL TO THE CONTRACT AND NO SEPARATE PAYMENT SHALL BE MADE.

STANDARD DRAWING INDEX

THE FOLLOWING STANDARD DRAWINGS APPLY TO THIS PROJECT:

- CITY OF HOMER
- 200.06 COMPACTION OF BACKFILL
 - 300.01 CURB AND GUTTER CROSS SECTIONS
 - 500.03 SANITARY SEWER MANHOLE HEIGHTS
 - 500.10 SANITARY SEWER MANHOLE RING ADJUSTMENT
 - 600.10 GATE VALVE EXTENSION ROD
 - 700.09 SIGN PLACEMENT CURB WITHOUT SIDEWALK
 - 800.05 STORM DRAIN MANHOLE RING ADJUSTMENT
 - 800.10 STORM DRAIN MANHOLE HEIGHTS
 - 800.11 STORM DRAIN PRECAST CATCH BASIN FOR TYPE 1 CURB + GUTTER

- STATE OF ALASKA
- CR-T-01.10 UNSIGNALIZED INTERSECTION STOP AND CROSSING

PROJECT SURVEY INFORMATION:

SEE SURVEY CONTROL SHEET A4.

CALL BEFORE YOU DIG!

CONTRACTOR SHALL CALL A MINIMUM OF 3 DAYS IN ADVANCE OF CONSTRUCTION

ALASKA DIGLINE... 907-278-3121 OR 800-478-3121

CALL OR GO TO WWW.AKONECALL.COM/STATEWIDE.HTM FOR MEMBER LIST OF WHO WILL BE NOTIFIED

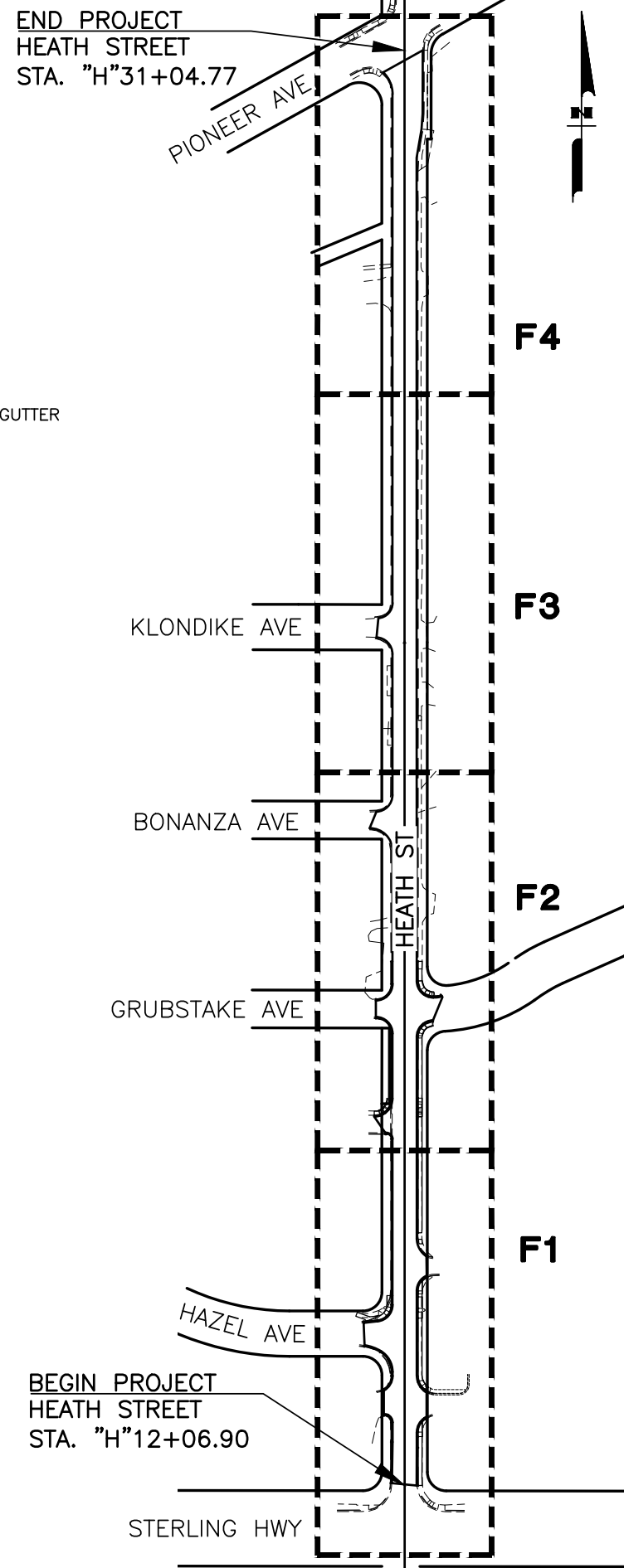

SHEET LAYOUT

SHEET NO.	TOTAL SHEETS	
A3	A4	
ADDENDUM NO.		
ATTACHMENT NO.		
REVISIONS		
NO.	DATE	DESCRIPTION

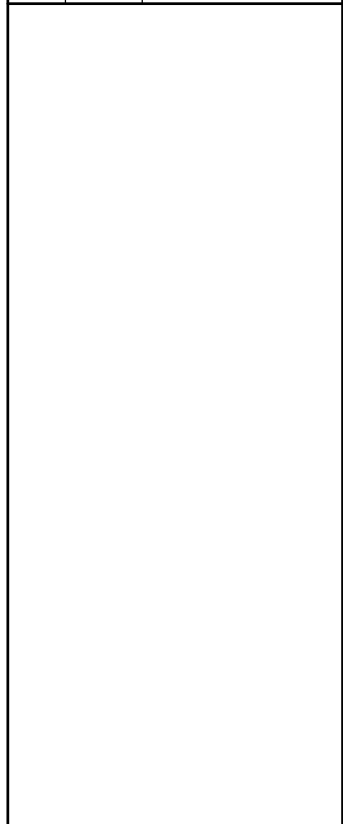

PLANS DEVELOPED BY:
 KINNEY ENGINEERING, LLC
 FOR
 CITY OF HOMER, ALASKA
 PUBLIC WORKS DEPARTMENT



CITY OF HOMER
 PAVEMENT RESTORATION
 HEATH STREET

SHEET LAYOUT AND
 GENERAL NOTES

PLANS PREPARED BY: KINNEY ENGINEERING, LLC 3909 ARCTIC BLVD. SUITE 400 ANCHORAGE, AK 99503 : COA# AECL 1102 : PROJECT LOCATION: HOMER, AK
 DRAWING LOCATION
 Z:\PROJECTS\00710.city of homer. term contract 2022\22-04.heath street\DWG\C\Sheets\00710_22-04_A4_Survey Control.dwg 5/4/2023 12:29 PM
 DRAFTED BY: BILL PADDOCK SCALE LAYOUT A4

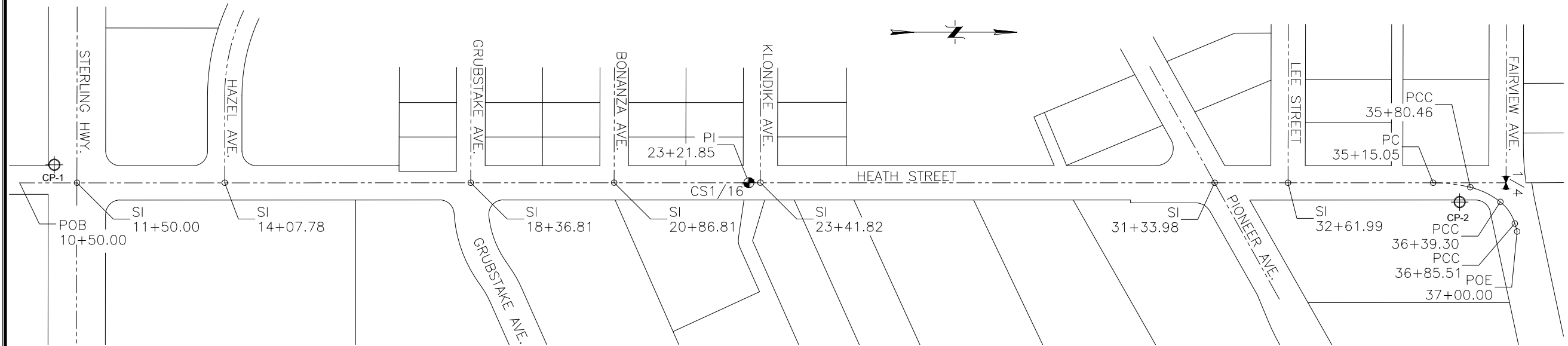

SURVEYOR'S CERTIFICATE

I HEREBY CERTIFY THAT I AM PROPERLY REGISTERED AND LICENSED TO PRACTICE LAND SURVEYING IN THE STATE OF ALASKA, THAT THIS PLAT REPRESENTS A SURVEY MADE BY ME OR UNDER MY DIRECT SUPERVISION, THAT THE MONUMENTS SHOWN HEREON ACTUALLY EXIST AS DESCRIBED, AND THAT ALL DIMENSIONS AND OTHER DETAILS ARE CORRECT TO THE BEST OF MY KNOWLEDGE.



DATE 11/8/2022 REGISTRATION NO. 7538-S

Stephen C. Smith
 REGISTERED LAND SURVEYOR

SURVEY CONTROL				
CONTROL POINT	NORTHING	EASTING	ELEVATION	DESCRIPTION
CP-1	101,318.3028	92,860.3461	37.88	PK NAIL IN SIDEWALK
CP-2	103,768.9137	92,925.4538	169.04	PK NAIL IN PAVEMENT

HEATH STREET ALIGNMENT DATA			
STATION	NORTHING	EASTING	RADIUS
POB 10+50.00	101,257.6974	92,891.8804	
SI 11+50.00	101,357.6974	92,891.8644	
SI 14+07.78	101,615.4774	92,891.8230	
SI 18+36.81	102,044.5024	92,891.7542	
SI 20+86.81	102,294.5089	92,891.7141	
PI 23+21.85	102,529.5472	92,891.6764	
SI 23+41.82	102,549.5151	92,891.6782	
SI 31+33.98	103,341.6792	92,891.7509	
SI 32+61.99	103,469.6878	92,891.7626	
PC 35+15.05	103,722.7434	92,891.7858	275.00'
PCC 35+80.46	103,787.5380	92,899.5343	136.00'
PCC 36+39.30	103,839.9993	92,925.1530	74.26'
PT 36+85.51	103,865.2605	92,962.9573	
POE 37+00.00	103,869.2373	92,976.8950	

SURVEY CONTROL

BASIS OF BEARING

1. BASIS OF BEARING FOR THIS SURVEY WAS DETERMINED BY A HIGH PRECISION GPS SURVEY USING TOPCON DUAL-FREQUENCY HiPer V RECEIVERS, DIFFERENTIALLY CORRECTED AND PROCESSED WITH MAGNET OFFICE VERSION 3.1 SOFTWARE. NAD83 ALASKA STATE PLANE GRID COORDINATES (U.S. SURVEY FEET) OBTAINED FROM THE GPS OBSERVATIONS WERE BASED ON THE NGS PUBLISHED VALUES FOR FEDERAL BASE NETWORK CONTROL STATION "HOMAIR" (PID TT0155).

2. TRUE BEARINGS AND DISTANCES WERE DETERMINED BY ROTATING AND SCALING FROM GRID USING FEDERAL BASE NETWORK CONTROL STATION "HOMAIR" AS A SCALING POINT. TRUE BEARINGS WERE DETERMINED BY ROTATING GRID INVERSE AZIMUTHS -1°17'13.4". TRUE DISTANCES WERE OBTAINED BY DIVIDING GRID INVERSE DISTANCES BY 0.999986696.

3. THE RESULTING SCALED COORDINATES WERE TRANSLATED TO A LOCAL COORDINATE SYSTEM BASED ON FEDERAL BASE NETWORK CONTROL STATION "HOMAIR" N=100,000 E=100,000. ALL COORDINATE VALUES REPRESENT GROUND DISTANCES IN U.S. SURVEY FEET ORIENTED TO TRUE NORTH.

BASIS OF VERTICAL DATUM

BASIS OF VERTICAL DATUM FOR THIS SURVEY IS THE NAVD88 NGS PUBLISHED VALUE FOR FEDERAL BASE NETWORK CONTROL STATION "HOMAIR" (PID TT0155). ORTHOMETRIC HEIGHTS (ELEVATIONS) WERE DETERMINED FROM ELLIPSOID HEIGHTS USING GEOID12B. ELEVATIONS ARE IN U.S. SURVEY FEET.

SHEET NO.	TOTAL SHEETS	
A4	A4	
ADDENDUM NO.		
ATTACHMENT NO.		
REVISIONS		
NO.	DATE	DESCRIPTION

PLANS DEVELOPED BY:
 KINNEY ENGINEERING, LLC
 FOR
 CITY OF HOMER, ALASKA
 PUBLIC WORKS DEPARTMENT



PHONE: (907) 235-3170
 FAX: (907) 235-3145

CITY OF HOMER
 PAVEMENT RESTORATION
 HEATH STREET

SURVEY CONTROL

PLANS PREPARED BY: KINNEY ENGINEERING, LLC 3909 ARCTIC BLVD. SUITE 400 ANCHORAGE, AK 99503 : COA# AECL 1102 : PROJECT LOCATION: HOMER, AK
 DRAFTED BY: BILL PADDOCK
 DRAWING LOCATION: SCALE
 Z:\PROJECTS\00710.city of homer. term contract 2022\22-04 heath street\DWGS\C\Sheets\00710_22-04_B1_TYP_SEC.dwg 7/26/2023 1:52 PM LAYOUT B1

NOTES:

1. FOR EMBANKMENT FILL, PROVIDE TYPE III FILL AND BACKFILL COMPACTED TO 95% OF MAXIMUM DENSITY.
2. IF UNSUITABLE SOILS ARE ENCOUNTERED AT THE BOTTOM OF EXCAVATION, INCREASE DEPTH AS DIRECTED BY THE ENGINEER.
3. ALL REMOVED PAVEMENT SHALL BECOME PROPERTY OF THE CONTRACTOR FOR STOCKPILE OR DISPOSAL.
4. CLEAR AND GRUB CUT/FILL LOCATIONS. APPLY 4 INCHES TOPSOIL AND SEED TO ALL DISTURBED AREAS OR AS DIRECTED BY THE ENGINEER.
5. EXCAVATION AND BACKFILL OF ROADWAY SECTION SHALL END AT THE LIP OF CURB EXTENDED. CURB RETURN ACROSS DRIVEWAYS AND APPROACHES SHALL ONLY RECEIVE EXCAVATION AND PLACEMENT OF 2" LEVELING COURSE AND 2" ASPHALT PAVEMENT.

* CUT OR FILL BACKSLOPE AT A 2:1 SLOPE UNLESS CATCH POINT IS OUTSIDE THE ROW. IF CATCH POINT IS OUTSIDE THE ROW CUT OR FILL BACKSLOPE TO THE ROW.

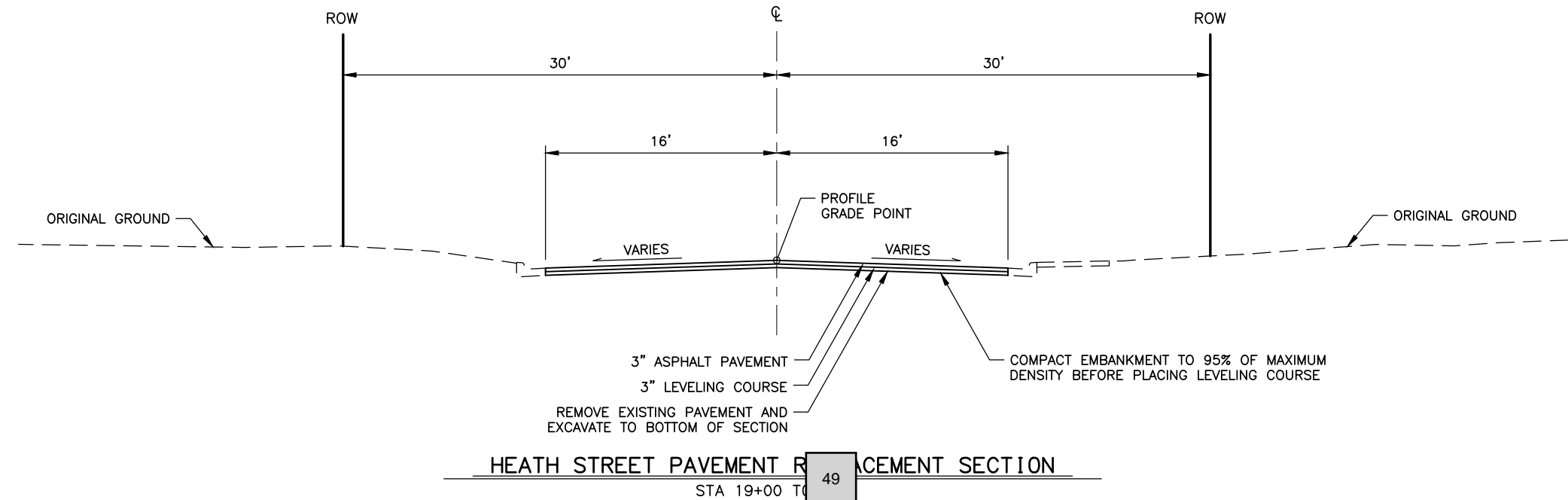
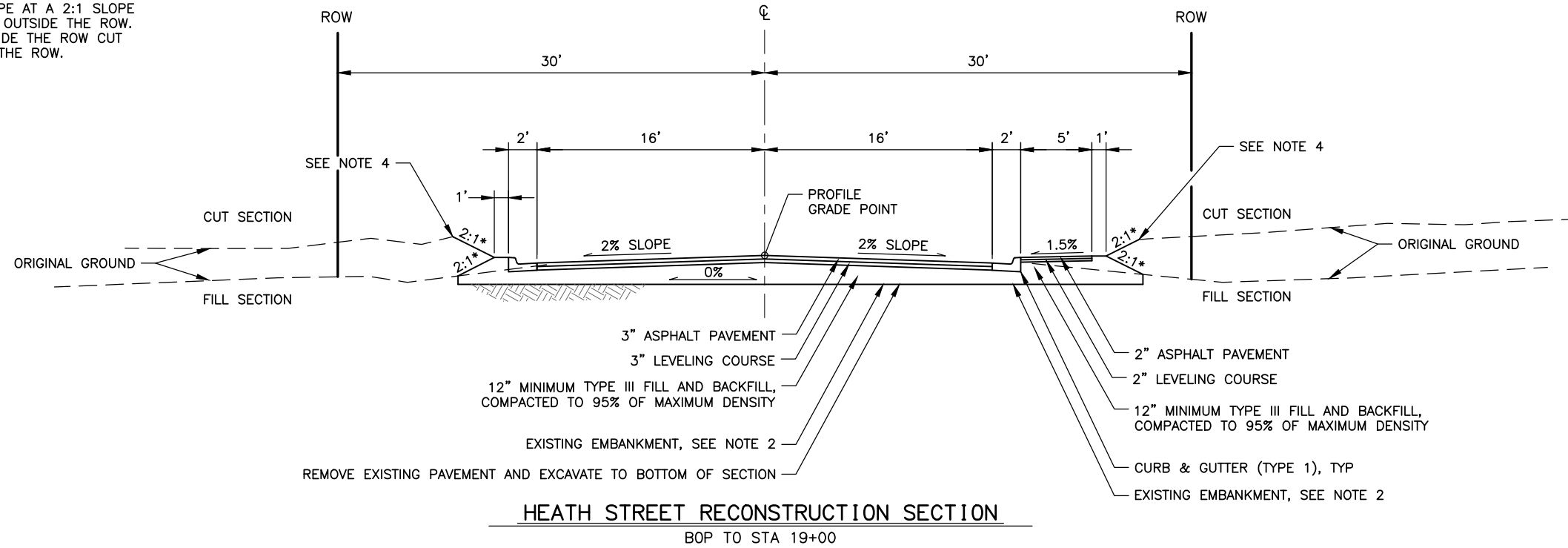

SHEET NO.		TOTAL SHEETS
B1		B1
ADDENDUM NO.		
ATTACHMENT NO.		
REVISIONS		
NO.	DATE	DESCRIPTION

PLANS DEVELOPED BY:
 KINNEY ENGINEERING, LLC
 FOR
 CITY OF HOMER, ALASKA
 PUBLIC WORKS DEPARTMENT



CITY OF HOMER
 PAVEMENT RESTORATION
 HEATH STREET
 TYPICAL SECTIONS

PLANS PREPARED BY: KINNEY ENGINEERING, LLC 3909 ARCTIC BLVD. SUITE 400 ANCHORAGE, AK 99503 : COA# AECL 1102 : PROJECT LOCATION: HOMER, AK
 DRAWING LOCATION
 Z:\PROJECTS\00710.ctb of homer. term contract 2022\22-04 health street\DWGS\C\Sheets\00710_22-04_C1_E00.dwg 9/1/2023 7:55 AM
 DRAFTED BY: BILL PADDOCK
 SCALE
 LAYOUT C1

ESTIMATE OF QUANTITIES				
ITEM NO.	SPEC. NO.	WORK DESCRIPTION	UNIT	ESTIMATED QUANTITY
A-1	101	MOBILIZATION AND DEMOBILIZATION	LS	1
A-2	102	CONSTRUCTION SURVEYING	LS	1
A-3	103	TRAFFIC MAINTENANCE	LS	1
A-4	202	CLEARING AND GRUBBING	LS	1
A-5	203	REMOVAL OF OBSTRUCTIONS	LS	1
A-6	204	EXCAVATION	CY	2,836
A-7	205	TYPE III FILL AND BACKFILL	TON	4,232
A-8	206	LEVELING COURSE	TON	1,215
A-9	219	REMOVE EXISTING PAVEMENT	SY	7,933
A-10	221	RECONSTRUCT APPROACH	EA	5
A-11	221	RECONSTRUCT DRIVEWAY	EA	4
A-12	302	CURB AND GUTTER, ALL TYPES	LF	1,287
A-13	306	P.C.C. CURB RAMP	EA	9
A-14	306	DETECTABLE WARNINGS	EA	6
A-15	401	ASPHALT PAVEMENT	TON	1,275
A-16	402	PAINTED TRAFFIC MARKINGS	LS	1
A-17	512	ADJUST MANHOLE RING	EACH	14
A-18	604	FURNISH AND INSTALL FIRE HYDRANT ASSEMBLY (OWNER FURNISHED)	EA	2
A-19	607	ADJUST VALVE BOX TO FINISH GRADE	EA	12
A-20	707	FURNISH & INSTALL STANDARD SIGN	EA	12
A-21	707	REMOVE AND RELOCATE SIGNS	EA	5
A-22	708	SEEDING (TYPE I)	MSF	3
A-23	710	TOPSOIL (4" DEPTH)	MSF	3
A-24	808	ADJUST CATCH BASIN TO FINISH GRADE	EA	5
A-25	809	REMOVE AND REPLACE CATCH BASIN FRAME AND GRATE	EA	1
A-26	8002	TRENCH AND BACKFILL (2' X 3')	LF	190
A-27	8004	SIGNAL POLE FOUNDATION	EA	2
A-28	8005	SIGNAL POLE	EA	2
A-29	8007	GRC STEEL CONDUIT (2")	LF	195
A-30	8008	JUNCTION BOX (TYPE 1A)	EA	2
A-31	8010	3 CONDUCTOR, #8 AWG XHHW-2	LF	135
A-32	8010	2 CONDUCTOR, #14 AWG XHHW-2	LF	160
A-33	8010	1 CONDUCTOR, #8 AWG	LF	195
A-34	8017	RECTANGULAR RAPID FLASHING BEACON	EA	1
A-35	9001	STORM WATER POLLUTION PREVENTION PLAN, TYPE 3	LS	1

TABLE OF ESTIMATING FACTORS		
ITEM NO.	ITEM DESCRIPTION	ESTIMATING FACTOR
205	TYPE III FILL AND BACKFILL	144 LBS. / C.F.
206	LEVELING COURSE	144 LBS. / C.F.
401	ASPHALT PAVEMENT	151 LBS. / C.F.

SHEET NO.	TOTAL SHEETS	
C1	C1	
ADDENDUM NO.		
ATTACHMENT NO.		
REVISIONS		
NO.	DATE	DESCRIPTION

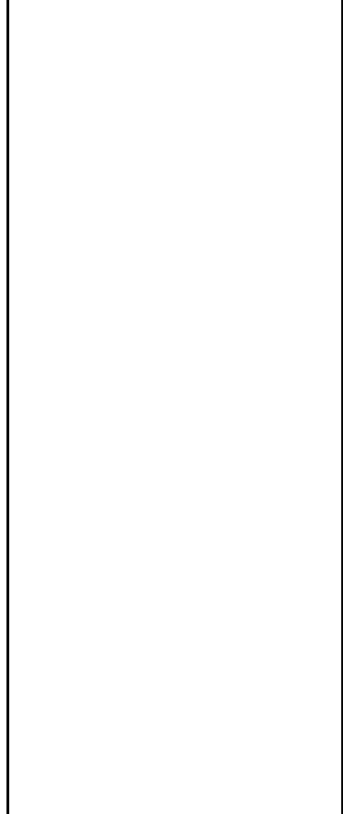

PLANS DEVELOPED BY:
 KINNEY ENGINEERING, LLC
 FOR
 CITY OF HOMER, ALASKA
 PUBLIC WORKS DEPARTMENT



CITY OF HOMER
 PAVEMENT RESTORATION
 HEATH STREET
 ESTIMATE OF QUANTITIES

PLANS PREPARED BY: KINNEY ENGINEERING, LLC 3909 ARCTIC BLVD. SUITE 400 ANCHORAGE, AK 99503 : COA# AECL 1102 : PROJECT LOCATION: HOMER, AK
 DRAFTING LOCATION SCALE LAYOUT E1
 DRAFTED BY: BILL PADDOCK
 6/14/2023 10:25 AM
 Z:\PROJECTS\00710.city of homer. term contract 2022\22-04 heath street\DWGS\C\Sheets\00710_22-04_E1-E4_DETAILS.dwg

SHEET NO.	TOTAL SHEETS	
E1	E4	
ADDENDUM NO.		
ATTACHMENT NO.		
REVISIONS		
NO.	DATE	DESCRIPTION

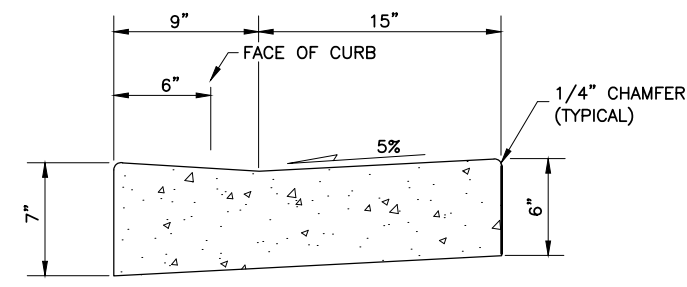

CURB RAMP CURB & GUTTER, TYPE 5

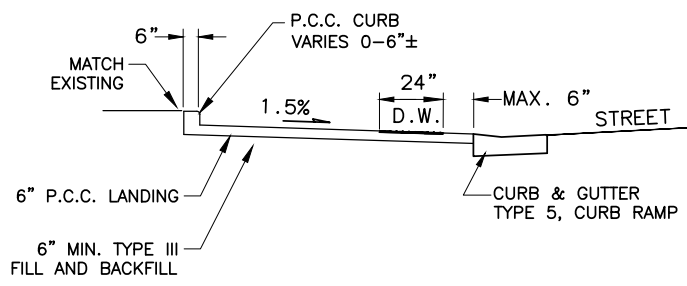
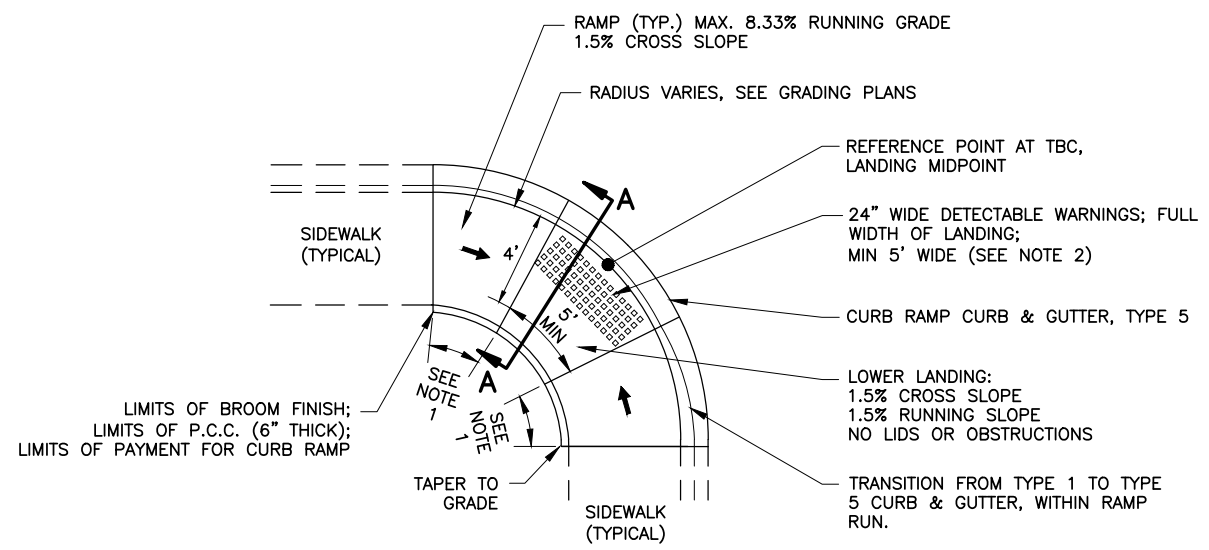

PARALLEL CURB RAMP

- NOTES:**
- RAMP LENGTHS SHALL NOT EXCEED 15' OR AS DIRECTED BY THE ENGINEER. SEE PLANS AND SUMMARY TABLES.
 - INSTALL DETECTABLE WARNINGS (D.W.) IN ACCORDANCE WITH MANUFACTURER'S RECOMMENDATIONS AND THESE DRAWINGS. SET DETECTABLE WARNINGS SO THAT THE FIELD AREA AT THE BASE OF THE DOMES IS FLUSH WITH THE SURROUNDING CONCRETE. NO LIP IS ALLOWED AT THE EDGE OF THE DETECTABLE WARNINGS.
 - CONSTRUCT RAMPS AND LANDINGS WITH A BROOM FINISH PERPENDICULAR TO CURB.

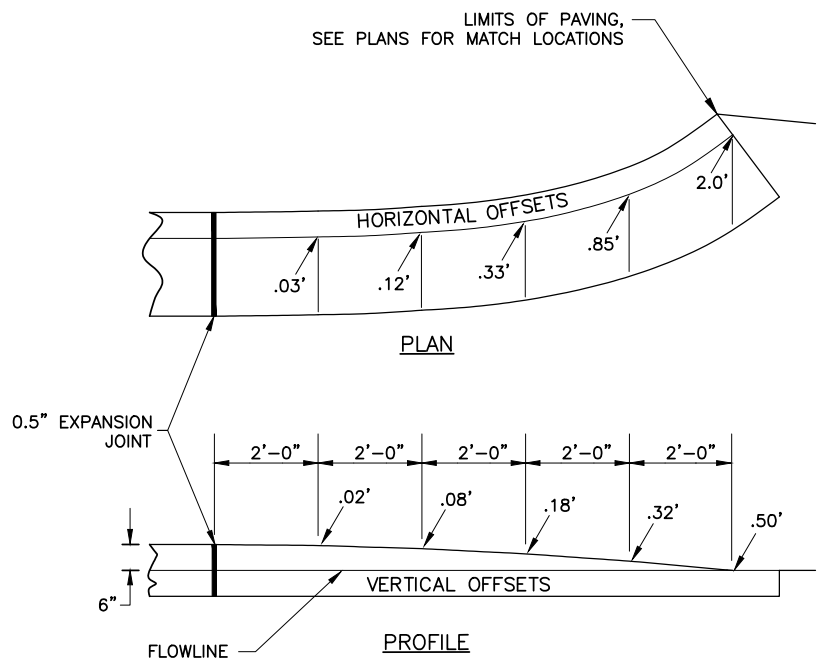

CURB AND GUTTER TERMINATION TRANSITION

PLANS DEVELOPED BY:
 KINNEY ENGINEERING, LLC
 FOR
 CITY OF HOMER, ALASKA
 PUBLIC WORKS DEPARTMENT

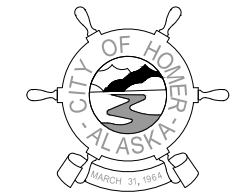

PHONE: (907) 235-3170
 FAX: (907) 235-3145



CITY OF HOMER
 PAVEMENT RESTORATION
 HEATH STREET

DETAILS

PLANS PREPARED BY: KINNEY ENGINEERING, LLC 3909 ARCTIC BLVD. SUITE 400 ANCHORAGE, AK 99503 : COA# AECL 1102 : PROJECT LOCATION: HOMER, AK
 DRAWING LOCATION
 Z:\PROJECTS\00710.city of homer. term contract 2022\22-04 heath street\DWGS\C\Sheets\00710_22-04_E1-E4_DETAILS.dwg 6/14/2023 10:25 AM
 DRAFTED BY: BILL PADDOCK
 SCALE
 LAYOUT E2

SHEET NO.	TOTAL SHEETS	
E2	E4	
ADDENDUM NO.		
ATTACHMENT NO.		
REVISIONS		
NO.	DATE	DESCRIPTION

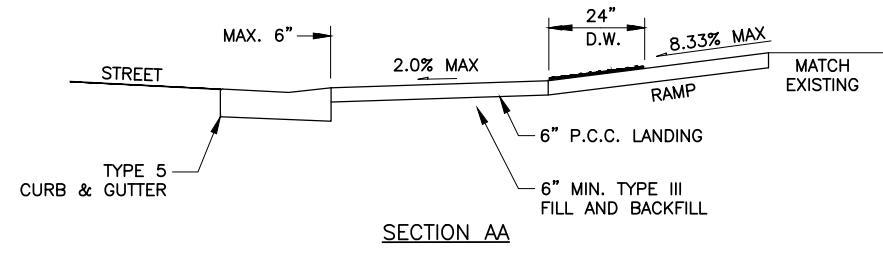
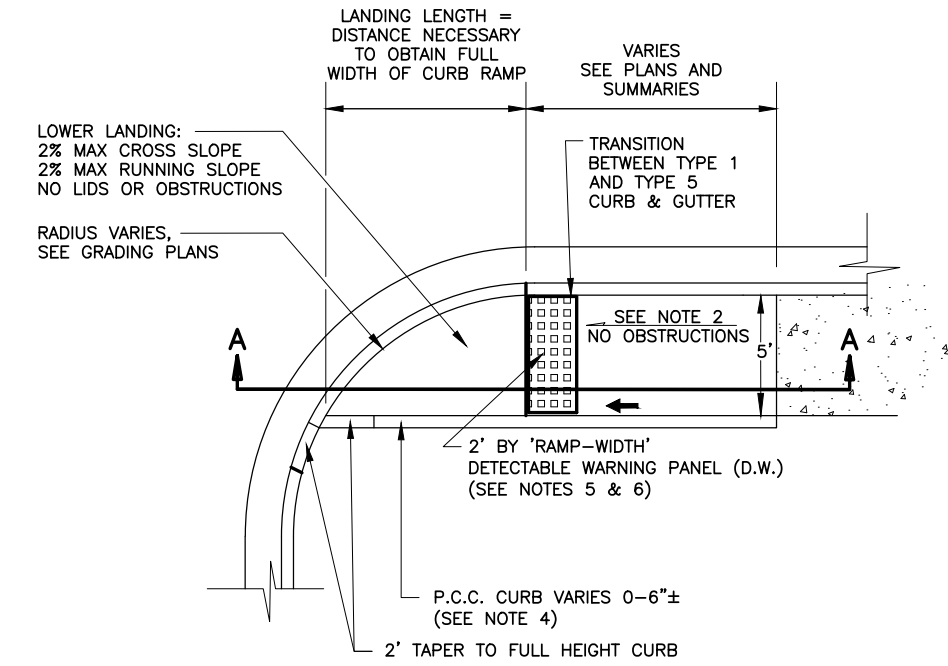

UNIDIRECTIONAL CURB RAMP

UNIDIRECTIONAL NOTES:

1. CONSTRUCT UNIDIRECTIONAL RAMPS AND LANDINGS WITH A BROOM FINISH PERPENDICULAR TO THE LONG DIRECTION OF THE RAMP.
2. CONTRACTOR SHALL CONSTRUCT THE RAMP PORTION OF THE CURB RAMP WITH A 1.5% MINIMUM AND 2% MAXIMUM CROSS SLOPE WITH NO MANHOLES, UTILITY JUNCTION BOXES, OR OTHER OBSTRUCTIONS. THE RUNNING SLOPE IS 8.33% MAXIMUM, BUT SHALL NOT REQUIRE THE RAMP LENGTH TO EXCEED 15 FEET.
3. CONTRACTOR SHALL CONSTRUCT LANDINGS WITH A MAXIMUM 2% RUNNING SLOPE AND MAXIMUM 2% CROSS SLOPE.
4. CONTRACTOR SHALL CONSTRUCT P.C.C. CURB BEHIND LANDING AND RAMPS WHERE SHOWN OR AS DIRECTED BY THE ENGINEER. P.C.C. CURB IS INCIDENTAL TO CURB RAMP AND NO ADDITIONAL PAYMENT WILL BE MADE.
5. DO NOT INSTALL DETECTABLE WARNINGS AT DRIVEWAYS.
6. CONTRACTOR SHALL INSTALL 24 INCH DETECTABLE WARNINGS I.A.W. MANUFACTURERS' RECOMMENDATIONS AND THE DRAWINGS. DETECTABLE WARNINGS SHALL BE INSTALLED IAW MANUFACTURERS RECOMMENDATIONS. D.W. SHALL EXTEND THE FULL WIDTH OF THE LANDING. INSTALL D.W. SO THAT THE FIELD AREA AT THE BASE OF THE DOMES IS FLUSH WITH THE SURROUNDING CONCRETE. ALLOW NO LIPS AT EDGE OF THE D.W. OR FLOW LINE. D.W. SHALL BE FEDERAL YELLOW, OR APPROVED EQUAL. WHERE POSSIBLE, FINISHED EDGES WILL BE PLACED ON THE OUTER BOUNDARIES OF THE D.W.

PLANS DEVELOPED BY:
 KINNEY ENGINEERING, LLC
 FOR
 CITY OF HOMER, ALASKA
 PUBLIC WORKS DEPARTMENT



PHONE: (907) 235-3170
 FAX: (907) 235-3145



CITY OF HOMER
 PAVEMENT RESTORATION
 HEATH STREET

DETAILS

PLANS PREPARED BY: KINNEY ENGINEERING, LLC 3909 ARCTIC BLVD. SUITE 400 ANCHORAGE, AK 99503 : COA# AECL 1102 : PROJECT LOCATION: HOMER, AK
 DRAWING LOCATION
 Z:\PROJECTS\00710.city of homer. term contract 2022\22-04 heath street\DWGS\C\Sheets\00710_22-04_E1-E4_DETAILS.dwg 6/14/2023 10:25 AM
 DRAFTED BY: BILL PADDOCK
 SCALE
 LAYOUT E4

SHEET NO.	TOTAL SHEETS	
E4	E4	
ADDENDUM NO.		
ATTACHMENT NO.		
REVISIONS		
NO.	DATE	DESCRIPTION

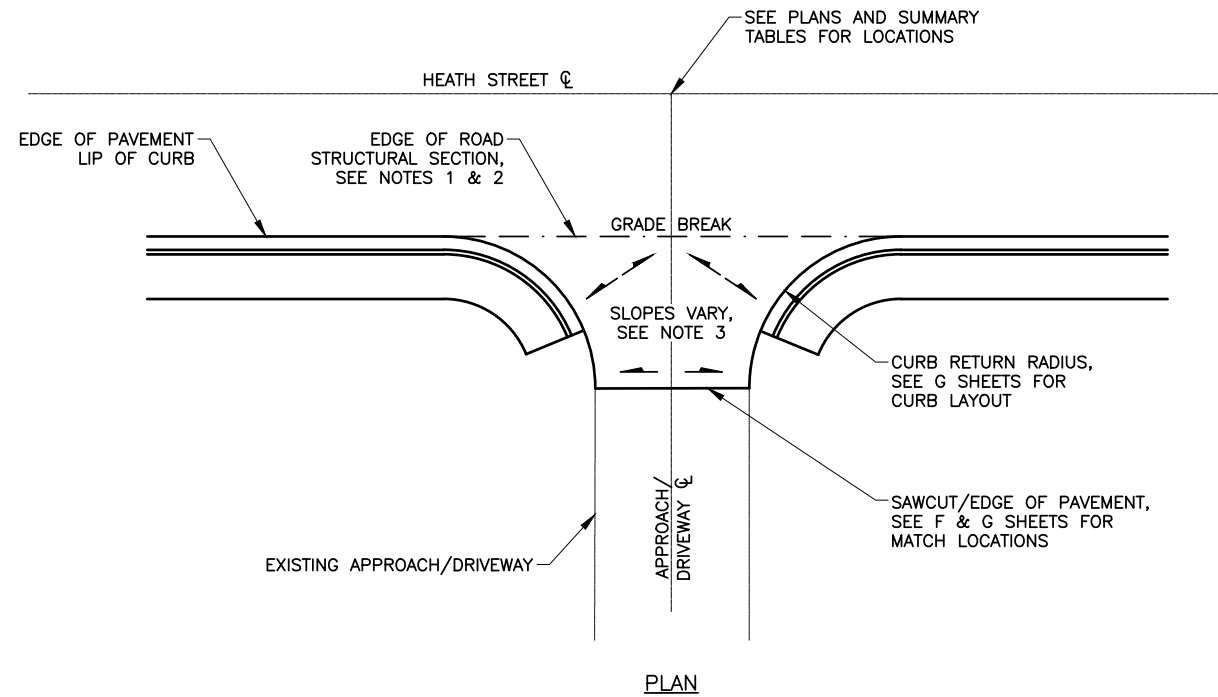

PLAN

APPROACH/DRIVEWAY DETAIL

NOTES:

1. MAINTAIN 2% CROWN ON HEATH STREET FOR 16 FOOT ROAD WIDTH PER TYPICAL SECTIONS AT APPROACH/DRIVEWAY INTERSECTIONS.
2. EXCAVATION AND BACKFILL OF ROADWAY SECTION SHALL END AT THE LIP OF CURB EXTENDED (GRADE BREAK). TRANSITION EXCAVATION/BACKFILL FROM UNDER THE SIDEWALKS ACROSS THE APPROACH/DRIVEWAY.
3. CONSISTENTLY WARP APPROACH/DRIVEWAY PAVEMENT AS NEEDED CONSTRUCT CURB LAYOUT AND EXISTING MATCH LOCATIONS AS SHOWN ON GRADING PLANS.

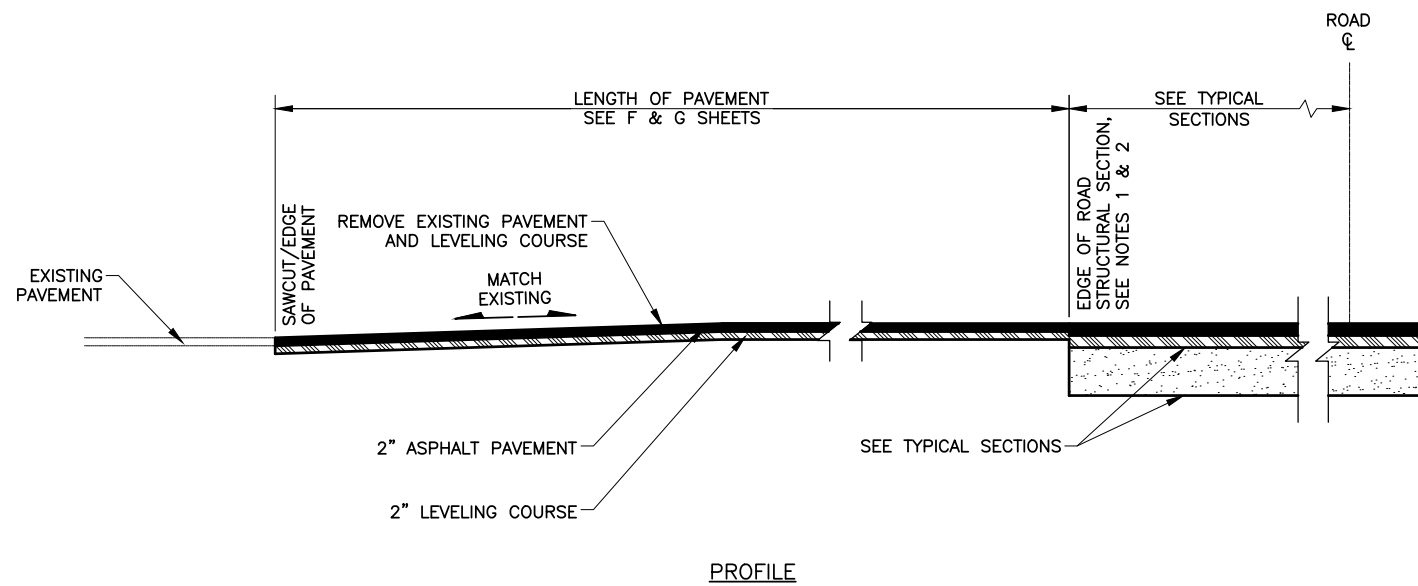

PROFILE

APPROACH/DRIVEWAY TRANSITION

PLANS DEVELOPED BY:
 KINNEY ENGINEERING, LLC
 FOR
 CITY OF HOMER, ALASKA
 PUBLIC WORKS DEPARTMENT

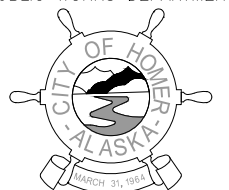

PHONE: (907) 235-3170
 FAX: (907) 235-3145

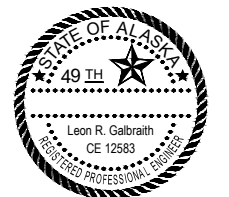

CITY OF HOMER
 PAVEMENT RESTORATION
 HEATH STREET

DETAILS

PLANS PREPARED BY: KINNEY ENGINEERING, LLC 3909 ARCTIC BLVD. SUITE 400 ANCHORAGE, AK 99503 : COA# AECL 1102 : PROJECT LOCATION: HOMER, AK
 DRAFTED BY: BILL PADDOCK
 SCALE: F1
 LAYOUT: F1
 DATE: 8/30/2023 12:07 PM
 FILE: Z:\PROJECTS\00710.city of homer. term contract 2022\22-04.heath street\DWG\00710_22-04_F1-F4_P&P.dwg

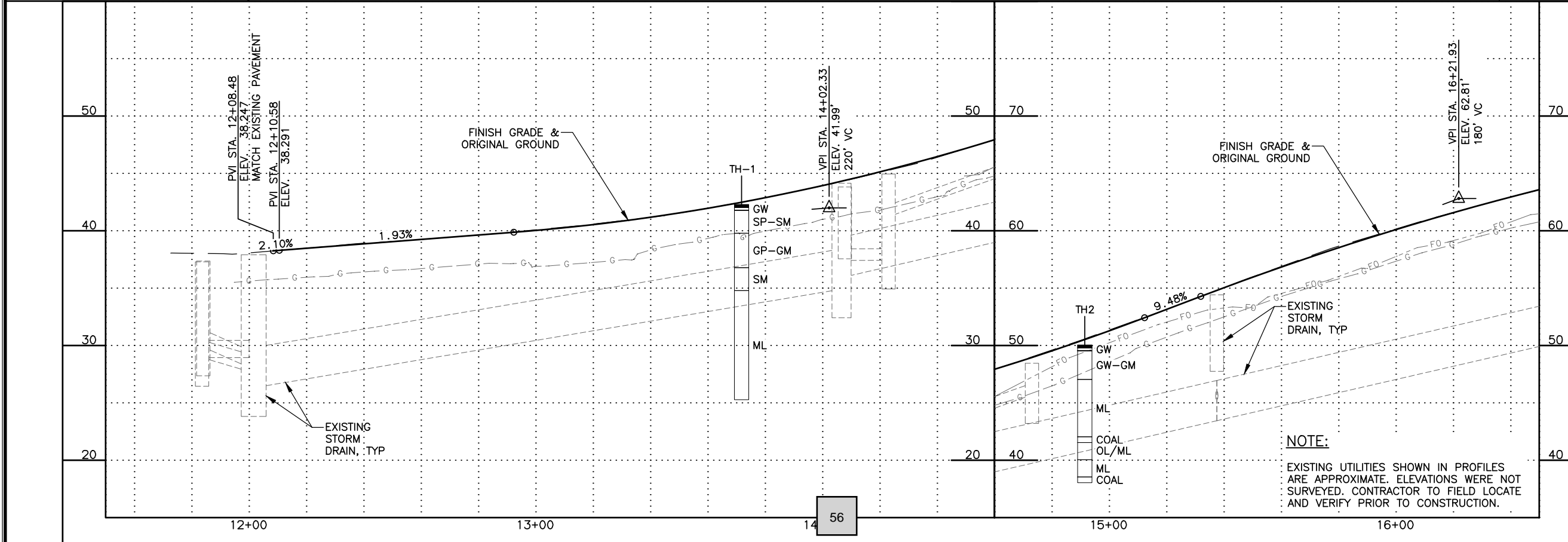
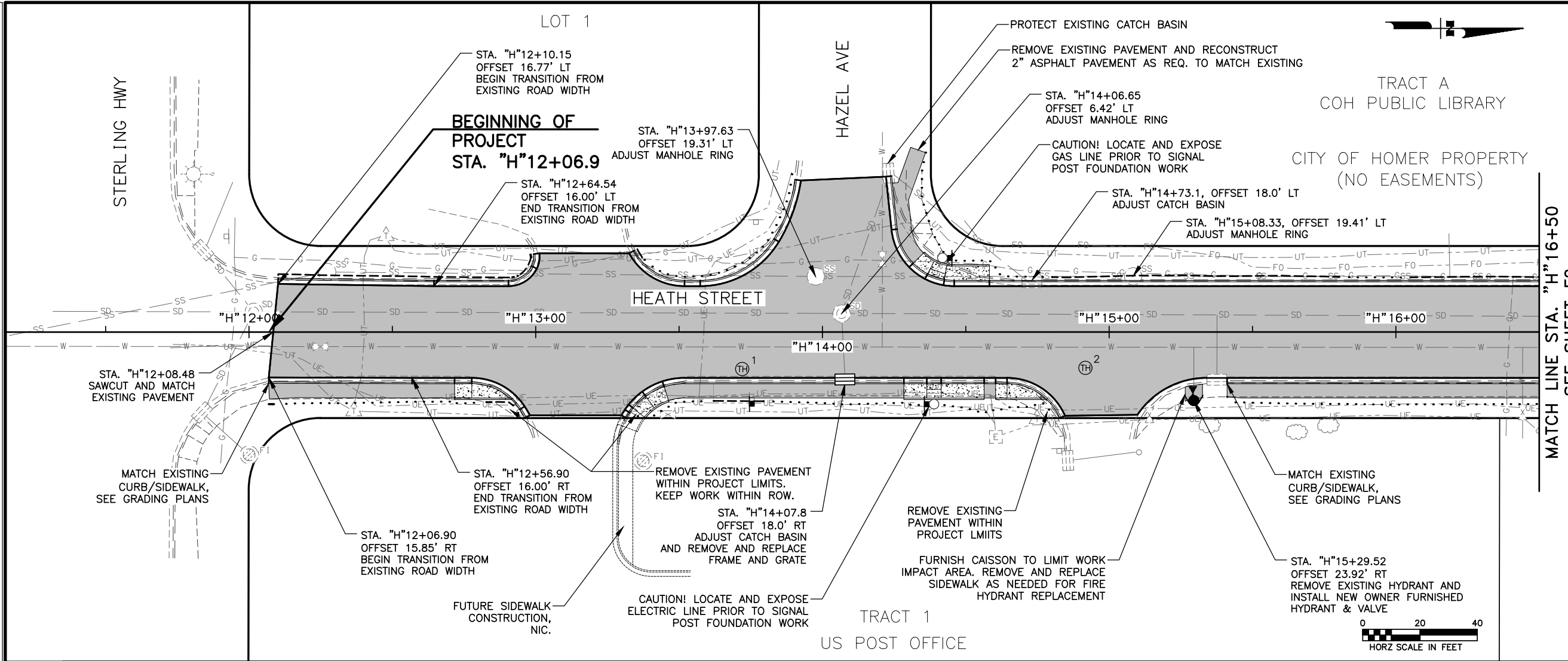

SHEET NO.		TOTAL SHEETS	
F1		F4	
ADDENDUM NO.			
ATTACHMENT NO.			
REVISIONS			
NO.	DATE	DESCRIPTION	

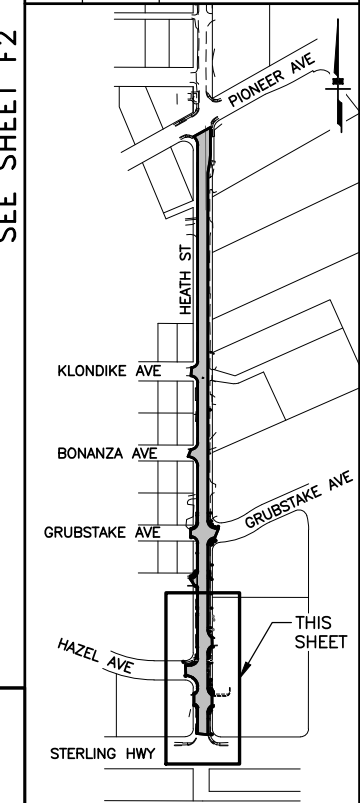

PLANS DEVELOPED BY:
 KINNEY ENGINEERING, LLC
 FOR
 CITY OF HOMER, ALASKA
 PUBLIC WORKS DEPARTMENT

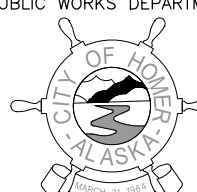

PHONE: (907) 235-3170
 FAX: (907) 235-3145



CITY OF HOMER
 PAVEMENT RESTORATION
 HEATH STREET
 HAZEL AVE CROSSING ALT 1
 PLAN AND PROFILE
 BOP TO
 STA. "H" 16+50

PLANS PREPARED BY: KINNEY ENGINEERING, LLC 3909 ARCTIC BLVD. SUITE 400 ANCHORAGE, AK 99503 : COA# AECL 1102 : PROJECT LOCATION: HOMER, AK
 DRAWING LOCATION
 Z:\PROJECTS\00710.city of homer. term contract 2022\22-04.heath street\DWG\C\Sheets\00710_22-04_F1-F4_P&P.dwg 8/30/2023 12:07 PM
 SCALE
 LAYOUT F2
 DRAFTED BY
 BILL PADDOCK

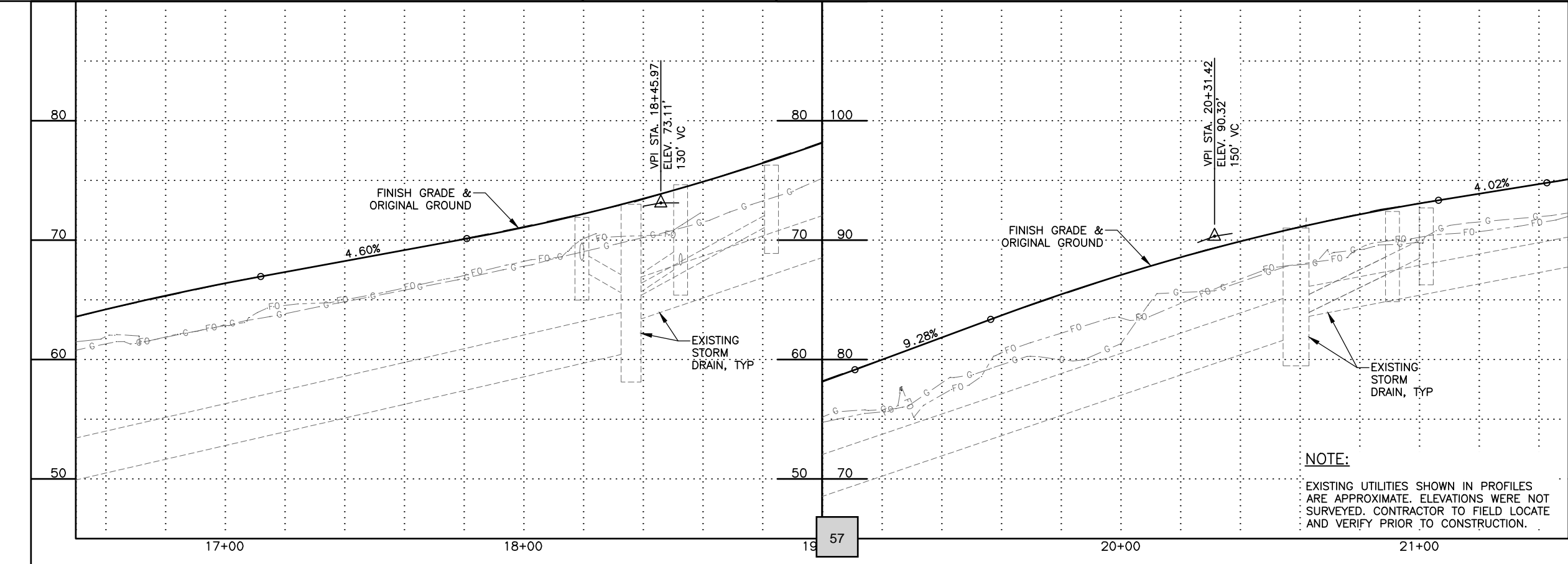
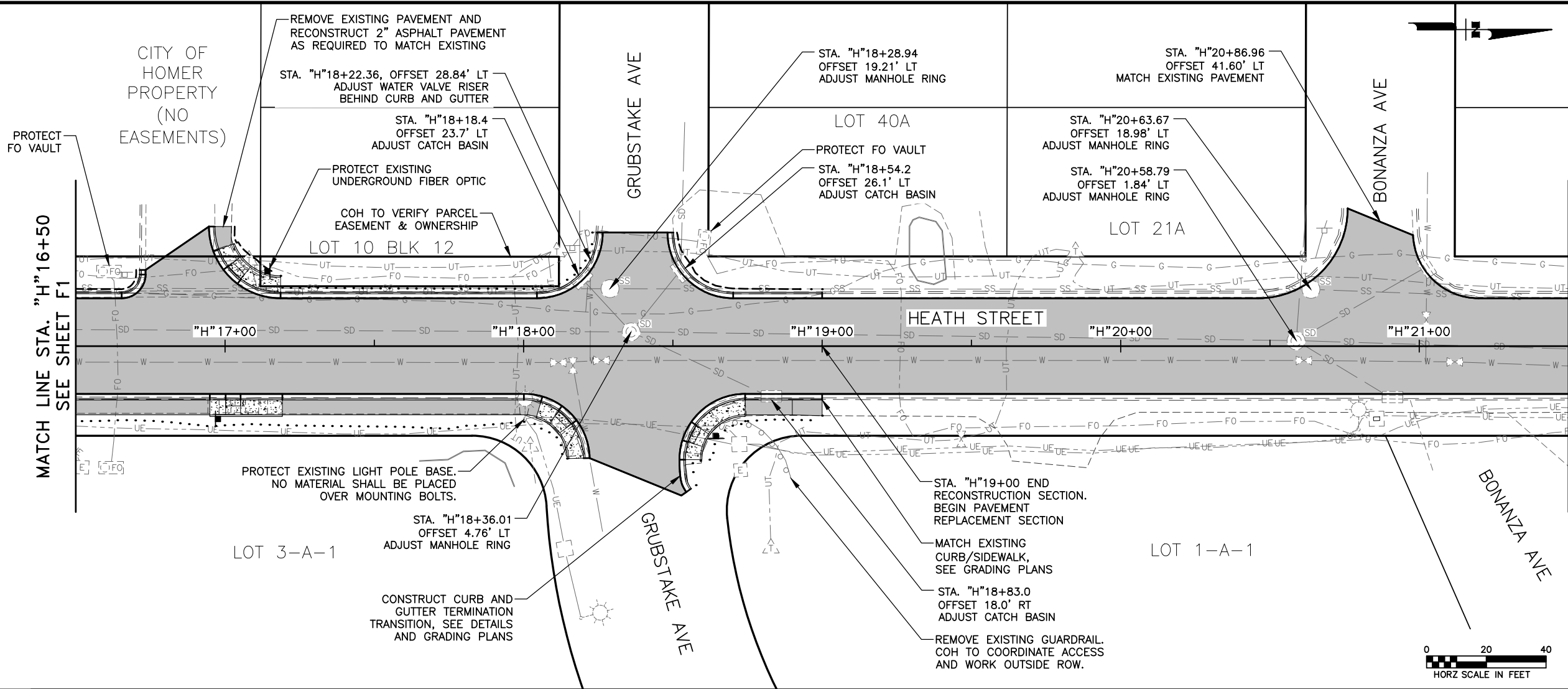

SHEET NO.		TOTAL SHEETS	
F2		F4	
ADDENDUM NO.			
ATTACHMENT NO.			
REVISIONS			
NO.	DATE	DESCRIPTION	

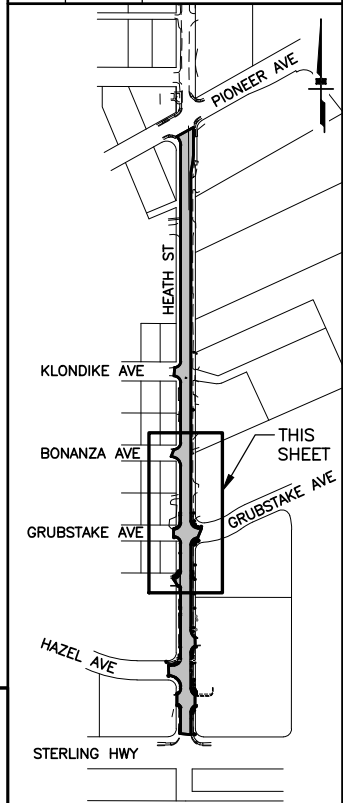

PLANS DEVELOPED BY:
 KINNEY ENGINEERING, LLC
 FOR
 CITY OF HOMER, ALASKA
 PUBLIC WORKS DEPARTMENT

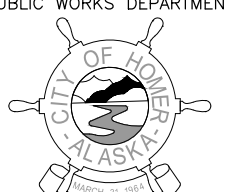

PHONE: (907) 235-3170
 FAX: (907) 235-3145



CITY OF HOMER
 PAVEMENT RESTORATION
 HEATH STREET

PLAN AND PROFILE
 STA. "H"16+50 TO
 STA. "H"21+50

PLANS PREPARED BY: KINNEY ENGINEERING, LLC 3909 ARCTIC BLVD. SUITE 400 ANCHORAGE, AK 99503 : COA# AECL 1102 : PROJECT LOCATION: HOMER, AK
 DRAWING LOCATION
 Z:\PROJECTS\00710.city of homer.term contract 2022\22-04.heath street\DWG\Sheet\00710_22-04_F1-F4_P&P.dwg 8/30/2023 12:07 PM
 SCALE
 LAYOUT F3
 DRAFTED BY
 BILL PADDOCK

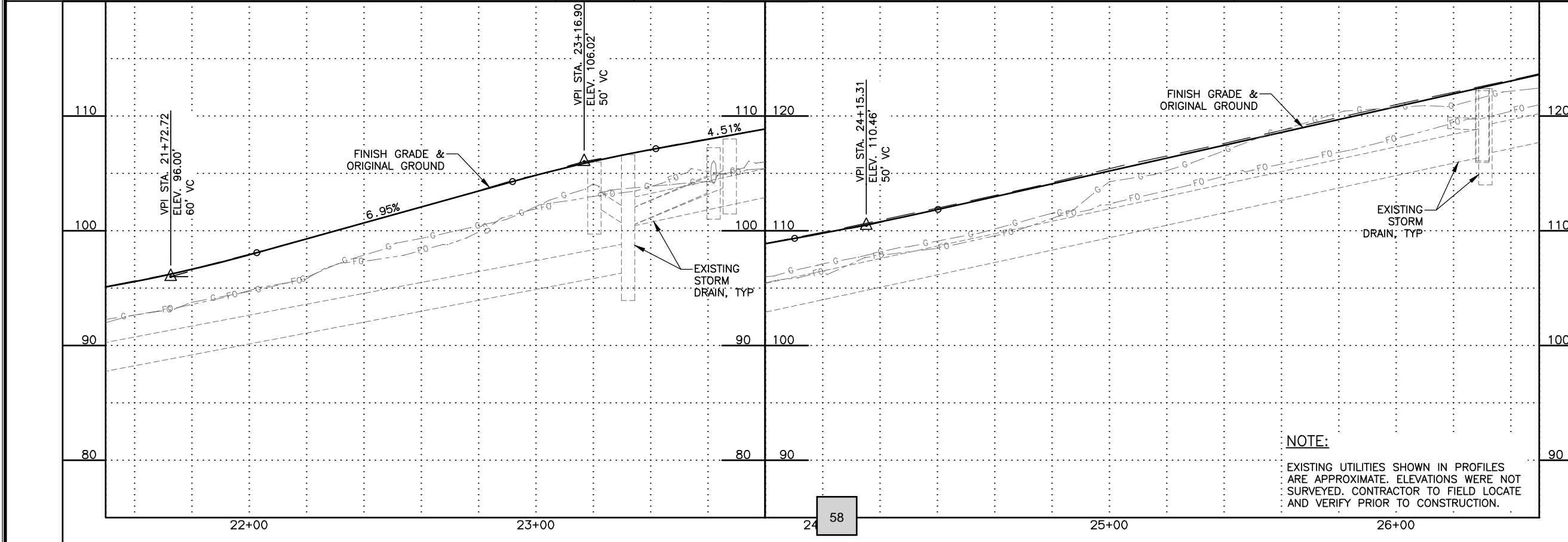
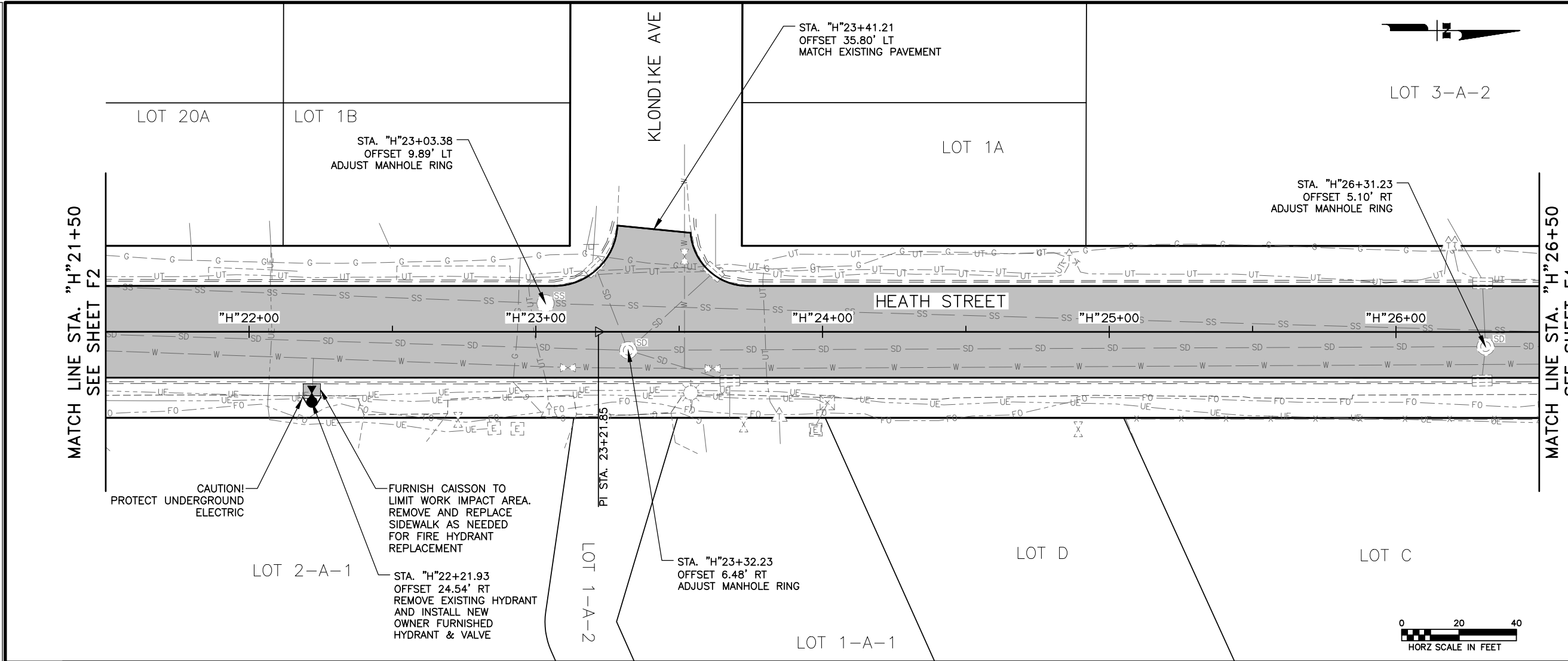

NOTE:
 EXISTING UTILITIES SHOWN IN PROFILES ARE APPROXIMATE. ELEVATIONS WERE NOT SURVEYED. CONTRACTOR TO FIELD LOCATE AND VERIFY PRIOR TO CONSTRUCTION.

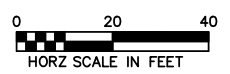
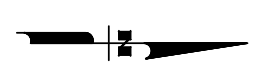

SHEET NO.		TOTAL SHEETS	
F3		F4	
ADDENDUM NO.			
ATTACHMENT NO.			
REVISIONS			
NO.	DATE	DESCRIPTION	

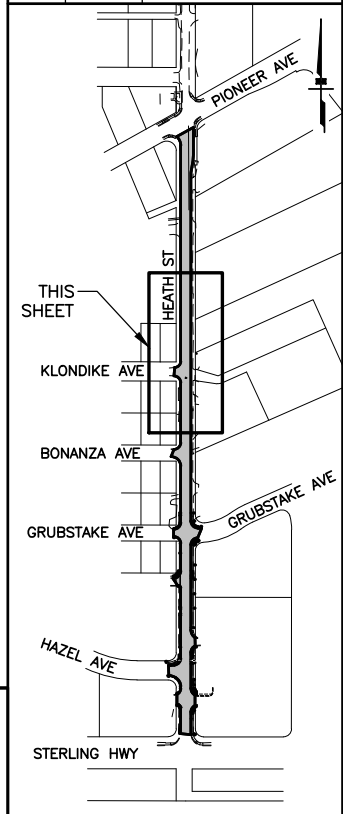

PLANS DEVELOPED BY:
 KINNEY ENGINEERING, LLC
 FOR
 CITY OF HOMER, ALASKA
 PUBLIC WORKS DEPARTMENT



PHONE: (907) 235-3170
 FAX: (907) 235-3145



CITY OF HOMER
 PAVEMENT RESTORATION
 HEATH STREET

PLAN AND PROFILE
 STA. "H"21+50 TO
 STA. "H"26+50

PLANS PREPARED BY: KINNEY ENGINEERING, LLC 3909 ARCTIC BLVD. SUITE 400 ANCHORAGE, AK 99503 : COA# AECL 1102 : PROJECT LOCATION: HOMER, AK
 DRAFTED BY: BILL PADDOCK
 SCALE: F4
 LAYOUT: F4
 8/30/2023 12:07 PM
 Z:\PROJECTS\00710.city of homer. term contract 2022\22-04.heath street\DWG\C\Sheets\00710_22-04_F1-F4_P&P.dwg

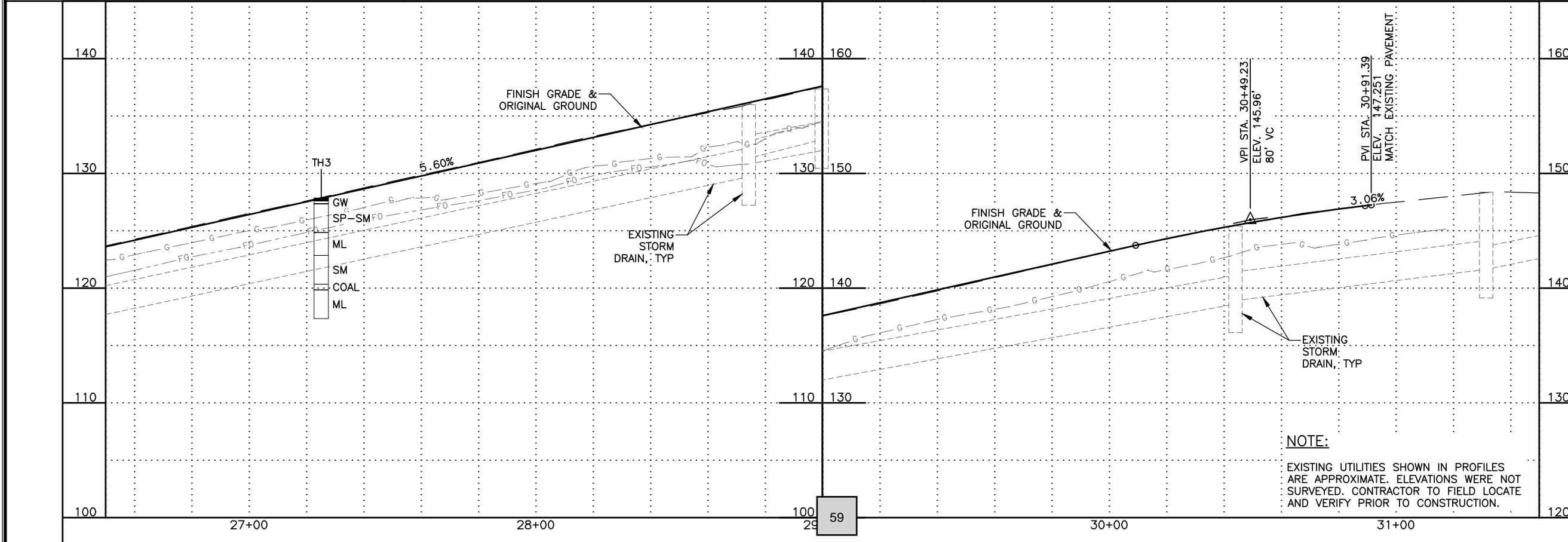
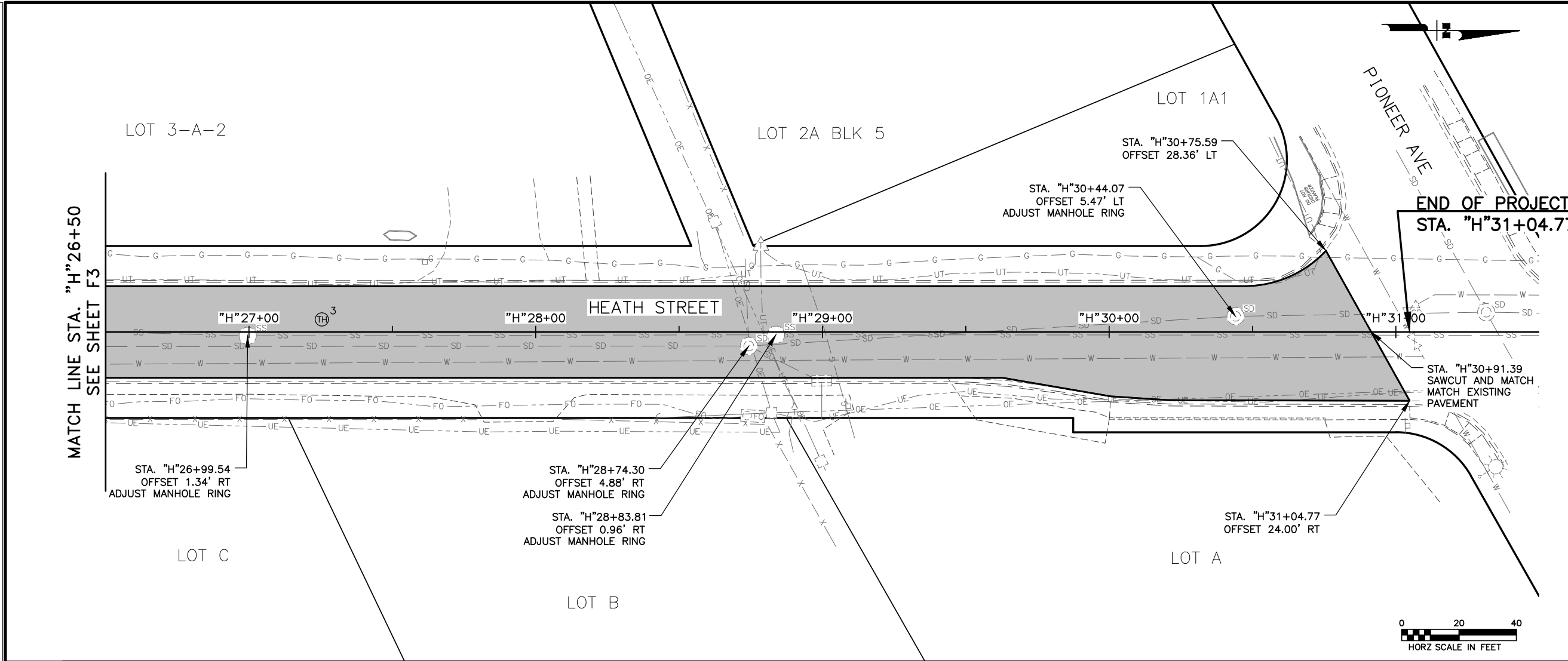

SHEET NO.		TOTAL SHEETS	
F4		F4	
ADDENDUM NO.			
ATTACHMENT NO.			
REVISIONS			
NO.	DATE	DESCRIPTION	

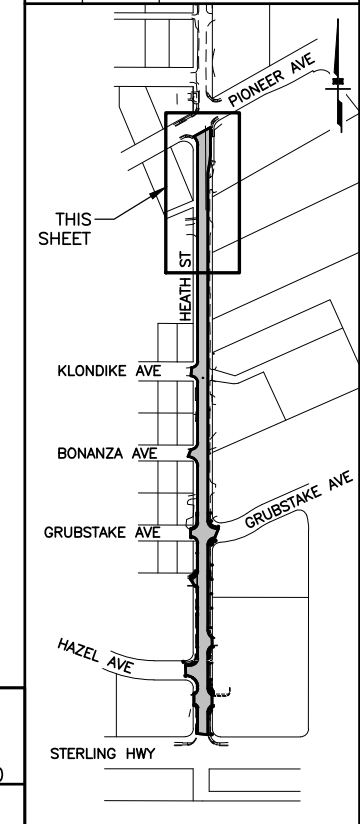

PLANS DEVELOPED BY:
 KINNEY ENGINEERING, LLC
 FOR
 CITY OF HOMER, ALASKA
 PUBLIC WORKS DEPARTMENT

CITY OF HOMER
 ALASKA

PHONE: (907) 235-3170
 FAX: (907) 235-3145



CITY OF HOMER
 PAVEMENT RESTORATION
 HEATH STREET

PLAN AND PROFILE
 STA. "H"26+50 TO
 EOP

PLANS PREPARED BY: KINNEY ENGINEERING, LLC 3909 ARCTIC BLVD., SUITE 400 ANCHORAGE, AK 99503 : COA# AECL 1102 : PROJECT LOCATION: HOMER, AK
 DRAFTED BY: BILL PADDOCK
 SCALE: 1" = 40'
 LAYOUT: G1
 DATE: 8/30/2023 12:07 PM
 FILE: Z:\PROJECTS\00710.city of homer. term contract 2022\22-04 heath street\DWG\C\Sheets\00710_22-04_G1-G3_GRADING.dwg

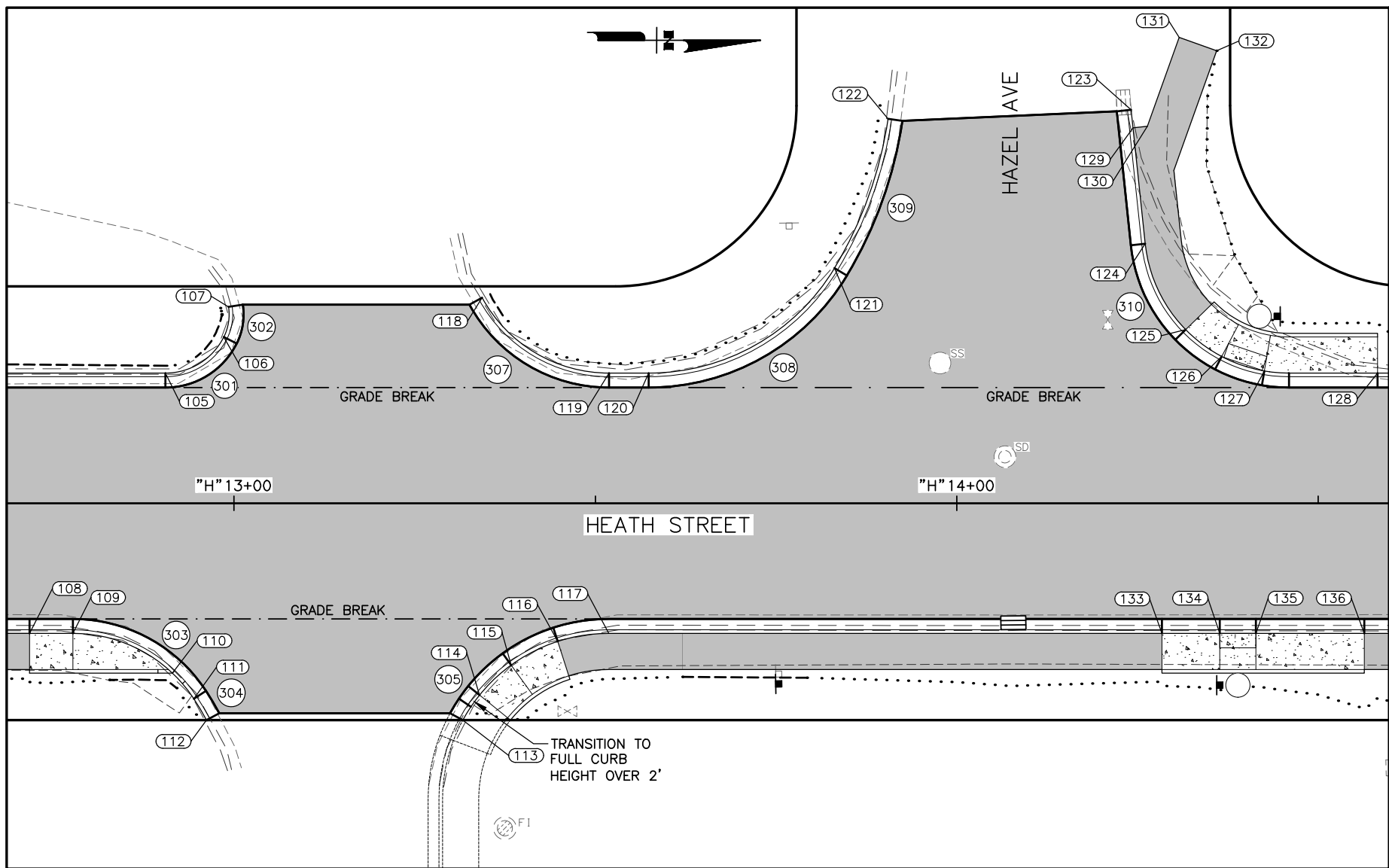
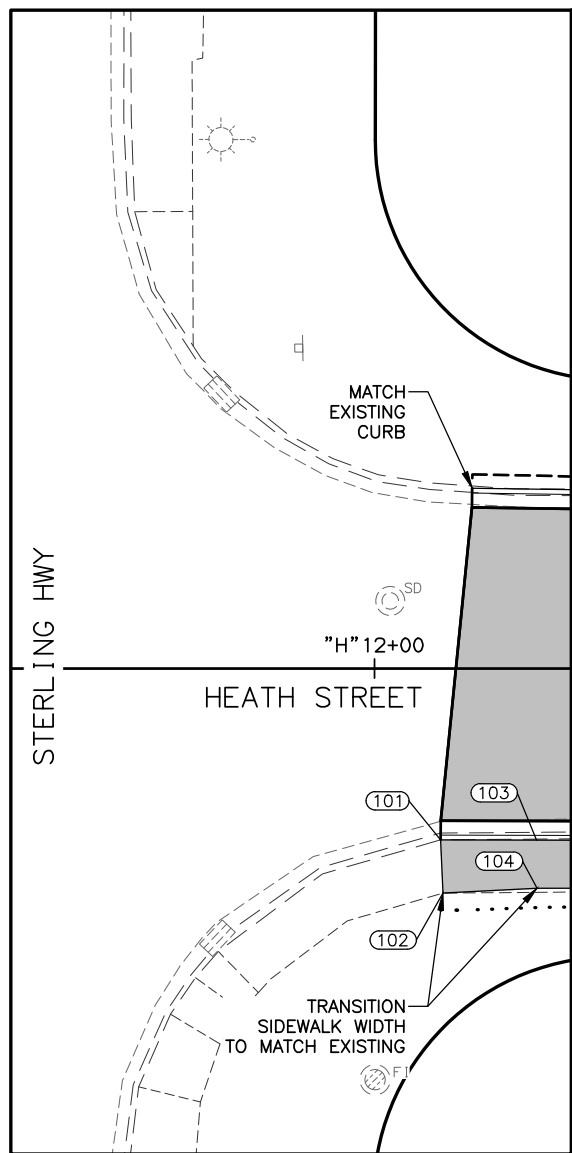

GRADING LAYOUT POINT SUMMARY				
PNT	STATION	OFFSET	ELEV	REMARKS
101	12+06.89	17.85 RT	38.5±	ME
102	12+07.14	23.39 RT	38.5±	ME
103	12+16.89	17.88 RT	38.53	VPI
104	12+16.93	22.88 RT	38.61	PI

GRADING LAYOUT POINT SUMMARY				
PNT	STATION	OFFSET	ELEV	REMARKS
105	12+90.51	18.00 LT	39.95	PC
106	12+98.58	23.00 LT	40.13	PCC
107	12+99.22	27.17 LT	40.4±	ME
108	12+71.71	18.00 RT	39.59	RAMP
109	12+77.71	18.00 RT	39.25	PC, LANDING
110	12+91.49	23.50 RT	39.50	LANDING
111	12+94.45	27.05 RT	40.57	PCC
112	12+96.20	30.00 RT	41.0±	ME
113	13+31.66	30.00 RT	42.0±	ME
114	13+33.97	26.54 RT	41.23	LANDING
115	13+38.34	22.39 RT	41.13	LANDING
116	13+44.79	19.11 RT	41.66	RAMP
117	13+51.86	18.00 RT	41.74	PT
118	13+34.33	28.43 LT	40.9±	ME
119	13+51.89	18.00 LT	41.74	PT
120	13+57.37	18.00 LT	41.97	PC

GRADING LAYOUT POINT SUMMARY				
PNT	STATION	OFFSET	ELEV	REMARKS
121	13+83.08	32.53 LT	44.16	PCC
122	13+90.49	53.19 LT	45.7±	ME
123	14+24.12	54.43 LT	45.6±	ME
124	14+26.08	35.90 LT	45.64	PC
125	14+31.67	24.02 LT	45.71	RAMP
126	14+36.66	20.30 LT	45.95	LANDING
127	14+42.55	18.29 LT	46.05	LANDING
128	14+58.22	18.00 LT	47.91	RAMP
129	14+24.38	51.93 LT	45.56	PI
130	14+26.37	52.14 LT	45.60	PI
131	14+30.78	64.45 LT	45.9±	ME
132	14+35.95	62.60 LT	45.8±	ME
133	14+28.38	18.00 RT	45.79	RAMP
134	14+36.38	18.00 RT	46.04	LANDING
135	14+41.38	18.00 RT	46.11	LANDING
136	14+56.38	18.00 RT	47.77	RAMP

RADIUS POINT SUMMARY			
PNT	STATION	OFFSET	RADIUS (FT)
301	12+90.51	27.00 LT	9
302	12+92.31	26.11 LT	7
303	12+77.71	38.00 RT	20
304	12+61.81	48.40 RT	39
305	13+51.86	41.00 RT	23
307	13+51.89	38.00 LT	20
308	13+57.37	48.00 LT	30
309	13+35.09	61.41 LT	56
310	14+45.96	38.00 LT	20

NOTES:

- ALL GRADING POINTS ARE TO TOP BACK OF CURB OR EDGE OF PATH UNLESS OTHERWISE NOTED.
- ALL RADIUS POINTS ARE TO TOP BACK OF CURB WHEN CURB & GUTTER IS PRESENT OR TO EDGE OF PAVEMENT WHEN CURB & GUTTER IS ABSENT.

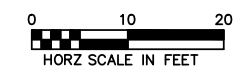

SHEET NO.	TOTAL SHEETS	
G1	G3	
ADDENDUM NO.		
ATTACHMENT NO.		
REVISIONS		
NO.	DATE	DESCRIPTION

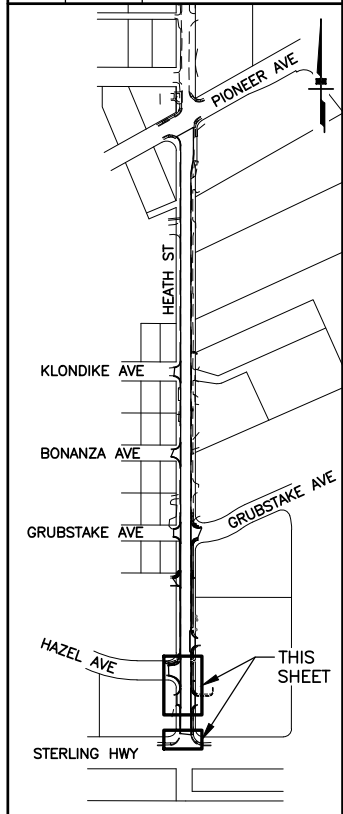

PLANS DEVELOPED BY:
 KINNEY ENGINEERING, LLC
 FOR
 CITY OF HOMER, ALASKA
 PUBLIC WORKS DEPARTMENT



PHONE: (907) 235-3170
 FAX: (907) 235-3145



CITY OF HOMER
 PAVEMENT RESTORATION
 HEATH STREET
 GRADING PLANS

PLANS PREPARED BY: KINNEY ENGINEERING, LLC 3909 ARCTIC BLVD. SUITE 400 ANCHORAGE, AK 99503 : COA# AECL 1102 : PROJECT LOCATION: HOMER, AK
 DRAFTING LOCATION
 Z:\PROJECTS\00710.city of homer. term contract 2022\22-04 heath street\DWG\00710_22-04_01-03_GRADING.dwg 8/30/2023 12:07 PM
 SCALE G2 LAYOUT G2

DRAFTED BY
 BILL PADDOCK

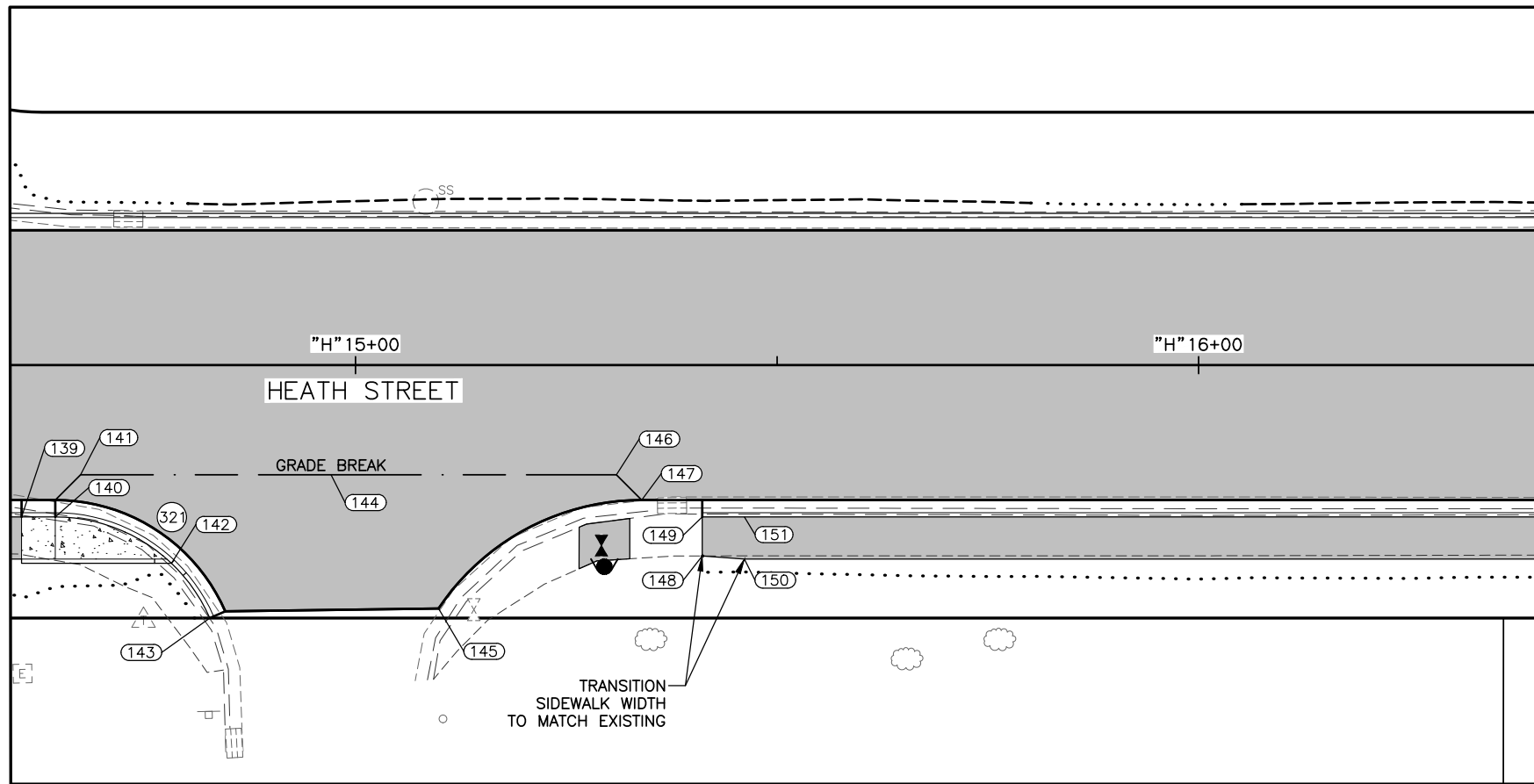

GRADING LAYOUT POINT SUMMARY

PNT	STATION	OFFSET	ELEV	REMARKS
139	14+60.38	18.00 RT	48.07	RAMP
140	14+64.38	18.00 RT	47.93	PC, LANDING
141	14+67.38	13.00 RT	48.24	GB, VPI
142	14+78.16	23.50 RT	48.18	LANDING
143	14+82.71	30.00 RT	49.1±	ME
144	14+97.10	13.00 RT	50.76	GB, VPI
145	15+09.84	28.87 RT	50.4±	PC, EP, ME
146	15+30.95	13.00 RT	53.92	GB, VPI
147	15+33.95	16.00 RT	54.15	PT, EP
148	15+41.13	22.63 RT	55.2±	ME
149	15+41.13	18.00 RT	55.3±	ME
150	15+46.13	23.00 RT	55.79	PI
151	15+46.13	18.00 RT	55.71	VPI

RADIUS POINT SUMMARY

PNT	STATION	OFFSET	RADIUS (FT)
321	14+64.38	38.00 RT	20

NOTES:

1. ALL GRADING POINTS ARE TO TOP BACK OF CURB OR EDGE OF PATH UNLESS OTHERWISE NOTED.
2. ALL RADIUS POINTS ARE TO TOP BACK OF CURB WHEN CURB & GUTTER IS PRESENT OR TO EDGE OF PAVEMENT WHEN CURB & GUTTER IS ABSENT.

SHEET NO.	TOTAL SHEETS	
G2	G3	
ADDENDUM NO.		
ATTACHMENT NO.		
REVISIONS		
NO.	DATE	DESCRIPTION

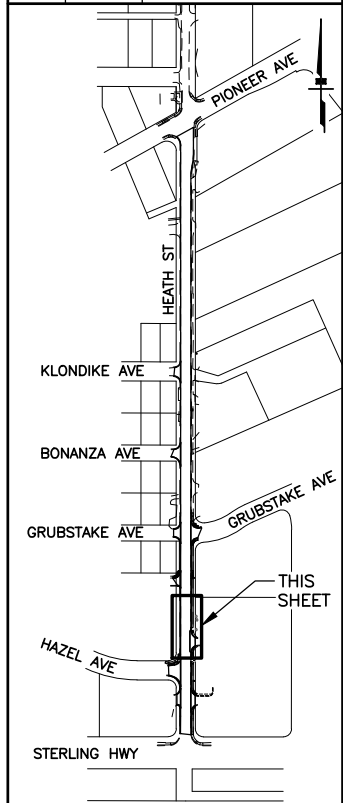

PLANS DEVELOPED BY:
 KINNEY ENGINEERING, LLC
 FOR
 CITY OF HOMER, ALASKA
 PUBLIC WORKS DEPARTMENT



CITY OF HOMER
 PAVEMENT RESTORATION
 HEATH STREET
 GRADING PLANS



PLANS PREPARED BY: KINNEY ENGINEERING, LLC 3909 ARCTIC BLVD., SUITE 400 ANCHORAGE, AK 99503 : COA# AECL 1102 : PROJECT LOCATION: HOMER, AK
 DRAFTING LOCATION SCALE LAYOUT G3
 8/30/2023 12:07 PM
 Z:\PROJECTS\00710.city of homer. term contract 2022\22-04 heath street\DWG\00710_22-04_01-G3_GRADING.dwg

DRAFTED BY
BILL PADDOCK

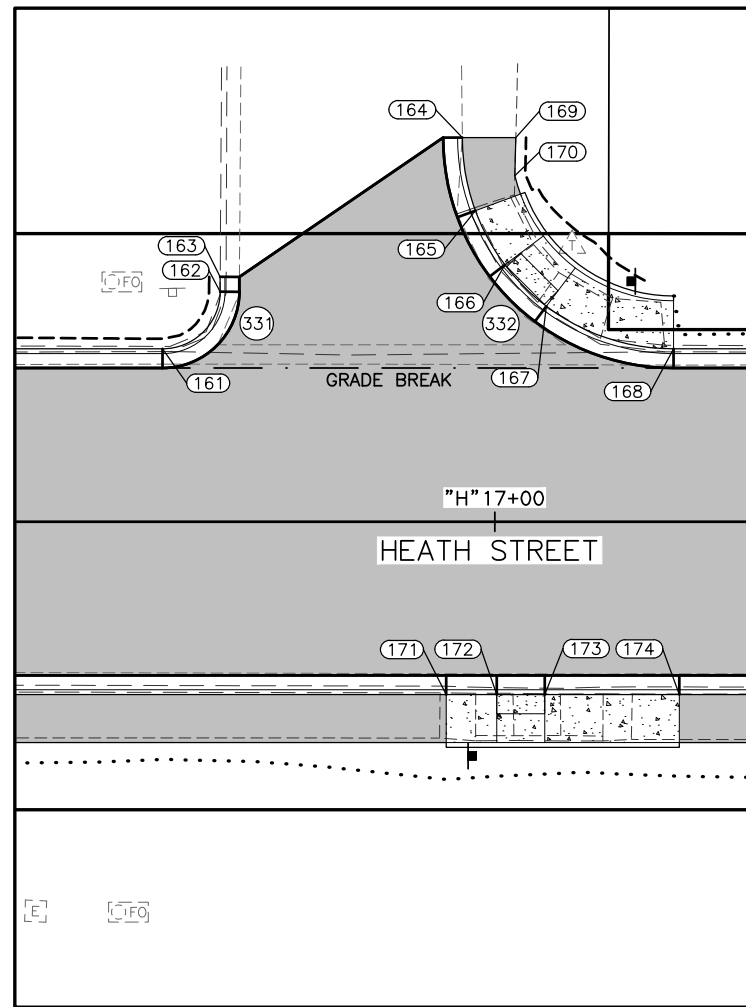

GRADING LAYOUT POINT SUMMARY				
PNT	STATION	OFFSET	ELEV	REMARKS
161	16+65.38	18.00 LT	64.63	PC
162	16+71.38	23.96 LT	64.94	PT
163	16+71.39	25.50 LT	65.0±	ME
164	16+96.62	40.00 LT	66.1±	PC, ME
165	16+97.97	32.39 LT	66.09	RAMP
166	17+01.06	26.75 LT	65.60	LANDING
167	17+05.36	22.44 LT	65.70	LANDING
168	17+18.62	18.00 LT	67.37	PT, RAMP
169	17+02.19	40.00 LT	66.2±	ME
170	17+02.09	36.03 LT	66.18	PC
171	16+94.93	18.00 RT	66.25	RAMP
172	17+00.21	18.00 RT	66.16	LANDING
173	17+05.21	18.00 RT	66.23	LANDING
174	17+19.21	18.00 RT	67.40	RAMP

RADIUS POINT SUMMARY			
PNT	STATION	OFFSET	RADIUS (FT)
331	16+65.38	24.00 LT	6
332	17+18.62	40.00 LT	22

NOTES:

- ALL GRADING POINTS ARE TO TOP BACK OF CURB OR EDGE OF PATH UNLESS OTHERWISE NOTED.
- ALL RADIUS POINTS ARE TO TOP BACK OF CURB WHEN 62' & GUTTER IS PRESENT OR TO EDGE OF PAVEMENT WHEN CURB & GUTTER IS ABSENT.

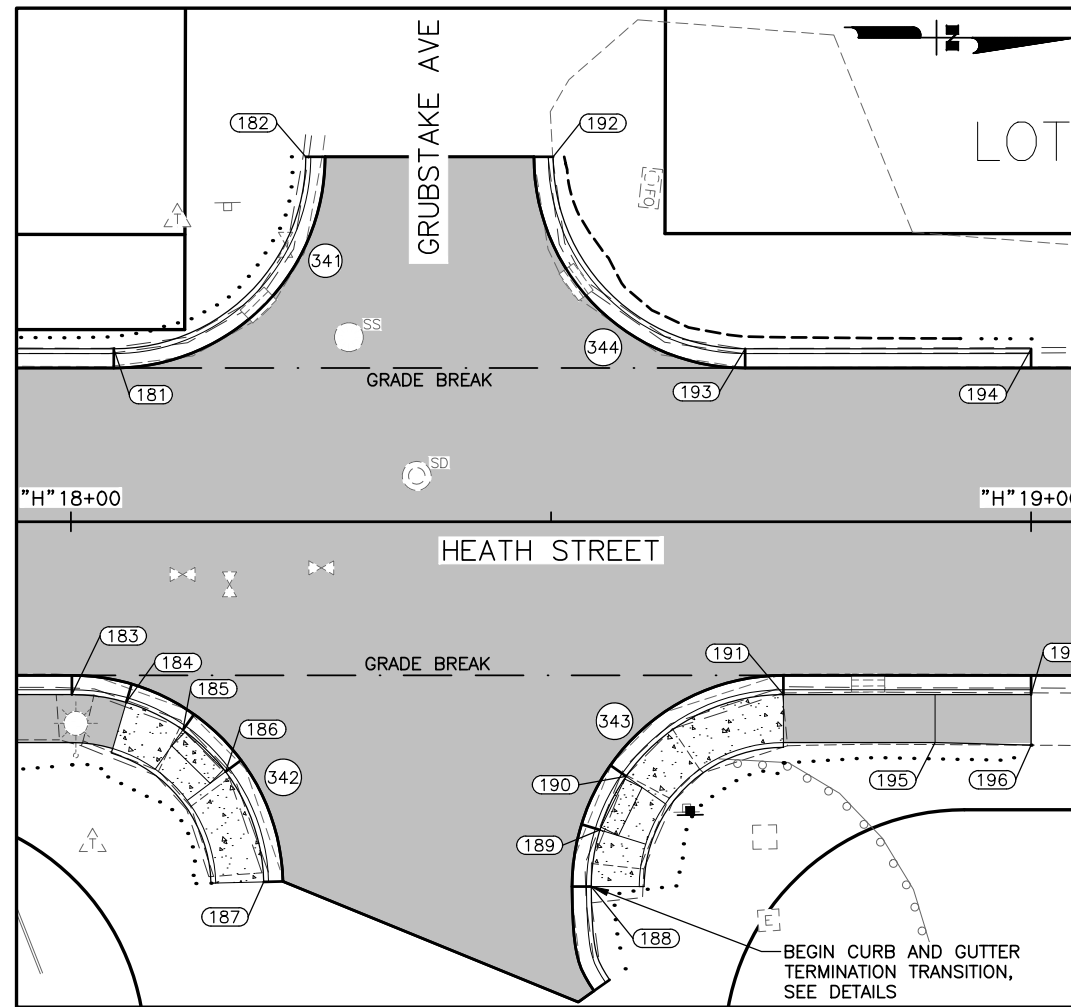

GRADING LAYOUT POINT SUMMARY				
PNT	STATION	OFFSET	ELEV	REMARKS
181	18+04.46	18.00 LT	71.42	PC
182	18+24.46	38.00 LT	73.7±	ME
183	18+00.09	18.00 RT	71.19	PC
184	18+05.76	18.82 RT	71.76	RAMP
185	18+11.67	21.69 RT	71.97	LANDING
186	18+16.12	26.04 RT	72.07	LANDING
187	18+20.08	37.52 RT	73.2±	PT, RAMP, ME
188	18+54.20	38.00 RT	74.12	PC, RAMP
189	18+55.09	32.11 RT	74.22	LANDING
190	18+57.82	26.52 RT	74.32	LANDING
191	18+74.20	18.00 RT	76.09	PT, RAMP
192	18+50.22	38.00 LT	73.9±	ME
193	18+70.22	18.00 LT	75.78	PT
194	19+00.00	18.00 LT	78.3±	ME
195	18+90.00	23.00 RT	77.50	PI
196	19+00.00	23.27 RT	78.34	ME
197	19+00.00	18.00 RT	78.3±	ME

RADIUS POINT SUMMARY			
PNT	STATION	OFFSET	RADIUS (FT)
341	18+04.46	38.00 LT	20
342	18+00.09	38.00 RT	20
343	18+74.20	38.00 RT	20
344	18+70.22	38.00 LT	20

SHEET NO.	TOTAL SHEETS	
G3	G3	
ADDENDUM NO.		
ATTACHMENT NO.		
REVISIONS		
NO.	DATE	DESCRIPTION

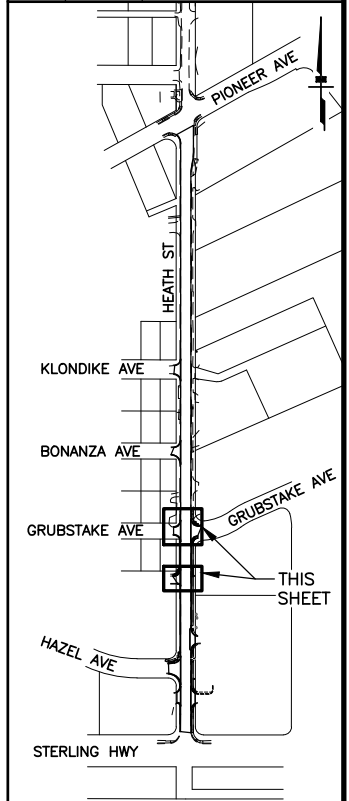

PLANS DEVELOPED BY:
KINNEY ENGINEERING, LLC
FOR
CITY OF HOMER, ALASKA
PUBLIC WORKS DEPARTMENT



PHONE: (907) 235-3170
FAX: (907) 235-3145



CITY OF HOMER
PAVEMENT RESTORATION
HEATH STREET

GRADING PLANS



PLANS PREPARED BY: KINNEY ENGINEERING, LLC 3909 ARCTIC BLVD. SUITE 400 ANCHORAGE, AK 99503 : COA# AECL 1102 : PROJECT LOCATION: HOMER, AK
 DRAWING LOCATION
 Z:\PROJECTS\00710_City of Homer_Term Contract 2022\22-04_Health Street\DWGS\C\Sheets\00710_22-04_H1_TRAF LOND.dwg 8/30/2023 2:30 PM

DRAFTED BY
 BILL PADDOCK

SCALE

LAYOUT

H1

SYMBOL LEGEND

EXISTING	PROPOSED	
		LOAD CENTER
		TYPE 1A JUNCTION BOX
		TYPE II JUNCTION BOX
		ELECTROLIER'
		LIGHTING OR SIGNAL CONDUIT
		CONDUIT CALLOUT
		SIGN POST & NUMBER
		PRIVATE SIGN
		ELECTRICAL TRANSFORMER
		SIGNAL POST
		PEDESTRIAN PUSH BUTTON
		FLASHER CONTROL PANEL
		RECTANGULAR RAPID FLASHING BEACON (RRFB)

PAVEMENT MARKING LEGEND

PROPOSED		
		PROJECT CENTERLINE
	8"W	8" WHITE SOLID STRIPE
	4"W	4" WHITE SOLID STRIPE
	4"W SKIP	4" WHITE SKIP STRIPE 10' STRIPES AND 30' SPACES
	8"W GUIDE SKIP	8" WHITE LANE GUIDE SKIP LANE CONTINUATION OR TURN SKIP 1' STRIPES AND 3' SPACES
	8"Y	8" YELLOW SOLID STRIPE
	4"Y	4" YELLOW SOLID STRIPE
	4"Y SKIP	4" YELLOW SKIP STRIPE 10' STRIPES AND 30' SPACES
	+20	STRIPING CHANGE STATION INTERVAL
	24"W (TYP)	2' CROSSWALK OR STOPBAR
	10'	LADDER CROSSWALK LAYOUT 2' WIDE RUNGS WITH 2' SPACES ALIGNED TO AVOID TIRE PATHS
	12'	(2)-4"Y 3" APART TYPICAL PAINTED MEDIAN 18"Y @ 45°

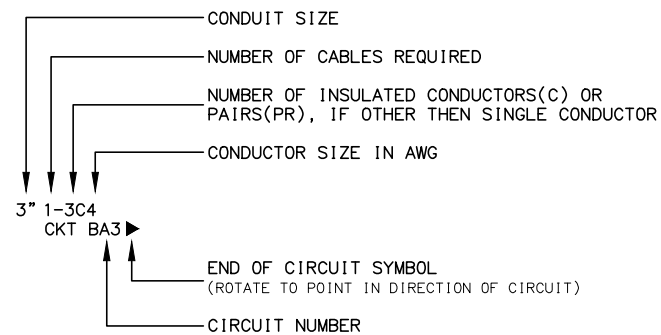

ABBREVIATIONS

CL - CENTERLINE	LTG - LIGHTING	PRE CON 2 - PREEMPTION CONTROLLER #
AWG - AMERICAN WIRE GAUGE	NB - NORTH BOUND	RMC - RIGID METAL CONDUIT
EB - EAST BOUND	OMNI - OMNI DIRECTIONAL ANTENNA	SB - SOUTH BOUND
HEAD - VEHICULAR SIGNAL HEAD	P1 - TRAFFIC SIGNAL POLE #	SIG - SERVICE TO CONTROLLER
INTX - INTERSECTION	PE - POLYETHYLENE CONDUIT	TC - TRAFFIC CONTROLLER
INTX L - INTERSECTION LIGHTING	PEC - PHOTOELECTRIC CELL	WB - WEST BOUND
LC - LOAD CENTER	PED B 28 - PEDESTRIAN PUSH BUTTON #	YAG1 - DIRECTIONAL ANTENNA
LFNC - LIQUIDTIGHT FLEXIBLE NONMETALLIC CONDUIT	PEDI - PEDESTRIAN SIGNAL HEAD	
	PRE 2 - PREEMPTION #	

NOTES:

FOUNDATIONS NOTES:

- STATION & C.L. REFERENCE ARE TO THE CENTER OF THE STRUCTURE.
- JUNCTION BOX LOCATIONS ARE APPROXIMATE. LOCATE J-BOXES SO THAT THEY ARE LOCATED OUT OF THE PATHWAY, SIDEWALK, CURB RAMPS, AND DRAINAGE COLLECTION AREAS, AND ARE ON THE DOWNSTREAM TRAFFIC SIDE OF POLE.
- INSTALL ANCHOR BOLTS IN CAST FOUNDATIONS TO BE WITHIN 1:40 OF PLUMB.
- TOPSOIL AND SEED ANY DISTURBED AREAS.

SIGNING & STRIPING NOTES:

- ALL STATION LOCATIONS FOR SIGN INSTALLATION ARE APPROXIMATE. INSTALL SIGNS AT LOCATIONS AS DIRECTED BY THE ENGINEER.
- FOR PERFORATED STEEL TUBE SIGNPOSTS, INSTALL THE CONCRETE FOUNDATION OPTION SHOWN. TRIM EACH PT POST TO LIMIT THE LENGTH INSERTED INTO THE FOUNDATION TO 12 INCHES.
- SELECTIVE AND HAND CLEARING SHALL BE PERFORMED AT THE DISCRETION OF THE ENGINEER. UPSTREAM OF ALL SIGN INSTALLATION LOCATIONS TO ACHIEVE MINIMUM SIGN VISIBILITY REQUIREMENTS. IF NOT INCLUDED AS A SEPARATE ITEM, THIS WORK SHALL BE SUBSIDIARY TO THE SIGN INSTALLATION ITEMS AND WORK.
- DIMENSIONS REFER TO THE CENTER OF STRIPE AND THE EDGE OF PAVEMENT.
- IF THE NEW AND EXISTING PAVEMENT MARKINGS ARE NOT ALIGNED AT MATCH LINE, TRANSITION BETWEEN THE TWO USING A 100:1 TAPER ON THE NEW PAVEMENT.
- WHERE NEW STRIPING IS TO EXTEND BEYOND PAVING LIMITS, REMOVE EXISTING STRIPING, TO THE EXTENT OF STRIPING LIMITS.
- USE THE FOLLOWING DEFINITIONS TO DECIPHER THE ABBREVIATED SIGN POST TYPES IN THE SIGN SUMMARY SHEETS.
 - PT MEANS A PERFORATED STEEL TUBE.
 - T MEANS A SQUARE STEEL TUBE.
 - P MEANS A ROUND STEEL PIPE.
- FABRICATE ALL SIGNS FROM 0.125" THICK ALUMINUM SHEETING, UNLESS STATED ELSEWHERE.
- FOR SIGNS SUPPORTED BY MULTIPLE POSTS, FABRICATE THE POSTS WITH THEIR TOPS LEVEL WITH ONE ANOTHER.

CALL BEFORE YOU DIG!

CONTRACTOR SHALL CALL A MINIMUM OF 3 DAYS IN ADVANCE OF CONSTRUCTION

ALASKA DIGLINE...907-278-3121 OR 800-478-3121

CALL OR GO TO WWW.AKONECALL.COM/STATEWIDE.HTM OR MEMBER LIST OF WHO WILL BE NOTIFIED

SHEET NO.	TOTAL SHEETS	
H1	H8	
ADDENDUM NO.		
ATTACHMENT NO.		
REVISIONS		
NO.	DATE	DESCRIPTION

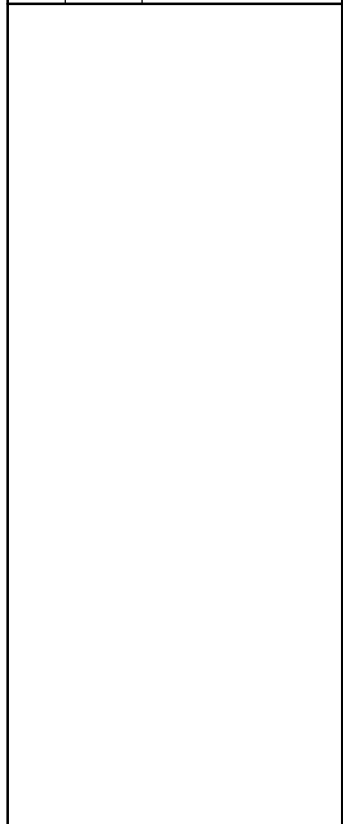

PLANS DEVELOPED BY:
 KINNEY ENGINEERING, LLC
 FOR
 CITY OF HOMER, ALASKA
 PUBLIC WORKS DEPARTMENT

PHONE: (907) 235-3170
 FAX: (907) 235-3145

CITY OF HOMER
 PAVEMENT RESTORATION
 HEATH STREET

TRAFFIC LEGEND
 AND NOTES

PLANS PREPARED BY: KINNEY ENGINEERING, LLC 3909 ARCTIC BLVD., SUITE 400 ANCHORAGE, AK 99503 : COA# AECL 1102 : PROJECT LOCATION: HOMER, AK
 DRAFTED BY: BILL PADDOCK
 SCALE: LAYOUT H2
 9/1/2023 7:56 AM
 Z:\PROJECTS\00710_City of Homer_Term Contract 2022\22-04_Heath Street\DWG\City\Sheets\00710_22-04_H2-H3_SIGN_STRIP.dwg

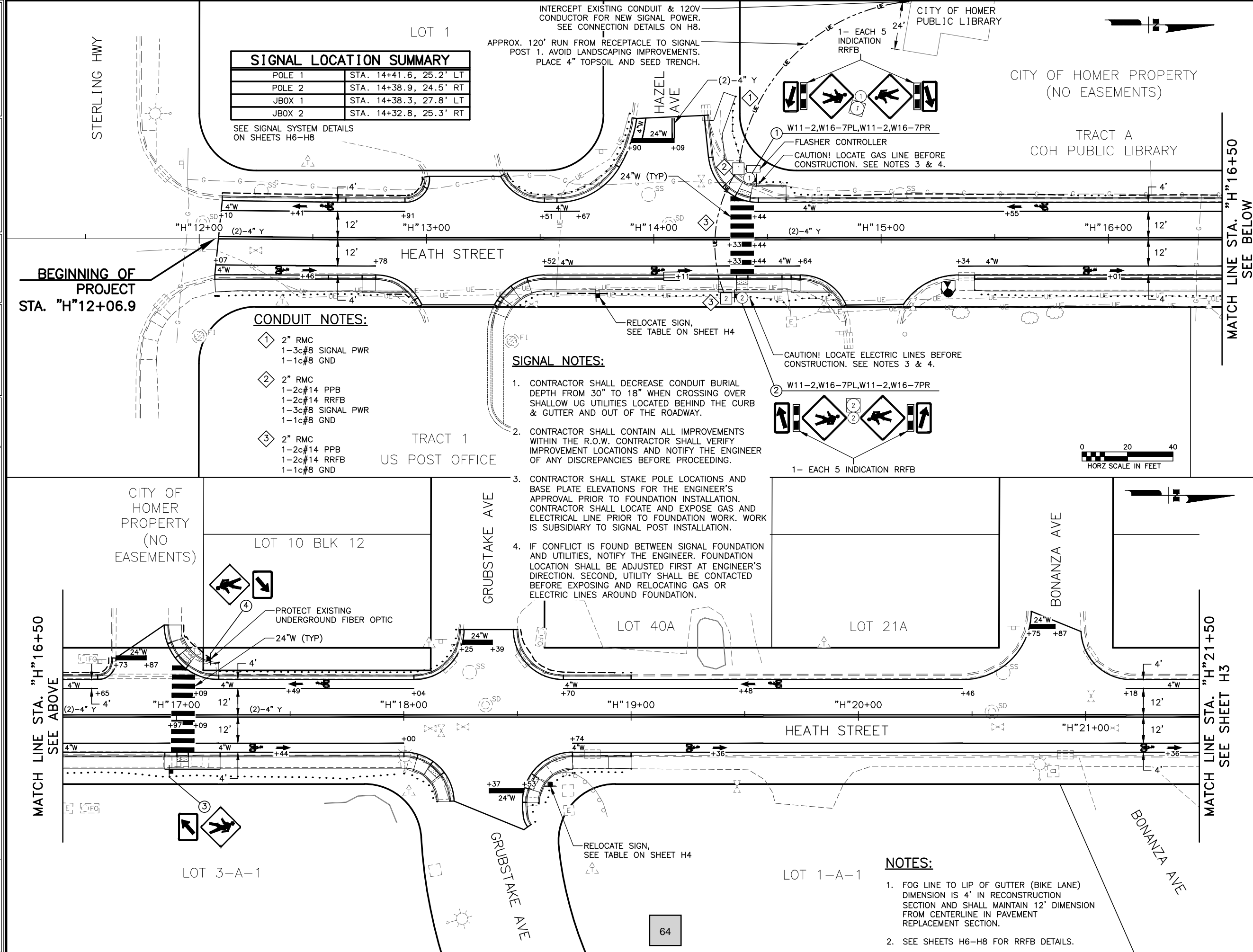

SIGNAL LOCATION SUMMARY	
POLE 1	STA. 14+41.6, 25.2' LT
POLE 2	STA. 14+38.9, 24.5' RT
JBOX 1	STA. 14+38.3, 27.8' LT
JBOX 2	STA. 14+32.8, 25.3' RT

SEE SIGNAL SYSTEM DETAILS ON SHEETS H6-H8

CONDUIT NOTES:

- ① 2" RMC
1-3c#8 SIGNAL PWR
1-1c#8 GND
- ② 2" RMC
1-2c#14 PPB
1-2c#14 RRFB
1-3c#8 SIGNAL PWR
1-1c#8 GND
- ③ 2" RMC
1-2c#14 PPB
1-2c#14 RRFB
1-1c#8 GND

SIGNAL NOTES:

1. CONTRACTOR SHALL DECREASE CONDUIT BURIAL DEPTH FROM 30" TO 18" WHEN CROSSING OVER SHALLOW UG UTILITIES LOCATED BEHIND THE CURB & GUTTER AND OUT OF THE ROADWAY.
2. CONTRACTOR SHALL CONTAIN ALL IMPROVEMENTS WITHIN THE R.O.W. CONTRACTOR SHALL VERIFY IMPROVEMENT LOCATIONS AND NOTIFY THE ENGINEER OF ANY DISCREPANCIES BEFORE PROCEEDING.
3. CONTRACTOR SHALL STAKE POLE LOCATIONS AND BASE PLATE ELEVATIONS FOR THE ENGINEER'S APPROVAL PRIOR TO FOUNDATION INSTALLATION. CONTRACTOR SHALL LOCATE AND EXPOSE GAS AND ELECTRICAL LINE PRIOR TO FOUNDATION WORK. WORK IS SUBSIDIARY TO SIGNAL POST INSTALLATION.
4. IF CONFLICT IS FOUND BETWEEN SIGNAL FOUNDATION AND UTILITIES, NOTIFY THE ENGINEER. FOUNDATION LOCATION SHALL BE ADJUSTED FIRST AT ENGINEER'S DIRECTION. SECOND, UTILITY SHALL BE CONTACTED BEFORE EXPOSING AND RELOCATING GAS OR ELECTRIC LINES AROUND FOUNDATION.

NOTES:

1. FOG LINE TO LIP OF GUTTER (BIKE LANE) DIMENSION IS 4' IN RECONSTRUCTION SECTION AND SHALL MAINTAIN 12' DIMENSION FROM CENTERLINE IN PAVEMENT REPLACEMENT SECTION.
2. SEE SHEETS H6-H8 FOR RRFB DETAILS.

SHEET NO.	TOTAL SHEETS	
H2	H8	
ADDENDUM NO.		
ATTACHMENT NO.		
REVISIONS		
NO.	DATE	DESCRIPTION

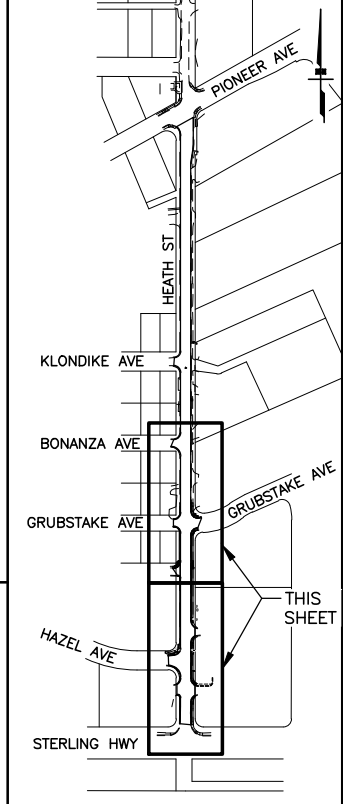

PLANS DEVELOPED BY:
 KINNEY ENGINEERING, LLC
 FOR
 CITY OF HOMER, ALASKA
 PUBLIC WORKS DEPARTMENT



CITY OF HOMER
 PAVEMENT RESTORATION
 HEATH STREET
 SIGNING, STRIPING
 AND SIGNAL PLANS
 BOP TO
 STA. "H"21+50

PLANS PREPARED BY: KINNEY ENGINEERING, LLC 3909 ARCTIC BLVD. SUITE 400 ANCHORAGE, AK 99503 : COA# AECL 1102 : PROJECT LOCATION: HOMER, AK
 DRAFTING LOCATION
 Z:\PROJECTS\00710.city of homer. term contract 2022\22-04 health street\DWGS\C\Sheets\00710_22-04_H4_SIGN SUM.dwg 9/1/2023 7:47 AM
 SCALE
 LAYOUT H4
 DRAFTED BY: BILL PADDOCK

SIGN SUMMARY														
SHEET NO.	SIGN NO.	LOCATION		TYPE	LEGEND	SIZE (FT)		AREA SQ FT	SIGN FACES	POSTS NO., SIZE, & TYPE	THICKNESS (in)		REMARKS	
		STATION	OFFSET			WIDTH	HEIGHT				FRAMED			
											YES	NO		
H2	1	14+42	LT	W11-2	PEDESTRIAN CROSSING	2.00	2.00	4.00	S	N/A	0.125		MOUNT ON PEDESTRIAN SIGNAL POST. SEE FRAMING/MOUNTING DETAILS ON H7.	
				W16-7PR	(ARROW)	2.00	1.00	2.00	S		0.125			
				W11-2	PEDESTRIAN CROSSING	2.00	2.00	4.00	N		0.125			MOUNT ON PEDESTRIAN SIGNAL POST. SEE FRAMING/MOUNTING DETAILS ON H7.
				W16-7PL	(ARROW)	2.00	1.00	2.00	N		0.125			
H2	2	14+39	RT	W11-2	PEDESTRIAN CROSSING	2.00	2.00	4.00	N	N/A	0.125		MOUNT ON PEDESTRIAN SIGNAL POST. SEE FRAMING/MOUNTING DETAILS ON H7.	
				W16-7PR	(ARROW)	2.00	1.00	2.00	N		0.125			
				W11-2	PEDESTRIAN CROSSING	2.00	2.00	4.00	S		0.125			MOUNT ON PEDESTRIAN SIGNAL POST. SEE FRAMING/MOUNTING DETAILS ON H7.
				W16-7PL	(ARROW)	2.00	1.00	2.00	S		0.125			
H2	3	16+97	RT	W11-2	PEDESTRIAN CROSSING	2.00	2.00	4.00	S	1- 2.5" PT		0.125		
				W16-7PL	(ARROW)	2.00	1.00	2.00	S			0.125		
H2	4	17+14	LT	W11-2	PEDESTRIAN CROSSING	2.00	2.00	4.00	N	1- 2.5" PT		0.125		
				W16-7PL	(ARROW)	2.00	1.00	2.00	N			0.125		
TOTAL SIGN AREA:								36.00 SF						

REMOVE AND RELOCATE SIGNS SUMMARY							
SHEET NO.	LOCATION				TYPE	LEGEND	REMARKS
	EXISTING		RELOCATED				
	STATION	OFFSET	STATION	OFFSET			
H2	13+75.37	23.40' RT	13+75.38	25' RT	R2-1	SPEED LIMIT 25	EXISTING 2.5" X 2.5" P.S.T.
H2	13+76.80	38.35' LT	13+76.80	38.35' LT	D3-1	HEATH ST	EXISTING 2" X 2" P.S.T. RELOCATE IN PLACE
					D3-1	HAZEL AVE	
					R1-1	STOP	
H2	16+66.43	23.88' LT	16+66.43	23.88' LT	R1-1	STOP	EXISTING 2" X 2" P.S.T. RELOCATE IN PLACE
H2	18+16.33	32.82' LT	18+16.33	32.82' LT	D3-1	HEATH ST	EXISTING 2.5" X 2.5" P.S.T. RELOCATE IN PLACE
					D3-1	GRUBSTAKE AVE	
					R1-1	STOP	
H2	18+64.12	29.82' RT	18+64.49	30.12' RT	D3-1	HEATH ST	EXISTING 2.5" X 2.5" P.S.T.
					D3-1	GRUBSTAKE AVE	
					R1-1	STOP	

NOTES:

- REMOVE EXISTING SIGN POST FOUNDATION IF PRESENT AND CONSTRUCT NEW SIGN POST FOUNDATION. SEE DETAIL THIS SHEET. WORK AND MATERIALS SUBSIDIARY TO REMOVE AND RELOCATE SIGNS PAY ITEM.

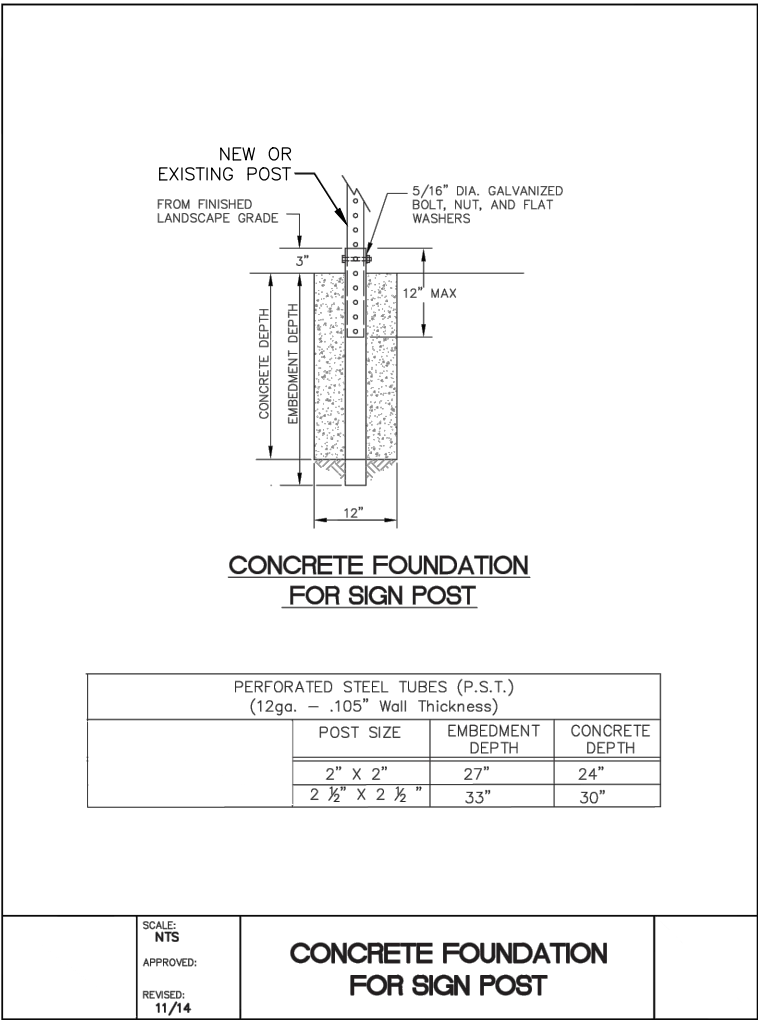

PERFORATED STEEL TUBES (P.S.T.) (12ga. - .105" Wall Thickness)			
	POST SIZE	EMBEDMENT DEPTH	CONCRETE DEPTH
	2" X 2"	27"	24"
	2 1/2" X 2 1/2"	33"	30"

SCALE: NTS
APPROVED:
REVISED: 11/14

CONCRETE FOUNDATION FOR SIGN POST

SHEET NO.	TOTAL SHEETS	
H4	H8	
ADDENDUM NO.		
ATTACHMENT NO.		
REVISIONS		
NO.	DATE	DESCRIPTION

PLANS DEVELOPED BY:
KINNEY ENGINEERING, LLC
FOR
CITY OF HOMER, ALASKA
PUBLIC WORKS DEPARTMENT

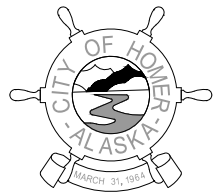

PHONE: (907) 235-3170
FAX: (907) 235-3145



CITY OF HOMER
PAVEMENT RESTORATION
HEATH STREET

SIGN SUMMARY

PLANS PREPARED BY: KINNEY ENGINEERING, LLC 3909 ARCTIC BLVD. SUITE 400 ANCHORAGE, AK 99503 : COA# AECL 1102 : PROJECT LOCATION: HOMER, AK
 DRAWING LOCATION
 Z:\PROJECTS\00710.city of homer. term contract 2022\22-04 heath street\DWG\00710_22-04_H5-HB_SIGN_DETAILS.dwg 9/1/2023 7:50 AM SCALE LAYOUT H6

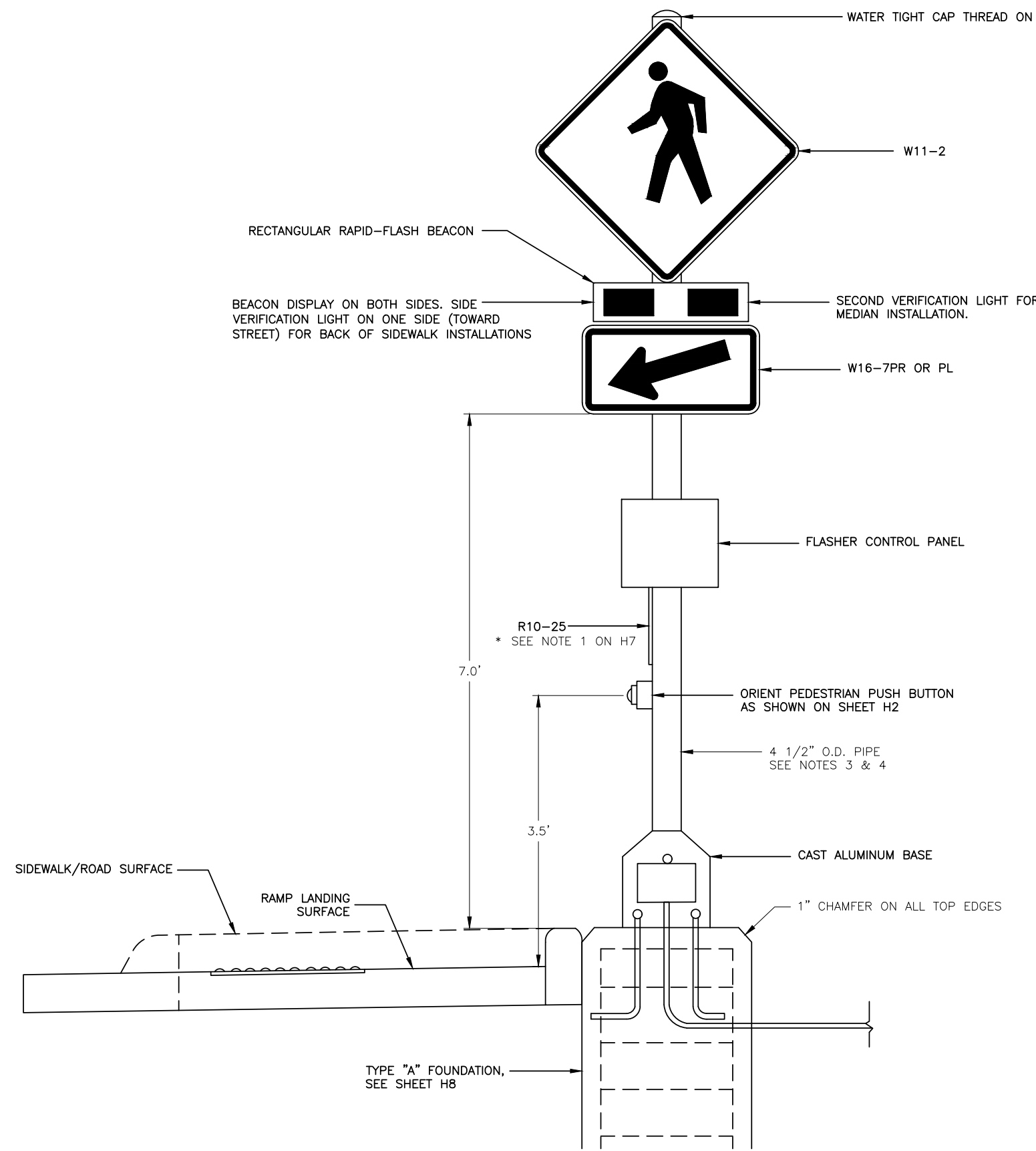

GENERAL NOTES:

1. LOCATE J-BOXES 1' FROM BACK OF EDGE OF PAVEMENT OR SIDEWALK.
2. WHEN CONDUIT RUNS ARE PARALLEL TO THE ROADWAY, INSTALL THEM 1' FROM THE BACK OF EDGE OF PAVEMENT.
3. USE SCHEDULE 40 STEEL PIPE THAT CONFORMS TO ASTM A 53 GRADE 8.
4. FURNISH ALL FLASHER POSTS HOT-DIP GALVANIZED ACCORDING TO ASTM A123.
5. SET THE END OF THE 2" RMC 2" ABOVE THE TOP OF THE FOUNDATION.
6. USE IRREVERSIBLE COMPRESSION CONNECTOR OR CADWELD TO BOND GROUNDING CONDUCTOR TO REINFORCEMENT CAGE. FASTEN #8 AWG GROUND WIRE TO OUTSIDE OF RMC WITH ELECTRICAL TAPE. SEE SPECIFICATIONS FOR BONDING AND GROUNDING REQUIREMENTS.
7. DRILL AND TAP THE POLE FOR ALL MOUNTING HOLES FOR SIGN AND PEDESTRIAN PUSH BUTTON HOUSING. REMOVE BURRS AFTER DRILLING. TREAT BARE STEEL SURFACES IN ACCORDANCE WITH AASHTO M36.
8. APPLY ANTI-SEIZE COMPOUND TO CAP SCREWS TAPPED DIRECTLY INTO POLE.
9. SEE SHEET H7 FOR MOUNTING AND BRACING AS REQUIRED FOR SIGNAGE.
10. SET FLASHING DURATION TO 25 SECONDS. FINAL TIMING TO BE ESTABLISHED IN THE FIELD BY THE ENGINEER.

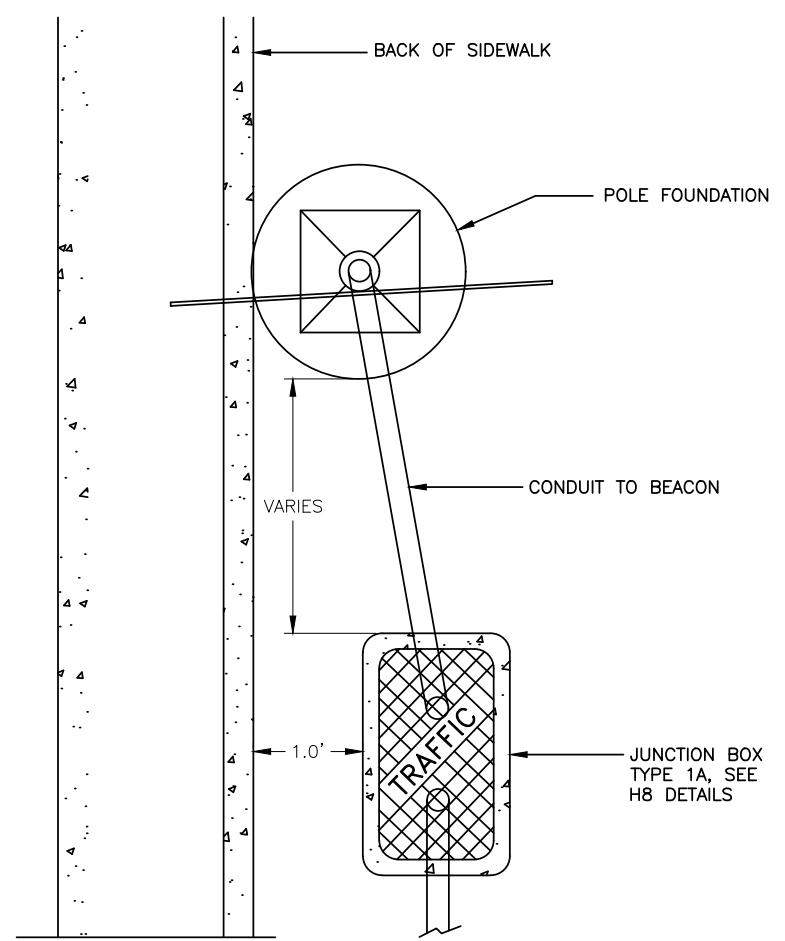

JUNCTION BOX PLAN VIEW DETAIL

SHEET NO.	TOTAL SHEETS	
H6	H8	
ADDENDUM NO.		
ATTACHMENT NO.		
REVISIONS		
NO.	DATE	DESCRIPTION

PLANS DEVELOPED BY:
 KINNEY ENGINEERING, LLC
 FOR
 CITY OF HOMER, ALASKA
 PUBLIC WORKS DEPARTMENT

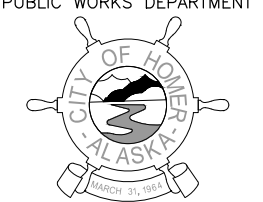

PHONE: (907) 235-3170
 FAX: (907) 235-3145



CITY OF HOMER
 PAVEMENT RESTORATION
 HEATH STREET
 RECTANGULAR RAPID
 FLASHING BEACON
 DETAILS

PLANS PREPARED BY: KINNEY ENGINEERING, LLC 3909 ARCTIC BLVD. SUITE 400 ANCHORAGE, AK 99503 : COA# AECL 1102 : PROJECT LOCATION: HOMER, AK
 DRAWING LOCATION
 Z:\PROJECTS\00710.city of homer. term contract 2022\22-04 heath street\DWGS\C\Sheets\00710_22-04_H5-HB_SIGN_DETAILS.dwg 9/1/2023 7:50 AM SCALE H7 LAYOUT H7 DRAFTED BY BILL PADDOCK

LIGHT/SIGNAL POLE SIGN FRAMING & MOUNTING DETAILS

PEDESTRIAN DETECTION SCHEDULE

POLE	PUSH BUTTON	PHASE	REMARKS
1	1	*	SEE NOTE 1
2	2	*	SEE NOTE 1

PEDESTRIAN DETECTION NOTES:

- INSTALL AN R10-25 SIGN WITH PEDESTRIAN PUSH BUTTON. SIGN SHALL NOT BE MEASURED FOR PAYMENT AND IS SUBSIDIARY TO RRFB PAY ITEM.
- INSTALL PUSH BUTTONS FACING EDGE OF PAVEMENT FOR POSTS MOUNTED ADJACENT THE ROADWAY.

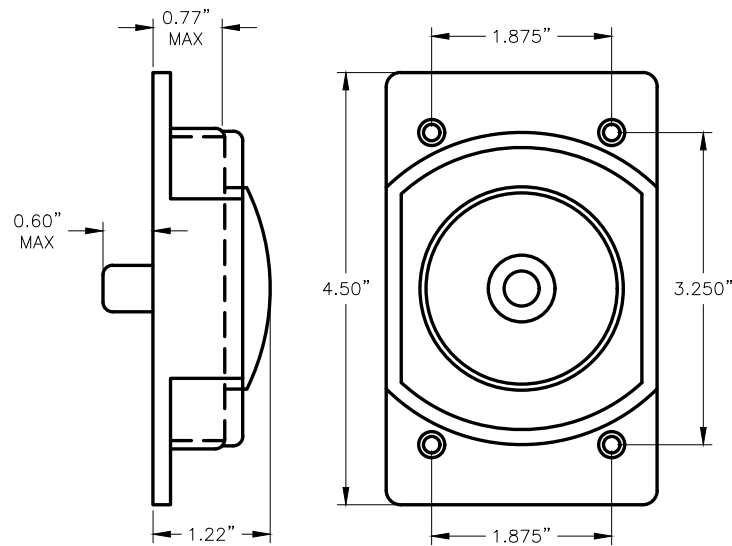

PEDESTRIAN PUSH BUTTON DETAIL

- IF $H > 48"$
3 WINDBEAMS REQUIRED
- IF $15" < H \leq 48"$
2 WINDBEAMS REQUIRED
- IF $H \leq 15"$
1 WINDBEAM REQUIRED
- USE 2 BANDS $H < 48"$
USE 4 BANDS $H \geq 48"$

- ① BAND LOCATIONS:
SPACE BANDS $H/5$
WHEN 4 ARE REQUIRED

- IF $W \geq 36"$
3 WINDBEAMS REQUIRED
- IF $W < 36"$
2 WINDBEAMS REQUIRED
- USE 2 BANDS $W < 48"$
USE 4 BANDS $W \geq 48"$

- ① BAND LOCATIONS:
SPACE BANDS $W/5$
WHEN 4 ARE REQUIRED

- ② WINDBEAM LOCATIONS:
SPACE WINDBEAMS TO
MATCH 1" SPACING OF
HOLES IN PERFORATED
STEEL TUBES. ADJUST
APPROXIMATE DIMENSIONS
FROM TOP AND BOTTOM
OF SIGN AS NECESSARY.

NOTE:
ATTACH SIGN TO WINDBEAMS WITH 3/16"
RIVETS AT 4" STAGGERED SPACING.

BANDING: 3/4" X 0.030" STAINLESS STEEL
DOUBLE BANDING (TYPICAL)
BUCKLES: 3/4" STAINLESS STEEL (TYPICAL)

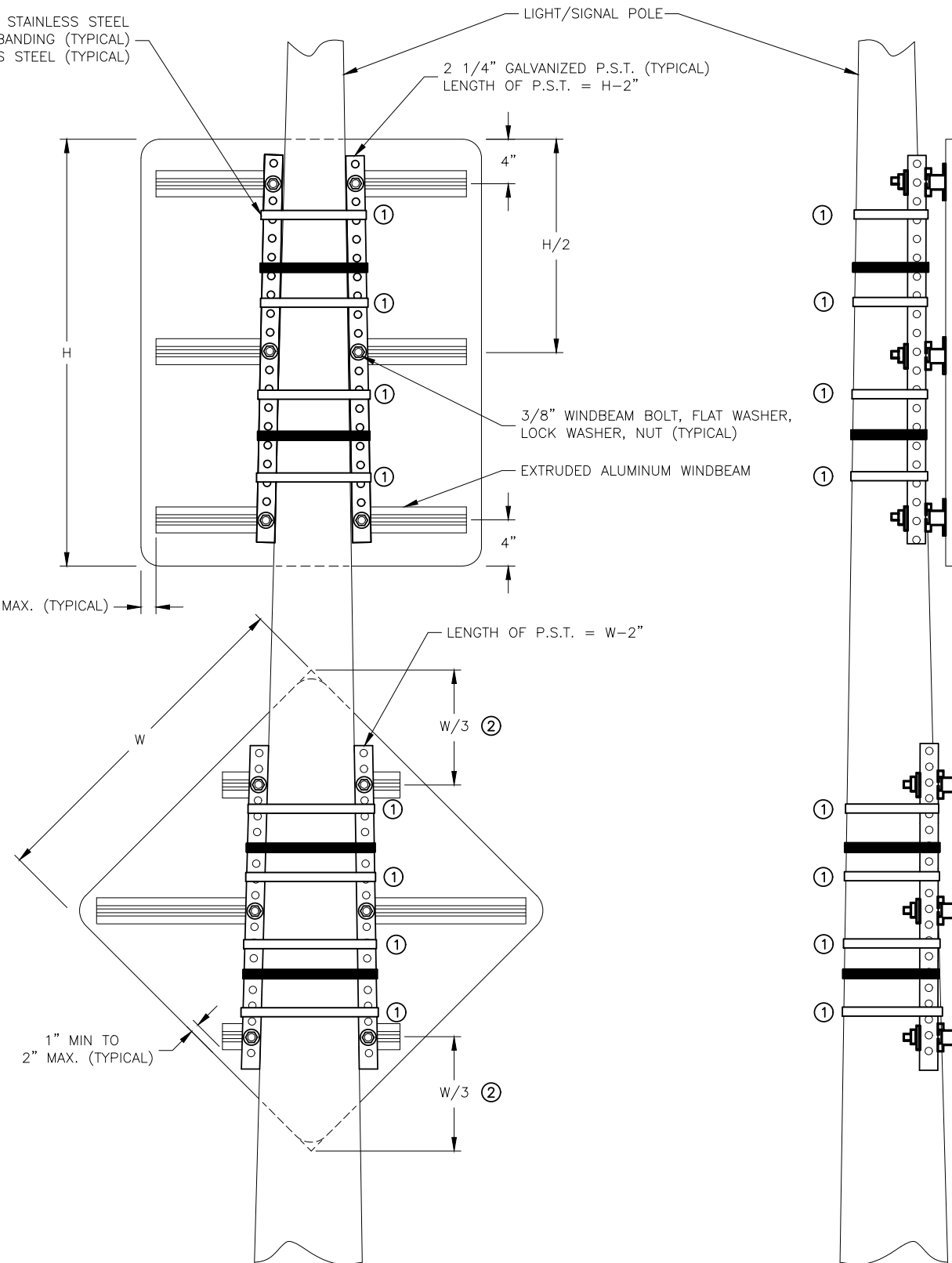

SHEET NO.	TOTAL SHEETS	
H7	H8	
ADDENDUM NO.		
ATTACHMENT NO.		
REVISIONS		
NO.	DATE	DESCRIPTION

PLANS DEVELOPED BY:
KINNEY ENGINEERING, LLC
FOR
CITY OF HOMER, ALASKA
PUBLIC WORKS DEPARTMENT

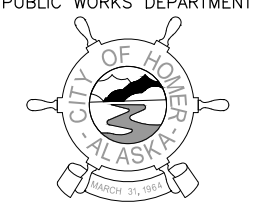

PHONE: (907) 235-3170
FAX: (907) 235-3145



CITY OF HOMER
PAVEMENT RESTORATION
HEATH STREET

SIGNAL DETAILS

PLANS PREPARED BY: KINNEY ENGINEERING, LLC 3909 ARCTIC BLVD. SUITE 400 ANCHORAGE, AK 99503 : COA# AECL 1102 : PROJECT LOCATION: HOMER, AK
 DRAFTED BY: BILL PADDOCK
 SCALE: H8
 LAYOUT: H8
 DATE: 9/1/2023 7:50 AM
 FILE: Z:\PROJECTS\00710_City of Homer Term Contract 2022\22-04_Heath Street\DWGS\Civil\00710_22-04_H8-HB_SIGN_DETAILS.dwg

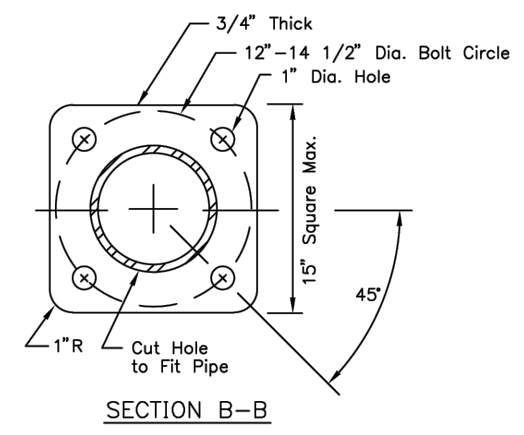
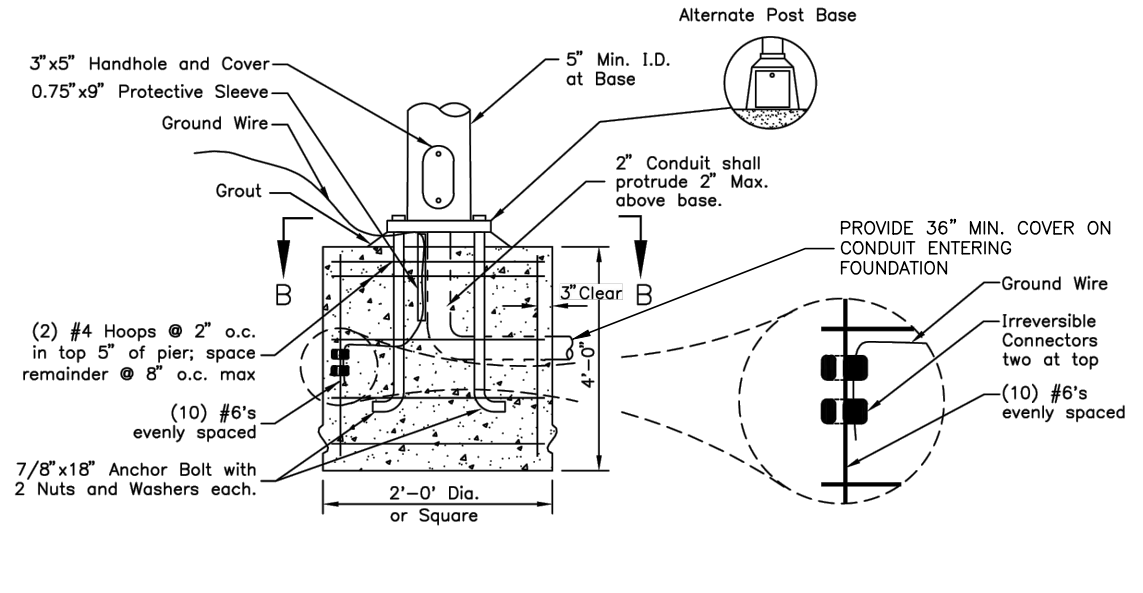

SIGNAL BASE POST TYPE "A" FOUNDATION
(NOT TO SCALE)

GENERAL NOTES:

1. INSTALL GROUND ROD WHEN CONTINUOUS ELECTRICALLY SECURE SYSTEM IS NOT PROVIDED BETWEEN CONTROLLER AND SERVICE GROUND.
2. ANCHOR BOLTS, NUTS AND WASHERS SHALL BE HIGH STRENGTH STEEL AND SHALL CONFORM TO A.S.T.M. A-325. GALVANIZING OF SAME SHALL CONFORM TO A.S.T.M. A-153.
3. ANCHOR BOLTS MAY BE FIELD CUT AND BENT.
4. DAMAGE TO GALVANIZED SURFACES AS A RESULT OF FIELD DRILLING AND OR CUTTING SHALL BE REPAIRED IN ACCORDANCE WITH FEDERAL SPECIFICATIONS TT-P-641.
5. USE CLASS A, OR AA CONCRETE.
6. REINFORCING STEEL TO CONFORM TO A.S.T.M. A-615 GRADE 60 (Fy=ksi).

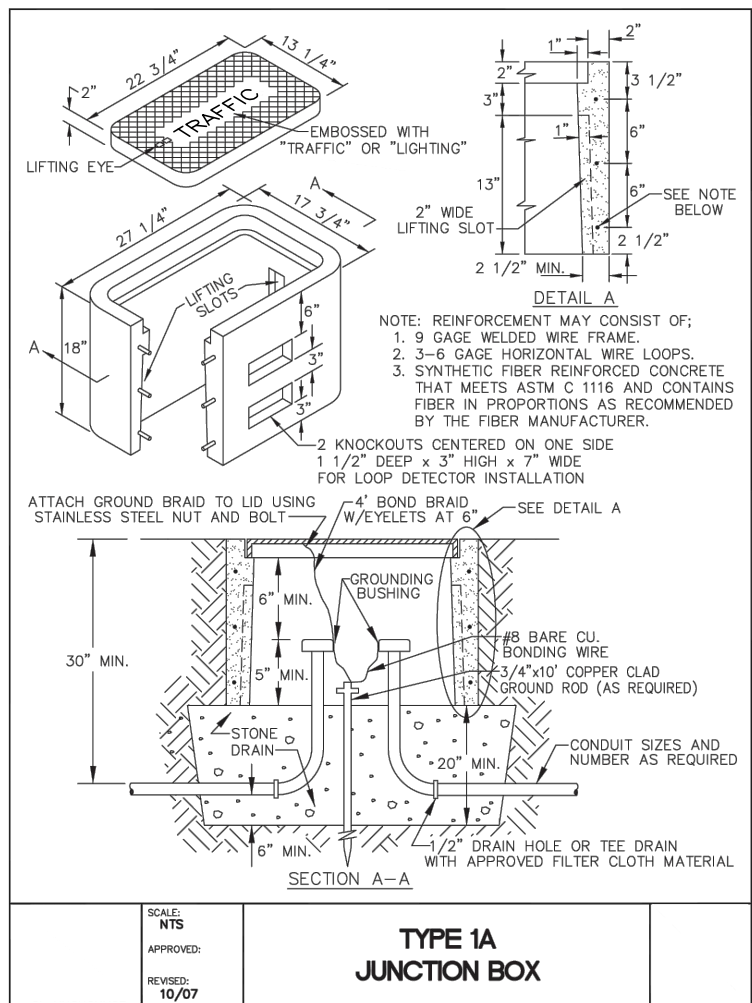

TYPE 1A JUNCTION BOX



EXISTING RECEPTACLE DETAIL

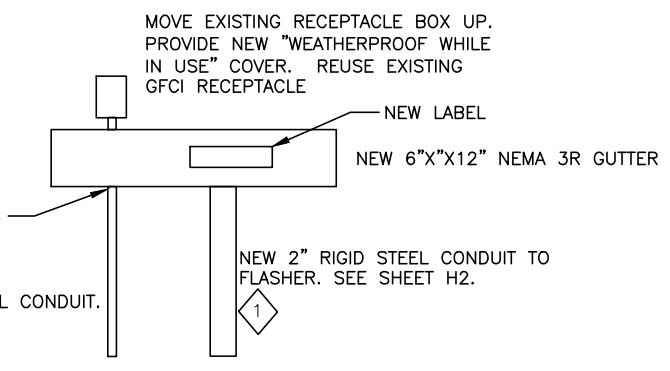

MODIFIED RECEPTACLE DETAIL

RECTANGULAR RAPID FLASHING BEACON (RRFB) POWER NOTES:

1. IT IS UNKNOWN IF THE IN COMING POWER TO THE RECEPTACLE IS IN THE 3/4" CONDUIT OR THE BACK OF THE WEATHER PROOF BOX. IF IT COMES THRU THE BACK OF THE BOX, MOUNT THE NEW GUTTER WHERE THE RECEPTACLE IS LOCATED AND MOVE THE BOX UP.
2. LOCATE THE PANEL SCHEDULE IN THE BUILDING AND ADD "PEDESTRIAN FLASHER" TO THE CIRCUIT DESCRIPTION OF THE EXTERIOR RECEPTACLE.
3. INSTALL A PHENOLIC LABEL "POWER TO PEDESTRIAN FLASHER" TO THE GUTTER COVER. LABEL SHALL BE COLORED WHITE, 1" HIGH WITH RED 3/4" LETTERING.
4. TAP THE POWER TO THE FLASHER AHEAD OF THE GFCI RECEPTACLE.
5. USE POLARIS INSULATED LUG KITS OR EQUAL FOR THE TAP IN THE GUTTER.
6. ALL MATERIALS AND LABOR REQUIRED FOR CONSTRUCTION OF RRFB POWER SERVICE CONNECTION IS SUBSIDIARY TO RRFB PAY ITEM A-34.

SHEET NO.	TOTAL SHEETS	
H8	H8	
ADDENDUM NO.		
ATTACHMENT NO.		
REVISIONS		
NO.	DATE	DESCRIPTION

PLANS DEVELOPED BY:
KINNEY ENGINEERING, LLC
FOR
CITY OF HOMER, ALASKA
PUBLIC WORKS DEPARTMENT



CITY OF HOMER
PAVEMENT RESTORATION
HEATH STREET

SIGNAL DETAILS

PLANS PREPARED BY: KINNEY ENGINEERING, LLC 3909 ARCTIC BLVD. SUITE 400 ANCHORAGE, AK 99503 : COA# AECL 1102 : PROJECT LOCATION: HOMER, AK
 DRAWING LOCATION
 Z:\PROJECTS\00710.city of homer. term contract 2022\22-04 heath street\DWGS\C\Sheets\00710_22-04_J1_ TRAFFIC CONTROL.dwg 5/1/2023 2:03 PM

DRAFTED BY
 BILL PADDOCK

SCALE

LAYOUT
 J1

SHEET NO.	TOTAL SHEETS	
J1	J2	
ADDENDUM NO.		
ATTACHMENT NO.		
REVISIONS		
NO.	DATE	DESCRIPTION

TRAFFIC MAINTENANCE NOTES:

1. THE CONTRACTOR SHALL SUBMIT A DETAILED TRAFFIC CONTROL PLAN (TCP) TO THE COH FOR REVIEW BY BOTH THE COH AND ADOT&PF. THE TCP MUST RECEIVE APPROVAL FROM BOTH THE COH AND ADOT&PF BEFORE STARTING ANY WORK.
2. PROVIDE, INSTALL, MAINTAIN, MOVE AND REMOVE THE SPECIFIED TRAFFIC CONTROL DEVICES AND ACCESS ACCORDING TO COH STANDARDS, CURRENT ALASKA TRAFFIC MANUAL, ALASKA SIGN DESIGN SPECIFICATION AND APPROVED TRAFFIC CONTROL PLAN (TCP) SETUPS.
3. MOUNT SIGNS SECURELY. MAINTAIN WORK SITE AND AFFECTED AREAS DAILY.
4. THE FINAL JUDGEMENT IN THE SELECTION NUMBER, AND APPLICATION OF THE TRAFFIC CONTROL DEVICES AND LOCATION OF ALL TRAFFIC CONTROL MEASURES WILL REST WITH THE ENGINEER.
5. COVER EXISTING SIGNS WHICH CONFLICT WITH CONSTRUCTION SIGNING.
6. CONSTRUCTION SIGNING SPECIFIED MAY BE ALTERED BY THE ENGINEER TO MEET CHANGING CONDITIONS AND TO PROTECT THE TRAVELING PUBLIC.
7. TYPE 'A' FLASHING WARNING LIGHTS SHALL BE USED IN CONJUNCTION WITH TYPE III BARRICADES, ROAD CLOSURE SIGNS, ADVANCE DETOUR SIGNING AND THE FIRST TYPE II BARRICADE ENCOUNTERED BY TRAFFIC WHEN USED FOR CHANNELIZING. TYPE 'C' STEADY BURN WARNING LIGHTS SHALL BE USED IN CONJUNCTION WITH REMAINING TYPE II BARRICADES USED FOR CHANNELIZING.
8. ALL CONSTRUCTION SIGNS SHALL HAVE HIGH LEVEL WARNING DEVICES ATTACHED.
9. WORK ZONES MAY OVERLAP DURING CONSTRUCTION UPON APPROVAL BY THE ENGINEER.
10. INTEGRATE TRAFFIC CONTROL WITH OTHER CONSTRUCTION IN THE AREA.
11. DETAILS NOT SHOWN, BUT NECESSARY TO IMPLEMENT THE TRAFFIC CONTROL PLAN SHALL COMPLY WITH THE ALASKA TRAFFIC MANUAL AND MUTCD.
12. ALL SPECIAL SIGNS SHALL BE BLACK ON ORANGE BACKGROUND WITH BORDERS HAVING 1.5" RADIUS AND 0.75" THICKNESS.
13. CONTRACTOR SHALL MAINTAIN PEDESTRIAN ACCESS.

PLANS DEVELOPED BY:
 KINNEY ENGINEERING, LLC
 FOR
 CITY OF HOMER, ALASKA
 PUBLIC WORKS DEPARTMENT



PHONE: (907) 235-3170
 FAX: (907) 235-3145



CITY OF HOMER
 PAVEMENT RESTORATION
 HEATH STREET

TRAFFIC CONTROL

REVISIONS		
NO.	DATE	DESCRIPTION

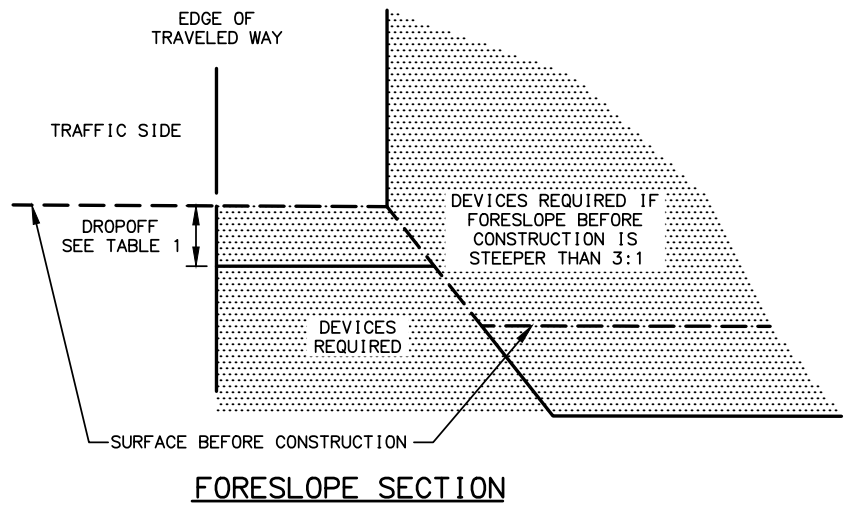
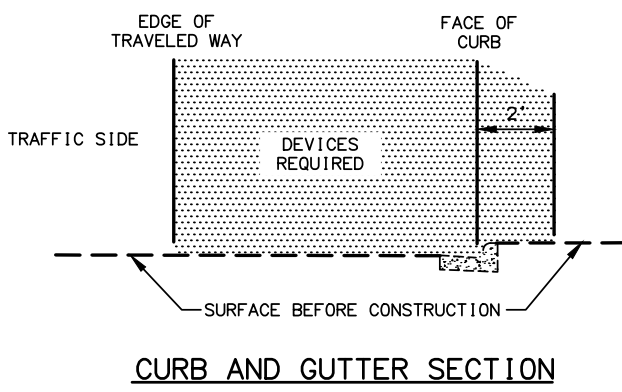
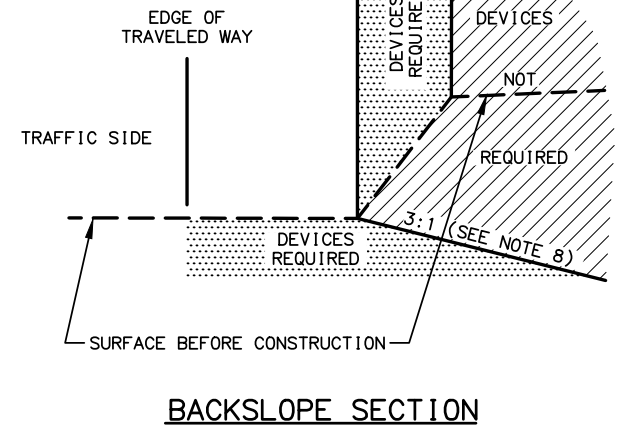
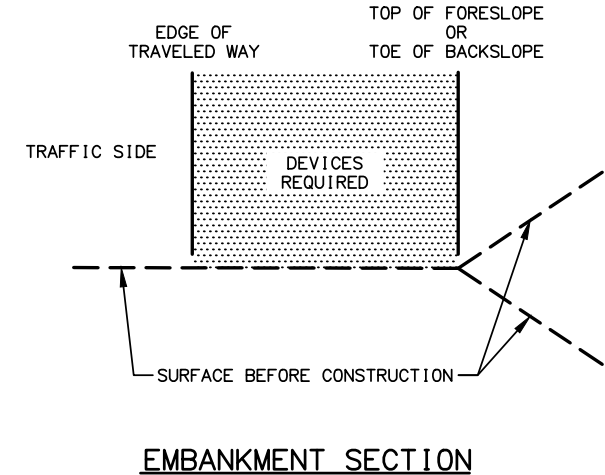

LEGEND

- WORK AREA WHERE TRAFFIC CONTROL DEVICES ARE REQUIRED
- WORK AREA WHERE TRAFFIC CONTROL DEVICES ARE NOT REQUIRED
- SURFACE BEFORE CONSTRUCTION
- CONSTRUCTION AREA BOUNDARY

ROADWAY TYPE	DROPOFF ≤ 2"	2" < DROPOFF ≤ 12"	DROPOFF ≥ 12"
AVERAGE DAILY TRAFFIC > 4000 OR SPEED > 40 MPH	TAPER ASPHALT AT 1:1 OR .45°	TYPE II BARRICADES OR DRUMS	TEMPORARY PORTABLE CONCRETE BARRIER OR TEMPORARY GUARDRAIL
ALL OTHER ROADWAYS	NONE REQUIRED	TUBULAR CANDLES OR DELINEATORS	TYPE II BARRICADES OR DRUMS

* SPACE THE DEVICES IN ACCORDANCE WITH REQUIREMENTS FOR SPACING TYPE II BARRICADES AND DRUMS SET FORTH IN THE ALASKA TRAFFIC MANUAL.

NOTES:

1. TRAFFIC CONTROL DEVICES REQUIRED BY THE GUIDELINES ON THIS SHEET ARE INTENDED FOR CONDITIONS WHICH WILL BE IN PLACE LONGER THAN ONE CONTINUOUS WORK SHIFT. AN APPROVED TRAFFIC CONTROL PLAN IS REQUIRED PRIOR TO BEGINNING WORK.
2. THE GROUND CROSS SECTION AT A LOCATION BEFORE CONSTRUCTION DETERMINES WHETHER TRAFFIC CONTROL DEVICES ARE NEEDED AT THE SAME LOCATION DURING CONSTRUCTION.
3. GUARDRAIL EXISTING AT A LOCATION BEFORE CONSTRUCTION SHALL REMAIN IN PLACE DURING CONSTRUCTION OR APPROVED ALTERNATE DEVICES INSTALLED.
4. INSTALL TRAFFIC CONTROL DEVICES BETWEEN THE EDGE OF TRAVELED WAY AND THE WORK AREA ON ANY ROADWAY OPENED TO TRAFFIC WHEN REQUIRED BY THIS DRAWING.
5. EXISTING ROADWAY ALIGNMENTS INSTALL TRAFFIC CONTROL DEVICES WHEN WORK OCCURS IN THE DEVICES REQUIRED AREAS SHOWN ON THIS DRAWING.
6. DETOURS, TEMPORARY ROADWAYS, OR NEW ROADWAYS NOT YET COMPLETE. INSTALL TRAFFIC CONTROL DEVICES WHEN ANY OF THE FOLLOWING CONDITIONS EXIST:
 - A. THE HORIZONTAL OR VERTICAL CURVATURE IS MORE SEVERE THAN BEFORE CONSTRUCTION BEGAN.
 - B. THE ROADWAY OR SHOULDER WIDTH IS LESS THAN BEFORE CONSTRUCTION BEGAN.
 - C. THE BACKSLOPE OR FORESLOPE IS STEEPER THAN BEFORE CONSTRUCTION BEGAN.
 - D. THE HEIGHT OF THE FORESLOPE IS GREATER THAN BEFORE CONSTRUCTION BEGAN.
7. DROPOFFS:
 INSTALL TRAFFIC CONTROL DEVICES IN ACCORDANCE WITH THE FORESLOPE SECTION DETAIL AND TABLE 1.
8. ON ANY NEWLY CONSTRUCTED SLOPE STEEPER THAN 4:1 TO 3:1 PROVIDE A TEN FOOT FLAT RECOVERY AREA AT THE TOE OF SLOPE OR INSTALL TRAFFIC CONTROL DEVICES IN ACCORDANCE WITH THE FORESLOPE SECTION DETAIL.
9. TRAFFIC CONTROL DEVICE REQUIREMENTS:
 - A. ON ROADWAYS WITH A SPEED LIMIT GREATER THAN 40 MILES PER HOUR OR AVERAGE DAILY TRAFFIC VOLUME GREATER THAN 4000 VEHICLES PER DAY INSTALL TEMPORARY PORTABLE CONCRETE BARRIER OR TEMPORARY GUARDRAIL. ON MULTI-LANE ROADWAYS CLOSE THE LANE CLOSEST TO THE WORK AREA AND INSTALL DRUMS.
 TERMINATE RUNS OF TEMPORARY PORTABLE CONCRETE BARRIER USING ONE OF THE FOLLOWING THREE METHODS:
 - I. TEMPORARY CRASH ATTENUATOR.
 - II. RIGID TO SEMI-RIGID GUARDRAIL TRANSITION WITH SLOTTED RAIL TERMINAL OR OTHER APPROVED CRASHWORTHY END TREATMENT.
 - III. FLARE THE ENDS OF THE TEMPORARY BARRIER AWAY FROM THE ROADWAY AT A RATE OF 15:1 ON A TRANSVERSE SLOPE OF 10:1 OR FLATTER TO THE OUTSIDE EDGE OF THE CLEAR ZONE AND INSTALL A SLOPING END TREATMENT, PER STANDARD DRAWING G-46.11.
 TERMINATE RUNS OF TEMPORARY GUARDRAIL USING EITHER OF THE FOLLOWING TWO METHODS:
 - I. SLOTTED RAIL TERMINAL OR OTHER APPROVED CRASHWORTHY END TREATMENT.
 - II. FLARE THE ENDS OF THE TEMPORARY GUARDRAIL AWAY FROM THE ROADWAY AT A RATE OF 15:1 ON TRANSVERSE SLOPE OF 10:1 OR FLATTER TO THE OUTSIDE EDGE OF THE CLEAR ZONE.
 - B. ON ALL OTHER ROADWAYS INSTALL TYPE II BARRICADES, DRUMS OR DELINEATORS WHEN DEVICES ARE REQUIRED. SPACE THE DEVICES IN ACCORDANCE WITH THE REQUIREMENTS FOR SPACING TYPE II BARRICADES AND DRUMS SET FORTH IN THE ALASKA TRAFFIC MANUAL.
10. DO NOT CONSTRUCT VERTICAL DROP OFFS GREATER THAN 1.5" WITHIN THE TRAFFIC LANE OR ACTIVE WHEEL TRACK. PROVIDE 2' OF SHY DISTANCE FROM EDGE OF ALL TRAFFIC CONTROL DEVICES TO THE EDGE OF THE TRAVELED WAY.

PLANS DEVELOPED BY:
 KINNEY ENGINEERING, LLC
 FOR
 CITY OF HOMER, ALASKA
 PUBLIC WORKS DEPARTMENT

PHONE: (907) 235-3170
 FAX: (907) 235-3145

Leon R. Galbraith
 CE 12583
 REGISTERED PROFESSIONAL ENGINEER

CITY OF HOMER
 PAVEMENT RESTORATION
 HEATH STREET
 TRAFFIC CONTROL
 DEVICES



Safety Benefits:

RRFBs can reduce crashes up to:

47%

for pedestrian crashes.⁴

RRFBs can increase motorist yielding rates up to:

98%

(varies by speed limit, number of lanes, crossing distance, and time of day).³



RRFBs used at a trail crossing.
Source: LJB

For more information on this and other FHWA Proven Safety Countermeasures, please visit

<https://highways.dot.gov/safety/proven-safety-countermeasures> and https://highways.dot.gov/sites/fhwa.dot.gov/files/2022-06/techSheet_RRFB_2018.pdf.

Rectangular Rapid Flashing Beacons (RRFB)

A marked crosswalk or pedestrian warning sign can improve safety for pedestrians crossing the road, but at times may not be sufficient for drivers to visibly locate crossing locations and yield to pedestrians. To enhance pedestrian conspicuity and increase driver awareness at uncontrolled, marked crosswalks, transportation agencies can install a pedestrian actuated Rectangular Rapid Flashing Beacon (RRFB) to accompany a pedestrian warning sign. RRFBs consist of two, rectangular-shaped yellow indications, each with a light-emitting diode (LED)-array-based light source.¹ RRFBs flash with an alternating high frequency when activated to enhance conspicuity of pedestrians at the crossing to drivers.

For more information on using RRFBs, see the Interim Approval in the *Manual on Uniform Traffic Control Devices (MUTCD)*.¹

Applications

The RRFB is applicable to many types of pedestrian crossings but is particularly effective at multilane crossings with speed limits less than 40 miles per hour.² Research suggests RRFBs can result in motorist yielding rates as high as 98 percent at marked crosswalks, but varies depending on the location, posted speed limit, pedestrian crossing distance, one- versus two-way road, and the number of travel lanes.³ RRFBs can also accompany school or trail crossing warning signs.

RRFBs are placed on both sides of a crosswalk below the pedestrian crossing sign and above the diagonal downward arrow plaque pointing at the crossing.¹ The flashing pattern can be activated with pushbuttons or passive (e.g., video or infrared) pedestrian detection, and should be unlit when not activated.

Considerations

Agencies should:²

- Install RRFBs in the median rather than the far-side of the roadway if there is a pedestrian refuge or other type of median.
- Use solar-power panels to eliminate the need for a power source.
- Reserve the use of RRFBs for locations with significant pedestrian safety issues, as over-use of RRFB treatments may diminish their effectiveness.

Agencies shall not:²

- Use RRFBs without the presence of a pedestrian, school or trail crossing warning sign.
- Use RRFBs for crosswalks across approaches controlled by YIELD signs, STOP signs, traffic control signals, or pedestrian hybrid beacons, except for the approach or egress from a roundabout.

¹ *MUTCD Interim Approval 21 - RRFBs at Crosswalks*.

² "Rectangular Rapid Flash Beacon" in PEDSAFE: Pedestrian Safety Guide and Countermeasure Selection System. FHWA, (2013).

³ Fitzpatrick et al. "Will You Stop for Me? Roadway Design and Traffic Control Device Influences on Drivers Yielding to Pedestrians in a Crosswalk with a Rectangular Rapid-Flashing Beacon." Report No. TTI-CTS-0010. Texas A&M Transportation Institute.

⁴ (CMF ID: 9024) NCHRP Research Report 841 Development of Crash Modification Factors for Uncontrolled Pedestrian Crossing Treatments, (2017).

CITY OF HOMER
FINANCIAL SUPPLEMENT

PROJECT NAME	<u>Heath Street Pavement Restoration Project</u>	DATE	<u>11/22/2023</u>
DEPARTMENT	<u>Public Works</u>	SPONSOR	<u>PW Director</u>
REQUESTED AMOUNT	<u>\$ 25,000</u>		

DESCRIPTION	<p>The City Council appropriated \$500,000 to the Pavement Restoration Program with Ordinance 22-26. Resolution 22-073 was adopted, authorizing a Task Order, in the amount of \$140,472, to Kinney Engineering, LLC ("Kinney") to design the Heath Street Pavement Restoration Project, one of the projects in that program, and the design work is now 95% complete.</p> <p>Public Works requested Kinney provide some out-of-scope work to evaluate and design a mid-block crossing at the intersection of Hazel Avenue and Heath Street as well as video camera the existing storm drain, for total cost of \$16,181.25, about 11.5% of the original contract value. The Pavement Restoration Program was closed during the FY24/25 budget process so additional funding is being requested from the HART Roads Fund. This appropriation is to cover the \$16,181.25 as well as a small contingency, for a total of \$25,000, to pay for completion of the design of the Heath Street Pavement Restoration Project.</p>
-------------	---

FUNDING SOURCE(S)	OPERATING	GF CARMA	GF FLEET CARMA	PORT RESERVES	WATER CARMA
	0%	0%	0%	0%	0%
	HAWSP	HART-ROADS	HART-TRAILS	PORT FLEET RESERVES	SEWER CARMA
	0%	100%	0%	0%	0%

FUNDING SOURCE 1: HART Roads (160)	FUNDING SOURCE 2:	FUNDING SOURCE 3:
Current Balance <u>\$ 5,878,660</u>	Current Balance _____	Current Balance _____
Encumbered <u>\$ 4,303,327</u>	Encumbered _____	Encumbered _____
Requested Amount <u>\$ 25,000</u>	Requested Amount _____	Requested Amount _____
Other Items on Current Agenda <u>\$ 0</u>	Other Items on Current Agenda _____	Other Items on Current Agenda _____
Remaining Balance <u>\$ 1,550,333</u>	Remaining Balance _____	Remaining Balance _____
FUNDING SOURCE 4:	FUNDING SOURCE 5:	FUNDING SOURCE 6:
Current Balance _____	Current Balance _____	Current Balance _____
Encumbered _____	Encumbered _____	Encumbered _____
Requested Amount _____	Requested Amount _____	Requested Amount _____
Remaining Balance _____	Remaining Balance _____	Remaining Balance _____

**CITY OF HOMER
HOMER, ALASKA**

City Manager
Public Works Director

ORDINANCE 23-62

AN ORDINANCE OF THE CITY COUNCIL AMENDING THE FY24 CAPITAL BUDGET BY APPROPRIATING AN ADDITIONAL \$25,000 FROM THE HOMER ACCELERATED ROADS AND TRAILS (HART) ROAD FUND TO COMPLETE THE DESIGN OF THE HEATH STREET PAVEMENT RESTORATION PROJECT.

WHEREAS, The City Council appropriated \$500,000 to the Pavement Restoration Program with Ordinance 22-26; and

WHEREAS, Resolution 22-073 was adopted, authorizing a Task Order, in the amount of \$140,472, to Kinney Engineering, LLC (“Kinney”) to design the Heath Street Pavement Restoration Project, one of the projects in that program, and the design work is now 95% complete; and

WHEREAS, Public Works requested Kinney provide some out-of-scope work to evaluate and design a mid-block crossing at the intersection of Hazel Avenue and Heath Street as well as video camera the existing storm drain, for total cost of \$16,181.25, about 11.5% of the original contract value; and

WHEREAS, The Pavement Restoration Program was closed during the FY24/25 budget process so additional funding is being requested from the HART Roads Fund; and

WHEREAS, This appropriation is to cover the \$16,181.25 as well as a small contingency, for a total of \$25,000, to pay for completion of the design of the Heath Street Pavement Restoration Project.

Section 1. The Homer City Council hereby amends the FY24 Capital Budget by appropriating \$25,000 to complete the design of the Heath Street Pavement Restoration Project as follows:

<u>Fund</u>	<u>Description</u>	<u>Amount</u>
160	HART Roads	\$25,000

Section 2. This is a budget amendment ordinance, is temporary in nature, and shall not be codified.

ENACTED BY THE CITY COUNCIL OF HOMER, ALASKA, this ___ day of ____, 2024.

45
46
47
48
49
50
51
52
53
54
55
56
57
58
59
60
61
62
63

CITY OF HOMER

KEN CASTNER, MAYOR

ATTEST:

MELISSA JACOBSEN, MMC, CITY CLERK

YES:

NO:

ABSENT:

ABSTAIN:

First Reading:

Public Hearing:

Second Reading:

Effective Date:



MEMORANDUM

Ordinance 23-63, An Ordinance of the City Council of Homer, Alaska Amending the FY24 Capital Budget by Renewing the Appropriation of Funds in the Amount of \$100,000 from the Port & Harbor Reserves Balance for the Purpose of Replacing the Fish Grinding Building and Completing Drainage Improvements. City Manager/Port Director.

Item Type: Backup Memorandum
Prepared For: Mayor and City Council
Date: 11/22/2023
From: Bryan Hawkins, Port Director
Through: Rob Dumouchel, City Manager

Summary Statement:

The City's Fiscal Years 2022 and 2023 Capital Budget, approved by City Council via Ordinance 21-36(S2)(A), appropriated \$100,000 from the Port and Harbor Reserves in support of the Fish Grinding Building Replacement project.

In June of 2022, City administration applied for Dingell-Johnson Sport Fish Restoration Act grant funds from the Alaska Department of Fish and Game to assist with project funding. The award of grant funds was recently approved by the Federal agency managing the awards and we anticipate receiving an obligating award document in January 2024. At that time, staff will prepare an Ordinance for City Council to consider for accepting and appropriating the grant funds.

The City's FY22 Capital budget appropriation will be used to meet the 25% local match requirement. However, the appropriation is set to lapse on June 30, 2024 and needs to be renewed to ensure the funds remain available.

Staff Recommendation:

Adopt Ordinance 23-63 to insure budgeted funds are available as match for Federal grant funds.

CITY OF HOMER
HOMER, ALASKA

City Manager

ORDINANCE 21-36(S-2)(A)

AN ORDINANCE OF THE CITY COUNCIL OF HOMER, ALASKA
ADOPTING THE FISCAL YEARS 2022 AND 2023 CAPITAL BUDGET.

THE CITY OF HOMER ORDAINS:

Section 1. Pursuant to the authority of Alaska Statutes Title 29, the following appropriations are made for the fiscal year ending June 2022:

Capital Projects Funds:

General Fund Fleet CARMA (152)	\$461,000	\$374,000
General Fund CARMA (156)	\$454,300	\$424,300
Utility CARMA (256)	\$1,092,748	\$773,248
Port Fleet Reserves (452)	\$107,000	
Port Reserves (456)	\$505,000	
HART Roads (160)	\$2,332,168	\$2,212,168 \$2,159,562
HART Trails (165)	\$350,000	\$340,000
HAWSP (205)	\$884,536	\$859,536 \$25,000
Total Capital Expenditures	\$6,186,752	\$6,041,752 \$4,708,110

Section 2. Pursuant to the authority of Alaska Statutes Title 29, the following appropriations are made for the fiscal year ending June 2023:

Capital Projects Funds:

General Fund Fleet CARMA (152)	\$0
General Fund CARMA (156)	\$0
Utility CARMA (256)	\$0
Port Fleet Reserves (452)	\$0
Port Reserves (456)	\$0
HART Roads (160)	\$0
HART Trails (165)	\$10,000
HAWSP (205)	\$0
Total Capital Expenditures	\$10,000

Section 3. The following transfers be made into Fund 152, Account 0375:

43 Transfer from:

44 <u>Account No.</u>	<u>Description</u>	<u>Amount</u>
45 152-0380	Admin	\$41,929
46 152-0381	Fire	\$120,128
47 152-0382	Police	\$19,756
48 152-0383	Public Works	\$72,700
49 152-0391	Insurance	\$139,818

51 Transfer to:

52 <u>Account No.</u>	<u>Description</u>	<u>Amount</u>
53 152-0375	General	\$393,832

54
55
56 Section 3. The amounts appropriated by this ordinance are appropriated to the
57 purposes stated in the adopted budget.
58

59 Section 4. This Ordinance is limited to approval of the Budget and appropriations for
60 Fiscal Year 2022 and 2023, is a non code Ordinance and shall become effective July 1, ^{2022.}
61 ₂₀₂₁

62 ENACTED BY THE CITY COUNCIL OF HOMER, ALASKA, this 26th day of July, 2021.

63
64 CITY OF HOMER

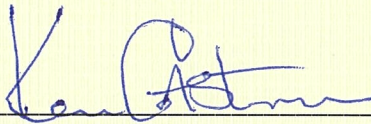
65 
66 _____
67 KEN CASTNER, MAYOR
68

69 ATTEST:

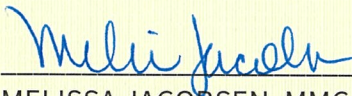
70
71 
72 _____
73 MELISSA JACOBSEN, MMC, CITY CLERK
74



75 AYES: 5
76 NOES: 0
77 ABSTAIN: 0
78 ABSENT: 0
79

80 First Reading: 6.14.21
81 Public Hearing: 6.28.21 & 7.26.21
82 Second Reading: 7.26.21
83 Effective Date: ~~7.27.21~~
7.1.21

1 **CITY OF HOMER**
2 **HOMER, ALASKA**

3 City Manager

4 **ORDINANCE 23-63**

5
6 AN ORDINANCE OF THE CITY COUNCIL OF HOMER, ALASKA
7 AMENDING THE FY24 CAPITAL BUDGET BY RENEWING THE
8 APPROPRIATION OF FUNDS IN THE AMOUNT OF \$100,000 FROM
9 THE PORT AND HARBOR RESERVES FOR THE PURPOSE OF
10 REPLACING THE FISH GRINDING BUILDING AND COMPLETING
11 DRAINAGE IMPROVEMENTS.
12

13 WHEREAS, The City’s Fish Grinding Building houses a fish waste grinding system that
14 annually processes, on average, 304,600 pounds of fish carcasses generated by non-
15 commercial sport fishing activity and collected from the City’s public fish cleaning tables for
16 environmentally sound disposal; and
17

18 WHEREAS, Replacing the twenty-two year old, badly-corroded metal clad building and
19 correcting a site drainage/water quality issue is a project in the City’s Capital Improvement;
20 Plan; and
21

22 WHEREAS, The City’s Fiscal Years 2022 and 2023 Capital Budget, approved by City
23 Council via Ordinance 21-36(S2)(A), appropriated \$100,000 in support of the Fish Grinding
24 Building project; and
25

26 WHEREAS, Expenditure of these funds was put on hold while City administration
27 applied for grant funds from the Dingell-Johnson Sport Fish Restoration Act to assist with
28 project costs; and
29

30 WHEREAS, The City was recently informed that an award for the project was Federally
31 approved and in the award process; and
32

33 WHEREAS, The City’s original appropriation that will be used as local match funds is set
34 to lapse on June 30, 2024 and needs to be renewed to ensure the funds remain available.
35

36 NOW, THEREFORE, THE CITY OF HOMER ORDAINS:
37

38 Section 1. The Homer City Council hereby amends the FY24 Capital Budget to renew
39 the appropriation of \$100,000 from the Port and Harbor Reserves for the purpose of replacing
40 the Fish Grinding Building and completing drainage improvements as follows:
41

42
43
44
45
46
47
48
49
50
51
52
53
54
55
56
57
58
59
60
61
62
63
64
65
66
67
68
69
70
71
72

<u>Fund</u>	<u>Description</u>	<u>Amount</u>
456-0380	Fish Grinding Building Construction	\$100,000

Section 2. This ordinance is a budget amendment only, is not of a permanent nature and is a non code ordinance.

ENACTED BY THE CITY COUNCIL OF HOMER, ALASKA this ____ day of _____, 2024.

CITY OF HOMER

KEN CASTNER, MAYOR

ATTEST:

MELISSA JACOBSEN, MMC, CITY CLERK

YES:

NO:

ABSTAIN:

ABSENT:

Introduction:

Public Hearing:

Second Reading:

Effective Date:



MEMORANDUM

Resolution 23-123, A Resolution of the City Council Approving a Sole Source Contract to Zenon Environmental Corporation to Purchase Five Membrane Filter Trains for the Water Treatment Plant with the First Payment due in 2024 in the Amount of \$92,774 and Payments in Subsequent Years Subject to Inflation and Future Council Appropriations, and Authorizing the City Manager to Negotiate and Execute the Appropriate Documents. City Manager/Public Works Director.

Item Type: Backup Memorandum
Prepared For: City Council
Date: November 13, 2023
From: Janette Keiser, PE, Public Works Director/City Engineer
Through: Rob Dumouchel, City Manager

I. Issue: The purpose of this Memorandum is to request approval to award a sole source contract to Zenon Environmental Corporation (“Zenon”) to purchase membrane replacement modules for the Water Treatment Plant (WTP), with the first payment in 2024 in the amount of \$92,224 and payments in subsequent years subject to future Council appropriations.

II. Background:

Homer’s drinking water treatment technology involves the use of modules of very small diameter membranes, which are hung on racks, similar to a drying rack of angel hair pasta. Water passes through the membranes, which trap sediment, organics and other particles. The original membrane trains were installed in 2009, with an expected life span of 10-14 years. Thus, they are at the end of their useful life, so we have developed a plan for replacing them over the next few years.

The FY24 CIP includes \$80,000 to purchase one membrane train. Ordinance 23-57 appropriated an additional \$35,000 from the Water CARMA Fund to fully cover the expected cost of the first membrane train in FY24. We will be asking for additional appropriations in future years to address future purchases.

We received a final proposal from Zenon for the new membrane trains. Zenon’s proposal covers membrane replacement over a period of five years, anticipating purchase of one membrane train each year. This locks in the base price for all five membrane trains. Prices will be adjusted for inflation.

The total value for the purchase of five membrane trains is \$463,870. The Annual Payment is \$92,774 for the first year. Payments for subsequent years will be subject to inflationary adjustments, in accordance with the US CPI-U, All Urban Consumers and future Council appropriations. In addition to the membrane trains themselves, this price includes fiber repair kits and other parts required to connect the new membranes to the existing frameworks. In the event future City Councils do not appropriate funds for future payments, we have the option to terminate the purchase agreement. Once terminated, there is no option to restart the agreement; we will need to start from scratch.

The City's water treatment plant operators have the skills, abilities and tools to install the new membrane trains once we receive them. We may ask HDR to help commission the new membrane trains to ensure smooth transition between old and new flow parameters. We will assess the need, and request funding, for this possibility when we get the first train.

Homer City Code allows exceptions to be made to bidding requirements in the cases where a sole source procurements is justified, HCC 3.16.060(i). A sole source procurement is justified in this case because Zenon (1) provided the original membrane trains and (2) is the only manufacturer of these specialized membranes in the country.

Zenon's cost proposal is deem fair and reasonable, because it is based on the price guarantee formula that was part of the original purchase in 2009, adjusted for inflation, shipping and other incidental costs we've been able to identify and negotiate, such as costs for the repair kits, etc. The membranes themselves are manufactured in Hungary and subject to U.S. Custom duties, which are subject to change. Because of this, we recommend a small contingency be provided to account for small cost adjustments.

Delivery is projected to be 52 weeks after receipt of a purchase order.

- III. RECOMMENDATION:** That the City Council approve a sole source contract to Zenon for the purchase of five membrane filter trains for the Water Treatment Plant, with the first payment due in 2024 in the amount of \$92,774 and payments in subsequent years subject to future Council appropriations.

1 **CITY OF HOMER**
2 **HOMER, ALASKA**

3 City Manager
4 Public Works Director

5 **RESOLUTION 23-123**

6
7 A RESOLUTION OF THE CITY COUNCIL OF HOMER, ALASKA
8 APPROVING A SOLE SOURCE CONTRACT TO ZENON
9 ENVIRONMENTAL CORPORATION TO PURCHASE FIVE MEMBRANE
10 FILTER TRAINS FOR THE WATER TREATMENT PLANT WITH THE
11 FIRST PAYMENT DUE IN 2024 IN THE AMOUNT OF \$92,774 AND
12 PAYMENTS IN SUBSEQUENT YEARS SUBJECT TO INFLATION AND
13 FUTURE COUNCIL APPROPRIATIONS AND AUTHORIZING THE
14 CITY MANAGER TO NEGOTIATE AND EXECUTE THE APPROPRIATE
15 DOCUMENTS.
16

17 WHEREAS, The City’s water is treated with a sophisticated system of long, small-
18 diameter hollow threads, which, when connected together in a frame, comprise a “membrane
19 filter”, referred to as a “train”; and
20

21 WHEREAS, The Water Treatment Plant (WTP), built in 2007, has room for six membrane
22 filter trains, of which five are operating, each with a life span of 10-15 years; and
23

24 WHEREAS, It is time to procure replacements for the units currently operating; and
25

26 WHEREAS, The FY24 Capital Budget includes \$80,000 to procure one membrane filter
27 train and Ordinance 23-57 appropriated an additional \$35,000 from the Water CARMA Fund to
28 fully cover the expected cost of the first membrane train in FY24; and
29

30 WHEREAS, the FY25 Capital Budget includes \$80,000 for the buy a second one, and we
31 expect to ask Council for authorization to buy one each in FY 26, FY 27 and FY 28; and
32

33 WHEREAS, The total value for the purchase of five membrane trains is \$463,870, with an
34 Annual Payment of \$92,774 for the first year; and
35

36 WHEREAS, Payments for subsequent years will be subject to inflationary adjustments,
37 in accordance with the US CPI-U, All Urban Consumers and future Council appropriations; and
38

39 WHEREAS, Homer City Code allows exceptions to be made to bidding requirements in
40 the cases where a sole source procurements is justified, HCC 3.16.060(i); and
41

42 WHEREAS, A sole source procurement is justified in this case because Zenon
43 Environmental Corporation, the manufacturer of the membrane units (1) provided the original

44 membrane trains and (2) is the only manufacturer of these specialized membranes in the
45 country; and

46
47 WHEREAS, Zenon’s cost proposal is deem fair and reasonable, because it is based on
48 the price guarantee formula that was part of the original purchase in 2009, adjusted for
49 inflation, shipping and other incidental costs we’ve been able to identify and negotiate, such
50 as costs for the repair kits, etc.; and

51
52 WHEREAS, In the event future City Councils do not appropriate funds for future
53 payments, we have the option to terminate the purchase agreement, but, once terminated,
54 there is no option to restart the agreement; we will need to start from scratch; and

55
56 WHEREAS, This is contingent on the adoption of Ordinance 23-57 appropriating
57 additional funds for the FY24 allocation.

58
59 NOW THEREFORE, BE IT RESOLVED that the Homer City Council does hereby authorize
60 issuance of a contract to Zenon Environmental Corporation for the purchase of five membrane
61 filter trains with a payment in the first year of \$92,774 and payments in subsequent years
62 subject to inflation and future Council appropriations.

63
64 PASSED AND ADOPTED by the Homer City Council this 27th day of November, 2023.

65
66 CITY OF HOMER
67
68
69 _____
70 KEN CASTNER, MAYOR

71 ATTEST:
72
73 _____
74 MELISSA JACOBSEN, MMC, CITY CLERK

75
76 Fiscal Note: FY24 Capital Budget and Ordinance 23-57.



MEMORANDUM

Resolution 23-124, A Resolution of the City Council of Homer, Alaska Approving the 2024 Regular Meeting Schedule for the City Council, Economic Development Advisory Commission, Library Advisory Board, Parks Art Recreation and Culture Advisory Commission, Planning Commission, Port and Harbor Advisory Commission, and Americans with Disabilities Act Advisory Board. City Clerk.

Item Type: Backup Memorandum
Prepared For: Mayor Castner and Homer City Council
Date: November 15, 2023
From: Melissa Jacobsen, MMC, City Clerk

Pursuant to Homer City Code 1.14.020 Notice-Regular meetings, City Council adopts a resolution setting out the days of each month, time, and location of City Council and City's Boards and Commissions regular meetings for the upcoming year.

In prior years the City Council held one meeting on the fourth Monday in November to allow for attendance at the Alaska Municipal League (AML) Annual Conference in early November, and one meeting the second Monday in December when they adopted the calendar year budget.

In 2022 AML changed the Annual Conference dates to December and the City has transitioned to a fiscal year budget schedule. Because of this change Council has adopted resolutions to change their meeting schedule in 2022 and 2023 to hold two regular meetings in November and no meetings in December. This change is reflected in the 2024 meeting schedule resolution.

Boards and Commissions reviewed their annual meeting schedules and recommended schedule changes are reflected in the 2024 meeting schedule resolution. Board and Commission minutes excerpts are included below.

ADA Advisory Board:

- A. 2024 Regular Meeting Schedule
Memorandum from City Clerk

ADA Coordinator Krause directed the board members to the memo in the packet and reviewed the proposed dates with them. She inserted that the Board can add or remove meetings, or leave it as is.

GEISLER/THORSRUD MOVED TO AMEND THE MEETING START TIME TO 4:00 P.M. FOR THE 2024 REGULAR MEETING SCHEDULE.

Ms. Krause added that when the meeting times were changed to start at 5:00 p.m., the Board received an applicant right away. Discussions continued about the pros and cons of starting meetings earlier. Board member Geisler noted that they could always change the time back if it doesn't work out.

VOTE: NON OBJECTION: UNANIMOUS CONSENT

Motion carried.

LEPLEY/GEISLER MOVED TO APPROVE THE 2024 MEETING SCHEDULE AS AMENDED.

There was no discussion.

VOTE: NON OBJECTION: UNANIMOUS CONSENT

Motion carried.

Economic Development Advisory Commission:

A. 2024 Meeting Schedule

AREVALO/BROWN MOVED TO STRIKE BOTH THE JULY AND DECEMBER MEETINGS FROM THE 2024 MEETING SCHEDULE AND RECOMMEND ADOPTION FOR THE AMENDED SCHEDULE TO CITY COUNCIL.

There was no discussion.

VOTE: NON OBJECTION: UNANIMOUS CONSENT.

Motion carried.

Library Advisory Board

A. 2024 Regular Meeting Schedule
Memorandum from City Clerk as backup.

Chair Finn reviewed the memorandum and the requested action of the Board. She announced that December she will be out of state and Boardmember Kuszmaul will be chairing the meeting.

KUSZMAUL/CARSSOW MOVED TO APPROVE THE 2024 REGULAR MEETING SCHEDULE AS PRESENTED.

CARSSOW/KUSZMAUL AMEND THE MOTION TO INCLUDE FORWARDING TO CITY COUNCIL FOR APPROVAL.

There was no discussion.

VOTE. NON-OBJECTION. UNANIMOUS CONSENT.

Motion carried.

Parks Art Recreation and Culture Advisory Commission

- B. 2024 Regular Meeting Schedule
Memorandum from City Clerk

FAIR/ARCHIBALD MOVED TO AMEND THE 2024 REGULAR MEETING SCHEDULE BY INCLUDING A SPECIAL MEETING ON THURSDAY, JANUARY 18TH, 2024 AT 5:30 P.M. HERE IN COUNCIL CHAMBERS.

Recreation Manager Illg added that this came from him because it can be assumed that there will be more for PARCAC to work on, and he believes the Commission would benefit from a meeting in January.

There was no objection.

VOTE (Amendment): NON-OBJECTION: UNANIMOUS CONSENT

Motion carried.

FAIR/ARCHIBALD MOVED TO ADOPT THE 2024 REGULAR MEETING SCHEDULE AS AMENDED.

There was no objection.

VOTE. NON-OBJECTION. UNANIMOUS CONSENT.

Motion carried.

Planning Commission

- A. 2024 Meeting Schedule

Chair Smith introduced the item and deferred to City Planner Foster.

City Planner Foster noted the memorandum from the City Clerk, he stated that he has based the Commission's meeting schedule off of the dates in the draft resolution. He further noted that this is the time that the Commission can make any changes to their meeting schedule.

City Planner Foster facilitated a brief discussion on the following:

- Commissioner Training during the Annual Planning Conference in February

SCHNEIDER/CONLEY MOVED TO ADOPT THE 2024 REGULAR MEETING SCHEDULE AS PRESENTED.

There was no discussion.

VOTE: NON-OBJECTION. UNANIMOUS CONSENT.

Motion carried.

Port & Harbor Advisory Commission:

10.B. Approve 2024 Meeting Schedule

Chair Matthews directed the Commissioners to the meeting schedule in the packet and asked if anyone had any issues with the schedule. The Commission noted that their originally scheduled meeting date for November falls on the same week as Thanksgiving.

SIEKANIEC/PITZMAN MOVED TO AMEND THE 2024 MEETING SCHEDULE BY MOVING THE NOVEMBER 2024 MEETING TO NOVEMBER 20TH, 2024 AND SUBMIT THE AMENDED SCHEDULE TO COUNCIL FOR APPROVAL.

There was no discussion.

VOTE: NON OBJECTION: UNANIMOUS CONSENT

Motion carried.

RECOMMENDATION: Adopt the resolution approving the 2024 Regular Meeting Schedule for Council, Boards, and Commissions.

1 **CITY OF HOMER**
2 **HOMER, ALASKA**

City Clerk

3
4 **RESOLUTION 23-124**

5
6 A RESOLUTION OF THE CITY COUNCIL OF HOMER, ALASKA,
7 ESTABLISHING THE 2024 REGULAR MEETING SCHEDULE FOR CITY
8 COUNCIL, ECONOMIC DEVELOPMENT ADVISORY COMMISSION,
9 LIBRARY ADVISORY BOARD, PARKS ART RECREATION AND
10 CULTURE ADVISORY COMMISSION, PLANNING COMMISSION,
11 PORT AND HARBOR ADVISORY COMMISSION, AND AMERICANS
12 WITH DISABILITIES ACT (ADA) ADVISORY BOARD.
13

14 WHEREAS, Pursuant to Homer City Code (HCC) Section 1.14.020, the City Council
15 annually sets the schedule for regular and some special meetings, noting the dates, times and
16 places of the City Council, Planning Commission, Advisory Commissions and Boards; and
17

18 WHEREAS, The public is informed of such meetings through notices located at the City
19 Clerk's Office, Clerk's Calendar on KBBI, the City Clerk's Website, and postings at the Public
20 Library; and
21

22 WHEREAS, HCC 1.14.020 - 040 states that meetings may be advertised in a local paper
23 of general circulation at least three days before the date of the meeting and that special
24 meetings should be advertised in the same manner or may be broadcast by local radio at least
25 twice a day for three consecutive days or two consecutive days before the day of the meeting
26 plus the day of the meeting; and
27

28 WHEREAS, HCC 1.14.010 notes that the notice of meetings applies to the City Council
29 and all commissions, boards, committees, subcommittees, task forces and any sub-unit of the
30 foregoing public bodies of the City, whether meeting in a formal or informal meeting; that the
31 failure to give the notice provided for under this chapter does not invalidate or otherwise affect
32 any action or decision of a public body of the City; however, this sentence does not change the
33 consequences of failing to give the minimum notice required under State Statute; that notice
34 will ordinarily be given by the City Clerk; and that the presiding officer or the person or persons
35 calling a meeting are responsible for notifying the City Clerk of meetings in sufficient time for
36 the Clerk to publish notice in a newspaper of general circulation in the City; and
37

38 WHEREAS, This Resolution does not preclude additional meetings such as emergency
39 meetings, special meetings, worksessions, and the like; and
40

41 WHEREAS, Council adopted Resolution 06-144 on October 9, 2006 establishing the
42 Regular Meeting site for all bodies to be the City Hall Cowles Council Chambers.

43
 44
 45
 46
 47
 48
 49
 50

NOW, THEREFORE, BE IT RESOLVED by the Homer City Council, that the 2024 meeting schedule is established for the City Council, Economic Development Advisory Commission, Library Advisory Board, Parks Art Recreation and Culture Advisory Commission, Planning Commission, Port and Harbor Advisory Commission, and the American with Disabilities Act (ADA) Advisory Board of the City of Homer, Alaska, as follows:

HOLIDAYS – City Offices closed:

January 1, New Year's Day, Monday	February 19, Presidents' Day, third Monday	March 25, Seward's Day, last Monday	May 27, Memorial Day, last Monday	July 4, Independence Day, Thursday	September 2, Labor Day, first Monday
October 18, Alaska Day, Friday	November 11, Veterans Day, Monday	November 28 Thanksgiving Day, Fourth Thursday	November 29, Friday, the day after Thanksgiving	December 25, Christmas, Wednesday	

51 *If a holiday is on a Sunday, the following Monday is observed as the legal holiday; if on a
 52 Saturday, the preceding Friday is observed as the legal holiday pursuant to the City of Homer
 53 Personnel Rules and Regulations.

54
 55

CITY COUNCIL (CC)

January 8, 22	February 12, 26	March 11, 26*	April 8, 22	May 13, 28*	June 10, 24
July 22**	August 12, 26	September 9, 23	October 1 Election	October 14, 28 Oath of Office October 14	Canvass Board October 4
November 5 Runoff Election	November 12, 25	December ***If needed			

56
 57
 58
 59
 60
 61
 62
 63
 64
 65
 66

*Second meeting in March and May will be held on a Tuesday due to Seward's Day and Memorial Day respectively, first meeting in November will be held on a Tuesday due to Veterans Day

**There will be no First Regular Meeting in July.

*** The City Council will not schedule a regular meeting in December to allow for attendance at AML Annual Conference and may hold Special Meetings as needed.

City Council's Regular Committee of the Whole Meetings at 5:00 p.m. to no later than 5:50 p.m. prior to every Regular Meeting which are held the second and fourth Monday of each month at 6:00 p.m. Council will not conduct a First Regular Meeting in July or a meeting in December.

67 AMERICANS WITH DISABILITIES ACT (ADA) ADVISORY BOARD (ADAAB)

	February 8		April 11	May 9	June 13
July 11	August 8		October 10	November 14	

68
 69 The Americans with Disabilities Act (ADA) Advisory Board Regular Meetings are held on the
 70 second Thursday at 4:00 p.m. in the months of February, April, May, June, July, August,
 71 October, November, with additional meetings called as needed.

72
 73 ECONOMIC DEVELOPMENT ADVISORY COMMISSION (EDC)

January 9	February 13	March 12	April 9	May 14	June 11
July 9	August 13	September 10	October 8	November 12	December 10

74
 75 Economic Development Advisory Commission Regular Meetings are held on the second
 76 Tuesday of each month at 6:00 p.m. with the exception of July and December.

77
 78 LIBRARY ADVISORY BOARD (LAB)

January 16	February 20	March 19	April 16	May 21	
	August 20	September 17	October 15	November 19	December 17

79
 80 Library Advisory Board Regular Meetings are held on the third Tuesday of January through May
 81 and August through December at 5:30 p.m.

82
 83 PARKS, ART, RECREATION AND CULTURE ADVISORY COMMISSION (PARC)

January 18 (special)	February 15	March 21	April 18	May 16	June 20
	August 15	September 19	October 17	November 21	

84
 85 Parks, Art, Recreation and Culture Advisory Commission Regular Meetings are held on the third
 86 Thursday February through June and August through November at 5:30 p.m.

87
 88 PLANNING COMMISSION (PC)

January 3, 17	February 7, 21	March 6, 20	April 3, 17	May 1, 15	June 5, 19
July 17*	August 7, 21	September 4, 18	October 2, 16	November 6*	December 4*

89 *There will be no First Regular Meeting in July or Second Regular Meetings in November and
 90 December.

91

92 Planning Commission Regular Meetings are held on the first and third Wednesday of each
93 month at 6:30 p.m.

94

95 PORT AND HARBOR ADVISORY COMMISSION (PHC)

January 24	February 28	March 27	April 24	May 22	June 26
July 24	August 28	September 25	October 23	November-27 20	December 11

96

97 Port and Harbor Advisory Commission Regular Meetings are held on the fourth Wednesday of
98 month January through October, and the second Wednesday of December at 5:30 p.m.

99

100 PASSED AND ADOPTED by the Homer City Council this _____ day of November, 2023.

101

102

CITY OF HOMER

103

104

105

KEN CASTNER, MAYOR

106

107

108 ATTEST:

109

110

111

MELISSA JACOBSEN, MMC, CITY CLERK

113

114 Fiscal Impact: Advertising of meetings in regular weekly meeting ad and advertising of any
115 additional meetings.

**MEMORANDUM**

Resolution 23-125, A Resolution of the City Council of Homer, Alaska Authorizing a Task Order with RESPEC Engineering in the Amount of \$61,990 for the Construction Documents and Engineering Support for the Fish Waste Grinder Building Replacement Project and Authorizing the City Manager to Negotiate and Execute the Appropriate Documents. City Manager/Port Director.

Item Type: Backup Memorandum
Prepared For: City Council
Date: November 21, 2023
From: Bryan Hawkins, Port Director
Through: Rob Dumouchel, City Manager

Homer harbor is a working harbor and that means we have to think about fish waste disposal. Homer's fish grinder and outfall line are our answer to the question of how we deal with all the fish carcasses on the Homer Spit. Our facility is fully permitted through DEC and gives us the pathway to dispose of fish waste in a way that doesn't negatively impact the environment around us. Every year hundreds of thousands of pounds of fish waste are processed through this facility. It's a foundational component of the recreational sport fishing, charter tours, and commercial fishing industry on the Spit.

Port Maintenance performs the maintenance on the fish grinder facility and they have done a great job keeping it functional, but when it comes to the building there is little they can do as it rots away at an accelerating rate. The City also needs to address the fish tote staging area in front of the building and the issue with gurry draining into the storm drain system. Installing a drainage system that will carry the fluids away from the street to the outfall pit is imperative to keep up with required permitting and safe management of effluent.

The need to replace the building and update the drainage pathways led to it being included in the City's CIP, and to FY22 Capital Budget funding for the conceptual design (\$15,000) and building replacement (\$100,000). Term contractor RESPEC was contracted through a Task Order with the City for conceptual design work. The resulting plan is to replace the metal building with a concrete block one and fit it out with marine tough materials like wood trusses, and fiberglass doors and plastic framed windows. In short, everything we can do to build a corrosion resistant building and upgrade these critical fisheries support facility.

The engineer's conceptual design and cost estimate provided by RESPEC under a Task Order was used to seek grant assistance from the Dingell-Johnson Sport Fish Restoration Act administered by Alaska Department of Fish and Game. Dingell-Johnson grant funds cover 75% of the total project cost and

require 25% local matching funds. We recently learned that a Dingell-Johnson award for the Fish Grinding Replacement Project was Federally approved and an award obligating document is anticipated to be delivered to the City in January 2024. At that time, staff will bring an Ordinance before City Council to accept and appropriate the grant funds. The Capital Budget appropriation for the Fish Grinding Building will be used as local match funds for the project.

In order to move the project forward and achieve construction in fall 2024, work needs to begin on the full engineered drawings/plans and associated construction documents. The project will also need engineering support during the construction build process. This engineering design work is an eligible expense under the Dingell-Johnson grant.

Given that RESPEC is already under contract with the City and has familiarity with the project, staff asked RESPEC for a quote for these further services, to which they replied with a scope of work and quote for that work in the amount of \$61,990. With RESPEC's engineering assistance we have made significant progress towards our objective of replacing the Fish Grinding building. Approving a Task Order to RESPEC for continued design services will assure continuity in the project and the most efficient and cost-saving construction schedule.

Recommendation

Approve Resolution 23-125 awarding Task Order to RESPEC for construction documents and engineering support during construction for the fish waste grinder building replacement project, for a total not to exceed \$61,990, and authorizing the City Manager to execute the appropriate documents.



STATEMENT OF SERVICES

CITY OF HOMER — FISH GRINDER BUILDING



NOVEMBER 2023



CITY OF HOMER – FISH GRINDER BUILDING

In March 2023, the City of Homer (CITY) issued RESPEC Company, LLC (ENGINEER) and 11.17 Design Studio (ARCHITECT) a task order (TO #23-12) to provide professional services to develop a conceptual design to replace the Fish Grinder Building and assist the City in developing a Design-Build RFP. The Engineer worked with the City to develop a concept and it was decided a conventional Design-Bid-Build process would better fit the City’s desired schedule. This Statement of Services serves to identify the Engineer’s and Architect’s proposed scope, deliverables, assumptions, owner’s responsibilities, schedule, and fee.

1.0 PROJECT SCOPE SUMMARY

The proposed scope of the Fish Grinder Building Project is as follows:

1. Replace the existing Fish Grinder Building with a new building constructed of cement masonry unit (CMU) blocks, wood trusses, and metal roofing.
2. Replace the electrical panels, transformer, lights, and electrical outlets.
3. Salvage and reinstall major mechanical equipment. Replace piping as needed.
4. Provide potable water hose connection with backflow preventer.
5. Install a concrete apron with approximately 40-foot trench drain along the northwest side of the building and 20-foot trench drain on the northeast side of the building. The trench drain shall drain through a pipe routed along the northeast side of the building to the existing outfall lift station.

2.0 ENGINEERING REQUIREMENTS

Upon this Agreement becoming effective, the ENGINEER shall perform the tasks:

- / Review record drawings of the Fish Grinder Building slab to confirm existing conditions.
- / Visit the site to confirm existing conditions and perform surface inspection of visible features.
- / Develop Design Narrative and Design Drawings for construction and Fire Marshal permitting.
- / Coordinate with equipment vendors to identify the basis of design equipment selections.
- / Coordinate and attend review meetings with Owner.
- / Facilitate a third party estimate to construct.

2.1 65% DESIGN DEVELOPMENT

- / Review as-built drawings, owner provided survey, and photos of the site to determine existing conditions.
- / Develop design documents per Project Scope summary listed above.
 - » Design narrative/ design criteria document
 - » Drawings
 - » Specifications (on the dra

2.2 CONSTRUCTION DOCUMENTS

- / Update the design based on comments received from 65% design and finalize design and issue signed Construction Documents.
 - » Design narrative/ design criteria document
 - » Drawings
 - » Specifications (on the drawings)

2.3 CONSTRUCTION ADMINISTRATION

- / Fire Marshal Permitting Assistance
- / ADEC Permitting Assistance
- / Bidding Assistance
 - » Respond to Bidder Questions
- / Services During Construction
 - » Respond to contractor RFI's/DCVR's
 - » Review Contractor Submittals
 - » Site visits during construction

3.0 ASSUMPTIONS

1. Salt water well and outfall pump station modifications are not included in the scope of this project.
2. Electrical site work is limited to intercepting the existing service feeder at the building exterior. Modifications to the existing underground service, and/or additional sitework is not included.
3. If applicable, fire alarm system design to be provided by others.
4. Record Drawings are not included in the scope of this project.
5. Assumed two RFI's/DCVR's per discipline and a maximum of two passes per submittal review.
6. All subconsultant and permitting fees paid by RESPEC will incur a 10% markup.
7. Fire marshal plan review fee will be no more than \$2,000.

4.0 OWNER RESPONSIBILITIES

1. Provide pre-design survey data for the project area.
2. Provide access to the existing Fish Grinder Building as needed.



5.0 SCHEDULE

The tentative schedule for the project is as follows and is to be finalized pending coordination with the OWNER:

1. Notice-to-Proceed: TBD
2. 65% Design Development 6 weeks after NTP
3. Construction Documents 4 weeks after receiving comments on 65%

6.0 METHOD OF PAYMENT

The Consultant will perform the design services on a lump sum basis for \$42,900, the Construction Administration services on a time and materials basis for \$13,040, the third party estimate will cost \$3,850, and the fee for the Fire Marshal plan review is assumed to be \$2,200 for a total of \$61,990. See attachment for additional information.

END OF STATEMENT OF SERVICES

1 **CITY OF HOMER**
2 **HOMER, ALASKA**

3 City Manager/
4 Port Director

5 **RESOLUTION 23-125**

6
7 A RESOLUTION OF THE CITY COUNCIL OF HOMER, ALASKA
8 AUTHORIZING A TASK ORDER WITH RESPEC ENGINEERING IN THE
9 AMOUNT OF \$61,990 FOR THE CONSTRUCTION DOCUMENTS AND
10 ENGINEERING SUPPORT FOR THE FISH GRINDING BUILDING
11 REPLACEMENT PROJECT AND AUTHORIZING THE CITY MANAGER
12 TO NEGOTIATE AND EXECUTE THE APPROPRIATE DOCUMENTS.

13
14 WHEREAS, The City's Fish Grinding building houses a fish waste grinding system that
15 processes hundreds of thousands of pounds of fish carcasses annually generated by fishing
16 activity and processing on the Spit; and

17
18 WHEREAS, The building's badly corroded metal structure and the need to correct site
19 drainage has led to the replacement project being added to the City's Capital Improvement
20 Plan and to an allocation in the FY23 Budget of \$15,000 for the conceptual design, and \$100,000
21 for building replacement; and

22
23 WHEREAS, The City applied for a Dingell-Johnson Sport Fish Restoration Act grant from
24 the Alaska Department of Fish and Game to assist with project costs and has been informed
25 that the award for the project has been Federally approved and an Obligating Award Document
26 is in process; and

27
28 WHEREAS, Engineered 100% design plans and construction documents, as well as
29 engineering project support are needed for this project to move forward in a timely manner;
30 and

31
32 WHEREAS, The City has a Term Contract with RESPEC, who developed the conceptual
33 design package for this project, and who has submitted a proposal for the engineered drawings
34 that would be used for the construction Request For Proposals to facilitate project completion
35 under the Dingell-Johnson grant; and

36
37 WHEREAS, Alaska Department Fish and Game has confirmed that engineering design
38 work would qualify for inclusion within the allowable scope of the Dingell-Johnson grant; and

39
40 PASSED AND ADOPTED by the Homer City Council on this 27th^h day of November,
41 2023.

43
44
45
46
47
48
49
50
51
52
53
54
55

CITY OF HOMER

KEN CASTNER, MAYOR

ATTEST:

MELISSA JACOBSEN, MMC, CITY CLERK

Fiscal Note:



MEMORANDUM

Resolution 23-126, A Resolution of the City Council of Homer, Alaska Agreeing to Participate in a Memorandum of Agreement for the Joint Exercise of a Tourism Promotion between the Kenai Peninsula Borough and the Cities of Kachemak, Kenai, Homer, Seldovia, Seward and Soldotna and Authorizing the City Manager to Negotiate and Execute the Appropriate Documents. City Manager.

Item Type: Backup Memorandum
Prepared For: City Council
Date: 16NOV23
From: Rob Dumouchel, City Manager

The Kenai Peninsula Borough (KPB) has an initiative to conduct regional tourism marketing for the Kenai Peninsula. KPB code § 19.10.030 restricts the Borough's ability to promote tourism outside of the unincorporated areas without some sort of an intergovernmental agreement. To overcome that obstacle, KPB staff provided me with a memorandum of agreement (MOA) that would give KPB authorization to include Homer in their tourism promotion efforts. The MOA does not obligate the City to spend any funds. The MOA does ensure that promotional materials would be shared in advance with City staff. An initial concern I had when approached by KPB was regarding how their campaign would complement tourism marketing efforts made by the Homer Chamber of Commerce. The Chamber's executive director was looped into the conversation and had positive feedback. If it is determined that we do not wish to participate in the MOU at a later date, we are able to withdraw at any time and for any reason.

RECOMMENDATION: Adopt Resolution 23-126



Office of Borough Mayor Peter Micciche

144 N. Binkley Street, Soldotna, Alaska 99669 • (907) 714-2150

From: Joe Rizzo, Communications Director, Kenai Peninsula Borough.

jrizzo@kpb.us

907-714-2158

To: Cities of Kenai, Soldotna, Homer, Seward, Kachemak, and Seldovia.

Coming on as the communications director for the Kenai Peninsula Borough, I wanted to help promote tourism in the KPB. Because KPB 19.10.030 stipulates that the KPB's efforts in tourism promotion are to be restricted to unincorporated areas, a memorandum of agreement is required for the borough to cooperatively work to promote tourism in cities around the KPB. The attached MOA will allow the borough to work collaboratively with cities and chambers of commerce in the promotion of tourism throughout our borough. You will be sent a docusign to execute the MOA.

We have already produced a tourism film that features the cities of Soldotna, Kenai, Homer and Seward (see link in the email). This MOA will allow us to continue and expand our efforts in promoting tourism in your respective cities. I look forward to working with you and your chambers of commerce to promote tourism and foster economic development in the borough.

We would like to start airing these promotional videos before the end of the year. Please contact me with any questions.

Memorandum of Agreement

Between Kenai Peninsula Borough and the Cities of
Kachemak, Kenai, Homer, Seldovia, Seward, and Soldotna
For the Joint Exercise of a Tourism Promotion

This Memorandum of Agreement (hereinafter the “Agreement”) is by and between the Kenai Peninsula Borough, whose address is 144 North Binkley Street, Soldotna, AK 99669, (hereinafter “Borough”) and the participating Cities of Kachemak, Kenai, Homer, Seldovia, Seward, and Soldotna (hereinafter “Cities,” or “City”) whose addresses are included on the signatory page below, for the purpose of intergovernmental joint exercise of tourism promotion (hereinafter “tourism promotion”).

WHEREAS, Article X, Section 13 of the Alaska Constitution authorizes local governments to enter into agreements for the cooperative or joint administration of any function or power, unless otherwise prohibited by law or charter; and

WHEREAS, AS 29.35.010(13) provides authority for the Borough to enter into intergovernmental cooperative agreements for the joint administration of a Borough function or power; and

WHEREAS, KPB 19.10.030 provides that the Borough may exercise its non-areawide tourism promotion powers with a city through joint exercise or administration with a city; and

WHEREAS, the Borough recently engaged a promotion video team to create tourism promotion videos for the Borough and as part of those videos the Borough’s intent would be to directly and indirectly promote the signatory cities within the Borough; and

WHEREAS, the parties hereto wish to memorialize the joint exercise and promotion of tourism which will constitute their agreement on terms and conditions related to tourism promotion, and provide for the potential for future joint ventures as well;

THE PARTIES THEREFORE AGREE, in consideration of the mutual promises contained in this Agreement and the services and fees provided, as set forth below:

1. PURPOSE AND INTENT

This Agreement is established and entered into between the parties for the purpose of jointly exercising promotion of tourism powers. This Agreement contemplates a basic promotion of tourism intergovernmental agreement and does not obligate the Borough or a city to fund or promote tourism.

2. BOROUGH’S OBLIGATIONS

- a. In its sole discretion, subject to appropriation and availability of funds, the Borough may from time to time promote Borough tourism in a manner that also promotes the great cities within the Borough.

- b. Should the Borough include a city in a promotion of tourism campaign, Borough administration will provide the city administration with a draft of the campaign, prior to publication or release, of the promotional materials for city review and approval.
- c. Any Borough tourism promotion campaign not approved by a city, will not include any direct or specific references to that city.

3. CITIES' OBLIGATIONS

- a. In its sole discretion, subject to appropriation and availability of funds, a city may from time to time promote tourism in a manner that also promotes the area outside of a city.
- b. A city that is provided a draft or pre-release screening of any promotional materials from the Borough agrees to respond within two weeks of receipt and agrees not to disseminate or release the materials which will be considered proprietary, confidential, and subject to deliberative process privilege until a final version is released or otherwise publicized.

4. WITHDRAWAL

Any party to this Agreement may withdraw from the Agreement at any time and for any reason with the understanding that if a party withdraws from this Agreement after a promotional campaign has begun any promotion of tourism materials that includes the city may not be able to be removed immediately. Such materials will be removed when it is reasonably practical to do so.

5. CITY AND KPB CODE AND STATE LAW

This Agreement does not supersede any City code, City charter, or KPB code or state law. If a provision of this Agreement conflicts with KPB or City code, City charter, or state law, the respective code and state law controls.

6. CONFIDENTIALITY

All draft or pre-release promotional materials are considered confidential and proprietary to the party providing the materials to the other party. For Borough materials, third-party requests for the materials prior to release will be referred to the Borough and the Borough will respond accordingly.

7. SOLE RESPONSIBILITY FOR CLAIMS.

Any party that runs a tourism promotion campaign pursuant to this Agreement is solely responsible for any claims that arise from the campaign.

8. DISCLAIMER OF WARRANTY.

Any tourism promotion under this Agreement is furnished as is, where is, with all faults and without warranty of any kind, express or implied, including any warranty of merchantability or fitness for any particular purpose.

**KENAI PENINSULA BOROUGH
144 N BINKLEY STREET
SOLDOTNA, AK 99669**

By: Peter A. Micciche, Mayor

Date: _____

ATTEST:

APPROVED AS TO FORM AND
LEGAL SUFFICIENCY:

Michele Turner, Borough Clerk

Sean Kelley, Borough Attorney

DRAFT

**KACHEMAK CITY
59906 BEAR CREEK DR.
HOMER, AK 99603**

By: William Overway, Mayor

Date: _____

ATTEST:

Laurie Wallace, City Clerk

DRAFT

**CITY OF KENAI
210 FIDALGO AVE.
KENAI, AK 99611**

By: Terry Eubank, City Manager

ATTEST:

Shellie Saner, City Clerk

DRAFT

**CITY OF HOMER
491 E. PIONEER AVE.
HOMER, AK 99603**

By: Rob Dumouchel, City Manager

Date: _____

ATTEST:

Melissa Jacobsen, City Clerk

DRAFT

**CITY OF SELDOVIA
PO DRAWER B
SELDOVIA, AK 99663**

By: Heidi Geagel, City Manager

Date: _____

ATTEST:

Liz Diament, City Clerk

DRAFT

**CITY OF SEWARD
PO BOX 167
SEWARD, AK 99664**

By: Kat Sorensen, City Manager

Date: _____

ATTEST:

Kris Peck, City Clerk

DRAFT

**CITY OF SOLDOTNA
177 N BIRCH ST.
SOLDOTNA, AK 99669**

By: Janette Bower, City Manager

Date: _____

ATTEST:

Johni Blankenship, City Clerk

DRAFT

1
2 **CITY OF HOMER**
3 **HOMER, ALASKA**

4
5
6
7
8
9
10
11
12
13
14
15
16
17
18
19
20
21
22
23
24
25
26
27
28
29
30
31
32
33
34
35
36
37
38
39
40
41
42

City Manager

RESOLUTION 23-126

A RESOLUTION OF THE CITY COUNCIL OF HOMER, ALASKA
AGREEING TO PARTICIPATE IN A MEMORANDUM OF AGREEMENT
FOR THE JOINT EXERCISE OF A TOURISM PROMOTION BETWEEN
THE KENAI PENINSULA BOROUGH AND THE CITIES OF
KACHEMAK, KENAI, HOMER, SELDOVIA, SEWARD AND SOLDOTNA
AND AUTHORIZING THE CITY MANAGER TO NEGOTIATE AND
EXECUTE THE APPROPRIATE DOCUMENTS.

WHEREAS, Kenai Peninsula Borough (KPB) Code 19.10.030 has been interpreted by KPB
staff to require a memorandum of agreement with incorporated cities in the borough in order
to promote tourism featuring those cities; and

WHEREAS, KPB will work to create a series of video advertisements, at least one of
which will feature tourism promotion for the City of Homer; and

WHEREAS, KPB wishes to enter into an intergovernmental memorandum of agreement
for tourism promotion which does not obligate the City of Homer to contribute any funds; and

WHEREAS, KPB will provide the City a draft or pre-screening of any promotional
materials for review before they are publicly released; and

WHEREAS, The City of Homer supports this regional marketing effort by KPB.

NOW, THEREFORE, BE IT RESOLVED that the City Council of Homer, Alaska hereby
agrees to allow the Kenai Peninsula Borough to feature the City of Homer in their tourism
promotion efforts and authorizes the City Manager to negotiate and execute the appropriate
documents.

PASSED AND ADOPTED by the Homer City Council this 27th day of November, 2023.

CITY OF HOMER

KEN CASTNER, MAYOR

43 ATTEST:

44

45 _____

46 MELISSA JACOBSEN, MMC, CITY CLERK

47

48 Fiscal Note: N/A



MEMORANDUM

Resolution 23-127, A Resolution of the City Council of Homer, Alaska Awarding the Contract for the Solid Waste Collection and Disposal Contract to Alaska Waste-Kenai Peninsula, LLC for a Three Year Term with Two One-Year Renewal Options in the amount of \$76,002 per year and Authorizing the City Manager to Negotiate and Execute the Appropriate Documents. City Manager/Port Director.

Item Type: Backup Memorandum
Prepared For: City Council
Date: November 20, 2023
From: Bryan Hawkins, Port Director
Through: Rob Dumouchel, City Manager

The City of Homer advertised a request for proposals (RFP) from qualified firms for solid waste collection and disposal for all city facilities. Bids were all-inclusive; successful proposers were required to provide detailed costs for collection and disposal, including labor, materials, equipment, tools and supervision. Proposers were reminded to pay close attention to the special conditions and needs for the Port and Harbor (i.e. wind, birds, customer service, and location/transportation) The City Clerk's Office received two proposals, one from Moore & Moore Services, Inc. and the other from Alaska Waste-Kenai Peninsula, LLC.

City staff met for the purpose of evaluating and scoring proposals using the grading criteria laid out in the RFP. Upon conclusion of the review it was determined that Alaska Waste had the responsive and lowest bid.

Recommendation

Approval of Resolution 23-127 awarding the three year solid waste collection and disposal contract, with two possible one year extensions, to Alaska Waste- Kenai Peninsula LLC for a total estimated cost of \$76,002 per year, and authorizing the City Manager to execute the appropriate documents.

**CITY OF HOMER
HOMER, ALASKA**

City Manager/
Port Director

RESOLUTION 23-127

A RESOLUTION OF THE CITY COUNCIL OF HOMER, ALASKA, AWARDING THE CONTRACT FOR THE SOLID WASTE COLLECTION AND DISPOSAL CONTRACT TO ALASKA WASTE-KENAI PENINSULA LLC, FOR A THREE YEAR CONTRACT WITH TWO ONE YEAR RENEWAL OPTONS, IN THE AMOUNT OF \$76,002 PER YEAR, AND AUTHORIZING THE CITY MANAGER TO EXECUTE THE APPROPRIATE DOCUMENTS.

WHEREAS, In accordance with the Procurement Policy the Request for Proposals was advertised in the Homer News on Oct 19th & 26th 2023, sent to two in-state plans rooms, and posted on the City of Homer website; and

WHEREAS, Proposals were due November 9, 2023 and two proposals were received; and

WHEREAS, Alaska Waste-Kenai Peninsula LLC was found to be the lowest responsive bidder; and

WHEREAS, This award is not final until written notification is received by the firm from the City of Homer.

NOW, THEREFORE, BE IT RESOLVED that the Homer City Council hereby awards the contract for solid waste collection and disposal to the firm of Alaska Waste-Kenai Peninsula LLC, in the amount of \$76,002 per year for a term of three years with two one year renewal options, and authorizes the City Manager to execute appropriate documents.

PASSED AND ADOPTED by the Homer City Council this 27th day of November, 2023.

CITY OF HOMER

KEN CASTNER, MAYOR

ATTEST:

MELISSA JACOBSEN, MMC, CITY CLERK

Fiscal note: 400-0601-5220 Harbor operations Refuse Disposal; 100-0140-5220 City Hall; 100-0150-5220 Fire Department; 100-0160-5220 Police Department; 100-0149-5220 Airport; 100-0165-5220 Animal Shelter; 100-0171-5220 Public Works

1
2 **CITY OF HOMER**
3 **HOMER, ALASKA**

Lord/Venuti

4
5 **RESOLUTION 23-128**

6
7 A RESOLUTION OF THE CITY COUNCIL OF HOMER, ALASKA
8 SUPPORTING THE CREATION OF A SISTER CITY DONATION
9 ACCOUNT TO SUPPORT THE 40TH ANNIVERSARY OF HOMER'S
10 RELATIONSHIP WITH TESHIO, HOKKAIDO JAPAN.
11

12 WHEREAS, The City of Homer has enjoyed a strong and enduring sister city relationship
13 with Teshio, Hokkaido Japan for 40 years, fostering cultural exchange, understanding, and
14 friendship; and
15

16 WHEREAS, The 40th anniversary of our sister city relationship in 2024 presents a unique
17 opportunity to celebrate this milestone with events and programming that enhance the
18 experience for our visitors from Teshio; and
19

20 WHEREAS, There is a desire in the community to provide hospitality that exceeds the
21 City's budget and resources in order to support a memorable and impactful visit and
22 celebration; and
23

24 WHEREAS, The community has expressed a strong interest in contributing to the
25 success of the sister city visit and desires a mechanism to provide financial support for events,
26 cultural programs, and other activities that will enrich the experience of our Teshio visitors;
27 and
28

29 WHEREAS, Establishing a dedicated donation fund will allow residents, visitors,
30 businesses, and organizations within the community to actively participate in and contribute
31 to the success of the 40th anniversary celebration.
32

33 NOW, THEREFORE, BE IT RESOLVED that the City Council of Homer, Alaska hereby
34 supports the creation of a Sister City Donation Fund to collect monetary contributions from
35 the community for the 40th anniversary celebration of our sister city relationship with Teshio,
36 Hokkaido Japan.
37

38 BE IT FURTHER RESOLVED that the City Council directs the City Manager to work with
39 the City Attorney to propose relevant updates to Homer City Code that would support the
40 efficient receipt and processing of donations.
41

42 PASSED AND ADOPTED by the Homer City Council this 27th day of November, 2023.
43
44

45
46
47
48
49
50
51
52
53

CITY OF HOMER

KEN CASTNER, MAYOR

ATTEST:

MELISSA JACOBSEN, MMC, CITY CLERK

NOVEMBER 27TH, 2023

City of Homer

THE KENAI PENINSULA ECONOMIC DEVELOPMENT DISTRICT





Kenai Peninsula Borough

Imagery Source: ArcGIS Online World Imagery

Map Date: 9/19/2019

Major Roads

KPB Boundary

0 5 10 Miles



The information depicted hereon is for a graphical representation only of best available sources. The Kenai Peninsula Borough assumes no responsibility for any errors on this map

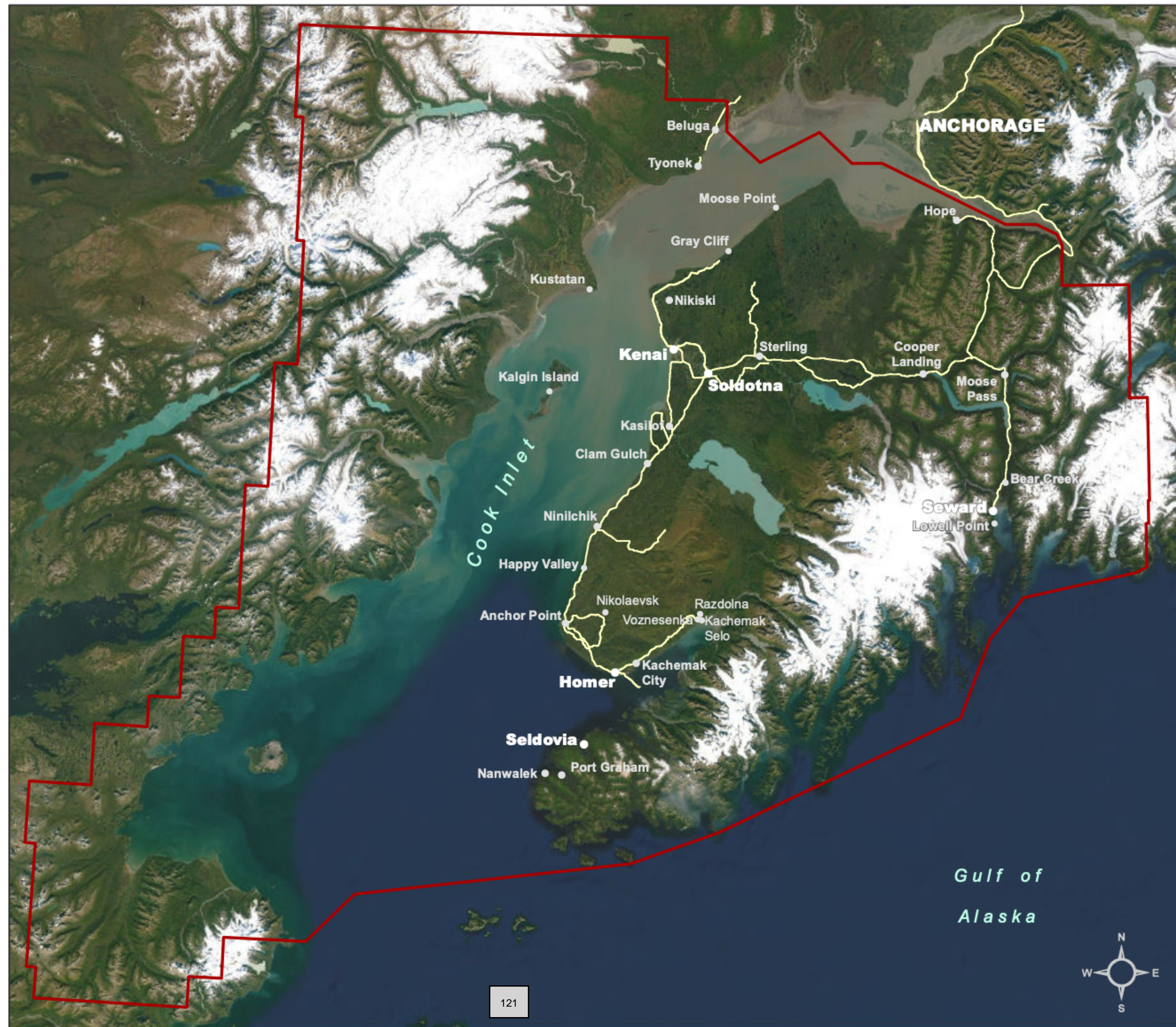



KPEDD OVERVIEW

The Kenai Peninsula Economic Development District (KPEDD) is a private non-government resource focused on the responsible and sustainable economic development for our region. Using a 30,000ft view of the economy, we locate financing and orchestrate community collaboration for economic planning and business incubation. We support infrastructure projects, workforce development and regional industries. KPEDD is funded by federal, state, regional and educational contracts.

Office Space for Lease

- Office
- Yard
- Competitive Pricing

Call (907) 283 - 3335 for more information.

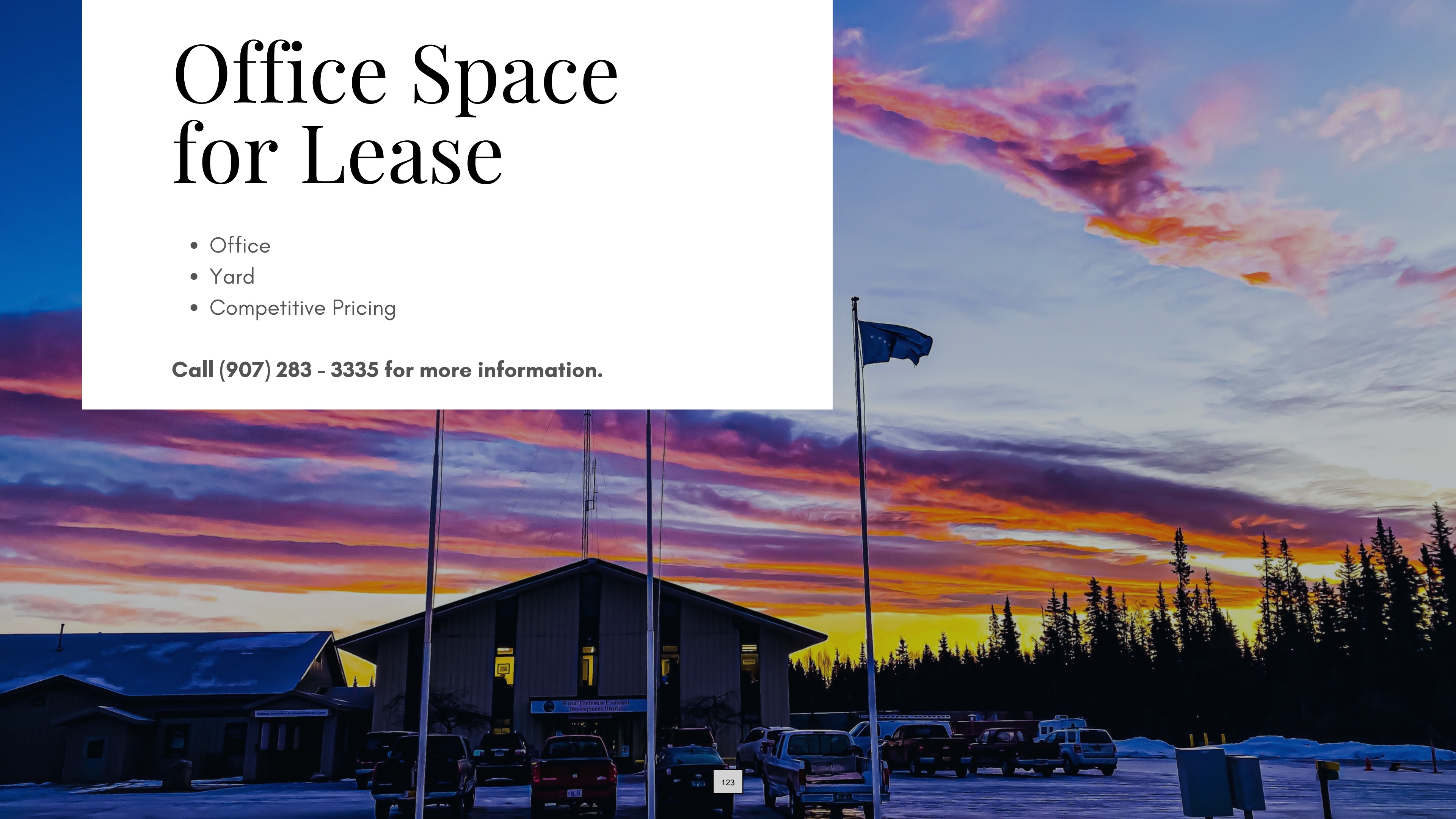

QUALITY OF LIFE

01

TECHNOLOGY/COMMUNICATION

Expand broadband access across the Borough

02

WORKFORCE & HUMAN CAPITAL

Industry partnerships and Vo-tech to attract, retain and train qualified workforce

03

INFRASTRUCTURE & LAND USE

Industry focused infrastructure and resiliency in transportation, infrastructure, mitigation and responsible use of lands

04

BUSINESS CLIMATE & ENTREPRENEURSHIP

Outreach, education, and information sharing with government support of businesses

05

REGIONAL PARTNERSHIPS

Coordinate with industry, municipalities, communities, and non-profits



Community Update

Borough Update

- Housing
- Transportation
- Childcare
- Workforce
Development

A large school of salmon swimming underwater, with a white text overlay. The salmon are in various stages of migration, showing vibrant red and orange hues. The background is a deep, dark blue-green, suggesting an underwater environment. The text is centered and reads "State Update" in a large, white, serif font.

State Update

- Mariculture
- Broadband
- Workforce Development

1. TECHNOLOGY & TELECOMMUNICATIONS

Continue leading broadband infrastructure development through the Broadband Taskforce; providing a platform for regular communication between federal and state funding agencies, providers, and consumers to ensure regional needs are met - including challenging fabric maps, prioritizing buildout locations, public outreach, stakeholder identification, and advocating at state and federal levels

3. INFRASTRUCTURE & LAND USE

Continue developing a viable and sustainable mariculture industry producing shellfish and aquatic plants, increase mariculture-related manufacturing, and supporting industries in the region. This will be a four-year industry-lead, coordinated effort with a long-term goal to grow the industry to \$100 million annually over the next 20 years producing a significant amount of tax revenue for the Kenai Peninsula Borough. This effort will utilize private partnerships that encourage private investment into local economies, increase food security, create jobs, reduce carbon dioxide in coastal waters, and increase revenue for state and local government.

The 2024 Industry Outlook Forum and Tribal Economic Forum will continue to provide a platform for federal and state agencies, Tribes and Tribal Corporations, industry leaders, and resource providers to discuss project updates, economic projections, and changing regulations that effect the region.

Present updates quarterly to the Kenai Peninsula Borough Assembly, incorporated and unincorporated communities and stakeholder groups.

5. REGIONAL PARTNERSHIPS

Continue hosting regional discussions and leading coordination efforts between Industry, municipalities, incorporated and unincorporated communities, educators, and non-profits.

**FY24 Projects
BASED ON
CEDS GOALS**

2. WORKFORCE & HUMAN CAPITAL

Coordination of Transportation, housing, and childcare access by connecting funding agencies and private investors with community advocacy groups, existing providers, and incorporated and unincorporated communities to fill gaps in resources, adjust existing services as needed, and identify funding opportunities to expand current infrastructure.

Transportation access for disabled and underserved populations Peninsula-wide

Affordable housing access for Homer and Seward

Expanded access to childcare Peninsula-wide

2. WORKFORCE & HUMAN CAPITAL

Upgrading and expanding both www.kpeddd.org and www.kenaipeninsulaworkforce.org sites with current infographic statistics, incorporating emerging industry clusters, adding new resources and layered GIS maps, stronger marketing strategies, and improving integration between the two platforms.

4. BUSINESS CLIMATE & ENTREPRENEURSHIP

Restructure the existing Microloan Program to allow for larger loans caps, measure private investment and job growth, decrease interest rates, utilize unused capacity, and mitigate unnecessary risk.

5. REGIONAL PARTNERSHIPS

Design a structure and application checklist for entities pursuing foundation and philanthropic funding, creating a consistent application resource that assists entities constructing a formal proposal. Strengthening the strategy and application process will guide consistent and sustainable development in our most vulnerable communities. The foundation funding request structure would include: 1. sources of funding (programs available, Identification of "best fit" for categorical requests), 2. background research (Identifying community needs and vulnerabilities, regional assets), 3. package structure and presentation (effectively communicating goals, project needs, and anticipated outcomes), 4. gathering and gauging community support (Identifying stakeholders, letters of support, tracking match), 5. measuring success (measurable and reportable deliverables, methods of measurements).



Cassidi Cameron

The Future of KPEDD

- Promotes active and representative citizen participation so that community members can meaningfully influence decisions that affect their quality of living in the communities they choose
- Extensive Local, Borough and State Government Experience
- Values that align with the KPEDD organization in promoting and facilitating growth, investment and development through actionable approaches
- Community Focused; emphasis on supporting and prioritizing quality of living in all areas of the Kenai Peninsula
- Prioritizes solution based strategies that strengthen stakeholder engagement and emphasize collaboration at all levels

Cassidi Cameron,
Special Projects Manager
(907) 519-8637
cassidi@kpedd.org

SAVE THE DATE



INDUSTRY OVERVIEW FORUM (IOF)
APRIL 25TH, 2024 HOSTED AT THE
SOLDOTNA REGIONAL SPORTS
COMPLEX



Follow Us On Social Media



Instagram

@kenaipeninsulaedd



YouTube

Kenai Peninsula
Economic
Development
District



Facebook

Search KPEDD or
@kenaipeninsulaedd



Websites

www.kpedd.org
www.kenaipeninsulaworkforce.org



LinkedIn

KENAI
PENINSULA
ECONOMIC
DEVELOPMENT
DISTRICT INC

A photograph of two brown moose standing in a lush green field. The moose are facing right, with the one in the foreground slightly ahead of the one behind it. The background is filled with tall grass and some small plants.

Thank You

Tim Dillon,
Executive Director
(907) 242-9709
tim@kpedd.org

Cassidi Cameron,
Special Projects Manager
(907) 519-8637
cassidi@kpedd.org



MEMORANDUM

Ordinance 23-55, An Ordinance of the City Council of Homer, Alaska Accepting and Appropriating an FY 2023 State Homeland Security Program Grant in the Amount of \$88,196.56 from the Alaska Division of Homeland Security & Emergency Management (DHS&EM) to Upgrade Homer Volunteer Fire Department Portable Radios and Provide a Backup Repeater for the City's Public Safety Communications System, Authorizing a Sole Source Request to Contract with PROCOMM Alaska and Authorizing the City Manager to Negotiate and Execute the Appropriate Documents. City Manager.

Item Type: Backup Memorandum
Prepared For: Mayor and City Council
Date: October 20, 2023
From: Chief Robl
Through: Rob Dumouchel

I am pleased to report that the City has been awarded a FY2023 Homeland Security grant in the amount of \$88,196.56 for upgrading public safety communications within the City.

The grant will accomplish two important upgrades. It funds the purchase and installation of a backup repeater for Homer's public safety radio system. When one repeater goes down we, we lose that radio resource as it is sent back to the factory for repair. The best case scenario is a 6 to 8-week outage, if they have the parts in stock. With the on-going supply chain troubles, though, it is likely it will be down for several months. This can have serious consequences during a major incident response.

The grant also provides funds to purchase twelve Homer Volunteer Fire Department portable radios with Bluetooth technology that can integrate with the Department's new Self-Contained Breathing Apparatus (SCBA). In 2020, the City replaced HVFD's non-NFPA-compliant SCBA. The new models allow responders' radios to connect via noise-cancelling Bluetooth technology in the SCBA headpieces for hands free communications. Noise cancelling greatly improves communications by reducing the ambient noise typical radio microphones pick up during voice transmissions in loud environments. Hands-free communication is extremely beneficial during rescue operations when hands are needed for other tasks and could possibly save a firefighter's life if they become injured or trapped in a fire and cannot use their hands.

Staff also requests to complete this project with a sole source contract to ProComm Alaska for the following reasons:

ProComm Alaska (PCA) has been servicing our radio system for 30 years. Their service has been superb and delivered in an extremely professional manner. They are intimately familiar with our system and the unique radio frequency anomalies in our area.

PCA is the only firm in the State of Alaska that is a certified APCO P25 Systems Specialist and authorized to function as a full service manufacturer's representative for Motorola. Their public safety communications technicians are certified with Motorola factory training.

Recommendation: Accept and appropriate the FY 2023 State Homeland Security Grant in the amount of \$88,196.56 and approve a sole source purchase request to ProComm Alaska for the associated equipment.

**CITY OF HOMER
HOMER, ALASKA**

City Manager

ORDINANCE 23-55

AN ORDINANCE OF THE CITY COUNCIL OF HOMER, ALASKA ACCEPTING AND APPROPRIATING AN FY 2023 STATE HOMELAND SECURITY PROGRAM GRANT IN THE AMOUNT OF \$88,196.56 FROM THE ALASKA DIVISION OF HOMELAND SECURITY & EMERGENCY MANAGEMENT (DHS&EM) TO UPGRADE HOMER VOLUNTEER FIRE DEPARTMENT PORTABLE RADIOS AND PROVIDE A BACKUP REPEATER FOR THE CITY'S PUBLIC SAFETY COMMUNICATIONS SYSTEM, AUTHORIZING A SOLE SOURCE REQUEST TO CONTRACT WITH PROCOMM ALASKA AND AUTHORIZING THE CITY MANAGER TO NEGOTIATE AND EXECUTE THE APPROPRIATE DOCUMENTS.

WHEREAS, The City's radio communication system supports the City of Homer's ability to prevent, protect against, respond to and recover from all hazard events; and

WHEREAS, Components of the system require upgrades to keep up with technological advances and maintain interoperability; and

WHEREAS, The City is pleased to have been awarded \$88,196.56 from the Division of Homeland Security and Emergency Management (DSH&EM) to procure and install a backup repeater and procure twelve portable radios for Homer Volunteer Fire Department that integrate with the Department's Bluetooth-enabled Self-Contained Breathing Apparatus; and

WHEREAS, Motorola equipment is the only equipment that will interface properly with the City's existing communications system and allow system functionality to remain the same; and

WHEREAS, The radio equipment must meet P25 Standards and ProComm Alaska is Motorola's only certified APCO P25 Systems Specialist in the State of Alaska; and

WHEREAS, ProComm Alaska is the only firm in the state of Alaska authorized as a full service manufacturer's representative for Motorola equipment, and has serviced City of Homer communications equipment for over thirty years, a sole source contract with ProComm is justified.

NOW, THEREFORE, THE CITY OF HOMER ORDAINS:

85
86 Introduction:
87 Public Hearing:
88 Second Reading:
89 Effective Date:



MEMORANDUM

Ordinance 23-56, An Ordinance of the City Council of Homer, Alaska Extending the Allocation for the Upgrade of the City's Microwave Wide Area Network through June 30, 2024. City Manager/Chief Technology Officer.

Item Type: Backup Memorandum
Prepared For: Mayor Castner and Homer City Council
Date: November 1, 2023
From: Bill Jirsa, Chief Technology Officer
Through: Rob Dumouchel, City Manager

The City of Homer's routed network connects the City's departments and transmits data and phone communications to support the City's basic operations. The network includes almost two dozen private point to point microwave links operated by the City's IT team.

Ordinance 18-44(A) recognized the importance of upgrading the communications network with a \$130,000 investment in equipment that would increase network capacity to meet demand and build greater redundancy into the network to ensure improved availability. After initial delays due to the pandemic and supply chain issues, Ordinance 21-66 extended the availability of the funds to December 31, 2023.

It was not until 2023 after the IT team increased staff to three technicians that the team was able to achieve significant progress with the complex task of designing and implementing the Licensed Microwave links. As of the end of October, the project is on track with the original budget, but a certain amount of work will not be complete by the end of the calendar year.

Forty-five percent of link replacements are complete and presently in service. Of the remaining work, materials for another 20% are on-site and installation work is in progress. Finally, for the last third of the microwave links, the materials are in the procurement process, and will not likely be received before the current deadline.

RECOMMENDATION: Extend the deadline until June 30, 2024 for the funds associated with Ordinance 18-44(A) Licensed Microwave WAN - \$130,000.

1 CITY OF HOMER
2 HOMER, ALASKA

City Manager

3
4 ORDINANCE 18-44(A)

5
6 AN ORDINANCE OF THE HOMER CITY COUNCIL APPROPRIATING
7 FUNDS FOR THE CALENDAR YEAR 2019 FOR THE GENERAL FUND,
8 THE WATER FUND, THE SEWER FUND, THE PORT/HARBOR FUND,
9 CAPITAL PROJECTS, AND INTERNAL SERVICE FUNDS.

10
11 THE CITY OF HOMER ORDAINS:

12
13 Section 1. Pursuant to the authority of Alaska Statutes Title 29, the following
14 appropriations are made for the calendar year ending December 2019:

15

16	General Fund	\$12,250,363
17	Water Fund	\$ 2,116,651
18	Sewer Fund	\$ 1,772,014
19	Port/Harbor Fund	\$ 4,750,515
20	Capital Projects	<u>\$ 858,024</u>
21		
22	Total Expenditures	\$21,747,567
23		
24	Internal Service Funds	\$2,143,964

25
26 Section 2. The amounts appropriated by this ordinance are appropriated to the objects
27 and purposes stated in the adopted budget.

28
29 Section 3. Grant funds. (a) If grant funds that are received during the fiscal year exceed
30 the amounts of such funds appropriated by this ordinance by not more than \$25,000, the
31 affected appropriation is increased by the amount of the increase in receipts.

32 (b) If grant funds that are received during the fiscal year exceed the amounts
33 appropriated by this ordinance by not more than \$25,000, the appropriation from city funds
34 for the affected program may be reduced by the excess if the reduction is consistent with
35 applicable federal and state statutes.

36 (c) If grant funds that are received during the fiscal year fall short of the amounts
37 appropriated by this ordinance, the affected appropriation is reduced by the amount of the
38 shortfall in receipts.

39
40 Section 4. Donations or charitable contributions. If donations or contributions are
41 received during the fiscal year that exceed the amounts of such funds appropriated by this

42 ordinance by not more than \$5,000, the affected appropriation is increased by the amount of
43 the increase in receipts.

44
45 Section 5. A copy of the adopted budget shall be certified by the City Clerk and filed in
46 the office of the City Clerk.

47
48 Section 6. The supporting Line Item Budget detail as presented by the Administration
49 and reviewed by the City Council is incorporated as part of this Budget Ordinance.

50
51 Section 7. The property tax mill levy is set at 4.5 mills for 2019.

52
53 Section 8. This Ordinance is limited to approval of the Budget and appropriations for
54 Calendar Year 2019, is a non code Ordinance and shall become effective January 1, 2019.

55
56 ENACTED BY THE CITY COUNCIL OF HOMER, ALASKA, this 10th day of December, 2018.

CITY OF HOMER

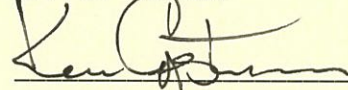

KEN CASTNER, MAYOR

62 ATTEST:

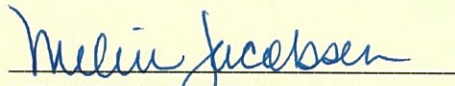

MELISSA JACOBSEN, MMC, CITY CLERK

68 YES: 5

69 NO: 0

70 ABSTAIN: 0

71 ABSENT: 1

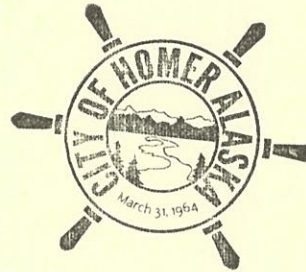

73 First Reading: 10-22-18

74 Public Hearing: 11-26-18, 12-10-18

75 Second Reading: 12-10-18

76 Effective Date: 01-01-19

78 Reviewed and approved as to form:

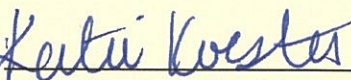

Katie Koester, City Manager

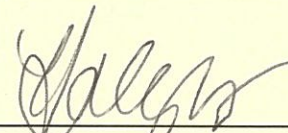

Holly C. Wells, City Attorney

83 Date: 1-15-19

Date: 1-28-19

1
2
3
4
5
6
7
8
9
10
11
12
13
14
15
16
17
18
19
20
21
22
23
24
25
26
27
28
29
30
31
32
33
34
35
36
37
38
39
40
41
42

**CITY OF HOMER
HOMER, ALASKA**

City Manager/
Library Director

ORDINANCE 21-66

AN ORDINANCE OF THE CITY COUNCIL OF HOMER, ALASKA
EXTENDING THE TIME LIMIT TO UPGRADE AND REPLACE THE
CITY'S MICROWAVE WIDE-AREA NETWORK THROUGH DECEMBER
31, 2023.

WHEREAS, The departments of the City of Homer are connected through a microwave
Wide-Area Network (WAN), which carries data over secure links and provides reliable
communications between buildings; and

WHEREAS, Ordinance 18-44(A) allocated \$130,000 for upgrading and replacing aging
equipment in the WAN; and

WHEREAS, This project was put on hold by construction work on the new police station,
then by Resolution 20-050, and further delayed by the need to carry out projects directly
related to COVID-19; and

WHEREAS, The original appropriation is set to lapse on Dec. 31, 2021.

NOW, THEREFORE, THE CITY OF HOMER ORDAINS:

Section 1. That the original appropriation for the microwave WAN upgrade,
authorized by Ordinance 18-44(A), be extended through Dec. 31, 2023.

Section 2. This ordinance is a budget amendment only, is not of a permanent nature and
is a non code ordinance.

ENACTED BY THE CITY COUNCIL OF HOMER, ALASKA this 8th day of November, 2021.

CITY OF HOMER

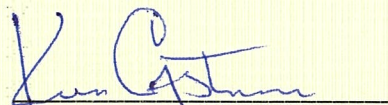
KEN CASTNER, MAYOR

43
44
45
46
47
48
49
50
51
52
53
54
55
56

ATTEST:

Melissa Jacobsen

MELISSA JACOBSEN, MMC, CITY CLERK

YES: 6

NO: 0

ABSTAIN: 0

ABSENT: 0

First Reading: 10-25-21

Public Hearing: 11-8-21

Second Reading: 11-8-21

Effective Date: 11-9-21

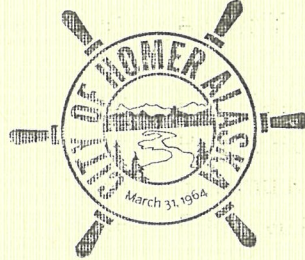

1 **CITY OF HOMER**
2 **HOMER, ALASKA**

3 City Manager/
4 Library Director

5 **ORDINANCE 23-56**

6
7 AN ORDINANCE OF THE CITY COUNCIL OF HOMER, ALASKA
8 EXTENDING THE TIME LIMIT TO UPGRADE AND REPLACE THE
9 CITY'S MICROWAVE WIDE-AREA NETWORK THROUGH JUNE 30,
10 2024.

11
12 WHEREAS, The departments of the City of Homer are connected through a Wide-Area
13 Network (WAN) of private microwave links which provide the City with voice and data
14 communications over a secure network between buildings; and

15
16 WHEREAS, Ordinance No. 18-44(A) allocated \$130,000 for upgrading and replacing aging
17 equipment in the microwave Wide-Area Network and establishing higher network speeds and
18 improving reliability; and

19
20 WHEREAS, Ordinance No. 21-66 extended the deadline that the project be completed until
21 December 31, 2023; and

22
23 WHEREAS, Design work for the final network is complete, roughly half of the equipment has
24 arrived, and the remainder is expected within the first half of 2024.

25
26 NOW, THEREFORE, THE CITY OF HOMER ORDAINS:

27
28 Section 1. That the original appropriation for the microwave WAN upgrade, authorized
29 by Ordinance 18-44(A) and extended to December 31, 2023 by Ordinance 21-66, now be
30 extended until June 30, 2024.

31
32 Section 2. This ordinance is a budget amendment only, is not of a permanent nature
33 and is a non code ordinance.

34
35 ENACTED BY THE CITY COUNCIL OF HOMER, ALASKA this ____ day of _____, 2023.

36
37
38 CITY OF HOMER

39
40 _____
41 KEN CASTNER, MAYOR
42
43

44 ATTEST:
45
46 _____
47 MELISSA JACOBSEN, MMC, CITY CLERK
48
49 YES:
50 NO:
51 ABSTAIN:
52 ABSENT:
53
54 First Reading:
55 Public Hearing:
56 Second Reading:
57 Effective Date:



MEMORANDUM

Ordinance 23-57, An Ordinance of the City Council of Homer, Alaska Amending the FY24 Capital Budget by Appropriating an Additional \$35,000 from the Water Capital Asset Repair and Maintenance Allowance Fund to Purchase One Membrane Filter Module for the Water Treatment Plant. City Manager/Public Works Director.

Item Type: Backup Memorandum
Prepared For: City Council
Date: October 31, 2023
From: Janette Keiser, PE, Public Works Director/City Engineer
Through: Rob Dumouchel, City Manager

I. Issue: The purpose of this Memorandum is to request an additional appropriation of \$30,061 from the Water CARMA for the purpose of paying increased costs of providing membrane replacement modules for the Water Treatment Plant (WTP).

II. Background:

Homer's drinking water treatment technology involves the use of modules of very small diameter membranes, which are hung on racks, similar to a drying rack of angel hair pasta. Water passes through the membranes, which trap sediment, organics and other particles. The WTP contains space for six of these racks, called "membrane trains" of which five are currently in use. The sixth rack allows Homer to accommodate larger flows as water demand increases over time. The original membrane trains were installed in 2009, with an expected life span of 10-14 years. Thus, we are at the end of their useful life, so we have developed a plan for replacing them over the next few years. The FY24 Capital Budget includes \$80,000 to purchase one membrane train and the FY25 Capital Budget includes \$80,000 to purchase a second membrane train. We now know the cost of the first membrane train, including a modest contingency, is \$95,000. We need an additional appropriation of \$30,061 to cover the extra cost of the first membrane train.

We will be asking for additional appropriations in future years to address future purchases. We are contemplating purchase of five membrane trains in total to replace each of the original membrane trains.

We are also requesting an additional \$15,061 to cover the costs of the HDR Task Order. We needed help to review the specifications of the membrane trains, as some of the characteristics of the technology has changed in the past 14 years. Plus, we need to ensure brand new membranes won't adversely affect our current flow conditions at the WTP. So, we commissioned HDR, the original WTP designers to help us negotiate design parameters and features for the new membrane trains as well as to negotiate price indices. HDR's Task Order 23-04 for this work was authorized by Resolution 23-006 and cost \$15,061. The work has been done. We now have a final proposal from the manufacturer, Zenon Environmental Corporation (Zenon), for the new membrane trains.

The Zenon's proposal covers membrane replacement over a period of five years, anticipating purchase of one membrane train each year. This locks in the base price for all five membrane trains. Prices will be adjusted for inflation.

The total value for the purchase of five membrane trains is \$463,870. The Annual Payment is \$92,774 for the first year. Payments for subsequent years will be subject to inflationary adjustments, in accordance with the US CPI-U, All Urban Consumers. In addition to the membrane trains themselves, this price includes fiber repair kits and other parts required to connect the new membranes to the existing frameworks. In the event future City Councils do not appropriate funds for future payments, we have the option to terminate the purchase agreement. Once terminated, there is no option to restart the agreement; we will need to start from scratch.

The City's water treatment plant operators have the skills, abilities and tools to install the new membrane trains once we receive them. We may ask HDR to help commission the new membrane trains to ensure smooth transition between old and new flow parameters. We will assess the need, and request funding, for this possibility when we get the first train.

Homer City Code allows exceptions to be made to bidding requirements in the cases where a sole source procurements is justified, HCC 3.16.060(i). A sole source procurement is justified in this case because Zenon (1) provided the original membrane trains and (2) is the only manufacturer of these specialized membranes in the country.

Zenon's cost proposal is deem fair and reasonable, because it is based on the price guarantee formula that was part of the original purchase in 2009, adjusted for inflation, shipping and other incidental costs we've been able to identify and negotiate, such as costs for the repair kits, etc. The membranes themselves are manufactured in Hungary and subject to U.S. Custom duties, which are subject to change. Because of this, we recommend a small contingency be provided to account for small cost adjustments.

Delivery is projected to be 52 weeks after receipt of a purchase order.

We are asking for a total increase in appropriation of \$35,000, which includes \$15,000 for the additional costs for the membrane trains and \$15,061 for the cost of the HDR Task Order and a contingency amount:

- HDR Task Order \$ 15,061
- Membrane train \$ 95,000
- Contingency \$ 4,939
- Total needed \$115,000
- Currently authorized \$ 80,000
- Additional \$ needed \$ 35,000

III. RECOMMENDATION: That the City Council appropriate an additional \$35,000 from the Water CARMAS fund to pay for the acquisition of membrane filter trains for the Water Treatment Plant, including (a) purchase of one membrane filter train and (b) consultant services related to the transaction.

CITY OF HOMER
FINANCIAL SUPPLEMENT

PROJECT NAME	<u>Additional Funding - WTP Membrane Filter</u>	DATE	<u>11/08/2023</u>
DEPARTMENT	<u>Public Works</u>	SPONSOR	<u>PW Director</u>
REQUESTED AMOUNT	<u>\$ 35,000</u>		

DESCRIPTION	<p>An additional funding of \$35,000 is necessary to complete the FY24 purchase after negotiating technical and financial factors and the cost of the consultant support.</p> <p>The City's water is treated with a sophisticated system of long, small-diameter hollow threads, which, when connected together in a frame, comprise a "membrane filter", referred to as a "train". The Water Treatment Plant (WTP), built in 2007, has room for five membrane filter trains, which have a predicted life span of 10-15 years. The WTP currently has five filter trains operating that are currently operating and past their expected useful life.</p>
-------------	---

FUNDING SOURCE(S)	OPERATING	GF CARMA	GF FLEET CARMA	PORT RESERVES	WATER CARMA
	0%	0%	0%	0%	100%
	HAWSP	HART-ROADS	HART-TRAILS	PORT FLEET RESERVES	SEWER CARMA
	0%	0%	0%	0%	0%

FUNDING SOURCE 1: WATER CARMA (256-0378)	FUNDING SOURCE 2:	FUNDING SOURCE 3:
Current Balance <u>\$ 2,119,591</u>	Current Balance _____	Current Balance _____
Encumbered <u>\$ 821,770</u>	Encumbered _____	Encumbered _____
Requested Amount <u>\$ 35,000</u>	Requested Amount _____	Requested Amount _____
Other Items on Current Agenda <u>\$ 0</u>	Other Items on Current Agenda _____	Other Items on Current Agenda _____
Remaining Balance <u>\$ 1,262,821</u>	Remaining Balance _____	Remaining Balance _____
FUNDING SOURCE 4:	FUNDING SOURCE 5:	FUNDING SOURCE 6:
Current Balance _____	Current Balance _____	Current Balance _____
Encumbered _____	Encumbered _____	Encumbered _____
Requested Amount _____	Requested Amount _____	Requested Amount _____
Remaining Balance _____	Remaining Balance _____	Remaining Balance _____

1 **CITY OF HOMER**
2 **HOMER, ALASKA**

3 City Manager/
4 Public Works Director

5 **ORDINANCE 23-57**

6
7 AN ORDINANCE OF THE CITY COUNCIL OF HOMER, ALASKA
8 AMENDING THE FY24 CAPITAL BUDGET BY APPROPRIATING AN
9 ADDITIONAL \$35,000 FROM THE WATER CAPITAL ASSET REPAIR
10 AND MAINTENANCE ALLOWANCE (CARMA) FUND TO PURCHASE
11 ONE MEMBRANE FILTER MODULE FOR THE WATER TREATMENT
12 PLANT.

13
14 WHEREAS, Ordinance 23-23(A-3) adopted the FY24/25 Capital Budget, which authorized
15 \$80,000 in FY24 to procure one membrane filter train; and

16
17 WHEREAS, An additional funding of \$35,000 is necessary to complete the FY24 purchase
18 after negotiating technical and financial factors and the cost of the consultant support; and

19
20 WHEREAS, The City’s water is treated with a sophisticated system of long, small-
21 diameter hollow threads, which, when connected together in a frame, comprise a “membrane
22 filter”, referred to as a “train”; and

23
24 WHEREAS, The Water Treatment Plant (WTP), built in 2007, has room for five membrane
25 filter trains, which have a predicted life span of 10-15 years; and

26
27 WHEREAS, The WTP currently has five filter trains operating that are currently operating
28 and past their expected useful life; and

29
30 WHEREAS, The FY25 Capital Budget includes \$80,000 to procure a second membrane
31 filter train, and the intent is to budget for the purchase of one each in FY26, FY27 and FY28.

32
33 NOW, THEREFORE, THE CITY OF HOMER ORDAINS:

34
35 Section 1. The Homer City Council hereby amends the FY24 Capital Budget by
36 appropriating an additional \$35,000 to fund the increased purchase price of one membrane
37 filter module for the Water Treatment Plant as follows:

38

<u>Fund</u>	<u>Description</u>	<u>Amount</u>
256-0378	WTP Membrane Train	\$35,000

39
40
41
42
43
44



MEMORANDUM

Ordinance 23-58 and 23-59 Amending the FY24 Capital Budget by Accepting and Appropriating Two Hazard Mitigation Grants from the Division of Homeland Security & Emergency Management to Replace the City's Raw Water Transmission Mains and for Costs Associated with Management and Administering Grant 4413-001 1R. City Manager

Item Type: Backup Memorandum
Prepared For: Mayor and City Council
Date: November 6, 2023
From: Jenny Carroll, Special Projects & Communications Coordinator
Through: Rob Dumouchel, City Manager

I am pleased to report that the City has been awarded a Hazard Mitigation Grant Program (HMGP) grant from the Alaska Division of Homeland Security & Emergency Management in the amount of \$2,109,033.00 to replace the City's Raw Water Transmission Mains. Due in large part to disruptions at FEMA caused by COVID-19, this grant has been nearly four years in the making and we are very excited to finally get the implementation phase of this very important project underway.

This project replaces the two 47-year old cast iron raw water transmission mains (8,800 linear feet total) that transfer raw water from Bridge Creek Reservoir to the water treatment plant. These aging cast iron transmission mains are brittle, highly corrosive and as such highly susceptible to earthquake damage. Multiple repairs have already been made to these mains. The last two repairs were in response to earthquake damage. Major damage to the raw water transmission mains would make it impossible to serve the town with treated drinking water and would reduce the City's ability to provide adequate water pressure for fire protection.

Both mains will be replaced with High Density Polyethylene (HDPE) pipe, which is extremely durable and is less susceptible to damage by earthquakes or other natural disasters. One of the current water mains, at 8 inches, is under-sized to meet the maximum capacity of the Water Treatment Plant. The other main, a 10-inch line, is at capacity now. The plan is to replace both lines with larger 12-inch HDPE pipe. The larger-diameter pipes provide system redundancy and will be able to transport an adequate amount of raw water to the treatment plant for plant maximum daily flow both now and for future expansion of the treatment facility.

Design has been completed and is eligible for reimbursement under the HMGP.

Additionally, FEMA has made \$105,452 available to help offset costs related to managing and administering the Federal award to ensure that federal, state, or tribal requirements are met. These funds are granted under a separate obligating award document and are presented to Council for approval through a separate Ordinance.

Recommendation: Accept and appropriate Ordinances to (a) accept HMGP grant funds in the amount of \$2,109,033.00 for project implementation and (b) accept the HMGP Management Cost award.



THE STATE
of **ALASKA**
GOVERNOR MIKE DUNLEAVY

**Department of Military and
Veterans' Affairs**

Division of Homeland Security
and Emergency Management

P.O. Box 5750
JBER, AK 99505-0750
Main: 907.428.7000
Fax: 907.428.7009
ready.alaska.gov

October 31, 2023

Rob Dumouchel, City Manager
Homer, City of
491 E. Pioneer Avenue
Homer, AK, 99603

RE: Obligating Award Document
4413- DR-0011R-AK, 2018 Earthquake
Homer, City of
Raw Water Transmission Line Replacement - Project

Mr. Dumouchel:

Enclosed is the Division Hazard Mitigation Grant Program (HMGP) Obligating Award Document (OAD) for the Homer Raw Water Transmission Line Replacement.

The total award amount for this project is \$2,109,033.00. You will find the terms of the grant and procedures in the HMGP OAD and the Division of Homeland Security and Emergency Management (DHS&EM) Subrecipient Handbook on our website: ready.alaska.gov.

A copy of the OAD is enclosed. Please return the award document to our office after signing the first and last page. To speed up the process, please email a signed copy to your state contact and the Division Representative below.

If you have any questions, please contact Garrett Brooks, your assigned Division Representative at (907) 428-7045 or by email at garrett.brooks@alaska.gov.

Sincerely,

A handwritten signature in blue ink, appearing to read "William A. Dennis".

William A. Dennis
Alternate Governor's Authorized Representative

Enclosure(s): (1) DHS&EM HMGP Obligating Award Document
(1) FEMA Award Package



**DEPARTMENT OF MILITARY AND VETERANS AFFAIRS
DIVISION OF HOMELAND SECURITY
AND EMERGENCY MANAGEMENT**

Obligating Award Document for
HAZARD MITIGATION GRANT PROGRAM
U.S. DEPT OF HOMELAND SECURITY

Federal Emergency Management Agency
Grant Programs Directorate

Federal Grant No. 4413-11 R CFDA No. 97.039

1. State Grant No. 4413-0011R	2. UEI # QPAPRFMET7Q1	3. Award <input checked="" type="radio"/> Amendment # <input type="radio"/>	4. Employer Tax ID # 92-0030963								
5. Recipient Name and Address Homer, City of 491 E Pioneer Ave. Homer, AK 99603		6. Issuing Office and Address Department of Military and Veterans Affairs Division of Homeland Security and Emergency Management PO Box 5750 Fort Richardson, Alaska 99505-5750 http://www.ready.alaska.gov/									
7. Effective Date of This Action October 10, 2023		8. Method of Payment: Electronic									
9. Grant Award and Terms and Conditions: (see attached Grant Terms and Conditions)											
<table> <tr> <td>Total Award Amount:</td> <td>\$ 2,109,033.00</td> </tr> <tr> <td>Federal Share:</td> <td>\$ 1,581,774.75</td> </tr> <tr> <td>State Matching Share:</td> <td>\$ 527,258.25</td> </tr> <tr> <td>Local Matching Share:</td> <td>\$</td> </tr> </table>				Total Award Amount:	\$ 2,109,033.00	Federal Share:	\$ 1,581,774.75	State Matching Share:	\$ 527,258.25	Local Matching Share:	\$
Total Award Amount:	\$ 2,109,033.00										
Federal Share:	\$ 1,581,774.75										
State Matching Share:	\$ 527,258.25										
Local Matching Share:	\$										
<p align="center">Grant Performance Period: <u>October 10, 2023</u> through <u>October 9, 2024</u></p> <p align="center">See Attached: <i>Approved Hazard Mitigation Grant Program (HMGP) Project Description and Budget Detail</i></p> <p align="center">For State Use Only: CC # File No. #</p>											
10. Grant Requirements, Assurances and Agreements: (see attached Grant Requirements, Assurances and Agreements)											
<p>The acceptance of a grant from the United States creates a legal duty on the part of the grantee to use the funds or property made available in accordance with the conditions of the grant. [GAO Accounting Principles and Standards for Federal Agencies, Chapter 2, Section 16.8(c)]. Funding for this grant is 75% Federal (FEMA) and 25% State (DHS&EM).</p>											
11. Special Conditions:											
See Record of Environmental Considerations											
12. Recipient is required to sign and return one (1) copy of this document with the terms and conditions to the issuing address in Block 6, within 30 days from the date in Block 17.											
13. Division of Homeland Security and Emergency Management Project Manager Kim Barenburg		Phone: (907) 428-7045 Fax: (907) 428-7009 Email: kim.barenburg@alaska.gov									
14. Signature of Jurisdiction Project Manager Printed Name and Title: Janette Keiser, Homer Public Works Director		Phone: 907-435-3141 Fax: 907-235-3145 Email: jkeiser@ci.homerak.us									
15. Signature of Jurisdiction Chief Financial Officer Printed Name and Title: Elizabeth Walton, Homer Finance Director		Phone: 907-235-8121 Fax: 907-235-3140 Email: ewalton@ci.homer.ak.us									
16. Signature of Jurisdiction Signatory Official Printed Name and Title: Rob Dumouchel, City Manager		Date: _____ Phone: 907-435-3102 Email: rdumouchel@ci.homer.ak.us									
17. Division of Homeland Security and Emergency Management Signatory Official William Dennis,  Alternate Governor's Authorized Representative		Date <u>1 Nov 23</u>									

Grant Terms and Conditions (continued from Section 9 of Award)

The total allocation of the 2018 Alaska Earthquake awarded to the Division of Homeland Security and Emergency Management (DHS&EM) is \$ 26,871,045 under Federal Grant DR-4413-AK, CFDA# **97.039**. The Homer, City of, hereby referred to as "Jurisdiction" has been awarded \$ 2,109,033, which shall be used to support activities essential to to replace 3800 linear feet of cast iron water lines with 12 inch-diameter seismically resilient HDPE pipes. The performance period of this grant award is October 10, 2023 through October 9, 2024. Project conditions must be completed by this date. The Jurisdiction cannot sub-grant all or any part of this award to any other entity or organization. All awards require confirmation within the first reporting quarter that expenditures in the budget category toward projects will be made, or DHS&EM will execute de-obligation of the funds. No transfers of funds between allocations will be authorized, only de-obligation of funds, except on a case-by-case basis.

(A) Changes to Award: All change requests must be submitted in writing, or electronically to the DHS&EM project manager, accompanied by a justification narrative and budget/spending plan, for review and approval. Changes must be consistent with the scope of the project and grant guidelines. Requests for changes will be considered only if the reporting requirements are current, and if terms and conditions have been met at the time of the request. Changes in the programmatic activities, or purpose of the project, changes in key persons specified on the grant award, contractual services for activities central to the purposes of the award, requests for additional funding, change in project site, or release of special conditions will result in an amendment to this award. No transfers of funds between allocations will be authorized, only de-obligation of funds, except on a case-by-case basis.

(B) Reporting Requirements: The Jurisdiction shall submit timely quarterly *HMGP Project Quarterly Report* to the Project Manager at DHS&EM. Instructions and blank forms are located electronically at <https://ready.alaska.gov/Grants/HMGP>, and may be reproduced. Jurisdictions must check the web site quarterly for the most current forms. Use of outdated forms **will not** be accepted. Quarterly reports are due:

Q1	October 1 – December 31	Report due January 20
Q2	January 1 – March 31	Report due April 20
Q3	April 1 – June 30	Report due July 20
Q4	July 1 – September 30	Report due October 20

HMGP Project Quarterly Report shall describe the status of the project, compare actual accomplishments to the objectives established for the reporting period in the project timeline, report reasons for deviation and justification for timeline adjustment requests, and must support the funds expended. Include any significant events or activities. Progress must be reported relative to the project timeline and milestones stated in the jurisdiction's application. The *Project Final Narrative Form* is a summary report, evaluating project activities and measuring performance against project goals and objectives for the entire performance period, and is required *in addition* to the last quarterly report.

(C) Reimbursements: Submit on the *HMGP Request for Funds* form. Reimbursement shall be based upon authorized and allowable expenditures consistent with project narrative and budget detail and grant guidelines, and submission of timely quarterly report. Payments may be withheld pending correction of deficiencies or for use of outdated forms. Reimbursement of expenditures may be requested at any time within the performance period. Expenditures must be supported with source documentation (e.g. copies of invoices, receipts, timesheets with name/wage/hours, cost allocation, warrants, etc.).

- **Personnel Costs:** Payroll reports signed and certified by the Chief Financial Officer that capture the employee name, position, coded allocation to the project, amount paid, are acceptable. Staff may not self-certify their own time and wages. The Jurisdiction shall retain all supporting payroll records, including time and attendance records signed by the employee and supervisor and copies of warrants as per the recordkeeping requirements in Section J.
- **Contracts:** All sole-source procurements, single vendor response to a competitive bid, and contracts over \$100,000 require DHS&EM pre-approval prior to implementation. Final signed copies of all contracts are required for submission to DHS&EM with the request for reimbursement.
- **Program Income and Local Match:** Program income may be used to supplement project costs, reduce project costs, or may be refunded to the federal government, and must be used for allowable program costs and be expended prior to requests for reimbursement. Local matching funds must clearly support the source, the amount, and the timing of all matching contributions.
- **Equipment:** See Sub-grantee's Handbook
- **Construction:** Projects must comply with the Davis-Bacon Act. Contractors or subcontractors for construction projects pay workers employed directly at the worksite no less than the prevailing wages and fringe benefits paid on projects of a similar character.
- **Final Payment:** The Jurisdiction has 60 days from the completion of the project to submit the supporting documentation to the DHS&EM Project Manager accompanied with the following completed forms:
 - HMGP Project Final Narrative Form
 - HMGP (Final) Quarterly Report Form
 - HMGP Statement of Documentation Form
 - HMGP (Final) Request for Funds Form

DHS&EM will conduct final inspections, and upon favorable review will make final payment. Final payment may also be conditioned upon a financial review, if determined necessary by DHS&EM. Adjustments to the final payment may be made following any audits conducted by the State of Alaska or the United States Inspector General. DHS&EM reserves the right to withhold disbursement of final payment to the Jurisdiction until the project has been completed and given final approval by DHS&EM.

- **Advance of Funds:** See Subrecipient Handbook.
- **Administrative Allowance:** The Jurisdiction is eligible to receive direct administrative monies upon completion and closure of the project to the extent authorized by federal law, and subject to project funding as specified in the project budget as

an approved line item. Administrative costs refer to the costs of requesting, obtaining, and administering the hazard mitigation grant program.

(D) Non-reimbursable Expenses:

- Contracts, single vendor response to a competitive bid, and procurements over \$100,000 not pre-approved by DHS&EM
- Sole source contracts and procurements not pre-approved by DHS&EM
- Supplanting
- Expenditures not supported with appropriate documentation when submitted for reimbursement. Only properly documented expenditures will be processed for payment. Unsupported expenditures will be returned to the jurisdiction for resubmission
- Expenditures for items such as general-use software (word processing, spreadsheet, graphics, etc.), general-use computers and related equipment (other than for allowable M&A activities, or otherwise associated preparedness or response functions), general-use vehicles, licensing fees, weapons systems and ammunition

(E) Property and Equipment Management: The Jurisdiction shall maintain an effective property management system; safeguards to prevent loss, damage or theft; maintenance procedures to keep equipment in good condition; and disposition procedures. A *Property Inventory Report* can be requested from DHS&EM Project Manager and shall be submitted to DHS&EM annually each **January 20 with the HMGP Project Quarterly Report** during the performance period, and continued submission is required annually until final disposition of the equipment. The Jurisdiction shall, when practical, prominently display the following on any equipment purchased with award funds: ***Purchased with funds provided by the U.S. Department of Homeland Security.*** No equipment purchased with these grant fund may be assigned to other entities or organizations without the expressed approval in writing from DHS&EM, prior to the Jurisdiction's encumbrance or expenditure for that equipment. Management of property and equipment shall be in accordance with State laws and procedures as outlined, and 44 CFR Part 13, sections 13.31 and 13.32.

(F) Procurement: Procurement shall comply with local procurement policies and procedures, and conform to applicable State and Federal law and the standards identified in the Procurement Standards Sections of *44 CFR Part 13, and 2 CFR 200 Subpart D "Uniform Administrative Requirements for Grants and Cooperative Agreements with State and Local Governments."* Contractors that develop or draft specifications, requirements, Statements of Work (SOW), and/or Requests for Proposals (RFP) for a proposed procurement shall be excluded from bidding or submitting a proposal to compete for the award of such procurement. Local bidder's preference is not allowed for federally funded procurements. Procurement transactions shall be conducted to provide maximum open and free competition. **Each sole-source procurement, single vendor response to a competitive bid, and all purchases in excess of \$100,000.00 require pre-approval of DHS&EM.**

(G) Contracts: Any contract entered into during this grant period shall comply with local, State and federal government contracting regulations. To the extent that recipients of a grant use contractors, the subrecipient shall use small, minority, women-owned or disadvantaged business concerns and contractors to the extent practicable. Contracts for professional and consultant services must include local, State and federal government required contract language, a project budget, and require pre-approval by DHS&EM prior to implementation. Contract deliverables must meet the intent of the grant application and grant requirements. Jurisdiction is required for compensation for individual consultant services, which must be reasonable and consistent with the amount paid for similar services in the market place. Detailed invoices and time and effort reports are required for consultants.

(H) Publications: Publications created with funding under this grant shall prominently contain the following statement: ***This document was prepared under a grant from the Federal Emergency Management Agency (FEMA)'s Grant Programs Directorate, U.S. Department of Homeland Security and the Alaska Division of Homeland Security and Emergency Management. Points of view or opinions expressed in this document are those of the authors and do not necessarily represent the official position or policies of FEMA's Grant Programs Directorate, the U.S. Department of Homeland Security or the State of Alaska.***

(I) Audit Requirements: As the federal grant recipient, the State of Alaska requires a subrecipient expending \$750,000 or more in federal funds in the organization's fiscal year to conduct an organization-wide audit in accordance with *2 CFR 200 Subpart E*. The Jurisdiction will permit the State of Alaska project officials, program officials and auditors to have access to the subrecipient and third-party contractor's records and financial statements as necessary for the State of Alaska to comply with *2 CFR Part 200 Subpart F Audit Requirements*. Copies of audit findings must be submitted to DHS&EM within 30 days after the Jurisdiction receives its audit report, or within a 9-month period of the grant closeout date, whichever is earlier, in accordance with *2 AAC 45.010*. Include the Federal agency name, program, grant number, and year; the Catalog of Federal Domestic Assistance (CFDA) title and number; and the name of the pass-through agency.

(J) Recordkeeping Requirements: Grant financial and administrative records shall be maintained for a period of three (3) years following the date of the closure of the grant award, or audit if required. Time and effort, personnel and payroll records for all individuals reimbursed under the award must be maintained. Property and equipment records shall be maintained for a period of three (3) years following the final disposition, replacement or transfer of the property and equipment.

(K) Performance Measures: *HMGP Project Quarterly Report* shall demonstrate performance and progress relative to:

1. Acceptable performance on applicable critical tasks in Exercises using approved scenarios
2. Progress in achieving project timelines and milestones
3. Percent measurable progress toward completion of project
4. How funds have been expended during reporting period, and explains expenditures related to the project

(L) Sub-recipient Monitoring Policy: Monitoring is required to ensure that program goals, objectives, timelines, budgets and other related program criteria are being met. DHS&EM reserves the right to monitor, review and conduct analysis of the Jurisdiction's financial, programmatic and administrative policies and procedures such as, accounting for receipts and expenditures, cash management, maintaining adequate financial records, means of allocating and tracking costs, contracting and procurement policies and records, payroll records and means of allocating staff costs, property/equipment management system(s), progress of project activities, etc. This may include desk and field audits. Technical assistance is available from DHS&EM staff. The **Monitoring Policy is available at** <https://ready.alaska.gov/Grants/HMGP>.

(M) Penalty for Non-Compliance: For the reasons listed below, special conditions may be imposed, reimbursements may be partially or wholly withheld, the award may be wholly or partly suspended or terminated, or future awards, reimbursements and award modifications may be withheld. DHS&EM may institute the following, but is not limited to, withholding authority to proceed to the next phase of a project, requiring additional or more detailed financial reports, additional project monitoring, and/or establish additional prior approvals. DHS&EM shall notify the Jurisdiction of its decision in writing stating the nature and the reason for imposing the conditions/restrictions, the corrective action required and timeline to remove them, and the method of requesting reconsideration of the imposed conditions/restrictions. The Jurisdiction must respond within five days of receipt of notification.

- a. Unwillingness or inability to attain project goals
- b. Unwillingness or inability to adhere to Special Conditions listed in Section 11
- c. Failure or inability to adhere to grant guidelines and federal compliance requirements
- d. Improper procedures regarding contracts and procurements
- e. Inability to submit reliable and/or timely reports
- f. Management systems which do not meet federal required management standards
- g. The Applicant must complete all work associated with the project. If the work is not completed, the applicant will be required to return all State and Federal funding.

(N) Termination for Cause: If performance is not occurring as agreed, the award may be reduced or terminated without compensation for reduction or termination costs. DHS&EM will provide five (5) days' notice to Jurisdiction stating the reasons for the action, steps taken to correct the problems, and the commencement date of the reduction or termination. DHS&EM will reimburse Jurisdiction only for acceptable work or deliverables, necessary and allowable costs incurred through the date of reduction or termination. Final payment may be withheld at the discretion of DHS&EM until completion of a final DHS&EM review. Any equipment purchased under a terminated grant may revert to DHS&EM at the option of DHS&EM.

(O) Termination for Convenience: Any project may be terminated upon convenience, in whole or in part, for the convenience of the Government. The U.S. Department of Homeland Security and the DHS&EM, by written notice, may terminate this grant, in whole or in part, when it is in the Government's interest. Allowable costs obligated and/or incurred through the date of termination shall be reimbursed. Any equipment purchased under a terminated grant may revert to DHS&EM at the option of DHS&EM.

Grant Requirements, Assurances and Agreements (continued from Section 10 of the Award)

(A) The performance period for this grant award is October 10, 2023 through October 9, 2024. Monies may not be obligated outside of the time period as stated on the grant document. An obligation occurs when funds are encumbered, as with a purchase order and/or commitment of salaries and benefits. All obligated and encumbered funds must be liquidated within 45 days of the end of the performance period when the *Final Performance Progress Reports* are due.

(B) The Jurisdiction shall comply with the requirements and restrictions of the Hazard Mitigation Grant Program Guidance, State Overview and Guidelines, State Preparedness Report, and the State Homeland Security Strategy. By signing this obligating award document, the Jurisdiction certifies it has read, understood, and accepted these documents as binding.

(C) The signature of the signatory officials on this award attests to the Jurisdiction's understanding, acceptance, and compliance with Acknowledgement of Federal Funding; Lobbying; Debarment, Suspension and other responsibility matters; Drug-free Workplace; Conflict of Interest, and Non-Supplanting certifications. Federal funds will not be used to supplant state or local funds. Federal funds may be used to supplement existing funds to augment program activities, and not replace those funds which have been appropriated in the budget for the same purpose. Potential supplanting may be the subject of application and pre-award, post-award monitoring, and audit. Any cost allocable to a particular Federal award or cost objectives under the principles provided for in 2 CFR Part §200, subpart E, may not be charged to other Federal awards to overcome fund deficiencies.

(D) The Jurisdiction shall ensure the accounting system used allows for separation of fund sources. These grant funds cannot be commingled with funds from other federal, state or local agencies, and each award is accounted for separately.

(E) The Jurisdiction shall comply with the requirements under 2 CFR 25.110, to maintain and keep the Jurisdiction information current within the System of Award Management (SAM). Also the Jurisdiction is requirement to be non-delinquent to the Federal government as required in 2 CFR 180.

(F) The Jurisdiction shall comply with Federal Laws and Regulations: *Title VI of the Civil Rights Act of 1964, Title VIII of the Civil Rights Act of 1968, Section 504 of the Rehabilitation Act of 1973, Title IX of the Education Amendments of 1972, Age Discrimination Act of 1975, Americans with Disabilities Act of 1990. Per Executive Order 13166.* The Jurisdiction will take reasonable steps to ensure Limited English Proficient (LEP) persons have meaningful access to its programs and activities.

Executive Order 13347 Individuals with Disabilities in Emergency Preparedness requires government to support safety and security for individuals with disabilities in situations involving disasters, including earthquakes, tornadoes, fires, floods, hurricanes, and acts of terrorism. *Executive Order 13224* prohibits transactions with and support to organizations associated with terrorism. Energy Policy and Conservation Act, National Environmental Policy Act (NEPA) of 1969 and the Coastal Wetlands Planning, Protection, and Restoration Act of 1990 (as applicable.) The USA PATRIOT Act of 2001, Trafficking Victims Protection Act of 2000, Hotel and Motel Fire Safety Act of 1990, Fly America Act of 1974, subrecipients who collect Personally Identifiable Information (PII) are required to have a publically-available privacy policy that describes what PII they collect, how they use the PII, whether they share PII with third parties, and how individuals may have their PII corrected where appropriate.

(G) The Jurisdiction certifies that it has an *Affirmative Action Plan/Equal Employment Opportunity Plan*. An *EEOP* is not required for recipients of less than \$25,000.00 or fewer than 50 employees.

(H) The Jurisdiction certifies that its employees are eligible to work in the U.S. as verified by Form I-9, Immigration and Naturalization Service Employment Eligibility.

(I) It is the responsibility of the Jurisdiction as the subrecipient of these federal and state funds to fully understand and comply with the requirements of:

1. Administrative requirements

2 CFR Part 200 *Uniform Administrative Requirements, Cost Principles, and Audit Requirements for Federal Awards*
http://www.ecfr.gov/cgi-bin/text-idx?tpl=/ecfrbrowse/Title02/2cfr200_main_02.tpl

2. Cost Principles

2 CFR Part 200 Subpart E *Cost Principles*

<http://www.ecfr.gov/cgi-bin/retrieveECFR?gp=&SID=a470d16f3403a225479f2a8a6c7c4058&n=pt2.1.200&r=PART&ty=HTML#sp2.1.200.e>

3. Audit Requirements

2 CFR Part 200 *Subpart F Audit Requirements*

<http://www.ecfr.gov/cgi-bin/retrieveECFR?gp=&SID=a470d16f3403a225479f2a8a6c7c4058&n=pt2.1.200&r=PART&ty=HTML#sp2.1.200.f>

- A. **Federal:** The applicant agrees that, as a condition of receiving any federal financial assistance, a Single audit of those federal funds will be performed, if required by law, and further agrees it will comply with all applicable audit requirements.
- B. **State:** If the applicant is an entity that received state financial assistance the applicant shall submit to the State coordinating agency, within one year after the end of the audit period, an annual audit report covering the audit period as required by 2 AAC 45.010.
- C. Subrecipients identified as "non-compliant" by the Alaska Dept. of Administration, Division of Finance, Single Audit Coordinator shall be subject to the following grant payment restrictions:
 1. The Division of Homeland Security & Emergency Management (DHS&EM) will not process grant payments of any nature directly to the subrecipient.
 2. Subrecipients will be required to fully comply with the Single Audit requirements as specified by the Alaska Dept. of Administration, Division of Finance, Single Audit Coordinator.
 3. Subrecipients will provide compliance evidence to DHS&EM from the state audit coordinator before any payment will be processed.
 4. DHS&EM may process On-Behalf-Of (OBO) payments to vendors for costs directly associated to the scope of work on approved awards.
 5. Performance periods will not be extended due to a subrecipients failure to comply with Single Audit requirement.
 6. Payments made in error to subrecipients that are "non-compliant" must be repaid to the State of Alaska within 90 days of receipt of notice from DHS&EM.

4. **Procurement and Contracts.** Contracts must be of a reasonable cost, generally be competitively bid, and must comply with Federal, State, and local procurement standards. Detailed requirements for eligible procurement methods and contract types can be found in 2 CFR Part 200 Subpart D. The applicant agrees to review and follow procurement and contract requirements necessary for compliance with the grant program. Further, the applicant understands that failure to comply with these requirements may result of loss of funding for the entire project.

- A. **Debarred/Suspended Vendors.** As required by Executive Orders 12549 and 12689, Debarment and Suspension, and implemented at 2 CFR Part 180, the applicant certifies that it and its principals:
1. Are not presently debarred, suspended, proposed for debarment, declared ineligible, sentenced to a denial of Federal benefits by a State or Federal court, or voluntarily excluded from covered transactions by any Federal department or agency;
 2. Have not within a three-year period preceding this award been convicted of a or had a civilian judgment rendered against them for commission of fraud or a criminal offense in connection with obtaining, attempting to obtain, or perform a public a public (Federal ,State, or local) transaction or contract under a public transaction; violation of Federal or State antitrust statutes or commission of embezzlement, theft, forgery, bribery, falsification or destruction of records, making false statements, or receiving stolen property;
 3. Are not presently indicted for otherwise criminally or civilly charged by a governmental entity (Federal, State, or local) with commission of any of the offenses enumerated in paragraph (2) of this certification; and

4. Have not within a three-year period preceding this application had one or more public transactions (Federal, State, or local) terminated for cause of default. Where the applicant is unable to certify to any of the statements in this certification, he or she shall attach an explanation to this application.
5. Conflict of Interest
2 CFR Part 200.112 – the jurisdiction must disclose in writing to DHS&EM any potential conflict of interest per the applicable Federal awarding agency policy in the award’s performance period.
6. False Claims Act, Program Fraud Civil Remedies, and Mandatory Disclosures
 - A. 31 U.S.C. §3729, no recipient of federal payments shall submit a false claim for payment.
 - B. 38 U.S.C. §3801-3812, details the administrative remedies for false claims and statements made.
 - C. 2 CFR Part 200.113 – the jurisdiction must disclose, in a timely manner and in writing to DHS&EM, all violations of Federal criminal law involving fraud, bribery, or gratuity potentially affecting the award.
7. Technology Requirements
28 CFR Part 23, Criminal Intelligence System Operating Policies
8. Duplication of Benefits
2 CFR Part 200, Subpart E, Cost Principles
9. Robert T. Stafford Disaster Relief and Emergency Assistance Act, Public Law 93-288, as amended, 42 U.S.C. §5121-5206, and Related Authorities, where applicable.
10. State Requirements
Alaska State Procurement Code AS 36.30, AS36.30.005-.030
www.state.ak.us/local/akpages/ADMIN/dgs/docs/as3630.doc
Alaska Administrative Code Title 2 Chapter 12, 2 AAC 12.74. <http://www.legis.state.ak.us/basis/aac.asp#2.12>
Alaska Administrative Manual <http://doa.alaska.gov/dof/manuals/aam/>

We certify we have read, understood, and accept the Grant Terms and Conditions, the Grant Requirements, and Assurances and Agreements, and Special Conditions in accordance with this Award.

Project Manager’s Signature

Chief Financial Officer’s Signature

Signatory Official

**CITY OF HOMER
HOMER, ALASKA**

City Manager

ORDINANCE 23-58

AN ORDINANCE OF THE CITY COUNCIL OF HOMER, ALASKA AMENDING THE FY24 CAPITAL BUDGET BY ACCEPTING AND APPROPRIATING A HAZARD MITIGATION GRANT PROGRAM AWARD IN THE AMOUNT OF \$2,109,033 FROM THE ALASKA DIVISION OF HOMELAND SECURITY & EMERGENCY MANAGEMENT (DHS&EM) TO REPLACE THE CITY'S RAW WATER TRANSMISSION MAINS AND AUTHORIZING THE CITY MANAGER TO NEGOTIATE AND EXECUTE THE APPROPRIATE DOCUMENTS.

WHEREAS, The DHS&EM Hazard Mitigation Grant Program assists States and local communities in implementing long-term hazard mitigation measures following a major disaster; and

WHEREAS, Municipalities in the Kenai Peninsula Borough were eligible to apply for Hazard Mitigation Grant Program funds after a federal disaster declaration was approved for the November 30, 2018 earthquake in Alaska; and

WHEREAS, The City of Homer applied for funds to replace the City's 47-year old, seismically vulnerable, cast iron raw water transmission mains with more resilient High Density Polyethylene pipe designed to the specifications in Seismic Guidelines for Water Pipelines (ALA, 2005); and

WHEREAS, The City is pleased to have been awarded \$2,109,033 from the DSH&EM Hazard Mitigation Grant Program to support activities essential to replace the cast iron water mains; and

WHEREAS, Protecting the City's critical water utility infrastructure from seismic damage significantly mitigates the likelihood, severity, and duration of adverse life, health and public safety consequences related to earthquake events.

NOW, THEREFORE, THE CITY OF HOMER ORDAINS:

Section 1. The Homer City Council hereby amends the FY24 Capital Budget by accepting and appropriating the Hazard Mitigation Grant 4413-001 1R from the Alaska Division of Homeland Security and Emergency Management in the amount of \$2,109,033 as follows:

43	<u>Fund</u>	<u>Description</u>	<u>Amount</u>
44	215-0838	DHS&EM Hazard Mitigation Grant 4413-001 1R	\$2,109,033

45
46 Section 2. The City Manager is authorized to negotiate and execute the appropriate
47 documents.

48
49 Section 3. This is a budget amendment ordinance, is temporary in nature, and shall
50 not be codified.

51
52 ENACTED BY THE CITY COUNCIL OF HOMER, ALASKA this 27th day of November, 2023.

53
54
55 CITY OF HOMER

56
57
58
59 _____
60 KEN CASTNER, MAYOR

61 ATTEST:

62
63
64 _____
65 MELISSA JACOBSEN, MMC, CITY CLERK

66
67 YES:
68 NO:
69 ABSTAIN:
70 ABSENT:
71
72 Introduction:
73 Public Hearing:
74 Second Reading:
75 Effective Date:



THE STATE
of **ALASKA**
GOVERNOR MIKE DUNLEAVY

**Department of Military and
Veterans' Affairs**

Division of Homeland Security
and Emergency Management

P.O. Box 5750
JBER, AK 99505-0750
Main: 907.428.7000
Fax: 907.428.7009
ready.alaska.gov

October 31, 2023

Rob Dumouchel, City Manager
Homer, City of
491 E Pioneer Avenue
Homer, AK, 99603

RE: Obligating Award Document
4413- DR-0011R-AK, 2018 Earthquake
Homer, City of
Raw Water Transmission Line Replacement – Management Cost

Mr. Dumouchel:

Enclosed is the Division Hazard Mitigation Grant Program (HMGP) Obligating Award Document (OAD) for the Homer Raw Water Transmission Line Replacement – Management Cost.

The total award amount for this project is \$105,452.00. You will find the terms of the grant and procedures in the HMGP OAD and the Division of Homeland Security and Emergency Management (DHS&EM) Subrecipient Handbook on our website: ready.alaska.gov.

A copy of the OAD is enclosed. Please return the award document to our office after signing the first and last page. To speed up the process, please email a signed copy to your state contact and the Division Representative below.

If you have any questions, please contact Garrett Brooks, your assigned Division Representative at (907) 428-7045 or by email at garrett.brooks@alaska.gov.

Sincerely,

A handwritten signature in blue ink, appearing to read "W. A. Dennis".

William A. Dennis
Alternate Governor's Authorized Representative

Enclosure(s): (1) DHS&EM HMGP Obligating Award Document
(1) FEMA Award Package



**DEPARTMENT OF MILITARY AND VETERANS AFFAIRS
DIVISION OF HOMELAND SECURITY
AND EMERGENCY MANAGEMENT**

Obligating Award Document for
HAZARD MITIGATION GRANT PROGRAM
U.S. DEPT OF HOMELAND SECURITY

Federal Emergency Management Agency
Grant Programs Directorate

Federal Grant No. 4413-11 R CFDA No. 97.039

1. State Grant No. 4413-0011R-mc	2. UEI # QPAPRFMET7Q1	3. Award <input checked="" type="radio"/> Amendment # <input type="radio"/>	4. Employer Tax ID # 92-0030963
5. Recipient Name and Address Homer, City of 491 E Pioneer Ave. Homer, AK 99603		6. Issuing Office and Address Department of Military and Veterans Affairs Division of Homeland Security and Emergency Management PO Box 5750 Fort Richardson, Alaska 99505-5750 http://www.ready.alaska.gov/	
7. Effective Date of This Action October 10, 2023		8. Method of Payment: Electronic	
9. Grant Award and Terms and Conditions: (see attached Grant Terms and Conditions)			
Total Award Amount:		\$ 105,452.00	
Federal Share:		\$ 105,452.00	
State Matching Share:		\$	
Local Matching Share:		\$	
Grant Performance Period: October 10, 2023 through October 9, 2024			
See Attached: Approved Hazard Mitigation Grant Program (HMGP) Project Description and Budget Detail			
For State Use Only:		CC #	File No. #
10. Grant Requirements, Assurances and Agreements: (see attached Grant Requirements, Assurances and Agreements) The acceptance of a grant from the United States creates a legal duty on the part of the grantee to use the funds or property made available in accordance with the conditions of the grant. [GAO Accounting Principles and Standards for Federal Agencies, Chapter 2, Section 16.8(c)]. Funding for this grant is 75% Federal (FEMA) and 25% State (DHS&EM).			
11. Special Conditions: See Record of Environmental Considerations			
12. Recipient is required to sign and return one (1) copy of this document with the terms and conditions to the issuing address in Block 6, within 30 days from the date in Block 17.			
13. Division of Homeland Security and Emergency Management Project Manager Kim Barenburg		Phone: (907) 428-7045 Fax: (907) 428-7009 Email: kim.barenburg@alaska.gov	
14. Signature of Jurisdiction Project Manager Printed Name and Title: Janette Keiser, Homer Public Works Director		Phone: 907-435-3141 Fax: 907-235-3145 Email: jkeiser@ci.homerak.us	
15. Signature of Jurisdiction Chief Financial Officer Printed Name and Title: Elizabeth Walton, Homer Finance Director		Phone: 907-235-8121 Fax: 907-235-3140 Email: ewalton@ci.homer.ak.us	
16. Signature of Jurisdiction Signatory Official Printed Name and Title: Rob Dumouchel, City Manager		Date: _____ Phone: 907-435-3102 Email: rdumouchel@ci.homer.ak.us	
17. Division of Homeland Security and Emergency Management Signatory Official William Dennis,  Alternate Governor's Authorized Representative		Date 11-1-23	

Grant Terms and Conditions (continued from Section 9 of Award)

The total allocation of the 2018 Alaska Earthquake awarded to the Division of Homeland Security and Emergency Management (DHS&EM) is \$ 28,671,046 under Federal Grant DR-4413-AK, CFDA# **97.039**. The Homer, City of, hereby referred to as "Jurisdiction" has been awarded \$ 105,462.00, which shall be used to support activities essential to management cost to replace 8800 linear feet of cast iron water lines with 12 inch-diameter seismically resilient HDPE pipes. The performance period of this grant award is October 10, 2023 through October 9, 2024. Project conditions must be completed by this date. The Jurisdiction cannot sub-grant all or any part of this award to any other entity or organization. All awards require confirmation within the first reporting quarter that expenditures in the budget category toward projects will be made, or DHS&EM will execute de-obligation of the funds. No transfers of funds between allocations will be authorized, only de-obligation of funds, except on a case-by-case basis.

(A) Changes to Award: All change requests must be submitted in writing, or electronically to the DHS&EM project manager, accompanied by a justification narrative and budget/spending plan, for review and approval. Changes must be consistent with the scope of the project and grant guidelines. Requests for changes will be considered only if the reporting requirements are current, and if terms and conditions have been met at the time of the request. Changes in the programmatic activities, or purpose of the project, changes in key persons specified on the grant award, contractual services for activities central to the purposes of the award, requests for additional funding, change in project site, or release of special conditions will result in an amendment to this award. No transfers of funds between allocations will be authorized, only de-obligation of funds, except on a case-by-case basis.

(B) Reporting Requirements: The Jurisdiction shall submit timely quarterly *HMGP Project Quarterly Report* to the Project Manager at DHS&EM. Instructions and blank forms are located electronically at <https://ready.alaska.gov/Grants/HMGP>, and may be reproduced. Jurisdictions must check the web site quarterly for the most current forms. Use of outdated forms **will not** be accepted. Quarterly reports are due:

Q1	October 1 – December 31	Report due January 20
Q2	January 1 – March 31	Report due April 20
Q3	April 1 – June 30	Report due July 20
Q4	July 1 – September 30	Report due October 20

HMGP Project Quarterly Report shall describe the status of the project, compare actual accomplishments to the objectives established for the reporting period in the project timeline, report reasons for deviation and justification for timeline adjustment requests, and must support the funds expended. Include any significant events or activities. Progress must be reported relative to the project timeline and milestones stated in the jurisdiction's application. The *Project Final Narrative Form* is a summary report, evaluating project activities and measuring performance against project goals and objectives for the entire performance period, and is required *in addition* to the last quarterly report.

(C) Reimbursements: Submit on the *HMGP Request for Funds* form. Reimbursement shall be based upon authorized and allowable expenditures consistent with project narrative and budget detail and grant guidelines, and submission of timely quarterly report. Payments may be withheld pending correction of deficiencies or for use of outdated forms. Reimbursement of expenditures may be requested at any time within the performance period. Expenditures must be supported with source documentation (e.g. copies of invoices, receipts, timesheets with name/wage/hours, cost allocation, warrants, etc.).

- **Personnel Costs:** Payroll reports signed and certified by the Chief Financial Officer that capture the employee name, position, coded allocation to the project, amount paid, are acceptable. Staff may not self-certify their own time and wages. The Jurisdiction shall retain all supporting payroll records, including time and attendance records signed by the employee and supervisor and copies of warrants as per the recordkeeping requirements in Section J.
- **Contracts:** All sole-source procurements, single vendor response to a competitive bid, and contracts over \$100,000 require DHS&EM pre-approval prior to implementation. Final signed copies of all contracts are required for submission to DHS&EM with the request for reimbursement.
- **Program Income and Local Match:** Program income may be used to supplement project costs, reduce project costs, or may be refunded to the federal government, and must be used for allowable program costs and be expended prior to requests for reimbursement. Local matching funds must clearly support the source, the amount, and the timing of all matching contributions.
- **Equipment:** See Sub-grantee's Handbook
- **Construction:** Projects must comply with the Davis-Bacon Act. Contractors or subcontractors for construction projects pay workers employed directly at the worksite no less than the prevailing wages and fringe benefits paid on projects of a similar character.
- **Final Payment:** The Jurisdiction has 60 days from the completion of the project to submit the supporting documentation to the DHS&EM Project Manager accompanied with the following completed forms:
 - HMGP Project Final Narrative Form
 - HMGP (Final) Quarterly Report Form
 - HMGP Statement of Documentation Form
 - HMGP (Final) Request for Funds Form

DHS&EM will conduct final inspections, and upon favorable review will make final payment. Final payment may also be conditioned upon a financial review, if determined necessary by DHS&EM. Adjustments to the final payment may be made following any audits conducted by the State of Alaska or the United States Inspector General. DHS&EM reserves the right to withhold disbursement of final payment to the Jurisdiction until the project has been completed and given final approval by DHS&EM.

- **Advance of Funds:** See Subrecipient Handbook.
- **Administrative Allowance:** The Jurisdiction is eligible to receive direct administrative monies upon completion and closure of the project to the extent authorized by federal law, subject to project funding as specified in the project budget as

an approved line item. Administrative costs refer to the costs of requesting, obtaining, and administering the hazard mitigation grant program.

(D) Non-reimbursable Expenses:

- Contracts, single vendor response to a competitive bid, and procurements over \$100,000 not pre-approved by DHS&EM
- Sole source contracts and procurements not pre-approved by DHS&EM
- Supplanting
- Expenditures not supported with appropriate documentation when submitted for reimbursement. Only properly documented expenditures will be processed for payment. Unsupported expenditures will be returned to the jurisdiction for resubmission
- Expenditures for items such as general-use software (word processing, spreadsheet, graphics, etc.), general-use computers and related equipment (other than for allowable M&A activities, or otherwise associated preparedness or response functions), general-use vehicles, licensing fees, weapons systems and ammunition

(E) Property and Equipment Management: The Jurisdiction shall maintain an effective property management system; safeguards to prevent loss, damage or theft; maintenance procedures to keep equipment in good condition; and disposition procedures. A *Property Inventory Report* can be requested from DHS&EM Project Manager and shall be submitted to DHS&EM annually each **January 20 with the HMGP Project Quarterly Report** during the performance period, and continued submission is required annually until final disposition of the equipment. The Jurisdiction shall, when practical, prominently display the following on any equipment purchased with award funds: ***Purchased with funds provided by the U.S. Department of Homeland Security.*** No equipment purchased with these grant fund may be assigned to other entities or organizations without the expressed approval in writing from DHS&EM, prior to the Jurisdiction's encumbrance or expenditure for that equipment. Management of property and equipment shall be in accordance with State laws and procedures as outlined, and 44 CFR Part 13, sections 13.31 and 13.32.

(F) Procurement: Procurement shall comply with local procurement policies and procedures, and conform to applicable State and Federal law and the standards identified in the Procurement Standards Sections of *44 CFR Part 13, and 2 CFR 200 Subpart D "Uniform Administrative Requirements for Grants and Cooperative Agreements with State and Local Governments."* Contractors that develop or draft specifications, requirements, Statements of Work (SOW), and/or Requests for Proposals (RFP) for a proposed procurement shall be excluded from bidding or submitting a proposal to compete for the award of such procurement. Local bidder's preference is not allowed for federally funded procurements. Procurement transactions shall be conducted to provide maximum open and free competition. **Each sole-source procurement, single vendor response to a competitive bid, and all purchases in excess of \$100,000.00 require pre-approval of DHS&EM.**

(G) Contracts: Any contract entered into during this grant period shall comply with local, State and federal government contracting regulations. To the extent that recipients of a grant use contractors, the subrecipient shall use small, minority, women-owned or disadvantaged business concerns and contractors to the extent practicable. Contracts for professional and consultant services must include local, State and federal government required contract language, a project budget, and require pre-approval by DHS&EM prior to implementation. Contract deliverables must meet the intent of the grant application and grant requirements. Jurisdiction is required for compensation for individual consultant services, which must be reasonable and consistent with the amount paid for similar services in the market place. Detailed invoices and time and effort reports are required for consultants.

(H) Publications: Publications created with funding under this grant shall prominently contain the following statement: ***This document was prepared under a grant from the Federal Emergency Management Agency (FEMA)'s Grant Programs Directorate, U.S. Department of Homeland Security and the Alaska Division of Homeland Security and Emergency Management. Points of view or opinions expressed in this document are those of the authors and do not necessarily represent the official position or policies of FEMA's Grant Programs Directorate, the U.S. Department of Homeland Security or the State of Alaska.***

(I) Audit Requirements: As the federal grant recipient, the State of Alaska requires a subrecipient expending \$750,000 or more in federal funds in the organization's fiscal year to conduct an organization-wide audit in accordance with *2 CFR 200 Subpart E*. The Jurisdiction will permit the State of Alaska project officials, program officials and auditors to have access to the subrecipient and third-party contractor's records and financial statements as necessary for the State of Alaska to comply with *2 CFR Part 200 Subpart F Audit Requirements*. Copies of audit findings must be submitted to DHS&EM within 30 days after the Jurisdiction receives its audit report, or within a 9-month period of the grant closeout date, whichever is earlier, in accordance with *2 AAC 45.010*. Include the Federal agency name, program, grant number, and year; the Catalog of Federal Domestic Assistance (CFDA) title and number; and the name of the pass-through agency.

(J) Recordkeeping Requirements: Grant financial and administrative records shall be maintained for a period of three (3) years following the date of the closure of the grant award, or audit if required. Time and effort, personnel and payroll records for all individuals reimbursed under the award must be maintained. Property and equipment records shall be maintained for a period of three (3) years following the final disposition, replacement or transfer of the property and equipment.

(K) Performance Measures: *HMGP Project Quarterly Report* shall demonstrate performance and progress relative to:

1. Acceptable performance on applicable critical tasks in Exercises using approved scenarios
2. Progress in achieving project timelines and milestones
3. Percent measurable progress toward completion of project
4. How funds have been expended during reporting period, and explains expenditures related to the project

(L) Sub-recipient Monitoring Policy: Monitoring is required to ensure that program goals, objectives, timelines, budgets and other related program criteria are being met. DHS&EM reserves the right to monitor, review and conduct analysis of the Jurisdiction's financial, programmatic and administrative policies and procedures such as, accounting for receipts and expenditures, cash management, maintaining adequate financial records, means of allocating and tracking costs, contracting and procurement policies and records, payroll records and means of allocating staff costs, property/equipment management system(s), progress of project activities, etc. This may include desk and field audits. Technical assistance is available from DHS&EM staff. The **Monitoring Policy is available at** <https://ready.alaska.gov/Grants/HMGP>.

(M) Penalty for Non-Compliance: For the reasons listed below, special conditions may be imposed, reimbursements may be partially or wholly withheld, the award may be wholly or partly suspended or terminated, or future awards, reimbursements and award modifications may be withheld. DHS&EM may institute the following, but is not limited to, withholding authority to proceed to the next phase of a project, requiring additional or more detailed financial reports, additional project monitoring, and/or establish additional prior approvals. DHS&EM shall notify the Jurisdiction of its decision in writing stating the nature and the reason for imposing the conditions/restrictions, the corrective action required and timeline to remove them, and the method of requesting reconsideration of the imposed conditions/restrictions. The Jurisdiction must respond within five days of receipt of notification.

- a. Unwillingness or inability to attain project goals
- b. Unwillingness or inability to adhere to Special Conditions listed in Section 11
- c. Failure or inability to adhere to grant guidelines and federal compliance requirements
- d. Improper procedures regarding contracts and procurements
- e. Inability to submit reliable and/or timely reports
- f. Management systems which do not meet federal required management standards
- g. The Applicant must complete all work associated with the project. If the work is not completed, the applicant will be required to return all State and Federal funding.

(N) Termination for Cause: If performance is not occurring as agreed, the award may be reduced or terminated without compensation for reduction or termination costs. DHS&EM will provide five (5) days' notice to Jurisdiction stating the reasons for the action, steps taken to correct the problems, and the commencement date of the reduction or termination. DHS&EM will reimburse Jurisdiction only for acceptable work or deliverables, necessary and allowable costs incurred through the date of reduction or termination. Final payment may be withheld at the discretion of DHS&EM until completion of a final DHS&EM review. Any equipment purchased under a terminated grant may revert to DHS&EM at the option of DHS&EM.

(O) Termination for Convenience: Any project may be terminated upon convenience, in whole or in part, for the convenience of the Government. The U.S. Department of Homeland Security and the DHS&EM, by written notice, may terminate this grant, in whole or in part, when it is in the Government's interest. Allowable costs obligated and/or incurred through the date of termination shall be reimbursed. Any equipment purchased under a terminated grant may revert to DHS&EM at the option of DHS&EM.

Grant Requirements, Assurances and Agreements (continued from Section 10 of the Award)

(A) The performance period for this grant award is October 10, 2023 through October 9, 2024. Monies may not be obligated outside of the time period as stated on the grant document. An obligation occurs when funds are encumbered, as with a purchase order and/or commitment of salaries and benefits. All obligated and encumbered funds must be liquidated within 45 days of the end of the performance period when the *Final Performance Progress Reports* are due.

(B) The Jurisdiction shall comply with the requirements and restrictions of the Hazard Mitigation Grant Program Guidance, State Overview and Guidelines, State Preparedness Report, and the State Homeland Security Strategy. By signing this obligating award document, the Jurisdiction certifies it has read, understood, and accepted these documents as binding.

(C) The signature of the signatory officials on this award attests to the Jurisdiction's understanding, acceptance, and compliance with Acknowledgement of Federal Funding; Lobbying; Debarment, Suspension and other responsibility matters; Drug-free Workplace; Conflict of Interest, and Non-Supplanting certifications. Federal funds will not be used to supplant state or local funds. Federal funds may be used to supplement existing funds to augment program activities, and not replace those funds which have been appropriated in the budget for the same purpose. Potential supplanting may be the subject of application and pre-award, post-award monitoring, and audit. Any cost allocable to a particular Federal award or cost objectives under the principles provided for in 2 CFR Part §200, subpart E, may not be charged to other Federal awards to overcome fund deficiencies.

(D) The Jurisdiction shall ensure the accounting system used allows for separation of fund sources. These grant funds cannot be commingled with funds from other federal, state or local agencies, and each award is accounted for separately.

(E) The Jurisdiction shall comply with the requirements under 2 CFR 25.110, to maintain and keep the Jurisdiction information current within the System of Award Management (SAM). Also the Jurisdiction is requirement to be non-delinquent to the Federal government as required in 2 CFR 180.

(F) The Jurisdiction shall comply with Federal Laws and Regulations: *Title VI of the Civil Rights Act of 1964, Title VIII of the Civil Rights Act of 1968, Section 504 of the Rehabilitation Act of 1973, Title IX of the Education Amendments of 1972, Age Discrimination Act of 1975, Americans with Disabilities Act of 1990. Per Executive Order 13166.* The Jurisdiction will take reasonable steps to ensure Limited English Proficient (LEP) p have meaningful access to its programs and activities.

Executive Order 13347 Individuals with Disabilities in Emergency Preparedness requires government to support safety and security for individuals with disabilities in situations involving disasters, including earthquakes, tornadoes, fires, floods, hurricanes, and acts of terrorism. *Executive Order 13224* prohibits transactions with and support to organizations associated with terrorism. Energy Policy and Conservation Act, National Environmental Policy Act (NEPA) of 1969 and the Coastal Wetlands Planning, Protection, and Restoration Act of 1990 (as applicable.) The USA PATRIOT Act of 2001, Trafficking Victims Protection Act of 2000, Hotel and Motel Fire Safety Act of 1990, Fly America Act of 1974, subrecipients who collect Personally Identifiable Information (PII) are required to have a publically-available privacy policy that describes what PII they collect, how they use the PII, whether they share PII with third parties, and how individuals may have their PII corrected where appropriate.

(G) The Jurisdiction certifies that it has an *Affirmative Action Plan/Equal Employment Opportunity Plan*. An *EEOP* is not required for recipients of less than \$25,000.00 or fewer than 50 employees.

(H) The Jurisdiction certifies that its employees are eligible to work in the U.S. as verified by Form I-9, Immigration and Naturalization Service Employment Eligibility.

(I) It is the responsibility of the Jurisdiction as the subrecipient of these federal and state funds to fully understand and comply with the requirements of:

1. Administrative requirements

2 CFR Part 200 *Uniform Administrative Requirements, Cost Principles, and Audit Requirements for Federal Awards*
http://www.ecfr.gov/cgi-bin/text-idx?tpl=/ecfrbrowse/Title02/2cfr200_main_02.tpl

2. Cost Principles

2 CFR Part 200 Subpart E *Cost Principles*

<http://www.ecfr.gov/cgi-bin/retrieveECFR?gp=&SID=a470d16f3403a225479f2a8a6c7c4058&n=pt2.1.200&r=PART&ty=HTML#sp2.1.200.e>

3. Audit Requirements

2 CFR Part 200 *Subpart F Audit Requirements*

<http://www.ecfr.gov/cgi-bin/retrieveECFR?gp=&SID=a470d16f3403a225479f2a8a6c7c4058&n=pt2.1.200&r=PART&ty=HTML#sp2.1.200.f>

- A. **Federal:** The applicant agrees that, as a condition of receiving any federal financial assistance, a Single audit of those federal funds will be performed, if required by law, and further agrees it will comply with all applicable audit requirements.
- B. **State:** If the applicant is an entity that received state financial assistance the applicant shall submit to the State coordinating agency, within one year after the end of the audit period, an annual audit report covering the audit period as required by 2 AAC 45.010.
- C. Subrecipients identified as "non-compliant" by the Alaska Dept. of Administration, Division of Finance, Single Audit Coordinator shall be subject to the following grant payment restrictions:
 1. The Division of Homeland Security & Emergency Management (DHS&EM) will not process grant payments of any nature directly to the subrecipient.
 2. Subrecipients will be required to fully comply with the Single Audit requirements as specified by the Alaska Dept. of Administration, Division of Finance, Single Audit Coordinator.
 3. Subrecipients will provide compliance evidence to DHS&EM from the state audit coordinator before any payment will be processed.
 4. DHS&EM may process On-Behalf-Of (OBO) payments to vendors for costs directly associated to the scope of work on approved awards.
 5. Performance periods will not be extended due to a subrecipients failure to comply with Single Audit requirement.
 6. Payments made in error to subrecipients that are "non-compliant" must be repaid to the State of Alaska within 90 days of receipt of notice from DHS&EM.

4. Procurement and Contracts. Contracts must be of a reasonable cost, generally be competitively bid, and must comply with Federal, State, and local procurement standards. Detailed requirements for eligible procurement methods and contract types can be found in 2 CFR Part 200 Subpart D. The applicant agrees to review and follow procurement and contract requirements necessary for compliance with the grant program. Further, the applicant understands that failure to comply with these requirements may result of loss of funding for the entire project.

- A. **Debarred/Suspended Vendors.** As required by Executive Orders 12549 and 12689, Debarment and Suspension, and implemented at 2 CFR Part 180, the applicant certifies that it and its principals:
 1. Are not presently debarred, suspended, proposed for debarment, declared ineligible, sentenced to a denial of Federal benefits by a State or Federal court, or voluntarily excluded from covered transactions by any Federal department or agency;
 2. Have not within a three-year period preceding this award been convicted of a or had a civilian judgment rendered against them for commission of fraud or a criminal offense in connection with obtaining, attempting to obtain, or perform a public a public (Federal ,State, or local) transaction or contract under a public transaction; violation of Federal or State antitrust statutes or commission of embezzlement, theft, forgery, bribery, falsification or destruction of records, making false statements, or receiving stolen property;
 3. Are not presently indicted for otherwise criminally or civilly charged by a governmental entity (Federal, State, or local) with commission of any of the offenses enumerated in paragraph (2) of this certification; and

4. Have not within a three-year period preceding this application had one or more public transactions (Federal, State, or local) terminated for cause of default. Where the applicant is unable to certify to any of the statements in this certification, he or she shall attach an explanation to this application.
5. Conflict of Interest
2 CFR Part 200.112 – the jurisdiction must disclose in writing to DHS&EM any potential conflict of interest per the applicable Federal awarding agency policy in the award’s performance period.
6. False Claims Act, Program Fraud Civil Remedies, and Mandatory Disclosures
 - A. 31 U.S.C. §3729, no recipient of federal payments shall submit a false claim for payment.
 - B. 38 U.S.C. §3801-3812, details the administrative remedies for false claims and statements made.
 - C. 2 CFR Part 200.113 – the jurisdiction must disclose, in a timely manner and in writing to DHS&EM, all violations of Federal criminal law involving fraud, bribery, or gratuity potentially affecting the award.
7. Technology Requirements
28 CFR Part 23, Criminal Intelligence System Operating Policies
8. Duplication of Benefits
2 CFR Part 200, Subpart E, Cost Principles
9. Robert T. Stafford Disaster Relief and Emergency Assistance Act, Public Law 93-288, as amended, 42 U.S.C. §5121-5206, and Related Authorities, where applicable.
10. State Requirements
Alaska State Procurement Code AS 36.30, AS36.30.005-.030
www.state.ak.us/local/akpages/ADMIN/dgs/docs/as3630.doc
Alaska Administrative Code Title 2 Chapter 12, 2 AAC 12.74. <http://www.legis.state.ak.us/basis/aac.asp#2.12>
Alaska Administrative Manual <http://doa.alaska.gov/dof/manuals/aam/>

We certify we have read, understood, and accept the Grant Terms and Conditions, the Grant Requirements, and Assurances and Agreements, and Special Conditions in accordance with this Award.

Project Manager’s Signature

Chief Financial Officer’s Signature

Signatory Official

**CITY OF HOMER
HOMER, ALASKA**

City Manager

ORDINANCE 23-59

AN ORDINANCE OF THE CITY COUNCIL OF HOMER, ALASKA AMENDING THE FY24 CAPITAL BUDGET BY ACCEPTING AND APPROPRIATING A HAZARD MITIGATION GRANT PROGRAM AWARD IN THE AMOUNT OF \$105,452 FROM THE ALASKA DIVISION OF HOMELAND SECURITY & EMERGENCY MANAGEMENT (DHS&EM) TO REIMBURSE CITY OF HOMER COSTS ASSOCIATED WITH MANAGING AND ADMINISTERING THE DHS&EM HAZARD MITIGATION GRANT 4413-001 1R AND AUTHORIZING THE CITY MANAGER TO NEGOTIATE AND EXECUTE THE APPROPRIATE DOCUMENTS.

WHEREAS, The DHS&EM Hazard Mitigation Grant Program assists States and local communities in implementing long-term hazard mitigation measures following a major disaster; and

WHEREAS, The City was awarded \$2,109,033 from the DSH&EM Hazard Mitigation Grant Program (HMGP) to support activities essential to replace the City’s cast iron water transmission mains; and

WHEREAS, The HMGP also makes Management Cost Funding available to grant recipients to reimburse administrative costs incurred in managing and administering the federal award to ensure that federal, state, or tribal requirements are met; and

WHEREAS, The City is pleased to have been awarded a HMGP Management Cost award of up to \$105,452 to help offset the costs of administering the Raw Water Transmission Main Hazard Mitigation Grant # 413-001 1R.

NOW, THEREFORE, THE CITY OF HOMER ORDAINS:

Section 1. The Homer City Council hereby amends the FY24 Capital Budget by accepting and appropriating a Hazard Mitigation Grant Program Management Cost award in the amount of \$105,452 from the Alaska Division of Homeland Security and Emergency Management as follows:

<u>Fund</u>	<u>Description</u>	<u>Amount</u>
215-XXXX	DHS&EM Hazard Mitigation Management Cost Award for Grant # 413-001 1R	\$105,452

43
44
45
46
47
48
49
50
51
52
53
54
55
56
57
58
59
60
61
62
63
64
65
66
67
68
69
70
71
72
73

Section 2. The City Manager is authorized to negotiate and execute the appropriate documents.

Section 3. This is a budget amendment ordinance, is temporary in nature, and shall not be codified.

ENACTED BY THE CITY COUNCIL OF HOMER, ALASKA this 27th day of November, 2023.

CITY OF HOMER

KEN CASTNER, MAYOR

ATTEST:

MELISSA JACOBSEN, MMC, CITY CLERK

YES:

NO:

ABSTAIN:

ABSENT:

Introduction:

Public Hearing:

Second Reading:

Effective Date:

1 CITY OF HOMER
2 HOMER, ALASKA

Lord

3
4 ORDINANCE 23-60

5
6 AN ORDINANCE OF THE CITY COUNCIL OF HOMER, ALASKA
7 AMENDING HOMER CITY CODE CHAPTER 7.04 TO ADD NEW
8 SECTION 7.04.015 LOCAL TRAFFIC PROVISIONS AND AMEND
9 SECTION 7.04.030 TRAFFIC FINE SCHEDULES TO REDUCE SPEED
10 LIMITS ON CITY CUL-DE-SACS TO 15MPH.

11
12 WHEREAS, Many streets in the City of Homer lack adequate sidewalks and/or footpaths
13 and the Homer City Council has prioritized efforts to increase pedestrian safety in recent years;
14 and

15
16 WHEREAS, Cul-de-sacs are often areas where young children play and people with
17 perhaps narrow / short driveways who at times are required to back up out of their driveways;
18 and

19
20 WHEREAS, Cul-de-sacs also can have bends/curves and may lack a clear line of site; and

21
22 WHEREAS, Community members have expressed concerns around excess speeding and
23 a desire to have slower speed limits to allow for pedestrians, bicyclists, and families to have a
24 safer environment to live; and

25
26 WHEREAS, Reducing the speed limit on cul-de-sacs to 15MPH is a reasonable, safe, and
27 effective way to keep the driving public in harmony with those dwelling in these areas.

28
29 NOW, THEREFORE, THE CITY OF HOMER ORDAINS:

30
31 Section 1. Homer City Code 7.04 is hereby amended as follows:

32
33 **7.04.015 Local Traffic Provisions.**

34
35 **a. Cul-de-sacs**

- 36 **1. Cul-de-sacs are streets having only one outlet, with provision for a turnaround at**
37 **their termination, and which are not intended to be extended or continue to**
38 **serve future subdivisions or adjacent land.**
39 **2. The speed limit in all cul-de-sacs within the city, from the nearest cross street to**
40 **the termination of the cul-de-sac, shall be 15 miles per hour.**

41
42 Section 2. Homer City Code 7.04.030 is hereby amended to include fines for violations
43 of 7.04.015(a)(2), to read as follows:

Code Section	Code Section Title	Fine Per Day
<u>HCC 7.04.015(a)(1)</u>	<u>Cul-de-sac speed limits</u>	<u>First violation \$10 per mile over the 15 mile per hour limit;</u> <u>Second violation \$20 per mile over the 15 mile per hour limit</u>
HCC 7.06.010(b)	Muffler not working properly	Corr/\$500.00

45
46
47
48
49
50
51
52
53
54
55
56
57
58
59
60
61
62
63
64
65
66
67
68
69
70
71
72
73
74
75

Section 3. This Ordinance is of a permanent and general character and shall be included in the City Code.

ENACTED BY THE CITY COUNCIL OF HOMER, ALASKA this ____ day of _____, 2023.

CITY OF HOMER

KEN CASTNER, MAYOR

ATTEST:

MELISSA JACOBSEN, MMC, CITY CLERK

YES:

NO:

ABSTAIN:

ABSENT:

First Reading:

Public Hearing:

Second Reading:

Effective Date:



City of Homer

www.cityofhomer-ak.gov

Office of the City Manager

491 East Pioneer Avenue
Homer, Alaska 99603

citymanager@cityofhomer-ak.gov

(p) 907-235-8121 x2222

(f) 907-235-3148

Memorandum

TO: Mayor Castner and Homer City Council
FROM: Rob Dumouchel, City Manager
DATE: November 21, 2023
SUBJECT: City Manager's Report for November 27, 2023 Council Meeting

First Quarter Sales Tax Update

The 2023 summer season saw small decreases in taxable revenues when compared to the year prior. You may remember that the fourth quarter of FY23 (April 2023 through June 2023) experienced an approximately 4.8% decline in taxable sales that many have attributed to the poor weather we experienced this summer. The first quarter of fiscal year 2024 (July 2023 through September 2023) was relatively better than Q4 FY23, but still approximately 2% behind the taxable sales of the year prior. It's worth mentioning that despite the small decline, it is still the second best quarter of all time behind only Q1 FY23.

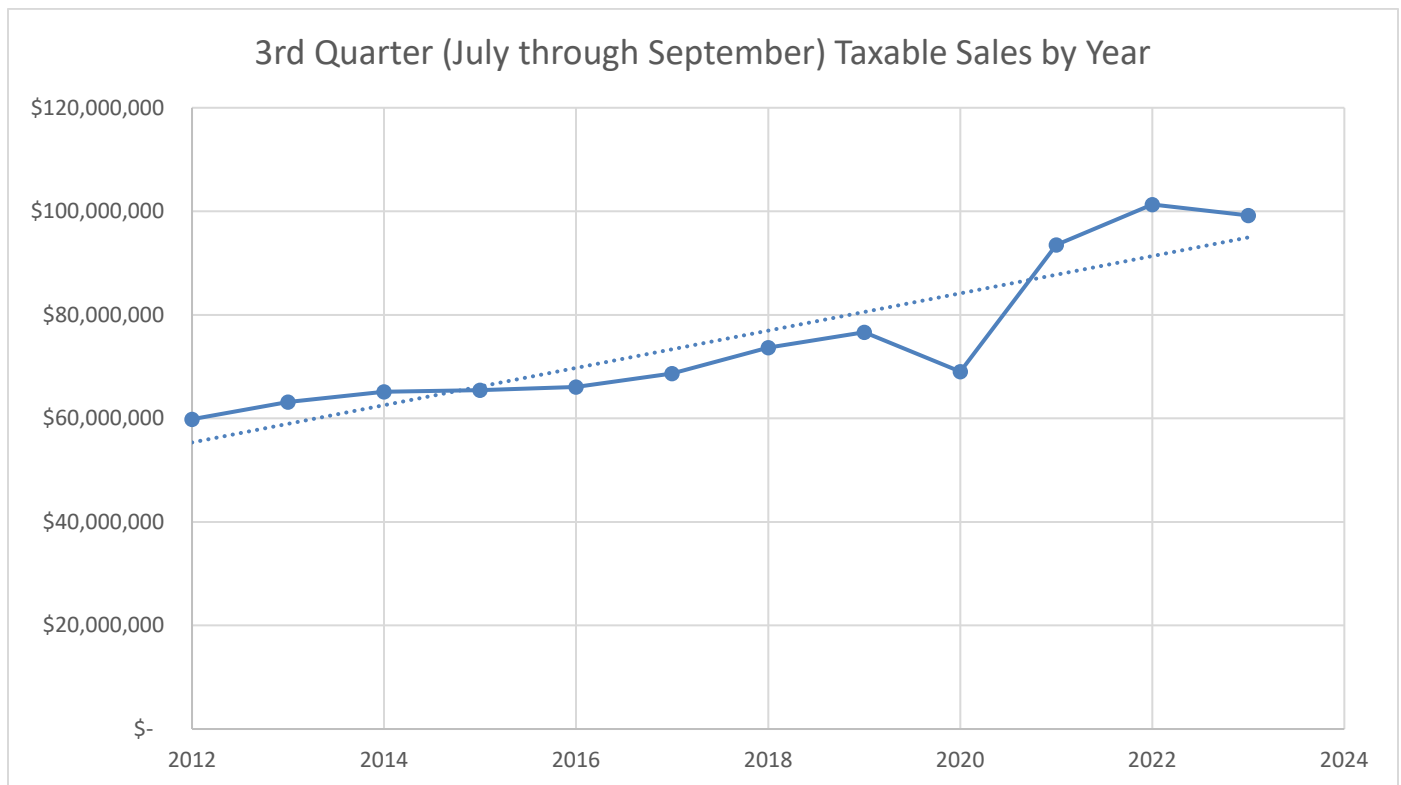

The Q1 FY24 performance puts us approximately \$101k behind FY23 in revenues (~\$63k to the General Fund, the rest split between HART, HAWSP, and the Police Station). The good news is that, as mentioned in a prior manager's report, other streams of income are pacing ahead of our expectations. Property taxes are expected to beat our budgeted numbers (\$4.4M expected based on KPB assessor's office data versus \$4.1M budgeted

for FY24) and the remote seller’s sales tax revenues are continuing to show growth (June through October revenue reports from ARSSTC show \$293k in revenue which is 67% of the \$435k budgeted for FY24).

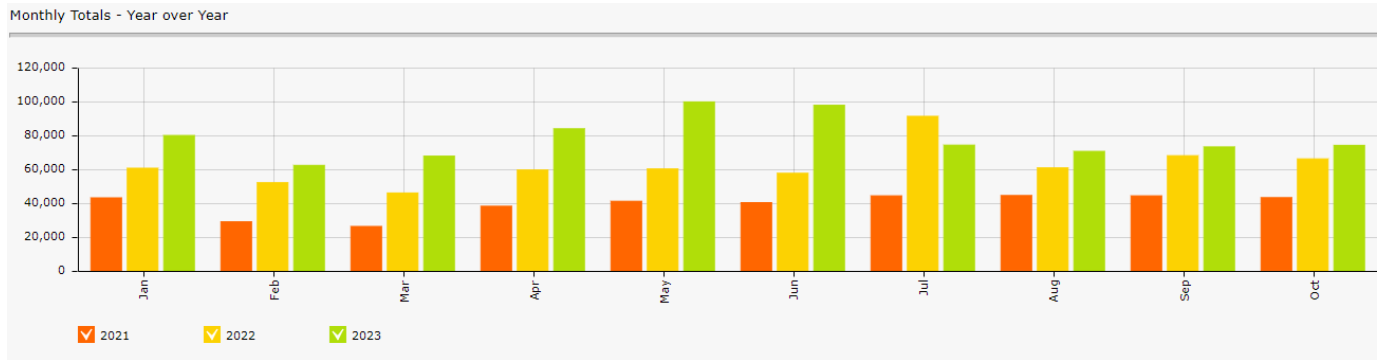

2021 to 2023 Year over year graph of remote sales tax revenues for January through October

Lighthouse Village Development Project

The City’s Planning Division received permit applications related to a proposed development to take place across three parcels near the base of the Homer Spit (1563 Homer Spit Road and 1491 Bay Avenue). The project proposes development of a hotel, employee housing, and triplex residential units. The following applications have been submitted for the Lighthouse Village Development project:

- Conditional Use Permit (CUP) 23-08 for Planned Unit Development (Homer City Code 21.24.030 (f)); the application includes the following:
 - CUP application for a Planned Unit Development
 - Development plans
 - Traffic impact analysis
 - Preliminary stormwater report
- Application to rezone one parcel (1491 Bay Avenue) from Rural Residential (RR) to General Commercial 1 (GC1) zone district.
- Proposal to vacate the B Street right-of-way within the Bayview Subdivision NO. 6 (HM 94-51), located in the SW1/4 SEC. 21, T. 6 S., 13 W., S.M.
- Proposed subdivision, Bayview Subdivision Lighthouse Village Replat, Preliminary Plat

These applications are scheduled for the Planning Commission’s regular meeting on December 6th. The applications are currently available for public review in the Clerk’s Office lobby and the agenda packet will be published on December 1, 2023. The site plan overview is attached to this report.

Short Term Rental Ordinance Update

Following the introduction of Ordinance 23-61 which would create a short term rental (STR) program, we’ve already had some positive stakeholder engagement experiences. The Economic Development Commission had a well-attended meeting featuring a fair amount of constructive public comment on the draft ordinance. Economic Development Manager Julie Engebretsen and I were also able to meet with representatives from the Homer Bed and Breakfast Association to discuss the proposal. Julie will also be speaking at a Guiding Growth event soon. More opportunities are on the way for public engagement on the topic, but we’re off to a great start.

Attachments:

December Employee Anniversaries

FY24 Q1 Financials
Homer Harbor Expansion Monthly Report
Lighthouse Village Development Site Plan



City of Homer

www.cityofhomer-ak.gov

Office of the City Manager

491 East Pioneer Avenue
Homer, Alaska 99603

citymanager@cityofhomer-ak.gov

(p) 907-235-8121 x2222

(f) 907-235-3148

Memorandum

TO: MAYOR CASTNER AND CITY COUNCIL
FROM: Andrea Browning
DATE: November 27, 2023
SUBJECT: December Employee Anniversaries

I would like to take the time to thank the following employees for the dedication, commitment and service they have provided the City and taxpayers of Homer over the years.

Mark Robl	Police	39	Years
Bryan Hawkins	Port	24	Years
Todd Cook	Public Works	14	Years
Sean Perry	Police	9	Years
Mike Zelinski	Public Works	9	Years
Josh Mershon	Port	4	Years
Regina Johanos	Library	3	Years
Jenna Luchaco	Public Works	2	Years
Del Masterhan	Port	2	Years
Matt Dominguez	IT	1	Year

General Fund
Expenditure Report
Actuals through September 2023
25% Fiscal Year Elapsed

Current Fiscal Analysis

	FY24		FY24 Q1	
	ADOPTED		ACTUAL	
	BUDGET		\$	%
Revenues				
Property Taxes	\$ 4,115,085	\$ 2,402,479	58%	
Sales and Use Taxes	8,939,282	2,510,608	28%	
Permits and Licenses	43,797	11,705	27%	
Fines and Forfeitures	10,303	90	1%	
Use of Money	0	51,141		
Intergovernmental	746,338	2,513	0%	
Charges for Services	396,890	189,618	48%	
Other Revenues	-	52,617		
Airport	198,448	54,135	27%	
Operating Transfers	1,728,989	-	0%	
Total Revenues	\$ 16,179,131	\$ 5,274,906	33%	
Expenditures & Transfers				
Administration	\$ 2,288,320	\$ 474,407	21%	
Clerks/Council	927,024	182,410	20%	
Planning	387,478	71,555	18%	
Library	1,079,132	274,341	25%	
Finance	898,578	187,993	21%	
Fire	1,881,175	448,434	24%	
Police	4,282,603	1,123,435	26%	
Public Works	3,512,438	807,157	23%	
Airport	229,618	41,779	18%	
City Hall, HERC	179,040	45,624	25%	
Non-Departmental	179,000	79,000	44%	
Total Operating Expenditures	\$ 15,844,405	\$ 3,736,135	24%	
Transfer to Other Funds				
Leave Cash Out	\$ 221,360	\$ -	0%	
Other	103,366	-	0%	
Total Transfer to Other Funds	\$ 324,725	\$ -	0%	
Transfer to CARMA				
General Fund Fleet CARMA	\$ -	\$ -	0%	
General Fund CARMA	-	-	0%	
Seawall CARMA	10,000	-	0%	
Total Transfer to CARMA Funds	\$ 10,000	\$ -	0%	
Total Expenditures & Transfers	\$ 16,179,131	\$ 3,736,135	23%	
Net Revenues Over (Under) Expenditures	\$ 0	\$ 1,538,771		

These numbers are preliminary and are subject to change

Water and Sewer Fund
Expenditure Report
Actuals through September 2023
25% Fiscal Year Elapsed

Current Fiscal Analysis

	FY24		FY24 Q1	
	ADOPTED		ACTUAL	
	BUDGET		\$	%
Revenues				
Water Fund	\$ 2,369,005	\$ 738,522	31%	
Sewer Fund	1,948,388	632,372	32%	
Total Revenues	\$ 4,317,393	\$ 1,370,894	32%	
Expenditures & Transfers				
<u>Water</u>				
Administration	\$ 309,507	\$ 101,539	33%	
Treatment Plant	684,568	184,108	27%	
System Testing	33,000	6,269	19%	
Pump Stations	115,707	21,220	18%	
Distribution System	372,744	90,517	24%	
Reservoir	19,025	2,223	12%	
Meters	285,597	15,105	5%	
Hydrants	214,533	52,457	24%	
<u>Sewer</u>				
Administration	\$ 303,612	\$ 102,932	34%	
Plant Operations	836,304	175,972	21%	
System Testing	18,000	2,927	16%	
Lift Stations	216,060	47,077	22%	
Collection System	306,884	60,079	20%	
Total Operating Expenditures	\$ 3,715,541	\$ 862,426	23%	
Transfer to Other Funds				
Leave Cash Out	\$ 15,769	\$ -	0%	
GF Admin Fees	-	-	0%	
Other	22,945	-	0%	
Total Transfer to Other Funds	\$ 38,714	\$ -	0%	
Transfers to CARMA				
Water	\$ 309,001	\$ -	0%	
Sewer	254,138	-	0%	
Total Transfer to CARMA Funds	\$ 563,138	\$ -	0%	
Total Expenditures & Transfers	\$ 4,317,393	\$ 862,426	20%	
Net Revenues Over(Under) Expenditures	\$ 0	\$ 508,468		

Port and Harbor Fund
Expenditure Report
Actuals through September 2023
25% Fiscal Year Elapsed

Current Fiscal Analysis

	FY24		FY24 Q1	
	ADOPTED		ACTUAL	
	BUDGET		\$	%
Revenues				
Administration	\$ 614,164	\$ 231,070	38%	
Harbor	3,961,361	2,225,313	56%	
Pioneer Dock	307,804	107,807	35%	
Fish Dock	578,477	332,034	57%	
Deep Water Dock	182,426	32,144	18%	
Outfall Line	4,800	-	0%	
Fish Grinder	7,390	6,463	87%	
Load and Launch Ramp	130,000	58,972	45%	
Total Revenues	\$ 5,786,422	\$ 2,993,801	52%	
Expenditures & Transfers				
Administration	\$ 1,143,305	\$ 353,573	31%	
Harbor	1,609,487	403,890	25%	
Pioneer Dock	86,345	22,838	26%	
Fish Dock	747,966	164,732	22%	
Deep Water Dock	104,705	22,786	22%	
Outfall Line	13,500	1,470	11%	
Fish Grinder	27,682	19,020	69%	
Harbor Maintenance	533,783	126,168	24%	
Main Dock Maintenance	51,393	12,540	24%	
Deep Water Dock Maintenance	61,893	13,939	23%	
Load and Launch Ramp	138,815	39,226	28%	
Total Operating Expenditures	\$ 4,518,876	\$ 1,180,182	26%	
Transfer to Other Funds				
Leave Cash Out	\$ 73,867	\$ -	0%	
GF Admin Fees	-	-	0%	
Debt Service	0	-	0%	
Other	375,092	-	0%	
Total Transfer to Other Funds	\$ 448,959	\$ -	0%	
Transfers to Reserves				
Harbor	\$ 818,588	\$ -	0%	
Load and Launch Ramp	-	-	0%	
Total Transfer to Reserves	\$ 818,588	\$ -	0%	
Total Expenditures & Transfers	\$ 5,786,422	\$ 1,180,182	20%	
Net Revenues Over(Under) Expenditures	\$ 0	\$ 1,813,619		



MEMORANDUM

Homer Harbor Expansion Study Monthly Written Update

Item Type: Informational Memorandum
Prepared For: Mayor and City Council
Date: November 21, 2023
From: Jenny Carroll, Special Projects and Communications Coordinator
Through: Rob Dumouchel, City Manager and Bryan Hawkins, Port Director

Purpose: This memorandum provides the Homer Harbor Expansion Study monthly written update to Homer City Council per Resolution 23-037.

The U.S. Army Corps of Engineers (USACE) Project Development Team (PDT) finalized and provided the City with the Project Management Plan (PMP), which defines study costs and timeline for deliverables. The PMP is provided as backup to a *Resolution Regarding the Homer Harbor Expansion Additional Funding and Management Plan*, which will be considered by City Council at the November 27, 2023 Regular City Council meeting. Please note that the USACE Pacific Ocean Division recommended that the PMP adhere to the initially set milestone dates for the study, despite being aware that they won't be met due to the Federal funding gap. The milestone dates in the PMP will be updated once continuation funding is secured. In the interim, these dates will underscore the necessity of securing continuation Federal funding to fulfill USACE deliverables up the USACE chain of command.

The PDT has slowed their work pace on the HHE study. The scheduled team meetings are now once per month rather than weekly. During this work reduction period, the USACE PDT:

- held Environmental Stakeholder Working Group meeting on September 28, 2023;
- is coordinating with USACE's Engineer Research & Development Center's Ecological Modeling Team to organize and conduct a two-day Ecological Modeling Workshop;
- is working on vertical team approval for the Homer Small Boat Harbor Vessel Economic Survey;
- is coordinating with agencies and making preparations to be ready for environmental field work and proposed geotechnical work.

HDR – Owner Representative: HDR activities will slow down parallel to the USACE. Since the last report, they:

- compiled and submitted a cost estimate for proposed geotechnical work to the USACE;

- continued to advance the Coastal Numerical Modeling (waves, tides/storm surge, sediment transport) of existing (baseline) conditions. Plan to complete baseline conditions analysis by the end of year;
- met with the Port & Harbor Advisory Commission to review the HHE Communications Plan;
- assist City staff to implement Communications Plan and continue to maintain and update [HHE website](#).

City of Homer:

- City staff prepared informational materials for the October 23 Committee of the Whole Council discussion of HHE next steps;
- Two HHE Council ‘champions’, Storm Hansen and Rachel Lord were assigned;
- At Council direction, staff prepared a draft Resolution regarding HHE next steps for review and editing by the Mayor and Council champions;
- City staff worked with the Mayor and Council champions to address a request from Governor Dunleavy’s office to formally request additional State HHE General Investigation matching funds in the Governor’s FY25 budget. The finalized request letter was provided as backup documentation to [Memorandum CC-23-254, submitted by Councilmembers Hansen and Lord for the November 13, 2023 City Council meeting](#).
- Communications/outreach: Information and updates about the study are being disseminated through the City's monthly newsletter and the Homer Harbor Expansion website. Email notifications were sent to inform mailing list subscribers about opportunities to provide public input during City Council meetings addressing the HHE General Investigation. The pace of social media outreach has temporarily slowed down due to staff turnover in the City Manager's office.

RECOMMENDATION:
Informational Only.

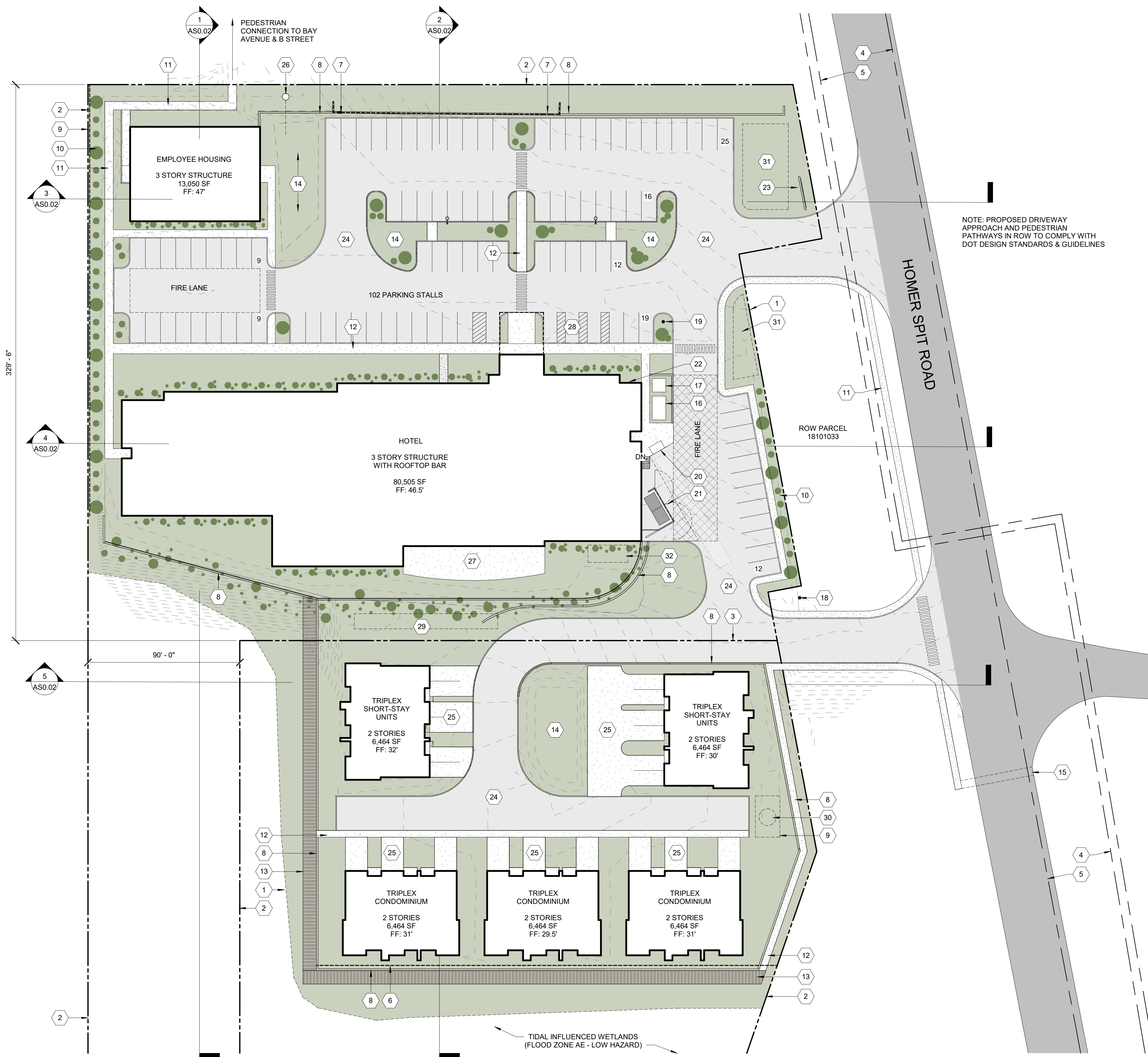

NOTE: PROPOSED DRIVEWAY APPROACH AND PEDESTRIAN PATHWAYS IN ROW TO COMPLY WITH DOT DESIGN STANDARDS & GUIDELINES

GENERAL NOTES

- EXISTING LOTS TO BE DEVELOPED:**
 LOT 163
 LOT 164-A
 LOT 164-B
 VACATED B-STREET ROW
- TOTAL SITE AREA:**
 6.95 ACRES
- PROPOSED BUILDABLE AREA TO BE DEVELOPED:**
 186,437 SF / 4.28 ACRES
- PROPOSED STRUCTURE SQUARE FOOTAGE:**
 EMPLOYEE HOUSING: 13,050 SF
 HOTEL: 80,505 SF
 TRIPLEX UNITS: (5) 6,464 SF
 TOTAL SF OF DEVELOPMENT: 125,875 SF
- CITY OF HOMER ZONING CODE:**
 ZONE: GENERAL COMMERCIAL 1 (GC1)
 BUILDING SETBACKS: 20' FROM ROW / 5' FROM OTHER LOTS
 LOCATED IN OVERLAY ZONE DISTRICT: NO
 LOCATED IN WETLAND LOCATION: NO
 LOCATED IN FLOOD ZONE: YES (AE, LOW HAZARD)
 LANDSCAPING REQUIREMENTS INCLUDE RIGHT-OF-WAY LANDSCAPED BUFFER ZONES.
- PUBLIC UTILITIES**
 PUBLIC WATER AND SEWER IS PROVIDED TO SITE (CITY OF HOMER PUBLIC WORKS)
 POWER IS PROVIDED TO SITE. 3-PHASE UPGRADE WILL BE REQUIRED (HOMER ELECTRIC ASSOCIATION)
- PARKING REQUIREMENTS:**
 NORTH LOT PARKING REQUIRED PER HCC 21.55.090:
 HOTEL - ONE PER GUEST ROOM @ 85 ROOMS = 85 STALLS
 DORMITORY - 1 PER TWO BEDS @ 40 BEDS = 20 STALLS
 NORTH LOT PARKING PROVIDED: TOTAL 102 STALLS
 SOUTH LOT PARKING REQUIRED PER HCC 21.55.090:
 DWELLINGS: TWO PER DWELLING UNIT (A REQUIRED PARKING SPACE MAY BE IN A GARAGE OR CARPORT IF THE STRUCTURE IS AT LEAST 12' WIDE, 20' LONG AND 8' HIGH) = 30 STALLS
 SOUTH LOT PARKING PROVIDED: TOTAL 30 STALLS

KEYNOTES

- 1 APPROXIMATE LIMITS OF CONSTRUCTION
- 2 PROPERTY LINE
- 3 PROPOSED PROPERTY LINE
- 4 EXISTING PUBLIC SEWER LINE
- 5 EXISTING PUBLIC WATER LINE
- 6 ARMY CORPS OF ENGINEERS PERMIT LINE
- 7 EXISTING RETAINING WALL
- 8 RETAINING WALL
- 9 SIGHT OBSCURING FENCE
- 10 LANDSCAPE BUFFER
- 11 PEDESTRIAN PATHWAY
- 12 CONCRETE SIDEWALK
- 13 PEDESTRIAN BOARDWALK
- 14 SWALE. SEE STORMWATER PLAN
- 15 EXISTING PEDESTRIAN CROSSWALK
- 16 GENERATOR
- 17 PAD MOUNT TRANSFORMER
- 18 EXISTING FIRE HYDRANT
- 19 FIRE HYDRANT
- 20 LOADING DOCK
- 21 TRASH ENCLOSURE
- 22 FDC CONNECTION POINT
- 23 MONUMENT SIGN
- 24 ASPHALT SURFACE
- 25 CONCRETE DRIVE AISLE
- 26 STORM / SEWER MANHOLE
- 27 CONCRETE PATIO
- 28 ACCESSIBLE PARKING STALLS
- 29 BELOW-GRADE STORMWATER STORAGE STRUCTURE
- 30 SANITARY SEWER LIFT STATION
- 31 SNOW REMOVAL AREA
- 32 BELOW-GRADE GREASE INTERCEPTOR

1 ARCHITECTURAL SITE PLAN
 AS0.01 SCALE: 1/32" = 1'-0"

No.	Date	Description



WOMER & ASSOCIATES
 ARCHITECTURE ENGINEERING PLANNING
 Suite 600 - 221 N. Wall St., Spokane, Washington 99201
 TEL: (509) 534-4884 FAX: (509) 534-4843 www.womer.com

LIGHTHOUSE VILLAGE DEVELOPMENT
 DOYON, LIMITED
 1563 & 1663 HOMER SPIT ROAD, HOMER, AK
 ARCHITECTURAL SITE PLAN

Job No: 867-001
Date: 11.15.2023
Designed LRE
Drawn LRE
Checked LRE

AS0.01



MEMORANDUM

Resolution 23-129, A Resolution of the City Council of Homer, Alaska Creating a Steering Committee to Aid in the Development of a New Comprehensive Plan. City Manager/City Planner.

Item Type: Backup Memorandum
Prepared For: City Council
Date: November 7, 2023
From: Ryan Foster, AICP, City Planner
Through: Rob Dumouchel, City Manager

A key task for the comprehensive plan update project is the design of an effective public participation process; which includes the formation of a steering committee comprised of a well-rounded group of community members to help guide the project. The proposed Steering Committee will consist of 3 members, with 2 City Commission Members, and 1 City Resident. City staff and project consultants will provide support to the Steering Committee.

If approved, the public notices requesting application submittals will be posted, with the goal of approving the creation of the steering committee in January of 2024, in time to help prepare for the first phase of public outreach events. The Mayor will nominate appointees to the Steering Committee from a list of applicants; nominees must be approved by City Council. There are three total goals for the comprehensive plan's steering committee:

Goal #1 – Assist in the refinement and execution of the public outreach process for the Comprehensive Plan.

Goal #2 – Participate in the Comprehensive Plan public outreach activities and events.

Goal #3 – Provide feedback and recommendations on Comprehensive Plan draft documents.

We will likely want to have a similar committee formed when we transition to the zoning code update, however, that is a much more technical document and it may be a good idea for Council to consider recruiting new members for that task when the time comes.

RECOMMENDED ACTION: Adopt a Resolution to form a steering committee to provide guidance in development of the comprehensive plan.

**CITY OF HOMER
HOMER, ALASKA**

City Manager/City Planner

RESOLUTION 23-129

A RESOLUTION OF THE CITY COUNCIL OF HOMER, ALASKA
CREATING A STEERING COMMITTEE TO AID IN THE DEVELOPMENT
OF A NEW COMPREHENSIVE PLAN.

WHEREAS, At the October 23, 2023, City Council Meeting, City Council approved the award of contract to Agnew Beck of Anchorage, AK for developing a new Comprehensive Plan; and

WHEREAS, The project scope of work includes the creation of a steering committee to aid in the guidance of developing the comprehensive plan; and

WHEREAS, City staff and project consultants will provide support to the steering committee.

NOW, THEREFORE, BE IT RESOLVED that the City Council of Homer, Alaska, hereby creates the Comprehensive Plan Steering Committee for the following purposes:

1. Goal #1 – Assist in the refinement and execution of the public outreach process for the Comprehensive Plan.
 - a. Scope of Work-
 - i. Work with consultants and City staff to refine and execute a public outreach program and schedule
 - b. Deliverables – Outreach plan, including notifications and schedule
 - c. Timeframe – January/February of 2024
2. Goal #2 – Participate in the Comprehensive Plan public outreach activities and events.
 - a. Scope of Work-
 - i. Work with each of your represented organizations to keep them informed on the project and encourage their participation
 - ii. Actively solicit participation from a wide range of people/organizations in the community
 - iii. Participate in event exercises and provide feedback
 - b. Deliverables – Contribute to the resulting work products of the outreach events
 - c. Timeframe – February-May of 2024



MEMORANDUM

Resolution 23-130, A Resolution of the City Council of Homer, Alaska Expressing Support for Continuation of the Homer Harbor Expansion General Investigation by Authorizing the City Manager to Sign an Updated Project Management Plant with the US Army Corps of Engineers, and Stating Intent to Fund 25% of the Updated General Investigation Cost. Lord/Hansen.

Item Type: Backup Memorandum
Prepared For: City Council
Date: November 21, 2023
From: Council Members Lord and Hansen

We developed Resolution 23-130 based on the following:

- Project status updates from staff at the October 23, 2023 Committee of the Whole
- Feedback from Council at the October 23, 2023 Committee of the Whole
- Meeting with Rob and Jenny to further ask questions and understand the project status
- Feedback from the Port & Harbor Commission (PHC) via the minutes of their October 11, 2023 meeting
- Conversation with PHC Chair to confirm understanding of those minutes

A few key points for this Resolution:

- The Reso authorizes signing the updated Project Management Plan. The Project Management Plan (PMP) is not a funding document; it is a Project Plan. It lays out the expectations of what the project must entail. We need to have an up-to-date PMP in order to have a Project to keep funding.
- This Reso itself is also not a funding document, though it does state the intent to bring forward an Ordinance for funding half of the additional local match from the Enterprise Reserves. It also states intent to continuing working alongside our State partners for securing the other half of the additional local match.

The City, as the Local Sponsor, can pull out of this project at any point. We can't get a refund on money spent, but we are not obligated to spend funds set aside for the General Investigation if we decide to walk away. We agree it would be ideal to not have changes to the PMP at this point in time, and that we wish there was not a pause in federal funding. However, if we are going to continue with this project we should probably recognize the lengthy and sometimes circuitous routes that large federal projects typically take. We should also be keeping the City's best interest in mind, and making sure that we do not overextend efforts beyond our partners' ability to fund and keep apace – this was a concern echoed by the PHC Chair. To that end, alongside the ordinance referenced in this

resolution we will work with staff to bring forward a clearer picture of the timeline and expended + expected City expenditures.

At this point in time, we concur with the Port and Harbor Commission and continue to believe that the City has valid and strong reasoning to explore a harbor expansion through the continuation of the General Investigation process and as such recommend passing Resolution 23-130.

1 **CITY OF HOMER**
2 **HOMER, ALASKA**

3 Lord/Hansen

4 **RESOLUTION 23-130**

5
6 A RESOLUTION OF THE CITY COUNCIL OF HOMER, ALASKA
7 EXPRESSING SUPPORT FOR CONTINUATION OF THE HOMER
8 HARBOR EXPANSION GENERAL INVESTIGATION BY AUTHORIZING
9 THE CITY MANAGER TO SIGN AN UPDATED PROJECT
10 MANAGEMENT PLAN WITH THE US ARMY CORPS OF ENGINEERS,
11 AND STATING INTENT TO FUND 25% OF THE UPDATED GENERAL
12 INVESTIGATION COST.
13

14 WHEREAS, Homer Harbor Expansion has been the City’s highest ranked priority capital
15 improvement project since 2004 to (1) meet moorage demand, (2) address overcrowding and
16 associated navigational safety concerns and high maintenance costs, and (3) support regional,
17 statewide and national marine transportation, the maritime economy and national security;
18 and
19

20 WHEREAS, The Homer Harbor Expansion’s General Investigation (GI) with the US Army
21 Corps of Engineers (USACE) was successfully initiated in 2023; and
22

23 WHEREAS, The cost of the General Investigation Study was set per the USACE Project
24 Management Plan (PMP) at \$3,000,000, as a shared partnership between the USACE, the State
25 of Alaska, and the City (\$1.5 million federal/ \$750,000 State of AK/ \$750,000 City of Homer); and
26

27 WHEREAS, After reaching the Alternatives and Measures Milestone, the USACE project
28 development team updated the PMP to include geotechnical and ship simulation data that
29 would have historically been in the pre-construction engineering and design phase of project
30 design, but USACE has found these to lead to significant cost overruns in the recent past and
31 has determined that these cost overruns are avoidable and additional work is now required to
32 complete the study with sufficient data to develop the most realistic benefit to cost ratio (BCA);
33 and
34

35 WHEREAS, Based on a cost estimate provided by USACE, this additional work for the GI
36 study phase comes with an additional cost of \$1,154,093 to be similarly shared between the
37 Federal and Local partners; and

38 WHEREAS, The City is at a decision point to either concur with the PMP changes, or reject them,
39 which would end the General Investigation and any further work on this project; and
40

41 WHEREAS, The City Council, with support from the Homer Port & Harbor Advisory
42 Commission, wishes to continue to pursue the completion of the General Investigation which
43 will require concurrence with the PMP and an additional \$577,046.50 in local sponsor match;
44 and

45 WHEREAS, This project has demonstrated statewide importance and the Council is
46 seeking a continued 50/50 local cost share with the State of Alaska to fund the total additional
47 local match in the amount of \$577,046.50; and

48
49 WHEREAS, Following this Resolution, the City Council will next consider a funding
50 ordinance to appropriate half of the total additional local match in the amount of \$288,524
51 from the Port and Harbor Reserves Harbor Match Account to officially set aside the City's share
52 of the local sponsor match; and

53
54 WHEREAS, Signing the updated Project Management Plan does not immediately
55 obligate the City to pay the local match; and

56
57 WHEREAS, It is acknowledged that the City is in a unique circumstance with a gap in
58 Federal funding for federal fiscal year 2024 which will create a slowdown and delay the General
59 Investigation, and that the continuation of the GI and expenditure of funds on the GI is
60 dependent upon continued Federal funding; and

61
62 WHEREAS, The City Council believes it is prudent to continue to explore the options for
63 a harbor expansion to meet the needs of our overcrowded fleet and to improve safety among
64 other reasons previous stated; and

65
66 WHEREAS, The City Council is greatly appreciative of our Federal and State partners and
67 recognizes the success and continuation of this project lies in continued active partnership and
68 investment between all three, and that the City will be prudent and continue to assess its
69 relative risk and investment for the completion of the General Investigation.

70
71 NOW THEREFORE BE IT RESOLVED that the City Council of Homer, Alaska hereby:
72 1. Authorizes the City Manager to sign the revised Project Management Plan by
73 negotiating and executing the required documents with USACE.
74 2. Directs the Council sponsors for this project to prepare an Ordinance to appropriate the
75 sum of \$288,523.25 from Port and Harbor Reserves Matching Fund Account to fund 50%
76 of the required local sponsor match.

77
78 BE IT FURTHER RESOLVED that the City Council of Homer, Alaska recognizes the critical
79 importance of continued regional and statewide partnerships for the Homer Harbor Expansion
80 and:

81 1. Directs the Council sponsors for this project to prepare a Resolution supporting and
82 requesting additional match funding from the State of Alaska in the amount of
83 \$288,523.
84 2. Authorizes the Council sponsors to contact the Kenai Peninsula Borough requesting a
85 similar Resolution of support for additional State match funding from the Borough
86 Assembly.

87

88 PASSED AND ADOPTED by the Homer City Council this 27th day of November, 2023.

89

90

CITY OF HOMER

91

92

93

KEN CASTNER, MAYOR

94

95

96 ATTEST:

97

98

99

100 _____
MELISSA JACOBSEN, MMC, CITY CLERK

101

102 Fiscal Note: N/A

From: [Kate Mitchell](#)
To: [Department Clerk](#)
Subject: Harbor resolution WE support
Date: Monday, November 20, 2023 12:02:54 PM

CAUTION: This email originated from outside your organization. Exercise caution when opening attachments or clicking links, especially from unknown senders.

Benjamin G. and Katherine A Mitchell have lived and worked in Homer for 45 years. We have businesses in town and our home is in the borough.
Because Homer had a dock and a boat harbor The Coast Guard chose Homer as the home port for the CGC Sedge. BMC Mitchell was assigned to that unit in 1978. Homer has been home ever since.
Because there was a harbor there was a possibility of successfully starting two Marine-related businesses. Homer Boat Yard and NOMAR The harbor and the marine trades businesses have grown and the economic impact is obvious.
We fully support the resolution to continue the study with the Corp of Engineers.
The small sacrifices made now will bring Homer into a better economic position in the future as the regional port for Alaska's growth in the future.
Had the Harbor been expanded 20 years ago when first proposed we would be reaping those benefits now.

From: renee@fortunesea.net
To: [Department Clerk](#)
Subject: Written comment November 27th City Council Regular Meeting
Date: Tuesday, November 21, 2023 10:21:22 AM

CAUTION: This email originated from outside your organization. Exercise caution when opening attachments or clicking links, especially from unknown senders.

Dear Mayor Castner and Council members,

I am writing in strong support of completing the General Investigation Study for the expansion of the Homer Harbor. I have raised a family in Homer tied to commercial fisheries and marine activities, and work managing ten tender/commercial fishing vessels along with marine haul out and repair. Our current harbor basin is already too small for the commercial, charter, governmental, and recreational vessels that utilize it with a large waiting list, along with the marine trades that support these industries & that provide livelihoods for a huge portion of our residents. Without moving forward with the General Investigation Study, the positive impacts of expansion will be lost to inaction. We as a city and community have invested so much time, effort and money in getting to this point, and to not carry it to the end would be a huge disservice to the community as a whole. In closing, I implore the City of Homer to invest in the completion of the General Investigation Study for the expansion of the Homer Harbor.

Sincerely,
Renee Alward
60082 Clarice Way
Homer, AK 99603
907-299-3358

Published on *City of Homer Alaska Official Website* (<https://www.cityofhomer-ak.gov>)

[Home](#) > [Submit Written Testimony to City Council](#) > [Webform results](#) > Submission #96

Submission information

Form: [Submit Written Testimony to City Council](#) [1]
Submitted by Visitor (not verified)
Tue, 11/21/2023 - 12:34pm
162.142.119.13

First Name Malcolm
Last Name Milne
Email milnemarine@yahoo.com
Phone Number 9073996296
Are You A City or Non-City Resident? Non-City Resident

Which City Council Meeting do you want to participate in? Regular Meeting

Date of Meeting you want to participate in? Mon, 11/27

What type of comments will you be giving?

Public Comments Upon Matters Already on the Agenda - Citizen may comment on regular agenda items not scheduled for public hearing such as Consent Agenda items, Memorandums, Pending Business, New Business, Resolutions, and Ordinances to be introduced.

Written Testimony

RE: e. Resolution 23-1xx, A Resolution of the City Council of Homer, Alaska Regarding the Homer Harbor Expansion Additional Funding and Management Plan. City Manager.

Hello Homer City Council Members,

My name is Malcolm Milne and I have fished out of Homer since 1995. I currently own and operate the F/V Captain Cook through my business Milne Marine and we currently have a year round stall lease in the Homer Harbor. I currently live outside of city limits. The F/V Captain Cook longlines for halibut in the spring and fall and seines for salmon in Lower Cook Inlet in the summer. We employ 2 to 3 crew depending on the season. All of the vessel maintenance is done through local marine trades.

I strongly support the continuing the investigation into the Homer Port Expansion. At this point I do not see details of the resolution but I am definitely in favor of going forward in exploring the possibilities of a port expansion. In my opinion it's similar to owning an older vehicle. You know at

some point you'll need to replace or repair it and the prudent thing to do is explore options in advance rather than be forced into an uniformed decision at a later point in time. It's hard to deny that Homer will continue to change as time goes on, the fact that Homer will have and need a harbor will probably not change. I hope this City Council will continue to explore what the future may hold.

Thank you for your attention.

Malcolm Milne

Electronic Signature

Malcolm Milne

I understand that checking this box constitutes a legal signature confirming that I acknowledge and agree that I am the person identified above and that I acknowledge and agree to the above Terms of Acceptance.

Source URL:<https://www.cityofhomer-ak.gov/node/60081/submission/51419>

Links

[1] <https://www.cityofhomer-ak.gov/cityclerk/submit-written-testimony-city-council>

Published on *City of Homer Alaska Official Website* (<https://www.cityofhomer-ak.gov>)

[Home](#) > [Submit Written Testimony to City Council](#) > [Webform results](#) > Submission #97

Submission information

Form: [Submit Written Testimony to City Council](#) [1]

Submitted by Visitor (not verified)

Tue, 11/21/2023 - 1:32pm

65.74.107.122

First Name David

Last Name Mastolier

Email dmastolier@gmail.com

Phone Number 9073991775

Are You A City or Non-City Resident? City Resident

Which City Council Meeting do you want to participate in? Regular Meeting

Date of Meeting you want to participate in? Mon, 11/27

What type of comments will you be giving?

Public Comments Upon Matters Already on the Agenda - Citizen may comment on regular agenda items not scheduled for public hearing such as Consent Agenda items, Memorandums, Pending Business, New Business, Resolutions, and Ordinances to be introduced.

Written Testimony

November 21, 2023

Letter of Support for the resolution to support the continuation of the General Investigation study.

Dear Mayor Castner and Distinguished Council Members,

I am expressing my support for the resolution to support the continuation of the General Investigation study. My support is for the following:

- Signing the revised project management plan for the study,
- An Ordinance to appropriate additional City match funds.
- And a Resolution to the State of Alaska seeking their continued partnership through additional match funds.

The insights derived from this study carry profound significance for the advancement of Homer. The ability to effectively accommodate our city's inevitable growth through well-informed construction and development plans is of paramount importance. The study may reveal that the harbor expansion is not feasible or could present a more cost-effective estimate for the project's final cost. Irrespective of the outcome, the information gathered will stand as a crucial resource

for future expansion projects, equipping our city with the ability to make well-considered decisions rooted in sound scientific analysis. Thus far, the considerable investment in this project underscores the critical nature of surmounting the current financial obstacle.

Understanding the potential of our assets is essential for crafting a resilient business strategy. Without necessitating an immediate commitment to the expanded harbor, the feasibility study will provide us with the indispensable data needed to make the most informed decisions—a cornerstone of any sound business plan.

This study could aptly be named the "Homer's Potential for Growth" study. As a leader in our community, you shoulder the responsibility of making decisions that will reverberate throughout our area for generations. This data, grounded in scientific rigor, will empower you with informed, forward-thinking answers.

We have already invested a substantial amount of resources in this project. To halt before obtaining a definitive answer would prove costlier in the long run and could also convey a lack of commitment or follow-through on our part. Let us proudly demonstrate to the State, USACE, and the Federal Government that Homer fully supports the feasibility study. We earnestly seek solid scientific data to guide our decision-making processes.

Best regards,

David L Mastolier

Homer Resident and Business Owner

Electronic Signature

David Mastolier

I understand that checking this box constitutes a legal signature confirming that I acknowledge and agree that I am the person identified above and that I acknowledge and agree to the above Terms of Acceptance.

Source URL: <https://www.cityofhomer-ak.gov/node/60081/submission/51421>

Links

[1] <https://www.cityofhomer-ak.gov/cityclerk/submit-written-testimony-city-council>