



Homer City Hall
491 E. Pioneer Avenue
Homer, Alaska 99603
www.cityofhomer-ak.gov

City of Homer Agenda

City Council Regular Meeting

Monday, February 22, 2021 at 6:00 PM

City Hall Cowles Council Chambers via Zoom Webinar

Dial: +1 669 900 6833 or +1 253 215 8782 or Toll Free 877 853 5247 or 888 788 0099

Webinar ID: 205 093 973 Password: 610853

CALL TO ORDER, PLEDGE OF ALLEGIANCE

AGENDA APPROVAL (Only those matters on the noticed agenda may be considered, pursuant to City Council's Operating Manual, pg. 6)

MAYORAL PROCLAMATIONS AND RECOGNITIONS

PUBLIC COMMENT ON MATTERS ALREADY ON THE AGENDA

RECONSIDERATION

CONSENT AGENDA (Items listed below will be enacted by one motion. If a separate discussion is desired on an item, that item may be removed from the Consent Agenda and placed on the Regular Meeting Agenda at the request of a Councilmember.)

- a. Homer City Council Unapproved Special and Regular Meeting Minutes for February 8, 2021. City Clerk. Recommend adoption.
- b. Memorandum 21-028 from Deputy City Planner Re: Wayfinding and Streetscape RFP. Recommend approval.
- c. Memorandum 21-029 from City Clerk Re: Approval of Letter from City Council in Support of Reinstating/Extending the State's Disaster Declaration. Recommend approval.
- d. Ordinance 21-08, An Ordinance of the City Council of Homer, Alaska Amending the 2021 Capital Budget and Authorizing Additional Expenditure of \$113,353.33 from the HART-Road Fund for the Woodard Creek Rehabilitation Project. City Manager/Public Works Director. Recommended dates Introduction February 22, 2021 Public Hearing and Second Reading March 8, 2021

Memorandum 21-030 from Public Works Director as backup

- e. Ordinance 21-09, An Ordinance of the City Council of Homer, Alaska, Amending the 2021 Capital Budget and Authorizing Expenditure of up to \$65,000 from the Police Fleet

CARMA Account to Purchase and Outfit a Patrol Vehicle. City Manager/Police Chief. Recommended dates Introduction February 22, 2021 Public Hearing and Second Reading March 8, 2021

Memorandum 21-031 from Police Chief as backup

- [f.](#) Ordinance 21-10, An Ordinance of the City Council of Homer, Alaska, Amending the 2021 Capital Budget and Authorizing Expenditure of an Additional \$17,148 from the Sewer Reserve Fund to Complete the Retrofit of High Energy Lights Fixtures at the Sewer Treatment Campus. City Manager/Public Works Director. Recommended date Introduction February 22, 2021 Public Hearing and Second Reading March 8, 2021

Memorandum 21-032 from Public Works Director as backup

- [g.](#) Ordinance 21-11, An Ordinance of the City Council of Homer, Alaska, Amending the 2021 Capital Budget and Authorizing an Additional \$88,569 from the HAWSP Fund to pay for a Betterment to the Tasmania Court Water and Sewer Special Assessment District Involving the Design/Construction of a Water Main Extension to Serve a Future Water Storage Tank. City Manager/Public Works Director. Recommended dates Introduction February 22, 2021 Public Hearing and Second Reading March 8, 2021

Memorandum 21-033 from Public Works Director as backup

- [h.](#) Ordinance 21-12, An Ordinance of the City Council of Homer, Alaska, Amending the 2021 Capital Budget and Authorizing Expenditure of \$ 12,700 from the HART-Road Fund for the Design of a Betterment to the Main Street Storm Drain and Sidewalk-Pioneer Avenue North Project that will provide for an ADA Access to Bayview Park and Associated Storm Drain Improvements. City Manager/Public Works Director. Recommended dates Introduction February 22, 2021 Public Hearing and Second Reading March 8, 2021

Memorandum 21-034 from Public Works Director as backup

- [i.](#) Ordinance 21-13, An Ordinance of the City Council of Homer, Alaska Appropriating an Amount not to Exceed \$2,512,000 from the Natural Gas Distribution Special Assessment Bond Sinking Fund to Retire the Debt to the Kenai Peninsula Borough that was Utilized for the Construction of the Homer Natural Gas Distribution Line. Mayor/City Manager. Recommended dates Introduction February 22, 2021 Public Hearing and Second Reading March 8, 2021

Memorandum 21-035 from Finance Director as backup

- [j.](#) Resolution 21-016, A Resolution of the City Council of Homer, Alaska Awarding a Term Contract to Coble Geophysical Services and Authorizing the City Manager to Negotiate and Execute the Appropriate Documents. City Manager/Public Works Director.

Memorandum 21-038 from Public Works Director as backup

- [k.](#) Resolution 21-018, A Resolution of the City Council of Homer, Alaska Supporting the Friends of the Homer Library Application to the National Park Service Alaska Rivers, Trails, and Conservation Assistance Program to Plan Improvements to the Library Properties, Tracts A and B, Glacier View No. 26. Venuti. Recommend adoption.

Memorandum 21-039 from Library Director as backup

VISITORS

- a. Unified Command Report (20 minutes)

ANNOUNCEMENTS / PRESENTATIONS / REPORTS (5 Minute limit per report)

- a. Committee of the Whole Report
- b. Mayor's Report
- c. Borough Report
- d. Economic Development Advisory Commission
- e. Parks Art Recreation and Culture Advisory Commission
- f. Public Works Campus Task Force

PUBLIC HEARING(S)

- [a.](#) Budget Priorities FY22-23

Memorandum 21-040 from City Manager Re: Budget Priorities FY22-23

- [b.](#) Ordinance 21-06, An Ordinance of the City Council of Homer, Alaska, Amending the 2021 Capital Budget and Authorizing Expenditure of \$142,800 from the Public Works Fleet CARMA Account and \$272,200 from the HART Road Fund to Purchase a Replacement Grader with Snow Gate and Snow Blade and Two Replacement Sanding Trucks. City Manager/Public Works Director. Introduction February 8, 2021, Public Hearing and Second Reading February 22, 2021.

Memorandum 21-023 from Public Works Director as backup.

- [c.](#) Ordinance 21-07, An Ordinance of the City Council of Homer, Alaska, Amending the 2021 Operating Budget by Appropriating Funds in the Amount of \$98,700 from the Port Reserves Fund for the Purpose of Haul out and Disposal of the Derelict Vessel *North Pacific* in preparation for Safe Disposal. City Manager/Port Director. Introduction February 8, 2021 Public Hearing and Second Reading February 22, 2021.

Memorandum 21-024 from Port Director as backup.

ORDINANCE(S)

- a. Ordinance 21-14, An Ordinance of the City Council of Homer, Alaska, Amending Homer City Code 2.08.040, Bylaws for Council Procedures to Establish that New Elected Members will be seated at a Special Meeting Following the Canvass of the Election; and 4.35.040 Certification of a Regular and Special Election. Evensen/Hansen-Cavasos. Introduction February 22, 2021 Public Hearing and Second Reading March 8, 2021

Memorandum 21-036 from City Manager as backup

CITY MANAGER'S REPORT

- a. City Manager's Report

PENDING BUSINESS

NEW BUSINESS

RESOLUTIONS

- a. Resolution 21-017, A Resolution of the City Council of Homer, Alaska Amending the Council Operating Manual to add Process for Filling a Council Vacancy. Evensen.

Memorandum 21-037 from City Manager as backup

COMMENTS OF THE AUDIENCE

COMMENTS OF THE CITY ATTORNEY

COMMENTS OF THE CITY CLERK

COMMENTS OF THE CITY MANAGER

COMMENTS OF THE MAYOR

COMMENTS OF THE CITY COUNCIL

ADJOURNMENT

Next Regular Meeting is Monday, March 8, 2021 at 6:00 p.m., Committee of the Whole at 5:00 p.m. All meetings scheduled to be held in the City Hall Cowles Council Chambers located at 491 E. Pioneer Avenue, Homer, Alaska.

Session 21-03 a Special Meeting of the Homer City Council was called to order on February 8, 2021 by Mayor Ken Castner at 4:00 p.m. at the City Hall Cowles Council Chambers located at 491 E. Pioneer Avenue, Homer, Alaska, and opened with the Pledge of Allegiance.

PRESENT: COUNCILMEMBER ADERHOLD, EVENSEN, HANSEN-CAVASOS, LORD, SMITH, VENUTI

STAFF: CITY MANAGER DUMOUCHEL
CITY CLERK JACOBSEN

AGENDA APPROVAL (Only those matters on the noticed agenda may be considered, pursuant to City Council's Operating Manual, pg. 6)

APPROVED without discussion.

PUBLIC COMMENT ON MATTERS ALREADY ON THE AGENDA (3 minute time limit)

NEW BUSINESS

- a. Memorandum 21-022 from City Clerk re: Request for Executive Session Pursuant to AS 44.62.310 (C)(1 & 3) Matters, the Immediate Knowledge of Which would Clearly have an Adverse Effect upon the Finances of the Government Unit, Pending Litigation, and Attorney/Client Privilege. (VanZant et al vs City of Homer 3HO-20-00251 CI)

Mayor Castner announced that City Attorney Gatti and Attorney Bowman from JDO will attend, along with Co-Council Jim Wilkins appointed by AMLJIA will participate in the Executive Session.

LORD/ADERHOLD MOVED TO ADJOURN INTO EXECUTIVE SESSION PURSUANT TO AS 44.62.310 (C)(1 & 3) MATTERS, THE IMMEDIATE KNOWLEDGE OF WHICH WOULD CLEARLY HAVE AN ADVERSE EFFECT UPON THE FINANCES OF THE GOVERNMENT UNIT, PENDING LITIGATION, AND ATTORNEY/CLIENT PRIVILEGE REGARDING VANZANT ET AL VS CITY OF HOMER 3HO-20-00251 CI.

City Clerk Jacobsen noted that Councilmember Evensen is having connection issues and would be logging in to the executive session meeting link.

VOTE: VENUTI, SMITH, HANSEN-CAVASOS, LORD, ADERHOLD

Council adjourned into executive session at 4:03 and Mayor Castner called the meeting back to order at 4:58 p.m.

Mayor Pro Tem Lord reported that Council met with the Attorneys to discuss Van Zant et al vs City of Homer and gave direction to proceed in accordance with the pretrial order.

COMMENTS OF THE AUDIENCE

ADJOURNMENT NO LATER THAN 4:50 P.M.

There being no further business to come before Council Mayor Castner adjourned the meeting at 4:59 p.m. The next Regular Meeting is Monday, February 8, 2021, at 6:00 p.m. Committee of the Whole at 5:00 p.m. All meetings scheduled to be held via Zoom Webinar in the City Hall Cowles Council Chambers located at 491 E. Pioneer Avenue, Homer, Alaska.

Melissa Jacobsen, MMC, City Clerk

Approved: _____

Session 21-04 a Regular Meeting of the Homer City Council was called to order on February 8, 2021 by Mayor Ken Castner at 6:00 p.m. at the City Hall Cowles Council Chambers located at 491 E. Pioneer Avenue, Homer, Alaska, and opened with the Pledge of Allegiance.

PRESENT: COUNCILMEMBER ADERHOLD, EVENSEN, HANSEN-CAVASOS, LORD, SMITH, VENUTI

STAFF: CITY MANAGER DUMOUCHEL
CITY CLERK JACOBSEN
SPECIAL PROJECTS & COMMUNICATIONS COORDINATOR CARROLL
PUBLIC WORKS DIRECTOR KEISER
FINANCE DIRECTOR WALTON
CITY ATTORNEY GATTI
PORT DIRECTOR/HARBORMASTER HAWKINS
LIBRARY DIRECTOR BERRY
PERSONNEL DIRECTOR BROWNING

AGENDA APPROVAL (Only those matters on the noticed agenda may be considered, pursuant to City Council's Operating Manual, pg. 6)

The following change was made: **CONSENT AGENDA** Ordinance 21-06 An Ordinance of the City Council of Homer, Alaska, Amending the 2021 Capital Budget and Authorizing Expenditure of \$142,800 from Public Works Fleet CARMA Account and \$272,200 from HART Road Fund to Purchase a Replacement Grader with Snow Gate and Snow Blade and Two replacement Sanding Trucks. City Manager/Public Works Director. HART Fund Pie Charts depicting appropriations and expenditures as backup **ANNOUNCEMENTS/PRESENTATIONS/REPORTS** Planning Commission Written Report

LORD/VENUTI MOVED TO ADOPT THE AGENDA AS AMENDED.

There was no discussion.

VOTE: NON OBJECTION: UNANIMOUS CONSENT

Motion carried.

MAYORAL PROCLAMATIONS AND RECOGNITIONS

PUBLIC COMMENT ON MATTERS ALREADY ON THE AGENDA

RECONSIDERATION

CONSENT AGENDA (Items listed below will be enacted by one motion. If a separate discussion is desired on an item, that item may be removed from the Consent Agenda and placed on the Regular Meeting Agenda at the request of a Councilmember.)

- a. Homer City Council unapproved regular meeting minutes for January 25, 2021. Recommend adoption.
- b. Memorandum 21-025 from City Manager re: Approval of Letter to Governor Dunleavy Expressing the Critical Importance of the Alaska Marine Highway System to the Coastal Communities of Alaska. Recommend approval.
- c. Ordinance 21-06, An Ordinance of the City Council of Homer, Alaska, Amending the 2021 Capital Budget and Authorizing Expenditure of \$142,800 from the Public Works Fleet CARMA Account and \$272,200 from the HART Road Fund to Purchase a Replacement Grader with Snow Gate and Snow Blade and Two Replacement Sanding Trucks. City Manager/Public Works Director. Introduction February 8, 2021, Public Hearing and Second Reading February 22, 2021.

Memorandum 21-023 from Public Works Director as backup.

- d. Ordinance 21-07, An Ordinance of the City Council of Homer, Alaska, Amending the 2021 Operating Budget by Appropriating Funds in the Amount of \$98,700 from the Port Reserves Fund for the Purpose of Haul out and Disposal of the Derelict Vessel *North Pacific* in preparation for Safe Disposal. City Manager/Port Director. Introduction February 8, 2021 Public Hearing and Second Reading February 22, 2021.

Memorandum 21-024 from Port Director as backup.

- e. Resolution 21-015, A Resolution of the City Council of Homer, Alaska, Acknowledging the January 2021 Surplus Equipment Sale Results. City Clerk. Recommend adoption.

City Clerk Jacobsen read the consent agenda and it's recommendations.

LORD/VENUTI MOVED TO APPROVE THE CONSENT AGENDA AS READ.

There was no discussion.

VOTE: NON OBJECTION: UNANIMOUS CONSENT

Motion carried.

VISITORS

- a. Unified Command Report (20 Minutes)

Public Health Nurse Lorne Carroll, reported briefly that the Public Health Nurses in our area have gone from spending about 80% of their time doing contact tracing down to about 51%, which is great because it makes them available for other things like distributing COVID vaccines and things that can't be put off like mitigation of tuberculosis and other communicable

diseases. He provided a case count update for reported cases at 107 million globally, 54,000 in the US, and 648 cases and three deaths on the Southern Kenai Peninsula. As the Public Health Nurses approach one year of full time response, they're making a special effort to hold a celebration of all the efforts this year, to help keep them engaged in the work they're doing.

Derotha Ferraro, South Peninsula Hospital PIO, provided a re-cap from last weekend's vaccine clinic, which is another example of teamwork and everyone pitching in to do whatever needed to be done. They administered 655 COVID 19 vaccinations during the two day event with no major issues or concerns. They were able to administer 60 vaccines per hour, up from 40 at the last event. They are outgrowing the current location and are looking forward to moving to the high school for upcoming events. 135 individuals got their second dose and 520 received their first dose with some reporting the usual side effects and no adverse reactions reported. She provided an update on remaining and upcoming doses, and changes in eligible tiers to receive the vaccine. Between the hospital and community partners well over 2000 first doses of vaccine have been distributed. Regarding COVID testing, SPH administered 668 tests over the last two weeks with 7 positives, putting us at about 1% positivity rate over the last two weeks. Hospital visitation is at the minor risk level, and long term care is still closed to visitors at this time.

Jenny Carroll, City of Homer PIO, reported that until just recently our public health measures have been the main way we've worked to mitigate the bad effects of COVID 19, like masking, social distancing, hand washing, and testing. Those are still important tools, and we have a new tool added with the vaccines. Vaccines help your body recognize the disease and have less severe reactions to it, and much less severity in cases. It's important to understand this isn't the end, but the beginning of the beginning of the end and we still have a long way to go for everyone to reach some kind of immunity against it. With continued masking, social distancing, and vaccinating, there will be a lot less COVID transmitting in the air, less illness, and better ability to get to a herd immunity. She appreciates everyone continuing to follow the mitigation measures we've been following for so long, it's making a difference.

There was a brief question and answer period between Mayor and Council and the Unified Command team.

ANNOUNCEMENTS / PRESENTATIONS / REPORTS (5 Minute limit per report)

a. Special Meeting Report

Councilmember Lord reported that Council met with the Attorneys in executive session to discuss Van Zant et al vs City of Homer and gave direction to proceed in accordance with pretrial order.

b. Committee of the Whole Report

Councilmember Lord reported Committee of the Whole was only 6 minutes and adjourned after brief discussion of the budget calendar.

c. Mayor's Report

Mayor Castner reported Council will be sitting as Board of Adjustment on Thursday the 11th to hear an appeal of a Planning Commission decision regarding a Conditional Use Permit. He said he's been spending a lot of time looking into the city wide gas service and the \$12.7 million debt we incurred because he's interested in seeing if there's a way to pay this off early and not accrue any additional interest.

d. Borough Report

Mayor Castner reported on behalf of Assembly Member Chesley regarding the Borough's efforts to address the leaking roof at the high school in phases.

e. Library Advisory Board

Library Advisory Board Chair Kuzmaul reported on the Board's recent meetings where they met with representatives of the Friends of the Homer Library to collaborate on planned giving, identified their four goals for the year including developing and initiating a planned giving program for the library endowment, review the library budget as part of the budget process, explore opportunities to increase library card registration and use by students, and improve services across the library service area. They reviewed the library fee schedule and recommend no changes at this time, and also the internet usage in the parking lot. In the first five months starting in April there were 1789 internet sessions, but in the five months from September through January there were 3988 internet sessions. They recognize this as a great service to ensure public internet access, especially while the library is closed to public access due to COVID. Curbside pick-up is still available at the library.

f. Planning Commission

Planning Commission Chair Smith provided a written report for the packet.

g. Port and Harbor Advisory Commission

Port and Harbor Advisory Commissioner Mike Stockburger reported at their last meeting the Commission discussed the budget transition, deferred maintenance and infrastructure replacement in the Harbor, rules for personal watercraft, and subleasing. Mayor Castner attended their meeting and helped them understand the budget transition, which was very helpful and the Commission appreciates Council's amending the truncated budget to use the general fund admin fees to cover the port and harbor deficit. He explained the Port and Harbor's reliance on their reserves to address maintenance of the facility and efforts they've taken to adjust moorage and other fees to be sustainable and avoid borrowing large amounts of money for maintenance.

PUBLIC HEARING(S)

- a. Ordinance 21-04, An Ordinance of the City Council of Homer, Alaska, Amending the FY21 Capital Budget and Authorizing the Expenditure of an Additional \$19,700 for the Airport and Library Security Camera Replacement Project. City Manager. Introduction January 25, 2021, Public Hearing and Second Reading February 8, 2021.

Memorandum 21-017 from Library Director as backup.

Mayor Castner opened the public hearing. There were no comments and the hearing was closed.

LORD/ADERHOLD MOVED TO ADOPT ORDINANCE 21-04 BY READING OF TITLE ONLY FOR SECOND AND FINAL READING.

There was no discussion.

VOTE: NON OBJECTION: UNANIMOUS CONSENT

Motion carried.

- b. Ordinance 21-05, An Ordinance of the City Council of Homer, Alaska Amending the FY21 Capital Budget and Authorizing an Expenditure in an Amount up to \$79,000 for Payment of the Water and Sewer Assessments for Lot 4, Hodnik Subdivision KPB Parcel No. 17936032 when Property Ownership Transfers to Kachemak Bay Moose Habitat, Inc and a Deed Restriction has been Recorded Regarding Conservation and Public Access on the Property. City Manager. Introduction January 25, 2021, Public Hearing and Second Reading February 8, 2021.

Mayor Castner opened the public hearing.

Larry Slone commented in opposition to Ordinance 21-05. Homer is surrounded by accessible moose habitat and if a choice is to be made between human habitation and moose habitation he believes humans should have priority in the City. It's his understanding approximately 40% of the value of the city's property is exempt for one reason or another and he doesn't agree with adding this to the citizen's tax burden.

There was no further testimony and the hearing was closed.

LORD/ADERHOLD MOVED TO ADOPT ORDINANCE BY READING OF TITLE ONLY FOR SECOND AND FINAL READING.

Councilmember Evensen commented in support of the ordinance. He addressed the benefits of conservation in the City and the value that green spaces bring to the economy. He noted the

inconsistency of taking this action regarding the ecosystem related to the noisy nuisance related winter activities happening on Beluga Lake.

Councilmember Aderhold commented this wetland area is contiguous and this lot is almost contiguous with the moose critical habitat area. She explained how the moose move through the area when they come down from the hillside because of the snow, and the critical habitat area is the quietest place they have to go. It's important to remember too, that in the fall these moose are elsewhere throughout the lower Peninsula and that we are relying on them for people to harvest. It's important that we provide habitat for moose. She also shared about the wetland value of the property as it's peatland that holds a lot of the water that would otherwise overflow onto road and create other problems.

Councilmember Lord noted for clarification that the City isn't purchasing the property and taking it off the tax rolls, it's being purchased by a private entity for the purpose of conservation.

VOTE: NON OBJECTION: UNANIMOUS CONSENT

Motion carried.

ORDINANCE(S)

CITY MANAGER'S REPORT

- a. City Manager's Report

City Manager Dumouchel addressed the City of Homer COVID Risk status update from Red to Orange for city facilities and staff.

Council commented on items in his report specific to ongoing slash burning and its ongoing impacts to the air quality for residents, Public Work's quick response to recent the Lucky Shot water main break and erosion in a ditch on Ben Walters, and the remote sales tax update.

PENDING BUSINESS

NEW BUSINESS

- a. Memorandum 21-026 from Finance Director re: FY22/23 Proposed Budget Schedule.

LORD/VENUTI MOVED TO APPROVE THE FY22/23 BUDGET SCHEDULE.

Councilmember Lord commented in support of the schedule, she values the opportunity for the Council, Commissions, and public to have opportunities along the lines to participate as the budget is being drafted.

Mayor Castner commented briefly regarding the tariff and fee schedule resolutions, and shared his idea that Council separate the operating budget from the capital budget. He thinks the capital budget gets overlooked and swept in with the operating budget. There isn't a lot of public participation regarding the capital budget and he would like to see them handled as separate ordinances.

Councilmember Lord asked to please make sure they have ample worksessions to ensure they have time for ample time for discussion and feedback. She doesn't know that she agrees with the notion of the capital budget being separate and she'd like more back up information regarding that. She feels over the last few years, they've received a lot of information regarding the capital budget with spreadsheets and narratives from administration, and then Council tends to make their changes.

Councilmember Aderhold and Smith also encouraged more worksession discussions throughout the budget process.

VOTE: NON OBJECTION: UNANIMOUS CONSENT

Motion carried.

RESOLUTIONS

- a. Resolution 21-014, A Resolution of the City Council of Homer, Alaska, Awarding a Contract to Sherman Technologies, LLC, of Wasilla, Alaska, In the Amount of \$76,100.00 for Upgrades to the Video Security Systems at the Homer Public Library and Homer Airport and Authorizing the City Manager to Execute the Appropriate Documents. City Clerk.

Memorandum 21-027 from Library Director as backup.

LORD/VENUTI MOVED TO ADOPT RESOLUTION 21-014 BY READING OF TITLE ONLY.

There was no discussion.

VOTE: NON OBJECTION: UNANIMOUS CONSENT

Motion carried.

COMMENTS OF THE AUDIENCE

Larry Slone commented regarding the good work of Public Works in dealing with the water main break on Lucky Shot. He also commented regarding the noise on Beluga Lake on Sunday afternoons and the noise from the machines on the lake impact him more negatively than the moose. That's one of the better benefits of the City in that the City has the capacity to monitor

and control that type of activity and that noise, and the noise is one thing that would drive him out of the City. He noted his comments regarding referring to the Mayor's veto as brutal. It was too harsh of a word, and he should have said blunt, as in a blunt instrument. He doesn't agree with a veto and sees it as an unwillingness to do the hard work of communicating or reflecting an extreme partisanship. In this case it was done in an effort to take care of something that slipped through the cracks.

COMMENTS OF THE CITY ATTORNEY

City Attorney Gatti had no comments.

COMMENTS OF THE CITY CLERK

City Clerk Jacobsen commented regarding an opening on the Library Advisory Board and for the Economic Development Advisory Commission Student Representative.

COMMENTS OF THE CITY MANAGER

City Manager Dumouchel commented regarding the opening for the Assistant to the City Manager position and encouraged interested parties apply.

COMMENTS OF THE MAYOR

Mayor Castner thanked Councilmember Aderhold for penning the letter to the Governor regarding the ferry system that was approved on the Consent Agenda.

COMMENTS OF THE CITY COUNCIL

Councilmember Hansen-Cavasos wished everyone a great week.

Councilmember Lord thanked the Kachemak Nordic Ski Club for their efforts in keeping the trails groomed and a successful COVID safe Junior Nordic Program. She encouraged citizens to stay engaged, Mayor and Council contacts are available on the City website, and she noted the City Manager's report is a great place to find information on what's happening in the City.

Councilmember Aderhold also encouraged citizen input, it's an important piece of the process. She share that the past weekend's weather was stunning and it was great to get out to bike and see all the skaters on the lake. She's happy that the daylight is returning.

Councilmember Smith concurred on the importance of public input and that he's available for open and constructive dialog.

Councilmember Venuti thanked residents who spent time on retail therapy, shoppers who pay sales tax and businesses who collect and remit it, and to online shoppers. She was happy to see the sales tax information in the Manager's report and appreciated the Mayor's comment about the service fee to the City from AML. She noted several celebrations happening in

February like President's Day and Love your Pet Day. She also encouraged citizens to contact Councilmember.

Councilmember Evensen wished everyone a great evening.

ADJOURNMENT

There being no further business to come before the Council Mayor Castner adjourned the meeting at 7:33 p.m. The next Regular Meeting is Monday, February 22, 2021, at 6:00 p.m. Committee of the Whole at 5:00 p.m. All meetings are scheduled to be held via Zoom Webinar in the City Hall Cowles Council Chambers located at 491 E. Pioneer Avenue, Homer, Alaska.

Melissa Jacobsen, MMC, City Clerk

Approved:_____



Memorandum 21-028

TO: MAYOR CASTNER AND HOMER CITY COUNCIL

THROUGH: ECONOMIC DEVELOPMENT COMMISSION
ROB DUMOUCHEL, CITY MANAGER

FROM: JULIE ENGBRETSSEN, DEPUTY CITY PLANNER

DATE: FEBRUARY 16, 2021

SUBJECT: WAYFINDING AND STREETScape RFP

Background:

After many fits and starts, the Wayfinding Streetscape RFP is ready for Council review! The Economic Development Advisory Commission has been working on the idea for several years. Council has approved funding for the project, with the caveat that the Request for Proposals (RFP) be reviewed by Council prior to issuance. The RFP is hereby provided for Council's review.

Project Recap:

The project goals are to develop a design and strategic plan for utilizing landmarks, city signage, pathways and streetscape elements to help visitors and residents more easily navigate and more fully experience Homer-- and be a catalyst for economic activity. The design standards will be adopted by Homer City Council and used to guide City investment such as the location and design of wayfinding signage, landscaping, benches, trash receptacles, pocket parks, and street banners. Ordinance 19-54(S-2)(A-2) authorized capital appropriation up to \$50,000 from the HART fund to develop a wayfinding streetscape plan.

At that time the ordinance was adopted, it was thought a separate task force or administrative body would be formed to work through the project. With COVID and reduced staff capacities, it now makes sense for the Economic Development Advisory Commission and staff to work with the selected consultant, rather than create an additional meeting group.

Next Steps:

Absent any objections by Council, the RFP will be issued and a consultant selected following the City's procurement policies. Approval of the contract will be authorized by the City Council via resolution. Projected project start is anticipated to be May 2021.

Recommendation: Voice non-objection to the issuance of the Wayfinding Streetscape RFP in accordance with the City's procurement policies.



City of Homer, Alaska Request for Proposals

**Development of Homer
Wayfinding-Streetscape Plan
March 2021**

REQUEST FOR PROPOSALS
Development of Homer Wayfinding-Streetscape Plan
City of Homer, Alaska

The City of Homer, Alaska is requesting proposals from qualified landscape architect, design, or other professional firms to develop a Wayfinding-Streetscape Plan for the City of Homer. The completed plan and design standards will be adopted by Homer City Council and used to guide City improvements/enhancements such as the location and design of wayfinding signage, landscaping, benches, trash receptacles, pocket parks, etc. It is the intent of this Request for Proposals (RFP) to have the successful firm enter into a Professional Services Contract with the City of Homer to provide the services outlined in the RFP.

Sealed proposals must be received by the City Clerk’s Office, City of Homer, 491 E. Pioneer Avenue, Homer, Alaska by **4:30 p.m., [DAY], [DATE], 2021**. Proposals received after the time fixed for the receipt of proposals shall not be considered. **All proposers must submit a City of Homer Plan Holders Registration form to be on the Plan Holders List to be considered responsive.**

There will be an optional Pre-Close RFP meeting/teleconference held prior to the closure of the RFP via Zoom **[DATE]**, 2021 at **[TIME]** p.m.

An electronic copy of the RFP Requirements and plan holder registration forms are available online at <http://www.cityofhomer-ak.gov/rfps>. Paper copies of the Proposal Documents may be purchased at the Office of the City Clerk upon payment of \$10 per set (\$15 for priority mail delivery). All fees are non-refundable.

For inquiries regarding the Scope of Work or clarification of the RFP, contact:

Julie Engebretsen, Deputy City Planner
491 E. Pioneer Avenue
Homer, Alaska 99603
Phone: (907) 299-9354
Email: jengebretsen@ci.homer.ak.us

For general RFP and proposal submission inquiries, contact the City Clerk’s Office, 491 E. Pioneer Avenue, Homer, AK 99603; Phone (907) 235-3130; Email clerk@ci.homer.ak.us.

The City of Homer reserves the right to accept or reject any or all proposals, to waive irregularities or informalities in the proposals, and to award the contract to the respondent that best meets the selection criteria and the City of Homer’s needs.

Dated this ___ day of _____, 2021

CITY OF HOMER

Rob Dumouchel, City Manager

Advertise: Homer News: **[DATE] & [DATE], 2021**
Peninsula Clarion: **[DATE], 2021 (Optional)**
Anchorage Daily News: **[DATE], 2021 (Optional)**

REQUEST FOR PROPOSAL
Development of Homer Wayfinding-Streetscape Plan
City of Homer, Alaska

The City of Homer, Alaska is requesting proposals from qualified landscape architect, design, or other professional firms to develop a Wayfinding-Streetscape Plan for the City of Homer. The completed plan and design standards will be adopted by Homer City Council and used to guide City improvements/enhancements such as the location and design of wayfinding signage, landscaping, benches, trash receptacles, pocket parks, etc. It is the intent of this Request for Proposals (RFP) to have the successful firm enter into a Professional Services Contract with the City of Homer to provide the services outlined herein.

COVID-19 NOTE: The City recognizes the COVID-19 pandemic drastically changes the ability to travel and conduct public meetings within the traditional public process framework. The City encourages proposers to adapt project methods to follow COVID-19 safety guidelines. City policies regarding COVID-19 shall be followed at the time of any direct in person public contact (such as social distancing, hand washing, and mask wearing).

The following subjects are discussed in this RFP to assist in preparing a proposal.

- I. Introduction
- II. Project Overview
- III. Scope of Work
- IV. RFP General Requirements & Submittal Instructions
- V. Proposal Format & Content Requirements
- VI. Evaluation Criteria & Selection Process
- VII. RFP Timeline & Award Schedule

Attachment A: Ordinance 19-54(S-2)(A-2) Authorization of a Wayfinding-Streetscape Plan

I. INTRODUCTION

The City of Homer, under advisement of the Economic Development Commission (EDC), is seeking to develop a design and strategic plan for utilizing landmarks, city signage, pathways and streetscape elements to help visitors and residents more easily navigate and more fully experience Homer-- and be a catalyst for economic activity.

While a range of factors are important to business success, knowledge of Homer’s various commercial districts, ease of navigation, the quality of the street environment and pedestrian experience are important to attracting business investment and consumer engagement in Homer’s commercial districts. Streetscape planning gives us the opportunity to increase business activity with pedestrian-friendly infrastructure, land use improvements, and public gathering or resting areas at reasonable intervals.

The goal is to develop a thoughtful wayfinding plan and an inviting streetscape improvement plan that supports a vibrant Pioneer Avenue corridor, Central Business District, and connections to the Homer Spit.

Definitions for this RFP:

Wayfinding – Signage and other visual markers to help people and vehicles navigate Homer.

Streetscape – Details such as street furniture, light pole banners, and landscaping the City and businesses can use to increase the attractiveness of the community.

Landscaping – Street trees, planters and flower types, and gardening beds (when practical).

II. PROJECT OVERVIEW

The Wayfinding-Streetscape Plan will be used by the City to guide future City purchases and placement of enhancements such as trash cans, benches, pocket parks, etc., to make landscaping decisions, and to fund and install wayfinding signage. Private businesses may choose to augment the City’s efforts by utilizing the plant list, by purchasing coordinating trash cans, benches, etc., or by hosting a wayfinding location.

The plan should be able to be implemented in phases over multiple years as budget becomes available. A limited City budget and staff capacity requires consideration of maintenance costs over time. The plan produced should prioritize improvements, identify potential funding sources, investment cost per year over a reasonable time horizon, and consider existing City resources and equipment to ensure effective ongoing maintenance.

III. SCOPE OF WORK

A. Area of Study

The area covered by this plan includes a concentration on Pioneer Avenue and the Central Business District, connections to and wayfinding between Ocean Drive and the Homer Spit, and orientation wayfinding at Baycrest Overlook, Homer Airport Terminal, and the Pioneer Dock (ferry terminal). The project area includes local and state rights-of-way.

B. Wayfinding-Streetscape Plan Objectives

1. Help distribute economic activity among Homer’s primary commercial districts by:
 - Informing the travelling public (vehicles and pedestrians) about Homer’s primary commercial districts; and
 - Assisting them in navigating between these districts and to key destinations within the Central Business District.
2. Encourage pedestrian activity and foster economic development along Pioneer Avenue and within the Central Business District by:
 - Providing realistic streetscape amenities that, when combined, create an inviting, safe, dynamic and desirable character and feel.

3. Use the plan to guide future City purchases and placements of wayfinding-streetscape enhancements.

C. Project Scope

The Wayfinding/Streetscape Plan will primarily emphasize:

1. Pedestrian experience
2. Attention to continuity of vehicle signage, particularly at route decision points and Homer's gateways;
3. Design that is cohesive, but not necessarily identical, and that enhances and reflects the distinctive and creative character of Homer; and
4. Consider all aspects of technological and physical wayfinding signage and tools, keeping signage 'clutter' to a minimum.

Wayfinding Scope

1. Assist pedestrians navigating Pioneer Avenue and to points of interest in the Central Business District.
2. Orientation wayfinding at Homer's gateways.
3. Making connections between Homer's destination areas (i.e. Old Town, the Spit, Farmer's Market, and others as identified and agreed upon.)
4. Identifying ways to help drivers identify and make turns from the highway onto other routes within the Central Business District, such as to Old Town and to Pioneer Avenue.

Streetscape Scope

1. Plan should propose realistic streetscape improvement options along Pioneer Avenue and to points of interest within the Central Business District.
2. A strategic approach for implementation of any combination of the following possible elements: Accessibility, Banners, Bicycle Amenities, Landscaping (plant lists, use of gardens), Bench Locations for Rests/View Areas, Pocket Parks, Pedestrian Crossings (safety and aesthetics), Decorative Hardscapes, Trash Cans.

D. Task Phases & Deliverables

The Proposer selected is expected to conduct, at minimum, the following tasks. In response to the RFP, the Proposer may expand on these tasks utilizing their experience and expertise in the subject areas, provide detail on how they are to be accomplished, and/or suggest additional tasks as warranted to meet the stated project objectives.

TASK I: Research, Analysis and Project Familiarization

- Initial meeting with City staff to finalize schedules, process, and communication.
- Review relevant plans and studies, including existing city logo and colors and park signage guidelines.
- Research and analyze existing condition of identified project area in relation to wayfinding, streetscape, parking, roadways, and safety/access/connectivity for pedestrians and bicyclists.

- Meet with Parks Maintenance staff on preferred street furniture, and level of landscape maintenance the city can sustain. Also discussion of summer and winter light pole banners for Pioneer Ave.
- Analyze local architectural elements, materials, themes, and existing planning documents, in order to develop appropriate design aesthetic.
- Using City staff and stakeholder input, field assessments, existing data and reports, Alaska DOT and City zoning code requirements, conduct an assessment of general geographic and environmental conditions and opportunities for wayfinding/streetscape improvements.
- Identify preferred locations for gateway and wayfinding signage based on major public destinations and amenities, traffic flow/volumes, and parking utilization.
- **Task I Deliverables:**
 - Draft selection of type and style of street furniture
 - Draft map of preferred locations for gateway and wayfinding signage based on major public destinations and amenities, traffic flow/volumes, and parking utilization.
 - Draft landscaping plant list and sample planting diagram or photographs

TASK II: Public Outreach and Opinion Gathering

- Meet with representatives of stakeholder organizations. This could be in the form of a Zoom Meeting with invited stake holders, focus groups or interviews, or some combination thereof. Stakeholder groups that will help facilitate this process include the Economic Development Advisory Commission, the Planning Commission, Homer City Council and Homer Chamber of Commerce Peonies on Pioneer work group.
- Establish a transparent, inclusive community engagement process for developing the plan through a series of public meetings and virtual participation methods.
- At these public meetings or virtual events, present and discuss (at a minimum) the following subjects:
 - Successful design concepts, schemes, specifications and tools implemented by other communities
 - Successful gateway and wayfinding programs and concepts; examples of landscape, (plantings, trees, peonies, shrubs), hardscape and street furniture features and amenities.
 - Present draft work from Task 1 Deliverables for feedback. Gather preferences for each project area to refine initial design themes and concepts.
- Engage members of the public to refine and articulate a shared vision of streetscape and wayfinding improvements. (Methods could include Zoom, bulletin boards if public facilities are open, or other innovative, inclusive public process methods.)
- **Task II Deliverables:**
 - Summary reports on feedback gathered from the public/stakeholders

- Revised sketches, maps, and photographs produced based on public feedback

TASK III: Alternative Design and Management Concepts

- Prepare and present a minimum of three (3) alternative design concepts for streetscape amenities and wayfinding signage based on input received at the public meetings. The designs should be in sufficient realistic detail and color, and should reflect the distinctive and unique character of Homer.
- Present wayfinding recommendations on sign sizes, styles, and placement in order to highlight the Pioneer Avenue and key destinations in the Central Business District, parking, and connections to other key locations and Homer gateway orientation signage.
- Design development drawings must include the scale of wayfinding signs in relation to pedestrian and vehicular levels.
- Recommendations/design concepts for streetscape amenities should include, at a minimum, parkway landscape improvements, street furnishing (e.g. trash receptacles, street furniture, and etc.), and hardscape cross walk improvements.
- Revise the individual sign type designs and locations per final comments of the Stakeholder groups (as needed).
- Create a pattern book or style guide with up to five (5) types of designs from the preferred alternative:
 - Vehicle signage for turns off of the highway
 - Shuttle stop or pocket park vignette with benches and signage to include planting examples, street furniture, and banners
 - Major wayfinding kiosk or signage
 - Reduced size wayfinding signage,
 - Trailhead or single marker signage.
- **Task III Deliverables:**
 - Summary report with the preliminary draft of the wayfinding-streetscape plan and recommendations.
 - Large format display graphics (.pdf) illustrating alternative design concepts for both the wayfinding and streetscape plans. Design of wayfinding signage should include all materials to be used for sign and post, background color and letter type, and installation procedures, layout map of the City showing all the final sign locations, sign details, and specifications.
 - Statement of Probable Cost for the fabrication, installation, and maintenance of the wayfinding system.

TASK IV: Final Design Concepts

- Complete refinements of final design concepts, phasing of improvements, and cost estimates based on all input from the public, stakeholder groups, and City staff.

- Once design concepts and locations are approved by staff, the consultant will prepare Final Design Intent Drawings (exact dimensions, letter heights, materials, mounting details, color specifications, and material performance standards) with written statement regarding rationale for design choices, materials, method of fabrication, and how systems can be modified over time.
- Present final concepts to the City Council.
- **TASK IV Deliverables:**
 - Final Wayfinding-Streetscape Plan, which will include the following:
 - Priorities for implementation (low, medium, and high Priority Action Items) for phasing in Streetscape improvements.
 - Conceptual cost estimates (low, medium, high) for all Wayfinding signage and Streetscape phases.
 - Design of wayfinding signage (all materials to be used for sign and post, background color and letter type, and installation procedures, layout map of the City showing all the final sign locations, sign details, and specifications). Compliant with AK DOT and ADA standards.
 - Large format display graphics illustrating final design concepts. These shall be in .pdf format and unlocked for editing.
 - One hard copy and electronic copy of final Wayfinding-Streetscape Plan as well as electronic copies of all presentations.

IV. RFP GENERAL REQUIREMENTS & SUBMITTAL INSTRUCTIONS

To achieve a uniform review process and obtain the maximum degree of comparability, it is required that the proposals be organized in the manner specified below. Proposals that do not address the items listed in this request may be considered incomplete and may be deemed non-responsive by the City.

- A. **Optional pre-close meeting:** There will be an optional meeting/teleconference held prior to the closure of the RFP. This will give all proposers involved the opportunity for questions/answers with City Staff to ensure all information is open and concise. The Pre-Close RFP meeting/teleconference will be held via Zoom **[DATE]**, 2021 at **[TIME]** p.m. Proposers participating via phone will call in at that time at 907-235-8121 ext. 2297.
- B. **All bidders must submit a City of Homer Plan Holders Registration form to be on the Plan Holders List and to be considered responsive.** Interested firms or individuals should submit the completed proposal using the following instructions:
- i. One original and seven (7) copies of the completed proposal in an opaque envelope marked as follows:

City of Homer 2021 RFP
Development of Homer Wayfinding-Streetscape Plan

Proposal Date
Bidders Name and Address

ii. The Proposal submittals shall be addressed to:

City of Homer
City Clerk's Office
491 E. Pioneer Avenue
Homer, Alaska 99603

- C. Proposals must be received by the City Clerk's Office at the above referenced address **no later than 4:00 p.m. [DAY], [DATE], 2021**. The time of receipt will be determined by the City Clerk's time stamp. Proposals received after that time shall not be considered.
- D. The City Clerk's Office does not provide envelopes for responsive firms to put their completed proposals in, nor will the Clerk's Office Staff write proposer's information on the envelope on their behalf. Facsimile, email, electronic or telephone proposals will not be accepted. City procurement policies require a paper submittal by the stated time and date.
- E. Proposals may be withdrawn by written, email, or facsimile notice received prior to the deadline for proposal submittal. Withdrawals received after the proposal submittal deadline will not be considered.
- F. Inquiries must be received at least 10 days prior to the RFP submittal deadline. Copies of all written requests and replies will be forwarded to each Proposer on the Official Plan Holders List. Only formal, written responses to properly submitted questions will be binding.
- G. Inquiries regarding the Scope of Work or clarification of the RFP must be directed to:

Julie Engebretsen, Deputy City Planner
491 E. Pioneer Avenue
Homer, Alaska 99603
Phone: (907) 299-9354
Email: jengebretsen@ci.homer.ak.us

H. General RFP and proposal submission inquiries must be directed to:

City Clerk's Office
491 E. Pioneer Avenue
Homer, AK 99603
Phone: (907) 235-3130
Email: clerk@ci.homer.ak.us

V. PROPOSAL FORMAT & CONTENT REQUIREMENTS

For ease of evaluation, the proposal should be presented in a format that corresponds to and references/labels the sections outlined in this RFP. Proposals should be prepared in such a way as to provide a straightforward, concise delineation of capabilities to satisfy the requirements of this RFP.

To be considered responsive, each proposal must include (at a minimum) the following:

- A. **Letter of Transmittal (one page maximum):** The transmittal letter shall briefly state the firm's understanding of the City's request, make a positive commitment to provide the professional services specified, and give the name, title, address, and phone number of the person(s) authorized to make representations for the firm. The letter shall be signed by a corporate officer or other individual who has the authority to bind the firm.
- B. **Proposal Narrative (8 pages maximum):** The proposal narrative must provide the following information:
1. Specify in detail the firm's ability to fulfill the Scope of Work that has been outlined in this RFP, including any additional contractual requirements the firm chooses to propose. Other items that must be included in the proposal:
 - Standard, all-inclusive cost schedule that is to be used in this contract, including staff time per task, travel expenses, and incidentals.
 - Schedule – An outline of the anticipated schedule for completing the Scope of Work beginning with issuance of a notice to proceed to submitting the final work product.
 - Insurance – Prior to commencement of work, the Proposer shall be required to provide proof of insurance and to keep it in full force and effect, at its own expense, the following minimum policy limits:
 - i. The City of Homer shall be named as additional insured during the project's duration.
 - ii. Worker's Compensation in accordance with the laws of the State of Alaska, and Employer's Liability Insurance with minimum limits of \$1,000,000/ \$1,000,000/ \$1,000,000.
 - iii. General Liability Insurance in an amount not less than \$1,000,000 per occurrence; \$1,000,000 personal and advertising injury; \$2,000,000 general aggregate; and \$2,000,000 products/completed operations aggregate for bodily injury or death and for property damage.
 - iv. Professional Liability with minimum limits of \$1,000,000 aggregate and each claim.
 - v. Automobile Liability Insurance covering owned, non-owned, or hired vehicles used by the firm, with limits not less than \$1,000,000 combined single limit for bodily injury and property damage.
 2. Proposed Project Manager and Team Members and Statement of Qualifications and Experience: This section shall introduce the project manager (Single Point of Contact) and members of the firm that will be performing the work for this project. This section will cover the project team/firm's qualifications for the proposed work and experience with similar projects. Full resumes are not required but can be included; 1-2 paragraphs on each member of the team will be sufficient. Knowledge of and experience with AK DOT or similar standards, and ADA compliant designs are highly desired.
 3. Methods and Work Plan: Proposer will outline a work plan detailing the firm's step-by-step procedures for accomplishing the Scope of Work and the City's objectives for this project.

4. References: List the names, titles, and phone numbers of at least three clients who obtained similar services from your firm. Ideally, projects/contracts managed by the proposed project manager and completed by the proposed project team should be referenced.

VI. EVALUATION CRITERIA & SELECTION PROCESS

A. Evaluation Criteria

Proposals will be evaluated on the following criteria and scored according to the point scale:

Proposed Contract, Work Plan, and Cost		45 Points
• Proposed schedule	-	
• Cost	15 points	
• Public and Economic Development Commission involvement plan	10 points	
• Work plan to be broken down by Tasks 1-IV. An innovative process is welcome as long as all tasks are accomplished.	20 points	
Proposed Project Manager and Team Members, Qualifications and Experience		40 Points
• Qualifications, experience, and training of staff to be assigned to project.	15 points	
• Firm’s knowledge of Homer/surrounding area and understanding our community to capture the essence of what makes Homer unique in the final designs.	5 points	
• Record of past performance of Firm in similar, previous projects.	10 points	
• Provide 3 references	10 points	
Quality of Submittal		15 Points
• Conformance with RFP requirements, including compliance and timely submission of all documents requested		
Total Possible Points		100 Points

B. Selection Process

A selection committee comprised of City Staff and selected members of the public will evaluate the proposals and make a recommendation to the City Manager and Homer City Council. If the Council approves, the City will offer the highest ranking Proposer an opportunity to negotiate a Contract.

Other Proposal selection terms, conditions, and exceptions:

1. Evaluators may discuss factual knowledge of, and may investigate proposer’s prior work experience and performance. This includes projects referenced in the proposal, available written evaluations, and contacted references that were listed or other persons knowledgeable

of a proposer's past performance. Factors such as overall experience relative to the proposed contract, quality of work, cost control, and the ability to meet schedules may be addressed during the evaluation.

2. This request for proposals is designed to be qualifications based, with cost playing a secondary role in the selection process. The City of Homer reserves the right to award a contract to the highest ranked firm based solely on the written proposal or request oral interviews. The highest ranked proposer will be invited to enter into negotiations with the City of Homer for the purposes of contract award. If an agreement with any proposer cannot be reached, the next highest ranked proposer may be contacted for negotiations. The City of Homer reserves the right to terminate contract negotiations with any proposer should it be in the City of Homer's best interest.
3. The City reserves the right to alter, amend, or modify any provisions of this RFP, or to withdraw this RFP, at any time prior to the award of a contract pursuant hereto, if it is in the best interest of the City to do so.
4. The City reserves the right to waive informalities and minor irregularities in proposals received. Alterations, modifications or variations to a proposal may not be considered unless authorized by the RFP or by addendum or amendment.
5. The City reserves the right to reject any and all proposals submitted and shall not be liable for any costs incurred by any proposer in response to this solicitation or for any work done prior to the issuance of a notice to proceed or signed contract.
6. Proposals will be kept confidential until contract is awarded, subject to law.

VII. RFP TIMELINE & AWARD SCHEDULE (to be completed after CC review)

These dates represent a tentative schedule of events. The City reserves the right to modify these dates at any time, with appropriate notice to applicable proposers on the Plan Holders List.

<u>ACTIVITY</u>	<u>DATE/TIME</u>
City Council Review of RFP	February 22, 2021
Publish Dates	Homer News: March 4 & 11, 2021 Peninsula Clarion: [DATE], 2021 (Optional) Anchorage Daily News: 11 & 18, 2021(Optional)
Optional Pre-proposal Meeting	[DATE], 2021 at [TIME] p.m.
Submittal Deadline for Proposals	[DATE], 2021 at 4:00 p.m. (March 25?)
Evaluation Period and Proposal Selection	[5-7 DAY PERIOD], 2021 (March 26- April 1)
Contract Approval by Homer City Council	[DATE], 2021 April 12
Contract Signing/Notice to Proceed	TBD – April 26
Initial Project Meeting	TBD /later April

1 CITY OF HOMER
2 HOMER, ALASKA

Venuti/Smith

3
4 ORDINANCE 19-54(S-2)(A-2)
5

6 AN ORDINANCE OF THE CITY COUNCIL OF HOMER, ALASKA
7 AMENDING THE 2019 CAPITAL BUDGET TO APPROPRIATE AN
8 AMOUNT NOT TO EXCEED \$50,000 FROM THE HART FUND FOR
9 THE PURPOSE OF DEVELOPING A WAYFINDING-STREETScape
10 PLAN FOR THE CITY OF HOMER, AUTHORIZING THE CITY
11 MANAGER TO PREPARE AN RFP FOR CONSULTANT SERVICES AND
12 ~~AUTHORIZING THE ESTABLISHMENT OF A WAYFINDING-~~
13 ~~STREETScape COMMITTEE TO WORK WITH THE CONSULTANT.~~
14

15 WHEREAS, The Homer City Council established the Economic Development Advisory
16 Commission (EDC) to advise City Council on ways to improve the local business climate; and
17

18 WHEREAS, The EDC completed a Business Retention & Expansion (BR&E) Survey with
19 the goal of identifying areas where the EDC can work to help improve the local business
20 climate; and
21

22 WHEREAS, Improved walkability, greenspace and initiatives that showcase Homer's
23 beauty (particularly in the Pioneer Avenue/Central Business District) were the most frequently
24 mentioned ideas for improving Homer's business climate and quality of life; and
25

26 WHEREAS, While a range of factors are important to business success, knowledge of
27 Homer's various commercial districts, ease of navigation, quality of the street environment
28 and pedestrian experience are critical to attracting business investment and encouraging
29 consumer engagement in Homer's commercial districts; and
30

31 **WHEREAS, Streetscape planning gives us the opportunity to increase business**
32 **activity, generate tax revenue and a high return on investment in our central business**
33 **district with pedestrian-friendly infrastructure and land use improvements such as a**
34 **connected, easily walkable set of sidewalks and trails that offer personal security and**
35 **traffic safety, public parking solutions, and public gathering or resting areas at**
36 **reasonable intervals; and**
37

38 WHEREAS, The EDC has determined that a wayfinding-streetscape plan (a plan and
39 design standards to guide City improvements and enhancements such as wayfinding signage,
40 landscaping, benches, trash receptacles, pocket parks, etc.) will support BR&E business
41 climate goals and be a catalyst for economic activity; and

42 WHEREAS, Establishing a wayfinding-streetscape (WF-SS) system is consistent with
43 goals in the City of Homer Comprehensive Plan, the Non-Motorized Transportation & Trail Plan
44 and the Homer Spit Comprehensive Plan; and

45
46 WHEREAS, A WF-SS plan builds upon citizen interest in Pioneer Avenue through the
47 Pioneer Avenue Revitalization Task Force’s efforts to make a more attractive, vibrant Pioneer
48 Avenue business district; and

49
50 WHEREAS, The scope and objectives for a WF-SS plan have been proposed by the EDC
51 and have been endorsed by the Homer Planning Commission, Park Arts, Recreation and
52 Culture Advisory Commission and by community organizations and businesses; and

53
54 WHEREAS, Best practices for WF-SS plan development would utilize input from a broad-
55 based local steering committee and the design and outreach expertise of a professional
56 consultant to work with the public, the City and State agencies responsible for managing
57 public right-of-ways; **and**

58
59 **WHEREAS, Upon completion of the WF-SS Plan RFP, City Council will consider a**
60 **resolution authorizing staff to assemble a WF-SS Committee to serve as a communication**
61 **link between citizens, user groups, city staff and the consultant, provide input on current**
62 **conditions and actively promote the project and public participation by communicating**
63 **with community members and their respective user groups; and**

64
65 **WHEREAS, The HART Roads Fund Balance is \$6,243,285.25 and HART Trails Fund**
66 **Balance is \$636,834.84.**

67
68 NOW THEREFORE, The City of Homer supports the Wayfinding-Streetscape Plan
69 proposal and Ordains:

70
71 Section 1. The FY2019 Capital budget is hereby amended by appropriating no more
72 than \$50,000 from the HART Fund (split 50/50 between HART Roads and HART Trails) to secure
73 the services of a professional consultant to facilitate the development of a WF-SS Plan through
74 a competitive bidding process, as follows:

75

Account No.	Description:	Amount:
<u>160-0375</u>	<u>HART Roads Fund</u>	<u>\$25,000</u>
<u>165-0375</u>	<u>Hart Trails Fund</u>	<u>\$25,000</u>

76
77
78
79
80 Section 2. City Council authorizes the City Manager to prepare a Request for Proposals
81 to secure these consultant services.

82

83 ~~Section 3. City Council authorizes formation of a WF-SS Task Force to work with~~
84 ~~the consultant as needed on the WF-SS Plan development.~~

85
86 Section 43. This is a budget amendment ordinance is temporary in nature, and shall not
87 be codified.

88 CITY OF HOMER

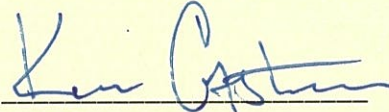
89
90
91 

92 KEN CASTNER, MAYOR

93
94 ATTEST:

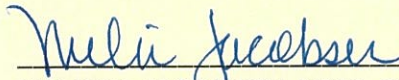
95 
96 _____
97 MELISSA JACOBSEN, MMC, CITY CLERK



98
99 YES: 6
100 NO: 0
101 ABSTAIN: 0
102 ABSENT: 0

103
104 First Reading: 11.25.19
105 Public Hearing: 12.9.19
106 Second Reading: 12.9.19
107 Effective Date: 12.10.19

108
109
110 Reviewed and approved as to form:

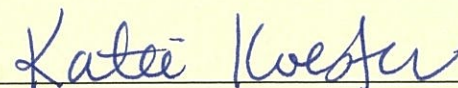
111
112 
113 _____
114 Katie Koester, City Manager

115
116 Date: 12.16.19 _____

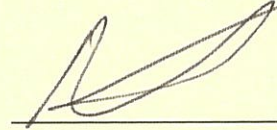

Michael Gatti, City Attorney

Date: 12/20/19 _____



City of Homer

www.cityofhomer-ak.gov

Office of the City Clerk

491 East Pioneer Avenue
Homer, Alaska 99603

clerk@cityofhomer-ak.gov

(p) 907-235-3130

(f) 907-235-3143

Memorandum 21-029

TO: MAYOR CASTNER AND HOMER CITY COUNCIL

FROM: MELISSA JACOBSEN, MMC, CITY CLERK

DATE: FEBRUARY 12, 2021

SUBJECT: APPROVAL OF LETTER FROM CITY COUNCIL IN SUPPORT OF REINSTATING/
EXTENDING THE STATE'S DISASTER DECLARATION

The attached letter is provided review and approval to submit to Senate President Peter Micciche and Speaker of the House Louise Stutes.

Recommendation: Approve the letter to be signed by the Mayor on behalf of the City Council.



City of Homer

www.cityofhomer-ak.gov

Homer City Council

491 East Pioneer Avenue
Homer, Alaska 99603

(p) 907-235-3130

(f) 907-235-3143

February 22, 2021

Senate President Peter Micciche
Speaker of the House Louise Stutes

Greetings,

The Homer City Council is writing to express our support for the Alaska State Legislature to pass SB 56, or a similar bill, which will reinstate/extend Alaska's disaster declaration due to the novel coronavirus pandemic. We appreciate the recent progress in the Senate in moving the bill to the Senate Finance Committee and the outreach from the Alaska House Coalition to Governor Dunleavy. However, the current disaster declaration expired February 15, 2021.

Unlike some states, the State of Alaska does not have broad public health powers. In Alaska, public health measures are directly linked with the disaster powers. The tools associated with the disaster declaration provides a safety net for the governor, his administration, and local governments to respond flexibly and strategically. For instance, the previous disaster declarations have helped Alaska become the most vaccinated state in the country. However, most of Alaska's population (and the US population) remains vulnerable to the novel coronavirus.

Reinstating the disaster declaration assures the State's authority to distribute vaccines through mass vaccine clinics, procure and direct scarce supplies, and suspend certain statutes and regulations to allow health care providers and businesses to perform efficiently under the current circumstances. We are particularly concerned about what nonrenewal means for the State's vaccination effort going forward, and our health care system's ability to quickly respond should the virus, or variants of the virus, cause a rebound of cases in the State.

The recovery of our local economy has been dependent on mitigating COVID-19 transmission and supplying vaccine to all those who want it. The disaster declaration was an essential component of our ability to effectively respond to support both these efforts. Under the declaration, Homer's Unified Command team worked closely with the State to

- Coordinate local public information and education efforts with the Statewide response.
- Procure important and scarce PPE, testing, and voluntary vaccination supplies through the declaration's procurement regulations waiver.
- Mitigate intra and interstate COVID-19 transmission through the State's testing program in hub airports. As a spoke airport supporting business, medical and tourism travel, testing opportunities at hub airports greatly mitigates the potential travel-related disease transmission.
- Work with local industries to establish critical infrastructure guidelines as needed.

Our citizens benefitted directly from the disaster declaration as well; we would not want to lose current or upcoming economic relief resources by letting the Disaster Declaration lapse, particularly including the following:

- The ability to quickly establish non-congregate sheltering contracts waiving the more formal and lengthy process.
- The ability to use telehealth for medical needs.
- The potential loss of \$8 million in federal SNAP benefits and possibly other federal benefits.

We urge the Alaska State Legislature to quickly pass SB 56 or a suitably amended bill to reinstate Alaska's COVID-19 Disaster Declaration.

Thank you for public service.

CITY OF HOMER

Ken Castner, Mayor

Cc: Governor Dunleavy
Senate Finance Members
House Finance Members
Senator Gary Stevens
Representative Sarah Vance
Alaska Municipal League

ORDINANCE REFERENCE SHEET
2021 ORDINANCE
ORDINANCE 21-08

An Ordinance of the City Council of Homer, Alaska Amending the 2021 Capital Budget and Authorizing Additional Expenditure of \$113,353.33 from the HART-Road Fund for the Woodard Creek Rehabilitation Project.

Sponsor: City Manager/Public Works Director.

1. City Council Regular Meeting February 22, 2021 Introduction

Memorandum 21-030 from Public Works Director as backup.

1 **CITY OF HOMER**
2 **HOMER, ALASKA**

3 City Manager/
4 Public Works Director

5 **ORDINANCE 21-08**

6
7 AN ORDINANCE OF THE CITY COUNCIL OF HOMER, ALASKA,
8 AMENDING THE 2021 CAPITAL BUDGET AND AUTHORIZING
9 ADDITIONAL EXPENDITURE OF \$113,353.33 FROM THE HART-
10 ROAD FUND FOR THE WOODARD CREEK CULVERT
11 REHABILITATION PROJECT.

12
13 WHEREAS, Water from Woodard Creek is conveyed under Fairview Avenue in two
14 culverts, which are owned/maintained by the City of Homer; and

15
16 WHEREAS, The culverts have experienced extensive corrosion and one them failed,
17 allowed gravel from Fairview Avenue’s road bed to fall into the culvert and get washed away,
18 thereby causing a sinkhole in Fairview Avenue; and

19
20 WHEREAS, The City made emergency repairs, but a permanent solution is necessary;
21 and

22
23 WHEREAS, A recommendation was made to install a permanent solution, which would
24 allow Woodard Creek to be “daylighted” at Fairview Avenue; that is, an arch culvert would be
25 designed and installed that would allow Woodard Creek to flow freely; and

26
27 WHEREAS, The conceptual cost estimate to design, furnish and install the large arch
28 culvert could be in the range of \$300,000 - \$500,000 and wouldn’t be completed until mid-2021;

29
30 WHEREAS, The City Council passed Ordinance 20-40(A) appropriating \$350,000 from the
31 HART Road Fund for the arch culvert solution; and

32
33 WHEREAS, The project has been designed to a 35% level and the updated cost estimate
34 shows the total expected project cost, including design, will be \$463,353.33; and

35
36 WHEREAS, An additional appropriation is necessary to complete the project.

37
38 NOW, THEREFORE, THE CITY OF HOMER ORDAINS:

39
40 Section 1. The City of Homer’s 2021 Capital Budget is hereby amended by appropriating
41 an additional \$113,353.33 from the HART-Roads Fund for the Woodard Creek Culvert
42 Rehabilitation Project.

43			
44	<u>Account No.</u>	<u>Description</u>	<u>Amount</u>
45	160-0779	HART Roads	\$113,353.33
46			

47 Section 2. This is a budget amendment ordinance, is not permanent in nature, and shall
48 not be codified.

49
50 ENACTED BY THE CITY COUNCIL OF HOMER, ALASKA, this ____ day of _____, 2021.

51
52 CITY OF HOMER
53
54 _____
55 KEN CASTNER, MAYOR

56 ATTEST:
57
58 _____
59 MELISSA JACOBSEN, MMC, CITY CLERK

60
61
62 YES:
63 NO:
64 ABSTAIN:
65 ABSENT:
66
67
68 First Reading:
69 Public Hearing:
70 Second Reading:
71 Effective Date:



Memorandum 21-030

TO: Mayor Castner and Homer City Council

Through: Robert Dumouchel, City Manager

FROM: Janette Keiser, PE, Director of Public Works/Acting City Engineer

DATE: February 2, 2021

SUBJECT: Woodard Creek Culvert Project – 35% Design

Issue: The design for the Woodard Creek Culvert Project is currently at 35% development. The purpose of this Memorandum is to discuss the cost increases we are anticipating and seek direction.

Background: The City issued a contract to design the Woodard Creek Culvert Project to Bishop Engineering, a Homer firm with extensive experience in structural engineering and local development. Bishop has progressed the design the 35% level, which is not enough to build from, but enough to envision what the project will look like and get a more reliable cost. For example, this level of design allows us to understand and work-around utility conflicts, plan for construction impacts and layout the basic dimensions of the new road/sidewalk cross-section.

The intent is to replacing the existing two 24” culverts that extend under Fairview Avenue with a single arch pipe that allows Woodard Creek to flow freely. Specifically, the smaller culverts will be replaced with 110 feet of corrugated arch pipe that is somewhat oblong, 73 inches (6’1”) wide and 55 inches (4’7”) high. This considerably increases the hydraulic capacity of the structure.

The estimated cost to construct the structure is \$417,813.33, which does not include any construction contingency. The cost of the design effort is \$45,540, bringing the total expected project cost to \$463,353.33. The Council approved, via Ordinance 20-40(A), \$350,000 for the design and construction of this project, leaving a balance of \$113,353.33.

Part of the extra cost is due to the effort to temporarily relocate the existing utilities, including a major water main, a primary gas main and a fiber optic cable. All of these utilities will need to be temporarily relocated and protected during the installation of the arch pipe. We knew these utilities existed, and we’ve added more conservative costs for their protection and relocation, to the cost estimate, in an abundance of caution. The updated cost estimate includes \$90,000 of utility protection costs. We also have a considerable cost, \$25,000, to divert the creek during construction. Obviously, this cost will depend on flow rates and we’ve taken a conservative approach. These costs for utility protection and creek diversion, would be incurred even if we replaced the two

existing culverts with the same size culverts. It's possible we could get lucky and not need to spend these amount of money on these items. We recommend continuing with the arch culvert project.

We will be sharing this information with the PARCAC at their February 4, 2021

How much money is in the HART-Roads Fund? According to a report distributed by Finance Director Walton on June 3, 2020, there was \$5,995,992 in the HART Roads fund as of March 31, 2020. Since then, my records show we have spent or obligated \$1,106,678 in projects in 2020 and I've asked for \$272,000 in Fleet Replacements for 2021. With these obligations, there is \$4,617,314 in the HART Roads Fund. Finance Director Walton told me there was \$6,472,383.26 in the HART Roads Fund as of December 31, 2020, but I'm not sure is that included all the various obligations made in 2020. Even so, there is sufficient funds in the HART Road Fund to cover the anticipated extra costs.

What other plans do we have for the HART-Roads Fund? As we promised last year, we are in the process of preparing a 5-year Roads Capital Improvement Plan, using our data-based Road Assessment Plan as a guide. We've identified several paved roads, assessed at a rating of Poor (2 out of a scale of 1-5), which would benefit from grinding and repaving this year. Further, we have some gravel roads that are poorly rated because of frost boils and thin driving surfaces. Our intent is to work on the roads rated Poor or worse, first, and then move on to roads that are rated Fair, to improve their condition before they deteriorate further. We're also looking at where drainage improvements need to be made, regardless of road condition. Further, we hope to be able to construct the Main Street side walk, whether grant funding is received or not, and start design on the next priority sidewalk. In short, we are working on a plan and hope to unveil it by the next budget cycle.

Finally, we have collected cost information from actual, local bids (Pioneer Avenue and Lake Street Reconstruction), which we will use to build a historical cost data base. This will improve our cost estimating methodology.

Recommendation:

That the City Council appropriate an additional \$113,353.33 for this project, from the HART Roads Fund.

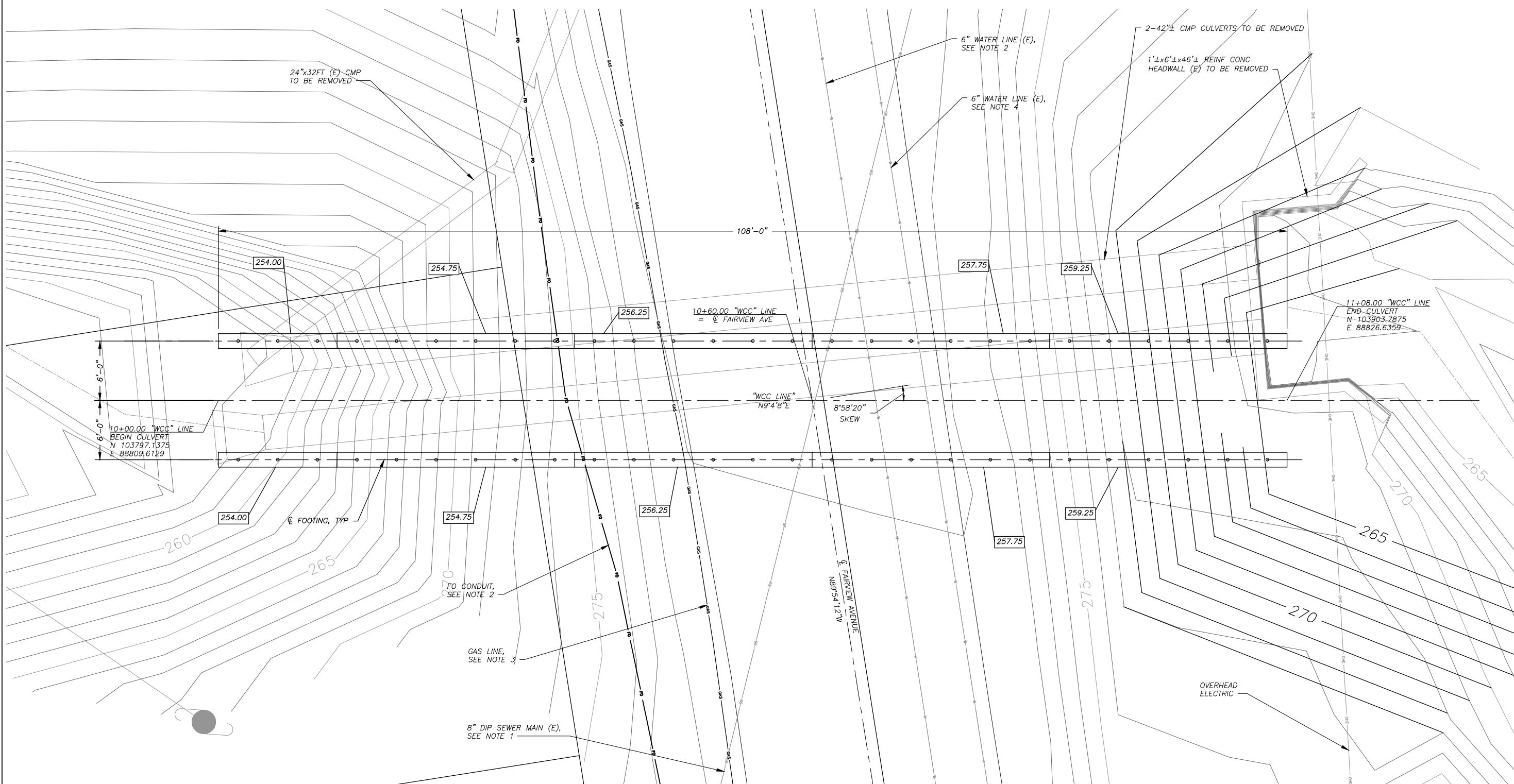
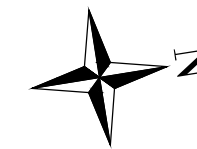

LEGEND:
 DENOTES BOTTOM OF FOOTING ELEVATION

PLAN
 1"=5'-0"

- NOTES:**
1. Utility to be relocated. Utility may be temporarily shut down during construction.
 2. Utility to be rerouted onto support bridge and remain in service during construction.
 3. Utility to be protected in place and remain in service during construction.
 4. Utility is abandoned and shall be removed within the limits of excavation.
 5. Before performing any excavations, call Alaska Digline at 811, (800) 478-3121, or (907) 278-3121.

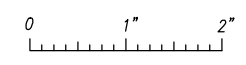

WOODARD CREEK CULVERT AT FAIRVIEW AVENUE (REPLACE)
 Homer, Alaska
 FOUNDATION PLAN

BISHOP ENGINEERING, LLC
 PO BOX 2501 HOMER, ALASKA 99603
 (907) 299-7609

DATE: 11/6/2020
 CHK'D: JSB
 SCALE: As Noted
 PROJ. NO.: 2020142

SHEET NO.:
 S-2

ENGINEER'S CONSTRUCTION ESTIMATE

95% PLAN ESTIMATE 65% PLAN ESTIMATE GENERAL PLAN ESTIMATE (35%)

PROJECT NAME: Woodard Creek Culvert @ Fairview Avenue (Replace)
DESCRIPTION: Project Estimate - 110 feet of 73"x55" pipe arch culvert
 (3"x1" 14GA, Aluminized)
 (15% Contingencies)
PRICES BY : John S. Bishop
QUANTITIES BY: John S. Bishop
CHECKED BY:

IN EST:
OUT EST:
LOCATION: Homer, Alaska
DEPTH: 4'-7"
LENGTH: 110 feet
WIDTH: 6'-1"
AREA: N/A
DATE: 1/22/2021
DATE: 1/22/2021
DATE:

CONTRACT ITEMS		QUANTITY	UNIT PRICE	UNIT	ITEM COST
1	Traffic Control	1	\$ 10,000.00	LS	\$ 10,000.00
2	Construction Survey	1	\$ 18,500.00	LS	\$ 18,500.00
3	Pavement Removal	1,500	\$ 3.00	SQFT	\$ 4,500.00
4	Remove Existing Culvert and Headwall	1	\$ 18,000.00	LS	\$ 18,000.00
5	Roadway Excavation	2,400	\$ 15.00	CY	\$ 36,000.00
6	Structure Backfill	1,600	\$ 40.00	CY	\$ 64,000.00
7	Geotextile Fabric	1,500	\$ 2.50	SQFT	\$ 3,750.00
8	Asphalt Concrete Pavement	1,500	\$ 6.00	SQFT	\$ 9,000.00
9	Creek Diversion Culvert	1	\$ 30,000.00	LS	\$ 30,000.00
10	Structural Concrete (Headwall Reconstruction)	4	\$ 1,000.00	CY	\$ 4,000.00
11	Bar Reinforcing Steel (Headwall Reconstruction)	800	\$ 2.50	LBS	\$ 2,000.00
12	Furnish Open Arch Culvert (Galvanized 12GA Multi-Plate)	8,140	\$ 3.30	LBS	\$ 26,862.00
13	Install Pipe Arch Culvert (Galvanized 12GA Multi-Plate)	8,140	\$ 3.00	LBS	\$ 24,420.00
14	Rock Slope Protection	1	\$ 25,000.00	LS	\$ 25,000.00
15	Water Line Temporary Relocation on Bridge and Reinstallation	1	\$ 40,000.00	LS	\$ 40,000.00
16	Sanitary Sewer Temporary Relocation on Bridge and Reinstallation	1	\$ 25,000.00	LS	\$ 25,000.00
17	Fiber Optic Temporary Relocation on Bridge and Reinstallation	1	\$ 15,000.00	LS	\$ 15,000.00
18	Gas Main Temporary Relocation on Bridge and Reinstallation	1	\$ 10,000.00	LS	\$ 10,000.00
19	SWPPP Construction	1	\$ 10,000.00	LS	\$ 10,000.00
20				\$	-
21				\$	-
22				\$	-
23				\$	-
24				\$	-
25				\$	-
26				\$	-
27				\$	-
28				\$	-
29				\$	-
30				\$	-

Comments	MOBILIZATION	10%	\$ 41,781.33
	SUBTOTAL		\$ 417,813.33
	CONTINGENCIES	15%	\$ 62,672.00
	TOTAL		\$ 480,000.00

DESCRIPTION	PRICE	UNIT	COST
DEMOLITION			

	HART - Roads spent or obligated
Fund Balance thru 3/31/20	\$ 5,995,992.62
Fund balance remaining - \$4,517,992	\$ 4,617,314.62
Fuel Island Replacement - \$95,000	\$ 95,000.00
Small Works Drainage Improvement Program - \$110,000	\$ 110,000.00
Small Works Road Repair Program - \$175,000	\$ 175,000.00
Main Street Storm Drain and Sidewalk Project - Pioneer Avenue North - \$98,000	\$ 98,000.00
Update 1979 Drainage Management Plan - \$90,000	\$ 90,000.00
HSWCD Consulting Contract - \$25,000	\$ 25,000.00
Horizon Court Landslide	\$ 20,000.00
Woodard Creek Culvert - \$500,000	\$ 350,000.00
Mt. Augustine Drainage Improvements	\$ 97,000.00
Road elements of Seawall Armor Rock Revetment project	\$ 46,678.00
Requests for grader and two sanding trucks	\$ 272,000.00
Total Projects Spent or Obligated	\$ 1,378,678.00

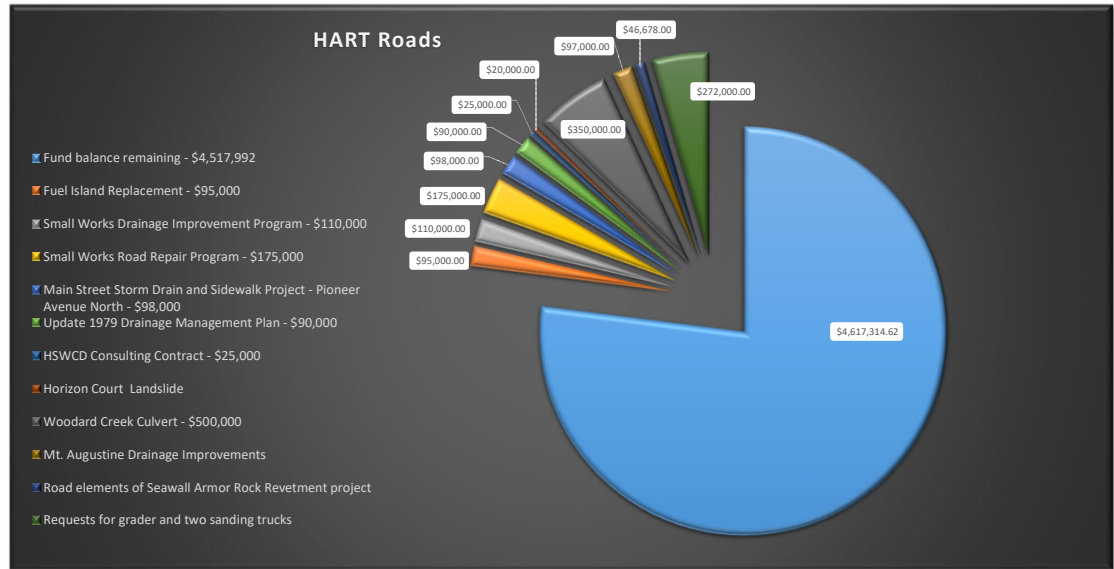

Conceptual Cost Estimate
Fairview Ave Woodard Creek Culvert Replacement

Assumptions:
 1/4 excavated material can be reused
 June-July Construction (2021)

	Units	Quantity	Unit Price	Cost
Mob/Demobilization	LS	1	\$65,000	\$65,000
Traffic Control	LS	1	\$16,500	\$16,500
Construction Survey	LS	1	\$18,500	\$18,500
Pavement Removal	SF	3000	\$3	\$9,000
Excavation (Offsite Disposal)	CY	1450	\$15	\$21,750
Remove Headwall/Existing Culvert	LS	1	\$17,500	\$17,500
F&I 60"x72" Pipe Arch Culvert	LF	65	\$300	\$19,500
Replace Headwall	LS	1	\$19,000	\$19,000
Outlet Erosion Control	LS	1	\$11,000	\$11,000
Classified Backfill	CY	1100	\$33	\$36,300
Geotextile Fabric	SF	3000	\$2.50	\$7,500
Slope Erosion Control	LS	1	\$11,000	\$11,000
Pavement Replacement	SF	3000	\$6	\$18,000
Protect Sewer Main	LS	1	\$25,000	\$25,000
Protect Water Mian	LS	1	\$40,000	\$40,000
Protect Gas main	LS	1	\$30,000	\$30,000
Protect Fiber Optic Cable	LS	1	\$15,000	\$15,000
Bypass Stream Flow	LS	1	\$30,000	\$30,000

Total Construction **\$410,550**

Design (12%) \$49,266.00

Permitting (4%) \$16,422.00

Inspection (5%) \$20,527.50

Contingency (8%) \$32,844.00

Total Project Cost **\$529,610**

43 ~~Section 1. Based on the foregoing WHEREAS clauses, which shall also function as a~~
44 ~~Statement of Facts, the Homer City Council finds that the failure of the Woodard Creek culverts~~
45 ~~under Fairview Avenue constitutes an emergency, per HCC 1.08.040.~~
46

47 ~~Section 2. The City Manager is authorized, per HCC 3.16.060, to execute an exemption~~
48 ~~to the procurement procedures set forth in Homer City Code Chapter 3.16, by issuing a sole~~
49 ~~source contract for the repair/rehabilitation of the Woodard Creek Culverts.~~
50

51 ~~Section 3: This is a budget amendment ordinance, is not permanent in nature, and shall~~
52 ~~not be codified.~~
53

54 **WHEREAS, The repairs are fragile and could be damaged by a storm event laden**
55 **with high water and debris, which could cause the road to fail again; and**
56

57 **WHEREAS, The City Council needs to decide what a permanent solution should**
58 **look like, so implementation can be expedited; and**
59

60 **WHEREAS, There are two options for implementing a permanent solution; and**
61

62 **WHEREAS, The first option is to “slip line” the existing culverts with a fiberglass**
63 **lining, which is installed in the culverts as they lay in place; and**
64

65 **WHEREAS, Frawner Corporation is the only contractor that slip lines existing**
66 **culverts, in the state of Alaska, which if this option is chosen would necessitate a sole**
67 **source contract with this contractor; and**
68

69 **WHEREAS, The City received a quote, in the amount of \$152,000, from Frawner**
70 **Corporation to design, fabricate and install slip lining for both culverts; and**
71

72 **WHEREAS, This quote did not include costs for traffic control, a**
73 **performance/payment bond, permits and other incidentals that a government public**
74 **works contract requires and we are in the process of working with Frawner to price out**
75 **these elements; and**
76

77 **WHEREAS, We estimate these “soft costs” will add approximately another 20% to**
78 **the project, bringing the estimated cost to \$182,400; and**
79

80 **WHEREAS, Frawner Corporation needs at least six weeks to design and procure**
81 **materials that are customized for our specific application; and**
82

83 WHEREAS, There is another option, which involves replacing the existing two
84 culverts with a large arch culvert, thereby allowing the creek to flow naturally and
85 increase hydraulic capacity; and
86

87 WHEREAS, The Woodard Creek Watershed Management Plan, promulgated by the
88 Woodard Creek Coalition and incorporated into the 2018 Homer Comprehensive Plan
89 identifies as a “Project for Future Consideration”, “working with the City of Homer to
90 daylight Woodard Creek at Fairview Avenue”; and
91

92 WHEREAS, Woodard Creek has already been day-lighted at Spruceview Avenue and
93 Soundview Avenue; and
94

95 WHEREAS, Now would be the best time to act on the objective of daylighting
96 Woodard Creek as part of a permanent solution to the Fairview Avenue culvert failure;
97 and
98

99 WHEREAS, The conceptual cost estimate to design, furnish and install the large
100 arch culvert could be in the range of \$300,000 --\$500,000 \$350,000 and wouldn't be
101 completed until mid-2021;
102

103 WHEREAS, The City Council adopted Resolution 17-038, on April 24, 2017,
104 amending the Homer Accelerated Roads and Trails Program (HART) Policy Manual; and
105

106 WHEREAS, The HART Manual identify various criteria for projects that may be
107 considered for HART funding; and
108

109 WHEREAS, The criteria, which would be met by repairing Fairview Avenue, include:

- 110 • Improves life, safety and traffic flow
- 111 • Corrects deficiencies of existing systems
- 112 • Corrects Drainage Problems

113 NOW, THEREFORE, THE CITY OF HOMER ORDAINS:
114

115 Section 1. The City Council declares the failure of the Woodard Creek Culvert at
116 Fairview Avenue to constitute an emergency.
117

118 Section 2. The City Council directs the City Manager and staff to execute a
119 permanent solution to the Fairview Avenue culvert failure at Woodard Creek, which
120 Select option (a) slip lines the existing two culverts or (b) daylights the Creek.
121

122 **Section 3. The City Manager is authorized, per HCC 3.16.060, to execute**
123 **exemptions to the procurement procedures set forth in Homer City Code Chapter 3.16, to**
124 **expedite the procurement of contracts to implement the preferred option.**
125

126 **Section 4. The City of Homer's 2020 Capital Budget is hereby amended by**
127 **appropriating up to \$500,000 350,000 from the HART-Roads Fund for the Woodard Creek**
128 **Culvert Rehabilitation Project.**
129

Account No.	Description	Amount
	HART Roads	\$500,000 350,000

132
133 **Section 5. This is a budget amendment ordinance, is not permanent in nature,**
134 **and shall not be codified.**
135

136 ENACTED BY THE CITY COUNCIL OF HOMER, ALASKA, this 1st day of July, 2020.
137

138 CITY OF HOMER

139 

140 KEN CASTNER, MAYOR

141 ATTEST:

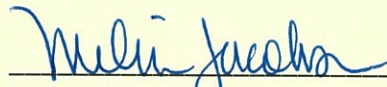
142 

143 MELISSA JACOBSEN, MMC, CITY CLERK

144 YES: 6

145 NO: 0

146 ABSTAIN: 0

147 ABSENT: 0

148 First Reading: 7/1/2020

149 Public Hearing: Emergency ordinance

150 Second Reading:

151 Effective Date: 7/1/2020

152 Reviewed and approved as to form:

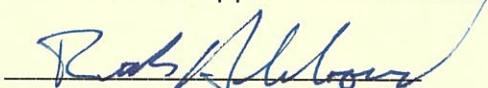
153 

154 Rick Abboud, Acting City Manager

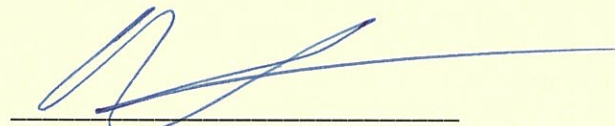
155 

156 Michael Gatti, City Attorney

157 Date: _____

158 Date: 8/10/2020

ORDINANCE REFERENCE SHEET
2021 ORDINANCE
ORDINANCE 21-09

An Ordinance of the City Council of Homer, Alaska, Amending the 2021 Capital Budget and Authorizing Expenditure of up to \$65,000 from the Police Fleet CARMA Account to Purchase and Outfit a Patrol Vehicle.

Sponsor: City Manager/Police Chief

1. City Council Regular Meeting February 22, 2021 Introduction

Memorandum 21-031 from Police Chief as backup.

**CITY OF HOMER
HOMER, ALASKA**

City Manager/Police Chief

ORDINANCE 21-09

AN ORDINANCE OF THE CITY COUNCIL OF HOMER, ALASKA
AMENDING THE 2021 CAPITAL BUDGET AUTHORIZING
EXPENDITURE OF UP TO \$65,000 FROM THE POLICE FLEET CARMA
ACCOUNT TO PURCHASE AND OUTFIT A PATROL VEHICLE.

WHEREAS, The FY20/21 budget approved the purchase of a replacement jail van for the
Police Department in FY21; and

WHEREAS, There is a greater need at this time for a patrol vehicle appropriately
outfitted for police use; and

WHEREAS, The Police Chief has made a request to replace the approved jail van with a
new request for a patrol vehicle; and

WHEREAS, There are sufficient funds available in the Police Fleet CARMA account to
purchase an appropriately outfitted patrol vehicle.

NOW THEREFORE, THE CITY OF HOMER ORDAINS:

Section 1. The City of Homer's FY21 Capital Budget is hereby amended by appropriating
up to \$65,000 to procure and outfit a police patrol vehicle as follows:

<u>Account</u>	<u>Description</u>	<u>Amount</u>
152-0382	Police Fleet CARMA	\$65,000

Section 2. This is a budget amendment ordinance only, is not permanent in nature, and
shall not be codified.

ENACTED BY THE CITY COUNCIL OF HOMER, ALASKA, this ____ day of _____, 2021.

CITY OF HOMER

KEN CASTNER, MAYOR

ATTEST:

43

44

45

46 _____
MELISSA JACOBSEN, MMC, CITY CLERK

47

48

49 YES:

50 NO:

51 ABSTAIN:

52 ABSENT:

53

54

55 First Reading:

56 Public Reading:

57 Second Reading:

58 Effective Date:



City of Homer

www.cityofhomer-ak.gov

Police Department

625 Grubstake Avenue
Homer, Alaska 99603

police@cityofhomer-ak.gov

(p) 907-235-3150

(f) 907-235-3151/ 907-226-3009

MEMORANDUM 21-031

DATE: 1-27-2021

FROM: Chief Robl

TO: City Manager Dumouchel

SUBJ: HPD Fleet Purchase

We have been operating our fleet with a take home policy for our police officers for over 25 years. Having a take home policy ensures officers can be called in from an off duty status and rapidly respond directly to the location of the call fully equipped and ready to render aide. We have found other advantages to the take home policy as well. We are currently budgeted for 13 police officers. We gained an additional position in 2020. We neglected to budget for an additional patrol vehicle last year. I would like to add one soon and keep up with a reasonable replacement schedule to keep our fleet safe and capable.

Most police departments do not operate patrol vehicles with over 100,000 miles on them. Many replace them at far fewer miles. We have always tried to run ours as long as we safely can. There is great risk with operating aged vehicles in emergency responses, you just never know when something is going to break that could cause an accident. We currently have two front line patrol vehicles that should be replaced as soon as possible with a third also very close to the end of its service time. An additional need is to replace our jail transport van. It has numerous problems and over 110,000 miles on it. These vehicles are identified as follows:

Unit 526	2009 Chevy Impala	148,000 miles
Unit 518	2007 Ford Expedition	124,000 miles, extremely rusty, literally falling apart
Unit 527	2014 Ford Explorer	93,500 miles, still operable but deteriorating
Unit 523	2008 Chevy Van	110,000 miles, this is our jail van

We have been purchasing four wheel drive vehicles with the police package on them. The police package has heavy duty electrical components in it to handle our equipment. It also comes with heavy duty brakes and suspensions. The police package is currently offered on Chevy Tahoe's, Ford Explorers and Expeditions and some pick-ups. Pick-ups don't work for our uses. The Tahoe's and Expeditions are our preferred vehicles. They have enough room for prisoner cages and the rest of our equipment. We have several Explorers. The spacing in the rear seat with the cage in it is very tight making it difficult to fit a large, resistive person in them. I intend to purchase Tahoe's and Expeditions in the future unless something better comes along.

The Alaska Department of Public Safety bids a contract with Chevrolet and Ford for police vehicles every year. The contract pricing is offered to all police agencies in the state. We have tried to obtain better pricing through the bid process but have not been able to do so. Sticking with the negotiated prices from DPS has

proven to be the way to go. The manufacturers typically have a window open for ordering police service vehicles. You can't order vehicles when the window is closed. COVID is complicating the process and slowing it down. Our last new vehicle orders took about a year to get to us. The cost of the vehicle is just a part of it. The vehicles have to be outfitted before they are ready to go. Outfitting is done at Alaska Safety in Anchorage, also on state contract prices. I have not seen the state contract prices for this year yet. We purchased two new Expeditions in 2020 at a cost of \$40,000 each. Outfitting them came in at \$12,600 each.

For CY 2020 we had originally planned and budgeted for replacing our jail van. We neglected to budget for an additional patrol vehicle. We currently have approximately \$80,000 available in our fleet reserve account. I would like permission to replace the Chevy Impala now using our existing fleet reserve funds. I request permission to spend up to \$55,000 on this purchase. For FY 2022 I will plan on budgeting to replace the 2007 Expedition and add an additional patrol vehicle to our fleet.

City Manager's Note: While the Chief is requesting \$55,000 to purchase and outfit a vehicle, I am directing staff to increase the value requested in the ordinance to \$65,000. This is not to allow for additional equipment purchases, but to account for the fact that there is an international disruption to automotive supply chains which could impact the prices of vehicles. Any funds not spent on the originally intended use (patrol vehicle and police-use outfitting) will be returned to the fleet reserve account.

ORDINANCE REFERENCE SHEET
2021 ORDINANCE
ORDINANCE 21-10

An Ordinance of the City Council of Homer, Alaska, Amending the 2021 Capital Budget and Authorizing Expenditure of an Additional \$17,148 from the Sewer Reserve Fund to Complete the Retrofit of High Energy Lights Fixtures at the Sewer Treatment Campus.

Sponsor: City Manager/Public Works Director.

1. City Council Regular Meeting February 22, 2021 Introduction

Memorandum 21-032 from Public Works Director as backup.

**CITY OF HOMER
HOMER, ALASKA**

City Manager/
Public Works Director

ORDINANCE 21-10

AN ORDINANCE OF THE CITY COUNCIL OF HOMER, ALASKA,
AMENDING THE 2021 CAPITAL BUDGET AND AUTHORIZING AN
ADDITIONAL \$17,148 FROM THE SEWER RESERVE FUND TO
COMPLETE THE RETROFIT OF HIGH ENERGY LIGHT FIXTURES AT
THE SEWER TREATMENT CAMPUS.

WHEREAS, The City Council adopted Ordinance 20-92 on December 14, 2020, appropriating funds from the Sewer Reserve fund in the amount of \$18,696 and funds from the Water Reserve Fund in the amount of \$16,546 to retrofit high energy light fixtures with LED light fixtures; and

WHEREAS, In the course of installing the LED fixtures in the Waste Water Treatment Plant (WWTP), it was discovered that 29 of the light fixtures are badly damaged from the highly corrosive environment in the WWTP, which means the fixtures, and some associated wiring, needs to be replaced completely; and

WHEREAS, the extra cost for this replacement work is \$17,148, as a change order to the purchase order issued to local contractor, Liberty Electric, Inc.

NOW, THEREFORE, the City Council of Homer ordains:

Section 1. That Ordinance 20-92 be amended to appropriate an additional \$17,148, from the Sewer Reserve Fund, for a total appropriation of \$35,844 to retrofit high energy light fixtures at the Sewer Treatment Plant Campus with low energy LED fixtures.

<u>Account No.</u>	<u>Description</u>	<u>Amount</u>
256-0379	Sewer Reserve Fund	\$17,148

Section 2. This is a budget amendment ordinance, is temporary in nature, and shall not be codified.

ENACTED BY THE CITY COUNCIL OF HOMER, ALASKA, this ___ day of _____, 2021.

CITY OF HOMER

KEN CASTNER, MAYOR

44 ATTEST:

45

46 _____

47 MELISSA JACOBSEN, MMC, CITY CLERK

48

49

50 YES:

51 NO:

52 ABSTAIN:

53 ABSENT:

54

55

56 First Reading:

57 Public Hearing:

58 Second Reading:

59 Effective Date:



City of Homer

www.cityofhomer-ak.gov

Public Works

3575 Heath Street
Homer, AK 99603

publicworks@cityofhomer-ak.gov

(p) 907- 235-3170

(f) 907-235-3145

Memorandum 21-032

TO: Mayor Castner and Homer City Council

THROUGH: Rob Dumouchel, City Manager

FROM: Janette Keiser, Director of Public Works

DATE: February 9, 2021

SUBJECT: Request for Change Order for Replacement of Light Fixtures at WWTP

Issue: City Council adopted Ordinance 20-92 appropriating \$18,696 to retrofit lighting at the Waste Water Treatment Plant (WWTP) Campus with low energy LED bulbs. We encountered serious corrosion in the existing fixtures, which requires a change order to replace them.

Background:

In the course of replacing high energy lighting in the WWTP, the contractor found that the fixtures themselves are damaged from the highly corrosive environment in the WWTP. The fixtures are original units, installed in 1990 and have been corroding for some time, but were in an inaccessible location. We are seeing most of these fixtures, up close and personal for the first time since they were installed, and never had the opportunity to notice the corrosion before.

We have a quote of \$17,148 to replace the fixtures, bringing the total value to \$35,844.

Sewer Reserve Fund Status:

Balance as of December 31, 2020	\$1,932,218
Allocated by Ordinance 20-57 for urgent projects	\$ 484,900
City's share of Seawall SAD allocated to Sewer Reserves	\$ 39,364
Allocated by Ordinance 20-92 for LED lighting at WWTP	\$ <u>18,696</u>
Balance	\$1,389,258

Action Recommended:

That the City authorize an additional expenditure of \$17, 148.00 from the Sewer Water Reserve Fund for a total expenditure of \$35,844 to retrofit high energy light fixtures at the WWTP.

Howea WWTIP

Installed in 1990

2-9-21

Liberty Electric, Inc.

PO Box 1730
Homer, AK 99603

Estimate

Date	Estimate #
2/8/2021	1263

Name / Address
City of Homer 491 E. Pioneer Ave. Homer, AK 99603

P.O. No.	Project
	Public Works

Item	Description	Qty	Cost	Total
bid item	Remove a total of 29 badly corroded lighting fixtures in Digester Room of the wastewater treatment plant and replace with HE Williams 96 Series led fixtures in vapor-tight fiberglass enclosures. Replace conduit and conductors as necessary for fixture replacement.	1	17,148.00	17,148.00

Subtotal			\$17,148.00
-----------------	--	--	-------------

Sales Tax (7.85%)			\$0.00
--------------------------	--	--	--------

Total			\$17,148.00
--------------	--	--	-------------

**CARMA Sewer
Reserve - Spent or
obligated**

Fund Balance thru 3/31	\$1,932,218
Utility Financial Management	\$17,500
Retrofit High Energy Light	\$18,696
Beluga Lift Station	\$19,573
Upgrade SCADA for Sewer Lif Stations	\$210,000
Replace Deep Shaft Air Compressors	\$85,000
Waste Water Treatment Plant - Digester Blowers	\$189,000
Fund Balance Remaining	\$1,876,449

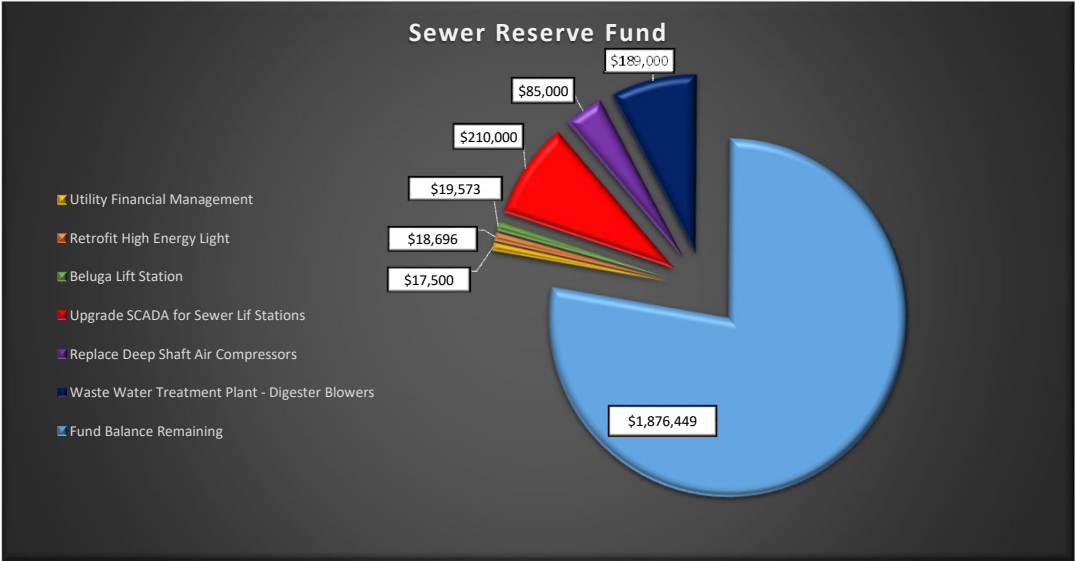

**CITY OF HOMER
HOMER, ALASKA**

City Manager/
Public Works Director

ORDINANCE 20-92

AN ORDINANCE OF THE CITY COUNCIL OF HOMER, ALASKA,
AMENDING THE 2020 CAPITAL BUDGET AND AUTHORIZING
EXPENDITURE OF \$18,696 FROM THE SEWER RESERVE FUND AND
\$16,546 FROM THE WATER RESERVE FUND TO RETROFIT HIGH
ENERGY LIGHT FIXTURES AT THE SEWER TREATMENT CAMPUS
AND AT THE WATER TREATMENT PLANT.

WHEREAS, The City's Sewer Treatment Plant Campus and Water Treatment Plant still
has some high energy light fixtures, which can be replaced with low energy LED fixtures; and

WHEREAS, Some of the fixtures are in challenging locations and require the use of a 3rd
party contractor with the special equipment to get to them; and

WHEREAS, The City requested quotes from local companies and received the lowest
responsive quote is \$18,696 for the Sewer Treatment Campus; and

WHEREAS, The City requested quotes from local companies and received one quote in
the amount of \$16,546 for the Water Treatment Plant.

NOW, THEREFORE, THE CITY COUNCIL OF HOMER ORDAINS:

Section 1. The City of Homer's 2020 Capital Budget is hereby amended by
appropriating \$18,696 from the Sewer Reserve Fund and \$16,546 from the Water Reserve Fund
to retrofit high energy light fixtures at the Sewer Treatment Plant Campus with low energy LED
fixtures.

<u>Account No.</u>	<u>Description</u>	<u>Amount</u>
256-0379	Sewer Reserve Fund	\$18,696
256-0378	Water Reserve Fund	\$16,546

Section 2. This is a budget amendment ordinance, is temporary in nature, and shall
not be codified.

ENACTED BY THE CITY COUNCIL OF HOMER, ALASKA, this 11th day of January, 2021.

43
44
45
46
47
48
49
50
51
52
53
54
55
56
57
58
59
60
61

CITY OF HOMER



KEN CASTNER, MAYOR

ATTEST:

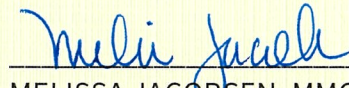

MELISSA JACOBSEN, MMC, CITY CLERK

YES: 5

NO: 0

ABSTAIN: 0

ABSENT: 1

First Reading: 12.14.20

Public Hearing: 1.11.21

Second Reading: 1.11.21

Effective Date: 1.12.21



ORDINANCE REFERENCE SHEET
2021 ORDINANCE
ORDINANCE 21-11

An Ordinance of the City Council of Homer, Alaska, Amending the 2021 Capital Budget and Authorizing an Additional \$88,569 from the HAWSP Fund to pay for a Betterment to the Tasmania Court Water and Sewer Special Assessment District Involving the Design/Construction of a Water Main Extension to Serve a Future Water Storage Tank.

Sponsor: City Manager/Public Works Director.

1. City Council Regular Meeting February 22, 2021 Introduction
Memorandum 21-033 from Public Works Director as backup

1 **CITY OF HOMER**
2 **HOMER, ALASKA**

3 City Manager/
4 Public Works Director

5 **ORDINANCE 21-11**

6
7 AN ORDINANCE OF THE CITY COUNCIL OF HOMER, ALASKA,
8 AMENDING THE 2021 CAPITAL BUDGET AND AUTHORIZING AN
9 ADDITIONAL \$88,569 FROM THE HAWSP FUND TO PAY FOR A
10 BETTERMENT TO THE TASMANIA COURT WATER SPECIAL
11 ASSESSMENT DISTRICT INVOLVING THE DESIGN/CONSTRUCTION
12 OF A WATER MAIN EXTENSION TO SERVE A FUTURE WATER
13 STORAGE TANK.

14
15 WHEREAS, The City Council, via Ordinance 20-68, dated October 26, 2020, appropriated
16 \$234,105 for the design and construction of a water main extension on Tasmania Court, in
17 conjunction with the Special Assessment District created by Ordinance 20-083 AND
18

19 WHEREAS, In 2014-2015, the City received a matching grant from the AK Dept of
20 Environmental Conservation to design a new water storage tank to replace the A-Frame Water
21 Storage Tank, which was demolished; and
22

23 WHEREAS, In addition to replacing the demolished tank, the new tank would add water
24 tank capacity, bringing the total capacity to 2,900,000 million gallons, which was outlined in
25 the City's 2006 Homer Water and Sewer Master Plan; and
26

27 WHEREAS, property was acquired for this tank and some of the main extension to reach
28 it has been installed; and
29

30 WHEREAS, An interesting feature of this tank is that the pipes feeding it would be
31 equipped with an in-line hydroelectric generator that would feed the pumps that maintain
32 pressure in this part of the system; and
33

34 WHEREAS, The City has an opportunity to build another segment of the water main
35 extension leading to this tank, as part of the Tasmania Water Special Assessment District as a
36 betterment to the project, the costs of which would not be added to the Assessment Roll; and
37

38 WHEREAS, The estimated cost for the design/construction of the betterment is \$88,569.
39

40 NOW THEREFORE, THE CITY OF HOMER ORDAINS:
41



City of Homer

www.cityofhomer-ak.gov

Public Works

3575 Heath Street
Homer, AK 99603

publicworks@cityofhomer-ak.gov

(p) 907- 235-3170

(f) 907-235-3145

Memorandum 21-033

TO: Mayor Castner and Homer City Council
Through: Robert Dumouchel, City Manager
FROM: Janette Keiser, PE, Director of Public Works/Acting City Engineer
DATE: February 8, 2021
SUBJECT: Tasmania Court Water Assessment District – Opportunity for Betterment

Issue: The design for the Tasmania Court Water Improvement Project is complete. We have an opportunity to add a betterment to this project, which would benefit the broader community.

Background:

A. Water Main Extension.

The City Council, via Ordinance 20-68, dated October 26, 2020, appropriated \$234,105 for the design and construction of a water main extension on Tasmania Court, in conjunction with the Special Assessment District created by Ordinance 20-083. The total expected project cost for the water project is \$165,919.

In 2014-2015, the City received a matching grant from the AK Dept of Environmental Conservation to design a new water storage tank to replace the A-Frame Water Storage Tank, which was demolished. In addition to replacing the demolished tank, the new tank would add water tank capacity, bringing the total capacity to 2,900,000 million gallons. The need for additional storage volumes was outlined in the City's 2006 Homer Water and Sewer Master Plan.



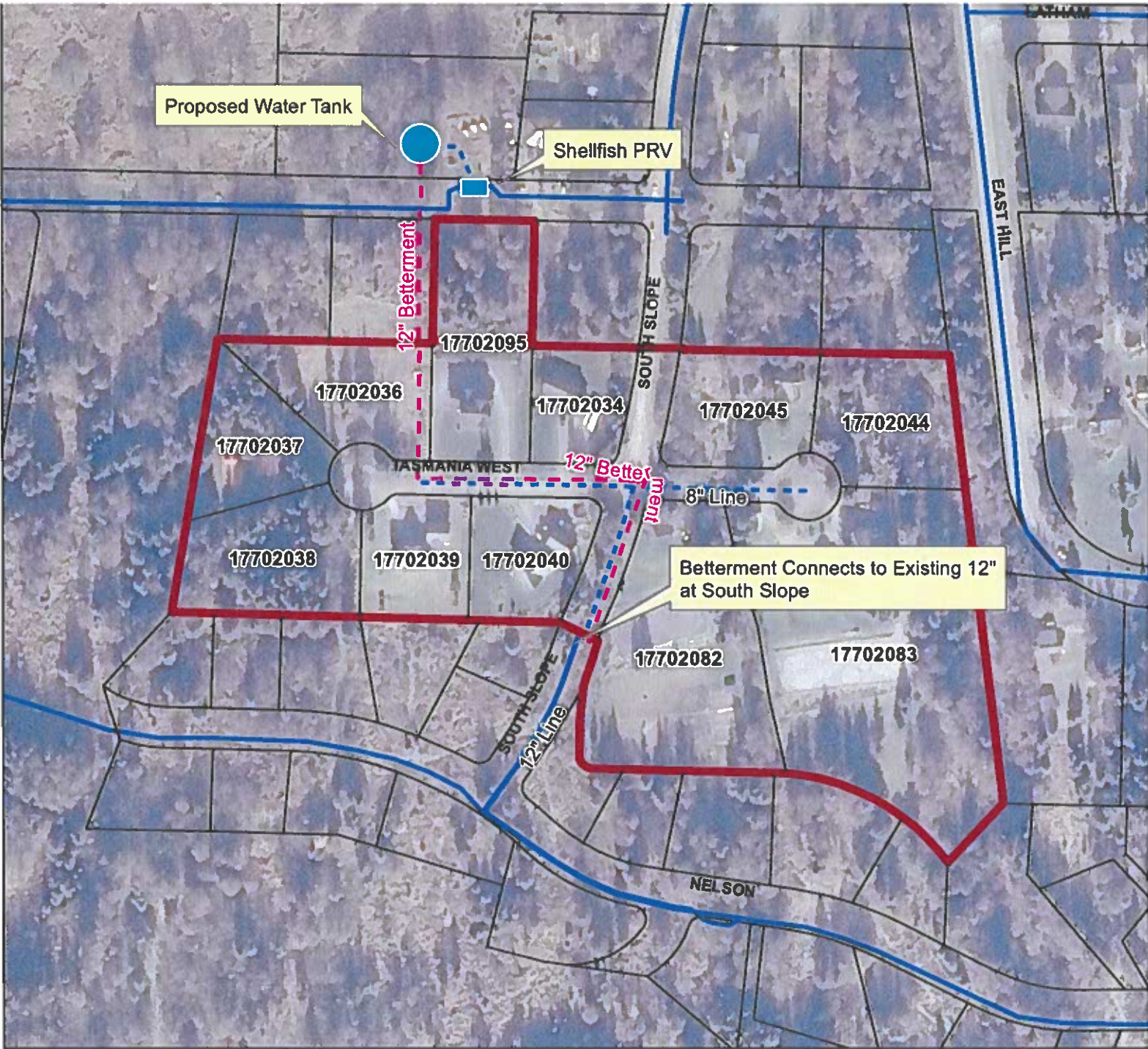

Further, property was acquired for this tank and some of the main extension to reach it has been installed. An interesting feature of this tank is that the pipes feeding it would be equipped with an in-line hydroelectric generator that would feed the pumps that maintain pressure in this part of the system.

We have an opportunity to build another segment of the mains leading to this tank, as part of the Tasmania Water Special Assessment District. This would be a betterment to the project, the costs of which would not be added to the Assessment Roll. The estimated cost for the design/construction of the betterment is \$88,569.

Recommendation: That the City Council appropriate \$88,569 from the HAWSP Fund to design and construction a water main extension to serve the future Shellfish Water Storage Tank, as a betterment to the Tasmania Court Water.



Legend

-  SAD Boundary
-  Existing Waterline
-  Betterment
-  Proposed Line

SHELLFISH WATER TANK & TASMANIA COURT WATERLINE EXTENSION PROPOSAL



N

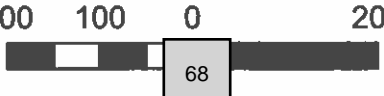

200 100 0 200 Feet



68



CITY OF HOMER ALASKA

DEPT. OF PUBLIC WORKS
February 16, 2021

Disclaimer:
It is expressly understood the City of Homer, its council, board, departments, employees and agents are not responsible for any errors or omissions contained herein, or deductions, interpretations or conclusions drawn therefrom.

Coordinate System: NAD 1983 StatePlane Alaska 4 FIPS 5004 Feet
 Projection: Transverse Mercator
 Datum: North American 1983
 False Easting: 1,640,416.6667
 False Northing: 0.0000
 Central Meridian: -150.0000
 Scale Factor: 0.9999
 Latitude Of Origin: 54.0000
 Units: Foot US

	HAWSP - Spent or obligated
Fund Balance thru 3/31	\$2,437,693
Tasmania Court Water Improvement	\$234,105
Alder Lane Water Improvement	\$253,193
Fund Balance Remaining	\$1,950,395

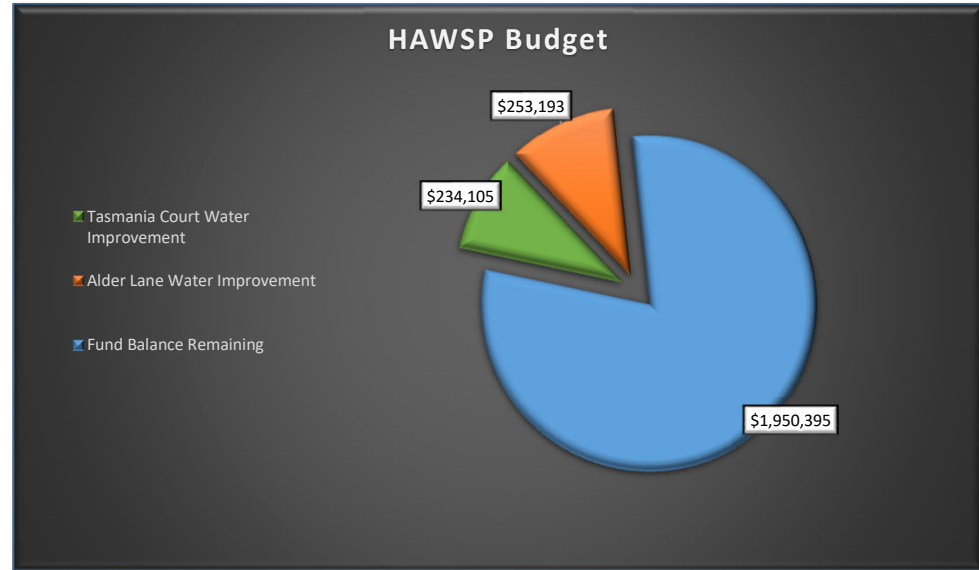

ORDINANCE REFERENCE SHEET
2021 ORDINANCE
ORDINANCE 21-12

An Ordinance of the City Council of Homer, Alaska, Amending the 2021 Capital Budget and Authorizing Expenditure of \$ 12,700 from the HART-Road Fund for the Design of a Betterment to the Main Street Storm Drain and Sidewalk-Pioneer Avenue North Project that will provide for an ADA Access to Bayview Park and Associated Storm Drain Improvements.

Sponsor: City Manager/Public Works Director.

1. City Council Regular Meeting February 22, 2021 Introduction

Memorandum 21-034 from Public Works Director as backup.

**CITY OF HOMER
HOMER, ALASKA**

City Manager/
Public Works Director

ORDINANCE 21-12

AN ORDINANCE OF THE CITY COUNCIL OF HOMER, ALASKA, AMENDING THE 2021 CAPITAL BUDGET AND AUTHORIZING EXPENDITURE OF \$12,700 FROM THE HART-ROAD FUND FOR THE DESIGN OF A BETTERMENT TO THE MAIN STREET STORM DRAIN AND SIDEWALK – PIONEER AVENUE NORTH PROJECT, THAT WILL PROVIDE FOR AN ADA ACCESS TO BAYVIEW PARK AND ASSOCIATED STORM DRAIN IMPROVEMENTS.

WHEREAS, The City Council previously appropriated funds to design a sidewalk and related storm drain improvements on Main Street; and

WHEREAS, The 35% design for the sidewalk project indicates it would be feasible to provide an ADA access to Bayview Park, which does not currently exist; as a betterment to the Main Street Sidewalk Project; and

WHEREAS, This could be done by extending the proposed storm drain line up the east side of the park and filling in the deep ditch that exists currently; and

WHEREAS, If we had the design for this element, it is possible the City could have it constructed as a precursor to the larger sidewalk project, and

WHEREAS, The estimated cost to design the storm drain and re-grading that would be necessary would cost \$12,700; and

WHEREAS, Sufficient funds exist in the HART-Road Fund to pay for this additional design cost.

NOW, THEREFORE, THE CITY OF HOMER ORDAINS:

Section 1. The City of Homer’s 2021 Capital Budget is hereby amended by appropriating a \$12,700 from the HART-Roads Fund for the design of an ADA access to Bayview Park, as a betterment to the Main Street Storm Drain and Sidewalk Project.

<u>Account No.</u>	<u>Description</u>	<u>Amount</u>
160-xxxx	HART Roads	\$12,700

43 Section 2. This is a budget amendment ordinance, is not permanent in nature, and shall
44 not be codified.

45
46

47 ENACTED BY THE CITY COUNCIL OF HOMER, ALASKA, this ___ day of _____, 2021.

48
49
50

CITY OF HOMER

51
52

KEN CASTNER, MAYOR

53 ATTEST:

54
55

56 _____
MELISSA JACOBSEN, MMC, CITY CLERK

57
58

59 YES:

60 NO:

61 ABSTAIN:

62 ABSENT:

63
64

65 First Reading:

66 Public Hearing:

67 Second Reading:

68 Effective Date:



Memorandum 21-034

TO: Robert Dumouchel, City Manager
FROM: Janette Keiser, PE, Director of Public Works
DATE: February 5, 2021
SUBJECT: Main Street Sidewalk – Opportunity to address drainage/access issue

Issue: I last reported the design for the Main Street Sidewalk project had progressed to the point we could identify challenges and opportunities in more detail. The purpose of this memorandum is to apprise you of a situation and ask for guidance.

Background: As I last reported, our intent is to build a sidewalk, on the west side of the street which requires us to replace the existing open ditches with a closed storm drain system, from Pioneer Ave. to Bayview Ave. Our vision was to go beyond Bayview Avenue, up Mountain View Drive to Dehel Avenue, so we could capture the access to Bayview Park. This would enable us to fill in the deep open ditch on the eastern side of Bayview Park. Then, we could upgrade access to the park from that side of the park, making it ADA accessible. There is currently no ADA accessible access to the Bayview Park. Indeed, it would be difficult for a person pushing a stroller to get into the park. This is sad, because the park itself, being completely fenced and of smaller scale, is particularly suited for young children.

Further, we get complaints about a frost boil, which occurs at Dehel Avenue in the spring, making the road difficult to navigate. It may be possible to address this, while we're there. These are laudable goals, but we've learned they are not cheap or easy, because the storm drainage in that short segment of road requires multiple storm drain manholes to accommodate the alignment changes.

The engineers have indicated it would cost \$12,700 to design the storm drain and other improvements required to extend the sidewalk to the north side of Bayview Park and an ADA access to Bayview Park as well as grading improvements at Dehel Avenue.

Council approved \$98,000 for the design of the Main Street sidewalk and related storm drain improvements. So far, we have obligated \$69,120 for design/survey efforts.

Recommendation: We issue a change order to HDL Engineering in the amount of \$12,700 to design the storm drain improvements on the east side of Bayview Park and an ADA access to Bayview Park, as part of the Main Street Sidewalk Project.

ORDINANCE REFERENCE SHEET
2021 ORDINANCE
ORDINANCE 21-13

An Ordinance of the City Council of Homer, Alaska Appropriating an Amount not to Exceed \$2,512,000 from the Natural Gas Distribution Special Assessment Bond Sinking Fund to Retire the Debt to the Kenai Peninsula Borough that was Utilized for the Construction of the Homer Natural Gas Distribution Line.

Sponsor: Mayor/City Manager

1. City Council Regular Meeting February 22, 2021 Introduction

Memorandum 21-035 from Finance Director as backup.

**CITY OF HOMER
HOMER, ALASKA**

Mayor/City Manager

ORDINANCE 21-13

AN ORDINANCE OF THE CITY COUNCIL OF HOMER, ALASKA APPROPRIATING AN AMOUNT NOT TO EXCEED \$2,512,000 FROM THE NATURAL GAS DISTRIBUTION SPECIAL ASSESSMENT BOND SINKING FUND TO RETIRE THE DEBT TO THE KENAI PENINSULA BOROUGH THAT WAS UTILIZED FOR THE CONSTRUCTION OF THE HOMER NATURAL GAS DISTRIBUTION LINE.

WHEREAS, By Ordinance 13-03(S)(2), adopted on February 25, 2013, the City of Homer (“City”) authorized the issuance of a Natural Gas Distribution Special Assessment Bond in the principal amount not to exceed \$12,700,000, and the delivery of a Loan Agreement (“Loan”) between the City and the Kenai Peninsula Borough (“Borough”); and

WHEREAS, By Ordinance 15-17(S), adopted June 15, 2015, the City amended Ordinance 13-03(S)(2) to provide for the prepayment of the principal of the Bond; and

WHEREAS, By Ordinance 16-03(S), adopted January 25, 2016, the City amended Ordinance 13-03(S)(2) to state the Bond amount to be \$12,359,388, and to establish a Loan payment regime of making 9 equal annual payments ending in September, 2024; and

WHEREAS, By Ordinance 16-43, adopted August 22, 2016, the City amended Ordinance 13-03(S)(2) to create a special trust fund designated as the “City of Homer Natural Gas Distribution Special Assessment Bond Sinking Fund” (“Sinking Fund”) allowing for prepayment of the Loan from the Borough and recalibration of yearly payments; and

WHEREAS, The Sinking Fund contains assessment payments, including interest, income from the Sinking Fund capital, and hypothecation of other City funds including Enstar’s payments of the Free Main Allowance (“FMA”); and

WHEREAS, It is in the City’s best financial interest to retire the loan as soon as the debt has been reduced to be less than the Sinking Fund balance available in any calendar year; and

WHEREAS, The funds available and projected to be collected in 2021 exceed the amount of the loan; and

WHEREAS, Retirement of the Loan in March, 2021 will save the City a significant amount of interest that is not otherwise offset by interest earnings available to the City.

43 NOW, THEREFORE, THE CITY OF HOMER ORDAINS:
44

45 Section 1. The City of Homer’s Natural Gas Distribution Special Assessment Bond
46 Sinking Fund schedule of payments is hereby amended by appropriating up to \$2,512,000 to
47 retire the Loan debt obligation to the Kenai Peninsula Borough.
48

<u>Account</u>	<u>Description</u>	<u>Amount</u>
49 175-0375	50 City of Homer Natural Gas Distribution 51 Special Assessment Bond Sinking Fund	52 \$2,512,000

53 Section 2. On or before July 1, 2021, the City Treasurer shall provide the Homer City
54 Council with a summary compilation of the costs and cost allocations funded by, A) the Bond,
55 and B) The Loan, and C) The Free Main Allowance, and D) uncollected assessments. Costs
56 include the cost of construction, interest payments paid in excess of interest payments
57 received, and any other costs that can be appropriately allocated to the project or the
58 capitalization of the Bond or Fund.
59

60 Section 3. This is a budget amendment ordinance only, is not permanent in nature, and
61 shall not be codified.
62

63 ENACTED BY THE CITY COUNCIL OF HOMER, ALASKA, this ____ day of _____, 2021.
64

65 CITY OF HOMER
66
67

68 _____
69 KEN CASTNER, MAYOR
70

71 ATTEST:
72

73 _____
74 MELISSA JACOBSEN, MMC, CITY CLERK
75

76 YES:

77 NO:

78 ABSTAIN:

79 ABSENT:
80

81 First Reading:

82 Public Reading:

83 Second Reading:

84 Effective Date:



City of Homer

www.cityofhomer-ak.gov

Finance Department

491 East Pioneer Avenue
Homer, Alaska 99603

finance@cityofhomer-ak.gov

(p) 907-235-8121

(f) 907-235-3140

Memorandum 21-035

TO: Mayor Castner and Homer City Council
THROUGH: Rob Dumouchel, City Manager
FROM: Elizabeth Walton, Finance Director
DATE: February 17, 2021
SUBJECT: Natural Gas Line Loan Early Payoff

The purpose of this memo is to provide Council with additional information regarding the Natural Gas Line loan with the Kenai Peninsula Borough (KPB).

Loan Background:

The original amount of the natural gas loan with KPB is \$12,359,388 and the current terms are as follows: eight payments (including 4% interest) beginning in September 2016 and ending in September 2024.

The Finance Department contacted KPB last week and requested an early payoff amount. The payoff amount provided as of 3/12/21 is \$2,511,190.83.

Advantages of Payoff:

The primary advantage of paying off the natural gas loan early is the savings in interest payments over the remaining term of the loan. The payment due in September 2021 is \$581,451 and of that \$100,707 represents interest. By paying the loan in full in March 2021 the City would save \$49,486 in interest in 2021 alone.

Funding Availability:

There is a dedicated bank account that contains the full amount of the Free Main Allowance (FMA) received. As of the January 2021 allocation, the balance of this account is just shy of \$1,972,000. This full amount would be available to pay off the loan. The natural gas assessment revenue expected to be received in 2021, will fill the remaining funding gap.

Recommendation:

Approve the Ordinance allowing for the early payoff of the Natural Gas Line loan with the Kenai Peninsula Borough.

1 **CITY OF HOMER**
2 **HOMER, ALASKA**

3 City Manager
4 Public Works Director

5 **RESOLUTION 21-016**

6
7 A RESOLUTION OF THE CITY COUNCIL OF HOMER, ALASKA,
8 AWARDING A TERM CONTRACT FOR PROFESSIONAL SERVICES TO
9 COBLE GEOPHYSICAL SERVICES; AND AUTHORIZING THE CITY
10 MANAGER TO NEGOTIATE AND EXECUTE THE APPROPRIATE
11 DOCUMENTS.

12
13 WHEREAS, Public Works maintains nine engineering services term contracts which are
14 awarded through a competitive qualifications-based procedure. This was last accomplished in
15 2017 and these contracts will expire in 2022; and

16
17 WHEREAS, Only three of these contracts are with local firms; and

18
19 WHEREAS, The City encourages Departments to use local businesses whenever possible
20 (i.e. – 5% local bidders preference), and

21
22 WHEREAS, The Public Works Department is currently working on multiple projects
23 involving groundwater issues; and

24
25 WHEREAS, Geoffrey Coble is a geophysicist, which expertise and extensive experience
26 with groundwater mapping, investigations and analysis and operates a professional services
27 consulting firm; and

28
29 WHEREAS, All term contracts will expire in 2022 and a new competitive process will be
30 completed; and

31
32 WHEREAS, This award is not final until written notification is received by the firm from
33 the City of Homer.

34
35 NOW, THEREFORE, BE IT RESOLVED that the City Council of Homer, Alaska, based on
36 the value of having a term contract with a local firm, possessing expertise and experience with
37 groundwater mapping, investigation and analysis, awards a short-term term contract for
38 engineering services (from February 2021 to April 2022) to Coble Geophysical Services, and
39 authorizes the City Manager to negotiate and execute the appropriate documents.
40
41

42 PASSED AND ADOPTED by the Homer City Council this ____ day of February, 2021.

43

44

CITY OF HOMER

45

46

47

KEN CASTNER, MAYOR

48

49 ATTEST:

50

51

52 MELISSA JACOBSEN, MMC, CITY CLERK

53

54 Fiscal Note: Each project completed under this term contract will have a separate account
55 number/project number associated for engineering/design or other project support.



Memorandum 21-038

TO: Mayor Castner and Homer City Council
THROUGH: Rob Dumouchel, City Manager
FROM: Janette Keiser, PE, Director of Public Works
DATE: January 29, 2021
SUBJECT: Term Contract for Engineering Services to Coble Geophysical Services

Issue: The City is involved in multiple infrastructure projects involving ground water. Geoffrey Coble is a local geophysicist with expertise and experience in the mapping and exploration of ground water. He would make an invaluable member to our ground water investigations. I propose issuing a Term Contract to Coble Geophysical Services so we can access his services as needs arise.

Background:

A. Multiple City Projects would benefit from attention to groundwater.

We are in the process of updating the City’s Drainage Management Plan. When people think about drainage, they usually think of surface water drainage. Our experience with Horizon Court and Mt. Augustine Road illustrates that a good portion of our drainage problems are, if not caused by ground water are certainly exacerbated by ground water. It’s only sensible to include a groundwater element in the Updated Drainage Management Plan, or at least include a groundwater expert in the peer review of the Plan. This is just one example. We are working on other projects, which involve the impacts of ground water on the natural and built environment.

Geoffrey Cobel, a Homer resident, is an expert in groundwater investigations. We would benefit from his expertise in multiple projects that are currently on-going as well as projects, which are still in the planning stages.

B. Normal Term Contract process.

To refresh your memory, here is a mini-treatise on the City’s Term Contract process. The Term Contract Roster has become the City’s most commonly used vehicle for engaging engineering/survey firms. It is a roster of firms, selected in accordance with the following process:

1. The City issues a publicly advertised Request for Qualifications (“RFQ”).
2. Staff evaluates the Statements of Qualifications (“SOQ”), using a set of criteria, which were published in the RFQ.

3. Staff selects the firm(s), which it deems most qualified and seeks City Council authorization to award “Term Contracts” to the selected firms.
4. The Term Contracts are executed. These are generic contracts, which do not prescribe any particular scopes of work.
5. As the City requires engineering services, the City Engineer invites the firms on the roster, qualified to perform the specific type of work, to submit a proposal for a designated scope of work.
6. City staff negotiates the scope, schedule and budget and issues a “Task Order” for the work.

Currently, the City has Term Contracts with nine firms, three of which are local firms. All the existing Term Contracts expire in 2022, at which time, the City will start the process over and generate a new roster.

C. Action Recommended:

That the City Council authorize a Term Contract to Cobel Geophysical Services.

1
2 **CITY OF HOMER**
3 **HOMER, ALASKA**

Venuti

4
5 **RESOLUTION 21-018**
6

7 A RESOLUTION OF THE CITY COUNCIL, OF HOMER, ALASKA
8 SUPPORTING THE FRIENDS OF THE HOMER LIBRARY
9 APPLICATION TO THE NATIONAL PARK SERVICE ALASKA RIVERS,
10 TRAILS AND CONSERVATION ASSISTANCE PROGRAM TO PLAN
11 IMPROVEMENTS TO THE LIBRARY PROPERTIES, TRACTS A AND B,
12 GLACIER VIEW SUBDIVISION NO. 26.
13

14 WHEREAS, The National Park Service (NPS) Rivers, Trails and Conservation Assistance
15 program (RTCA) supports community-led natural resource conservation and recreation
16 projects around the nation; and
17

18 WHEREAS, Successful local projects facilitated by the NPS RTCA include the Woodard
19 Creek Watershed Plan, Kachemak Bay Water Trail, and Kachemak Heritage Land Trust
20 Poopdeck Property Master Plan; and
21

22 WHEREAS, the Homer Library has a been at its current site for 16 years and would like
23 to better utilize its grounds to expand low-key no-cost recreational opportunities to all users,
24 provide a location for library sponsored events, provide wetland education in an urban setting,
25 and increase cultural appreciation by incorporating land acknowledgement; and
26

27 WHEREAS, The library grounds consist of the parcel with the library building (Glacier
28 View Subdivision No. 26 Tract A) and an adjacent property to the west with a trail and
29 greenspace (Tract B); and
30

31 WHEREAS, The western parcel (Tract B) is underutilized and has great potential to be
32 developed for library activities and public enjoyment; and
33

34 WHEREAS, The Friends of Homer Library, in partnership with the library, the City of
35 Homer and community partners including Center for Alaska Coastal Studies, Pratt Museum,
36 Ninilchik and Port Graham Village Tribes, wish to apply for an RTCA Technical Assistance grant.
37

38 NOW, THEREFORE, BE IT RESOLVED that the City Council of Homer, Alaska hereby
39 supports the Friends of the Homer Library application to the NPS RTCA program for the
40 purposes of planning improvements to the library properties Tracts A and B, Glacier View
41 Subdivision No. 26.
42

43 PASSED AND ADOPTED by the Homer City Council this 22nd day of February, 2021.

44

45

CITY OF HOMER

46

47

48

49

50

KEN CASTNER, MAYOR

51

52 ATTEST:

53

54

55

MELISSA JACOBSEN, MMC, CITY CLERK

56

57

58 Fiscal note: N/A



Memorandum 21-039

TO: Homer City Council

THROUGH: Rob Dumouchel, City Manager

FROM: David Berry, Library Director

DATE: Jan. 26, 2021

SUBJECT: Western Lot Trail Project

The Friends of Homer Library (FHL) are moving ahead with planning for trail improvements on the western lot, immediately to the west of the library building. FHL is seeking planning assistance from the National Park Service through the Rivers, Trails and Conservation Assistance Program (<https://www.nps.gov/orgs/rtca/index.htm>). The RTCA provides no monetary support for projects, but it does provide expertise with formal planning and design, and with developing a long-term structure to ensure that projects are sustainable.

The RTCA application requires demonstrated support from community partners. FHL has already secured support from a variety of interested organizations, but would particularly like to request a City Council resolution expressing such support, given that the land is a City-owned lot.

Here is the project summary, copied directly from the current draft application:

Project Summary

Our project idea is to utilize an existing 2.24-acre land parcel, which belongs and is adjacent to the Homer Public Library, and create a new community space within the city center that extends the library's mission beyond the limits of the physical building. We hope to maintain the character of the landscape while making use of its location to turn it into a greater asset for the community.

The project has three broad aims:

1. Develop passive and active program components that educate and inspire curiosity about the cultural and natural history of Homer and the Library's large service area surrounding Kachemak Bay. To accomplish this successfully, we intend to develop partnerships with several community entities that encourage the use of outdoor space, provide historical resources, and promote knowledge about local Native culture and language.

2. Build on work being done by Kachemak Heritage Land Trust and the City of Homer to connect existing trails within the city, improve accessibility, and establish way-finding signage.
3. Conserve and provide access to the wetlands that exist on the land. Our project area also contains a small wetland portion, offering an opportunity to both educate about the role of wetlands in an ecosystem and allow access without damage.

If successful, the RTCA application will help FHL formalize its plans and produce a proposal that can be brought to the community at large.

RECOMMENDATION

FHL requests a resolution from the City Council expressing support for the RTCA grant application.



Poopdeck Trail and Surrounding Property

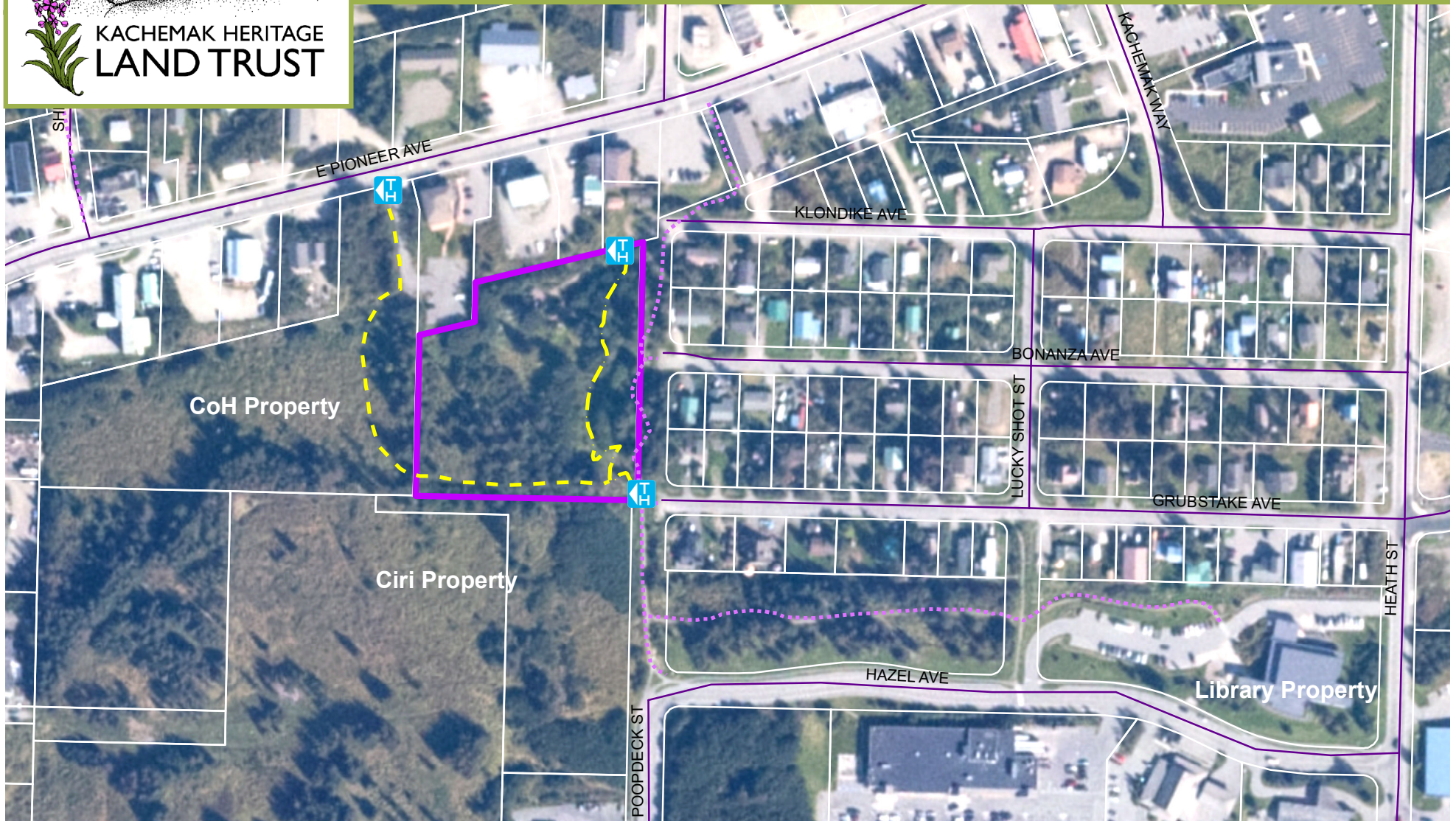

Legend

- Trailheads
- Poopdeck Trail
- City Trails
- Streets
- KHLT Poopdeck Property
- Parcels

0 150 300 600 Feet

Coordinate System: Transverse Mercator
 NAD 1983 State Plane Alaska 4 FIPS 5004 Feet.
 Created 12/27/2020
 The information depicted on this map is a graphical
 representation of best available sources.
 KHLT assumes no responsibility for any errors on this map.





Poopdeck Trail and Surrounding Property

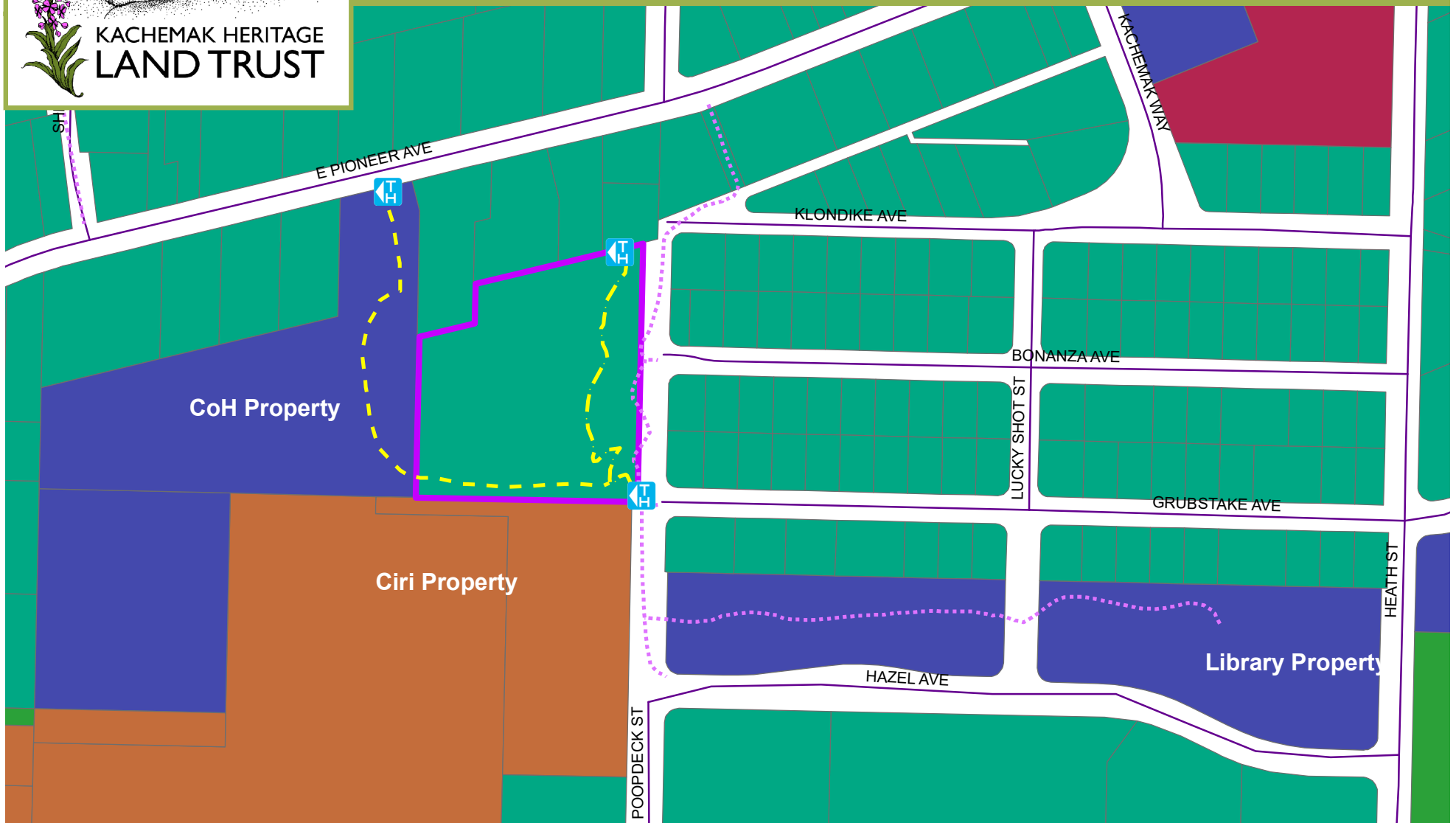

Legend

- | | | | | | | | |
|--|----------------|--|------------------------|--|---------|--|------------------|
| | Trailheads | | Streets | | Borough | | Native |
| | Poopdeck Trail | | KHLT Poopdeck Property | | Federal | | Native Allotment |
| | City Trails | | Municipal | | Private | | State |
| | Parcels | | | | | | |



Coordinate System: Transverse Mercator
 NAD 1983 State Plane Alaska 4 FIPS 5004 Feet.
 Created 12/27/2020
 The information depicted on this map is a graphical representation of best available sources.
 KHLT assumes no responsibility for any errors on this map.





City of Homer

www.cityofhomer-ak.gov

Office of the City Manager

491 East Pioneer Avenue
Homer, Alaska 99603

citymanager@cityofhomer-ak.gov

(p) 907-235-8121 x2222

(f) 907-235-3148

Memorandum 21-040

TO: Mayor Castner and Homer City Council
FROM: Rob Dumouchel, City Manager
DATE: February 17, 2021
SUBJECT: Budget Priorities Public Hearing & Committee of the Whole

My understanding is that a public hearing and Committee of the Whole discussion early on in the budget process has been a common element of the budget development schedule. In the FY22/23 budget development schedule we have retained this element. The purpose of this public hearing and discussion is to allow Council and the public the ability to comment on any budget issues, ideas, priorities, etc. they may have.

What is different for this budget cycle is that Administration intends to host a series of work sessions for different parts of the budget while we are in the process of developing the draft that will come to Council for introduction in May. The work session concepts are as follows:

- Administration and Finance Departments
- Police and Fire Departments
- Public Works Department
- Port & Harbor Department
- Overhead and Admin Fees
- Fleet and Capital Projects
- Reserves

The dates and the order of work sessions is yet to be determined, but I will be working with the Clerk's office to begin schedule these meetings shortly.

Staff Recommendation: Discuss budget priorities with staff and hold a public hearing.

ORDINANCE REFERENCE SHEET
2021 ORDINANCE
ORDINANCE 21-06

An Ordinance of the City Council of Homer, Alaska, Amending the 2021 Capital Budget and Authorizing Expenditure of \$142,800 from the Public Works Fleet CARMA Account and \$272,200 from the HART Road Fund to Purchase a Replacement Grader with Snow Gate and Snow Blade and Two Replacement Sanding Trucks.

Sponsor: City Manager/Public Works Director.

1. City Council Regular Meeting February 8, 2021 Introduction
Memorandum 21-023 from Public Works Director as backup.
2. City Council Regular Meeting February 22, 2021 Public Hearing and Second Reading

1 **CITY OF HOMER**
2 **HOMER, ALASKA**

3 City Manager/
4 Public Works Director

5 **ORDINANCE 20-06**

6
7 AN ORDINANCE OF THE CITY COUNCIL OF HOMER, ALASKA,
8 AMENDING THE 2021 CAPITAL BUDGET AND AUTHORIZING
9 EXPENDITURE OF \$142,800 FROM THE PUBLIC WORKS FLEET
10 CARMA ACCOUNT AND \$272,200 FROM THE HART-ROAD FUND TO
11 PURCHASE A REPLACEMENT GRADER, WITH SNOW GATE AND
12 SNOW BLADE, AND TWO REPLACEMENT SANDING TRUCKS.

13
14 WHEREAS, The Fleet Replacement Schedule [EW1] shown in the FY 20/21 approved
15 budget called for, among other things, the replacement of a road grader with snow gate and
16 snow blade; and

17
18 WHEREAS, A request was made for the replacement of two sanding trucks; and

19
20 WHEREAS, The equipment we seek to replace have been heavily used, at, or beyond,
21 the end of their useful life and are mission critical elements of Public Works road
22 maintenance services; and

23
24 WHEREAS, The City Council adopted Resolution 17-038 on April 24, 2017, amending the
25 Homer Accelerated Roads and Trails Program (HART) Policy Manual; and

26
27 WHEREAS, The HART Policy Manual establishes criteria to be used for determining
28 which projects qualify for HART-Road funding; and

29
30 WHEREAS, Replacing the subject equipment would meet at least two of the criteria set
31 forth in the HART Policy Manual, namely (1) improving safety and (2) reducing maintenance
32 costs; and

33
34 WHEREAS, The HART-Roads Fund has sufficient funds to contribute a share of the
35 purchase price of the subject replacement equipment; and

36
37 WHEREAS, The City created a Capital Asset Repair and Maintenance Allowance Fund
38 (“CARMA”) for *“appropriation and expenditure for...major maintenance of City facilities...as*
39 *identified and recommended by the City Manager and authorized by the City Council”*; and

40
41 WHEREAS, the Public Works’ CARMA Fleet Account has sufficient funds to contribute a
42 share of the purchase price of the subject replacement equipment.

43 NOW, THEREFORE, THE CITY OF HOMER ORDAINS:
44

45 Section 1. The City of Homer's FY21 Capital Budget is hereby amended by appropriating
46 \$415,000 as follows to procure replacement equipment.

47

<u>Account No.</u>	<u>Description</u>	<u>Amount</u>
48 Fund 160	HART Roads	\$272,200
50 152-0383	Public Works Fleet CARMA	<u>\$142,800</u>
51	Total	\$415,000

52

53 Section 2. This is a budget amendment ordinance, is not permanent in nature, and shall
54 not be codified.

55
56 ENACTED BY THE CITY COUNCIL OF HOMER, ALASKA, this ___ day of _____, 2021.

57
58 CITY OF HOMER

59
60 _____
61 KEN CASTNER, MAYOR

62 ATTEST:

63
64 _____
65 MELISSA JACOBSEN, MMC, CITY CLERK

66
67
68 YES:

69 NO:

70 ABSTAIN:

71 ABSENT:

72
73 First Reading:

74 Public Hearing:

75 Second Reading:

76 Effective Date:

77



City of Homer

www.cityofhomer-ak.gov

Public Works

3575 Heath Street
Homer, AK 99603

publicworks@cityofhomer-ak.gov

(p) 907- 235-3170

(f) 907-235-3145

Memorandum 21-023

TO: MAYOR CASTNER AND HOMER CITY COUNCIL
THROUGH: ROB DUMOUCHEL, CITY MANAGER
FROM: JANETTE KEISER, DIRECTOR OF PUBLIC WORKS
DATE: JANUARY 27, 2021
SUBJECT: FLEET REPLACEMENT – GRADER AND SANDING TRUCKS

Issue: The Fleet Replacement Schedule shown in the FY 20/21 approved budget called for the replacement of a grader. We seek approval to acquire the grader, with a snow gate and snow blade, as well as two other pieces of mission critical equipment.

Background: The approved Fleet Replacement Schedule for FY 20/21 identified the replacement of a grader. In addition to the grader, we have asked for replacement of a work truck for Parks as well as two sanding trucks. In view of funding constraints, we've re-evaluated our need for these vehicles. We believe we can defer the purchase of the new work vehicle for Parks without compromising mission-critical functions. We request approval to procure the grader, and appurtenances as well as the sanding trucks, because they support mission critical activities.

The Grader. Public Works has four graders, two of which, including Unit E150, the one we need to replace, are 35+ years old. The AK DOT/PF's policy is to replace graders at 15 years and a running life is 12,000 hours. Unit E150 has had a running life of 13,500 hours. To date, we have spent over \$150,000 in labor/materials to keep the Unit E150 running. Currently, the engine and transmission are weak, likely requiring a rebuild sometime soon. The Anchorage School District had a similar machine, which was only 25 years old, with 11,000 hours of running life. They recently rebuilt their machine at the costs of \$145,000. We've been told the cost of rebuilding our machine could cost approximately \$150,000 - \$175,000, because it requires more extensive repairs. Unit E150 is currently in our shop undergoing repairs, due to broken parts. It will cost several thousand dollars and a week of down time to replace the parts.

Even if we could rebuild Unit E150, there is another problem. The unit is undersized and does not have all wheel drive, meaning it does not handle Homer's heavy wet snow well, especially in the remoter parts of the City. Last week, it had to be returned to the shop and traded in for a heavier grader, which does have all wheel drive.

The cost to procure a suitable grader, with an accompanying snow gate and blade, is \$315,000, from the AK DOT/PF's bid sheet. The 2020/21 Budget showed a price of \$200,000 for a new graders. This

was an estimate compiled by the Administration, without the benefit of researching actual current prices. Plus, it did not necessarily include the cost of the accessories, without which the grader is practically useless to us.

The Sanding Trucks.

- a. Unit E 135 is eight years old and one of our two heavy-duty sanding trucks, which run all around the City sanding roads in the winter and as general service trucks in the summer. When sanding, it carries a full load of sand and plow, which stresses its capacity. The road sand contains calcium chloride. While this is a good de-icer, which keeps the sand pourable, it causes corrosion. Plus, these trucks are ridden hard! As an example, the brake pads on a normal work truck need to be replaced every 3 years. We replace the brake pads on the sanding trucks every year. This truck has spent more than its fair share of time in the shop. To date, we have spent \$44,088 in labor and materials for repair and service costs. Our estimated cost for a new truck chassis \$50,000.
- b. Unit E 116 is a 15-year old sanding truck, which services the airport – the tarmac and parking area. It’s a 1-ton truck, which, when fully loaded with sand and a plow, is at, or beyond, capacity. This stresses the drive train and all other mechanical elements, but it works at airport because of terrain is flat. That’s why this truck has lasted longer than if it were operating on City roads. Still according to our asset management software program, we have spent \$43,358 in labor/materials so far to repair this vehicle. It’s at the end of its useful life as a sanding truck and we need to replace it. The estimated cost of a new replacement truck chassis is \$50,000.

Funding:

That Unit 150, the grader, with snow gate and snow blade, and Units E 135 and E 116, sanding trucks, be replaced.

	Original Approved Budget/Request	New Estimated Costs
Unit E150, grader	\$200,000	\$315,000
Unit E135, sanding truck	\$ 48,000	\$ 50,000
Unit E116, sanding truck	<u>\$ 45,000</u>	<u>\$ 50,000</u>
	\$293,000	\$415,000

Public Works has \$142,800 in its Fleet CARMA account, meaning supplemental funds need to come from another account. I recommend accessing the HART-Roads Fund for the balance of \$272,200.

As of a report dated 12-31-20, the HART- Roads Fund was worth \$6,472,383.66, subject to change upon final audit results. Since then, \$1,278,678 has been spent or obligated, leaving \$6,200,183.6 in the Fund.

Recommendation:

That the City Council authorize the procurement of a replacement grader, with snow gate and snow blade, as well as two replacement sanding trucks, \$142,400 appropriated from the Public Works Fleet CARMA account and \$272,200 appropriated from the HART-Roads Fund.

ORDINANCE REFERENCE SHEET
2021 ORDINANCE
ORDINANCE 21-07

An Ordinance of the City Council of Homer, Alaska Amending the 2021 Operating Budget by Appropriating Funds in the Amount of \$98,700 from the Port Reserves Fund for the Purpose of Haul-Out and Disposal of the Derelict Vessel *North Pacific* in Preparation for Safe Disposal.

Sponsor: City Manager/Port Director

1. City Council Regular Meeting February 8, 2021 Introduction

Memorandum 21-024 from Port Director as backup.

2. City Council Regular Meeting February 22, 2021 Public Hearing and Second Reading

1 **CITY OF HOMER**
2 **HOMER, ALASKA**

3 City Manager/
4 Port Director

5 **ORDINANCE 21-07**

6
7 AN ORDINANCE OF THE CITY COUNCIL OF HOMER, ALASKA,
8 AMENDING THE 2021 OPERATING BUDGET BY APPROPRIATING
9 FUNDS IN THE AMOUNT OF \$98,700 FROM THE PORT RESERVES
10 FUND FOR THE PURPOSE OF HAUL OUT AND DISPOSAL OF THE
11 DERELICT VESSEL *NORTH PACIFIC* IN PREPARATION FOR SAFE
12 DISPOSAL.

13
14 WHEREAS, On April 11, 2020 the vessel *North Pacific* had an incident where structural
15 integrity of the vessel failed and required an emergency repair and de-watering process to save
16 it from sinking to the bottom of the harbor; and

17
18 WHEREAS, After the April 11th event the City of Homer worked in partnership with the
19 U.S. Coast Guard (USCG) to have the vessel recognized as an environmental hazard threat to
20 public waterways and to engage the Federal Oil Spill Liability Trust Fund (OSLTF) to hire an
21 environmental pollution mitigation firm to remove all the hydrocarbons from the vessel; and

22
23 WHEREAS, The USCG completed removal of all environmentally hazardous substances
24 from the vessel and certified it clean and ready for disposal in October 2020; and

25
26 WHEREAS, The USCG is currently pursuing legal action against the owner of the vessel
27 *North Pacific* for abandonment and reimbursement of the cost for hazardous material disposal;
28 and

29
30 WHEREAS, To ensure that the Homer harbor and public waterways are safe from further
31 environmental hazard, the City of Homer must now arrange for removal and scrap disposal of
32 the cleaned vessel, a cost and effort not covered under the OSLTF fund; and

33
34 WHEREAS, The City has received a bid in the amount of \$15,000 from C & C Diving and
35 Salvage for the pre-haul out scrapping and preparatory vessel work; a bid in the amount of
36 \$20,000 from Fortune Sea Marine Services for haul out of the vessel *North Pacific*; and

37
38 WHEREAS, The City has received a bid from Alaska Scrap & Recycling in the amount of
39 \$63,700 for the scrapping and disposal of the vessel once hauled out; in which Alaska Scrap &
40 Recycling is willing to take as a credit toward future lease, wharfage, and dockage fee's
41 associated with the Port of Homer.

43 NOW, THEREFORE, The City of Homer Ordains:
44

45 Section 1: The FY 2021 Operating budget is hereby amended by appropriating funds in
46 the amount of \$98,700^[EW1] from the Port Reserve Fund for the purpose of haul out of the
47 derelict vessel *North Pacific* for future disposal to mitigate possible environmental threats to
48 public waterways and the Homer Harbor, as follows:
49

50	<u>Account No.</u>	<u>Description</u>	<u>Amount</u>
51	456-0380	Scrap & Haul-out for <i>North Pacific</i>	\$98,700

52
53
54 Section 2: The City Manager is authorized to apply a credit equal to, but not to exceed
55 \$63,700, to Alaska Scrap & Recycling in exchange for the scrapping and disposal of the vessel
56 *North Pacific*, to be applied toward future billable services and fees provided by the Port of
57 Homer including, but not limited to, rent for land leases, wharfage, and dockage.
58

59 Section 3: This is a budget amendment ordinance, is not permanent in nature, and shall
60 not be codified.
61

62 ENACTED BY THE CITY COUNCIL OF HOMER, ALASKA, this ___ day of _____,
63 2021.
64

65 CITY OF HOMER
66

67 _____
68 KEN CASTNER, MAYOR
69

70 ATTEST:
71

72 _____
73 MELISSA JACOBSEN, MMC, CITY CLERK
74

75 YES:

76 NO:

77 ABSTAIN:

78 ABSENT:
79

80 First Reading:

81 Public Hearing:

82 Second Reading:

83 Effective Date:
84



Memorandum 21-024

TO: HOMER CITY COUNCIL & MAYOR CASTNER
THRU: ROB DUMOUCHEL, CITY MANAGER
FROM: BRYAN HAWKINS, HARBORMASTER
DATE: JANUARY 28 2021
SUBJECT: ORD 21-07 DERELICT VESSEL NORTH PACIFIC- HAUL OUT AND DISPOSAL

The vessel North Pacific has been in the Homer Harbor for the past several years. In 2016 it was issued a Nuisance letter by the City and began the derelict vessel process. The owners abandoned the vessel in 2018 and ceased paying their moorage. On April 11 2020 the structural integrity of the hull failed and the vessel began taking on water in the engine room. There was a release that occurred during the de-watering process, inside the containment boom that encircled the boat, and a pollution incident that I reported to NRC documented as case # 1275399. Luckily, with a quick response we were able mitigate the damage to the public waterway by installing a pressure patch inside the vessel's engine room that stopped the flooding. However, because of the very poor hull condition, the North Pacific will, if left to its own devices, eventually end up at the bottom of the harbor.



Since April 11th we have been working in partnership with the US Coast Guard (USCG) to find a permanent solution to the environmental threat and minimize economic loss that the derelict vessel North Pacific presents to this community. The City reached out to the USCG with a plan to share the burden of disposal for this derelict vessel (See Attachment) that asked the Coast Guard to help with the removal and cleaning

of the environmental hazards and help with legally pursuing the negligent owner, while the City in turn shouldered the removal and scrapping of the vessel from the Homer Harbor which is a cost not covered under the available relief funds managed by the Coast Guard.

The USCG went through processes to officially recognize the North Pacific as an environmental hazard threat to public waterways which allowed them to use the Federal Oil Spill Liability Trust Fund (OSLTF) to remove all the hydrocarbons from the vessel. The Coast Guard legal unit is also currently pursuing legal action against the owner of the vessel North Pacific for abandonment and reimbursement of the cost for hazardous material disposal.

With the vessel now declared clean, for our part of the deal we've reached out to get quotes for the removal and disposal of the vessel. Logistically this will have to happen in 3 phases:

Phase 1 – Prep.

Scope of Work: This includes an inspection of the vessel at the steel grid to make sure that the integrity of the hull is strong enough to endure the stresses involved in hauling the boat out and onto the uplands area of the Marine Haul Out facility for scrapping, as well as cutting and removing by crane lift any deck gear and dredging equipment from the top sections of the boat prior to dragging it out onto the beach.

Price: We received two quotes, both from highly qualified local firms that have history working within the Harbor. We propose the lower priced quote from C&C Diving and Salvage of \$15,000.

Timeline: February - Taking advantage of the high tide cycles

Phase 2 –Haul Out

Scope of Work: Haul Out of the vessel from the tidal flats to the uplands utilizing an airbag system.

Price: This was a sole source bid, there was only one contractor in the area with the correct equipment and willingness to take on this vessel. Fortune Sea Marine Services for \$20,000.

Timeline: March

Phase 3 – Scrapping and Disposal

Scope of Work: Demolish and dispose of all metals, insulation, garbage, etc., related to the Vessel North Pacific from the uplands lot next to Outer Dock Road

Price: This was a sole source bid, there is only one recycling scrap company with the proper equipment and disposal avenues on the peninsula that is available for the job. Alaska Scrap and Recycling for \$63,700. Alaska Scrap and Recycling is willing to accept a credit of their bid amount toward future lease, wharfage, and dockage fee's associated with the Port of Homer in exchange for the demolition and removal of the North Pacific.

Timeline: July

Recommendation

Approval and adoption of ordinance 21-07

Attached

2020 05 12 Letter to USCG Re Vessel North Pacific Environmental Hazard Threat



City of Homer

www.cityofhomer-ak.gov

Port and Harbor

4311 Freight Dock Road
Homer, AK 99603

port@cityofhomer-ak.gov

(p) 907-235-3160

(f) 907-235-3152

May 12 2020

Dear Sir,

As the Port director and Harbormaster for the City Of Homer, I am working to find a permanent solution to the environmental threat and minimize economic loss that the derelict vessel North Pacific presents to this community. Firstly, I believe it's important to state up front that the City of Homer is not the owner of the vessel North Pacific. The owner is North Pacific Gold LLC. However, due to the neglect of the owner and the imminent threat of pollution to our waterways, the community has been left with no choice but to supply the manpower, equipment, and expertise in order to protect against a sunken vessel pollution release and avoid a tremendously expensive and embarrassing salvage effort in our community's harbor. I believe our two agencies are the best equipped to deal with this threat, and suggest a joint venture between the U.S. Coast Guard and the Homer Harbor to safely remove this threat in as economical a way as possible and to pursue restitution from Paul Thompson Jr, president of North Pacific Gold LLC.

On April 11 2020 the structural integrity of the hull failed when, during an extreme minus tide, the North Pacific set down on the harbor floor causing a crack in the hull and the vessel began taking on water in the engine room. There was a release that occurred during the de-watering process, inside the containment boom that encircled the boat, and a pollution incident that I reported to NRC documented as case # 1275399. Luckily, with a quick response we were able mitigate the damage to the public waterway by installing a pressure patch inside the vessel's engine room that stopped the flooding. However, because of her draft and very poor condition, she will try to sink again. To keep this from happening I'm proposing the following plan:

I'm requesting that the United States Coast Guard:

- ✓ Officially recognize that the vessel North Pacific poses an imminent threat to the environment and public due to the near sinking and pollution release in Homer Harbor that occurred on April 11, 2020. More specifically, taking note of the issue of vessel draft, obvious hull condition/neglect, depth of Homer Harbor, and the pollution potential that exists when the hull is compromised.
- ✓ Officially recognize North Pacific Gold LLC as the owner of the vessel North Pacific so that Coast Guard personnel can pursue the restitution of cost for the pollution mitigation from the vessel owner Paul Thompson Jr. and North Pacific Gold LLC.
- ✓ Engage the pollution fund to hire a firm to clean all of the hydrocarbons from the vessel to mitigate the environmental threat and the danger to the public

The City of Homer is offering in partnership:

- ✓ Once the vessel is cleaned of hydrocarbons, the City of Homer and Port staff will move the pollution free hull from its current location in Homer Harbor to the Homer haul out and repair yard for removal from the water.



City of Homer

www.cityofhomer-ak.gov

Port and Harbor

4311 Freight Dock Road
Homer, AK 99603

port@cityofhomer-ak.gov

(p) 907-235-3160

(f) 907-235-3152

- ✓ The City will engage the firm Alaska Scrap & Recycling to responsibly demolish the North Pacific and dispose of the vessel from the system. "Responsibly demolish" means that all salvageable material will be recycled, all waste material will be removed to the landfill, and the disposal site will be cleaned and return to original condition.

An evaluation of the April 11th event brought to light new information about the vessel and underlined just how present the threat of this vessel sinking is. The North Pacific is a deep draft single keel vessel that has been extended and widened at some point in her life. Because of her draft, the North Pacific sets down on the bottom of the harbor during any minus tide. Earlier that week we experienced an extreme low tide -5.2 and that translated into nearly the full weight of the vessel resting on the keel, and we believe that the stress of settling the old unmaintained hull on the harbor floor caused a bracket welded to the bottom of the bilge to crack, and that it was this cracked weld that started the leak resulting in a full response effort from the harbor staff and diver/salvage team. Because of the lessons learned on April 11th, we know that the vessel hull condition is such that future hull integrity issues from setting down are expected at each minus tide, and this vessel will try to sink again. Given these new factors, I would ask the Coast Guard to reconsider the issue of using the pollution fund and engage a firm to clean all of the hydrocarbons from the vessel to mitigate the environmental threat and the danger to the public.

I believe that if we work together to take these steps we will remove the North Pacific's environmental threat to the public permanently. Further, it will assist in holding the owners of the vessel North Pacific Gold LLC responsible for their property. Please be advised that the City is also continuing our efforts to that effect, and at this time we are working with our attorneys to pursue legal action against the firm for back debt and abandonment of their vessel on the public's property and for disposal costs.

I want to thank the USCG for their support and guidance over the years; our community is being well served. I have always viewed our relationship as a partnership in service as we all have the same goals of safety, service and stewardship.

Respectfully,

Bryan Hawkins, Homer Harbormaster/Port Director

Attachments- July 24 2019 Letter from Attorneys of Birch Horton Bittner & Cherot Re legal ownership of the North Pacific
May 4 2020 C&C diving Inspection/Incident Report
North Pacific History

ORDINANCE REFERENCE SHEET
2021 ORDINANCE
ORDINANCE 21-14

An Ordinance of the City Council of Homer, Alaska, Amending Homer City Code 2.08.040, Bylaws for Council Procedures to Establish that New Elected Members will be seated at a Special Meeting Following the Canvass of the Election; and 4.35.040 Certification of a Regular and Special Election.

Sponsor: Evensen/Hansen-Cavasos

1. City Council Regular Meeting February 22, 2021 Introduction

Memorandum 21-036 from City Manager as backup.

1 **CITY OF HOMER**
2 **HOMER, ALASKA**

3 Evensen/
4 Hansen-Cavasos

5 **ORDINANCE 21-14**

6
7 AN ORDINANCE OF THE CITY COUNCIL OF HOMER, ALASKA
8 AMENDING HOMER CITY CODE 2.08.040, BYLAWS FOR COUNCIL
9 PROCEDURES TO ESTABLISH THAT NEWLY ELECTED MEMBERS
10 WILL BE SEATED AT A SPECIAL MEETING FOLLOWING THE
11 CANVASS OF THE ELECTION; AND 4.35.040 CERTIFICATION OF
12 ELECTION TO CLARIFY THE TIME FOR CERTIFICATION OF A
13 REGULAR AND SPECIAL ELECTION.

14
15 WHEREAS, Holding a special meeting to certify an election and swear in newly elected
16 members designates a time to celebrate the service of outgoing members and welcome new
17 members; and

18
19 WHEREAS, Certifying an election as soon as possible after the canvass board has
20 completed its work allows City business to proceed with as little disruption as possible; and

21
22 WHEREAS, Holding a special meeting to certify election results and swear in newly
23 elected members on the same day of the regular meeting is a convenient and efficient use of
24 meeting time; and

25
26 WHEREAS, This ordinance also clarifies that special elections will be certified by special
27 meeting.

28
29 NOW THEREFORE, THE CITY OF HOMER ORDAINS:

30
31 Section 1. Homer City Code 2.08.040, Bylaws for Council Procedure is hereby amended
32 to read as follows:

33
34 2.08.040 Bylaws for Council procedure.

35
36 The following bylaws shall govern the procedures of the City Council of the City:

37
38 a. To abide by existing Alaska State laws pertaining to cities of the first class.

39
40 b. To abide by the current edition of Robert's Rules of Order insofar as this treatise is
41 consistent with these bylaws, other provisions of the Homer City Code, or unwritten

42 standing rules adopted by the City Council. In all other cases, bylaws, the code or the
43 standing rule shall prevail.

44
45 c. The Council’s agenda format specified in the City of Homer City Council Operating
46 Manual, as the same may be amended from time to time, is incorporated herein by
47 reference.

- 48 1. The manual may be revised with Council approval;
49 2. A copy of the manual shall be available to the public during regular business
50 hours at the Homer City Hall and be available during City Council meetings.

51
52 d. Regular Meetings.

- 53 1. Second and fourth Mondays of each month at 6:00 p.m., unless otherwise
54 provided by two-thirds vote of the City Council;
55 2. The agenda shall be provided to each Council member 36 hours prior to
56 meeting, by City Clerk;
57 3. Adding items to or removing items from the agenda will be by unanimous
58 consent of the Council;
59 4. Public notice of a regular meeting shall be made as provided in Chapter 1.14
60 HCC.

61
62 e. Special Meetings.

- 63 1. Called by Mayor or majority of the Council;
64 **2. Held for certification of regular election results and swearing in newly**
65 **elected members following the completion of the canvass by the Election**
66 **Board, prior to convening Committee of the Whole.**
67 **3. Held for certification of a special election, when necessary, following the**
68 **completion of the canvass by the Election Board.**
69 ~~2~~ **3.** If a majority of members are given at least 36 hours’ oral or written notice
70 and reasonable efforts are made to notify all members, a special meeting may
71 be held at the call of the presiding officer or at least one-third of the members;
72 ~~3~~ **4.** Agenda shall be as per subsection (c) of this section;
73 ~~4~~ **5.** Public notice of a special meeting shall be made as provided in Chapter 1.14
74 HCC.

75
76 f. Emergency Meetings.

- 77 1. By unanimous consent of quorum;
78 2. Required justifiable reason;
79 3. Informal agenda – limited to emergency;
80 4. Public notice shall be made as provided in Chapter 1.14 HCC.

81
82 g. Teleconference participation in meetings may be authorized pursuant to HCC
83 2.08.100 through 2.08.120.

84
85
86
87
88
89
90
91
92
93
94
95
96
97
98
99
100
101
102
103
104
105
106
107
108
109
110
111
112
113
114
115
116
117
118
119
120
121
122
123
124
125

h. Quorum – Voting. Four Council members shall constitute a quorum. Four affirmative votes are required for the passage of an ordinance, resolution, or motion. A member of the Council acting as Mayor Pro Tem shall not lose his vote as the result of serving in such office. The Mayor is not a Council member and may vote only in the case of a tie. The final vote on each ordinance, resolution, or substantive motion may be a roll call vote or may be done in accordance with subsection (k) of this section (see AS 29.20.160(c)(d)).

i. Motions to Reconsider. A member of the Council who voted with the prevailing side on any issue may move to reconsider the Council’s action at the same meeting or at the next regular meeting of the body. Notice of reconsideration shall be given to the Mayor or City Clerk within 48 hours from the time the original action was taken.

j. Abstentions. All Council members present shall vote unless abstention is required by law (AS 29.20.160(d)).

k. Consensus. The Council may, from time to time, express its opinion or preference concerning a subject brought before it to consideration. The statement, representing the will of the body and a meeting of the minds of the members, may be given by the presiding officer as the consensus of the body as to that subject without taking a motion and roll call vote.

l. Vacancies. An elected municipal office is vacated under the following conditions and upon the declaration of vacancy by the Council. The Council shall declare an elective office vacant when the person elected:

1. Fails to qualify or take office within 30 days after his election or appointment;
2. Resigns and his resignation is accepted;
3. Is physically or mentally unable to perform the duties of the office as determined by two-thirds vote of the Council;
4. Is convicted of a felony or misdemeanor described in AS 15.56 and two-thirds of the members of the Council concur in expelling the person elected;
5. Misses three consecutive regular meetings unless excused;
6. Is convicted of a felony or of an offense involving a violation of the oath of office;
7. Is convicted of a violation of AS 15.13 concerning Alaska Public Offices Commission reporting requirements;
8. No longer physically resides in the municipality and the City Council by two-thirds vote declares the seat vacant; and
9. Is physically absent from the municipality for 90 consecutive days unless excused by the City Council.

126 m. Salaries of Elected Officials.

127 1. The Mayor and each Council member shall be paid a stipend of \$75.00 for each
128 council-meeting-day in which the person participates in person, or \$50.00 per
129 council-meeting-day in which a majority of the person's participation time is
130 telephonic. A council-meeting-day is any calendar day in which the person
131 participates in any one or more of the following:

132
133 a. A scheduled and publicly noticed meeting of the City Council,
134 including without limitation a regular meeting, special meeting,
135 committee of the whole meeting and meeting in executive session.

136 b. A scheduled and publicly noticed meeting of the Board of Adjustment,
137 Board of Ethics, or other board or commission that is composed of the
138 Mayor and Council members.

139 c. Training or continuing education programs, and work sessions, that
140 are required by law or commonly recognized best practice to perform the
141 duties of Mayor or Council member.

142
143 The City shall not spend any funds for elected officials' membership in
144 the Public Employees Retirement System. An elected official may not
145 receive any other compensation for service to the City unless specifically
146 authorized to do so by ordinance. Per diem payments or
147 reimbursements for expenses are not compensation under this section.

148
149 Section 2. Homer City Code 4.35.040 Certification of election is hereby amended to read
150 as follows:

151
152 4.35.040 Certification of election.

153
154 ~~The Council shall certify the results of the election at the next regular Council meeting~~
155 ~~following completion of the canvass by the Canvass Board~~

156
157 **a. The Council shall certify the results of a regular election at a special**
158 **meeting scheduled prior to Committee of the Whole following completion**
159 **of the canvass by the Canvass Board.**

160 **b. The Council shall certify a special election at the next regular Council**
161 **meeting or a special Council meeting following completion of the canvass**
162 **by the Canvass Board.**

163
164 Section 3: This ordinance is of a permanent and general character and shall be
165 included in the City Code.

166

167 ENACTED BY THE CITY COUNCIL OF THE CITY OF HOMER THIS __ DAY OF _____,
168 2021.

169

170

CITY OF HOMER

171

172

173

KEN CASTNER, MAYOR

174

175

176 ATTEST:

177

178

179 MELISSA JACOBSEN, MMC, CITY CLERK

180

181 YES:

182 NO:

183 ABSTAIN:

184 ABSENT:

185

186 First Reading:

187 Public Hearing:

188 Second Reading:

189 Effective Date:



City of Homer

www.cityofhomer-ak.gov

Office of the City Manager

491 East Pioneer Avenue
Homer, Alaska 99603

citymanager@cityofhomer-ak.gov

(p) 907-235-8121 x2222

(f) 907-235-3148

Memorandum 21-036

TO: Mayor Castner and Homer City Council
FROM: Rob Dumouchel, City Manager
DATE: February 10, 2021
SUBJECT: Ordinance to Seat Newly Elected Officials at a Special Meeting

In 2019, Ordinance 19-55 was introduced. It sought to clarify when a Councilmember would be seated after winning an election. The ordinance was introduced shortly after a contentious election and it did not prevail at that time. Councilmembers Evensen and Hansen-Cavasos reached out to administration to reintroduce this ordinance because they continue to believe it would benefit the City and its elected officials.

The sponsors believe this change brings positive benefits such as:

- Providing a better environment for welcoming newly elected officials
- Providing a better environment for thanking outgoing officials for their public service and celebrating their commitments, accomplishments, etc.
- Allows the City to certify an election in a more streamlined way

Staff recommendation: Introduce the ordinance.



City of Homer

www.cityofhomer-ak.gov

Office of the City Manager

491 East Pioneer Avenue
Homer, Alaska 99603

citymanager@cityofhomer-ak.gov

(p) 907-235-8121 x2222

(f) 907-235-3148

Memorandum

TO: Mayor Castner and Homer City Council
FROM: Rob Dumouchel, City Manager
DATE: February 17, 2021
SUBJECT: City Manager's Report for February 22, 2021 Council Meeting

FY22/23 Budget

I have asked staff to begin thinking about the fee schedule and planning any necessary consultations with boards/committees/commissions for input in the coming month. The City Clerk and Finance Director will be my leads on this topic.

At the last Council meeting there were requests for an increased number of work sessions as we prep the budget. I have sketched out a plan for a series of work sessions which will focus on specific topics and departments. The draft series could include the following meetings: Overhead and Admin Fees; Reserves; Fleet and Capital Projects; Administration and Finance; Police and Fire; Public Works (including Water and Sewer); and Harbor. I haven't set any dates yet, but we will look to do a mix of on- and off-cycle work session meetings during the months of March and April. The Clerk will coordinate with Council on availability and scheduling.

On a related topic, we have been prepping for the next audit and are actively working with BDO to confirm a schedule for FY2020 audit services.

Sidewalks, Trails, and Pedestrian Connectivity

A group of staff from Planning and Public Works have joined up with Councilmembers Lord and Smith to develop solutions which would improve safety and connectivity for pedestrians in Homer. This project will look at both road-adjacent pedestrian facilities (i.e., sidewalks) and alternative connections (i.e., trails). For the first phase of this project, I have staff conducting a geospatial analysis of existing facilities and identifying gaps. Once we have a clear vision of where the opportunities and needs are, we will conduct a public engagement event to get feedback from the public. Expect regular updates on this project in future reports.

Potential Updates to the Special Event Code

Since arriving, I have noticed that HCC Chapter 19.02 doesn't seem to fit the unique situations or scale of events in Homer very well. I would like to investigate potential improvements to this chapter of the code and possibly others that have an impact on events. I will be building a team to review and propose ideas for improving the code and I am looking for interested Councilmembers to join this effort.

Pioneer Avenue Water Main

On February 3rd a water main break was identified on Pioneer Avenue in front of the Independent Living Center Building. Public Works planned a response t by and started at 4am the next morning to excavate

and repair the problem. The water main break was repaired by lunchtime. The crew creatively used our Vactor Truck to strategically dewater the excavation and “dig” closer to the water pipe, thereby minimizing the size of the open hole which allowed our crew to access the break without disturbing the pavement on Pioneer. A piece of the concrete curb and sidewalk was removed, but has since been replaced by a contractor. No customers lost access to water during the repair operation.



The photo above shows Paul Raymond (at street level), Jason Hanenberger, and Mike Szocinski working on the Pioneer Avenue water main break.

Public Works Project Updates

Director Keiser has written memos providing updates to Council on various ongoing projects. See attached for updates regarding the Tasmania Court Water and Sewer Improvement Projects, Alder Lane Water Extension Project, and Mt. Augustine Road Drainage Improvement Project.

Hornaday Park Demolition Project

Demolition of the restroom and concession stand facilities at Hornaday Park began on February 10th. The facilities are being demolished because they have exceeded their useful life, don't meet ADA or building code standards, and have major deficiencies which have led to them being closed to the public and the interim use of portable toilets. All demolition work is being done by City staff and the transfer station has waived tipping fees for disposal of the building debris.



Share the Road Signage

The Public Works Department has procured some share the road signage (modeled below by Asset Management Specialist Owen Meyer) to test in areas around town where conflicts between different types of road users may occur. Look for signs to be installed on Bartlett Street, Kachemak Way, and Ben Walters Way.



Small Boat Station

Looking to the future, the Port of Homer would be an ideal location for a US Coast Guard small boat station. See the attached memo from the Harbormaster for more information on the history and path forward for this potential project.

Lobbying Update

Staff met with State Senator(s) Bishop and Stevens to discuss issues affecting the City of Homer and the Southern Kenai Peninsula region. Topics included the Homer DMV and expansion of the Port & Harbor.

Noise on Beluga Lake

I have had a few Councilmembers reach out to discuss noise issues in the City. I have started a conversation with the City Planner and the Police Chief to get a better view of the history of this issue in Homer as well as what rules and regulations we have available to the City to mitigate excessive noise. I will report back at a future meeting with more information.

Lt. Browning Completes Northwestern University Police Staff and Command Program

Lt. Ryan Browning of the Homer Police Department has successfully completed the Northwestern University Center for Public Safety's School of Police Staff and Command program. The program provides upper-level college instruction in a total of twenty-seven core blocks of instruction and additional optional blocks during each session. The major topics of study include: leadership; human resources; employee relations; organizational behavior; applied statistics; planning and policy development; and budgeting and resource allocation. Congratulations Lt. Browning!

COVID-Related Updates

COVID Risk Status

On February 1st I moved the City from the "Red" to "Orange" level on our COVID risk framework. We remain in orange. The return of activities to the HERC and the Library by appointment has gone well so far with a minimal number of individuals refusing to comply with City masking regulations.

Enclosures:

1. Memo from PW Director Keiser regarding Tasmania Court
2. Memo from PW Director Keiser regarding Alder Lane
3. Memo from PW Director Keiser regarding Mt. Augustine Road
4. Memo from Harbor Master Hawkins regarding USCG Small Boat Station



City of Homer

www.cityofhomer-ak.gov

Public Works

3575 Heath Street
Homer, AK 99603

publicworks@cityofhomer-ak.gov

(p) 907- 235-3170

(f) 907-235-3145

Memorandum

TO: City Council

Through: Robert Dumouchel, City Manager

FROM: Janette Keiser, PE, Director of Public Works/Acting City Engineer

DATE: February 3, 2021

SUBJECT: Tasmania Court Water and Sewer Improvement Projects

Issue: The design for the Tasmania Court Water Improvement Project is complete. The process of creating a Tasmania Court Sewer Improvement Special Assessment District is underway. The purpose of this Memorandum is to provide updated information about these projects. No action is needed at this point.

Background:

A. Water Main Extension.

The City Council, via Ordinance 20-68, dated October 26, 2020, appropriated \$234,105 for the design and construction of a water main extension on Tasmania Court, in conjunction with the Special Assessment District created by Ordinance 20-083.

The City issued a contract to design the Tasmania Court water main extension to Bishop Engineering, a Homer firm with extensive experience in local development projects. The survey work was provided by Geovera LLC, another local firm. Bishop has completed the design and it has been submitted to the AK Department of Environmental Conservation for statutorily required plan review.

The water main extension project includes installation of 930 feet of 8" HDPE pipe, two fire hydrants and 11 water service stub-outs. The estimated cost for the construction work is \$152,119, which includes a 10% construction contingency. The actual cost of the design/survey effort is \$13,800, bringing the total expected project cost for the water portion to \$165,919.

We are in the process of applying for a long-term, low-interest loan from the AK Dept. of Environmental Conservation's Drinking Water Revolving Loan Fund to finance the water side project. No Council action is needed at this time. In the near future, we will come back to Council for formal action related to the ADEC loan.

B. Sewer Main Extension

The City Council, via Ordinance 20-091(A), dated September 28, 2020, initiated the process of creating a Special Assessment District that would extend the sewer mains so the properties, which would be receiving City water service, could also be served with City sewer service. We created several alternative sewer extension configurations, with a cost estimate and preliminary assessment roll for each alternative. We then held a neighborhood meeting, as provided in the Homer City Code, to discuss the various alternatives with the property owners.

One of the alternatives was to use an “effluent only” system, which would connect the existing septic tanks, so long as they are in good repair, to a small diameter gravity main. The City has been successfully using this configuration for some of its customers, particularly those residing in Kachemak City. One of the other alternatives was to use a traditional gravity collection system, which would avoid existing septic tanks. Many of the property owners told horror stories about the problems they’ve been having with their septic tank/leachfield systems. Most of them wanted nothing more to do with septic tanks!

We realized we needed to evaluate each property individually to get a better understand of how to lay out sewer mains that would serve the whole neighborhood effectively. Jean Hughes, PW Inspector, visited with each property owner to see what their existing systems looked like and how we could connect them to a neighborhood collection system. We are using that information to update the conceptual design, cost estimate and preliminary assessment roll. Once we do that, we will have another neighborhood meeting. Our intent is to move the process along so that we can construct the sewer main portion of the project at the same time we install the water main portion.

No Council action is required at this point. As the Sewer Special Assessment District process moves forward, we will come back for applicable action.



City of Homer

www.cityofhomer-ak.gov

Public Works

3575 Heath Street
Homer, AK 99603

publicworks@cityofhomer-ak.gov

(p) 907- 235-3170

(f) 907-235-3145

Memorandum

TO: City Council

Through: Robert Dumouchel, City Manager

FROM: Janette Keiser, PE, Director of Public Works/Acting City Engineer

DATE: February 3, 2021

SUBJECT: Alder Lane Water Improvement Project – 35% Design

Issue: The design for the Alder Lane Water Improvement Project is complete. The purpose of this Memorandum is to provide updated information about the project. No action is needed at this point.

Background: The City Council, via Ordinance 20-83, dated November 9, 2020, appropriated \$253,193 for the design and construction of a water main extension on Alder Lane, in conjunction with the creation of a Special Assessment District by Ordinance 20-095.

The City issued a contract to design the Alder Lane water main extension to Bishop Engineering, a Homer firm with extensive experience in local development projects. The survey work was provided by Geovera LLC, another local firm. Bishop has completed the design and it has been submitted to the AK Department of Environmental Conservation for statutorily required plan review.

The project includes installation of 1,220 feet of 8” HDPE pipe, three fire hydrants and nine water service stub-outs. The estimated cost for the construction work is \$187,671, which includes a 10% construction contingency. The actual cost of the design/survey effort is \$13,220, bringing the total expected project cost to \$200,891.

Further, we are in the process of applying for a long-term, low-interest loan from the AK Dept. of Environmental Conservation’s Drinking Water Revolving Loan Fund to finance the project. We will come back to Council for formal action related to this loan in the future.

CITY OF HOMER ALDER LANE

WATER MAIN EXTENSION
JANUARY 30, 2021

Homer City Council

Mayor
Ken Castner

Councilmembers
Donna Aderhold
Joey Evenson
Storm Hansen-Cavasos
Rachel Lord
Heath Smith
Caroline Venuti

Public Works Director
Janette Keiser, PE

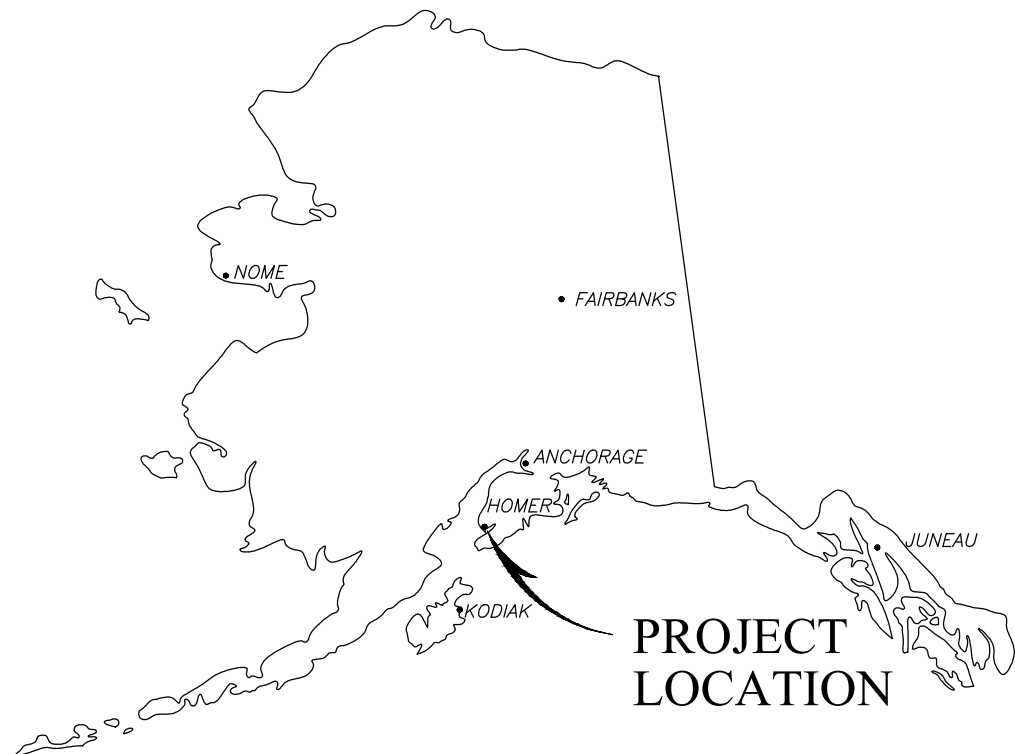

LOCATION MAP

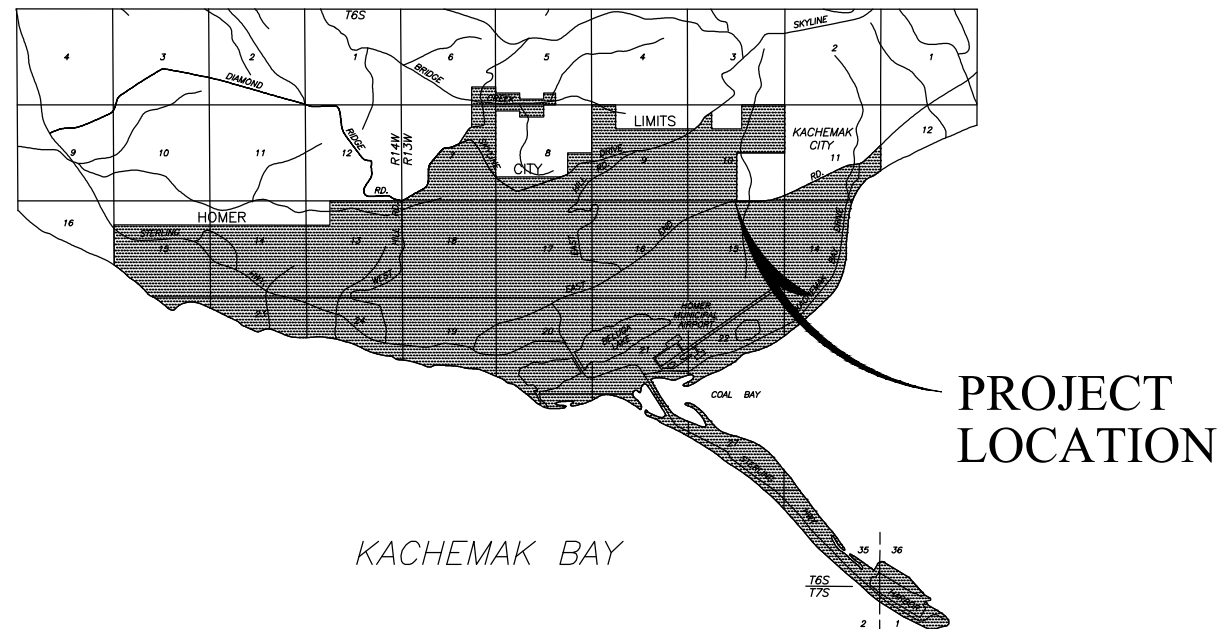

HOMER AREA MAP

SCALE: 1" = 1 MILE

INDEX TO DRAWINGS

TITLE

WATER MAIN EXTENSION PLAN & PROFILE 10+00.00 TO 14+00.00
WATER MAIN EXTENSION PLAN & PROFILE 14+00.00 TO 19+00.00
WATER MAIN EXTENSION PLAN & PROFILE 19+00.00 TO 22+20.00
CONSTRUCTION DETAILS
CONSTRUCTION NOTES
EROSION CONTROL PLAN
EROSION CONTROL DETAILS

SHEET

C-1
C-2
C-3
C-4
C-5
C-6
C-7

Notes:

1. Before performing any excavations, call Alaska Digline at: 811, (800) 478-3121, or (907) 278-3121.
2. These plans shall be used in conjunction the City of Homer "Standard Construction Details" in adoption on January 30, 2021.

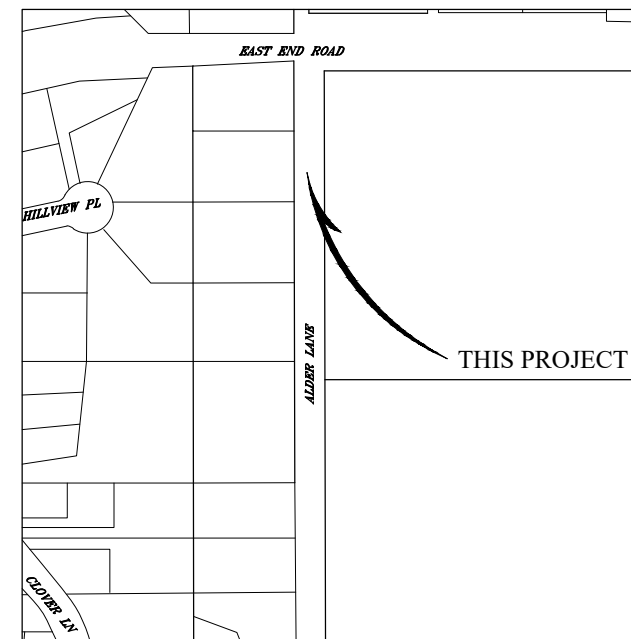

VICINITY MAP

SCALE: 1" = 400'

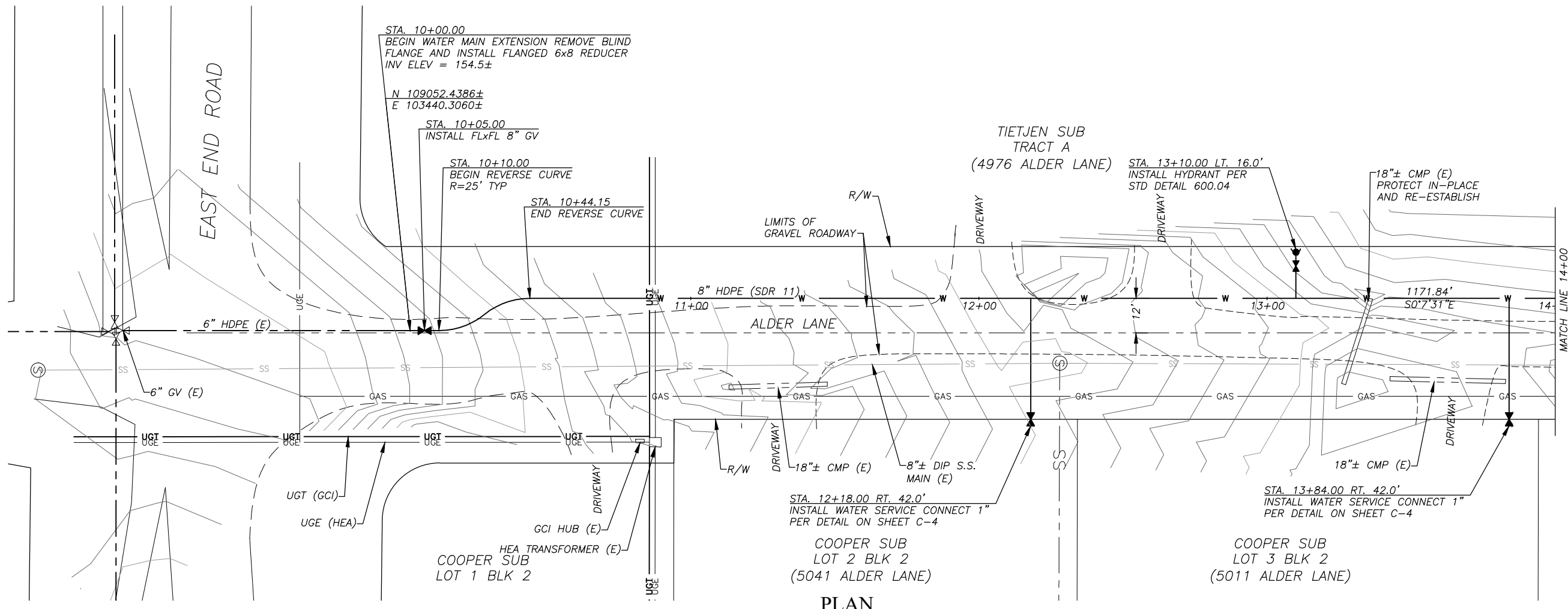
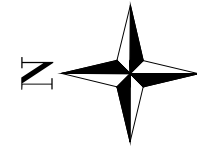

PLAN

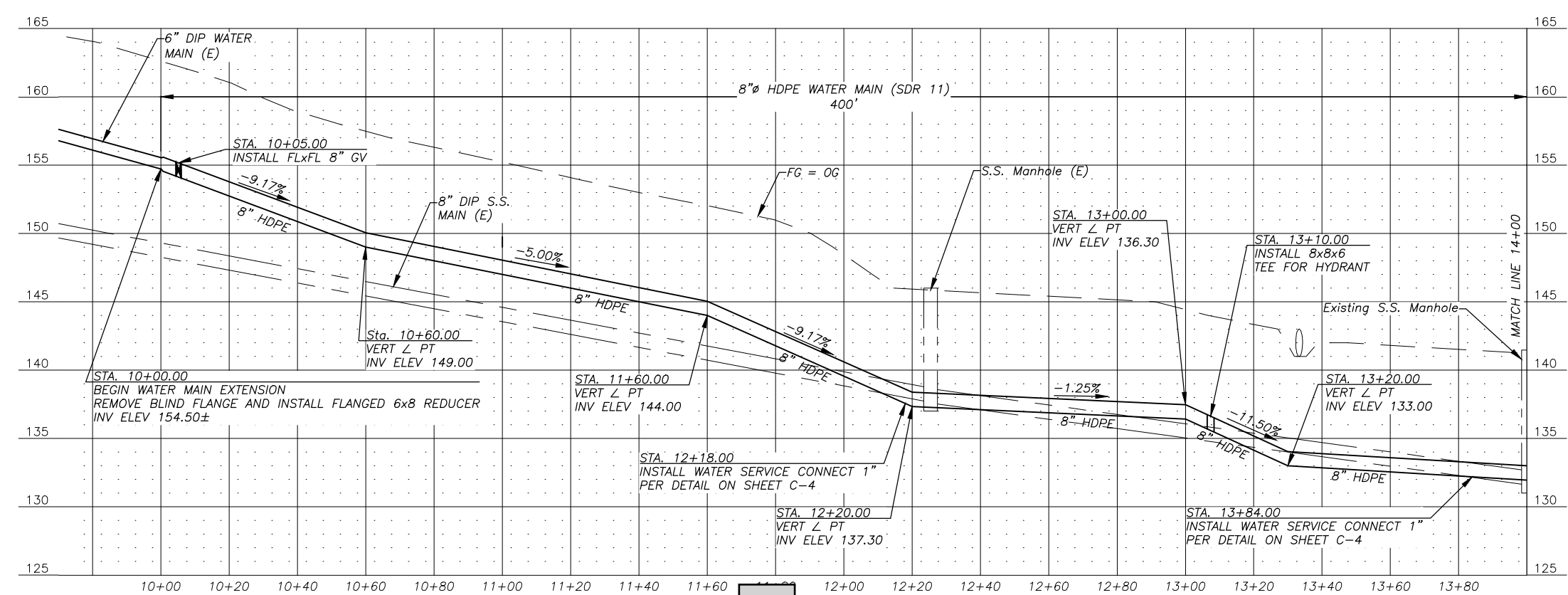
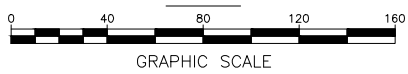

PROFILE 116

- NOTES:**
1. Before performing any excavations, call Alaska Digline at 811, (800) 478-3121, or (907) 278-3121.

ALDER LANE WATER MAIN EXTENSION
WATER MAIN PLAN + PROFILE
STA 10+00.00 to 14+00.00

BISHOP ENGINEERING, LLC
 PO BOX 2501 HOMER, ALASKA 99603
 (907) 299-7609

DATE: 1/30/2021
 CHK'D: JSB
 SCALE: AS NOTED
 PROJ. NO.: 2021002

SHEET NO.:
C-1

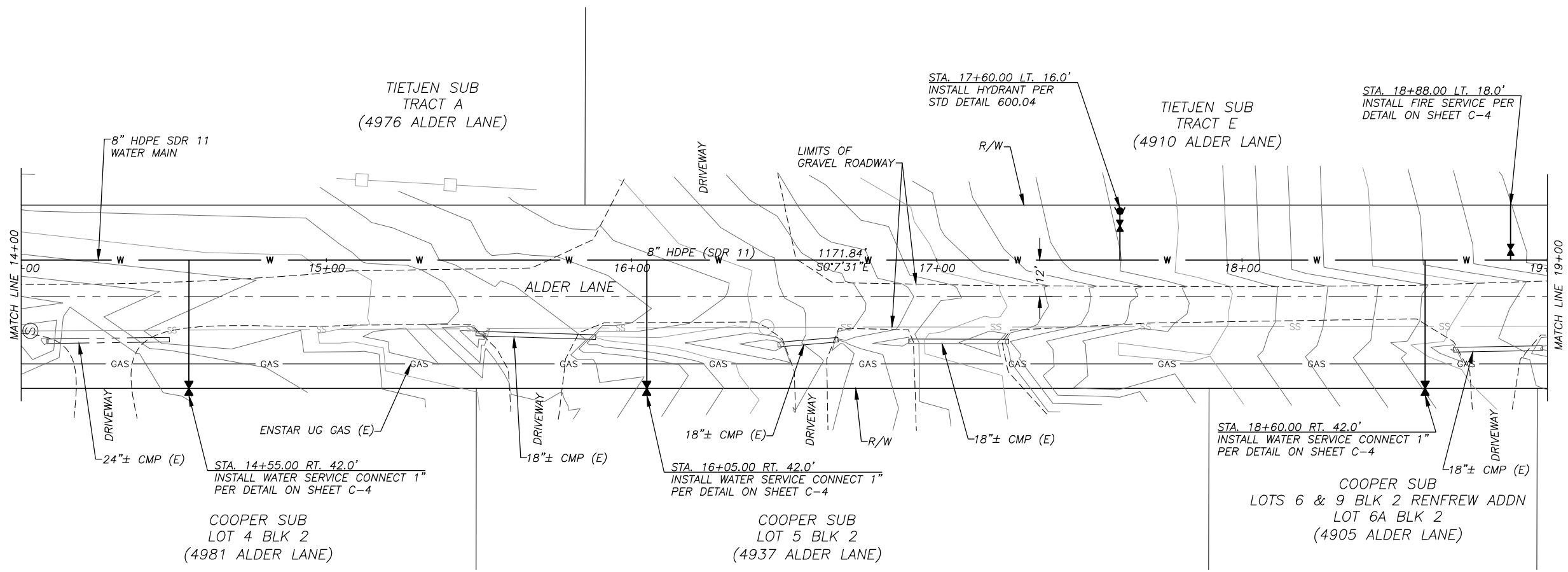
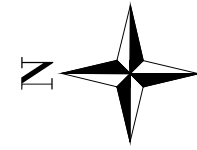

PLAN

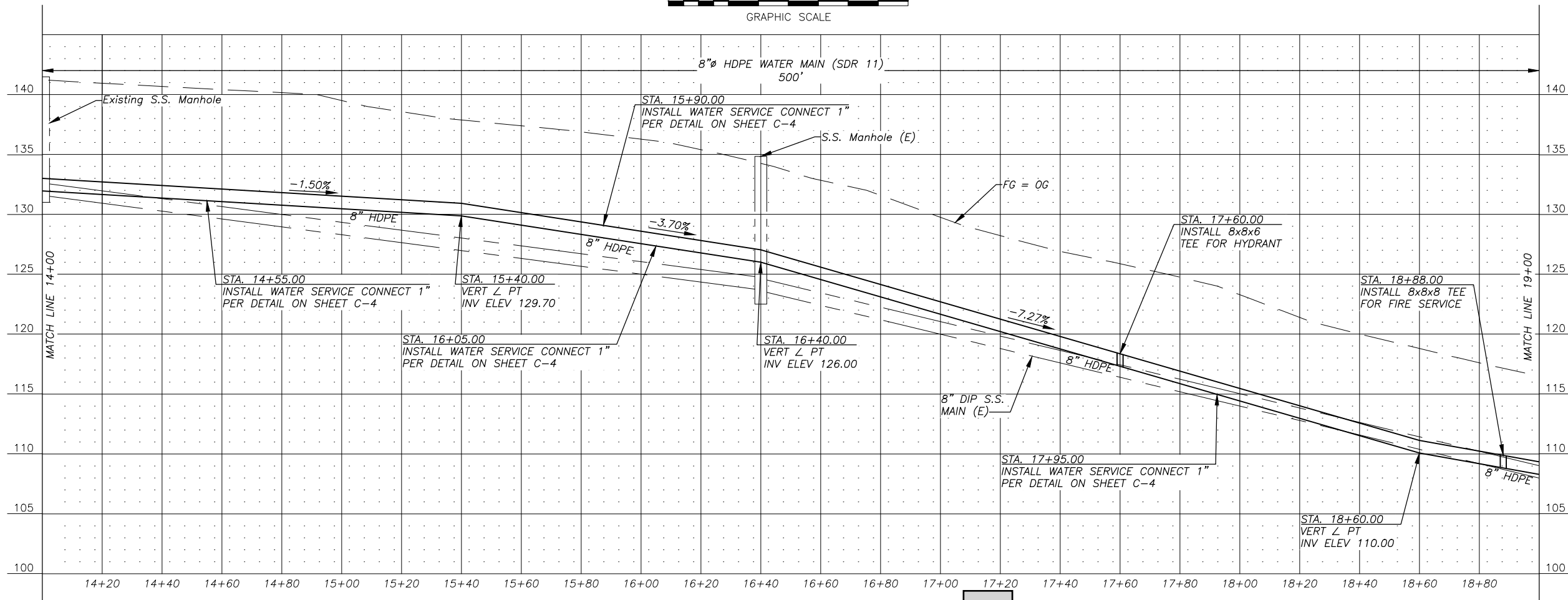
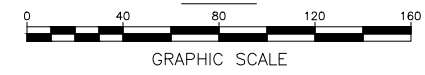

PROFILE 117

- NOTES:
- Before performing any excavations, call Alaska Digline at 811, (800) 478-3121, or (907) 278-3121.

ALDER LANE WATER MAIN EXTENSION
WATER MAIN PLAN + PROFILE
STA 14+00.00 to 19+00.00

BISHOP ENGINEERING, LLC
 PO BOX 2501 HOMER, ALASKA 99603
 (907) 299-7609

DATE: 1/30/2021
 CHK'D: JSB
 SCALE: AS NOTED
 PROJ. NO.: 2021002

SHEET NO.:
C-2

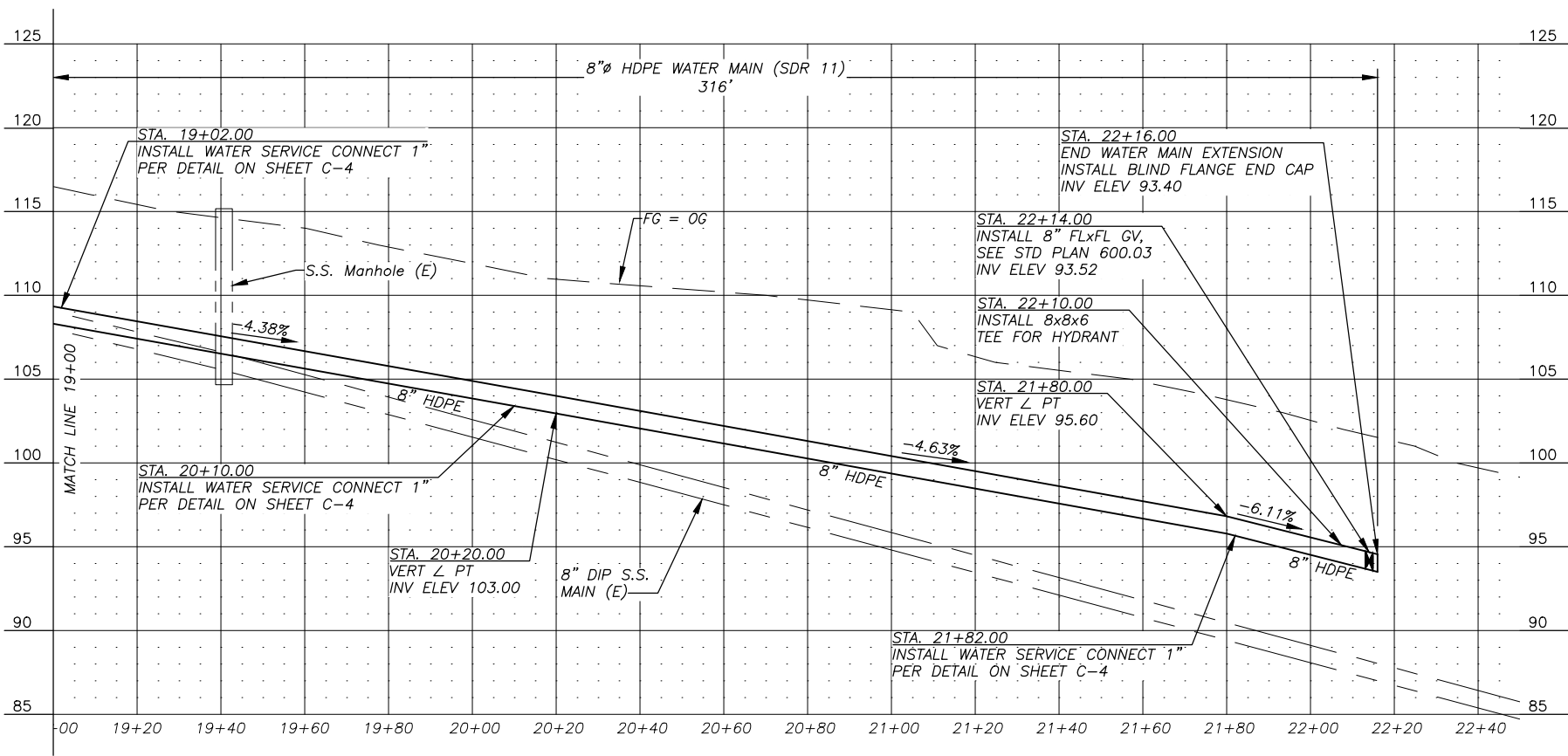
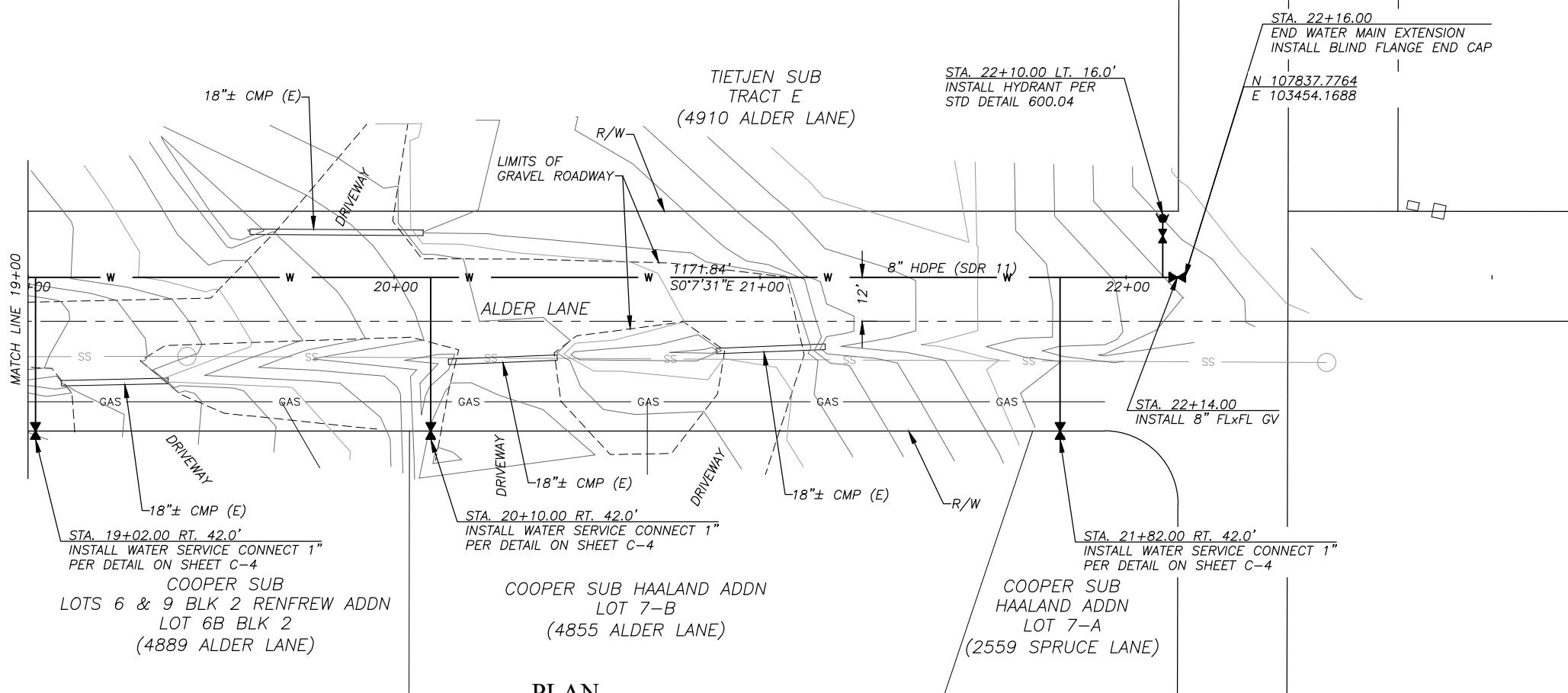
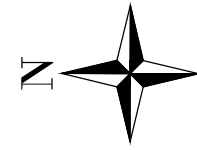

PROFILE 118

ALDER LANE WATER MAIN EXTENSION
WATER MAIN PLAN + PROFILE
STA 19+00.00 to 22+16.00

BISHOP ENGINEERING, LLC
 PO BOX 2501 HOMER, ALASKA 99603
 (907) 299-7609

DATE: 1/30/2021
 CHK'D: JSB
 SCALE: AS NOTED
 PROJ. NO.: 2021002

SHEET NO.:
 C-3

- NOTES:**
- Before performing any excavations, call Alaska Digline at 811, (800) 478-3121, or (907) 278-3121.

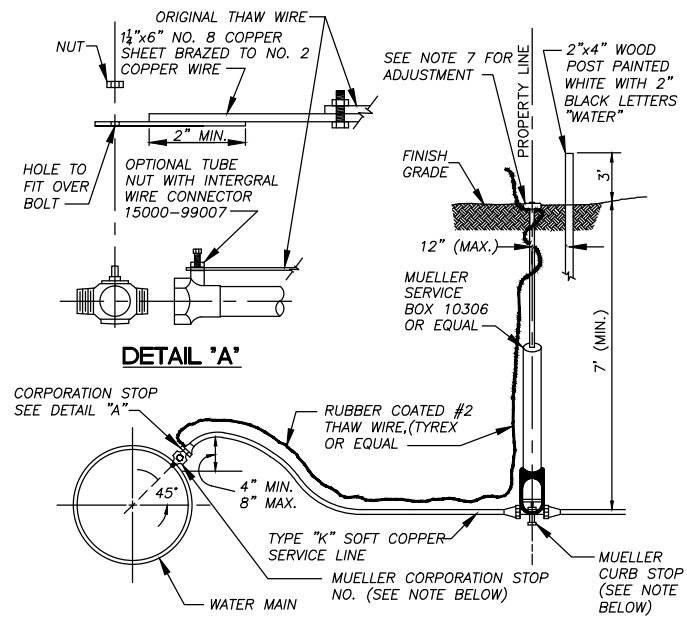

- NOTES:
1. USE MUELLER CORPORATION STOP NO. 15025 FOR PIPE-THREAD SADDLES.
 2. USE MUELLER CORPORATION STOP NO. 15000 FOR STEEL PIPE.
 3. USE MUELLER CURB STOP NO. H-15204 OR EQUAL FOR COPPER TO COPPER CONNECTIONS.
 4. ROD TO BE ATTACHED TO CURB STOP WITH NO. 6 GAUGE COPPER WIRE, NO SUBSTITUTIONS.
 5. MUELLER SERVICE CLAMPS TO BE USED ON ALL PLATIC PIPE, DOUBLE STRAP OR EQUAL.
 6. HDPE MAINLINES SHALL UTILIZE A SIDEWALL BRANCH SADDLE WITH INTEGRAL BRASS CC THREAD INSERT TO RECEIVE CORPORATION STOP.
 7. CURB BOX FINISH ELEVATION SHALL BE AS FOLLOWS:
 - PAVED AREA 0.5" BELOW FINISH GRADE
 - GRAVEL AREA 1" TO 3" BELOW FINISH GRADE
 - YARD/UNDEVELOPED AREA 0" TO 3" ABOVE FINISH GRADE

WATER SERVICE CONNECT 1"Ø
NOT TO SCALE

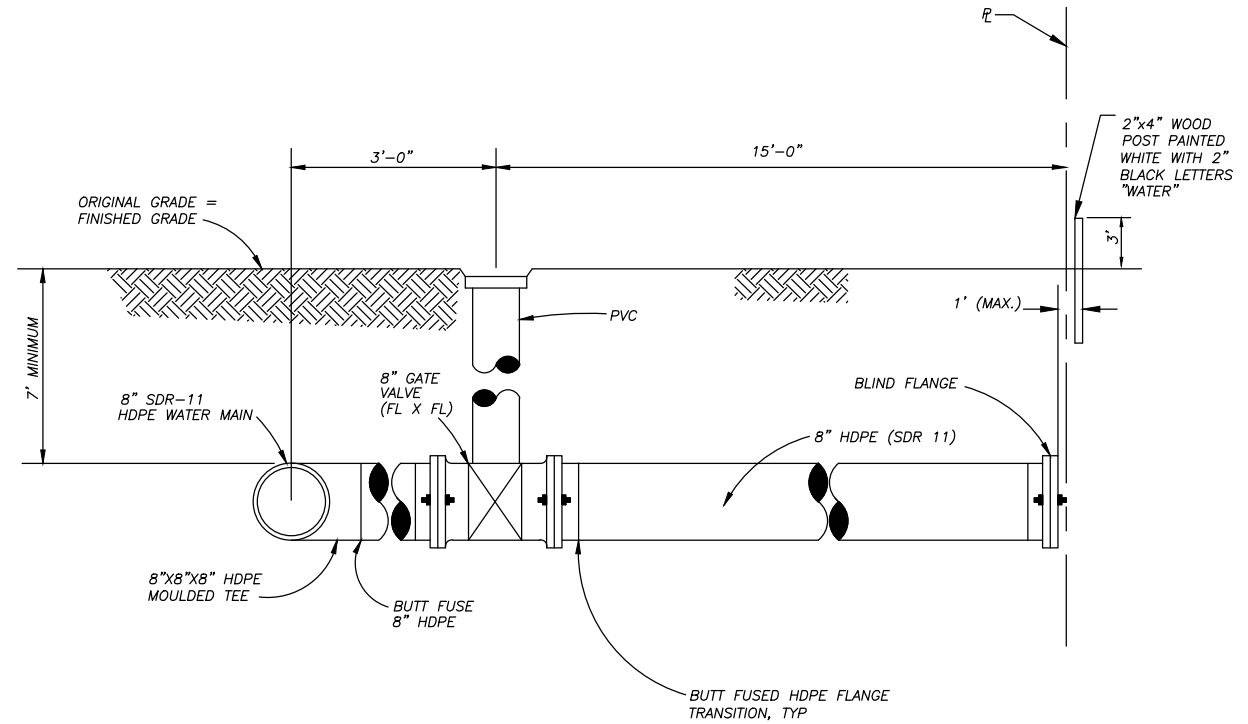

FIRE SERVICE
NOT TO SCALE

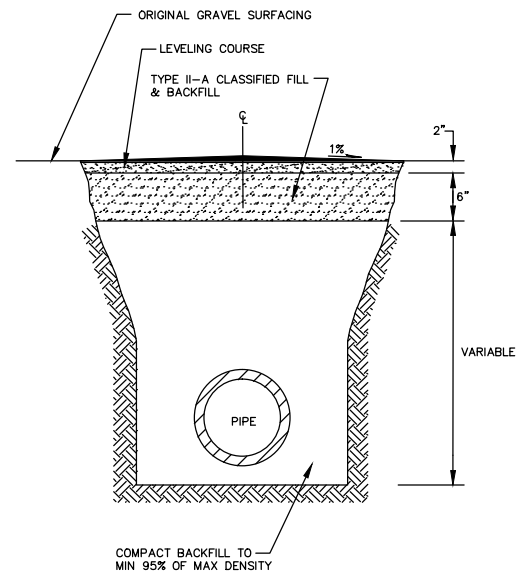

- NOTE:
1. CONTRACTOR SHALL CONSTRUCT A 1% CROWN WITH THE PEAK CENTERED OVER THE CENTERLINE OF THE EXCAVATION.

RESURFACING DETAIL
GRAVEL SURFACE
NOT TO SCALE

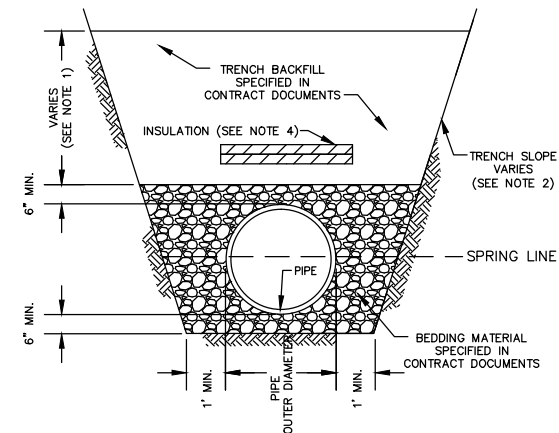

- NOTES:
1. TRENCH BACKFILL MATERIAL PLACED AND COMPACTED TO DEPTHS SHOWN IN THE DRAWINGS OR AS DETERMINED BY ENGINEER. COMPACT TRENCH BACKFILL TO A MINIMUM OF 95% MAXIMUM DENSITY.
 2. TRENCH WALL SLOPES WILL VARY WITH SOIL STRENGTH AND CHARACTER. SLOPES SHALL CONFORM TO OSHA SAFETY STANDARDS.
 3. BACKFILL SHALL BE FREE OF CLAYS AND ORGANIC MATERIALS.
 4. WHEN SPECIFIED IN CONTRACT DOCUMENTS, SEE STANDARD DETAIL 20-9 FOR INSULATION DETAILS.

TRENCH BACKFILL AND
BEDDING LAYOUT
NOT TO SCALE

NOTES:

1. Before performing any excavations, call Alaska Digline at 811, (800) 478-3121, or (907) 278-3121.

ALDER LANE WATER MAIN EXTENSION

CONSTRUCTION DETAILS

BISHOP ENGINEERING, LLC
PO BOX 2501 HOMER, ALASKA 99603
(907) 299-7609

DATE: 1/30/2021
CHK'D: JSB
SCALE: AS NOTED
PROJ. NO.: 2021002

SHEET NO.:

C-4

CITY OF HOMER STANDARD DRAWINGS INDEX

200.03	STANDARD LOCATION FOR NEW UTILITIES
200.04	TYPICAL UTILITY LOCATIONS
200.05	TYPICAL WATER AND SEWER LOCATIONS
200.06	COMPACTION OF BACKFILL WITHIN RIGHT-OF-WAY
200.07	CLASS B AND C BEDDING
200.08	TRENCH BACKFILL
400.02	RESURFACING DETAIL TYPICAL GRAVEL SECTION
600.03	TYPICAL VALVE BOX
600.04	SINGLE PUMPER "L" BASE HYDRANT ASSEMBLY
600.05	HYDRANT GUARD POSTS
600.06	FIRE HYDRANT ACCESS PAD
600.10	GATE VALVE EXTENSION ROD

LEGEND & SYMBOLS

EDGE EXISTING GRAVEL	- - - - -
CUT CATCH LINE	- - - - -
FILL CATCH LINE	- · - · - ·
CENTERLINE	+ - - - - +
UNDERGROUND ELECTRIC	— UGE —
OVERHEAD ELECTRIC	— OHE —
UNDERGROUND TELEPHONE	— UGT —
WATER MAIN	— W —
SANITARY SEWER	— SS —
CONTOURS MAJOR	— 85 —
CONTOURS MINOR	— —
TEST PIT LOCATION	⊕ TP-1
SIGN	⊥
PIPE CULVERT W/ END SECTION	
FIRE HYDRANT	
VALVE OR RISER	
EXISTING VALVE OR RISER	
PRESSURIZED SEWER SERVICE POLY VALVE	

ABBREVIATIONS

AKDOT&PF	ALASKA DEPT. OF TRANSPORTATION & PUBLIC FACILITIES
ASDS	ALASKA SIGN DESIGN SPECIFICATIONS
APDES	ALASKA POLLUTION DISCHARGE ELIMINATION SYSTEM
Δ	DELTA / CENTRAL ANGLE OF CURVE
BP	BEGIN PROJECT
C/L	CENTERLINE
CMP	CORREGATED METAL PIPE
CO	CONTRACTING OFFICER
COH	CITY OF HOMER
CY	CUBIC YARD
DIA	DIAMETER
DIST	DISTANCE
E	EASTING
EL	ELEVATION
ELEV	ELEVATION
EP	END PROJECT
ESMT	EASEMENT
(E)	EXISTING
FL	FLANGE
FT	FOOT
GV	GATE VALVE
HDPE	HIGH-DENSITY POLYETHYLENE
IN	INCH
INV	INVERT
L	LENGTH OF CURVE
LF	LINEAR FOOT
LT	LEFT
MIN	MINIMUM
MAX	MAXIMUM
MJ	MECHANICAL JOINT
MPH	MILES PER HOUR
MSF	1000 SQUARE FEET
MUTCD	MANUAL ON UNIFORM TRAFFIC CONTROL DEVICES
N	NORTHING
OHE	OVERHEAD ELECTRIC
PC	POINT OF CURVATURE
PI	POINT OF INTERSECTION
PRC	POINT OF REVERSE CURVATURE
PVC	POINT OF VERTICAL CURVATURE
PVI	POINT OF VERTICAL INTERSECTION
PVT	POINT OF VERTICAL TANGENCY
PT	POINT OF TANGENCY
R	RADIUS
RT	RIGHT
R/W	RIGHT-OF-WAY
SEC	SECTION
SI	STREET INTERSECTION
SF	SQUARE FOOT
SMH	SEWER MANHOLE
S.S.	SANITARY SEWER
STA.	STATION
STD	STANDARD
SY	SQUARE YARD
UGE	UNDERGROUND ELECTRIC
UGT	UNDERGROUND TELEPHONE
UTIL	UTILITY
TYP.	TYPICAL
W	WATER MAIN OR SERVICE

CONSTRUCTION NOTES

- CONTRACTOR SHALL COMPLETE CONSTRUCTION IN ACCORDANCE WITH THE CITY OF HOMER STANDARD SPECIFICATIONS 2011 EDITION INCLUDING ITEMS. DRAWINGS, TECHNICAL SPECIFICATIONS, AND SPECIAL PROVISIONS TAKE PRECEDENCE OVER THE STANDARD SPECIFICATIONS.
- THE CONTRACTOR SHALL ADHERE TO ALL REQUIREMENTS CONTAINED IN LOCAL, STATE AND FEDERAL PERMITS OBTAINED BY THE CITY FOR CONSTRUCTION OF THIS PROJECT. COPIES OF THE PERMITS SHALL BE MAINTAINED AT THE JOB SITE.
- CONTRACTOR SHALL MAINTAIN "REDLINE" RECORD DRAWINGS ON A CLEAN SET OF CONSTRUCTION DRAWINGS. THE CONTRACTOR SHALL MAINTAIN THE "REDLINES" CURRENT ON A DAILY BASIS WHICH SHALL BE AVAILABLE TO THE ENGINEER FOR INSPECTION ON THE JOB SITE. CONTRACTOR SHALL RECORD SURVEY NOTES FOR SUBMITTAL WITH RECORD DRAWINGS, INCLUDING HORIZONTAL AND VERTICAL LOCATIONS OF ALL UTILITIES ENCOUNTERED IN THE FIELD.
- ALL IMPORTED MATERIAL SHALL BE COMPACTED TO A MINIMUM OF 95% OF MAXIMUM DENSITY AS DETERMINED BY AASHTO T 180.
- LOCATIONS DEPICTED FOR THE UTILITIES AND OTHER EXISTING FEATURES ARE APPROXIMATE. SOME UTILITIES HAVE BEEN LOCATED FROM RECORD DRAWINGS AND UTILITY COMPANY LOCATES. CONTRACTOR SHALL LOCATE AND VERIFY ALL UTILITIES PRIOR TO CONSTRUCTION.
- UNDERGROUND ELECTRICAL AND TELECOMMUNICATIONS LINES OCCUR WITHIN THE PROJECT AREA; CONTRACTOR SHALL COORDINATE WORK ACCORDINGLY. ALL WORK IN CLOSE PROXIMITY TO EXISTING UNDERGROUND LINES SHALL COMPLY WITH THE APPLICABLE FEDERAL, STATE AND LOCAL STATUTES, CODES AND GUIDELINES, AND THE ELECTRICAL FACILITY CLEARANCE REQUIREMENTS OF THE GOVERNING UTILITY. CONTRACTOR SHALL HAND DIG WITHIN TWO FEET OF BURIED ELECTRICAL CABLE.
- THIS PROJECT IS REQUIRED TO BE CONSTRUCTED IN ACCORDANCE WITH THE APDES GENERAL CONSTRUCTION PERMIT FOR STORM WATER POLLUTION. THE CONTRACTOR SHALL ADHERE TO THE REQUIREMENTS OF THE PERMIT.
- ALL DISTANCES SHOWN ARE HORIZONTAL GROUND DISTANCES IN U.S. SURVEY FEET.
- THE CONTRACTOR SHALL SUBMIT A TRAFFIC CONTROL PLAN TO THE CITY ENGINEER FOR APPROVAL AT LEAST TWO WEEKS PRIOR TO THE START OF CONSTRUCTION ACTIVITIES.
- LIMITS OF EXCAVATION AND BACKFILL SHALL BE AS SHOWN ON THE PLANS OR AS DIRECTED BY THE ENGINEER.
- CONTRACTOR SHALL CONSTRUCT EROSION CONTROL DEVICES AS SHOWN IN THE PLANS AND PROCEDURES AND REQUIREMENTS DOCUMENTED IN THE SWPPP PERMIT.
- IF CONTAMINATED SOIL, GROUNDWATER, OR FREE-PRODUCT ARE ENCOUNTERED, THE CONSTRUCTION CONTRACTOR SHALL IMMEDIATELY CONTACT THE ENGINEER WHO WILL IMMEDIATELY CONTACT THE ADEC PREVENTION AND EMERGENCY RESPONSE (PERP) OFFICE STAFF AT (907) 465-5340 / FAX (907) 465-2237 IN ACCORDANCE WITH SPILL REPORTING REQUIREMENTS UNDER 18 AAC 75.300, AND COORDINATE MANAGEMENT OF ALL CONTAMINATED MEDIA WITH EMERGENCY RESPONSE PERSONNEL.
- THE CONTRACTOR SHALL PROVIDE DOCUMENTATION THAT DEMONSTRATES THE PIPE MATERIAL IS CERTIFIED TO CONFORM TO ANSI/NSF STANDARD 61.
- THE CONTRACTOR SHALL REDUCE THE CONCENTRATION OF RESIDUAL CHLORINE IN THE FLUSHED WATER BY NEUTRALIZATION BEFORE THE WATER IS RELEASED OVERLAND OR TO ANY CREEKS, STREAMS, AND TEMPORARY OR PERMANENT DRAINAGE SWALES OR DITCHES. THE RESIDUAL CHLORINE LEVEL BEFORE RELEASE SHALL NOT EXCEED 19 PPB (PARTS PER BILLION). THE PROCEDURE USED TO ADD AND MIX THE NEUTRALIZING AGENT INTO THE FLUSHED WATER SHALL ACHIEVE A THOROUGHLY AND EVENLY MIXED SOLUTION. MEASUREMENTS OF RESIDUAL CHLORINE SHALL BE TAKEN AT THE POINT OF RELEASE FROM THE NEWLY INSTALLED WATER SYSTEM INTO THE NEUTRALIZING CHAMBER AND AT THE POINT OF RELEASE FROM THE CONTRACTOR'S CONTROL AT 10 MINUTE INTERVALS OR MORE FREQUENTLY AS DIRECTED BY THE ENGINEER. ACCEPTABLE AGENTS FOR NEUTRALIZATION INCLUDE:
 - A. CALCIUM THIOSULFATE,
 - B. ASCORBIC ACID, OR
 - C. SODIUM ASCORBATE.

THE CONTRACTOR SHALL FOLLOW THE MANUFACTURER'S INSTRUCTIONS ON THE AMOUNTS OF AGENT ADDED TO THE FLUSHED WATER BASED ON THE RESIDUAL CHLORINE CONCENTRATION MEASURED AT THE POINT OF RELEASE FROM THE NEWLY INSTALLED WATER SYSTEM INTO THE NEUTRALIZING CHAMBER.
- THE CONTRACTOR SHALL PROVIDE DOCUMENTATION THAT DEMONSTRATES THE CHEMICAL ADDITIVE FOR DISINFECTION IS CERTIFIED TO CONFORM TO ANSI/NSF STANDARD 60.
- DISCHARGES OF EFFLUENT FROM HYDROSTATIC TESTING AND DISINFECTION SHALL CONFORM SECTIONS 4.0 "CONTROL MEASURES", 5.1 "LAND DISPOSAL DISCHARGES OF HYDROSTATIC TESTING", AND 6.0 "REPORTING AND RECORDKEEPING" OF THE ALASKA POLLUTANT DISCHARGE ELIMINATION SYSTEM "GENERAL PERMIT FOR HYDROSTATIC AND AQUIFER PUMP TESTING" PERMIT NUMBER AKG003000.

NOTES:

- Before performing any excavations, call Alaska Digline at 811, (800) 478-3121, or (907) 278-3121.



ALDER LANE WATER MAIN EXTENSION

CONSTRUCTION NOTES

BISHOP ENGINEERING, LLC
PO BOX 2501 HOMER, ALASKA 99603
(907) 299-7609

DATE: 1/30/2021
CHK'D: JSB
SCALE: AS NOTED
PROJ. NO.: 2021002

SHEET NO.:

C-5

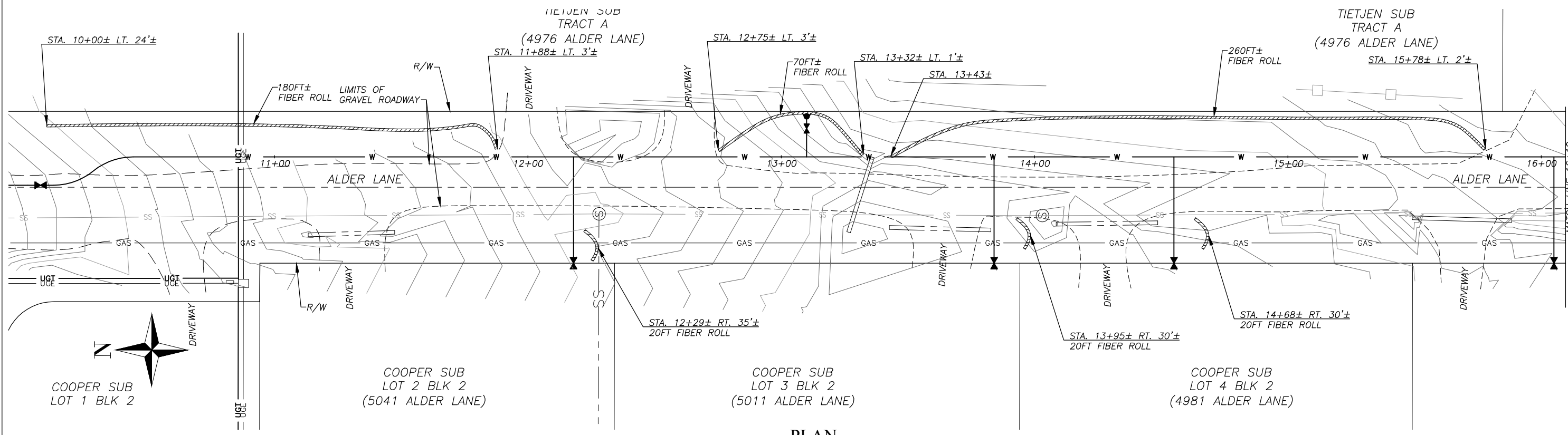

PLAN

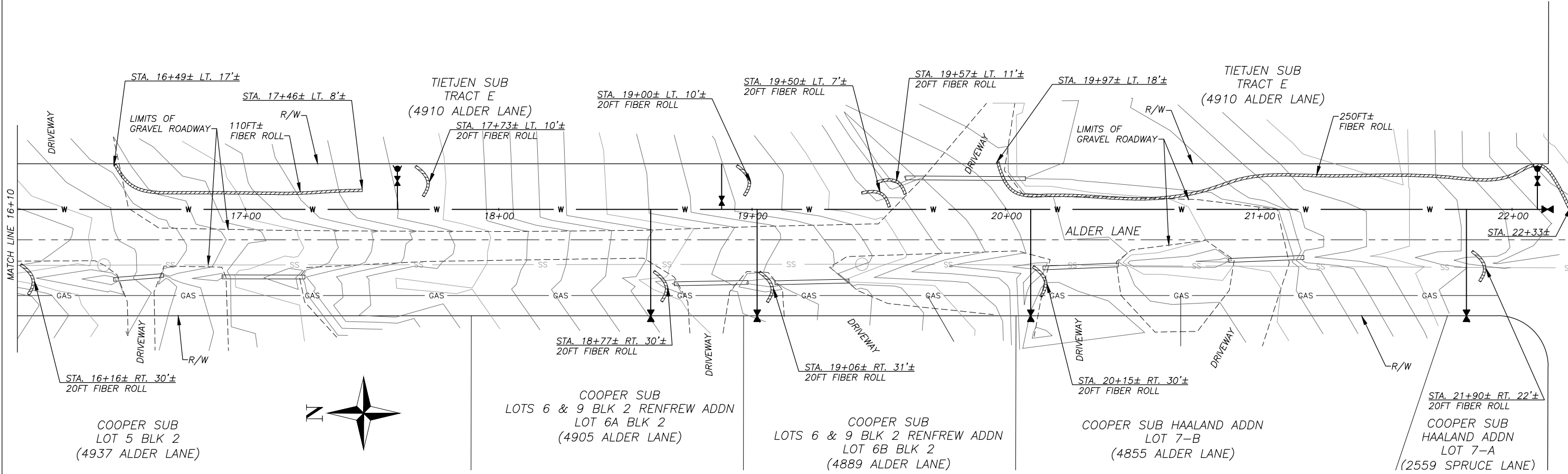
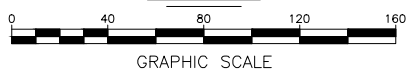

PLAN

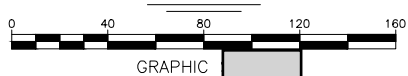

- NOTES:
- Before performing any excavations, call Alaska Digline at 811, (800) 478-3121, or (907) 278-3121.

ALDER LANE WATER MAIN EXTENSION
EROSION CONTROL PLAN

BISHOP ENGINEERING, LLC
 PO BOX 2501 HOMER, ALASKA 99603
 (907) 299-7609

DATE: 1/30/2021
 CHK'D: JSB
 SCALE: AS NOTED
 PROJ. NO.: 2021002

SHEET NO.:
C-6

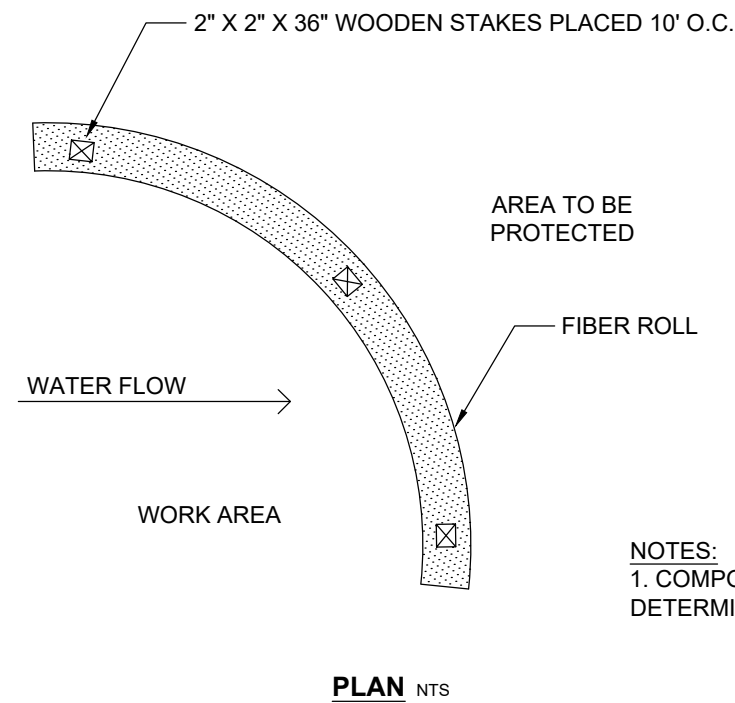
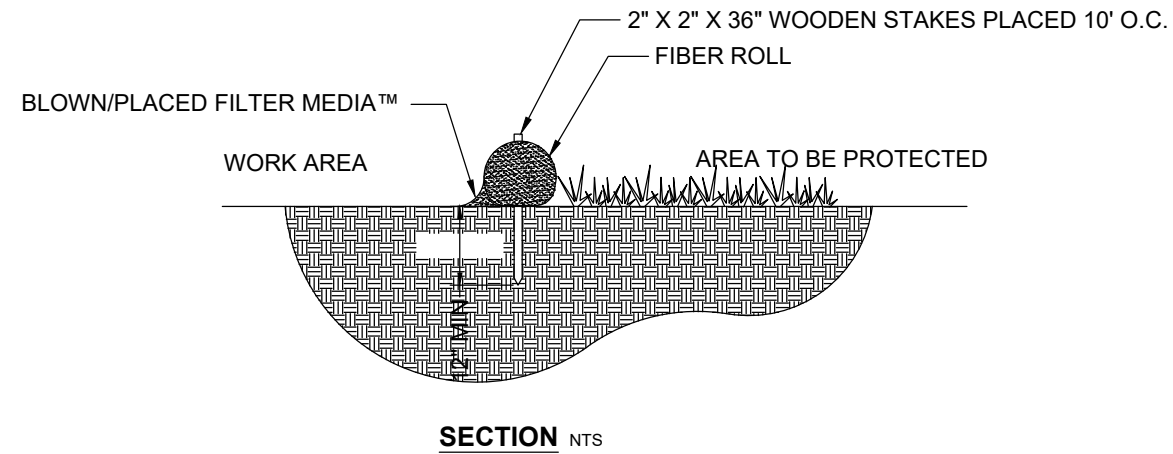

NOTES:
 1. COMPOST MATERIAL TO BE DISPERSED ON SITE, AS DETERMINED BY ENGINEER.

FIBER ROLL SEDIMENT CONTROL

NTS

NOTES:

1. Before performing any excavations, call Alaska Digline at 811, (800) 478-3121, or (907) 278-3121.

ENGINEER'S CONSTRUCTION ESTIMATE

AS-BUILT ESTIMATE 95% PLAN ESTIMATE GENERAL PLAN ESTIMATE (35%)

PROJECT NAME: Alder Lane Water Main Extension
DESCRIPTION: Install 8" HDPE main extension along Alder Lane, three hydrants, and 9 services.
PRICES BY : Quiet Creek Sub Estimate base with 3 yr cost inflation
QUANTITIES BY: John S. Bishop
CHECKED BY:

IN EST:
OUT EST:
LOCATION: Homer, AK
DEPTH: N/A
LENGTH: 1220 LF
WIDTH: N/A
AREA: N/A
DATE: 1/22/2021
DATE: 1/22/2021
DATE:

	CONSTRUCTION ITEM (FURNISH AND INSTALL UNO)	QUANTITY	UNIT PRICE	UNIT	ITEM COST
1	8" HDPE SDR 11 pipe furnish and install	1,220	\$ 80.00	LF	\$ 97,600.00
2	Single Pumper Hydrant	3	\$ 9,000.00	EA	\$ 27,000.00
3	1" Water Service Connection (near side)	1	\$ 2,500.00	EA	\$ 2,500.00
4	1" Water Service Connection (far side)	8	\$ 3,500.00	EA	\$ 28,000.00
5					\$ -
6					\$ -
7					\$ -
8					\$ -
9					\$ -
10					\$ -
11					\$ -
12					\$ -
13					\$ -
14					\$ -
15					\$ -
16					\$ -
17					\$ -
18					\$ -
19					\$ -
20					\$ -
21					\$ -
22					\$ -
23					\$ -
24					\$ -
25					\$ -
26					\$ -
27					\$ -
28					\$ -
29					\$ -
30					\$ -

Comments	SUBTOTAL		\$ 155,100.00
	MOBILIZATION	10%	\$ 15,510.00
	CONTIGENCIES	25%	\$ 38,775.00
	TOTAL		\$ 209,385.00

DESCRIPTION	PRICE	UNIT	COST
DEMOLITION			



City of Homer

www.cityofhomer-ak.gov

Public Works

3575 Heath Street
Homer, AK 99603

publicworks@cityofhomer-ak.gov

(p) 907- 235-3170

(f) 907-235-3145

Memorandum

TO: City Council
Through: Robert Dumouchel, City Manager
FROM: Janette Keiser, PE, Director of Public Works
DATE: February 3, 2021
SUBJECT: Mt. Augustine Road Drainage Improvement Project – 35% Design

Issue: The design for the Mt. Augustine Road Drainage Improvement Project Woodard Creek Culvert Project is currently at 35% development. The purpose of this Memorandum is to discuss the progress and identify issues.

Background: The intent of the project is to capture water flowing near the intersection of Mt. Augustine Road and the Sterling Highway and convey it to a “*naturally occurring ravine, gully, watercourse or runnel*”, pursuant to Resolution 20-098, adopted October 12, 2020. The City Council appropriated \$97,000 from the HART Roads Fund for this project, via Ordinance 20-85, adopted November 9, 2020.

The City issued a contract to design the project Nelson Engineering, a Kenai firm with extensive experience in road and drainage improvement design, including projects for the City of Homer. Nelson has progressed the design the 35% level, which is not enough to build from, but enough to envision what the project will look like, get a more reliable cost and identify issues. For example, this level of design allows us to understand the probable downstream impacts of the proposed drainage.

As part of their scope of work, Nelson Engineering investigated the hydraulic conditions at the intersection of Mt. Augustine Rd. and the Sterling Highway, identified one or more naturally occurring drainage way(s), which could receive the water coming from this intersection, and explored the probable downstream impacts of using said drainage way(s). Then, Nelson Engineering designed a system including 243 feet of culvert and two storm drain manholes to convey the drainage from the intersection to the naturally occurring drainage way selected to receive the drainage. Nelson Engineering also followed the water downstream and made recommendations for downstream improvements that would be needed to accommodate the extra water flow. Finally, Nelson Engineering updated the cost estimate for the culvert/storm drain system.

The estimated cost to construct the culvert/storm drain system is \$100,055. The cost of the design/survey effort is \$15,639, bringing the total expected project cost to design and construct the basic project to \$115,694. Part of the extra cost is due to the need to go around an existing light pole and electrical utilities, which requires us to extend the culvert and install an additional storm drain manhole. This exceeds the amount appropriated by Ordinance 20-85 by \$18,694.

This does not include what we may need to do to address downstream impacts, which we are exploring in more detail. We know at least four privately-owned culverts will need to be up-sized and some ditches will need to be deepened and re-graded. It's possible we could do this work in-house using the Small Works Drainage Repair Program, which Council established last year. Further, we want to engage Coble Geophysical Services to investigate the relationship between groundwater flows and the surface drainage in this area, particularly as this relationship affects downstream impacts down to the bluff.

At this point, we are providing information, not asking for additional funds. When we've more thoroughly explored the downstream issues, we will come back to Council to seek direction and if Council wants to proceed, additional funds.

Engineer's Cost Estimate - Mt. Augustine Drive Drainage 35% Review

BID SCHEDULE					
Item Number	Pay Item Description	Unit	Estimated Quantity	Unit Bid Price	Amount Bid
101	Mobilization and Demobilization	Lump Sum	1	\$ 10,000.00	\$ 10,000.00
102	Construction Surveying	Lump Sum	1	\$ 5,000.00	\$ 5,000.00
103	Traffic Maintenance	Lump Sum	1	\$ 5,000.00	\$ 5,000.00
203a	Removal of Obstructions (Culvert Pipe)	Linear Foot	85	\$ 16.00	\$ 1,360.00
203b	Removal of Obstructions (Storm Drain Manhole)	Each	1	\$ 1,500.00	\$ 1,500.00
204(2)	Ditch Excavation	Linear Foot	50	\$ 5.00	\$ 250.00
205.00	Type III Classified Backfill	CY	20	\$ 40.00	\$ 800.00
206	Leveling Course	Ton	15	\$ 45.00	\$ 675.00
208	Compaction Control by the Contractor	Lump Sum	1	\$ 2,000.00	\$ 2,000.00
212	Rip Rap, Class I	Ton	30	\$ 150.00	\$ 4,500.00
219	Remove Existing Pavement	Square Yard	100	\$ 10.00	\$ 1,000.00
401	2" Asphalt Pavement (Type II), For Roadway	Ton	12	\$ 160.00	\$ 1,920.00
708	Seeding (Type I)	Lump Sum	1	\$ 1,000.00	\$ 1,000.00
710	Topsoil (4")	Lump Sum	1	\$ 1,000.00	\$ 1,000.00
711	Relocate Utilities (Electric)	Lump Sum	1	\$ 2,000.00	\$ 2,000.00
802a	Corrugated HDPE Pipe 18 Inch	LF	35	\$ 120.00	\$ 4,200.00
802b	Corrugated HDPE Pipe 24 Inch	LF	210	\$ 145.00	\$ 30,450.00
802c	Culvert End Section, 24 Inch	Each	1	\$ 400.00	\$ 400.00
804	Storm Drain Manhole (Type I)	Each	3	\$ 9,000.00	\$ 27,000.00
Contractor's Name: _____				Total Est.:	\$ 100,055.00



Memorandum

TO: ROB DUMOUCHEL, CITY MANAGER
FROM: BRYAN HAWKINS, HARBORMASTER
DATE: FEBRUARY 11 2021
SUBJECT: FUTURE COAST GUARD SMALL BOAT STATION PLANS FOR HOMER

Informational for City Manager Report-

Two years ago we began talking to Admiral Bell about the future plans for the Coast Guard and Homer. We know that their 110' Cutter Naushon will be decommissioned eventually and we're concerned that we would be losing the asset and 16 jobs out of the community. At that time, with a strategic look at the vessel traffic and needs of the area, the Admiral suggested that it's time for Homer to have a small boat station, which sounds small because of the word "small" but in fact it's kind of a big deal! This would mean faster response vessels for search and rescue and an established permanent station with 24 hour staffing capability.

(Examples of the new 45' fast response type cutters that would be stationed at the small boat station)



Last February, when down in Juneau for the legislative Fly-In, the Homer delegation met with the Admiral and his staff to discuss the Port Expansion project and the small boat station. At that time he committed his team to work on the small boat station justifications and application so that he could submit it to Command for consideration.

In our latest correspondence with D17 Juneau it was reported that the project has been approved and signed off on by the Pacific Area Commander, and it will be distributed to whatever other departments are going to have a hand in its establishment. Funding is the problem for a quick resolution to this. As of now, the earliest the funding will be available is 2028, and dates for when construction will begin, or when it will be complete haven't yet been set. Once this project continues through the chain of hands that need visibility on it, it's reported that they will get a clearer picture of the absolutes such as construction dates.

We have forwarded this information on to our lobbyists and plan to ask for support and follow up in our meetings with our Federal Delegation.

Recommendation

Continued Council and City support for the project and the Coast Guard's presence in Homer, keeping it in the forefront of legislative representative's priorities and any applicable funding or grant opportunities.

Informational

**CITY OF HOMER
HOMER, ALASKA**

Evensen

RESOLUTION 21-017

A RESOLUTION OF THE CITY COUNCIL OF HOMER, ALASKA
AMENDING THE COUNCIL OPERATING MANUAL TO ADD PROCESS
FOR FILLING A COUNCIL VACANCY.

WHEREAS, Alaska Statutes 29.20.180 and HCC 2.08.050 generally address filling a
vacancy on the City Council; and

WHEREAS, Council has followed a process of opening an application period, holding
interviews, and Council making the appointment, however this process is not documented;
and

WHEREAS, It is beneficial for any sitting Council, the administration, and the public to
have a process outlined in the Council Operating Manual.

NOW, THEREFORE, BE IT RESOLVED that the City Council of Homer, Alaska amends the
Council Operating Manual to add process for filling a Council Vacancy.

BE IT FURTHER RESOLVED the Council Operating Manual section PROCEDURES
GENERAL INFORMATION – (HOW TO’S) shall be amended to include in the following:

COUNCIL VACANCY

Title 29 and HCC 2.08.050 delegate responsibility for the appointment to a vacated
Council seat exclusively to the City Council. Upon the Council’s acceptance of a vacancy
the City Clerk shall prepare an advertisement soliciting applications for candidates for
appointment to the vacated seat to be submitted within a time certain. Applications,
which are a public record, shall be submitted on a form approved by Council who shall
schedule interviews of the candidates. Upon conclusion of the interviews Council shall
appoint in its sole discretion the candidate to fill the vacated seat. A Council member
appointed in accordance with HCC 2.08.050 shall serve until the next regular election,
when a successor shall be elected to serve the balance of the term.

PASSED AND ADOPTED by the Homer City Council this 22nd day of February, 2021.

CITY OF HOMER

KEN CASTNER, MAYOR

45 ATTEST:

46

47

48

49 _____
MELISSA JACOBSEN, MMC, CITY CLERK

50

51 Fiscal note: NA



City of Homer

www.cityofhomer-ak.gov

Office of the City Manager

491 East Pioneer Avenue
Homer, Alaska 99603

citymanager@cityofhomer-ak.gov

(p) 907-235-8121 x2222

(f) 907-235-3148

Memorandum 21-037

TO: Mayor Castner and Homer City Council
FROM: Rob Dumouchel, City Manager
DATE: February 3, 2021
SUBJECT: Update to Council Operating Manual Regarding Council Vacancies

Councilmember Evensen contacted my office with a concern related to a lack of clarity regarding the process required when replacing Councilmembers who vacate their seats on the City Council. He has worked with my office to try to find a solution which ensures a process which is logical and encourages public participation is used to fill any vacancy. In consultation with the City Attorney, the suggestion is that Council adopt a change to the Council Operating Manual which requires the Council to advertise for applicants and interview those in which the Council has an interest.

The suggested modification to the Council Operating Manual reads as follows:

COUNCIL VACANCY

Title 29 and HCC 2.08.050 delegate responsibility for the appointment to a vacated Council seat exclusively to the City Council. Upon the Council's acceptance of a vacancy the City Clerk shall prepare an advertisement soliciting applications for candidates for appointment to the vacated seat to be submitted within a time certain. Applications, which are a public record, shall be submitted on a form approved by Council who shall schedule interviews of the candidates. Upon conclusion of the interviews Council shall appoint in its sole discretion the candidate to fill the vacated seat.

Regarding the interviews discussed in the draft language above, the intent is that those interested in filling a Council vacancy be asked to participate in a public interview where all those interviewed respond to the same series of questions. This is an opportunity for both the Council and the public to hear directly from those looking to serve a truncated term in a vacated seat.

For reference, the power of appointment to a vacated seat is exclusively delegated to the Council under Alaska Statutes 29.20.180 and Homer City Code 2.08.050. Both code sections are provided below:

AS § 29.20.180

(a) If a vacancy occurs in a governing body, the remaining members shall, within 30 days unless a different period is provided by ordinance, appoint a qualified person to fill the vacancy. If less than 30 days remain in a term, a vacancy may not be filled.

(b) Notwithstanding (a) of this section, if the membership is reduced to fewer than the number required to constitute a

HCC § 2.08.050

a. If a vacancy occurs in the City Council the remaining members shall, within 30 days, appoint a qualified person to fill the vacancy. If less than 30 days remain in a term, a vacancy may not be filled.

b. Notwithstanding subsection (a) of this section, if the membership is reduced to fewer than the number required to constitute a quorum, the remaining members shall, within seven

<p>quorum, the remaining members shall, within seven days, appoint a number of qualified persons to constitute a quorum.</p> <p>(c) A person appointed under this section serves until the next regular election, when a successor shall be elected to serve the balance of the term.</p>	<p>days, appoint a number of qualified persons to constitute a quorum.</p> <p>c. A simple majority, not a quorum, vote of the remaining Council members is required to select and appoint persons to fill Council vacancies.</p> <p>d. A person appointed under this section serves until the next regular election, when a successor shall be elected to serve the balance of the term.</p> <p>e. A vacancy in the office of Mayor occurring within six months before a regular election shall be filled by the Council. The person appointed serves until the next regular election when a successor is elected to serve the balance of the term. If a member of the Council is appointed Mayor, the member shall resign the seat on the Council. If a vacancy occurs more than six months before a regular election, the governing body shall call a special election to fill the unexpired term.</p>
---	--

Staff recommendation: Pass a resolution amending the Council Operating Manual to include a section on filling Council vacancies.