



Board of Trustees

William J. Fountain, Supervisor
Larry N. Ciofu, Clerk
Kathleen A. Horning, Treasurer

Brett Lubeski, Trustee
Summer L. McMullen, Trustee
Denise M. O'Connell, Trustee
Joseph M. Petrucci, Trustee

Board of Trustees Regular Meeting Agenda
Hartland Township Hall
Tuesday, June 16, 2026
7:00 PM

1. Call to Order
 2. Pledge of Allegiance
 3. Roll Call
 4. Approval of the Agenda
 5. Call to the Public
 6. Approval of the Consent Agenda
 - [a.](#) Approve Payment of Bills
 - [b.](#) Approve Post Audit of Disbursements Between Board Meetings
 - [c.](#) 06-02-26 Hartland Township Board Regular Meeting Minutes
 - [d.](#) Budget Amendment for Valbridge Advisors
 - [e.](#) Gen-X – Waldenwoods Fireworks Permit Application
 - [f.](#) Long Lake Fireworks Display Permit – 7-11-26
 - [g.](#) Gen-X – Waldenwoods Fireworks Permit Application
 7. Pending & New Business
 - [a.](#) 2026 Compliance Resolution for NPDES Permit
 8. Board Reports
- [BRIEF RECESS]
9. Information / Discussion
 - [a.](#) Work Session Regarding Code Enforcement
 - [b.](#) Manager's Report
 10. Adjournment

Hartland Township Board of Trustees Meeting Agenda Memorandum

Submitted By: Susan Case, Finance Clerk

Subject: Approve Payment of Bills

Date: June 9, 2026

Recommended Action

Move to approve the bills as presented for payment.

Discussion

Bills presented total \$419,531.01. The bills are available in the Finance office for review.

Notable invoices include:

- \$14,300.00 – Dougies Disposal – (Trash pickup for Parks & large item clean up event)
- \$18,002.38 – Hartland Township Water O&M – (May 2026 out of dept labor/equipment)
- \$143,948.70 – Livingston County Sheriff – (Qtr 1 & Qtr 2 payments per agreement)
- \$207,714.16 - Livingston County Drain Commission – (May 2026 Sewer System O&M)
- \$13,235.00 – San Marino Excavating – (Dumpsters for large item clean up event)
- \$10,864.00 – Spalding Dedecker – (Various engineering invoices)

Financial Impact

Is a Budget Amendment Required? Yes No

All expenses are covered under the adopted FY27 budget.

Attachments

Bills for 06.16.2026

Vendor Code	Vendor name	Post Date	Invoice	Bank	Invoice Description	Gross Amount
Ref #	Address	CK Run Date	PO	Hold		Discount
Invoice Date	City/State/Zip	Disc. Date	Disc. %	Sep CK		Net Amount
		Due Date		1099		
ALLSTAR 54465	ALLSTAR ALARM LLC	06/01/2026 06/16/2026	453140	FOA N	7/1/26 - 9/30/26 MONITORING AT HERO	150.00
06/01/2026	8345 MAIN STREET WHITMORE LAKE MI, 48189	/ / 06/16/2026	0.0000	N N		0.00 150.00
Open						

GL NUMBER	DESCRIPTION	AMOUNT
101-265-801.000	CONTRACTED SERVICES	150.00

VENDOR TOTAL: 150.00

ARGENT 54536	ARGENT INSTITUTIONAL TRUST COMPANY	06/09/2026 06/16/2026	82731	FOA N	BOND FEES FOR NEW WATER BOND	500.00
05/28/2026	4343 EASTON COMMONS, SUITE 120 COLUMBUS OH, 43219	/ / 06/16/2026	0.0000	N N		0.00 500.00
Open						

GL NUMBER	DESCRIPTION	AMOUNT
539-000-996.000	BOND FEES	500.00

VENDOR TOTAL: 500.00

CINTAS 54467	CINTAS CORPORATION	05/22/2026 06/16/2026	4270122587	FOA N	MATS	48.11
05/22/2026	P.O. BOX 630910 CINCINNATI OH, 45263	/ / 06/16/2026	0.0000	N N		0.00 48.11
Open						

GL NUMBER	DESCRIPTION	AMOUNT
101-265-801.000	CONTRACTED SERVICES	48.11

CINTAS 54537	CINTAS CORPORATION	06/09/2026 06/16/2026	4271765379	FOA N	MATS CLEANING	49.57
06/08/2026	P.O. BOX 630910 CINCINNATI OH, 45263	/ / 06/16/2026	0.0000	N N		0.00 49.57
Open						

GL NUMBER	DESCRIPTION	AMOUNT
101-265-801.000	CONTRACTED SERVICES	49.57

CINTAS 54463	CINTAS CORPORATION	05/31/2026 06/16/2026	9374818150	FOA N	EYEWASH SERVICE AGREEMENT	99.18
05/31/2026	P.O. BOX 630910 CINCINNATI OH, 45263	/ / 06/16/2026	0.0000	N N		0.00 99.18
Open						

Vendor Code	Vendor name	Post Date	Invoice	Bank	Invoice Description	Gross Amount
Ref #	Address	CK Run Date	PO	Hold		Discount
Invoice Date	City/State/Zip	Disc. Date	Disc. %	Sep CK		Net Amount

GL NUMBER	DESCRIPTION	AMOUNT
536-000-801.000	CONTRACTED SERVICES	99.18

VENDOR TOTAL: 196.86

CITYOFBRIG 54522	CITY OF BRIGHTON	06/01/2026	9263	FOA	CONFINED SPACE ENTRY TRAINING CLASS	403.60
	420 S THIRD STREET	06/16/2026		N		
06/01/2026	BRIGHTON MI, 48116	/ /	0.0000	N		0.00
		06/16/2026		N		403.60

Open

GL NUMBER	DESCRIPTION	AMOUNT
536-000-957.000	EDUCATION/TRAINING/CONVENTION	403.60

VENDOR TOTAL: 403.60

CONSUMER 54524	CONSUMERS ENERGY	06/01/2026	205814976321	FOA	JUNE 2026 - PARSHALLVILLE RD	52.25
	PO BOX 740309	06/16/2026		N		
06/01/2026	CINCINNATI OH, 45274-0309	/ /	0.0000	N		0.00
		06/16/2026		N		52.25

Open

GL NUMBER	DESCRIPTION	AMOUNT
206-000-920.002	UTILITIES - ELECTRIC	52.25

VENDOR TOTAL: 52.25

DOUGIES 54520	DOUGIES DISPOSAL & RECYCLING	05/25/2026	223102	FOA	CLEAN UP EVENT	13,950.00
	PO BOX 241	06/16/2026		N		
05/25/2026	HARTLAND MI, 48353	/ /	0.0000	N		0.00
		06/16/2026		Y		13,950.00

Open

GL NUMBER	DESCRIPTION	AMOUNT
101-441-801.000	CONTRACTED SERVICES	13,950.00

DOUGIES 54526	DOUGIES DISPOSAL & RECYCLING	06/05/2026	223486	FOA	JUNE 2026 PARKS TRASH	350.00
	PO BOX 241	06/16/2026		N		
06/05/2026	HARTLAND MI, 48353	/ /	0.0000	N		0.00
		06/16/2026		Y		350.00

Open

GL NUMBER	DESCRIPTION	AMOUNT
101-751-801.000	CONTRACTED SERVICES	350.00

Vendor Code	Vendor name	Post Date	Invoice	Bank	Invoice Description	Gross Amount
Ref #	Address	CK Run Date	PO	Hold		Discount
Invoice Date	City/State/Zip	Disc. Date	Disc. %	Sep CK		Net Amount

VENDOR TOTAL: 14,300.00

0070	DTE ENERGY	05/02/2026	1018187601-05/20	FOA	MAY 2026 - SETTLERS PARK	
54533		06/16/2026		N		81.70
	P.O BOX 740786					
05/02/2026	CINCINNATI OH, 45201	/ /	0.0000	N		0.00
		06/16/2026		N		81.70

Open

GL NUMBER	DESCRIPTION	AMOUNT
101-751-920.002	UTILITIES - ELECTRIC	81.70

0070	DTE ENERGY	05/02/2026	1033132801-05/20	FOA	MAY 2026 - VETERANS MEMORIAL	
54534		06/16/2026		N		23.02
	P.O BOX 740786					
05/02/2026	CINCINNATI OH, 45201	/ /	0.0000	N		0.00
		06/16/2026		N		23.02

Open

GL NUMBER	DESCRIPTION	AMOUNT
101-751-920.002	UTILITIES - ELECTRIC	23.02

0070	DTE ENERGY	05/31/2026	200416326765	FOA	MAY 2026 - MILLPOINTE, WALNUT RIDGE,	
54518		06/16/2026		N		1,797.74
	P.O BOX 740786					
05/31/2026	CINCINNATI OH, 45201	/ /	0.0000	N		0.00
		06/16/2026		N		1,797.74

Open

GL NUMBER	DESCRIPTION	AMOUNT
101-000-282.001	MILLPOINTE STREETLIGHTS DEPOSIT	242.15
101-000-282.002	FIDDLAR GROVE STREETLIGHT DEPOSIT	66.51
101-000-282.003	WALNUT RIDGE STREETLIGHTS DEPOSIT	26.66
101-448-921.000	STREET LIGHTS	1,462.42
		<u>1,797.74</u>

0070	DTE ENERGY	05/02/2026	294850801-05/202	FOA	MAY 2026 - PRV	
54535		06/16/2026		N		65.75
	P.O BOX 740786					
05/02/2026	CINCINNATI OH, 45201	/ /	0.0000	N		0.00
		06/16/2026		N		65.75

Open

GL NUMBER	DESCRIPTION	AMOUNT
536-000-920.002	UTILITIES - ELECTRIC	65.75

VENDOR TOTAL: 1,968.21

ELECTROCYC	ELECTROCYCLE INC	06/09/2026	79081	FOA	DOCUMENT DESTRUCTION	
------------	------------------	------------	-------	-----	----------------------	--

Vendor Code	Vendor name	Post Date	Invoice	Bank	Invoice Description	Gross Amount
Ref #	Address	CK Run Date	PO	Hold		Discount
Invoice Date	City/State/Zip	Disc. Date	Disc. %	Sep CK		Net Amount
54541		06/16/2026		N		42.00
	23953 RESEARCH DR					
06/09/2026	FARMINGTON HILLS MI, 48335	/ /	0.0000	N		0.00
		06/16/2026		N		42.00

Open

GL NUMBER	DESCRIPTION	AMOUNT
101-172-801.000	CONTRACTED SERVICES	42.00

VENDOR TOTAL: 42.00

0150	HARTLAND CONSOLIDATED SCHOOLS	05/31/2026	175901	FOA	MAY 2026 FUEL	
54491		06/16/2026		N		839.47
	9525 E HIGHLAND ROAD					
06/02/2026	HOWELL MI, 48843	/ /	0.0000	N		0.00
		06/16/2026		N		839.47

Open

GL NUMBER	DESCRIPTION	AMOUNT
101-239-860.000	GASOLINE	135.70
536-000-860.000	GASOLINE	703.77
		839.47

VENDOR TOTAL: 839.47

0001	HARTLAND TOWNSHIP GENERAL FUND	05/31/2026	060226	FOA	MAY 2026 - DOG LICENSE PMTS	
54494		06/16/2026		N		15.00
06/02/2026	,	/ /	0.0000	N		0.00
		06/16/2026		N		15.00

Open

GL NUMBER	DESCRIPTION	AMOUNT
701-000-290.250	DOG LICENSES ESCROW	15.00

VENDOR TOTAL: 15.00

WATERO&M	HARTLAND TOWNSHIP WATER O & M	05/31/2026	MAY 2026	FOA	OUT OF DEPT LABOR	
54468		06/16/2026		N		16,649.49
05/31/2026	HARTLAND MI, 48353	/ /	0.0000	N		0.00
		06/16/2026		N		16,649.49

Open

GL NUMBER	DESCRIPTION	AMOUNT
101-751-801.009	CONTRACT SERVICES - WATER SYSTEM	6,456.65
101-265-801.009	CONTRACT SERVICES - WATER SYSTEM	5,006.47
101-567-801.009	CONTRACT SERVICES - WATER SYSTEM	3,913.29
206-000-801.009	CONTRACT SERVICES - WATER SYSTEM	206.76
101-441-801.000	CONTRACTED SERVICES	1,066.32

16,649.49

Vendor Code	Vendor name	Post Date	Invoice	Bank	Invoice Description	Gross Amount
Ref #	Address	CK Run Date	PO	Hold		Discount
Invoice Date	City/State/Zip	Disc. Date	Disc. %	Sep CK		Net Amount
		Due Date		1099		

WATERO&M	HARTLAND TOWNSHIP WATER O & M	05/31/2026	MAY 2026 - EQUIP	FOA	OUT OF DEPT COSTS - EQUIPMENT	
54469		06/16/2026		N		1,352.89
05/31/2026	HARTLAND MI, 48353	/ /	0.0000	N		0.00
		06/16/2026		N		1,352.89

Open

GL NUMBER	DESCRIPTION	AMOUNT
101-751-801.010	CONTRACT EQUIPMENT - WATER SYS	431.90
101-265-801.010	CONTRACT EQUIPMENT - WATER SYS	383.23
101-567-801.010	CONTRACT EQUIPMENT - WATER SYS	428.88
101-441-801.000	CONTRACTED SERVICES	71.82
206-000-801.010	CONTRACT EQUIPMENT - WATER SYS	37.06
		<u>1,352.89</u>

VENDOR TOTAL: 18,002.38

0015	LIVINGSTON COUNTY SHERIFF	06/03/2026	APR - JUN 2026	FOA	QTRLY PAYMENT PER AGREEMENT	
54503		06/16/2026		N		71,974.35
06/03/2026	HOWELL MI, 48843	/ /	0.0000	N		0.00
		06/16/2026		N		71,974.35

Open

GL NUMBER	DESCRIPTION	AMOUNT
101-302-801.000	CONTRACTED SERVICES	71,974.35

0015	LIVINGSTON COUNTY SHERIFF	06/03/2026	JAN - MAR 2026	FOA	QTRLY PAYMENT PER AGREEMENT	
54502		06/16/2026		N		71,974.35
06/03/2026	HOWELL MI, 48843	/ /	0.0000	N		0.00
		06/16/2026		N		71,974.35

Open

GL NUMBER	DESCRIPTION	AMOUNT
101-302-801.000	CONTRACTED SERVICES	71,974.35

VENDOR TOTAL: 143,948.70

0220	LIVINGSTON COUNTY TREASURER	05/31/2026	060226	FOA	MAY 2026 - DOG LICENSE PMTS	
54495		06/16/2026		N		235.00
06/02/2026	200 E. GRAND RIVER HOWELL MI, 48843	/ /	0.0000	N		0.00
		06/16/2026		N		235.00

Open

GL NUMBER	DESCRIPTION	AMOUNT
701-000-290.250	DOG LICENSES ESCROW	235.00

VENDOR TOTAL: 235.00

Vendor Code	Vendor name	Post Date	Invoice	Bank	Invoice Description	Gross Amount
Ref #	Address	CK Run Date	PO	Hold		Discount
Invoice Date	City/State/Zip	Disc. Date	Disc. %	Sep CK		Net Amount
		Due Date		1099		

2909	LIVINGSTON CTY DRAIN COMMISSIO	05/29/2026	4149	FOA	MAY 2026 SEWER SYSTEM O&M	
54464		06/16/2026		N		207,714.16
	2300 E. GRAND RIVER					
05/29/2026	HOWELL MI, 48843	/ /	0.0000	N		0.00
		06/16/2026		N		207,714.16

Open

GL NUMBER	DESCRIPTION	AMOUNT
590-000-801.008	LCDC CONTRACT SERVICES	207,714.16

VENDOR TOTAL: 207,714.16

MRWA	MICHIGAN RURAL WATER ASSOCIATION	07/01/2026	2020-18053	FOA	ANNUAL DUES	
54492		06/16/2026		N		875.00
	2127 UNIVERSITY PARK DR, STE 340					
07/01/2026	OKEMOS MI, 48864	/ /	0.0000	N		0.00
		06/16/2026		N		875.00

Open

GL NUMBER	DESCRIPTION	AMOUNT
536-000-804.000	MEMBERSHIP & DUES	875.00

VENDOR TOTAL: 875.00

LCDPA	MICHIGAN.COM	07/01/2026	JULY 2026	FOA	ACCOUNT PA8741424	
54532		06/16/2026		N		63.00
	PO BOX 742520					
07/01/2026	CINCINNATI OH, 45274-2520	/ /	0.0000	N		0.00
		06/16/2026		N		63.00

Open

GL NUMBER	DESCRIPTION	AMOUNT
101-101-804.000	MEMBERSHIP & DUES	63.00

VENDOR TOTAL: 63.00

1180	PETER'S TRUE VALUE HARDWARE	06/02/2026	82561	FOA	SUPPLIES FOR SPRINKLERS AT TWP HALL	
54493		06/16/2026		N		41.52
	3455 W. HIGHLAND ROAD					
06/02/2026	MILFORD MI, 48380	/ /	0.0000	N		0.00
		06/16/2026		N		41.52

Open

GL NUMBER	DESCRIPTION	AMOUNT
101-265-802.100	IRRIGATION REPAIRS	41.52

1180	PETER'S TRUE VALUE HARDWARE	06/04/2026	K82612	FOA	TOWNSHIP HALL IRRIGATION	
54521		06/16/2026		N		49.44
	3455 W. HIGHLAND ROAD					
06/04/2026	MILFORD MI, 48380	/ /	0.0000	N		0.00

Vendor Code	Vendor name	Post Date	Invoice	Bank	Invoice Description	Gross Amount
Ref #	Address	CK Run Date	PO	Hold		Discount
Invoice Date	City/State/Zip	Disc. Date	Disc. %	Sep CK		Net Amount

		06/16/2026		N		49.44
--	--	------------	--	---	--	-------

Open

GL NUMBER	DESCRIPTION	AMOUNT
101-265-802.100	IRRIGATION REPAIRS	49.44

1180	PETER'S TRUE VALUE HARDWARE	06/09/2026	K82665	FOA	NUTS/BOLTS/WASHERS	
54538		06/16/2026		N		10.78
	3455 W. HIGHLAND ROAD					
06/09/2026	MILFORD MI, 48380	/ /	0.0000	N		0.00
		06/16/2026		N		10.78

Open

GL NUMBER	DESCRIPTION	AMOUNT
536-000-740.000	OPERATING SUPPLIES	10.78

VENDOR TOTAL: 101.74

JOHNSON	ROSATI, SCHULTZ, JOPPICH&AMTSBUECHLER	04/30/2026	1085655	FOA	APRIL 2026	
54402		06/16/2026		N		672.00
	27555 EXECUTIVE DRIVE, SUITE 250					
05/12/2026	FARMINGTON HILLS MI, 48331	/ /	0.0000	N		0.00
		06/16/2026		Y		672.00

Open

GL NUMBER	DESCRIPTION	AMOUNT
101-722-826.000	LEGAL FEES	672.00

VENDOR TOTAL: 672.00

SANMARINO	SAN MARINO EXCAVATING, INC.	05/18/2026	163932	FOA	LARGE ITEM CLEAN UP DAY DUMPSTERS	
54525		06/16/2026		N		13,235.00
	5550 MITCHEL WAY					
05/18/2026	HOWELL MI, 48843	/ /	0.0000	N		0.00
		06/16/2026		N		13,235.00

Open

GL NUMBER	DESCRIPTION	AMOUNT
101-441-801.000	CONTRACTED SERVICES	13,235.00

VENDOR TOTAL: 13,235.00

SELECTION	SELECTION.COM	06/01/2026	683774	FOA	BACKGROUND CHECKS FOR CLERKS OFFICE	
54473		06/16/2026		N		50.00
	155 TRI-COUNTY PKWY, STE 150					
06/01/2026	CINCINNATI OH, 45246	/ /	0.0000	N		0.00
		06/16/2026		Y		50.00

Open

GL NUMBER	DESCRIPTION	AMOUNT
-----------	-------------	--------

Vendor Code	Vendor name	Post Date	Invoice	Bank	Invoice Description	Gross Amount
Ref #	Address	CK Run Date	PO	Hold		Discount
Invoice Date	City/State/Zip	Disc. Date	Disc. %	Sep CK		Net Amount

101-215-716.000	EMPLOYMENT EXPENSE					50.00
VENDOR TOTAL:						50.00

SHARE CORP	SHARE CORPORATION	05/25/2026	339895	FOA	SUPPLIES	
54471	P.O. BOX 8867	06/16/2026		N		907.55
05/25/2026	CAROL STREAM IL, 60197	/ /	0.0000	N		0.00
		06/16/2026		N		907.55

Open

GL NUMBER	DESCRIPTION	AMOUNT				
536-000-740.000	OPERATING SUPPLIES	628.65				
101-751-740.000	OPERATING SUPPLIES	278.90				
		907.55				
VENDOR TOTAL:						907.55

SPALDING	SPALDING DEDECKER	03/31/2026	107550	FOA	LOC CREDIT UNION THRU 03/31/26	
54261		06/16/2026		N		5,928.00
04/15/2026	ROCHESTER HILLS MI, 48307	/ /	0.0000	N		0.00
		06/16/2026		N		5,928.00

Open

GL NUMBER	DESCRIPTION	AMOUNT				
101-400-801.100-0072	LOC UNION DEVE EXPENSES	5,928.00				
SPALDING	SPALDING DEDECKER	03/31/2026	107552	FOA	SQUARE ONE THRU 3/31/26	
54263		06/16/2026		N		4,286.00
04/15/2026	ROCHESTER HILLS MI, 48307	/ /	0.0000	N		0.00
		06/16/2026		N		4,286.00

Open

GL NUMBER	DESCRIPTION	AMOUNT				
101-400-801.100-0070	SQUARE ONE EXPENSES	4,286.00				
SPALDING	SPALDING DEDECKER	05/19/2026	107928	FOA	DUPLEX ALONG AVON ST THRU 5/3/26	
54427		06/16/2026		N		650.00
05/19/2026	905 SOUTH BLVD EAST ROCHESTER HILLS MI, 48307	/ /	0.0000	N		0.00
		06/16/2026		N		650.00

Open

GL NUMBER	DESCRIPTION	AMOUNT				
101-400-801.100	PROFESSIONAL REVIEW COSTS	650.00				
VENDOR TOTAL:						10,864.00

STAPLES	STAPLES	06/06/2026	6065783141	FOA	SORTER	
---------	---------	------------	------------	-----	--------	--

Vendor Code	Vendor name	Post Date	Invoice	Bank	Invoice Description	Gross Amount
Ref #	Address	CK Run Date	PO	Hold		Discount
Invoice Date	City/State/Zip	Disc. Date	Disc. %	Sep CK		Net Amount
		Due Date		1099		
54527		06/16/2026		N		20.46
	PO BOX 660409					
06/06/2026	DALLAS TX, 75266-0409	/ /	0.0000	N		0.00
		06/16/2026		N		20.46

Open

GL NUMBER	DESCRIPTION	AMOUNT
101-191-727.000	SUPPLIES & POSTAGE	20.46
STAPLES 54528	STAPLES	
	06/06/2026 6065783142	FOA TONER & FOLDERS
	06/16/2026	N 146.40
	PO BOX 660409	
06/06/2026	DALLAS TX, 75266-0409	/ / 0.0000 N 0.00
		06/16/2026 N 146.40

Open

GL NUMBER	DESCRIPTION	AMOUNT
101-191-727.000	SUPPLIES & POSTAGE	146.40
STAPLES 54529	STAPLES	
	06/06/2026 6065783143	FOA RECORD BOOK, FORKS
	06/16/2026	N 64.60
	PO BOX 660409	
06/06/2026	DALLAS TX, 75266-0409	/ / 0.0000 N 0.00
		06/16/2026 N 64.60

Open

GL NUMBER	DESCRIPTION	AMOUNT
101-215-727.000	SUPPLIES & POSTAGE	26.28
101-265-740.000	OPERATING SUPPLIES	38.32
		<u>64.60</u>

STAPLES	STAPLES	Post Date	Invoice	Bank	Invoice Description	Amount
54530		06/06/2026	6065783144	FOA	CALCULATOR, MOUSE PAD	
		06/16/2026		N		70.97
	PO BOX 660409					
06/06/2026	DALLAS TX, 75266-0409	/ /	0.0000	N		0.00
		06/16/2026		N		70.97

Open

GL NUMBER	DESCRIPTION	AMOUNT
101-253-727.000	SUPPLIES & POSTAGE	70.97

VENDOR TOTAL: 302.43

SCADA	UIS SCADA INC	Post Date	Invoice	Bank	Invoice Description	Amount
54523		06/04/2026	530383905	FOA	CALIBRATED TOWER LEVEL	
		06/16/2026		N		1,456.00
	2290 BISHOP CIRCLE EAST					
06/04/2026	DEXTER MI, 48130	/ /	0.0000	N		0.00
		06/16/2026		N		1,456.00

Open

Vendor Code	Vendor name	Post Date	Invoice	Bank	Invoice Description	Gross Amount
Ref #	Address	CK Run Date	PO	Hold		Discount
Invoice Date	City/State/Zip	Disc. Date	Disc. %	Sep CK		Net Amount

GL NUMBER	DESCRIPTION	AMOUNT
536-000-930.001	REPAIRS & MAINTENANCE SYSTEM	1,456.00

VENDOR TOTAL: 1,456.00

VC3, INC. 54539	VC3, INC. C/O PNC BANK P.O. BOX 746804 ATLANTA GA, 30374-6804	04/08/2026 06/16/2026	244708	FOA N	365 MONTHLY BILLING APRIL	551.46
04/08/2026		/ /	0.0000	N		0.00
		06/16/2026		N		551.46

Open

GL NUMBER	DESCRIPTION	AMOUNT
101-258-801.000	CONTRACTED SERVICES	551.46

VC3, INC. 54540	VC3, INC. C/O PNC BANK P.O. BOX 746804 ATLANTA GA, 30374-6804	04/08/2026 06/16/2026	244711	FOA N	CLOUD PROTECTION/DATA RECOVERY APRIL	302.00
04/08/2026		/ /	0.0000	N		0.00
		06/16/2026		N		302.00

Open

GL NUMBER	DESCRIPTION	AMOUNT
101-258-801.000	CONTRACTED SERVICES	302.00

VENDOR TOTAL: 853.46

WSP 54496	WSP USA INC CHICAGO IL, 60674-8618	05/29/2026 06/16/2026	40378472	FOA N	WWTP 2024-2026 THROUGH 5/1/26	1,783.20
05/29/2026		/ /	0.0000	N		0.00
		06/16/2026		N		1,783.20

Open

GL NUMBER	DESCRIPTION	AMOUNT
101-441-801.007	TREATMENT PLANT SAMPLING	1,783.20

VENDOR TOTAL: 1,783.20

TOTAL - ALL VENDORS: 419,531.01

FUND TOTALS:

Fund 101 - GENERAL FUND	206,528.05
Fund 206 - FIRE OPERATING	296.07
Fund 536 - WATER SYSTEM FUND	4,242.73
Fund 539 - WATER REPLACEMENT FUND	500.00
Fund 590 - SEWER OPERATIONS & MAINTENANCE FUND	207,714.16
Fund 701 - TRUST AND AGENCY	250.00

Hartland Township Board of Trustees Meeting Agenda Memorandum

Submitted By: Susan Case, Finance Clerk

Subject: Approve Post Audit of Disbursements Between Board Meetings

Date: June 9, 2026

Recommended Action

Move to approve the presented disbursements under the post-audit resolution.

Discussion

The following disbursements have been made since the last board meeting:

Accounts Payable – \$44,331.11

June 15, 2026 Payroll - \$94,491.86

Financial Impact

Is a Budget Amendment Required? Yes No

All expenses are covered under the adopted FY27 budget.

Attachments

Post Audit Bills List 05.28.2026

Post Audit Bills List 06.04.2026

Payroll for 06.15.2026

Check Date	Bank	Check #	Payee	Description	GL #	Amount
05/28/2026	FOA	47090	PRIORITY HEALTH	ACCRUED MEDICAL BENEFITS	001-000-257.100	4,082.48
		47090		EMPLOYMENT EXPENSE	101-172-716.000	2,098.50
		47090		EMPLOYMENT EXPENSE	101-192-716.000	1,526.14
		47090		EMPLOYMENT EXPENSE	101-209-716.000	763.07
		47090		EMPLOYMENT EXPENSE	101-215-716.000	3,777.27
		47090		EMPLOYMENT EXPENSE	101-400-716.000	763.07
		47090		EMPLOYMENT EXPENSE	101-441-716.000	4,197.00
		47090		EMPLOYMENT EXPENSE	536-000-716.000	3,204.91
						20,412.44
05/28/2026	FOA	47091	VERIZON WIRELESS	REPAIRS & MAINTENANCE	101-209-930.000	80.02
		47091		TELEPHONE	101-265-851.000	799.52
		47091		OPERATING SUPPLIES	101-751-740.000	45.02
		47091		TELEPHONE	536-000-851.000	211.77
		47091		CONTRACTED SERVICES & RENTALS	577-000-801.000	40.01
						1,176.34
TOTAL - ALL FUNDS				TOTAL OF 2 CHECKS		21,588.78

--- GL TOTALS ---

001-000-257.100	ACCRUED MEDICAL BENEFITS	4,082.48
101-172-716.000	EMPLOYMENT EXPENSE	2,098.50
101-192-716.000	EMPLOYMENT EXPENSE	1,526.14
101-209-716.000	EMPLOYMENT EXPENSE	763.07
101-209-930.000	REPAIRS & MAINTENANCE	80.02
101-215-716.000	EMPLOYMENT EXPENSE	3,777.27
101-265-851.000	TELEPHONE	799.52
101-400-716.000	EMPLOYMENT EXPENSE	763.07
101-441-716.000	EMPLOYMENT EXPENSE	4,197.00
101-751-740.000	OPERATING SUPPLIES	45.02
536-000-716.000	EMPLOYMENT EXPENSE	3,204.91
536-000-851.000	TELEPHONE	211.77
577-000-801.000	CONTRACTED SERVICES & RENTALS	40.01
	TOTAL	21,588.78

Check Date	Bank	Check #	Payee	Description	GL #	Amount
06/04/2026	FOA	47122	APPLIED CAPITAL, LLC	LEASES - COPIER	101-172-960.000	437.84
06/04/2026	FOA	47123	CROMAINE DISTRICT LIBRARY	DPPT ESCROW	701-000-290.200	1,151.20
06/04/2026	FOA	47124	ENTECH, INC.	CONTRACTED SERVICES	101-441-801.000	1,845.80
06/04/2026	FOA	47125	HARTLAND CONSOLIDATED SCHOOLS	DPPT ESCROW	701-000-290.200	384.25
06/04/2026	FOA	47126	HARTLAND CONSOLIDATED SCHOOLS	DPPT ESCROW	701-000-290.200	664.72
06/04/2026	FOA	47127	HARTLAND CONSOLIDATED SCHOOLS	DPPT ESCROW	701-000-290.200	7,704.70
06/04/2026	FOA	47128	HARTLAND ROAD FUND	DPPT ESCROW	701-000-290.200	1,134.96
06/04/2026	FOA	47129	HARTLAND TOWNSHIP FIRE OPER	DPPT ESCROW	701-000-290.200	1,626.98
06/04/2026	FOA	47130	HARTLAND TOWNSHIP GENERAL FUND	DPPT ESCROW	701-000-290.200	1,416.31
06/04/2026	FOA	47131	HOFFON, CHARLES & KERRIE	DPPT ESCROW	701-000-290.200	147.44
06/04/2026	FOA	47132	LIV. EDUCATIONAL SERVICE AGENC	DPPT ESCROW	701-000-290.200	2,268.68
06/04/2026	FOA	47133	LIVINGSTON COUNTY TREASURER	DPPT ESCROW	701-000-290.200	3,505.32
06/04/2026	FOA	47134	PETTY CASH (TREASURER)	MEMBERSHIP & DUES	101-253-804.000	10.00
		47134		SUPPLIES & POSTAGE	101-400-727.000	10.65
						20.65
06/04/2026	FOA	47135	STATE OF MICHIGAN	DUE TO STATE	001-000-214.229	433.48
			TOTAL - ALL FUNDS	TOTAL OF 14 CHECKS		22,742.33

--- GL TOTALS ---

001-000-214.229	DUE TO STATE	433.48
101-172-960.000	LEASES - COPIER	437.84
101-253-804.000	MEMBERSHIP & DUES	10.00
101-400-727.000	SUPPLIES & POSTAGE	10.65
101-441-801.000	CONTRACTED SERVICES	1,845.80
701-000-290.200	DPPT ESCROW	20,004.56
	TOTAL	22,742.33

Hartland Township Board of Trustees Meeting Agenda Memorandum

Submitted By: Larry Ciofu, Clerk

Subject: 06-02-26 Hartland Township Board Regular Meeting Minutes

Date: June 11, 2026

Recommended Action

Move to approve the Hartland Township Board Regular Meeting Minutes for June 2, 2026.

Discussion

Draft minutes are attached for review.

Financial Impact

None

Attachments

6-2-26 HTB Minutes - DRAFT

DRAFT

1. Call to Order

The meeting was called to order by Supervisor Fountain at 7:00 p.m.

2. Pledge of Allegiance

3. Roll Call

PRESENT: Supervisor Fountain, Clerk Ciofu, Treasurer Horning, Trustee Lubeski, Trustee McMullen, Trustee O'Connell, Trustee Petrucci

ABSENT: None

Also present were Township Manager Mike Luce, Assessor Amanda Carrigan, and Planning Director Troy Langer

4. Approval of the Agenda

Treasurer Horning requested to move Item 7a to 7b and Item 7b to 7a.

Move to approve the agenda for the June 2, 2026 Hartland Township Board meeting as amended.

Motion made by Trustee O'Connell, Seconded by Trustee Petrucci.

Voting Yea: Supervisor Fountain, Clerk Ciofu, Treasurer Horning, Trustee Lubeski, Trustee McMullen, Trustee O'Connell, Trustee Petrucci

Voting Nay: None

5. Call to the Public

No one came forward.

6. Approval of the Consent Agenda

Move to approve the consent agenda for the June 2, 2026 Hartland Township Board meeting as presented.

Motion made by Trustee Petrucci, Seconded by Trustee McMullen.

Voting Yea: Supervisor Fountain, Clerk Ciofu, Treasurer Horning, Trustee Lubeski, Trustee McMullen, Trustee O'Connell, Trustee Petrucci

Voting Nay: None

- a. Approve Payment of Bills
- b. Approve Post Audit of Disbursements Between Board Meetings
- c. 05-19-26 Hartland Township Board Regular Meeting Minutes
- d. Investment Policy Update

7. Pending & New Business

- a. Zoning Amendment #26-001 – Amendment to permit accessory dwelling units (ADU) in single family zoned districts.

HARTLAND TOWNSHIP BOARD OF TRUSTEES REGULAR MEETING MINUTES

June 02, 2026 – 7:00 PM

Planning Director Troy Langer stated this is an amendment to permit accessory dwelling units (ADUs) in our single-family residential zoning districts. He gave a brief overview of ADUs that would be smaller dwelling units that could either be attached to principal dwelling unit, such as in a basement, an attic, or as a garage conversion, or as a complete detached structure for that dwelling unit. He stated the Planning Committee (PC) referred this to the Ordinance Review Committee that looked at this topic, reviewed other ADU ordinances, and prepared a draft for the PC. The PC approved it, and it went to the Livingston County Planning Commission (LCPC) for review, and they have made a recommendation. Director Langer then reviewed the more important issues of the amendment. Items discussed were permitting ADUs in all residential districts except for detached ADUs only being allowed in the CA districts which has minimum lot sizes of 2 acres, parking and driveway requirements, compliance with normal zoning district standards, the requirement that the property owner must reside on the property in either the primary dwelling or the ADU, and the ability for ADUs to share in common water, septic, electric, gas and sewer utilities with the proper permits of applicable governmental authorities. Further discussion was held on attached ADUs being subject to the same zoning district requirements, and if detached, are treated as an accessory structure and are subject to all of those regulations, and size requirements, both minimum and maximum. Director Langer gave a brief overview of detached ADUs in the CA district that may be part of a pole barn and the cap on the size of the ADU in a pole barn. He stated this has been reviewed by the Township Attorney who suggested limiting ADUs to just family to limit the scope of what ADUs can be used for and this was included in the packet tonight. He did state the PC decide to not do this as the goal of the ADU ordinance from the PC was to provide some affordable housing for people in the community and did not want to limit it to just family, and that there were some concerns with enforcement of this. Supervisor Fountain and Director Langer led a brief discussion on lake front property and ADUs, and the size of detached ADUs in relation to the size of the principal dwelling.

Move to approve Zoning Amendment Text Amendment #26-001, as outlined in the staff memorandum, draft ordinance amendment, and resolution , as attached.

Motion made by Clerk Ciofu, Seconded by Trustee Petrucci. Roll call vote taken.
Voting Yea: Supervisor Fountain, Clerk Ciofu, Treasurer Horning, Trustee Lubeski,
Trustee McMullen, Trustee O'Connell, Trustee Petrucci
Voting Nay: None Motion passes: 7 - 0 - 0.

b. Appraisal for Tax Tribunal Case, Docket 25-000900-TT - Ramco Properties

Assessor Amanda Carrigan stated in 2025 Ramco Properties placed a full tax tribunal appeal for all of their properties surrounding Meijer's comprised of six parcels. She stated that at that time Ramco had gone through an acquisition of the property and upon that acquisition they filed the tribunal case with us. She stated we have been working with their attorneys for over the past year to reach a valuation. She stated right now their value is at about \$2.4 million for roughly 40 acres of land that includes three out lots that are around one acre each and another portion of property that goes through the property. Assessor Carrigan stated that sales in the vicinity of this property support our valuation and we firmly believe our valuation is accurate based on the acreage that is there. She stated we have been unable to reach any kind of agreement on the valuation at this point so it appears we will be moving forward with the appeal. She stated we are at the point in the tribunal process where we need to submit our valuation disclosure to the tribunal which is basically obtaining a third-party valuation that would support our valuation. Assessor Carrigan stated Valbridge Appraisal has done appraisals for us in the past and she reached out for an estimate for all six parcels and the original estimate came it at about \$25,000. She stated there was a small parcel where the fountain is at that is included in their appeal, but we are not going to pay to have this evaluated separately. She stated what is before the Board is \$20,000 for the appraisal itself for 2025

HARTLAND TOWNSHIP BOARD OF TRUSTEES REGULAR MEETING MINUTES

June 02, 2026 – 7:00 PM

and 2026 and an amount for the appraiser’s time should he have to attend depositions and for appearing at the trial if required, for a total amount of \$23,600. She stated we have budgeted \$10,000 for this and we would need a budget amendment of \$13,600. The appraisal is due to the tribunal in August, and it takes about six weeks to complete it.

Move to approve the engagement of Valbridge Property Advisors for the 2025/2026 appraisal for Tax Tribunal Case, Docket 25-000900-TT - Ramco Properties vs. Hartland Township.

Motion made by Treasurer Horning, Seconded by Trustee O'Connell.

Voting Yea: Supervisor Fountain, Clerk Ciofu, Treasurer Horning, Trustee Lubeski, Trustee McMullen, Trustee O'Connell, Trustee Petrucci

Voting Nay: None

c. Deputy Clerk Salary Adjustment

Clerk Ciofu stated that in light of the discussions we had on certification for the Deputy Clerk and Deputy Treasurer, Deputy Clerk Heather Cosgrove has received her Michigan Professional Municipal Clerk (MiPMC) certification, and he stated the purpose of the designation is outlined in the memo. He also stated with the things Deputy Clerk Cosgrove has done over and above her job duties, specifically applying for and obtaining a \$10,000 Americans with Disabilities ADA grant through the Michigan Municipal Clerk Association on her own that funded ADA improvements in the Township Hall. He stated all things considered he would like to increase her salary to \$31.00 per hour effective with the next pay period if approved.

Move to approve a salary adjustment for the Deputy Clerk to \$31.00 per hour and the necessary budget amendment to Department 215.

Motion made by Trustee O'Connell, Seconded by Trustee Lubeski.

Voting Yea: Supervisor Fountain, Clerk Ciofu, Treasurer Horning, Trustee Lubeski, Trustee McMullen, Trustee O'Connell, Trustee Petrucci

Voting Nay: None

8. Board Reports

Trustee McMullen - No report.

Trustee Petrucci - No report.

Clerk Ciofu - No report.

Treasurer Horning - Stated they are in the middle of creating the new tax roll for the bills to go out in a couple of weeks. She stated she is waiting on some items from Assessing and should have it over to the County tomorrow. She stated all of the new people are doing great and they are working through the issues of changing computers and email names and stated it is actually going very smoothly.

Trustee O'Connell - Stated that HDFA Fire Chief Carroll has been out in public, at the Farmer's Market and the Memorial Day Parade, talking to the citizens about the fire millage that is coming up in August.

Trustee Lubeski - No report.

Supervisor Fountain - Stated the Hartland Chamber has their Annual Polo Event this weekend with tickets still available for the Saturday Event and that Sunday is the Family Day Event.

[BRIEF RECESS]

9. Information / Discussion

a. Manager's Report

HARTLAND TOWNSHIP BOARD OF TRUSTEES REGULAR MEETING MINUTES

June 02, 2026 – 7:00 PM

Manager Luce stated he and Public Works Director Scott Hable met with residents of Dunham Lake Estates with regards to the paving of the internal roads of Dunham Lakes Estates. He stated they informed them it would probably be a little over \$6,000 per parcel to take on this project without including their neighbors on Tipsico Lake Rd. He stated that it would reduce the per parcel amount by around \$2,000 if the Tipsico Lake Rd residents participated in the project but it is uncertain if they would do so now that Hartland Township and Livingston County Road (LCRC) are sharing the cost to pave Tipsico Lake Rd. in this area. Consensus of the residents was to move forward without the Tipsico Lake residents, and they requested a meeting with the LCRC to see if there is any available funding for this project from them. Manager Luce stated San Marino has been submitting the SAD petition forms that are being reviewed by the Clerk's department and they are still waiting on the lead individual from San Marino to inform us they are complete with their submission of signatures. Manager Luce stated that East Peterson/West Peterson, which is Pleasant Valley Homeowners Association, are also looking to get their SAD going. Manager Luce stated the Hartland Polo Event is this Saturday, with the Family Fun Day on Sunday and tickets are available.

Manager Luce stated we have three new employees the are fitting in very well within the Township. He also stated that we are in the process of looking at new IT service companies as we have had ongoing issues with VC3. He stated we have met with another IT service company, and he provided a brief update of their organization, services, response times, and cost. Manager Luce is going to come back to the Board with a recommendation to move to another IT service company in the near future. A brief discussion was held on how a transfer of service would be implemented if approved by the Board. Trustee McMullen suggested another IT service company that she has worked with and Manager Luce stated they have looked at them in this process. Manager Luce stated the HERO Center has inquired as to whether one of their Board members, Pastor Russ Greer would be able to use the Teen Center for his Sunday services. Pastor Greer currently holds his services at the Hartland Music Hall but was recently informed that because of the vintage organ in the Music Hall he would be required to provide a large liability insurance liability policy for his church to continue to use the Music Hall. A brief discussion was held on this issue, and it was the consensus of the Board that if a nominal rental amount and a appropriate liability insurance policy could be worked out with the HERO Board, the Board would not have an issue with this. Manager Luce stated there is a pre-construction with Chick-Fil-A tomorrow and they have their demolition permit and should be moving forward quickly. He also stated we would be receiving Sheetz final construction plans in the next few days. Trustee Petrucci inquired as to setting up a meeting with the HDFA next week.

- b. Workshop - Revisions to Zoning Amendment 26-002 Backyard Chickens / Code Enforcement.

Manager Luce gave a brief overview of the Boards discussion at the last meeting regarding the proposed backyard chicken zoning ordinance and stated he added Code Enforcement to this as they are somewhat related with regards to this issue, and that the PC has had discussions on the Code Enforcement role in the community. As to the chicken ordinance, he stated the PC has recommended reducing the acreage requirement to have chickens from 2.5 acres to .62 acres (30,000 sq.ft.). Manager Luce displayed maps of properties in the Township that were over 2.5 acres, over 1 acre, and .62 acres as a comparison. Manager Luce and Planning Director Troy Langer then led a discussion on the proposed amendment to the zoning ordinance for chickens. Items discussed were the current zoning for allowing chickens, the review of other township ordinances, the proposed ordinance restriction on having roosters, a review of the subdivision

HARTLAND TOWNSHIP BOARD OF TRUSTEES REGULAR MEETING MINUTES

June 02, 2026 – 7:00 PM

and lakes areas that would allow for chickens under the new ordinance, the lack of any architectural standards for the chicken coops that would be required in the proposed ordinance, and setback requirements. Other items briefly discussed were potential disease considerations, HOA by-laws that would supersede the proposed ordinance and potential input from HOA's on the issue, potential nuisance issues, potential owner maintenance issues, and code enforcement issues. The Board was divided on the issue and Director Langer stated he would take the Board concerns back to the PC. Supervisor Fountain made a recommendation to hold a future work session regarding the Code Enforcement that was to be included in this discussion item tonight and it was the consensus of the Board to add it to the next meeting agenda.

10. Adjournment

Move to adjourn the meeting at 9:00 p.m.

Motion made by Trustee O'Connell, Seconded by Trustee Lubeski.

Voting Yea: Supervisor Fountain, Clerk Ciofu, Treasurer Horning, Trustee Lubeski, Trustee McMullen, Trustee O'Connell, Trustee Petrucci

Voting Nay: None

Submitted by:

Larry N. Ciofu, Clerk

Hartland Township Board of Trustees Meeting Agenda Memorandum

Submitted By: Susan Dryden-Hogan, Finance Director

Subject: Valbridge Property Advisors Budget Amendment

Date: June 16, 2026

Recommended Action

Motion to approve the attached budget amendment to increase the Assessor's legal fees to pay for the approved appraisal of Ramco Properties by Valbridge Property Advisors.

Discussion

The previous agenda item proposed and approved at the June 2, 2026, meeting, was missing the specific details on the budget amendment for the appraisal. The attached budget amendment corrects the missing information.

Financial Impact

Is a Budget Amendment Required? Yes No

See processed budget amendment attached.

Attachments

Budget Amendment Ramco Appraisal

JOURNAL ENTRY

JE: 91082

Post Date: 06/16/2026

Entered By: SUSAN

Entry Date: 06/11/2026

Journal: BA

Description: VALBRIDGE PROPERTY ADVISORS

BUDGET AMENDMENT TO INCREASE ASSESSING LEGAL FEES
FOR RAMCO PROPERTTIES APPRAISAL - SEE BOARD APPROVAL
ON 6/2/26

GL #	Description	Increase/(Decrease)
101-209-826.000	LEGAL FEES	13,600.00
	Revenue Change:	0.00
	Expenditure Change:	13,600.00
	Budgeted Change To Fund Balance:	(13,600.00)

APPROVED BY: Susan Dyden

Hartland Township Board of Trustees Meeting Agenda Memorandum

Submitted By: Larry Ciofu, Clerk

Subject: Gen-X – Waldenwoods Fireworks Permit Application

Date: June 12, 2026

Recommended Action

Move to approve the Permit for a Fireworks Display for Gen-X Pyrotechnics on July 4, 2026 at Waldenwoods Resort.

Discussion

Gen-X Pyrotechnics has applied to perform a fireworks display at 2975 Old US-23, which is Waldenwoods, on Saturday, July 4, 2026. The applicant intends to launch the fireworks from a barge on Lake Walden. The Hartland-Deerfield Fire Authority Fire Marshal has reviewed this Application and is recommending approval contingent on following the items listed in their June 3, 2026, letter (attached).

Financial Impact

None

Attachments

Gen-X – 2026 Waldenwoods – 7-4-26

2026 Waldenwoods

GEN-X PYROTECHNICS

Gen-X Pyrotechnics offers the highest quality custom pyrotechnics designed specifically to meet the needs of our clients. We are a local company that markets on word of mouth advertising and now on the web. We specialize in one of a kind shows.

In this constantly changing world of pyrotechnics we strive to learn the most up-to-date innovations so we can continue to hone our craft.

We take pride in being trained in all the local and federal safety regulations and guidelines.

Jason Trudeau

Jason Trudeau



248.252.0029



genxpyro@comcast.net
info@genxpyrotechnics.com



www.genxpyrotechnics.com



MARINE SPECIAL EVENT APPLICATION AND PERMIT

Issued under authority of Part 801, Marine, Part 811 ORV and Part 821 Snowmobile, of the Natural Resource and Environmental Protection Act, Act 451, P. A. of 1994, as amended. Failure to comply with the provisions of this Act is a misdemeanor and may result in fines and/or imprisonment.

DNR USE ONLY
Permit Number

APPLICANT: This completed and signed application must be received by the appropriate DNR office at least 30 days prior to the event, or the permit may not be authorized. Locations and addresses on next page.

Form with fields for Name of Applicant, Sponsoring Organization, Event Name, Address, City, State, ZIP, Email, Telephone, Event Date, Starting/Finishing Times, Type of Event (Marine, Off-Road Vehicle, Snowmobile), Location of Event, and Medical Support Units.

APPLICANT: Read all pages and attachments before certification and signature.

CERTIFICATION

I hereby certify that I have read, understand, and agree to abide by the conditions contained on page 2, governing this permit in the conduct of the operations under this permit, and that the information provided is true and accurate to the best of my knowledge.

Signature: Jason Trudeau, Date: 5/7/26

APPLICANT: Submit completed and signed application to appropriate DNR office at least 30 days prior to event or permit may not be authorized. Locations and addresses on next page.

FOR DNR USE ONLY

Investigation Findings & Recommendations section with text for state any problems and fields for Investigating Officer, Badge Number, Signature, and Date of Investigation.

AUTHORIZATION

Authorization section with checkboxes for Event Authorized/Not Authorized, Number of Law Enforcement Patrol Boats Vehicles, Special Conditions, and fields for District Law/Permit Supervisor, Signature, and Date.

Waldenwoods

Exhibit A

Distance- 600 ft diameter (NFPA regulation)

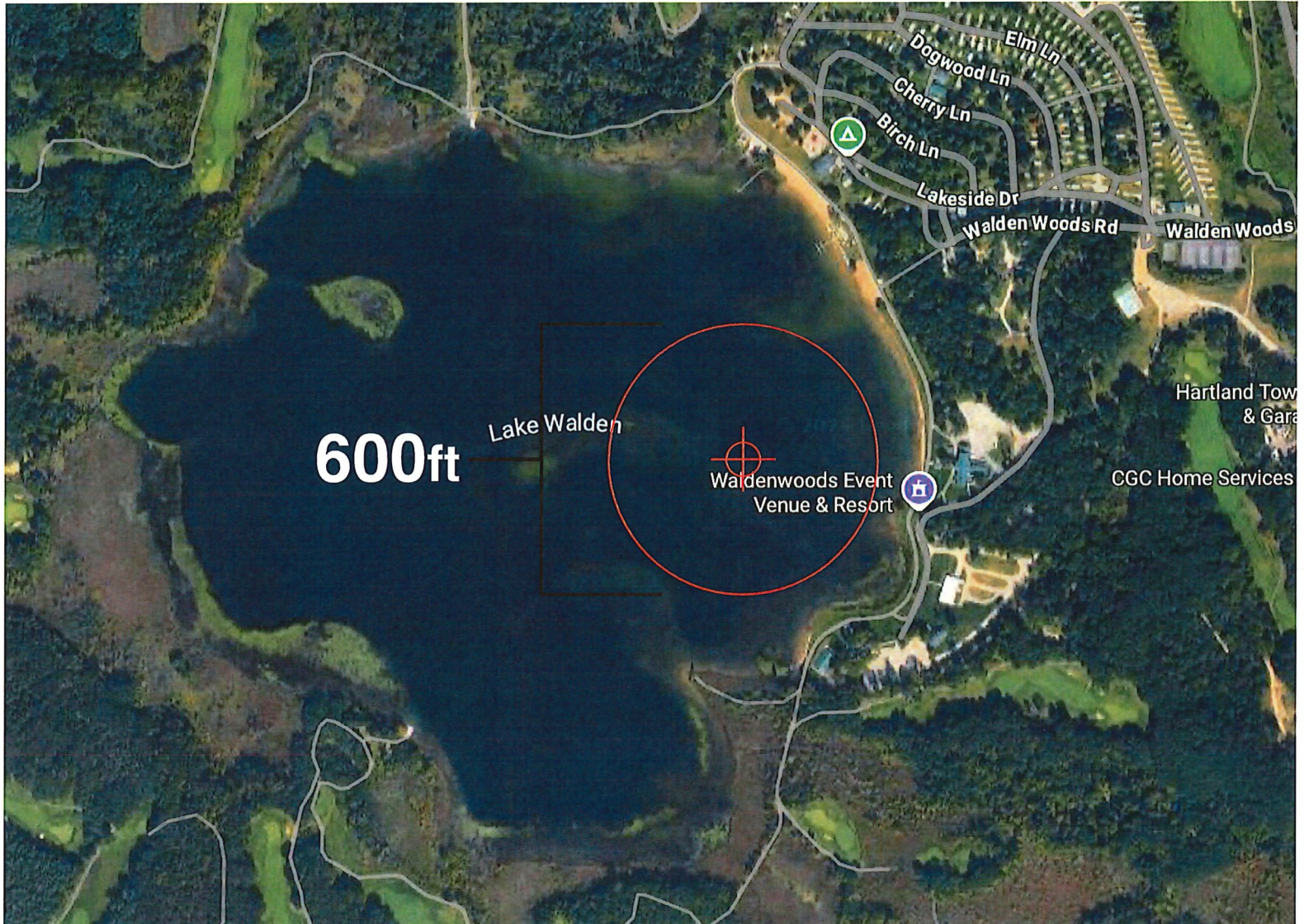

Key

 : Placement of display

 : Perimeter of 300 ft will be held around display

In accordance with the provisions of Title XI, Organized Crime Control Act of 1970, and the regulations issued thereunder (27 CFR Part 555), you may engage in the activity specified in this license or permit within the limitations of Chapter 40, Title 18, United States Code and the regulations issued thereunder, until the expiration date shown. **THIS LICENSE IS NOT TRANSFERABLE UNDER 27 CFR 555.53.** See "WARNINGS" and "NOTICES" on reverse.

Direct ATF Correspondence To ATF - Chief, FELC 244 Needy Road Martinsburg, WV 25405-9431	License/Permit Number 4-MI-125-54-7F-01210
Chief, Federal Explosives Licensing Center (FELC) <i>Mama Howard</i>	Expiration Date June 1, 2027
Name GEN X PYROTECHNICS	

Premises Address (Changes? Notify the FELC at least 10 days before the move.)
**2906 PINE NEEDLE DR
WHITE LAKE, MI 48383-**

Type of License or Permit
54-USER OF EXPLOSIVES

Purchasing Certification Statement
The licensee or permittee named above shall use a copy of this license or permit to assist a transferee of explosives to verify the identity and the licensed status of the licensee or permittee as provided by 27 CFR Part 555. The signature on each copy must be an original signature. A faxed, scanned or e-mailed copy of the license or permit with a signature intended to be an original signature is acceptable. The signature must be that of the Federal Explosives Licensee (FEL) or a responsible person of the FEL. I certify that this is a true copy of a license or permit issued to the licensee or permittee named above to engage in the business or operations specified above under "Type of License or Permit."

Mailing Address (Changes? Notify the FELC of any changes.)
**GEN X PYROTECHNICS
2906 PINE NEEDLE DR
WHITE LAKE, MI 48383-**

Licensee/Permittee Responsible Person Signature	Position/Title
Printed Name	Date

Previous Edition is Obsolete GEN X PYROTECHNICS-2906 PINE NEEDLE DR-48383-4-MI-125-54-7F-01210-June 1, 2027-54-USER OF EXPLOSIVES ATF Form 5400.14/5400.15 Part I Revised September 2011

Federal Explosives License (FEL) Customer Service Information
Toll-free Telephone Number: (877) 283-3352
Fax Number: (304) 616-4401
E-mail: FELC@atf.gov
ATF Homepage: www.atf.gov

Change of Address (27 CFR 555.54(a)(1)). Licensees or permittees may during the term of their current license or permit remove their business or operations to a new location at which they intend regularly to carry on such business or operations. The licensee or permittee is required to give notification of the new location of the business or operations not less than 10 days prior to such removal with the Chief, Federal Explosives Licensing Center. The license or permit will be valid for the remainder of the term of the original license or permit. **(The Chief, FELC, shall, if the licensee or permittee is not qualified, refer the request for amended license or permit to the Director of Industry Operations for denial in accordance with § 555.54.)**

Right of Succession (27 CFR 555.59). (a) Certain persons other than the licensee or permittee may secure the right to carry on the same explosive materials business or operations at the same address shown on, and for the remainder of the term of, a current license or permit. Such persons are: (1) The surviving spouse or child, or executor, administrator, or other legal representative of a deceased licensee or permittee; and (2) A receiver or trustee in bankruptcy, or an assignee for benefit of creditors. (b) In order to secure the right provided by this section, the person or persons continuing the business or operations shall furnish the license or permit for for that business or operations for endorsement of such succession to the Chief, FELC, within 30 days from the date on which the successor begins to carry on the business or operations.

Cut Here ✂

Federal Explosives License/Permit (FEL) Information Card

License/Permit Name: **GEN X PYROTECHNICS**

Business Name:

License/Permit Number: **4-MI-125-54-7F-01210**

License/Permit Type: **54-USER OF EXPLOSIVES**

Expiration: **June 1, 2027**

Please Note: Not Valid for the Sale or Other Disposition of Explosives.

(Continued on reverse side)



05/16/2024

NOTICE OF CLEARANCE

for individuals transporting, shipping, receiving, or possessing explosive materials.

ISSUED TO: GEN X PYROTECHNICS

Federal Explosives license/permit no.: 4-MI-125-54-7F-01210

NOTICE DATE: 05/16/2024

Expiration Date: **June 1, 2027**

EXPIRATION DATE: This Notice expires when superseded by a newer Notice which will list all current responsible persons and employee possessors, or when the license or permit expires - whichever comes first.

Explosives License/Permit Type: 54-USER OF EXPLOSIVES

- 1 **WARNING.** Only those individuals listed below as **RESPONSIBLE PERSONS** and **EMPLOYEE POSSESSORS** with a background clearance status of "CLEARED" or "PENDING" are authorized to transport, ship, receive, or possess explosive materials in the course of employment with you.
- 2 **"DENIED" STATUS.** If an employee possessor has a background clearance status of "DENIED", you **MUST** take immediate steps to remove the employee from a position requiring the transporting, shipping, receiving, or possessing of explosive materials. Also, if the employee has been listed as a person authorized to accept delivery of explosive materials, you **MUST** remove the employee from such list and immediately, and in no event later than the second business day after such change, notify distributors of such change, as stated in 27 CFR 555.33(a).
- 3 **CHANGE IN RESPONSIBLE PERSONS.** You **MUST** report any change in responsible persons to the Chief, Federal Explosives Licensing Center, within 30 days of the change and new responsible persons **MUST** include "appropriate identifying information" as defined in 27 CFR 555.11. Fingerprints and photos are **NOT** required, however they will be required upon renewal of the license or permit.
- 4 **CHANGE OF EMPLOYEES.** You **MUST** report any change of employee/possessors to the Chief, FELC, within 30 days. Reports relating to newly hired employees must be submitted on ATF Form 5400.28 for **EACH** employee.

Premises Address:	2906 PINE NEEDLE DR WHITE LAKE, MI 48383
Mailing Address:	GEN X PYROTECHNICS 2906 PINE NEEDLE DR WHITE LAKE, MI 48383

This 'Notice of Clearance' is provided to you as required by 18 U.S.C. 843(h) and **MUST** be retained as part of your permanent records and be made available for examination or inspection by ATF officers as required by 27 CFR 555.121. If you receive a Notice subsequent to this Notice, this Notice will no longer be valid.

In accordance with 27 CFR 555.33, Background Checks and Clearances, and 27 CFR 555.57, Change of Control, Change in Responsible Persons, and Change of Employees, ATF's Federal Explosives Licensing Center (FELC) has conducted background checks on the individual(s) you identified as a responsible person(s) and an employee/possessor(s) on your application, or reported after the issuance of your license/permit.

The following is a SUMMARY of the results of the background checks conducted on the individuals you reported as responsible persons and employee/possessors. ATF will be notifying ALL individuals listed on this document of their respective status by separate letter mailed to their residence address.

PLEASE BE ADVISED THAT IT IS UNLAWFUL FOR ANY PERSON REFLECTING A STATUS OF "DENIED" TO TRANSPORT, SHIP, RECEIVE, OR POSSESS EXPLOSIVE MATERIALS.

Please carefully review this Notice to ensure that all the information is accurate. If this Notice is incorrect, please return the Notice to the Chief, FELC, with a statement showing the nature of the error(s). The Chief, FELC, shall correct the error, and return a corrected Notice.

Number of RESPONSIBLE PERSON(S) : 1
Number of EMPLOYEE POSSESSOR(S): 4

LAST NAME, First Name, Middle Name	Clearance Status
RESPONSIBLE PERSONS:	
0001 TRUDEAU, JASON ANTHONY	1 Cleared
EMPLOYEE POSSESSORS:	
0001 BECK, TYLER RUSSELL	4 Cleared
0002 CARRIGER, JOSHUA ROY	Cleared
0003 DIETLE, DEREK JAMES	Cleared
0004 DIETLE, JACK ANTHONY	Cleared

continued

LAST NAME, First Name, Middle Name	Clearance Status
------------------------------------	------------------

4-MI-125-54-7F-01210 expiration date: June 1, 2027 GEN X PYROTECHNICS OF 2906 PINE NEEDLE DR, WHITE LAKE, MI 48383



U.S. Department of Justice
 Bureau of Alcohol, Tobacco, Firearms and Explosives
 Federal Explosives Licensing Center
 244 Needy Road
 Martinsburg, West Virginia 25405

901090: MH/FLS
 5400
 File Number: **4MI01210**

05/16/2024

SUBJECT: RESPONSIBLE PERSON LETTER OF CLEARANCE for:

JASON ANTHONY TRUDEAU

CEO
 (248)252-0029

2906 PINE NEEDLE DR
 WHITE LAKE, MI 48383

and is ONLY valid under the following Federal explosives license/permit:

4-MI-125-54-7F-01210

GEN X PYROTECHNICS
 2906 PINE NEEDLE DR
 WHITE LAKE, MI 48383

Dear JASON TRUDEAU:

You have been approved as a responsible person under the above-listed Federal explosive license or permit. You may lawfully direct the management or policies of the business or operations as they pertain to explosives. You may also lawfully transport, ship, receive or possess explosive materials incident to your duties as a responsible person. **This clearance is only valid under the license or permit referenced above.**

Sincerely,

Marna Howard
 Chief, Federal Explosives Licensing Center (FELC)

FELC Customer Service. If you believe that information on your "Letter of Clearance" is incorrect, please return a COPY of the letter to the Chief, Federal Explosives Licensing Center (FELC), with a statement showing the nature of the error. The Chief, FELC, shall correct the error, and return an amended letter to you.

Mail: ATF
 Chief, FELC
 Attn.: LOC Correction
 244 Needy Road
 Martinsburg, West Virginia 25405

Fax: 1-304-616-4401
 Chief, FELC
 Attn.: LOC Correction

Call toll-free: 1-877-283-3352

WWW.ATF.GOV

4MI01210-R-05/16/2024--TRUDEAU-JASON-ANTHONY--CEO

JASON ANTHONY TRUDEAU

Responsible Person Letter of Clearance for:

MICHIGAN MI USA

COMMERCIAL DRIVER LICENSE



T 630 373 067 896

ISS 11-21-2022

DOB 11-23-1968

EXP 11-23-2026

112368

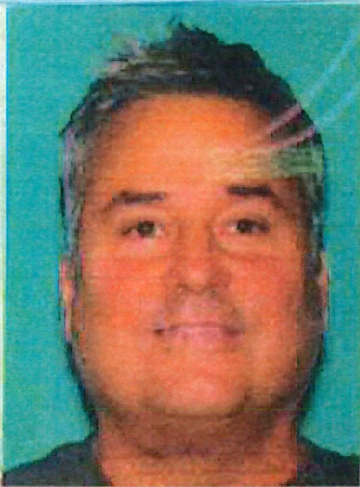

JASON ANTHONY TRUDEAU

2906 PINE NEEDLE DR
WHITE LAKE, MI 48383-3283

Sex M

Hgt 601

Eyes BRO

Lic Type CC

End H

Restrictions K-CDL Intrastate only, L-No air brake equipped
CMV



Jason Trudeau

DD: 1205615691182

Rev 08-16-2021

MSDS - *Material Safety Data Sheet*
UN0335, FIREWORKS 1.3G, PGII

Emergency Call Info Trac (800) 535-5053 ACE Pyro Contract #100630

Section II - Hazardous Ingredients / Identity Information

Contains Pyrotechnic Compositions that are mixtures of solid oxidizers and fuels that contained in paper and cardboard containers. No Hazard exists during normal handling and storage.

OSHA PEL - N/A ACGIH TLV - N/A

OTHER LIMITS - N/A

Section III - Physical / Chemical Characteristics

Boiling Point: - N/A Specific Gravity: - N/A

Vapor Pressure: - N/A Melting Point: - N/A

Vapor Density: - N/A Evaporation Rate: - N/A

Solubility in Water: - N/A

Appearance and Odor: - Pyrotechnic Composition is contained in paper or cardboard casings that may be shaped as cylinders, balls or tubes. Odor is not apparent.

Section IV - Fire and Explosion Hazard Data

Flash Point: - N/A Flammable Limits: - N/A

LEL: - N/A UEL: - N/A

Extinguishing Media: Deluge with large quantities of water as quickly as possible by FIRE HOSE from a PROTECTED location. Materials are self-oxidizing.

Special Fire Fighting Procedures: Do not attempt to fight a fire in the immediate area of 1.3G Fireworks- EVACUATE THE AREA.

Section IV - Fire and Explosion Hazard Data- Continued

Unusual Fire and Explosion Hazards: Fireworks 1.3G MAY MASS EXPLODE IN A FIRE. DO NOT ALLOW FIREWORKS TO GET WET- Hazardous Decomposition May Result in a FIRE or EXPLOSION. EXPLOSION MAY OCCUR IF EXPOSED TO SPARKS OR FLAME.

Section V - Reactivity Data

Stability: - Stable

Conditions to Avoid: - Open Flames, Sparks, High Temperatures, Friction or Impact.

Incompatibility (*Materials to Avoid*): - Do Not Allow Fireworks to Get Wet.

Hazardous Decomposition or Byproducts: - Decomposition does not occur under normal circumstances. Smoke Generated by Fireworks may contain gasses that are irritating to the eyes or mucous membranes. Prolonged Exposure and Inhalation of smoke may cause shortness of breath or more serious problems when a chronic respiratory condition exists.

Hazardous Polymerization: Will Not Occur

Conditions to Avoid: - Storage in High Temperatures, Moist or Wet Conditions, Keep away From Open Flame or Sparks.

Section VI – Health Hazard Data

Route(s) of Entry: - N/A Inhalation: -N/A Skin: - N/A Ingestion: - N/A

Health Hazards (Acute and Chronic): - N/A

Carcinogenicity: N/A NTP?: - N/A IARC Monographs?: -N/A

OSHA Regulated: - NO

Signs and Symptoms of Exposure: - Prolonged Exposure to smoke that is Generated during Normal use of Fireworks may cause Irritation to Eyes and to Mucous Membranes.

Medical Conditions Generally Aggravated by Exposure: - Eye Sensitivity, Respiratory Conditions.

Emergency and First Aid Procedure: - EYES should be flushed with water. Move to Fresh Air and avoid additional Inhalation of Smoke.

Section VII – Precautions for Safe Handling and Use

Steps to Be Taken in Case Material is Released or Spilled: - If Fireworks are spilled, carefully pick up the material and place in a Cardboard Carton. Keep OPEN FLAMES and Sparks AWAY and NO SMOKING.

Waste Disposal Method: - Fireworks that fail to go off should be soaked in a bucket of water and returned to the source where it was obtained. Dry components or powder should be carefully swept up and placed in a cardboard container then soaked with water. Burning of Fireworks Waste must be performed in compliance with local and state laws.

Precautions in Handling and Storing: - Keep from OPEN FLAMES, NO SMOKING, AVOID IMPACT of MATERIALS and CONTAINERS of MATERIALS, STORE FIREWORKS IN A COOL AND DRY ENVIORNMENT. FIREWORKS 1.3G MUST BE STORED AND TRANSPORTED IN COMPLIANCE WITH FEDERAL, STATE AND LOCAL LAWS.

Other Precautions: - UN0335 Fireworks 1.3G can cause SERIOUS INJURY or DEATH. They should only be Handled by Properly Trained and Qualified Personnel. When Shooting these Fireworks; PERSONNEL SHOULD WEAR PROPER EYE PROTECTION, HEAD PROTECTION AND NON-SYNTHETIC CLOTHING.

Section VIII – Control Measures

Respiratory Protection: N/A

Ventilation: - N/A Local Exhaust: - N/A Special: - N/A

Mechanical: -N/A Other: - N/A

Protective Gloves:- N/A Eye Protection: - When Shooting Fireworks 1.3G

Other Protective Clothing or Equipment: - Protective Head Gear and Non-Synthetic Clothing when Shooting Fireworks 1.3G.

Work / Hygienic Practices: - Store Fireworks in a Cool Dry and Well Ventilated area. Protect Against Physical Damage and Moisture. Fireworks should be Isolated from all Heat Sources, Sparks and Open Flame. No Smoking.

Firework Disposal Procedure

Please follow the two simple guidelines below for the proper disposal of any unused display fireworks

1. If any display fireworks are found, submerge the firework in a five-gallon bucket of water.
2. Contact Jason Trudeau with Gen-X Pyrotechnics for proper pickup.

Gen-X Pyrotechnics will pick up any unused display fireworks and take them to an authorized facility for a proper disposal.



248.252.0029



genxpyro@comcast.net
info@genxpyrotechnics.com



www.genxpyrotechnics.com



HARTLAND DEERFIELD FIRE AUTHORITY
HARTLAND AREA FIRE DEPT.

3205 Hartland Road
Hartland, MI. 48353-1825

Voice: (810) 632-7676
E-Mail: firemarshal@hartlandareafire.com

June 3, 2026

To: Hartland Township Board
Attn: Clerk Larry Ciofu
2655 Clark Rd.
Hartland, MI 48353

Re: Waldenwoods application for fireworks on July 4, 2026

Based upon the review of the application named above and inspection of the proposed site for the fireworks display for July 4, 2025, the Fire Department recommends approval of the request contingent upon the following:

- 1) Gen-X Pyrotechnics, Inc. is responsible for ensuring that NFPA 1123 is followed.
- 2) Based upon vegetation / weather conditions, the fire department may have a brush truck at the launching site with sufficient personnel to handle any fire emergencies that may arise.
- 3) No one will be allowed within 100 yards of the launch site during the display.
- 4) Smoking and open flame will not be permitted within 50 feet of the launch site. Exception: Items required for the ignition of the displays by trained and certified professionals.
- 5) The display will not begin until all persons are off the lake. The display will be stopped in the event anyone ventures onto the lake, and the display will not be resumed until the lake is cleared.
- 6) It is understood that the fire department will not allow the display to commence or continue if these conditions are not met, or in the event of conditions arising, such as adverse weather or faulty firing of the displays, or any condition which this department deems unsafe for the display to continue.
- 7) Insurance as agreed upon by the Hartland Township Board.
- 8) Final approval and permitting by the Hartland Township Board.

The Long Lake fireworks display continues to be a spectacular addition to events while keeping the safety and welfare of all spectators, workers, and buildings first on their agenda. Should you have any other questions, or we can be of further assistance, please call.

Fire Marshal

Hartland Township Board of Trustees Meeting Agenda Memorandum

Submitted By: Larry Ciofu, Clerk

Subject: Long Lake Fireworks Display Permit – 7-11-26

Date: June 12, 2026

Recommended Action

Move to approve the Permit for Fireworks Display on Long Lake on July 11, 2026.

Discussion

Long Lake has applied to perform fireworks on Long Lake on July 11, 2025. Gen-X Pyrotechnics will perform the fireworks and intends to launch the fireworks from a barge on Long Lake

The Hartland-Deerfield Fire Authority Fire Marshal has reviewed this Application and is recommending approval contingent on following the items listed in their June 3, 2026, letter (attached).

Financial Impact

None

Attachments

Long Lake 7-11-26 Fireworks Permit

2026 Long Lake Hartland

GEN-X PYROTECHNICS

Gen-X Pyrotechnics offers the highest quality custom pyrotechnics designed specifically to meet the needs of our clients. We are a local company that markets on word of mouth advertising and now on the web. We specialize in one of a kind shows.

In this constantly changing world of pyrotechnics we strive to learn the most up-to-date innovations so we can continue to hone our craft.

We take pride in being trained in all the local and federal safety regulations and guidelines.

Jason Trudeau

Jason Trudeau



248.252.0029



genxpyro@comcast.net
info@genxpyrotechnics.com



www.genxpyrotechnics.com



MARINE SPECIAL EVENT APPLICATION AND PERMIT

Issued under authority of Part 801, Marine, Part 811 ORV and Part 821 Snowmobile, of the Natural Resource and Environmental Protection Act, Act 451, P. A. of 1994, as amended. Failure to comply with the provisions of this Act is a misdemeanor and may result in fines and/or imprisonment.

DNR USE ONLY
Permit Number

APPLICANT: This completed and signed application must be received by the appropriate DNR office at least 30 days prior to the event, or the permit may not be authorized. Locations and addresses on next page.

Form with fields for Name of Applicant, Sponsoring Organization, Event Date, Location of Event, and various checkboxes for event types like Marine, Fireworks, etc.

APPLICANT: Read all pages and attachments before certification and signature.

CERTIFICATION section with signature line for Jason Trudeau and date 5/7/26.

APPLICANT: Submit completed and signed application to appropriate DNR office at least 30 days prior to event or permit may not be authorized. Locations and addresses on next page.

FOR DNR USE ONLY section containing Investigation Findings & Recommendations and fields for Investigating Officer, Badge Number, Signature, and Date of Investigation.

AUTHORIZATION section with checkboxes for event authorization and fields for Number of Law Enforcement Patrol Boats Vehicles and Special Conditions.

Long Lake Hartland

Exhibit A

Distance- 840 ft diameter (NFPA regulation)

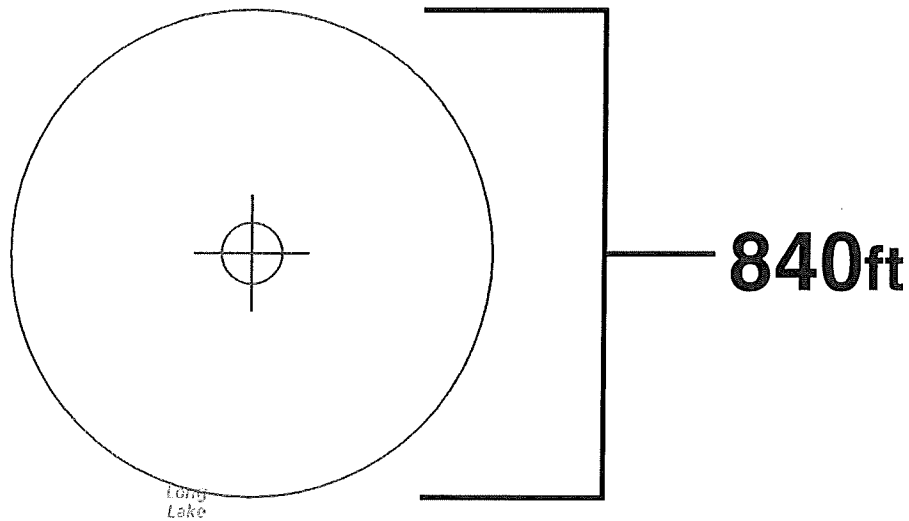
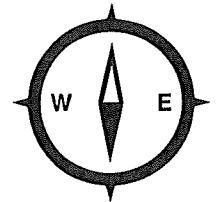

Key

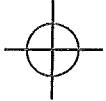
 : Placement of barge

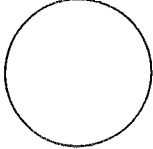
 : Perimeter of 420 ft will be held around barge during display

Federal Explosives License/Permit (18 U.S.C. Chapter 40)

In accordance with the provisions of Title XI, Organized Crime Control Act of 1970, and the regulations issued thereunder (27 CFR Part 555), you may engage in the activity specified in this license or permit within the limitations of Chapter 40, Title 18, United States Code and the regulations issued thereunder, until the expiration date shown. **THIS LICENSE IS NOT TRANSFERABLE UNDER 27 CFR 555.53.** See "WARNINGS" and "NOTICES" on reverse.

Direct ATF Correspondence To ATF - Chief, FELC 244 Needy Road Martinsburg, WV 25405-9431	License/Permit Number 4-MI-125-54-7F-01210
Chief, Federal Explosives Licensing Center (FELC) <i>Mama Howard</i>	Expiration Date June 1, 2027
Name GEN X PYROTECHNICS	

Premises Address (Changes? Notify the FELC at least 10 days before the move.)
**2906 PINE NEEDLE DR
 WHITE LAKE, MI 48383-**

Type of License or Permit
54-USER OF EXPLOSIVES

Purchasing Certification Statement
 The licensee or permittee named above shall use a copy of this license or permit to assist a transferor of explosives to verify the identity and the licensed status of the licensee or permittee as provided by 27 CFR Part 555. The signature on each copy must be an original signature. A faxed, scanned or e-mailed copy of the license or permit with a signature intended to be an original signature is acceptable. The signature must be that of the Federal Explosives Licensee (FEL) or a responsible person of the FEL. I certify that this is a true copy of a license or permit issued to the licensee or permittee named above to engage in the business or operations specified above under "Type of License or Permit."

Mailing Address (Changes? Notify the FELC of any changes.)
 GEN X PYROTECHNICS
 2906 PINE NEEDLE DR
 WHITE LAKE, MI 48383-

Licensee/Permittee Responsible Person Signature	Position/Title
Printed Name	Date

Previous Edition is Obsolete GEN X PYROTECHNICS:2906 PINE NEEDLE DR:48383:4-MI-125-54-7F-01210:June 1, 2027:54-USER OF EXPLOSIVES

ATF Form 5400.14/5400-15 Part I
Revised September 2011

Federal Explosives License (FEL) Customer Service Information

Federal Explosives Licensing Center (FELC)
 244 Needy Road
 Martinsburg, WV 25405-9431

Toll-free Telephone Number: (877) 283-3352
 Fax Number: (304) 616-4401
 E-mail: FELC@atf.gov

ATF Homepage: www.atf.gov

Change of Address (27 CFR 555.54(a)(1)). Licensees or permittees may during the term of their current license or permit remove their business or operations to a new location at which they intend regularly to carry on such business or operations. The licensee or permittee is required to give notification of the new location of the business or operations not less than 10 days prior to such removal with the Chief, Federal Explosives Licensing Center. The license or permit will be valid for the remainder of the term of the original license or permit. **(The Chief, FELC, shall, if the licensee or permittee is not qualified, refer the request for amended license or permit to the Director of Industry Operations for denial in accordance with § 555.54.)**

Right of Succession (27 CFR 555.59). (a) Certain persons other than the licensee or permittee may secure the right to carry on the same explosive materials business or operations at the same address shown on, and for the remainder of the term of, a current license or permit. Such persons are: (1) The surviving spouse or child, or executor, administrator, or other legal representative of a deceased licensee or permittee; and (2) A receiver or trustee in bankruptcy, or an assignee for benefit of creditors. (b) In order to secure the right provided by this section, the person or persons continuing the business or operations shall furnish the license or permit for for that business or operations for endorsement of such succession to the Chief, FELC, within 30 days from the date on which the successor begins to carry on the business or operations.

Cut Here <>

Federal Explosives License/Permit (FEL) Information Card

License/Permit Name: **GEN X PYROTECHNICS**

Business Name:

License/Permit Number: **4-MI-125-54-7F-01210**

License/Permit Type: **54-USER OF EXPLOSIVES**

Expiration: **June 1, 2027**

Please Note: Not Valid for the Sale or Other Disposition of Explosives.

(Continued on reverse side)



NOTICE OF CLEARANCE

for individuals transporting, shipping, receiving, or possessing explosive materials.

ISSUED TO: GEN X PYROTECHNICS

Federal Explosives license/permit no.: 4-MI-125-54-7F-01210

NOTICE DATE: 05/16/2024

Expiration Date: June 1, 2027

EXPIRATION DATE: This Notice expires when superseded by a newer Notice which will list all current responsible persons and employee possessors, or when the license or permit expires - whichever comes first.

Explosives License/Permit Type: 54-USER OF EXPLOSIVES

- ① **WARNING.** Only those individuals listed below as **RESPONSIBLE PERSONS** and **EMPLOYEE POSSESSORS** with a background clearance status of "CLEARED" or "PENDING" are authorized to transport, ship, receive, or possess explosive materials in the course of employment with you.
- ② **"DENIED" STATUS.** If an employee possessor has a background clearance status of "DENIED", you **MUST** take immediate steps to remove the employee from a position requiring the transporting, shipping, receiving, or possessing of explosive materials. Also, if the employee has been listed as a person authorized to accept delivery of explosive materials, you **MUST** remove the employee from such list and immediately, and in no event later than the second business day after such change, notify distributors of such change, as stated in 27 CFR 555.33(a).
- ③ **CHANGE IN RESPONSIBLE PERSONS.** You **MUST** report any change in responsible persons to the Chief, Federal Explosives Licensing Center, within 30 days of the change and new responsible persons **MUST** include "appropriate identifying information" as defined in 27 CFR 555.11. Fingerprints and photos are **NOT** required, however they will be required upon renewal of the license or permit.
- ④ **CHANGE OF EMPLOYEES.** You **MUST** report any change of employee/possessors to the Chief, FELC, within 30 days. Reports relating to newly hired employees must be submitted on ATF Form 5-400.28 for **EACH** employee.

Premises Address:	2906 PINE NEEDLE DR WHITE LAKE, MI 48383
Mailing Address:	GEN X PYROTECHNICS 2906 PINE NEEDLE DR WHITE LAKE, MI 48383

This 'Notice of Clearance' is provided to you as required by 18 U.S.C. 843(h) and **MUST** be retained as part of your permanent records and be made available for examination or inspection by ATF officers as required by 27 CFR 555.121. If you receive a Notice subsequent to this Notice, this Notice will no longer be valid.

In accordance with 27 CFR 555.33, Background Checks and Clearances, and 27 CFR 555.57, Change of Control, Change in Responsible Persons, and Change of Employees, ATF's Federal Explosives Licensing Center (FELC) has conducted background checks on the individual(s) you identified as a responsible person(s) and an employee/possessor(s) on your application, or reported after the issuance of your license/permit.

The following is a SUMMARY of the results of the background checks conducted on the individuals you reported as responsible persons and employee/possessors. ATF will be notifying ALL individuals listed on this document of their respective status by separate letter mailed to their residence address.

PLEASE BE ADVISED THAT IT IS UNLAWFUL FOR ANY PERSON REFLECTING A STATUS OF "DENIED" TO TRANSPORT, SHIP, RECEIVE, OR POSSESS EXPLOSIVE MATERIALS.

Please carefully review this Notice to ensure that all the information is accurate. If this Notice is incorrect, please return the Notice to the Chief, FELC, with a statement showing the nature of the error(s). The Chief, FELC, shall correct the error, and return a corrected Notice.

Number of RESPONSIBLE PERSON(S) : 1	
Number of EMPLOYEE POSSESSOR(S): 4	
LAST NAME, First Name, Middle Name	Clearance Status
RESPONSIBLE PERSONS:	
1	
0001 TRUDEAU, JASON ANTHONY	Cleared
EMPLOYEE POSSESSORS:	
4	
0001 BECK, TYLER RUSSELL	Cleared
0002 CARRIGER, JOSHUA ROY	Cleared
0003 DIETLE, DEREK JAMES	Cleared
0004 DIETLE, JACK ANTHONY	Cleared

continued	
LAST NAME, First Name, Middle Name	Clearance Status

4-MI-125-54-7F-01210 expires 06/01/2027 GEN X PYROTECHNICS OF 2906 PINE NEEDLE DR, WHITE LAKE, MI 48383



U.S. Department of Justice
 Bureau of Alcohol, Tobacco, Firearms and Explosives
 Federal Explosives Licensing Center
 244 Needy Road
 Martinsburg, West Virginia 25405

901090: MH/FLS
 5400
 File Number: 4MI01210

05/16/2024

SUBJECT: RESPONSIBLE PERSON LETTER OF CLEARANCE for:

JASON ANTHONY TRUDEAU

CEO
 (248)252-0029

2906 PINE NEEDLE DR
 WHITE LAKE, MI 48383

and is ONLY valid under the following Federal explosives license/permit:

4-MI-125-54-7F-01210

GEN X PYROTECHNICS
 2906 PINE NEEDLE DR
 WHITE LAKE, MI 48383

Dear JASON TRUDEAU:

You have been approved as a responsible person under the above-listed Federal explosive license or permit. You may lawfully direct the management or policies of the business or operations as they pertain to explosives. You may also lawfully transport, ship, receive or possess explosive materials incident to your duties as a responsible person. **This clearance is only valid under the license or permit referenced above.**

Sincerely,

Marna Howard
 Chief, Federal Explosives Licensing Center (FELC)

FELC Customer Service. If you believe that information on your "Letter of Clearance" is incorrect, please return a COPY of the letter to the Chief, Federal Explosives Licensing Center (FELC), with a statement showing the nature of the error. The Chief, FELC, shall correct the error, and return an amended letter to you.

Mail: ATF
 Chief, FELC
 Attn.: LOC Correction
 244 Needy Road
 Martinsburg, West Virginia 25405

Fax: 1-304-616-4401
 Chief, FELC
 Attn.: LOC Correction

Call toll-free: 1-877-283-3352

WWW.ATF.GOV

4MI01210-R-05/16/2024--TRUDEAU,JASON-ANTHONY--CEO

JASON ANTHONY TRUDEAU

Responsible Person Letter of Clearance for:

MICHIGAN^{MI}
USA

COMMERCIAL DRIVER LICENSE

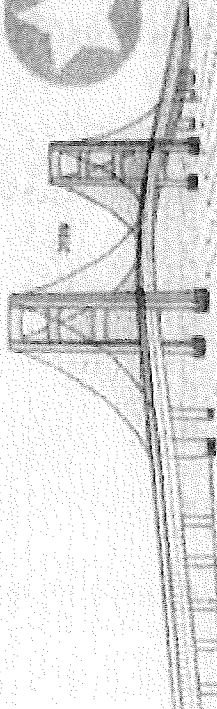
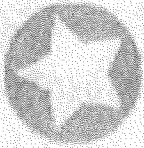

T 630 373 067 896
DOB **11-23-1968**

ISS **11-21-2022**
EXP **11-23-2026**

142368

JASON ANTHONY TRUDEAU
2906 PINE NEEDLE DR
WHITE LAKE, MI 48363-3283



Jason Trudeau

Sex **M**

Hgt **601**

Eyes **BRO**

Lic Type **CC**

End **H**



Restrictions **K-CDL Intrastate only, L-No air brake equipped
CMV**

DD: 1205615691182

Rev 08-16-2021

MSDS - *Material Safety Data Sheet*
UN0335, FIREWORKS 1.3G, PGII

Emergency Call Info Trac (800) 535-5053 ACE Pyro Contract #100630

Section II - Hazardous Ingredients / Identity Information

Contains **Pyrotechnic Compositions** that are mixtures of solid oxidizers and fuels that contained in paper and cardboard containers. No Hazard exists during normal handling and storage.

OSHA PEL - N/A ACGIH TLV - N/A

OTHER LIMITS - N/A

Section III - Physical / Chemical Characteristics

Boiling Point: - N/A Specific Gravity: - N/A

Vapor Pressure: - N/A Melting Point: - N/A

Vapor Density: - N/A Evaporation Rate: - N/A

Solubility in Water: - N/A

Appearance and Odor: - Pyrotechnic Composition is contained in paper or cardboard casings that may be shaped as cylinders, balls or tubes. Odor is not apparent.

Section IV - Fire and Explosion Hazard Data

Flash Point: - N/A Flammable Limits: - N/A

LEL: - N/A UEL: - N/A

Extinguishing Media: Deluge with large quantities of water as quickly as possible by FIRE HOSE from a PROTECTED location. Materials are self-oxidizing.

Special Fire Fighting Procedures: Do not attempt to fight a fire in the immediate area of 1.3G Fireworks- EVACUATE THE AREA.

Section IV - Fire and Explosion Hazard Data- Continued

Unusual Fire and Explosion Hazards: Fireworks 1.3G MAY MASS EXPLODE IN A FIRE. DO NOT ALLOW FIREWORKS TO GET WET- Hazardous Decomposition May Result in a FIRE or EXPLOSION. EXPLOSION MAY OCCUR IF EXPOSED TO SPARKS OR FLAME.

Section V - Reactivity Data

Stability: - Stable

Conditions to Avoid: - Open Flames, Sparks, High Temperatures, Friction or Impact

Incompatibility (Materials to Avoid): - Do Not Allow Fireworks to Get Wet.

Hazardous Decomposition or Byproducts: - Decomposition does not occur under normal circumstances. Smoke Generated by Fireworks may contain gasses that are irritating to the eyes or mucous membranes. Prolonged Exposure and Inhalation of smoke may cause shortness of breath or more serious problems when a chronic respiratory condition exists.

Hazardous Polymerization: Will Not Occur

Conditions to Avoid: - Storage in High Temperatures, Moist or Wet Conditions, Keep away From Open Flame or Sparks.

Section VI – Health Hazard Data

Route(s) of Entry: - N/A **Inhalation:** -N/A **Skin:** - N/A **Ingestion:** - N/A

Health Hazards (Acute and Chronic): - N/A

Carcinogenicity: N/A **NTP?:** - N/A **IARC Monographs?:** -N/A

OSHA Regulated: - NO

Signs and Symptoms of Exposure: - Prolonged Exposure to smoke that is Generated during Normal use of Fireworks may cause Irritation to Eyes and to Mucous Membranes.

Medical Conditions Generally Aggravated by Exposure: - Eye Sensitivity, Respiratory Conditions.

Emergency and First Aid Procedure: - EYES should be flushed with water. Move to Fresh Air and avoid additional Inhalation of Smoke.

Section VII – Precautions for Safe Handling and Use

Steps to Be Taken in Case Material is Released or Spilled: - If Fireworks are spilled, carefully pick up the material and place in a Cardboard Carton. Keep OPEN FLAMES and Sparks AWAY and NO SMOKING.

Waste Disposal Method: - Fireworks that fail to go off should be soaked in a bucket of water and returned to the source where it was obtained. Dry components or powder should be carefully swept up and placed in a cardboard container then soaked with water. Burning of Fireworks Waste must be performed in compliance with local and state laws.

Precautions in Handling and Storing: • Keep from OPEN FLAMES, NO SMOKING, AVOID IMPACT of MATERIALS and CONTAINERS of MATERIALS, STORE FIREWORKS IN A COOL AND DRY ENVIORMENT. FIREWORKS 1.3G MUST BE STORED AND TRANSPORTED IN COMPLIANCE WITH FEDERAL, STATE AND LOCAL LAWS.

Other Precautions: - UN0335 Fireworks 1.3G can cause SERIOUS INJURY or DEATH. They should only be Handled by Properly Trained and Qualified Personnel. When Shooting these Fireworks; PERSONNEL SHOULD WEAR PROPER EYE PROTECTION, HEAD PROTECTION AND NON-SYNTHETIC CLOTHING.

Section VIII – Control Measures

Respiratory Protection: N/A

Ventilation: - N/A **Local Exhaust:** - N/A **Special:** - N/A

Mechanical: -N/A **Other:** - N/A

Protective Gloves:- N/A **Eye Protection:** - When Shooting Fireworks 1.3G

Other Protective Clothing or Equipment: - Protective Head Gear and Non-Synthetic Clothing when Shooting Fireworks 1.3G.

Work / Hygienic Practices: - Store Fireworks in a Cool Dry and Well Ventilated area. Protect Against Physical Damage and Moisture. Fireworks should be Isolated from all Heat Sources, Sparks and Open Flame. No Smoking.



Firework Disposal Procedure

Please follow the two simple guidelines below for the proper disposal of any unused display fireworks

1. If any display fireworks are found, submerge the firework in a five-gallon bucket of water.
2. Contact Jason Trudeau with Gen-X Pyrotechnics for proper pickup.

Gen-X Pyrotechnics will pick up any unused display fireworks and take them to an authorized facility for a proper disposal.



248.252.0029



genxpyro@comcast.net
info@genxpyrotechnics.com



www.genxpyrotechnics.com

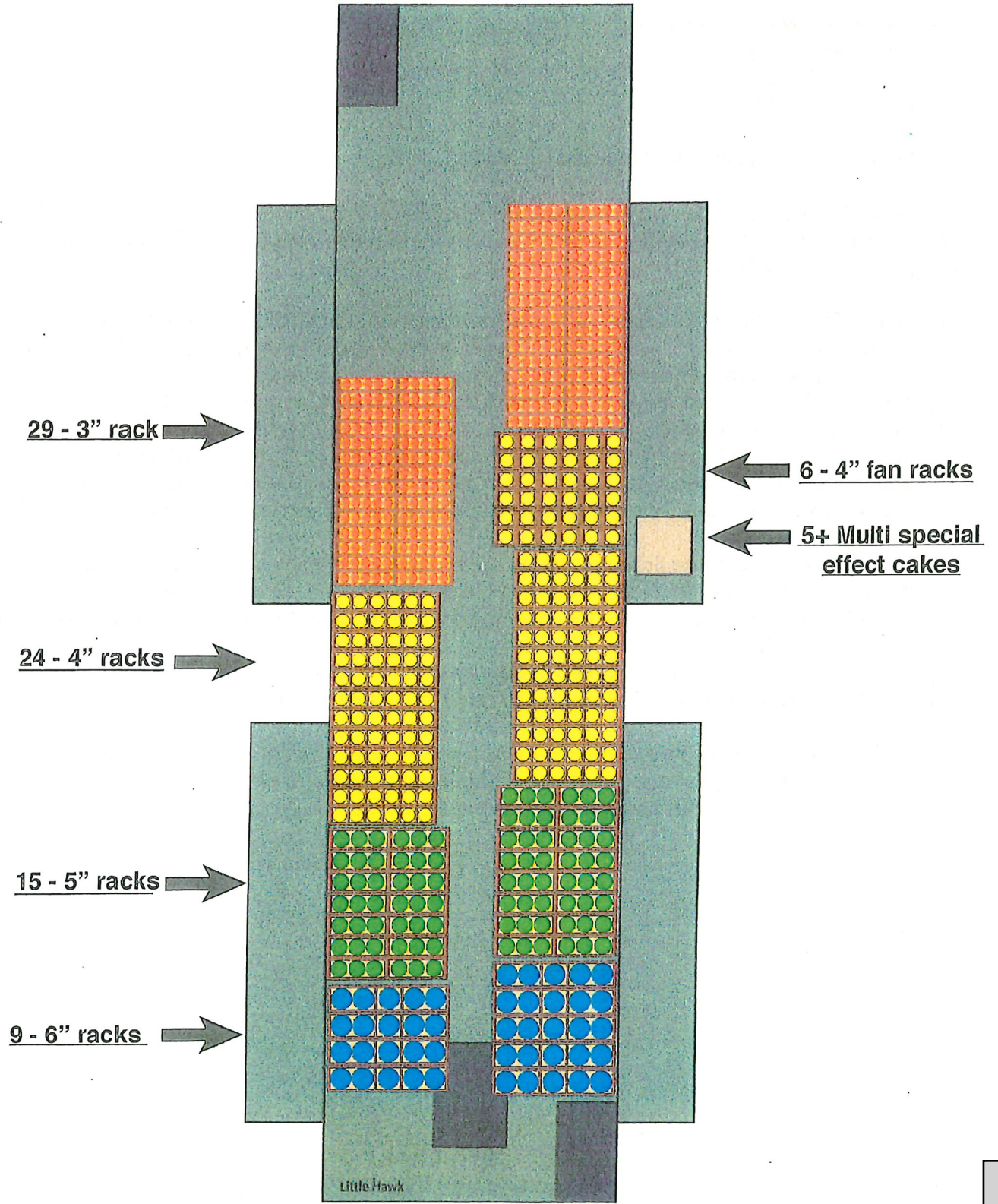



HARTLAND DEERFIELD FIRE AUTHORITY
HARTLAND AREA FIRE DEPT.

3205 Hartland Road
Hartland, MI. 48353-1825

Voice: (810) 632-7676
E-Mail: firemarshal@hartlandareafire.com

June 3, 2026

To: Hartland Township Board
Attn: Clerk Larry Ciofu
2655 Clark Rd.
Hartland, MI 48353

Re: Long Lake application for fireworks on July 11, 2026

Based upon the review of the application named above and inspection of the proposed site for the fireworks display for July 11, 2025, the Fire Department recommends approval of the request contingent upon the following:

- 1) Gen-X Pyrotechnics, Inc. is responsible for ensuring that NFPA 1123 is followed.
- 2) Based upon vegetation / weather conditions, the fire department may have a brush truck at the launching site with sufficient personnel to handle any fire emergencies that may arise.
- 3) No one will be allowed within 100 yards of the launch site during the display.
- 4) Smoking and open flame will not be permitted within 50 feet of the launch site. Exception: Items required for the ignition of the displays by trained and certified professionals.
- 5) The display will not begin until all persons are off the lake. The display will be stopped in the event anyone ventures onto the lake, and the display will not be resumed until the lake is cleared.
- 6) It is understood that the fire department will not allow the display to commence or continue if these conditions are not met, or in the event of conditions arising, such as adverse weather or faulty firing of the displays, or any condition which this department deems unsafe for the display to continue.
- 7) Insurance as agreed upon by the Hartland Township Board.
- 8) Final approval and permitting by the Hartland Township Board.

The Long Lake fireworks display continues to be a spectacular addition to events while keeping the safety and welfare of all spectators, workers, and buildings first on their agenda. Should you have any other questions, or we can be of further assistance, please call.

A handwritten signature in cursive script, appearing to read "Jan Olanke".

Fire Marshal

Hartland Township Board of Trustees Meeting Agenda Memorandum

Submitted By: Larry Ciofu, Clerk

Subject: Gen-X – Waldenwoods Fireworks Permit Application

Date: June 12, 2026

Recommended Action

Move to approve the Permit for a Fireworks Display for Gen-X Pyrotechnics on July 25, 2026 at Waldenwoods Resort.

Discussion

Gen-X Pyrotechnics has applied to perform a fireworks display at 2975 Old US-23, which is Waldenwoods, on Saturday, July 25, 2026. The applicant intends to launch the fireworks from a barge on Lake Walden. The Hartland-Deerfield Fire Authority Fire Marshal has reviewed this Application and is recommending approval contingent on following the items listed in their June 3, 2026, letter (attached).

Financial Impact

None

Attachments

Gen-X – 2026 Waldenwoods – 7-25-26

2026 Waldenwoods

GEN-X PYROTECHNICS

Gen-X Pyrotechnics offers the highest quality custom pyrotechnics designed specifically to meet the needs of our clients. We are a local company that markets on word of mouth advertising and now on the web. We specialize in one of a kind shows.

In this constantly changing world of pyrotechnics we strive to learn the most up-to-date innovations so we can continue to hone our craft.

We take pride in being trained in all the local and federal safety regulations and guidelines.

Jason Trudeau

Jason Trudeau



248.252.0029



genxpyro@comcast.net
info@genxpyrotechnics.com



www.genxpyrotechnics.com



MARINE SPECIAL EVENT APPLICATION AND PERMIT

Issued under authority of Part 801, Marine, Part 811 ORV and Part 821 Snowmobile, of the Natural Resource and Environmental Protection Act, Act 451, P. A. of 1994, as amended. Failure to comply with the provisions of this Act is a misdemeanor and may result in fines and/or imprisonment.

DNR USE ONLY
Permit Number

APPLICANT: This completed and signed application must be received by the appropriate DNR office at least 30 days prior to the event, or the permit may not be authorized. Locations and addresses on next page.

Form with fields for Name of Applicant (Gen-X Pyrotechnics), Sponsoring Organization (Waldenwoods), Name of Person in Charge (Jason Trudeau), Street Address (2906 Pine Needle Dr), City (White Lake, MI 48383), Event Date (7-25-2026), and Type of Event (Marine).

APPLICANT: Read all pages and attachments before certification and signature.

CERTIFICATION section with signature line for Jason Trudeau and date 5/7/26.

APPLICANT: Submit completed and signed application to appropriate DNR office at least 30 days prior to event or permit may not be authorized. Locations and addresses on next page.

FOR DNR USE ONLY section containing Investigation Findings & Recommendations and fields for Investigating Officer, Badge Number, Signature, and Date of Investigation.

AUTHORIZATION section with checkboxes for EVENT IS AUTHORIZED and EVENT IS NOT AUTHORIZED, and fields for Number of Law Enforcement Patrol Boats Vehicles and Special Conditions.

Waldenwoods

Exhibit A

Distance- 600 ft diameter (NFPA regulation)

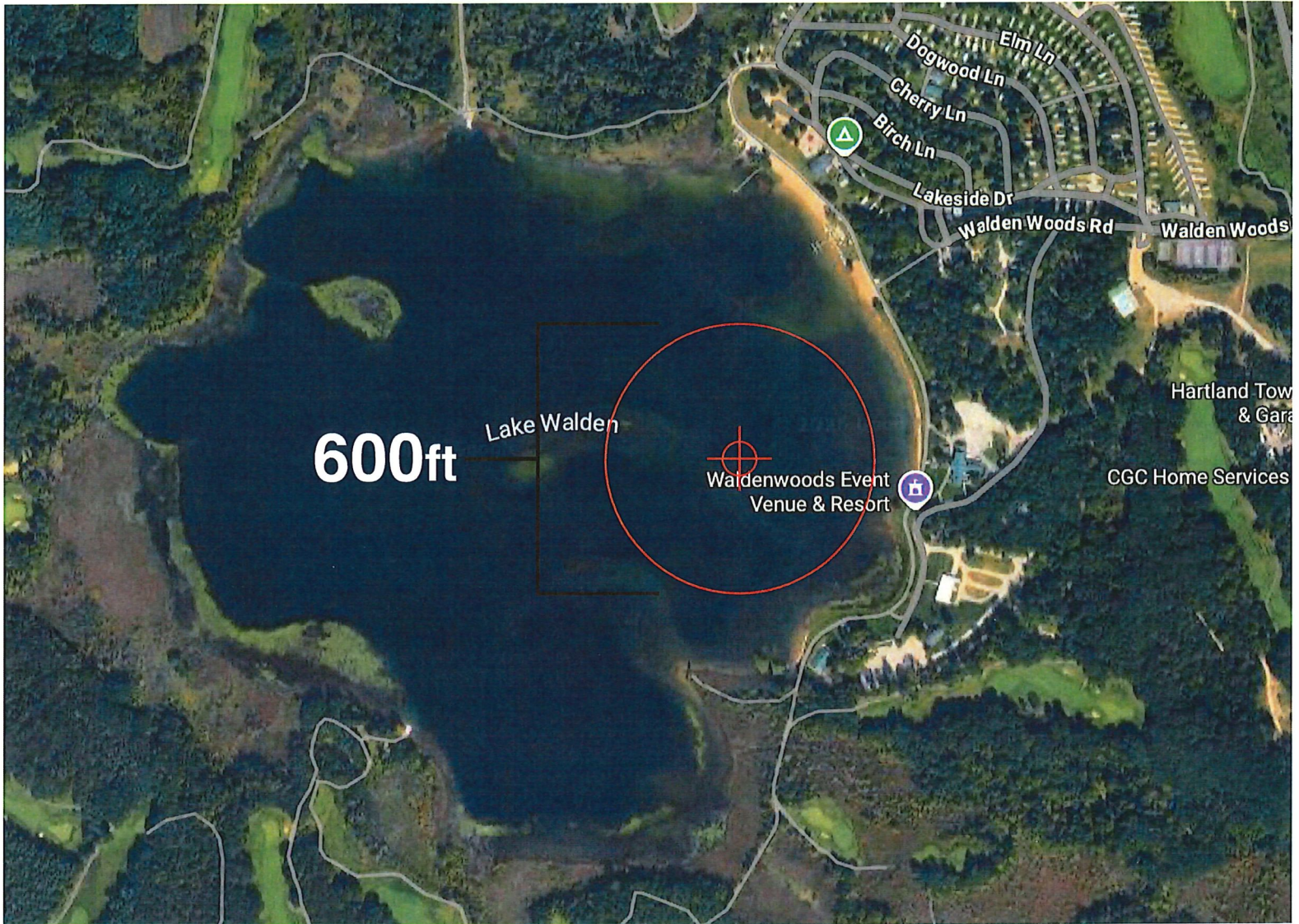

Key



: Placement of display

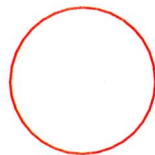

: Perimeter of 300 ft will be held around display

Federal Explosives License/Permit (18 U.S.C. Chapter 40)

In accordance with the provisions of Title XI, Organized Crime Control Act of 1970, and the regulations issued thereunder (27 CFR Part 555), you may engage in the activity specified in this license or permit within the limitations of Chapter 40, Title 18, United States Code and the regulations issued thereunder, until the expiration date shown. **THIS LICENSE IS NOT TRANSFERABLE UNDER 27 CFR 555.53.** See "WARNINGS" and "NOTICES" on reverse.

Direct ATF Correspondence To: ATF - Chief, FELC
244 Needy Road
Martinsburg, WV 25405-9431

License/Permit Number: **4-MI-125-54-7F-01210**

Chief, Federal Explosives Licensing Center (FELC)

Expiration Date: **June 1, 2027**

Mama Howard
Name

GEN X PYROTECHNICS

Premises Address (Changes? Notify the FELC at least 10 days before the move.)

**2906 PINE NEEDLE DR
WHITE LAKE, MI 48383-**

Type of License or Permit

54-USER OF EXPLOSIVES

Purchasing Certification Statement

The licensee or permittee named above shall use a copy of this license or permit to assist a transferee of explosives to verify the identity and the licensed status of the licensee or permittee as provided by 27 CFR Part 555. The signature on each copy must be an original signature. A faxed, scanned or e-mailed copy of the license or permit with a signature intended to be an original signature is acceptable. The signature must be that of the Federal Explosives Licensee (FEL) or a responsible person of the FEL. I certify that this is a true copy of a license or permit issued to the licensee or permittee named above to engage in the business or operations specified above under "Type of License or Permit."

Mailing Address (Changes? Notify the FELC of any changes.)

GEN X PYROTECHNICS
2906 PINE NEEDLE DR
WHITE LAKE, MI 48383-

Licensee/Permittee Responsible Person Signature

Position/Title

Printed Name

Date

Previous Edition is Obsolete GEN X PYROTECHNICS:2906 PINE NEEDLE DR:48383-4 MI-125-54-7F-01210:June 1, 2027:54-USER OF EXPLOSIVES

ATF Form 5400.14/5400.15 Part I
Revised September 2011

Federal Explosives License (FEL) Customer Service Information

Federal Explosives Licensing Center (FELC)
244 Needy Road
Martinsburg, WV 25405-9431

Toll-free Telephone Number: (877) 283-3352
Fax Number: (304) 616-4401
E-mail: FELC@atf.gov

ATF Homepage: www.atf.gov

Change of Address (27 CFR 555.54(a)(1)). Licensees or permittees may during the term of their current license or permit remove their business or operations to a new location at which they intend regularly to carry on such business or operations. The licensee or permittee is required to give notification of the new location of the business or operations not less than 10 days prior to such removal with the Chief, Federal Explosives Licensing Center. The license or permit will be valid for the remainder of the term of the original license or permit. **(The Chief, FELC, shall, if the licensee or permittee is not qualified, refer the request for amended license or permit to the Director of Industry Operations for denial in accordance with § 555.54.)**

Right of Succession (27 CFR 555.59). (a) Certain persons other than the licensee or permittee may secure the right to carry on the same explosive materials business or operations at the same address shown on, and for the remainder of the term of, a current license or permit. Such persons are: (1) The surviving spouse or child, or executor, administrator, or other legal representative of a deceased licensee or permittee; and (2) A receiver or trustee in bankruptcy, or an assignee for benefit of creditors. (b) In order to secure the right provided by this section, the person or persons continuing the business or operations shall furnish the license or permit for that business or operations for endorsement of such succession to the Chief, FELC, within 30 days from the date on which the successor begins to carry on the business or operations.

Cut Here ✂

(Continued on reverse side)

Federal Explosives License/Permit (FEL) Information Card

License/Permit Name: **GEN X PYROTECHNICS**

Business Name:

License/Permit Number: **4-MI-125-54-7F-01210**

License/Permit Type: **54-USER OF EXPLOSIVES**

Expiration: **June 1, 2027**

Please Note: Not Valid for the Sale or Other Disposition of Explosives.



NOTICE OF CLEARANCE

for individuals transporting, shipping, receiving, or possessing explosive materials.

ISSUED TO: GEN X PYROTECHNICS

Federal Explosives license/permit no.: 4-MI-125-54-7F-01210

NOTICE DATE: 05/16/2024

Expiration Date: **June 1, 2027**

EXPIRATION DATE: This Notice expires when superseded by a newer Notice which will list all current responsible persons and employee possessors, or when the license or permit expires - whichever comes first.

Explosives License/Permit Type: 54-USER OF EXPLOSIVES

- 1 **WARNING.** Only those individuals listed below as **RESPONSIBLE PERSONS** and **EMPLOYEE POSSESSORS** with a background clearance status of "CLEARED" or "PENDING" are authorized to transport, ship, receive, or possess explosive materials in the course of employment with you.
- 2 **"DENIED" STATUS.** If an employee possessor has a background clearance status of "DENIED", you **MUST** take immediate steps to remove the employee from a position requiring the transporting, shipping, receiving, or possessing of explosive materials. Also, if the employee has been listed as a person authorized to accept delivery of explosive materials, you **MUST** remove the employee from such list and immediately, and in no event later than the second business day after such change, notify distributors of such change, as stated in 27 CFR 555.33(a).
- 3 **CHANGE IN RESPONSIBLE PERSONS.** You **MUST** report any change in responsible persons to the Chief, Federal Explosives Licensing Center, within 30 days of the change and new responsible persons **MUST** include "appropriate identifying information" as defined in 27 CFR 555.11. Fingerprints and photos are **NOT** required, however they will be required upon renewal of the license or permit.
- 4 **CHANGE OF EMPLOYEES.** You **MUST** report any change of employee/possessors to the Chief, FELC, within 30 days. Reports relating to newly hired employees must be submitted on ATF Form 5400.28 for **EACH** employee.

Premises Address:	2906 PINE NEEDLE DR WHITE LAKE, MI 48383
Mailing Address:	GEN X PYROTECHNICS 2906 PINE NEEDLE DR WHITE LAKE, MI 48383

This 'Notice of Clearance' is provided to you as required by 18 U.S.C. 843(h) and **MUST** be retained as part of your permanent records and be made available for examination or inspection by ATF officers as required by 27 CFR 555.121. If you receive a Notice subsequent to this Notice, this Notice will no longer be valid.

In accordance with 27 CFR 555.33, Background Checks and Clearances, and 27 CFR 555.57, Change of Control, Change in Responsible Persons, and Change of Employees, ATF's Federal Explosives Licensing Center (FELC) has conducted background checks on the individual(s) you identified as a responsible person(s) and an employee/possessor(s) on your application, or reported after the issuance of your license/permit.

The following is a SUMMARY of the results of the background checks conducted on the individuals you reported as responsible persons and employee/possessors. ATF will be notifying ALL individuals listed on this document of their respective status by separate letter mailed to their residence address.

PLEASE BE ADVISED THAT IT IS UNLAWFUL FOR ANY PERSON REFLECTING A STATUS OF "DENIED" TO TRANSPORT, SHIP, RECEIVE, OR POSSESS EXPLOSIVE MATERIALS.

Please carefully review this Notice to ensure that all the information is accurate. If this Notice is incorrect, please return the Notice to the Chief, FELC, with a statement showing the nature of the error(s). The Chief, FELC, shall correct the error, and return a corrected Notice.

Number of RESPONSIBLE PERSON(S) : 1
Number of EMPLOYEE POSSESSOR(S): 4

LAST NAME, First Name, Middle Name	Clearance Status
RESPONSIBLE PERSONS:	
0001 TRUDEAU, JASON ANTHONY	1 Cleared
EMPLOYEE POSSESSORS:	
0001 BECK, TYLER RUSSELL	4 Cleared
0002 CARRIGER, JOSHUA ROY	Cleared
0003 DIETLE, DEREK JAMES	Cleared
0004 DIETLE, JACK ANTHONY	Cleared

continued

LAST NAME, First Name, Middle Name	Clearance Status
------------------------------------	------------------

4-MI-125-54-7F-01210 expiration date: June 1, 2027 GEN X PYROTECHNICS OF, 2906 PINE NEEDLE DR, WHITE LAKE, MI 48383



U.S. Department of Justice
 Bureau of Alcohol, Tobacco, Firearms and Explosives
 Federal Explosives Licensing Center
 244 Needy Road
 Martinsburg, West Virginia 25405

901090: MH/FLS
 5400
 File Number: **4MI01210**

05/16/2024

SUBJECT: RESPONSIBLE PERSON LETTER OF CLEARANCE for:

JASON ANTHONY TRUDEAU

CEO
 (248)252-0029

2906 PINE NEEDLE DR
 WHITE LAKE, MI 48383

and is ONLY valid under the following Federal explosives license/permit:

4-MI-125-54-7F-01210

GEN X PYROTECHNICS
 2906 PINE NEEDLE DR
 WHITE LAKE, MI 48383

Dear JASON TRUDEAU:

You have been approved as a responsible person under the above-listed Federal explosive license or permit. You may lawfully direct the management or policies of the business or operations as they pertain to explosives. You may also lawfully transport, ship, receive or possess explosive materials incident to your duties as a responsible person. **This clearance is only valid under the license or permit referenced above.**

Sincerely,

Marna Howard
 Chief, Federal Explosives Licensing Center (FELC)

FELC Customer Service. If you believe that information on your "Letter of Clearance" is incorrect, please return a COPY of the letter to the Chief, Federal Explosives Licensing Center (FELC), with a statement showing the nature of the error. The Chief, FELC, shall correct the error, and return an amended letter to you.

Mail: ATF
 Chief, FELC
 Attn.: LOC Correction
 244 Needy Road
 Martinsburg, West Virginia 25405

Fax: 1-304-616-4401
 Chief, FELC
 Attn.: LOC Correction

Call toll-free: 1-877-283-3352

WWW.ATF.GOV

4MI01210-R-05/16/2024-TRUDEAU-JASON-ANTHONY-CEO

JASON ANTHONY TRUDEAU

Responsible Person Letter of Clearance for:

MICHIGAN MI USA



COMMERCIAL DRIVER LICENSE

T 630 373 067 896
DOB 11-23-1968

ISS 11-21-2022
EXP 11-23-2026

112368

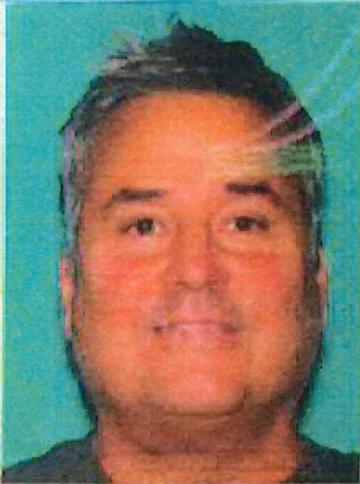

JASON ANTHONY TRUDEAU
2906 PINE NEEDLE DR
WHITE LAKE, MI 48383-3283

Sex M

Hgt 601

Eyes BRO

Lic Type CC

End H

**Restrictions K-CDL Intrastate only, L-No air brake equipped
CMV**

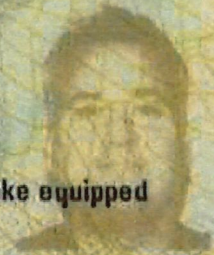

Jason Trudeau

DD: 1205615691182

Rev 08-16-2021

MSDS - *Material Safety Data Sheet*
UN0335, FIREWORKS 1.3G, PGII

Emergency Call Info Trac (800) 535-5053 ACE Pyro Contract #100630

Section II - Hazardous Ingredients / Identity Information

Contains Pyrotechnic Compositions that are mixtures of solid oxidizers and fuels that contained in paper and cardboard containers. No Hazard exists during normal handling and storage.

OSHA PEL - N/A ACGIH TLV - N/A

OTHER LIMITS - N/A

Section III - Physical / Chemical Characteristics

Boiling Point: - N/A Specific Gravity: - N/A

Vapor Pressure: - N/A Melting Point: - N/A

Vapor Density: - N/A Evaporation Rate: - N/A

Solubility in Water: - N/A

Appearance and Odor: - Pyrotechnic Composition is contained in paper or cardboard casings that may be shaped as cylinders, balls or tubes. Odor is not apparent.

Section IV - Fire and Explosion Hazard Data

Flash Point: - N/A Flammable Limits: - N/A

LEL: - N/A UEL: - N/A

Extinguishing Media: Deluge with large quantities of water as quickly as possible by FIRE HOSE from a PROTECTED location. Materials are self-oxidizing.

Special Fire Fighting Procedures: Do not attempt to fight a fire in the immediate area of 1.3G Fireworks- EVACUATE THE AREA.

Section IV - Fire and Explosion Hazard Data- Continued

Unusual Fire and Explosion Hazards: Fireworks 1.3G MAY MASS EXPLODE IN A FIRE. DO NOT ALLOW FIREWORKS TO GET WET- Hazardous Decomposition May Result in a FIRE or EXPLOSION. EXPLOSION MAY OCCUR IF EXPOSED TO SPARKS OR FLAME.

Section V - Reactivity Data

Stability: - Stable

Conditions to Avoid: - Open Flames, Sparks, High Temperatures, Friction or Impact.

Incompatibility (Materials to Avoid): - Do Not Allow Fireworks to Get Wet.

Hazardous Decomposition or Byproducts: - Decomposition does not occur under normal circumstances. Smoke Generated by Fireworks may contain gasses that are irritating to the eyes or mucous membranes. Prolonged Exposure and Inhalation of smoke may cause shortness of breath or more serious problems when a chronic respiratory condition exists.

Hazardous Polymerization: Will Not Occur

Conditions to Avoid: - Storage in High Temperatures, Moist or Wet Conditions, Keep away From Open Flame or Sparks.

Section VI – Health Hazard Data

Route(s) of Entry: - N/A Inhalation: -N/A Skin: - N/A Ingestion: - N/A

Health Hazards (Acute and Chronic): - N/A

Carcinogenicity: N/A NTP?: - N/A IARC Monographs?: -N/A

OSHA Regulated: - NO

Signs and Symptoms of Exposure: - Prolonged Exposure to smoke that is Generated during Normal use of Fireworks may cause Irritation to Eyes and to Mucous Membranes.

Medical Conditions Generally Aggravated by Exposure: - Eye Sensitivity, Respiratory Conditions.

Emergency and First Aid Procedure: - EYES should be flushed with water. Move to Fresh Air and avoid additional Inhalation of Smoke.

Section VII – Precautions for Safe Handling and Use

Steps to Be Taken in Case Material is Released or Spilled: - If Fireworks are spilled, carefully pick up the material and place in a Cardboard Carton. Keep OPEN FLAMES and Sparks AWAY and NO SMOKING.

Waste Disposal Method: - Fireworks that fail to go off should be soaked in a bucket of water and returned to the source where it was obtained. Dry components or powder should be carefully swept up and placed in a cardboard container then soaked with water. Burning of Fireworks Waste must be performed in compliance with local and state laws.

Precautions in Handling and Storing: - Keep from OPEN FLAMES, NO SMOKING, AVOID IMPACT of MATERIALS and CONTAINERS of MATERIALS, STORE FIREWORKS IN A COOL AND DRY ENVIORNMENT. FIREWORKS 1.3G MUST BE STORED AND TRANSPORTED IN COMPLIANCE WITH FEDERAL, STATE AND LOCAL LAWS.

Other Precautions: - UN0335 Fireworks 1.3G can cause SERIOUS INJURY or DEATH. They should only be Handled by Properly Trained and Qualified Personnel. When Shooting these Fireworks; PERSONNEL SHOULD WEAR PROPER EYE PROTECTION, HEAD PROTECTION AND NON-SYNTHETIC CLOTHING.

Section VIII – Control Measures

Respiratory Protection: N/A

Ventilation: - N/A Local Exhaust: - N/A Special: - N/A

Mechanical: -N/A Other: - N/A

Protective Gloves:- N/A Eye Protection: - When Shooting Fireworks 1.3G

Other Protective Clothing or Equipment: - Protective Head Gear and Non-Synthetic Clothing when Shooting Fireworks 1.3G.

Work / Hygienic Practices: - Store Fireworks in a Cool Dry and Well Ventilated area. Protect Against Physical Damage and Moisture. Fireworks should be Isolated from all Heat Sources, Sparks and Open Flame. No Smoking.

Firework Disposal Procedure

Please follow the two simple guidelines below for the proper disposal of any unused display fireworks

1. If any display fireworks are found, submerge the firework in a five-gallon bucket of water.
2. Contact Jason Trudeau with Gen-X Pyrotechnics for proper pickup.

Gen-X Pyrotechnics will pick up any unused display fireworks and take them to an authorized facility for a proper disposal.



248.252.0029



genxpyro@comcast.net
info@genxpyrotechnics.com



www.genxpyrotechnics.com



HARTLAND DEERFIELD FIRE AUTHORITY
HARTLAND AREA FIRE DEPT.

3205 Hartland Road
Hartland, MI. 48353-1825

Voice: (810) 632-7676
E-Mail: firemarshal@hartlandareafire.com

June 3, 2026

To: Hartland Township Board
Attn: Clerk Larry Ciofu
2655 Clark Rd.
Hartland, MI 48353

Re: Waldenwoods application for fireworks on July 25, 2026

Based upon the review of the application named above and inspection of the proposed site for the fireworks display for July 25, 2025, the Fire Department recommends approval of the request contingent upon the following:

- 1) Gen-X Pyrotechnics, Inc. is responsible for ensuring that NFPA 1123 is followed.
- 2) Based upon vegetation / weather conditions, the fire department may have a brush truck at the launching site with sufficient personnel to handle any fire emergencies that may arise.
- 3) No one will be allowed within 100 yards of the launch site during the display.
- 4) Smoking and open flame will not be permitted within 50 feet of the launch site. Exception: Items required for the ignition of the displays by trained and certified professionals.
- 5) The display will not begin until all persons are off the lake. The display will be stopped in the event anyone ventures onto the lake, and the display will not be resumed until the lake is cleared.
- 6) It is understood that the fire department will not allow the display to commence or continue if these conditions are not met, or in the event of conditions arising, such as adverse weather or faulty firing of the displays, or any condition which this department deems unsafe for the display to continue.
- 7) Insurance as agreed upon by the Hartland Township Board.
- 8) Final approval and permitting by the Hartland Township Board.

The Long Lake fireworks display continues to be a spectacular addition to events while keeping the safety and welfare of all spectators, workers, and buildings first on their agenda. Should you have any other questions, or we can be of further assistance, please call.

Fire Marshal

Hartland Township Board of Trustees Meeting Agenda Memorandum

Submitted By: Scott Hable, Public Works Director

Subject: 2026 Compliance Resolution for NPDES Permit

Date: June 16, 2026

Recommended Action

Move to adopt into policy for compliance with the Hartland Township NPDES permit requirements for the illicit discharge elimination program.

Discussion

Earlier this year, Hartland Township was notified by EGLE that we would no longer be able to stay under Livingston County’s stormwater permit “umbrella” and would need to obtain our own stormwater permit for properties owned by the township. We have worked with SDA to go through the process of obtaining this permit as mandated by EGLE. This has included extensive back and forth with SDA and EGLE on properties owned by the Township, as well as a full day site visit from EGLE.

The National Pollutant Discharge Elimination System (NPDES) Permit is a permit program which aims to protect water resources by addressing point source water pollution. Initiated by the Clean Water Act in 1972, the NPDES permit program controls the discharge of pollutants into surface waters by imposing effluent limitations to protect water quality. Although the NPDES is a federal program, the Michigan Department of Environment, Great Lakes, and Energy (EGLE) has been granted the authority to implement the program.

Financial Impact

Is a Budget Amendment Required? Yes No

There is no cost to this resolution.

Attachments

NPDES Resolution

BOARD OF TRUSTEES

2655 Clark Road
Hartland, Michigan 48353
(810) 632-7498 Office
(810) 632-6950 Fax



Supervisor
William J. Fountain

Clerk
Larry N. Ciofu

Treasurer
Kathleen A. Horning

Trustees
Brett J. Lubeski
Summer McMullen
Denise O'Connell
Joseph M. Petrucci

RESOLUTION NO. 26-R012

TO ADOPT INTO POLICY FOR COMPLIANCE WITH THE HARTLAND TOWNSHIP (TOWNSHIP) NATIONAL POLLUTANT DISCHARGE ELIMINATION (NPDES) PERMIT REQUIREMENTS FOR THE ILLICIT DISCHARGE ELIMINATION PROGRAM (IDEP)

At a regular meeting of the Township Board of Hartland Township, Livingston County, Michigan, held at the Township Hall in said Township on _____ at 7:00 p.m.

PRESENT:

ABSENT:

The following preamble and resolution were offered by _____ and seconded by _____

WHEREAS, the purpose is to provide a regulatory mechanism regarding the Illicit Discharge Elimination Program associated with Township owned entities within the Township's Urban Areas, and

WHEREAS, the definitions for purpose of this policy shall be as follows:

Discharge of Stormwater to Surface Waters – Precipitation that does not infiltrate into the ground or evaporate due to impervious surfaces but instead flows into drain/sewer systems which may include open ditches, detention ponds, or storm sewer that eventually flows to a surface water and/or county drain.

Municipal Separate Storm Sewer System (MS4) – A system of drainage (including roads, storm drains, pipes, and ditches, etc.) that is not a combined sewer or part of a sewage treatment plant. During wet weather, pollutants are transported through MS4s to local waterbodies.

National Pollutant Discharge Elimination System (NPDES) Permit – Permit program which aims to protect water resources by addressing point source water pollution. Initiated by the Clean Water Act of 1972, the NPDES permit program controls the discharge of pollutants into surface waters by imposing effluent limitations to protect water quality. Although the NPDES is a federal program, the Michigan Department of Environmental, Great Lakes, and Energy (EGLE) has been granted the authority to implement the program.

Illicit Discharge – Any discharge to, or seepage into, an MS4 that is not composed entirely of stormwater or uncontaminated groundwater,

Illicit Connection – A physical connection to an MS4 that primarily conveys non-stormwater discharges other than uncontaminated groundwater into the MS4; or a physical connection not

authorized or permitted by the local authority, where a local authority requires authorization or a permit for physical connections.

WHEREAS, the Township Policy shall prohibit non-stormwater discharges, including illicit discharges, illicit connections, and direct dumping/disposal into the Township's MS4, except for the following non-stormwater discharges:

- A. Prohibiting the discharges and flows from firefighting activities is excluded, as long as they are identified as not being significant sources of pollutants to waters of the state.
- B. The Township will exclude prohibiting the discharges and flows from the following if they are identified as not being a significant contributor to violations of water quality standards
 - a. Water line flushing and discharges from potable water sources.
 - b. Landscape irrigation runoff, lawn watering runoff, and irrigation waters.
 - c. Diverted stream flows and flows from riparian habitats and wetlands.
 - d. Rising groundwater and springs.
 - e. Uncontaminated groundwater infiltration and seepage
 - f. Uncontaminated pumped groundwater, except for groundwater cleanups specifically authorized by NPDES permits.
 - g. Foundation drains, water from crawl space pumps, footing drains, and basement sump pumps.
 - h. Air conditioning condensation.
 - i. Waters from non-commercial car washing.
 - j. Street wash water.
 - k. Dechlorinated swimming pool water from single-, two-, or three- family residences as long as they are identified as not being significant sources of pollutants to the waters of the state.

WHEREAS, the Township will eliminate non-stormwater discharges and flows to the Township's MS4 in accordance with the Township's Illicit Discharge Elimination Plan.

NOW, THEREFORE, IT IS RESOLVED, the Township hereby adopts this resolution to comply with the Hartland Township National Pollutant Discharge Elimination System Permit requirements for the Illicit Discharge Elimination Permit and shall incorporate this resolution into its Policies and Procedures and shall place it in a format consistent with its other policies (numbering, tracking, adoption date, etc.)

A vote on the foregoing resolution was taken and was as follows:

RESULT:
MOVER:
SECONDER:
AYES:
NAYS:
ABSENT:
ABSTAINED:

STATE OF MICHIGAN)
)
COUNTY OF LIVINGSTON)

I, the undersigned, the duly qualified and acting Township Clerk of the Township of Hartland, Livingston County, Michigan, DO HEREBY CERTIFY that the foregoing is a true and complete copy of certain proceedings taken by the Township Board of said Township at a regular meeting held on the 16th day of June, 2026.

Larry N. Ciofu Hartland Township Clerk

Hartland Township Board of Trustees Meeting Agenda Memorandum

Submitted By: Michael Luce, Township Manager

Subject: Work Session Regarding Code Enforcement

Date: June 11, 2026

Recommended Action

None at this time.

Discussion

Manager Luce and Director Langer will be leading a discussion on the current approach to Code Enforcement.