



CITY OF GUSTAVUS CITY COUNCIL GENERAL MEETING

Monday, April 13, 2026 at 7:00 PM
Gustavus City Hall

COUNCIL MEMBERS

Mayor Sally McLaughlin
Vice Mayor Lucas Beck
Council Members: Renee Patrick,
Justin Marchbanks, Karen Hutten,
Jim Kearns, Mike Taylor

CITY HALL

City Administrator – Kathy Leary
City Clerk – Liesl Barker
City Treasurer – Ben Sadler
Phone: 907-697-2451
clerk@gustavus-ak.gov

AGENDA

VIRTUAL MEETING INFORMATION

<https://tinyurl.com/yeywrv9y>

ID: 515 501 9406 **PASSCODE:** 1236 **TEL:** 253-215-8782

ROLL CALL

Reading of the City of Gustavus Mission Statement

APPROVAL OF MINUTES

1. 03-09-2026 General Meeting Minutes

MAYOR'S REQUEST FOR AGENDA CHANGES

COMMITTEE / STAFF REPORTS

2. Gustavus Volunteer Fire Department Quarterly Report
3. City Clerk Quarterly Report
4. City Treasurer Monthly Report
5. City Administrator Monthly Report

PUBLIC COMMENT ON NON-AGENDA ITEMS

CONSENT AGENDA

Mayor McLaughlin recommends approval of all the items on the consent agenda.

6. FY26-16NCO An introduction of an ordinance providing for the amendment of the City held accounts in fiscal year 2026 - DRC Bobcat Attachments
7. FY26-17NCO An introduction of an ordinance providing for the amendment of the city held accounts in fiscal year 2026 - Grant Planning and Strategy (Public Hearing 05-11-2026)
8. CY26-04 Resolution by the City of Gustavus updating the Benefits Policy and Procedure for Eligible Regular Position Employees
9. CY26-05 A resolution by the City of Gustavus Revising Policy and Procedure for mileage reimbursement for City Employees and City Council Members
10. CY26-06 A resolution by the City of Gustavus in support of HB321, redesignating the Dude Creek Critical Habitat Area as a State Wildlife Refuge with Expanded Boundaries
11. CY26-07 A Resolution approving a Cost-of-Living Pay Adjustment for the City of Gustavus employees in regular positions

ORDINANCE FOR PUBLIC HEARING

- [12.](#) FY26-14NCO An ordinance providing for the amendment for the City held accounts in Fiscal Year 2026 - Closing Capital Project CP24-01 DRC Expansion (Introduced 03-09-2026)
- [13.](#) FY26-15NCO An ordinance providing for the amendment of the City Budget and City held accounts in Fiscal Year 2026 - Road Maintenance (Introduced 03-09-2026)

UNFINISHED BUSINESS

NEW BUSINESS

- [14.](#) QUASI-JUDICIAL Matter City of Gustavus waives the right to file a protest of the Bear Track Inn, LLC New Restaurant Endorsement, Outdoor Recreation Lodge Liquor License
- [15.](#) CY26-08 A resolution by the City of Gustavus Establishing Policy and Procedure for Travel and Attendance at Conference and Training Activities
- [16.](#) Approve City of Gustavus Capital Improvement Plan 2026-2030
- [17.](#) Approve Project Planning Short Form for DRC Bobcat Snow Removal Attachments
18. Approve MOA with Kathie Wasserman

CITY COUNCIL REPORTS

- [19.](#) Mayor Monthly Report

CITY COUNCIL QUESTIONS AND COMMENTS

PUBLIC COMMENT ON NON-AGENDA ITEMS

EXECUTIVE SESSION

20. To discuss subjects that tend to prejudice the reputation and character of a person; City Treasurer performance evaluation.

ADJOURNMENT

POSTED ON: April 8, 2026 at P.O, Library, City Hall & <https://cms.gustavus-ak.gov/>

ADA NOTICE

Any person with a disability who requires accommodations in order to participate in this meeting should telephone the City Clerk's office at (907) 697-2451, at least 48 hours prior to the meeting in order to make a request for a disability related modification or accommodation.

MISSION STATEMENT

The City of Gustavus is a distinctive Alaskan City that provides high quality public services in a thoughtful, cost effective and professional manner to sustain a safe, beautiful tolerant environment to live, work, and play with respect for individual freedom and each other.



CITY OF GUSTAVUS CITY COUNCIL GENERAL MEETING

Monday, March 09, 2026 at 7:00 PM
Gustavus City Hall

COUNCIL MEMBERS

Mayor Sally McLaughlin
Vice Mayor Lucas Beck
Council Members: Renee Patrick,
Justin Marchbanks, Karen Hutten,
Jim Kearns, Mike Taylor

CITY HALL

City Administrator – Kathy Leary
City Clerk – Liesl Barker
City Treasurer – Ben Sadler
Phone: 907-697-2451
clerk@gustavus-ak.gov

MINUTES - PENDING

VIRTUAL MEETING INFORMATION

<https://tinyurl.com/b3v6w832>

ID: 515 501 9406

PASSCODE: 5589

TEL: 253-215-8782

ROLL CALL

PRESENT

Mayor Sally McLaughlin
Vice Mayor Lucas Beck
Council Member Renee Patrick
Council Member Karen Hutten
Council Member Mike Taylor
Council Member James Kearns
Council Member Justin Marchbanks



Reading of the City of Gustavus Mission Statement

Mission Statement read by Hutten.

APPROVAL OF MINUTES

1. 02-09-2026 General Meeting Minutes
2. 02-23-2026 Special Meeting Minutes

Motion made by Kearns to approve the 02-09-2026 General Meeting Minutes and the 02-23-2026 Special Meeting Minutes by unanimous consent.

Seconded by Beck

Hearing no objections the 02-09-2026 General Meeting Minutes and the 02-23-2026 Special Meeting Minutes were approved by unanimous consent.

MAYOR'S REQUEST FOR AGENDA CHANGES

There were no requests for agenda changes.

Hearing no objections, McLaughlin announced the agenda set as presented by unanimous consent.

COMMITTEE / STAFF REPORTS

3. Conservation Lands Advisory Committee Quarterly Report

City of Gustavus, Alaska
City Council General Meeting Minutes - PENDING
March 9, 2026
Page 1 of 7

Lands Committee Chair, Mike Taylor submitted a written report and provided an oral summary.

Clarifying Questions: None

4. Library Quarterly Report

Library Administrative Director, Melisa Gomb submitted a written report and provided an oral summary.

Clarifying Questions: Patrick

5. City Treasurer Monthly Report

City of Gustavus City Treasurer, Ben Sadler provided monthly financial documents and gave an oral summary.

Clarifying Questions: McLaughlin

6. City Administrator Monthly Report

City of Gustavus City Administrator, Kathy Leary provided a written report and provided an oral report.

Clarifying Questions:

Hutten

McLaughlin

PUBLIC COMMENT ON NON-AGENDA ITEMS

Susan Warner - Clarification on abbreviation and budget meeting date

CONSENT AGENDA - None

ORDINANCE FOR PUBLIC HEARING

- 7. FY26-13NCO An Ordinance providing for the amendment of the city held accounts in fiscal year 2026 - closing Capital Project CP19-06 DRC Composting Facility (Introduced 02-09-2026)

McLaughlin opened the public hearing at 7:31 PM.

Public Testimony: None

Mayor McLaughlin closed the public hearing at 7:31 PM.

Council Debate: None

Voting Yea: Mayor McLaughlin, Vice Mayor Beck, Council Member Patrick, Council Member Hutten, Council Member Taylor, Council Member Kearns, Council Member Marchbanks

7 yea/ 0 nay

Motion passed

UNFINISHED BUSINESS - None

NEW BUSINESS

- 8. FY26-14NCO An introduction of an ordinance providing for the amendment for the City held accounts in Fiscal Year 2026 - Closing Capital Project CP24-01 DRC Expansion (Public Hearing 04-13-2026)

Motion by Beck to introduce FY26-14NCO An introduction of an ordinance providing for the amendment for the City held accounts in Fiscal Year 2026 - Closing Capital Project CP24-01 DRC Expansion (Public Hearing 04-13-2026).

Seconded by Kearns

Public Comment: None

Council Debate:

Kearns

Voting Yea: Mayor McLaughlin, Vice Mayor Beck, Council Member Patrick, Council Member Hutten, Council Member Taylor, Council Member Kearns, Council Member Marchbanks

7 yea/ 0 nay

Motion passed

9. FY26-15NCO An introduction of an ordinance providing for the amendment of the City Budget and City held accounts in Fiscal Year 2026 - Road Maintenance (Public Hearing 04-13-2026)

Motion by Kearns to introduce FY26-15NCO An introduction of an ordinance providing for the amendment of the City Budget and City held accounts in Fiscal Year 2026 - Road Maintenance (Public Hearing 04-13-2026).

Seconded by Patrick

Conflict of interest declared for Council Member Marchbanks- Marchbanks will not participate in debate or voting.

Public Comment: None

Council Debate:

Taylor

McLaughlin

Voting Yea: Mayor McLaughlin, Vice Mayor Beck, Council Member Patrick, Council Member Hutten, Council Member Taylor, Council Member Kearns

Voting Abstaining: Council Member Marchbanks

6 yea/ 0 nay

Motion Passed

10. Approve the proposal to engage with a new city attorney, Megan J. Costello, Foghorn Law Office, LLC

Motion made by Hutten to Approve the proposal to engage with a new city attorney, Megan J. Costello, Foghorn Law Office, LLC

Seconded by Patrick

Public Comment: None

Council Debate: Taylor

Voting Yea: Mayor McLaughlin, Vice Mayor Beck, Council Member Patrick, Council Member Hutten, Council Member Taylor, Council Member Kearns, Council Member Marchbanks

7 yea/ 0 nay

Motion passed

- 11. Approve Alaska Department of Environmental Conservation (ADEC) Village Safe Water Program to submit Gustavus Septage Management Project as part of their Capital Improvement Plan

Motion made by Patrick to Approve Alaska Department of Environmental Conservation (ADEC) Village Safe Water Program to submit Gustavus Septage Management Project as part of their Capital Improvement Plan

Seconded by Hutten

Public Comment: None

Council Debate:

Hutten

City Administrator Leary

McLaughlin

Taylor

City Administrator Leary

Kearns

Marchbanks

Taylor

City Administrator Leary

McLaughlin

Hutten

Kearns

Voting Yea: Mayor McLaughlin, Vice Mayor Beck, Council Member Patrick, Council Member Hutten, Council Member Taylor, Council Member Kearns, Council Member Marchbanks

7 yea/ 0 nay

Motion passed

- 12. Approve Project Development Short Form for Grant and Projects Master Dashboard and Compliance Tracker

Motion made by Hutten to approve Project Development Short Form for Grant and Projects Master Dashboard and Compliance Tracker

Seconded by Taylor

Public Comment: None

Council Debate:

Taylor

Hutten

City Administrator Leary

Kearns

Voting Yea: Mayor McLaughlin, Vice Mayor Beck, Council Member Patrick, Council Member Hutten, Council Member Taylor, Council Member Kearns, Council Member Marchbanks

7 yea/0 nay

Motion passed

- 13. Approve Grant Consulting Agreement with Alcyon Consulting Grant writing and Consulting Services in the amount of \$6,500.00

Motion made by Kearns to approve Grant Consulting Agreement with Alcyon Consulting Grant writing and Consulting Services in the amount of \$6,500.00

Seconded by Beck

Public Comment: None

Council Debate:

Beck

Hutten

Kearns

City Administrator Leary

Beck

McLaughlin

City Administrator Leary

Hutten

Motion made by Hutten to amend the agreement with ALCYON to include "Travel Expenses. The Client shall reimburse Consultant for any and all reasonable travel-related expenses incurred by Consultant in connection with Consultant's performance of the Services included in this proposal. All travel expenses must be preapproved by Client before booking. Reimbursable travel expenses shall include main cabin airfare (or similar), airport parking, shuttle, and other reasonable transportation expenses. Lodging and per diem will be calculated based on DoD per diem rates for the community. All travel related to this Professional Services Contract will be considered contractual services and will be subject to 1099 tax reporting."

Seconded Kearns

Council Debate:

Taylor

Patrick

McLaughlin

Kearns

City Administrator Leary

Hutten

0 yea/ 7 nay

Motion failed

Continued Council Debate on the original motion

Patrick

City Administrator Leary

Kearns

Motion made by Kearns to amend the consulting agreement to have the project be completed within 8 weeks of commencement.

Seconded by Patrick

Hutten

City Administrator Leary

Voting Yea: Mayor McLaughlin, Vice Mayor Beck, Council Member Patrick, Council Member Hutten, Council Member Taylor, Council Member Kearns, Council Member Marchbanks

7 yea/ 0 nay

Motion passed

Back to main motion as amended -no further council debate

Voting Yea: Mayor McLaughlin, Vice Mayor Beck, Council Member Patrick, Council Member Hutten, Council Member Taylor, Council Member Kearns, Council Member Marchbanks

7 yea/ 0 nay

Motion passed

14. Approve Master Services Agreement with RESPEC Company, LLC

Motion made by Beck to approve Master Services Agreement with RESPEC Company, LLC

Seconded by Hutten

Public Comment: None

Council Debate: None

Voting Yea: Mayor McLaughlin, Vice Mayor Beck, Council Member Patrick, Council Member Hutten, Council Member Taylor, Council Member Kearns, Council Member Marchbanks

7 yea/ 0 nay

Motion passed

CITY COUNCIL REPORTS

15. Mayor Monthly Report

Mayor, Sally McLaughlin provided a written report and provided an oral report.

Clarifying Questions: None

CITY COUNCIL QUESTIONS AND COMMENTS

Beck - encourages public comment on fish box tax policy

Beck - Thanking Mayor McLaughlin for her leadership during the winter storm

PUBLIC COMMENT ON NON-AGENDA ITEMS

Whitney Rapp

EXECUTIVE SESSION

None

ADJOURNMENT

Since there is no further business, the meeting is adjourned. The time 8:42pm.

POSTED ON: March 4, 2026 at P.O, Library, City Hall & <https://cms.gustavus-ak.gov/>

ADA NOTICE

Any person with a disability who requires accommodations in order to participate in this meeting should telephone the City Clerk's office at (907) 697-2451, at least 48 hours prior to the meeting in order to make a request for a disability related modification or accommodation.

MISSION STATEMENT

The City of Gustavus is a distinctive Alaskan City that provides high quality public services in a thoughtful, cost effective and professional manner to sustain a safe, beautiful tolerant environment to live, work, and play with respect for individual freedom and each other.

Sally A. McLaughlin, Mayor

Date

Attest: Liesl M. Barker, City Clerk

Date

EMS- 24

FIRE-0

Gustavus Volunteer Fire Department April Quarterly Report – Fire Chief Update

Good evening, Council Members,

I am pleased to provide an update on the activities and progress of the Gustavus Volunteer Fire Department for the first quarter of the year.

To date, the department has responded to a total of 24 EMS calls and zero fire calls.

In February, I had the opportunity to attend the Alaska Fire Chiefs Association Leadership Summit in Juneau. This was a valuable experience that allowed me to connect with fire service leaders from across the state, share ideas, and discuss challenges and solutions. I also had the chance to engage with state representatives.

I'm also very encouraged by our continued growth. This quarter, we successfully recruited five new responders, bringing our total membership to 29.

We hosted both an Emergency Trauma Technician (ETT) course and an EMT-I bridge class. As a result, we now have five new EMT-I certified responders, with two additional members preparing to complete their certification exams.

Additionally, six of our responders traveled to Fairbanks for two weeks to complete the skills portion of their Firefighter I certification. I am proud to report that all participants successfully passed the practical skills evaluation. We are currently awaiting the results of their written examinations.

Overall, this quarter reflects strong progress in staffing, training, and regional engagement. I appreciate the continued support from the Council and look forward to building on this momentum in the months ahead.

Thank you.

Respectfully,

Johan Janse van Rensburg
Interim Fire Chief
Gustavus Volunteer Fire Department



Quarterly Clerk Report
04-13-2026
Submitted on 04-08-2026
Submitted by: Liesl Barker

Happy Spring Gustavus! The last few months I have spent most of my spare time working on our new website. We are happy to be launching it at the end of this month!

I have been informed that the meeting management system I use is going to be upgraded/migrated to a new system. I don't have much information, but we will be fully on the new system by the end of June 2027. I also wanted to remind the council that our website will need to be ADA compliant by April of 2027. This requirement will involve paying for another added program called Audio Eye. Using Audio Eye in conjunction with inputting information properly into the backend of the website will make sure that the city is compliant with the new regulations. I am waiting for a quote for this program, it will need to be purchased during our upcoming fiscal year 2027.

Clerk Development/Training – Thank you for your continued support and invest in me professionally!

For completion of my Certified Municipal Clerk (CMC) certification, I need to have completed 50 experience points and 60 education points. I currently have approximately 37.25/50 experience and 60/60 education points. I am looking forward to attending the International Institute of Municipal Clerks conference in Reno Nevada this May. This conference will be providing me with the points I need to complete my certification. I am excited for several of the sessions during this conference that are going to cover topics such as Tips for AI Productivity, Effective Policy Making and implementation, Moving beyond Making a motion, managing workplace personalities and team dynamics, de-escalating disruptive behaviors in municipal offices, public speaking, leading from the middle during a crisis just to name a few.

After completing the CMC I hope to have continued support of working towards my Registered Parliamentarian Certification and my Master Municipal Clerk Certification (MMC). I will use online training as much as possible to help achieve these certifications. During my last report I requested the opportunity to attend Northwest Clerks Institute this June to take Professional Development 3, the last part of a three-part series. I applied and was awarded a scholarship, so I will be attending this course. I am very grateful for this opportunity. These points earned should be able to apply to my MMC.

Goals and projects for 2026

- Launch new website
- Preparing website for ADA compliance
- Continuing to work to change the city hall set up so community members as well as council members can see the electronically displayed packet and improve the camera/video recording to help make the zoom experience better and more personable for our community members attending meeting remotely or viewing the recording.
- Update our records retention schedule and records policy
- Continue to serve a lesion for the ordinance committee
- Start micro-training videos on topics for council



The City Council attendance history.

This record starts with October 7, 2024, special meeting where the new council was sworn in.

Meeting Date	Renee Patrick Seat A-exp. 2028	Open Seat B-exp. 2028	Hutten Seat C-exp. 2026	Kearns Seat D-exp. 2026	McLaughlin Seat E-exp. 2027	Beck Seat F-exp. 2027	M Taylor Seat G-exp. 2027
10-13-2025 General Council Meeting		VACANT					
10-20-2025 Special Council Meeting		VACANT					
11-03-2025 Work Session		VACANT					
11-04-2025 Special Work Session - Council training		VACANT	via zoom				
	Renee Patrick Seat A-exp. 2028	Marchbanks (exp. 2026) Seat B-exp. 2028	Hutten Seat C-exp. 2026	Kearns Seat D-exp. 2026	McLaughlin Seat E-exp. 2027	Beck Seat F-exp. 2027	M Taylor Seat G-exp. 2027
11-10-2025 General Council Meeting		sworn in					
12-01-2025 Work Session				via zoom			
12-08-2025 General Council Meeting						via zoom	
01-12-2026 Special Work Session							
01-19-2026 Special General Council Meeting				via zoom			
01-26-2026 Special Work Session - CIP				via zoom			
02-02-2026 Work Session	via zoom			via zoom			
02-09-2026 General Meeting				via zoom			
02-23-2026 Spcecial Meeting				via zoom			
03-02-2026 Work Session							
03-09-2026 General Meeting							
03-25-2026 Special Work Session Budget	via zoom		via zoom				
04-06-2026 Work Session			via zoom	via zoom			

Special Meeting/Work Session Present							
General Meeting Present							
Absent (unexcused)							
Absent (excused)							
Section 2.20.100 - Vacancies.							
(f) Is unexcused from any five (5) meetings in a calendar year including, but not limited to work sessions, and regular or special meetings.							
Section 2.30.040 - City council member attendance policy for regular meetings.							
(a) Any absence of a city council member from a regular meeting of the city council shall be deemed to be unexcused unless the city council member is absent from the meeting as a result of attending to official business on behalf of the City of Gustavus, for extenuating medical reasons, or for other significant cause as determined by the city council, in which case the absence shall be deemed to be excused.							

Questions?

Respectfully Submitted,

Liesl Barker, City Clerk

City of Gustavus
Profit & Loss Budget vs. Actual COG Accrual
 July 2025 through March 2026

	Jul '25 - Mar 26	Budget	\$ Over Budget	% of Budget
Ordinary Income/Expense				
Income				
Returned Check Charges	37.50			
Admin Fees	5.00			
Business License Fees	2,575.00	3,500.00	-925.00	73.6%
Donations	867.70	500.00	367.70	173.5%
DRC Income				
C Chest paid at City Hall	1,007.00			
Community Chest Sales	7,684.25	13,000.00	-5,315.75	59.1%
Landfill Fees paid @ City Hall	32,460.37			
Landfill Fees/Sales	42,049.41	100,000.00	-57,950.59	42.0%
Recyclable Material Sales	12,565.81	7,000.00	5,565.81	179.5%
Total DRC Income	95,766.84	120,000.00	-24,233.16	79.8%
Federal Revenue				
Natl Forest Receipts-Encumbered	48,039.26	0.00	48,039.26	100.0%
Payment In Lieu of Taxes	168,632.84	150,000.00	18,632.84	112.4%
Total Federal Revenue	216,672.10	150,000.00	66,672.10	144.4%
Fundraising	415.00	500.00	-85.00	83.0%
Grant Income	0.00	15,000.00	-15,000.00	0.0%
GVFD Income				
Ambulance Billing	3,467.16	9,000.00	-5,532.84	38.5%
ASP	950.00	1,000.00	-50.00	95.0%
Training	0.00	150.00	-150.00	0.0%
Total GVFD Income	4,417.16	10,150.00	-5,732.84	43.5%
Interest Income	246.79	88,876.46	-88,629.67	0.3%
Lands Income				
Gravel Pit Gravel Sales	12,056.00	30,000.00	-17,944.00	40.2%
Gravel Pit Bond (Bond - Gravel Pit Contractor)	2,000.00			
Total Lands Income	14,056.00	30,000.00	-15,944.00	46.9%
Lease Income	8,192.39	16,000.00	-7,807.61	51.2%
Library Income	2,228.25	1,000.00	1,228.25	222.8%
Marine Facilities Income				
Facilities Usage Fees				
Landing Craft Use Fee	2,600.00			
Single Use Fee	60.00			
Facilities Usage Fees - Other	0.00	2,600.00	-2,600.00	0.0%
Total Facilities Usage Fees	2,660.00	2,600.00	60.00	102.3%
Commercial Vessel Registration	2,000.00	12,500.00	-10,500.00	16.0%
Private Vessel Registration				
Kayak Registration	10.00			
Private Vessel Registration - Other	1,360.00	5,000.00	-3,640.00	27.2%
Total Private Vessel Registration	1,370.00	5,000.00	-3,630.00	27.4%
Storage Area Fee	2,100.00	2,600.00	-500.00	80.8%
Total Marine Facilities Income	8,130.00	22,700.00	-14,570.00	35.8%
State Revenue				
Community Assistance Program	77,698.75	58,200.33	19,498.42	133.5%
Shared Fisheries Business Tax	0.00	231.87	-231.87	0.0%
Total State Revenue	77,698.75	58,432.20	19,266.55	133.0%
Tax Income				
Retail Tax Income	417,024.57	450,000.00	-32,975.43	92.7%
Remote Sellers Retail Tax	69,324.09	75,000.00	-5,675.91	92.4%

City of Gustavus
Profit & Loss Budget vs. Actual COG Accrual
 July 2025 through March 2026

	Jul '25 - Mar 26	Budget	\$ Over Budget	% of Budget
Room Tax Income	101,044.85	100,000.00	1,044.85	101.0%
Fish Box Tax	9,000.00	9,000.00	0.00	100.0%
Penalties & Interest	7,293.98	3,000.00	4,293.98	243.1%
Tax Exempt Cards	170.00	300.00	-130.00	56.7%
Total Tax Income	603,857.49	637,300.00	-33,442.51	94.8%
Total Income	1,035,165.97	1,153,958.66	-118,792.69	89.7%
Gross Profit	1,035,165.97	1,153,958.66	-118,792.69	89.7%
Expense				
Administrative Costs	528.00			
Bad Debt	783.40			
Bank Service Charges				
Returned NSF Check	25.00			
Bank Service Charges - Other	7,774.03	11,550.00	-3,775.97	67.3%
Total Bank Service Charges	7,799.03	11,550.00	-3,750.97	67.5%
Building				
Insurance	18,401.38	20,300.00	-1,898.62	90.6%
Maintenance & Repair	1,875.47	4,000.00	-2,124.53	46.9%
Total Building	20,276.85	24,300.00	-4,023.15	83.4%
Contractual Services				
Medical Director	4,000.00	10,600.00	-6,600.00	37.7%
City Engineer	1,320.00	10,000.00	-8,680.00	13.2%
Ambulance Billing Expense	677.86	1,000.00	-322.14	67.8%
Managed IT Services	20,465.00	25,020.00	-4,555.00	81.8%
Contractual Services - Other	18,916.76	25,988.00	-7,071.24	72.8%
Total Contractual Services	45,379.62	72,608.00	-27,228.38	62.5%
Dues/Fees	5,676.42	11,850.00	-6,173.58	47.9%
Economic Development Services				
GVA	15,200.00	15,200.00	0.00	100.0%
Total Economic Development Services	15,200.00	15,200.00	0.00	100.0%
Election Expense	184.48	250.00	-65.52	73.8%
Equipment				
Equipment Fuel	2,228.69	2,900.00	-671.31	76.9%
Equipment Purchase	3,624.90	4,800.00	-1,175.10	75.5%
Insurance	411.01	377.00	34.01	109.0%
Maintenance & Repair	830.27	1,900.00	-1,069.73	43.7%
Equipment - Other	194.48			
Total Equipment	7,289.35	9,977.00	-2,687.65	73.1%
Events & Celebrations	876.71	1,200.00	-323.29	73.1%
Freight/Shipping	16,367.98	30,250.00	-13,882.02	54.1%
Fundraising Expenses	35.73	500.00	-464.27	7.1%
General Liability	12,861.14	19,625.00	-6,763.86	65.5%
Library Materials	2,286.47	10,500.00	-8,213.53	21.8%
Marine Facilities				
Insurance	805.25	3,300.00	-2,494.75	24.4%
Maintenance & Repairs	0.00	500.00	-500.00	0.0%
Total Marine Facilities	805.25	3,800.00	-2,994.75	21.2%
Occupational Health	0.00	500.00	-500.00	0.0%
Payroll Expenses				
Wages	308,520.19	407,512.40	-98,992.21	75.7%
Payroll Taxes	28,914.85	39,118.15	-10,203.30	73.9%
Paid Time off	8,838.51	22,878.92	-14,040.41	38.6%

City of Gustavus
Profit & Loss Budget vs. Actual COG Accrual
 July 2025 through March 2026

	Jul '25 - Mar 26	Budget	\$ Over Budget	% of Budget
Sick Leave	3,983.27	7,883.30	-3,900.03	50.5%
Health Insurance (company paid)	37,880.40	23,645.52	14,234.88	160.2%
Health Insurance Stipend	5,600.00	12,000.00	-6,400.00	46.7%
457(b) Employer Contribution	10,957.78	28,532.75	-17,574.97	38.4%
Workers Comp Insurance	9,993.57	11,358.61	-1,365.04	88.0%
Payroll Expenses - Other	-14,376.24	1,751.10	-16,127.34	-821.0%
Total Payroll Expenses	400,312.33	554,680.75	-154,368.42	72.2%
Professional Services	1,045.00	30,000.00	-28,955.00	3.5%
Public Relations	0.00	500.00	-500.00	0.0%
Repair & Replacement Fund	18,554.91	18,554.91	0.00	100.0%
Road Maintenance				
Snow Plowing	57,785.86			
Road Maintenance - Other	159,551.91	215,000.00	-55,448.09	74.2%
Total Road Maintenance	217,337.77	215,000.00	2,337.77	101.1%
Social Services				
GCEP dba The Rookery	0.00	8,000.00	-8,000.00	0.0%
Total Social Services	0.00	8,000.00	-8,000.00	0.0%
Stipend	2,160.00	4,000.00	-1,840.00	54.0%
Supplies				
Program	1,167.17	1,550.00	-382.83	75.3%
Supplies - Other	15,927.02	19,700.00	-3,772.98	80.8%
Total Supplies	17,094.19	21,250.00	-4,155.81	80.4%
Telecommunications	17,770.67	21,521.00	-3,750.33	82.6%
Training	5,088.00	19,004.00	-13,916.00	26.8%
Travel	10,750.67	19,638.00	-8,887.33	54.7%
Utilities				
Electricity	5,373.14	10,200.00	-4,826.86	52.7%
Fuel Oil	6,947.09	7,500.00	-552.91	92.6%
Utilities - Other	-836.59			
Total Utilities	11,483.64	17,700.00	-6,216.36	64.9%
Vehicle				
Fuel	1,330.82	1,500.00	-169.18	88.7%
Insurance	5,435.11	5,500.00	-64.89	98.8%
Maintenance & Repair	1,779.57	3,000.00	-1,220.43	59.3%
Mileage Reimbursement	922.25	2,000.00	-1,077.75	46.1%
Total Vehicle	9,467.75	12,000.00	-2,532.25	78.9%
Total Expense	847,415.36	1,153,958.66	-306,543.30	73.4%
Net Ordinary Income	187,750.61	0.00	187,750.61	100.0%
Net Income	187,750.61	0.00	187,750.61	100.0%

City of Gustavus
Balance Sheet
As of March 31, 2026

	<u>Mar 31, 26</u>
ASSETS	
Current Assets	
Checking/Savings	
AMLIP Capital Improv Current (0630598.1)	206,997.39
AMLIP Capital Improv Long-Term (0630598.2)	832,493.24
AMLIP Repair & Replacement (0630598.3)	429,810.07
AMLIP Gravel Pit Fund (0630598.8)	34,025.32
AMLIP Reserve (0630598.12)	1,194,778.77
APCM.Endowment Fund	1,794,899.95
FNBA - Checking	316,790.07
FNBA Endowment Fund - Checking	53,149.38
Petty Cash	286.69
Total Checking/Savings	<u>4,863,230.88</u>
Accounts Receivable	5,263.58
Other Current Assets	696.28
Total Current Assets	<u>4,869,190.74</u>
TOTAL ASSETS	<u>4,869,190.74</u>
LIABILITIES & EQUITY	
Liabilities	
Current Liabilities	<u>184,248.42</u>
Total Liabilities	184,248.42
Equity	
Fund Balance	3,346,607.68
Opening Bal Equity	1,084,743.57
Net Income	253,591.07
Total Equity	<u>4,684,942.32</u>
TOTAL LIABILITIES & EQUITY	<u>4,869,190.74</u>

Accounts Receivable Detail	
As of 03/31/2026	
\$719.04	Delinquent Sales Tax
\$4,583.90	Ambulance Transport Billing - In Progress
\$25.00	ASP Customer Invoice
(\$64.36)	Net of Other Customer Account Balances
\$5,263.58	Total

FNBA Checking Account - Unrestricted Funds Balance	
As of 03/31/2026	
FDIC: The standard deposit insurance coverage limit is \$250,000 per depositor, per FDIC-insured bank, per ownership category.	
City of Gustavus has a tri-party agreement in place that collateralizes our account, providing protection for the full value of our account balances.	
FNBA Checking Account Balance:	\$316,790.07
Obligated Funds Currently in Checking Account:	
GVFD	FY26-05 Wildlands Fire Truck
	-\$11,000.00
Library	SoA OWL Internet Subsidy
	\$225.00
Unrestricted Funds:	\$306,015.07

Pending Transfers:		Introduced	Pub. Hearing	
FY26-15NCO	Road Maintenance	3/9/2026	4/13/2026	Budget Amendment

Per the Unrestricted Fund Balance Policy (Res. CY18-18), the unrestricted fund balance should be 17-35% of 35% of the current Fiscal year's operating expenses, with a target of 25%.

FY26 budgeted operating expenses:	\$1,153,958.66
25% =	\$288,489.67
17% =	\$196,172.97
35% =	\$403,885.53

0630598.1 AMLIP Capital Project Current - Funds allocated through NCOs for funded Capital Projects	Date and NCO
---	---------------------

		AMLIP	Project	Remaining	
Admin	CP19-03 Gustavus Beach Improv.	\$4,433.54	\$0.00	\$4,433.54	Moved to AMLIP Current 08/15/2023 - NCO FY24-02
DRC	CP19-06 DRC Composting Facility	\$430.00	\$430.00	\$0.00	Closed out w/ NCO FY26-13
DRC	CP21-05 DRC Main Bldg Replacement: Design	\$326.60	\$326.60	\$0.00	Moved to AMLIP Current 08/15/2023 - NCO FY24-02
DRC	CP24-01 DRC Balefill Expansion	\$45,944.19	\$20,654.92	\$25,289.27	Moved to AMLIP Current 05/13/2024 - NCO FY24-13
Admin	CP24-04 Heat Pump Project	\$29,585.71	\$0.00	\$29,585.71	Moved to AMLIP Current 09/11/2024 - NCO FY25-03
GVFD	CP24-05 AFG FEMA Match	\$33,404.77	\$0.00	\$33,404.77	Moved to AMLIP Current 10/21/2024 - NCO FY25-05
Admin	CP25-01 City Hall Meter	\$16,089.26	\$0.00	\$16,089.26	Moved to AMLIP Current 05/12/2025 - NCO FY25-24
GVFD	CP26-02 Fire Fighter 1 Training	\$32,000.00	\$7,139.56	\$24,860.44	Moved to AMLIP Current 10/30/2025 - NCO FY26-07
Admin	Gravel Pit Funds	\$36,300.00	\$6,100.00	\$30,200.00	Moved to AMLIP Current 01/22/2026 - NCO FY26-11
		(\$445.38)			
	Interest earned FY26	\$8,928.70			Mathmatical error when transferring funds at end of FY25
		\$206,997.39	\$34,651.08	\$163,862.99	

Pending Transfers:		Amount	Introduced	Public Hearing	
FY26-13NCO	DRC Composting Facility	\$66,645.85	2/9/2026	3/9/2026	Close Out
FY26-14NCO	DRC Expansion	\$45,944.19	3/9/2026	4/13/2026	Close Out
FY26-16NCO	DRC Bobcat Attachments	\$17,500.00	4/13/2026	5/11/2026	Introduction
FY26-17NCO	Grant Planning & Strategy	\$6,500.00	4/13/2026	5/11/2026	Introduction

- **Grants/Projects update:**

- Compost Facility

No Update – During her visit, I drove Senator Murkowski and her staff to the DRC (among other locations) and showed her the where the compost quonset used to be and the site if the anticipated compost facility upgrades. I explained that SWIFR has not been funded for the last two cycles and that is why we have submitted CDS requests for the last few years.

DRC - Recycling Center

Update – RESPEC, engineering contractor is working on the 15 design. We had our monthly update meeting with the Region 10 project person, and I have submitted a budget revision to include temporary personnel costs in order to bring Paul Berry on to assist with the project. We additionally had to reallocate some budget line items to accommodate the increase in engineering costs. WE are awaiting approval for the revision from the EPA grants manager on the revision request.

- Good River Bridge Repair and Embankment Stabilization Project

No Update –Waiting on the 100% design documents which will be in early May to submit a supplemental request. John Barry and I will be preparing this request with input from RESPEC to submit to the Denali Commission.

- PIDP – Dock/Floats Protection - MARAD funding

No Update –The grant has been submitted, and we are awaiting notification – one way or the other. The new NOFO is out, and we are working with ADOT on a couple of improvements in preparation of a 2026 application.

[MARAD-250225-001 Updated PIDP Notice of Funding Opportunity | MARAD](#)

- FLAP – Federal Lands Access Program for the sidepath from Good River corner to the NPS Boundary

Update – We were just notified that we were approved for the funding for this project. The Program Decision Committee (PDC) approved \$650,00 for Phase I design and once presented with the final option/scope of the project, the remaining budget is \$2,615,000. This is a total of \$3,265,000. We will first need to determine when FHWA will have the funds available. If the funds are only available later on like FY28 or 29, it is possible that we might be able to start Design before then using other funds and then paying it back when the funds become available. ADOT is looking into this. Kirk Miller, engineer at ADOT is ready to go as soon as we know about funding. This project will need to be added to the STIP.

- Rural and Tribal Assistance Pilot Program (RTA) Application

Update –We were just notified that we were not funded under this program, which was first come first served. Even though the application was entered as soon as the portal opened, it did not make the cut. They received more than 799 applications of which 49 communities were funded, and funding was exhausted before they reviewed our application. <https://www.transportation.gov/buildamerica/RuralandTribalGrants>

- FEMA – AFG Water Tender

No Update – Apparently the FEMA offices are still on hold. We requested an extension for the period of performance on 2/9/26, resent a message and received a canned out of office response due to federal funding hold.

- Septage Management

Update I submitted a PER update funding request through VSW based on the changes that occurred during the PER period. We have not heard back on this yet. We had a meeting with Senator Kiehl, Mayor Beth Weldon, representatives from Juneau Public Works, John Barry, Justin Marchbanks, Mayor McLaughlin, Theo Graber from RCAC, Kristin Freiburger of Shannon and Wilson, Trevor Richards of Juneau Septic, and Norma Fleek w

prompted the meeting. I am not sure that we really got anywhere in the brief time we had. I think the next step is to get information about regulatory details from ADEC before we can proceed to engage more with CBJ.

- Safe Streets for All (SS4A)

No Update – Waiting on AML for next steps in the process. AML is the subrecipient for SS4A.

- Thriving Communities Cohort

- *Update* - At the Infrastructure Development Symposium this week (4/7-4/9) there is a Thriving Communities cohort meeting the afternoon of 4/8. Some of the topics/training will include:
 - Build project management skills tailored to rural Alaska
 - Connect directly with federal funding partners
 - Learn from peers advancing similar projects

We are working on task order details to engage the chosen firm on the next steps.

- RE-VEEP

Update - New! An opportunity came forward for the Library to submit a grant application through the Alaska Energy Authority. This agency award grants to eligible entities within Alaska to finance building-scale renewable energy, energy efficiency, and conservation projects in public buildings and facilities located in rural Alaska. Through these types of projects, communities are able reduce their energy consumption and costs. Melisa submitted a grant for an energy audit and a boiler replacement, and we were just notified that it was approved for \$14,500.

Strengthening Gateway Communities: We had a meeting with the NPS on 3/20. The meeting was to have been with someone from the Regional Office, but they were not in attendance. There are minutes from this meeting and the previous meeting which can be shared with council.

- A list of other tasks/items:
 - **Storm Event:** We had the Recovery Scoping Meeting on 3/24. Now the work begins of separating the various categories of damages and mitigation projects. I have been working with Ben and GBC to gather costs and figure out which category they go in for possible cost recovery. I will be a JBER on Friday to work with the DHSEM staff to wind our way through the morass of paperwork needed to document the projects and associated costs, much of which was snow removal.
 - Regularly attended scheduled Infrastructure Office Hours and other meetings and seminars, including community engagement, grant/project updates, and our Thriving Communities cohort.
 - Various HR items – (including evaluations)
 - Worked with Melisa and Mark Berry on a RE-VEEP Grant submission for an energy audit and boiler replacement in the library. (Recently approved!)
 - Continued coordination on roads and snow issues.
 - RESPEC kickoff meeting for the DRC facility with John Barry.
 - Contract with and meet with Alcyon Consulting for the grant support documentation project and attended a kickoff meeting
- Council Questions or Comments?

**CITY OF GUSTAVUS, ALASKA
ORDINANCE FY26-16NCO**

**AN ORDINANCE FOR THE CITY OF GUSTAVUS PROVIDING FOR THE AMENDMENT OF
THE CITY HELD ACCOUNTS IN FISCAL YEAR 2026 - DRC BOBCAT ATTACHMENTS**

BE IT ENACTED BY THE GUSTAVUS CITY COUNCIL AS FOLLOWS:

Section 1. Classification. This is a **Non-Code Ordinance**

Section 2. For the Fiscal Year of 2026, the following City held account balance transfers are to be made for the reasons stated.

Section 3. For the current fiscal year, City held accounts are amended to reflect the changes as follows:

CITY HELD ACCOUNTS	Amounts		
	Account Balance*	Amended Balance	Change
CP-26-05 DRC Bobcat Attachments <i>Funding to be transferred to Capital Current</i>	\$ 0.00	\$ 17,500.00	\$ 17,500.00
AMLIP Capital Improv Long-Term	\$ 832,493.24	\$ 814,993.24	\$ 17,500.00
Total Change in City Held Account Balances			\$ 0.00

Section 4. The City held accounts are hereby amended as indicated.

Section 5. Effective Date. This ordinance becomes effective upon its adoption by the Gustavus City Council.

DATE INTRODUCED: April 13, 2026
DATE OF PUBLIC HEARING: May 11, 2026

PASSED and **APPROVED** by the Gustavus City Council this __th day of _____, 2026.

Sally A McLaughlin, Mayor

Attest: Ben Sadler, City Treasurer

Attest: Liesl M Barker, City Clerk

**CITY OF GUSTAVUS, ALASKA
ORDINANCE FY26-17NCO**

**AN ORDINANCE FOR THE CITY OF GUSTAVUS PROVIDING FOR THE AMENDMENT OF
THE CITY HELD ACCOUNTS IN FISCAL YEAR 2026 – GRANT PLANNING & STRATEGY**

BE IT ENACTED BY THE GUSTAVUS CITY COUNCIL AS FOLLOWS:

Section 1. Classification. This is a **Non-Code Ordinance**

Section 2. For the Fiscal Year of 2026, the following City held account balance transfers are to be made for the reasons stated.

Section 3. For the current fiscal year, City held accounts are amended to reflect the changes as follows:

CITY HELD ACCOUNTS	Amounts		
	Account Balance*	Amended Balance	Change
CP-26-04 Grant Planning & Strategy \$ <i>Funding to be transferred to Capital Current</i>	0.00	\$ 6,500.00	\$ 6,500.00
AMLIP Capital Improv Long-Term	\$ 832,493.24	\$ 825,993.24	\$ 6,500.00
Total Change in City Held Account Balances			\$ 0.00

Section 4. The City held accounts are hereby amended as indicated.

Section 5. Effective Date. This ordinance becomes effective upon its adoption by the Gustavus City Council.

DATE INTRODUCED: April 13, 2026
DATE OF PUBLIC HEARING: May 11, 2026

PASSED and **APPROVED** by the Gustavus City Council this __th day of _____, 2026.

Sally A McLaughlin, Mayor

Attest: Ben Sadler, City Treasurer

Attest: Liesl M Barker, City Clerk

**CITY OF GUSTAVUS, ALASKA
RESOLUTION CY26-04**

**A RESOLUTION BY THE CITY OF GUSTAVUS UPDATING THE BENEFITS POLICY AND
PROCEDURE FOR ELIGIBLE REGULAR POSITION EMPLOYEES**

WHEREAS, in 2023, with Resolution CY23-12, the Gustavus City Council updated Policy and Procedure for Eligible Regular Position Employees; and

WHEREAS, in the process of implementing the Policy and Procedure, it became apparent that some clarifications and revisions were necessary; and

WHEREAS, the City of Gustavus recognizes that from time to time these policies need to be updated or amended; and

WHEREAS, the City of Gustavus recognizes that formal action is needed to further clarify procedures under the City of Gustavus Policy and Procedure For Eligible Regular Position Employees.

NOW THEREFORE, BE IT RESOLVED that effective upon adoption, the City of Gustavus updates its Employee Benefits Policy and Procedure for Eligible Regular Position Employees as attached:

PASSED and **APPROVED** by the Gustavus City Council this __th day of _____, 2026.

Bold and Underlined items are additions. Strikeout items are deletions.

Sally A. McLaughlin, Mayor

Attest: Liesl M. Barker, City Clerk

CITY OF GUSTAVUS
POLICIES AND PROCEDURES

**TITLE: CITY OF GUSTAVUS BENEFITS POLICY AND PROCEDURE FOR ELIGIBLE
REGULAR POSITION EMPLOYEES EFFECTIVE SEPTEMBER 11TH, 2023**

BACKGROUND:

By Ordinance FY2012-13 adopted April 12, 2012, the Gustavus City Council approved a major revision to Title 3, Personnel. Revised Title 3 provides that it is the policy of the City of Gustavus to establish and amend, from time to time, by resolution, a written benefits policy, which describes various non-wage compensations that the City provides to employees in addition to wages or salaries. [CoG 3.05.01]

Consistent with the provisions of revised Title 3, the City Council adopted by Resolution 2018-01 this “City of Gustavus Benefits Policy,” which applies to all eligible Regular Position employees. This updated policy, effective, replaces all previous City of Gustavus benefits and leave policies. [CoG 3.04.01(b) (1)]

I. Health Insurance

The City of Gustavus offers a group health insurance plan to all Regular Exempt and Non-Exempt Position employees. This self-only plan (no spouse or dependent coverage) is offered to all eligible employees, and the City may only exempt those eligible employees who provide proof that they have health insurance offered by other means.

Any qualified employees opting into the City’s healthcare plan will enter at a City/Employee 80%/20% contribution ratio respectively.

For those employees who do not choose to elect the group health insurance plan offered by the City, a \$200.00 monthly stipend is offered. This stipend is similar to a monthly bonus in that it is subject to payroll taxes, is reported as income, does not count toward the accrual of paid time off (PTO), and is not included in the base wages considered for the City match in the Retirement Savings Plan. The stipend is included during the regularly scheduled payroll.

POLICY:

To qualify for participation in this program, the employee must be ~~(1)~~ a Regular Exempt or Non-Exempt Position employee. For employees that elect not to participate in the health insurance program offered by the City, evidence that they are insured via other means is required.

PROCEDURE:

- (A) For those employees NOT selecting City provided insurance:
On a monthly basis, the City Treasurer will add the health insurance stipend to the employee’s paycheck in an amount of \$200 gross wages for all Regular Exempt and non-Exempt employees. All stipend amounts are subject to tax reporting and withholding, and the employee will be paid a net amount. If an employee is on unpaid leave during the month and drops below an average of 20 hours worked per week for

the month, the stipend will be prorated based on the percentage of the actual hours worked divided by 20 hours per week for the month.

Employees declining enrollment because of other health care coverage may in the future enroll if they have involuntarily lost their other coverage and an enrollment application is received by the insurance company within 60 days after their other coverage ends. See the group insurance documentation for details.

(B) For those employees enrolling in City provided insurance:

Employees may enroll during the group health plan renewal period each summer with coverage beginning September 1. For new employees, enrollment is effective on the first of the month following the date of hire, or as prescribed by the Insurance providers policy and procedure. Prior to September 1 each year, the Employees may enroll in the city insurance program, or decline enrollment with proof of other coverage, for the following 12 months. Employees may not cancel insurance or sign up for insurance except during this open enrollment period unless they meet the exceptions provided by the insurance company. See the group insurance documentation for details.

If an employee is on unpaid leave during the month and drops below an average of 20 hours worked per week, the city-paid portion of the premium will be prorated based on the percentage of the actual hours worked divided by 20 hours per week for the month with the employee responsible for paying the city for the remainder of the premium before their next paycheck is issued. For employees with an unpaid furlough, the employee may either pay the full premium cost in advance to the city each month for the months not working or may cancel their enrollment and re-enroll once they begin working again. For employees with an assigned work schedule of less than 20 hours per week for the month (e.g. no unpaid leave is being taken), the city-paid portion will remain at 80%.

II. **Deferred Compensation Program, a 457(b) Retirement Savings Plan**

The City participates in a 457(b)-deferred compensation program with Lincoln Financial Group. A 457(b) plan is a type of tax-advantaged deferred-compensation retirement plan that is available to state or local governments and their agencies. The employer provides the plan and the employee defers compensation into it on a pre-tax basis. Participation is voluntary. The participant contributes a flat amount or percentage of his/her choice each month, which is withdrawn from the monthly paycheck. The City will match the employee's monthly contribution up to a maximum of 7% of the employee's straight time pay, overtime pay, and paid time off pay for the month. Health insurance stipends are not included in the percentage matched. Regular Position employees may contact the City Clerk or Treasurer for more information.

III. **Human Resources – Reporting workplace harassment, discrimination, and misconduct**

The City partners with Work Shield in handling workplace harassment, discrimination, and misconduct issues. If a City employee, Council Member or a volunteer experiences any form of harassment, discrimination or other workplace misconduct – from a co-worker, manager, independent contractor or someone else from work, you can report the incident directly to Work Shield or the incident can be reported to the City Treasurer who can submit a report on the employee's behalf.

To report an incident please visit workshieldportal.com or call 866.946.5558. The Work Shield's Digital ID Card can be downloaded to an Apple Wallet or Google Wallet app for access anytime, anywhere.

All employees and volunteers shall be given a copy of the Employee Welcome Letter, Employer Harassment and Discrimination Protection Plan, link to Work Shield Training Video during employee onboarding. All departments shall display the Work Shield Breakroom Poster in an area that all employees can access.

IV. Paid Holidays [CoG 3.05.02]

The City of Gustavus observes the following ten holidays:

1. New Year's Day (January 1)
2. Martin Luther King Day
3. President's Day (third Monday in February)
4. Memorial Day (last Monday in May)
5. Independence Day (July 4)
6. Labor Day (first Monday in September)
7. Veterans Day (November 11)
8. Thanksgiving (fourth Thursday in November)
9. Day after Thanksgiving
10. Christmas (December 25)

- The City will grant an eight-hour day of paid holiday time to all full-time Regular Position employees or a pro-rated amount based on the employee's approved base hours. The Table below is an example of calculating holidays.

Hours of Holiday Pay	Work Schedule
8	full-time employee
7	87.5% (35 hours/week)
6	75% (30 hours/week)
4	50% (20 hours/week)

- Holiday pay will be calculated based on the employee's straight-time pay rate as of the date of the holiday. Paid time off for holidays will not be counted as hours worked for the purpose of determining overtime. Employees will not receive additional compensation when a recognized holiday falls on a day an employee is on Paid Time Off. Employees will not receive compensation for a holiday that occurs on a day that the employee is on an unpaid leave of absence.
- For city employees whose normal work week is Monday through Friday, if a city-observed holiday falls on a Saturday, the holiday will be observed on the previous Friday, and if a city-observed holiday falls on Sunday, the holiday will be observed the following Monday. For city employees working on Saturday, if the city-observed holiday falls on Saturday, it will be observed on that day. All city workplaces will be closed on Sunday.

V. Sick Leave and Paid Time Off (PTO)

Sick Leave

The City of Gustavus is aware that from time to time employees need to take care of sick family members or need to take time to address an illness. This benefit will be granted to all Regular Position employees in a pro-rated amount based on the employee's approved base hours. The City will grant 40 hours of paid sick leave per fiscal year. The Table below is an example of calculating the benefit.

Hours of Sick Leave	Work Schedule
40	full-time employee
35	87.5% (35 hours/week)
30	75% (30 hours/week)
20	50% (20 hours/week)

This benefit can be used for personal sick time, sick time to care for a family member within the employee's household, and travel to doctor's appointments or care facility. Absence for periods that exceed three (3) working-days may require a doctor's note or other documentation of the requirement for the absence from a professionally recognized care provider.

The following provisions apply to the Sick Leave benefit:

- Sick Leave does not have a cash monetary value and cannot be sold back to the City.
- Sick leave may accrue without restriction.
- Annual sick leave allocation begins July 1 of each year.
- An employee must receive approval from his/her supervisor for Sick Leave. In cases of emergency illness, an employee must let his/her supervisor know about the absence as soon as possible.

PTO

The City of Gustavus recognizes that employees have diverse needs for time off from work. PTO will cover all forms of personal time off and vacation. This benefit will be granted to all Regular Position employees in proportion to the hours worked each month.

Paid Time Off is a provision for time taken off from an employee's regularly scheduled work hours. PTO may not be applied to days and hours the employee is not scheduled to work. With the exception of the permitted 120-hour carry-over of unused PTO hours at the start of a new fiscal year, PTO not taken during regularly scheduled work hours will be forfeited. Unused accrued PTO is cashed out only when an employee terminates.

- An employee's annual PTO benefit accrues in accordance with employment longevity as shown in the table below. Accrual rates for a new longevity category begin on the first day of the month of the employment anniversary.
- Annual PTO benefit accruals begin July 1 of each year and end June 30 of each year.

- A maximum of 120 hours of PTO may be carried over into the next fiscal year, unless under extenuating circumstances as determined by the Mayor, an employee may exceed the maximum 120 hours of PTO and carryover the balance into the next fiscal year.
- Accrued PTO hours beyond 120 at the end of the fiscal year will be forfeited unless extenuating circumstances are approved by the Mayor.
- An employee must receive approval from his/her supervisor for planned PTO. Approval of PTO is contingent upon the needs of the department/facility. Scheduling of PTO will attempt to balance the needs of the individual and the department/facility. In cases of emergency or illness, an employee must let his/her supervisor know about the absence as soon as possible.
- Upon termination an employee shall be paid the value at the time of cash-out of remaining PTO.
- PTO must be used in full before an employee may request unpaid leave.

Longevity Categories

PTO is accrued on an hourly basis and is credited on the monthly paycheck in proportion to the actual hours paid that month. Accruals are based on longevity, that is, the number of years employed in a Regular Position with the City of Gustavus. The following table depicts Annual PTO accrual for a fulltime Regular Position, 2,080 hours/year.

Longevity (calculated from the employee's first day of work, regardless of FTE)	Annual PTO Accrual, Fulltime equivalent (FTE)	Accrual Rate of PTO hours per actual hours paid*
Less than two (2) years	80 hours	0.03833
Two (2) through five (5) years	120 hours	0.05778
Six (6) or greater years	160 hours	0.07694

*"Actual hours paid" means the total paid hours, including holiday hours and used PTO hours, but not including bonuses, stipends, or pay adjustments when correcting a payroll error.

Formula

- The same accrual rate works for any employee in a given Longevity Category. Accrual rate = annual PTO accrual allotment divided by 2080, then rounded to what the QuickBooks payroll software allows.
- Accrued PTO hours on a monthly (or any) paycheck for hourly employees = (number of hours paid) x (accrual rate)

- Accrued PTO hours on a monthly paycheck for salaried employees = (annual hours of PTO accrual from the table above)/ 12 months (prorated if unpaid leave is used that month)

Jury Duty / Jury Leave

In order that city employees may fulfill their civic responsibility as jurors or subpoenaed witnesses, all regular employees are granted leave of absence with pay for these purposes. It is the responsibility of the employee to keep her/his supervisor or department head informed of the anticipated time to be spent away from the job for this purpose. Employees will be compensated for jury duty that occurs on their regularly scheduled workday in the amount listed in their base hour’s agreement.

Any pay received by regular employees from a court system must be promptly submitted by the employee to the city to offset part of the cost of such absences. Temporary employees receive leave without pay and may retain the payment from the court. The Table below is an example of calculating jury duty/jury leave.

Hours of Jury Duty/Leave Pay	Work Schedule
8	full-time employee
7	87.5% (35 hours/week)
6	75% (30 hours/week)
4	50% (20 hours/week)

V. Compensatory Time Off

The City of Gustavus does not offer Compensatory Time Off.

VI. Flexible Work Schedule

The City of Gustavus recognizes that alternative work schedules can foster a positive work/life balance. To this end, regular position employees may be allowed by their supervisor to have a flexible work schedule. Hours worked by each regular position employee may be flexed during the work month as approved by their supervisor, provided core business hours are covered and job duties are being completed. The Mayor and/or City Administrator may designate core hours for each employee. For non-exempt employees, hours worked per week may not exceed 40 hours without prior approval for overtime (Municipal Code 3.06.020).

Signed _____ Mayor of the City of Gustavus _____ Date _____

**CITY OF GUSTAVUS ALASKA
RESOLUTION CY26-05**

**A RESOLUTION BY THE CITY OF GUSTAVUS REVISING POLICY AND
PROCEDURE FOR MILEAGE REIMBURSEMENT FOR CITY EMPLOYEES AND CITY
COUNCIL MEMBERS**

WHEREAS, in 2016, with CY16-13, the Gustavus City Council established policy and procedure for mileage reimbursement; and,

WHEREAS, in the process of implementing the Policy and Procedure, it became apparent that some clarifications and revisions were necessary; and,

WHEREAS, the City of Gustavus recognizes that from time to time policies need to be updated or amended; and,

WHEREAS, the City of Gustavus recognizes that formal action is needed to address revisions necessary to Policy and Procedure.

NOW THEREFORE, BE IT RESOLVED that effective upon adoption, the City of Gustavus updates its Policy and Procedure for Mileage Reimbursement for City Employees and City Council Members as attached:

PASSED and **APPROVED** by the Gustavus City Council this ___ day of _____, 20XX, and effective upon adoption.

Bold and Underlined items are additions. Strikeout items are deletions.

Sally A. McLaughlin, Mayor

Attest: Liesl M. Barker, City Clerk

**CITY OF GUSTAVUS
POLICIES AND PROCEDURES**

Policy and Procedure for Policy on mileage reimbursement to City employees and Council Members for personal vehicles used during the performance of their job or City business

POLICY:

City employees and Council members may request mileage reimbursement for personal vehicles used for travel related to City or department business, **either locally or when traveling out of town.**

PROCEDURE:

Mileage logs will be maintained per IRS specification and ~~need to~~ **must** include the date, ~~start and finish odometer readings,~~ destination, purpose for the travel, and total miles driven.

Payment for mileage will be determined by the business mileage rates set forth annually by the IRS.

Mileage logs will be submitted within 10 days of the end of a calendar quarter (March 31, June 30, September 30, and December 31) to the ~~Mayor~~ **Treasurer** for review and approval.

Funds will be disbursed from the employees' or Council Member's respective department budget.

Each department budget will have a line item designated for mileage reimbursement for private vehicles used in the performance of City or department business.

The ~~City Clerk/Treasurer~~ will release the funds after ~~Mayor~~ approval **by the Mayor or designee**, and verifying that the funds are available.

Sally A. McLaughlin, Mayor

Date

**CITY OF GUSTAVUS, ALASKA
RESOLUTION CY26-06**

**A RESOLUTION BY THE CITY OF GUSTAVUS IN SUPPORT OF HB321, REDESIGNATING
THE DUDE CREEK CRITICAL HABITAT AREA AS A STATE WILDLIFE REFUGE WITH
EXPANDED BOUNDARIES**

WHEREAS, the community of Gustavus has long supported the Dude Creek Critical Habitat Area since its establishment in 1988, to wit: City of Gustavus Resolutions No. 2010-18, CY15-33, CY16-14, and CY18-11; and,

WHEREAS, In 2004, The Nature Conservancy purchased several tracts of land of great conservation value from the Alaska Mental Health Trust, two of which were Tracts A and B of Gustavus Flats, Trust Land Survey No. 26 2004-01, located within Township 40 South, Range 58 East, Copper River 27 Meridian, containing 1,279.09 acres, more or less; and,

WHEREAS, Tracts A and B were conveyed to the Alaska Department of Natural Resources under an agreement that they would be included in the Dude Creek Critical Habitat Area; and,

WHEREAS, the Tract A and B lands represent superb wildlife habitat consistent with that of the original Dude Creek Critical Habitat Area, and worthy of management as a critical habitat area or a State wildlife refuge; and,

WHEREAS, HB321 would redesignate the Dude Creek CHA as the Dude Creek Wildlife Refuge with expanded boundaries incorporating Tracts A and B of the Gustavus Flats.

NOW, THEREFORE BE IT RESOLVED, that the Gustavus City Council supports inclusion of Tracts A and B in a redesignated Dude Creek Wildlife Refuge, and recommends passage of HB321 to those ends.

PASSED and APPROVED by the Gustavus City Council this 13th day of April 2026, and effective upon adoption.

Sally A. McLaughlin, Mayor

Attest: Liesl M. Barker, City Clerk

**CITY OF GUSTAVUS, ALASKA
RESOLUTION CY26-07**

A RESOLUTION PROVIDING FOR A COST-OF-LIVING PAY ADJUSTMENT FOR CITY OF GUSTAVUS EMPLOYEES IN REGULAR POSITIONS

WHEREAS, the Gustavus City Council adopted an “Employee Payment and Earnings Policy” on June 8, 2006; and

WHEREAS, the Gustavus City Council adopted Resolution 2011-23 on December 8, 2011, which updates the Section of the “Employment Payment and Earnings Policy” entitled “Pay Raises”; and

WHEREAS, the adopted Policy of “Pay Raises” states that the Gustavus City Council may grant, from time to time, by Resolution, periodic adjustments to the City’s pay schedule. The City Council will consider the cumulative change in the Consumer Price Index (Anchorage) since the last such pay adjustment in formulating such adjustments. Such periodic pay adjustments, if any, will apply to all Regular Position employees of the City of Gustavus. A Regular Position is a full-time or part-time year-round position in which the employee generally works the same schedule every week, although actual hours each week may vary with season or with workload; and

WHEREAS, in adopting this policy, the Gustavus City Council has determined that adjusting the pay of its Regular Position employees in an amount equal to the change in the consumer price index (CPI) for Anchorage, the standard measure of CPI for Alaska, is appropriate; and

WHEREAS, the logical time to approve the Cost-of-Living Pay Adjustment is before the Gustavus City Council has adopted the next fiscal year budget; and

WHEREAS, the consumer price index (CPI) for Anchorage rose 1.9% for the calendar year 2025.

NOW THEREFORE BE IT RESOLVED, that the Gustavus City Council grants a 1.9% Cost-of-Living Pay Adjustment to current hourly rates (nonexempt) and base salary (exempt) for all Regular Position Employees effective July 1, 2026.

PASSED and APPROVED by the Gustavus City Council this ____ day of _____, 2026, and effective upon adoption.

Sally A. McLaughlin, Mayor

Attest: Liesl M. Barker, City Clerk

**CITY OF GUSTAVUS, ALASKA
ORDINANCE FY26-14NCO**

**AN ORDINANCE FOR THE CITY OF GUSTAVUS PROVIDING FOR THE AMENDMENT OF
THE CITY HELD ACCOUNTS IN FISCAL YEAR 2026 –
CLOSING CAPITAL PROJECT CP24-01 DRC EXPANSION**

BE IT ENACTED BY THE GUSTAVUS CITY COUNCIL AS FOLLOWS:

Section 1. Classification. This is a **Non-Code Ordinance**

Section 2. For the Fiscal Year of 2026, the following City held account balance transfers are to be made for the reasons stated.

Section 3. For the current fiscal year, City held accounts are amended to reflect the changes as follows:

CITY HELD ACCOUNTS	Amounts		
	Account Balance*	Amended Balance	Change
CP24-01 DRC Expansion <i>Transferring funds and closing out CP24-01</i>	\$ 45,944.19	\$ 0.00	\$ 45,944.19
AMLIP Capital Improv Long-Term <i>This transfer will move funds from AMLIP Capital Current to Capital Improvements Long Term.</i>	\$ 694,770.71	\$ 740,714.90	\$ 45,944.19
Total Change in City Held Account Balances			\$ 0.00

Section 4. The City held accounts are hereby amended as indicated.

Section 5. Effective Date. This ordinance becomes effective upon its adoption by the Gustavus City Council.

DATE INTRODUCED: *March 09, 2026*

DATE OF PUBLIC HEARING: *April 13, 2026*

PASSED and **APPROVED** by the Gustavus City Council this XX day of _____, 2026.

Sally A McLaughlin, Mayor

Attest: Ben Sadler, City Treasurer

Attest: Liesl M Barker, City Clerk

**CITY OF GUSTAVUS, ALASKA
ORDINANCE FY26-15NCO**

**AN ORDINANCE FOR THE CITY OF GUSTAVUS PROVIDING FOR THE AMENDMENT OF
THE CITY BUDGET AND CITY HELD ACCOUNTS IN FISCAL YEAR 2026 – ROAD
MAINTENANCE**

BE IT ENACTED BY THE GUSTAVUS CITY COUNCIL AS FOLLOWS:

Section 1. Classification. This is a **Non-Code Ordinance**

Section 2. For the Fiscal Year of 2026, the following City held account balance transfers are to be made for the reasons stated.

Section 3. For the current fiscal year, the City Budget and City held accounts are amended to reflect the changes as follows:

CITY HELD ACCOUNTS	Amounts		
	Account Balance*	Amended Balance	Change
FNBA Checking/Road Maintenance	\$ 321,796.09	\$ 396,796.09	\$ 75,000.00
<i>Funding to be transferred directly to FNBA Checking in advance of road maintenance costs for immediate use. Budget to be amended from \$215,000 to \$290,000.</i>			
AMLIP Capital Improv Long-Term	\$ 763,773.71	\$ 688,773.71	\$ 75,000.00
Total Change in City Held Account Balances			\$ 0.00

Section 4. The City held accounts and Budget are hereby amended as indicated.

Section 5. Effective Date. This ordinance becomes effective upon its adoption by the Gustavus City Council.

DATE INTRODUCED: *March 9, 2026*

DATE OF PUBLIC HEARING: *April 13, 2026*

PASSED and **APPROVED** by the Gustavus City Council this ___th day of _____, 2026.

Sally A McLaughlin, Mayor

Attest: Ben Sadler, City Treasurer

Attest: Liesl M Barker, City Clerk



April 1, 2026

City of Gustavus

VIA Email: clerk@gustavus-ak.gov

License Type:	Outdoor Recreation Lodge	License Number:	60695
Licensee:	Bear Track Inn, LLC		
Doing Business As:	Bear Track Inn		
Premises Address	5021 Rink Creek Rd, Gustavus, AK 99826		
Endorsement(s):	New Restaurant Endorsement #60696		

- New Application**
 Transfer of Ownership Application
 Transfer of Location Application
 Transfer of Controlling Interest Application

We have received a completed application for the above listed license (see attached application documents) within your jurisdiction. This is the notice required under AS 04.11.480.

A local governing body may protest the approval of an application(s) pursuant to AS 04.11.480 by furnishing the director **and** the applicant with a clear and concise written statement of reasons for the protest within 60 days of receipt of this notice, and by allowing the applicant a reasonable opportunity to defend the application before a meeting of the local governing body, as required by 3 AAC 305.085(d). If a protest is filed, the board will deny the application unless the board finds that the protest is arbitrary, capricious, and unreasonable. To protest the application referenced above, please submit your protest within 60 days and show proof of service upon the applicant.

AS 04.11.491 – AS 04.11.509 provide that the board will deny a license application if the board finds that the license is prohibited under as a result of an election conducted under AS 04.11.507.

AS 04.11.420 provides that the board will not issue a license when a local governing body protests an application on the grounds that the applicant’s proposed licensed premises are located in a place within the local government where a local zoning ordinance prohibits the alcohol establishment, unless the local government has approved a variance from the local ordinance.

Sincerely,
Anna White, Licensing Examiner II
For
Kevin Richard, Director
amco.localgovernmentonly@alaska.gov



Document reference ID : 7678

Licensing Application Summary

Application ID: 7678
Applicant Name: Bear Track Inn Llc
License Type applied for: Outdoor Recreation Lodge License (ORL) (AS 04.09.280)
Application Status: In Review
Application Submitted On: 03/31/2026 11:57 AM AKDT

Entity Information

Business Structure: Limited liability company
FEIN/SSN Number: [REDACTED]
Member Managed or Manager Managed: Member Managed
Alaska Entity Number (CBPL): 60389D
Alaska Entity Formed Date: 02/28/1997
Home State: AK

Entity Contact Information

Name	Phone	Email	Relation
David Olney	316-209-8012	david.olney@hyatt.com	Designated Licensee
Michelle Olney	316-734-7731	beartrackinn@gmail.com	Executive Management
Jane Sheahan	314-691-5071	glacierbeartrac@gmail.com	Executive Management
Mailing Address:	PO Box 255, Gustavus, AK, 99826, USA		

Tell Us About You

Authority Type: I am authorized user by the designated licensee with binding authority
Prefix: Mr
Legal First Name: David
Legal Last Name: Olney
Email Address: david.olney@hyatt.com
Phone Number: 316-209-8012

Additional Authorized Users

Item #14.

Legal Name	Relation with Applicant
Michelle Olney	Executive Management

Registered Agent Information

Name	David Olney
Agent's Phone Number	316-209-8012
Agent's Email	david.olney@hyatt.com
Address	4007 Lower Honoapiilani Rd , UNIT 213, Lahaina, HI, 96761, USA
The registered agent is either an individual resident of the state or a domestic corporation authorized to transact business in the state and whose business office is the same as the registered office?	Yes

Ownership / Principal Party Details

Principal Parent Entity	Principal Party	Role	%Ownership
Bear Track Inn Llc	David Olney	Manager, Member	49
Bear Track Inn Llc	Jane Sheahan	Member	51

Premises Address

Address:	5021 Rink Creek Rd, Gustavus, AK, 99826, USA
Does the proposed site include a valid street address?	Yes

Basic Business information

Business/Trade Name:	Bear Track Inn
What is your primary business at this location?	Hotel

Premises Contact Details

Contact Person Name	David W Olney
Business Phone Number	907-697-3017
Alternate Phone Number	316-209-8012
Email Address	beartrackinn@gmail.com

Local Government and Community Council Details

City/Municipality	Gustavus
Borough	Unorganized Borough

Do you, the applicant, own the land, building, and/or warehouse at this proposed licensed location?

Yes

Property Utilization Status

An Existing Facility

Property Ownership Deed

[BTI and Trust Lease.pdf](#)

Premises Diagram

Will the license or permit embrace the entire premises address?

Yes

Premises Diagram

- [Lodge Layout for consumption space 3-18-26 - Full Diagram.pdf](#)

Security Plan

- [Security Plan for Alcohol Management and Prevention of Unauthorized Access.pdf](#)

Seasonal Information

Are you conducting seasonal business?

Yes

Please Provide your six-month operating period

05/01-9/30

Operation Period Details

Bear Track Inn is 14 room seasonal activity lodge for excursions into and around Glacier Bay. Situated on the tranquil shores of Gustavus, Alaska sits a stunning, hand-crafted lodge – Glacier Bay’s Bear Track Inn. Since 1997, The Bear Track Inn has featured award-winning accommodations, incredible activities, outstanding gourmet meals, and true Alaskan ambiance and hospitality – all with Glacier Bay National Park and Preserve serving as our backdrop. Our lodge operates in the summertime to offer visitors the best chance to explore the nature and wonders that make up Glacier Bay.

Other Licenses Involvement

Does any representative or owner named in this application have any direct or indirect financial interest in any other alcoholic beverage business that does business in or is licensed in Alaska?

Yes

Description

David Olney and Jane Sheahan hold ownership of Excursion Restaurant, LLC that holds REPL #3794 dba Excursion Restaurant. We understand that this license will no longer be utilized soon because of this ORL application.

Outdoor Recreation Lodge Statement

Is the applicant a licensed business that provides overnight accommodations and meals, is primarily involved in offering opportunities for persons to engage in outdoor recreation activities and has a minimum of two guest rooms? : Yes

Describe your outdoor recreation lodge facilities and recreation activities offered? : Guided tours of Glacier Bay National Park and Preserve, world-class sport fishing, wildlife viewing, whale watching, kayaking next to glaciers and hiking tours around Gustavus.

Individual Certification and Financial Interest

Item #14.

I hereby certify that no person other than a proposed licensee listed on the liquor license application has a direct or indirect financial interest, as defined in AS 04.11.450(f) in the business for which a liquor license is being applied for.

I hereby certify that any ownership change shall be reported to the board as required under AS 04.11.040, AS 04.11.045, AS 04.11.050, and AS 04.11.055.

Public Notice Posting Attestation and Publishers Affidavit

Have you posted your application at both required locations for ten consecutive days?	Yes
What was the other conspicuous location of your post? (Please include the full address)	USPS, 123 Postmark Dr, Gustavus, AK 99826
What was the first day you posted your application?	03/19/2026
If the newspaper advertisement was published did you advertise once a week for three consecutive weeks or if by radio twice week for three successive weeks?	Yes
What was the final date your advertisement was published/broadcasted?	08/23/2025

Newspaper/Publishers Affidavit

[Proof of Advertising - Juneau 2025.pdf](#)

Upload Paper form Application

[Original ORL Submission wit Email Correspondence.pdf](#)

I attest that I have met the public posting notice requirement set forth under AS 04.11.310 by posting a copy of my application for the 10-day period at the location of the proposed licensed premises and at another conspicuous location in the area of the proposed premises as listed in this application.

I hereby attest that I am the person herein named and subscribing to this application and that I have read the complete application, and I know the full content thereof. I declare that all of the information contained herein, and evidence or other documents submitted are true and correct. I understand that any falsification or misrepresentation of any item or response in this application, or any attachment, or documents to support this application, is sufficient grounds for denying or revoking a license/permit. I further understand that it is a Class A misdemeanor under Alaska Statute 11.56.210 to falsify an application and commit the crime of unsworn falsification.

Attestations

I certify that all proposed licensees (as defined in AS 04.11.260) and affiliates have been listed on this application.

I certify that I understand that providing a false statement on this form or any other form provided by AMCO is grounds for rejection or denial of this application or revocation of any license issued.

I certify that all licensees, agents, and employees who sell or serve alcoholic beverages or check the identification of a patron will complete an approved alcohol server education course, if required by AS 04.21.025, and, while selling or serving alcoholic beverages, will carry or have available to show a current course card or a photocopy of the card certifying completion of approved alcohol server education course, if required by 3 AAC 305.700.

I agree to provide all information required by the Alcoholic Beverage Control Board in support of this application.

I hereby certify that I am the person herein named and subscribing to this application and that I have read the complete application, and I know the full content thereof. I declare that all of the information contained herein, and evidence or other documents submitted are true and correct. I understand that any falsification or misrepresentation of any item or response in this application, or any attachment, or documents to support this application, is sufficient grounds for denying or revoking a license/permit. I further understand that it is a Class A misdemeanor under Alaska Statute 11.56.210 to falsify an application and commit the crime of unsworn falsification.

I certify that all proposed licensees have been listed with Division of Corporation, Business, and Professional Licensing.

I certify that I and any individual identified in the business entity ownership section of this application, has or will read AS 04 and its implementing regulations.

I certify that we provide overnight accommodations and meals, we also have at least 2 guest rooms, and they are primarily involved in offering for outdoor recreation activities.

Item #14.

Signature

This application was digitally signed by : David Olney on 03/18/2026 06:44 PM AKDT

Payment Info

Payment Type : CC

Payment Id: d4b44ae6-d23e-44b7-b24f-9a8bb905b60b

Receipt Number: 101290004

Payment Date: 03/31/2026 12:20 PM AKDT

Documents

#	File Name	Type	Added On
1	Lodge Layout for consumption space 3-18-26 - Full Diagram.pdf	License Location Diagram Document	03/18/2026 06:16 PM AKDT
2	Security Plan for Alcohol Management and Prevention of Unauthorized Access.pdf	License Location Diagram Security Plan Document	03/18/2026 06:16 PM AKDT
3	BTI and Trust Lease.pdf	License property ownership document	03/18/2026 06:43 PM AKDT
4	Proof of Advertising - Juneau 2025.pdf	Publishers Affidavit	03/31/2026 12:09 PM AKDT
5	Original ORL Submission wit Email Correspondence.pdf	License Paper Form Application Document	03/31/2026 12:09 PM AKDT

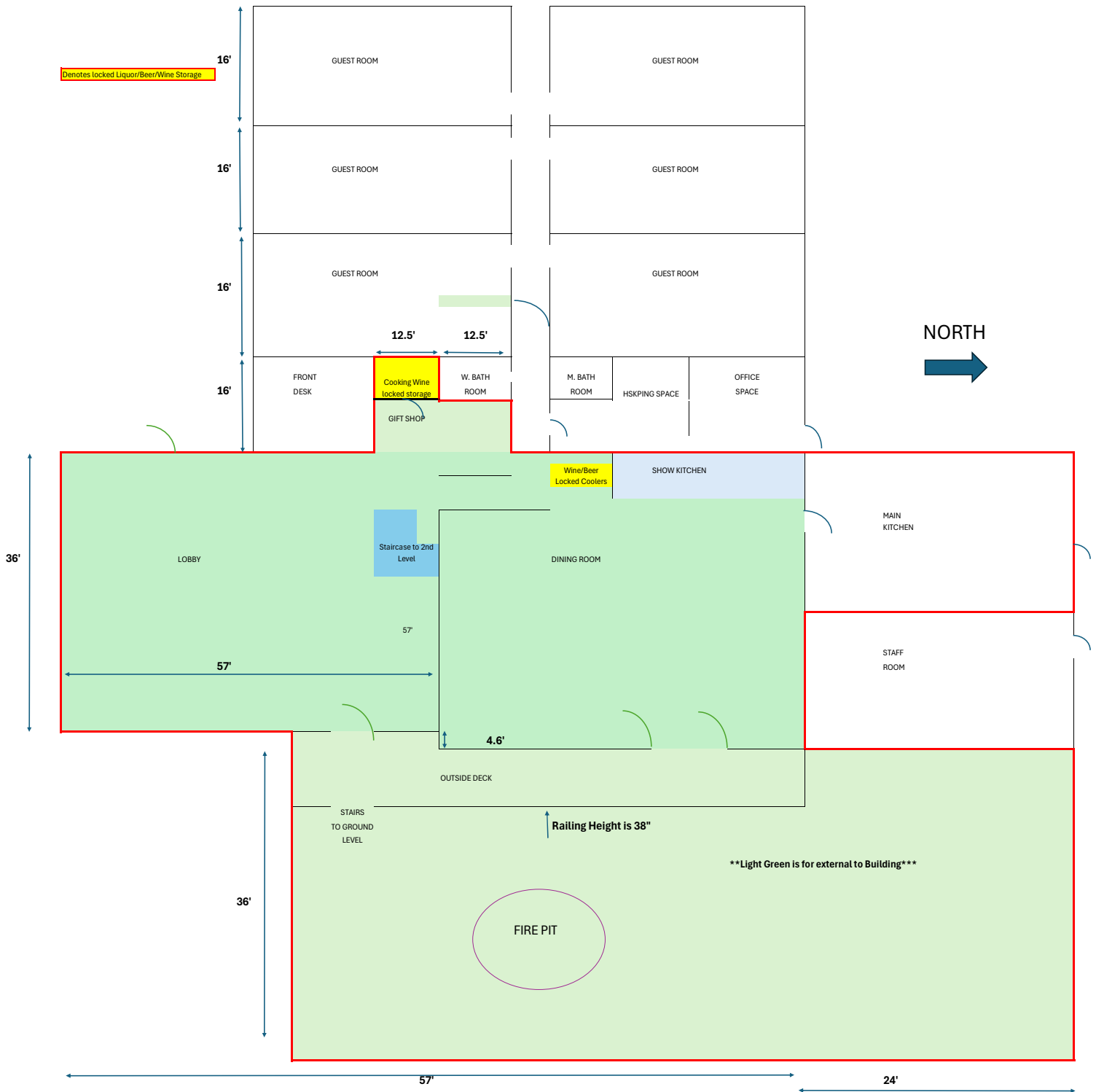

External Perimeter is naturally contained/secured by a stream on South and four foot grass/wetlands on the East. Bush Line on North side.

Note that the Property is at the edge of town and does not have any residential properties within 500 yards of the lodge

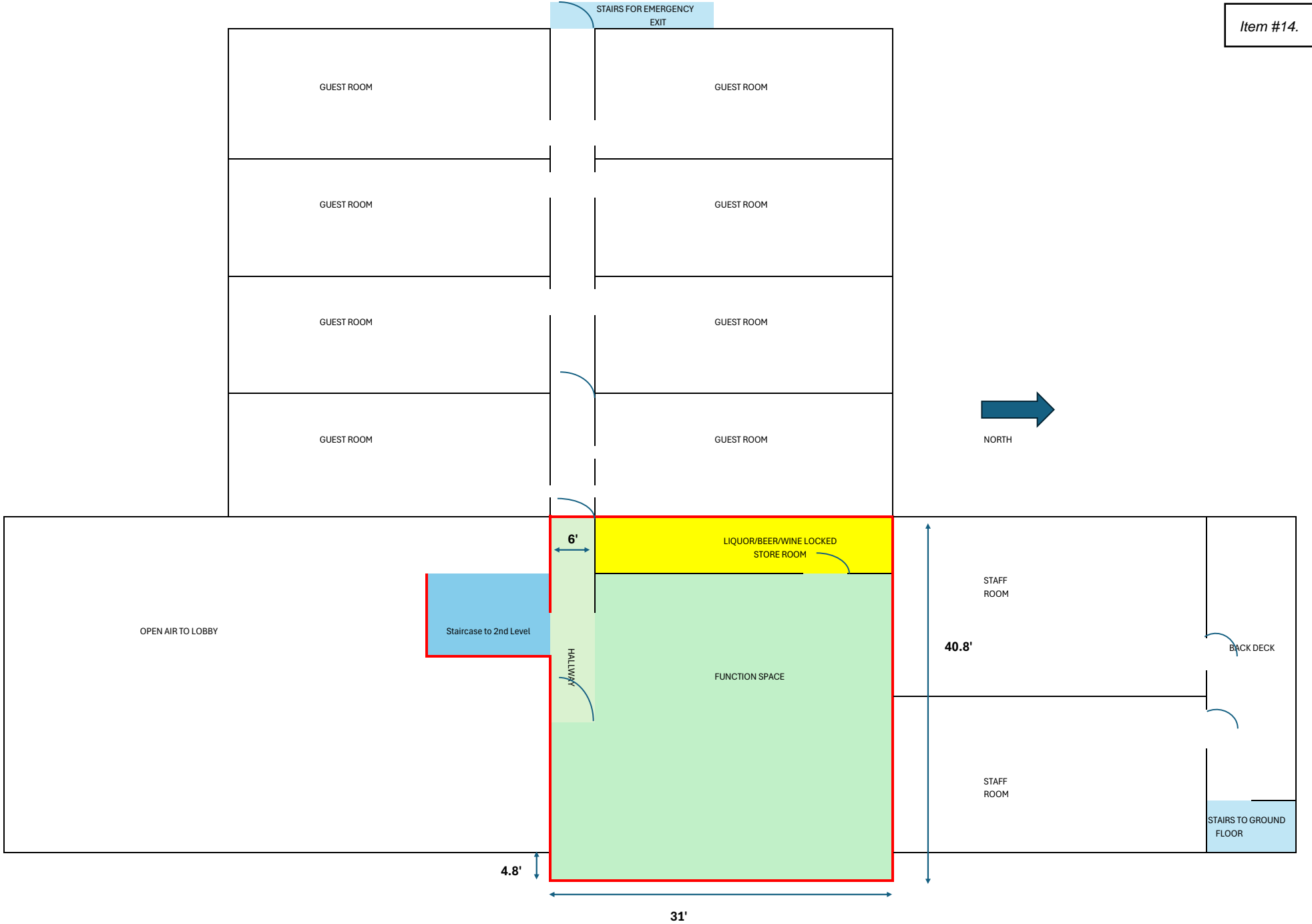

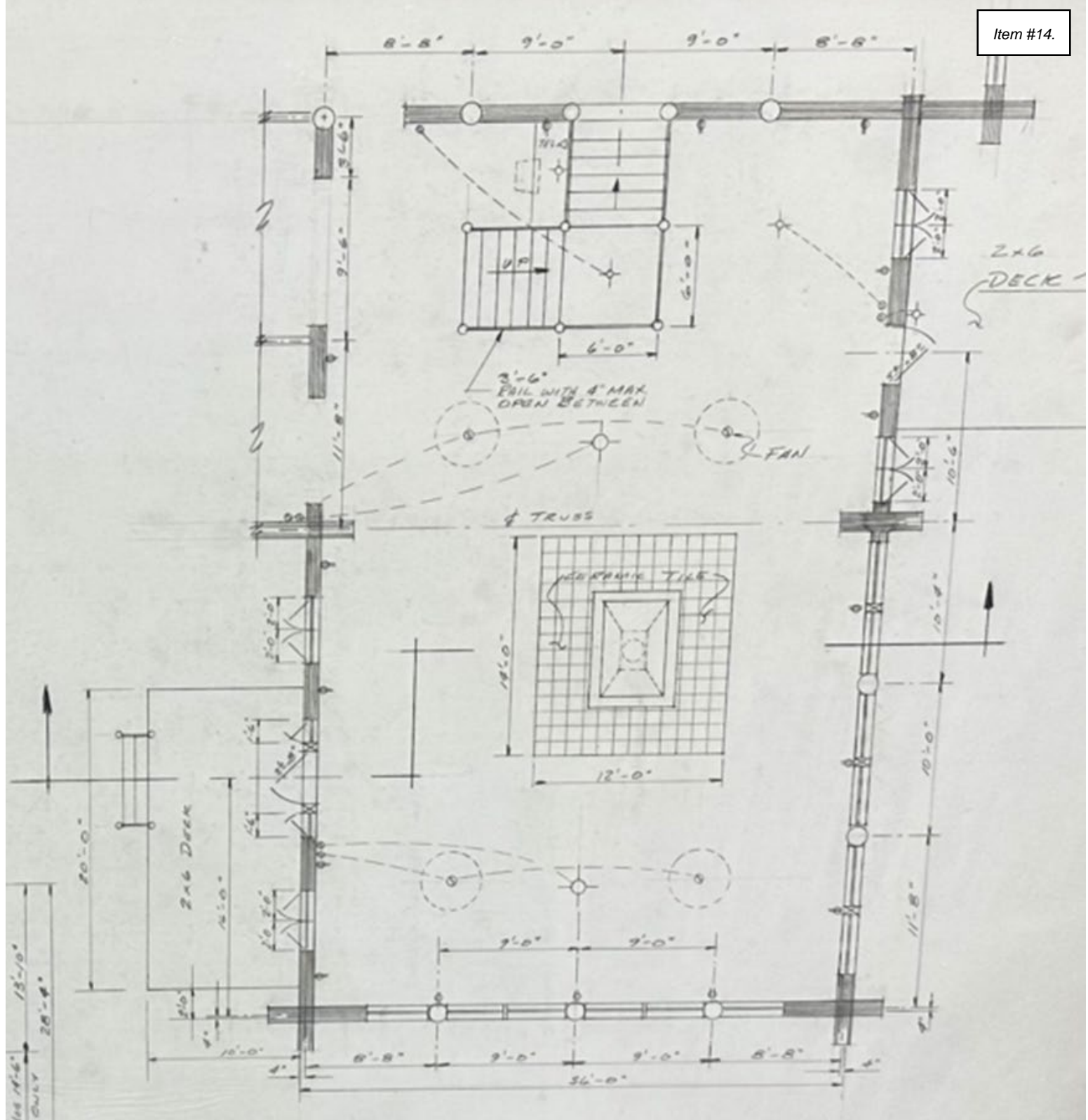

- LOBBY -
SCALE 1/8" = 1'-0"

TOP OF FRAMING TO N-6' GUEST WING ONLY 13'-10"

GLACIER BAY'S BEAR TRACK INN 7-5-96



THIS DRAWING IS AN INSTRUMENT OF SERVICE AND IS THE PROPERTY OF JOHN F. OLNEY AND MAY NOT BE REPRODUCED OR COPIED IN ANY MANNER WITHOUT HIS PERMISSION.

SHEET 8 OF 14

JOHN F. OLNEY CIVIL ENGINEER • LAND SURVEYOR 1800 N. LESTER BLVD. PRINCETON, ALASKA 99574 (907) 844-2000

AMCO Received 3/18/2026

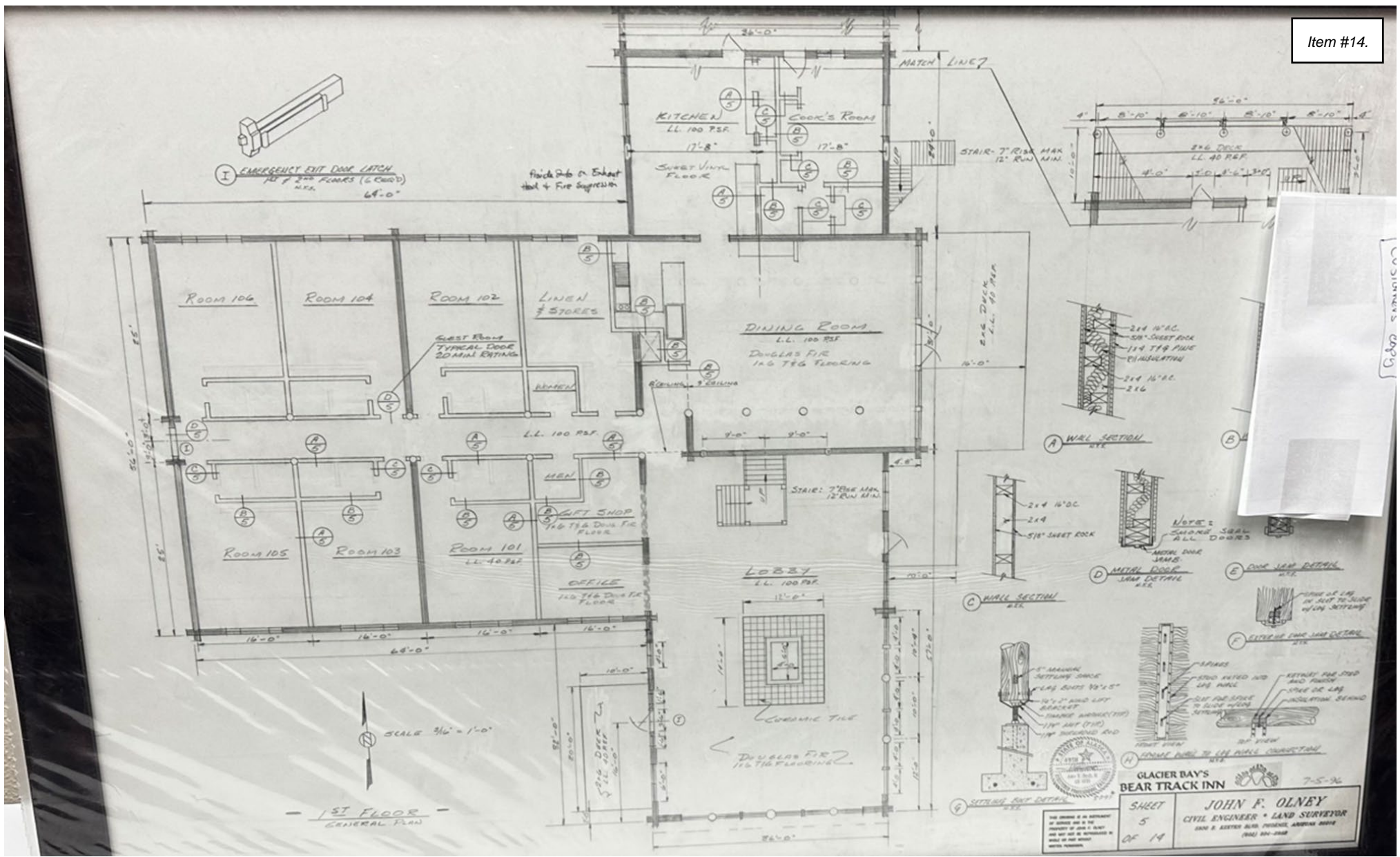

1970
 JOHN F. OLNEY
 CIVIL ENGINEER - LAND SURVEYOR
 5000 B. BERTER BLVD. PUEBLO, COLORADO 81001
 (303) 261-1000

SHEET	5
OF 14	

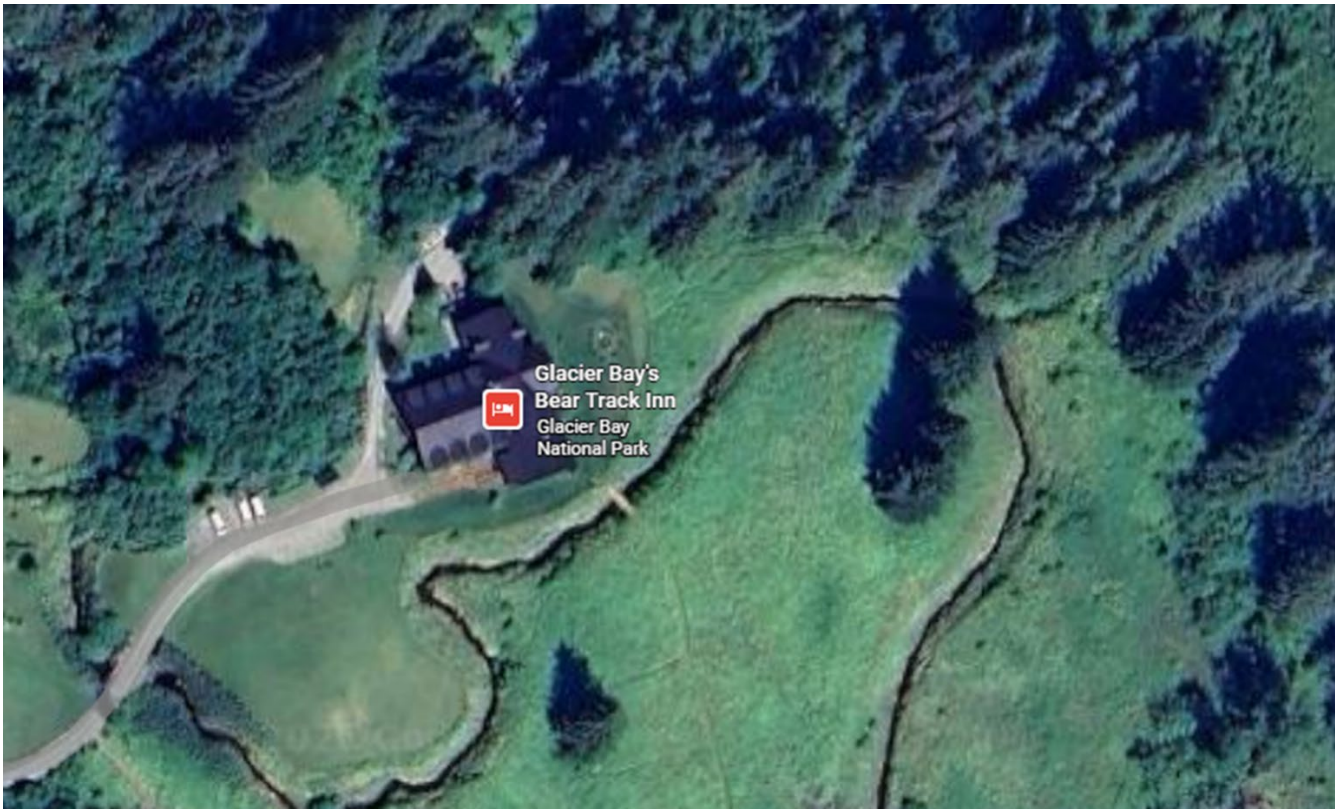

Below circled in black is the Estate including ecreated land to the ocean.

The yellow to the east is now State land (previously National Park). It was traded to setup a Hydro-Electric plant.

The two properties to the East are heritage lands which is inaccessible by road or path and unused.

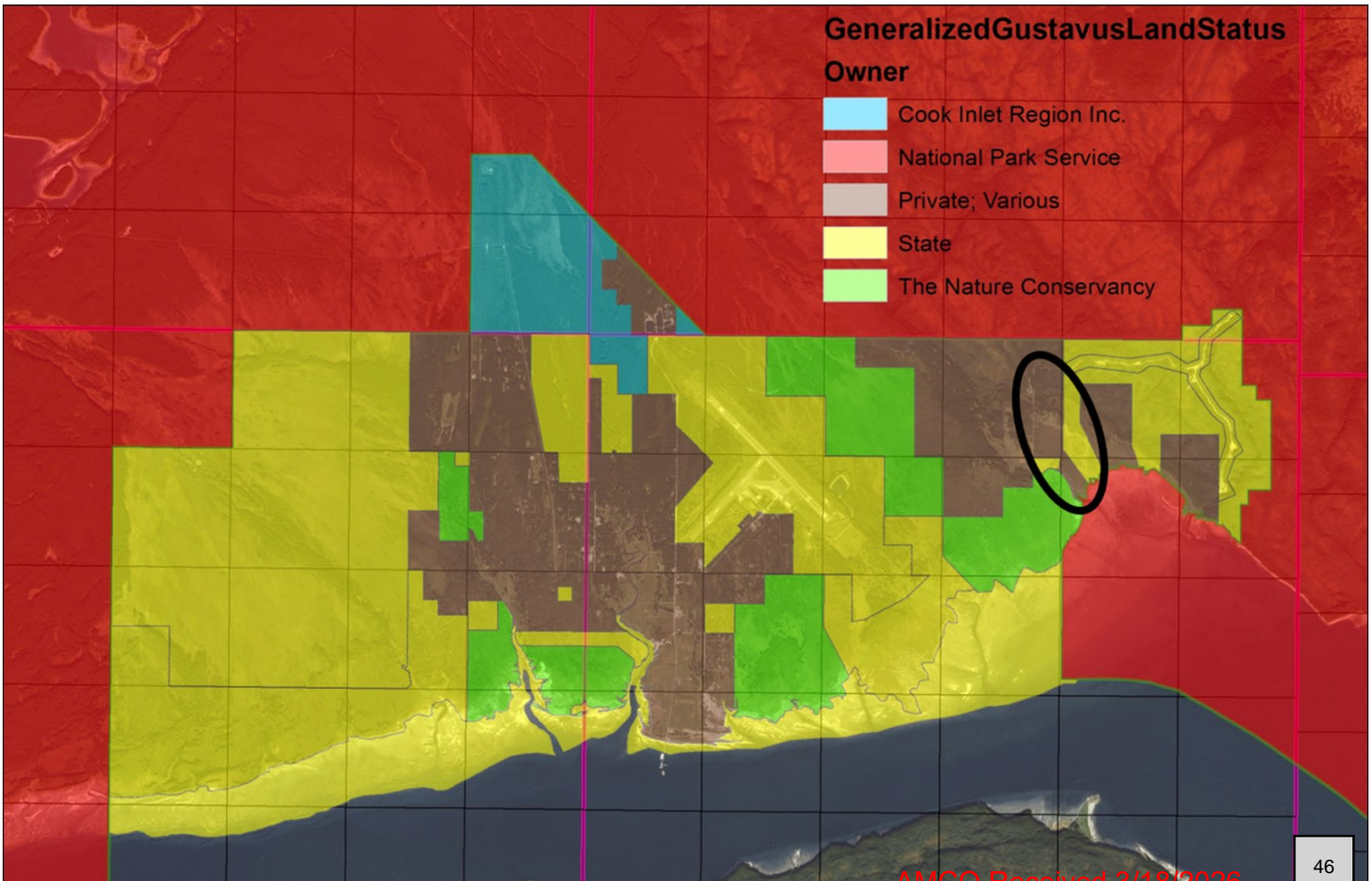

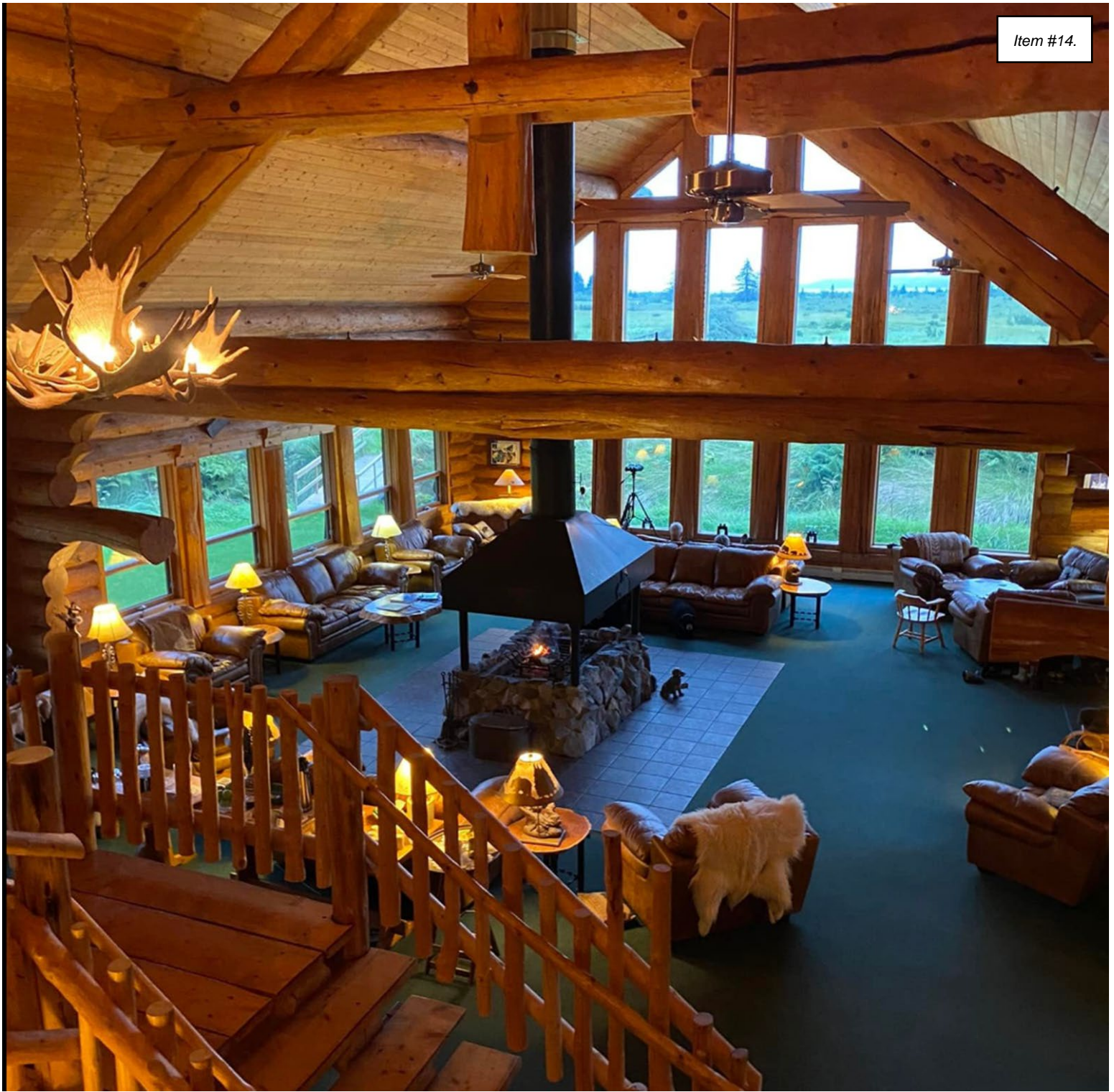

Lobby Picture #1



Lobby Picture #2



Dining Room Photo #1

Item #14.



Dining Room Photo #2



Deck Photo



Close

Lodge Exterior

Security Plan for Alcohol Management and Prevention of Unauthorized Access

Objective

To ensure the prevention of alcohol transfer across the premises boundary and restrict access to alcohol by minors through robust personnel practices, physical barriers, and effective management strategies.

1. Personnel Practices

a. Designated Personnel – Management and TIPS trained staff

- **Roles and Responsibilities:**
 - Monitor all entry and exit points to prevent unauthorized alcohol transfer.
 - Conduct ID checks at restaurant to verify the age of individuals purchasing or consuming alcohol.
 - Patrol the premises to ensure compliance with alcohol regulations.
- **Training:**
 - All security personnel will undergo training in alcohol compliance laws, recognizing fake IDs, and conflict de-escalation techniques.
 - Staff will be educated on the importance of preventing underage drinking and the legal consequences of non-compliance.

b. Staff Accountability

- All employees handling alcohol will be required to complete alcohol service training (e.g., TIPS or equivalent).
- Employees will be instructed to report any suspicious activity, such as attempts to pass alcohol to minors or transfer it across boundaries.

2. Physical Barriers

a. Perimeter

- **Access Points:**
 - Entry and exit points are limited to lodge front door which is monitored by management and/or TIPS trained personnel at all times.
- **Outdoor space (Dining room deck and Firepit area designated on premise)**
 - Access is restricted to entry/exit by the lobby deck door and the dining room doors. The northern access is restricted to employees only and the

southern access is secured due to homesteader's creek and the front of the lodge (sloped to ensure proper rain/snow runoff).

- Management and TIPS certified employees will be servicing this area and patrolling this area every 15 minutes.
- When minors are present, we have a dedicated employee that plays yard games and makes smores.
- We promote our team members and management to "talk story" with the clients as the majority of our clientele are interested in our staff's journeys.

b. Alcohol Service Areas

- Alcohol will only be served and consumed in designated areas

2. Management of the Area

a. Surveillance

- **CCTV Monitoring:**
 - Security cameras are installed across the lodge property.

c. Incident Reporting

- Any attempts to transfer alcohol across the boundary or provide alcohol to minors will be documented in an incident log.
- Management personnel will immediately intervene and, if necessary, involve local law enforcement.

4. Enforcement and Compliance

- Regular audits will be conducted to ensure all security measures are functioning as intended.
- The security plan will be reviewed and updated annually or as needed to address emerging risks or changes in regulations.

By implementing these measures, the premises will maintain a safe and compliant environment, effectively preventing the unauthorized transfer of alcohol and access by minors.



Document reference ID : 7680

Licensing Application Summary

Application ID: 7680
Applicant Name: Bear Track Inn Llc
License Type applied for: Restaurant Endorsement (RE) (AS 04.09.450)
Application Status: In Review
Application Submitted On: 03/31/2026 05:28 PM AKDT

Entity Information

Business Structure: Limited liability company
FEIN/SSN Number: ██████████
Member Managed or Manager Managed: Member Managed
Alaska Entity Number (CBPL): 60389D
Alaska Entity Formed Date: 02/28/1997
Home State: AK

Entity Contact Information

Name	Phone	Email	Relation
David Olney	316-209-8012	david.olney@hyatt.com	Designated Licensee
Michelle Olney	316-734-7731	beartrackinn@gmail.com	Executive Management
Jane Sheahan	314-691-5071	glacierbeartrac@gmail.com	Executive Management

Mailing Address: PO Box 255, Gustavus, AK, 99826, USA

Tell Us About You

Authority Type: I am authorized user by the designated licensee with binding authority
Prefix: Mr
Legal First Name: David
Legal Last Name: Olney
Email Address: david.olney@hyatt.com
Phone Number: 316-209-8012

Additional Authorized Users

Item #14.

Legal Name	Relation with Applicant
Michelle Olney	Executive Management
Jane Sheahan	Executive Management

Registered Agent Information

Name	David Olney
Agent's Phone Number	316-209-8012
Agent's Email	david.olney@hyatt.com
Address	4007 Lower Honoapiilani Rd , UNIT 213, Lahaina, HI, 96761, USA
The registered agent is either an individual resident of the state or a domestic corporation authorized to transact business in the state and whose business office is the same as the registered office?	Yes

Ownership / Principal Party Details

Principal Parent Entity	Principal Party	Role	%Ownership
Bear Track Inn Llc	David Olney	Manager, Member	49
Bear Track Inn Llc	Jane Sheahan	Member	51

Premises Address

Address:	5021 Rink Creek Rd, Gustavus, AK, 99826, USA
Does the proposed site include a valid street address?	Yes

Primary license number

Primary License Information	Application ID - 7678 - New Outdoor Recreation Lodge License Application - In Review
------------------------------------	---

Basic Business information

Business/Trade Name:	Bear Track Inn
-----------------------------	----------------

Local Government and Community Council Details

City/Municipality	Gustavus
Borough	Unorganized Borough

Premises Diagram

Item #14.

Will the license or permit embrace the entire premises address?

Yes

Premises Diagram

- [Lodge Layout for consumption space 3-18-26 - Full Diagram.pdf](#)

Security Plan

- [Security Plan for Alcohol Management and Prevention of Unauthorized Access.pdf](#)

Restaurant Detail

Dining after standard closing hours: AS 04.16.010(c)

Yes

Dining by persons 16 – 20 years of age: AS 04.16.049(a)(2)

Yes

Dining by persons under the age of 16 years, accompanied by a person over the age of 21: AS 04.16.049(a)(3)

Yes

Employment for any persons under 21 years of age: AS 04.16.049(c)

Yes

List where within the premises minors are anticipated to have access in the course of either dining or employment. (Example: Minors will only be allowed in the dining area. OR Minors will only be employed and present in the Kitchen.)

The restaurant is in a 14 room remote lodge that will have children of all ages on the premises including lobby and dining room. We will have employees under the age of 21 in the dining room and kitchen assisting with meals, culinary prep and stewarding (dishwashing). We will always have two employees with AK liquor cards during lunch and dinner service.

Describe the policies, practices and procedures that will be in place to ensure that minors do not gain access to alcohol while dining or employed at your premises.

All stored alcohol is behind locked doors and during dinner service a manager or AK liquor card carrying associate are the only ones allowed to access and serve guests. The wine and beer coolers are in plain sight at the entrance to the restaurant which is monitored by management throughout service. Additionally, we have a camera on the wine and beer coolers for additional security.

Is an owner, manager, or assistant manager who is 21 years of age or older always present on the premises during business hours?

Yes

Food Service Permit

Is your license located in Municipality of Anchorage?

No

Do you have Approved food service permit for this premises?

Yes

Copy of the current food service permit for this premises OR the plan review approval.

[4985
Excursion
Restaurant
2026.pdf](#)

Entertainment & Service

Are any forms of entertainment offered or available within the licensed business or within the proposed licensed premises?

No

Food and beverage service offered or anticipated is:

Table
Service

Restaurant Declaration

Item #14.

Please upload the finalized or expected Food and Alcohol Menu.

[Food and Beverage Menu.pdf](#)

There are tables or counters at my establishment for consuming food in a dining area on the premises. I have included with this form a menu, or an expected menu, listing the meals to be offered to patrons.

This menu includes entrées that are regularly sold and prepared by the licensee at the licensed premises.

I certify that the license for which I am requesting designation is either a Beverage Dispensary, Beverage Dispensary Tourism, Club, Sporting Activity or Event License, Outdoor Recreation Lodge, Golf Course, Destination Resort, OR Restaurant or Eating Place, Seasonal REPL Tourism License.

Hours Of Operation

Sunday	05:30 AM - 10:30 PM
Monday	05:30 AM - 10:30 PM
Tuesday	05:30 AM - 10:30 PM
Wednesday	05:30 AM - 10:30 PM
Thursday	05:30 AM - 10:30 PM
Friday	05:30 AM - 10:30 PM
Saturday	05:30 AM - 10:30 PM

Attestations

I certify that all proposed licensees (as defined in AS 04.11.260) and affiliates have been listed on this application.

I certify that I understand that providing a false statement on this form or any other form provided by AMCO is grounds for rejection or denial of this application or revocation of any license issued.

I certify that all licensees, agents, and employees who sell or serve alcoholic beverages or check the identification of a patron will complete an approved alcohol server education course, if required by AS 04.21.025, and, while selling or serving alcoholic beverages, will carry or have available to show a current course card or a photocopy of the card certifying completion of approved alcohol server education course, if required by 3 AAC 305.700.

I agree to provide all information required by the Alcoholic Beverage Control Board in support of this application.

I hereby certify that I am the person herein named and subscribing to this application and that I have read the complete application, and I know the full content thereof. I declare that all of the information contained herein, and evidence or other documents submitted are true and correct. I understand that any falsification or misrepresentation of any item or response in this application, or any attachment, or documents to support this application, is sufficient grounds for denying or revoking a license/permit. I further understand that it is a Class A misdemeanor under Alaska Statute 11.56.210 to falsify an application and commit the crime of unsworn falsification.

I certify that all proposed licensees have been listed with Division of Corporation, Business, and Professional Licensing.

I certify that I and any individual identified in the business entity ownership section of this application, has or will read AS 04 and its implementing regulations.

I certify I have provided a menu of a variety of types of food appropriate for meals that are prepared on the licensed premises.

I certify that non-employees under 21 years of age will not enter and remain on the licensed premises except for the purposes of dining only.

I certify that the sale and service of food and alcoholic beverages and any other business on the licensed premises is under the sole control of the licensee.

I certify the licensed premises is a bona fide restaurant as defined in AS 04.21.080(b).

I certify there is supervision on the licensed premises adequate to reasonably ensure that a person under 21 years of age will not gain access to alcoholic beverages.

Item #14.

Signature

This application was digitally signed by : David Olney on 03/23/2026 03:32 PM AKDT

Payment Info

Payment Type : CC

Payment Id: 573338dd-3661-462b-af2c-d4790a0faab6

Receipt Number: 101287656

Payment Date: 03/23/2026 05:38 PM AKDT

Documents

#	File Name	Type	Added On
1	Lodge Layout for consumption space 3-18-26 - Full Diagram.pdf	License Location Diagram Document	03/18/2026 06:55 PM AKDT
2	Security Plan for Alcohol Management and Prevention of Unauthorized Access.pdf	License Location Diagram Security Plan Document	03/18/2026 06:55 PM AKDT
3	Food and Beverage Menu.pdf	LicenseRestaurantDeclarationFoodAlcoMenuDocument	03/18/2026 07:10 PM AKDT
4	4985 Excursion Restaurant 2026.pdf	LicenseRestaurantDetailFoodServicePermitDocument	03/23/2026 03:30 PM AKDT
5	Application Summary-7680.pdf	License Paper Form Application Document	03/31/2026 05:28 PM AKDT



Sherried Halibut Chowder
Herbed Vegetable Potato Cream

Tender Chicken Breast Florentine Soup
with White Onions and Spinach in a white wine broth

Tender greens Tomato Salad
Shaved White Onion, Oven Roasted Croutons Tossed with an Herb Cream Dressing and Topped with Parmesan Cheese

****Chefs Special: Surf and Turf****
Fresh Dungeness Crab and Steak
served with Champagne Butter, Oven Roasted Baked Potato, and Chefs Vegetables
Chefs Recommended Wine: 7 Deadly Zins, Zinfandel

Prime Rib
Served with Pan Au Jus, Oven Roasted Baked Potato and Hericover

<p><i>Pan Seared Halibut</i> <i>Topped with Lobster Cream Sauce served with Snap Peas and Pesto Orzo</i> <i>Chefs Recommended Wine: Kim Crawford, Rose</i></p>	<p><i>Fire Roasted Ribeye</i> <i>served with Blue Cheese Mashed Potatoes and Asperagus</i> <i>Chefs Recommended Wine: Justin, Paso Robles, Cabernet</i></p>
--	---

Wild King Salmon
Oven Roasted Tender, Flakey Filet
Topped with a Hollandaise,
served with Potato Croquette and Asparagus
Chefs Recommended Wine: Layer Cake, South Australia, Shiraz

New York Strip Au Poirve
Topped with Ginger Scallion Sauce served with Blue Cheese Mashed Potato with Hericover
Chefs Recommended Wine: Norton Reserva, Argentina, Malbec

Peach Cobbler
or
Homemade Chocolate Ice Cream

Please consult the wine menu for a glass of port or sherry to accompany your dessert.

Executive Chef – Trey Yager
Sous-Chef – Tyler Fennel
Sous-Chef – David Taitingfong

Please be aware raw or undercooked foods such as eggs, shellfish, seafood, poultry, and meat could lead to illness

Wines by the Glass**Red**

AXR, Napa	Blend	15
Norton Reserve, Argentina	Malbec	18
Layer Cake, South Australia	Shiraz	14
J. Lohr, Los Osos	Merlot	14
Justin, Paso Robles	Cabernet	24

Wines by the Bottle**Red**

Decoy	Cabernet	80
Justin, Paso Robles	Cabernet	75
Louis Martini, Napa Valley	Cabernet	130
Caymus, Napa 2019	Cabernet	250
Cakebread Cellars, Napa 2014	Cabernet	240
Silver Oak, Napa Valley	Cabernet	350
Knights Bridge Linville 2019	Cabernet	390
Norton Reserve, Argentina	Malbec	150
Layer Cake, South Australia	Shiraz	55
7 Deadly Zins	Zinfandel	60
J. Lohr, Los Osos	Merlot	51
Chateau St. Jean, California	Merlot	45
La Crema, Sonoma	Pinot Noir	75

Potazzinc, Italy	Brunello di Montalcino	325
2021 Knights Bridge Draco Dormiere Reserve		850

After Dinner

Graham Porto "Six Grapes"	10
10yr Fonseca Port	12
20yr Sandeman Old Tawny Port	16

Wines by the Glass**White**

Rodney Strong, Sonoma	Chardonnay	14
La Crema, Sonoma	Chardonnay	18
Zenato delle Venezie, Italy	Pinot Grigio	14
Chateau St. Michelle, California	Riesling	12
Emmolo	Sauvignon Blanc	15

Wines by the Bottle**White**

Rodney Strong, Sonoma	Chardonnay	48
Rodney Strong, Chalk Hill	Chardonnay	60
Kiara, Stag's Leap	Chardonnay	90
La Crema, Sonoma	Chardonnay	65
Emmolo	Sauvignon Blanc	60
Kim Crawford, New Zealand	Sauvignon Blanc	45
Honig, Napa Valley,	Sauvignon Blanc	85
Zenato delle Venezie, Italy	Pinot Grigio	45
Santa Margherita, Italy	Pinot Grigio	75
Chateau St. Michelle, California	Riesling	35
Champalou, France	Vouvray	90

Sparkling Wines

Korbel Brut	Champagne	75
Emmolo	Champagne	120

Alaskan Brewing Co.

Amber	6.50
White Ale	6.50
Hard Seltzer	6.50



Alaska Food Code 2026 Food Establishment Permit

Division of Environmental Health
Food Safety & Sanitation Program

Permit Number: 4985
Issued to: **BEAR TRACK INN LLC**
For: **Excursion Restaurant**
For Operation of: **FF-1 Food Service**
Located at: **5021 Rink Creek RD Gustavus, AK 99826**

This permit, issued under the provisions of 18 AAC 31, is valid until the noted expiration date or unless suspended or revoked by the department.

This permit is not transferable for change of ownership, facility location, or type of operation. It must be posted in plain view in the establishment and is the property of the State of Alaska.

Expiration Date:
December 31, 2026

Program Manager:

If you have questions or concerns regarding safe food handling practices call or text 907-764-9825 or visit our website to file a complaint (dec.alaska.gov/eh/fss/report-illness-issue/)



BEAR TRACK INN LLC
4007 Lower Honoapiilani RD APT 213
Lahaina, HI 96761

YOUR PERMIT IS PRINTED ON THE REVERSE SIDE OF THIS PAGE.

**CITY OF GUSTAVUS, ALASKA
RESOLUTION CY26-08**

**A RESOLUTION BY THE CITY OF GUSTAVUS ESTABLISHING POLICY & PROCEDURE
FOR TRAVEL AND ATTENDANCE AT CONFERENCE AND TRAINING ACTIVITIES**

WHEREAS, the City of Gustavus recognizes that City employees’ attendance at professional conferences, conventions and training will improve and/or enhance their abilities in their work and them to obtain innovative techniques to improve existing and future services, as allowed by the budget; and,

WHEREAS, travel may be required for participation in state and federal grants, to fulfill professional license requirements, for professional personnel development, and to further the City’s economic development efforts; and,

WHEREAS, travel may be required for on-going staff and council member training and for attendance at professional conferences; and,

WHEREAS, a clear policy and procedure for obtaining travel and attendance approval and to make travel arrangements is necessary for consistency and conformity;

NOW THEREFORE BE IT RESOLVED, that the City Council of Gustavus, Alaska hereby adopts the attached Policy and Procedure for Travel and Attendance at Conference and Training Activities.

PASSED and **APPROVED** by the Gustavus City Council this XXth day of _____, 20XX, and effective upon adoption.

Sally A McLaughlin, Mayor

Attest: Liesl M Barker, City Clerk

CITY OF GUSTAVUS POLICIES AND PROCEDURES

Policy and Procedure for Travel and Attendance at Conference and Training Activities

POLICY:

The City of Gustavus encourages City employees' attendance at professional conferences, conventions, and training which will improve and/or enhance their abilities in their work and enable them to obtain innovative techniques to improve existing and future services, as allowed by the budget.

This includes training required by state and federal grants, professional license requirements, training to pursue state and federal grants, professional personnel development, to further the City's economic development efforts, for on-going staff and council member training and to attend conferences. The city will cover costs for travel related to city business as outlined in the following procedure. If personal travel is associated with city business, then the employee must work with their supervisor to determine when in their itinerary city business is being conducted.

PROCEDURE:

Employees requesting approval for travel and attendance at activities will need to complete a **Travel Authorization Form** to submit to his/her Department Head which shall then be reviewed by the City Administrator and/or Mayor for approval. Once approval is obtained, proceed with the following steps:

1. Submit a Purchase Order (PO) Request for each reservation to the treasurer.
2. The treasurer will advise when Alaska Airlines miles should be used.
3. Once the PO is approved, reservations may be made.
4. Flights - The treasurer or clerk will handle all flight bookings.
 - * *For steps 6-8: If you have a city credit card make the remaining reservations and send copies of receipts to the city clerk*
 - * *If you do not have a city credit card, coordinate arrangements with the clerk or treasurer*
5. Hotel - make hotel reservations
6. Ferry – make the reservation
7. Rental Vehicles – Select the best available price to meet the need
8. Send all purchase receipts to the treasurer
9. If booking on someone else's behalf, send all travel confirmation information to the traveler.
10. Meal per diem checks will be issued by the Treasurer prior to departure
11. Upon return, complete the travel expense report, include any travel claims that were not prepaid, and turn it into the city treasurer.
12. Submit a report to your supervisor or include in quarterly report, as applicable
 - If, during your trip, you experience any delays or alterations, contact your department head for guidance on how to handle changing flights, hotel accommodation, etc.*

In the event that more requests for funds are made than we can comfortably approve at one time, funds for travel will be allocated according to the following:

- Mandatory training necessary for an employee to continue in their current position due to changes in certification requirements, processes or procedures
- Training in safe work practices or emergency response
- Conference/training to improve services provided by the City
- Conference/training to improve performance in an employee's current position

Mandatory training will be given preference over voluntary training:

Mandatory: you are required to travel or attend a training, either due to certification needs or having been directed by the City Administrator or City Council.

Voluntary: training that will benefit or enhance the employee's performance or department, but is not required

A. Registration Fees

The City will pay all registration costs, including meal costs that are incorporated into the total. The City, however, will not pay for meal expenses for a one-day training or conference where out of town travel is not necessary for attendance.

B. Lodging

Hotel accommodations may be made by the Clerk, Treasurer or the employee. If the conference/training is associated with hotel discounts, reservations at these hotels shall be sought first. When necessary, payment of lodging on a City credit card may be authorized, but valid documentation must be submitted with the travel expense report upon completion of travel.

For travelers without a city credit card, request and return the hotel's credit card authorization form. Contact the hotel to have the form sent to the treasurer or clerk. Ensure it is on file several days before travel.

Employees should demonstrate appropriate effort to secure reasonably priced accommodation. The employee must cover the expense of any extra hotel nights needed to accommodate personal travel that is associated with travel for city business.

C. Meal/Per Diem Allowance

The meal per diem allowance is paid in advance in lieu of reimbursement of actual expenses. There are two meal allowance rates, one for Alaska and the CONUS (Federal) rate for travel outside of Alaska. The allowance is prorated based on the time periods in travel status. Traveler must be in travel status for at least one hour of the period for a specific meal. Any meal expenses beyond the amount allocated by the per diem are the responsibility of the traveler. Per diem does not include meals provided by conference host.

ALASKA RATE:

- Breakfast (Midnight to 10 AM) \$30
- Lunch (10 AM to 3 PM) \$34
- Dinner (3 PM to Midnight) \$50
- Total Daily Amount \$114

The CONUS rate can be found here: <https://www.gsa.gov/travel/plan-book/per-diem-rates>

D. Transportation

All travel arrangements (airfare, hotel, registration) must be purchased by the City and made by the Clerk or Treasurer. Alaska Airlines flights are booked through the City's EasyBiz account. All air travel will be booked for standard coach class seating. No employee will be required to fly on a red-eye flight. Should the employee choose to be seated in business/first class, the difference in price will be paid by the employee. Travel must be by the most direct and efficient means. An employee may request travel by an indirect route for his/her own convenience or request a deviation of travel (choice of a route which includes personal time off during the trip or an indirect route). If there is a price increase due to the deviation, the employee must pay the difference. Travelers may use their personal upgrades if there is no extra cost to the City. Personal excess baggage fees will not be paid by the City.

E. Mileage Reimbursement

An employee may use a privately owned vehicle and may request reimbursement at the established rate and procedure per City of Gustavus policy.

F. Ground Transportation

Vehicle rentals are to be requested within the travel authorization form. Should it become necessary to rent a vehicle when it was not previously approved on the travel authorization, it is to be included on the travel expense report after trip completion and approved at that point. City insurance coverage applies only to travel on official business. Hotel courtesy shuttles shall be used whenever possible. Taxis, Uber, Lyft and Turo services may be used when necessary.

G. Other Expenses

Other allowable expenses include business telephone calls, WiFi, parking, and other expenses necessary to conduct City business. The City does not reimburse for traffic violations, parking fines, lost airline tickets, laundry service, or similar expenses.

I. Travel Claims and Required Documents

Any travel claims that were not prepaid must be submitted to the Treasurer for approval prior to reimbursement. Travel claims must be submitted within one week following the completion of travel. Copies of the following documents must be attached to the City of Gustavus Travel Expense Report:

- Tickets
- Receipts for other expenses
- Hotel receipts

Attachment: Travel Authorization Form

City of Gustavus, Alaska
Resolution CY26-08
Page 3 of 4

- Transportation receipts
- Lodging Receipts
- Copy of approved Travel Authorization Form
- Completed Travel Expense Report

J. Wages Paid During Travel

Travel shall be scheduled at the mutual convenience of the City and the employee, reasonably based on the circumstances of travel and the schedule of the employee. The city recognizes that travel may disrupt regular work schedules. When possible, the employee’s work schedule should be adjusted to accommodate the additional time worked without creating overtime liability.

Compensable time:

- a. When participating in training activities, hours worked will coincide with the scheduled hours for the training course. Hours worked may not be equal to the hours an employee would have worked had the employee been at their regular place of work, depending on the schedule of the training.
- b. Time spent traveling to a training or conference are considered hours worked based on scheduled flight times and a reasonable time for transit to and from airports, up to a maximum of 8 hours per trip. Travel between your home and point of departure is not compensable time.
- c. Time during which travel is delayed by weather or other disruptions *may* be considered hours worked, if the employee is actively engaged in work related travel or city business; however, in no instance will hours worked exceed a total of 8 hours of travel time per day because of travel delays.
- d. Overtime pay will be applied when 40 hours of training are exceeded in a work week.
- e. Mandatory training will be fully compensated.
- f. Regular meal periods are not included in compensable time.

The city recognizes that in special circumstances travel arrangements may need to deviate from the procedures outlined here. If necessary, and determined to be in the city’s best interest, deviations may be approved by the employee’s supervisor or the mayor.

If an employee plans to take personal leave immediately following a city-related trip, personal leave begins at the end of the scheduled conference.

City Council travel should adhere to the procedures described above and will be arranged by the City Clerk or Treasurer.

Sally A. McLaughlin, Mayor

Date



Travel Authorization Form



Name	<input type="text"/>	Training/Conference	<input type="text"/>	Submitted by	<input type="text"/>
Department & position	<input type="text"/>	Location of Travel	<input type="text"/>	Date submitted	4/8/2026
Time Period	1/0/00			Athorized by	<input type="text"/>

Explain why you would like to attend:

If traveling outside of Alaska		GSA Rate:	GSA:	GSA:	GSA:		
Date	Description Day (Travel or Training/Conference)	Breakfast AK=\$30	Lunch AK=\$34	Dinner AK=\$50	Total	Anticiapted Overtime Hours	
					\$0.00	0.00	Registration Fees 0.00
					\$0.00	0.00	Airefare/Ferry 0.00
					\$0.00	0.00	Ground Transport 0.00
					\$0.00	0.00	Accomdatons 0.00
					\$0.00	0.00	Meals Per Diem 0.00
					\$0.00	0.00	Grand Total 0.00
					\$0.00	0.00	
					\$0.00	0.00	
Total					0.00	0.00	

Airefare/Ferry (round trip)

Name of Company	Cost
Total	\$0.00

Accomdatons

Name of Company	Cost
Total	\$0.00

Registration for Conference/Trainaing

Name of Session/training/conference	Cost
Total	\$0.00

Ground transportation (Milage reimbursment \$0.70 per mile)

Name of Company / approx. miles	Cost
Total	\$0.00

Are there scholarship oppertunites for this training/conference?

If yes, how much and when is the form due?	<input type="text"/>
--	----------------------

Will your travel deviate from this plan for personal purposes?	<input type="text"/>
--	----------------------



Travel Authorization Form



Name	Liesl Barker	Training/Conference	AAMC Annual Conference	Submitted by	Liesl Barker
Department & position	Administration / Clerk	Location of Travel	Anchorage	Date submitted	4/8/2026
Time Period	12/6/2026			Athorized by	

Explain why you would like to attend:

I am requesting to go to the Alaska Municipal Clerks Conference including the additional Academy and Athenian training and education session. This gives provides the clerk with the maximum education and points towards the MMC certification for the least amount of money. There will be sessions on records management, OMA, how to use AI responsibly and effectively, resolution, ordinance and policy creation. Including all of my committee and chair work along with the conference sessions this will provide me with 12 points to put towards my MMC.

If traveling outside of Alaska GSA Rate:		GSA: \$	GSA: \$	GSA: \$			
Date	Description Day (Travel or Training/Conference)	Breakfast AK=\$30	Lunch AK=\$34	Dinner AK=\$50	Total	Anticipated Overtime Hours	
12/6/2026	Travel Day	N/A	N/A	\$50.00	\$50.00		Registration Fees 500.00
12/7/2026	Training Day 1	\$30.00	\$34.00	\$50.00	\$114.00		Airefare/Ferry 1,025.00
12/8/2026	Training Day 2	IN	IN	\$50.00	\$50.00		Ground Transport 80.00
12/9/2026	Training Day 3	\$30.00	IN	IN	\$30.00		Accomdatons 1,200.00
12/10/2026	Training Day 4	\$30.00	IN	\$50.00	\$80.00		Meals Per Diem 388.00
12/11/2026	Travel Day	\$30.00	\$34.00	N/A	\$64.00	1.00	Grand Total 3,193.00
					\$0.00		
					\$0.00		
					\$0.00	1.00	
Total					388.00		

Airfare/Ferry (round trip)

Name of Company	Cost
Alaska Airlines (round trip)	\$600.00
Alaska SeaPlanes (round trip)	\$425.00
Total	\$1,025.00

Accomdatons

Name of Company	Cost
Marriot Downtown Anchorage	\$1,200.00
Total	\$1,200.00

Registration for Conference/Trainaing

Name of Session/training/conference	Cost
AAMC	\$500.00
Total	\$500.00

Ground transportation (Milage reimbursment \$0.70 per mile)

Name of Company / approx. miles	Cost
Uber (round trip airport to hotel)	\$80.00
Total	\$80.00

Are there scholarship oppertunites for this training/conference?

If yes, how much and when is the form due?	Yes there is a scholarship available applications are due by 11/01/2026 for upto \$750.00
--	---

Will your travel deviate from this plan for personal purposes?	No
--	----



City of Gustavus
PO Box 1
Gustavus, Alaska 99826
Phone: (907) 697-2451

City of Gustavus Capital Improvement Plan

Version: COG_CIP: 2026-2030

Approved by the Gustavus City Council on XXX XX, 2026

Introduction: The Capital Improvement Program

This is the ninth comprehensive Capital Improvement Plan for the City of Gustavus. The initial completed plan was approved by the Gustavus City Council on May 14, 2018.

The document as a whole will be reviewed by the City Council each winter to re-evaluate priorities, update cost estimates, and choose the priorities for submission to the State of Alaska legislature through their CAPSIS online submission form for capital improvement project requests. Resolutions supporting the projects chosen for the state funding request should be passed at the January or February general meeting in advance of submission of capital improvement project requests to the state through the online CAPSIS portal, due by mid-February. The last legislative grant the City received through the CAPSIS program was in 2024; the City received \$90,000.00 to purchase the Wildlands Fire Truck with Skid Unit.

In-house funding for capital projects will be determined by the City Council, with the appropriate AMLIP accounts being tapped [e.g. AMLIP Capital Improv Current, AMLIP Capital Improv Long-Term, AMLIP Repair & Replacement (R&R)]. Current year capital improvement priorities will be determined with consideration for urgency of need for the project, phases of multi-year projects, availability of project managers, consolidation between departments for projects of similar focus, etc. In FY23 the City's AMLIP account policy was changed to better utilize the accounts and to ensure that the City was getting the most out of its reserves.

A separate policy and procedure exists for project nomination and development, including a short-form and a more extensive form (i.e. scoping). Project development documents must be approved by the Gustavus City Council before projects are funded.

The last city-wide inventory of assets took place in 2018. Repair and replacement (R&R) annual saving amounts were then calculated based on the following formulas, as recommended by the State of Alaska Department of Commerce, Community, and Economic Development (DCCED), Division of Community and Regional Affairs (DCRA), Rural Utility Business Advisor (RUBA) Program. In 2024 the City Treasurer started working on building an asset management plan to use in conjunction with this document.

- For replacement of items with a life expectancy of more than one year but not more than 10 years, the city should set aside 100% of the replacement value in order to purchase the item when needed. To calculate the amount to set aside each year, divide the replacement cost by its life expectancy.
- For replacement of items with a life expectancy of more than 10 years, the city should set aside 10% of the replacement value of each item. To determine how much to set aside each year, multiply the estimated replacement cost by 10%, then divide that by the life expectancy of the asset. These are typically larger assets that the city would be seeking outside funding for, and the R&R savings could then be used as a down payment for a loan, a match for a grant, etc.
- Beginning in FY19, the annual operating budget includes an expense line-item for each department for contributions to the AMLIP Repair & Replacement (R&R) account. The amount for each department is calculated using the formulas above for the assets within that department.

Integration of the CIP with Strategic Plan Goals

Capital budgets are generally for large infrastructure development and improvement. Capital budgeting is an important public policy and management decision making tool and can affect a municipality's long-term debt and general fund balances. Substantial funding is generally at stake in capital budget decisions, and the decision that a government makes shapes the future

of the community. Capital projects commit resources into the future and affect a community's long-term spending capacity; these decisions can be felt for decades. Budgeting for capital improvement projects is not included in Gustavus Ordinance nor is it outlined in policy and procedure. The City now uses the CIP as a guide for ongoing and future projects, although other projects can be initiated and completed based on the community's needs that are not listed in the CIP.

There is strong evidence that capital budgeting and strategic planning are strongly linked (Beckett-Camarata, 2003). Strategic Planning is founded on a vision and continues long after the initial groundwork is set.

In December 2019, an infrastructure survey was distributed to Gustavus citizens, primarily online, for a two-week period. The purpose of the survey was to rank the relative priority of potential infrastructure improvements for City Council attention, based on both importance and urgency. Important tasks were defined as contributing to our long-term mission, values, and goals. Urgent tasks would demand immediate attention. 180 respondents ranked Importance (low, medium, high) and Urgency (within 3-6 months, within 1 year, within 2 or more years), placing highest priority on obtaining adequate and reliable ferry service and lowest on Parks and Recreation facilities. The respondents ranked the 13 infrastructure areas as follows:

1. Ferries, 2. Safe Public Water, 3. the Electrical Intertie Project, 4. Roads, 5. Clean Energy, 6. the Disposal and Recycling Center, 7. Internet, 8. Beach, 9. Gravel Pits, 10. Marine Facilities, 11. Bike routes and trails, 12. City Buildings, and 13. Parks and Recreation facilities.

The Gustavus City Council has proposed revising the City of Gustavus Strategic Plan. The draft Strategic Plan's Appendix A: Infrastructure Data Table, Combined Results, and result graphs has additional details.

Literature Review

Literature Cited:

Beckett-Camarata, J. (2003). An examination of the relationship between the municipal strategic plan and the capital budget and its effect on financial performance. *Journal of Public Budgeting, Accounting & Financial Management*, 15(1), 23-40. doi:10.1108/jpbafm-15-01-2003-b002

DiNapoli, T. P. (2009). *Strategic planning* (New York (State)). Office of the State Comptroller. Division of Local Government & School Accountability. Albany, NY: New York State, Office of the State Comptroller, Division of Local Government and School Accountability.

Ongoing Projects, Funded in Previous Years

- Good River Bridge Repairs
 - Status: originally funded in FY19-FY20 operating budget. \$15,000 was allocated through FY22-03NCO for engineering studies. The City secured \$710,000 from the Denali Commission in 2024, and engineering work began in August 2025. The engineering firm is finishing up the 65% design documents to be available in early February (2026). Although they had to complete a retaining wall structural analysis due to not being able to locate as built drawings for the retaining wall from original construction, we are on schedule to have the 100 percent design by early May.
- Heat Pump Project (CP24-04)
 - Status: In 2024 the City allocated \$36,000 for this project; in 2024/25 we installed a heat pump in the DRC office and the Bike Shop, and 1 of 2 heat pumps in the Firehall. The addition of the second heat pump at the firehall is waiting on an electrical upgrade. A service application was made to AP&T in March of 2025, and we received an estimate in April 2025. AP&T has to install higher grade wiring under the paved road which requires earth boring equipment. It is anticipated that this will be accomplished sometime in Spring/Summer 2026.
- Disposal & Recycling Center Composting Facility (CP19-06)
 - Status: in progress; reinitiated design work after 2020 RFQ overbid. Work initially to be completed in 2024; initial funding approved with FY19-22NCO; 2018 design work funded through operating budget; applied for state funds in FY19 Legislative Request; project modified/expanded for 2019 from original Disposal & Recycling Center Composting Facility project and Composting Quonset Replacement project; Applied for SWIFR grant in CY23 but was not funded; Reapplied for SWIFR in FY24; Applied for CDS for FY25 and again for FY26. Neither the CDS nor the SWIFR grant were funded. It is unclear whether there will be additional SWIFR funds will be made available to other than the Tribal program under this authorization. We will submit a CDS again. Since the heavy snow event took down the Quonset, perhaps that will bump us up in the priority list. We are looking at EPA and USDA as funding NOFO's are posted as a next step in seeking funding for this project.
- DRC Main Building Replacement (CP21-05)
 - Status: Phase 1 (Design) funding approved with FY22-08NCO Approved for Congressionally Directed Spending Grant for \$3,027,000.00 in CY24; An RFP for Engineering Services was issued mid November 2025. Bids were significantly higher than budget estimates. Negotiations with one of the bidders on the scope and cost of their services is underway. During federal administration changes, the original projected timeline was delayed since freezing of federal spending on projects under federal agencies caused the grant award approval to be several months behind. We continue to work with the Region 10 EPA Project Manager.
- GVFD Truck with Skid Unit
 - Status: The City received a Legislative Grant through the CAPSIS program in CY24 for \$90,000; currently the City has purchased the truck, installed a snowplow, ordered lights, sirens, and decals, and is currently waiting for the skid unit to be built (estimated delivery May 2026)
- GVFD Water Tender
 - Status: The GVFD received a 2023 Assistance to Firefighters Grant for \$668,095.23 in CY24; the truck currently is being built. A Period of Performance (POP) extension is being requested to the AFG FEMA Grants Program since we were recently informed that the delivery of the tender likely won't occur until fall of 2026.

- Gustavus Beach Improvements (CP19-03)
 - Status: in progress; funding approved with FY19-19NCO; Hardened Beach Trail funded with FY23-06NCO, completed in CY23. Various other minor improvements have been made such as signage upgrades and relocation and log barriers to the west side of the beach to discourage motorized vehicle traffic on the beach lands.
- City Hall / Fire Hall Electric Meter (CP25-01)
 - Status: Funded in house with FY25-24NCO; Currently waiting on AP&T to perform work
- Purchase Salmon River Boat Harbor Tract
 - Status: Currently in negotiations with DNR

See Appendix A for a full narrative for each project.

Completed Projects in FY25

- Salmon River Park Playground Equipment (CP23-03)
- DRC Expansion – Fencing (CP24-01)
- New City Council Computers (CP26-01)

Other Community Projects

This is an incomplete list of other capital projects occurring in the City of Gustavus by other organizations, included here for context only.

- The City is partnering with the Federal Highway Administration and Safe Streets for All in an effort to provide a bike path along Gustavus Road & Mountain View Road.

Part 1: FY25 Legislative Request for State of Alaska Capital Budget

City of Gustavus FY25 State Legislative Priorities
Submitted via CAPSIS on 02/13/26.

- | | |
|--|-----------|
| 1. Heavy Equipment Procurement – Cat950 Loader w/ Attachments
Scoping document approved 02/09/2026. | \$538,530 |
| 2. Glen’s Ditch Design, Cleaning, and Bridge Installation
Scoping document approved by City Council 01/16/2024. | \$100,000 |

See Appendix B for a full narrative for each project.

Part 2: FY26 Projects

City of Gustavus – Fund In-House for FY26

- City Road Improvements Phase 2: Road Improvements \$ 50,000
- DRC Bobcat Attachments \$ 17,779

Seek Funding for FY26

- DRC Recycling and Compost Yard Improvements
 - Status: continue seeking grant funding
- GVFD Extrication Equipment
 - Status: continue seeking grant funding

Additional Priority for FY26

- Salmon River Bank Stabilization Consultation
- Public Drinking Water Source

See Appendix C for a full narrative for each project.

Part 3: Mid-Range Projects & Long-Range Projects

- Disposal & Recycling Center Baler Purchase
- Disposal & Recycling Center Glass Pulverizer – Refurbish or Replace
- City Hall & Fire Hall Energy Audit Repairs
- City Vehicle
- City Hall Partial Remodel
- Disposal & Recycling Center Shredder
- Disposal & Recycling Center Drive-On/Vehicle Scale
- Volunteer Fire Dept. Building Expansion & Roof Repair
- Gustavus Public Library Building Expansion
- Salmon River Harbor Waterless Restrooms
- Salmon River Harbor Public Floats

See Appendix D for a full narrative for each project.

Appendix A

Good River Bridge Repairs Phase 2: Construction

Project Description & Benefit

This project implements the engineering recommendations completed in a previous project to repair the Good River Bridge.

Plans & Progress

A Request for Quotation (RFQ) is being developed and issued based on the engineering report created to address the Good River Bridge issues.

Total Project Cost

\$710,000

City Buildings Air-Source Heat Pump Conversion

Project Description & Benefit

This project would perform an evaluation of converting existing oil-based heating systems of city buildings to air-source heat pumps and perform installation as approved. This project would further the City’s commitment to make greener building improvements.

Total Project Cost

Approximate cost \$36,000

Disposal & Recycling Center Main Building Replacement

Project Description & Benefit

The proposal provides for a long-term solution to the necessary space of the next 20-years. The DRC is a regional and state example of recycling and solid waste disposal for rural communities because of the years of developing environmental best practices.

To construct a new main building of 6,000SF with at least 4 large doors and 3 man-doors. There will be a concrete floor as well as areas of the building that have concrete push walls.

The existing main building is too small to safely operate the functions of the DRC. The goal of the project is to construct the new building providing adequate, safe space for customers and staff.

In addition to the new building, three phase power is an important foundation to improving the Disposal & Recycling Center (DRC), as most industrial scale equipment, even equipment the DRC is using now, uses three phase power. It provides more power and can power larger motors than single phase power can. This project would complete the installation of three phase power at the DRC by bringing three phase power from Dock Road to the DRC.

A quote from AP&T was requested for what it would cost to provide three phase power to the DRC. This quote is a part of the planning process for the future of the facility.

City of Gustavus Resolution 2009-11 in support of the extension of a three-phase electrical feeder along Dock Road included a whereas as follows:

“Whereas, the Gustavus Disposal and Recycling Center presently has three phase equipment and would benefit from being able to connect to three phase grid power...”

Total Project Cost

\$3,027,000.00

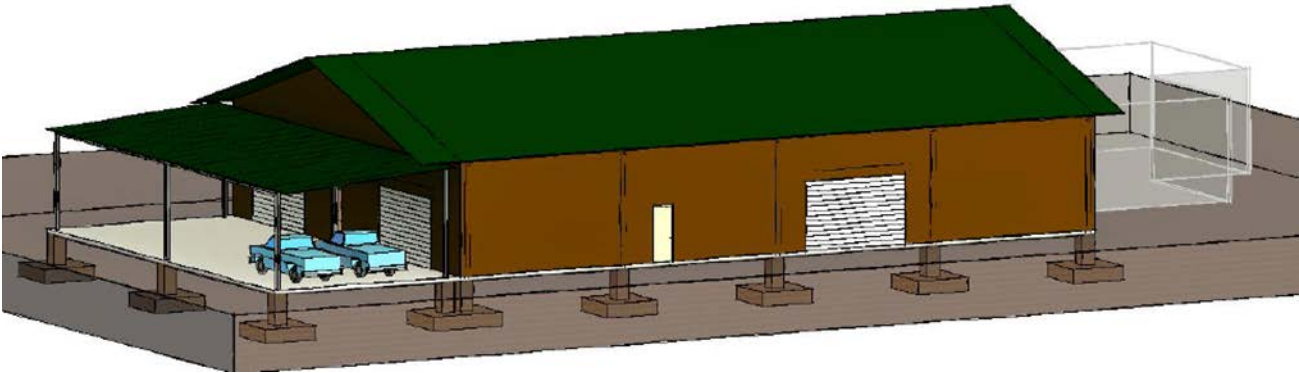

Gustavus Volunteer Fire Department Truck with Skid Unit

Project Description & Benefit

This project originally was intended to replace Engine 27, which is contaminated with PFAS and is no longer useable. The loss of Engine 27 has changed operations in the fire department. Engine 27 was used in two ways. One as a portable fire hydrant staging at the water source to fill water tenders more quickly. The other was to gain access with a pump down tight driveways that Engine 1 cannot maneuver. Replacing Engine 27 will be done with a smaller 4x4 truck equipped with a Skid Unit, Plow Attachment, and possibly a Patient Basket. This would serve many of the GVFD’s current needs. This vehicle will also replace GVFD Utility Pick-Up Truck

and the Quick Attack/Wildland Firefighting Truck previously requested in this document. There are multiple different used trucks available through the year from various dealers.

This benefits the community by adding another vehicle to respond to fires. It will be smaller making it able to maneuver the roads better and quicker when they are wash boarded. It should be emphasized that the addition of this vehicle significantly increases the GVFD’s ability to respond, especially to fires outside the reach of the Engine 1. Rough roads, limited access, fast response – wouldn’t you want this capability if your house was in the path of a fire, or worse yet – on fire?

A skid unit is a 150-200-gallon tank with a pump on board which allows firefighters to have a small portable fire pump and water tank to take to a small wildland fire. This would include a 1-inch rubber hose, intake, and a separate discharge valve(s). There also would be a spot where we could attach a patient basket so if the patient is somewhere the ambulance would not be able to reach, we have a vehicle to transport a patient, aiding responders in transporting the patient from the scene to the ambulance. This also would allow us to take the unit off the truck during the winter to store it inside.

Total Project Cost

\$90,000

GVFD Water Tender/Road Water Truck

Project Description & Benefit

The Gustavus Volunteer Fire Department currently has two water tenders: a 1981 International and a 1987 international. Both tenders carry 1500 gallons of water each. Tender 1 is an automatic transmission, and Tender 2 is a manual transmission, which can be tough for a volunteer to drive. Neither truck was made for tendering water to a fire, but they are functional.

According to NFPA and OSHA, each tender should have two people during operations: one person driving and one person to help the driver operate safely by helping them back up, stopping traffic, and help with tendering operations. When a fire happens, GVFD would prefer to have as many volunteers working on the fire scene as possible and not engaged in driving vehicles.

This project would invest into one larger 4000-gallon water tender that also has road sprayers. Not only would it reduce manpower of the fire department in an operational scene, but the truck could be used in the summer months spraying water on gravel roads, reducing the dust. One of the current tenders does have a road spraying system. With only a 1500-gallon capacity, however, a lot of time is spent filling the truck with water, and it is challenging to get enough water on the roads to make a difference.

Both Tender 1 and Tender 2 could have some sort of resale value. The trucks are not unusable; GVFD could just be more efficient in our operations with one truck that carries more water.

Total Project Cost

\$521,152

GVFD Electric Meter Installation

Project Description & Benefit

City Hall currently shares its electric meter with the firehall. This project would install a separate electric meter at the firehall to better track power usage at both buildings and provide independent power supplies.

Total Project Cost

\$16,089

Purchase Salmon River Boat Harbor Tract

Project Description & Benefit

The goal is to purchase the central 9.65 acre tract B2 of the Salmon River Harbor, and the adjacent river tidelands in front of Tracts B2 and B3, which would put the entire Salmon River Harbor under City of Gustavus ownership.

Plans & Progress

The City Council approved a scoping document for this project on 03/11/2024. The City is currently working with DNR to apply for the land transfer.

Total Project Cost

Alaska DNR will set the rate for the parcel after receiving the City's application for the land transfer.

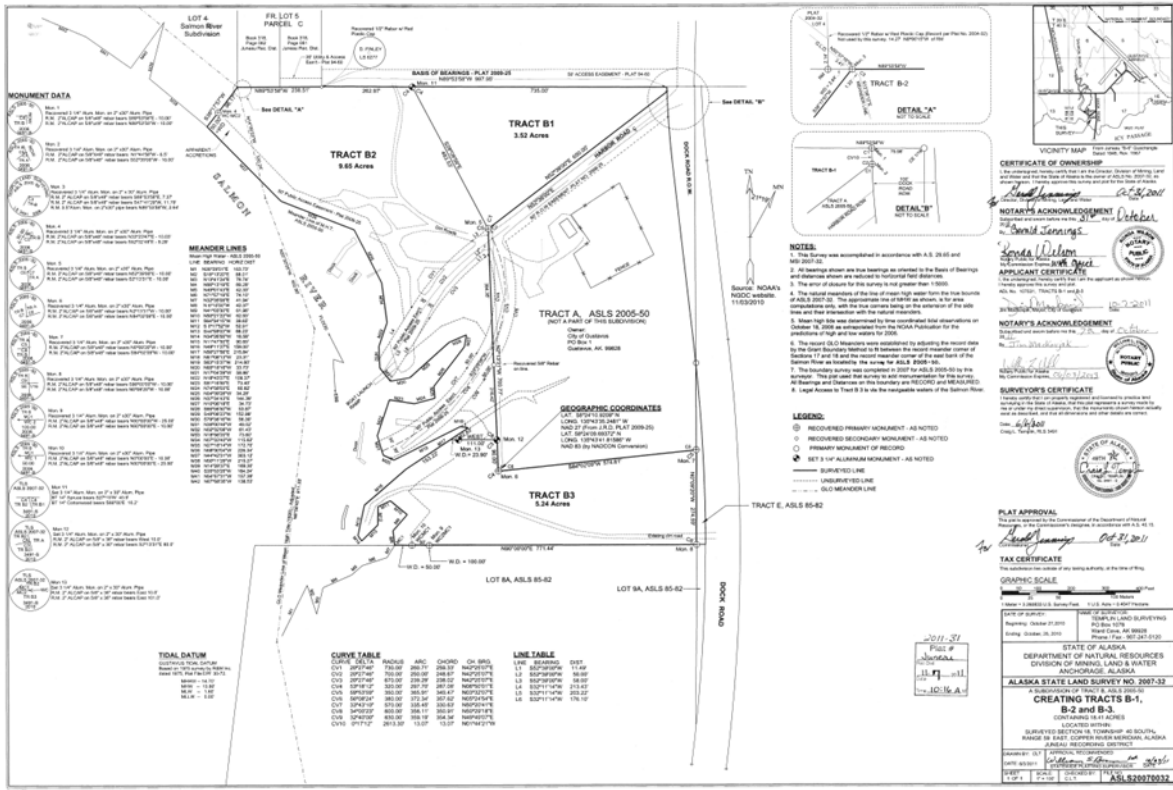

Appendix B

Priority 1. Heavy Equipment Procurement – CAT950 Loader w/ Attachments

Project Description & Benefit

The City of Gustavus requires an adequately sized, versatile wheel loader to protect, manage, and maintain local assets, most importantly our almost 24 miles of gravel roads, parking lots, and includes other operational needs such as at the DRC and gravel pit, that undersized equipment cannot handle. Extremely outdated, in some cases undersized, and unreliable private equipment results in high rental costs, equipment downtime, additional contractual costs, causes delays in emergency responses, and puts critical infrastructure and public assets at risk. Enhanced capability is needed for emergency cleanup, snow removal, and securing areas, thereby protecting public safety and reducing liability and must be a priority for the City. Acquisition of a new machine to successfully execute winter and supplementary road and drainage maintenance activities and assisting with other city operations, without disruption of services, will enhance risk mitigation, provide for operational proficiency, and provide long-term cost savings. Investing in this loader is an initiative-taking, necessary measure to protect local assets from deterioration and damage. It will provide a return on investment through improved operational efficiency, and improved response times to emergencies.

Total Project Cost

\$538,530

Priority 2. Glen’s Ditch Design, Cleaning, Bridge Project

Project Description & Benefit

The goal of this project would be to clean vegetative debris from approximately 2,800 ft of Glen’s Ditch from Gustavus Road to approximately the Nagoonberry Trail parking area, and to replace undersized culverts at three locations, two of which could be replaced with bridges, to enable the ditch to carry high flows from heavy rain events. From Gustavus Rd to the southern boundary of the old Glen Parker homestead, Glens Ditch and Glens Ditch Road are in a 60-foot-wide easement. The road has been maintained by the City since 2004 within the easement but the City has not maintained the ditch. From that southern boundary of Glen’s homestead south approximately 350 ft to the Nagoonberry Trail parking area, the road and ditch are on the Gustavus Forelands Preserve property of The Nature Conservancy. The City maintains Glen’s Ditch Rd and the parking area cooperatively with The Nature Conservancy. For that section the City will seek agreement with The Conservancy local manager for the ditch cleaning work.

Appendix C

City Road Improvements Phase 2: Implementation

Project Description & Benefit

This project would implement the recommendations for improvements as informed by a previous project’s work with a road engineer and using the city’s LIDAR data. The project continues with improvements that includes specific work as follows:

- a. Ditch stabilization along Wilson Rd and Rink Creek Rd to prevent washouts
- b. Preventive Maintenance Program
- c. Road Material Improvement
- d. Alternate road surface procedures

Plans & Progress

Awaiting results of road engineer analysis.

Total Project Cost

Phase 2, implementation of the engineer’s recommendations regarding the topics listed above, is of unknown cost and could include annual costs rotating preventative maintenance by neighborhood.

Disposal & Recycling Center Composting Facility

Due to 2025/2026 Winter storm, new scoping and project description needed at this time.

GVFD Extrication Equipment

Project Description & Benefit

This project would purchase a new set of extrication equipment for the Gustavus Volunteer Fire Department (GVFD). GVFD currently has old extrication equipment that was used by Sitka Fire Department before given to the GVFD pre-1999. The main use for this equipment is to cut people out of cars and other similar situations quickly and safely.

The technology of extrication has changed drastically in the past few years and is now battery operated. They are still just as powerful as the older ones, just easier to use - no cables and less people to operate. A set of extrication equipment includes a spreader, cutter, ram, combi tool, and a battery bank with spare batteries.

Right now, GVFD would call DOT for assistance and use their hydraulic equipment, which is newer, lighter, and easier to use than ours.

Total Project Cost
\$35,000

City Hall Driveway Relocation or Riverbank Stabilization

Project Description & Benefit

The Salmon River is eroding the driveway that leads to City Hall. It is a slow rate of erosion, but it appears inevitable that the driveway will eventually become unsafe or too narrow to provide access to City Hall. Options that have been considered informally include riverbank stabilization and driveway relocation through some of the existing trees behind the picnic shelter. This driveway is also used by the public to access the old ball field, especially during the Coho salmon run, and by one household to access their home. As part of this access design, the city may want to consider creating an electric vehicle charging station, for use by a city vehicle and possibly the public.

Landscape design consultation is included as a Phase 1 for this project. This would be Phase 2: implementation of the chosen design.

Plans & Progress

State of Alaska visited the Salmon River in April 2018 and took pictures of the erosion by City Hall and its approach to the rock riprap under the Salmon River bridge. The riverbank and driveway are state land. Communication with the state continued during winter 2020-2021 as additional erosion occurred. There have been no further updates.

Total Project Cost

Unknown

Public Drinking Water Source

Project Description & Benefit

This project would contract with a company to produce a report that will identify a water source(s) to create a point-source for public drinking water access, a method of treatment that meets the applicable Alaska Department of Environmental Conservation regulations for standards to provide drinking water, and a proposed system for operating the water utility.

This project would also contract for the installation of a water program that provides for the installation of the necessary equipment to operate a water utility.

Based on the Council's determination on the implementation of the water utility, this project could also facilitate the operation of the water utility.

Total Project Cost

Unknown at this time. However, other communities that have used a point-source for a water utility for a community similar in size to Gustavus have spent approximately \$100,000. If a VSW grant is received, the study should provide estimated costs.

Appendix D

Disposal & Recycling Center Baler Purchase

Project Description & Benefit

To address the inefficiencies of the current balers, it is proposed to purchase a new, or high-quality used, horizontal baler such as the American Baler Company's NF 4560 or the Harris Barracuda. These balers are oriented horizontally rather than vertically which allows them to have more steel in their construction, a stronger baling chamber, larger hydraulics, and a larger three phase motor. These improvements give the machine greater compression which improves bale density. Denser bales benefit the operation whether the material being baled is being shipped out or the material is being placed in the mound. With a denser bale, more material can be made to fit in a given area.

A "closed-door" baler type has been selected which allows for baling a wide variety of materials (independently) such as raw garbage, aluminum cans, cardboard, and scrap metal/white goods. The baler would be fitted with an in-feed hopper to allow greater throughput of material (unlike the current balers which are hand-fed). Both models can also utilize an in-feed conveyor at such a time in the future that a further increase in the amount of material flow requires it. A horizontal layout also allows the baler to use the strength of its large hydraulic ram to push bales out of the baling chamber. This is unlike the DRC's current vertical balers which rely on the less robust dump tray mechanism to remove bales from the baling chamber. Dump tray mechanisms are only able to force bales part way out of the baling chamber which for certain materials (raw waste, metals, and plastics) requires the Operator to use a loader to force the bale the rest of the way out of the baling chamber; this extraction method is difficult and risks damage to the baler.

Plans & Progress

Construction of the new DRC building and installation of three phase power must occur before a new baler can be installed and used.

Total Project Cost

\$300,000



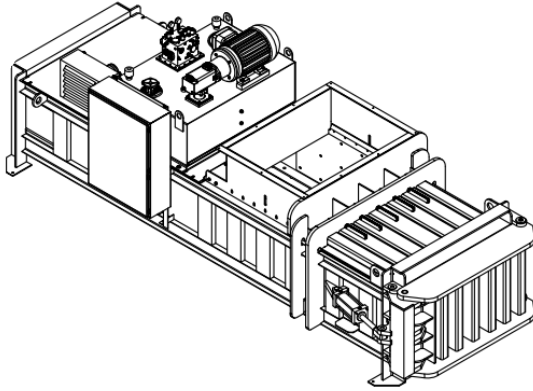

Installation would include the hiring of a construction firm to lift the baler off the shipping flat, move it to its designated place of operation, anchoring it into the concrete, installing any attachments that were removed for shipping, connecting all electrical equipment (disconnect and conduit), and installing hydraulic oil if it was removed for shipping. If a new unit is purchased, final electrical connections and training from the sales staff comes with the purchase.

Disposal & Recycling Center Glass Pulverizer – Refurbish or Replace

Project Description & Benefit

In 2023, the DRC's Glass Aggregate Systems H-100VT glass pulverizer will be 20 years old. The unit will have processed over 800,000 pounds of glass in its work life, and while the numerous smaller, high wear components are continuously replaced, the entire unit will either require extensive refurbishment of its internal glass handling mechanisms or outright replacement. The cost of full replacement is being used for planning purposes.

Total Project Cost

New H-100VT as of 01/2020 \$42,172
 Estimated shipping \$7,000
 Total cost \$50,000



City Hall & Fire Hall Energy Audit Repairs

Project Description & Benefit

These projects will be informed by a to-be-scheduled energy audit and engineering plan.

City Vehicle

Project Description & Benefit

The City of Gustavus has a need for a shared vehicle to accomplish city business. City Hall, Marine Facilities, the Library, and the Disposal and Recycling Center (DRC) all require regular or occasional use of vehicle transport. Currently, employees use personal vehicles, with some employees requesting mileage reimbursement and others not. The City Hall employees use their personal vehicles several times per week for trips to the Post Office and library for mail and for posting announcements. The harbormaster uses his personal vehicle to haul trash to the DRC, to clean the waterless restrooms at the beach and Salmon River Park, and to monitor activities at the dock and harbor. The DRC operator uses his personal vehicle to pick-up solid waste from City Hall and the Community Chest once per week and for hauling jerry jugs of fuel for equipment at the DRC. The fire chief uses his personal vehicle to respond to emergencies and uses the ambulance to haul non-offensive trash and recyclables. The Gustavus Volunteer Fire Department may purchase a utility pick-up truck, which would satisfy their needs.

While this system has worked for a number of years, a city-owned vehicle will allow a more professional appearance (especially important for the marine facilities position), and an electric vehicle will encourage and highlight the city's renewable energy source. Electric vehicles are relatively inexpensive (~\$10,000) to purchase.

Plans & Progress

Ideas for a vehicle include an electric vehicle and/or an open small pick-up truck that could easily haul trash.

Total Project Cost

\$ 10,000 for vehicle, \$2-4,000 for charging station at City Hall.

City Hall Partial Building Remodel

Project Description & Benefit

The City Hall original building is in need of a facelift. An addition was built 2012-2015, and this part of the building also needs some work (floor insulation hanging in places). The front room has not been remodeled in some time. The walls have been painted and a new dais has been acquired. However, new carpet should be installed at least in the Chambers, the three windows on the east side of the building should be replaced, and updated lighting (LED) fixtures should be installed.

Plans & Progress

As part of this remodel, the City may want to consider creating an electric vehicle charging station, for use by a City vehicle and possibly the public.

The improvements will benefit the Gustavus community by providing a comfortable, safe, and professional space to conduct City business. The recent improvements (paint, dais, staining the ramp, new City Hall sign, podium, wireless projector, etc.) have already made a difference. These improvements project the pride and professionalism of our local government.

Total Project Cost

\$15,000

Disposal & Recycling Center Shredder

Project Description & Benefit

This project is for the purchase and installation of a shredder at the DRC. A shredder is a volume-reduction tool used to reduce the size of large, bulky wastes such as mattresses, bulky rigid plastics, or tires, into small uniform pieces that can either be landfilled or shipped as a recyclable, depending on the item. A shredder can also be used to shred wood waste and cardboard for use in the composting or the waste-to-energy operation (mentioned below). The shredder would be hopper fed similar to the proposed horizontal baler. The DRC's new building has included the necessary space for the installation of a shredder.



Total Project Cost

Approximate cost for a smaller shredder such as the SSI M50 would be \$55,000 plus shipping and installation. Total costs would be around \$85,000.

Disposal & Recycling Center Drive-On/Vehicle Scale

Project Description & Benefit

This project is for the purchase of a drive-on/vehicle scale at the DRC. The purpose of a drive-on scale is to facilitate large deliveries of waste to the DRC. A customer would drive on the scale, the gross weight would be determined, the customer would unload their waste into the appropriate area, and then the vehicle re-weighed with the customer charged for the difference or net weight of the waste. A drive-on scale could also be used by the City to charge for gravel coming from the City owned gravel pit. The scale can be operated remotely, similar to the

Dray's fuel pumps, or could be attended by reconfiguring the DRC office.



Total Project Cost

Approximate cost for a new scale, shipping and installation is estimated to be around \$45,000.

Volunteer Fire Department Building Expansion and Roof Repair

Project Description & Benefit

The main structure of the Gustavus Volunteer Fire Department (GVFD) building was built by volunteers around 1981. In the early 1990's, it was expanded to include a third bay. Since, then, the needs of the fire department have continued to grow. This project would expand the fire hall garage, which will create more storage space, bring the building into safety compliance, and provide overnight living quarters. The living quarters will allow for a Firehall live-in program which will reduce response times during non-business hours.

GVFD has a full-time Fire Chief, hired by the City of Gustavus in July 2016, and a non-profit organization coordinating 30 volunteers for fire and EMS response and dispatch services. Skill training is conducted one night every week, with CPR, EMT, and ETT classes offered every year. In August 2017, the City of Gustavus purchased a 2003 Pierce International fire engine for \$113,800 plus shipping. The city also continues to successfully receive multiple annual grants for training and equipment. The GVFD is a thriving and growing organization.

This expansion would create a kitchen and full bathroom upstairs along with bunk rooms. It would also create a larger classroom/training room. It would update the building's aging electrical and lighting in hopes of making the building more energy efficient. Safety improvements would include an additional second story exit and a vehicle exhaust system for the garage. In the garage, it would create separate rooms for storage of EMS supplies and Fire Equipment. It also would create some much-needed space in the garage to be able to work on various equipment without having to remove vehicles into the elements. A bigger garage space also will allow us to store equipment that is currently outside.

The Gustavus Citizens will benefit by having a larger and more organized department, which will ultimately make the operation run more efficiently. The direct beneficiaries are the volunteers at the fire department. Expanded space will also result in longer life for GVFD equipment which is currently stored outside.

In 2016, a local construction company working on the roof noticed lots of roofing materials that were tacked down inadequately and believed there could be damage underneath some of the roof on the main building due to water leakage. This is a hot roof, which is sealed and does not allow air to circulate. If a hot roof gets condensation inside, mold can spread rapidly.

The project would include two phases, Design is Phase 1 (included in FY20 legislative request and the list of Mid-Range Projects) and Build is Phase 2. Both are contingent on funding. As soon as Phase 1 is complete, funding would be sought for Phase 2.

Total Project Cost \$700,000

Gustavus Public Library Building Expansion

Project Description & Benefit

The Gustavus Public Library was built by volunteers, grants and donations. When the blueprints were drawn the building was designed for an expansion at some future date. As the population of Gustavus has grown significantly since the late 80's and early 90's, we find that we need more space to better serve the public. As librarians, we are taught to constantly and methodically weed out books to keep things moving and pertinent to the public. However, even with these efforts, we receive comments of the library being "too cluttered".

During the Spring, Summer and Fall months, we are a hub for visitors. Many come to learn about Alaska or Gustavus and its history itself. As a part of this expansion, we would like to see a small portion sectioned off as the "Alaska Room" where those interested can go spend some quiet closed off time (if desired) browsing the bookshelves for the exact local topic they are looking for or one would be able to sit at a small table with some friends and have a small meeting.

The other part of the expansion would serve children, specifically teens. We desperately need a space that tweens and teens *want* to be in, semi-secluded and surrounded by fun and informational books and magazines. The existing "kid's room" space would stay roughly the same but move into the new expansion, leaving more room in the main circulation area for adult and juvenile books.

Plans & Progress

Original blueprints detail a possible expansion. The project would include two phases, Design is Phase 1 (included in FY20 legislative request and the list of Mid-Range Projects) and Build is Phase 2. Both are contingent on funding. As soon as Phase 1 is complete, funding would be sought for Phase 2.

Total Project Cost

Unknown

Salmon River Harbor Waterless Restrooms

Project Description & Benefit

This project would construct waterless restrooms at the Salmon River Harbor, using the same or similar kit as the waterless restrooms at the beach and at Salmon River Park.

Plans & Progress

None.

Total Project Cost

\$40,000 for ROMTEC SST Traditional Double Restroom Kit plus shipping to Gustavus

\$30,000-\$50,000 for site preparation and installation

Salmon River Harbor Public Floats

Project Description & Benefit

This project would install public floats at the Salmon River Harbor.

Plans & Progress

Wooden floats formerly used at the Gustavus Multi-Modal Dock facility may be available for use.

Total Project Cost

Unknown.

Project Planning: Attachment A
City of Gustavus
PROJECT DEVELOPMENT SHORT FORM

Item #17.

Project Eligibility: All projects may start with a Project Development Short Form. More complex projects will require the Project Development Long Form. Complex projects include those with a multi-phase, multi-year planning and implementation process, significant funding requirement, and/or broad impact.

Does the proposed project represent a complex project? YES NO

If no, please fill out the additional Project Budget section of this form.

Will the proposed project result in a fixed asset (e.g., land, major equipment, building or other structure, road or trail) with an anticipated life of at least two years? YES NO

Will the project provide broad community benefit? YES NO

If you answered yes to any of the above questions, please provide the following additional information.

1. Project title: DRC Bobcat Snow Removal Attachments

Project description and benefit. The goal of this project is to purchase snow removal attachments for the DRC's skid steers to be better equipped at handling snow at the DRC and to help with snow removal around town if requested. One attachment would be helpful, two would equip both machines. If the city purchases a loader as well, the city will be well equipped with three machines able to effectively plow snow.

2. Plans and progress. A quote has been received from Bobcat in Juneau describing the various options for snow removal. The top two choices right now are an **84" Snow V-Blade** and an **86" Snow Blade - Heavy Duty** from Bobcat. It was also suggested to look into alternative suppliers such as <https://skidpro.com/>. A quote has not been requested or received from an alternative supplier.

3. Project cost:

A. TOTAL COST (including funds already secured) = \$16,779 + shipping TBD (Assume \$1000+ shipping from Seattle to Gustavus for each attachment.)

B. NA

4. Timeline: Indicate when you hope to complete each phase of the project.

A. For projects that consist of land or equipment purchase only, state when the purchase would be made:

After the project is approved.

For construction projects:

B. Preconstruction phase to be completed by _____.

C. Construction phase to be completed by _____.

5. Provide a quality digitized photo, drawing, map, or other graphic image of your project if possible.



6. Date and name of person submitting form.

Ian Barrier 03-04-2026

Project Budget

Proposed Budget Line Items

Construction project Budget estimate	Cost	Operational budget estimate (annual)	Cost
Administrative	\$	Personnel	\$
Project management	\$	Benefits	\$
Land, structures, ROW, easements	\$	Training	\$
Engineering work	\$	Travel	\$
Permitting, inspection		Equipment	\$
Site work	\$	Contractual	\$
Demolition and construction	\$	Supplies	\$
Waste disposal	\$	Utilities	\$
Equipment	\$	Insurance	\$
Freight	\$	Repair & maintenance	\$
Contingencies	\$	Other (list)	\$
Other (list)	\$	Total direct costs	\$
		Indirect costs	\$
		Income (fees, taxes)	\$
		Balance: costs-income	\$

Mayor's Monthly Report

April 2026

Spring is coming! I've seen robins, heard juncos singing and am watching the snow *slowly* melt away. We just need a few more degrees of warmth and this past winter will become a distant memory!

Xunaa Borough: On Friday, February 27th Hoonah and the LBC filed responses to the appellate brief submitted by our attorney in December. The attorneys working on our appeal requested, and were granted, a 30-day extension to file the response brief, making our due date April 20, 2026. After that, the Court will hear oral arguments and then have up to six months to make a decision.

In the meantime, the city council has approved hiring consultant Kathie Wasserman to work with Gustavus, Pelican and Elfin Cove to perform a study to determine the feasibility of forming a borough with our three communities. This study will assess the ability to meet the LBC standards for incorporation, i.e. Relationship of Interest, Resources, Population, Boundaries and Best Interests of the State. The study will look at the different classifications of boroughs, the powers that a borough must adopt, the extent of local support, impacts on the communities, ability to provide essential services, tax revenue and other considerations as deemed appropriate.

Staff Meeting: The March staff meeting was spent finalizing the draft Travel Policy & Procedure. There was a lot of good input and discussion. Thanks to Vice Mayor Beck for all his help with this policy. The P&P is on the agenda for approval tonight.

Overdue Congratulations to Liesl! In December at the Alaska Association of Municipal Clerks conference, Liesl was awarded an Above & Beyond Award for fundraising efforts as part of her work on the Vendor Committee. We appreciate all you do *above and beyond* your work here for the betterment of Alaska's municipal clerks!

Congratulations to the six GVFD volunteers who spent two weeks in Fairbanks completing the skills training portion of their Firefighter I course; this is after working independently all winter to complete the online portion of the hybrid course. They completed the physically demanding skills training and all six passed the Alaska Practical Skills testing. Now they await the results of the State Firefighter I written exam. Thank you to Johan, Haley, Stephen, Lizz, Quinn and Sol – we greatly appreciate your time and commitment in completing the Firefighter I course. The Director of Fire Sciences at UAF reported that it was an honor to work with and train our firefighters; additionally, I received high praise for Johan's leadership and mentoring during the two weeks. We are proud of you, and of all our volunteers!

I'd like to take a moment here to highlight the extraordinary efforts put forth over the past few months by our **EMS Coordinator, Leah Okin**. Not only has she taught several weeks of classes, but she also helped coordinate and cover for the Interim Fire Chief's absence for training and has been

an integral part of the Fire Department's operations in assisting Johan in his role as Interim Chief with her knowledge and experience. Thank you!

Mugs and Matters: I've enjoyed visiting with folks at the Fireweed on Friday mornings. Please consider stopping by some week – there are no rules, and you do not need to have a concern or a topic of discussion. Stop and say hello, stay for a few minutes or the whole hour – I'd appreciate the opportunity to visit with more community members and to get to know one another better.

Saturday Market: We were tentatively planning another appearance at the Second Saturday Market in April. However, with several council members out of town in April, we are now planning on May 9th.

Other

I spent time this past month on:

- Mugs & Matters at the Fireweed, Fridays at 11
- Worked on Policy & Procedure amendments
- Worked on updating the Long-Term Storage Use Agreement
- Weekly Zoom meetings with Kathie Wasserman & community leaders on feasibility study
- Gateway Communities meetings with NPS staff
- Leadership roundtable conversation with US Senator Lisa Murkowski and her staff
- Communications with members of the public
- ACoM training - Budget Session Reality Check
- Spoke with KTOO reporter several times regarding PFAS and septage issues
- Attended septage meeting with Kathy, CBJ personnel and others
- Worked on developing the budget with the Treasurer and City Administrator

As always, community members, council members and city staff are encouraged to contact me if you have concerns or want to share thoughts or ideas.

Or join me at the Fireweed, Fridays at 11!

Sally McLaughlin, Mayor