



CITY OF GROSSE POINTE WOODS
CITY COUNCIL MEETING AGENDA
Monday, June 15, 2026 at 7:00 PM

*Robert E. Novitke Municipal Center - Council Chambers/Municipal Court,
20025 Mack Plaza, Grosse Pointe Woods, MI 48236
(313) 343-2440*

1. CALL TO ORDER

A. Administrative Memo: June 11, 2026

2. ROLL CALL

3. PLEDGE OF ALLEGIANCE

4. RECOGNITION OF COMMISSION MEMBERS

5. ACCEPTANCE OF AGENDA

6. CONSENT AGENDA

A. Approval of Minutes

1. Council 06/01/26

2. Committee-of-the-Whole 06/01/26 with Recommendation

B. Items Received and Placed on File

1. Historical Commission Minutes 04/09/26

C. Monthly Financial Report

1. May 2026

D. Bids/Proposals/Contracts

1. Fiscal Year End 2025-2026 Budget Amendments

- a) Memo 06/03/26 - Treasurer/Comptroller Schmidt - City Manager Como
- b) List of Accounts and Budget Amendment Amounts

2. Commit Fund Balance for Construction Projects and Equipment Purchases

- a) Memo 06/15/26 - Treasurer/Comptroller Schmidt
- b) FYE 2025-2026 Fund Balance Commitments

3. Vendors with Expenses Over \$20,000

- a) Memo 06/05/26 - Treasurer/Comptroller Schmidt
- b) FY 2026-2027 Open Purchase Orders over \$20,000

4. Unpaid Invoices

- a) Memo 06/15/26 - Treasurer/Comptroller Schmidt
- b) Summer 2026 Roll To Tax Invoices (Landscaping) Final Copy

cc: Council - 7
City Manager
City Attorney

Treasurer/Comptroller
City Clerk
Email Group/Media

Post - 3

5. Recommendation - Tree Removal Contract for 2026/2027
 - a) Memo 06/09/26 - Director of Public Services Kowalski
 - b) Proposed Tree Removal Contract
 - c) Bid Documents
 - d) Certificate of Insurance

6. Recommendation - Mack and Vernier Intersection Gateway Improvement
 - a) Memo 06/09/26 - Director of Public Services Kowalski
 - b) Images of Center Island/Gateway
 - c) Bid Package Summary - Stucky Vitale Architects
 - d) MDOT Quote
 - e) Estimate #23566 01/04/26 - Tocco Mannino
 - f) Contract/Proposal 05/01/26 - Phillips Sign & Lighting

7. Recommendation - Trucking Services
 - a) Memo 06/09/26 - Director of Public Services Kowalski
 - b) Email 06/09/26 - Grosso Trucking & Supply Co.
 - c) Certificate of Insurance
 - d) Proposed Agreement

8. Participation in PFAS Settlement Program - DuPont and 3M
 - a) Memo 06/11/26 - City Manager Como
 - b) Proposed GLWA Member Partner Contract
 - c) Proposed Resolution

9. Recommendation - Pavilion at Ghesquiere Park
 - a) Memo 06/11/26 - Director of Parks and Recreation Gafa
 - b) Committee-of-the-Whole Minutes Excerpt 06/01/26
 - c) Quote #PQ000665 - 06/11/26 - 16' x 24' Pavilion with Specifications
 - d) Quote #PQ000666 - 06/11/26 - 20' x 24' Pavilion with Specifications

E. Proclamation(s)

1. Juneteenth National Independence Day (June 19)

F. Claims and Accounts

1. Anderson, Eckstein & Westrick, Inc. (AEW) - City Engineers
 - a) Vernier & Mack Ave. Intersection Improvement - Invoice No. 165754 - Proj. No. 0160-0455 - 06/08/26 - \$2,653.27.
 - b) 2025 Miscellaneous Concrete Program - Invoice No. 165757 - Proj. No. 0160-0493 - 06/08/26 - \$6,706.01.
 - c) 2025-2026 General Engineering - Invoice No. 165758 - Proj. No. 0160-0498 - 06/08/26 - \$2,310.00.
 - d) 2025-2026 GIS Maintenance - Invoice No. 165759 - Proj. No. 0160-0499 - 06/08/26 - \$1,310.18.
 - e) Lee Ct. Doyle Ct. & Thorntree Water Mains - Invoice No. 165849 - Proj. No. 0160-0497 - 06/08/26 - \$17,538.64.
 - f) 2025 Concrete Pavement Repair Program - Proj. No. 0160-0493 - Payment Invoice No. 03 - Mattioli Cement Co., LLC - 05/28/26 - \$77,249.40.

2. Hallahan & Associates, P.C. - Professional Services - Invoice No. 24132 - May 2026 - 06/02/26 - \$2,239.56.

3. Tomlinson & McGrail, PLLC - Legal Billing - Invoice No. 419 - May 2026 - 06/01/26 - \$1,472.50.

7. PRESENTATION(S)

A. Arbor Day Recognition & Poster Contest Winners

8. NEW BUSINESS/PUBLIC COMMENT

We welcome comments from residents. If you wish to speak, please state your name and address. You will have a maximum of three (3) minutes to address the City Council. City Council members will listen to your concerns, but will not answer questions. If you have a question or need additional information, we will be happy to direct you to the appropriate person after the meeting. Thank you for your cooperation.

9. ADJOURNMENT

**Paul P. Antolin, MiPMC
City Clerk**

IN ACCORDANCE WITH PUBLIC ACT 267 (OPEN MEETINGS ACT)
POSTED AND COPIES GIVEN TO NEWSPAPERS

The City of Grosse Pointe Woods will provide necessary, reasonable auxiliary aids and services, such as signers for the hearing impaired, or audio tapes of printed materials being considered at the meeting to individuals with disabilities. All such requests must be made at least five days prior to a meeting. Individuals with disabilities requiring auxiliary aids or services should contact the City of Grosse Pointe Woods by writing or call the City Clerk's office, 20025 Mack Plaza, Grosse Pointe Woods, MI 48236 (313) 343-2440 or Telecommunications Device for the Deaf (TDD) 313 343-9249

***** NOTE TO PETITIONERS: YOU, OR A REPRESENTATIVE, ARE REQUESTED TO BE IN ATTENDANCE AT THE MEETING SHOULD THE COUNCIL HAVE QUESTIONS REGARDING YOUR REQUEST. *****

OFFICE OF THE CITY MANAGER

Subject: Recommendations for the Regular Council Meeting of June 15, 2026

- Item 1 CALL TO ORDER
Prerogative of the Mayor to call this meeting to order.
- Item 2 ROLL CALL
Prerogative of the Mayor to request a Roll Call from the City Clerk.
- Item 3 PLEDGE OF ALLEGIANCE
Prerogative of the Mayor to lead the City Council, Administration, and members of the audience in the Pledge of Allegiance.
- Item 4 RECOGNITION OF COMMISSION MEMBERS
Prerogative of the Mayor to request Commission Members in attendance at tonight's meeting to approach the podium and introduce themselves and the Commission on which they serve.
- Item 5 ACCEPTANCE OF AGENDA
Prerogative of the City Council that all items on tonight's agenda be received, placed on file, and taken in order of appearance.
- Item 6 CONSENT AGENDA
All items listed under the consent agenda are considered routine by the Council and will be enacted by one motion and a second. There will be no separate discussion of these items. If discussion of an item is required, it will be removed from the consent agenda and considered. One member may request that an item be removed and no second is required.

Prerogative of the City Council to approve all items (6A-6F) listed under the consent agenda as presented.

A. Approval of Minutes

1. Council 06/01/26
2. Committee-of-the-Whole 06/01/26 with Recommendation*

*Recommendation being addressed under item 6D9 on tonight's agenda.

B. Items Received and Placed on File

1. Historical Commission Minutes 04/09/26

C. Monthly Financial Report

1. May 2026

D. Bids/Proposals/Contracts

1. Fiscal Year End 2025-2026 Budget Amendments
 - a) Memo 06/03/26 - Treasurer/Comptroller Schmidt-City Manager Como
 - b) List of Accounts and Budget Amendment Amounts
2. Commit Fund Balance for Construction Projects and Equipment Purchases
 - a) Memo 06/15/26 - Treasurer/Comptroller Schmidt
 - b) FYE 2025-2026 Fund Balance Commitments
3. Vendors with Expenses Over \$20,000
 - a) Memo 06/05/26 - Treasurer/Comptroller Schmidt
 - b) FY 2026-2027 Open Purchase Orders over \$20,000
4. Unpaid Invoices
 - a) Memo 06/15/26 - Treasurer/Comptroller Schmidt
 - b) Summer 2026 Roll To Tax Invoices (Landscaping) Final Copy
5. Recommendation - Tree Removal Contract for 2026/2027
 - a) Memo 06/09/26 - Director of Public Services Kowalski
 - b) Proposed Tree Removal Contract
 - c) Bid Documents
 - d) Certificate of Insurance
6. Recommendation - Mack and Vernier Intersection Gateway Improvement
 - a) Memo 06/09/26 - Director of Public Services Kowalski
 - b) Images of Center Island/Gateway
 - c) Bid Package Summary - Stucky Vitale Architects
 - d) MDOT Quote
 - e) Estimate #23566 01/04/26 - Tocco Mannino
 - f) Contract/Proposal 05/01/26 - Phillips Sign & Lighting
7. Recommendation - Trucking Services
 - a) Memo 06/09/26 - Director of Public Services Kowalski
 - b) Email 06/09/26 - Grosso Trucking & Supply Co.
 - c) Certificate of Insurance
 - d) Proposed Agreement
8. Participation in PFAS Settlement Program – DuPont and 3M
 - a) Memo 06/11/26 – City Manager Como
 - b) Proposed GLWA Member Partner Contract
 - c) Proposed Resolution
9. Recommendation - Pavilion at Ghesquiere Park
 - a) Memo 06/11/26 – Director of Parks and Recreation Gafa
 - b) Committee-of-the-Whole Minutes Excerpt 06/01/26
 - c) Quote #PQ000665 - 06/11/26 – 16’ x 24’ Pavilion with Specifications
 - d) Quote #PQ000666 - 06/11/26 – 20’ x 24’ Pavilion with Specifications

E. Proclamation(s)

1. Juneteenth National Independence Day (June 19)

F. Claims and Accounts

1. Anderson, Eckstein & Westrick, Inc. (AEW) - City Engineers
 - a) Vernier & Mack Ave. Intersection Improvement - Invoice No. 165754 - Proj. No. 0160-0455 - 06/08/26 - \$2,653.27.
 - b) 2025 Miscellaneous Concrete Program - Invoice No. 165757 - Proj. No. 0160-0493 - 06/08/26 - \$6,706.01.
 - c) 2025-2026 General Engineering - Invoice No. 165758 - Proj. No. 0160-0498 - 06/08/26 - \$2,310.00.
 - d) 2025-2026 GIS Maintenance - Invoice No. 165759 - Proj. No. 0160-0499 - 06/08/26 - \$1,310.18.
 - e) Lee Ct. Doyle Ct. & Thorntree Water Mains - Invoice No. 165849 - Proj. No. 0160-0497 - 06/08/26 - \$17,538.64.
 - f) 2025 Concrete Pavement Repair Program - Proj. No. 0160-0493 - Payment Invoice No. 03 - Mattioli Cement Co., LLC - 05/28/26 - \$77,249.40.
2. Hallahan & Associates, P.C. - Professional Services - Invoice No. 24132 - May 2026 - 06/02/26 - \$2,239.56.
3. Tomlinson & McGrail, PLLC - Legal Billing - Invoice No. 419 - May 2026 - 06/01/26 - \$1,472.50.

*Prerogative of the Mayor/Council to read aloud the proclamation regarding Juneteenth National Independence Day (June 19).

Item 7 PRESENTATION(S)

Item 7A ARBOR DAY RECOGNITION AND POSTER CONTEST WINNERS
Prerogative of the City Council to receive the Tree City USA flag from the Tree Commission and announce the winners of the 2026 Arbor Day Poster Contest.

Item 8 NEW BUSINESS/PUBLIC COMMENT
Prerogative of the Mayor to ask if there is any New Business to come before the City Council from the City Council or Administration; and then, to ask members of the audience if there is any Public Comment to come before the City Council.

*Reiterate the 3-minute time limit.

Item 9 ADJOURNMENT
Upon the conclusion of New Business/Public Comment with no further business to be conducted by the City Council, prerogative of the City Council to motion for adjournment of tonight's meeting.

Respectfully submitted,

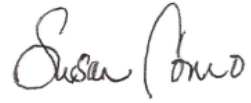
A handwritten signature in black ink that reads "Susan Como". The signature is written in a cursive style with a large initial 'S'.

Susan Como
City Manager

MINUTES OF THE REGULAR CITY COUNCIL MEETING OF THE CITY OF GROSSE
POINTE WOODS HELD ON MONDAY, JUNE 1, 2026, IN THE COUNCIL-COURTROOM OF
THE ROBERT E. NOVITKE MUNICIPAL CENTER, 20025 MACK PLAZA DR., GROSSE
POINTE WOODS, MICHIGAN.

The meeting was called to order at 7:05 p.m. by Mayor Bryant.

PRESENT: Mayor Bryant
Council Members: Brown, Gafa, Koester, Motschall
ABSENT: Granger, McConaghy

Also Present: City Manager Como
City Attorney Romer
City Treasurer/Comptroller Schmidt
City Clerk Antolin
City Planner Mangan

Motion by Motschall, seconded by Koester, that Councilmembers Granger and McConaghy be excused from tonight's meeting.

Motion carried by the following vote:

Yes: Brown, Bryant, Gafa, Koester, Motschall
No: None
Absent: Granger, McConaghy

Council, Administration, and the audience Pledged Allegiance to the U.S. Flag.

The following Commission members were in attendance:

- Catherine Dumke, Senior Citizens' Commission
- David Bryk, Historical Commission
- Chris Fenton, Planning Commission

Motion by Gafa, seconded by Brown, that all items on tonight's **agenda be received, placed on file, and taken in order of appearance.**

Motion carried by the following vote:

Yes: Brown, Bryant, Gafa, Koester, Motschall
No: None
Absent: Granger, McConaghy

Motion by Koester, seconded by Gafa, that all items (6A-6G) on the consent agenda be approved as presented.

A. Appointment(s)

1. Community Tree Commission (Mayor)
 - a) Biographical Sketch - Dean Knuth - Term to Expire: 12/31/28

B. Approval of Minutes

1. Council 05/18/26
2. Zoning Board of Appeals 05/18/26

C. Items Received and Placed on File

1. Beautification Advisory Commission Minutes 04/08/26
2. Citizens' Recreation Commission Minutes 04/14/26
3. Planning Commission Minutes 04/28/26 with Recommendation*
*This recommendation is being addressed at tonight's Council meeting under Public Hearing(s).
4. Tree Commission Minutes 04/01/26
5. Michigan Liquor Control Commission (MLCC) Notice of Transfer Ownership 2026 SDD License Only with Sunday Sales Permit from Merit Woods Pharmacy, Inc (19325 Mack Ave., GPW) to Nino Salvaggio of Livonia, LLC (18700 Haggerty Rd., Livonia)
 - a) Letter 05/12/26 - Michigan Liquor Control Commission (MLCC)
 - b) Email 05/24/26 - City Attorney Walling

D. Bids/Proposals/Contracts

1. Non-Union Employees
 - a) Memo 06/01/26 - City Manager Como - Treasurer/Comptroller Schmidt
2. Tentative Agreement for Union Contract
 - a) Tentative Agreement - Fraternal Order of Police Labor Council
3. Consent to Change of Control - Priority Waste, LLC (For Informational Purposes Only)
 - a) Letter 04/14/26 - Priority Waste, LLC

E. Proclamation(s)

1. National Gun Violence Awareness Day (June 5)

F. Resolution(s)

1. FY 2026-2027 Industrial Waste Control (IWC) Charges
 - a) Memo 06/01/26 - City Manager Como - Treasurer/Comptroller Schmidt
 - b) Fee Schedule
 - c) Proposed Resolution

G. Claims and Accounts

1. Anderson, Eckstein & Westrick, Inc. (AEW) - City Engineers
 - a) Vernier Rd. & Mack Ave. Intersection Improvement - Invoice No. 165183 - Proj. No. 0160-0455 - 05/11/26 - \$1,833.92.
 - b) 2025 Miscellaneous Concrete Program - Invoice No. 165184 - Proj. No. 0160-0493 - 05/11/26 - \$2,951.39.
 - c) 2025-2026 General Engineering - Invoice No. 165189 - Proj. No. 0160-0498 - 05/11/26 - \$2,456.20.
 - d) 2026-2027 Rate Study - Invoice No. 165190 - Proj. No. 0160-0505 - 05/11/26 - \$5,500.00.
 - e) Lee Ct., Doyle Ct. & Thorntree Water Mains - Invoice No. 165254 - Proj. No. 0160-0497 - 05/12/26 - \$16,388.91.
 - f) Doyle Ct. & Lee Ct. Water Main Replacement - Proj. No. 0160-0497 - Payment Invoice No. 02 - Fontana Construction, Inc. - 05/27/26 - \$211,606.47.
2. McKenna - Building/Planning Services
 - a) Building Services - Invoice No. 21849-121 - April 2026 - 05/26/26 - \$48,767.70.
 - b) Planning Services - Invoice No. 22-064-53 - April 2026 - 05/26/26 - \$2,820.00.
 - c) GPW MSHDA Zoning Ordinance Update - Invoice No. 25-030-12 - April 2026 - 05/22/26 - \$1,500.00.
3. Rosati, Schultz, Joppich & Amtsbuechler, P.C. - Legal Services - Invoice No. 1085740 - April 2026 - 05/15/26 - \$10,387.68.
4. WCA Assessing - Assessing Services - Invoice No. 051326 - June 2026 - 05/13/26 - \$7,911.08.

Motion carried by the following vote:

Yes: Brown, Bryant, Gafa, Koester, Motschall
No: None
Absent: Granger, McConaghy

Mayor Bryant and City Council read aloud the proclamation regarding National Gun Violence Awareness Day (June 5).

The Girl Scout Troop 77262 presented their Bronze Award Project to build and install bat houses for Ghesquiere Park. This project would help increase the local bat population by providing more habitat options. Bats are a natural pest control and can consume thousands of insects in a single night improving the environment by using less pesticides. The goal is to create a safe shelter for bats to thrive and help the community.

Girl Scout Troop 77262 greatly appreciates the approval and assistance with the installation of the bat houses.

Motion by Koester, seconded by Motschall, that the City Council authorize Girl Scout Troop 77262 to install bat houses at locations deemed appropriate (12 – 20 ft. above ground) and to have city resources to assist with the installation.

Motion carried by the following vote:

Yes: Brown, Bryant, Gafa, Koester, Motschall
No: None
Absent: Granger, McConaghy

Motion by Gafa, seconded by Koester, that the City Council receive and place on file the documents submitted by the Girl Scout Troop 77262.

Motion carried by the following vote:

Yes: Brown, Bryant, Gafa, Koester, Motschall
No: None
Absent: Granger, McConaghy

A portrait titled “The Prayer at Valley Forge” by Arnold Friberg was presented and donated by GPW residents, Burgess and Traci Foster, in commemoration of America’s 250 Anniversary of independence. Mr. Foster provided a historical background of the painting’s significance and importance.

Motion by Motschall, seconded by Koester, that the City Council receive and place on file the documented speech submitted by Mr. Foster.

Motion carried by the following vote:

Yes: Brown, Bryant, Gafa, Koester, Motschall
No: None
Absent: Granger, McConaghy

Motion by Motschall, seconded by Koester, that the City Council accept the portrait titled “The Prayer at Valley Forge” by Arnold Friberg as a gift to the city donated by Burgess and Traci Foster.

Motion carried by the following vote:

Yes: Brown, Bryant, Gafa, Koester, Motschall
No: None
Absent: Granger, McConaghy

THE MEETING WAS THEREUPON OPENED AT 7:41 P.M. FOR A **PUBLIC HEARING** TO HEAR THE APPLICATION OF JEFFREY SCOTT ARCHITECTS, WHICH IS REQUESTING A **SPECIAL LAND USE FOR 20481 MACK AVENUE, FOR AN OFF-ICE HOCKEY TRAINING FACILITY (DETROIT PREMIER HOCKEY)**. THE SITE IS LOCATED ON MACK AVENUE BETWEEN BEAUFAIT AND FLEETWOOD DRIVES AND IS ZONED C – COMMERCIAL BUSINESS DISTRICT WHERE “MISCELLANEOUS BUSINESS ESTABLISHMENTS” ARE A SPECIAL LAND USE.

Motion by Motschall, seconded by Koester, that for purposes of the public hearing the following items be received and placed on file:

- 1) Special Land Use (SLU) Review #1 (04/10/26) - City Planners Mangan/Smith
- 2) Zoning Application 03/18/26 - Ben Warda (Applicant)
- 3) Operational Summary
- 4) Spring Facility Daily Schedule
- 5) Planning Commission Minutes Excerpt 04/28/26
- 6) Affidavit of Property Owners Notified with List and Parcel Map
- 7) Affidavit of Legal Publication

Motion carried by the following vote:

Yes: Brown, Bryant, Gafa, Koester, Motschall
No: None
Absent: Granger, McConaghy

City Planner Mangan provided an overview of the request as presented on the Special Land Use Review #1 dated, April 10, 2026.

The Chair asked if anyone from the audience wished to speak in favor of the request. No one wished to be heard.

The Chair asked if anyone from the audience wished to speak in opposition to the proposed request. No one wished to be heard.

Motion by Motschall, seconded by Koester, that the public hearing be closed at 7:45 p.m.
PASSED UNANIMOUSLY.

Motion by Gafa, seconded by Brown, that the City Council concur with the City Planners’ recommendation as presented and approve the Special Land Use request for an off-ice training facility (Detroit Premier Hockey) at 20481 Mack Avenue, subject to the following conditions:

1. All doors and windows parallel to Mack Avenue remain uncovered at all times to contribute to an active street presence.
2. Downward directed and shielded exterior lighting will be installed on the rear building façade, replacing the existing lighting.

This recommendation is based on the following findings:

- A. **Consistency with the Master Plan.** The subject site is designated as “Corridor Mixed Use” on the Future Land Use Map of the 2024 Master Plan. The proposed use aligns with the intended uses of the Corridor Mixed Use designation, which includes retail, restaurant, and personal service establishments serving nearby residents. Additionally, the current zoning district of the site (C, Commercial Business) is consistent with the Corridor Mixed Use designation.
- B. **Compatible Surrounding Land Uses.** The site is located on an existing commercial corridor. Improvements to the rear exterior lighting will provide a better transition for the adjacent residential properties.
- C. **No Anticipated Nuisance or Public Hazard.** The nature of the proposed business (off-ice hockey training facility offering fitness classes and private lessons) is not anticipated to create disruptive noise, smoke, odor, glare, or vibration.
- D. **Support for Walkable, Mixed-Use Development.** The site is located on Mack Avenue, a commercial corridor designed to accommodate pedestrian-oriented businesses and promote a walkable environment. The reuse of an existing commercial storefront supports compact, efficient development. The windows and doors parallel to Mack Avenue will remain unblinded and uncovered by glass advertising clings and decals. Activity inside will be visible from Mack Avenue, contributing to a positive street presence.
- E. **Compliance with Zoning Ordinance Intent.** The proposed fitness training facility is consistent with the intent of the C, Commercial Business District to support local business development that benefits both residents and merchants.

Motion carried by the following vote:

Yes: Brown, Bryant, Gafa, Koester, Motschall
No: None
Absent: Granger, McConaghy

Under New Business, the following individuals were heard:

- City Manager Como presented a photo of the commemorative 250th Anniversary flag that the GP Chamber of Commerce purchased for the communities who wanted to display support for the monumental event. The complimentary flags will be placed on the flag poles along Mack Avenue.
- Councilmember Gafa commented on the successful and well attended Memorial Day Event. He commended all involved for an excellent job.

Under Public Comment, the following individuals were heard:

- David Bryk, 915 Briarcliff Dr. – On behalf of the Historical Commission, gave a shout out to the following for the Memorial Day event: Mother Nature for the beautiful weather, Stephanie Listman for the great job as Committee Chair of the event, Councilmember Motschall for an outstanding job as MC, DPW for setup and breakdown, Swing Shift Orchestra, Retired Air Force Brigadier General Doug Slocum as Keynote Speaker and all others who helped the event become a great success.
- Judith Burkhardt, 2039 Country Club Dr. – Thanked the Mayor and Council for reading aloud the proclamation regarding gun violence. She provided some historical background and the significance of the color “orange” and addressed the importance of awareness. Ms. Burkhardt stated that local communities are lighting up one of their buildings in orange to show support and requested GPW do the same. She also requested that the city place orange ribbons around trees to display awareness.

Motion by Koester, seconded by Motschall, that the City Council authorize the city to install orange lights and displayed on the appropriate days for gun violence awareness and to place orange ribbons on city trees.

Motion carried by the following vote:

Yes: Brown, Bryant, Gafa, Koester, Motschall

No: None

Absent: Granger, McConaghy

- Micaela Fraser, 1891 Country Club Dr. – Expressed gratitude for the city’s continued support for gun violence awareness. She also presented a poster that portrayed past events of support from Grosse Pointe Woods and other local communities.
- Burgess Foster, 2051 Oxford Rd. – Offered to give public lectures regarding American history in relation to the 250th Anniversary on behalf of the city at the GPW Public Library. Mayor Bryant directed City Manager Como to coordinate with Mr. Foster to discuss this matter.

Motion by Motschall, seconded by Koester, to **adjourn tonight’s meeting** at 8:00 p.m. PASSED UNANIMOUSLY.

Respectfully submitted,

Paul P. Antolin
City Clerk

Arthur W. Bryant
Mayor

MINUTES OF THE COMMITTEE-OF-THE-WHOLE OF THE CITY OF GROSSE POINTE WOODS HELD ON MONDAY, JUNE 1, 2026, IN THE COUNCIL CHAMBERS/ COURTROOM OF THE ROBERT E. NOVITKE MUNICIPAL CENTER, 20025 MACK PLAZA DRIVE, GROSSE POINTE WOODS, MICHIGAN.

Mayor Bryant called the meeting to order at 8:07 p.m.

PRESENT: Mayor Bryant
Council Members: Brown, Gafa, Koester, Motschall
ABSENT: Granger, McConaghy

Also Present: City Manager Como
City Attorney Romer
City Clerk Antolin
City Treasurer/Comptroller Schmidt

Motion by Motschall, seconded by Koester, that Councilmembers Granger and McConaghy be excused from tonight’s meeting.

Motion carried by the following vote:
Yes: Brown, Bryant, Gafa, Koester, Motschall
No: None
Absent: Granger, McConaghy

Motion by Motschall, seconded by Koester, that all items on tonight's agenda be received, placed on file, and taken in order of appearance.

Motion carried by the following vote:
Yes: Brown, Bryant, Gafa, Koester, Motschall
No: None
Absent: Granger, McConaghy

The first item discussed was regarding the installation of a pavilion at Ghesquiere Park.

City Manager Como stated that the Grosse Pointe Woods Foundation (the Foundation) approached City Administration and was interested in pursuing another project as the City Hall front lawn improvements were temporarily put on hold. There was an interest to have a shaded area in Ghesquiere Park and the idea of a pavilion was presented.

Members of the Foundation, Lisa Fuller and Michelle Billingsley, were introduced. Member Fuller stated it is difficult to request funding when no projects are in progress or upcoming. In order to keep the Foundation viable, projects need to be active and ongoing, short- or long-term. The concept of a pavilion at Ghesquiere Park was actually recommended in their Park Improvement Plan by the Citizens' Recreation Commission back in 2018.

After careful consideration, the Foundation decided they would be interested and enthusiastic to help fund a project to install a pavilion at Ghesquiere Park. With the help of City Manager Como and Director of Parks and Recreation Gafa, they were able to get quotes for the project. Member Fuller stated with the support of the Foundation, they are willing to commit to a grant request of \$35,000. If they can do better in their fundraising, they are willing to share any additional money they receive.

Discussion ensued regarding the placement of the pavilion relative to the other sections of the park, including the playground, bathrooms, baseball fields, and the possible installation of pickleball courts. The size of the pavilion was also mentioned with a pavilion possibly holding 4 to 6 tables.

Mayor Bryant expressed support of the project.

Councilmember Brown asked about the timeframe of completion and governance of the pavilion. The quotes estimate 24 weeks but hopefully sooner. Administration would like to have, at least, the foundation poured in the fall and the remainder of the project completed as soon as possible. Regarding governance, it is City Council's decision, however, Administration would prefer to keep it for the public. There was a majority consensus of the Committee-of-the-Whole to make it non-reservable. There is a concern that someone will arrive early and try to claim the pavilion for the whole day. This will be considered moving forward.

Picnic tables were briefly discussed and there will be a consideration to add more.

Councilmember Koester requested to mark-off the area considered to place the pavilion so City Council can have an actual visual of the concept and to include trash cans on the plan presented.

Motion by Koester, seconded by Motschall, that the Committee-of-the-Whole recommend to City Council approval of one of the two options presented to install a pavilion at Ghesquiere Park.

Motion carried by the following vote:

Yes: Brown, Bryant, Gafa, Koester, Motschall
No: None
Absent: Granger, McConaghy

The previous motion and recommendation will be addressed at the next City Council meeting on June 15, 2026.

The next item discussed was regarding a plaque placed on a stone recognizing the Frank Schulte Trail (Ghesquiere Park Walking Path) to be placed near the Cook Schoolhouse. This plaque commemorates Frank Schulte’s achievements and contributions to the city and its parks. This will be funded out of Administration’s account.

Motion by Motschall, seconded by Brown, that the Committee-of-the-Whole receives and place on file the documents with the plaque options and the various wording options on the plaque.

Motion carried by the following vote:

Yes: Brown, Bryant, Gafa, Koester, Motschall
No: None
Absent: Granger, McConaghy

Sample pictures of plaques and a list of wording options were presented to the Committee-of-the-Whole. There was a majority consensus to select the plaque with half the city logo protruding at the top and verbiage option #3 as follows:

3. Concise & Strong

Honoring (Name)

For outstanding dedication to our parks
and the betterment of our community.

The Committee-of-the-Whole decided it was more appropriate to switch around the words “parks” and “community” to read as follows:

Honoring (Name)

For outstanding dedication to our community
and the betterment of our parks.

The wording will be placed on the plaque under the words “Dedicated 2026”.

Under New Business/Public Comment, no one wished to be heard.

Motion by Motschall, seconded by Koester, that the meeting of the Committee-of-the-Whole be adjourned at 8:32 p.m. PASSED UNANIMOUSLY.

Respectfully submitted,

Paul P. Antolin
City Clerk

Arthur W. Bryant
Mayor

Commission Approved May 14, 2026

RECEIVED

APR 30 2026

CITY OF GROSSE POINTE WOODS
CLERK'S DEPARTMENT

City of Grosse Pointe Woods
Historical Commission Minutes
April 9, 2026

I. Call to Order

The regular meeting of the Grosse Pointe Woods Historical Commission was called to order at 7:37 p.m. by Chair Sean Murphy.

II. Roll Call

Present: Krystle English, Shirley Hartert, Stephanie Listman, Lynne Millies, Sean Murphy, Becky Veitengruber, Giles Wilborn

Excused: David Bryk, Colleen D'Agostino, Suzanne Kent

Also Present: City Council Representative Jim Motschall

Guests: Katie Dowgiewicz (GPW resident), Bob McGovern (GPW resident)

III. Approval of Agenda

Motion by Hartert, seconded by Millies, to approve the agenda for April 9, 2026.

Ayes: all. Motion carried.

IV. Approval of Minutes

Motion by Listman, seconded by Hartert, to approve the minutes for March 12, 2026.

Ayes all. Motion carried.

V. Items

Treasurer's Report

Hartert reported that the Historical Commission balance is \$5.00. The Cook Schoolhouse balance is \$9,036.10 and the approved budget for the Historical Commission is \$2,042.00 thru 06/30/2026.

VI. Old Business

A. Cook School

1. *Motion* by Hartert, seconded by Millies to accept the gift from Fox Creek Questers- a framed copy of each: The U.S. Constitution and The Bill of Rights. Ayes: all. Motion carried.

2. *Motion* by Hartert, seconded by English, to repair/replace the Cook School medallion on the cupola, on the face of the building. Ayes: all. Motion carried.

3. Discussion of placement of the Betsy Ross flag (gifted by Fox Creek Questers), in the Cook Schoolhouse.

B. Memorial Day 2026

Ideas and plans for Memorial Day "Circle of Honor" were shared by Listman.

Discussion ensued amongst commission.

VII. New Business

Murphy shared a draft of the commission's 2024 and 2025 Annual Reports.

VIII. Call to Audience

- A. Council Representative Motschall shared city updates and events.
- B. GPW residents K. Dowgiewicz and B. McGovern attended the meeting to observe and learn more about the commission and their duties.

IX. Adjournment

The meeting adjourned at 8:38p.m.

Respectfully submitted: Becky Veitengruber, Secretary

The next meeting of the Grosse Pointe Woods Historical Commission will take place at the Cook Schoolhouse, 20025 Mack Ave., Grosse Pointe Woods, MI on May14, 2026 at 7:30 p.m.

**City of Grosse Pointe Woods
CITY ADMINISTRATOR'S
FINANCIAL REPORT
(Section 4.7, City Charter)
MAY 2026**



**City Treasurer/Comptroller
Utility Billing/Accounting
Municipal Court/Violations
DPW
Parks & Recreation**

**City of Grosse Pointe Woods
CITY COMPTROLLER
Monthly Financial Report May 2026**

Purchase orders issued	40
Payrolls checks prepared	313
General/other checks prepared	189

**ACCOUNTING DEPARTMENT
Monthly Financial Report May 2026**

FOLLOWING REPORTS SUBMITTED HEREWITH:

- * ACCOUNTS PAYABLE CHECK REGISTER
- * INVESTMENTS BY FINANCIAL INSTITUTIONS ORDER
- * GENERAL FUND – DETAILED REVENUE COMPARED TO BUDGET

**CITY TREASURER
Monthly Financial Report May 2026**

INVESTMENTS:

- * Two (2) investments matured and two (2) investments were reinvested.

Check Date	Bank	Check #	Payee	Description	Account	Dept	Amount
Fund: 101 GENERAL FUND							
05/07/2026	1	75432*#	ANDERSON ECKSTEIN & WESTRICK INC	FY 2024-25 GENERAL ENGINEERING	818.000	265	3,691.72
				FY 2024-25 GENERAL ENGINEERING	818.000	441	1,476.69
				CHECK 1 75432 TOTAL FOR FUND 101:			<u>5,168.41</u>
05/07/2026	1	75433	ARBOR PRO TREE SERVICE	TREE REMOVAL SERVICES	818.000	523	1,190.00
				TREE REMOVAL SERVICES	818.000	523	4,800.00
				TREE REMOVAL SERVICES	818.000	523	1,880.00
				CHECK 1 75433 TOTAL FOR FUND 101:			<u>7,870.00</u>
05/07/2026	1	75434	AT&T MOBILITY LLC	CONTRACTUAL	818.000	286	36.43
05/07/2026	1	75437	CDW GOVERNMENT INC	FY 2025-26 IT SUPPLIES	757.000	228	104.40
				FY 2025-26 IT SUPPLIES	757.000	228	313.49
				CHECK 1 75437 TOTAL FOR FUND 101:			<u>417.89</u>
05/07/2026	1	75438*#	CINTAS CORP LOC #31	CITY HALL OFFICE MATS	818.000	265	105.88
				DPW OFFICE MATS	818.000	441	27.49
				DPW OFFICE MATS	818.000	441	27.49
				CHECK 1 75438 TOTAL FOR FUND 101:			<u>160.86</u>
05/07/2026	1	75439	CINTAS FIRE 636525	CINTAS FIRE INSPECTION - AB	818.000	774	1,000.00
				CINTAS FIRE INSPECTION - CONCESSION	818.101	774	1,000.00
				CINTAS FIRE INSPECTION MAINTENANCE	818.102	774	31.80
				CINTAS FIRE INSPECTION MAINTENANCE	818.102	774	942.87
				CINTAS FIRE INSPECTION - FILTER ROOM	818.103	774	1,000.00
				CINTAS FIRE INSPECTION - BATH HOUSE	818.104	774	1,000.00
				CHECK 1 75439 TOTAL FOR FUND 101:			<u>4,974.67</u>
05/07/2026	1	75440*#	CITY OF GROSSE POINTE WOODS	OPERATING SUPPLIES	757.000	441	7.41
05/07/2026	1	75442	CIVICPLUS, LLC	CIVICPLUS RECREATION MANAGEMENT	972.000	775	11,377.41
05/07/2026	1	75443	MARLISE COLE	CONTRACTUAL SERVICES	818.000	780	385.00
05/07/2026	1	75444	D&H WINDOW CLEANING, INC.	CONTRACTUAL SERVICES	818.000	265	90.00

Check Date	Bank	Check #	Payee	Description	Account	Dept	Amount
Fund: 101 GENERAL FUND							
05/07/2026	1	75448	JILL DOUGHTY	CONTRACTUAL SERVICES	818.000	780	595.00
05/07/2026	1	75449	DTE ENERGY	MUN. STREET LGHT	926.000	594	49,961.99
05/07/2026	1	75450	EXWAY ELECTRIC	OPERATING SUPPLIES	757.000	775	19.95
				OPERATING SUPPLIES	757.000	775	52.96
				CHECK 1 75450 TOTAL FOR FUND 101:			<u>72.91</u>
05/07/2026	1	75451	GOODBYE GEESE	GOOSE PATROL SERVICE	818.102	774	2,000.00
05/07/2026	1	75457#	LEONARD BROS DATA MANAGEMENT INC	CONTRACTUAL SERVICES	818.000	193	104.00
				OFF-SITE RECORDS AND STORAGE RETRIEVA	818.000	310	403.76
				CHECK 1 75457 TOTAL FOR FUND 101:			<u>507.76</u>
05/07/2026	1	75458*#	LOWE'S	OPERATING SUPPLIES	757.000	265	160.49
				OPERATING SUPPLIES	757.000	441	266.09
				EQUIPMENT MAINT & REPAIR	930.000	441	143.45
				OPER SUPPLY - POOL MAINT	757.104	774	112.22
				CHECK 1 75458 TOTAL FOR FUND 101:			<u>682.25</u>
05/07/2026	1	75459	MACOMB COUNTY HEALTH DEPT	OPER SUPPLY - POOL MAINT	757.104	774	486.00
05/07/2026	1	75461	MCKENNA ASSOCIATES INC	CONTRACTUAL	818.000	371	3,600.00
				CONTRACTUAL	818.000	371	6,066.25
				CONTRACTUAL	818.000	371	74,504.85
				CHECK 1 75461 TOTAL FOR FUND 101:			<u>84,171.10</u>
05/07/2026	1	75462	MICHIGAN ASSOCIATION OF PLANNING	GROUP MEMBER DUES 7/1/26 - 6/30/27	880.500	105	775.00
05/07/2026	1	75463	MIDWEST PUBLIC SAFETY GROUP	GETAC CLOUD - MONTHLY PLAN 3	818.000	310	20,203.20
				GETAC VIDEO LICENSE & SOFTWARE	818.000	310	984.60
				CHECK 1 75463 TOTAL FOR FUND 101:			<u>21,187.80</u>
05/07/2026	1	75468*#	POINTE ALARM LLC	DPW TV MAINTENANCE	818.000	441	89

Check Date	Bank	Check #	Payee	Description	Account	Dept	Amount
Fund: 101 GENERAL FUND							
				DOG PARK ACCESS MAINTENANCE	818.000	775	259.99
				GHEQUIERE PARK TELEVISION MONITORING	818.000	775	742.63
				CHENE TROMBLEY PARK TV MONITORING	818.000	775	344.99
				CHECK 1 75468 TOTAL FOR FUND 101:			<u>1,437.55</u>
05/07/2026	1	75470	REVOLUTION FLAG SERVICE	U.S. FLAGS (8X12)	930.000	441	380.00
				U.S. FLAGS (5X8)	930.000	441	480.00
				MICHIGAN FLAGS (4X6)	930.000	441	160.00
				POW FLAG (4X6)	930.000	441	156.00
				250TH FLAF (3X5)	930.000	441	204.00
				CHECK 1 75470 TOTAL FOR FUND 101:			<u>1,380.00</u>
05/07/2026	1	75471	ROSATI, SCHULTZ, JOPPICH &	LEGAL FEES-GEN'L CITY	801.000	266	6,787.62
				LABOR CONSULTANT	810.000	266	4,323.00
				CHECK 1 75471 TOTAL FOR FUND 101:			<u>11,110.62</u>
05/07/2026	1	75475#	STAPLES ADVANTAGE	FY 2025-26 OFFICE SUPPLIES	757.000	193	50.91
				FY 2025-26 OFFICE SUPPLIES	728.000	211	88.18
				ELECTIONS SUPPLIES	731.000	215	447.80
				CHECK 1 75475 TOTAL FOR FUND 101:			<u>586.89</u>
05/07/2026	1	75476	STATE OF MICHIGAN	JUST TRNG FEES	806.000	286	3,245.40
05/07/2026	1	75477	MARYANNE THIBODEAU	CONTRACTUAL SERVICES	818.000	780	560.00
05/07/2026	1	75478	ROY THIBODEAU	CONTRACTUAL SERVICES	818.000	780	280.00
05/07/2026	1	75480	UNITED FACILITY SUPPLIES, INC.	JANITORIAL & MAINTENANCE SUPPLIES	757.106	774	471.81
				JANITORIAL & MAINTENANCE SUPPLIES	757.106	774	591.94
				JANITORIAL & MAINTENANCE SUPPLIES	757.106	774	326.17
				CHECK 1 75480 TOTAL FOR FUND 101:			<u>1,389.92</u>
05/07/2026	1	75481*#	VERIZON WIRELESS	ADMIN	921.000	211	167.71
				CONTRACTUAL SERVICES	818.000	228	69
				PUBLIC SAFETY	921.000	349	521

Check Date	Bank	Check #	Payee	Description	Account	Dept	Amount
Fund: 101 GENERAL FUND							
				UTILITIES	921.000	594	55.90
				UTILITIES	921.000	594	178.92
				LFP	921.000	774	139.75
				CHECK 1 75481 TOTAL FOR FUND 101:			<u>1,133.41</u>
05/07/2026	1	75482	WAYNE COUNTY	COURT FINES & COSTS	660.000	000	140.00
05/07/2026	1	75483	WAYNE COUNTY APPRAISAL, LLC	CONTRACTUAL SERVICES	818.000	257	7,911.08
05/07/2026	1	75486	GEORGE YOUNG	COMMUNITY RELATIONS	880.000	780	160.00
05/07/2026	1	75488#	ZEPPELIN SERVICES INC	JANITORIAL SVC - MUNI BLDGS	818.000	265	2,138.00
				DPW OFFICES AND BATHROOM CLEANING	818.000	441	1,161.00
				CHECK 1 75488 TOTAL FOR FUND 101:			<u>3,299.00</u>
05/07/2026	1	75489	BRITTANEY MCMAHON	DAMAGE DEPOSIT P&R	295.000	000	200.00
05/07/2026	1	75490	JOAN SHIMKO	OVER/UNDER	689.000	000	19.91
05/14/2026	1	75491	A.M. LEONARD INC.	OPERATING SUPPLIES	757.000	523	188.52
05/14/2026	1	75492#	AQUATIC SOURCE, LLC	MEMBERSHIP & DUES	958.000	752	375.00
				MISC. POOL EQUIPMENT	931.000	774	443.00
				CHECK 1 75492 TOTAL FOR FUND 101:			<u>818.00</u>
05/14/2026	1	75493	ARBOR PRO TREE SERVICE	TREE REMOVAL SERVICES	818.000	523	1,805.00
				TREE REMOVAL SERVICES	818.000	523	1,840.00
				CHECK 1 75493 TOTAL FOR FUND 101:			<u>3,645.00</u>
05/14/2026	1	75494	ARGENT INSTITUTIONAL TRUST COMPA	FEES & CHARGES	958.000	211	500.00
05/14/2026	1	75496	CDW GOVERNMENT INC	FY 2025-26 IT SUPPLIES	757.000	228	379.04
05/14/2026	1	75497	CONSUMERS ENERGY	UTILITIES	921.000	774	178.36
				UTILITIES	921.000	774	1,202.79
				UTILITIES	921.000	774	399.23
				UTILITIES	921.000	774	59

Check Date	Bank	Check #	Payee	Description	Account	Dept	Amount
Fund: 101 GENERAL FUND							
				CHECK 1 75497 TOTAL FOR FUND 101:			1,839.80
05/14/2026	1	75498	DATA EXCHANGE SOLUTIONS, LLC	GOVTRANSFER.COM USER LICENSES	818.000	305	984.00
05/14/2026	1	75499	DEWOLF AND ASSOCIATES	TRAINING	961.000	310	445.00
05/14/2026	1	75500#	DTE ENERGY	UTILITIES	921.000	594	1,621.32
				UTILITIES	921.000	594	31.90
				UTILITIES	921.000	594	839.82
				UTILITIES	921.000	775	147.59
				UTILITIES	921.000	775	19.19
				UTILITIES	921.000	780	66.37
				CHECK 1 75500 TOTAL FOR FUND 101:			<u>2,726.19</u>
05/14/2026	1	75501*#	DTE ENERGY	UTILITIES	921.000	349	159.53
				UTILITIES	921.000	594	671.91
				UTILITIES	921.000	594	339.83
				UTILITIES	921.000	775	78.18
				UTILITIES	921.000	780	60.57
				CHECK 1 75501 TOTAL FOR FUND 101:			<u>1,310.02</u>
05/14/2026	1	75502#	EMCURA OCC. MED.	TB TESTING	818.000	305	1,620.00
				RESPIRATORY MEDICAL CLEARANCE	818.000	339	1,120.00
				CHECK 1 75502 TOTAL FOR FUND 101:			<u>2,740.00</u>
05/14/2026	1	75503	FIREPROOF AUTHENTICS	MAINTENANCE UNIFORMS	757.102	774	680.00
05/14/2026	1	75505*#	GILBERTS PRO HARDWARE	MINOR OPERATING SUPPLIES ALL DEPTS.	757.000	265	365.71
				POLICE SUPPLIES	757.000	310	15.36
				MINOR OPERATING SUPPLIES ALL DEPTS.	757.000	441	4.97
				MINOR OPERATING SUPPLIES ALL DEPTS.	757.102	774	114.17
				MINOR OPERATING SUPPLIES ALL DEPTS.	757.104	774	1,133.94
				MINOR OPERATING SUPPLIES ALL DEPTS.	757.107	774	115.69
				OPERATING SUPPLIES	757.000	775	106.22
				CHECK 1 75505 TOTAL FOR FUND 101:			<u>1,856</u>

CHECK DISBURSEMENT REPORT FOR CITY OF GROSSE POINTE WOODS
 CHECK DATE FROM 05/01/2026 - 05/31/2026

Check Date	Bank	Check #	Payee	Description	Account	Dept	Amount
Fund: 101 GENERAL FUND							
05/14/2026	1	75506	GLS NORTH AMERICA	EXTRICATION PREP FOR TRAINING	961.000	339	1,100.00
05/14/2026	1	75507	GROSSE POINTE CHAMBER OF COMMERC	GPCC 2026 COMM. IMPACT DAY SPONSORSHI	880.000	101	500.00
05/14/2026	1	75509	HAROLD J. LOVE, PLLC	PSYCHOLOGICAL TESTING	835.100	305	750.00
05/14/2026	1	75510	HENRY FORD EMPLOYER SOLUTIONS	CONTRACT SVSC-PK MAINT	818.102	774	125.00
05/14/2026	1	75511	IACP	CONFERENCE REGISTRATION	123.000	000	500.00
05/14/2026	1	75512*#	K/E ELECTRIC SUPPLY CORP.	OPERATING SUPPLIES	757.000	775	60.26
05/14/2026	1	75513	LAUNDRY IN THE D, INC.	MONTHLY PRISONER LAUNDRY EXPENSES	808.000	310	96.00
05/14/2026	1	75514	LEWIS EQUIPMENT COMPANY	OPER SUPPLY - POOL MAINT	757.104	774	145.80
05/14/2026	1	75516	MCCOY MAINTENANCE	MONTHLY JAIL CELL CLEANING & BIO-HAZA	808.000	310	375.00
05/14/2026	1	75517	CATHERINE NORDBY	DAMAGE DEPOSIT P&R	295.000	000	200.00
05/14/2026	1	75518	NUCO2	CO2 DELIVERY	757.105	774	1,481.81
05/14/2026	1	75520	ROSE PEST SOLUTIONS	MONTHLY PEST CONTROL AT CITY HALL	818.000	265	167.00
05/14/2026	1	75522	KEITH SHERWOOD	OPERATING SUPPLIES	757.000	441	25.00
05/14/2026	1	75525	RONALD WEHRMANN	SENIOR CIT COMM	880.600	105	100.00
05/14/2026	1	75526	WICKLANDER-ZULAWSKI & ASSOC	HOMICIDE TRAINING	961.000	310	770.00
05/14/2026	1	75527	AMANDA YORK	CITIZENS RECREATION	880.200	105	140.28
05/20/2026	1	75528	ALLEMONS LANDSCAPE CENTER	OPER SUPPLY- LANDSCAPE	757.102	774	84.98
05/20/2026	1	75529	AMERICAN MESSAGING	UTILITIES	921.000	349	134.41
05/20/2026	1	75531*#	AT&T MOBILITY LLC	CONTRACTUAL SERVICES	818.000	228	124.32
				UTILITIES	921.000	349	282.32
				CHECK 1 75531 TOTAL FOR FUND 101:			406.64
05/20/2026	1	75534	CDW GOVERNMENT INC	FY 2025-26 IT SUPPLIES	757.000	228	509
				FY 2025-26 IT SUPPLIES	757.000	228	244

Check Date	Bank	Check #	Payee	Description	Account	Dept	Amount
Fund: 101 GENERAL FUND							
				CHECK 1 75534 TOTAL FOR FUND 101:			754.38
05/20/2026	1	75536*#	CINTAS CORP LOC #31	CITY HALL OFFICE MATS	818.000	265	105.88
				DPW OFFICE MATS	818.000	441	27.49
				DPW OFFICE MATS	818.000	441	27.49
				CHECK 1 75536 TOTAL FOR FUND 101:			<u>160.86</u>
05/20/2026	1	75537	CINTAS FIRE 636525	FIRE EXTINGUISHER MAINTENANCE	818.000	265	2,400.30
				FIRE EXTINGUISHER MAINTENANCE	818.000	265	4,168.31
				CHECK 1 75537 TOTAL FOR FUND 101:			<u>6,568.61</u>
05/20/2026	1	75538*#	CITY OF GROSSE POINTE WOODS	UTILITIES	921.000	211	323.12
				UTILITIES	921.000	349	445.39
				UTILITIES	921.000	594	168.47
				UTILITIES	921.000	594	104.80
				CHECK 1 75538 TOTAL FOR FUND 101:			<u>1,041.78</u>
05/20/2026	1	75539	CONSUMERS ENERGY	UTILITIES	921.000	774	544.91
05/20/2026	1	75540	ELISE COYLE	ELECTIONS SUPPLIES	731.000	215	20.99
				OPERATING SUPPLIES	757.000	215	37.25
				CHECK 1 75540 TOTAL FOR FUND 101:			<u>58.24</u>
05/20/2026	1	75541	DEWOLF AND ASSOCIATES	TRAINING	961.000	310	595.00
05/20/2026	1	75545	GROSSE POINTE NEWS	5/7 PUBLICATION - PH 26-27 BUDGET	903.000	215	721.50
				LEGAL NOTICES	903.000	215	166.50
				LEGAL NOTICES	903.000	215	74.00
				CHECK 1 75545 TOTAL FOR FUND 101:			<u>962.00</u>
05/20/2026	1	75547	HALLAHAN & ASSOCIATES PC	LEGAL/OUTSIDE CONSULTANTS- MTT	801.300	266	21.13
05/20/2026	1	75548	HENRY FORD EMPLOYER SOLUTIONS	PHYSICAL EXAMS	835.100	305	433.00
				PHYSICAL EXAMS	835.100	305	715

Check Date	Bank	Check #	Payee	Description	Account	Dept	Amount
Fund: 101 GENERAL FUND							
				CHECK 1 75548 TOTAL FOR FUND 101:			1,148.00
05/20/2026	1	75552*#	JOS. KUTCHEY & SONS, LLC	FLOWERS - ELEVATED LIGHT POLE PLANTE	930.000	441	244.50
05/20/2026	1	75553	K & S VENTURES INC	PUBLIC SAFETY GUN RANGE - REPAIR HEAT	930.000	265	5,835.00
05/20/2026	1	75554	KALAHARI RESORTS & CONVENTIONS	NIGHTS IN HOTEL - KAPOOR	961.000	310	556.00
				ROOM TAX - KAPOOR	961.000	310	48.65
				NIGHTS IN HOTEL - HENDRIX	961.000	310	556.00
				ROOM TAX - HENDRIX	961.000	310	48.65
				CHECK 1 75554 TOTAL FOR FUND 101:			<u>1,209.30</u>
05/20/2026	1	75555	KERR PUMP AND SUPPLY, INC.	OPER SUPPLY - POOL MAINT	757.104	774	195.00
05/20/2026	1	75558	LEXISNEXIS RISK DATA MGT, LLC	MONTHLY SEARCH & CONTRACT FEES	818.000	310	309.00
05/20/2026	1	75559	MACQUEEN	FIRE GEAR PURCHASES	757.000	339	116.76
				BELUGA LAMINATED GLASS CUTTING KIT	757.000	339	499.00
				FREIGHT	757.000	339	35.01
				CHECK 1 75559 TOTAL FOR FUND 101:			<u>650.77</u>
05/20/2026	1	75560	MARCO	OPERATING SUPPLIES	757.000	228	11.66
				CONTRACTUAL SERVICES	818.000	228	378.61
				EQUIPMENT MAINT & REPAIR	930.000	228	386.87
				CHECK 1 75560 TOTAL FOR FUND 101:			<u>777.14</u>
05/20/2026	1	75561	MARCO TECHNOLOGIES, LLC	EQUIPMENT MAINT & REPAIR	930.000	228	333.91
				EQUIPMENT MAINT & REPAIR	930.000	228	126.72
				EQUIPMENT MAINT & REPAIR	930.000	228	162.01
				CHECK 1 75561 TOTAL FOR FUND 101:			<u>622.64</u>
05/20/2026	1	75562	JEFFRY MARTEL	SOUTHWEST AIRLINES - AIRFARE	961.000	310	628.41
05/20/2026	1	75563	RACHELLE MATOUK	TRAINING & SEMINARS	958.001	286	23.00
05/20/2026	1	75567	MR. C'S CAR WASH	MONTHLY CAR WASHES	818.000	310	6

Check Date	Bank	Check #	Payee	Description	Account	Dept	Amount
Fund: 101 GENERAL FUND							
05/20/2026	1	75570	OVERHEAD DOOR WEST COMMERCIAL, I	CONTRACTUAL SERVICES	818.000	265	445.00
05/20/2026	1	75571	PEPPERMILL RESORT SPA & CASINO	HOTEL ROOM	961.000	310	900.00
				NON-EXEMPT ROOM TAX	961.000	310	117.00
				TOURISM TAX	961.000	310	12.00
				CHECK 1 75571 TOTAL FOR FUND 101:			<u>1,029.00</u>
05/20/2026	1	75572	PRINT XPRESS	ARBOR DAY POSTERS	880.700	105	330.00
				EASTERN RED CEDAR FLYERS	880.700	105	240.00
				CHECK 1 75572 TOTAL FOR FUND 101:			<u>570.00</u>
05/20/2026	1	75573	SCHOOLS EDUCATORS POLICE LIAISON	101310961000	961.000	310	525.00
05/20/2026	1	75576	TOMLINSON & MCGRAIL, PLLC	LEGAL COUNSEL-COURT	801.100	266	2,015.00
05/20/2026	1	75577	TIMOTHY VANHAGEN	CLOTHING/UNIFORM ALLOWANCE	725.000	531	108.57
05/28/2026	1	75579	RYAN ADAMSKI	CLOTHING/UNIFORM ALLOWANCE	725.000	531	72.64
05/28/2026	1	75580	ALLEMONS LANDSCAPE CENTER	CITY FLOWERS	880.100	105	1,055.50
05/28/2026	1	75581	PAUL ANTOLIN	TRAINING & SEMINARS	958.001	215	272.76
05/28/2026	1	75582	ARBOR PRO TREE SERVICE	TREE REMOVAL SERVICES	818.000	523	9,200.00
05/28/2026	1	75584#	CHARLES SCHWAB & CO., INC.	MEDICARE REIMBURSEMENT	722.100	209	541.03
				MEDICARE REIMBURSEMENT	722.100	345	4,240.55
				MEDICARE REIMBURSEMENT	722.100	531	1,023.42
				CHECK 1 75584 TOTAL FOR FUND 101:			<u>5,805.00</u>
05/28/2026	1	75585	COMFORT INN & SUITES	TRAINING	961.000	310	330.75
05/28/2026	1	75587*#	DTE ENERGY		921.000	211	2,991.55
					921.000	349	4,123.49
				UTILITIES	921.000	594	31.90
				1200 POLE ELECTRIC APR 2026	921.000	594	134.79
				1200 POLE GAS APR 2026	921.000	594	178.00
				UTILITIES	921.000	594	23.00

Check Date	Bank	Check #	Payee	Description	Account	Dept	Amount
Fund: 101 GENERAL FUND							
				UTILITIES	921.000	774	9,714.54
				UTILITIES	921.000	774	429.08
				UTILITIES	921.000	774	66.16
				UTILITIES	921.000	774	1,180.68
				UTILITIES	921.000	775	150.32
					921.000	780	970.23
				CHECK 1 75587 TOTAL FOR FUND 101:			<u>19,994.60</u>
05/28/2026	1	75588#	DTE ENERGY		921.000	211	630.25
					921.000	349	868.72
					921.000	780	204.41
				CHECK 1 75588 TOTAL FOR FUND 101:			<u>1,703.38</u>
05/28/2026	1	75594	INTERIOR ENVIRONMENTS	BROCHURE FLYER HOLDER COMMUNITY CENTE	930.000	780	1,234.67
05/28/2026	1	75596	KERR PUMP AND SUPPLY, INC.	OPER SUPPLY - POOL MAINT	757.104	774	25.50
05/28/2026	1	75599	DAWN LEVICK	DAMAGE DEPOSIT P&R	295.000	000	200.00
05/28/2026	1	75600	LIFELOC TECHNOLOGIES, INC.	OPERATING SUPPLIES	757.000	310	92.95
05/28/2026	1	75601	LOU'S PET SHOP INC.	K9 SUPPLIES	757.200	310	437.22
05/28/2026	1	75602	MARCHIORI CATERING	MONTHLY LUNCH FOR SENIOR MOVIES	880.603	780	230.00
05/28/2026	1	75604	MOEHRING WOODS FLOWERS	HISTORICAL COMM	880.300	105	85.00
05/28/2026	1	75605	NASRO	MEMBERSHIP & DUES	958.000	305	50.00
05/28/2026	1	75607	NT SPORTS GROUP, INC.	LFP PICKLE BALL NETS FOR COURTS	757.000	775	159.00
				CLOSED MESH 9' POLYPROPYLENE	757.000	775	948.00
				TOURNAMENT NET	757.000	775	582.00
				CENTER STRAP	757.000	775	54.00
				SHIPPING & HANDLING	757.000	775	203.00
				CHECK 1 75607 TOTAL FOR FUND 101:			<u>1,946.00</u>
05/28/2026	1	75608	ORKIN	PEST CONTROL SERVICES DPW	818.000	441	89.36
05/28/2026	1	75611	REVOLUTION FLAG SERVICE	U.S. FLAGS (2X3)	930.000	441	562.00

CHECK DISBURSEMENT REPORT FOR CITY OF GROSSE POINTE WOODS
 CHECK DATE FROM 05/01/2026 - 05/31/2026

Check Date	Bank	Check #	Payee	Description	Account	Dept	Amount
Fund: 101 GENERAL FUND							
				ROTATING BANNER POLE	930.000	441	837.50
				CHECK 1 75611 TOTAL FOR FUND 101:			<u>1,400.00</u>
05/28/2026	1	75616#	STAPLES ADVANTAGE	FY 2025-26 OFFICE SUPPLIES	757.000	193	31.90
				FY 2025-26 OFFICE SUPPLIES	728.000	211	14.99
				FY 2025-26 OFFICE SUPPLIES	728.000	211	38.93
				CHECK 1 75616 TOTAL FOR FUND 101:			<u>85.82</u>
05/28/2026	1	75617	SUPERIOR MATERIALS LLC	LFP POOL CONCRETE	757.104	774	1,472.08
05/28/2026	1	75618	LARINDA WATKINS	DAMAGE DEPOSIT P&R	295.000	000	200.00
05/28/2026	1	75619	GEORGE YOUNG	COMMUNITY RELATIONS	880.000	780	120.00
				Total for fund 101 GENERAL FUND			322,206.95

Check Date	Bank	Check #	Payee	Description	Account	Dept	Amount
Fund: 202 MAJOR STREET FUND							
05/07/2026	1	75431	ALL SEASONS OUTDOOR EQUIPMENT	VEHICLE PARTS AND/OR EQUIPMENT	757.000	463	11.65
05/07/2026	1	75458*#	LOWE'S	OPERATING SUPPLIES	757.000	474	27.80
05/14/2026	1	75515	MARSHALL LANDSCAPE INC	FY 2024-25 LAWN CARE	818.000	463	600.00
05/14/2026	1	75521*	THE SHERWIN-WILLIAMS COMPANY	PAINT & SUPPLIES	757.000	463	442.55
05/20/2026	1	75530	ANDERSON ECKSTEIN & WESTRICK INC	AEW FEES - CONSTRUCTION	974.803	451	2,382.28
05/20/2026	1	75551	JOE'S TRAILER SALES	OPERATING SUPPLIES	757.000	463	29.99
05/28/2026	1	75586*	DORNBOS SIGN, INC.	SIGNS	757.000	474	477.11
05/28/2026	1	75592*	HOME DEPOT CREDIT SERVICES	DPW SIGN ROOM TOOLS	757.000	474	372.00
05/28/2026	1	75603	MARSHALL LANDSCAPE INC	FY 2024-25 LAWN CARE	818.000	463	750.00
Total for fund 202 MAJOR STREET FUND							5,093.38

Check Date	Bank	Check #	Payee	Description	Account	Dept	Amount
Fund: 203 LOCAL STREET FUND							
05/07/2026	1	75464	NATHAN MIKULA	OPERATING SUPPLIES	757.000	463	45.56
05/07/2026	1	75484	WEINGARTZ SUPPLY CO	SUPPLIES FOR GROUNDS MAINTENANCE	757.000	463	489.00
05/14/2026	1	75505*#	GILBERTS PRO HARDWARE	MINOR OPERATING SUPPLIES ALL DEPTS.	757.000	463	96.91
05/14/2026	1	75521*	THE SHERWIN-WILLIAMS COMPANY	PAINT & SUPPLIES	757.000	463	1,327.65
05/20/2026	1	75532	BID'S LAWN & GARDEN CENTER	SUPPLIES FOR GROUNDS MAINTENANCE	757.000	463	89.97
05/20/2026	1	75556	KOGELMANN'S CREEKSIDE SOD FARM,	SOD-DAMAGE FROM PLOWS	757.000	463	696.00
05/28/2026	1	75586*	DORNBOS SIGN, INC.	SIGNS	757.000	474	1,431.34
05/28/2026	1	75592*	HOME DEPOT CREDIT SERVICES	DPW SIGN ROOM TOOLS	757.000	474	1,116.00
Total for fund 203 LOCAL STREET FUND							5,292.43

Check Date	Bank	Check #	Payee	Description	Account	Dept	Amount
Fund: 213 PARKWAY BEAUTIFICATION							
05/07/2026	1	75441	CITY OF GROSSE POINTE WOODS	PETTY CASH	004.000	000	400.00
05/20/2026	1	75552*#	JOS. KUTCHEY & SONS, LLC	FLOWERS - ELEVATED LIGHT POLE PLANTE	880.310	803	8,600.00
05/28/2026	1	75583	MARY CASINELLI	BEAUTIFICATION COMMISSION	880.310	803	64.59
05/28/2026	1	75610	PRINT XPRESS	BEAUTIFICATION COMMISSION	880.310	803	105.47
Total for fund 213 PARKWAY BEAUTIFICATION							9,170.06

Check Date	Bank	Check #	Payee	Description	Account	Dept	Amount
Fund: 226 SOLID WASTE/DISPOSAL							
05/07/2026	1	75454	GROSSO TRUCKING & SUPPLY CO	TRUCKING SERVICES-SOLID WASTE	818.000	528	1,225.00
05/07/2026	1	75456	INDIAN SUMMER RECYCLING	YARD WASTE DISPOSAL	818.000	528	3,284.80
05/07/2026	1	75469	PRIORITY WASTE LLC	SOLID WASTE PICKUP	818.000	528	120,974.98
05/14/2026	1	75508	GROSSE POINTES-CLINTON	REFUSE DISPOSAL FEES	818.000	528	21,246.14
				REFUSE DISPOSAL FEES	818.000	528	22,700.61
				CHECK 1 75508 TOTAL FOR FUND 226:			<u>43,946.75</u>
05/20/2026	1	75543	ERG ENVIRONMENTAL SERVICES	HAZARDOUS WASTE DAY BATTERY RECYCLING	818.000	528	1,624.47
05/20/2026	1	75546	GROSSO TRUCKING & SUPPLY CO	TRUCKING SERVICES-SOLID WASTE	818.000	528	2,025.00
05/28/2026	1	75591	GROSSO TRUCKING & SUPPLY CO	TRUCKING SERVICES-SOLID WASTE	818.000	528	1,875.00
				Total for fund 226 SOLID WASTE/DISPOSAL			174,956.00

CHECK DISBURSEMENT REPORT FOR CITY OF GROSSE POINTE WOODS
 CHECK DATE FROM 05/01/2026 - 05/31/2026

Check Date	Bank	Check #	Payee	Description	Account	Dept	Amount
Fund: 260 SOM MIDC GRANT							
05/07/2026	1	75445	JEFFREY R. DAVIS, P.C.	COURT APPOINTED ATTORNEY	801.400	286	292.50
				COURT APPOINTED ATTORNEY	801.400	286	1,267.75
				CHECK 1 75445 TOTAL FOR FUND 260:			<u>1,560.25</u>
05/07/2026	1	75466	PERNICANO LAW PLLC	COURT APPOINTED ATTORNEY	801.400	286	115.00
				COURT APPOINTED ATTORNEY	801.400	286	115.00
				CHECK 1 75466 TOTAL FOR FUND 260:			<u>230.00</u>
05/07/2026	1	75485	DAVID WORDEN PLLC	COURT APPOINTED ATTORNEY	801.400	286	162.50
				COURT APPOINTED ATTORNEY	801.400	286	357.50
				CHECK 1 75485 TOTAL FOR FUND 260:			<u>520.00</u>
05/20/2026	1	75549	J.A. HLYWA, P.C.	COURT APPOINTED ATTORNEY	801.400	286	585.00
05/20/2026	1	75557	KEVIN KORESKY	COURT APPOINTED ATTORNEY	801.400	286	162.50
05/20/2026	1	75566	MIHELICH & KAVANAUGH, PLC	COURT APPOINTED ATTORNEY	801.400	286	1,001.00
05/20/2026	1	75574	GENEVIEVE TAYLOR, PLLC	COURT APPOINTED ATTORNEY	801.400	286	650.00
05/20/2026	1	75578	DAVID WORDEN PLLC	COURT APPOINTED ATTORNEY	801.400	286	552.50
				Total for fund 260 SOM MIDC GRANT			5,261.25

06/11/2026 10:50 AM
User: lbishop
DB: Gpw

CHECK DISBURSEMENT REPORT FOR CITY OF GROSSE POINTE WOODS
CHECK DATE FROM 05/01/2026 - 05/31/2026

Check Date	Bank	Check #	Payee	Description	Account	Dept	Amount
Fund: 284 OPIOID SETTLEMENT FUND							
05/28/2026	1	75613	ROTARY ACTION GROUP	BOTTLES FOR DRUG KIOSK	757.000	320	2,080.00
Total for fund 284 OPIOID SETTLEMENT FUND							2,080.00

06/11/2026 10:50 AM
User: lbishop
DB: Gpw

CHECK DISBURSEMENT REPORT FOR CITY OF GROSSE POINTE WOODS
CHECK DATE FROM 05/01/2026 - 05/31/2026

Check Date	Bank	Check #	Payee	Description	Account	Dept	Amount
Fund: 401 MUNICIPAL IMPRV FUND							
05/28/2026	1	75609#	PENCHURA, L.L.C.	HANDICAP ACCESSIBLE FRIENDSHIP SWING	674.020	000	0.00
				HANDICAP ACCESSIBLE FRIENDSHIP SWING	977.104	902	28,020.56
				CHECK 1 75609 TOTAL FOR FUND 401:			<u>28,020.56</u>
				Total for fund 401 MUNICIPAL IMPRV FUND			28,020.56

Check Date	Bank	Check #	Payee	Description	Account	Dept	Amount
Fund: 585 PARKING FUND							
05/07/2026	1	75481*#	VERIZON WIRELESS	CONTRACTUAL SERVICES	818.000	571	80.33
05/14/2026	1	75505*#	GILBERTS PRO HARDWARE	MINOR OPERATING SUPPLIES ALL DEPTS.	757.000	571	48.10
05/14/2026	1	75519	PASSPORT LABS, INC.	OPERATING SUPPLIES	757.000	571	163.22
Total for fund 585 PARKING FUND							291.65

Check Date	Bank	Check #	Payee	Description	Account	Dept	Amount
Fund: 592 WATER / SEWER FUND							
05/07/2026	1	75432*#	ANDERSON ECKSTEIN & WESTRICK INC	FY 2024-25 GENERAL ENGINEERING	818.000	537	738.34
				FY 2024-25 GIS MAINTENANCE	977.000	537	2,539.08
				AEW DESIGN FEES - LEE CT, DOYLE CT	977.310	537	1,013.39
				AEW CONSTRUCTION FEES - LEE CT, DOYLE	977.310	537	680.29
				CONSTRUCTION ENGINEERING	818.000	542	1,347.35
				CHECK 1 75432 TOTAL FOR FUND 592:			<u>6,318.45</u>
05/07/2026	1	75435#	BADGER METER, INC	BEACON FIXED NETWORK SERVICE	818.000	536	6,322.00
				OPERATING SUPPLIES	757.000	537	205.94
				CHECK 1 75435 TOTAL FOR FUND 592:			<u>6,527.94</u>
05/07/2026	1	75440*#	CITY OF GROSSE POINTE WOODS	OPERATING SUPPLIES	757.000	537	130.52
05/07/2026	1	75452	GRAINGER	MISC. SUPPLIES AND EQUIPMENT	757.000	537	14.53
				MISC. SUPPLIES AND EQUIPMENT	757.000	537	37.83
				MISC. SUPPLIES AND EQUIPMENT	757.000	537	15.00
				CHECK 1 75452 TOTAL FOR FUND 592:			<u>67.36</u>
05/07/2026	1	75453#	GREAT LAKES BATTERY	BATTERIES FOR SPRINKLER TIMERS	757.000	537	209.70
				OPERATING SUPPLIES	757.000	542	39.90
				CHECK 1 75453 TOTAL FOR FUND 592:			<u>249.60</u>
05/07/2026	1	75455	HYDROCORP LLC	RESIDENTIAL CROSS CONNECTION PROGRAM	975.395	537	5,140.69
				CROSS CONNECTION PROGRAM	975.395	537	878.80
				CHECK 1 75455 TOTAL FOR FUND 592:			<u>6,019.49</u>
05/07/2026	1	75458*#	LOWE'S	OPERATING SUPPLIES	757.000	537	147.85
05/07/2026	1	75465	O'REILLY AUTO PARTS	OPERATING SUPPLIES	757.000	537	239.88
05/07/2026	1	75468*#	POINTE ALARM LLC	TORREY ROAD PUMP STATION MONITORING	818.000	542	476.38
05/07/2026	1	75473	SOUTHEAST MACOMB SANITARY DISTRI	WC SEWER EXCESS FIXED CHARGES	920.102	537	179,792

CHECK DISBURSEMENT REPORT FOR CITY OF GROSSE POINTE WOODS
 CHECK DATE FROM 05/01/2026 - 05/31/2026

Check Date	Bank	Check #	Payee	Description	Account	Dept	Amount
Fund: 592 WATER / SEWER FUND							
05/07/2026	1	75474	STANDARD ELECTRIC COMPANY	OPERATING SUPPLIES	757.000	537	339.27
05/07/2026	1	75481*#	VERIZON WIRELESS	UTILITIES	921.000	542	46.59
				UTILITIES	921.000	542	36.51
				CHECK 1 75481 TOTAL FOR FUND 592:			<u>83.10</u>
05/07/2026	1	75487	ZEE COMPANY	MONTHLY WATER TREATMENT CONTRACT	818.000	536	240.00
05/14/2026	1	75501*#	DTE ENERGY	UTILITIES	921.000	542	260.15
05/14/2026	1	75504*#	GEORGE'S DISCOUNT AUTO	OPERATING SUPPLIES	757.000	542	43.68
05/14/2026	1	75505*#	GILBERTS PRO HARDWARE	MINOR OPERATING SUPPLIES ALL DEPTS.	757.000	537	265.91
05/14/2026	1	75524	STATE OF MICHIGAN	TRAINING & SEMINARS	958.001	536	140.00
05/20/2026	1	75531*#	AT&T MOBILITY LLC	UTILITIES	921.000	542	79.48
05/20/2026	1	75538*#	CITY OF GROSSE POINTE WOODS	UTILITIES	921.000	542	341.54
05/20/2026	1	75544	FONTANA CONSTRUCTION INC	WATER MAIN & SEWER REPAIRS AND WATER	818.000	537	3,580.00
				LEE CT AND DOYLE CT WATER MAIN REPLAC	977.300	537	42,300.00
				CHECK 1 75544 TOTAL FOR FUND 592:			<u>45,880.00</u>
05/20/2026	1	75550	INSITUFORM TECHNOLOGIES USA, LLC	2025 SEWER REHABILITATION PROGRAM CON	976.002	537	44,418.26
05/20/2026	1	75568	NATIONAL LADDER	UNIFORMS FOR TPOAM DPW AND LFP EMPLOY	725.000	545	471.44
				UNIFORMS FOR TPOAM DPW AND LFP EMPLOY	725.000	545	28.56
				CHECK 1 75568 TOTAL FOR FUND 592:			<u>500.00</u>
05/28/2026	1	75587*#	DTE ENERGY	UTILITIES	921.000	542	1,262.50
05/28/2026	1	75590	GREAT LAKES WATER AUTHORITY	WATER SERVICE	920.000	537	36,577

CHECK DISBURSEMENT REPORT FOR CITY OF GROSSE POINTE WOODS
 CHECK DATE FROM 05/01/2026 - 05/31/2026

Check Date	Bank	Check #	Payee	Description	Account	Dept	Amount
Fund: 592 WATER / SEWER FUND							
				DWSD WATER FIXED CHARGES	920.100	537	78,700.00
				DWSD IWC CHARGES	920.103	537	3,307.39
				CHECK 1 75590 TOTAL FOR FUND 592:			<u>118,584.47</u>
05/28/2026	1	75597	KOGELMANN'S CREEKSIDE SOD FARM,	SOD-DAMAGE FROM WATER MAIN BREAKS	757.000	537	253.00
05/28/2026	1	75598	LASERCOM, LLC	FY 2025-26 WATER BILL POSTAGE	757.000	538	1,750.00
				FY 2025-26 WATER BILL POSTAGE	757.000	538	241.24
				CONTRACTUAL SERVICES	818.000	538	323.95
				CHECK 1 75598 TOTAL FOR FUND 592:			<u>2,315.19</u>
				Total for fund 592 WATER / SEWER FUND			414,976.11

Check Date	Bank	Check #	Payee	Description	Account	Dept	Amount
Fund: 594 BOAT DOCK FUND							
05/28/2026	1	75589	MICHAEL GORMELY	DOCKING FEES	651.002	000	77.00
Total for fund 594 BOAT DOCK FUND							77.00

CHECK DISBURSEMENT REPORT FOR CITY OF GROSSE POINTE WOODS
 CHECK DATE FROM 05/01/2026 - 05/31/2026

Check Date	Bank	Check #	Payee	Description	Account	Dept	Amount
Fund: 661 MTR VEH & EQUIPMENT FUND							
05/07/2026	1	75436	BERGER CHEVROLET, INC.	2026 CHEVROLET TAHOE	977.349	901	55,986.00
05/07/2026	1	75438*#	CINTAS CORP LOC #31	MECHANICS UNIFORMS	725.000	535	23.45
				MECHANICS UNIFORMS	725.000	535	23.45
				CHECK 1 75438 TOTAL FOR FUND 661:			<u>46.90</u>
05/07/2026	1	75460	MACQUEEN	AUTO EQUIP & TRUCK PARTS	939.100	534	101.52
05/07/2026	1	75467	PIRTEK MADISON HEIGHTS	PARTS FOR DPW #10 FORD F750 TRUCK	939.100	534	795.53
05/07/2026	1	75479	TRACTION	MISC. AUTO & EQUIPMENT PARTS, ETC.	939.100	534	205.18
05/14/2026	1	75495	BLUE WATER INDUSTRIAL PRODUCTS	OXYGEN, ACETYLENE & PROPANE MECHANICS	939.100	534	120.00
05/14/2026	1	75504*#	GEORGE'S DISCOUNT AUTO	AUTO & TRUCK PARTS & SUPPLIES	939.100	534	2,975.44
				AUTO & TRUCK PARTS & SUPPLIES	939.200	534	1,005.98
				VEHICLE MAINTENANCE - P&R	939.300	534	155.75
				CHECK 1 75504 TOTAL FOR FUND 661:			<u>4,137.17</u>
05/14/2026	1	75505*#	GILBERTS PRO HARDWARE	MINOR OPERATING SUPPLIES ALL DEPTS.	939.100	534	216.31
05/14/2026	1	75512*#	K/E ELECTRIC SUPPLY CORP.	OPERATING SUPPLIES	757.000	534	495.29
05/20/2026	1	75535	CERTIFIED LABORATORIES	VEHICLE MAINTENANCE - DPW	939.100	534	300.45
05/20/2026	1	75536*#	CINTAS CORP LOC #31	MECHANICS UNIFORMS	725.000	535	23.45
				MECHANICS UNIFORMS	725.000	535	23.45
				CHECK 1 75536 TOTAL FOR FUND 661:			<u>46.90</u>
05/20/2026	1	75542	ED RINKE CHEVROLET	AUTO & TRUCK PARTS	939.100	534	35.80
05/20/2026	1	75564	MCMASTER-CARR	OPERATING SUPPLIES	757.000	534	478.22
05/20/2026	1	75565	MICHIGAN CAT	PARTS FOR EQUIPMENT REPAIRS	939.100	534	539.33
05/20/2026	1	75569	OSCAR W LARSON CO	REPAIRS TO ABOVEGROUND FUEL TANK	930.000	534	894.36
05/20/2026	1	75575	TERMINAL SUPPLY CO	VEHICLE MAINTENANCE - DPW	939.100	534	199

CHECK DISBURSEMENT REPORT FOR CITY OF GROSSE POINTE WOODS
CHECK DATE FROM 05/01/2026 - 05/31/2026

Check Date	Bank	Check #	Payee	Description	Account	Dept	Amount
Fund: 661 MTR VEH & EQUIPMENT FUND							
05/28/2026	1	75595	INTERSTATE BILLING SERVICES, INC	VEHICLE MAINTENANCE - DPW	939.100	534	400.49
05/28/2026	1	75612	RKA PETROLEUM COMPANIES, INC.	FUEL PURCHASE	939.500	534	8,177.46
				FUEL PURCHASE	939.500	534	4,957.84
				CHECK 1 75612 TOTAL FOR FUND 661:			<u>13,135.30</u>
				Total for fund 661 MTR VEH & EQUIPMENT FUND			78,133.75

Check Date	Bank	Check #	Payee	Description	Account	Dept	Amount
Fund: 677 WORKERS COMP FUND							
05/07/2026	1	75472	SEDGWICK CLAIMS MGMT SERVICES, I	PREPAID EXPENSE	123.000	000	6,178.75
05/14/2026	1	75523	STATE OF MI - SECOND INJURY FUND	INSURANCE PREM.	955.000	210	75.68
05/28/2026	1	75606	NICKEL & SAPH, INC.	PREPAID EXPENSE	123.000	000	78,426.00
Total for fund 677 WORKERS COMP FUND							84,680.43

Check Date	Bank	Check #	Payee	Description	Account	Dept	Amount
Fund: 678 MEDICAL CARE FUND							
05/07/2026	1	75446	DELTA DENTAL	DELTA DENTAL RETIREE	717.020	210	425.87
				DELTA DENTAL RETIREE	717.020	210	3,281.00
				CHECK 1 75446 TOTAL FOR FUND 678:			<u>3,706.87</u>
05/07/2026	1	75447	DELTA DENTAL	DENTAL	719.010	210	866.91
				DENTAL	719.010	210	6,678.85
				CHECK 1 75447 TOTAL FOR FUND 678:			<u>7,545.76</u>
05/20/2026	1	75533	BLUE CROSS BLUE SHIELD OF MI	MEDICARE ADVANTAGE RETIREE	717.010	210	22,689.00
05/28/2026	1	75593	HUMANA INSURANCE CO.	HUMANA RETIREE	717.030	210	28,164.85
05/28/2026	1	75614	STANDARD INSURANCE COMPANY RC	LIFE & LTD INSURANCE	720.000	210	1,670.85
05/28/2026	1	75615	STANDARD INSURANCE COMPANY RC	LIFE RETIREE	717.040	210	18.70
				Total for fund 678 MEDICAL CARE FUND			63,796.03
			TOTAL - ALL FUNDS				<u>1,194,035.60</u>

'*'-INDICATES CHECK DISTRIBUTED TO MORE THAN ONE FUND
 '#'-INDICATES CHECK DISTRIBUTED TO MORE THAN ONE DEPARTMENT

City of Grosse Pointe Woods
Investments as of May 31, 2026

Investment	General Fund #101	Cable Fund #214	Parking Fund #585	Water/Sewer #592	Workers Comp #677	Motor Vehicle Fund #661	Total	% of Total
Federal Home Loan BKS	\$200,000						\$200,000	1.36%
Federal Home Loan Mortgage	\$250,000						\$250,000	1.70%
Federal Farm CR BKS	\$200,000			\$450,000			\$650,000	4.42%
Federal Agric Mtg	\$250,000			\$250,000			\$500,000	3.40%
Federal Nat'l Mtg Assn	\$250,000			\$750,000			\$1,000,000	6.81%
1st Source Bk - CD				\$200,000			\$200,000	1.36%
Advia Cr Un - CD	\$250,000						\$250,000	1.70%
Bank of America - CD	\$250,000			\$250,000			\$500,000	3.40%
Community Unity Bk - CD				\$250,000			\$250,000	1.70%
Dort Finl Cr Un - CD	\$200,000						\$200,000	1.36%
Farmers St Bk - CD	\$250,000	\$250,000					\$500,000	3.40%
First Nat'l Bank East Lansing, MI - CD	\$250,000						\$250,000	1.70%
Horizon Bk - CD				\$250,000			\$250,000	1.70%
JPMorgan Chase Bk - CD	\$245,000						\$245,000	1.67%
Sturgis Bk & Tr Co - CD				\$249,000			\$249,000	1.70%
CIBC*	\$314,474			\$1,251,352	\$132,423	\$437,735	\$2,135,983	14.54%
Huntington Bank*				\$589,950			\$589,950	4.02%
Federal Farm Cr Bks - Comerica	\$1,350,000			\$540,000			\$1,890,000	12.87%
Federal Home Loan Bank-Comerica	\$115,000	\$255,000		\$525,000			\$895,000	6.09%
Federal Home Loan Mortgage - Comerica	\$950,000			\$800,000			\$1,750,000	11.91%
Federal Nat'l Mtg Assn - Comerica	\$680,000		\$505,850	\$250,000		\$249,150	\$1,685,000	11.47%
Macomb Cty Retiree Hlth Care	\$250,000						\$250,000	1.70%
TOTAL	\$6,254,474	\$505,000	\$505,850	\$6,605,302	\$132,423	\$686,885	\$14,689,933	
Total Invested w/Multi Bank							\$5,494,000	

PERIOD ENDING 05/31/2026

*NOTE: Available Balance / Pct Budget Used does not reflect amounts encumbered.

GL NUMBER	DESCRIPTION	2025-26 AMENDED BUDGET	YTD BALANCE	ACTIVITY FOR	AVAILABLE	% BDGT USED
			NORMAL (ABNORMAL)	MONTH 05/31/2026 INCREASE (DECREASE)	BALANCE NORMAL (ABNORMAL)	
Fund 101 - GENERAL FUND						
000		18,138,005.77	15,994,636.97	285,320.02	2,143,368.80	88.18
931 - TRANSFER IN		80,000.00	80,000.00	0.00	0.00	100.00
TOTAL REVENUES		18,218,005.77	16,074,636.97	285,320.02	2,143,368.80	88.23
101 - CITY COUNCIL		110,573.00	89,273.54	3,991.71	21,299.46	80.74
105 - COMMISSIONS		53,317.00	23,306.48	2,868.88	30,010.52	43.71
172 - ADMINISTRATION		443,660.00	417,001.92	23,133.86	26,658.08	93.99
193 - CITY COMPTROLLER		526,566.00	436,826.05	25,952.68	89,739.95	82.96
209 - ADMIN-FRINGE BENEFITS		261,400.00	260,065.83	541.03	1,334.17	99.49
211 - OVERHEAD		153,430.55	125,738.75	5,641.36	27,691.80	81.95
215 - CITY CLERK/ELECTIONS		510,683.00	439,365.23	24,162.43	71,317.77	86.03
228 - MIS		544,584.00	450,107.69	22,853.85	94,476.31	82.65
229 - MIS FRINGE BENEFITS		31,280.00	31,280.00	0.00	0.00	100.00
257 - CITY ASSESSOR		122,855.00	96,648.56	7,911.08	26,206.44	78.67
265 - CITY HALL & GROUNDS		353,135.00	209,101.19	24,921.70	144,033.81	59.21
266 - CITY ATTORNEY		265,000.00	124,309.18	13,146.75	140,690.82	46.91
286 - COURT EXPENDITURES		423,319.00	322,804.25	21,417.90	100,514.75	76.26
305 - PUB SAF-ADMIN		387,332.00	301,186.48	22,731.23	86,145.52	77.76
310 - POLICE SERVICES		5,302,259.80	4,552,296.01	376,347.22	749,963.79	85.86
326 - SUPPORT SERVICES		165,927.00	130,848.11	14,523.28	35,078.89	78.86
339 - FIRE SERV/SAFETY INS		77,726.00	48,932.80	2,870.77	28,793.20	62.96
345 - PUB-SAF FRINGES		2,184,845.00	2,137,945.77	153,043.26	46,899.23	97.85
349 - OVERHEAD		262,659.48	226,760.72	6,535.61	35,898.76	86.33
371 - BUILDING INSPECTIONS		674,250.00	539,904.06	84,171.10	134,345.94	80.07
441 - PUBLIC WORKS-ADMIN		180,883.00	128,978.25	9,537.16	51,904.75	71.30
463 - ROUTINE MAINTENANCE		426,273.00	352,264.23	21,860.20	74,008.77	82.64
523 - FORESTRY SERVICES		332,385.00	97,945.91	26,019.04	234,439.09	29.47
531 - PUB WKS-FRINGE		398,730.00	392,310.48	6,115.57	6,419.52	98.39
594 - OVERHEAD		685,058.29	583,048.53	54,343.41	102,009.76	85.11
752 - PARKS & REC-ADMIN		18,938.00	14,216.03	1,162.20	4,721.97	75.07
774 - LFP EXPENDITURES		1,729,215.00	1,213,020.11	81,764.95	516,194.89	70.15
775 - CITY PARKS		139,133.00	141,386.76	22,929.23	(2,253.76)	101.62
780 - COMMUNITY CENTER		290,604.00	236,900.56	16,716.22	53,703.44	81.52
795 - PARKS & REC FRINGE		108,409.00	106,188.40	0.00	2,220.60	97.95
799 - OVERHEAD		27,133.65	27,134.00	0.00	(0.35)	100.00
967 - TRANSFERS OUT ADMIN.		425,539.00	425,538.99	0.00	0.01	100.00
968 - TRANSFER OUT DPS		310,904.00	310,904.00	0.00	0.00	100.00
969 - TRANSFER OUT DPW		220,000.00	220,000.00	0.00	0.00	100.00
970 - TRANSFERS OUT PARKS/RECR.		70,000.00	70,000.00	0.00	0.00	100.00
TOTAL EXPENDITURES		18,218,006.77	15,283,538.87	1,077,213.68	2,934,467.90	83.89
Fund 101 - GENERAL FUND:						
TOTAL REVENUES		18,218,005.77	16,074,636.97	285,320.02	2,143,368.80	88.23
TOTAL EXPENDITURES		18,218,006.77	15,283,538.87	1,077,213.68	2,934,467.90	83.89
NET OF REVENUES & EXPENDITURES		(1.00)	791,098.10	(791,893.66)	(791,099.10)	79,109.8

PERIOD ENDING 05/31/2026

*NOTE: Available Balance / Pct Budget Used does not reflect amounts encumbered.

GL NUMBER	DESCRIPTION	2025-26		YTD BALANCE	ACTIVITY FOR	AVAILABLE	% BDGT USED
		AMENDED BUDGET	NORMAL	(ABNORMAL)	MONTH 05/31/2026	BALANCE	
					INCREASE (DECREASE)	NORMAL (ABNORMAL)	
Fund 101 - GENERAL FUND							
Revenues							
Dept 000							
101-000-402.000	OPERATING LEVY	12,148,178.00		11,885,110.67	0.00	263,067.33	97.83
101-000-402.001	MTT PROPERTY TAX REFUND	0.00		0.00	0.00	0.00	0.00
101-000-402.002	PPT LOSS DISTRIBUTION	0.00		0.00	0.00	0.00	0.00
101-000-404.000	ACT 359 - PR	50,000.00		49,035.91	2.05	964.09	98.07
101-000-411.000	DELQ TAXES	20,000.00		8,825.91	2,487.26	11,174.09	44.13
101-000-432.000	PILOT	30,000.00		27,909.84	9,469.24	2,090.16	93.03
101-000-445.000	INTEREST & PENALTY	55,000.00		66,985.65	0.00	(11,985.65)	121.79
101-000-447.000	SUMMER ADMIN FEE	290,000.00		309,686.58	12.85	(19,686.58)	106.79
101-000-447.100	WINTER ADMIN FEE	200,000.00		225,027.78	11.14	(25,027.78)	112.51
101-000-477.000	CABLE FRANCHISE FEE	280,000.00		181,083.29	51,292.89	98,916.71	64.67
101-000-477.100	AT&T LICENSE AGREEMENT	55,000.00		53,086.44	0.00	1,913.56	96.52
101-000-478.000	BUILDERS LIC/PERM	376,767.00		462,770.30	44,306.00	(86,003.30)	122.83
101-000-479.000	PLUMBERS LIC/PERM	53,600.00		50,315.50	5,387.50	3,284.50	93.87
101-000-480.000	ELECTRICAL LIC/PERM	89,706.00		77,252.65	7,386.00	12,453.35	86.12
101-000-481.000	PROPERTY MAINTENANCE PERMIT	89,706.00		33,010.00	1,550.00	56,696.00	36.80
101-000-482.000	PROPERTY MAINTENANCE FEE	13,107.00		7,283.00	0.00	5,824.00	55.57
101-000-483.000	FORECLOSURE ORDINANCE FEES	1,121.00		0.00	0.00	1,121.00	0.00
101-000-484.000	MECHANICAL PERMIT	78,493.00		63,253.70	6,250.00	15,239.30	80.59
101-000-485.000	ANIMAL LICENSES	7,000.00		8,809.00	1,001.00	(1,809.00)	125.84
101-000-486.000	BICYCLE LICENSES	0.00		10.00	0.00	(10.00)	100.00
101-000-487.000	SITE PLAN REVIEW FEE	4,000.00		21,615.25	875.00	(17,615.25)	540.38
101-000-491.000	TREE TRIM LICENSES	0.00		0.00	0.00	0.00	0.00
101-000-500.100	MISC PERMIT REVENUE	1,000.00		3,085.00	600.00	(2,085.00)	308.50
101-000-511.000	ARPA FUNDS #21.027	0.00		0.00	0.00	0.00	0.00
101-000-512.000	STATE OF MI-CARES/COVID	0.00		0.00	0.00	0.00	0.00
101-000-528.000	FEDERAL GRANT REVENUE	0.00		0.00	0.00	0.00	0.00
101-000-543.010	PS GPPS SRO GRANT	76,000.00		104,562.38	24,074.35	(28,562.38)	137.58
101-000-543.030	STATE CPE GRANT	0.00		(5,000.00)	0.00	5,000.00	100.00
101-000-543.100	FORFEITURE MONEY	0.00		0.00	0.00	0.00	0.00
101-000-543.200	STATE OF MI - PS RECEIPTS	0.00		13,962.59	13,962.59	(13,962.59)	100.00
101-000-543.300	MDART REVENUE	0.00		21,821.19	0.00	(21,821.19)	100.00
101-000-548.100	TREE GRANT	0.00		0.00	0.00	0.00	0.00
101-000-549.000	FIRE GRANT	0.00		0.00	0.00	0.00	0.00
101-000-568.000	STATE LIQUOR LIC	10,000.00		7,993.15	0.00	2,006.85	79.93
101-000-569.000	SOM - OTHER REVENUE	0.00		65,294.61	29,917.33	(65,294.61)	100.00
101-000-569.800	MSHDA GRANT	50,000.00		25,000.00	0.00	25,000.00	50.00
101-000-569.900	ST OF MI-ELECTION REIMBURSEMENT	0.00		0.00	0.00	0.00	0.00
101-000-573.000	SOM-LOCAL COMMUNITY STABILIZATION AUTH	60,000.00		73,622.90	16,754.35	(13,622.90)	122.70
101-000-574.000	STATE SHARE REV-CONS	1,831,031.00		1,184,204.00	0.00	646,827.00	64.67
101-000-574.001	STATE SHARE REV-CVTRS	253,470.00		177,152.00	0.00	76,318.00	69.89
101-000-585.000	SCHOOL ELECTIONS	0.00		0.00	0.00	0.00	0.00
101-000-586.000	SMART GRANTS	15,000.00		0.00	0.00	15,000.00	0.00
101-000-590.000	GROSSE POINTE CHAMBER FOUNDATION	0.00		2,626.33	2,626.33	(2,626.33)	100.00
101-000-611.000	REIMBURSE COURT APPTD ATTY FEES	1,500.00		335.00	0.00	1,165.00	22.33
101-000-621.000	PROBATION FEES	5,000.00		6,258.00	830.00	(1,258.00)	125.16
101-000-629.000	GPS DISPATCH SERVICES	94,314.00		70,735.50	0.00	23,578.50	75.00
101-000-642.000	LFP VENDING SALES	0.00		0.00	0.00	0.00	0.00
101-000-642.010	LAKE FRONT PARK MERCHANDISE	1,850.00		340.00	200.00	1,510.00	18.38
101-000-642.020	OTHER REVENUE	14,400.00		7,370.00	1,600.00	7,030.00	51.18
101-000-646.000	COMMUNITY CENTER REVENUE	29,400.00		36,180.00	5,890.00	(6,780.00)	123.06
101-000-653.000	ACTIVITY FEES	150.00		168.00	0.00	(18.00)	112.00
101-000-653.100	ACTIVITY FEES - P&R	25,760.00		16,900.00	0.00	8,860.00	65.60
101-000-653.105	ACTIVITY FEES - MINI GOLF	5,550.00		4,142.00	0.00	1,408.00	74.63

PERIOD ENDING 05/31/2026

*NOTE: Available Balance / Pct Budget Used does not reflect amounts encumbered.

GL NUMBER	DESCRIPTION	2025-26 AMENDED BUDGET	YTD BALANCE	ACTIVITY FOR	AVAILABLE	% BDGT USED
			NORMAL (ABNORMAL)	MONTH 05/31/2026 INCREASE (DECREASE)	BALANCE NORMAL (ABNORMAL)	
Fund 101 - GENERAL FUND						
Revenues						
101-000-653.106	GOLF SIMULATOR	32,000.00	0.00	0.00	32,000.00	0.00
101-000-653.110	ACTIVITY FEES - GPW SENIORS	4,200.00	4,957.00	18.00	(757.00)	118.02
101-000-653.120	ACTIVITY FEES - COMM CENTER	4,200.00	0.00	0.00	4,200.00	0.00
101-000-653.130	ACTIVITY FEES - MISC	0.00	0.00	0.00	0.00	0.00
101-000-653.200	SWIM LESSONS	24,000.00	7,355.00	120.00	16,645.00	30.65
101-000-653.210	TEAMS - SWIM	36,000.00	30,561.00	11,310.00	5,439.00	84.89
101-000-653.211	LFSA SPONSORS	0.00	0.00	0.00	0.00	0.00
101-000-653.220	ARC - MISC	0.00	0.00	0.00	0.00	0.00
101-000-653.230	ADULT CLASSES	0.00	0.00	0.00	0.00	0.00
101-000-653.240	CHILD CLASSES	0.00	0.00	0.00	0.00	0.00
101-000-653.260	HOB NOBBIN EVENT	0.00	0.00	0.00	0.00	0.00
101-000-653.270	TENNIS	29,000.00	16,964.80	6,360.00	12,035.20	58.50
101-000-653.310	CC PROGRAM - ADULT	29,980.00	33,291.01	3,728.00	(3,311.01)	111.04
101-000-653.320	CC PROGRAMS - CHILD	3,240.00	0.00	0.00	3,240.00	0.00
101-000-653.340	CC PROGRAMS - SENIOR	6,435.00	1,787.00	221.00	4,648.00	27.77
101-000-653.350	CC PROGRAMS - TRIPS	5,000.00	(565.00)	0.00	5,565.00	(11.30)
101-000-653.400	ACTIVITY FEES - GAZEBO RENTAL	17,000.00	10,925.00	2,900.00	6,075.00	64.26
101-000-653.410	ACTIVITY FEES- PAVILION RENTAL	0.00	3,750.00	0.00	(3,750.00)	100.00
101-000-653.420	ACTIVITY FEES - TENT RENTAL	0.00	0.00	0.00	0.00	0.00
101-000-656.000	VIOLATIONS	25,000.00	14,423.44	1,681.27	10,576.56	57.69
101-000-657.000	CODE VIOLATIONS -BLDG DEPT	3,000.00	117.00	0.00	2,883.00	3.90
101-000-660.000	COURT FINES & COSTS	160,000.00	126,947.84	11,491.62	33,052.16	79.34
101-000-660.010	O.U.I.L. REIMBURSEMT	25,000.00	20,147.37	1,519.00	4,852.63	80.59
101-000-665.000	INTEREST INCOME	100,000.00	278,345.80	13,182.38	(178,345.80)	278.35
101-000-669.030	GAIN ON MKT VALUE	0.00	0.00	0.00	0.00	0.00
101-000-673.000	SALE OF ASSETS	0.00	0.00	0.00	0.00	0.00
101-000-674.020	DONATIONS	0.00	2,500.00	0.00	(2,500.00)	100.00
101-000-674.400	K9 DONATION GPAAS	19,663.00	18,232.00	0.00	1,431.00	92.72
101-000-676.000	WORKERS COMP - REIMBURSEMENT	0.00	0.00	0.00	0.00	0.00
101-000-676.010	NAVITUS REIMBURSEMENT	0.00	0.00	0.00	0.00	0.00
101-000-677.060	REIMBURSE PENSION ADMIN FEE	14,000.00	14,000.00	0.00	0.00	100.00
101-000-677.070	REIMB PARKING LOT SERVICES	15,000.00	12,864.39	4,364.63	2,135.61	85.76
101-000-677.080	REIMBURSEMENT - HEALTHCARE	0.00	11,434.36	0.00	(11,434.36)	100.00
101-000-677.090	RETIREE DRUG SUBSIDY	0.00	0.00	0.00	0.00	0.00
101-000-677.100	INSURANCE HARD CAP	0.00	0.00	0.00	0.00	0.00
101-000-679.000	PROCEEDS-ATT CELL	0.00	0.00	0.00	0.00	0.00
101-000-682.000	GPF-PROVENCAL	0.00	0.00	0.00	0.00	0.00
101-000-683.000	OTHER INCOME	10,000.00	9,366.52	525.00	633.48	93.67
101-000-683.010	MISC. PUBLIC SAFETY RECEIPTS	15,000.00	19,594.11	539.25	(4,594.11)	130.63
101-000-683.020	MEDSTAR LEASE	0.00	0.00	0.00	0.00	0.00
101-000-683.030	AWARE-PS	0.00	0.00	0.00	0.00	0.00
101-000-683.040	VEHICLE SALVAGE TITLE FEES	0.00	0.00	0.00	0.00	0.00
101-000-683.050	POLICE IMPOUND FEES	5,000.00	4,400.00	495.00	600.00	88.00
101-000-683.060	CITY CLERK MISC. RECEIPTS	4,000.00	5,119.68	190.00	(1,119.68)	127.99
101-000-683.070	ASSESSING MISC RECEIPTS	0.00	0.00	0.00	0.00	0.00
101-000-683.080	OTHER INCOME - ADMIN	0.00	0.00	0.00	0.00	0.00
101-000-689.000	OVER/UNDER	100.00	294.53	188.99	(194.53)	294.53
101-000-692.100	TRF F/PRIOR YR RES	1,235,084.77	0.00	0.00	1,235,084.77	0.00
101-000-698.000	INSURANCE PROCEEDS	0.00	0.00	0.00	0.00	0.00
Total Dept 000		18,138,005.77	15,994,636.97	285,320.02	2,143,368.80	88

PERIOD ENDING 05/31/2026

*NOTE: Available Balance / Pct Budget Used does not reflect amounts encumbered.

GL NUMBER	DESCRIPTION	2025-26	YTD BALANCE	ACTIVITY FOR	AVAILABLE	% BDGT USED
		AMENDED BUDGET	05/31/2026 NORMAL (ABNORMAL)	MONTH 05/31/2026 INCREASE (DECREASE)	BALANCE NORMAL (ABNORMAL)	
Fund 101 - GENERAL FUND						
Revenues						
101-931-699.203	TRF F/LOCAL STREETS	0.00	0.00	0.00	0.00	0.00
101-931-699.210	TRF F/AMBULANCE	0.00	0.00	0.00	0.00	0.00
101-931-699.213	TRANSFER FROM PARKWAY BEAUT.	0.00	0.00	0.00	0.00	0.00
101-931-699.226	TRANSFER FROM SOLID WASTE	50,000.00	50,000.00	0.00	0.00	100.00
101-931-699.245	TRF F/BLOCK GRANT	0.00	0.00	0.00	0.00	0.00
101-931-699.401	TRF F/MUNICIPAL IMPROVEMENTS	0.00	0.00	0.00	0.00	0.00
101-931-699.420	TRANS F/ CAPITAL IMPROVEMENT	0.00	0.00	0.00	0.00	0.00
101-931-699.585	TRANSFER F/PARKING	0.00	0.00	0.00	0.00	0.00
101-931-699.592	TRF WATER/SEWER	25,000.00	25,000.00	0.00	0.00	100.00
101-931-699.594	TRF F/BOAT DOCKS	5,000.00	5,000.00	0.00	0.00	100.00
101-931-699.598	TRF F/COMMODITY SALE	0.00	0.00	0.00	0.00	0.00
101-931-699.661	TRANSF F/MOTOR VEHICLE	0.00	0.00	0.00	0.00	0.00
Total Dept 931 - TRANSFER IN		80,000.00	80,000.00	0.00	0.00	100.00
TOTAL REVENUES		18,218,005.77	16,074,636.97	285,320.02	2,143,368.80	88.23
Expenditures						
Dept 101 - CITY COUNCIL						
101-101-702.000	SALARIES & WAGES	28,500.00	26,125.00	2,375.00	2,375.00	91.67
101-101-715.000	FICA	2,180.00	1,998.63	181.71	181.37	91.68
101-101-721.000	WORKERS COMP	0.00	0.00	0.00	0.00	0.00
101-101-757.000	OPERATING SUPPLIES	700.00	77.92	0.00	622.08	11.13
101-101-880.000	COMMUNITY RELATIONS	4,550.00	2,969.22	1,435.00	1,580.78	65.26
101-101-881.000	EMPLOYEE RELATIONS	25,000.00	21,421.19	0.00	3,578.81	85.68
101-101-958.000	MEMBERSHIP & DUES	16,873.00	16,681.00	0.00	192.00	98.86
101-101-958.001	TRAINING & SEMINARS	2,770.00	341.00	0.00	2,429.00	12.31
101-101-967.100	SPECIAL PROJECTS	30,000.00	19,659.58	0.00	10,340.42	65.53
Total Dept 101 - CITY COUNCIL		110,573.00	89,273.54	3,991.71	21,299.46	80.74
Dept 105 - COMMISSIONS						
101-105-880.100	BEAUTIFICATION COMM	3,200.00	1,155.50	1,055.50	2,044.50	36.11
101-105-880.200	CITIZENS RECREATION	17,500.00	14,740.85	283.38	2,759.15	84.23
101-105-880.300	HISTORICAL COMM	2,542.00	1,317.00	85.00	1,225.00	51.81
101-105-880.500	PLANNING COMM	23,075.00	1,663.90	775.00	21,411.10	7.21
101-105-880.600	SENIOR CIT COMM	3,000.00	1,764.53	100.00	1,235.47	58.82
101-105-880.700	TREE ADV. COMM	4,000.00	2,664.70	570.00	1,335.30	66.62
Total Dept 105 - COMMISSIONS		53,317.00	23,306.48	2,868.88	30,010.52	43.71
Dept 172 - ADMINISTRATION						
101-172-702.000	SALARIES & WAGES	247,648.00	212,942.40	15,134.32	34,705.60	85.99
101-172-710.999	SICK/VAC PAY	14,000.00	28,974.81	0.00	(14,974.81)	206.96
101-172-715.000	FICA	21,164.00	18,397.48	1,072.00	2,766.52	86.93
101-172-717.000	RETIREE HEALTH CARE	2,700.00	1,800.00	150.00	900.00	66.67
101-172-718.000	H.S.A.	4,000.00	4,000.00	0.00	0.00	100.00
101-172-719.000	HOSP/DENTAL/OPTICAL	39,750.00	42,750.00	0.00	(3,000.00)	107.17
101-172-720.000	LIFE & LTD INSURANCE	820.00	820.00	0.00	0.00	100.00
101-172-721.000	WORKERS COMP	2,500.00	2,500.00	0.00	0.00	100.00

PERIOD ENDING 05/31/2026

*NOTE: Available Balance / Pct Budget Used does not reflect amounts encumbered.

GL NUMBER	DESCRIPTION	2025-26 AMENDED BUDGET	YTD BALANCE	ACTIVITY FOR	AVAILABLE	% BDGT USED
			05/31/2026 NORMAL (ABNORMAL)	MONTH 05/31/2026 INCREASE (DECREASE)	BALANCE NORMAL (ABNORMAL)	
Fund 101 - GENERAL FUND						
Expenditures						
101-172-722.000	RETIREMENT	58,200.00	61,145.84	6,312.54	(2,945.84)	105.06
101-172-722.100	MEDICARE REIMBURSEMENT	0.00	0.00	0.00	0.00	0.00
101-172-723.000	SUPPLEMENTAL ANNUITY	15,928.00	15,928.00	0.00	0.00	100.00
101-172-725.200	MESC INSURANCE	0.00	0.00	0.00	0.00	0.00
101-172-757.000	OPERATING SUPPLIES	5,500.00	1,242.69	0.00	4,257.31	22.59
101-172-818.000	CONTRACTUAL SERVICES	25,000.00	24,182.03	0.00	817.97	96.73
101-172-930.000	EQUIPMENT MAINT & REPAIR	200.00	0.00	0.00	200.00	0.00
101-172-958.000	MEMBERSHIP & DUES	1,750.00	595.00	0.00	1,155.00	34.00
101-172-958.001	TRAINING & SEMINARS	3,000.00	1,723.67	465.00	1,276.33	57.46
101-172-960.000	EDUCATION-TRAINING	1,500.00	0.00	0.00	1,500.00	0.00
101-172-977.000	EQUIPMENT	0.00	0.00	0.00	0.00	0.00
Total Dept 172 - ADMINISTRATION		443,660.00	417,001.92	23,133.86	26,658.08	93.99
Dept 193 - CITY COMPTROLLER						
101-193-702.000	SALARIES & WAGES	257,110.00	207,751.23	17,731.77	49,358.77	80.80
101-193-709.000	OVERTIME FINANCE STAFF	750.00	62.15	0.00	687.85	8.29
101-193-710.999	SICK/VAC PAY	10,000.00	2,897.60	0.00	7,102.40	28.98
101-193-715.000	FICA	20,491.00	15,346.49	1,297.22	5,144.51	74.89
101-193-717.000	RETIREE HEALTH CARE	4,500.00	4,125.14	375.01	374.86	91.67
101-193-718.000	H.S.A.	3,000.00	3,000.00	0.00	0.00	100.00
101-193-719.000	HOSP/DENTAL/OPTICAL	39,750.00	39,750.00	0.00	0.00	100.00
101-193-720.000	LIFE & LTD INSURANCE	1,020.00	1,020.00	0.00	0.00	100.00
101-193-721.000	WORKERS COMP	3,900.00	3,900.00	0.00	0.00	100.00
101-193-722.000	RETIREMENT	82,053.00	73,718.93	6,311.87	8,334.07	89.84
101-193-722.100	MEDICARE REIMBURSEMENT	0.00	0.00	0.00	0.00	0.00
101-193-723.000	SUPPLEMENTAL ANNUITY	24,768.00	24,768.00	0.00	0.00	100.00
101-193-725.000	CLOTHING/UNIFORM ALLOWANCE	0.00	0.00	0.00	0.00	0.00
101-193-725.200	MESC INSURANCE	0.00	0.00	0.00	0.00	0.00
101-193-757.000	OPERATING SUPPLIES	17,750.00	16,271.29	82.81	1,478.71	91.67
101-193-757.100	OPER SUPP-TAX PREP REIMBURSEMENT	0.00	0.00	0.00	0.00	0.00
101-193-818.000	CONTRACTUAL SERVICES	51,144.00	41,376.22	104.00	9,767.78	80.90
101-193-930.000	EQUIPMENT MAINT & REPAIR	1,500.00	0.00	0.00	1,500.00	0.00
101-193-958.000	MEMBERSHIP & DUES	1,289.00	1,289.00	0.00	0.00	100.00
101-193-958.001	TRAINING & SEMINARS	3,850.00	1,550.00	50.00	2,300.00	40.26
101-193-960.000	EDUCATION-TRAINING	1,941.00	0.00	0.00	1,941.00	0.00
101-193-972.000	MINOR EQUIP	1,750.00	0.00	0.00	1,750.00	0.00
Total Dept 193 - CITY COMPTROLLER		526,566.00	436,826.05	25,952.68	89,739.95	82.96
Dept 209 - ADMIN-FRINGE BENEFITS						
101-209-703.000	BS&A MOCK SALARY EXPENSE	0.00	0.00	0.00	0.00	0.00
101-209-717.000	RETIREE HEALTH CARE	254,000.00	254,000.00	0.00	0.00	100.00
101-209-722.100	MEDICARE REIMBURSEMENT	7,400.00	6,065.83	541.03	1,334.17	81.97
101-209-724.200	MESC INSURANCE	0.00	0.00	0.00	0.00	0.00
101-209-725.200	MESC INSURANCE	0.00	0.00	0.00	0.00	0.00
Total Dept 209 - ADMIN-FRINGE BENEFITS		261,400.00	260,065.83	541.03	1,334.17	99.49
Dept 211 - OVERHEAD						

PERIOD ENDING 05/31/2026

*NOTE: Available Balance / Pct Budget Used does not reflect amounts encumbered.

GL NUMBER	DESCRIPTION	2025-26 AMENDED BUDGET	YTD BALANCE	ACTIVITY FOR	AVAILABLE		% BDGT USED
			05/31/2026 NORMAL (ABNORMAL)	MONTH 05/31/2026 INCREASE (DECREASE)	NORMAL	(ABNORMAL)	
Fund 101 - GENERAL FUND							
Expenditures							
101-211-725.300	COBRA-EMPLOYEE HEALTHCARE	0.00	0.00	0.00		0.00	0.00
101-211-728.000	OFFICE SUPPLIES	18,000.00	10,493.11	142.10		7,506.89	58.30
101-211-815.000	FLOOD REPAIRS	0.00	0.00	0.00		0.00	0.00
101-211-818.000	CONTRACTUAL SERVICES	0.00	0.00	0.00		0.00	0.00
101-211-921.000	UTILITIES	55,000.00	41,698.17	4,112.63		13,301.83	75.81
101-211-955.000	INSURANCE	55,930.55	55,931.00	0.00		(0.45)	100.00
101-211-958.000	FEES & CHARGES	24,500.00	17,616.47	1,386.63		6,883.53	71.90
101-211-960.100	LOSS ON MKT VALUE	0.00	0.00	0.00		0.00	0.00
Total Dept 211 - OVERHEAD		153,430.55	125,738.75	5,641.36		27,691.80	81.95
Dept 215 - CITY CLERK/ELECTIONS							
101-215-702.000	SALARIES & WAGES	185,166.00	165,498.47	14,243.56		19,667.53	89.38
101-215-702.809	WAGES- SEASONAL OFFICE	15,000.00	7,525.92	0.00		7,474.08	50.17
101-215-709.000	OVERTIME-CLERK STAFF	5,448.00	2,229.50	79.05		3,218.50	40.92
101-215-710.999	SICK/VAC PAY	6,000.00	12,159.13	0.00		(6,159.13)	202.65
101-215-711.000	LONGEVITY/COLA	0.00	0.00	0.00		0.00	0.00
101-215-715.000	FICA	16,188.00	13,177.47	871.22		3,010.53	81.40
101-215-717.000	RETIREE HEALTH CARE	5,400.00	4,950.00	450.00		450.00	91.67
101-215-718.000	H.S.A.	6,000.00	6,000.00	0.00		0.00	100.00
101-215-719.000	HOSP/DENTAL/OPTICAL	73,500.00	73,500.00	0.00		0.00	100.00
101-215-720.000	LIFE & LTD INSURANCE	971.00	971.00	0.00		0.00	100.00
101-215-721.000	WORKERS COMP	3,000.00	3,000.00	0.00		0.00	100.00
101-215-722.000	RETIREMENT	77,233.00	69,959.33	5,973.96		7,273.67	90.58
101-215-722.100	MEDICARE REIMBURSEMENT	0.00	0.00	0.00		0.00	0.00
101-215-723.000	SUPPLEMENTAL ANNUITY	23,312.00	23,312.00	0.00		0.00	100.00
101-215-725.000	CLOTHING/UNIFORM ALLOWANCE	0.00	0.00	0.00		0.00	0.00
101-215-725.200	MESC INSURANCE	0.00	0.00	0.00		0.00	0.00
101-215-731.000	ELECTIONS SUPPLIES	36,487.00	20,136.00	468.79		16,351.00	55.19
101-215-757.000	OPERATING SUPPLIES	4,258.00	2,617.86	217.25		1,640.14	61.48
101-215-818.000	CONTRACTUAL SERVICES	14,460.00	9,532.13	0.00		4,927.87	65.92
101-215-903.000	LEGAL NOTICES	8,500.00	7,785.38	962.00		714.62	91.59
101-215-930.000	EQUIPMENT MAINT. & REPAIR	14,180.00	12,390.00	0.00		1,790.00	87.38
101-215-958.000	MEMBERSHIP & DUES	930.00	645.00	0.00		285.00	69.35
101-215-958.001	TRAINING & SEMINARS	3,950.00	1,382.34	272.76		2,567.66	35.00
101-215-960.000	EDUCATION-TRAINING	0.00	0.00	0.00		0.00	0.00
101-215-972.000	MINOR EQUIPMENT	10,700.00	2,593.70	623.84		8,106.30	24.24
Total Dept 215 - CITY CLERK/ELECTIONS		510,683.00	439,365.23	24,162.43		71,317.77	86.03
Dept 228 - MIS							
101-228-702.000	SALARIES & WAGES	164,858.00	148,079.01	12,681.38		16,778.99	89.82
101-228-710.999	SICK/VAC PAY	5,000.00	3,485.83	3,485.83		1,514.17	69.72
101-228-715.000	FICA	12,994.00	11,310.10	1,233.07		1,683.90	87.04
101-228-717.000	RETIREE HEALTH CARE	1,800.00	1,650.00	150.00		150.00	91.67
101-228-722.000	RETIREMENT	68,762.00	23,701.53	2,029.78		45,060.47	34.47
101-228-722.100	MEDICARE REIMBURSEMENT	0.00	0.00	0.00		0.00	0.00
101-228-723.000	SUPPLEMENTAL ANNUITY	20,756.00	20,756.00	0.00		0.00	100.00
101-228-757.000	OPERATING SUPPLIES	50,900.00	47,252.02	1,562.97		3,647.98	92.70
101-228-818.000	CONTRACTUAL SERVICES	150,514.00	135,298.89	701.31		15,215.11	89.23
101-228-930.000	EQUIPMENT MAINT & REPAIR	32,100.00	28,964.29	1,009.51		3,135.71	90.33

PERIOD ENDING 05/31/2026

*NOTE: Available Balance / Pct Budget Used does not reflect amounts encumbered.

GL NUMBER	DESCRIPTION	2025-26 AMENDED BUDGET	YTD BALANCE	ACTIVITY FOR	AVAILABLE	% BDGT USED
			05/31/2026 NORMAL (ABNORMAL)	MONTH 05/31/2026 INCREASE (DECREASE)	BALANCE NORMAL (ABNORMAL)	
Fund 101 - GENERAL FUND						
Expenditures						
101-228-958.000	MEMBERSHIP & DUES	0.00	0.00	0.00	0.00	0.00
101-228-958.001	TRAINING & SEMINARS	0.00	0.00	0.00	0.00	0.00
101-228-972.000	MINOR EQUIPMENT	1,400.00	1,100.86	0.00	299.14	78.63
101-228-972.349	MINOR EQUIP PUB SAF	5,600.00	4,403.44	0.00	1,196.56	78.63
101-228-972.599	MINOR EQUIP PUB WKS	2,800.00	2,201.72	0.00	598.28	78.63
101-228-972.799	MINOR EQUIP PARKS	7,200.00	3,302.58	0.00	3,897.42	45.87
101-228-977.000	EQUIPMENT	17,100.00	16,399.70	0.00	700.30	95.90
101-228-977.299	EQUIPMENT - GENL GOVERNMENT	2,800.00	2,201.72	0.00	598.28	78.63
Total Dept 228 - MIS		544,584.00	450,107.69	22,853.85	94,476.31	82.65
Dept 229 - MIS FRINGE BENEFITS						
101-229-715.000	FICA	0.00	0.00	0.00	0.00	0.00
101-229-717.000	RETIREE HEALTH CARE	2,200.00	2,200.00	0.00	0.00	100.00
101-229-718.000	H.S.A.	1,700.00	1,700.00	0.00	0.00	100.00
101-229-719.000	HOSP/DENTAL/OPTICAL	24,500.00	24,500.00	0.00	0.00	100.00
101-229-720.000	LIFE & LTD INSURANCE	880.00	880.00	0.00	0.00	100.00
101-229-721.000	WORKERS COMP	2,000.00	2,000.00	0.00	0.00	100.00
101-229-725.200	MESC INSURANCE	0.00	0.00	0.00	0.00	0.00
Total Dept 229 - MIS FRINGE BENEFITS		31,280.00	31,280.00	0.00	0.00	100.00
Dept 257 - CITY ASSESSOR						
101-257-702.000	SALARIES & WAGES	0.00	0.00	0.00	0.00	0.00
101-257-710.999	SICK/VAC PAY	0.00	0.00	0.00	0.00	0.00
101-257-715.000	FICA	0.00	0.00	0.00	0.00	0.00
101-257-717.000	RETIREE HEALTH CARE	0.00	0.00	0.00	0.00	0.00
101-257-718.000	H.S.A.	0.00	0.00	0.00	0.00	0.00
101-257-719.000	HOSP/DENTAL/OPTICAL	0.00	0.00	0.00	0.00	0.00
101-257-720.000	LIFE & LTD INSURANCE	0.00	0.00	0.00	0.00	0.00
101-257-721.000	WORKERS COMP	0.00	0.00	0.00	0.00	0.00
101-257-722.000	RETIREMENT	0.00	0.00	0.00	0.00	0.00
101-257-722.100	MEDICARE REIMBURSEMENT	0.00	0.00	0.00	0.00	0.00
101-257-723.000	SUPPLEMENTAL ANNUITY	0.00	0.00	0.00	0.00	0.00
101-257-725.200	MESC INSURANCE	0.00	0.00	0.00	0.00	0.00
101-257-757.000	OPERATING SUPPLIES	500.00	0.00	0.00	500.00	0.00
101-257-818.000	CONTRACTUAL SERVICES	93,805.00	85,891.87	7,911.08	7,913.13	91.56
101-257-831.000	ASSESSMENT/TAX ROLL PREP	28,550.00	10,756.69	0.00	17,793.31	37.68
101-257-831.200	PRIOR YR TAX REFUNDS	0.00	0.00	0.00	0.00	0.00
101-257-958.000	MEMBERSHIP & DUES	0.00	0.00	0.00	0.00	0.00
101-257-958.001	TRAINING & SEMINARS	0.00	0.00	0.00	0.00	0.00
Total Dept 257 - CITY ASSESSOR		122,855.00	96,648.56	7,911.08	26,206.44	78.67
Dept 265 - CITY HALL & GROUNDS						
101-265-702.000	SALARIES & WAGES	117,195.00	48,620.33	3,453.66	68,574.67	41.49
101-265-702.801	P & R WAGES PART-TIME UNION	0.00	0.00	0.00	0.00	0.00
101-265-709.000	OVERTIME-CH & GROUNDS	16,125.00	7,741.62	0.00	8,383.38	48.87
101-265-715.000	FICA	10,199.00	3,951.61	239.86	6,247.39	38.68
101-265-717.000	RETIREE HEALTH CARE	3,600.00	1,535.00	114.37	2,065.00	42.92

*NOTE: Available Balance / Pct Budget Used does not reflect amounts encumbered.

GL NUMBER	DESCRIPTION	2025-26	YTD BALANCE	ACTIVITY FOR	AVAILABLE	% BGDG USED
		AMENDED BUDGET	05/31/2026 NORMAL (ABNORMAL)	MONTH 05/31/2026 INCREASE (DECREASE)	BALANCE NORMAL (ABNORMAL)	
Fund 101 - GENERAL FUND						
Expenditures						
101-265-722.000	RETIREMENT	49,216.00	23,508.56	1,440.52	25,707.44	47.77
101-265-722.100	MEDICARE REIMBURSEMENT	0.00	0.00	0.00	0.00	0.00
101-265-757.000	OPERATING SUPPLIES	15,000.00	7,930.85	526.20	7,069.15	52.87
101-265-818.000	CONTRACTUAL SERVICES	116,800.00	94,118.22	13,312.09	22,681.78	80.58
101-265-930.000	EQUIPMENT MAINT & REPAIR	25,000.00	21,695.00	5,835.00	3,305.00	86.78
Total Dept 265 - CITY HALL & GROUNDS		353,135.00	209,101.19	24,921.70	144,033.81	59.21
Dept 266 - CITY ATTORNEY						
101-266-719.000	HOSP/DENTAL/OPTICAL	0.00	0.00	0.00	0.00	0.00
101-266-801.000	LEGAL FEES-GEN'L CITY	75,000.00	62,924.24	6,787.62	12,075.76	83.90
101-266-801.100	LEGAL COUNSEL-COURT	40,000.00	19,669.50	2,015.00	20,330.50	49.17
101-266-801.200	LEGAL COUNSEL-BLDG & PLANNING	10,000.00	1,204.50	0.00	8,795.50	12.05
101-266-801.300	LEGAL/OUTSIDE CONSULTANTS- MTT	40,000.00	778.74	21.13	39,221.26	1.95
101-266-801.301	MTT-APPRAISALS & OTHER CONSULTANTS	30,000.00	0.00	0.00	30,000.00	0.00
101-266-810.000	LABOR CONSULTANT	35,000.00	12,603.00	4,323.00	22,397.00	36.01
101-266-812.000	CLAIMS/OUTSIDE COUNSEL	35,000.00	27,129.20	0.00	7,870.80	77.51
101-266-955.300	EXPENSES	0.00	0.00	0.00	0.00	0.00
101-266-958.000	MEMBERSHIP & DUES	0.00	0.00	0.00	0.00	0.00
101-266-958.001	TRAINING & SEMINARS	0.00	0.00	0.00	0.00	0.00
Total Dept 266 - CITY ATTORNEY		265,000.00	124,309.18	13,146.75	140,690.82	46.91
Dept 286 - COURT EXPENDITURES						
101-286-702.000	SALARIES & WAGES	181,240.00	156,385.30	13,397.58	24,854.70	86.29
101-286-705.000	PSO COURT OVERTIME	15,000.00	9,251.11	623.82	5,748.89	61.67
101-286-709.000	OVERTIME	1,000.00	0.00	0.00	1,000.00	0.00
101-286-710.999	SICK/VAC PAY	7,500.00	0.00	0.00	7,500.00	0.00
101-286-715.000	FICA	14,675.00	11,747.63	998.46	2,927.37	80.05
101-286-717.000	RETIREE HEALTH CARE	2,700.00	2,499.37	232.54	200.63	92.57
101-286-718.000	H.S.A.	2,700.00	2,700.00	0.00	0.00	100.00
101-286-719.000	HOSP/DENTAL/OPTICAL	36,750.00	36,750.00	0.00	0.00	100.00
101-286-720.000	LIFE & LTD INSURANCE	545.00	545.00	0.00	0.00	100.00
101-286-721.000	WORKERS COMP	3,000.00	3,000.00	0.00	0.00	100.00
101-286-722.000	RETIREMENT	48,983.00	34,284.88	2,860.67	14,698.12	69.99
101-286-722.100	MEDICARE REIMBURSEMENT	0.00	0.00	0.00	0.00	0.00
101-286-723.000	SUPPLEMENTAL ANNUITY	14,786.00	14,786.00	0.00	0.00	100.00
101-286-725.000	CLOTHING/UNIFORM ALLOWANCE	0.00	0.00	0.00	0.00	0.00
101-286-725.200	MESC INSURANCE	0.00	0.00	0.00	0.00	0.00
101-286-757.000	OPERATING SUPPLIES	25,800.00	14,855.80	0.00	10,944.20	57.58
101-286-801.400	COURT APPOINTED ATTORNEY	0.00	0.00	0.00	0.00	0.00
101-286-805.000	PROBATION FEES	0.00	0.00	0.00	0.00	0.00
101-286-806.000	SOM TRANSMITTAL FEES	43,200.00	24,343.00	3,245.40	18,857.00	56.35
101-286-807.000	WITNESS FEES	500.00	0.00	0.00	500.00	0.00
101-286-808.000	JAIL FEES	0.00	0.00	0.00	0.00	0.00
101-286-818.000	CONTRACTUAL	14,100.00	8,067.97	36.43	6,032.03	57.22
101-286-930.000	EQUIPMENT MAINT & REPAIR	2,000.00	0.00	0.00	2,000.00	0.00
101-286-958.000	MEMBERSHIP & DUES	1,140.00	975.00	0.00	165.00	85.53
101-286-958.001	TRAINING & SEMINARS	6,200.00	2,613.19	23.00	3,586.81	42.55
101-286-960.000	EDUCATION-TRAINING	1,500.00	0.00	0.00	1,500.00	0.00
101-286-977.000	EQUIPMENT	0.00	0.00	0.00	0.00	0.00

PERIOD ENDING 05/31/2026

*NOTE: Available Balance / Pct Budget Used does not reflect amounts encumbered.

GL NUMBER	DESCRIPTION	2025-26 AMENDED BUDGET	YTD BALANCE		ACTIVITY FOR		AVAILABLE		% BDGT USED
			NORMAL	(ABNORMAL)	MONTH	(DECREASE)	NORMAL	(ABNORMAL)	
Fund 101 - GENERAL FUND									
Expenditures									
Total Dept 286 - COURT EXPENDITURES		423,319.00	322,804.25		21,417.90		100,514.75		76.26
Dept 305 - PUB SAF-ADMIN									
101-305-702.000	SALARIES & WAGES	192,735.00	168,374.33		14,483.72		24,360.67		87.36
101-305-709.000	OVERTIME	600.00	590.63		0.00		9.37		98.44
101-305-715.000	FICA	14,790.00	13,073.22		1,118.27		1,716.78		88.39
101-305-717.000	RETIREE HEALTH CARE	3,600.00	3,222.50		300.00		377.50		89.51
101-305-722.000	RETIREMENT	29,482.00	26,838.45		2,277.24		2,643.55		91.03
101-305-722.100	MEDICARE REIMBURSEMENT	0.00	0.00		0.00		0.00		0.00
101-305-818.000	CONTRACTUAL SERVICES	75,942.00	51,144.95		2,604.00		24,797.05		67.35
101-305-835.100	PRE-EMPLOYMENT TESTING	10,400.00	7,206.95		1,898.00		3,193.05		69.30
101-305-851.000	RADIO MAINTENANCE	38,608.00	21,005.83		0.00		17,602.17		54.41
101-305-930.000	EQUIPMENT MAINT & REPAIR	7,000.00	0.00		0.00		7,000.00		0.00
101-305-958.000	MEMBERSHIP & DUES	4,375.00	3,900.00		50.00		475.00		89.14
101-305-958.001	TRAINING & SEMINARS	9,800.00	5,829.62		0.00		3,970.38		59.49
Total Dept 305 - PUB SAF-ADMIN		387,332.00	301,186.48		22,731.23		86,145.52		77.76
Dept 310 - POLICE SERVICES									
101-310-702.100	SAL & WAGES - LT	336,457.00	288,170.66		24,445.27		48,286.34		85.65
101-310-702.200	SAL & WAGES - SGT	627,165.00	552,731.67		45,791.89		74,433.33		88.13
101-310-702.400	SAL & WAGES - PSO	1,937,714.00	1,599,103.59		128,597.91		338,610.41		82.53
101-310-702.500	SAL & WAGES DISPATCH	224,403.00	202,742.82		16,276.75		21,660.18		90.35
101-310-702.600	SAL & WAGES-SECRETARY/CLERICAL	83,140.00	67,153.45		5,978.80		15,986.55		80.77
101-310-709.100	OVERTIME - LT	17,000.00	23,775.09		2,718.23		(6,775.09)		139.85
101-310-709.200	OVERTIME - SGT	40,000.00	50,821.53		2,330.63		(10,821.53)		127.05
101-310-709.400	OVERTIME - PSO	95,000.00	146,485.10		9,396.43		(51,485.10)		154.19
101-310-709.500	OVERTIME - DISPATCH	15,000.00	10,800.78		1,222.81		4,199.22		72.01
101-310-709.600	OVERTIME-SECRETARY/CLERICAL	300.00	0.00		0.00		300.00		0.00
101-310-715.000	FICA	69,051.00	59,279.19		4,755.37		9,771.81		85.85
101-310-717.000	RETIREE HEALTH CARE	36,000.00	31,237.08		2,753.84		4,762.92		86.77
101-310-722.000	RETIREMENT	1,534,704.00	1,311,204.22		103,623.74		223,499.78		85.44
101-310-722.100	MEDICARE REIMBURSEMENT	0.00	0.00		0.00		0.00		0.00
101-310-757.000	OPERATING SUPPLIES	59,449.00	45,896.74		108.31		13,552.26		77.20
101-310-757.200	K9 SUPPLIES	3,000.00	935.68		437.22		2,064.32		31.19
101-310-808.000	JAIL FEES	12,250.00	6,900.51		471.00		5,349.49		56.33
101-310-818.000	CONTRACTUAL SERVICES	87,423.80	80,776.91		21,906.56		6,646.89		92.40
101-310-818.100	K9 CONTRACTED SERVICES	4,464.60	2,325.80		0.00		2,138.80		52.09
101-310-930.000	EQUIPMENT MAINT & REPAIR	19,802.27	19,525.22		0.00		277.05		98.60
101-310-930.200	K9 EQUIPMENT AND REPAIR	7,635.40	7,204.40		0.00		431.00		94.36
101-310-958.000	MEMBERSHIP & DUES	0.00	0.00		0.00		0.00		0.00
101-310-960.000	EDUCATION-TRAINING	0.00	0.00		0.00		0.00		0.00
101-310-961.000	TRAINING	32,857.73	17,755.88		5,532.46		15,101.85		54.04
101-310-961.030	CPE TRAINING	0.00	0.00		0.00		0.00		0.00
101-310-961.200	K9 TRAINING	4,500.00	4,500.00		0.00		0.00		100.00
101-310-972.000	MINOR EQUIPMENT	54,943.00	22,969.69		0.00		31,973.31		41.81
Total Dept 310 - POLICE SERVICES		5,302,259.80	4,552,296.01		376,347.22		749,963.79		85.06
Dept 326 - SUPPORT SERVICES									

PERIOD ENDING 05/31/2026

*NOTE: Available Balance / Pct Budget Used does not reflect amounts encumbered.

GL NUMBER	DESCRIPTION	2025-26 AMENDED BUDGET	YTD BALANCE	ACTIVITY FOR	AVAILABLE	% BDGT USED
			05/31/2026 NORMAL (ABNORMAL)	MONTH 05/31/2026 INCREASE (DECREASE)	BALANCE NORMAL (ABNORMAL)	
Fund 101 - GENERAL FUND						
Expenditures						
101-326-702.000	SALARIES & WAGES	137,292.00	111,388.46	13,491.20	25,903.54	81.13
101-326-715.000	FICA	10,503.00	8,521.25	1,032.08	1,981.75	81.13
101-326-757.000	OPERATING SUPPLIES	14,132.00	9,584.40	0.00	4,547.60	67.82
101-326-831.100	K-9 DIVISION	0.00	0.00	0.00	0.00	0.00
101-326-832.000	ANIMAL COLLECTION	3,000.00	1,354.00	0.00	1,646.00	45.13
101-326-972.000	MINOR EQUIPMENT	1,000.00	0.00	0.00	1,000.00	0.00
Total Dept 326 - SUPPORT SERVICES		165,927.00	130,848.11	14,523.28	35,078.89	78.86
Dept 339 - FIRE SERV/SAFETY INS						
101-339-757.000	OPERATING SUPPLIES	36,670.00	28,854.10	650.77	7,815.90	78.69
101-339-818.000	CONTRACTUAL SERVICES	11,310.00	4,760.67	1,120.00	6,549.33	42.09
101-339-930.000	EQUIPMENT MAINT & REPAIR	9,848.02	7,293.02	0.00	2,555.00	74.06
101-339-961.000	TRAINING	17,747.98	6,060.29	1,100.00	11,687.69	34.15
101-339-972.000	MINOR EQUIPMENT	2,150.00	1,964.72	0.00	185.28	91.38
Total Dept 339 - FIRE SERV/SAFETY INS		77,726.00	48,932.80	2,870.77	28,793.20	62.96
Dept 345 - PUB-SAF FRINGES						
101-345-703.000	BS&A MOCK SALARY EXPENSE	0.00	0.00	0.00	0.00	0.00
101-345-710.999	SICK/VAC PAY	125,000.00	90,744.97	10,633.73	34,255.03	72.60
101-345-711.000	LONGEVITY/COLA	17,600.00	17,641.67	0.00	(41.67)	100.24
101-345-713.000	HOLIDAY PAY	104,033.00	98,105.17	94,254.46	5,927.83	94.30
101-345-715.000	FICA	3,638.00	4,790.04	1,533.92	(1,152.04)	131.67
101-345-717.000	RETIREE HEALTH CARE	690,000.00	690,166.14	88.64	(166.14)	100.02
101-345-718.000	H.S.A.	70,000.00	69,089.59	0.00	910.41	98.70
101-345-719.000	HOSP/DENTAL/OPTICAL	863,000.00	876,250.00	0.00	(13,250.00)	101.54
101-345-720.000	LIFE & LTD INSURANCE	7,380.00	7,380.00	0.00	0.00	100.00
101-345-721.000	WORKERS COMP	98,800.00	98,800.00	0.00	0.00	100.00
101-345-722.000	RETIREMENT	54,545.00	51,904.00	42,291.96	2,641.00	95.16
101-345-722.100	MEDICARE REIMBURSEMENT	58,000.00	47,543.62	4,240.55	10,456.38	81.97
101-345-723.000	SUPPLEMENTAL ANNUITY	46,849.00	46,849.00	0.00	0.00	100.00
101-345-725.000	CLOTHING/UNIFORM ALLOWANCE	33,800.00	31,487.45	0.00	2,312.55	93.16
101-345-725.100	CLOTHING - CITY SHARE	8,200.00	6,461.97	0.00	1,738.03	78.80
101-345-725.200	MESC INSURANCE	1,000.00	732.15	0.00	267.85	73.22
101-345-960.000	EDUCATION-TRAINING	3,000.00	0.00	0.00	3,000.00	0.00
Total Dept 345 - PUB-SAF FRINGES		2,184,845.00	2,137,945.77	153,043.26	46,899.23	97.85
Dept 349 - OVERHEAD						
101-349-728.000	OFFICE SUPPLIES	13,285.00	7,564.39	0.00	5,720.61	56.94
101-349-818.000	CONTRACTUAL SERVICES	71,033.00	51,868.96	0.00	19,164.04	73.02
101-349-818.001	CODE VIOLATIONS	12,500.00	5,315.00	0.00	7,185.00	42.52
101-349-921.000	UTILITIES	70,000.00	66,171.37	6,535.61	3,828.63	94.53
101-349-955.000	INSURANCE	95,778.48	95,778.00	0.00	0.48	100.00
101-349-955.050	K9 INSURANCE	63.00	63.00	0.00	0.00	100.00
Total Dept 349 - OVERHEAD		262,659.48	226,760.72	6,535.61	35,898.76	86.61

PERIOD ENDING 05/31/2026

*NOTE: Available Balance / Pct Budget Used does not reflect amounts encumbered.

GL NUMBER	DESCRIPTION	2025-26	YTD BALANCE	ACTIVITY FOR	AVAILABLE	% BDGT USED
		AMENDED BUDGET	05/31/2026 NORMAL (ABNORMAL)	MONTH 05/31/2026 INCREASE (DECREASE)	BALANCE NORMAL (ABNORMAL)	
Fund 101 - GENERAL FUND						
Expenditures						
Dept 371 - BUILDING INSPECTIONS						
101-371-702.000	SALARIES & WAGES	0.00	0.00	0.00	0.00	0.00
101-371-709.000	OVERTIME	0.00	0.00	0.00	0.00	0.00
101-371-710.999	SICK/VAC PAY	0.00	0.00	0.00	0.00	0.00
101-371-711.000	LONGEVITY/COLA	0.00	0.00	0.00	0.00	0.00
101-371-715.000	FICA	0.00	0.00	0.00	0.00	0.00
101-371-717.000	RETIREE HEALTH CARE	0.00	0.00	0.00	0.00	0.00
101-371-718.000	H.S.A.	0.00	0.00	0.00	0.00	0.00
101-371-719.000	HOSP/DENTAL/OPTICAL	0.00	0.00	0.00	0.00	0.00
101-371-720.000	LIFE & LTD INSURANCE	0.00	0.00	0.00	0.00	0.00
101-371-721.000	WORKERS COMP	0.00	0.00	0.00	0.00	0.00
101-371-722.000	RETIREMENT	0.00	0.00	0.00	0.00	0.00
101-371-722.100	MEDICARE REIMBURSEMENT	0.00	0.00	0.00	0.00	0.00
101-371-723.000	SUPPLEMENTAL ANNUITY	0.00	0.00	0.00	0.00	0.00
101-371-725.000	CLOTHING/UNIFORM ALLOWANCE	0.00	0.00	0.00	0.00	0.00
101-371-725.200	MESC INSURANCE	0.00	0.00	0.00	0.00	0.00
101-371-757.000	OPERATING SUPPLIES	2,500.00	0.00	0.00	2,500.00	0.00
101-371-818.000	CONTRACTUAL	671,750.00	539,904.06	84,171.10	131,845.94	80.37
101-371-818.001	CODE VIOLATIONS	0.00	0.00	0.00	0.00	0.00
101-371-958.000	MEMBERSHIP & DUES	0.00	0.00	0.00	0.00	0.00
101-371-958.001	TRAINING & SEMINARS	0.00	0.00	0.00	0.00	0.00
101-371-960.000	EDUCATION-TRAINING	0.00	0.00	0.00	0.00	0.00
101-371-977.000	EQUIPMENT	0.00	0.00	0.00	0.00	0.00
Total Dept 371 - BUILDING INSPECTIONS		674,250.00	539,904.06	84,171.10	134,345.94	80.07
Dept 441 - PUBLIC WORKS-ADMIN						
101-441-702.000	SALARIES & WAGES	22,371.00	20,094.19	1,720.82	2,276.81	89.82
101-441-715.000	FICA	1,711.00	1,379.84	118.10	331.16	80.65
101-441-717.000	RETIREE HEALTH CARE	720.00	659.94	59.99	60.06	91.66
101-441-722.000	RETIREMENT	9,331.00	8,381.40	717.78	949.60	89.82
101-441-722.100	MEDICARE REIMBURSEMENT	0.00	0.00	0.00	0.00	0.00
101-441-757.000	OPERATING SUPPLIES	15,000.00	14,734.89	303.47	265.11	98.23
101-441-818.000	CONTRACTUAL SERVICES	58,500.00	47,314.99	3,156.95	11,185.01	80.88
101-441-835.100	PRE-EMPLOYMENT TESTING	3,350.00	1,780.32	0.00	1,569.68	53.14
101-441-851.000	RADIO MAINTENANCE	0.00	0.00	0.00	0.00	0.00
101-441-930.000	EQUIPMENT MAINT & REPAIR	68,800.00	33,513.68	3,460.05	35,286.32	48.71
101-441-958.000	MEMBERSHIP & DUES	1,100.00	1,119.00	0.00	(19.00)	101.73
Total Dept 441 - PUBLIC WORKS-ADMIN		180,883.00	128,978.25	9,537.16	51,904.75	71.30
Dept 463 - ROUTINE MAINTENANCE						
101-463-702.000	SALARIES & WAGES	251,006.00	206,214.26	12,677.53	44,791.74	82.16
101-463-709.000	OVERTIME	40,000.00	26,321.52	1,609.04	13,678.48	65.80
101-463-715.000	FICA	22,262.00	16,568.46	996.92	5,693.54	74.42
101-463-717.000	RETIREE HEALTH CARE	8,100.00	6,169.34	617.78	1,930.66	76.16
101-463-722.000	RETIREMENT	104,905.00	96,990.65	5,958.93	7,914.35	92.46
Total Dept 463 - ROUTINE MAINTENANCE		426,273.00	352,264.23	21,860.20	74,008.77	82

PERIOD ENDING 05/31/2026

*NOTE: Available Balance / Pct Budget Used does not reflect amounts encumbered.

GL NUMBER	DESCRIPTION	2025-26	YTD BALANCE	ACTIVITY FOR	AVAILABLE	% BDGT USED
		AMENDED BUDGET	05/31/2026 NORMAL (ABNORMAL)	MONTH 05/31/2026 INCREASE (DECREASE)	BALANCE NORMAL (ABNORMAL)	
Fund 101 - GENERAL FUND						
Expenditures						
Dept 523 - FORESTRY SERVICES						
101-523-702.000	SALARIES & WAGES	173,164.00	29,403.02	3,401.58	143,760.98	16.98
101-523-709.000	OVERTIME	3,000.00	0.00	0.00	3,000.00	0.00
101-523-715.000	FICA	13,477.00	2,078.74	241.55	11,398.26	15.42
101-523-717.000	RETIREE HEALTH CARE	3,600.00	544.14	47.65	3,055.86	15.12
101-523-722.000	RETIREMENT	72,644.00	12,263.95	1,418.79	60,380.05	16.88
101-523-757.000	OPERATING SUPPLIES	6,500.00	479.06	194.47	6,020.94	7.37
101-523-818.000	CONTRACTUAL SERVICES	60,000.00	53,177.00	20,715.00	6,823.00	88.63
Total Dept 523 - FORESTRY SERVICES		332,385.00	97,945.91	26,019.04	234,439.09	29.47
Dept 531 - PUB WKS-FRINGE						
101-531-703.000	BS&A MOCK SALARY EXPENSE	0.00	0.00	0.00	0.00	0.00
101-531-710.999	SICK/VAC PAY	15,000.00	15,309.75	4,561.95	(309.75)	102.07
101-531-711.000	LONGEVITY/COLA	2,600.00	2,600.00	0.00	0.00	100.00
101-531-715.000	FICA	1,346.00	1,446.60	348.99	(100.60)	107.47
101-531-717.000	RETIREE HEALTH CARE	25,000.00	25,000.00	0.00	0.00	100.00
101-531-718.000	H.S.A.	15,200.00	15,200.00	0.00	0.00	100.00
101-531-719.000	HOSP/DENTAL/OPTICAL	221,050.00	224,050.00	0.00	(3,000.00)	101.36
101-531-720.000	LIFE & LTD INSURANCE	1,520.00	1,520.00	0.00	0.00	100.00
101-531-721.000	WORKERS COMP	14,650.00	14,650.00	0.00	0.00	100.00
101-531-722.000	RETIREMENT	0.00	1,084.46	0.00	(1,084.46)	100.00
101-531-722.100	MEDICARE REIMBURSEMENT	14,000.00	11,474.25	1,023.42	2,525.75	81.96
101-531-723.000	SUPPLEMENTAL ANNUITY	71,264.00	71,264.00	0.00	0.00	100.00
101-531-725.000	CLOTHING/UNIFORM ALLOWANCE	12,000.00	8,711.42	181.21	3,288.58	72.60
101-531-725.200	MESC INSURANCE	0.00	0.00	0.00	0.00	0.00
101-531-960.000	EDUCATION-TRAINING	5,100.00	0.00	0.00	5,100.00	0.00
Total Dept 531 - PUB WKS-FRINGE		398,730.00	392,310.48	6,115.57	6,419.52	98.39
Dept 594 - OVERHEAD						
101-594-728.000	OFFICE SUPPLIES	2,500.00	291.89	0.00	2,208.11	11.68
101-594-818.000	CONTRACTUAL SERVICES	0.00	0.00	0.00	0.00	0.00
101-594-921.000	UTILITIES	80,000.00	73,621.33	4,381.42	6,378.67	92.03
101-594-926.000	MUN. STREET LGHT	575,000.00	481,577.31	49,961.99	93,422.69	83.75
101-594-955.000	INSURANCE	27,558.29	27,558.00	0.00	0.29	100.00
Total Dept 594 - OVERHEAD		685,058.29	583,048.53	54,343.41	102,009.76	85.11
Dept 752 - PARKS & REC-ADMIN						
101-752-702.000	SALARIES & WAGES	9,506.00	8,538.28	731.26	967.72	89.82
101-752-715.000	FICA	727.00	653.14	55.94	73.86	89.84
101-752-717.000	RETIREE HEALTH CARE	0.00	0.00	0.00	0.00	0.00
101-752-722.000	RETIREMENT	3,965.00	0.00	0.00	3,965.00	0.00
101-752-722.100	MEDICARE REIMBURSEMENT	0.00	0.00	0.00	0.00	0.00
101-752-757.000	OPERATING SUPPLIES	1,000.00	860.89	0.00	139.11	86.09
101-752-958.000	MEMBERSHIP & DUES	3,740.00	4,163.72	375.00	(423.72)	111.33
Total Dept 752 - PARKS & REC-ADMIN		18,938.00	14,216.03	1,162.20	4,721.97	75.11

PERIOD ENDING 05/31/2026

*NOTE: Available Balance / Pct Budget Used does not reflect amounts encumbered.

GL NUMBER	DESCRIPTION	2025-26	YTD BALANCE	ACTIVITY FOR	AVAILABLE	% BGDGT USED
		AMENDED BUDGET	05/31/2026 NORMAL (ABNORMAL)	MONTH 05/31/2026 INCREASE (DECREASE)	BALANCE NORMAL (ABNORMAL)	
Fund 101 - GENERAL FUND						
Expenditures						
Dept 774 - LFP EXPENDITURES						
101-774-702.000	SALARIES & WAGES	88,026.00	96,370.06	8,283.89	(8,344.06)	109.48
101-774-702.801	P & R WAGES PART-TIME UNION	157,245.00	122,993.16	14,513.42	34,251.84	78.22
101-774-702.802	P & R WAGES P/T GATE & OFFICE	111,709.00	68,546.64	6,127.87	43,162.36	61.36
101-774-702.803	P & R P/T - ACTIVITIES BLDG	95,404.00	52,240.05	3,940.51	43,163.95	54.76
101-774-702.804	P & R WAGES SEASON -MGT	70,904.00	38,539.43	1,458.00	32,364.57	54.35
101-774-702.805	P & R WAGES SEASON - LIFEGUARD	182,897.00	78,917.75	2,487.69	103,979.25	43.15
101-774-702.806	P & R WAGES SEASON INSTRUCT-CO	65,778.00	44,556.27	513.00	21,221.73	67.74
101-774-702.807	P & R WAGES SEASON BH & BRIDGE	0.00	0.00	0.00	0.00	0.00
101-774-702.808	WAGES- SEASONAL MAINTENANCE	59,570.00	57,666.81	7,643.06	1,903.19	96.81
101-774-702.809	WAGES- SEASONAL OFFICE	15,050.00	5,710.97	0.00	9,339.03	37.95
101-774-702.811	P & R WAGES SPECIAL EVENT ASST	3,577.00	1,707.41	0.00	1,869.59	47.73
101-774-702.812	P & R WAGES- WATERSLIDE ATTENDANTS	16,131.00	4,347.86	0.00	11,783.14	26.95
101-774-709.000	OVERTIME-LFP-DPW	16,000.00	17,831.25	316.42	(1,831.25)	111.45
101-774-715.000	FICA	67,495.00	44,552.55	3,437.58	22,942.45	66.01
101-774-717.000	RETIREE HEALTH CARE	1,440.00	1,924.38	134.99	(484.38)	133.64
101-774-722.000	RETIREMENT	44,224.00	44,604.57	3,553.01	(380.57)	100.86
101-774-722.100	MEDICARE REIMBURSEMENT	0.00	0.00	0.00	0.00	0.00
101-774-757.000	OPERATING SUPPLY-ACTIVITY BLDG	13,113.00	5,942.98	0.00	7,170.02	45.32
101-774-757.101	OPER SUPP-CONCESSION STAND	10,000.00	0.00	0.00	10,000.00	0.00
101-774-757.102	OPER SUPPLY- LANDSCAPE	29,900.00	27,482.38	1,061.97	2,417.62	91.91
101-774-757.103	OPER SUPPLY - LIFEGUARD	11,250.00	3,311.64	170.00	7,938.36	29.44
101-774-757.104	OPER SUPPLY - POOL MAINT	35,700.00	7,468.98	3,570.54	28,231.02	20.92
101-774-757.105	OPER SUPPLY-POOL CHEMICAL	58,127.00	40,807.36	1,481.81	17,319.64	70.20
101-774-757.106	OPER SUPPLY-JANITOR SUPPLIES	20,100.00	19,953.97	1,389.92	146.03	99.27
101-774-757.107	OPER SUPPLY-MISC	5,150.00	4,038.62	115.69	1,111.38	78.42
101-774-757.108	OPER SUPPLY - MINI GOLF	0.00	0.00	0.00	0.00	0.00
101-774-757.109	SWIM TEAM MERCHANDISE	0.00	0.00	0.00	0.00	0.00
101-774-757.110	LFP VENDING EXPENSES	0.00	0.00	0.00	0.00	0.00
101-774-818.000	CONTRACTUAL SERVICES-ACT BLDG	17,950.00	12,435.62	1,082.99	5,514.38	69.28
101-774-818.101	CONTRACT SVCS-CONSESSIONS	1,500.00	1,500.00	1,000.00	0.00	100.00
101-774-818.102	CONTRACT SVSC-PK MAINT	32,500.00	19,545.67	3,099.67	12,954.33	60.14
101-774-818.103	CONTRACT SVCS-POOL MAINT	18,820.00	16,363.37	1,000.00	2,456.63	86.95
101-774-818.104	CONTRACT SVCS-BATH HOUSE	30,555.00	17,703.02	1,000.00	12,851.98	57.94
101-774-818.105	CONTRACT SVCS-SWIM TEAM	11,900.00	12,558.50	25.00	(658.50)	105.53
101-774-818.106	CONTRACT SVCS-RED CROSS	5,000.00	2,829.00	0.00	2,171.00	56.58
101-774-818.107	CONTRACT SVCS-TENNIS	24,800.00	16,999.84	0.00	7,800.16	68.55
101-774-818.108	CONTRACT SVC-ENRICHMENT	0.00	0.00	0.00	0.00	0.00
101-774-818.109	CONTRACT SVCS-ADULT CLASSES	2,450.00	0.00	0.00	2,450.00	0.00
101-774-818.110	CONTRACT SVCS-MISC	9,000.00	0.00	0.00	9,000.00	0.00
101-774-921.000	UTILITIES	184,500.00	137,441.71	13,914.92	47,058.29	74.49
101-774-930.000	EQUIPMENT MAINT & REPAIR	0.00	0.00	0.00	0.00	0.00
101-774-931.000	MISC PARK/POOL REPAIR	30,000.00	20,004.71	443.00	9,995.29	66.68
101-774-955.100	PROPERTY TAXES	104,450.00	103,104.76	0.00	1,345.24	98.71
101-774-972.000	MINOR EQUIPMENT	30,000.00	25,272.70	0.00	4,727.30	84.24
101-774-977.000	EQUIPMENT	47,000.00	37,746.12	0.00	9,253.88	80.31
101-774-977.100	RADIO SYSTEM	0.00	0.00	0.00	0.00	0.00
Total Dept 774 - LFP EXPENDITURES		1,729,215.00	1,213,020.11	81,764.95	516,194.89	70.15
Dept 775 - CITY PARKS						
101-775-702.000	SALARIES & WAGES	24,520.00	47,937.81	2,569.76	(23,417.81)	195

User: lbishop

DB: Gpw

PERIOD ENDING 05/31/2026

*NOTE: Available Balance / Pct Budget Used does not reflect amounts encumbered.

GL NUMBER	DESCRIPTION	2025-26	YTD BALANCE	ACTIVITY FOR	AVAILABLE	% BDGT USED
		AMENDED BUDGET	05/31/2026	MONTH 05/31/2026	BALANCE	
			NORMAL (ABNORMAL)	INCREASE (DECREASE)	NORMAL (ABNORMAL)	
Fund 101 - GENERAL FUND						
Expenditures						
101-775-709.000	OVERTIME	15,000.00	9,105.97	2,549.31	5,894.03	60.71
101-775-709.200	OVERTIME - DPW @ P&R	0.00	0.00	0.00	0.00	0.00
101-775-715.000	FICA	3,023.00	4,052.25	360.02	(1,029.25)	134.05
101-775-717.000	RETIREE HEALTH CARE	720.00	1,389.12	9.29	(669.12)	192.93
101-775-722.000	RETIREMENT	16,484.00	23,793.20	2,135.16	(7,309.20)	144.34
101-775-722.100	MEDICARE REIMBURSEMENT	0.00	0.00	0.00	0.00	0.00
101-775-757.000	OPERATING SUPPLIES	17,050.00	4,687.53	2,185.39	12,362.47	27.49
101-775-818.000	CONTRACTUAL SERVICES	34,336.00	22,021.32	1,347.61	12,314.68	64.13
101-775-921.000	UTILITIES	8,000.00	8,835.40	395.28	(835.40)	110.44
101-775-972.000	MINOR EQUIPMENT	20,000.00	19,564.16	11,377.41	435.84	97.82
101-775-977.000	EQUIPMENT	0.00	0.00	0.00	0.00	0.00
Total Dept 775 - CITY PARKS		139,133.00	141,386.76	22,929.23	(2,253.76)	101.62
Dept 780 - COMMUNITY CENTER						
101-780-702.000	SALARIES & WAGES	78,962.00	84,818.18	8,136.81	(5,856.18)	107.42
101-780-709.000	OVERTIME	1,000.00	860.37	0.00	139.63	86.04
101-780-710.999	SICK/VAC PAY	0.00	0.00	0.00	0.00	0.00
101-780-715.000	FICA	6,041.00	6,301.48	618.32	(260.48)	104.31
101-780-717.000	RETIREE HEALTH CARE	1,800.00	1,772.15	225.01	27.85	98.45
101-780-718.000	HSA	2,000.00	0.00	0.00	2,000.00	0.00
101-780-719.000	HOSP/DENTAL/OPTICAL	24,500.00	24,500.00	0.00	0.00	100.00
101-780-720.000	LIFE & LTD INSURANCE	412.00	412.00	0.00	0.00	100.00
101-780-721.000	WORKERS COMP	3,000.00	3,000.00	0.00	0.00	100.00
101-780-722.000	RETIREMENT	17,018.00	19,095.71	2,265.68	(2,077.71)	112.21
101-780-723.000	SUPPLEMENTAL ANNUITY	5,137.00	5,137.00	0.00	0.00	100.00
101-780-757.000	OPERATING SUPPLIES	11,450.00	13,588.24	0.00	(2,138.24)	118.67
101-780-818.000	CONTRACTUAL SERVICES	32,670.00	21,073.40	2,122.65	11,596.60	64.50
101-780-880.000	COMMUNITY RELATIONS	37,880.00	26,269.72	412.00	11,610.28	69.35
101-780-880.603	SENIOR PROGRAMS	40,684.00	13,207.08	230.00	27,476.92	32.46
101-780-921.000	UTILITIES	22,000.00	15,126.99	1,301.58	6,873.01	68.76
101-780-930.000	EQUIPMENT MAINT & REPAIR	5,000.00	1,568.74	1,234.67	3,431.26	31.37
101-780-958.000	MEMBERSHIP & DUES	1,050.00	169.50	169.50	880.50	16.14
101-780-958.001	TRAINING & SEMINARS	0.00	0.00	0.00	0.00	0.00
101-780-972.000	MINOR EQUIPMENT	0.00	0.00	0.00	0.00	0.00
101-780-977.000	EQUIPMENT	0.00	0.00	0.00	0.00	0.00
Total Dept 780 - COMMUNITY CENTER		290,604.00	236,900.56	16,716.22	53,703.44	81.52
Dept 795 - PARKS & REC FRINGE						
101-795-703.000	BS&A MOCK SALARY EXPENSE	0.00	0.00	0.00	0.00	0.00
101-795-710.999	SICK/VAC PAY	3,000.00	371.39	0.00	2,628.61	12.38
101-795-715.000	FICA	230.00	26.79	0.00	203.21	11.65
101-795-717.000	RETIREE HEALTH CARE	61,000.00	61,027.89	0.00	(27.89)	100.05
101-795-718.000	H.S.A.	1,400.00	1,983.33	0.00	(583.33)	141.67
101-795-719.000	HOSP/DENTAL/OPTICAL	19,550.00	19,550.00	0.00	0.00	100.00
101-795-720.000	LIFE & LTD INSURANCE	609.00	609.00	0.00	0.00	100.00
101-795-721.000	WORKERS COMP	8,450.00	8,450.00	0.00	0.00	100.00
101-795-723.000	SUPPLEMENTAL ANNUITY	14,170.00	14,170.00	0.00	0.00	100.00
101-795-725.200	MESC INSURANCE	0.00	0.00	0.00	0.00	0.00

REVENUE AND EXPENDITURE REPORT FOR CITY OF GROSSE POINTE WOODS
 PERIOD ENDING 05/31/2026

*NOTE: Available Balance / Pct Budget Used does not reflect amounts encumbered.

GL NUMBER	DESCRIPTION	2025-26 AMENDED BUDGET	YTD BALANCE	ACTIVITY FOR	AVAILABLE	% BDGT USED
			NORMAL (ABNORMAL)	MONTH 05/31/2026 INCREASE (DECREASE)	BALANCE NORMAL (ABNORMAL)	
Fund 101 - GENERAL FUND						
Expenditures						
Total Dept 795 - PARKS & REC FRINGE		108,409.00	106,188.40	0.00	2,220.60	97.95
Dept 799 - OVERHEAD						
101-799-955.000	INSURANCE	27,133.65	27,134.00	0.00	(0.35)	100.00
Total Dept 799 - OVERHEAD		27,133.65	27,134.00	0.00	(0.35)	100.00
Dept 967 - TRANSFERS OUT ADMIN.						
101-967-995.203	TRANSFER TO LOCAL ROAD	0.00	0.00	0.00	0.00	0.00
101-967-995.226	TRANSFER TO SOLID WASTE	0.00	0.00	0.00	0.00	0.00
101-967-995.245	TRANSFER TO GRANT FUND	0.00	0.00	0.00	0.00	0.00
101-967-995.260	TRF TO SOM MIDC GRANT	3,176.00	3,176.49	0.00	(0.49)	100.02
101-967-995.304	TRF TO ROAD BOND FUND	0.00	0.00	0.00	0.00	0.00
101-967-995.307	TRANSFER TO CAP IMPROVEMENT DEBT	212,363.00	212,362.50	0.00	0.50	100.00
101-967-995.420	TRF TO CAPITAL IMPROVEMENT	0.00	0.00	0.00	0.00	0.00
101-967-995.661	TRF TO MOTOR VEHICLE	10,000.00	10,000.00	0.00	0.00	100.00
101-967-995.677	TRANSFER TO WORKER'S COMP	0.00	0.00	0.00	0.00	0.00
101-967-995.731	TRANSFER TO PENSION FUND	0.00	0.00	0.00	0.00	0.00
101-967-995.737	TRANSFER TO OPEB	200,000.00	200,000.00	0.00	0.00	100.00
Total Dept 967 - TRANSFERS OUT ADMIN.		425,539.00	425,538.99	0.00	0.01	100.00
Dept 968 - TRANSFER OUT DPS						
101-968-995.261	TRF TO 911 FUND	0.00	0.00	0.00	0.00	0.00
101-968-995.401	TRF TO MUNICIPAL IMPROVEMENT	43,500.00	43,500.00	0.00	0.00	100.00
101-968-995.420	TRF TO CAPITAL IMPROVEMENT	0.00	0.00	0.00	0.00	0.00
101-968-995.661	TRF TO MOTOR VEHICLE	267,404.00	267,404.00	0.00	0.00	100.00
Total Dept 968 - TRANSFER OUT DPS		310,904.00	310,904.00	0.00	0.00	100.00
Dept 969 - TRANSFER OUT DPW						
101-969-995.202	TRANSF TO MAJ ST FD	0.00	0.00	0.00	0.00	0.00
101-969-995.203	TRANSF TO LOC ST FD	0.00	0.00	0.00	0.00	0.00
101-969-995.261	TRF TO 911 FUND	0.00	0.00	0.00	0.00	0.00
101-969-995.401	TRF TO MUNICIPAL IMPROVEMENT	50,000.00	50,000.00	0.00	0.00	100.00
101-969-995.420	TRF TO CAPITAL IMPROVEMENT	0.00	0.00	0.00	0.00	0.00
101-969-995.585	TRANS TO PARKING	0.00	0.00	0.00	0.00	0.00
101-969-995.661	TRF TO MOTOR VEHICLE	170,000.00	170,000.00	0.00	0.00	100.00
Total Dept 969 - TRANSFER OUT DPW		220,000.00	220,000.00	0.00	0.00	100.00
Dept 970 - TRANSFERS OUT PARKS/RECR.						
101-970-995.401	TRF TO MUNICIPAL IMPROVEMENT	25,000.00	25,000.00	0.00	0.00	100.00
101-970-995.661	TRF TO MOTOR VEHICLE	45,000.00	45,000.00	0.00	0.00	100.00
Total Dept 970 - TRANSFERS OUT PARKS/RECR.		70,000.00	70,000.00	0.00	0.00	100.00
TOTAL EXPENDITURES		18,218,006.77	15,283,538.87	1,077,213.68	2,934,467.90	83.89

REVENUE AND EXPENDITURE REPORT FOR CITY OF GROSSE POINTE WOODS

PERIOD ENDING 05/31/2026

*NOTE: Available Balance / Pct Budget Used does not reflect amounts encumbered.

GL NUMBER	DESCRIPTION	2025-26	YTD BALANCE	ACTIVITY FOR	AVAILABLE	% BDGT USED
		AMENDED BUDGET	05/31/2026 NORMAL (ABNORMAL)	MONTH 05/31/2026 INCREASE (DECREASE)	BALANCE NORMAL (ABNORMAL)	
Fund 101 - GENERAL FUND						
Fund 101 - GENERAL FUND:						
	TOTAL REVENUES	18,218,005.77	16,074,636.97	285,320.02	2,143,368.80	88.23
	TOTAL EXPENDITURES	18,218,006.77	15,283,538.87	1,077,213.68	2,934,467.90	83.89
	NET OF REVENUES & EXPENDITURES	(1.00)	791,098.10	(791,893.66)	(791,099.10)	79,109,8

PERIOD ENDING 05/31/2026

*NOTE: Available Balance / Pct Budget Used does not reflect amounts encumbered.

GL NUMBER	DESCRIPTION	2025-26 AMENDED BUDGET	YTD BALANCE 05/31/2026 NORM (ABNORM)	ACTIVITY FOR MONTH 05/31/26 INCR (DECR)	AVAILABLE BALANCE NORM (ABNORM)	YTD BALANCE 05/31/2025 NORM (ABNORM)	% BGDGT USED	PREV YEAR % BGDGT USED
Fund 101 - GENERAL FUND								
000		18,138,005.77	15,994,636.97	285,320.02	2,143,368.80	15,470,909.83	88.18	86.20
931	- TRANSFER IN	80,000.00	80,000.00	0.00	0.00	80,000.00	100.00	100.00
TOTAL REVENUES		18,218,005.77	16,074,636.97	285,320.02	2,143,368.80	15,550,909.83	88.23	86.26
101	- CITY COUNCIL	110,573.00	89,273.54	3,991.71	21,299.46	70,314.86	80.74	73.47
105	- COMMISSIONS	53,317.00	23,306.48	2,868.88	30,010.52	19,152.69	43.71	57.57
172	- ADMINISTRATION	443,660.00	417,001.92	23,133.86	26,658.08	337,436.59	93.99	82.09
193	- CITY COMPTROLLER	526,566.00	436,826.05	25,952.68	89,739.95	414,117.45	82.96	76.17
209	- ADMIN-FRINGE BENEFITS	261,400.00	260,065.83	541.03	1,334.17	260,369.41	99.49	99.68
211	- OVERHEAD	153,430.55	125,738.75	5,641.36	27,691.80	112,522.67	81.95	80.63
215	- CITY CLERK/ELECTIONS	510,683.00	439,365.23	24,162.43	71,317.77	457,165.82	86.03	86.69
228	- MIS	544,584.00	450,107.69	22,853.85	94,476.31	384,681.17	82.65	77.85
229	- MIS FRINGE BENEFITS	31,280.00	31,280.00	0.00	0.00	50,365.00	100.00	100.00
257	- CITY ASSESSOR	122,855.00	96,648.56	7,911.08	26,206.44	94,545.36	78.67	81.02
265	- CITY HALL & GROUNDS	353,135.00	209,101.19	24,921.70	144,033.81	204,210.23	59.21	62.85
266	- CITY ATTORNEY	265,000.00	124,309.18	13,146.75	140,690.82	98,513.48	46.91	37.17
286	- COURT EXPENDITURES	423,319.00	322,804.25	21,417.90	100,514.75	329,678.72	76.26	72.45
305	- PUB SAF-ADMIN	387,332.00	301,186.48	22,731.23	86,145.52	280,086.78	77.76	82.92
310	- POLICE SERVICES	5,302,259.80	4,552,296.01	376,347.22	749,963.79	4,186,350.98	85.86	87.28
326	- SUPPORT SERVICES	165,927.00	130,848.11	14,523.28	35,078.89	137,689.67	78.86	80.13
339	- FIRE SERV/SAFETY INS	77,726.00	48,932.80	2,870.77	28,793.20	46,769.49	62.96	60.79
345	- PUB-SAF FRINGES	2,184,845.00	2,137,945.77	153,043.26	46,899.23	2,114,175.27	97.85	97.29
349	- OVERHEAD	262,659.48	226,760.72	6,535.61	35,898.76	203,632.68	86.33	83.33
371	- BUILDING INSPECTIONS	674,250.00	539,904.06	84,171.10	134,345.94	450,392.14	80.07	74.26
441	- PUBLIC WORKS-ADMIN	180,883.00	128,978.25	9,537.16	51,904.75	105,684.49	71.30	78.24
463	- ROUTINE MAINTENANCE	426,273.00	352,264.23	21,860.20	74,008.77	333,501.49	82.64	82.85
523	- FORESTRY SERVICES	332,385.00	97,945.91	26,019.04	234,439.09	92,042.17	29.47	29.62
531	- PUB WKS-FRINGE	398,730.00	392,310.48	6,115.57	6,419.52	348,286.85	98.39	96.17
594	- OVERHEAD	685,058.29	583,048.53	54,343.41	102,009.76	569,612.74	85.11	88.42
752	- PARKS & REC-ADMIN	18,938.00	14,216.03	1,162.20	4,721.97	9,326.44	75.07	48.16
774	- LFP EXPENDITURES	1,729,215.00	1,213,020.11	81,764.95	516,194.89	1,092,117.53	70.15	66.54
775	- CITY PARKS	139,133.00	141,386.76	22,929.23	(2,253.76)	257,103.86	101.62	178.38
780	- COMMUNITY CENTER	290,604.00	236,900.56	16,716.22	53,703.44	179,488.67	81.52	74.50
795	- PARKS & REC FRINGE	108,409.00	106,188.40	0.00	2,220.60	108,988.13	97.95	97.27
799	- OVERHEAD	27,133.65	27,134.00	0.00	(0.35)	21,342.62	100.00	100.00
967	- TRANSFERS OUT ADMIN.	425,539.00	425,538.99	0.00	0.01	428,412.99	100.00	97.89
968	- TRANSFER OUT DPS	310,904.00	310,904.00	0.00	0.00	460,569.04	100.00	100.00
969	- TRANSFER OUT DPW	220,000.00	220,000.00	0.00	0.00	160,000.00	100.00	100.00
970	- TRANSFERS OUT PARKS/RECR.	70,000.00	70,000.00	0.00	0.00	810,000.00	100.00	100.00
TOTAL EXPENDITURES		18,218,006.77	15,283,538.87	1,077,213.68	2,934,467.90	15,228,647.48	83.89	84.48
Fund 101 - GENERAL FUND:								
TOTAL REVENUES		18,218,005.77	16,074,636.97	285,320.02	2,143,368.80	15,550,909.83	88.23	86.26
TOTAL EXPENDITURES		18,218,006.77	15,283,538.87	1,077,213.68	2,934,467.90	15,228,647.48	83.89	84.48
NET OF REVENUES & EXPENDITURES		(1.00)	791,098.10	(791,893.66)	(791,099.10)	322,262.35	79,109.8	100.00

**MONTHLY FINANCIAL REPORT
GROSSE POINTE WOODS MUNICIPAL COURT**

TO: City Administrator Susan Como
Municipal Judge Theodore A. Metry

FROM: Court Clerk Rachelle Matouk

RE: Court Revenue and activity for May, 2026

COURT REVENUES:	May-25	May-26	Monthly Variance	Fiscal Year to Date 24/25	Fiscal Year to Date 25/26	Fiscal Year to Date Variance
Total Parking	\$16,466.00	\$19,442.00	\$2,976.00	\$165,299.51	\$157,275.00	-\$8,024.51
Overpayment	\$1.00	\$0.00	-\$1.00	\$631.75	\$1,172.80	\$541.05
OUIL Reimbursement	\$0.00	\$0.00	\$0.00	\$1,824.15	\$2,628.00	\$803.85
Cost To Compel	\$1,390.00	\$1,719.00	\$329.00	\$19,115.98	\$17,534.37	-\$1,581.61
Total Court Costs	\$1,079.83	\$1,876.27	\$796.44	\$16,501.83	\$14,319.27	-\$2,182.56
Penal Fine-Library Fund	\$110.00	\$0.00	-\$110.00	\$850.00	\$370.00	-\$480.00
Total Moving	\$10,769.78	\$11,881.62	\$1,111.84	\$133,963.09	\$118,603.68	-\$15,359.41
Court Appt Atty Reimbursement	\$0.00	\$0.00	\$0.00	\$250.00	\$275.00	\$25.00
Miscellaneous	\$457.00	\$527.00	\$70.00	\$8,019.00	\$9,678.50	\$1,659.50
Total Probation	\$292.00	\$830.00	\$538.00	\$4,082.00	\$6,258.00	\$2,176.00
TOTAL	\$30,565.61	\$36,275.89	\$5,710.28	\$350,537.31	\$328,114.62	-\$22,422.69

**DEPARTMENT OF PUBLIC WORKS
MAY, 2026
MAINTENANCE REPORT**

SUBJECT	TASK	TOTAL HOURS
Building & Grounds	Torrey Rd Pump Station	80
	City Hall/Public Safety/Community Center/Court	
	Cook School	
	Electrical	
	DPW	32
	Miscellaneous	56
Equipment & Garage	Service Equipment	304
	Parts Chaser	
	Clean/Paint	
	Miscellaneous	
Forestry	Trimmed/Elevated/Removed	
	Stumps/Clean Up	
	Wind Storm Damage Clean Up	
	Trees Planted	
	Miscellaneous	
Street Maintenance	Cut Grass	296
	Flowers/Flower Beds/Shrubs	328
	Mulch	64
	Leaf Loads:	Hrs.
	Clean Islands/Parking Lots	
	Asphalt Patch	
	Street Sweeping Miles: 286	Hrs. 144
	Street Paint	
	Repair Sod Damage/Square for Sod	232
	Weeds	160
	Wood Chipping	192
	Edging	56
	Concrete	
	Christmas Lights	
	Snow Plowing: Miles:	Hrs.
	Sidewalk Plow Hours	
	Street Salting - Loads: Miles:	Hrs.
	City Hall/ School Crossings	
	Miscellaneous	
	Elections	Set Up/Tear Down
Signs	New Signs- New Posts-Repairs	
Wtr/Wtr Transmission	Meters: Service/Sprinkler System/Shut Offs	208
	Fire Hydrant Service/Repair	
	Water Main Break	32
	Water Service Line Inspections	
	Stop Box	16
	Reservoir	
	Miscellaneous / Miss Dig	288

Sewers/Catch Basins	Sewer Repairs/Sinkholes/Drain Tap/Catch Basins	48
	Manholes: Locate/Expose/Raise	
	Sewer Jetting	
	Miscellaneous	
Parking Meters	Collect Coins	56
	Repairs	
	Miscellaneous	88
Parks & Recreation	Lake Front Park	320
	Lake Front Park - Docks	
	Other City Parks	
	Miscellaneous	
	Total Hours for	3,000

**CITY OF GROSSE POINTE WOODS-DEPT OF PUBLIC WORKS
MONTHLY REPORT - WATER MAINS ONLY
DATE - MAY 2026**

MAN HOURS - DPW

TOTAL NUMBER REGULAR HOURS	12	TOTAL COST OF REGULAR HOURS	\$499.80
TOTAL NUMBER OVERTIME HOURS	47	TOTAL COST OF OVERTIME HOURS	\$3,028.89
TOTAL NUMBER DOUBLETIME HOURS	0	TOTAL COST OF DOUBLETIME HOURS	\$0.00

MATERIALS

TOTAL COST OF MATERIALS	\$1,069.95
-------------------------	------------

EQUIPMENT HOURS

TOTAL NUMBER OF HOURS	85	TOTAL COST OF EQUIPMENT	\$6,308.08
-----------------------	----	-------------------------	------------

TOTAL COST OF REPAIRS FOR THE MONTH

TOTAL COST OF REPAIRS	\$10,906.72
-----------------------	-------------

NUMBER OF WATER MAIN BREAKS	2
-----------------------------	---

Summary - Registrations (Courses)

Title	Revenue Acct#	Revenue	Void / CC Refunds	Total
Fitness Classes				
Community Center	101.000.653.310	\$3,286.00	\$0.00	\$3,286.00
Totals For Fitness Classes		\$3,286.00	\$0.00	\$3,286.00
Senior Programs				
Movies	101.000.653.340	\$221.00	\$0.00	\$221.00
Senior Holiday Social	101.000.653.110	\$18.00	\$0.00	\$18.00
Totals For Senior Programs		\$239.00	\$0.00	\$239.00
Special Events				
Lake Front Park	101.000.653.100	\$0.00	\$0.00	\$0.00
Totals For Special Events		\$0.00	\$0.00	\$0.00
Grand Totals		\$3,525.00	\$0.00	\$3,525.00

Summary - Memberships

Item	Revenue Acct#	Revenue	Void / CC Refund	Total
Dog Park Pass	101.000.642.020	900.00	0.00	900.00
Care Giver Pass	101.000.642.020	420.00	0.00	420.00
Fitness Class Single	101.000.653.310	3,222.00	0.00	3,222.00
Miniature Golf - 8 visits Single	101.000.653.105	0.00	0.00	0.00
Grand Totals		4,542.00	0.00	4,542.00

Summary - Merchandise Sales

Description	Revenue Acct#	Qty Sold	Qty Refunded	Revenue	Void / CC Refund	Total
Miniature Golf - \$2 per person	101.000.653.105	0	0	2.00	0.00	2.00
Grand Totals				2.00	0.00	2.00

Summary - Facility Rentals

Title	Revenue Acct#	Revenue	Void / CC Refund	Total
Optional Rates				
Serving alcohol	101.000.646.000	50.00	0.00	50.00
Totals For Optional Rates		50.00	0.00	50.00
Room Rates				
All Rooms	101.000.646.000	1,435.00	0.00	1,435.00
Cook School House	101.000.646.000	0.00	0.00	0.00
Garden Room	101.000.646.000	505.00	0.00	505.00
Lake Room	101.000.646.000	100.00	0.00	100.00
Park Room	101.000.646.000	2,460.00	0.00	2,460.00
Pavilion	101.000.653.400	2,675.00	0.00	2,675.00
Totals For Room Rates		7,175.00	0.00	7,175.00
Security Deposits				
Security Deposit-CC	101.000.295.000	800.00	(400.00)	400.00
Totals For Security Deposits		800.00	(400.00)	400.00
Grand Total		8,025.00	(400.00)	7,625.00

Summary - Area Rentals

Title	Revenue Acct#	Revenue	Void / CC Refund	Total
Dock Rentals				
Waiting List Fees	594-000-651.000	0.00	0.00	0.00
Launch Fees	594-000-651.001	865.00	0.00	865.00
Boat Dock Fees	594-000-651.002	10,765.00	(77.00)	10,688.00
Winter Boat Storage	594-000-651.003	0.00	0.00	0.00
Totals For Dock Rentals		11,630.00	(77.00)	11,553.00
Grand Total		11,630.00	(77.00)	11,553.00

Revenue Account Summary

Revenue Account#	Revenue	Void / CC Refund	Receipt Total	Cash	Check	Cash & Check Total	Credit Card	ACH	Acct Credit	Other
101.000.040.010	0.00	0.00	0.00	0.00	0.00	0.00	0.00	0.00	0.00	0.00
101.000.295.000	400.00	(400.00)	800.00	0.00	400.00	400.00	400.00	0.00	0.00	0.00
101.000.642.010	200.00	0.00	200.00	200.00	0.00	200.00	0.00	0.00	0.00	0.00
101.000.642.020	1,350.00	0.00	1,350.00	590.00	60.00	650.00	700.00	0.00	0.00	0.00
101.000.646.000	4,550.00	0.00	4,550.00	985.00	2,420.00	3,405.00	1,145.00	0.00	0.00	0.00
101.000.653.100	0.00	0.00	0.00	0.00	0.00	0.00	0.00	0.00	0.00	0.00
101.000.653.105	2.00	0.00	2.00	2.00	0.00	2.00	0.00	0.00	0.00	0.00
101.000.653.110	18.00	0.00	18.00	2.00	16.00	18.00	0.00	0.00	0.00	0.00
101.000.653.200	10,020.00	0.00	10,020.00	60.00	60.00	120.00	9,900.00	0.00	0.00	0.00
101.000.653.210	15,165.00	0.00	15,165.00	0.00	125.00	125.00	15,040.00	0.00	0.00	0.00
101.000.653.270	7,205.00	(110.00)	7,315.00	110.00	745.00	855.00	6,460.00	0.00	0.00	0.00
101.000.653.310	3,286.00	0.00	3,286.00	1,632.00	732.00	2,364.00	922.00	0.00	0.00	0.00
101.000.653.340	221.00	0.00	221.00	91.00	130.00	221.00	0.00	0.00	0.00	0.00
101.000.653.400	2,675.00	0.00	2,675.00	150.00	875.00	1,025.00	1,650.00	0.00	0.00	0.00
101.000.653.410	0.00	0.00	0.00	0.00	0.00	0.00	0.00	0.00	0.00	0.00
101.000.683.000	0.00	0.00	0.00	0.00	0.00	0.00	0.00	0.00	0.00	0.00
594.000.651.000	0.00	0.00	0.00	0.00	0.00	0.00	0.00	0.00	0.00	0.00
594.000.651.001	865.00	0.00	865.00	465.00	160.00	625.00	240.00	0.00	0.00	0.00
594.000.651.002	10,688.00	(77.00)	10,765.00	920.00	5,645.00	6,565.00	4,200.00	0.00	0.00	0.00
594.000.651.003	0.00	0.00	0.00	0.00	0.00	0.00	0.00	0.00	0.00	0.00
Grand Totals	56,645.00	(587.00)	57,232.00	5,207.00	11,368.00	16,575.00	40,657.00	0.00	0.00	0.00

Refunds - Check Request

Revenue Account#	Refund Total
101.000.295.000	(\$400.00)
101.000.646.000	\$0.00
101.000.653.270	(\$110.00)
594.000.651.002	(\$77.00)
Grand Total	(\$587.00)



CITY OF GROSSE POINTE WOODS

Office of the Treasurer/Comptroller

Memorandum

DATE: June 3, 2026

TO: Mayor Bryant and City Council

FROM: Steven Schmidt, Treasurer/Comptroller
Sue Como, City Manager

SUBJECT: Fiscal Year End 2025-2026 Budget Amendments

RECEIVED

JUN 05 2026

**CITY OF GROSSE POINTE WOODS
CLERK'S DEPARTMENT**

After reviewing the preliminary year-end financial statements, I recommend the following budget amendments for the General Fund, Major Street Fund, Local Street Fund, Act 302 Fund, Solid Waste Fund, Senior Services Fund, Water and Sewer Fund, Boat Dock Fund, and Commodity Sale Fund. These changes do affect the Fund Balance in the Local Street Fund, but not in the other funds, for those funds we were able to increase revenue or reduce another expenditure to account for the overages.

The General Fund departments that require a budget amendment are Administration, Overhead and City Parks Department. This is primarily due to an increase in utilities and personnel related costs.

The Special Revenue Funds of Major Street Fund, Local Street Fund, Act 302 Fund, and Solid Waste Fund have an increase primarily due to increases in personnel related costs. Senior Service is to match the millage received and disbursed.

The Enterprise Funds of Water and Sewer Fund, Boat Dock and Commodity Fund have an increase primarily due to increases in personnel related costs, bank fees and utilities.

I respectfully request City Council to approve the following budget amendments:

General Fund	\$ 0
Major Street Fund	\$ 0
Local Street Fund	\$ 112,500
Act 302 Fund	\$ 0
Solid Waste Fund	\$ 0
Senior Service Fund	\$ 0
Water and Sewer Fund	\$ 0
Boat Dock Fund	\$ 0
Commodity Sale Fund	\$ 0

See the attached spreadsheet with details of the accounts and budget amendment amounts.

Thank you.

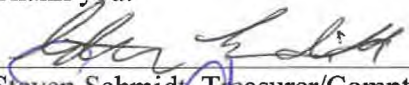
 Steven Schmidt, Treasurer/Comptroller

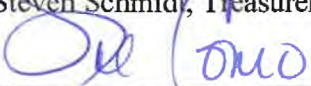
 Sue Como, City Manager

**City of Grosse Pointe Woods
FY 2025-2026 Year End Budget Amendments**

Account Number	Department	Account Name	Increase/ (Decrease)
General Fund			
Expenses			
101-172-710.999	ADMINISTRATION	SICK/VAC PAY	15,000.00
101-172-722.000	ADMINISTRATION	RETIREMENT	15,000.00
101-523-702.000	FORESTRY	SALARIES & WAGES	(106,500.00)
101-349-921.000	OVERHEAD	UTILITIES	15,000.00
101-594-921.000	OVERHEAD	UTILITIES	10,000.00
101-775-702.000	CITY PARKS	SALARIES & WAGES	35,000.00
101-775-715.000	CITY PARKS	SOCIAL SECURITY	2,500.00
101-775-722.000	CITY PARKS	RETIREMENT	10,000.00
101-775-921.000	CITY PARKS	UTILITIES	4,000.00
		TOTAL EXPENSE INCREASE	-
Major Street Fund			
Expenses			
202-451-975.300	CONSTRUCTION	JOINT & CRACK SEALIN	5,500.00
202-478-702.000	WINTER MAINTENANCE	SALARIES & WAGES	(25,000.00)
202-523-702.000	FORESTRY SERVICES	SALARIES & WAGES	10,000.00
202-523-709.000	FORESTRY SERVICES	OVERTIME	1,500.00
202-523-722.000	FORESTRY SERVICES	RETIREMENT	5,000.00
202-530-958.000	ADMINISTRATION	FEES & CHARGES	3,000.00
		TOTAL EXPENSE INCREASE	-
Local Street Fund			
Revenue			
203-000-665.000		INTEREST INCOME	14,000.00
203-000-692.000		TRF PRIOR YR RESERVES	112,500.00
		TOTAL REVENUE INCREASE	126,500.00
Expenses			
203-451-977.804	CONSTRUCTION	CONSTRUCTION	(40,000.00)
203-463-702.000	ROUTINE MAINTENANCE	SALARIES & WAGES	90,000.00
203-463-715.000	ROUTINE MAINTENANCE	SOCIAL SECURITY	8,000.00
203-463-722.000	ROUTINE MAINTENANCE	RETIREMENT	25,000.00
203-474-702.000	TRAFFIC	SALARIES & WAGES	4,000.00
203-478-702.000	WINTER MAINTENANCE	SALARIES & WAGES	(14,500.00)
203-478-709.000	WINTER MAINTENANCE	OVERTIME	(9,000.00)
203-478-715.000	WINTER MAINTENANCE	SOCIAL SECURITY	(2,000.00)
203-478-722.000	WINTER MAINTENANCE	RETIREMENT	(9,000.00)
203-523-702.000	FORESTRY	SALARIES & WAGES	53,000.00
203-523-709.000	FORESTRY	OVERTIME	8,000.00

203-523-722.000	FORESTRY	RETIREMENT	26,000.00
203-530-722.000	ADMINISTRATION	RETIREMENT	(13,000.00)
		TOTAL EXPENSE INCREASE	126,500.00
ACT 302 Fund			
Revenue			
211-000-542.000		ACT 302 TRNG GRANTS	1,000.00
		TOTAL REVENUE INCREASE	1,000.00
Expenses			
211-320-960.000	ADMINISTATON	EDUCATION-TRAINING	1,000.00
		TOTAL EXPENSE INCREASE	1,000.00
Solid Waste Fund			
Revenue			
226-000-665.000	SOLID WASTE/DISPOSAL	INTEREST REVENUE	10,500.00
		TOTAL REVENUE INCREASE	10,500.00
Expenses			
226-528-702.000	SOLID WASTE/DISPOSAL	SALARIES & WAGES	8,000.00
226-528-958.000	SOLID WASTE/DISPOSAL	FEES & CHARGES	2,500.00
		TOTAL EXPENSE INCREASE	10,500.00
Senior Service Fund			
Revenue			
297-000-406.000		SENIOR SERVICE MILLAGE	2,742.98
		TOTAL REVENUE INCREASE	2,742.98
Expenses			
297-672-818.000		CONTRACTUAL SERVICES	2,742.98
		TOTAL EXPENSE INCREASE	2,742.98
Water and Sewer Fund			
Expenses			
592-536-812.000	ADMINISTATON	CLAIMS/OUTSIDE COUNSEL	(120,000.00)
592-536-722.000	ADMINISTATON	RETIREMENT	(22,000.00)
592-537-702.000	SEWER REPAIR	SALARIES & WAGES	93,500.00
592-537-715.000	SEWER REPAIR	FICA	8,000.00
592-537-722.000	SEWER REPAIR	RETIREMENT	43,000.00
592-542-722.000	STORM PUMPING	RETIREMENT	(17,500.00)
592-542-921.000	STORM PUMPING	UTILITIES	15,000.00
		TOTAL EXPENSE INCREASE	-
Boat Dock Fund			
Revenue			
594-000-665.000		INTEREST INCOME	15,000.00
		TOTAL REVENUE INCREASE	15,000.00
Expenses			
594-785-702.000	ADMINISTATON	SALARIES & WAGES	15,000.00
		TOTAL EXPENSE INCREASE	15,000.00
Commodity Sales Fund			
Revenue			

598-000-665.000		INTEREST INCOME	700.00
		TOTAL REVENUE INCREASE	700.00
Expenses			
598-787-958.000	OPERATIONS & MAINTENANCE	FEES & CHARGES	700.00
		TOTAL EXPENSE INCREASE	700.00



CITY OF GROSSE POINTE WOODS
Office of the City Treasurer/Comptroller

RECEIVED

JUN 10 2026

CITY OF GROSSE POINTE WOODS
CLERK'S DEPARTMENT

Memorandum

DATE: June 15, 2026
TO: Mayor and City Council
FROM: Steven Schmidt, Treasurer/Comptroller
SUBJECT: Commit Fund Balance for Construction Projects and Equipment Purchases

The Governmental Accounting Standards Board (GASB 54) requires City Council action to “commit” or carry forward any budgeted expenses that are paid in the next fiscal year.

The attached spreadsheet details fiscal year 2025-2026 budget expenses that will be carried over into fiscal year 2026-2027.

I respectfully request City Council to commit Fund Balance in the following funds:

FUND	AMOUNT
101-GENERAL FUND	46,260.79
202-MAJOR ROADS	493,914.05
203-LOCAL ROADS	33,126.00
216- PA 1 MCOLES TRAINING FUND	1,036.00
401-MUNICIPAL IMPROVEMENT	43,592.65
585-PARKING	63,818.73
592-WATER AND SEWER	944,117.14
594- BOAT DOCK	0.00
661-MOTOR VEHICLE	20,664.26
TOTAL	1,646,529.62

Total Carryover at June 30, 2026 is \$1,646,529.62

Steven Schmidt
Treasurer/Comptroller

APPROVED FOR COUNCIL CONSIDERATION:

Sue Como
City Manager Signature

City of Grosse Pointe Woods
Fiscal Year End 2025-2026 Fund Balance Commitments

Account #	PO Limit	Amount Paid	Balance Carry Forward	PO #	Date PO Obtained	Vendor	Description
661534939.100	\$ 1,498.00	\$ -	\$ 1,498.00	24-48555	7/9/2024	Century Industries	Soundstage Remote Controls
202451974.803	\$ 10,000.00	\$ 9,241.75	\$ 758.25	25-48934	5/13/2025	Stucky Vitale	Mack and Vernier Design Engineering
202451977.117	\$ 10,000.00	\$ -	\$ 10,000.00	25-48956	5/21/2025	Stucky Vitale	Mack and Vernier Landscaping
101774972.000	\$ 5,800.00	\$ 2,100.00	\$ 3,700.00	25-49176	7/8/2025	Main Awning & Tent Co. Inc.	Tent - LFP pool
101441930.000	\$ 14,985.00	\$ -	\$ 14,985.00	25-49215	7/23/2025	Wolverine Power Systems	DPW Generator Cover
661901977.200	\$ 159,606.40	\$ 142,417.08	\$ 17,189.32	20-45789	5/5/2020	GROUNDWATER & ENVIRONMENTAL SERVICE	UST LEAK MUSTA FUND
592542818.000	\$ 200,000.00	\$ 110,000.00	\$ -	23-48021	9/19/2023	AEW	DESIGN FEES FOR TORREY ROAD PUMP STATION GENERATOR AEW Project No. 0160-0473
592542818.000		\$ 18,201.90	\$ 71,798.10				CONSTRUCTION ENGINEERING FOR TORREY ROAD PUMP STATION GENERATOR
592542974.000	\$ 2,150,000.00	\$ 1,855,507.11	\$ 191,882.89	24-48157	1/24/2024	Rauhorn Electric, Inc.	TORREY ROAD PUMP STATION GENERATOR AEW Project No. 0160-0473
592542974.000		\$ -	\$ 102,610.00				Contingency
401902977.104	\$ 15,000.00	\$ 14,360.49	\$ 639.51	24-48613	8/15/2024	AEW	Design Engineering GHESQUIERE PARK RESTROOM RENOVATION
401902977.104	\$ 38,333.00	\$ 25,000.00	\$ -	24-48614	8/15/2024	AEW	Design Engineering LAKE FRONT PARK CONCESSION STAND RENOVATION
401902977.104		\$ 11,629.86	\$ 1,703.14				Construction Engineering
202451975.300	\$ 41,667.00	\$ 10,303.12	\$ 3,446.88	24-48682	10/8/2024	Scodeller Construction	2024 Pavement Joint and Crack Sealing - AEW Project No. 0160-0476
203451975.300		\$ 20,918.46	\$ 6,998.54				2024 Pavement Joint and Crack Sealing
202451974.803	\$ 375,000.00	\$ 309,706.79	\$ 65,293.21	24-48747	12/23/2024	AEW	Engineering Mack and Vernier Intersection Improvements- AEW Project No. 0160-0455
202451977.117	\$ 725,000.00	\$ 500,959.51	\$ 34,808.18	25-48933	5/19/2025	MDOT	Mack & Vernier Intersection Improvement
202451977.117		\$ -	\$ 189,232.31				Contingency
101000283.000	\$ 15,600.00	\$ -	\$ 15,600.00	25-48988	6/5/2025	AEW	Survey Bournemouth and Sunningdale
202451974.201	\$ 108,334.00	\$ 4,504.27	\$ 2,162.73	25-49187	7/15/2025	AEW	Concrete Pavement / Parking Repair Program Engineering - AEW Project No. 0160-0493
203451974.201		\$ 6,906.41	\$ 3,093.59				Concrete Pavement / Parking Repair Program Engineering
585571978.300		\$ 29,160.42	\$ 12,506.58				Concrete Pavement / Parking Repair Program Engineering
592537975.401		\$ 36,166.81	\$ 13,833.19				Concrete Pavement / Parking Repair Program Engineering
202451974.200	\$ 541,666.00	\$ 24,792.76	\$ 8,540.24	25-49188	7/15/2025	Mattiolo Cement Company	Concrete Pavement / Parking Repair Program AEW Project No. 0160-0493
203451974.200		\$ 37,189.15	\$ 12,810.85				Concrete Pavement / Parking Repair Program Engineering
585571977.000		\$ 157,020.85	\$ 51,312.15				Concrete Pavement / Parking Repair Program Engineering
592537975.400		\$ 194,210.00	\$ 55,790.00				Concrete Pavement / Parking Repair Program Engineering
592537976.001	\$ 58,333.00	\$ 42,173.88	\$ 16,159.12	25-49189	7/15/2025	AEW	Engineering - Sewer Lining AEW Project No. 0160-0495
592537976.002	\$ 291,667.00	\$ 165,397.49	\$ 126,269.51	25-49190	7/15/2025	Insituform Technologies USA, Inc.	2025 SEWER REHABILITATION PROGRAM CONSTRUCTION - AEW PROJECT NO. 0160-0495
202451975.300	\$ 41,667.00	\$ 8,714.95	\$ 5,035.05	25-49192	7/15/2025	Scodeller Construction	2025 Pavement Joint and Crack Sealing - AEW Project No. 0160-0494
203451975.300		\$ 17,693.98	\$ 10,223.02				2024 Pavement Joint and Crack Sealing
592537977.310	\$ 112,500.00	\$ 38,250.00	\$ -	25-49194	7/15/2025	AEW	Design Engineering Lee Ct and Doyle Ct Water Mains - AEW PROJECT NO. 0160-0497
592537977.310		\$ 17,069.20	\$ 57,180.80				Engineering
592537977.300	\$ 562,500.00	\$ 253,906.47	\$ 245,664.03	26-49468	1/27/2026	Fontana Construction	Lee Ct and Doyle Ct Water Mains - AEW PROJECT NO. 0160-0497
592537977.300		\$ -	\$ 62,929.50				Contingency

202451977.117	\$ 95,223.48	\$ -	\$ 85,223.48	26-49663	6/9/2026	Phillips Sign and Lighting	MACK AND VERNIER INTERSECTION GATEWAY IMPROVEMENT
202451977.117			\$ 10,000.00				Contingency
202451977.117	\$ 16,493.72	\$ -	\$ 16,493.72	26-49662	6/9/2026	MOTOR CITY ELECTRIC, CO.	MACK AND VERNIER INTERSECTION GATEWAY IMPROVEMENT
202451977.117	\$ 62,920.00	\$ -	\$ 52,920.00	26-49661	6/9/2026	TOCCO MANNINO LANDSCAPING	MACK AND VERNIER INTERSECTION GATEWAY IMPROVEMENT
202451977.117			\$ 10,000.00				Contingency
401902977.102	\$ 41,250.00	\$ -	\$ 19,750.00	25-49169	7/1/2025	Rely-on Construction	Paint & Flooring
401902977.102		\$ -	\$ 21,500.00				Kitchen Renovation
661901977.000	\$ 1,976.94	\$ -	\$ 1,976.94	26-49655	6/5/2026	Canfield Equipment	Furnish & Install 2025 Tahoe
101310961.000	\$ 734.96	\$ -	\$ 734.96	26-49653	6/4/2026	Office Furniture EX	Dispatch Chair
101310961.000	\$ 313.82	\$ -	\$ 313.82	26-49652	6/4/2026	Action Target	Targets for Training
216320960.000	\$ 1,036.00	\$ -	\$ 1,036.00	26-49656	6/5/2026	Mantis	Firearms Training Equipment
101310757.000	\$ 15,000.00	\$ 11,102.00	\$ 3,898.00	25-49004	7/1/2025	CMP	Pistols
101305930.000	\$ 581.01	\$ -	\$ 581.01	26-49646	6/3/2026	The Raynor Group	Dispatch Chair
101310972.000	\$ 1,558.00	\$ -	\$ 1,558.00	25-49038	7/1/2025	Midwest Public Saftey	Getac Docs
101339757.000	\$ 5,500.00	\$ 610.00	\$ 4,890.00	25-49055	7/1/2025	Team Life	AED Supplies

101- General Fund	\$ 46,260.79
202- Major Roads	\$ 493,914.05
203- Local Roads	\$ 33,126.00
216- PA 1 MCOLES Training Fund	\$ 1,036.00
401- Municipal Improvement	\$ 43,592.65
585- Parking	\$ 63,818.73
592- Water and Sewer	\$ 944,117.14
594- Boat Dock	\$ -
661 - Motor Vehicle	\$ 20,664.26
Total	\$ 1,646,529.62



CITY OF GROSSE POINTE WOODS

Office of the Treasurer/Comptroller

Memorandum

RECEIVED

JUN 10 2026

CITY OF GROSSE POINTE WOODS
CLERK'S DEPARTMENT

DATE: June 5, 2026

TO: Mayor and City Council

FROM: Steven Schmidt, Treasurer/Comptroller

SUBJECT: Vendors with expenses over \$20,000

In accordance with City Charter, I am providing a list of vendors with anticipated expenditures in excess of \$20,000 during FY 2026-2027. I respectfully request City Council's approval to issue open purchase orders to these vendors as detailed in the attached report.

Thank you.

Fund Certification:

I hereby certify that unencumbered funds are available for the above purchases, and that the account numbers have been verified.



 Treasurer/Comptroller Signature

APPROVED FOR COUNCIL CONSIDERATION:



 City Manager Signature

City of Grosse Pointe Woods
Open Purchase Order=> \$20,000
Fiscal Year 2026-2027

PO/Req Number	Vendor Name	Description	Dept	Budget Line #	FY 2026-27 Breakdown Request	FY 2026-27 Total Request
26-49576	CDW GOVERNMENT INC	FY 2026-27 IT SUPPLIES	MIS	101-228-757.000	25,000.00	25,000.00
26-49577	BS&A SOFTWARE	FY 2026-27 BSA .NET MAINT-3/4 YEAR	MIS	101-228-818.000	16,950.00	67,021.25
		FY 2026-27 BSA .CLOUD UPGRADE-1/4 YEAR		101-228-818.000	14,971.25	
		BSA CLOUD IMPLEMENTATION- 2ND 1/2		101-228-818.000	35,100.00	
26-49588	CDW GOVERNMENT INC	MICROSOFT 365 LICENSE-G3 ENTERPRISE	MIS	101-228-818.000	47,250.00	47,250.00
26-49606	ANDERSON ECKSTEIN	FY 2026-27 GIS MAINTENANCE	PUBLIC WRK	592-537-977.000	21,000.00	21,000.00
26-49607	ANDERSON ECKSTEIN	FY 2026-27 GENERAL ENGINEERING	PUBLIC WRK	101-441-818.000	10,000.00	40,000.00
		FY 2026-27 GENERAL ENGINEERING		101-265-818.000	25,000.00	
		FY 2026-27 GENERAL ENGINEERING		592-537-818.000	5,000.00	
26-49609	BADGER METER INC	METER SUPPLIES	PUBLIC WRK	592-537-757.000	10,000.00	115,000.00
		BEACON SOFTWARE EYEONWATER CONSUMER APP		592-536-818.000	15,000.00	
		WATER METER READER CELLULAR FEES		592-536-818.000	90,000.00	
26-49610	CADILLAC ASPHALT, LLC	COLD PATCH STREET/WATER MAINS	PUBLIC WRK	202-463-757.000	4,000.00	20,000.00
		COLD PATCH STREET/WATER MAINS		203-463-757.000	12,000.00	
		COLD PATCH STREET/WATER MAINS		592-537-757.000	4,000.00	
26-49611	FONTANA CONSTRUCTION INC	WATER MAIN & SEWER REPAIRS AND WATER SERVICE LINE REPLACEMENTS	PUBLIC WRK	592-537-818.000	150,000.00	150,000.00
26-49612	GEORGE'S DISCOUNT AUTO	AUTO & TRUCK PARTS & SUPPLIES	PUBLIC WRK	661-534-939.100	30,000.00	51,500.00
		AUTO & TRUCK PARTS & SUPPLIES		661-534-939.200	16,000.00	
		AUTO & TRUCK PARTS & SUPPLIES		661-534-939.300	3,500.00	
		AUTO & TRUCK PARTS & SUPPLIES		661-534-939.400	2,000.00	
26-49613	GILBERTS PRO HARDWARE	MINOR OPERATING SUPPLIES ALL DEPTS.	PUBLIC WRK	101-441-757.000	2,000.00	30,200.00
		MINOR OPERATING SUPPLIES ALL DEPTS.		101-265-757.000	2,800.00	
		MINOR OPERATING SUPPLIES ALL DEPTS.		101-774-757.000	2,000.00	
		MINOR OPERATING SUPPLIES ALL DEPTS.		101-774-757.101	200.00	
		MINOR OPERATING SUPPLIES ALL DEPTS.		101-774-757.102	12,000.00	
		MINOR OPERATING SUPPLIES ALL DEPTS.		101-774-757.104	4,000.00	
		MINOR OPERATING SUPPLIES ALL DEPTS.		101-774-757.107	500.00	
		MINOR OPERATING SUPPLIES ALL DEPTS.		101-775-757.000	400.00	
		MINOR OPERATING SUPPLIES ALL DEPTS.		203-463-757.000	500.00	
		MINOR OPERATING SUPPLIES ALL DEPTS.		585-571-757.000	300.00	
		MINOR OPERATING SUPPLIES ALL DEPTS.		592-537-757.000	1,500.00	
		MINOR OPERATING SUPPLIES ALL DEPTS.		592-542-757.000	1,000.00	
		MINOR OPERATING SUPPLIES ALL DEPTS.		594-785-757.000	2,500.00	
		MINOR OPERATING SUPPLIES ALL DEPTS.		661-534-939.100	500.00	
26-49614	GROSSE POINTES-CLINTON	REFUSE DISPOSAL FEES	PUBLIC WRK	226-528-818.000	265,200.00	265,200.00
26-49615	HYDROCORP	COMMERCIAL CROSS CONNECTION PROGRAM	PUBLIC WRK	592-537-975.395	10,722.00	74,878.00
		COMMERCIAL CROSS CONNECTION PROGRAM		592-537-975.395	64,156.00	
26-49616	INDIAN SUMMER RECYCLING	YARD WASTE DISPOSAL	PUBLIC WRK	226-528-818.000	55,000.00	55,000.00
26-49617	JAMES J. LEAMON LANDSCAPE DESIGN	SIDEWALK REPAIR PROGRAM	PUBLIC WRK	202-451-976.100	40,000.00	200,000.00
		SIDEWALK REPAIR PROGRAM		203-451-976.100	100,000.00	
		SIDEWALK REPAIR PROGRAM		592-537-976.100	60,000.00	
26-49618	K & S VENTURES INC	HEATING & COOLING MAINTENANCE	PUBLIC WRK	101-441-818.000	3,000.00	31,500.00
		HEATING & COOLING MAINTENANCE		101-265-818.000	19,000.00	
		HEATING & COOLING MAINTENANCE		101-774-818.000	1,500.00	
		HEATING & COOLING MAINTENANCE		101-774-818.104	3,000.00	
		HEATING & COOLING MAINTENANCE		101-774-931.000	3,000.00	
		HEATING & COOLING MAINTENANCE		592-542-818.000	2,000.00	
26-49619	MARSHALL LANDSCAPE INC	LAWN CARE	PUBLIC WRK	101-774-818.102	4,000.00	22,845.00
		LAWN CARE		101-775-818.000	2,520.00	
		LAWN CARE		202-463-818.000	7,525.00	
		LAWN CARE		585-571-818.000	8,800.00	
26-49620	POINTE ALARM LLC	GHSQUIERE PARK TELEVISION MONITORING	PUBLIC WRK	101-775-818.000	8,880.00	23,200.00

		CHENE TROMBLEY PARK TV MONITORING		101-775-818.000	4,200.00	
		DPW TV MAINTENANCE		101-441-818.000	1,200.00	
		DOG PARK ACCESS MAINTENANCE		101-775-818.000	3,120.00	
		TORREY ROAD PUMP STATION MONITORING		592-542-818.000	5,800.00	
26-49621	PRIORITY WASTE LLC	SOLID WASTE PICKUP	PUBLIC WRK	226-528-818.000	1,345,760.00	1,345,760.00
26-49622	RKA PETROLEUM COMPANIES	FY 2026-27 FUEL PURCHASE	PUBLIC WRK	661-534-939.500	115,000.00	115,000.00
26-49625	ZEPPELIN SERVICES INC	JANITORIAL SVC - MUNI BLDGS	PUBLIC WRK	101-265-818.000	24,884.72	69,447.72
		JANITORIAL SVC - MUNI BLDGS		101-774-818.104	16,988.00	
		DPW OFFICES AND BATHROOMS CLEANING		101-441-818.000	14,100.00	
		ADDITIONAL CLEANNING-MENS BATHHOUSE LFP		101-774-818.104	13,475.00	
26-49626	LASERCOM, LLC	FY 2026-27 WATER BILLING MONTHLY MAIL	FINANCE	592-538-818.000	4,500.00	47,500.00
		FY 2026-27 WATER BILL POSTAGE		592-538-757.000	27,000.00	
		FY 2026-27 TAX BILLS POSTAGE		101-193-757.000	11,000.00	
		FY 2026-27 TAX BILLS		101-257-831.000	5,000.00	
26-49628	PURCHASE POWER	FY 2026-27 POSTAGE	FINANCE	101-211-728.000	8,500.00	23,000.00
		FY 2026-27 POSTAGE		101-286-757.000	5,000.00	
		FY 2026-27 POSTAGE		101-349-728.000	5,000.00	
		FY 2026-27 POSTAGE		101-193-757.000	4,500.00	
26-49631	AXON ENTERPRISE, INC.	TASER LICENSE - FYE 2026-2027	PUBLIC SAFT	101-310-818.000	20,280.00	20,280.00
26-49632	BERGER CHEVROLET, INC.	CHEVROLET TAHOE	PUBLIC SAFT	661-901-977.349	55,986.00	84,912.00
		CHEVROLET EQUINOX		661-901-977.349	28,926.00	
26-49633	CANFIELD EQUIPMENT SERVICE, INC.	UPFITTING FOR CHEVROLET TAHOE	PUBLIC SAFT	661-901-977.349	17,985.00	23,489.00
		UPFITTING FOR CHEVROLET EQUINOX		661-901-977.349	5,504.00	
26-49634	CITY OF GROSSE POINTE FARMS	ANNUAL RADIO MAINTENANCE FEE - FYE 2026-2027	PUBLIC SAFT	101-305-851.000	35,000.00	35,000.00
26-49635	MACQUEEN	FIRE GEAR PURCHASES - FYE 2026-2027	PUBLIC SAFT	101-339-757.000	34,500.00	34,500.00
26-49636	MEDSTAR INC	ADVANCED LIFE SUPPORT SERVICES - FYE 2026-2027	PUBLIC SAFT	101-349-818.000	71,431.00	71,431.00
26-49637	MOTOROLA SOLUTIONS, INC.	UPGRADE TO PREP RADIOS - FYE 2026-2027	PUBLIC SAFT	101-305-818.000	35,000.00	35,000.00
26-49638	OAKLAND COUNTY	CLEMIS FEES & LEADS ONLINE - FYE 2026-2027	PUBLIC SAFT	101-305-818.000	36,253.00	36,253.00
26-49640	AQUATIC SOURCE, LLC	ACID, PULSAR, CYNURIAC ACI	PARKS	101-774-757.105	62,000.00	86,750.00
		MISC. POOL EQUIPMENT		101-774-931.000	15,000.00	
		2026 POOL CLOSE & 2027 POOL OPENING		101-774-818.103	9,750.00	
26-49641	SAM'S CLUB MC/SYNCRB	POOL DECK & LIFEGUARD EQUIPMENT	PARKS	101-774-757.103	3,500.00	29,000.00
		MISC. EQUIPMENT FOR PARK		101-774-757.107	1,500.00	
		SWIM TEAM/SYNCHRO		101-774-818.105	2,000.00	
		MISC. SUPPLIES COMMUNITY CENTER		101-780-757.000	3,500.00	
		SENIOR PROGRAM SUPPLIES		101-780-880.603	8,500.00	
		MISC. SPECIAL EVENT SUPPLIES		101-780-880.000	10,000.00	
26-49642	1006556 - LAURA DIGAN	GROUP TENNIS SUMMER 2	PARKS	101-774-818.107	6,000.00	24,200.00
		GROUP TENNIS FALL - 2026		101-774-818.107	5,000.00	
		GROUP TENNIS SPRING - 2027		101-774-818.107	5,200.00	
		GROUP TENNIS SUMMER 1		101-774-818.107	8,000.00	
Total					3,321,116.97	3,321,116.97



CITY OF GROSSE POINTE WOODS
MEMORANDUM

RECEIVED
JUN 10 2026

CITY OF GROSSE POINTE WOODS
CLERK'S DEPARTMENT

Date: June 15, 2026
To: Mayor Bryant and City Council
From: Steven Schmidt, Treasurer/Comptroller
Re: Unpaid Invoices

Attached is a list of unpaid invoices for services rendered by the City to residential properties.

Grass Cutting/Property Maintenance	\$ 2,740.50
Cross Connection Fees	\$ 0.00
Total Unpaid Invoices	\$ 2,740.50

Staff has made several attempts to collect these fees but have been unsuccessful. I am requesting City Council to authorize the transfer of the unpaid invoices to the real property tax bills in July 2026.

Thank you.

Steven Schmidt, Treasurer/Comptroller

APPROVED FOR COUNCIL CONSIDERATION:

Sue Como City Manager

SUMMER 2026 ROLL TO TAX INVOICES (LANDSCAPING) FINAL COPY

Invoice #	Date Filed	Invoice Sent	Customer Name	Address	Street	PARCEL #	Service Provided	Amount	Due Date	Final Notice
W65166	9/4/25	9/4/25	Mahone Jr., Thelester	2110	Vernier Rd	003-08-0010-000	Grass cut and disposal of debris	\$1,014.00	10/6/25	5/1/26
W65167	9/4/25	9/4/25	Behravesch-Koegler Shahin A	1447	Sunningdale	101-000-482-000	Grass cut & removal of weeds	\$91.00	10/6/25	5/1/26
W65168	9/4/25	9/4/25	Dicicco, Ronald	20810	Marter Rd.	101-000-482-000	Grass cut & Trim	\$65.00	10/6/25	5/1/26
W65671	10/15/25	10/15/25	Zampardo, Marilyn	2032	Anita	101.000.482.000	Grass cut, Removal of weeds	\$477.50	11/17/25	5/1/26
W65673	10/15/25	10/15/25	Jossens, Arthur	1798	Kenmore	101.000.482.000	Removal of weeds and trash	\$644.00	11/17/25	5/1/26
W65679	10/15/25	10/15/25	Behravesch-Koegler Shahin A	1447	Sunningdale	101.000.482.000	Grass Cut & Trim	\$176.00	11/17/25	5/1/26
W66148	12/3/25	12/3/25	Behravesch-Koegler Shahin A	1447	Sunningdale	101.000.482.00	Grass Cut, Cleanup of leaves	\$273.00	1/5/26	5/1/26
TOTAL:								\$2,740.50		

** Notices were sent out 3x via Mail **

MEMO 26-09

TO: Susan Como, City Manager
 FROM: James Kowalski, Director of Public Services *JK*
 DATE: June 9, 2026
 SUBJECT: Recommendation – Tree Removal Contract for 2026/2027

RECEIVED

JUN 10 2026

**CITY OF GROSSE POINTE WOODS
 CLERK'S DEPARTMENT**

An "Invitation to Bid" for the removal of large city trees was posted on the Michigan Intergovernmental Trade Network (MITN) website on April 30, 2026. The information was also advertised in the Grosse Pointe News. The following bids were received at the bid opening on May 26, 2026.

COMPANY	12" to 19"	20" to 27"	28" to 35"	36" to 43"	Over 44"	Charge For Emergency Call-Out	Total tree removal Pricing
M.D.L. Tree Service	\$550.00	\$950.00	\$1,500.00	\$2,100.00	\$2,800.00	\$150.00 per man hour	\$8,050.00
Tree Man Services	\$580.00	\$991.00	\$991.00	\$2,230.00	\$2,500.00	\$1,000.00	\$8,292.00
Arbor Pro Tree Services, Inc.	\$510.00	\$880.00	\$1,180.00	\$2,110.00	\$3,740.00	\$95.00 per man hour	\$8,515.00
Owen Tree Service, Inc.	\$300.00	\$2,200.00	\$2,700.00	\$3,500.00	\$3,500.00	\$550.00 per hour	\$12,750.00
Amezola Tree Service	\$1,450.00	\$1,850.00	\$2,650.00	\$3,450.00	\$4,450.00	\$1,800.00 per man hour	\$15,650.00
Tree Services of Troy	\$1,300.00	\$1,800.00	\$3,300.00	\$4,200.00	\$5,500.00	\$225 per hour	\$16,325.00
Metro Detroit Tree & Firewood	\$1,800.00	\$2,800.00	\$3,900.00	\$6,500.00	\$7,800.00	\$1,000.00	\$23,800.00

M.D.L. Tree Service submitted the low bid in the amount of \$8,050.00. M.D.L. Tree Service has done work in communities near Grosse Pointe Woods and their work is satisfactory.

I recommend the City enter into a contract for city street tree removals from July 1, 2026 through June 30, 2027, with M. D. L. Tree Service, 33560 Giftos, Clinton Township, MI 48035. This is a budgeted item included in the 2026/2027 budget in the amount of \$65,000.00 in account 101-523-818.000. Attached is a copy of the proposed contract approved by the city attorney and used in prior years that will be effective from July 1, 2026 through June 30, 2027, as well as a current certificate of insurance.

Please contact me if you have any questions concerning this matter.

Recommend approval of the above stated and do not believe any benefit will accrue to the City by seeking further competitive bids. Approved for Council consideration.

Susan Como

Susan Como, City Manager

6/10/26

Date

Fund Certification:

Account numbers and amounts have been verified as presented.



Steven Schmidt, Treasurer/Comptroller

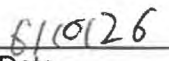

Date

TREE REMOVAL CONTRACT

THIS AGREEMENT is entered into this ____ day of _____, 2026, by and between the City of Grosse Pointe Woods, a Municipal Corporation, Wayne County, Michigan, (“City”), and M. D. L. Tree Service, 33560 Giftos, Clinton Township, MI 48035 (“Contractor”).

WHEREAS, the City advertised for bids for the removal of trees on City property within the City of Grosse Pointe Woods, and prepared certain instructions, specifications and contract documents to bidders, and

WHEREAS, the Contractor made a bid in accordance with the advertisement and contract documents, and the bid has been accepted by the City on _____, and

THEREFORE, IT IS AGREED BETWEEN THE PARTIES AS FOLLOWS:

1. Award of Contract: M. D. L. Tree Service is hereby awarded a non-exclusive contract to perform removal of city street trees.
2. Term of Contract: This contract will cover the fiscal year beginning July 1, 2026 and continue through June 30, 2027.
3. Rates: M. D. L. Tree Service will remove city street trees as instructed by the City at the agreed sums of \$550.00 for 12” to 19” diameter trees, \$950.00 for 20” to 27” diameter trees, \$1,500.00 for 28” to 35” diameter trees, \$2,100.00 for 36” to 43” diameter trees, and \$2,800.00 for over 44” diameter trees.
4. Termination: Notwithstanding the term of this contract, this agreement may be terminated by either party with 30 days written notice to the other party for any reason.
5. Insurance: M. D. L. Tree Service will keep in full force and affect insurance coverage in accordance with the bid specifications dated April 30, 2026 and shall add the City as an additional insured on its commercial general liability insurance. M. D. L. Tree Service shall furnish proof of such insurance to the City of Grosse Pointe Woods.
6. Compliance with City Ordinances: M. D. L. Tree Service shall be required to comply with all city ordinances and pertinent state laws during the terms of this Agreement including, but not limited to, hours of operation.
7. City Indemnification: M. D. L. Tree Service agrees to indemnify and hold harmless the City from any actions, suits, debts, judgments, damages and/or claims arising out of M. D. L. Tree Service ‘s performance of this Agreement.

8. Incorporation of Bid Documents: The original bid documents dated April 30, 2026, including the notice to bidders, specifications, insurance coverage, and the bid sheet are incorporated into this Agreement by reference. In the event of any inconsistencies between the bid documents and this Agreement, the Agreement controls.

Witnessed by:

CITY OF GROSSE POINTE WOODS, MI
A Municipal Corporation

BY: _____
Susan Como, City Manager

M. D. L. Tree Service
Contractor

BY: _____

City Tree Removal

May 26, 2026

10:00 a.m.

Not required ↗

COMPANY	SIGNED	BID BOND	BID AMOUNT
Metro Detroit Tree + Firewood	✓		23,800.00
MDL	✓		8,050.00
Arbor Pro	✓		8,420.00
Amazola Tree Svc	✓		13,850.00
Owen Tree Svc.	✓		12,750.00
Tree Service of Troy	✓		16,100.00
Tree Man Services LLC	✓		8,292.00

Signed: (All Present)

[Signature]

[Signature]

[Signature]

Company Name	Full Bid	Emergency	Bid minus emergency	Bid including emergency	Comments
Amezola Tree Service	\$12,850.00	\$1800 per man hour plus \$250 if crane needed		\$15,650.00	didn't include \$1,800 in full bid total
Arbor Pro	\$8,420.00	\$95 per man hour		\$8,515.00	didn't include \$95 in full bid total
MDL Tree Service	\$8,050.00	\$150 per man hour	\$7,900.00		used \$150 in full bid total
Metro Detroit Tree & Firwood	\$23,800.00	\$1,000	\$22,800.00		doesn't say if this is an hourly rate
Owen Tree Service Inc	\$12,750.00	\$550 per man hour	\$12,200.00		
Tree Man Services	\$8,292.00	\$1,000	\$7,292.00		doesn't say if this is an hourly rate
Tree Service of Troy	\$16,100.00	\$225 per man hour		\$16,325.00	didn't include \$225 in full bid total



CITY OF GROSSE POINTE WOODS
2025 Mack Plaza Drive
Grosse Pointe Woods, MI 48236

April 30, 2026

NOTICE TO BIDDERS

Bid sheets should be submitted in a sealed, opaque envelope bearing the following notation:

CITY CLERK
CITY OF GROSSE POINTE WOODS
2025 MACK PLAZA
GROSSE POINTE WOODS, MI 48236-2397

CLEARLY MARKED

CITY TREE REMOVAL

BIDS WILL BE OPENED

TUESDAY, May 26, 2026
AT 10:00 AM

The bidder by execution of the proposal thereby declares that the bid is made without collusion with any other person, firm or corporation making any other bid, or who otherwise would make a bid, and agrees to furnish all bid items in strict accordance with all Federal Regulatory Measures.

All bids must be submitted on the city's bid sheet.

Submission of a bid will be construed as a conclusive presumption that the bidder is thoroughly familiar with the bid sheet and specifications, and that he understands and agrees to abide by each and all of the stipulations and requirements contained therein.

Additional copies of the specifications and bid sheets may be obtained from the City Clerk.

The City of Grosse Pointe Woods reserves the right to accept or reject any and all bids, to waive any informality in the bidding process or minor deviations from the specifications in a proposal and to accept any bid that deems itself in the best interest of the city.

SPECIFICATIONS

1. Contractor must have city tree license.
2. Contractor must provide insurance coverage as follows:
 - Body Injury Liability \$1,000,000.00
 - Property Damage Liability \$1,000,000.00
 - Workmen's Compensation Statute
3. Any and all damages caused by removal of city tree will be the responsibility of the contractor who is awarded the bid.
4. Contractor must have necessary equipment and materials to satisfactorily remove trees in the shortest possible time. Equipment required must included the following:
 - Tree Boom, minimum 50'
 - Chippers
 - Chipper Trucks
 - Stump Machine
 - Semi-trailer (to remove logs)
 - Loader
 - Different size chain saws
 - Clean up equipment (brooms, shovels, blowers, etc.)
 - Crane required
5. All wood must be disposed of outside city limits.
6. Each group of trees must be removed **WITHIN FIFTEEN (15) CALENDAR DAYS** after receiving notice from the city's Department of Public Works. This will be strictly enforced by the City of Grosse Pointe Woods.
7. All trees removed from city property must be cut to ground level (no more than 3" high).
8. Contractor must clean up all debris caused from removal of trees.
9. Should the contractor fail to perform the work to the satisfaction of the city or fail to comply with any of the provisions of this agreement, the city may terminate this agreement upon twenty-four (24) hour written notice to the contractor.
10. **Size of trees to be bid on is determined by measuring them 4' from the ground level.**
11. **Contractor receiving bid will be under contract with the City of Grosse Pointe Woods from July 1, 2026 through June 30, 2027.**

12. Contractor receiving bid and who is under contract with the City of Grosse Pointe Woods must be able to respond to emergencies (wind damage, tornados, storms, etc.) within a period of 2-4 hours depending on severity of storm damage to be determined by the Director of Public Services.
13. Any questions regarding the specifications and/or bid may be directed to James Kowalski at the Department of Public Works (313) 343-2460.

BIDDER'S REFERENCE PAGE

(Submit with Bid)

The Contractor shall submit verifiable references for municipal work and be familiar with all aspects of safe tree removal operations. Each reference shall be for work actually performed by the Bidder (sub-contractor references are not applicable).

ALL REFERENCES WILL BE TREATED AS THE CONTRACTOR'S CONFIDENTIAL BUSINESS INFORMATION. Previous work for the Owner may be used as a reference. Complete each item for all 3 references.

Owner/Agency: City of Saint Clair Shores
Address: 19700 Pleasant Drive
Address:
City, State, Zip S.C.S. MI 48080
Contact: Geoff Brown
Phone: 586-291-5257

Owner/Agency: Becker Landscaping
Address: 15251 E. 12 Mile Road
Address: Rossville, MI 48066
City, State, Zip
Contact: Karl Becker
Phone: 877-774-0090

Owner/Agency: Landscape Services
Address: 22932 Rasch Drive
Address:
City, State, Zip Clinton Twp. MI 48035
Contact: Paul Dopke
Phone: 586-741-5296

CITY OF GROSSE POINTE WOODS

IT IS UNDERSTOOD THAT THE CITY OF GROSSE POINTE WOODS IS A GOVERNMENTAL UNIT AND AS SUCH IS EXEMPT FROM THE PAYMENT OF ALL STATE AND FEDERAL TAXES APPLYING ON THE ABOVE MENTIONED WORK, THEREFORE, THE ABOVE PRICES DO NOT INCLUDE THIS AMOUNT.

The bidder by execution of the proposal thereby declares that the bid is made without collusion with any other person, firm or corporation making any other bid, or who otherwise would make a bid, and agrees to furnish all bid items in strict accordance with all Federal Regulatory Measures.

All bids must be submitted on the city's bid sheet.

Submission of a bid will be construed as a conclusive presumption that the bidder is thoroughly familiar with the bid sheet and specifications, and that he understands and agrees to abide by each and all of the stipulations and requirements contained therein.

BIDDERS ARE REQUESTED TO SUBMIT ALL AVAILABLE DATA AND DESCRIPTIVE LITERATURE COVERING THE PROPOSED SERVICES TO BE FURNISHED.

THE UNDERSIGNED, by execution of this bid, certified that he is the Owner of the firm named as bidder in the bid; and that he signs the bid on behalf of the firm; and that he is authorized to execute the same in behalf of said firm.

NAME AND ADDRESS OF BIDDER:

COMPANY NAME M. D. L. Tree Service

ADDRESS 33560 Giffords

CITY Clinton Township STATE MI ZIP 48035

SUBMITTED BY Richard Myerch Owner
(NAME) (TITLE)

SIGNATURE [Signature]

TELEPHONE 586-506-4687 FAX _____

DATE 5-22-26 cell mike.mdltree@gmail.com

THIS PAGE MUST BE RETURNED WITH BID SHEET

CITY OF GROSSE POINTE WOODS

BID SHEET

CITY TREE REMOVAL

THE UNDERSIGNED DECLARES THAT A CAREFUL EXAMINATION HAS BEEN MADE OF THE SPECIFICATIONS INCLUDED IN THIS BID PACKAGE AND UNDERSTANDS ALL OF THE REQUIREMENTS OF SAME. IT IS FURTHER UNDERSTOOD THAT THE UNDERSIGNED WILL CONTRACT TO DELIVER WITHIN THE SPECIFIED TIME AND DATE, AFTER THE ISSUANCE OF THE CITY'S PURCHASE ORDER, ANY SERVICES AS CONTAINED IN THIS BID AND IN ACCORDANCE WITH SPECIFICATIONS; TO-WIT:

PER TREE COST FOR REMOVAL OF CITY TREES ON CITY OF GROSSE POINTE WOODS PROPERTY

12" to 19" diameter	\$ <u>550.⁰⁰</u>
20" to 27" diameter	\$ <u>950.⁰⁰</u>
28" to 35" diameter	\$ <u>1500.⁰⁰</u>
36" to 43" diameter	\$ <u>2100.⁰⁰</u>
Over 44" diameter	\$ <u>2800.⁰⁰</u>
Charge Per Emergency Call-Out	\$ <u>150 per man / hour</u>
Total Bid	\$ <u>8,050</u>

COMPANY NAME MDL Tree Service

CONTACT PERSON Rick Mlynarek

TELEPHONE 586-506-4687 **FAX** _____



CERTIFICATE OF LIABILITY INSURANCE

DATE (MM/DD/YYYY)
06/09/2026

THIS CERTIFICATE IS ISSUED AS A MATTER OF INFORMATION ONLY AND CONFERS NO RIGHTS UPON THE CERTIFICATE HOLDER. THIS CERTIFICATE DOES NOT AFFIRMATIVELY OR NEGATIVELY AMEND, EXTEND OR ALTER THE COVERAGE AFFORDED BY THE POLICIES BELOW. THIS CERTIFICATE OF INSURANCE DOES NOT CONSTITUTE A CONTRACT BETWEEN THE ISSUING INSURER(S), AUTHORIZED REPRESENTATIVE OR PRODUCER, AND THE CERTIFICATE HOLDER.

IMPORTANT: If the certificate holder is an ADDITIONAL INSURED, the policy(ies) must have ADDITIONAL INSURED provisions or be endorsed. If SUBROGATION IS WAIVED, subject to the terms and conditions of the policy, certain policies may require an endorsement. A statement on this certificate does not confer rights to the certificate holder in lieu of such endorsement(s).

PRODUCER RSC Insurance Brokerage Inc/Ralph C Wilson Agency 26026 Telegraph Road Suite 100 Southfield MI 48033		CONTACT NAME: Lauren Francis PHONE (A/C, No, Ext): (248) 355-1414 FAX (A/C, No): (248) 304-0877 E-MAIL ADDRESS:	
INSURED MDL Tree Service, Inc 3356D Giftos Clinton Twp MI 48035		INSURER(S) AFFORDING COVERAGE INSURER A: Scottsdale Insurance Company A NAIC # 41297 INSURER B: Motorists Commercial Mutual Insurance Company A 13331 INSURER C: Travelers - Assigned Risk A INSURER D: INSURER E: INSURER F:	

COVERAGES CERTIFICATE NUMBER: 25-26 REVISION NUMBER:

THIS IS TO CERTIFY THAT THE POLICIES OF INSURANCE LISTED BELOW HAVE BEEN ISSUED TO THE INSURED NAMED ABOVE FOR THE POLICY PERIOD INDICATED. NOTWITHSTANDING ANY REQUIREMENT, TERM OR CONDITION OF ANY CONTRACT OR OTHER DOCUMENT WITH RESPECT TO WHICH THIS CERTIFICATE MAY BE ISSUED OR MAY PERTAIN, THE INSURANCE AFFORDED BY THE POLICIES DESCRIBED HEREIN IS SUBJECT TO ALL THE TERMS, EXCLUSIONS AND CONDITIONS OF SUCH POLICIES. LIMITS SHOWN MAY HAVE BEEN REDUCED BY PAID CLAIMS.

INSR LTR	TYPE OF INSURANCE	ADDL INSD	SUBR VWD	POLICY NUMBER	POLICY EFF (MM/DD/YYYY)	POLICY EXP (MM/DD/YYYY)	LIMITS
A	<input checked="" type="checkbox"/> COMMERCIAL GENERAL LIABILITY <input type="checkbox"/> CLAIMS-MADE <input checked="" type="checkbox"/> OCCUR GENL AGGREGATE LIMIT APPLIES PER: <input checked="" type="checkbox"/> POLICY <input type="checkbox"/> PRO-JECT <input type="checkbox"/> LOC OTHER:			CPS8103198	11/17/2025	11/17/2026	EACH OCCURRENCE \$ 1,000,000 ✓ DAMAGE TO RENTED PREMISES (Ea occurrence) \$ 300,000 MED EXP (Any one person) \$ 5,000 PERSONAL & ADV INJURY \$ 1,000,000 GENERAL AGGREGATE \$ 2,000,000 PRODUCTS - COMP/OP AGG \$ 2,000,000 Errors & Omissions \$ 25,000
B	AUTOMOBILE LIABILITY <input checked="" type="checkbox"/> ANY AUTO <input type="checkbox"/> OWNED AUTOS ONLY <input type="checkbox"/> SCHEDULED AUTOS <input type="checkbox"/> HIRED AUTOS ONLY <input type="checkbox"/> NON-OWNED AUTOS ONLY			5000004025	12/20/2025	12/20/2026	COMBINED SINGLE LIMIT (Ea accident) \$ 1,000,000 ✓ BODILY INJURY (Per person) \$ BODILY INJURY (Per accident) \$ PROPERTY DAMAGE (Per accident) \$ \$
	<input type="checkbox"/> UMBRELLA LIAB <input type="checkbox"/> OCCUR <input type="checkbox"/> EXCESS LIAB <input type="checkbox"/> CLAIMS-MADE DED RETENTION \$						EACH OCCURRENCE \$ AGGREGATE \$ \$
C	WORKERS COMPENSATION AND EMPLOYERS' LIABILITY ANY PROPRIETOR/PARTNER/EXECUTIVE OFFICER/MEMBER EXCLUDED? (Mandatory In NH) If yes, describe under DESCRIPTION OF OPERATIONS below	Y/N	N/A	6KUBA416843425	08/21/2025	08/21/2026	<input checked="" type="checkbox"/> PER STATUTE <input type="checkbox"/> OTH-ER E.L. EACH ACCIDENT \$ 100,000 ✓ E.L. DISEASE - EA EMPLOYEE \$ 100,000 E.L. DISEASE - POLICY LIMIT \$ 500,000

DESCRIPTION OF OPERATIONS / LOCATIONS / VEHICLES (ACORD 101, Additional Remarks Schedule, may be attached if more space is required)
The City of Grosse Pointe Woods, all employees, elected and appointed officials, boards and commissions and volunteers are added as Additional Insured (General Liability) with respect to work/services performed/products supplied by Named Insured as per written contract/agreement. ✓

CERTIFICATE HOLDER The City of Grosse Pointe Woods 20025 Mach Plaza Grosse Pointe Woods MI 48236	CANCELLATION SHOULD ANY OF THE ABOVE DESCRIBED POLICIES BE CANCELLED BEFORE THE EXPIRATION DATE THEREOF, NOTICE WILL BE DELIVERED IN ACCORDANCE WITH THE POLICY PROVISIONS. AUTHORIZED REPRESENTATIVE
--	--

MEMO 26-10

RECEIVED

JUN 10 2026

CITY OF GROSSE POINTE WOODS
CLERK'S DEPARTMENT

TO: Susan Como, City Manager

FROM: James Kowalski, Director of Public Services

J.K.

DATE: June 9, 2026

SUBJECT: Recommendation – Mack and Vernier Intersection Gateway Improvement

The City contracted with Stucky Vitale Architects to design the center island landscaping and gateway signage improvements for the Mack Avenue and Vernier Road intersection. The final design was approved by City Council on October 20, 2025.

On December 18, 2025, bids were opened for construction of the project. The bid package included landscape improvements, brick knee wall, signage, lighting, electrical work, and irrigation. The following bids were received.

Lucia Landscape (partial bid)	\$46,914.32
Trigriffin Group	\$187,087.00
DeAngelis Diamond Construction	\$191,264.21

Staff determined the project could be completed more cost effectively by utilizing qualified local contractors with a proven track record of work for the City, with the Department of Public Works serving as project coordinator. The following bids were received to complete the project.

Motor City Electric. Co.	\$16,493.72
Tocco Mannino Landscaping	\$52,920.00
Phillips Sign & Lighting	\$85,223.48

Total Project Cost \$154,637.20

Total Project Cost with Contingencies \$174,637.20

Therefore, I recommend the City award the Mack and Vernier Intersection Gateway Improvement to the following:

Motor City Electric Co., 9440 Grinnell Ave., Detroit, MI 48213 in the amount of \$16, 493.72.

Tocco Mannino Landscaping, 27739 Groesbeck Highway, Roseville, MI 48066 in the amount of \$52,920.00, with a \$10,000.00 contingency should anything arise, for a total amount of \$62,920.00.

Phillips Sign and Lighting, 40920 Executive Drive, Harrison Twp., MI 48045 in the amount of \$85,223.48, with a \$10,000.00 contingency should anything arise, for a total amount of \$95,223.48.

Funding for this project is provided entirely through the Congressional Direct Spending Grant and budgeted in the Mack Ave. Improvements account no. 202-451-977.117.

Please contact me if you have any questions concerning this matter.

Recommend approval of the above stated and do not believe any benefit will accrue to the City by seeking further competitive bids. Approved for Council consideration.

Susan Como

Susan Como, City Manager

6/10/26
Date

Fund Certification:

Account numbers and amounts have been verified as presented.



Steven Schmidt, Treasurer/Comptroller

6/10/26
Date

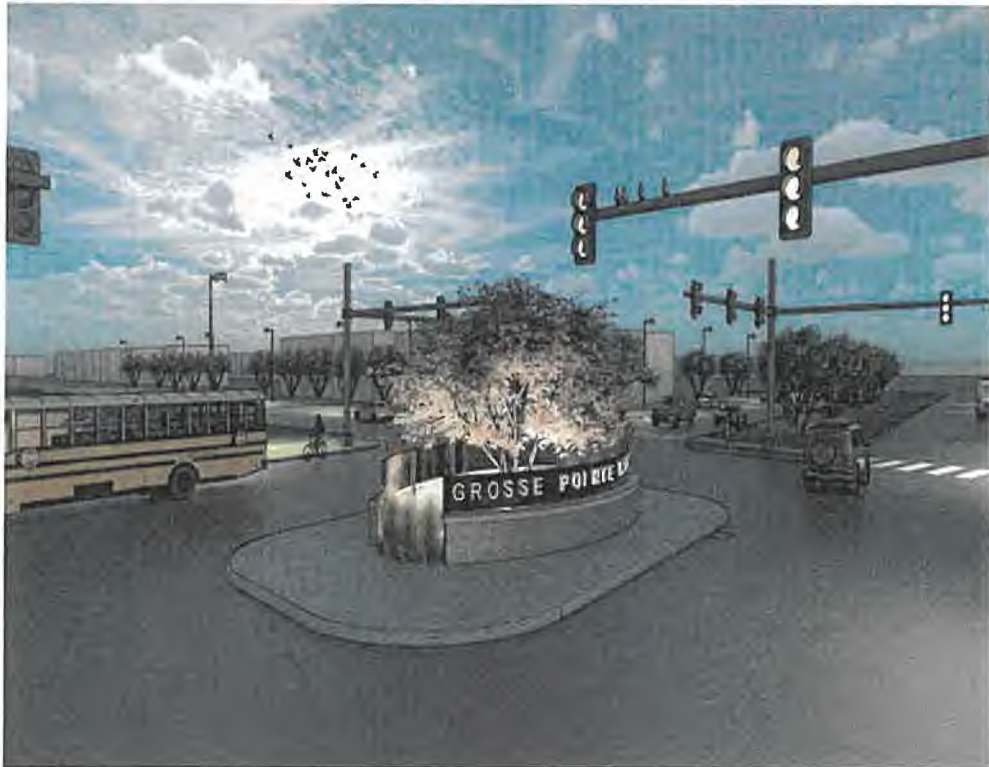



STACEY WENIG ARCHITECTS
 2177 WOODWARD AVENUE
 BIRMINGHAM, AL 35202-0915
 P. 205.546.6700
 F. 205.546.8954
 WWW.STACEYWENIG.COM

JOHN & JEFFREY
 1000 15TH AVENUE, SUITE 1000
 BIRMINGHAM, AL 35202-0915
 P. 205.546.6700
 F. 205.546.8954
 WWW.JOHNJEFFREY.COM

PRELIMINARY
 NOT FOR CONSTRUCTION

Prepared by:
 GREGORY PORTER
 VISION

Key Plan:
 [North Arrow Symbol]

Issued for:
 CONCEPT REVIEW 03.14.15
 CONCEPT REVIEW 10.14.15

Drawn by:
 GWP
 Checked by:
 JWP
 Sheet Title:
 031515-104

Project No.:	104
Sheet No.:	A621



MACK & VERNIER INTERSECTION IMPROVEMENTS
 GROSSE POINTE WOODS, MI
 BID PACKAGE SUMMARY
 SVA PROJECT #2024.162

COMPANY NAME	CONTACT	PHONE #
DEANGELIS DIAMOND CONS	YOUSIF HUBALLAH	(313) 467-4746
LUCIA LANDSCAPING	KENITO MORIMANNO	(313) 881-9241
TRIGRIFFIN GROUP	DOMINIC PIZZO	(313) 312-4272

	DESCRIPTION	DEANGELIS DIAMOND CONST	LUCIA LANDSCAPING	TRIGRIFFIN GROUP
1	DIVISION 1 - GENERAL CONDITIONS			
	SUPERVISION (PART TIME)	\$ 5,910.00		\$ 22,000.00
	AS-BUILTS	\$ 385.00		\$ 3,500.00
	TESTING	\$ 3,200.00		\$ 1,500.00
	ON GOING CLEAN UP	BY TRADES		\$ 1,250.00
	FINAL CLEAN UP	\$ 1,000.00		\$ 1,750.00
	DUMPSTERS	\$ 480.00		\$ 950.00
	TEMPORARY FACILITIES (PORTA-POTTY)	\$ 380.00		\$ 250.00
2	DIVISION 2 - SITE WORK			
	UTILITIES REWORK (ALLOWANCE)	\$ 3,500.00		\$ 15,500.00
	LANDSCAPING (ALLOWANCE)	\$ 7,000.00	\$ 4,938.13	\$ 7,000.00
3	DIVISION 3 - CONCRETE			
	EXCAVATION AND BACKFILL	\$ 1,500.00		\$ 5,500.00
	CONCRETE FLAT WORK (STAMPED CONC)	\$ 34,800.00		\$ 22,500.00
	POST FOOTINGS	\$ 3,500.00		\$ 5,750.00
4	DIVISION 9 - FINISHES			
	MISC PAINTING TOUCH-UP	\$ 1,700.00		\$ 1,250.00
5	DIVISION 10 - SPECIALTIES			
	FENCE POSTS	\$ 1,940.00		\$ 1,950.00
	METAL FABRIC	\$ 27,500.00		\$ 12,500.00
	SIGNAGE	\$ 8,667.00		\$ 5,500.00
	UNILOCK SEAT WALLS	\$ 26,941.00	\$ 30,157.03	\$ 26,941.00
6	DIVISION 16 - ELECTRICAL			
	SERVICE AND DISTRIBUTION	\$ -		\$ 23,757.00
	LIGHTING AND POWER	\$ 39,800.00	\$ 8,750.00	\$ 15,500.00
	TOTAL ALL DIVISIONS	\$ 168,203.00	\$ 43,845.16	\$ 174,848.00
	GC OVERHEAD & PROFIT CONTINGENCY (5%)	\$ 8,410.15	\$ 2,192.26	\$ 8,742.40
	ALL OTHER WORK	\$ 11,287.00		
	PERMIT FEES (2%)	\$ 3,364.06	\$ 876.90	\$ 3,496.96
	TOTAL PROJECT BUDGET (100%)	\$ 191,264.21	\$ 46,914.32	\$ 187,087.36
	TESTING (NOT REQUIRED)	\$ 3,200.00		\$ 1,500.00
	MISC PAINTING TOUCH-UP (NOT REQUIRED)	\$ 1,700.00		\$ 1,250.00
	CONCRETE PAVERS (ALTERNATE)	\$ 36,945.00	\$ 42,905.41	\$ 33,209.00



MDOT QUOTE

Contractor: Motor City Electric Utilities Co. **Contract ID#:** 0
Contractor Address: 9440 Grinnell, Detroit, MI **MCEU Job #:** 0 **MCEU Extra#** 4
Time Period: From: Saturday, January 0, 1900 **To:** Saturday, January 0, 1900
Description of Work: install rack/HH for DTE Power

PAYROLL

NAME OF EMPLOYEE	CLASS OF WORK	Date:	Mon	Tue	Wed	Thu	Fri	Sat	Sun	TOTAL HOURS	HOURLY RATE	AMOUNT
	Outside GF	REG	16							16.0	\$ 56.82	\$ 909.12
		OT								0.0	\$ 85.23	\$ -
	Foreman	REG								0.0	\$ 53.27	\$ -
		OT								0.0	\$ 79.91	\$ -
	Journeyman	REG	16							16.0	\$ 47.35	\$ 757.60
		OT								0.0	\$ 71.03	\$ -
	Operator 'A'	REG	16							16.0	\$ 40.09	\$ 641.44
		OT								0.0	\$ 60.14	\$ -
	Groundman/Drvr	REG								0.0	\$ 32.00	\$ -
		OT								0.0	\$ 48.00	\$ -
Total Hours										48.0		

Labor Cost: \$ 2,308.16

FRINGES

	Per Hour	Percent of Gross	Total Hours	Total Labor	Amount
Health & Welfare	\$ 7.30		48.0		\$ 350.40
NLMCC	\$ 0.01		48.0		\$ 0.48
AMF	\$ 0.03		48.0		\$ 1.44
LU Training	\$ 0.20		48.0		\$ 9.60
NEBF		3%		\$ 2,308.16	\$ 69.24
ALBAT		1%		\$ 2,308.16	\$ 23.08
Annuity		29%		\$ 2,308.16	\$ 669.37
NECA		1%		\$ 2,308.16	\$ 23.08

Fringe Cost: \$ 1,146.69

Sub Total: \$ 3,454.85

Road Work Mark up for Bond Premium Insurance & Payroll Taxes per Special Provision: 55% \$ 1,900.17

Total Labor \$ 5,355.02

EQUIPMENT

Description	Date:	Mon	Tue	Wed	Thu	Fri	Sat	Sun	TOTAL HOURS	HOURLY RATE	AMOUNT
Foreman Truck	16								16.0	\$ 25.00	\$ 400.00
Service Truck Idle									0.0		\$ -
Service Truck									0.0		\$ -
Dump Truck									0.0		\$ -
Dump Truck Idle									0.0		\$ -
Dump Truck									0.0		\$ -
Dump Truck Idle									0.0		\$ -
Dump Truck	16								16.0	\$ 75.00	\$ 1,200.00
Dump Truck Idle									0.0		\$ -
Equipment Trailer									0.0		\$ -
Equipment Trailer Idle									0.0		\$ -
Excavator #93 Cat 314D									0.0		\$ -
Excavator #93 Idle									0.0		\$ -
Excavator Mini 305E	16								16.0	\$ 30.00	\$ 480.00
Excavator Mini Idle									0.0		\$ -
Backhoe 420D									0.0		\$ -
Plate Compactor									0.0		\$ -
Utility Trailer	16								16.0	\$ 10.00	\$ 160.00
Bore Machine									0.0		\$ -
Bore Truck									0.0		\$ -
Equipment Total											\$ 2,240.00

STATEMENT OF BILLS FOR MATERIALS AND FREIGHT

ITEM	Unit	Mon	Tue	Wed	Thu	Fri	Sat	Sun	TOTAL	UNIT PRICE	AMOUNT
	Measure								QTY		
									0.0		\$ -
Rack Material	Ea	1							1.0	\$ 2,000.00	\$ 2,000.00
12 x 12 Poly HH	Ea	1							1.0	\$ 500.00	\$ 500.00
Wiring 4. 1c #2 xhhw cu cable	Ft	400							400.0	\$ 12.00	\$ 4,800.00
									0.0		\$ -
Material Subtotal:											\$ 7,300.00
Sales Tax 6%:											\$ 438.00
Material markup 15%:											\$ 1,160.70
Material Total											\$ 8,898.70

SUBCONTRACTORS

Subcontractor Name	Qty	Unit Price	Total
			\$ -
Subcontractor Subtotal			\$ -
Subcontractor markup 5%			\$ -
Subcontractor Total			\$ -
TOTAL THIS QUOTE			\$ 16,493.72

Secure Application
Your privacy and security are important



Review your proposal

Review each line item. Then just click the accept button to confirm and set up service.

Review the proposal below. Check any services that you want.



27739 Groesbeck Highway
Roseville, MI 48066
Phone - 313-884-1101
Fax - 586-872-2912
www.toccomannino.com

Estimate

GPW

20025 Mack Plaza Drive
Grosse Pointe Woods, MI 48236

Estimate - #23566
Date - 1/4/2026
Prepared by - Phil Mannino {emp}
Total - \$52,920.00



Estimate Description	Amount
<input type="checkbox"/> <u>Retaining Wall</u> Install 70 linear feet of Unilock Rivercrest wall (buff) and ledgestone coping shown on the design provided by Stucky Vitale Architects. Materials will be installed over crushed stone foundation and landscape adhesive will be applied to all layers (see specs on design)	18450.00
<input type="checkbox"/> <u>Brick Pavers</u> Excavate unstable or unsuitable materials Install of 21aa compacted base material and compact Install 1-2" compacted sand base and 920 sq/ft of Unilock Brussels pavers Install concrete restraint and polymeric sand between paver joints (See design provided by Stucky Vitale Architects for specs)	23920.00
<input type="checkbox"/> <u>Front Landscaping</u> Create a new garden natural bed edge and prep the garden bed with compost. Install new plant material and hardwood mulch 10 Karl forester 30 blue fescue landscape 1 bloodgood maple (cost \$1,150.00)	3400.00
<input type="checkbox"/> <u>New Irrigation System</u> Install 1 node timer and valve to feed new soaker lines installed to all new plant material	800.00
<input type="checkbox"/> <u>Landscape Lighting</u> Install 1 vista transformer 150 watt with digital timer (city responsible to install outlet for transformer) Install 14 alliance w/300 LED well lights (outer perimeter) Install 2 alliance w/100 up lights on tree (Includes labor, wire, and silicone wire nuts)	6350.00

Note: this proposal does not include any fencing or footings

Subtotal	\$52,920.00
Discounts	\$0.00
Sales Tax	\$0.00
Total	\$52,920.00

Payment Terms:

A 50% down payment of the project total to be paid upon acceptance of this proposal with the remainder due upon completion of project. On larger projects, progress payments will be negotiated. Please ask about our financing options for qualified applicants. **Payments over \$3,000 via Credit card online have a 3 % processing fee.**

Agreement:

All work is to be completed in according to standard practices. Any alteration or deviations from above specifications involving extra cost of more materials or labor cost will be executed only upon written order and will become an extra charge over and above the proposal.

Acceptance of proposal:

The above prices specifications and conditions are satisfactory and are here by accepted. You are authorized to do the work as specified.

Signature:

Client: GPW

Date: _____



40920 Executive Drive, Harrison Twp, MI 48045-1363 Phone: (586) 468-7110 www.phillipssign.com

Contract:

The City of Grosse Pointe Woods
Intersection at Mack & Vernier, Grosse Pointe Woods, MI. 48236
phone: (313) 363-1257 - email: Jkowalski@gpwmi.us
contact: Jim Kowalski

RE: Intersection at Mack & Vernier, Grosse Pointe Woods, MI. 48236

Item: #1

Ground Signs

consists of:

PS&L to fabricate (2) single faced non illuminated ground signs.

Each sign to be about 24" tall x 30' wide.

Each sign to consist of a 2' x 8' wide stainless steel mesh backer with a painted finish.

Each mesh backer to have fabricated metal non lit letters to read "GROSSE POINTE WOODS".

Letters to be about 12" tall x 1 1/2" deep.

Letters to be fabricated from aluminum with a painted finish.

Letters to have metal backs painted to match.

PS&L to fabricate aluminum backer plates for mounting letters to mesh.

Backer plates to be slightly smaller than letters and will be painted to match letters.

Each mesh screen to be mounted to (9) 2 1/2" OD round aluminum pipes with aluminum baseplates.

Pipes to have an acrylic polyurethane finish.

Top of pipes to have caps fabricated from aluminum with an acrylic polyurethane finish.

Concrete footings are by others.

Client to excavate and pour concrete footings to anchor new sign footings.

PS&L to provide and set (36) break away anchor bolts per sign.

Top of each sign to be about 48" above grade.

PS&L to fabricate aluminum plate mounting collars for metal mesh backers.

Mounting collars to have an acrylic polyurethane finish.

PS&L to fabricate (1) top and bottom radius retainer for each sign.

Retainers to have an acrylic polyurethane finish.

PS&L to install @ site and verify locations with client.

***Note: Footings are by others.**

All masonry work is by others.

Price quoted assumes signs can be installed with standard wedge anchors - not breakaway.

Continued on next page.

[Click here to view your proposal](#)

Click link above to view & accept your proposal

Thank you!

Based on your selections your Subtotal is: 0.00

Thank you for using our online account management solution! If you have any questions or concerns you may contact us by email by [clicking here](#)

About your proposal:
313-884-1101

Contract:
Continued from previous page.

	Item: #1				
	Ground Signs				
permit cost:	per city				
sign cost:	76,368.48				
6% sales tax:					
installation:	8,855.00				
total:	85,223.48				
down payment:	42,611.74				
balance C.O.D.:	42,611.74				

• Price is subject to review after 15 days due to fluctuating material costs. X _____

(print)

acceptance: _____ date: _____
 (print) **JOHN ROSE** **5/1/26**
 salesperson: _____ date: _____

Warranty (Materials & Labor) - 5 years on construction workmanship, 1 year on lighting & electrical components.

* Warranty excludes existing items, mdo signs, banners, acts of God and vandalism. Electrical UL listed.

EXTRAS - Sign Permit, Electrical Permit, and X **TBD** staff time fee (for permit procurement), as required.

- Client is responsible for landlord approval and final electrical hook-up. Installation based on normal conditions X _____
- Additional costs may be incurred if problems are encountered during excavation of footing (i.e., poor soil conditions, buried objects, sprinklers, etc.). PS&L assumes no responsibility for any sprinkler damage X _____
- PS&L assumes no responsibility for damage to landscaping/grass due to install. X _____
- If clean art work is not provided, art work will be generated at a rate of **\$50.00** Per Hr. X _____
- Engineer sealed drawings, if required, to be provided at additional cost. X _____
- PS&L takes all precautionary steps to protect parking surfaces during installations. PS&L cannot be held liable for parking lot repairs if required. X _____
- Price quoted assumes reasonable access for installation and wiring of signage and components. X _____
- Installation quotations are estimates subject to verification of technical survey and confirmed access to signage. X _____
- No sign construction will begin prior to obtaining permits without written authorization of client. X _____
- Any additional required endorsements or changes to PS&L's current liability insurance certificate may be subject to additional costs. X _____
- Photographs and/or videos of signage may be used by PS&L for marketing purposes. X _____
- Credit Card orders over \$1,000.00 will be subject to a 3% fee. X _____
- Invoices over 30 days are subject to 2% finance charges. X _____
- All signs and related materials remain the property of Phillips Sign & Lighting until payment is made in full. In the event of non-payment in accordance with the terms of this contract, Phillips Sign & Lighting reserves the right to remove the signage from the customer's location at the customer's expense. X _____

MEMO 26-11

TO: Susan Como, City Manager
FROM: James Kowalski, Director of Public Services *JK*
DATE: June 9, 2026
SUBJECT: Recommendation – Trucking Services

RECEIVED

JUN 10 2026

CITY OF GROSSE POINTE WOODS
CLERK'S DEPARTMENT

Grosso Trucking & Supply Co. has the current contract to provide trucking services for the City through June 30, 2026. They have extended the pricing from 2025/26 fiscal year for 2026/27 fiscal year. The company is fully insured and bonded and has provided very good and reliable trucking services for the city since 2015. Grosso Trucking again requests an annual fee of \$2,500.00/year for leaving his loader in the DPW yard. His drivers load their trucks themselves at no additional cost to the city allowing DPW employees to work on other tasks.

Only one other bid for trucking services was received the last time a bid was mailed in 2011 and the prices not only exceeded Grosso Trucking's new prices but also included \$52,000/year for a loader plus \$45.00/hour for labor plus fuel with a 3% fuel surcharge. Grosso Trucking's employees also assist with clean up in the DPW yard. I do not believe any benefit would accrue to the city by seeking additional bids.

I recommend the city enter into a contract with Grosso Trucking & Supply Co., 10015 Marine City Hwy., Fair Haven, MI 48023 to continue to provide trucking and hauling services from July 1, 2026 through June 30, 2027. This is a budgeted item included in the 2026/27 budget in the amount of \$105,000.00 in Solid Waste/Disposal contractual services account 226-528-818.000. Attached is a copy of the proposed contract approved by the city attorney and used in prior years that will be effective from July 1, 2026 through June 30, 2027, as well as a current certificate of insurance.

Please contact me if you have any questions concerning this matter.

Recommend approval of the above stated and do not believe any benefit will accrue to the City by seeking further competitive bids. Approved for Council consideration.

Susan Como

Susan Como, City Manager

6/10/26

Date

Fund Certification:

Account numbers and amounts have been verified as presented.

Steven Schmidt

Steven Schmidt, Treasurer/Comptroller

6/10/26

Date

Jeanne Duffy

From: Grosso Trucking <grossotrucking@yahoo.com>
Sent: Tuesday, June 9, 2026 3:03 PM
To: Jeanne Duffy
Subject: Grosso Updated Prices

CAUTION: This email originated from outside of the organization. DO NOT click links, open attachments or reply to this message unless you recognize the sender and know the content is safe:

Hello,

We just wanted to update the prices for you, everything is going to stay the same, besides the Peastone went up to \$34.00/ton. Have a great day!

Thanks,
Grosso Trucking & Supply Co.

Alyssa-Office Manager
Direct Email- alyssa.grossotrucking@yahoo.com
Office # (586) 725-2935



CERTIFICATE OF LIABILITY INSURANCE

DATE (MM/DD/YYYY)
12/23/2025

THIS CERTIFICATE IS ISSUED AS A MATTER OF INFORMATION ONLY AND CONFERS NO RIGHTS UPON THE CERTIFICATE HOLDER. THIS CERTIFICATE DOES NOT AFFIRMATIVELY OR NEGATIVELY AMEND, EXTEND OR ALTER THE COVERAGE AFFORDED BY THE POLICIES BELOW. THIS CERTIFICATE OF INSURANCE DOES NOT CONSTITUTE A CONTRACT BETWEEN THE ISSUING INSURER(S), AUTHORIZED REPRESENTATIVE OR PRODUCER, AND THE CERTIFICATE HOLDER.

IMPORTANT: If the certificate holder is an ADDITIONAL INSURED, the policy(ies) must have ADDITIONAL INSURED provisions or be endorsed. If SUBROGATION IS WAIVED, subject to the terms and conditions of the policy, certain policies may require an endorsement. A statement on this certificate does not confer rights to the certificate holder in lieu of such endorsement(s).

PRODUCER Cora Insurance Group LLC 50787 Corporate Dr Shelby Township MI 48315		CONTACT NAME: Brenda Boomer PHONE (A/C, No, Ext): (248) 847-2673 FAX (A/C, No): E-MAIL ADDRESS: brendab@coreinsured.com	
INSURED Grosso Trucking and Supply Company 10015 Marine City Hwy Ira MI 48023		INSURER(S) AFFORDING COVERAGE INSURER A: Michigan Millers Ins. Co. NAIC # 14508 INSURER B: Michigan Millers Mutual Insurance Company INSURER C: ICW Group A INSURER D: INSURER E: INSURER F:	

COVERAGES **CERTIFICATE NUMBER:** 26r27 master cert **REVISION NUMBER:**

THIS IS TO CERTIFY THAT THE POLICIES OF INSURANCE LISTED BELOW HAVE BEEN ISSUED TO THE INSURED NAMED ABOVE FOR THE POLICY PERIOD INDICATED. NOTWITHSTANDING ANY REQUIREMENT, TERM OR CONDITION OF ANY CONTRACT OR OTHER DOCUMENT WITH RESPECT TO WHICH THIS CERTIFICATE MAY BE ISSUED OR MAY PERTAIN, THE INSURANCE AFFORDED BY THE POLICIES DESCRIBED HEREIN IS SUBJECT TO ALL THE TERMS, EXCLUSIONS AND CONDITIONS OF SUCH POLICIES. LIMITS SHOWN MAY HAVE BEEN REDUCED BY PAID CLAIMS.

INSR LTR	TYPE OF INSURANCE	ADDITIONAL INSURED	SUBROGATION	POLICY NUMBER	POLICY EFF (MM/DD/YYYY)	POLICY EXP (MM/DD/YYYY)	LIMITS
A	<input checked="" type="checkbox"/> COMMERCIAL GENERAL LIABILITY <input type="checkbox"/> CLAIMS-MADE <input checked="" type="checkbox"/> OCCUR <input checked="" type="checkbox"/> AI, WOS, PNC - CG855AI, WOS, AI, CG2037-BLKT GEN'L AGGREGATE LIMIT APPLIES PER: <input checked="" type="checkbox"/> POLICY <input type="checkbox"/> PRO-JECT <input type="checkbox"/> LOC OTHER:	Y		C0128091	01/01/2026	01/01/2027	EACH OCCURRENCE \$ 1,000,000 ✓ DAMAGE TO RENTED PREMISES (Ea occurrence) \$ 100,000 MED EXP (Any one person) \$ 5,000 PERSONAL & ADV INJURY \$ 1,000,000 GENERAL AGGREGATE \$ 3,000,000 PRODUCTS - COMP/OP AGG \$ 3,000,000 \$
A	AUTOMOBILE LIABILITY <input type="checkbox"/> ANY AUTO OWNED AUTOS ONLY <input checked="" type="checkbox"/> HIRED AUTOS ONLY <input checked="" type="checkbox"/> AI, WOS <input checked="" type="checkbox"/> SCHEDULED AUTOS <input checked="" type="checkbox"/> NON-OWNED AUTOS ONLY <input checked="" type="checkbox"/> PNC			V0106282	01/01/2026	01/01/2027	COMBINED SINGLE LIMIT (Ea accident) \$ 1,000,000 ✓ BODILY INJURY (Per person) \$ BODILY INJURY (Per accident) \$ PROPERTY DAMAGE (Per accident) \$ \$
B	<input checked="" type="checkbox"/> UMBRELLA LIAB <input checked="" type="checkbox"/> OCCUR <input type="checkbox"/> EXCESS LIAB <input type="checkbox"/> CLAIMS-MADE DED <input checked="" type="checkbox"/> RETENTION \$ 10,000			L0302785	01/01/2026	01/01/2027	EACH OCCURRENCE \$ 1,000,000 ✓ AGGREGATE \$ 1,000,000 \$
C	WORKERS COMPENSATION AND EMPLOYERS' LIABILITY ANY PROPRIETOR/PARTNER/EXECUTIVE OFFICER/MEMBER EXCLUDED? (Mandatory in MI) If yes, describe under DESCRIPTION OF OPERATIONS below	Y/N Y	N/A	ICWWCBINDER	01/01/2026	01/01/2027	<input checked="" type="checkbox"/> PER STATUTE <input type="checkbox"/> OTHER E.L. EACH ACCIDENT \$ 1,000,000 ✓ E.L. DISEASE - EA EMPLOYEE \$ 1,000,000 E.L. DISEASE - POLICY LIMIT \$ 1,000,000

DESCRIPTION OF OPERATIONS / LOCATIONS / VEHICLES (ACORD 101, Additional Remarks Schedule, may be attached if more space is required)
The City of Grosse Pointe Woods is named as an additional insured with respects to general liability including completed operations as required by written contract. XCU is included. Waiver of subrogation applies in favor of the additional insured with respects to General liability as required by written contract. ✓

CERTIFICATE HOLDER City of Grosse Pointe Woods 20025 Mack Plaza Dr Grosse Pointe Woods MI 48236	CANCELLATION SHOULD ANY OF THE ABOVE DESCRIBED POLICIES BE CANCELLED BEFORE THE EXPIRATION DATE THEREOF, NOTICE WILL BE DELIVERED IN ACCORDANCE WITH THE POLICY PROVISIONS. AUTHORIZED REPRESENTATIVE
---	--

GROSSO TRUCKING & SUPPLY CO. AGREEMENT

This agreement is entered into on this ___ day of _____, 2026 between the CITY OF GROSSE POINTE WOODS, a Municipal Corporation, of 20025 Mack Plaza, Grosse Pointe Woods, Michigan (“City”), and Grosso Trucking & Supply Co., 10015 Marine City Hwy., Fair Haven, Michigan 48023;

WHEREAS, Grosso Trucking & Supply Co. is engaged in hauling leaves/brush, scrap, concrete, wood chips, debris, dirt, and sand; and

WHEREAS, the City desires to utilize the services of Grosso Trucking & Supply Co. as an independent contractor:

THEREFORE, IT IS AGREED BETWEEN THE PARTIES AS FOLLOWS:

1. **Award of Contract**: Grosso Trucking & Supply Co. is hereby awarded a non-exclusive contract to perform hauling services for the City.
2. **Term of Contract**: This contract will cover the fiscal year beginning July 1, 2026 and continue through June 30, 2027.
3. **Rates**: Grosso Trucking & Supply Co. will perform hauling services as instructed by the City at the agreed sums of \$7.00 per yard for leaves/brush, \$7.00 per yard for removal of wood chips and clean concrete, \$10.00 per yard for excavation spoils, \$7.00 per yard for delivery of compost; \$13.65 per yard for sand in; \$18.40 for 21A crushed concrete in; and \$17.00 per yard for screened topsoil in.
4. **Termination**: Notwithstanding the term of this contract, this agreement may be terminated by either party with 30 days written notice to the other party for any reason.
5. **Insurance**: Grosso Trucking & Supply Co. will keep in full force and affect insurance coverage in accordance with the bid specifications dated April 7, 2011, and shall furnish proof of such insurance to the City of Grosse Pointe Woods.
6. **Compliance with City Ordinances**: Grosso Trucking & Supply Co. shall be required to comply with all city ordinances and pertinent state laws during the terms of this Agreement including, but not limited to, hours of operation.

7. City Indemnification: Grosso Trucking & Supply Co. agrees to indemnify and hold harmless the City from any actions, suits, debts, judgments, damages and/or claims arising out of Grosso Trucking & Supply Co.'s performance of this Agreement.

8. Incorporation of Bid Documents: The original bid documents including the notice to bidders dated April 7, 2011, specifications, insurance coverage, and the bid sheet are incorporated into this Agreement by reference. In the event of any inconsistencies between the bid documents and this Agreement, the Agreement controls.

WITNESS:

City of Grosse Pointe Woods

By:

Susan Como
City Manager

Grosso Trucking & Supply Co.

By:

Steve Grosso
Owner

CITY OF GROSSE POINTE WOODS MEMORANDUM

Date: June 11, 2026

To: Mayor and City Council

From: Susan Como, City Manager 

Subject: Participation in PFAS Settlement Program – DuPont and 3M

I want to advise all of you with an opportunity for the City to participate in the national PFAS settlement program involving DuPont and 3M and to seek direction regarding the City's participation.

Background

DuPont and 3M have agreed to settlements totaling approximately \$13 billion to resolve claims related to per- and polyfluoroalkyl substances (PFAS) contamination. The settlement funds are available to eligible Community Water Systems (CWS) throughout the country.

As a member partner of the Great Lakes Water Authority (GLWA), the City of Grosse Pointe Woods qualifies as a Category 2 Community Water System and is eligible to participate in the settlement, provided the City timely submits the required documentation and formally elects to participate.

Failure to participate within the required deadlines could result in the City forfeiting any future claim to settlement proceeds or other rights related to PFAS claims against the settling defendants.

Potential Benefits

Settlement payments are generally calculated based on factors such as:

- Historical water system flow rates;
- The size of the community water system; and
- PFAS concentrations identified through required testing.

Based on preliminary information presented during a recent informational webinar potential settlement proceeds for Grosse Pointe Woods could be several thousand dollars, depending on testing results and other qualifying factors.

Importantly, settlement proceeds are described as unrestricted funds, although additional clarification is being sought regarding whether funds must be deposited into the water and sewer fund or may be used for broader municipal purposes.

Participation Requirements

To participate, the City must provide documentation that includes:

- Annual flow rate data from 2013 through 2025;
- Maximum flow rate information;
- Source water sampling and laboratory results;
- IRS Form W-9; and
- Additional supporting information as required by settlement administrators.

The settlement process also requires baseline testing of the GLWA's source water. The City's water supply will not be tested for this settlement since GLWA is the treating entity. GLWA chose not to participate in the settlement but is actively assisting its retail customers to make claims based on GLWA's source water.

Legal Representation

The City has been approached to participate through a legal team already representing numerous GLWA member communities. The lead national firm is Stag Liuzza, which has significant experience handling PFAS settlement claims. Locally, the law firm of Rosati, Schultz, Joppich & Amtsbuechler, P.C. (RSJA) has been asked to serve as local counsel, with attorney Beth Saarela coordinating efforts on behalf of participating municipalities. The proposed representation would be under a contingent fee arrangement. Under this structure:

- The City would incur no legal fees unless a settlement recovery is obtained. This includes any employee's time spent on preparing/submitting of documents, phone calls, meetings, etc.
- The fee would be 1/3 of the City's recovered settlement. 8% of the fee initially is paid to the Court's Settlement Fund Administrator. The remaining 25% is divided between national and local counsel as follows:
- The contingent fee would be divided between Stag Liuzza (75%) and RSJA (25%).

Deadlines

The current deadlines associated with participation are:

- **July 1, 2026** – Submission of baseline testing information.
- **July 31, 2026** – Settlement participation and filing deadline (based on information currently available).

Because of these deadlines, the legal team has requested confirmation of the City's intent to participate as soon as possible to allow sufficient time to complete testing, gather records, and prepare the required filings.

Based on the information available to date, participation appears to present a significant opportunity for the City with minimal financial risk. The primary obligations involve administrative coordination, completion of testing requirements, and approval of the necessary legal agreements and resolutions.

City Attorney Walling has reviewed the attached required Resolution and Contract.

Administration recommends that City Council authorizes approving the attached Resolution and Contract to allow the City to participate in the PFAS settlement program and direct staff to work with legal counsel to ensure all filing requirements and deadlines are met.

Additional information will be provided to City Council upon receipt of the formal engagement materials from counsel.

Attachments

Client has disclosed all potential adverse parties to the Attorneys, and neither the Attorneys nor the Client perceive any conflict of interest in the Attorneys undertaking this engagement on behalf of the Client. If either the Client or the Attorneys, during the representation, receive information indicating that a potential conflict of interest may develop or exist, the Client and the Attorneys agree to bring such information to the immediate attention of the other, and the Attorneys shall proceed to take such steps as may be appropriate in the circumstances.

1. ATTORNEY FEES AND COMMON BENEFIT ASSESSMENT. As compensation for legal services, Client agrees to pay Attorneys for legal services rendered and to be rendered on account of the Client's Claims (hereinafter "Attorney Fees"). Attorney Fees shall be one-third (1/3) of the Gross Amount Recovered for Client's Claims. For any recovery made, Client understands and agrees that Attorney Fees will be divided as follows: 25% to ROSATI SCHULTZ and 75% to STAG LIUZZA, LLC.

Pursuant to Court order, every AFFF settlement claimant must pay an eight percent (8%) common benefit assessment of the Gross Amount Recovered. As a benefit to Client, said Common Benefit Assessment will be credited against the one-third (1/3) Attorneys' Fees herein. Therefore, Client will not separately bear or reimburse Attorneys for the Common Benefit Assessment and Attorneys will be paid a net total contingency fee of 25 1/3%.

Attorney Fees shall all be calculated before the deduction of costs and expenses, as set forth in Section 2 herein. **Client shall only pay attorney fees contingent upon a recovery and shall not pay any attorney fees if there is no recovery.**

2. COSTS AND EXPENSES. In addition to paying Attorney Fees, in the event of a successful recovery, the Client agrees to reimburse all costs and expenses, as set forth herein only in the event of a recovery, which shall be deducted from the Client's share of that recovery. Attorneys may advance expenses on behalf of Client, and Client shall not be responsible for incurring or reimbursing any expenses if the amount of recovery is less than the costs incurred. **Client shall only reimburse costs or expenses advanced by Attorneys in the event of a recovery by settlement or judgment.** But in no event will fees exceed the Compensation as set forth in Paragraph 1, above. If no recovery is made, Attorneys shall bear all unreimbursed costs and expenses incurred, and client shall not be liable for any such costs or expenses incurred by Attorneys. Further, if recovery is insufficient to fully reimburse litigation costs, Attorneys shall bear, and Client shall not be liable for, all costs in excess of the amount of recovery. Subject to the foregoing terms, the Client agrees to reimburse the Attorneys' litigation costs and expenses upon receipt of any settlement funds or collected judgment. But in no event will fees exceed the Compensation as set forth in Paragraph 1, above.

The Attorneys shall have the right and authority, without prior approval of the Client, to incur such litigation costs and expenses as may be necessary or advisable in furtherance of Client's Claims. Litigation costs and expenses may include (but are not limited to) the following: filing fees; deposition costs; expert witness fees; transcript costs; witness fees; subpoena costs; sheriff's and service of process fees; trial consultant fees; mock trial costs; shadow jury fees; mediation fees; court costs; trial exhibit costs; copy costs; photographic, electronic or digital evidence production

or presentation; investigation fees; travel expenses; and any other case-specific expenses directly related to the representation undertaken. Additionally, the Client specifically authorizes the Attorneys to charge as recoverable costs such items such as: computer legal research charges (e.g. Westlaw and/or Lexis); long distance telephone expenses; postage charges; Federal Express, UPS, and other delivery service charges; internal photocopying at a rate of \$.30 per page; facsimile costs at a rate of \$.25 per page; and mileage and outside courier charges, all of which must be incurred solely for the purposes of the representation undertaken. Finally, the Client acknowledges that Client will not be charged costs and expenses for any overhead costs of the Attorneys' practice, including office rent; utility costs; charges for local telephone service; office supplies; fixed asset expenses; and ordinary secretarial and staff services. But in no event will fees exceed the Compensation as set forth in Paragraph 1, above.

3. NO GUARANTEE. Client acknowledges that the Attorneys have made no promise or guarantee regarding the outcome of my legal matter. Client acknowledges that Client's Claims may result in no recovery. Client further acknowledge that the Attorneys shall have the right to cancel this agreement and withdraw from this matter if, in the Attorneys 'professional opinion, the matter does not have merit, the Client does not have a reasonably good possibility of recovery, Client refuses to follow the recommendations of the Attorneys, Client fails to abide by the terms of this agreement, the Client fails to provide requested information or assistance, if the continued representation by Attorney would result in a violation of the Rules of Professional Conduct, or at any other time as permitted under the Rules of Professional Conduct.

4. ELECTRONIC DATA COMMUNICATION AND STORAGE. In the interest of facilitating our services to Client, Attorneys may communicate by facsimile transmission, send data over the internet, store electronic data via computer software applications hosted remotely on the internet, or allow access to data through third-party vendors 'secured portals or clouds. Electronic data that is confidential to Client may be transmitted or stored using these methods. Attorneys may use third-party service providers to store or transmit this data. In using these data communication and storage methods, Attorneys employ measures designed to maintain data security. Attorneys will make reasonable efforts to keep such communications and data access secure in accordance with the Attorneys 'obligations under applicable laws and professional standards. Attorneys also require all Attorneys 'third-party vendors to do the same. However, Client acknowledges that some information transmitted to the Attorneys will be public records, and the Client has no expectation that public records will be confidential. Client acknowledges that Attorneys have no control over the unauthorized interception or breach of any communications or data once it has been sent or has been subject to unauthorized access, notwithstanding all reasonable security measures employed by us or our third-party vendors, and Client consents to our use of these electronic devices and applications and submission of confidential client information to third-party service providers during this engagement.

5. PRIVILEGE. The Client acknowledges that this contract is intended to and does hereby assign, transfer, set over, and deliver unto the Attorneys as its fee for representation of the Client in this matter an interest in the claim(s), the proceeds, or any recovery therefrom under the terms and conditions aforesaid, in accordance with the provisions any state law that applies to this contract.

6. **MODIFICATION.** It contains the entire and complete understanding between the parties and can only be modified by a written amendment signed by all parties.

7. **TERMINATION OF REPRESENTATION.** Client acknowledges that Client has the right to terminate the representation upon written notice to that effect. Client acknowledges that Client will be responsible for any contingent attorney fees or related expenses incurred prior to the discharge or termination, based on all the facts and circumstances, including the risk taken by the Attorneys in accepting Client's legal representation on a contingency fee basis. Client agrees to cooperate with Attorneys and to comply with all reasonable requests of Attorneys. Client warrants and represents to the Attorneys that all information Client has provided to, or will in the future provide to, the Attorneys regarding Client's Claim is true and correct to the best of Client's knowledge, information, and belief. The Attorneys have the right to withdraw from this representation after giving reasonable notice. If the Attorneys are discharged or otherwise cease to serve as Client's legal counsel prior to full payment of the settlements, then Attorneys shall receive as compensation for services, and in consideration of the work that Attorneys performed to achieve the settlement amount allocated to Client, the full contingency fee earned or reasonably earned by Attorneys. At the conclusion of this matter, the Attorneys will retain Client's legal files for a period of five (5) years after the Attorneys close their files. At the expiration of the five-year period, the Attorneys may destroy these files unless Client notifies the Attorneys in writing that Client wishes to take possession of the files. The Attorneys reserve the right to charge administrative fees and costs associated with retrieving, copying, and delivering such files. But in no event will fees exceed the Compensation as set forth in Paragraph 1, above.

8. **ENTIRE AGREEMENT.** The undersigned representative of Client has read this agreement, a copy of which Client has received, in its entirety, and Client agrees to and understands the terms and conditions set forth herein. Client acknowledges that there are no other terms or oral agreements existing between the Attorneys and Client. This agreement may not be amended or modified in any way without the prior written consent of the Attorneys and the Client.

9. **AUTHORITY.** Client acknowledges having been advised to and given the full opportunity to obtain independent representation in the making of this agreement and voluntarily entering into this agreement after such opportunity. Client representative signing below represents that Client enters into this agreement with proper authorization and approval under state and local law, and that the Client representative is specifically authorized to execute this agreement.

EFFECT OF SIGNING

Client understands that this is a binding legal document. Client further understands that this Agreement may be executed in one or more counterparts, each of which shall be deemed an original, but all of which together shall be deemed to be one and the same agreement. A signed copy of this Agreement delivered by facsimile, e-mail, or other means of electronic transmission shall be deemed to have the same legal effect as delivery of an original signed copy of this Agreement.

Date

SUSAN COMO, CITY MANAGER

Date

**MICHAEL G. STAG
FOR STAG LIUZZA, LLC**

Date

**ELIZABETH SAARELA
FOR ROSATI, SCHULTZ, JOPPICH &
AMTSBEUHLER, PC**

**A RESOLUTION OF GLWA MEMBER PARTNER
THE CITY OF GROSSE POINTE WOODS
AUTHORIZING THE EXECUTION OF THE LEGAL SERVICES AGREEMENT
FOR THE 3M AND DUPONT PUBLIC DRINKING WATER SETTLEMENTS**

Minutes of a Meeting of the City Council of the City of Grosse Pointe Woods, County of Wayne, Michigan, held in the City Hall of said City on June 15, 2026, at 7:00 o'clock P.M. Prevailing Eastern Time.

PRESENT:

Councilmembers _____

ABSENT:

Councilmembers _____

The following preamble and Resolution were offered by Councilmember _____ and supported by Councilmember _____.

WHEREAS, a civil action and/or claims in Aqueous Film-Forming Foams Litigation MDL No. 2873 (“AFFF”) the City of Grosse Pointe Woods (the “City”) is committed to delivering clean drinking water to its customers; and

WHEREAS, the City is also committed to taking reasonable steps to recover cost reimbursements that may be available in the 3M and DuPont Public Drinking Water Settlements and to reduce costs to its consumers; and

WHEREAS, STAG LIUZZA, L.L.C., and ROSATI SCHULTZ JOPPICH & AMTSBEUHLER, PC have put together a team of uniquely qualified and experienced attorneys (“the Firm”) who have joined together to assist public entities seeking to recover cost reimbursements that may be available in the 3M and DuPont Public Drinking Water Settlements; and

WHEREAS, the Firm is comprised of experienced attorneys in both in PFAS litigation and in the representation of public entities pursuing legal claims involving cost recovery in the drinking water settlements; and

WHEREAS, the City Council has determined it to be in the City’s best interest to enter into the Legal Services Agreement with the Firm and the filing of claims for the 3M and DuPont Public Drinking Water Settlements in the Aqueous Film-Forming Foams Litigation MDL No. 2873 (“AFFF”); and

WHEREAS, the City desires to authorize the execution of the as Exhibit “A” to be signed by the City Manager; and

NOW THEREFORE BE IT RESOLVED by the City Council that the Manager of the City is hereby authorized to execute the Legal Services Agreement with the Firm based upon the terms and conditions set forth herein and, in a manner, substantially similar to the Agreement attached hereto as Exhibit "A."

AYES:

NAYES:

RESOLUTION DECLARED _____.

Paul P. Antolin, City Clerk

CERTIFICATION

I hereby certify that the foregoing is a true and complete copy of a resolution adopted by the City Council of the City of Grosse Pointe Woods , County of Oakland, and State of Michigan, at a regular meeting held this ____ day of _____, 2026, and that public notice of said meeting was given pursuant to and in full compliance with Act No. 267, Public Acts of Michigan, 1976, and that the minutes of said meeting have been kept and made available to the public as required by said Act.

Paul P. Antolin, City Clerk
City of Grosse Pointe Woods

MEMO 26-7

TO: Susan Como, City Manager
FROM: Owen Gafa, Director of Parks and Recreation
DATE: June 11, 2026
SUBJECT: Recommendation – Pavilion at Ghesquiere Park

Quotes were sought for the installation of a new pavilion at Ghesquiere Park.

Midstates Recreation 16' x 24': \$45,027.00

Midstates Recreation 20' x 24': \$49,885.00

Quotes were presented at the Committee-of-the-Whole meeting held on June 1, 2026. The quotes were reviewed and a motion by City Council sitting as the Committee-of-the-Whole was made to recommend City Council approve one of the two options presented to install a pavilion at Ghesquiere Park as well as obtain updated quotes. The Grosse Pointe Woods Foundation is willing to commit a grant of \$35,000.00.

If you have any questions concerning this matter, please contact me.

Approved for Council consideration.

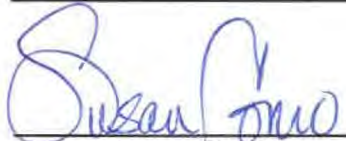
Susan Como, City Manager

Date

COMMITTEE-OF-THE-WHOLE
MINUTES EXCERPT
06/01/26

Motion by Koester, seconded by Motschall, that the Committee-of-the-Whole recommend to City Council approval of one of the two options presented to install a pavilion at Ghesquiere Park.

Motion carried by the following vote:

Yes: Brown, Bryant, Gafa, Koester, Motschall
No: None
Absent: Granger, McConaghy

The previous motion and recommendation will be addressed at the next City Council meeting on June 15, 2026.



PROJECT QUOTE

Quote # PQ000665
 Quote Date 6/11/2026
 Valid Until 8/1/2026
 Sales Person Brion Kilpela
 Drawing Nbr.:
[Project:](#)

1279 Hazelton-Etna Road SW
 Pataskala, OH 43062
 614-855-3790
 www.midstatesrecreation.com

C000001346

SOLD TO:	SHIP TO:
MI Grosse Pointe Woods Grosse Pointe Woods 20025 Mack Ave Grosse Pointe Woods, MI 48236	MI Grosse Pointe Woods Ghesquiere Park 19955 Mack Ave Grosse Pointe Woods, MI 48236

ITEM	QTY.	UOM	RATE	AMOUNT
COVERWORX 01: Coverworx NOTES: GA-1624-SW Steelworx Gable 16'x24', 4 Post Design w/ 412 Slope w/ 8'0" low eave, w/ Polyester Powder Coated Frame w/ 24 ga MultiRib Precut Metal Roofing Frame Color:? Roof Color:?	1.0	EA	\$19,820.00	\$19,820.00
COVERWORX 02: Sealed Drawings	1.0	EA	\$1,000.00	\$1,000.00
COVERWORX FREIGHT: Coverworx Freight; Shipping Charges are estimated and are subject to actual shipping charges incurred at time of shipment.	1.0	EA	\$1,250.00	\$1,250.00
INSTALLATION 01: Installation Charges NOTES: Installation Charges: Take delivery of shelter Provide (4) 30"x60" reinforced footings. Erect pavilion listed above. Haul footing spoils off site. Site work, concrete pad and restoration by others.	1.0	EA	\$22,957.00	\$22,957.00
NOTES: Notes NOTES: Proposal does not include site plan, soil borings, permitting or third party inspections. Footing size is estimated and cost may change based on final footing design. Dewatering is not included. If ground water is encountered it will need to be assessed at that time. Lead time for shelter approx 24-25 weeks form receipt of purchase order.	1.0	EA	\$0.00	\$0.00
			Subtotal	45,027.00
			Tax Total	0.00
			Total	45,027.00

Acceptance of Proposal

(Please be sure you have read, signed, and initialed and understand the terms and conditions) The items, prices, and conditions listed herein are satisfactory and are hereby accepted.

Signature (Approval) _____

Printed Name _____

Title _____

Date _____

TERMS AND CONDITIONS

QUOTE CONDITIONS AND ACCEPTANCE:

This quote is only valid until: 7/11/2026 12:00:00 AM.

*** _____ (Pls Initial)

It is the Buyer's responsibility to verify quantities and description of items quoted. Once your order has been placed, any changes including additions, deletions, or color changes, could result in price increases, additional fees and could cause delays.

EXCLUSIONS:

Unless specified, this quote excludes all of the following but not limited to:

- Required Permits/Inspections
- Background Checks
- Davis Bacon
- Prevailing Wage or Certified Payroll
- Performance/Payment Bonds Site Restoration Site work
- Saw cutting/core drilling, and landscaping
- Removal of existing equipment Unloading
- Receiving of inventory or equipment
- Storage of equipment
- Equipment assembly and/or installation Safety surfacing
- Borders or drainage requirements
- Landscaping Repairs due to poor access or in inclement weather

FREIGHT AND DELIVERY: (if applicable)

*** _____ (Pls Initial)

Shipping is FOB Origin (means the buyer accepts the title of the goods at the shipment point and assumes all risk once the seller ships the product). All equipment will arrive unassembled. Buyer is responsible to meet and provide adequate personnel/equipment to unload truck. A Check List, detailing all items shipped, will be included with the shipment. Unless taking delivery is specifically included in quote. Buyer is responsible for ensuring the Sales Order Breakdown and Item Numbers on all boxes and pieces match the Check List.

*** _____ (Pls Initial)

Shortages or damages must be noted on the driver's delivery receipt. Shortages or damages not noted become the buyers financial responsibility.

Please notify Midstates Recreation immediately of any damages.

Shortages and Concealed Damage must be reported to Midstates Recreation within 10 days of delivery.

A reconsignment fee will be charged for any changes made to delivery address after order has been placed.

TAXES:

All orders are subject to applicable sales tax unless a tax exemption form is on file at the time the order is placed.

PAYMENT TERMS:

An approved Credit Application is required for new customers or customers that haven't been active in the last 18 months. Terms are check with order, or 50% down payment with approved credit (terms do vary based on references). Balance of product & freight will be invoiced upon shipment, due Net 10 days. 100 % prepayment required on Replacement Parts. A 3% charge will be added to all credit card orders over \$ 3,000.

For all non-taxpayer-funded entities: A 1.5% monthly service charge will be assessed on all balances over 30 days.

RESTOCKING:

Items canceled, returned or refused will be subject to a minimum 25% restocking fee. All return freight charges are the responsibility of the Buyer.

MAINTENANCE/WARRANTY:

Manufacturer`s standard product warranties apply and cover equipment replacement and freight costs only; labor is not included. Midstates Recreation offers no additional warranties.

Maintenance of the equipment and safety surfacing is the responsibility of the customer. Any unauthorized alterations or modifications to the equipment (including layout) will void your warranty.

Site Preparation & Third-Party Work Disclaimer:

If excavation, grading, or material placement is performed by a party other than Midstates Recreation, **all work must be coordinated with Midstates Recreation to ensure alignment with project requirements.**

If excavation, grading, or material placement is performed by a party other than Midstates Recreation, all work must be coordinated with Midstates Recreation to ensure alignment with project requirements.

We are not responsible for any delays, performance issues, or additional costs resulting from improper compaction, grading, or site preparation by others. Any deficiencies in third-party work that impact our ability to install as specified may require correction at the owner`s expense.

INSTALLATION: (if applicable)

Spoils are to remain onsite. Permits/inspections are the owner`s responsibility and associated costs.

Customer must locate all underground private utilities before your scheduled installation.

A third-party private utility service can be provided at an additional cost if necessary. Additional charges may apply if obstruction(s) are encountered beneath the surface. Not responsible for damaged/broken parts on existing playground equipment. Not responsible for crossing sidewalks.

Acceptance of Terms & Conditions

Acceptance of this proposal, made by an authorized agent of your company, indicates agreement to the above terms and conditions.

Customer Signature	Printed Name and Title	Date
---------------------------	-------------------------------	-------------



10 Year Limited Warranty

Coverworx-Recreational Architecture, a division of Ross and Barr, Inc. (hereinafter "Coverworx") warrants that the structure or product purchased will be free from defects in materials and workmanship under normal use for period of ten (10) years from the delivery date. The entire liability of Coverworx and its suppliers, and the exclusive remedy shall be for Coverworx to repair and replace materials found to be defective. The repair or replacement of materials shall be at the expense of Coverworx. This limited warranty applies to all product(s) under normal use and is void if any damage has resulted from abnormal use, abuse, accident, vandalism, poor or careless installation, lack of maintenance, misapplication, service or modifications by someone other than Coverworx or its suppliers. This warranty excludes color fading within ten (ten) nautical miles of any area retaining salt water or brackish water. Any replacement part under warranty is warranted for the remaining original warranty period or 1 year, whichever is longer.

Steel roof finish shall be warranted for 20 years under a separate roof manufacturer's warranty. Powder coat paint shall be warranted for 10 years after acceptance from owner against peeling, flaking, and rusting under normal use and conditions as described above.

In the event of a defect claim, Coverworx shall be notified in writing within (thirty) 30 days from discovery, no later than thirty (30) days from the receipt of the notice. Coverworx management will determine whether to repair or replace defective materials and respond in writing to advise how Coverworx will proceed on the warranty claim. Coverworx disclaims all other warranties, express or implied, including but not limited to, implied warranties of merchantability and fitness for a particular purpose for the product and any accompanying materials required for installation. Coverworx will not be liable for any damages arising out of the use or inability to use the product, regardless of whether notification of such damages has been given.

11800 East 9 Mile Road, Warren, MI 48089
(586) 759-5490 Office (586) 754-9130 Fax (800) 657-6118 Toll Free
www.Coverworx.net info@coverworx.net

Model: Steelworx Gable Shelter, 16' x 24'
Model # GA-1624-SW

Manufacturing Mission: To provide all prefabricated components and installation instructions for a 16' wide (measured from eave to eave) by 24' long free standing bolt together, tubular steel constructed shelter kit.

Design Criteria: Structure shall be designed to meet site specific snow and wind load design criteria using most current applicable building codes. All structural members are ASTM A-500 U.S. grade B steel. Welded connection plates shall be ASTM A-36 hot rolled steel. All fabrication performed to latest AISC standards by AWS Certified welders. All framing connections are done using A325 grade bolts within concealed access openings from above and will later be concealed by the roofing. All roof framing shall be flush against the roof decking to eliminate the possibility of bird nesting.

Tubular Steel Columns and Beams: Standard column dimension shall be 5" x 5" x 3/16" tubular steel welded to 5/8" base plates for surface mounting. Main support beams are 7" x 5" x 3/16" and purlins are 6" x 4" x 1/8". Steel sizes are preliminary and may change due to ongoing review and final engineering.

Roofing: 24 Ga. pre-cut steel Multi-Rib panels with Kynar 500 finish in a variety of colors with white underside. Standard roof slope is a 4/12 pitch with a eave height of 8'-0". Attached to structural framing with exposed self tapping screws painted to match roof color. Matching 24 Ga. trim included.

Frame Finish: All steel framework will receive a corrosion protective TGIC Polyester powder coat, electro-statically applied and cured at 400°F. A large selection of standard colors are available.

Foundation: All columns need to be anchored to concrete footings (footing design provided separately). Columns can be surface mounted to footings with anchor bolts at or below finish slab elevation or they can be embedded directly into the footing without base plates upon request. Anchor bolts and bracing templates are included. Optional base plate covers are available at an additional cost.

Hardware: All structural hardware and roofing fasteners shall be provided.

Warranty: 10 years against manufacturer defects.

Not Included: Concrete work of any kind, unloading of product and installation.

Additional Options: Refer to catalog or www.coverworx.com for available options and upgrades.

Frame Color: _____ **Roof Color:** _____



11800 East 9 Mile Road
Warren, MI 48089
Office: (586) 486-1088
Fax: (586) 754-9130
Toll Free: (800) 657-6118
Email: info@coverworx.com
www.CoverWorx.com

Steelworx Gable Shelter - 16' x 24'

Model: GA-1624-SW

DESIGN SPECIFICATIONS

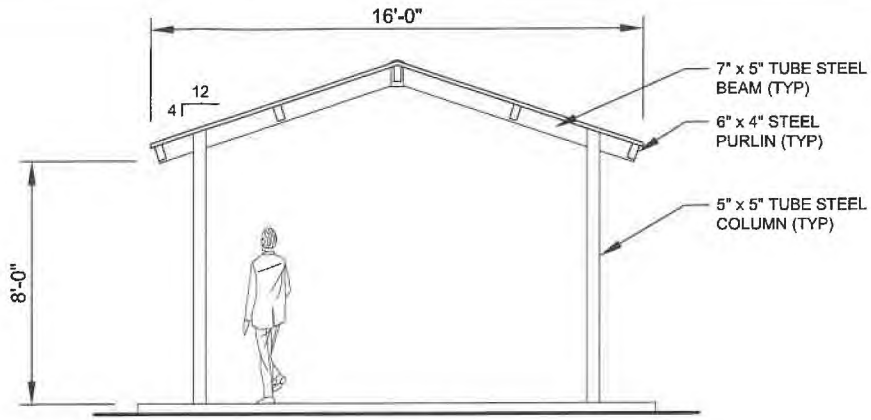

FRONT ELEVATION
SCALE: NTS

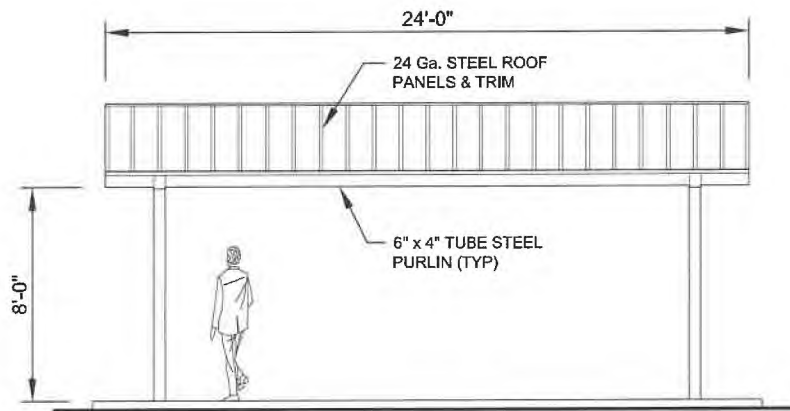

SIDE ELEVATION
SCALE: NTS

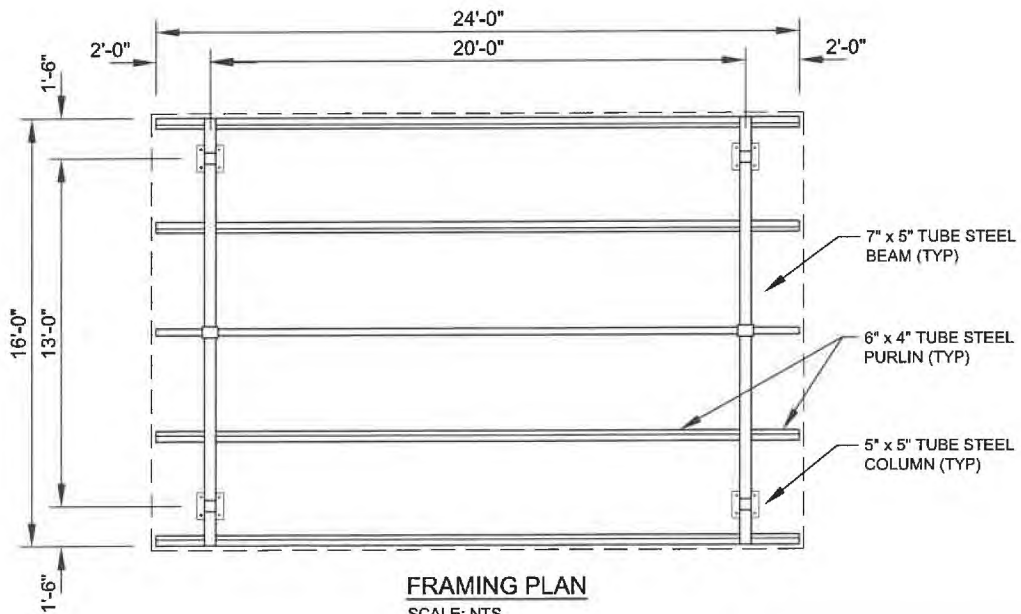

FRAMING PLAN
SCALE: NTS



11800 East 9 Mile Road
Warren, MI 48089
Office: (586) 486-1088
Fax: (586) 754-9130
Toll Free: (800) 657-6118
Email: info@coverworx.com
www.CoverWorx.com

Steelworx Gable Shelter - 16' x 24'

Model: GA-1624-SW

DESIGN SPECIFICATIONS



Steelworx

COLOR

COLORS & OPTIONS

At Coverworx, we offer an extensive palette of colors for our Steel Frame, Metal Roof, and Trim work panels, giving you the freedom to create a look that's uniquely yours. Whether you're aiming for a classic, modern, or entirely bespoke style, our range of options allows you to mix and match frame finishes and metal roof colors to perfectly complement your project.

Explore our selection to find the ideal combination that meets your aesthetic preferences and practical needs. Our team is dedicated to helping you achieve the exact look you envision.

For custom color requests or to discuss specific design details, please reach out to our expert Coverworx sales staff. We're here to provide you with all the information you need and to guide you through the process of crafting a distinctive and stylish outcome for your project.



Metal Roof Colors*

*Colors are representational. Actual colors may vary. Contact us to discuss custom color options.



					
Roman Blue	Patrician Bronze	Copper Penny	Mansard Brown		
					
Surrey Beige	Galvalume Plus	Brandywine	Medium Bronze		
					
Evergreen	Ash Gray	Tudor Brown	Bone White	Champagne Metallic	Regal Blue
					
Almond	Bright Red	Dark Bronze	Leadcoat	Terra Cotta	Charcoal
					
Slate Gray	Hartford Green	Colonial Red	Silver Metallic	Regal White	Buckskin
					
Patina Green	Texas Silver Metallic	Sandstone	Matte Black	Prewathered Galvalume	



Steel Roof Panel Colors

Steel roof panels come in a variety of colors and options to fit different aesthetic and functional needs.

All roof panels are Galvalume coated 24 ga. steel with a white bottom and a 20 year warranted Kynar 500 top finish available in a variety of colors. Panels are fastened to frame with either exposed painted screws or concealed clips as with standing seam panels. Some panels may have color limitations. Fiberglass shingles are available upon request.



Steel Frame (Powder Coat) Colors*

*Colors are representational. Actual colors may vary. Contact us to discuss custom color options

 Hartford Green	 Regal White	 Colonial Red	 Timber Tan	 Surrey Beige
 Brandywine	 Clay	 Medium Bronze	 Patrician Bronze	 Brite Red
 Evergreen	 Dark Bronze	 Autumn Red	 Bone White	 Tudor Brown
 Roman Blue	 Mansard Brown	 Slate Gray	 Sandstone	 Charcoal
 Matte Black	 Light Stone	 Patina Green	 Ash Grey	 Regal Blue
 Buckskin	 Almond			

Note: An optional super durable TGIC and graffiti resistant TGIC color or clear coat is available for an upcharge.

Custom RAL Powder colors available

Frame only



Choose from over 100 color options to fit your exact requirements!

Powder coating with zinc rich primer and TGIC polyester



Shot blasted steel with factory applied zinc rich primer and TGIC Polyester (2.5 – 3.5 mil thickness on exterior).

Powder Coat Application Process



Surface Preparation

SPG commercial blast to a profile of 1.0 mil.

Prime Coat

Zinc-rich epoxy primer is applied to a 2.5 – 3.5 mil thickness and then baked at 350°F for 20 minutes to gel the primer. This doesn't completely cure the primer; so when the top coat is applied, it allows the primer and top coat to cross-link for better adhesion.

Top Coat – TGIC Polyester applied to a 2.5 – 3.5 mil thickness and baked at 400°F



PROJECT QUOTE

Quote # PQ000666
 Quote Date 6/11/2026
 Valid Until 8/1/2026
 Sales Person Brion Kilpela
 Drawing Nbr.:
[Project.:](#)

1279 Hazelton-Etna Road SW
 Pataskala, OH 43062
 614-855-3790
 www.midstatesrecreation.com

C000001346

SOLD TO:	SHIP TO:
MI Grosse Pointe Woods Grosse Pointe Woods 20025 Mack Ave Grosse Pointe Woods, MI 48236	MI Grosse Pointe Woods Ghesquiere Park 19955 Mack Ave Grosse Pointe Woods, MI 48236

ITEM	QTY	UOM	RATE	AMOUNT
COVERWORX 01: Coverworx NOTES: GA-2024-SW Steelworx Gable 20'x24', 4 Post Design w/ 4:12 Slope w/ 8'0" low eave, w/ Polyester Powder Coated Frame w/ 24 ga MultiRib Precut Metal Roofing Frame Color:? Roof Color:?	1.0	EA	\$21,985.00	\$21,985.00
COVERWORX 02: Sealed Drawings	1.0	EA	\$1,000.00	\$1,000.00
COVERWORX FREIGHT: Coverworx Freight; Shipping Charges are estimated and are subject to actual shipping charges incurred at time of shipment.	1.0	EA	\$1,250.00	\$1,250.00
INSTALLATION 01: Installation Charges NOTES: Installation Charges: Take delivery of shelter Provide (4) 30"x60" reinforced footings. Erect pavilion listed above. Haul footing spoils off site. Site work, concrete pad and restoration by others.	1.0	EA	\$25,650.00	\$25,650.00
NOTES: Notes NOTES: Proposal does not include site plan, soil borings, permitting or third party inspections. Footing size is estimated and cost may change based on final footing design. Dewatering is not included. If ground water is encountered it will need to be assessed at that time. Lead time for shelter approx 24-25 weeks form receipt of purchase order.	1.0	EA	\$0.00	\$0.00
			Subtotal	49,885.00
			Tax Total	0.00
			Total	49,885.00

Acceptance of Proposal

(Please be sure you have read, signed, and initialed and understand the terms and conditions) The items, prices, and conditions listed herein are satisfactory and are hereby accepted.

Signature (Approval) _____

Printed Name _____

Title _____

Date _____

TERMS AND CONDITIONS

QUOTE CONDITIONS AND ACCEPTANCE:

This quote is only valid until: 7/11/2026 12:00:00 AM.

*** _____ (Pls Initial)

It is the Buyer's responsibility to verify quantities and description of items quoted. Once your order has been placed, any changes including additions, deletions, or color changes, could result in price increases, additional fees and could cause delays.

EXCLUSIONS:

Unless specified, this quote excludes all of the following but not limited to:

- Required Permits/Inspections
- Background Checks
- Davis Bacon
- Prevailing Wage or Certified Payroll
- Performance/Payment Bonds Site Restoration Site work
- Saw cutting/core drilling, and landscaping
- Removal of existing equipment Unloading
- Receiving of inventory or equipment
- Storage of equipment
- Equipment assembly and/or installation Safety surfacing
- Borders or drainage requirements
- Landscaping Repairs due to poor access or in inclement weather

FREIGHT AND DELIVERY: (if applicable)

*** _____ (Pls Initial)

Shipping is FOB Origin (means the buyer accepts the title of the goods at the shipment point and assumes all risk once the seller ships the product). All equipment will arrive unassembled. Buyer is responsible to meet and provide adequate personnel/equipment to unload truck. A Check List, detailing all items shipped, will be included with the shipment. Unless taking delivery is specifically included in quote. Buyer is responsible for ensuring the Sales Order Breakdown and Item Numbers on all boxes and pieces match the Check List.

*** _____ (Pls Initial)

Shortages or damages must be noted on the driver's delivery receipt. Shortages or damages not noted become the buyers financial responsibility.

Please notify Midstates Recreation immediately of any damages.

Shortages and Concealed Damage must be reported to Midstates Recreation within 10 days of delivery.

A reconsignment fee will be charged for any changes made to delivery address after order has been placed.

TAXES:

All orders are subject to applicable sales tax unless a tax exemption form is on file at the time the order is placed.

PAYMENT TERMS:

An approved Credit Application is required for new customers or customers that haven't been active in the last 18 months. Terms are check with order, or 50% down payment with approved credit (terms do vary based on references). Balance of product & freight will be invoiced upon shipment, due Net 10 days. 100 % prepayment required on Replacement Parts. A 3% charge will be added to all credit card orders over \$ 3,000.

For all non-taxpayer-funded entities: A 1.5% monthly service charge will be assessed on all balances over 30 days.

RESTOCKING:

Items canceled, returned or refused will be subject to a minimum 25% restocking fee. All return freight charges are the responsibility of the Buyer.

MAINTENANCE/WARRANTY:

Manufacturer`s standard product warranties apply and cover equipment replacement and freight costs only; labor is not included. Midstates Recreation offers no additional warranties.

Maintenance of the equipment and safety surfacing is the responsibility of the customer. Any unauthorized alterations or modifications to the equipment (including layout) will void your warranty.

Site Preparation & Third-Party Work Disclaimer:

If excavation, grading, or material placement is performed by a party other than Midstates Recreation, **all work must be coordinated with Midstates Recreation to ensure alignment with project requirements.**

If excavation, grading, or material placement is performed by a party other than Midstates Recreation, all work must be coordinated with Midstates Recreation to ensure alignment with project requirements.

We are not responsible for any delays, performance issues, or additional costs resulting from improper compaction, grading, or site preparation by others. Any deficiencies in third-party work that impact our ability to install as specified may require correction at the owner`s expense.

INSTALLATION: (if applicable)

Spoils are to remain onsite. Permits/inspections are the owner`s responsibility and associated costs.

Customer must locate all underground private utilities before your scheduled installation.

A third-party private utility service can be provided at an additional cost if necessary. Additional charges may apply if obstruction(s) are encountered beneath the surface. Not responsible for damaged/broken parts on existing playground equipment. Not responsible for crossing sidewalks.

Acceptance of Terms & Conditions

Acceptance of this proposal, made by an authorized agent of your company, indicates agreement to the above terms and conditions.

Customer Signature	Printed Name and Title	Date



10 Year Limited Warranty

Coverworx-Recreational Architecture, a division of Ross and Barr, Inc. (hereinafter "Coverworx") warrants that the structure or product purchased will be free from defects in materials and workmanship under normal use for period of ten (10) years from the delivery date. The entire liability of Coverworx and its suppliers, and the exclusive remedy shall be for Coverworx to repair and replace materials found to be defective. The repair or replacement of materials shall be at the expense of Coverworx. This limited warranty applies to all product(s) under normal use and is void if any damage has resulted from abnormal use, abuse, accident, vandalism, poor or careless installation, lack of maintenance, misapplication, service or modifications by someone other than Coverworx or its suppliers. This warranty excludes color fading within ten (ten) nautical miles of any area retaining salt water or brackish water. Any replacement part under warranty is warranted for the remaining original warranty period or 1 year, whichever is longer.

Steel roof finish shall be warranted for 20 years under a separate roof manufacturer's warranty. Powder coat paint shall be warranted for 10 years after acceptance from owner against peeling, flaking, and rusting under normal use and conditions as described above.

In the event of a defect claim, Coverworx shall be notified in writing within (thirty) 30 days from discovery, no later than thirty (30) days from the receipt of the notice. Coverworx management will determine whether to repair or replace defective materials and respond in writing to advise how Coverworx will proceed on the warranty claim. Coverworx disclaims all other warranties, express or implied, including but not limited to, implied warranties of merchantability and fitness for a particular purpose for the product and any accompanying materials required for installation. Coverworx will not be liable for any damages arising out of the use or inability to use the product, regardless of whether notification of such damages has been given.

11800 East 9 Mile Road, Warren, MI 48089
(586) 759-5490 Office (586) 754-9130 Fax (800) 657-6118 Toll Free
www.Coverworx.net info@coverworx.net

Model: Steelworx Gable Shelter, 20' x 24'
Model # GA-2024-SW

Manufacturing Mission: To provide all prefabricated components and installation instructions for a 20' wide (measured from eave to eave) by 24' long free standing bolt together, tubular steel constructed shelter kit.

Design Criteria: Structure shall be designed to meet site specific snow and wind load design criteria using most current applicable building codes. All structural members are ASTM A-500 U.S. grade B steel. Welded connection plates shall be ASTM A-36 hot rolled steel. All fabrication performed to latest AISC standards by AWS Certified welders. All framing connections are done using A325 grade bolts within concealed access openings from above and will later be concealed by the roofing. All roof framing shall be flush against the roof decking to eliminate the possibility of bird nesting.

Tubular Steel Columns and Beams: Standard column dimension shall be 5" x 5" x 3/16" tubular steel welded to 5/8" base plates for surface mounting. Main support beams are 7" x 5" x 3/16" and purlins are 6" x 4" x 1/8". Steel sizes are preliminary and may change due to ongoing review and final engineering.

Roofing: 24 Ga. pre-cut steel Multi-Rib panels with Kynar 500 finish in a variety of colors with white underside. Standard roof slope is a 4/12 pitch with a eave height of 8'-0". Attached to structural frame with exposed screws painted to match roof color. Matching 24 Ga. trim included.

Frame Finish: All steel framework will receive a corrosion protective TGIC Polyester powder coat, electro-statically applied and cured at 400°F. A large selection of standard colors are available.

Foundation: All columns need to be anchored to concrete footings (footing design provided separately). Columns can be surface mounted with anchor bolts at or below finish slab elevation or they can be embedded directly into the footing. Optional base plate covers are available at an additional cost.

Hardware: All structural hardware and roofing fasteners shall be provided.

Warranty: 10 years against manufacturer defects.

Not Included: Concrete work of any kind, unloading of product and installation.

Frame Color: _____ Roof Color: _____



11800 East 9 Mile Road
Warren, MI 48089
Office: (586) 486-1088
Fax: (586) 754-9130
Toll Free: (800) 657-6118
Email: info@coverworx.com
www.CoverWorx.com

Steelworx Gable Shelter - 20' x 24'

Model: GA-2024-SW

DESIGN SPECIFICATIONS

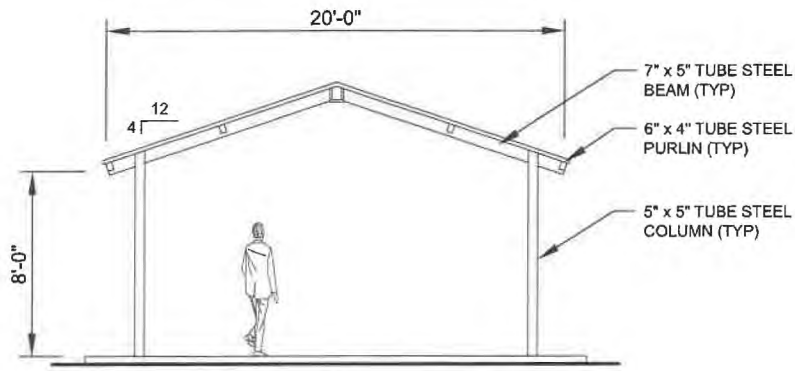

FRONT ELEVATION

SCALE: NTS

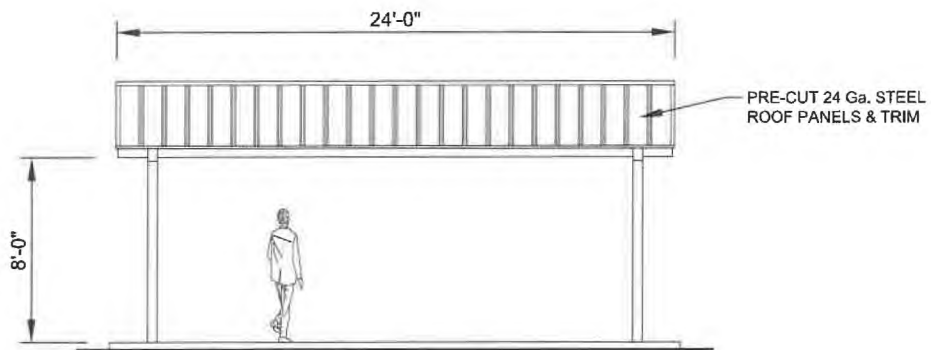

SIDE ELEVATION

SCALE: NTS

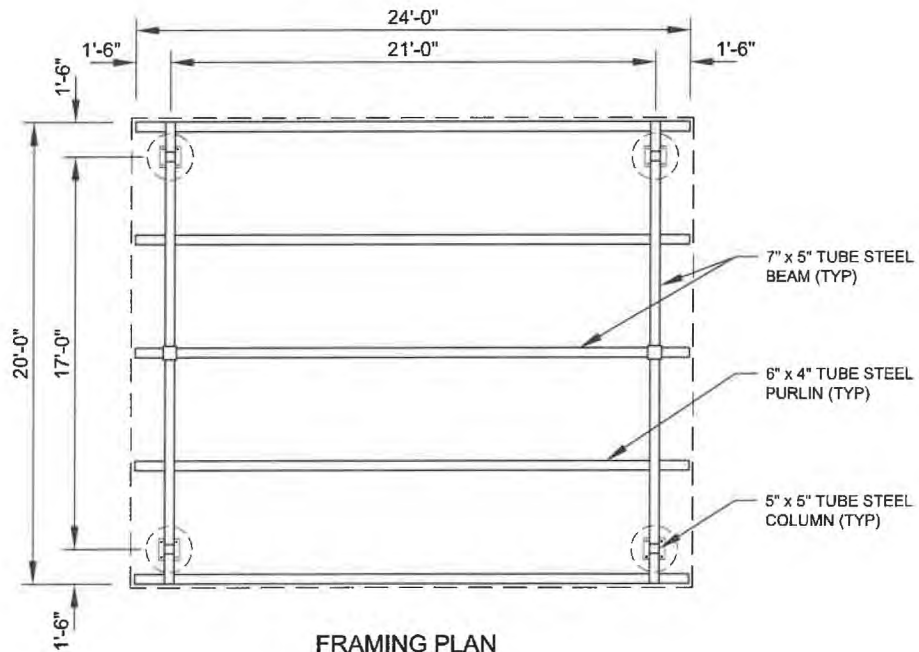

FRAMING PLAN

SCALE: NTS



11800 East 9 Mile Road
 Warren, MI 48089
 Office: (586) 486-1088
 Fax: (586) 754-9130
 Toll Free: (800) 657-6118
 Email: info@coverworx.com
 www.CoverWorx.com

Steelworx Gable Shelter - 20' x 24'

Model: GA-2024-SW

DESIGN SPECIFICATIONS



Steelworx

COLOR

COLORS & OPTIONS

At Coverworx, we offer an extensive palette of colors for our Steel Frame, Metal Roof, and Trim work panels, giving you the freedom to create a look that's uniquely yours. Whether you're aiming for a classic, modern, or entirely bespoke style, our range of options allows you to mix and match frame finishes and metal roof colors to perfectly complement your project.

Explore our selection to find the ideal combination that meets your aesthetic preferences and practical needs. Our team is dedicated to helping you achieve the exact look you envision.

For custom color requests or to discuss specific design details, please reach out to our expert Coverworx sales staff. We're here to provide you with all the information you need and to guide you through the process of crafting a distinctive and stylish outcome for your project.



Metal Roof Colors*

*Colors are representational. Actual colors may vary. Contact us to discuss custom color options.



Roman Blue



Patrician Bronze



Copper Penny



Mansard Brown



Surrey Beige



Galvalume Plus



Brandywine



Medium Bronze



Evergreen



Ash Gray



Tudor Brown



Bone White



Champagne Metallic



Regal Blue



Almond



Bright Red



Dark Bronze



Leadcoat



Terra Cotta



Charcoal



Slate Gray



Hartford Green



Colonial Red



Silver Metallic



Regal White



Buckskin



Patina Green



Texas Silver Metallic



Sandstone



Matte Black



Preweathered Galvalume



Steel Roof Panel Colors

Steel roof panels come in a variety of colors and options to fit different aesthetic and functional needs.

All roof panels are Galvalume coated 24 ga. steel with a white bottom and a 20 year warranted Kynar 500 top finish available in a variety of colors. Panels are fastened to frame with either exposed painted screws or concealed clips as with standing seam panels. Some panels may have color limitations. Fiberglass shingles are available upon request.



Steel Frame (Powder Coat) Colors*

*Colors are representational. Actual colors may vary. Contact us to discuss custom color options

 Hartford Green	 Regal White	 Colonial Red	 Timber Tan	 Surrey Beige
 Brandywine	 Clay	 Medium Bronze	 Patrician Bronze	 Brite Red
 Evergreen	 Dark Bronze	 Autumn Red	 Bone White	 Tudor Brown
 Roman Blue	 Mansard Brown	 Slate Gray	 Sandstone	 Charcoal
 Matte Black	 Light Stone	 Patina Green	 Ash Grey	 Regal Blue
 Buckskin	 Almond			

Note: An optional super durable TGIC and graffiti resistant TGIC color or clear coat is available for an upcharge.

Custom RAL Powder colors available

Frame only



Choose from over 100 color options to fit your exact requirements!

Powder coating with zinc rich primer and TGIC polyester



Shot blasted steel with factory applied zinc rich primer and TGIC Polyester (2.5 – 3.5 mil thickness on exterior).

Powder Coat Application Process



Surface Preparation

SPG commercial blast to a profile of 1.0 mil.

Prime Coat

Zinc-rich epoxy primer is applied to a 2.5 – 3.5 mil thickness and then baked at 350°F for 20 minutes to gel the primer. This doesn't completely cure the primer; so when the top coat is applied, it allows the primer and top coat to cross-link for better adhesion.

Top Coat – TGIC Polyester applied to a 2.5 – 3.5 mil thickness and baked at 400°F

CITY OF GROSSE POINTE WOODS
PROCLAMATION

WHEREAS, on June 19, 1865, when Major General Gordon Granger and some 2,000 Union troops reached Galveston Bay, Texas and informed more than 150,000 enslaved black people of their freedom by executive decree, this day became known by the newly freed people in Texas as “Juneteenth”. Juneteenth marks the United States second independence day.

WHEREAS, it has taken decades for many Americans to recognize Juneteenth it has long been celebrated by the African American community. Most Americans assumed the Emancipation Proclamation of 1863 legally freed all slaves. The reality was the proclamation wasn’t being implemented in places still under Confederate control. In 1862 the Union Army captured New Orleans and slave owners moved their slaves to the westernmost Confederate state of Texas. Those still in bondage were not free until June 19, 1865 – almost two and a half years past the Emancipation Proclamation issued by President Abraham Lincoln; and

WHEREAS, encouraged by advocates and the Congressional Black Caucus, the United States Congress swiftly passed the **Juneteenth National Independence Day Act** on June 16, 2021 and was signed by President Joseph Biden on June 17, 2021 making Juneteenth the 11th holiday recognized by the federal government. The holiday is also called “Freedom Day”, “Juneteenth Independence Day”, “Jubilee Day”, Black Independence Day” or “Emancipation Day”.

NOW, THEREFORE, I, ARTHUR W. BRYANT, Mayor of the City of Grosse Pointe Woods, Michigan, on behalf of the City Council, and all citizens of Grosse Pointe Woods, proclaim our honor in commemorating on this **JUNE 19, JUNETEENTH**. Our humble community celebrates the power and resilience of Black Americans and in the words of President Biden, “recommit ourselves to the work of equity, equality, and justice.”

Arthur W. Bryant
Mayor Arthur W. Bryant
June 15, 2026



ANDERSON, ECKSTEIN & WESTRICK, INC.
CIVIL ENGINEERS SURVEYORS ARCHITECTS
 51301 SCHOENHERR RD. SHELBY TOWNSHIP, MI 48315
 www.aewinc.com p(586)726-1234

INVOICE

June 08, 2026
 Project No: 0160-0455-0
 Invoice No: 165754

CITY OF GROSSE POINTE WOODS
 ACCOUNTS PAYABLE
 20025 MACK AVENUE
 GROSSE POINTE WOODS 48236-2397

Project 0160-0455-0 VERNIER & MACK AVE INTERSECTION IMPROVE.
 PURCHASE ORDER #24-48747 - \$375,000.00
 FOR: CONSTRUCTION OBSERVATION, CONSTRUCTION ENGINEERING, & CONTRACT ADMIN.
Professional Services from May 04, 2026 to May 31, 2026

Phase 03 CONSTRUCTION
Professional Personnel

	Hours	Rate	Amount	
CONTRACT ADMINISTRATION				
PROJECT MANAGER	2.50	140.00	350.00	
GRADUATE ENG I / SURV I / ARCH I	1.00	102.20	102.20	
TECHNICIAN III	2.90	85.70	248.53	
TECHNICIAN II	1.30	75.80	98.54	
TECHNICIAN I	1.00	68.50	68.50	
SENIOR PROJECT MANAGER	.20	142.00	28.40	
CONSTRUCTION OBSERVATION				
GRADUATE ENG I / SURV I / ARCH I	3.00	102.20	306.60	
TEAM LEADER	10.00	102.20	1,022.00	
TECHNICIAN III	5.00	85.70	428.50	
Totals	26.90		2,653.27	
Total Labor				2,653.27

Billing Limits	Current	Prior	To-Date	
Total Billings	2,653.27	311,540.71	314,193.98	
Limit			375,000.00	
Remaining			60,806.02	
		Total this Phase		\$2,653.27
		Total this Invoice		\$2,653.27

Outstanding Invoices

Number	Date	Balance
165183	5/11/2026	1,833.92
Total		1,833.92

PO 48747
 # 202-451-974.803
 ok - J.K
 SS

RECEIVED

JUN 10 2026

CITY OF GROSSE POINTE WOODS
CLERK'S DEPARTMENT



ANDERSON, ECKSTEIN & WESTRICK, INC.
CIVIL ENGINEERS SURVEYORS ARCHITECTS
51301 SCHOENHERR RD. SHELBY TOWNSHIP, MI 48315
www.aewinc.com p(586)726-1234

INVOICE

CITY OF GROSSE POINTE WOODS
ACCOUNTS PAYABLE
20025 MACK AVENUE
GROSSE POINTE WOODS 48236-2397

June 08, 2026
Project No: 0160-0493-0
Invoice No: 165757

Project 0160-0493-0 2025 MISCELLANEOUS CONCRETE PROGRAM
PURCHASE ORDER #25-49187 - \$108,334.00
FOR: CONSTRUCTION ENG., CONSTRUCTION OBSERVATION, CONTRACT ADMIN.
Professional Services from May 04, 2026 to May 31, 2026

Professional Personnel

	Hours	Rate	Amount	
PRINTS				
TECHNICIAN II	.70	75.80	53.06	
PRELIMINARY ENGINEERING				
TEAM LEADER	2.50	102.20	255.50	
CONTRACT ADMINISTRATION				
TEAM LEADER	1.00	102.20	102.20	
TECHNICIAN III	2.50	85.70	214.25	
SENIOR PROJECT MANAGER	.60	142.00	85.20	
CONSTRUCTION OBSERVATION				
TEAM LEADER	5.00	102.20	511.00	
TECHNICIAN III	64.00	85.70	5,484.80	
Totals	76.30		6,706.01	
Total Labor				6,706.01

Billing Limits	Current	Prior	To-Date
Total Billings	6,706.01	76,737.91	83,443.92
Limit			108,334.00
Remaining			24,890.08

Total this Invoice \$6,706.01

Outstanding Invoices

Number	Date	Balance
165184	5/11/2026	2,951.39
Total		2,951.39

PO 49187
202-451-974.201 \$40237
203-451-974.201 \$603.54
585-571-977.000 \$2,548.28
592-537-975.400 \$3,151.82

OK - JK

RECEIVED

JUN 10 2026



ANDERSON, ECKSTEIN & WESTRICK, INC.
CIVIL ENGINEERS SURVEYORS ARCHITECTS
51301 SCHOENHERR RD. SHELBY TOWNSHIP, MI 48315
www.aewinc.com p(586)726-1234

CITY OF GROSSE POINTE WOODS
CLERKS DEPARTMENT

INVOICE

June 08, 2026
Project No: 0160-0498-0
Invoice No: 165758

CITY OF GROSSE POINTE WOODS
ACCOUNTS PAYABLE
20025 MACK AVENUE
GROSSE POINTE WOODS 48236-2397

Project 0160-0498-0 2025-2026 GENERAL ENGINEERING

PURCHASE ORDER #25-48971 - \$40,000.00

Professional Services from May 04, 2026 to May 31, 2026

Phase 01 GENERAL ENGINEERING

Professional Personnel

	Hours	Rate	Amount
GENERAL			
PROJECT MANAGER			
WILBERDING, ROSS	.50	140.00	70.00
Checking in w/ E. Hall on suggested changes to pumping flow rates. Covering booster station in Ed's absences.			
WILBERDING, ROSS	.50	140.00	70.00
Covering Booster Station Pumping in Ed's absence			
WILBERDING, ROSS	2.00	140.00	280.00
Covering Booster Station Pumping in Ed's absence, meeting w/ WC to discuss curb bumpouts on Mack at RRFB x-ings and summary email to J. Kowalski			
WILBERDING, ROSS	.50	140.00	70.00
Covering Booster Station Pumping in Ed's absence.			
WILBERDING, ROSS	2.00	140.00	280.00
Covering Booster Station Pumping in Ed's absence. Downloading, compiling and summarizing GPW flow data for PFAS settlement			
WILBERDING, ROSS	2.00	140.00	280.00
Email summary of PFAS webinar. Review of purchase order closeouts			
WILBERDING, ROSS	1.50	140.00	210.00
Looking into cost for speed radar sign. Preparing monthly engineering meeting agenda.			
WILBERDING, ROSS	2.00	140.00	280.00
Meet w/ E. Hall & L. Hortopan re: TRPS On/Off SCADA Logic and next steps. Reviewing email corr. and original spec package for Priority Waste change of control letter and provide response to S. Como.			
WILBERDING, ROSS	1.00	140.00	140.00
Reviewing curb bump outs for Mack x-ings north of Vernier w/ M. Crook and drafting email to initiate coordination w/ WCDPS			
WILBERDING, ROSS	4.50	140.00	630.00
Reviewing storage tank SCADA analysis results w/ E. Hall. Dry run of controlling pump station in preparation for E. Hall's absence. Measuring float chamber at TRPS to determine elevation for the 0' wet well depth. Schematic of Mack x-ing bumpouts for email to WCDPS. Participating in PFAS settlement informational webinar.			
Totals	16.50		2,310.00
Total Labor			2,310.00

Project	0160-0498-0	2025-2026 GENERAL ENGINEERING	Invoice	165758
---------	-------------	-------------------------------	---------	--------

Billing Limits	Current	Prior	To-Date	
Total Billings	2,310.00	34,926.90	37,236.90	
Limit			40,000.00	
Remaining			2,763.10	
		Total this Phase		\$2,310.00
		Total this Invoice		\$2,310.00

Outstanding Invoices

Number	Date	Balance
165189	5/11/2026	2,456.20
Total		2,456.20

PO 48971
 # 101-441-818.000 \$577.50
 # 101-265-818.000 \$1,443.75
 # 592-537-818.000 \$288.75
 ok- g.k
 SS

RECEIVED

JUN 10 2026



ANDERSON, ECKSTEIN & WESTBERG, INC.
CIVIL ENGINEERS SURVEYORS ARCHITECTS
51301 SCHOENHERR RD. SHELBY TOWNSHIP, MI 48315
www.aewinc.com p(586)726-1234

CITY OF GROSSE POINTE WOODS
PUBLIC WORKS DEPARTMENT

INVOICE

June 08, 2026

Project No: 0160-0499-0

Invoice No: 165759

CITY OF GROSSE POINTE WOODS
ACCOUNTS PAYABLE
20025 MACK AVENUE
GROSSE POINTE WOODS 48236-2397

Project 0160-0499-0 2025-2026 GIS MAINTENANCE
PURCHASE ORDER #25-48970 - \$21,000.00

Professional Services from May 04, 2026 to May 31, 2026

Phase 01 GENERAL

Professional Personnel

	Hours	Rate	Amount	
GIS UPDATES				
GIS MANAGER	1.50	132.00	198.00	
SENIOR GIS ANALYST	3.00	102.20	306.60	
GIS ANALYST	9.40	85.70	805.58	
Totals	13.90		1,310.18	
Total Labor				1,310.18

Billing Limits	Current	Prior	To-Date
Total Billings	1,310.18	15,593.30	16,903.48
Limit			21,000.00
Remaining			4,096.52

Total this Phase \$1,310.18

Total this Invoice \$1,310.18

PO 48970
592-537-977.000
OK - JK
SS

RECEIVED

JUN 10 2026

CITY OF GROSSE POINTE WOODS
CLERK'S DEPARTMENT



ANDERSON, ECKSTEIN & WESTRICK, INC.
CIVIL ENGINEERS SURVEYORS ARCHITECTS
51301 SCHOENHERR RD. SHELBY TOWNSHIP, MI 48315
www.aewinc.com p(586)726-1234

INVOICE

June 08, 2026

Project No:

0160-0497-0

Invoice No:

165849

CITY OF GROSSE POINTE WOODS
ACCOUNTS PAYABLE
20025 MACK AVENUE
GROSSE POINTE WOODS 48236-2397

Project 0160-0497-0 LEE CT. DOYLE CT & THORNTREE WATER MAINS
PURCHASE ORDER #25-49194 - \$38,250.00 - DESIGN FEES
PURCHASE ORDER #25-49194 - \$74,250.00 - CONSTRUCTION FEES
FOR: CONSTRUCTION OBSERVATION, CONSTRUCTION ENGINEERING & CONTRACT ADMIN.
Professional Services from May 04, 2026 to May 31, 2026

Phase 02 CONSTRUCTION

Professional Personnel

	Hours	Rate	Amount	
CONSTRUCTION STAKEOUT				
SENIOR PROJECT MANAGER	.50	142.00	71.00	
SENIOR TEAM LEADER	4.50	126.00	567.00	
PRINTS				
TECHNICIAN II	.20	75.80	15.16	
CONTRACT ADMINISTRATION				
PROJECT MANAGER	19.50	140.00	2,730.00	
TECHNICIAN III	5.40	85.70	462.78	
SENIOR PROJECT MANAGER	.90	142.00	127.80	
CONSTRUCTION OBSERVATION				
GRADUATE ENG I / SURV I / ARCH I	1.00	102.20	102.20	
TEAM LEADER	11.00	102.20	1,124.20	
TECHNICIAN III	121.00	85.70	10,369.70	
GENERAL				
GRADUATE ENG I / SURV I / ARCH I	1.00	102.20	102.20	
Totals	165.00		15,672.04	
Total Labor				15,672.04

Unit Billing

3 PERSON CREW-CONSTRUCTION STAKEOUT	9.0 HOURS @ 207.40	1,866.60	
Total Units		1,866.60	1,866.60

Billing Limits

	Current	Prior	To-Date
Total Billings	17,538.64	16,388.91	33,927.55
Limit			74,250.00
Remaining			40,322.45

Total this Phase \$17,538.64

Total this Invoice \$17,538.64

PO 49194
#592-537-977.310
OK - [Signature]
SS

Outstanding Invoices

Number	Date	Balance
165254	5/12/2026	16,388.91
Total		16,388.91



ANDERSON, ECKSTEIN & WESTRICK, INC.

CIVIL ENGINEERS - SURVEYORS - ARCHITECTS

Shelby Township - Roseville - Livonia
586.726.1234 | www.aewinc.com

RECEIVED

JUN 10 2026

CITY OF GROSSE POINTE WOODS
CLERK'S DEPARTMENT

May 28, 2026

Steven Schmidt, Controller
City of Grosse Pointe Woods
20025 Mack Avenue
Grosse Pointe Woods, Michigan 48236-2397

Reference: Payment Invoice 03
2025 Concrete Pavement Repair Program
City of Grosse Pointe Woods
AEW Project No. 0160-0493

Dear Mr. Schmidt:

Enclosed please find Construction Payment Invoice 03 for the project referenced above. For work performed through May 24, 2026, we recommend issuing payment for the **Current Payment Amount (see Page 5)** in the amount of **\$ 77,249.40** to Mattioli Cement Co., LLC 6085 McGuire Rd. Fenton, MI 48430.

If you have questions or require additional information, please contact our office.

Sincerely,

DocuSigned by:
Frank D. Varicalli
C4D17CC8031F4D4...

PO49188
202-451-974.200 \$ 4,634.96
203-451-974.200 \$ 6,952.45
585-571-977.000 \$ 29,354.77
592-537-975.400 \$ 36,307.22

Frank D. Varicalli
Infrastructure Rehab Group Lead

dc - J.K
SS
CC

cc: Jim Kowalski, Director of Public Services
Jeanne Duffy, Grosse Pointe Woods
Susan Como, City Manager
Paul Antolin, City Clerk
Scott Lockwood, AEW, Inc.
Ross Wilberding, AEW, Inc.
Mattioli Cement Co., LLC



Anderson, Eckstein & Westrick, Inc.

Detailed Payment

0160-0493

Description 2025 Concrete Pavement Repair Program

Payment Number 3

Pay Period 11/24/2025 to 05/24/2026

Prime Contractor Mattioli Cement Co., LLC
6085 McGuire Rd.
Fenton, MI 48430

Payment Status Approved

Awarded Project Amount \$541,666.00

Authorized Amount \$541,666.00

Remarks % Complete 94.2%

Line Number	Item ID	Unit	Unit Price	Authorized Quantity	Current Paid Quantity	Previous Paid Quantity	Total Quantity Paid To Date	Total Quantity Placed To Date	Current Payment Amount	Total Amount Paid To Date
-------------	---------	------	------------	---------------------	-----------------------	------------------------	-----------------------------	-------------------------------	------------------------	---------------------------

Section: 1 - Description

0001	1027051	LSUM	\$15,000.000	1.000	0.000	1.000	1.000	1.000	\$0.00	\$15,000.00
_: Bonds, Insurance and Initial Set-Up Expense (3% Max)										
0002	2040020	Ft	\$20.000	150.000	0.000	0.000	0.000	0.000	\$0.00	\$0.00
Curb and Gutter, Rem										

Line Number	Item ID	Unit	Unit Price	Authorized Quantity	Current Paid Quantity	Previous Paid Quantity	Total Quantity Paid To Date	Total Quantity Placed To Date	Current Payment Amount	Total Amount Paid To Date
0003	2040055	Syd	\$15.000	100.000	47.200	154.200	201.400	201.400	\$708.00	\$3,021.00
Sidewalk, Rem										
0004	2047011	Syd	\$15.000	100.000	17.500	13.872	31.372	31.372	\$262.50	\$470.58
_: Driveway, Conc, Rem										
0005	2057021	Cyd	\$42.000	100.000	0.000	0.000	0.000	0.000	\$0.00	\$0.00
_: Subgrade Undercutting, Modified										
0006	3060021	Cyd	\$23.000	15.000	0.000	0.000	0.000	0.000	\$0.00	\$0.00
Maintenance Gravel, LM										
0007	4030004	Ea	\$520.000	15.000	5.000	12.000	17.000	17.000	\$2,600.00	\$8,840.00
Dr Structure Cover, Adj, Case 1, Modified										
0008	4030280	Ft	\$265.000	24.000	3.000	3.000	6.000	6.000	\$795.00	\$1,590.00
Dr Structure, Adj, Add Depth										
0009	4030304	Ea	\$195.000	20.000	4.000	6.000	10.000	10.000	\$780.00	\$1,950.00
Dr Structure, Tap, 4 inch										
0010	4030310	Ea	\$600.000	2.000	0.000	0.000	0.000	0.000	\$0.00	\$0.00
Dr Structure, Tap, 10 inch										
0011	4037050	Ea	\$600.000	5.000	0.000	0.000	0.000	0.000	\$0.00	\$0.00
_: Dr Structure Frame and Cover, Manhole										
0012	4037050	Ea	\$675.000	10.000	0.000	0.000	0.000	0.000	\$0.00	\$0.00
_: Dr Structure Frame and Cover, Storm Catch Basin										
0013	4037050	Ea	\$1,000.000	1.000	0.000	0.000	0.000	0.000	\$0.00	\$0.00
_: Dr Structure Trap, 10 inch										

Detailed Payment:

0160-0493

05/28/2026

Line Number	Item ID	Unit	Unit Price	Authorized Quantity	Current Paid Quantity	Previous Paid Quantity	Total Quantity Paid To Date	Total Quantity Placed To Date	Current Payment Amount	Total Amount Paid To Date
0014	4037050	Ea	\$1,000.000	1.000	0.000	0.000	0.000	0.000	\$0.00	\$0.00
_: Dr Structure Trap, 12 inch										
0015	4037050	Ea	\$610.000	5.000	3.000	0.000	3.000	3.000	\$1,830.00	\$1,830.00
_: External Structure Wrap, 12 inch										
0016	4037050	Ea	\$775.000	10.000	0.000	11.000	11.000	11.000	\$0.00	\$8,525.00
_: External Structure Wrap, 18 inch										
0017	4047001	Ft	\$19.000	250.000	22.000	135.000	157.000	157.000	\$418.00	\$2,983.00
_: Underdrain, Subgrade, 4 inch, Modified										
0018	6020207	Ft	\$31.000	300.000	38.600	224.300	262.900	262.900	\$1,196.60	\$8,149.90
Joint, Expansion, E2										
0019	6030030	Ea	\$7.000	4,103.000	270.000	1,610.000	1,880.000	1,880.000	\$1,890.00	\$13,160.00
Lane Tie, Epoxy Anchored										
0020	6030044	Syd	\$60.000	4,000.000	585.400	3,826.600	4,412.000	4,412.000	\$35,124.00	\$264,720.00
Pavt Repr, Nonreinf Conc, 8 inch										
0021	6030046	Syd	\$65.000	400.000	0.000	205.000	205.000	205.000	\$0.00	\$13,325.00
Pavt Repr, Nonreinf Conc, 9 inch										
0022	6037001	Ft	\$6.000	6,500.000	898.500	4,930.600	5,829.100	5,829.100	\$5,391.00	\$34,974.60
_: Full Depth Sawcutting through Existing Pavement, Sidewalk, Driveway or Curb										
0023	6037001	Ft	\$40.000	100.000	0.000	0.000	0.000	0.000	\$0.00	\$0.00
_: Joint, Expansion, Erg, Modified										
0024	6037011	Syd	\$15.000	4,400.000	585.400	4,016.300	4,601.700	4,601.700	\$8,781.00	\$69,025.50
_: Pavt Repr, Rem, Modified										

Detailed Payment:

0160-0493

05/28/2026

Page 3 158

Line Number	Item ID	Unit	Unit Price	Authorized Quantity	Current Paid Quantity	Previous Paid Quantity	Total Quantity Paid To Date	Total Quantity Placed To Date	Current Payment Amount	Total Amount Paid To Date
0025	8010005	Syd	\$59.000	100.000	17.500	35.300	52.800	52.800	\$1,032.50	\$3,115.20
Driveway, Nonreinf Conc, 6 inch										
0026	8020038	Ft	\$40.000	150.000	0.000	0.000	0.000	0.000	\$0.00	\$0.00
Curb and Gutter, Conc, Det F4										
0027	8030010	Ft	\$66.000	100.000	0.000	15.000	15.000	15.000	\$0.00	\$990.00
Detectable Warning Surface										
0028	8030044	Sft	\$7.500	500.000	0.000	1,261.200	1,261.200	1,261.200	\$0.00	\$9,459.00
Sidewalk, Conc, 4 inch										
0029	8030046	Sft	\$7.900	100.000	425.000	1,838.200	2,263.200	2,263.200	\$3,357.50	\$17,879.28
Sidewalk, Conc, 6 inch										
0030	8037010	Sft	\$9.000	300.000	0.000	108.500	108.500	108.500	\$0.00	\$976.50
_: Sidewalk Ramp, Conc, 8 inch										
0031	8127051	LSUM	\$30,000.000	1.000	0.200	0.800	1.000	1.000	\$6,000.00	\$30,000.00
_: Traffic Control and Maintenance										
0032	8167011	Syd	\$4.000	200.000	0.000	119.400	119.400	119.400	\$0.00	\$477.60
_: Surface Restoration, Seeding										
Section Totals:									\$70,166.10	\$510,462.16
Total Payments:									\$70,166.10	\$510,462.16

Summary

Current Approved Work:	\$70,166.10	Approved Work To Date:	\$510,462.16
Current Stockpile Advancement:	\$0.00	Stockpile Advancement To Date:	\$0.00
Current Stockpile Recovery:	\$0.00	Stockpile Recovery To Date:	\$0.00
Current Retainage:	-\$7,083.30	Retainage To Date:	\$20,000.00
Current Retainage Released:	\$0.00	Retainage Released To Date:	\$0.00
Current Liquidated Damages:	\$0.00	Liquidated Damages To Date:	\$0.00
Current Adjustment:	\$0.00	Adjustments To Date:	\$0.00
Current Payment:	\$77,249.40	Payments To Date:	\$490,462.16
Previous Payment:	\$70,858.78	Previous Payments To Date:	\$413,212.76

I certify the items included on this report constitute my estimate of work completed and due the contractor as of the date of this document.

DocuSigned by:
Frank D. Varicalli
 C4D17CC8031F404...

05/28/2026

Frank D. Varicalli

RECEIVED

JUN 10 2026

CITY OF GROSSE POINTE WOODS
CLERK'S DEPARTMENT

Hallahan & Associates, P.C.

Attorneys at Law

1750 S. Telegraph Road, Suite 202
Bloomfield Hills, Michigan 48302-0179
(248) 731-3089

City of Grosse Pointe Woods
c/o WCA Assessing
38110 Executive Drive
Westland, MI 48185\

SUMMARY OF PROFESSIONAL SERVICES

Dates Involved: May 1-31, 2026

Invoice Number: 24132

Timekeeper Summary:

Name	Hours	Rate	Fees
Laura M. Hallahan	1.50	\$211.28	\$ 316.92
Seth A. O'Loughlin	8.70	\$211.28	\$ 1,838.13
Kelsea M. Melcher	0.40	\$211.28	\$ 84.51
Total	10.60		\$ 2,239.56

Expenses: \$ 0.00

Amount of This Invoice: \$ 2,239.56

Previous Balance (\$ 0.00)

Amount Due: \$ 2,239.56

Hallahan & Associates, P.C.

Attorneys at Law
 1750 S. Telegraph Road, Suite 202
 Bloomfield Hills, Michigan 48302-0179
 (248) 731-3089

Email

June 2, 2026

City of Grosse Pointe Woods
 c/o WCA Assessing
 Aaron P. Powers, MMAO, Managing Director
 38110 Executive
 Westland, MI 48185

Please include invoice No.
with your payment

Invoice No. 24132
\$2,239.56

Professional services rendered through May 31, 2026

	Hours	Amount
<u>DRSN Real Estate GP LLC - 18-000573</u>		
05/13/26 SAO Communicate in firm regarding timing of appellate oral argument and conflict with hearing; reach out to opposing counsel regarding moving hearing to afternoon on day 1 of case.	0.10	21.13
05/14/26 SAO Communicate in firm regarding oral argument preparation; discuss with opposing counsel how to address conflict.	0.30	63.38
05/21/26 KMM Review case file; prepare for oral argument.	1.50	316.92
05/26/26 KMM Prepare for oral argument; review case file; research regarding Petitioner's claims.	2.80	591.58
05/27/26 KMM Prepare for oral argument; research regarding Petitioner's claims; in-firm discussion with S. O'Loughlin regarding Petitioner's claims and upcoming oral argument.	1.80	380.30
05/29/26 KMM Prepare for oral argument; research regarding Petitioner's claims.	2.60	549.33
Subtotal:	9.10	1,922.64
<u>DRSN Real Estate GP LLC - 21-001599</u>		
05/26/26 LMH Review/analyze outline for Court of Appeals Oral argument.	0.80	169.02
Subtotal:	0.80	169.02
<u>DRSN Real Estate GP LLC - 22-001222</u>		
05/22/26 LMH Review/analyze Petitioner's Motion to amend; update case access chart; prepare answer to Motion to Amend.	0.70	147.90
Subtotal:	0.70	147.90
Professional services rendered	10.60	\$2,239.56

Timekeeper Summary

Name	Hours	Rate
Laura M. Hallahan	1.50	211.28
Kelsea M. Melcher	8.70	211.28
Seth A. O'Loughlin	0.40	211.28

Previous balance \$21.13

	<u>Amount</u>
Accounts receivable transactions	
5/26/2026 Payment received. Check No. 75547.	(\$21.13)
Total payments and adjustments	(\$21.13)
AMOUNT DUE	<u>\$2,239.56</u>

SS
8C
101-266-801,300

RECEIVED

JUN 10 2026

Tomlinson & McGrail, PLLC

CITY OF GROSSE POINTE WOODS
CLERK'S DEPARTMENT

INVOICE

22600 Hall Road, Ste. 205
Clinton Township, MI 48036

Invoice # 419
Date: 06/01/2026
Due On: 07/01/2026

City of Grosse Pointe Woods
20025 Mack Plaza
Grosse Pointe Woods, MI 48236

00008-City of Grosse Pointe Woods

Prosecutions

Type	Date	Notes	Quantity	Rate	Total
Service	05/06/2026	Prepare and attend municipal prosecutions	1.70	\$155.00	\$263.50
Service	05/08/2026	P v Williams - Rec and Rev Scheduling Order; Calendar; File	0.40	\$155.00	\$62.00
Service	05/11/2026	P v Ware - Rec and Rev Application to Set Aside Conviction w/ attachments	0.30	\$155.00	\$46.50
Service	05/11/2026	P v Williams - Rec and Rev Notice of Filing of Transcript	0.20	\$155.00	\$31.00
Service	05/13/2026	Prepare and attend municipal prosecutions	2.00	\$155.00	\$310.00
Service	05/18/2026	P v Williams- Rec and Rev email w/ updated Briefing Schedule; Calendar	0.20	\$155.00	\$31.00
Service	05/18/2026	P v Land - Rec and Rev incident report w/ request for S/C; Research; Reply email	0.60	\$155.00	\$93.00
Service	05/19/2026	P v Carter - Rec and Rev corresp. from AG	0.20	\$155.00	\$31.00
Service	05/27/2026	Attend prosecutions.	3.00	\$155.00	\$465.00
Service	05/29/2026	P v Troutman - Rec and Rev VM from D; Email court	0.20	\$155.00	\$31.00
Service	05/29/2026	Rec and Rev email from court	0.20	\$155.00	\$31.00
				Subtotal	\$1,395.00

00049-City of Grosse Pointe Woods

General

Type	Date	Notes	Quantity	Rate	Total
Service	05/11/2026	TC w/ Reed re: deceased animal - Bourmemouth; Rec and Rev email from Reed; Reply email	0.50	\$155.00	\$77.50
				Subtotal	\$77.50
				Total	\$1,472.50

Detailed Statement of Account

Current Invoice

Invoice Number	Due On	Amount Due	Payments Received	Balance Due	
419	07/01/2026	\$1,472.50	\$0.00	\$1,472.50	
				Outstanding Balance	\$1,472.50
				Total Amount Outstanding	\$1,472.50

Please make all amounts payable to: Tomlinson & McGrail, PLLC

Please pay within 30 days.

101-266-801.100

SS
8C