



GRAND LAKE BOARD OF TRUSTEES WORKSHOP AND MEETING AGENDA

Monday, December 08, 2025 at 4:30 PM

Town Hall Board Room – 1026 Park Avenue

*The Town of Grand Lake upholds the Six Pillars of Character:
Citizenship, Trustworthiness, Respect, Responsibility, Fairness and Caring*

Please join my meeting from your computer, tablet or smartphone.

<https://us06web.zoom.us/j/85932245929>

You can also dial in using your phone.

United States: 719-359-4580

Meeting ID: 859 3224 5929

WORK SESSION 4:30 PM

1. Call to Order
2. Roll Call
3. Conflicts of Interest
4. Items of Discussion
 - A. KFFR
 - B. Community Engagement Update

EVENING MEETING 6:00 PM

1. Call to Order
2. Pledge of Allegiance
3. Announcements
4. Roll Call
5. Conflicts of Interest
6. Mayor's Report
7. Manager's Report
 - [A.](#) December 8, 2025
8. Public Comments (Limited to 3 Minutes)

9. Consent Agenda

A. Accounts Payable- December 8, 2025

B. Meeting Minutes- November 24, 2025

10. Items of Discussion

A. Consideration of a Waiver Request Under GLMC 6-5-7(F)(3)(a) for Verts Grand Lake LLC Regarding a Change in Controlling Beneficial Owners

B. Consideration of Final Payment for the Town's Commitment for Improvements at Portal Crossing

C. Consideration of Resolution 54-2025, Appointing the Town Treasurer

D. Consideration of Resolution 56-2025, Approving the Purchase of an SMI Snowmaker

E. Consideration of Resolution 56-2025, Approving an Agreement with Vertosoft for ERP Services

F. Consideration of Ordinance No. 06-2025 – Board of Trustees Discussion and Decision on Proposed Text Amendments Regarding the Central Business District and Associated Design Standards.

11. Future Items for Consideration

12. Adjourn Meeting



MANAGER UPDATE

11/24/2025

To: Town of Grand Lake Board of Trustees

From: Steve Kudron, Town Manager

Activities & Events Recap

- Grand Lake Tree Lighting was an amazing success. Estimates are that close to two thousand attended our annual event. The snow started falling right as the carolers started singing and lines for cocoa and cookies were long but all were served and happy with the time to share with friends and neighbors. Thanks to those who were able to attend.
- The Pavilion Heaters were installed and worked great for our first winter season event. A special thanks for Rand with Grand Lake Electric and Grand Lake Plumbing & Heating to work through the Holiday to ensure they were ready for the Event!
- The Ice rink in Town Square Park has been filled and is frozen. We expect to open it any day.
- The Town has been invited to participate in a second interview regarding the successfully submitted the Colorado Energy Impact Accelerator grant request for a Complete Streets Activity and Mobility plan.

Department Notes

- **Admin**
 - Holiday Dinner was December 5, 2025 – What a great turnout. I am grateful to all who were able to come and enjoy this wonderful event.
 - An offer for admin/billing has been accepted. Please welcome Bailey Kracke to the Town Team!
- **Finance**
 - Stephanie Rhone has joined our staff and is already at work learning our systems and procedures. Please welcome Stephanie when you see her!
- **Code Enforcement**
 - Several construction projects are continuing through the winter months. They are predominately interior finishing.
 - STR enforcement continues.

- **Planning**
 - Currently several developments are in different stages of process with the Planning department. The Commission will see these and refer as appropriate.
 - There is an opening on the Grand Lake Planning Commission. A full commission ensures the best representation possible.
 - The Next scheduled Planning Commission meeting is December 17, 2025

- **Public Works**
 - Plow routes and snow removal plans are in place. This year on snow days work will begin at 4am with primary road accessibility by 7am – prior to school bus arrival.
 - Bathroom one at the Pavilion has been remodeled and sealed. We will be working on Bathroom two as weather allows
 - The Town’s contract for road monitoring services has begun. This contract, signed in September 2025, provides real time monitoring of temperature, snow accumulation and actual conditions. Meters will be placed upon arrival.
 - **Parks**
 - Federal gate closures are now in place. Please respect these seasonal safety closures.
 - Holiday lights are all operating

- **Grand Lake Center**
 - Regular cleaning process is in place and working well between staff and public works

- **Marketing/Events/Community Engagement**
 - The Town has received notice that we have been included into the Colorado Tourism Office’s winter social coop program. This program will highlight the town’s unique place in the state’s marketing strategy that will benefit businesses alike.
 - Staff is engaging in our marketing partners to ensure an effective transition to the Town’s marketing direction.

- **Intergovernmental**
 - The Kawuneeche Valley Cooperative met for our regularly scheduled steering committee and outreach meeting on December 2, 2025. The project continues to grow, with permit applications for a third enclosure on this side of the Park. Please let me know if you would ever like to have a tour of the two exclosures currently along the Colorado River in the Park.
 - The meeting with the Winter Park transit operators was very successful. The County has committed to matching the funds necessary for operations.

- **Water Department**
 - Those using bleeder valves should have turned them on to reduce the chance of frozen pipes.

- **Marina**
 - Marina is winterized. Water and services turned off for the winter
 - The Crestliner Boat has been sold to the highest bidder. Plans are being made for them to pick it up.
 - Our Pontoon trade ins have been successfully transferred to Denver.
- **Pay as You Throw**
 - Normal Operations
- **Space to Create**
 - Makers Space continues to progress. Much of the framing inside the Makers Space has been completed. Wall insulation and panels are scheduled for installation this week
 - Northstar Systembuilt has started production of the residences at Space to Create. Members of the design and development team will visit the production plant on January 5-7, 2026.

Upcoming Event Highlights:

- Happenings at the House: Grand Lake Community House. Special guest Bernie McGinn

Town offices will be closed the following for the Holidays:

- December 25, 2025 & December 26, 2025 – CLOSED
- December 31, 2025 - Closed at Noon
- January 1, 2026 - CLOSED

For all the great events happening in Grand Lake as well as Rocky Mountain Folk School classes, check out the December newsletter on the Town’s website.

Next Board Meeting: December 22, 2025. Traditionally, the Trustees have voted to cancel this meeting. If such a motion is made, the next regular meeting will be held January 12, 2026



To: Mayor Bergquist & Trustees

Date: December 8, 2025

RE: Accounts Payable- December 8, 2025

BACKGROUND:

Pursuant to standard procedure, the Town Board of Trustees reviews and approves accounts payable at each Board meeting.

FISCAL NOTE

The accounts payable documentation was distributed to the Board via email on December 7, 2025, for review.

STAFF RECOMMENDATION

Staff recommends approval of the accounts payable as presented.

SUGGESTED MOTIONS

I move to approve (or deny) the accounts payable for December 8, 2025.



GRAND LAKE BOARD OF TRUSTEES WORKSHOP AND MEETING MINUTES

Monday, November 24, 2025, at 6:30 PM

Town Hall Board Room – 1026 Park Avenue

*The Town of Grand Lake upholds the Six Pillars of Character:
Citizenship, Trustworthiness, Respect, Responsibility, Fairness and Caring*

1. Call to Order

Mayor Bergquist called the Board of Trustees meeting to order at 6:05 P.M. in the Town Hall Board Room.

2. Pledge of Allegiance

Mayor Bergquist led the Pledge of Allegiance.

3. Announcements

Mayor Bergquist requested that all cell phones be turned off during the meeting.

4. Roll Call

Mayor Bergquist, Mayor Pro-Tem Sobon, Trustees Arntson, Causseaux, Mills, Miller, Town Manager Kudron, and Town Clerk Carrell were present.

Mayor Bergquist noted Trustee Arntson needed to step out for a moment and would return shortly.

Trustee motioned to excuse Trustee Schoenherr’s absence from tonight’s regular meeting. Trustee seconded the motion, and Town Clerk Carrell called for a vote.

Trustee Miller	Aye
Trustee Mills	Aye
Trustee Causseaux	Aye
Mayor Pro-Tem Sobon	Aye
Mayor Bergquist	Aye

5. Conflicts of Interest

None.

6. Mayor's Report

Mayor Bergquist acknowledged that the past month has been challenging for town staff, board members, and the community, describing recent events as disappointing and “disgusting.” She expressed hope that after tonight’s proceedings, everyone can move past these difficulties and work toward the strong, supportive community she believes Grand Lake can be. She also wished everyone a safe and happy Thanksgiving and noted that the town’s activities, including the upcoming tree lighting, will soon pick up.

7. Manager's Report

A. November 24, 2025

Activities & Events Recap

- Seussical the Musical was a rousing success for our local High School thespians! Standing room only was reported for all three shows, and some found tickets sold out! More than 600 patrons attended the shows over the three days. The program would love to be able to keep producing shows in 2026, one in the winter and one in the spring. We will be presenting a request for these shows at the December 8 meeting.
- Grand Lake Tree Lighting will be this Friday, November 28, 2025. It would be great if all of the Trustees were able to attend this annual Town tradition.
- Conservation Trust. Grant applications have been sent to continue the Ambassador program for 2026 with HTA, and the preliminary 2025 action report has been presented. Let me know if you would like details on any of these topics
- The Colorado Water Board has approved the Shoshone water pact with Grand County, the Colorado River District and other stakeholders. The \$99million dollar purchase will ensure downstream flows protecting the Colorado River headwaters for the future.
- The Town and the Three Lakes Watershed Association has completed interviews with the Windy Gap Environmental Fund for a \$150k grant for stormwater mitigation on the west side of Town. This project has been revised to fit within the current grant scope and cost.
- The Town successfully submitted the Colorado Energy Impact Accelerator grant request for a Complete Streets Activity and Mobility plan. This plan and implementation is designed to develop transportation and accessibility corridors to support multi model transportation options related to mass transit inclusion to the Grand Lake RMNP gateway corridor.

Department Notes

- Admin
 - Holiday Dinner is December 5, 2025 – Invites have been sent out
 - Admin/Billing support final interviews were held November 24, 2025. We anticipate an offer being sent this week
- Finance
 - Stephanie Rhone will be joining our staff on December 1, 2025 as the new Town Treasurer. She will be in the office for a few hours before her start date to become familiar with our processes. We are fortunate to add her to our team. Please welcome Stephanie when you see her!
 - 2026 Wage analysis is being completed and will be ready for the December 8, 2025, meeting
 - The 2025 Audit engagement will be presented at the December 8, 2025 meeting

- Code Enforcement
 - Several construction projects are continuing through the winter months. They are predominately interior finishing.
 - STR enforcement continues.
- Planning
 - There are several projects in predevelopment. The Commission and Board will continue to be updated as update on those specific project updates
 - The local Planning Capacity grant is being adjusted to allow for some more services in house to be paid by the grant. As a result, I am expecting to bring a planner in house in the next couple of weeks, once the amendment to the grant is complete. The planner has been identified and has acquired housing for his term.
- Public Works
 - Heaters are being installed in the pavilion this week. Our contractors will have it done in time for Tree Lighting
 - Remodel of pavilion bathrooms will be complete this week
 - Park Avenue tree removal is completed
 - Plow routes and snow removal plans are in place. The year on snow days work will begin at 4am with primary road accessibility by 7am – prior to school bus arrival.
 - Parks
 - The boat ramp has been removed for the season.
 - Federal gate closures are now in place. Please respect these seasonal safety closures.
- Grand Lake Center
 - Staff has completed their seasonal analysis with fee changes recommended
 - Regular cleaning process is in place and working well between staff and public works
 - Public Works has completed the replacement of faucets at the Center as well as performing repair on the modular buildings.
- Marketing/Events/Community Engagement
 - Tree lighting is November 28th this year. Please all attend
 - The Town has received notice that we have been included into the Colorado Tourism Office’s winter social coop program. This program will highlight the town’s unique place in the state’s marketing strategy that will benefit businesses alike.
- Intergovernmental
 - Mayor Managers Commissioners Meeting was held November 17, 2025. The Board has been asked to consider a coop to provide mental help services in Grand County EMS and Sheriffs offices for onsite support.
 - Grand Places 2050 met November 20, 2025 in Winter Park. Key items included a discussion with the Colorado Open Lands – the Land Trust that has recently merged with Middle Park

- I will be meeting with the Winter Park transit operators later this week to discuss logistics for implementation
- Water Department
 - Q4 waters bills have been sent and payment is due the end of November.
- Marina
 - Marina is winterized. Water and services turned off for the winter
 - Pontoon boats have been ordered. More information on the Denver Boat Show to Follow
 - The Marina Manager and I have completed an evaluation of rates for the 2026 season. Fee changes have been included in the 2026 fee schedule.
- Pay as You Throw
 - Normal Operations
- Space to Create
 - Makers Space continues to progress. Some engineering/construction changes have been required since the contractor's erection of the building. These corrections have been approved to be made by Elk Mountain Construction to keep the project on track. Jimmy Strickland and his crew continue to overperform for the Town. The decision to work predominantly with local businesses has proven to be a great choice.
 - The Town has received its full grant payment from Colorado Creative Industries. This allows us to keep our schedule and maintain our projected summer 2026 ribbon cutting.
 - Northstar Systembuilt has started production of the residences at Space to Create. Members of the design and development team will visit the plant the first week of January. They will be able to view the first eight modules in different stages of production.

Upcoming Event Highlights:

- Tree Lighting November 28, 2025
- Winter Craft Bazaar – Grand Lake Community House – November 28 & 29, 2025

For all the great events happening in Grand Lake as well as Rocky Mountain Folk School classes, check out the December newsletter on the Town's website.

Next Board Meeting: December 8, 2025

8. Public Comments (Limited to 3 Minutes)

Enoch Jeffs of Phaze Concrete explained that they have received some funding and submitted two billing paths, both of which have been paid, but the second path was substantially overpaid. They are unclear about what payments correspond to in their records and have had difficulty getting clarification from their contact, Steve. They are seeking to reconcile payments and submit a final bill to close out the project, hoping to resolve the issues in the next few days.

9. Consent Agenda

- A. Accounts Payable- November 24, 2025**
- B. Meeting Minutes- October 17, 2025**
- C. Meeting Minutes- October 21, 2025**
- D. Meeting Minutes- October 27, 2025**
- E. Meeting Minutes- November 10, 2025**

Trustee Arntson motioned to approve the consent agenda for November 24, 2025. Mayor Pro-Tem Sobon seconded the motion, and Town Clerk Carrell called for a vote.

Trustee Causseaux	Aye
Trustee Mills	Aye
Trustee Miller	Aye
Trustee Arntson	Aye
Mayor Pro-Tem Sobon	Aye
Mayor Bergquist	Aye

10. Financial Review

A. September Sales Tax & October Financial Review

Town Manager Kudron provided a financial update, noting a current deficit of approximately \$99,000 primarily due to large Space to Create expenditures before receiving grant reimbursements. He explained that transfers from reserves were used temporarily, with a \$3 million grant from Colorado Creative Industries and a \$4 million grant from the Department of Local Affairs expected to offset obligations and replenish reserves. Excluding Space to Create, the general fund would show a modest positive change, and other funds—including Capital Improvement, Water, and Marina—are performing positively with expenses generally below budget. He also reviewed reserve calculations, upcoming budget certification requirements, and emphasized that the financial statements give important context for the 2026 budget.

Nichole Kirkpatrick, contracted Town Treasurer, highlighted the town’s strong financial performance in 2025, noting that actual results have exceeded budget projections. She emphasized the town’s healthy cash position, efficient management of operating versus reserve funds, and the benefit of earning interest—4.26% in October—on reserve accounts, which increases financial stability and liquidity. She also noted that with the upcoming inclusion of the \$3 million grant, every town fund is expected to show a positive change in fund balance.

11. Items of Discussion

A. Public Hearing FY 2026 Budget

Town Manager Kudron provided an informal presentation of the budget, noting that it was formally submitted to the board on August 18, with public workshops being held on September 25 and October 14. He confirmed that this public hearing satisfies CRS requirements and stated that no formal public comments on the budget were received, though some informal input was passed along.

Mayor Bergquist opened the public hearing. No public comments were received. The public hearing was then closed.

Contract Town Treasurer Nichole Kirkpatrick presented updates to the 2026 budget, highlighting a dozen changes since the November 10 draft. Key updates include an increase in projected sales tax revenue by \$234,000, higher rental income, modest increases in the sale of assets, and adjustments to professional services and Tabor reserve amounts. Expenditures were reduced in areas such as attainable housing, winter lights, capital expenditures, gym floor, weight room, cardio room, water trucks, and marina services. Overall, revenues increased by \$245,000 and expenditures decreased by \$27,000 compared to the previous draft. Kirkpatrick expressed confidence in the updated budget numbers.

B. Consideration to Approve Resolution 50-2025, Summarizing Expenditures & Revenues for Each Fund & Adopting a Budget for the Town of Grand Lake, Colorado, for the Calendar Year Beginning on the First Day of January 2026, and Ending on the Last Day of December 2026

Trustee Arntson motioned to approve Resolution 50-2025, summarizing expenditures and revenues for each fund and adopting a budget for the Town of Grand Lake, Colorado, for the calendar year beginning on the first day of January 2026, and ending on the last day of December 2026. Trustee Miller seconded the motion, and Town Clerk Carrell called for a vote.

Trustee Mills	Aye
Trustee Causseaux	Aye
Trustee Miller	Aye
Trustee Arntson	Aye
Mayor Pro-Tem Sobon	Aye
Mayor Bergquist	Aye

C. Consideration to Approve Resolution 51-2025, Approving Sums of Money to the Various Funds & Spending Agencies, in the Amounts and for the Purposes as Set Forth Below, for the Town of Grand Lake, Colorado, for the 2026 Budget Year

Trustee Arntson made a motion to approve Resolution 51-2025, approving sums of money to the various funds and spending agencies, in the amounts and for the purposes as set forth below, for the Town of Grand Lake, Colorado, for the 2026 budget year with an edit to the Marina Operations Expenses current should show \$407,977.00, total marina expenditures should be \$497,227. Trustee Miller seconded the motion, and Town Clerk Carrell called for a vote.

Trustee Causseaux	Aye
Trustee Mills	Aye
Trustee Miller	Aye
Trustee Arntson	Aye
Mayor Pro-Tem Sobon	Aye
Mayor Bergquist	Aye

D. Consideration of Resolution 52-2025, a Resolution Levying Property Taxes for the Year 2026, to Help Defray the Costs of Government for the Town of Grand Lake, Colorado, for the 2025 Budget Year

Trustee Arntson motioned to approve Resolution 52-2025, levying property taxes for the year 2026, to help defray the costs of government for the Town of Grand Lake, Colorado, for the 2025 budget year. Trustee Miller seconded the motion, and Town Clerk Carrell called for a vote.

Trustee Mills	Aye
Trustee Miller	Aye
Trustee Arntson	Aye
Trustee Causseaux	Aye
Mayor Pro-Tem Sobon	Aye
Mayor Bergquist	Aye

E. Consideration to Approve Resolution 53-2025, a Resolution Setting Certain Fees & Deposits

Trustee Arntson motioned to approve Resolution 53-2025, setting certain fees and deposits. Trustee Miller seconded the motion, and Town Clerk Carrell called for a vote.

Trustee Causseaux	Aye
Trustee Mills	Aye
Trustee Arntson	Aye
Trustee Miller	Aye
Mayor Pro-Tem Sobon	Aye
Mayor Bergquist	Aye

F. Consideration to Approve a Severance Agreement with Matthew Reed-Tolonen

Trustee Arntson motioned to approve the severance agreement with Matthew Reed-Tolonen. Trustee Mills seconded the motion, and Town Clerk Carrell called for a vote.

Trustee Arntson	Aye
Trustee Causseaux	Aye
Trustee Mills	Aye
Trustee Miller	Aye
Mayor Pro-Tem Sobon	Aye
Mayor Bergquist	Nay

G. Consideration of Resolution 49-2025, Updating the Rules and Regulations for the Operation of the Grand Lake Area Cemetery

On October 29, 2025, Town Clerk Carrell and the Grand Lake Cemetery Committee conducted their end-of-season review of the 2025 summer operations, maintenance, and activities. The meeting assessed completed work, identified areas for improvement, and began planning for the upcoming year. Proposed updates to the Cemetery Rules & Regulations include prohibiting pre-planning of grave plots, allowing plots only for deceased individuals, and requiring families to remain at least 30 feet away during traditional burial excavations. These updates are intended to align the regulations with current practices, ensure consistent administration, and improve public understanding.

Trustee Causseaux motioned to approve Resolution 49-2025, updating the rules and regulations for the operation of the Grand Lake Area Cemetery. Trustee Mills seconded the motion, and Town Clerk Carrell called for a vote.

Trustee Arntson	Aye
Trustee Miller	Aye
Trustee Causseaux	Aye
Trustee Mills	Aye
Mayor Pro-Tem Sobon	Aye
Mayor Bergquist	Nay

12. Future Items for Consideration

- Future Musicals Community House
- Treasurer Appointment

13. Adjourn Meeting

Mayor Pro-Tem Sobon moved to adjourn the meeting, and Trustee Mills seconded. Town Clerk Carrell called for a vote. All were in favor.

This meeting of the Board of Trustees was adjourned at 8:14 PM.

(Attest)

Alayna Carrell, Town Clerk

Christina Bergquist, Mayor



To: Mayor and Board of Trustees
From: Alayna Carrell, Town Clerk
Date: December 8, 2025
Re: Verts Grand Lake LLC – Request for Waiver to Add New Controlling Beneficial Owners

Background:

Verts Grand Lake LLC has requested a waiver under GLMC 6-5-7(F)(3)(a) to allow a change in Controlling Beneficial Owners (CBOs) within the two-year restriction period following the issuance of their license.

- The Marijuana Enforcement Division (MED) has approved Matthew Ingles and Nicholas Higbee as CBOs.
- The new CBOs collectively hold less than 51% ownership interest in the business.
- The applicant submitted a written statement supporting the waiver request, along with the full MED change of ownership application.

Purpose of the Two-Year Restriction:

The two-year restriction on ownership structure changes was adopted to preserve the integrity of the Town’s marijuana licensing lottery. Its intent is to prevent individuals or ownership groups from submitting multiple lottery applications using slight variations in ownership percentages to increase their chances of being selected, and then later restructuring the ownership to their preferred configuration after winning. This safeguard is common in jurisdictions that use a lottery system and is designed to prevent applicants from gaming the process.

The “good cause” waiver exists to allow legitimate ownership changes within those two years when needed, such as responding to business, market, or personnel changes—situations that do not undermine the purpose of the restriction.

Code Considerations:

- GLMC 6-5-7(F)(3) restricts changes to CBO ownership for the first two years of a license. The Board may grant a waiver under 6-5-7(F)(3)(a) if good cause is shown and the waiver does not undermine the purpose of the Section or negatively impact the health, safety, or welfare of the Town.
- Because ownership remains below 51%, a public hearing is not required.
- All documentation required under GLMC 6-5-13 has been submitted. Additional information may be requested by the Board if needed.



Staff Recommendation:

Staff recommends that the Board review the submitted materials, discuss the waiver request, and consider approval of the waiver.

Suggested Motion:

“I move to approve the requested waiver under GLMC 6-5-7(F)(3)(a) allowing Verts Grand Lake LLC to add new Controlling Beneficial Owners.”

Verts Grand Lake LLC
Change of Ownership – Waiver Request
November 7, 2025

Dear Town of Grand Lake Board of Trustees,

Per GLMC 6-5-7(F)(3)(a), Verts Grand Lake LLC (Verts) respectfully requests of waiver of the Town’s prohibition on altering its ownership as it pertains to Controlling Beneficial Owners (CBOs).

Verts currently operates with three CBOs that serve as the company’s Board of Managers:

- Alexander Close, Chief Executive Officer
- Ashley Ingles, Chief People Officer
- Daniel Rowland, Chief Regulatory & Communications Officer

The company proposes to name two additional CBOs and Managers:

- Nicholas Higbee, Chief Operating Officer
- Matthew Ingles, General Manager

Nicholas already oversees the operations of the entire Verts Neighborhood Dispensary organization, including the Grand Lake store. He is proposed to be added to the company’s Board of Managers, which requires CBO approval by the State of Colorado’s Marijuana Enforcement Division (MED).

Matthew already serves as the store’s General Manager and owns the property on which the business operates. He is proposed to become a shareholder of more than 10 percent of the company and to be added to the company’s Board of Managers, both of which require CBO approval by the MED.

We believe these proposed additions are good cause for the waiver to be granted because they neither undermine the Town’s prohibition on Common Control nor do they negatively impact the health, safety, or welfare of the Town.

In fact, we believe these additions are necessary to continue the company’s successful operations and reward two people who have been instrumental in building and safely guiding the business.

Nothing about the business will change fundamentally because of these changes. The store will continue to operate as Verts Neighborhood Dispensary and be guided by the three original founders who initially applied for the license. The only change will be that two

individuals who have been involved from the very beginning will be formally recognized as CBOs.

Both Nicholas and Matthew have filed their Finding of Suitability applications with the MED to be approved as CBOs, and Verts has filed its Change of Ownership application with the MED to approve the new ownership structure. Pending those approvals, we hope the Town will approve the changes well.

We are happy to answer any questions and look forward to the Board's consideration of this matter.

Sincerely,

Daniel W. Rowland

Daniel Rowland
Verts Neighborhood Dispensary



MEMORANDUM

Meeting Date: 11/10/2025

To: Town of Grand Lake Board of Trustees
From: Steve Kudron, Town Manager

Re: Portal Crossing Close-out

Trustees:

Last year, the Town agreed to materially participate in the completing of the ROW at Portal Crossing. As the Streetscape Plan had the project included in the original plan, the Bond issuance and subsequent project completion did not. The Board agreed to participate up to \$100,000 in the costs to complete the Grand Ave right of way at Portal Crossing. In May of 2025, the Town required additional improvements than had been previously approved by the Town’s planning department. The owner is asking for additional participation of the additional costs.

I’ve included the original improvement costs as well as the additional improvements. The Town has provided materials to offset some of the participation. This includes \$6,000 for storm drain materials and \$11,396 for Boardwalk materials. The Board should consider the circumstances of this commitment and recommend to staff a final payment number.

Suggested Motion:

I move to recommend payment of \$_____ as final payment for the Town’s commitment for improvements at Portal Crossing

Combined ROW Costs of Improvements

Portal Crossing Subdivision

November 4, 2025

Previously completed improvements	\$262,183.33
Completed improvements per Mathew Reed- Tolonen	129,089.57
Total	\$391,272.90

Cost of Improvements Schedule

Grading	\$4,000.00
Road Base delivery and gravel \$395.00 per load x 15 loads	5,925.00
Topsoil - \$800.00 per load x 4 loads	3,200.00
Sod - \$.63 x 2,400 square feet + delivery fee \$500.00	2,012.00
Sprinkler system	4,000.00
Gravel pathways	300.00
Trees - 6 / 16' evergreen trees + freight \$1,200.00	19,200.00
Benches	800.00
Concrete (light poles)	1,100.00
J Bolts	442.12
Sonotube	425.56
Light poles (per text from Kim and Matt)	19,400.00
Electric service	7,500.00
Electrical installation per 7 poles (\$2,746.99 less if 4 poles)	16,831.00
Concrete Boardwalk installed	64,159.00
Concrete Boardwalk to be installed 90' x 8'4" x \$21.50	16,118.55
Rebar \$9.60 @ 185 pieces	1,776.00
8x8 treated beams 300'	4,009.10
Asphalt	81,600.00
Striping	1,385.00
Labor 2 men @ 80 hours each x \$50.00 per hour =	8,000.00
Total	\$262,183.33

Additional expenditure list for grade change and retaining wall construction per Town Superintendent (Mathew Reed-Tolonen) at 505 Grand Avenue (Portal Crossing Subdivision)

Required Changes May, 2025

Core Engineering	\$5,627.50
Azimuth Survey	760.00
Azimuth Survey	430.00
Ascent Group Engineering	390.00
Premier Concrete	7,560.00
Acord asphalt (difference between prior approval and last minute change)	16,738.40
Ritz Builders	35,855.96
Rocky Point Builders	8,950.00
CRT Rental	2,337.12
CRT Rental	1,370.56
Flinstone Gravel	14,848.49
Flinstone Gravel	137.41
Panoramic Irrigation	4,000.00
J & L Excavation	2,870.00
Scott Zweifel	3,600.00
The Tree Farm	1,122.50
B & J Plumbing	2,800.00
Overhead, Insurance, Comp	19,187.63
Total	\$129,089.57

*Deduction for materials furnished by town after Town participation (-) \$11,396.61



MEMORANDUM

Meeting Date: 12/8/2025

To: Town of Grand Lake Board of Trustees
From: Steve Kudron, Town Manager

Re: Appointment of Town Treasurer

Background

Pursuant to State statute C.R.S. 31-4-304 and Town Code Chapter 2, Article 10, the Town is required to appoint a Town Treasurer after each biennial election. This officer is required to take an oath or affirmation of office. At the November 22, 2021, Board of Trustees meeting, Heike Wilson was appointed to the position of Town Treasurer.

On December 30, 2024, Heike (Wilson) Fawkes resigned her position as Town Treasurer. After utilizing the services of a contract accountant and interviewing several well-qualified candidates, the Town Manager hired Stephanie Rhone to take the position. The Board needs to make an appointment to legally fill the position vacated by Ms. Fawkes.

Recommendation

Staff recommends that Heike Wilson be appointed to serve out the remainder of the term of Town Treasurer by approving the following language:

I move that Stephanie Rhone be appointed Town Treasurer for the Town of Grand Lake.

**TOWN OF GRAND LAKE, COLORADO
RESOLUTION NO. 54-2025
A RESOLUTION APPOINTING THE TOWN TREASURER**

WHEREAS, the Board of Trustees of the Town of Grand Lake, Colorado (the “Board”), pursuant to Colorado statute, is vested with the authority of administering the affairs of the Town of Grand Lake, Colorado (the “Town”); and

WHEREAS, the Town of Grand Lake Municipal Code (the “Code”) Section 2-10-1 authorizes the Board to appoint the Town Treasurer; and

WHEREAS, Stephanie Rhone has been employed by the Town since December 1, 2025 and is qualified to serve as Town Treasurer; and

WHEREAS, to Board finds it in the best interest of the Town to appoint Stephanie Rhone as Town Treasurer.

NOW, THEREFORE, BE IT RESOLVED BY THE BOARD OF TRUSTEES OF THE TOWN OF GRAND LAKE, COLORADO, AS FOLLOWS:

Section 1. The Board of Trustees of the Town of Grand Lake, Colorado hereby appoint Stephanie Rhone as the Town Treasurer.

Section 2. Severability: If any Article, Section, paragraph, sentence, clause, or phrase of this Resolution is held to be unconstitutional or invalid for any reason, such decision shall not affect the validity of the remaining portions of this Resolution. The Board of Trustees declares that it would have passed this Resolution and each part or parts thereof irrespective of the fact that any one part or parts be declared unconstitutional or invalid.

Section 3. Repeal: Existing Resolutions or parts of Resolutions covering the same matters as embraced in this Resolution are hereby repealed and all Resolutions or parts of Resolutions inconsistent with the provisions of this Resolution are hereby repealed, except that this repeal shall not affect or prevent the prosecution or punishment of any person for any act done or committed in violation of any Resolution hereby repealed prior to the taking effect of this Resolution.

INTRODUCED, READ, AND ADOPTED AT A REGULAR MEETING OF THE BOARD OF TRUSTEES OF THE TOWN OF GRAND LAKE ON THIS 8TH DAY OF DECEMBER, 2025.

TOWN OF GRAND LAKE, COLORADO

BY: _____
Christina Bergquest, Mayor

ATTEST:

Alayna Carrell, Town Clerk



MEMORANDUM

Meeting Date: 12/8/2025

To: Town of Grand Lake Board of Trustees
From: Steve Kudron, Town Manager

Re: SMI Snowmaker Request

Trustees:

With the Board's recent approval of the 2026 Budget—including an \$80,000 line item for the purchase of an HKD snowmaker—I am submitting this memo to recommend the purchase of an **SMI Polecat with Booster** for **\$29,950 plus freight** from the factory.

After reviewing our operational needs, evaluating available equipment, and consulting with staff, it is clear that the SMI Polecat offers the best combination of performance, reliability, and cost-effectiveness for the Town's snowmaking operations.

The 2026 Budget includes funding to replace and upgrade aging snowmaking equipment to ensure consistent snow coverage on Town-managed winter recreation areas. While the budget anticipated the purchase of an HKD unit, subsequent evaluation has shown that the SMI Polecat with Booster provides comparable or superior performance at a significantly lower cost. This creates an opportunity to meet our operational needs while preserving budget capacity for future snowmaking improvements.

Some of the benefits to this purchase include:

Significant Cost Savings:

The approved budget allocates \$80,000 for a new snowmaker. The SMI Polecat with Booster costs **\$29,950 plus freight**, less than half of the anticipated expenditure.

These savings allows the Town to:

- Stretch capital dollars further
- Potentially purchase additional snowmaking equipment or accessories
- Reduce long-term replacement costs
- Maintain flexibility for future winter operations investments

The financial efficiency of this purchase is a major advantage.

Proven performance and Reliability

The SMI Polecat is widely used in municipal and resort snowmaking operations due to its:

- High output at marginal temperatures
- Consistent snow quality
- Durable construction
- Low maintenance requirements

The addition of the booster increases water pressure and improves performance in variable conditions, an important factor in Grand Lake's climate.

Staff can operate and maintain the unit with minimal additional training.

Long Term Value

Because the Polecat is a well-supported, widely used model, parts and service are readily available. Its lower upfront cost combined with long service life makes it a strong long-term investment for the Town.

Based on performance, cost savings, and operational benefits, I recommend that the Board authorize the purchase of the **SMI Polecat with Booster** for **\$29,950 plus freight**.

This purchase fulfills the intent of the 2026 budget while delivering greater value and flexibility than originally anticipated. It strengthens our snowmaking capabilities, supports winter recreation, and ensures reliable operations for years to come.

I am happy to provide additional details or answer any questions during the next Board meeting.

Suggested Motion:

I move to recommend the SMI Polecat Purchase Agreement be Approved with a Down Payment to be made with 2025 and final payment completed in 2026.

**TOWN OF GRAND LAKE, COLORADO
RESOLUTION NO. 55-2025**

**A RESOLUTION APPROVING THE PURCHASE OF AN SMI
SNOWMAKER**

WHEREAS, the Board of Trustees of the Town of Grand Lake, Colorado (the “Board”), pursuant to Colorado statute, is vested with the authority of administering the affairs of the Town of Grand Lake, Colorado (the “Town”); and

WHEREAS, the Town requires certain machinery and attachments to that machinery to support the Town’s winter special events and winter time character of Grand Lake (the services”); and

WHEREAS, the Town currently relies on storms as the only method of receiving snow, and the existing winter conditions for snow have become less reliable; and

WHEREAS, the Board finds it beneficial to purchase a new SMI Snowmaker machine to perform the Services and has budgeted for the same; and

WHEREAS, to Board finds it in the best interest of the Town to approve the quote for the Standard Polecat Snowmaker is attached hereto as Exhibit A and incorporated herein by reference.

**NOW, THEREFORE, BE IT RESOLVED BY THE BOARD OF TRUSTEES OF
THE TOWN OF GRAND LAKE, COLORADO, AS FOLLOWS:**

Section 1. The price quote for an SMI Standard Polecat Snowmaker (the “Quote”), attached hereto and incorporated herein as Exhibit A, is hereby approved subject to the conditions below, and the Mayor or their designee is hereby authorized and directed to execute the same.

Section 2. The Mayor or their designee is hereby authorized and directed to negotiate and approve on behalf of the Town such revisions to the Quote as the Mayor or their designee determines are necessary or desirable for the protection of the Town, so long as the essential terms and conditions of the Quote are not altered.

Section 3. Severability: If any Article, Section, paragraph, sentence, clause, or phrase of this Resolution is held to be unconstitutional or invalid for any reason, such decision shall not affect the validity of the remaining portions of this Resolution. The Board of Trustees declares that it would have passed this Resolution and each part or parts thereof irrespective of the fact that any one part or parts be declared unconstitutional or invalid.

Section 4. Repeal: Existing Resolutions or parts of Resolutions covering the same matters as embraced in this Resolution are hereby repealed and all Resolutions or parts of Resolutions inconsistent with the provisions of this Resolution are hereby repealed, except that this repeal shall not affect or prevent the prosecution or punishment of any person for any act done or committed in violation of any Resolution hereby repealed prior to the taking effect of this

Resolution.

INTRODUCED, READ, AND ADOPTED AT A REGULAR MEETING OF THE BOARD OF TRUSTEES OF THE TOWN OF GRAND LAKE ON THIS 8th DAY OF DECEMBER, 2025.

TOWN OF GRAND LAKE, COLORADO

BY: _____
Christina Bergquest, Mayor

ATTEST:

Alayna Carrell, Town Clerk



December 5, 2025

Steve Kudron
Town Manager
Town of Grand Lake
Grand Lake, CO

Steve:

SMI is pleased to offer you the following SMI snowmaking equipment for the Town of Grand Lake.

1. Equipment and Pricing

(1) SMI Standard PoleCat Snowmaker on 3-wheel galvanized turntable chassis with extendable jacks for frame leveling, snow groomer lifting brackets, 15 HP fan, 5 HP Hydrovane compressor, 18 nozzle heated air and water side center nucleator, heated nucleator regulator, heated check valve to prevent backflow into the compressor, 3 valve heated stainless steel valve manifold with heated 3-way self-draining ball valves, 30 mesh water filter and 1 1/2" female QD on water inlet, no oscillation, manual vertical adjustment jack, LED flood light, strobe light, control panel with manual controls, 150ft of power cord with 60A Hubbell plug end. Includes 15 HP heated booster pump mounted vertically to the chassis enclosure and pump start/stop controls in the control panel. Pump inlet pressure not to exceed 120psi. Power source 480V 60Hz 3-phase. US\$39,500 each

2. Delivery and Conditions

Pricing is F.O.B. from Midland, MI. Town of Grand Lake is responsible for all freight, duties, taxes and customs clearance. SMI equipment to carry a one-season warranty on any defective parts and workmanship.

3. Payment Terms

\$5,000 down
Freight due Net 30 on invoice after delivery
Balance Due January 15, 2025

Please let us know if you have any questions or comments.

With Best Regards and
Thinking Snow!

Steve Fellman
Steve Fellman

SNOW MAKERS

ON-BOARD BOOSTER PUMP



Your Solution to Low Water Pressure

With our On-Board Booster Pump, you can boost snowmaking pressure from 40-120 psi to optimal pressures. This pump is perfect for venues with lower operating water pressure, such as parks or resorts with older infrastructure.

System Includes

- Manual or Automatic Standard or Kid Polecat configuration.
- 15 HP Booster Pump.
- Heated cover to insulate and protect the pump.
- 3 wheel galvanized steel carriage w/ Snowcat lifting brackets.
- Spring-loaded drain allows the operator to avoid manual drainage.

Specs

- **Fan:** 15 HP (11 kW) or 10 HP (7.5 kW)
- **Fan Speed:** 1760 rpm at 480V/60Hz or 1450 rpm at 400V/50Hz
- **Compressor:** 5 HP or 10 HP Hydrovane
- **Heating:** 225 W
- **Spray Manifold Heater:** 1,300 W (480V/60Hz)
- **Water Pressure:** minimum 40 psi and maximum 120 psi inlet water pressure to the booster pump.
- **Valves:**
 - Standard Polecat: 3 self-draining heated 3-way valves
 - Kid Polecat: 2 self-draining heated 3-way valves
- **Nucleators:** Central nozzle with six jets
- **Filtration system:** stainless steel filter with a washable 30 or 60 mesh screen
- **Positioning:** 360° horizontal rotation, -10° to 60° elevation adjustment
- **Oscillator:** automatic 70° arc of rotation





Heated Cover

The Booster Pump comes with a heated cover to insulate and protect the pump.

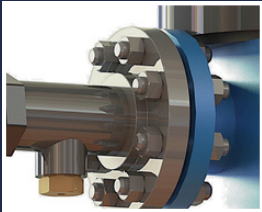

Drain Valve

Drain valve is connected to the bottom of the Booster Pump which automatically drains water during operations.

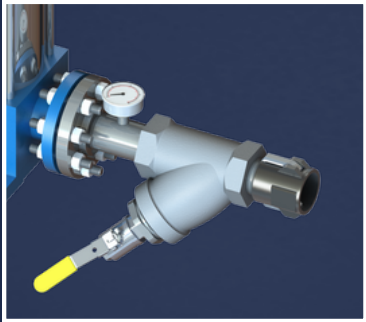

Wye Line Water Filter

Additional water filter for dirty water and easy maintenance.

Standard Polecat with Booster Pump Specs

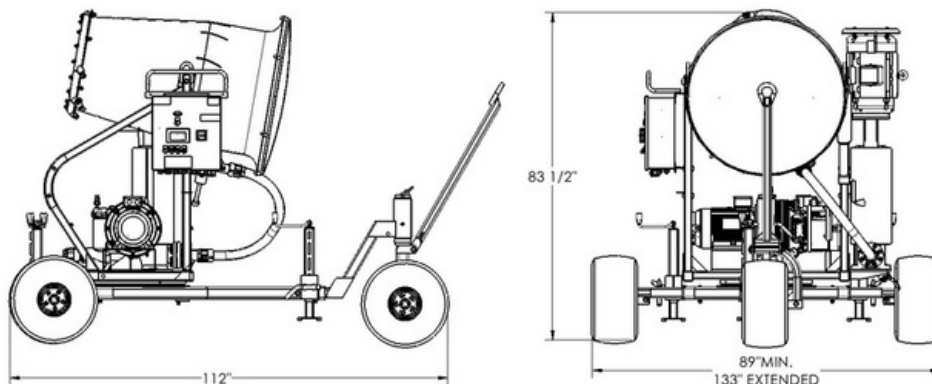

Electrical

- Voltage: 480V
- Frequency: 60 Hz
- Current: 34 A
- Heating: 225 W

Power

- Fan: 10 HP or 15 HP
- Compressor: 5 HP or 10 HP
- Pump: 15 HP

Weight (lbs)

- Standard Polecat (10 HP): 2,264 lbs
- Standard Polecat (5 HP): 2,153 lbs

Operation

- Rotational Fan Speed: 1,800 RPM
- Turbine Inclination: 45°
- Oscillation: 35 deg (optional)

Water

- Operating Pressure
 - 40 psi minimum to 120 psi maximum inlet pressure
- Boost Pressure:
 - Up to 450 psi boost at minimum flow
 - Up to 250 psi boost at maximum flow
- Water Filter: 30 or 60 mesh

Nozzles

- Nucleator: Single 6-Jet Center Nucleator
- Manual Standard Polecat:
 - Always On Nozzles: 6
 - Switchable Nozzles: 12
 - *Total Nozzles: 18*
- Automatic Standard Polecat:
 - Always On Nozzles: 6
 - Switchable Nozzles: 12
 - *Total Nozzles: 18*

Kid Polecat with Booster Pump Specs

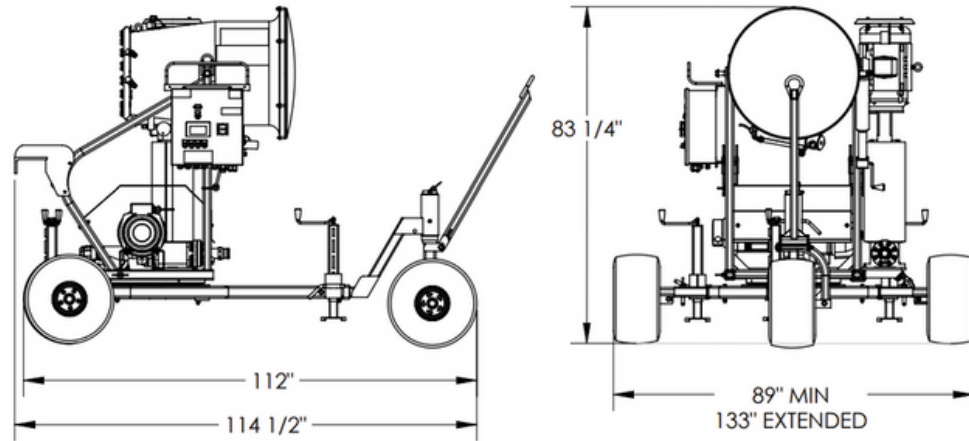

Electrical

- Electrical: Three phase
- Heating: 250W
 - Optional spray nozzle heater (500-1300 W)

Power

- Fan: 7.5 HP
- Compressor: 5 HP
- Pump: 15 HP

Weight (lbs)

- Kid Polecat (10 HP): 2,100 lbs
- Kid Polecat (5 HP): 1,989 lbs

Operation

- Rotational Fan Speed: 1,800 RPM
- Turbine Inclination: 45°
- Oscillation: 35 deg

Water

- Operating Pressure
 - 40 psi minimum to 120 psi maximum inlet pressure
- Boost Pressure:
 - Up to 450 psi boost at minimum flow
 - Up to 250 psi boost at maximum flow
- Water Filter: 30 mesh

Nozzles

- Nucleator: Single 6-Jet Center Nucleator
- Manual and Automatic Kid Polecat:
 - Always On Nozzles: 6
 - Switchable Nozzles: 12
 - *Total Nozzles: 18*



Ready to start? Let's build your system.

Snow Machines Inc.
www.snowmakers.com
1512 Rockwell Dr, Midland, MI 48642
P : 1 (989) 631 -6091





MEMORANDUM

Meeting Date: 12/8/2025

To: Town of Grand Lake Board of Trustees
From: Steve Kudron, Town Manager

Re: ERP System Upgrade

Honorable Mayor and Trustees,

After a comprehensive review of the Town’s current financial, budgeting, and utility billing systems, as well as an evaluation of modern municipal ERP platforms, I am recommending that the Town of Grand Lake transition from the legacy Caselle system to the OpenGov ERP suite. This recommendation is based on the Town’s growing operational needs, the limitations of our current system, and the significant improvements in efficiency, transparency, and long-term sustainability that OpenGov can provide.

My Rationale for Transition

Modernization of Core Financial Operations

Caselle has served the Town for many years, but it is fundamentally a legacy system. Its architecture limits integration, automation, and real time reporting. Staff frequently rely on manual workarounds, duplicate data entry, and static reports that require additional manipulation.

OpenGov offers a fully cloud based, modern financial platform designed specifically for local governments. Key benefits include:

- Real time financial reporting and dashboards that improve decision making and reduce staff time spent compiling data.
- Automated workflows for purchasing, approvals, and audit trails.
- Improved internal controls through role-based permissions and transparent process tracking.

Enhanced Budgeting and Long-Range Planning

Our current budgeting process is heavily manual, spreadsheet driven, and time intensive. It limits our ability to model scenarios, track performance, or communicate budget information clearly to the public.

OpenGov’s budgeting and planning module provides:

- Dynamic forecasting tools for multiyear financial planning.
- Scenario modeling to evaluate the impact of policy decisions.
- Collaborative budgeting workflows that streamline department submissions and revisions.
- Public facing budget transparency tools that strengthen trust and community engagement.

Improved Water Billing and Customer Service

Caselle’s utility billing module lacks modern features that residents increasingly expect, including online account access, mobile-friendly payment options, and automated notifications.

OpenGov’s utility billing system provides:

- Online customer portals for payments, usage history, and account management.
- Automated billing and reminders that reduce staff workload and improve collection rates.
- Integration with meter data for more accurate billing and fewer adjustments.

Cloud-Based Reliability and Security

OpenGov is fully cloud-hosted, offering:

- High reliability and uptime without the need for local servers.
- Automatic updates that ensure the Town always has the latest features and security protections.
- Robust cybersecurity standards that exceed what small municipalities can typically maintain in-house.

Better Integration Across Departments

One of the most significant limitations of Caselle is its siloed structure. OpenGov provides a unified platform where financials, budgeting, procurement, and utility billing all share the same data environment.

This means:

- No more duplicate entry
- Fewer errors
- Faster reporting
- More consistent information across departments

Long-Term Sustainability

Caselle’s development pace has slowed, and its feature set no longer aligns with the expectations of modern municipal operations. OpenGov, by contrast, is rapidly evolving and heavily invested in supporting small and mid-sized governments. Selecting OpenGov positions Grand Lake for long term operational success and ensures we are not left behind as technology and public expectations continue to advance.

Urchase of this item through our contract partner Sourcewell, guarantees the best pricing and satisfies state requirements for such purchases.

Recommendation

Based on the analysis of system capabilities, staff feedback, and the Town’s strategic goals, I recommend that the Board of Trustees authorize the Town to enter into an agreement with OpenGov for ERP, budgeting, and utility billing services. This transition represents a meaningful investment in the Town’s operational capacity, financial transparency, and customer service. It will reduce inefficiencies, modernize our internal processes, and provide a platform capable of supporting Grand Lake’s needs for many years to come.

I look forward to discussing this recommendation with you and answering any questions you may have. Our representative Isabel Zarrow is available to answer any questions as well.

Suggested Motion:

I move to direct the Mayor to sign the Resolution for ERP Services with OpenGov as detailed in the Statement of Work and Services Agreement.

**TOWN OF GRAND LAKE, COLORADO
RESOLUTION NO. 56-2025**

**A RESOLUTION APPROVING AN AGREEMENT WITH VERTOSOFT
FOR ERP SERVICES**

WHEREAS, the Board of Trustees of the Town of Grand Lake, Colorado (the “Board”), pursuant to Colorado statute, is vested with the authority of administering the affairs of the Town of Grand Lake, Colorado (the “Town”); and

WHEREAS, the Town requires certain enterprise resource planning services (the “Services”) more particularly described in the quote Q-16754 and the Open Gov Statement of Work, (collectively the “Contract”) attached hereto as Exhibit A and incorporated herein by this reference; and

WHEREAS, the Board and the contractor acknowledge the Contract is a multiyear fiscal obligation of the Town and is therefore subject to annual appropriation, and notwithstanding any provision to the contrary contained in the Contract or related documents, any non-appropriation event shall not be deemed a breach of the Contract by the Town; and

WHEREAS, to Board finds it in the best interest of the Town to approve the Contract for the Services attached hereto as Exhibit A and incorporated herein by reference.

NOW, THEREFORE, BE IT RESOLVED BY THE BOARD OF TRUSTEES OF THE TOWN OF KEENESBURG, COLORADO, AS FOLLOWS:

Section 1. The Contract for a Services (the “Quote”), attached hereto and incorporated herein as Exhibit A, is hereby approved subject to the conditions below, and the Mayor or their designee is hereby authorized and directed to execute the same.

Section 2. The Mayor or their designee is hereby authorized and directed to negotiate and approve on behalf of the Town such revisions to the Contract as the Mayor or their designee determines are necessary or desirable for the protection of the Town, so long as the essential terms and conditions of the Contract are not altered.

Section 3. The Board and the contractor acknowledge the Contract is a multiyear fiscal obligation of the Town and is therefore subject to annual appropriation, and notwithstanding any provision to the contrary contained in the Contract or related documents, any non-appropriation event shall not be deemed a breach of the Contract by the Town

Section 4. Severability: If any Article, Section, paragraph, sentence, clause, or phrase of this Resolution is held to be unconstitutional or invalid for any reason, such decision shall not affect the validity of the remaining portions of this Resolution. The Board of Trustees declares that it would have passed this Resolution and each part or parts thereof irrespective of the fact that any one part or parts be declared unconstitutional or invalid.

Section 5. Repeal: Existing Resolutions or parts of Resolutions covering the same matters as embraced in this Resolution are hereby repealed and all Resolutions or parts of Resolutions inconsistent with the provisions of this Resolution are hereby repealed, except that this repeal shall not affect or prevent the prosecution or punishment of any person for any act done or committed in violation of any Resolution hereby repealed prior to the taking effect of this Resolution.

INTRODUCED, READ, AND ADOPTED AT A REGULAR MEETING OF THE BOARD OF TRUSTEES OF THE TOWN OF GRAND LAKE ON THIS 8TH DAY OF DECEMBER, 2025.

TOWN OF GRAND LAKE, COLORADO

BY: _____
Christina Bergquest, Mayor

ATTEST:

Alayna Carrell, Town Clerk



1602 Village Market Blvd SE, Suite 320
Leesburg, VA20175 USA

Cage Code: 7QV38
UEI Number Y7D5MXRU2839
DUNS# 080431574
Federal Tax ID: 81-3911287
Business Size: Small Business

Date: 12/2/2025, 2:05 PM

Phone: 571 707-4130
Fax: 571-291-4119
Email: opengov@vertosoft.com

Vertosoft Contact: Carly Moore
Phone: (540) 998-8361
Email: carly.moore@vertosoft.com

Vertosoft Quote for OpenGov - Town of Grand Lake, CO

Contract: Sourcewell: 060624-VTO

Quote #: Q-16754
Expires On: 12/31/2025

Ship To
Town of Grand Lake, CO
Steve Kudron
(970) 966-0067
skudron@toglco.com

Quote For:
Name:
Company: Town of Grand Lake, CO
Email:
Phone:

PAYMENT TERMS	DELIVERY METHOD	PAYMENT METHOD	VERTOSOFT CUST ID	SUPPLIER REF #
Net 30	Electronic	Check/ACH/Credit Card		

Overall POP Start Date: 1/1/2026
Overall POP End Date: 12/31/2030

Term 1 01/01/2026-12/31/2026

PART #	DESCRIPTION	QTY	UNIT PRICE	EXTENDED
OG-SWBA-U20-AR-3Y	Budgeting & Planning - Under \$20 Million - 3Y	1.00	\$15,744.65	\$15,744.65
OG-SWDD-U20-AR-3Y	Core Financials - Under \$20 Million - 3Y	1.00	\$20,676.17	\$20,676.17
OG-TWEA-U20-AR-3Y	Financials Expert Services: Elevate - Under \$20 Million - 3Y	1.00	\$4,646.95	\$4,646.95
OG-TWHR-U20-AR-3Y	Utility Billing Base Subscription - Under \$20 Million - 3Y	1.00	\$10,070.84	\$10,070.84
OG-TWHS-U20-AR-3Y	Utility Billing: Additional Service Area - Water - Under \$20 Million - 3Y	1.00	\$6,829.39	\$6,829.39
OG-PSBG-U20-OT-0Y	Professional Services Deployment - Prepaid - Under \$20 Million - 0Y	1,740.00	\$56.65	\$98,571.00
Term 1 TOTAL:				\$156,539.00

Term 2

01/01/2027-12/31/2027

PART #	DESCRIPTION	QTY	UNIT PRICE	EXTENDED
OG-SWBA-U20-AR-3Y	Budgeting & Planning - Under \$20 Million - 3Y	1.00	\$16,531.86	\$16,531.86
OG-SWDD-U20-AR-3Y	Core Financials - Under \$20 Million - 3Y	1.00	\$21,710.03	\$21,710.03
OG-TWEA-U20-AR-3Y	Financials Expert Services: Elevate - Under \$20 Million - 3Y	1.00	\$4,879.29	\$4,879.29
OG-TWHR-U20-AR-3Y	Utility Billing Base Subscription - Under \$20 Million - 3Y	1.00	\$10,574.39	\$10,574.39
OG-TWHS-U20-AR-3Y	Utility Billing: Additional Service Area - Water - Under \$20 Million - 3Y	1.00	\$7,170.86	\$7,170.86
Term 2 TOTAL:				\$60,866.43

Term 3

01/01/2028-12/31/2028

PART #	DESCRIPTION	QTY	UNIT PRICE	EXTENDED
OG-SWBA-U20-AR-3Y	Budgeting & Planning - Under \$20 Million - 3Y	1.00	\$17,358.46	\$17,358.46
OG-SWDD-U20-AR-3Y	Core Financials - Under \$20 Million - 3Y	1.00	\$22,795.51	\$22,795.51
OG-TWEA-U20-AR-3Y	Financials Expert Services: Elevate - Under \$20 Million - 3Y	1.00	\$5,123.26	\$5,123.26
OG-TWHR-U20-AR-3Y	Utility Billing Base Subscription - Under \$20 Million - 3Y	1.00	\$11,103.11	\$11,103.11
OG-TWHS-U20-AR-3Y	Utility Billing: Additional Service Area - Water - Under \$20 Million - 3Y	1.00	\$7,529.39	\$7,529.39
Term 3 TOTAL:				\$63,909.73

Term 4

01/01/2029-12/31/2029

PART #	DESCRIPTION	QTY	UNIT PRICE	EXTENDED
OG-SWBA-U20-AR-3Y	Budgeting & Planning - Under \$20 Million - 3Y	1.00	\$18,226.39	\$18,226.39
OG-SWDD-U20-AR-3Y	Core Financials - Under \$20 Million - 3Y	1.00	\$23,935.30	\$23,935.30
OG-TWEA-U20-AR-3Y	Financials Expert Services: Elevate - Under \$20 Million - 3Y	1.00	\$5,379.42	\$5,379.42
OG-TWHR-U20-AR-3Y	Utility Billing Base Subscription - Under \$20 Million - 3Y	1.00	\$11,658.26	\$11,658.26
OG-TWHS-U20-AR-3Y	Utility Billing: Additional Service Area - Water - Under \$20 Million - 3Y	1.00	\$7,905.86	\$7,905.86
Term 4 TOTAL:				\$67,105.23

Term 5

01/01/2030-12/31/2030

PART #	DESCRIPTION	QTY	UNIT PRICE	EXTENDED
OG-SWBA-U20-AR-3Y	Budgeting & Planning - Under \$20 Million - 3Y	1.00	\$19,137.71	\$19,137.71
OG-SWDD-U20-AR-3Y	Core Financials - Under \$20 Million - 3Y	1.00	\$25,132.03	\$25,132.03
OG-TWEA-U20-AR-3Y	Financials Expert Services: Elevate - Under \$20 Million - 3Y	1.00	\$5,648.39	\$5,648.39

PART #	DESCRIPTION	QTY	UNIT PRICE	Section 10, Item E.
OG-TWHR-U20-AR-3Y	Utility Billing Base Subscription - Under \$20 Million - 3Y	1.00	\$12,241.17	\$12,241.17
OG-TWHS-U20-AR-3Y	Utility Billing: Additional Service Area - Water - Under \$20 Million - 3Y	1.00	\$8,301.16	\$8,301.16
Term 5 TOTAL:				\$70,460.46

Grand Total: \$418,880.85

Annual invoices will be delivered by the start of each consecutive annual period. Payment of invoices shall be annually in advance. Customer's use of the OpenGov Services is pursuant to the OpenGov End User License Agreement set forth at <https://opengov.com/terms-of-service/end-user-license-agreement/>. Any Professional Services shall be performed pursuant to the attached Statement of Work, if any.

Quote Terms

By purchasing the products and services described in this order form, the Customer is expressly agreeing to the End User Agreement published at <https://www.vertosoft.com/terms-and-conditions-opengov>

Taxes: Sales tax shall be added at the time of an invoice, unless a copy of a valid tax exemption or resale certificate is provided.

Credit Card Orders: Additional fees may apply if paying by credit card.

All Purchase Orders must include: End User Name, Phone Number, Email Address, Purchase Order Number, Government Contract Number or Our Quote Number, Bill-To and Ship-To Address (Cannot ship to a PO Box), Period of Performance (if applicable), and a Signature of a duly Authorized Representative.



Statement of Work
Expert Services

Town of Grand Lake, CO

Creation Date: 12/1/2025
SoW Expiration Date: 2/1/2026
Document Number: PS-10545.2
Created by: Emily Scheckel

Introduction

This Statement of Work (SOW) outlines the terms and scope of OpenGov Expert Services to be provided by OpenGov to [Customer Name] (the "Customer") pursuant to the applicable Order Form. The objective of this SOW is to define the engagement framework and responsibilities of both parties to ensure the successful execution of the expert services.

1. Scope of Services

1. Service Overview:

- 1.1. Expert services for the operation, monitoring, and optimization of Financial Management.
- 1.2. Access to OpenGov Professional Services resources for post-implementation activities (e.g. training, consulting, configuration, or staff augmentation).
- 1.3. Elevate is the base expert services level offering foundational guidance and assistance.
- 1.4. OpenGov will perform the work under this SOW remotely unless on-site activities are explicitly selected in the annual plan.
- 1.5. If on-site activities are selected, the Customer is responsible for paying travel expenses as incurred on a quarterly basis. If applicable, the not to exceed amount for the quoted expenses will be included on the Project Charter.
- 1.6. OpenGov will use personnel and resources located across the United States, and may also include OpenGov-trained implementation partners to support the delivery of services.

2. Key Activities:

- 2.1. Annual planning session within the first 30 days of the contract year to define the activities to be completed that year and resources allocated to those activities.
- 2.2. The Project Charter is defined as the annual plan of activities, tasks, assignments, timeline, and milestones to be performed by OpenGov and Customer within the contract year.
- 2.3. Creation of a Project Charter between OpenGov and Customer outlining the agreed upon expert services for that year. Once the Project Charter timeline is mutually agreed upon, any changes will require a Change Order per Section 6.

3. Timeline

- 3.1. Expert Services are delivered annually per the Order Form, with a contract year potentially shorter than twelve months if specified on the Order Form.

4. OpenGov Responsibilities

- 4.1. Assign qualified personnel to perform the agreed upon activities.
- 4.2. Ensure timely and professional execution of deliverables as outlined in the Project Charter.

- 4.3. Maintain clear and regular communication with the Customer as needed for planning and execution of agreed upon activities.
 - 4.4. In the event of requested changes to the Project Charter, a change order will be drafted and sent to Customer for signature.
- 5. Customer Responsibilities**
- 5.1. Assist OpenGov in coordinating and attend the annual planning session within the first 30 days of a new subscription term.
 - 5.2. Provide access to the relevant personnel, systems, and data per activities defined in the Project Charter.
 - 5.3. Review and approve deliverables within a timely manner as outlined in the Project Charter.
 - 5.4. Designate a point of contact for ongoing communication and decision-making.
 - 5.5. Submit a change order request if changes to the Project Charter are needed.
- 6. Change Order Process**
- 6.1. Any change to the scope as outlined in the Project Charter must be agreed to in writing by both Customer and OpenGov, and documented via a Change Order.
 - 6.2. Verbal agreement is not binding on OpenGov or Customer.
 - 6.3. A Change Order is defined as work that is added to or deleted from the original scope of this SOW.

OpenGov 

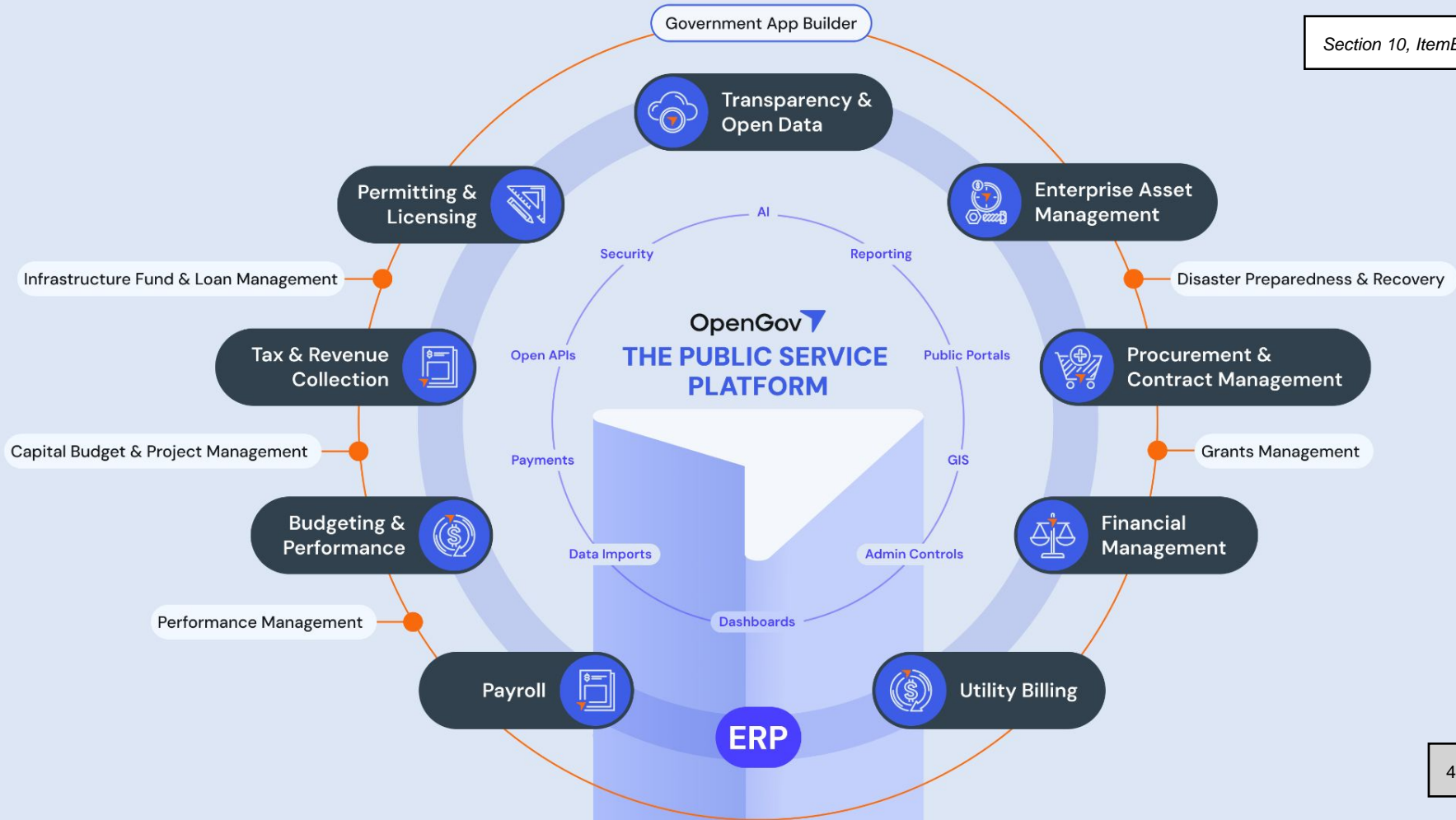

Contributing Factors

- ★ Town is operating on Caselle, a 20+ year–old system that is outdated and difficult to audit.
- ★ Heavy reliance on manual processes, spreadsheets, and disconnected tools (iWorQ, CivicRec, Paychex, Square, etc.).
- ★ Utility billing is manual and inefficient, with limited integration to meter reads.
- ★ Financial reporting requires workarounds, journal entries, and specialized knowledge to extract basic information.
- ★ Small finance team with limited capacity is stretched by system inefficiencies and lack of automation.
- ★ Lack of transparency, real-time data, and cross–department integration undermines decision–making and scalability.

Desired Capabilities

- ★ A modern, intuitive ERP that staff can use without specialized expertise or manual workarounds.
- ★ Fully integrated financials, budgeting, and utility billing with seamless data flow across departments.
- ★ Automated, transparent reporting that supports audits, decision-making, and growth in new programs.
- ★ Streamlined utility billing with reliable meter-read integration and simplified customer management.
- ★ A sustainable system that reduces dependency on external contractors and supports internal staff development.
- ★ Responsive, high-quality support from a long-term technology partner committed to continuous improvement.



Financial Management

The ERP of High-Performance
Public Servants

CENTRALIZED ACCOUNTING

Section 10, Item E.

General Ledger, AP, Purchasing, AR, Fixed Assets, Cash Receipts, and Bank Rec

DIGITAL WORKFLOWS

Eliminate paper with auditable processes and documents in one place

FINANCIAL REPORTING

Self-service reports and inquiries for finance, departments, execs, and auditors

UTILITY BILLING

Simplified billing and flexible payments for metered and unmetered services

MODERN CLOUD

A single source for strategic decision-making, spend control, revenue collection.



Budgeting & Performance

End-to-end Collaborative Budgeting

PERFORMANCE MANAGEMENT

Section 10, Item E.

Set goals, create and track metrics, then connect spending to outcomes

OPERATING BUDGET

Collaborative tools to drive an automated and strategic process

CAPITAL PLANNING

Prioritize, plan, and promote your biggest investments

WORKFORCE PLANNING

Simplify planning for your most important asset – your people

ONLINE BUDGET BOOK

Publish an interactive GFOA award-winning budget book directly from your budgeting system



Utility Billing

Simplified and Customer-First
Utility Billing

PUBLIC PORTAL

Easy access for the public to review their account and pay bills with multiple options

METER MANAGEMENT

Support reading, imports, work orders, and historical data on multiple meter types

FULL SERVICE HISTORY

Manage accounts, view digital documents, and reference historical activity in one centralized place

FINANCIAL INTEGRATION

Full Integration with OpenGov Financials

REPORTING

Financial & Performance

- Understand the whole picture
- Align staff, electeds, public
- Monitor performance
- Communicate initiatives
- Improve decision-making
- Seamless integration with Publications

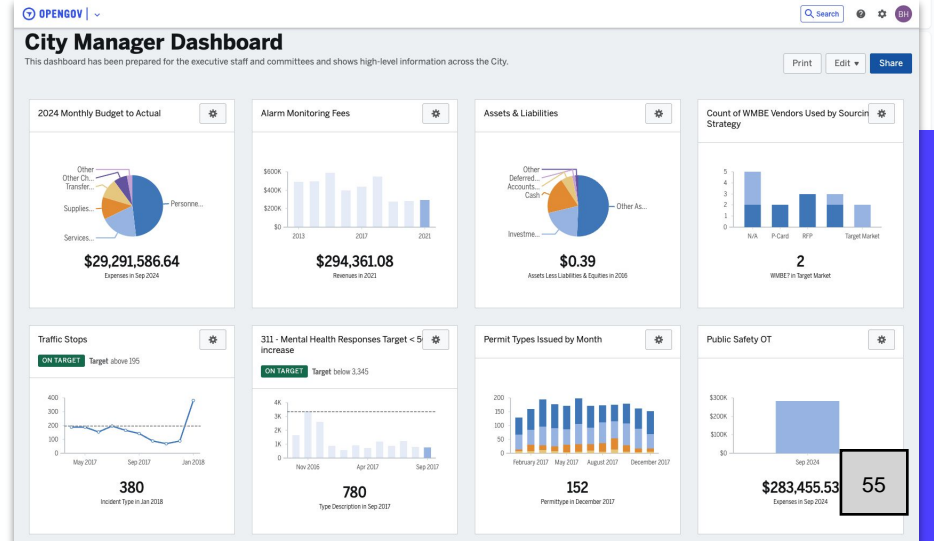
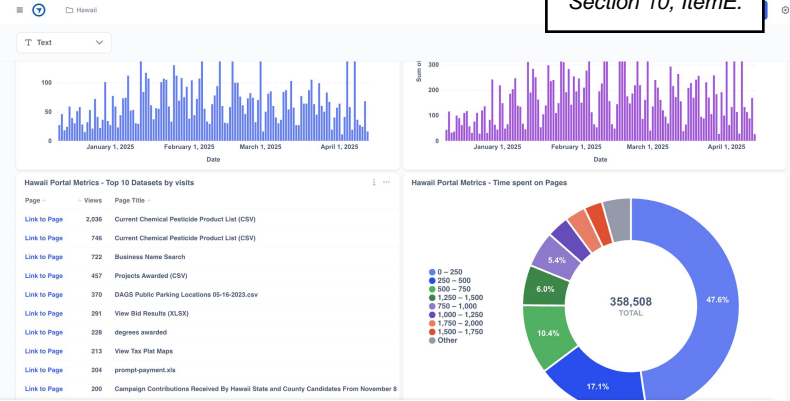

Implementation

- Over 500+ Years of Government Experience
- 8 Stevie Awards for Customer Service Excellence
- Tried and True – Thousands of Successful Implementations
- Average time from contract start to project go-live **(3-4 months)**

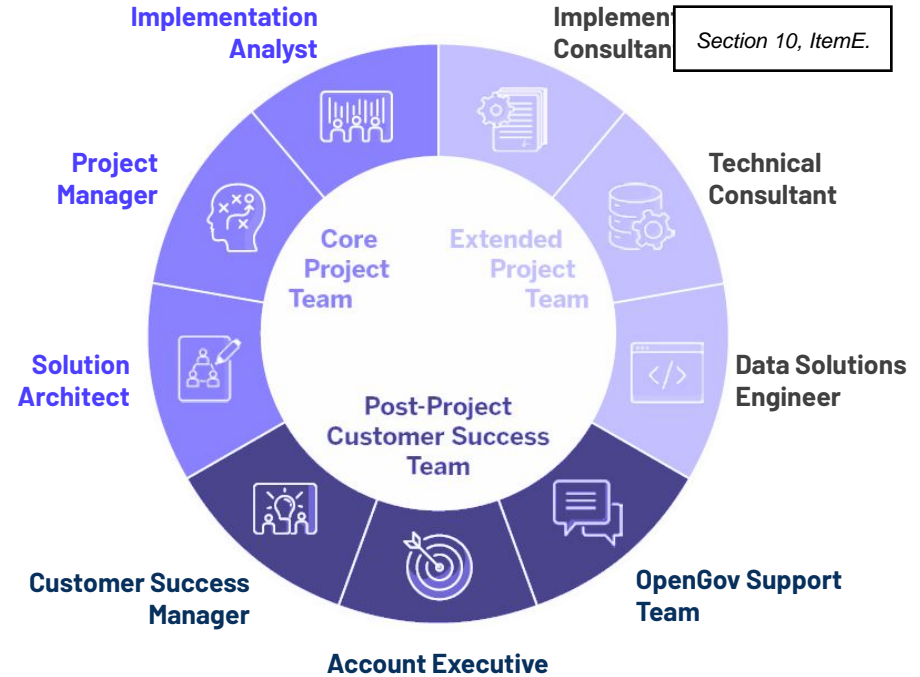

OpenGov enables us to create a better, more collaborative budget, one that deploys resources more efficiently across departments; and demonstrates to the public, Council, and our bond ratings agency the impact of savings and investments for our city."

Bob DaSilva, Mayor, City of East Providence, RI

Deployment Methodology & Engagement

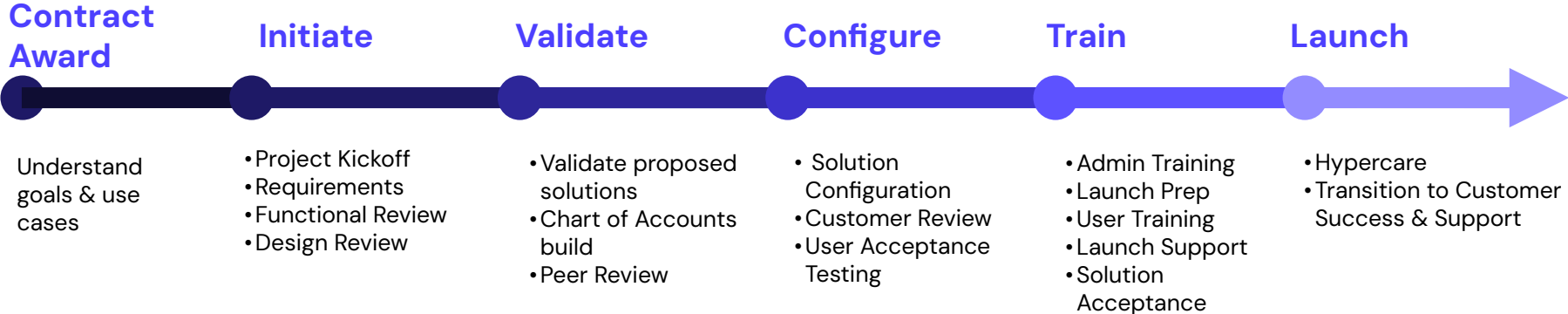
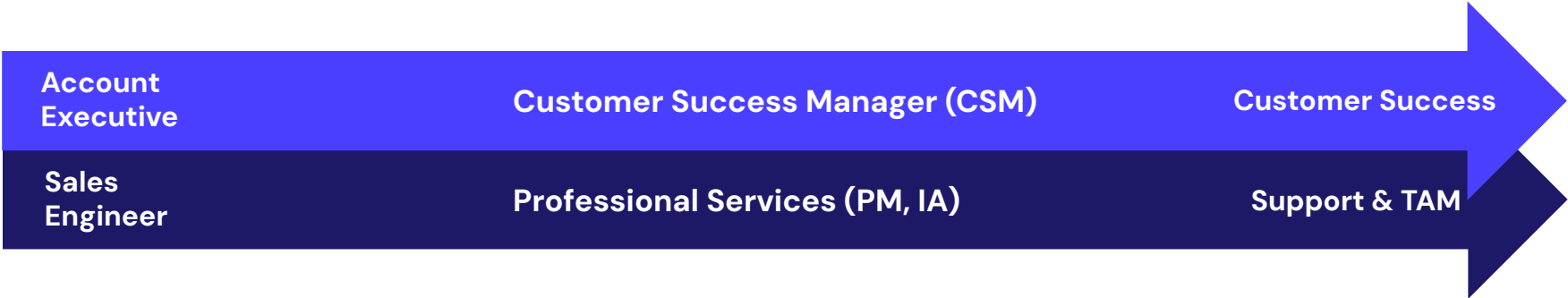

Thank You!



BOARD OF TRUSTEES STAFF MEMORANDUM

DATE: December 8, 2025
TO: Mayor and Board of Trustees
FROM: Emily Weber, Contract Staff - Planning Department
SUBJECT: LEGISLATIVE – Ordinance 06-2025 – Board of Trustees discussion and decision on the proposed text amendments regarding the Central Business District and associated design standards.

Overview and Analysis

At the direction of the Board of Trustees, staff prepared language for the Central Business District (CBD) Design Standards guidebook. The guidebook is intended to be a supplemental resource to reinforce the language in the Town Code related to the historic western character of Grand Lake. To support the guidebook, staff proposes text amendments to the Town Code that modify the boundary of the CBD and reference the design standards.



Proposed Central Business District Boundary

The proposed text amendments and guidebook establish clear, actionable design standards that ensure new development and redevelopment are compatible with Grand Lake’s unique identity while supporting development feasibility. The guidebook enhances existing code language and further emphasizes the desired character. Additionally, the guidebook provides a more precise definition of “historic western” character in the context of Grand Lake by identifying common architectural elements that contribute to this identity.



Background

The proposed text amendments and guidebook have been discussed in multiple forums over the past several months. Feedback was gathered during regular public hearings, a Board workshop in September, and through general Planning Commission and Board of Trustees discussions at public meetings. The proposed design standards reflect a compilation of all input received throughout this process.

On October 22, 2025, the Planning Commission and Board of Trustees held a joint work session to review the intent and details of the proposed design standards language. Based on feedback from that discussion, staff revised the language and presented it to the Planning Commission for consideration on December 3, 2025.

The Board of Trustees serves as the decision-making body with authority to adopt legislative actions, such as code changes. The Planning Commission’s role is to review proposed text amendments and the accompanying guidebook, then provide a recommendation to the Board. The recommendation from the most recent Planning Commission meeting is included later in this staff report.

Summary of Guidebook

The proposed Central Business District Design Standards guidebook is intended to supplement the Town Code by providing clear guidance on key design elements that define Grand Lake’s unique character. These standards draw inspiration from the Town’s historical and existing structures and are organized into six main categories: color and material selections, ground level interest, connectivity, parking, rooflines, and windows.

The guidebook’s purpose is to clarify and reinforce elements already addressed in the Town Code. In some cases, the standards build upon existing provisions. For example, the street wall standard. Where the Town Code allows for discretion, the guidebook introduces a maximum setback to maintain a consistent street wall along Grand Avenue. Additionally, for areas where the Code is suggestive or subjective, the guidebook expands on architectural elements and includes supporting visuals to aid interpretation. In situations where prescriptive standards may not be appropriate, the intent is to guide design decisions in a way that preserves and enhances the character of Grand Lake. The full guidebook is provided as an attachment to this staff report.

Proposed Text Amendments

1. Section 12-2-26 (A) of the Municipal Code of the Town of Grand Lake with the addition of the **bold underlined** language as follows:

- (A) *Mixed-Use Regulations for the CT, C and RST Districts.*
 - 1. Mixed-use developments in the above listed districts will be subject to the following supplementary regulations. These regulations are minimum requirements and will also apply to Planned Developments within these districts.
 - 2. Multiple family dwellings may be constructed above commercial uses provided:
 - (a) Access to dwelling units is not through commercial establishments.
 - (b) Trash, service and loading areas shall be screened from view from the dwelling units and from street entrances to dwelling units.
 - (c) Outdoor lighting associated with commercial uses within the structure, including lighting for parking, service and loading areas, shall be designed and located such that the direct source is not visible from any dwelling unit within nor shall there be any glare.
 - (d) At least two (2) means of ingress and egress from each floor of dwelling units shall be provided and that all other regulations as may pertain to fire protection be met.



3. Mixed-Use projects shall conform to the following schedule of (Private) Open Space Land Area Requirements:

Group	Gross Square Footage of Floor Area Of Structure or Land Use Area	Land Use or Floor Area	Minimum Open Space Land Area Required
I.	75%—99%	Commercial (C.)/ Office (O.)	20%
	25%—1%	Residential (R.)	
II.	50%—75%	C. & O.	25%
	50%—25%	R.	
III.	25%—50%	C. & O.	35%
	75%—50%	R.	
IV.	10%—25%	C. & O.	45%
	90%—75%	R.	
V.	1%—9%	C. & O.	50%
	99%—91%	R.	

4. In all applicable districts, the developer shall submit a proposal for the Open Space Land Area Required for Mixed-Use projects. The Open Space Land Area Requirement is to be provided on-site, in accordance with the Section 12-2-6 Definitions.

5. **When a mixed-use development is located within the Central Business District, it must comply with all applicable design standards outlined in the Central Business District Design Standards guidebook.**

2. Section 12-7-2 - Purpose of the Municipal Code of the Town of Grand Lake with the addition of the **bold underlined** language as follows:

An historical perspective is extremely important to the Town, therefore it is the intent that new materials and innovations will strengthen and be harmonious with the "historic western" feel of the Town. A creative and rigorous approach to the best selection and application of building materials will generate a more inviting, vibrant and harmonious appearance to the Town.

As Grand Lake becomes more densely built, there is a need to create a symbiotic relationship between buildings and public and open spaces. The Town of Grand Lake seeks to preserve the historical, rustic, and unique western small-town character of Grand Lake while also integrating its preservation with new and pioneering creative designs. Intending to help enhance quality and strengthen visual continuity while preserving historically significant properties, allowing innovation and encouraging creativity, the purpose of these standards is to stimulate creative design solutions for individual properties while promoting and preserving a sense of cohesiveness among the entire Town of Grand Lake.

A successful project will combine the design elements of composition, scale, proportion and rhythm in proposed materials, surfaces and massing, designing buildings, open and public spaces that are timeless and in character with our Town and harmonious to the human eye. In addition, materials, surfaces and massing create a sense of entry and a desirable sense of place.

The provisions of this Article shall apply to any structure, including temporary facilities, within the Town limits on or after the effective date of the Ordinance for the following:

- (A) New construction of any building.
- (B) Exterior remodeling or painting of any existing building, even if a Town of Grand Lake Building Permit is not required.
- (C) Re-roofing, enlargements, expansions of or additions to any existing building.



Where a property is located within the Central Business District and meets the above criteria, both the design standards in this Article and those in the Central Business District Design Standards guidebook shall apply. If a conflict arises between the provisions of this Article and the Central Business District Design Standards, the more stringent shall apply. Where the Central Business District Design Standards guidebook is silent, the provisions of this Article shall apply.

3. Section 12-7-3 - Definitions of the Municipal Code of the Town of Grand Lake with the removal of the ~~strikethrough~~ language and the addition of the **bold underlined** language as follows:

Central Business District — Commercially zoned, or commercial transitionally zoned lots **generally** located **between Broadway Street and Hancock Street and between Park Avenue and Lake Avenue. Properties within the CBD are subject to the Central Business District Design Standards, a supplemental guidebook that establishes specific design requirements and development goals for this district. The guidebook also provides a map identifying the exact boundaries of the Central Business District.** ~~on or between Hancock Street and Haskell Street, on Grand Avenue, and between Hancock Street and Vine Street on Park Avenue, and between Hancock Street and Ellsworth Street on Lake Avenue.~~

4. Section 12-7-3 (C) (3) (e) of the Municipal Code of the Town of Grand Lake with the removal of the ~~strikethrough~~ language and the addition of the **bold underlined** language as follows:

(e) *Infill/building additions in the central business district.*

1. When a new use (infill)/addition is proposed to an existing commercial development the newly constructed portion of the building should appear as an originally conceived part of the design. The new additions should match the scale and reflect the proportions of the original structure where they adjoin or are adjacent. New construction of a different height and bulk, than that of the original structure, should not occur abruptly.
2. New additions should match the existing approved architecture of the existing central business district. See for example, Figures 1 and 2 below. Such matching approval shall be in the sole discretion of the Town. The extension of canopy elements, lighting, boardwalks, planting areas, fenestration (window) patterns, structural rhythms, and use of materials should exhibit a seamless transition between existing and new construction.
3. Large setbacks from the street rights-of-way should be discouraged for new building construction.
4. New construction should not incorporate precise replication of town center architecture but utilize similar colors, materials, textures, pattern, repetition, rhythm, and proportions to achieve architectural unity.
5. **All properties within the Central Business District shall meet the standards established in the Central Business District Design Standards guidebook.**

Planning Commission Discussion and Recommendation

At its December 3, 2025 meeting, the Planning Commission reviewed the proposed code amendments and guidebook and heard public comments. Feedback from the public included concerns about prohibiting metal as a building material, with general support for allowing metal as an accent material consistent with the existing Town Code, given its durability and fire resistance. Additional comments



noted that requiring mullions could create maintenance challenges and that the proposed 10-foot maximum setback is too restrictive for outdoor dining, with a preference for a 15-foot maximum setback.

Commissioners discussed several aspects of the guidebook and expressed that it is not comprehensive enough, particularly in identifying prohibited uses such as parking garages in certain locations. They also voiced concern that the process may be moving too quickly and suggested hosting a public open house for broader input. Regarding specific design standards, the Commission agreed that metal is acceptable as an accent material, except for corrugated metal, and clarified that setback and maximum setback measurements should be taken from the building wall. Parking requirements were also discussed, with some concern about commercial parking reductions and strong support for maintaining residential parking requirements, which have been updated since the previous work session. Commissioners expressed a general dislike for subjective standards and recommended removing subjectivity wherever possible.

The Planning Commission voted to recommend approval of Resolution 15-2025 regarding the proposed text amendments and applicable design standards, subject to the following conditions:

Regarding the Guidebook

1. In section 1 (Color and Material Selections), clarify that metal is a permitted roof material.
2. Revise Standard 1.3.a to list metal as an acceptable accent material, excluding corrugated metal, while allowing oxidizing metal.
3. Revise Standard 2.2.a so that the maximum front setback is measured from the building wall.
4. Revise Standard 2.3.b to clarify that the 12-foot setback is measured from the building wall.
5. Revise Standard 3.1 by removing items a, b, and c to avoid overly prescriptive requirements. If awnings remain as a callout, specify that natural materials shall be used.
6. Revise Standard 3.2 by removing items a and b, leaving only the provision that open space requirements are waived for mixed-use buildings.
7. Revise Standard 4.1 to include an exception stating that if parking is not permitted to be constructed per the Town, payment or construction is not required.
8. Remove Standard 5.3.d entirely.
9. Revise Standard 6.3 to include prescriptive requirements.

Regarding the Text Amendments

10. Confirm that the description within the Central Business District definition matches the boundaries shown in the guidebook.
11. Revise Section 12-7-3(C)(3)(e) to ensure consistency with the guidebook.

Staff Comments and Analysis on Planning Commission Recommendations

The table below outlines potential changes based on the Planning Commission’s recommendations. ~~Strikethrough~~ text indicates language to be removed, while **bold and underlined** text reflects additions.

	Text Changes Based on Recommendations	Staff Comments
1	Design Intent: Cultivate a cohesive visual identity throughout the CBD that reflects the historical and rustic character of Grand Lake as a mountain town.	A clarification to ensure that metal roofing remains an acceptable material as permitted by the Town Code.



	<p>Primary building materials should be authentic, durable, and evoke a western aesthetic. Colors and finishes should be muted and convey high-quality design and detailing. <u>The following design standards apply exclusively to siding materials and do not include roof materials.</u></p>	
2	<p>1.3.a: Metal materials shall not be used as a primary or accent element within the CBD. <u>Corrugated metal shall not be used as an accent material. Acceptable metal materials, as defined in Town Code Section 12-7-4, are permitted for use as accent materials.</u></p>	<p>There is mixed feedback on whether metal materials complement the character of Grand Lake. However, corrugated metal is universally considered undesirable within the commercial district.</p>
3	<p>2.2.a: The maximum setback may be measured from a covered overhang. For example, a covered outdoor patio located 10 feet from the property line would meet the requirement. <u>shall be measured from the building wall. Structured overhangs or covered patios do not count toward the maximum setback; measurement must be taken from the building wall itself.</u></p>	<p>The intent of the original language was to allow for outdoor seating options. Under the recommended language, outdoor seating is limited to the 40% lot frontage, if desired. The clarification regarding structures is necessary because, according to Town Code, any element with a roof supported by columns is considered part of the building. Therefore, structured overhangs would normally count toward setback measurements under Town Code standards.</p>
4	<p>2.3.b: The setback shall be a minimum of 12 feet, measured from the face of the building, including any covered structural elements. <u>building wall.</u></p>	<p>The Board may want to consider additional clarifications about any additional “structure” within the setback zone. Example: structured overhangs.</p>
5	<p>3.1: Development shall construct the boardwalk in the adjacent right-of-way. This requirement applies to all street-facing facades.</p> <p>a. A covered boardwalk is encouraged to protect pedestrians from the natural elements.</p> <p>b. Awnings may be used instead of a covered boardwalk. The awning roof and cladding material shall not be metal; however, metal framing may be permitted.</p> <p>c. The design of boardwalks and covered walkways shall comply with Town Code Article 11-4.</p> <p>d. Where a building is set back to the maximum allowable distance along Grand Avenue, it is encouraged that pedestrian elements, like the continuation of the boardwalk, are used to connect the building to the public right-of-way.</p>	<p>At the work session, the language stated that the boardwalk “shall” be covered by a structural element. However, feedback indicated a desire for variation and therefore the language was changed to “encouraged.” Current Code states “Covered walkways and arcades should be provided on all buildings frontages where pedestrian traffic is likely.” The Planning Commission’s recommendation aims to eliminate subjectivity. If the desire is still to require a covering of some sort but in a more definitive manner, a possible standard could read: <i>“Buildings are required to provide one of the following: (a) a structural boardwalk covering; (b) natural material awnings over doors; or (c) an architectural offset that offers some form of protection from the elements.”</i></p>
6	<p>3.2: Open space requirements are waived for mixed-use buildings.</p> <p>a. Where open space is proposed, it is encouraged to be along frontages other than Grand Avenue.</p> <p>b. For buildings set back to the maximum allowable distance along Grand Avenue, it is encouraged that public seating, art installations, or landscaping elements be incorporated to enhance the pedestrian experience.</p>	<p>By removing subjective language such as “encouraged,” the recommendation becomes more objective. However, using subjective terms can help convey the aesthetic vision the Town aims to achieve. Omitting any reference to preferred open space eliminates it as a consideration during development plan reviews.</p>
7	<p>4.1: Development within the CBD is exempt from the</p>	<p>This clarification allows for limited exceptions</p>



	<p>commercial parking requirements outlined in the Town Code when the subject property is adjacent to existing and constructed public parking spaces located within the ROW.</p> <p>a. If public parking spaces are not currently constructed within the ROW directly adjacent to the subject property, the applicant shall be responsible for constructing the necessary parking spaces or pay a fee in lieu to meet the commercial parking requirement.</p> <p>b. <u>If the Town does not permit parking within the ROW adjacent to the subject property, the developer is not required to construct the spaces or pay the fee in lieu.</u></p>	<p>where parking is not permitted in the Town.</p>
8	<p>5.3: A basic building form is preferred. Any variation should be subordinate to the overall massing and contribute to a cohesive design.</p> <p>a. Varying building heights may be used to reflect different modules.</p> <p>b. Larger buildings should be divided into smaller modules that reflect the scale and lot widths of traditional Town structures.</p> <p>c. Moderate wall plane offsets, such as notches or projections, may be used to add interest.</p> <p>d. Excessive variation that results in a visually busy or disjointed design is discouraged.</p>	<p>The Planning Commission’s recommendation aims to remove subjective standards. For example, the term “excessive variation” is inherently subjective, yet the intent is to prevent an overly “busy” building form. Historic and existing structures in the Town are generally simple in form, with minimal changes in materials, offsets, or insets. The goal is to articulate what is not desired without being overly prescriptive. Overly prescriptive aesthetic standards can unintentionally eliminate uniqueness and may affect properties differently due to their specific circumstances.</p>
9	<p>6.3: Mullions shall be incorporated into window designs to reinforce the historic character of the district. <u>Mullions must be a minimum of two inches and a maximum of four inches in width in-between the windows.</u></p>	<p>Being overly prescriptive may influence window placement, which is partially determined by the interior layout and design. Note: that a mullion divides two or more separate windows, whereas a muntin divides individual panes within a single window.</p>
10	<p>Central Business District: Commercially zoned, or commercial transitionally zoned lots generally located between Broadway Street and Hancock Street and between Park Avenue and Lake Avenue. <u>Hancock Street on the east to Broadway Street on the west, and from Park Avenue on the north to the shoreline of Grand Lake on the south. The boundary also includes properties along Lake Avenue and curves around the Grand Lake Yacht Club before returning to Hancock Street.</u></p> <p>Properties within the CBD are subject to the Central Business District Design Standards, a supplemental guidebook that establishes specific design requirements and development goals for this district. The guidebook provides a map identifying the exact boundaries of the Central Business District.</p>	<p>The intent of the original language was to use the term “generally” to loosely define the area and then reference the guidebook, which can be updated periodically without requiring a code amendment. An alternative approach would be to specify the exact boundary line within the definition. An example: beginning at the intersection of Hancock Street and Park Avenue, the boundary runs west along the midpoint of Park Avenue, including all lots south of Park Avenue, until reaching Vine Street. At Vine Street, the boundary turns south along the midpoint of Vine Street, including all lots east of that midpoint, until it intersects with the alley half a block north of Grand Avenue. From there, the boundary runs west along the midpoint of the alley, including all lots south of that midpoint, until reaching Broadway Street, etc.</p>
11	<p><i>Potential to remove “Large setbacks from the street rights-of-way should be discouraged for new building construction.” This is covered in the guidebook.</i></p>	<p>In general, this section has a lot of subjectivity and overlaps with the guidebook. Further review required.</p>



Board of Trustees Consideration

The Board of Trustees of the Town of Grand Lake, Colorado, pursuant to Colorado statute and the provisions of the Grand Lake Municipal Code, is vested with the authority to make amendments to the Town Code. Board members are encouraged to review and evaluate the proposed text amendments and supplemental design guidelines, taking into account the Planning Commission’s recommendations and public comments received during the public hearing. In doing so, the Board should consider the implications of these amendments and guidelines and proceed to make an appropriate motion.

Sample Board of Trustees Motions

Approval with or without conditions

I move to approve Ordinance xx-2025, amending Town Code Sections 12-2-26, 12-7-2, 12-7-3, and 12-7-4 regarding the Central Business District and Applicable Design Standards.

OR... with the following conditions:

-
-

Denial

I move to deny Ordinance xx-2025, amending Town Code Sections 12-2-26, 12-7-2, 12-7-3, and 12-7-4 regarding the Central Business District and Applicable Design Standards, based on the following factors:

-
-

Attachments

- Draft Central Business District Design Standards Guidebook
- Draft Ordinance

Central Business District (CBD) Design Standards



TOWN OF GRAND LAKE
COLORADO

2025

INTRODUCTION

This document supplements the design guidelines that appear in the Town of Grand Lake Municipal Code and applies specifically to the Central Business District (CBD) that is defined in the Town Code Section 12-7-3. The intent of the CBD is to establish standards that protect and enhance the downtown area as a viable commercial district while preserving the historic aesthetic and architectural character of the Town of Grand Lake. The following shall apply:

- A. The CBD Design Standards shall apply to all development on parcels within the CBD, regardless of the proposed use (e.g., commercial, mixed-use, and residential).
- B. Wherever there is a conflict or inconsistency between the CBD Design Standards and other regulations of the land development code, the regulations set forth in these standards shall control and govern the development and redevelopment within the CBD.
- C. Where the CBD Design Standards are silent, the underlying zone district regulations come into effect.

THE CENTRAL BUSINESS DISTRICT



The CBD Boundaries

Photos of historic buildings from Grand Lake and the surrounding area:



Spider House (Grand County)



Engel's Ski Shop (Grand County)



Cozens Ranch (Grand County)



Nowatta Cottage

DEFINING WESTERN CHARACTER

This document provides design standards that further define the concept of historic western character to guide the design of new infill buildings, additions, and other improvements within the Central Business District (CBD). These standards build upon the language in the Town Code Design Standards and aim to clarify how historic western character should be interpreted in the context of Grand Lake's unique identity.

Historic western character is not a specific architectural style, but rather an approach to design rooted in the community's historical and cultural traditions. It encompasses building forms, materials, and details commonly found in historic structures throughout Grand Lake. The intent is to promote authentic design that reflects the town's heritage, distinguishing genuine historical influences from imitations.

HISTORICAL CONTEXT (FROM THE COMPREHENSIVE PLAN)

- Prior to settlement in the late 1860s, the area was used by Native American tribes—including the Ute, Northern Cheyenne, and Arapaho—for hunting.
- The mining boom of the 1870s brought outfitters to supply nearby mining towns.
- The Grand Lake Townsite was officially platted in 1881.
- By 1900, Grand Lake had become a popular summer destination, attracting over 1,000 seasonal visitors annually.
- The Grand Lake Yacht Club was established in 1902.
- Rocky Mountain National Park was designated in 1915.
- Trail Ridge Road was completed in 1939, solidifying Grand Lake's role as a gateway community.

Photos of historic buildings from Grand Lake and the surrounding area:



Grand Lake Community House



Grand Lake Lodge



Kauffman House



Smith Eslick Cottage Camp

BUILDINGS LISTED ON THE COLORADO HISTORIC REGISTER

- **Grand Lake Community House (1922):** Located in the historic town square, hosts a variety of public and private events.
- **Grand Lake Lodge (1920):** Continues to serve visitors to Rocky Mountain National Park and Grand Lake.
- **Kauffman House (1892):** Originally a hotel for summer tourists, now operates as a museum.
- **Smith Eslick Cottage Camp (1915):** An early example of a motor court.

COMMON ARCHITECTURAL ELEMENTS DEFINING THE CHARACTER OF GRAND LAKE

The following architectural elements are encouraged and should be incorporated into developments proposed in the CBD.

- **Building Forms**
Simple and functional structures with gabled or pitched roofs. Many feature false fronts with stepped parapets to create a more prominent street presence. Dormers are often used to break up rooflines.
- **Covered Walkways and Porches**
Commercial buildings commonly include covered walkways and overhanging roofs that slope toward the right-of-way, enhancing pedestrian comfort and supporting a walkable downtown. Covered porches are a recurring feature in historic buildings.
- **Materials**
Natural materials such as wood and log construction dominate, typically in muted tones. Accent colors and occasional white-painted buildings are acceptable if provided in a historical context.

Photos of historic buildings from Grand Lake and the surrounding area:



Pine Cone Inn



Rapids Lodge

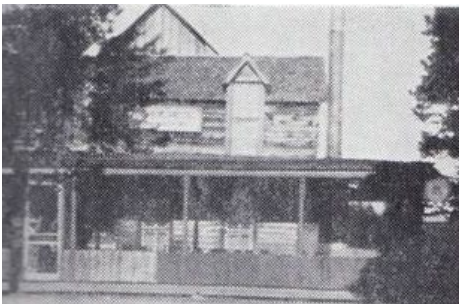

Rustin Inn



Zick's Grocery and Café

- **Street Orientation**
Buildings are oriented toward the street, maintaining a consistent street wall and contributing to the Town's cohesive visual identity.
- **Signage**
Overhanging signs are prevalent, often featuring western-style fonts that reinforce the Town's character.
- **Second-Floor Railings**
Found on buildings like the Spider House, Grand Lake Lodge, and Nowata Cottage, these add vertical interest and support multi-level design.
- **False Parapets**
Used to conceal pitched roofs, as seen in Zick's Grocery and Café, contributing to the traditional western storefront aesthetic.
- **Gabled Roofs with Dormers**
A defining roof form across historic structures, adding depth and character.
- **Boardwalk Precedents**
Covered boardwalks are inspired by buildings such as Pine Cone Inn, Rapids Lodge, Grand Lake Lodge, Kauffman House, and Rustin Inn.

APPLICABLE DESIGN STANDARDS

1. Color and Material Selections

DESIGN INTENT:

Cultivate a cohesive visual identity throughout the CBD that reflects the historical and rustic character of Grand Lake as a mountain town. Primary building materials should be authentic, durable, and evoke a western aesthetic. Colors and finishes should be muted and convey high-quality design and detailing.



Tonal monochromatic primary and accent color.

DESIGN STANDARD:

- 1.1 The primary color of a building shall be a neutral earth tone. Muted and warm shades of neutral colors are appropriate. Bright, pastel, or true primary hues are not permitted. Reference Chart 1 – Exterior Color Comparison for acceptable primary building colors.
- 1.2 Trim, fascia, window panes, and doors are considered accent elements. Accent colors shall be limited to the following:
 - a. Monochromatic (same as the primary color).
 - b. Tonal monochromatic (a lighter or darker shade of the primary color).
 - c. A contrasting color that complements the primary color. Intense colors are discouraged.
- 1.3 Limited accent materials, such as natural stone, may be permitted to enhance the visual interest and reflect the rustic character of Grand Lake.
 - a. Metal materials shall not be used as a primary or accent element within the CBD.



Too colorful: more than just a single primary and accent color, non-earth tones.



Oxydizing metal as accent material.

- b. Accent materials are limited to the amount defined in Town Code Section 12-7-3.
- c. Accent materials shall be encouraged around the base of the structure and architectural features, such as a chimney.
- d. Excessive change in accent materials is discouraged to avoid an overly busy appearance.

1.4 A material sample board must be presented to the Planning Commission and Board of Trustees for review prior to approval of a development application. Paint colors must be applied to desired materials (rather than a color swatch) to accurately show what the final color and material combination will look like.

1.5 If a variance is requested for building color or material, documentation demonstrating historical use of the proposed color or material within Grand Lake is required as precedent.



Bright, high-contrast accent color.

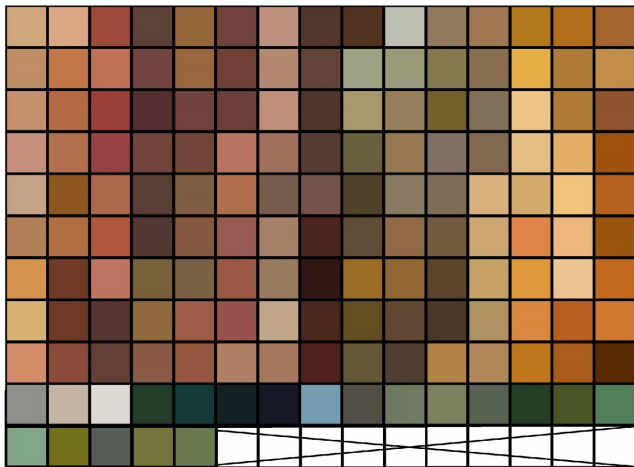

Chart 1 – Exterior Color Comparison

2. Ground Level Interest

DESIGN INTENT:

The CBD serves as the Town’s central commercial and visitor destination. As such, building design at the street and ground level should prioritize the pedestrian experience by offering visual interest, weather protection, and a welcoming environment that encourages foot traffic. The goal is to create a comfortable and engaging streetscape through a consistent street wall and clean, visually appealing commercial facades.

Buildings should be perceived as two stories in height, supported by a required stepback above the second story. This stepback helps reduce the visual bulk and mass of buildings and ensures new development remains compatible with the traditional scale and character of the area.



Commercial use on ground floor. Consistent streetwall.



0' setback with building footprint touching the public right-of-way.



Three-story building without a third-story stepback.

DESIGN STANDARD:

- 2.1 Commercial uses are required on the ground floor for the first 50 feet of depth from the property line along all street-facing frontages (does not apply to alleys).
 - a. Residential uses may be permitted on the ground floor beyond the initial 50 feet.
 - b. Mixed-use developments where residential use occupies more than 50% of the total building square footage are exempt from the Conditional Use requirements outlined in Town Code Section 12-2-18 – Regulations for Commercial District-C.

- 2.2 All development within the CBD shall maintain a maximum front setback of 10 feet from Grand Avenue, measured from the property line.
 - a. The maximum setback may be measured from a covered overhang. For example, a covered outdoor patio located 10 feet from the property line would meet the requirement.

Allowed Setback Scenarios:

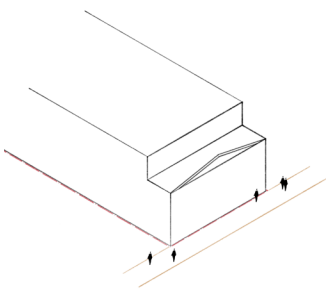

50' building width: 100% of the street-facing facade set at the 0' minimum setback.

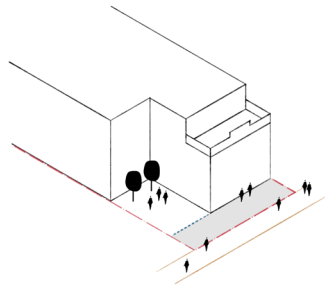

50' building width: 60% of the street-facing facade set at the 10' maximum setback, 40% devoted to outdoor pedestrian space.

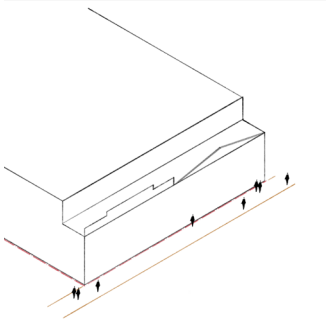

100' building width: 100% of the street-facing facade set at the 0' minimum setback.

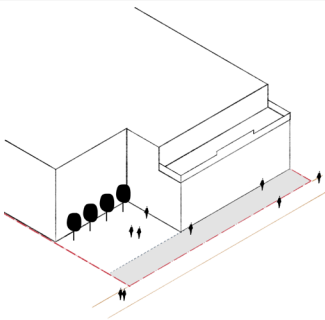

100' building width: 60% of the street-facing facade set at the 10' maximum setback, 40% devoted to outdoor pedestrian space.

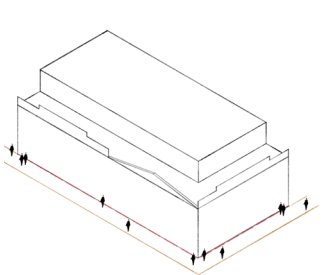

Corner Lot: 100% of both street-facing facades set at a 0' setback.

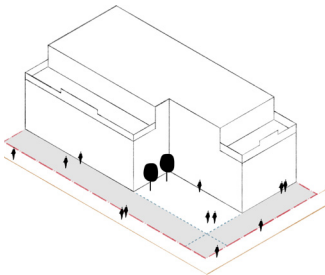

Corner Lot: The 60-40 ratio applies specifically to Grand Avenue. Developments can exercise flexibility on other street-facing frontages to add open space, if desired. This image shows 60% of both street-facing facades set at a 10' setback with 40% receded for outdoor pedestrian space.

- b. The maximum setback applies to 60% of the lot frontage. The remaining 40% of the lot frontage does not have a maximum setback requirement.

2.3 A third-story stepback is required on all street frontages after the first two stories.

- a. On corner lots, the stepback is required on both street-facing frontages (excluding alleys).
- b. The stepback shall be a minimum of 12 feet, measured from the face of the building, including any covered structural elements.

2.4 The street wall, as defined in the Town Code, shall be maintained.

- a. The maximum setback reinforces the street wall edge.
- b. Development is encouraged to incorporate creative public seating and open space within the maximum setback area if applicable or along street-facing frontages other than Grand Avenue.

3. Connectivity

DESIGN INTENT:

The CBD is intended to prioritize pedestrian experience. As such, developments shall ensure safe, year-round pedestrian access and connectivity for all users, including the elderly and those requiring ADA accessibility. Pedestrian connectivity refers to the movement of people from the public realm to and through a site, as well as connections to adjacent sites. Internal pedestrian access should enhance walkability and provide clear, intuitive links to the public realm.



Development incorporates covered walkway on all street-facing facades.

DESIGN STANDARD:

- 3.1 Development shall construct the boardwalk in the adjacent right-of-way. This requirement applies to all street-facing facades.
 - a. A covered boardwalk is encouraged to protect pedestrians from the natural elements.
 - b. Awnings may be used instead of a covered boardwalk. The awning roof and cladding material shall not be metal; however, metal framing may be permitted.
 - c. The design of boardwalks and covered walkways shall comply with Town Code Article 11-4.
 - d. Where a building is set back to the maximum allowable distance along Grand Avenue, it is encouraged that pedestrian elements, like the continuation of the boardwalk, are used to connect the building to the public right-of-way.



No covered walkway or awning incorporated in the adjacent public right-of-way.



Maximum building setback of 10' allows for outdoor pedestrian and landscaping elements.

3.2 Open space requirements are waived for mixed-use buildings.

- a. Where open space is proposed, it is encouraged to be along frontages other than Grand Avenue.
- b. For buildings set back to the maximum allowable distance along Grand Avenue, it is encouraged that public seating, art installations, or landscaping elements be incorporated to enhance the pedestrian experience.



Maximum setback allows for outdoor pedestrian and landscaping elements. Up to 40% of the building facade may be set back further than 10' for street-facing open space.

4. Parking

DESIGN INTENT:

The CBD is intended to foster a compact, pedestrian-oriented environment where development is not centered around vehicle access. The emphasis is on creating a high-quality pedestrian experience, with the expectation that visitors and residents will park once and access multiple destinations on foot. Much of the CBD includes existing or potential right-of-way (ROW) parking. Parking requirement reductions are intended to support this walkable downtown character.



Parking spaces constructed within the ROW directly adjacent to the subject property.

DESIGN STANDARD:

- 4.1 Development within the CBD is exempt from the commercial parking requirements outlined in the Town Code when the subject property is adjacent to existing and constructed public parking spaces located within the ROW.
- a. If public parking spaces are not currently constructed within the ROW directly adjacent to the subject property, the applicant shall be responsible for constructing the necessary parking spaces or pay a fee in lieu to meet the commercial parking requirement.

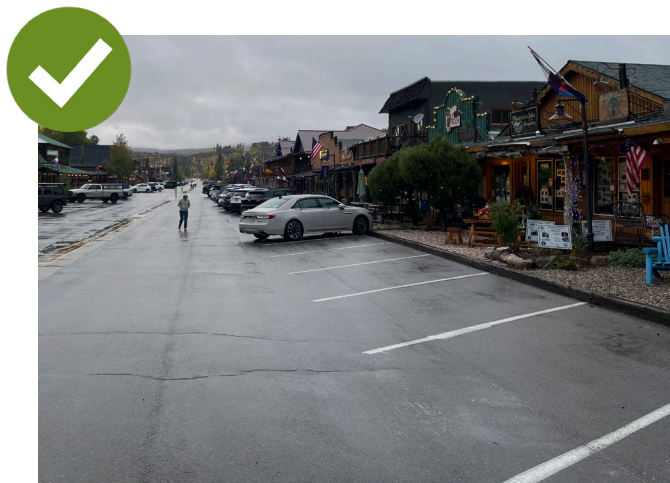

Parking constructed within the ROW allows pedestrians to park once and access multiple destinations on foot.

5. Roofline

DESIGN INTENT:

Buildings should reflect the simple forms and traditional character of Grand Lake's historic architecture. Roof forms should be either flat with stepped parapets (commonly referred to as "false fronts") or sloped in gable or hipped configurations. New buildings should maintain the scale of traditional structures, which includes not only overall height and width, but also the proportions and relationships of architectural features. These features should use simple vertical and horizontal articulation to establish human scale, add visual interest, and avoid monotonous facades.

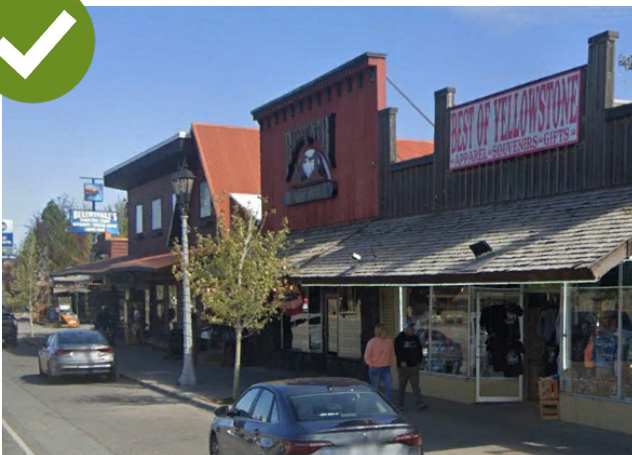

Flat and sloped roofs are appropriate.

DESIGN STANDARD:

- 5.1 Roof forms shall be simple in design.
 - a. Flat roofs are appropriate, especially on larger buildings, and should include variation in the cornice line.
 - b. Sloped roofs are appropriate and should reflect the pitch and proportions of traditional buildings.
 - c. A combination of flat and sloped roofs is acceptable but should remain visually simple and not overly complex.

- 5.2 The second story roofline shall be either gabled or, if flat, include a false parapet.
 - a. For buildings with three stories and a stepback, the second-story roofline should maintain the traditional sawtooth or ziggurat profile as that is the profile most prominent to the pedestrian.

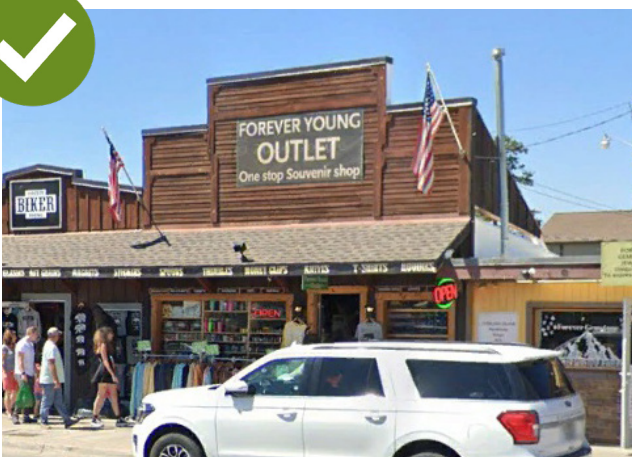

Flat roofs feature a false parapet.



Larger buildings should be divided into smaller modules that reflect the scale and lot widths of traditional Town structures.

- 5.3 A basic building form is preferred. Any variation should be subordinate to the overall massing and contribute to a cohesive design.
- a. Varying building heights may be used to reflect different modules.
 - b. Larger buildings should be divided into smaller modules that reflect the scale and lot widths of traditional Town structures.
 - c. Moderate wall plane offsets, such as notches or projections, may be used to add interest.
 - d. Excessive variation that results in a visually busy or disjointed design is discouraged.



Excessive variation that results in a visually busy or disjointed design is discouraged.

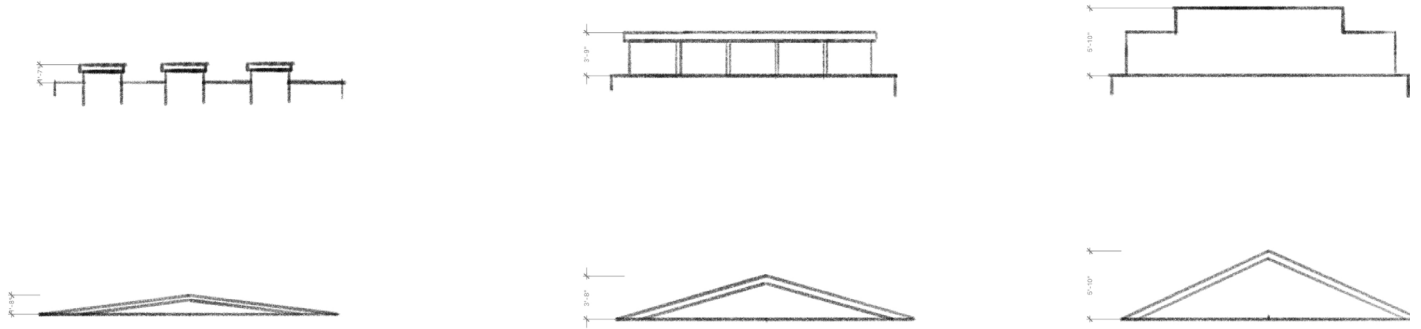

Examples of parapet designs.

6. Windows

DESIGN INTENT:

The arrangement, rhythm, and proportions of windows and doors play a key role in shaping the character of the CBD. Building facades should maintain a transparency-to-wall ratio that supports the commercial vibrancy and pedestrian engagement typical of traditional downtown environments.



Windows occupy at least 50% of the first-story facade, and mullions are incorporated into window designs.

DESIGN STANDARD:

- 6.1 Windows shall occupy at least 50% of the first-story façade to support pedestrian interaction and commercial visibility.
 - a. Upper stories are not required to meet the 50% transparency standard.
- 6.2 Storefront windows shall be designed with sills at least 10 inches but no more than 36 inches above the boardwalk to maintain building base treatments.
- 6.3 Mullions shall be incorporated into window designs to reinforce the historic character of the district.



No defined material base at the bottom of the first-story windows. No incorporation of mullions.

CENTRAL BUSINESS DISTRICT (CBD) DESIGN STANDARDS, 2025



**TOWN OF GRAND LAKE
BOARD OF TRUSTEES
ORDINANCE NO. 06-2025**

**AN ORDINANCE AMENDING TOWN CODE SECTIONS 12-2-26, 12-7-2, 12-7-3, AND
12-7-4 REGARDING THE CENTRAL BUSINESS DISTRICT AND APPLICABLE
DESIGN STANDARDS**

WHEREAS, the Board of Trustees of the Town of Grand Lake, Colorado, pursuant to Colorado statute and the provisions of the Grand Lake Municipal code, is vested with the authority of administering the affairs of the Town of Grand Lake, Colorado (“The Town”); and

WHEREAS, the Town of Grand Lake Municipal Code Chapter 12, Article 2, Section 26 governs the regulations for mixed-use development; and

WHEREAS, the Town of Grand Lake Municipal Code Chapter 12, Article 7 governs the Design Review Standards for development within the Town; and

WHEREAS, the Town of Grand Lake Municipal Code Chapter 12, Article 7 defines the Central Business District within the limits of the Town of Grand Lake; and

WHEREAS, the Planning Commission, at its regular meeting on December 5, 2025, discussed amending the definition of the “Central Business District” to modify its boundaries and incorporate the supplemental Central Business District Design Standards guidebook; and

WHEREAS, the Planning Commission reviewed and recommended conditional approval of the amendments to Town Code Sections 12-2-26, 12-7-2, 12-7-3, and 12-7-4 to revise the definition of “Central Business District” and update applicable design guidelines; and

WHEREAS, the Board of Trustees, at its regular meeting on December 8, 2025, reviewed and discussed the Planning Commission’s recommendation; and

WHEREAS, the Board of Trustees finds that amending the “Central Business District” boundary and definition, and adopting supplemental design guidelines, will further the intent of the Design Review Standards outlined in the Town Code.

**NOW THEREFORE BE IT RESOLVED BY THE BOARD OF TRUSTEES OF THE
TOWN OF GRAND LAKE, COLORADO,**

- 1. Section 12-2-26 (A) of the Municipal Code of the Town of Grand Lake is hereby amended

with the addition of the **bold underlined** language as follows:

(A) *Mixed-Use Regulations for the CT, C and RST Districts.*

1. Mixed-use developments in the above listed districts will be subject to the following supplementary regulations. These regulations are minimum requirements and will also apply to Planned Developments within these districts.
2. Multiple family dwellings may be constructed above commercial uses provided:
 - (a) Access to dwelling units is not through commercial establishments.
 - (b) Trash, service and loading areas shall be screened from view from the dwelling units and from street entrances to dwelling units.
 - (c) Outdoor lighting associated with commercial uses within the structure, including lighting for parking, service and loading areas, shall be designed and located such that the direct source is not visible from any dwelling unit within nor shall there be any glare.
 - (d) At least two (2) means of ingress and egress from each floor of dwelling units shall be provided and that all other regulations as may pertain to fire protection be met.
3. Mixed-Use projects shall conform to the following schedule of (Private) Open Space Land Area Requirements:

Group	Gross Square Footage of Floor Area Of Structure or Land Use Area	Land Use or Floor Area	Minimum Open Space Land Area Required
I.	75%—99%	Commercial (C.)/ Office (O.)	20%
	25%—1%	Residential (R.)	
II.	50%—75%	C. & O.	25%
	50%—25%	R.	
III.	25%—50%	C. & O.	35%
	75%—50%	R.	
IV.	10%—25%	C. & O.	45%
	90%—75%	R.	
V.	1%—9%	C. & O.	50%
	99%—91%	R.	

4. In all applicable districts, the developer shall submit a proposal for the Open Space Land Area Required for Mixed-Use projects. The Open Space Land Area Requirement is to be provided on-site, in accordance with the Section 12-2-6 Definitions.
5. **When a mixed-use development is located within the Central Business District, it must comply with all applicable design standards outlined in the Central Business District Design Standards guidebook.**

2. Section 12-7-2 of the Municipal Code of the Town of Grand Lake is hereby amended with the addition of the **bold underlined** language as follows:

An historical perspective is extremely important to the Town, therefore it is the intent that new materials and innovations will strengthen and be harmonious with the "historic western" feel of the Town. A creative and rigorous approach to the best selection and application of building materials will generate a more inviting, vibrant and harmonious appearance to the Town.

As Grand Lake becomes more densely built, there is a need to create a symbiotic relationship between buildings and public and open spaces. The Town of Grand Lake seeks to preserve the historical, rustic, and unique western small-town character of Grand Lake while also integrating its preservation with new and pioneering creative designs. Intending to help enhance quality and strengthen visual continuity while preserving historically significant properties, allowing innovation and encouraging creativity, the purpose of these standards is to stimulate creative design solutions for individual properties while promoting and preserving a sense of cohesiveness among the entire Town of Grand Lake.

A successful project will combine the design elements of composition, scale, proportion and rhythm in proposed materials, surfaces and massing, designing buildings, open and public spaces that are timeless and in character with our Town and harmonious to the human eye. In addition, materials, surfaces and massing create a sense of entry and a desirable sense of place.

The provisions of this Article shall apply to any structure, including temporary facilities, within the Town limits on or after the effective date of the Ordinance for the following:

- (A) New construction of any building.
- (B) Exterior remodeling or painting of any existing building, even if a Town of Grand Lake Building Permit is not required.
- (C) Re-roofing, enlargements, expansions of or additions to any existing building.

Where a property is located within the Central Business District and meets the above criteria, both the design standards in this Article and those in the *Central Business District Design Standards* guidebook shall apply. If a conflict arises between the provisions of this Article and the *Central Business District Design Standards*, the more stringent shall apply. Where the *Central Business District Design Standards* guidebook is silent, the provisions of this Article shall apply.

3. Section 12-7-3 of the Municipal Code of the Town of Grand Lake is hereby amended with the removal of the ~~strikethrough~~ language and the addition of the **bold underlined** language as follows:

Central Business District — Commercially zoned, or commercial transitionally zoned lots **generally** located **between Broadway Street and Hancock Street and between Park**

Avenue and Lake Avenue. Properties within the CBD are subject to the Central Business District Design Standards, a supplemental guidebook that establishes specific design requirements and development goals for this district. The guidebook provides a map identifying the exact boundaries of the Central Business District. ~~on or between Hancock Street and Haskell Street, on Grand Avenue, and between Hancock Street and Vine Street on Park Avenue, and between Hancock Street and Ellsworth Street on Lake Avenue.~~

4. Section 12-7-3 (C) (3) (e) of the Municipal Code of the Town of Grand Lake is hereby amended with the removal of the ~~strikethrough~~ language and the addition of the **bold underlined** language as follows:

(e) *Infill/building additions in the central business district.*

1. When a new use (infill)/addition is proposed to an existing commercial development the newly constructed portion of the building should appear as an originally conceived part of the design. The new additions should match the scale and reflect the proportions of the original structure where they adjoin or are adjacent. New construction of a different height and bulk, than that of the original structure, should not occur abruptly.
2. New additions should match the existing approved architecture of the existing central business district. See for example, Figures 1 and 2 below. Such matching approval shall be in the sole discretion of the Town. The extension of canopy elements, lighting, boardwalks, planting areas, fenestration (window) patterns, structural rhythms, and use of materials should exhibit a seamless transition between existing and new construction.
3. Large setbacks from the street rights-of-way should be discouraged for new building construction.
4. New construction should not incorporate precise replication of town center architecture but utilize similar colors, materials, textures, pattern, repetition, rhythm, and proportions to achieve architectural unity.

5. All properties within the Central Business District shall meet the standards established in the Central Business District Design Standards guidebook.

5. **Severability:** If any section, paragraph, sentence, clause, or phrase of this Ordinance is held to be unconstitutional or invalid for any reason, such decision shall not affect the validity of the remaining portions of this Ordinance. The Board of Trustees declares that it would have passed this Ordinance and each part or parts thereof irrespective of the fact that any one part or parts be declared unconstitutional or invalid.
6. **Repeal:** Existing ordinances or parts of ordinances covering the same matters as embraced in this Ordinance are hereby repealed and all resolutions or parts of ordinances inconsistent with

the provisions of this Ordinance are hereby repealed.

DULY MOVED, SECONDED AND ADOPTED BY THE BOARD OF TRUSTEES OF THE TOWN OF GRAND LAKE, COLORADO THIS 8TH DAY OF DECEMBER 2025.

(S E A L)

ATTEST:

TOWN OF GRAND LAKE

Alayna Carrell
Town Clerk

Christina Bergquist,
Mayor

Votes Approving:
Votes Opposed:
Absent:
Abstained:

