



## CITY COUNCIL WORK SESSION

Monday, April 01, 2024 at 6:00 PM  
Council Chambers and YouTube Livestream

Website: [www.forestparkga.gov](http://www.forestparkga.gov)  
YouTube: <https://bit.ly/3c28p0A>  
Phone Number: (404) 366.4720

FOREST PARK CITY HALL  
745 Forest Parkway  
Forest Park, GA 30297

The Honorable Mayor Angelyne Butler, MPA

The Honorable Kimberly James

The Honorable Hector Gutierrez

The Honorable Allan Mears

The Honorable Dabouze Antoine

The Honorable Latresa Akins-Wells

Ricky L. Clark Jr, City Manager

Randi Rainey, City Clerk

Danielle Matricardi, City Attorney

## AGENDA

### VIRTUAL NOTICE

To watch the meeting via YouTube - <https://bit.ly/3c28p0A>

The Council Meetings will be livestream and available on the City's

YouTube page - "*City of Forest Park GA*"

CALL TO ORDER/WELCOME:

ROLL CALL:

ADOPTION OF THE AGENDA WITH ANY ADDITIONS / DELETIONS:

NEW BUSINESS:

1. **Council Discussion and Approval on the Renewal of the GEMA/Homeland Security Statewide Mutual Aid Agreement-Executive Offices**

**Background/History:** Pre-existing agreements for mutual aid assistance in emergencies help to ensure the timely provision of mutual aid assistance and reimbursement of costs incurred by those parties who render such assistance. This agreement also provides the framework to support mutual assistance in managing an emergency or disaster occurring within any political subdivision that is a Participating Party, whether arising from natural disaster, technological hazard, human caused disaster, civil emergency, community disorders, or other significant events or homeland security activities.

The City of Forest Park has been a Participating Party of this agreement, with the most recent renewal in 2020. This agreement asks to be renewed/approved every 4 years.

GEMA/HS Area 7 Field Coordinator Sheri Russo is available to help further explain and/or answer additional questions.

**2. Council Discussion and Approval of an Emergency Requisition Associated with the Public Safety Building** – Planning and Community Development Department

**Background/History:**

This emergency requisition is a proposal and recommendation from Grounded Engineering Services based on a geotechnical investigation of undeveloped portions of property associated with the Gillem Public Safety Building, specifically the concrete trash dumpster located at the edge of the parking lot. The geotechnical investigation was in response to the appearance of subsidence / sinkholes on the property in areas that were outside the limits of construction and disturbance for the project. Site Mix Pressure Grouting LLC will inject cement – based, high mobility geotechnical grout through driven injections pipes and into the soils surrounding the concrete trash dumpster pad at the edge of the parking lot to protect it from sinking.

**3. Council Discussion and Approval of the City Center Boundary Topographic and Utility Survey-** Planning and Community Development Department/Capital Projects

**Background/History:**

Precision Planning Inc. (PPI) is working with the City to design and prepare plans for the City Center project to include City Hall, Municipal Court, Police Headquarters and Recreation Facility. The new facility will be based on Preliminary Design drawings completed by Precision Planning, Inc. in December 2023. Falcon Design Consultants, LLC (FDC) has prepared a Task Order (TO) to assist the City of Forest Park with a boundary/topographic survey and underground utility locate for the future City Center location.

**4. Council Discussion and Approval to upfit seventeen (17) Police Vehicles-** Police Department

**Background/History:**

Due to an aging fleet, Mayor and Council approved for the police department to purchase new patrol vehicles. Once the aforementioned vehicles were acquired, the vehicles were in need of being upfitted with equipment. The equipment installed on the vehicles will include, but not limited to: emergency lights, emergency sirens, storage racks, computer mounts, etc.

The Forest Park Police Department intends to proceed with HG2, a vendor already serving the city of Forest Park, to carry out the installation. The funding for this upfit, totaling \$241,043.00, has already been approved as part of the Capital Improvements Vehicles budget.

**5. Council Discussion and Approval to Purchase seven (7) portable Radios for the Police Department-**Police Department

**Background/History:**

The Forest Park Police Department has 95 sworn positions allocated to it. When the portable radios were initially ordered a few years ago, the order did not cover all the sworn positions, nor did it factor in potential losses or damages to equipment. With all allotted positions now spoken for, the police department needs additional radios for incoming police officers and radios to keep as a spare.

Therefore, the department requests approval to purchase seven (7) extra portable radios to meet its equipment requirements.

**6. Council Discussion and Approval to purchase one (1) Police Vehicle-Police Department**

**Background/History:**

Historically, vehicle acquisitions were tailored to meet staffing needs, but due to the recent decrease in vacancies and the recent loss of a vehicle, the existing fleet does not align with the current requirements. At present, all positions (excluding the deputy chief position) are spoken for in the Police Department.

The Forest Park Police Department is aiming to procure 1 Dodge Challenger at a total cost of \$47,140. The funds for this purchase has already been approved via Capital Improvements. This investment is intended to address immediate vehicle needs, align with the current staffing levels, and contribute to the overarching mission of the police department.

**7. Council Discussion and Approval for the Purchase of Playground Equipment for Pocket Parks-Public Works Department**

**Background/History:**

In line with our ongoing efforts to enhance the parks throughout the City, staff is presenting a proposal for the purchase of new playground equipment for the pocket parks located in Wards 3, 4, and 5. The details of the proposal are outlined below:

**Proposal Details:**

Total Cost: \$275,271.25

**Allocation by Ward:**

Ward #3 – Theater Park: \$68,817.81

Ward #4 – Perkins Park: \$68,817.81

Ward #4 – Second St Park: \$68,817.81

Ward #5 – Alder Park: \$68,817.81

**Components of Playground Equipment:** Each playground equipment consists of over 13 unique components directly attached to the main playground structure, offering various play experiences for children.

**Additional Equipment:** ADA compliant Single Spigot water fountain (except Alder Park, due to lack of water source).

Recycled 6' plastic bench.

Plastic border timbers and 1 ADA border half ramp for each site (this holds mulch in place).

Loose fill rubber mulch (to be installed on top of existing mulch, providing cost savings to the City).

Contract Details: The proposed purchasing agreement is with PlaySouth Playground Creator, under the following contract:

Burke Sourcewell Contract #010521-BUR

Forest Park member #77837

Funding: The funding for this proposal will be drawn from each Ward's Project line item to cover the total cost.

Conclusion: This proposal includes all materials and labor, excluding the water fountains, which will be replaced by Public Works upon delivery. The initiative aims to provide safe and engaging play spaces for children across the City.

**8. Council Discussion and Approval - CPRG Grant Agreement with Clayton County-Public Works Department**

**Background/History:**

The City of Forest Park is committed to fostering cleaner air and a healthier environment for our residents. As part of this commitment, we are exploring the possibility of participating in a project with Clayton County to apply for grant funds through the EPA Climate Pollution Grant program. This grant would enable us to acquire EV vehicles and establish charging infrastructure within our community.

**Project Objectives:**

Phasing out aging government vehicles with zero-emissions electric vehicles.

Installing charger stations.

Building out utilities and power infrastructure to support EV usage.

Purchasing electric vehicles to replace traditional combustion engine vehicles.

**Grant Details:**

No local match is required for this grant, making it a financially advantageous opportunity for the City.

The project will involve a collaboration with 9 localities across the Atlanta metropolitan region to collectively reduce greenhouse gas emissions in the transportation sector. Staff recommends that the City Council discuss and approve our participation in entering into a grant agreement with Clayton County for the Climate Pollution Grant program to build a greener and more sustainable future for Forest Park.

**EXECUTIVE SESSION:** (When an Executive Session is required, one will be called for the following issues: Personnel, Litigation or Real Estate)

**ADJOURNMENT:**

In compliance with the Americans with Disabilities Act, those requiring accommodation for meetings should notify the City Clerk's Office at least 24 hours prior to the meeting at 404-366-4720.



**File Attachments for Item:**

**1. Council Discussion and Approval on the Renewal of the GEMA/Homeland Security Statewide Mutual Aid Agreement-Executive Offices**

**Background/History:** Pre-existing agreements for mutual aid assistance in emergencies help to ensure the timely provision of mutual aid assistance and reimbursement of costs incurred by those parties who render such assistance. This agreement also provides the framework to support mutual assistance in managing an emergency or disaster occurring within any political subdivision that is a Participating Party, whether arising from natural disaster, technological hazard, human caused disaster, civil emergency, community disorders, or other significant events or homeland security activities.

The City of Forest Park has been a Participating Party of this agreement, with the most recent renewal in 2020. This agreement asks to be renewed/approved every 4 years.

GEMA/HS Area 7 Field Coordinator Sheri Russo is available to help further explain and/or answer additional questions.



Subject: GEMA/HS Statewide Mutual Aid Agreement - Renewal

Department: Fire / EMA

Date Submitted: 03/08/2024

Work Session Date: n/a

Council Meeting Date: March 18, 20224

Background/History: Pre-existing agreements for mutual aid assistance in emergencies help to ensure the timely provision of mutual aid assistance and reimbursement of costs incurred by those parties who render such assistance. This agreement also provides the framework to support mutual assistance in managing an emergency or disaster occurring within any political subdivision that is a Participating Party, whether arising from natural disaster, technological hazard, human caused disaster, civil emergency, community disorders, or other significant events or homeland security activities.

The City of Forest Park has been a Participating Party of this agreement, with the most recent renewal in 2020. This agreement asks to be renewed/approved every 4 years.

GEMA/HS Area 7 Field Coordinator Sheri Russo is available to help further explain and/or answer additional questions.

Cost: \$ n/a

Budgeted for: \_\_\_ Yes \_\_\_ No

Financial Impact: n/a

Action Requested from Council: \_\_\_ Discussion Only \_\_\_X\_\_\_ Approval at Regular Meeting

# STATEWIDE MUTUAL AID AND ASSISTANCE AGREEMENT

Item #1.

County/Municipality: City of Forest Park, Clayton County

The State of Georgia is vulnerable to a wide range of natural and man-made disasters and emergencies. The Georgia Emergency Management Act, as amended (The Act) gives the local governments of the State the authority to make agreements for mutual aid assistance in emergencies. Pre-existing agreements for mutual aid assistance in emergencies help to ensure the timely provision of mutual aid assistance and the reimbursement of costs incurred by those parties who render such assistance.

This mutual aid agreement is entered pursuant to authorities contained in Articles I through III, Chapter 3, Title 38, Official Code of Georgia Annotated.

## ARTICLE I STATEMENT OF AGREEMENT, DEFINITIONS AND AUTHORITIES

This Agreement is made and entered into between the participating political subdivisions, which approve and execute this Agreement, hereinafter called "Participating Parties" and the Georgia Emergency Management and Homeland Security Agency (GEMA/HS). For purposes of this Agreement, the following terms and expressions shall apply:

- (1) "Agreement" means this agreement, generally referred to as the "Statewide Mutual Aid Agreement" (SWMAA).
- (2) "Assistance" includes personnel, equipment, facilities, services, supplies and other resources furnished to a Requesting Party pursuant to this Agreement during an emergency or disaster.
- (3) "Assisting Party" means a party that provides assistance pursuant to this Agreement during an emergency or disaster.
- (4) "Authorized Representative" means a Participating Party's elected or appointed official or employee who has been authorized in writing by that party to request, to offer, or otherwise to provide mutual aid assistance.
- (5) "Participating Party" means a county or municipality of the State of Georgia that has become party to this Agreement by its approval and execution of this agreement.
- (6) "Participating Parties" means the combination of counties and municipalities that have become parties to this Agreement by their approval and execution of this Agreement.
- (7) "Requesting Party" means a party that requests assistance pursuant to this Agreement during an emergency or disaster.

Any term or expression not defined in this Agreement shall have the meaning specified in the Georgia Emergency Management Act, as amended (the Act) and rules promulgated thereunder, unless used in a context that clearly suggests a different meaning.

ARTICLE II  
GENERAL PURPOSE

The purpose of this Agreement is to:

1. Provide the framework to support mutual assistance in managing an emergency or disaster occurring within any political subdivision that is a Participating Party, whether arising from natural disaster, technological hazard, human caused disaster, civil emergency, community disorders, insurgency, enemy attack, acts of terrorism, other significant events or homeland security activity; and
2. Identify those persons who are authorized to act on behalf of the Participating Party signing this Agreement as their Authorized Representative(s) concerning the provision of mutual aid resources and requests for mutual aid resources related to any mutual aid assistance sought from another Participating Party, or from or through the State of Georgia. Appendix A of this Agreement shall contain the name(s) of the Participating Party's Authorized Representative for purposes of this Agreement. Appendix A can be amended by the authorizing Participating Party as needed with no effect on the entire Agreement. All such amendments to Appendix A shall be done in writing and the Participating Party shall notify GEMA/HS and all other Participating Parties of such amendment within thirty (30) days.

ARTICLE III  
ACKNOWLEDGEMENT OF PRINCIPLES

The prompt, full and effective utilization of resources of the Participating Parties, including any resources on hand or available from the State or Federal Government or any other source, that are essential to the safety, care and welfare of the people shall be the underlying principle on which all articles of this Agreement shall be understood.

In the event of a conflict between any provision of this Agreement and any existing intrastate mutual aid agreement affecting a Participating Party, the provisions of this Agreement shall be controlling.

On behalf of the governing authority of each political subdivision of this State participating in the Agreement, the director of emergency management of such political subdivision will be responsible for formulation of the appropriate mutual aid plans and procedures necessary to implement this Agreement.

ARTICLE IV  
PARTICIPATING PARTY RESPONSIBILITIES

(a) It shall be the responsibility of each Participating Party to formulate procedures and programs for intergovernmental cooperation in the performance of the responsibilities listed in this Article. In formulating such plans, and in carrying them out, each Participating Party, insofar as practical, shall:

- (1) Protect and assure uninterrupted delivery of services, medicines, water, food, energy and fuel, search and rescue, and critical lifeline equipment, services, and resources, both human and material; and

(2) Inventory and set procedures for the loan and delivery of human and material resources, together with procedures for reimbursement.

(b) Whenever a Participating Party requires mutual aid assistance from another Participating Party and/or the State of Georgia, the Requesting Party may request assistance by:

(1) Contacting the Participating Party who is the owner/operator/employer of the supplies, equipment and/or personnel being sought for mutual aid assistance (the Assisting Party); or

(2) Contacting GEMA/HS to serve as the facilitator of such request for those resources being sought for mutual aid that are owned/operated/employed by Participating Parties (where such Participating Parties have submitted a record of those resources to GEMA/HS for such use); and/or, when such resources being sought for mutual aid are owned/operated/employed directly by the State of Georgia.

The provisions of this Agreement shall only apply to requests for assistance made by an Authorized Representative. Requests may be verbal or in writing. If verbal, the request must be confirmed in writing within 30 days of the verbal request. Requests shall provide the following information:

(1) A description of the emergency service function for which assistance is needed, such as but not limited to fire services, law enforcement, emergency medical, transportation, communications, public works and engineering, building inspection, planning and information assistance, mass care, resource support, health and medical services, damage assessment, volunteer and donated goods and search and rescue; and

(2) The amount and type of personnel, equipment, materials and supplies needed, and a reasonable estimate of the length of time each will be needed; and

(3) The specific place and time for staging of the Assisting Party's response and a point of contact at that location.

The Assisting Party will (a) maintain daily personnel time records, material records and a log of equipment hours (or miles, if appropriate) and (b) report work progress to the Requesting Party at mutually agreed upon intervals.

#### ARTICLE V LIMITATIONS

Any Participating Party requested to render mutual aid shall take such action as is necessary to provide and make available the resources covered by this Agreement in accordance with the terms hereof; provided that it is understood that the Participating Party who is asked to render aid may withhold resources to the extent necessary to meet the current or anticipated needs of the Participating Party's own political subdivision to remain in compliance with such Participating Party's policy, rule or law.

The Assisting Party's mutual aid resources will continue under the command and control of their own

supervisors, but the organizational units will be under the operational control of the emergency services authorities of the Requesting Party unless the Assisting Party approves an alternative.

In the event the Governor should declare a State of Emergency, any and all provisions of this Agreement which may conflict with the declared State of Emergency shall be superseded by the terms and conditions contained within the State of Emergency.

#### ARTICLE VI LIABILITY AND IMMUNITY

(a) In accordance with O.C.G.A. § 38-3-35(a), no political subdivision of the state, nor the agents or representatives of the state or any political subdivision thereof, shall be liable for personal injury or property damage sustained by any person appointed or acting as a volunteer emergency management worker or member of any agency engaged in emergency management activity. The foregoing shall not affect the right of any person to receive benefits or compensation to which he might otherwise be entitled under Chapter 9 of Title 34, Code Section 38-3-30, any pension law, or any act of Congress.

(b) In accordance with O.C.G.A. § 38-3-35(b), no political subdivision of the state nor, except in cases of willful misconduct, gross negligence, or bad faith, the employees, agents, or representatives of the state or any political subdivision thereof, nor any volunteer or auxiliary emergency management worker or member of any agency engaged in any emergency management activity complying with or reasonably attempting to comply with Articles 1 through 3, Chapter 3, Title 38, Official Code of Georgia Annotated; or any order, rule, or regulation promulgated pursuant to Articles 1 through 3 of title, or pursuant to any ordinance relating to precautionary measures enacted by any political provisions of Articles 1 through 3 of said chapter and title, or pursuant to any ordinance relating to precautionary measures enacted by any political subdivision of the state shall be liable for the death of or the injury to person or for damage to property as a result of any such activity.

(c) It is the express intent of the parties that the immunities specified in accordance with O.C.G.A. § 38-3-35 shall apply in addition to any other immunity provided by statute or case law.

#### ARTICLE VII RIGHTS AND PRIVILEGES

In accordance with O.C.G.A. § 38-3-30(a), whenever the employees of any Assisting Party or political subdivision are rendering outside aid pursuant to this agreement and the authority contained in Code Section 38-3-27, the employees shall have the same powers, duties, rights, privileges and immunities as if they were performing their duties in the political subdivisions in which they are normally employed.

#### ARTICLE VIII REIMBURSEMENT

In accordance with O.C.G.A. § 38-3-30(b), The Requesting Party shall be liable for any loss of or damage to equipment used or placed within the jurisdiction of the Requesting Party and shall pay any expense incurred in the operation and maintenance thereof. No claim for the loss, damage or expense shall be allowed unless, within 60 days after the same is sustained or incurred, an itemized notice of

the claim under oath is served by mail or otherwise upon the designated fiscal officer of the Requesting Party. Appendix B of this Agreement shall contain the name(s) of the Participating Party's designated fiscal officer for purposes of this Agreement. Appendix B can be amended by the authorizing Participating Party as needed with no effect on the entire Agreement. Appendix B can be amended by the authorizing Participating Party as needed with no effect on the entire Agreement. All such amendments to Appendix B shall be done in writing and the Participating Party shall notify GEMA/HS and all other Participating Parties of such amendment within thirty (30) days.

The Requesting Party shall also pay and reimburse the Assisting Party for the compensation paid to employees furnished by the Assisting Party during the time of the rendition of the aid, as well as the actual travel and per diem expenses of such employees while they are rendering the aid. The reimbursement shall include any amounts paid or due for compensation due to personal injury or death while the employees are engaged in rendering the aid. The term "employee," as used herein, shall mean, and this provision shall apply with equal effect to, paid, volunteer and auxiliary employees and emergency management workers.

Expenses to be reimbursed by the Requesting Party shall include the following:

- (1) Labor costs, which shall include all usual wages, salaries, compensation for hours worked, mobilization and demobilization, the Assisting Party's portion of payroll taxes (as employer), insurance, accrued paid leave and other fringe benefits, but not those amounts paid or due as a benefit to the Assisting Parties personnel under the terms of the Georgia Workers Compensation Act; and
- (2) Equipment costs, which shall include the fair rental value, the cost of fuel and other consumable supplies, service and repairs. If the equipment is damaged while in use under this Agreement and the Assisting Party receives payment for such damage under any contract for insurance, the Requesting Party may deduct such payment from any item or items invoiced; and
- (3) Material costs, which shall include the total reasonable cost for the use and consumption of any and all consumable supplies delivered by the Assisting Party for the benefit of the Requesting Party; and
- (4) Meals, lodging and other related expenses, which shall include charges for meals, lodging and other expenses relating to the provision of assistance pursuant to this Agreement shall be the actual and reasonable costs incurred by the Assisting Party.

The Assisting Party shall maintain records and submit invoices within 60 days for reimbursement as specified hereinabove and the Requesting Party shall pay the invoice no later than 30 days following the invoice date.

#### ARTICLE IX IMPLEMENTATION

This Agreement shall become operative immediately upon its approval and execution by GEMA/HS and any two political subdivisions of this State; thereafter, this Agreement shall become effective as to any other political subdivision of this State upon its approval and execution by such political subdivision.

Any Participating Party may withdraw from this Agreement by mailing notice of withdrawal, approved by the governing authority of such political subdivision, but no such withdrawal shall take effect until 30 days after the governing authority of the withdrawing political subdivision has given notice in writing of such withdrawal to the governing authorities of all other Participating Parties. Such action shall not relieve the withdrawing political subdivision from obligations assumed hereunder prior to the effective date of withdrawal.

Copies of this Agreement shall, at the time of their approval, be deposited with each of the respective Participating Parties and with GEMA/HS.

ARTICLE X  
TERM OF AGREEMENT

This Agreement, once executed, is valid until March 1, 2028. Agreement of the Participating Parties to extend the term of this agreement at any time during the last year of its original term or the last year of any subsequent four-year term shall extend the term of this agreement for four years. Each four-year extension shall constitute a separate agreement.

ARTICLE XI  
VALIDITY

If any provision of this Agreement is declared unconstitutional, or the applicability thereof to any person or circumstances is held invalid, the constitutionality of the remainder of this Agreement and the applicability thereof to other persons and circumstances shall not be affected thereby.

Agreed:

\_\_\_\_\_  
Chief Executive Officer - Signature

\_\_\_\_\_  
Chief Executive Officer – Print Name

County/Municipality: \_\_\_\_\_

Date: \_\_\_\_\_/\_\_\_\_\_/\_\_\_\_\_

\_\_\_\_\_  
GEMA/HS Director – Signature

\_\_\_\_\_  
GEMA/HS Director – Print Name

Date: \_\_\_\_\_/\_\_\_\_\_/\_\_\_\_\_







**RESOLUTION NO. 2024-\_\_\_****A RESOLUTION TO AUTHORIZE AND ENTER IN TO A STATEWIDE MUTUAL AID AND ASSISTANCE AGREEMENT.**

WHEREAS, the City of Forest Park (“City”) is a municipal corporation duly organized and existing under the laws of the State of Georgia;

WHEREAS, the City Council desires to renew its participation in the Statewide Mutual Aid and Assistance Agreement, as it is set to expire this year;

WHEREAS, the agreement provides the framework to support mutual assistance in managing an emergency or disaster occurring within any political subdivision that is a Participating Party, whether arising from natural disaster, technological hazard, human caused disaster, civil emergency, community disorders, or other significant events or homeland security activities.

THEREFORE, THE CITY COUNCIL OF THE CITY OF FOREST PARK HEREBY RESOLVES:

**SECTION 1. Approval.** The Statewide Mutual Aid and Assistance Agreement as presented to the Council on April 1, 2024 is hereby approved.

**SECTION 2. Public Record.** This document shall be maintained as a public record by the City Clerk and shall be accessible to the public during all normal business hours of the City of Forest Park.

**SECTION 3. Authorization of Execution.** The Mayor is hereby authorized to sign all documents necessary to effectuate this Resolution.

**SECTION 4. Attestation.** The City Clerk is authorized to execute, attest to, and seal any documents which may be necessary to effectuate this ordinance, subject to approval as to form by the City Attorney.

**SECTION 5. Effective Date.** This resolution shall become effective immediately upon its adoption by the Mayor and City Council of the City of Forest Park as provided in the City Charter.

[SIGNATURES WILL APPEAR ON THE FOLLOWING PAGE]

SO RESOLVED this \_\_\_\_ day of \_\_\_\_\_, 2024.

\_\_\_\_\_  
Angelyne Butler, Mayor

ATTEST:

\_\_\_\_\_  
Randi Rainey, City Clerk (SEAL)

APPROVED AS TO FORM:

\_\_\_\_\_  
City Attorney

**File Attachments for Item:**

**2. Council Discussion and Approval of an Emergency Requisition Associated with the Public Safety Building** – Planning and Community Development Department

**Background/History:**

This emergency requisition is a proposal and recommendation from Grounded Engineering Services based on a geotechnical investigation of undeveloped portions of property associated with the Gillem Public Safety Building, specifically the concrete trash dumpster located at the edge of the parking lot. The geotechnical investigation was in response to the appearance of subsidence / sinkholes on the property in areas that were outside the limits of construction and disturbance for the project. Site Mix Pressure Grouting LLC will inject cement – based, high mobility geotechnical grout through driven injections pipes and into the soils surrounding the concrete trash dumpster pad at the edge of the parking lot to protect it from sinking.



CITY OF  
**FORESTPARK**

## City Council Agenda Item

**Subject:** Discussion and Approval of an Emergency Requisition Associated with the Public Safety Building – Executive Office

**Submitted By:** James Shelby

**Date Submitted:** March 26, 2024

**Work Session Date:** April 1, 2024

**Council Meeting Date:** April 1, 2024

### Background/History:

This emergency requisition is a proposal and recommendation from Grounded Engineering Services based on a geotechnical investigation of undeveloped portions of property associated with the Gillem Public Safety Building, specifically the concrete trash dumpster located at the edge of the parking lot. The geotechnical investigation was in response to the appearance of subsidence / sinkholes on the property in areas that were outside the limits of construction and disturbance for the project. Site Mix Pressure Grouting LLC will inject cement – based, high mobility geotechnical grout through driven injections pipes and into the soils surrounding the concrete trash dumpster pad at the edge of the parking lot to protect it from sinking.

**Cost:** \$ 15,700.00

**Budgeted for:**  Yes  No

**Financial Impact:** No Financial Impact to General Fund

URA Bond 586-61-3510-54-1300

**Action Requested from Council:** Approval of an emergency requisition.

# CITY OF FOREST PARK PURCHASE REQUISITION FORM

For purchases valued \$1,000 and up

This form must be completed prior to creating a Purchase Order

<b>Department :</b>	PCD	<b>Requisition Date:</b>	3-26-24
<b>Prepared By:</b>	James Shelby		
<b>Explanation</b>			
This Requisition is for: Proposal based on a geotechnical investigation			
<input checked="" type="checkbox"/> Services	of undeveloped portions of property associated with the Gillem Public Safety building. Site mix Pressure Grouting LLC will inject cement based, into the soils under and around trash dumpster		
<input type="checkbox"/> Goods			
<input type="checkbox"/> Public Works Construction			
<input type="checkbox"/> Other	Pad - 22' x 15' - EMERGENCY		
<b>Justification for Request:</b>			
See attached <u>3</u> page(s) or _____ line item(s) and attached specifications _____ pages			

### Budget

<b>Attach proof of available funds and provide the following:</b>	
<b>Budget Line Item:</b>	586-61-3510-54-1300
<b>Funds Available:</b>	URA Bonds - COST OF GOODS SOLD 15,700.00

### Vendor

New vendors must complete the Vendor/Supplier Information Form and provide a w-9 and E-Verify Affidavit

<b>Select whether vendor is a new or current vendor of the City and provide the following:</b>	
<input checked="" type="checkbox"/> New <input type="checkbox"/> Current	<b>Vendor Name:</b> SITE MIX PRESSURE GROUTING LLC
<b>Current Vendor Number:</b>	
<b>If Statewide Contract, provide the following:</b> (Attach one quote. Three quotes are not needed)	
<b>Statewide Contract ID number:</b>	
<b>If Requisition is replacing a current Contract, provide the following:</b>	
<b>Current Contract Number:</b>	<b>Contract Expiration Date:</b>

### Solicitation

Complete this section only if a formal bid or RFP advertisement is needed.

<b>Also attach Solicitation Request Form</b>	
<b>Estimated cost of goods or services:</b>	
<b>Is cooperative purchase option available?</b>	
<b>Date goods or services are needed:</b>	

### Signatures

<b>Department Head Authorization:</b>		<b>Date:</b>	3-26-24
<b>Purchasing Authorization:</b>		<b>Date:</b>	
<b>Finance Director:</b>		<b>Date:</b>	
<b>City Manager:</b>		<b>Date:</b>	

**Instructions:**

1. Complete requisition form in its entirety. (No previous versions of the Requisition Form will be accepted)
2. Attach 3 quotes (or justification if 3 quotes could not be obtained) and proof of budgeted funds.
3. Have New Vendors to send Vendor Information Form, w-9, and E-Verify directly to [accounts payable@forestparkga.gov](mailto:accounts payable@forestparkga.gov).
4. Email Requisition form and additional documents to [procurement@forestparkga.gov](mailto:procurement@forestparkga.gov).
5. Once a fully signed requisition has been returned to you, create PO and proceed with purchase.
6. Once service is received, submit signed Requisition, Invoice, and PO to Accounts Payable (copy Procurement) for payment.

**Please complete, sign, and return Requisition Form along with all required documents to [procurement@forestparkga.gov](mailto:procurement@forestparkga.gov)**  
 Requisition will not be approved and PO will not be paid if not completed properly.



# SiteMix Pressure Grouting, LLC

2310 Perimeter Park Drive  
Atlanta, GA 30341  
770-452-0390  
SiteMixGrouting.com

March 25, 2024

TO: Grounded Engineering Services, LLC  
4148 Industry Way  
Suite E  
Flowery Branch, GA 30542  
Attn: Chris Settles, P.E.  
cjs@groundedservices.com

SUBJECT: Proposal for Pressure Grouting Under Trash Dumpster Pad

JOB SITE: 2090 Anvil Block Road, Conley GA 30260

## SCOPE OF WORK:

To inject cement-based, high-mobility geotechnical (HMG) grout through driven injection pipes and into soils under and around trash dumpster pad measuring approximately 22' x 15'. The job will take two days with the first day grouting along the perimeter of the pad to establish a grout curtain. There will be approximately 16 injections, averaging 3-8 feet in depth or until refusal. The injections will be made in order to stabilize soil and establish a grout curtain as discussed and specified. After the grout curtain is established around the perimeter of the pad a grouting course will be implemented under the pad in order to stabilize soils and increase load bearing capacity of the soils. Injections will be made through drilled holes and driven injection pipes. There will be approximately 12 injections made 3-8 feet in depth on 5-foot centers. Approximately 140-200 cubic feet required. All drilled holes will be patched with hydraulic cement. Injection rates, distances between points and depths are subject to change based on observed conditions or recommendations from Engineer.

SiteMix Pressure Grouting, LLC., hereinafter referred to as SPG, proposes to furnish:

A working crew of three (3) men including an experienced superintendent plus the following:

1. Portable grout plant that includes mixer and pump
2. 100 feet of grout hose
3. Hand tools including drills
4. Necessary water hoses and other supplies for completing the work

Grounded Engineering Services, LLC, hereinafter referred to as the Buyer, agrees to furnish free of charge to SPG:

1. Water at point of placement for mixing and clean up (3/4" water bib). There is a hydrant directly next to the pad. Customer will need to provide a meter with regulator.
2. Access to areas where work is to be performed for checking and /or performing work.



3. Identify and mark all underground structures such as water lines, gas lines, electrical lines, irrigation lines, septic tanks and all associated fixtures. SPG will not be responsible for damage to any underground structures.
4. See Contract Conditions

The work outlined above is to be performed for amounts listed below, including applicable insurance and taxes.

1. The sum of \$3,650.00 per working day (M-F, 8a-5p) will be charged for all labor, mobilization and setup. Approximately 2-3 days.
2. The sum of \$23.75 per placed cubic foot of high-mobility cementitious grout will be charged. Approximately 140-200 cubic feet.
3. Payment due Net 30

This proposal is extended through May 31, 2024

Proposal Presented By:

John Knieper, Managing Member  
SiteMix Pressure Grouting, LLC.  
2310 Perimeter Park Drive  
Atlanta, GA 30341

The above prices, specifications and conditions are satisfactory and are hereby accepted. You are authorized to perform the work as specified. Payment will be made as outlined in Contract Conditions below.

Proposal Accepted By (Print Name): \_\_\_\_\_

Signature: \_\_\_\_\_

Date: \_\_\_\_/\_\_\_\_/\_\_\_\_

A deposit of  is required prior to the scheduling or beginning any work.

**CONTRACT CONDITIONS**

**CONTRACT TIME:**

It is understood the work to be performed is in one continuous operation.

**PRIOR NEGOTIATIONS:**

All prior negotiations, proposals, correspondence and memoranda between buyer and SPG are superseded by this proposal. This proposal, in its entirety, shall be made an integral part of and incorporated into any purchase order, proposal or contract agreement resulting from it. SPG offer is subject to possible revision in Scope, Price and Terms if not accepted in writing by buyer within 30 days.

**PRE-BID INFORMATION:**

Information used in planning the work covered in this proposal has been furnished by the buyer, but SPG assumes no responsibility for its accuracy. If the conditions are not in accordance with the information furnished to SPG by buyer or others, the recommended procedures and Scope of Work of this proposal may not necessarily control, and any additional expenses incurred by SPG as a result of this difference will be reimbursed to SPG by buyer.

**HIDDEN CONDITIONS:**

It is understood that in undertaking to correct/repair conditions present, other conditions that were hidden may become known. Such consequences will be beyond SPGI's control, and assumes no responsibility for such consequences, although SPG will use the best skills and experience to avoid or minimize them.

**TERMINATION OF CONTRACT:**

If conditions exist beyond SPGI's control making it impossible for us to render performance as specified and buyer elects to terminate the contract, SPG will be entitled to a cancellation charge for any job set-up, in addition to reimbursement in full for all of SPGI's cost (including labor, materials and overhead) plus a reasonable profit for all work performed to date of written notification of termination by buyer.

**PAYMENT TERMS:**

Cash, Check or Credit Card paid in full at the job site on same day and time completed. Failure to pay as indicated renders all warranties null and void and all costs of collections and attorney's fees and court costs is the Buyer's responsibility. All amounts owed and not paid at completion of job shall be assessed a finance charge of one and one-half percent (1 1/2%) per month (18% per annum).

**LIEN RIGHTS:**

It is mutually agreed that SPG shall retain any and all rights conferred upon it by the lien status of any state, federal territorial government.



Item #2.



Page 23



Item #2.



Page 24







# NON-COMPETITIVE PROCUREMENT REQUEST

Please Check the Type of Procurement Request:

- Emergency
- Sole or Single Source

DATE: 3/27/2024

FROM: Department: Planning and Community Development  
Director/Department Head: James Shelby

TO: John Wiggins, Director of Finance  
Department of Finance – Procurement  
745 Forest Parkway, Forest Park, Georgia 30296

Requisition Number: \_\_\_\_\_  
 Suggested Supplier: Site Mix Pressure Grouting LLC  
 Description of Product/Services: Soil Stabilization and Bulk-In-Filling Grouting  
 Estimate Amount of Purchase: \$ 15,700.00

1. Explain why the product/service requested is the only product/service that can satisfy your requirements and explain alternatives that are unacceptable. Be specific with regard to specification, features, characteristics, requirements, capabilities and compatibility. Describe what steps have been undertaken.

Due to the nature of the request for sole source and emergency is in response to a geotechnical investigation of the appearance of subsidence / sinkholes on the property in areas that were outside the limits of construction and disturbance for the project. Site Mix Pressure Grouting LLC

2. Will this purchase obligate the City of Forest Park to a particular vendor for future purchases? (Either in terms of maintenance that only this vendor will be able to perform and/or if we purchase this item, will we need more “like” items in the future to match this one?)

**No. This is a service.**

3. Explain the impact to the City or Public if this Sole, Single or Emergency Source is not approved.

The emergency source will prevent the city from spending additional public funds on a concrete garbage dumpster if it damaged/destroyed by falling into a sinkhole.

Department contact for additional information: NAME: James Shelby Phone#: 404 - 201 - 1099

I hereby request that this non-competitive procurement request be approved for the procurement of the above statement of work, material, equipment, commodity, or service.

Signature: [Signature]  
(Department Head)

Date: 03/27/2024

**Do Not Write Below – Department of Finance – Procurement Only**

Procurement Officer Comments:

This procurement meets the standard for an emergency.

Approved

Disapproved

Signed: [Signature]  
John Wiggins  
 Director of Finance – Procurement

Date: 3/28/2024

**RESOLUTION NO. 2024-\_\_\_\_\_**

**A RESOLUTION TO AUTHORIZE EMERGENCY PROCUREMENT OF SERVICES FROM SITEMIX PRESSURE GROUTING, LLC TO REMEDY SUBSIDENCE AND SINKHOLES ON CITY PROPERTY.**

WHEREAS, the City of Forest Park (“City”) is a municipal corporation duly organized and existing under the laws of the State of Georgia and is charged with being fiscally responsible concerning the use and expenditure of all public funds; and

WHEREAS, a geotechnical investigation was performed on the property where the Gillem Public Safety Building is also located; and

WHEREAS, the investigation determined that it is immediately necessary to stabilize the area to avoid further subsidence and sinkholes on the property; and

WHEREAS, Sec. 3-1-44 of the City’s Code of Ordinances provides that emergency public works contracts less than \$100,000 in value do not have to comply with competitive bid award requirements; and

WHEREAS, SiteMix Pressure Grouting, LLC can perform the work for \$15,700; and

WHEREAS, this emergency procurement is necessary to protect the health, safety, and welfare of the citizens of Forest Park; and

THEREFORE, THE CITY COUNCIL OF THE CITY OF FOREST PARK HEREBY RESOLVES:

**SECTION 1. Approval of Vendor.** The proposal from SiteMix Pressure Grouting, LLC as presented to the Council on April 1, 2024, is hereby approved.

**SECTION 2. Public Record.** This document shall be maintained as a public record by the City Clerk and shall be accessible to the public during all normal business hours of the City of Forest Park.

**SECTION 3. Authorization of Execution.** The Mayor is hereby authorized to sign all documents necessary to effectuate this Resolution.

**SECTION 4. Attestation.** The City Clerk is authorized to execute, attest to, and seal any documents which may be necessary to effectuate this ordinance, subject to approval as to form by the City Attorney.

**SECTION 5. Effective Date.** This resolution shall become effective immediately upon its adoption by the Mayor and City Council of the City of Forest Park as provided in the City Charter.

SO RESOLVED this \_\_\_\_ day of \_\_\_\_\_, 2024.

\_\_\_\_\_  
Angelyne Butler, Mayor

ATTEST:

\_\_\_\_\_ (SEAL)  
City Clerk

APPROVED AS TO FORM:

\_\_\_\_\_  
City Attorney



**File Attachments for Item:**

**3. Council Discussion and Approval of the City Center Boundary Topographic and Utility Survey-**  
Planning and Community Development Department/Capital Projects

**Background/History:**

Precision Planning Inc. (PPI) is working with the City to design and prepare plans for the City Center project to include City Hall, Municipal Court, Police Headquarters and Recreation Facility. The new facility will be based on Preliminary Design drawings completed by Precision Planning, Inc. in December 2023. Falcon Design Consultants, LLC (FDC) has prepared a Task Order (TO) to assist the City of Forest Park with a boundary/topographic survey and underground utility locate for the future City Center location.



CITY OF  
**FORESTPARK**

# City Council Agenda Item

**Subject:** City Center Boundary Topographic and Utility Survey– PCD-Capital Projects

**Submitted By:** James Shelby-Project Manager

**Date Submitted:** 3-26-2024

**Work Session Date:** April 1, 2024

**Council Meeting Date:** April 1, 2024

**Background/History:**

Precision Planning Inc. (PPI) is working with the City to design and prepare plans for the City Center project to include City Hall, Municipal Court, Police Headquarters and Recreation Facility. The new facility will be based on Preliminary Design drawings completed by Precision Planning, Inc. in December 2023. Falcon Design Consultants, LLC (FDC) has prepared a Task Order (TO) to assist the City of Forest Park with a boundary/topographic survey and underground utility locate for the future City Center location.

**Cost: \$ 15,250.00**

**Budgeted for:**  X  Yes   No

**No Impact on the General Funds**

2015 SPLOST: 325-22-1510-54-2502

**Action Requested from Council:**

Approval of a Task Order for Falcon Design Consultants, LLC to prepared a Task Order (TO) to assist the City of Forest Park with a boundary/topographic survey and underground utility locate for the future City Center location.

**Task Order FDC 2024.03**

To: City of Forest Park  
 745 Forest Pkwy.  
 Forest Park, GA 30297  
 Attn: Mr. James Shelby

Date: March 13, 2024  
 From: Falcon Design Consultants, LLC

Project: **City Center**  
 TO No.: **FDC 2024.03**

**Background Information and Project Scope**

*Falcon Design Consultants, LLC (FDC)* has prepared this Task Order (TO) to assist the City of Forest Park with a boundary/topographic survey and underground utility locate for the future City Center location.

**Task – A. Boundary/Topographic Survey**

- Work to include field work and office time to complete boundary survey.
- Work to be performed using Georgia Plat Standards.
- Work to include field run topographic data.

**Task – B. Underground Utility Locate**

- Survey crew will survey locate the painted underground utilities.
- Work performed by Utility Marking, LLC.

**Fee Estimate**

The budget below includes staff time and expenses necessary to perform the scope of work outlined above. This budget is for the scope of work referenced above.

<b><u>Design and Bid Services:</u></b>	<b><u>Estimated Budget</u></b>
A. Boundary/Topographic Survey:	\$9,500.00
B. Underground Utility Locate:	\$5,750.00
<b>TOTAL LUMP SUM FEE</b>	<b>\$15,250.00</b>

**Authorized:**

As our authorization to proceed with the scope of work, schedule and fee structure outlined herein, please sign in the space provided below and return one copy to this office for our records.

**AUTHORIZATION TO PROCEED – THIS TASK ORDER ONLY**

Authorized by: \_\_\_\_\_ Title: \_\_\_\_\_  
 Print Name: \_\_\_\_\_ Date: \_\_\_\_\_

**Approved for Funding**

Authorized by: \_\_\_\_\_ Title: \_\_\_\_\_  
 Print Name: \_\_\_\_\_ Date: \_\_\_\_\_

Budget Line Item # \_\_\_\_\_

**Task Order FDC 2024.03**

Authorized by: 

Title: Managing Partner

Print Name: Adam Price, P.E.

Date: 03/13/2024

**RESOLUTION NO. 2024-\_\_\_\_\_**

**A RESOLUTION TO AUTHORIZE THE ISSUANCE OF A TASK ORDER TO FALCON DESIGN CONSULTANTS LLC TO LOCATE UNDERGROUND UTILITIES AND COMPLETE A BOUNDARY AND TOPOGRAPHIC SURVEY FOR CITY CENTER PROJECT.**

WHEREAS, the City of Forest Park (“City”) is a municipal corporation duly organized and existing under the laws of the State of Georgia and is charged with being fiscally responsible concerning the use and expenditure of all public funds; and

WHEREAS, the City desires to issue a task order to Falcon Design Consultants, LLC to locate underground utilities and complete a boundary and topographic survey for the future City Center location.

THEREFORE, THE CITY COUNCIL OF THE CITY OF FOREST PARK HEREBY RESOLVES:

**SECTION 1. Approval of Vendor.** Falcon Design Consultants, LLC’s task order to locate underground utilities and prepare a boundary and topographic survey (Task Order FDC 2024.03) as presented to the Council on April 1, 2024, is hereby approved. Work shall commence upon the issuance of a notice to proceed from the City.

**SECTION 2. Public Record.** This document shall be maintained as a public record by the City Clerk and shall be accessible to the public during all normal business hours of the City of Forest Park.

**SECTION 3. Authorization of Execution.** The Mayor is hereby authorized to sign all documents necessary to effectuate this Resolution.

**SECTION 4. Attestation.** The City Clerk is authorized to execute, attest to, and seal any documents which may be necessary to effectuate this ordinance, subject to approval as to form by the City Attorney.

**SECTION 5. Effective Date.** This resolution shall become effective immediately upon its adoption by the Mayor and City Council of the City of Forest Park as provided in the City Charter.

[SIGNATURES APPEAR ON FOLLOWING PAGE]

SO RESOLVED this 4th day of March, 2024.

\_\_\_\_\_  
Angelyne Butler, Mayor

ATTEST:

\_\_\_\_\_  
City Clerk (SEAL)

APPROVED AS TO FORM:

\_\_\_\_\_  
City Attorney

**File Attachments for Item:**

**4. Council Discussion and Approval to upfit seventeen (17) Police Vehicles- Police Department**

**Background/History:**

Due to an aging fleet, Mayor and Council approved for the police department to purchase new patrol vehicles. Once the aforementioned vehicles were acquired, the vehicles were in need of being upfitted with equipment. The equipment installed on the vehicles will include, but not limited to: emergency lights, emergency sirens, storage racks, computer mounts, etc.

The Forest Park Police Department intends to proceed with HG2, a vendor already serving the city of Forest Park, to carry out the installation. The funding for this upfit, totaling \$241,043.00, has already been approved as part of the Capital Improvements Vehicles budget.



CITY OF  
**FORESTPARK**

# City Council Agenda Item

Council Discussion and Approval to upfit 17 Police Vehicles

**Subject:**

**Submitted By:** Brandon Criss (Police Chief)

**Date Submitted:** March 26, 2024

**Work Session Date:** April 1, 2024

**Council Meeting Date:** April 1, 2024

**Background/History:**

Due to an aging fleet, Mayor and Council approved for the police department to purchase new patrol vehicles. Once the aforementioned vehicles were acquired, the vehicles were in need of being upfitted with equipment. The equipment installed on the vehicles will include, but not limited to: emergency lights, emergency sirens, storage racks, computer mounts, etc.

The Forest Park Police Department intends to proceed with HG2, a vendor already serving the city of Forest Park, to carry out the installation. The funding for this upfit, totaling \$241,043.00, has already been approved as part of the Capital Improvements budget.

**Cost: \$**

\$241,043.00

**Budgeted for:** X    **Yes**    **No**

\_\_\_\_\_

**Financial Impact:** \$241,043.00

**Action Requested from Council: Vote for Approval**





HG2 Emergency Lighting  
 20962 Sheridan St  
 Fort Lauderdale FL 33332

Inv Item #4.

Date	Invoice No.
03/12/24	4456

407-426-7700  
 sales@hg2lighting.com

407-426-7700  
 www.hg2lighting.com

Bill To
Forest Park Police Dept

Ship To

P.O. Number	Terms	REP	Vehicle	Vin#

Item	Description	Quantity	Rate	Amount
Misc	Whelen Legacy 54" Core	1	0.00	0.00
Rear Visor	Rear Visor Blue/White 2022 Ford PI Utility	1	0.00	0.00T
Misc	Whelen Core Controler Remote Head	1	0.00	0.00
Misc	OBD Intergration Cable	1	0.00	0.00
Misc	Expansion Module 24 Channel	1	0.00	0.00
Misc	100 Watt Speaker	1	0.00	0.00
Misc	Rumbler Low Frequency Siren with Brackets	1	0.00	0.00
Misc	BlueWhite Under Mirror Lights	1	0.00	0.00
Misc	Blue/White Tag Lights	1	0.00	0.00
Misc	Push Bumper with 4 Light Channel	1	0.00	0.00
Misc	Full Prisoner Transport Cage with Door Panels and Window Bars	1	0.00	0.00
Misc	Center Console with Cup Holder arm Rest and Built in Printer Mount	1	0.00	0.00
MagMic	Magnetic Mic	2	0.00	0.00T
Misc	Dual Weapon Mount	1	0.00	0.00
Misc	Brother Pocketjet printer with USB Cable and Power Cord	1	0.00	0.00
Misc	Laptop Stand with Universal Cradle	1	0.00	0.00
Labor	Labor/Installation		0.00	0.00T
Misc	Bundle Package Price Contract	17	14,179.00	241,043.00

Subtotal	\$241,043.00
Sales Tax (0.0%)	\$0.00
<b>Total</b>	<b>\$241,043.00</b>

**File Attachments for Item:**

**5. Council Discussion and Approval to Purchase seven (7) portable Radios for the Police Department**-Police Department

**Background/History:**

The Forest Park Police Department has 95 sworn positions allocated to it. When the portable radios were initially ordered a few years ago, the order did not cover all the sworn positions, nor did it factor in potential losses or damages to equipment. With all allotted positions now spoken for, the police department needs additional radios for incoming police officers and radios to keep as a spare.

Therefore, the department requests approval to purchase seven (7) extra portable radios to meet its equipment requirements.



CITY OF  
**FORESTPARK**

# City Council Agenda Item

**Subject:** Council Discussion and Approval to Purchase 7 portable Radios for the Police Department

**Submitted By:** Brandon Criss (Police Chief)

**Date Submitted:** March 26,2024

**Work Session Date:** April 1, 2024

**Council Meeting Date:** April 1, 2024

**Background/History:**

The Forest Park Police Department has 95 sworn positions allocated to it. When the portable radios were initially ordered a few years ago, the order did not cover all the sworn positions, nor did it factor in potential losses or damages to equipment. With all allotted positions now spoken for, the police department needs additional radios for incoming police officers and radios to keep as a spare.

Therefore, the department requests approval to purchase 7 extra portable radios to meet its equipment requirements.

<b>Cost: \$</b>	<b>Budgeted for:</b>	<input checked="" type="checkbox"/>	<b>Yes</b>	<input type="checkbox"/>	<b>No</b>
39,148		_____	_____	_____	

**Financial Impact: \$39,148**

**Action Requested from Council: Vote for Approval**

RESOLUTION NO. 2024-\_\_\_\_\_

**A RESOLUTION TO AUTHORIZE THE PURCHASE OF SEVEN (7) PORTABLE RADIOS FOR THE FOREST PARK POLICE DEPARTMENT.**

WHEREAS, the City of Forest Park (“City”) is a municipal corporation duly organized and existing under the laws of the State of Georgia and is charged with being fiscally responsible concerning the use and expenditure of all public funds; and

WHEREAS, the City’s Police Department requires additional portable radios for its incoming police officers; and

WHEREAS, pursuant to Sec. 3-1-9(b)(3) of the City’s Code of Ordinances, competitive bids are not required for purchases made pursuant to a state contract; and

WHEREAS, the State of Georgia has an existing contract with Motorola Solutions (Contract No. 99999-SPD0000172-011) under which the City can purchase the portable radios;

WHEREAS, this equipment is necessary to protect the health, safety, and welfare of the citizens of Forest Park; and

THEREFORE, THE CITY COUNCIL OF THE CITY OF FOREST PARK HEREBY RESOLVES:

**SECTION 1. Approval of Vendor.** The quote from Motorola Solutions for portable radios as presented to the Council on April 1, 2024, is hereby approved.

**SECTION 2. Public Record.** This document shall be maintained as a public record by the City Clerk and shall be accessible to the public during all normal business hours of the City of Forest Park.

**SECTION 3. Authorization of Execution.** The Mayor is hereby authorized to sign all documents necessary to effectuate this Resolution.

**SECTION 4. Attestation.** The City Clerk is authorized to execute, attest to, and seal any documents which may be necessary to effectuate this ordinance, subject to approval as to form by the City Attorney.

**SECTION 5. Effective Date.** This resolution shall become effective immediately upon its adoption by the Mayor and City Council of the City of Forest Park as provided in the City Charter.

SO RESOLVED this \_\_\_\_ day of \_\_\_\_\_, 2024.

\_\_\_\_\_  
Angelyne Butler, Mayor

ATTEST:

\_\_\_\_\_  
(SEAL)  
City Clerk

APPROVED AS TO FORM:

---

City Attorney

# CITY OF FOREST PARK PURCHASE REQUISITION FORM

For purchases valued \$1,000 and up

This form must be completed prior to creating a Purchase Order

<b>Department :</b>	Police	<b>Requisition Date:</b>	3/26/2024
<b>Prepared By:</b>	Lakeya Payton		

### Explanation

This Requisition is for: New radios for the police department.

Services

Goods

Public Works Construction

Other \_\_\_\_\_

### Justification for Request:

See attached \_\_\_\_\_ page(s) or \_\_\_\_\_ line item(s) and attached specifications \_\_\_\_\_ pages

### Budget

#### Attach proof of available funds and provide the following:

Budget Line Item:	100-31-3210-53-1711
Funds Available:	\$43,304.91

### Vendor

New vendors must complete the Vendor/Supplier Information Form and provide a w-9 and E-Verify Affidavit.

#### Select whether vendor is a new or current vendor of the City and provide the following:

<input type="checkbox"/> New	<input checked="" type="checkbox"/> Current	Vendor Name:	MOTOROLA SOLUTIONS
		Current Vendor Number:	026969
<b>If Statewide Contract, provide the following:</b> (Attach one quote. Three quotes are not needed)			
		Statewide Contract ID number:	99999-SPD0000172-011
<b>If Requisition is replacing a current Contract, provide the following:</b>			
		Current Contract Number:	Contract Expiration Date:

### Solicitation

Complete this section only if a formal bid or RFP advertisement is needed.

#### Also attach Solicitation Request Form

Estimated cost of goods or services:	\$39,148.20
Is cooperative purchase option available?	
Date goods or services are needed:	

### Signatures

<b>Department Head Authorization:</b>		Date:	3/26/24
<b>Purchasing Authorization:</b>		Date:	
<b>Finance Director:</b>		Date:	
<b>City Manager:</b>		Date:	

**Instructions:**

1. Complete requisition form in its entirety. (No previous versions of the Requisition Form will be accepted)
2. Attach 3 quotes (or justification if 3 quotes could not be obtained) and proof of budgeted funds.
3. Have New Vendors to send Vendor Information Form, w-9, and E-Verify directly to [accountspayable@forestparkga.gov](mailto:accountspayable@forestparkga.gov).
4. Email Requisition form and additional documents to [procurement@forestparkga.gov](mailto:procurement@forestparkga.gov).
5. Once a fully signed requisition has been returned to you, create PO and proceed with purchase.
6. Once service is received, submit signed Requisition, Invoice, and PO to Accounts Payable (copy Procurement) for payment.

**Please complete, sign, and return Requisition Form along with all required documents to [procurement@forestparkga.gov](mailto:procurement@forestparkga.gov)**  
 Requisition will not be approved and PO will not be paid if not completed properly.



THE CITY OF FOREST PARK  
 FOREST PARK  
 GEORGIA



Radio  
026969

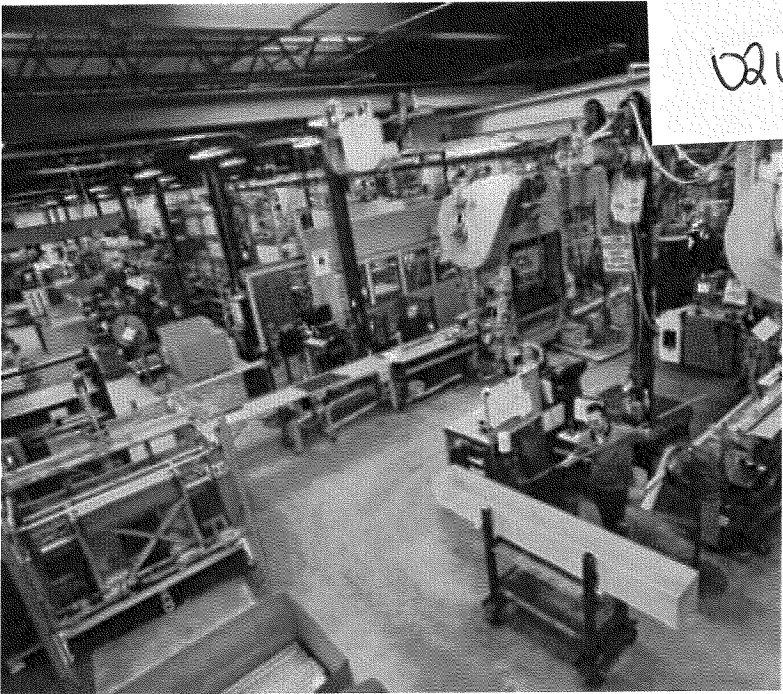

FOREST PARK, CITY OF

03/20/2024



03/20/2024

FOREST PARK, CITY OF  
4539 JONESBORO RD  
FOREST PARK, GA 30297

Dear Lowens,

Motorola Solutions is pleased to present FOREST PARK, CITY OF with this quote for quality communications equipment and services. The development of this quote provided us the opportunity to evaluate your requirements and propose a solution to best fulfill your communications needs.

This information is provided to assist you in your evaluation process. Our goal is to provide FOREST PARK, CITY OF with the best products and services available in the communications industry. Please direct any questions to Dena Nunz at [dena.nunz@deirr.com](mailto:dena.nunz@deirr.com).

We thank you for the opportunity to provide you with premier communications and look forward to your review and feedback regarding this quote.

Sincerely,

Dena Nunz

Motorola Solutions Manufacturer's Representative





Billing Address:  
 FOREST PARK, CITY OF  
 4539 JONESBORO RD  
 FOREST PARK, GA 30297  
 US

Quote Date:03/20/2024  
 Expiration Date:05/19/2024  
 Quote Created By:  
 Dena Nunz  
 dena.nunz@deirr.com

End Customer:  
 FOREST PARK, CITY OF  
 Lowens

Line #	Item Number	Description	Qty	List Price	Sale Price	Ext. Sale Price
	APX™ 6000 Series	APX6000				
1	H98UCF9PW6BN	APX6000 700/800 MODEL 2.5 PORTABLE	7	\$3,595.00	\$2,624.35	\$18,370.45
1a	H869BZ	ENH: MULTIKEY	7	\$363.00	\$264.99	\$1,854.93
1b	Q361AR	ADD: P25 9600 BAUD TRUNKING	7	\$330.00	\$240.90	\$1,686.30
1c	QA00580AC	ADD: TDMA OPERATION	7	\$495.00	\$361.35	\$2,529.45
1d	QA05100AA	ENH: STD 1 YR WARRANTY APPLIES NO SFS	7	\$0.00	\$0.00	\$0.00
1e	H38BT	ADD: SMARTZONE OPERATION	7	\$1,320.00	\$963.60	\$6,745.20
1f	QA09113AB	ADD: BASELINE RELEASE SW	7	\$0.00	\$0.00	\$0.00
1g	Q806BM	ADD: ASTRO DIGITAL CAI OPERATION	7	\$567.00	\$413.91	\$2,897.37
1h	Q629AK	ENH: AES ENCRYPTION AND ADP	7	\$523.00	\$381.79	\$2,672.53
2	LSV00Q00202A	DEVICE PROGRAMMING	7	\$121.43	\$121.43	\$850.01
3	NNTN8860B	CHARGER, SINGLE-UNIT, IMPRES 2, 3A, 115VAC, US/NA	7	\$186.50	\$136.15	\$953.05
4	PMMN4065AL	MICROPHONE,IMPRES RSM, IP57	7	\$115.24	\$84.13	\$588.91

Grand Total

\$39,148.20(USD)



Any sales transaction following Motorola's quote is based on and subject to the terms and conditions of the valid and executed written contract between Customer and Motorola (the "Underlying Agreement") that authorizes Customer to purchase equipment and/or services or license software (collectively "Products"). If no Underlying Agreement exists between Motorola and Customer, then Motorola's Standard Terms of Use and Motorola's Standard Terms and Conditions of Sales and Supply shall govern the purchase of the Products.  
 Motorola Solutions, Inc.: 500 West Monroe, United States - 60661 ~ #: 36-1115800

**Notes:**

- Unless otherwise noted, this quote excludes sales tax or other applicable taxes (such as Goods and Services Tax, sales tax, Value Added Tax and other taxes of a similar nature). Any tax the customer is subject to will be added to invoices.

DRAFT



Any sales transaction following Motorola's quote is based on and subject to the terms and conditions of the valid and executed written contract between Customer and Motorola (the "Underlying Agreement") that authorizes Customer to purchase equipment and/or services or license software (collectively "Products"). If no Underlying Agreement exists between Motorola and Customer, then Motorola's Standard Terms of Use and Motorola's Standard Terms and Conditions of Sales and Supply shall govern the purchase of the Products.

Motorola Solutions, Inc.: 500 West Monroe, United States - 60661 ~ #: 36-1115800



<b>Purchase Order Checklist</b>	
<b>Marked as PO/ Contract/ Notice to Proceed on Company Letterhead</b> (PO will not be processed without this)	
<b>PO Number/ Contract Number</b>	
<b>PO Date</b>	
<b>Vendor = Motorola Solutions, Inc.</b>	
<b>Payment (Billing) Terms/ State Contract Number</b>	
<b>Bill-To Name on PO must be equal to the Legal Bill-To Name</b>	
<b>Bill-To Address</b>	
<b>Ship-To Address (If we are shipping to a MR location, it must be documented on PO)</b>	
<b>Ultimate Address (If the Ship-To address is the MR location then the Ultimate Destination address must be documented on PO )</b>	
<b>PO Amount must be equal to or greater than Order Total</b>	
<b>Non-Editable Format (Word/ Excel templates cannot be accepted)</b>	
<b>Bill To Contact Name &amp; Phone # and EMAIL for customer accounts payable dept</b>	
<b>Ship To Contact Name &amp; Phone #</b>	
<b>Tax Exemption Status</b>	
<b>Signatures (As required)</b>	

**File Attachments for Item:**

**6. Council Discussion and Approval to purchase one (1) Police Vehicle-Police Department**

**Background/History:**

Historically, vehicle acquisitions were tailored to meet staffing needs, but due to the recent decrease in vacancies and the recent loss of a vehicle, the existing fleet does not align with the current requirements. At present, all positions (excluding the deputy chief position) are spoken for in the Police Department.

The Forest Park Police Department is aiming to procure 1 Dodge Challenger at a total cost of \$47,140. The funds for this purchase has already been approved via Capital Improvements. This investment is intended to address immediate vehicle needs, align with the current staffing levels, and contribute to the overarching mission of the police department.



CITY OF  
**FORESTPARK**

# City Council Agenda Item

**Subject:** Council Discussion and Approval to purchase 1 Police Vehicle

**Submitted By:** Brandon Criss (Police Chief)

**Date Submitted:** March 26, 2024

**Work Session Date:** April 1, 2024

**Council Meeting Date:** April 1, 2024

**Background/History:**

Historically, vehicle acquisitions were tailored to meet staffing needs, but due to the recent decrease in vacancies and the recent loss of a vehicle, the existing fleet does not align with the current requirements. At present, all positions (excluding the deputy chief position) are spoken for in the Police Department.

The Forest Park Police Department is aiming to procure 1 Dodge Challenger at a total cost of \$47,140. The funds for this purchase has already been approved via Capital Improvements. This investment is intended to address immediate vehicle needs, align with the current staffing levels, and contribute to the overarching mission of the police department.

<b>Cost: \$</b>	<b>Budgeted for:</b>	<input checked="" type="checkbox"/>	<input type="checkbox"/>	<input type="checkbox"/>
47140		_____	_____	

**Financial Impact: \$47,140**

**Action Requested from Council: Vote for Approval**

# CITY OF FOREST PARK PURCHASE REQUISITION FORM

**For purchases valued \$1,000 and up**

This form must be completed prior to creating a Purchase Order

<b>Department :</b>	Police	<b>Requisition Date:</b>	03/04/2024
<b>Prepared By:</b>	L.E. Owens		

Explanation	
This Requisition is for:	(1) 2023 Dodge Challenger for use at the Police Department
<input type="checkbox"/> Services	
<input checked="" type="checkbox"/> Goods	(3) Quotes attached, item is not on statewide contract
<input type="checkbox"/> Public Works Construction	
<input type="checkbox"/> Other _____	

Justification for Request:
See attached _____ page(s) or _____ line item(s) and attached specifications _____ pages

Budget	
Attach proof of available funds and provide the following:	
Budget Line Item:	300-31-3210-54-2502
Funds Available:	\$333,884.00

Vendor			
New vendors must complete the Vendor/Supplier Information Form and provide a w-9 and E-Verify Affidavit.			
Select whether vendor is a new or current vendor of the City and provide the following:			
<input checked="" type="checkbox"/> New	<input type="checkbox"/> Current	Vendor Name:	Five Star CDJR of Warner Robbins
Current Vendor Number:			
If Statewide Contract, provide the following: (Attach one quote. Three quotes are not needed)			
Statewide Contract ID number:			
If Requisition is replacing a current Contract, provide the following:			
Current Contract Number:		Contract Expiration Date:	

Solicitation	
Complete this section only if a formal bid or RFP advertisement is needed.	
Also attach Solicitation Request Form	
Estimated cost of goods or services:	
Is cooperative purchase option available?	
Date goods or services are needed:	

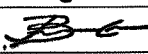
Signatures			
Department Head Authorization:		Date:	3/4/24
Purchasing Authorization:		Date:	
Finance Director:		Date:	
City Manager:		Date:	

**Instructions:**

1. Complete requisition form in its entirety. (No previous versions of the Requisition Form will be accepted)
2. Attach 3 quotes (or justification if 3 quotes could not be obtained) and proof of budgeted funds.
3. Have New Vendors to send Vendor Information Form, w-9, and E-Verify directly to [accountspayable@forestparkga.gov](mailto:accountspayable@forestparkga.gov).
4. Email Requisition form and additional documents to [procurement@forestparkga.gov](mailto:procurement@forestparkga.gov).
5. Once a fully signed requisition has been returned to you, create PO and proceed with purchase.
6. Once service is received, submit signed Requisition, Invoice, and PO to Accounts Payable (copy Procurement) for payment.

**Please complete, sign, and return Requisition Form along with all required documents to [procurement@forestparkga.gov](mailto:procurement@forestparkga.gov)**  
**Requisition will not be approved and PO will not be paid if not completed properly.**



# Five Star CDJR of Warner Robins

Date: 3/4/2024  
Salesperson: \_\_\_\_\_  
Manager: Christian Salinas

## FOR INTERNAL USE ONLY

**CUSTOMER**      CITY OF FOREST PARK POLICE DEPT      Home Phone : \_\_\_\_\_

Address : \_\_\_\_\_      Work Phone : \_\_\_\_\_

E-Mail : \_\_\_\_\_      Cell Phone : \_\_\_\_\_

### VEHICLE

Stock # : 526183      New / Used : **New**      VIN : 2C3CDZFJ9PH668380      Mileage: 37  
Vehicle : 2023 Dodge Challenger      Color : White Knuckle C  
Type : R/T Scat Pack 2dr Rear-Wheel Drive      LADX22

Market Value Selling Price	51,455.00
Discount	3,087.00
Rebate	2,000.00
Adjusted Price	46,368.00
Dealer Service Charge	799.00
Non Tax Fees	3.00
Cash Deposit	.00
Balance	47,170.00

Customer Approval: \_\_\_\_\_ Management Approval: \_\_\_\_\_

By signing this authorization form, you certify that the above personal information is correct and accurate, and authorize the release of credit and employment information. By signing above, I provide to the dealership and its affiliates consent to communicate with me about my vehicle or any future vehicles using electronic, verbal and written communications including but not limited to eMail, text messaging, SMS, phone calls and direct mail. Terms and Conditions subject to credit approval. For Information Only. This is not an offer or contract for sale.

Type Comments Here:



Item #6.

Date: 3/4/2024  
Salesperson: Curtis Weaver  
Manager: Brad Campbell

**FOR INTERNAL USE ONLY**

**CUSTOMER** Mr. Loyd Owens Home Phone : (404) 308-4700  
Address : \_\_\_\_\_ Work Phone : \_\_\_\_\_  
E-Mail : lowens@forestparkga.gov Cell Phone : (404) 308-4700

**VEHICLE**  
Stock # : PH678082 New / Used : **New** VIN : 2C3CDZFJ7PH678082 Mileage: 10  
Vehicle : 2023 Dodge Challenger Color : White Knuckle C  
Type : R/T Scat Pack 2dr Rear-Wheel Drive LADX22

Market Value Selling Price	51,455.00
Discount	2,058.00
Rebate	2,000.00
Adjusted Price	47,397.00
Dealer Service Charge	799.00
Non Tax Fees	41.00
Cash Deposit	.00
Balance	48,237.00

Customer Approval: \_\_\_\_\_ Management Approval: \_\_\_\_\_  
By signing this authorization form, you certify that the above personal information is correct and accurate, and authorize the release of credit and employment information. By signing above, I provide to the dealership and its affiliates consent to communicate with me about my vehicle or any future vehicles using electronic, verbal and written communications including but not limited to eMail, text messaging, SMS, phone calls and direct mail. Terms and Conditions subject to credit approval. For Information Only. This is not an offer or contract for sale.

Type Comments Here:

[Empty box for comments]



Item #6.



Date/Time: 3/4/2024 1:59:34 PM  
Buyer: Cap Owens  
Home Phone: (404) 308-4700  
Cell Phone: (404) 308-4700  
Address: Forest Park, GA 30297

Salesperson: Abez-Ike Redwood

2023 Dodge Challenger R/T Scat Pack L323031



VIN: 2C3CDZFJ3PH587360  
Odometer: 11  
Color: White Knuckle Clearcoat  
Body Type: 2dr Car

MSRP/Retail	\$53,740.00
Total Savings + Rebate	\$2,000.00
Selling price with Savings	\$51,740.00
Trade Allowance	0.00
Trade Payoff	0.00
Government Fee	\$122.00
Proc/Doc Fee	\$599.99
Total Taxes	0.00
Cash Down	0.00
Amount Financed	\$52,461.99

X \_\_\_\_\_  
Customer Signature Date

X \_\_\_\_\_  
Manager Signature Date

**File Attachments for Item:**

**7. Council Discussion and Approval for the Purchase of Playground Equipment for Pocket Parks-**  
Public Works Department

**Background/History:**

In line with our ongoing efforts to enhance the parks throughout the City, staff is presenting a proposal for the purchase of new playground equipment for the pocket parks located in Wards 3, 4, and 5. The details of the proposal are outlined below:

Proposal Details:

Total Cost: \$275,271.25

Allocation by Ward:

Ward #3 – Theater Park: \$68,817.81

Ward #4 – Perkins Park: \$68,817.81

Ward #4 – Second St Park: \$68,817.81

Ward #5 – Alder Park: \$68,817.81

Components of Playground Equipment: Each playground equipment consists of over 13 unique components directly attached to the main playground structure, offering various play experiences for children.

Additional Equipment: ADA compliant Single Spigot water fountain (except Alder Park, due to lack of water source).

Recycled 6' plastic bench.

Plastic border timbers and 1 ADA border half ramp for each site (this holds mulch in place).

Loose fill rubber mulch (to be installed on top of existing mulch, providing cost savings to the City).

Contract Details: The proposed purchasing agreement is with PlaySouth Playground Creator, under the following contract:

Burke Sourcewell Contract #010521-BUR

Forest Park member #77837

Funding: The funding for this proposal will be drawn from each Ward's Project line item to cover the total cost.

Conclusion: This proposal includes all materials and labor, excluding the water fountains, which will be replaced by Public Works upon delivery. The initiative aims to provide safe and engaging play spaces for children across the City.



CITY OF  
**FORESTPARK**

## City Council Agenda Item

**Title of Agenda Item:** Proposal for Purchase of Playground Equipment for Pocket Parks

**Submitted By:** Nigel Wattley

**Date Submitted:** 3-28-2024

**Work Session Date:** 3-28-2024

**Council Meeting Date:** 4-1-2024

### Background/History:

In line with our ongoing efforts to enhance the parks throughout the City, staff is presenting a proposal for the purchase of new playground equipment for the pocket parks located in Wards 3, 4, and 5. The details of the proposal are outlined below:

#### Proposal Details:

- Total Cost: \$275,271.25
- Allocation by Ward:
  - Ward #3 – Theater Park: \$68,817.81
  - Ward #4 – Perkins Park: \$68,817.81
  - Ward #4 – Second St Park: \$68,817.81
  - Ward #5 – Alder Park: \$68,817.81

#### Components of Playground Equipment:

- Each playground equipment consists of over 13 unique components directly attached to the main playground structure, offering various play experiences for children.
- Additional Equipment:
  - ADA compliant Single Spigot water fountain (except Alder Park, due to lack of water source)
  - Recycled 6' plastic bench.
  - Plastic border timbers and 1 ADA border half ramp for each site (this holds mulch in place)
  - Loose fill rubber mulch (to be installed on top of existing mulch, providing cost savings to the City)

#### Contract Details:

- The proposed purchasing agreement is with PlaySouth Playground Creator, under the following contract:
  - Burke Sourcewell Contract #010521-BUR
  - Forest Park member #77837

#### Funding:

- The funding for this proposal will be drawn from each Ward's Project line item to cover the total cost.

Conclusion: This proposal includes all materials and labor, excluding the water fountains, which will be replaced by Public Works upon delivery. The initiative aims to provide safe and engaging play spaces for children across the City.

---

**Action Requested from Council:**

Consideration and Approval to enter into a contract.

---

**Cost:** \$ 275,271.25

**Budgeted for:**  X  **Yes**   **No**

**Financial Impact:**

---

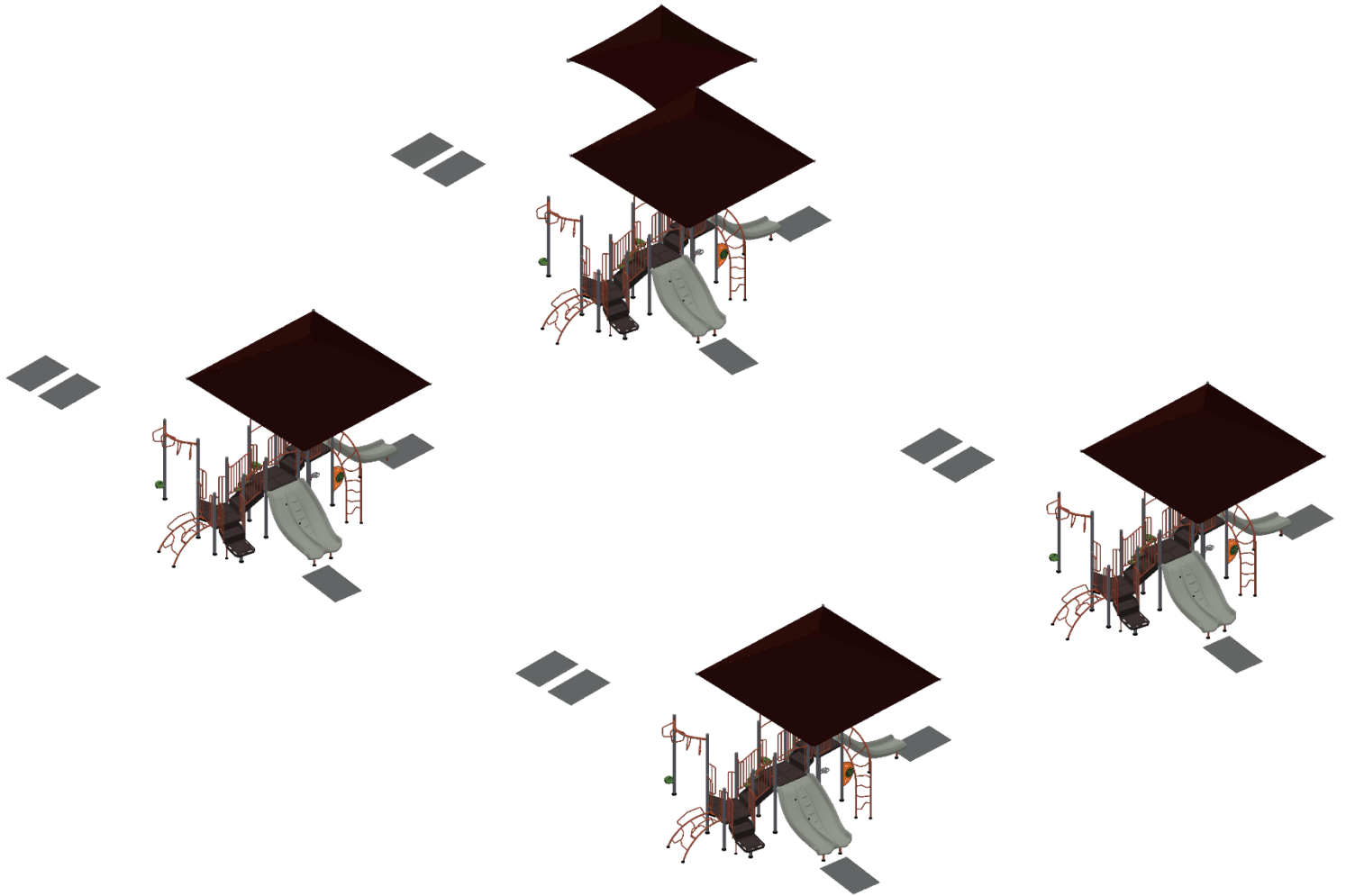

PlaySouth Playground Creators

PO Box 492467 | Atlanta, GA 30349 | 770-719-9005

Proposal 132-181806-1 | 3/11/2024





PO Box 492467  
 Atlanta, GA 30349  
 (770) 719-9005

Date: **3.13.2024**  
 Quote #: **FP3.24.01**  
 Rep: Tom Bengtson  
 Direct: (770) 823-8487

Item #7.

**QUOTATION**

	Bill to:	Ship to:
Name	City of Forest Park	Forest Park Public Works
Address	745 Forest Pkwy	5230 Jones Rd.
City, State Zip	Forest Park, GA 30297	Forest Park, GA 30297
Contact/Phone	Nigel Wattely (404)608-2310	
Email	<a href="mailto:nwattely@forestparkga.gov">nwattely@forestparkga.gov</a>	County: Clayton

Qty	Model Number	Description	Unit Price	TOTAL AMOUNT
1	132-181806-1	4 x SY-3007, 12'x12'x8'H single post shade, 16 x swing/slide mats		\$ 169,345.00
3	GRK85	<b>OPEN MARKET:</b> Single Spigot Water Fountain (Delivered, Not Installed) <i>Pricing on Open Market Items below includes Freight and Installation</i>		\$ 15,450.00
4	RPBCH	Recycled plastic bench (6') w/ back (grey seat/back, black post/frame)		\$ 3,800.00
1	APS4	Plastic border timbers (4'x8"H) and 1 x ADA border half ramp for each site		\$ 18,750.00
1	LFRLMCH	Loose fill rubber mulch (Brown) Installed to add 2" depth to existing mulch.		\$ 27,000.00
				<b>Less Sourcewell Contract Discount</b>
				<b>\$ (25,401.75)</b>
<p><b>Burke Sourcewell Contract #010521-BUR</b>  <b>Forest Park member #: 77837</b></p> <p><b>Notes to Customer:</b> All site prep to be performed by customer.          Playground sites require a 1% gradient of compact soil.          Existing mulch must be moved/removed from install site.          All equipment and mulch to be staged and delivered to Public Works warehouse.          Customer to deliver all equipment and mulch to each site/park as needed.</p> <p><b>NOTES:</b>          *This quote is valid for 30 days only. Please allow 12-14 weeks lead time for production, transit and installation.          **Please return this signed quote along with the official Purchase Order. The balance is due in full within 30 days after delivery.          *Care will be taken, but PlaySouth is not responsible for landscaping and grass that is accidentally damaged during this construction project.          * Any necessary utility relocation is sole responsibility of the customer. Please locate utilities prior to ordering equipment.          * Pricing does not include permitting if required by city. Any permits will be responsibility of the customer.</p>				

SubTotal \$ 208,943.25

Freight \$ 6,950.00

**COLORS:**

NEED INFO  
 \_\_\_\_\_  
 \_\_\_\_\_  
 \_\_\_\_\_  
 \_\_\_\_\_  
 \_\_\_\_\_

Sales Tax Rate	
Installation (Burke Only)	\$ 59,378.00
<b>GRAND TOTAL</b>	<b>\$ 275,271.25</b>

Authorized signature & date:

**Your signature, date and color selections must be completed above for order acceptance.**  
**Full payment is due within 30 days after completion. Standard rock clause will apply to installation services.**

**Thank you for considering PlaySouth Playground Creators!!**





**COLOR KEY**

- CHARCOAL
- REDWOOD
- ORANGE
- GRANITE
- OLIVE/BLACK











March 11, 2024

Nigel Wattley  
Forest Park  
745 Forest Pkwy  
Forest Park, GA 30297  
Phone: (470) 898-4130

Dear Nigel Wattley:

PlaySouth Playground Creators is delighted to provide Forest Park with this playground equipment proposal.

This design was developed with your specific needs in mind, and we look forward to discussing this project further with you to ensure your complete satisfaction. PlaySouth Playground Creators is confident that this proposal will satisfy Forest Park's functional, environmental, and safety requirements -- and most importantly -- bring joy and excitement to the children and families directly benefiting from your new playground.

You have our personal commitment to support this project and your organization in every manner possible, and we look forward to developing a long-standing relationship with Forest Park. We appreciate your consideration and value this opportunity to earn your business.

Sincerely,

**Tom Bengtson**  
*Sales Representative*

PlaySouth Playground Creators  
PO Box 492467  
Atlanta, GA 30349

[www.bciburke.com](http://www.bciburke.com)

Phone: 770-719-9005  
Fax: 770-719-9005  
[tom@playsouth.net](mailto:tom@playsouth.net)



## About PlaySouth Playground Creators

PlaySouth Playground Creators is based in Newnan, Georgia and was established in 2015 with 3 seasoned commercial playground industry veterans with over 60 years combined experience. Most of the relationships we enjoy with our vendors and suppliers actually began decades ago while employed at other playground companies. These relationships are important because they facilitate the timely and accurate deliveries we need to keep the work flowing on schedule and to meet deadlines. We've now doubled the size of our team and continue on a strong growth track because of our commitment to providing exceptional customer service! Additionally, our exclusive sub-contractor installer and PlaySouth's founder have worked together on projects for over 20 years and have built a seamless working model of communication and execution of the projects.

We are proud of our exclusive distributorship of Burke Commercial Playground Equipment throughout the entire state of Georgia, and we have received numerous awards and recognition from Burke for our territory coverage and the excellent customer service we provide to all of our mutual customers across the state. Without a doubt, the combined Burke and PlaySouth warranty coverage gives you the longest protection and lowest cost of ownership in the industry! We also represent other strong manufacturers in the recreation products industry so that we can offer shades, steel shelters, site amenities, field and court equipment and related products for your facilities.

The PlaySouth team stands ready to accomplish the work outlined in our proposal. We have the financial strength, well-trained personnel, supplier and subcontractor relationships, and all of the necessary tools and equipment to successfully perform your playground delivery and installation. Our current workload is very manageable, and we can assure you that we continue to have the resources in place to execute this work should it be awarded to us.

Thank you for your consideration of BCI Burke and PlaySouth!

---

David A. (Andy) Bryant, President  
PlaySouth, LLC



**Burke**  
PLAY THAT MOVES YOU.

### Why choose PlaySouth and Burke?

PlaySouth is the exclusive authorized distributor for BCI Burke commercial playground equipment throughout the state of Georgia. Burke is celebrating its Centennial this year – 100 years of manufacturing quality commercial playgrounds all over the world! Our team at PlaySouth has over 75 years of combined experience in the commercial playground industry including sales, project management, installations and ongoing customer support.

PlaySouth contracts exclusively with a playground installation firm over 20 years old, owned and operated by a nationally Certified Playground Safety Inspector. In addition to this CPSI designation the onsite superintendent has been factory trained and certified by Burke at their plant, as well as by the National Playground Contractors Association (NPCAI).

### WARRANTY PROTECTION:

A strong differentiator between us and our competitors centers around warranty coverage for your new playground purchase. Burkes “Generations Warranty” provides a complete, non-prorated warranty for specific periods of time based on the material. There is **no deduction** for age of the item that fails under the warranty period, and the shipping is **free** for the covered part. What’s really different about Burke’s factory warranty is that Burke extends new warranty coverage on the replacement part for **the full warranty period all over again!**

In addition to Burke’s strong warranty, PlaySouth offers a **Supplemental Warranty** that gives you **free labor** to replace any part provided by Burke under their warranty! This is absolutely the lowest cost of ownership in the industry!! Complete details are in our proposal packet.

### PROJECT TIMELINE:

**Production/manufacturing** – this part of the lead time is seasonally affected. In late fall through the winter months lead times are typically 4-5 weeks from order entry to ship date. Then beginning in March the lead times begin building up to their peak of between 8-12 weeks during the summer and early fall months.

**Installation** – after the equipment ships, there’s about 4-5 business days in transit until our crew receives the shipment and begins work. This project will take approximately 2 weeks of installation time. Start-to-finish, your playground will take us between 8 to 14 weeks from order date until the children are playing on it, depending on the time of year that the order is placed.



**Burke**  
PLAY THAT MOVES YOU™

## PlaySouth Current Clients

### **Marietta City Schools**

Multiple Locations in Marietta- seven different elementary schools  
Jimmy Pace 404.580.5598 [jpace@marietta-city.k12ga.us](mailto:jpace@marietta-city.k12ga.us)  
More than \$775,000 in product installation in the last three years

### **Tift County Parks and Recreation**

Puckett Park playground  
Tim Petrea: (229)382-3262  
\$130,000 in product installation in 2023.

### **Douglasville Parks and Recreation**

Fowler Field Park  
Chris Bass [bassc@douglasville.gov](mailto:bassc@douglasville.gov)  
More than \$250,000 in product installation in the last 2 years.

### **Cobb County Parks**

Multiple Locations in Cobb County- Mud Creek Soccer, Old Clarkdale Park, East Cobb Park, Traemore Park, Lost Mountain Park, Sweat Mountain Park, Sewell Park  
Mackie Temple 678.776.6647 [james.temple@cobbcounty.org](mailto:james.temple@cobbcounty.org)  
More than \$750,000 in product installation in the last three years

### **Lanier County Schools**

Lanier County Elementary School  
Gene Culpepper (Superintendent) (229)563-4282 [Gene.Culpepper@lanier.k12.ga.us](mailto:Gene.Culpepper@lanier.k12.ga.us)  
More than \$350,000 in playground and surfacing installation in July 2023.

Lowndes County Schools- \$123,000  
Alpharetta Parks and Recreation- \$125,000  
Pace Academy- \$1,135,000  
Primrose Academy- \$135,000  
DeKalb County Parks- \$795,000  
Ben Hill County- \$40,000  
First Baptist Lagrange- \$175,000

Fulton County Schools- \$88,000  
Fayette County School- \$44,000  
Smyrna FUMC- \$225,000  
Sixes Property Mgt.- \$325,000  
Forsyth County Parks- \$633,000  
Fayetteville City Center Park- \$175,000  
Antioch Baptist Sylvester- \$50,000



# COOPERATIVE PURCHASING OPTIONS

## PLAYGROUNDS WITHOUT ALL THE PAPERWORK

Purchasing with contracts may sound intimidating, but getting your community playspace doesn't need to be a painful process of writing specifications, issuing RFP's and jumping through hoops – it can be simplified – we promise! As you continue planning for your new playground, review the Purchasing Contracts offered through our partners.

### EQUALIS GROUP

Equalis is an innovative cooperative purchasing organization that believes in the power of partnership and that when you work together you achieve more. The basic premise of the Equalis cooperative purchasing organization is to leverage the combined buying power of all members for better pricing and favorable contract terms. Equalis Group uses the lead agency model for competitively bid contracts, provides our participants the savings they expect and offers efficiencies and peace of mind within the procurement process. It is our mission to continuously improve the measurable and meaningful impact of cooperative services for everyone throughout the supply chain.

### GOVMVMT

GOVMVMT is a non-profit group purchasing organization that meets the highest industry standards while putting the public's interest at the forefront of everything they do. Each one of GOVMVMT's first-class suppliers has consciously joined their mission to create the most credible, ethical, and public agency-focused non-profit cooperative purchasing program in the country.

### GSA

Federal parks, child development programs, military bases and other agencies are a major priority for BCI Burke, and agencies can purchase Burke playgrounds through Burke's GSA contract for installation virtually anywhere in the world.

### OMNIA PARTNERS

OMNIA Partners, Public Sector (Subsidiary National IPA) is the largest and most experienced organization in purchasing and supply chain management. Comprised of participants and suppliers in the public sector, we bring together industry-leading buying power and world-class suppliers to offer an extensive portfolio of competitively solicited and publicly awarded contracts and partnerships. OMNIA Partners is proud to offer more value and resources to state and local government, higher education, K-12 education and non-profits.

### SOURCEWELL

As a leader in cooperative purchasing, Sourcewell is passionate about helping members fulfill their public service missions. Sourcewell builds strong relationships with members and vendors to develop practical solutions together.

The easiest way to Join Our Movement is to call your local Representative at 800.266.1250 or visit [bciburke.com/rep](http://bciburke.com/rep). Our passion is bringing play to communities like yours and we can't wait to help you get started!



## DESIGN SUMMARY

PlaySouth Playground Creators is very pleased to present this Proposal for consideration for the Pocket Parks located in Forest Park. BCI Burke Company, LLC has been providing recreational playground equipment for over 100 years and has developed the right mix of world-class capabilities to meet the initial and continuing needs of Forest Park. We believe our proposal will meet or exceed your project's requirements and will deliver the greatest value to you.

The following is a summary of some of the key elements of our Proposal:

- Project Name: Pocket Parks
- Project Number: 132-181806-1
- User Capacity: 216
- Age Groups: 5 to 12
- Dimensions: 96' 3"x87' 9"
- Designer Name: Lee Olig

PlaySouth Playground Creators has developed a custom playground configuration based on the requirements as they have been presented for the Pocket Parks playground project. Our custom design will provide a safe and affordable playground environment that is aesthetically pleasing, full of fun for all users and uniquely satisfies your specific requirements. In addition, proposal # 132-181806-1 has been designed with a focus on safety, and is fully compliant with ASTM F1487 and CPSC playground safety standards.

We invite you to review this proposal for the Pocket Parks playground project and to contact us with any questions that you may have.

Thank you in advance for giving us the opportunity to make this project a success.



Item #7.

112' 7"

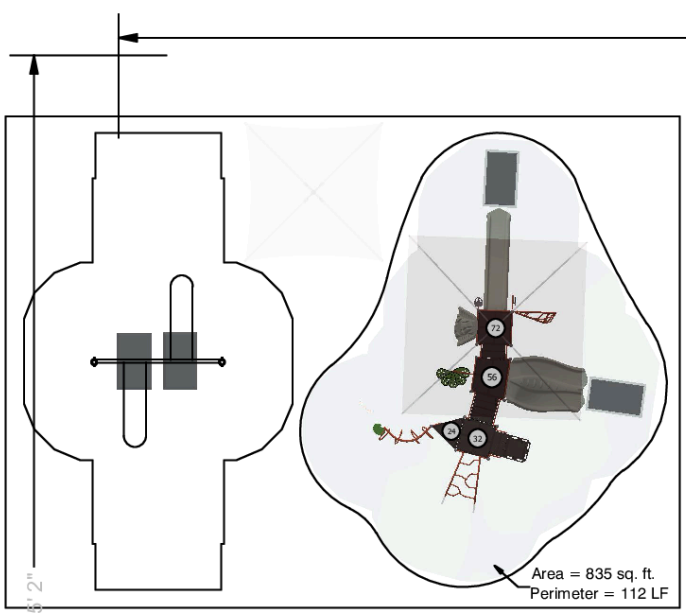

Park - 1

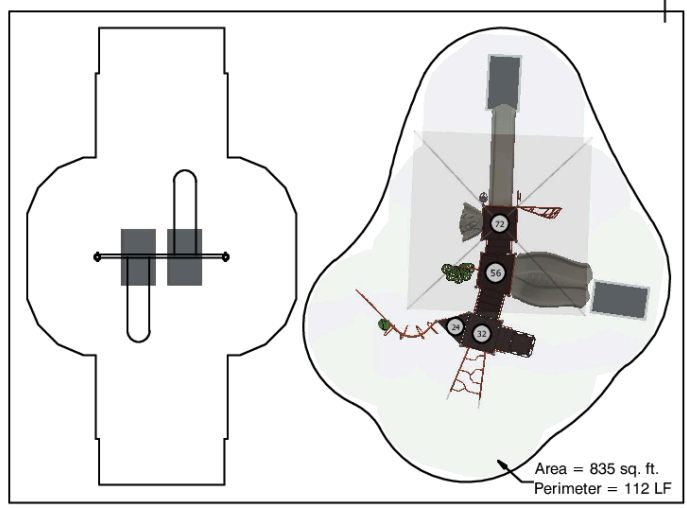

Park - 2

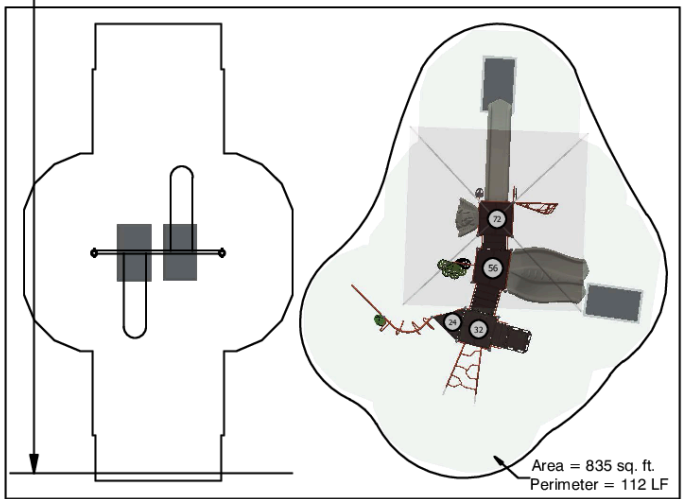

Park - 3

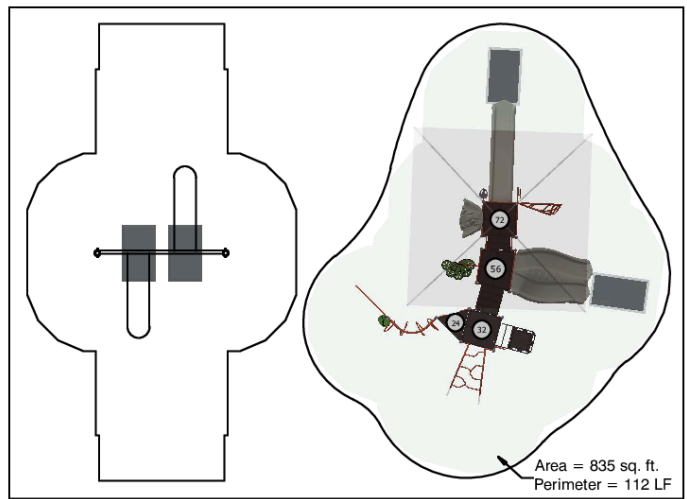

Park - 4

**SERIES** Synergy | ShadePlay Max | Burke Basics

**GROUP:** SY-3007|ShadePlay|Freestanding

**DESIGNED FOR AGES:** 5 to 12

**Pocket Parks**  
Forest Park, GA 30297

**SITE PLAN VIEW**

03/11/2024

**PlaySouth Playground Creators**  
132-181806-1

Designer: Lee Olig

BCI BURKE COMPANY, LLC | PO BOX 549 FOND DU LAC, WI 54936-0549 | 920.921.9220 | BCIBURKE.COM



**OVERALL BOUNDING OF USE ZONES** \*\*The space requirements shown here are to ASTM standards. Requirements for other standards may be different.

Area: 10702.6 sq.ft.  
Perimeter: 415.3 ft.

**STRUCTURE SIZE:** 2"x112' 7"

**POST SIZE(S):** 5"

PLAYGROUND ACCESSIBILITY (Provided/Required)					
TOTAL EVENTS	ELEVATED EVENTS	TRANSFER ACCESSIBLE EVENTS	RAMP ACCESSIBLE EVENTS	GROUND EVENTS	TYPES OF GROUND EVENTS
45	36 / 18	28 / 9	0 / 9	9 / 12	3 / 5

The use and layout of play components identified in this plan conform to the CPSC guidelines. U.S. CPSC recommends the separation of age groups in playground layouts.

Warning: Accessible safety surfacing material is required beneath and around this equipment that is compliant with ASTM, CPSC, and ADAAG requirements.

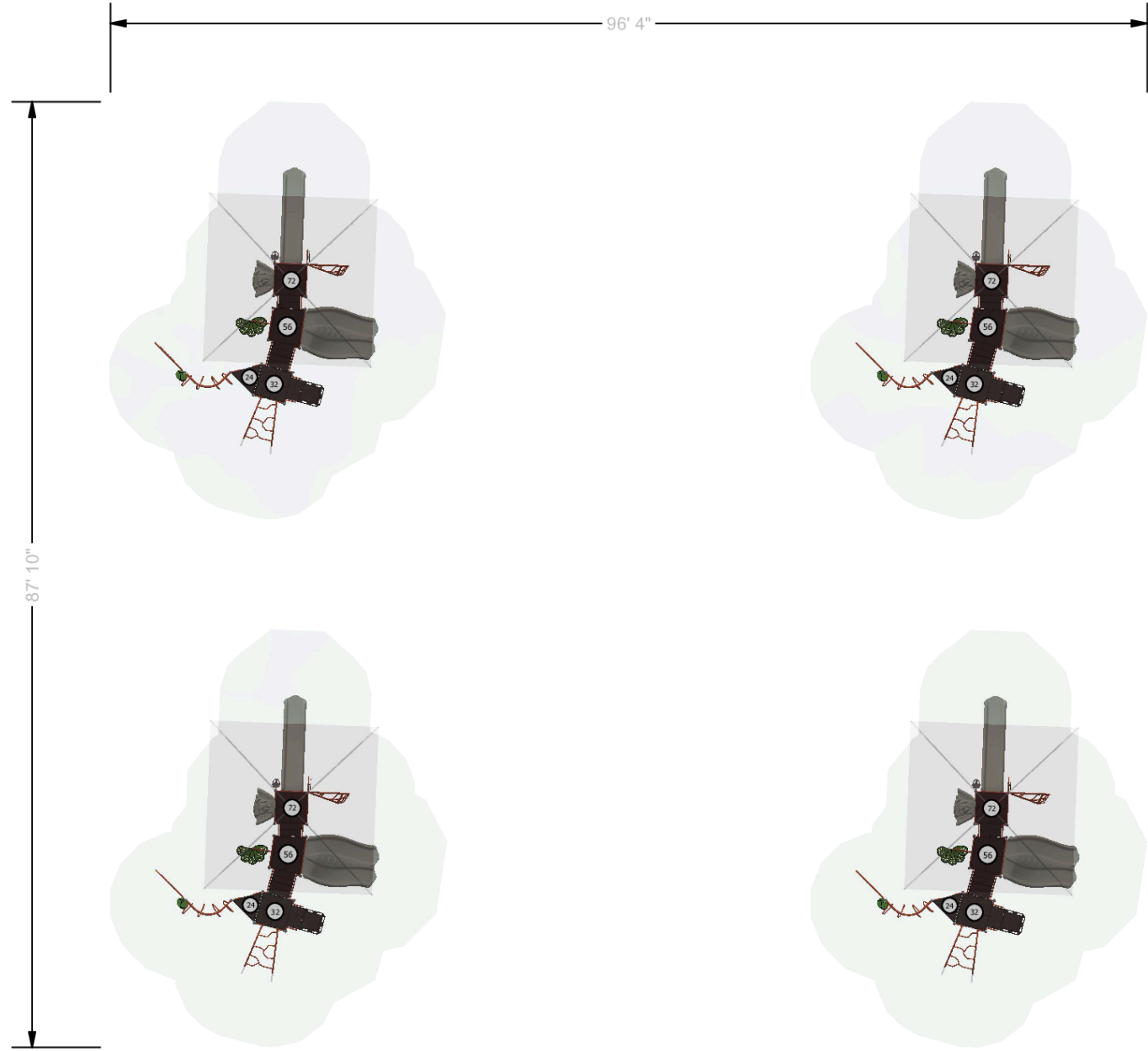

**SERIES** Synergy

**GROUP:** SY-3007

**DESIGNED FOR AGES:** 5 to 12

**Pocket Parks**

Forest Park, GA 30297

**SITE PLAN VIEW**

03/11/2024

**PlaySouth Playground Creators**

132-181806-1

Designer: Lee Olig

BCI BURKE COMPANY, LLC | PO BOX 549 FOND DU LAC, WI 54936-0549 | 920.921.9220 | BCI@BURKE.COM

**OVERALL BOUNDING OF USE ZONES**  
 Area: 10702.6 sq.ft.  
 Perimeter: 415.3 ft.  
**STRUCTURE SIZE:** 2"x112' 7"  
**POST SIZE(S):** 5"

\*\*The space requirements shown here are to ASTM standards. Requirements for other standards may be different.

**PLAYGROUND ACCESSIBILITY (Provided/Required)**

TOTAL EVENTS	ELEVATED EVENTS	TRANSFER ACCESSIBLE EVENTS	RAMP ACCESSIBLE EVENTS	GROUND EVENTS	TYPES OF GROUND EVENTS
45	36 / 18	28 / 9	0 / 9	9 / 12	3 / 5

The use and layout of play components identified in this plan conform to the CPSC guidelines. U.S. CPSC recommends the separation of age groups in playground layouts.

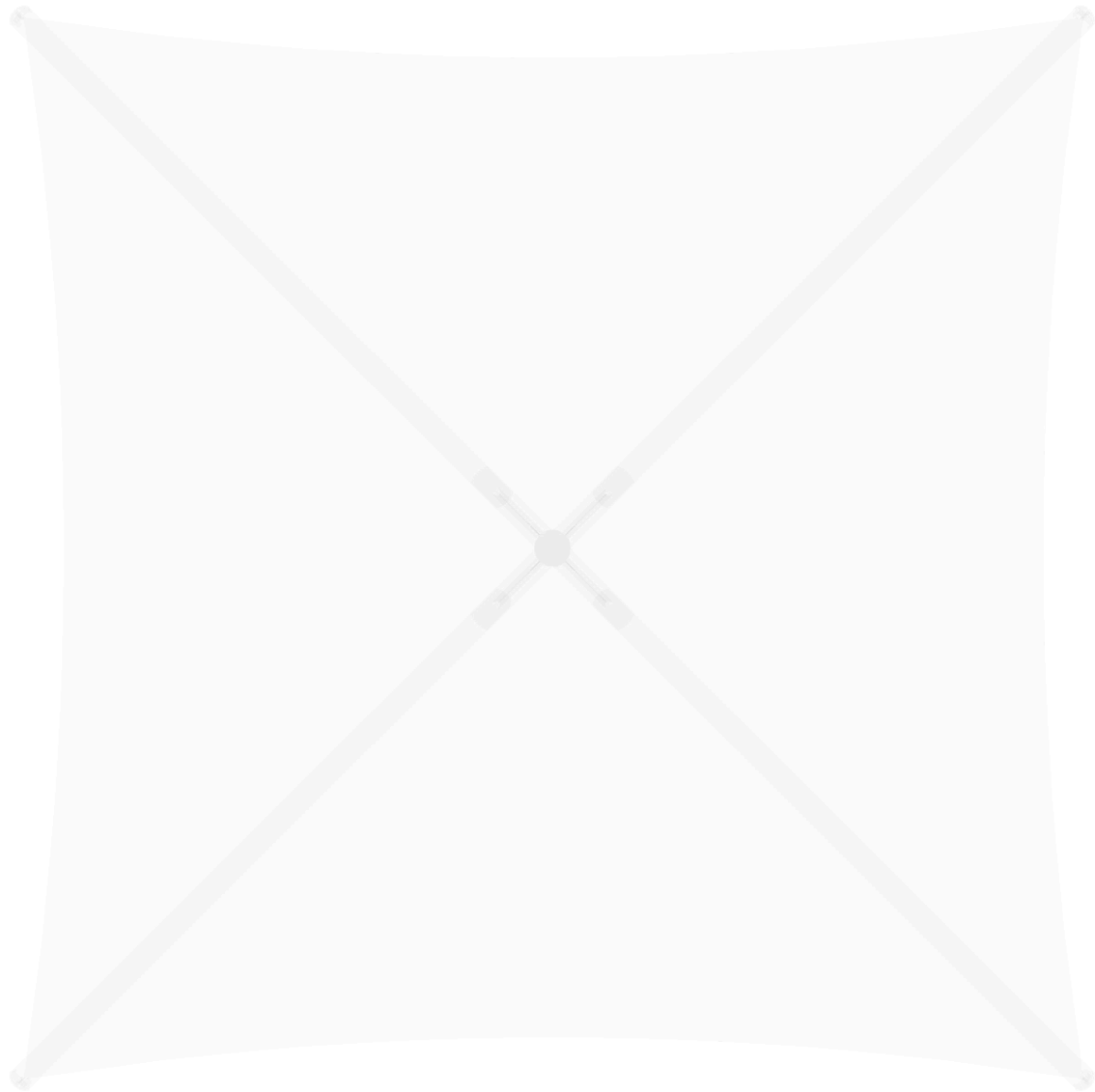

**SERIES** ShadePlay Max

**GROUP:**  
ShadePlay

**DESIGNED FOR AGES:**  
5 to 12

**Pocket Parks**

Forest Park, GA 30297

**SITE PLAN VIEW**

03/11/2024

**PlaySouth Playground Creators**

132-181806-1

Designer: Lee Olig

BCI BURKE COMPANY, LLC | PO BOX 549 FOND DU LAC, WI 54936-0549 | 920.921.9220 | BCI@BURKE.COM



**OVERALL BOUNDING OF USE ZONES**  
 Area: 10702.6 sq.ft.  
 Perimeter: 415.3 ft.  
**STRUCTURE SIZE:** 2"x112' 7"  
**POST SIZE(S):** 5"

\*\*The space requirements shown here are to ASTM standards. Requirements for other standards may be different.

PLAYGROUND ACCESSIBILITY (Provided/Required)					
TOTAL EVENTS	ELEVATED EVENTS	TRANSFER ACCESSIBLE EVENTS	RAMP ACCESSIBLE EVENTS	GROUND EVENTS	TYPES OF GROUND EVENTS
45	36 / 18	28 / 9	0 / 9	9 / 12	3 / 5

The use and layout of play components identified in this plan conform to the CPSC guidelines. U.S. CPSC recommends the separation of age groups in playground layouts.

Item #7.

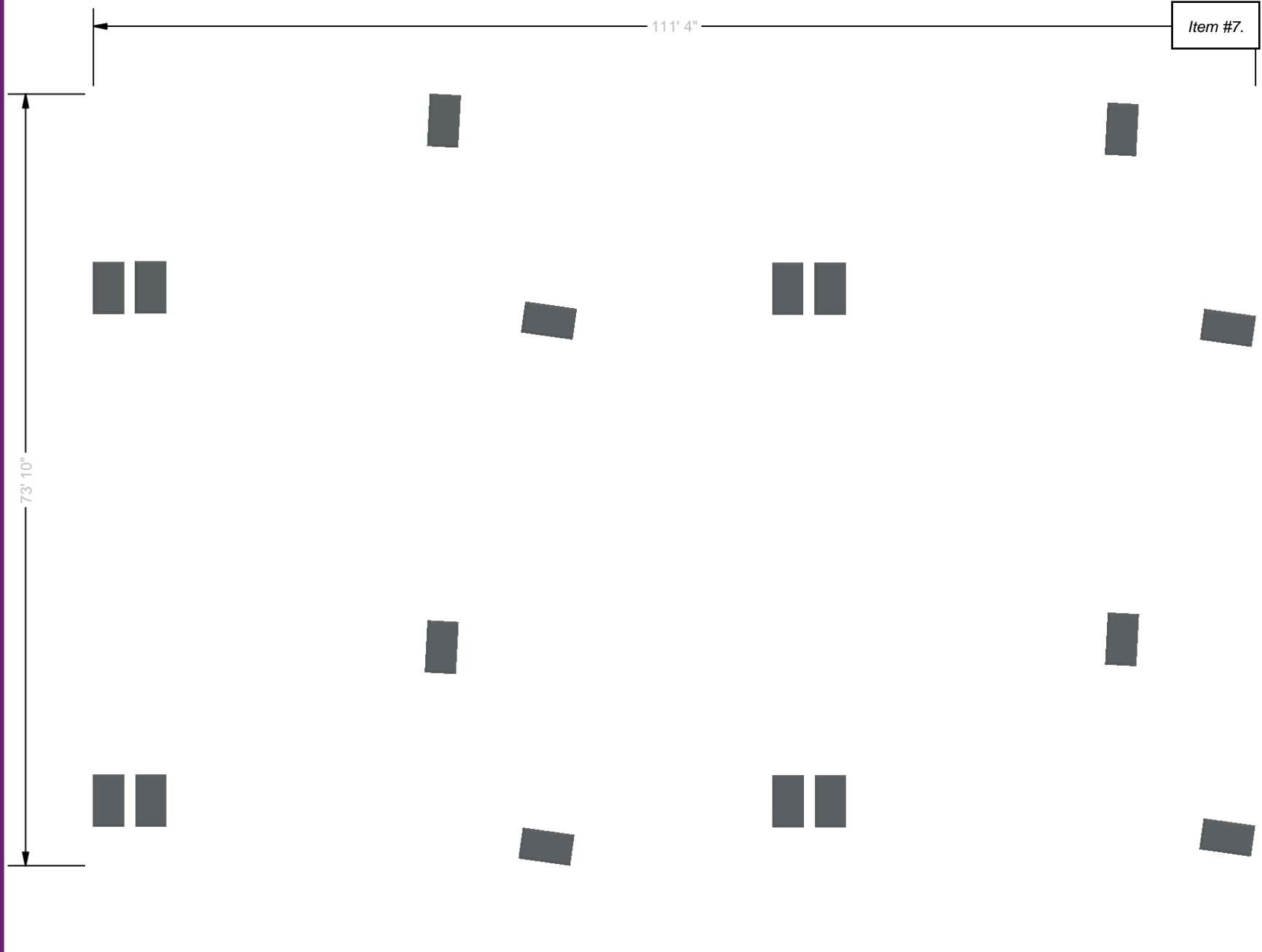

**SERIES** Burke Basics **SITE PLAN VIEW**

**GROUP:**  
Freestanding

**DESIGNED FOR AGES:**  
5 to 12

**Pocket Parks**  
Forest Park, GA 30297

**Burke**  
PLAY THAT MOVES YOU

**PlaySouth Playground Creators**  
03/11/2024  
132-181806-1  
Designer: Lee Olig

BCI BURKE COMPANY, LLC | PO BOX 549 FOND DU LAC, WI 54936-0549 | 920.921.9220 | BCI@BURKE.COM

**OVERALL BOUNDING OF USE ZONES**  
Area: 10702.6 sq.ft.  
Perimeter: 415.3 ft.  
**STRUCTURE SIZE:** 2"x112' 7"  
**POST SIZE(S):** 5"

\*\*The space requirements shown here are to ASTM standards. Requirements for other standards may be different.

PLAYGROUND ACCESSIBILITY (Provided/Required)					
TOTAL EVENTS	ELEVATED EVENTS	TRANSFER ACCESSIBLE EVENTS	RAMP ACCESSIBLE EVENTS	GROUND EVENTS	TYPES OF GROUND EVENTS
45	36 / 18	28 / 9	0 / 9	9 / 12	3 / 5

The use and layout of play components identified in this plan conform to the CPSC guidelines. U.S. CPSC recommends the separation of age groups in playground layouts.

Warning: Accessible safety surfacing material is required beneath and around this equipment that is compliant with ASTM, CPSC, and ADAAG requirements.

ITEM	COMP.	DESCRIPTION	Item #7.
1	290-0102	SQUARE PLATFORM	
2	390-0288	BETA CLIMBER 32"-40"	
3	290-0110	CLIMBER ENCLOSURE	
4	390-0150	TRANSFER STATION, BARRIER 32"	
5	390-0101	24" TRANSITION STAIR W/BARRIERS	
6	290-0103	TRAPEZOID PLATFORM	
7	390-0106	16" TRANSITION STAIR W/BARRIERS	
8	590-0140	SPINNER CRESCENT PANEL	
9	490-0167	SINGLE LEAF SEAT	
10	390-0291	VIA CLIMBER 64"-72"	
11	290-0104	OFFSET ENCLOSURE	
12	490-0144	VELO SLIDE 64"-72"	
13	490-0141	SLIDE SIT DOWN BAR	
14	390-0261	MANITOU CLIMBER 72"	
15	490-0126	15' X 15' SHADEPLAY CANOPY	
16	390-0280	PETAL STEP CLIMBER 56"	
17	490-0137	LUGE SLIDE 48"-56"	
18	490-0138	DOUBLE SLIDE SIT DOWN BAR	
19	290-0106	TRIANGLE PLATFORM	
20	290-0101	8" CLOSURE PLATE	
21	390-0276	90 DEGREE OVERHEAD, SYNERGY	
22	590-0104	3-IN-A-ROW RING PANEL	
23	390-0225	SYNERGY LAUNCH PAD	
24	390-0129	CRUX CLIMBER 24"	

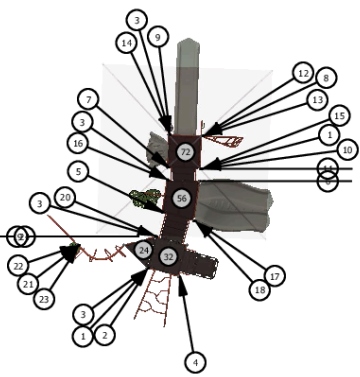
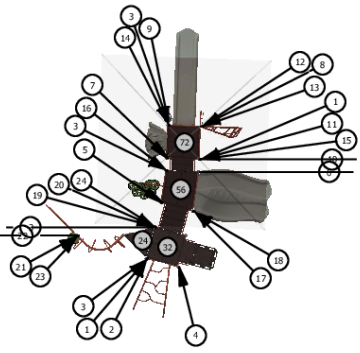
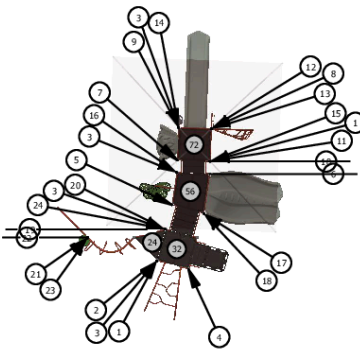
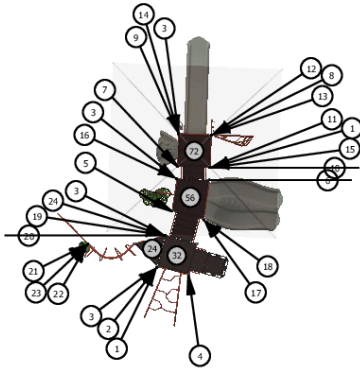

**SERIES** Synergy

**GROUP:** SY-3007

**DESIGNED FOR AGES:** 5 to 12

**COMPONENT VIEW**

**Pocket Parks**

Forest Park, GA 30297

**Burke**  
PLAY THAT MOVES YOU

03/11/2024

**PlaySouth Playground Creators**

132-181806-1

Designer: Lee Olig

BCI BURKE COMPANY, LLC | PO BOX 549 FOND DU LAC, WI 54936-0549 | 920.921.9220 | BCI@BURKE.COM

ITEM	COMP.	DESCRIPTION	Item #7.
1	560-2751	12' X 12' X 10' SHADEPLAY MAXSINGLE POS	

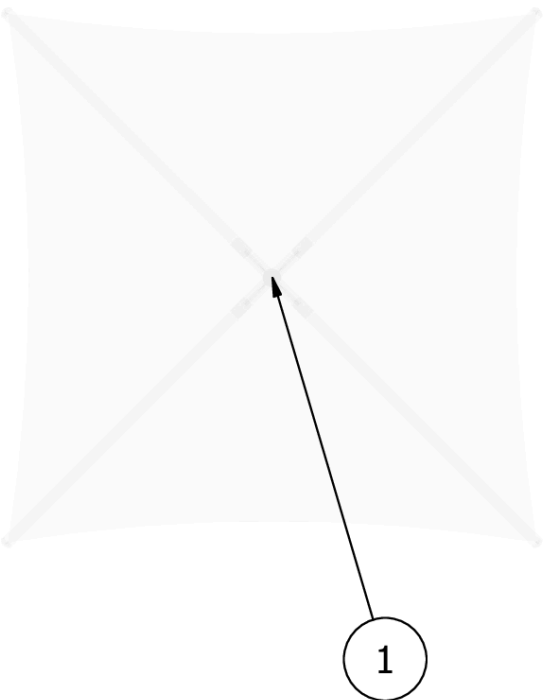

**SERIES** ShadePlay Max

**COMPONENT VIEW**

**GROUP:**  
ShadePlay  
**DESIGNED FOR AGES:**  
5 to 12

**Pocket Parks**  
Forest Park, GA 30297

**Burke**  
PLAY THAT MOVES YOU

03/11/2024  
**PlaySouth Playground Creators**  
132-181806-1  
Designer: Lee Olig

ITEM	COMP.	DESCRIPTION	Item #7.
1	046-0536	PLAYMAT 3' X 5' X 2"	

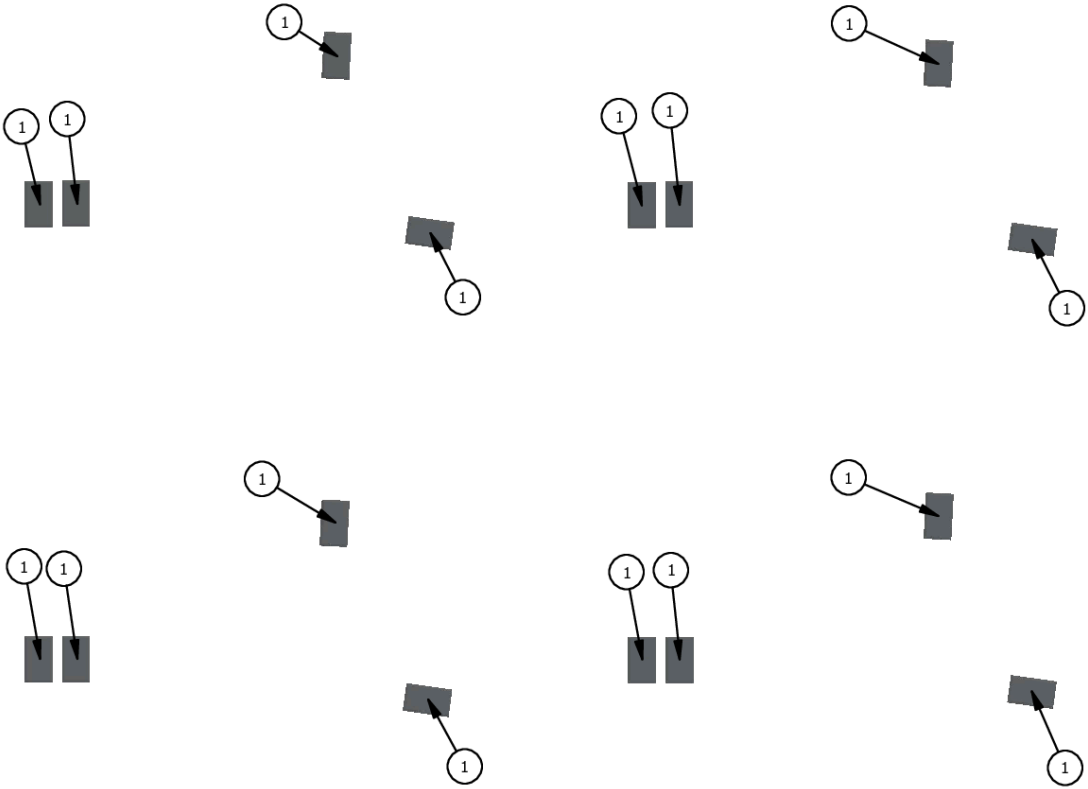

**SERIES** Burke Basics

**COMPONENT VIEW**

**GROUP:**  
Freestanding  
**DESIGNED FOR AGES:**  
5 to 12

**Pocket Parks**  
Forest Park, GA 30297

**Burke**  
PLAY THAT MOVES YOU

03/11/2024  
**PlaySouth Playground Creators**  
132-181806-1  
Designer: Lee Olig



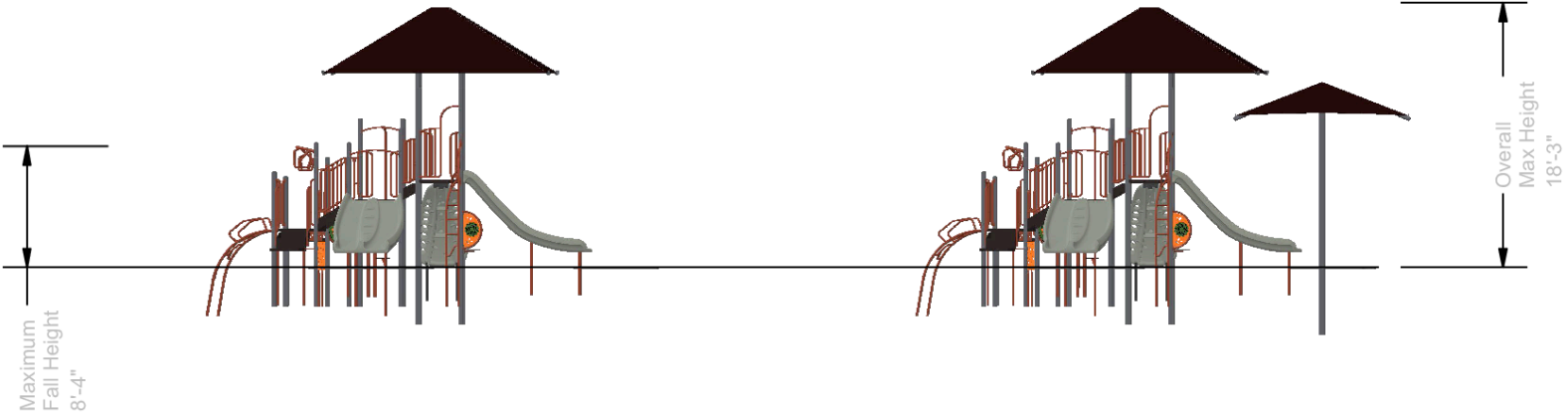

**SERIES** Synergy | ShadePlay Max | Burke Basics

**ELEVATION VIEW**

**GROUP:**  
SY-3007 | ShadePlay | Freestanding  
**DESIGNED FOR AGES:**  
5 to 12

**Pocket Parks**  
Forest Park, GA 30297

**Burke**  
PLAY THAT MOVES YOU

03/11/2024  
**PlaySouth Playground Creators**  
132-181806-1  
Designer: Lee Olig

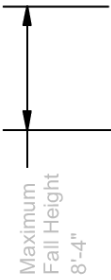

**SERIES** Synergy

**GROUP:**  
SY-3007

**DESIGNED FOR AGES:**  
5 to 12

**Pocket Parks**

Forest Park, GA 30297

**Burke**  
PLAY THAT MOVES YOU

**ELEVATION VIEW**

03/11/2024

**PlaySouth Playground Creators**

132-181806-1

Designer: Lee Olig

BCI BURKE COMPANY, LLC | PO BOX 549 FOND DU LAC, WI 54936-0549 | 920.921.9220 | BCI@BURKE.COM

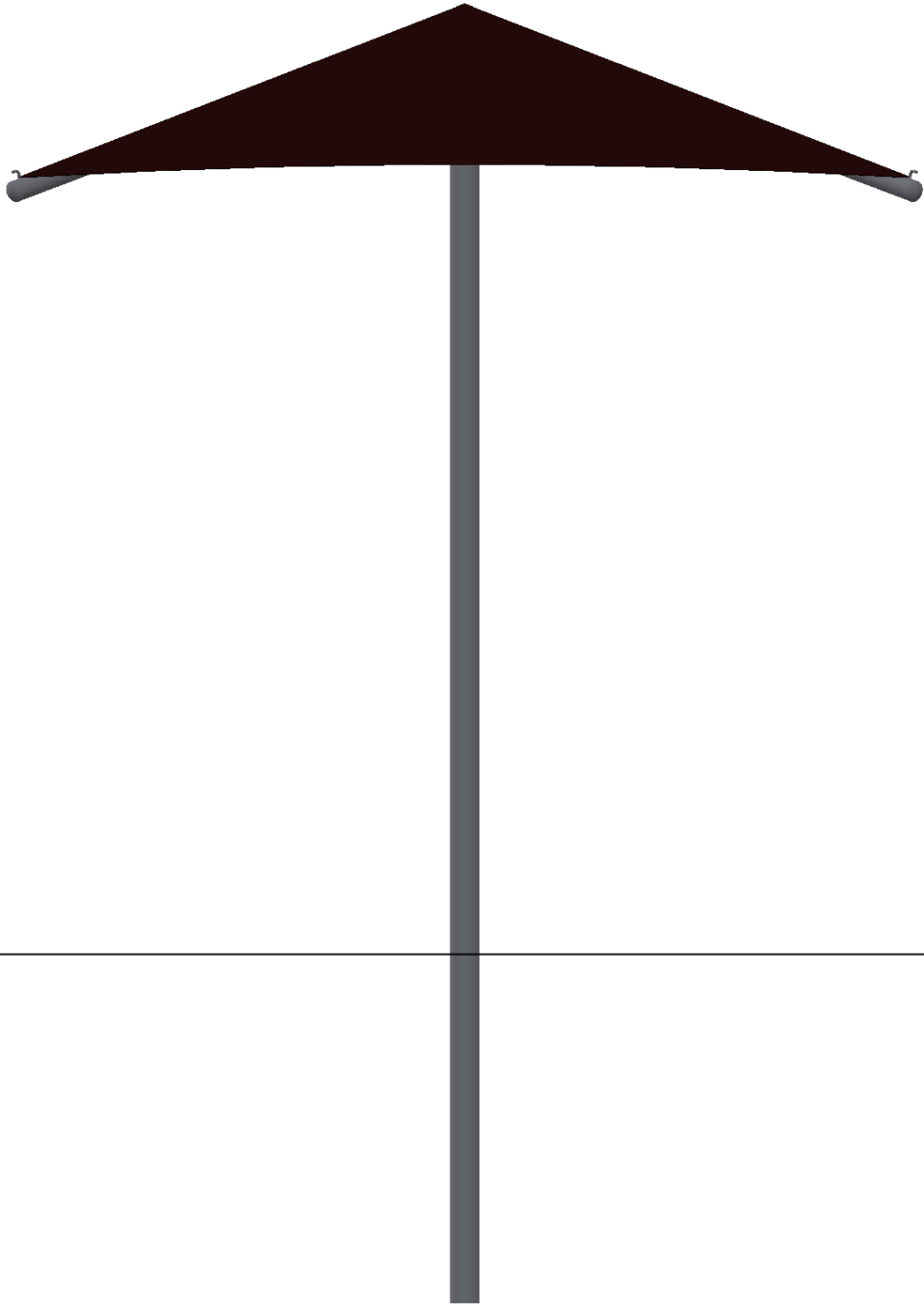

Maximum  
Fall Height  
0'-0"

**SERIES** ShadePlay Max

**GROUP:**  
ShadePlay

**DESIGNED FOR AGES:**  
5 to 12

**Pocket Parks**

Forest Park, GA 30297

**Burke**  
PLAT THAT MOVES YOU.

**ELEVATION VIEW**

03/11/2024

**PlaySouth Playground Creators**

132-181806-1

Designer: Lee Olig



**SERIES** Burke Basics

**ELEVATION VIEW**

**GROUP:**  
Freestanding  
**DESIGNED FOR AGES:**  
5 to 12

**Pocket Parks**  
Forest Park, GA 30297  
**Burke**  
PLAY THAT MOVES YOU.

03/11/2024  
**PlaySouth Playground Creators**  
132-181806-1  
Designer: Lee Olig

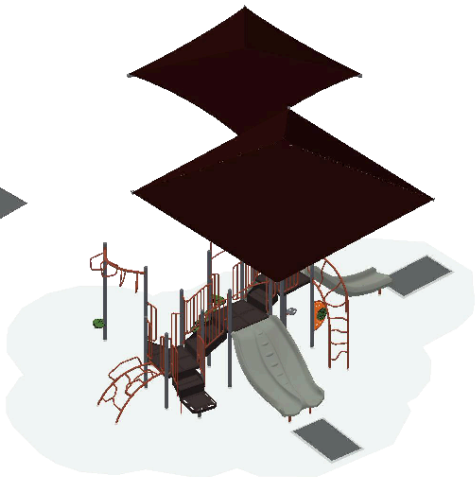

**SERIES** Synergy | ShadePlay Max | Burke Basics

**ISOMETRIC VIEW**

**GROUP:**

SY-3007 | ShadePlay | Freestanding

**Pocket Parks**

Forest Park, GA 30297

03/11/2024

**DESIGNED FOR AGES:**

5 to 12

**PlaySouth Playground Creators**

132-181806-1

Designer: Lee Olig



BCI BURKE COMPANY, LLC | PO BOX 549 FOND DU LAC, WI 54936-0549 | 920.921.9220 | BCI@BURKE.COM



**SERIES** Synergy

**GROUP:**  
SY-3007

**DESIGNED FOR AGES:**  
5 to 12

**ISOMETRIC VIEW**

**Pocket Parks**

Forest Park, GA 30297

03/11/2024

**PlaySouth Playground Creators**

132-181806-1

Designer: Lee Olig

**Burke**  
PLAY THAT MOVES YOU

BCI BURKE COMPANY, LLC | PO BOX 549 FOND DU LAC, WI 54936-0549 | 920.921.9220 | BCI@BURKE.COM

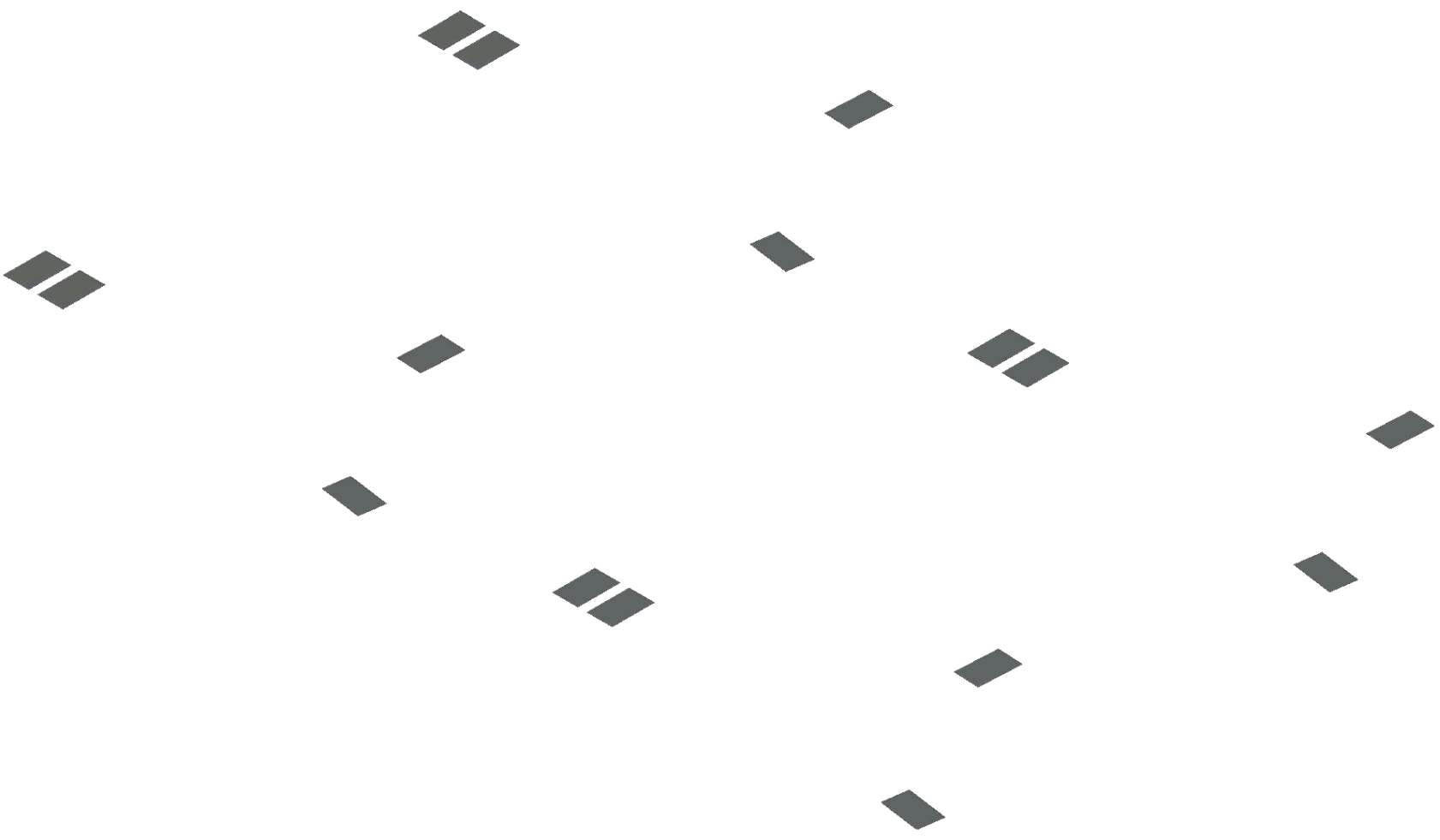

**SERIES** Burke Basics **ISOMETRIC VIEW**

**GROUP:**  
Freestanding  
**DESIGNED FOR AGES:**  
5 to 12

**Pocket Parks**  
Forest Park, GA 30297

03/11/2024  
**PlaySouth Playground Creators**  
132-181806-1  
Designer: Lee Olig





**Proposal 132-181806-1 | 3/11/2024 | 2024 Pricing**

The play components identified in this proposal are IPEMA certified. The use and layout of these components conform to the requirements of ASTM F1487. To verify product certification, visit [www.ipema.org](http://www.ipema.org).



The space requirements shown in this proposal are to ASTM standards. Requirements for other standards may be different.

Component No.	Description	Qty	User Cap	Ext. User Cap	Weight	Ext. Weight
---------------	-------------	-----	----------	---------------	--------	-------------

**SY-3007**

**Synergy**

072-0300-107C	3 1/2" OD X 107" CAPPED POST	4	0	0	40	160
072-0300-111C	3 1/2" OD X 111" CAPPED POST	4	0	0	41	164
072-0300-123C	3 1/2" OD X 123" CAPPED POST	8	0	0	45	360
072-0300-135C	3 1/2" OD X 135" CAPPED POST	12	0	0	50	600
072-0300-147C	3 1/2" OD X 147" CAPPED POST	4	0	0	54	216
072-0300-155C	3 1/2" OD X 155" CAPPED POST	8	0	0	57	456
072-0302-201S	3 1/2" OD X 201" SWAGED POST	16	0	0	73	1168
290-0101	8" CLOSURE PLATE	4	0	0	5	20
290-0102	SQUARE PLATFORM	8	4	32	59	472
290-0103	TRAPEZOID PLATFORM	4	4	16	64	256
290-0104	OFFSET ENCLOSURE	4	0	0	26	104
290-0106	TRIANGLE PLATFORM	4	2	8	33	132
290-0110	CLIMBER ENCLOSURE	16	0	0	21	336
390-0101	24" TRANSITION STAIR W/BARRIERS	4	5	20	143	572
390-0106	16" TRANSITION STAIR W/BARRIERS	4	1	4	91	364
390-0129	CRUX CLIMBER 24"	4	3	12	24	96
390-0150	TRANSFER STATION, BARRIER 32"	4	4	16	156	624
390-0225	SYNERGY LAUNCH PAD	4	1	4	8	32
390-0261	MANITOU CLIMBER 72"	4	4	16	86	344
390-0276	90 DEGREE OVERHEAD, SYNERGY	4	4	16	33	132
390-0280	PETAL STEP CLIMBER 56"	4	4	16	61	244
390-0288	BETA CLIMBER 32"-40"	4	1	4	75	300
390-0291	VIA CLIMBER 64"-72"	4	3	12	75	300
490-0126	15' X 15' SHADEPLAY CANOPY	4	0	0	306	1224
490-0137	LUGE SLIDE 48"-56"	4	4	16	168	672
490-0138	DOUBLE SLIDE SIT DOWN BAR	4	0	0	6	24
490-0141	SLIDE SIT DOWN BAR	4	0	0	5	20
490-0144	VELO SLIDE 64"-72"	4	2	8	113	452
490-0167	SINGLE LEAF SEAT	4	1	4	7	28
590-0104	3-IN-A-ROW RING PANEL	4	2	8	54	216
590-0140	SPINNER CRESCENT PANEL	4	1	4	17	68
600-0104	NPPS SUPERVISION SAFETY KIT	1	0	0	3	3
660-0103	MAINTENANCE KIT, STRUCTURE	1	0	0	7	7
660-0104	INSTALLATION KIT, STRUCTURE	1	0	0	5	5

Total User Capacity: 216  
 Total Weight: 10171 lbs.  
 Total Price: \$160,656

**Freestanding**

**Burke Basics**

046-0536	PLAYMAT 3' X 5' X 2"	16	0	0	136	2176
660-0101	INSTALL KIT, BURKE BASICS - P...	1	0	0	2	2

Total User Capacity: 0  
 Total Weight: 2178 lbs.  
 Total Price: \$3,344

**ShadePlay**

**ShadePlay Max**

560-2751	12' X 12' X 10' SHADEPLAY MAX...	1	0	0	358	358
----------	----------------------------------	---	---	---	-----	-----

Total User Capacity: 0  
 Total Weight: 358 lbs.  
 Total Price: \$4,297

**Special Notes:**

Prices do not include freight, unloading, material storage, site excavation/preparation, removal of existing equipment, removal of excess soil from footing holes, site security, safety surfacing, installation, or sales tax (if applicable). Prices are based on standard colors per CURRENT YEAR BCI Burke Catalog. Custom colors, where available, would be an extra charge. **Pricing is valid for 30 days from the date of this proposal.**

**COLOR SELECTION LIST | Default Color Option**

---

**GROUP 1 (SY-3007)**

Deck: Brown  
Post: Charcoal  
Acc: Redwood  
Panel: Olive-Black-Olive  
Flat: Orange  
Plastic: Granite  
Canopy: Mahogany

---

**GROUP 2 (ShadePlay)**

Post: Charcoal  
Canopy: Mahogany

# COLORS THAT MOVE YOU

## POWDER COAT PAINT



## SOLIS HUE TOPPERS

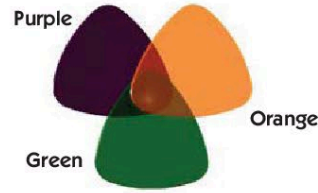

## ROCKIT CLIMBERS

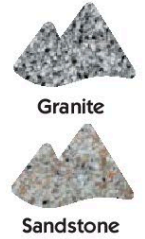

## PLATFORMS



## HDPE PLASTIC PANELS

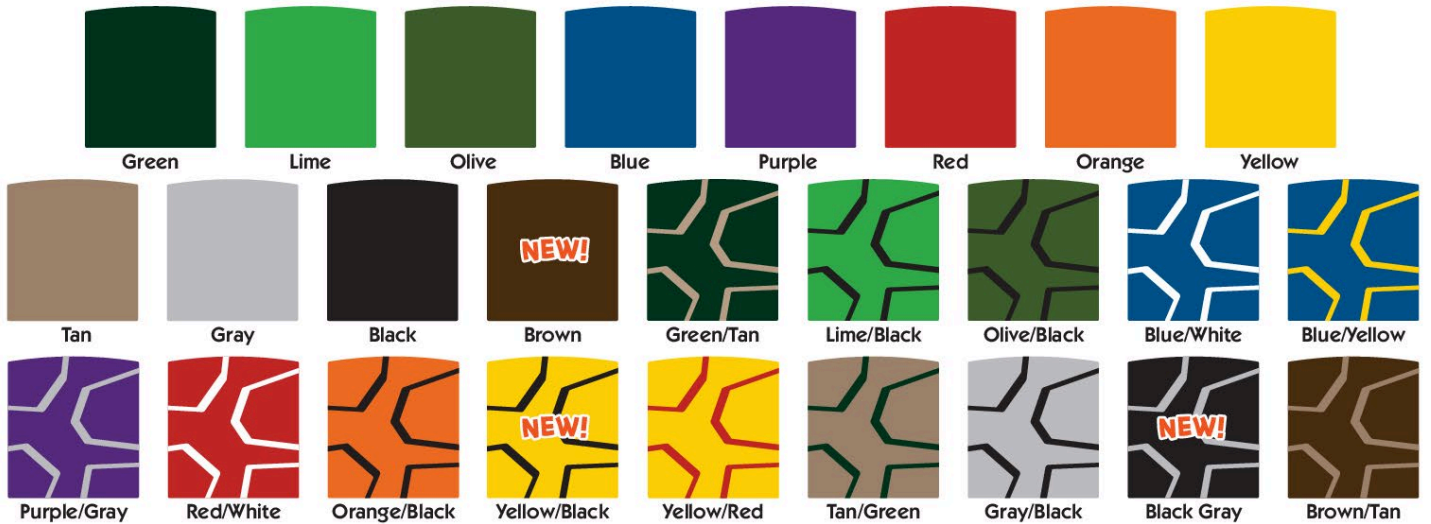

## SHADE CANOPIES

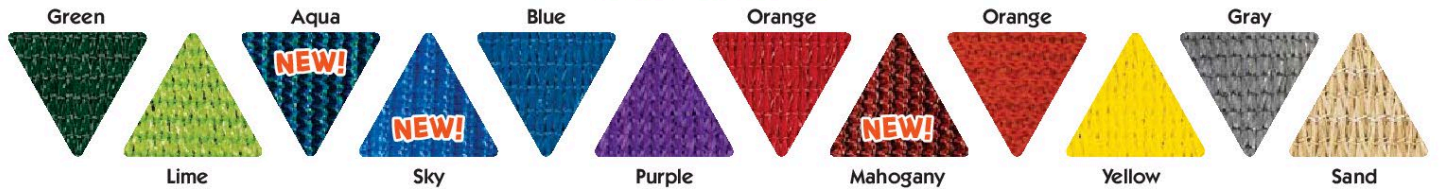

## ROTOMOLD PLASTIC

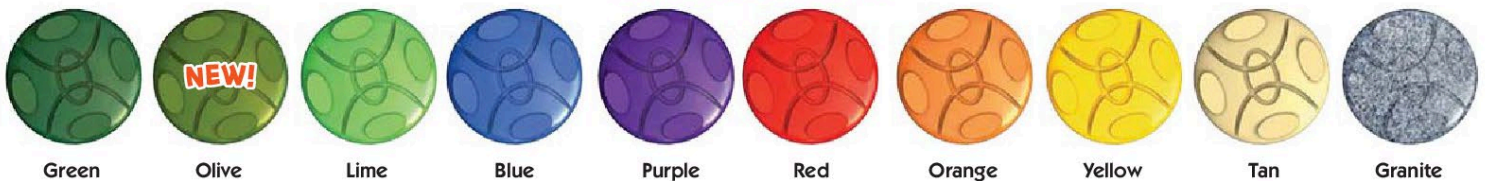

VISIT [BCIBURKE.COM/COLOR](http://BCIBURKE.COM/COLOR) TO CUSTOMIZE YOUR PLAYGROUND COLORS!



# BURKE GENERATIONS WARRANTY®

## The Longest and Strongest warranty in the industry

BCI Burke Company, LLC ("Burke") warrants that all standard products are warranted to be free from defects in materials and workmanship, under normal use and service, for a period of one (1) year from the date of shipment.

## We stand behind our products. In addition, the following products are warranted, under normal use and service from the date of shipment as follows:

- One Hundred (100) Year Limited Warranty on aluminum and steel upright posts (including Intensity®, Synergy™, Nucleus®, Voltage®, Little Buddies®, ELEVATE®, ACTIVATE®, INVIGORATE™) against structural failure due to corrosion, deterioration or workmanship.
- One Hundred (100) Year Limited Warranty on KoreKonnect® clamps against structural failure due to corrosion, deterioration or workmanship.
- One Hundred (100) Year Limited Warranty on Hardware (nuts, bolts, washers)
- One Hundred (100) Year Limited Warranty on bolt-through fastening and clamp systems (Synergy™, Intensity®, Nucleus®, Voltage®, Little Buddies®, ELEVATE®).
- Twenty-Five (25) Year Limited Warranty on spring assemblies and aluminum cast animals.
- Fifteen (15) Year Limited Warranty on structure platforms and decks, metal roofs, table tops, bench tops, railings and barriers against structural failure due to materials or workmanship.
- Fifteen (15) Year Limited Warranty on all plastic components including StoneBorders against structural failure due to materials or workmanship.
- Ten (10) Year Limited Warranty on ShadePlay Canopies fabric, threads, and cables against degradation, cracking or material breakdown resulting from ultra-violet exposure, natural deterioration or manufacturing defects. This warranty is limited to the design loads as stated in the specifications.
- Ten (10) Year Limited Warranty on NaturePlay® Boulders and GFRC products against structural failure due to natural deterioration or workmanship. Natural wear, which may occur with any concrete product with age, is excluded from this warranty
- Ten (10) Year Limited Warranty on Full Color Custom Signage against manufacturing defects that cause delamination or degradation of the sign. Full Color Custom Signs also carry a two (2) year warranty against premature fading of the print and graphics on the signs.
- Five (5) Year Limited Warranty on Intensity® and RopeVenture® cables and LEVEL X® flex bridge against premature wear due to natural deterioration or manufacturing defects. Determination of premature wear will be at the manufacturer's discretion.
- Five (5) Year Limited Warranty on moving parts, including swing components, against structural failure due to materials or workmanship.
- Five (5) Year Limited Warranty on PlayEnsemble® cables and mallets against defects in materials and workmanship.
- Three (3) Year Limited Warranty on electronic panel speakers, sound chips and circuit boards against electronic failure caused by manufacturing defects.

The warranty stated above is valid only if the equipment is erected in conformity with the layout plan and/or installation instructions furnished by BCI Burke Company, LLC using approved parts; have been maintained and inspected in accordance with BCI Burke Company, LLC instructions. Burke's liability and your exclusive remedy hereunder will be limited to repair or replacement of those parts found in Burke's reasonable judgment to be defective. Any claim made within the above stated warranty periods must be made promptly after discovery of the defect. A part is covered only for the original warranty period of the applicable part. Replacement parts carry the applicable warranty from the date of shipment of the replacement from Burke. After the expiration of the warranty period, you must pay for all parts, transportation and service charges.

Burke reserves the right to accept or reject any claim in whole or in part. Burke will not accept the return of any product without its prior written approval. Burke will assume transportation charges for shipment of the returned product if it is returned in strict compliance with Burke's written instructions.

**THE FOREGOING WARRANTIES ARE EXCLUSIVE AND IN LIEU OF ANY OTHER WARRANTY, EXPRESS OR IMPLIED, INCLUDING BUT NOT LIMITED TO ANY IMPLIED WARRANTY OR MERCHANTABILITY OR FITNESS FOR A PARTICULAR PURPOSE. IF THE FOREGOING DISCLAIMER OF ADDITIONAL WARRANTIES IS NOT GIVEN FULL FORCE AND EFFECT, ANY RESULTING ADDITIONAL WARRANTY SHALL BE LIMITED IN DURATION TO THE EXPRESS WARRANTIES AND BE OTHERWISE SUBJECT TO AND LIMITED BY THE TERMS OF BURKE'S PRODUCT WARRANTY. SOME STATES DO NOT ALLOW THE EXCLUSION OF CERTAIN IMPLIED WARRANTIES, SO THE ABOVE LIMITATION MAY NOT APPLY TO YOU.**

**Warranty Exclusions:** The above stated warranties do not cover: "cosmetic" defects, such as scratches, dents, marring, or fading; damage due to incorrect installation, vandalism, misuse, accident, wear and tear from normal use, exposure to extreme weather; immersion in salt or chlorine water, unauthorized repair or modification, abnormal use, lack of maintenance, or other cause not within Burke's control; and

**Limitation of Remedies:** Burke is not liable for consequential or incidental damages, including but not limited to labor costs or lost profits resulting from the use of or inability to use the products or from the products being incorporated in or becoming a component of any other product. If, after a reasonable number of repeated efforts, Burke is unable to repair or replace a defective or nonconforming product, Burke shall have the option to accept return of the product, or part thereof, if such does not substantially impair its value, and return the purchase price as the buyer's entire and exclusive remedy. Without limiting the generality of the foregoing, Burke will not be responsible for labor costs involved in the removal of products or the installation of replacement products. Some states do not allow the exclusion of incidental damages, so the above exclusion may not apply to you.

The environment near a saltwater coast can be extremely corrosive. Some corrosion and/or deterioration is considered "normal wear" in this environment. Product installed within 500 yards of a saltwater shoreline will only be covered for half the period of the standard product warranty, up to a maximum of five years, for defects caused by corrosion. Products installed in direct contact with saltwater or that are subjected to salt spray are not covered by the standard warranty for any defects caused by corrosion.

Contact your local Burke Representative for warranty information regarding Burke Turf® and Burke Tile products.

### Terms of Sale

**Pricing:** Prices published in this catalog are in USD, are approximate and do not include shipping & handling, surfacing, installation nor applicable taxes. All prices are subject to change without notice. Contact your Burke representative for current pricing. Payments are to be made in USD.

**Weights:** Weights are approximate and may vary with actual orders.

**Installation:** All equipment is shipped unassembled. For a list of factory-certified installers in your area, please contact your Burke representative.

**Specifications:** Product specifications in this catalog were correct at the time of publication. However, product improvements are ongoing at Burke, and we reserve the right to change or discontinue specifications without notice.

**Loss or Damage in Transit:** A signed bill of lading is our receipt from a carrier that our shipment to you was complete and in good condition upon arrival. Before you sign, please check the Bill of Lading carefully when the shipment arrives to make sure nothing is missing and there are no damages. Once the shipment leaves our plant, we are no longer responsible for any damage, loss or shortage.

For more information regarding the warranty, call Customer Service at 920-921-9220 or 1-800-356-2070.

01/2021

# SUPPLEMENTAL PLAYGROUND WARRANTY

*For Burke playgrounds installed by PlaySouth Playground Creators*

Customer Name

Project Name

In addition to BCI Burke’s non-prorated Generations Warranty, PlaySouth Playground Creators will at no additional cost to you, perform **free replacement** of any part failure covered under Burke’s warranty! After our receipt of the replacement parts from Burke, these warranty repairs are performed by factory trained and industry certified personnel to assure you that your new playground will continue to provide fun, safe and durable play for years to come!

**This zero-cost warranty provides you with the absolute lowest cost of ownership!**

*\*See BCI Burke’s Generations Warranty for complete details.*

\_\_\_\_\_ *for PlaySouth Playground Creators*

\_\_\_\_\_ *Date*







## Unknown Obstacles and Rock Clause

The installation of playground equipment, shade structures, site furnishings and similar products requires the excavation of soil to install concrete footers. It is not uncommon to encounter small loose rock, small tree roots, packed clay or similar natural items in the soil as we dig, which is considered part of our standard operating procedures. However, on infrequent occasions we may encounter more substantial underground obstacles that either could not be anticipated, or are not native to the original soil. These include (but are not limited to) solid rock, below-grade tree stumps, old foundations and/or concrete footers, fill material or other such unknown obstacles.

If during the progress of the work, preexisting subsurface or latent physical conditions are encountered at the site, differing materially from the scope of work indicated in the contract, or if preexisting unknown physical conditions of an unusual nature, differing materially from those ordinarily encountered and generally recognized as inherent in the typical work provided for in the contract, are encountered at the site, the party discovering such conditions shall promptly notify the other party in writing of the specific differing site conditions before the affected remedial work is performed.

Typically, if any unknown underground obstacles are encountered that impede the progress of the excavation more than 15 minutes, we will inform the customer immediately and request a change order to be executed on a time and material basis for remedial of the underground obstacle(s). Hourly rates will be specified in the change order. There will be a minimum of a 1-hour labor charge or a \$50.00 minimum charge (whichever is higher), plus reimbursement of equipment rental fees (if any) on all change orders.

**GRJ85**



*Item #7.*

Page 89

RESOLUTION NO. 2024-\_\_\_\_\_

**A RESOLUTION TO AUTHORIZE THE PURCHASE PLAYGROUND EQUIPMENT FOR POCKET PARKS.**

WHEREAS, the City of Forest Park (“City”) is a municipal corporation duly organized and existing under the laws of the State of Georgia and is charged with being fiscally responsible concerning the use and expenditure of all public funds; and

WHEREAS, the City’s Police Department requires additional portable radios for its incoming police officers; and

WHEREAS, the City desires to enhance its parks by purchasing new playground equipment for the pocket parks located in Wards 3, 4, and 5; and

WHEREAS, pursuant to Sec. 3-1-9(b)(3) of the City’s Code of Ordinances, competitive bids are not required for purchases made pursuant to a state contract; and

WHEREAS, the State has an existing Sourcewell contract for Burke playground equipment (Contract No. 010521-BUR) under which the City can purchase the necessary equipment.

THEREFORE, THE CITY COUNCIL OF THE CITY OF FOREST PARK HEREBY RESOLVES:

**SECTION 1. Approval of Vendor.** The quote from PlaySouth Playground Creators for Burke playground equipment as presented to the Council on April 1, 2024, is hereby approved.

**SECTION 2. Public Record.** This document shall be maintained as a public record by the City Clerk and shall be accessible to the public during all normal business hours of the City of Forest Park.

**SECTION 3. Authorization of Execution.** The Mayor is hereby authorized to sign all documents necessary to effectuate this Resolution.

**SECTION 4. Attestation.** The City Clerk is authorized to execute, attest to, and seal any documents which may be necessary to effectuate this ordinance, subject to approval as to form by the City Attorney.

**SECTION 5. Effective Date.** This resolution shall become effective immediately upon its adoption by the Mayor and City Council of the City of Forest Park as provided in the City Charter.

SO RESOLVED this \_\_\_\_ day of \_\_\_\_\_, 2024.

\_\_\_\_\_  
Angelyne Butler, Mayor

ATTEST:

\_\_\_\_\_  
(SEAL)  
City Clerk

APPROVED AS TO FORM:

---

City Attorney

## **File Attachments for Item:**

### **8. Council Discussion and Approval - CPRG Grant Agreement with Clayton County-Public Works Department**

#### **Background/History:**

The City of Forest Park is committed to fostering cleaner air and a healthier environment for our residents. As part of this commitment, we are exploring the possibility of participating in a project with Clayton County to apply for grant funds through the EPA Climate Pollution Grant program. This grant would enable us to acquire EV vehicles and establish charging infrastructure within our community.

#### **Project Objectives:**

Phasing out aging government vehicles with zero-emissions electric vehicles.

Installing charger stations.

Building out utilities and power infrastructure to support EV usage.

Purchasing electric vehicles to replace traditional combustion engine vehicles.

#### **Grant Details:**

No local match is required for this grant, making it a financially advantageous opportunity for the City.

The project will involve a collaboration with 9 localities across the Atlanta metropolitan region to collectively reduce greenhouse gas emissions in the transportation sector. Staff recommends that the City Council discuss and approve our participation in entering into a grant agreement with Clayton County for the Climate Pollution Grant program to build a greener and more sustainable future for Forest Park.



CITY OF  
**FORESTPARK**

## City Council Agenda Item

---

**Title of Agenda Item:** CPRG Grant Agreement with Clayton County

**Submitted By:** Nigel Wattlely

**Date Submitted:** 3-28-2024

**Work Session Date:** 3-28-2024

**Council Meeting Date:** 4-1-2024

---

### Background/History:

The City of Forest Park is committed to fostering cleaner air and a healthier environment for our residents. As part of this commitment, we are exploring the possibility of participating in a project with Clayton County to apply for grant funds through the EPA Climate Pollution Grant program. This grant would enable us to acquire EV vehicles and establish charging infrastructure within our community.

### Project Objectives:

Phasing out aging government vehicles with zero-emissions electric vehicles.

Installing charger stations.

Building out utilities and power infrastructure to support EV usage.

Purchasing electric vehicles to replace traditional combustion engine vehicles.

### Grant Details:

No local match is required for this grant, making it a financially advantageous opportunity for the City.

The project will involve a collaboration with 9 localities across the Atlanta metropolitan region to collectively reduce greenhouse gas emissions in the transportation sector. Staff recommends that the City Council discuss and approve our participation in entering into a grant agreement with Clayton County for the Climate Pollution Grant program to build a greener and more sustainable future for Forest Park.

---

### **Action Requested from Council:**

Discussion and Approval to enter into an agreement.



---

**Cost:** \$ 0

**Budgeted for:**  **Yes**  **No**

**Financial Impact:**

None

---



March 25, 2024

David Vazquez  
 Chief Resilience Officer  
 Office of Sustainability & Resilience  
 Clayton County  
 1590 Adamson Parkway, Suite 370 Morrow, GA 30260

RE: City of Forest Park/Clayton County commits to the *Atlanta EV Fleet Alliance: Accelerating Local Government Fleet Electrification in the Atlanta Metropolitan Area for Cleaner Air and Healthier Communities* project

Dear Mr. Vazquez,

I am writing to express the City of Forest Park's commitment to participate as a coalition member of the *Atlanta EV Fleet Alliance: Accelerating Local Government Fleet Electrification in the Atlanta Metropolitan Area for Cleaner Air and Healthier Communities* project. Forest Park, which is located within Clayton County, also commits to sign a Memorandum of Agreement (MOA) for the Clayton County Government's coalition application to the US Environmental Protection Agency (US EPA) Climate Pollution Reduction Grant (CPRG) if the project is approved. The *Atlanta EV Fleet Alliance* project aims to significantly lower greenhouse gas emissions (GHG) in the transportation sector by phasing out aging government vehicles, introducing zero emissions electric vehicles, and installing EV charging infrastructure in 9 localities across the Atlanta metropolitan region.

The City of Forest Park is dedicated to the Atlanta E.V. Fleet Alliance project as it aligns with our values of sustainability and reducing carbon emissions, ultimately enhancing the well-being of our community by fostering cleaner air and a healthier environment for all residents. Additionally, by embracing electric vehicle technology, we aim to lead by example in embracing innovative solutions to combat climate change and create a greener, more resilient future.

Our participation in the project will help ensure its success as we will participate and be committed to contributing to the coalition task force aimed at accelerating the electrification of local government fleets in the Atlanta metro area. As an active participant, Forest Park will diligently document and share our experiences, insights, and best practices with fellow members. Through this collaborative effort, we aim to facilitate knowledge exchange, training for staff and

foster successful EV fleet transitions, ultimately promoting cleaner air and healthier communities across the region.

The City of Forest Park was a founding member of the Atlanta EV Alliance coalition. If awarded funding, we will work with the Clayton County Government and Coalition members to carry out the project activities outlined within the CPRG grant proposal and MOA. The MOA will clearly describe the agreed-upon roles, responsibilities, contributions, resources, and commitments each partner will provide to ensure project success, as well as the coalition's operating model and statement of accountability to US EPA.

Please give the Atlanta EVAlliance application the highest consideration for funding.

Sincerely,

Bobby E. Jinks Jr.  
Director Public Works, City of Forest Park



**CLIMATE  
POLLUTION  
REDUCTION  
GRANTS**

U.S. Environmental Protection Agency



## Linkage to EPA Strategic Plan:

Support Goal 1, “Tackle the Climate Crisis”; Objective 1.1, “Reduce Emissions that Cause Climate Change.”

Under this objective, EPA will “aggressively reduce the emissions of greenhouse gases from all sectors while increasing energy and resource efficiency and the use of renewable energy.”

## What the EPA is looking for in successful applications:

1. Stimulate transformation toward a decarbonized economy and demonstrate approaches that are **replicable** to unlock opportunities for even greater emissions reductions;
2. Result in benefits (and do not result in negative impacts) to **low-income and disadvantaged communities**, such as CAP and HAP reductions, equitable economic growth, and improved quality of life outcomes, where applicable;
3. Support measures for which dedicated funding or financing from other sources is **unavailable** or that leverage other sources of public and private funding to the fullest extent possible prior to seeking CPRG funding;
4. Achieve GHG emission reductions that are long-lasting and certain;
5. Incorporate high labor standards, emphasize job quality, and support equitable workforce development; and,



## Our Proposal

**EV Fleet Alliance: Accelerating Local Government Fleet Electrification in the Atlanta Metropolitan Area for Cleaner Air and Healthier Communities**

# Coalition Members

---

**Lead Applicant:**

Clayton County

City	County
Clayton	Clayton
Forest Park City	Clayton
Jonesboro City	Clayton
Lovejoy City	Clayton
Cobb	Cobb
Douglasville City	Douglas
East Point City	Fulton
South Fulton	Fulton
Union City	Fulton





# GHG Reduction measure

The project will lower greenhouse gas emissions (GHG) in the transportation sector by phasing out aging government vehicles and introducing zero emissions electric vehicles in 9 localities across the Atlanta metropolitan region.

# Project Scope

With US EPA CPRG Implementation grant funds, the **Atlanta Metro EV Fleet Alliance** team will accomplish the following:

- Technical Analysis and Transition Planning for each locality (1 year)
- Install charger stations
- Build out utilities and power infrastructure
- Purchase of Electric Vehicles

# Questions to coalition members

---



# Vehicles

1. Do you have an estimate on the number of older vehicles you would like to transition to EV?
2. If so, what kind of vehicles are they? (sedans, vans, heavy duty trucks, medium duty trucks, passenger truck, refuse trucks, school buses, transit buses)



# Chargers

1. Do you have estimates for the number of EV chargers that you would like to install? If so, do you know the kind of chargers (Level 1, Level 2, DCFC)?
2. If you have estimates for the charging infrastructure, do you know the kind of utility work that would be needed for this installation?
3. How viable is solar energy in your district (as a possibility for the power source for charging stations)

# Next Steps for Coalition Members

- Priority this week: budget and scope
- Weekly meetings
- Letter of intent to sign MOU (we will send a template)



# More information on the Notice for Funding Opportunity (NOFO)

**AGENCY:** Environmental Protection Agency (EPA)  
**TITLE:** Climate Pollution Reduction Grants Program: Implementation Grants General Competition  
**ACTION:** Notice of Funding Opportunity (NOFO) Amendment No. 3  
**FUNDING OPPORTUNITY NUMBER:** EPA-R-OAR-CPRGI-23-07  
**Assistance Listing No:** 66.046  
**DATE:** January 16, 2024



# Number and Amount of Awards

*Table 1: Grants Ranges and Funding by Tier*

<b>Tier</b>	<b>Grant Ranges</b>	<b>Funds Targeted for Each Tier</b>	<b>Anticipated Number of Grants to be Awarded</b>
Tier A	\$200,000,000 – \$500,000,000	\$2 billion	4-10
Tier B	\$100,000,000 – \$199,999,999	\$1.3 billion	6-13
Tier C	\$50,000,000 – \$99,999,999	\$0.6 billion	6-12
Tier D	\$10,000,000 – \$49,999,999	\$0.3 billion	6-30
Tier E	\$2,000,000 – \$9,999,999	\$0.1 billion	10-50

Applications must request EPA assistance funds within the range of \$2 million to \$500 million, as specified in Section II.B. Applications that request EPA assistance funds less than \$2 million or in excess of \$500 million are not eligible and will not be reviewed.

A stylized sun graphic on the left side of the page. It consists of a solid yellow circle at the bottom left, with several yellow dashed lines of varying lengths radiating upwards and to the right, suggesting rays of light. The background is a gradient from orange at the top to white at the bottom, with a large white semi-circle on the right side.

# PROJECT NARRATIVE (25 PAGES)



# Section 1: Overall Project Summary and Approach

- Description of GHG Reduction Measures
- Demonstration of Funding Need - Applicants must demonstrate a strong need for CPRG implementation funding that is unmet by other funding sources
- Transformative Impact
  - Pioneering, replicable, and scalable policies or programs to increase the deployment of existing GHG emission reduction technologies or mitigation approaches;
  - GHG emission reductions from hard-to-abate sectors where GHG emission reduction measures are not widely adopted; or,
  - Market transformations that accelerate the deployment and market adoption of emerging GHG emission reduction technologies or practices.

## Section 2: Impact of GHG Reduction Measures (60 possible points)

Applications should describe the magnitude of both near-term and long-term cumulative GHG emission reductions, the relative cost-effectiveness of those reductions, and the reasonableness and quality of the assumptions and calculations used to determine the reductions and cost-effectiveness of those reductions

- Magnitude of GHG Reductions from 2025 through 2030 (20 possible points)
- Magnitude of GHG Reductions from 2025 through 2050 (10 possible points)
- Cost Effectiveness of GHG Reductions (15 possible points)
- Documentation of GHG Reduction Assumptions (15 possible points)
  - *Applicants must provide a technical appendix, along with the project narrative, demonstrating the reasonableness of their GHG emission reduction estimates.*

# Section 3: Environmental Results – Outputs, Outcomes, and Performance Measures (30 possible points)

- Expected Outputs and Outcomes
- Performance Measures and Plan – describe proposed performance measures that will be the mechanism to track, measure, and report progress toward achieving the expected outputs and outcomes for each GHG reduction measure.
- Authorities, Implementation Timeline, and Milestones -

## Section 4: Low-Income and Disadvantaged Communities (35 possible points)

### Community Benefits

- Applications should discuss and quantify, where possible, direct and indirect benefits and potential disbenefits to low-income and disadvantaged communities.
  - Examples: Improved public health resulting from reductions in co-pollutants (e.g., CAPs, such as NO<sub>x</sub>, ozone, PM<sub>2.5</sub>, and HAPs), such as reductions in new asthma cases
  - Creation of high-quality jobs and new workforce training opportunities in low-income and disadvantaged communities with an emphasis on expanding opportunities for individuals that face barriers to employment
    - Applications may request funding to be used for high-quality workforce development activities tied to a proposed measure that benefit individuals in low-income and disadvantaged communities.

## Section 4 cont...

### Community Engagement

- Applicant must answer:
  - How input by low-income and disadvantaged communities has been incorporated into this application; and
  - How meaningful engagement with low-income and disadvantaged communities will be continuously included in the development and implementation of the GHG reduction measures throughout the life of this grant.
- Examples: Creating a community work group or advisory board made up of community members; Holding community consultations or public input meetings

\*\*Letters of commitment should be included



## Section 5: Job Quality (5 possible points)

Applications should describe concrete, specific strategies to ensure CPRG implementation grant funds and the implementation of the GHG reduction measures generate high-quality jobs with a diverse, highly skilled workforce and support “high road” labor practices.

Examples of strategies include, but are not limited to:

- Clear commitments to paying at least the median area income for all workers (where prevailing wage is not required by law);
- Requiring employers, including contractors and subcontractors, to provide family- sustaining benefits and retirement contributions;
- Employees are represented by a collective bargaining agreement;
- Formal partnerships with labor organizations and other workers’ rights groups;

## Section 6: Programmatic Capability and Past Performance (30 possible points)

- Past Performance (10 possible points)
  - Submit a list of up to five federally funded or non-federally funded assistance agreements that the applicant is performing or has performed within the last three years.
- Reporting Requirements (10)
- Staff Expertise (10)

# Section 7: Budget (45 possible points)

- Staffing and contractual costs necessary to implement GHG reduction measures;
- Building, materials, equipment, and infrastructure costs to implement GHG reduction measures;
- Programs to disburse funds to consumers, businesses, and other parties, in the form of subsidies, incentives, or other mechanisms, that result in GHG emission reductions;
- Subawards to municipalities, other states, air pollution control agencies, regional planning organizations, non-governmental organizations (NGOs), academic institutions, etc.;
- Studies, assessments, data collection, etc., needed to develop and implement GHG reduction measures;
- Evaluation and metrics-tracking activities;
- Planning and implementing meetings, workshops, and convenings to foster collaboration among and between levels of government, the public, and key stakeholders;
- Outreach and education for stakeholders and members of the public;
- Modeling and analytical costs, including purchase or licensing of software, data, or tools;
- Training and staff capacity-building costs to implement GHG reduction measures;
- Supplies (e.g., office supplies, software, printing, etc.)

# Application Materials

Standard Form 424, *Application for Federal Assistance*. Please note that the organizational Unique Entity Identifier (UEI) must be included on the SF-424.

Standard Form 424A, *Budget Information for Non-Construction Programs*

EPA Form 4700-4, *Pre-Award Compliance Review Report*. See EPA's Applicant

EPA Form 5700-54, *Key Contacts Form*

Grants.gov Lobbying Form

Standard Form LLL, *Disclosure of Lobbying Activities*. (Required if applicable)

*Project Narrative Attachment Form*.

- Workplan (up to 25 pages)
- Budget Narrative (up to 10 additional pages of descriptive budget narrative)
- Technical appendix (up to 10 additional pages). Explains the assumptions and methodology for determining the estimated GHG emission reductions for each measure