



CITY of ESCONDIDO

COUNCIL MEETING AGENDA

WEDNESDAY, MAY 15, 2024

4:00 PM - Closed Session (Cancelled)

5:00 PM - Regular Session

Escondido City Council Chambers, 201 North Broadway, Escondido, CA 92025

WELCOME TO YOUR CITY COUNCIL MEETING

We welcome your interest and involvement in the legislative process of Escondido. This agenda includes information about topics coming before the City Council and the action recommended by City staff.

MAYOR

Dane White

DEPUTY MAYOR

Christian Garcia (District 3)

COUNCILMEMBERS

Consuelo Martinez (District 1)

Joe Garcia (District 2)

Michael Morasco (District 4)

CITY MANAGER

Sean McGlynn

CITY ATTORNEY

Michael McGuinness

CITY CLERK

Zack Beck

HOW TO WATCH

The City of Escondido provides three ways to watch a City Council meeting:

In Person



201 N. Broadway

On TV



Cox Cable Channel 19 and U-verse Channel 99

Online

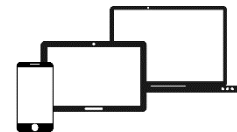

www.escondido.gov



CITY of ESCONDIDO

COUNCIL MEETING AGENDA

WEDNESDAY, MAY 15, 2024

HOW TO PARTICIPATE

The City of Escondido provides two ways to communicate with the City Council during a meeting:

In Person



Fill out Speaker Slip and Submit to City Clerk

In Writing



<https://escondido-ca.municodemeetings.com>

ASSISTANCE PROVIDED

If you need special assistance to participate in this meeting, please contact our ADA Coordinator at 760-839-4869. Notification 48 hours prior to the meeting will enable the city to make reasonable arrangements to ensure accessibility. Listening devices are available for the hearing impaired – please see the City Clerk.





CITY of ESCONDIDO

COUNCIL MEETING AGENDA

WEDNESDAY, MAY 15, 2024

REGULAR SESSION

5:00 PM Regular Session

MOMENT OF REFLECTION

City Council agendas allow an opportunity for a moment of silence and reflection at the beginning of the evening meeting. The City does not participate in the selection of speakers for this portion of the agenda, and does not endorse or sanction any remarks made by individuals during this time. If you wish to be recognized during this portion of the agenda, please notify the City Clerk in advance.

FLAG SALUTE

The City Council conducts the Pledge of Allegiance at the beginning of every City Council meeting.

CALL TO ORDER

Roll Call: C. Garcia, J. Garcia, Martinez, Morasco, White

PROCLAMATIONS

National Public Works Week, May 19-25, 2024

PRESENTATIONS

Quarterly San Diego County Water Authority Presentation

4th Grade Water Poster Contest Winners

ORAL COMMUNICATIONS

In addition to speaking during particular agenda items, the public may address the Council on any item which is not on the agenda provided the item is within the subject matter jurisdiction of the City Council. State law prohibits the Council from discussing or taking action on such items, but the matter may be referred to the City Manager/staff or scheduled on a subsequent agenda. Speakers are limited to only one opportunity to address the Council under Oral Communications.

CONSENT CALENDAR

Items on the Consent Calendar are not discussed individually and are approved in a single motion. However, Council members always have the option to have an item considered separately, either on their own request or at the request of staff or a member of the public.



CITY of ESCONDIDO

COUNCIL MEETING AGENDA

WEDNESDAY, MAY 15, 2024

1. AFFIDAVITS OF PUBLICATION, MAILING, AND POSTING (COUNCIL/RRB)

2. APPROVAL OF WARRANT REGISTERS (COUNCIL)

Request approval for City Council and Housing Successor Agency warrant numbers:

- 383471 – 383701 dated May 01, 2024

Staff Recommendation: Approval (Finance Department: Christina Holmes)

3. APPROVAL OF MINUTES: Special Meeting of April 30, 2024

4. WAIVER OF READING OF ORDINANCES AND RESOLUTIONS

5. CONTINUING EMERGENCY REPAIR OF THE ESCONDIDO LAND OUTFALL

Request the City Council approve Resolution No. 2024-57, declaring that pursuant to the terms of Section 22050 of the California Public Contract Code, the City Council finds there is a need to continue emergency repairs of the Escondido Land Outfall. The resolution, which must be passed by four-fifths vote, also declares that public interest and necessity demand the immediate expenditure to safeguard life, health, or property.

Staff Recommendation: Approval (Utilities Department: Angela Morrow, Interim Director of Utilities)

Presenter: Angela Morrow, Interim Director of Utilities

- a) Resolution No. 2024-57

PUBLIC HEARING

6. RANCHITO DRIVE SEWER REPAYMENT AGREEMENT

Request the City Council adopt Resolution No. 2024-55 approving the Sewer Repayment Agreement for Ranchito Drive and authorizing the Mayor to execute the agreement on behalf of the City of Escondido ("City").

Staff Recommendation: Approval (Development Services Department: Christopher McKinney, Deputy City Manager/Interim Director of Development Services)

Presenter: Owen Tunnell, Interim City Engineer

- a) Resolution No. 2024-55



CITY of ESCONDIDO

COUNCIL MEETING AGENDA

WEDNESDAY, MAY 15, 2024

CURRENT BUSINESS

7. FINANCIAL REPORT FOR THE QUARTER ENDED MARCH 31, 2024

Request the City Council receive and file the third quarter financial report for Fiscal Year 2023/24.

Staff Recommendation: Approval (Finance Department: Christina Holmes, Director of Finance)

Presenter: Christina Holmes, Director of Finance

FUTURE AGENDA

8. FUTURE AGENDA

The purpose of this item is to identify issues presently known to staff or which members of the City Council wish to place on an upcoming City Council agenda. Council comment on these future agenda items is limited by California Government Code Section 54954.2 to clarifying questions, brief announcements, or requests for factual information in connection with an item when it is discussed.

Staff Recommendation: None (City Clerk's Office: Zack Beck)

COUNCILMEMBERS SUBCOMMITTEE REPORTS AND OTHER REPORTS

CITY MANAGER'S WEEKLY ACTIVITY REPORT

The most current information from the City Manager regarding Economic Development, Capital Improvement Projects, Public Safety, and Community Development. This report is also available on the City's website, www.escondido.gov.

ORAL COMMUNICATIONS

In addition to speaking during particular agenda items, the public may address the Council on any item which is not on the agenda provided the item is within the subject matter jurisdiction of the City Council. State law prohibits the Council from discussing or taking action on such items, but the matter may be referred to the City Manager/staff or scheduled on a subsequent agenda. Speakers are limited to only one opportunity to address the Council under Oral Communications.

ADJOURNMENT

UPCOMING MEETING SCHEDULE

Wednesday, May 22, 2024	4:00 & 5:00 PM	Closed Session, Regular Meeting, <i>Council Chambers</i>
Wednesday, June 05, 2024	4:00 & 5:00 PM	Closed Session, Regular Meeting, <i>Council Chambers</i>



CITY *of* ESCONDIDO

COUNCIL MEETING AGENDA

WEDNESDAY, MAY 15, 2024

SUCCESSOR AGENCY

Members of the Escondido City Council also sit as the Successor Agency to the Community Development Commission, Escondido Joint Powers Financing Authority, and the Mobilehome Rent Review Board.



AFFIDAVITS

OF

ITEM

POSTING –

- RANCHITO REPAYMENT AGREEMENT – S22-0003



CITY OF ESCONDIDO
OFFICE OF THE CITY CLERK
201 NORTH BROADWAY
ESCONDIDO, CA 92025-2798
760-839-4617

NOTICE OF PUBLIC HEARING

The Escondido City Council will hold a public hearing, in the City Council Chambers, Escondido City Hall, 201 N. Broadway, Escondido, CA at **5 p.m.** on **Wednesday, May 15, 2024**, to consider the item below:

RANCHITO REPAYMENT AGREEMENT – S22-0003

REQUEST: SEWER REPAYMENT AGREEMENT FOR RANCHITO DRIVE

The Laurinda Suzan Barnes Trust Dated December 16, 2020 constructed sewer improvements for the purpose of serving the property at 640 Ranchito Drive, Escondido, CA 92025 (“Property”) that will also serve or otherwise benefit, directly or indirectly, three other parcels in the vicinity of the Property and desires to be repaid for a portion of the cost of the improvements from the owners of other benefitted parcels.

BENEFITED PROPERTY LOCATION: 612, 633, 640 RANCHITO DRIVE AND APN 239-051-10.

ENVIRONMENTAL STATUS: The activity is not a “Project” as defined under Section 15378 of the California Environmental Quality Act State Guidelines. Therefore, pursuant to State Guidelines Section 15060(c)(3) no environmental review is required.

If you challenge this item in court, you may be limited to raising only those issues you or someone else raised at the public hearing described in this notice, or in written correspondence delivered to the City Council at, or prior to, the public hearing.

PUBLIC COMMENT: To submit comments in writing, please do so at the following link: <https://escondido-ca.municodemeetings.com/bc-citycouncil/webform/public-comment>. All comments received from the public will be made a part of the record of the meeting.

The City of Escondido remains committed to complying with the Americans with Disabilities Act (ADA). Qualified individuals with disabilities who wish to participate in City programs, services, or activities and who need accommodations are invited to present their requests to the City by filing out a Request for Accommodations Form or an Inclusion Support Request Form for Minors, or by calling 760-839-4643, preferably at least 72 hours in advance of the event or activity. Forms can be found on the City’s website at: <https://www.escondido.org/americans-with-disabilities-act>.

The staff report will be available at the Escondido Engineering Division, 201 N. Broadway, Escondido, CA 92025; and on the City’s website at <https://escondido-ca.municodemeetings.com/> after Thursday, May 9, 2024.

For additional information, please contact Jason Christman, Principal Engineer, at 760-839-4615, or via email at jchristman@escondido.org.

DocuSigned by:

A58535D0BDC1430...
Zack Beck, City Clerk
City of Escondido
Dated: May 2, 2024

**Published in THE ESCONDIDO TIMES ADVOCATE:
5/2/24**



STAFF REPORT

May 15, 2024
File Number 0400-40

SUBJECT

APPROVAL OF WARRANT REGISTERS (COUNCIL)

DEPARTMENT

Finance

RECOMMENDATION

Request approval for City Council and Housing Successor Agency warrant numbers:

383471 – 383701 dated May 01, 2024

Staff Recommendation: Approval (Finance Department: Christina Holmes)

ESSENTIAL SERVICE – Yes, Internal requirement per Municipal Code Section 10-49.

COUNCIL PRIORITY –

FISCAL ANALYSIS

The total amount of the warrants for the following periods are as follows:

April 25, 2024 – May 01, 2024 is \$1,510,205.86

PREVIOUS ACTION – None

BACKGROUND

The Escondido Municipal Code Section 10-49 states that warrants or checks may be issued and paid prior to audit by the City Council, provided the warrants or checks are certified and approved by the Director of Finance as conforming to the current budget. These warrants or checks must then be ratified and approved by the City Council at the next regular Council meeting.



CITY of ESCONDIDO

COUNCIL MEETING MINUTES

REGULAR SESSION

4:00 PM Special Meeting

MOMENT OF REFLECTION

City Council agendas allow an opportunity for a moment of silence and reflection at the beginning of the evening meeting. The City does not participate in the selection of speakers for this portion of the agenda, and does not endorse or sanction any remarks made by individuals during this time. If you wish to be recognized during this portion of the agenda, please notify the City Clerk in advance.

FLAG SALUTE

The City Council conducts the Pledge of Allegiance at the beginning of every City Council meeting.

CALL TO ORDER

Roll Call: C. Garcia, J. Garcia, Martinez, Morasco, White

ORAL COMMUNICATIONS

None

CURRENT BUSINESS

1. RATIFICATION OF LOCAL EMERGENCY PROCLAMATION AND APPROVE EMERGENCY REPAIR OF THE ESCONDIDO LAND OUTFALL

Request the City Council take the following actions: Adopt Resolution No. 2024-52, ratifying Proclamation No. 2024-01 by the Director of Emergency Services and declaring that pursuant to the California Public Contract Code and Escondido Municipal Code, the City Council affirms that it was appropriate for City staff to forego competitive bidding procedures and to award a contract for emergency repairs of the Escondido Land Outfall. Approve a Budget Adjustment in the amount of \$1,700,000. (File Number 0600-10; A-3503)

Staff Recommendation: Approval (Utilities Department: Angela Morrow, Interim Director of Utilities)

Presenter: Angela Morrow, Interim Director of Utilities

- a) Resolution No. 2024-52



CITY of ESCONDIDO

COUNCIL MEETING MINUTES

Motion: White; Second: J. Garcia; Approved: 5-0

FUTURE AGENDA

2. FUTURE AGENDA

The purpose of this item is to identify issues presently known to staff or which members of the City Council wish to place on an upcoming City Council agenda. Council comment on these future agenda items is limited by California Government Code Section 54954.2 to clarifying questions, brief announcements, or requests for factual information in connection with an item when it is discussed.

Staff Recommendation: None (City Clerk's Office: Zack Beck)

COUNCILMEMBERS SUBCOMMITTEE REPORTS AND OTHER REPORTS

CITY MANAGER'S WEEKLY ACTIVITY REPORT

The most current information from the City Manager regarding Economic Development, Capital Improvement Projects, Public Safety, and Community Development. This report is also available on the City's website, www.escondido.org.

ORAL COMMUNICATIONS

None

ADJOURNMENT

Mayor White adjourned the meeting at 4:14 p.m.

MAYOR

CITY CLERK



STAFF REPORT

ITEM NO. 4

SUBJECT

WAIVER OF READING OF ORDINANCES AND RESOLUTIONS –

ANALYSIS

The City Council/RRB has adopted a policy that is sufficient to read the title of ordinances at the time of introduction and adoption, and that reading of the full text of ordinances and the full text and title of resolutions may be waived.

Approval of this consent calendar item allows the City Council/RRB to waive the reading of the full text and title of all resolutions agendized in the Consent Calendar, as well as the full text of all ordinances agendized in either the Introduction and Adoption of Ordinances or General Items sections. **This particular consent calendar item requires unanimous approval of the City Council/RRB.**

Upon approval of this item as part of the Consent Calendar, all resolutions included in the motion and second to approve the Consent Calendar shall be approved. Those resolutions removed from the Consent Calendar and considered under separate action may also be approved without the reading of the full text and title of the resolutions.

Also, upon the approval of this item, the Mayor will read the titles of all ordinances included in the Introduction and Adoption of Ordinances section. After reading of the ordinance titles, the City Council/RRB may introduce and/or adopt all the ordinances in one motion and second.

RECOMMENDATION

Staff recommends that the City Council/RRB approve the waiving of reading of the text of all ordinances and the text and title of all resolutions included in this agenda. Unanimous approval of the City Council/RRB is required.

Respectfully Submitted,

Zack Beck
City Clerk



STAFF REPORT

May 15, 2024

File Number 0600-10; A-3503

SUBJECT

CONTINUING EMERGENCY REPAIR OF THE ESCONDIDO LAND OUTFALL

DEPARTMENT

Utilities Department

RECOMMENDATION

Request the City Council Approve Resolution No. 2024-57, declaring that pursuant to the terms of Section 22050 of the California Public Contract Code, the City Council finds there is a need to continue emergency repairs of the Escondido Land Outfall. The resolution, which must be passed by four-fifths vote, also declares that public interest and necessity demand the immediate expenditure to safeguard life, health, or property.

Staff Recommendation: Approval (Utilities: Angela Morrow)

Presenter: Angela Morrow, Interim Director of Utilities

ESSENTIAL SERVICE – Yes, Keep City Clean for Public Health and Safety; Sewer

COUNCIL PRIORITY – Improve Public Safety

FISCAL ANALYSIS

A contract with CCL Contracting, Inc. has been executed for the repair in an amount not to exceed \$1,681,802. The contract is a 'time and materials' contract, meaning that the contractor will bill for staff time, equipment, and construction materials necessary to complete the repairs. Funding for the emergency Land Outfall repairs is available in the Wastewater Capital Improvement Project ("CIP") budget for Outfall Maintenance, CIP No. 800078.

PREVIOUS ACTION

On April 30, 2024, the City Council: 1) adopted Resolution No. 2024-52, declaring that pursuant to the terms of Section 22050 of the California Public Contract Code, the City Council affirms that it was appropriate for City staff to forego normal bidding procedures and to award a contract for emergency repairs of the Escondido Land Outfall. The resolution, which must be passed by four-fifths vote, also declares that public interest and necessity demand the immediate expenditure to safeguard life, health, or property; and 2) approved a Budget Adjustment in the amount of \$1,700,000.



CITY *of* ESCONDIDO

STAFF REPORT

BACKGROUND

Utilities staff continue to coordinate with staff from the SEJPA, the San Diego Regional Water Quality Control Board ("Regional Board"), San Diego Gas & Electric ("SDG&E"), Army Corps of Engineers, Department of Fish and Wildlife, County of San Diego, City of Encinitas, San Elijo Nature Center and the Nature Collective.

CCL Contracting, Inc. mobilized at the site and has begun excavating the Land Outfall pipeline.

RESOLUTIONS

- a. Resolution No. 2024-57
- b. Resolution No. 2024-57 – Exhibit "A": Public Improvement Agreement – Emergency Repair of Escondido Land Outfall Project

RESOLUTION NO. 2024-57

A RESOLUTION OF THE CITY COUNCIL OF THE CITY OF ESCONDIDO, CALIFORNIA, FINDING THAT AN EMERGENCY CONTINUES TO REQUIRE THE IMMEDIATE REPAIR OF THE ESCONDIDO LAND OUTFALL

WHEREAS, the City Council recognizes that a section of the City’s Land Outfall pipeline is at risk of an imminent, catastrophic failure; and

WHEREAS, pursuant to Resolution No. 2024-52, the City Council previously found that this risk constitutes an emergency and approved staff to proceed to purchase services without adopting plans, specifications, working details, or giving notice of bids to award contracts; and

WHEREAS, staff entered into a Public Improvement Agreement (“Agreement”) with CCL Contracting, Inc., in an amount not to exceed one million six hundred eighty-one thousand eight hundred two dollars (\$1,681,802); and

WHEREAS, pursuant to Section 22050 of the Public Contract Code, the City Council must review the emergency action every 14 days and determine by a four-fifths vote there is a need to continue the action.; and

WHEREAS, this City Council desires at this time and deems it to be in the best public interest to continue the emergency action.

NOW, THEREFORE, BE IT RESOLVED by the City Council of the City of Escondido, California, as follows:

1. That the above recitations are true.

2. That the City Council finds the failure of the Land Outfall pipeline is a public health and safety emergency, that this emergency will not permit the delay that would result from a competitive bidding process, and that the proposed action and expenditure is still necessary to respond to the emergency requiring immediate repair of the Land Outfall pipeline.



CITY OF ESCONDIDO
PUBLIC IMPROVEMENT AGREEMENT

This Public Improvement Agreement ("Agreement") is made and entered into as of the last date of signature below ("Effective Date"),

Between: CITY OF ESCONDIDO
a California municipal corporation
201 N. Broadway
Escondido, CA 92025
Attn: Randy Manns
760-839-6290, ext. 7031
("CITY")

And: CCL Contracting, Inc.
a California corporation
1938 Don Lee Place
Escondido, CA 92029
Attn: Tom Carmichael
760-743-2254
("CONTRACTOR").

(The CITY and CONTRACTOR each may be referred to herein as a "Party" and collectively as the "Parties.")

WHEREAS, the City Manager, in his role as Director of Emergency Services, has made findings that an emergency exists at a City of Escondido facility immediately affecting public safety, and has authorized this contract for emergency repair services under Chapter 7 and Section 10-80 of the Escondido Municipal Code;

WHEREAS, the Parties desire to enter into this Agreement for the performance of work relating to the Land Outfall Emergency Repair Project ("Project"), occurring on property located near the northern border of the San Elijo Lagoon, adjacent to Manchester Road, as further described herein, and as depicted in Attachment "A" to this Agreement, which is incorporated by this reference;

NOW, THEREFORE, in consideration of the mutual covenants, promises, terms, and conditions set forth herein, and the mutual benefits derived therefrom, the Parties hereby agree as follows:

1. Project Documents. The following documents pertaining to the CITY's Land Outfall Emergency Repair Project, including all modifications, addenda, and amendments thereto, are incorporated herein by this reference as is fully set forth herein and shall be collectively referred to herein as the "Project Documents": Change Orders, Shop Drawing Transmittals, Information Required of CONTRACTOR, Insurance Certificates, Guarantees, General Conditions, Supplementary General Conditions, Special Conditions, Plans, Drawings, Specifications, the Agreement, and all modifications, addenda, and amendments thereto ("Project Documents") are incorporated herein by this reference as if fully set forth herein. The Project Documents are complementary, and what is called for by any one shall be as binding as if called for by all.
2. Description and Performance of Work. CONTRACTOR shall furnish all work described in Attachment "B" to this Agreement, which is incorporated herein by this reference ("Work"). All Work to be performed and materials to be furnished shall be completed in a good workmanlike manner, free from defects, in strict accordance with the plans, drawings, specifications, and requirements set forth in the Project Documents and all provisions of this Agreement.
3. Compensation. In exchange for CONTRACTOR's completion of the Work, the CITY shall pay such rates for labor and equipment pursuant to Attachment "C" to this Agreement, and CONTRACTOR shall accept in full, an amount not to exceed the sum of **\$1,681,802.00** ("Contract Price"). CONTRACTOR shall be compensated only for performance of the Work described in this Agreement. No compensation shall be provided for any other work or services without the CITY's prior written consent.
4. Term and Time of Performance. CONTRACTOR shall commence work as soon as possible from the CITY's notice to proceed. CONTRACTOR shall diligently perform and complete the Work with professional quality and technical accuracy by **August 30, 2024** ("Completion Date"). Extension of terms or time of performance shall be subject to the CITY's sole discretion.
5. Time Is of the Essence. If the Work is not completed by the Completion Date, it is understood that the CITY will suffer damage. It being impractical and infeasible to determine the amount of actual damage, in accordance with Government Code section 53069.85, the Parties agree that CONTRACTOR shall pay to the CITY as fixed and liquidated damages, and not as a penalty, the sum of **\$1,500** per day for each calendar day of delay until the Work is completed and accepted ("Liquidated Damages Amount"). The Liquidated Damages Amount shall be deducted from any payments due to, or that become due to, CONTRACTOR. CONTRACTOR and CONTRACTOR'S surety shall be liable for the Liquidated Damages Amount.
6. Insurance Requirements.
 - a. CONTRACTOR shall procure and maintain, at its own cost, during the entire term of this Agreement, insurance against claims for injuries to persons or damages to property that may arise from or in connection with the performance of the Work, and the results of such Work, by CONTRACTOR, its agents, representatives, employees, or subcontractors. Insurance coverage shall be at least as broad as the following:
 - (1) *Commercial General Liability*. Insurance Services Office ("ISO") Form CG 0001 11188 covering Commercial General Liability on an "occurrence" basis, including products and completed operations, property damage, bodily injury (including emotional distress), sickness, disease, or death of any person other than the CONTRACTOR's employees, and personal and advertising injury, and damages because of injury or destruction of tangible property, including loss of use resulting there from, with limits no less than \$3,000,000 combined single limit coverage per occurrence for bodily injury and property damage; or, if a general aggregate limit is applicable, either: (i) the general aggregate

limit shall specifically apply to the project identified in the bid specifications or to the location of such project which is the subject of these bid specifications with coverage to be no less than \$3,000,000, or (ii) the general aggregate shall be at least \$3,000,000 combined single limit coverage per occurrence for bodily injury and property damage.

- (2) *Automobile Liability.* ISO Form CA 00 01 covering any auto (Code 1), or if CONTRACTOR has no owned autos, hired (Code 8) and non-owned autos (Code 9), including damages because of bodily injury, death of a person, or property damage arising out of the ownership, maintenance, or use of a motor vehicle, all mobile equipment, and vehicles moving under CONTRACTOR's control and engaged in the Work, with limits no less than \$3,000,000 combined single limit per accident for bodily injury and property damage.
 - (3) *Workers' Compensation.* Workers' Compensation as required by the State of California, with Statutory Limits, and Employer's Liability Insurance with limits of no less than \$1,000,000 per accident for bodily injury or disease.
 - (4) *Contractors Pollution Liability.* Contractors Pollution Liability insurance applicable to work being performed, with a limit no less than \$2,000,000 per claim and \$2,000,000 aggregate per policy period of one year.
 - (5) If CONTRACTOR maintains broader coverage and/or higher limits than the minimums otherwise required by this Agreement, the CITY requires and shall be entitled to the broader coverage and/or the higher limits maintained by CONTRACTOR.
- b. Each insurance policy required by this Agreement must be acceptable to the City Attorney and shall meet the following requirements:
- (1) *Compliance with General Condition Requirements.* Insurance coverage shall comply with and meet all requirements set forth in Article 5.2 of General Conditions
 - (2) *Acceptability of Insurers.* Insurance coverage must be provided by an insurer authorized to conduct business in the state of California with a current A.M. Best's rating of no less than A-:VII, or as approved by the CITY.
 - (3) *Additional Insured Status.* The Commercial General Liability, the Automobile Liability, and Contractors Pollution Liability policies must name the CITY (including its officials, officers, agents, employees, and volunteers) specifically as an additional insured under the policy on a separate endorsement page. The Commercial General Liability additional insured endorsement shall be at least as broad as ISO Form CG 20 10 11 85, or if not available, through the addition of *both* CG 20 10, CG 20 26, CG 20 33, or CG 20 38, *and* CG 20 37 if a later edition is used. The Automobile Liability additional insured endorsement shall be at least as broad as ISO Form CA 20 01.
 - (4) *Transportation Pollution Liability Endorsement.* The Automobile Liability policy shall be endorsed to include Transportation Pollution Liability insurance, covering materials to be transported by Contractor pursuant to the contract. This coverage may also be provided on the Contractors Pollution Liability policy.
 - (5) *Primary Coverage.* CONTRACTOR's insurance coverage shall be primary coverage at least as broad as ISO CG 20 01 04 13 with respect to the CITY, its officials, officers, agents, employees, and volunteers. Any insurance or self-insurance maintained by the

CITY, its officials, officers, agents, employees, or volunteers shall be in excess of CONTRACTOR's insurance and shall not contribute with it.

- (6) *Notice of Cancellation.* Each insurance policy shall provide that coverage shall not be canceled, except with prior written notice to the CITY.
 - (7) *Subcontractors.* If applicable, CONTRACTOR shall require and verify that all subcontractors maintain insurance meeting all the requirements stated within this Agreement, and CONTRACTOR shall ensure that the CITY (including its officials, officers, agents, employees, and volunteers) is an additional insured on any insurance required from a subcontractor.
 - (8) *Waiver of Subrogation.* CONTRACTOR hereby grants to the CITY a waiver of any right to subrogation that any insurer of CONTRACTOR may acquire against the CITY by virtue of the payment of any loss under such insurance. CONTRACTOR agrees to obtain any endorsement that may be necessary to affect this waiver of subrogation, but this subsection shall apply regardless of whether or not the CITY has received a waiver of subrogation endorsement from the insurer. Any Workers' Compensation policy required by this Agreement shall be endorsed with a waiver of subrogation in favor of the CITY for all work performed by the CONTRACTOR, its agents, representatives, employees and subcontractors.
 - (9) *Self-Insurance.* CONTRACTOR may, with the CITY's prior written consent, fulfill some or all of the insurance requirements contained in this Agreement under a plan of self-insurance. CONTRACTOR shall only be permitted to utilize such self-insurance if, in the opinion of the CITY, CONTRACTOR's (i) net worth and (ii) reserves for payment of claims of liability against CONTRACTOR are sufficient to adequately compensate for the lack of other insurance coverage required by this Agreement. CONTRACTOR's utilization of self-insurance shall not in any way limit the liabilities assumed by CONTRACTOR pursuant to this Agreement.
 - (10) *Self-Insured Retentions.* Self-insured retentions must be declared to and approved by the CITY.
- c. *Verification of Coverage.* At the time CONTRACTOR executes this Agreement, CONTRACTOR shall provide the CITY with original Certificates of Insurance including all required amendatory endorsements (or copies of the applicable policy language effecting the insurance coverage required by this Agreement), which shall meet all requirements under this Agreement. The CITY reserves the right to require complete, certified copies of all required insurance policies, including endorsements required by this Agreement, at any time.
 - d. *Special Risks or Circumstances.* The CITY reserves the right, at any point during the term of this Agreement, to modify the insurance requirements in this Agreement, including limits, based on the nature of the risk, prior experience, insurer, coverage, or other special circumstances.
 - e. *No Limitation of Obligations.* The insurance requirements within this Agreement, including the types and limits of insurance coverage CONTRACTOR must maintain, and any approval of such insurance by the CITY, are not intended to and shall not in any manner limit or qualify the liabilities and obligations otherwise assumed by CONTRACTOR pursuant to this Agreement, including but not limited to any provisions within this Agreement concerning indemnification.

- f. *Compliance.* Failure to comply with any of the insurance requirements in this Agreement, including but not limited to a lapse in any required insurance coverage during the term of this Agreement, shall be a material breach of this Agreement. Compliance by CONTRACTOR with the requirement to carry insurance and furnish certificates, policies, Additional Insured Endorsement and Declarations Page evidencing the same shall not relieve the CONTRACTOR from liability assumed under any provision of this Agreement, including, without limitation, the obligation to defend and indemnify the CTY and the City Engineer. In the event that CONTRACTOR fails to comply with any insurance requirement set forth in this Agreement, in addition to any other remedies the CITY may have, the CITY may, at its sole option, (i) immediately terminate this Agreement; or (ii) order CONTRACTOR to stop Work under this Agreement and/or withhold any payment that becomes due to CONTRACTOR until CONTRACTOR demonstrates compliance with the insurance requirements in this Agreement.

7. Indemnification, Duty to Defend, and Hold Harmless.

- a. CONTRACTOR (including CONTRACTOR's agents, employees, and subcontractors, if any) shall indemnify, defend, and hold harmless the CITY, its officials, officers, agents, employees, and volunteers from and against any and all claims, demands, actions, causes of action, proceedings (including but not limited to legal and administrative proceedings of any kind), suits, fines, penalties, judgments, orders, levies, costs, expenses, liabilities, losses, damages, or injuries, in law or equity, including without limitation the payment of all consequential damages and attorney's fees and other related litigation costs and expenses (collectively, "Claims"), of every nature caused by, arising out of, or in connection with CONTRACTOR's (including CONTRACTOR's agents, employees, and subcontractors, if any) Work pursuant to this Agreement or its failure to comply with any of its obligations contained herein, except where caused by the active negligence, sole negligence, or willful misconduct of the CITY.
- b. CONTRACTOR (including CONTRACTOR's agents, employees, and subcontractors, if any) shall indemnify, defend, and hold harmless the CITY, its officials, officers, agents, employees, and volunteers from and against any and all Claims caused by, arising under, or resulting from any violation, or claim of violation, of the San Diego Municipal Storm Water Permit (Order No. R9-2013-0001, as amended) of the California Regional Water Quality Control Board, Region 9, San Diego, that the CITY might suffer, incur, or become subject to by reason of, or occurring as a result of, or allegedly caused by, any Work performed pursuant to this Agreement.
- c. All terms and provisions within this Section 7 shall survive the termination of this Agreement.

8. Bonds.

- a. CONTRACTOR shall furnish and deliver to the CITY, simultaneously with the execution of this Agreement, the following surety bonds:
 - (1) *Faithful Performance Bond.* CONTRACTOR shall furnish to the CITY a surety bond in an amount equal to the Contract Price as security for faithful performance of this Agreement.
 - (2) *Labor and Materials Bond.* CONTRACTOR shall furnish to the CITY a surety bond in an amount equal to the Contract Price as security for payment to persons performing labor and furnishing materials in connection with the Project.
- b. All bonds furnished to the CITY pursuant to this Agreement shall be in the form set forth herein and approved by the City Attorney.

- c. All bonds shall be executed by sureties that are named in the current list of "Companies Holding Certificates of Authority as Acceptable Sureties on Federal bonds and as Acceptable Reinsuring Companies" as published in Circular 570 (amended) by the Audit Staff, Bureau of Government Financial Operations, U.S. Treasury Department. All bonds signed by an agent must be accompanied by a certified copy of such agent's authority to act.
 - d. If the surety on any bond furnished by the CONTRACTOR is declared bankrupt or becomes insolvent or its right to do business is terminated in any state where any part of the Work is located, the CONTRACTOR shall, within seven days thereafter, substitute another bond and surety, which must be acceptable to the CITY. No portion of the Work shall be performed without bonds, in a form and issued by a surety acceptable to the City. If one or more of such bonds shall, at any time, not be in full force and effect, CONTRACTOR shall immediately cease performance of the Work until CONTRACTOR is in full compliance with the bonding requirements of this Agreement and California law. All delays and costs incurred or resulting from such occurrence shall be to the exclusive account of CONTRACTOR. Failure of the CONTRACTOR to promptly cure any failure to have the necessary bonds in full force and effect shall be grounds for immediate termination of this Agreement.
 - e. All bonds shall be obtained from surety companies that are duly licensed or authorized in the State of California. Such surety companies shall also meet any additional requirements and qualifications as may be provided in the Supplementary General Conditions.
9. Substitution of Securities. This Agreement is subject to California Public Contract Code section 22300, which permits the substitution of securities for any monies withheld by the CITY to ensure performance of this Agreement. At the request and expense of the CONTRACTOR, securities equivalent to the amount withheld shall be deposited with the CITY, or with a state- or federally-chartered bank in this state as the escrow agent, who shall then pay those moneys to CONTRACTOR. Upon satisfactory completion and acceptance of the Work, such securities shall be returned to the CONTRACTOR.
10. Contractor Default. In the event CONTRACTOR, for a period of 10 calendar days after receipt of written demand from the CITY to do so ("Cure Period"), fails to furnish tools, equipment, or labor in the necessary quantity or quality required by this Agreement, or fails to prosecute the Work and all parts thereof in a diligent and workmanlike manner, or after commencing to do so within the Cure Period, fails to continue to do so, then the CITY in its sole discretion may exclude the CONTRACTOR from the Property, or any portion thereof, and take exclusive possession of the Property or any portion thereof, together with all material and equipment thereon, and may complete the Work or any portion of the Work, either by (i) furnishing the necessary tools, equipment, labor, or materials; or (ii) letting the unfinished portion of the work, or any portion thereof, to another contractor; or (iii) demanding the surety hire another contractor; or (iv) any combination of such methods. The CITY's procuring of the completion of the Work, or the portion of the Work taken over by the CITY, shall be a charge against the CONTRACTOR and may be deducted from any money due or to become due to CONTRACTOR from the CITY, or the CONTRACTOR shall pay the CITY the amount of such charge, or the portion thereof unsatisfied. The sureties provided for under this Agreement shall become liable for payment if CONTRACTOR fails to pay in full any such cost incurred by the CITY. The permissible charges for any such procurement of the completion of the Work include actual costs and fees incurred to third party individuals and entities (including but not limited to consultants, attorneys, inspectors, and designers) and actual costs incurred by the CITY for the increased dedication of time of the CITY's employees to the Project.

11. Other Legal Requirements Incorporated. Each and every provision of law and clause required by law to be inserted in this Agreement or its attachments shall be deemed to be inserted herein, and this Agreement shall be read and enforced as though such law or clause were included herein, and if through mistake or otherwise any such provision is not inserted, or is not currently inserted, then upon application of either Party, the Agreement shall forthwith be physically amended to make such insertion or correction, without further changes to the remainder of the Agreement.
12. Merger Clause. This Agreement, together with its attachments or other documents described or incorporated herein, if any, constitutes the entire agreement and understanding of the CITY and CONTRACTOR concerning the subject of this Agreement and supersedes and replaces all prior negotiations, understandings, or proposed agreements, written or oral, except as otherwise provided herein. In the event of any conflict between the provisions of this Agreement and any of its attachments or related documents, if any, the provisions of this Agreement shall prevail.
13. Attorney's Fees and Costs. In any action to enforce the terms and conditions of this Agreement, the prevailing Party shall be entitled to reasonable attorney's fees and costs.
14. Independent Contractor. CONTRACTOR is an independent contractor, and no agency or employment relationship is created by the execution of this Agreement.
15. Amendment. This Agreement shall not be amended except in a writing signed by the CITY and CONTRACTOR, and pursuant to action of the Escondido City Council.
16. Anti-Waiver Clause. None of the provisions of this Agreement shall be waived by the CITY because of previous failure to insist upon strict performance, nor shall any provision be waived because any other provision has been waived by the CITY, in whole or in part.
17. Severability. This Agreement shall be performed and shall be enforceable to the full extent allowed by applicable law, and the illegality, invalidity, waiver, or unenforceability of any provision of this Agreement shall not affect the legality, validity, applicability, or enforceability of the remaining provisions of this Agreement.
18. Governing Law. This Agreement and all rights and obligations arising out of it shall be construed in accordance with the laws of the State of California. Venue for any action arising from this Agreement shall be conducted only in the state or federal courts of San Diego County, California.
19. Counterparts. This Agreement may be executed on separate counterparts, each of which shall be an original and all of which taken together shall constitute one and the same instrument. Delivery of an executed signature page of this Agreement by electronic means, including an attachment to an email, shall be effective as delivery of an executed original. The Agreement on file with the City is the copy of the Agreement that shall take precedence if any differences exist between or among copies or counterparts of the Agreement.
20. Provisions Cumulative. The foregoing provisions are cumulative to, in addition to, and not in limitation of any other rights or remedies available to the CITY.
21. Business License. CONTRACTOR shall obtain a City of Escondido Business License prior to execution of this Agreement and shall maintain such Business License throughout the term of this Agreement.
22. Compliance with Laws, Permits, and Licenses. CONTRACTOR shall keep itself informed of and comply with all applicable federal, state, and local laws, statutes, codes, ordinances, regulations, rules, and other legal requirements in effect during the term of this Agreement. This shall include, but shall not be limited to, all California Labor Code laws regarding payment of prevailing wages

and all OSHA regulations. CONTRACTOR shall obtain any and all permits, licenses, and other authorizations necessary to perform the work under this Agreement. Neither the CITY, nor any elected or appointed boards, officers, officials, employees, or agents of the CITY, shall be liable, at law or in equity, as a result of any failure of CONTRACTOR to comply with this section.

23. Prevailing Wages and Department of Industrial Relations Compliance. Pursuant to California Labor Code section 1770 et seq., CONTRACTOR agrees that a prevailing rate and scale of wages, in accordance with applicable laws, shall be paid in performing this Agreement. CONTRACTOR shall keep itself informed of and comply with all applicable federal, state, and local laws, statutes, codes, ordinances, regulations, rules, and other legal requirements pertaining to the payment of prevailing wages, including but not limited to the keeping of certified payroll records, overtime pay, employment of apprentices, and workers' compensation coverage, as further set forth in the General Conditions. CONTRACTOR shall file the required workers' compensation certificate before commencing work under this Agreement. This project is subject to compliance monitoring and enforcement by the Department of Industrial Relations. CONTRACTOR shall post all job site notices required by regulation. CONTRACTOR, as well as any subcontractors, shall be registered pursuant to California Labor Code section 1725.5 to be qualified to bid on, be listed in a bid proposal (subject to the requirements of Public Contract Code section 4104), or engage in the performance of any public works contract subject to the requirements of Division 2, Part 7, Chapter 1 of the California Labor Code. Neither the CITY, nor any elected or appointed boards, officers, officials, employees, or agents of the CITY, shall be liable, at law or in equity, as a result of any failure of CONTRACTOR to comply with this section.
24. Immigration Reform and Control Act of 1986. CONTRACTOR shall keep itself informed of and shall comply with the Immigration Reform and Control Act of 1986 ("IRCA"). CONTRACTOR represents and warrants that all of its employees and the employees of any subcontractor retained by CONTRACTOR who perform any portion of the Work under this Agreement are and will be authorized to perform the Work in full compliance with the IRCA. CONTRACTOR affirms that as a licensed contractor and employer in the State of California, all new employees must produce proof of eligibility to work in the United States within the first three days of employment and that only employees legally eligible to work in the United States will perform the Work. CONTRACTOR agrees to comply with the IRCA before commencing any portion of the Work, and continuously throughout the performance of the Work and the term of this Agreement.
25. Effective Date. Unless a different date is provided in this Agreement, the effective date of this Agreement shall be the latest date of execution set forth by the names of the signatories below.

(SIGNATURE PAGE FOLLOWS)

IN WITNESS WHEREOF, this Agreement is executed by the Parties or their duly authorized representatives as of the Effective Date:

CITY OF ESCONDIDO

Date: 4/29/24

Sean McGlynn, City Manager

CCL Contracting, Inc.

Date: 4/26/24

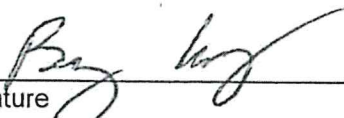

Signature

Bryan Luby Secretary
Name & Title (please print)

798819
Contractor's License No.

33-0970168
Tax ID/Social Security No.

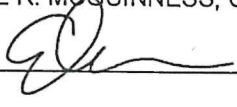
APPROVED AS TO FORM:
OFFICE OF THE CITY ATTORNEY
MICHAEL R. MCGUINNESS, City Attorney

BY: 

THE CITY OF ESCONDIDO DOES NOT DISCRIMINATE AGAINST QUALIFIED PERSONS WITH DISABILITIES.

Attachment "A"

Project Location



Attachment "B"

Scope of Work, Drawings, and Figures

Land Outfall Emergency Repair Project

SCOPE OF WORK

1. LOCATE POINT OF FAILURE IN PIPELINE
2. INSTALL DEWATERING TANKS AND PUMP SYSTEM
3. CONSTRUCT 300 LF +/- 20" BYPASS PIPING TO DOWNSTREAM 20" POC
4. EXCAVATE 12' LONG X10' WIDE (CLEAR) PIT AROUND FAILURE POINT
5. INSTALL LINESSTOP WITH 20" OUTLET FOR BYPASS PIPE
6. START BYPASS
7. REMOVE AND REPLACE FAILED SECTION OF PIPE
8. REMOVE LINESSTOP AND BYPASS PIPING
9. RETURN OUTFALL TO NORMAL OPERATION

Contractor Exclusions:

Treatment of groundwater, SDG&E bracing of pole, plants and irrigation, asphalt paving and striping, permits, message and arrow boards, beam and plate shoring system, purchase of new telephone poles

Contractor Assumptions:

Pipeline repair is based on location as shown on documents, and does not include removal and replacement of existing pipe; repair assumed to be to a small hole at one location; ten-hour work day Monday through Friday.

Dewatering disposal is based on a water intrusion rate of 15 GPM; two 12,000-gallon tanks are included for onsite storage

Restoration to include DG path, removal/replacement of existing horizontal telephone poles, hydroseed with erosion control mix, one application

300 lineal feet of 20-inch diameter HDPE is included

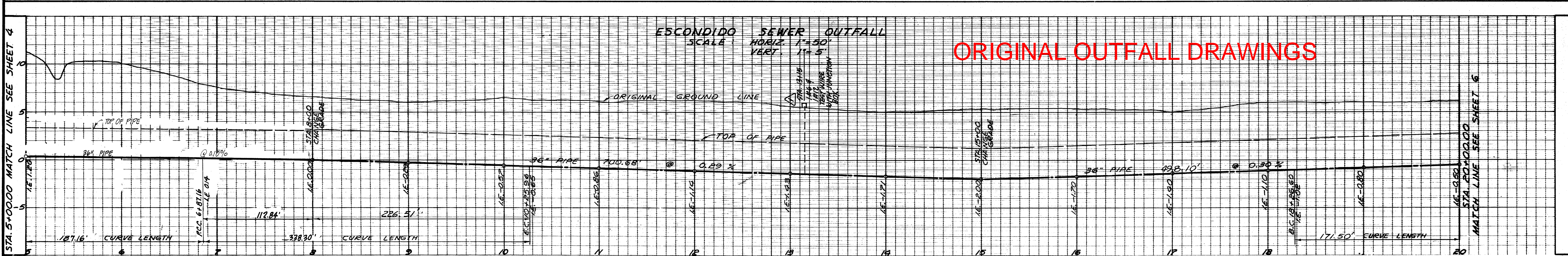
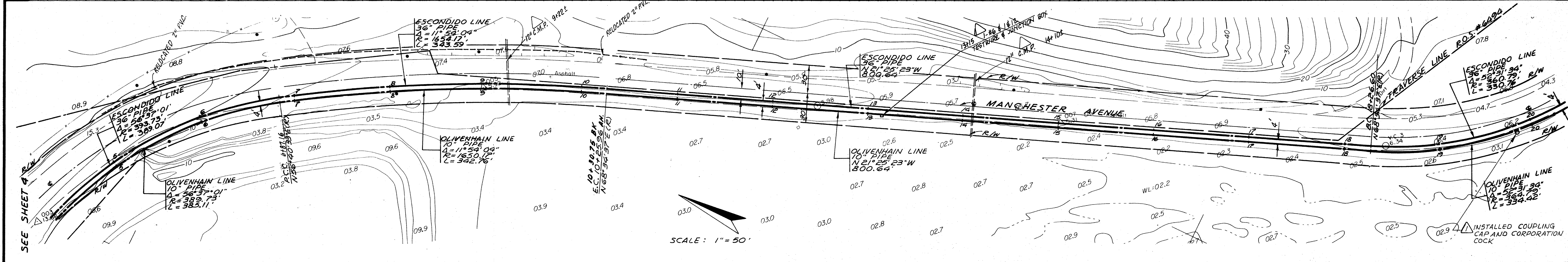
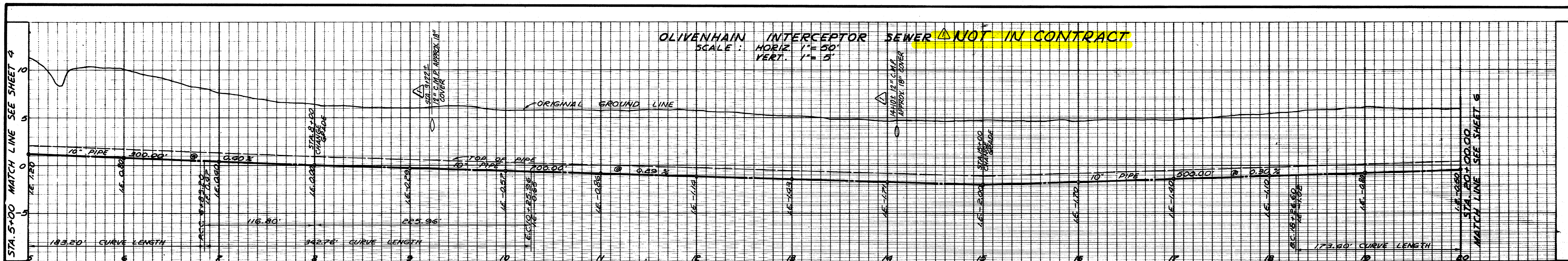

BENCH MARK:
 OC-0033 1/2" I.P. SET IN CONC.
 MKD. BY STEEL POST APPROX. 1.2 MI.
 SO. OF INTS. SAN ELIJO AVE. AND
 KILKENNY DR. EL. 8.031

STATIONING:
 BASE LINE FOR STATIONING IS
 OLIVENHAIN LINE. ALL OTHER
 STATIONING IS FROM THIS LINE.

PLAN REVISION CHANGE BY DATE APPROVAL 1 AS-BUILT 07/19/71 JTT	E. F. COOK & ASSOCIATES, LTD. 5858 MOUNT ALIFAN DRIVE SAN DIEGO, CALIFORNIA TELEPHONE 714-279-2823 CONSULTING CIVIL ENGINEERS E. F. Cook California 7-30-71 APPROVED BY R. C. E. 9447 DATE	NESTE, BRUDIN & STONE INCORPORATED CIVIL ENGINEERS 230 West Third Avenue Escondido, Calif. 7-30-71 Date Raymond N. Stone Calif. Reg. No. 7653	CITY OF ESCONDIDO ENGINEERING DIVISION APPROVED: <i>John P. Williams</i> 7-30-71 CITY ENGINEER R.C.E. 7967 DATE	CARDIFF SANITATION DISTRICT COUNTY OF SAN DIEGO APPROVED: R.C.E. 13459 DIRECTOR, DEPT. OF SANI. AND FLOOD DATE CHECKED: _____ DATE PROJECT NO. SB 5401	ESCONDIDO OUTFALL and OLIVENHAIN INTERCEPTOR SEWERS DESIGNED BY L. HALL DATE 6-30-71 DRAWN BY JTT SCALE: HOR CHECKED BY _____ VER FIELD BOOK _____ SUPV. CHECK
			CONSTRUCTION RECORD STARTED _____ COMPLETED _____ AS BUILT _____ INSPECTOR _____	SHEET 5 OF 21	

Photogrammetry by SAN-10 AERIAL SURVEYS.

OLIVENHAIN - ESCONDIDO JOINT SEWER PROJECT SB-16.01-094.70

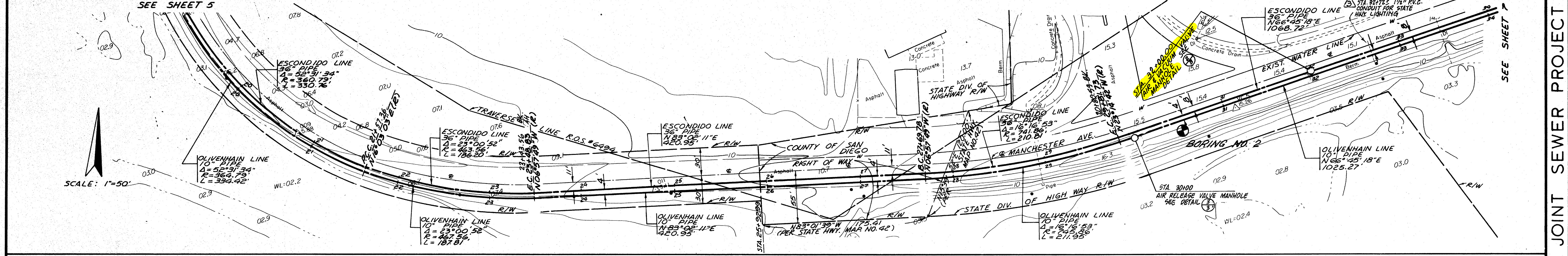
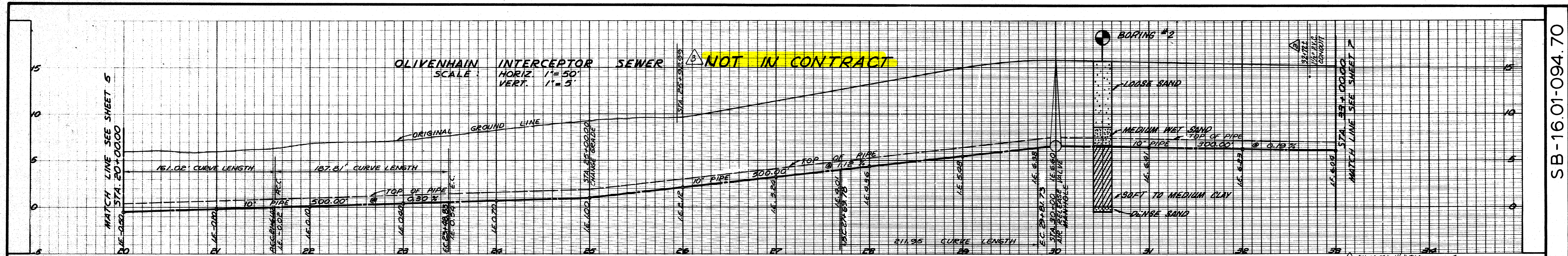

ORIGINAL OUTFALL DRAWINGS

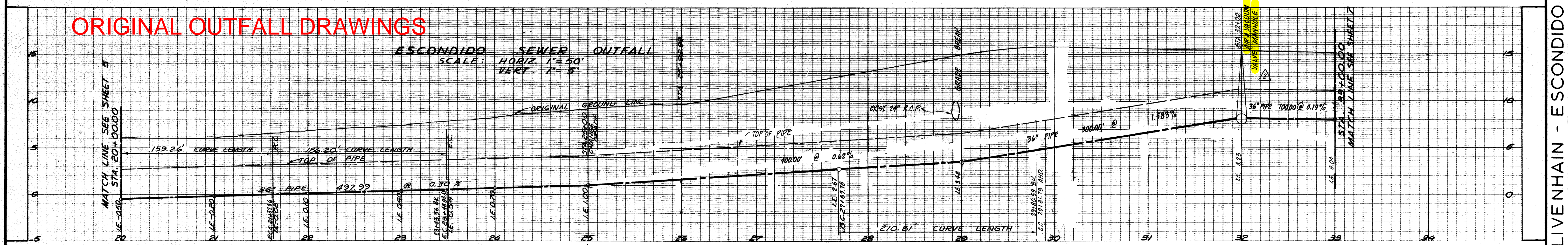

BENCH MARK:
OC-0033 1/2" I.P. SET IN CONC.
MKD. BY STEEL POST APPROX. 1.2 MI.
SO. OF INTS. SAN ELIJO AVE. AND
KILKENNY DR. EL. 8.031

STATIONING:
BASE LINE FOR STATIONING IS
OLIVENHAIN LINE. ALL OTHER
STATIONING IS FROM THIS LINE.

APPROVED BY: _____
NESTE, BRUDIN & STONE, INC. CITY OF ESCONDIDO
Grade Change From Sta. 25+00 to Sta. 53+00. R.B.H. 7-31-72
Air & Vacuum Valve Manhole Moved From Sta. 30+00 to Sta. 32+00. R.B.H. 7-31-72

PLAN REVISION			
CHANGE	BY	DATE	APPROVAL
13145-BUILT	M.V.S.	1-15-74	JEP

E.F. COOK & ASSOCIATES, LTD.
5888 MOUNT ALIFAN DRIVE SAN DIEGO, CALIFORNIA
TELEPHONE 714-279-2823
CONSULTING CIVIL ENGINEERS
E.F. Cook CALIFORNIA 7-30-71
APPROVED BY R.C.E. 9447 DATE

NESTE, BRUDIN & STONE
INCORPORATED
CIVIL ENGINEERS
230 West Third Avenue Escondido, Calif.
7-30-71
Date Call. Reg. No. 7683

CITY OF ESCONDIDO
ENGINEERING DIVISION
APPROVED: _____ 7-30-71
CITY ENGINEER R.C.E. 7967 DATE
CHECKED: _____ DATE

CARDIFF SANITATION DISTRICT
COUNTY OF SAN DIEGO
APPROVED: _____ R.C.E. 13459
DIRECTOR, DEPT. OF SANI. AND FLOOD DATE
CHECKED: _____ DATE

ESCONDIDO OUTFALL and OLIVENHAIN INTERCEPTOR SEWERS
DESIGNED BY L. HALL DATE 6-30-71
DRAWN BY JTT SCALE: HOR
CHECKED BY _____ VER
FIELD BOOK _____ SUPV. CHECK
PROJECT NO. SB 5401

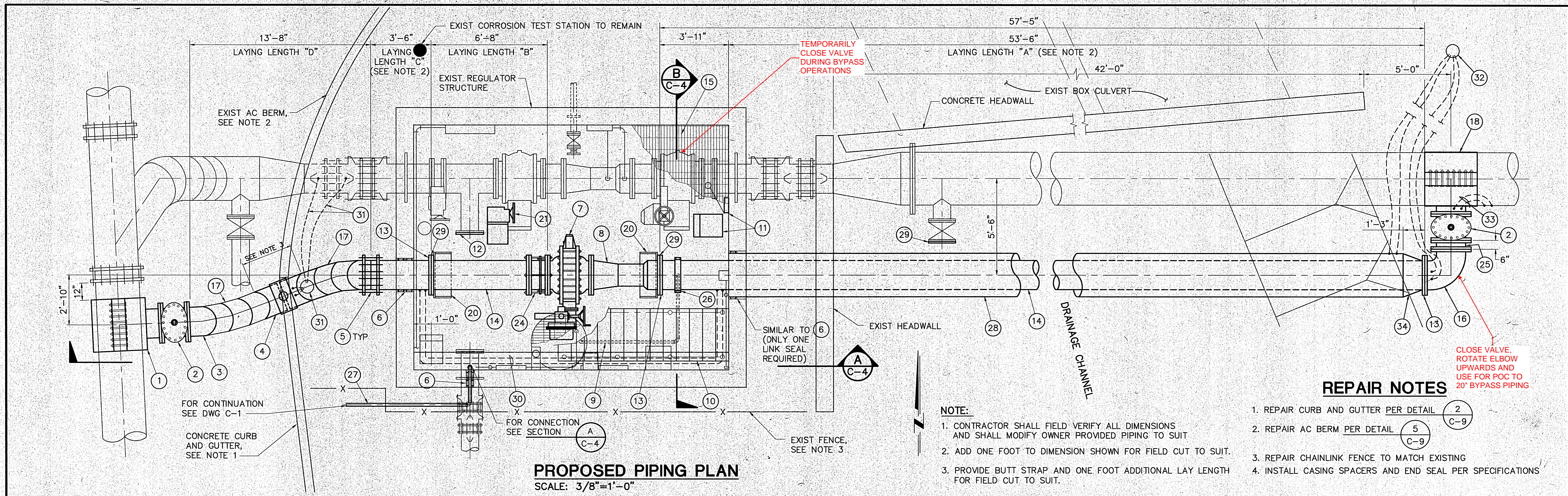

PRE-PURCHASE PIPE LEGEND

- 3 4 17 20" STEEL PIPE, L = 13'-8", (LAYING LENGTH "D")
- 13 20" FLANGE ADAPTER (WELDED)
- 14 20" STEEL PIPE, 30' MAX. LENGTHS OF PIPE SECTION, L = 53'-6"
- 14 20" STEEL PIPE, L = 6'-8", (LAYING LENGTH "B")
- 14 20" STEEL PIPE, FLG x PE, L = 3'-6", (LAYING LENGTH "C")
- 25 20" x 20" PIPE SPOOL, FLG x FLG, L = 0'-6", QTY = 1

NOTE:

- ADD ONE FOOT TO DIMENSION SHOWN FOR FIELD CUT TO SUIT.
- PROVIDE BUTT STRAP AND ONE FOOT ADDITIONAL LAY LENGTH FOR FIELD CUT TO SUIT.

CORROSION CONTROL NOTES

- SEE CORROSION CONTROL DRAWINGS AND NOTES ON CP-1 AND CP-2
- BOND ALL VALVES, FLANGES AND COUPLINGS NOT DESIGNATED AS INSULATORS PER DET 1, DWG CP-2. BOND ACROSS INSULATORS AND MOTORIZED VALVE IN VAULT PER PIPING PLAN THIS SHEET. FIELD ROUTE BOND WIRES.
- ALLOW METALLIC CONTACT BETWEEN 20" STEEL SPOOL AND 30" STEEL CASING.
- TEST STATION (ITEM 32, SHEET C-3) TO BE MOUNTED BEHIND CURB ON MANCHESTER AVE.
- ALL NON-TAPE COATED OR MORTAR COATED STEEL OR IRON SURFACES INCLUDING TAPPING SADDLES, VALVES, FLANGES OR COUPLINGS (EXCEPT THE CASING), SHALL BE WRAPPED WITH PETROLATUM WAX TAPE PER AWWA C-217 AND SPECIFICATIONS SECTION 16641.
- ALL WAX TAPE COMPONENTS SHALL BE INSPECTED AND APPROVED BY THE ENGINEER FOR COMPLIANCE WITH THE SPECIFICATIONS PRIOR TO BACKFILLING.

LEGEND

- 1 30"x20" TAPPING SADDLE
- 2 20" TAPPING VALVE
- 3 20" STEEL FLG x PE FABRICATED FITTING
- 4 20" STEEL SPOOL
- 5 20" FLEXIBLE COUPLING (RESTRAINED)
- 6 LINK SEAL PER DET 4, DWG C-9
- 7 20" BALL VALVE W/ELECTRIC MOTOTR OPERATOR (MODULATING)
- 8 20"x15" VENTURI FLOW METER
- 9 2" DRAIN TO SUMP
- 10 STAIRS W/RAILING, SEE STRUCTURAL DRAWINGS
- 11 RELOCATED VENT AND CIRCULAR METER
- 12 INSTALL 12" BLIND FLANGE ON EXIST TEE
- 13 20" FLANGE ADAPTER (WELDED)
- 14 20" STEEL SPOOL
- 15 GRATING, SEE STRUCTURAL DRAWINGS
- 16 20" D.I.P. 90° FLG BEND
- 17 20" STEEL PE x PE FABRICATED FITTING
- 18 36" x 20" TAPPING SADDLE
- 19 CONCRETE PIPE SUPPORT PER DET 1, DWG C-10
- 20 STEEL PIPE SUPPORT PER DET 2, DWG C-10
- 21 AC MOTOR OPERATOR
- 22 20" FLG x FLG SPOOL
- 23 SUPPORT ANGLE FOR GRATING
- 24 DISMANTLING JOINT
- 25 20" STEEL FLG X FLG SPOOL
- 26 20" x 2" SADDLE PER DET 3, DWG C-9
- 27 2" SCH 80 PVC DRAIN TO PUMP STATION WET WELL
- 28 STEEL SLEEVE - SIZE BY TUNNELING CONTRACTOR
- 29 INSULATING FLANGE KIT
- 30 2 - NO. 2 HMWPE BOND WIRES
- 31 AT-GRADE 4-WIRE CP TEST STATION PER DET 3, DWG CP-1
- 32 AT-GRADE 4-WIRE CASING TEST STATION PER DET 4, DWG CP-1
- 33 NO. 4 HMWPE BOND WIRES
- 34 END SEAL

DATE: 10/20/99
DESIGNED BY: CHR
DRAWN BY: PAC/PAP
CHECKED BY: SLD
SCALE:

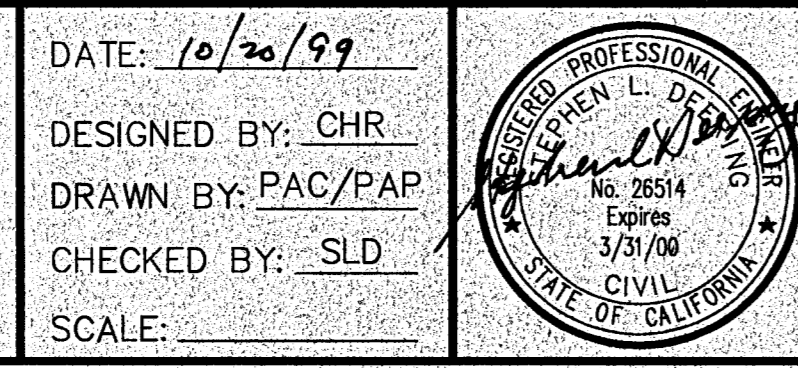

DUDEK & ASSOCIATES
A California Corporation
Corporate Office: 760.942.5147
605 Third Street Encinitas, CA 92024 Fax 760.632.0164

REVISIONS				
NO.	BY	DATE	REMARKS	

SAN ELIJO
JOINT POWERS AUTHORITY
SAN ELIJO
WATER RECLAMATION FACILITIES

ESCONDIDO REGULATOR STRUCTURE AND SAN ELIJO EFFLUENT PIPE
PROPOSED PIPING PLAN

SHEET 5
OF 26
1830MCB.DWG

C-3

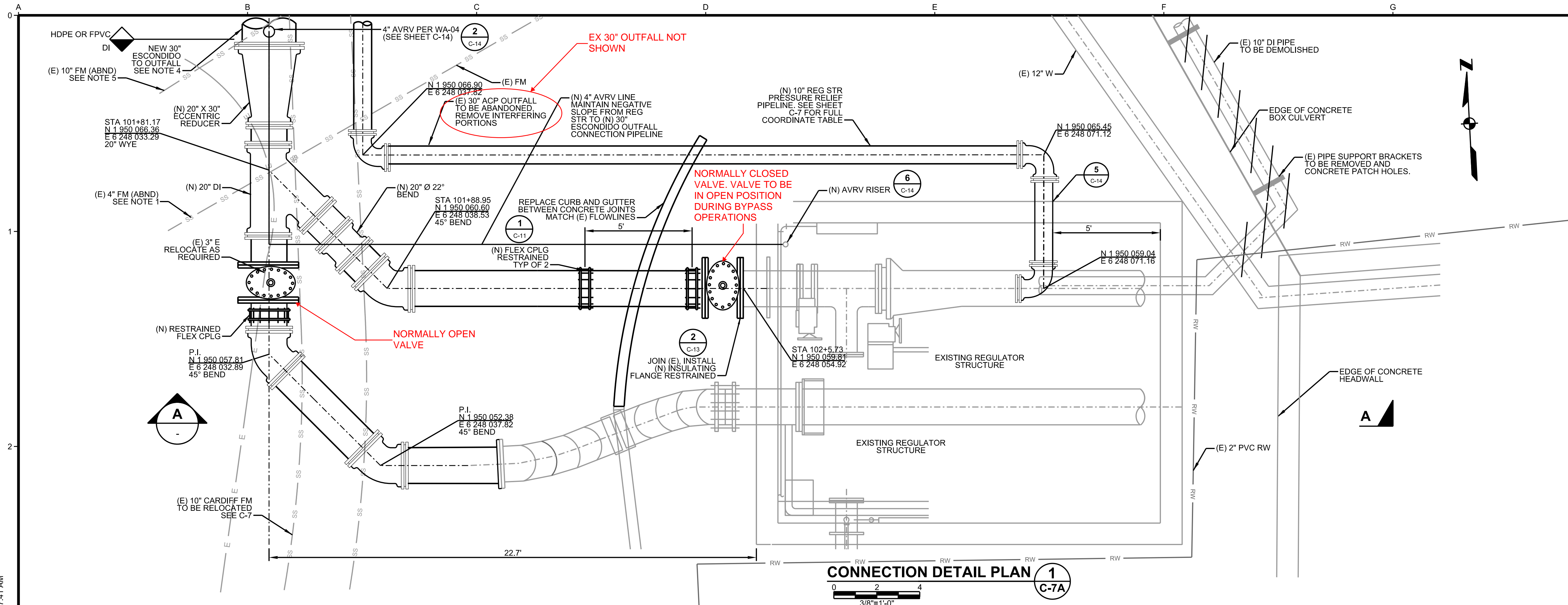

- NOTES:**
1. CONTRACTOR TO VERIFY CONNECTION POINTS PRIOR TO FABRICATION OF PIPING.
 2. RESTRAIN ALL JOINTS AND FITTINGS.
 3. REMOVE INTERFERING PORTIONS OF ABANDONED AND RELOCATED PIPELINES; FILL WITH CEMENT-SLURRY (EXISTING 30\"/>

- LAND OUTFALL SHUTDOWN REQUIREMENTS:**
1. CONTRACTOR SHALL PREPARE A SHUTDOWN PLAN FOR REVIEW AND APPROVAL BY THE SE/JPA AND CITY OF ESCONDIDO PRIOR TO ANY PLANNED SHUTDOWN.
 2. CONTRACTOR SHALL NOTIFY THE SE/JPA AND CITY OF ESCONDIDO A MINIMUM OF 72 HOURS IN ADVANCE OF ANY PLANNED SHUTDOWN.
 3. PLANNED SHUTDOWNS SHALL ONLY BE PERFORMED BETWEEN THE HOURS OF 3:00 AM AND 7:30 AM MONDAY THROUGH THURSDAY, AND SHALL NOT BE MORE THAN 4 HOURS IN DURATION.
 4. SHUTDOWNS SHALL BE APPROVED AT OWNER'S DISCRETION. SHUTDOWNS WILL NOT BE ALLOWED IF RAIN HAS OCCURRED WITHIN 48 HOURS OR IS FORECAST WITHIN 48 HOURS OF THE PLANNED SHUTDOWN.

CONNECTION DETAIL PLAN 1
 3/8"=1'-0"

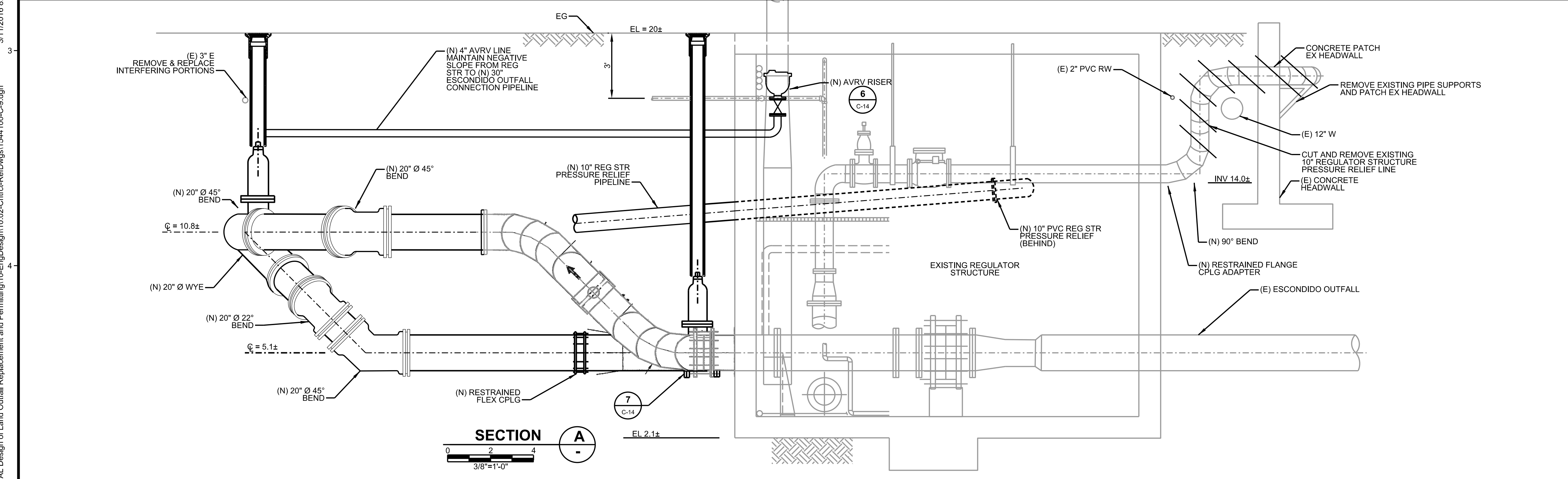

SECTION A
 3/8"=1'-0"

RECORD DRAWING
 These Record Drawings have been prepared based on information provided by the contractor and others. Kennedy/Jenks Consultants has not verified the accuracy or completeness of information provided to them and does not warrant the accuracy of these Record Drawings. Users of these Record Drawings assume risk of loss resulting from their use.

USE OF DOCUMENTS

THIS DOCUMENT, INCLUDING THE INCORPORATED DESIGNS, IS AN INSTRUMENT OF SERVICE FOR THIS PROJECT AND SHALL NOT BE USED FOR ANY OTHER PROJECT WITHOUT THE WRITTEN AUTHORIZATION OF KENNEDY/JENKS CONSULTANTS.

2	RECORD DRAWINGS	8/20/18	CY
1	LAND OUTFALL SHUTDOWN REQUIREMENTS	2-17-17	CY

NO.	REVISION	DATE	BY

SCALES

0 1" = 25mm

IF THIS BAR IS NOT DIMENSION SHOWN, ADJUST SCALES ACCORDINGLY.

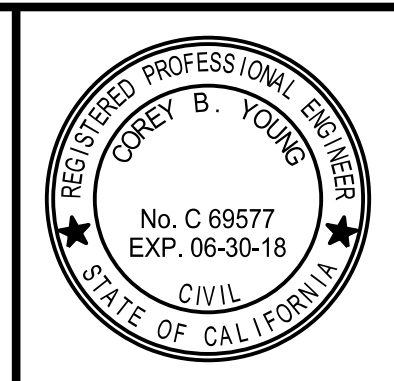

DESIGNED
CY

DRAWN
BG

CHECKED
AS

SAN ELIJO JOINT POWERS AUTHORITY

SAN ELIJO LAND OUTFALL RELACEMENT PROJECT

Kennedy/Jenks Consultants
 9665 Granite Ridge Drive, Suite 210 San Diego, CA 92123

CIVIL

REGULATOR STRUCTURE CONNECTION DETAILS

JOB NO.
1544100.01

DATE
JANUARY 2017

DRAWING NO.
C-9

SHEET 15 OF 23

P:\2015\1544100.01_SE/JPA FINAL Design of Land Outfall Replacement and Permitting\10-02-Cntrct-Ref\Drawings\1544100-C-9.dgn 3/11/2016 8:47:41 AM

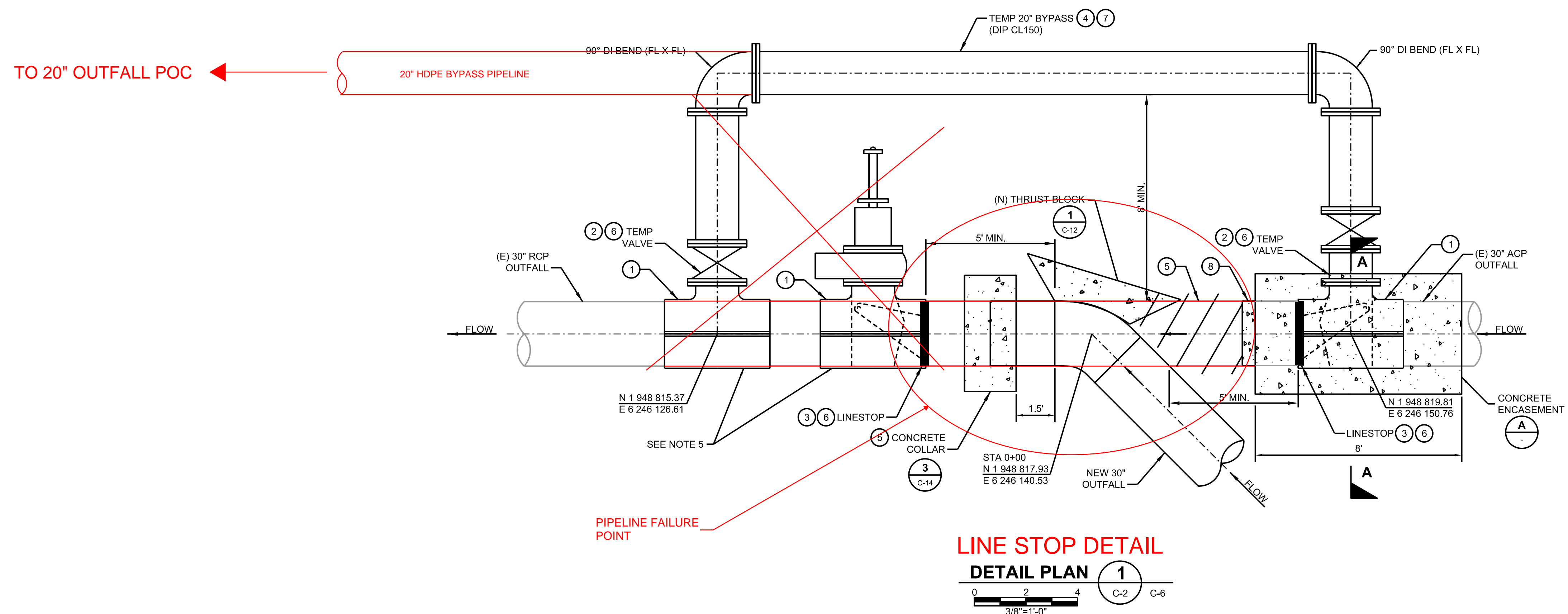

- WORK ORDER:**
- INSTALL 3 TAPPING SLEEVES/TEES ON EXISTING OUTFALL.
 - INSTALL TEMP. VALVES (CLOSED) ON TAPPING TEES.
 - INSTALL LINESTOP INSIDE TEE.
 - INSTALL 20" BYPASS & OPEN TEMP. VALVES.
 - CUT AND REMOVE INTERFERING PORTIONS OF EXISTING OUTFALL AND CONNECT NEW OUTFALL WITH CONCRETE COLLAR.
 - REMOVE LINESTOP, CLOSE TEMP VALVES AND INSTALL BLIND FLANGE ON VALVES.
 - REMOVE TEMP. BYPASS.
 - FILL EXISTING 30" ACP WITH CEMENT-SLURRY AND INSTALL CONCRETE PLUG PER STANDARD SPECIFICATIONS SECTION 306-3.3. SEE GENERAL AND ASBESTOS ABATEMENT NOTES ON G-3.

- HOT TAPPING NOTES:**
- PROVIDE SMITH BLAIR FLANGE JOINT TAPPING SLEEVE 623, 30" BY 20" OUTLET WITH AWWA CLASS D FLANGE, OR APPROVED EQUAL, WHERE SHOWN ON DRAWINGS. MEASURE EXISTING PIPE CIRCUMFERENCE PRIOR TO ORDERING SLEEVE AND VALVE. SLEEVES SHALL BE FULL WRAP STYLE WITH THE OUTLET SET AT THE HORIZONTAL CENTERLINE OF THE TAPPED PIPE.
 - PROVIDE AWWA C509 RESILIENT WEDGE NON RISING STEM TAPPING VALVE RATED FOR 150 PSI WITH FUSION EPOXY COATING FOR THIS PROJECT. AS SPECIFIED BELOW:
 - A. PROVIDE A MUELLER RESILIENT WEDGE NON-RISING STEM (NRS), OR EQUAL. PROVIDE VALVE IN FLANGE BY FLANGE CONFIGURATION WITH BONDING SCREWS. PROVIDE 24-INCH FLANGE AND 24 X 30-INCH HDPE REDUCER WITH 24-INCH FLANGE X MECHANICAL JOINT ADAPTOR SUITABLE FOR NOT LESS THAN 150 PSI WITH 304 STAINLESS STEEL BOLTS AND NUTS AND ANTI-SEIZE COMPOUND.
 - C. THE CONTRACTOR SHALL COORDINATE THE FLANGE DRILLING WITH THE SLEEVE MANUFACTURER SO THAT THE BOLT CIRCLES MATCH.
 - D. PROVIDE 2" RISER STEM WITH 2" OPERATING NUT.
 - WRAP THE ENTIRE ASSEMBLY WITH POLYETHYLENE WRAP PER AWWA C105.
 - RESTRAIN ALL JOINTS OR INSTALL THRUST BLOCKS AS NEEDED.
 - TAPPING TEE TO BE FUSION EPOXY COATED.

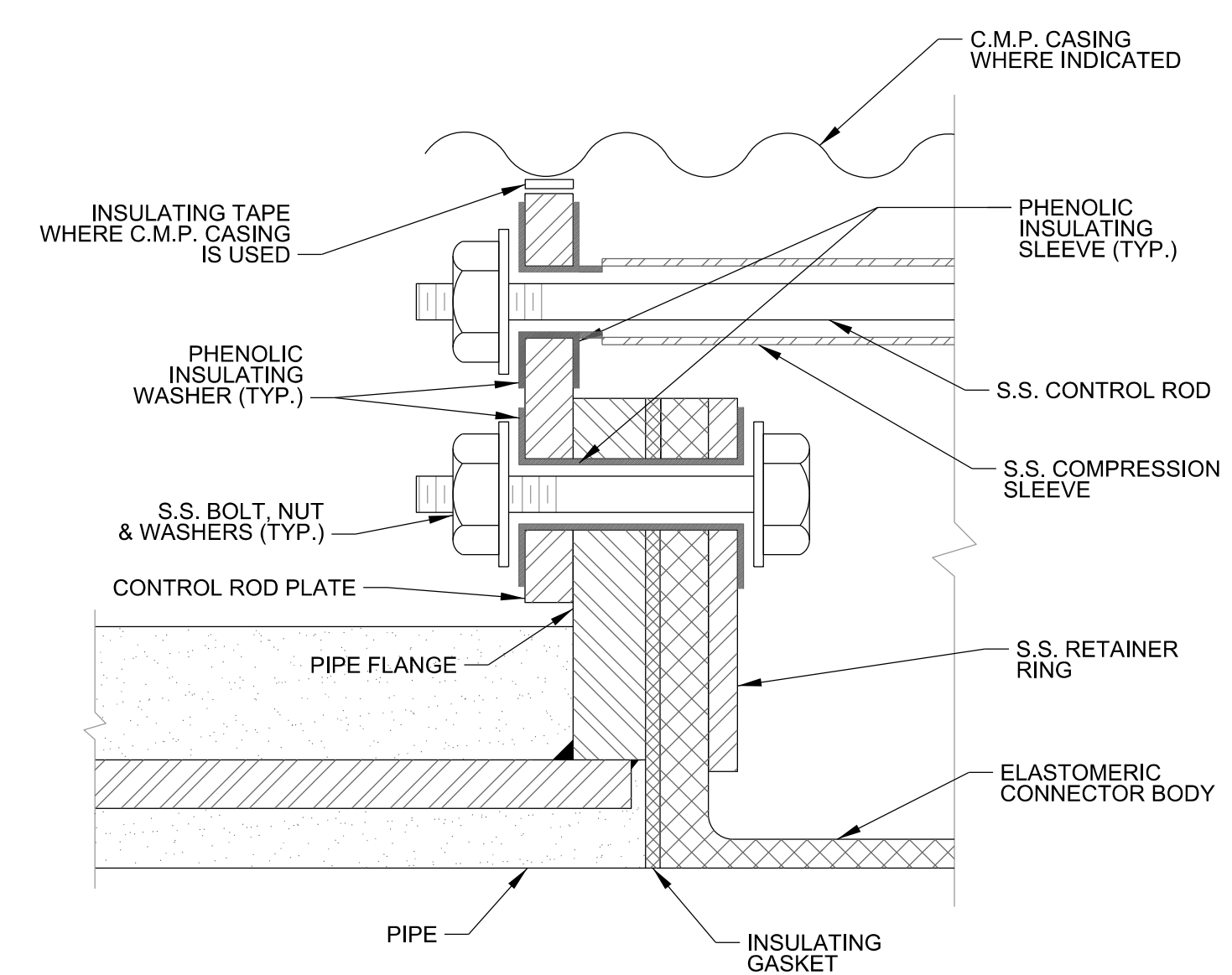

RESTRAINED INSULATED FLANGE
DETAIL 2
SCALE: NTS
C-9

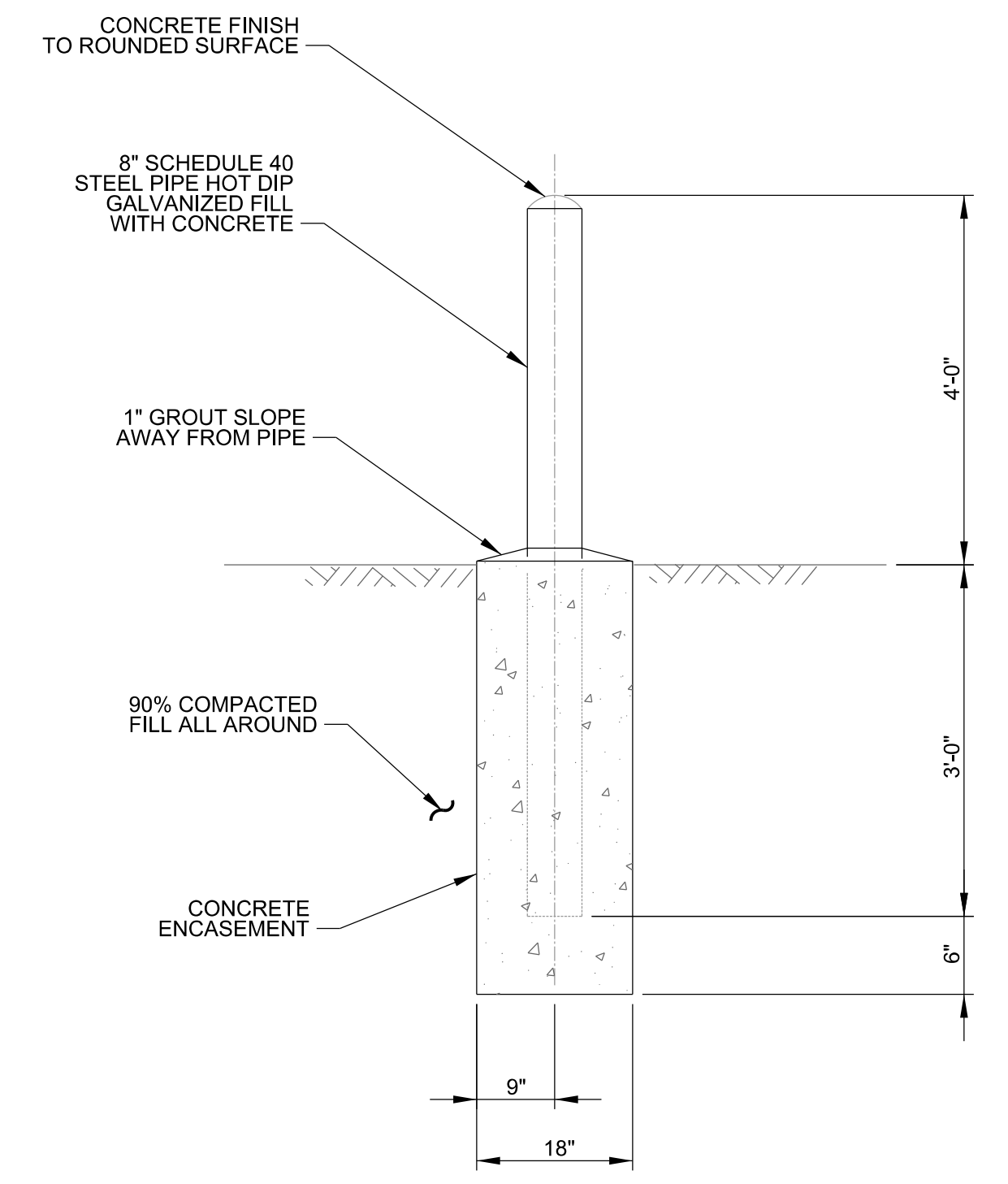

TYPICAL BOLLARD
DETAIL 3
SCALE: NTS
C-6

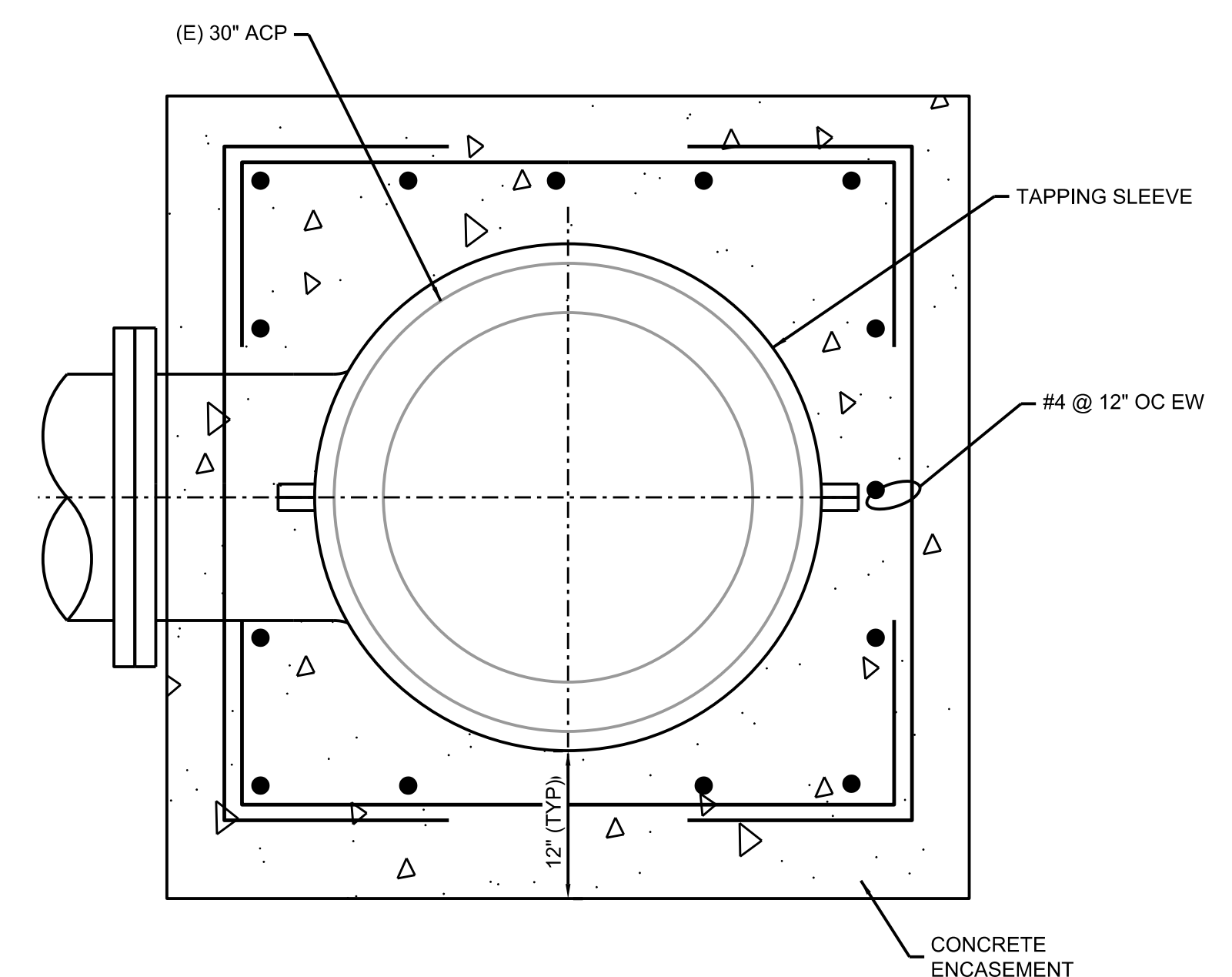

SECTION A
SCALE: NTS

RECORD DRAWING
These Record Drawings have been prepared based on information provided by the contractor and others. Kennedy/Jenks Consultants has not verified the accuracy or completeness of information provided to them and does not warrant the accuracy of these Record Drawings. Users of these Record Drawings assume risk of loss resulting from their use.

P:\2015\1544100_01_SE\JPA_FINAL Design of Land Outfall Replacement and Permitting\10-02-Contract-Ref\Drawings\1544100-C-13.dgn 3/11/2016 8:50:01 AM

USE OF DOCUMENTS

THIS DOCUMENT, INCLUDING THE INCORPORATED DESIGNS, IS AN INSTRUMENT OF SERVICE FOR THIS PROJECT AND SHALL NOT BE USED FOR ANY OTHER PROJECT WITHOUT THE WRITTEN AUTHORIZATION OF KENNEDY/JENKS CONSULTANTS.

NO.	REVISION	DATE	BY
1	RECORD DRAWINGS	8/20/18	CY

NO.	REVISION	DATE	BY
1	RECORD DRAWINGS	8/20/18	CY

SCALES

0 1" = 1'-0"

0 25mm = 1'-0"

IF THIS BAR IS NOT DIMENSION SHOWN, ADJUST SCALES ACCORDINGLY.

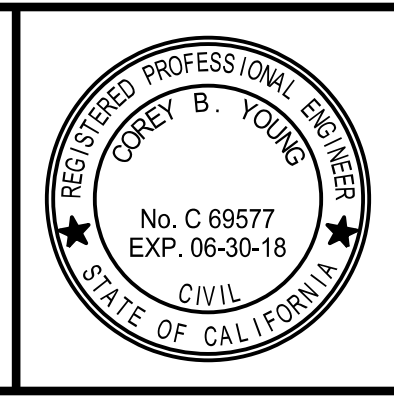

DESIGNED: CY
DRAWN: BG
CHECKED: AS

SAN ELIJO JOINT POWERS AUTHORITY
SAN ELIJO LAND OUTFALL RELACEMENT PROJECT
Kennedy/Jenks Consultants
9665 Granite Ridge Drive, Suite 210 San Diego, CA 92123

CIVIL
MISC. DETAILS - 3

JOB NO. 1544100.01
DATE: JANUARY 2017
DRAWING NO. **C-13**
SHEET 19 OF 23

FIGURE 1

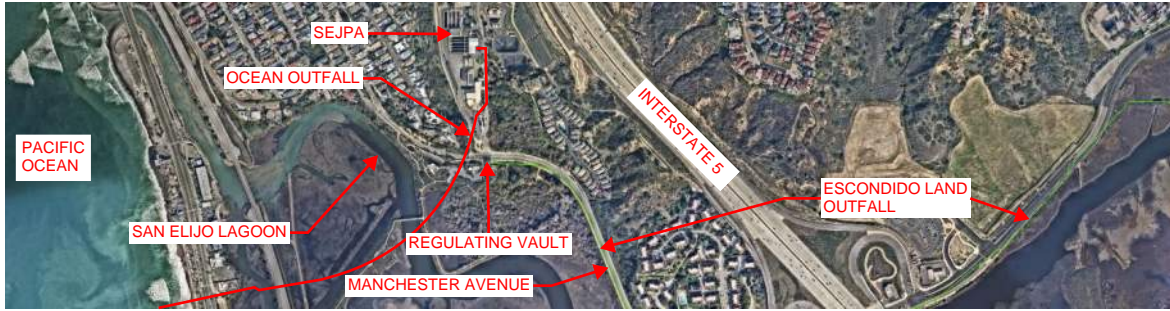

FIGURE 2

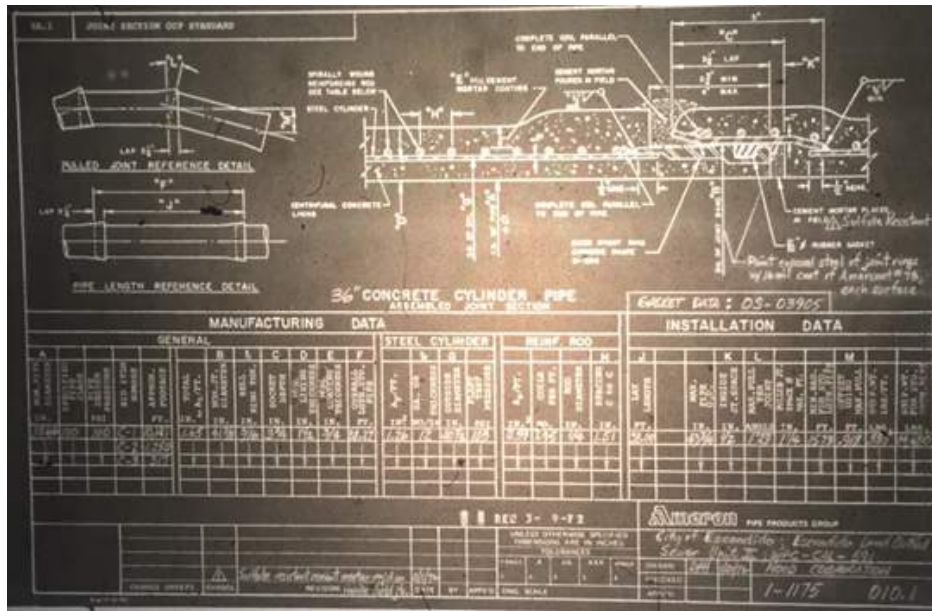

FIGURE 3



Item 5.

FIGURE 4

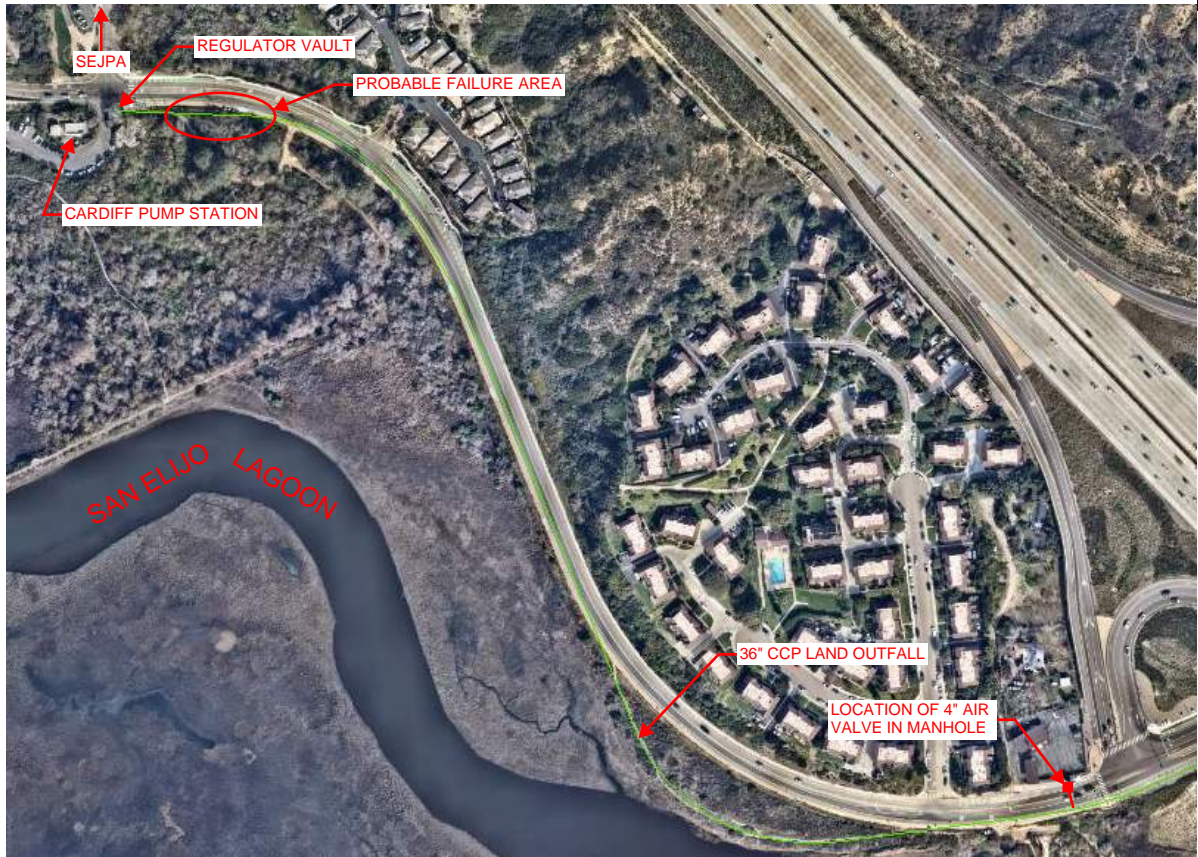

FIGURE 5



Attachment "C"

City Overhead & Profit Rates
Contractor Labor Rates and Equipment Rates

Overhead & Profit Rates

Below is the Overhead & Profit Schedule table applicable to the Land Outfall Emergency Repair Project

O & P Schedule			
Component	Overhead	Profit	Total
Labor	10%	10%	20%
Material	10%	5%	15%
Equipment	10%	5%	15%
Subcontractor Extra Work	7%	3%	10%

Due to the emergency nature of the necessary work required for the repair of the land outfall pipeline, and the expedited time required to mitigate the repair, the percentages in the Overhead & Profit Schedule table, above, supersedes the table in section 11.3.C of the City of Escondido General Conditions.

In addition, subcontractor rates referenced in sections 11.3.E and 11.3.F will also follow the rates for Subcontractor Extra Work in the table above.

CCL Contracting, Inc. Labor Rates

Based on Prevailing Wage Determinations through June 30, 2024

Classification	Hourly	OT 1.5 per Hour	OT 2.0 per Hour
Operating Engineer	\$106.46	\$134.85	\$163.25
Grade Checker	\$106.46	\$134.85	\$163.25
Foreman	\$108.25	\$140.75	\$173.25
Laborer	\$80.80	\$102.32	\$123.84

CCL CONTRACTING, INC.
EQUIPMENT RATES (Caltrans)
Apr 2024 - Mar 2025

	Code	<u>EQUIPMENT RATES - Bare (based on 8 hour day)</u>	
Truck	00-06	Pickup Truck 1/2 ton	\$ 37.19 HR
Truck	06-12	Pickup Truck 3/4 ton	\$ 41.96 HR
Truck	12-20	Truck 1 - 1/2 Ton	\$ 54.23 HR
TRUON	2AXL	Grout Truck w/mixer	\$ 54.23 HR
TRUON	2AXL	Bobtail Truck	\$ 73.10 HR
TRUON	2AXL	Water Truck 2000 Gal	\$ 73.10 HR
BRMSW	3-6	Street Sweeper	\$ 180.37 HR
LDRRT	1861M4	CAT 420 Backhoe 4WD	\$ 66.46 HR
LDRRT	1865E	CAT 430F Backhoe	\$ 82.56 HR
HCECL		312 CAT 320 BL Excavator	\$ 106.35 HR
HCECL		335 CAT 325 BL Excavator	\$ 154.50 HR
	336EL	CAT 336 Excavator	\$ 242.08 HR
LDRRT		2088 CAT 930K Loader	\$ 126.07 HR
LDRRT		2478 CAT IT28 Loader	\$ 107.71 HR
LDRRT		1731 CASE 580 super E	\$ 46.77 HR
TRACS	A	CAT 248 Skid Steer w/grinder	\$ 36.90 HR
ROVIB		8031 Roller CAT CB224B	\$ 42.65 HR
ROVIB		8026 Roller CAT CB214	\$ 40.69 HR
ROVIB		7855 Roller Wacker R1000	\$ 43.29 HR
ELGEN 015-025		Generator - Diesel Powered	\$ 19.57 HR
ELGEN 003-008		Generator - 5000 Watt	\$ 5.52 HR
AIRCP		Compressor 185 CFM	\$ 27.47 HR
WELD 0-250		Welder 0-250 Amps	\$ 6.13 HR
BITDT		Tacker - Trailer Mounted	\$ 9.43 HR
ELGEN 4 light		Light Tower	\$ 10.94 HR
AIRTO 60		Jackhammer 60#	\$ 1.77 HR
COMHG 250		Wacker	\$ 11.34 HR
		Vibro-Plate	\$ 13.50 HR
		Water Wagon	\$ 19.25 HR
PUMWA	020-030	Pump - 500 GPM	\$ 8.34 HR
		Cutoff Saw	\$ 90.00 DY
TRAF A	SOL1	CMS - Solar	\$ 12.91 HR
TRAF C	TM	Arrow Board - trailer mount	\$ 4.47 HR
TRAF C	RM	Arrow Board - roof mount	\$ 1.14 HR
		Signs (ea.)	\$ 6.00 DY
		Cones per 100	\$ 26.67 DY
		Triton Barricades (ea.)	\$ 12.00 DY
NONOP		Plates 8x10 1"	\$ 8.00 DY
		Shores	\$ 10.00 DY
Trailers		Tilt bed	\$ 12.80 HR
		Move On & Off	T&M
		Outside Rentals - cost plus 15%	

SECTION A-00700 - GENERAL CONDITIONS

SECTION INDEX

	<u>Page Number</u>
ARTICLE 1 – DEFINITIONS	A-00700-5
 ARTICLE 2 – PRELIMINARY MATTERS	
2.1 Delivery of Bonds and Insurance Certificates.....	10
2.2 Copies of Documents.....	10
2.3 Escrow of Bid Documents	10
2.4 Commencement of Contract Times; Notice to Proceed	13
2.5 Starting the Work.....	13
2.6 Continuing the Work.....	13
2.7 Preconstruction Meeting	13
2.8 City Observed Holidays.....	13
 ARTICLE 3 – INTENT AND USE OF CONTRACT DOCUMENTS	
3.1 Review of Contract Documents, Drawings, and Specifications.....	14
3.2 Detail Drawings and Instructions	15
3.3 Referenced Standard	16
3.4 Amending Contract Documents	16
3.5 No Assignment.....	16
3.6 Reuse of Documents	16
 ARTICLE 4 – SITE OF THE WORK	
4.1 Availability of Lands	16
4.2 Soils Investigation Report and Claims for Concealed or Unknown Conditions.....	17
4.3 Physical Conditions – Underground Utilities.....	17
4.4 Hazardous Materials	19
4.5 Reference Points.....	20
 ARTICLE 5 – BONDS AND INSURANCE	
5.1 Bonds.....	20
5.2 Liability, Property, Fire, Builder's Risk, and Other Insurance Requirements.....	21
5.3 Proof of Carriage Insurance	22
 ARTICLE 6 – CONTRACTOR'S RESPONSIBILITIES	
6.1 Communications	24
6.2 Independent CONTRACTOR	24
6.3 CONTRACTOR License.....	25
6.4 CONTRACTOR Registration.....	25
6.5 Change In Name and Nature of CONTRACTOR's Legal Entity	25
6.6 CONTRACTOR Superintendent.....	25
6.7 CONTRACTOR Supervision	25
6.8 Field Measurements, Layout, Record Drawings, and Field Engineering.....	26
6.9 Details of the Work	26
6.10 Means and Methods	26
6.11 Subcontractors.....	26
6.12 Duty to Provide Fit Workers.....	27
6.13 Overtime	27
6.14 Materials and Work.....	28
6.15 Access to CONTRACTOR's Records	29
6.16 CONTRACTOR's Substitution of "Or Equal" Items.....	29

6.17 Permits 30
6.18 Patent Fees and Royalties 31
6.19 Laws and Regulations 31
6.20 Taxes..... 31
6.21 Use of Premises 31
6.22 Safety and Protection 32
6.23 Emergencies 33
6.24 Submittals 33
6.25 CONTRACTOR's General Warranty and Guarantee 37
6.26 Indemnification 39
6.27 CONTRACTOR's Daily Reports 40
6.28 CONTRACTOR Payments..... 40
6.29 Dial Before You Dig 40
6.30 Documents on Work 41
6.31 Temporary Utilities 41
6.32 Sanitary Facilities 41
6.33 Cleaning Up..... 41
6.34 Wage Rates 42
6.35 Hours of Work..... 43
6.36 Apprentices..... 44
6.37 First Aid..... 45
6.38 Protection of Persons and Property..... 45
6.39 Accessibility Requirements 46

ARTICLE 7 – OTHER WORK

7.1 Other Contracts 46
7.2 Integration of Work..... 47

ARTICLE 8 – THE CITY'S RESPONSIBILITIES

8.1 Communications 47
8.2 Observations on the Site 47
8.3 Project Representation 47
8.4 Clarifications, Requests for Information 47
8.5 Authorized Variations in Work 47
8.6 Rejecting Work 47
8.7 CONTRACTOR Submittals, Change Orders, and Payments..... 47
8.8 Decisions on Disputes 48
8.9 Limitation of City's Responsibilities 48
8.10 Lands, Easements, and Surveys..... 48
8.11 Reports and Drawings 48
8.12 Suspension of Work..... 48
8.13 Termination of Agreement..... 48
8.14 Undisclosed Hazardous Environmental Conditions 48

ARTICLE 9 – ENGINEER'S STATUS DURING CONSTRUCTION

9.1 The Engineer of Work 49

ARTICLE 10 – CHANGES IN THE WORK

10.1 General 49
10.2 Allowable Quantity Variations 50

ARTICLE 11 – CHANGE OF CONTRACT PRICE

11.1 General 50

11.2 Cost of Work – Force Account (Based on Time and Materials) 52
 11.3 Overhead and Profit (O&P) Percentage Schedule 54
 11.4 CONTRACTOR's Daily Extra Work Report..... 55
 11.5 CONTRACTOR Shall Provide Notice 55
 11.6 Costs Related to Weather/Force Majeure..... 56

ARTICLE 12 – CHANGE OF CONTRACT TIMES

12.1 General 56
 12.2 Extensions of Contract Times for Delay Due to Weather 57
 12.3 Ownership of Project Schedule Float/Early Completion 57
 12.4 Extensions of Time Liquidated Damages 57

ARTICLE 13 – INSPECTIONS AND TESTS; CORRECTION, REMOVAL, OR ACCEPTANCE OF DEFECTIVE WORK

13.1 Authority of Inspector 58
 13.2 Inspection 58
 13.3 Notice of Defective Work..... 58
 13.4 Access to Work 58
 13.5 Inspections and Tests 58
 13.6 The City May Stop the Work..... 60
 13.7 Correction or Removal of Defective Work 60
 13.8 Acceptance of Defective Work..... 60
 13.9 The City May Correct Defective Work 60
 13.10 Correction Period 61

ARTICLE 14 – PAYMENTS TO CONTRACTOR, RETENTION AND COMPLETION

14.1 Application for Progress Payment..... 61
 14.2 Unit Price Bid Schedule..... 64
 14.3 Schedule of Values (Lump Sum Price Breakdown) 64
 14.4 Allowances 64
 14.5 Waiver, Conditional Release, Release of Claims (Forms) 65
 14.6 Retention 71
 14.7 Substitution of Securities, Escrow Account 71
 14.8 CONTRACTOR's Warranty of Title, Assignment of Antitrust Actions..... 72
 14.9 Review of Application for Progress Payment 72
 14.10 Partial Occupation / Utilization 74
 14.11 Project Completion..... 74
 14.12 Final Application for Payment..... 75
 14.13 Final Payment and Acceptance..... 75
 14.14 Release of Retention and Other Deductions..... 76

ARTICLE 15 – SUSPENSION OF WORK AND TERMINATION

15.1 City's Right to Terminate Agreement..... 76
 15.2 Termination of the Agreement by the City for Convenience 77

ARTICLE 16 – CONSTRUCTION CLAIMS, WAIVER AND RELEASE FORMS, DISPUTES, FALSE CLAIMS ACT

16.1 CONTRACTOR Claims 78
 16.2 Disputes – The City's and Engineer's Decisions 79
 16.3 False Claims Act Certification..... 80

ARTICLE 17 – MISCELLANEOUS

17.1	Giving Notice	80
17.2	Title to Materials Found on the Work	81
17.3	Right to Audit.....	81
17.4	Survival of Obligations	81
17.5	Controlling Law	81
17.6	Severability.....	81
17.7	Waiver	81
17.8	Prohibited Interests.....	82
17.9	California Public Contract Code § 9204.....	82
17.10	California Public Contract Code § 20104.....	85
17.11	California Public Contract Code § 20104.2.....	85
17.12	California Public Contract Code § 20104.4.....	86
17.13	California Public Contract Code § 20104.6.....	87

ARTICLE 1 – DEFINITIONS

Wherever used in these General Conditions or in the other Contract Documents, the following terms have the meanings indicated in this Article 1, with meanings applicable to both the singular and plural forms thereof. Descriptions of these terms are binding, and form an integral part of these General Conditions.

Addenda – Written or graphic representations issued prior to the opening of Bids which make additions, deletions, or revisions to the Contract Documents.

Agreement – The written Public Improvement Agreement Contract between the City and the CONTRACTOR covering the Work to be performed; other documents are attached to the Agreement and made a part thereof as provided therein.

Application for Payment – The form accepted by the City which is to be used by the CONTRACTOR to request progress payments or final payment and which is to be accompanied by such supporting documentation as is required by the Contract Documents.

Approval – The written authorization by the Engineer or City for specific applications. Approvals required by the Escondido City Council shall mean the approval of a specific resolution by that Council.

Asbestos – Any material that contains more than one percent (1%) asbestos and is friable or is releasing asbestos fibers into the air above current action levels established by the United States Occupational Safety and Health Administration.

As directed, accepted, rejected, approved, or others of similar meaning which authorize any exercise of judgment shall be distinctly understood to mean that such power to direct, accept, reject, and approve shall be vested only in the City and/or the Engineer.

As shown, as indicated, and as detailed refer to drawings accompanying the specification.

Bid – The offer or proposal of the Bidder, submitted on the prescribed form, setting forth the price or prices for the Work.

Bonds – Bid, performance, and Payment Bonds as well as other instruments of security.

Called For – As called for, shown, noted, and/or indicated in the specifications and/or drawings.

City – The City of Escondido with whom the CONTRACTOR has entered into the Agreement and for whom the Work is to be provided.

Clarification – A document issued by the Engineer to the CONTRACTOR that interprets the requirement(s) and/or design intent of the Contract Documents, which may not represent an addition, deletion, or revision in the Work or an adjustment in the Contract Price or the Contract Times.

Competent Person – *"One who is capable of identifying existing and predictable hazards in the surroundings or working conditions which are unsanitary, hazardous, or dangerous to employees, and has authorization to take prompt corrective measures to eliminate them."* Excerpt from the California Occupational Safety and Health Standards Board.

Confined Space – *"Confined space means a space that:*

- (1) *Is large enough and so configured that an employee can bodily enter and perform assigned work;*
- (2) *Has limited or restricted means for entry or exit (for example, tanks, vessels, silos, storage bins, hoppers, vaults, and pits are spaces that may have limited means of entry); and*
- (3) *Is not designed for continuous employee occupancy."* Excerpt from Title 8, General Industry Safety Orders Section 5157.

Construction Administration Documents: Terms, uses and protocols- Notwithstanding any other provisions in the General Conditions, the following terms and definitions shall be used.

- (1) **CCD** – The term "CCD" shall mean Construction Change Directive. The CCD is a written instrument prepared by the City or its designee and submitted to the CONTRACTOR. The CCD is a written order directing a change in the Work and stating the required pricing method, if any, in the contract sum, and the Contract Time adjusted to reflect a previously approved Fragnet, if any. The CCD, without invalidating the Contract, may order changes in the Work within the general scope of the Contract, consisting of additions, deletions, or other revisions within. The CCD shall become

effective when the City has signed the CCD (CONTRACTOR signature is not required). If the CCD results in additional time, the CONTRACTOR shall provide a Fragnet Submittal within **fourteen (14) days**. If the Fragnet Submittal is approved, the Contract Time adjustment shall be incorporated into originating CCD, or incorporated into a separate CCD and/or a Change Order (CO). The approved Fragnet, if any, shall become incorporated into the next monthly schedule update to reflect the time impact(s).

- (2) **CO** – The term "CO" shall mean Change Order. The Change Order shall state the change in Work and the contract sum and/or time adjustments, if any. RFP's, FO's and/or CCDs may be incorporated into a Change Order after any adjustments in the contract sum and/or time have been reviewed and accepted by the City. The Change Order and items contained therein cannot be incorporated into the progress payments until the Change Order has been fully executed and accepted by the Contractor and the City.
- (3) **COR** – The term "COR" shall mean Change Order Request. The COR is a written instrument prepared by the CONTRACTOR and submitted to the City. The COR is the CONTRACTOR's method for requesting the full and complete terms for changes in the contract sum and/or time, if any. All of the terms of the COR need to be presented without reservations so that the City and/or Engineer can consider the full impact of the COR. The request shall provide an explanation of the basis for entitlement referenced by or based on the Contract Documents. The City shall endeavor to respond to the COR on or within **twenty-one (21) days** of receipt.
- (4) **FO** – The term "FO" shall mean Field Order. A Field Order may be approved by the Inspector, at the City's discretion. A written order signed by the City, which may or may not involve a change in the Work, without invalidating the Contract, within the general scope of the Contract. If the FO results in additional time, the CONTRACTOR shall provide a Fragnet Submittal within **fourteen (14) days**. If the Fragnet Submittal is approved, the Contract Time adjustment shall be incorporated into the next monthly schedule update to reflect the time impact, if any.
- (5) **RFI** – The term "RFI" shall mean Request for Information. An RFI is a written instrument prepared by the CONTRACTOR and submitted to the City or its designee. An RFI shall be considered a tool for requesting additional information above and beyond that which is available in the Contract Documents and all reference standards, as well as fulfilling the Contract coordination requirements for which the CONTRACTOR is obligated to perform. The RFI shall not be used for requesting design and/or material substitutions.

Prior to issuing an RFI, the CONTRACTOR, Subcontractors, material suppliers and the like shall thoroughly review the Contract Documents and refer to all reference standards for the information sought.

When submitting an RFI, the document shall specify the date issued and the date the information is needed by. However, the contractual response time shall be **fourteen (14) days** from the date the City or its designee receives the RFI. The CONTRACTOR shall plan its work and submit questions in sufficient time to accommodate the response time. For those contracts requiring a CPM schedule, the CONTRACTOR shall include in the RFI the CPM Activity Number and the originating Subcontractor.

The CONTRACTOR shall make efforts to coordinate the work in a timely fashion so as to alleviate priority RFIs. If the RFI is considered a priority, the CONTRACTOR shall state the word "Priority" on the document, and the CONTRACTOR shall provide weekly

RFI Priority Schedules. The CONTRACTOR shall issue and maintain weekly RFI Priority Schedules.

The RFI Priority Schedule shall include a listing of pending requests, including the most current request, which ranks the RFIs in order of priority. The Engineer shall endeavor to respect the CONTRACTOR's requested order of priorities and requested response dates.

The Engineer's response to the RFI shall be considered a Supplemental Instruction (SI) in which the contract sum and/or time is not altered. If the RFI response alters the contract sum and/or time, a Construction Change Directive (CCD) or a Request for Proposal (RFP) may be issued for the changed condition(s).

Should the CONTRACTOR determine the response to the RFI creates changes in the contract sum and/or time, the CONTRACTOR must submit a Change Order Request (COR) to the City for review and decision along with a Fragnet if required.

- (6) **RFP** – The term "RFP" shall mean Request for Proposal. The RFP is a written instrument prepared by the City and submitted to the CONTRACTOR. The RFP is a request for changes in the contract sum and/or time, and a proposal for potential change in contract conditions, for which the contract sum and/or time may or may not be affected. The CONTRACTOR shall provide the full and complete terms of the request in a Change Order Request (COR) within **fourteen (14) days**: If the RFP results in added time, the CONTRACTOR shall provide a Fragnet Submittal within the same **fourteen (14) days**. If the City accepts the full terms of the RFP, the RFP shall be incorporated into a Construction Change Directive (CCD) and/or a Change Order (CO), and/or a Field Order (FO) and the approved Fragnet, if any, shall become incorporated into the next monthly schedule update to reflect the time impact(s).
- (7) **SI** – The term "SI" shall mean Supplemental Instruction. The SI is a written instrument prepared by the Engineer and submitted to the CONTRACTOR. The SI can order changes in the Work that do not affect the contract sum and/or time. Supplemental Instructions can also be made in an RFI response by issuing a formal SI document or by written letter from the City's or its designee's office.

Contract Price – The total monies payable by the City to the CONTRACTOR under the terms and conditions of the Contract Documents.

Contract Time – The duration of the Project as defined in the Agreement.

Contractor – The individual, partnership, corporation, joint venture, or other legal entity with whom the City has executed the Agreement.

Day – Days shall be considered calendar days and measured from midnight to the next midnight.

Defective work- Work that is unsatisfactory, faulty, or deficient; or that does not conform to the Contract Documents; or that does not meet the requirements of any inspection, reference standard, test, or approval referred to in the Contract Documents; or Work that has been damaged prior to the final payment.

Deficiency List – A list maintained by the City, representing an ongoing list of items that do not conform to the Contract Documents. The Deficiency List is added to the Punch-List when the CONTRACTOR asserts that the Work is complete.

Deficiency Notice – A notice from the City to the CONTRACTOR describing work that does not conform to the Contract Documents.

Delay Days – Delay Days shall be considered working days. Assuming a 5-day workweek, delay days shall be converted into calendar days by a factor of 1.4. Hence 10 Delay Days equal 14 Calendar Days. Delay Days will be evaluated and identified as one of the three categories listed below. Excusable delays will create adjustments in the Contract Time. Compensable delays will create

adjustments in both the contract sum and Contract Time. In the event of concurrent delays caused by the City and CONTRACTOR or its subcontractors, material men or suppliers, no delay damages are recoverable by either the City or the CONTRACTOR, but an extension in time shall be granted for each contemporaneous Delay Day occurring on the critical path. Contemporaneous delays shall be evaluated using a schedule fragnet(s), schedule updates, daily reports, notices, and any other records of delaying events. In the event of a delay, the CONTRACTOR shall provide a Notice of Delay in accordance with Article 11.5 "CONTRACTOR SHALL PROVIDE NOTICE" and submit a schedule fragnet depicting the delay with all substantiating documentation within **fourteen (14) days** of the event.

<u>Excusable & Compensable</u>	<u>Excusable & Non-Compensable</u>	<u>Inexcusable</u>
Delays caused by the City, the Engineer, or the City's separate Contractor(s).	<ol style="list-style-type: none"> 1. Unusual weather 2. Strikes or labor shortages 3. Acts of God 4. Fires, war, acts of government & pestilence 5. Unusual and unanticipated delays in manufacturing and/or deliveries of materials and/or equipment 6. Concurrent Delays 	Delays caused by the CONTRACTOR, Subcontractor(s), material-men or suppliers.

- (1) **Concurrent Delay** – Delays caused by both the Contractor and the City and occurring at the same time; existing together, relating to same activity or activities, and affecting the critical path.
- (2) **Contemporaneous Delay** – Delays existing or happening in the same period of time.

Drawings – The drawings, plans, maps, profiles, diagrams, and other graphic representations which indicate the character, location, nature, extent, and scope of the Work and which have been prepared by the Engineer and are included and/or referred to in the Contract Documents. Shop Drawings are not Drawings as so defined.

Effective Date of the Agreement – The Effective Date is indicated in the Agreement, but if no such date is indicated, the Effective Date is when the Agreement is signed and delivered by the last of the two parties.

Engineer – The individual, partnership, corporation, joint venture, or other legal entity designated by the City, if any is so designated, in the Supplementary General Conditions. Such designation may include more than one individual or entity, and may be changed by the City with written notification to the CONTRACTOR.

Engineer of Work - The responsible Engineer who wet stamped and signed the Contract Specifications and Drawings. The responsibilities of the Engineer of Work are set forth in California Business and Professions code and other laws as may be applicable. The responsibilities under law of the Engineer of Work are not modified by these General Conditions.

Fragnet – Also known as a "Sub-network." Refer to the specification section titled CONSTRUCTION SCHEDULING for the definition of a Fragnet and the requirements thereof. A Fragnet will be required for time impact analysis and time extensions. CONTRACTOR's failure to provide a Notice of Delay within **24 hours**, and submit a Fragnet for time impact analysis and time extension(s) on or within **14 days** of the delaying event, shall forfeit and invalidate all considerations for time and/or payment. (Refer to the definition of "Delay Days" for additional information.) The costs to prepare Fragnets and schedule updates resulting from approved Fragnets

are part of the Work, regardless of number and difficulty. The City will provide a response to the Fragnet on or within **14 days**.

Hazardous Waste – The term Hazardous Waste shall have the meaning provided in Section 1004 of the Solid Waste Disposal Act (42 USC Section 6906), as amended from time to time.

Inspector – The City's appointed representative(s) for inspection of in-progress or completed Work.

Laws and Regulations; Laws or Regulations – Any and all applicable laws, rules, regulations, ordinances, codes, and/or orders of any and all governmental bodies, agencies, authorities and courts having jurisdiction.

Materials – Materials incorporated in the project or used or consumed in the performance of the Work.

Milestone – A principal event specified in the Contract Documents relating to an intermediate completion date of a separately identifiable part of the Work or a period of time within which the separately identifiable part of the Work should be performed prior to Project Completion of all the Work.

Notice of Award – The written notice by the City to the apparent successful bidder stating that, upon compliance by the apparent successful bidder with the precedent conditions enumerated therein within the time specified, the City will enter into an Agreement.

Notice of Completion – A form signed by the City indicating that the Work is Complete ("Project Completion") and stating the date of completion. After acceptance of the Work by the City's governing body, the Escondido City Council, and due authority is given to the Deputy Director of Public Works, the form is signed by the Deputy Director of Public Works and filed with the San Diego County Recorder. This filing starts the 30-day lien filing period on the Work.

Notice to Proceed – The written notice issued by the City to the CONTRACTOR authorizing the CONTRACTOR to proceed with the Work and establishing the date of commencement of the Contract Times.

Partial Utilization – Use by the City of a completed part of the Work for the purpose for which it is intended prior to Project Completion.

Project – The total construction project of which the Work to be provided under the Contract Documents may be the whole or a part as indicated elsewhere in the Contract Documents.

Project Completion – The acceptance by the Escondido City Council of the Work of improvement (as in the Notice of Completion).

Project Documents and/or Contract Documents – Includes collectively, to wit: Notice Inviting Sealed Bids/Notice to Contractors, Instructions to Bidders, Bid Form, Designation of Subcontractors, Workers' Compensation Certificate, Change Orders, Shop Drawing Transmittals, Information Required of CONTRACTOR, Non-collusion Affidavit, Faithful Performance Bond, Payment Bond, Insurance Certificates, Guarantees, General Conditions, Supplementary General Conditions, Special Conditions, Plans, Drawings, Specifications, the Agreement and all modifications, addenda, and amendments thereto.

Provide – Term shall include "provide complete in place," that is, "furnish and install."

Punch-List – A list generated by the Engineer, in conjunction with the City, of missing work, of damaged existing facilities, and a list of any and all work described by the Contract Documents that has not been completed in conformance with the Contract Documents. A Punch-List may be amended by the City from time to time based on the results of CONTRACTOR re-work and the discovery of additional non-conforming work.

Resident Project Representative – The authorized representative of the City/Engineer who is assigned to the Site or any part thereof.

Safety Orders/Records – Those issued by the Division of Industrial Safety and OSHA standards for construction.

Samples – Physical examples of materials, equipment, or workmanship that are representative of some portion of the Work and which establish the standards by which such portion of the Work will be judged.

Shop Drawings – All drawings, diagrams, illustrations, schedules, and other data which are specifically prepared by or for the CONTRACTOR and submitted by the CONTRACTOR to illustrate some portion of the Work.

Site – The physical locale where the Project is to be constructed, including all public rights-of-way, utilities, improvements, and shall be limited solely by formal, recorded property lines adjacent to the physical locale where the Project is to be constructed.

Specifications – Those technical or additional project management provisions that are binding on the Work as described in the Supplementary General Conditions.

Stipulated Prices or Markups – Prices or markups set forth as a condition of the Contract.

Stop Notice – A legal remedy for subcontractors and suppliers who contribute to public works but who are not paid for their work, which secures payment from construction funds possessed by the City. The Stop Notice may also be issued by public entities, such as the department of Labor, as a notice to withhold due to failure to pay the required wages to workers.

Subcontractor – A licensed entity of any tier (whether having a direct contractual relationship with Contractor or another Subcontractor) that provides labor to the Project and/or furnishes material worked to a special design according to plans, drawings, and specifications of this work, but does not include one who merely furnishes material not so worked.

Supplementary General Conditions – The part of the Contract Documents which make additions, deletions, or revisions to these General Conditions.

Supplier – A manufacturer, fabricator, distributor, material-man, or vendor having a direct contract with the CONTRACTOR or with any Subcontractor to furnish materials, equipment, or product to be incorporated in the WORK by the CONTRACTOR or any Subcontractor.

Surety – The person, firm, or corporation that executes as surety the CONTRACTOR's Bid Security, faithful performance bond and/or payment bond.

Utilities – All pipelines, conduits, ducts, cables, wires, tracks, manholes, vaults, tanks, tunnels, or other such facilities or attachments, and any encasements containing such facilities which have been installed underground or above the ground to furnish any of the following services or materials: water, sewage, sludge, drainage, fluids, electricity, gases, steam, liquid petroleum products, telephone or other communications, cable television, traffic control, or other control systems.

Work – The entire completed construction or the various separately identifiable parts thereof required to be furnished under the Contract Documents. Work is the result of performing or furnishing labor and furnishing and incorporating materials and equipment into the construction, and performing or furnishing services and furnishing documents, all as required by the Contract Documents.

Workers – Workers include laborers, workers, and mechanics.

ARTICLE 2 – PRELIMINARY MATTERS

2.1 DELIVERY OF BONDS AND INSURANCE CERTIFICATES. When the CONTRACTOR delivers the signed Agreement to the City, the CONTRACTOR shall also deliver to the City such Bonds and insurance policies and certificates and documents as the CONTRACTOR may be required to furnish in accordance with the Contract Documents.

2.2 COPIES OF DOCUMENTS. The City will furnish to the CONTRACTOR as many copies of the Contract Documents specified in the Instructions to Bidders. Additional copies will be provided, upon request, at the cost of duplication.

2.3 ESCROW OF BID DOCUMENTS

A. SCOPE:

1. The CONTRACTOR shall submit, within **ten (10) days** after the award of contract one (1) copy of all documentary information generated in preparation of the bid price for the project. This material is hereinafter referred to as the "Escrow Bid Documents." The Escrow Bid Documents will be held in escrow for the duration of the contract.

2. The CONTRACTOR agrees that the Escrow Bid Documents constitute all of the information used in preparation of the bid, and that no other bid preparation information will be considered in resolving claims.
 3. Nothing in the Escrow Bid Documents shall change or modify the terms or conditions of the Contract.
- B. **PROPERTY:** The Escrow Bid Documents are and will always remain the property of the CONTRACTOR, subject only to joint review by the City and the CONTRACTOR, as provided in paragraph (G) "EXAMINATION." The City stipulates and expressly acknowledges that the Escrow Bid Documents constitute trade secrets and are proprietary and confidential. This acknowledgment is based on the City's express understanding that the information contained in the Escrow Bid Documents is not known outside the CONTRACTOR's business, is known only to a limited extent and only by a limited number of employees of the CONTRACTOR, is safeguarded while in CONTRACTOR's possession, is extremely valuable to CONTRACTOR and could be extremely valuable to CONTRACTOR's competitors by virtue of it reflecting CONTRACTOR's contemplated techniques of construction. The City acknowledges that the CONTRACTOR expended substantial sums of money in developing the information included in the Escrow Bid Documents and further acknowledges that it would be difficult for a competitor to replicate the information contained therein. The City further acknowledges that the Escrow Bid Documents and the information used in the CONTRACTOR's business were intended to give the CONTRACTOR an opportunity to obtain an advantage over competitors who do not know of or use the contents of the documentation. The City agrees to safeguard the Escrow Bid Documents and all the information contained therein against disclosure to the fullest extent permitted by law.
- C. **PURPOSE:** Escrow Bid Documents will be used to assist in the negotiation for the settlement of claims. They will not be used for evaluation of the CONTRACTOR's anticipated methods of construction or to assess the CONTRACTOR's qualification for performing the Work.
- D. **FORMAT AND CONTENTS:**
1. CONTRACTOR may submit Escrow Bid Documents in the usual cost-estimating format. Escrow Bid Documents shall be adequate to enable complete understanding and proper interpretation for their intended use.
 2. Escrow Bid Documents shall clearly itemize the estimated costs of performing the Work. Items shall be separated into sub-items as required to present a complete and detailed cost estimate and allow a detailed cost review. The Escrow Bid Documents shall include all quantity takeoffs, labor, equipment, calculations of rate production and progress, copies of quotations from Subcontractors and suppliers, memoranda, narratives, consultant's reports, add/deduct sheets, and all other information used by the CONTRACTOR to arrive at the prices contained in the bid proposal. Estimated costs shall be broken down into the CONTRACTOR's usual estimate categories such as direct labor, repair labor, material, equipment, construction equipment operation, construction equipment ownership, expendable materials, materials and Subcontractor cost as appropriate. Plant and equipment, indirect costs shall be detailed in the CONTRACTOR's usual format. The CONTRACTOR's allocation of plant and equipment, indirect costs, contingencies, markup and other items shall be included.
 3. All costs shall be identified for all items. Sub-items amounting to less than \$10,000.00 estimated unit costs are acceptable without a detailed cost estimate,

provided that labor, equipment, materials, construction equipment, expendable materials and subcontracts, as applicable, are included, provided that indirect costs, contingencies, and markups, as applicable, are allocated.

4. Bidding materials provided by the City shall not be included in the Escrow Bid Documents unless needed to comply with the requirements of this specification.

E. SUBMITTAL:

1. The Escrow Bid Documents shall be submitted by the CONTRACTOR in a sealed container(s) within **10 days** after the day of award of the contract. The container shall be clearly marked on the outside with the CONTRACTOR's name, date of submittal, project name and the words "Escrow Bid Documents."
2. The Escrow Bid Documents shall be accompanied by an index to inventory the contents of the submittal and a Bid Documentation Certification, signed by the individual who executed the bidding proposal, stating that the material in the Escrow Bid Documents constitutes all documentary information used in preparation of the bid and that he/she has personally examined the contents of the Escrow Bid Documents container and has found that the documents in the container(s) are complete and organized as shown by the CONTRACTOR's index.
3. The City shall examine the index. This examination is to ensure that the index is detailed and complete and conforms to the "format and contents" as stated in paragraph (D) above. If all the documentation required in paragraph (D) "FORMAT AND CONTENTS" has not been indexed in the original submittal a revised index shall be submitted at the CITY's discretion. Timely submission of complete Escrow Bid Documents is an essential element of the CONTRACTOR's responsibility. Failure to provide the necessary Escrow Bid Documents may be sufficient cause for the CITY to assess damages under the contract. If the CONTRACTOR's proposal is based on subcontracting any part of the Work, each Subcontractor, whose total subcontract price exceeds the lesser of five percent (5%) of the total contract price proposed by the CONTRACTOR or \$200,000 shall provide separate Escrow Bid Documents to be submitted with those of the CONTRACTOR. These submittals will be examined in the same manner and at the same time as the examination described above. If the CONTRACTOR wishes to subcontract any portion of the Work or requests substitutions of any Subcontractor after award, the CITY retains the right to require the CONTRACTOR to submit Escrow Bid Documents from the proposed Subcontractor before the subcontract or substitution is approved.

F. STORAGE: The escrow bid documents will be placed in escrow, for the life of the contract, in a mutually agreeable institution. The city will pay the cost of storage.

G. EXAMINATION:

1. The Escrow Bid Documents shall be examined by the City, the Engineer and CONTRACTOR, at any time deemed necessary by either the City or the CONTRACTOR, to assist in the negotiation for the settlement of claims.
2. Examination of the Escrow Bid Documents is subject to the following conditions:
 - a. As trade secrets, the Escrow Bid Documents are proprietary and confidential as described in paragraph (B).

- b. The City and the CONTRACTOR shall each designate, in writing to the other party and a minimum of **five (5) days** prior to examination, representatives who are authorized to examine the Escrow Bid Documents. No other person shall have access to the Escrow Bid Documents.
- c. Access to the Escrow Bid Documents under this paragraph will take place only in the presence of duly designed representatives of both the City and the CONTRACTOR.

H. **FINAL DISPOSITION:** The escrow bid documents will be returned to the contractor at such time as the contract has been completed and final settlement has been achieved.

2.4 **COMMENCEMENT OF CONTRACT TIMES; NOTICE TO PROCEED.** The Contract Times will start to run on the commencement date stated in the Notice to Proceed.

2.5 **STARTING THE WORK**

- A. The CONTRACTOR shall begin to perform the Work on the commencement date stated in the Notice to Proceed, but no Work shall be done at the Site prior to said commencement date. The Work shall be commenced immediately after Notice to Proceed, and shall be diligently prosecuted until completion.
- B. Before undertaking each part of the Work, the CONTRACTOR shall review the Contract Documents in accordance with Article 3 of these General Conditions.

2.6 **CONTINUING THE WORK.** The CONTRACTOR shall carry on the Work and adhere to the progress schedule during all disputes or disagreements with the City. No Work shall be delayed or postponed pending resolution of any disputes or disagreements, except as the CONTRACTOR and the City may otherwise agree in writing.

2.7 **PRECONSTRUCTION MEETING.** A preconstruction meeting shall be called after the award and execution of the Contract and prior to construction. The CONTRACTOR (a Principal and Project Superintendent) shall attend. The CONTRACTOR shall plan on spending no less than **four (4) hours** of time with Subcontractor(s) and project superintendent(s) for this meeting.

2.8 **CITY OBSERVED HOLIDAYS.** CONTRACTOR is required to observe City holidays. The City observes the following holidays:

- 1. New Years Day
- 2. Martin Luther King, Jr. Day
- 3. Presidents' Day
- 4. Memorial Day
- 5. Independence Day
- 6. Labor Day
- 7. Veterans Day
- 8. Thanksgiving Day
- 9. Day after Thanksgiving
- 10. Christmas Day

ARTICLE 3 – INTENT AND USE OF CONTRACT DOCUMENTS

3.1 CONTRACTOR MUST REVIEW CONTRACT DOCUMENTS, DRAWINGS AND SPECIFICATIONS

- A. Drawings and Specifications are intended to be complementary (that which is required by one shall be required by the other; to the extent there is more than one reference which exists, the reference requiring the more stringent and/or best standards and requirements shall be furnished and installed) and delineate and describe the Project and its component parts to such a degree as will enable a skilled and competent CONTRACTOR to intelligently bid upon the Work, coordinate the Work and to carry out the Work to a successful conclusion. If, as and to the extent that Public Contract Code section 1104 is deemed to apply after the Award of Contract, CONTRACTOR shall not be required to assume responsibility for the completeness and accuracy of architectural or engineering plans and specifications, notwithstanding any other provision in the Project Documents, except to the extent that CONTRACTOR discovered or should have discovered and reported any errors and omissions to the City, including but not limited to as the result of any review of the plans and specifications by CONTRACTOR required by the Instructions to Bidders or other Project Documents, whether or not actually performed by CONTRACTOR.
- B. Drawings and Specifications are intended to comply with all laws, ordinances, rules and regulations of constituted authorities having jurisdiction, and where referred to in the Project Documents, these laws, ordinances, rules and regulations shall be considered as a part of the Agreement within the limits specified. The CONTRACTOR shall bear all expenses of correcting Work done contrary to applicable laws, ordinances, rules and regulations and if the CONTRACTOR performed the Work (1) without first consulting the City for further instructions regarding the Work, or (2) disregarded the City's instructions regarding the Work.
- C. Questions regarding interpretation of drawings and specifications shall be submitted in writing to be clarified by the City; provided, however, that in the event the City determines that CONTRACTORS requests for information (RFI's) are not justified or do not reflect adequate or competent supervision, coordination, and / or knowledge by the CONTRACTOR or its Subcontractors, CONTRACTOR shall be required to pay the City's reasonable and customary fees in processing and responding to such requests. Should the CONTRACTOR commence Work or any part thereof without seeking clarification, and/or performing its own coordination obligations, the CONTRACTOR waives any claim for extra Work or damages as a result of any ambiguity, conflict or lack of information.
- D. Figured dimensions on drawings shall govern, but Work not dimensioned or mis-described shall be as directed. Work not particularly shown, mis-described or specified shall be the same as similar parts that are shown or specified. Large scale drawings shall take precedence over smaller scale drawings as to shape and details of construction. Specifications shall govern as to materials, workmanship, and installation procedures. Drawings and specifications are intended to be fully cooperative and to agree. If through the process of contract-required coordination, CONTRACTOR observes that drawings and specifications are in conflict, CONTRACTOR shall promptly notify the City in writing, and any necessary changes shall be adjusted as provided in Article 10 titled CHANGES IN THE Work; provided, however, that the specification calling for the higher quality material or workmanship shall prevail without additional cost to the City.

- E. Materials or Work described in words, which so applied, have a well known technical or trade meaning shall be deemed to refer to such recognized standards.
- F. It is not the intention of the Agreement to go into detailed descriptions of any materials and/or methods commonly known to the trade under "trade name" or "trade term." The mere mention or notation of such "trade name" or "trade term" shall be considered a sufficient notice to CONTRACTOR that it will be required to complete the Work so named with all its incidental and accessory items according to the best practices of the trade.
- G. The naming of any material and/or equipment shall mean furnishing and installing, including all incidental and accessory items thereto and/or labor necessary to achieve full and complete functioning of the material and/or equipment according to the best practices of the trade(s) involved, unless specifically noted otherwise.

3.2 AGREEMENT TO THOROUGHLY REVIEW DETAIL DRAWINGS AND INSTRUCTIONS

- A. All parts of the described and shown construction drawings shall be of the best quality of their respective kinds and in executing the Agreement, the CONTRACTOR agrees to use all diligence to become fully informed as to the required construction and finish, and in no case to proceed with the different parts of the Work without obtaining first from the City such directions and/or drawings as may be necessary for the proper performance of the Work.
- B. In case of ambiguity, conflict, or lack of information, the City shall furnish additional instructions by means of drawings or otherwise, as necessary for proper execution of the Work. All such drawings and instructions shall be consistent with Project Documents, true developments thereof, and reasonably inferable therefrom. Such additional instructions shall be furnished with reasonable promptness, provided that CONTRACTOR informs the City of the relationship of the request to the critical path of construction. Refer to the term, use and protocol of an RFI defined in Article 1 entitled "Definitions" under "Construction Administration Documents."
- C. Work shall be executed in conformity therewith and CONTRACTOR shall do no Work without proper drawings and instructions.
- D. The City may furnish necessary additional details to more fully explain the Work, which details shall be considered as part of the Project Documents.
- E. Should any details be more elaborate, in the opinion of the CONTRACTOR, than scale drawings and specifications warrant, CONTRACTOR shall give written notice thereof to the Engineer within **21 days** of receipt. In case no notice is given to the Engineer within **21 days**, it will be assumed the details are reasonable development of the scale drawings. In case proper notice is given, then it will be considered, and if found justified, the Engineer will either modify the drawings or shall recommend a change order for any extra Work that may be involved.
- F. If it is found at any time, before or after completion of the Work, that the CONTRACTOR has varied from the drawings and/or specifications, in materials, quality, form, finish, or in the amount or value of the materials and labor used, the City shall take the issue under advisement and consider the following options:
 - 1. That all such improper Work should be removed, remade, replaced, and all Work disturbed by these changes be made good at the CONTRACTOR's expense; or

2. That the City deduct from any amount due CONTRACTOR, the sum of money equivalent to the difference in value between the Work performed and that called for by the drawings and specifications. The City shall determine such difference in value. The City, at its option, may pursue a recommendation made by the Engineer.

- 3.3 REFERENCED STANDARD. No provision of any referenced standard specification, manual or code shall be effective to change the duties and responsibilities of the City, the CONTRACTOR, the Engineer, or any of their consultants, agents, or employees, from those set forth in the Contract Documents, nor shall it be effective to assign to the City, Engineer, or any of Engineer's consultants, agents, or employees any duty or authority to direct the performance of the Work or any duty or authority to undertake responsibility inconsistent with the provisions of the Contract Documents.

- 3.4 AMENDING CONTRACT DOCUMENTS. The Contract Documents may be amended only in writing to provide for additions, deletions, and revisions in the Work or to modify the terms and conditions thereof by a Change Order (pursuant to Article 10-CHANGES IN THE WORK).

- 3.5 NO ASSIGNMENT. The CONTRACTOR shall not assign, transfer, convey, sublet or otherwise dispose of this Agreement or of its rights, title or interest in or to the same or any part thereof. If the CONTRACTOR shall assign, transfer, convey, sublet or otherwise dispose of the Agreement or its right, title or interest therein, or any part thereof, such attempted or purported assignment, transfer, conveyance, sublease or other disposition shall be null, void and of no legal effect whatsoever; and the Agreement may, at the option of the City, be terminated, revoked and annulled, and the City shall thereupon be relieved and discharged from any and all liability and obligations growing out of the same to the CONTRACTOR, and to its purported assignee or transferee.

- 3.6 REUSE OF DOCUMENTS. Neither the CONTRACTOR, nor any Subcontractor or Supplier, nor any other person or organization performing any of the Work under a contract with the City shall have or acquire any title to or ownership rights in any of the Drawings, Technical Specifications, or other documents used on the Work, and they shall not reuse any of them on the extensions of the Project or any other project without written consent of City.

ARTICLE 4 – SITE OF THE WORK

- 4.1 AVAILABILITY OF LANDS. The City will furnish, as indicated in the Contract Documents, the lands upon which the Work is to be performed, rights-of-way and easements for access thereto, and such other lands which are designated for the use of the CONTRACTOR. Easements for permanent structures or permanent changes in existing facilities will be obtained and paid for by the City, unless otherwise provided in the Contract Documents. Nothing contained in the Contract Documents shall be interpreted as giving the CONTRACTOR exclusive occupancy of the lands or rights-of-way provided. The CONTRACTOR shall provide for all additional lands and access thereto that may be required for temporary construction facilities or storage of materials and equipment; provided, that the CONTRACTOR shall not enter upon nor use any property not under the control of the City until a written temporary construction easement agreement has been executed by the CONTRACTOR and the property owner, and a copy of said easement furnished to the Engineer prior to said use; and, neither the City nor the Engineer will be liable for any claims or damages resulting from the CONTRACTOR's trespass on or use of any such properties. The CONTRACTOR shall provide the City with a signed release from the property owner confirming that the lands have been satisfactorily restored upon completion of the Work.

4.2 SOILS INVESTIGATION REPORT & CLAIMS FOR CONCEALED OR UNKNOWN CONDITIONS

- A. SUBSURFACE EXPLORATIONS: Reference is made to the Supplementary General Conditions for identification of those reports of explorations and tests, if any, of subsurface conditions at the Site that have been utilized by the City or its Engineer in the preparation of the Contract Documents.
- B. SOILS INVESTIGATION REPORT. When a soils investigation report has been prepared or referenced by the City or its Engineer to assist with the design of the facility, such report is available for the CONTRACTOR's use in preparing its bid and Work under this Agreement. All soil and test-hole data, water table elevations, and soil analyses shown on the drawings or included in the Specifications apply only at the location of the test holes and to the depths indicated. Geotechnical reports for the test holes, if any, which have been drilled are available from the City. Any additional subsurface exploration shall be done by the CONTRACTOR or Bidder at their own expense. The indicated elevation of a water table is that which existed on the date when test holes were made and the level of the groundwater was determined. It is the CONTRACTOR's responsibility to determine the level of ground water or water table at the time of project construction. A difference in elevation between the level of ground water or water table indicated on the soil boring logs and groundwater actually encountered during construction is a risk of the CONTRACTOR's bid amount, and will not be considered as a basis for extra Work or additional compensation.
- C. CONTRACTOR SHALL NOTIFY THE CITY OF UNKNOWN CONDITIONS. If, during the course of Work under this Agreement, CONTRACTOR encounters subsurface or otherwise concealed physical conditions that differ materially from those indicated in the Contract Documents, or unknown physical conditions of an unusual nature, which differ materially from those ordinarily found to exist and generally recognized as inherent in contract activities of the character provided for in the Contract Documents, then CONTRACTOR shall notify the City of the discovery of the condition before the condition is materially changed, disturbed and/or covered, and before any additional Work is performed. The CONTRACTOR must notify the City, in writing of unforeseen conditions, or differing Site conditions, promptly upon their discovery and before they are disturbed. Reference Article 11.5 "CONTRACTOR SHALL PROVIDE NOTICE".
- D. WARNING: THE CITY DOES NOT WARRANT THE SOILS AT THE PROJECT SITE. SOILS INVESTIGATION REPORTS ARE PROVIDED FOR CONTRACTOR'S INFORMATION ONLY. THE CITY OF ESCONDIDO DOES NOT WARRANT THE SOILS CONDITIONS OF THE SITE AND CONTRACTOR IS FULLY RESPONSIBLE TO ASCERTAIN SITE CONDITIONS FOR THE PURPOSES OF DETERMINING CONSTRUCTION MEANS AND METHODS PRIOR TO COMMENCING CONSTRUCTION. IF ANY CONTRACTOR WISHES TO PERFORM A PRE-BID SITE INSPECTION, WHICH INCLUDES SOILS TESTING, A METHOD TO DO SO IS AVAILABLE AND IS DESCRIBED IN PARAGRAPHS 4.7 and 4.8 OF THE "INSTRUCTIONS TO BIDDERS".

4.3 PHYSICAL CONDITIONS - UNDERGROUND UTILITIES

- A. The information and data indicated in the Contract Documents with respect to existing underground Utilities at or contiguous to the Site are based on information and data furnished to the City or the Engineer by the owners of such underground Utilities. The Contract plans depict the various utilities as they are believed to exist, however, the

CONTRACTOR shall not rely on the locations and depths indicated. The CONTRACTOR shall comply with California Government Code Section 4216 ("Section 4216"). The CONTRACTOR shall determine the location and depth of all utilities that are indicated and those that are not indicated as follows:

1. As provided in Section 4216, at least **2 working days** prior to commencing any excavation, but not more than **14 calendar days**, the CONTRACTOR shall contact the regional notification center (Underground Service Alert of Southern California) and obtain an inquiry identification number. Refer to Article 6.28.
2. Where underground main distribution conduits such as water, gas, sewer, electric power, telephone, or cable television are shown on the Plans, the CONTRACTOR shall assume that every property parcel will be served by a service connection of each type of utility.
3. Section 4216 does not require the Local Agency to mark out non-pressurized sewer lines, non-pressurized storm drains or other non-pressurized drain lines.
4. The California Department of Transportation, CALTRANS, is not required by Section 4216 to become a member of the regional notification center. The CONTRACTOR shall call CALTRANS directly for location of its subsurface installations.
5. The CONTRACTOR shall determine the location and depth of all utilities (the top and the bottom), including joint trenches and service connections, which have been marked by the respective owners and which may affect or be affected by its operations. The CONTRACTOR shall determine the location and depth of all utilities not required to be marked out by the Local Agency.
6. The CONTRACTOR shall further determine the location and depths of all utilities that were not known or indicated on the project plans, but, after CONTRACTOR compliance with Section 4216, were marked out by the utility owners.
7. The CONTRACTOR shall not assume that existing utilities are buried at depths and locations specified in the pertinent standard drawings. In Escondido, existing utilities are frequently found at depths and locations that are not in conformance with the existing standard drawings.
8. The CONTRACTOR shall have the responsibility for coordinating as many call-backs of utility owners and CONTRACTOR mobilizations as may be required to determine the exact location, or identity, of all utilities. Utilities that are indicated on the Contract plans in a certain location, and are marked out in a different location by the utility owner, are considered by this Contract to be the same utility. The City is not responsible for errors in mark-outs made by the Utility owners.
9. The CONTRACTOR shall have full responsibility for the safety and protection of all existing utilities, to the extent allowed by California Government Code Section 4215, and repairing any damage thereto resulting from the Work. The CONTRACTOR shall use hand tools and/or vacuum equipment and use reasonable care to protect existing utilities.
10. Unknown Utility on the Contract plans, but marked out in the field by the utility owner: The Work of potholing, protecting in place, trenching over or under, repairing the road surface, backfilling with the utility owner's preference of material, plotting on the record drawings, and describing a previously unknown utility is fully contemplated by the City as being a regular occurrence on trenching projects.

11. Unknown utilities not marked out by the utility owner: Should the CONTRACTOR come across utilities that are not known nor marked out by the utility owner, the CONTRACTOR shall immediately call Underground Service Alert and the City. The City is not responsible for the consequences of the failure of a Utility owner to mark out its facilities.
12. Abandoned Utilities. Abandoned utilities are considered as unknown utilities for the purpose of CONTRACTOR payment, unless they are indicated on the project plans.
13. The CONTRACTOR shall call for a "standby inspector" when requested to do so by a utility owner, and follow their direction.

B. Locating Subsurface Installations (excerpted from California Government Code section 4216):

1. The excavator shall determine the exact location of subsurface installations in conflict with the excavation by excavating with hand tools within the area of the approximate location of subsurface installations as determined by the field marking provided in accordance with (California Government Code) section 4216.3 before using any power-operated or power-driven excavating or boring equipment within the approximate location of the subsurface installation, except that power-operated or power-driven excavating or boring equipment may be used for the removal of any existing pavement if there are no subsurface installations contained in the pavement. If mutually agreeable with the operator (*the operator is the owner of the Utility in this case*) and the excavator (*the excavator is the CONTRACTOR in this case*), the excavator may utilize power-operated or power-driven excavating or boring equipment within the approximate location of a subsurface installation and to any depth. (*Clarification added*)
2. If the exact location of the subsurface installation cannot be determined by hand excavating in accordance with subdivision B1, the excavator (the CONTRACTOR) shall request the operator (the owner of the Utility) to provide additional information to the excavator, to the extent that information is available to the operator, to enable the excavator to determine the exact location of the installation. (*Clarification added*)

4.4 HAZARDOUS MATERIALS

- A. The provisions of Articles 4.2, 4.3, and 4.4 are not intended to apply to Asbestos, PCBs, Petroleum, Hazardous Waste, or Radioactive Material uncovered or revealed at the Site.
- B. Reference is made to the Supplementary General Conditions for identification of those reports and drawings relating to Asbestos, Hazardous Waste, PCBs, Petroleum and/or Radioactive Material identified at the Site that have been utilized by the Engineer in the preparation of the Contract Documents, if any.
- C. Copies of these reports and drawings may be examined at the office of the City during regular business hours. Please make an appointment. The CONTRACTOR may rely upon the accuracy of the technical data contained in such reports and drawings, except for such physical dimensions that can be field verified; however, the interpretation of such technical data, including any interpolation or extrapolation thereof, and opinions contained in such reports and drawings are not to be relied on by the CONTRACTOR.

- D. The City shall be responsible for any Asbestos, Hazardous Waste, PCBs, Petroleum, or Radioactive Material uncovered or revealed at the Site which was not shown or indicated in Drawings or Specifications or identified in the Contract Documents to be within the scope of the Work and which may present a substantial danger to persons or property exposed thereto in connection with the Work at the Site. The City will not be responsible for any such material brought to the Site by CONTRACTOR, Subcontractors, Suppliers, or anyone else for whom CONTRACTOR is responsible.

4.5 REFERENCE POINTS

- A. The City will provide access to the bench-mark book maintained by the City Surveyor, and provide any survey reference material that may be on file. The CONTRACTOR shall furnish all other lines, grades, and bench-marks required for proper execution of the Work.
- B. The CONTRACTOR shall preserve all bench marks, stakes, and other survey marks and in case of their removal or destruction by any party, the CONTRACTOR shall be responsible for the accurate replacement of such reference points by personnel qualified under the applicable state codes governing land surveyors. The recording of any replacement corners, or other points, shall be the responsibility of the CONTRACTOR.

ARTICLE 5 – BONDS AND INSURANCE

5.1 BONDS

- A. CONTRACTOR shall furnish a surety bond in an amount equal to **one hundred percent (100%)** of the contract price as security for faithful performance of this Agreement and shall furnish a separate bond in an amount equal to **one hundred percent (100%)** of the contract price as security for payment to persons performing labor and furnishing materials in connection with this Project. Bonds shall be in the form set forth in these Project Documents.
- B. All Bonds shall be in the form prescribed by the Contract Documents except as provided otherwise by Laws or Regulations, and shall be executed by such sureties as are named in the current list of "Companies Holding Certificates of Authority as Acceptable Sureties on Federal bonds and as Acceptable Reinsuring Companies" as published in Circular 570 (amended) by the Audit Staff, Bureau of Government Financial Operations, U.S. Treasury Department. All Bonds signed by an agent must be accompanied by a certified copy of such agent's authority to act.
- C. If the surety on any Bond furnished by the CONTRACTOR is declared a bankrupt or becomes insolvent or its right to do business is terminated in any state where any part of the Work is located, the CONTRACTOR shall, within **seven (7) days** thereafter, substitute another Bond and surety, which must be acceptable to the City. No Work shall be performed without Bonds, in a form and issued by a surety acceptable to the City, required by the Contract Documents to be in full force and effect. If one or more of such Bonds shall, at any time, not be in full force and effect, CONTRACTOR shall immediately cease performance until it is in full compliance with the bonding requirements of the Contract Documents and California law. All delays and costs incurred and/or resulting from such occurrence shall be to the exclusive account of CONTRACTOR. Failure of the CONTRACTOR to promptly cure any failure to have the necessary Bonds in full force and effect shall be grounds for termination for default.
- D. All Bonds required by the Contract Documents to be purchased and maintained by CONTRACTOR shall be obtained from surety companies that are duly licensed or

authorized in the State in which the Project is located to issue Bonds for the limits so required. Such surety companies shall also meet such additional requirements and qualifications as may be provided in the Supplementary General Conditions.

5.2 LIABILITY, PROPERTY, FIRE, BUILDER'S RISK AND OTHER INSURANCE REQUIREMENTS

- A. **LIABILITY AND PROPERTY DAMAGE.** Before the commencement of the Work and for the minimum amount of limits set forth herein the CONTRACTOR shall purchase from and maintain such commercial general liability insurance per occurrence for bodily injury, personal injury and property damage as set forth in the Agreement and automobile liability insurance per accident for bodily injury and property damage combined single limit as set forth in the Agreement as will protect the CONTRACTOR, and those required to be endorsed as additional insured from claims set forth below, which may arise out of or result from the CONTRACTOR's operations under the Contract and for which the CONTRACTOR may be legally liable, whether such operations are by the CONTRACTOR, by a Subcontractor, by Sub-subcontractor, by anyone directly or indirectly employed by any of them, or by anyone for whose acts any of them may be liable:
1. Claims for damages because of bodily injury (including emotional distress), sickness, disease, or death of any person other than the CONTRACTOR's employees. This coverage shall be provided in a form at least as broad as Insurance Services Office (ISO) Form CG 0001 11188;
 2. Claims for damages arising from personal or advertising injury in a form at least as broad as ISO Form CG 0001 11188;
 3. Claims for damages because of injury or destruction of tangible property, including loss of use resulting there from, arising from operations under the Project Documents; and
 4. Claims for damages because of bodily injury, death of a person, or property damage arising out of the ownership, maintenance, or use of a motor vehicle, all mobile equipment, and vehicles moving under their own power and engaged in the Work; and
 5. Claims involving blanket contractual liability applicable to the CONTRACTOR's obligations under the Project Documents, including liability assumed by and the indemnity and defense obligations of the CONTRACTOR and the Subcontractors; and
 6. Claims involving Operations/Premises and Completed Operations/Products, Independent CONTRACTOR's coverage, and Broad Form property damage, without any exclusions for collapse, explosion, demolition, underground coverage, and excavating. Coverage for completed operations must be at least as broad as CG 2010 11/85.
- B. If commercial general liability insurance or another insurance form with a general aggregate limit is used, the general aggregate limit shall apply separately to the project location (with the ISO CG 2503 or insurer's equivalent endorsement provided to the City).
- C. Any deductible or self-insured retention must be declared to and approved by the City. At the option of the City, either the insurer shall reduce or eliminate such deductibles or self-

insured retentions as respects the City, its Board of Trustees, members of its Board of Trustees, officers, employees, agents and volunteers; or the CONTRACTOR shall procure a bond guaranteeing payment of losses and related investigations, claim administration and defense expenses.

- D. **CONSENT OF INSURER.** Partial occupancy or use in accordance with the Contract Documents shall not commence until the City's insurance company providing property insurance has consented to such partial occupancy or use by endorsement or otherwise. The City and the CONTRACTOR shall take reasonable steps to obtain consent of the insurance company and shall, without mutual consent, take no action with respect to partial occupancy or use that would cause cancellation, lapse, or reduction of the insurance.
- E. **FIRE INSURANCE.** Before the commencement of the Work, the CONTRACTOR shall procure, maintain, and cause to be maintained at the CONTRACTOR's expense, fire insurance on all Work subject to loss or damage by fire and the entire structure on which the Work of this Contract is to be done to the insurable value thereof. The amount of fire insurance shall be subject to approval by the City and shall be sufficient to protect the Project against loss or damage in full until the Work is accepted by the City. Should the Work being constructed be damaged by fire or other causes during construction, it shall be replaced in accordance with the requirements of the drawings and specifications without additional expense to the City.
- F. **OTHER INSURANCE.** The CONTRACTOR shall provide all other insurance required to be maintained under applicable laws, ordinances, rules, and regulations.
- G. **COMPLIANCE.** In the event of the failure of any CONTRACTOR to furnish and maintain any insurance required by this Article, the CONTRACTOR shall be in default under the Contract. Compliance by CONTRACTOR with the requirement to carry insurance and furnish certificates, policies, Additional Insured Endorsement and Declarations Page evidencing the same shall not relieve the CONTRACTOR from liability assumed under any provision of the Contract Documents, including, without limitation, the obligation to defend and indemnify the City and the Engineer.
- H. **BUILDER'S RISK/ "ALL RISK" INSURANCE.** The Contractor, during the progress of the Work and until final acceptance of the Work by City upon completion of the entire Contract, shall maintain Builder's Risk/"All Risk," course-of-construction insurance satisfactory to City issued on a completed value basis on all outstanding projects and on all insurable Work included under the Contract Documents. Coverage is to provide extended coverage and insurance against vandalism, theft, malicious mischief, perils of fire, sprinkler leakage, civil authority, sonic boom, earthquake, collapse, flood, wind, lightning, smoke, riot, debris removal (including demolition), and reasonable compensation for the Engineer's services and expenses required as a result of such insured loss upon the entire Work which is the subject of the Contract Documents, including completed Work and Work in progress to the full insurable value thereof. Such insurance shall include the City and the Engineer as an additional named insured and any other person with an insurable interest designated.

5.3 PROOF OF CARRIAGE INSURANCE

- A. CONTRACTOR shall not commence Work nor shall it allow any Subcontractor to commence Work under this Agreement until all required insurance certificates and endorsements have been obtained and delivered in duplicate to and approved by the City.

Such insurance shall be with an insurance company with a minimum rating of "A/VII", as rated by the current edition of Best's Key Rating Guide, published by A.M. Best Co., Oldwick, New Jersey 08858 and admitted or qualified to do business in California.

- B. Certificates and insurance policies shall include the following:
1. A clause stating:
"This policy shall not be canceled or reduced in required limits of liability or amount of insurance until notice has been mailed to City stating date of cancellation or reduction. Date of cancellation or reduction may not be less than **30 days** after date of mailing notice."
 2. Language stating in particular those insured, extent of insurance, location and operation to which insurance applies, expiration date, to whom cancellation and reduction notice will be sent, and length of notice period.
 3. Separate additional insured endorsement specifically naming the City as a named additional insured under the policy described and that such insurance policy shall be primary to any insurance or self-insurance maintained by the City.
- C. In case of CONTRACTOR's failure to provide insurance as required by the Agreement, the City may, at the City's option, take out and maintain at the expense of the CONTRACTOR, such insurance in the name of CONTRACTOR, or Subcontractor, as the City may deem proper and may deduct the cost of taking out and maintaining such insurance from any sums which are due or to become due to the CONTRACTOR under this Agreement.
- D. The CONTRACTOR shall purchase and maintain the insurance required under this Article. Such insurance shall include the specific coverages set out herein and be written for not less than the limits of liability and coverages provided in this Article, or required by Laws or Regulations, whichever are greater. All insurance shall be maintained continuously during the life of the Agreement up to the date of Project Completion when all punch-list items have been completed. The CONTRACTOR's liabilities under this Agreement shall not be deemed limited in any way to the insurance coverage required.
1. CONTRACTOR shall have insurance in the following amounts:
 - a. Commercial general liability insurance with at least three million dollars (\$3,000,000) combined single limit coverage per occurrence for bodily injury and property damage; or, if a general aggregate limit is applicable, either: (i) the general aggregate limit shall specifically apply to the project identified in the bid specifications or to the location of such project which is the subject of these bid specifications with coverage to be no less than three million dollars (\$3,000,000), or (ii) the general aggregate shall be at least three million dollars (\$3,000,000) combined single limit coverage per occurrence for bodily injury and property damage; and
 - b. Automobile liability insurance of three million dollars (\$3,000,000) combined single limit per accident for bodily injury and property damage; and
 - c. Workers' compensation and employer's liability insurance as required by the California Labor Code, as amended.
 2. Each insurance policy required above, except for workers' compensation, shall name the City specifically and separately as an additional insured under the policy on a separate ISO CG 2010 endorsement or equivalent, to the satisfaction of the

City Attorney. The company providing insurance must provide at least **30 days** written notice of cancellation or termination, if such cancellation or termination of the policy is to occur prior to the indicated expiration date on the face of the certificate. General and auto liability insurance coverage must be provided by a Best's 'A' rated, Class VII carrier, admitted in California, and shall be in form satisfactory to the City Attorney. Insurance companies that are not admitted in California must be on the list of approved Non-Admitted Insurers able to write in the state of California and must additionally provide a service of suit endorsement. All insurance requirements must be in a form satisfactory to the City Attorney. Failure to comply with insurance requirements under this Agreement or failure to have completed insurance documents on file within **15 working days** after CONTRACTOR executes this Agreement shall be a material breach of this Agreement.

3. Workers' Compensation and Employer's Liability In accordance with the provisions of Section 3700 of the California Labor Code, the CONTRACTOR and every Subcontractor shall be required to secure the payment of compensation to its employees. The CONTRACTOR shall provide, during the life of the Agreement, workers' compensation insurance for all of its employees engaged in Work under this Agreement, on or at the site of the Project, and, in case any of its Work is sublet, the CONTRACTOR shall require the Subcontractor similarly to provide workers' compensation insurance for all the latter's employees. Any class of employee or employees not covered by a Subcontractor's insurance shall be covered by the CONTRACTOR's insurance. In case any class of employees engaged in Work under this Agreement, on or at the site of the Project, is not protected under the workers' compensation statute, the CONTRACTOR shall provide or shall cause a Subcontractor to provide, adequate insurance coverage for the protection of such employees not otherwise protected before the Subcontractor commences Work. The CONTRACTOR shall file with the City certificates of its insurance protecting workers and a **30 day** notice shall be provided to the City before the cancellation or reduction of any policy of CONTRACTOR or Subcontractor. The CONTRACTOR and each Subcontractor shall provide a waiver of subrogation in favor of the City and Engineer.

ARTICLE 6 – CONTRACTOR'S RESPONSIBILITIES

None of the following responsibilities, as between City and CONTRACTOR, shall be delegated by CONTRACTOR to another individual or entity.

6.1 COMMUNICATIONS.

- A. Written communications shall be directly to the City, however, the City reserves the right to direct the CONTRACTOR to communicate directly with a construction manager or other consultant, and to copy the City with correspondence.
- B. Notice to Surrounding Properties. CONTRACTOR must provide Notice of Construction to all property owners and businesses at least 3 days before commencement of such work. A sample form notice is found in the Proposed Contract Documents, at page A-00670-1.

- 6.2 INDEPENDENT CONTRACTOR. CONTRACTOR is and shall at all times be deemed to be an independent CONTRACTOR and shall be wholly responsible for the manner in which it performs the services required of it by the terms of the Project Documents. Nothing herein contained shall be construed as creating the relationship of employer and employee, or principal and agent, between the City and CONTRACTOR or any of CONTRACTOR's subcontractors (of

every tier), suppliers, agents or employees. CONTRACTOR assumes exclusively the responsibility for the acts of its subcontractors (of every tier), suppliers, agents, and employees as they relate to the services to be provided during the course and scope of their employment. CONTRACTOR, its subcontractors (of every tier), suppliers, agents and employees shall not be entitled to any rights or privileges of City employees and shall not be considered in any manner to be City employees. The City shall be permitted to monitor all the activities of the CONTRACTOR to determine compliance with the terms of the Project Documents.

- 6.3 CONTRACTOR LICENSE. CONTRACTORS are required by law to be licensed and regulated by the Contractors' State License Board. Any CONTRACTOR not so licensed is subject to penalties under the law, and the contract will be considered void pursuant to Section 7028.7 of the Business and Professions Code. Any questions concerning a CONTRACTOR may be referred to the Registrar, Contractors' State License Board, 3132 Bradshaw Road, P.O. Box 2600, Sacramento, CA 95826. CONTRACTOR shall be duly licensed at all times during performance. Substantial compliance shall not be sufficient.
- 6.4 CONTRACTOR REGISTRATION: CONTRACTOR, as well as any subcontractors, shall be registered pursuant to Cal. Lab. Code § 1725.5 to be qualified to bid on, be listed in a bid proposal, (subject to the requirements of Section 4104 of the Public Contract Code) or engage in the performance of any public work contract that is subject to the requirements of Chapter 1, Part 7, Division 2 of the California Labor Code.
- 6.5 CHANGE IN NAME AND NATURE OF CONTRACTOR'S LEGAL ENTITY. Before CONTRACTOR makes any change in the name or legal nature of the CONTRACTOR's entity, CONTRACTOR shall first notify the City in writing and cooperate with the City in making such changes as the City may request in the Project Documents.
- 6.6 CONTRACTOR SUPERINTENDENT. During progress of the Work, CONTRACTOR shall keep on the Work site a competent, English-speaking Superintendent satisfactory to the City. Before commencing the Work herein, CONTRACTOR shall give written notice to the City of the name, qualifications and experience of such Superintendent. If, at any time, the Superintendent is found unsatisfactory by the City, CONTRACTOR shall replace the Superintendent with one acceptable to the City. Superintendent shall not be changed or removed from the project except with written consent of the City, unless a Superintendent proves to be unsatisfactory to CONTRACTOR and ceases to be in its employ, in which case, CONTRACTOR shall notify the City in writing and replace said Superintendent with one acceptable to the City. Superintendent shall represent CONTRACTOR and all directions given to Superintendent shall be as binding as if given to CONTRACTOR. During planned absences longer than one Workday (e.g. vacation), CONTRACTOR shall, at least **ten (10) days** prior, provide written notice to the City the name of the individual proposed to assume the responsibilities of Superintendent during his/her absence.
- 6.7 CONTRACTOR SUPERVISION. Without a right to claim additional reimbursement, CONTRACTOR shall staff the project with a sufficient number of experienced, skilled and knowledgeable personnel to meet the needs (both administrative and supervisory) of the Project, and shall supervise and direct the Work competently and efficiently, devoting such attention thereto and applying such skills as may be necessary to perform the Work in accordance with the Project Documents. CONTRACTOR shall carefully study and compare all plans, drawings, specifications, and other instructions and shall at once report to the City any error, inconsistency or omission which CONTRACTOR or its employees may discover. The CONTRACTOR represents itself to the City as a skilled, knowledgeable, and experienced CONTRACTOR. The CONTRACTOR shall carefully study and compare the Project Documents with each other, and shall at once report to the City any errors, inconsistencies, or omissions discovered. The CONTRACTOR shall be liable to the City for damage resulting from errors, inconsistencies, or omissions in the Project Documents that the CONTRACTOR recognized and which CONTRACTOR knowingly failed to

report and which a similarly skilled, knowledgeable, and experienced CONTRACTOR would have discovered.

- 6.8 **FIELD MEASUREMENTS, LAYOUT, RECORD DRAWINGS AND FIELD ENGINEERING.** The CONTRACTOR shall verify all indicated dimensions at its expense before ordering materials or equipment, or before performing Work. The CONTRACTOR shall take field measurements, verify field conditions, and shall carefully compare such field measurements and conditions and other information known to the CONTRACTOR with the Project Documents before commencing Work. Errors, inconsistencies or omissions discovered shall be reported to the City at once. Upon commencement of any item of Work, the CONTRACTOR shall be responsible for dimensions related to such item of Work and shall make any corrections necessary to make Work properly fit at no additional cost to the City. This responsibility for verification of dimensions is a non-delegable duty and may not be delegated to Subcontractors or agents. The CONTRACTOR shall keep up-to-date record drawings of this project through the course of the project. The City shall approve these record drawings periodically, and the release of progress payments may be delayed if the record drawings are not kept up to date. After the project punch- list has been completed, the CONTRACTOR shall supply a single clean set of accurate blue-line (as-built) plans to the City. Failure to submit these as-builts will delay the Final Notice of Completion and final payment.
- 6.9 **DETAILS OF THE WORK.** Omissions from the plans, drawings or specifications, or the mis-description of customary and usual details of Work which are manifestly necessary to carry out the intent of the plans, drawings and specifications, or which are customarily performed, shall not relieve the CONTRACTOR from performing such omitted or mis-described Work, but they shall be performed as if fully and correctly set forth and described in the plans, drawings and specifications.
- 6.10 **MEANS AND METHODS.** The CONTRACTOR shall be solely responsible for the means, methods, techniques, sequences, and procedures of construction. The CONTRACTOR shall be responsible to see that the finished Work complies accurately with the Project Documents. The CONTRACTOR shall be solely responsible for all safety precautions and programs incidental thereto.
- 6.11 **SUBCONTRACTORS**
- A. CONTRACTOR agrees to bind every Subcontractor by terms of the Project Documents as far as such terms are applicable to Subcontractor's Work. If CONTRACTOR shall subcontract any part of the Work, CONTRACTOR shall be as fully responsible to the City for acts and omissions of any Subcontractor and of persons either directly or indirectly employed by any Subcontractor, as it is for acts and omissions of persons directly employed by CONTRACTOR. Nothing contained in Project Documents shall create any contractual relation between any Subcontractor and the City, nor shall the Contract Documents be construed to be for the benefit of any Subcontractor.
 - B. The City's consent to any Subcontractor shall not in any way relieve CONTRACTOR of any obligations under the Project Documents and no such consent shall be deemed to waive any provision of any Project Document.
 - C. CONTRACTOR must submit with its bid a Designation of Subcontractors pursuant to the Subletting and Subcontracting Fair Practices Act. If CONTRACTOR specifies more than one Subcontractor for the same portion of Work or fails to specify a Subcontractor, and such portion of the Work exceeds one-half of one percent of the total bid, CONTRACTOR agrees that it is fully qualified to perform and shall perform such Work itself, unless CONTRACTOR provides for substitution or addition of Subcontractors. Substitution or addition of Subcontractors shall be permitted only as authorized under the

Subletting and Subcontracting Fair Practices Act, California Public Contract Code Section 4100, et seq.

- D. In accordance with California Business and Professions Code Section 7059, if CONTRACTOR is designated as a "specialty CONTRACTOR" (as defined in Section 7058 of the Business and Professions Code), all of the Work to be performed outside of the CONTRACTOR's license specialty shall be performed by a licensed Subcontractor in compliance with the Subletting and Subcontracting Fair Practices Act, California Public Contract Code Section 4100, et seq.
- E. INELIGIBLE SUBCONTRACTOR. Pursuant to Public Contract Code Section 6109, no CONTRACTOR may perform Work on a public works project with a subcontractor who is ineligible to perform Work on the project pursuant to sections 1777.1 or 1777.7 of the Labor Code.
- F. A copy of each subcontract, if in writing, or, if not in writing, then a written statement signed by the CONTRACTOR giving the name of the Subcontractor and the terms and conditions of such subcontract, shall be filed with the City before the Subcontractor begins Work. Each subcontract shall contain an express reference to and incorporate the Agreement between the City and the CONTRACTOR and the terms of that Agreement and all parts of the Project Documents shall be made a part of such subcontract insofar as applicable to the Work covered thereby. Each subcontract will provide for termination in accordance with the Article entitled City's RIGHT TO TERMINATE AGREEMENT of these General Conditions. Each subcontract shall provide for its annulment by the CONTRACTOR at the order of the City if in the City's opinion the Subcontractor fails to comply with the requirements of the Project Documents insofar as the same may be applicable to this Work. Nothing herein contained shall relieve the CONTRACTOR of any liability or obligation hereunder.

6.12 DUTY TO PROVIDE FIT WORKERS

- A. CONTRACTOR and Subcontractors shall at all times enforce strict discipline and good order among their employees and shall not employ on the Work any unfit person or anyone not skilled in the Work assigned to such person. It shall be the responsibility of CONTRACTOR to ensure compliance with this Article.
- B. Any person in the employ of the CONTRACTOR or Subcontractors whom the City or Engineer may deem incompetent, unfit, troublesome or otherwise undesirable shall be excluded from the Work site and shall not again be employed on it except with the written consent of the City.

6.13 OVERTIME.

- A. Except as otherwise provided in this Article, the CONTRACTOR shall receive no additional compensation for overtime Work, i.e., Work in excess of **8 hours** in any **1 calendar day** or **40 hours** in any **1 calendar week**, even though such overtime Work may be required under emergency conditions and may be ordered by the City in writing. Additional compensation will be paid to the CONTRACTOR for overtime Work only in the event extra Work is ordered by the City and the Change Order specifically authorizes the use of overtime Work and then only to such extent as overtime wages are regularly being paid by the CONTRACTOR for overtime Work of a similar nature in the same locality.
- B. All increased or additional costs of inspection and/or testing, performed by or on behalf of the City, during overtime Work by the CONTRACTOR which is allowed solely for the convenience of the CONTRACTOR shall be borne by the CONTRACTOR. The City

has the authority to deduct the costs of all such inspection and testing from any partial payments otherwise due to the CONTRACTOR. Payment for inspection overtime beyond a normal Workday (9 hours), Saturdays, Sundays or Union observed holidays will be deducted from the CONTRACTOR's payment at the rate of One Hundred Twelve Dollars and Fifty Cents (\$112.50) per hour (one hour minimum) pursuant to City of Escondido Resolution No. 2007-115(RR).

6.14 MATERIALS AND WORK

- A. Except as otherwise specifically stated in this Agreement, CONTRACTOR shall provide and pay for all materials, supplies, tools, equipment, labor, transportation, administration, management, superintendence, temporary constructions of every nature, and all other services and facilities of every nature whatsoever necessary to execute and complete the Project within the specified time.
- B. Unless otherwise specified, all materials shall be new and the best of their respective kinds and grades as noted or specified free from defects, and workmanship shall be of excellent quality.
- C. Materials shall be furnished in ample quantities and at such times as to insure uninterrupted progress of Work and shall be stored properly and protected as required.
- D. CONTRACTOR shall, after issuance of the Notice to Proceed by the City, place orders for materials and/or equipment as specified so that delivery may be made without delays to the Work. CONTRACTOR shall, upon demand by the City, furnish to the City documentary evidence showing that orders have been placed.
- E. The City reserves the right, due to any neglect in not complying with the above instructions, to place orders for such materials and/or equipment as it may deem advisable in order that the Work may be completed by the date specified in the Agreement, and all expenses incidental to the procuring of these materials and/or equipment shall be paid for by the CONTRACTOR.
- F. No materials, supplies, or equipment for Work under this Agreement shall be purchased subject to any chattel mortgage or under a conditional sale or other agreement by which an interest therein or in any part thereof is retained by the seller or supplier. CONTRACTOR warrants good title to all material, supplies, and equipment installed or incorporated in the Work and agrees upon completion of all Work to deliver the premises, together with all improvements and appurtenances constructed or placed thereon by it, to the City free from any claims, liens, or charges. CONTRACTOR further agrees that neither it nor any person, firm, or corporation furnishing any materials or labor for any Work covered by this Agreement shall have any right to any lien upon the premises or any improvement or appurtenance thereon, except that CONTRACTOR may install metering devices or other equipment of utility companies or of political subdivisions, title to which is commonly retained by the utility company or political subdivision. In the event of installation of any such metering device or equipment, CONTRACTOR shall advise the City as to the owner thereof.
- G. Nothing contained in this Article, however, shall defeat or impair the rights of persons furnishing material or labor under any bond given by CONTRACTOR for their protection or any rights under any law permitting such persons to look to funds due CONTRACTOR in the hand of the City, and this provision shall be inserted in all subcontracts and material contracts and notice of its provisions shall be given to all

persons furnishing materials or labor when no formal contract is entered into for such materials or labor.

- H. Materials and/or equipment and the attendant liability for its protection and safety shall remain with the CONTRACTOR until incorporated in the Work and accepted by the City, no part of the materials and/or equipment shall be removed from its place of storage except for immediate installation in the Work; and CONTRACTOR shall keep an accurate inventory of all materials and/or equipment in a manner satisfactory to the City or its authorized representative.

6.15 ACCESS TO CONTRACTOR'S RECORDS. The CONTRACTOR agrees that the City (including the City's designees) have the right to access, review, obtain and copy upon reasonable written notice (which shall be no greater than **3 working days**), all Records pertaining to the Agreement and/or the Project, including the bid. The CONTRACTOR agrees to provide the City with any relevant information requested and shall permit the State or the City access to its premises upon reasonable notice for purposes of interviewing employees and inspecting Records. The CONTRACTOR agrees to maintain such Records for a period of **3 years** after final payment under the contract. Should the project be funded by the State Revolving Fund, the CONTRACTOR shall maintain records for **20 years**.

6.16 CONTRACTOR SUBSTITUTION OF "OR EQUAL" ITEMS

- A. CONTRACTOR shall follow all instructions and requirements set forth in the "INSTRUCTIONS TO BIDDERS", for compliance with this Article.
- B. Whenever in specifications any materials, process, service or equipment is indicated or specified by brand name, trade name, proprietary name or by name of manufacturer, such specification shall be deemed to be used for the purpose of facilitating description of material, process, service or equipment desired and shall be deemed to be followed by the words "or equal", CONTRACTOR may, unless otherwise stated, offer any material, process, service, or equipment which shall be substantially equal or better in every respect to that so indicated or specified subject to the City's approval.
- C. If material, process, service, or equipment offered by CONTRACTOR is not, in the City's sole discretion determined to be, equal or better in every respect to that specified, then CONTRACTOR shall furnish the material, process, service, or equipment specified. The burden of proof as to equality of any material, process, service, or equipment shall rest with CONTRACTOR. This provision authorizing submission of "or equal" substantiating data shall not in any way authorize an extension of time for performance of this Agreement.
- D. "Or equal" and substitution requests with substantiating data shall be submitted for consideration no later than **14** calendar days prior to bid opening.
- E. The City may choose to allow an "or equal" substitution, if the City determines, in its sole discretion, that the requested substitution is an equal product, and that there is a cost savings resulting in a deductive change order, an increase in the performance with the substituted product, or any other reason deemed by the City to be in the City's best interest to allow the substitution.
- F. If a CONTRACTOR initiated material substitution occurs after the Award of Contract, CONTRACTOR must establish that the specified material is no longer being manufactured or available, that the substituted material is the best possible material

substitution for that which is no longer available, or that there is some other benefit to the City in approving said substitution.

- G. If the City allows the substitution anytime after the Award of Contract, the CONTRACTOR will be responsible for reasonable fees incurred by the Engineer or Engineer's consultants in reviewing the proposed substitution which fees may be deducted from progress payments to CONTRACTOR.
- H. In the event CONTRACTOR furnishes material, process, service, or equipment more expensive than that specified, any difference in cost of such material, process, service, or equipment so furnished shall be borne by CONTRACTOR. Any engineering, design fees, or approval agencies' fees required to make adjustments in material or Work of all trades directly or indirectly affected by the approved substituted items shall be borne entirely by CONTRACTOR. Any difference in cost between an approved substitution that is lower in cost than the originally specified item shall be refunded by CONTRACTOR to the City.
- I. All costs associated with and caused by a CONTRACTOR's "or equal" submittal, including any consequential design changes needed to accommodate the "or equal", and any delay caused to the project schedule resulting from the review of the requested "or equal" submittal shall be borne by the CONTRACTOR.

6.17 PERMITS

- A. Unless otherwise provided in the Supplementary General Conditions, the CONTRACTOR shall obtain and pay for all construction permits and licenses from the agencies having jurisdiction, including the furnishing of insurance and bonds if required by such agencies. The enforcement of such requirements shall not be made the basis for claims for additional compensation by CONTRACTOR. When necessary, the City will assist the CONTRACTOR, in obtaining such permits and licenses. The CONTRACTOR shall pay all governmental charges and inspection fees necessary for the prosecution of the Work, which are applicable at the time of opening of Bids. The CONTRACTOR shall pay all charges of utility owners for inspection or connections to the Work. Compensation for all permit fees is included in the Lump Sum payment for Mobilization.
- B. The CONTRACTOR shall indemnify, defend and hold harmless the City and its officers, employees and agents from any and all liability arising out of any violation, or claim of violation of the San Diego Municipal Storm Water Permit (Order No. 2001-01), and updates, of the California Regional Water Quality Control Board Region 9, San Diego, which the City might suffer, incur, or become subject by reason of or occurring as a result of or allegedly caused by performance of the Work.
- C. Prior to beginning Work, the CONTRACTOR shall obtain a no-fee Encroachment Permit from the office of the City of Escondido Field Engineer, 201 N. Broadway, unless otherwise specified in the Supplemental General Conditions. CONTRACTOR shall adhere to all requirements and provisions of said Encroachment Permit as though fully set forth herein.
- D. The CONTRACTOR shall be responsible for complying with the requirements of all permits acquired by the City.

Except for the permits specifically set forth in 'A' above, the CONTRACTOR shall acquire all permits required by Laws or Regulations, including, without limitation, the following specific permits (if applicable):

1. State permits to construct and/or operate sources of air pollution.
2. Certificates and permits are required for sources such as, but not limited to:
 - a. Fuel burning equipment
 - b. Gasoline and petroleum distillate storage containers
 - c. Land disturbing activities
 - d. Processing equipment (sand, gravel, concrete batch plant, etc.)
 - e. Odors
3. Stormwater Permit.
4. Permit-Required Confined Space

The workplace in which the Work is to be performed may contain permit-required confined spaces (permit spaces) as defined in 29 CFR 1910.146 and, if so, permit space entry is allowed only through compliance with a confined space entry program meeting the requirements of 29 CFR 1910.146.

5. Others as required in the Supplementary General Conditions.

6.18 PATENT FEES AND ROYALTIES. The CONTRACTOR shall pay all license fees and royalties and assume all costs incident to the use in the performance of the Work or the incorporation in the Work of any invention, design, process, product, or device which is the subject of patent rights or copyrights held by others. If a particular invention, design, process, product, or device is specified in the Contract Documents for use in the performance of the Work and if to the actual knowledge of the City or the Engineer its use is subject to patent rights or copyrights calling for the payment of any license fee or royalty to others, the existence of such rights will be disclosed by the City in the Contract Documents. The CONTRACTOR's indemnification obligation under this Article, for all claims and liabilities arising out of any infringement of patent rights or copyrights incident to the use in the performance of the Work or resulting from the incorporation in the Work of any invention, design, process, product, or device not specified in the Contract Documents shall be in accordance with Article 6.16 of these General Conditions.

6.19 LAWS AND REGULATIONS. The CONTRACTOR shall observe and comply with all Laws and Regulations which in any manner affect those engaged or employed on the Work, the materials used in the Work, or the conduct of the Work. If any discrepancy or inconsistency should be discovered between the Contract Documents and any such Laws or Regulations, the CONTRACTOR shall report the same in writing to the Engineer. Any particular Law or Regulation specified or referred to elsewhere in the Contract Documents shall not in any way limit the obligation of the CONTRACTOR to comply with all other provisions of federal, state, and local laws and regulations. The CONTRACTOR's indemnification obligations for all claims or liability arising from violation of any such law, ordinance, code, order, or regulation, whether by CONTRACTOR or by its employees, Subcontractors or Suppliers shall be in accordance with Article 6.16 of these General Conditions.

6.20 TAXES. The CONTRACTOR shall pay all sales, consumer, use, and other similar taxes required to be paid by the CONTRACTOR in accordance with the laws and regulations of the place of the Project which are applicable during the performance of the Work.

6.21 USE OF PREMISES. The CONTRACTOR shall confine construction equipment, the storage of materials and equipment, and the operations of workers to the Site, the land and areas identified in and permitted by the Contract Documents, and the other land and areas permitted by Laws and

Regulations, rights-of-way, permits, and easements. The CONTRACTOR shall assume full liability and responsibility for any damage to any such land or area, or to the owner or occupant thereof or of any land or areas contiguous thereto, resulting from the performance of the Work. Should any claim be made against the City or the Engineer by any such owner or occupant because of the performance of the Work, the CONTRACTOR shall promptly attempt to settle with such other party by agreement or otherwise resolve the claim through litigation at the CONTRACTOR's sole liability any expense. The CONTRACTOR's indemnification obligations for all claims and liability, arising directly, indirectly, or consequentially out of any action, legal or equitable, brought by any such owner or occupant against the City, the Engineer, their consultants, subconsultants, and the officers, directors, employees and agents of each and any of them to the extent caused by or based upon the CONTRACTOR's performance of the Work shall be in accordance with Article 6.25 of these General Conditions.

6.22 SAFETY AND PROTECTION

- A. The CONTRACTOR shall be solely responsible for initiating, maintaining, and supervising all safety precautions and programs in connection with the Work. The CONTRACTOR shall take all necessary precautions for the safety of, and shall provide the necessary protection to prevent damage, injury or loss to:
1. All persons at the Site and other persons and organizations who may be affected thereby;
 2. All the Work materials and equipment to be incorporated therein, whether in storage on or off the Site; and
 3. Other property at the Site or adjacent thereto, including trees, shrubs, lawns, walks, pavements, roadways, structures, mailboxes, and utilities not designated for removal, relocation, or replacement in the course of the performance of the Work.
- B. The CONTRACTOR shall comply with all applicable Laws and Regulations relating to the safety of persons or property or to the protection of persons or property from damage, injury, or loss and shall erect and maintain all necessary safeguards for such safety and protection. The CONTRACTOR shall notify owners of adjacent property and utilities when prosecution of the Work may affect them, and shall cooperate with them in the protection, removal, relocation, and replacement of their property. CONTRACTOR's duties and responsibilities for safety and for protection of the Work shall continue until such time as all the Work is completed and in accordance with Article 14.11. that the Work is acceptable.
- C. During the entire construction period, it shall be the responsibility of the contractor to maintain conditions at the project location so as to meet in all aspects the requirements of the California Code of Regulations, Title 8, Industrial Relations, Chapter 4, Division of Industrial Safety Orders CAL/OSHA. This provision shall cover the CONTRACTOR's employees and all other persons working upon or visiting the project location. To this end, the Contractor shall inform himself and his representatives of CAL/OSHA standards.
- D. The CONTRACTOR shall designate a qualified and experienced safety representative at the Site whose duties and responsibilities shall be the prevention of accidents and the maintaining and supervising of safety precautions and programs.
- E. MSDS. Materials that contain hazardous substances or mixtures may be required on the Work. A Material Safety Data Sheet (MSDS.) shall be made available at the Site by the CONTRACTOR for every hazardous product used. Material usage shall strictly conform to OSHA safety requirements and all manufacturer's warnings and application instructions

listed on the MSDS and on the product container label. The CONTRACTOR shall be responsible for the exchange of every MSDS or other hazard communication information required to be made available to or exchanged between or among employers at the Site in accordance with Laws or Regulations.

- F. The CONTRACTOR shall notify the City if it considers a specified product or its intended use to be unsafe. This notification must be given to the City prior to the product being ordered, or if provided by some other party, prior to the product being incorporated in the Work.
 - G. **CONFINED SPACES.** The CONTRACTOR will not enter any confined space without using a Confined Space Entry Permit. The CONTRACTOR shall be responsible for implementing, administering and maintaining a confined space entry program (CSEP) in accordance with Sections 5156, 5157 and 5158, Title 8, CCR.
 - H. The CONTRACTOR shall provide a **COMPETENT PERSON** for all excavation operations.
- 6.23 **EMERGENCIES.** In emergencies affecting the safety or protection of persons or the Work or property at the Site or adjacent thereto, CONTRACTOR, without special instruction or authorization from the City or Engineer, is obligated to immediately act to prevent threatened damage, injury, or loss. CONTRACTOR shall give City prompt written notice if CONTRACTOR believes that any significant changes in the Work or variations from the Contract Documents have been caused thereby. If City determines that a change in the Contract Documents is required because of the action taken by CONTRACTOR in response to such an emergency, a Change Order will be issued to document the action.
- 6.24 **SUBMITTALS.** The City requires submittals for all materials, equipment, parts and systems.
- A. **SHOP DRAWINGS**
 - 1. The City may designate a consultant to receive and review submittals and may require the CONTRACTOR to transmit the submittals to that consultant. Commensurate with the requirements of the project schedule, the CONTRACTOR shall check and verify all field measurements and shall submit to the City six (6) copies, checked, coordinated and approved by CONTRACTOR, of all shop or setting list drawings, schedules, and materials list required for the Work of various trades: If this project consists of any remodel / modernization Work, field dimensions require verification prior to the preparation of the Shop Drawings. The City shall review such drawings, schedules and materials list only for conformance with the design concept of Project and compliance with information given in Project Documents, and return with notations and with guidance as to required corrections within **30 days**. CONTRACTOR shall make any corrections required by the City, file three (3) corrected copies with the City, and furnish such other copies as may be needed for construction within **30 days**. The City's approval of such drawings, schedules, or materials list shall not relieve CONTRACTOR from responsibility for deviations unless CONTRACTOR has in writing called the City's attention to such deviations at time of submission by clearly writing the phrase "**DEVIATION REQUEST**" in bold type at the head of the submittal, and secured the City's written approval, nor shall it relieve CONTRACTOR from responsibility for errors in shop drawings or schedules.

2. The City is entitled to additional review time. The additional review time may be required to review complex and difficult submittals, including but not limited to structural steel shop drawings, mechanical equipment, electrical equipment, and special system components and parts. The CONTRACTOR shall breakout critical submittals into separate packages so as to expedite the review process of an individual item. The coordination of the overall submittal packages shall be the responsibility of the CONTRACTOR.
3. Shop Drawings requiring "**Deferred Approval**" require a substantial amount of time for City review and approval. The Project Documents will identify those shop drawings requiring Deferred Approval, if any. The Contractor shall apply its skill and knowledge to expedite the Deferred Approval(s) from preparation to approval. The Contractor shall schedule the project activities to avoid critical path delays as a result of the Deferred Approval process. Notwithstanding anything to the contrary herein, the CONTRACTOR shall make submittals of all Deferred Approvals to the City within **120 days** of the Award of Contract. The City shall review such Deferred Approval submittal, and shall return as approved or disapproved with guidance as to the required corrections within **60 days**. If resubmittals are required, the City shall endeavor to review and return the resubmittal within **60 days**. CONTRACTOR shall allow sufficient time in its scheduling for corrections and resubmittals of Deferred Approval items in conformance with these requirements.
4. All submittals of shop drawings, catalog cuts, data sheets, schedules and material lists shall be complete and shall conform to contract drawings and specifications. The CONTRACTOR shall prepare layout and coordination drawings to demonstrate the accuracy and fit of the materials and Work.
5. The term "shop drawing" as used herein shall be understood to include, but not be limited to, coordination efforts by CONTRACTOR involving detail design calculations for the development of the Shop Drawing, fabrication and installation drawings, lists, graphs and operating instructions.
6. Shop drawings shall be submitted at a time sufficiently early to accommodate the rate of construction progress required under the Project Documents. CONTRACTOR will be required to pay the City or its consultant's reasonable and customary fees in order to expedite review of Shop Drawings which are not submitted in a timely fashion.
7. All submittals shall be accompanied by an accurately completed transmittal form using the format bound herein, or as approved by the City. Any shop drawing submittal not accompanied by such a form, or where all applicable items on the form are not completed, will be returned for resubmittal. The CONTRACTOR may authorize a material or equipment supplier to deal directly with the City with regard to Shop Drawings. However, ultimate responsibility for the accuracy and completeness of the information contained in the submittal shall remain with the CONTRACTOR.
8. Normally, a separate transmittal form shall be used for each specific item, scheduled activity task, or class of material or equipment for which a submittal is required. However, due to the critical nature of a submittal, a submittal can be broken into separate sub-submittals in order to obtain the review of a more

critical portion(s) of a submittal prior to the review of other sub-submittals. The transmittal form shall include the CPM Activity / Submittal Task Number, Early Start (ES), Early Finish (EF), Late Finish (LF) and the float for the activity. Transmittal of shop drawings on various items using a single transmittal form will be permitted only when the items taken together constitute a manufacturer's "package" or are so functionally related that expediency indicates review of the group or package as a whole.

9. CONTRACTOR's review and approval of Shop Drawings and submittals shall include the following stamp:

"The CONTRACTOR has reviewed and approved not only the field dimensions but the construction criteria and has also made written notation regarding any information in the Shop Drawings or submittal that does not conform to the Project Documents. This Shop Drawing or submittal has been coordinated with all other shop drawings and submittals received to date by CONTRACTOR and this duty of coordination has not been delegated to Subcontractors, material suppliers, the Engineer, or the architects on this project. The Contractor also indicates that it has not relied upon the dimensions shown on the drawings, specifications and schedules, and that the Contractor has double-checked all dimensions for accuracy and fit.

Signature of CONTRACTOR"

10. Within **30 days** after receipt of Shop Drawings, the City will endeavor to return one or more prints of each drawing to CONTRACTOR with City's comments noted thereon. The CONTRACTOR shall make a complete and acceptable submittal to the City by the second submission of drawings. The City shall withhold funds due the CONTRACTOR to cover additional costs of the City's review beyond the second submission and any other costs incurred by the City.
11. If prints of the shop drawing are returned to the CONTRACTOR marked "**NO EXCEPTIONS TAKEN**," formal revision of said drawing will not be required. If prints of the drawing are returned to the CONTRACTOR marked "**MAKE CORRECTIONS NOTED**," formal resubmittal of said drawings will not be required. If prints of the drawing are returned to the CONTRACTOR marked "**REVISE AND RESUBMIT**," the CONTRACTOR shall revise said drawing and shall resubmit six (6) copies of the revised drawing to the City. If prints of the drawing are returned to the CONTRACTOR marked "**REJECTED RESUBMIT**," the CONTRACTOR shall resubmit six (6) new copies of the drawing to the ARCHITECT. Submittals being resubmitted for revisions or submitted due to previous rejection, the CONTRACTOR shall provide a written response indicating the nature of the correction(s) and/or cloud the revised item(s).
12. Fabrication of an item shall not be commenced before the City has reviewed the pertinent Shop Drawings and returned copies to the CONTRACTOR marked with "NO EXCEPTIONS TAKEN," or "MAKE CORRECTIONS NOTED." Revisions indicated on shop drawings shall be considered as changes necessary to meet the requirements of the Project Documents and shall not be taken as the

basis of claims for extra Work. The review of such drawings by the City will be limited to checking for general agreement with the Project Documents, and shall in no way relieve the CONTRACTOR of responsibility for errors or omissions contained therein, nor shall such review operate to waive or modify any provision contained in the Project Documents. Fabricating dimensions, quantities of material, applicable code requirements, and other contract requirements shall be the CONTRACTOR's responsibility.

13. No Work represented by required Shop Drawings shall be purchased or commenced until the applicable submittal has been approved. The Work shall conform to the approved Shop Drawings and all other requirements of the Project Documents. The CONTRACTOR shall not proceed with any related Work which may be affected by the Work covered under Shop Drawings until the applicable Shop Drawings have been approved, particularly where piping, machinery, and equipment and the required arrangements and clearances are involved.
14. Except where the preparation of a Shop Drawing is dependent upon the approval of a prior shop drawing, all shop drawings pertaining to the same class or portion of the Work shall be submitted simultaneously.
15. THE CONTRACTOR SHALL HAVE NO CLAIM FOR DAMAGES OR EXTENSION OF TIME DUE TO ANY DELAY RESULTING FROM THE CONTRACTOR HAVING TO MAKE THE REQUIRED REVISIONS TO SHOP DRAWINGS UNLESS REVIEW BY THE CITY IS DELAYED BEYOND THE TIME PROVIDED HEREIN AND THE CONTRACTOR CAN ESTABLISH THAT IT BEARS NO RESPONSIBILITY FOR CAUSING AND/OR CONTRIBUTING TO THE DELAY AND THAT THE CITY'S DELAY IN REVIEW ACTUALLY RESULTED IN A DELAY TO THE CRITICAL PATH IN THE CONTRACTOR CONSTRUCTION SCHEDULE.

B. PAYROLL SUBMITTALS

1. Copies of all payrolls shall be submitted weekly to the City. Payrolls shall contain the full name, address and social security number of each employee, the employee's correct classification, rate of pay, daily and weekly number of hours worked, itemized deductions made and actual wages paid. They shall also indicate apprentices and ratio of apprentices to journeymen. The employee's address and social security number need only appear on the first payroll on which that name appears. The payroll shall be accompanied by a "Statement of Compliance" signed by the employer or the employer's agent indicating that the payrolls are correct and complete and that the wage rates contained therein are not less than those required by the Contract. The CONTRACTOR shall be responsible for the submission of copies of payrolls of all subcontractors. The CONTRACTOR shall ensure that the payrolls match the Daily Work Reports. The CONTRACTOR shall certify that no Work was done on the job if no Work was done on the job.
2. If by the 15th of the month, the CONTRACTOR has not submitted satisfactory payrolls for all Work performed during the monthly period ending on or before the 1st of that month, the City will retain an amount equal to ten percent (10%) of the estimated value of the Work performed (exclusive of Mobilization) during the month from the next monthly estimate, except that this retention shall not exceed \$10,000 nor be less than \$1,000. Retentions for failure to submit

satisfactory payrolls shall be additional to all other retentions provided for in the Contract. The retention for failure to submit payrolls for any monthly period will be released for payment on the monthly estimate for partial payments next following the date that all the satisfactory payrolls for which the retention was made are submitted.

- 3. The CONTRACTOR shall also submit a second copy of all certified payrolls with all personal information fully redacted. The CONTRACTOR and each subcontractor shall preserve their payroll records for a period of **3 years** from the date of completion of the Contract. The form of the certification shall be as follows:

I, _____ (print name), the undersigned,
 am _____ (position in business) with the authority to act
 for and on behalf of

 (Name of business and/or CONTRACTOR), certify under penalty of
 perjury that the records or copies thereof submitted and consisting of
 _____ (description,
 number of pages) are the originals or true, full and correct copies of the
 originals which depict the payroll record(s) of the actual disbursements
 by way of cash, check, or whatever form to the individual or individuals
 named.

Dated: _____

Signature: _____

- C. **SUBMITTAL OF HOME OFFICE OVERHEAD.** CONTRACTOR shall furnish within **7 days** after the Notice to Proceed, a certified statement and detailed calculation from its accountant establishing the job site and pro rata home office overhead rates for CONTRACTOR and major Subcontractors, as determined by the City. Such shall be updated quarterly and filed with the City.
- D. **SUBMITTAL OF HOURLY RATES.** CONTRACTOR shall furnish within **7 days** after the Notice to Proceed, a complete listing of CONTRACTORS and Subcontractors hourly labor rates, indicating the direct hourly wage rate, payroll taxes and insurance costs.
- E. **ESCROW BID DOCUMENTS.** The Escrow Bid Documents shall be submitted by the CONTRACTOR in a sealed container(s) within **10 days** after the day of award of the contract. The container shall be clearly marked on the outside with the CONTRACTOR's name, date of submittal, project name and the words "Escrow Bid Documents."
- F. **SWPPP/BMP.** CONTRACTOR shall submit the required Storm Water Pollution Prevention Plan or Best Management Practices, before commencement of any Work.

6.25 **CONTRACTOR'S GENERAL WARRANTY AND GUARANTEE**

- A. CONTRACTOR warrants that the Work (which includes all equipment furnished by CONTRACTOR as part of the materials) shall:
 - 1. Be free from defects in workmanship, integration and material; be free from defects in any design performed by CONTRACTOR;

2. Be new, and conform and perform to the requirements stated in the specifications and where detail requirements are not so stated, shall conform to applicable industry standards; and
 3. Be suitable for the use stated in the specifications.
- B. The warranty period for discovery of defective Work shall commence on the date stamped on the Notice of Completion verifying County recordation and continue for the period set forth in the specifications or for **1 year** if not so specified. If, during the warranty period, the Work is not available for use due to defective Work, such time of unavailability shall not be counted as part of the warranty period. The warranty period for corrected defective Work shall continue for a duration equivalent to the original warranty period.
- C. The City shall give CONTRACTOR prompt written notice after discovery of any defective or incomplete Work. CONTRACTOR shall correct any such defective or incomplete Work, as well as any damage to any other part of the Work resulting from such defective or incomplete Work, and shall provide repair, replacement, or reimbursement, at its sole expense, in a manner approved by the City and with due diligence and dispatch as required to make the Work ready for use by the City, ordinary wear and tear, unusual abuse or neglect excepted. Such corrections shall include, but not be limited to, any necessary adjustments, modifications, changes of design (unless of City's design), removal, repair, replacement or reinstallation, and shall include all necessary parts, materials, tools, equipment, transportation charges and labor as may be necessary, and cost of removal and replacement of Work shall be performed at a time and in such a manner so as to minimize the disruption to the City's use of the Work.
- D. In the event of failure of CONTRACTOR or Surety to commence and pursue with diligence any such repairs or replacements within **10 days** after being notified in writing, the City is hereby authorized to proceed to have defects repaired or replaced and made good at the expense of the CONTRACTOR and the Surety who hereby agree to pay any costs and charges therefore immediately on demand.
- E. If, in the opinion of the City, defective Work creates a dangerous condition or requires immediate correction or attention to prevent further loss to the City or to prevent interruption of operations of the City, the City will attempt to give the written notice required by this Article. If the CONTRACTOR or Surety cannot be contacted or neither complies with the City's requirements for correction within a reasonable time as determined by the City, the City may, notwithstanding the provisions of this Article, proceed to make such correction or provide such attention and the costs of such correction or attention shall be charged against the CONTRACTOR and Surety. Such action by the City will not relieve the CONTRACTOR and Surety of the guarantees provided in this Article or elsewhere in the Project Documents.
- F. This Article does not in any way limit the guarantees on any items for which a longer guarantee is specified or on any items for which a manufacturer gives a guarantee for a longer period. CONTRACTOR shall furnish to City all appropriate guarantee or warranty certificates upon completion of the Project or upon request by the City.
- G. All guarantees required under this Article shall be in writing on a Guarantee form approved by the City.
- H. CONTRACTOR shall provide to the City instruction manuals for all items which require same.

- I. Nothing herein shall limit any other rights or remedies available to the City, and any and all written/express guarantees are in addition to rights provided under California law, including the rights granted under Code of Civil Procedure sections 337.1 and 337.15.
- J. CONTRACTOR warrants and guarantees that all Work will be in accordance with the Project Documents and will not be defective. The CONTRACTOR shall guarantee all parts of the Work against defective materials or workmanship furnished by the CONTRACTOR for a period of **1 year** from the date of final acceptance by the City.

6.26 INDEMNIFICATION

- A. To the fullest extent permitted by Laws and Regulations, the CONTRACTOR shall indemnify, defend, and hold harmless the City, the Engineer, their consultants, subconsultants, and the officers, directors, employees, and agents of each and any of them, against and from all claims and liability arising under, by reason of, related, or incidental to the Project Documents or any performance of the Work, but not from the sole negligence or willful misconduct of the City and/ or the Engineer. Such indemnification by the CONTRACTOR shall include, but not be limited to, the following:
 - 1. CONTRACTOR shall indemnify, defend, and hold harmless the City and its officers, employees and agents, from all liability or claim of liability arising by reason of injury or damage to persons (including death) and/or property (both tangible and intangible) occurring as a result of Work done pursuant to the terms of this Agreement, and name same as coinsured in any policy in the Contract Documents;
 - 2. CONTRACTOR shall further indemnify, defend and hold harmless the City and its officers, employees and agents from and against any and all liabilities, claims, actions, causes of action, proceedings, suits, administrative proceedings, damages, fines, penalties, judgments, orders, liens, levies, costs and expenses of whatever nature, including reasonable attorneys' fees and disbursements, arising out of any violation, or claim of violation of the San Diego Municipal Storm Water Permit, and updates, of the California Regional Water Quality Control Board Region 9, San Diego, which the City might suffer, incur, or become subject by reason of or occurring as a result of or allegedly caused by work performed by CONTRACTOR.
 - 3. Liability or claims resulting directly or indirectly from the negligence or carelessness of the CONTRACTOR, its employees, or agents in the performance of the Work, or in guarding or maintaining the same, or from any improper materials, implements, or appliances used in its construction, or by or on account of any act or omission of the CONTRACTOR, its employees, or agents;
 - 4. Liability or claims arising directly or indirectly from bodily injury, occupational sickness or disease, or death of the CONTRACTOR's, Subcontractor's, or Supplier's own employees, or agents engaged in the Work resulting in actions brought by or on behalf of such employees against the City and/ or the Engineer;
 - 5. Liability or claims arising directly or indirectly from or based on the violation of any Laws or Regulations, whether by the CONTRACTOR, its employees, or agents;

6. Liability or claims arising directly or indirectly from the use or manufacture by the CONTRACTOR, its employees, or agents in the performance of this Agreement of any copyrighted or uncopyrighted composition, secret process, patented or unpatented invention, article, or appliance, unless otherwise specifically stipulated in this Agreement;
 7. Liability or claims arising directly or indirectly from the breach of any warranties, whether express or implied, made to the City and/or Engineer or any other parties by the CONTRACTOR, its employees, or agents;
 8. Liability or claims arising directly or indirectly from the willful misconduct of the CONTRACTOR, its employees, or agents;
 9. Liability or claims arising directly or indirectly from any breach of the obligations assumed in this Agreement by the CONTRACTOR;
 10. Liability or claims arising directly or indirectly from, relating to, or resulting from a hazardous condition created by the CONTRACTOR, Subcontractors, Suppliers, or any of their employees or agents, and;
 11. Liability or claims arising directly, or indirectly, or consequentially out of any action, legal or equitable, brought against the City, the Engineer, their consultants, subconsultants, and the officers, directors, employees and agents of each or any of them, to the extent caused by the CONTRACTOR's use of any premises acquired by permits, rights of way, or easements, the Site, or any land or areas contiguous thereto or its performance of the Work thereon.
- B. The indemnification obligation under this Article shall not be limited in any way by any limitation on the amount or type of insurance carried by CONTRACTOR or by the amount or type of damages, compensation, or benefits payable by or for the CONTRACTOR or any Subcontractor or other person or organization under workers' compensation acts, disability benefit acts, or other employee benefit acts.
- 6.27 **CONTRACTOR'S DAILY REPORTS.** At the close of each working day, the CONTRACTOR shall submit a daily report to the Inspector, on forms approved by the City, together with applicable delivery tickets, listing all labor, materials, and equipment involved for that day, and for other services and expenditures when authorized concerning extra Work items. Extra or disputed work shall be specifically described and separated from Contract Work on the report. An attempt shall be made to reconcile the report daily, and the Inspector and the CONTRACTOR shall sign it. In the event of disagreement, pertinent notes shall be entered by each party to explain points that cannot be resolved immediately. Each party shall retain a signed copy of the report. Reports by Subcontractors or others shall be submitted through the CONTRACTOR.
- 6.28 **CONTRACTOR PAYMENTS.** To each of its subcontractors, not later than the **5th day** following each payment to CONTRACTOR by the City the respective amounts allowed CONTRACTOR on account of Work performed by the respective subcontractor's to the extent of such subcontractor's interest therein. If CONTRACTOR does not pay one or more SUBCONTRACTORS the amount (less retention) applied for and received in a payment application, CONTRACTOR shall return said amount back to the City within **5 days**.
- 6.29 **DIAL BEFORE YOU DIG.** The CONTRACTOR shall make notification to the regional notification center for utility markouts and keep a record of the inquiry identification number.

The CONTRACTOR shall follow the requirements of California Government Code Section 4216-4216.9. Refer to Article 4.3.

6.30 DOCUMENTS ON WORK. CONTRACTOR shall keep on the job site at all times one legible copy of all Project Documents, including addenda and change orders, and Title 19 of the California Code of Regulations, and all approved drawings, plans, schedules and specifications. Said documents shall be kept in good order and available to the City, Engineer, architect, and all authorities having jurisdiction. CONTRACTOR shall be acquainted with and comply with the provisions of said regulations as they relate to this Project. CONTRACTOR shall also be acquainted with and comply with all California Code of Regulations provisions relating to conditions on this Project, particularly Titles 8 and 17.

6.31 TEMPORARY UTILITIES

A. All utilities, including but not limited to electricity, water, gas, and telephone used on the Work shall be furnished and paid for by CONTRACTOR. CONTRACTOR shall furnish and install necessary temporary distribution systems, including meters, if necessary, from distribution points to all points on the site where the utility is necessary to carry on the Work. Upon completion of the Work, CONTRACTOR shall remove all temporary distribution systems.

B. If this Contract is for a modernization, reconstruction and or an addition to existing building(s),

1. CONTRACTOR may, with written permission of the City, use the City's existing utilities by making prearranged payments to the City for utilities used by CONTRACTOR for construction.

2. CONTRACTOR shall arrange, schedule and pay for all temporary utilities to the entire facility and/or portion(s) of the facility, including but limited to electrical power, water and gas. The entire facility and/or portion of the facility shall be any area that is affected by a utility disruption and/or affects the function and use of the facility.

6.32 SANITARY FACILITIES. The CONTRACTOR shall provide sanitary temporary toilet and hand washing facilities in no fewer numbers than required by law and such additional facilities as may be directed by the Inspector for the use of all workers. The toilet facilities shall be maintained in a sanitary condition at all times and shall be left at the site until removal is directed by the Inspector. Use of toilet facilities in the Work under construction shall not be permitted.

6.33 CLEANING UP

A. For Projects located in the Right-of-Way the CONTRACTOR shall, on a continuous basis, keep Work site free from CONTRACTOR generated debris such as waste, rubbish, and excess materials, dirt, mud, dust, and non-functioning equipment caused by this Work and shall follow the Technical Specifications "TEMPORARY ENVIRONMENTAL CONTROLS & CONSTRAINTS" and "TEMPORARY ENCROACHMENT, MAINTENANCE, AND RESTORATION OF THE CITY RIGHT-OF-WAY".

B. For Building Projects, or projects that are off the street, CONTRACTOR shall at all times keep Work site free from CONTRACTOR generated debris such as waste, rubbish, and excess materials and equipment caused by this Work, at the least on a daily basis. CONTRACTOR shall not leave debris under, in, or about the Work site. Upon completion of CONTRACTOR Work, CONTRACTOR shall clean all interior and exterior materials

installed by CONTRACTOR, and in addition to, all buildings, including fixtures, equipment, walls, floors, ceilings, roofs, window sills and ledges, horizontal projections, and any areas where debris has collected as a direct or indirect result of the CONTRACTOR Work. Such cleaning shall consist of polishing all glass, plumbing fixtures, and finish hardware and similar finish surfaces and equipment. If the project consists of any street improvements (paving / gutter and/or sidewalk surfaces), drain inlets and any pipeline facilities, such Work shall also be free of any debris and sediments.

6.34 WAGE RIGHTS [Job Site Notices]

- A. Pursuant to the provisions of the Labor Code, the governing board of the City has obtained the general prevailing rate of per diem wages and the general prevailing rate for holiday and overtime Work in the locality in which this public Work is to be performed for each craft, classification or type of worker needed for this Project from the Director of the Department of Industrial Relations ("Director.") These rates are on file with the Clerk of the City's governing board and copies will be made available to any interested party on request. CONTRACTOR shall post a copy of such wage rates at the Work site.
- B. Holiday and overtime Work, when permitted by law, shall be paid for at a rate of at least one and one-half times the above specified rate of per diem wages, unless otherwise specified. Holidays shall be defined in the Collective Bargaining Agreement applicable to each particular craft, classification or type of worker employed.
- C. CONTRACTOR shall pay and shall cause to be paid each worker engaged in Work on the Project not less than the general prevailing rate of per diem wages determined by the Director, regardless of any contractual relationship which may be alleged to exist between the CONTRACTOR or any Subcontractor and such workers.
- D. If during the period this bid is required to remain open, the Director of Industrial Relations determines that there has been a change in any prevailing rate of per diem wages in the locality in which this public Work is to be performed, such change shall not alter the wage rates in the Notice Calling for Bids or the contract subsequently awarded.
- E. Pursuant to Labor Code section 1775, CONTRACTOR and any subcontractor shall as a penalty to the City, forfeit fifty dollars (\$50) for each calendar day, or portion thereof, for each worker paid less than the prevailing rate of per diem wages, determined by the Director, for such craft or classification in which such worker is employed for any public Work done under the Agreement by CONTRACTOR or by any Subcontractor under it. The amount of the penalty shall be determined by the Labor Commission and shall be based on consideration of the CONTRACTOR's or subcontractor's mistake, inadvertence or neglect in failing to pay the correct prevailing rate of per diem wage, or the previous record of the CONTRACTOR in meeting his or her prevailing rate of per diem wage obligations, or the CONTRACTOR's or subcontractor's willful failure to pay the correct prevailing rate of per diem wages. A mistake, inadvertence or neglect in failing to pay the correct prevailing rate of per diem wage is not excusable if the CONTRACTOR or subcontractor had knowledge of his or her obligations under this part. The difference between such prevailing rate of per diem wage and the amount paid to each worker for each calendar day or portion thereof for which each worker was paid less than the prevailing rate of per diem wage shall be paid to each worker

by the CONTRACTOR or subcontractor.

- F. Any workers employed to perform Work on the Project, which Work is not covered by any craft or classification listed in the general prevailing rate of per diem wages determined by the Director shall be paid not less than the minimum rate of wages specified therein for the craft or classification which most nearly corresponds to Work to be performed by them, and such minimum wage rate shall be retroactive to time of initial employment of such persons in such craft or classification.
- G. Pursuant to Labor Code section 1773.1, per diem wages are deemed to include employer payments for health and welfare, pension, and vacation pay.
- H. CONTRACTOR shall post at appropriate conspicuous points on the site of the Project, a schedule showing all determined minimum wage rates and all authorized deductions, if any, from unpaid wages actually earned.

6.35 HOURS OF WORK

- A. As provided in Article 3 (commencing at section 1810), Chapter 1, Part 7, Division 2 of the Labor Code, **8 hours** of labor shall constitute a legal day's Work. The time of service of any worker employed at any time by the CONTRACTOR or by any Subcontractor on any subcontract under this Agreement upon the Work or upon any part of the Work contemplated by this Agreement shall be limited and restricted by the Agreement to **8 hours** per day, and **40 hours** during any one week, except as hereinafter provided. Notwithstanding the provisions hereinabove set forth, Work performed by employees of CONTRACTOR in excess of **8 hours** per day and **40 hours** during any one week, shall be permitted upon this public Work upon compensation for all hours worked in excess of **8 hours** per day at not less than one and one-half times the basic rate of pay.
- B. The CONTRACTOR shall keep and shall cause each Subcontractor to keep an accurate record showing the name of and actual hours worked each calendar day and each calendar week by each worker employed by CONTRACTOR in connection with the Work or any part of the Work contemplated by this Agreement. The record shall be kept open at all reasonable hours to the inspection of the City and to the Division of Labor Standards Enforcement, Department of Industrial Relations.
- C. Pursuant to Labor Code section 1813, the CONTRACTOR or subcontractor shall pay to the City a penalty of twenty-five Dollars (\$25) for each worker employed in the execution of this Contract by the CONTRACTOR or by any Subcontractor for each calendar day during which such worker is required or permitted to Work more than **8 hours** in any one calendar day and **40 hours** in any one calendar week in violation of the provisions of Article 3 (commencing at section 1810), Chapter 1, Part 7, Division 2 of the Labor Code.
- D. Any Work necessary to be performed at the Contractor's request or due to the Contractor's actions after the normal working hours of 7:00 a.m. to 4:30 p.m., Monday through Friday, or on weekends or City Holidays, shall be performed without any additional expense to the City. If Contractor seeks to Work after regular working hours, or weekends or holidays, written notice shall be given and costs for inspection, if incurred by the City, shall be reimbursed within **3 days** of presentation or the City may issue, unilaterally, a deductive Change Order crediting the same.

6.36 APPRENTICES

- A. The CONTRACTOR acknowledges and agrees that, if this Agreement involves a dollar amount greater than or a number of working days greater than that specified in Labor Code section 1777.5, this Agreement is governed by the provisions of Labor Code section 1777.5. It shall be the responsibility of the CONTRACTOR to ensure compliance with this Article and with Labor Code section 1777.5 for all apprenticing occupations.
- B. Apprentices of any crafts or trades may be employed and, when required by Labor Code section 1777.5, shall be employed provided they are properly registered in full compliance with the provisions of the Labor Code.
- C. Every such apprentice shall be paid the standard wage paid to apprentices under the regulations of the craft or trade at which he or she is employed, and shall be employed only at the Work of the craft or trade to which he or she is registered.
- D. Only apprentices, as defined in section 3077, who are in training under apprenticeship standards and written apprentice agreements under Chapter 4 (commencing at section 3070), Division 3 of the Labor Code, are eligible to be employed on public works. The employment and training of each apprenticeship shall be in accordance with the provisions of the apprenticeship standards and apprentice agreements under which he or she is training.
- E. Pursuant to Labor Code section 1777.5, the CONTRACTOR and any Subcontractors employing workers in any apprenticeship craft or trade in performing any Work under this Agreement shall apply to the applicable joint apprenticeship committee for a certificate approving the CONTRACTOR or Subcontractor under the applicable apprenticeship standards for the employment and training of apprentices.
- F. Every CONTRACTOR and Subcontractor shall submit contract award information to the applicable joint apprenticeship committee which shall include an estimate of journeyman hours to be performed under the Agreement, the number of apprentices to be employed and the approximate dates the apprentices will be employed.
- G. If the CONTRACTOR or Subcontractor willfully fails to comply with Labor Code Section 1777.5, then, upon a determination of noncompliance by the Administrator of Apprenticeship, it shall:
 - 1. Be denied the right to bid on any subsequent project for one year from the date of such determination; and
 - 2. Forfeit as a penalty to the City fifty dollars (\$50) per day for each calendar day of noncompliance, which shall be withheld from any payment due or to become due under the terms of this Agreement. Interpretation and enforcement of these provisions shall be in accordance with the rules and procedures of the California Apprenticeship Council.
- H. The CONTRACTOR and all Subcontractors shall comply with Labor Code section 1777.6, which section forbids certain discriminatory practices in the employment of apprentices.
- I. CONTRACTOR shall become fully acquainted with the law regarding apprentices prior to commencement of the Work. Special attention is directed to sections 1777.5, 1777.6, and 1777.7 of the Labor Code, and Title 8, California Code of Regulations, section 200 et seq.

Questions may be directed to the State Division of Apprenticeship Standards, 455 Golden Gate Avenue, San Francisco, California.

6.37 **FIRST AID.** The CONTRACTOR shall maintain emergency first aid treatment for CONTRACTOR's workers on the Project which complies with the Federal Occupational Safety and Health Act of 1970 (29 U.S.C.A., Sec. 651 et seq.).

6.38 **PROTECTION OF PERSONS AND PROPERTY**

- A. The CONTRACTOR, (on behalf of itself, all Subcontractors and Suppliers (of every tier), shall be responsible for all damages to persons or property (whether furnished or installed, owned or not owned) that occur as a result of its fault or negligence in connection with the prosecution of this Agreement and shall take all necessary measures and be responsible for the proper care and protection of all materials delivered and Work performed until completion and final acceptance by the City. The CONTRACTOR shall remove all mud, water, or other elements as may be required for the proper protection and prosecution of its work, including the placement of gravel beds and gravel roads for access to and around the Work. CONTRACTOR shall provide such heat, covering, and enclosures as are necessary to protect all Work, materials, equipment, appliances, and tools against damage by weather conditions. All Work shall be solely at the CONTRACTOR's risk with the exception of damage to the Work caused by "acts of God" as defined in Public Contract Code Section 7105.
- B. CONTRACTOR shall take, and require Subcontractors to take, all necessary precautions for the safety of workers and shall comply with all applicable federal, state, local and other safety laws, standards, orders, rules, regulations, and building codes to prevent accidents or injury to persons on, about, or adjacent to the Work site and to provide a safe and healthful place of employment. CONTRACTOR shall furnish, erect and properly maintain at all times, as directed by the City or Engineer or as required by the conditions and progress of Work, all necessary safety devices, safeguards, construction canopies, signs, audible devices for protection of the blind, safety rails, belts and nets, barriers, lights, and watchmen for protection of workers and the public and shall post danger signs warning against hazards created by such features in the course of construction. CONTRACTOR shall designate a responsible employee, whose duty shall be to post information regarding protection and obligations of workers and other notices required under occupational safety and health laws, to comply with reporting and other occupational safety requirements, and to protect the life, safety and health of workers. The name and position of the person so designated shall be reported in writing to the City by CONTRACTOR. CONTRACTOR shall correct any violations of safety laws, standards, orders, rules, or regulations. Upon the issuance of a citation or notice of violation by the Division of Occupational Safety and Health, such violation shall be corrected immediately by the CONTRACTOR at CONTRACTOR's expense.
- C. In an emergency affecting safety of person or of Work or of adjoining property, CONTRACTOR, without special instruction or authorization from the City, architect or Engineer, is hereby permitted to act, at its discretion, to prevent such threatened loss or injury; and CONTRACTOR shall so act if so authorized or instructed by the City, architect or Engineer. Any compensation claimed by CONTRACTOR on account of emergency Work shall be determined by written agreement with the City.
- D. CONTRACTOR shall take adequate precautions to protect existing roads, sidewalks, curbs, pavements, utilities, adjoining property, mailboxes (including temporary re-location) and structures (including, without limitation, protection from settlement or loss of lateral

support), and to avoid damage thereto, and repair any damage thereto caused by construction operations.

- 6.39 ACCESSIBILITY REQUIREMENTS: Construction shall be in conformance with all applicable codes per the Department of the State Architect, Title 24 Guidelines for Accessibility by Disabled Persons.

ARTICLE 7 – OTHER WORK

7.1 OTHER CONTRACTS

- A. CONTRACTOR is aware that this Project site may be split into several phases, and or separate contracts. The City reserves the right to let other contracts in connection with this Work, and it shall be the duty of the CONTRACTOR to actively schedule and coordinate its Work with the City's forces, City's Contractor(s) and or other multiple prime contracts. No extra costs or delays shall be considered as a result of any such scheduling, coordination and cooperation. CONTRACTOR shall afford other contractors reasonable opportunity for introduction and storage of their materials and execution of their Work and shall properly connect and coordinate its Work with such other contractors.
- B. If any part of CONTRACTOR's Work depends for proper execution or results upon Work of any other Contractor, the CONTRACTOR shall inspect and promptly report to the City in writing any defects in such Work that render it unsuitable for such proper execution and results. CONTRACTOR will be held accountable for damages to the City for that Work which it failed to inspect or should have inspected. CONTRACTOR's failure to inspect and report shall constitute its acceptance of other CONTRACTOR's Work as fit and proper for reception of its Work, except as to defects which may develop in other CONTRACTOR's Work after execution of CONTRACTOR's Work.
- C. To ensure proper execution of its subsequent Work, CONTRACTOR shall measure and inspect Work already in place and shall at once report to the City in writing any discrepancy between executed Work and Project Documents.
- D. It is the obligation of CONTRACTOR to ascertain to its own satisfaction the scope of the Project and nature of any other contracts that have been or may be awarded by City in prosecution of the Project to the end that CONTRACTOR may perform this Agreement in the light of such other contracts, if any.
- E. Nothing herein contained shall be interpreted as granting to CONTRACTOR exclusive occupancy at the site of the Project. CONTRACTOR shall not cause any unnecessary hindrance or delay to any other contractor working on the Project. If simultaneous execution of any contract for the Project is likely to cause interference with performance of some other contract or contracts, the City shall decide which contractor shall cease Work temporarily and which contractor shall continue or whether Work can be coordinated so that contractors may proceed simultaneously.
- F. If the Project is split into phases then CONTRACTOR has made allowances for any delays or damages which may arise from coordination with contractors for other phases. If any delays should arise from a contractor working on a different phase, CONTRACTOR's sole remedy for damages, including delay damages, shall be against the contractor who caused such damage and not the City. CONTRACTOR shall provide access to contractors for other phases as necessary to prevent delays and damages to contractors working on other phases of construction.

7.2 INTEGRATION OF WORK

- A. CONTRACTOR shall perform all cutting, fitting, patching, and preparation of Work as required to make its several parts come together properly, and fit it to receive or be received by Work of other contractors; including both the CONTRACTOR's and City's forces. In the event of clarifications, the CONTRACTOR shall follow all Supplemental Instructions (SI's) given by the City.
- B. All costs caused by defective or ill-timed Work shall be borne by CONTRACTOR.
- C. CONTRACTOR shall not endanger any Work by cutting, excavating, or otherwise altering Work and shall not cut or alter Work of any other CONTRACTOR without the written consent of the City. CONTRACTOR shall be solely responsible for protecting existing Work on adjacent properties and shall obtain all required permits for shoring and excavations near property lines.
- D. When modifying existing Work or installing new Work adjacent to existing Work, CONTRACTOR shall match, as closely as conditions of the site and materials will allow, the finishes, textures, and colors of the original Work, refinishing existing Work as required, at no additional cost to the City.

ARTICLE 8 – THE CITY'S RESPONSIBILITIES

- 8.1 COMMUNICATIONS. Except as may be otherwise provided in these General Conditions or the Supplementary General Conditions, the City will communicate directly with the CONTRACTOR.
- 8.2 OBSERVATIONS ON THE SITE. The City will make observations on the Site during construction to monitor the progress and quality of the Work and to determine, in general, if the Work is proceeding in accordance with the Project Documents. Neither, the City, the Engineer, nor their representatives will be required to make exhaustive or continuous inspections to check the quality or quantity of the Work.
- 8.3 PROJECT REPRESENTATION. The City may furnish a third party or a City employee to act as Resident Project Representative to assist in observing the performance of the Work.
- 8.4 CLARIFICATIONS, REQUESTS FOR INFORMATION. The City will issue with reasonable promptness such answers to requests for information (RFI) which shall be consistent with or reasonably inferable from the overall intent of the Project Documents.
- 8.5 AUTHORIZED VARIATIONS IN WORK. The City may authorize the execution of variations in the Work from the requirements of the Project Documents complying with Articles 10, 11, and 12 of these General Conditions that cover changes in the Work, Contract Price, and Contract Times.
- 8.6 REJECTING WORK. The City has the authority to reject Work not in accordance with the Contract Documents and will also have authority to require special inspection or testing of the Work as provided in Article 13.
- 8.7 CONTRACTOR SUBMITTALS, CHANGE ORDERS, AND PAYMENTS
 - A. The City will review all CONTRACTOR submittals.
 - B. The City's responsibilities for Change Orders are set forth in Articles 10, 11, and 12.
 - C. The City's responsibilities for Applications for Payment are set forth in Article 14.

- 8.8 DECISIONS ON DISPUTES. The City will be the interpreter of the requirements of the Contract Documents and of the acceptability of the Work thereunder. Disputes, and other matters relating to the acceptability of the Work and interpretation of the requirements of the Contract Documents pertaining to the performance of the Work shall be determined by the City. Any requests from the CONTRACTOR with respect to changes in the Contract Price or Contract Times shall be resolved in accordance with the requirements set forth in Articles 10, 11, 12 and 17.
- 8.9 LIMITATION OF CITY'S RESPONSIBILITIES
- A. Neither the City's authority to act under this Article or other provisions of the Contract Documents nor any decision made by the City in good faith either to exercise or not exercise such authority shall give rise to any duty or responsibility of the City to the CONTRACTOR, any Subcontractor, any Supplier, any surety for any of them, or any other person or organization performing any of the Work.
- B. Whenever in the Project Documents the terms "as ordered," "as directed," "as required," "as allowed," "as reviewed," "as approved," or terms of like effect or import are used, or the adjectives "reasonable," "suitable," "acceptable," "proper," or "satisfactory," or adjectives of like effect or import are used to describe a requirement, direction, review, or judgment of the City as to the Work, it is intended that such requirement, direction, review, or judgment will be solely to evaluate the Work for compliance with the requirements of the Project Documents, and conformance with the design concept of the completed Project as a functioning whole as indicated by the Project Documents, unless there is a specific statement indicating otherwise. The use of any such term or adjective shall not be effective to assign to the City any duty or authority to supervise or direct the performance of the Work.
- C. The City shall not supervise, direct or have control or authority over, nor be responsible for CONTRACTOR's means, methods, techniques, sequences, or procedures of construction or the safety precautions and programs incident thereto, or for any failure of CONTRACTOR to comply with Laws and Regulations applicable to the furnishing or performance of the Work. The City will not be responsible for CONTRACTOR's failure to perform or furnish the Work in accordance with the Project Documents.
- 8.10 LANDS, EASEMENTS, AND SURVEYS. The City's duties in respect of providing lands and easements and providing engineering survey data to establish reference points are set forth in Article 4
- 8.11 REPORTS AND DRAWINGS. The City will identify to the CONTRACTOR copies of reports of physical conditions at the Site and drawings of existing structures which have been utilized in preparing the Contract Documents, in the Supplementary General Conditions.
- 8.12 SUSPENSION OF Work. The City's right to stop Work or suspend Work is set forth in Article 15.
- 8.13 TERMINATION OF AGREEMENT. The City's right to terminate services of the Contractor is set forth in Article 15.
- 8.14 UNDISCLOSED HAZARDOUS ENVIRONMENTAL CONDITIONS. The City's responsibility with respect to an undisclosed hazardous environmental condition is set forth in Article 4.4.

ARTICLE 9 – ENGINEER'S STATUS DURING CONSTRUCTION

9.1 THE ENGINEER OF WORK

- A. The City may retain the Engineer of Work to assist the City with post-design services. The Engineer of Work's status during construction is addressed in the Supplemental General Conditions.
- B. The Engineer will make observations on the Site during construction to monitor the progress and quality of the Work and to determine, in general, if the Work is proceeding in accordance with the Contract Documents. The Engineer will not be required to make exhaustive or continuous inspections to check the quality or quantity of the Work.

ARTICLE 10 – CHANGES IN THE WORK

10.1 GENERAL

- A. CO, FO, CCD. Without invalidating the Agreement and without notice to any surety, the City may at any time or from time to time, order additions, deletions, or revisions in the Work. Such additions, deletions or revisions will be authorized by a Change Order (CO), Field Order (FO) or Construction Change Directive (CCD) as defined in Article 1. Upon receipt of any such document, notwithstanding the issuance, execution, and approval of a Change Order, CONTRACTOR shall promptly proceed to implement the additions, deletions, or revisions in the Work in accordance with the applicable conditions of the Contract Documents. A CO, FO and CCD may be issued to the CONTRACTOR at any time.
- B. UNILATERAL CHANGE ORDER If the City and CONTRACTOR fail to agree to the quantification of costs and/or time to be placed into a Bilateral Change Order, the City, at its own discretion, may issue a Unilateral Change Order for those costs and/or time impacts that is deemed appropriate for the changed Work conditions. Notwithstanding the issuance, execution, and approval of a Change Order, the CONTRACTOR shall proceed immediately with the changed Work upon receipt of a Construction Change Directive (CCD), or Field Order (FO). Should the CONTRACTOR disagree with any terms and conditions set forth in an approved Unilateral Contract Change Order, the CONTRACTOR shall submit a written protest to the City within **fifteen (15) days** after the receipt of the approved Unilateral Contract Change Order. The protest shall state the points of disagreement, and, if possible, the Contract Specification references, quantities and costs involved. If a written protest is not submitted to the City, payment will be made as set forth in the approved Unilateral Contract Change Order, and that payment shall constitute full compensation for all Work included therein or required thereby. Unprotested, approved Unilateral Contract Change Orders will be considered as executed Contract Change Orders as that term is used in Articles 10, 11, and 12.
- C. The CONTRACTOR shall not be entitled to an increase in the Contract Price nor an extension of the Contract Times with respect to any Work performed that is not required by the Contract Documents as amended, modified, or supplemented by Change Order, except in the case of an emergency.
- D. If notice of any change in the Work is required to be given to a surety, the giving of any such notice shall be the CONTRACTOR's responsibility. If the change in the Work affects the Contract Price, the City may require an adjustment to the amount of any applicable Bond and the amount of each applicable Bond shall be adjusted accordingly.

- E. If the City and the CONTRACTOR are unable to agree as to the extent, if any, of an increase in the Contract Price or an extension or shortening of the Contract Times that may be allowed as a result of a Field Order, the City may direct the CONTRACTOR to proceed as outlined in Article 11.2. in order to minimize the impact on and delays to the Work, and the CONTRACTOR may make a claim as provided in Articles 11, 12 and 17.
- F. The City of Escondido has the sole authority to approve or disapprove or to delegate the approval or disapproval of Contract Change Orders.

10.2 ALLOWABLE QUANTITY VARIATIONS

- A. In the event of an increase or decrease in the quantity of any bid item under a unit price contract, the total amount of Work actually done or materials or equipment furnished will be paid for according to the unit price established for such Work under the Contract Documents, wherever such unit price has been established; provided, that an adjustment in the Contract Price may be made for changes which result in an increase or decrease in excess of twenty-five percent (25%) of the estimated quantity of any unit price bid item of the Work.
- B. In the event a part of the Work is to be entirely eliminated and no lump sum or unit price is named in the Contract Documents to cover such eliminated Work, the price of the eliminated Work shall be agreed upon by the City and the CONTRACTOR by Change Order. The schedule of values submitted by CONTRACTOR shall be referred to in evaluating the price to be reduced, but shall not be determinative unless both parties agree.

ARTICLE 11 – CHANGE OF CONTRACT PRICE

11.1 GENERAL

- A. The Contract Price constitutes the total compensation payable to the CONTRACTOR for performing the Work. All duties, responsibilities, and obligations whether implied, inferred or express, assigned to or undertaken by the CONTRACTOR to complete the Work shall be at its expense without change in the Contract Price.
- B. The Contract Price may only be changed by a Change Order. The value of any Work covered by a Change Order or of any claim for an increase or decrease in the Contract Price shall be determined in one of the following three ways:
 - 1. **UNIT PRICES.** Where the Work involved is covered by unit prices contained in the Contract Documents, by application of unit prices to the quantities of the items involved;
 - 2. **AGREED UPON LUMP SUM.** By mutual acceptance of a lump sum, which may include an allowance for overhead and profit not necessarily in accordance with Article 11.4; or
 - 3. **COST OF WORK.** On the basis of the cost of the Work, force account payment (determined as provided in Article 11.2) plus the CONTRACTOR's overhead and profit (determined as provided in Article 11.3).
- C. **AGREED ENTITLEMENT.** When the City is in agreement regarding entitlement due the CONTRACTOR on a particular issue that the CONTRACTOR has brought to the attention of the City with a notice, and finds that there is a clear entitlement for additional compensation, the CONTRACTOR and the City will choose a method to be used for

calculating the value of the extra Work from the three methods described in Article 11.1.B.1, 2, or 3 above.

1. **CHANGE USING UNIT PRICES METHOD.** When a change in Contract Price using unit prices is applied, described in Article 11.1.B.1 (UNIT PRICES), a Field Order, signed by the City, will be given to the CONTRACTOR. The increase in line item quantities shall be tracked and documented in the daily extra Work report (Article 11.4) which must identify the quantities used/consumed/handled and shall be presented to the City's on-site representative on a daily basis for review, for pertinent comments, and counter-signature. The CONTRACTOR will invoice the City for the line item quantity used for the extra Work following the conditions of Article 14, "PAYMENTS TO CONTRACTOR, RETENTION AND COMPLETION". A reconciliation Contract Change Order will be executed when the final quantities used are known. The Contract Change Order will account for the over or under amount of line item quantities.
 2. **CHANGE USING AGREED UPON LUMP SUM METHOD.** When the payment method described in Article 11.1.B.2 (LUMP SUM) is used, a Field Order or a Contract Change Order, signed by the City, will be given to the CONTRACTOR. The CONTRACTOR will invoice the City for the extra Work following the conditions of Article 14.
 3. **CHANGE USING FORCE ACCOUNT "COST OF Work" METHOD.** When no agreement can be reached on the method of payment for the extra Work, the method described in Article 11.1.B.3 (COST OF WORK), force account payment (determined as provided in Article 11.2) shall be used. A Field Order will be given to the CONTRACTOR, signed by the City, describing the Work. The City reserves the right to place a "not to exceed" amount on the Field Order based on a City cost estimate. If the approximate value of the cost of extra Work approaches the "not to exceed" value, the CONTRACTOR shall notify the City in order that a further decision may be made as to how to proceed. When the extra Work is completed a Contract Change Order for the accumulated total value of the extra Work shall be executed, should the value of the Work exceed the Field Order allowance. The extra Work shall be documented in the Daily Extra Work Report (Article 11.4).
- D. **DISAGREEMENT REGARDING ENTITLEMENT.** When there is no agreement between the CONTRACTOR and the City on an issue of Work that has not yet been started that the CONTRACTOR has brought to the City pursuant to Article 11.5 "CONTRACTOR SHALL PROVIDE NOTICE", and the City does not find that there is any entitlement for additional compensation due the CONTRACTOR, the Work in question may be designated "DISPUTED WORK". During the performance of any such "DISPUTED WORK" the CONTRACTOR shall:
1. Although not to be construed as proceeding under agreed-upon extra Work provisions, the CONTRACTOR shall keep and furnish records breaking down the Work as described in the following Article 11.2. Daily records shall be furnished according to Article 11.4.
 2. The CONTRACTOR shall continue with the disputed Work according to Article 2.6.

11.2 COST OF WORK - FORCE ACCOUNT (BASED ON TIME AND MATERIALS)

- A. **GENERAL:** The term "cost of Work" means the sum of all costs necessarily incurred and paid by the CONTRACTOR for labor, materials, and equipment in the proper performance of extra Work. Except as otherwise may be agreed to in writing by the City, such costs shall be in amounts no higher than those prevailing in the locality of the Project, shall include only the following items and shall include the costs itemized in Article 11.3.D.1. to be compensated for as a part of the stipulated overhead and profit allowance.
- B. **LABOR:** The costs of labor will be the actual cost for wages prevailing for each craft or type of workers performing the extra Work at the time the extra Work is done, plus employer payments of payroll taxes, workers compensation insurance, liability insurance, health and welfare, pension, vacation, apprenticeship funds, and other direct costs resulting from federal, state or local laws, as well as assessments or benefits required by lawful collective bargaining agreements. Labor costs for equipment operators and helpers will be paid only when such costs are not included in the invoice for equipment rental. The labor costs for foremen shall be proportioned to all of their assigned Work and only that applicable to extra Work shall be paid. Non-direct labor costs including superintendence shall be considered part of the markup set out in Article 11.3. Payment for the cost of labor and subsistence or travel allowance will be made at the rates paid by the CONTRACTOR to other workers operating similar equipment already on the Site, or in the absence of such labor, established by collective bargaining agreements for the type of workmen and location of the extra Work, whether or not the operator is actually covered by such an agreement.
- C. **MATERIALS:** The cost of materials reported shall be at invoice or lowest current price at which materials are locally available and delivered to the Site in the quantities involved, plus the cost of freight, delivery and storage, subject to the following:
1. All trade discounts and rebates shall accrue to the City, and the CONTRACTOR shall make provisions so that they may be obtained;
 2. For materials secured by other than a direct purchase and direct billing to the purchaser, the cost shall be deemed to be the price paid to the actual supplier as determined by the City. Except for actual costs incurred in the handling of such materials, markup will not be allowed;
 3. Payment for materials from sources owned wholly or in part by the purchaser shall not exceed the price paid by the purchaser for similar materials from said sources on extra Work items or the current wholesale price for such materials delivered to the Site, whichever price is lower; and
 4. If in the opinion of the City the cost of material is excessive, or the CONTRACTOR does not furnish satisfactory evidence of the cost of such material, then the cost shall be deemed to be the lowest current wholesale price for the quantity concerned delivered to the Site less trade discount. The City reserves the right to furnish materials for the extra Work and no claim will be allowed by the CONTRACTOR for costs and profit on such materials.
- D. **EQUIPMENT:** The CONTRACTOR will be paid for the use of equipment at the rental rate listed for such equipment specified in the current edition of the "Labor Surcharge and Equipment Rental Rates" published by the State of California Business, Transportation & Housing Agency (CALTRANS). Such rental rate will be used to compute payments for

equipment whether the equipment is under the CONTRACTOR's control through direct ownership, leasing, renting, or another method of acquisition. The rental rate to be applied for use of each item of equipment will be the rate resulting in the least total cost to the City for the total period of use. If it is deemed necessary by the CONTRACTOR to use equipment not listed in the publication specified, an equitable rental rate for the equipment will be established by the City. The CONTRACTOR may furnish cost data which might assist the City in the establishment of the rental rate. Payment for equipment shall be subject to the following:

1. All equipment shall, in the opinion of the City, be in good working condition and suitable for the purpose for which the equipment is to be used;
 2. Before construction equipment is used on the extra Work, the CONTRACTOR shall plainly stencil or stamp an identifying number thereon at a conspicuous location, and shall furnish to the City a description of the equipment with its identifying number;
 3. Unless otherwise specified, manufacturer's ratings and manufacturer approved modifications shall be used to classify equipment for the determination of applicable rental rates. Equipment which has no direct power unit shall be powered by a unit of at least the minimum rating recommended by the manufacturer;
 4. Individual pieces of equipment or tools having a replacement value of \$250 or less, whether or not consumed by use, will be considered to be small tools and no payment will be made therefore.
- E. EQUIPMENT RENTAL TIME: The rental time to be paid for equipment on the Site will be the time the equipment is in productive operation on the extra Work being performed and, in addition, will include the time required to move the equipment to the location of the extra Work and return it to the original location or to another location requiring no more time than that required to return it to its original location; except, that moving time will not be paid if the equipment is used on other than the extra Work, even though located at the Site of the extra Work. Loading and transporting costs will be allowed, in lieu of moving time, when the equipment is moved by means other than its own power, except that no payment will be made for loading and transporting costs when the equipment is used at the Site of the extra Work on other than the extra Work. Rental time will not be allowed while equipment is inoperative due to breakdowns. The rental time of equipment on the Work site will be computed subject to the following:
1. When hourly rates are listed, any part of an hour less than **thirty (30) minutes** of operation will be considered to be half-hour (1/2 – hour) of operation, and any part of an hour in excess of **30 minutes** will be considered **1 hour** of operation;
 2. When daily rates are listed, any part of a day less than **4 hours** operation will be considered to be **1/2 – day** of operation. When owner-operated equipment is used to perform extra Work to be paid for on a time and materials basis, the CONTRACTOR will be paid for the equipment and operator, as set forth in this Article.
 3. Payment for the equipment will be made in accordance with the provisions in Article 11.

F. SURETIES: All Work performed hereunder shall be subject to all of the provisions of the Contract Documents and the CONTRACTOR's sureties shall be bound with reference thereto as under the original Agreement. Copies of all amendments to Bonds or supplemental Bonds shall be submitted to the City for review prior to the performance of any Work hereunder.

11.3 OVERHEAD & PROFIT (O&P) PERCENTAGE SCHEDULE. The allowance for overhead and profit must not exceed the values in the Overhead & Profit Schedule table below.

- A. For Change Orders, whether additive or deductive and work classified as Extra Work, the allowance for overhead and profit must include full compensation for superintendence, insurance premiums, bond premiums, taxes, field office expense, extended overhead, home office overhead, and any other items of expense e.g., Change Order estimating and preparation cost, claims preparation cost, schedule analysis, project management, and field engineering.
- B. Extended overhead must be any and all costs incurred either in the field or at your office resulting from Extra Work excluding direct costs related to direct hourly labor, equipment, or materials necessary to complete the Extra Work.
- C. Overhead & Profit Schedule table

O & P Schedule		
Component	Overhead	Profit
Labor	10%	10%
Material	10%	5%
Equipment	10%	5%
Subcontractor Extra Work	3.5%	1.5%

- D. Work paid under Allowance Bid items for permits, governmental fees, or direct payments specified in the Contract Documents will not be subject to any markups.
- E. When all or any part of the Extra Work is performed by a Subcontractor, the allowance specified herein will be applied to the labor, materials, and equipment costs of the Subcontractor, to which you may add 5% of the Subcontractor's total cost for the Extra Work.
- F. Regardless of the number of hierarchical tiers of Subcontractors, the 5% which is your allowance 3.5% (for overhead) and 1.5% (for profit) may be applied one time only to the performing Subcontractor's total cost.
- G. You will only be reimbursed, with 6% markup, for the warranty extensions beyond the time required by the Contract Documents if requested by the City.
- H. The O&P Schedule shall be used for "Negotiated Sum" (described in Article 11.1.B.2) and/or "Time and Materials" (described in Article 11.1.B.3) Work. Unit Price Work shall not have the overhead and profit markup applied to the Work, on the basis that the Unit Price includes overhead and profit margins.

CONTRACTOR shall set up separate cost codes for each extra Work item and account for all labor, materials and equipment for each cost code. This includes using said cost codes for all labor expended on extra Work, and coding delivery tickets and P.O.'s as well. The same cost code shall appear on the daily report to account for labor, materials and

equipment devoted/used that day for each extra Work item. Failure to comply with this requirement shall be a waiver of the right to collect the same.

- E. IT IS EXPRESSLY UNDERSTOOD THAT THE VALUE OF SUCH EXTRA WORK OR CHANGES, AS DETERMINED BY ANY OF THE AFOREMENTIONED METHODS, EXPRESSLY INCLUDES ANY AND ALL OF CONTRACTOR'S COSTS AND EXPENSES, BOTH DIRECT AND INDIRECT, RESULTING FROM EFFORTS TO IDENTIFY, QUOTE AND/OR NEGOTIATE THE CHANGE(S) AS WELL AS ADDITIONAL TIME REQUIRED ON THE PROJECT, OR RESULTING FROM DELAYS TO THE PROJECT, INCLUDING BUT NOT LIMITED TO ACCELERATION, CUMULATIVE AFFECT OF THE CHANGE(S), EXPEDITING THE WORK, FRAGNETS, ETC.

NO RESERVATION OF RIGHTS, EXPRESS OR IMPLIED, WILL BE PERMITTED OR ALLOWED.

11.4 CONTRACTOR'S DAILY EXTRA WORK REPORT

- A. General. At the close of each working day, the CONTRACTOR shall submit a daily report to the Inspector, on forms approved by the City, together with applicable delivery tickets, listing all labor, materials, and equipment involved for that day, and for other services and expenditures when authorized concerning extra Work items. An attempt shall be made to reconcile the report daily, and the Inspector and the CONTRACTOR shall sign it. The report shall clearly differentiate between extra or disputed Work and Contract Work. In the event of disagreement, pertinent notes shall be entered by each party to explain points that cannot be resolved immediately. Each party shall retain a signed copy of the report. Reports by Subcontractors or others shall be submitted through the CONTRACTOR. The CONTRACTOR shall organize and forward copies of the CONTRACTOR's and Inspector's reports to the City upon the completion of each "Time and Material" activity.
- B. CONTRACTOR shall maintain its records in such a manner as to provide a clear distinction between the direct costs of any extra Work and/or deductive Work and the original Contract Work. This requirement pertains to the costs for wholly or partially approved Change Order Requests (COR's), Construction Change Directives (CCD's), Change Orders (CO's), Field Orders (FO's), and Work CONTRACTOR considers to be potential Change Orders.

- 11.5 CONTRACTOR SHALL PROVIDE NOTICE. If the CONTRACTOR should claim that any instruction, request, drawing, specification, action, condition, omission, default, or other situation obligates the City to pay additional compensation to CONTRACTOR or to grant an extension of time, or constitutes a waiver of any provision in the Agreement, the CONTRACTOR shall provide written "Notice" to the City **within 5 days** after sustaining of such damage, or being notified of an adverse decision, and provide within **14 days** of the event the factual basis supporting the claim (unless otherwise specified). For requests for additional compensation for alleged changed conditions, such as finding rock, notice shall be made before the condition instigating the notice is disturbed. The written "Notice" shall state the summary points for which the factual bases will support the claim and cite in detail the Project Documents (including plans and specifications) upon which the claim is to be based. CONTRACTOR's failure to notify the City within such a period shall be deemed a waiver and relinquishment of such a claim. If such notice is given within the specified time, the procedure for its consideration shall be as stated above in these General Conditions. In addition, on or before the end of the month for which the claim has been filed, the CONTRACTOR shall also file with the City the **WAIVER AND RELEASE FORMS**, for which the claim and the amount of the claim is identified. If the claim is

not indicated on the **WAIVER AND RELEASE FORMS**, CONTRACTOR's claim shall be forfeited and invalidated and it shall not be entitled to consideration for time or payment on account of any such claim.

- 11.6 **COSTS RELATING TO WEATHER/ FORCE MAJEURE.** The CONTRACTOR shall have no claims against the City for damages for any injury to Work, materials, or equipment, resulting from the action of the elements whether caused by weather, earthquakes, or other natural events. If, however, in the opinion of the City, the CONTRACTOR has made all reasonable efforts to protect the materials, equipment, and Work, the CONTRACTOR may be granted a reasonable extension of Contract Times to make proper repairs, renewals, and replacements of the Work, materials, or equipment. All costs incurred as a result of any force majeure, including abnormally or unusually severe weather, earthquakes or other natural perils shall not be compensable from the City and the risks associated therewith shall be exclusively borne by CONTRACTOR. To the extent CONTRACTOR elects to protect itself from any/all of said risks, it shall insure against the same.

ARTICLE 12 – CHANGE OF CONTRACT TIMES

12.1 GENERAL

- A. Contract times are stated in the Notice Inviting Sealed Bids, Section 00030, The Public Improvement Agreement, and the Supplemental General Conditions, Section 00800, of these Contract Documents.
- B. The Contract Times may only be changed by a Change Order. Any claim for an extension of the Contract Times shall be based on written notice delivered by the CONTRACTOR to the City promptly (but in no event later than 24 hours) after the start of the event giving rise to the claim and stating the general nature of the claim. Reference Article 11.5 "CONTRACTOR SHALL PROVIDE NOTICE". Notice of the extent of the claim with supporting data shall be delivered within **5 days** after the start of such event (unless the City allows an additional period of time for the submission of additional or more accurate data in support of the claim) and shall be accompanied by the CONTRACTOR's written statement that the adjustment claimed is the entire adjustment to which the CONTRACTOR is entitled as a result of said event. All claims for adjustment in the Contract Times will be determined by the City. No claim for an adjustment in the Contract Times will be valid if not submitted in accordance with the requirements of this Article 12.1.B. An increase in Contract Times does not mean that the CONTRACTOR is due an increase in Contract Price. Only compensable time extensions will result in an increase in Contract Price.
- C. Extra Work executed by the CONTRACTOR in conjunction, simultaneously or concurrently with the Work does not create a compensable time extension.
- D. Extra Work executed by the CONTRACTOR during Contract Schedule Float does not create a compensable time extension.
- E. The value of time expended on extra Work is fully compensated by the markups for overhead and profit found on the table in Article 11.3.
- F. All time limits stated in the Contract Documents are of the essence of the Agreement.
- G. When CONTRACTOR is prevented from completing any part of the Work within the Contract Times (or Milestones) due to delay beyond the control of CONTRACTOR, the Contract Times (or Milestones) will be extended in an amount equal to the time lost on the critical path of the Work due to such delay, if a claim is made therefore as provided in Article 12.1.B. Delays beyond the control of CONTRACTOR shall include, but not be limited

to, acts or neglect by the City; acts or neglect of those performing other Work as contemplated by Article 7; and fires, floods, epidemics, abnormal weather conditions, or acts of God. Delays attributable to and within the control of any Subcontractor or Supplier (of any tier) shall be deemed to be delays within the control of the CONTRACTOR.

H. In no event will the City be liable to CONTRACTOR, any Subcontractor, any Supplier, any other person or organization, or to any surety for or employee or agent of any of them, for any increase in the Contract Price or other damages arising out or resulting from the following:

1. Delays caused by or within the control of CONTRACTOR;
2. Delays beyond the control of both the City and CONTRACTOR including but not limited to fires, floods, epidemics, abnormal weather conditions, acts of God, or acts or neglect by those performing other Work as contemplated by Article 7; or
3. City-caused/responsible delays, concurrent with items 1 and/or 2 above.

12.2 EXTENSIONS OF CONTRACT TIMES FOR DELAY DUE TO WEATHER. The CONTRACTOR's construction schedule shall anticipate delay due to seasonal weather.

12.3 OWNERSHIP OF PROJECT SCHEDULE FLOAT/EARLY COMPLETION SCHEDULE

A. Total Float is the number of days by which a part of the Work in the Construction Schedule may be delayed from its early dates without necessarily extending the Contract Time. Contract Float is the number of days between the CONTRACTOR's anticipated date for early completion of the Work, or specified part, and the corresponding Contract Time. Total float and Contract Float belong to the Project and are not for the exclusive benefit of any party. They shall be available to the City, the construction manager, their consultants, or the CONTRACTOR, to accommodate changes in the Work, or to mitigate the effects of events which may delay performance or completion. The City will monitor and optimize the use of float for the benefit of the Project.

B. IF CONTRACTOR SUBMITS A REVISED SCHEDULE SHOWING AN EARLIER COMPLETION DATE FOR THE PROJECT, THE CITY'S ACCEPTANCE OF THIS REVISED SCHEDULE SHALL NOT ENTITLE CONTRACTOR TO ANY DELAY CLAIM OR DAMAGES DUE TO ANY SUCH REVISED SCHEDULE. CONTRACTOR AND ALL SUBCONTRACTORS SHALL INCLUDE, AS DEEMED APPROPRIATE, SUFFICIENT AMOUNTS TO COVER THE HOME OFFICE AND FIELD OVERHEAD COSTS COMMENSURATE WITH THE PUBLISHED CONTRACT DURATION. FAILURE TO INCLUDE OVERHEAD COSTS IN THEIR BIDS THROUGH THE CONTRACT DURATION SHALL BE AT THE RISK OF CONTRACTOR AND ITS SUBCONTRACTORS.

12.4 EXTENSION OF TIME - LIQUIDATED DAMAGES

A. The CONTRACTOR and the City hereby agree that the exact amount of damages for failure to complete the Work within the time specified is extremely difficult or impossible to determine. CONTRACTOR shall be assessed the sum set forth in the **Agreement**, as liquidated damages for each and every day the Work required under the Project Documents remains unfinished past the time for completion, as set forth in the **Agreement**, and any extensions of time granted by the City to the CONTRACTOR under the terms of the Project Documents. The CONTRACTOR will pay to the City or the City may retain from amounts otherwise payable to the CONTRACTOR, said amount for each day after failure to meet the requirements of the contract completion as scheduled in the Agreement. For purposes of this article, the Work shall be considered "complete" in accordance with these General Conditions, except that the Work may be considered

complete without formal acceptance by the City Council so long as the City Council, at its next regularly scheduled meeting, accepts the Work.

- B. CONTRACTOR shall not be charged for liquidated damages, as set forth above, because of any delays in completion of Work which are not the fault or negligence of CONTRACTOR, including but not restricted to acts of God, as long as CONTRACTOR informs City of such events. As soon as CONTRACTOR become aware of any delay and no later than **14 days** from the commencement of the delay, CONTRACTOR shall notify the City in writing of causes of delay in accordance with the contract scheduling specifications. CONTRACTOR shall provide documentation and justification to substantiate the delay and its relation to the Project's critical path. Extension of time shall apply only to that portion of Work affected by the delay, and shall not apply to other portions of Work not so affected.

ARTICLE 13 – INSPECTIONS AND TESTS; CORRECTION, REMOVAL, OR ACCEPTANCE OF DEFECTIVE WORK

- 13.1 **AUTHORITY OF INSPECTOR.** Any Work performed by the CONTRACTOR upon the instructions or comments by the Inspector may be confirmed by the CONTRACTOR, at the CONTRACTOR's option, in writing by the City. Any extra Work performed without the written instruction of the City shall be at CONTRACTOR's sole cost and expense and there will be no delay damages incurred by City for such Work.
- 13.2 **INSPECTION.** No Work shall be carried on except with the knowledge of the Inspector(s). The Inspector shall have free access to any or all parts of Work at any time. CONTRACTOR shall furnish Inspector reasonable opportunities for obtaining such information as may be necessary to keep Inspector fully informed respecting progress and manner of Work and character of materials. Inspection of Work shall not relieve CONTRACTOR from any obligation to fulfill the Project Documents. Inspector shall have authority to stop Work whenever provisions of Project Documents are not being complied with and such noncompliance is discovered. CONTRACTOR shall instruct its employees accordingly.
- 13.3 **NOTICE OF DEFECTIVE Work.** Prompt notice of Defective Work known to the City will be given to the CONTRACTOR. Defective Work discovered or uncovered will be noticed to the CONTRACTOR as soon as practicable. All Defective Work, whether or not in place, may be rejected, corrected, or accepted as provided in this Article 13. Defective Work may be rejected even if approved by prior inspection.
- 13.4 **ACCESS TO WORK.** The City, Engineer, their consultants, subconsultants, other representatives and personnel of the City, independent testing laboratories, and governmental agencies with jurisdictional interests shall have access to the Work at reasonable times for their observation, inspecting, and testing. CONTRACTOR shall provide them proper and safe conditions for such access, including sheeting and shoring as may be necessary, and advise them of CONTRACTOR's Site safety procedures, and programs so that they may comply therewith as applicable.
- 13.5 **INSPECTIONS AND TESTS**
- A. The CONTRACTOR shall give the City not less than **2 working days** notice of readiness of the Work for all required general inspections, tests, or approvals, and shall cooperate with inspection and testing personnel to facilitate required inspections or tests. Specialty inspections shall be scheduled **7 days** in advance.

- B. The City shall employ and pay for the services of an independent testing laboratory to perform all inspections, tests, or approvals required by the Contract Documents except:
1. For inspection, tests, or approvals covered by Articles 13.5.C. and 13.5.D. below;
 2. That costs incurred in connection with tests or inspections conducted pursuant to Article 13.5.G. shall be paid for by the CONTRACTOR.
- C. If Laws and Regulations of any public body having jurisdiction require any Work (or any part thereof) to be inspected, tested, or approved by an employee or other representative of such public body, CONTRACTOR shall assume full responsibility for arranging and obtaining such inspections, tests or approvals; pay all costs in connection therewith; and furnish the City the required certificates of inspection or approval.
- D. The CONTRACTOR shall be responsible for arranging and obtaining and shall pay all costs in connection with any inspections, tests, or approvals required for the City's acceptance of materials or equipment to be incorporated in the Work or acceptance of materials, mix designs, or equipment submitted for approval prior to the CONTRACTOR's purchase thereof for incorporation in the Work. Such inspections, tests, or approvals shall be performed by organizations acceptable to the City.
- E. The City will make, or have made, such inspections and tests as the City deems necessary to see that the Work is being accomplished in accordance with the requirements of the Contract Documents. Unless otherwise specified in the Supplementary General Conditions, the cost of such inspection and testing will be borne by the City. In the event such inspections or tests reveal non-compliance with the requirements of the Contract Documents, the CONTRACTOR shall bear the cost of corrective measures deemed necessary by the City, as well as the cost of subsequent reinspection and retesting. Neither observations by the Engineer nor inspections, tests, or approvals by others shall relieve the CONTRACTOR from the CONTRACTOR's obligation to perform the Work in accordance with the Contract Documents.
- F. If any Work that is to be inspected, tested, or approved is covered without written concurrence of the City, it must, if requested by the City, be uncovered for observation. Such uncovering shall be at the CONTRACTOR's expense.
- G. If any Work is covered contrary to the written request of the City, it must, if requested by the City, be uncovered for the City's observation and recovered at the CONTRACTOR's expense.
- H. If the City considers it necessary or advisable that covered Work be observed by the City or inspected or tested by others, the CONTRACTOR, at the City's request, shall uncover, expose, or otherwise make available for observation, inspection, or testing as the City may require, that portion of the Work in question, furnishing all necessary labor, material, and equipment. If it is found that such Work is Defective Work, the CONTRACTOR shall bear all direct, indirect, and consequential costs and damages of such uncovering, exposure, observation, inspection, and testing and of satisfactory reconstruction, including but not limited to, fees and charges of engineers, architects, attorneys, and other professionals. However, if such Work is not found to be Defective Work, the CONTRACTOR will be allowed an increase in the Contract Price, directly attributable to such uncovering, exposure, observation, inspection, testing, and reconstruction; and, if the parties are unable to agree as to the amount or extent thereof, the CONTRACTOR may make a request for additional compensation therefore as provided in Articles 10, 11 and 12.

- I. All initial tests shall be performed under the direction of the City. All re-testing due to failure shall be performed under the direction of the City, and the cost of all re-testing shall be borne by the CONTRACTOR. The costs and potential loss of productivity to accommodate re-testing shall be borne by the CONTRACTOR.
- J. A City Inspector, or designee, may be required on the job site at all times Work is in progress as determined by the City. Inspection will be required by the appropriate agency for the following type of Work: trenching, special or sand bedding, laying pipe, any welding, backfill, compaction and pavement replacement. Special Work hours required by the Contract are considered normal hours.
- 13.6 THE CITY MAY STOP THE WORK. If Defective Work is identified, the City may order the CONTRACTOR to stop performance of the Work, or any portion thereof, until the cause for such order has been eliminated; however, this right of the City to stop the Work shall not give rise to any duty on the part of the City to exercise this right for the benefit of the CONTRACTOR or any other party.
- 13.7 CORRECTION OR REMOVAL OF DEFECTIVE WORK. If required by the City, the CONTRACTOR shall promptly either correct all Defective Work, whether or not fabricated, installed, or completed, or, if the Work has been rejected by the Engineer, remove it from the Site and replace it with non-defective Work. The CONTRACTOR shall bear all direct, indirect, and consequential costs and damages of such correction or removal, including but not limited to fees and charges of engineers, architects, attorneys, and other professionals made necessary thereby.
- 13.8 ACCEPTANCE OF DEFECTIVE WORK. If, instead of requiring correction or removal and replacement of Defective Work, the City prefers to accept the Defective Work, the City may do so. The CONTRACTOR shall bear all direct, indirect, and consequential costs attributable to the City's evaluation of and determination to accept such Defective Work. If any such acceptance occurs prior to final payment, a Change Order will be issued incorporating the necessary revisions in the Contract Documents with respect to the Work, and the City shall be entitled to an appropriate decrease in the Contract Price.
- 13.9 THE CITY MAY CORRECT DEFECTIVE WORK
- A. If the CONTRACTOR fails within a reasonable time after written notice from the City to correct Defective Work, or to remove and replace Defective Work as required by the City in accordance with Article 13.7, or if the CONTRACTOR fails to perform the Work in accordance with the Contract Documents, or if the CONTRACTOR fails to comply with any other provision of the Contract Documents, the City may, after **7 days** written notice to the CONTRACTOR, correct and remedy any such deficiency.
- B. In exercising the rights and remedies under this paragraph, the City shall proceed with corrective and remedial action. In connection with such corrective and remedial action, the City may exclude the CONTRACTOR from all or part of the Site, take possession of all or part of the Work, and suspend the CONTRACTOR's services related thereto and incorporate in the Work all materials and equipment for which the City has paid the CONTRACTOR whether stored at the Site or elsewhere. The CONTRACTOR shall provide the City, City's representatives, Engineer, and Engineer's consultants access to the Site to enable the City to exercise the rights and remedies under this Article.
- B. All direct, indirect, and consequential costs and damages incurred by the City in exercising the rights and remedies under this paragraph will be charged against the CONTRACTOR and a Change Order will be issued incorporating the necessary revisions in the Contract Documents with respect to the Work; and the City shall be entitled to an appropriate

decrease in the Contract Price. If the parties are unable to agree as to the amount of the adjustment, the City may make a claim therefore as provided in Article 11. Such claim will include, but not be limited to, all costs of repair or replacement of Work of others, destroyed or damaged by correction, removal, or replacement of CONTRACTOR's Defective Work and all direct, indirect, and consequential damages associated therewith.

- D. The CONTRACTOR shall not be allowed an extension of Contract Times (or Milestones) because of any delay in the performance of the Work attributable to the exercise by the City of the City's rights and remedies under this paragraph.

13.10 CORRECTION PERIOD

- A. The correction period for Defective Work shall be the longer of:
 - 1. One year after the date of final acceptance;
 - 2. Such time as may be prescribed by Laws and Regulations;
 - 3. Such time as specified by the terms of any applicable special guarantee required by the Contract Documents; or
 - 4. Such time as specified by any specific provision of the Contract Documents.
- B. If, during the correction period as defined in Article 13.10A above, any Work is found to be Defective Work, the City shall have the same remedies as set forth in Articles 13.7, 13.8, and 13.9 above.
- C. Where Defective Work (and damage to other Work resulting therefrom) has been corrected, removed, or replaced under this paragraph, the correction period hereunder with respect to such Work will be extended for an additional period of **1 year** after such correction or removal and replacement has been satisfactorily completed.

ARTICLE 14 – PAYMENTS TO CONTRACTOR, RETENTION AND COMPLETION

14.1 APPLICATION FOR PROGRESS PAYMENT

- A. On the 25th of each month, the CONTRACTOR shall submit to the City for review, the Application for Payment filled out and signed by the CONTRACTOR covering the Work completed as of the date of the Application for Payment and accompanied by the appropriate waiver(s) and release upon "Progress Payment" and such supporting documentation as is required by the Project Documents.
- B. The Application for Payment shall identify, as a subtotal, the estimated amount of the CONTRACTOR total earnings to date; plus the value of materials stored at the Site, pursuant to Article 14.1.K, which have not yet been incorporated in the Work; and less a deductive adjustment for materials installed which were not previously incorporated in the Work, but for which payment was allowed under the provisions for payment for materials stored at the Site, but not yet incorporated in the Work.
- C. The net payment due the CONTRACTOR shall be the above-mentioned subtotal from which shall be deducted five percent (5%) retention and the total amount of all previous payments made to the CONTRACTOR. The City shall have the right to issue joint checks to CONTRACTOR and SUBCONTRACTOR and/or Suppliers.

- D. Work completed as estimated shall be an estimate only and no inaccuracy or error in said estimate shall operate to release CONTRACTOR or Surety from any damages arising from such Work or from enforcing each and every provision of this Agreement, and the City shall have the right subsequently to correct any error made in any estimate for payment.
- E. CONTRACTOR SHALL NOT BE ENTITLED TO HAVE ANY PAYMENT ESTIMATES PROCESSED OR BE ENTITLED TO HAVE ANY PAYMENT FOR WORK PERFORMED SO LONG AS ANY LAWFUL OR PROPER DIRECTION CONCERNING WORK, OR ANY PORTION THEREOF, GIVEN BY THE CITY OR ENGINEER SHALL REMAIN UNCOMPLIED WITH BY THE CONTRACTOR.
- F. The City has discretion to require from the CONTRACTOR any of the following information with the application for payment:
1. Certified payroll covering the period of the prior application for payment;
 2. Unconditional waivers and releases from all Subcontractors/suppliers for which payment was requested under the prior application(s) for payment;
 3. Receipts or bills of sale for any items.
 4. Signature of the Inspector, confirming that the maintenance of the Record Drawings is being kept up-to-date, and that the Record Drawings are not being used as a construction set.
- G. NO PAYMENT BY THE CITY HEREUNDER SHALL BE INTERPRETED TO IMPLY THAT THE CITY HAS INSPECTED, APPROVED, OR ACCEPTED ANY PART OF THE WORK. The final payment of **5%** of the value of the Work done under this Agreement, if unencumbered, shall be made within **55 days** after the City records the Notice of Completion. ACCEPTANCE WILL BE MADE ONLY BY ACTION OF THE ESCONDIDO CITY COUNCIL.
- H. Payments for Change Order items can be included into the monthly progress payments, only after the Change Order has been fully executed and approved by the CITY and the CONTRACTOR, and only to the extent that Change Order Work has been performed.
- I. The value of materials stored at the Site shall be an amount based upon the value of all acceptable materials and equipment not incorporated in the Work but delivered and suitably stored at the Site or at another location agreed to in writing; provided, each such individual item has a value of more than \$5,000 and will become a permanent part of the Work. The Application for Payment shall also be accompanied by a bill of sale, invoice, or other documentation warranting that the CONTRACTOR has received the materials and equipment free and clear of all Liens and evidence that the materials and equipment are covered by appropriate property insurance and other arrangements to protect the City's interest therein, all of which will be satisfactory to the City.
- J. Unless otherwise provided, on or before making request for final payment of the undisputed amount due under the Agreement, CONTRACTOR shall submit to the City, in writing a summary of all claims for compensation under or arising out of this Agreement which were timely submitted. The acceptance by CONTRACTOR of the payment of the final amount shall constitute a waiver of all claims against the City under or arising out of this Agreement, except those previously made, in a timely manner and in writing, and identified by CONTRACTOR as unsettled at the time of CONTRACTOR's final request for payment.

K. Materials included in the progress payments shall be stored properly and protected as required to prevent damage, including but not limited to, rust, dents, scratches, and decay. Materials stored on-site and subject to payment, shall be gated and secured to prevent theft and/or vandalism. When the CONTRACTOR requests payment for materials not incorporated in the Work, the following terms and conditions shall apply:

1. For permanent materials delivered to the project site, or stored in an approved location off-site, an allowance of one-hundred percent (100%) of the material costs plus freight charges as invoiced may be made. The allowance will be based upon validated invoices or bills for such materials, including freight charges, and a copy thereof shall be made a part of the documented records for the project. All permanent materials approved for payment will have been tested by the City for compliance with the requirements of the Project Documents. Payment will only be made for permanent materials that conform to the requirements of the Project Documents.
2. No allowance shall be made for fuels, form lumber, falsework, temporary structures or other materials of any kind that will not become an integral part of the finished contraction.
3. All permanent materials, for which an allowance is requested, shall be stored in an approved manner where damage is not likely to occur. If any of the stored materials are lost or become damaged in any manner, CONTRACTOR shall be responsible for repairing or replacement of such damaged materials. The value of the lost or damaged materials shall be deducted from the CONTRACTOR's subsequent progress payments until replacement has been accomplished.
4. Permanent materials, for which payment has been made, either wholly or partially, shall not be removed from the approved location until such time that it is incorporated into the Work, unless approved by the City and/or the Engineer.
5. The following must accompany the written request for payment of stored materials:
 - a. Consent of the Surety specifying the material type and the bid items in which the material is to be used.
 - b. Validating invoices showing that payment for the material has been made.
 - c. A written statement from CONTRACTOR attesting that the invoices, as submitted do not include charges and/or fees for placing, handling, erecting or any other charges and/or markups other than the actual material cost, sales tax if applicable, and freight charges.
 - d. Bill of lading showing delivery of the material.
 - e. Inspection test reports, and certifications if required by the Contract Documents.
 - f. CONTRACTOR shall obtain a negotiable warehouse receipt, endorsed over to the City for materials and/or equipment stored in an off-site warehouse.
 - g. Certificate of insurance clearly indicating that the materials or equipment is fully insured against theft, fire, vandalism, malicious mischief, as well as other coverage required under the Project Documents.
6. Nothing in these General Conditions shall be interpreted as requiring the City to pay for stored materials. The City shall decide on a case-by-case basis whether stored materials can be paid for. Some factors the City will consider are:

CONTRACTOR's ability to meet the Project Schedule and milestones, the effectiveness of CONTRACTOR's quality control plan, how record drawings are being maintained and kept up, the status of the material submittals, and the on-going cleanliness of the Project and the Project Site. No payment will be made for stored materials that have not been submitted and accepted.

7. If the permanent materials are stored off-site, CONTRACTOR must pay the City's representative's transportation and lodging to see the permanent materials.
8. Full title to the materials and/or equipment shall vest with the City at the time of delivery to the site, warehouse or other storage location.

14.2 UNIT PRICE BID SCHEDULE. Progress payments on account of unit price Work will be based on the number of units completed as determined by the City and/or its representative.

14.3 SCHEDULE OF VALUES (LUMP SUM PRICE BREAKDOWN)

A. CONTRACTOR shall furnish on a form approved by the City:

1. Within **10 days** of award of the contract and commensurate with the specification section entitled **CONSTRUCTION SCHEDULES**, provide a detailed preliminary estimate giving a complete breakdown of contract price for each area of the project and/or site, which shall include all Subcontractor/supplier agreements showing the dollar amounts of these agreements to justify the schedule of values, and showing separate line items for the material cost(s) and installation cost(s).
2. A periodical itemized estimate of Work done for purpose of making partial payments thereon, that is until the cost loaded CPM construction schedule has been developed (if required by the Contract).
3. Within **10 days** of a request by City, a schedule of estimated monthly payments which shall be due CONTRACTOR under the **Agreement**.

B. Values employed in making up any of these schedules are subject to the City's written approval and will be used only for determining the basis of partial payments and will not be considered as fixing a basis for additions to or deductions from contract price.

1. Unless otherwise agreed in writing, payment for CONTRACTOR's mobilization costs shall be cost loaded as follows:

Mobilization Payment Schedule	
Upon Mobilization	50% of Mobilization item may be billed for bonding, insurance and yard set-up costs
25%	10% of Mobilization item may be billed
50%	10% of Mobilization item may be billed
75%	10% of Mobilization item may be billed
100% (clean up completed)	20% remaining to pay for de mobilization

14.4 ALLOWANCES

A. The following costs shall be included in all allowances;

1. Cost of the product to CONTRACTOR or Subcontractor, less applicable trade discounts.
2. Delivery to the site.

3. Applicable taxes.
- B. CONTRACTOR costs included in the Contract Sum include, but are not limited to;
1. Arrangement of product(s) shipping and handling at site, including unloading, uncrating, and storage.
 2. Protection of products from the elements and from damage.
 3. Labor for installation, adjustments and finishing products.
 4. Product warranties.
 5. Scheduling changes and updates.
 6. Other expenses required to complete installation.
 7. CONTRACTOR and Subcontractor(s) overhead and profit.
- C. The adjustments in costs will be made if the net cost is more or less than the specified amount of the allowance. The net cost of the adjustment shall be the amount of the difference between the specified allowance and the actual cost of the material, with the exception of a not-to-exceed fifteen percent (15%) mark-up for overhead and profit. The Contract Sum will be adjusted by Change Order.
1. Submit any claims for anticipated additional costs, or other expenses caused by the selection of the allowance, prior to execution of the Work.
 2. Submit documentation for actual additional costs, or other expenses caused by the selection the allowance, prior to execution of the Work.
 3. Failure to submit claims within the designated time will constitute a waiver of claims for additional costs.
- D. City may separately bid the materials, subject to the specified allowances. The successful bidder will be assigned to CONTRACTOR, and shall be considered a Subcontractor to the CONTRACTOR. Upon assignment, the CONTRACTOR shall all make the necessary submittals, prepare necessary shop drawings and coordinate all related Work. CONTRACTOR shall make all necessary adjustments and revisions to the Project Schedule for such allowances and Subcontractor assignments.

14.5 WAIVER, CONDITIONAL RELEASE, RELEASE OF CLAIMS

- A. Commensurate with the statutes of Public Contract Code section 7100 et seq., provisions in public works contracts with public entities which provide that acceptance of a payment otherwise due a CONTRACTOR is a waiver of all claims against the public entity arising out of the Work performed under the contract or which condition the right to payment upon submission of a release by the CONTRACTOR of all claims against the public entity arising out of performance of the public Work are against public policy and null and void. This section shall not prohibit a public entity from placing in a public works contract and enforcing a contract provision which provides that payment of undisputed contract amounts is contingent upon the CONTRACTOR furnishing the public entity with a release of all claims against the public entity arising by virtue of the public works contract related to those amounts. The CONTRACTOR from the operation of the release may specifically exclude disputed contract claims in stated amounts.
- B. Neither the City nor original CONTRACTOR by any term of their contract, or otherwise, shall waive, affect, or impair the claims and liens of other persons whether with or without notice except by their written consent, and any term of the contract to that effect

shall be null and void. Any written consent given by any claimant pursuant to this subdivision shall be null, void, and unenforceable unless and until the claimant executes and delivers a waiver and release. Such a waiver and release shall be binding and effective to release the City, construction lender, and surety on a payment bond from claims and liens only if the waiver and release follows substantially one of the forms set forth in this section and is signed by the claimant or his or her authorized agent, and, in the case of a conditional release, there is evidence of payment to the claimant. Evidence of payment may be by the claimant's endorsement on a single or joint payee check that has been paid by the bank upon which it was drawn or by written acknowledgment of payment given by the claimant.

- C. No oral or written statement purporting to waive, release, impair or otherwise adversely affect a claim is enforceable or creates any estoppel or impairment of a claim unless:
 - 1. It is pursuant to a waiver and release prescribed herein, or
 - 2. The claimant had actually received payment in full for the claim.
- D. This section does not affect the enforceability of either an accord and satisfaction regarding a bona fide dispute or any agreement made in settlement of an action pending in any court provided the accord and satisfaction or agreement and settlement make specific reference to the, stop notice, or bond claims.
- E. The waiver and release given by any claimant hereunder shall be null, void, and unenforceable unless it follows substantially the following forms in the following circumstances. Each waiver in this provision shall contain the following language, in at least as large a type as the largest type otherwise on the document:

-ARTICLE CONTINUES ON NEXT PAGE -

1. Where the claimant is required to execute a waiver and release in exchange for, or in order to induce the payment of, a progress payment and the claimant is not, in fact, paid in exchange for the waiver and release or a single payee check or joint payee check is given in exchange for the waiver and release, the waiver and release shall follow substantially the form:

CONDITIONAL WAIVER AND RELEASE UPON "PROGRESS PAYMENT"

Upon receipt by the undersigned of a check from: _____
(Maker of Check)
in the sum of \$ _ payable to: _____ (Amount of Check)
(Payee or Payees of Check)

and when the check has been properly endorsed and has been paid by the bank upon which it is drawn, this document shall become effective to release any mechanic's lien, stop notice, or bond right the undersigned has on the job of

_____ located at: _____
(CITY) (Job Description)

to the following extent. This release covers a progress payment for labor, services, equipment, or material furnished to

_____ through: _____
(Your Customer) (Date)

only and does not cover any retention's retained before or after the release date; extras furnished before the release date for which payment has not been received; extras or items furnished after the release date. Rights based upon Work performed or items furnished under a written change order which has been fully executed by the parties prior to the release date are covered by this release unless specifically reserved by the claimant in this release. This release of any mechanic's lien, stop notice, or bond right shall not otherwise affect the contract rights, including rights between parties to the contract based upon a rescission, abandonment, or breach of the contract, or the right of the undersigned to recover compensation for furnished labor, services, equipment, or material covered by this release if that furnished labor, services, equipment, or material was not compensated by the progress payment. Before any recipient of the document relies on it, said party should verify evidence of payment to the undersigned.

_____ (Company Name) _____ (Date)

By: _____
(Title)

Exclusions: Listing of Claims, of which Notice has been given:

1. Claim for: _____ In the amount of: \$ _____
2. Claim for: _____ In the amount of: \$ _____
3. Claim for: _____ In the amount of: \$ _____
4. Claim for: _____ In the amount of: \$ _____
5. Claim for: _____ In the amount of: \$ _____

- 2. Where the claimant is required to execute a waiver and release in exchange for, or in order to induce payment of, a progress payment and the claimant asserts in the waiver it has, in fact, been paid the progress payment, the waiver and release shall follow substantially the following form:

UNCONDITIONAL WAIVER AND RELEASE UPON "PROGRESS PAYMENT"

The undersigned has been paid and has received a progress payment in the sum of \$ _____ for labor, services, equipment, or material furnished to

(Your Customer)

on the job of: _____ located at: _____
(CITY) (Job Description)

and does hereby release any mechanic's lien, stop notice, or bond right that the undersigned has on the above referenced job to the following extent. This release covers a progress payment for labor, services, equipment, or materials furnished to

_____ through: _____
(Your Customer) (Date)

only and does not cover any retention's retained before or after the release date; extras furnished before the release date for which payment has not been received; extras or items furnished after the release date. Rights based upon Work performed or items furnished under a written change order which has been fully executed by the parties prior to the release date are covered by this release unless specifically reserved by the claimant in this release. This release of any mechanic's lien, stop notice, or bond right shall not otherwise affect the contract rights, including rights between parties to the contract based upon a rescission, abandonment, or breach of the contract, or the right of the undersigned to recover compensation for furnished labor, services, equipment, or material covered by this release if that furnished labor, services, equipment, or material was not compensated by the progress payment.

(Company Name) (Date)

By: _____
(Title)

Exclusions: Listing of Claims, of which Notice has been given:

- 1. Claim for: _____ In the amount of: \$ _____
- 2. Claim for: _____ In the amount of: \$ _____
- 3. Claim for: _____ In the amount of: \$ _____
- 4. Claim for: _____ In the amount of: \$ _____
- 5. Claim for: _____ In the amount of: \$ _____

"NOTICE: THIS DOCUMENT WAIVES RIGHTS UNCONDITIONALLY AND STATES THAT YOU HAVE BEEN PAID FOR GIVING UP THOSE RIGHTS. THIS DOCUMENT IS ENFORCEABLE AGAINST YOU IF YOU SIGN IT, EVEN IF YOU HAVE NOT BEEN PAID. IF YOU HAVE NOT BEEN PAID, USE A CONDITIONAL RELEASE FORM."

- 3. Where the claimant is required to execute a waiver and release in exchange for, or in order to induce the payment of, a final payment and the claimant is not, in fact, paid in exchange for the waiver and release or a single payee check or joint payee check is given in exchange for the waiver and release, the waiver and release shall follow substantially the form:

CONDITIONAL WAIVER AND RELEASE UPON "FINAL PAYMENT"

Upon receipt by the undersigned of a check from _____

in the sum of \$ _____ payable to: _____

and when the check has been properly endorsed and has been paid by the bank upon which it is drawn, this document shall become effective to release any mechanic's lien, stop notice, or bond right the undersigned has on the job of

_____ located at: _____
(CITY) (Job Description)

This release covers the final payment to the undersigned for all labor, services, equipment, or material furnished on the job, except for disputed claims for additional Work in the amount of \$ _____

Before any recipient of this document relies on it, the party should verify evidence of payment to the undersigned.

(Company Name) (Date)

By: _____
(Title)

Exclusions: Listing of Claims, of which Notice has been given:

- 1. Claim for: _____ In the amount of: \$ _____
- 2. Claim for: _____ In the amount of: \$ _____
- 3. Claim for: _____ In the amount of: \$ _____
- 4. Claim for: _____ In the amount of: \$ _____
- 5. Claim for: _____ In the amount of: \$ _____

- 4. Where the claimant is required to execute a waiver and release in exchange for, or in order to induce payment of, a final payment and the claimant asserts in the waiver it has, in fact, been paid the final payment, the waiver and release shall follow substantially the form:

UNCONDITIONAL WAIVER AND RELEASE UPON "FINAL PAYMENT"

The undersigned has been paid in full for all labor, services, equipment or material

furnished to: _____
(Your Customer)

on the job of: _____ located at: _____
(CITY) (Job Description)

and does hereby waive and release any right to a mechanic's lien, stop notice, or any right against a labor and material bond on the job, except for disputed claims for extra Work in the amount of \$ _____.

(Company Name) (Date)

By: _____
(Title)

Exclusions: Listing of Claims, of which Notice has been given:

- 1. Claim for: _____ In the amount of: \$ _____
- 2. Claim for: _____ In the amount of: \$ _____
- 3. Claim for: _____ In the amount of: \$ _____
- 4. Claim for: _____ In the amount of: \$ _____
- 5. Claim for: _____ In the amount of: \$ _____

"NOTICE: THIS DOCUMENT WAIVES RIGHTS UNCONDITIONALLY AND STATES THAT YOU HAVE BEEN PAID FOR GIVING UP THOSE RIGHTS. THIS DOCUMENT IS ENFORCEABLE AGAINST YOU IF YOU SIGN IT, EVEN IF YOU HAVE NOT BEEN PAID. IF YOU HAVE NOT BEEN PAID, USE A CONDITIONAL RELEASE FORM."

14.6 RETENTION. The City shall retain 5% percent of the estimated value of the Work done as part security for the fulfillment of the CONTRACT by the CONTRACTOR.

14.7 SUBSTITUTION OF SECURITIES, ESCROW ACCOUNT

- A. Pursuant to the requirements of Public Contract Code Section 22300, upon CONTRACTOR's request, the City will make payment to CONTRACTOR of any earned retention funds withheld from payments under this Agreement if CONTRACTOR deposits with the City or in escrow with a California or federally chartered bank acceptable to the City, securities eligible for the investment pursuant to Government Code Section 16430 or bank or savings and loan certificates of deposit, upon the following conditions:
1. CONTRACTOR shall be the beneficial owner of any securities substituted for monies withheld and shall receive any interest thereon.
 2. All expenses relating to the substitution of securities under Section 22300 and under this Article, including, but not limited to the City's overhead and administrative expenses, and expenses of the escrow agent shall be the responsibility of the CONTRACTOR.
 3. If CONTRACTOR shall choose to enter into an escrow agreement, such agreement form shall be provided by the City upon request, and which shall allow for the conversion to cash to provide funds to meet defaults by the CONTRACTOR including, but not limited to, termination of the CONTRACTOR's control over the Work, stop notices filed pursuant to law, assessment of liquidated damages or amounts to be kept or retained under the provisions of the Project Documents.
 4. Securities, if any, shall be returned to CONTRACTOR only upon satisfactory completion of the Agreement.
- B. To minimize the expense caused by such substitution of securities, CONTRACTOR shall, prior to or at the time CONTRACTOR requests to substitute security, deposit sufficient security to cover the entire amount to be then withheld and to be withheld under the General Conditions of this Agreement. Should the value of such substituted security at any time fall below the amount for which it was substituted, or any other amount which the City determines to withhold, CONTRACTOR shall immediately and at CONTRACTOR's expense deposit additional security qualifying under Section 22300 until the total security deposited is no less than equivalent to the amount subject to withholding under the Agreement.
- C. In the alternative, under Section 22300, the CONTRACTOR may request City to make payment of earned retentions directly to the escrow agent at the expense of the CONTRACTOR. Also at the CONTRACTOR's expense, the CONTRACTOR may direct investment of the payments in securities, and the CONTRACTOR shall receive interest earned on such investment upon the same conditions as provided for securities deposited by CONTRACTOR. Upon satisfactory completion of the contract, CONTRACTOR shall receive from the escrow agent all securities, interest and payments received by escrow agent from the City pursuant to the terms of Section 22300. If CONTRACTOR elects to receive interest on monies withheld in retention by the City, CONTRACTOR shall, at the request of any subcontractor, make that option available to the subcontractor regarding any monies withheld in retention by the CONTRACTOR from the subcontractor. If the CONTRACTOR elects to receive any interest on any monies withheld in retention by the City, then the subcontractor shall receive the identical rate of interest received by the

Contractor on any retention monies withheld from the subcontractor by the CONTRACTOR, less any actual pro rata costs associated with administering and calculating that interest. In the event the interest rate is a fluctuating rate, the rate for the subcontractor shall be determined by calculating the interest rate paid during the time that retentions were withheld from the subcontractor. If the CONTRACTOR elects to substitute securities in lieu of retention, then, by mutual consent of the CONTRACTOR and subcontractor, the subcontractor may substitute securities in exchange for the release of monies held in retention by CONTRACTOR. This shall apply only to those subcontractors performing more than five percent (5%) of the CONTRACTOR's total bid. The CONTRACTOR shall not require any subcontractor to waive any provision of this section.

- D. If any provision of this Article shall be found to be illegal or unenforceable, then, notwithstanding, the remainder of this Article shall remain in full force and effect, and only such provision shall be deemed stricken.

14.8 CONTRACTOR'S WARRANTY OF TITLE, ASSIGNMENT OF ANTITRUST ACTIONS.

- A. Public Contract Code Section 7103.5 provides:

1. In entering into a public works contract or a subcontract to supply goods, services, or materials pursuant to a public works contract, the CONTRACTOR or Subcontractor offers and agrees to assign to the awarding body (the City) all rights, title, and interest in and to all causes of action it may have under Section 4 of the Clayton Act (15 U.S.C. Section 15) or under the Cartwright Act (Chapter 2 (commencing with Section 16700) of Part 2 of Division 7 of the Business and Professions Code), arising from purchases of goods, services, or materials pursuant to the public works contract or the subcontract. This assignment shall be made and become effective at the time the awarding body tenders final payment to the CONTRACTOR, without further acknowledgment by the parties.
2. CONTRACTOR, for itself and all Subcontractors, agrees to assign to the City all rights, title, and interest in and to all such causes of action CONTRACTOR and all Subcontractors may have under the Agreement. This assignment shall become effective at the time the City tenders final payment to the CONTRACTOR, and CONTRACTOR shall require assignments from all Subcontractors to comply herewith.

14.9 REVIEW OF APPLICATIONS FOR PROGRESS PAYMENT

- A. The City's designee will, within **7 days** after receipt of each Application for Payment, either indicate approval by counter-signature on the application for progress payment, or return the application to the CONTRACTOR indicating in writing the City's reasons for refusing to recommend payment. In the latter case, the CONTRACTOR may make the necessary corrections and resubmit the application. **30 days** after presentation of the Application for Payment with the City's recommendation, the amount recommended will become due and when due, will be paid by the City to the CONTRACTOR.
- B. The City may withhold a sufficient amount or amounts of any payment or payments otherwise due to CONTRACTOR, as in its judgment may be necessary to cover:
1. Payments which may be past due and payable for just claims against CONTRACTOR or any Subcontractors, or against and about the performance of Work on the Project.
 2. The cost of defective or incomplete or damaged Work which CONTRACTOR has not remedied.

3. Liquidated damages assessed against CONTRACTOR.
4. Penalties for violation of labor laws.
5. The cost of materials ordered by the City pursuant to Article 13.
6. The cost of completion of this Agreement if there exists a reasonable doubt that this Agreement can be completed for the balance then unpaid to CONTRACTOR.
7. Damage caused by CONTRACTOR to another contractor.
8. Site clean-up provided by the City (or others on contract to the city) on behalf of the CONTRACTOR for failure of the CONTRACTOR to provide timely and adequate clean up as required by the Project Documents, in the opinion of the City.
9. Payments to indemnify, defend, or hold harmless the City.
10. Any payments due to the City including but not limited to payments for failed tests, utilities or imperfections.
11. Extra services for the Engineer, including but not limited to, services rendered in the evaluation of CONTRACTOR substitution requests, Requests For Information (RFI's), Change Order Requests (COR's) and Claims.
12. Extra services for the INSPECTOR including but not limited to re-inspection required due to CONTRACTOR's failed tests or installation of unapproved or defective materials and CONTRACTOR's requests for inspection and CONTRACTOR's failure to attend the inspection, and Work performed after regular Work hours, or during weekend and/or holidays.
13. Stop Notices/Liens have been filed in connection with the Work and the City has exercised its discretion to not accept a specific Bond intended to discharge of such Liens.
14. Claims by third party entities and/or individuals.
15. Persistent failure to comply with directions given to perform.
16. Costs and/or damages resulting from delay, termination and/or other causes which increase or which may increase the City's costs in administering the contract.
17. There are other items entitling the City to a set-off against the amount recommended.

The City must give the CONTRACTOR written notice stating the reasons for such action and pay the CONTRACTOR in the next application for progress payment, the amount so withheld, or any adjustment thereto agreed to by the City and CONTRACTOR, when CONTRACTOR corrects to the City's satisfaction the reason for such action.

- C. If the above grounds are in the opinion of the City removed by or at the expense of CONTRACTOR, payment shall be made for amounts withheld because of them.
- D. **PAYMENTS WITHHELD.** The City may apply such withheld amount or amounts to payment of such claims or obligations at its discretion. In so doing, the City shall make such payments on behalf of CONTRACTOR. If any payment is so made by the City, then such amount shall be considered as a payment made under contract by the City to CONTRACTOR and the City shall not be liable to CONTRACTOR for such payments

made in good faith. Such payments may be made without prior judicial determination of claim or obligations. The City will render CONTRACTOR an accounting of such funds disbursed on behalf of CONTRACTOR. To minimize/avoid claims of interference and/or that proposed payment was improper, the City shall endeavor to communicate to CONTRACTOR as to the CONTRACTOR's opinion regarding any proposed payment to a third party individual/entity, prior to City making the same. If CONTRACTOR fails to respond in writing detailing the reason(s) for making any such payment within two (2) working days, City shall have the right, but not the duty, to make any such payment without concern that CONTRACTOR will later claim such payment was improper and/or interfered with CONTRACTOR's relationship and/or prospective economic advantage. In such event, all such claims by CONTRACTOR shall be deemed waived.

- E. As an alternative to payment of such claims or obligations, the City, in its sole discretion, may reduce the total contract price as provided in the Article 13.

14.10 PARTIAL OCCUPATION /UTILIZATION

- A. The City reserves the right to occupy buildings and/or portions of the site at any time before completion, and such occupancy shall not constitute final acceptance of any part of Work covered by this Agreement, nor shall such occupancy extend the date specified for completion of the Work, nor shall any such occupancy affect any liquidated damages. The City shall have the right to utilize or place into service any item of equipment or other usable portion of the Work prior to completion of the Work. Whenever the City plans to exercise said right, the CONTRACTOR will be notified in writing by the City, identifying the specific portion or portions of the Work to be so utilized or otherwise placed into service.
- B. It shall be understood by the CONTRACTOR that until such written notification is issued, all responsibility for care and maintenance of all of the Work shall be borne by the CONTRACTOR. Upon issuance of said written notice of Partial Utilization, the City will accept responsibility for the protection and maintenance of all such items or portions of the Work described in the written notice.
- C. The CONTRACTOR shall retain full responsibility for satisfactory completion of the Work, regardless of whether a portion thereof has been partially utilized by the City, and the CONTRACTOR's **1 year** correction period shall commence only after the date of Project Completion for the entire Work.

14.11 PROJECT COMPLETION

- A. The City shall accept completion of the Agreement and have the Notice of Completion recorded when the entire Work including CONTRACTOR's Punch List(s) and City's final review comments shall have been completed to the satisfaction of the City. The Work may only be accepted as complete by action of the Escondido City Council. Completion means final completion, and the concept of substantial completion shall not apply to this Agreement.

- B. However, the City, at its sole option, may accept completion of the Agreement and have the Notice of Completion recorded when the entire Work including individual portions of the Work shall have been completed to the satisfaction of the City, except for minor corrective items, as distinguished from incomplete items.
- C. A final walk through of the Project to determine completion of the Agreement and to record the Notice of Completion shall occur only upon a valid claim by CONTRACTOR that the Project is complete except for minor corrective items. Any erroneous claims of completion by CONTRACTOR resulting in a premature walk through shall be at CONTRACTOR's sole cost and expense and the City shall make adjustments to the Contract Price by reducing the amount thereof to pay for any costs incurred by the City due to the erroneous claims by the CONTRACTOR that the Project is complete. Minor corrective items shall be identified in the final walk through of the Project.
- D. If the CONTRACTOR fails to complete the minor corrective items prior to the expiration of the **35 day** period immediately following recording of the Notice of Completion, the City shall withhold from the final payment an amount equal to twice the estimated cost, as determined by the City, of each item until such time as the item is completed. At the end of such **35 day** period, if there are items remaining to be corrected, the City may elect to proceed as provided in the Article 13.

14.12 FINAL APPLICATION FOR PAYMENT. After the CONTRACTOR has completed all of the Work, the punch-list, and delivered all maintenance and operating instructions, schedules, guarantees, Bonds, certificates of inspection, marked-up as-built record documents and other documents, all as required by the Project Documents, and after the Engineer and the City have indicated that the Work is acceptable, the CONTRACTOR may make application for final payment following the procedure for progress payments. The final Application for Payment shall be accompanied by all documentation called for in the Contract Documents, together with complete and legally effective unconditional waiver releases (Reference Article 14.5) by CONTRACTOR and all SUBCONTRACTORS/suppliers that filed preliminary notices of all previous progress payments, conditional waiver and release upon "final payment", and waivers or releases of all Liens arising out of or filed in connection with the Work.

14.13 FINAL PAYMENT AND ACCEPTANCE

- A. If, on the basis of the City's observation of the Work during construction and final inspection, and the City's review of the final Application for Payment and accompanying documentation, all as required by the Contract Documents, the City is satisfied that the Work has been completed and the CONTRACTOR's other obligations under the Contract Documents have been fulfilled, the City designee will recommend payment of the final application for progress payment.
- B. After acceptance of the Work by the Escondido City Council, the City will make final disposition to the CONTRACTOR of the amount remaining after deducting all prior payments and all amounts to be kept or retained under the provisions of the Contract Documents, including the following items:
 - 1. Liquidated damages, as applicable; and
 - 2. Amounts withheld by the City under Article 14.9.B. which have not been released.
- C. As a condition of final payment, the CONTRACTOR shall be required to execute a release releasing the City from any and all claims of liability for payment on the Project except for such amounts as may be specifically described and excluded from the release.

- 14.14 RELEASE OF RETENTION AND OTHER DEDUCTIONS. After recording the Notice of Completion with the San Diego County Recorder's Office to initiate the Lien period, and not more than **55 calendar days** thereafter, the City will release to the CONTRACTOR the retention funds withheld pursuant to the Agreement, less any deductions to cover pending claims against the City.

ARTICLE 15 – SUSPENSION OF WORK AND TERMINATION

15.1 CITY'S RIGHT TO TERMINATE AGREEMENT

- A. If the CONTRACTOR refuses or fails to complete the Work or any separable part thereof with such diligence as will ensure its completion within the time specified or any extension thereof, or fails to complete said Work within such time, or if the CONTRACTOR should file a petition for relief as a debtor, or should relief be ordered against CONTRACTOR as a debtor under Title 11 of the United States Code, or if CONTRACTOR should make a general assignment for the benefit of its creditors, or if a receiver should be appointed on account of its insolvency, or if it should refuse or should fail to supply enough properly skilled workers or proper materials to complete the Work in the time specified, or if CONTRACTOR should fail to make prompt payment to Subcontractors for materials or labor, or disregard laws or ordinances or instructions of the City, or if CONTRACTOR or its Subcontractors should otherwise violate any provision of this Agreement, including, but not limited to, the performance of defective Work, disregard or violate the Laws or Regulations of any public body having jurisdiction; disregard or violate provisions of the Contract Documents or City's instructions; fail to prosecute the Work according to the approved progress schedule; fail to provide a qualified superintendent, competent workmen, or materials or equipment meeting the requirements of the Contract Documents; or disregard the authority of the City, then the City may, without prejudice to any other right or remedy, serve written notice upon CONTRACTOR and its surety of City's intention to terminate this agreement. Such notice shall contain the reasons for such intention to terminate. Unless within **seven (7) days** after the service of such notice such condition shall cease or such violation shall cease and arrangements satisfactory to the City for the correction thereof have been made, this Agreement shall cease and terminate. In such case, CONTRACTOR shall not be entitled to receive any further payment until the Work is finished to the City's satisfaction.
- B. In the event of any such termination, the City shall immediately serve written notice thereof upon surety and CONTRACTOR, and surety shall have the duty to take over and perform this Agreement, provided, however, that if surety within **7 days** after service upon it of notice of termination does not give the City written notice of its intention to unqualifiedly by honor its duty to take over and perform this Agreement, or does not commence actual, on site performance thereof within **15 days** after service of the notice of termination by the City on surety, the City may take over the Work and prosecute it to completion by Agreement or by any other method it may deem advisable for the account and at the expense of CONTRACTOR, and CONTRACTOR and its surety shall be liable to the City for any excess cost or other damages, including the added time devised by City personnel and/or consultants, including attorneys, occasioned by the City thereby. Time is of the essence in this Agreement. If the City takes over the Work as herein above provided, the City may, without liability for so doing, take possession of and utilize in completing the Work such materials, supplies, equipment and other property belonging to the CONTRACTOR as may be on the site of the Work and necessary therefore.

- C. If the expense of finishing the Work, including compensation for additional engineering, architectural, managerial, legal, consulting, personnel, and administrative services, shall exceed the unpaid balance of the Agreement, CONTRACTOR and/or its surety shall pay the difference to the City. Expense incurred by the City as herein provided, and damage incurred through CONTRACTOR's default, shall be certified to City by the Engineer, or ARCHITECT if applicable. If the unpaid balance under the Agreement shall exceed the expense of finishing the Work, including compensation for additional architectural, managerial, legal, consulting, personnel, and administrative services, such excess shall be paid to CONTRACTOR or its creditor(s).
- D. If the CONTRACTOR fails to remedy the conditions constituting default within the time allowed, the City may then issue the notice of termination.
- E. In the event that sufficient funds are not appropriated to complete the Project or the City determines that sufficient funds are not available to complete the Project, the City may terminate or suspend the completion of the Project at any time by giving written notice to the CONTRACTOR. In the event that the City exercises this option, the City shall pay for any and all Work and materials completed or delivered onto the site, and the value of any and all Work then in progress and orders actually placed which cannot be canceled up to the date of notice of termination. The value of Work and materials paid for shall include a factor of fifteen percent (15%) for the CONTRACTOR's overhead and profit and there shall be no other costs or expenses paid to CONTRACTOR. All Work, materials and orders paid for pursuant to this provision shall become the property of the City. The City may, without cause, order CONTRACTOR in writing to suspend, delay or interrupt the Project in whole or in part for such period of time as the City may determine. Adjustment shall be made for increases in the cost of performance of the Agreement caused by suspense, delay or interruption.
- F. The foregoing provisions are in addition to and not in limitation of any other rights or remedies available to the City.

15.2 TERMINATION OF AGREEMENT BY THE CITY FOR CONVENIENCE

- A. Upon **7 days** written notice to the CONTRACTOR the City may, without cause and without prejudice to any other right or remedy of the City, elect to terminate the Agreement. In such case, the CONTRACTOR shall be paid (without duplication of any items):
 - 1. For completed and acceptable Work executed in accordance with the Contract Documents, prior to the effective date of termination, including fair and reasonable sums for overhead and profit of such Work;
 - 2. For expenses sustained prior to the effective date of termination in performing services and furnishing labor, materials, or equipment as required by the Contract Documents in connection with uncompleted Work, plus fair and reasonable sums for overhead and profit on such expenses;
 - 3. For all reasonable claims, costs, losses, and damages incurred in settlement of terminated contracts with Subcontractors, Suppliers, and others; and
 - 4. For reasonable expenses directly attributable to termination.
- B. CONTRACTOR shall not be paid on account of loss of anticipated profits or revenue or other economic loss arising out of or resulting from such termination.

ARTICLE 16 – CONSTRUCTION CLAIMS, WAIVER AND RELEASE FORMS, DISPUTES, FALSE CLAIMS ACT.

16.1 CONTRACTOR CLAIMS

- A. NOTICE. If the CONTRACTOR shall claim compensation for any damage sustained by reason of the acts of the City or its agents, or if the CONTRACTOR disagrees with the City's or Engineer's/Architect's decisions regarding a CONTRACTOR's Change Order Request (COR), the CONTRACTOR shall provide written "Notice" to the City **within 5 days** after sustaining of such damage, or being notified of an adverse decision, and provide within **14 days** of the event the factual basis supporting the claim (unless otherwise specified). The written "Notice" shall state the summary points for which the factual bases will support the claim and cite in detail the Project Documents (including plans and specifications) upon which the claim is to be based. CONTRACTOR's failure to notify the City within such a period shall be deemed a waiver and relinquishment of such a claim. If such notice is given within the specified time, the procedure for its consideration shall be as stated above in these General Conditions.
- B. WAIVER AND RELEASE FORMS. In addition, on or before the end of the month for which the claim has been filed, the CONTRACTOR shall also file with the City the **WAIVER AND RELEASE FORMS**, for which the claim and the amount of the claim is identified. If the claim is not indicated on the **WAIVER AND RELEASE FORMS**, CONTRACTOR's claim shall be forfeited and invalidated and it shall not be entitled to consideration for time or payment on account of any such claim.
- C. REQUIRED DOCUMENTATION FOR CLAIMS FOR TIME: Fragnet – Sometimes known as a "Sub-network". A Fragnet will be required for time impact analysis and time extensions. CONTRACTOR's failure to provide a "Notice of Delay" within **24 hours**, and submit a Fragnet for time impact analysis and time extension(s) on or within **14 days** of the delaying event, shall forfeit and invalidate all considerations for time and/or payment. The costs to prepare Fragnets and schedule updates resulting from approved Fragnets are part of the Work, regardless of number and difficulty. The City will provide a response to the Fragnet on or within **14 days** from the completed submission.
- D. Except for tort claims, all claims by the CONTRACTOR for a time extension, payment of money or damages arising from Work done by, or on behalf of, the CONTRACTOR pursuant to the Agreement and payment of which is not otherwise expressly provided for or the claimant is not otherwise entitled to, or as to the amount of payment which is disputed by the City of \$375,000 or less, is subject to the settlement and arbitration provisions procedures set forth in Public Contract Code Section 20104, et seq. The text of those provisions are provided in full in Article 17.
- E. All of the following claims by the CONTRACTOR are subject to the claim resolution procedures set forth in Public Contract Code Section 9204. The text of that section is provided in full in Article 17.
1. A time extension;
 2. Payment of money or damages arising from Work done by, or on behalf of, the CONTRACTOR pursuant to the Agreement and payment of which is not otherwise expressly provided for, or CONTRACTOR is not otherwise entitled to; and
 3. Payment of an amount that is disputed by the City.

- F. Any claim must be a separate demand sent by registered mail or certified mail with return receipt requested. The CONTRACTOR shall furnish reasonable documentation to support the claim, which shall include all of the materials described in Section 16.1.
- G. The City shall conduct a reasonable review of the claim within **45 days** and shall provide the CONTRACTOR a written statement identifying what portion of the claim is disputed and what portion is undisputed. The City and the CONTRACTOR may, by mutual agreement, extend the time period for response. Any payment due on an undisputed portion of the claim shall be processed and made within **60 days** after the City issues its written statement.
- H. If a subcontractor or a lower tier subcontractor lacks legal standing to assert a claim because of privity of contract does not exist, the CONTRACTOR may present a claim to the City on behalf of a subcontractor or lower tier subcontractor. A subcontractor may request in writing that the CONTRACTOR present a claim for work which was performed by the subcontractor or by a lower tier subcontractor on behalf of the subcontractor. The subcontractor requesting that the claim be presented to the City shall furnish reasonable documentation to support the claim, which shall include all of the materials described in Section 16.1. Within **45 days** of receipt of this written request, the CONTRACTOR shall notify the subcontractor in writing as to whether the CONTRACTOR presented the claim to the City. If the CONTRACTOR did not present the claim, the CONTRACTOR must provide the subcontractor with a statement of the reasons for not presenting the claim to the City.

16.2 DISPUTES –THE CITY'S AND ENGINEER'S DECISIONS

- A. If the CONTRACTOR disputes the City's written response to the claim, or if the City does not respond to the claim within the time prescribed, the CONTRACTOR may demand in writing an informal conference to meet and confer for settlement of the issues in dispute. The CONTRACTOR must send the demand by registered mail or certified mail, return receipt requested. Upon receipt, the City shall schedule a meet and confer conference within **30 days** for settlement of the dispute.
- B. If any portion of the claim remains in dispute after the meet and confer conference, the City shall provide the CONTRACTOR a written statement identifying the portion of the claim that remains in dispute and the portion that is undisputed within **10 business days** following the conclusion of the conference. Any payment due on an undisputed portion of the claim shall be processed and made within **60 days** after the City issues its written statement. Any disputed portion of the claim, as identified by the CONTRACTOR in writing, shall be submitted to nonbinding mediation. The City shall conduct a reasonable review of the claim within **45 days** and shall provide the CONTRACTOR a written statement identifying what portion of the claim is disputed and what portion is undisputed. The City and the CONTRACTOR may, by mutual agreement, extend the time period for response. Any payment due on an undisputed portion of the claim shall be processed and made within 60 days after the City issues its written statement.
- C. The City and CONTRACTOR shall mutually agree to a mediator within **10 business days** after the disputed portion of the claim has been identified in writing. The City and the CONTRACTOR shall share the associated costs of mediation equally. If the parties cannot agree upon a mediator, each party shall select a mediator and those mediators shall select a qualified neutral third party to mediate with regard to the disputed portion of the claim. Each party shall bear the fees and costs charged by its respective mediator in connection with the selection of the neutral mediator. If mediation is unsuccessful, the parts of the claim remaining in dispute shall be subject to applicable procedures outside Section 9204. The mediation

conducted shall excuse any further obligation under Section 20104.4 to mediate after litigation has been commenced.

D. Failure by the City to respond to a claim from the CONTRACTOR within the time periods described above or to otherwise meet the time requirements described above shall result in the claim being deemed rejected in its entirety.

E. Amounts not paid in a timely manner as outlined above will bear interest at 7% per year.

16.3 FALSE CLAIMS ACT CERTIFICATION. All claims submitted by the CONTRACTOR shall be accompanied by a notarized certificate containing the following language:

Under penalty perjury and with specific reference to the California False Claims Act, Government Code Section 12650 et. seq., the undersigned,

_____ (name)

_____ of (title)

_____ (company)

hereby certifies that the claim for the additional compensation and time, if any, made herein for the Work on this Contract is a true statement of the actual costs incurred or estimated future costs, and time sought, and is fully documented and supported under the Agreement.

Dated _____

/s/ _____

Subscribed and sworn before me this _____ day

of _____

Notary Public

My Commission Expires _____

Failure to submit the notarized certificate will be sufficient cause for denying the claim.

ARTICLE 17 – MISCELLANEOUS

17.1 GIVING NOTICE

A. Any notice from one party to the other or otherwise under the Agreement shall be in writing and shall be dated and signed by party giving such notice or by a duly authorized representative of such party. Any such notice shall not be effective for any purpose whatsoever unless served in one of the following manners, and copied to the City:

1. If notice is given to the City, by personal delivery thereof to the City or by deposit in the United States mail, enclosed in a sealed envelope addressed to the City, and sent by registered or certified mail with postage prepaid;
2. If notice is given to CONTRACTOR, by personal delivery thereof to said CONTRACTOR or to CONTRACTOR's superintendent at the site of the Project,

or by deposit in the United States mail, enclosed in a sealed envelope addressed to said CONTRACTOR at its regular place of business or at such address as may have been established for the conduct of Work under this Agreement, and sent by registered or certified mail with postage prepaid;

3. If notice is given to the surety or other persons, by personal delivery to such surety or other person or by deposit in the United States mail, enclosed in a sealed envelope, addressed to such surety or person at the address of such surety or person last communicated by the surety or other person to the party giving notice, and sent by registered or certified mail with postage prepaid.

- 17.2 **TITLE TO MATERIALS FOUND ON THE WORK.** The City reserves the right to retain title to all soils, stone, sand, gravel, and other materials developed and obtained from excavations and other operations connected with the Work. Unless otherwise specified in the Contract Documents, neither the CONTRACTOR nor any Subcontractor shall have any right, title, or interest in or to any such materials. The CONTRACTOR will be permitted to use in the Work, without charge, any such materials which meet the requirements of the Contract Documents.
- 17.3 **RIGHT TO AUDIT.** If the CONTRACTOR submits a claim to the City for additional compensation, the City shall have the right, as a condition to considering the claim, and as a basis for evaluation of the claim, and until the claim has been settled, to audit the CONTRACTOR's Documents and books to the extent they are relevant. This right shall include the right to examine books, records, documents, and other evidence and accounting procedures and practices, sufficient to discover and verify all direct and indirect costs of whatever nature claimed to have been incurred or anticipated to be incurred and for which the claim has been submitted. The right to audit shall include the right to inspect the CONTRACTOR's plant, or such parts thereof, as may be or have been engaged in the performance of the Work. The CONTRACTOR further agrees that the right to audit encompasses all subcontracts and is binding upon Subcontractors. The rights to examine and inspect herein provided for shall be exercisable through such representatives as the City deems desirable during the CONTRACTOR's normal business hours at the office of the CONTRACTOR. The CONTRACTOR shall make available to the City for auditing, all relevant accounting records and documents, and other financial data, and upon request, shall submit true copies of requested records to the City.
- 17.4 **SURVIVAL OF OBLIGATIONS.** All representations, indemnifications, warranties, and guaranties made in, required by or given in accordance with the Contract Documents, as well as all continuing obligations indicated in the Contract Documents, will survive final payment, completion and acceptance of the Work or termination or completion of the Agreement.
- 17.5 **CONTROLLING LAW.** This Agreement is to be governed by the law of the state of California, in which the Project is located, with venue in North San Diego County.
- 17.6 **SEVERABILITY.** If any term or provision of this Agreement is declared invalid or unenforceable by any court of lawful jurisdiction, the remaining terms and provisions of the Agreement shall not be affected thereby and shall remain in full force and effect.
- 17.7 **WAIVER.** The waiver by the City of any breach or violation of any term, covenant or condition of this Agreement or of any Agreement provision, ordinance, or law shall not be deemed to be a waiver of any other term, covenant, condition, ordinance, or law or of any subsequent breach or violation of the same or of any other term, covenant, condition, ordinance, or law. The subsequent payment of any monies or fee by the City which may become due hereunder shall not be deemed to be a waiver of any preceding breach or violation by CONTRACTOR or any term, covenant, condition of this Agreement or of any applicable law or ordinance.

- 17.8 PROHIBITED INTERESTS. No official of the City who is authorized in such capacity and on behalf of the City to negotiate, make, accept, or approve, or to take part in negotiating, making, accepting or approving any architectural, engineering, inspection, construction or material supply contract or any subcontract in connection with construction of the Project, shall become directly or indirectly interested financially in this Project or in any part thereof. No officer, employee, Engineer, attorney, architect or inspector of or for City who is authorized in such capacity and on behalf of the City to exercise any executive, supervisory or other similar functions in connection with construction of Project shall become directly or indirectly interested financially in this Project or in any part thereof. CONTRACTOR shall receive no compensation and shall repay the City for any compensation received by or from CONTRACTOR hereunder, should CONTRACTOR aid, abet or knowingly participate in violation of this Article.
- 17.9 California Public Contract Code § 9204. Legislative findings and declarations regarding timely and complete payment of contractors for public works projects; claims process.
- (a) The Legislature finds and declares that it is in the best interests of the state and its citizens to ensure that all construction business performed on a public works project in the state that is complete and not in dispute is paid in full and in a timely manner.
- (b) Notwithstanding any other law, including, but not limited to, Article 7.1 (commencing with Section 10240) of Chapter 1 of Part 2, Chapter 10 (commencing with Section 19100) of Part 2, and Article 1.5 (commencing with Section 20104) of Chapter 1 of Part 3, this section shall apply to any claim by a contractor in connection with a public works project.
- (c) For purposes of this section:
- (1) "Claim" means a separate demand by a contractor sent by registered mail or certified mail with return receipt requested, for one or more of the following:
- A. A time extension, including, without limitation, for relief from damages or penalties for delay assessed by a public entity under a contract for a public works project.
- B. Payment by the public entity of money or damages arising from work done by, or on behalf of, the contractor pursuant to the contract for a public works project and payment for which is not otherwise expressly provided or to which the claimant is not otherwise entitled.
- C. Payment of an amount that is disputed by the public entity.
- (2) "Contractor" means any type of contractor within the meaning of Chapter 9 (commencing with Section 7000) of Division 3 of the Business and Professions Code who has entered into a direct contract with a public entity for a public works project.
- (3) A. "Public entity" means, without limitation, except as provided in subparagraph B., a state agency, department, office, division, bureau, board, or commission, the California State University, the University of California, a city, including a charter city, county, including a charter county, city and county, including a charter city and county, district, special district, public authority, political subdivision, public corporation, or nonprofit transit corporation wholly owned by a public agency and formed to carry out the purposes of the public agency.
- B. "Public entity" shall not include the following:
- (i) The Department of Water Resources as to any project under the jurisdiction of that department.
- (ii) The Department of Transportation as to any project under the jurisdiction of that department.
- (iii) The Department of Parks and Recreation as to any project under the jurisdiction of that department.

- (iv) The Department of Corrections and Rehabilitation with respect to any project under its jurisdiction pursuant to Chapter 11 (commencing with Section 7000) of Title 7 of Part 3 of the Penal Code.
 - (v) The Military Department as to any project under the jurisdiction of that department.
 - (vi) The Department of General Services as to all other projects.
 - (vii) The High-Speed Rail Authority.
- (4) "Public works project" means the erection, construction, alteration, repair, or improvement of any public structure, building, road, or other public improvement of any kind.
- (5) "Subcontractor" means any type of contractor within the meaning of Chapter 9 (commencing with Section 7000) of Division 3 of the Business and Professions Code who either is in direct contract with a contractor or is a lower tier subcontractor.
- (d) (1) (A) Upon receipt of a claim pursuant to this section, the public entity to which the claim applies shall conduct a reasonable review of the claim and, within a period not to exceed 45 days, shall provide the claimant a written statement identifying what portion of the claim is disputed and what portion is undisputed. Upon receipt of a claim, a public entity and a contractor may, by mutual agreement, extend the time period provided in this subdivision.
- (B) The claimant shall furnish reasonable documentation to support the claim.
- (C) If the public entity needs approval from its governing body to provide the claimant a written statement identifying the disputed portion and the undisputed portion of the claim, and the governing body does not meet within the 45 days or within the mutually agreed to extension of time following receipt of a claim sent by registered mail or certified mail, return receipt requested, the public entity shall have up to three days following the next duly publicly noticed meeting of the governing body after the 45-day period, or extension, expires to provide the claimant a written statement identifying the disputed portion and the undisputed portion.
- (D) Any payment due on an undisputed portion of the claim shall be processed and made within 60 days after the public entity issues its written statement. If the public entity fails to issue a written statement, paragraph (3) shall apply.
- (2) (A) If the claimant disputes the public entity's written response, or if the public entity fails to respond to a claim issued pursuant to this section within the time prescribed, the claimant may demand in writing an informal conference to meet and confer for settlement of the issues in dispute. Upon receipt of a demand in writing sent by registered mail or certified mail, return receipt requested, the public entity shall schedule a meet and confer conference within 30 days for settlement of the dispute.
- (B) Within 10 business days following the conclusion of the meet and confer conference, if the claim or any portion of the claim remains in dispute, the public entity shall provide the claimant a written statement identifying the portion of the claim that remains in dispute and the portion that is undisputed. Any payment due on an undisputed portion of the claim shall be processed and made within 60 days after the public entity issues its written statement. Any disputed portion of the claim, as identified by the contractor in writing, shall be submitted to nonbinding mediation, with the public entity and the claimant sharing the associated costs equally. The public entity and claimant shall mutually agree to a mediator within 10 business days after the disputed portion of the claim has been identified in writing. If the parties cannot agree upon a mediator, each party shall select a mediator and those mediators shall select a qualified neutral third party to mediate with regard to the disputed portion of the claim. Each party shall bear the fees and costs charged by its respective mediator in connection

- with the selection of the neutral mediator. If mediation is unsuccessful, the parts of the claim remaining in dispute shall be subject to applicable procedures outside this section.
- (C) For purposes of this section, mediation includes any nonbinding process, including, but not limited to, neutral evaluation or a dispute review board, in which an independent third party or board assists the parties in dispute resolution through negotiation or by issuance of an evaluation. Any mediation utilized shall conform to the timeframes in this section.
 - (D) Unless otherwise agreed to by the public entity and the contractor in writing, the mediation conducted pursuant to this section shall excuse any further obligation under Section 20104.4 to mediate after litigation has been commenced.
 - (E) This section does not preclude a public entity from requiring arbitration of disputes under private arbitration or the Public Works Contract Arbitration Program, if mediation under this section does not resolve the parties' dispute.
- (3) Failure by the public entity to respond to a claim from a contractor within the time periods described in this subdivision or to otherwise meet the time requirements of this section shall result in the claim being deemed rejected in its entirety. A claim that is denied by reason of the public entity's failure to have responded to a claim, or its failure to otherwise meet the time requirements of this section, shall not constitute an adverse finding with regard to the merits of the claim or the responsibility or qualifications of the claimant.
- (4) Amounts not paid in a timely manner as required by this section shall bear interest at 7 percent per annum.
- (5) If a subcontractor or a lower tier subcontractor lacks legal standing to assert a claim against a public entity because privity of contract does not exist, the contractor may present to the public entity a claim on behalf of a subcontractor or lower tier subcontractor. A subcontractor may request in writing, either on his or her own behalf or on behalf of a lower tier subcontractor, that the contractor present a claim for work which was performed by the subcontractor or by a lower tier subcontractor on behalf of the subcontractor. The subcontractor requesting that the claim be presented to the public entity shall furnish reasonable documentation to support the claim. Within 45 days of receipt of this written request, the contractor shall notify the subcontractor in writing as to whether the contractor presented the claim to the public entity and, if the original contractor did not present the claim, provide the subcontractor with a statement of the reasons for not having done so.
- (e) The text of this section or a summary of it shall be set forth in the plans or specifications for any public works project that may give rise to a claim under this section.
 - (f) A waiver of the rights granted by this section is void and contrary to public policy, provided, however, that (1) upon receipt of a claim, the parties may mutually agree to waive, in writing, mediation and proceed directly to the commencement of a civil action or binding arbitration, as applicable; and (2) a public entity may prescribe reasonable change order, claim, and dispute resolution procedures and requirements in addition to the provisions of this section, so long as the contractual provisions do not conflict with or otherwise impair the timeframes and procedures set forth in this section.
 - (g) This section applies to contracts entered into on or after January 1, 2017.
 - (h) Nothing in this section shall impose liability upon a public entity that makes loans or grants available through a competitive application process, for the failure of an awardee to meet its contractual obligations.
 - (i) This section shall remain in effect only until January 1, 2020, and as of that date is repealed, unless a later enacted statute, that is enacted before January 1, 2020, deletes or extends that date.

17.10 California Public Contract Code § 20104. Application of article; provisions included in plans and specifications.

- (a) (1) This article applies to all public works claims of three hundred seventy-five thousand dollars (\$375,000) or less which arise between a contractor and a local agency.
- (2) This article shall not apply to any claims resulting from a contract between a contractor and a public agency when the public agency has elected to resolve any disputes pursuant to Article 7.1 (commencing with Section 10240) of Chapter 1 of Part 2.
- (b) (1) "Public work" means "public works contract" as defined in Section 1101 but does not include any work or improvement contracted for by the state or the Regents of the University of California.
- (2) "Claim" means a separate demand by the contractor for (A) a time extension, (B) payment of money or damages arising from work done by, or on behalf of, the contractor pursuant to the contract for a public work and payment of which is not otherwise expressly provided for or the claimant is not otherwise entitled to, or (C) an amount the payment of which is disputed by the local agency.
- (c) The provisions of this article or a summary thereof shall be set forth in the plans or specifications for any work which may give rise to a claim under this article.
- (d) This article applies only to contracts entered into on or after January 1, 1991.

17.11 California Public Contract Code § 20104.2. Claims; requirements; tort claims excluded.

For any claim subject to this article, the following requirements apply:

- (a) The claim shall be in writing and include the documents necessary to substantiate the claim. Claims must be filed on or before the date of final payment. Nothing in this subdivision is intended to extend the time limit or supersede notice requirements otherwise provided by contract for the filing of claims.
- (b) (1) For claims of less than fifty thousand dollars (\$50,000), the local agency shall respond in writing to any written claim within 45 days of receipt of the claim, or may request, in writing, within 30 days of receipt of the claim, any additional documentation supporting the claim or relating to defenses to the claim the local agency may have against the claimant.
- (2) If additional information is thereafter required, it shall be requested and provided pursuant to this subdivision, upon mutual agreement of the local agency and the claimant.
- (3) The local agency's written response to the claim, as further documented, shall be submitted to the claimant within 15 days after receipt of the further documentation or within a period of time no greater than that taken by the claimant in producing the additional information, whichever is greater.
- (c) (1) For claims of over fifty thousand dollars (\$50,000) and less than or equal to three hundred seventy-five thousand dollars (\$375,000), the local agency shall respond in writing to all written claims within 60 days of receipt of the claim, or may request, in writing, within 30 days of receipt of the claim, any additional documentation supporting the claim or relating to defenses to the claim the local agency may have against the claimant.
- (2) If additional information is thereafter required, it shall be requested and provided pursuant to this subdivision, upon mutual agreement of the local agency and the claimant.
- (3) The local agency's written response to the claim, as further documented, shall be submitted to the claimant within 30 days after receipt of the further documentation, or within a period of time no greater than that taken by the claimant in producing the additional information or requested documentation, whichever is greater.
- (d) If the claimant disputes the local agency's written response, or the local agency fails to respond within the time prescribed, the claimant may so notify the local agency, in writing, either within 15 days of receipt of the local agency's response or within 15 days of the local

agency's failure to respond within the time prescribed, respectively, and demand an informal conference to meet and confer for settlement of the issues in dispute. Upon a demand, the local agency shall schedule a meet and confer conference within 30 days for settlement of the dispute.

- (e) Following the meet and confer conference, if the claim or any portion remains in dispute, the claimant may file a claim as provided in Chapter 1 (commencing with Section 900) and Chapter 2 (commencing with Section 910) of Part 3 of Division 3.6 of Title 1 of the Government Code. For purposes of those provisions, the running of the period of time within which a claim must be filed shall be tolled from the time the claimant submits his or her written claim pursuant to subdivision (a) until the time that claim is denied as a result of the meet and confer process, including any period of time utilized by the meet and confer process.
- (f) This article does not apply to tort claims and nothing in this article is intended nor shall be construed to change the time periods for filing tort claims or actions specified by Chapter 1 (commencing with Section 900) and Chapter 2 (commencing with Section 910) of Part 3 of Division 3.6 of Title 1 of the Government Code.

17.12 California Public Contract Code § 20104.4. Civil action procedures; mediation and arbitration; trial de novo; witnesses.

The following procedures are established for all civil actions filed to resolve claims subject to this article:

- (a) Within 60 days, but no earlier than 30 days, following the filing or responsive pleadings, the court shall submit the matter to nonbinding mediation unless waived by mutual stipulation of both parties. The mediation process shall provide for the selection within 15 days by both parties of a disinterested third person as mediator, shall be commenced within 30 days of the submittal, and shall be concluded within 15 days from the commencement of the mediation unless a time requirement is extended upon a good cause showing to the court or by stipulation of both parties. If the parties fail to select a mediator within the 15-day period, any party may petition the court to appoint the mediator.
- (b)
 - (1) If the matter remains in dispute, the case shall be submitted to judicial arbitration pursuant to Chapter 2.5 (commencing with Section 1141.10) of Title 3 of Part 3 of the Code of Civil Procedure, notwithstanding Section 1141.11 of that code. The Civil Discovery Act (Title 4 (commencing with Section 2016.010) of Part 4 of the Code of Civil Procedure) shall apply to any proceeding brought under this subdivision consistent with the rules pertaining to judicial arbitration.
 - (2) Notwithstanding any other provision of law, upon stipulation of the parties, arbitrators appointed for purposes of this article shall be experienced in construction law, and, upon stipulation of the parties, mediators and arbitrators shall be paid necessary and reasonable hourly rates of pay not to exceed their customary rate, and such fees and expenses shall be paid equally by the parties, except in the case of arbitration where the arbitrator, for good cause, determines a different division. In no event shall these fees or expenses be paid by state or county funds.
 - (3) In addition to Chapter 2.5 (commencing with Section 1141.10) of Title 3 of Part 3 of the Code of Civil Procedure, any party who after receiving an arbitration award requests a trial de novo but does not obtain a more favorable judgment shall, in addition to payment of costs and fees under that chapter, pay the attorney's fees of the other party arising out of the trial de novo.
- (c) The court may, upon request by any party, order any witnesses to participate in the mediation or arbitration process.

17.13 California Public Contract Code § 20104.6. Payment on undisputed portion of claim; interest on arbitration awards or judgments.

- (a) No local agency shall fail to pay money as to any portion of a claim which is undisputed except as otherwise provided in the contract.
- (b) In any suit filed under Section 20104.4, the local agency shall pay interest at the legal rate on any arbitration award or judgment. The interest shall begin to accrue on the date the suit is filed in a court of law.



STAFF REPORT

March 15, 2024

File Number 0600-10; A-3504

SUBJECT

RANCHITO DRIVE SEWER REPAYMENT AGREEMENT

DEPARTMENT

Development Services Department, Engineering Division

STAFF RECOMMENDATION

It is requested that the City Council adopt Resolution No. 2024-55 approving the Sewer Repayment Agreement for Ranchito Drive and authorizing the Mayor to execute the agreement on behalf of the City of Escondido ("City").

Staff Recommendation - Approval (Deputy City Manager - Chris McKinney)

Presenter: Owen Tunnell, Interim City Engineer

ESSENTIAL SERVICE – Yes, Land Use/Development; Sewer

COUNCIL PRIORITY – Encourage Housing Development

FISCAL ANALYSIS

In accordance with the adopted fee schedule, the City's cost of administering sewer repayment agreements is paid through a 5 percent fee on each sewer repayment collected. In addition, in accordance with the Policy Statement for Repayment Agreements, adopted as Resolution No. 84-124, the applicant is responsible for the cost of public noticing.

BACKGROUND

The property owner of 640 Ranchito Drive ("Property Owner") extended a public sewer main within Ranchito Drive by 300-feet from its existing terminus. The construction of these improvements makes service available to the other three other parcels of land shown on Exhibit B of Resolution No. 2024-55 Exhibit "A". The Property Owner has requested that a repayment agreement be executed so that as other property owners connect to this sewer in the future, the Property Owner is reimbursed for the fair share cost from each benefiting parcel.

Article 18D, Section 6-465.9 of the Municipal Code allows the City "to enter into a repayment agreement with a developer when said developer has constructed local drainage or sanitary sewer facilities." The code states that the amount of the repayment is limited to the actual cost of of the facility at the time it is constructed.



CITY of ESCONDIDO

STAFF REPORT

An Agreement for Repayment of Public Utility Improvement Costs has been prepared in accordance with the Policy Statement for Repayment Agreements, adopted as Resolution No. 84-124. The Agreement requires that before a building permit requiring sewer capacity may be issued or a connection to the public sewer main made, the benefited parcel will pay its fair share costs as outlined in the repayment schedule below.

The sewer main benefits four properties, including the Property Owner that paid for its installation. The property owner has provided documentation of the total cost of the sewer main extension of \$229,799.85 inclusive of City fees. This cost has been allocated to each other property owner based on lot acreage.

Benefited Parcel #	Assessor's Parcel Number	Lot Acreage	% of Total Area	Assessed Cost
1	239-051-10	1.01	20%	\$46,419.57
2	239-050-13	1.19	24%	\$54,692.36
3	239-051-11	1.85	37%	\$85,025.94
4	239-050-11	0,95	19%	\$43,661.97

ENVIRONMENTAL REVIEW

The activity is not a "Project" as defined under Section 15378 of the California Environmental Quality Act State Guidelines. Therefore, pursuant to State Guidelines Section 15060(c)(3) no environmental review is required.

CONCLUSION

On April 16 2024, the Engineering Division sent a letter to each benefited parcel owner informing them of the proposed public hearing and providing a copy of the proposed agreement. The Engineering Division was contacted by one affected property owner who did not express objection to the proposed agreement. In addition, notice of the public hearing was made on May 2, 2024 in the Times Advocate. Staff recommends that a public hearing be held and that Resolution No. 2024-55 be adopted approving the Sewer Repayment Agreement for Ranchito Drive.

RESOLUTIONS

- A. Resolution No. 2024-55
- B. Resolution No. 2024-55, Exhibit "A" Agreement for Repayment of Public Utility Improvement Costs

RESOLUTION NO. 2024-55

A RESOLUTION OF THE CITY COUNCIL OF THE CITY OF ESCONDIDO, CALIFORNIA, APPROVING RANCHITO DRIVE SEWER REPAYMENT AGREEMENT

WHEREAS, Laurinda Suzan Barnes Trust (“Property Owner”), is the owner of that certain real property located at 640 Ranchito Drive, the City of Escondido, County of San Diego, State of California, having assessor’s parcel number 239-050-11-00 (“Property”); and

WHEREAS, Property Owner has constructed public utility improvements in the manner shown on City approved drawings numbered S22-0003 for the purpose of serving the Property; and

WHEREAS, Property Owner has signed an agreement drawn for the purpose of spreading the cost of constructing the public sewer main to the adjoining benefited parcels; and

WHEREAS, the City Council desires at this time and deems it to be in the best public interest to approve a Repayment Agreement for Public Utility Improvement Costs with the Property Owner.

NOW, THEREFORE, BE IT RESOLVED by the City Council of the City of Escondido, California, as follows:

1. That the above recitations are true.
2. That the Property Owner has signed an agreement drawn for the purpose of spreading the cost of constructing the public sewer main to the adjoining benefited parcels.
3. That the City Council approves and authorizes a Repayment Agreement for Public Utility Improvement Costs. That the Mayor is hereby authorized to execute, on behalf of the City, an agreement with Laurinda Suzan Barnes Trust, owner of 640 Ranchito Drive. A copy of the agreement is attached as Exhibit “A” and incorporated by this reference.

AGREEMENT FOR REPAYMENT OF
PUBLIC UTILITY IMPROVEMENT COSTS

THIS AGREEMENT FOR REPAYMENT OF PUBLIC UTILITY IMPROVEMENT COSTS (“Agreement”) is made and entered into as the last date of signature below (“Effective Date”), by and between the CITY OF ESCONDIDO, a California municipal corporation (“City”), and the LAURINDA SUZAN BARNES TRUST DATED DECEMBER 16, 2020 (“Property Owner”). (The City and Property Owner may each be referred to herein as a “Party” and collectively as the “Parties.”)

RECITALS

- A. Property Owner is the owner of that certain real property located at 640 Ranchito Drive, the City of Escondido, County of San Diego, State of California, having assessor’s parcel number 239-050-11-00, and more particularly described in page 4 of **Exhibit A**, attached hereto and incorporated herein by this reference (“Property”).
- B. Property Owner is required to construct public utility improvements in the manner shown on City approved drawings numbered S22-0003 for the purpose of serving the Property.
- C. The public utility improvements will also serve or otherwise benefit, directly or indirectly, other parcels in the vicinity of the Property, which are each described in pages 1-3 of Exhibit A (referred to herein individually as “Benefited Parcel” and collectively as “Benefited Parcels”). Furthermore, Property Owner desires to be repaid for a portion of the cost of the public utility improvements from the owners of the Benefitted Parcels.
- D. The City finds that the public interest is served by the construction of the public utility improvements described herein.

NOW, THEREFORE, in consideration of the recitals and mutual obligations of the parties as herein expressed, City and Property Owner agree as follows:

1. The Benefited Parcels are designated on the attached Repayment Plat marked **Exhibit B**, which is made a part of this Agreement.
2. Before a building permit requiring additional capacity may be issued for a Benefited Parcel, or upon connection of any buildings on a Benefited Parcel to the public utility improvement, the owner of such Benefited Parcel shall be required to pay to the City such amount as set forth in the attached Repayment Schedule marked **Exhibit C**, which is made a part of this Agreement.
3. No repayments shall be made to Property Owner pursuant to this Agreement until all the required public utility improvements have been made and a Notice of Completion has been filed by the City. Repayments collected prior to the Notice of Completion being filed shall be held by the City and forwarded to Property Owner after the Notice of Completion is filed by the City. Repayments collected after filing of the Notice of Completion shall be forwarded to Property Owner within a reasonable time after processing.
4. Upon completion, the public utility improvements required by this Agreement shall be the sole property of the City. Property Owner shall have no claim or property rights in the public utility improvements themselves by reasons of this Agreement or under any other theory of law or equity.

5. All repayments collected by the City shall be sent to the Property Owner at the following address:

Laurinda Suzan Barnes
Trustee of The Laurinda Suzan Barnes Trust
640 Ranchito Drive
Escondido, CA 92025

6. In the event the Property Owner fails to complete the required public utility improvements in a timely manner, the City Council may by resolution void this Agreement.

7. The Property Owner is solely responsible for errors or inaccuracies in the contents of attached Exhibits "A", "B", and "C". Such errors which may result in Property Owner's failure to receive any or all amounts to which he/she might otherwise be entitled under this Agreement shall not be the responsibility of City or in any way give rise to a claim against City.

8. Property Owner shall bear the cost of sending Notices as required by Section 5 of Resolution No. 84-124 in connection with the approval of this Agreement by City Council.

(Signature page follows)

IN WITNESS WHEREOF, This Agreement is executed by the Parties or their duly authorized representatives:

CITY OF ESCONDIDO

Date: _____

By: _____
Dane White, Mayor

PROPERTY OWNER

Date: 3/27/24

By: Laurinda Suzan Barnes, Trustee
Laurinda Suzan Barnes, Trustee of The
Laurinda Suzan Barnes Trust dated December
16, 2020

(ABOVE SIGNATURES MUST BE NOTARIZED; ACKNOWLEDGMENT PAGES FOLLOW)

APPROVED AS TO FORM:
OFFICE OF THE CITY ATTORNEY
MICHAEL R. MCGUINNESS, City Attorney

BY: _____

ACKNOWLEDGMENT

A notary public or other officer completing this certificate verifies only the identity of the individual who signed the document, to which this certificate is attached, and not the truthfulness, accuracy, or validity of that document.

STATE OF CALIFORNIA]

COUNTY OF _____]

On _____, before me,
_____, a Notary Public, personally appeared
_____, who proved to me on the basis of
satisfactory evidence to be the person(s) whose name(s) is/are subscribed to the within instrument
and acknowledged to me that he/she/they executed the same in his/her/their authorized
capacity(ies), and that by his/her/their signature(s) on the instrument the person(s), or the entity
upon behalf of which the person(s) acted, executed the instrument.

I certify under PENALTY OF PERJURY under the laws of the State of California that the
foregoing paragraph is true and correct.

WITNESS my hand and official seal.

Signature: _____ (Seal)

City

ACKNOWLEDGMENT

A notary public or other officer completing this certificate verifies only the identity of the individual who signed the document, to which this certificate is attached, and not the truthfulness, accuracy, or validity of that document.

STATE OF CALIFORNIA]
COUNTY OF San Diego]

On March 27, 2024, before me,

Eric Lopez, a Notary Public, personally appeared

Laurinda Suzan Barnes, who proved to me on the basis of

satisfactory evidence to be the person(s) whose name(s) is/are subscribed to the within instrument and acknowledged to me that he/she/they executed the same in his/her/their authorized capacity(ies), and that by his/her/their signature(s) on the instrument the person(s), or the entity upon behalf of which the person(s) acted, executed the instrument.

I certify under PENALTY OF PERJURY under the laws of the State of California that the foregoing paragraph is true and correct.

WITNESS my hand and official seal.

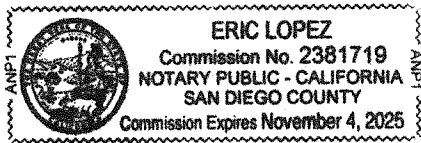

Signature: *Eric Lopez* (Seal)

Property Owner

EXHIBIT "A"
Benefited Parcel 1
APN 239-051-10-00

LEGAL DESCRIPTION

THE LAND REFERRED TO HEREIN BELOW IS SITUATED IN THE COUNTY OF SAN DIEGO, STATE OF CALIFORNIA, AND IS DESCRIBED AS FOLLOWS:

PARCEL A:

PARCEL 3 OF PARCEL MAP NO. 7437, IN THE CITY OF ESCONDIDO, COUNTY OF SAN DIEGO, STATE OF CALIFORNIA, FILED IN THE OFFICE OF THE COUNTY RECORDER OF SAN DIEGO COUNTY, JUNE 15, 1978 AS FILE NO. 78-249097 OF OFFICIAL RECORDS.

EXCEPTING THEREFROM IN FAVOR OF THE GRANTOR AN EASEMENT AND RIGHT OF WAY FOR INGRESS AND EGRESS, ROAD AND UTILITY PURPOSES, INCLUDING BUT NOT LIMITED TO ELECTRIC POWER, TELEPHONE, GAS, WATER, SEWER AND CABLE TELEVISION LINES AND APPURTENANCES THERETO, OVER, UNDER, ALONG AND ACROSS THAT PORTION LYING WITHIN THE "PROPOSED 30 FOOT PRIVATE ROAD EASEMENT" AS DELINEATED AND DESIGNATED ON SAID PARCEL MAP.

PARCEL B:

AN EASEMENT AND RIGHT OF WAY FOR ROAD AND UTILITY PURPOSES OVER, UNDER, ALONG AND ACROSS THAT PORTION OF PARCEL 1 OF PARCEL MAP NO. 7437, IN THE CITY OF ESCONDIDO, COUNTY OF SAN DIEGO, STATE OF CALIFORNIA, FILED IN THE OFFICE OF THE COUNTY RECORDER OF SAN DIEGO COUNTY, JUNE 15, 1978 AS FILE NO. 78-249097 OF OFFICIAL RECORDS, LYING WITHIN THE "PROPOSED 30 FOOT PRIVATE ROAD EASEMENT" AS DELINEATED AND DESIGNATED ON SAID PARCEL MAP.

PARCEL C:

AN EASEMENT AND RIGHT OF WAY FOR ROAD AND UTILITY PURPOSES OVER, UNDER, ALONG AND ACROSS A STRIP OF LAND 20.00 FEET IN WIDTH, LYING WITHIN THE OAKS TRACT IN RANCHO SAN BERNARDO, IN THE COUNTY OF SAN DIEGO, STATE OF CALIFORNIA, ACCORDING TO MAP THEREOF NO. 1415, FILED IN THE OFFICE OF THE COUNTY RECORDER OF SAN DIEGO COUNTY, FEBRUARY 8, 1912, THE SOUTHWESTERLY AND SOUTHERLY LINES OF SAID 20.00 FOOT STRIP BEING THE NORTHEASTERLY AND NORTHERLY LINES OF PARCELS 1 AND 3 OF PARCEL MAP NO. 7437, IN THE CITY OF ESCONDIDO, COUNTY OF SAN DIEGO, STATE OF CALIFORNIA, FILED IN THE OFFICE OF THE COUNTY RECORDER OF SAN DIEGO COUNTY, JUNE 15, 1978 AS FILE NO. 78-249097 OF OFFICIAL RECORDS.

EXCEPTING THEREFROM THAT PORTION LYING WITHIN ENCINO DRIVE AS SHOWN ON GREEN ACRES ESTATES, ACCORDING TO MAP THEREOF NO. 3036, FILED IN THE OFFICE OF THE COUNTY RECORDER OF SAN DIEGO COUNTY, NOVEMBER 4, 1953.

EXHIBIT "A"
Benefited Parcel 2
APN 239-050-13-00

LEGAL DESCRIPTION

All that portion of the Oaks Tract in the Rancho San Bernardo, in the City of Escondido, County of San Diego, State of California, according to Map thereof No. 1415, filed in the Office of the County Recorder of San Diego County, February 8, 1912, described as follows:

Commencing at a point in the Northerly line of said Oaks Tract, being also the Northerly line of said Rancho San Bernardo, which is distant thereon South $77^{\circ}20'30''$ East 3191.88 feet from the Northeast corner of Homeland Acres Addition to Escondido No. 2, according to Map thereof No. 1241, filed in the Office of the County Recorder of said County; thence South $22^{\circ}14'30''$ East 363.00 feet to the most Easterly corner of land described in Deed to Leonard S. Gustafson, et ux, recorded October 10, 1955 as Document No. 132495 of Official Records; thence along the Southerly line of said land South $82^{\circ}43'50''$ West 215.32 feet to the True Point of Beginning; thence South $13^{\circ}13'50''$ West 198.37 feet to a line drawn parallel with and 20 feet Northerly at right angles from the Northerly line of land described in Deed to Theodore E. Fleming et ux, recorded April 26, 1960 as File No. 85356 of Official Records; thence South $7^{\circ}53'50''$ East 20 feet to the Northerly line of said land; thence along said Northerly line as follows: South $82^{\circ}06'10''$ West 94.67 feet to the beginning of a tangent 535.40 foot radius curve concave Southerly; thence Westerly along said curve through a central angle of $8^{\circ}36'10''$ a distance of 80.39 feet to a point of reverse curvature with a tangent 400 foot radius curve concave Northerly; thence Westerly along said curve through a central angle of $10^{\circ}55'50''$ a distance of 76.31 feet to the Point of Tangency; thence tangent to said curve South $84^{\circ}25'50''$ West 25.14 feet; thence North $5^{\circ}34'10''$ West 20 feet; thence North $12^{\circ}08'20''$ East 210 feet to the Southerly line of said Gustafson land; thence along said Southerly line North $82^{\circ}43'50''$ East 274.24 feet to the True Point of Beginning.

Parcel 2:

An easement and right of way for road and public utility purposes together with the right to convey the same to any person or persons over and across that certain 40 foot easement reserved for road purposes as shown on Record of Survey No. 5651.

EXHIBIT "A"
Benefited Parcel 3
APN 239-051-11-00

LEGAL DESCRIPTION

EXHIBIT "A"

THE LAND REFERRED TO HEREIN IS SITUATED IN THE COUNTY OF SAN DIEGO, STATE OF CALIFORNIA, AND IS DESCRIBED AS FOLLOWS:

PARCEL A:

PARCEL 4 OF PARCEL MAP NO. 7437, IN THE CITY OF ESCONDIDO, COUNTY OF SAN DIEGO, STATE OF CALIFORNIA, FILED IN THE OFFICE OF THE COUNTY RECORDER OF SAN DIEGO COUNTY ON JUNE 15, 1978.

PARCEL B:

AN EASEMENT AND RIGHT OF WAY FOR ROAD AND PUBLIC UTILITY PURPOSES OVER AND ACROSS A STRIP OF LAND 20.00 FEET IN WIDTH LYING WITHIN THE OAKS TRACT IN THE RANCHO SAN BERNARDO, IN THE CITY OF ESCONDIDO, COUNTY OF SAN DIEGO, STATE OF CALIFORNIA, ACCORDING TO MAP THEREOF NO. 1415, FILED IN THE OFFICE OF THE COUNTY RECORDER OF SAN DIEGO COUNTY, ON FEBRUARY 8, 1912, SAID STRIP OF LAND LYING ADJACENT TO AND 20.00 FEET NORTHERLY AT RIGHT ANGLES FROM THE NORTHERLY BOUNDARY OF PARCEL MAP NO. 7437, HEREINABOVE DESCRIBED. SAID 20.00 FOOT STRIP OF LAND TERMINATES EASTERLY IN THE 50.00 FOOT EASEMENT FOR ROAD PURPOSES SHOWN ON RECORD OF SURVEY MAP NO. 1387, AND WESTERLY IN THE EASTERLY BOUNDARY OF ENCINO DRIVE AS SHOWN ON GREEN ACRES ESTATES, ACCORDING TO MAP THEREOF NO. 3036, FILED IN THE OFFICE OF THE COUNTY RECORDER OF SAN DIEGO COUNTY, ON NOVEMBER 4, 1953.

PARCEL C:

AN EASEMENT AND RIGHT OF WAY FOR ROAD AND PUBLIC UTILITY PURPOSES OVER, UNDER, ALONG AND ACROSS THAT PORTION OF PARCEL 1 OF PARCEL MAP NO. 7437, AS SHOWN ON SAID PARCEL MAP AS "PROPOSED 30' PRIVATE ROAD EASEMENT" AND "PROPOSED 20' PRIVATE ROAD EASEMENT".

EXHIBIT "A"
Benefited Parcel 4
APN 239-050-11-00

LEGAL DESCRIPTION

THE LAND REFERRED TO HEREIN BELOW IS SITUATED IN THE COUNTY OF SAN DIEGO, STATE OF CALIFORNIA, AND IS DESCRIBED AS FOLLOWS:

PARCEL 1:

ALL THAT PORTION OF THE OAKS TRACT, IN THE RANCHO SAN BERNARDO, IN THE CITY OF ESCONDIDO, COUNTY OF SAN DIEGO, STATE OF CALIFORNIA, ACCORDING TO MAP THEREOF NO. 1415, FILED IN THE OFFICE OF THE COUNTY RECORDER OF SAN DIEGO COUNTY, FEBRUARY 8, 1912, DESCRIBED AS FOLLOWS:

BEGINNING AT A POINT IN THE NORTHERLY LINE OF SAID OAKS TRACT BEING ALSO THE NORTHERLY LINE OF SAID RANCHO SAN BERNARDO, WHICH IS DISTANT THEREON SOUTH 77 DEGREES 20 MINUTES 30 SECONDS EAST, 3191.88 FEET FROM THE NORTHEAST CORNER OF HOMELAND ACRES ADDITION TO ESCONDIDO NO. 2, ACCORDING TO MAP THEREOF NO. 1241, FILED IN THE OFFICE OF THE COUNTY RECORDER OF SAN DIEGO COUNTY THENCE SOUTH 22 DEGREES 14 MINUTES 30 SECONDS EAST, 363.06 FEET TO THE MOST EASTERLY CORNER OF LAND DESCRIBED IN DEED TO LEONARD S. GUSTAFSON, ET UX RECORDED OCTOBER 10, 1955 AS INSTRUMENT NO. 132495 OF OFFICIAL RECORDS, SAID POINT BEING THE TRUE POINT OF BEGINNING THENCE ALONG THE SOUTHERLY LINE OF SAID LAND, SOUTH 82 DEGREES 43. MINUTES 50 SECONDS WEST, 215.32 FEET; THENCE SOUTH 13 DEGREES 13 MINUTES 50 SECONDS WEST, 198.37 FEET TO A LINE DRAWN PARALLEL WITH AND 20.00 FEET NORTHERLY AT RIGHT ANGLES FROM THE NORTHERLY LINE OF LAND DESCRIBED IN DEED TO THEODORE E. FLEMING ET UX RECORDED APRIL 26, 1960 AS INSTRUMENT NO. 1960-85356 OF OFFICIAL RECORDS; THENCE SOUTH 07 DEGREES 53 MINUTES 50 SECONDS EAST, 20.00 FEET TO THE NORTHERLY LINE OF SAID LAND; THENCE ALONG SAID NORTHERLY LINE AS FOLLOWS: NORTH 82 DEGREES 06 MINUTES 10 SECONDS EAST, 188.02 FEET TO THE BEGINNING OF A TANGENT 500.00 FEET RADIUS CURVE, CONCAVE SOUTHERLY; THENCE EASTERLY ALONG SAID CURVE 50.03 FEET THROUGH AN ANGLE OF 05 DEGREES 44 MINUTES 00 SECONDS; THENCE LEAVING SAID CURVE NORTH 02 DEGREES 09 MINUTES 50 SECONDS WEST, 20.00 FEET; THENCE NORTH 10 DEGREES 43 MINUTES 40 SECONDS EAST, 140.96 FEET TO A LINE WHICH BEARS SOUTH 06 DEGREES 21 MINUTES 50 SECONDS EAST FROM THE TRUE POINT OF BEGINNING;- THENCE NORTH 06 DEGREES 21 MINUTES 50 SECONDS WEST, 51.71 FEET TO THE TRUE POINT OF BEGINNING.

PARCEL 2:

AN EASEMENT AND RIGHT OF WAY FOR ROAD AND PUBLIC UTILITY PURPOSES, TOGETHER WITH THE RIGHT TO CONVEY THE SAME TO ANY PERSON OR PERSONS OVER AND ACROSS THAT CERTAIN 40.00 FEET EASEMENT RESERVED FOR ROAD PURPOSES AS SHOWN ON RECORD OF SURVEY NO. 5651.







 Item 6.

 DOC. NO. -

 SHEET: 1 OF

EXHIBIT "B"

- LEGEND:**
-  EXISTING LOT LINES
 -  MANHOLES
 -  SEWER CLEANOUT
 -  SEWER LATERAL

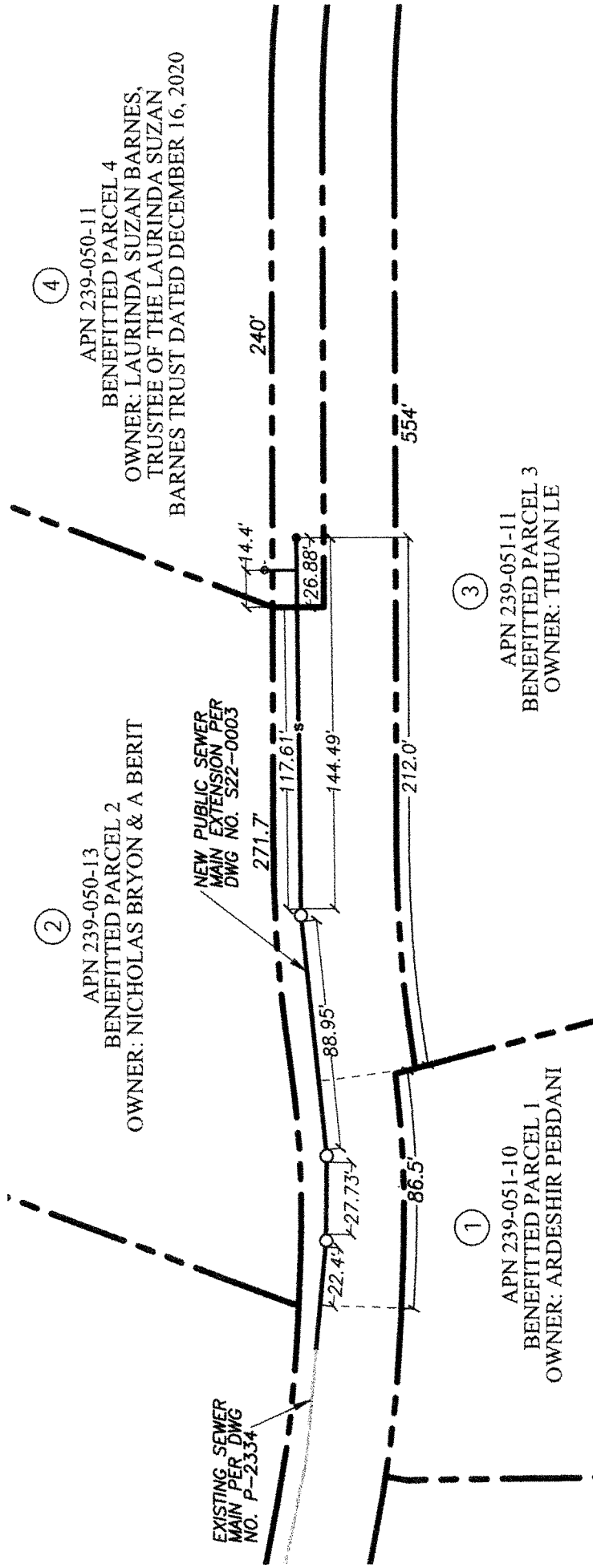

RANCHITO DRIVE

Prepared by: FUSION ENG TECH
 1810 GILLESPIE WAY
 SUITE #207
 EL CAJON, CA 92020
 (619) 736-2800 1/5/24 Date

ENGINEERING SERVICES
 201 North Broadway, CA 92025 (760) 839-4651

RANCHITO DRIVE
SEWER MAIN REPAYMENT EXHIBIT

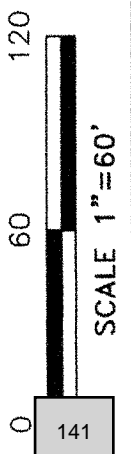

Item 6.

EXHIBIT "C" REPAYMENT SCHEDULE - CITY OF ESCONDIDO - RANCHITO DRIVE									
				SEWER					
				TOTAL COST		\$ 229,799.85			
BENEFITED PARCEL NUMBER	ASSESSOR'S NUMBER	OWNER NAME	ADDRESS	LOT ACREAGE	% OF TOTAL AREA	ASSESSED COST			
1	239-051-10	Ardeshir Pabdani	12463 Rancho Bernardo Rd #369 San Diego, CA 92128	1.01	20%	\$46,419.57			
2	239-050-13	Nicholas Bryon & A Berit	612 Ranchito Drive Escondido, CA 92025	1.19	24%	\$54,692.36			
3	239-051-11	Thuan Le	633 Ranchito Drive Escondido, CA 92025	1.85	37%	\$85,025.94			
4	239-050-11	Laurinda Barnes	640 Ranchito Drive Escondido, CA 92025	0.95	19%	\$43,661.97			
				TOTALS	5	100%	\$229,799.85		

\$229,799.85
 Less Property Owner's Portion \$43,661.97
 Total Repayment to Property Owner \$186,137.88

Cost Report

Actual Cost Per Bid \$218,857.00
 Plus 5% City Fee \$10,942.85
 Amount to Spread \$229,799.85



STAFF REPORT

May 8, 2024
File Number 0430-35

SUBJECT

FINANCIAL REPORT FOR THE QUARTER ENDED MARCH 31, 2024

DEPARTMENT

Finance

RECOMMENDATION

Request the City Council receive and file the third quarter financial report for FY2023/24 (Attachment "1")

Staff Recommendation: Approval (Finance: Christina Holmes)

Presenter: Christina Holmes, Director of Finance

ESSENTIAL SERVICE – Yes, Police Services; Fire/EMS Services; Keep City Clean for Public Health and Safety; Land Use/Development; Clean Water; Sewer

COUNCIL PRIORITY – Eliminate Structural Deficit

FISCAL ANALYSIS

See Below.

PREVIOUS ACTION

On March 20, 2024, the City Council received the second quarter report for FY2023/24.

BACKGROUND

The City Council Budget and Financial Policies require that the City of Escondido ("City") present quarterly financial reports each fiscal year. The purpose of this report is to provide City Council and the public a financial update of selected funds of the City. This report provides the City Council with the analysis of unaudited revenues and expenditures for Fiscal Year 2023/24 in comparison to the adopted Fiscal Year 2022/23 budget for the General Fund. The financial highlights for are summarized below.



CITY of ESCONDIDO

STAFF REPORT

Operating revenue has not kept pace with the growing costs of providing City services since the Great Recession, and as a result, the General Fund long-term financial plan has projected annual deficits creating a structural budget deficit. The City has maintained a hardline on expenditures, controlled costs by deferring maintenance and capital project costs, sought measures that ensure efficiency, and continued to utilize one-time grants and other sources of funding. Revenue-generating opportunities have also been explored and implemented as appropriate per City Council direction.

To address the predicted structural budget gap for the 2023/24 fiscal year, Departments were directed to submit their FY2023/24 General Fund operating budget at the same level as the prior year, FY2022/23, where possible. Once all revised General Fund budgets were submitted to the Finance Department, and a summary of projected revenue and expenditures was prepared, the General Fund operating budget projected a net operating deficit of \$11,295,840.

In order to continue to provide essential City services, City Council approved a combination of using reserve balances as well as deferring major purchases to future years in order to close the budget deficit:

- Utilizing the Section 115 Pension Trust Fund for the increase in CalPERS costs, estimated at \$1,500,640, for FY2023/24.
- Deferring vehicle replacements to future years for all General Fund departments, except for Public Safety vehicles, to save \$1,148,800 and utilizing reserves from the Fleet Services Fund of \$3,610,070.
- Changing the funding methodology of the General Liability Reserve Fund and reducing reserves by \$2,995,840.
- Including the Historical Cost Savings Reduction of \$1,000,000 in recognition of annual savings from vacant positions during the fiscal year, offset by a Cost Savings Contingency amount of \$400,000, to give some flexibility in managing available resources to be used throughout the fiscal year under the direction of the City Manager.
- Utilizing funds from the Revenue Loss provision of the American Rescue Plan Act to close the remaining General Fund operating budget deficit of \$1,440,490 in FY2023/24.

The projected FY2023/24 General Fund revenue estimate is \$127.4 million, estimated to increase \$7.5 million or 6 percent over the FY2022/23 amended revenue projection. The total proposed FY2023/24 General Fund Operating Budget is \$130.7 million, which increased by approximately \$5.6 million or 4.4 percent compared to the FY2022/23 Operating Budget.

At the end of the third quarter, General Fund revenues are at 62 percent of the amended budget, while expenditures are at 71 percent. Attachment "1" to this staff report includes an analysis of General Fund operating revenues, expenditures, and reserve balances as of March 2024.



CITY *of* ESCONDIDO

STAFF REPORT

ATTACHMENTS

- a. Attachment "1" – FY2023/24 Third Quarter Financial Status Report



**FY2023/24 Financial Status Report
Third Quarter Ending March 31, 2024**

OVERVIEW

This report summarizes the City’s financial position through the third quarter ending March 31, 2024 for the General Fund. The purpose of the report is to provide City Council, City Management, and the Escondido community an update on the City’s fiscal status based on the most recent financial information available. The revenue projections and budget information include adjustments for encumbrances, carryovers, and any other supplemental appropriations approved by the City Council as of March 31, 2024.

This report is for internal use only. The figures presented here are unaudited and have not been prepared in accordance with Generally Accepted Accounting principles (GAAP).

GENERAL FUND

Operating revenue has not kept pace with the growing costs of providing City services since the Great Recession, and as a result, the General Fund long-term financial plan has projected annual deficits creating a structural budget deficit. The City has maintained a hardline on expenditures, controlled costs by deferring maintenance and capital project costs, sought measures that ensure efficiency, and continued to utilize one-time grants and other sources of funding. Revenue-generating opportunities have also been explored and implemented as appropriate per City Council direction.

To address the predicted structural budget gap for the 2023/24 fiscal year, Departments were directed to submit their FY2023/24 General Fund operating budget at the same level as the prior year, FY2022/23, where possible. Once all revised General Fund budgets were submitted to the Finance Department, and a summary of projected revenue and expenditures was prepared, the General Fund operating budget projected a net operating deficit of \$11,295,840. In order to continue to provide essential City services, staff made recommendations to close the deficit that included a combination of using reserve balances as well as deferring major purchases to future years.

The projected FY2023/24 General Fund revenue estimate is \$127.4 million, estimated to increase \$7.5 million or 6% over the FY2022/23 amended revenue projection. The total proposed FY2023/24 General Fund Operating Budget is \$130.7 million, which increased by approximately \$5.6 million or 4.4% compared to the FY2022/23 Operating Budget.

At the end of the third quarter, General Fund revenues are at 62% of the amended budget, while expenditures are at 71%, shown in the table below.

**General Fund
Comparison of Projected FY2023/24 Operating Budget to Actuals**

	FY2023/24 ADOPTED BUDGET	FY2023/24 AMENDED BUDGET	ACTUAL RESULTS MARCH 2024	%
Total Operating Revenue	\$127,403,060	\$128,145,240	\$79,873,250	62%
Total Operating Expenditures	(130,892,070)	(133,182,965)	(93,986,810)	71%
Operating Transfers	1,852,000	1,561,100	1,561,100	-
One-Time Revenue Sources – American Rescue Plan Act	1,637,010	1,637,010	1,637,010	-
Net Operating Surplus / (Deficit)	\$-	(\$1,839,615)	(\$10,915,450)	-

GENERAL FUND REVENUE

	FY2023/24 AMENDED BUDGET	ACTUAL RESULTS MARCH 2024	ACTUAL RESULTS MARCH 2023	Prior Year vs. Current Year
Sales Tax	\$49,507,600	27,440,710	27,965,050	(524,340)
Property Tax	35,068,340	20,742,160	19,694,810	1,047,350
Other Taxes	16,483,370	10,840,320	12,128,400	(1,288,080)
Charges for Services	15,078,000	11,743,720	10,559,610	1,184,110
Permits and Licenses	3,724,000	3,808,580	3,871,830	(63,250)
Fines and Forfeitures	873,000	508,190	510,050	(1,860)
Intergovernmental	2,674,930	1,677,160	1,349,090	328,070
Rental Income	3,829,000	2,375,250	2,284,070	91,180
Other Revenue	907,000	737,160	1,110,660	(373,500)
TOTAL OPERATING REVENUE	\$128,145,240	\$79,873,250	\$79,473,570	\$399,680

Sales tax is the largest General Fund revenue source at 39% of total operating revenue followed by property tax, other taxes, and charges for services. The chart below shows the major categories of revenue collected through March 31, 2024 compared to the revenue collected in the prior year through March 31, 2023. Overall operating revenue increased \$399,680 compared to the same time last fiscal year.

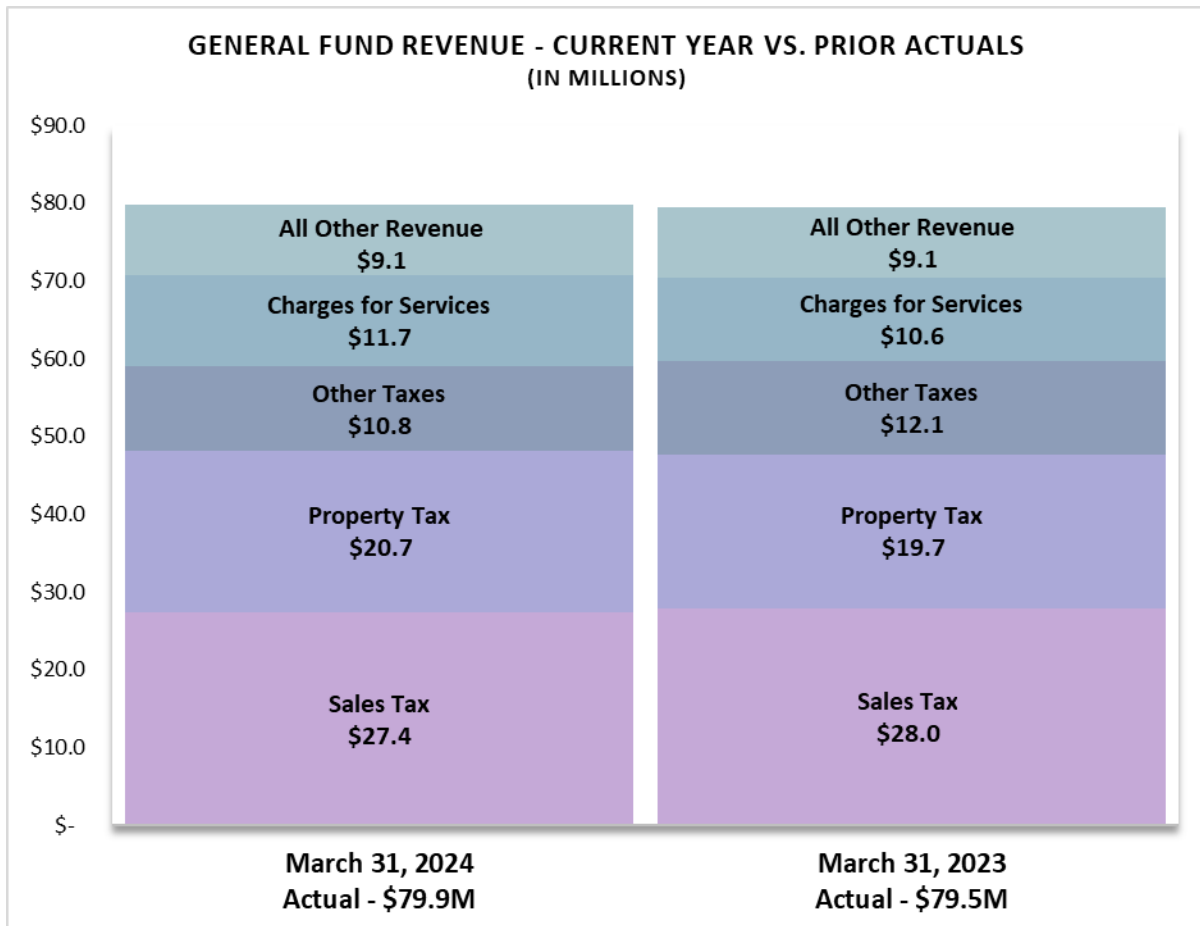

Sales Tax (39% of Total General Fund Revenue): \$27.4 million

The City works closely with its sales tax consultant, AvenulInsights, in projecting sales tax revenue. Based on AvenulInsights’ analysis of the trend in year-to-date tax receipts and an examination of the local economy, the City’s sales tax revenue is anticipated to decline in Fiscal Year 2023/24 by \$1,504,600 or 3% to reach \$49.5 million. A recession in 2024 is possible, but continued low unemployment and tight labor markets indicate that a severe downturn is unlikely. The forecast provided by AvenulInsights assumes a very mild recession or slowdown starting in the first quarter of FY2023/24 and lasting for the remainder of the fiscal year.

Actual sales tax receipts are under the March 2023 amount by \$524,430, indicating that the economy is continuing to slow from the post pandemic surge in spending.

Transportation

The largest sales tax segment, 35% of total sales tax revenue, is Transportation, which includes new and used auto sales, auto repair shops, and service stations.

Sales revenues decreased by 9% compared to the same quarter in the prior year. Despite an increase in new car registrations, the automobile and transportation sector declined 2.6% statewide. Like other industry groups, elevated financing costs are expected to create headwinds for auto sales.

Petroleum per barrel costs increased significantly in the spring of 2022, and as a result, receipts received from fuel and service stations increased by about 31% compared to the same quarter in the prior year. However, gas prices have steadily dropped for two consecutive quarters.

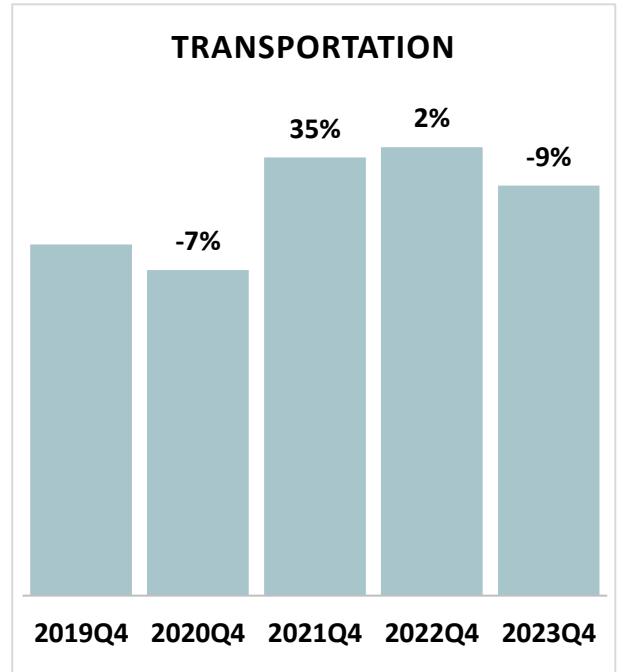

County Pool

Sales tax revenue received through the County Pool is now the second largest sales tax segment accounting for 17% of total sales tax revenue.

Effective in April 2019, new taxable sales are distributed to the City under the AB 147 Wayfair decision which extended the sales and use taxes to online and out-of-state retailers engaged in business in California.

However, the increase in activity from the countywide pool experienced during the pandemic has slowed; total receipts decreased by \$1,216,724, or 14%, compared to the prior year. In addition, more in-state fulfillment has diverted tax allocations away from pools and toward fulfillment center sites

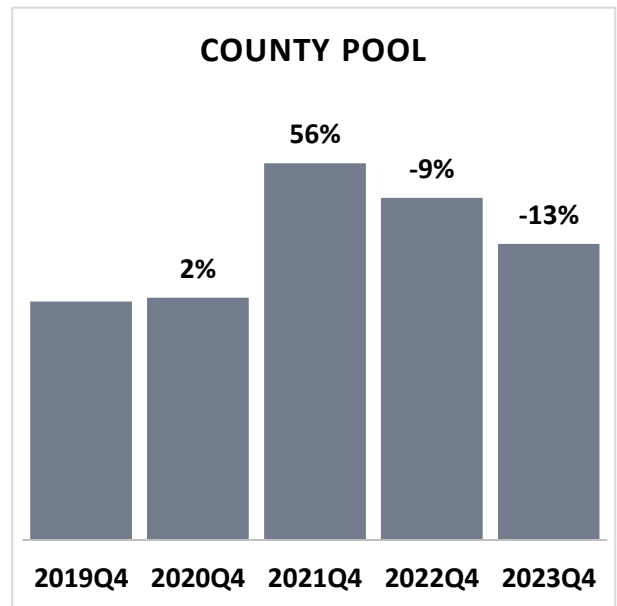

Construction

The Construction sales tax segment which accounts for revenue generated from building materials, including both wholesale and general retail, decreased from the prior year by about 5%.

Overall construction activities have increased steadily since the start of the pandemic in 2020 inflation increased this revenue further in 2023. However, building and construction projects continued slowing as higher interest rates constrained commercial development, public infrastructure projects and new housing starts.

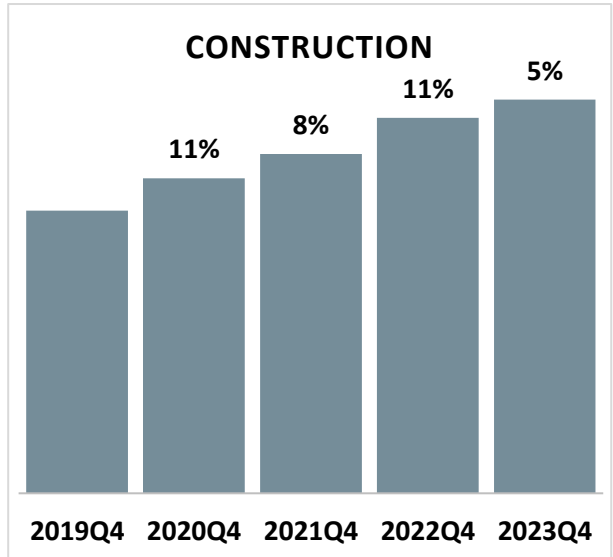

General Retail

General Retail and Food Products combined make up 25% of the total sales tax revenue for the City and declined slightly compared to the prior fiscal year.

The decline was likely driven by tighter family budgets, elevated interest rates, and diminished savings compared to the previous two fiscal years.

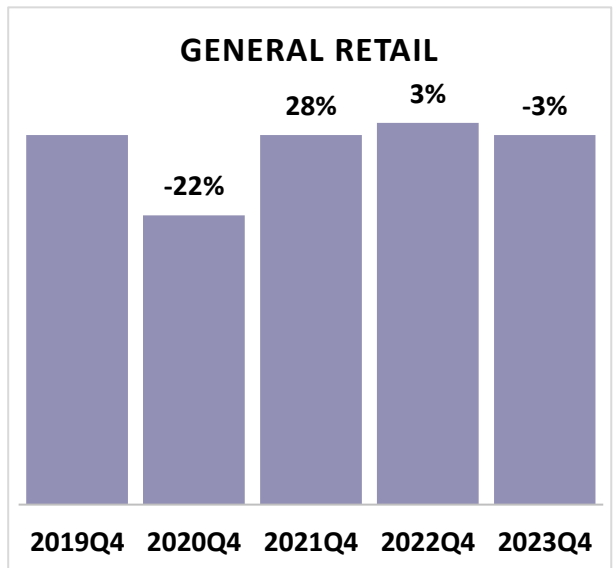

Property Tax (27% of Total General Fund Revenue): \$20.7 million

Property Tax revenue increased by \$1,047,350 or about 5.3% compared to this time in prior year.

The largest portions of property tax revenue are distributed by the County in December and April each year. The FY2023/24 Operating Budget projected property tax growth of 7%. This is attributed to an increase in current secured and unsecured tax projections, along with an increase in property transfer taxes based on the current and projected development activity, such as permits, inspections, and plan checks, which indicate continued growth in property sales.

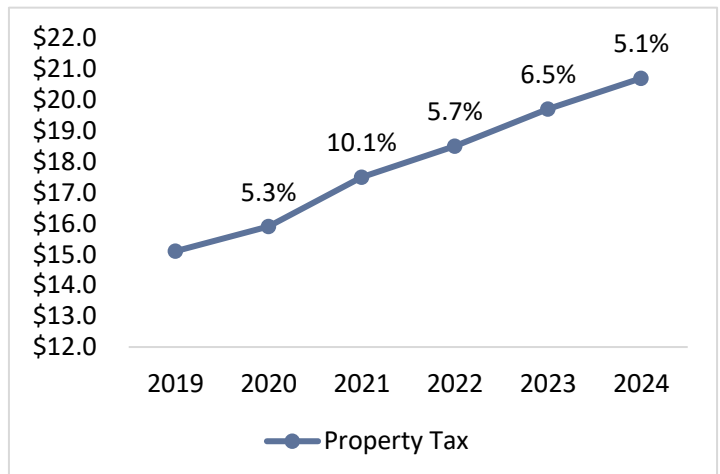

Other Taxes (13% of Total General Fund Revenue): \$10.8 million

Other Taxes include franchise fee revenues, transient occupancy tax, and business license revenue and combined have decreased by \$1,288,080 compared to the prior year.

Franchise Fees

The City collects franchise fee revenues from San Diego Gas and Electric (SDG&E), cable companies conducting business within City limits, and Escondido Disposal Incorporated (EDI). Revenues received from franchise agreements decreased by \$1.2 million from the prior fiscal year. In the first two quarters of 2023, the Escondido Palomar Energy Plant was shut down for maintenance. This resulted in zero electric emissions during this time and therefore no franchise fee revenue was due to the City. The plant was fully operational again in August.

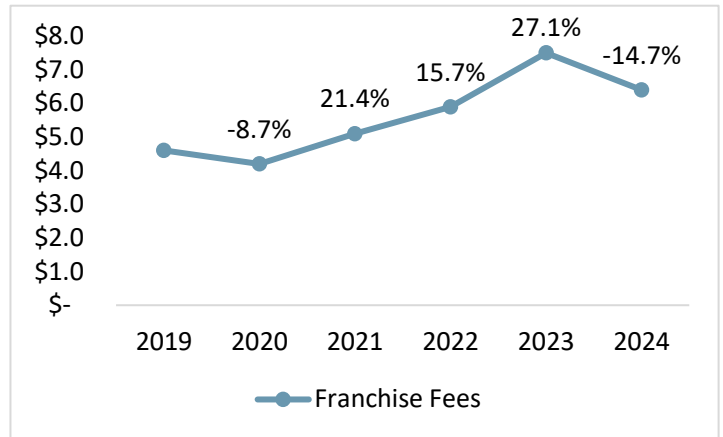

Transient Occupancy Tax

Transient occupancy tax, also known as hotel tax, decreased by \$251,692 compared to the prior year. The tourism industry was impacted significantly as a result of the closures, and many forecasted its recovery would take much longer than it has. Between FY2021/22 and FY2022/23, transient occupancy tax receipts increased by 49% from the pre-pandemic levels in March 2020. It is expected that those receipts will remain flat going forward as the activity stabilizes in the industry.

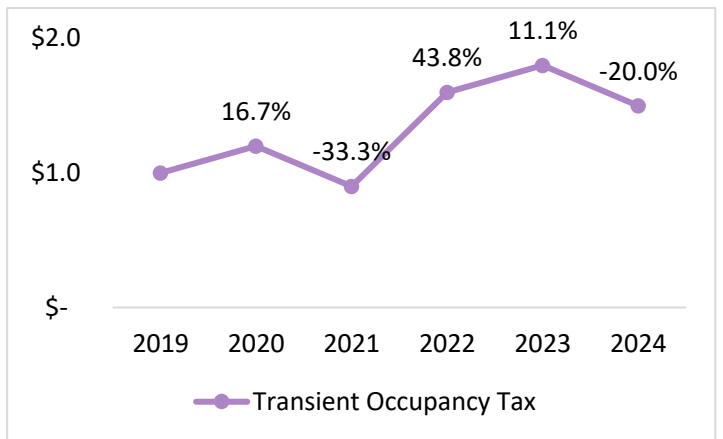

Business License Revenue

All entities doing business in the City are required to have a valid business license. The business license tax is calculated based on annual gross receipts; business license revenue from the 2023 calendar year is based off of 2022 gross receipts. Business license revenues decreased by \$24,567 compared to the prior fiscal year.

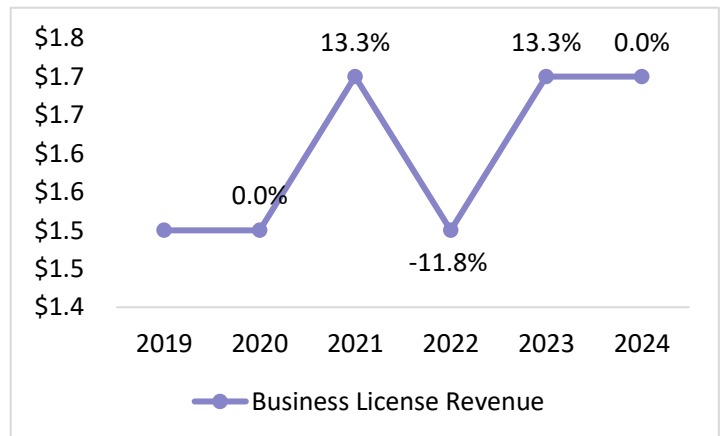

Charges for Services (12% of Total General Fund Revenue): \$11.7 million

Charges for Services include paramedic fees, Community Services fees for recreational and community activities, and charges for development related services, which include Engineering and Planning fees.

This category of revenue has increased by \$1.2 million primarily due to paramedic billing. The City is receiving *new revenue* due to the Ground Emergency Medical Transportation Program implemented at the end of FY2022/23 that utilizes Federal funding to supplement the ambulance billing revenue received for medical transports. As a result of this new program, additional funds of \$2,944,065 have been recorded since the inception of the program.

The increase in revenue is offset by the timing of Community Services and Development Services fees.

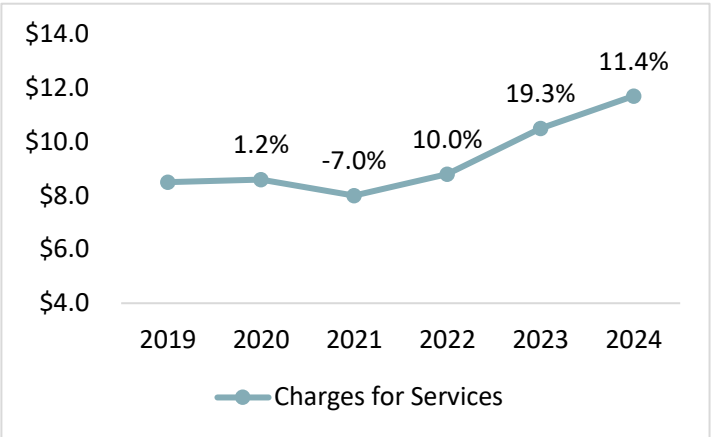

Intergovernmental (3% of Total General Fund Revenue): \$3.8 million

Intergovernmental revenue includes the Rincon fire services agreement, state mandated cost claims, various grants, and revenue received from the fire mutual aid reimbursements.

Overall revenue has decreased \$63,254 compared to the prior year.

The City's Fire Department staff can be deployed to assist other State agencies with responses to fires and other incidents. The California Office of Emergency Services reimburses the City for the time and resources of the staff deployed. As of March 2024, reimbursements of \$245,988 have been recorded.

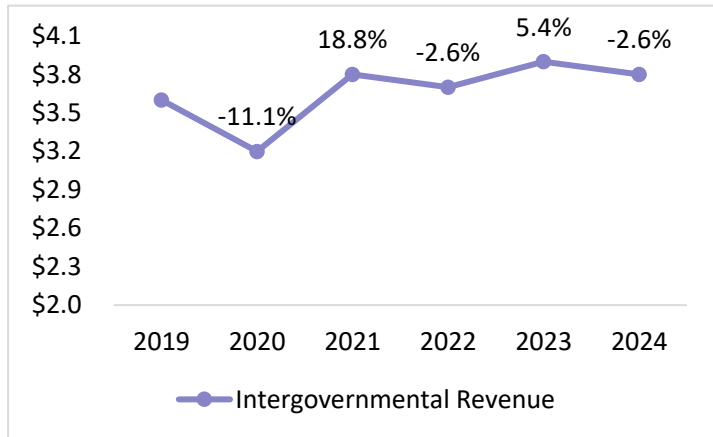

Permits and Licenses (2% of Total General Fund Revenue): \$1.7 million

Revenue generated from permits and licenses increased by \$328,070 compared to fiscal year 2022/23. Construction and development activity continues driving building permit revenue compared to previous fiscal years.

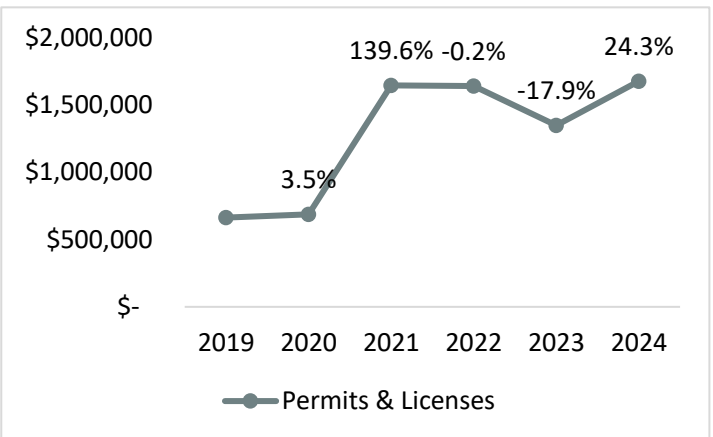

Fines & Forfeitures (1% of Total General Fund Revenue):
\$508,190

Fines & Forfeitures represent fees collected for vehicle code fines, parking ticket fines, other court fines, code enforcement citations, and impound fees. Overall revenue has decreased by \$1,860 compared to the prior fiscal year.

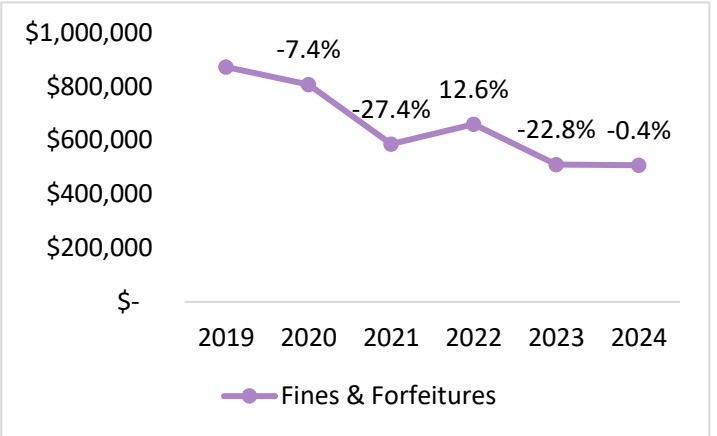

Rental Income (3% of Total General Fund Revenue):
\$2.4 million

The City receives lease and rental income from City owned properties, such as the North County Mall. Overall revenue has increased by \$91,184 compared to the prior fiscal year.

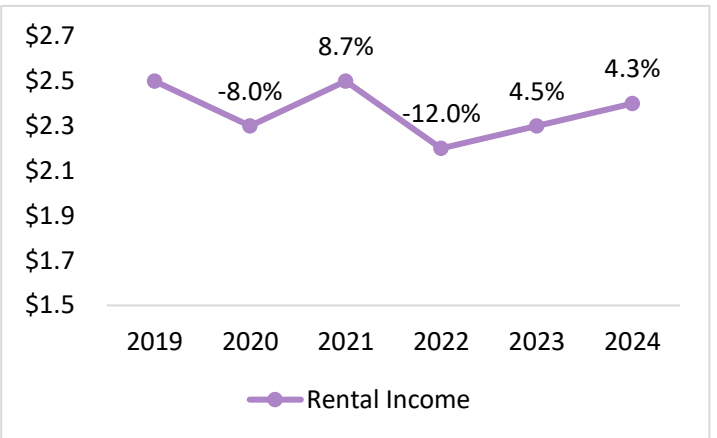

Investment and Other Revenues (1% of Total General Fund Revenue):
\$737,160

Investments and Other Revenue includes interest earned from investing activities, and other miscellaneous receipts and has decreased by \$373,500 compared to the prior year.

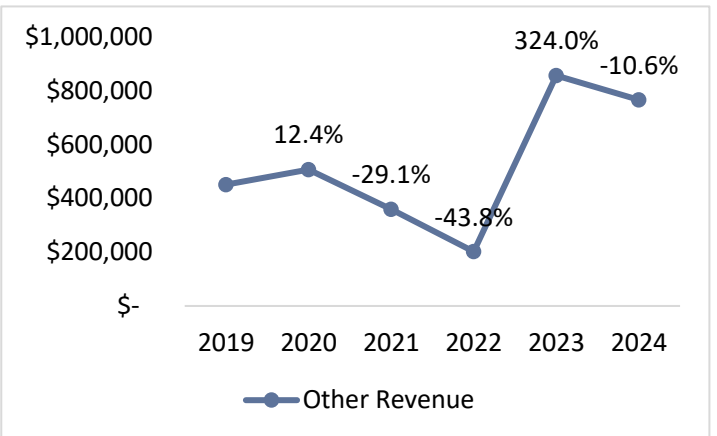

GENERAL FUND OPERATING EXPENDITURES

The total adopted FY2023/24 General Fund Operating Budget is \$131.4 million, an increase of approximately \$5.6 million or 4.4% compared to the FY2022/23 Operating Budget. In order to address an \$11.3 million budget deficit, vehicle replacements were deferred to future years, reserve funds are being utilized from the Fleet Services Fund, General Liability Fund, Section 115 Pension Trust and the American Rescue Plan Act Lost Revenue category of funds.

The following table includes cumulative expenditure comparisons for General Fund departments as of March 2024.

	FY2023/24 AMENDED BUDGET	ACTUAL RESULTS MARCH 2024	ACTUAL RESULTS MARCH 2023	Prior Year vs. Current Year
General Government Services	\$8,571,385	\$5,414,200	\$5,190,040	222,650
Community Services	9,721,210	6,780,640	6,428,830	351,810
Development Services	8,455,740	4,818,970	5,199,740	(380,770)
Public Works	12,939,245	9,519,330	9,367,690	151,640
Police	55,167,635	39,717,820	38,343,490	1,374,330
Fire	34,506,435	24,492,800	23,359,280	1,133,520
California Center for the Arts	3,247,370	2,504,080	1,957,930	546,150
Other Expenditures	577,830	740,480	1,260,120	(519,640)
TOTAL OPERATING EXPENDITURES	\$133,186,850	\$93,988,320	\$91,107,120	\$2,879,690

The City continues to be impacted by a competitive labor market, as a result of recurring vacant positions and long recruitment efforts there are expenditure savings in regular salary and benefits through March 2024. However, the vacant positions have also increased the overtime expenditures which are at 102% of the amount budgeted for the fiscal year. The increase in overtime expenses will be offset by the savings in employee services.

	FY2023/24 AMENDED BUDGET	ACTUALS MARCH 2024	% of Budget
Employee Services	\$106,029,055	\$71,959,730	68%
Employee Services - Overtime	6,396,095	6,519,370	102%
SUBTOTAL EMPLOYEE SERVICES	105,925,850	78,479,100	70%
Maintenance and Operations	26,301,620	18,763,300	71%
Internal Service Charges	12,464,710	9,348,535	75%
Allocations	(17,404,630)	(12,602,700)	72%
SUBTOTAL OPERATING EXPENDITURES	21,361,700	15,509,195	73%
Historical Cost Savings Reduction	(600,000)	-	-
TOTAL OPERATING EXPENDITURES	\$133,186,850	\$93,988,300	70%

The following table shows each department's operating expenses through March 2024 compared to the amended budget for FY2023/24:

GENERAL GOVERNMENT SERVICES	FY2023/24 ADOPTED BUDGET	BUDGET ADJUSTMENTS	FY2023/24 AMENDED BUDGET	ACTUAL RESULTS MARCH 2024	% Of Budget
City Council	\$396,390	\$90,000 (Community Survey)	\$486,390	\$272,873	56%
City Manager	1,530,580	66,880	1,597,460	1,162,570	73%
City Attorney	198,290	40,165	238,455	96,976	41%
City Clerk	680,240	7,515	687,755	501,614	73%
City Treasurer	233,490	2,165	235,655	201,619	85%
Finance	1,809,720	34,235	1,843,955	1,106,987	60%
Human Resources & Risk Management	795,320	14,900	810,220	533,505	66%
Information Systems & GIS	1,547,210	45,800	1,602,990	855,094	53%
Communications & Digital Media	1,046,040	22,465	1,068,505	757,724	71%
TOTAL GENERAL GOVERNMENT	\$8,237,280	\$333,300*	\$8,571,385	\$3,633,026	42%

* Approved March 20, 2024 – Community Survey \$90,000. Remaining budget adjustments are due to reallocation of employee services from Non-Departmental. Net Budget Impact = \$0

COMMUNITY SERVICES	FY2023/24 ADOPTED BUDGET	BUDGET ADJUSTMENTS	FY2023/24 AMENDED BUDGET	ACTUAL RESULTS MARCH 2024	% Of Budget
Recreation	\$4,573,720	\$ 9,315	\$4,583,035	\$2,941,489	64%
Main Library	3,771,040	-	3,771,040	2,994,782	79%
Older Adult Services	727,170	7,905	735,075	488,129	67%
Senior Nutrition	630,460	1,600	632,060	356,234	60%
TOTAL COMMUNITY SERVICES	\$9,702,390	\$18,820*	\$9,721,210	\$36,780,635	70%

*Adjustments are due to reallocation of employee services from Non-Departmental. Net Budget Impact = \$0

DEVELOPMENT SERVICES	FY2023/24 ADOPTED BUDGET	BUDGET ADJUSTMENTS	FY2023/24 AMENDED BUDGET	ACTUAL RESULTS MARCH 2024	% Of Budget
Planning	\$2,391,860	\$65,095	\$2,456,955	\$1,360,631	55%
Building	1,688,550	15	1,688,565	778,597	46%
Engineering	3,251,450	38,845	3,290,295	2,067,519	63%
Code Compliance	1,011,200	8,725	1,019,925	612,218	60%
TOTAL DEVELOPMENT SERVICES	\$8,343,060	\$112,680*	\$8,455,740	\$4,818,965	57%

*Adjustments are due to reallocation of employee services from Non-Departmental. Net Budget Impact = \$0

PUBLIC WORKS	FY2023/24 ADOPTED BUDGET	BUDGET ADJUSTMENTS	FY2023/24 AMENDED BUDGET	ACTUAL RESULTS MARCH 2024	% Of Budget
Street Maintenance	\$8,177,050	\$402,164	\$8,579,210	\$6,621,655	77%
Park Maintenance	4,221,420	138,621	4,360,035	3,066,164	70%
Radio Communications	-	-	-	(168,492)	0%
TOTAL DEVELOPMENT SERVICES	\$12,398,470	\$540,775	\$12,939,245	\$9,519,327	74%

*Carryovers from FY2022/23 = \$487,580. Remaining budget adjustments are due to reallocation of employee services from Non-Departmental. Net Budget Impact = \$0

POLICE DEPARTMENT	FY2023/24 ADOPTED BUDGET	BUDGET ADJUSTMENTS	FY2023/24 AMENDED BUDGET	ACTUAL RESULTS MARCH 2024	% Of Budget
Police Department	\$54,209,820	\$957,815*	\$55,167,635	\$39,717,818	72%

*Approved March 20, 2024 – reduced allocations to the utility funds of \$870,000. Remaining budget adjustments are due to reallocation of employee services from Non-Departmental. Net Budget Impact = \$0

FIRE DEPARTMENT	FY2023/24 ADOPTED BUDGET	BUDGET ADJUSTMENTS	FY2023/24 AMENDED BUDGET	ACTUAL RESULTS MARCH 2024	% Of Budget
Fire Department	\$33,599,220	\$907,215*	\$34,506,435	\$24,492,795	71%

*Approved March 20, 2024 – reduced allocations to the utility funds of \$630,000. Approved March 20, 2024 – increase in M&O offset by reimbursements from CalOES of \$217,750. Remaining budget adjustments are due to reallocation of employee services from Non-Departmental. Net Budget Impact = \$0

CENTER FOR THE ARTS	FY2023/24 ADOPTED BUDGET	BUDGET ADJUSTMENTS	FY2023/24 AMENDED BUDGET	ACTUAL RESULTS MARCH 2024	% Of Budget
California Center for the Arts	\$3,247,370	\$-	\$3,247,370	\$2,504,079	77%

GENERAL FUND RESERVES

In December 2015, City Council adopted a Fund Balance Policy and established a General Fund target Reserve balance of 25% of General Fund operating revenues in order to maintain adequate levels of fund balance. This goal is based on a risk-based analysis to mitigate current and future risks, adequately provide for cash flow requirements, and to fund one-time unanticipated expenditure requirements.

Total General Fund budgeted operating revenue in FY2023/24 is \$127,403,060 and 25% of this amount is \$29,982,308. The current General Fund Reserve balance is \$17,392,319, or 14% of budgeted operating revenue, which is below the identified acceptable risk-based analysis adopted by City Council and general government practices.

Section 115 Irrevocable Pension Trust Fund

In February 2018, City Council authorized the establishment of a Section 115 Irrevocable Pension Trust Fund. The Trust Fund is used to set aside and hold money to meet future pension liabilities and can be used to provide economic relief during recessionary cycles and/or rate increases that are significantly above anticipated projected employee rate increases. Funds placed in this Trust can also be used to offset the City's "normal" CalPERS costs, such that if funds are necessary for other purposes, a certain amount of flexibility is present. Another benefit is that funds held in the Trust can be invested in the same manner as funds in a typical pension fund rather than as part of the City's General Fund, which means a potentially higher rate of return.

When the Pension Trust Fund was established, a funding policy for contributions to the Fund was recommended and included the four years of annual Successor Agency Redevelopment Loan Repayments of \$14 million that began in FY2018/19, future proceeds from the sale of City Property belonging to the General Fund, and a portion of General Fund surplus at the end of each fiscal year, if one exists.

On March 31, 2024, the Section 115 Pension Trust Fund had a balance of \$34,143,093 which included City contributions of \$31,257,650 plus investment earnings net of expenses of \$2,885,443. The Trust Fund has a 3-year rate of return of 1.20%, a 1-year rate of return of 9.69%, and a 3-month rate of return of 2.46%.

The following table provides a summary of the activity since the establishment of the Trust Fund.

<i>Section 115 Pension Trust Fund</i>	
<i>Initial Deposit – General Fund</i>	\$1,984,000
<i>General Fund Operating Results (5 years)</i>	20,705,235
<i>Successor Agency Advance Repayments</i>	8,568,415
<i>Investment Earnings, net of expenses</i>	2,885,443
<i>Balance as of March 31, 2024</i>	\$34,143,093

FOR MORE INFORMATION

This summary report is based on detailed information generated by the City's Finance department. If you have any questions or would like additional information on this report, please contact the Finance department at (760) 839-4676 or visit www.escondido.org.



CITY of ESCONDIDO
FUTURE AGENDA

5/22/2024

PROCLAMATION: CAMERON CURRY DAY, MAY 22, 2024

CONSENT CALENDAR - (J. SCHOENECK) - FARMERS MARKET OPERATING AGREEMENT - Request that the City Council approve the Operating Agreement for the Sunday/Tuesday farmers market.

ESSENTIAL SERVICE:

COUNCIL PRIORITY: INCREASE RETENTION AND ATTRACTION OF PEOPLE AND BUSINESSES TO ESCONDIDO

CONSENT CALENDAR - (C. MCKINNEY) - RICK ENGINEERING PROFESSIONAL SERVICES - It is requested that the City Council approve the contract services for staff augmentation to process development reviews for Storm Water, Planning, Land Development and Real Property documents.

ESSENTIAL SERVICE: YES, LAND USE/DEVELOPMENT

COUNCIL PRIORITY: Encourage Housing Development

CONSENT CALENDAR - (J. PERPETUA) - ADOPTION OF MASTER SERVICE AGREEMENT WITH ORIGAMI RISK FOR RISK MANAGEMENT INFORMATION

ESSENTIAL SERVICES: YES - INTERNAL REQUIREMENT

COUNCIL PRIORITY:

CONSENT CALENDAR - (R.VAN DE HEY) - COMPUTER REPLACEMENT PURCHASE

ESSENTIAL SERVICES: YES - INTERNAL REQUIREMENT

WORKSHOP - (C. HOLMES) - OPERATING BUDGET

ESSENTIAL SERVICE: YES - INTERNAL REQUIREMENT

COUNCIL PRIORITY: ELIMINATE STRUCTURAL DEFICIT

CURRENT BUSINESS - (C.HOLMES) - CIP BUDGET REPORT

CURRENT BUSINESS - (M. MCGUINNESS/C. MCKINNEY) - CCAE MANAGEMENT AGREEMENT

ESSENTIAL SERVICE:

COUNCIL PRIORITY: ELIMINATE STRUCTURAL DEFICIT; INCREASE RETENTION AND ATTRACTION OF PEOPLE AND BUSINESSES TO ESCONDIDO

CURRENT BUSINESS - (M. MCGUINNESS/J. SCHOENECK) - LS&S MANAGEMENT AGREEMENT

ESSENTIAL SERVICE:

COUNCIL PRIORITY: ELIMINATE STRUCTURAL DEFICIT; INCREASE RETENTION AND ATTRACTION OF PEOPLE AND BUSINESSES TO ESCONDIDO

5/29/2024 - NO MEETING (MEMORIAL DAY)