



Historic Preservation Commission Meeting Agenda

Wednesday, April 26, 2023 at 4:00 PM

City Hall, 102 Sherman Street, Deadwood, SD 57732

1. **Call Meeting to Order**
2. **Roll Call**
3. **Approval of Minutes**
 - a. [Minutes of April 12, 2023 Meeting](#)
4. **Voucher Approvals**
 - a. [HP Operating Vouchers](#)
 - b. [HP Grant Voucher](#)
 - c. [HP Revolving Vouchers](#)
5. **HP Programs and Revolving Loan Program**
 - a. [HP Loan Requests](#)
 - Larry & Marci Shama - 51 Van Buren - Retaining Wall Loan
 - Aaron Sternhagen - 318 Williams - Retaining Wall Loan
 - Tom & Nyla Griffith - 21 Lincoln - Life Safety Loan
 - Ron & Tate Underhill - 33 Taylor - Windows Extension
 - Cody Emrick/Emrick Real Estate - 9 Shine - Retaining Wall Loan Extension
 - Bonnie Fosso - 170 Pleasant - Life Safety Loan Extension
6. **Old or General Business**
 - a. [2023 Scholarship Recipients Presentation](#)
 - Cody Rogers
 - Jagger Livengood
 - Emily Thomas
 - b. [Replace failing large format scanner for City Archives](#)
 - c. [Records Research for GIS Layer](#)
7. **New Matters Before the Deadwood Historic District Commission**
8. **New Matters Before the Deadwood Historic Preservation Commission**
9. **Items from Citizens not on Agenda**

(Items considered but no action will be taken at this time.)
10. **Staff Report**

(Items considered but no action will be taken at this time.)
11. **Committee Reports**

(Items considered but no action will be taken at this time.)

12. **Adjournment**

Note: *All Applications MUST arrive at the City of Deadwood Historic Preservation Office by 5:00 p.m. MST on the 1st or 3rd Wednesday of every month in order to be considered at the next regularly scheduled Historic Preservation Commission Meeting.*

Please practice the CDC's social distancing recommendations

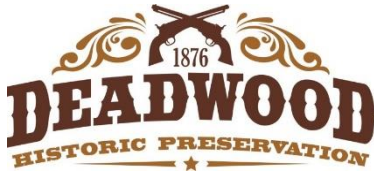

Historic Preservation Commission Meeting Minutes

Wednesday, April 12, 2023 at 4:00 PM

City Hall, 102 Sherman Street, Deadwood, SD 57732

1. Call Meeting to Order

A quorum present, Commission Chair Posey called the Deadwood Historic Preservation Commission meeting to order on April 12, 2023 at 4:00 p.m.

2. Roll Call

PRESENT

HP Commission Chair Bev Posey

HP Commission Vice Chair Leo Diede

HP Commissioner Trevor Santochi

HP Commissioner Jill Weber

City Commissioner Charlie Struble-Mook

ABSENT

HP Commission 2nd Vice Chair Robin Carmody

HP Commissioner Tony Williams

HP Commissioner Vicki Dar

STAFF PRESENT

Kevin Kuchenbecker, Historic Preservation Officer

Bonny Anfinson, Program Coordinator

Mike Walker, Director, Neighborworks

3. Approval of Minutes

a. Minutes of the March 22, 2023 Meeting

It was moved by Commissioner Diede and seconded by Commissioner Santochi to approve the minutes of the March 22, 2023 meeting. Voting Yea: Posey, Diede, Santochi, Weber.

4. Voucher Approvals

a. HP Operating Vouchers

It was moved by Commissioner Diede and seconded by Commissioner Santochi to approve the HP Operating Vouchers in the amount of \$47,093.77. Voting Yea: Posey, Diede, Santochi, Weber.

b. HP Grant Vouchers

It was moved by Commissioner Diede and seconded by Commissioner Santochi to approve the HP Grant Vouchers in the amount of \$1,535.06. Voting Yea: Posey, Diede, Santochi, Weber.

- c. HP Revolving Vouchers

It was moved by Commissioner Santochi and seconded by Commissioner Diede to approve the HP Revolving Vouchers in the amount of \$34,230.91. Voting Yea: Posey, Diede, Santochi, Weber.

5. HP Programs and Revolving Loan Program

6. Old or General Business

- a. Request from KR Deadwood Sherman Street 2020, LLC to be entered into the Historic Façade Easement Program for the façades at 51, 53, 55 Sherman Street, Deadwood, SD.

Mr. Kuchenbecker stated this new application is for tuck pointing and brick repair, window repair and replacement, installation of fabric awnings, replace store front broken glass, replace exterior wooden doors with wooden doors and paint all the windows. As per the program requirements: the standard maximum amount per building is 80 percent of the qualified expenditures. The standard amount is not to exceed \$3,000 per linear foot of prominent façade frontage and \$1,000 per linear foot for the secondary façade. Based on the linear footage the maximum funds allowed for this project would be \$427,000.00. Staff has reviewed this request and would recommend accepting the tuck pointing and brick repair, installation of fabric awnings, replace store front broken glass, replace exterior wooden doors with wooden replica doors and paint all the windows for a total cost of \$268,000.00 as qualified expenses. The cost of the window replacement in the amount of \$256,500.00 was previously denied as part of the original easement request. It would be up to the Commission to determine if the replacement windows would be part of the qualified expense. The total project is estimated at \$11,000,000.00. The total façade is \$427,000.00 on the application. The applicant is here if you have any questions. Commissioner Santochi stated he concurs with staff's recommendation in that the windows should not be included. Can we approve this without the windows? Mr. Kuchenbecker stated you can approve without the windows. Staff stated the windows were denied by this commission previously. Mr. Kuchenbecker stated because we only have four commissioners present the vote would have to be unanimous otherwise the motion fails. Then you would have to do a second motion. I would recommend if it fails to continue this item so there would be a full board for consideration. Chair Posey stated I don't believe we should be paying for these windows as quietly agreed to when this plan was made. Commissioner Santochi stated that was his understanding as well. Mr. Kuchenbecker stated so everyone understands quietly made means communicated in the project approval. Mr. Keating, property owner, stated thank you very much, we appreciate your support. We are excited to show you the building as it progresses. We are planning on opening on July 1. We appreciate your service. The City staff has been great to work with. Mr. Kuchenbecker stated the interior ghost mural will be done in May and once tuckpointing is complete the exterior ghost murals will be done. ***It was moved by Commissioner Santochi and seconded by Commissioner Diede to accept the application from KR Deadwood Sherman Street 2020, LLC for the Historic Façade Easement Program for 51, 53 and 55 Sherman Street for tuck pointing and brick repair, installation of fabric***

awnings, replace store front broken glass, replace exterior wooden doors with wooden doors and paint all the windows and to not include the window replacement costs for a total qualified amount of \$268,000.00. Voting Yea: Posey, Diede, Santochi, Weber.

b. 2023 Scholarship Program Recipient Approval

Mr. Kuchenbecker stated the Projects Committee reviewed the 2023 scholarship applications. There were twelve applicants. The Committee recommends accepting Cody Rogers and Jagger Livengood into the \$1,000 scholarship fund and Emily Thomas into the \$500 vocational scholarship fund. ***It was moved by Commissioner Diede and seconded by Commissioner Santochi to approve the applications from Cody Rogers and Jagger Livengood for a \$1,000 scholarship each and Emily Thomas for a \$500 scholarship for the 2023 Scholarship Program as budgeted in this fiscal year. Voting Yea: Posey, Diede, Santochi, Weber.***

7. New Matters Before the Deadwood Historic District Commission

a. COA 230023 - KR Deadwood Sherman St. 2020 LLC - 53 Sherman St. - Install Fabric Awnings

Mr. Kuchenbecker stated the applicant is requesting permission to add three fixed fabric awnings to the middle building and one fixed awning on back of the building. Staff verified it is a Forest Green canvas fabric material, Sunbrella. The proposed work and changes does not encroach upon, damage or destroy a historic resource nor does it have an adverse effect on the character of the building or the historic character of the State and National Register Historic Districts or the Deadwood National Historic Landmark District. ***It was moved by Commissioner Santochi and seconded by Commissioner Weber based upon the guidance found in DCO 17.68.050, I find that the exterior alteration proposed is congruous with the historical, architectural, archaeological or cultural aspects of the district and move to grant Certification of Appropriateness. Voting Yea: Posey, Diede, Santochi, Weber.***

8. New Matters Before the Deadwood Historic Preservation Commission

9. Items from Citizens not on Agenda

(Items considered but no action will be taken at this time.)

10. Staff Report

(Items considered but no action will be taken at this time.)

Mr. Kuchenbecker stated Mike Runge has Job Corp interns starting next Tuesday. We had the pre-bid for the Event Complex Concession Building. We have several retaining walls out to bid and the wall at 20 Denver has collapsed onto the street. The engineer is coming up next week to look at it. Working on a new zoning map for the city website. The FEMA project is on the City Commission agenda to go out for bid. The pre-con meeting is this Friday for Tim Lane Bridge project. The State Historic Preservation Society Conference is next week.

11. Committee Reports

(Items considered but no action will be taken at this time.)

Commissioner Santochi stated the plant swap is May 25. There will be free pet licensing and vaccinations. They plan to bring back the farmer's market.

Commission Posey stated the Butt Brigade is May 23.

12. Adjournment

The Historic Preservation Commission Meeting adjourned at 4:28 p.m.

ATTEST:

Chairman, Historic Preservation Commission

Minutes by Bonny Anfinson, Program Coordinator

13.

Note: All Applications **MUST** arrive at the City of Deadwood Historic Preservation Office by 5:00 p.m. MST on the 1st or 3rd Wednesday of every month in order to be considered at the next regularly scheduled Historic Preservation Commission Meeting.

Please practice the CDC's social distancing recommendations

Historic Preservation Commission

Bill List - 2023

OPERATING ACCOUNT: Historic Preservation	
HP Operating Account Total:	\$ 193,988.21

Approved by _____ on ____/____/____
HP Chairperson

HPC	04/26/23
Batch	05/02/23

PACKET: 06143 05/02/23 - HP OPERATING -
 VENDOR SET: 01 CITY OF DEADWOOD
 SEQUENCE : ALPHABETIC
 DUE TO/FROM ACCOUNTS SUPPRESSED

-----ID-----			GROSS	P.O. #		
POST DATE	BANK CODE	-----DESCRIPTION-----	DISCOUNT	G/L ACCOUNT	-----ACCOUNT NAME-----	DISTRIBUTION
=====						
01-0776	ALBERTSON ENGINEERING, INC.					
I-18846		540 MAIN BROADWAY RETAIN WALL	6,175.55			
5/02/2023	FNBAP	DUE: 5/05/2023 DISC: 5/05/2023		1099: N		
		540 MAIN BROADWAY RETAIN WALL		215 4577-755	CAPITAL ASSETS RETAINING	6,175.55
		=== VENDOR TOTALS ===	6,175.55			
=====						
01-4711	AMAZON CAPITAL SERVICES					
I-1L3L-P3VL-4RTN		DOC SCAN-AR POSTITS-HP CRMR-P	225.56			
5/02/2023	FNBAP	DUE: 5/02/2023 DISC: 5/02/2023		1099: N		
		PORTABLE DOCUMENT SCANNER-ARCH		215 4573-335	HIST. INTERP. ARCHIVE DE	199.00
		POST IT NOTES - HP		215 4641-426	SUPPLIES	12.57
		FRENCH VANILLA CREAMER - PB		101 4192-426	SUPPLIES	13.99
I-1WCW-3CC1-19XV		BUS CARD HLDR-HP CAR CHRGR-ST	46.98			
5/02/2023	FNBAP	DUE: 5/02/2023 DISC: 5/02/2023		1099: N		
		16 PCKT BUSINESS CARD HLDR-HP		215 4641-426	SUPPLIES	37.99
		USB CAR CHARGER - STREETS		101 4310-426	SUPPLIES	8.99
		=== VENDOR TOTALS ===	272.54			
=====						
01-4880	DAR, VICKI					
I-042623		HIST CONF TRAVEL REIMBURSEMEN	196.74			
5/02/2023	FNBAP	DUE: 5/02/2023 DISC: 5/02/2023		1099: N		
		HIST CONF TRAVEL REIMBURSEMENT		215 4641-427	TRAVEL	196.74
		=== VENDOR TOTALS ===	196.74			
=====						
01-0951	DEADWOOD ALIVE					
I-1300-23		APRIL 2023	20,000.00			
4/26/2023	FNBAP	DUE: 5/26/2023 DISC: 5/26/2023		1099: N		
		APRIL 2023		215 4573-345	HIST. INTERP. LIVING HIS	20,000.00
		=== VENDOR TOTALS ===	20,000.00			
=====						
01-0475	DEADWOOD CHAMBER & VISITORS BU					
I-041223HP		BILL LIST FOR APRIL 26, 2023	164,081.56			
5/02/2023	FNBAP	DUE: 5/02/2023 DISC: 5/02/2023		1099: N		
		2ND QUARTER H&IC		215 4572-215	VISITOR MGMT HISTORY/INF	17,500.00
		HPC MARKETING		215 4572-210	VISITOR MGMT MARKETING	146,581.56
		=== VENDOR TOTALS ===	164,081.56			

PACKET: 06143 05/02/23 - HP OPERATING -

VENDOR SET: 01 CITY OF DEADWOOD

SEQUENCE : ALPHABETIC

DUE TO/FROM ACCOUNTS SUPPRESSED

-----ID-----			GROSS	P.O. #		
POST DATE	BANK CODE	-----DESCRIPTION-----	DISCOUNT	G/L ACCOUNT	-----ACCOUNT NAME-----	DISTRIBUTION
=====						
01-4976	EAGLESON, CHARLES					
I-042623		HIST CONF TRAVEL REIMBURSEMEN	34.00			
5/02/2023	FNBAP	DUE: 5/02/2023 DISC: 5/02/2023		1099: Y		
		HIST CONF TRAVEL REIMBURSEMENT		215 4641-427	TRAVEL	34.00
=== VENDOR TOTALS ===			34.00			
=====						
01-2742	LEAD-DEADWOOD BASEBALL ASSOCIA					
I-042623		2023 SIGN RENEWAL	250.00			
5/02/2023	FNBAP	DUE: 5/02/2023 DISC: 5/02/2023		1099: N		
		2023 SIGN RENEWAL		215 4572-235	VISITOR MGMT ADVOCATE	250.00
=== VENDOR TOTALS ===			250.00			
=====						
01-1827	MS MAIL & MARKETING					
I-13783HP		APRIL NEWSLETTER	672.97			
5/02/2023	FNBAP	DUE: 5/02/2023 DISC: 5/02/2023		1099: Y		
		APRIL NEWSLETTER		215 4641-423	PUBLISHING	672.97
=== VENDOR TOTALS ===			672.97			
=====						
01-1838	RAMKOTA HOTEL					
I-1083UO		HISTORY CONF - TREVOR SANTOCH	108.00			
5/02/2023	FNBAP	DUE: 5/02/2023 DISC: 5/02/2023		1099: N		
		HISTORY CONF - TREVOR SANTOCHI		215 4641-427	TRAVEL	108.00
I-1083UP		HISTORY CONF - MIKE RUNGE	108.00			
5/02/2023	FNBAP	DUE: 5/02/2023 DISC: 5/02/2023		1099: N		
		HISTORY CONF - MIKE RUNGE		215 4641-427	TRAVEL	108.00
I-1083UQ		HISTORY CONF - VICKI DAR	216.00			
5/02/2023	FNBAP	DUE: 5/02/2023 DISC: 5/02/2023		1099: N		
		HISTORY CONF - VICKI DAR		215 4641-427	TRAVEL	216.00
I-1083UR		HISTORY CONF - LEO DIEDE	108.00			
5/02/2023	FNBAP	DUE: 5/02/2023 DISC: 5/02/2023		1099: N		
		HISTORY CONF - LEO DIEDE		215 4641-427	TRAVEL	108.00
I-1083US		HISTORY CONF - BONNY ANFINSON	108.00			
5/02/2023	FNBAP	DUE: 5/02/2023 DISC: 5/02/2023		1099: N		
		HISTORY CONF - BONNY ANFINSON		215 4641-427	TRAVEL	108.00
=== VENDOR TOTALS ===			648.00			

PACKET: 06143 05/02/23 - HP OPERATING -

VENDOR SET: 01 CITY OF DEADWOOD

SEQUENCE : ALPHABETIC

DUE TO/FROM ACCOUNTS SUPPRESSED

-----ID-----			GROSS	P.O. #		
POST DATE	BANK CODE	-----DESCRIPTION-----	DISCOUNT	G/L ACCOUNT	-----ACCOUNT NAME-----	DISTRIBUTION
=====						
01-0451	RUNGE, MIKE					
I-042623		HIST CONF TRAVEL REIMBURSEMEN	14.00			
5/02/2023	FNBAP	DUE: 5/02/2023 DISC: 5/02/2023		1099: N		
		HIST CONF TRAVEL REIMBURSEMENT		215 4641-427	TRAVEL	14.00
		=== VENDOR TOTALS ===	14.00			
=====						
01-4632	SANTOCHI, TREVOR					
I-042623		HIST CONF TRAVEL REIMBURSEMEN	170.74			
5/02/2023	FNBAP	DUE: 5/02/2023 DISC: 5/02/2023		1099: Y		
		HIST CONF TRAVEL REIMBURSEMENT		215 4641-427	TRAVEL	170.74
		=== VENDOR TOTALS ===	170.74			
=====						
01-1406	STRETCH'S GLASS & CUSTOM PARTS					
I-1024346		DISPLAY GLASS CITY HALL - ARC	1,236.71			
5/02/2023	FNBAP	DUE: 5/02/2023 DISC: 5/02/2023		1099: N		
		DISPLAY GLASS CITY HALL - ARCH		215 4573-335	HIST. INTERP. ARCHIVE DE	1,236.71
I-1024347		DISPLAY EDGE CITY HALL- ARCH	235.40			
5/02/2023	FNBAP	DUE: 5/02/2023 DISC: 5/02/2023		1099: N		
		DISPLAY EDGE CITY HALL- ARCH		215 4573-335	HIST. INTERP. ARCHIVE DE	235.40
		=== VENDOR TOTALS ===	1,472.11			
		=== PACKET TOTALS ===	193,988.21			

PACKET: 06143 05/02/23 - HP OPERATING -
 VENDOR SET: 01 CITY OF DEADWOOD
 SEQUENCE : ALPHABETIC
 DUE TO/FROM ACCOUNTS SUPPRESSED

** T O T A L S **

INVOICE TOTALS	193,988.21
DEBIT MEMO TOTALS	0.00
CREDIT MEMO TOTALS	0.00

BATCH TOTALS	193,988.21
--------------	------------

** G/L ACCOUNT TOTALS **

BANK	YEAR	ACCOUNT	NAME	AMOUNT	=====LINE ITEM=====		=====GROUP BUDGET=====	
					ANNUAL BUDGET	BUDGET OVER AVAILABLE BUDG	ANNUAL BUDGET	BUDGET OVER AVAILABLE BUDG
	2023	101-2020	ACCOUNTS PAYABLE	22.98-*				
		101-4192-426	SUPPLIES	13.99	72,000		66,549.15	
		101-4310-426	SUPPLIES	8.99	140,000		72,356.75	
		215-2020	ACCOUNTS PAYABLE	193,965.23-*				
		215-4572-210	VISITOR MGMT MARKETING	146,581.56	414,000		248,756.83	799,000 566,755.53
		215-4572-215	VISITOR MGMT HISTORY/INF	17,500.00	70,000		35,000.00	799,000 695,837.09
		215-4572-235	VISITOR MGMT ADVOCATE	250.00	200,000		150,248.70	799,000 713,087.09
		215-4573-335	HIST. INTERP. ARCHIVE DE	1,671.11	40,600		32,340.52	
		215-4573-345	HIST. INTERP. LIVING HIS	20,000.00	148,000		114,000.00	
		215-4577-755	CAPITAL ASSETS RETAINING	6,175.55	400,000		387,135.07	
		215-4641-423	PUBLISHING	672.97	15,000		12,948.28	
		215-4641-426	SUPPLIES	50.56	15,000		13,502.31	
		215-4641-427	TRAVEL	1,063.48	7,500		1,313.01	
		999-1301	DUE FROM FUND 101	22.98 *				
		999-1306	DUE FROM FUND 215	193,965.23 *				
			** 2023 YEAR TOTALS	193,988.21				

4/26/2023 12:24 PM

A/P Regular Open Item Register

Section 4 Item a.

PACKET: 06143 05/02/23 - HP OPERATING -
VENDOR SET: 01 CITY OF DEADWOOD
SEQUENCE : ALPHABETIC
DUE TO/FROM ACCOUNTS SUPPRESSED

** POSTING PERIOD RECAP **

FUND	PERIOD	AMOUNT
101	5/2023	22.98
215	4/2023	20,000.00
215	5/2023	173,965.23

NO ERRORS NO WARNINGS

** END OF REPORT **

TOTAL ERRORS: 0 TOTAL WARNINGS: 0

Historic Preservation Commission 2023 Grant Funds

HP GRANT ACCOUNT: Historic Preservation	
HP Grant Account Total:	\$ 2,190.91

Approved by _____ on ___/___/___
HP Chairperson

Approved by _____ on ___/___/___
HP Officer

HPC	04/26/23
Batch	05/02/23

PACKET: 06150 05/02/23 - HP GRANTS - BA

VENDOR SET: 01 CITY OF DEADWOOD

SEQUENCE : ALPHABETIC

DUE TO/FROM ACCOUNTS SUPPRESSED

-----ID-----			GROSS	P.O. #		
POST DATE	BANK CODE	-----DESCRIPTION-----	DISCOUNT	G/L ACCOUNT	-----ACCOUNT NAME-----	DISTRIBUTION
=====						
01-2849		DAKOTA LUMBER CO				
<hr/>						
I-2304-240590		18 DENVER DRUMMOND	2,190.91			
5/02/2023	FNBAP	DUE: 5/02/2023 DISC: 5/02/2023		1099: N		
		18 DENVER DRUMMOND		216 4653-962-03	WINDOWS GRANT EXPENSE	1,809.86
		18 DENVER DRUMMOND		216 4653-962-04	SIDING GRANT EXPENSE	381.05
		=== VENDOR TOTALS ===	2,190.91			
		=== PACKET TOTALS ===	2,190.91			

PACKET: 06150 05/02/23 - HP GRANTS - BA

VENDOR SET: 01 CITY OF DEADWOOD

SEQUENCE : ALPHABETIC

DUE TO/FROM ACCOUNTS SUPPRESSED

** T O T A L S **

INVOICE TOTALS	2,190.91
DEBIT MEMO TOTALS	0.00
CREDIT MEMO TOTALS	0.00

BATCH TOTALS	2,190.91
--------------	----------

** G/L ACCOUNT TOTALS **

BANK	YEAR	ACCOUNT	NAME	AMOUNT	=====LINE ITEM=====		=====GROUP BUDGET=====	
					ANNUAL BUDGET	BUDGET OVER AVAILABLE BUDG	ANNUAL BUDGET	BUDGET OVER AVAILABLE BUDG
	2023	216-2020	ACCOUNTS PAYABLE	2,190.91-*				
		216-4653-962-03	WINDOWS GRANT EXPENSE	1,809.86	80,000		78,107.59	
		216-4653-962-04	SIDING GRANT EXPENSE	381.05	60,000		59,283.03	
		999-1307	DUE FROM FUND 216	2,190.91 *				
			** 2023 YEAR TOTALS	2,190.91				

4/26/2023 9:52 AM

A/P Regular Open Item Register

Section 4 Item b.

PACKET: 06150 05/02/23 - HP GRANTS - BA

VENDOR SET: 01 CITY OF DEADWOOD

SEQUENCE : ALPHABETIC

DUE TO/FROM ACCOUNTS SUPPRESSED

** POSTING PERIOD RECAP **

FUND	PERIOD	AMOUNT
216	5/2023	2,190.91

NO ERRORS

NO WARNINGS

** END OF REPORT **

TOTAL ERRORS: 0 TOTAL WARNINGS: 0

4/26/2023 11:17am

HP REVOLVING LOAN FUND
 A/P Invoices Report
 4/1/2023 - 4/30/2023
 Batch = 2

Page 1 of 2

Detail Memo	Fund	Acct	Cc1	Cc2	Cc3	Acct Description	Debit	Credit
04/2023								
Keith Umenthum - 982271 - 4/26/2023 - 396.78 - Batch: 2 - Header Memo: Work Done-770 Main St-Dragon Belly								
Work Done-770 Main St-Dragon Belly	100	1201				NOTES RECEIVABLE	396.78	
Work Done-770 Main St-Dragon Belly	100	2000				ACCOUNTS PAYABLE		396.78
Total:							396.78	396.78
Keith Umenthum - 982272 - 4/26/2023 - 902.70 - Batch: 2 - Header Memo: Work Done-772 Main St-Dragon Belly								
Work Done-772 Main St-Dragon Belly	100	1201				NOTES RECEIVABLE	902.70	
Work Done-772 Main St-Dragon Belly	100	2000				ACCOUNTS PAYABLE		902.70
Total:							902.70	902.70
SoDak Title - OE-0154-23 - 4/26/2023 - 120.00 - Batch: 2 - Header Memo: OE Report-318 Williams-Sternhagen								
OE Report-318 Williams-Sternhagen	100	5200				CLOSING COSTS DISBURSED	120.00	
OE Report-318 Williams-Sternhagen	100	2000				ACCOUNTS PAYABLE		120.00
Total:							120.00	120.00
SoDak Title - OE-0155-23 - 4/26/2023 - 120.00 - Batch: 2 - Header Memo: OE Report-21-25 Lincoln-Griffith								
OE Report-21-25 Lincoln-Griffith	100	5200				CLOSING COSTS DISBURSED	120.00	
OE Report-21-25 Lincoln-Griffith	100	2000				ACCOUNTS PAYABLE		120.00
Total:							120.00	120.00
SoDak Title - OE-0157-23 - 4/26/2023 - 120.00 - Batch: 2 - Header Memo: OE Report-51 Van Buren-Shama								
OE Report-51 Van Buren-Shama	100	5200				CLOSING COSTS DISBURSED	120.00	
OE Report-51 Van Buren-Shama	100	2000				ACCOUNTS PAYABLE		120.00
Total:							120.00	120.00
The FHT Company, LLC - VARIOUS - 4/26/2023 - 5,436.57 - Batch: 2 - Header Memo: Work and Materials-7 Emery-Bobolz								
Work and Materials-7 Emery-Bobolz	100	1201				NOTES RECEIVABLE	5,436.57	

4/26/2023 11:17am

HP REVOLVING LOAN FUND
 A/P Invoices Report
 4/1/2023 - 4/30/2023
 Batch = 2

Page 2 of 2

Detail Memo	Fund	Acct	Cc1	Cc2	Cc3	Acct Description	Debit	Credit
04/2023 (cont'd from page 1)								
The FHT Company, LLC - VARIOUS - 4/26/2023 - 5,436.57 - Batch: 2 - Header Memo: Work and Materials-7 Emery-Bobolz (cont'd from page 1)								
Work and Materials-7 Emery-Bobolz	100	2000				ACCOUNTS PAYABLE		5,436.57
Total:							5,436.57	5,436.57
The FHT Company, LLC - VARIOUS 41723 - 4/26/2023 - 9,715.74 - Batch: 2 - Header Memo: Work and Materials-57 Van Buren-Bobolz								
Work and Materials-57 Van Buren-Bobolz	100	1201				NOTES RECEIVABLE	9,715.74	
Work and Materials-57 Van Buren-Bobolz	100	2000				ACCOUNTS PAYABLE		9,715.74
Total:							9,715.74	9,715.74
Total:							16,811.79	16,811.79
Report Total:							16,811.79	16,811.79

With Cut Off Days From 30 Through 9999
NHS of Black Hills

Loan #	Interest Paid To	Next Due	Scheduled Payment	Late Fees Accrued	NSF Fees Accrued	Past Due Interest	Past Due Principal	Total Due	Current Balance	Suspense /Partial Balance	Impound Balance	Aging Days
>>> Investor: HP	NHS Revolving Loan,											
CHPRRW0ER	08/22/2022	03/01/2023	0.00	0.00	0.00	0.00	-2368.69	-2368.69	2368.69	0.00	0.00	56

Last Worked: / / By: Action Date: / / Work Date: / /
 Flags: 982 Collector Code: Loan Officer:
 Home Telephone: (307) 290-2261 Work Telephone: Last Transaction: 08/22/2022
 Borrower: Emrick Real Estate Group, LL,

Extension requested 04.26.2023

Totals:	Scheduled Payment	Late Fees Accrued	NSF Fees Accrued	Past Due Interest	Past Due Principal	Total Due	Current Balance	Suspense /Partial Balance	Impound Balance
	0.00	0.00	0.00	0.00	-2368.69	-2368.69	2368.69	0.00	0.00

Range Of Days:	11 Through 29	30 Through 59	60 Through 89	90 Plus	Total
Number Of Accounts	0.00	1.00	0.00	0.00	1.00
Late Charge Due	0.00	0.00	0.00	0.00	0.00
NSF Charge Due	0.00	0.00	0.00	0.00	0.00
Interest Due	0.00	0.00	0.00	0.00	0.00
Principal Due	0.00	-2368.69	0.00	0.00	-2368.69
Total Amount Due	0.00	-2368.69	0.00	0.00	-2368.69
Balances Due	0.00	2368.69	0.00	0.00	2368.69
Suspense/Partial Balance	0.00	0.00	0.00	0.00	0.00
Impound Balances	0.00	0.00	0.00	0.00	0.00
Percent Delinquent (\$)	0.0000	0.1134	0.0000	0.0000	0.1134
Percent Delinquent (#)	0.0000	0.6993	0.0000	0.0000	0.6993
Number Of Active Loans	143	Total Active Loan Balance		2089431.61	

With Cut Off Days From 30 Through 9999
NHS of Black Hills

Loan #	Interest Paid To	Next Due	Scheduled Payment	Late Fees Accrued	NSF Fees Accrued	Past Due Interest	Past Due Principal	Total Due	Current Balance	Suspense /Partial Balance	Impound Balance	Aging Days
>>> Investor: HPRW Deadwood H.P. RW,												
CHPRRWCEM	08/23/2022	03/01/2023	0.00	0.00	0.00	0.00	0.00	0.00	3675.38	0.00	0.00	56

Last Worked: / / By: Action Date: / / Work Date: / /
 Flags: 982 Collector Code: Loan Officer:
 Home Telephone: (307) 290-2261 Work Telephone: (307) 290-2261 Last Transaction: 08/23/2022
 Borrower: Emrick Real Estate Group, LL,

Extension requested 04.26.2023

Totals:	Scheduled Payment	Late Fees Accrued	NSF Fees Accrued	Past Due Interest	Past Due Principal	Total Due	Current Balance	Suspense /Partial Balance	Impound Balance
	0.00	0.00	0.00	0.00	0.00	0.00	3675.38	0.00	0.00

Range Of Days:	11 Through 29	30 Through 59	60 Through 89	90 Plus	Total
Number Of Accounts	0.00	1.00	0.00	0.00	1.00
Late Charge Due	0.00	0.00	0.00	0.00	0.00
NSF Charge Due	0.00	0.00	0.00	0.00	0.00
Interest Due	0.00	0.00	0.00	0.00	0.00
Principal Due	0.00	0.00	0.00	0.00	0.00
Total Amount Due	0.00	0.00	0.00	0.00	0.00
Balances Due	0.00	3675.38	0.00	0.00	3675.38
Suspense/Partial Balance	0.00	0.00	0.00	0.00	0.00
Impound Balances	0.00	0.00	0.00	0.00	0.00
Percent Delinquent (\$)	0.0000	0.3880	0.0000	0.0000	0.3880
Percent Delinquent (#)	0.0000	7.1429	0.0000	0.0000	7.1429
Number Of Active Loans	14	Total Active Loan Balance	947384.25		

Deadwood HP Total Loans 3/31/2023	
Accounting Balance (Fund EZ)	This Month
Loans per Balance Sheet - Acct 100-1201	\$2,076,390.15
TOTAL	\$ 2,076,390.15
Loan Base:	This Month
Investor Trial Balance Report	\$ 2,065,890.15
	\$1,920.00 Baucom
	\$ 4,100.00 Baucom
	\$ 4,480.00 Baucom
3/22/2023 Meeting Packet	
TOTAL	\$ 2,076,390.15
	Difference \$ -

Deadwood HP Total Loans 3/31/2023	
Accounting Balance (Fund EZ)	
Loans per Balance Sheet	\$2,076,390.15
TOTAL	\$ 2,076,390.15
Loan Base:	
Pool Trial Balance Report	\$ 2,065,890.15
	\$1,920.00 Baucom
	\$ 4,100.00 Baucom
	\$ 4,480.00 Baucom
3/31/2023 Meeting Packet	
TOTAL	\$ 2,076,390.15
	Difference \$ -

4/20/2023 10:21am

HP REVOLVING LOAN FUND
Balance Sheet
As of Date: 3/31/2023

Page 1 of 1

	Current Year	Prior Year
Assets		
Current Assets		
CASH-SAVINGS	2,128,283.62	(3,941.06)
CASH-INVESTED	772,126.55	769,246.19
ACCRUED INTEREST RECEIVABLE	1,536.42	1,536.42
LATE FEES RECEIVABLE	3,986.87	3,986.87
Accounts Receivable-Haverberg	0.00	1,391,698.39
Total Current Assets	2,905,933.46	2,162,526.81
Other Assets		
NOTES RECEIVABLE	2,076,390.15	2,165,795.87
Total Other Assets	2,076,390.15	2,165,795.87
Total Assets	4,982,323.61	4,328,322.68
Liabilities & Net Assets		
Liabilities		
Current Liabilities		
Allowance for Uncollected	5,862.89	14,330.94
ACCOUNTS PAYABLE	(1,449.34)	(1,449.34)
YE Accounts Payable	1,449.34	1,449.34
Total Current Liabilities	5,862.89	14,330.94
Total Liabilities	5,862.89	14,330.94
Net Assets		
NET ASSETS	4,608,323.95	4,608,323.95
Fund Balance	56,035.78	56,035.78
NET EARNINGS(LOSS)	(1,565,629.10)	(2,228,098.08)
PRIOR YEAR EARNINGS (LOSS)	116,204.47	116,204.47
HP BUDGET	(13,474.38)	(13,474.38)
PRIOR YEAR HP BUDGET	1,775,000.00	1,775,000.00
Total Net Assets	4,976,460.72	4,313,991.74
Total Liabilities & Net Assets	4,982,323.61	4,328,322.68

4/20/2023 10:21am

HP REVOLVING LOAN FUND
Statement of Revenue and Expense
Current Period: 3/1/2023 - 3/31/2023
Year-to-Date: 1/1/2023 - 3/31/2023

Page 1 of 1

	Current Year Current Period	Current Year Year-to-Date	Prior Year Current Period	Prior Year Year-to-Date
Revenue				
PERM LOAN INTEREST	1,099.31	2,752.34	613.20	2,090.19
SAVINGS INTEREST	410.38	1,958.76	307.64	892.95
SERVICE FEES	235.00	990.00	225.00	780.00
LATE FEES	50.00	231.08	25.00	175.00
APPLICATION FEES	667.57	2,108.97	1,415.00	5,388.70
CLOSING COSTS	285.96	688.96	702.99	3,022.01
Interest Income Settlement	0.00	0.00	4,656.60	14,022.36
Total Revenue	<u>2,748.22</u>	<u>8,730.11</u>	<u>7,945.43</u>	<u>26,371.21</u>
Expenses				
PROF & ADMIN FEES	4,233.75	11,069.00	3,473.75	14,143.90
CLOSING COSTS DISBURSE	180.00	669.00	810.00	2,089.15
Elderly Grant Expense	0.00	0.00	0.00	17,581.76
Siding Grant Expense	298.31	9,326.71	0.00	0.00
Loss on asset	5,897.08	5,897.08	0.00	0.00
Total Expenses	<u>10,609.14</u>	<u>26,961.79</u>	<u>4,283.75</u>	<u>33,814.81</u>
Excess or (Deficiency) of Revenue Over Expenses	<u>(7,860.92)</u>	<u>(18,231.68)</u>	<u>3,661.68</u>	<u>(7,443.60)</u>

Time: 12:12:25
Date: 03/31/2023

TRIAL BALANCE: POOLS
Range Of Investors
All Pools
NHS of Black Hills
Version: 3.1.22

Page:
Run By: SUSAN

Investor Loan #	Loan #	Borrower	Ln Tp	Bs Cd	Int Paid To Date	Due Date	Last Tran Date	Borrower Rate	Split Rate	Investor Rate	Service Code	Service Fee	Payment Amount	Current Pool Balance	Impound Balance	Suspense Balance
>>> INVESTOR #: HP POOL #: C0 DISTRIBUTION RATE: 0.0000 COMPUTATION: Actual/Actual																
HPC0DWDH	HPC0DWDH	Deadwood Histor	2	0	03/01/23	04/01/23	03/02/23	0.0000	No	0.0000	Curr	0.0000	416.67	22645.00	0.00	0.00
LIFE SAFTY	HPLSNGT07	Nugget Saloon L	2	0	02/01/23	03/01/23	02/01/23	0.0000	No	0.0000	Curr	0.0000	165.72	29895.27	0.00	0.00
Group Totals:													582.39	52540.27	0.00	0.00
>>> INVESTOR #: HP POOL #: CUFR DISTRIBUTION RATE: 0.0000 COMPUTATION: Actual/Actual																
HPC0UFNUC	HPC0UFNUC	Nugget Saloon,	2	0	02/01/23	03/01/23	02/01/23	0.0000	No	0.0000	Curr	0.0000	694.44	229226.24	0.00	0.00
HPCUPFLA	HPCUPFLAL	Deadwood Ma'in,	2	0	03/01/23	04/01/23	03/02/23	0.0000	No	0.0000	Curr	0.0000	1041.67	239583.30	0.00	0.00
Group Totals:													1736.11	468809.54	0.00	0.00
>>> INVESTOR #: HP POOL #: R0 DISTRIBUTION RATE: 0.0000 COMPUTATION: Actual/Actual																
HPLSFOSSC	HPLSFOSSO	Fosso,Bonnie R	2	0	03/01/23	04/01/23	03/02/23	0.0000	No	0.0000	Curr	0.0000	69.45	20733.10	0.00	0.00
HPLSKIR	HPLSKIR	Kirkpatrick,Eli	2	0	04/01/23	05/01/23	03/08/23	0.0000	No	0.0000	Curr	0.0000	104.17	11965.00	0.00	0.00
HPLSRLPON	HPLSRLPON	Pontius,James	2	0	04/01/23	05/01/23	03/06/23	0.0000	No	0.0000	Curr	0.0000	113.04	2460.19	0.00	0.00
HPLSTHOM	HPLSTHOM5	Thompson, Lee	2	0	03/01/23	04/01/23	03/02/23	0.0000	No	0.0000	Curr	0.0000	103.54	18863.50	0.00	0.00
HPR0SJOM	HPR0SJOM	Sjomeling,Danie	2	0	03/01/23	04/01/23	03/13/23	0.0000	No	0.0000	Curr	0.0000	136.43	14734.29	0.00	0.00
HPRLFKN	HPRLFKN	Knipper, Anita	2	0	04/01/23	05/01/23	03/24/23	0.0000	No	0.0000	Curr	0.0000	208.33	17500.12	0.00	0.00
HPRLFLSK5	HPRLFLSK5	Knox, Shanna	2	0	03/01/23	04/01/23	02/27/23	0.0000	No	0.0000	Curr	0.0000	104.17	19895.67	0.00	0.00
HPRLLSWES	HPRLLSWES	Westendorf, Rand	2	0	03/01/23	04/01/23	03/01/23	0.0000	No	0.0000	Curr	0.0000	166.67	12980.00	0.00	0.00
LIFE SAFTY	HPRLSBLOO	Bloom, Kevin	2	0	04/01/23	05/01/23	03/27/23	0.0000	No	0.0000	Curr	0.0000	104.17	22778.16	0.00	0.00
LIFE SFTY	HPRLSBRE	Breland, Philip	2	0	12/01/23	01/01/24	11/21/22	0.0000	No	0.0000	Curr	0.0000	416.67	19999.96	0.00	0.00
HPRLSFAS	HPRLSFAS	Fasnacht, Glenn	2	0	03/01/23	04/01/23	03/03/23	0.0000	No	0.0000	Curr	0.0000	160.55	17339.56	0.00	0.00
HPRLSHERT	HPRLSHERT	Herd, David	2	0	04/01/23	05/01/23	03/30/23	0.0000	No	0.0000	Curr	0.0000	208.33	19166.76	0.00	0.00
LIFE SAFTY	HPRLSJNWM	Johnson, Michael	2	0	04/01/23	05/01/23	03/30/23	0.0000	No	0.0000	Curr	0.0000	138.89	24444.44	0.00	0.00
Life Sfty	HPRLSJHON	Johnson, Joette	2	0	01/01/23	04/01/23	01/03/23	0.0000	No	0.0000	Curr	0.0000	138.89	47071.10	0.00	0.00
HPRLSRITZ	HPRLSRITZ	Ritz, Jody	2	0	04/01/23	05/01/23	03/27/23	0.0000	No	0.0000	Curr	0.0000	51.77	6479.55	0.00	0.00
LIFE SAFTY	HPRLSTHOM	Thompson li, Mar	2	0	02/13/23	04/01/23	02/13/23	0.0000	No	0.0000	Curr	0.0000	104.17	25000.00	0.00	0.00
HPRLSTHOR	HPRLSTHOR	Thoresen, Skylar	2	0	03/01/23	04/01/23	03/08/23	0.0000	No	0.0000	Curr	0.0000	31.12	1710.88	0.00	0.00
HPRLSTREN	HPRLSTREN	Trenz, Sylvia	2	0	03/01/23	04/01/23	02/24/23	0.0000	No	0.0000	Curr	0.0000	96.47	22092.26	0.00	0.00
Life SFTY	HPRLSUNDE	Underhill, Ronal	2	0	04/01/23	05/01/23	03/30/23	0.0000	No	0.0000	Curr	0.0000	104.17	22460.34	0.00	0.00
HPRLSWEB	HPRLSWEB	Weber, Todd	2	0	04/01/23	05/01/23	03/08/23	0.0000	No	0.0000	Curr	0.0000	66.43	15079.44	0.00	0.00
HPRLRBUS	HPRLRBUS	Bussiere, Erica	2	0	01/01/23	02/01/23	01/11/23	0.0000	No	0.0000	Curr	0.0000	60.78	5833.72	0.00	0.00

Time: 12:12:25
Date: 03/31/2023

Page:
Run By: SUSAN

TRIAL BALANCE: POOLS
Range Of Investors
All Pools
NHS of Black Hills
Version: 3.1.22

Investor Loan #	Loan #	Borrower	Ln Tp	Bs Cd	Int Paid To Date	Due Date	Last Tran Date	Borrower Rate	Split Rate	Investor Rate	Service Code	Service Fee	Payment Amount	Current Pool Balance	Impound Balance	Suspense Balance
LIFE SAFETY	HPSLRUNG	Runge,Michael	2	0	04/01/23	05/01/23	03/20/23	0.0000	No	0.0000	Curr	0.0000	208.33	12600.00	0.00	0.00
Group Totals:													2898.54	381188.04	0.00	0.00
>>> INVESTOR #: HP POOL #: R3.0 DISTRIBUTION RATE: 0.0000 COMPUTATION: Actual/Actual																
PRESERVAT	HPRPRVJCH	Johnson,Michael	2	0	04/01/23	05/01/23	03/30/23	3.0000	No	3.0000	Curr	0.0000	172.65	24557.74	0.00	0.00
HPRPSVHOH	HPRPSVHOH	Hohn,John	2	0	04/01/23	05/01/23	03/30/23	3.0000	No	3.0000	Curr	0.0000	126.97	9092.25	0.00	0.00
PRESV 3	HPRPVUND3	Underhill,Ronal	2	0	04/01/23	05/01/23	03/30/23	3.0000	No	3.0000	Curr	0.0000	138.65	24617.35	0.00	0.00
HPRREFALL	HPRREFALL	Allen,Jesse	2	0	03/01/23	04/01/23	03/22/23	3.0000	No	3.0000	Curr	0.0000	103.56	17911.66	0.00	0.00
HPRREFGAT	HPRREFGAT	Galthmann,Naomi	2	0	03/01/23	04/01/23	03/10/23	3.0000	No	3.0000	Curr	0.0000	139.02	12889.09	0.00	0.00
Group Totals:													680.85	89068.09	0.00	0.00
>>> INVESTOR #: HP POOL #: R3.5 DISTRIBUTION RATE: 0.0000 COMPUTATION: Actual/Actual																
HPRPRSCH	HPRPRSCH	Schramm,Steven	2	0	04/01/23	05/01/23	03/03/23	3.5000	No	3.5000	Curr	0.0000	60.83	6631.51	0.00	0.00
Prsv 1	HPRPRSUN1	Underhill,Ronal	2	0	04/01/23	05/01/23	03/30/23	3.5000	No	3.5000	Curr	0.0000	144.99	23173.34	0.00	0.00
HPRPRVSJC	HPRPRVSJO	Sjomeling,Danie	2	0	03/01/23	04/01/23	03/13/23	3.5000	No	3.5000	Curr	0.0000	131.85	21934.61	0.00	0.00
Prsv 2	HPRPVUN2	Underhill,Ronal	2	0	04/01/23	05/01/23	03/30/23	3.5000	No	3.5000	Curr	0.0000	144.99	23594.08	0.00	0.00
Group Totals:													482.66	75333.54	0.00	0.00
>>> INVESTOR #: HP POOL #: R4 DISTRIBUTION RATE: 0.0000 COMPUTATION: Actual/Actual																
HPLSFLOYD	HPLSFLOYD	Floyd,Dustin	2	1	03/15/23	04/01/23	03/15/23	4.0000	No	4.0000	Fixed \$	0.0000	93.46	5167.49	0.00	0.00
REFI LS	HPLSLEWIS	Lewis,Tracy	2	0	03/01/23	04/01/23	03/13/23	4.0000	No	4.0000	Curr	0.0000	113.24	21308.48	0.00	0.00
HPRLFFS47	HPRLFFS47	Fosso,Bonnie R	2	0	03/01/23	04/01/23	03/02/23	4.0000	No	4.0000	Curr	0.0000	119.29	22413.07	0.00	0.00
HPRLFLWS4	HPRLFLWS4	Lewis,Tracy	2	0	03/01/23	04/01/23	03/13/23	4.0000	No	4.0000	Curr	0.0000	28.88	4750.79	0.00	0.00
PRESV	HPRPRLFJO	Johnson,Joette	2	0	01/01/23	04/01/23	01/03/23	4.0000	No	4.0000	Curr	0.0000	119.35	24210.29	0.00	0.00
HPRLMORG	HPRLMORG	Morgan,Richard	2	0	04/01/23	05/01/23	03/30/23	4.0000	No	4.0000	Curr	0.0000	247.95	17449.07	0.00	0.00
Group Totals:													720.17	95299.19	0.00	0.00
>>> INVESTOR #: HP POOL #: R5 DISTRIBUTION RATE: 0.0000 COMPUTATION: Actual/Actual																
HPRLSCHMI	HPRLSCHMI	Schmidt,Mike	2	0	03/17/23	05/01/23	03/17/23	5.0000	No	5.0000	Curr	0.0000	506.82	26402.88	0.00	0.00
Group Totals:													506.82	26402.88	0.00	0.00
>>> INVESTOR #: HP POOL #: RIP POOL INFORMATION NOT SET UP																
FOUNDATIO	CHPRFNDBY	Byrne,Tiffany	11	1	01/26/22	08/01/23	02/07/22	0.0000	No	0.0000	Curr	0.0000	0.01	0.00	0.00	0.00
FOUNDATIO	CHPRFNDSM	Smith,Gordon	11	1	10/25/22	10/01/23	10/27/22	0.0000	No	0.0000	Curr	0.0000	0.01	0.00	0.00	0.00

Time: 12:12:25
Date: 03/31/2023

TRIAL BALANCE: POOLS

Page:
Run By: SUSAN*

Range Of Investors
All Pools

NHS of Black Hills

Version: 3.1.22

Investor Loan #	Loan #	Borrower	Ln Tp	Bs Cd	Int Paid To Date	Due Date	Last Tran Date	Borrower Rate	Split Rate	Investor Rate	Service Code	Service Fee	Payment Amount	Current Pool Balance	Impound Balance	Suspense Balance
Life Sfty	CHPRLSBOB	The Fht Company	11	1	03/04/22	09/01/23	03/04/22	0.0000	No	0.0000	Curr	0.0000	0.01	1017.00	0.00	0.00
LIFE SFTY	CHPRLSBY	Byrne,Tiffany	11	1	01/26/22	08/01/23	02/07/22	0.0000	No	0.0000	Curr	0.0000	0.01	0.00	0.00	0.00
RIP- LS	CHPRLSPOT	Cara Mia Llc,Ca	11	1	11/22/22	10/01/23	11/22/22	0.0000	No	0.0000	Curr	0.0000	0.01	6940.00	0.00	0.00
Life Sfty	CHPRLSRIH	Richerson,Jacqu	11	1	06/22/22	06/01/23	02/08/23	0.0000	No	0.0000	Curr	0.0000	0.01	9602.00	0.00	0.00
Life Sfty	CHPRLSSMI	Smith,Gordon	11	1	10/27/22	10/01/23	10/27/22	0.0000	No	0.0000	Curr	0.0000	0.01	891.00	0.00	0.00
FOUNDATIO	CHPRND7EM	The Fht Company	11	1	05/04/22	09/01/23	05/04/22	0.0000	No	0.0000	Curr	0.0000	0.01	9250.00	0.00	0.00
PRESERVN	CHPRPRV7E	The Fht Company	11	1	01/01/23	09/01/23	05/17/22	0.0000	No	0.0000	Curr	0.0000	0.01	10350.99	0.00	0.00
PRESERVAT	CHPRPRVCO	Paha Sapa Holdi	11	1	02/04/22	08/01/23	02/04/22	0.0000	No	0.0000	Curr	0.0000	0.01	1632.99	0.00	0.00
PRESERV	CHPRPRVRI	Richerson,Jacqu	11	1	10/27/22	11/01/23	03/22/23	0.0000	No	0.0000	Curr	0.0000	0.01	2522.82	0.00	0.00
RIP- Presv	CHPRPSVP	Cara Mia Llc,Ca	11	1	09/28/21	10/01/23	11/22/22	0.0000	No	0.0000	Curr	0.0000	0.01	24099.56	0.00	0.00
PRESERVAT	CHPRPVBYR	Byrne,Tiffany	11	1	02/07/22	08/01/23	02/07/22	0.0000	No	0.0000	Curr	0.0000	0.01	2300.67	0.00	0.00
RW Payable	CHPRRW0ER	Emrick Real Est	11	1	08/22/22	03/01/23	08/22/22	0.0000	No	0.0000	Curr	0.0000	0.01	2368.69	0.00	0.00
SIDING	CHPRSIDBY	Byrne,Tiffany	11	1	01/26/22	08/01/23	02/07/22	0.0000	No	0.0000	Curr	0.0000	0.01	0.00	0.00	0.00
VAC HOME	CHPRVACBO	The Fht Company	11	1	05/17/22	09/01/23	05/17/22	0.0000	No	0.0000	Curr	0.0000	0.01	5120.00	0.00	0.00
VACANT HM	CHPRVACBY	Byrne,Tiffany	11	1	04/19/22	08/01/23	04/19/22	0.0000	No	0.0000	Curr	0.0000	0.01	2958.80	0.00	0.00
WINDOWS	CHPRWIN7E	The Fht Company	11	1	03/02/22	09/01/23	03/04/22	0.0000	No	0.0000	Curr	0.0000	0.01	0.00	0.00	0.00
WINDOWS	CHPRWINBL	Blair,Christoph	11	1	01/20/22	08/01/23	02/07/22	0.0000	No	0.0000	Curr	0.0000	0.01	0.00	0.00	0.00
WINDOWS	CHPRWINBY	Byrne,Tiffany	11	1	01/26/22	08/01/23	02/07/22	0.0000	No	0.0000	Curr	0.0000	0.01	0.00	0.00	0.00
WINDOWS	CHPRWINCO	Paha Sapa Holdi	11	1	07/06/22	08/01/23	07/19/22	0.0000	No	0.0000	Curr	0.0000	0.01	5842.35	0.00	0.00
WINDOW	CHPRWINHO	Hohn,John	11	1	12/05/22	12/01/23	12/22/22	0.0000	No	0.0000	Curr	0.0000	0.01	0.00	0.00	0.00
WINDOWS	CHPRWINPO	Cara Mia Llc,Ca	11	1	07/19/22	08/01/23	01/04/23	0.0000	No	0.0000	Curr	0.0000	0.01	7237.90	0.00	0.00
Siding	CHPSIDBRE	Breland,Philip	11	1	10/06/22	10/01/23	10/05/22	0.0000	No	0.0000	Curr	0.0000	0.01	0.00	0.00	0.00
Windows	CHPWINBRE	Breland,Philip	11	1	10/06/22	10/01/23	10/05/22	0.0000	No	0.0000	Curr	0.0000	0.01	0.00	0.00	0.00
WIN DOOR	CHPWINUN	Underhill,Ronal	11	1	08/19/20	05/01/23	08/20/20	0.0000	No	0.0000	Curr	0.0000	0.01	0.00	0.00	0.00
LIFE SAFTY	HCHPLSCOU	Paha Sapa Holdi	11	1	09/21/22	08/01/23	10/18/22	0.0000	No	0.0000	Curr	0.0000	0.01	15116.27	0.00	0.00
LIFE SAFTY	HPRLSDRAG	Dragon Belly, L	11	1	12/02/22	11/01/23	12/21/22	0.0000	No	0.0000	Curr	0.0000	0.01	2806.84	0.00	0.00

Group Totals: 0.28 110057.88 0.00 0.00

>>> INVESTOR #: HP POOL #: RIP-R DISTRIBUTION RATE: 0.0000 COMPUTATION: Actual/Actual

WIN 770	CHPRWI770	Dragon Belly, L	11	1	03/08/23	02/01/24	03/08/23	0.0000	No	0.0000	Curr	0.0000	0.01	1111.18	0.00	0.00
WIN 772	CHPRWI772	Dragon Belly, L	11	1	02/08/23	02/01/24	02/09/23	0.0000	No	0.0000	Curr	0.0000	0.01	0.00	0.00	0.00

Group Totals: 0.02 1111.18 0.00 0.00

>>> INVESTOR #: HP POOL #: RRW0 DISTRIBUTION RATE: 0.0000 COMPUTATION: Actual/Actual

Time: 12:12:25
Date: 03/31/2023

TRIAL BALANCE: POOLS

Page:
Run By: SUSAN

Range Of Investors
All Pools
NHS of Black Hills
Version: 3.1.22

Investor Loan #	Loan #	Borrower	Ln Tp	Bs Cd	Int Paid To Date	Due Date	Last Tran Date	Borrower Rate	Split Rate	Investor Rate	Service Code	Service Fee	Payment Amount	Current Pool Balance	Impound Balance	Suspense Balance
HPRRWOMIK	HPRRWOMIK	Mikla,Christine	2	0	04/01/23	05/01/23	03/24/23	0.0000	No	0.0000	Curr	0.0000	164.59	34529.17	0.00	0.00
RW PAYABLE	HPRRWOCWE	Owens,Tracy	2	0	03/01/23	04/01/23	03/06/23	0.0000	No	0.0000	Curr	0.0000	118.98	28197.66	0.00	0.00
HPRWCOOH	HPRWCOOH0	Coomes,Tim	2	0	03/01/23	04/01/23	02/06/23	0.0000	No	0.0000	Curr	0.0000	146.44	10543.30	0.00	0.00
HPRWOLSN	HPRWOLSN5	Olson,Steven	2	0	02/01/23	03/01/23	02/18/23	0.0000	No	0.0000	Curr	0.0000	41.37	7587.76	0.00	0.00
RW Payable	HPRWOREAU	Reausaw,Bernie	2	0	05/01/23	06/01/23	03/15/23	0.0000	No	0.0000	Curr	0.0000	740.68	21479.89	0.00	0.00
RW PAYABLE	HPRWPGASR	Gaspar Iii,Jose	2	0	04/01/23	05/01/23	03/24/23	0.0000	No	0.0000	Curr	0.0000	252.24	17404.57	0.00	0.00
RW PAYABLE	HPRWPPWEB	Weber,Todd	2	0	03/01/23	04/01/23	03/08/23	0.0000	No	0.0000	Curr	0.0000	161.58	14380.93	0.00	0.00

Group Totals: 1625.88 134123.28 0.00 0.00

>>> INVESTOR #: HP POOL #: RRW4 DISTRIBUTION RATE: 0.0000 COMPUTATION: Actual/Actual

HPRWSWAN	HPRWSWAN2	Swaney,David	2	0	03/01/23	04/01/23	03/10/23	4.0000	No	4.0000	Curr	0.0000	60.22	11421.85	0.00	0.00
----------	-----------	--------------	---	---	----------	----------	----------	--------	----	--------	------	--------	-------	----------	------	------

Group Totals: 60.22 11421.85 0.00 0.00

>>> INVESTOR #: HP POOL #: RRW5 DISTRIBUTION RATE: 0.0000 COMPUTATION: Actual/Actual

CLIENT RW	HPRWBOB05	Bobolz,Lance	2	0	03/01/23	04/01/23	03/10/23	5.0000	No	5.0000	Curr	0.0000	116.04	14137.75	0.00	0.00
-----------	-----------	--------------	---	---	----------	----------	----------	--------	----	--------	------	--------	--------	----------	------	------

Group Totals: 116.04 14137.75 0.00 0.00

>>> INVESTOR #: HP POOL #: RSFND DISTRIBUTION RATE: 0.0000 COMPUTATION: Actual/Actual

HPCFNDKNI	HPCFNDKNI	Knipper,Anita	2	0	11/07/19	11/07/29	11/07/19	0.0000	No	0.0000	Curr	0.0000	0.00	9970.52	0.00	0.00
HPFND771	HPFND770	Dragon Belly LI	2	0	03/17/20	03/01/30	03/18/20	0.0000	No	0.0000	Curr	0.0000	0.00	9461.50	0.00	0.00
HPFND772	HPFND772	Dragon Belly LI	2	0	03/17/20	03/01/30	03/18/20	0.0000	No	0.0000	Curr	0.0000	0.00	9817.75	0.00	0.00
HPFNDHILL	HPFNDHILL	Hills Partnersh	2	0	12/30/19	11/30/29	01/29/20	0.0000	No	0.0000	Curr	0.0000	0.00	8250.95	0.00	0.00
Foundation	HPFNDPOT	Cara Mia, Llc,C	2	0	10/24/22	10/01/32	10/27/22	0.0000	No	0.0000	Curr	0.0000	0.00	10000.00	0.00	0.00
FOUNDATIONI	HPRFNDBOB	The Fhe Company	2	0	11/30/32	12/01/32	12/02/22	0.0000	No	0.0000	Curr	0.0000	0.00	10000.00	0.00	0.00
FOUNDATIONI	HPRFNDBRE	Breland,Philip	2	0	11/11/22	11/01/32	11/11/22	0.0000	No	0.0000	Curr	0.0000	0.00	10000.00	0.00	0.00
FOUNDATIONI	HPRFNDBUS	Bussiere,Erica	2	0	12/24/20	01/01/31	12/24/20	0.0000	No	0.0000	Curr	0.0000	0.00	10000.00	0.00	0.00
HPRFNDHOI	HPRFNDHOH	Hohn,John	2	0	10/23/22	11/01/32	10/24/22	0.0000	No	0.0000	Curr	0.0000	0.00	10000.00	0.00	0.00
FOUNDATIONI	HPRFNDJOH	Johnson,Michael	2	0	11/18/22	11/01/32	11/18/22	0.0000	No	0.0000	Curr	0.0000	0.00	10000.00	0.00	0.00
Foundation	HPRFNDMUN	Munce,Jeffrey	2	0	12/28/20	12/01/30	12/29/20	0.0000	No	0.0000	Curr	0.0000	0.00	10000.00	0.00	0.00
FOUNDATIONI	HPRFNDUND	Underhill,Ronal	2	0	03/09/21	03/01/31	03/09/21	0.0000	No	0.0000	Curr	0.0000	0.00	10000.00	0.00	0.00

Group Totals: 0.00 117500.72 0.00 0.00

>>> INVESTOR #: HP POOL #: RSPE DISTRIBUTION RATE: 0.0000 COMPUTATION: Actual/Actual

CHPSNEBRC	CHPSNEBRG	Berg,Tim	1	1	11/18/15	11/12/25	12/31/18	0.0000	No	0.0000	Curr	0.0000	0.01	5691.42	0.00	0.00
-----------	-----------	----------	---	---	----------	----------	----------	--------	----	--------	------	--------	------	---------	------	------

Time: 12:12:25
Date: 03/31/2023

Page:
Run By: SUSAN*

TRIAL BALANCE: POOLS
Range Of Investors
All Pools
NHS of Black Hills
Version: 3.1.22

Investor Loan #	Loan #	Borrower	Ln Tp	Bs Cd	Int Paid To Date	Due Date	Last Tran Date	Borrower Rate	Split Rate	Investor Rate	Service Code	Service Fee	Payment Amount	Current Pool Balance	Impound Balance	Suspense Balance
CHPSNEMIT	CHPSNEMIT	Mitchell,George	11	1	04/22/13	08/30/23	09/19/13	0.0000	No	0.0000	Curr	0.0000	0.01	10000.00	0.00	0.00
CHPSNEWO	CHPSNEWO	Wood,George F.	11	1	02/06/14	01/30/24	04/01/14	0.0000	No	0.0000	Curr	0.0000	0.01	7155.88	0.00	0.00
CHPSNSTE0	CHPSNSTE0	Steinficht,Dore	11	1	06/17/13	06/17/23	06/12/13	0.0000	No	0.0000	Curr	0.0000	0.00	5561.23	0.00	0.00
CHPSPESJO	CHPSPESJO	Sjomelling,Rober	11	1	06/19/14	03/21/24	07/24/14	0.0000	No	0.0000	Curr	0.0000	0.01	10000.00	0.00	0.00
HP SNE	HPSNEWHT0	White,V. Caroly	2	0	07/01/17	06/01/27	06/15/17	0.0000	No	0.0000	Curr	0.0000	0.00	10000.00	0.00	0.00

Group Totals: 0.04 48408.53 0.00 0.00

>>> INVESTOR #: HP POOL #: RSSID DISTRIBUTION RATE: 0.0000 COMPUTATION: Actual/Actual

CHPSIDCOO	CHPSIDCOO	Coomes,Tim	11	1	03/13/14	02/24/24	05/04/21	0.0000	No	0.0000	Curr	0.0000	0.01	10000.00	0.00	0.00
CHPSIDENG	CHPSIDENG	Ensminger,Rick	11	1	05/24/13	05/24/23	06/20/13	0.0000	No	0.0000	Curr	0.0000	0.00	10000.00	0.00	0.00
CHPSIDJLS	CHPSIDJLS	Julius,Thomas	11	1	08/16/16	09/09/25	01/31/18	0.0000	No	0.0000	Curr	0.0000	0.01	2937.88	0.00	0.00
CHPSIDLW0	CHPSIDLW0	Lewis,Tracy	2	0	03/20/17	03/01/27	04/01/17	0.0000	No	0.0000	Curr	0.0000	0.00	10000.00	0.00	0.00
CHPSIDSHP	CHPSIDSHP	Shepherd,Lanny	11	1	11/18/15	10/30/25	12/31/18	0.0000	No	0.0000	Curr	0.0000	0.01	6997.50	0.00	0.00
CHPSIDWRT	CHPSIDWRT	Wright,Alan	11	1	04/08/15	09/17/24	08/06/15	0.0000	No	0.0000	Curr	0.0000	0.01	10000.00	0.00	0.00
SIDING	HPRSID106	Oberlander,Bruc	2	0	10/22/20	10/01/30	10/23/20	0.0000	No	0.0000	Curr	0.0000	0.00	10000.00	0.00	0.00
HPRSIDANT	HPRSIDANT	Antrim,James	2	0	07/02/21	06/01/31	07/02/21	0.0000	No	0.0000	Curr	0.0000	0.00	10000.00	0.00	0.00
SIDING	HPRSIDBL0	Bloom,Kevin	2	0	10/23/20	10/01/30	10/23/20	0.0000	No	0.0000	Curr	0.0000	0.00	5834.70	0.00	0.00
SIDING	HPRSIDCGU	Paha Sapa Holdi	2	0	03/07/23	04/01/33	03/21/23	0.0000	No	0.0000	Curr	0.0000	0.00	10000.00	0.00	0.00
SIDING	HPRSIDJOH	Johnson,Michael	2	0	11/18/22	11/01/32	11/18/22	0.0000	No	0.0000	Curr	0.0000	0.00	10000.00	0.00	0.00
SIDING	HPRSIDUND	Underhill,Ronal	2	0	10/17/22	11/01/32	10/24/22	0.0000	No	0.0000	Curr	0.0000	0.00	10000.00	0.00	0.00
HPSID770	HPSID700	Dragon Belly, L	2	0	03/24/20	03/01/30	03/23/20	0.0000	No	0.0000	Curr	0.0000	0.00	3331.80	0.00	0.00
HPSIDKNI	HPSIDKNI	Knipper,Anita	2	0	11/07/19	11/07/29	11/07/19	0.0000	No	0.0000	Curr	0.0000	0.00	10000.00	0.00	0.00
HPSIDSMT0	HPSIDSMT0	Smith,Edwin	11	1	11/25/16	12/01/26	12/20/16	0.0000	No	0.0000	Curr	0.0000	0.01	10000.00	0.00	0.00
HP SIDING	HPSIDWHT0	White,V. Caroly	2	0	07/01/17	06/01/27	06/15/17	0.0000	No	0.0000	Curr	0.0000	0.00	10000.00	0.00	0.00

Group Totals: 0.05 139101.88 0.00 0.00

>>> INVESTOR #: HP POOL #: RSWIN DISTRIBUTION RATE: 0.0000 COMPUTATION: Actual/Actual

CHPWJL2	CHPWJL2	Julius,Thomas	11	1	08/02/16	04/27/26	09/28/17	0.0000	No	0.0000	Curr	0.0000	0.01	15066.88	0.00	0.00
CHPWJLW0	CHPWJLW0	Lewis,Tracy	2	0	03/17/17	03/01/27	04/01/17	0.0000	No	0.0000	Curr	0.0000	0.00	8268.42	0.00	0.00
CHPWJNRS	CHPWJNRS	Morris,Wayne	11	1	08/26/15	08/26/25	12/31/18	0.0000	No	0.0000	Curr	0.0000	0.01	4536.00	0.00	0.00
CHPWJNSHP	CHPWJNSHP	Shepherd,Lanny	11	1	12/23/15	10/30/25	12/31/18	0.0000	No	0.0000	Curr	0.0000	0.01	2940.00	0.00	0.00
HPCWJNKN	HPCWJNKN	Knipper,Anita	2	0	11/07/19	11/07/29	11/07/19	0.0000	No	0.0000	Curr	0.0000	0.00	20000.00	0.00	0.00
WINDOW	HPRWIN106	Oberlander,Bruc	2	0	10/22/20	10/01/30	10/23/20	0.0000	No	0.0000	Curr	0.0000	0.00	3200.00	0.00	0.00
HPRWINANT	HPRWINANT	Antrim,James	2	0	07/01/21	06/01/31	07/02/21	0.0000	No	0.0000	Curr	0.0000	0.00	20000.00	0.00	0.00

Time: 12:12:25
Date: 03/31/2023

TRIAL BALANCE: POOLS

Page:
Run By: SUSAN

Range Of Investors
All Pools

NHS of Black Hills

Version: 3.1.22

Investor Loan #	Loan #	Borrower	Ln Tp	Bs Cd	Int Paid To Date	Due Date	Last Tran Date	Borrower Rate	Split Rate	Investor Rate	Service Code	Service Fee	Payment Amount	Current Pool Balance	Impound Balance	Suspense Balance
WINDOWS	HPRWINJOH	Johnson,Michael	2	0	11/18/22	11/01/32	11/18/22	0.0000	No	0.0000	Curr	0.0000	0.00	16800.00	0.00	0.00
Windows	HPRWINMUN	Munce,Jeffrey	2	0	12/28/20	12/01/30	12/28/20	0.0000	No	0.0000	Curr	0.0000	0.00	19850.00	0.00	0.00
HPWIN772	HPWIN772	Dragon Belly LI	2	0	03/17/20	03/01/30	03/18/20	0.0000	No	0.0000	Curr	0.0000	0.00	6660.40	0.00	0.00
HPWINBOB0	HPWINBOB0	The Fhe Company	2	0	05/14/20	05/01/30	05/14/20	0.0000	No	0.0000	Curr	0.0000	0.00	18000.00	0.00	0.00
HPWINHILL	HPWINHILL	Hills Partnersh	2	0	12/30/19	12/30/29	01/29/20	0.0000	No	0.0000	Curr	0.0000	0.00	751.56	0.00	0.00
HPWINKIN	HPWINKIN	Kinkler,Brian	2	0	01/17/20	02/01/30	01/17/20	0.0000	No	0.0000	Curr	0.0000	0.00	1600.00	0.00	0.00
HPWINPET	HPWINPET	Dragon Belly LI	2	0	03/17/20	03/01/30	03/18/20	0.0000	No	0.0000	Curr	0.0000	0.00	13718.64	0.00	0.00
HP WIN	HPWINREA0	Reasaw,Bernie	2	0	11/01/18	11/01/28	12/18/18	0.0000	No	0.0000	Curr	0.0000	0.00	20000.00	0.00	0.00
WIN FORG	HPWINSHAM	Shama,Larry	2	0	10/01/17	09/01/27	11/10/17	0.0000	No	0.0000	Curr	0.0000	0.00	16793.63	0.00	0.00
HPWINSMT0	HPWINSMT0	Smith,Edwin	11	1	11/25/16	12/01/26	12/20/16	0.0000	No	0.0000	Curr	0.0000	0.01	3200.00	0.00	0.00
HP WINDOW	HPWINWHT0	White,V. Caroly	2	0	07/01/17	06/01/27	06/15/17	0.0000	No	0.0000	Curr	0.0000	0.00	10000.00	0.00	0.00

Group Totals: 0.04 201385.53 0.00 0.00

>>> INVESTOR #: HP POOL #: RVAC DISTRIBUTION RATE: 0.0000 COMPUTATION: Actual/Actual

CHPVBLOOM	CHPVBLOOM	Bloom,Kevin D.	11	1	09/19/14	07/01/23	10/31/13	0.0000	No	0.0000	Curr	0.0000	0.01	10000.00	0.00	0.00
VAC HOME	HPRVACJOH	Johnson,Michael	2	0	11/18/22	11/01/32	11/18/22	0.0000	No	0.0000	Curr	0.0000	0.00	10000.00	0.00	0.00
VACANT	HPRVACPOT	Cara Mia Lic,Ca	2	0	10/24/22	10/01/32	10/27/22	0.0000	No	0.0000	Curr	0.0000	0.00	10000.00	0.00	0.00
VACANT	HPRVACTHO	Thompson II,Mar	2	0	02/13/23	02/01/33	02/13/23	0.0000	No	0.0000	Curr	0.0000	0.00	10000.00	0.00	0.00
VAC HM	HPRVACUND	Underhill,Ronal	2	0	03/09/21	03/01/31	03/09/21	0.0000	No	0.0000	Curr	0.0000	0.00	10000.00	0.00	0.00
HPRVACWEI	HPRVACWEB	Weber,Todd	2	0	07/02/21	07/01/31	07/02/21	0.0000	No	0.0000	Curr	0.0000	0.00	10000.00	0.00	0.00
VACANT LN	HPVACBIAL	Bialas,Kurt	2	0	03/01/18	03/01/28	03/05/18	0.0000	No	0.0000	Curr	0.0000	0.00	10000.00	0.00	0.00
HPVANCMJN	HPVANCMJ0	Johnson,Michael	2	0	12/01/18	12/01/28	12/12/18	0.0000	No	0.0000	Curr	0.0000	0.00	10000.00	0.00	0.00
HPVCNTBLV	HPVCNTBLM	Bloom,Christoph	2	1	08/18/16	08/18/26	10/01/16	0.0000	No	0.0000	Curr	0.0000	0.00	10000.00	0.00	0.00
HP VACANT	HPVCNWHT0	White,V. Caroly	2	0	07/01/17	06/01/27	06/15/17	0.0000	No	0.0000	Curr	0.0000	0.00	10000.00	0.00	0.00

Group Totals: 0.01 100000.00 0.00 0.00

Investor Totals: 9408.12 2065890.15 0.00 0.00

>>> INVESTOR #: HPRW POOL #: PERM DISTRIBUTION RATE: 0.0000 COMPUTATION: Actual/Actual Payrr

CITY RW	CONRWBOB0	Bobolz,Lance	11	1	12/01/17	12/01/27	01/01/18	0.0000	No	0.0000	Curr	0.0000	0.01	18042.61	0.00	0.00
CONRWCOG	CONRWCOOM	Coomes,Tim	11	1	02/11/19	03/01/29	02/11/19	0.0000	No	0.0000	Curr	0.0000	0.01	67491.73	0.00	0.00
CONRWFEN	CONRWFEN0	Fenton,Kris	11	1	06/13/18	06/01/28	07/01/18	0.0000	No	0.0000	Curr	0.0000	0.01	17584.40	0.00	0.00

Time: 12:12:25
Date: 03/31/2023

TRIAL BALANCE: POOLS
Range Of Investors
All Pools
NHS of Black Hills
Version: 3.1.22

Page:
Run By: SUSAN*

Investor Loan #	Loan #	Borrower	Ln Tp	Bs Cd	Int Paid To Date	Due Date	Last Tran Date	Borrower Rate	Split Rate	Investor Rate	Service Code	Service Fee	Payment Amount	Current Pool Balance	Impound Balance	Suspense Balance
CONRWMIKL	CONRWMIKL	Mikla,Christine	2	0	03/08/21	04/01/26	03/08/21	0.0000	No	0.0000	Curr	0.0000	0.00	91445.00	0.00	0.00
RW GRANT	CONRWOLSN	Olson,Steven	11	1	12/21/17	06/01/23	01/01/18	0.0000	No	0.0000	Curr	0.0000	0.01	91133.36	0.00	0.00
RW Forgiv	CONRWREAU	Reusaw,Bernie	2	0	09/24/20	10/01/30	09/24/20	0.0000	No	0.0000	Curr	0.0000	0.00	105468.23	0.00	0.00
CONRWVWH	CONRWVWHI	White,V. Caroly	11	1	09/20/16	09/20/26	09/26/16	0.0000	No	0.0000	Curr	0.0000	0.01	90073.00	0.00	0.00
CRW GRANT	CONRWVHT2	White,V. Caroly	11	1	10/18/17	11/01/27	11/08/17	0.0000	No	0.0000	Curr	0.0000	0.01	8699.04	0.00	0.00
CITY RW	HPCONBOBO	Bobolz,Lance	11	1	01/01/18	01/01/28	01/01/18	0.0000	No	0.0000	Curr	0.0000	0.01	199815.00	0.00	0.00
RW FORG	HPRRWOWE	Owens,Tracy	2	0	11/16/22	11/01/27	11/16/22	0.0000	No	0.0000	Curr	0.0000	0.00	103803.20	0.00	0.00
RW CITY	HPRWCSHEP	Shepherd,Lanny	2	0	11/13/20	10/01/30	11/13/20	0.0000	No	0.0000	Curr	0.0000	0.00	18616.85	0.00	0.00
RW FORG	HPRWFGASR	Gaspar Iii,Jose	2	0	12/20/21	01/01/27	12/20/21	0.0000	No	0.0000	Curr	0.0000	0.00	48928.95	0.00	0.00
RW Forgiv	HPRWFWEB	Weber,Todd	2	0	08/05/20	08/01/30	08/06/20	0.0000	No	0.0000	Curr	0.0000	0.00	82607.50	0.00	0.00
Group Totals:													0.07	943708.87	0.00	0.00
>>> INVESTOR #: HPRW POOL #: RIP DISTRIBUTION RATE: 0.0000 COMPUTATION: Actual/Actual Paymer																
RW CITY	CHPRRWCEM	Emrick Real Est	11	1	08/23/22	08/01/23	08/23/22	0.0000	No	0.0000	Curr	0.0000	0.01	3675.38	0.00	0.00
Group Totals:													0.01	3675.38	0.00	0.00
Investor Totals:													0.08	947384.25	0.00	0.00
Report Totals:													9408.20	3013274.40	0.00	0.00

Deadwood Historic Preservation
Revolving Loan Fund

Updated 01.26.2023

Investor # HP - DHP Revolving Loan Fund

Pool Code	Loan Type	Interest Rate	Program
C0	Commercial	0.00%	Revolving Loan Fund
C1	Commercial	1.00%	Revolving Loan Fund
C2	Commercial	2.00%	Revolving Loan Fund
C3	Commercial	3.00%	Revolving Loan Fund
C4	Commercial	4.00%	Revolving Loan Fund
C5	Commercial	5.00%	Revolving Loan Fund
C6	Commercial	6.00%	Revolving Loan Fund
C7	Commercial	7.00%	Revolving Loan Fund
CFAC	Commercial	0.00%	Façade Easement Loan
CUFR	Commercial	0.00%	Upper Floor Revitalization Loan
RIP-C	Commercial	0.00%	Contruccion projects in process

Pool Code	Loan Type	Interest Rate	Program
R0	Residential	0.00%	Revolving Loan Fund
R3.0	Residential	3.00%	Revolving Loan Fund
R3.5	Residential	3.50%	Revolving Loan Fund
R4	Residential	4.00%	Revolving Loan Fund
R4.5	Residential	4.50%	Revolving Loan Fund
RRW0	Residential	0.00%	Retaining Wall - Owner Loan
RRW4	Residential	4.00%	Retaining Wall- Owner Loan
RRW5	Residential	5.00%	Retaining Wall- Owner Loan
RSFND	Residential	0.00%	Foundation- 10-Yr forgivable
RSSID	Residential	0.00%	Siding Program- 10-Yr forgivable
RSWIN	Residential	0.00%	Window Program- 10-Yr forgivable
RSPE	Residential	0.00%	Special Needs Elderly
RVAC	Residential	0.00%	Vacant Home- 10-yr forgivable
RIP-R	Residential	0.00%	Construction projects in process
PERM	Residential	0.00%	City portion of RW- Perm Loan
RIP	Residential	0.00%	City portion of RW- In Construction

Investor # HPRW = DHP City Portion of Retaining Wall- Forgivable

OFFICE OF
**PLANNING, ZONING AND
 HISTORIC PRESERVATION**
 108 Sherman Street
 Telephone (605) 578-2082
 Fax (605) 722-0786



Mike Runge
 Archivist
 Telephone (605) 578-2082
 michael@cityofdeadwood.com

MEMORANDUM

Date: April 17, 2023
To: Deadwood Historic Preservation Commission
From: Mike Runge, City Archivist
Re: **Replace failing large format scanner for City Archives**

The City Archives would like to replace its large format scanner. The City Archives current scanner, donated by the Lawrence County Register of Deeds in 2009, began to fail in the fall of 2022. This scanner has been used to digitize the City's collection of architectural plans, plat maps, historical maps, newspapers, advertisement posters, and oversized ephemera.

Prior to procuring quotes, I contacted several organizations that use large format scanners. Deadwood History, Inc.; Minnehaha County Register of Deeds; Pennington County Planning & Zoning; Lawrence County Register of Deeds; South Dakota School of Mines; Albertson Engineering and Avid 4 Engineering and asked what type of scanners were used and the usability of the scanning software. Based on these conversations, four of the seven used Contex IQ Quattro brand scanners.

Based on these results, coupled with the City Archives needs, the Contex IQ Quattro X4490 would best suit the City Archives based on the ease of use, scanning width, graphics, optical resolution, and software package.

Four quotes for the Contex IQ Quattro X4490 are listed below and attached to this memorandum.

Company Name	Make/Model	Cost	Comments	Rental Y/N	Cost:
Century Business Products / Steve Cogdill	Contex IQ Quattro X4490	\$7,400.56		N	
Document Imaging	Contex IQ Quattro X4490	\$8,990.00	does not include PC. Extra cost \$1400.00	Y	\$2400 per year
Large Document Solutions	Contex IQ Quattro X4490	\$7,250.00	there is a \$400.00 s/h fee. They will take both old scanners	n	
Franz	Contex IQ Quattro 4490	\$7,253.00	there is a \$500.00 delivery fee	n	

RECOMMENDATION:

Allow the City of Deadwood Archives to purchase the Contex IQ Quattro X4490 large format scanner from Large Document Solutions. The cost for this purchase will not exceed \$7,700.00 dollars. Funding for this purchase will come out of the 2023 Machinery/Equipment line item.

IQ Quattro X

36" 44"

**THE INDUSTRY-
LEADING SCANNER
FOR LARGE FORMAT
TECHNICAL
DRAWINGS**

NEW!

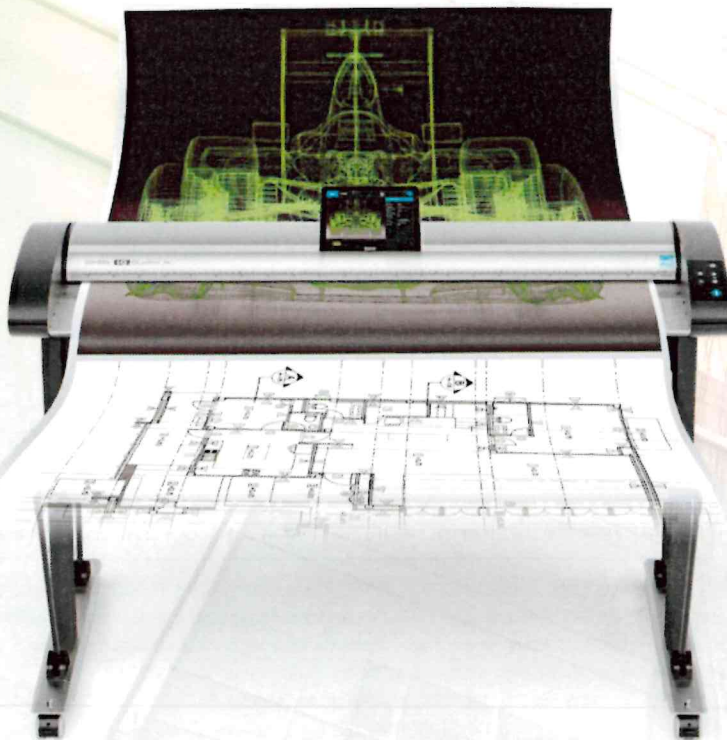

SCAN FASTER AND SMARTER WITH MORE PRECISION IN EVERY PIXEL

The all new and perfected IQ Quattro X is a must have for every high-production environment.

Faster: IQ Quattro X is the 5th generation of Context CIS scanners, with enhanced speed and 3 times faster data transfer, the scanner is the essence of productivity.

Smarter: The Nextimage Remote app offers you a completely new way of working. The new app saves valuable operator time by bringing all main functions essential for basic scanning and copying in front of the operator directly on the scanner.

Better: Context Live Alignment is a new IQ Quattro X technology designed to improve image alignment across sensors ensuring precise and sharp alignment all the time, no matter the speed.

Improved technology: Context USB 3.0 implementation with xDTR3 is blisteringly fast and you won't have to worry about shoe shining or rescanning to get the width right.

Image quality

The 48-bit CIS technology captures every detail from your document, then passes the best 24-bits through to the file at up to 1200 dpi optical resolution.

Fastest CIS scanner

The IQ Quattro X scanners produce a scan speed of up to 17.8 inches per second in RGB color and 200 dpi.

3-position speed control

Great for use with delicate originals. Temporarily shift down to slower scan speeds without using presets or altering software.

Green technology

Energy Star® version 3.0 compliant using only 0.5W in standby mode.

High productivity

Enhanced speed and data transfer rates makes the IQ Quattro X the essence of productivity.

Michael Runge

From: Leah Lewis <Leah@largedocuments.com>
Sent: Monday, April 17, 2023 11:59 AM
To: Michael Runge
Cc: Kevin Brinks; Brittany Schoede
Subject: Re: City of Deadwood Archives

Good morning Mike,

I hope you had a great weekend! Thank you for sharing this information and for the opportunity to match your lowest quote.

It looks like several of the companies quoted the Contex Q1 pricing, which unfortunately increased quite a bit at the start of Q2. We certainly would like to earn your business, so we can revise our quote to \$7,250 plus \$400 s/h. Kevin's motto is some money is always better than no money. 😊

Please let us know if you would like a formal quote to move forward.

Many thanks!
 Leah

LEAH LEWIS
 President
 Leah@largedocuments.com | 866.338.4464

Large Document Solutions
 7936 E. Arapahoe Ct. | Suite 3800 | Centennial, CO 80112
www.largeformatscanners.com

From: Michael Runge <Michael@cityofdeadwood.com>
Sent: Monday, April 17, 2023 9:00 AM
To: Kevin Brinks <Kevin@largedocuments.com>
Subject: City of Deadwood Archives

Good morning Kevin:
 Hope you had a good weekend. Below are the numbers for the Quattro X scanner and software. I am showing you these since you mentioned that you could match prices.

Thanks for your help,
 Mike

Company Name	Make/Model	Cost	Comments
Century Business Products	Contex IQ Quattro X4490	\$7,400.56	
Document Imaging	Contex IQ Quattro X4490	\$8,990.00	does not include PC. Extra cost \$1400.00
Large Document Solutions	Contex IQ Quattro X4490	\$8,915.00	
Franz	Contex IQ Quattro X4490	\$7,253.00	there is a \$500.00 delivery fee

Michael Runge

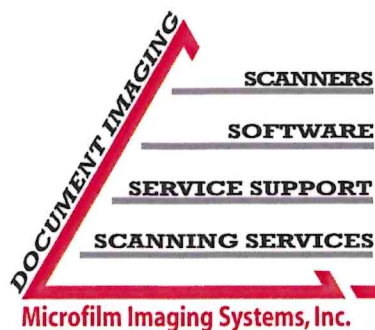

2530 Harney Street • Omaha, NE 68131
 (402) 346-7211 • 800-346-1365
 Fax (402) 346-6643
 www.MicrofilmImaging.com

April 13, 2023

Michael Runge
 City of Deadwood Historic Preservation Office
 108 Sherman St
 Deadwood SD 57732

605-578-2082

Michael.runge@cityofdeadwood.com

Dear Michael,

I am pleased to submit our quotation for the Contex Models Quatro SD4490 Large Format Scanner.

SPECIFICATIONS

Purchase Price Contex Quatro SD 4490 \$8990.00

Inches scanned per second:

Black and White	17.5
Color	17.5

Price Includes:

Scanner Stand – Scan Station Pro
 Scanner – new model Quatro SD 4450
 21" Touch Screen Monitor/Display
 NextImage Software = best possible images because the operator can make adjustments to the image prior to saving the file. The software will connect to a printer for Scan to Print
 One Plastic Sleeve for scanning fragile documents D or E size
 Shipping FOB destination - included
 Two year Parts Warranty
 One year phone support included
 One year optional on-site tech support - MIS \$ 960.00/year

The price does not include a PC.

We can bundle in the i7 PC if your IT approves. \$1400.00

Michael Runge

From: Steve Cogdill <scogdill@cbpnow.com>
Sent: Thursday, April 13, 2023 4:15 PM
To: Michael Runge
Subject: scanners
Attachments: Contex_Datasheet_IQ-Quattro-X_V1.1_EN 36 44.pdf

Follow Up Flag: Follow up
Flag Status: Flagged

Mike,

Here is what I have come up with for a scanner the IQ Quattro X3650 this is a 36 inch scanner, selling price of \$5,365.76. The next is a 44 inch scanner IQ Quattro X4490 selling price of \$7,400.56. I have attached the brochure on them.

Thank you,

STEVE COGDILL

Branch Manager
Senior Solution Analyst

Rapid City | 605-343-1260
Scottsbluff | 308-632-3356
TOLL-FREE | 800-529-1950
ONLINE | www.cbpnow.com



This electronic mail (including any attachments) may contain information that is privileged, confidential, and/or otherwise protected from disclosure to anyone other than its intended recipient(s). Any dissemination or use of this electronic email or its contents (including any attachments) by persons other than the intended recipient(s) is strictly prohibited. If you have received this message in error, please notify us immediately by reply email so that we may correct our internal records. Please then delete the original message (including any attachments) in its entirety. Thank you.

Michael Runge

From: Jeff Luhring <jluhring@franzrepro.com>
Sent: Monday, April 17, 2023 7:43 AM
To: Michael Runge
Subject: Franz IQ X4490 quote
Attachments: ContexDatashet_IQ-Quattro 4490.pdf

Hi Mike,

Franz price for the wide format 44" scanner is \$7,253.00 before tax plus a \$500 delivery fee with installation and set up. This unit includes the nextimage software but would require a PC.

Thanks for your patience. Shoot any questions and/or decisions via email.

Thanks again, Jeff

C 763 402-5546



Jeff Luhring
Sales Representative

jluhring@franzrepro.com

763-503-3401 ext.150

2781 Freeway Blvd

Brooklyn Center, MN 55430

FranzRepro.com

Shop.FranzRepro.com



SUPPLIES

SERVICE

MINNEAPOLIS • ROCHESTER • SIOUX FALLS • BISMARCK • FARGO • SALT LAKE CITY

OFFICE OF
PLANNING, ZONING AND
HISTORIC PRESERVATION
108 Sherman Street
Telephone (605) 578-2082
Fax (605) 722-0786



MEMORANDUM

Date: April 19, 2023
To: Deadwood Historic Preservation Commission
From: Historic Preservation Office
Re: **Records Research for GIS layer**

The Historic Preservation Office would like to hire Julie Stone as an independent contractor to research, compile and print off paper copies for M.S. 72 & 86 to be incorporated into the City's GIS program. A breakdown of the work is included in the attached email dated April 18, 2023 attached to the memorandum.

RECOMMENDATION:

Allow the Historic Preservation Office to hire Julie Stone as an independent contractor to research, compile and print off paper copies for M.S. 72 & 86 to be incorporated into the City's GIS program. The retainer for this project will not exceed \$15,000.00 dollars. Funding for this research will be paid out of the 2023 Public Education/Advocacy Budget line item.

Michael Runge

From: Julie Stone <julieastone@gmail.com>
Sent: Tuesday, April 18, 2023 9:45 AM
To: Kevin Kuchenbecker
Cc: Michael Runge; Jason Fisher
Subject: Re: City of Deadwood Abstract Project

A. Cost of copies and labor to order and to inventory documents of M.S. 72 & 86:

I estimate a cost of **\$2,500**. (**\$1,520** for copies and up to **\$980** this: Lawrence County prefers the customer to determine the range of page numbers for multi-page documents. Sometimes the scan numbers do not match the document numbers indexed. Being available asserts that we will acquire all necessary documents to match our spreadsheet.

(Copies for M.S. 86 = \$850.00+/- and copies for the work of M.S. 72 will cost about \$675.00, for a grand total cost = \$1,520.) Labor to order and inventory the documents (13 hrs at \$75/hr.= \$980, this could be less)

B. The upcoming research contained within the "priority" area of M.C. 76 has 50 lots and the "mineral survey" portion within in the tract index books.

It's difficult to gauge because we are doing a different research tactic now that we can buy copies vs. taking notes and later typing our written notes, or bringing our computer to LC. I would think we could do M.C. 76 within 50 hrs, with copies costing about \$600 for a total of \$4,350, or so? It's hard to estimate but that's our best "guesstimate".

I would propose a request for \$15,000 as a retainer to be drawn on, which would hopefully take us through the end of M.C. 76 and 38, and possibly further east. The further we can look ahead, the better.

Obviously, if we finish under the bid amount, we just carry that amount over to the next project.

Let me know if you have any questions or comments please.

On Mon, Apr 17, 2023 at 11:43 AM Kevin Kuchenbecker <kevin@cityofdeadwood.com> wrote:

Based on this and the previous emails, I would like to get this in front of the HPC and City Commissions. Can we get a proposal on probable costs to work through the next portion of the overall project?

Kevin Kuchenbecker

Planning, Zoning and

Historic Preservation Officer

From: Julie Stone <julieastone@gmail.com>
Sent: Monday, April 17, 2023 10:43 AM
To: Michael Runge <Michael@cityofdeadwood.com>