



## Regular City Council Meeting

Crest Hill, IL

July 06, 2026

7:00 PM

Council Chambers

20600 City Center Boulevard, Crest Hill, IL 60403

## Agenda

1. **OPENING OF MEETING**
2. **PLEDGE OF ALLEGIANCE**
3. **ROLL CALL**
4. **CITIZEN/SPECIAL REQUEST/PUBLIC HEARINGS/PRESENTATIONS**
5. **PUBLIC COMMENT FOR AGENDA ITEMS ONLY: *(Limit 3 minutes per person)***
6. **CONSENT AGENDA:** *(All items on the Consent Agenda are considered routine by one motion. These items will not be separately discussed unless an Alderperson so requests, in which event the item will be removed from the Consent Agenda and considered separately.)*
  - A. Approve the Minutes from the Work Session Meeting Held on June 08, 2026
  - B. Approve the Minutes of the Regular City Council Meeting Held on June 15, 2026
  - C. Approve the Minutes of the Work Session Meeting Held on June 22, 2026
  - D. Police Pension Board Appointment
  - E. Approve a Special Event Police Services Agreement with the American Italian Cultural Society for August 7, 8 & 9, 2026
  - F. Approval to Purchase a New 2027 Airtow T14-12 Trailer in the Amount of \$21,530.00
  - G. Approval to Purchase a New 2027 Ford Police Interceptor Utility including a Comprehensive K9 Equipment Package in the Amount of \$63,707.87
  - H. Approval to Purchase a New 2027 Ford Police Interceptor Utility including a Comprehensive Patrol Equipment Package in the Amount of \$59,457.13
  - I. Approve a Resolution Approving an Amendment to January 27, 2026 Agreement for General Services Per-and-Polyfluoroalkyl Substances (PFAS) Treatment Equipment and Pilot Testing Services by and between the City of Crest Hill, Will County, Illinois and Strand & Associates, Inc.

- J. Approve the Backflow Solutions, Inc. Agreement to Assist in the Administration, Tracking, and Notification Requirements Associated with the City’s Backflow Prevention Program
- K. Approve the 2026 50/50 Tree Planting Program
- L. Award the Contract to Austin Tyler Construction, Incorporated for the 2026 Roadway Rehabilitation Program in the Amount of \$1,799,817.55
- M. Approve a Resolution for a Professional Services Agreement for a 2027 Financial Plan for Water and Sewer Utility (Rate Update) by and between the City of Crest Hill, Will County, Illinois and Burns & McDonnell in the Amount of \$27,700.00
- N. Approve a Resolution for a Professional Services Agreement for Crest Hill Municipal Park/Plaza by and between the City of Crest Hill, Will County, Illinois and Spaceco in the Amount of \$77,800.00
- O. Approve a Resolution for a Professional Services Agreement for Crest Hill Municipal Park/Plaza Planning and Landscaping by and between the City of Crest Hill, Will County, Illinois and RVI Planning + Landscaping in the Amount of \$60,400.00
- P. Approval of Change Order No. 11 from Vissering Construction Inc. with the Direction to Send it to the IEPA for Approval. Change Order will Increase the Amount of the Contract to \$50,051,690
- Q. Approve a Resolution Approving the Job Description for the Position of Audio Visual and FOIA Specialist and Authorizing the Hiring of Ava Cox as a Police Department A/V & FOIA Specialist at a Salary not to Exceed \$61,878.00
- R. Approve an Emergency Payment for Public Works Biosolids Handling at the East & West Wastewater Treatment Plants in the Amount of \$83,125.00
- S. Approval of the 2026 Memorial Day/Police Memorial Event Report
- T. Approval of the 84th Lidice Ceremony 2026 Memorial Report
- U. Approve the Reduction of the March 2026 Utility Bill to \$136.29, Noting that the Residents are Responsible Going Forward for their Usage & Bill

**7. REPORTS & COMMUNICATIONS FROM DEPARTMENTS & ELECTED OFFICIALS**

- A. Mayor's Report:
- B. City Clerk's Report:
- C. City Treasurer's Report:

- A. Approval of the List of Bills Issued through July 7, 2026, in the Amount of \$2,297,115.55
- B. Approval of the Regular and Overtime Payroll from June 1, 2026, through June 14, 2026, in the Amount of \$319,298.60
- C. Approval of an Additional Regular and Overtime Payroll from June 15, 2026, through June 28, 2026, in the Amount of \$321,854.45
- D. City Attorney:
- E. City Administrator:
  - 1. IML Conference and Training Policy for Elected Officials
  - 2. Approve a Resolution Authorizing the Selection and Hiring of Administrative Intern Kishae White at an Hourly Rate Not to Exceed \$20.00
  - 3. Will County Emergency Notification System Changes to Smart 911
- F. Public Works Department:
- G. City Engineer:
- H. Finance:
- I. Police Department:
- J. Community Development:
  - 1. Approval to Authorize the Replacement of Interior Windows & Speaker Systems in the Interior City Hall Foyer for an Amount Not to Exceed \$53,500

**11. UNFINISHED BUSINESS:**

**12. NEW BUSINESS:**

**13. COMMITTEE/LIAISON REPORTS:**

**14. CITY COUNCIL COMMENTS:**

**15. PUBLIC COMMENT: (*Limit 3 minutes per person*)**

**16. EXECUTIVE SESSION:**

**17. ADJOURNMENT:**

The Agenda for each regular meeting and special meeting (except a meeting held in the event of a bona fide emergency, rescheduled regular meeting, or any reconvened meeting) shall be posted at the City Hall and at the location where the meeting is to be held at least forty-eight (48) hours in advance of the holding of the meeting. The City Council shall also post on its website the agenda for any regular or special meetings. The City Council may modify its agenda for any regular or special meetings. The City Council may modify its agenda before or at the meeting for which public notice is given, provided that, in no event may the City Council act upon any matters which are not posted on the agenda at least forty-eight (48) hours in advance of the time for the holding of the meeting.

MINUTES OF THE WORK SESSION  
CITY COUNCIL OF CREST HILL  
WILL COUNTY, ILLINOIS  
June 8, 2026

The June 8, 2026, the City Council work session was called to order by Mayor Raymond R. Soliman at 7:00 p.m. in the Council Chambers, 20600 City Center Blvd. Crest Hill, Will County, Illinois.

The following Council members were present: Mayor Raymond Soliman, City Clerk Christine Vershay-Hall, City Treasurer Jamie Malloy, Alderman Scott Dyke, Alderman Darrell Jefferson, Alderwoman Claudia Gazal, Alderperson Tina Oberlin, Alderman Mark Cipiti, Alderman Nate Albert, Alderman Joe Kubal.

Also Present were: City Administrator Blaine Wing (left at 11:00 p.m.), Finance Director Glenn Gehrke, Community & Economic Development Director Daniel Ritter, City Engineer Ron Wiedeman, Assistant City Administrator/HR Director Ashley Monroe, City Attorney Mike Stiff.

Absent were: Alderman Angelo Deserio.

Mayor Soliman stated that he received an email from Alderman Angelo Deserio and he is unable to make it for the meeting.

**MAYOR**

1. **Police Pension Board Appointment**

Mayor Soliman introduced a mayoral appointment to the Crest Hill Police Pension Board. He explained that one of the two Mayor-appointed board members had passed away on April 11, and that he was recommending Mr. Bill Barler, a Crest Hill resident of Carillon Lakes, to fill the vacancy for a two-year term expiring May 1, 2028. Mayor Soliman noted the position is uncompensated and requires attendance at approximately four meetings per year. Mr. Barler addressed the Council, sharing that he and his wife had become residents in February 2022 after attending a parade in the area and were enthusiastic about the community. The Council raised no questions.

Mayor Soliman conducted an informal vote to approve the Police Pension Board Appointment.

AYES: Ald. Dyke, Jefferson, Gazal, Oberlin, Cipiti, Albert, Kubal.

NAYES: None.

ABSENT: Ald. Deserio.

**CLERK**

There were no agenda items.

**TREASURER**

City Treasurer Jamie Malloy briefly introduced a matter concerning a resident on Cora Street who had received a water bill of approximately \$4,200 and was seeking a payment

plan. Mayor Soliman redirected this discussion to City Administrator Item 6, as the relevant parties were present in the audience.

## **CITY ADMINISTRATOR**

### 6. Discussion of Draft Water & Sewer Payment Plan Options

City Treasurer Malloy noted she had previously emailed the Council regarding the matter and clarified that her initial identification of the staff contact had been in error.

Finance Director Glenn Gehrke provided background, explaining a series of compounding circumstances that led to a \$4,200 water bill being assessed to new homeowners. The situation originated in December of the prior year when a continuous water flow—traced to a washing machine spigot—began at the property. The outgoing owners paid a January bill, after which the water meter's communication wire broke, cutting off the City's remote reading capability. The City attempted to reach the prior owner but received no response. When the property sold in January and the new owners eventually transferred the account into their name in March, the City's meter system was repaired and once again detected a continuous flow. The new owners promptly shut it off upon notification. However, because the final read given to the prior owner had been an estimate made when the meter was non-communicative, significant usage was billed to the new owners.

Council discussion was extensive. Several members, including Alderman Dyke and Alderwoman Gazal, expressed concern that the City bore partial responsibility given that the meter's communication failure was not followed up with a physical visit to the property, and that an estimated final read rather than an actual read was used at closing. Director Gehrke and City Administrator Blaine Wing acknowledged there was no formal policy requiring a physical visit when a meter communication error occurs, and that a policy requiring an actual read at the time of property transfer did not exist. Administrator Wing noted that the City's finance and public works staff were preparing payment plan policy options and had been reviewing what neighboring municipalities do, with a proposed tiered structure: the Finance Director would have authority to negotiate plans up to \$2,500, the City Administrator up to \$5,000, and anything above that threshold would come before the Council.

City Attorney Mike Stiff noted that City Council had historically extended payment accommodations on a case-by-case basis without a formal policy and advised that a straw poll could be taken that evening to provide interim relief while a formal policy was developed for the June 15th meeting. He further recommended the Council place a moratorium on the scheduled June 19th water shutoff for the affected residents.

After deliberation, the majority of the Council supported both waiving half the outstanding balance and establishing a payment plan for the remaining amount. Alderman Jefferson suggested that, given all the unanswered documentation questions, the water simply remain on under an interest-free

balance until matters were fully sorted, and that staff meet with the residents to develop a plan. Council members Alderman Dyke, Alderperson Oberlin, Alderman Cipiti, and Alderman Kubal supported the more immediate half-waiver approach, while Nate Albert aligned with Alderman Jefferson's preference for further review.

Mayor Soliman conducted an informal vote to reduce the resident's portion owed for the water bill to \$2,100, waive the shut off of water on June 19<sup>th</sup> and to develop a payment plan and terms with the residents.

AYES: Ald. Dyke, Jefferson, Gazal, Oberlin, Kubal.

NAYES: Ald. Cipiti, Albert.

ABSENT: Ald. Deserio.

### **ECONOMIC DEVELOPMENT DEPARTMENT**

3. Plan Commission Recommendation for a Special Use Permit for a Self-Service Storage Facility with Respect to Real Property Located at 103 Elsie Ave in Crest Hill, Illinois (application of Bernadino Estrada)

Community & Economic Development Director Dan Ritter presented the Plan Commission's unanimous recommendation for approval of a special use permit for a self-service storage facility at 103 Elsie Avenue. Director Ritter described the property as a large building-covered parcel located one parcel off Broadway Avenue, surrounded on three sides by residential uses, making many commercial applications impractical. The applicant, Bernardino Estrada, had cleaned up and improved the property's exterior. Currently, one tenant would be utilizing the full interior for storage, with the potential to subdivide into multiple units in the future. The Plan Commission's conditions included restricted hours of operation and a prohibition on storage of flammable, explosive, toxic, hazardous, or radioactive materials. At Alderwoman Gazal's suggestion, an additional condition was added prohibiting outdoor storage of boats, trailers, or recreational vehicles, as the site's limited parking made such storage impractical, but Council wished it codified.

No members of the public approached the podium.

Mayor Soliman conducted an informal vote approving the application of Bernardino Estrada with an additional condition on outdoor storage.

AYES: Ald. Dyke, Jefferson, Gazal, Oberlin, Cipiti, Albert, Kubal.

NAYES: None.

ABSENT: Ald. Deserio.

4. Plan Commission Recommendation for Rezoning, Plat of Easement, a Special Use Permit for a Contractor-Based Business known as Concrete Raising & Waterproofing Inc., and Variations Request from the Crest Hill Zoning Ordinance with Respect to Real Property Located at 1818-1820 N Broadway Street in Crest Hill, Illinois (application of Javier Salazar)

Director Ritter presented the Plan Commission's recommendation for approval of a rezoning from B-2 (General Business District) to B-3 (Business Service District), a special use permit for contractor-based business Concrete Raising & Waterproofing, Inc., and associated variations for the property located at 1818–1820 N. Broadway Street. Director Ritter explained that petitioner Javier Salazar had owned the property for approximately a year and a half, had operated legally under a prior zoning classification before a code change rendered the use legally nonconforming, and was now seeking to formalize and expand his operations with exterior storage of equipment and materials in a screened, paved rear yard.

Director Ritter noted that Mr. Salazar had already made significant improvements to the property—painting the building, repairing windows, removing a deteriorating awning, and clearing code violations—and had been cooperative throughout the planning process. Attorney Sara K. Gray, representing the petitioner, confirmed that Mr. Salazar had agreed to substantial additional requirements including removal of a septic system, capping of an existing well, and connection to City water and sewer. The City, in turn, planned to extend a water main along the property's frontage on Broadway Street, with the petitioner required to connect and to install a sidewalk and landscaping within six months of water main completion. Alderman Dyke and Community & Economic Development Director Ritter praised the improvements already made to the site.

No members of the public approached the podium.

Mayor Soliman conducted an informal vote approving the application of Javier Salazar.

AYES: Ald. Dyke, Jefferson, Gazal, Oberlin, Cipiti, Albert, Kubal.

NAYES: None.

ABSENT: Ald. Deserio.

5. Discussion on Adding a New Liquor License Category – Limited Beer and Wine Restaurant

Director Ritter presented a staff recommendation to create a new Class H-1 liquor license category for limited beer and wine service in restaurants. Director Ritter explained that all surrounding communities offer some version of a beer-and-wine-only license, that the full restaurant liquor license at \$1,200 annually poses a significant cost burden for establishments where alcohol is not a primary revenue source, and that the new category would carry all the same food service and seating requirements as the existing restaurant license while restricting service to beer and wine only, including draft.

Marta and Andy Wysocki, owners of The Black Sheep restaurant, explained that customer demand for beer and wine accompaniment to their food was the driver of the request, and that at a prior business they had lost money on liquor sales due to the cost of the full license, insurance, and state fees. They confirmed they had no plans for video gaming and that their space at

approximately 1,600–1,700 square feet would not accommodate gaming terminals. Director Ritter noted that the state requires a minimum of 3,000 square feet for a video gaming terminal license, which would preclude The Black Sheep regardless. Mayor Soliman stated that this liquor license was for patrons who come in to eat and want a beer or wine with the consumption of food.

Council discussion focused primarily on the appropriate annual fee. Alderperson Oberlin noted that Joliet’s comparable license is \$750 and suggested matching that figure; Romeoville’s lower fee of \$500 was noted to be for packaged goods only, not draft. Staff’s initial proposal had been \$800. Council consensus settled on \$750 as the annual fee, aligning with the Joliet benchmark.

Mayor Soliman conducted an informal vote to approve the creation of a new Class H-1 Liquor License category for limited beer and wine restaurant service, with an annual fee of \$750.

AYES: Ald. Kubal, Albert, Cipiti, Oberlin, Gazal, Jefferson, Dyke.

NAYES: None.

ABSENT: Ald. Deserio.

## **FINANCE DEPARTMENT**

### 1. Community Portal for Caselle to use Credit Card on Website

Finance Director Glenn Gehrke presented a proposal to implement a community online portal through the City’s Caselle ERP system, enabling residents to view utility bills, make online payments, and submit permit applications. The new portal would require a change in credit card payment processor, increasing the processing fee passed to residents from the current 2.25% to 3%. Director Gehrke noted this translates to approximately \$9 more per year for the average resident paying a \$200 bi-monthly bill by credit card, and that in-person payment at City Hall would continue to carry no processing fee. Monthly costs for the portal service are approximately \$155 total across base service, business licensing, miscellaneous, permits, and accounts receivable modules. An optional module for customizable forms (e.g., garage sale permits) carries a \$1,200 startup fee and \$60/month ongoing, which was not included in the current proposal.

Director Gehrke noted the portal would allow real-time posting of payments into Caselle, eliminate manual data entry by staff, and provide residents with visible usage history—a feature noted as particularly relevant in light of the earlier water billing discussion.

Mayor Soliman conducted an informal vote to approve the community portal in Caselle to use credit cards on the website.

AYES: Ald. Gazal, Dyke, Kubal, Albert, Cipiti, Oberlin.

NAYES: None.

ABSENT: Ald. Deserio, Jefferson.

## ENGINEERING DEPARTMENT

1. A Resolution for a Professional Services Agreement for a 2026 Water System Model Update and Water Main Replacement Prioritization Plan by and Between the City of Crest Hill, Will County, Illinois and Strand and Associates, Inc. in the amount of \$150,000.00

City Engineer Ron Wiedeman presented a proposal for Strand and Associates to perform an updated water system hydraulic model for the City. He noted the last such study was completed in 2021, and that subsequent water main improvements warranted a new model. The model is used to determine water pressures at fire hydrants and throughout the distribution system, and informs decisions for new development, extensions, and fire protection planning. The total cost of the professional services agreement is \$150,000.

Mayor Soliman conducted an informal vote to approve a Resolution for a Professional Services Agreement for a 2026 Water System Model Update and Water Main Replacement Prioritization Plan by and Between the City of Crest Hill, Will County, Illinois and Strand and Associates, Inc. in the amount of \$150,000.00.

AYES: Ald. Oberlin, Cipiti, Albert, Kubal, Gazal, Dyke.

NAYES: None.

ABSENT: Ald. Deserio, Jefferson.

2. Discussion on the Approval of an Agreement with the State of Illinois, Capital Development Board and the City of Crest Hill for the Extension of a Watermain from Well 11 to Broadway

City Engineer Wiedeman presented an agreement between the City of Crest Hill and the Illinois Capital Development Board for the extension of a water main from Well 11 to Broadway Street, running through an easement on Department of Corrections property. He explained that the project originated from a letter he had written to the state raising water quality concerns related to the Stateville Prison connection, which initiated discussions that led to this agreement. Under its terms, the Capital Development Board will reimburse the City for all costs associated with designing and constructing the water main, including survey, design, construction, engineering, soil boring, attorney, and easement documentation costs, estimated at approximately \$1,800,000. The agreement had been reviewed by City Engineer Wiedeman and City Attorney Stiff, who noted it had been adapted from a standard state form and that the state and Illinois State Police were responsible under the agreement for negotiating and securing the necessary easements.

Alderman Jefferson confirmed the project would be located east of the current Division Street construction and would not conflict with that work.

Mayor Soliman conducted an informal vote for Approval of an Agreement with the State of Illinois, Capital Development Board and the City of Crest Hill for the Extension of a Watermain from Well 11 to Broadway.

AYES: Ald. Dyke, Jefferson, Gazal, Oberlin, Cipiti, Albert, Kubal.

NAYES: None.

ABSENT: Ald. Deserio.

4. A Resolution Approving an Amendment to the Construction Agreement by and between the City of Crest Hill, Will County, Illinois and P.T. Ferro Construction Company for the Division Roadway Reconstruction Improvement

City Engineer Wiedeman presented Change Order No. 1 to the Division Street reconstruction contract with P.T. Ferro Construction Company, in the amount of \$120,000. He explained that borings conducted during design had not revealed the full extent of peat bogs discovered once existing pavement was removed. Following the recommendation of the project's soil engineer, additional unsuitable material was excavated and replaced with engineered stone base to ensure the pavement achieves its intended design life.

Mayor Soliman conducted an informal vote for a Resolution Approving an Amendment to the Construction Agreement by and between the City of Crest Hill, Will County, Illinois and P.T. Ferro Construction Company for the Division Roadway Reconstruction Improvement.

AYES: Ald. Kubal, Albert, Cipiti, Oberlin, Gazal, Jefferson, Dyke.

NAYES: None.

ABSENT: Ald. Deserio.

5. Discussion on Assistant City Engineer Position

City Engineer Wiedeman presented a proposal to post and hire an Assistant City Engineer, noting that the position had been budgeted in the current fiscal year. He outlined two primary rationales: first, as a succession planning measure given that he anticipates retiring in approximately two years; and second, to address the growing volume of engineering work, including oversight of construction projects, utility inspections, development reviews, and upcoming major capital projects such as the Grand Prairie development. City Engineer Wiedeman and City Administrator Wing indicated the position would be posted in-house first, targeting candidates with several years of experience in civil engineering. The anticipated timeline called for posting in August–September, reviewing candidates in fall, and a January 2027 start date.

HR Director Ashley Monroe noted that current market comparables for assistant city engineer positions in the Chicagoland area range from \$100,000 to \$150,000 annually. Staff proposed a salary range of \$100,000 to \$125,000 to attract qualified candidates with a path to the City Engineer position upon City Engineer Wiedeman's retirement. Engineer Wiedeman noted that when the assistant eventually moves into the director role, the

successor support position would likely be a field engineer at a lower salary range rather than a licensed professional engineer.

Mayor Soliman conducted an informal vote for an approval for an in-house search for an assistant city engineer position in the salary range of \$100,000 to \$125,000 with an approval of the job description.

AYES: Ald. Oberlin, Cipiti, Albert, Kubal, Dyke, Jefferson, Gazal.

NAYES: None.

ABSENT: Ald. Deserio.

### **CITY ADMINISTRATOR**

1. Discussion on America250 Commemoration  
City Administrator Blaine Wing presented the City's planned activities to commemorate the 250th anniversary of the United States. In addition to the light pole banners discussed under the Engineering Department item, Wing noted that three official America250 flags had been purchased and would fly beneath the U.S. flag at City Hall, Public Works, and the East Plant. Commemorative banners would be displayed in the Council Chambers. City Hall lighting would be set to red, white, and blue throughout July. Staff are coordinating with civic groups to lead the Pledge of Allegiance at July meetings. Social media and the City's digital sign would feature 250th content. An IML draft resolution encouraging resident participation in national 250th celebrations was being prepared for Council consideration. Alderwoman Gazal and Alderperson Oberlin commented that patriotic bunting would look nice around the dias in Council chambers. This item required no formal action and will be placed on the consent agenda.

### **ENGINEERING DEPARTMENT**

3. Provide direction to staff and budget number to purchase and install 250<sup>th</sup> Banner and/or Standard Banner  
City Engineer Wiedeman jointly presented a proposal for the purchase and installation of decorative banners on the 29 light poles surrounding City Hall in commemoration of America's 250th anniversary. Engineer Wiedeman reported that the cost per banner from Unlimited Graphics is approximately \$850–\$900 each, installation via a rented bucket truck would cost approximately \$450, and production takes about two and a half weeks, creating a tight timeline ahead of the Fourth of July.

Engineer Wiedeman recommended a mixed approach: purchasing approximately four to six banners featuring America250 branding for placement at prominent entry points, with the remaining banners featuring a standard Crest Hill design that could be reused in future years. Council supported this approach, favoring a mix of the top three designs shown, with the America250 banners placed in pairs at key locations and the Crest Hill-branded banners filling the remainder. Council gave staff latitude to finalize the specific design selection and bring the formal vote to the June 15

meeting, with ordering to proceed promptly to meet the pre-July 4th installation deadline.

Mayor Soliman conducted an informal vote for a four to six 250 banners and then non-250 mixed design banners. All Council members were in favor.

## **ECONOMIC DEVELOPMENT DEPARTMENT**

### **1. Partial Tap-On Fee Discussion**

Community & Economic Development Director Dan Ritter reported on research conducted with City Attorney Stiff regarding the applicability of previously granted tap-on fee waivers that Alderman Dyke brought up at a previous meeting. Director Ritter noted that the City significantly revised its tap-on fee structure in 2019 and 2021 to base fees on actual system usage rather than flat generic rates, which eliminated the need for case-by-case waivers. With respect to a 2013 ordinance that had granted a waiver for a specific R-1 lot on Weber Road, Director Ritter confirmed that the waiver applied only to the exact use specified—a single R-1 residential lot—and would not extend to any redevelopment, subdivision, or change of use. No further direction from the Council was required on this item.

### **2. Discussion on Regulation of Tarped Vehicles**

Director Ritter and City Attorney Stiff presented findings from preliminary research into the regulation of tarped vehicles. Director Ritter noted that a 2013 city ordinance currently prohibits tarped vehicles on public streets as a public nuisance, but that no regulation exists addressing tarped vehicles on private property. Research into surrounding communities—including Joliet, Romeoville, Plainfield, Lockport, and Shorewood—found no regulations governing tarped vehicles on private property in those municipalities either.

Alderman Dyke expressed strong concern about the volume of vehicles in Ward 1 that appear to be inoperable but are covered with tarps, making it impossible for code enforcement to confirm whether tires are flat, registration is current, or whether a vehicle has moved. He indicated there were similar issues with vehicles backed into driveways with plates obscured. Alderman Dyke stated that he could come up with a count of these vehicles but stated that it is a problem in Ward 1. Resident Linda Dyke corroborated these concerns with specific examples from the ward.

Attorney Stiff explained that regulating tarped vehicles on private property is legally more complex than on public streets. Declaring something a nuisance on private property requires a defensible rationale tied to genuine negative community impact. Furthermore, lifting a tarp to inspect a vehicle would require an administrative search warrant, raising constitutional concerns. He and Director Ritter noted that the most legally defensible avenue remains the inoperable vehicle statute, which does allow eventual towing from private property after extensive notice and due process, but enforcement is difficult when a vehicle is concealed.

Suggestions raised by Council included regulating the number of tarped vehicles, establishing time limits for tarping, and potentially requiring a permit—though Director Ritter noted each approach carried its own enforcement and legal challenges. Alderman Cipiti asked what additional research can be done if area communities have been researched. Alderman Jefferson stated that through the Secretary of State all vehicles must be registered, insured and plated. Linda Dyke stated that she was going to make a video of tarped cars in Ward 1 to be played at the next meeting. Resident Stuart Soifer suggested looking at less urban communities, such as Fox Lake, which may have ordinances addressing similar issues. Director Ritter indicated he had found some examples but that they tended to address tarping of already-determined-inoperable vehicles rather than tarped vehicles generally.

Mayor Soliman conducted an informal vote to direct Director Ritter and City Attorney Stiff to continue research and return with a legally defensible regulatory framework.

AYES: Ald. Kubal, Albert, Cipiti, Oberlin, Gazal, Jefferson, Dyke.

NAYES: None.

ABSENT: Ald. Deserio.

6. Direction on Zoning Ordinance and City Code Amendments – Updates to Use Chart and Sign Code

Director Ritter sought Council direction to allow staff to undertake a comprehensive review and update of the City’s zoning use chart and sign code. Director Ritter noted that while the current zoning ordinance was formally adopted in 2018, much of its use chart dated to 1978 and did not reflect current market conditions. Areas of focus would include potentially tightening regulations on discount and rummage stores, tobacco retailers, auto repair, and truck and trailer parking given their concentration in certain areas, as well as reconsidering uses that may be overly restricted. The sign code update would aim to modernize standards to improve streetscape aesthetics and reflect recent legal changes stemming from Supreme Court decisions, while remaining business friendly. Both the use chart and sign code updates would go through the Plan Commission public hearing process before coming to the City Council for action.

Mayor Soliman conducted an informal vote to allow staff to undertake a comprehensive review and update to the City’s zoning use chart and sign code.

AYES: Ald. Dyke, Jefferson, Gazal, Oberlin, Cipiti, Albert, Kubal.

NAYES: None.

ABSENT: Ald. Deserio.

**CITY ADMINISTRATOR**

2. Discussion on List of Bills & Payroll to be Read by City Treasurer
- City Administrator Blaine Wing stated, "In my memo in the packet on page ten, I explain that several months ago there was a request to have the Treasurer start reading again and no longer have the list of bills in the consent portion of the agenda. Again, in my memo, I list and just verbally explain that neither the Finance Director nor myself have any problem with the Treasurer going forward. This would just be an update to our consent agenda policy so if that's what Council would like to do, it was also noted that other than just the list of bills that potentially payroll would be another item that could be read by the Treasurer. So, we would just need direction to adjust the policy. If this was unanimous, we would bring that as a consent item and start doing that going forward with our pulling it from the consent agenda and it would be then up to the Treasurer to read those items, either the one or both. So, we're just looking for direction tonight from Council." After a pause, Mayor Soliman asked, "Anybody on Council?" Alderman Cipiti asked, "Regardless of where it's at, that doesn't change the ability for anyone up here to have a question regarding it and it can be pulled. If it's on the consent agenda, it can be pulled if there's questions. That question can be asked if the Treasurer has it. I'm just, it doesn't change anything as far as the ability to address what's in those reports." Administrator Wing answered, "Yeah, so it would no longer be pulled because it would be a listed item underneath the Treasurer component, but Council would be fully able to ask questions. Both items would still need to be approved. Again, we're approving the payroll and/or we're approving the list of bills so you would just make a motion to discuss that and there would need to be a second. Underneath the consent agenda, it just requires one person to pull it for discussion so I mean there is a slight you know, between the one and the other but it would no longer need to be pulled for discussion." Alderman Cipiti asked, "And it was put into the consent agenda because that's typical of how it started?" Administrator Wing stated, "Yeah, so we looked at the other communities that are in the Grand Prairie Water Commission and the list of bills, and the payroll are in their consent agendas so when we were looking to neighboring communities, again there's not an explanation for the reasons why. Previously it was read by the Treasurer and again if that's what Council would like to do. We knew that when we were creating the consent agenda there's going to be some adjustments and if that's what Council would like, we're happy to do it. There's not a legal reason that it needs to either be in the consent agenda or not." Alderwoman Gazal said, "Well, like you said, in the past the Treasurers, they always did that and also different departments, they still have their stuff to present separately. If you look at ever since you passed the consent agenda and every agenda form, you're going to see that certain departments they still have their own thing to represent regardless of consent or not, they still have theirs separate, so I don't see that there's a problem of doing it." Administrator Wing stated, "Again, I'm not saying that there is a problem. I'm just..." Alderwoman Gazal said, "Like I said, when I brought it up because I told you the gentlemen that reach out that it does look like we have elected officials and we have department heads that they need to say something. Like, we're

paying people to just sit there and look pretty. I mean, we've got to have some kind of record to show that we're all valuable here and we all have something to share and give, whatever however you want to phrase it." Mayor Soliman asked, "Anybody else?" Alderman Albert stated, "I think it should remain in the consent agenda for efficiency's sake. We can pull out if we need to discuss it further, but we don't need to have three separate votes for all this stuff." Alderman Cipiti asked, "How does the City Treasurer feel about this? I'd like to hear her thoughts." City Treasurer Malloy stated, "Truthfully, either way it doesn't really upset me. I'm more than happy to read the overtime also as well as..." Administrator Wing added, "the list of bills." Treasurer Malloy answered, "the list of bills, yeah, thank you! It's getting late, Blaine. It's been a long day." Administrator Wing stated, "We're all on the same team so..." Alderman Jefferson stated, "The way I was always trained was you always give a financial report, you know." Treasurer Malloy replied, "I'm glad to do it." Alderman Jefferson continued, "Things have changed over a period of time so this may be the new way to go putting it in consent but just going back to my roots, I was always you never look over finances with a minimum of concern and consent is kind of like with a minimum of concern. To me, but hey I can catch up to 2026." Alderman Albert said, "Our previous Treasurer used to report the payroll and overtime, but never we actually voted on it." Alderwoman Gazal stated, "That's not true." Administrator Wing stated, "I can't speak to the past, but once I got here and worked with the Clerk's office and the Attorney really the community should be approving it so again under consent it would be approved under that line item and/or if the Treasurer is reading it, that's where it would say approved so there would need to be a motion and a second to approve it." Mayor Soliman asked, "Anybody else?" Alderman Kubal stated, "The consent agenda was put in place to allow us to more a little more efficient here and this looks like we're backtracking now and creating extra time for I don't, you know, so I don't understand it myself. I think it belongs in the consent agenda. This isn't an item that we're going to be discussing on a regular basis. That's my opinion." Mayor Soliman asked, "Anybody else?" Alderperson Oberlin stated, "Well, I will agree with what they said we did it that way for efficiency and if it doesn't matter to the Treasurer which place it goes then why would we not just leave it in the consent agenda unless there was a problem on a particular evening? I don't think the consent agenda is something that I take lightly in any respect so I take everything seriously. It's just a more efficient way of getting things done with less motions and seconds." Mayor Soliman asked, "Scott?" Alderman Dyke stated, "I don't know, I guess in a way sometimes maybe residents like to hear their Treasurer maybe make a report or something. You know we did it that way for so many years just to say here's a list of bills for this amount, granted you name it off in the consent agenda just doesn't seem the same, I guess." Ray Soliman asked, "Mark?" Alderman Cipiti stated, "Well, I kind of like the way it was before with the Treasurer actually presenting those two items, but that's, you know, just what I'm most used to. Doesn't mean that I'm going to insist on it. Regardless of where it's placed, the items are still available to be raised and questioned and discussion to be had. I guess, you know, I do like the idea of the Treasurer presenting those things because

that is you know what they present is nice to hear from the Treasurer, but just my thoughts.” Mayor Soliman stated, “So I’m not sure if you’re in favor of leaving it on consent or having the Treasurer read it.” Alderman Cipiti replied, “Probably leaning toward the Treasurer reading it is my preference.” Mayor Soliman stated, “Okay, so I see four for let the Treasurer read it and three keep it on consent, so I guess we’ll have to wait for [Alderman Deserio] and see what he wants.” Alderwoman Gazal stated, “See here’s the thing, you always pick and choose. Only when [Alderman Deserio] is not here, you want to say I just want to wait for [Alderman Deserio], but for years when a person wasn’t here you just voted and you moved on. It’s a guy that he is never here, so obviously he doesn’t care.” Administrator Wing said, “So, for me again without it being a consensus one way or another, it would be placed on Council’s agenda for the upcoming meeting to discuss, so tonight even if you gave me direction it’s not, as long as there’s not one person who is giving consensus, Council would have to discuss this at the upcoming agenda. It would not be able to be a consensus item, so this is feedback so it won’t go on consent, so it would go on for Council to discuss on next Monday.”

3. Hiring an Intern

City Administrator Wing and HR Director Monroe presented a proposal to hire one graduate-level administrative intern through Northern Illinois University’s (NIU) Master of Public Administration program. Administrator Wing noted the position had been budgeted in the current fiscal year and that the NIU program—ranked third nationally—provides a structured internship with a minimum one-year commitment. The intern would work part-time, approximately 16 to 24 hours per week depending on course schedule, at an hourly rate of \$18 to \$21, below the threshold requiring IMRF pension enrollment and offers no benefits. HR Director Monroe described the intern’s expected duties as including research support for labor negotiations and contract renewals, communications and website projects, analysis for various policy initiatives, and event support. HR Director Monroe stated that she would be the primary supervisor of the intern. She also noted the position could provide AV and streaming support as the City transitions away from a staff member currently managing those duties.

Director Ritter added that in his experience across multiple communities, NIU interns had delivered significant research value on projects that department heads otherwise lacked bandwidth to complete. Administrator Wing and Director Ritter both noted the program had produced individuals who went on to become city managers and senior directors, and that providing a path to a future director-level role would make the position attractive to high-quality candidates.

Alderwoman Gazal confirmed that it was a paid position and raised concerns about the continued growth of City staffing, asking how many more employees the City will need. Alderman Kubal and Alderman Jefferson expressed support due to history with interns, characterizing the program as a cost-effective resource. Alderperson Oberlin and Alderman

Cipiti asked specific questions about who the intern would report to, the frequency of intern work updates to Council, how long the intern would be employed and how does an intern go to school in DeKalb and work in Crest Hill. HR Director Monroe confirmed that NIU was holding candidate interviews at the end of the month, and that Council authorization was needed to proceed.

Mayor Soliman conducted an informal vote to approve an administrative intern job description and range of hourly pay.

AYES: Ald. Dyke, Jefferson, Oberlin, Cipiti, Albert, Kubal.

NAYES: Ald. Gazal.

ABSENT: Ald. Deserio.

4. Lockport Township Back to School Request

City Administrator Wing presented a request from Lockport Township to support a Back-to-School Fair to be held at City Hall on July 31, 2026, from 1:00 to 3:00 p.m., with setup beginning at noon. The Events Committee, represented by Alderwoman Gazal and Alderman Jefferson, reviewed and supported the request. Administrator Wing indicated the request included use of the Council Chambers and community room as well as financial support of up to \$750. Administrator Wing noted he would connect Township representatives with the Alderman Jefferson's existing vendor contacts, which have historically allowed similar events to be run at no supply cost.

Mayor Soliman conducted an informal vote to support the Lockport Township Back to School fair program for an amount up to \$750.

AYES: Ald. Kubal, Albert, Cipiti, Oberlin, Gazal, Jefferson, Dyke.

NAYES: None.

ABSENT: Ald. Deserio.

5. 1,4 Dioxane Legal Services Agreement

City Attorney Stiff recapped the background of this item, noting that in December 2024 he had presented to the Council in executive session regarding potential litigation related to 1,4 dioxane contamination detected in the City's water supply concurrent with PFAS testing. The Council had at that time given direction to proceed with a legal services agreement. The same law firms that handled the City's PFAS litigation—the Driscoll Law Firm and Kevin Madonna's law firm—would represent the City in this matter on a contingency fee basis, meaning no upfront cost to the City. All filing fees and litigation costs would be advanced by the attorneys and reimbursed from any settlement or verdict proceeds, in addition to their contingency fee.

Attorney Stiff noted he had negotiated final revisions to the agreement, substituting "City Administrator" for "general manager" as the City's point of contact and adjusting the signature line for the Mayor. He provided talking points to enable staff and Council to respond to resident inquiries

about 1,4 dioxane. He anticipated the litigation would follow a path similar to the PFAS cases, with an individual City lawsuit being consolidated into a multi-plaintiff federal proceeding.

Council members expressed support, noting that as the City was transitioning to Lake Michigan water, the contingency arrangement presented no financial risk and offered the potential for recovery.

Mayor Soliman conducted an informal vote to draft a legal services agreement.

AYES: Ald. Oberlin, Cipiti, Albert, Kubal, Dyke, Jefferson, Gazal.

NAYES: None.

ABSENT: Ald. Deserio.

### **POLICE DEPARTMENT**

There were no agenda items.

### **PUBLIC WORKS DEPARTMENT**

There were no agenda items.

### **PUBLIC COMMENTS**

No members of the public came forward to address the Council.

### **EXECUTIVE SESSION**

1. 5ILCS 120/2 (c)(1): The appointment, employment, compensation, discipline, performance, or dismissal of specific employees of the public body or legal counsel for the public body, including hearing testimony on a complaint lodged against an employee of the public body or against legal counsel for the public body to determine its validity.
2. 5ILCS 120/2 (c)/(5): The purchase or lease of real property for the use of the public body, including meetings held for the purpose of discussing whether a particular parcel should be acquired.
3. 5ILCS 120/2 (c)(2): Collective negotiating matters between the public body and its employees or their representative, or deliberations concerning salary schedules for one or more classes of employees.

Alderman Oberlin made a motion to enter executive session for 5ILCS 120/2(c)(1), 5ILCS 120/2 (c)/(5) and 5ILCS 120/2 (c)(2). Seconded by Alderman Jefferson. Roll call: Ayes: Dyke, Jefferson, Oberlin, Albert, Kubal. Nays: None. Absent: Deserio, Gazal, Cipiti. MOTION CARRIED.

Executive session: 10:45 PM.

Aldersperson Oberlin made a motion to reconvene from the executive session for 5ILCS 120/2(c)(1), 5ILCS 120/2 (c)/(5) and 5ILCS 120/2 (c)(2). Seconded by Alderwoman Gazal. Roll call: Ayes: Jefferson, Gazal, Oberlin, Cipiti, Albert, Kubal, Dyke. Nays: None. Absent: Deserio. MOTION CARRIED.

Reconvened: 11:20 p.m.

There being no further business before the Council, and no action needed from the executive sessions, the meeting is adjourned.

The meeting adjourned at 11:20 p.m.

Approved this \_\_\_\_ day of \_\_\_\_\_, 2026.

As presented \_\_\_\_\_

As amended \_\_\_\_\_

\_\_\_\_\_  
CHRISTINE VERSHAY-HALL, CITY CLERK

\_\_\_\_\_  
RAYMOND R. SOLIMAN, MAYOR

DRAFT

MINUTES OF THE REGULAR MEETING  
CITY COUNCIL OF CREST HILL  
WILL COUNTY, ILLINOIS  
June 15, 2026

1. OPENING OF MEETING

The regular meeting of the City of Crest Hill was called to order by Mayor Raymond R. Soliman at 7:00 p.m. in the Council Chambers, 20600 City Center Boulevard, Crest Hill, Will County, Illinois.

2. PLEDGE OF ALLEGIANCE

Mayor Soliman asked everyone to rise for the pledge of allegiance and remain standing. The Pledge of Allegiance was recited in unison.

Mayor Soliman opened the meeting with a tribute to Father Anthony Nyamai, pastor of St. Carlo Acutis Parish for four years, who passed away the preceding Saturday at approximately 48 years of age. Mayor Soliman described Father Anthony as a holy and humble man who led the parish through the closing of Saint Anne's, the merger with Saint Ambrose Parish, and the establishment of the newly named St. Carlo Acutis Church. Mayor Soliman also called for a moment of silence in honor of the eight crew members aboard a B-52 that crashed in California earlier that day, asking those present to keep their families in their prayers.

3. ROLL CALL

Roll call indicated the following present: Mayor Raymond Soliman, City Clerk Christine Vershay-Hall, City Treasurer Jamie Malloy, Alderman Scott Dyke, Alderman Angelo Deserio, Alderman Darrell Jefferson, Alderwoman Claudia Gazal, Alderperson Tina Oberlin, Alderman Mark Cipiti, Alderman Nate Albert, and Alderman Joe Kubal.

Also present were: City Administrator Blaine Wing, Police Deputy Chief Ryan Dobczyk, Finance Director Glenn Gehrke, City Engineer Ron Wiedeman, Community & Economic Development Director Dan Ritter, Assistant City Administrator/HR Director Ashley Monroe, and City Attorney Mike Stiff.

4. CITIZEN/SPECIAL REQUEST/PUBLIC HEARINGS

4A. State Representative Dagmara "Dee" Avelar

Mayor Soliman stated that State Representative Dagmara "Dee" Avelar was present to speak. State Representative Avelar, representing the 85th District, provided an update on the recently concluded legislative session. She highlighted that the state passed its eighth consecutive balanced budget for Fiscal Year 2027, with a focus on affordability for working families.

Representative Avelar reported that the 85th District secured approximately \$1.5 million for capital improvements, including infrastructure upgrades and public safety initiatives.

Representative Avelar briefly addressed the BUILD legislation, acknowledging that municipalities have voiced strong concerns about preserving local control, and stated that she and her colleagues are continuing to listen and negotiate.

Turning to the Stateville Correctional Center site, Representative Avelar described the RISE (Rehabilitation, Restoration Inside Safe Environment) Initiative, through which the state plans to construct two modern correctional facilities in Crest Hill: a men's facility with approximately 1,500 beds and a women's facility with approximately 800 beds. She emphasized that the facilities would include educational programming, vocational training, medical and mental health services, and reentry-focused programming, and that Crest Hill was selected as the preferred location following an extensive multi-site evaluation.

Mayor Soliman thanked Representative Avelar for her longstanding partnership with the City, specifically noting her advocacy for the Lake Michigan water project and her support through grants to the Police Department. Mayor Soliman expressed agreement on the importance of preserving local control with regard to the BUILD legislation. Alderwoman Claudia Gazal requested a meeting with Representative Avelar to discuss the SAFE-T Act and its local impact on the Police Department. Alderperson Tina Oberlin commended Representative Avelar for her active involvement in committee meetings and community work.

5. PUBLIC COMMENT FOR AGENDA ITEMS ONLY:

No one approached the podium to make public comments on the agenda items.

6. CONSENT AGENDA:

Mayor Ray Soliman asked if any of the Council members wished to have any items removed from the consent agenda for more discussion.

Alderwoman Gazal requested to remove item 6S (Approval of the List of Bills Issued through June 30, 2026, in the Amount of \$3,931,037.08) from the consent agenda.

Mayor Soliman proceeded to read the consent agenda items:

- 6A. Approve the Minutes from the Regular City Council Meeting Held on June 1, 2026.
- 6B. Approve a Resolution of the City of Crest Hill in Support of the Illinois America250 Commemoration. **Resolution #1421**
- 6C. Approve a Resolution Approving an Agreement for Inner circle-Phase 1 Water Main and Roadway Rehabilitation by and between the City of Crest Hill, Will County, Illinois and P.T. Ferro Construction Company for an Amount of \$933,295.46. **Resolution #1422**

- 6D. Approve a Resolution Approving an Agreement for Oakland Avenue-Phase 2 Water Main Replacement and Road Reconstruction Improvement by and between the City of Crest Hill, Will County, Illinois and P.T. Ferro Construction Company for an Amount of \$1,686,708.10. **Resolution #1423**
- 6E. Approval of Pay Request #41 from Vissering Construction Inc. with Direction to Send it to the IEPA for Approval and Disbursement for a Total Amount of \$214,092.50.
- 6F. Approval of an Ordinance Approving a Special Use Permit for a Self-Service Storage Facility (Case # SU-26-6-5-2) with Respect to Real Property Located at 103 Elsie Avenue in Crest Hill, Illinois (Application of Bernardino Estrada). **Ordinance #2063**
- 6G. Approval of an Ordinance Approving Rezoning the Subject Property from B-2 (General Business District) to B-3 (Business Service District), Plat of Utility and Sidewalk Easement, a Special Use Permit for a Contractor-Based Business known as Concrete Raising & Waterproofing Inc., and Requested Variations from the Crest Hill Zoning Ordinance with Respect to Real Property Located at 1818-1820 N Broadway Street in Crest Hill, Illinois (Application of Javier Salazar). **Ordinance #2064**
- 6H. Approve a Resolution for a Professional Services Agreement for a 2026 Water System Model Update and Water Main Replacement Prioritization Plan by and between the City of Crest Hill, Will County, Illinois and Strand and Associates, Inc. in the Amount of \$150,000.00. **Resolution #1424**
- 6I. Approve a Resolution Approving a Customer Work Agreement by and between the City of Crest Hill and the State of Illinois Capital Development Board for the Design and Construction of a New Water Main Extension from Well Number 11 East along Division Street to the Illinois State Police District 5 Headquarters and the New Illinois State Police Crime Lab. **Resolution #1425**
- 6J. Approval of an Ordinance Amending Section 5.08.100 (License; Classifications Designated; Fees) of Chapter 5.08 (Alcoholic Beverages) of Title 5 (Business Licenses and Regulations) of The City of Crest Hill Code of Ordinances. **Ordinance #2065**
- 6K. Approve a Resolution Approving an Amendment to the Construction Agreement by and between the City of Crest Hill, Will County, Illinois and P.T. Ferro Construction Company for the Division Roadway Reconstruction Improvement. **Resolution #1426**
- 6L. Approval of the Caselle Community Connect Convenience Proposal.
- 6M. Approve an Ordinance Approving the Salary of City Administrator Blaine Wing from June 1, 2026, through May 31, 2027. **Ordinance #2066**
- 6N. Approve a Resolution Approving the Job Description for the Position of Assistant City Engineer and Authorizing the Advertising, Selection, and Hiring

of an Assistant City Engineer at a Salary not to Exceed \$125,000.00 Annually.  
**Resolution #1427**

- 6O. Approve a Resolution Approving a Grievance Settlement Agreement with the International Union of Operating Engineers Authorizing the Execution of that Agreement. **Resolution #1428**
- 6P. Approve a Resolution Approving a Legal Services Agreement by and between the City of Crest Hill, Will County, IL, and the Driscoll Law Firm, LLC, Madonna & Madonna, LLP, Douglas & London, P.C. and Levin, Papantonio, Proctor, Buchanan, O'Brien, Barr, Mougey, P.A. **Resolution #1429**
- 6Q. Approve the City of Crest Hill to Provide Space and Financial Support to the Lockport Township Back to School Program up to \$750.00.
- 6R. Approval of the Regular and Overtime Payroll from May 18, 2026, through May 31, 2026, in the Amount of \$321,154.28.
- 6S. Approval of the List of Bills Issued through June 30, 2026, in the Amount of \$3,931,037.08. (REMOVED for Discussion)

Mayor Soliman asked for a motion to approve the consent agenda items excluding item 6S.

Aldersperson Oberlin made a motion to Approve the Consent Agenda items 6A through 6R. Seconded by Alderman Deserio. Roll Call: Ayes: Dyke, Deserio, Jefferson, Gazal, Oberlin, Cipiti, Albert, Kubal. Nays: None. Absent: None. MOTION CARRIED.

Mayor Soliman stated that they would now discuss the item that was removed from the Consent Agenda to discuss separately.

- 6S. Approval of the List of Bills Issued through June 30, 2026, in the Amount of \$3,931,037.08.

Alderwoman Gazal indicated that she had pulled this item because she wished the City Treasurer to present the report. Mayor Soliman stated that the Council will be discussing this item as number two under the City Administrator. City Administrator Blaine Wing and City Attorney Mike Stiff clarified that under the current consent agenda policy, approved by the Council the prior year, these items are placed on the consent agenda unless pulled for discussion, and that the policy could be changed through a future vote. The item was considered separately.

Mayor Soliman asked for a motion to approve item 6S.

Alderman Kubal made a motion to approve consent agenda item 6S. Seconded by Alderman Albert. Roll Call: Ayes: Deserio, Oberlin, Albert, Kubal, Dyke. Nays: Jefferson, Gazal, Cipiti. Absent: None. MOTION CARRIED.

City Clerk Christine Vershay-Hall provided the resolution and ordinance numbers:

- 6B: Resolution 1421
- 6C: Resolution 1422
- 6D: Resolution 1423
- 6F: Ordinance 2063
- 6G: Ordinance 2064
- 6H: Resolution 1424
- 6I: Resolution 1425
- 6J: Ordinance 2065
- 6K: Resolution 1426
- 6M: Ordinance 2066
- 6N: Resolution 1427
- 6O: Resolution 1428
- 6P: Resolution 1429

Mayor Soliman stated that there were some guests in the audience.

Sara Gray, attorney for Javier Salazar of 1818-1820 Broadway Street as listed in consent agenda item 6G, came to the podium. Mr. Salazar got called away for work and couldn't make it to the meeting. Ms. Gray stated that her client wants to invest in Crest Hill. Mr. Salazar wants his business to look good and do well in Crest Hill.

Bernardino Estrada of 103 Elsie Avenue as listed in consent agenda item 6F, made some comments from the gallery. Mayor Soliman welcomed him to the City of Crest Hill.

7. REPORTS & COMMUNICATIONS FROM DEPARTMENTS & ELECTED OFFICIALS

7A. MAYOR'S REPORT:

There were no items to report. Alderperson Oberlin noted it was good to see the Mayor up and moving around following a recent surgery.

7B. CITY CLERK'S REPORT:

1. Approve a Block Party Application on Wilcox St. for Jessica Munoz on Saturday, July 4th, 2026.

City Clerk Christine Vershay-Hall reported that a resident on Wilcox Street had requested a block party on July 4th from noon to 11:00 p.m., requesting closure of Wilcox Street from Ludwig Avenue to Rose Avenue.

Alderman Dyke made a motion to Approve the Block Party Application on Wilcox Street. Seconded by Alderman Deserio. Roll Call: Ayes: Jefferson, Gazal, Oberlin, Cipiti, Albert, Kubal, Dyke, Deserio. Nays: None. Absent: None. MOTION CARRIED.

7C. CITY TREASURER'S REPORT:

City Treasurer Jamie Malloy thanked the Council for the time dedicated to the prior week's work session to assist residents Rachel and Jonathan.

Treasurer Malloy then informed the Council of a personal health concern, disclosing that she is an asthmatic and has experienced multiple asthma attacks while working in the Public Works building, where she has been stationed. She noted that reliance on her albuterol inhaler has significant physical consequences and that she had been in discussion with Human Resources Director Ashley Monroe regarding accommodations under the Americans with Disabilities Act. Treasurer Malloy expressed appreciation for the respectful treatment she has received from Public Works staff but stated she would need assistance going forward. Mayor Soliman noted that City Administrator Wing and Human Resources Director Monroe had been working on the issue. Alderman Jefferson offered to speak with Treasurer Malloy after the meeting regarding additional external resources.

7D. CITY ATTORNEY:

There were no items to report.

7E. CITY ADMINISTRATOR:

1. Approve a Resolution Approving the Job Description for the Position of Administrative Intern and Authorizing the Selection, and Hiring of a Part-Time Administrative Intern at an Hourly Rate not to Exceed \$21.00.

City Administrator Wing introduced the item and deferred to Human Resources Director Ashley Monroe, who explained that the position would be filled through Northern Illinois University's graduate Master of Public Administration internship program. She described the role as offering cost-effective flexibility to amplify existing city work, with potential assignments in building permit process analysis, council-directed initiative research, marketing and economic development support, records management, audio-visual equipment operation, communications and social media, community event support, and council meeting assistance. The hourly rate range of \$18 to \$21 was identified as consistent with feedback from NIU and comparable communities, with approval needed promptly so that NIU could plan its intern placement schedule.

Alderwoman Gazal expressed concerns about the breadth of the role, specifically questioning who would train the intern on AV equipment given that the current AV operator was departing, and whether the City needed staff in targeted, experienced positions rather than a "floater." She argued that the City should be filling defined vacancies rather than creating a generalist role. City Administrator Wing clarified that he and Human Resources Director Monroe would be trained by the departing AV operator beforehand, who would also create instructional videos and written guides. The discussion reflected differing views on whether

generalist intern support was appropriate at this stage of the City's growth.

Alderman Albert made a motion to Approve the Resolution approving the job description for the position of Administrative Intern and Authorizing the selection, and Hiring of a Part-Time Administrative Intern at an Hourly Rate not to exceed \$21.00. Seconded by Alderman Kubal. Roll Call: Ayes: Albert, Kubal, Deserio, Oberlin, Mayor Soliman. Nays: Dyke, Jefferson, Gazal, Cipiti. Absent: None. MOTION CARRIED. **Resolution #1430**

2. Discussion on List of Bills & Payroll to be Read by City Treasurer

City Administrator Wing outlined that when the consent agenda policy was established the prior year, the payroll and list of bills items were included in the consent agenda based on a review of practices in comparable communities including Joliet, Shorewood, Channahon, and Romeoville. He confirmed that neither he nor Finance Director Glenn Gehrke had any objection to the City Treasurer reading those items at each meeting, and that the matter was at the Council's discretion.

The discussion involved several Council members. Alderwoman Gazal and Alderman Jefferson both expressed the view that as an elected official, the City Treasurer should have the opportunity to formally present those items rather than have them absorbed into the consent agenda. Multiple Council members cited the principle of respecting the elected nature of the Treasurer's position and argued the change would add only minimal time to meetings. City Attorney Stiff confirmed the policy could be changed by vote.

Alderman Jefferson made a motion to remove the List of Bills and Payroll from the Consent Agenda and put it under the Treasurer's report. Seconded by Alderwoman Gazal. Roll Call: Ayes: Cipiti, Albert, Dyke, Deserio, Jefferson, Gazal. Nays: Oberlin, Kubal. Absent: None. MOTION CARRIED.

3. Discussion/Agreement Regarding Payment of Outstanding Water Bill

City Administrator Wing introduced a proposed payment agreement drafted by City Attorney Stiff regarding an outstanding water bill for residents at 1817 Cora Street (referred to as Jonathan and Rachel). The Council had discussed the matter at length during the June 8th work session. City Attorney Stiff explained that the agreement called for a 10% down payment of \$201, followed by monthly payments of \$159 over 12 months, applied to 50% of the total outstanding balance — as the Council had previously agreed to reduce the obligation to half. The residents' regular bi-monthly water usage billing would continue separately.

Finance Director Glenn Gehrke provided a detailed timeline: the continuous water flow that generated the large bill originated on December 23rd under the previous owner; the new owners closed on the property on January 18th but were not entered into the City's system until March 6th–10th; the water meter's MXU transmitter had a broken wire that prevented remote readings, which was repaired on March 16th; and a subsequent continuous flow was identified and shut off by the residents on March 25th. He noted that an estimated final bill of \$238.42 had been issued to the prior owner rather than a metered final read, leaving a gap of approximately \$361.58 that should have been the prior owner's responsibility.

Several Council members expressed hesitation about approving the agreement as written. Alderman Albert stated he was surprised at the pace of the decision and questioned whether even 50% was a fair assessment, noting the amount still exceeded his own annual water bill. Alderman Jefferson raised concern about the residents agreeing to a payment plan without yet knowing what their regular water usage would be, as this was their first billing period. Finance Director Gehrke offered to calculate an estimated bill based on two months of usage data since the continuous flow was corrected (March 25th through May 25th) to give the residents a clearer picture. Alderwoman Gazal also raised the need for a formal policy to prevent similar situations at property closings. City Attorney Stiff noted that, separate from this matter, the City would be following up with title companies regarding the existing ordinance requiring a final meter read before closing.

Alderman Dyke, who had initially made a motion to approve the agreement, and Alderwoman Gazal, who had seconded it, both withdrew their respective motion and second following the discussion. The Council instead voted to table the matter and take it back to a work session for further review, with the intent of returning it for action at the July 6th Council meeting.

Alderman Albert made a motion to Table the Discussion and Agreement regarding Payment of an Outstanding Water Bill.

Seconded by Alderwoman Gazal. Roll Call: Ayes: Cipiti, Albert, Kubal, Dyke, Deserio, Jefferson, Gazal, Oberlin. Nays: None. Absent: None. MOTION CARRIED.

Alderman Dyke made a motion to Not shut off the water at 1817 Cora Street as long as the residents stay current with their current usage. Seconded by Alderperson Albert. Roll Call: Ayes: Kubal, Dyke, Deserio, Jefferson, Gazal, Oberlin, Cipiti, Albert. Nays: None. Absent: None. MOTION CARRIED.

Alderman Dyke asked Administrator Wing if the Council can discuss during a work session using the executive board room for executive sessions again. Alderman

Dyke stated that Council never had to ask the residents to leave Council chambers before to go out on the hallway, even in the former City Hall. Alderman Dyke wants to talk about what the room capacity is, what the fire code would be and if Council isn't going to use the executive board room what other use can the City have for it.

Alderman Jefferson asked if Council get an update on the forensic audit investigation. Administrator Wing stated that he put an update in the Friday report to Council and asked if he wanted it put in for discussion. Alderman Jefferson stated that he would like it on for discussion at a work session.

7F. PUBLIC WORKS DEPARTMENT:

There were no items to report.

7G. CITY ENGINEER:

There were no items to report.

7H. FINANCE:

There were no items to report.

7I. POLICE DEPARTMENT:

1. Approval to Purchase a Police LSV 4- Seater Valor Utility Cart in the Amount of \$27,500.00.

Deputy Chief Ryan Dobczyk presented the Police Department's request to purchase a four-seat electric Valor Utility Cart at a price of \$27,500. He noted that the cart had been demoed at the City's Neighbor's Night Out event the prior year and received positive feedback. Anticipated uses included field searches in areas inaccessible to patrol vehicles, support for the department's drone program (the cart includes a drone charging station at no additional charge), community events such as parades and Winterfest, and future use at the planned park development. Deputy Chief Dobczyk noted that a \$10,000 grant from ComEd was pending and that a disbursement check from the Cooperative Police Team had already been received, meaning the combined funds could potentially cover the full cost of the vehicle. He also indicated the price was expected to increase later in the year, adding urgency to the request.

Several Council members raised questions, including the cart's off-road capability, life expectancy, whether a trailer would be required for transport, and the fact that the item had not appeared on the prior work session agenda. City Administrator Wing explained the timing was due to the availability of the vehicle and the last-minute nature of the opportunity, with the other deputy chief having learned of it on the Tuesday following the work session. He confirmed the cart is street legal in the state of Illinois up to 30 miles per hour (extendable to 35 mph by municipal ordinance), is assigned a VIN number, and has an estimated fleet life cycle of 8 to 12 years based on comparable municipalities. The vehicle carries a 3-year warranty with a 5-year

battery warranty. Alderman Cipiti expressed a preference for additional discussion at a work session, while Alderwoman Gazal countered that sufficient information had been provided and noted the City had already approved other expenditures with less scrutiny.

Alderperson Oberlin made a motion to Approve the purchase of a Police LSV 4-seater Valor Utility Cart in the amount of \$27,500. Seconded by Alderwoman Gazal. Roll Call: Ayes: Albert, Kubal, Deserio, Jefferson, Gazal, Oberlin. Nays: Dyke, Cipiti. Absent: None. MOTION CARRIED.

7J. COMMUNITY DEVELOPMENT:

Community & Economic Development Director Dan Ritter had no agenda items. He provided an update on the Route 66 signage project, noting that one sign had already been installed at Merichka's, with the remaining two signs planned for installation at the gas station/Dunkin' Donuts on Broadway Street and at the Park District Prairie Bluff Golf Course restaurant.

Alderwoman Gazal asked for an update on the old City hall demolition timeline. Director Ritter confirmed that abatement work at the old City Hall was nearing completion, with utility disconnections expected that month and demolition targeted for the beginning to middle of July.

8. UNFINISHED BUSINESS:

Alderman Cipiti requested that an announcement be made regarding recent storm cleanup efforts for residents, which led to a report from City Administrator Wing. City Administrator Wing provided a comprehensive update on the city's response to the severe storms that struck the previous Wednesday and Thursday. The City utilized its emergency alert system, website, and social media to communicate with residents. At the peak, approximately 20% of the community was without power. Public Works deployed two chipper crews, working overtime through the weekend, to address tree and debris damage, with 63 significant tree limbs or downed trees documented. The Police Department, Fire Districts, and Building Department all participated in the response, addressing street closures, minor flooding, and structural damage. The City set up dumpsters at City Hall and Public Works to allow residents to dispose of spoiled food and storm-related waste, with those dumpsters expected to remain through Friday. Alderman Dyke was concerned about residents using the dumpsters for dumping non-storm items, but Administrator Wing stated that the dumpsters were placed accordingly by buildings that have cameras available. If the provided dumpsters aren't being used for storm clean-up, Republic will be called to remove the dumpsters. City Administrator Wing noted the City performed a mini-Emergency Operations Center debrief the morning after the storms and identified some lessons learned, including the need to address generator gaps at certain City facilities. He indicated a request for portable generator connections would be coming to the Council in the near future. City Engineer Wiedeman's office noted that new generators had already been procured for the City's water wells. Alderman Jefferson asked about the process of picking up tree limbs and branches that resulted from the storms. Administrator Wing stated

the two chipper crews will continue their work through Friday and then starting next week, resident should utilize Republic weekly schedule for pick-up. Mayor Soliman extended public thanks to the Public Works Department, Police Department, Fire Department, and all City employees for their work through the storm response.

Aldersperson Oberlin stated that she saw the crews out shaving the high points on the sidewalks in her area, so she wanted to assure the residents that this work was legitimate.

9. NEW BUSINESS:

There was no new business.

10. COMMITTEE/LIAISON REPORTS:

Aldersperson Oberlin reported on the LADICE Program event, thanking numerous contributors including City Administrator Blaine Wing, Building Commissioner Don Seeman, Public Works Director Gary Richardson, Mayor Ray Soliman, City Attorney Mike Stiff, and members of the public works crew — Angel, Don, Pete, John, and Henry Thompson — for their help with setup and teardown. She also recognized Lockport Township firefighters, Crest Hill police department, Alderman Albert for their attendance and acknowledged Alderman Deserio and his wife for a donation of flowers. Aldersperson Oberlin noted the event had a large turnout and featured well-received speakers.

Alderswoman Gazal announced that the back-to-school fair, approved earlier in the meeting under the Consent Agenda, would be held on July 31st from 1:00 to 3:00 p.m. in partnership with Lockport Township.

11. CITY COUNCIL COMMENTS:

Council members offered brief comments, with Alderman Albert, Aldersperson Oberlin, Alderman Dyke, Alderman Deserio, Alderman Jefferson, and Alderswoman Gazal each wishing residents and present company a Happy Father's Day. Alderman Albert extended condolences to Father Anthony's family and parishioners. Alderman Dyke, Alderman Jefferson and Alderswoman Gazal wished to thank the storm responders. Alderswoman Gazal thanked City Administrator Wing for his leadership following the storms. Alderman Deserio acknowledged the summer solstice is approaching and wished for everyone to have a fun and safe summer. Alderman Dyke and Alderswoman Gazal wished everyone a safe and happy Fourth of July, with Alderswoman Gazal reflected on the significance of the nation's 250th anniversary.

12. PUBLIC COMMENT:

No one approached the podium for public comment.

13. EXECUTIVE SESSION:

1. 5ILCS 120/2 (c)/(5): The purchase or lease of real property for the use of the public body, including meetings held for the purpose of discussing whether a particular parcel should be acquired.

Mayor Soliman asked for a motion to go into executive session on 5ILCS 120/2 (c)(5).

Aldersperson Oberlin made a motion to go into executive session on 5ILCS 120/2 (c)(5) at 9:00 p.m. Seconded by Alderwoman Gazal. Roll Call: Ayes: Dyke, Deserio, Jefferson, Gazal, Oberlin, Cipiti, Albert, Kubal. Naves: None. Absent: None. MOTION CARRIED.

Mayor Soliman asked for a motion to reconvene from the executive session on 5ILCS 120/2 (c)(5).

Aldersperson Oberlin made a motion to reconvene from the executive session on 5ILCS 120/2 (c)(5) at 9:55 p.m. Seconded by Alderman Deserio. Roll Call: Ayes: Jefferson, Gazal, Oberlin, Cipiti, Albert, Kubal, Dyke, Deserio. Naves: None. Absent: None. MOTION CARRIED.

14. ADJOURNMENT:

There being no further business before the Council, a motion for adjournment was in order.

Alderman Dyke made a motion to adjourn at 9:55 p.m. Seconded by Alderman Deserio. Roll Call: Ayes: Gazal, Oberlin, Cipiti, Albert, Kubal, Dyke, Deserio, Jefferson. Naves: None. Absent: None. MOTION CARRIED.

Approved this \_\_\_ day of \_\_\_\_\_, 2026,  
As presented \_\_\_\_\_  
As amended \_\_\_\_\_

\_\_\_\_\_  
CHRISTINE VERSHAY-HALL, CITY CLERK

\_\_\_\_\_  
RAYMOND R. SOLIMAN, MAYOR

MINUTES OF THE WORK SESSION  
CITY COUNCIL OF CREST HILL  
WILL COUNTY, ILLINOIS  
June 22, 2026

The June 22, 2026, the City Council work session was called to order by Mayor Raymond R. Soliman at 7:00 p.m. in the Council Chambers, 20600 City Center Blvd. Crest Hill, Will County, Illinois.

The following Council members were present: Mayor Raymond Soliman, City Clerk Christine Vershay-Hall, City Treasurer Jamie Malloy, Alderman Darrell Jefferson, Alderwoman Claudia Gazal, Alderperson Tina Oberlin, Alderman Mark Cipiti, Alderman Nate Albert.

Also Present were: City Administrator Blaine Wing, Finance Director Glenn Gehrke, Community & Economic Development Director Daniel Ritter, Building Commissioner Don Seeman, Assistant City Administrator & HR Director Ashley Monroe, City Attorney Mike Stiff.

Absent were: Alderman Scott Dyke and Alderman Joe Kubal.

Mayor Soliman commented that he spoke with both Alderman Dyke and Alderman Kubal and they were both absent and excused for the meeting.

Mayor Ray Soliman requested that the Council start with Public Works Department item number one first, as representatives from Backflow Solutions, Inc. were present.

**PUBLIC WORKS DEPARTMENT**

1. Presentation of Backflow Solutions, Inc. (BSI) Agreement to Assist in the Administration, Tracking, and Notification Requirements Associated with the City's Backflow Prevention Program  
Victoria Rodriguez and Lauren Bullock, representatives of Backflow Solutions, Inc. (BSI), presented the company's services related to administration of municipal backflow prevention programs, including compliance tracking, notice generation, customer service support, cloud-based data management, and required survey administration under Illinois EPA rules. It was stated that the company works with more than 170 Illinois communities and approximately 1,000 water systems nationwide.

Public Works Director Gary Richardson explained that the City had effectively lost continuity with prior service arrangements and currently lacked reliable records for commercial backflow devices. He said the City needed a reputable system to establish compliance records, assist with state reporting, and help protect the integrity of the municipal water system. He emphasized that this was a budgeted item and said the startup cost for transferring to the new provider would be waived.

Mayor Soliman asked whether the program would cover both commercial and residential properties. Director Richardson responded that the current proposal was for commercial properties only, with residential implementation envisioned as a later step once the City had better control of the larger commercial component.

Alderman Jefferson asked about the risk of not having a functioning reporting system. Director Richardson responded bluntly that the danger was contamination of the water supply and regulatory consequences with the Illinois EPA if the City could not produce records showing compliance.

Alderwoman Gazal asked whether the quoted cost was annual or covered the entire term. Director Richardson explained that the approximately \$21,000 figure covered the three-year survey cycle and setup work, while recurring annual costs after that would be much lower. The BSI representative added that the annual cost was only about \$500 and that the first-year annual fee was being waived.

Alderman Cipiti asked if all buildings have a backflow prevention system. Building Commissioner Don Seeman added that some buildings, such as those with sprinkler systems, are required to have backflow devices, but the City did not yet know with certainty whether all applicable commercial buildings were equipped and in compliance. Director Richardson stated that the survey process and coordination with the fire department would help establish a more complete inventory.

Mayor Ray Soliman stated that the program was long-overdue and especially important in advance of the City's transition to Lake Michigan water. Mayor Soliman conducted an informal vote to approve the BSI agreement.

AYES: Ald. Deserio, Jefferson, Gazal, Oberlin, Cipiti, Albert.  
NAYES: None.  
ABSENT: Ald. Dyke, Kubal.

**MAYOR**

There were no agenda items.

**CLERK**

There were no agenda items.

**TREASURER**

There were no agenda items.

**CITY ADMINISTRATOR**

1. IML Conference Discussion  
City Administrator Blaine Wing presented a discussion item regarding policy parameters for attendance, registration, reimbursement, and

accountability for the upcoming IML conference and similar trainings. He explained that City Council had requested the matter be discussed in advance of the 2026 conference, particularly in light of prior concerns about conference-related expenses.

City Administrator Blaine Wing proposed a formal policy under which registrations for elected officials, as well as planning commission and civil service commission members attending conferences or training, would be coordinated through the administrative office. He stated that registration, hotel arrangements, parking, and cancellations would be centralized, and that requests to register or cancel should be made by email for documentation purposes. He also outlined a meal reimbursement approach using the IRS per diem for the Chicago area, rather than requiring receipts for every meal and incidental expense.

Discussion also addressed registration timing, cancellation accountability, and attendance expectations. Alderperson Oberlin agreed that if an official registered for multiple days, the expectation should be that the person actually attend the registered days absent an emergency. It was noted that the IML rate structure makes a three-day registration cheaper than some shorter registration combinations, so the policy language would need to account for that pricing reality while still requiring meaningful attendance.

Council discussion supported a minimum attendance expectation of at least two days when a three-day registration was purchased for cost efficiency.

Alderwoman Gazal questioned both the scope and structure of the proposal. She asked whether the discussion was related only to the IML conference or also to other boards and commissions. City Administrator Blaine Wing clarified that staff had attempted to create a broader policy applicable to training opportunities beyond the IML conference, but he acknowledged that the Council could choose to limit the policy to IML for elected officials.

Alderwoman Gazal also objected to dividing meal reimbursement into prescribed breakfast, lunch, and dinner amounts. She stated that council members had historically been allowed a set daily amount of \$100, within which they could choose how to spend their meal budget, subject to receipts. She expressed concern that providing a cash per diem up front was not sufficiently transparent for taxpayer-funded expenses. Alderwoman Gazal and Alderperson Oberlin both agreed that receipts should continue to be required.

Finance Director Glenn Gehrke explained that a per diem is a standard allowance model and would simplify administration, but acknowledged that the City could continue to use a receipt-based reimbursement system if Council preferred. City Administrator Blaine Wing stated that staff were simply presenting options and would revise the policy direction based on Council's feedback. Alderman Cipiti asked how the per diem would work. Director Gehrke stated that a check will be given in advance to each person attending the conference.

Alderman Albert spoke about the day rate (\$275) versus the 3-day rate (\$375), stating that if you sign up for two days it is actually more expensive than the 3-day rate. He wanted to know if you can transfer a day pass to another person if you cannot attend one of the days of the conference. Administrator Wing stated that there are no transfer capabilities on the passes.

City Administrator Blaine Wing also raised the issue of missed early-bird registration deadlines. City Attorney Mike Stiff suggested allowing late registration if the attendee paid the difference between the early-bird and regular registration rates. Council members indicated support for that concept.

Mayor Soliman conducted an informal vote on one major policy point: using a \$100 per day meal reimbursement cap with receipts required, rather than the IRS per diem approach.

AYES: Ald. Albert, Cipiti, Oberlin, Gazal, Deserio.

NAYES: Ald. Jefferson.

ABSENT: Ald. Dyke, Kubal.

## **ECONOMIC DEVELOPMENT DEPARTMENT**

### 1. Discuss Commercial Grant Program Revisions (Formerly Façade Program)

Community & Economic Development Director Dan Ritter presented proposed revisions to the City's existing façade improvement grant program, reframing it as a broader commercial property improvement grant program. Director Ritter explained that the prior program had seen very limited use, with only two grants advanced in recent years, and that those experiences revealed the need for clearer standards and better alignment with the City's redevelopment goals.

The revised draft would move away from funding tenant-specific improvements such as wall signs and instead focus on permanent property improvements that have longer-term public value, including façade work, permanent ground signage, landscaping, site circulation improvements, and similar exterior upgrades. Director Ritter said the intent was to direct public funds toward projects that visibly improve aging commercial corridors and encourage more substantial reinvestment.

Council members responded favorably. Alderperson Oberlin noted one provision regarding permit fee waivers and asked whether permit costs were included within the grant award or in addition to it. Director Ritter responded that permit costs would be incorporated into the grant reimbursement process and agreed that the language should be clarified.

Director Ritter also recommended eliminating after-the-fact grant applications, explaining that such applications are difficult to verify, undermine the program's incentive purpose, and complicate review of

whether costs were reasonable. He stated that the City intended to promote the revised program more actively once the updated policy was finalized, including through business retention visits, direct outreach to property owners, social media, and newsletters.

Alderman Gazal expressed support for stronger promotion of the program and said she would like to see it targeted toward deteriorated commercial properties that most need assistance. She also asked whether the budget could be increased in the future if demand grows. Director Ritter replied that the current budget was \$12,750, but if interest exceeded available funding, a request could be brought back to the Council for additional appropriation.

Questions were also raised about whether multiple grants could be awarded to the same property over time. Staff indicated that the draft contemplated limits on funding for the same improvement category over a period of years, but that clarification would be added to make the policy easier to understand.

Mayor Soliman conducted an informal vote, and council members present indicated support for staff to continue refining the revised program and bring it back for formal action.

AYES: Ald. Gazal, Jefferson, Deserio, Albert, Cipiti, Oberlin.

NAYES: None.

ABSENT: Ald. Dyke, Kubal.

## 2. Plumbing and Windows Discussion

City Administrator Blaine Wing introduced a discussion regarding ongoing plumbing failures and damaged interior security windows at the police department/city hall building. He stated that the City had sought to address the underlying causes of building problems rather than merely continuing short-term fixes, and noted that with additional permanent facilities staff now in place, the City would be better positioned to oversee future maintenance and repair work.

### **Plumbing Discussion**

City Administrator Blaine Wing summarized prior efforts to address the recurring plumbing backups, including replacement of low-flow toilets that were not appropriate for the system. He said those changes had reduced the frequency of clogs but had not solved the fundamental problem. He then outlined three escalating potential responses: (1) installation of a grinder/ejector pump, (2) separation of police department and city hall plumbing lines, and (3) extensive demolition and pipe replacement under the slab.

Discussion of this item was extensive and reflected longstanding frustration over the building's construction history. Alderman Oberlin criticized the original planning, oversight, and construction of the building. Alderman Cipiti stated that the building has been described as "the gift that keeps on

giving” and argued that the City had acted beyond its expertise by serving as its own general contractor. He asked whether any contractors or inspectors involved in the original work could still be held accountable and expressed concern that taxpayers continue to bear the cost of correcting serious deficiencies. City Administrator Wing responded that warranty periods had expired, and City Attorney Stiff explained that while warranty claims were likely unavailable, a breach of contract theory might still be possible depending on the contract terms and facts. However, Attorney Stiff cautioned that litigation would be expensive, uncertain, and potentially complicated by the City’s own inspection and approval role during construction. It was also noted that prior Councils had discussed litigation and chose not to proceed.

Building Commissioner Don Seeman identified Omega Plumbing as the original plumbing contractor. Alderman Jefferson and Alderperson Oberlin questioned how improper back-pitched sewer lines could have passed inspection, and Alderman Jefferson expressed frustration that the City lacked more complete close-out documentation from construction. Alderman Jefferson said he found it difficult to explain to residents why the City could be facing another major repair bill for what appeared to be fundamental construction failures.

Building Commissioner Seeman then described the proposed grinder/ejector pump installation in technical terms. He explained that recurring clogs originate in the locker room area and are worsened by back-pitched piping that allows solids to build up rather than flow properly. The proposed pump would grind solids and force the material through the system with pressure. He emphasized that this recommendation came after review with Highland Plumbing and a plumbing engineer.

Alderwoman Gazal remained skeptical that the pump alone represented a durable solution and stated that it sounded temporary rather than permanent. Public Works Director Gary Richardson and City Administrator Blaine Wing explained that the most practical approach appeared to be to start with the lower-cost measures before considering demolition of the slab, which could require months of police department displacement and create significant structural risk. City Administrator Wing said the combined effect of a grinder/ejector system and line separation would likely provide a much longer-term solution and was preferable to immediately moving to the most invasive and costly option.

Still, several members asked for further review. Public Works Director Richardson suggested bringing in additional commercial plumbing contractors currently working in the City to examine the system and provide their assessment. This idea received support from the Council. Building Commissioner Seeman and Public Works Director Richardson agreed to coordinate that further evaluation and obtain additional opinions, including review of camera footage showing where the back pitch exists. No formal action was taken on the plumbing matter at this time.

### **Windows Discussion**

The discussion then shifted to the damaged bullet-resistant interior windows in the reception/vestibule area. City Administrator Wing stated that the City had obtained a proposal to replace the windows within the existing frames and had explored alternatives. He said new internal maintenance oversight and procedures would be put in place to ensure the replacement windows were cleaned only according to manufacturer requirements.

Alderwoman Gazal challenged the suggestion that improper chemical cleaning was the primary cause of the damage, stating that a previous explanation to the Council had been that structural settlement was responsible. Building Commissioner Seeman responded that the windows are polycarbonate and that the manufacturer had provided written guidance stating they must be cleaned only with water and that chemical cleaners such as Windex can cause the type of deterioration seen. He also explained that the windows had previously been removed during ADA-related modifications and reinstalled by a different contractor, which had voided the original warranty.

Council discussion reflected some disagreement over the likely cause of the cracking, but there was general recognition that the windows now needed replacement regardless of how the damage occurred. Building Commissioner Seeman reported that using a different style similar to the police department's windows would cost more because it would require frame modifications and additional wall work. The proposal before the City would replace the existing glazing in the same openings, with an optional two-way communication system added.

Mayor Soliman summarized the pricing as approximately \$44,750 for the window work plus \$8,750 for the communication devices, for a total of about \$53,500. Mayor Soliman conducted an informal vote for the approval of the window repair.

AYES: Ald. Deserio, Gazal, Oberlin, Albert.

UNSURE: Ald. Jefferson, Cipiti.

NAYES: None.

ABSENT: Ald. Dyke, Kubal.

City Administrator Wing stated that the item would be brought to the July 6th council meeting but would not be placed on the consent agenda due to the couple of unsure votes.

City Administrator Wing stated, "Again, the rest of my memo is as it was kind of noted this building is 'the gift that keeps on giving,' so while we're talking about it, I'll just note that again this building also does not have commercial heating and cooling so at some point we'll need to be addressing that. In the future, we'll be looking at a budget so we're setting aside dollars. I'm going to squeeze out as much as we can with our non-commercial heating and cooling, but that's why we have different rooms

that are hotter and colder at certain times. Again, typically the commercial equipment would last ten, fifteen, twenty years, this one will probably give us maybe another three to five, so we'll need to be saving money to replace our heating and cooling system. Again, some of the other toilets in City Hall are also not the commercial so that they do the restrictors as well, so we'll need to most likely change out some of those. We do have some leaky ceilings and roof issues that we continue to work with the contractors that have originally installed so that some things might be the membrane, other ones might be condensation and some other things. Outdoors we have some non-sealed bricks around the memorial, so they didn't put in the sand that actually has the, I forget, the poly, it's the glue in it. So, if we don't do some of that work and just normal maintenance that will then start to shift and we're going to have more work there so we're going to have to spend some time there. And then additionally, some of the City Hall side, there were not the, I guess, appropriate I'll call them kind of fire wall or kind of coordinated off areas it's a big open area with paths so if somebody got in and we had an active shooter event, there's not a few doors or barriers that would segment off so for basically security improvements there will most likely need be potentially some walls, doors. We also don't have on the back a fence, somebody could basically come through and if somebody did, now again we will have bullet-resistant windows, but on the back none of those windows are bullet-resistant and so somebody could get in on that side so most likely would be recommending a fence and not replacing the windows. So, there will be some other improvements that will be..." Alderwoman Gazal asked, "Where are you putting the fence, you said?" Administrator Wing responded, "So, the fence would probably be extended from where the police car, where you're going in to close off before you get to the employee parking back over here, so it would be..." Alderwoman Gazal stated, "You also talked about walls and windows." Administrator Wing said, "Yeah, so interiorly there's probably some doors and walls that would most likely, maybe one or two, to segment off the various areas. Right now, if somebody got in, you would have full access." Alderwoman Gazal stated, "Oh, so we're only saying let's protect the Mayor and some staff, but who cares about the building department. We know exactly why you're putting up those doors. I was told exactly about your conversations about the doors. It's to avoid one particular person, it's not for safety, so let's not go there." Administrator Wing said, "Okay." Alderwoman Gazal stated, "I don't like those games." Administrator Wing said, "So, for safety I've been talking about those potential walls and doors prior to anybody even moving as I first got here and our UPS and FedEx delivery actually come in, so it would actually add a barrier to protect both the building side and the other employees, so you may be talking about some other walls and some other conversations, but the overall security and safety of the employees and individuals here is something that I do take very seriously. And again..." Alderwoman Gazal added, "Oh, I take very seriously too, the staff. All the public works department that doesn't have safety, but you want to protect a particular corner of the building, and I know exactly why you're doing it so come on, let's just not. Like I said, I don't like to play the games. Just be forward and tell us exactly why you want to do it." Administrator Wing said, "I will have the drawings in..." Alderwoman Gazal countered,

“Because you have the park district sitting there as well, so are we going to put a cage around her too? I mean we might as well just put walls just like the prison.” Administrator Wing answered, “We’ll have security experts come in and talk with Council so that you can hear so it’s just not for me, so it’s not just Blaine trying to come up with some plan and hopefully then you’ll be able to ask questions of the security expert as they go through and point out the deficiencies that we have in that section of City Hall. That’s all I had.” Alderman Cipiti asked, “Blaine, you said there’s been work with the roofing contractor that installed the roof when it was built?” Administrator Wing stated, “I did, there has been.” Alderman Cipiti asked, “Are they addressing the leaking ceiling and the roof issues, is that what you’re speaking to?” Administrator Wing answered, “They have been, yeah.” Building Commissioner Seeman stated, “So, Adler Roofing has come out so over time some of these have the standing seam roofs, the metal roofs like that, they can separate with the wind or anything. Adler has come out and is one of the only contractors that has come out and if there are issues, they are taking care of them, and I don’t know if we’ve ever gotten an invoice from them. I think that they have been you know, they gave us the warranty and Chris, the owner, has sent his guys out here and if we have an issue, they have been taking care of it.” Alderman Cipiti stated, “So, they’re standing by their work?” Commissioner Seeman answered, “They have been standing by their work, yes.” Alderman Cipiti asked, “From the original installation?” Commissioner Seeman replied, “Yes.” Alderman Cipiti asked, “Omega Plumbing has refused to do that?” Commissioner Seeman responded, “We haven’t, Omega Plumbing has not been. When we had started having issues here, it was talked about with previous City Administrator that bring in a separate contractor because we didn’t want them basically Omega telling us that something was, it was fine and everything so that’s why. I’ve never talked to Omega Plumbing for any of this.” Alderman Cipiti stated, “It would seem like in the same way we dealt with Adler since they are the original contractor for the roof that we would have, at some point, and I’m not saying you, personally, but anyone from the City would have gone to Omega to say, hey, we’re having these horrible back-up issues, we determined the sewer pipes are going uphill instead of downhill. Give them a chance to stand behind their work. I mean if we’ve never done that. Of course, they are not going to come back and say, ‘How are things going?’ They already got paid. But that’s just how I look at it.” Alderwoman Gazal asked, “Are we going to protect the Council too since we’re doing such high efficiency security when we’re here?” Administrator Wing said, “Yes, we’ll have the...” Alderwoman Gazal said, “Or do we not count? We probably put some railing there and security door. Maybe we can have a police there and check everybody before they come in or maybe we can put metal detectors in everywhere. You know, I’m very frustrated because few staff contacted me and I know for a fact exactly why he’s doing this and it just bugs me because I’m not going to pay a penny to have one particular elected official away from this building. I will not vote for that, and I will make sure all the residents know why exactly you guys are doing it. And call me bold, call me drama, call me pita because that’s my nickname here. I don’t care. I’m always going to say the truth. I know exactly why you guys are doing this and it’s very frustrating that you

don't come transparent and tell me this is why you're going to do it." Administrator Wing stated, "Again we will bring in different security and safety experts and have them explain what they recommend." Alderwoman Gazal said, "Maybe we should have bodyguards too, for each elected official." Mayor Soliman asked, "Do you have anything else, Blaine?" Administrator Wing answered, "I do not."

### **ENGINEERING DEPARTMENT**

There were no agenda items.

### **POLICE DEPARTMENT**

There were no agenda items.

### **PUBLIC WORKS DEPARTMENT**

2. Approval of the purchase of a new 2027 Ford Police Interceptor Utility Including a Comprehensive K9 Equipment Package in the Amount of \$63,7070.87
3. Approval of the Purchase of a New 2027 Ford Police Interceptor Utility Including a Comprehensive Patrol Equipment Package in the Amount of \$59,457.13

Public Works Director Gary Richardson presented both police vehicle purchases together. He explained that fleet management falls within the Public Works Department budget and responsibilities and said he chose to present the items directly because he is responsible for equipment planning and replacement. He stated that replacing aging vehicles reduces maintenance costs, improves operational reliability, and preserves resale value when older vehicles are surplus in a timely manner.

Director Richardson reported that recent vehicle and equipment surplus activity had returned approximately \$25,000, with two more pieces still pending at auction. He stated that the proposed purchases included one updated hybrid patrol vehicle and one interceptor outfitted for K9 use, and that the quoted prices included the necessary upfitting packages. City Treasurer Jamie Malloy advised the Council that Finance Director Glenn Gehrke wanted them to know that all items presented by Director Richardson that evening have been budgeted.

Alderman Cipiti asked why a police official was not presenting the purchase, noting that similar requests had previously come through the police department. Director Richardson responded that the fleet function is part of public works and that, with no one previously occupying his role, the department had often done the vehicle planning work behind the scenes. Alderman Jefferson asked which vehicles were being replaced. Director Richardson replied that two older units that had recently been sold were a 2007 and a 2008 gray interceptor, and that the department was working to reallocate the fleet so the newest vehicles would remain in front-line use.

Mayor Soliman conducted an informal vote for both vehicles after it was determined that there was a typo in the K9 unit price and that price should be listed as \$63,707.87.

AYES: Ald. Oberlin, Cipiti, Albert, Deserio, Jefferson, Gazal.

NAYES: None.

ABSENT: Ald. Dyke, Kubal.

4. Approval of the Purchase of a New 2027 Airtow T14-12 Trailer in the Amount of \$21,530.00

Public Works Director Gary Richardson stated, “My next one is for our medium-sized equipment, the approval for an Airtow T14-12 Trailer that we had budgeted for in our budget for this upcoming budget in the public works department. As I’ve been here and assessing the department, we have smaller equipment that we just cannot move around, such as skid steers. If you’ve ever seen a skid steer, it goes down the street at 2 miles per hour. We drive everything around in this City and that is a big issue of mine because it takes us an hour to get somewhere from where we’re located to the other side of town or getting caught by the train and he’s in a skid steer. This trailer will allow us to move our skid steer around. The skid steer is too heavy for the regular mowing-type trailers so this is a lift-tilt trailer that you can drive right on and drive off. It also helps us with the scissor lift that we have. I remember when I first got here, you guys had to rent a scissor lift for this building. Just the other day, they had to get a trailer for the scissor lift to do the blinds. This will allow us to move our scissor lift around. I hate to say this, but our guys have been working and cutting the trees sometimes on a ladder on the back of the truck. That is unsafe. So, this lift will help us.”

Alderwoman Gazal stated, “Gary, just for the record, can you state for the record when I contacted you today that you’re not purchasing this because of the golf cart, whatever you want to call it, for the police department. Can you state that is not what for?” Director Richardson stated, “You did call me and questioned me about this. That was, honestly, the first time I heard it. I was not here last week. For the record, I have not talked to police. If you’ve ever been in my office, all of my pictures of what I’m trying to purchase are up on my board and so yes, I don’t know about the LSV.” Alderwoman Gazal stated, “Okay, I just wanted that for the record, so I don’t get blamed or say that we voted for that and now we’re voting for this because of the golf thing because it seems like it came back-to-back and the way you explain it, it’s totally something different but then yet the old trailer that you have, the existing trailer I should say that can be used for that golf cart or whatever, the equipment for the police.” Director Richardson said, “So, by knowing what they are purchasing, it is not a heavy duty, you don’t need a heavy-duty trailer for it. What we trail our mowers on; it would be weighted just enough for that. I understand your comment, I did not know about this trailer, and I went to the administrator and said I need you to pile me up on the 22<sup>nd</sup> because the next two I’m on vacation. So, that’s why all of my stuff hit at one time. That was the plan, I didn’t know about

anything else.” Alderwoman Gazal answered, “Okay. Thank you for clarifying again.”

Mayor Soliman conducted an informal vote to approve the purchase of the 2027 trailer in the amount of \$21,530.00.

AYES: Ald. Gazal, Jefferson, Deserio, Albert, Cipiti, Oberlin.

NAYES: None.

ABSENT: Ald. Dyke, Kubal.

5. Presentation of the 2026 50/50 Tree Planting Program

Public Works Director Gary Richardson presented the proposed continuation of the City’s 50/50 tree planting program for fall 2026. He explained that the program allows residents to plant trees on their property while sharing the cost with the City, with applications and payments submitted to the Public Works Department for review and location approval. He stated that the City would coordinate planting with Fields on Caton Farm, Inc.

Discussion focused on eligibility, participation levels, and whether the guidelines should continue to disqualify residents who had received a tree in the previous year. One council member questioned whether prior-year recipients should be excluded if overall program participation remained below the available capacity. City Administrator Blaine Wing responded that, historically, the City had not filled the program to capacity in recent years. Council discussion favored giving first priority to new applicants while still allowing repeat participants if openings remained.

Director Richardson noted that he had carried forward language from prior program materials and said the Council could revise that restriction if it wished. There was also discussion about the number of trees customarily allocated by ward in the past, although members favored a more flexible first-come, first-served approach rather than rigid ward allocations.

It was asked if costs remained the same as in the prior year. Director Richardson responded that he had not yet received updated pricing from the vendor and that, as of the meeting date, costs remained unchanged.

Further discussion addressed planting locations. Director Richardson said the program is intended for residents, but that parkway planting may be allowed where appropriate based on spacing, underground conditions, and City review. He explained that the City manages utility locating for its own infrastructure and coordinates other locating requirements as needed.

Mayor Soliman conducted an informal vote to approve the continuation of the 50/50 Tree planting Program, with revisions discussed to prioritize new applicants and clarify utility easement considerations.

AYES: Ald. Albert, Cipiti, Oberlin, Gazal, Jefferson, Deserio.

NAYES: None.

ABSENT: Ald. Dyke, Kubal.

**ENGINEERING DEPARTMENT**

There were no agenda items.

**PUBLIC COMMENTS**

Resident Stuart Soifer addressed the Council regarding the 50/50 Tree Planting Program. He stated that his homeowners association had long operated under an understanding that individual homeowners could participate in the City’s tree program and, with association approval, have those trees planted on association-owned common property rather than on their own small private lots. He explained that the homeowners would apply through the City and the association would reimburse the homeowner for the cost share. He asked if this longstanding practice remains allowed.

Mayor Soliman responded that his understanding was that homeowners associations had been included historically so long as program requirements were met. Public Works Director Gary Richardson added that if a resident qualifies for the program and chooses to plant the tree elsewhere within the HOA context, which has been treated as a matter of the resident’s arrangement within the association.

There being no further business before the Council, and no action needed from the executive sessions, the meeting is adjourned.

The meeting adjourned at 9:30 p.m.

Approved this \_\_\_ day of \_\_\_\_\_, 2026.

As presented \_\_\_\_\_

As amended \_\_\_\_\_

\_\_\_\_\_  
CHRISTINE VERSHAY-HALL, CITY CLERK

\_\_\_\_\_  
RAYMOND R. SOLIMAN, MAYOR



**Agenda Memo**

**Crest Hill, IL**

**Meeting Date:** July 6, 2026  
**Submitter:** Mayor Raymond R. Soliman  
**Department:** Mayor's Office  
**Agenda Item:** Police Pension Board Appointment

**Summary:** I am recommending Mr. Bill Barler for appointment to the City of Crest Hill Pension Board for a 2 year term expiring May 1, 2028. Please see attached information and feel free to contact me with any questions.

**Recommended Council Action:**

**Financial Impact:**

**Funding Source:**

**Budgeted Amount:**

**Cost:**

**Attachments:**

RECEIVED APR 20 2026

COMMISSIONER APPLICATION

- Plan Commission
- Veterans' Committee
- Civil Service Commission
- Events Committee
- Police Pension Board
- Beautification Committee

Name: MILES WILLIAM BARLER Phone: [REDACTED]

Home Address: [REDACTED] CREST HILL, 60403

Years as Crest Hill Resident: 4 1/2 Registered Voter: YES

Email Address: [REDACTED]

Present Employer: RETIRED Position: N/A

College or University, if appropriate: 2 YEAR DEGREE, CITY COLLEGE OF CHICAGO

Degree and Major: ASSOCIATE DEGREE: LAW ENFORCEMENT

Previous experiences related to Commission of interest:  
ASSOCIATE DEGREE: LAW ENFORCEMENT, EXPLORER SCOUT POLICE PROGRAM - 3 YRS.

Current membership in local organizations and offices held:  
MEDINAH SHRINERS: HOSPITAL LAISON, GREETERS CLUB, ANTIQUE CAR CLUB, POTENTIALS AIDE, "ROARING '57'S"

Past membership in local organizations and offices held: CARILLON LAKES VETERANS' CLUB, OAKLAWN MASONIC LODGE: SENIOR WARDEN - 10 YRS ASSOCIATE MEDINAH SHRINERS: 10 YRS, PRES. "ROARING '57'S" - 2016 + 20. MEMBER

Please attach resume and letter of intent and add additional pertinent information you feel would exemplify you as a Commission member - Why do you want to serve?

I FEEL IT IS A CITIZEN'S OBLIGATION TO TAKE AN ACTIVE PART IN THEIR LOCAL GOVERNMENT, TO MAKE MEANINGFUL CHANGES AND BENEFIT THEIR COMMUNITY.

Miles "Bill" Barler \_\_\_\_\_  
Signature Date: 4/18/26

Return Application to: Raymond R. Soliman, Mayor

Miles Barler · [REDACTED] &gt;

5/8/2026 7:33 PM

## Resume for Miles "Bill" Barler

To raysoliman@comcast.net · Raymond Soliman &lt;rsoliman@cityofcresthill.com&gt; Copy

Barler Miles · [REDACTED]

# **RESUME FOR MILES "BILL" BARLER**

## **EDUCATION:**

1970: Graduated Gage Park High School - Chicago IL.

1970 - 1972: Chicago Junior College, Bogan Campus. Received Associates Degree in Law Enforcement.

1972 - 1977: Took classes part-time at Moraine Valley College while working full time.

## **EMPLOYMENT:**

1968 - 1972: City of Chicago Public Library, worked as stock boy, restocking and organizing books and periodicals.

1972 - 1979: Central Steel & Wire Company, Chicago. Job responsibilities included loading of trucks for delivery of products to customers. Overseeing the loading and unloading of trucks, approximately 95 per 8 hour shift. At this time I was working the midnite to 8:00 shift. Moved to day shift in 1974. Where i supervised the operation of 3 steel cutting and slitting machines. On 7/11/77, I was severely injured while checking the status of a machine used to cut steel coils into sheets. The injury caused the amputation of the 4 fingers on my right hand. After 2 years of rehabilitation and 11 reconstructive surgeries, I was left with partial fingers on the right hand. After returning to work at Central Steel, I was offered a janatorial position. Deciding this was not my future, I left CS&W for other opportunities.

1980 - 1985: Commercial Services Inc., Elmhurst, IL.. This was a local company working in the Midwest. With approximately 95 field staff. Work involved doing commercial property inspections for major insurance companies (including Aetna, Cigna, Industrial Risk Insurers, and others). We would arrive at a risk, make a detailed evaluation of the type of construction the building was, then make an interior review of the occupancy, related hazards such as flammable liquids storage, spray painting and processes such plastics or fiberglass work, workman's comp and health hazards. Also, evaluated were issues such as property protection, fire sprinklers, portable extinguishers, other fire suppression equipment, along with the local fire department and hydrant distance and location. I then compiled this information into a comprehensive report which was sent to the requesting insurance carrier, for their use in evaluating their risk regarding insuring an individual property.

In 1983 I was promoted from field inspector to supervisor, among my duties, included review of field work, answering questions from both field inspectors and customers, as well as training new hires.

1985 - 2011: Insurance Services Office: Chicago, IL.. This was a nationwide company established in 1878 after the Great Chicago Fire to help to mitigate the risk of insuring commercial properties. The company had 29 offices across the country and over 950+ field staff. Starting Work at "ISO", responsibilities were similar to those at Commercial Services. Inspecting commercial properties and preparing reports for major insurance companies. I was required to follow a very specific set of rules and regulations set forth by our training in preparing these reports. Knowing full well that an incomplete or inaccurate report, could result in catastrophic property loss and even injury or death to employees or first responders. I was also responsible for doing ride alongs with field staff for quality review purposes. In 1990 I was promoted to IN-House Field Inspector whose responsibilities included answering technical questions for field staff, phone questions from customers, and accompanying our sales staff on customer calls to answer specific questions.

In 1993 i was promoted to a position of national trainer. This made me and 3 other trainers responsible for design, development, and delivery of new and refresher training material for our 950+ field people. I traveled the country conducting training classes which ran from 2 days to 3 weeks.

After 6 years on the road, in 1999 I returned to the Chicago office as line supervisor for our quality review unit. Overseeing the work of 8 quality review analysts, along with providing technical assistance to the field staff in the western half of the country. These responsibilities were my primary duties, although I continued to do customer calls with our sales staff and field ride alongs until my retirement in July of 2011.

I participated in many courses/classes in my 26 year career with Insurance Services Office, including but not limited to:

CPCU: Certified Property Casualty Underwriter (10 semesters of class)

CFPE: Certified Fire Protection Engineer (8 semesters of class)

PTD: Professional Trainers Designation (4 semesters of training)

Fire Protection & Suppression Systems - IRI (4 weeks of training)

Basics of Building Constuction (1 week of training)

Advance Building Construction (1 week of training)

Construction and The Effects of Fire (2 weeks of training)

## **ACTIVITIES:**

I have been an active member of the Riverside Masonic Lodge and the Medinah Shriners for 15 years. As a Shriner we do 45-50 parades a year to help support the 26 Shriner's Hospitals across the country. Our parade unit is the "Roaring '57s", in which we drive go-karts bodied as 1957 Chevys. I have held several positions in the Shrine including Aide to the Potentate, parade manager and twice president of the "Roaring '57s", member of the Greeters, Antique Car Club and others.

Both my wife and I are avid car nuts, we have owned several classic cars over our 52 years of marriage. We belong to several car clubs in the area.



**Agenda Memo**

**Crest Hill, IL**

---

**Meeting Date:** 07-06-2026  
**Submitter:** Police Chief Edward Clark  
**Department:** Police Department  
**Agenda Item:** Approval Request of a Special Event Police Services Agreement with the American Italian Cultural Society

**Summary:** The American Italian Cultural Society is having it's annual Festa Italiana on August 7, 8 and 9, 2026. They are requesting police services for all three days. The hours are 5pm until 11 pm on the 7<sup>th</sup>, 5 pm until 11 pm on the 8<sup>th</sup> and noon until 9 pm on the 9<sup>th</sup>. This request has been presented and approved multiple times in the past. I am asking formal approval.

**Recommended Council Action:** Approval of a Special Event Police Services Agreement with the American Italian Cultural Society.

**Financial Impact:** None

**Funding Source:**

**Budgeted Amount:**

**Cost:** None

**Attachments:** SEPSA, Certificate of Insurance

## EXHIBIT A

**SPECIAL EVENT POLICE SERVICES AGREEMENT**

This Agreement ("Agreement") is made this 6th day of July 2026 ("Effective Date"), between the CITY OF CREST HILL ("City"), an Illinois Municipal Corporation at 20600 City Center Boulevard, Crest Hill, Illinois, and AICS ("ORGANIZATION") located at 1918 Danman Dr. Illinois (collectively, the "Parties").

WHEREAS, City is empowered to provide for the health, safety and welfare in the City of Crest Hill; and

WHEREAS, pursuant to the Illinois Municipal Code, 65 ILCS 5/11-1-1, et seq., "the corporate authorities of each municipality may pass and enforce all necessary police ordinances" through its sworn law enforcement officers (each law enforcement officer an "Officer"); and

WHEREAS, pursuant to the Illinois Municipal Code, 65 ILCS 5/7-4-8, the police of any municipality may exercise their police power in any adjoining municipality; and

WHEREAS, the ORGANIZATION desires to contract with the CITY to provide law enforcement services and assist in providing for safety, security and order for its event on August 7, 8, 9 (date) at AICS (location) from \_\_\_\_\_ to \_\_\_\_\_ (time) ("Special Event"); and Fri 5-11pm, Sat 5-11pm Sun 12-9pm

WHEREAS, City desires to outline the circumstances in which it will allow its Officers to participate in Special Event Policing.

NOW, THEREFORE, in consideration of the mutual covenants and promises set forth in this Agreement, the Parties agree as follows:

1. SERVICES:

1.1 CITY shall assign Officers to Special Events to perform police patrols and law enforcement duties ("Services"). The Services shall only encompass duties and functions customarily rendered by CITY and Officers assigned to ORGANIZATION shall at all times be subject to the control and direction of CITY.

1.2 Each Officer shall dress in the standard law enforcement uniform issued by the CITY, to include all necessary and required accoutrements that are authorized by the CITY and customarily worn by officers, such as a registered firearm, radio, vest, safety equipment, etc.

1.3 ORGANIZATION shall not exercise control over Officer's enforcement of laws

and Officers shall not enforce any rules and regulations that are not otherwise violations of the law, as determined by Officer and CITY. Officers shall be subject to, and shall abide by, all City and departmental rules and regulations as well as complying with all local, state and federal laws.

1.4 CITY may, in its sole discretion, interrupt Officer's Services in the event of emergencies and other exigent circumstances outside the scope of this Agreement. Such interruption or termination of Services shall not be considered a breach of this Agreement. ORGANIZATION shall only be obligated to pay for the amount of time Officer was present at Special Event.

2. **TERM AND TERMINATION:** This Agreement shall become effective on the Effective Date and shall remain in force until otherwise canceled by the parties. Either Party may terminate this Agreement at any time without cause by providing thirty (30) days prior written notice to the other party. The Chief of Police or Mayor has sole authority to terminate this Agreement on behalf of CITY.

3. **PAYMENT:** In exchange for Services rendered, ORGANIZATION shall pay fees ("Fees") in the amounts and according to the terms set forth as follows:

**One Officer without Vehicle:**

Current Overtime Hourly Rate\* x Number of Hours +15% Admin Fee = Fees  
Ex: \$45.00 x 3 + 15% = \$155.25

**One Officer with Vehicle:**

Current Overtime Hourly Rate\* x Number of Hours +20% Admin Fee = Fees  
Ex: \$45.00 x 3 + 20% = \$162.00

\*Overtime Hourly Rate is set by the current Collective Bargaining Agreement between the City and the Metropolitan Alliance of Police Chapter 15

CITY shall provide ORGANIZATION with a statement of said compensation to be reimbursed within thirty (30) days of the statement. In the event City has to initiate suit to collect payment due under the terms of this Agreement, ORGANIZATION agrees that it shall be responsible for CITY'S attorney fees and court costs.

4. **LIABILITY INSURANCE:** As a requirement of this Agreement, ORGANIZATION shall add the CITY as an additional insured on its general liability policy with a minimum \$1,000,000 single occurrence limit for the Special Event and provide proof prior to the Special Event. If ORGANIZATION does not provide proof of insurance at least one week prior to Special Event, then CITY may terminate this Agreement immediately and such termination shall not constitute a breach.

5. **CITY'S STATUS AS INDEPENDENT CONTRACTOR.** ORGANIZATION and CITY enter into this Agreement at arms' length. CITY at all times shall be considered an independent contractor for all purposes under this Agreement, including the performance of Services. Nothing

in this Agreement Shall be deemed or construed to create a joint venture, partnership or employer/employee relationship between the Parties. Neither ORGANIZATION nor CITY shall hold itself out as the representative or agent of the other Party. Neither ORGANIZATION nor CITY has the right and neither shall seek to exercise any control over the other Party, its employees, its Officers or its agents. CITY, its employees, and Officers assigned to the Special Event shall not be deemed employees or joint employees of ORGANIZATION for any purpose. CITY retains the sole right and authority to recruit, hire, promote, discipline, demote, discharge, determine rates of pay for, establish the terms and conditions of employment of, and/or to direct and control the manner in which its employees and Officers discharge their professional and work duties. CITY is responsible for instructing and training its Officers consistent with this Agreement. CITY retains the sole right and authority to decide and direct which Officers it shall assign, at what times, and to which Facilities to provide Services under this Agreement. CITY shall be solely responsible for all employee wages, timesheets, payroll deductions, federal and state taxes, unemployment compensation contributions, social security taxes, and benefits of its employees and Officers. Neither CITY nor its employees, agents or Officers are entitled to receive any benefits, including but not limited to salary, vacation pay, sick leave, retirement benefits, social security, workers' compensation, health, disability, unemployment and stock options that ORGANIZATION may provide to its employees. It is understood that ORGANIZATION will not provide and shall not be responsible for worker's compensation coverage for CITY or any Officer. Responsibility for providing such coverage remains solely with CITY. When rendering Services at the Facilities, Officers act solely as the agents of CITY.

6. MISCELLANEOUS:

- 6.1 ASSIGNMENT OF RIGHTS: This Agreement, or any of the parties' respective rights or obligations hereunder, may not be assigned or transferred, directly or indirectly, by operation of law or otherwise, by either party without the prior written consent of the other party.
- 6.2 SURVIVAL: No termination or expiration of this Agreement shall affect the rights and obligations of the parties accruing prior to the effective date of termination or expiration.
- 6.3 NO THIRD-PARTY BENEFICIARIES: Nothing in this Agreement is intended to or shall be deemed to confer any rights upon any person who is not a party hereto, including any Officer.
- 6.4 NO FIDUCIARY RELATIONSHIP: Nothing in this Agreement creates any relationship of trust or other fiduciary relationship between the parties hereto, or any Officer.
- 6.5 COUNTERPARTS: This Agreement may be executed in one or more counterparts, all of which shall be deemed one and the same agreement and shall

become effective when each of the parties has signed one or more counterparts.

6.6 ENTIRE AGREEMENT; MODIFICATION: This Agreement with Exhibits constitutes the entire agreement of the parties and supersedes all prior agreements, negotiations, dealings, and understandings, whether written or oral, between the parties regarding the subject matter hereof. No waivers, amendments, or modifications of this Agreement or any part thereof shall be valid unless in writing signed by both parties. Any non-written waiver of any of the terms and conditions hereof shall not be construed as a general waiver by the CITY and the CITY shall be free to reinstate any such term or condition.

6.7 SEVERABILITY: The parties each agree that if any provision of this Agreement is or becomes invalid or prohibited under applicable law, such provision shall be ineffective to the extent of any such prohibition without impairing the remaining provisions in any way.

IN WITNESS WHEREOF, the parties through their authorized representatives have executed this Agreement as of the dates written below.

**CITY OF CREST HILL**

\_\_\_\_\_  
Mayor Date

Attest:

\_\_\_\_\_  
City Clerk Date

**ORGANIZATION**

By: *Daniel Brun* *7-6-26*  
Date

Its: *president + CO-Chair*

PRODUCER Phone: (815) 727-2611 Fax: (815) 727-2648

**A FAZIO INC.**  
**550 RUBY ST**  
**P O BOX 1248**  
**JOLIET IL 60434-1248**

THIS CERTIFICATE IS ISSUED AS A MATTER OF INFORMATION ONLY AND CONFERS NO RIGHTS UPON THE CERTIFICATE HOLDER. THIS CERTIFICATE DOES NOT AMEND, EXTEND OR ALTER THE COVERAGE AFFORDED BY THE POLICIES BELOW.

**INSURERS AFFORDING COVERAGE**

**NAIC #**

Agency Lic#: Cust #2015860

INSURED  
**AMERICAN-ITALIAN CULTURAL SOCIETY**  
**1918 DONMAUR DR**  
**CREST HILL IL 60403**

INSURER A:	<b>Auto Owners Insurance</b>	
INSURER B:	<b>Amguard Ins Co</b>	<b>42390</b>
INSURER C:	<b>Owners Insurance Company</b>	<b>32700</b>
INSURER D:	<b>Auto Owners Insurance Company</b>	<b>18988</b>
INSURER E:	<b>Auto Owners Insurance Company</b>	<b>18988</b>

**COVERAGES**

THE POLICIES OF INSURANCE LISTED BELOW HAVE BEEN ISSUED TO THE INSURED NAMED ABOVE FOR THE POLICY PERIOD INDICATED, NOTWITHSTANDING ANY REQUIREMENT, TERM OR CONDITION OF ANY CONTRACT OR OTHER DOCUMENT WITH RESPECT TO WHICH THIS CERTIFICATE MAY BE ISSUED OR MAY PERTAIN. THE INSURANCE AFFORDED BY THE POLICIES DESCRIBED HEREIN IS SUBJECT TO ALL THE TERMS, EXCLUSIONS AND CONDITIONS OF SUCH POLICIES. AGGREGATE LIMITS SHOWN MAY HAVE BEEN REDUCED BY PAID CLAIMS.

INSR LTR	ADD'L INSRD	TYPE OF INSURANCE	POLICY NUMBER	POLICY EFFECTIVE DATE (MM/DD/YY)	POLICY EXPIRATION DATE (MM/DD/YY)	LIMITS	
		<b>GENERAL LIABILITY</b> <input checked="" type="checkbox"/> COMMERCIAL GENERAL LIABILITY <input checked="" type="checkbox"/> CLAIMS MADE <input checked="" type="checkbox"/> OCCUR _____ GEN'L AGGREGATE LIMIT APPLIES PER: <input checked="" type="checkbox"/> POLICY <input type="checkbox"/> PRO-JECT <input type="checkbox"/> LOC	<b>07024227</b>	<b>10/09/25</b>	<b>10/09/26</b>	EACH OCCURRENCE	\$ <b>1,000,000</b>
						DAMAGE TO RENTED PREMISES (Ea occurrence)	\$ <b>100,000</b>
						MED. EXP (Any one person)	\$ <b>10,000</b>
						PERSONAL & ADV INJURY	\$ <b>1,000,000</b>
						GENERAL AGGREGATE	\$ <b>1,000,000</b>
						PRODUCTS-COMP/OP AGG.	\$ <b>1,000,000</b>
		<b>AUTOMOBILE LIABILITY</b> <input type="checkbox"/> ANY AUTO <input type="checkbox"/> ALL OWNED AUTOS <input type="checkbox"/> SCHEDULED AUTOS <input checked="" type="checkbox"/> HIRED AUTOS <input checked="" type="checkbox"/> NON-OWNED AUTOS _____	<b>4733702800</b>	<b>10/09/25</b>	<b>10/09/26</b>	COMBINED SINGLE LIMIT (Ea accident)	\$ <b>1,000,000</b>
						BODILY INJURY (Per person)	\$ <b>1,000,000</b>
						BODILY INJURY (Per accident)	\$ <b>0</b>
						PROPERTY DAMAGE (Per accident)	\$ <b>0</b>
		<b>GARAGE LIABILITY</b> <input type="checkbox"/> ANY AUTO				AUTO ONLY - EA ACCIDENT	\$
						OTHER THAN AUTO ONLY: EA ACC	\$
						AGG	\$
		<b>EXCESS / UMBRELLA LIABILITY</b> <input checked="" type="checkbox"/> OCCUR <input type="checkbox"/> CLAIMS MADE  <input checked="" type="checkbox"/> DEDUCTIBLE <input checked="" type="checkbox"/> RETENTION \$ <b>10,000</b>	<b>4114774101</b>	<b>10/09/25</b>	<b>10/09/26</b>	EACH OCCURRENCE	\$ <b>1,000,000</b>
						AGGREGATE	\$ <b>1,000,000</b>
							\$
							\$
							\$
		<b>WORKERS COMPENSATION AND EMPLOYERS' LIABILITY</b> ANY PROPRIETOR/PARTNER/EXECUTIVE OFFICER/MEMBER EXCLUDED? If yes, describe under SPECIAL PROVISIONS below	<b>R2WC434468</b>	<b>12/31/25</b>	<b>12/31/26</b>	<input checked="" type="checkbox"/> WC STATU-TORY LIMITS <input type="checkbox"/> OTHER	
						E.L. EACH ACCIDENT	\$ <b>1,000,000</b>
						E.L. DISEASE-EA EMPLOYEE	\$ <b>1,000,000</b>
						E.L. DISEASE-POLICY LIMIT	\$ <b>1,000,000</b>
		<b>OTHER: LIQUOR LIABILITY</b>					<b>1,000,000</b>

**DESCRIPTION OF OPERATIONS/LOCATIONS/VEHICLES/EXCLUSIONS ADDED BY ENDORSEMENT/ SPECIAL PROVISIONS**  
**SOCIAL CLUB WITH LIQUOR SALES**

**CERTIFICATE HOLDER**

**CANCELLATION**

**CITY OF CREST HILL**  
**1610 PLAINFIELD RD.**  
**CREST HILL, IL 60403**

Attention:

SHOULD ANY OF THE ABOVE DESCRIBED POLICIES BE CANCELLED BEFORE THE EXPIRATION DATE THEREOF, THE ISSUING INSURER WILL ENDEAVOR TO MAIL 30 DAYS WRITTEN NOTICE TO THE CERTIFICATE HOLDER NAMED TO THE LEFT, BUT FAILURE TO DO SO SHALL IMPOSE NO OBLIGATION OR LIABILITY OF ANY KIND UPON THE INSURER, IT'S AGENTS OR REPRESENTATIVES.

AUTHORIZED REPRESENTATIVE

Tyler Steffens

**IMPORTANT**

If the certificate holder is an ADDITIONAL INSURED, the policy(ies) must be endorsed. A statement on this certificate does not confer rights to the certificate holder in lieu of such endorsement(s).

If SUBROGATION IS WAIVED, subject to the terms and conditions of the policy, certain policies may require an endorsement. A statement on this certificate does not confer rights to the certificate holder in lieu of such endorsement(s).

**DISCLAIMER**

The Certificate of Insurance on the reverse side of this form does not constitute a contract between the issuing insurer(s), authorized representative or producer, and the certificate holder, nor does it affirmatively or negatively amend, extend or alter the coverage afforded by the policies listed thereon.



---

**Agenda Memo**
**Crest Hill, IL**

---

<b>Meeting Date:</b>	7/6/2026
<b>Submitter:</b>	Gary Richardson, Director of Public Works
<b>Department:</b>	Public Works
<b>Agenda Item:</b>	Approval of the purchase of a new 2027 Airtow T14-12 trailer in the amount of \$21,530.00

**Summary:**

The Public Works Department is requesting approval for the purchase of a new 2027 Airtow T14-12 trailer with a 12,000 lb. capacity from Bauman Trailer Sales & Service, Inc. The Public Works Department regularly transports heavy equipment, including a scissor lift, forklifts, a floor scrubber, and other machinery, throughout the City for maintenance, repairs, and project work. Currently, the available equipment and methods for transporting these items are limited and present safety and efficiency concerns.

Key features of the proposed unit include:

- Ground-level loading capability for safer equipment transport
- Heavy-duty capacity suitable for City-owned equipment
- Included spare tire and trickle charger for reliability

The purchase of this piece of equipment will improve safety when transporting heavy equipment, increase efficiency in completing tasks, reduce reliance on rented or borrowed equipment, and protect City assets by ensuring proper transportation methods.

**Recommended Council Action:**

Approve the purchase of a new 2027 Airtow T14-12 trailer in the amount of \$21,530.00

**Financial Impact:**

The total cost for the vehicle and equipment is \$21,530.00 budgeted within 11-00-7304.

**Attachments:**

A quote for a new 2027 Airtow T14-12 trailer in the amount of \$21,530.00 from Bauman Trailer Sales & Service, Inc.



**BILL OF SALES** Item F.

**Bauman Trailer Sales & Service, Inc**  
 303 South Eureka Street  
 Goodfield, IL, USA, 61742  
 P: (309) 965-2791  
 E: brent@baumantrailersales.com

**SOLD TO**

**City Of Crest Hill**  
 2090 Oakland Ave.  
 Crest Hill, IL, USA, 60403

P: (779) 227-4416  
 E: bsemplinski@cityofcresthill.com

**INVOICE# CO-0004983**  
**June 04, 2026**  
**Order: CO-0004983**

Sold by: Brent Salisbury

**UNIT PURCHASED**

<b>NEW - 2027 AIRTOW, T14-12</b>		<b>OMi</b>	
[Color exterior: Blue]			
T14-12 12,000lb capacity GVWR-15,745lb			
<b>Unit Pricing</b>	Base Unit	\$20,710.00	
	6 amp trickle charger	\$237.00	
	16" Spare Tire	\$410.00	<b>\$21,357.00</b>
<b>Products &amp; Fees</b>	TF - Title Fee	\$165.00	
	LF - License Fee-Municipal Plate	\$8.00	<b>\$173.00</b>

**TOTALS**

Units	\$21,357.00
Products & Fees	\$173.00
<b>Sub-Total</b>	<b>\$21,530.00</b>
<b>Total</b>	<b>\$21,530.00</b>
Balance Due	\$21,530.00

Methods of payment include cash, check\*, card\*\*, money order, wire transfer, and approved financing, with all financing terms determined solely by the third-party lender. \*Checks must list an Illinois address. \*\*Credit card payments are limited to USD \$500.00 and are subject to a 3% surcharge; debit cards are not subject to this fee.

All warranty coverage, terms, and claim approval are determined solely by the manufacturer. The dealer provides no additional warranty beyond assisting the Buyer in submitting the warranty claims to the manufacturer.

Special/custom ordered trailers cannot be cancelled once production has begun.

A \$500 non-refundable deposit is required to hold a unit in your name and must be picked up within 7 days.

By signing below, I the Buyer, acknowledge that I have received, reviewed, and agree to be bound by all terms, conditions, disclosures, and documents associated with this transaction.

Buyer : \_\_\_\_\_

Seller : \_\_\_\_\_



---

**Agenda Memo**
**Crest Hill, IL**

---

<b>Meeting Date:</b>	7/6/2026
<b>Submitter:</b>	Gary Richardson, Director of Public Works
<b>Department:</b>	Public Works
<b>Agenda Item:</b>	Approval of the purchase of a new 2027 Ford Police Interceptor Utility including a comprehensive K9 equipment package in the amount of \$63,707.87.

**Summary:**

The Police Department requires a fully equipped patrol vehicle to support the K-9 unit's operations. K-9 vehicles must be specially outfitted to ensure the safety of both the officer and the K-9, as well as to comply with operational standards.

The 2027 Ford Police Interceptor Utility includes standard police-package features such as AWD drivetrain, police-calibrated braking system, heavy-duty cooling, and factory-installed upfitter provisions for emergency equipment.

The comprehensive equipment package includes all necessary components to outfit the vehicle for K-9 service, including:

- Emergency lighting, siren, and control systems
- Push bumper with integrated lighting
- K-9 containment unit (E/Z Rider platform)
- K-9 safety system (Hot-N-Pop Pro temperature monitoring, alarm system, remote door popper)
- Ventilation fan and safety accessories

These components ensure compliance with K-9 safety standards and allow for safe and effective deployment in the field.

**Recommended Council Action:**

Approve the purchase of a new 2027 Ford Police Interceptor Utility including a comprehensive K9 equipment package in the amount of \$63,707.87.

**Financial Impact:**

The total cost for the vehicle and equipment is \$63,707.87 budgeted within 11-00-7301.

**Attachments:**

A 2027 Ford Police Interceptor Utility through Currie Motors Fleet quote and a comprehensive K9 equipment package outfitting quote from Fleet Safety Supply.

Fleet Safety Supply  
P.O. Box 649  
Naperville, IL 60566  
(630) 527-1341 Phone/Fax

Item G.

# Price Quote

DATE	ESTIMATE NO.
5/27/2026	80074

<b>NAME / ADDRESS</b>
City of Crest Hill 20600 City Center Boulevard Crest Hill, IL 60403

<b>TERMS</b>	<b>FOB</b>	<b>P.O.</b>
Net 30 Days	Naperville,IL	

ITEM	DESCRIPTION	QTY	COST	TOTAL
	2026 Utility - K9			
	*** All lights set to steady and controlled by Core siren ***			
SE-BK2019ITU20	Push Bumper PB450L4 Alum Push Bumper, Full, (4) Whelen Ions, 2020+ Ford Utility Interceptor *** Specify colors: Trios	1	965.60	965.60
WH-CEM16	WCX Expansion Module 16 output, Four Input Module	1	236.52	236.52
WH-RX2SP3J	Lightbar, Siren, and Speaker package WCX DUO JUSTICE 56" DDEE (Red/White and Blue/White) PROMO, includes MKAJ29	1	2,195.10	2,195.10
WH-STPBK105	LIGHTBAR STRAP KIT #105 BLACK, Police Interceptor Utility 2020-2022, (Black Straps and Bolts Only for Mounting Kit, For Use with MKEZ or MKAJ Only, (Not available for all vehicles))	1	0.00	0.00
WH-C399S6	Single Unit 200 Watt Siren with Integrated 3 Section Control Head and 8 Push-Buttons, 4-Position Slide Switch with a 7-Position Rotary Knob, Manual, Airhorn Plus 3 Traffic Advisor™ Switches and Microphone with Extension Cable,	1	1,009.80	1,009.80
WH-C399RSP	SCANPort Installation Kit for C399R and C399S	1	0.00	0.00
WH-SA315U	SA315U SPEAKER, BLACK PLASTIC	1	0.00	0.00
WH-SAK75D	SA-315 MT KIT DRVR 25 FORD PIU	1	0.00	0.00
WH-CV2V	WeCanX Vehicle-to-Vehicle Module (includes internal antenna)	1	241.65	241.65
	Speaker exchange			
WH-SA315U	SA315U SPEAKER, BLACK PLASTIC	-1	0.00	0.00
WH-SAK75D	SA-315 MT KIT DRVR 25 FORD PIU	-1	0.00	0.00
FS-ES100C	Speaker, 100W, high output compact	1	0.00	0.00
FS-ESB-FPIU20NDB	2020 Utility Speaker Bracket, Single, for use with push bumpers	1	0.00	0.00
	Additional speaker			
FS-ES100C	Speaker, 100W, high output compact	1	225.00	225.00
FS-ESB-FPIU20NDB	2020 Utility Speaker Bracket, Single, for use with push bumpers	1	48.02	48.02

Thank you for using Fleet Safety Supply!!!

**TOTAL**

Fleet Safety Supply  
P.O. Box 649  
Naperville, IL 60566  
(630) 527-1341 Phone/Fax

Item G.

# Price Quote

DATE	ESTIMATE NO.
5/27/2026	80074

NAME / ADDRESS
City of Crest Hill 20600 City Center Boulevard Crest Hill, IL 60403

TERMS	FOB	P.O.
Net 30 Days	Naperville,IL	

ITEM	DESCRIPTION	QTY	COST	TOTAL
CO-S24014	Preemption installed in lightbar Bracket for Strobe Reflector	1	5.95	5.95
CO-LMTUBE	Replacement Strobe Tube, Microthin	1	127.50	127.50
TE-401-1228-PREHI	Single head preemption emitter, (Power Supply only)	1	435.00	435.00
WH-U180D	Mounted under mirrors U-Series™ 180° Linear Super-LED® Surface Mount Round Lightheads, Clear Lens (Red/White)	1	250.29	250.29
WH-U180E	U-Series™ 180° Linear Super-LED® Surface Mount Round Lightheads, Clear Lens (Blue/White)	1	250.29	250.29
WH-U18050	2020-2025 Ford Police Interceptor Utility, Under-the-Side View Mirror Mount for Two U-Series Lightheads, Pair (For Use with Ford's Factory Side Marker LED Side View Mirror Option)	1	29.40	29.40
WH-I2J	Rear Side Cargo Windows Ion Duo Series Linear-LED, Universal Light, Includes Universal Mount, Scan-Lock™ Flash Patterns and a 5-Wire Pig Tail, Individual Control of each Color, Black Housing (Red/Blue)	2	166.86	333.72
WH-I2J	Rear Window Ion Duo Series Linear-LED, Universal Light, Includes Universal Mount, Scan-Lock™ Flash Patterns and a 5-Wire Pig Tail, Individual Control of each Color, Black Housing (Red/Blue)	2	166.86	333.72
SO-ETFBSN-P	Taillight Flasher Flashback 100% Solid State Tail Light Flasher	1	78.95	78.95
	License Plate			

Thank you for using Fleet Safety Supply!!!	<b>TOTAL</b>
--------------------------------------------	--------------

Fleet Safety Supply  
P.O. Box 649  
Naperville, IL 60566  
(630) 527-1341 Phone/Fax

Item G.

# Price Quote

DATE	ESTIMATE NO.
5/27/2026	80074

**NAME / ADDRESS**

City of Crest Hill  
20600 City Center Boulevard  
Crest Hill, IL 60403

TERMS	FOB	P.O.
Net 30 Days	Naperville,IL	

ITEM	DESCRIPTION	QTY	COST	TOTAL
FS-MPSW9-RBW	Wide 9 Tri-color (Red/Blue/White)	2	219.63	439.26
FSS-MPSW9LPBRK...	License Plate Bracket for Single Surface Mount MicroPulse Wide 9 with wire Slot (1 Pair)	1	75.00	75.00
SO-ECVDMLTAL00	Dome light over console Dome Light - Universal Mount Options ALL LED Red/White	1	97.95	97.95
WH-WSMIC321	Second microphone in rear Microphone	1	153.90	153.90
WH-01-0448144-000	KIT, MICROPHONE EXTENSION	1	104.49	104.49
MM-MMSU-1	Magnetic Mic Single Unit	1	39.95	39.95
HS-C-VS-0618-INUT	Console 2020 Ford Interceptor Utility Specific Flat Console, Horizontal console with 24" total internal mounting space	1	526.96	526.96
HS-C-EB40-WCS-1P	Equipment Mounting Bracket, 4" Mounting Space, Fits Whelen Core-S Control System	1	0.00	0.00
HS-C-EB25-MRD-1P	Face Plate (1 Piece), M1225, CM300	1	0.00	0.00
HS-C-EB25-T81-1P	Mounting bracket for Kenwood TK7180 (1 Piece)	1	0.00	0.00
HS-C-EB25-MWG-1P	2.5" plate for the Watchguard M500	1	0.00	0.00
HS-CUP2-1001	Self-Adjusting Double Cup Holder, Internally mounted dual cup holder, Self-adjusts to fit cups up to 3.5" in diameter, Occupies 4" of equipment bracket space, with a depth of 3" 4"	1	57.16	57.16
HS-C-FP-2	2" Filler Plate (2.0")	1	0.00	0.00
HS-C-FP-35	3.5 Filler Plate	1	0.00	0.00
HS-C-FP-3	3" Filler Plate	1	0.00	0.00
HS-C-ARPB-1014	Brother PocketJet Roll-Feed Printer Mount and Armrest: Top Mount	1	290.49	290.49
MM-MMSU-1	Magnetic Mic Single Unit	2	39.95	79.90

Thank you for using Fleet Safety Supply!!!

**TOTAL**

Fleet Safety Supply  
P.O. Box 649  
Naperville, IL 60566  
(630) 527-1341 Phone/Fax

Item G.

# Price Quote

DATE	ESTIMATE NO.
5/27/2026	80074

NAME / ADDRESS
City of Crest Hill 20600 City Center Boulevard Crest Hill, IL 60403

TERMS	FOB	P.O.
Net 30 Days	Naperville,IL	

ITEM	DESCRIPTION	QTY	COST	TOTAL
KE-091-264	Dual Port USB-C & USB-A SVR	1	110.90	110.90
	Computer Mount			
HS-C-HDM-204	Pole only, Telescoping device mounting base, Heavy duty mount, Side mount, 8" High, W-SHRTHANDLE	1	198.10	198.10
HS-C-MD-112	11" Slide Out Locking Swing Arm with Motion Adapter	1	306.15	306.15
HS-CG-X	Chargeguard	1	97.50	97.50
	Antenna *** confirm what is needed ***			
AP-AP-MF4G-C2W3...	Antenna Plus MultiMax 4G EZConnect Antenna, AP-MF4G-C2W3G-Q-B1	1	169.79	169.79
AP-CH-C2W3G-1-2-1...	CH-C2W3G-1-2-1-14 - Antenna Plus EZConnect Cable Harness 14' - 2 LTE (SMA M) - 3 WiFi (RP SMA M) - 1 GNSS (SMA M)	1	214.97	214.97
	K9 Container			
AA-EZPF_INTERC.S...	E/Z-Rider K9 Platform Unit for an Interceptor SUV 2020 - Current .125 aluminum body Double walled front with 3/4" bars for added protection Mill finish aluminum for easy cleaning surface Punched Grate style rear window for clear rear view Punched Grate style window guards in rear for officer vision and easy Cool Guard attachment Poly carbonate wings to keep the K9 from reaching vehicle interior Matte black Powder coat finish All units come with a rubber mat Sliding center door for emergency exit *Includes Window Guards and Door Panels* ** 57"W x 29"D x 40"H ** (complete model number: EZPF_INTERC.SUV_2020-Current)	1	3,556.80	3,556.80
AA-PC/K9 Matte	FREE Optional Matte Black Powder Coating	1	0.00	0.00
AA-Rubber Mat, Large	Deluxe, Non-Toxic, Custom Fit Rubber Liner	1	0.00	0.00
AA-Light	LED Light (White & Red), comes with switch and wiring diagram.	1	0.00	0.00

Thank you for using Fleet Safety Supply!!!	<b>TOTAL</b>
--------------------------------------------	--------------

Fleet Safety Supply  
P.O. Box 649  
Naperville, IL 60566  
(630) 527-1341 Phone/Fax

Item G.

# Price Quote

DATE	ESTIMATE NO.
5/27/2026	80074

**NAME / ADDRESS**

City of Crest Hill  
20600 City Center Boulevard  
Crest Hill, IL 60403

TERMS	FOB	P.O.
Net 30 Days	Naperville,IL	

ITEM	DESCRIPTION	QTY	COST	TOTAL
AA-New Hinged Univ...	*****New Hinged Universal Water Dish***** PC Matte Black	1	170.30	170.30
ACE-HP-5020	K9 Electronics HOT-N-POP® PRO (Model# HP-5020) Includes: Control Head, Intelabox, Protective Relay Module, S.O.S Horn Honk™ Output, Siren Activation Output, Lightbar Activation Output, Dual Window Drop Kit, Dual Temperature Sensors, Remote with Holster for Door Popper, Heavy-Duty Solenoid Kit, Gas Spring with Heavy-Duty Stainless Steel Mounts, System Wiring Harnesses, Installation Instructions, Vehicle Specific Wiring Information *Vehicle Make, Model and Year Required When Ordering, User Guide, Two Year Warranty, Tech Support	1	1,595.00	1,595.00
ACE-AWD-7040	AceWatchDog™ for use with Pro Alarm Systems Includes External Modem, Antenna, Power Cord, Interface cable, and one year AceWatchDog™ Server Service. For use with Intelabox Sold after 2013 with PCB "W" or greater.	1	899.00	899.00
ACE-H-NKLB-P	"No K9 Left Behind"	1	75.00	75.00
ACE-HAP-EVS-K	Engine Vibration Stall Sensor	1	165.00	165.00
ACE-HA-FKT10P-F...	10" Fan Kit with Heavy-Duty Guard Includes: FAN-10 Fan (only) 10" Dia. Max Air Flow 650CFM HA-FFH-K, Fan Mounting Kit includes 4-Mounting Feet and Hardware H-FAM-P, Fan Activation Module, Manural Switch & Materials (no fan) HA-FHW, Heavy-Duty Fan Guard (fan not included)	1	324.00	324.00
SE-GK10271U	Gun Mount Single T-Rail Mount, (1) Universal Lock with #2 key	1	334.97	334.97

Thank you for using Fleet Safety Supply!!!

**TOTAL**

Fleet Safety Supply  
P.O. Box 649  
Naperville, IL 60566  
(630) 527-1341 Phone/Fax

Item G.

# Price Quote

DATE	ESTIMATE NO.
5/27/2026	80074

**NAME / ADDRESS**  
City of Crest Hill  
20600 City Center Boulevard  
Crest Hill, IL 60403

TERMS	FOB	P.O.
Net 30 Days	Naperville,IL	

ITEM	DESCRIPTION	QTY	COST	TOTAL
SE-TK0841ITU20	Rear Storage Cargo Box, *REQUIRED Setina #12VS Rear Cargo Partition Or Freestanding Brackets NOT INCLUDED; *NOT COMPATIBLE WITH EZ Lift Cargo Deck DSE- Drawer, Sliding With Electric Key Pad Lock BSN- Base Sliding With No Lock (complete model number: TK0841ITU20)	1	1,686.32	1,686.32
FSS-MAGPUL	Magpul DAKA	1	185.50	185.50
BO-0332002150	75 Amp Relay	1	33.00	33.00
	<b>Subtotal</b>			<b>18,753.87</b>

Thank you for using Fleet Safety Supply!!!	<b>TOTAL</b>	<b>\$18,753.87</b>
--------------------------------------------	--------------	--------------------



**2027 Ford Utility  
Interceptor Contract #204**

**\$44,954.00**



**Currie Motors Fleet**

*Nice People to do Business With!*

Good Thru 10/26/26



## 2027 Ford Utility Interceptor

**\$44,954.00**

### Standard Features

**MECHANICAL** ● **3.3L V-6 TI-VCT Motor Gasoline –Standard** ● AWD Drivetrain Transmission – 10-speed automatic, police calibrated ● Brakes – Police calibrated high-performance ● 4- Wheel heavy-duty disc w/heavy-duty front and rear calipers

● Brake Rotors – large mass for high thermal capacity and calipers with large swept area. ● Electric Power-Assist Steering (EPAS) – Heavy-Duty ● DC/DC converter – 220-Amp ● Cooling System – Heavy-duty, Engine oil cooler and transmission oil cooler ● Engine Idle Hour Meter ● Powertrain mounts – Heavy-Duty ● Class III Trailer Hitch Receiver and (2) recovery hooks ● Class III Trailer Tow Lighting Package ● Wheels— Heavy-duty steel, vented with center cap— Full size spare tire w/TPMS ● 50-State Emissions System ● H8 AGM Battery ● **Engine Idle Control** ● Manual Police Pursuit Mode

**EXTERIOR** ● Antenna, Roof-mounted ● Cladding – Lower body-side cladding ● Door Handles – Black

● Exhaust, True Dual ● **Daytime Running Lamps – Configurable ON/OFF through instrument cluster** ● Door-Lock Cylinders (Front Driver / Passenger / Lift-gate) ● Glass – 2nd Row, Rear Quarter and Lift-gate Privacy Glass ● Grille – Black ● Headlamps – Automatic, LED Low-and-High-Beam ● Lift-gate – Manual 1-Piece – Fixed Glass w/Door-Lock Cylinder ● Mirrors – **Black Caps Power Electric Remote Heated Manual Folding with Integrated Spotter** ● Spare – Full size 18" Tire w/TPMS ● Spoiler – Painted Black ● Lift-gate Handle ● Tail lamps – LED ● Tires – 255/60R18 A/S BSW ● Wheel-Lip Molding – Black ● Wheels – 18" x 8.0 painted black steel with polished stainless steel hub cover ● Windshield – Acoustic Laminated ● **Rear Tail Light Housing**

**INTERIOR/COMFORT** ● Cargo Hooks in cargo area ● Climate Control – Dual-Zone Electronic Automatic Temperature Control ● Door-Locks— Power ● Fixed Pedals (Driver Dead Pedal) ● Floor – Heavy-Duty Thermoplastic Elastomer ● Glove Box – Locking/non-illuminated ● Grab Handles ● Heated Sanitization Solution ● **Lift gate Release Switch located in overhead console (45 second timeout feature)** ● Lighting— Overhead Console— Red/White Task Lighting in Overhead Console— 3rd row overhead map light ● Mirror – Day/night Rear View ● Particulate Air Filter ● Power points – (1) First Row ● Rear-door closeout panels ● Rear-window Defrost ● Scuff Plates – Front & Rear ● Seats— 1st Row Police Grade Cloth Trim, Dual Front Buckets with reduced bolsters — 1st Row – Driver 6-way lower track (fore/aft. Up/down, tilt with manual recline, 2-way manual lumbar) — 1st Row – passenger 2-way manual track (fore/aft. with manual recline) — Built-in steel intrusion plates in both driver/passenger seatbacks — 2nd Row Vinyl, 35/30/35 Split Bench Seat (manual fold-flat, no tumble) ● Speed (Cruise) Control ● Speedometer –

Calibrated (includes digital readout) ●Steering Wheel – Manual / Tilt / Telescoping, Speed Controls and 4 user – configurable latching switches Sun visors, color-keyed, non-illuminated ●Universal Top Tray – Center of I/P for mounting aftermarket equipment ●Windows, Power, 1-touch Up/Down Front Driver/Passenger-Side with disable feature ● **Power Passenger Seat ● Courtesy Lights Disabled ● Rear Dome Light ●Aux. Rear A/C**

**SAFETY/SECURITY ●Advance Trac® w/RSC® ●Airbags, dual-stage driver & front-passenger, side seat, passenger-side knee, Roll Curtain Airbags and Safety Canopy®●Anti-Lock Brakes (ABS) with Traction Control ● Brakes – Police calibrated high-performance regenerative braking system ●Belt-Minder® (Front Driver / Passenger)●Child-Safety Locks ●Individual Tire Pressure Monitoring System (TPMS)●LATCH (Lower Anchors and Tethers for Children) system on rear outboard seat locations ●Rearview Camera viewable on 8"Center Stack ● Seat Belts, Pretensioner /Energy-Management System w/adjustable height in 1st Row ●SOS Post-Crash Alert System™● Perimeter Alert ● Remote Keyless Fob ●BLIS ●Cross Traffic Brake Assist ●Pre-Collision Mitigation System ●Reverse Sensing System**

**Police Up-fit Friendly ●Consistent 11-inch space between driver and passenger seats for aftermarket consoles (9-inch center console mounting plate)●Console mounting plate ●Dash pass-thru opening for aftermarket wiring ●Headliner- easy to service ●Two (2) 50 amp battery ground circuits – power distribution junction block (repositioned behind 2nd row seat floorboard). ● Grill Wiring ●100 Watt siren/Speaker Prep Kit**

**Functional ●Audio— AM/FM / MP3 Capable / Clock / 4-speakers— SYNC® interface — Includes hands-free voice command support — USB Port — (1) — 8" Color LCD Screen Center- Stack "Smart Display"● Easy Fuel® Capless Fuel-Filler ●Fleet Telematics Modem to support Ford Pro™ Telematics ●Front door tether straps (driver/passenger)●Power pigtail harness ●Simple Fleet Key; 4-keys●Two-way radio pre-wire ●Two (2) 50 amp battery power circuits – power distribution junction block (behind 2nd row passenger seat floorboard)●Wipers – Front Speed- Sensitive Intermittent; Rear Dual Speed Wiper ●Up fitter Interface System ●PAITRO output tied to lift gate release switch ●3 Year 36,000 Mile Warranty-5 Year 100,000 mile Powertrain Warranty ●Delivery under 75 miles**



Agenda Memo

Crest Hill, IL

<b>Meeting Date:</b>	7/6/2026
<b>Submitter:</b>	Gary Richardson, Director of Public Works
<b>Department:</b>	Public Works
<b>Agenda Item:</b>	Approval of the purchase of a new 2027 Ford Police Interceptor Utility including a comprehensive patrol equipment package in the amount of \$59,457.13.

**Summary:**

The Police Department requires a fully equipped patrol vehicle to support the department’s operational needs. The 2027 Ford Police Interceptor Utility includes standard police-package features such as AWD drivetrain, police-calibrated braking system, heavy-duty cooling, and factory-installed upfitter provisions for emergency equipment.

The comprehensive patrol equipment package includes all necessary components to outfit the vehicle for service, including:

- Emergency lighting, siren, and control systems
- Push bumper with integrated lighting
- Rear prisoner transport seating and partition
- Weapon mounting/storage system
- Communication console, mounts, and electronics

This purchase of this vehicle will ensure the Police Department maintains a properly equipped and reliable fleet for patrol operations.

**Recommended Council Action:**

Approve the purchase of a new 2027 Ford Police Interceptor Utility including a comprehensive patrol equipment package in the amount of \$59,457.13.

**Financial Impact:**

The total cost for the vehicle and equipment is \$59,457.13 budgeted within 11-00-7301.

**Attachments:**

A 2027 Ford Police Interceptor Utility through Currie Motors Fleet quote and a comprehensive patrol equipment package outfitting quote from Fleet Safety Supply.

Fleet Safety Supply  
P.O. Box 649  
Naperville, IL 60566  
(630) 527-1341 Phone/Fax

Item H.

# Price Quote

DATE	ESTIMATE NO.
5/27/2026	80073

NAME / ADDRESS
City of Crest Hill 20600 City Center Boulevard Crest Hill, IL 60403

TERMS	FOB	P.O.
Net 30 Days	Naperville,IL	

ITEM	DESCRIPTION	QTY	COST	TOTAL
	2026 Utility - Patrol			
	*** All lights set to steady and controlled by Core siren ***			
SE-BK2019ITU20	Push Bumper PB450L4 Alum Push Bumper, Full, (4) Whelen Ions, 2020+ Ford Utility Interceptor *** Specify colors: Trios	1	965.60	965.60
WH-CEM16	WCX Expansion Module 16 output, Four Input Module	1	236.52	236.52
WH-RX2SP3J	Lightbar, Siren, and Speaker package WCX DUO JUSTICE 56" DDEE (Red/White and Blue/White) PROMO, includes MKAJ29	1	2,195.10	2,195.10
WH-STPBK105	LIGHTBAR STRAP KIT #105 BLACK, Police Interceptor Utility 2020-2022, (Black Straps and Bolts Only for Mounting Kit, For Use with MKEZ or MKAJ Only, (Not available for all vehicles))	1	0.00	0.00
WH-C399S6	Single Unit 200 Watt Siren with Integrated 3 Section Control Head and 8 Push-Buttons, 4-Position Slide Switch with a 7-Position Rotary Knob, Manual, Airhorn Plus 3 Traffic Advisor™ Switches and Microphone with Extension Cable,	1	1,009.80	1,009.80
WH-C399RSP	SCANPort Installation Kit for C399R and C399S	1	0.00	0.00
WH-SA315U	SA315U SPEAKER, BLACK PLASTIC	1	0.00	0.00
WH-SAK75D	SA-315 MT KIT DRVR 25 FORD PIU	1	0.00	0.00
WH-CV2V	WeCanX Vehicle-to-Vehicle Module (includes internal antenna)	1	241.65	241.65
	Speaker exchange			
WH-SA315U	SA315U SPEAKER, BLACK PLASTIC	-1	0.00	0.00
WH-SAK75D	SA-315 MT KIT DRVR 25 FORD PIU	-1	0.00	0.00
FS-ES100C	Speaker, 100W, high output compact	1	0.00	0.00
FS-ESB-FPIU20NDB	2020 Utility Speaker Bracket, Single, for use with push bumpers	1	0.00	0.00
	Additional speaker			
FS-ES100C	Speaker, 100W, high output compact	1	225.00	225.00
FS-ESB-FPIU20NDB	2020 Utility Speaker Bracket, Single, for use with push bumpers	1	48.02	48.02

Thank you for using Fleet Safety Supply!!!	<b>TOTAL</b>
--------------------------------------------	--------------

Fleet Safety Supply  
P.O. Box 649  
Naperville, IL 60566  
(630) 527-1341 Phone/Fax

Item H.

# Price Quote

<b>DATE</b>	<b>ESTIMATE NO.</b>
5/27/2026	80073

<b>NAME / ADDRESS</b>
City of Crest Hill 20600 City Center Boulevard Crest Hill, IL 60403

<b>TERMS</b>	<b>FOB</b>	<b>P.O.</b>
Net 30 Days	Naperville,IL	

ITEM	DESCRIPTION	QTY	COST	TOTAL
CO-S24014	Preemption installed in lightbar Bracket for Strobe Reflector	1	5.95	5.95
CO-LMTUBE	Replacement Strobe Tube, Microthin	1	127.50	127.50
TE-401-1228-PREHI	Single head preemption emitter, (Power Supply only)	1	435.00	435.00
WH-U180D	Mounted under mirrors U-Series™ 180° Linear Super-LED® Surface Mount Round Lightheads, Clear Lens (Red/White)	1	250.29	250.29
WH-U180E	U-Series™ 180° Linear Super-LED® Surface Mount Round Lightheads, Clear Lens (Blue/White)	1	250.29	250.29
WH-U18050	2020-2025 Ford Police Interceptor Utility, Under-the-Side View Mirror Mount for Two U-Series Lightheads, Pair (For Use with Ford's Factory Side Marker LED Side View Mirror Option)	1	29.40	29.40
WH-I2J	Rear Side Cargo Windows Ion Duo Series Linear-LED, Universal Light, Includes Universal Mount, Scan-Lock™ Flash Patterns and a 5-Wire Pig Tail, Individual Control of each Color, Black Housing (Red/Blue)	2	166.86	333.72
WH-I2J	Rear Window Ion Duo Series Linear-LED, Universal Light, Includes Universal Mount, Scan-Lock™ Flash Patterns and a 5-Wire Pig Tail, Individual Control of each Color, Black Housing (Red/Blue)	2	166.86	333.72
SO-ETFBSN-P	Taillight Flasher Flashback 100% Solid State Tail Light Flasher	1	78.95	78.95
	License Plate			

Thank you for using Fleet Safety Supply!!!

**TOTAL**

Fleet Safety Supply  
P.O. Box 649  
Naperville, IL 60566  
(630) 527-1341 Phone/Fax

Item H.

# Price Quote

DATE	ESTIMATE NO.
5/27/2026	80073

NAME / ADDRESS
City of Crest Hill 20600 City Center Boulevard Crest Hill, IL 60403

TERMS	FOB	P.O.
Net 30 Days	Naperville,IL	

ITEM	DESCRIPTION	QTY	COST	TOTAL
FS-MPSW9-RBW	Wide 9 Tri-color (Red/Blue/White)	2	219.63	439.26
FSS-MPSW9LPBRK...	License Plate Bracket for Single Surface Mount MicroPulse Wide 9 with wire Slot (1 Pair)	1	75.00	75.00
SO-ECVDMLTAL00	Dome light over console Dome Light - Universal Mount Options ALL LED Red/White	1	97.95	97.95
WH-WSMIC321	Second microphone in rear Microphone	1	153.90	153.90
WH-01-0448144-000	KIT, MICROPHONE EXTENSION	1	104.49	104.49
MM-MMSU-1	Magnetic Mic Single Unit	1	39.95	39.95
HS-C-VS-0618-INUT	Console 2020 Ford Interceptor Utility Specific Flat Console, Horizontal console with 24" total internal mounting space	1	526.96	526.96
HS-C-EB40-WCS-1P	Equipment Mounting Bracket, 4" Mounting Space, Fits Whelen Core-S Control System	1	0.00	0.00
HS-C-EB25-MRD-1P	Face Plate (1 Piece), M1225, CM300	1	0.00	0.00
HS-C-EB25-T81-1P	Mounting bracket for Kenwood TK7180 (1 Piece)	1	0.00	0.00
HS-C-EB25-MWG-1P	2.5" plate for the Watchguard M500	1	0.00	0.00
HS-CUP2-1001	Self-Adjusting Double Cup Holder, Internally mounted dual cup holder, Self-adjusts to fit cups up to 3.5" in diameter, Occupies 4" of equipment bracket space, with a depth of 3" 4"	1	57.16	57.16
HS-C-FP-2	2" Filler Plate (2.0")	1	0.00	0.00
HS-C-FP-35	3.5 Filler Plate	1	0.00	0.00
HS-C-FP-3	3" Filler Plate	1	0.00	0.00
HS-C-ARPB-1014	Brother PocketJet Roll-Feed Printer Mount and Armrest: Top Mount	1	290.49	290.49
MM-MMSU-1	Magnetic Mic Single Unit	2	39.95	79.90

Thank you for using Fleet Safety Supply!!!

**TOTAL**

Fleet Safety Supply  
P.O. Box 649  
Naperville, IL 60566  
(630) 527-1341 Phone/Fax

Item H.

# Price Quote

DATE	ESTIMATE NO.
5/27/2026	80073

NAME / ADDRESS
City of Crest Hill 20600 City Center Boulevard Crest Hill, IL 60403

TERMS	FOB	P.O.
Net 30 Days	Naperville,IL	

ITEM	DESCRIPTION	QTY	COST	TOTAL
KE-091-264	Dual Port USB-C & USB-A SVR	1	110.90	110.90
	Computer Mount			
HS-C-HDM-204	Pole only, Telescoping device mounting base, Heavy duty mount, Side mount, 8" High, W-SHRTHANDLE	1	198.10	198.10
HS-C-MD-112	11" Slide Out Locking Swing Arm with Motion Adapter	1	306.15	306.15
HS-CG-X	Chargeguard	1	97.50	97.50
	Antenna *** confirm what is needed ***			
AP-AP-MF4G-C2W3...	Antenna Plus MultiMax 4G EZConnect Antenna, AP-MF4G-C2W3G-Q-B1	1	169.79	169.79
AP-CH-C2W3G-1-2-1...	CH-C2W3G-1-2-1-14 - Antenna Plus EZConnect Cable Harness 14' - 2 LTE (SMA M) - 3 WiFi (RP SMA M) - 1 GNSS (SMA M)	1	214.97	214.97
	Partition			
SE-PK1130ITU20TM	#10XL Coated Poly Partition, 2020 Interceptor Utility, includes 2 pc. lower extension panel	1	891.89	891.89
	Rear Seat and Screen			
PG-S4705UINT20OS...	Rear Transport Seats With Outboard Seat Belts, Standard Transport Seat w/ 7 Ga. Steel Screen Window Cargo Barrier, and Outboard Seat Belts, Retractable seat belts, 2020+ Ford Utility (complete model number: S4705UINT20OSB-R)	1	2,123.49	2,123.49
	Gun Mount			
LU-LOFT-PIU20-SG...	20+ Ford FPIU Loft Single Shotgun Storage Tray w/ Auto Open - Interior Dimension 16.5" x 40" LOFT-PIU20-SG-AO Includes Shotgun Lock, Butt Cup, Momentary Push Button Switch. (Optional Accessories Available) (complete model number: LOFT-PIU20-SG-AO)	1	1,242.15	1,242.15
LU-LOFT-AO-KEYO...	Auto Opening LOFT Optional Key Override System (LOFT-AO-KEYOVER)	1	194.21	194.21
LU-LOFT-UNIV-UG	Optional UPGRADE to universal lock from standard trap door lock	1	245.32	245.32

Thank you for using Fleet Safety Supply!!!	<b>TOTAL</b>
--------------------------------------------	--------------





**2027 Ford Utility  
Interceptor Contract #204**

**\$44,954.00**



**Currie Motors Fleet**

*Nice People to do Business With!*

Good Thru 10/26/26



## 2027 Ford Utility Interceptor

**\$44,954.00**

### Standard Features

**MECHANICAL** ● **3.3L V-6 TI-VCT Motor Gasoline – Standard** ● AWD Drivetrain Transmission – 10-speed automatic, police calibrated ● Brakes – Police calibrated high-performance ● 4- Wheel heavy-duty disc w/heavy-duty front and rear calipers

● Brake Rotors – large mass for high thermal capacity and calipers with large swept area. ● Electric Power-Assist Steering (EPAS) – Heavy-Duty ● DC/DC converter – 220-Amp ● Cooling System – Heavy-duty, Engine oil cooler and transmission oil cooler ● Engine Idle Hour Meter ● Powertrain mounts – Heavy-Duty ● Class III Trailer Hitch Receiver and (2) recovery hooks ● Class III Trailer Tow Lighting Package ● Wheels— Heavy-duty steel, vented with center cap— Full size spare tire w/TPMS ● 50-State Emissions System ● H8 AGM Battery ● **Engine Idle Control** ● Manual Police Pursuit Mode

**EXTERIOR** ● Antenna, Roof-mounted ● Cladding – Lower body-side cladding ● Door Handles – Black

● Exhaust, True Dual ● **Daytime Running Lamps – Configurable ON/OFF through instrument cluster** ● Door-Lock Cylinders (Front Driver / Passenger / Lift-gate) ● Glass – 2nd Row, Rear Quarter and Lift-gate Privacy Glass ● Grille – Black ● Headlamps – Automatic, LED Low-and-High-Beam ● Lift-gate – Manual 1-Piece – Fixed Glass w/Door-Lock Cylinder ● Mirrors – **Black Caps Power Electric Remote Heated Manual Folding with Integrated Spotter** ● Spare – Full size 18" Tire w/TPMS ● Spoiler – Painted Black ● Lift-gate Handle ● Tail lamps – LED ● Tires – 255/60R18 A/S BSW ● Wheel-Lip Molding – Black ● Wheels – 18" x 8.0 painted black steel with polished stainless steel hub cover ● Windshield – Acoustic Laminated ● **Rear Tail Light Housing**

**INTERIOR/COMFORT** ● Cargo Hooks in cargo area ● Climate Control – Dual-Zone Electronic Automatic Temperature Control ● Door-Locks— Power ● Fixed Pedals (Driver Dead Pedal) ● Floor – Heavy-Duty Thermoplastic Elastomer ● Glove Box – Locking/non-illuminated ● Grab Handles ● Heated Sanitization Solution ● **Lift gate Release Switch located in overhead console (45 second timeout feature)** ● Lighting— Overhead Console— Red/White Task Lighting in Overhead Console— 3rd row overhead map light ● Mirror – Day/night Rear View ● Particulate Air Filter ● Power points – (1) First Row ● Rear-door closeout panels ● Rear-window Defrost ● Scuff Plates – Front & Rear ● Seats— 1st Row Police Grade Cloth Trim, Dual Front Buckets with reduced bolsters — 1st Row – Driver 6-way lower track (fore/aft. Up/down, tilt with manual recline, 2-way manual lumbar) — 1st Row – passenger 2-way manual track (fore/aft. with manual recline) — Built-in steel intrusion plates in both driver/passenger seatbacks — 2nd Row Vinyl, 35/30/35 Split Bench Seat (manual fold-flat, no tumble) ● Speed (Cruise) Control ● Speedometer –

Calibrated (includes digital readout) ●Steering Wheel – Manual / Tilt / Telescoping, Speed Controls and 4 user – configurable latching switches Sun visors, color-keyed, non-illuminated ●Universal Top Tray – Center of I/P for mounting aftermarket equipment ●Windows, Power, 1-touch Up/Down Front Driver/Passenger-Side with disable feature● **Power Passenger Seat ● Courtesy Lights Disabled ● Rear Dome Light ●Aux. Rear A/C**

**SAFETY/SECURITY ●Advance Trac® w/RSC® ●Airbags, dual-stage driver & front-passenger, side seat, passenger-side knee, Roll Curtain Airbags and Safety Canopy®●Anti-Lock Brakes (ABS) with Traction Control ● Brakes – Police calibrated high-performance regenerative braking system ●Belt-Minder® (Front Driver / Passenger)●Child-Safety Locks ●Individual Tire Pressure Monitoring System (TPMS)●LATCH (Lower Anchors and Tethers for Children) system on rear outboard seat locations ●Rearview Camera viewable on 8"Center Stack ● Seat Belts, Pretensioner /Energy-Management System w/adjustable height in 1st Row ●SOS Post-Crash Alert System™● Perimeter Alert ● Remote Keyless Fob ●BLIS ●Cross Traffic Brake Assist ●Pre-Collision Mitigation System ●Reverse Sensing System**

**Police Up-fit Friendly ●Consistent 11-inch space between driver and passenger seats for aftermarket consoles (9-inch center console mounting plate)●Console mounting plate ●Dash pass-thru opening for aftermarket wiring ●Headliner- easy to service ●Two (2) 50 amp battery ground circuits – power distribution junction block (repositioned behind 2nd row seat floorboard). ● Grill Wiring ●100 Watt siren/Speaker Prep Kit**

**Functional ●Audio— AM/FM / MP3 Capable / Clock / 4-speakers— SYNC® interface — Includes hands-free voice command support — USB Port — (1) — 8" Color LCD Screen Center- Stack "Smart Display"● Easy Fuel® Capless Fuel-Filler ●Fleet Telematics Modem to support Ford Pro™ Telematics ●Front door tether straps (driver/passenger)●Power pigtail harness ●Simple Fleet Key; 4-keys●Two-way radio pre-wire ●Two (2) 50 amp battery power circuits – power distribution junction block (behind 2nd row passenger seat floorboard)●Wipers – Front Speed- Sensitive Intermittent; Rear Dual Speed Wiper ●Up fitter Interface System ●PAITRO output tied to lift gate release switch ●3 Year 36,000 Mile Warranty-5 Year 100,000 mile Powertrain Warranty ●Delivery under 75 miles**



## Agenda Memo

Crest Hill, IL

<b>Meeting Date:</b>	July 6, 2026
<b>Submitter:</b>	Ronald J Wiedeman
<b>Department:</b>	Engineering
<b>Agenda Item:</b>	A Resolution approving an Amendment to January 27, 2026, Agreement for General Services Per-and-Polyfluoroalkyl Substances (PFAS) Treatment Equipment and Pilot Testing Services By and Between the City of Crest Hill, Will County, Illinois and Strand & Associates, Inc.

**Summary:** As a follow, up to council decision at the October 27<sup>th</sup> 2025 workshop meeting on PFAS Treatment Alternatives, tonight Staff along with Tanner Smid of Strand and Associates will provide an update to the alternatives selected.

1. Blending Alternative-Reduce or eliminate the water contribution from selected wells with higher PFAS reading under a 24-hour operation.
2. Pilot Study-Complete a pilot Study on PFAS Treatment Systems at selected well locations.
3. Approval of next steps in PFAS Pilot Study-Preparation of a Treatment Protocol. This work will consist of the following
  - a. Collect and review data provided by vendors who responded to the RPF.
  - b. Prepare treatment goals for the Pilot Study
  - c. Prepare a preliminary design full scale design showing how the treatment methods selected will work in the City's existing Well houses.
  - d. How treatment media will be disposed.
  - e. Number of Samples required, testing samples and analyzing the Data.
  - f. Prepare opinion of probable costs summary of pilot rental, sampling, operation and media disposal.

The Cost to complete the work above is \$34,000.00 and is estimated to be completed by October 2, 2026, where it will be submitted to the IEPA for submittal. The next step in the Pilot process cannot begin until the City has IEPA approval and since we do not have control over the IEPA the timeframe of the approval is not known by the City, but estimated at 3-6 months.

The approval of this Amendment to the January 27<sup>th</sup> Agreement will raise the total contract value approved from \$10,000.00 to \$44,000.00.

**Recommended Council Action:** A Resolution approving an Amendment to January 27, 2026, Agreement for General Services Per-and-Polyfluoroalkyl Substances (PFAS) Treatment Equipment and Pilot Testing Services By and Between the City of Crest Hill, Will County, Illinois and Strand & Associates, Inc.

**Financial Impact:**

**Funding Source:** Water Fund

**Budgeted Amount:** \$825,000.00

**Cost:** \$34,000.00

This will change the total approved contract from \$10,000.00 to \$44,000.00

**Attachments:**

Resolution Amendment 1

Exhibit A-Amendment 1-Strand-Pilot Study.

PFAS Pilot Proposal Presentation.

**RESOLUTION NO. \_\_\_\_\_**

**A RESOLUTION APPROVING AN AMENDMENT TO JANUARY 27, 2026  
AGREEMENT FOR GENERAL SERVICES PER-AND-POLYFLUOROROALKYL  
SUBSTANCES (PFAS) TREATMENT EQUIPMENT AND PILOT TESTING SERVICES  
BY AND BETWEEN THE CITY OF CREST HILL, WILL COUNTY, ILLINOIS AND  
STRAND & ASSOCIATES, INC**

---

**WHEREAS**, the Corporate Authorities of the City of Crest Hill, Will County, Illinois, have the authority to adopt resolutions and to promulgate rules and regulations that pertain to the City's government and affairs and protect the public health and, safety, and welfare of its citizens; and

**WHEREAS**, pursuant to Section 2-2-12 of the Illinois Municipal Code (65 ILCS 5/2-2-12), the City Council possesses the authority to enter into contracts that serve the legitimate corporate purposes of the City; and

**WHEREAS**, Stand & Associates, Inc. (the "COMPANY"), is an entity that is in the business of providing Professional General Engineering Services per-and-polyfluoroalkyl substances (PFAS) treatment equipment and pilot testing services proposal approved on January 27, 2026 by the City Administrator. (the "Project") in the amount of \$10,000; and

**WHEREAS**, The COMPANY was directed by staff to perform work that was outside the original contract scope. This additional work effort requested by staff will increase the original contract amount of the contract by \$34,000.00 to a total of \$34,0.00, which Amendment 1 is attached hereto as Exhibit A and incorporated herein; and

**WHEREAS**, the City Council has determined that it is in the best interests of the City and its residents to approve the Change Order and amendment to the total contract price to avoid delays and keep the project on schedule; and

**WHEREAS**, City Staff and the City Council have reviewed Exhibit A and determined that the conditions, terms, and provisions are fair, reasonable, and acceptable to the City and that the Contract approved on January 27, 2026 by the City Administrator should be amended to include the Amendment 1 attached as Exhibit A

**NOW, THEREFORE, BE IT RESOLVED** by the City Council of the City of Crest Hill, Illinois, pursuant to its statutory authority, as follows:

**SECTION 1: PREAMBLE.** The City Council hereby finds that all the recitals contained in the preamble to this Resolution are true, correct and complete and are hereby incorporated by reference hereto and made part hereof.

**SECTION 2: AGREEMENT APPROVED.** The City Council hereby finds and declares that the conditions, terms, and provisions of the Amendment to the Contract approved January 27, 2026 by

the City Administrator is attached as (Exhibit A) in the amount of \$34,000.00 are fair, reasonable, and acceptable to the City and that the same is hereby approved in form and substance. Therefore, the City Council hereby authorizes and directs the Mayor to execute and deliver, and the Clerk to attest, the Contract Amendment 1, and further to take any and all other actions, including without limitation the execution and delivery of any and all documents, necessary and appropriate to effectuate the intent of this Resolution, which is to increase the total contract amount of the Contract approved January 27, 2026 by the City Administrator by \$34,000.00 to \$44,000.00.

**SECTION 3: SEVERABILITY.** If any section, paragraph, clause or provisions of this Resolution is held invalid, the invalidity of such section, paragraph, clause or provision shall not affect any other provision of this Resolution.

**SECTION 4: REPEALER.** All ordinances, resolutions or orders, or parts thereof, which conflict with the provisions of this Resolution, are to the extent of such conflict hereby repealed.

**SECTION 5: EFFECTIVE DATE.** This Resolution shall be in full force and effect immediately upon its passage and publication according to law.

*[Intentionally Blank]*

PASSED THIS 6th DAY JULY, 2026.

	Aye	Nay	Absent	Abstain
Alderman Scott Dyke	_____	_____	_____	_____
Alderman Angelo Deserio	_____	_____	_____	_____
Alderwoman Claudia Gazal	_____	_____	_____	_____
Alderman Darrell Jefferson	_____	_____	_____	_____
Alderperson Tina Oberlin	_____	_____	_____	_____
Alderman Mark Cipiti	_____	_____	_____	_____
Alderman Nate Albert	_____	_____	_____	_____
Alderman Joe Kubal	_____	_____	_____	_____
Mayor Raymond R. Soliman	_____	_____	_____	_____

APPROVED THIS 6th DAY OF JULY, 2026.

\_\_\_\_\_  
Raymond R. Soliman, Mayor

ATTEST:

\_\_\_\_\_  
Christine Vershay-Hall, City Clerk

EXHIBIT A  
(STAND & ASSOCIATES Inc.  
AMENDMENT #3)



June 23, 2026

City of Crest Hill  
2090 Oakland Avenue  
Crest Hill, IL 60403

Attention: Mr. Ronald Wiedeman, Director of Engineering

Re: Amendment No. 1 to the January 27, 2026, Agreement for General Services  
Per-and Polyfluoroalkyl Substances (PFAS) Treatment Equipment and Pilot Testing Services

This is Amendment No. 1 to the referenced Agreement.

Under **Scope of Services**, ADD the following:

- “9. Conduct an initial scope review meeting for PFAS Treatment Protocol with OWNER.
10. Prepare a draft PFAS Treatment Protocol that includes:
  - a. Project background and existing conditions.
  - b. Treatment goals.
  - c. Pilot study overview.
  - d. Preliminary full-scale design.
  - e. Data management.
  - f. Residuals/waste management.
  - g. Sampling.
  - h. Data analysis.
11. Prepare an opinion of probable cost summary that includes the following costs:
  - a. Pilot rental.
  - b. Sampling.
  - c. Operation.
  - d. Media disposal.
12. Attend OWNER’s final Vendor selection and draft PFAS Treatment Protocol review meeting.
13. Prepare a prefinal PFAS Treatment Protocol based on OWNER’s selected Vendor(s).
14. Submit the prefinal PFAS Treatment Protocol to the IEPA and OWNER for review.
15. Meet with OWNER to discuss IEPA comments.
16. Revise the PFAS Treatment Protocol based on IEPA and OWNER comments, as appropriate, and submit the final PFAS Treatment Protocol to IEPA and OWNER.”

City of Crest Hill, Illinois  
Page 2  
June 23, 2026

Under **Compensation**, CHANGE \$10,000 to "\$44,000."

Under **Schedule**,

CHANGE April 5, 2026, to "December 31, 2026."

ADD "**Scope of Services** Item Nos. 9 through 14 are scheduled for completion by October 2, 2026, and Item Nos. 15 and 16 are anticipated to be completed by December 31, 2026."

IN WITNESS WHEREOF the parties hereto have made and executed this Amendment.

ENGINEER:

OWNER:

STRAND ASSOCIATES, INC.®

CITY OF CREST HILL, ILLINOIS

  
\_\_\_\_\_  
Joseph M. Bunker      Date 6/23/26  
Corporate Secretary

\_\_\_\_\_  
Raymond R. Soliman      Date  
Mayor



Strand Associates, Inc.® (SAI)

# Per- and Polyfluoroalkyl Substances (PFAS) Pilot Study Proposals

Pilot Study Proposal Review Session

June 9, 2026



## Today's Agenda

- Pilot Overview
- PFAS Pilot Vendors
- Full-Scale System
- Cost Comparison

# Crest Hills Well 7 and 10

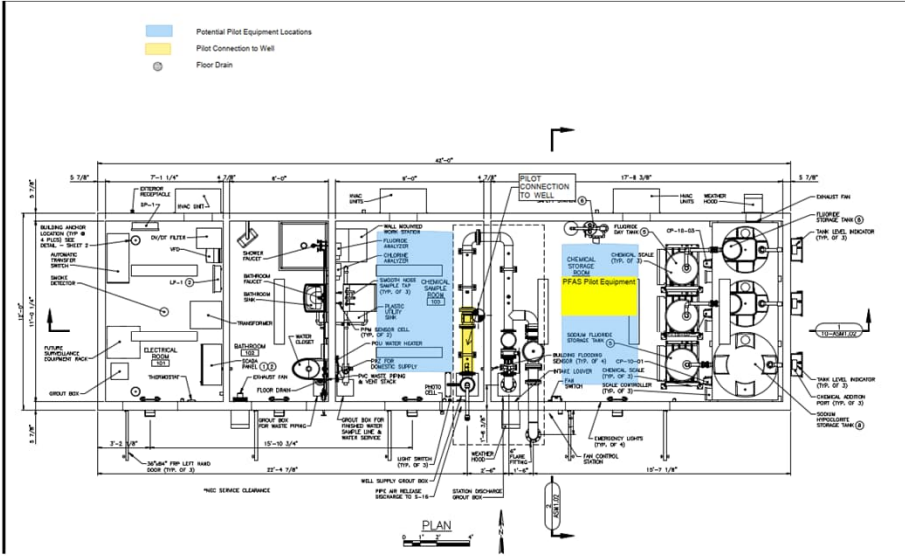

Well #	Drill Year	Well Depth (ft)	Typical Pumping Rate (gpm)	Latest PFOA results (ppt)
Well No.7	1979	296	350 to 400	7.23
Well No. 10	2002	325	250 to 300	5.35

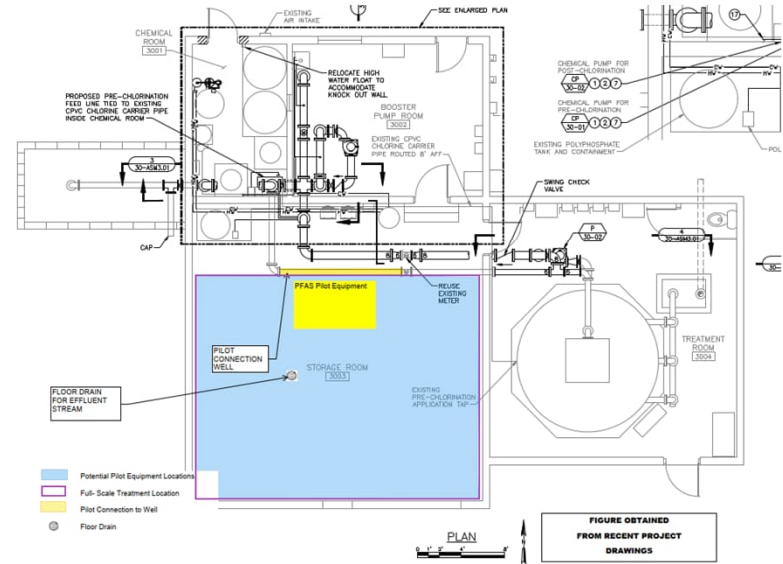

## USEPA and IEPA Standards

- USEPA proposed enforceable regulations for six PFAS in drinking water as of April 10, 2024.
- PFOA, PFOS, PFNA, PFHxs, PFBS, HFPO-DA
- Illinois adopted the USEPA limits in March 2025.
- The municipality must provide a notification to the public with information on the levels of these compounds in drinking water starting in 2027.
- Four of the City’s eight wells have historical sampling results in excess of new limits.

PFAS Compound	MCL (ppt)	Units	Well 1 (ppt)	Well 4 (ppt)	Well 7 (ppt)	Well 10 (ppt)
PFOA	4	ppt or ng/L	15	-	8	13
PFHxS	10	ppt or ng/L	-	11	-	-



## PFAS Pilot Vendors

- **ATEC:** IX, GAC, Fluro-sorb
  - Pilot equipment: 5' L x 3' W x 8' T
  - Water Quality Samples: Monthly ; PFAS Samples: Weekly, Final PFAS Report
  - Rapid Small Scale Column Test: Short test time: 24 hours a day/ 7 days a week
  - Need to Hire third party for Waste Disposal
- **Sentinel Water Solutions:** IX system Recommended
  - Cartridge filter for Iron and manganese just in case
  - Will transport Crest Hill waste to landfill
  - Bi-weekly testing, monthly progress reports, Final PFAS Report
  - Longer than 12 Month operation
- **Water Surplus:** IX System Recommended
  - Well 7: only operate when well is running due to iron in water(12-18 hrs)
  - Well 10: 24/7 Pilot operation and 500 gallon Tank
  - Anticipated 12-month operation
  - Water Quality Samples: Quarterly ; Iron: Weekly ; PFAS: Monthly
  - Need to hire third party for Waste Disposal via incineration



Figure 1. PFAS Pilot System

## Full-Scale System

- **ATEC:** Will Provide exact drawings with Full-Scale system once the test determines the exact size and layout of the system.
  - Configuration will be a lead/lag system
- **Sentinel Water Solutions:** IX system: 72" diameter x 111" Height
  - both sites are designed for 5 min EBCT per train
  - Treatment Trains are split into two parallel trains of 2 vessels per train
  - capable of lead/lag, parallel, or single vessel isolation
- **Water Surplus:** IX System: Quad 48" x 60" for Well 7 and Triplex 48" x 60" at Well 10.
  - parallel configuration, which allows for backwash to be performed, even while filtered product water is forwarded to distribution.
  - Media typically removed using VAC truck. Support layer will be added and backwashed.
  - Semi-automatic: pilot valves will be included and will be used to manually operate the 3-way backwash valves.

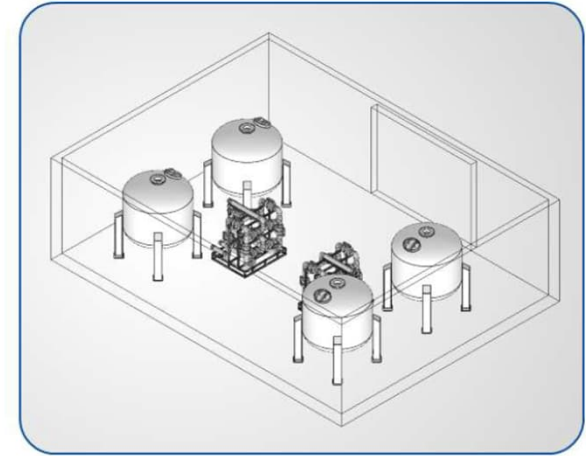

Sample Well 10 Layout



# Cost Comparison

Cost Comparison (IX system)			
	Atec	Sentinel Water Solutions	Water Surplus
Pilot Study Fee	\$225,600	\$106,500	\$81,750
Full scale Treatment Well #7 (IX)	\$315,346	\$445,200	\$662,690
Full scale Treatment Well #10(IX)	\$224,610	\$445,200	\$647,690
Media Replacement Well #7(IX)	NEED	\$87,000	\$83,000
Media Replacement Well #10(IX)	NEED	\$74,000	\$68,000
<b>Total</b>		<b>\$1,277,000</b>	<b>\$1,542,880</b>

Table 1 ATEC PFAS Adsorption System Budgetary System Pricing & Design Details			
Project Name:		Crest Hill, IL	
Engineering Consultant:		Strand - Tanner Smid	
Rep Company Details:		LAI	
Proposal Prepared by:		Kirk Newcomb - East Region Sales Manager	
Proposal Prepared on:		May 21, 2026	
Full-Scale Equipment Design Criteria Summary			
Design Scenario:			
Well Name or Number:	7	7	7
Capacity, MGD	0.6	0.6	0.6
Plant Capacity (gpm)	400	400	400
PFAS Compounds (EPA Limit)			
PFOA (4 ppt)	unknown	unknown	unknown
PFOS (4 ppt)	unknown	unknown	unknown
PFHxS (10 ppt)	unknown	unknown	unknown
PFNA (10 ppt)	unknown	unknown	unknown
HFPO-DA (GenX) (10 ppt)	unknown	unknown	unknown
Hazard Index (PFHX, PFNA, HFPO-DA, PFBS) (unitless)	unknown	unknown	unknown
Lead Vessels - Media Type			
	FluoroSorb	Ion Exchange	GAC
Diameter of Vessels, in	48	48	60
Vessel Sideshell Height, in	72	72	72
Diameter of Vessels, ft	4.0	4.0	5.0
Surface areas, per vessel, sq ft	12.6	12.6	19.63
Number of Vessels	2	2	6
Number of Filter Banks	1	1	1
Loading Rate, gpm/sq ft	15.9	15.9	3.4
Media type	FS	IX	GAC
Media Depth, in	50	50	55
Media, c.f.	105	105	540
EBCT, min	2.0	2.0	10.1
Lag Vessels - Media Type			
	FluoroSorb	Ion Exchange	GAC
Diameter of Vessels, in	48	48	60
Vessel Sideshell Height, in	72	72	72
Diameter of Vessels, ft	4.0	4.0	5.0
Surface areas, per vessel, sq ft	12.6	12.6	19.6
Number of Vessels	2	2	6
Number of Filter Trains	1	1	1
Loading Rate, gpm/sq ft	15.9	15.9	3.4
Media type	FS	IX	GAC
Media Depth, in	50	50	55
Media, c.f.	105	105	540
EBCT, min	2.0	2.0	10.1
Configuration & Pricing			
System Configuration	2 x 2-72-48-FS50	2 x 2-72-48-IX50	2 x 6-72-60-GAC55
Price per Filter Train	\$ 89,165	\$ 147,673	\$ 304,800
Number of Filter Trains	2	2	2
Total System Price	\$ 178,330	\$ 295,346	\$ 609,600
Shipping & Handling Fee	\$ 20,000	\$ 20,000	\$ 20,000
<b>Total</b>	<b>\$ 198,330</b>	<b>\$ 315,346</b>	<b>\$ 629,600</b>
System Description	Fully Skidded PFAS Adsorption System consisting of 1 lead banks followed by 1 lag banks of 2 pressure vessels of 48-inch diameter with 72-inch sidewalls including a 50-inch bed of FS media, controls, valves & header piping	Fully Skidded PFAS Adsorption System consisting of 1 lead banks followed by 1 lag banks of 2 pressure vessels of 48-inch diameter with 72-inch sidewalls including a 50-inch bed of IX media, controls, valves & header piping	Fully Skidded PFAS Adsorption System consisting of 1 lead banks followed by 1 lag banks of 6 pressure vessels of 60-inch diameter with 72-inch sidewalls including a 55-inch bed of GAC media, controls, valves & header piping



# ATEC: Full Scale GAC & Fluoro-Sorb

Table 1 ATEC PFAS Adsorption System Budgetary System Pricing & Design Details			
Project Name:		Crest Hill, IL	
Engineering Consultant:		Strand - Tanner Smid	
Rep Company Details:		LAI -	
Proposal Prepared by:		Kirk Newcomb - East Region Sales Manager	
Proposal Prepared on:		May 21, 2026	
Full-Scale Equipment Design Criteria Summary			
Design Scenario:			
Well Name or Number:			
Capacity, MGD	0.6	0.6	0.6
Plant Capacity (gpm)	400	400	400
PFAS Compounds (EPA Limit)			
PFOA (4 ppt)	unknown	unknown	unknown
PFOS (4 ppt)	unknown	unknown	unknown
PFHxS (10 ppt)	unknown	unknown	unknown
PFNA (10 ppt)	unknown	unknown	unknown
HFPO-DA (GenX) (10 ppt)	unknown	unknown	unknown
Hazard Index (PFHx, PFNA, HFPO-DA, PFBS) (unitless)	unknown	unknown	unknown
Lead Vessels - Media Type			
	FluoroSorb	Ion Exchange	GAC
Diameter of Vessels, in	48	48	60
Vessel Sideshell Height, in	72	72	72
Diameter of Vessels, ft	4.0	4.0	5.0
Surface areas, per vessel, sq ft	12.6	12.6	19.63
Number of Vessels	2	2	6
Number of Filter Banks	1	1	1
Loading Rate, gpm/sq ft	15.9	15.9	3.4
Media type	FS	IX	GAC
Media Depth, in	50	50	55
Media, c.f.	105	105	540
EBCT, min	2.0	2.0	10.1
Lag Vessels - Media Type			
	FluoroSorb	Ion Exchange	GAC
Diameter of Vessels, in	48	48	60
Vessel Sideshell Height, in	72	72	72
Diameter of Vessels, ft	4.0	4.0	5.0
Surface areas, per vessel, sq ft	12.6	12.6	19.6
Number of Vessels	2	2	6
Number of Filter Trains	1	1	1
Loading Rate, gpm/sq ft	15.9	15.9	3.4
Media type	FS	IX	GAC
Media Depth, in	50	50	55
Media, c.f.	105	105	540
EBCT, min	2.0	2.0	10.1
Configuration & Pricing			
System Configuration	2 x 2-72-48-FS50	2 x 2-72-48-IX50	2 x 6-72-60-GAC55
Price per Filter Train	\$ 89,165	\$ 147,673	\$ 304,800
Number of Filter Trains	2	2	2
Total System Price	\$ 178,330	\$ 295,346	\$ 609,600
Shipping & Handling Fee	\$ 20,000	\$ 20,000	\$ 20,000
<b>Total</b>	<b>\$ 198,330</b>	<b>\$ 315,346</b>	<b>\$ 629,600</b>
System Description	Fully Skidded PFAS Adsorption System consisting of 1 lead banks followed by 1 lag banks of 2 pressure vessels of 48-inch diameter with 72-inch sidewalls including a 50-inch bed of FS media, controls, valves & header piping	Fully Skidded PFAS Adsorption System consisting of 1 lead banks followed by 1 lag banks of 2 pressure vessels of 48-inch diameter with 72-inch sidewalls including a 50-inch bed of IX media, controls, valves & header piping	Fully Skidded PFAS Adsorption System consisting of 1 lead banks followed by 1 lag banks of 6 pressure vessels of 60-inch diameter with 72-inch diameter with 72-inch sidewalls including a 55-inch bed of GAC media, controls, valves & header piping



Table 1 ATEC PFAS Adsorption System Budgetary System Pricing & Design Details	
Project Name:	Crest Hill, IL
Engineering Consultant:	Strand - Tanner Smid
Rep Company Details:	LAI -
Proposal Prepared by:	Kirk Newcomb - East Region Sales Manager
Proposal Prepared on:	May 21, 2026

Full-Scale Equipment Design Criteria Summary				
Design Scenario:				
Well Name or Number:	10	10	10	10
Capacity, MGD	0.4	0.4	0.4	0.4
Plant Capacity (gpm)	300	300	300	300
PFAS Compounds (EPA Limit)				
PFOA (4 ppt)	unknown	unknown	unknown	unknown
PFOS (4 ppt)	unknown	unknown	unknown	unknown
PFHxS (10 ppt)	unknown	unknown	unknown	unknown
PFNA (10 ppt)	unknown	unknown	unknown	unknown
HFPO-DA (GenX) (10 ppt)	unknown	unknown	unknown	unknown
Hazard Index (PFHx, PFNA, HFPO-D)	unknown	unknown	unknown	unknown
Lead Vessels - Media Type				
	FluoroSorb	Ion Exchange	GAC	
Diameter of Vessels, in	60	60	60	60
Vessel Sideshell Height, in	72	72	72	72
Diameter of Vessels, ft	5.0	5.0	5.0	5.0
Surface areas, per vessel, sq ft	19.6	19.6	19.63	19.63
Number of Vessels	1	1	1	6
Number of Filter Banks	1	1	1	1
Loading Rate, gpm/sq ft	15.3	15.3	2.5	2.5
Media type	FS	IX	GAC	
Media Depth, in	48	48	41	41
Media, c.f.	79	79	403	403
EBCT, min	2.0	2.0	10.0	10.0
Lag Vessels - Media Type				
	FluoroSorb	Ion Exchange	GAC	
Diameter of Vessels, in	60	60	60	60
Vessel Sideshell Height, in	72	72	72	72
Diameter of Vessels, ft	5.0	5.0	5.0	5.0
Surface areas, per vessel, sq ft	19.6	19.6	19.6	19.6
Number of Vessels	1	1	1	6
Number of Filter Trains	1	1	1	1
Loading Rate, gpm/sq ft	15.3	15.3	2.5	2.5
Media type	FS	IX	GAC	
Media Depth, in	48	48	41	41
Media, c.f.	79	79	403	403
EBCT, min	2.0	2.0	10.0	10.0
Configuration & Pricing				
System Configuration	2 x 1-72-60-FS48	2 x 1-72-60-IX48	2 x 6-72-60-GAC41	
Price per Filter Train	\$ 58,424	\$ 102,305	\$ 304,800	
Number of Filter Trains	2	2	2	
Total System Price	\$ 116,848	\$ 204,610	\$ 609,600	
Shipping & Handling Fee	\$ 20,000	\$ 20,000	\$ 20,000	
<b>Total</b>	<b>\$ 136,848</b>	<b>\$ 224,610</b>	<b>\$ 629,600</b>	
System Description	Fully Skidded PFAS Adsorption System consisting of 1 lead banks followed by 1 lag banks of 1 pressure vessels of 60-inch diameter with 72-inch sidewalls including a 48-inch bed of FS media, controls, valves & header piping	Fully Skidded PFAS Adsorption System consisting of 1 lead banks followed by 1 lag banks of 1 pressure vessels of 60-inch diameter with 72-inch sidewalls including a 41-inch bed of IX media, controls, valves & header piping	Fully Skidded PFAS Adsorption System consisting of 1 lead banks followed by 1 lag banks of 6 pressure vessels of 60-inch diameter with 72-inch sidewalls including a 41-inch bed of GAC media, controls, valves & header piping	



# Questions?



Source: © marish – vectorstock.com





---

**Agenda Memo**
**Crest Hill, IL**

---

<b>Meeting Date:</b>	7/6/2026
<b>Submitter:</b>	Gary Richardson, Director of Public Works
<b>Department:</b>	Public Works
<b>Agenda Item:</b>	Presentation of Backflow Solutions, Inc agreement to assist in the administration, tracking, and notification requirements associated with the City's backflow prevention program.

**Summary:**

The City of Crest Hill's Code of Ordinances requires the protection of the public water supply through the installation, testing, and maintenance of backflow prevention assemblies. These assemblies are critical in preventing contamination or pollution of the potable water system due to backflow conditions. Under the City's ordinance, all required backflow prevention devices must be tested regularly by certified personnel, and records of those tests must be maintained to ensure compliance with state and local regulations.

The purpose of this memorandum is to inform Council of the City's agreement with Backflow Solutions, Inc. (BSI) to assist in the administration, tracking, and notification requirements associated with the City's backflow prevention program.

Under the agreement, BSI will provide a comprehensive, backflow management program to support the City's compliance efforts. Key services will include:

- Backflow Test Tracking System where BSI will maintain a secure, online database to track all backflow prevention assemblies and testing records within the City.
- BSI will issue required notices to water customers when backflow testing is due, overdue, or has failed, ensuring timely compliance with ordinance requirements.
- City staff will have 24/7 access to program data, including reports and compliance tracking tools.
- BSI will provide customer service support to residents, businesses, and certified testers.
- The system verifies tester credentials and automatically validates test results in accordance with applicable standards.
- BSI handles the printing and mailing of notifications and maintains records of all communications for compliance tracking.

The implementation of BSI services will:

- Improve compliance with the City's backflow prevention ordinance
- Streamline recordkeeping and reporting processes
- Enhance communication with residents and businesses
- Provide accurate, real-time data for enforcement and decision-making

Partnering with BSI Online will modernize the City's backflow prevention program and ensure continued protection of the public water supply while improving efficiency and regulatory compliance.

**Financial Impact:**

**Funding Source:** Water Contractual Service 07-06-5300

**Budgeted Amount:** \$22,000.00

**Cost:** Approximately \$21,000.00

**Attachments:**

Backflow Solutions Inc Proposal

## SUBSCRIPTION AGREEMENT

This SUBSCRIPTION AGREEMENT (the "Agreement") is made and entered into as of \_\_\_\_\_ (the "Effective Date") by and between **Backflow Solutions, Inc. (BSI Online)**, an Illinois corporation ("BSI") and the City of Crest Hill, IL (the "Water Purveyor"). BSI and the Water Purveyor hereby enter into an online agreement whereby BSI will perform certain notification and data management functions on behalf of the Water Purveyor. The Water Purveyor will provide BSI with the information described hereafter and require all companies performing backflow assembly tests within the Water Purveyor's jurisdiction to submit test results online to BSI Online.

### 1. **BSI RESPONSIBILITIES.**

- a. Maintain the secure online database to ensure a functional backflow assembly tracking system that is easy to understand and use by licensed testers. BSI shall also maintain an internet website where testers shall input all data related to the backflow tests performed in the Water Purveyor's jurisdiction.
- b. BSI to send notifications annually to the Water Purveyor's identified customers who have a backflow assembly due for testing. The number of notifications sent will align with the Program Package chosen by the Water Purveyor.
- c. BSI to assist with backflow-related customer support to the Water Purveyor, their customers, and the local backflow testing community. All support is provided virtually via phone or email.
- d. BSI to provide the Water Purveyor with reports, access to data, and an unlimited number of users.

### 2. **WATER PURVEYOR RESPONSIBILITIES.**

- a. Provide BSI with the most current backflow assembly test records in CSV, XLS, or XLXS format.
- b. Provide BSI with a point of contact for program questions, comments, and/or concerns while contracted with BSI.
- c. Should enforcement efforts be necessary, this is the sole responsibility of the Water Purveyor.
- d. To facilitate the payment process, please provide BSI with a point of contact for future invoices.

Contact Name: \_\_\_\_\_ Email: \_\_\_\_\_

Billing Address: \_\_\_\_\_

### 3. **PACKAGE OPTIONS FOR ANNUAL BACKFLOW TRACKING.**

- a. **The Water Purveyor shall choose the preferred Program Package from the below three (3) options.** This choice relates directly to BSI Responsibilities in 1b above. Any future alterations to BSI's Program Package or the Water Purveyor's choice of Program Package shall be subject to an Amendment to this Agreement.
- b. The cost of mailing materials, postage, and labor are built into the pricing below, unless otherwise noted in the Cost clause of this Agreement.
- c. **TIER 1: STANDARD PACKAGE**
  - i. BSI to send up to two (2) notifications, Test Due Notice and Overdue Notice, to water customers that have testable assemblies, advising them their assembly is due for testing. The Test Due Notice shall be sent approximately thirty-two (32) days prior to the scheduled due date. The Overdue Notice shall be sent one (1) day after the scheduled due date has passed if backflow test results have not been entered to the online database.
  - ii. BSI charges the Water Purveyor **\$495 annually**. Testers shall pay BSI a data entry charge of **\$15.95 per test report submission**.
- d. **TIER 2: PREMIUM PACKAGE**
  - i. BSI to send up to three (3) notifications, Test Due Notice, Overdue Notice, and Failed Notice, to water customers that have testable assemblies, advising them their assembly is due for testing. The Test Due Notice shall be sent approximately thirty-two (32) days prior to the scheduled due date. The Overdue Notice shall be sent one (1) day after the scheduled due date has passed if backflow test results have not been entered to the online database. The Failed Notice will be sent one (1) day after a failed test report has been entered into the online database.



- ii. BSI charges the Water Purveyor **\$995 annually**. Testers shall pay BSI a data entry charge of **\$16.95 per test report submission**.

e. **TIER 3: ELITE PACKAGE**

- i. BSI to send up to four (4) notifications, Test Due Notice, Overdue Notice, Final Notice, and Failed Notice, to water customers that have testable assemblies, advising them their assembly is due for testing. The Test Due Notice shall be sent approximately thirty-two (32) days prior to the scheduled due date. The Overdue Notice shall be sent one (1) day after the scheduled due date has passed if backflow test results have not been entered to the online database. The Final Notice will be sent at a time frame determined by the Water Purveyor and will typically have language congruent with the Water Purveyor's ordinance, bylaw, or local code. The Failed Notice will be sent one (1) day after a failed test report has been entered into the online database.
- ii. BSI charges the Water Purveyor **\$1,995 annually**. Testers shall pay BSI a data entry charge of **\$18.95 per test report submission**.

4. **COST AND ADDITIONAL SERVICES (IF APPLICABLE).**

- a. **ANNUAL BACKFLOW TRACKING.** Water Purveyor opts for Program Package: Premium Package. BSI to charge Water Purveyor \$995 annually. BSI to waive the Annual Tracking Fee for Year 1.
  - i. **INDUCEMENT.** Water Purveyor acknowledges and agrees that to induce BSI to provide the service contemplated by this Agreement, for each Test Report submitted to the online database the **data entry charge of \$16.95 per report** (the "Filing Fee") shall be **paid by the tester** prior to uploading the test data to the online database.
  - ii. **IMPLEMENTATION.** BSI to charge Water Purveyor a one-time implementation fee of \$0.
  - iii. **OPTIONAL REBATE PROGRAM.** If the Water Purveyor should add additional funds to BSI's Filing Fee, BSI will charge a 5% processing fee to the rebate amount.
  - iv. **PRICE ESCALATION.** BSI reserves the right to escalate prices under this agreement. \$2 or annual average CPI, whichever is greater.
  - v. **CUSTOM REQUESTS.** Any changes or requests that differ from BSI's established scope of work on the following page(s) or the request for additional services will be subject to additional fees.
- b. **MAIL SURVEY.** Water Purveyor opts for the Gold Survey – Turnkey. BSI to charge the Water Purveyor \$3 per address. BSI to charge Water Purveyor a one-time implementation fee of \$0.
  - i. BSI will establish a custom URL and web form on our website for electronic survey submission.
  - ii. BSI is responsible for printing, mailing, and cataloging all results.
  - iii. Customers receive one (1) postcard with instructions for electronic survey submission.
  - iv. Electronic responses will be submitted via custom URL to BSI.
  - v. Comprehensive report sent to Water Purveyor upon completion.

5. **PRIVACY.**

- a. BSI gathers data from the Water Purveyor to assist in the management of the backflow program. BSI will make no use of any personal information provided for any purpose other than the carrying out of its duties. This restriction shall include the sale, assignment, transfer, or release of such information to any third party.

6. **PERIOD OF SERVICE.**

- a. **TERM.** The Initial Term of this Agreement shall be 3 years commencing on \_\_\_\_\_ of \_\_\_\_\_, 2026 ("Effective Date") and ending \_\_\_\_\_ of \_\_\_\_\_, 2029.
- b. **TERMINATION.** If the Water Purveyor wishes to discontinue the services provided in this Agreement, BSI requires at least thirty (30) days written notice. No refund of amounts will be given for early termination.

7. **DATA ACCESS.**

- a. The Water Purveyor will have access to the data until the Termination Date, which is 30-days from when we receive notice of Termination.



- b. Any access requested after the Termination Date is subject to applicable data access, storage, and/or user management fees.
- c. If the Water Purveyor does not remit required payments, BSI may suspend or deny access until payment is received.

IN WITNESS WHEREOF, the parties have executed this Agreement as of the date first set forth above.

**BACKFLOW SOLUTIONS, INC.,**

An Illinois corporation ("BSI")

Signature: \_\_\_\_\_

Name: Victoria Rodriguez

Title: Sales Representative

Date: \_\_\_\_\_

Address:

12609 South Laramie Avenue

Alsip, Illinois 60803

**THE CITY OF CREST HILL, IL**

A body politic and corporate (the "Water Purveyor")

Signature: \_\_\_\_\_

Name: \_\_\_\_\_

Title: \_\_\_\_\_

Date: \_\_\_\_\_

Address:

\_\_\_\_\_

\_\_\_\_\_



## TRACKING SCOPE OF WORK

**Data Transition\*** - BSI will prep your electronic file for import into the BSI Online system. CSV, XLS, and XLXS are preferred. We can assist with paper records for a fee.

*\*BSI establishes the database to consolidate assemblies into a smaller number of accounts per unique address. This established and trusted process helps reduce the amount of mail and notifications sent to a unique property. If you request separate accounts per assembly (unique address receiving multiple letters), a data storage/processing fee will be charged.*

**Cloud-Based Test Submittal** - Test entry is cloud-based, enabling the testers to access the program from anywhere, whether they are in the field or at their office. This allows for real-time submittal of test reports.

**Key Performance Indicators & Reporting** - BSI Online provides real-time data, including pre-built and customizable reports. All information is accessible 24/7 and downloadable in CSV format.

**Users** - Water Purveyor can have an unlimited number of simultaneous users. Our solution allows each user to have different roles and permissions tailored to the Water Purveyor's needs.

**User Logs** - BSI Online is built on the foundation of accountability and transparency. All transactions are time-stamped with usernames, allowing the Water Purveyor to monitor issues, comments, or concerns in real time.

**Notifications\* & Archived Copies** - Water Purveyor chooses the preferred program package. BSI automates two (2) to four (4) notifications to customers with identified testable backflow assemblies. All mailings are handled in-house, leveraging decades of experience to ensure timely and efficient delivery. Notifications are sent via USPS First-Class Mail and furnished with the Water Purveyor logo. All notifications are time-stamped per property for full transparency.

*\*With our tracking scope of work, BSI is only sending letters to properties that have backflow assembly information. Should the Water Purveyor desire BSI to generate and mail other/additional letters such as notices to properties that do not have assembly information (remediation and installation notices), this is considered an extra service and must be purchased separately.*

**Additional Notifications** - To help increase testing compliance for known assemblies, clients can utilize our Letter Template feature to create, generate, print, and mail compliance or enforcement letters.

**Returned Mail\*** - BSI can assist with returned mail. Our return address would be listed on notification letters. We would research why it got returned, find a new mailing address, and re-send the notification letter.

*\*Should the Water Purveyor be unwilling or unable to provide BSI with the requested customer billing information, returned mail will be sent back to the Water Purveyor for research and action.*

**Validation of Test Results** - Each test form is coded to automatically determine pass/fail based on the State standards per assembly type. Results are instantly updated in BSI Online, with copies of each test report accessible to the tester, Water Purveyor, and water customer.

**Validation of Credentials** - BSI verifies tester and testing company credentials, including test gauge calibrations. Expired credentials trigger the tester to be locked out until updated documentation is submitted to BSI and properly vetted. This proactive approach is integral to the integrity of your program.

**Expert Support** - We offer unlimited virtual customer service at no additional cost. Dedicated teams for testers and water customers ensure inquiries are handled by our expert personnel, reducing the burden on your staff. The Water Purveyor is also assigned a dedicated account manager focused on ensuring program success.

**Water Customer Portal** - All properties have a unique identifier, a Customer Confirmation Number (CCN). Water customers can use the CCN to access their records, including notifications, the most recent backflow test reports, and a list of licensed backflow testing companies that meet the criteria set by the Water Purveyor.

**Product Support** - Our in-house development team quickly identifies and resolves user issues to ensure continued system reliability and operational efficiency.

**AWS Security** - BSI partners with Amazon Web Services (AWS) for industry-leading security, cloud-based data storage, and flexibility as your program grows.





---

**Agenda Memo**
**Crest Hill, IL**

---

**Meeting Date:** 7/6/2026

**Submitter:** Gary Richardson, Director of Public Works

**Department:** Public Works

**Agenda Item:** Presentation of the 2026 50/50 Tree Planting Program

**Summary:**

The Public Works Department, in conjunction with The Fields on Caton Farm, Inc, plan to conduct the City of Crest Hill's Tree Planting Program in the fall of 2026. Through this program residents are able plant trees on their property and have The City help share the cost.

Residents will submit completed applications along with payment for their cost of the tree to the Public Works Department for review. Staff will then review the application making sure the tree location selected follows the guidelines for the program. Following review of the applications The City will work with The Fields on Caton Farm, Inc to coordinate planting of the trees.

This program allows residents to add to the beautification of their property, while sharing the cost with The City.

**Recommended Council Action:**

Approve the 50/50 Tree Planting Program for 2026.

**Financial Impact:**

Funds for this program are budgeted within 01-03-5300.

**Attachments:**

Program guidelines.



## City of Crest Hill 50/50 Tree Planting Program Guidelines

The City of Crest Hill is proud to continue its Forestry Program, designed to promote community reforestation and enhance neighborhood beautification. Through this program, residents are invited to participate in a cost-sharing opportunity, where the City will contribute 50% toward the purchase of a new tree for eligible properties. The following guidelines outline the details and requirements of the program.

1. Applications will be accepted on a first come, first served basis, regardless of applicant's ward, until allocated funds are exhausted for the 2026-2027 fiscal year.
2. The City of Crest Hill will pay up to 50% of the cost as provided by The Fields toward the purchase of a tree in cooperation with the homeowner.
3. One tree will be allowed per household/address.
4. Homeowners and nonprofit groups will have the opportunity to participate in this program. If demand exceeds available funding and applications are received simultaneously, a lottery system will be used to determine priority.
5. To maximize community participation, new 50/50 tree participants would take priority over previous recipients.
6. Trees will be planted on property by the landscaper (The Fields). The one-year guarantee will be in effect directly between the homeowner and the landscaper.
7. The homeowner must pay their portion of the cost in advance before delivery/planting is made.
8. The City of Crest Hill is not responsible for any damage or restoration to private property resulting from the delivery or planting of the tree.
9. A variety of trees species will be offered. The list and pricing will be updated annually and included with the application materials.
10. A sketch showing the approximate placement of the tree must be submitted with the application.
11. Once the tree has been paid for, and a planting date is set, The Fields will contact JULIE and have underground utilities located. **TREES CANNOT BE PLACED OVER ANY UTILITY LINES, OR IN ANY UTILITY EASEMENTS, INCLUDING WATER AND SEWER LINES.**
12. Trees shall **NOT** be planted within a 20' radius of utility structures such as manholes, hydrants, valve boxes, and light poles, subject to approval by the Director of Public Works.
13. Residents can choose to plant trees in the parkway when appropriate.

If you have any questions regarding the tree program, please contact Administrative Assistant Kim Linden at (815) 741-5108 or [klinden@cityofcresthill.com](mailto:klinden@cityofcresthill.com).



Agenda Memo

Crest Hill, IL

<b>Meeting Date:</b>	July 6, 2026
<b>Submitter:</b>	Ronald J Wiedeman
<b>Department:</b>	Engineering
<b>Agenda Item:</b>	Award the contract to Austin Tyler Construction, Incorporated in the amount of \$1,799,817.55 for the 2026 Roadway Rehabilitation Program.

**Summary:** Bids were advertised and solicited for qualified contractors to provide unit price costs for the 2025 Roadway Rehabilitation Program. The locations included in this year program are as follows:

- Kingsbrook Dr. from Borio Dr. to North End. Pavement rating-poor.
- Longmeadow Dr. from Borio Dr. from Kingsbrook Dr. Pavement rating-poor.
- Carlton St. from Caton Farm Rd to Prestwick Dr.-Pavement rating-serious.
- Dundee Dr. from Carlton Dr. to Loch Ln. Pavement rating-serious.
- Chaney Ave. from Oakland Ave. to Hoffman St. Pavement rating-very poor.
- Hoffman St. from Chaney to Elsie Ave. Pavement rating-very poor.
- Elsie Ave. from Clement to Hoffman St. Pavement rating-very poor
- Stern Ave. from Oakland to Clement St. Pavement rating-very poor
- Fox Meadow Dr. from Gaylord Rd to Springside Dr. Pavement rating-poor/serious
- Silver Rock Dr. from Fox Meadow Dr. to Springside Dr. Pavement rating-poor/serious
- Foxtail Ct. Pavement rating-poor
- Caton Farm Rd from Oakland to Broadway- Pavement rating-serious.

The city solicited bids through IDOT’s construction bulletin looking for qualified contractors. A total of five (5) local pre-qualified contractors picked up bids and five (5) submitted bids. The bids were received and opened for the improvement via QuestCDN an electronic bid services, until 10:00 AM local time. The following is a list of the bids received:

Results

1. Austin Tyler Construction, Inc.	\$1,766,817.55
2. D Construction, Inc.	\$1,792,053.03
3. P.T. Ferro Construction	\$1,822,148.43
4. Gallagher Asphalt Co	\$1,845,551.23
5. Building Paving, LLC	\$2,170,991.56

The engineering estimate was \$2,358,659.50

I have reviewed the quotes and found them to be correct and in order, and I feel that the bids do reflect the market as it exists today.

**Recommended Council Action:** Award the contract to Austin Tyler Construction, Incorporated in the amount of \$1,799,817.55 for the 2026 Roadway Rehabilitation Program.

**Financial Impact:**

**Funding Source:** General Fund

**Budgeted Amount:** \$5,970,000.00

**Cost:** 1,766,817.55

**Attachments:**

Bid Tab-2026 Roadway Rehab

LOR Wiedeman Bid Award Recommendation\_2026\_0626.pdf



**CHRISTOPHER B. BURKE ENGINEERING, LTD.**  
16221 W. 159th Street Suite 201 Lockport, Illinois 60441 TEL (815) 770-2850

June 26, 2026

City of Crest Hill  
20600 City Center Blvd.  
Crest Hill, Illinois 60403

Attention: Ronald Wiedeman, PE – City Engineer

Subject: City of Crest Hill  
2026 Roadway Rehabilitation Program  
(CBBEL No: 250457)  
**Engineer’s Award Recommendation**

Dear Mr. Wiedeman:

On Friday, June 26, 2026 at 10:00 A.M. bids were received electronically for the subject project. Five bids were received for this project. Christopher B. Burke Engineering, Ltd. (CBBEL) has reviewed the contract proposals for the 2026 Roadway Rehabilitation Program and all documents were in compliance with City and contract requirements. The bids have been reviewed and tabulated and are as follows:

<b>Engineer’s Estimate</b>	<b>\$ 2,358,659.50</b>
Austin Tyler Const. Inc.	\$ 1,766,817.55
D. Construction, Inc.	\$ 1,792,053.03
P.T. Ferro Construction Co.	\$ 1,822,148.43
Gallagher Asphalt Corporation	\$ 1,845,551.23
Builders Paving, LLC	\$ 2,170,991.56

Austin Tyler Construction, Inc. was the low bidder with a proposal of \$1,766,817.55. We have reviewed Austin Tyler’s bid documents and found them to be in order. Therefore, CBBEL recommends awarding the project to Austin Tyler Construction, Inc. in the amount of \$1,766,817.55.

Enclosed for your reference are the bid tabulation and bid summary. Should you have any questions, please do not hesitate to contact me.

Sincerely,

Alex Schaefer, PE  
Senior Project Manager  
Enclosure as Noted

## 2026 Roadway Rehabilitation Program BID SUMMARY

CBBEL Project No. 250457

Bids Opened June 26, 2026

<b>CONTRACTOR</b>	<b>BID</b>	
ENGINEER'S ESTIMATE	\$	2,358,659.50
Austin Tyler Const. , Inc	\$	1,766,817.55
D. Construction, Inc.	\$	1,792,053.03
P.T. Ferro Construction Co.	\$	1,822,148.43
Gallagher Asphalt Corporation	\$	1,845,551.23
Builders Paving, LLC	\$	2,170,991.56

**2026 Roadway Rehabilitation Program**  
 Bid Tabulation  
 CBBEL Project No. 250457

Bids Opened June 26, 2026

ITEM NO	SP	PAY CODE	ITEM	UNIT	QUANTITY	ENGINEER'S ESTIMATE		Austin Tyler Const. , Inc		D. Construction, Inc.		P.T. Ferro Construction Co.		Gallagher Asphalt Corporation		Builders Paving, LLC	
						UNIT PRICE	TOTAL	UNIT PRICE	TOTAL	UNIT PRICE	TOTAL	UNIT PRICE	TOTAL	UNIT PRICE	TOTAL	UNIT PRICE	TOTAL
1		20101200	TREE ROOT PRUNING	EACH	15	\$250.00	\$ 3,750.00	\$0.01	\$ 0.15	\$200.00	\$ 3,000.00	\$0.01	\$ 0.15	\$99.00	\$ 1,485.00	\$110.00	\$ 1,650.00
2	#	20200500	EARTH EXCAVATION (WIDENING)	CU YD	1390	\$60.00	\$ 83,400.00	\$44.00	\$ 61,160.00	\$30.00	\$ 41,700.00	\$50.00	\$ 69,500.00	\$60.00	\$ 83,400.00	\$67.00	\$ 93,130.00
3		20201200	REMOVAL AND DISPOSAL OF UNSUITABLE MATERIALS	CU YD	357	\$60.00	\$ 21,420.00	\$41.00	\$ 14,637.00	\$30.00	\$ 10,710.00	\$40.00	\$ 14,280.00	\$20.00	\$ 7,140.00	\$50.00	\$ 17,850.00
4	#	20700220	POROUS GRANULAR EMBANKMENT	CU YD	357	\$60.00	\$ 21,420.00	\$49.00	\$ 17,493.00	\$45.00	\$ 16,065.00	\$55.00	\$ 19,635.00	\$20.00	\$ 7,140.00	\$50.00	\$ 17,850.00
5	#	21400100	GRADING AND SHAPING DITCHES	FOOT	3500	\$15.00	\$ 52,500.00	\$13.00	\$ 45,500.00	\$10.00	\$ 35,000.00	\$4.75	\$ 16,625.00	\$5.25	\$ 18,375.00	\$13.00	\$ 45,500.00
6		28000305	TEMPORARY DITCH CHECKS	FOOT	140	\$15.00	\$ 2,100.00	\$15.00	\$ 2,100.00	\$10.00	\$ 1,400.00	\$15.00	\$ 2,100.00	\$15.00	\$ 2,100.00	\$12.50	\$ 1,750.00
7		28000510	INLET FILTERS	EACH	79	\$200.00	\$ 15,800.00	\$50.00	\$ 3,950.00	\$200.00	\$ 15,800.00	\$0.01	\$ 0.79	\$150.00	\$ 11,850.00	\$200.00	\$ 15,800.00
8	#	30300112	AGGREGATE SUBGRADE IMPROVEMENT 12"	SQ YD	2189	\$30.00	\$ 65,670.00	\$17.00	\$ 37,213.00	\$16.10	\$ 35,242.90	\$20.00	\$ 43,780.00	\$30.00	\$ 65,670.00	\$51.00	\$ 111,639.00
9		35600716	HOT-MIX ASPHALT BASE COURSE WIDENING 10"	SQ YD	1990	\$85.00	\$ 169,150.00	\$42.00	\$ 83,580.00	\$46.31	\$ 92,156.90	\$58.00	\$ 115,420.00	\$58.00	\$ 115,420.00	\$87.00	\$ 173,130.00
10		40600290	BITUMINOUS MATERIALS (TACK COAT)	POUND	24100	\$0.75	\$ 18,075.00	\$0.35	\$ 8,435.00	\$0.01	\$ 241.00	\$0.01	\$ 241.00	\$1.05	\$ 25,305.00	\$0.01	\$ 241.00
11		40600982	HOT-MIX ASPHALT SURFACE REMOVAL - BUTT JOINT	SQ YD	649	\$15.00	\$ 9,735.00	\$22.00	\$ 14,278.00	\$0.01	\$ 6.49	\$0.01	\$ 6.49	\$0.01	\$ 6.49	\$5.00	\$ 3,245.00
12		40603080	HOT-MIX ASPHALT BINDER COURSE, IL-19.0, N50	TON	1256	\$88.00	\$ 110,528.00	\$77.25	\$ 97,026.00	\$76.50	\$ 96,084.00	\$75.00	\$ 94,200.00	\$79.00	\$ 99,224.00	\$81.00	\$ 101,736.00
13		40604012	HOT-MIX ASPHALT SURFACE COURSE, MIX "D", IL-9.5, N70	TON	1770	\$95.00	\$ 168,150.00	\$79.50	\$ 140,715.00	\$79.21	\$ 140,201.70	\$83.00	\$ 146,910.00	\$87.00	\$ 153,990.00	\$86.00	\$ 152,220.00
14		40604060	HOT-MIX ASPHALT SURFACE COURSE, MIX "D", IL-9.5, N50	TON	3827	\$90.00	\$ 344,430.00	\$79.50	\$ 304,246.50	\$80.62	\$ 308,532.74	\$80.00	\$ 306,160.00	\$85.00	\$ 325,295.00	\$86.00	\$ 329,122.00
15	#	42400200	PORTLAND CEMENT CONCRETE SIDEWALK, 5-INCH (SPECIAL)	SQ FT	1106	\$16.00	\$ 17,696.00	\$10.00	\$ 11,060.00	\$11.00	\$ 12,166.00	\$11.50	\$ 12,719.00	\$10.00	\$ 11,060.00	\$11.00	\$ 12,166.00
16	#	42400800	DETECTABLE WARNINGS	SQ FT	160	\$35.00	\$ 5,600.00	\$26.00	\$ 4,160.00	\$27.50	\$ 4,400.00	\$20.00	\$ 3,200.00	\$21.00	\$ 3,360.00	\$27.00	\$ 4,320.00
17		44000100	PAVEMENT REMOVAL	SQ YD	834	\$25.00	\$ 20,850.00	\$23.00	\$ 19,182.00	\$17.00	\$ 14,178.00	\$30.00	\$ 25,020.00	\$40.00	\$ 33,360.00	\$26.00	\$ 21,684.00
18		44000200	DRIVEWAY PAVEMENT REMOVAL	SQ YD	541	\$20.00	\$ 10,820.00	\$18.00	\$ 9,738.00	\$19.80	\$ 10,711.80	\$24.00	\$ 12,984.00	\$35.00	\$ 18,935.00	\$28.00	\$ 15,148.00
19		44000600	SIDEWALK REMOVAL	SQ FT	1106	\$3.00	\$ 3,318.00	\$3.00	\$ 3,318.00	\$2.20	\$ 2,432.20	\$4.00	\$ 4,424.00	\$3.00	\$ 3,318.00	\$4.00	\$ 4,424.00
20	#	44201713	CLASS D PATCHES, 6 INCH (SPECIAL)	SQ YD	1061	\$40.00	\$ 42,440.00	\$53.00	\$ 56,233.00	\$59.00	\$ 62,599.00	\$60.00	\$ 63,660.00	\$25.00	\$ 26,525.00	\$65.00	\$ 68,965.00
21	#	44201785	CLASS D PATCHES, 12 INCH (SPECIAL)	SQ YD	732	\$100.00	\$ 73,200.00	\$122.00	\$ 89,304.00	\$117.00	\$ 85,644.00	\$88.00	\$ 64,416.00	\$50.00	\$ 36,600.00	\$125.00	\$ 91,500.00
22	#	48101202	AGGREGATE SHOULDERS, TYPE B	CU YD	370	\$75.00	\$ 27,750.00	\$78.00	\$ 28,860.00	\$60.00	\$ 22,200.00	\$70.00	\$ 25,900.00	\$89.00	\$ 32,930.00	\$75.00	\$ 27,750.00
23		60266600	VALVE BOXES TO BE ADJUSTED	EACH	4	\$350.00	\$ 1,400.00	\$260.00	\$ 1,040.00	\$300.00	\$ 1,200.00	\$225.00	\$ 900.00	\$275.00	\$ 1,100.00	\$425.00	\$ 1,700.00
24	#	60406000	FRAMES AND LIDS, TYPE 1, OPEN LID	EACH	23	\$550.00	\$ 12,650.00	\$365.00	\$ 8,395.00	\$600.00	\$ 13,800.00	\$500.00	\$ 11,500.00	\$400.00	\$ 9,200.00	\$500.00	\$ 11,500.00
25	#	60406100	FRAMES AND LIDS, TYPE 1, CLOSED LID	EACH	2	\$550.00	\$ 1,100.00	\$365.00	\$ 730.00	\$600.00	\$ 1,200.00	\$500.00	\$ 1,000.00	\$400.00	\$ 800.00	\$500.00	\$ 1,000.00
26	#	X7010216	TRAFFIC CONTROL AND PROTECTION, (SPECIAL)	L SUM	1	\$120,000.00	\$ 120,000.00	\$20,000.00	\$ 20,000.00	\$35,000.00	\$ 35,000.00	\$119,000.00	\$ 119,000.00	\$49,500.00	\$ 49,500.00	\$48,000.00	\$ 48,000.00
27		70300100	SHORT TERM PAVEMENT MARKING	FOOT	1090	\$1.00	\$ 1,090.00	\$2.00	\$ 2,180.00	\$0.01	\$ 10.90	\$1.50	\$ 1,635.00	\$0.01	\$ 10.90	\$1.50	\$ 1,635.00
28		70300150	SHORT TERM PAVEMENT MARKING REMOVAL	SQ FT	364	\$3.00	\$ 1,092.00	\$3.00	\$ 1,092.00	\$0.01	\$ 3.64	\$2.00	\$ 728.00	\$0.01	\$ 3.64	\$1.00	\$ 364.00
29		70300211	TEMPORARY PAVEMENT MARKING LETTERS AND SYMBOLS - PAINT	SQ FT	115	\$5.00	\$ 575.00	\$2.60	\$ 299.00	\$0.01	\$ 1.15	\$0.01	\$ 1.15	\$0.01	\$ 1.15	\$5.00	\$ 575.00
30		70300221	TEMPORARY PAVEMENT MARKING - LINE 4" - PAINT	FOOT	20318	\$1.00	\$ 20,318.00	\$0.40	\$ 8,127.20	\$0.01	\$ 203.18	\$0.01	\$ 203.18	\$0.01	\$ 203.18	\$0.30	\$ 6,095.40
31		70300241	TEMPORARY PAVEMENT MARKING - LINE 6" - PAINT	FOOT	523	\$1.50	\$ 784.50	\$0.40	\$ 209.20	\$0.01	\$ 5.23	\$0.01	\$ 5.23	\$0.01	\$ 5.23	\$1.00	\$ 523.00
32		70300261	TEMPORARY PAVEMENT MARKING - LINE 12" - PAINT	FOOT	87	\$2.00	\$ 174.00	\$0.40	\$ 34.80	\$0.01	\$ 0.87	\$0.01	\$ 0.87	\$0.01	\$ 0.87	\$2.00	\$ 174.00
33		70300281	TEMPORARY PAVEMENT MARKING - LINE 24" - PAINT	FOOT	38	\$3.00	\$ 114.00	\$2.60	\$ 98.80	\$0.01	\$ 0.38	\$0.01	\$ 0.38	\$0.01	\$ 0.38	\$8.00	\$ 304.00
34		78009000	MODIFIED URETHANE PAVEMENT MARKING - LETTERS AND SYMBOLS	SQ FT	115	\$15.00	\$ 1,725.00	\$6.30	\$ 724.50	\$6.60	\$ 759.00	\$6.00	\$ 690.00	\$6.00	\$ 690.00	\$7.00	\$ 805.00
35		78009004	MODIFIED URETHANE PAVEMENT MARKING - LINE 4"	FOOT	20318	\$1.50	\$ 30,477.00	\$0.85	\$ 17,270.30	\$0.85	\$ 17,270.30	\$0.85	\$ 17,270.30	\$0.85	\$ 17,270.30	\$0.82	\$ 16,660.76
36		78009006	MODIFIED URETHANE PAVEMENT MARKING - LINE 6"	FOOT	867	\$3.00	\$ 2,601.00	\$1.55	\$ 1,343.85	\$1.65	\$ 1,430.55	\$1.50	\$ 1,300.50	\$1.50	\$ 1,300.50	\$1.50	\$ 1,300.50
37		78009012	MODIFIED URETHANE PAVEMENT MARKING - LINE 12"	FOOT	117	\$6.00	\$ 702.00	\$3.15	\$ 368.55	\$3.30	\$ 386.10	\$3.00	\$ 351.00	\$3.00	\$ 351.00	\$3.00	\$ 351.00
38		78009024	MODIFIED URETHANE PAVEMENT MARKING - LINE 24"	FOOT	368	\$15.00	\$ 5,520.00	\$6.30	\$ 2,318.40	\$6.60	\$ 2,428.80	\$6.00	\$ 2,208.00	\$6.00	\$ 2,208.00	\$7.00	\$ 2,576.00
39		78300201	PAVEMENT MARKING REMOVAL - GRINDING	SQ FT	15488	\$2.00	\$ 30,976.00	\$0.50	\$ 7,744.00	\$0.50	\$ 7,744.00	\$0.50	\$ 7,744.00	\$0.50	\$ 7,744.00	\$0.25	\$ 3,872.00
40	#	X3580300	AGGREGATE BASE REPAIR (SPECIAL)	TON	289	\$25.00	\$ 7,225.00	\$22.00	\$ 6,358.00	\$25.00	\$ 7,225.00	\$15.00	\$ 4,335.00	\$15.00	\$ 4,335.00	\$25.00	\$ 7,225.00
41	#	X3580302	PREPARATION OF BASE (SPECIAL)	SQ YD	6914	\$2.00	\$ 13,828.00	\$1.25	\$ 8,642.50	\$1.50	\$ 10,371.00	\$1.75	\$ 12,099.50	\$0.01	\$ 69.14	\$3.00	\$ 20,742.00
42	#	X6026050	SANITARY MANHOLES TO BE ADJUSTED	EACH	5	\$1,500.00	\$ 7,500.00	\$900.00	\$ 4,500.00	\$1,400.00	\$ 7,000.00	\$1,300.00	\$ 6,500.00	\$700.00	\$ 3,500.00	\$3,100.00	\$ 15,500.00
43	#	X8860105	DETECTOR LOOP REPLACEMENT	FOOT	75	\$30.00	\$ 2,250.00	\$62.00	\$ 4,650.00	\$71.50	\$ 5,362.50	\$59.25	\$ 4,443.75	\$60.00	\$ 4,500.00	\$72.00	\$ 5,400.00
44	#	Z0013798	CONSTRUCTION LAYOUT	LSUM	1	\$20,000.00	\$ 20,000.00	\$12,000.00	\$ 12,000.00	\$5,000.00	\$ 5,000.00	\$10,000.00	\$ 10,000.00	\$12,000.00	\$ 12,000.00	\$25,000.00	\$ 25,000.00
45	#	Z0018400	DRAINAGE & UTILITY STRUCTURES TO BE ADJUSTED	EACH	32	\$675.00	\$ 21,600.00	\$370.00	\$ 11,840.00	\$500.00	\$ 16,000.00	\$500.00	\$ 16,000.00	\$350.00	\$ 11,200.00	\$1,050.00	\$ 33,600.00
46	#	Z0017700	DRAINAGE & UTILITY STRUCTURES TO BE RECONSTRUCTED	EACH	4	\$1,500.00	\$ 6,000.00	\$900.00	\$ 3,600.00	\$1,500.00	\$ 6,000.00	\$750.00	\$ 3,000.00	\$1,450.00	\$ 5,800.00	\$2,450.00	\$ 9,800.00
47	#	LR400520	HOT IN-PLACE RECYCLING - SURFACE RECYCLING	SQ YD	47538	\$6.50	\$ 308,997.00	\$5.20	\$ 247,197.60	\$6.45	\$ 306,620.10	\$4.98	\$ 236,739.24	\$6.10	\$ 289,981.80	\$6.30	\$ 299,489.40
48	#	NA	COMBINATION CONCRETE CURB AND GUTTER REMOVAL AND REPLACEMENT	FOOT	479	\$55.00	\$ 26,345.00	\$52.00	\$ 24,908.00	\$48.70	\$ 23,327.30	\$58.00	\$ 27,782.00	\$60.00	\$ 28,740.00	\$51.00	\$ 24,429.00
49	#	NA	HOT-MIX ASPHALT DRIVEWAY PAVEMENT, 4" (SPECIAL)	SQ YD	541	\$55.00	\$ 29,755.00	\$67.00	\$ 36,247.00	\$48.00	\$ 25,968.00	\$48.00	\$ 25,968.00	\$84.00	\$ 45,444.00	\$55.00	\$ 29,755.00
50	#	NA	HOT-MIX ASPHALT SURFACE REMOVAL, FULL DEPTH	SQ YD	6914	\$9.00	\$ 62,226.00	\$2.60	\$ 17,976.40	\$4.85	\$ 33,532.90	\$3.75	\$ 25,927.50	\$4.30	\$ 29,730.20	\$7.00	\$ 48,398.00
51	#	NA	HOT-MIX ASPHALT SURFACE REMOVAL, VARIABLE DEPTH - EDGE GRIND 1.25" MAX. DEPTH	SQ YD	14823	\$3.00	\$ 44,469.00	\$1.60	\$ 23,716.80	\$1.20	\$ 17,787.60	\$2.00	\$ 29,646.00	\$2.15	\$ 31,869.45	\$2.50	\$ 37,057.50
52	#	NA	HOT-MIX ASPHALT SURFACE REMOVAL, VARIABLE DEPTH - EDGE GRIND 1.75" MAX. DEPTH	SQ YD	1540	\$4.00	\$ 6,160.00	\$5.65	\$ 8,701.00	\$2.35	\$ 3,619.00	\$4.00	\$ 6,160.00	\$4.60	\$ 7,084.00	\$6.20	\$ 9,548.00
53	#	NA	PARKWAY RESTORATION - SEEDING	SQ YD	4524	\$16.00	\$ 72,384.00	\$14.00	\$ 63,336.00	\$12.00	\$ 54,288.00	\$11.85	\$ 53,609.40	\$14.00	\$ 63,336.00	\$9.50	\$ 42,978.00
54	#	NA	PROJECT SIGNS	EACH	19	\$1,800.00	\$ 34,200.00	\$1,300.00	\$ 24,700.00	\$300.00	\$ 5,700.00	\$1.00	\$ 19.00	\$800.00	\$ 15,200.00	\$450.00	\$ 8,550.00
55	#	NA	PORTLAND CEMENT CONCRETE DRIVEWAY PAVEMENT (HI-EARLY STRENGTH), 6"	SQ YD	1492	\$110.00	\$ 164,120.00	\$90.00	\$ 134,280.00	\$114.40	\$ 170,684.80	\$100.00	\$ 149,200.00	\$77.00	\$ 114,884.00	\$92.00	\$ 137,264.00
56	#	NA	PCC MEDIAN EXTENSION (GAYLORD ROAD)	LSUM	1	\$12,500.00	\$ 12,500.00	\$10,000.00	\$ 10,000.00	\$1,650.00	\$ 1,650.00	\$5,000.00	\$ 5,000.00	\$5,000.00	\$ 5,000.00	\$8,000.00	\$ 8,000.00
# DENOTES SPECIAL PROVISION																	
						<b>TOTAL</b>	<b>\$ 2,358,659.50</b>	<b>\$ 1,766,817.55</b>	<b>\$ 1,792,053.03</b>	<b>\$ 1,822,148.43</b>	<b>\$ 1,845,551.23</b>	<b>\$ 2,170,991.56</b>					

**2026 Roadway Rehabilitation Program**

Bid Tabulation  
CBBEL Project No. 250457

Bids Opened June 26, 2026

ITEM NO	SP	PAY CODE	ITEM	UNIT	QUANTITY	ENGINEER'S ESTIMATE		Austin Tyler Const. , Inc		D. Construction, Inc.		P.T. Ferro Construction Co.		Gallagher Asphalt Corporation		Builders Paving, LLC	
						UNIT PRICE	TOTAL	UNIT PRICE	TOTAL	UNIT PRICE	TOTAL	UNIT PRICE	TOTAL	UNIT PRICE	TOTAL	UNIT PRICE	TOTAL
1		20101200	TREE ROOT PRUNING	EACH	15	\$250.00	\$ 3,750.00	\$0.01	\$ 0.15	\$200.00	\$ 3,000.00	\$0.01	\$ 0.15	\$99.00	\$ 1,485.00	\$110.00	\$ 1,650.00
2	#	20200500	EARTH EXCAVATION (WIDENING)	CU YD	1390	\$60.00	\$ 83,400.00	\$44.00	\$ 61,160.00	\$30.00	\$ 41,700.00	\$50.00	\$ 69,500.00	\$60.00	\$ 83,400.00	\$67.00	\$ 93,130.00
3		20201200	REMOVAL AND DISPOSAL OF UNSUITABLE MATERIALS	CU YD	357	\$60.00	\$ 21,420.00	\$41.00	\$ 14,637.00	\$30.00	\$ 10,710.00	\$40.00	\$ 14,280.00	\$20.00	\$ 7,140.00	\$50.00	\$ 17,850.00
4	#	20700220	POROUS GRANULAR EMBANKMENT	CU YD	357	\$60.00	\$ 21,420.00	\$49.00	\$ 17,493.00	\$45.00	\$ 16,065.00	\$55.00	\$ 19,635.00	\$20.00	\$ 7,140.00	\$50.00	\$ 17,850.00
5	#	21400100	GRADING AND SHAPING DITCHES	FOOT	3500	\$15.00	\$ 52,500.00	\$13.00	\$ 45,500.00	\$10.00	\$ 35,000.00	\$4.75	\$ 16,625.00	\$5.25	\$ 18,375.00	\$13.00	\$ 45,500.00
6		28000305	TEMPORARY DITCH CHECKS	FOOT	140	\$15.00	\$ 2,100.00	\$15.00	\$ 2,100.00	\$10.00	\$ 1,400.00	\$15.00	\$ 2,100.00	\$15.00	\$ 2,100.00	\$12.50	\$ 1,750.00
7		28000510	INLET FILTERS	EACH	79	\$200.00	\$ 15,800.00	\$50.00	\$ 3,950.00	\$200.00	\$ 15,800.00	\$0.01	\$ 0.79	\$150.00	\$ 11,850.00	\$200.00	\$ 15,800.00
8	#	30300112	AGGREGATE SUBGRADE IMPROVEMENT 12"	SQ YD	2189	\$30.00	\$ 65,670.00	\$17.00	\$ 37,213.00	\$16.10	\$ 35,242.90	\$20.00	\$ 43,780.00	\$30.00	\$ 65,670.00	\$51.00	\$ 111,639.00
9		35600716	HOT-MIX ASPHALT BASE COURSE WIDENING 10"	SQ YD	1990	\$85.00	\$ 169,150.00	\$42.00	\$ 83,580.00	\$46.31	\$ 92,156.90	\$58.00	\$ 115,420.00	\$58.00	\$ 115,420.00	\$87.00	\$ 173,130.00
10		40600290	BITUMINOUS MATERIALS (TACK COAT)	POUND	24100	\$0.75	\$ 18,075.00	\$0.35	\$ 8,435.00	\$0.01	\$ 241.00	\$0.01	\$ 241.00	\$1.05	\$ 25,305.00	\$0.01	\$ 241.00
11		40600982	HOT-MIX ASPHALT SURFACE REMOVAL - BUTT JOINT	SQ YD	649	\$15.00	\$ 9,735.00	\$22.00	\$ 14,278.00	\$0.01	\$ 6.49	\$0.01	\$ 6.49	\$0.01	\$ 6.49	\$5.00	\$ 3,245.00
12		40603080	HOT-MIX ASPHALT BINDER COURSE, IL-19.0, N50	TON	1256	\$88.00	\$ 110,528.00	\$77.25	\$ 97,026.00	\$76.50	\$ 96,084.00	\$75.00	\$ 94,200.00	\$79.00	\$ 99,224.00	\$81.00	\$ 101,736.00
13		40604012	HOT-MIX ASPHALT SURFACE COURSE, MIX "D", IL-9.5, N70	TON	1770	\$95.00	\$ 168,150.00	\$79.50	\$ 140,715.00	\$79.21	\$ 140,201.70	\$83.00	\$ 146,910.00	\$87.00	\$ 153,990.00	\$86.00	\$ 152,220.00
14		40604060	HOT-MIX ASPHALT SURFACE COURSE, MIX "D", IL-9.5, N50	TON	3827	\$90.00	\$ 344,430.00	\$79.50	\$ 304,246.50	\$80.62	\$ 308,532.74	\$80.00	\$ 306,160.00	\$85.00	\$ 325,295.00	\$86.00	\$ 329,122.00
15	#	42400200	PORTLAND CEMENT CONCRETE SIDEWALK, 5-INCH (SPECIAL)	SQ FT	1106	\$16.00	\$ 17,696.00	\$10.00	\$ 11,060.00	\$11.00	\$ 12,166.00	\$11.50	\$ 12,719.00	\$10.00	\$ 11,060.00	\$11.00	\$ 12,166.00
16	#	42400800	DETECTABLE WARNINGS	SQ FT	160	\$35.00	\$ 5,600.00	\$26.00	\$ 4,160.00	\$27.50	\$ 4,400.00	\$20.00	\$ 3,200.00	\$21.00	\$ 3,360.00	\$27.00	\$ 4,320.00
17		44000100	PAVEMENT REMOVAL	SQ YD	834	\$25.00	\$ 20,850.00	\$23.00	\$ 19,182.00	\$17.00	\$ 14,178.00	\$30.00	\$ 25,020.00	\$40.00	\$ 33,360.00	\$26.00	\$ 21,684.00
18		44000200	DRIVEWAY PAVEMENT REMOVAL	SQ YD	541	\$20.00	\$ 10,820.00	\$18.00	\$ 9,738.00	\$19.80	\$ 10,711.80	\$24.00	\$ 12,984.00	\$35.00	\$ 18,935.00	\$28.00	\$ 15,148.00
19		44000600	SIDEWALK REMOVAL	SQ FT	1106	\$3.00	\$ 3,318.00	\$3.00	\$ 3,318.00	\$2.20	\$ 2,433.20	\$4.00	\$ 4,424.00	\$3.00	\$ 3,318.00	\$4.00	\$ 4,424.00
20	#	44201713	CLASS D PATCHES, 6 INCH (SPECIAL)	SQ YD	1061	\$40.00	\$ 42,440.00	\$53.00	\$ 56,233.00	\$59.00	\$ 62,599.00	\$60.00	\$ 63,660.00	\$25.00	\$ 26,525.00	\$65.00	\$ 68,965.00
21	#	44201785	CLASS D PATCHES, 12 INCH (SPECIAL)	SQ YD	732	\$100.00	\$ 73,200.00	\$122.00	\$ 89,304.00	\$117.00	\$ 85,644.00	\$88.00	\$ 64,416.00	\$50.00	\$ 36,600.00	\$125.00	\$ 91,500.00
22	#	48101202	AGGREGATE SHOULDERS, TYPE B	CU YD	370	\$75.00	\$ 27,750.00	\$78.00	\$ 28,860.00	\$60.00	\$ 22,200.00	\$70.00	\$ 25,900.00	\$89.00	\$ 32,930.00	\$75.00	\$ 27,750.00
23		60266600	VALVE BOXES TO BE ADJUSTED	EACH	4	\$350.00	\$ 1,400.00	\$260.00	\$ 1,040.00	\$300.00	\$ 1,200.00	\$225.00	\$ 900.00	\$275.00	\$ 1,100.00	\$425.00	\$ 1,700.00
24	#	60406000	FRAMES AND LIDS, TYPE 1, OPEN LID	EACH	23	\$550.00	\$ 12,650.00	\$365.00	\$ 8,395.00	\$600.00	\$ 13,800.00	\$500.00	\$ 11,500.00	\$400.00	\$ 9,200.00	\$500.00	\$ 11,500.00
25	#	60406100	FRAMES AND LIDS, TYPE 1, CLOSED LID	EACH	2	\$550.00	\$ 1,100.00	\$365.00	\$ 730.00	\$600.00	\$ 1,200.00	\$500.00	\$ 1,000.00	\$400.00	\$ 800.00	\$500.00	\$ 1,000.00
26	#	X7010216	TRAFFIC CONTROL AND PROTECTION, (SPECIAL)	L SUM	1	\$120,000.00	\$ 120,000.00	\$20,000.00	\$ 20,000.00	\$35,000.00	\$ 35,000.00	\$119,000.00	\$ 119,000.00	\$49,500.00	\$ 49,500.00	\$48,000.00	\$ 48,000.00
27		70300100	SHORT TERM PAVEMENT MARKING	FOOT	1090	\$1.00	\$ 1,090.00	\$2.00	\$ 2,180.00	\$0.01	\$ 10.90	\$1.50	\$ 1,635.00	\$0.01	\$ 10.90	\$1.50	\$ 1,635.00
28		70300150	SHORT TERM PAVEMENT MARKING REMOVAL	SQ FT	364	\$3.00	\$ 1,092.00	\$3.00	\$ 1,092.00	\$0.01	\$ 3.64	\$2.00	\$ 728.00	\$0.01	\$ 3.64	\$1.00	\$ 364.00
29		70300211	TEMPORARY PAVEMENT MARKING LETTERS AND SYMBOLS - PAINT	SQ FT	115	\$5.00	\$ 575.00	\$2.60	\$ 299.00	\$0.01	\$ 1.15	\$0.01	\$ 1.15	\$0.01	\$ 1.15	\$5.00	\$ 575.00
30		70300221	TEMPORARY PAVEMENT MARKING - LINE 4" - PAINT	FOOT	20318	\$1.00	\$ 20,318.00	\$0.40	\$ 8,127.20	\$0.01	\$ 203.18	\$0.01	\$ 203.18	\$0.01	\$ 203.18	\$0.30	\$ 6,095.40
31		70300241	TEMPORARY PAVEMENT MARKING - LINE 6" - PAINT	FOOT	523	\$1.50	\$ 784.50	\$0.40	\$ 209.20	\$0.01	\$ 5.23	\$0.01	\$ 5.23	\$0.01	\$ 5.23	\$1.00	\$ 523.00
32		70300261	TEMPORARY PAVEMENT MARKING - LINE 12" - PAINT	FOOT	87	\$2.00	\$ 174.00	\$0.40	\$ 34.80	\$0.01	\$ 0.87	\$0.01	\$ 0.87	\$0.01	\$ 0.87	\$2.00	\$ 174.00
33		70300281	TEMPORARY PAVEMENT MARKING - LINE 24" - PAINT	FOOT	38	\$3.00	\$ 114.00	\$2.60	\$ 98.80	\$0.01	\$ 0.38	\$0.01	\$ 0.38	\$0.01	\$ 0.38	\$8.00	\$ 304.00
34		78009000	MODIFIED URETHANE PAVEMENT MARKING - LETTERS AND SYMBOLS	SQ FT	115	\$15.00	\$ 1,725.00	\$6.30	\$ 724.50	\$6.60	\$ 759.00	\$6.00	\$ 690.00	\$6.00	\$ 690.00	\$7.00	\$ 805.00
35		78009004	MODIFIED URETHANE PAVEMENT MARKING - LINE 4"	FOOT	20318	\$1.50	\$ 30,477.00	\$0.85	\$ 17,270.30	\$0.85	\$ 17,270.30	\$0.85	\$ 17,270.30	\$0.85	\$ 17,270.30	\$0.82	\$ 16,660.76
36		78009006	MODIFIED URETHANE PAVEMENT MARKING - LINE 6"	FOOT	867	\$3.00	\$ 2,601.00	\$1.55	\$ 1,343.85	\$1.65	\$ 1,430.55	\$1.50	\$ 1,300.50	\$1.50	\$ 1,300.50	\$1.50	\$ 1,300.50
37		78009012	MODIFIED URETHANE PAVEMENT MARKING - LINE 12"	FOOT	117	\$6.00	\$ 702.00	\$3.15	\$ 368.55	\$3.30	\$ 386.10	\$3.00	\$ 351.00	\$3.00	\$ 351.00	\$3.00	\$ 351.00
38		78009024	MODIFIED URETHANE PAVEMENT MARKING - LINE 24"	FOOT	368	\$15.00	\$ 5,520.00	\$6.30	\$ 2,318.40	\$6.60	\$ 2,428.80	\$6.00	\$ 2,208.00	\$6.00	\$ 2,208.00	\$7.00	\$ 2,576.00
39		78300201	PAVEMENT MARKING REMOVAL - GRINDING	SQ FT	15488	\$2.00	\$ 30,976.00	\$0.50	\$ 7,744.00	\$0.50	\$ 7,744.00	\$0.50	\$ 7,744.00	\$0.50	\$ 7,744.00	\$0.25	\$ 3,872.00
40	#	X3580300	AGGREGATE BASE REPAIR (SPECIAL)	TON	289	\$25.00	\$ 7,225.00	\$22.00	\$ 6,358.00	\$25.00	\$ 7,225.00	\$15.00	\$ 4,335.00	\$15.00	\$ 4,335.00	\$25.00	\$ 7,225.00
41	#	X3580302	PREPARATION OF BASE (SPECIAL)	SQ YD	6914	\$2.00	\$ 13,828.00	\$1.25	\$ 8,642.50	\$1.50	\$ 10,371.00	\$1.75	\$ 12,099.50	\$0.01	\$ 69.14	\$3.00	\$ 20,742.00
42	#	X6026050	SANITARY MANHOLES TO BE ADJUSTED	EACH	5	\$1,500.00	\$ 7,500.00	\$900.00	\$ 4,500.00	\$1,400.00	\$ 7,000.00	\$1,300.00	\$ 6,500.00	\$700.00	\$ 3,500.00	\$3,100.00	\$ 15,500.00
43	#	X8860105	DETECTOR LOOP REPLACEMENT	FOOT	75	\$30.00	\$ 2,250.00	\$62.00	\$ 4,650.00	\$71.50	\$ 5,362.50	\$59.25	\$ 4,443.75	\$60.00	\$ 4,500.00	\$72.00	\$ 5,400.00
44	#	Z0013798	CONSTRUCTION LAYOUT	LSUM	1	\$20,000.00	\$ 20,000.00	\$12,000.00	\$ 12,000.00	\$5,000.00	\$ 5,000.00	\$10,000.00	\$ 10,000.00	\$12,000.00	\$ 12,000.00	\$25,000.00	\$ 25,000.00
45	#	Z0018400	DRAINAGE & UTILITY STRUCTURES TO BE ADJUSTED	EACH	32	\$675.00	\$ 21,600.00	\$370.00	\$ 11,840.00	\$500.00	\$ 16,000.00	\$500.00	\$ 16,000.00	\$350.00	\$ 11,200.00	\$1,050.00	\$ 33,600.00
46	#	Z0017700	DRAINAGE & UTILITY STRUCTURES TO BE RECONSTRUCTED	EACH	4	\$1,500.00	\$ 6,000.00	\$900.00	\$ 3,600.00	\$1,500.00	\$ 6,000.00	\$750.00	\$ 3,000.00	\$1,450.00	\$ 5,800.00	\$2,450.00	\$ 9,800.00
47	#	LR400520	HOT IN-PLACE RECYCLING - SURFACE RECYCLING	SQ YD	47538	\$6.50	\$ 308,997.00	\$5.20	\$ 247,197.60	\$6.45	\$ 306,620.10	\$4.98	\$ 236,739.24	\$6.10	\$ 289,981.80	\$6.30	\$ 299,489.40
48	#	NA	COMBINATION CONCRETE CURB AND GUTTER REMOVAL AND REPLACEMENT	FOOT	479	\$55.00	\$ 26,345.00	\$52.00	\$ 24,908.00	\$48.70	\$ 23,327.30	\$58.00	\$ 27,782.00	\$60.00	\$ 28,740.00	\$51.00	\$ 24,429.00
49	#	NA	HOT-MIX ASPHALT DRIVEWAY PAVEMENT, 4" (SPECIAL)	SQ YD	541	\$55.00	\$ 29,755.00	\$67.00	\$ 36,247.00	\$48.00	\$ 25,968.00	\$48.00	\$ 25,968.00	\$84.00	\$ 45,444.00	\$55.00	\$ 29,755.00
50	#	NA	HOT-MIX ASPHALT SURFACE REMOVAL, FULL DEPTH	SQ YD	6914	\$9.00	\$ 62,226.00	\$2.60	\$ 17,976.40	\$4.85	\$ 33,532.90	\$3.75	\$ 25,927.50	\$4.30	\$ 29,730.20	\$7.00	\$ 48,398.00
51	#	NA	HOT-MIX ASPHALT SURFACE REMOVAL, VARIABLE DEPTH - EDGE GRIND 1.25" MAX. DEPTH	SQ YD	14823	\$3.00	\$ 44,469.00	\$1.60	\$ 23,716.80	\$1.20	\$ 17,787.60	\$2.00	\$ 29,646.00	\$2.15	\$ 31,869.45	\$2.50	\$ 37,057.50
52	#	NA	HOT-MIX ASPHALT SURFACE REMOVAL, VARIABLE DEPTH - EDGE GRIND 1.75" MAX. DEPTH	SQ YD	1540	\$4.00	\$ 6,160.00	\$5.65	\$ 8,701.00	\$2.35	\$ 3,619.00	\$4.00	\$ 6,160.00	\$4.60	\$ 7,084.00	\$6.20	\$ 9,548.00
53	#	NA	PARKWAY RESTORATION - SEEDING	SQ YD	4524	\$16.00	\$ 72,384.00	\$14.00	\$ 63,336.00	\$12.00	\$ 54,288.00	\$1					



## Agenda Memo

Crest Hill, IL

<b>Meeting Date:</b>	July 6, 2026
<b>Submitter:</b>	Ronald J Wiedeman
<b>Department:</b>	Engineering
<b>Agenda Item:</b>	A Resolution for a professional services agreement for a (Rate Update) by and Between the City of Crest Hill, Will County, Illinois and Burns & McDonnell in the amount of \$27,700.00.

**Summary:** Attached is a proposal from Burns & McDonnell to update the city's financial plan for water and sewer utilities. When the 2023 water and sewer update was completed for FY2024 staff had informed council that from time to time the current financial plan would need to be updated to adjust and include more up to date costs of the city water and sewer capital program along with more refined construction costs provided by Grand Prairie Water Commission for the city's share of the construction of a new water supply line. This update will review the city's utility revenues, operating expenses, debt payments, balances and capital expenditures for FY2024 through FY2027 period.

This update will provide the city a better idea at the start of the FY2028 fund year where the city stands based on its current utility rate structure and how this rate structure will cover expected expenses in the future for the construction of the new water supply line from Lake Michigan and future operating expenses, debt payments and capital expenditures.

The final product will be a technical memorandum summarizing the finding and these findings which will be presented to the Council at a future workshop meeting.

The schedule is to have this work completed and presented to the Council in November of this year.

**Recommended Council Action:** A Resolution for a professional services agreement for a 2027 financial plan update for water and sewer utility (Rate Update) by and Between the City of Crest Hill, Will County, Illinois and Burns & McDonnell in the amount of \$27,700.00.

**Financial Impact:**

**Funding Source:** Water Fund

**Budgeted Amount:** \$712,000.00

**Cost Approved to Date:** 27,700.00

Total Amount approved out of 07-06-5330 to date is \$177,700.00.

**Attachments:**

Resolution-Rate Update 2027

Exhibit A-Crest Hill-2027 Water and Sewer Financial Plan Update Proposal(6.15-26)

**RESOLUTION NO. \_\_\_\_\_**

**A RESOLUTION FOR A PROFESSIONAL SERVICES AGREEMENT FOR A 2027 FINANCIAL PLAN FOR WATER AND SEWER UTILITY (RATE UPDATE) BY AND BETWEEN THE CITY OF CREST HILL, WILL COUNTY, ILLINOIS AND BURNS AND MCDONALD IN THE AMOUNT OF \$27,700.00**

---

WHEREAS, the Corporate Authorities of the City of Crest Hill, Will County, Illinois, have the authority to adopt resolutions and to promulgate rules and regulations that pertain to the City’s government and affairs and protect the public health and, safety, and welfare of its citizens; and

WHEREAS, pursuant to Section 2-2-12 of the Illinois Municipal Code (65 ILCS 5/2-2-12), the City Council possesses the authority to enter into contracts that serve the legitimate corporate purposes of the City; and

WHEREAS, Burns and McDonnell. (the “COMPANY”), is an entity that is in the business of providing professional services, 2027 financial plan update for water and sewer utility (the “Services”); and

WHEREAS, the City Council desires to engage the Company to provide the Services and the Company is ready, willing to perform the Services for the City; and

WHEREAS, City Staff have negotiated an Agreement for 2027 financial plan update for water and sewer utility (the “Agreement”) with the Company for the purposes of engaging the Company to perform the Services ( a copy of the Agreement is attached hereto as Exhibit A and fully incorporated herein); and

WHEREAS, the Staff and City Council has reviewed the Agreement and determined that the conditions, terms, and provisions of the Agreement are fair, reasonable, and acceptable to the City; and

WHEREAS, the City Council has determined that it is in the best interest of the City and its citizens to enter into the Agreement with the Company.

NOW, THEREFORE, BE IT RESOLVED by the City Council of the City of Crest Hill, Illinois, pursuant to its statutory authority, as follows:

SECTION 1: PREAMBLE. The City Council hereby finds that all of the recitals contained in the preamble to this Resolution are true, correct and complete and are hereby incorporated by reference hereto and made part hereof.

SECTION 2: AGREEMENT APPROVED. The City Council hereby finds and declares that the conditions, terms, and provisions of this Agreement (Exhibit A) in the amount of 27,700.00 are fair, reasonable, and acceptable to the City and that the same is hereby approved in form and substance.

Therefore, the City Council hereby authorizes and directs the Mayor to execute and deliver, and the Clerk to attest, the Agreement, and further to take any and all other actions, including without limitation the execution and delivery of any and all documents, necessary and appropriate to effectuate the intent of this Resolution, which is to enter into the Agreement with the Company.

SECTION 3: SEVERABILITY. If any section, paragraph, clause or provisions of this Resolution is held invalid, the invalidity of such section, paragraph, clause or provision shall not affect any other provision of this Resolution.

SECTION 4: REPEALER. All ordinances, resolutions or orders, or parts thereof, which conflict with the provisions of this Resolution, are to the extent of such conflict hereby repealed.

SECTION 5: EFFECTIVE DATE. This Resolution shall be in full force and effect immediately upon its passage and publication according to law.

*[Intentionally Blank]*

PASSED THIS 6TH DAY JULY, 2026.

	Aye	Nay	Absent	Abstain
Alderman Scott Dyke	_____	_____	_____	_____
Alderman Angelo Deserio	_____	_____	_____	_____
Alderwoman Claudia Gazal	_____	_____	_____	_____
Alderman Darrell Jefferson	_____	_____	_____	_____
Alderperson Tina Oberlin	_____	_____	_____	_____
Alderman Mark Cipiti	_____	_____	_____	_____
Alderman Nate Albert	_____	_____	_____	_____
Alderman Joe Kubal	_____	_____	_____	_____
Mayor Raymond R. Soliman	_____	_____	_____	_____

APPROVED THIS 6TH DAY OF JULY, 2026.

\_\_\_\_\_  
Raymond R. Soliman, Mayor

ATTEST:

\_\_\_\_\_  
Christine Vershay-Hall, City Clerk

# EXHIBIT A

June 15, 2026

Mr. Ron Wiederman, P.E.  
Director of Engineering  
City of Crest Hill  
20600 City Center Blvd  
Crest Hill, IL 60403

Re: 2026 Water & Sewer Utility Financial Plan Update

Dear Ron,

This letter proposal follows up on our prior message exchange regarding the update of the City of Crest Hill's financial plan for your water and sewer utility. We plan to follow a similar approach as our prior engagements for updating the financial models and proposed rate increases. The major elements of scope are anticipated to include:

- ▶ Review the utility's revenues, operating expenses, debt payments, balances, and capital expenditures that City records indicate were actually incurred in 2024 through 2026 and are estimated to be incurred in 2027. During this review we will compare these results to projections in our studies completed last year. The purpose of this review is to understand variances that may influence future projections.
- ▶ Update the financial plan for each utility to reflect
  - FY2027 budget
  - Beginning balances available at the start of current fiscal year (FY2027)
  - Updated assumptions regarding growth, usage, inflation, and interest rates
  - Updated water supply costs from the Grand Prairie Water Commission (expected to be available in July, 2026)
  - Conduct review meetings with you and other City staff
  - Provide a technical memorandum summarizing findings

We are pleased to continue supporting you and the City of Crest Hill. I am open to adjustments you may wish to consider that tailor our approach to meet the City's needs. Please reach out to me either by phone or email at 816-782-6055 / [acraven@burnsmcd.com](mailto:acraven@burnsmcd.com).

Sincerely,

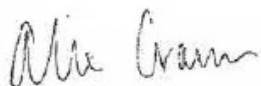

Alex Craven / Project Manager

## Scope of Services

### *Task 1 – Initiate Project*

The objective of Task 1 is to initiate the Study.

To begin the Study, we will need to obtain the following key data sets:

- A. Detailed actual revenues and expenses for FY2024-FY2026.
- B. Beginning cash balances for FY 2027
- C. Billing summaries by class including accounts, volumes and revenues for 2024 through 2026.
- D. The 2027 utility budget.
- E. Existing annual debt service expenses
- F. The most recent capital improvement plan, with estimates over a 10-year planning period.

We will host a Teams meeting to initiate this Study, including a review of key issues or concerns the City may have that impacts financial planning, and a review of scope and milestones.

### *Task 2 – Update Financial Planning*

The objective of Task 2 is to update the water and sewer utility financial plan for the next ten years, and perform a variance analysis to understand the degree to which actual financial results have varied from plans created in the prior analysis.

#### *Task 2.1 – Evaluate Current Usage Levels and Prepare Revenue Forecast*

Projected annual utility service revenues under existing rates will be developed. Burns & McDonnell will review historical growth in the number of customers by class since 2023 and then forecast the annual number of customers for each rate class for each year of the forecast period.

Burns & McDonnell will assess trends in water usage and wastewater volume per account for each customer class. Based on the usage analysis and other available information, Burns & McDonnell will estimate the future usage per customer for each rate class for the utility. The estimates of the annual number of customers and the annual usage per customer will provide the basis for forecasting annual water sales and wastewater volume usage over the Study period.

Burns & McDonnell will also develop projections of revenues from other existing sources, consistent with prior analysis.

#### *Task 2.2 – Project Capital Flow of Funds*

Burns & McDonnell will review the capital improvement plan (CIP) and develop a capital planning flow of funds. This plan will acknowledge anticipated sources and uses of capital funds to implement the CIP. Funding sources will include existing balances, issuance of proposed revenue or general obligation bonds, IEPA loans, connection fees, and other sources as applicable. Uses of funds will include the CIP, cost of potential debt issuance, and other costs as identified through consultation with the City.

#### *Task 2.3 – Project Operating Revenue Requirements*

Historical O&M will be updated since 2023 and projected O&M will be based on the FY2027 budget, with inflation to project future periods. The Grand Prairie Water Commission's cost calculator, expected to be available in July or August, will be used to refresh water supply costs.

Annual debt service requirements on any outstanding debt will be included in the operating forecast. To the extent additional financing of expected capital improvements is indicated to be required, estimates of new debt service requirements will also be incorporated in the forecast. In addition, the impacts of any financial performance requirements or targets, i.e. debt service coverage requirement, reserve levels, target operating ratio, etc., whether imposed internally or externally, will be considered.

Projections of any other utility system cash expenditures not included in any of the above categories will also be captured in the financial forecast. Such expenditures may include transfers or routine capital expenditures.

#### *Task 2.4 – Review Historical Results & Variance Analysis*

The City of Crest Hill's most recent financial forecast was developed in 2023. Understandably there have been changes to the City's utility revenues and costs since the prior analysis was conducted. We will compare the projections of the most recent forecast to the actual revenues and costs since the prior analysis was completed to identify areas of material difference and how those potential variances may impact new forecasting.

#### *Task 2.5 – Review and Finalize Operating Cash Flow*

Burns & McDonnell will summarize the annual forecasts of the water and sewer utility revenues, as well as the projected operating requirements in the form of pro-forma cash flow analyses. These analyses will identify potential annual operating surpluses or deficits anticipated during the study period. The total projected annual surplus or deficit will provide an indication of whether the existing rates will generate sufficient revenues to cover the utility's costs for each year of the forecast period, and whether an overall revenue adjustment is necessary. Compliance with loans and revenue bond covenants under existing rates will also be evaluated as applicable.

We will use the same financial planning principles followed in the rate study and prior financial plan updates (reserves, debt service coverage, etc.) to evaluate the sufficiency of revenues over the forecast period. To the extent that revenues under existing rates are not sufficient to cover current and future operating and capital costs, revenue increases will be proposed to meet the funding requirements.

Burns & McDonnell will review the preliminary forecast results with the City. During this meeting, Burns & McDonnell will review assumptions and results for each component of the cash flow forecast. During the meeting, adjustments may be made "real time" to optimize the financial plans and meet the City's needs.

#### Task 2 Deliverables and Meetings:

- ▶ Deliverables:
  - Water and Sewer Pro-forma cashflows
  - Historical Revenue and Expense Variance Analysis
- ▶ Formal Meeting: Teams Meeting to Review Cash Flows and Variance Analysis

### Task 3 – Proposed Rate Development

The objective of Task 3 is to develop proposed water and sewer rates under the existing rate structure to meet future operating and capital needs as identified in Task 2. Utilizing the existing rate structure we will develop proposed rates from 2028 to 2032 using the system wide revenue increases developed in Task 2.5.

Burns & McDonnell will prepare a comparison of typical bills under both the existing and the proposed rates for representative water and sewer customer user profiles. A comparison will also be completed to show the average water and sewer bills of regional peers. The bill profile as well as the set of regional peer communities will be the same as used in prior studies.

#### Task 3 Deliverables and Meetings:

- ▶ Deliverables:
  - Proposed Water and Sewer Rates
  - Regional Data/Typical Bill Comparison

### Task 4 - Deliverables

Burns & McDonnell will summarize the Study results in a draft memorandum, reviewing the key findings and documenting how the analysis and recommendations were developed. Feedback from the City will be incorporated into the memo as appropriate.

## Project Timeline

A timeline of proposed major milestones is shown below and assumes a start date of July 1<sup>st</sup>.

Activity	Target Date
Initiate Study with Council Approval	August
Data Received	Week of August 24 <sup>th</sup>
First Draft Financial Plan	Week of September 14 <sup>th</sup>
Finalize Financial Plan	Week of September 28 <sup>th</sup>
Develop Regional & Typical Bill Comparison	Week of October 5 <sup>th</sup>
Draft & Finalize Rates	Week of October 12 <sup>th</sup>
Draft Memorandum	Week of October 19 <sup>th</sup>
Finalize Memo	Week of November 2 <sup>nd</sup>

\* Timely receipt of data is required to maintain this schedule.

## Estimated Level of Effort and Cost

We propose to complete the scope described in this letter for a lump sum fee that shall not exceed \$27,700 which will be billed monthly on a percent complete basis. All meetings are assumed to be conducted virtually.

## General Assumptions

1. Project timeline is dependent on availability of client data.
2. City will review and approve key project deliverables in a timely manner.
3. City will attend requested meetings.
4. Key data sets, such as customer billing registers operating cost chart of accounts have not changed since our prior engagement.
5. Comments and feedback from City management regarding study deliverables will not require substantial rework of the analysis or deliverables.

## Terms & Conditions

All services will be performed under the terms and conditions of the attached “Terms and Conditions for Professional Services”, which is incorporated and made a part of this agreement.



## Burns & McDonnell Services Agreement Terms and Conditions

**Project:** 2026 Water & Sewer Utility Financial Plan Update

**Date of Services Proposal:** June 15, 2026

**Client:**  
City of Crest Hill ("Client")

**THIS CONTRACT CONTAINS A LIMITATION OF REMEDIES AND BINDING ARBITRATION PROVISION WHICH MAY BE ENFORCED BY THE PARTIES.**

**Client Signature:**

Name (printed): \_\_\_\_\_

This Agreement is made as of June 15, 2026, by and between Client and Burns & McDonnell Engineering Company, Inc. (hereinafter called "BMcD").

### SECTION 1 — AUTHORIZATION OF SERVICES

Services shall be undertaken only upon signing of the attached Services Proposal by Client. Such Services are more specifically identified in the Services Proposal.

### SECTION 2 — SERVICES OFFERED BY BMcD

The Services are specifically identified in the attached letter, proposal, agreement, or statement of work as identified above ("Services Proposal"). BMcD will rely on information provided by Client in the undertaking of the Services.

### SECTION 3 — PERIOD OF SERVICE

The provisions of this Agreement have been agreed to in anticipation of the orderly and continuous progress of the Project through completion of the services stated in the Proposal. BMcD's obligation to render services hereunder will extend for a period that may reasonably be required for the completion of Services. BMcD shall make reasonable efforts to comply with deliverable schedules (if any) and consistent with BMcD's professional responsibility.

### SECTION 4 — COMPENSATION

4.1 Client shall pay BMcD for Services rendered and reimbursable expenses as stated in the Services Proposal. Invoices are payable upon receipt. A late payment charge of 1.5 percent per month or any partial month will be added to amounts not received within thirty (30) days of the statement date. Time is of the essence in payments of statements, and timely payment is a material part of the consideration of this Agreement. Costs, including reasonable attorney's fees, incurred by BMcD in collecting any delinquent amount shall be reimbursed by the Client. If a portion of BMcD's statement is disputed by Client, the undisputed portion shall be paid by Client by the due date. The Client shall advise BMcD in writing of the basis for any disputed portion of any statement.

4.2 Taxes, other than United States federal and state income taxes, and Kansas City, Missouri earnings tax, as may be imposed by the United States, state, and local authorities, shall be in addition to the payment stated under "Amount of Payment."

4.3 BMcD may engage or obtain assistance from its affiliates and subsidiaries including, without limitation, Burns & McDonnell Canada Ltd., Burns & McDonnell Global, Inc., Burns & McDonnell Western Enterprises, Inc., and Burns & McDonnell India Pvt. Ltd. ("Labor Sources") to fulfill performance obligations of BMcD under this Agreement. The Parties agree that contracts, purchase orders, or similar agreements between BMcD and any Labor Sources are not subcontracts and persons from such Labor Sources shall be billed to Client according to the rate sheet / billing rate defined for the applicable contract, purchase order, or similar agreement. Personnel from Labor Sources shall be considered agents of BMcD and able to act on behalf of BMcD within the scope of the authority granted such personnel according to job function and billing classification.

### SECTION 5 — LIMITATION OF REMEDIES

5.1 **INDEMNIFICATION.** Client and BMcD each agree to indemnify and hold harmless the other, and the other's officers, directors, and employees, from and against third party damages, including reasonable attorney's fees, to the extent such damages and expenses are caused by the indemnitor's own negligent acts, errors, or omissions. In the event damages or expenses are caused by the joint or concurrent

negligence of Client and BMcD, they shall be borne by each Party in proportion to its own negligence.

5.2 **WAIVER OF CONSEQUENTIAL DAMAGES.** BMcD is not liable for any special, indirect, incidental, punitive, or consequential damages to Client. The excluded damages include, but are not limited to, by way of example, (a) Client's loss of: anticipated profits, savings, revenue, use of equipment, sublicensed software, licensed software, services, or data; (b) cost of capital; (c) cover costs, or cost of any substitute performance or replacement of equipment, facilities or services; (d) third party consequential damages; and (e) indirect damages as a result of property loss.

5.3 **LIMITATION OF LIABILITY.** Notwithstanding any other provision herein, BMcD's maximum liability to Client for all claims arising out of or related to these Services and this Agreement shall be limited to the specific remedies provided herein, but shall not exceed the greater of \$100,000 USD or the amount paid by Client to BMcD under the Agreement. The limitations of liability provided herein in this Section 5.3 shall apply should it be judicially determined that the specific remedies provided elsewhere in this Agreement fail in their essential purpose.

5.4 To the greatest extent allowed by law, the damages waived or excluded, or otherwise limited in this Section 5 Limitation of Remedies, shall be allowed, and shall apply to any and all claims or causes of action as to between the parties, including but not limited to breach of contract, breach of warranty, any tort claim including negligence, strict liability, or any other legal or statutory theory of recovery.

### SECTION 6 — INSURANCE; STANDARD OF CARE; WARRANTY

6.1 During the course of performance of its services, BMcD will maintain Worker's Compensation insurance with limits as required by statute, Employer's Liability insurance with limits of \$1,000,000, Commercial General Liability with limits of \$1,000,000 per occurrence and \$2,000,000 general aggregate, and Automobile Liability insurance with combined single limit of \$1,000,000 per accident.

6.2 Client and BMcD and their respective officers, directors, agents, or employees waive all rights of recovery against each other, and their insurers' right to subrogation, for property damage and property loss covered by their respective property insurance (including deductibles and self-insurance) during and after the completion of BMcD's Services.

6.3 BMcD will perform the Services associated with the Services Proposal consistent with the standards and practices of others providing similar services under similar circumstances at time of performance ("Standard of Care"). Client shall promptly notify BMcD in writing of any failure of BMcD to comply with this standard or any perceived deficiency in its Services. During performance of the Services Proposal, and for one year after completion of Services, should BMcD receive such notice, BMcD at its sole option, may (a) reperform the Services to bring the same into conformance with the requirements of the Services Proposal and the applicable Standard of Care, or (b) BMcD may liquidate damages to Client by paying to Client, as refund or otherwise, that portion of the compensation for that portion of the Services which are found to be deficient, or otherwise were not able to be corrected or bought into conformance with Services Proposal requirements by reperformance or replacement after commercially reasonable attempts by BMcD to do so.

6.4 The mutually negotiated obligations and representations contained in Section 6.3 are BMcD's sole obligation and Client's exclusive remedy with respect to defects in the quality of Services or failure to meet the Standard of Care, regardless of the cause of action pled including, without limitation, all types of negligence. Client's improper operation,

maintenance, or unauthorized use of the Services shall relieve BMcD of any liability or damages arising out of such improper or unauthorized use.

6.5 No warranty, express or implied, is included in this Agreement, including any warranty for fitness for a particular purpose, merchantability, or noninfringement of intellectual property rights or any implied warranty arising from statute, course of dealing, course of performance, or usage of trade.

6.6 Cost estimates, projections, and forecasts prepared by BMcD relating to construction costs and schedules, operation and maintenance costs, equipment characteristics and performance, and operating results are opinions based on BMcD's experience, qualifications, and judgment. Since BMcD has no control over weather, cost and availability of labor, material and equipment, labor productivity, construction contractors' procedures and methods, unavoidable delays, construction contractors' methods of determining prices, economic conditions, competitive bidding or market conditions, and other factors affecting such opinions. BMcD does not guarantee that actual rates, costs, performance, schedules, and related items will not vary greatly from the opinions prepared by BMcD.

#### SECTION 7 — CHANGES; TERM; DELAYS

7.1 Client may request changes within the general scope of BMcD's Services, with an appropriate change to the Services Proposal in compensation and schedule, upon execution of a mutually acceptable amendment or change order signed by an authorized representative of the Client and BMcD

7.2 Should Client fail to fulfill its responsibilities as provided in the Services Proposal to the extent that BMcD is unduly hindered in BMcD's services or if Client fails to make any payment to BMcD on account of BMcD's services and expenses within ninety (90) days after receipt of BMcD's invoice therefor, BMcD may, after giving seven (7) days' written notice to Client, suspend services under this Agreement, with impunity and without liability, until Client has satisfied Client's obligations under this Agreement, and an equitable adjustment to schedule has been mutually agreed by a change order.

7.3 Either Party may terminate this Agreement for the other's material breach by written notice specifying in detail the nature of the breach, effective in thirty (30) days unless the other party first cures such breach. However, termination for breach will become effective immediately upon such notice, without opportunity to cure, if the breach cannot be remedied by performance after notice of termination. Failure on the part of the Client to make payments to BMcD when due shall be considered substantial nonperformance and cause for termination.

7.4 In the event of premature termination of the Agreement by the Client and through no fault of BMcD, BMcD shall be entitled to: (1) recover all reasonable costs and expenses incurred to date of termination, plus all costs incurred to assemble and close Project files and documents; (2) unavoidable down time in the reassignment of Project staff; (3) termination penalties/expenses related to third parties retained by BMcD in regard to its obligations under this contract; and (4) a termination amount of 15 percent of the remaining portion of the total compensation (or estimated compensation) agreed to herein or by separate authorization to cover lost profits, damages, and lost opportunity costs which cannot otherwise be accurately calculated.

7.5 In the event the services of BMcD are suspended or delayed by the Client, BMcD shall be entitled to additional compensation for reasonable costs incurred by BMcD and its subconsultants (if any) in temporarily suspending or delaying performance of the Services (including, but not limited to, unavoidable staff that is idled or placed on standby, reassignment of staff, or any termination expenses incurred where staff reassignment is not reasonably possible).

#### SECTION 8 — DISPUTE RESOLUTION

8.1 If a dispute arises relating to the performance of the services to be provided and, should that dispute result in arbitration or enforced through litigation, it is agreed that the substantially prevailing party (as determined in equity by the court) shall be entitled to recover all reasonable costs of litigation, including staff time, court costs, attorney's fees and other related expenses.

8.2 The parties shall participate in good faith negotiations to resolve any and all disputes. Should negotiations fail, the parties agree to submit to and participate in a third party-facilitated mediation as a condition precedent to resolution by litigation. Unless otherwise agreed to, mediation shall be conducted under the rules of the American Arbitration Association and shall be held in Kansas City, Missouri.

8.3 If the parties are unable to resolve their dispute after at least one session of mediation, then any claim, dispute or other matter in question arising out of or related to this Agreement (including disputes involving an

officer, director or employee of either party), whether in contract shall be subject to arbitration in accordance with the Arbitration Rules of the American Arbitration Association then in effect. The demand for arbitration shall be filed in writing with the other party to this Agreement and with the American Arbitration Association. Any legal action necessary to compel, confirm, vacate, enforce, modify or otherwise affect the mediation or arbitration shall be filed in state or federal courts in the State of Missouri and each party expressly consents to jurisdiction therein.

8.4 Causes of action between the parties shall accrue, and applicable statutes of limitation shall commence to run the date BMcD's services are substantially complete.

#### SECTION 9 — GENERAL

9.1 *Use of BMcD Intellectual Property.* All deliverables prepared or furnished by BMcD (and BMcD's independent professional associates and consultants) pursuant to this Agreement are instruments of service which contains BMcD intellectual property and BMcD shall have the ownership and property interest therein whether or not the Project is completed. Client may make and retain copies for information and reference in connection with the use and occupancy of the Project by Client and others; however, such documents or intellectual property are not intended or represented to be suitable for reuse by Client or others on extensions of the Project or on any other project. Client shall not disclose or disseminate any BMcD intellectual property without prior written authorization by BMcD. Any reuse, modification, or completion by others without written verification or adaptation by BMcD for the specific purpose intended will be at Client's sole risk and without liability or legal exposure to BMcD, or to BMcD's independent professional associates or consultants, and Client shall indemnify and hold harmless BMcD and BMcD's independent professional associates and consultants from and against all claims, damages, losses, and expenses, including attorneys' fees arising out of or resulting therefrom. Any such verification or adaptation will entitle BMcD to further compensation at rates to be agreed upon by Client and BMcD.

9.2 *Rights and Benefits.* BMcD's services will be performed solely for the benefit of the Client and not for the benefit of any other entities.

9.3 *Successor and Assigns.* Client and BMcD each binds itself and its successors, executors, administrators, and assigns to the other party of this Agreement and to the successors, executors, administrators, and assigns of such other party, in respect to all covenants of this Agreement; except as above, neither Client nor BMcD shall assign, sublet, or transfer its interest in the Agreement without the written consent of the other.

9.4 *Controlling Law.* This Agreement shall be subject to, interpreted, and enforced according to the laws of the State of Missouri without regard to any conflicts of law provisions.

9.5 *Entire Agreement.* This Agreement represents the entire Agreement between BMcD and Client relative to the Scope of Services herein. All previous or contemporaneous agreements, representations, promises, and conditions relating to BMcD's services described herein are superseded. Since terms contained in purchase orders do not generally apply to professional services, in the event Client issues to BMcD a purchase order, no preprinted terms thereon shall become a part of this Agreement. Said purchase order document, whether or not signed by BMcD, shall be considered as a document for the Client's internal management of its operations.



Agenda Memo

Crest Hill, IL

<b>Meeting Date:</b>	July 6, 2026
<b>Submitter:</b>	Ronald J Wiedeman
<b>Department:</b>	Engineering
<b>Agenda Item:</b>	A Resolution for a Professional Services Agreement for Crest Hill Municipal Park/Plaza By and Between the City of Crest Hill, Will County, Illinois and Spaceco in the Amount of \$77,800.00

**Summary:** Council previously approved in August of 2023, the following work to be completed based on the Park Layout prepared by Hitchcock Design Group dated December 3, 2021(50% Design Plans).

Items highlighted below Staff are moving forward to bid out in 2026 with construction in the fall of 2026 and early spring 2027.

1. Work Approved.
  - a. Finalize grading and seeding plans for area shown in exhibit 1.
    - i. Turf, in the current plan, is to be restored by using seed and blanket.
  - b. Finalize design of water and sanitary service stubs to future bathroom facility.
  - c. Finalize the park drainage system within the area shown in exhibit 1.
  - d. Finalize design to install an underground irrigation system for the grass field and landscaping areas for the entire park. (Separate Contract)
  - e. Finalize design to install a portion of a sidewalk system along the south end of the plaza to provide access to the playground. See exhibit 1.
  - f. Finalize design to install concrete curb and drainage beneath playground area. See exhibit 1
  - g. Determine pedestrian and security lighting layout design. See exhibit 1.
  - h. Install playground equipment.

All work above has been completed and is ready to be bid except for the following items:

- Need to determine final park playground equipment and layout with council.

Engineer Estimates of Construction have been completed based on the work discussed above and as summarized below.

- Phase 1 Total-\$1,300,000.00
- Lockport Township Park District Funding towards Phase 1-\$250,000.00
- Therefore, City Share for Phase 1-\$1,050,000.00

Funding for the City Center Municipal Park/PLaza was included in the 2027 city budget at \$2,000,000.00.

Additional items, if approved, can be included with the Phase 1 work

Option 1-Municipal Park Parking Lot- Construct the parking lot as shown on exhibit 2. The only change staff would recommend to the parking lot configuration previously presented to Council is to revise the proposed location of the west driveway. The original configuration had this driveway connecting to City Center Blvd, staff suggestion is to connect directly to the existing Library access drive. If the driveway change is approved staff will work with the Library for approval and coordination to complete this work.

Option 2-Concrete Flatwork and Walking Paths-Construct the walking paths as shown on exhibit 2. These paths would be constructed in concrete or hot mix asphalt or a combination of both. The final determination of materials used for construction will be presented at a future workshop meeting.

Option 3- Parking lot and security lighting; bollard lighting; Electrical boxes-Install lighting for the parking lot, security and pedestrian bollard lighting. This work will also include the installation of receptacle boxes. The lighting being proposed will match the pendent lighting install along City Center Blvd and the pedestrian bollard lighting will match what is already installed around the City Hall Complex.

Option 4-Picnic Shelter- Staff suggest that a shade structure be included as part of the initial park work. The final determination of materials and size structure will be presented at a future workshop meeting for discussion and approval.

Completing the phase 1 along with some or all of the options above will put the park in a condition where it can be used for future city events, movies in the park, farmers’ markets, national night out, etc. Seeding the park will take minimum of 1 year to grow a turf in order to host events like those suggested.

Options For Council Considerations.

1. Proceed with Phase 1 project as currently prepared and ready for Bid.
2. Proceed with Phase 1 and include options 1-4 or any combination of as determined by council.
3. Do nothing.

Funding for the City Center Municipal Park/Plaza was included in the 2027 city budget at a funding limit of \$2,000,00.00.

Staff recommendation is to move forward with bidding the work already prepared for phase 1 and including options 1, and 3. For option 3, we would suggest designing the entire lighting system for the whole park, but installing new lighting from the playground to the south edge of pavement of the parking lot only.

The schedule to get the bids out for the Phase 1 working including options 1 and 3 would be the following if the Design Engineering is approved by July 8<sup>th</sup>.

- Phase 1 with Options 1 early August 2026
- Irrigation Mid to Late August 2026
- Lighting Phase 1 area only September 2026
- 

Below are construction engineering estimates for the staff recommendation and including all options for Council’s Information.

Staff Recommendation

- Phase 1 Total-\$1,300,000.00
- Options 1& 3 Only -\$425,000.00
- Grand Total Phase 1 with Options 1-3-\$1,725,000.00

- Lockport Township Park District Funding towards Phase 1-\$250,000.00
- Therefore, City Share for Phase 1-\$1,475,000.00

Phase 1 plus all options

- Phase 1 Total-\$1,300,000.00
- Options 1-4-\$925,000.00
- Grand Total Phase 1 with Options 1-3-\$2,225,000.00
- Lockport Township Park District Funding towards Phase 1-\$250,000.00
- Therefore, City Share for Phase 1-\$1,975,000.00

**Recommended Council Action:**

A Resolution for a Professional Services Agreement for Crest Hill Municipal Park/Plaza By and Between the City of Crest Hill, Will County, Illinois and Spaceco in the Amount of \$77,800.00

**Financial Impact:**

**Funding Source:** Capital Fund

**Budgeted Amount:** \$150,000.00 Engineering

**Cost:** \$77,800.00

**Attachments:**

Resolution-Spaceco

Exhibit A-PRP.10656.05JCK062526

**RESOLUTION NO. \_\_\_\_\_**

**A RESOLUTION FOR A PROFESSIONAL SERVICES AGREEMENT FOR CREST HILL MUNICIPAL PARK BY AND BETWEEN THE CITY OF CREST HILL, WILL COUNTY, ILLINOIS AND SPACECO IN THE AMOUNT OF \$77,800.00**

---

WHEREAS, the Corporate Authorities of the City of Crest Hill, Will County, Illinois, have the authority to adopt resolutions and to promulgate rules and regulations that pertain to the City’s government and affairs and protect the public health and, safety, and welfare of its citizens; and

WHEREAS, pursuant to Section 2-2-12 of the Illinois Municipal Code (65 ILCS 5/2-2-12), the City Council possesses the authority to enter into contracts that serve the legitimate corporate purposes of the City; and

WHEREAS, Spaceco. (the “COMPANY”), is an entity that is in the business of providing Professional Engineering Services, for the Crest Hill Municipal Park (the “Services”); and

WHEREAS, the City Council desires to engage the Company to provide the Services and the Company is ready, willing to perform the Services for the City; and

WHEREAS, City Staff have negotiated an Agreement for a Crest Hill Municipal Park (the “Agreement”) with the Company for the purposes of engaging the Company to perform the Services ( a copy of the Agreement is attached hereto as Exhibit A and fully incorporated herein); and

WHEREAS, the Staff and City Council has reviewed the Agreement and determined that the conditions, terms, and provisions of the Agreement are fair, reasonable, and acceptable to the City; and

WHEREAS, the City Council has determined that it is in the best interest of the City and its citizens to enter into the Agreement with the Company.

NOW, THEREFORE, BE IT RESOLVED by the City Council of the City of Crest Hill, Illinois, pursuant to its statutory authority, as follows:

SECTION 1: PREAMBLE. The City Council hereby finds that all of the recitals contained in the preamble to this Resolution are true, correct and complete and are hereby incorporated by reference hereto and made part hereof.

SECTION 2: AGREEMENT APPROVED. The City Council hereby finds and declares that the conditions, terms, and provisions of this Agreement (Exhibit A) in the amount of 77,800.00.00 are fair, reasonable, and acceptable to the City and that the same is hereby approved in form and substance. Therefore, the City Council hereby authorizes and directs the Mayor to execute and deliver, and the Clerk to attest, the Agreement, and further to take any and all other actions, including

without limitation the execution and delivery of any and all documents, necessary and appropriate to effectuate the intent of this Resolution, which is to enter into the Agreement with the Company.

SECTION 3: SEVERABILITY. If any section, paragraph, clause or provisions of this Resolution is held invalid, the invalidity of such section, paragraph, clause or provision shall not affect any other provision of this Resolution.

SECTION 4: REPEALER. All ordinances, resolutions or orders, or parts thereof, which conflict with the provisions of this Resolution, are to the extent of such conflict hereby repealed.

SECTION 5: EFFECTIVE DATE. This Resolution shall be in full force and effect immediately upon its passage and publication according to law.

*[Intentionally Blank]*

PASSED THIS 6TH DAY JULY, 2026.

	Aye	Nay	Absent	Abstain
Alderman Scott Dyke	_____	_____	_____	_____
Alderman Angelo Deserio	_____	_____	_____	_____
Alderwoman Claudia Gazal	_____	_____	_____	_____
Alderman Darrell Jefferson	_____	_____	_____	_____
Alderperson Tina Oberlin	_____	_____	_____	_____
Alderman Mark Cipiti	_____	_____	_____	_____
Alderman Nate Albert	_____	_____	_____	_____
Alderman Joe Kubal	_____	_____	_____	_____
Mayor Raymond R. Soliman	_____	_____	_____	_____

APPROVED THIS 6TH DAY OF JULY, 2026.

\_\_\_\_\_  
Raymond R. Soliman, Mayor

ATTEST:

\_\_\_\_\_  
Christine Vershay-Hall, City Clerk

# EXHIBIT A

June 18, 2026  
**Revised: June 25, 2026**

**VIA EMAIL**

Ron Wiedeman, P.E.  
City Engineer  
City of Crest Hill  
20600 City Center Blvd  
Crest Hill, IL 60403  
815-656-0086  
[rwiedeman@cityofcresthill.com](mailto:rwiedeman@cityofcresthill.com)

**RE: PROFESSIONAL ENGINEERING SERVICES PROPOSAL  
PHASE 1 - IMPROVEMENTS  
CREST HILL MUNICIPAL PLAZA  
CREST HILL, ILLINOIS  
(SPACECO Project No. 10656.05)**

Dear Ron:

In response to your request, SPACECO, Inc. and Ciorba Group are pleased to provide you with this proposal for professional engineering services related to the proposed Phase-1 Municipal Plaza improvements on about 3.5 acres in Crest Hill, Illinois. The purpose of these services is to provide final engineering design, construction plans, and specifications for the **paving**, mass-grading, storm sewer, wet utility services, drainage, lighting/electrical, and soil erosion and sediment control aspects of the proposed Phase-1 development. The following describes our Understanding of the Assignment, Scope of Services, and Fee.

**UNDERSTANDING OF THE ASSIGNMENT**

- **The proposed plan includes construction of a parking lot, driveway, sidewalks, playground area including ribbon curb, curb islands, mass graded field (sodded or seeded), storm sewer, wet utility services, and soil erosion and sediment control measures for the portion of the proposed Municipal Plaza area shown in yellow on attached "Exhibit A". The proposed Phase-1 improvements will consider the future plaza improvements, and the future concession/restroom building.**
- **It is our understanding that a lighting design is required for the proposed Municipal Plaza that will be constructed between the White Oak Library and City Hall, as shown on the Geometric Plan included under "Exhibit A". The lighting for the entire plaza area**

will be designed, however only the area highlighted in yellow will be constructed under Phase I. The City will work with RVI Planning & Landscape Architecture to finalize the Plaza Area north of the parking lot.

- The lighting design will include revising the preliminary photometric calculations as prepared by Christopher B. Burke Engineering and dated February 5, 2024. The calculations will be used as a basis for the design, with calculations updated based on the final Parking Lot and Plaza geometry, and preferred site lighting units.
- The proposed lighting will be designed in accordance with National Electric Code, Illuminating Engineering Society (IES), and Local Ordinance.
- The City has provided the following as the preferred site lighting units:
  - Pedestrian Pathway Lighting: Should consist of the City's pendant style luminaire mounted on an 18-foot black powder coated light pole. The lighting unit should match the decorative lighting unit installed along City Center Boulevard.
  - Event Security Lighting: Should consist of a LED luminaire mounted on a 35-foot black powder coated aluminum light pole. This lighting would be used to illuminate the lawn area for night events only.
  - Parking Lot Lighting: Should consist of proposed pathway lighting units on the north side of the parking lot, and the City's pendant style luminaire mounted on a 30-foot black powder coated light pole on the south side of the parking lot.
  - Playground Lighting: Should consist of 42" lighted bollards, that match those installed at City Hall.
  - All luminaires should be furnished with a 7-pin twistlock receptacle, which will allow the luminaires to be integrated into future site lighting controls.
- The City has requested the following be included in the site electrical design:
  - Centralized lighting controller to power the site lighting and electrical. The lighting controller should be sized to accommodate future sound and WIFI equipment.
  - Festoon receptacles mounted to pathway light poles for holiday decorations.
  - Six pad mounted receptacle cabinets located around the



## **THE SITE**

- The site is currently vacant.
- Vehicular access to the site will be the city center property and the library property.

## **THE WORK**

**We will prepare the following for the on-site paving, lighting/electrical, grading, utility service, and drainage aspects of the proposed Phase-1 improvements for the development:**

- **Consultations**
- **Preliminary Photometric Calculations**
- **Final Civil and Lighting/Electrical Design Documents**
- Bid Quantity Forms

SPACECO is also available to perform construction observation, layout staking, and record drawings, for which the scope and fees can be agreed upon later.

## **ASSUMPTIONS**

In preparing this proposal, we have attempted to provide you with a complete package of the engineering services anticipated at this point in time. In doing so, we have made some assumptions, based on the available information, which will need to be verified during the engineering process. If any findings differ from these assumptions, additional design may be needed, which will be considered in a separate agreement for services after the limits of work are clarified.

- Construction administration services and construction layout staking services are not included in this agreement and will be included in a supplemental agreement.
- The site was never used for storage of hazardous materials.
- There will be no modifications to existing adjacent streets except for curb cuts.
- The utilities to be used have adequate capacity and are immediately adjacent to the parcel.
- The sewers will flow by gravity with no lift stations.
- Our sanitary sewer design will be for domestic waste only; process waste collection or treatment design is not expected and is not included in this scope.
- A drainage study and design for any drainage identified as located outside of the project area is not included.

- Regional stormwater detention has been provided offsite. Therefore, on-site stormwater detention will not be required for this project.
- Photometric calculations for the bollard lighting around the playground will not be required.
- Photometric calculations will be revised for the updated geometry to connect the parking lot to the Library Dive Aisle, and remove the access drive off of City Center Blvd.
- The City has provided preferred pedestrian path lighting unit.
- Work not included in this scope of work, but a separate proposal can be provided upon request:
  - Additional event power (excluding the 6 pad mounted receptacle cabinets).
  - Site irrigation
  - Concession building power, plumbing, and HVAC

### **PROVIDED BY OTHERS**

- Boundary & Topographic Survey (by Spaceco, Inc. under separate contract)
- Dry Utility Service Coordination (by City of Crest Hill)
- Permitting (Except As Noted)
- Environmental Assessments, Mitigation, or Clean-Up
- **Design of the Playground (by Lockport Township Park District)**
- **Site Hardscape Layout & Furniture (by RVi)**
- **Landscape & Irrigation System Design (by RVi/ City)**
- **Park Sound System (by RVi)**
- Traffic Analysis
- Geotechnical Reports
- CCDD Reporting
- Construction Observation
- Bid Package Preparation / Bid Coordination

## **SCOPE OF BASIC SERVICES**

### **SPACECO, INC.**

**TASK 1- FINAL ENGINEERING:** This task will consist of the preparation of the design documents for submittal to the municipality and permit applications to the regulatory agencies that govern the work.

**Preparation of Plan Drawings:** The plan drawings will include the final design drawings, technical specifications, and other documentation for the final design of on-site engineering improvements. The plans will be in English units of measurement. This work will include; paving, plan notes, typical sections, water service, sanitary sewer service, limited storm sewers, mass grading, erosion control, and details. Our design of underground utilities will be up to five feet from the outside of the building wall for service connections.

Construction specifications will be shown on the drawings for storm sewer, sanitary sewer, watermain, pavement and grading. We will reference the "Standard Specifications for Road and Bridge Construction" adopted April 1, 2024 by the Illinois Department of Transportation, and the latest edition of the "Standard Specifications for Water and Sewer Main Construction in Illinois". SPACECO, Inc.'s preparation of the specifications shall not be construed to relieve the Contractor in any way from his sole responsibility for the quality and workmanship of the work and for strict compliance with the permitted plans and specifications.

**Soil Erosion and Sediment Control Plan:** We will prepare a Soil Erosion and Sediment Control Plan for inclusion into the Final Engineering Plans. We will also file with the Illinois Environmental Protection Agency (IEPA) a National Pollutant Discharge Elimination Systems (NPDES) Notice of Intent (NOI) form for the grading activities. The plan will include the appropriate notes, details, and specifications that are the anticipated minimum initial controls and measures that will be required during the duration of construction activities until the site is stabilized and the Notice of Termination (NOT) form is filed. This plan is an integral component of the Storm Water Pollution Prevention Plan (SWPPP) that the IEPA requires as part of the NPDES NOI filing. We assume that the Client is familiar with the requirements of the IEPA NPDES and SWPPP programs and that you will be undertaking the required reporting, monitoring, and maintenance aspects of the programs. If requested, SPACECO, Inc. can provide the required reporting and monitoring work under a separate agreement of services.

SPACECO is not responsible for implementation of the Storm Water Pollution Prevention Plan (SWPPP), including maintenance and/or repair of soil erosion and sediment control measures, for compliance with the General NPDES Permit for Storm Water Discharges from Construction Site Activities.

**Permit Applications:** We will submit an initial application to the Illinois Environmental Protection Agency for a Notice of Intent (NOI) for mass-grading purposes. Permit

application fees are not included in our fee. This does not warrant that such approval will be obtained.

TASK 2 - PREPARATION OF A STORM WATER POLLUTION PREVENTION PLAN (SWPPP):

We will prepare a SWPPP for the project in accordance with Part IV of the General NPDES Permit No. ILR10. Please note that completion of this task will require input from the project engineer and signed certification statements from all contractors, subcontractors, and the operator as identified in the SWPPP. An up-to-date copy of the SWPPP must be maintained on the project site during construction activities. To meet Illinois Environmental Protection Agency (IEPA) requirements, the SWPPP will be maintained within a 3-ring binder and include the following information: Notice of Intent; IEPA Notice of Coverage; Owner Certification; Contractor Certifications; Sample Site Monitoring Form; Copy of the IEPA General Permit ILR10; Soil Erosion and Sediment Control Plan Drawings.

TASK 3 - BID QUANTITY FORMS: We will prepare bid quantity forms showing the item description and quantities from the final engineering plans for insertion into bid documents prepared by the City. This scope does not include providing consultation or assistance during the construction bidding process such as attendance at pre-bid or bid opening meetings or assistance in the preparation of the bid package.

TASK 4- CONSULTATION/MEETINGS/CONFERENCE CALL: SPACECO, Inc. will provide consultation including attendance at group meetings or conference calls with the Client, municipal staff, governmental agencies and utility companies to properly advise the Client of the engineering concerns. This task will be billed at an hourly rate on a Time and Materials basis.

## **CIORBA GROUP**

### Task 5 – Meetings, Data Collection & Coordination

Ciorba will meet with Owner and/or Design Team virtually to discuss project scope, preferred equipment, and lighting design requirements.

Included in this task are the following meetings and site visits for the project:

- Site Visit to Coordinate Electric Service with Com Ed
- Virtual Meeting with Owner and Design Team to Discuss Preliminary Design Submittal
- Virtual Meeting with Owner and Design Team to Discuss Prefinal Design Submittal
- Virtual Meeting to coordinate Lighting Controls and future Sound/Wi-Fi System.

### Task 6 – Preliminary Photometric Calculations Submittal

Based on information collected in Task 5, lighting calculations will be performed in accordance with Illuminating Engineering Society (IES) Recommendations for the following:

- RP-8-25 Recommended Practice: Lighting Roadway and Parking Facilities
- RP 43-22 Recommended Practice: Lighting Exterior Applications

Photometric calculations will be performed for the following areas:

- Parking Lot Area
- Pedestrian Pathway
- Event/Plaza Area

Photometric calculations will be performed using AGi32 lighting calculation software to provide updated calculations for:

- Revised parking lot geometry. The parking lot will now be connected to the Library Dive Aisle, versus the access drive off of City Center Blvd as shown in Spaceco's Phase I plans, dated 2/11/2024.
- Revised pedestrian path lighting. The City would like the path lighted by the City's pedestrian decorative lighting unit, as installed along City Center Boulevard.
- Revised Event/Plaza security lighting. Based on RVI Planning & Landscape Architecture final plaza layout.

A revised lighting design report will be prepared and will include the following information:

- Project design criteria
- Photometric design forms and calculations
- Revised luminaire catalog cut information
- Light pole layout plans

The photometric calculation submittal will be sent to SPACECO to be submitted to the City for their review and approval.

## Task 7 – Lighting Design Submittal

### Pre-Final Lighting Design Submittal

Upon approval of the photometric calculations, a lighting design will be performed in accordance with City Local and National Electric Codes.

The lighting design submittal will include lighting plans, detail drawings, engineer's opinion of construction cost (EOPCC), and specifications. Lighting plans will provide locations of light poles, sources of electrical power, lighting controller cabinet, and conduit/cable routing and sizes. Detail drawings will include light pole details, lighting controller cabinet details, lighting controller one-line diagram (for basic lighting controls), electric service, light pole handhole wiring diagrams, concrete foundations, handhole, and conduit installation. Lighting specifications and EOPCC will be based on IDOT standard pay coded items. Voltage drop calculations will be performed and provided upon request.

The design will also include:

- Sizing a ground mounted receptacle for a large Christmas Tree.
- Including festoon receptacle circuits on the pedestrian path lighting units.
- Ground mounted GFCI receptacles adjacent to trees around the site, as directed by the City.
- Coordination with the City and RVI about future audio mounted to light poles and WIFI available at the site.
- Lighting control system vendor coordination.

The lighting design submittal package will be provided to SPACECO to be submitted to the City for review and comment.

### Final Lighting Design Submittal

Upon receiving comments from the City, Ciorba will revise the lighting plans, EOPCC, and provide a written disposition of review comments. The revised lighting design package will be provided to SPACECO to be submitted to CDOT for review and comment.

## Task 8 – QC/QA

Ciorba will perform internal quality control/quality assurance in accordance with our QC/QA procedures.

## Task 9 – Project Management & Administration

Work associated with project oversight, project progress reports, and updating the schedule will be performed under this task.

## **SUPPLEMENTAL SERVICES**

Normal and customary engineering and surveying services do not include service in respect to the following categories of work which are usually referred to as Supplemental Services. If the Client shall so advise SPACECO, Inc., we shall perform or obtain from others such services. SPACECO, Inc. will be paid on an hourly basis or based on subsequent proposal/contract agreements, at the option of Client. Additional Supplemental Services for the project include, but are not limited to the following:

- Services due to major changes in the general scope of the project.
- Revising studies, reports, and design documents which the Client, the municipality, and/or other governmental agencies have previously approved.
- Providing Engineering Design and Construction Services for:
  - Unusual or unanticipated improvements.
  - Additional off-site improvements requested by the Client or governmental agencies.
  - Improvements necessary to the project development beyond those being included under Basic Services herein.
  - Lift stations.
  - Structural Engineering.
  - Retaining walls over three feet in height.
  - Wetland permitting.
  - NPDES/Erosion Control Report.
  - Traffic impact studies, capacity analyses, warrant studies, intersection design studies, construction documents for any traffic control devices (signals, etc.).
- Meetings with the Client, Contractor(s), the municipal staff, or others during the course of design or construction not included under Basic Services.
- Providing construction observation in support of the engineering plans. Visiting the site for preparing punchlists, reductions of Letter of Credit or for comparing the Contractor's invoices against the approved final design plans and the Engineer's quantity take-offs.
- Giving testimony as an expert witness for the Client in litigation or other court proceedings involving this project.
- Environmental assessments, geotechnical investigations.
- Preparation of any plats (ALTA Surveys, etc.) or documents not explicitly identified under Basic Services.
- Construction Observation Services
- Field construction staking.
- Record drawings.
- Photocopying and final printing. Reimbursable expenses including messenger, overnight delivery services, facsimile, photography, postage, mileage, tolls and mounting drawings.

**FEES****Spaceco, Inc.**

	<u>Amount</u>
Task 1–Final Engineering	\$16,500 Lump Sum
Task 2– Preparation of SWPPP	\$1,800 Lump Sum
Task 3- Bid Quantity Forms	\$4,000 Lump Sum
Task 4- Consultation/Meetings/Conference Calls	Hourly, Budget \$4,000*
Reimbursable Expenses	Cost +10%, Budget \$300*
<b>Total:</b>	<b>\$26,600*</b>

\*Assumes Task 4 and reimbursable expenses are billed at the budgeted amount.

**Ciorba Group**

	<u>Amount</u>
Task 5–Meetings, Data Collection & Coordination	\$5,500 Lump Sum
Task 6– Preliminary Photometric Calculation Submittal	\$7,300 Lump Sum
Task 7- Lighting Design Submittal	\$33,000 Lump Sum
Task 8- QA/QC	\$2,700 Lump Sum
Task 9- Project Management & Administration	\$2,700 Lump Sum
<b>Total:</b>	<b>\$51,200</b>

Our services will be invoiced monthly on a percent complete basis. Payments are due within thirty days after invoicing.

Work identified as payable on an hourly basis will be billed to you at the rates specified on the enclosed Schedule of Charges for Professional Services. We will establish our contract in accordance with the enclosed General Terms and Conditions, which are expressly incorporated into and are an integral part of this contract for professional services. If you wish to discuss the terms, conditions and provisions of this agreement, I would be pleased to do so at your earliest convenience. We reserve the right to increase our fees by 5% on each annual anniversary of this Agreement. All reproductions and delivery services will be billed to the Client on a cost plus 10% basis.

If this proposal meets with your approval, please sign and return to us for our files.

Sincerely,

SPACECO, Inc.



James Kapustiak, P.E., P.L.S.  
Senior Project Manager

c: R. Stawik - SPACECO, Inc.  
Ciorba (Tasks 5-9)  
File Copy

ACCEPTED FOR: \_\_\_\_\_

BY: \_\_\_\_\_

TITLE: \_\_\_\_\_

DATE: \_\_\_\_\_

JANUARY 01, 2026

# Standard Charges for Professional Services

## Hourly Rate

Principal	\$405.00
Vice President	\$330.00
Senior Project Manager	\$220.00
Senior Design Engineer	\$215.00
Senior Project Designer	\$190.00
Project Manager	\$205.00
Project Engineer	\$190.00
Design Engineer	\$160.00
Intern	\$80.00
Construction Department Manager	\$220.00
Construction Engineer II	\$160.00
Construction Engineer I	\$130.00
CAD Manager	\$180.00
CAD Technician II	\$175.00
CAD Technician I	\$155.00
Survey Department Manager	\$250.00
Survey Group Manager	\$210.00
Survey Manager	\$190.00
Project Surveyor	\$180.00
Land Surveyor Technician	\$155.00
One Man Survey Crew	\$170.00
Two Man Survey Crew	\$280.00
Three Man Survey Crew	\$390.00
Hydrographic Boat with Equipment	\$550.00/Day
Administrative Assistant	\$105.00

## Reimbursable Expenses

Fax	\$0.50/page
Outside copy service, messenger, overnight delivery, photos	Cost + 10%
Mileage	\$0.67/mile
Electronic Transfer	\$40.00
Drone	\$200/day
GPS Unit	\$150.00/day

Spaceco reserves the right to increase these rates and costs by 5% after December 31, 2026.

**Rosemont**

P:(847) 696-4060

9575 W. Higgins Rd, Suite 700  
Rosemont, IL 60018

SPACECO, INC.  
GENERAL TERMS AND CONDITIONS  
WITH THE CITY OF CREST HILL

1. Relationship Between Engineer and Client: SPACECO, Inc. (Engineer) shall serve as Client's professional engineer consultant in those phases of the Project to which this Agreement applies. This relationship is that of a buyer and seller of professional services and as such the Engineer is an independent contractor in the performance of this Agreement and it is understood that the parties have not entered into any joint venture or partnership with the other. The Engineer shall not be considered to be the agent of the Client. Nothing contained in this Agreement shall create a contractual relationship with a cause of action in favor of a third party against either the Client or Engineer.

Furthermore, causes of action between the parties to this Agreement pertaining to acts of failures to act shall be deemed to have accrued and the applicable statute of limitations shall commence to run not later than the date of substantial completion.

2. Responsibility of the Engineer: Engineer will strive to perform services under this Agreement in accordance with generally accepted and currently recognized engineering practices and principles, and in a manner consistent with that level of care and skill ordinarily exercised by members of the profession currently practicing in the same locality under similar conditions. No other representation, express or implied, and no warranty or guarantee is included or intended in this Agreement, or in any report, opinion, document, or otherwise.

Notwithstanding anything to the contrary which may be contained in this Agreement or any other material incorporated herein by reference, or in any Agreement between the Client and any other party concerning the Project, the Engineer shall not have control or be in charge of and shall not be responsible for the means, methods, techniques, sequences or procedures of construction, or the safety, safety precautions or programs of the Client, the construction contractor, other contractors or subcontractors performing any of the work or providing any of the services on the Project. Nor shall the Engineer be responsible for the acts or omissions of the Client, or for the failure of the Client, any architect, engineer, consultant, contractor or subcontractor to carry out their respective responsibilities in accordance with the Project documents, this Agreement or any other agreement concerning the Project. Any provision which purports to amend this provision shall be without effect unless it contains a reference that the content of this condition is expressly amended for the purposes described in such amendment and is signed by the Engineer.

3. Changes: Client reserves the right by written change order or amendment to make changes in requirements, amount of work, or engineering time schedule adjustments, and Engineer and Client shall negotiate appropriate adjustments acceptable to both parties to accommodate any changes, if commercially possible.

4. Suspension of Services: Client may, at any time, by written order to Engineer (Suspension of Services Order) require Engineer to stop all, or any part, of the services required by this Agreement. Upon receipt of such an order, Engineer shall immediately comply with its terms and take all reasonable steps to minimize the costs associated with the services affected by such order. ~~Client, however, shall pay all costs incurred by the suspension, including all costs necessary to maintain continuity and for the resumption~~

~~of the services upon expiration of the Suspension of Services Order.~~ Engineer will not be obligated to provide the same personnel employed prior to suspension, when the services are resumed, in the event that the period of suspension is greater than thirty (30) days.

- 5. Termination: This Agreement may be terminated by either party upon thirty (30) days written notice in the event of substantial failure by the other party to perform in accordance with the terms hereof through no fault of the terminating party. This Agreement may be terminated by Client, under the same terms, whenever Client shall determine that termination is in its best interests. Cost of termination, including salaries, overhead and fee, incurred by Engineer either before or after the termination date shall be reimbursed by Client.
- 6. Documents Delivered to Client: Drawings, specifications, reports, and any other Project Documents prepared by Engineer in connection with any or all of the services furnished hereunder shall be delivered to the Client for the use of the Client. Engineer shall have the right to retain originals of all Project Documents and drawings for its files. Furthermore, it is understood and agreed that the Project Documents such as, but not limited to reports, calculations, drawings, and specifications prepared for the Project, whether in hard copy or machine readable form, are instruments of professional service intended for one-time use in the construction of this Project. These Project Documents are and shall remain the property of the Engineer. The Client may retain copies, including copies stored on magnetic tape or disk, for information and reference in connection with the occupancy and use of the Project.

When and if record drawings are to be provided by the Engineer, Client understands that information used in the preparation of record drawings is provided by others and Engineer is not responsible for accuracy, completeness, nor sufficiency of such information. Client also understands that the level of detail illustrated by record drawings will generally be the same as the level of detail illustrated by the design drawing used for project construction. If additional detail is requested by the Client to be included on the record drawings, then the Client understands and agrees that the Engineer will be due additional compensation for additional services.

~~It is also understood and agreed that because of the possibility that information and data delivered in machine readable form may be altered, whether inadvertently or otherwise, the Engineer reserves the right to retain the original tapes/disks and to remove from copies provided to the Client all identification reflecting the involvement of the Engineer in their preparation. The Engineer also reserves the right to retain hard copy originals of all Project Documentation delivered to the Client in machine readable form, which originals shall be referred to and shall govern in the event of any inconsistency between the two.~~

The Client understands that the automated conversion of information and data from the system and format used by the Engineer to an alternate system or format cannot be accomplished without the introduction of inexactitudes, anomalies, and errors. In the event Project Documentation provided to the Client in machine readable form is so converted, the Client agrees to assume all risks associated therewith and, to the fullest

extent permitted by law, to hold harmless and indemnify the Engineer from and against all claims, liabilities, losses, damages, and costs, including but not limited to attorney's fees, arising therefrom or in connection therewith.

The Client recognizes that changes or modifications to the Engineer's instruments of professional service introduced by anyone other than the Engineer may result in adverse consequences which the Engineer can neither predict nor control. Therefore, and in consideration of the Engineer's agreement to deliver its instruments of professional service in machine readable form, the Client agrees, to the fullest extent permitted by law, to hold harmless and indemnify the Engineer from and against all claims, liabilities, losses, damages, and costs, including but not limited to attorney's fees, arising out of or in any way connected with the modification, misinterpretation, misuse, or reuse by others of the machine readable information and data provided by the Engineer under this Agreement. The foregoing indemnification applies, without limitation, to any use of the Project Documentation on other projects, for additions to this Project, or for completion of this Project by others, excepting only such use as may be authorized, in writing, by the Engineer.

- 7. Reuse of Documents: All Project Documents including but not limited to reports, opinions of probable costs, drawings and specifications furnished by Engineer pursuant to this Agreement are intended for use on the Project only. They cannot be used by Client or others on extensions of the Project or any other project. Any reuse, without specific written verification or adaptation by Engineer, shall be at Client's sole risk, and Client shall indemnify and hold harmless Engineer from all claims, damages, losses, and expenses including attorney's fees arising out of or resulting therefrom.

The Engineer shall have the right to include representations of the design of the Project, including photographs of the exterior and interior, among the Engineer's promotional and professional materials. The Engineer's materials shall not include the Client's confidential and proprietary information if the Client has previously advised the Engineer in writing of the specific information considered by the Client to be confidential and proprietary. For the purposes of this Agreement, the parties acknowledge that such information shall be confidential and proprietary and shall not be used by Engineer for any purpose without Client's written consent.

- 8. Standard of Practice: The Engineer will strive to conduct services under this agreement in a manner consistent with that level of care and skill ordinarily exercised by members of the profession currently practicing in the same locality under similar conditions as of the date of this Agreement.

- 9. Compliance With Laws: The Engineer will strive to exercise usual and customary professional care in his/her efforts to comply with those laws, codes, ordinance and regulations which are in effect as of the date of this Agreement.

~~With specific respect to prescribed requirements of the Americans with Disabilities Act of 1990 or certified state or local accessibility regulations (ADA), Client understands ADA is a civil rights legislation and that interpretation of ADA is a legal issue and not a design issue and, accordingly, retention of legal counsel (by Client) for purposes of interpretation is advisable. As such and with respect to ADA, Client agrees to waive any~~

~~action against Engineer, and to indemnify and defend Engineer against any claim arising from Engineer's alleged failure to meet ADA requirements prescribed.~~

~~Further to the law and code compliance, the Client understands that the Engineer will strive to provide designs in accordance with the prevailing Standards of Practice as previously set forth, but that the Engineer does not warrant that any reviewing agency having jurisdiction will not for its own purposes comment, request changes and/or additions to such designs. In the event such design requests are made by a reviewing agency, but which do not exist in the form of a written regulation, ordinance or other similar document as published by the reviewing agency, then such design changes (at substantial variance from the intended design developed by the Engineer), if effected and incorporated into the project documents by the Engineer, shall be considered as Supplementary Task(s) to the Engineer's Scope of Service and compensated for accordingly.~~

10. Indemnification: ~~Engineer shall indemnify and hold harmless Client up to the amount of this contract fee (for services) from loss or expense, including reasonable attorney's fees for claims for personal injury (including death) or property damage to the extent caused by the sole negligent act, error or omission of Engineer.~~

~~Client shall indemnify and hold harmless Engineer under this Agreement, from loss or expense, including reasonable attorney's fees, for claims for personal injuries (including death) or property damage arising out of the sole negligent act, error omission of Client.~~

~~In the event of joint or concurrent negligence of Engineer and Client, each shall bear that portion of the loss or expense that its share of the joint or concurrent negligence bears to the total negligence (including that of third parties), which caused the personal injury or property damage.~~

~~Engineer shall not be liable for special, incidental or consequential damages, including, but not limited to loss of profits, revenue, use of capital, claims of customers, cost of purchased or replacement power, or for any other loss of any nature, whether based on contract, tort, negligence, strict liability or otherwise, by reasons of the services rendered under this Agreement.~~

11. Opinions of Probable Cost: ~~Since Engineer has no control over the cost of labor, materials or equipment, or over the Contractor(s) method of determining process, or over competitive bidding or market conditions, his/her opinions of probable Project Construction Cost provided for herein are to be made on the basis of his/her experience and qualifications and represent his/her judgement as a design professional familiar with the construction industry, but Engineer cannot and does not guarantee that proposal, bids or the Construction Cost will not vary from opinions of probable construction cost prepared by him/her. If prior to the Bidding or Negotiating Phase, Client wishes greater accuracy as to the Construction Cost, the Client shall employ an independent cost estimator Consultant for the purpose of obtaining a second construction cost opinion independent from Engineer.~~

12. Governing Law & Dispute Resolutions: This Agreement shall be governed by and construed in accordance with Articles previously set forth by (Item 9 of) this Agreement, together with the laws of the **State of Illinois**.

~~Any claim, dispute or other matter in question arising out of or related to this Agreement, which can not be mutually resolved by the parties of this Agreement, shall be subject to mediation as a condition precedent to arbitration (if arbitration is agreed upon by the parties of this Agreement) or the institution of legal or equitable proceedings by either party. If such matter relates to or is the subject of a lien arising out of the Engineer's services, the Engineer may proceed in accordance with applicable law to comply with the lien notice or filing deadlines prior to resolution of the matter by mediation or by arbitration.~~

~~The Client and Engineer shall endeavor to resolve claims, disputes and other matters in question between them by mediation which, unless the parties mutually agree otherwise, shall be in accordance with the Construction Industry Mediation Rules of the American Arbitration Association currently in effect. Requests for mediation shall be filed in writing with the other party to this Agreement and with the American Arbitration Association. The request may be made concurrently with the filing of a demand for arbitration but, in such event, mediation shall proceed in advance of arbitration or legal or equitable proceedings, which shall be stayed pending mediation for a period of 60 days from the date of filing, unless stayed for a longer period by agreement of the parties or court order.~~

~~The parties shall share the mediator's fee and any filing fees equally. The mediation shall be held in the place where the Project is located, unless another location is mutually agreed upon. Agreements reached in mediation shall be enforceable as settlement agreements in any court having jurisdiction thereof.~~

The validity, construction and interpretation of this Agreement shall be governed by the laws of the State of Illinois without regard to the conflict of law provisions. The parties hereto irrevocably agree that all actions or proceedings in any way, manner or respect arising out of or from or related to this Agreement shall be only litigated in the Circuit Court, Twelfth Judicial Circuit, Will County, Illinois. Each party hereby consents and submits to personal jurisdiction in the State of Illinois and waives any right such party may have to transfer the venue of any such action of proceeding.

13. Successors and Assigns: The terms of this Agreement shall be binding upon and inure to the benefit of the parties and their respective successors and assigns: provided, however, that neither party shall assign this Agreement in whole or in part without the prior written approval of the other.
14. Waiver of Contract Breach: The waiver of one party of any breach of this Agreement or the failure of one party to enforce at any time, or for any period of time, any of the provisions hereof, shall be limited to the particular instance, shall not operate or be deemed to waive any future breaches of this Agreement and shall not be construed to be a waiver of any provision, except for the particular instance.

15. Entire Understanding of Agreement: This Agreement represents and incorporates the entire understanding of the parties hereto, and each party acknowledges that there are no warranties, representations, covenants or understandings of any kind, matter or description whatsoever, made by either party to the other except as expressly set forth herein. Client and the Engineer hereby agree that any purchase orders, invoices, confirmations, acknowledgments or other similar documents executed or delivered with respect to the subject matter hereof that conflict with the terms of the Agreement shall be null, void and without effect to the extent they conflict with the terms of this Agreement.
16. Amendment: This Agreement shall not be subject to amendment unless another instrument is duly executed by duly authorized representatives of each of the parties and entitled "Amendment of Agreement".
17. Severability of Invalid Provisions: If any provision of the Agreement shall be held to contravene or to be invalid under the laws of any particular state, county or jurisdiction where used, such contravention shall not invalidate the entire Agreement, but it shall be construed as if not containing the particular provisions held to be invalid in the particular state, country or jurisdiction and the rights or obligations of the parties hereto shall be construed and enforced accordingly.
18. Force Majeure: Neither Client nor Engineer shall be liable for any fault or delay caused by any contingency beyond their control including but not limited to acts of God, wars, strikes, walkouts, fires, natural calamities, or demands or requirements of governmental agencies.
19. Subcontracts: Engineer may subcontract portions of the work, but each subcontractor must be approved by Client in writing.
20. Access and Permits: Client shall arrange for Engineer to enter upon public and private property and obtain all necessary approvals and permits required from all governmental authorities having jurisdiction over the Project. Client shall pay costs (including Engineer's employee salaries, overhead and fee) incident to any effort by Engineer toward assisting Client in such access, permits or approvals, if Engineer perform such services.
21. Designation of Authorized Representative: Each party (to this Agreement) shall designate one or more persons to act with authority in its behalf in respect to appropriate aspects of the Project. The persons designated shall review and respond promptly to all communications received from the other party.
22. Notices: Any notice or designation required to be given to either party hereto shall be in writing, and unless receipt of such notice is expressly required by the terms hereof shall be deemed to be effectively served when deposited in the mail with sufficient first class postage affixed, and addressed to the party to whom such notice is directed at such party's place of business or such other address as either party shall hereafter furnish to the other party by written notice as herein provided.
23. Limit of Liability: ~~The Client and the Engineer have discussed the risks, rewards, and benefits of the project and the Engineer's total fee for services. In recognition of the~~

~~relative risks and benefits of the Project to both the Client and the Engineer, the risks have been allocated such that the Client agrees that to the fullest extent permitted by law, the Engineer's total aggregate liability to the Client for any and all injuries, claims, costs, losses, expenses, damages of any nature whatsoever or claim expenses arising out of this Agreement from any cause or causes, including attorney's fees and costs, and expert witness fees and costs, shall not exceed the total Engineer's fee for professional engineering services rendered on this project as made part of this Agreement. Such causes included but are not limited to the Engineer's negligence, errors, omissions, strict liability or breach of contract. It is intended that this limitation apply to any and all liability or cause of action however alleged or arising, unless otherwise prohibited by law.~~

24. Client's Responsibilities: The Client agrees to provide full information regarding requirements for and about the Project, including a program which shall set forth the Client's objectives, schedule, constraints, criteria, special equipment, systems and site requirements.

The Client agrees to furnish and pay for all legal, accounting and insurance counseling services as may be necessary at any time for the Project, including auditing services which the Client may require to verify the Contractor's Application for Payment or to ascertain how or for what purpose the Contractor has used the money paid by or on behalf of the Client.

The Client agrees to require the Contractor, to the fullest extent permitted by law, to indemnify, hold harmless, and defend the Engineer, its consultants, and the employees and agents of any of them from and against any and all claims, suits, demands, liabilities, losses, damages, and costs ("Losses"), including but not limited to costs of defense, arising in whole or in part out of the negligence of the Contractor, its subcontractors, the officers, employees, agents, and subcontractors of any of them, or anyone for whose acts any of them may be liable, regardless of whether or not such Losses are caused in part by a party indemnified hereunder. Specifically excluded from the foregoing are Losses arising out of the preparation or approval of maps, drawings, opinions, reports, surveys, change orders, designs, or specifications, and the giving of or failure to give directions by the Engineer, its consultants, and the agents and employees of any of them, provided such giving or failure to give is the primary cause of Loss. The Client also agrees to require the Contractor to provide to the Engineer the required certificate of insurance.

The Client further agrees to require the Contractor to name the Engineer, its agents and consultants on the Contractor's policy or policies of comprehensive or commercial general liability insurance. Such insurance shall include products and completed operations and contractual liability coverages, shall be primary and noncontributing with any insurance maintained by the Engineer or its agents and consultants, and shall provide that the Engineer be given thirty days, unqualified written notice prior to any cancellation thereof.

~~In the event the foregoing requirements, or any of them, are not established by the Client and met by the Contractor, the Client agrees to indemnify and hold harmless the~~

~~Engineer, its employees, agents, and consultants from and against any and all Losses which would have been indemnified and insured against by the Contractor, but were not.~~

When Contract Documents prepared under the Scope of Services of this contract require insurance(s) to be provided, obtained and/or otherwise maintained by the Contractor, the Client agrees to be wholly responsible for setting forth any and all such insurance requirements. Furthermore, any document provided for Client review by the Engineer under this Contract related to such insurance(s) shall be considered as sample insurance requirements and not the recommendation of the Engineer. Client agrees to have their own risk management department review any and all insurance requirements for adequacy and to determine specific types of insurance(s) required for the project. Client further agrees that decisions concerning types and amounts of insurance are specific to the project and shall be the product of the Client. As such, any and all insurance requirements made part of Contract Documents prepared by the Engineer are not to be considered the Engineer's recommendation, and the Client shall make the final decision regarding insurance requirements.

25. Information Provided by Others: The Engineer shall indicate to the Client the information needed for rendering of the services of this Agreement. The Client shall provide to the Engineer such information as is available to the Client and the Client's consultants and contractors, and the Engineer shall be entitled to rely upon the accuracy and completeness thereof. The Client recognizes that it is impossible for the Engineer to assure the accuracy, completeness and sufficiency of such information, either because it is impossible to verify, or because of errors or omissions which may have occurred in assembling the information the Client is providing. Accordingly, the Client agrees, to the fullest extent permitted by law, to indemnify and hold the Engineer and the Engineer's subconsultants harmless from any claim, liability or cost (including reasonable attorneys' fees and cost of defense) for injury or loss arising or allegedly arising from errors, omissions or inaccuracies in documents or other information provided by the Client to the Engineer.
26. Payment: ~~Client shall be invoiced once each month for work performed during the preceding period. Client agrees to pay each invoice within thirty (30) days of its receipt. The client further agrees to pay interest on all amounts invoiced and not paid or objected to for valid cause within said thirty (30) day period at the rate of eighteen (18) percent per annum (or the maximum interest rate permitted under applicable law, whichever is the lesser) until paid. Client further agrees to pay Engineer's cost of collection of all amounts due and unpaid after sixty (60) days, including court costs and reasonable attorney's fees, as well as costs attributed to suspension of services accordingly and as follows:~~

Client shall be invoiced once each month for work performed during the preceding period. Payment shall be made by the Client according to the terms and provisions of the Illinois Prompt Payment Act, Engineer will provide to the Client a detailed statement of tasks performed by it and reimbursement for expenses, if any. The maximum interest rate under this Section shall be the amount set forth in the Act.

Collection Costs. In the event legal action is necessary to enforce the payment provisions of this Agreement, the Engineer shall be entitled to collect from the Client any judgement or settlement sums due, reasonable attorneys' fees, court costs and expenses incurred by the Engineer in connection therewith and, ~~in addition, the reasonable value of the Engineer's time and expenses spent in connection with such collection action, computed at the Engineer's prevailing fee schedule and expense policies.~~

Suspension of Services. If the Client fails to make payments when due or otherwise is in breach of this Agreement, the Engineer may suspend performance of services upon five (5) calendar days' notice to the Client. The Engineer shall have no liability whatsoever to the Client for any costs or damages as a result of such suspension caused by any breach of this Agreement by the Client. ~~Client will reimburse Engineer for all associated costs as previously set forth in (Item 4 of) this Agreement.~~

27. When construction observation tasks are part of the service to be performed by the Engineer under this Agreement, the Client will include the following clause in the construction contract documents and Client agrees not to modify or delete it:

Kotecki Waiver. Contractor (and any subcontractor into whose subcontract this clause is incorporated) agrees to assume the entire liability for all personal injury claims suffered by its own employees, including without limitation claims under the Illinois Structural Work Act, asserted by persons allegedly injured on the Project; waives any limitation of liability defense based upon the Worker's Compensation Act, court interpretations of said Act or otherwise; and to the fullest extent permitted by law, agrees to indemnify and hold harmless and defend Owner and Engineer and their agents, employees and consultants (the "Indemnitees") from and against all such loss, expense, damage or injury, including reasonable attorneys' fees, that the Indemnitees may sustain as a result of such claims, except to the extent that Illinois law prohibits indemnity for the Indemnitees' own negligence. The Owner and Engineer are designated and recognized as explicit third party beneficiaries of the Kotecki Waiver within the general contract and all subcontracts entered into in furtherance of the general contract.

28. Job Site Safety/Supervision & Construction Observation: The Engineer shall neither have control over or charge of, nor be responsible for, the construction means, methods, techniques, sequences of procedures, or for safety precautions and programs in connection with the Work since they are solely the Contractor's rights and responsibilities. The Client agrees that the Contractor shall supervise and direct the work efficiently with his/her best skill and attention; and that the Contractor shall be solely responsible for the means, methods, techniques, sequences and procedures of construction and safety at the job site. The Client agrees and warrants that this intent shall be carried out in the Client's contract with the Contractor. The Client further agrees that the Contractor shall be responsible for initiating, maintaining and supervising all safety precautions and programs in connection with the work; and that the Contractor shall take all necessary precautions for the safety of, and shall provide the necessary

protection to prevent damage, injury or loss to all employees on the subject site and all other persons who may be affected thereby. The Engineer shall have no authority to stop the work of the Contractor or the work of any subcontractor on the project.

When construction observation services are included in the Scope of Services, the Engineer shall visit the site at intervals appropriate to the stage of the Contractor's operation, or as otherwise agreed to by the Client and the Engineer to: 1) become generally familiar with and to keep the Client informed about the progress and quality of the Work; 2) to strive to bring to the Client's attention defects and deficiencies in the Work and; 3) to determine in general if the Work is being performed in a manner indicating that the Work, when fully completed, will be in accordance with the Contract Documents. However, the Engineer shall not be required to make exhaustive or continuous on-site inspections to check the quality or quantity of the Work. If the Client desires more extensive project observation, the Client shall request that such services be provided by the Engineer as Additional and Supplemental Construction Observation Services in accordance with the terms of this Agreement.

The Engineer shall not be responsible for any acts or omissions of the Contractor, subcontractor, any entity performing any portions of the Work, or any agents or employees of any of them. The Engineer does not guarantee the performance of the Contractor and shall not be responsible for the Contractor's failure to perform its Work in accordance with the Contract Documents or any applicable laws, codes, rules or regulations.

When municipal review services are included in the Scope of Services, the Engineer (acting on behalf of the municipality), when acting in good faith in the discharge of its duties, shall not thereby render itself liable personally and is, to the maximum extent permitted by law, relieved from all liability for any damage that may accrue to persons or property by reason of any act or omission in the discharge of its duties. Any suit brought against the Engineer which involve the acts or omissions performed by it in the enforcement of any provisions of the Client's rules, regulation and/or ordinance shall be defended by the Client until final termination of the proceedings. The Engineer shall be entitled to all defenses and municipal immunities that are, or would be, available to the Client.

29. ~~Insurance and Indemnification: The Engineer and the Client understand and agree that the Client will contractually require the Contractor to defend and indemnify the Engineer and/or any subconsultants from any claims arising from the Work. The Engineer and the Client further understand and agree that the Client will contractually require the Contractor to procure commercial general liability insurance naming the Engineer as an additional named insured with respect to the work. The Contractor shall provide to the Client certificates of insurance evidencing that the contractually required insurance coverage has been procured. However, the Contractor's failure to provide the Client with the requisite certificates of insurance shall not constitute a waiver of this provision by the Engineer.~~

~~The Client and Engineer waive all rights against each other and against the Contractor and consultants, agents and employees of each of them for damages to the extent~~

~~covered by property insurance during construction. The Client and Engineer each shall require similar waivers from the Contractor, consultants, agents and persons or entities awarded separate contracts administered under the Client's own forces.~~

30. Hazardous Materials/Pollutants: Unless otherwise provided by this Agreement, the Engineer and Engineer's consultants shall have no responsibility for the discovery, presence, handling, removal or disposal of or exposure of persons to hazardous materials/pollutants in any form at the Project site, including but not limited to mold/mildew, asbestos, asbestos products, polychlorinated biphenyl (PCB) or other toxic/hazardous/pollutant type substances.

Furthermore, Client understands that the presence of mold/mildew and the like are results of prolonged or repeated exposure to moisture and the lack of corrective action. Client also understands that corrective action is a operation, maintenance and repair activity for which the Engineer is not responsible.

June 13, 2005



## Agenda Memo

Crest Hill, IL

<b>Meeting Date:</b>	July 6, 2026
<b>Submitter:</b>	Ronald J Wiedeman
<b>Department:</b>	Engineering
<b>Agenda Item:</b>	A Resolution for a Professional Services Agreement for Crest Hill Municipal Park/Plaza By and Between the City of Crest Hill, Will County, Illinois and RVI+ Planning and Landscaping in the Amount of \$60,400.00.

**Summary:** Council previously approved in August of 2023, the following work to be completed based on the Park Layout prepared by Hitchcock Design Group dated December 3, 2021 (50% Design Plans).

Items highlighted below Staff are moving forward to bid out in 2026 with construction in the fall of 2026 and early spring 2027.

### 1. Work Approved.

- a. Finalize grading and seeding plans for area shown in exhibit 1.
  - i. Turf, in the current plan, is to be restored by using seed and blanket.
- b. Finalize design of water and sanitary service stubs to future bathroom facility.
- c. Finalize the park drainage system within the area shown in exhibit 1.
- d. Finalize design to install an underground irrigation system for the grass field and landscaping areas for the entire park. (Separate Contract)
- e. Finalize design to install a portion of a sidewalk system along the south end of the plaza to provide access to the playground. See exhibit 1.
- f. Finalize design to install concrete curb and drainage beneath playground area. See exhibit 1
- g. Determine pedestrian and security lighting layout design. See exhibit 1.
- h. Install playground equipment.

All work above has been completed and is ready to be bid except for the following items:

- Need to determine final park playground equipment and layout with council.

Engineer Estimates of Construction have been completed based on the work discussed above and as summarized below.

- Phase 1 Total-\$1,300,000.00
- Lockport Township Park District Funding towards Phase 1-\$250,000.00
- Therefore, City Share for Phase 1-\$1,050,000.00

Funding for the City Center Municipal Park/Plaza was included in the 2027 city budget at \$2,000,000.00.

Additional items, if approved, can be included with the Phase 1 work

Option 1-Municipal Park Parking Lot- Construct the parking lot as shown on exhibit 2. The only change staff would recommend to the parking lot configuration previously presented to Council is to revise the proposed location of the west driveway. The original configuration had this driveway connecting to City Center Blvd, staff suggestion is to connect directly to the existing Library access drive. If the driveway change is approved staff will work with the Library for approval and coordination to complete this work.

Option 2-Concrete Flatwork and Walking Paths-Construct the walking paths as shown on exhibit 2. These paths would be constructed in concrete or hot mix asphalt or a combination of both. The final determination of materials used for construction will be presented at a future workshop meeting.

Option 3- Parking lot and security lighting; bollard lighting; Electrical boxes-Install lighting for the parking lot, security and pedestrian bollard lighting. This work will also include the installation of receptacle boxes. The lighting being proposed will match the pendent lighting install along City Center Blvd and the pedestrian bollard lighting will match what is already installed around the City Hall Complex.

Option 4-Picnic Shelter- Staff suggest that a shade structure be included as part of the initial park work. The final determination of materials and size structure will be presented at a future workshop meeting for discussion and approval.

Completing the phase 1 along with some or all of the options above will put the park in a condition where it can be used for future city events, movies in the park, farmers' markets, national night out, etc. Seeding the park will take minimum of 1 year to grow a turf in order to host events like those suggested.

Options For Council Considerations.

1. Proceed with Phase 1 project as currently prepared and ready for Bid.
2. Proceed with Phase 1 and include options 1-4 or any combination of as determined by council.
3. Do nothing.

Funding for the City Center Municipal Park/Plaza was included in the 2027 city budget at a funding limit of \$2,000,00.00.

Staff recommendation is to move forward with bidding the work already prepared for phase 1 and including options 1, and 3. For option 3, we would suggest designing the entire lighting system for the whole park, but installing new lighting from the playground to the south edge of pavement of the parking lot only.

The schedule to get the bids out for the Phase 1 working including options 1 and 3 would be the following if the Design Engineering is approved by July 8<sup>th</sup>.

- Phase 1 with Options 1 early August 2026
- Irrigation Mid to Late August 2026
- Lighting Phase 1 area only September 2026
- 

Below are construction engineering estimates for the staff recommendation and including all options for Council's Information.

Staff Recommendation

- Phase 1 Total-\$1,300,000.00
- Options 1& 3 Only -\$425,000.00
- Grand Total Phase 1 with Options 1-3-\$1,725,000.00

- Lockport Township Park District Funding towards Phase 1-\$250,000.00
- Therefore, City Share for Phase 1-\$1,475,000.00

Phase 1 plus all options

- Phase 1 Total-\$1,300,000.00
- Options 1-4-\$925,000.00
- Grand Total Phase 1 with Options 1-3-\$2,225,000.00
- Lockport Township Park District Funding towards Phase 1-\$250,000.00
- Therefore, City Share for Phase 1-\$1,975,000.00

**Recommended Council Action:**

A Resolution for a Professional Services Agreement for Crest Hill Municipal Park/Plaza By and Between the City of Crest Hill, Will County, Illinois and RVI+ Planning and Landscaping in the Amount of \$60,400.00.

**Financial Impact:**

**Funding Source:** Capital Fund

**Budgeted Amount:** \$150,000.00 Engineering

**Cost:** \$60,400.00

**Attachments:**

Resolution-RVI

Exhibit A-RVI-PSA Design-City of Crest Hill-Crest Hill Center Park-6.26

**RESOLUTION NO. \_\_\_\_\_**

**A RESOLUTION FOR A PROFESSIONAL SERVICES AGREEMENT FOR CREST HILL MUNICIPAL PARK PLANNING AND LANDSCAPING BY AND BETWEEN THE CITY OF CREST HILL, WILL COUNTY, ILLINOIS AND RVI PLANNING + LANDSCAPING IN THE AMOUNT OF \$60,400.00**

---

WHEREAS, the Corporate Authorities of the City of Crest Hill, Will County, Illinois, have the authority to adopt resolutions and to promulgate rules and regulations that pertain to the City’s government and affairs and protect the public health and, safety, and welfare of its citizens; and

WHEREAS, pursuant to Section 2-2-12 of the Illinois Municipal Code (65 ILCS 5/2-2-12), the City Council possesses the authority to enter into contracts that serve the legitimate corporate purposes of the City; and

WHEREAS, RVI Planning + Landscaping. (the “COMPANY”), is an entity that is in the business of providing Professional Engineering Services, for the Crest Hill Municipal Park Planning and Landscaping (the “Services”); and

WHEREAS, the City Council desires to engage the Company to provide the Services and the Company is ready, willing to perform the Services for the City; and

WHEREAS, City Staff have negotiated an Agreement for a Crest Hill Municipal Park Planning and Landscaping (the “Agreement”) with the Company for the purposes of engaging the Company to perform the Services ( a copy of the Agreement is attached hereto as Exhibit A and fully incorporated herein); and

WHEREAS, the Staff and City Council has reviewed the Agreement and determined that the conditions, terms, and provisions of the Agreement are fair, reasonable, and acceptable to the City; and

WHEREAS, the City Council has determined that it is in the best interest of the City and its citizens to enter into the Agreement with the Company.

NOW, THEREFORE, BE IT RESOLVED by the City Council of the City of Crest Hill, Illinois, pursuant to its statutory authority, as follows:

SECTION 1: PREAMBLE. The City Council hereby finds that all of the recitals contained in the preamble to this Resolution are true, correct and complete and are hereby incorporated by reference hereto and made part hereof.

SECTION 2: AGREEMENT APPROVED. The City Council hereby finds and declares that the conditions, terms, and provisions of this Agreement (Exhibit A) in the amount of 60,400.00 are fair, reasonable, and acceptable to the City and that the same is hereby approved in form and substance.

Therefore, the City Council hereby authorizes and directs the Mayor to execute and deliver, and the Clerk to attest, the Agreement, and further to take any and all other actions, including without limitation the execution and delivery of any and all documents, necessary and appropriate to effectuate the intent of this Resolution, which is to enter into the Agreement with the Company.

SECTION 3: SEVERABILITY. If any section, paragraph, clause or provisions of this Resolution is held invalid, the invalidity of such section, paragraph, clause or provision shall not affect any other provision of this Resolution.

SECTION 4: REPEALER. All ordinances, resolutions or orders, or parts thereof, which conflict with the provisions of this Resolution, are to the extent of such conflict hereby repealed.

SECTION 5: EFFECTIVE DATE. This Resolution shall be in full force and effect immediately upon its passage and publication according to law.

*[Intentionally Blank]*

PASSED THIS 6TH DAY JULY, 2026.

	Aye	Nay	Absent	Abstain
Alderman Scott Dyke	_____	_____	_____	_____
Alderman Angelo Deserio	_____	_____	_____	_____
Alderwoman Claudia Gazal	_____	_____	_____	_____
Alderman Darrell Jefferson	_____	_____	_____	_____
Alderperson Tina Oberlin	_____	_____	_____	_____
Alderman Mark Cipiti	_____	_____	_____	_____
Alderman Nate Albert	_____	_____	_____	_____
Alderman Joe Kubal	_____	_____	_____	_____
Mayor Raymond R. Soliman	_____	_____	_____	_____

APPROVED THIS 6TH DAY OF JULY, 2026.

\_\_\_\_\_  
Raymond R. Soliman, Mayor

ATTEST:

\_\_\_\_\_  
Christine Vershay-Hall, City Clerk

# EXHIBIT A

## Exhibit A

# Proposal for Professional Services

CREST HILL CITY CENTER PARK

Prepared for: City of Crest Hill  
By: Eric Hornig, Principal

PUBLIC PLACES



## PROPOSAL FOR PROFESSIONAL SERVICES

June 30, 2026

Ron Wiedeman, Director of Engineering  
City of Crest Hill ("Client")  
20600 City Center Boulevard, Crest Hill, Illinois 60403  
RVI Project Number: 26006459

RE: **Crest Hill City Center Park**

Dear Ron,

Thank you for the opportunity to continue our design and planning efforts with your team. RVI Planning + Landscape Architecture ("Consultant") is pleased to submit the attached proposal for professional services for City Center Park, 20600 City Center Boulevard ("Project"). Below is a summary of services.

- Prepare design development and construction documents (Phase I Only), including plans, details, technical specifications, and coordination with civil and electrical engineering disciplines.
- Develop and update construction cost opinions and implementation phasing strategies to support informed decision-making and budget planning.
- Support regulatory review and permitting efforts through preparation of required documentation and responses to agency comments.
- Assist with bidding and contractor procurement, including preparation of bid documents, contractor outreach, pre-bid coordination, bid evaluation, and award recommendations.

The known relevant local governmental authorities ("RGA's") having jurisdiction over the Project are: City of Crest Hill (Site Plan) and IEPA (erosion control if > 1 acre is ultimately disturbed).

The Consultant will coordinate with the following consultants, hired separately by the Client, in the performance of this Agreement: SpaceCo (Civil Engineering) and CBBEL (Electrical Engineering).

Please review the attached scope of services and if acceptable, please provide your approval by signing Article 11. Thank you again for the opportunity!

Sincerely,

A handwritten signature in black ink, appearing to read 'Eric Hornig', is written over a light blue circular background.

Eric Hornig, Principal  
Naperville, IL



## PROFESSIONAL SERVICES AGREEMENT

**Project Name: Crest Hill City Center Park**

**RVi# 26006459**

**Client Name: City of Crest Hill**

**Client Address: 20600 City Center Boulevard**

Based upon our understanding of project requirements and discussions with you, we have developed the following scope of services.

### ARTICLE 1. BASIC SERVICES

The Consultant shall provide, for the Basic Fee plus reimbursable expenses, services described in the following phases.

#### 1.1 (TASK 01) PRELIMINARY SERVICES

1. Attend a Kickoff Meeting to establish the project program and communication protocols.
2. Obtain and review plans, maps, and records provided by the Owner (from previous phases of design & development).
3. Prepare a project schedule delineating each phase, major milestones, and any public meetings required.

#### **DELIVERABLES:**

- Program Summary
- Project Schedule

#### 1.2 (TASK 02) DESIGN DEVELOPMENT SERVICES – PHASE 1

1. Based on the Client approved Phase I Schematic Design Elements and previously prepared documentation, Consultant will prepare Design Development drawings for the landscape components.
  - a. The Design Development drawings shall include plans, sections, elevations and typical details to fix and describe the size and character of the landscape components approved by the Client for further design.
  - b. The Design Development drawings will establish major materials and finishes.
  - c. The Design Development drawings and all subsequent phases shall be limited to those landscape components approved by the Client in the Schematic Design phase. Current elements anticipated to advance:
    - Parking lot aisle adjustment
    - Walkways and plazas
    - Turf restoration (including seed versus sod comparison)
2. Update the opinion of probable cost for the construction based on the Design Development drawings.
3. (1 Virtual Mtg, 1 in Person) Review the Design Development Documents and supporting information with Client representatives for approval and authorization to proceed at the 50% and 95% completion stages. Prepare written summaries of discussions and update the Project Program following each meeting.

#### **DELIVERABLES:**

- Design Development Landscape Plans in 24x36 format (digital pdf format)
- Updated cost opinion
- Meeting summaries & update program

#### 1.3 (TASK 03) CONSTRUCTION DOCUMENTATION SERVICES – PHASE I

1. Based on the phasing approved by the Client illustrated on the Design Development drawings, prepare Construction Documents for the landscape components. Initiation of the Construction Documents will rely on Client approval and the complete civil engineers' drawings and shall include:
  - a. Typical detail drawings, that set forth in the requirements for construction of the landscape components, including depiction of their size, shape, dimensions, and locations; and
  - b. Specifications that identify the materials, equipment, workmanship and quality standards (or performance criteria), for landscape components.
  - c. Likely sheets to be represented as known at this time include:
    - Cover sheet, project identification, and general information

- Layout and materials plans
  - Construction details
  - Seed/Sod restoration plan
2. Prepare an opinion of probable cost based on the Construction Documents.
  3. (1 Virtual Mtg, 1 in Person) Review the Construction Documents and supporting information with Client representatives for approval and authorization to proceed at the 50% and 95% completion stages. Prepare written summaries of discussions and update the Project Program following each meeting.

**DELIVERABLES:**

- Construction Documents in 24x36 format and digitally (example: list number, size, scale and type if available)
- Specifications in CSI Masterspec Format
- Updated cost opinion
- Meeting summaries & update program

1.4 (TASK 04) REGULATORY SERVICES

1. The following required permits are in effect on the date of this Agreement:
  - a. IEPA (SWPPP Erosion Control)
  - b. City of Crest Hill
2. Upon approval and authorization to proceed, prepare documents reasonably required for review by RGAs to comply with permitting requirements. Client's civil engineer will be solely responsible for preparing the official submittal and application, for submitting it to the appropriate RGA, and for processing it through the administrative approval process.
3. As requested by Client participate, in the permitting process including:
  - a. Evaluate and respond to RGA review and comments;
  - b. Review with the Client, modifications requested by RGAs, and at Client's direction, modify the documents accordingly for re-submission;

1.5 (TASK 05) BIDDING PHASE SERVICES

1. Following the Client's approval of the Construction Documents, Consultant will assist the Client in obtaining bids utilizing a single general contractor approach and in awarding contracts for construction for the Project by issuing Bid Documents including:
  - a. Advertisement and Invitation to Bid
  - b. Project Manual including Instructions to Bidders, Bid forms, sample Contract, General Conditions, and Technical Specifications
  - c. Construction Drawings
2. Prepare a Contractor Invitation List identifying reputable contractors for consideration.
3. Provide the Bid Documents to Client representatives for use in printing, advertising, and coordinating the bid letting (legal notice publishing by Client).
4. Coordinate and administer the bid process through the City provided plan room service QuestCDN.
5. (Mtg) Participate in a Pre-Bid Meeting for interested bidders and issue written Pre-bid Meeting Minutes to all participants.
6. Review Bidders Request for Information (RFI) and issue written Addenda, when appropriate, to all bidders regarding changes to or clarifications of the Bid Documents.
7. (Mtg) Attend the Bid Opening and record bids received.
8. Review the bids, tabulate the results, check bidder's references, and issue a Bid Tabulation and Award Recommendation to the Client.
9. Prepare and submit the Owner/Contractor Agreement to the Client representative and selected Contractor. Once approved, issue a Notice to Proceed to the Contractor.

**DELIVERABLES:**

- Bid tabulation
- Bid award recommendation letter

1.6 (TASK 06) SCHEMATIC DESIGN VALIDATION (HOURLY ESTIMATE)

1. Scope to be determined as the project unfolds and shall be billed on an hourly basis.

## ARTICLE 2. ADDITIONAL SERVICES

All services requested by the Client that are not listed in Article 1 of this Agreement are considered Additional Services. Additional Services are not included in the Basic Fee and shall be paid for by the Client as set forth in Article 4.2 of this Agreement.

2.1 Additional Services include, without limitation, the following:

1. Providing services other than those set forth in Article 1 of this Agreement;
2. Expert witness services performed in preparing for and serving in connection with public hearings, litigation, arbitration, mediation, and/or negotiations;
3. Public or other presentations beyond those described in Basic Services;
4. Preparation of presentation materials for marketing or purposes other than in-progress approvals; construction of presentation models; or preparation of finish quality renderings for the Project;
5. Revisions to drawings previously provided by Consultant due to changes in the Projects' scope, budget or schedule; instructions that are inconsistent with written approvals or instructions previously given; or enactment or revision of codes, laws, or regulations subsequent to the preparation of such documents;
6. Services related to ADA/accessibility/compliance issues for existing site improvements which may be triggered by the design services for new improvements contemplated by this Agreement;
7. Any consultation, drawings, reports and other work products related to permits, approvals and ordinances; or, review and processing of permits, approvals and ordinances with agencies or municipalities having regulatory controls over the development not described in Basic Services;
8. Providing work in connection with the services of a construction manager retained by the Client;
9. Preparing drawings, specifications, supporting data and providing other services in connection with change orders to the extent that the adjustment in the basic compensation resulting from the adjusted construction costs is not commensurate with the services required of the Consultant; providing such change orders are required by causes not solely within the control of the Consultant;
10. Providing services made necessary by the default of the contractor, or by major defects or deficiencies in the work of the contractor;
11. Construction phase services
12. Preparation of as-built drawings;

## ARTICLE 3. INFORMATION TO BE PROVIDED BY CLIENT

- 3.1 Client shall provide, in a timely manner, all criteria and full information regarding Client's requirements for, and limitations on, the Project, including without limitation:
  1. Legal description and to-scale boundary survey of the property;
  2. All deed restrictions, environmental restrictions, covenants, and all existing or pending municipal, county, state, and federal permits or approvals, and other pertinent information as required during the process;
  3. Topographic survey including 1' contours (unless otherwise agreed by Consultant in writing), tree survey, drainage and flood plain locations, overlay zones or districts, environmental and geotechnical data, utilities, easements, rights-of-way and other existing or proposed physical improvements and impacts of the property. All files to be in AutoCAD format;
  4. Financial/economic information setting forth the budget limitations for the Project;
  5. A geotechnical investigation and report, including design recommendations, will be provided by the Client; and
  6. Designate a representative to serve as the point of contact for the project.

## ARTICLE 4. COMPENSATION

### 4.1 BASIC SERVICES

The Client shall compensate the Consultant as follows:

**Lump Sum:** Consultant's compensation shall include the lump sum of \$36,800.00 dollars for Basic Services (the "Basic Fee"), plus the total for Additional Services performed on an hourly basis at the rates set forth in Section 4.4, plus reimbursable expenses as set forth in Section 4.5. Consultant's total compensation for Basic Services shall be allocated among the various phases of the Project as set forth below and will be billed monthly based on percent of work complete for each phase of the Project, along with Additional Services and reimbursable expenses incurred during the billing period. The amounts indicated do not include amounts resulting from substantial change in the scope of the Project or services. The Client agrees to pay the Consultant the following fees for the Basic Services:

Task 01:	Preliminary Services	\$ 3,100.00
Task 02:	Design Development Services (Phase I)	\$ 17,800.00
<u>Task 03:</u>	<u>Construction Documentation Services (Phase I)</u>	<u>\$ 15,900.00</u>
	<b>Total Lump Sum Fee:</b>	<b>\$36,800.00</b>

**Hourly:** Consultant's compensation shall include the total for Basic Services (the "Basic Fee") and Additional Services performed on an hourly basis at the rates set forth in Section 4.4, plus reimbursable expenses as set forth in Section 4.5. Consultant's estimated compensation for Basic Services for each phase of the Project is set forth below. The amounts indicated do not include amounts for Additional Services or resulting from substantial change in scope of the Project or services. The Client agrees to pay the Consultant the following estimated fees for the Basic Services:

Task 04:	Regulatory Services	\$ 1,500.00
Task 05:	Bidding Phase Services	\$ 5,700.00
Task 06:	Schematic Design Validation	\$15,900.00
Task 98:	Additional Community/Public Meetings/Staff Meetings	Hourly as requested
<u>Task 99:</u>	<u>Reimbursables</u>	<u>\$ 500.00</u>
	<b>Total Hourly Fee:</b>	<b>\$ 23,600.00</b>

**Total Lump Sum & Hourly Fee: \$ 60,400.00**

#### 4.2 ADDITIONAL SERVICES

The Client shall pay the Consultant for authorized Additional Services performed, including fees and reimbursable expenses. Fees for Additional Services will be included as a separate item on the monthly billing statement.

#### 4.3 INVOICING AND PAYMENT

Consultant will invoice Client monthly for Basic Services and Additional Services performed, and for reimbursable expenses incurred in accordance with the Terms and Conditions of this Agreement. Amounts invoiced are due and payable ten (10) days following the date of the invoice, at the office of **RVi, 1611 West 5<sup>th</sup> Street, Suite 175, Austin, Texas 78703**. Amounts remaining unpaid sixty (60) days following the date of the invoice shall bear interest at the rate of 12.0% per annum, or at the maximum legal rate allowable, which shall be calculated from the date of the invoice. In no event shall Consultant's failure to bill monthly constitute default under the Terms and Conditions of this Agreement. *Consultant retains the right to halt work pending receipt of any overdue payments, and the right to withhold delivery of final work product if Client does not comply with the payment terms above. Client shall pay all costs and expenses, including without limitation, reasonable attorney's fees and expenses incurred by RVi in connection with the collection of overdue accounts of Client.*

The Client's billing contact information is outlined in the attached exhibit "Client's Billing Contacts"

#### 4.4 HOURLY RATES

The following hourly rates shall apply to the fees described herein and any Additional Services requested of the Consultant. The rates set forth below shall be adjusted in accordance with the normal salary review practices of the Consultant.

Principal	\$230.00 - \$350.00
Associate Principal	\$200.00 - \$275.00
Practice Director	\$165.00 - \$275.00
Project Director	\$165.00 - \$260.00
Project Manager	\$145.00 - \$250.00
Landscape Architect (PLA)/Planner (AICP)	\$155.00 - \$250.00
Designer/Planner/Intern	\$95.00 - \$225.00
Technical, Administrative	\$90.00 - \$200.00

#### 4.5 REIMBURSABLE EXPENSES

Reimbursable expenses are in addition to compensation for Basic Services and Additional Services and include expenses incurred by the Consultant in the interest of the Project. Reimbursable expenses include such items as telecommunications, reprographics, computer plots/mapping, deliveries, photography, reproductions; postage; automobile transportation; expenses in connection with out-of-town travel; special consultants; cost of maps, surveys, drawings and reports necessary to conduct the work and not otherwise furnished by the Client; fees paid for securing approval of authorities having jurisdiction over the project; expense of any additional insurance coverage or limits including professional liability insurance requested by the Client in excess

of that normally carried by the Consultant and the Consultant's sub-consultants and third-party consultant charges. Reimbursable expenses will be billed at 1.15 times direct cost to the Consultant.

#### ARTICLE 5. CHANGES

- 5.1 Changes. The Consultant and the Client may make changes to the Agreement at any time, but only by written amendment signed by both parties, or by Client's oral request confirmed by Consultant in writing (or email) indicating its acceptance. If such changes cause an increase or decrease in the Consultants' cost of, or time required for, performance of any services, Consultant shall be entitled to an equitable adjustment in compensation and/or completion time.
- 5.2 Regulatory Changes. In the event that there are modifications or additions to regulatory requirements relating to the services to be performed under the Agreement after the date of execution of the Agreement, the increased or decreased cost of performance of the services provided for in the Agreement and subsequent Proposals shall be reflected in an appropriate written amendment to the Agreement.

#### ARTICLE 6. RESPONSIBILITIES OF THE PARTIES

- 6.1 Access. Client will provide Consultant with access to the Project site or to any other site as required by Consultant for performance of the Services.
- 6.2 Client shall designate a single person to act with authority on Client's behalf in respect to all aspects of the Project, examine and respond promptly to Consultant's submissions, and give prompt written notice to Consultant whenever it observes or otherwise becomes aware of any defect in the work. If the Client retains a Construction Manager ("CM") for the Project, the Client shall clearly set forth the duties, responsibilities the CM has been assigned by the Client. The Consultant shall be entitled to rely upon the CM's decisions and directions.
- 6.3 Changed Conditions. Consultant shall have the authority to determine the continued adequacy of the Agreement in light of conditions first discovered or information first provided to Consultant after the execution of the Agreement. Should Consultant determine that the Agreement is no longer adequate in light of such conditions, the Consultant shall identify the changed conditions necessitating renegotiation and the Consultant and the Client shall promptly and in good faith enter into renegotiation of the Agreement. If the terms cannot be agreed to, the parties agree that either party has the right to terminate the Agreement.
- 6.4 Permits. Client is responsible for obtaining and complying with all required permits or other approvals of, and for giving any required notices to, all governmental and quasi-governmental authorities having jurisdiction over the Project. Before Consultant performs the Services, Client will provide Consultant evidence satisfactory to Consultant that all required permits or other approvals have been obtained and that all required notices have been given. Client will provide to Consultant copies of any such permits or any such notices, together with any other relevant information that will alert Consultant to the requirements of such permits, approvals, or notifications.
- 6.5 Other Information. Consultant may rely upon commonly used sources of data including but not limited to database searches, publicly available topographic information, GPS coordinates, demographics, and other public information as required. Consultant does not warrant the accuracy of the information obtained from those sources and has not been requested to independently verify such information.
- 6.6 Site Visits. Unless otherwise specifically set forth in the Agreement or a fully executed written Amendment, Client-requested site visits are on an as-requested fee basis for the purpose of visual observation only for general conformance with the Landscape Construction Documents at the time of observation. Client has not retained the Consultant to make inspections or to provide periodic, continuous or exhaustive Project review and observation services. Consultant's site visits do not include any obligation to identify or notify Client of any jobsite safety issues. Consultant is not obligated to conduct any tests in connection with site visits. Consultant at all times reserves the right to make site visits solely for its own collection of information relevant to, and for the benefit of, the performance of its Services.
- 6.7 Construction Exclusion. Consultant's scope of work does not include, and Consultant shall have no authority or responsibility for supervising, directing, performing or controlling any contractor's work, or the means, methods, techniques, sequences, safety measures, or procedures of construction selected by any contractor or subcontractor. Accordingly, Consultant shall have no responsibility or liability for the acts or omissions of any contractor, subcontractor, supplier or any other entity furnishing materials or performing any work on the Project, including, but not limited to, compliance with any applicable law.
- 6.8 No Warranty. Consultant and Client acknowledge and agree that Consultant makes no warranties, express or implied, regarding the Services provided in connection with the Project and that the Services provided by Consultant are in the nature of professional services, the essence of which are the provision of advice, judgment, opinion and professional skill.
- 6.9 Estimates of Probable Costs. Client and Consultant agree that any construction cost estimates provided by Consultant are solely for the purpose of providing information for use in revising the Instruments of Service, and that Consultant makes no warranty, express or implied, that any estimates will not differ from bids received from contractors or the negotiated cost of the work. Opinions of cost are based on the experience and judgment of Consultant and are merely opinions. Consultant does not warrant that actual costs will not vary from those opinions because, among other things, Consultant has no control over market conditions. If the fixed limit of construction cost is exceeded by the lowest bona fide bid or negotiated proposal by more than 20%, Consultant will at the Client's request, revise the Contract Documents to comply with the project budget at no additional charge. In any event, Consultant's modification of Instruments of Service shall be its sole responsibility and Client's sole remedy for any difference between Consultant's construction cost estimates and bids received or the negotiated cost of the work.

**ARTICLE 7. TERMINATION**

- 7.1 This Agreement may be terminated by either party, at any time prior to completion of Consultant's services, upon not less than seven days' written notice, should the other party fail substantially to perform in accordance with the terms of the Agreement through no fault of the party initiating the termination; provided however, that such notice shall state the reason(s) for termination, and such termination shall not be effective if the party to whom the notice is directed, within such seven-day period, fully cures its failure to perform.
- 7.2 If the Client fails to make payments to the Consultant in accordance with the Agreement, such failure shall be considered failure to substantially perform and cause for termination or, at the Consultant's option and upon not less than seven days' written notice, cause for suspension of performance of services without terminating the Agreement. In the event of a suspension of services, the Consultant shall have no liability to the Client for delay, hindrance or damage caused the Client because of such suspension of services. The Consultant shall be paid all sums due prior to suspension and any expenses incurred in the interruption and resumption of the Consultant's services before having to resume services.
- 7.3 If the Project is suspended or the Consultant's services are suspended for more than 90 consecutive days, the Consultant may terminate the Agreement by giving not less than seven days' written notice. Consultant shall be compensated for services performed prior to notice of such suspension. When the Project is resumed, the Consultant shall be compensated for any expenses incurred in the interruption and resumption of the Consultant's services. The Consultant's fees for the remaining services and the time schedules shall be equitably adjusted.
- 7.4 This Agreement may be terminated by either party, without cause and for its convenience, at any time prior to completion of Consultant's services, upon not less than seven days' written notice to the other party. In the event that a termination by Consultant for cause is later determined to have been wrongful, then the termination shall be deemed a termination for convenience.
- 7.5 In the event of termination not the fault of the Consultant, the Client shall, within fifteen days following the termination, pay Consultant for all services performed prior to termination, together with reimbursable and sub-consultant expenses incurred before termination and all Termination Expenses. Termination Expenses are in addition to compensation for the services of the Agreement and include expenses directly attributable to termination for which the Consultant is not otherwise compensated, plus an amount for the Consultant's anticipated profit on the value of the services not performed by the Consultant. Client waives any and all claims, causes of action and damages that it has or may have against Consultant arising out of termination not the fault of the Consultant, including termination without cause.

**ARTICLE 8. LIMITATIONS OF LIABILITY**

- 8.1 Limitation of Liability. Client and Consultant have considered the relative risks and benefits of the Project to both Client and Consultant, and agree to allocate risks such that, to the fullest extent permitted by the law, the total liability of Consultant, its directors, officers, partners, employees, subconsultants and subcontractors (the "Limited Parties"), to Client for any and all injuries, claims, losses, expenses (including attorney's fees and costs), or damages of any nature whatsoever, shall be limited such that the total aggregate liability of the Limited Parties shall not exceed the Consultant's total compensation received for services rendered and reimbursable expenses incurred in connection with the Project. This limitation shall apply to any and all liabilities and causes of action, however alleged or arising and regardless of the nature of the fault, unless otherwise prohibited by law. To the extent that any portion of this limitation is prohibited by law, such prohibited portion shall be deemed excluded from this provision, and the remainder shall remain in effect. Moreover, Client further acknowledges and understands that accessibility standards, guidelines and requirements are subject to varying interpretations, and as such, Client hereby expressly waives all claims, causes of action, liabilities and damages arising out of or in any way related to non-compliance with any and all accessibility standards, guidelines and requirements, including, without limitation, those promulgated through, by or under the Americans with Disabilities Act ("ADA"), the Fair Housing Act ("FHA"), and any of their state counterparts.
- 8.2 Waiver of Special/Consequential Damages. Notwithstanding any other provision of this Agreement, Client and Consultant agree that neither party, nor their respective directors, officers, employees shall in any event be liable to the other for any punitive, special, incidental, or consequential damages, including, without limitation, damages incurred for lost business opportunity or profits, arising out of or relating to the Agreement or the Project, the same being hereby expressly waived by both parties. This waiver shall apply to any and all causes of action, however alleged or arising and regardless of the nature of the fault or whether it was committed by the Client or by Consultant.
- 8.3 Delays. Consultant is not responsible for delays or hindrances caused by factors beyond Consultant's reasonable control, including but not limited to delays and hindrances resulting from strikes, lockouts, work slowdowns or stoppages, accidents, acts of God, failure of any governmental or other regulatory authority to act in a timely manner, failure of the Client to furnish timely information or approve or disapprove of Consultant's Services or work product or respond to Consultant's inquiries promptly, or delays caused by faulty performance by the Client or by contractors of any level. When such delays occur, the Client agrees Consultant is not responsible for damages, nor shall Consultant be deemed to be in default of the Agreement. To the extent necessary as caused by any delay, Consultant shall be entitled to an extension of time equal to the delay and an equitable adjustment in compensation.
- 8.4 Project Enhancement. If, due to Consultant's error or omission, any required item or component of the Project is omitted from Consultant's documents, Consultant shall not be responsible for paying the cost to add such item or component to the extent that such item or component would have been otherwise necessary to the Project or otherwise adds value or betterment to the Project. In no event will Consultant be responsible for any cost or expense that provides betterment, upgrade, or enhancement of the Project.

**ARTICLE 9. RELATIONSHIP OF PARTIES**

- 9.1 Independent Contractor. It is understood that the relationship of Consultant to Client shall be that of an independent contractor. Neither Consultant nor employees of Consultant shall be deemed to be employees of Client.
- 9.2 No Fiduciary Duty. Client recognizes that neither Consultant nor any of Consultant's subconsultants or subcontractors owes any fiduciary responsibility to Client.
- 9.3 Corporate Services. Client agrees that Consultant has entered the Agreement in its corporate capacity, and that all services are provided by Consultant in its corporate capacity. Client agrees that it shall look solely to Consultant in its corporate capacity and not to any of Consultant's directors, officers, partners or employees in any individual capacity with respect to obtaining any remedy.
- 9.4 No Third-Party Beneficiaries. Consultant's work product, including without limitation all services and all Instruments of Service that are provided in connection with the Project, are intended solely for the benefit and exclusive use of the other party, and any benefits arising out of those obligations or any other services performed by Consultant in connection with the Project that may accrue to third parties are entirely incidental. Nothing contained in this Agreement shall create a contractual relationship with or a cause of action in favor of a third party. There are no intended third-party beneficiaries to the Agreement.

#### ARTICLE 10. MISCELLANEOUS PROVISIONS

- 10.1 Merger. The Agreement, including any attachments, represents the entire and integrated agreement between the Client and the Consultant. The Agreement supersedes all prior negotiations, representations or agreements, whether written or oral, and the same shall have no force or effect. The Agreement may be amended only by written instrument signed by both Client and authorized representative Consultant.
- 10.2 Execution. This Agreement may be executed in any number of multiple counterparts, all of which taken together shall constitute one and the same agreement.
- 10.3 Lien Rights. Client grants to Consultant a contractual lien, in addition to all constitutional, statutory and equitable liens that may exist, on the real property identified in the Agreement as the Project location, and on all improvements thereon, to secure payment for all debts owed, now or in the future, to Consultant by Client, arising from services provided and reimbursable expenses and sub-consultant costs incurred by Consultant in connection with the Project. Client grants Consultant the authority and right to file a copy of the Agreement in the Deed Records of the county or counties where the Project is located to give notice of Consultant's lien rights. If Client is not an owner of the real property or improvements at the Project location, then Client hereby assigns to Consultant, to the extent of Consultant's services on the Project, Client's lien rights under the relevant state law, including without limitation, Chapter 53 of the Texas Property Code.
- 10.4 Instruments of Service.
1. All designs, drawings, specifications, documents, calculations, and other work products, whether in hard copy or electronic form, prepared by the Consultant are Instruments of Service, and such Instruments of Service, as well as the concepts, designs, and ideas expressed in the Instruments of Service are for use solely with respect to the Project. The Consultant is deemed the author and owner of the Instruments of Service, regardless of whether or not services are completed, and Consultant shall retain all common law, statutory and other reserved rights, including copyrights.
  2. Upon full payment by Client to Consultant under this Agreement Consultant grants to the Client a non-exclusive license to reproduce and utilize the Consultant's Instruments of Service: (i) to complete the development or construction of the Project, as applicable; (ii) for reference in operating, maintaining and repairing the Project; and (iii) for reference in undertaking any future alteration, improvement, addition or renovation of the Project. Absent full payment by Client under this Agreement, Consultant grants no rights in Instruments of Service.
  3. Reuse, change or alteration of Instruments of Service by the Client or by others acting through or on behalf of the Client is not permitted without the written consent of Consultant. ANY SUCH REUSE, CHANGE OR ALTERATION BY THE CLIENT OR THIRD PARTIES IS AT THEIR OWN RISK AND CLIENT AGREES TO HOLD HARMLESS AND INDEMNIFY THE CONSULTANT, ITS OFFICERS, PARTNERS, EMPLOYEES, AND SUBCONSULTANTS FROM ALL CLAIMS, DAMAGES, LOSSES, EXPENSES AND COSTS (INCLUDING ATTORNEYS' FEES), INCLUDING, BUT NOT LIMITED TO, CLAIMS FOR CONSULTANT'S ALLEGED NEGLIGENCE, ARISING OUT OF OR RELATED TO SUCH REUSE, CHANGE OR ALTERATION.
- 10.5 Attorney's Fees Client shall pay Consultant, in addition to any other amounts found to be owing, all costs of collection arising from unpaid invoices, including reasonable attorney's fees.
- 10.6 Governing Law. The Agreement shall be governed by and construed in accordance with the laws of the State of Texas.
- 10.7 Venue. Consultant and Client agree that the venue of any action under the Agreement shall be exclusively in the jurisdiction of the Consultant office in which the work was performed.
- 10.8 Severability. If any provision of the Agreement is held to be illegal, invalid or unenforceable under present or future laws, such provision shall be fully severable, and the Agreement shall be construed and enforced as if such illegal, invalid or unenforceable provision is not a party hereof, and the remaining provisions shall remain in full force and effect. In lieu of any illegal, invalid or unenforceable provision, there shall be added automatically as a part of the Agreement, a provision as similar in terms to such illegal, invalid or unenforceable provision as may be possible and be legal, valid and enforceable.

- 10.9 Construction of Agreements. The parties acknowledge that each party and, if it so chooses, its counsel have reviewed and revised the Agreement and that the normal rule of construction to the effect that any ambiguities are to be resolved against the drafting party shall not be employed in the interpretation of the Agreement or any amendments or exhibits.
- 10.10 Successor and Assigns. Neither Client nor Consultant shall assign, sublet, or transfer this interest in the Agreement without the written consent of the other. Client's representative signing Agreement warrants that he or she has full authority to bind Client to the Agreement. Nothing in this provision restricts Consultant's ability to hire subcontractor(s) in connection with the services to be provided.
- 10.11 Dispute Resolution. Other than a dispute arising from alleged non-payment, all claims, disputes or other matters in question arising out of or related to the Agreement or the services provided thereunder ("Disputes") shall be resolved in accordance with the dispute resolution procedures set forth herein. Specifically, unless both parties agree to waive the requirement in writing, all Disputes shall be subject to non-binding mediation as a condition precedent to the institution of arbitration or any other legal proceedings by either party.
  - 1. Mediation. The Client and Consultant shall endeavor to resolve all Disputes between them by mediation. The parties shall share the mediator's fee and any filing fees equally. The mediation shall be held in the county where the Project is located, unless another location is mutually agreed upon. Agreements reached in mediation shall be enforceable as settlements agreements in any court having jurisdiction thereof. If a Dispute relates to or is the subject of a lien arising out of the Consultant's services, the Consultant may proceed in accordance with applicable law to comply with the lien notice or filing deadlines prior to resolution of the matter by mediation or other legal proceedings.
  - 2. Arbitration. All claims, disputes and other matters in question arising out of or related to the Agreement or the services provided thereunder and not resolved first through mediation shall be decided by binding arbitration which, unless the parties mutually agree otherwise, shall be in accordance with the Construction Industry Arbitration Rules of the American Arbitration Association currently in effect. The demand for arbitration shall be filed in writing with the other party to the Agreement and with the American Arbitration Association. No arbitration arising out of or relating to the Agreement shall include, by consolidation or joinder or in any other manner, an additional person or entity not a party to the Agreement. The foregoing agreement to arbitration shall be specifically enforceable in accordance with applicable law in any court having jurisdiction. The award rendered by the arbitrator or arbitrators shall be final, and judgment may be entered upon it in accordance with applicable law in any court having jurisdiction.
- 10.12 Survival of Provisions. Termination of the Services for any reason whatsoever shall not affect (a) any right or obligation of any party that is accrued or vested prior to such termination, and any provision of the Agreement relating to any such right or obligation shall be deemed to survive the termination of the Services or (b) any continuing obligation, liability or responsibility of Consultant and of Client which would otherwise survive termination of the Services.
- 10.13 Texas Board of Architectural Examiners. To the extent that this Agreement includes landscape architectural services, under Chapter 1052 of the Texas Occupations Code, the Texas Board of Architectural Examiners - 333 Guadalupe, Suite 2-350, Austin, Texas 78701-3945, telephone (512) 305-9000 - has jurisdiction over complaints regarding the professional practices of persons registered as Landscape Architects in Texas.
- 10.14 For projects in North Carolina: Services in North Carolina are contracted through and provided by Atwell, PLLC dba RVI Planning + Landscape Architecture under North Carolina C-661.

**ARTICLE 11. APPROVED AND ACCEPTED**

Client approves and accepts the Agreement and authorizes Consultant to commence work upon Consultant's receipt of the properly executed and signed Agreement and specific amendments. If the Agreement is not executed by Client within thirty (30) days of the date tendered, it shall become invalid unless: (1) Consultant extends the time in writing; or (2) at the sole option of Consultant, Consultant accepts Client's oral, email or other written authorization to proceed with services, in which event the terms of the authorization shall be deemed to include all the terms of this Agreement. Consultant's performance of the services under such authorization shall be in reliance on the inclusion and incorporation of all the terms of the Agreement in the authorization.

**RVi Planning + Landscape Architecture, Inc.**

**City of Crest Hill**

Signature: 

Printed Name: Eric Hornig

Title: Principal

Date: June 11, 2026

Signature: \_\_\_\_\_

Printed Name: \_\_\_\_\_

Title: \_\_\_\_\_

Date: \_\_\_\_\_



CLIENT'S BILLING CONTACTS

Monthly invoices will be sent **by email** per the information provided by the Client below:

Name: \_\_\_\_\_

Title: \_\_\_\_\_

Invoicing address: \_\_\_\_\_

Telephone Number: \_\_\_\_\_

Fax Number: \_\_\_\_\_

Email Address: \_\_\_\_\_

Due date for timely processing of invoices: \_\_\_\_\_

If a special invoice is required, please attach a sample to the executed Professional Services Agreement.



EXHIBIT A: LIMIT OF WORK





Agenda Memo

Crest Hill, IL

**Meeting Date:** 7/6/2026

**Submitter:** Gary Richardson Director of Public Works

**Department:** Public Works

**Agenda Item:** Approval of Change Order No. 11 from Vissering Construction Inc. with the direction to send it to the IEPA for approval. Change Order will increase the amount of the contract to \$50,051,690.

**Summary:**

Strand Engineering and Public Works staff have reviewed the attached change order # 11, from Vissering Construction Inc for the West Plant Expansion Project and are asking the council to approve this change. Vissering’s change order #11 will increase the contract amount by \$355,982.

Original Contract Price \$50,640,000

Previous Change Order Adjustments (\$944,292)

Adjustment in Contract Price this Change Order \$355,982

Current Contract Price including this Change Order \$50,051,690

**Recommended Council Action:**

Approve a change order #11 from Vissering Construction Inc with direction to send it to the IEPA for approval. Change Order will increase the amount of the contract to \$50,051,690.

**Financial Impact:**

**Funding Source:** IEPA Loan

**Attachments:**

Strand Memo for Change Order #11



May 6, 2026

**CHANGE ORDER NO. 11**

**PROJECT:** West Sewage Treatment Plant (STP) Improvements  
**OWNER:** City of Crest Hill, Illinois  
**CONTRACT:** 1-2022  
**CONTRACTOR:** Vissering Construction Company

**Description of Change**

11a	Work described in the enclosed Contractor’s Cost Proposal Request (CPR) 044 Revision 1 (dated October 30, 2025) and Engineer’s CPR 044 (dated August 26, 2025) related to providing a platform lift to the second floor at Building E70.	ADD	\$26,124
11b	Work described in the enclosed Contractor’s CPR 048 Revision 2 (dated April 13, 2026) related to settled biosolids removal, dewatering, and disposal at the aeration tanks and anaerobic digesters.	ADD	\$233,169
11c	Work described in the enclosed Contractor’s CPR 050 Revision 1 (dated March 5, 2026) and Engineer’s CPR 050 Revision 1 (dated January 28, 2026) related to adding a run dry protection sensor, conduit, and wire to the plant water pump system.	ADD	\$12,113
11d	Work described in the enclosed Contractor’s CPR 051 (dated February 24, 2026) and enclosed Engineer’s CPR 051 Revision 1 (dated February 5, 2026) related to supervisory control and data acquisition data storage changes to the Historian License.	ADD	\$55,146
11e	Work described in the enclosed Contractor’s CPR 052 (dated April 20, 2026) and enclosed Engineer’s CPR 052 (dated April 9, 2026) related to providing additional emergency-stop push buttons for the tertiary filter equipment.	ADD	\$11,722
11f	Work described in the enclosed Contractor’s CPR 054 (dated May 4, 2026) related to repowering the Anaerobic Digester Building on a time and material basis.	ADD	\$17,708
<b>TOTAL VALUE OF THIS CHANGE ORDER:</b>		<b>ADD</b>	<b>\$355,982</b>

**Contract Price Adjustment**

Original Contract Price	\$50,640,000
Previous Change Order Adjustments	(\$944,292)
Adjustment in Contract Price this Change Order	\$355,982
<b>Current Contract Price including this Change Order</b>	<b>\$50,051,690</b>

City of Crest Hill–Vissering Construction Company  
Contract 1-2022, Change Order No. 11  
Page 2  
May 6, 2026

**Contract Substantial Completion Date Adjustment**

Original Contract Substantial Completion Date	December 1, 2024
Contract Substantial Completion Date Adjustments due to previous Change Orders	548 days
Contract Substantial Completion Date Adjustments due to this Change Order	0 days
Current Substantial Contract Completion Dates including all Change Orders	June 1, 2026

**Contract Final Completion Date Adjustment**

Original Contract Final Completion Date	March 1, 2025
Contract Final Completion Date Adjustments due to previous Change Orders	640 days
Contract Final Completion Date Adjustments due to this Change Order	0 days
Current Final Contract Completion Dates including all Change Orders	December 1, 2027

This document shall become a supplement to the Contract and all provisions will apply hereto.

**RECOMMENDED**

	May 6, 2026
_____ ENGINEER–Strand Associates, Inc.®	_____ Date

**APPROVED**

	May 7, 2026
_____ CONTRACTOR–Vissering Construction Company	_____ Date

**APPROVED**

	6/29/2026
_____ OWNER–City of Crest Hill, Illinois	_____ Date



**PROPOSAL  
WORKSHEET SUMMARY**

Project: CITY OF CREST HILL - WEST SEWAGE TREATMENT PLANT IMPROVEMENTS

Change Order Request #: 044

To: Strand Associates, Inc.  
Dominic Gattone, PE

Date: 10/30/2025  
A/E Project #: IDFPR No. 184-001273  
VCC Project #: 11108.00

WORK DESCRIPTION
Per CPR044 - Make changes to the platform lift installation, which replaced the elevator as part of CPR/CO#1.

Line No	Cost Description	Labor Amt	Material Amt	Equip & Other Amt	Sub-Contractor Amt	Sub-Total
1	Connelly Electric - See Attached				\$ 1,325.00	\$ 1,325.00
2	Vissering Construction	\$ 5,280.00	\$ 1,836.00	\$ 88.00		\$ 7,204.00
3	Ameri Glide - Original Pricing - See Attached		\$ (19,670.00)			\$ (19,670.00)
4	Ameri Glide - Final Pricing - See Attached		\$ 29,014.00			\$ 29,014.00
5	Doors/Frames/Hardware - LaForce - See Attached		\$ 2,076.00			\$ 2,076.00
6	Signage - Spec Ten - See Attached		\$ 275.00			\$ 275.00
7	Tape & Paint Drywall - RP Coatings - See Attached				\$ 2,610.00	\$ 2,610.00
8						\$ -
9						\$ -
10						\$ -
11						\$ -
12						\$ -
13						\$ -
14						\$ -
15						\$ -
16						\$ -
17						\$ -
18						\$ -
19						\$ -
20						\$ -
21						\$ -
22						\$ -
23						\$ -
24						\$ -
25						\$ -
<b>Sub-Total</b>		<b>\$ 5,280.00</b>	<b>\$ 13,531.00</b>	<b>\$ 88.00</b>	<b>\$ 3,935.00</b>	<b>\$ 22,834.00</b>

**ACCEPTANCE OF PROPOSAL (OWNER): City of Crest Hill**

Name/Title: Gary Richardson, Public Works Director  
Signature: \_\_\_\_\_  
Date: \_\_\_\_\_

Contractor's Net:	\$ 18,899.00
Sub-Contractor's Net:	\$ 3,935.00
Net Subtotal:	\$ 22,834.00
Contractor's Fee: (15% on Own Work, 5% on Subs, & 0% on Credits):	\$ 3,031.60
Sub-Total:	\$ 25,865.60
Bonds & Insurance - 1%:	\$ 258.66
<b>Worksheet Total:</b>	<b>\$ 26,124.00</b>

**ACCEPTANCE OF PROPOSAL (A/E): Strand Associates, Inc.**

Name/Title: Dominic Gattone, PE  
Signature: \_\_\_\_\_  
Date: \_\_\_\_\_

**ACCEPTANCE OF PROPOSAL (CONTRACTOR): VISSERING CONSTRUCTION CO**

Name/Title: Tony Marzetta, Project Manager  
Signature: \_\_\_\_\_  
Date: October 30, 2025



40 S. Addison Rd.  
Addison, IL 60101

# CHANGE NOTICE

Item P.

**Connelly CCN #** 024  
**Field Ticket #**  
**Date:** 10/2/2025  
**Project Name:** Crest Hill WWTP - West Sewage Treatment Plant  
**Project Number:** 22-0686  
**Page Number:** 1

**Client Address:**

**Vissering Construction**

1631 Gaylord Rd.  
Crest Hill, IL 60403  
Telephone: 815.673.5511  
Contact: Tony Marazetta

**Site Address:**

**Vissering Construction**

Contact: Tony Marazetta  
1631 Gaylord Rd.  
Crest Hill, IL 60403

---

**Work Description**

---

This quote covers direct costs only and we reserve the right to claim for impact and consequential costs.  
 This price is good for acceptance within **10** days from the date of receipt.  
 We request a time extension of **0** days.  
 We will supply and install all materials, labor, and equipment as per your instructions on **Connelly CCN # 024**.

**Description:**

This CCN was generated in response to CPR044 - Platform Lift.

Per the Cost Proposal No. 44, the purpose of this request is to make changes to the platform lift installation, which replaced the elevator as part of Cost Proposal Request (CPR)/Change Order No. 1.

---

**Itemized Breakdown**

---

Description	Qty	Total Mat.	Total Hrs.
Misc. Materials	1	100.00	8.00
<b>Totals</b>	<b>1</b>	<b>100.00</b>	<b>8.00</b>

---

**Summary**

---

**MATERIAL**

General Materials		100.00
<b>Material Total</b>		<b>100.00</b>
Foreman	(8.00 Hrs @ \$130.91)	1,047.28
Overhead	(@ 10.000 %)	114.73
Markup	(@ 5.000 %)	63.10
<b>Subtotal</b>		<b>1,325.11</b>
<b>Final Amount</b>		<b>\$1,325.11</b>

[Skip Navigation](#)

XSSMLXL

 [\(855\) 334-8018](tel:(855)334-8018) [\(855\) 334-8018](tel:(855)334-8018) [Call Now Free Quote Cart](#)

- [On Sale](#)
- [Stair Lifts](#)
- [Vertical Platform Lifts](#)
- [Elevators](#)
- [Lift Chairs](#)
- [Dumbwaiters](#)
- [Mobility Scooters](#)
- [Power Wheelchairs](#)

- 
- [Support](#)
  - [Blog](#)
  - [FAQs](#)
  - [Cart](#)

Search Products

[\(855\) 334-8018](tel:(855)334-8018)



What products can we help y

Questions? Call our experts.  
[\(855\) 334-8018](tel:(855)334-8018)

Search

[Cart](#)

Need Help?



Customer Service:

[1 \(800\) 580-0831](tel:18005800831)*8am-5pm EST - Mon-Fri*

Free Quote

Need Help?

Technical Support:

[1 \(800\) 791-6419](tel:18007916419)

Customer Service:

[1 \(800\) 580-0831](tel:18005800831)*8am-5pm EST - Mon-Fri*

Request Info

- [On Sale](#)
- [Stair Lifts](#)
- [Lift Chairs](#)
- [Platform Lifts](#)
- [Elevators](#)
- [Dumbwaiters](#)
- [Other Products](#)
- [Accessible Vehicles](#)[Accessories](#)[Mobility Scooters](#)[Pool Lifts](#)[Power Wheelchairs](#)[Vehicle Lifts](#)[Walk-in Tubs](#)[Wheelchair Ramps](#)[Order Replacement Parts](#)
- [Resources](#)

1. **Shopping Cart**
2. Addresses
3. Payment
4. Review

# Your Shopping Cart

"

Product	Qty Quantity	Price	Total
	<input type="text" value="1"/>	\$19,670.00	<b>\$19,670.00</b>
<a href="#">AmeriGlide - Hercules 750 - Commercial</a>			

**Category: Vertical Platform Lifts**

**Base Price** **\$6,499.00**

**Commercial DC 750 Includes**

2252 Keys \$0.00  
 Rocker Switch or NEMA 3R \$0.00

**Handling** \$0.00  
**Shipping** \$0.00  
**Order Total** **\$19,670.00**

<b>Product</b>	<b>Qty Quantity</b>	<b>Price</b>	<b>Total</b>
		<b>Base Price</b>	<b>\$6,499.00</b>
Manually Resettable Audible Platform Alarm		\$0.00	
Pit Switch		\$0.00	
Grab Bar		\$0.00	
Platform Lights		\$0.00	
Main Disconnect		\$0.00	
AC Power Cord and Interlock Wiring Kit (for Interlocks Included with Doors, Gates)		\$0.00	
		<b><u>Power Source</u></b>	
DC Battery Powered (2 x U1 Batteries Included)		\$0.00	
		<b><u>Number of Stops</u></b>	
Two Stop		\$0.00	
		<b><u>Lifting Height</u></b>	
160" Maximum Lift Height (190" Tower)		+\$7,999.00	
		<b><u>Select Tower Bracket Type</u></b>	
Ground Bracket (for 115",130", 160")		\$0.00	
		<b><u>Color of Unit</u></b>	
Grey (standard)		\$0.00	
		<b><u>Fascia Panels</u></b>	
No Fascia Panels		\$0.00	
		<b><u>Platform / Tower Configuration</u></b>	
Same Side Entry/Exit (For Hoistway Installs Only)		+\$999.00	
		<b>Handling</b>	\$0.00
		<b>Shipping</b>	\$0.00
		<b>Order Total</b>	<b>\$19,670.00</b>

Item P.

Product	Qty Quantity	Price	Total <span style="border: 1px solid black; padding: 2px;">Item P.</span>
<b>Base Price</b>		<b>\$6,499.00</b>	
<b><u>Guard Panels / Cab</u></b>			
42" High Steel Guard Panels (Standard)		\$0.00	
<b><u>Wing Walls</u></b>			
No Wing Walls		\$0.00	
<b><u>Platform Canopy for 42" Panels (Rather Than Full Cab)</u></b>			
No Canopy		\$0.00	
<b><u>Platform Dimensions (Dimensions are All Clear)</u></b>			
36" x 54"		\$0.00	
<b><u>Platform Controls</u></b>			
Lighted Buttons for COP		+\$399.00	
<b><u>Entrance Gates &amp; Doors (Interlock Included with Door/Gate)</u></b>			
38" to 42" W x 42 H Upper Landing Gate (includes Call/Send in frame)		+\$1,695.00	
<b><u>Delivery Options</u></b>			
Site Shipping - Customer Provided Fork Lift OR Loading Dock on Site		\$0.00	
<b><u>Delivery State</u></b>			
Illinois		+\$2,079.00	
		<b>Handling</b>	\$0.00
		<b>Shipping</b>	\$0.00
		<b>Order Total</b>	<b>\$19,670.00</b>

**Need more information?**



Item P.



5110 Atlantic Ave.  
 Raleigh, NC 27616  
 1 (800) 790-1635

## Sales Quotation #93993

For Vissering Construction  
 Created 10/13/25  
 Good Through 10/20/25  
 Prepared By Kenny Guzman

Item	Qty	Price	Ext.
<b>AmeriGlide - Hercules 750 - Commercial</b>	1	\$29,014.00	\$29,014.00
<b>Commercial DC 750 Includes</b>			
2252 Keys		incl.	
Rocker Switch or NEMA 3R		incl.	
Manually Resettable Audible Platform Alarm		incl.	
Pit Switch		incl.	
Grab Bar		incl.	
Platform Lights		incl.	
Main Disconnect		incl.	
AC Power Cord and Interlock Wiring Kit (for Interlocks Included with Doors, Gates)		incl.	
<b>Power Source</b>			
DC Battery Powered (2 x U1 Batteries Included)		incl.	
<b>Number of Stops</b>			
Two Stop		incl.	
<b>Lifting Height</b>			
160" Maximum Lift Height (190" Tower)		\$7,999.00	
<b>Select Tower Bracket Type</b>			
No Bracket Desired (for 44", 64", 78", 98")		incl.	
<b>Color of Unit</b>			
Grey (standard)		incl.	
<b>Fascia Panels</b>			

Item	Qty	Price
No Fascia Panels		incl.
<b>Platform / Tower Configuration</b>		
Same Side Entry/Exit (For Hoistway Installs Only)		\$999.00
<b>Guard Panels / Cab</b>		
42" High Steel Guard Panels (Standard)		incl.
<b>Wing Walls</b>		
No Wing Walls		incl.
<b>Platform Canopy for 42" Panels (Rather Than Full Cab)</b>		
No Canopy		incl.
<b>Platform Dimensions (Dimensions are All Clear)</b>		
36" x 54"		incl.
<b>Platform Controls</b>		
Lighted Buttons for COP		\$399.00
<b>Call/Send Options</b>		
Keyed Call/Send Flush Mount - Lower Landing		\$250.00
Keyed Call/Send Flush Mount - Upper Landing		\$250.00
<b>Other Options</b>		
Fixed Ramp for Bottom Landing		\$599.00
<b>Delivery Options</b>		
Site Shipping - Flatbed & Forklift Delivery (Available in Most Areas)		\$850.00
<b>Delivery State</b>		
Illinois		\$2,079.00
<b>Entrance Gates &amp; Doors (Interlock Included with Door/Gate)</b>		
Door 80" H x 36" W Fire Rated	2 @ \$2,250.00 ea = \$4,500.00	
<b>Auto Operators and Closers</b>		
Auto Operator for Door Qty.	2 @ \$2,295.00 ea = \$4,590.00	
		<b>Item</b> \$29,014.00
		<b>Total</b>
		<b>Est. Tax</b> \$0.00
		<b>Shipping</b> \$0.00
		<b>Total</b> \$29,014.00

if clicking buy now does not work, copy and paste or type the following into your browser:  
<https://www.ameriglide.com/redeemQuote.html?q=YD6GNGV18P7NE1Y4>

**Buy Now**

## QUOTATION

DATE: 9/19/2025

VISSERING CONSTRUCTION  
175 BENCHMARK INDUSTRIAL DR  
P O BOX 417  
STREATOR, IL 61364  
USA

RE: CREST HILL WWTP CPR044  
Our Quote #: 527894QU  
Contact: AUSTIN NGUYEN  
Phone: 608.222.2424

- This quotation is subject to acceptance within 30 calendar days from the date of this quotation. If not accepted by that date it may be withdrawn or modified without notice.
- Tax quoted is LaForce's interpretation of taxes required, tax is subject to change depending on building permit and tax exempt certificate information.
- All quotes are subject to the potential addition of a cost surcharge contingent upon the final resolution of proposed import tariffs. Any surcharge(s), if applicable, will be disclosed at the time they are received.

FREIGHT INCLUDED  
F.O.B. JOBSITE (MATERIAL ONLY)

### HOLLOW METAL FRAMES/ HOLLOW METAL DOORS/ HARDWARE:

Bid Total with Tax Included	<u>\$2,231.00</u>
Tax breakout for base bid only (if alternate pricing is accepted, tax amount subject to change)	<u>\$155.00</u>
Base Bid Amount Less Tax	<u>\$2,076.00</u>

- 1 WELDED HM FRAMES
- 1 HM DOORS
- 1 LOT OF HARDWARE

### GENERAL QUALIFICATIONS

- Our price for all materials is based upon receipt of full approval and release within 4 months from bid day for delivery by the manufacturer's standard leadtimes as quoted. If this timetable does not meet the requirements of this project, please call us to discuss further.
- JAMB DEPTH QUOTED AS 5 3/4
- FRAME QUOTED AS 90 MINUTE RATED
- DOOR QUOTED AS 90 MINUTE RATED

### LEADTIMES AFTER SUBMITTAL APPROVAL AND ANSWERS TO ALL QUESTIONS

HOLLOW METAL FRAMES: 6-8 WEEKS  
HOLLOW METAL DOORS: 10-13 WEEKS  
HARDWARE TO SHIP WITH DOORS

**THIS QUOTATION INCLUDES AND IS SUBJECT TO THE ONE PAGE OF TERMS AND CONDITIONS LOCATED AT THE END OF THIS QUOTATION.**

# SPEC TEN, etc., LLC

"a Division 10 & more company"

1586 North Road

E. Fairfield, Vermont 05448

Tel. (802) 849-9222 Fax (802) 849-9244

email: [andy@spectenvt.com](mailto:andy@spectenvt.com)

TO: Julie Eurich  
Vissering Constr. Co.

**QUOTE # 225-00**

Date: 09-16-2025

TERMS: TBD\*

FOB: Freight Allowed

## QUOTATION

<b>WWTP</b>
<b>CREST HILL, IL</b>

<i>We are pleased to quote the following, <b>per plans and specs... furnished only and delivered</b> to jobsite. (Excludes all taxes)</i>	<b><u>TOTAL PRICE</u></b>
(2) Attachment "A" In Case Of Fire Do Not Use Lift signs	\$ 275.00

**Hardware and fasteners by others.**

NO RETAINAGE PERMITTED \*Deposits may be required on certain sections.

**VALID FOR 30 DAYS**

**SIGNATURE: Andy R. Tetrault, President**





October 29, 2025

To: Vissering Construction  
 Re: Crest Hill West Sewage Treatment Plant  
 RFP 044

**Tape and paint new drywall  
 Paint door and frame**

**Labor**  
 18 hrs @ \$ 120.00 /hr..... \$ **2,160**

**Materials & Equipment**

1 rolls joint tape @	\$	5.50 /roll.....	\$	<b>6</b>
2 buckets joint compound @	\$	22.50 /bucket.....	\$	<b>45</b>
1 gal drywall primer @	\$	15.00 /gal.....	\$	<b>15</b>
2 gal acrylic finish @	\$	22.00 /gal.....	\$	<b>44</b>
Subtotal.....				\$ <b>2,270</b>
15% Markup.....				\$ <b>340</b>
<b>Total Add .....</b>				\$ <b>2,610</b>

Doug Penrod  
 RP Coatings, Inc.  
 Cell: 618-978-7595  
 Email: doug@rpcoatings.com



Cost Proposal Request  
 West Sewage Treatment Plant Improvements  
 City of Crest Hill  
 Contract 1-2022  
 August 26, 2025

COST PROPOSAL NO.: 044

TO: Vissering Construction  
 ISSUED BY: Dominic Gattone, P.E.

DISTRIBUTION

Tony Marzetta, Project Manager	Vissering Construction (Contractor)
Julius Hansen	City of Crest Hill
Dominic Gattone, P.E.	Strand Associates, Inc.®

Please submit an itemized quotation for changes in the Contract Price and Time incidental to proposed modifications to the Contract Documents described herein. The purpose of this request is to make changes to the platform lift installation, which replaced the elevator as part of Cost Proposal Request (CPR)/Change Order No. 1.

DESCRIPTIONS AFFECTING THE DRAWINGS

**Drawing E70-ASM1.01**

- 044-01 Frame and drywall the northern and eastern shaft fenestration surrounding the newly proposed door on the first floor. See attached drawing.
- 044-02 Change manufacturer provided first-floor half-height door with full height mandoor. Rewire electrical componentry from manufacturer-provided call-station to interlock doorway hardware (automatic door opener) with platform lift system operation, as described below.
- Add row to Drawing 99-ASM6.01 Door 7002C, size 3'-6" x 7'-0", type - STL, active - HG, swing - RHR, frame type - 1, frame material - STL, hardware group - as provided by product manufacturer, active, lintel - B-1, Details, head - F-99-ASM6.02, jamb - F-99-ASM6.02, sill - N/A
- 044-03 Provide attached pictograph (Attachment A) at first floor and second floor call stations. Pictograph shall conform to Section 10 14 00 - Plastic and Metal Signs.

**Clarification: Fire Protection System shall remain in shaft as shown on E70-FP1.02.**

**Drawing E70-ASM1.02**

- 044-04 Frame northern shaft fenestration on second floor. See attached drawing. Standard manufacturer-provided door, its respective wiring, and call-station shall remain at the second floor.

DESCRIPTIONS AFFECTING THE SPECIFICATIONS

- 044-05 Add Section 08 71 10 - Automatic Door Operators, attached.

**Clarification: It is the intent of this CPR to have the door opener/closer system interlocked with the platform travel. With the changing of the first-floor door, the new door operation shall work in an identical way to the manufacturer's stock door. For example, the door will automatically unlock/open when the platform arrives from the second floor after an operator adjustable time delay. Additionally, the door will automatically open**



when the call button is pressed and the platform has arrived and stationed at the first floor. The door shall not open when the platform is not stationed there. If the first-floor door were to open and the platform is not in the down position, power to the platform shall be terminated.

Attachment A -

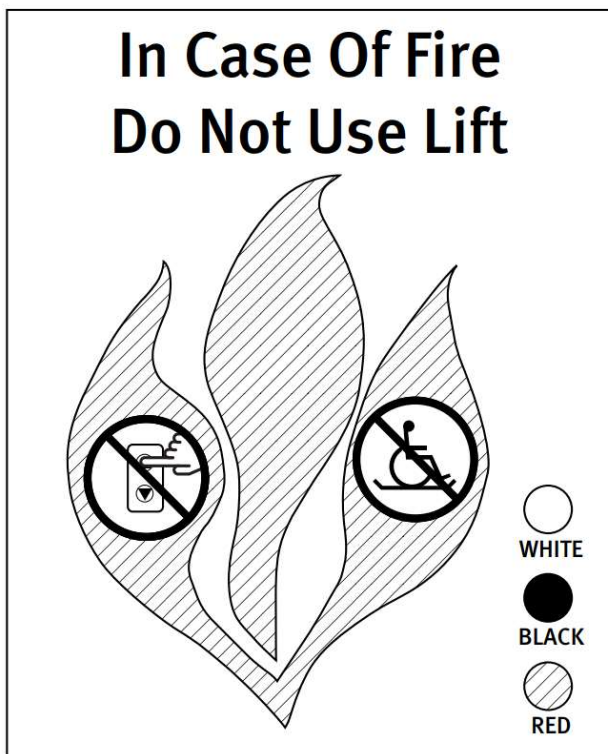

## SECTION 08 71 10

## AUTOMATIC DOOR OPERATORS

PART 1–GENERAL

## 1.01 SUMMARY

- A. This Section includes the following types of automatic door operators: Exterior and interior, automatic door operators, low energy, with bottom load headers and surface or concealed mounting.

## 1.02 REFERENCES

General: Standards listed by reference, including revisions by issuing authority, form a part of this specification section to extent indicated. Standards listed are identified by issuing authority, authority abbreviation, designation number, title or other designation established by issuing authority. Standards subsequently referenced herein are referred to by issuing authority abbreviation and standard designation.

- A. Underwriters Laboratories (UL): UL 325–Standard for Door, Drapery, Gate, Louver, and Window Operators and Systems.
- B. American National Standards Institute (ANSI)/Builders' Hardware Manufacturers Association (BHMA):
1. ANSI/BHMA A156.10: Standard for Power Operated Pedestrian Doors.
  2. ANSI/BHMA A156.19: Standard for Power Assist and Low Energy Power Operated Doors.
- C. American Society for Testing and Materials (ASTM):
1. ASTM B221–Standard Specification for Aluminum and Aluminum-Alloy Extruded Bars, Rods, Wire, Profiles, and Tubes.
  2. ASTM B209–Standard Specifications for Aluminum and Aluminum-Alloy Sheet and Plate.
- D. Builders' Hardware Manufacturers Association (BHMA): BHMAA156.10–Standard for Power Operated Pedestrian Door.
- E. American Association of Automatic Door Manufacturers (AAADM).
- F. National Fire Protection Association (NFPA):
1. NFPA 101–Life Safety Code.
  2. NFPA 70–National Electric Code.
- G. International Conference of Building Officials (ICBO): UBC 1997: Uniform Building Code.
- H. California Department of Forestry and Fire Protection, Office of the State Fire Marshall.
- I. International Standards Organization (ISO): ISO 9001–Standard for Manufacturing Quality Management Systems.

- J. National Association of Architectural Metal Manufacturers (NAAMM): Metal Finishes Manual for Architectural and Metal Products.
- K. American Architectural Manufacturers Association (AAMA):
  - 1. AAMA 607.1–Clear Anodic Finishes for Architectural Aluminum.
  - 2. AAMA 611 Voluntary Specification for Anodized Architectural Aluminum.

### 1.03 DEFINITIONS

- A. Activation Device: Device that, when actuated, sends an electrical signal to the door operator to open the door.

### 1.04 PERFORMANCE REQUIREMENTS

- A. Provide automatic door operators capable of withstanding loads and thermal movements based on testing manufacturer's standard units in assemblies similar to those indicated for this Project.
- B. Operating Range: Minus 30°F (Minus 34°C) to 130°F (54°C).
- C. Opening-Force Requirements for Egress Doors: In the event power failure to the operator, swinging automatic entrance doors shall open with a manual force, not to exceed 30 lbf (133 N) applied at 1 inch (25 mm) from the latch edge of the door.
- D. Break Away Requirements: Automatic door operators shall breakaway with no more than 50 lbf (222 N) applied at 1 inch (25 mm) from the latch edge of the door.
- E. Door Energy: The kinetic energy of a door in motion shall not exceed 1.25 lbf-ft (1.69 Nm).
- F. Closing Time:
  - 1. Doors shall be field adjusted to close from 90 degrees to 10 degrees in 3 seconds or longer.
  - 2. Doors shall be field adjusted to close from 10 degrees to fully closed in not less than 1.5 seconds.

### 1.05 SUBMITTALS

- A. Submit listed submittals in accordance with Conditions of the Contract and Division 01 submittal procedures.
- B. Shop Drawings: Include plans, elevations, sections, details, hardware mounting heights, and attachments to other work. Indicate wiring for electrical supply.
- C. Color Samples for selection of factory-applied color finishes.
- D. Closeout Submittals: Provide the following with project close-out documents.
  - 1. Owner's Manual.
  - 2. Warranties.

## 1.06 QUALITY ASSURANCE

- A. Installer Qualifications: Manufacturer's authorized representative, with certificate issued by AAADM, who is trained for installation and maintenance of units required for this Project.
- B. Manufacturer Qualifications: A qualified manufacturer with a manufacturing facility certified under ISO 9001 and with company certificate issued by AAADM.
- C. Certifications: Automatic door operators shall be certified by the manufacturer to meet performance design criteria in accordance with the following standards:
  - 1. ANSI A156.10.
  - 2. NFPA 101.
  - 3. UL 325 Listed (Fire Door Operator).
  - 4. ICBO (UBC Standard 10-1).
  - 5. California Department of Forestry and Fire Protection, Listed.
- D. Source Limitations: Obtain automatic door operators through one source from a single manufacturer.
- E. Product Options: Drawings indicate sizes, profiles, and dimensional requirements of automatic door operators and are based on the specific system indicated. Refer to Division 01 Section "Product Requirements."
- F. Power Operated Door Standard: ANSI/BHMA A156.19.
- G. Electrical Components, Devices, and Accessories: Listed and labeled as defined in NFPA 70, Article 100, by a testing agency acceptable to authorities having jurisdiction, and marked for intended use.
- H. Emergency-Exit Door Requirements: Comply with requirements of authorities having jurisdiction for swinging automatic entrance doors serving as a required means of egress.

## 1.07 PROJECT CONDITIONS

- A. Field Measurements: General Contractor shall verify openings to receive automatic door operators by field measurements before fabrication and indicate measurements on Shop Drawings.
- B. Mounting Surfaces: General Contractor shall verify all surfaces to be plumb, straight and secure; substrates to be of proper dimension and material.
- C. Other trades: General Contractor Advise of any inadequate conditions or equipment.

## 1.08 COORDINATION

- A. Templates: Check Shop Drawings of other work to confirm that adequate provisions are made for locating and installing automatic door operators to comply with indicated requirements.
- B. Electrical System Roughing-in: Coordinate layout and installation of automatic door operators with connections to, power supplies and remote activation devices.

- C. System Integration: Integrate automatic door operators with other systems as required for a complete working installation.
  1. Provide electrical interface control capability for card reader or keypad operation of automatic door operators on doors with electric locking.
  2. Where required for proper operation, provide a time relay to signal automatic door operator to activate only after electric lock system is released.

#### 1.09 WARRANTY

- A. Automatic door operators shall be free of defects in material and workmanship for a period of one year from the date of substantial completion.
- B. During the warranty period OWNER shall engage a factory-trained technician to perform service and affect repairs. A safety inspection shall be performed after each adjustment or repair and a completed inspection form shall be submitted to OWNER.
- C. During the warranty period all warranty work, including but not limited to emergency service, shall be performed during normal working hours.

### PART 2-PRODUCTS

#### 2.01 AUTOMATIC DOOR OPERATORS

- A. Manufacturer: Stanley Access Technologies; M-Force™ Series automatic door operator.

#### 2.02 MATERIALS

- A. Aluminum: Alloy and temper recommended by manufacturer for type of use and finish indicated.
  1. Headers: 6063-T6.
  2. Extruded Bars, Rods, Profiles, and Tubes: ASTM B 221.
  3. Sheet and Plate: ASTM B 209.

#### 2.03 COMPONENTS

- A. Header Case: Header case shall not exceed 4 1/2-inch by 6-inch (114 mm) in section and shall be fabricated from extruded aluminum designed to conceal door operators and controls. The operator shall be sealed against dust, dirt, and corrosion within the header case. Access to the operator and electronic control box shall be provided from the bottom by a removable cover. Removable cover shall be secured in place by screws.
- B. Door Arms: Door arms shall be manufacturer's standard units designed specifically for use with automatic door operators provided.
  1. Visible Arms: A combination of door arms and linkage shall provide positive control of door through entire swing; units shall permit use of butt hung, center pivot, and offset pivot-hung doors.
  2. Concealed Arms: A single straight arm, designed for top mounting in door panel, shall provide positive control of door through entire swing; units shall be specifically designed for use on center pivot doors.

- C. Fasteners and Accessories: Manufacturer's standard corrosion-resistant, non-staining, non-bleeding fasteners and accessories compatible with adjacent materials.
- D. Signage: Provide signage in accordance with ANSI/BHMAA156.19.

#### 2.04 SWINGING DOOR OPERATORS

- A. Provide door operators of size recommended by manufacturer for door size, weight, and movement; for condition of exposure; and for long-term, maintenance-free operation under normal traffic load for type of occupancy indicated.
- B. Electromechanical Operators: Self-contained unit powered by a minimum 3/16 horsepower, permanent-magnet DC motor; through a high torque reduction gear system.
  - 1. Operation: Power opening and spring closing.
  - 2. Operator Type: Low energy; readily convertible to full energy; no tools required to change type.
  - 3. Handing: Non-handed; no tools required to change handing.
  - 4. Capacity: Rated for door panels weighing up to 350 pounds.
  - 5. Mounting: Surface applied or concealed as indicated.
  - 6. Features:
    - a. Adjustable opening and closing speeds.
    - b. Adjustable opening and closing force.
    - c. Adjustable back-check.
    - d. Adjustable hold-open time between 0 and 30 seconds.
    - e. Reverse on obstruction.
    - f. Variable rate open/closed speed control.
    - g. Closed loop speed control with active braking and acceleration.
    - h. Variable obstruction recycle time delay.
    - i. Optional Switch to open/Switch to close operation.
    - j. When operators are provided in pairs, adjustable features are independently adjustable for each operator.
- C. Field Adjustable Spring Closing Operation: The operator shall close the door by spring energy employing the motor, as a dynamic brake to provide closing speed control. The closing spring shall be a helical compression spring, adjustable for positive closing action. The spring shall be adjustable, without removing the operator from the header, to accommodate a wide range of field conditions.
- D. Independent Adjustable Closing and Latching Speed Control: The operator shall employ a rheostat module to allow for independent field adjustment of closing and latching speeds using the motor as a dynamic brake.
- E. Field Adjustable Open Stop: The operator shall provide a field adjustable open stop to accommodate opening angles from 80 to 135 degrees without the need for additional components.
- F. Consistent Cycle: The operator shall deliver an even, consistent open manual push force across the entire transition from door fully closed to door fully open. Additionally, the force shall be field adjustable to accommodate a wide range of on-site conditions.
- G. Quiet Performance: The operator shall be designed to output audible noise ratios less than or equal to 50 dba.

- H. Manual Use: The operator shall function as a manual door closer in the direction of swing with or without electrical power. The operator shall deliver an even, consistent open force across the entire transition from door fully closed to door fully open, except as restricted by platform lift controls.
- I. Electrical service to door operators shall be provided under Division 26 Electrical. Minimum service to be 120 VAC, 10 amps for doors with operators in pairs, 5 amps for single doors.

## 2.05 ELECTRICAL CONTROLS

- A. Electrical Control System: Electrical control system shall include a microprocessor controller and a high-resolution position encoder. The encoder shall monitor revolutions of the operator shaft and send signals to microprocessor controller to define door position. Systems utilizing external magnets and magnetic switches are not acceptable.
- B. Life Cycle Data Counter: The microprocessor control shall incorporate a nonresettable counter to track door operation cycles.
- C. Controller Protection: The microprocessor controller shall incorporate the following features to provide trouble free operation:
  1. Automatic Reset Upon Power Up.
  2. Main Fuse Protection.
  3. Electronic Surge Protection.
  4. Internal Power Supply Protection.
  5. Resettable sensor supply fuse protection.
  6. Software "Watchdog" protection in the case of software malfunction.
- D. Push Button Interface with LED: The controller shall have push button switches with LED readout to allow for selection or change of the following parameters: carpet or timer logic, single or dual door, activation options, normal back check or large back check, push-to-open assist on/off.
- E. Soft Start/Stop: A "soft-start" "soft-stop" motor driving circuit shall be provided for smooth normal opening and recycling.
- F. Safety Search Circuitry: Provide system to recycle the swinging panels when an obstruction is encountered during the closing cycle. If an obstruction is detected, the system shall search for that object on the next closing cycle by reducing door closing speed prior to the previously encountered obstruction location and will continue to close in check speed until doors are fully closed, at which time the doors will reset to normal speed. If obstruction is encountered again, the door will come to a full stop. The doors shall remain stopped until obstruction is removed and operate signal is given, resetting the door to normal operation.
- G. Programmable Controller: Microprocessor controller shall be programmable and shall be designed for connection to a local configuration tool. Local configuration tool shall be software driven and shall be utilized via Palm<sup>®</sup> handheld interface. The following parameters may be adjusted via the configuration tool.
  1. Operating speeds and forces as required to meet ASNI/BHMA A156.10.
  2. Adjustable and variable features as specified in Paragraph 2.04.B.6.
  3. Firmware update.
  4. Trouble shooting.
    - a. I/O Status.

- b. Electrical component monitoring including parameter summary.
  - 5. Entrance profile copy/paste.
  - 6. Software for local configuration tool shall be available as a free download from the automatic door operators' manufacturer's internet site.
- H. Emergency Breakout Switch: A cam actuated emergency breakout switch shall be provided to disconnect power to the motor when an in-swinging door is manually pushed in the emergency out direction. The operator will then automatically reset and power will be resumed.
- I. Control Switch: Automatic door operators shall be equipped with a three position function switch to control the operation of the door. Control switch shall provide three modes of operation, Automatic, Off, and Hold-Open.
- J. Power Switch: Automatic door operators shall be equipped with a two position On/Off switch to control power to the door.

## 2.06 ALUMINUM FINISHES

- A. Comply with NAAMM Metal Finishes Manual for Architectural and Metal Products for recommendations for applying and designing finishes. Finish designations prefixed by AA comply with system established by Aluminum Association for designing finishes.
- B. Class II, Clear Anodic Finish: AA-M12C22A31 Mechanical Finish: as fabricated; Chemical Finish: etched, medium matte; Anodic Coating: Architectural Class II, clear coating 0.40 mils minimum complying with AAMA 611-98, and the following
  - 1. AAMA 607.1.
  - 2. Applicator must be fully compliant with all applicable environmental regulations and permits, including wastewater and heavy metal discharge.

## PART 3-EXECUTION

### 3.01 INSPECTION

- A. Examine conditions, with Installer present, for compliance with requirements for installation tolerances, header support, and other conditions affecting performance of swinging automatic entrance doors. Proceed with installation only after unsatisfactory conditions have been corrected.

### 3.02 INSTALLATION

- A. Do not install damaged components. Fit joints to produce hairline joints free of burrs and distortion. Rigidly secure non-movement joints.
- B. Mounting: Install automatic door operators/headers plumb and true in alignment with established lines and grades. Anchor securely in place.
  - 1. Install surface-mounted hardware using concealed fasteners to greatest extent possible.
  - 2. Set headers, arms and linkages level and true to location with anchorage for permanent support.

- C. Door Operators: Connect door operators to electrical power distribution system as specified in Division 26 Sections.
- D. Sealant: Comply with requirements specified in Section 07 90 00–Caulking and Sealants to provide weather tight installation.

### 3.03 FIELD QUALITY CONTROL

- A. Testing Services: Factory Trained Installer shall test and inspect each swinging automatic entrance door to determine compliance of installed systems with applicable ANSI standards.

### 3.04 ADJUSTING

- A. Adjust door operators, controls, and hardware for smooth and safe operation, for weather tight closure, and complying with requirements in ANSI/BHMA A156.19 by AAADM Certified Technician.

### 3.05 CLEANING AND PROTECTION

- A. Clean surfaces promptly after installation. Remove excess sealant compounds, dirt, and other substances. Repair damaged finish to match original finish.

END OF SECTION

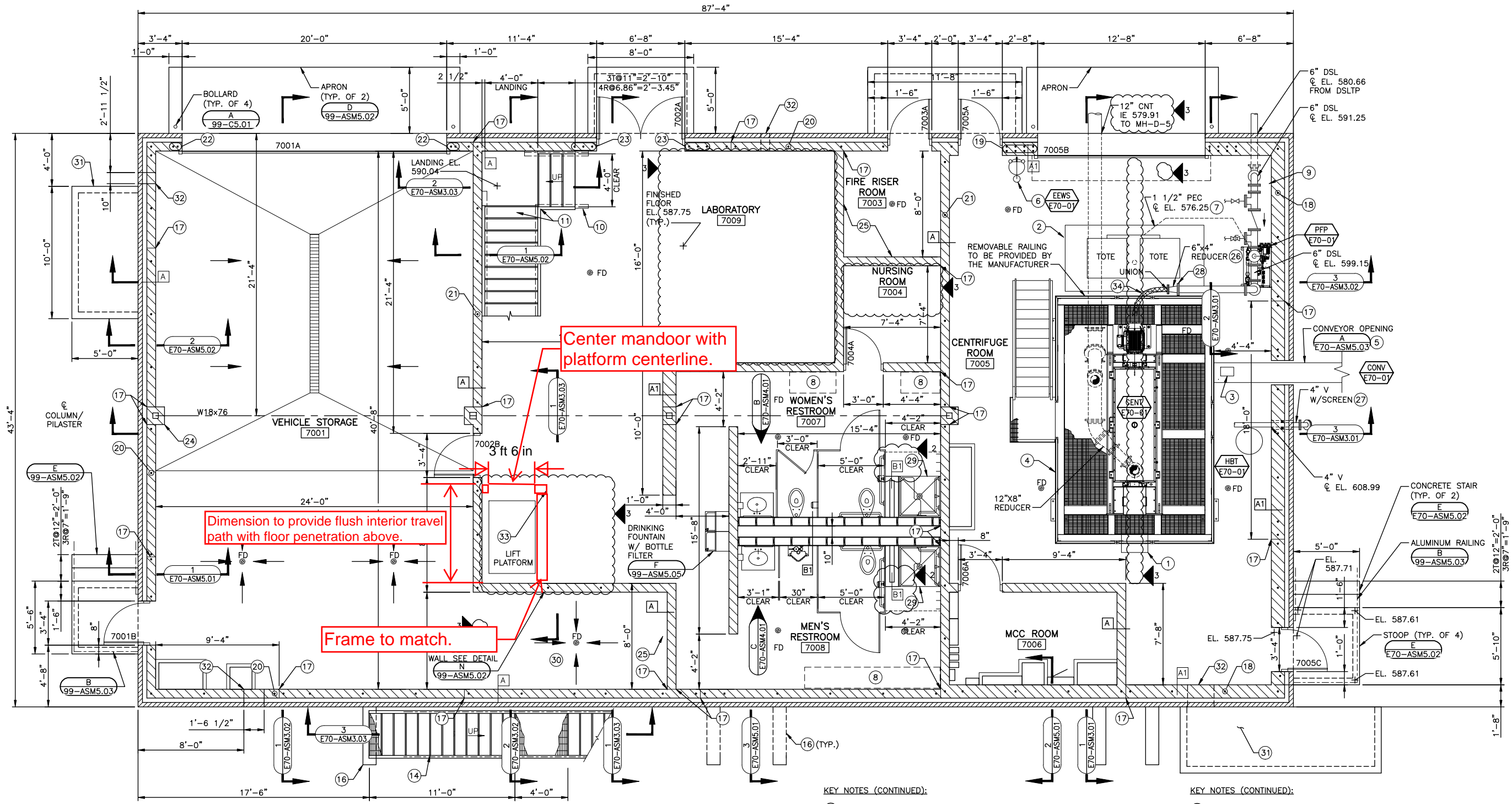

LOWER LEVEL PLAN

- GENERAL NOTES:**
- SEE ROOM FINISH SCHEDULE AND SPECIFICATION FOR TREATMENTS OF WALLS, FLOORS AND CEILINGS NOT CALLED OUT ON DRAWINGS.
  - SEE SPECIFICATIONS FOR LAB AND SCADA/CONTROL ROOM FURNITURE.
  - EXCEPT WHERE SHOWN OTHERWISE, ROOM FURNITURE AND ARCHITECTURAL CASEWORK (SHELVING, COUNTERS, ETC.) SHALL BE PROVIDED BY CONTRACTOR AS SHOWN AND SPECIFIED.
  - RESTRAIN ALL DUCTILE IRON JOINTS BURIED UNDER SLAB.
  - SEE 99-ASM6.03 FOR GENERAL STRUCTURE NOTES.

- KEY NOTES:**
- HYDRAULIC BACK DRIVE.
  - POLYMER TOTE CONTAINMENT, SEE SPECIFICATIONS.
  - PROVIDE INSPECTION HATCHES ON THE CONVEYORS AT LOCATIONS ACCESSIBLE TO OPERATORS. PROVIDE ADDITIONAL HATCH BENEATH PLATFORM. COORDINATE SIZE TO AVOID CONFLICT W/ PLATFORM.
  - ACCESS WALKWAYS AND STAIRS BY EQUIPMENT MANUFACTURER.
  - CONVEYOR SHALL BE HEAT TRACED AND INSULATED ACCORDING TO THE SPECIFICATIONS. CONVEYOR SHALL BE HEAT TRACED AND INSULATED FROM BUILDING E70 TO THE END OF THE CONVEYOR.
  - EMERGENCY EYE WASH AND SAFETY SHOWER.
  - PROVIDE LONG RADIUS ELBOWS FOR UNDERSLAB PEC CHEMICAL PIPE.
  - SPACE RESERVED FOR ADA LOCKERS AND ADA BENCHES.
  - MOUNT PEC PIPING TO WALL. PROVIDE SUPPORTS AS NECESSARY.
  - 1'-0" HANDRAIL EXTENSION (TYP.)

- KEY NOTES (CONTINUED):**
- CONCRETE PAN STAIRS WITH VINYL TREAD AND RISER FINISH. 4'-5" OUT-TO-OUT. SEE SPECIFICATION 09 65 13 FOR FINISH.
  - NOT USED
  - METAL SHROUD FOR MACHINE SPACE BY ELEVATOR MANUFACTURER.
  - ALUMINUM GRATING STAIRS (E) 99-ASM5.04
  - NOT USED
  - STAIR FOUNDATION (G) 99-ASM5.02
  - MCJ-2 (L) 99-ASM5.02 FOR MCJ'S IN BRICK VENEER, SEE ELEVATION VIEWS.
  - #6@40" VERTICAL MASONRY REINFORCING (TYP. AT EXTERIOR 12" BLOCK WALLS).
  - 1~#6 EACH FACE @ 8" VERTICAL MASONRY REINFORCING (TYP. 1ST 4 CORES AT OHC DOOR JAMBS).
  - #4@48" VERTICAL MASONRY REINFORCING (TYP. EXTERIOR 8" BLOCK WALLS).

- KEY NOTES (CONTINUED):**
- #4@48" VERTICAL MASONRY REINFORCING.
  - 1~#4 VERTICAL BAR @ 8" TYP. 1ST 2 CORES AT JAMBS.
  - 1~#4 VERTICAL @ 8" TYP. 1ST 3 CORES AT JAMBS.
  - MASONRY PILASTER (TYP. OF 4) (B) E70-ASM5.03
  - NON-BEARING MASONRY WALL (N) 99-ASM5.02
  - 4"x1/2" REDUCER AND 1/2" FLEXIBLE HOSE TO BE PROVIDED BY CENTRIFUGE MANUFACTURER.
  - NON-CORRODING INSECT SCREEN BETWEEN TWO FLANGES ON DOWNWARD TURNED 45° FLANGED FITTING.
  - PRESSURE GAUGE CONNECTION, SEE DETAIL (J) 99-P5.01
  - BARRIER FREE SHOWER, SEE DETAIL (B) 99-ASM5.06
  - TOOL STORAGE AND ACCESS TO ELEVATOR CONTROL PANEL.
  - HVAC EQUIPMENT PAD. VERIFY SIZE AND LOCATION W/HVAC SCHEDULES.
  - HVAC OPENING. SEE H-DRAWINGS AND LINTEL SCHEDULE.
  - PROVIDE LINTEL B-1 AT LIFT PLATFORM ENTRY AND EQUIPMENT ACCESS DOORWAYS AND EQUIPMENT ACCESS.
  - FLEXIBLE HOSE BY MANUFACTURER TO LEFT OF UNION.
  - NOT USED

NO.	ISSUED FOR	DATE
1	ISSUED FOR BID	5/12/2022
2	CONFORMED DRAWINGS	12/1/2022
3	CHANGE ORDER NO. 1	X/7/2023

**DEWATERING AND OPERATIONS BUILDING  
LOWER LEVEL PLAN**

WEST SEWAGE TREATMENT PLANT IMPROVEMENTS  
CITY OF CREST HILL  
WILL COUNTY, ILLINOIS

**JOB NO.**  
3894.051  
**PROJECT MGR.**  
DOMINIC GATTONE



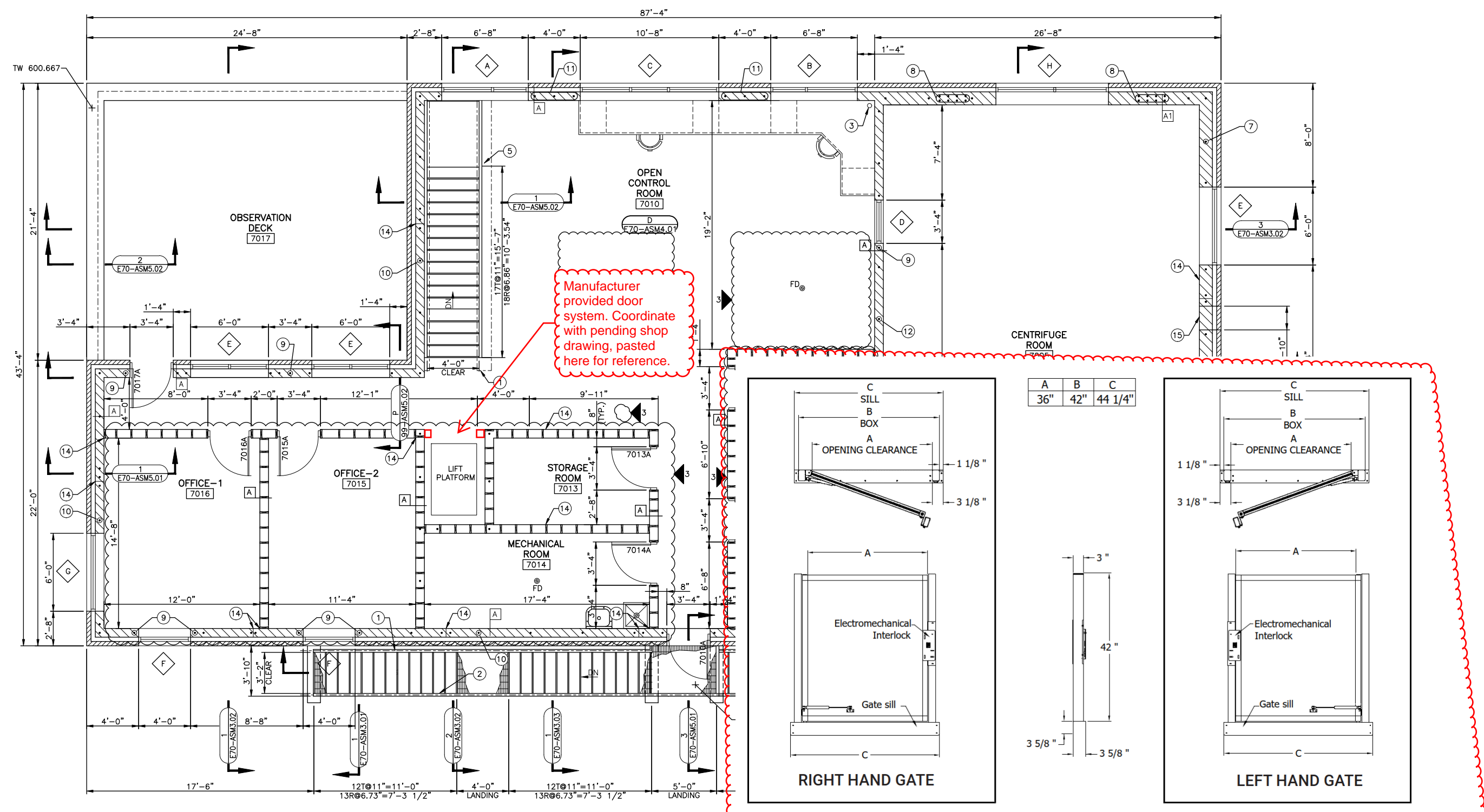

Manufacturer provided door system. Coordinate with pending shop drawing, pasted here for reference.

A	B	C
36"	42"	44 1/4"

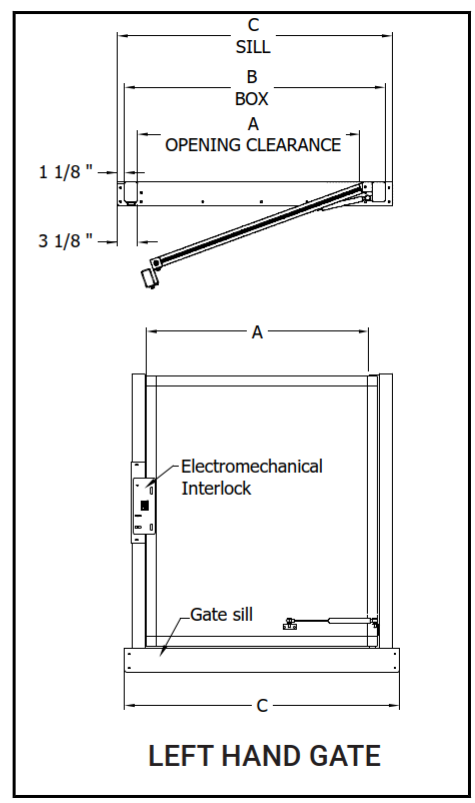
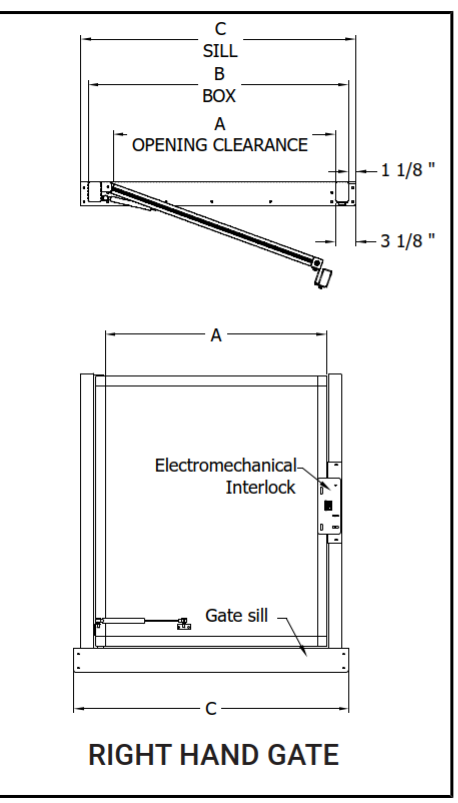

UPPER LEVEL PLAN  
0 1' 2' 4' 8'

GENERAL NOTES:

- SEE ROOM FINISH SCHEDULE AND SPECIFICATION FOR TREATMENTS OF WALLS, FLOORS AND CEILINGS NOT CALLED OUT ON DRAWINGS.
- SEE SPECIFICATIONS FOR LAB AND SCADA/CONTROL ROOM FURNITURE.
- EXCEPT WHERE SHOWN OTHERWISE, ROOM FURNITURE AND ARCHITECTURAL CASEWORK (SHELVING, COUNTERS, ETC.) SHALL BE PROVIDED BY CONTRACTOR AS SHOWN AND SPECIFIED.
- SEE 99-ASM6.03 FOR GENERAL STRUCTURAL NOTES.

KEY NOTES:

- 1'-0" HANDRAIL EXTENSION (TYP.)
- ALUMINUM STAIRS, 3'-10" OUT-TO-OUT. (E 99-ASM5.04)
- PROVIDE GROMMET IN COUNTERTOP.
- HVAC OPENING. SEE H-DRAWINGS AND LINTEL SCHEDULE.
- 42" HIGH GUARD RAIL AROUND FLOOR OPENING.
- NOT USED.
- #6@40" MASONRY VERTICAL BARS. (TYP. AT EXTERIOR 12" BLOCK)
- 1~#6 EA. FACE @ 8" SEE DRAWING E70-ASM1.01.

KEY NOTES (CONTINUED):

- 1~#4 AT WINDOW JAMBS UNLESS NOTED.
- #4@48" (TYP. AT EXTERIOR 8" BLOCK).
- 1~#4 @ 16" O.C. IN 4'-0" JAMB.
- #4@48" (TYP. WHERE SHOWN IN INTERIOR BLOCK).
- NOT USED
- MCJ-2 99-ASM5.02 SEE ELEVATION VIEWS FOR MCJ-1'S IN VENEER.
- OPENING IN CONVEYOR, SEE LINTEL SCHEDULE.

DEWATERING AND OPERATIONS BUILDING  
UPPER LEVEL PLAN

WEST SEWAGE TREATMENT PLANT IMPROVEMENTS  
CITY OF CREST HILL  
WILL COUNTY, ILLINOIS

JOB NO.  
3894.051  
PROJECT MGR.  
DOMINIC GATTONE



SHEET  
17 200  
E70-ASMT.UZ



Cost Proposal Request  
 West Sewage Treatment Plant Improvements  
 City of Crest Hill  
 Contract 1-2022  
 August 26, 2025

COST PROPOSAL NO.: 044

TO: Vissering Construction  
 ISSUED BY: Dominic Gattone, P.E.

DISTRIBUTION

Tony Marzetta, Project Manager	Vissering Construction (Contractor)
Julius Hansen	City of Crest Hill
Dominic Gattone, P.E.	Strand Associates, Inc.®

Please submit an itemized quotation for changes in the Contract Price and Time incidental to proposed modifications to the Contract Documents described herein. The purpose of this request is to make changes to the platform lift installation, which replaced the elevator as part of Cost Proposal Request (CPR)/Change Order No. 1.

DESCRIPTIONS AFFECTING THE DRAWINGS

**Drawing E70-ASM1.01**

- 044-01 Frame and drywall the northern and eastern shaft fenestration surrounding the newly proposed door on the first floor. See attached drawing.
- 044-02 Change manufacturer provided first-floor half-height door with full height mandoor. Rewire electrical componentry from manufacturer-provided call-station to interlock doorway hardware (automatic door opener) with platform lift system operation, as described below.
- Add row to Drawing 99-ASM6.01 Door 7002C, size 3'-6" x 7'-0", type - STL, active - HG, swing - RHR, frame type - 1, frame material - STL, hardware group - as provided by product manufacturer, active, lintel - B-1, Details, head - F-99-ASM6.02, jamb - F-99-ASM6.02, sill - N/A
- 044-03 Provide attached pictograph (Attachment A) at first floor and second floor call stations. Pictograph shall conform to Section 10 14 00 - Plastic and Metal Signs.

**Clarification: Fire Protection System shall remain in shaft as shown on E70-FP1.02.**

**Drawing E70-ASM1.02**

- 044-04 Frame northern shaft fenestration on second floor. See attached drawing. Standard manufacturer-provided door, its respective wiring, and call-station shall remain at the second floor.

DESCRIPTIONS AFFECTING THE SPECIFICATIONS

- 044-05 Add Section 08 71 10 - Automatic Door Operators, attached.

**Clarification: It is the intent of this CPR to have the door opener/closer system interlocked with the platform travel. With the changing of the first-floor door, the new door operation shall work in an identical way to the manufacturer's stock door. For example, the door will automatically unlock/open when the platform arrives from the second floor after an operator adjustable time delay. Additionally, the door will automatically open**



when the call button is pressed and the platform has arrived and stationed at the first floor. The door shall not open when the platform is not stationed there. If the first-floor door were to open and the platform is not in the down position, power to the platform shall be terminated.

Attachment A -



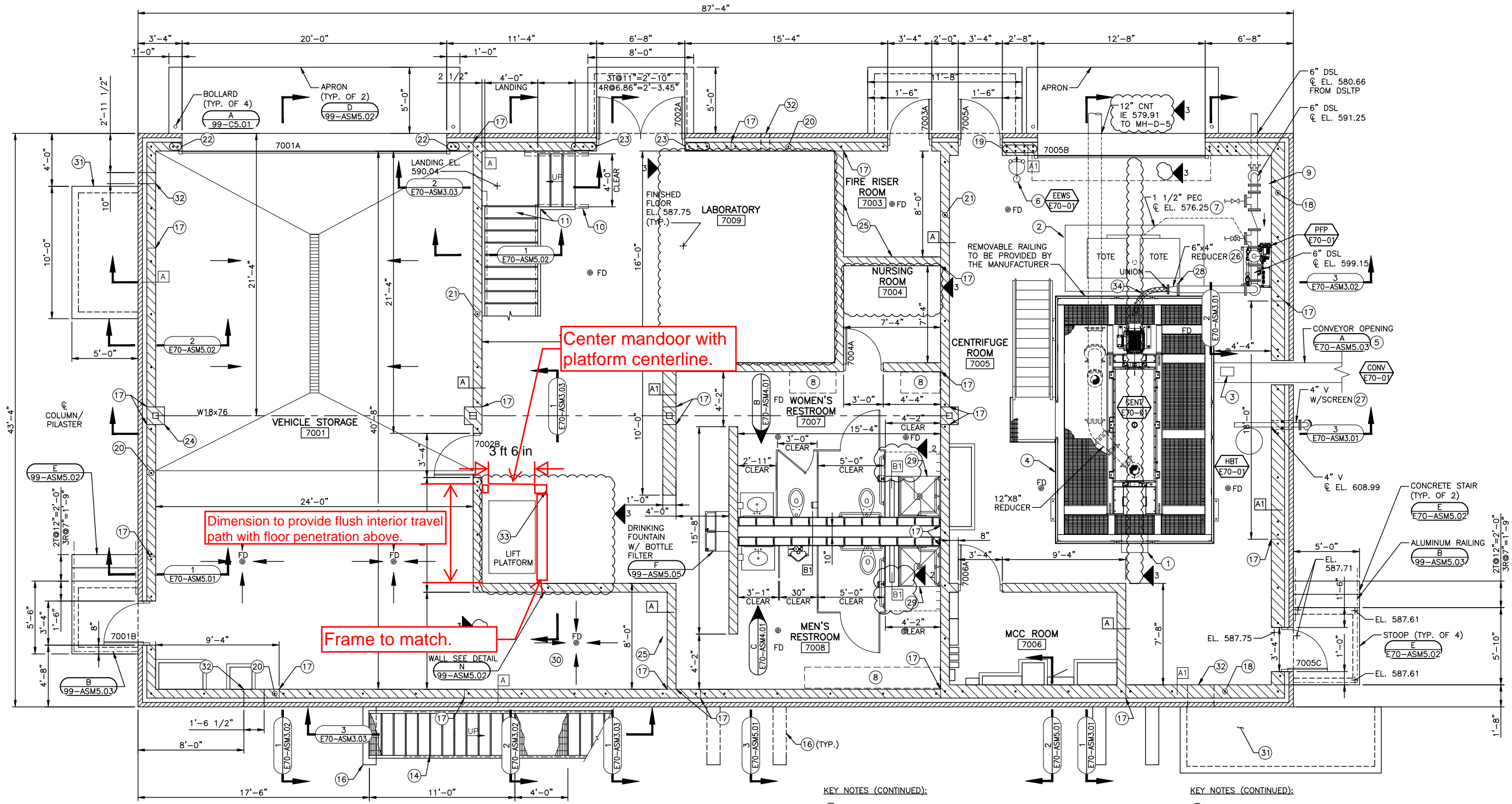

Dimension to provide flush interior travel path with floor penetration above.

Center mandoor with platform centerline.

Frame to match.



- GENERAL NOTES:**
- SEE ROOM FINISH SCHEDULE AND SPECIFICATION FOR TREATMENTS OF WALLS, FLOORS AND CEILINGS NOT CALLED OUT ON DRAWINGS.
  - SEE SPECIFICATIONS FOR LAB AND SCADA/CONTROL ROOM FURNITURE.
  - EXCEPT WHERE SHOWN OTHERWISE, ROOM FURNITURE AND ARCHITECTURAL CASEWORK (SHELVING, COUNTERS, ETC.) SHALL BE PROVIDED BY CONTRACTOR AS SHOWN AND SPECIFIED.
  - RESTRAIN ALL DUCTILE IRON JOINTS BURIED UNDER SLAB.
  - SEE 99-ASM6.03 FOR GENERAL STRUCTURE NOTES.

- KEY NOTES:**
- HYDRAULIC BACK DRIVE.
  - POLYMER TOTE CONTAINMENT, SEE SPECIFICATIONS.
  - PROVIDE INSPECTION HATCHES ON THE CONVEYORS AT LOCATIONS ACCESSIBLE TO OPERATORS. PROVIDE ADDITIONAL HATCH BENEATH PLATFORM. COORDINATE SIZE TO AVOID CONFLICT W/ PLATFORM.
  - ACCESS WALKWAYS AND STAIRS BY EQUIPMENT MANUFACTURER.
  - CONVEYOR SHALL BE HEAT TRACED AND INSULATED ACCORDING TO THE SPECIFICATIONS. CONVEYOR SHALL BE HEAT TRACED AND INSULATED FROM BUILDING E70 TO THE END OF THE CONVEYOR.
  - EMERGENCY EYE WASH AND SAFETY SHOWER.
  - PROVIDE LONG RADIUS ELBOWS FOR UNDERSLAB PEC CHEMICAL PIPE.
  - SPACE RESERVED FOR ADA LOCKERS AND ADA BENCHES.
  - MOUNT PEC PIPING TO WALL. PROVIDE SUPPORTS AS NECESSARY.
  - 1'-0" HANDRAIL EXTENSION (TYP.)

- KEY NOTES (CONTINUED):**
- CONCRETE PAN STAIRS WITH VINYL TREAD AND RISER FINISH. 4'-5" OUT-TO-OUT. SEE SPECIFICATION 09 65 13 FOR FINISH.
  - NOT USED
  - METAL SHROUD FOR MACHINE SPACE BY ELEVATOR MANUFACTURER.
  - ALUMINUM GRATING STAIRS (E 99-ASM5.04)
  - NOT USED
  - STAIR FOUNDATION (G 99-ASM5.02)
  - MCJ-2 (L 99-ASM5.02) FOR MCJ'S IN BRICK VENEER, SEE ELEVATION VIEWS.
  - #6@40" VERTICAL MASONRY REINFORCING (TYP. AT EXTERIOR 12" BLOCK WALLS).
  - 1~#6 EACH FACE @ 8" VERTICAL MASONRY REINFORCING (TYP. 1ST 4 CORES AT OHC DOOR JAMBS).
  - #4@48" VERTICAL MASONRY REINFORCING (TYP. EXTERIOR 8" BLOCK WALLS).

- KEY NOTES (CONTINUED):**
- #4@48" VERTICAL MASONRY REINFORCING.
  - 1~#4 VERTICAL BAR @ 8" TYP. 1ST 2 CORES AT JAMBS.
  - 1~#4 VERTICAL @ 8" TYP. 1ST 3 CORES AT JAMBS.
  - MASONRY PILASTER (TYP. OF 4) (B E70-ASM5.03)
  - NON-BEARING MASONRY WALL (N 99-ASM5.02)
  - 4"x1/2" REDUCER AND 1/2" FLEXIBLE HOSE TO BE PROVIDED BY CENTRIFUGE MANUFACTURER.
  - NON-CORRODING INSECT SCREEN BETWEEN TWO FLANGES ON DOWNWARD TURNED 45° FLANGED FITTING.
  - PRESSURE GAUGE CONNECTION, SEE DETAIL (J 99-P5.01)
  - BARRIER FREE SHOWER, SEE DETAIL (B 99-ASM5.06)
  - TOOL STORAGE AND ACCESS TO ELEVATOR CONTROL PANEL.
  - HVAC EQUIPMENT PAD. VERIFY SIZE AND LOCATION W/HVAC SCHEDULES.
  - HVAC OPENING. SEE H-DRAWINGS AND LINTEL SCHEDULE.
  - PROVIDE LINTEL B-1 AT LIFT PLATFORM ENTRY AND EQUIPMENT ACCESS DOORWAYS AND EQUIPMENT ACCESS.
  - FLEXIBLE HOSE BY MANUFACTURER TO LEFT OF UNION.
  - NOT USED

NO.	ISSUED FOR	DATE
1	ISSUED FOR BID	5/12/2022
2	CONFORMED DRAWINGS	12/1/2022
3	CHANGE ORDER NO. 1	X/7/2023

**DEWATERING AND OPERATIONS BUILDING  
LOWER LEVEL PLAN**

WEST SEWAGE TREATMENT PLANT IMPROVEMENTS  
CITY OF CREST HILL  
WILL COUNTY, ILLINOIS

**JOB NO.**  
3894.051  
**PROJECT MGR.**  
DOMINIC GATTONE



**SHEET**  
17 OF 203  
**E70-ASMT.01**

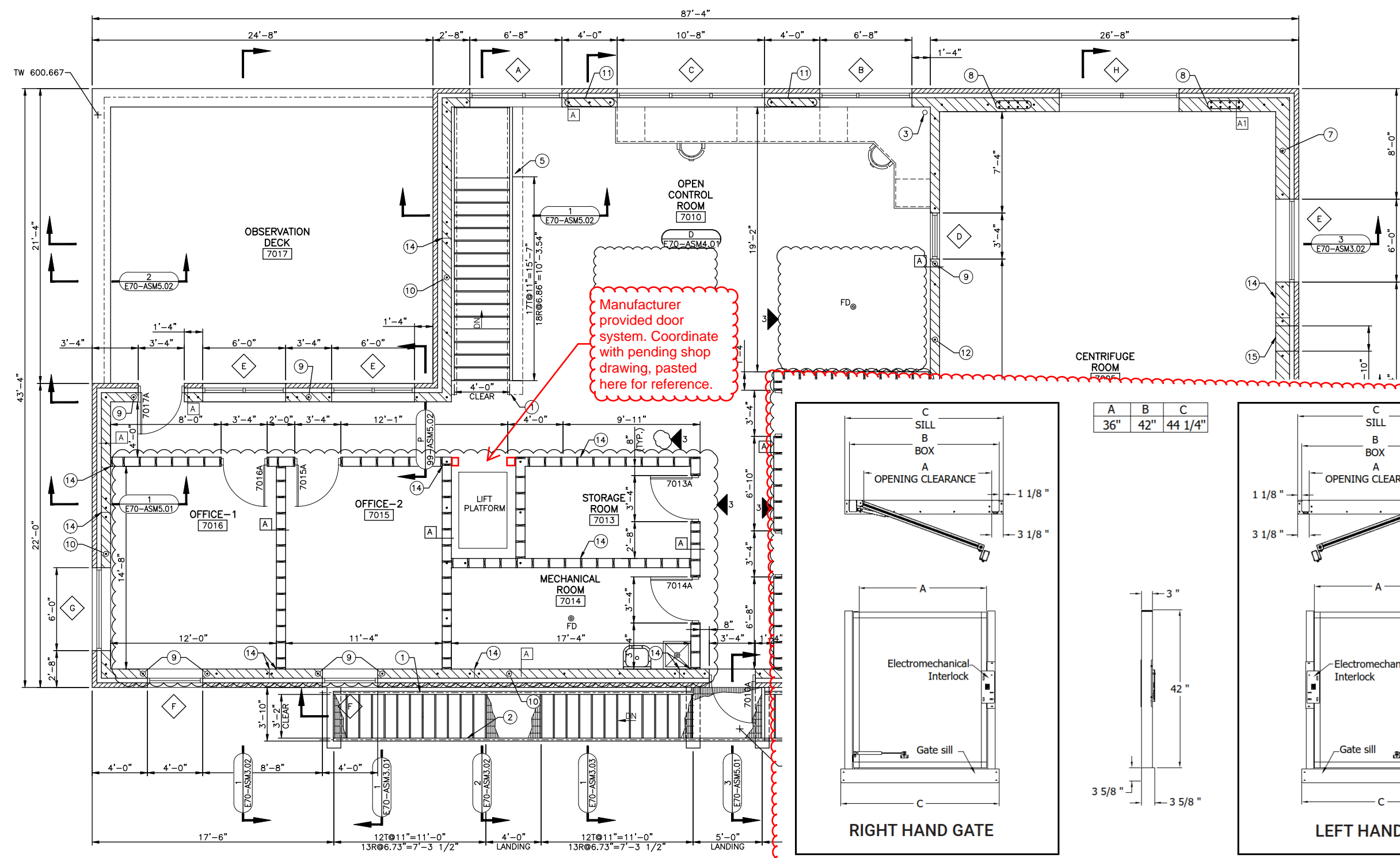

Manufacturer provided door system. Coordinate with pending shop drawing, pasted here for reference.

A	B	C
36"	42"	44 1/4"

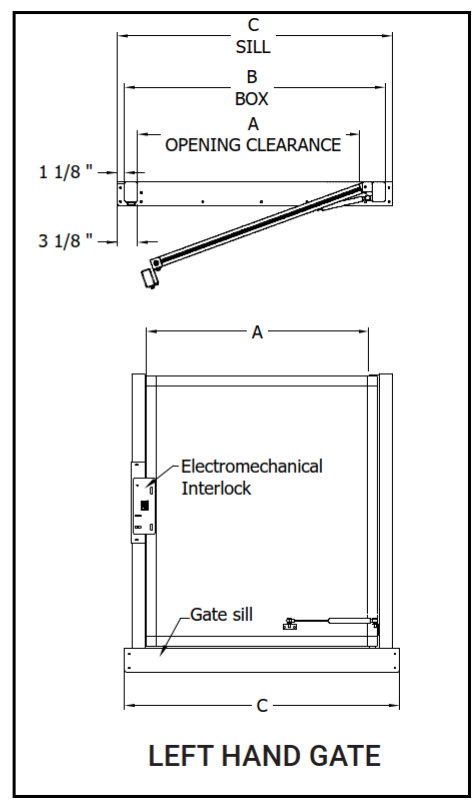
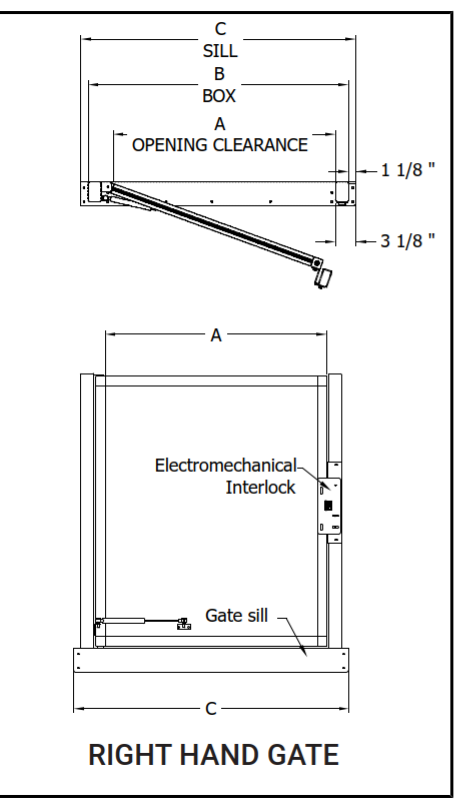

UPPER LEVEL PLAN  
0 1' 2' 4' 8'

GENERAL NOTES:

- SEE ROOM FINISH SCHEDULE AND SPECIFICATION FOR TREATMENTS OF WALLS, FLOORS AND CEILINGS NOT CALLED OUT ON DRAWINGS.
- SEE SPECIFICATIONS FOR LAB AND SCADA/CONTROL ROOM FURNITURE.
- EXCEPT WHERE SHOWN OTHERWISE, ROOM FURNITURE AND ARCHITECTURAL CASEWORK (SHELVING, COUNTERS, ETC.) SHALL BE PROVIDED BY CONTRACTOR AS SHOWN AND SPECIFIED.
- SEE 99-ASM6.03 FOR GENERAL STRUCTURAL NOTES.

KEY NOTES:

- 1'-0" HANDRAIL EXTENSION (TYP.)
- ALUMINUM STAIRS, 3'-10" OUT-TO-OUT. (E 99-ASM5.04)
- PROVIDE GROMMET IN COUNTERTOP.
- HVAC OPENING. SEE H-DRAWINGS AND LINTEL SCHEDULE.
- 42" HIGH GUARD RAIL AROUND FLOOR OPENING.
- NOT USED.
- #6@40" MASONRY VERTICAL BARS. (TYP. AT EXTERIOR 12" BLOCK)
- 1~#6 EA. FACE @ 8" SEE DRAWING E70-ASM1.01.

KEY NOTES (CONTINUED):

- 1~#4 AT WINDOW JAMBS UNLESS NOTED.
- #4@48" (TYP. AT EXTERIOR 8" BLOCK).
- 1~#4 @ 16" O.C. IN 4'-0" JAMB.
- #4@48" (TYP. WHERE SHOWN IN INTERIOR BLOCK).
- NOT USED
- MCJ-2 99-ASM5.02 SEE ELEVATION VIEWS FOR MCJ-1'S IN VENEER.
- OPENING IN CONVEYOR, SEE LINTEL SCHEDULE.

DEWATERING AND OPERATIONS BUILDING  
UPPER LEVEL PLAN

WEST SEWAGE TREATMENT PLANT IMPROVEMENTS  
CITY OF CREST HILL  
WILL COUNTY, ILLINOIS

JOB NO.  
3894.051  
PROJECT MGR.  
DOMINIC GATTONE



SHEET  
17 204  
E70-ASMT.UZ

## SECTION 08 71 10

## AUTOMATIC DOOR OPERATORS

PART 1–GENERAL

## 1.01 SUMMARY

- A. This Section includes the following types of automatic door operators: Exterior and interior, automatic door operators, low energy, with bottom load headers and surface or concealed mounting.

## 1.02 REFERENCES

General: Standards listed by reference, including revisions by issuing authority, form a part of this specification section to extent indicated. Standards listed are identified by issuing authority, authority abbreviation, designation number, title or other designation established by issuing authority. Standards subsequently referenced herein are referred to by issuing authority abbreviation and standard designation.

- A. Underwriters Laboratories (UL): UL 325–Standard for Door, Drapery, Gate, Louver, and Window Operators and Systems.
- B. American National Standards Institute (ANSI)/Builders' Hardware Manufacturers Association (BHMA):
1. ANSI/BHMA A156.10: Standard for Power Operated Pedestrian Doors.
  2. ANSI/BHMA A156.19: Standard for Power Assist and Low Energy Power Operated Doors.
- C. American Society for Testing and Materials (ASTM):
1. ASTM B221–Standard Specification for Aluminum and Aluminum-Alloy Extruded Bars, Rods, Wire, Profiles, and Tubes.
  2. ASTM B209–Standard Specifications for Aluminum and Aluminum-Alloy Sheet and Plate.
- D. Builders' Hardware Manufacturers Association (BHMA): BHMAA156.10–Standard for Power Operated Pedestrian Door.
- E. American Association of Automatic Door Manufacturers (AAADM).
- F. National Fire Protection Association (NFPA):
1. NFPA 101–Life Safety Code.
  2. NFPA 70–National Electric Code.
- G. International Conference of Building Officials (ICBO): UBC 1997: Uniform Building Code.
- H. California Department of Forestry and Fire Protection, Office of the State Fire Marshall.
- I. International Standards Organization (ISO): ISO 9001–Standard for Manufacturing Quality Management Systems.

- J. National Association of Architectural Metal Manufacturers (NAAMM): Metal Finishes Manual for Architectural and Metal Products.
- K. American Architectural Manufacturers Association (AAMA):
  - 1. AAMA 607.1–Clear Anodic Finishes for Architectural Aluminum.
  - 2. AAMA 611 Voluntary Specification for Anodized Architectural Aluminum.

### 1.03 DEFINITIONS

- A. Activation Device: Device that, when actuated, sends an electrical signal to the door operator to open the door.

### 1.04 PERFORMANCE REQUIREMENTS

- A. Provide automatic door operators capable of withstanding loads and thermal movements based on testing manufacturer's standard units in assemblies similar to those indicated for this Project.
- B. Operating Range: Minus 30°F (Minus 34°C) to 130°F (54°C).
- C. Opening-Force Requirements for Egress Doors: In the event power failure to the operator, swinging automatic entrance doors shall open with a manual force, not to exceed 30 lbf (133 N) applied at 1 inch (25 mm) from the latch edge of the door.
- D. Break Away Requirements: Automatic door operators shall breakaway with no more than 50 lbf (222 N) applied at 1 inch (25 mm) from the latch edge of the door.
- E. Door Energy: The kinetic energy of a door in motion shall not exceed 1.25 lbf-ft (1.69 Nm).
- F. Closing Time:
  - 1. Doors shall be field adjusted to close from 90 degrees to 10 degrees in 3 seconds or longer.
  - 2. Doors shall be field adjusted to close from 10 degrees to fully closed in not less than 1.5 seconds.

### 1.05 SUBMITTALS

- A. Submit listed submittals in accordance with Conditions of the Contract and Division 01 submittal procedures.
- B. Shop Drawings: Include plans, elevations, sections, details, hardware mounting heights, and attachments to other work. Indicate wiring for electrical supply.
- C. Color Samples for selection of factory-applied color finishes.
- D. Closeout Submittals: Provide the following with project close-out documents.
  - 1. Owner's Manual.
  - 2. Warranties.

## 1.06 QUALITY ASSURANCE

- A. Installer Qualifications: Manufacturer's authorized representative, with certificate issued by AAADM, who is trained for installation and maintenance of units required for this Project.
- B. Manufacturer Qualifications: A qualified manufacturer with a manufacturing facility certified under ISO 9001 and with company certificate issued by AAADM.
- C. Certifications: Automatic door operators shall be certified by the manufacturer to meet performance design criteria in accordance with the following standards:
  - 1. ANSI A156.10.
  - 2. NFPA 101.
  - 3. UL 325 Listed (Fire Door Operator).
  - 4. ICBO (UBC Standard 10-1).
  - 5. California Department of Forestry and Fire Protection, Listed.
- D. Source Limitations: Obtain automatic door operators through one source from a single manufacturer.
- E. Product Options: Drawings indicate sizes, profiles, and dimensional requirements of automatic door operators and are based on the specific system indicated. Refer to Division 01 Section "Product Requirements."
- F. Power Operated Door Standard: ANSI/BHMA A156.19.
- G. Electrical Components, Devices, and Accessories: Listed and labeled as defined in NFPA 70, Article 100, by a testing agency acceptable to authorities having jurisdiction, and marked for intended use.
- H. Emergency-Exit Door Requirements: Comply with requirements of authorities having jurisdiction for swinging automatic entrance doors serving as a required means of egress.

## 1.07 PROJECT CONDITIONS

- A. Field Measurements: General Contractor shall verify openings to receive automatic door operators by field measurements before fabrication and indicate measurements on Shop Drawings.
- B. Mounting Surfaces: General Contractor shall verify all surfaces to be plumb, straight and secure; substrates to be of proper dimension and material.
- C. Other trades: General Contractor Advise of any inadequate conditions or equipment.

## 1.08 COORDINATION

- A. Templates: Check Shop Drawings of other work to confirm that adequate provisions are made for locating and installing automatic door operators to comply with indicated requirements.
- B. Electrical System Roughing-in: Coordinate layout and installation of automatic door operators with connections to, power supplies and remote activation devices.

- C. System Integration: Integrate automatic door operators with other systems as required for a complete working installation.
  - 1. Provide electrical interface control capability for card reader or keypad operation of automatic door operators on doors with electric locking.
  - 2. Where required for proper operation, provide a time relay to signal automatic door operator to activate only after electric lock system is released.

#### 1.09 WARRANTY

- A. Automatic door operators shall be free of defects in material and workmanship for a period of one year from the date of substantial completion.
- B. During the warranty period OWNER shall engage a factory-trained technician to perform service and affect repairs. A safety inspection shall be performed after each adjustment or repair and a completed inspection form shall be submitted to OWNER.
- C. During the warranty period all warranty work, including but not limited to emergency service, shall be performed during normal working hours.

### PART 2-PRODUCTS

#### 2.01 AUTOMATIC DOOR OPERATORS

- A. Manufacturer: Stanley Access Technologies; M-Force™ Series automatic door operator.

#### 2.02 MATERIALS

- A. Aluminum: Alloy and temper recommended by manufacturer for type of use and finish indicated.
  - 1. Headers: 6063-T6.
  - 2. Extruded Bars, Rods, Profiles, and Tubes: ASTM B 221.
  - 3. Sheet and Plate: ASTM B 209.

#### 2.03 COMPONENTS

- A. Header Case: Header case shall not exceed 4 1/2-inch by 6-inch (114 mm) in section and shall be fabricated from extruded aluminum designed to conceal door operators and controls. The operator shall be sealed against dust, dirt, and corrosion within the header case. Access to the operator and electronic control box shall be provided from the bottom by a removable cover. Removable cover shall be secured in place by screws.
- B. Door Arms: Door arms shall be manufacturer's standard units designed specifically for use with automatic door operators provided.
  - 1. Visible Arms: A combination of door arms and linkage shall provide positive control of door through entire swing; units shall permit use of butt hung, center pivot, and offset pivot-hung doors.
  - 2. Concealed Arms: A single straight arm, designed for top mounting in door panel, shall provide positive control of door through entire swing; units shall be specifically designed for use on center pivot doors.

- C. Fasteners and Accessories: Manufacturer's standard corrosion-resistant, non-staining, non-bleeding fasteners and accessories compatible with adjacent materials.
- D. Signage: Provide signage in accordance with ANSI/BHMAA156.19.

#### 2.04 SWINGING DOOR OPERATORS

- A. Provide door operators of size recommended by manufacturer for door size, weight, and movement; for condition of exposure; and for long-term, maintenance-free operation under normal traffic load for type of occupancy indicated.
- B. Electromechanical Operators: Self-contained unit powered by a minimum 3/16 horsepower, permanent-magnet DC motor; through a high torque reduction gear system.
  - 1. Operation: Power opening and spring closing.
  - 2. Operator Type: Low energy; readily convertible to full energy; no tools required to change type.
  - 3. Handing: Non-handed; no tools required to change handing.
  - 4. Capacity: Rated for door panels weighing up to 350 pounds.
  - 5. Mounting: Surface applied or concealed as indicated.
  - 6. Features:
    - a. Adjustable opening and closing speeds.
    - b. Adjustable opening and closing force.
    - c. Adjustable back-check.
    - d. Adjustable hold-open time between 0 and 30 seconds.
    - e. Reverse on obstruction.
    - f. Variable rate open/closed speed control.
    - g. Closed loop speed control with active braking and acceleration.
    - h. Variable obstruction recycle time delay.
    - i. Optional Switch to open/Switch to close operation.
    - j. When operators are provided in pairs, adjustable features are independently adjustable for each operator.
- C. Field Adjustable Spring Closing Operation: The operator shall close the door by spring energy employing the motor, as a dynamic brake to provide closing speed control. The closing spring shall be a helical compression spring, adjustable for positive closing action. The spring shall be adjustable, without removing the operator from the header, to accommodate a wide range of field conditions.
- D. Independent Adjustable Closing and Latching Speed Control: The operator shall employ a rheostat module to allow for independent field adjustment of closing and latching speeds using the motor as a dynamic brake.
- E. Field Adjustable Open Stop: The operator shall provide a field adjustable open stop to accommodate opening angles from 80 to 135 degrees without the need for additional components.
- F. Consistent Cycle: The operator shall deliver an even, consistent open manual push force across the entire transition from door fully closed to door fully open. Additionally, the force shall be field adjustable to accommodate a wide range of on-site conditions.
- G. Quiet Performance: The operator shall be designed to output audible noise ratios less than or equal to 50 dba.

- H. Manual Use: The operator shall function as a manual door closer in the direction of swing with or without electrical power. The operator shall deliver an even, consistent open force across the entire transition from door fully closed to door fully open, except as restricted by platform lift controls.
- I. Electrical service to door operators shall be provided under Division 26 Electrical. Minimum service to be 120 VAC, 10 amps for doors with operators in pairs, 5 amps for single doors.

## 2.05 ELECTRICAL CONTROLS

- A. Electrical Control System: Electrical control system shall include a microprocessor controller and a high-resolution position encoder. The encoder shall monitor revolutions of the operator shaft and send signals to microprocessor controller to define door position. Systems utilizing external magnets and magnetic switches are not acceptable.
- B. Life Cycle Data Counter: The microprocessor control shall incorporate a nonresettable counter to track door operation cycles.
- C. Controller Protection: The microprocessor controller shall incorporate the following features to provide trouble free operation:
  1. Automatic Reset Upon Power Up.
  2. Main Fuse Protection.
  3. Electronic Surge Protection.
  4. Internal Power Supply Protection.
  5. Resettable sensor supply fuse protection.
  6. Software "Watchdog" protection in the case of software malfunction.
- D. Push Button Interface with LED: The controller shall have push button switches with LED readout to allow for selection or change of the following parameters: carpet or timer logic, single or dual door, activation options, normal back check or large back check, push-to-open assist on/off.
- E. Soft Start/Stop: A "soft-start" "soft-stop" motor driving circuit shall be provided for smooth normal opening and recycling.
- F. Safety Search Circuitry: Provide system to recycle the swinging panels when an obstruction is encountered during the closing cycle. If an obstruction is detected, the system shall search for that object on the next closing cycle by reducing door closing speed prior to the previously encountered obstruction location and will continue to close in check speed until doors are fully closed, at which time the doors will reset to normal speed. If obstruction is encountered again, the door will come to a full stop. The doors shall remain stopped until obstruction is removed and operate signal is given, resetting the door to normal operation.
- G. Programmable Controller: Microprocessor controller shall be programmable and shall be designed for connection to a local configuration tool. Local configuration tool shall be software driven and shall be utilized via Palm® handheld interface. The following parameters may be adjusted via the configuration tool.
  1. Operating speeds and forces as required to meet ASNI/BHMA A156.10.
  2. Adjustable and variable features as specified in Paragraph 2.04.B.6.
  3. Firmware update.
  4. Trouble shooting.
    - a. I/O Status.

- b. Electrical component monitoring including parameter summary.
  - 5. Entrance profile copy/paste.
  - 6. Software for local configuration tool shall be available as a free download from the automatic door operators' manufacturer's internet site.
- H. Emergency Breakout Switch: A cam actuated emergency breakout switch shall be provided to disconnect power to the motor when an in-swinging door is manually pushed in the emergency out direction. The operator will then automatically reset and power will be resumed.
- I. Control Switch: Automatic door operators shall be equipped with a three position function switch to control the operation of the door. Control switch shall provide three modes of operation, Automatic, Off, and Hold-Open.
- J. Power Switch: Automatic door operators shall be equipped with a two position On/Off switch to control power to the door.

## 2.06 ALUMINUM FINISHES

- A. Comply with NAAMM Metal Finishes Manual for Architectural and Metal Products for recommendations for applying and designing finishes. Finish designations prefixed by AA comply with system established by Aluminum Association for designing finishes.
- B. Class II, Clear Anodic Finish: AA-M12C22A31 Mechanical Finish: as fabricated; Chemical Finish: etched, medium matte; Anodic Coating: Architectural Class II, clear coating 0.40 mils minimum complying with AAMA 611-98, and the following
  - 1. AAMA 607.1.
  - 2. Applicator must be fully compliant with all applicable environmental regulations and permits, including wastewater and heavy metal discharge.

## PART 3-EXECUTION

### 3.01 INSPECTION

- A. Examine conditions, with Installer present, for compliance with requirements for installation tolerances, header support, and other conditions affecting performance of swinging automatic entrance doors. Proceed with installation only after unsatisfactory conditions have been corrected.

### 3.02 INSTALLATION

- A. Do not install damaged components. Fit joints to produce hairline joints free of burrs and distortion. Rigidly secure non-movement joints.
- B. Mounting: Install automatic door operators/headers plumb and true in alignment with established lines and grades. Anchor securely in place.
  - 1. Install surface-mounted hardware using concealed fasteners to greatest extent possible.
  - 2. Set headers, arms and linkages level and true to location with anchorage for permanent support.

- C. Door Operators: Connect door operators to electrical power distribution system as specified in Division 26 Sections.
- D. Sealant: Comply with requirements specified in Section 07 90 00–Caulking and Sealants to provide weather tight installation.

### 3.03 FIELD QUALITY CONTROL

- A. Testing Services: Factory Trained Installer shall test and inspect each swinging automatic entrance door to determine compliance of installed systems with applicable ANSI standards.

### 3.04 ADJUSTING

- A. Adjust door operators, controls, and hardware for smooth and safe operation, for weather tight closure, and complying with requirements in ANSI/BHMA A156.19 by AAADM Certified Technician.

### 3.05 CLEANING AND PROTECTION

- A. Clean surfaces promptly after installation. Remove excess sealant compounds, dirt, and other substances. Repair damaged finish to match original finish.

END OF SECTION



**PROPOSAL  
WORKSHEET SUMMARY**

Project: CITY OF CREST HILL - WEST SEWAGE TREATMENT PLANT IMPROVEMENTS

Change Order Request #: 48 - Rev 2

To: Strand Associates, Inc.  
Dominic Gattone, PE

Date: 4/13/2026  
A/E Project #: IDFPR No. 184-001273  
VCC Project #: 11108.00

WORK DESCRIPTION
1) Aeration Tank Cleaning including removal of PVC Diffusers
2) Anaerobic Tank Cleaning (2 Tanks)
3) Mobilization

Line No	Cost Description	Labor Amt	Material Amt	Equip & Other Amt	Sub-Contractor Amt	Sub-Total
1	Stewart Spreading - See Attached - Aeration Tank				\$ 181,760.00	\$ 181,760.00
2	Stewart Spreading - See Attached - Anaerobic Tank				\$ 18,200.00	\$ 18,200.00
3	Stewart Spreading - See Attached - Mobilization (\$7500 x 2 trips)				\$ 15,000.00	\$ 15,000.00
4	Vissering Construction - VCC Labor to Coordinate Work	\$ 4,480.00				\$ 4,480.00
5						\$ -
6						\$ -
7						\$ -
8						\$ -
9						\$ -
10						\$ -
11						\$ -
12						\$ -
13						\$ -
14						\$ -
15						\$ -
16						\$ -
17						\$ -
18						\$ -
19						\$ -
20						\$ -
21						\$ -
22						\$ -
23						\$ -
24						\$ -
25						\$ -
<b>Sub-Total</b>		<b>\$ 4,480.00</b>	<b>\$ -</b>	<b>\$ -</b>	<b>\$ 214,960.00</b>	<b>\$ 219,440.00</b>

**ACCEPTANCE OF PROPOSAL (OWNER): City of Crest Hill**

Name/Title: Gary Richardson, Public Works Director  
Signature: \_\_\_\_\_  
Date: \_\_\_\_\_

Contractor's Net: \$ 4,480.00  
Sub-Contractor's Net: \$ 214,960.00  
Net Subtotal: \$ 219,440.00  
Contractor's Fee: (15% on Own Work, 5% on Subs, & 0% on Credits): \$ 11,420.00  
Sub-Total: \$ 230,860.00  
Bonds & Insurance - 1%: \$ 2,308.60  
**Worksheet Total: \$ 233,169.00**

**ACCEPTANCE OF PROPOSAL (A/E): Strand Associates, Inc.**

Name/Title: Dominic Gattone, PE  
Signature: \_\_\_\_\_  
Date: \_\_\_\_\_

**ACCEPTANCE OF PROPOSAL (CONTRACTOR): VISSERING CONSTRUCTION CO**

Name/Title: Tony Marzetta, Project Manager  
Signature: \_\_\_\_\_  
Date: December 1, 2025



April 13, 2026

**Vissering Construction**  
**175 Benchmark Industrial Drive**  
**Streator, IL 61364**  
**Attention: Mr. Tony Marzetta**

**RE: PROPOSAL FOR CREST HILL 8-AERATION AND 2-ANAEROBIC TANK CLEANINGS AND DISPOSAL**

**Stewart Spreading will provide:**

- Mobilization and demobilization of trained personnel and required equipment to and from Crest Hill Plant for safety conscious operations;
- All labor, equipment & technical expertise necessary for cleaning of tanks;
- Residuals removal, loading into Stewart Spreading's trailers for transportation to an appropriate landfill or land application site for final disposal;
- Cut and Remove PVC Aeration Diffusers from Aeration Tanks. PVC Diffusers will be removed during cleaning operations and is included in lump sum pricing. *Note: Does not include brackets. Disposal of PVC Aeration Diffusers to be provided by Vissering Construction.*
- Includes basic wash down / cleaning of Digesters and Aeration tank interiors with booster pump, hydrant water provided by Crest Hill WWTP. Remaining wash water that cannot be pumped out will be vacuumed out. *Note: Basic interior tank wash down included is the same level of cleaning that we always provide but does not include pressure washing.*
- Paying the landfill tipping fees for Aeration tank contents that has been dewatered;
- Provide generator required for tank cleaning operations;
- Land application of liquid biosolids will be invoiced to Crest Hill at the their current Biosolids agreement rates;
- Land application will be according to IEPA, USEPA & IEMA regulations and following agricultural timelines;
- All proper licensing, safety certifications and insurance documentation;
- Provide operation reports that meet IEPA regulations;
- Provide certificate of insurance with additionally insured endorsement for the duration of the project;
- Appropriately documented invoice within 30 days of completion.

**Vissering Construction / Crest Hill will provide:**

- Safely secured continuous plant access for tank cleaning operations;
- Water from hydrant at 60 psi & 60 GPM within 100' of the work area;
- A return for filtrate within 100' of the work area;
- Disposal of PVC diffusers;
- Land application of liquid biosolids from digesters will be invoiced to Crest Hill at the their current Biosolids agreement/contract rates;
- Payment of invoice within 30 days of project completion.
- Provide required testing, permits and landfill profile;
- A 2% monthly fee for all payments received beyond 30 days of invoice;



**Proposal Pricing:**

**Aeration Tank Cleaning (includes removal of PVC Diffusers) ..... \$181,760.00 Lump Sum**

- Aeration tanks cleaning (8-Tanks) includes volume of up to 3', if volume exceeds 3, overage will be invoiced at \$1.42 per gallon.

**Anaerobic Tank Cleaning (2-Tanks) ..... \$18,200.00 Lump Sum**

- Anaerobic tanks include volume up to 13,000 gallons total, if volume exceeds 13,000 gallons, overage will be invoiced at \$1.40 per gallon.
- Land application of liquid biosolids will be invoiced to Crest Hill at the their current Biosolids agreement/contract rates.

**Mobilization ..... \$7,500.00 per mobilization**

**Notes:**

- During Aeration Tank Cleaning, PVC Diffusers will be removed and is included in the lump sum pricing. *Note: Does not include removal of the brackets or disposal of PVC diffusers;*
- The 2 Digesters and 8 Aeration tank cleaning pricing includes basic wash down / cleaning with a booster pump. hydrant water to be provided by Crest Hill WWTP. Remaining wash water that cannot be pumped out will be vacuumed out. *Note: Basic interior tank wash down included is the same level of cleaning that we always provide but does not include pressure washing.*
- Aeration and digester tank volumes will be measured prior to beginning of tank cleaning operations. All parties will mutually agree upon the tank volume and sign off on the content sheet.
- Rates are based on work being performed Monday – Friday, during normal working hours.
- Proposal is valid for 10 days.

*Please let us know if there are any questions.*

ACCEPTED BY:  
**Stewart Spreading, Inc.**

*Greg Halmagyi*

Greg Halmagyi, Bus. Div. Mgr. 4/13/2026

Name/Title                      Date

Approved By:  
**Vissering Construction**

\_\_\_\_\_

\_\_\_\_\_ Date



Cost Proposal Request  
West Sewage Treatment Plant Improvements  
City of Crest Hill, Illinois  
Contract 1-2022  
January 28, 2026

Item P.

COST PROPOSAL NO.: 050

TO: Vissering Construction Company  
ISSUED BY: Dominic Gattone, P.E.

DISTRIBUTION

Tony Marzetta, Project Manager  
Gary Richardson  
Dominic Gattone, P.E.  
Vissering Construction Company (Contractor)  
City of Crest Hill, Illinois  
Strand Associates, Inc.®

Please submit an itemized quotation for changes in the Contract Price and Time incidental to proposed modifications to the Contract Documents described herein. The purpose of this request connect the PLW Pumping Skid Run-dry signal to the SCADA system. The Grundfos package system was supplied with a liquid level switch to provide run dry protection.

DESCRIPTIONS AFFECTING THE SPECIFICATIONS

26 09 00 - 3.05C

050-01 Add the following as '3.':  
"There is a low liquid level switch (LSL-C45-01) that shall shut down the motor in the event of a low level condition ("Hand" and "Auto" modes). Manual reset shall be required to restart the motor. Provide a hardwired time delay (0 to 5 seconds) to prevent nuisance tripping resulting from momentary power interruptions. Provide 120-volt fused power for the liquid level switch. Provide red pilot light on associated MCC bucket that shall be energized when the level switch is activated."

DESCRIPTIONS AFFECTING THE DRAWINGS

**C45-E1.01**

050-02 Provide a NEMA 12 "PLW Liquid Level Switch Control Enclosure," sized as needed, on adjacent wall for termination of level switch conductors. Splice manufacturer-recommended cable to manufacturer-furnished cable with Raychem D-1744 (NAS 1744) wire-to-wire splice to extend the wiring to enclosure in 3/4" conduit. Provide 24VDC power supply, overcurrent protection, and terminal blocks as required to provide 24VDC power to level switch and for termination of control conductors. Provide interposing relays as required to interface with 120VAC motor control wiring from MCC-C45. Enclosure shall be provided by 26 09 00 System Supplier.

050-03 Provide 4~#14 in 3/4" conduit from enclosure to MCC-C45 for shutdown signal and power wiring. Provide 2~#14 in 3/4" conduit from MCC-C45 to SCC-C45 for discrete input signal to PLC for liquid level switch shutdown signal.



**PROPOSAL  
WORKSHEET SUMMARY**

Project: CITY OF CREST HILL - WEST SEWAGE TREATMENT PLANT IMPROVEMENTS

Change Order Request #: 050

To: Strand Associates, Inc.  
Dominic Gattone, PE

Date: 3/5/2026  
A/E Project #: IDFPR No. 184-001273  
VCC Project #: 11108.00

WORK DESCRIPTION
Per CPR 050 - PLW Pump Run Dry Protection

Line No	Cost Description	Labor Amt	Material Amt	Equip & Other Amt	Sub-Contractor Amt	Sub-Total
1	CONNELLY ELECTRIC				\$ 5,286.00	\$ 5,286.00
2	WUNDERLICH-MALEC				\$ 6,250.00	\$ 6,250.00
3						\$ -
4						\$ -
5						\$ -
6						\$ -
7						\$ -
8						\$ -
9						\$ -
10						\$ -
11						\$ -
12						\$ -
13						\$ -
14						\$ -
15						\$ -
16						\$ -
17						\$ -
18						\$ -
19						\$ -
20						\$ -
21						\$ -
22						\$ -
23						\$ -
24						\$ -
25						\$ -
<b>Sub-Total</b>		\$ -	\$ -	\$ -	\$ 11,536.00	\$ 11,536.00

**ACCEPTANCE OF PROPOSAL (OWNER): City of Crest Hill**

Name/Title: Gary Richardson, Public Works Director

Signature: \_\_\_\_\_

Date: \_\_\_\_\_

Contractor's Net:	\$ -
Sub-Contractor's Net:	\$ 11,536.00
Net Subtotal:	\$ 11,536.00
Contractor's Fee: (15% on Own Work, 5% on Subs, & 0% on Credits):	\$ 576.80
Sub-Total:	\$ 12,112.80
Bonds & Insurance - 1%:	\$ -
<b>Worksheet Total:</b>	<b>\$ 12,113.00</b>

**ACCEPTANCE OF PROPOSAL (A/E): Strand Associates, Inc.**

Name/Title: Dominic Gattone, PE

Signature: \_\_\_\_\_

Date: \_\_\_\_\_

**ACCEPTANCE OF PROPOSAL (CONTRACTOR): VISSERING CONSTRUCTION CO**

Name/Title: Tony Marzetta, Project Manager

Signature: \_\_\_\_\_

Date: March 5, 2026



Cost Proposal Request  
West Sewage Treatment Plant Improvements  
City of Crest Hill, Illinois  
Contract 1-2022  
January 28, 2026

Item P.

COST PROPOSAL NO.: 050

TO: Vissering Construction Company  
ISSUED BY: Dominic Gattone, P.E.

DISTRIBUTION

Tony Marzetta, Project Manager  
Gary Richardson  
Dominic Gattone, P.E.  
Vissering Construction Company (Contractor)  
City of Crest Hill, Illinois  
Strand Associates, Inc.®

Please submit an itemized quotation for changes in the Contract Price and Time incidental to proposed modifications to the Contract Documents described herein. The purpose of this request connect the PLW Pumping Skid Run-dry signal to the SCADA system. The Grundfos package system was supplied with a liquid level switch to provide run dry protection.

DESCRIPTIONS AFFECTING THE SPECIFICATIONS

26 09 00 - 3.05C

050-01 Add the following as '3.':  
"There is a low liquid level switch (LSL-C45-01) that shall shut down the motor in the event of a low level condition ("Hand" and "Auto" modes). Manual reset shall be required to restart the motor. Provide a hardwired time delay (0 to 5 seconds) to prevent nuisance tripping resulting from momentary power interruptions. Provide 120-volt fused power for the liquid level switch. Provide red pilot light on associated MCC bucket that shall be energized when the level switch is activated."

DESCRIPTIONS AFFECTING THE DRAWINGS

**C45-E1.01**

050-02 Provide a NEMA 12 "PLW Liquid Level Switch Control Enclosure," sized as needed, on adjacent wall for termination of level switch conductors. Splice manufacturer-recommended cable to manufacturer-furnished cable with Raychem D-1744 (NAS 1744) wire-to-wire splice to extend the wiring to enclosure in 3/4" conduit. Provide 24VDC power supply, overcurrent protection, and terminal blocks as required to provide 24VDC power to level switch and for termination of control conductors. Provide interposing relays as required to interface with 120VAC motor control wiring from MCC-C45. Enclosure shall be provided by 26 09 00 System Supplier.

050-03 Provide 4~#14 in 3/4" conduit from enclosure to MCC-C45 for shutdown signal and power wiring. Provide 2~#14 in 3/4" conduit from MCC-C45 to SCC-C45 for discrete input signal to PLC for liquid level switch shutdown signal.



40 S. Addison Rd.  
Addison, IL 60101

# CHANGE NOTICE

Item P.

**Connelly CCN #** 028  
**Field Ticket #**  
**Date:** 2/17/2026  
**Project Name:** Crest Hill WWTP - West Sewage Treatment Plant  
**Project Number:** 22-0686  
**Page Number:** 1

**Client Address:**

**Vissering Construction**

1631 Gaylord Rd.  
Crest Hill, IL 60403  
Telephone: 815.673.5511  
Contact: Tony Marazetta

**Site Address:**

**Vissering Construction**

Contact: Tony Marazetta  
1631 Gaylord Rd.  
Crest Hill, IL 60403

---

**Work Description**

---

This quote covers direct costs only and we reserve the right to claim for impact and consequential costs.  
 This price is good for acceptance within **10** days from the date of receipt.  
 We request a time extension of **3** days.  
 We will supply and install all materials, labor, and equipment as per your instructions on **Connelly CCN # 028**.

**Description:**

**This CCN was generated in response to the distribution of CPR050 which involved the connection of the PLW Pumping Skid Run-dry signal to the SCADA system.**

---

**Itemized Breakdown**

---

Description	Qty	Total Mat.	Total Hrs.
3/4" GRC (GALV)	100	434.71	6.00
3/4" GRC MYERS HUB	4	17.34	1.80
3/4" GRC COUPLING	10	31.03	0.17
3/4" GRC 90 ELBOW	3	27.76	1.20
3/4" 1-H MALL STRAP	20	38.61	0.80
3/4" MINERLC/BOLT	20	19.01	5.00
3/4" LT FLEX	3	9.54	0.15
3/4" LT STRAIGHT CONN	3	11.22	0.54
#14 THHN	500	108.95	2.50
CABLE TAG	1	14.30	1.00
FD 1GANG BOX	1	27.22	0.70
BOX SUPP HOLD-ITS #977	2	8.13	0.50
Install Enclosure, FBO	1	0.00	4.00
Connect to Instrument Panel	1	0.00	2.00
Connect to SCADA Cabinet	1	0.00	2.00
Splice to MFR-furnished cable	1	0.00	1.00
<b>Totals</b>	<b>671</b>	<b>747.82</b>	<b>29.36</b>

---

**Summary**

---

**MATERIAL**

General Materials 747.82

**Material Total**

Foreman 1,960.74  
 Journeyman 1,860.74

(14.68 Hrs @ \$133.77)  
 (14.68 Hrs @ \$127.07)

# CHANGE NOTICE

Site Address:

**Vissering Construction**  
1631 Gaylord Rd.  
Crest Hill, IL 60403

**Connelly CCN #** 028  
**Field Ticket #**  
**Date:** 2/17/2026  
**Project Name:** Crest Hill WWTP - West Sewage Treatment Pla  
**Project Number:** 22-0686  
**Page Number:** 2

---

### Summary (Cont'd)

---

Overhead	(@ 10.000 %)	457.70
Markup	(@ 5.000 %)	251.73
<b>Subtotal</b>		<b>5,286.38</b>
<b>Final Amount</b>		<b>\$5,286.38</b>



March 5, 2026

**Project Name: West Sewage Treatment Plant Improvements**

**Project Location: City of Crest Hill, Illinois**

**Consulting Engineer: Strand Associates, Inc**

**WME Change Order – 12 Rev B**

---

Vissering Construction  
Tony Marzetta - [tmarzetta@vissering.com](mailto:tmarzetta@vissering.com)  
Project 11108.00

**Reference: CPR050 PLW Pumping Skid**  
**Note: Reduced to (1) LSL per return comments.**

Wunderlich-Malec Environmental is pleased to offer the following add proposal.

Total price for the Add is \$6,250.00 Net Excluding Tax

Enhancement Hours Requested for the Programming Changes: 2

Breakout  
See Attached

This proposal consists of two (2) pages. If you have any questions regarding this proposal, please do not hesitate to contact me at 952-843-5846

Yours Truly,

*Ken Kawiecki*

SIGNED ELECTRONICALLY

Ken Kawiecki  
[ken.kawiecki@wmeng.com](mailto:ken.kawiecki@wmeng.com)  
Wunderlich-Malec Environmental  
"Employee Owned, Customer Committed"

EEO/Affirmative Action Employer

Change Order 12						
COMPONENT	MFR	MODEL	QTY	COST	TOTAL	Note
Hinge Enclosure	Hoffman	A1412CHQR	1	\$215.00	\$215.00	
Hinge Enclosure Sub Panel	Hoffman	A14P12	1	\$12.00	\$12.00	
Circuit Breaker - 5 Amp	AB	1489-M1C050	1	\$34.00	\$34.00	
Power Supply	AB	1606-XLS15E	1	\$50.00	\$50.00	
Relay	AB	700-HK32D24-4	1	\$13.00	\$13.00	
Relay Base	AB	700-HN122	1	\$6.00	\$6.00	
Timer	Idec	GT5Y-4	1	\$60.00	\$60.00	
Timer Base	Idec		1	\$6.00	\$6.00	
Fues Holder	AB	1492-H5	1	\$8.00	\$8.00	
Fuse	Bussmann	MDL4	1	\$5.00	\$5.00	
Terminals	AB	1492-J3	12	\$0.40	\$4.80	
Ground Bar	Square D	PK9TGA	1	\$15.00	\$15.00	
Shop Stock	WME	Multiple	1	\$50.00	\$50.00	
<b>MCC Additions</b>						
Red Light	AB	800H-PTHR16R	1	\$30.00	\$30.00	
Contract Block	AB	800T-XA2	1	\$14.00	\$14.00	
Relay	AB	700-HK32A1-4	1	\$15.00	\$15.00	
Relay Base	AB	700-HN122	1	\$6.00	\$6.00	
TOTAL					\$522.80	
					\$78.42	15% Markup
					<b>Sub Total Material Sell</b>	<b>\$601.22</b>
Freight (Inbound / Outbound)			1	\$150.00	\$150.00	
Project Mangement		03 13	5	\$185.00	\$925.00	
Engineering		03 11	8	\$160.00	\$1,280.00	
CAD		03 21	8	\$105.00	\$840.00	
Production		02 51	8	\$105.00	\$840.00	
Test		02 61	2	\$105.00	\$210.00	
Programming - PLC - See Below		03 31	0	\$160.00	\$0.00	
Programming - OIT / SCADA - See Below		03 41	0	\$160.00	\$0.00	
Field Modifications		03 71	8	\$140.00	\$1,120.00	
Startup		03 71	2	\$140.00	\$280.00	
					<b>Labor Sell</b>	<b>\$5,495.00</b>
<b>Total (Equipment, Labor, Expenses)</b>					<b>\$6,246.22</b>	
<b>Enhancement Request</b>			<b>Hours</b>			
Programming - PLC and SCADA			2			



Cost Proposal Request  
West Sewage Treatment Plant Improvements  
City of Crest Hill, Illinois  
Contract 1-2022  
February 5, 2026

Item P.

COST PROPOSAL NO.: 048

TO: Vissering Construction Company  
ISSUED BY: Dominic Gattone, P.E.

DISTRIBUTION

Tony Marzetta, Project Manager  
Gary Richardson  
Dominic Gattone, P.E.  
Vissering Construction Company (Contractor)  
City of Crest Hill, Illinois  
Strand Associates, Inc.®

Please submit an itemized quotation for changes in the Contract Price and Time incidental to proposed modifications to the Contract Documents described herein. The purpose of this request is to eliminate connection to the East Sewage Treatment Plant SCADA System and its Historian server over the City/Comcast ENS network.

DESCRIPTIONS AFFECTING THE SPECIFICATIONS

**Section 26 09 01 SCADA Programming**

048-01 Provide a rack-mounted server for use as a local historian server. Server shall be installed in the Structure 70 network rack and powered from the UPS furnished with the rack. Server shall be Dell PowerEdge with the following minimum specifications:

- Single 16-core processor, 32-thread
- BOSS with RAID 1 configuration, minimum 256G
- Separate RAID 5 storage volume, minimum 3TB, space for minimum 3 solid-state drives
- Minimum 64 GB RAM
- Chassis with space for 8 drives
- iDRAC with out of band hardware management platform and remote troubleshooting
- 6 NICs
- Windows Server 2025 OS with downgrade license keys for 2019 & 2022 OS's
- 5-year support contract

Submit server selection for review by Engineer before ordering. The server shall be configured for the following VMs: Domain Controller, Demilitarized Zone (DMZ), Historian, and Access Anywhere. Server configuration shall be reviewed with Engineer once server is received (assume 2 hour meeting).

048-02 Subsection 2.01 SCADA System Computers and Software -E.3.j - Delete "Remote IDAS to Connect to Existing East STP Historian Server" from the Table 2.01 SCADA Computer Software Schedule. Add a 5,000-tag Historian Server license (to be installed on the new West STP Historian Server VM described above) and Historian Client licenses on each of the SCADA1, SCADA2, and SCADA4 desktop computers.

048-03 Subsection 2.01 SCADA System Computers and Software -E.3.j - Provide an InTouch AccessAnywhere Application Server and one read/write InTouch runtime license on the new West STP Access Anywhere Server VM described above. Provide an AccessAnywhere Gateway on the new West STP DMZ Server VM described above.



048-04 Subsection 2.01 SCADA System Computers and Software - G. Delete entire Paragraphs 2 and 3.

DESCRIPTIONS AFFECTING THE DRAWINGS

**Drawing 99-E6.03 - Electrical SCADA Riser Diagram**

048-05 See attached mark-up.

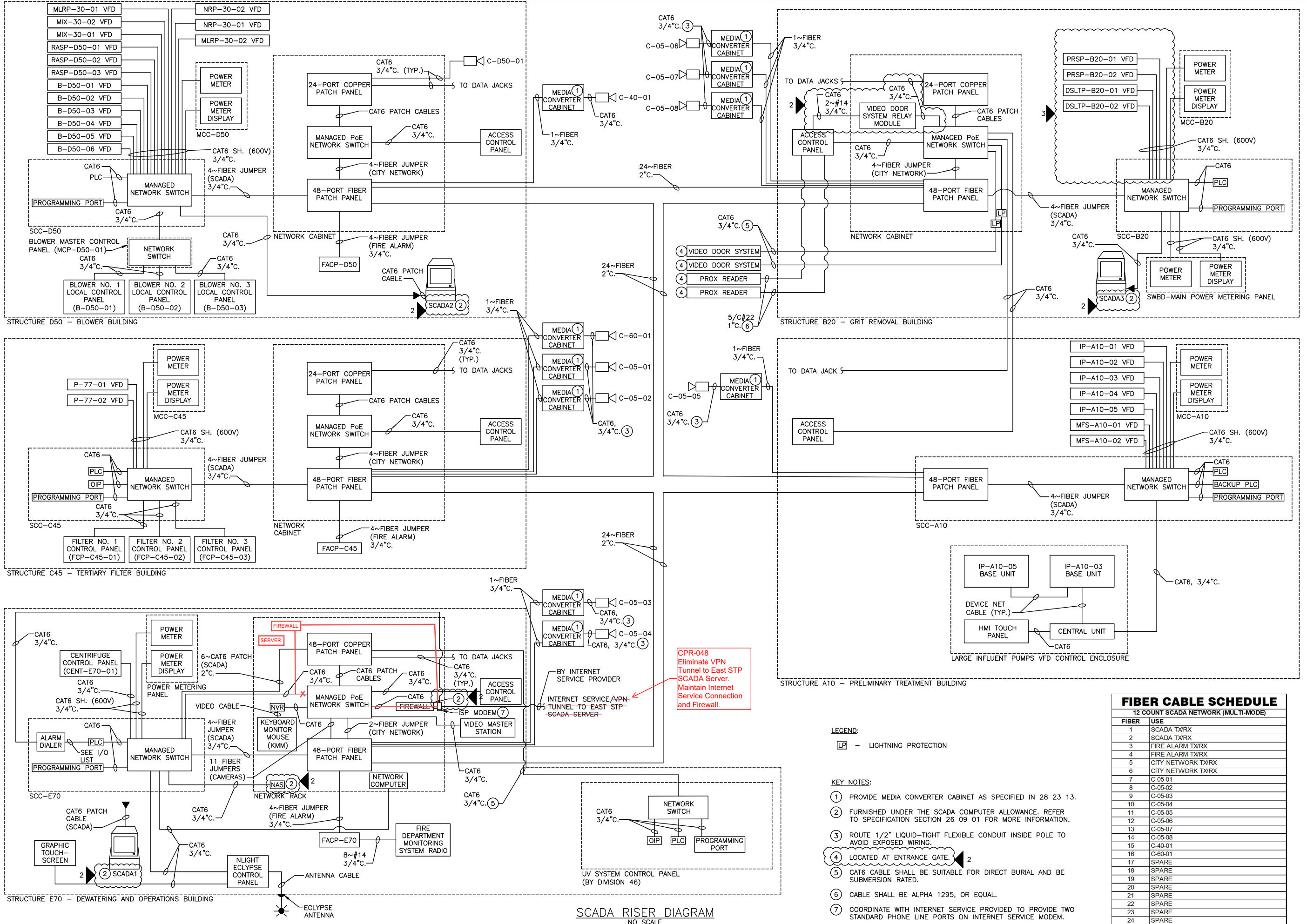

SCADA RISER DIAGRAM  
NO SCALE

CPR-048  
Eliminate VPN  
Tunnel to East STP  
SCADA Server.  
Maintain Internet  
Service Connection  
and Firewall.

LEGEND:

- LP - LIGHTNING PROTECTION
- KEY NOTES:
  - ① PROVIDE MEDIA CONVERTER CABINET AS SPECIFIED IN 28 23 13.
  - ② FURNISHED UNDER THE SCADA COMPUTER ALLOWANCE. REFER TO SPECIFICATION SECTION 26 09 01 FOR MORE INFORMATION.
  - ③ ROUTE 1/2" LIQUID-TIGHT FLEXIBLE CONDUIT INSIDE POLE TO AVOID EXPOSED WIRING.
  - ④ LOCATED AT ENTRANCE GATE.
  - ⑤ CAT6 CABLE SHALL BE SUITABLE FOR DIRECT BURIAL AND BE SUBMERSION RATED.
  - ⑥ CABLE SHALL BE ALPHA 1295, OR EQUAL.
  - ⑦ COORDINATE WITH INTERNET SERVICE PROVIDED TO PROVIDE TWO STANDARD PHONE LINE PORTS ON INTERNET SERVICE MODEM.

FIBER CABLE SCHEDULE

12 COUNT SCADA NETWORK (MULTI-MODE)	
FIBER	USE
1	SCADA TX/RX
2	SCADA TX/RX
3	FIRE ALARM TX/RX
4	FIRE ALARM TX/RX
5	CITY NETWORK TX/RX
6	CITY NETWORK TX/RX
7	C-05-01
8	C-05-02
9	C-05-03
10	C-05-04
11	C-05-05
12	C-05-06
13	C-05-07
14	C-05-08
15	C-40-01
16	C-60-01
17	SPARE
18	SPARE
19	SPARE
20	SPARE
21	SPARE
22	SPARE
23	SPARE
24	SPARE

NO.	REVISIONS	DATE
1	ISSUED FOR BID	5/12/2022
2	CONFORMED DRAWINGS	12/1/2022
3	CHANGE ORDER NO. 1	3/3/2023

**ELECTRICAL**  
**SCADA RISER DIAGRAM**  
 WEST SEWAGE TREATMENT PLANT IMPROVEMENTS  
 CITY OF CREST HILL  
 WILL COUNTY, ILLINOIS

**JOB NO.**  
 3894.051  
**PROJECT MGR.**  
 DOMINIC GATTONE





**PROPOSAL  
WORKSHEET SUMMARY**

Project: CITY OF CREST HILL - WEST SEWAGE TREATMENT PLANT IMPROVEMENTS

Change Order Request #: 051

To: Strand Associates, Inc.  
Dominic Gattone, PE

Date: 2/24/2026  
A/E Project #: IDFPR No. 184-001273  
VCC Project #: 11108.00

WORK DESCRIPTION
RF051 - Historian License

Line No	Cost Description	Labor Amt	Material Amt	Equip & Other Amt	Sub-Contractor Amt	Sub-Total
1	WUNDERLICH-MALEC				\$ 52,520.00	\$ 52,520.00
2						\$ -
3						\$ -
4						\$ -
5						\$ -
6						\$ -
7						\$ -
8						\$ -
9						\$ -
10						\$ -
11						\$ -
12						\$ -
13						\$ -
14						\$ -
15						\$ -
16						\$ -
17						\$ -
18						\$ -
19						\$ -
20						\$ -
21						\$ -
22						\$ -
23						\$ -
24						\$ -
25						\$ -
<b>Sub-Total</b>		\$ -	\$ -	\$ -	\$ 52,520.00	\$ 52,520.00

**ACCEPTANCE OF PROPOSAL (OWNER): City of Crest Hill**

Name/Title: Gary Richardson, Public Works Director

Signature: \_\_\_\_\_

Date: \_\_\_\_\_

Contractor's Net:	\$ -
Sub-Contractor's Net:	\$ 52,520.00
Net Subtotal:	\$ 52,520.00
Contractor's Fee: (15% on Own Work, 5% on Subs, & 0% on Credits):	\$ 2,626.00
Sub-Total:	\$ 55,146.00
Bonds & Insurance - 1%:	\$ -
<b>Worksheet Total:</b>	<b>\$ 55,146.00</b>

**ACCEPTANCE OF PROPOSAL (A/E): Strand Associates, Inc.**

Name/Title: Dominic Gattone, PE

Signature: \_\_\_\_\_

Date: \_\_\_\_\_

**ACCEPTANCE OF PROPOSAL (CONTRACTOR): VISSERING CONSTRUCTION CO**

Name/Title: Tony Marzetta, Project Manager

Signature: \_\_\_\_\_

Date: February 24, 2026



February 24, 2026

**Project Name: West Sewage Treatment Plant Improvements**

**Project Location: City of Crest Hill, Illinois**

**Consulting Engineer: Strand Associates, Inc**

**WME Change Order – 13 Rev A**

---

Vissering Construction  
Tony Marzetta - [tmarzetta@vissering.com](mailto:tmarzetta@vissering.com)  
Project 11108.00

**Reference: CPR048 Historian**

Wunderlich-Malec Environmental is pleased to offer the following add proposal.

Total price for the Add is \$52,520.00 Net Excluding Tax

Enhancement Hours Requested for the Programming Changes: 24

Breakout  
See Attached

Note: Downgrade Pack to 2019 is no longer available, WME is including the downgrade pack to 2002.

This proposal consists of eleven (11) pages. If you have any questions regarding this proposal, please do not hesitate to contact me at 952-843-5846

Yours Truly,

*Ken Kawiecki*

SIGNED ELECTRONICALLY

Ken Kawiecki  
[ken.kawiecki@wmeng.com](mailto:ken.kawiecki@wmeng.com)  
Wunderlich-Malec Environmental  
"Employee Owned, Customer Committed"

EEO/Affirmative Action Employer



BU Project – Dell Server

Prepared for:

Wunderlich-Malec Systems

Attn: Ken Kawiecki

Prepared by:

High Point Networks, LLC

Hardware

Qty	Item	Description	Price	Ext. Price
1	210-BNMR	PowerEdge R470 Server, Enterprise	\$16,662.32	\$16,662.32
1	210-BNMR	PowerEdge R470 Server, Enterprise		
1	321-BLDY	2.5" Chassis with up to 8 Hard Drives (SAS/SATA), Smart Flow, Rear IO, H965i		
1	338-CTBM	Intel Xeon 6 Performance 6511P 2.3G, 16C/32T, 72M Cache, Turbo, (150W) DDR5-6400		
1	412-BBKQ	Extended heatsink without DIMM blanks		
1	370-AAIP	Performance Optimized		
1	370-BCCX	6400MT/s RDIMMs		
1	780-BCDP	RAID 5		
1	403-BDMY	PERC H965i Controller, Front, DCMHS		
1	384-BBBL	Performance BIOS Settings		
1	800-BBDM	UEFI BIOS Boot Mode with GPT Partition		
1	387-BBEY	No Energy Star		
1	384-BDQL	PowerEdge 1U High Performance Silver Fan		
1	450-BDRV	Dual, Redundant(1+1), Hot-Plug MHS Power Supply, 800WMM(100-240Vac) Titanium		
1	330-BCWK	Riser Config 6, 2x16 FH Slots (Gen5), 1x16 Onboard OCP		
1	330-BCYF	PowerEdge R470 Motherboard fo RTS 1.1, ROW		
1	780-BCZQ	No OCP Blanks or Cables Required		
1	470-AEYU	No Cables Required		

## Hardware

Qty	Item	Description	Price	Ext. Price
1	325-BFXF	PowerEdge 1U Standard Bezel		
1	350-BDDK	Dell Luggage Tag for x8 and x10 Chassis		
1	403-BDMM	BOSS-N1 controller card + with 2 M.2 480GB (RAID 1) (22x80)		
1	634-CVGB	Windows Server 2025 Standard,16CORE,FI,No Med,No CAL, Multi Language		
1	634-CSHS	Secure Enterprise Key Manager License 3.0		
1	634-CSHT	Secured Component Verification		
1	634-CSHY	iDRAC10, Enterprise 17G		
1	379-BFXS	Dell Connectivity Client - Enabled		
1	634-CZRP	Dell Connectivity Module 17G		
1	634-CZWJ	Dell Secure Onboarding Client 17G - Disabled		
1	350-BCYJ	Blank Left Ear Module		
1	379-BETF	iDRAC Legacy Password for OCP cards		
1	770-BDMT	Cable Management Arm		
1	770-BECD	ReadyRails Sliding Rails (A15)		
1	340-DNSW	PowerEdge Shipping		
1	340-DSBN	PowerEdge R470 Shipping		
1	340-DNSY	PowerEdge 1U Shipping Material		
1	389-FHHX	PowerEdge CCC, No CE Label Marking		
1	709-BBFM	Basic Next Business Day 36 Months		
1	865-BBMY	ProSupport and Next Business Day Onsite Service Initial, 36 Month(s)		
1	865-BBMZ	ProSupport and Next Business Day Onsite Service Extension, 24 Month(s)		
1	883-BBFN	No Field Deployment		
4	370-BCCY	32GB RDIMM, 6400MT/s, Dual Rank		
3	161-BCBX	2.4TB Hard Drive SAS ISE 12Gbps 10K 512e 2.5in Hot-Plug		

## Hardware

Qty	Item	Description	Price	Ext. Price
2	450-AALV	Power Cord - NEMA 5-15P to C13, 3M, 125V, 15A (North America, Guam, North Marianas, Philippines, Samoa, Vietnam)		
1	540-BFPS	Broadcom 57412 Quad Port 10GbE Base-T adapter, OCP 3.0 NIC +Sec		
1	528-DHTW	Windows Server 2025 Standard,16CORE,DF Recovery Image, Multi Lang, (Downgrade not included)		
1	528-DHVD	Windows Server 2025 Standard,No Media,WS2022 Std Downgrade DF Media, Multi Language		
1	634-CVBQ	Windows Server 2025 Standard,No Media, WS2022 Std Downgrade w/DVD Media,Multi Lang		
1	634-CVGJ	Windows Server 2025 Standard,16CORE,Media Kit, Multi Lang, (Downgrade not included)		
1	634-CVFT	Windows Server 2025 Standard Edition, Add License,16CORE,NO MEDIA/KEY		
			<b>Subtotal:</b>	<b>\$16,662.32</b>

## Quote Summary

Description	Amount
Hardware	\$16,662.32
<b>Total:</b>	<b>\$16,662.32</b>



# PowerEdge R470

Unprecedented Single-Socket Server with Optimized Power and Balanced Performance

## Boost Datacenter Efficiencies and Performance

The Dell PowerEdge R470 is a 1U, single-socket rack server engineered for high-performance computing with optimal power efficiency and balanced performance, driving cost savings and boosting data center productivity. Its advanced design maximizes rack utilization by offering more cores in a single socket enabling better performance in a smaller footprint while minimizing energy consumption. This makes it ideal for workloads like cloud scale web and app microservices, data services, virtualization, and scale-out database.

Purpose-built for enterprise and scalable infrastructures, the PowerEdge R470 seamlessly integrates into existing environments. Equipped with an Intel® Xeon® processor with E-cores that are tailored for energy efficiency and performance-per-watt, offering both improved power efficiency and higher rack density. With GPU support, it further enhances computational power while reducing overall operational costs, especially on energy consumption impact.

The server is available in rear I/O hot aisle and front I/O cold aisle configurations, with the front I/O cold aisle improving serviceability, reducing maintenance time, and enhancing overall efficiency, reliability, and uptime. Dell's Smart Power and Cooling Technology, optimized for air cooling, significantly reduces energy consumption, delivering long-term operational savings and supporting sustainability goals.

## Cyber Resilient Architecture for Zero Trust IT environment & operations

Security is integrated into every phase of the PowerEdge lifecycle, including protected supply chain and factory-to-site integrity assurance. The Silicon-based root of trust anchors end-to-end boot resilience while Multi-Factor Authentication (MFA) and role-based access controls safeguard trusted operations.

## Increase efficiency and accelerate operations with autonomous collaboration

The Dell OpenManage systems management portfolio tames the complexity of managing and securing IT infrastructure. Using Dell Technologies' intuitive end-to-end tools, IT can deliver a secure, integrated experience by reducing process and information silos in order to focus on growing the business. The Dell OpenManage portfolio is the key to your innovation engine, unlocking the tools and automation that help you scale, manage, and protect your technology environment.

## Sustainability

From recycled materials in our products and packaging, to thoughtful, innovative options for energy efficiency, the PowerEdge portfolio is designed to make, deliver, and recycle products to help reduce the carbon footprint and lower your operation costs. We even make it easy to retire legacy systems responsibly with Dell Technologies.

## Rest easier with Dell Technologies Services

Maximize your PowerEdge Servers with comprehensive services designed to meet you wherever you are. Accelerate time to value in achieving high AI use cases with **Professional Services for AI**, choose from tailored deployment options with the **ProDeploy Suite**, receive proactive and predictive support with our **ProSupport Suite**, and so much more with our services available across 170 locations and backed by our 60K+ employees and partners.

### PowerEdge R470

The Dell PowerEdge R470 is powered by Intel Xeon 6 Processors, DDR5 Memory, NVMe BOSS, Energy Star compliant and advanced cooling.

Ideal for:

- Cloud scale web and app microservices
- Data services
- Virtualization
- Scale-out database

Feature	Technical Specifications	
Processor	One Intel® Xeon 6 E-core processor with up to 144 cores per processor or One Intel® Xeon 6 P-core processor with up to 86 Cores with R1S option	
Memory	<ul style="list-style-type: none"> <li>16 DDR5 DIMM slot, supports RDIMM 4TB max, speeds up to 6400 MT/s</li> <li>Intel® Xeon® 6 E-core processor - supports 1 TB max</li> <li>Intel® Xeon® 6 P-core processor with up to 86 cores with R1S option - supports 4 TB max</li> <li>Supports registered ECC DDR5 DIMMs only</li> </ul> Note: The installed processor may reduce the operating speed of the DIMM	
Storage controllers	<ul style="list-style-type: none"> <li>Internal Controllers (RAID): PERC H365i DC-MHS, front PERC H965i DC-MHS, PERC H365i adapter, PERC H965i adapter</li> <li>External Controllers: HBA465e, H965e(RAID)</li> <li>Internal Boot: Boot Optimized Storage Subsystem (BOSS-N1 DC-MHS): HWRAID 1, 2 xM.2 NVMe SSDs, M.2 interposer with upto 2 x M.2 NVMe SSDs or USB</li> </ul>	
Drive Bays	Front bays: <ul style="list-style-type: none"> <li>Up to 8 x EDSFF E3.S Gen5 NVMe max 491.52 TB</li> <li>Up to 16 x EDSFF E3.S Gen5 NVMe max 983.04 TB</li> <li>Up to 8 x 2.5-inch SATA/NVMe max 491.52 TB</li> <li>Up to 10 x 2.5 - inch SATA/NVMe (with 4 x 2.5 -inch universal) max 614.4 TB</li> <li>Up to 4 x 3.5 - inch SATA max 128 TB (only supported with rear 2 x E3.S drives; not supported as standalone front-only configuration)</li> </ul> Rear bays: <ul style="list-style-type: none"> <li>Up to 2 x EDSFF E3.S Gen5 NVMe max 122.88 TB</li> </ul>	
Power Supplies	<ul style="list-style-type: none"> <li>800W Platinum/Titanium 100-240 VAC or 240 HVDC, hot swap redundant</li> <li>1100 W Platinum/Titanium 100-240 VAC or 240 HVDC, hot swap redundant</li> <li>1500 W Titanium 100-240 VAC or 240 HVDC, hot swap redundant</li> <li>1500 W 277 Vac and HVDC Titanium, hot swap redundant</li> <li>1400W -48v DC Titanium, hot swap redundant</li> </ul>	
Cooling Options	Air cooling	
Fans	<ul style="list-style-type: none"> <li>Up to 4 sets (dual fan module) hot swappable fans</li> </ul>	
Dimensions	<ul style="list-style-type: none"> <li>Height – 42.8 mm (1.69 inches)</li> <li>Width – 482 mm (19.0 inches)</li> <li>Depth – 816.92 mm (32.16 inches) with bezel</li> <li>Depth – 815.14 mm (32.09 inches) without bezel</li> <li>Depth (Front I/O Configuration) — 829.44 mm (32.09 inches) without bezel</li> </ul> Note: Front I/O configuration will not have a bezel.	
Form Factor	1U rack server	
Embedded Management	<ul style="list-style-type: none"> <li>iDRAC</li> <li>iDRAC Direct</li> <li>iDRAC RESTfull API with redfish</li> <li>RACADM CLI</li> <li>iDRAC Service Module</li> </ul>	
Bezel	Optional security bezel	
Security	<ul style="list-style-type: none"> <li>Cryptographically signed firmware</li> <li>Data at Rest Encryption (SEDs with local or external key mgmt)</li> <li>Secure Boot</li> <li>Secured Component Verification (Hardware integrity check)</li> <li>Secure Erase</li> <li>Silicon Root of Trust</li> <li>System Lockdown (requires iDRAC10 Enterprise or Datacenter)</li> <li>TPM 2.0 FIPS, CC-TCG certified</li> <li>Chassis Intrusion Detection</li> </ul>	
OCP network options	<ul style="list-style-type: none"> <li>Up to two OCP NIC card 3.0: Two slots on the front or two slots on the rear (optional)</li> </ul> Slot Numbers: 2,5,31,32	
Embedded NIC	<ul style="list-style-type: none"> <li>1 Gb dedicated BMC Ethernet port</li> </ul>	
GPU Options	Up to 4 x 75 W SW	
DPU Options	NVIDIA BlueField-3 2 x 200 GbE B3220	
Ports	Front Ports <ul style="list-style-type: none"> <li>1 x USB 2.0 Type - C port</li> <li>1 x USB 2.0 Type A port (optional)</li> <li>1 x Mini-DisplayPort (optional)</li> <li>1 x DB9 Serial (with front I/O configuration)</li> <li>1 x Dedicated BMC Ethernet port (with front I/O configuration)</li> </ul> Internal Ports <ul style="list-style-type: none"> <li>1 x USB 3.1 Type A port</li> </ul>	Rear Ports <ul style="list-style-type: none"> <li>1 x Dedicated BMC Ethernet port</li> <li>2 x USB 3.1 Type A ports</li> <li>1 x VGA</li> </ul>
PCIe	Up to 4 Gen5 PCIe slots (x16 connectors) <ul style="list-style-type: none"> <li>Slot 1 -1 x8 Gen5 Low Profile</li> <li>Slot 1 -1 x16 Gen5 (x16 connector) full height, half length on rear riser</li> <li>Slot 4 -1 x16 Gen5 (x16 connector) full height, half length on rear riser</li> <li>Slot 31 -1 x16 Gen5 (x16 connector) full height, half length on rear riser</li> <li>Slot 32 -1 x16 Gen5 (x16 connector) full height, half length on rear riser</li> </ul>	

Feature	Technical Specifications
Operating System and Hypervisors	<ul style="list-style-type: none"> <li>• Canonical Ubuntu Server LTS</li> <li>• Red Hat Enterprise Linux</li> <li>• SUSE Linux Enterprise Server</li> <li>• VMware ESXi</li> <li>• Windows Server</li> <li>• Windows Server Datacenter</li> </ul> For specifications and interoperability details, see <a href="https://Dell.com/OSsupport">Dell.com/OSsupport</a> .
OEM-ready version available	From bezel to BIOS to packaging, your servers can look and feel as if they were designed and built by you. For more information, visit <a href="https://Dell.com/OEM">Dell.com/OEM</a> .

**NOTE:** From bezel to BIOS to packaging, your servers can look and feel as if they were designed and built by you with our OEMR platforms, while XL platforms provide extended transitions and stability for OEM Solutions customers. For more information, visit [Dell.com](https://Dell.com) -> Solutions -> OEM Solutions.

## APEX on Demand

APEX Flex on Demand Acquire the technology you need to support your changing business with payments that scale to match actual usage. For more information, visit [www.delltechnologies.com/en-us/payment-solutions/flexible-consumption/flex-on-demand.htm](https://www.delltechnologies.com/en-us/payment-solutions/flexible-consumption/flex-on-demand.htm).

**NOTE:** This document provides a comprehensive list of product features. However, features marked with an asterisk (\*) may not be available at launch but introduced in future updates. Please note that this document does not confirm the availability or release timeline of any feature. For the most accurate and up-to-date information on feature availability, please refer to the product configurator page on [dell.com](https://dell.com).

## Discover more about PowerEdge servers



Learn more about services for PowerEdge servers



Learn more about our systems management solutions



Search our Resource Library



Follow PowerEdge servers on X (formerly Twitter)



Contact a Dell Technologies Expert for [Sales](#) or [Support](#)

We have prepared a quote for you



## Crest Hill - West STP Additions

---

QUOTE

PREPARED FOR

Wunderlich-Malec Engineering/Systems, Inc.



804.378.8981    spalumbo@insourcess.com    www.insource.solutions

Friday, February 06, 2026

Wunderlich-Malec Engineering/Systems, Inc.  
Ken Kawiecki  
6101 Blue Circle Dr  
Eden Prairie, MN 55343-9108  
ken.kawiecki@wmeng.com

Dear Ken,

Thank you for your partnership.

At InSource, our mission is to help organizations operate smarter, stronger, and more competitively. We understand that success in today's environment requires more than just the right software or hardware—it requires a trusted partner who can bring together technology, services, and expertise to deliver sustainable results.

For years, we've worked alongside clients across many industries, providing solutions that improve productivity, reduce complexity, and support long-term growth. We take pride in being more than a provider—we strive to be an extension of your team, ensuring that every engagement delivers measurable value.

We're also committed to the future. By investing in innovation and supporting the next generation of professionals, we work to strengthen not only our clients but the industries and communities we serve.

We look forward to continuing to earn your trust and helping you achieve your goals.

**To place your order:**

Please send your purchase order to [orderentry@insourcess.com](mailto:orderentry@insourcess.com) or by fax to **804.378.8970**.

*Note: When sending purchase orders, please include a copy of your company's tax-exempt certificate (if applicable), as this omission could delay your order.*

Sales Operations Coordinator  
Richmond, VA



804.378.8981    spalumbo@insourcess.com    www.insource.solutions

SiteID: 149388  
Crest Hill WWTP,  
1610 Plainfield Road, Crest Hill Illinois 60435

### Software

Item	Description	Price	Qty	Ext. Price
1 HstClt-01-N-231	<b>AVEVA Historian Client Desktop 2023 R2, Concurrent User Single</b>	\$2,683.00	3	\$8,049.00
2 InTch-06-N-231	<b>AVEVA InTouch HMI 2023 R2 Workstation 100K Tag with I/O</b>	\$9,398.00	1	\$9,398.00
<b>Customer FIRST</b>	<b>Customer FIRST Contract #110227 - Pro-rated 7 months to Expire 10/8/2026</b>	<b>\$1,355.00</b>	<b>1</b>	<b>\$1,355.00</b>
Subtotal:				<b>\$18,802.00</b>



Cost Proposal Request  
West Sewage Treatment Plant Improvements  
City of Crest Hill, Illinois  
Contract 1-2022  
February 5, 2026

Item P.

COST PROPOSAL NO.: ~~048~~ 051

TO: Vissering Construction Company  
ISSUED BY: Dominic Gattone, P.E.

DISTRIBUTION

Tony Marzetta, Project Manager  
Gary Richardson  
Dominic Gattone, P.E.  
Vissering Construction Company (Contractor)  
City of Crest Hill, Illinois  
Strand Associates, Inc.®

Please submit an itemized quotation for changes in the Contract Price and Time incidental to proposed modifications to the Contract Documents described herein. The purpose of this request is to eliminate connection to the East Sewage Treatment Plant SCADA System and its Historian server over the City/Comcast ENS network.

DESCRIPTIONS AFFECTING THE SPECIFICATIONS

**Section 26 09 01 SCADA Programming**

048-01 Provide a rack-mounted server for use as a local historian server. Server shall be installed in the Structure 70 network rack and powered from the UPS furnished with the rack. Server shall be Dell PowerEdge with the following minimum specifications:

- Single 16-core processor, 32-thread
- BOSS with RAID 1 configuration, minimum 256G
- Separate RAID 5 storage volume, minimum 3TB, space for minimum 3 solid-state drives
- Minimum 64 GB RAM
- Chassis with space for 8 drives
- iDRAC with out of band hardware management platform and remote troubleshooting
- 6 NICs
- Windows Server 2025 OS with downgrade license keys for 2019 & 2022 OS's
- 5-year support contract

Submit server selection for review by Engineer before ordering. The server shall be configured for the following VMs: Domain Controller, Demilitarized Zone (DMZ), Historian, and Access Anywhere. Server configuration shall be reviewed with Engineer once server is received (assume 2 hour meeting).

048-02 Subsection 2.01 SCADA System Computers and Software -E.3.j - Delete "Remote IDAS to Connect to Existing East STP Historian Server" from the Table 2.01 SCADA Computer Software Schedule. Add a 5,000-tag Historian Server license (to be installed on the new West STP Historian Server VM described above) and Historian Client licenses on each of the SCADA1, SCADA2, and SCADA4 desktop computers.

048-03 Subsection 2.01 SCADA System Computers and Software -E.3.j - Provide an InTouch AccessAnywhere Application Server and one read/write InTouch runtime license on the new West STP Access Anywhere Server VM described above. Provide an AccessAnywhere Gateway on the new West STP DMZ Server VM described above.



048-04 Subsection 2.01 SCADA System Computers and Software - G. Delete entire Paragraphs 2 and 3.

DESCRIPTIONS AFFECTING THE DRAWINGS

**Drawing 99-E6.03 - Electrical SCADA Riser Diagram**

048-05 See attached mark-up.

Item P.

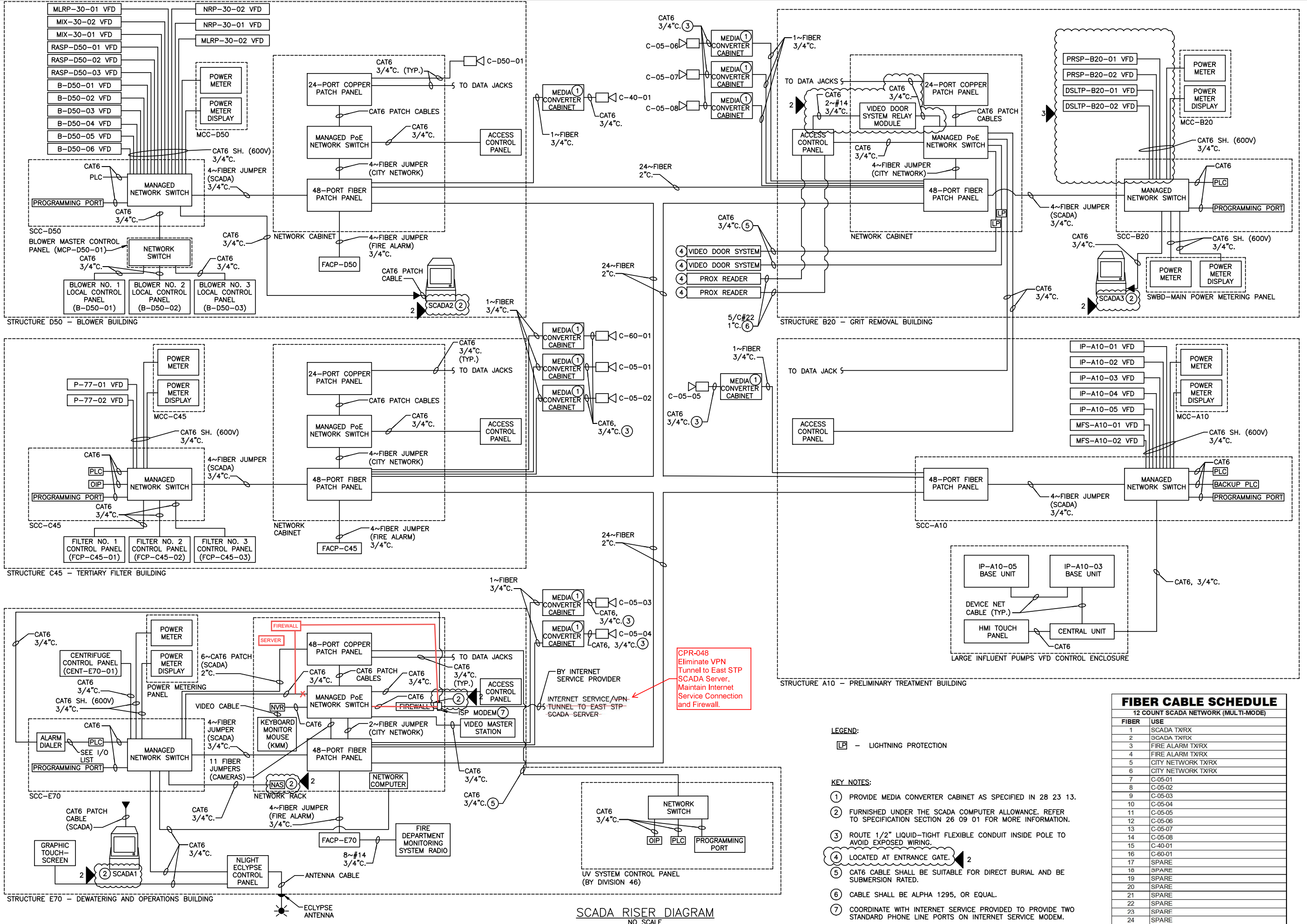

SCADA RISER DIAGRAM  
NO SCALE

**FIBER CABLE SCHEDULE**

12 COUNT SCADA NETWORK (MULTI-MODE)

FIBER	USE
1	SCADA TX/RX
2	SCADA TX/RX
3	FIRE ALARM TX/RX
4	FIRE ALARM TX/RX
5	CITY NETWORK TX/RX
6	CITY NETWORK TX/RX
7	C-05-01
8	C-05-02
9	C-05-03
10	C-05-04
11	C-05-05
12	C-05-06
13	C-05-07
14	C-05-08
15	C-40-01
16	C-60-01
17	SPARE
18	SPARE
19	SPARE
20	SPARE
21	SPARE
22	SPARE
23	SPARE
24	SPARE

- LEGEND:**
- LP - LIGHTNING PROTECTION
- KEY NOTES:**
- PROVIDE MEDIA CONVERTER CABINET AS SPECIFIED IN 28 23 13.
  - FURNISHED UNDER THE SCADA COMPUTER ALLOWANCE. REFER TO SPECIFICATION SECTION 28 09 01 FOR MORE INFORMATION.
  - ROUTE 1/2" LIQUID-TIGHT FLEXIBLE CONDUIT INSIDE POLE TO AVOID EXPOSED WIRING.
  - LOCATED AT ENTRANCE GATE.
  - CAT6 CABLE SHALL BE SUITABLE FOR DIRECT BURIAL AND BE SUBMERSION RATED.
  - CABLE SHALL BE ALPHA 1295, OR EQUAL.
  - COORDINATE WITH INTERNET SERVICE PROVIDED TO PROVIDE TWO STANDARD PHONE LINE PORTS ON INTERNET SERVICE MODEM.

**REVISIONS**

NO.	ISSUED FOR	DATE
1	ISSUED FOR BID	5/12/2022
2	CONFORMED DRAWING	12/1/2022
3	CHANGE ORDER NO. 1	3/7/2023

**ELECTRICAL  
SCADA RISER DIAGRAM**

WEST SEWAGE TREATMENT PLANT IMPROVEMENTS  
CITY OF CREST HILL  
WILL COUNTY, ILLINOIS

**JOB NO.**  
3894.051

**PROJECT MGR.**  
DOMINIC GATTONE

**STRAND ASSOCIATES**

**SHEET** 240  
99-E6.03



Cost Proposal Request  
West Sewage Treatment Plant Improvements  
City of Crest Hill, Illinois  
Contract 1-2022  
April 9, 2026

Item P.

COST PROPOSAL NO.: 052

TO: Vissering Construction Company  
ISSUED BY: Dominic Gattone, P.E.

DISTRIBUTION

Tony Marzetta, Project Manager  
Gary Richardson  
Dominic Gattone, P.E.  
Vissering Construction Company (Contractor)  
City of Crest Hill, Illinois  
Strand Associates, Inc.®

Please submit an itemized quotation for changes in the Contract Price and Time incidental to proposed modifications to the Contract Documents described herein. The purpose of this request is to add additional emergency stop push buttons nearer the tertiary filter equipment.

DESCRIPTIONS AFFECTING THE DRAWINGS

**Drawing C45-E1.01 - Tertiary Filter Building - Electrical Plan**

052-01 Provide emergency stop pushbutton in NEMA 4X control station enclosure by Tertiary Disc Filter manufacturer and 2~#14 in 3/4” conduit from each e-stop to the associated filter control panel. Pressing the e-stop shall stop backwash pump, filter drum drive, and spray bar oscillating motor of its respective filter. Provide panel modifications as required. See attached mark-up.

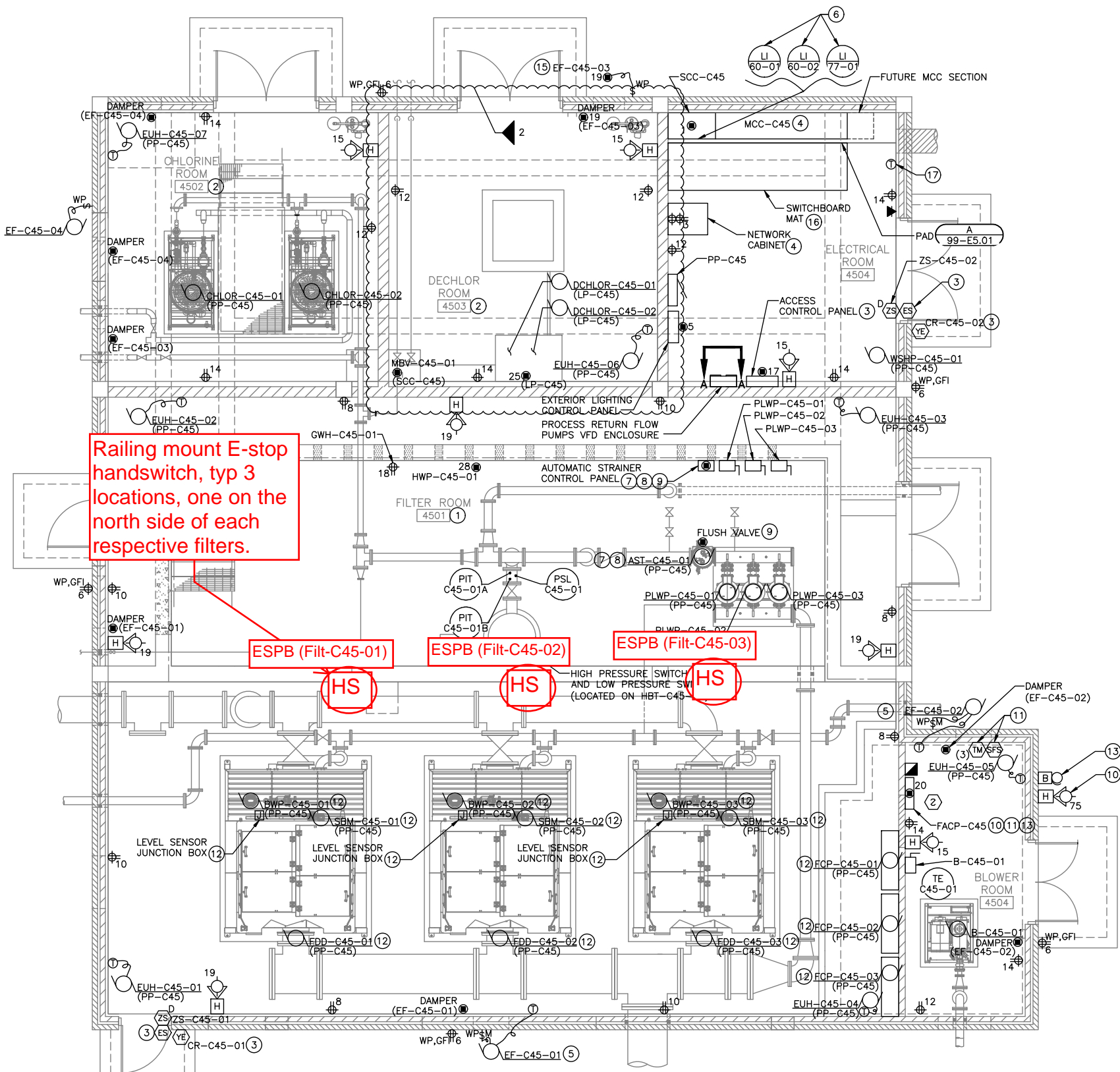

Railing mount E-stop handswitch, typ 3 locations, one on the north side of each respective filters.

ESPB (Filt-C45-01)

ESPB (Filt-C45-02)

ESPB (Filt-C45-03)

HS

HS

HS

ELECTRICAL PLAN

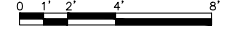

GENERAL NOTES:

- REFER TO SPECIFICATION SECTION 01 11 00 FOR INFORMATION ON CONSTRUCTION SEQUENCING.
- REFER TO SPECIFICATION SECTION 26 09 90 FOR WIRING ASSOCIATED WITH THE SCADA SYSTEM.
- SEE DRAWING C45-ASM1.01 FOR LOCATIONS OF FIRE-RATED WALLS.
- DAMPERS NOT SHOWN WITH A CIRCUIT NUMBER SHALL BE POWERED FROM A CONTROL POWER TRANSFORMER IN THE ASSOCIATED MCC BUCKET.
- THERE SHALL BE A MINIMUM OF 4" BETWEEN VFDS AND VFD ENCLOSURES. VFDS SHALL BE A MINIMUM OF 1'-0" AFF.

KEY NOTES:

- ALL ELECTRICAL WORK AND EQUIPMENT IN THIS ROOM SHALL BE RATED NEMA 4X. CONDUIT SHALL BE ALUMINUM AND SUPPORT MEMBERS SHALL BE STAINLESS STEEL.
- ALL ELECTRICAL WORK AND EQUIPMENT IN THIS ROOM SHALL BE RATED NEMA 4X. CONDUIT SHALL BE PVC AND SUPPORT MEMBERS SHALL BE FRP.
- PROVIDE A FLUSH-MOUNTED BOX ON BUILDING EXTERIOR FOR CARD READER. PROVIDE 3/4" CONDUIT FROM BOX TO ACCESS CONTROL PANEL IN THE ELECTRICAL ROOM. PROVIDE 3/4" CONDUIT FROM BOX TO DOOR FRAME FOR ELECTRIC STRIKE. WIRING SHALL BE FURNISHED AND INSTALLED BY THE SECTION 28 10 00 SYSTEM SUPPLIER.
- BOND THE COMMUNICATION CABINET GROUND BAR TO THE GROUND BUS IN MCC-C45 WITH A #6 GROUND CONDUCTOR IN 3/4" PVC CONDUIT. MOUNT RECEPTACLES INSIDE THE COMMUNICATION CABINET.
- FAN SHALL BE CONTROLLED BY THE ROOM THERMOSTAT SUCH THAT THE FAN RUNS WHEN THE ROOM TEMPERATURE RISES ABOVE THE THERMOSTAT SETPOINT AND SHUTS DOWN WHEN THE TEMPERATURE FALLS BELOW THE THERMOSTAT SETPOINT.
- LEVEL INDICATORS SHALL BE FLUSH-MOUNTED ON THE DOOR OF THE SCC. REFER TO SPECIFICATION SECTION 26 09 00 PART 3 FOR ADDITIONAL INFORMATION.
- PROVIDE 2~#14 FROM CONTROL PANEL TO THE LOW PRESSURE SWITCH AND 2~#14 FROM CONTROL PANEL TO THE HIGH PRESSURE SWITCH IN 3/4" CONDUIT. SWITCHES ARE LOCATED AT THE AUTOMATIC STRAINER (AST-C45-01).
- PROVIDE 3~#12 AND #12 GROUND IN 3/4" CONDUIT FROM CONTROL PANEL TO SCREEN MOTOR DRIVE MOTOR NO. 1 AT THE AUTOMATIC STRAINER (AST-C45-01). PROVIDE 3~#12 AND #12 GROUND IN 3/4" CONDUIT FROM CONTROL PANEL TO SCREEN MOTOR DRIVE MOTOR NO. 2 AT THE AUTOMATIC STRAINER.
- PROVIDE 4~#14 FROM CONTROL PANEL TO THE FLUSH VALVE IN 3/4" CONDUIT.
- EXTERIOR ALARM STROBE SHALL BE POWERED THROUGH FACP SUCH THAT IT IS ONLY ACTIVATED WHEN SMOKE DETECTOR OR FIRE ALARM FLOW SWITCH IS ACTIVATED.
- FIRE ALARM FLOW SWITCH AND TAMPER SWITCHES PROVIDED BY DIVISION 21 AND WIRED TO FACP BY DIVISION 28. PROVIDE REQUIRED ADDRESSABLE CONTROL MODULES AND SUPERVISORY RELAYS TO MONITOR EACH DEVICE.
- PROVIDE CONDUCTORS/CONDUIT TO DEVICES AS SHOWN IN THE TERTIARY DISC FILTER SYSTEM CONDUIT AND WIRE SCHEDULE.
- FIRE SUPPRESSION SYSTEM ALARM BELL FURNISHED BY DIVISION 21 AND INSTALLED AND WIRED BY DIVISION 28. ALARM BELL SHALL BE POWERED FROM THE FACP.
- THERE SHALL BE A MINIMUM OF 6" BETWEEN THE TOP OF THE VFD AND THE BOTTOM OF THE VFD CONTROLS ENCLOSURE.
- FAN SHALL RUN CONTINUOUSLY.
- PROVIDE SWITCHBOARD MAT AS SPECIFIED IN SECTION 12 48 43 SPANNING ENTIRE FRONT OF MCC AND SCC.
- THERMOSTAT PROVIDED BY DIVISION 23. PROVIDE 3/4" CONDUIT FROM THERMOSTAT TO WSHP-C45-01 FOR DIVISION 23 INSTALLED WIRING.

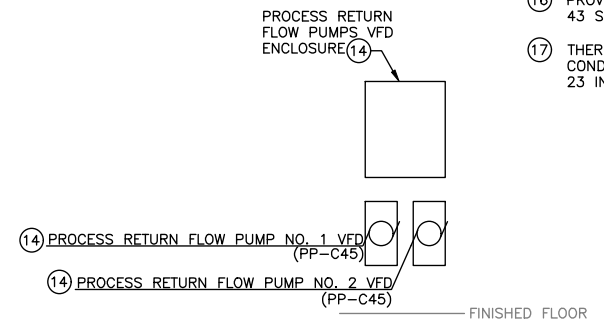

SECTION A

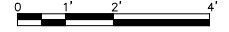

CONDUIT DESIGNATION	ORIGIN	TERMINATION	CONDUIT SIZE	CONDUCTORS*
DRUM DRIVE MOTOR POWER	FCP-C45-01	FDD-C45-01	3/4"	3-#12
DRUM DRIVE MOTOR OVERTEMP	FCP-C45-01	FDD-C45-01	3/4"	2-#14
BACKWASH PUMP MOTOR POWER	FCP-C45-01	BWP-C45-01	3/4"	3-#10
BACKWASH PUMP MOTOR OVERTEMP	FCP-C45-01	BWP-C45-01	3/4"	2-#14
SPRAY BAR OSCILLATION DRIVE MOTOR POWER	FCP-C45-01	SBM-C45-01	3/4"	3-#12
DISC FILTER LEVEL SENSORS	FCP-C45-01	FILT-C45-01 LEVEL SENSOR JUNCTION BOX	3/4"	10-#14

\* PROVIDE GROUND WIRE FOR EACH PIECE OF EQUIPMENT SIZED PER THE NEC.  
 \*\*SCHEDULE TYPICAL FOR FCP-C45-01, FCP-C45-02, AND FCP-C45-03.

NO.	ISSUED FOR	DATE
1	ISSUED FOR BID	5/12/2022
2	CONFORMED DRAWINGS	12/1/2022
3	CHANGE ORDER NO. 1	X/X/2023

REVISIONS  
 TERTIARY FILTER BUILDING  
 ELECTRICAL PLAN  
 WEST SEWAGE TREATMENT PLANT IMPROVEMENTS  
 CITY OF CREST HILL  
 WILL COUNTY, ILLINOIS

JOB NO.  
3894.051

PROJECT MGR.  
DOMINIC GATTONE

SHEET  
13 242  
C45-ET.UT



**PROPOSAL  
WORKSHEET SUMMARY**

Project: CITY OF CREST HILL - WEST SEWAGE TREATMENT PLANT IMPROVEMENTS

Change Order Request #: 052

To: Strand Associates, Inc.  
Dominic Gattone, PE

Date: 4/20/2026  
A/E Project #: IDFPR No. 184-001273  
VCC Project #: 11108.00

WORK DESCRIPTION
CPR052: E Stop for Filters

Line No	Cost Description	Labor Amt	Material Amt	Equip & Other Amt	Sub-Contractor Amt	Sub-Total
1	CONNELLY ELECTRIC				\$ 6,645.00	\$ 6,645.00
2	WESTECH		\$ 4,025.00			\$ 4,025.00
3						\$ -
4						\$ -
5						\$ -
6						\$ -
7						\$ -
8						\$ -
9						\$ -
10						\$ -
11						\$ -
12						\$ -
13						\$ -
14						\$ -
15						\$ -
16						\$ -
17						\$ -
18						\$ -
19						\$ -
20						\$ -
21						\$ -
22						\$ -
23						\$ -
24						\$ -
25						\$ -
<b>Sub-Total</b>		\$ -	\$ 4,025.00	\$ -	\$ 6,645.00	\$ 10,670.00

**ACCEPTANCE OF PROPOSAL (OWNER): City of Crest Hill**

Name/Title: Gary Richardson, Public Works Director  
Signature: \_\_\_\_\_  
Date: \_\_\_\_\_

Contractor's Net:	\$ 4,025.00
Sub-Contractor's Net:	\$ 6,645.00
Net Subtotal:	\$ 10,670.00
Contractor's Fee: (15% on Own Work, 5% on Subs, & 0% on Credits):	\$ 936.00
Sub-Total:	\$ 11,606.00
Bonds & Insurance - 1%:	\$ 116.06
<b>Worksheet Total:</b>	<b>\$ 11,722.00</b>

**ACCEPTANCE OF PROPOSAL (A/E): Strand Associates, Inc.**

Name/Title: Dominic Gattone, PE  
Signature: \_\_\_\_\_  
Date: \_\_\_\_\_

**ACCEPTANCE OF PROPOSAL (CONTRACTOR): VISSERING CONSTRUCTION CO**

Name/Title: Tony Marzetta, Project Manager  
Signature: \_\_\_\_\_  
Date: April 20, 2026



Cost Proposal Request  
West Sewage Treatment Plant Improvements  
City of Crest Hill, Illinois  
Contract 1-2022  
April 9, 2026

COST PROPOSAL NO.: 052

TO: Vissering Construction Company  
ISSUED BY: Dominic Gattone, P.E.

DISTRIBUTION

Tony Marzetta, Project Manager	Vissering Construction Company (Contractor)
Gary Richardson	City of Crest Hill, Illinois
Dominic Gattone, P.E.	Strand Associates, Inc.®

Please submit an itemized quotation for changes in the Contract Price and Time incidental to proposed modifications to the Contract Documents described herein. The purpose of this request is to add additional emergency stop push buttons nearer the tertiary filter equipment.

DESCRIPTIONS AFFECTING THE DRAWINGS

**Drawing C45-E1.01 - Tertiary Filter Building - Electrical Plan**

052-01 Provide emergency stop pushbutton in NEMA 4X control station enclosure by Tertiary Disc Filter manufacturer and 2~#14 in 3/4" conduit from each e-stop to the associated filter control panel. Pressing the e-stop shall stop backwash pump, filter drum drive, and spray bar oscillating motor of its respective filter. Provide panel modifications as required. See attached mark-up.

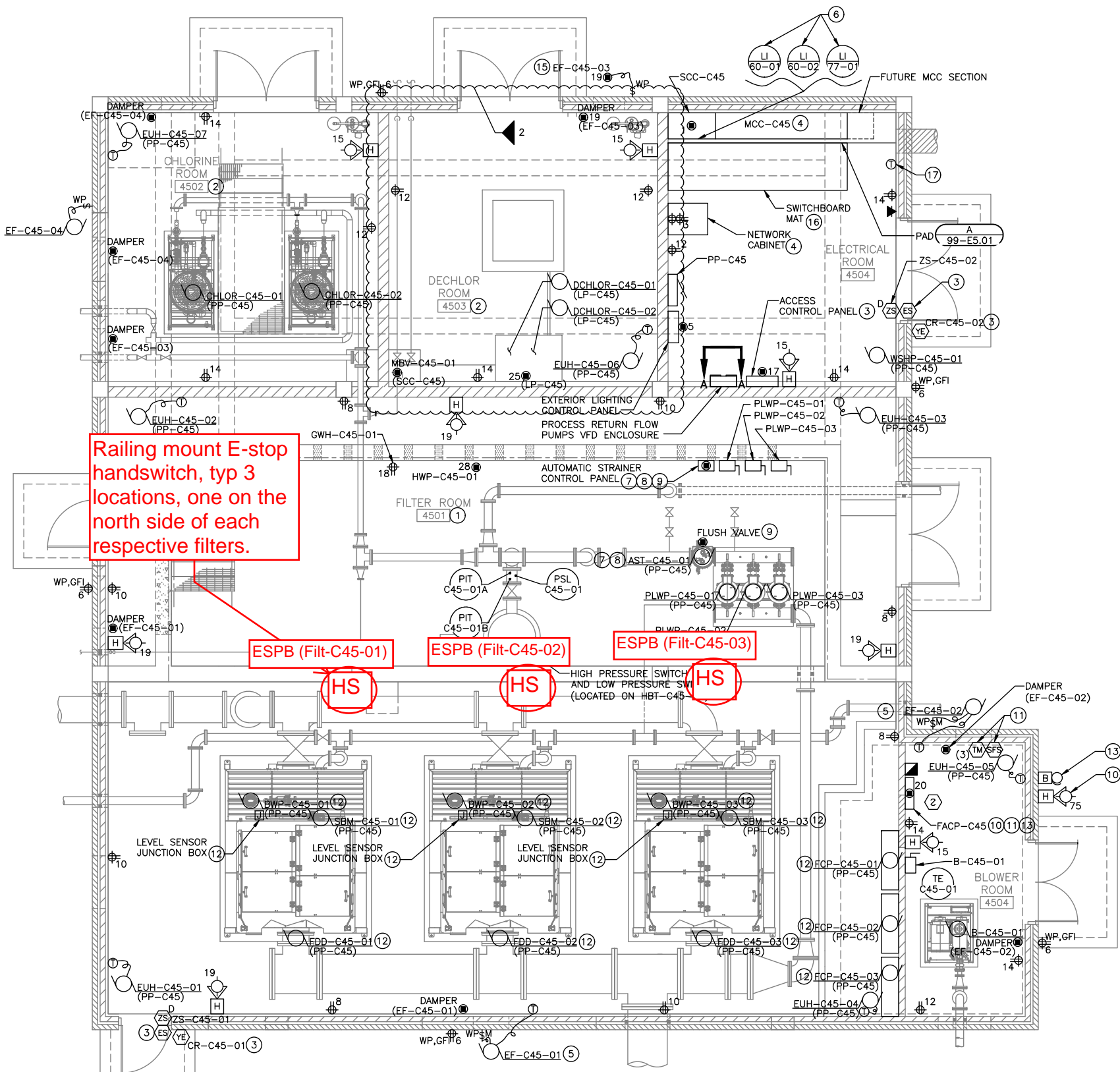

- GENERAL NOTES:**
- REFER TO SPECIFICATION SECTION 01 11 00 FOR INFORMATION ON CONSTRUCTION SEQUENCING.
  - REFER TO SPECIFICATION SECTION 26 09 90 FOR WIRING ASSOCIATED WITH THE SCADA SYSTEM.
  - SEE DRAWING C45-ASM1.01 FOR LOCATIONS OF FIRE-RATED WALLS.
  - DAMPERS NOT SHOWN WITH A CIRCUIT NUMBER SHALL BE POWERED FROM A CONTROL POWER TRANSFORMER IN THE ASSOCIATED MCC BUCKET.
  - THERE SHALL BE A MINIMUM OF 4" BETWEEN VFDS AND VFD ENCLOSURES. VFDS SHALL BE A MINIMUM OF 1'-0" AFF.

- KEY NOTES:**
- ALL ELECTRICAL WORK AND EQUIPMENT IN THIS ROOM SHALL BE RATED NEMA 4X. CONDUIT SHALL BE ALUMINUM AND SUPPORT MEMBERS SHALL BE STAINLESS STEEL.
  - ALL ELECTRICAL WORK AND EQUIPMENT IN THIS ROOM SHALL BE RATED NEMA 4X. CONDUIT SHALL BE PVC AND SUPPORT MEMBERS SHALL BE FRP.
  - PROVIDE A FLUSH-MOUNTED BOX ON BUILDING EXTERIOR FOR CARD READER. PROVIDE 3/4" CONDUIT FROM BOX TO ACCESS CONTROL PANEL IN THE ELECTRICAL ROOM. PROVIDE 3/4" CONDUIT FROM BOX TO DOOR FRAME FOR ELECTRIC STRIKE. WIRING SHALL BE FURNISHED AND INSTALLED BY THE SECTION 28 10 00 SYSTEM SUPPLIER.
  - BOND THE COMMUNICATION CABINET GROUND BAR TO THE GROUND BUS IN MCC-C45 WITH A #6 GROUND CONDUCTOR IN 3/4" PVC CONDUIT. MOUNT RECEPTACLES INSIDE THE COMMUNICATION CABINET.
  - FAN SHALL BE CONTROLLED BY THE ROOM THERMOSTAT SUCH THAT THE FAN RUNS WHEN THE ROOM TEMPERATURE RISES ABOVE THE THERMOSTAT SETPOINT AND SHUTS DOWN WHEN THE TEMPERATURE FALLS BELOW THE THERMOSTAT SETPOINT.
  - LEVEL INDICATORS SHALL BE FLUSH-MOUNTED ON THE DOOR OF THE SCC. REFER TO SPECIFICATION SECTION 26 09 00 PART 3 FOR ADDITIONAL INFORMATION.
  - PROVIDE 2~#14 FROM CONTROL PANEL TO THE LOW PRESSURE SWITCH AND 2~#14 FROM CONTROL PANEL TO THE HIGH PRESSURE SWITCH IN 3/4" CONDUIT. SWITCHES ARE LOCATED AT THE AUTOMATIC STRAINER (AST-C45-01).
  - PROVIDE 3~#12 AND #12 GROUND IN 3/4" CONDUIT FROM CONTROL PANEL TO SCREEN MOTOR DRIVE MOTOR NO. 1 AT THE AUTOMATIC STRAINER (AST-C45-01). PROVIDE 3~#12 AND #12 GROUND IN 3/4" CONDUIT FROM CONTROL PANEL TO SCREEN MOTOR DRIVE MOTOR NO. 2 AT THE AUTOMATIC STRAINER.
  - PROVIDE 4~#14 FROM CONTROL PANEL TO THE FLUSH VALVE IN 3/4" CONDUIT.
  - EXTERIOR ALARM STROBE SHALL BE POWERED THROUGH FACP SUCH THAT IT IS ONLY ACTIVATED WHEN SMOKE DETECTOR OR FIRE ALARM FLOW SWITCH IS ACTIVATED.
  - FIRE ALARM FLOW SWITCH AND TAMPER SWITCHES PROVIDED BY DIVISION 21 AND WIRED TO FACP BY DIVISION 28. PROVIDE REQUIRED ADDRESSABLE CONTROL MODULES AND SUPERVISORY RELAYS TO MONITOR EACH DEVICE.
  - PROVIDE CONDUCTORS/CONDUIT TO DEVICES AS SHOWN IN THE TERTIARY DISC FILTER SYSTEM CONDUIT AND WIRE SCHEDULE.
  - FIRE SUPPRESSION SYSTEM ALARM BELL FURNISHED BY DIVISION 21 AND INSTALLED AND WIRED BY DIVISION 28. ALARM BELL SHALL BE POWERED FROM THE FACP.
  - THERE SHALL BE A MINIMUM OF 6" BETWEEN THE TOP OF THE VFD AND THE BOTTOM OF THE VFD CONTROLS ENCLOSURE.
  - FAN SHALL RUN CONTINUOUSLY.
  - PROVIDE SWITCHBOARD MAT AS SPECIFIED IN SECTION 12 48 43 SPANNING ENTIRE FRONT OF MCC AND SCC.
  - THERMOSTAT PROVIDED BY DIVISION 23. PROVIDE 3/4" CONDUIT FROM THERMOSTAT TO WSHP-C45-01 FOR DIVISION 23 INSTALLED WIRING.

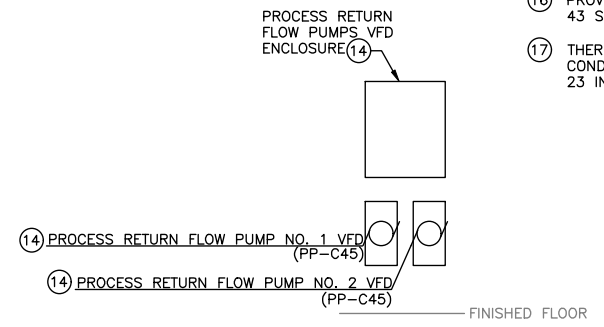

**TERTIARY DISC FILTER SYSTEM CONDUIT AND WIRING SCHEDULE\*\***

CONDUIT DESIGNATION	ORIGIN	TERMINATION	CONDUIT SIZE	CONDUCTORS*
DRUM DRIVE MOTOR POWER	FCP-C45-01	FDD-C45-01	3/4"	3~#12
DRUM DRIVE MOTOR OVERTEMP	FCP-C45-01	FDD-C45-01	3/4"	2~#14
BACKWASH PUMP MOTOR POWER	FCP-C45-01	BWP-C45-01	3/4"	3~#10
BACKWASH PUMP MOTOR OVERTEMP	FCP-C45-01	BWP-C45-01	3/4"	2~#14
SPRAY BAR OSCILLATION DRIVE MOTOR POWER	FCP-C45-01	SBM-C45-01	3/4"	3~#12
DISC FILTER LEVEL SENSORS	FCP-C45-01	FILT-C45-01 LEVEL SENSOR JUNCTION BOX	3/4"	10~#14

\* PROVIDE GROUND WIRE FOR EACH PIECE OF EQUIPMENT SIZED PER THE NEC.  
 \*\*SCHEDULE TYPICAL FOR FCP-C45-01, FCP-C45-02, AND FCP-C45-03.

**REVISIONS**

NO.	ISSUED FOR	DATE
1	ISSUED FOR BID	5/12/2022
2	CONFORMED DRAWINGS	12/1/2022
3	CHANGE ORDER NO. 1	X/X/2023

**TERTIARY FILTER BUILDING ELECTRICAL PLAN**  
 WEST SEWAGE TREATMENT PLANT IMPROVEMENTS  
 CITY OF CREST HILL  
 WILL COUNTY, ILLINOIS

JOB NO. 3894.051  
 PROJECT MGR. DOMINIC GATTONE





40 S. Addison Rd.  
Addison, IL 60101

**Client Address:**

**Vissering Construction**

1631 Gaylord Rd.  
Crest Hill, IL 60403  
Telephone: 815.673.5511  
Contact: Tony Marazetta

# CHANGE NOTICE

Item P.

**Connelly CCN #** 031  
**Field Ticket #**  
**Date:** 4/10/2026  
**Project Name:** Crest Hill WWTP - West Sewage Treatment Plant  
**Project Number:** 22-0686  
**Page Number:** 1

**Site Address:**

**Vissering Construction**

Contact: Tony Marazetta  
1631 Gaylord Rd.  
Crest Hill, IL 60403

---

**Work Description**

---

This quote covers direct costs only and we reserve the right to claim for impact and consequential costs.  
 This price is good for acceptance within **10** days from the date of receipt.  
 We request a time extension of **4** days.  
 We will supply and install all materials, labor, and equipment as per your instructions on **Connelly CCN # 031**.

**Description:**

This CCN has been generated in response to the distribution of CPR052: E stop for filters dated 4/9/2026. This includes pricing on mounting these control stations as well as conduit/wire between them and the control panels. Also includes terminating the wiring within the Westech control panels.

---

**Itemized Breakdown**

---

Description	Qty	Total Mat.	Total Hrs.
3/4" ARC (AL)	70	137.00	5.60
3/4" ARC MYERS HUB	6	41.50	6.60
3/4" ARC LB CONDULET	3	45.48	2.70
3/4" ARC 90 ELBOW	6	131.65	2.40
3/4" ARC STRAP	14	197.82	2.10
#14 XHHW	200	53.22	1.40
ALUMINUM MTG PLATE	3	300.30	3.00
CABLE TAG	1	0.75	0.16
Test	1	100.00	2.00
SS U-bolts	6	31.20	1.50
Mount E-Stop to Plate	3	0.00	3.00
Connect to Filter Panels	3	0.00	3.00
Connect to E-Stop	3	0.00	3.00
<b>Totals</b>	<b>319</b>	<b>1,038.93</b>	<b>36.46</b>

---

**Summary**

---

**MATERIAL**

General Materials		1,038.93
<b>Material Total</b>		<b>1,038.93</b>
Foreman	(12.15 Hrs @ \$133.77)	1,625.31
Journeyman	(24.31 Hrs @ \$127.07)	3,089.07
<b>Subtotal</b>		<b>5,753.31</b>

246

# CHANGE NOTICE

Site Address:

**Vissering Construction**  
1631 Gaylord Rd.  
Crest Hill, IL 60403

**Connelly CCN #** 031  
**Field Ticket #**  
**Date:** 4/10/2026  
**Project Name:** Crest Hill WWTP - West Sewage Treatment Pla  
**Project Number:** 22-0686  
**Page Number:** 2

---

<b>Summary (Cont'd)</b>		
Overhead	(@ 10.000 %)	575.33
Markup	(@ 5.000 %)	316.43
<b>Subtotal</b>		<b>6,645.07</b>
<b>Final Amount</b>		<b>\$6,645.07</b>

# Change Order Proposal

3665 South West Temple, Salt Lake City, UT 84115 Phone:  
801.265.1000

Job Name: Crest Hill West STP	Ref. PO/Contract: 11108.00-11500.00
WesTech Job No: 24851A	Cust. Job No: -
Customer: Vissering Construction Company	Revision No: COB.0
Customer Contact: Tony Marzetta	Date: 4/20/2026
WesTech Contact: Kib Huefner	Validity Period: 30 days
WesTech Email: khuefner@westechwater.com	

## SCOPE

Item	Description of Change and Statement of Reason	Net Price (USD)
A	E-Stop Station (Qty 3), NEMA 4X, SS  Includes additional programming for quick-stop buttons (currently directly wired to the VFDs and a digital input on the PLC). WesTech will send a rental Tosibox to make the programming changes remotely.	\$4,025.00
Payment Terms	See Terms of Original Contract	
Freight Terms	FSP-FFA - FOB Shipping Point - Full Freight to Jobsite (USA ONLY)	Included
Freight Terms	Crest Hill, IL	
	Taxes (sales, use, VAT, IVA, IGV, duties, import fees, etc.)	Not Included
<b>Total, Excluding Taxes If Applicable</b>		<b>\$4,025.00</b>

## TERMS

- (1) Unless specifically identified above or attached to the contrary, this Job Change Order does not impact Terms and Conditions for the Purchase of Goods and Services of the Existing Agreement.
- (2) Added equipment and the Tosibox for remote programming will ship approximately 1 - 2 weeks from order execution.
- (3) Please note that the Tosibox must be returned no more than 30 days after services are completed. If not returned, the customer will be charged the full cost of a replacement.
- (4) This order is subject to all specifications above as well as attachments included.

## AUTHORIZATION

Vissering Construction Company

WesTech Engineering, LLC.

Signed by: \_\_\_\_\_ Date \_\_\_\_\_

Signed by: \_\_\_\_\_ Date \_\_\_\_\_

Title: \_\_\_\_\_

Title: \_\_\_\_\_





**PROPOSAL  
WORKSHEET SUMMARY**

Project: CITY OF CREST HILL - WEST SEWAGE TREATMENT PLANT IMPROVEMENTS

Change Order Request #: 054

To: Strand Associates, Inc.  
Dominic Gattone, PE

Date: 5/4/2026  
A/E Project #: IDFPR No. 184-001273  
VCC Project #: 11108.00

WORK DESCRIPTION
Re-Power Digester Building

Line No	Cost Description	Labor Amt	Material Amt	Equip & Other Amt	Sub-Contractor Amt	Sub-Total
1	Connelly Electric				\$ 16,698.00	\$ 16,698.00
2						\$ -
3						\$ -
4						\$ -
5						\$ -
6						\$ -
7						\$ -
8						\$ -
9						\$ -
10						\$ -
11						\$ -
12						\$ -
13						\$ -
14						\$ -
15						\$ -
16						\$ -
17						\$ -
18						\$ -
19						\$ -
20						\$ -
21						\$ -
22						\$ -
23						\$ -
24						\$ -
25						\$ -
<b>Sub-Total</b>		\$ -	\$ -	\$ -	\$ 16,698.00	\$ 16,698.00

**ACCEPTANCE OF PROPOSAL (OWNER): City of Crest Hill**  
 Name/Title: Gary Richardson, Public Works Director  
 Signature: \_\_\_\_\_  
 Date: \_\_\_\_\_

Contractor's Net: \$ -  
 Sub-Contractor's Net: \$ 16,698.00  
 Net Subtotal: \$ 16,698.00  
 Contractor's Fee: (15% on Own Work, 5% on Subs, & 0% on Credits): \$ 834.90  
 Sub-Total: \$ 17,532.90  
 Bonds & Insurance - 1%: \$ 175.33  
**Worksheet Total: \$ 17,708.00**

**ACCEPTANCE OF PROPOSAL (A/E): Strand Associates, Inc.**  
 Name/Title: Dominic Gattone, PE  
 Signature: \_\_\_\_\_  
 Date: \_\_\_\_\_

**ACCEPTANCE OF PROPOSAL (CONTRACTOR): VISSERING CONSTRUCTION CO**  
 Name/Title: Tony Marzetta, Project Manager  
 Signature: \_\_\_\_\_  
 Date: May 4, 2026



40 S. Addison Rd.  
Addison, IL 60101

**Client Address:**

**Vissering Construction**

1631 Gaylord Rd.  
Crest Hill, IL 60403  
Telephone: 815.673.5511  
Contact: Tony Marazetta

# CHANGE NOTICE

Item P.

**Connelly CCN #** 033  
**Field Ticket #**  
**Date:** 5/1/2026  
**Project Name:** Crest Hill WWTP - West Sewage Treatment Plant  
**Project Number:** 22-0686  
**Page Number:** 1

**Site Address:**

**Vissering Construction**

Contact: Tony Marazetta  
1631 Gaylord Rd.  
Crest Hill, IL 60403

---

**Work Description**

---

This quote covers direct costs only and we reserve the right to claim for impact and consequential costs.  
 This price is good for acceptance within **10** days from the date of receipt.  
 We request a time extension of **0** days.  
 We will supply and install all materials, labor, and equipment as per your instructions on **Connelly CCN # 033**.

**Description:**

This CCN was generated in reponse to the work completed on the following work order tickets to complete piping across existing Admin building from existing MCC to refeed MCC-2:

- WO#64619 dated 4/24/2026
- WO#64620 dated 4/27/2026
- WO#64621 dated 4/28/2026
- WO#64622 dated 4/29/2026
- WO#64623 dated 4/30/2026

---

**Itemized Breakdown**

---

Description	Qty	Total Mat.	Total Hrs.
1 1/2" EMT	150	657.01	10.50
1 1/2" EMT DC COMP CONN	6	14.80	2.70
1 1/2" EMT DC SS CPLG	20	37.11	2.00
1 1/2" EMT LB SET SCREW	3	153.27	3.30
1 1/2" EMT 90 ELBOW	2	23.99	0.80
1 1/2" EMT STRAP 1-H	5	33.75	0.21
1 1/2" EMT STRUT CLAMP	10	25.11	0.40
1 1/2" GRC (GALV)	150	1,764.84	13.50
1 1/2" GRC MYERS HUB	4	29.62	3.00
1 1/2" GRC LB CONDULET	1	30.67	1.50
1 1/2" GRC STRUT CLAMP	10	22.00	0.40
#6 THHN	310	380.81	3.41
#3 THHN	930	2,205.10	13.95
P-1000 1 5/8" STRUT	10	56.48	1.20
Eaton FRS-R-100 Fuse	2	240.00	0.80
10" x 10" x 6" NEMA 12 Box w/ Piano Hinge Cover	2	400.00	3.00
<b>Totals</b>	<b>1,615</b>	<b>6,074.58</b>	<b>60.67</b>

---

**Summary**

---

**MATERIAL**

Site Address:

**CHANGE NOTICE****Vissering Construction**1631 Gaylord Rd.  
Crest Hill, IL 60403**Connelly CCN #** 033**Field Ticket #****Date:** 5/1/2026**Project Name:** Crest Hill WWTP - West Sewage Treatment Plant**Project Number:** 22-0686**Page Number:** 2**Summary (Cont'd)**

General Materials		6,074.58
<b>Material Total</b>		<b>6,074.58</b>
Foreman	(2.00 Hrs @ \$135.17)	270.34
Journeyman	(65.00 Hrs @ \$124.80)	8,112.00
<b>Subtotal</b>		<b>14,456.92</b>
Overhead	(@ 10.000 %)	1,445.69
Markup	(@ 5.000 %)	795.13
<b>Subtotal</b>		<b>16,697.74</b>
<b>Final Amount</b>		<b>\$16,697.74</b>



**CONNELLY**  
ELECTRIC

40 S. Addison Road  
Suite 100  
Addison, IL 60101

p 630.543.9059  
f 630.543.9077  
www.connelyelectric.com

Item P.

**WORK ORDER**

Job Location: Crest Hill NWRC  
1601 Gaylord Rd. Crest Hill 60403

Bill to: Vissering

DATE OF WORK	JOB #	WORK ORDER #	SUPERVISING ELECTRICIAN	HOURS			OT HOURS		
				GF	FRMN	JW	GF	FRMN	JW
4/24/26	CCN#033	64619	Zane Roth		2	11			

Description: Piping across existing Admin building from existing MCC to refeed MCC-2

QUANTITY	MATERIAL DESCRIPTION
6	1 1/2" EMT Connectors
150'	1 1/2" EMT
2	1 1/2" LB Fitting
1	1 1/2" LR fitting
10	1 1/2" EMT Street Straps
5	1 1/2" EMT Minis
10'	1 3/8" Struts
2	1 1/2" Factory EMT 90
2	Eaton FRS-R-100 Fuses

**SUB CONTRACTOR WORK DESCRIPTION**

LIFT	N/A
BOOM	
CORING	
EXCAV	
SUB	
CRANE	
OTHER	

Customer Vissering  
Signature [Signature]  
Date 4/27/2026  
White - Office Canary - Customer

- Extra
- Change Order
- T & M



**CONNELLY**  
ELECTRIC

40 S. Addison Road  
Suite 100  
Addison, IL 60101

p 630.543.9059  
f 630.543.9077  
www.connelyelectric.com

Item P.

**WORK ORDER**

Job Location: Crest Hill WWRC  
1601 Gaylord Rd Crest Hill 60403

Bill to: Vissering

DATE OF WORK	JOB #	WORK ORDER #	SUPERVISING ELECTRICIAN	HOURS			OT HOURS		
				GF	FRMN	JW	GF	FRMN	JW
4/27/26	CCN#033	64620	Zane Roth			14			

Description: Piping across Existing Admin building from existing MCC to Refuel MCC-2

QUANTITY	MATERIAL DESCRIPTION
	<u>N/A</u>

**SUB CONTRACTOR WORK DESCRIPTION**

LIFT	
BOOM	
CORING	
EXCAV	
SUB	
CRANE	
OTHER	

Customer Vissering  
Signature [Signature]  
Date 4/27/2026  
White - Office Canary - Customer

- Extra
- Change Order
- T & M



**CONNELLY**  
ELECTRIC

40 S. Addison Road  
Suite 100  
Addison, IL 60101

p 630.543.9059  
f 630.543.9077  
www.connelyelectric.com

Item P.

**WORK ORDER**

Job Location: Crest Hill WWRC  
1601 Gaylord RD Crest Hill 60403

Bill to: Vissering

DATE OF WORK	JOB #	WORK ORDER #	SUPERVISING ELECTRICIAN	HOURS			OT HOURS		
				GF	FRMN	JW	GF	FRMN	JW
4/28/26	CCN#033	64621	Zane Roth			16			

Description: Piping across existing Admin building + outside of building  
From existing MCC to refeed MCC-2

QUANTITY	MATERIAL DESCRIPTION
100'	1 1/2" RMC
10	1 1/2" RMC strut stops
20	1 1/2" EMT Couplings
2	10" x 10" x 6" Nema 12 boxes w/ Piano hinge covers
4	1 1/2" Myers Hubs

**SUB CONTRACTOR WORK DESCRIPTION**

LIFT	N/A
BOOM	
CORING	
EXCAV	
SUB	
CRANE	
OTHER	

Customer Vissering  
Signature [Signature]  
Date 4/28/26  
White - Office Canary - Customer

- Extra
- Change Order
- T & M





**CONNELLY**  
ELECTRIC

40 S. Addison Road  
Suite 100  
Addison, IL 60101

p 630.543.9059  
f 630.543.9077  
www.connelyelectric.com

Item P.

**WORK ORDER**

Job Location: 1601 Gaylord Rd  
Crest Hill IL 60403

Bill to: Vissering

Crest Hill UWRC

DATE OF WORK	JOB #	WORK ORDER #	SUPERVISING ELECTRICIAN	HOURS			OT HOURS		
				GF	FRMN	JW	GF	FRMN	JW
4/30/26	CON#033	64623	Zane Roth			16			

Description: Piping across roadway to re-feed MCC-2  
Pull wire from MCC-1 to MCC-2  
terminate wire on both ends

QUANTITY	MATERIAL DESCRIPTION
360'	#3 THHN Brown
310'	#3 THHN Orange
310'	#3 THHN Yellow
310'	#6 THHN Green
50'	1 1/2" RMC

**SUB CONTRACTOR WORK DESCRIPTION**

LIFT	<u>N/A</u>
BOOM	
CORING	
EXCAV	
SUB	
CRANE	
OTHER	

Customer Vissering  
Signature [Signature]  
Date 4/30/2026

- Extra
- Change Order
- T & M



<b>Meeting Date:</b>	July 6, 2026
<b>Submitter:</b>	Ashley Monroe, Assistant City Administrator/HR
<b>Department:</b>	Administration / Human Resources
<b>Agenda Item:</b>	A Resolution Approving the Job Description and Authorizing the Hiring of Ava Cox as Police Department Audio Visual and FOIA Specialist at a rate not to exceed 61,878.00.

**Summary:** On December 18, 2023 City Council approved Resolution 1197, approving the job description, recruitment and hire of an Audio Visual and FOIA Specialist at a rate not to exceed \$61,878.

Due to the recent vacancy of this position, the City posted the position and received sixteen applications. Staff conducted seven interviews and confirmed that one of these individuals meets desired criteria.

For this hire, staff proposes a starting rate of at least \$61,878.00 (\$29.75/hour) based on the applicant’s request for the salary. This amount is less than was budgeted in FY 2026 for the vacated position (\$68,276).

The addition of body cameras has made this position vital for Police Department operations for the past two years. The position is classified as full-time exempt, and performs a variety of specialized tasks, including body cam video redactions in response to FOIA requests, court preparations, and support for FOIA response in the Police Department.

The job description has been updated from the previous version to reflect current formatting and responsibilities of the position.

**Fiscal Impact:** The annual pay for this position is proposed at a rate of \$61,878.

**Recommended Council Action:** A Resolution Approving the Job Description and Authorizing the Hiring of Ava Cox as Police Department Audio Visual and FOIA Specialist at a rate not to exceed \$61,878.00.

**Attachments:**  
Resolution  
Job Description

**RESOLUTION NO.****A RESOLUTION APPROVING THE JOB DESCRIPTION FOR THE POSITION OF  
AUDIO VISUAL & FOIA SPECIALIST AND AUTHORIZING THE HIRING OF  
AVA COX AS A POLICE DEPARTMENT A/V & FOIA SPECIALIST AT A  
SALARY NOT TO EXCEED \$61,878.00.**

---

WHEREAS, the Corporate Authorities of the City of Crest Hill, Will County, Illinois, have the authority to adopt resolutions and to promulgate rules and regulations that pertain to the City's government and affairs and protect the public health, safety, and welfare of its citizens; and

WHEREAS, the Illinois Legislature passed the SAFE-T Act (Public Act 101-0652), which mandates Illinois Police Departments to obtain and utilize officer body-worn camera systems; and

WHEREAS, pursuant to 50 ILCS 706/10-15 the Crest Hill Police Department was mandated to obtain and implement officer body-worn camera systems by 2025; and

WHEREAS, the Corporate Authorities of the City of Crest Hill have previously approved the creation of a F.O.I.A. Audio/Video Specialist position (the "Position"); and

WHEREAS, the Crest Hill Police Department has implemented use of officer body-worn cameras; and

WHEREAS, the Corporate Authorities have determined that with the use of said equipment, it is necessary and appropriate to approve a detailed job description for the Police Department Audio/Video & FOIA Specialist to ensure the proper retention, redaction, and dissemination of video and audio footage; and

WHEREAS, the City of Crest Hill had determined that it needs to appoint a qualified candidate for the Position who will be able to handle the large volume of digital data which will be generated with the purchase of officer body-worn cameras; and

WHEREAS, the Crest Hill Police Department has updated the job description for the purpose of finding and hiring a new qualified candidate (a copy of the job description is attached hereto as Exhibit A and fully incorporated herein); and

WHEREAS, the City Council has reviewed the updated job description and determined that it is acceptable to the City and should be approved; and

WHEREAS, the City Council has determined that it is in the best interests of the City and its citizens to allow the job description to be approved, and the Chief of Police, and his designees shall be authorized to interview and hire qualified candidate, Ava Cox, for the Position at a salary not to exceed \$61,878 annually.

NOW, THEREFORE, BE IT RESOLVED by the City Council of the City of Crest Hill, Illinois, pursuant to its statutory authority, as follows:

SECTION 1: PREAMBLE. The City Council hereby finds that all the recitals contained in the preamble to this Resolution are true, correct, and complete and are hereby incorporated by reference thereto and made a part hereof.

SECTION 2: JOB DESCRIPTION APPROVED. The City Council hereby finds and declares that the Job Description for Police Department Audio/Video & FOIA Specialist (Exhibit A) should be and is hereby approved in form and substance. Therefore, the City Council hereby authorizes and directs the Chief of Police or his designees to interview and select a qualified candidate for the position at a salary not to exceed \$61,878.00 annually.

SECTION 3: SEVERABILITY. If any section, paragraph, clause, or provision of this Resolution is held invalid, the invalidity of such section, paragraph, clause, or provision shall not affect any other provision of this Resolution.

SECTION 4: REPEALER. All ordinances, resolutions or orders, or parts thereof, which conflict with the provisions of this Resolution, are to the extent of such conflict hereby repealed.

SECTION 5: EFFECTIVE DATE. This Resolution shall be in full force and effect immediately upon its passage and publication according to law.

*[Intentionally Blank]*

*[Intentionally Blank]*

PASSED THIS 6<sup>TH</sup> DAY OF JULY, 2026.

	Aye	Nay	Absent	Abstain
Alderman Scott Dyke	_____	_____	_____	_____
Alderman Angelo Deserio	_____	_____	_____	_____
Alderwoman Claudia Gazal	_____	_____	_____	_____
Alderman Darrell Jefferson	_____	_____	_____	_____
Alderperson Tina Oberlin	_____	_____	_____	_____
Alderman Mark Cipiti	_____	_____	_____	_____
Alderman Nate Albert	_____	_____	_____	_____
Alderman Joe Kubal	_____	_____	_____	_____
Mayor Raymond R. Soliman	_____	_____	_____	_____

\_\_\_\_\_  
Christine Vershay-Hall, City Clerk

APPROVED THIS 6<sup>TH</sup> DAY OF JULY, 2026.

\_\_\_\_\_  
Raymond R. Soliman, Mayor

ATTEST:

\_\_\_\_\_  
Christine Vershay-Hall, City Clerk

# EXHIBIT A



**Position:** A/V & FOIA Specialist  
**Department:** Police Department

**Status:** Exempt  
**Last Updated:** 7/6/2026

**Salary Range:** \$61,878 – \$81,903

**General Purpose:** The purpose of the Audio Visual & FOIA Specialist position is to maintain all video and audio footage, including, but not limited to Police Department audio/video arrest and booking room audio/video, squad car in camera audio/video, and body worn camera audio/video. The incumbent will also provide assistance to the Records Supervisor and Deputy Chief of Operations with assistance with all Freedom of Information (FOI) requests.

**Supervision Received:**

The A/V & FOIA Specialist works under the immediate supervision of the Deputy Chief of Operations.

**Supervision Exercised:**

None.

**Duties and Responsibilities:**

The A/V & FOIA Specialist shall have the following duties:

- (A) Maintain proficiency in FOIs by completing and passing the annual FIOA Officer training as required by the Illinois Attorney General and attend continuing education (online or in-person) as it relates to FOIs
- (B) Remain knowledgeable and updated on any laws and/or regulations relating to FOIs and its requirements such as, but not limited to, the Law Enforcement-Worn Body Camera Act (50 ILCS 706), Freedom of Information Act (5 ILCS 140/1), and the Illinois Attorney General's Binding PAC Opinions regarding FOIs
- (C) Interpret and properly apply exemptions and redactions concerning all FOIA requests
- (D) Listen to different levels of audio volumes and quality with the ability to discern multiple voices during chaotic scenes for proper redactions
- (E) Understand the rules of evidence and chain of custody including being able to testify and appear in court as deemed necessary
- (F) Process record systems such as Motorola P1Records, BEAST Evidence Management System, and DACRA, etc.
- (G) Regular maintenance, monitoring, and editing of Police Department audio/video footage
- (H) Coordinate with management and City staff on completing essential projects by established deadlines
- (I) Respond accurately and timely to questions and inquiries from the general public, attorneys, and City staff regarding assigned work
- (J) Reliable and regular attendance is required
- (K) Ensure adherence to local, state and federal regulations and codes.
- (L) Any and other duties, as assigned.

## **Minimum Qualifications**

### **Education and Experience:**

- Associate Degree.
- A minimum of 2.5 years of professional level, related work experience or equivalent combination of related education and experience is required, with 4+ years' combined experience preferred.
- Proven work experience as a FOIA Officer, video editor, audio or video production, or similar role is preferred.

### **Knowledge, Skills and Abilities:**

- Knowledge and understanding of the Crest Hill Police Department Policy and Procedure involving the handling of evidence, both digital and physical.
- Excellent analytical and technical skills.
- Strong organizational, clerical, time management, and customer service skills.
- Ability to apply critical attention to detail to ensure accuracy in recording and reporting data.
- Ability to prepare reports and properly maintain and organize office files and records.
- Ability to use discretion, good judgment, and maintain confidential information.
- Ability to view and listen to graphic and disturbing content.
- Ability to communicate effectively both verbally and in writing.
- Ability to apply common sense understanding to carry out detailed instructions, make responsible decisions, prioritize multiple tasks, and work independently to meet deadlines.
- Ability to enhance relations with coworkers and the public with a professional demeanor, sensitivity, and tactfulness.
- Ability to visually inspect assigned projects.
- Ability to read printed materials.
- Ability to hear and verbally communicate in person and before groups.
- Ability to, on occasion, lift, carry materials and objects up to 35 pounds.

### **Physical Demands and Working Conditions:**

#### **Tools & Equipment, Physical Demands, Working Conditions**

##### **Tools and Equipment:**

The following list of tools and equipment is a representative and not necessarily all-inclusive inventory of items needed to successfully perform the essential job duties:

Telephone, facsimile, photocopier, printer, document scanner, personal computer, calculator, audio/visual equipment, motorized vehicles and equipment, common hand and power tools, and mobile radio.

##### **Physical Demands:**

The physical demands described below are representative of those that must be met by an employee to successfully perform the essential job duties. Reasonable accommodations may be made to enable individuals with disabilities to perform the essential duties.

While performing the duties of this job, the employee is regularly required to sit for extended periods of time, possess average ordinary visual acuity necessary to prepare or inspect documents or operate office equipment, talk reach with hands and arms, walk, run, drive, climb and descend stairs, bend, crouch, lift and/or move up to 40 pounds. Frequent and regular movements are required using wrists, hands, and

fingers to feel, handle, or operate equipment, tools, or controls. Effective audio-visual discrimination and perception to make observations quickly and accurately, correctly identify red, yellow, blue, and green, distance and peripheral vision, depth perception and the ability to adjust focus is also required. Hearing must be sufficient for average or normal conversations, to understand verbal direction, and to detect abnormal equipment operation and alarms.

**Working Conditions:**

Work activities are conducted in an office environment and in the field with noise levels usually normal. Work is required both indoors and outdoors in the inspection of existing buildings and construction sites. Work occasionally occurs near moving mechanical parts in cold, hot, wet, humid, and dark conditions. Employees working in this capacity are occasionally exposed to fumes or airborne particles, toxic or caustic chemicals, with risk of electric shock and vibration. While performing the duties of this job employees will be required to stand, talk, hear, use hands and fingers to handle, feel, or operate objects, tools, climb ladders, kneel, crouch, and bend regularly. Sufficient visual acuity, adequate hearing and speaking ability is required. This position routinely uses standard office equipment including computers, phones, photocopiers, filing cabinets, adding machines, and fax machines.

The weekly work schedule is normally 40 hours in duration, Monday through Friday and may be extended in the event of an emergency, disaster, workload, or the need to complete time-sensitive work.

**Disclaimer:**

The above statements are intended to describe the general nature and level of work being performed and are not intended to be an exhaustive list of all responsibilities, duties and skills which may be required. The position also requires meeting the essential requirements of the Physical Demands and Working Conditions, with or without reasonable accommodation.

\_\_\_\_\_  
Department Head Date

\_\_\_\_\_  
Asst City Administrator/HR Director Date

\_\_\_\_\_  
City Administrator Date



**Agenda Memo**

**Crest Hill, IL**

---

**Meeting Date:** July 6, 2026  
**Submitter:** Blaine Wing, City Administrator  
**Department:** Administration  
**Agenda Item:** Emergency Payment Public Works

**Summary:** As you'll read in Gary's memo, our current biosolids waste hauler contacted us this week to advise us that they could not take our material. The Public Works staff quickly located two (2) alternatives, evaluated them, and needed to move forward. This quickly reached emergency status, and I authorized Gary to move forward with this immediate action while he and the team work on a longer-term solution.

**Recommended Council Action:** Discussion only; Vote on July 6<sup>th</sup>.

**Financial Impact:** \$83,125.00

**Funding Source:** General Fund

**Budgeted Amount:** \$195,750.00

**Cost:** \$83,125.00

**Attachments:** Emergency Biosolids Handling – East & West Wastewater Treatment Plants Memo

**To:** Mayor Soliman and City Council  
**From:** Gary Richardson, Director of Public Works  
**Date:** June 25, 2026  
**Re:** Emergency Biosolids Handling – East & West Wastewater Treatment Plants

The purpose of this memorandum is to inform the City Council of an urgent biosolids management issue at the East and West Wastewater Treatment Plants (STPs), and to present available disposal options along with associated costs and risks.

Both facilities are currently experiencing a significant accumulation of biosolids. Approximately 1.4 million gallons must be removed immediately in order to:

- Maintain regulatory compliance
- Ensure continued plant operations
- Prevent odor generation and potential complaints within the community

Stewart Spreading is no longer able to spread biosolids at the Stateville site. If Stewart Spreading continues hauling to an alternative location, the cost would be \$0.145 per gallon. For approximately 1.35 million gallons, the total cost would be \$195,750.

New Era Spreading has offered hauling services to two southern disposal sites with capacities of 600,000 gallons and 350,000 gallons, respectively. The total volume that can be hauled under this option is approximately 950,000 gallons at a rate of \$0.0875 per gallon, resulting in a total cost of \$83,125.

The City faces an urgent need to reduce its biosolids inventory. Prompt approval of disposal services is critical to minimizing environmental impact, maintaining regulatory compliance, and avoiding community nuisance issues.

Given the urgency and current constraints, staff recommends utilizing New Era Spreading to achieve a lower-cost disposal of approximately 950,000 gallons.



## Agenda Memo

Crest Hill, IL

<b>Meeting Date:</b>	July 6, 2026
<b>Submitter:</b>	Raymond R. Soliman, Mayor
<b>Department:</b>	Mayor's Office
<b>Agenda Item:</b>	2026 Veterans/Police Memorial Report

**Summary:** For many years the City has been hosting the Veterans/Police Memorial Ceremony and the 2026 event continued on that legacy. Although there was a budget request for up to \$2,000 to support the May 25<sup>th</sup> event, the City's costs were much less (\$494.36).

The Veterans/Police Committee provided flowers, cookies, water, pop, band, and stamps (for letters). There were also numerous volunteers, and in-kind items, including:

- Tents (Park District Tents.): In-kind
- Tables: In-kind
- Chairs: In-kind
- Trash: In-kind

The City expenses include the following:

- Non-Salary Employee Event Day costs: \$94.36
- Audio/Video and Recording: Invoiced at \$400.00

Overall, the 2026 event was well attended with an estimated attendance of around 150, not including the band. My thanks again goes out to everyone who helped make this year's event special, especially those who volunteered their time and services.

**Recommended Council Action:** Approval



## Agenda Memo

Crest Hill, IL

<b>Meeting Date:</b>	July 6, 2026
<b>Submitter:</b>	Blaine Wing, City Administrator Tina Oberlin, Alderperson
<b>Department:</b>	Administration & Elected Officials
<b>Agenda Item:</b>	84 <sup>th</sup> Lidice Memorial Ceremony Report

**Summary:** For many years the City of Crest Hill has been hosting or co-hosting the Lidice Memorial Ceremony. The event in 2026 was held with the help of mostly volunteers and minimal staff assistance. Although the City budgeted up to \$2,000 to help support this year's event that took place on Sunday, June 7<sup>th</sup>, the cost to the City was \$400.

The T.G. Masaryk School provided flowers, refreshments, and music.

In-kind items included:

- Tents: In-kind
- Tables: In-kind
- Chairs: In-kind
- Trash: In-kind

City expenses include the following:

- Audio/Video and Recording: Invoiced \$400.00

Alderperson Oberlin will provide additional verbal comments during the report, but overall, the 2026 event was well attended (approximately 150), had substantial volunteers, donations, and required minimal financial support from the City.

**Recommended Council Action:** Approval



---

**Agenda Memo****Crest Hill, IL**

---

<b>Meeting Date:</b>	July 6, 2026
<b>Submitter:</b>	Blaine Wing, City Administrator
<b>Department:</b>	Administration
<b>Agenda Item:</b>	1817 Cora Reduction in Utility Bill

**Summary:** Following the June 29<sup>th</sup> Work Session discussion, staff adjusted the March 2026 utility bill to reflect the minimal usage amount. See attached.

Besides addressing specific issue, staff with the assistance of the City Attorney, will be working on several other items, including:

- Moving to monthly billing.
- Having automatic meters that will allow for remote shutoffs and turning on water.
- Updating our procedures and policies to improve communication with customers and our departments.
- Updating the City's code, so that there are clear rules when property is sold.

**Recommended Council Action:** Authorize the reduction of the utility bill for March 2026 to \$136.29, noting that the residents are responsible going forward for their usage and bills.

REMINDERS: When making your utility payment, please verify you are using your CORRECT ACCOUNT NUMBER in the correct format, including the dashes, which can be found on this statement. If you have any questions, please call the Water Department at 815-741-5104.

Please make sure you are using the correct address when making payments thru your on-line banking.

City of Crest Hill  
20600 City Center Blvd.  
Crest Hill, IL 60403

PLEASE SEE OTHER SIDE FOR ADDITIONAL BILLING INFORMATION

STATEMENT DATE: 05/22/2026  
NAME: [REDACTED] DE LA TORRE  
SERVICE ADDRESS: 1817 CORA ST  
SERVICE PERIOD: 03/23/2026 - 05/22/2026

ACCOUNT NUMBER: [REDACTED]

Description	Prior Read Date	Current Read Date	Prior Read	Current Read	Usage	ACT/EST	Charges
PREVIOUS BALANCE							0.00
Water	03/22/2026	05/04/2026		499,670	22,049	400 ACT	\$2,254.07 52.67
Sewer	03/22/2026	05/04/2026		499,670	22,049	400 ACT	\$1,880.81 36.32
Debt Service	03/22/2026	05/04/2026		499,670	22,049	400 ACT	\$57.33 1.04
Refuse - Garbage/recycle/yard							\$46.16 46.16

TOTAL CURRENT CHARGES <sup>136.19</sup> \$4,238.37

TOTAL AMOUNT DUE BY 06/19/2026 ~~\$4,238.37~~ 136.19

TOTAL AMOUNT DUE AFTER 06/19/2026 ~~\$4,552.79~~ 136.19

PLEASE RETURN BOTTOM PORTION WITH YOUR PAYMENT • KEEP TOP PORTION FOR YOUR RECORDS

PLEASE DO NOT FOLD OR STAPLE



STATEMENT DATE: 05/22/2026  
NAME: JOHNATHAN DE LA TORRE  
SERVICE ADDRESS: 1817 CORA ST  
ACCOUNT NUMBER: [REDACTED]



TOTAL AMOUNT DUE BY 06/19/2026 \$4,238.37 136.19

AMOUNT DUE IF PAID AFTER 06/19/2026 \$4,552.79 136.19

AMOUNT ENCLOSED

11 1 (0004473)  
26-206-03E

[REDACTED] DE LA TORRE  
1817 CORA ST  
CREST HILL, IL 60403-2530



Report Criteria:

Detail report type printed  
 [Report]. Check Issue Date = 06/25/2026,06/26/2026,07/07/2026

Vendor Number	Name	Invoice Number	Description	Invoice Date	Invoice Amount	Check Amount	Check Number	Check Issue Date	GL Period	GL Account
16	Action Flag C	AF4967	FLAGS FOR CITY HALL	05/20/2026	1,072.41	1,072.41	26653	07/07/2026	626	01045400
Total 16:					1,072.41	1,072.41				
26	Aflac	340741 June	AFLAC 06-2026	06/26/2026	2,164.30	2,164.30	26655	07/07/2026	626	01002439
Total 26:					2,164.30	2,164.30				
46	Republic Ser	0721-008885	JUN 2026 MONTHLY S	06/20/2026	125,274.79	125,274.79	26725	07/07/2026	626	80005300
Total 46:					125,274.79	125,274.79				
82	Vestis	6030528373	UNIFORMS FOR STP	06/10/2026	28.55	28.55	26744	07/07/2026	626	07075344
		6030528373	UNIFORMS FOR WATE	06/10/2026	17.23	17.23	26744	07/07/2026	626	07065344
		6030528375	UNIFORMS FOR FLEE	06/10/2026	15.56	15.56	26744	07/07/2026	626	01035344
		6030528375	UNIFORMS FOR STRE	06/10/2026	57.42	57.42	26744	07/07/2026	626	01035344
		6030528375	MATS FOR PUBLIC WO	06/10/2026	29.17	29.17	26744	07/07/2026	626	01035300
		6030528375	UNIFORMS FOR BUILD	06/10/2026	9.18	9.18	26744	07/07/2026	626	01045344
		6030528375	UNIFORMS FOR STP	06/10/2026	12.08	12.08	26744	07/07/2026	626	07075344
		6030530698	UNIFORMS FOR STP	06/17/2026	28.85	28.85	26744	07/07/2026	626	07075344
		6030530698	UNIFORMS FOR WATE	06/17/2026	17.53	17.53	26744	07/07/2026	626	07065344
		6030530700	UNIFORMS FOR FLEE	06/17/2026	15.56	15.56	26744	07/07/2026	626	01035344
		6030530700	UNIFORMS FOR STRE	06/17/2026	57.42	57.42	26744	07/07/2026	626	01035344
		6030530700	MATS FOR PUBLIC WO	06/17/2026	29.17	29.17	26744	07/07/2026	626	01035300
		6030530700	UNIFORMS FOR BUILD	06/17/2026	9.18	9.18	26744	07/07/2026	626	01045344
		6030530700	UNIFORMS FOR STP	06/17/2026	14.10	14.10	26744	07/07/2026	626	07075344
Total 82:					341.00	341.00				
102	AT&T 831-00	2317976114	FIBER INTERNET EAS	06/19/2026	2,503.11	2,503.11	26660	07/07/2026	626	07085350
Total 102:					2,503.11	2,503.11				
103	AT&T 831-00	0104586112	MONTHLY STATEMENT	06/19/2026	177.96	177.96	26661	07/07/2026	626	01105300
Total 103:					177.96	177.96				
138	Bauer Built	200214230	FLEET- UNIT #100 RIG	06/17/2026	55.65	55.65	26663	07/07/2026	626	01075400
Total 138:					55.65	55.65				
187	Christopher	211137	DESIGN-CATON FARM	06/11/2026	9,827.50	9,827.50	26668	07/07/2026	626	05005330
		211138	THEODORE RETAININ	06/11/2026	4,232.50	4,232.50	26668	07/07/2026	626	13005330
		211139	BIKE PATH STUDY	06/11/2026	5,105.00	5,105.00	26668	07/07/2026	626	01035330
		211140	JASLININE DITCH STU	06/11/2026	1,662.50	1,662.50	26668	07/07/2026	626	13005330
		211141	DESIGN SERVICES FO	06/11/2026	6,384.50	6,384.50	26668	07/07/2026	626	12007602
		211142	LINCOLN & CRESTWO	06/11/2026	34,803.12	34,803.12	26668	07/07/2026	626	12007602
		211144	2026 CRACK FILLING	06/11/2026	3,167.50	3,167.50	26668	07/07/2026	626	01035330
		211145	HILLCREST WATER M	06/11/2026	1,705.00	1,705.00	26668	07/07/2026	626	12007620
		311143	2026 STREET PROGR	06/11/2026	4,065.00	4,065.00	26668	07/07/2026	626	13005330
Total 187:					70,952.62	70,952.62				

Vendor Number	Vendor Name	Invoice Number	Description	Invoice Date	Invoice Amount	Check Amount	Check Number	Check Issue Date	GL Period	GL Account
296	Edward Clark	Meal Reimbu	MEAL EXPENSES-CLA	06/08/2026	50.00	50.00	26685	07/07/2026	626	01025343
Total 296:					50.00	50.00				
400	D & I Electro	429474	BUGLAR ALARM MONI	07/01/2026	197.97	197.97	26672	07/07/2026	626	01065350
Total 400:					197.97	197.97				
451	Dynegy 1266	May 2026	WELL #4 ELECTRIC	06/09/2026	720.20	720.20	26680	07/07/2026	626	07065353
Total 451:					720.20	720.20				
452	Dynegy 6760	May 2026	EAST PLANT ELECTRI	06/09/2026	5,459.89	5,459.89	26684	07/07/2026	626	07085353
Total 452:					5,459.89	5,459.89				
453	Dynegy 6635	April 2026	ELECTRIC FOR WEST	06/09/2026	12,401.03	12,401.03	26683	07/07/2026	626	07085353
		Feb 2026 Adj	ELECTRIC FOR WEST	06/09/2026	5,448.51	5,448.51	26683	07/07/2026	626	07085353
		Jan 2026 Adj	ELECTRIC FOR WEST	06/09/2026	6,371.37	6,371.37	26683	07/07/2026	626	07085353
		March 2026	ELECTRIC FOR WEST	06/09/2026	15,175.03	15,175.03	26683	07/07/2026	626	07085353
		May 2026	ELECTRIC FOR WEST	06/09/2026	6,691.49	6,691.49	26683	07/07/2026	626	07085353
Total 453:					46,087.43	46,087.43				
454	Dynegy 0817	May 2026	WELL #11 ELECTRIC	06/09/2026	1,546.43	1,546.43	26678	07/07/2026	626	07065353
Total 454:					1,546.43	1,546.43				
455	Dynegy 0098	May 2026	WELL 10 ELECTRIC	06/09/2026	742.58	742.58	26676	07/07/2026	626	07065353
Total 455:					742.58	742.58				
457	Dynegy 6385	May 2026	WELL 9 & 12 ELECTRI	06/09/2026	1,553.40	1,553.40	26682	07/07/2026	626	07065353
Total 457:					1,553.40	1,553.40				
458	Dynegy 0906	May 2026	WELL #7 ELECTRIC	06/09/2026	757.51	757.51	26679	07/07/2026	626	07065353
Total 458:					757.51	757.51				
459	Dynegy 1656	May 2026	WELL #8 ELECTRIC	06/09/2026	1,021.69	1,021.69	26681	07/07/2026	626	07065353
Total 459:					1,021.69	1,021.69				
461	Dynegy 0425	May 2026	WELL #1 ELECTRIC	06/09/2026	936.66	936.66	26677	07/07/2026	626	07065353
Total 461:					936.66	936.66				
475	EJ USA Inc	11026003977	HYDRANT PARTS	06/09/2026	3,784.02	3,784.02	26686	07/07/2026	626	07065470
Total 475:					3,784.02	3,784.02				
605	Gordon Flesc	IN15652575	GORDON FLESCH SE	06/10/2026	238.42	238.42	26689	07/07/2026	626	01165300
Total 605:					238.42	238.42				
640	Hawkins Inc	7459466	SULFUR DIOXIDE & C	06/15/2026	380.00	380.00	26692	07/07/2026	626	07065421

Vendor Number	Name	Invoice Number	Description	Invoice Date	Invoice Amount	Check Amount	Check Number	Check Issue Date	GL Period	GL Account
		7459466	SULFUR DIOXIDE & C	06/15/2026	380.00	380.00	26692	07/07/2026	626	07085421
Total 640:					760.00	760.00				
664	Highland Plu	17984	FURNISHED LABOR A	06/10/2026	385.00	385.00	26694	07/07/2026	626	01045360
Total 664:					385.00	385.00				
685	Houseal Lavi	8627	HOUSEAL LAVIGNE C	06/16/2026	2,593.28	2,593.28	26695	07/07/2026	626	01165300
Total 685:					2,593.28	2,593.28				
826	JP Morgan C	Comcast 025	WSTP	05/12/2026	389.96	389.96	479	06/25/2026	526	07085300
		Comcast 055	PHONE SVC POLICE	06/09/2026	254.80	254.80	479	06/25/2026	526	01025300
		Comcast 060	WELL 10	05/21/2026	250.24	250.24	479	06/25/2026	526	07065300
		CSU Civil En	PAVER SOFTWARE	05/22/2026	999.00	999.00	479	06/25/2026	526	01035330
		Dollar Tree 0	AWARDS CEREMONY I	05/14/2026	16.25	16.25	479	06/25/2026	526	01025400
		Dollar Tree 0	FRAMES-AWARDS CE	05/14/2026	6.00	6.00	479	06/25/2026	526	01025400
		Embassy Sui	TRAVEL EXPENSE-HO	06/09/2026	616.53	616.53	479	06/25/2026	526	01025342
		Expedia 06/0	TRAVEL EXPENSE-HO	06/02/2026	444.01	444.01	479	06/25/2026	526	01025342
		FAADroneZo	FAA DRONE ZONE	06/03/2026	5.00	5.00	479	06/25/2026	526	01025310
		Flags USA Ju	FLAG	06/04/2026	30.38	30.38	479	06/25/2026	526	01045400
		Food 4 Less	SODA	05/14/2026	19.47	19.47	479	06/25/2026	526	01025400
		ILCMA Ritter	ILCMA MEMBERSHIP R	05/18/2026	179.00	179.00	479	06/25/2026	526	01165324
		IPELRA Wing	TRAINING FOR BLAIN	05/25/2026	175.00	175.00	479	06/25/2026	526	01105341
		Microsoft G1	EXCHANGE LIC (1)	06/10/2026	8.40	8.40	479	06/25/2026	526	01065300
		NASRO 8114	OUTLAW-NASRO MEM	05/19/2026	50.00	50.00	479	06/25/2026	526	01025345
		National Min	NATIONAL MINORITY	05/29/2026	195.00	195.00	479	06/25/2026	526	01025341
		Potsolve 104	POTSOLVE	06/16/2026	210.12	210.12	479	06/25/2026	526	01105300
		Sams Club 0	PW TOUCH A TRUCK	05/15/2026	184.52	184.52	479	06/25/2026	526	01108001
		Speedway 05	ICE	05/14/2026	12.19	12.19	479	06/25/2026	526	01025400
		The UPS Sto	UPS-SHIPPING	05/20/2026	15.40	15.40	479	06/25/2026	526	01025310
		The UPS Sto	POSTAGE	05/29/2026	259.33	259.33	479	06/25/2026	526	07095322
		Will Cnty Eye	CED BREAKFAST FOR	05/18/2026	180.00	180.00	479	06/25/2026	526	01165324
Total 826:					4,500.60	4,500.60				
846	Kimball Midw	104542275	GLOVES	06/09/2026	307.50	307.50	26700	07/07/2026	626	07085402
Total 846:					307.50	307.50				
914	Low Voltage	35707	HANDICAP DOOR REP	06/17/2026	290.00	290.00	26702	07/07/2026	626	01045360
Total 914:					290.00	290.00				
921	M&J Undergr	Inner Circle P	INNERCIRCLE WM AN	05/31/2026	260,206.56	260,206.56	26703	07/07/2026	626	12007620
Total 921:					260,206.56	260,206.56				
956	McMaster Ca	66753126	FLEET- AIR COMPRES	06/15/2026	471.67	471.67	26705	07/07/2026	626	01075400
Total 956:					471.67	471.67				
961	Menards	5255	FACILITIES- HAND TR	05/22/2026	99.99	99.99	26706	07/07/2026	626	01045400
		5932	FLEET- GRINDER WHE	06/04/2026	107.89	107.89	26706	07/07/2026	626	01075400
		5939	PW MAINTENANCE SU	06/04/2026	53.97	53.97	26706	07/07/2026	626	01035400
		6041	WELL MAINTENANCE	06/06/2026	56.99	56.99	26706	07/07/2026	626	07065361

Vendor Number	Vendor Name	Invoice Number	Description	Invoice Date	Invoice Amount	Check Amount	Check Number	Check Issue Date	GL Period	GL Account
		6041	WATER OFFICE SUPP	06/06/2026	14.99	14.99	26706	07/07/2026	626	07065401
		6180	WELL MAINTENANCE	06/09/2026	75.50	75.50	26706	07/07/2026	626	07065361
		6188	FLEET- PIPE FOR WAT	06/09/2026	91.39	91.39	26706	07/07/2026	626	01075400
		6242	WELL MAINTENANCE	06/10/2026	55.92	55.92	26706	07/07/2026	626	07065361
		6253	BUILDING MAINTENAN	06/10/2026	26.95	26.95	26706	07/07/2026	626	01045400
		6290	PW MAINTENANCE SU	06/11/2026	134.34	134.34	26706	07/07/2026	626	01035400
		6353	BUILDING MAINTENAN	06/12/2026	99.96	99.96	26706	07/07/2026	626	01045400
		Total 961:			817.89	817.89				
1016	Municipal Ele	072204	RADAR CERTIFICATIO	01/28/2026	699.00	699.00	26708	07/07/2026	626	01025310
		Total 1016:			699.00	699.00				
1017	DACRA Adju	2026-05-043	DACRA MONTHLY SER	05/31/2026	1,250.00	1,250.00	26673	07/07/2026	626	01025300
		2026-05-043	DACRA MONTHLY SER	05/31/2026	1,250.00	1,250.00	26673	07/07/2026	626	01165300
		Total 1017:			2,500.00	2,500.00				
1058	Nicor 94-96-3	May 2026	WSTP NICOR GAS	06/09/2026	280.20	280.20	26714	07/07/2026	626	07085350
		Total 1058:			280.20	280.20				
1059	Nicor 39-52-5	May 2026	WELL #10 NICOR	06/08/2026	69.58	69.58	26712	07/07/2026	626	07065350
		Total 1059:			69.58	69.58				
1066	Nicor 08-01-5	May 2026	WELL #7 NICOR GAS	06/02/2026	249.32	249.32	26709	07/07/2026	626	07065350
		Total 1066:			249.32	249.32				
1067	Nicor 89-80-1	May 2026	EAST PLANT NICOR	06/02/2026	597.84	597.84	26713	07/07/2026	626	07085350
		Total 1067:			597.84	597.84				
1099	OReilly Auto	6763-150524	FLEET- EXHAUST SEA	06/19/2026	19.98	19.98	26716	07/07/2026	626	01075400
		Total 1099:			19.98	19.98				
1116	Altorfer Indus	P58C007634	FLEET- UNIT #215 BAT	06/08/2026	108.96	108.96	26657	07/07/2026	626	01075400
		P58C007641	FLEET- UNIT #215 BAT	06/09/2026	691.04	691.04	26657	07/07/2026	626	01075400
		P58C007641	FLEET- UNIT #215 BAT	06/09/2026	32.53	32.53	26657	07/07/2026	626	01075400
		Total 1116:			832.53	832.53				
1148	Physicians I	42546 29426	RANDOM DRUG SCRE	06/06/2026	162.00	162.00	26699	07/07/2026	626	01015300
		Total 1148:			162.00	162.00				
1164	Pomp's Tire	2120054236	FLEET- UNIT #221 FRO	06/10/2026	843.60	843.60	26717	07/07/2026	626	01075400
		Total 1164:			843.60	843.60				
1165	Porter Lee C	33631	4" RESIN RIBBONS DE	06/18/2026	369.06	369.06	26718	07/07/2026	626	01025400
		Total 1165:			369.06	369.06				

Vendor Number	Vendor Name	Invoice Number	Description	Invoice Date	Invoice Amount	Check Amount	Check Number	Check Issue Date	GL Period	GL Account
1174	PreCise MR	IN200-20136	FLEET- PRECISE GPS	06/18/2026	486.00	486.00	26719	07/07/2026	626	01035300
Total 1174:					486.00	486.00				
1214	Reasonable	11959	TREE REMOVAL	06/18/2026	1,500.00	1,500.00	26724	07/07/2026	626	07065300
Total 1214:					1,500.00	1,500.00				
1243	Ray OHerron	2443844	UNIFORM EQUIPMENT	11/07/2025	179.98	179.98	26722	07/07/2026	626	01025344
		2446093	UNIFORM EQUIPMENT	11/19/2025	182.94	182.94	26722	07/07/2026	626	01025344
		2446394	UNIFORM EQUIPMENT	11/20/2025	30.99	30.99	26722	07/07/2026	626	01025344
		2446686	UNIFORM EQUIPMENT	11/21/2025	171.80	171.80	26722	07/07/2026	626	01025344
		2451053	UNIFORM EQUIPMENT	12/17/2025	640.38	640.38	26722	07/07/2026	626	01025344
		2451235	UNIFORM EQUIPMENT	12/17/2025	1,084.14	1,084.14	26722	07/07/2026	626	01025344
		2451237	UNIFORM EQUIPMENT	12/17/2025	1,084.14	1,084.14	26722	07/07/2026	626	01025344
		2452451	UNIFORM EQUIPMENT	12/23/2025	1,287.36	1,287.36	26722	07/07/2026	626	01025344
		2452452	UNIFORM EQUIPMENT	12/23/2025	1,356.83	1,356.83	26722	07/07/2026	626	01025344
		2453327	UNIFORM EQUIPMENT	12/31/2025	104.47	104.47	26722	07/07/2026	626	01025344
		2453801	UNIFORM EQUIPMENT	01/05/2026	81.26	81.26	26722	07/07/2026	626	01025344
		2455861	UNIFORM EQUIPMENT	01/15/2026	161.47	161.47	26722	07/07/2026	626	01025344
		2456052	UNIFORM-MACHUGA	01/16/2026	910.12	910.12	26722	07/07/2026	626	01025344
		2457506	UNIFORM EQUIPMENT	01/23/2026	910.12	910.12	26722	07/07/2026	626	01025344
		2460141	UNIFORM EQUIPMENT	02/06/2026	910.14	910.14	26722	07/07/2026	626	01025344
		2460988	UNIFORM EQUIPMENT	02/11/2026	302.58	302.58	26722	07/07/2026	626	01025344
		2462370	UNIFORM EQUIPMENT	02/18/2026	153.08	153.08	26722	07/07/2026	626	01025344
		2462371	UNIFORM EQUIPMENT	02/18/2026	96.58	96.58	26722	07/07/2026	626	01025344
		2470535	UNIFORM EQUIPMENT	04/02/2026	294.50	294.50	26722	07/07/2026	626	01025344
		2473036	UNIFORM EQUIPMENT	04/15/2026	40.00	40.00	26722	07/07/2026	626	01025344
		2477504	UNIFORM EQUIPMENT	05/06/2026	100.00	100.00	26722	07/07/2026	626	01025344
		2477996	UNIFORM EQUIPMENT	05/08/2026	84.05	84.05	26722	07/07/2026	626	01025344
		2477998	MOURNING BANDS	05/08/2026	45.15	45.15	26722	07/07/2026	626	01025344
		2478017	UNIFORM EQUIPMENT	05/08/2026	40.00	40.00	26722	07/07/2026	626	01025344
		2478568	UNIFORM EQUIPMENT	05/12/2026	217.80	217.80	26722	07/07/2026	626	01025344
		2478914	UNIFORM EQUIPMENT	05/13/2026	150.33	150.33	26722	07/07/2026	626	01025344
		2479992	UNIFORM EQUIPMENT	05/19/2026	67.10	67.10	26722	07/07/2026	626	01025344
		2481051	UNIFORM EQUIPMENT	05/27/2026	79.99	79.99	26722	07/07/2026	626	01025344
		2483787	UNIFORM EQUIPMENT	06/10/2026	171.00	171.00	26722	07/07/2026	626	01025344
		2486961	UNIFORM EQUIPMENT	06/29/2026	43.20	43.20	26722	07/07/2026	626	01025344
		2486986	UNIFORM EQUIPMENT	06/29/2026	1,899.96	1,899.96	26722	07/07/2026	626	01025344
		2487002	PMAG CLOCK 17 9MM	06/29/2026	153.36	153.36	26722	07/07/2026	626	01025341
		CM#2441247	RAY O'HERRON CREDI	10/24/2025	8,710.00-	8,710.00-	26722	07/07/2026	626	01025344
		CM#2441607	RAY O'HERRON CREDI	10/27/2025	2,500.00-	2,500.00-	26722	07/07/2026	626	01025344
Total 1243:					1,824.82	1,824.82				
1283	SEECO Con	20174	CONSTRUCTION MAT	04/30/2026	1,052.00	1,052.00	26729	07/07/2026	626	35007512
Total 1283:					1,052.00	1,052.00				
1302	Shorewood H	01-521660	FLEET- AIR FILTERS,S	06/16/2026	138.34	138.34	26730	07/07/2026	626	01075400
Total 1302:					138.34	138.34				
1326	Ray Soliman	June 2026 (2	MONTHLY GAS MILEA	05/29/2026	50.00	50.00	26723	07/07/2026	626	01015342
Total 1326:					50.00	50.00				

Vendor Number	Vendor Name	Invoice Number	Description	Invoice Date	Invoice Amount	Check Amount	Check Number	Check Issue Date	GL Period	GL Account
1336	Spesia & Tayl	26134	Gener	06/22/2026	22,121.12	22,121.12	26733	07/07/2026	626	01105302
		27687	Mathe	06/22/2026	2,625.00	2,625.00	26733	07/07/2026	626	01165300
		825311	Math	05/19/2026	1,118.00	1,118.00	26733	07/07/2026	626	01165324
Total 1336:					25,864.12	25,864.12				
1353	Stanard & As	SA00006497	STRUCTURED ORAL	06/23/2026	3,529.05	3,529.05	26734	07/07/2026	626	01025341
Total 1353:					3,529.05	3,529.05				
1355	Joe Johnson	U00466	FLEET- STREET SWEE	05/28/2026	334,860.00	334,860.00	26698	07/07/2026	626	11007301
Total 1355:					334,860.00	334,860.00				
1366	Stewart Spre	4813	AERATION AND ANAE	06/17/2026	164,850.00	164,850.00	26736	07/07/2026	626	07085373
Total 1366:					164,850.00	164,850.00				
1373	Strand Assoc	0240270	WELLHOUSE GENERA	06/11/2026	3,291.09	3,291.09	26737	07/07/2026	626	07065330
		0240374	CCT DOMONSTRATIVE	06/11/2026	531.01	531.01	26737	07/07/2026	626	07065332
		0240375	EAST AND WEST REC	06/11/2026	5,000.00	5,000.00	26737	07/07/2026	626	12007602
		0240376	CE SERVICES CIPP W	06/11/2026	19,033.61	19,033.61	26737	07/07/2026	626	12007620
		0240377	CATON FARM WM EXT	06/11/2026	2,618.44	2,618.44	26737	07/07/2026	626	12007620
		0240379	CHEMICAL FEED UPG	06/11/2026	4,612.73	4,612.73	26737	07/07/2026	626	12007620
		0240380	PFAS PILOT TESTING	06/11/2026	3,101.34	3,101.34	26737	07/07/2026	626	07065330
		0240381	BROADWAY WM SERV	06/11/2026	2,234.48	2,234.48	26737	07/07/2026	626	07065330
		0240449	DESIGN CIPP WATER	06/11/2026	3,126.04	3,126.04	26737	07/07/2026	626	12007602
Total 1373:					43,548.74	43,548.74				
1393	Southwest A	430551	SWARM PROPERTY/W	05/01/2026	453,427.00	453,427.00	26731	07/07/2026	626	07095323
		430551	SWARM PROPERTY/W	05/01/2026	473,000.00	473,000.00	26731	07/07/2026	626	01105323
Total 1393:					926,427.00	926,427.00				
1425	Third Millenni	34653	COCH UTILITY BILL RE	06/24/2026	471.59	471.59	26739	07/07/2026	626	07095321
Total 1425:					471.59	471.59				
1432	Ron Tirapelli	201856	FLEET-UNIT #937 ALIG	05/27/2026	115.45	115.45	26727	07/07/2026	626	01075400
		676310	FLEET- UNIT #934 EXH	06/18/2026	1,001.90	1,001.90	26727	07/07/2026	626	01075400
Total 1432:					1,117.35	1,117.35				
1503	Uni-Max Man	5815	JANITORAL SERVICES	06/15/2026	3,760.00	3,760.00	26740	07/07/2026	626	01045300
Total 1503:					3,760.00	3,760.00				
1515	Unlimited Gr	128468	STOP WORK ORDERS	06/19/2026	550.00	550.00	26741	07/07/2026	626	01165401
Total 1515:					550.00	550.00				
1521	USABlueBoo	INV0106989	STP LAB SUPPLIES	06/09/2026	606.13	606.13	26742	07/07/2026	626	07085420
		INV0106998	STP LAB SUPPLIES	06/09/2026	118.90	118.90	26742	07/07/2026	626	07085420
		INV0107742	PROBE	06/17/2026	1,383.00	1,383.00	26742	07/07/2026	626	07085420
		INV0107742	PORTABLE MULTIMET	06/17/2026	2,577.00	2,577.00	26742	07/07/2026	626	07085420

Vendor Number	Vendor Name	Invoice Number	Description	Invoice Date	Invoice Amount	Check Amount	Check Number	Check Issue Date	GL Period	GL Account
Total 1521:					4,685.03	4,685.03				
1548	Verizon Wirel	6145022218	VERIZON WIRELESS S	06/01/2026	30.02	30.02	26743	07/07/2026	626	01065350
		6145022218	VERIZON WIRELESS S	06/01/2026	1,423.32	1,423.32	26743	07/07/2026	626	01105350
		6145022218	VERIZON WIRELESS S	06/01/2026	227.00	227.00	26743	07/07/2026	626	07065350
		6145022218	VERIZON WIRELESS S	06/01/2026	98.03	98.03	26743	07/07/2026	626	07075350
		6145022218	VERIZON WIRELESS S	06/01/2026	98.03	98.03	26743	07/07/2026	626	07085350
		6146816704	MONTHLY STATEMENT	06/23/2026	1,360.98	1,360.98	26743	07/07/2026	626	01065350
Total 1548:					3,237.38	3,237.38				
1844	Anthony Smit	Meal Reimbu	MEAL REIMBURSEME	06/02/2026	30.00	30.00	26659	07/07/2026	626	01025343
Total 1844:					30.00	30.00				
1853	Buckeye Pow	PI2040877	WELL 11 GENERATOR	06/11/2026	1,485.00	1,485.00	26664	07/07/2026	626	07065300
Total 1853:					1,485.00	1,485.00				
1879	Nicor 24-47-6	May 2026	NICOR MONTHLY STAT	06/08/2026	224.48	224.48	26711	07/07/2026	626	01105350
Total 1879:					224.48	224.48				
1880	Nicor 17-28-8	May 2026	POLICE DEPARTMENT	06/08/2026	234.54	234.54	26710	07/07/2026	626	01105350
Total 1880:					234.54	234.54				
1914	AT&T 831-00	0800276116	INTERNET PW	06/07/2026	1,338.52	1,338.52	26662	07/07/2026	626	01035300
Total 1914:					1,338.52	1,338.52				
1921	Dell Financial	5226014	DELL COMPUTER LEA	06/15/2026	7,341.00	7,341.00	26674	07/07/2026	626	01065301
Total 1921:					7,341.00	7,341.00				
1950	Pure Water P	2497190	WATER FOR PW	05/29/2026	65.00	65.00	26721	07/07/2026	626	01035343
		2497190	WATER FOR WEST PL	05/29/2026	47.50	47.50	26721	07/07/2026	626	07085343
		2504760	WATER FOR ELROSE	06/05/2026	65.00	65.00	26721	07/07/2026	626	01045401
		2504760	PAPER STATEMENT F	06/05/2026	3.00	3.00	26721	07/07/2026	626	01035401
Total 1950:					180.50	180.50				
1953	Amazon Capi	11GX-QYMJ-	FLEET- POLICE STOC	06/12/2026	1,190.89	1,190.89	26658	07/07/2026	626	01075400
		13T6-166Y-4	PAPER TOWELS, KNIV	06/16/2026	164.60	164.60	26658	07/07/2026	626	01025400
		13YF-4F3C-4	CURRENCY STRAPS	06/09/2026	14.77	14.77	26658	07/07/2026	626	01125401
		13YF-4F3C-4	ENVELOPES	06/09/2026	28.40	28.40	26658	07/07/2026	626	01125401
		1FC4-7W3L-	SUPPLIES	06/16/2026	115.57	115.57	26658	07/07/2026	626	01125401
		1HF4-33KP-	FOLDERS	06/22/2026	31.82	31.82	26658	07/07/2026	626	01125401
		1HNN-CF7G-	OFFICE SUPPLIES	06/17/2026	10.48	10.48	26658	07/07/2026	626	01105401
		1KDM-XFTV-	CREDIT CARD LOG BO	06/17/2026	9.99	9.99	26658	07/07/2026	626	01105401
		1KHW-VR7D	50GB DVD DISKS	06/22/2026	85.95	85.95	26658	07/07/2026	626	01025400
		1KQC-KC6W	250TH BUNTING	06/15/2026	33.99	33.99	26658	07/07/2026	626	01045400
		1N7H-VDY7-	FLEET- COMPRESSIO	06/17/2026	113.29	113.29	26658	07/07/2026	626	01075400
		1NFG-Y9Q9-	SHIPPING ENVEIOPES	06/22/2026	54.97	54.97	26658	07/07/2026	626	01025400
		1NFK-FR11-	FACILITIES- FUEL CAN	06/08/2026	370.44	370.44	26658	07/07/2026	626	01045400
		1QXL-D3NH-	PRE-PRINTED ENVEL	06/29/2026	107.93	107.93	26658	07/07/2026	626	01025401

Vendor Number	Name	Invoice Number	Description	Invoice Date	Invoice Amount	Check Amount	Check Number	Check Issue Date	GL Period	GL Account
		1RJ-1Y4R-	TOWEL BAR FOR BUN	06/10/2026	36.99	36.99	26658	07/07/2026	626	01105401
		1RJ-1Y4R-	SCREEN PROTECTOR	06/10/2026	49.63	49.63	26658	07/07/2026	626	01035401
		1RJ-1Y4R-	SCREEN PROTECTOR	06/10/2026	49.62	49.62	26658	07/07/2026	626	07065401
		1RJ-1Y4R-	SCREEN PROTECTOR	06/10/2026	49.62	49.62	26658	07/07/2026	626	07085401
		1RJ-1Y4R-	TONER	06/10/2026	72.19	72.19	26658	07/07/2026	626	01025401
		1THM-3VVT-	FLEET- UNIT #200 FUS	06/08/2026	12.89	12.89	26658	07/07/2026	626	01075400
		CM#19FJ-M9	TONER-REFUND	06/17/2026	72.19-	72.19-	26658	07/07/2026	626	01025401
		CM#1NG3-G	FLEET- DAMAGED RE	06/15/2026	383.31-	383.31-	26658	07/07/2026	626	01075400
Total 1953:					2,148.53	2,148.53				
1954	Charles J De	127 June 202	ADMINISTRATIVE HEA	06/10/2026	300.00	300.00	26667	07/07/2026	626	01015300
Total 1954:					300.00	300.00				
1971	Graybar Fina	20494525	PHONE SYSTEM MON	06/25/2026	2,110.85	2,110.85	26691	07/07/2026	626	07095300
Total 1971:					2,110.85	2,110.85				
1977	AIS Inc	99177	SERVER SUPPORT	06/09/2026	6,000.00	6,000.00	26656	07/07/2026	626	07095301
		99177	SERVER SUPPORT	06/09/2026	11,817.60	11,817.60	26656	07/07/2026	626	01065301
		99178	MIMECAST SECURITY	06/09/2026	1,362.50	1,362.50	26656	07/07/2026	626	01065300
		99328	REMOTE SUPPORT	06/09/2026	1,198.75	1,198.75	26656	07/07/2026	626	01065300
		99370	REMOTE SUPPORT	06/09/2026	1,258.75	1,258.75	26656	07/07/2026	626	01065300
		99380	LAPTOP	06/09/2026	1,426.16	1,426.16	26656	07/07/2026	626	01035300
Total 1977:					23,063.76	23,063.76				
1983	Cornwell Eng	016304-01-0	LAKE MICHIGAN COR	06/05/2026	7,922.50	7,922.50	26670	07/07/2026	626	07065330
Total 1983:					7,922.50	7,922.50				
1985	SpectrumVol	880229 July	MONTHLY STATEMENT	07/01/2026	264.51	264.51	26732	07/07/2026	626	01105350
Total 1985:					264.51	264.51				
1988	Heidi Outlaw	Training Rei	TRAVEL REIMBURSEM	06/19/2026	26.01	26.01	26693	07/07/2026	626	01025342
		Training Rei	MEAL REIMBURSEME	06/19/2026	66.28	66.28	26693	07/07/2026	626	01025343
Total 1988:					92.29	92.29				
2024	Comcast Bus	275305023	ROUTER EQUIPMENT	06/15/2026	13,756.61	13,756.61	26669	07/07/2026	626	01065301
Total 2024:					13,756.61	13,756.61				
2036	Tolemi	CRESIL004	RENTAL REGISTRATO	05/22/2026	12,000.00	12,000.00	26715	07/07/2026	626	01165300
Total 2036:					12,000.00	12,000.00				
2043	Donald E. Mo	May 2026	DONALD E. MORRIS S	05/29/2026	11,488.70	11,488.70	26675	07/07/2026	626	01165300
Total 2043:					11,488.70	11,488.70				
2047	Road 2 Etern	259	MEMORIAL DAY CERE	06/26/2026	400.00	400.00	26726	07/07/2026	626	01108001
		259	LIDICE CEREMONY VI	06/26/2026	400.00	400.00	26726	07/07/2026	626	01108001

Vendor Number	Vendor Name	Invoice Number	Description	Invoice Date	Invoice Amount	Check Amount	Check Number	Check Issue Date	GL Period	GL Account
Total 2047:					800.00	800.00				
2061	Jeffrey Reick	Meal Reimbu	REICK-TRAINING MEA	06/26/2026	15.00	15.00	26697	07/07/2026	626	01025343
Total 2061:					15.00	15.00				
2089	Craig Machu	Meal Reimbu	MEAL REIMBURSEME	06/05/2026	45.00	45.00	26671	07/07/2026	626	01025343
		Meal Reimbu	MEAL REIMBURSEME	06/23/2026	54.98	54.98	26671	07/07/2026	626	01025343
		Meal Reimbu	MEAL REIMBURSEME	06/16/2026	15.00	15.00	26671	07/07/2026	626	01025343
		Meal Reimur	REIMBURSEMENT-MA	06/23/2026	15.00	15.00	26671	07/07/2026	626	01025343
Total 2089:					129.98	129.98				
2091	Lenny's Gas	6422	FLEET- VEHICLE WAS	06/03/2026	88.00	88.00	26688	07/07/2026	626	01075400
Total 2091:					88.00	88.00				
2094	William McCl	25	PLAN COMMISSION M	06/16/2026	100.00	100.00	26745	07/07/2026	626	01105300
		25	CITY COUNCIL MEETI	06/16/2026	150.00	150.00	26745	07/07/2026	626	01105300
		25	CITY COUNCIL MEETI	06/16/2026	150.00	150.00	26745	07/07/2026	626	01105300
		26	PLAN COMMISSION M	06/16/2026	100.00	100.00	26745	07/07/2026	626	01105300
		26	CITY COUNCIL MEETI	06/16/2026	150.00	150.00	26745	07/07/2026	626	01105300
		26	CITY COUNCIL MEETI	06/16/2026	150.00	150.00	26745	07/07/2026	626	01105300
		27	CITY COUNCIL MEETI	06/16/2026	150.00	150.00	26745	07/07/2026	626	01105300
		27	CITY COUNCIL MEETI	06/16/2026	150.00	150.00	26745	07/07/2026	626	01105300
Total 2094:					1,100.00	1,100.00				
2128	Caselle LLC	INV-21042	ANNUAL MAINTENANC	06/22/2026	1,860.00	1,860.00	26666	07/07/2026	626	01065300
Total 2128:					1,860.00	1,860.00				
2142	Engineering	87320	2025 WATER AUDIT	06/16/2026	2,959.00	2,959.00	26687	07/07/2026	626	07065331
Total 2142:					2,959.00	2,959.00				
2174	Sustainable	60826	MENTZER SERVICES 0	06/08/2026	2,185.00	2,185.00	26738	07/07/2026	626	01165300
		60926	MENTZER SERVICES 0	06/09/2026	4,427.50	4,427.50	26738	07/07/2026	626	01165300
		61026	MENTZER SERVICES 0	06/10/2026	3,910.00	3,910.00	26738	07/07/2026	626	01165300
Total 2174:					10,522.50	10,522.50				
2183	Jacob Poor	Training/SBO	POOR TRAINING & SB	06/10/2026	135.00	135.00	26696	07/07/2026	626	01165341
Total 2183:					135.00	135.00				
2204	LocalGov Sta	2026-011 CH	RECRUITMENT SUPER	06/17/2026	19,950.00	19,950.00	26701	07/07/2026	626	01105300
Total 2204:					19,950.00	19,950.00				
2210	Grand Prairie	AR-0000000	GPWC MAY 26 MONTH	05/31/2026	49,992.00	49,992.00	26690	07/07/2026	626	07065332
Total 2210:					49,992.00	49,992.00				
2227	Adam Crosse	ICC Member	ICC CERTIFICATE REI	06/24/2026	255.00	255.00	26654	07/07/2026	626	01165341

Vendor Number	Vendor Name	Invoice Number	Description	Invoice Date	Invoice Amount	Check Amount	Check Number	Check Issue Date	GL Period	GL Account
Total 2227:					255.00	255.00				
2253	Method Engi	3707	MARKETING SUPPOR	06/12/2026	3,080.00	3,080.00	26707	07/07/2026	626	01105300
Total 2253:					3,080.00	3,080.00				
2277	M.J. Electric	2515307050	WELL HOUSE SCADA	06/19/2026	25,000.00	25,000.00	26704	07/07/2026	626	07065301
Total 2277:					25,000.00	25,000.00				
2297	Precision Pro	INV-3448	VEGETATION CUTTIN	05/08/2026	105.00	105.00	26720	07/07/2026	626	01165300
		INV-3449	VEGETATION CUTTIN	05/08/2026	105.00	105.00	26720	07/07/2026	626	01165300
		INV-3519	VEGETATION CUTTIN	05/20/2026	105.00	105.00	26720	07/07/2026	626	01165300
		INV-3520	VEGETATION CUTTIN	06/03/2026	105.00	105.00	26720	07/07/2026	626	01165300
		INV-3521	VEGETATION CUTTIN	06/03/2026	105.00	105.00	26720	07/07/2026	626	01165300
		INV-3522	VEGETATION CUTTIN	06/03/2026	105.00	105.00	26720	07/07/2026	626	01165300
		INV3535	VEGETATION CUTTIN	06/10/2026	105.00	105.00	26720	07/07/2026	626	01165300
		INV-3536	VEGETATION CUTTIN	06/10/2026	105.00	105.00	26720	07/07/2026	626	01165300
		INV-3543	VEGETATION CUTTIN	06/11/2026	130.00	130.00	26720	07/07/2026	626	01165300
		INV-3558	VEGETATION CUTTIN	06/16/2026	1,369.24	1,369.24	26720	07/07/2026	626	01165300
		INV-3567	DEBRIS REMOVAL 605	06/24/2026	576.15	576.15	26720	07/07/2026	626	01165300
		INV-3568	VEGETATION CUTTIN	06/24/2026	210.00	210.00	26720	07/07/2026	626	01165300
		INV-3569	VEGETATION CUTTNG	06/24/2026	105.00	105.00	26720	07/07/2026	626	01165300
		INV-3570	DEBRIS REMOVAL 555	06/24/2026	158.75	158.75	26720	07/07/2026	626	01165300
Total 2297:					3,389.14	3,389.14				
2298	Stantec Cons	2575703	GPWC-GAYLORD AND	06/12/2026	17,350.08	17,350.08	26735	07/07/2026	626	13005330
Total 2298:					17,350.08	17,350.08				
2299	Schulte Supp	S1243333.00	VALVE BOX LIFTERS	05/21/2026	310.99	310.99	26728	07/07/2026	626	01035400
Total 2299:					310.99	310.99				
2301	Carillon Lake Electrical Co		REIMBURSEMENT FO	06/03/2026	652.00	652.00	26665	07/07/2026	626	01045360
Total 2301:					652.00	652.00				
2305	Naperville Co	7380	POLICE RECRUITMEN	06/25/2026	15,000.00	15,000.00	26652	06/26/2026	526	01025310
Total 2305:					15,000.00	15,000.00				
Grand Totals:					2,297,115.55	2,297,115.55				

Report Criteria:

Detail report type printed  
 [Report].Check Issue Date = 06/25/2026,06/26/2026,07/07/2026



## Agenda Memo

Crest Hill, IL

<b>Meeting Date:</b>	July 6, 2026
<b>Submitter:</b>	Blaine Wing, City Administrator
<b>Department:</b>	Administration
<b>Agenda Item:</b>	IML Conference and Training Policy for Elected Officials

**Summary:** At the October 6, 2025, City Council meeting it was requested that the recent IML Conference expenses be discussed. We then had the discussion on October 13<sup>th</sup>. That meeting concluded with Council requesting that before the next IML Conference, that agreement is obtained before registering for the 2026 IML Conference.

Following the June 22<sup>nd</sup> work session discussion, the following policy points for elected officials (Mayor, Council, Clerk, and Treasurer) regarding registering, attendance, reimbursement, stipends, expenditures, etc. should be considered for approval and adoption.

- As of July 6, 2026, the policy would have ALL registrations for training and conferences run through the Administrative Assistant position (currently Marybel). Marybel will register all of the above people for conferences and training, hotels, and parking, per their emailed request to register or cancel.
- All transportation (train, bus, uber, taxi, uber, and mileage; up to \$100 per day) would be by reimbursement.
- Expense receipts for food, snack, and incidental expenses receipts are needed for reimbursement up to \$100 per day, with a \$300 limit for IML Conferneces.
- If someone needs to cancel, for a non-emergency reason, the specific elected official shall reimburse the City for all expenses. (The City will attempt to cancel without incurring expenses.)
- If someone chooses not to attend a training or conference for at least two (2) days, that person would need to reimburse the City.
- If someone leaves the conference or training early (not meeting the minimum two (2) days, except for an emergency), they shall reimburse the City for the conference or training, hotel, and parking costs, on a pro rata basis.
- A final report of all expenses will be created by the Finance Department and presented to City Council within 45 days of the training or conference.
- Any requests for exceptions would be discussed and voted on (approved or not) by City Council.

**Recommended Council Action:** Approve and implement the elected official training and conference policy as bullet pointed above.

**Financial Impact:** Up to \$10,000 depending on the number of elected officials who attend.

**Funding Source:** General Fund

**Budgeted Amount:** \$10,000.00

**Cost:** Not yet finalized.

**Attachments:** No attachments



## City Council Memo

Crest Hill, IL

<b>Meeting Date:</b>	July 6, 2026
<b>Submitter:</b>	Ashley Monroe, Assistant City Administrator/HR Administration /
<b>Department:</b>	Human Resources
<b>Agenda Item:</b>	A Resolution Authorizing the Selection and Hiring of Administrative Intern Kishae White at an Hourly Rate Not To Exceed \$20.00.

**Summary:** At the June 15, 2026 City Council meeting, Resolution 1430 permitted the City Administrator to proceed with the interview and hire of an Administrative Intern through Northern Illinois University's Master of Public Administration (MPA) program. This part-time, hourly position would provide project and operations support for all City Departments, over the span of a minimum of one year.

In order to participate, the City registered with NIU and posted our internship scope of work. We received notice that nine students were interested in working with the City of Crest Hill. The City selected its top five candidates and were scheduled to interview 4 of 5 of those selected by staff. On June 25, 2026, Ashley attended the recruitment interview process for select graduate students, at NIU in DeKalb, Illinois and interviewed four graduate students. Based on the interviews and considering the potential use for operational support, staff has selected a desired candidate. Although Council authorized a rate up to \$21, the hourly rate for the intern is proposed as \$20.00 per hour.

The intern mutually matched to the City is from the Crest Hill area and progressed quickly through her higher education, graduating college a year early, getting a paralegal certification, and an acceptance to law school. Through her recent internship with an attorney serving the Chicago area, they explored work in public service, leading her to the NIU MPA program. Kishae's work in retail, legal, volunteerism, and her interview responses demonstrate a level of responsibility, community-mindedness, and pragmatism that would benefit our operations in this part-time position.

**Fiscal Impact:** During the FY26 budget process, approximately \$20,000 was approved for this purpose. No permanent employee benefits or pension benefits will be provided. Based on an hourly rate of \$20, a schedule of no more than 20-24 hours weekly, and the position being filled for approximately nine remaining months of the fiscal year, we will not exceed the planned budget.

**Recommended Council Action:** A Resolution Authorizing the Selection and Hiring of Administrative Intern Kishae White at an Hourly Rate Not To Exceed \$20.00.

**Attachments:**  
Resolution

**RESOLUTION NO.     -**

**A RESOLUTION AUTHORIZING THE SELECTION, AND HIRING OF  
ADMINISTRATIVE INTERN KISHAE WHITE AT AN HOURLY RATE NOT TO  
EXCEED \$20.00**

---

WHEREAS, the Corporate Authorities of the City of Crest Hill, Will County, Illinois, have the authority to adopt resolutions and to promulgate rules and regulations that pertain to the City's government and affairs and protect the public health, safety, and welfare of its citizens; and

WHEREAS, pursuant to 65 ILCS 5/3.1-50-5, the City Council is authorized to determine the compensation of all city employees; and

WHEREAS, the City recognizes the importance of supporting educational and professional development opportunities that provide students and emerging professionals with practical experience in local government operations; and

WHEREAS, interns can provide valuable support to City departments through research, data analysis, special projects, and prioritized initiatives that advance the City's organizational goals and improve service delivery; and

WHEREAS, providing a part-time internship opportunity cost-effectively strengthens the City's current capacity to support community events, programs, and initiatives that enhance the quality of life for residents and promote civic engagement; and

WHEREAS, the City has determined to collaborate with the Northern Illinois University (NIU) Master of Public Administration program to secure a graduate intern for a commitment period of one year; and

WHEREAS, the City Council has determined with the approval of previous Resolution 1430 that it is in the best interests of the City and its citizens to allow the City Administrator and his designee shall be authorized to interview and hire a qualified candidate for the Position at an hourly rate not to exceed \$20.00.

NOW, THEREFORE, BE IT RESOLVED by the City Council of the City of Crest Hill, Illinois, pursuant to its statutory authority, as follows:

SECTION 1: PREAMBLE. The City Council hereby finds that all the recitals contained in the preamble to this Resolution are true, correct, and complete and are hereby incorporated by reference thereto and made a part hereof.

SECTION 2: The City Council hereby authorizes and directs the City Administrator to hire qualified candidate, Kishae White, for the Position at an hourly rate not to exceed \$20.00.

SECTION 3: SEVERABILITY. If any section, paragraph, clause, or provision of this Resolution is held invalid, the invalidity of such section, paragraph, clause, or provision shall not affect any other provision of this Resolution.

SECTION 4: REPEALER. All ordinances, resolutions or orders, or parts thereof, which conflict with the provisions of this Resolution, are to the extent of such conflict hereby repealed.

SECTION 5: EFFECTIVE DATE. This Resolution shall be in full force and effect immediately upon its passage and publication according to law.

*[Intentionally Blank]*

PASSED THIS 6<sup>TH</sup> DAY OF JULY, 2026.

	Aye	Nay	Absent	Abstain
Alderman Scott Dyke	_____	_____	_____	_____
Alderman Angelo Deserio	_____	_____	_____	_____
Alderwoman Claudia Gazal	_____	_____	_____	_____
Alderman Darrell Jefferson	_____	_____	_____	_____
Alderperson Tina Oberlin	_____	_____	_____	_____
Alderman Mark Cipiti	_____	_____	_____	_____
Alderman Nate Albert	_____	_____	_____	_____
Alderman Joe Kubal	_____	_____	_____	_____
Mayor Raymond R. Soliman	_____	_____	_____	_____

\_\_\_\_\_  
Christine Vershay-Hall, City Clerk

APPROVED THIS 6<sup>TH</sup> DAY OF JULY, 2026.

\_\_\_\_\_  
Raymond R. Soliman, Mayor

ATTEST:

\_\_\_\_\_  
Christine Vershay-Hall, City Clerk



## City Council Memo

Crest Hill, IL

<b>Meeting Date:</b>	July 6, 2026
<b>Submitter:</b>	Blaine Wing, City Administrator
<b>Department:</b>	Administration
<b>Agenda Item:</b>	Will County Emergency Notification system changes to Smart 911

**Summary:** Earlier this year, the City was notified by the Will County Emergency Management Agency that the Everbridge emergency notification system was being retired and replaced with the RAVE system as of July 1, 2026. After many years of use, data included in the emergency system can become outdated, and the County is encouraging current residents sign into an updated system to register their contact information. Existing Everbridge subscribers were sent a notification about the transition and encouraged to register for the new system, Smart911.

Smart911, which operates similarly to the Everbridge platform, provides expanded features. City of Crest Hill Administration, Police, and Public Works staff have access to the platform and can share messages specific to Crest Hill, such as news about road closures or service disruptions. Messages are delivered to voluntary participants via email, phone message, and mobile app. There are no changes to the City's reverse 9-1-1 system, which does not require registration.

The Smart911 platform also provides the opportunity to sign up for a free Safety Profile. This voluntary profile allows entry of contacts, medical information, household members, pets, vehicles, and additional addresses. This information can quickly assist emergency responders.

The City has shared information on our social media channels and City website, along with issuance of a press release on June 26, 2026. More information can be found on the City's website page:

<https://www.cityofcresthill.com/166/Emergency-Alerts-Sign-Up>

To register for Smart911, residents should visit the Will County Smart911 Registration page:

<https://willcounty911.gov/smart-911/org>.

**Recommended Council Action:** Public Information

**Attachments:**

Press Release from Will County Emergency Management Agency  
Crest Hill Press Release (June 26, 2026)



Blaine Wing  
City Administrator  
(815) 741-5124  
bwing@cresthill.gov

FOR IMMEDIATE RELEASE  
June 26, 2026



Smart 9-1-1 in Will County

## Crest Hill encourages residents to sign up for Smart 911 system

Crest Hill, IL; June 26, 2026 – The City of Crest Hill is encouraging residents to register for Smart911, the new emergency notification system that is replacing Everbridge throughout Will County.

Beginning July 1, 2026, the Everbridge alerts system maintained by the Will County Emergency Management Agency, will no longer be available. Existing Everbridge subscribers will receive a notification about the transition and will be encouraged to register for the new system, Smart911. Residents who currently receive City emergency or community notifications through Everbridge must create a new Smart911 account to continue receiving alerts.

Smart911 allows residents to receive important notifications by text message, phone call, email, or mobile app. In addition to emergency alerts, the City of Crest Hill may use the system to share information about road closures, public safety incidents, service disruptions, and other important community updates.

Crest Hill residents are also encouraged to create a free Smart911 Safety Profile, which allows them to voluntarily provide emergency responders with helpful information such as emergency contacts, medical information, household members, pets, vehicles, and additional addresses.

To register, visit the Will County Smart911 Registration page: <https://willcounty911.gov/smart-911/.org>.

### About the City of Crest Hill

The City of Crest Hill is a vibrant community in Will County, Illinois, dedicated to providing high-quality public services, maintaining critical infrastructure, and enhancing the quality of life for residents, businesses, and visitors.

For additional information, visit Will County’s Smart 9 1 1 website or contact [rave@willcounty911.gov](mailto:rave@willcounty911.gov) for questions and support.

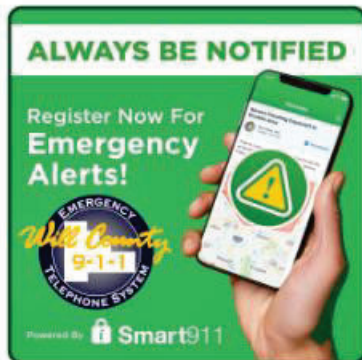



## Agenda Memo

Crest Hill, IL

<b>Meeting Date:</b>	July 6, 2026
<b>Submitters:</b>	Blaine Wing and Don Seeman
<b>Departments:</b>	Administration and Building
<b>Agenda Item:</b>	Interior City Hall Foyer Window Replacement

**Summary:** As City Council has heard over the past few years, there are several outstanding issues in City Hall/Police Station building. Some of these have been known since 2023, and it appears that minor corrective action(s) were taken.

### Internal Foyer Windows:

The bullet resistant windows were damaged (most likely by using a chemical cleaner) several years ago and have not been replaced. The City request proposal from several firms, with only one (1) vendor providing a proposal with pricing to do the work. Besides replacing the glass, the replacement solution also included microphones and speakers, to allow the public/staff to speak and hear each other.

Staff are recommending moving forward with the attached proposal to resolve this issue.

Note, to ensure that the windows are not mistakenly cleaned with chemicals, several things will be done:

- Warning stickers will be placed on the windows.
- City staff, not rotating staff members will be cleaning the windows.
- The newly installed blinds will be closed at the end of each day, with a “closed sign” placed. Thus, the side of windows that cannot be cleaned with anything but water, will have a barrier, and then warning sticker, to reinforce that the windows cannot be cleaned with anything other than water.
- The Crew Leader and Superintendent will make sure that the window cleaning are done monthly under their supervision.

### Other Known Issues:

- Non-commercial heating and cooling equipment
- Non-commercial toilets (most in City Hall are low-flow and residential)
- Leaking ceiling and roof issues
- Cracked and broken concrete
- Non-sealed bricks (around memorial)
- Possible security improvements (walls, doors, fences, etc.) to segment and protect areas

**Recommended Council Action:** Approval, not to exceed \$53,500.00

**Financial Impact:** \$53,500.00

**Funding Source:** General Fund

**Attachments:** Window Attachments



valleysecurityco.com | p: 847-888-9972  
660 Schneider Drive | South Elgin, IL 60177

June 10<sup>th</sup>, 2026

**Re: Crest Hill-Front Lobby Glazing Replacements**

Valley Security Company is pleased to provide you with this proposal for the Crest Hill Public Safety Building.

Our base proposal includes furnish and install of the following:

- (4) 70-1/2" x 44-3/4" Bullet resistant level 4 Glass Clad Polycarbonate Glazing
- (1) 36-3/4" x 44-1/4" Bullet resistant level 4 Glass Clad Polycarbonate Glazing
- (1) 41" x 56-3/4" Bullet resistant level 4 Glass Clad Polycarbonate Glazing
- Reusing the existing window mount speak port.

**Base Price \$44,750.00**

Alternate Pricing to furnish and install (4) countertop speaker system- \$ 8,750.00

- Uses 120v outlet

Bid Exclusions:

- Electrical
- Low Voltage
- Drywall Repairs/Painting
- Countertops

Valley Security Company would like to thank you for the opportunity to submit this proposal. If you should have any questions on the proposal, please feel free to contact me.

Respectfully submitted,

Max Miller  
Project Manager  
**Valley Security Company**

ACCEPTANCE:

Valley Security Company is hereby authorized to furnish all materials and / or labor required to complete the work referred to in this proposal for which the undersigned agrees to pay the amount mentioned in said proposal, and per the terms thereof.

SIGNED \_\_\_\_\_ DATE \_\_\_\_\_

Please sign, date, and return a copy of this contract for our files.

# Armortex® SC-300 Electronic Two-Way Communicator

Specifications | CAD & PDF Drawings

- Aluminum Construction
- Two way Hands Free communication
- Voice Activated Switch
- Background Noise Level Monitoring
- Level Detection and
- Attenuation Control
- Linear Volume Control
- 4" wide x 8" high

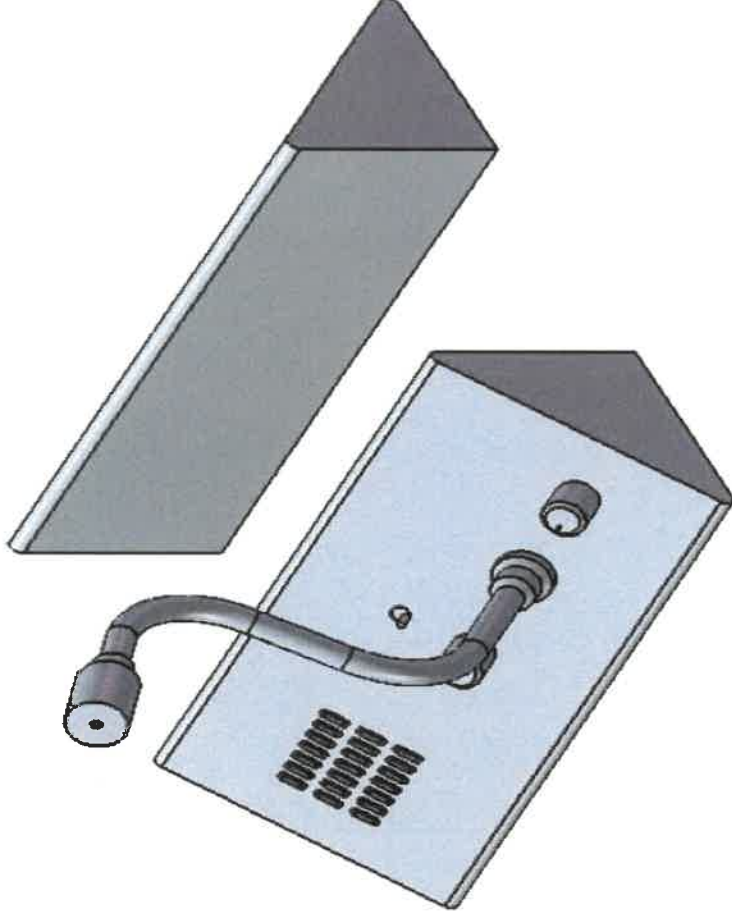

ARMORTEX® 5926 Corridor Pkwy, Schertz, TX 78154  
armortex.com | T 800-880-8306 | F 210-661-8308

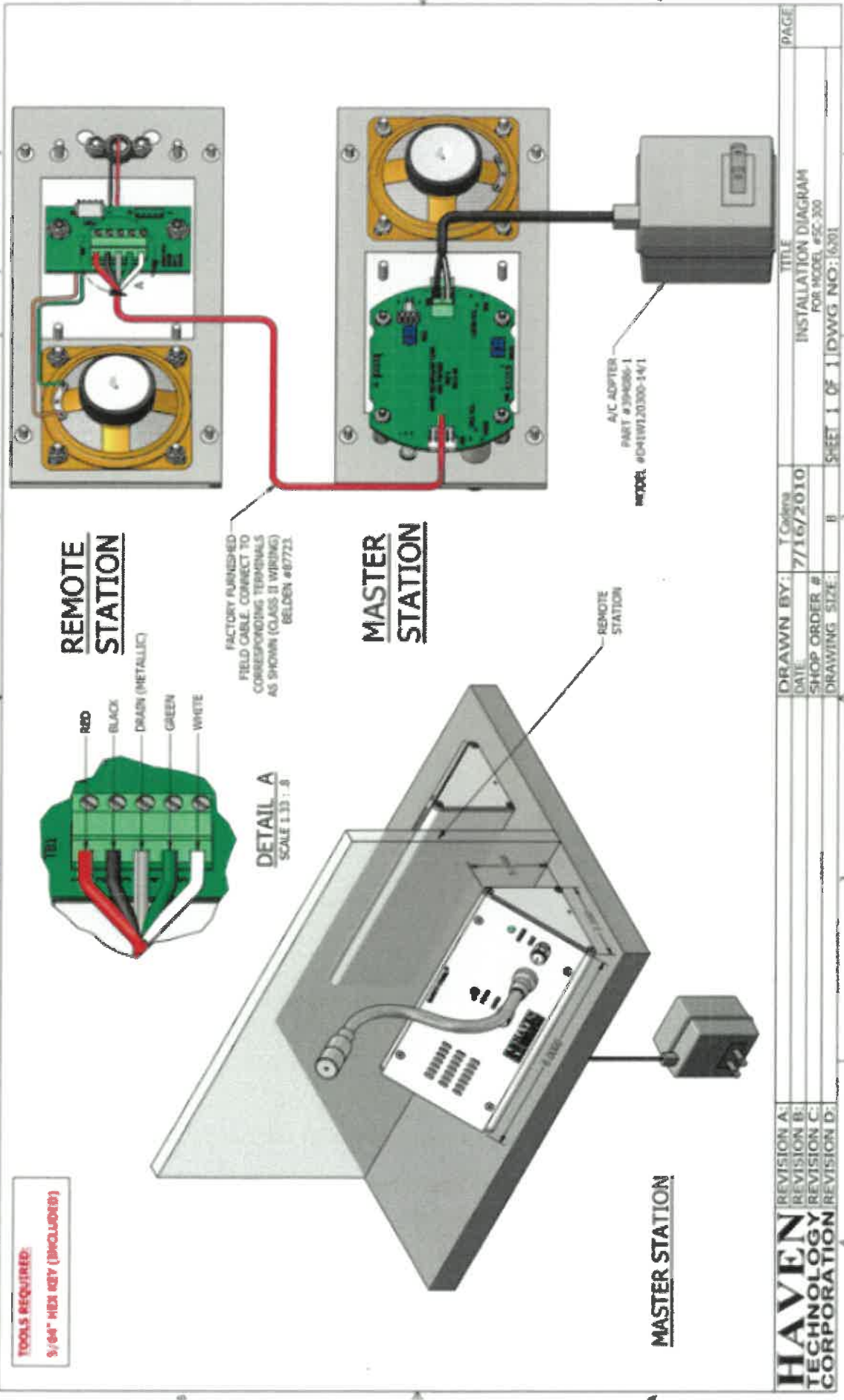

REVISION A:	T Collins	TITLE	INSTALLATION DIAGRAM	PAGE
REVISION B:	7/16/2010	DATE	FOR MODEL #SC-300	
REVISION C:		SHOP ORDER #		
REVISION D:		DRAWING SIZE:	SHEET 1 OF 1 (DWG NO: 16201)	

**HAVEN**  
TECHNOLOGY  
CORPORATION