



AGENDA

CITY COUNCIL

91136 N Willamette Street

541-682-7852 | coburgoregon.org

Tuesday, July 11, 2023 at 6:00 PM

CALL THE CITY COUNCIL MEETING TO ORDER Council Meeting are held in-person at City Hall, and by Zoom. To participate by Zoom pre-register with the City by 3PM the day of the meeting. Council meetings are recorded and live stream both available at coburgoregon.org

PLEDGE OF ALLEGIANCE

ROLL CALL

MAYOR COMMENTS

AGENDA REVIEW

CITIZEN TESTIMONY (*Sign up prior to meeting. Limit 3 minutes.*)

RESPONSE(S) BY CITY COUNCIL

CONSENT AGENDA (*Councilors may remove an item from the "Consent" agenda for discussion by requesting such action prior to consideration.*)

1. Appointment Michelle Shattuck to the Park Tree Committee

SPECIAL GUEST

2. Natural Hazard Mitigation Plan Overview
Brendan Irsfeld, Lane County

ORDINANCES AND RESOLUTIONS

3. **Public Hearing**
ORDINANCE A-163-U AN ORDINANCE ADOPTING THE OREGON CRIMINAL CODE, OREGON UNIFORM CONTROLLED SUBSTANCES ACT, OREGON LIQUOR CONTROL ACT, AND THE OREGON MOTOR VEHICLE CODE; REPEALING CONFLICTING ORDINANCES
4. **RESOLUTION 2023-14** A RESOLUTION AUTHORIZING THE CITY TO SEEK STATE TRANSPORTATION FUNDS THROUGH THE 2023 SMALL CITY ALLOTMENT GRANT PROGRAM

COUNCIL ACTION ITEMS

5. Paverite USA Agreement for Sealcoating Pavement Preservation
6. Paverite USA Agreement for Crack Fill Pavement Preservation

ADMINISTRATIVE INFORMATION REPORTS

7. Citizen Inquiry Quarterly Report
8. Administrative Monthly Report

COUNCIL COMMENTS

UPCOMING AGENDA ITEMS

Mural Policy Resolution
Construction Contracts

FUTURE MEETINGS

July 18 Park Tree Committee
July 19 Planning Commission
July 25 Finance | Audit
August 8 City Council

ADJOURNMENT

The City of Coburg will make reasonable accommodations for people with disabilities. Please notify City Recorder 72 hours in advance at 541-682-7852 or sammy.egbert@ci.coburg.or.us

All Council meetings are recorded and retained as required by ORS 166-200-0235.



COBURG CITY COUNCIL ACTION/ISSUE ITEM

TOPIC: Park Tree Committee Appointment

Meeting Date: July 11, 2023
 Staff Contact: Sammy Egbert, City Recorder
 Contact: 541-682-7852, sammy.egbert@ci.coburg.or.us

REQUESTED COUNCIL ACTION

Consider appointment of Michelle Shattuck to the Park Tree Committee.

Recommended Motion: *I move to recommend Mayor Bell appoint Michelle Shattuck to the Park Tree Committee Advisory Committee.*

POLICIES OR CITY COUNCIL GOAL(S)

- **Citizen Committees and Commissions**
-

HISTORY OR BACKGROUND

Park Tree currently has six (6) members. Bylaws allow for a maximum of seven (7) members.

Recruitment was posted May 1, 2023 and closed on June 19, 2023. One application was received and the applicant met the required qualifications.

Park Tree Committee voted at the June 20, 2023 meeting to recommend that Michelle Shattuck be appointed to serve as the 7th member of the Park Tree Advisory Committee.

PARK TREE ADVISORY COMMITTEE BYLAWS, ARTICLE IV – MEMBERSHIP

Section 1. Membership

The Committee shall consist of a maximum of seven (7) voting Committee Members, hereinafter referred to as Members.

Section 2. Qualifications

The voting Members must reside within the Coburg Fire District with a majority residing within Coburg City limits.

Section 3. Application for Membership

Prospective Members shall file an application with the City Recorder.

Section 4. Method of Appointment

All voting Members shall be appointed by City Council. An applicant must have the approval of the Committee prior to appointment by City Council. All existing members wishing to continue to serve will automatically be included in the appointments for the upcoming calendar year. All terms expire on December 31.

RECOMMENDATION AND ALTERNATIVES

1. Appoint applicant as the Committee recommends.
 2. Extend the recruitment.
 3. Operate the committee with six (6) members
-

BUDGET / FINANCIAL IMPACT

None

PUBLIC INVOLVEMENT

None.

NEXT STEPS

If appointed, prior to the Park Tree Committee next meeting, a meeting will be setup with the committee staff and committee Chair to provide an overview of responsibilities, current projects, and answer any questions you may have about your new role. This meeting should take place prior to your first meeting.

ATTACHMENTS

- A. Michelle Shattuck application
-

REVIEWED THROUGH:

Anne Heath, City Administrator



PARK TREE COMMITTEE VACANCY

Closes: June 19, 2023 or until filled

May 1, 2023

The City of Coburg Park Tree Committee is seeking applications from citizens interested in serving on the committee. This committee serves in an advisory capacity to the Coburg City Council.

Parks/Tree Committee: The Committee shall have the ability, as vested by the City Council, and be required to: Recommend to the City Council, after public input, the adoption, amendment or repeal of ordinances, resolutions, or requirements pertaining to the preservation, enhancement and advancement of the viability and attractiveness of the Parks, Street Trees, and related facilities.

- Make recommendations to the City Council concerning City policies and decisions relating to Street Trees
- Participate in studies in the area of Parks
- Act in an advisory capacity to the City Council in matters pertaining to public recreation, including playgrounds
- Review and make recommendations to the City Council pertaining to the annual budget of the Parks Fund
- Make recommendations to City Council for revisions to the Parks and Open Space Master Plan. Review and make long-range recommendations concerning the planning of a program for parks and recreation. Promote and stimulate public interest and involvement

Meetings: Monthly (3rd Tuesday)

Membership: Maximum of Seven (7) voting committee members

Vacancies: One (1)

Membership Requirements:

- Applicants are required to reside within the Coburg Fire District.
- If applicant is a minor the application must be co-signed by a parent or guardian.

Application Deadline: 5:00 p.m., Monday, June 19, 2023 or until filled.

Contact: Sammy Egbert, sammy.egbert@ci.coburg.or.us or 541-682-7852

www.coburgoregon.org

Received by
City of Coburg
MAY 23 2023



CITY OF COBURG

91136 N Willamette | P.O. Box 8316
Coburg, Oregon 97408

APPLICATION FOR BOARDS, COMMISSIONS AND COMMITTEES

Please indicate the position you are applying for:

- Planning Commission
- Budget Committee
- Historic Preservation (Heritage Committee)*
- Park/Tree Committee
- Finance/Audit Committee
- Other please indicate _____

Name: MICHELLE SHATTUCK Phone: 541 521 0931

Email: michellekshattuck60@icloud.com

Physical Address: 32695 E LOCUST ST. Mailing Address: Coburg OR 97408

Occupation: Retired Teacher

How long have you lived in Coburg? 33 yrs How long have you lived in Oregon? Born here

Are you a registered Voter? Yes No 63 years

List boards, councils, or commissions, if any, that you have served on:

Master Garden Board
M.S. Historian
Mentor for Master Garden Program
I am a pruning specialist.

List and briefly describe community or service oriented organizations of which you are or have been a member:

I am involved with Coburg's Heritage Committee.
We are recognizing our historical homes with plaques.
Food Pantry - Coburg
I help pick up food and distribute at the pantry.

Describe any goals, ideas or objectives you have for the City of Coburg:

I'd like to see some benches added around our largest park. I would like to see more shade trees planted on the edges.

List any skills, training, or experience that you have that might be useful to this position:

I am easy to work with.
I have a background in starting plants from seed.
I can research and find answers to questions needed.
I am a gardener.

Why would you like to be appointed to this position?

I know several people on this committee.
I am interested in helping my community.

Signature: Michelle K. Shattuck Date: 5-16-23



COBURG CITY COUNCIL ACTION/ISSUE ITEM

TOPIC: Natural Hazard Mitigation Plan Overview

Meeting Date: July 11th 2023

Staff Contact: Burke Hansen Public Works Supervisor/Emergency Management Coordinator
Contact: 541-682-7857 | burke.hansen@ci.coburg.or.us

REQUESTED COUNCIL ACTION

Information only

BACKGROUND

Please go to the below link for entire draft document:

<https://www.lanecounty.org/cms/One.aspx?portalId=3585881&pageId=19017673>

(Below information provided by Lane County Office of Emergency Management)

The Current NHMP was adopted in 2018 and expires October 2023. Oregon Emergency Management (OEM) is responsible for the initial review and coordination of the plan between the local government and the Federal Emergency Management Agency (FEMA). FEMA is responsible for the final review and approval of the plan. According to [44 CFR §201.6\(d\)\(3\)](#), NHMPs must be updated once every five years in order to continue to be eligible for FEMA hazard mitigation project grant funding.

The NHMP's purpose is to maintain a process that leads to hazard mitigation actions. It identifies hazards, vulnerabilities, and risks facing local, state, or tribal governments, and prioritizes actions to reduce the risks. Lane County's NHMP is a Multi-jurisdictional, county-wide plan that assesses and outlines mitigation strategies for hazards specific to our geography, including for the eight incorporated cities in the county that choose to be part of the plan: Coburg, Creswell, Dune City, Florence, Lowell, Oakridge, Veneta, and Westfir. In addition to the cities, we have three utility partners as annexes to our plan: Blachly-Lane Electric Co-op, Consumers Power Inc., and Emerald People's Utility District.

A Final plan should result in opportunities for funding projects related to natural hazard mitigation.

Staff met to discuss any updates needed to the Coburg Annex portion of the plan. Staff feels there are no concerns at this stage.

BUDGET

The City provided staff time and resources for the ANNEX update with the base plan being funded and prepared by Lane County.

RECOMMENDATIONS AND ALTERNATIVES

1. Staff recommends that the City supports the County base plan and Annex for the City of Coburg.
 2. Opt out of plan. Staff does not recommend this action
-

PUBLIC INVOLVEMENT

Lane County provided a County wide survey to gain information for the base plan. City staff placed links/QR codes in both the city newsletter and Facebook.

NEXT STEPS

- Adopt plan after final approval from FEMA
-

ATTACHMENTS

- A. Lane County Multi-Jurisdictional Natural Hazard Mitigation Plan (Draft)
 - B. Annex 1 - City of Coburg
-

Reviewed by:

Anne Heath, City Administrator



Lane County

Multi-Jurisdictional Natural Hazard Mitigation Plan

Version 4.0

October 2023—October 2028

Developed by the Lane County Hazard Mitigation & Emergency Management Steering Committee, in accordance with PUBLIC LAW 93–288 (Robert T. Stafford Disaster Relief and Emergency Assistance Act), as amended, 42 U.S.C. 5121-5207; PUBLIC LAW 106–390 (Disaster Mitigation Act of 2000); et al.

Many thanks to our partners for their efforts to complete the Lane County Multi-Jurisdictional Natural Hazard Mitigation Plan, Version 4.0.



One of the tests of leadership is the ability to recognize a problem before it becomes an emergency.

— Arnold H. Glasow, American author

ACKNOWLEDGMENTS

This plan and the work it represents was funded in part by Lane County, Natural Hazard Mitigation Grant Funds (DR-4499), and supported by the following agencies:

Project Management Team

Hannah Shafer, RARE AmeriCorps Service Member, Lane County Emergency Management
Brendan J. Irsfeld, Senior Management Analyst, Lane County Emergency Management

Natural Hazard Mitigation Steering Committee

Burke Hansen, Public Works Supervisor, City of Coburg
Cole Haselip, Management Analyst, City of Veneta
Curtis Thomas, Planner, City of Creswell
Devon Ashbridge, Public Information Officer, Lane County
D'Lynn Willams, Mayor, City of Westfir
Gary Luke, GIS Analyst, Lane County
James Cleavenger, City Administrator, City of Oakridge
Jamie Mills, City Manager, City of Dunes City
Jeff Carlson, Safety, Compliance & Loss Control Specialist, Consumer Power, Inc.
Jeremy Caudle, City Manager, City of Lowell
Joanna Rodgers, Community Health Analyst, Lane County
Matt McRae, Long-Term Recovery Manager, Lane County
Matt Tarnoff, Roads Division Analyst, Lane County
Megan Heurion, Senior Program Services Coordinator, Lane County
Megan Messmer, Assistant City Manager, City of Florence
Patence Winningham-Melcher, Emergency Manager, Lane County
Rachel Serslev, Senior Planner and Floodplain Administrator, Lane County
Sasha Vartanian, Transportation Planning Supervisor, Lane County
Selene Jaramillo, Emergency Program Coordinator, Lane County

Consultant Team

Michael Howard, Program Director, Oregon Partnership for Disaster Resilience
Anna Murphy, Graduate Research Assistant, School of Planning, Public Policy and Management

Contributing Stakeholder Organizations

Bureau of Land Management	Oregon Department of Geology and Mineral Industries
City of Cottage Grove	Rainbow Water District
City of Eugene, Emergency Management	Southern Willamette Forest Collaborative
City of Springfield, Emergency Management	Springfield Utility Board
Eugene Water and Electric Board	University of Oregon, Emergency Management
Lane Regional Air Protection Agency	U.S. Forest Service
Long Tom Watershed Council	Willamalane Park District
Mapleton Water and School Districts	
Oregon Department of Forestry	

Table of Contents

- Executive Summary..... 1
- Section 1: Lane County Profile 4
 - Section 1.1: Geography and Natural Environment..... 4
 - Section 1.1.1: Water 5
 - Section 1.1.2: Climate 5
 - Section 1.1.3: Land Coverage..... 6
 - Section 1.2: Demographics & Communities 6
 - Section 1.2.1: Population and Households 7
 - Section 1.2.2: Participating Cities 11
 - Section 1.2.3: Social Vulnerability..... 13
 - Section 1.3: Economy..... 13
 - Section 1.4: Built Environment 14
 - Section 1.4.1: Transportation 14
 - Section 1.4.2: Critical Facilities..... 15
- Section 2: Risk Assessment 17
 - Section 2.1: Identifying Hazards in Lane County..... 18
 - Section 2.1.1: Hazard Mitigation Background and Context..... 19
 - Section 2.1.2: Prior Disaster Declarations in Lane County..... 19
 - Section 2.1.3: Changes since the Previous Plan..... 22
 - Section 2.2: Hazard Profiles 23
 - Section 2.2.1: Drought 24
 - Section 2.2.2: Earthquake 34
 - Section 2.2.3: Extreme Weather 42
 - Section 2.2.4: Flood..... 52
 - Section 2.2.5: Landslide and Debris Flow 65
 - Section 2.2.6: Tsunami..... 70
 - Section 2.2.7: Volcano..... 75
 - Section 2.2.8: Wildfire..... 79
 - Section 2.2.9: Windstorms..... 93
 - Section 2.2.10: Winter Storm..... 99
 - Section 2.3: Vulnerability Assessment..... 105

- Section 2.3.1: Vulnerability to People..... 105
- Section 2.3.2: Vulnerability to Buildings 111
- Section 2.3.3: Vulnerability to Community Lifelines and Critical Infrastructure 116
- Section 2.4: Summary of Natural Hazard Risk in Lane County 122
 - Section 2.4.1: Hazard Quantification for Lane County MNHMP Update, Version 4.0..... 122
 - Section 2.4.2: Data Limitations 123
 - Section 2.4.3: Hazard Vulnerability Summary by Region and Countywide 124
- Section 3: Capability Assessment..... 126
 - Section 3.1: Capabilities via Planning, Structural Codes, and Land Use Regulations 126
 - Section 3.1.1: Plan Integration..... 126
 - Section 3.1.2: Structural Building Codes..... 127
 - Section 3.1.3: Land Use Regulations – Zoning Codes and Hazard Overlays 129
 - Section 3.1.4: Mitigation-Focused Programs..... 130
 - Section 3.2: Capabilities via Personnel 134
 - Section 3.2.1: Lane County Staff 134
 - Section 3.2.2: Plan Participants’ Staff 134
 - Section 3.2.3: Partnerships with Special Districts, Nongovernmental Organizations, and Educational Institutions 135
 - Section 3.3: Capabilities via Capital Goods and Financial Resources 135
 - Section 3.3.1: Capital Goods and Facilities 135
 - Section 3.3.2: Financial Resources 136
 - Section 3.4: Findings from the Capability Assessment 137
 - Section 3.4.1: Strengths 138
 - Section 3.4.2: Weaknesses..... 138
 - Section 3.4.3: Opportunities 139
 - Section 3.4.4: Threats 140
- Section 4: Mitigation Strategy 141
 - Section 4.1: Hazard Mitigation Strategy Summary..... 141
 - Section 4.2: Action Item Identification and Prioritization Methodology..... 143
 - Section 4.2.1: Reviewing Current Action Items from Version 3.0 (2018) 143
 - Section 4.2.2: Identifying Current Mitigation Work Not Included in Version 3.0..... 144
 - Section 4.2.3: Opportunities for Plan Integration..... 144
 - Section 4.2.4: Exploratory Scenario Planning (XSP) Workshops..... 146

- Section 4.3: Mitigation Action Items for Version 4.0..... 146
 - Section 4.3.1: Seismic Hardening of Critical Infrastructure 146
 - Section 4.3.2: Enhance Community Resiliency 151
 - Section 4.3.3: Construct a Regional Operating Picture of Hazard Risk and Impacts 152
 - Section 4.3.4: Establish Foundation Actions for Long-Term Climate Adaptation..... 155
 - Section 4.3.5: Promote Regional Collaboratives for Advancing Mitigation Efforts 157
- Section 4.4: Previous Plan Action Items and Progress Report..... 159
- Section 5: Plan Maintenance and Implementation 169
 - Section 5.1: Implementation, Monitoring, Evaluation, and Update..... 169
 - Section 5.1.1: Plan Implementation and Monitoring 169
 - Section 5.1.2: Plan Evaluation..... 170
 - Section 5.1.3: Five-Year Plan Update for Version 5.0 (2027 – 2028)..... 171
 - Section 5.2: Integration with Existing and Future Plans 171
 - Section 5.3: Engaging the Public about Hazard Risk and Mitigation 172
- Section 6: Planning Process 174
 - Section 6.1: Meetings of the NHM-SC 174
 - Section 6.2: Planning Team Meetings..... 177
 - Section 6.3: Public Outreach and Input 177
 - Section 6.3.1: Summary of the Rural Lane County Survey Results 178
 - Section 6.3.2: Public Comments 179
 - Section 6.3.3: Ongoing Public Engagement 179
 - Section 6.4: Exploratory Scenario Planning (XSP) Regional Workshops..... 181
 - Section 6.4.1: Pre-Planning Prior to Workshops..... 182
 - Section 6.4.2: Workshop 1 (Identifying Trends and Mitigation Capabilities) 182
 - Section 6.4.3: Workshop 2 (Identifying Mitigation Priorities and Action Items)..... 185

LIST OF TABLES

Table 1.1: Population Growth in Lane County, Incorporated Cities and Unincorporated Communities 2000 – 2020 8

Table 1.2: Racial and Ethnic Distribution of Population in Lane County, Incorporated Cities, and Estimates for Unincorporated Area..... 9

Table 1.3: Demographic Estimates for Lane County, Incorporated Cities, and Unincorporated Areas.. 10

Table 1.4: Housing Characteristics for Lane County, Incorporated Cities, and Estimates for Unincorporated Lane County..... 11

Table 1.5: Critical Facilities for Emergency Services in Lane County 16

Table 2.1: Profiled Natural Hazards for Lane County with Identification Method 18

Table 2.2: Federal Disaster Declarations including Lane County, 1950 – 2022..... 20

Table 2.3: State Disaster Declarations (EO) & Fire Management Assistance Declarations Affecting Lane County, 2012 – 2023..... 21

Table 2.4: Classifications and Defining Criteria for Hazard Extent, Probability of Future Occurrence, and Overall Vulnerability 23

Table 2.5: Drought Classifications and Associated Values across Four (4) Drought Monitoring Indices 28

Table 2.6: SPEI and PDSI Values for Years of Notable Drought Conditions in Lane County since 2000.. 29

Table 2.7: DSCI Calculated through the Categorical Weighted Sum Approach for Cumulative Percentage of Area, example using USDM Data for Week of September 14, 2021 29

Table 2.8: Average DSCI Values by Month for Declared Drought Years 2010, 2015, and 2021 31

Table 2.9: Reported Instances of Drought Impact since 2000 for Lane County 32

Table 2.10: Summary Comparison of Earthquake Event Severity and Associated Impacts 38

Table 2.11: National Weather Service Heat Index, Air Temperature and Relative Humidity 47

Table 2.12: Wind Chill Index for Effects of Extreme Cold 47

Table 2.13: Occurrences of Extreme Heat, Daily Highs Exceeding 90°F with Corresponding Heat Index in Lane County since 2000..... 49

Table 2.14: Flood Stage and Stage Type Descriptions with Example Impacts 53

Table 2.15: Extent of Historic Flooding Events in the Willamette Valley by Acres Inundated 59

Table 2.16: Historic River Crests of Flooding Events for Three (3) Locations in Lane County, 1861 – 2012 60

Table 2.17: Recorded Flood Events at General Gauge Locations in Lane County, 2017 – 2023 61

Table 2.18: Recorded Floods at General Gauge Locations in Lane County, 2000 – 2016 63

Table 2.19: Common Triggers of Landslides and Debris Flows, Natural and Human Causes 65

Table 2.20: Volcano Alert-Level Terms..... 76

Table 2.21: Aviation Color Codes 76

Table 2.22: Volcanoes in Proximity to Lane County..... 77

Table 2.23: Threat Potential for Volcanoes in Oregon..... 77

Table 2.24: Volcanic Event History 78

Table 2.25: Priority Action Items Identified in the 2020 Update of the Lane County Community Wildfire Protection Plan 80

Table 2.26: Adjective Class Rating Method under the Wildland Fire Assessment System 81

Table 2.27: Number of Days in Lane County where AQI Exceeded 100 with Correlation to Days Attributable to Wildfire Smoke, 2010 – 2022 83

Table 2.28: List of Notable Fires in Lane County 2009 – 2022, Extent and Estimated Suppression Costs 91

Table 2.29: Communities at Risk (CAR) Identified in Lane County by Region..... 93

Table 2.30: Modified Beaufort Wind Scale for Wind Speed Effects when Reaching Gale Force Winds or Above..... 96

Table 2.31: Notable Windstorms in Lane County since 2000 97

Table 2.32: Regional Snowfall Index that includes Number of Winter Storms to Occur in Lane County since 2016 101

Table 2.33: Federal Disaster Declarations for Winter Storms that included Lane County, 2000 – 2023 102

Table 2.34: Executive Orders Issued by Oregon Governor for Winter Storms that included Lane County, 2000 – 2023 103

Table 2.35: Social Vulnerability, Estimate Totals for Lane County, Incorporated Cities, and Unincorporated Communities based on Socioeconomic Factors..... 107

Table 2.36: Social Vulnerability, Estimate Totals for Lane County, Incorporated Cities, and Unincorporated Communities based on Household Composition Factors..... 107

Table 2.37: Social Vulnerability, Estimate Totals for Lane County, Incorporated Cities, and Unincorporated Communities based on Minority Status & Language Factors..... 108

Table 2.38: Social Vulnerability, Estimate Totals for Lane County, Incorporated Cities, and Unincorporated Communities based on Housing and Transportation Factors 108

Table 2.39: Estimated Population Exposure to Floodplains, High Risk Amplification and Liquefaction Susceptibility, and Wildland-Urban Interface 109

Table 2.40: Population Exposure to High Susceptibility Landslide Risk, Valley-Central Region Study for Eugene-Springfield, Coburg, and Lane County 110

Table 2.41: Exposure Analysis of Lane County Partially or Entirely within High-Hazard Areas 112

Table 2.42: Repetitive Flood Loss Record for Lane County as of February 2023 113

Table 2.43: Building Exposure to High-Susceptibility Landslide Areas for Eugene-Springfield, Coburg, and Lane County..... 115

Table 2.44: Estimated Count of Buildings within the Tsunami Inundation Zone for Local and Distant Tsunamis, Coastal Lane County 116

Table 2.45: Highwater Locations along Frequently Flooded Roadways, Priority Areas 118

Table 2.46: Hazard Quantification Results for Lane County..... 123

Table 2.47: Primary Hazard Impact Assessment for Natural Hazards, Lane County 124

Table 2.48: Expected Annual Loss (EAL) Estimates for Lane County Resulting from Natural Hazards . 125

Table 3.1: State Adopted Structural Building Codes as of 2022 128

Table 3.2: Local Land Use Regulations and Hazard Overlay Zones, Lane County, Oregon..... 130

Table 3.3: Communities in Lane County Participating in Firewise USA® in Good Standing 133

Table 4.1: Mitigation Strategy Goals, Lane County MNHMP compared to Oregon NHMP Goals..... 142

Table 4.2: Approaches for Action Item Identification and Prioritization Corresponding to Portions of the MNHMP Planning Process 143

Table 6.1: Members of the 2023 Natural Hazards Mitigation Steering Committee 175

Table 6.2: NHM-SC Meeting Dates and Agenda Topics 175

Table 6.3: Lane County MNHMP Update Planning Team Meetings, County and Plan Participants 177

Table 6.4: Dates of Regional XSP Workshops with Attendee Count 181

Table 6.5: Lane County MNHMP Regional Workshop 1, Driving Forces of Change Identified by Regions 183
Table 6.6: Lane County MNHMP Workshop 1, Critical Certainties and Uncertainties by Region 184
Table 6.7: Examples of Action Items Resulting from XSP Workshop 2 186

LIST OF FIGURES

Figure 1.1: Incorporated Cities and Unincorporated Communities in Lane County 7

Figure 2.1: Time Series of Drought Conditions and Area Coverage in Lane County since 2000 30

Figure 2.2: Comparison of Drought Severity via Snapshot of Conditions in Oregon for mid-August, Years 2015 & 2021 32

Figure 2.3: Cross Section of Cascadia Subduction Zone and other Sources of Earthquakes in the Pacific Northwest 36

Figure 2.4: Estimated Severity of Earthquake Amplification (Ground-Shaking) in Lane County 39

Figure 2.5: Timeline of Identified Ruptures of the Cascadia Subduction Zone in the past 10,000 Years 40

Figure 2.6: Relative Liquefaction Risk for Soils in Lane County 42

Figure 2.7: Floodplain Hazard Areas in Lane County 56

Figure 2.8: Floodplain Hazard Areas in the Coast Region 57

Figure 2.9: Floodplain Hazard Areas in the Valley Region 58

Figure 2.10: Floodplain Hazard Areas in Cascades Region 59

Figure 2.11: Infographic Explaining how Tectonic Plate Movement Generates Tsunamis 70

Figure 2.12: Tsunami Inundation Zone Estimates based on a CSZ Earthquake Producing a Local Tsunami 72

Figure 2.13: Timeline of Identified Ruptures of the Cascadia Subduction Zone in the past 10,000 Years (Tsunami) 74

Figure 2.14: Overall Wildfire Risk in Lane County 85

Figure 2.15: Overall Wildfire Risk in Coast Region of Lane County 86

Figure 2.16: Overall Wildfire Risk for Valley Region of Lane County 87

Figure 2.17: Overall Wildfire Risk for Cascades Region of Lane County 88

Figure 2.18: Overall Wildfire Impact for Lane County 89

Figure 2.19: Study Area for IMS-60 Assessing Landslide Vulnerability 114

Figure 2.20: Public Health Priority Graph of Natural Hazards and Cascading Impacts for State of Oregon 121

ACROYMNS & ABBREVIATIONS

CFR	Code of Federal Regulations
COOP	Continuity of Operations Plan
CRP	Climate Resilience Plan
CRS	Community Rating System
CSZ	Cascadia Subduction Zone
CWPP	Community Wildfire Protection Plan
DLCD	Department of Land Conservation (Oregon)
DOGAMI	Department of Geology and Mineral Industries (Oregon)
DRP	Disaster Recovery Plan
EF	Enhanced Fujita Scale
EOP	Emergency Operations Plan
EWEB	Eugene Water and Electric Board
FEMA	Federal Emergency Management Agency
FIRM	Flood Insurance Rate Map
FMA	Flood Mitigation Assistance
GAO	Government Accounting Office
GIS	Geographic Information Systems
HazMat	Hazardous Materials
HMGP	Hazard Mitigation Grant Program
HMP	Hazard Mitigation Plan
HWY	Highway
IA	Incident Annex
IFC	International Fire Code
IMS	Interpretive Map Series
IMT2	Incident Management Team Type 2
KBDI	Keetch-Byram Drought Index
LC	Lane County
LCEM	Lane County Emergency Management
LCFDB	Lane County Fire Defense Board
LCRCP	Lane County Rural Comprehensive Plan
LMD	Land Management Division (Lane County)
MGMT	Management
MNHMP	Multi-Jurisdictional Natural Hazards Mitigation Plan
MMI	Modified Mercalli Intensity
MWERS	McKenzie Watershed Emergency Response System
NCDC	National Climatic Data Center
NDM	National Drought Monitor
NFIP	National Flood Insurance Program
NHMP	Natural Hazards Mitigation Plan
NHM-SC	Natural Hazards Mitigation Steering Committee (Lane County)
NID	National Inventory of Dams
NOAA	National Oceanic and Atmospheric Association

NRC	Natural Resources Conservation
NRCS	Natural Resources Conservation Service
NRS	National Response System
NSSL	National Severe Storms Laboratory
NWS	National Weather Service
OEESC	Oregon Energy Efficiency Specialty Code
OEM	Oregon Department of Emergency Management
OESC	Oregon Electrical Specialty Code
OFC	Oregon Fire Code
OMDISC	Oregon Manufactured Dwelling Installation Specialty Code
OMSC	Oregon Mechanical Specialty Code
OPSC	Oregon Plumbing Specialty Code
OR	Oregon
ORS	Oregon Revised Statute(s)
ORSC	Oregon Residential Specialty Code
OSSC	Oregon Structural Specialty Code
PA	Public Assistance
PDM	Pre-Disaster Mitigation
PDSI	Palmer Drought Severity Index
PGA	Peak Ground Acceleration
PNW	Pacific Northwest
PSU	Portland State University
PW	Public Works (Lane County)
RFC	Repetitive Flood Claim
RFPD	Rural Fire Protection District
RLP	Repetitive Loss Property
SFHA	Special Flood Hazard Area
SRGP	Seismic Resiliency Grant Program
SRL	Severe Repetitive Loss
SUB	Springfield Utility Board
UGB	Urban Growth Boundary
USACE	United States Army Corps of Engineers
USGS	United State Geological Survey

Executive Summary

The 2023 version of the ‘Lane County Multi-Jurisdiction Natural Hazards Mitigation Plan’ (referred to as **the Plan** or **MNHMP**) aims to support all of Lane County, including rural areas and incorporated cities, in becoming more aware of natural hazards and their associated risks. Lane County is a unique place in the Willamette Valley offering residents and visitors varied geographies and environments in which to live, explore, and play. Spanning from sea to summit, Lane County boasts a pristine rural atmosphere, coastal communities, and one of Oregon’s metropolitan areas in the cities of Eugene and Springfield.

Yet, the area experiences the impacts of natural hazards and Lane’s people must be prepared to withstand these events in the coming years. Natural disasters are becoming more common and expensive both in Oregon and the United States. From 2011 to 2021, Lane County experienced six (6) federally declared natural disasters, three (3) of which have occurred within the past five (5) years, and received \$66.16 million in FEMA obligation funds, more than any county in Oregon.¹ The combined estimated damage from these events far exceeds this federal aid.

Research shows that every \$1 spent on mitigation saves \$6-7 in response and recovery costs.² This Plan builds upon the work already identified in the current version of the MNHMP, last updated in 2018. This Plan recognizes that taking sustained actions to protect people and property from hazards is the responsibility of the whole community. Effective hazard mitigation is dependent on individuals taking responsibility—both personally and professionally—for achieving a better understanding of natural hazards, the risks they pose and, committing to actions aimed at reducing those risks.

It also incorporates information from the Community Wildfire Protection Plan (2020) as well as the recent Climate Action Plan (2022).

The **Mitigation Planning Goals** are:

- Goal 1:** Prevent loss of life and reduce injuries and illness.
- Goal 2:** Minimize and prevent damage to buildings and infrastructure.
- Goal 3:** Reduce recovery period and minimize economic losses for the community.
- Goal 4:** Maintain and improve ability of Lane County, municipal governments, and critical service providers to quickly resume operations.
- Goal 5:** Protect natural, historic, and cultural resources.
- Goal 6:** Increase awareness of hazards and understanding of mitigation methods.
- Goal 7:** Improve attractiveness to individuals and businesses by demonstrating effectiveness in dealing with a disaster.

¹ Chester, A., & Lawton, J. (2022). *Atlas of disaster: Oregon – Rebuild by design*. Rebuild by Design. <https://rebuildbydesign.org/atlas-of-disaster/>.

² Multi-Hazard Mitigation Council. (2019). *Natural Hazard Mitigation Saves: 2019 Report*. Principal Investigator K. Porter; Co-Principal Investigators N. Dash, C. Huyck, J. Santons, C. Scarthorn, and J. Yuan; Directors, MMC. Investigator Intern: A. Cohen-Porter, 2019, National Institute of Building Sciences. Washington, DC.

Based on the planning goals, the following **objectives** were identified to develop action items that were achievable and pertinent:

Objective 1: Harden critical facilities and essential systems.

Objective 2: Limit cascading impacts on property and infrastructure resulting from natural hazards by enhancing system and community resiliency.

Objective 3: Enhance the operating picture about natural hazard risk areas in Lane County through regional risk analysis of its community lifelines.

Objective 4: Promote long-term community resilience through studies to generate recommended actions for long-term projects.

Objective 5: Develop a regional approach to coordinating hazard mitigation efforts and projects across Lane County to expand participation in mitigation efforts beyond government and utilities.

This Plan will strive to engage the whole community in achieving improved disaster resilience with each year. To facilitate wider dissemination of this Plan and to keep the community engaged in continuously providing input, the document is available at the Lane County Emergency Management website at <http://lanecounty.org/prepare> under the Plans section.

This Plan update is a joint product of Lane County Emergency Management; the Lane County Natural Hazard Mitigation Steering Committee (NHM-SC); elected officials, executives and staff from the Cities of Coburg, Creswell, Dunes City, Florence, Lowell, Oakridge, Veneta, and Westfir; and community members who participated in the Public Engagement process.

Hazard Identification and Risk Assessment

This Plan identifies 10 natural hazards impacting Lane County in coordination with input from many stakeholders, historical events, after action reports (AARs), and exploring disaster declarations databases. Since 2018, Lane County has experienced three (3) Presidential Disaster Declarations with damage reports estimated at a combined total of \$76,148,654.

- DR-4562 (September 2020; Labor Day Wildfires & Straight-line Winds)
- DR-4499 (January 2020; COVID 19 Pandemic)
- DR-4432 (February 2019; Oregon Sever Winter Storm)

This Plan further assesses Lane County's vulnerability to these hazards in terms of human life, property, infrastructure, economy, and environment. Considering these factors, analysis shows that Lane County is most vulnerable to severe winter storms, windstorms, wildfire, flood, earthquake, and tsunami for the coastal region.

Mitigation Strategy

Lane County's vast expanse of diverse geological features combined with the interplay of human actions and natural occurrences make it inevitable that Lane County will continue to experience natural hazards.

This Plan outlines **Action Items** that can be taken to mitigate either multiple hazards at once or a specific hazard. A number of action items are intentionally broad because implementation will require additional steps to zero in on the specific problem(s) to solve and how best to execute an effective strategy with the available resources and capabilities.

Lane County Emergency Management is limited in assigned resources to convene and oversee this Plan. Given this resource limitation, implementation of the action items will rely heavily on the cooperation of action item owners and stakeholders once the actions have been specified in detail, when necessary.

The participating jurisdictions (cities) are committed to utilizing this Plan to access mitigation grant funds to assist the implementation of action items. Opportunities to partner and share costs with affiliated agencies and neighboring jurisdictions for multi-objective projects are encouraged.

Future Updates

This Plan update satisfies the Local Mitigation Plan requirements spelled out in 44 CFR (Code of Federal Regulations) Part 201 – Mitigation Planning which states:

§ 201.6 Local Mitigation Plans

The local mitigation plan is the representation of the jurisdiction's commitment to reduce risks from natural hazards, serving as a guide for decision makers as they commit resources to reducing the effects of natural hazards. Local plans will also serve as the basis for the State to provide technical assistance and to prioritize project funding.

The Natural Hazard Mitigation Steering Committee (NHM-SC) will continue to meet quarterly and discuss what changes need to be captured in the next Plan update.

Section 1: Lane County Profile

The first section profiles Lane County by identifying its natural and geographical environments, population, economy, and built environment. The characteristics of the county and the cities existing within it provides a foundation for assessing the risk natural hazards pose to people and property.

Section 1.1: Geography and Natural Environment

Lane County resides in western Oregon within the southern Willamette Valley, extending west to east from the Pacific coastline to the western Cascades Range. This range along with the Coast Range in western Lane create three distinct ecoregions: the Coast, the Willamette Valley, and the Cascades.³ Lane County contains a land area of approximately 4,620 square miles,⁴ several rivers, and many natural landscapes. The diverse natural environment provides opportunities for acquiring natural resources, supporting a collection of economic industries, and for many people, a chance to live close to forests and pasturelands in the open country.



Dexter Lake in Lane County, Oregon | Rick Obst via Wikimedia Commons

³ Based on the Environmental Protection Agency's Level III Ecoregions of the Continental United States classification system.

⁴ *State of Oregon: Blue book - Lane County*. (n.d.). State of Oregon: Oregon Secretary of State. Retrieved November 19, 2022, from <https://sos.oregon.gov/blue-book/Pages/local/counties/lane.aspx>.

Section 1.1.1: Water

There are seven (7) watersheds within the county's borders containing several rivers, including the Willamette, Siuslaw, McKenzie, Mohawk, Long Tom, and the two Fork Rivers (Middle and Coast) of the Willamette. Manmade and natural lakes exist throughout all regions of the county, with some of the largest including Fern Ridge, Cougar, Blue River, Lookout, Dexter, Dorena, Hills Creek, Fall Creek, Waldo, Triangle, Siltcoos, and Woahink. The County also includes about 30 miles of the Pacific coastline comprised as a combination of beaches and dunes, coastal lakes and shore lands, and estuaries.

The McKenzie River serves as the primary drinking water source for the Eugene-Springfield metropolitan area and the unincorporated communities in the McKenzie River Valley. Many of the rivers and associated creeks supply groundwater accessed by well systems, both those privately owned and those operated as part of a public water system. The North Florence Sole Source Dunal Aquifer provides drinking water for Florence⁵ and extends upward to encompass Heceta Beach. Further information about drinking water systems and infrastructure is discussed in the **Built Environment** sub-section found in the County Profile.

Section 1.1.2: Climate

Climate across Lane County is typically described by cool wet winters and warm dry summers. The countywide annual average precipitation is approximately 46 inches, while average temperatures historically range from a mean temperature of 40°F in January to 70°F in July.⁶ However, these averages are skewed by the diverse geography that exists due to the Coast and Cascade Ranges as well as Pacific Ocean. For example, average annual precipitation historically for the City of Florence is nearly 70 inches compared to the countywide average. Rainfall is common in the Willamette Valley during the winter months, but also experiences less total precipitation with annual averages in Eugene reaching approximately 41 inches historically (period of record 1991-2020).⁷ Communities in the Cascade foothills experience fluctuating precipitation annually, but average annual totals are closest to the countywide average of 46 inches.

Lane County experiences dry summers where precipitation is often lowest between the months of June and September. These months are most likely to experience consecutive dry days (days without precipitation) and higher temperatures, such as those associated with heat waves. As with precipitation, average temperatures documented for the county do not reflect the climatic variability between the three ecoregions. The region on the west side of the Coast Range tends to experience the mildest climate, with temperate highs during the summer. The cooling effect of the Pacific Ocean provides this relief from extreme high temperatures that can emerge inland within the foothills of the Coast Range. Highest temperatures during June through August can reach into the 90s and low 100s in areas such as Mapleton.

Temperatures in the Willamette Valley tend to reflect the greater extremes. Warm air in the summer raises temperatures to the highest levels experienced in the county while cold air can drop temperatures into the teens or single digits in extreme cases during winter months. These effects are

⁵ Murray, Smith & Associates, Inc. (2011). *Water System Master Plan Update* (No. 09-1045.410). City of Florence.

⁶ *State of Oregon: Blue book - Lane County*. (n.d.). State of Oregon: Oregon Secretary of State. Retrieved November 19, 2022, from <https://sos.oregon.gov/blue-book/Pages/local/counties/lane.aspx>.

⁷ Rockey, C.C.D. (2022). "Climate of Eugene." NOAA Technical Memorandum/NWS-WR-250. Portland, OR.

similar in communities within both the McKenzie River Valley and Cascade foothills in southeastern Lane County.⁸

Section 1.1.3: Land Coverage

Most of Lane County (90%) is covered by forests, the two largest being the Siuslaw National Forest in the west and the Willamette National Forest in the east. These forests are made mostly of Evergreen trees, with a mixture of deciduous trees in both the Coast and Cascade ranges, though this mixture of tree species is greater on the western side of the county.

Agricultural land exists predominantly in the Valley region with some areas in the Cascade foothills also used for agriculture. Most of the land supports livestock and growing hay. The northern portion of the Valley region contains the greatest amount of agricultural land in the county devoted to cultivating crops. These lands border both sides of Interstate 5 near the cities of Coburg and Junction City. South of the metropolitan area, crop lands exist in areas close to Goshen, Jasper, and Pleasant Hill, all northeast of Creswell. The little agricultural land that exists in the Coast Range is near the community of Blachly along Pope Creek.

Lane County includes several woody wetlands. These wetlands exist along the McKenzie River, both the Coast and Middle Fork Rivers, and numerous lakes such as Fern Ridge, Dorena, Siltcoos, Clear and Munsel, and Dexter. Wetlands provide an ideal habitat for wildlife and plant species, serve important ecological functions, and are sensitive to climatic changes as well as development. Healthy wetlands also provide natural mitigation against flooding due to their capacity to store water and control overflows. Statewide planning [Goal 5 under ORS 660.016](#) prescribes how local governments manage and protect wildland habitats and species protected under state and federal regulations.⁹

Section 1.2: Demographics & Communities

Lane County is the fourth most populous county in Oregon with an estimated population of 383,958 in 2022.¹⁰ The population is dispersed among 12 incorporated cities, the largest of which is the City of Eugene (the county seat), and nearly two dozen unincorporated communities. Seven (7) of the cities are in the Willamette Valley, while two (2) cities reside on the Pacific coastline, and the remaining three (3) lie in the Cascade foothills. Unincorporated communities exist throughout all three regions. Figure 1.1 shows the geographic distribution of communities across Lane County. The following sub-sections provide demographic information about Lane County, the 12 cities, and estimates for the unincorporated population of Lane County.

⁸ Ibid.

⁹ Oregon Revised Statutes. (n.d.). Chapter 660, Division 16: Requirements and Application Procedures for Complying with Statewide Goal 5.

¹⁰ Population Research Center. (2022). *Annual Population Report Tables: Table 3*. Portland State University. Portland, OR.

Figure 1.1: Incorporated Cities and Unincorporated Communities in Lane County

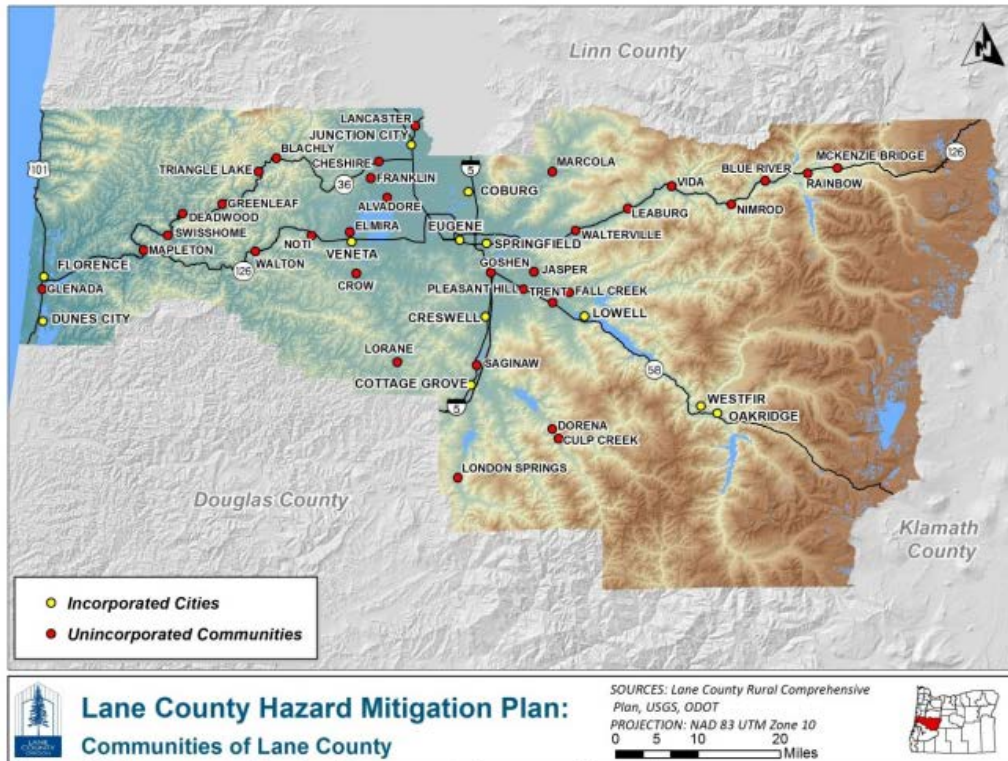

Section 1.2.1: Population and Households

Lane County grew by approximately 31,256 residents between 2010 and 2020. Most of that growth occurred in the Eugene-Springfield metropolitan area though approximately a quarter of all new residents to Lane County settled outside this area. Cottage Grove, Florence, Junction City, and Veneta received the majority of the nearly 9,000 people that did not move to the metro in the past decade (see Table 1.1).

No city has grown its population as rapidly in the past 20 years than Veneta, which doubled the number of residents from 2000 to 2020. Growth over this time is also noticeable in the cities of Creswell, Junction City, Lowell, and Coburg. Though the county has gained residents during this time, the total population of unincorporated communities is estimated to be mostly unchanged over the past 20 years. About one in four residents live in unincorporated Lane County. The only areas of the county that did not grow substantially in population, and even have shrunk in the past 20 years, is in southeastern Lane within the cities of Oakridge and Westfir. Table 1.1 displays the total population countywide and for unincorporated communities and incorporated cities as estimated by the previous three (3) U.S. Decennial Censuses.¹¹

¹¹ U.S. Decennial Census used in these population estimates due to a lack of data for the individual cities within Lane County from the PSU Population Research Center prior to 2010.

Table 1.1: Population Growth in Lane County, Incorporated Cities and Unincorporated Communities 2000 – 2020

Jurisdiction	2000	2010	2020	Growth Rate 2000 - 2020
Lane County	322,959	351,715	382,971	18.5%
Unincorporated Totals	99,856	96,150	99,459	-0.4%
Incorporated Cities				
Coburg	947	1,035	1,306	37.9%
Cottage Grove	8,537	9,686	10,574	23.9%
Creswell	3,200	5,031	5,641	76.3%
Dunes City	1,219	1,303	1,428	17.1%
Eugene	137,799	156,185	176,654	28.2%
Florence	7,020	8,466	9,396	33.8%
Junction City	4,797	5,392	6,787	41.5%
Lowell	857	1,045	1,196	39.6%
Oakridge	3,158	3,205	3,206	1.5%
Springfield	52,729	59,403	61,851	17.3%
Veneta	2,529	4,561	5,214	106.2%
Westfir	311	253	259	-16.7%

Source: U.S. Census Bureau, Decennial Census 2000, 2010, 2020, Tables DP1 & P1

Lane County is also growing more diverse racially and ethnically. Latino/a individuals represent the fastest growing demographic within the county, increasing by 131.5 percent between 2010 and 2020 more than doubling the population in Lane County.¹² A number of respondents to the American Community Survey also indicate they are two or more races comprising 7 to 13 percent of some city’s populations. Table 1.2 provides an estimated percentage of racial and ethnic demographics for Lane County, the 12 cities, and the unincorporated areas.



Goodpasture Covered Bridge, McKenzie River | Photo by Melanie Ryan Griffin via Travel Oregon

¹² U.S. Census Bureau, Decennial Census, 2010 & 2020.

Table 1.2: Racial and Ethnic Distribution of Population in Lane County, Incorporated Cities, and Estimates for Unincorporated Area

Jurisdiction	Asian	Black or African-American	Hispanic or Latino/a	Native American and Alaska Native	Native Hawaiian and Other Pacific Islanders	Some Other Race	Two or More Race	White
Lane County	18.0%	2.4%	9.4%	3.4%	0.7%	5.6%	7.5%	91.6%
Unincorporated Lane	2.8%	1.4%	6.2%	3.4%	0.4%	3.2%	5.7%	97.0%
Coburg	4.1%	0.0%	3.0%	2.0%	2.6%	1.8%	3.7%	93.2%
Cottage Grove	2.9%	2.2%	11.6%	4.8%	0.3%	4.8%	7.1%	92.5%
Creswell	1.4%	1.2%	4.4%	3.2%	3.7%	2.8%	7.0%	96.7%
Dunes City	4.5%	0.0%	5.5%	5.5%	0.4%	3.4%	4.6%	91.5%
Eugene	6.8%	3.1%	10.6%	3.0%	0.8%	6.6%	8.7%	89.3%
Florence	1.9%	2.3%	5.4%	2.2%	0.6%	2.8%	4.2%	95.0%
Junction City	0.0%	0.4%	9.7%	4.1%	0.0%	4.0%	5.6%	97.4%
Lowell	2.5%	2.0%	0.0%	2.0%	0.4%	0.0%	2.5%	95.6%
Oakridge	0.0%	0.0%	3.8%	3.0%	0.0%	0.6%	2.5%	98.8%
Springfield	3.6%	2.4%	12.6%	4.5%	0.6%	7.9%	8.3%	90.1%
Veneta	6.3%	1.2%	11.7%	3.1%	5.1%	7.4%	13.9%	90.8%
Westfir	0.0%	0.0%	3.8%	0.3%	0.0%	1.0%	0.0%	98.7%

Source: American Community Survey, 5-YR Estimates, Table DP05

NOTE: Given margin of errors for smaller populations, which include most cities in Lane County, percentages are unlikely to add up exactly 100 percent. Population estimates provide suggestion about the proportion of the total population comprised of each racial or ethnic demographic.

Lane County also contains a number of areas where the population is much older as a proportion of the total population. Notably, the populations of Dunes City and Florence contain a fairly high older population comprising nearly half of all residents (see Table 1.3). For most cities, about one in five residents is over the age of 65, which is descriptive of Lane County as a whole. The proportion of individuals older than 65 in unincorporated Lane County is estimated to be higher than the county average where three in ten people are older residents. Additional estimates for demographic information for Lane County, cities, and the unincorporated areas is displayed in Table 1.3.



Historic Siuslaw River Bridge over the Siuslaw River, as seen from Florence, Oregon | Photo by Tony Webster via Wikipedia Commons

Table 1.3: Demographic Estimates for Lane County, Incorporated Cities, and Unincorporated Areas

Jurisdiction	Under 18	Over 65	Bachelor's Degree or Higher*	Median Household Income	Veteran Population*
Lane County	18.0%	20.6%	29.4%	\$ 61,712	7.8%
Unincorporated Area	18.2%	31.2%	24.3%	unavailable	8.8%
Incorporated Cities					
Coburg	28.7%	23.1%	30.9%	\$ 71,750	6.1%
Cottage Grove	22.0%	15.6%	18.9%	\$ 52,994	7.7%
Creswell	23.9%	15.0%	21.8%	\$ 78,974	10.7%
Dunes City	11.0%	48.7%	31.2%	\$ 68,906	12.9%
Eugene	16.3%	16.1%	38.3%	\$ 59,338	6.3%
Florence	12.3%	42.8%	24.3%	\$ 50,615	12.6%
Junction City	22.6%	17.6%	23.5%	\$ 58,017	9.9%
Lowell	21.7%	20.7%	17.5%	\$ 52,431	10.1%
Oakridge	20.2%	19.8%	11.7%	\$ 33,088	9.7%
Springfield	21.5%	14.8%	18.4%	\$ 54,503	8.6%
Veneta	22.4%	19.8%	15.5%	\$ 53,885	9.9%
Westfir	26.8%	20.0%	10.4%	\$ 56,250	9.0%

Source: Portland State University, Population Research Center; American Community Survey 1- and 5-year estimate tables, Tables S0101, S1501, S1602, S1701, S1810, S1901, S2101

*Calculated using the total estimated population over 18 years old

Throughout Lane County, some areas have a higher rate of home ownership compared to the proportion of renters living in the city. About one in five people in unincorporated in Lane County is estimated to rent compared to own their homes. This ownership rate is similar to the cities of Coburg, Dunes City, Lowell, Veneta, and Westfir, which all include higher ownership rates. In Cottage Grove, Eugene, Oakridge, and Springfield, the ratio of owners to renter is more balanced. Table 1.4 provides a summary for basic estimates of the housing demographics in Lane County.

Table 1.4: Housing Characteristics for Lane County, Incorporated Cities, and Estimates for Unincorporated Lane County

Jurisdiction	Total Households	Total Housing Units	Occupancy Rate	% of Owner	% of Renter
Lane County	160,158	167,832	95.43%	60.9%	39.1%
Unincorporated Lane	41,117	43,385	94.77%	81.8%	19.3%
Coburg	519	564	92.02%	78.4%	21.6%
Cottage Grove	4,247	4,452	95.40%	56.4%	43.6%
Creswell	2,174	2,250	96.62%	67.1%	32.9%
Dunes City	592	821	72.11%	81.6%	18.4%
Eugene	74,740	78,322	95.43%	51.1%	48.9%
Florence	4,714	5,293	89.06%	64.7%	35.3%
Junction City	2,726	2,767	98.52%	65.1%	34.9%
Lowell	417	442	94.34%	80.1%	19.9%
Oakridge	1,456	1,555	93.63%	59.8%	40.2%
Springfield	25,140	25,593	98.23%	53.5%	46.5%
Veneta	2,167	2,226	97.35%	83.1%	16.9%
Westfir	149	162	91.98%	91.3%	8.7%

Source: American Community Survey, 1-YR Estimates, Table DP04

Section 1.2.2: Participating Cities

In addition to Lane County, the following incorporated cities participated in the update to the Lane County Multi-Jurisdictional Natural Hazards Mitigation Plan: City of Coburg, City of Creswell, City of Dunes City, City of Florence, City of Lowell, City of Oakridge, City of Veneta, and City of Westfir. The following subsection provides basic profiles of these cities and in alphabetical order. Each profile includes basic location and history of the community. Detailed information for each city is found in multi-jurisdictional annexes that compromise Volume II of this Plan, which include hazard quantification results and specific mitigation action items. Refer to the preceding tables (Tables 1.1 – 1.4) in this section for demographic information about each city.

City of Coburg

The City of Coburg is in north-central Lane County near Interstate 5 approximately four (4) miles north of Eugene, one (1) mile north of the McKenzie River, and two (2) miles east of the Willamette River-McKenzie River confluence. Coburg was incorporated in 1893 and is part of a National Historic District, possessing buildings that date back to 1875. The current incorporated area encompasses approximately one (1) square mile. According to certified estimates from Portland State University, Coburg’s population was 1,316 in 2022. This population represents a nearly 36 percent (36%) increase over the 2000 Census population (969) and approximately 26.5 percent (26.5%) increase since 2010 (1,040).

City of Creswell

The City of Creswell is in central Lane County near Interstate 5 approximately 10 miles south of Eugene, and one (1) mile east of the Coast Fork Willamette River. Creswell was incorporated in 1909, and the current incorporated area encompasses approximately 1.7 square miles. According to certified estimates from Portland State University, Creswell's city population was 5,662 in 2022. This population represents a 58 percent (58%) increase over the 2000 Census population (3,579) and a 12.5 percent (12.5%) increase since 2010 (5,030).

City of Dunes City

The City of Dunes City is in southwestern Lane County near US Highway 101 approximately seven (7) miles south of Florence, a mile and a half east of the Pacific Ocean, and surrounds Woahink Lake. Dunes City was incorporated in 1963 and the current incorporated area encompasses approximately 3.5 square miles. According to certified estimates from Portland State University, Dunes City's population was 1,450 in 2022. This population represents a nearly 17 percent (17%) increase over the 2000 Census population (1,241) and an 11 percent (11%) increase since 2010 (1,305).

City of Florence

The City of Florence is in western Lane County at the junction of US Highway 101 and State Highway 126 West. Florence is approximately 50 miles west of Eugene, located on the north bank of the Siuslaw River and approximately one (1) mile east of the Pacific Ocean. Florence was incorporated in 1893 and the current incorporated area encompasses approximately 5.9 square miles. According to certified estimates from Portland State University, Florence's population was 9,561 in 2022. This population represents 31.5 percent (31.5%) increase over the 2000 Census population (7,273) and a nearly 13 percent (13%) increase since 2010 (8,465).

City of Lowell

The City of Lowell is in central Lane County next to the Dexter Reservoir on the Middle Fork Willamette River. Lowell is approximately 21 miles southeast of Eugene and 24 miles northwest from Oakridge. Lowell was incorporated in 1954 and the current incorporated area encompasses approximately 1.2 square miles. According to certified estimates from Portland State University, Lowell's population was 1,235 in 2022. This population represents a 44 percent (44%) increase over the 2000 Census population (857) and an 18 percent (18%) increase since 2010 (1,045).

City of Oakridge

The City of Oakridge is in southeastern Lane County on State Highway 58. Oakridge is approximately 40 miles southeast of Eugene, located on the north bank of the Middle Fork Willamette River and surrounded by the Willamette National Forest. Oakridge was incorporated in 1912 and the current incorporated area encompasses approximately 2.2 square miles. According to certified estimates from Portland State University, Oakridge's population was 3,224 in 2022. This population represents a 2.4 percent (2.4%) increase over the 2000 Census population (3,148) and a 0.60 percent (.60%) increase since 2010 (3,205).

City of Veneta

The City of Veneta is in west-central Lane County along State Highway 126 West. Veneta is approximately 10 miles west of Eugene and approximately two (2) miles southwest of the Fern Ridge Reservoir. Veneta was incorporated in 1962 and the current incorporated area encompasses approximately 2.6 square miles. According to certified estimates from Portland State University, Veneta's population was 5,211 in 2022. This population represents an 89 percent (89%) increase over the 2000 Census population (2,755) and a 14 percent (14%) increase since 2010 (4,565).

City of Westfir

The City of Westfir is in southeastern Lane County approximately two (2) miles east/north of State Highway 58. Westfir is approximately 35 miles southeast of Eugene, located along north bank of the Middle Fork Willamette River and surrounded by the Willamette National Forest. Westfir was incorporated in 1979 and the current incorporated area encompasses approximately 0.33 square miles. According to certified estimates from Portland State University, Westfir's population was 264 in 2022. This population represents a 4.3 percent (4.3%) decrease from the 2000 Census population (276) and a 3.5 percent (3.5%) increase since 2010 (255).

Section 1.2.3: Social Vulnerability

Natural hazards disproportionately impact individuals based on a variety of characteristics often determined by age, gender, race and ethnicity, disability, language spoken, access to Internet connections or devices, household size, housing tenure, and household composition. Equally important is recognizing seasonal, outdoor workforces and transient populations that move about Lane County affecting the total number of people physically present within the County's political boundaries, including tourists and visitors. People experiencing homelessness also face a disproportionately public health and exposure risk to natural hazards.

Section 2.3.1 of Volume I in this Plan presents a detailed social vulnerability analysis of at-risk groups in Lane County along with a discussion about the most significant driving factors of social vulnerability in the county. The social vulnerability analysis examines specific hazard impacts to different indicators of social vulnerability to highlight the capabilities required to effectively mitigate the risk for these groups. Generally, Lane County has a high proportion of older individuals, some which live alone and in remote areas with limited transportation access. There are also people living with disabilities and experiencing cost pressures from rising costs of living, particularly to afford housing, food, and fuel costs.

Section 1.3: Economy

Historically, Lane County relied on timber sales and agricultural operations as core industries powering the economy. With the significant decline of the timber industry in Oregon, the county's economic profile has shifted to become more diversified among industries. As of 2021 data, the three (3) leading economic industries by employment in Lane County are estimated to be education services, health care and social assistance (27%), retail trade (13.5%), and professional, scientific, and management, and administrative and waste management services (10.5%).¹³ Other notable industries for employment

¹³ U.S. Census Bureau. (2021). *American Community Survey 1-YR Estimates, Table S2405*.

include manufacturing (9.5%), arts, entertainment, and recreation, and accommodation and food services (9.5%), and construction (7%).

Despite the diversification in employment among industries, lower wage and part-time positions have grown more numerous in Lane County over the past two decades. At the same time, specialized positions requiring higher education have also expanded as a share of the regional economy. The divergence in these job types creates the potential for greater disparities between communities concerning their capability to effectively mitigate risk on properties or respond to a hazard event. In addition, some communities within Lane County are aging more rapidly compared to other regions. Older adults face challenges mitigating risk given physical abilities to perform land treatments or home hardening work, managing pre-existing health conditions, or living on a fixed-income or in poverty (see discussion in the Social Vulnerability sub-section of the Risk Assessment, Section 2, of this Plan).

Section 1.4: Built Environment

Oregon’s land use system intentionally separates agricultural and forest land from developable land. The use of urban growth boundaries (UGBs) to limit growth of incorporated cities creates distinct development patterns in cities and the land between them. The built environment includes roadways, bridges, functional facilities (i.e., water treatment plants, dams), buildings (residences and commercial businesses), and infrastructure (i.e., industrial piping, utility connections). According to the most recent risk assessment conducted at the state level for critical local facilities, Lane County contains 297 structures amounting to approximately \$2.54 billion in value.¹⁴

When assessing the built environment for risk to natural hazards, it is helpful to categorize different structures according to function. FEMA’s Community Lifelines model provides a straightforward classification structure for the built environment, which includes the categories transportation, communication, energy, food, water, and shelter (as one category), health and medical, safety and security, and hazardous materials.¹⁵ The following section profiles the transportation network in Lane County along with some of the relevant critical facilities with respect to energy, and safety and security. Details about critical facilities within individual cities can be found within each city’s annex in Volume II.

Section 1.4.1: Transportation

Lane County contains several state highways as well as approximately 36 miles of Interstate 5 (I-5).¹⁶ State highways include 126 east and west segments, Highway 58, 99, and 36. A segment of Highway 101 extends near the Pacific coastline through the cities of Dunes City and Florence as it extends north into Lincoln County. Narrower, older roads branch from these state highways within unincorporated communities while portions of the state highways run through the main districts of certain cities (such as Highway 126 West through Veneta and Highway 58 through Oakridge). Highway 126 East provides the primary transportation route for unincorporated communities in the McKenzie River Valley.

¹⁴ Oregon Emergency Management Office. (2020). “Oregon Natural Hazard Mitigation Plan: Risk Assessment, Appendix Item 9.1.9 – 2020 Statewide Loss Estimates: Local Critical Facilities Table (Excel).” State of Oregon.

¹⁵ Federal Emergency Management Agency, (2023). “Community Lifelines.” FEMA.gov, <https://www.fema.gov/emergency-managers/practitioners/lifelines>.

¹⁶ Lane County. (n.d.). *Public Works, Road Management Information System*. Retrieved on December 1, 2022.

Most county-owned roadways exist in the Willamette Valley, consistent with the concentration of population in the cities Eugene and Springfield. Several county roads extend throughout the Siuslaw National Forest in the Coast Range and in the southern portion of the valley extending towards the Cascade foothills near the communities of Dorena and Culp Creek. County roads, state highways, and I-5 support the primary transportation system in Lane County, mostly facilitating the movement of motor vehicles. While a majority of people drive personal vehicles, regional public transportation services between the Eugene-Springfield metropolitan area and other cities also utilizes the road network.

Of the major roadways in Lane County, four (4) routes are designated in Oregon Department of Transportation's (ODOT) Seismic Routes in preparing the infrastructure for the impacts of a Cascadia Subduction Zone (CSZ) earthquake. Highway 58 is designated as a Phase I route, communicating that retrofits, replacements, or triage is needed along the route. The section of Interstate 5 in Lane County, along with Highways 99 and 126 West are each categorized as Phase II and III routes while Highway 101 in western Lane is designated a Phase IV route. All routes categorized as between Phases II and IV undergo a triage approach to either: identify detours; address lower costs routes if detours are not feasible, or repair/mitigate the route after an event for areas that would sustain minor damage.¹⁷ For more information about Lane County's roadway vulnerability to earthquake hazards, see Section 2: Risk Assessment for more details.

In addition to the road system, a railway exists serving both freight and passenger transportation. The rail line enters Lane County from the southeast passing Odell Lake in Klamath County and runs northwest through the Cascades passing through Oakridge, Westfir, just south of Dexter and Trent, and Springfield before reaching Eugene. The Eugene station functions as a passenger stop both for regional routes in the Pacific Northwest and long-haul routes originating south from California serving stations in Oregon and Washington. From Eugene, the railway turns north, passing through Junction City before crossing into Linn County.

Lastly, a regional airport provides commercial passenger flights in and out of the Willamette Valley to locations in the western United States. Eugene Airport, also known as Mahlon Sweet Field, is a public airport 7 miles northwest of Eugene. Owned and operated by the city of Eugene, it is the fifth-largest airport in the Pacific Northwest. Aside from Mahlon, five other smaller airports exist in Lane County currently in Oakridge, Creswell, Cottage Grove, Florence, and McKenzie Bridge.

Section 1.4.2: Critical Facilities

Critical Infrastructure and Key Resources (CIKR) support the delivery of critical and essential services that supports the security, health, and economic vitality of the county. CIKR includes the assets, systems, networks, and functions that provide vital services to cities, states, regions, and, sometimes, the nation, disruption to which could significantly impact services, produce cascading effects, and result in large-scale human suffering, property destruction, economic loss, and damage to public confidence and morale.

¹⁷ Oregon Department of Transportation. (2021). "ODOT Seismic Implementation: Policies and Design Guidelines." *Oregon Department of Transportation*.

Key facilities that should be considered in infrastructure protection planning include:

- Structures or facilities that produce, use, or store highly volatile, flammable, explosive, toxic, and/or water-reactive materials.
- Government facilities, such as departments, agencies, and administrative offices.
- Hospitals, nursing homes, and housing likely to contain occupants who may not be sufficiently mobile to avoid death or injury during a hazard event.
- Police stations, fire stations, vehicle and equipment storage facilities, and emergency operation centers (EOCs) required for disaster response before, during, and after hazard events.
- Public and private utilities and infrastructure that are vital to maintaining or restoring basic services to areas damaged by hazard events.
- Communications and cyber systems, assets and networks such as secure county servers and fiber optic communications lines.

Critical Facilities are defined as facilities needed to maintain government functions and protect life, health, safety, and welfare of the public within Lane County. These facilities often fall within the Community Lifelines framework adopted by FEMA. Examination into Lane County’s vulnerability in the context of Community Lifelines can be found in Section 2.3: Vulnerability Assessment. Table 1.5 displays critical facilities for emergency services within Lane County.

Table 1.5: Critical Facilities for Emergency Services in Lane County

Community	Fire Stations	Medical Facilities	Military Facilities	Police Stations
Coburg	2	0	0	1
Cottage Grove	1	3	1	1
Creswell	1	0	0	1
Dunes City	1	0	0	0
Eugene	10	7	3	13
Florence	3	14	2	2
Junction City	1	0	0	2
Lowell	1	0	0	0
Oakridge	1	0	0	1
Springfield	5	7	0	1
Veneta	1	0	0	0
Westfir	1	0	0	0
Unincorporated	43	1	0	1
Lane County Totals	71	32	6	23

Source: DLCD. 2020. Oregon Natural Hazards Mitigation Plan: 2020 Statewide Loss Estimates: Local Critical Facilities Table (Excel)

Section 2: Risk Assessment

44 CFR §201.6(c)(2): *[The plan must include the following]:* A risk assessment that provides the factual basis for activates proposed in the strategy to reduce losses from identified hazards. Local risk assessments must provide sufficient information to enable the jurisdiction to identify and prioritize appropriate mitigation actions to reduce losses from identified hazards. The risk assessment must include:

(i) A description of the type, location, and extent of all natural hazards that can affect the jurisdiction. The plan **must** include information on previous occurrences of hazards and the probability of future hazard events.

(ii) A description of the jurisdiction’s vulnerability to the hazards described in paragraph (c)(2)(i) of this section. This description **must** include an overall summary of each hazard and its impact on the community. All plans approved after October 1, 2008 **must** also address NFIP insured structures that have been repetitively damaged by floods. The plan should describe vulnerability in terms of:

- (A) The types and numbers of existing and future buildings, infrastructure, and critical facilities located in the identified hazard areas;
- (B) An estimate of the potential dollar losses to vulnerable structures identified in paragraph (c)(2)(ii)(A) of this section and a description of the methodology used to prepare the estimate;
- (C) Providing a general description of land uses and development trends within the community so that mitigation options can be considered in future land use decisions.

(iii) For multi-jurisdictional plans, the risk assessment section **must** assess each jurisdiction’s risks where they vary from the risks facing the entire planning area.

A risk assessment identifies hazards that can impact the planning area and describes how those hazards affect people, buildings, systems, and the environment. Completing the risk assessment provided the planning team and project stakeholders with insight about the most damaging potential impacts to the community resulting from natural hazards. From an understanding about the severity of each hazard type, project participants could better approach mitigation from an all-hazards approach where actions address the impacts of multiple hazard types.

The risk assessment follows a four-step process and presents the results in a separate sub-section in the risk assessment. The first topic describes **the hazards that exist in Lane County**, how they were identified, and the regions within the county susceptible to each hazard. The second topic **profiles each hazard** in accordance with the requirements of 44 CFR 201.6(c)(2)(ii), which prescribe examining six (6) elements of hazard risk. The third subsection profiles Lane County’s **vulnerability to these hazards** through an analysis of the risk to people, buildings, and systems. Lastly, the concluding subsection presents the **hazard risk quantification** along with a summary of overall risk in Lane County. The findings from the risk assessment process informs how to develop a mitigation strategy and identify action items that address the most critical needs over the next five (5) years.

Section 2.1: Identifying Hazards in Lane County

The NHM-SC worked with the planning team to identify natural hazards impacting Lane County. To identify the hazards, the planning team reviewed historical records using databases such as the Storm Events Database, Declared Disasters database, after action reports (AARs) published by the Oregon Department of Emergency Management (OEM), as well as local documents retained by Lane County Department of Emergency Management (LCEM). In addition, the team cross referenced these hazards with the previous version of the Lane County MJ-NJMP (2018), the Oregon Natural Hazard Mitigation Plan (2020), the Eugene-Springfield Area NHMP (2020), the Cottage Grove NHMP (2017), and the recently adopted Lane County Climate Resilience Plan (2022).

Though each hazard is profiled individually, this Plan analyzed the potential for hazards to be triggered by the impacts of other events and included these findings in a **cascading impacts and secondary hazards** element within each profile. Additionally, each profile addresses how **climate change** may impact the frequency and severity of future hazard events. These impacts are evaluated both in terms of individual driving factors as well as the interrelated variables that influence hazard events.

Table 2.1 lists the hazards profiled and evaluated as part of this plan. Order listing of the hazards is alphabetical and does not imply relative significant or severity of a particular hazard type.

Table 2.1: Profiled Natural Hazards for Lane County with Identification Method

Natural Hazard	Identification Method
Drought	Previous Occurrences
Earthquake	Previous Occurrence
*Extreme Weather	Previous Occurrences
Flood	Previous Occurrences
Landslide & Debris Flow	Previous Occurrences
Tsunami	Previous Occurrences
Volcano	Potential Occurrence
Wildfire	Previous Occurrences
Windstorm	Previous Occurrences
Winter Storm	Previous Occurrences

Source: Lane County Natural Hazard Mitigation Steering Committee (NHM-SC)

*New natural hazard added to the Lane County MNHMP, Version 4.0 (2023)

Section 2.1.1: Hazard Mitigation Background and Context

Hazard mitigation is one of the five mission areas of the National Preparedness Goal and defined as an activity to “reduce the loss of life and property by **lessening the impact of future disasters**” (emphasis added).¹⁸ Mitigation is distinct from the other mission areas of response, capability, recovery, and preparedness. Other plans in Lane County that address risk reduction and hazard preparedness efforts include the Emergency Operations Plan (EOP) and the Continuity of Operations Plan (COOP). Currently, Lane County has not adopted a countywide Disaster Recovery Plan (DRP). Addressing this gap is one of the action items included in the Lane County Strategic Plan: 2022- 2024 to advance the strategic goal to “maintain and invest in resilience infrastructure that creates the highest return for safety, community connectivity, enjoyment of life, and local economic success.”¹⁹

Reducing the potential for loss of life and injury to individuals is a central objective of mitigation. Equally important is how mitigation can safeguard a community from economic and financial devastation in the aftermath of a hazard event. An approved Hazard Mitigation Plan is a basic requirement for federal mitigation funds eligibility, per Section 322 of the Stafford Act, 42 U.S.C. 5165. Detailed requirements for plan approval are outlined in the Code of Federal Regulations (CFR) Title 44, Part 206, Subpart N.

Section 2.1.2: Prior Disaster Declarations in Lane County

Lane County has experienced 18 federally declared disasters since 1950, with three (3) disasters occurring since the last update of this Plan. In addition, Lane County has been included in 14 declarations of a state of emergency or under a fire management assistance (FMAG) declaration since 2012 (see Tables 2.2 and 2.3). Three (3) of these 14 declarations were also federally declared disasters. Two of the most expensive disasters in County history have occurred since the last update of this Plan. With currently available data, the 2020 Holiday Farm Fire is the costliest natural disaster to occur in Lane County on record, which is characteristic of many Oregon counties affected by the 2020 Labor Day Wildfires. Examining the entries in both Tables 2.2 and 2.3., there is an emerging pattern of identifying hazard impacts between the wet, winter seasons and the drier, summer seasons.



Plow clears path to the Bear Mountain Communications Site after “Snowmageddon”, DR-4432, 2019 | Photo: Lane County Emergency Management

¹⁸ Federal Emergency Management Agency. (2015). *National Preparedness Goal*. p. 10.

¹⁹ Lane County. (2022). “Lane County Strategic Plan: 2022 – 2024.” County Administration Office. p. 8.

Table 2.2: Federal Disaster Declarations including Lane County, 1950 – 2022

Disaster # (DR)	Disaster Reference Title	Incident Timeframe	Estimated Damage (Lane County)	Estimated Damage (Oregon)	% of Statewide Total
4562	Oregon Wildfires and Straight-Line Winds	September 7 - November 3, 2020	\$ 61,963,740	\$ 380,911,704	16%
4499	Oregon Covid-19 Pandemic	January 20, 2020 - May 11, 2023	data unavailable	data unavailable	unknown
4432	Oregon Severe Winter Storms, Flooding, Landslides, and Mudslides	February 23 - 26, 2019	\$ 14,184,914	\$ 30,028,943	47%
4296	Oregon Severe Winter Storm and Flooding	December 14 - 17, 2016	\$ 8,946,741	\$ 17,000,000	53%
4258	Oregon Severe Winter Storms, Straight-line Winds, Flooding, Landslides, and Mudslides	December 6 - 23, 2015	\$ 1,303,000	\$ 27,100,000	5%
4169	Oregon Severe Winter Storm	February 6 - 11, 2014	\$ 6,731,297	\$ 8,304,174	81%
4055	Oregon Severe Winter Storm, Flooding, Landslides, and Mudslides	January 17 - 21, 2012	\$ 1,400,483	\$ 14,100,000	10%
1510	Oregon Severe Winter Storms	December 26, 2003 - January 14, 2004	\$ 1,237,444	\$ 10,200,000	12%
1405	Oregon Severe Winter Windstorm with High Winds	February 7 - 8, 2002	\$ 3,896,333	\$ 4,800,000	81%
1160	Oregon Severe Winter Storms/Flooding	December 25, 1996 - January 6, 1997	data unavailable	data unavailable	unknown
1107	Oregon Severe Storms/High Winds	December 10 - 12, 1996	\$ 1,384,411	data unavailable	unknown
1099	Oregon Severe Storms/Flooding	February 4 - 21, 1996	\$ 1,904,828	data unavailable	unknown
1036	El Niño	May 1 - October 31, 1994	data unavailable	data unavailable	unknown
413	Storms, Snowmelt, Flooding	January 25, 1974	data unavailable	data unavailable	unknown
319	Storms, Flooding	January 21, 1972	data unavailable	data unavailable	unknown
184	Heavy Rains and Flooding	December 24, 1964	data unavailable	data unavailable	unknown
136	Severe Windstorm	October 12 - 16, 1962	data unavailable	\$ 200,000,000	unknown
49	Flooding	December 29, 1955	\$ 2,738,000	\$ 50,000,000	5%

Source: Federal Emergency Management Agency; Oregon Department of Emergency Management; Lane County Multi-Jurisdiction Natural Hazards Mitigation Plan (2018)

NOTE: Damage Totals reported in actual (original time period) dollars and are not adjusted for inflation.



Damage along OR-126, McKenzie Highway during the Holiday Farm Fire (2020) | Source: Oregon Department of Transportation

Table 2.3: State Disaster Declarations (EO) & Fire Management Assistance Declarations Affecting Lane County, 2012 – 2023

Reference #	Description	Hazard Type	Incident Timeframe
FM-5457-OR	Oregon Cedar Creek Fire	Wildfire	September 9, 2022 - continuing
EO 22-20	Cedar Creek Fire	Wildfire	September 9, 2022
EO 22-01	Severe Winter Storm that includes High Winds, Heavy Rain, Flooding, and Landslides	Winter Storm	December 30, 2021 - January 10, 2022
EO 21-37	Severe Winter Weather that includes Snow Accumulation and Sustained Temperatures Below Freezing Across the State	Extreme Cold	December 24, 2021
EO 21-28	Middle Fork Complex	Wildfire	August 9, 2021
EO 21-26	Excessive High Temperatures Causing a Threat to Life, Health, and Infrastructure	Extreme Heat	August 10 - 15, 2021
EO 21-25	State of Drought Emergency due to Lack of Precipitation, High Temperatures, and Low Streamflow	Drought	July 21 - December 31, 2021
FM-5357-OR	Oregon Holiday Farm Fire	Wildfire	September 8, 2020 - continuing
EO 20-40	Holiday Farm Fire	Wildfire	September 8, 2020
EO 19-02	Severe Winter Storm that includes Heavy Snow and Ice Accumulation, High Winds, Flooding, and Landslides	Winter Storm	February 24, 2019
EO 17-06	Severe Winter Storm that includes High Winds, Flooding, and Landslides	Winter Storm	January 11, 2017 - March 2017
EO 16-02	Severe Winter Storm with High Winds, Flooding, and Landslides	Winter Storm	December 7, 2015 - January 25, 2016
EO 15-05	State of Drought Emergency due to Drought, Low Snowpack Levels, and Low Water Conditions	Drought	May 21, 2015 - December 31, 2015
EO 12-05	Damaging Winds, Heavy Rains, Flooding, Mudslides, and Landslides	Extreme Weather	March 11, 2012

Source: Federal Emergency Management Agency; State of Oregon Office of the Governor; Lane County Multi-Jurisdiction Natural Hazard Mitigation Plan, Version 3.0 (2018)

NOTES: FM = Fire Management Assistance Declaration; EO = Executive Order (Year-Order Number)

*Events included in Table 2.3 include incidents that resulted in federal disaster declarations and do not imply unique hazard events that occurred in the stated timeframe. These events are included to provide context for the state context of hazard events that warrant declarations of states of emergencies despite not rising to the level of a federally declared disaster. The Cedar Creek Fire (2022) is a recent example of a wildfire that triggered both an Executive Order and Fire Management Assistance declaration but was not declared a federal disaster. Evaluating both declared disasters and statewide declarations of emergencies provides a fuller picture of the cyclical pattern of hazard events in Lane County and suggestive increase of occurrences in the past 10 years.

Section 2.1.3: Changes since the Previous Plan

The planning team and NHM-SC discussed the relevance of specific hazard types to be included in the MNHMP. Changes occurred since Version 3.0 of the Plan about what hazards to include. Version 4.0 introduces a new hazard type and removes three hazard types included in the 2018 version of the Plan.

New Hazard Types

Included in the 2023 update is the addition of the hazard **Extreme Weather**. This description includes extreme temperatures and atmospheric-driven storms, such as thunderstorms and tornados. The decision to include an Extreme Weather profile reflected events that occurred in Lane County since the previous Plan update. Elements of this hazard profile (e.g., extreme heat) are also included in the current Oregon Natural Hazard Mitigation Plan (2020). Lastly, addressing the impacts of extreme temperatures and storms further aligns this Plan’s risk assessment with assessments included in the Community Wildfire Protection Plan (2020) and action items listed in the Lane County Climate Resilience Plan (2022).

Removed Hazard Types

The NHM-SC in consultation with the planning team decided to remove three hazard types from the base plan that were previously included in Version 3.0 of this Plan (2018): dam failure, hazardous materials, and pandemic. An explanation for removing each hazard profile for the update to this Plan follows.

Dam Failure: Inclusion of dam failure risk is an optional element of a local hazard mitigation plan.²⁰ Lane County is home to many dams, some of which are classified as high hazard structures. Evaluating the issue of dam failure during this Plan’s update, the NHM-SC and planning team agreed that dam failure should be addressed as a cascading impact of natural hazards rather than its own separate hazard type given this Plan’s emphasis on natural hazards. There have been no recorded dam failures in Lane County occurring in the past 75 years separate from the occurrence of a natural hazard event (e.g., an earthquake or flood). The natural hazards profiled in Version 4.0 (2023) of this Plan address potential dam failure impacts within each hazard profile as relevant. Additionally, information about Lane County’s dams and their hazard designation can be found in Volume III: Appendix A of this Plan.

Hazardous Materials: The NHM-SC and planning team agreed to characterize the risk of a hazardous materials spill as a cascading impact of natural hazard events. Within Lane County, sites storing hazardous materials are localized and in the event of a spill, procedures and policies within the Emergency Operations Plan (EOP) take effect to address the situation. Considering the scope of this Plan, hazardous materials are treated as a potential impact of natural hazard events that can compound injuries and loss of life during an emergency. Information about how hazardous materials can be impacted by natural hazard events are found within associated portions of the hazard profiles. Furthermore, where the risk of such released materials is localized within some cities of Lane County, the city annexes included in Volume II of the Plan address these vulnerabilities.

²⁰ Federal Emergency Management Agency. (2023). *Local Policy Guidance for Hazard Mitigation Plans*. FP 206-21-0002. OMB Collection #1660-0062.

Pandemic: These events are unique in originating from the mutation of organic compounds into bacteria or viruses that cause illness and death in severe cases. Their spread at the outset of an outbreak can be rapid and occur anywhere on the planet. Given the relatively little control any municipality has in preventing an outbreak of a virus, most activities prescribed to limit the spread of an outbreak, treat infections, and safeguard the public are addressed in EOPs, COOPs, and functional Public Health plans managed by multiple jurisdictions across the county. LCEM’s role in responding to pandemics evolved considerably during the recent Covid-19 global pandemic. Upon assessing the most suitable placement for pandemic response and reduction in spread of any virus, the NHM-SC decided to remove pandemics from the scope of this Plan update.

Section 2.2: Hazard Profiles

After identifying what natural hazards can impact Lane County, the planning team profiled each hazard along several required and encouraged elements. This subsection profiles the 10 natural hazards impacting Lane County as determined by the NHM-SC. Information is presented in the most objective manner possible, with data sources and limitations of available information noted where relevant. Each hazard profile reports on eight (8) elements: a description of the hazard type, the cascading impacts triggering other hazards caused by the event, the impact area in Lane County, the extent (or severity) of hazards, previous occurrences of events, probability of future occurrences, impacts of climate change on hazards, and overall vulnerability of the county. Hazards are presented alphabetically for ease of reference and order should not infer relative importance.

As part of the assessing characteristics for each hazard type, the Plan uses classifications to assess specific impact types, such as how disruptive an event can be to critical infrastructure or how much of the overall population an event can affect. Table 2.4 provides a summary of the different classifications used in the risk assessment along with their defining criteria. These classifications were used in the previous version of this Plan and remained appropriate for use in the Plan update.

Table 2.4: Classifications and Defining Criteria for Hazard Extent, Probability of Future Occurrence, and Overall Vulnerability

Classification	Definition
Future Probability	
High	Greater than 50 percent (50%) probability of occurrence in a given year.
Moderate	A 10 to 50 percent (10% - 50%) probability of occurrence in a given year.
Low	Less than 10 percent (10%) probability of occurrence in a given year.
Hazard Extent	
Level 4 - Catastrophic	Severe property damage on a regional or metropolitan scale; shutdown of critical facilities, utilities and infrastructure for extended periods, and/or multiple injuries/fatalities.
Level 3 - Critical	Severe property damage on neighborhood scale; temporary shutdown of critical facilities, utilities and infrastructure, and/or injuries or fatalities.
Level 2 - Limited	Isolated occurrences of moderate to severe property damage; brief shutdown of critical facilities, utilities and infrastructure, and/or potential injuries.
Level 1 - Negligible	Isolated occurrences of minor property damage; minor disruption of critical facilities, utilities and infrastructure, and/or potential minor injuries.
Overall Vulnerability	
High	High probability of future occurrence and critical or catastrophic potential severity (hazard extent).
Moderate	Moderate/high probability of future occurrence and limited potential severity (hazard extent).
Low	Low/moderate probability of future occurrence and negligible/limited potential severity.

Source: NHM-SC

Section 2.2.1: Drought

Lane County is susceptible to drought. The probability of drought in Lane County is **high** based on observed conditions in recent years and the expectation of a warmer climate in the future. The vulnerability of people and structures to drought countywide is **low**. Vulnerability to drought is classified as low considering a limited impact to people, buildings, and community lifelines despite the high probability for future occurrence. Drought most immediately impacts the natural environment and can produce shortages in water resources if severe conditions persist over several years.

Hazard Description

Drought is a period of insufficient water to meet demand.²¹ Types of droughts have different classifications depending on the context of the drought's impact. For example, **meteorological** drought describes a period experiencing a lack of typical precipitation whereas **agricultural** drought describes an area with insufficient water supply for agricultural production.²² Generally, drought describes a change where precipitation is lower than usual, and supply is unable to meet demand for a variety of needs. It is a difficult hazard to evaluate and strategically mitigate because drought occurs over a few years to multiple decades lacking clearly defined beginning and ending events.

Scarce precipitation for consecutive years can deplete both ground and surface water. If consumption exceeds the ability of water supplies to replenish, overtime, water resources can become scarce. Reduced snowpack also impacts the ability for water bodies to replenish during winter months before the spring. Short term effects of drought include excessively dry soil causing stress for plants and trees and increased probability for wildfires due to dried vegetation's potential for igniting. When rainfall is less than adequate for extended periods, stream and river flows decline, water levels in lakes and reservoirs fall, and the water table drops increasing the depth water wells must reach to access groundwater.

Drought can also contribute to harmful algal blooms (HABs). These blooms occur when water temperatures are warmer than average and there is reduced mixing between warm and cold water. As the algae grows, it reinforces those favorable conditions accelerating the bloom's total growth and can result in the death of freshwater species.²³ The impact to the natural environment can disrupt and strain ecosystems while also causing economic losses to businesses that source product from freshwater species or are outdoor, recreationalist-based operations. Nationwide estimates state that HABs cause approximately \$82 million in economic losses each year.²⁴ People may be at risk from eating contaminated seafood or from airborne toxins produced by the algal blooms. Lane County has experienced algal blooms on water bodies in recent years alongside warmer average temperatures and a declared drought in 2021.

²¹ Redmond, K.T. (2002). "The depiction of drought: a commentary." *Bulletin of the American Meteorological Society*, 83, 1443-1147.

²² Fleishman, E., editor. (2023). *Sixth Oregon climate assessment*. Oregon Climate Change Research Institute, Oregon State University, Corvallis, OR. DOI: 10.5399/osu/1161.

²³ Environmental Protection Agency. (2022). "Climate Change and Harmful Algal Blooms." United States Environmental Protection Agency, EPA.gov. Retrieved December 7, 2022. <https://www.epa.gov/nutrientpollution/climate-change-and-harmful-algal-blooms>.

²⁴ NOAA, (2023). "Why do harmful algal blooms occur?" National Ocean Service website. Retrieved December 7, 2022. https://oceanservice.noaa.gov/facts/why_habs.html.

In the United States, drought typically does not require evacuation and does not constitute an immediate threat to life or property. The effects of drought may not be noticed immediately but become apparent after weeks or months. The effect to the water table may take up to a year or more to be observed.

Drought impacts communities by initiating curtailment measures of water use, increasing wildfire risk warnings (red flag warnings), and reducing streamflow enough to affect how well treatment plants filter clean drinking water. Water supply utilities encourage judicious use of water during drought and may implement curtailment or restrict certain activities such as outdoor burning and use of fireworks. Authorities available during a state declaration of a drought emergency are identified in ORS 536.750-780. These authorities provide the state Water Resources Commission (OWRC) the option to issue temporary permits for emergency water use, permit changing uses of water or point of diversion without adhering to reporting or notice requirements, and grant preference of use to rights for human consumption or stock watering use.²⁵

Along with the impact to communities, persistent and higher severity droughts also impact natural ecosystems, which can affect critical resources for local economies throughout Oregon. Culturally significant resources such as certain animal species for Indigenous communities throughout the state and Pacific Northwest are also impacted by persistent drought.²⁶

Cascading Impacts and Secondary Hazards

Drought is unique in how it impacts the community and tends to mostly affect water systems and agricultural operations. Depletion of groundwater and water table levels is a direct impact of drought. Some risk exists that the reduced streamflow of rivers and other water bodies could disrupt hydroelectrical dams and power stations. Although the potential exists, this impact has not been experienced much in Lane County during recent droughts.

Drought's relationship to other hazards include how it affects wildfire risk and the potential for flooding.

Flooding: Impacts to soils that result from drought can also lead to a greater likelihood of flooding during heavy rainfall. When soils dry out and lose moisture, they contract and harden. As a result, the soil's capacity to absorb water is limited and when a high volume of water reaches these dried soils, the water cannot be absorbed and runs off down slopes, which can result in flooding. A summer thunderstorm can bring this type of precipitation when drought severity is often at its most extreme. More often these conditions exist during the transition between the dry and wet season where, following a severe drought year, Pacific storms bring heavy rainfall to a dry landscape.

Wildfire: Ongoing drought can accelerate drying of vegetation and create conditions that elevate wildfire risk. Droughts often coincide with periods of above-average temperatures and these factors result in drier fuels. If the drought was preceded by rapid vegetation growth in the wet season, then more vegetation is available as hazardous fuels, drying out under drought conditions. The reduction in

²⁵ Oregon Revised Statutes 536.750.

²⁶ Fleishman, E., editor. (2023). *Sixth Oregon climate assessment*. Oregon Climate Change Research Institute, Oregon State University, Corvallis, OR. DOI: 10.5399/osu/1161.

available water resources and reduced water flows may also present challenges for accessing water in response to containing wildfires.

Geographic Location

Drought regularly occurs in virtually all climate zones, including areas with high and low average precipitation. While Lane County is in a temperate region where precipitation is generally adequate for restoring water levels, it is not immune from occurrences of severe or exceptional drought. In general, drought impacts are recorded more frequently in the Willamette Valley and Cascade foothills and somewhat less frequently and severely at the coastline and upper elevations of the Coast and Cascades ranges.

Coast Region: Despite receiving a greater share of precipitation on average compared to the rest of Lane County, drought occurs in the Coast region. During the 2015 drought, coastal Lane County was rated as “abnormally dry” in April and experiencing “Extreme Drought” by September.²⁷ Periods of low precipitation in the summer that follow a dry winter can suggest that drought conditions will exist during the summer months. Though temperatures remain moderate compared to the Valley and Cascades regions, lack of water can result in noticeable drought impacts in lower and developed areas of the Coast Range, which tend to be more pronounced on the leeward side of the mountains (eastern-facing side).

Drought impacts can persist in the Coast region past the summer months when the landscape experiences a lack of precipitation. Most recently, in 2021, drought conditions emerged in May as most of the region was experiencing “moderate drought” that transitioned into “severe drought” just a week later. Conditions in the Coast region deteriorated into “extreme drought” by mid-August, which reflected the drought conditions observed in most of Lane County at the time. The area remained in some form of “moderate to severe” drought until mid-April 2022.²⁸ It will be important in the next several years to monitor drought conditions in the Coast region, particularly its association with potential fire risk in the Coast Range Mountains and Siuslaw National Forest.

Valley Region: Drought impacts can be more pronounced downstream given the lower elevations of communities in the southern Willamette Valley. In addition to developed areas along Interstate 5, the Valley region is home to agricultural operations that rely on water resources during the growing season to irrigate crops during peak average temperatures that occur in June through about mid-September. Agricultural activity in the Willamette Valley includes commercial crop production, floriculture, and seed collection. Animal husbandry also requires water for the raising and care of livestock. Given the prevalence of farm and pastureland in the Willamette Valley, drought impacts can disrupt operations, threaten crop yields, and result in the need for curtailing water usage, all of which can significantly contribute to economic losses.²⁹

Along with agriculture and ranching, the Willamette Valley is also the most populated region of Lane County, containing nearly 90 percent of all residents and about half of those people residing within the Eugene-Springfield metropolitan area. The concentration of residents in the Valley region creates

²⁷ U.S. Drought Monitor. Map Archive.

²⁸ Ibid.

²⁹ National Drought Mitigation Center, Drought Impact Reporter Dashboard, Lane County, Impact ID 31907. *University of Nebraska-Lincoln*, Lincoln, NE.

demand for water resources, including clean drinking water, operability for utility and plumbing systems, and stream force to generate electricity. During severe and extreme droughts, groundwater tables can drop creating the need for deeper wells to access subsurface water and potential shortages for areas of the Valley region. Competing needs of agricultural and horticulturists with those of daily residents and businesses can result in curtailment of water usage and competition for scarce resources. For example, during the 2015 drought emergency, Junction City introduced mandatory restrictions on water use and other local communities promoted voluntarily water use curtailment.³⁰ Future curtailment requests were due to aging infrastructure and equipment failures in the systems.

Cascades Region: Higher elevations of the western Cascades tend to experience fewer impacts from drought during prolonged dry periods. The combination of proximity to surface water sources, including snowpack, along with lower average temperatures can help reduce the severity of drought conditions in the Cascades. However, as droughts persist, even places at higher elevations can experience drought impacts such as stressing the health of tree species in the Willamette National Forest. Among drought impacts reported during the 2015 year, several reports cited ongoing drought conditions since 2012 that contributed to killing Douglas fir trees along with damaging Ponderosa pine that are typically more drought resistant.

Drought impacts tend to be more pronounced in the Cascade foothills compared to higher elevations. During the 2015 drought, Oakridge imposed mandatory water restrictions that prevented residents from using water for lawn care, fill swimming pools, or washing vehicles in driveways.³¹ Ongoing drought conditions in the Willamette National Forest contributes to heightened wildfire risk, which had been a contributing factor in the ignition and spread of the 2020 Labor Day fires throughout Oregon.

Hazard Extent

Tracking drought is challenging due to numerous definitions and measurements protocols. Several inputs contribute to drought and evaluating the magnitude of an event. The Standard Precipitation Index (SPI) is one index used to measure levels of precipitation. The index can be useful for evaluating conditions in the short-term context of assessing agricultural needs and for examining long-term hydrological applications. The Palmer Drought Severity Index (PDSI) is another commonly used measure for moisture depletion or abundance on a regional scale. The PDSI differs from the SPI in that it accounts for precipitation, temperature, and the local Available Water Content (AWC) of the soil. Lastly, the Standardized Precipitation-Evapotranspiration Index (SPEI) compares the water balance between precipitation and water loss through evapotranspiration.³² As indexes, these tools process thousands of data points to quantify drought magnitude, which can then be translated into terminology to describe the relative severity of a drought (i.e., moderate, severe, or extreme).

The Drought Mitigation Center at the University of Nebraska tracks drought conditions across the United States and provides situation maps at the state and county level. As shown in Table 2.5, the U.S. Drought Monitor (USDM) attempts to synthesize multiple drought related indices and impacts that represent a consensus among federal and academic scientists. Some of those indices include: the PDSI, the Climate

³⁰ Ibid. Impact ID 31966.

³¹ Ibid.

³² This term refers to water loss from the soil that results both from evaporation (when surface water transfers into the atmosphere as water vapor) and transpiration (when water vapor exits plants through leaves).

Prediction Center’s Soil Moisture Model, USGS weekly stream flow map (based on an average of daily stream flow), National Climatic Data Center’s SPI, and the recently introduced SPEI.



Drought impacts can reduce water levels in surface water bodies.

Source: U.S. Department of Agriculture

Table 2.5: Drought Classifications and Associated Values across Four (4) Drought Monitoring Indices

Category	Description	Possible Impacts	Ranges			
			Palmer Drought Severity Index (PDSI)	CPC Soil Moisture Model	USGS Weekly Streamflows (Percentiles)	Standardized Precipitation Index (SPI)
D0	Abnormally Dry	Short-term dryness slowing planting, growth of crops or pastures	*-1.0 to -1.9	21 to 30	21 to 30	*-0.5 to -0.7
D1	Moderate Drought	Some damages to crops, pastures; streams, reservoirs, or wells low, some water shortages developing or imminent; voluntary water use restrictions requested	*-2.0 to 2.9	11 to 20	11 to 20	*-0.8 to -1.2
D2	Severe Drought	Crop or pasture losses likely; water shortages common; water restrictions imposed	*-3.0 to -3.9	6 to 10	6 to 10	*-1.3 to -1.5
D3	Extreme Drought	Major crop/pasture losses; widespread water shortages or restrictions	*-4.0 to -4.9	3 to 5	3 to 5	*-1.6 to -1.9
D4	Exceptional Drought	Exceptional and widespread crop/pasture losses; shortages of water in reservoirs, streams, and wells creating water emergencies	*-5.0 or less	0 to 2	0 to 2	*-2.0 or less

Source: U.S. Drought Monitor, Drought Classification

The 12-month SPEI is notably useful for evaluating drought magnitude in the Pacific Northwest given its reliable prediction of annual streamflow.³³ Therefore, it is an effective quantitative metric to examine the severity of droughts that have occurred in Lane County. Table 2.6 displays SPEI figures for Lane

³³ Fleishman, E., editor. (2023). *Sixth Oregon climate assessment: Drought*. Oregon Climate Change Research Institute, Oregon State University, Corvallis, OR. DOI: 10.5399/osu/1161.

County since 2000. The calculation for SPEI values uses the 12-month water year (October through September).

Table 2.6: SPEI and PDSI Values for Years of Notable Drought Conditions in Lane County since 2000

Year	SPEI Value	PDSI Value	Classification
2001	-1.92	-2.23	Severe
2003	-0.64	-3.10	Moderate
2005	-1.57	-0.77	Abnormally Dry
2009	-0.74	-1.97	Moderate
2014	-0.81	0.28	Moderate
2015	-1.26	-3.96	Severe
2018	-1.18	-3.63	Severe-Extreme
2020	-1.86	-3.42	Severe-Extreme
2021	-0.72	1.87	Severe-Extreme

Source: West Wide Drought Tracker, University of Nebraska

Other indices propose evaluating drought magnitude through a combination of the severity index along with coverage area. One measurement is the Drought Severity and Coverage Index (DSCI). The DSCI allows examination of variations in drought severity across a continuous area.³⁴ For example, for one week of drought, the DSCI would calculate the percentage of the area affected by each of the drought severity classifications. These percentages allow one to convert USDM data from spatially specific to figures that organize data within geopolitical boundaries. Two approaches exist for applying DSCI.

First, the sum of the amount of area covered by each drought severity class can be calculated to compare drought intensity across a politically defined area. The percentage number representing area covered is multiplied by the corresponding drought severity class (i.e., x1 for D0, x2 for D1, x3 for D2, etc.) and these products are added to produce a number between 0 and 500. A DSCI of 500 would indicate that 100 percent of land area is experiencing exceptional drought (D4 severity class). Table 2.7 shows an example calculation based on Lane County data for the week of September 14, 2021, one of five (5) weeks that registered the highest DSCI value since 2000 (for which DSCI values are available).

Table 2.7: DSCI Calculated through the Categorical Weighted Sum Approach for Cumulative Percentage of Area, example using USDM Data for Week of September 14, 2021

Week	None	Severity Class					DSCI
		D0	D1	D2	D3	D4	
9/14/2021	0.00	0.00	0.00	20.63	68.44	10.94	390
Weighted Value	N/A	0.00	0.00	61.89	273.76	54.70	390.35

Source: U.S. Drought Monitor

³⁴ Akyuz, F.A. (2017). "Drought Severity and Coverage Index." United States Drought Monitor. University of Nebraska, Lincoln, NE.

A second approach is to use the weighted category sums of multiple weeks and take the average of these DSCI scores to produce a monthly DSCI average for a given year. Since drought often occurs over several weeks to several months, it is useful to examine monthly DSCI averages for drought years (whether identified through precipitation and water data or acknowledged through emergency declarations). To directly compare droughts that last similar durations to one another, the weekly DSCI figure could be added over several weeks to produce a sum value expressing drought intensity. For example, comparing two (2), eight-week droughts to one another, the event with the higher cumulative DSCI can be said to be the more intense, severe drought (see comparison presented in Table 2.8 of this section).

According to historical records of drought impact in Lane County and current understanding of how drought impacts drinking water systems and hydroelectric production, hazard extent for drought is classified as **Level 1 – Negligible**. *This classification for hazard extent has not changed since the previous version of this Plan.*

Previous Occurrences

Since drought is unique compared to other hazards in that starting and ending dates are approximate, there are different approaches for identifying occurrences of drought. One can use different statistical metrics to identify when the area experienced drought and, depending on the impacts and conditions assessed, these metrics can number into the dozens. Widely used indicators to identify drought occurrences include the SPEI and SPI (see Hazard Extent section for this profile).

Figure 2.1 shows the conditions of drought observed in Lane County since 2000. The image displays how nearly all of Lane County experienced severe drought in 2001 and briefly in 2014, 2015, late 2018, and 2021. Subsequently, the governor has issued four (4) states of emergency declarations due to drought in the last 50 years that included Lane County, which occurred in 1992,³⁵ 2010, 2015, and 2021.³⁶

Figure 2.1: Time Series of Drought Conditions and Area Coverage in Lane County since 2000

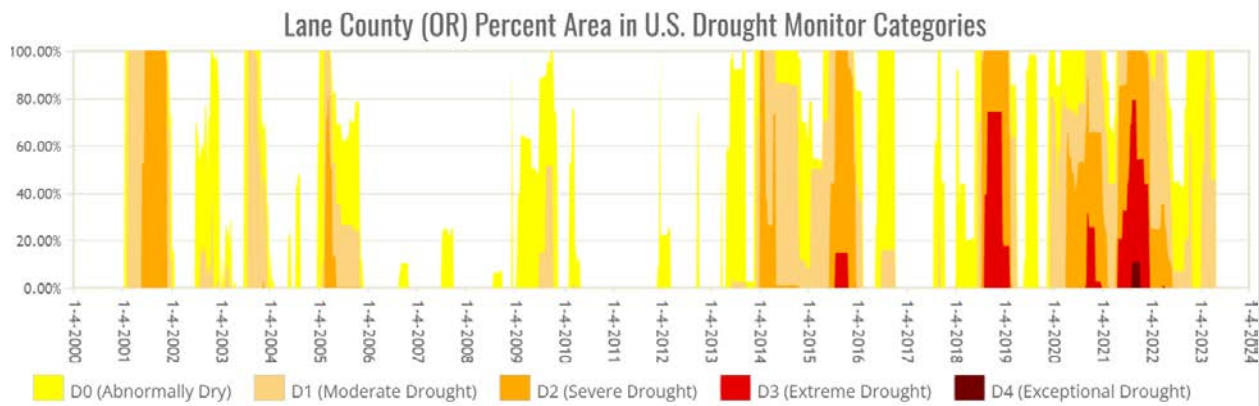

Source: U.S. Drought Monitor

³⁵ The 1992 drought in Oregon is distinguishable by the fact that a drought declaration was issued by the Oregon Governor for every county in the state during this year (OWRD, n.d.).

³⁶ Office of the Governor. (n.d.). "Executive Orders."

The four (4) years in which Lane County was included in an emergency drought declaration, drought impact varied. Using the DSCI approach discussed in the Hazard Extent section, Table 2.8 displays averaged monthly DSCI values starting with the beginning of the water year in Oregon in October. The 1992 drought year is excluded from this table due to a lack of available DSCI figures for Lane County prior to 2000.

Table 2.8: Average DSCI Values by Month for Declared Drought Years 2010, 2015, and 2021

Month	Drought Years		
	2010	2015	2021
October	124	174	291
November	51	96	280
December	0	81	269
January	0	89	224
February	27	111	160
March	71	105	111
April	14	117	145
May	3	171	300
June	0	211	316
July	0	258	336
August	0	315	380
September	0	315	384

Source: U.S. Drought Monitor

As shown in Table 2.8, the 2021 drought year was comparatively more severe compared to either 2015 or 2010. The monthly DSCI averages from May through September of 2021 consistently rated 300 or higher compared to the same period in 2015 where those values climbed over the course of the summer. Figure 2.2 further validates this finding through a visual comparison of drought conditions in mid-August. The map comparison adds context to show that Lane County experienced a greater coverage area experiencing extreme drought compared to 2015. These maps also demonstrate that much of Oregon in 2021 experienced extreme drought, with most of Central Oregon east of the Cascades experiencing exceptional drought, whereas this same area experienced mostly a moderate drought during the same time of year in 2015.

Figure 2.2: Comparison of Drought Severity via Snapshot of Conditions in Oregon for mid-August, Years 2015 & 2021

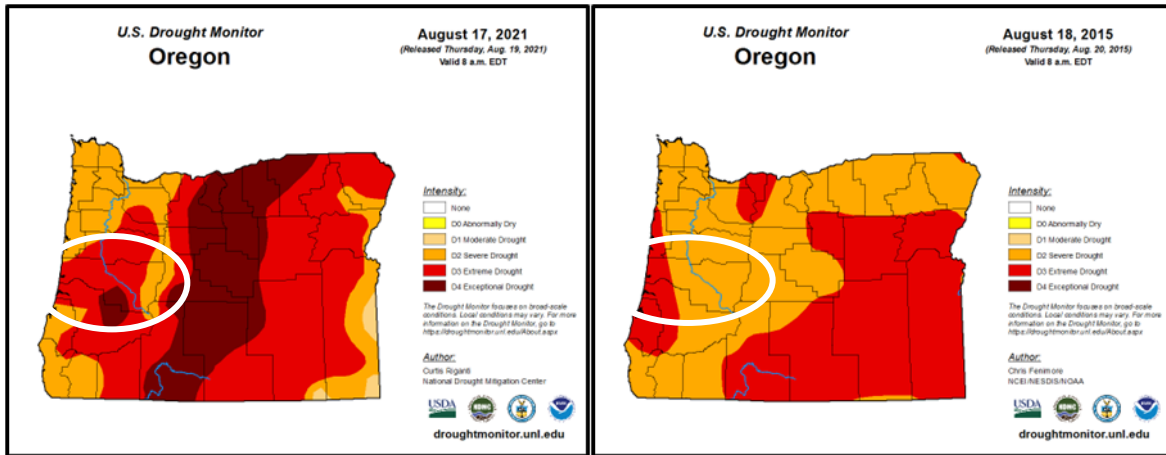

Source: U.S. Drought Monitor

According to the National Drought Mitigation Center’s *Drought Impact Reporter* there have been 30 reports of drought impacts specific to Lane County from 2000 through 2022. Drought impacts frequently include the loss of trees and timber due to heat stress and lack of water, proliferation of insect species due to warmer climate conditions, and at times mandatory water restrictions. For example, both Oakridge and Junction City imposed mandatory water restrictions during in July and August of 2015.³⁷ These reports typically involve impacts on a relatively local scale and specify type. In Lane County, water supply and quality were the most prevalent type of impact, followed by relief and water use restrictions, and agriculture, respectively. Table # summarizes the distribution of reported drought impacts based on impact category.

Table 2.9: Reported Instances of Drought Impact since 2000 for Lane County

Impact Category	Number of Instances
Agriculture	10
Business & Industry	6
Energy	0
Fire	10
Plants & Wildlife	12
Relief, Response & Restrictions	14
Society & Public Health	1
Tourism & Recreation	2
Water Supply & Quality	9

Source: National Drought Mitigation Center, *Drought Impact Reporter Dashboard*

NOTE: A report entry for drought impact often covers multiple impact categories, therefore, the count of instances should not add to 30 total, the number of individual records produced from the search affecting specifically Lane County.

³⁷ National Drought Mitigation Center, *Drought Impact Reporter Dashboard*, Lane County, OR, Jan. 01, 2000 – Dec. 31, 2022 Filtered Dates. *University of Nebraska-Lincoln*, Lincoln, NE.

Probability of Future Occurrence

Future drought forecasting is typically generated through analysis of ocean current and temperature patterns relative to current and recent conditions. Drought emergency declarations have increased in frequency within the last decade compared to the earlier part of the twenty-first century. Records also show that in 17 of the last 23 water years Oregon has experienced below average precipitation, with 2020 ranking as the fifth driest water year on record. Average temperatures in Oregon also exceeded the historical average in 18 of the last 23 water years.³⁸

Given the history of droughts in Lane County, especially in examining recent trends both within Oregon and the broader western United States, the probability of future occurrences of drought in Lane County is classified as **high**. *This classification has not changed since the previous plan.*

Impacts Resulting from Climate Change

Lane County's climate is projected to warm over the next several decades.³⁹ This includes increasing daily average temperatures, a reduction in overall volumes of precipitation and snowpack, and more frequent heat waves, all of which contribute to a greater probability of future droughts.⁴⁰ Furthermore, the natural multi-year cycle between "El Niño" and "La Niña" systems in the Pacific Ocean also affect the likelihood of future drought.

During El Niño episodes, trade winds along the equator weaken and warmer water is pushed east towards the American continents. The result is drier and warmer than average conditions in the northern region of the North American continent during winter months.⁴¹ With drier conditions present, existing droughts can be extended or drought conditions can emerge where these impacts were previously nonexistent. Moderate and weaker El Niño episodes can result in a reduction in precipitation during winter months, resulting in less snowpack in the Pacific Northwest.⁴² Unusually strong El Niño episodes, which most recently occurred in 1982-83 and 1997-98, may lead to above average precipitation and wet winters.⁴³ Though difficult to forecast, at the time of this Plan update climatologists are predicting a strong likelihood of an El Niño developing winter of 2023 or early 2024.

The variability of precipitation is also expected to increase in the coming decades. Variability in this context refers to a departure from the historical norm in terms of the frequency of precipitation (also known as "wet days") as well as a departure from the historical average of total annual precipitation. One instance of drought that climate change has already impacted is "snow droughts" or when annual precipitation is within historical averages yet seasonal snowpack is below historical averages. The 2015 drought that affected Lane County and much of western Oregon is an example of a "snow drought."⁴⁴

Overall Vulnerability

Environmental impacts and economic losses, particularly to agriculture, recreation, and forestry are the most prevalent vulnerability concerns due to drought. However, areas of the county have also

³⁸ Fleishman, E., editor. (2023). *Sixth Oregon climate assessment: Drought*. Oregon Climate Change Research Institute, Oregon State University, Corvallis, OR. DOI: 10.5399/osu/1161.

³⁹ Lane County Climate Resilience Plan, 2022.

⁴⁰ Fleishman, E., editor. (2023). *Sixth Oregon climate assessment*.

⁴¹ NOAA, (2023). "What are El Niño and La Niña?" National Ocean Service website.

⁴² Halpert, M. (2014). "United States El Niño Impacts." Climate.gov, NOAA.

⁴³ Ibid.

⁴⁴ Oregon Office of Emergency Management. (2020). "Oregon Natural Hazard Mitigation Plan."

experienced some water scarcity, introducing concerns about resource availability, particularly during an ongoing drought. Currently, drought is not expected to immediately impact public health and safety and has a limited impact on the built environment. A limited impact should not be taken to mean a lack of any impact. If more development occurs within Lane County alongside persistent drought conditions, water curtailment and other conservation measures may be required.

With this context of drought's current limited impact and the high probability of future occurrences, overall vulnerability to drought is classified as **low**. *This classification has not changed since the previous version of this Plan.*

Section 2.2.2: Earthquake

Lane County is exposed to earthquakes from a few sources. Fault lines exist throughout western Oregon that can produce earthquakes strong enough to impact buildings and endanger people's safety. More often, these earthquakes are less intense. The second source is the proximity of Oregon to the Cascadia Subduction Zone (CSZ). Although the probability of earthquake in Lane County is **low**, the vulnerability to earthquake is classified as **high**. Vulnerability is highest in the Coastal and Valley regions with the Cascades region possessing moderate vulnerability. High vulnerability to earthquakes indicates **low** probability of future occurrences along with **catastrophic** severity.

Hazard Description

An earthquake is the motion or trembling of the earth caused by an abrupt release of stored energy in the rocks beneath the planet's surface. The energy released results in vibrations known as seismic waves that cause the ground to shake. Duration of strong shaking can range from a few seconds to a few minutes and is commonly followed by aftershocks that can continue for several days following the original event. Tsunamis are directly related to oceanic earthquake activity. A CSZ earthquake will produce a tsunami that will reach the Oregon coast shortly after the ground stops shaking; for more information about the impacts and vulnerabilities related to coastal Lane County, see the Tsunami hazard profile in Section 2.2.6 and refer to the annexes submitted by the Cities of Dunes City and Florence in Volume II of this Plan.

Earthquakes in the Pacific Northwest can result from either shallow crustal quake within the North American Plate, deep intraplate incidents within the subducting Juan de Fuca Plate, earthquakes resulting from volcanic activity, and the offshore CSZ.⁴⁵ The greatest risk originates from intraplate earthquakes and from a megathrust earthquake produced by the CSZ.

Earthquakes can damage or destroy structures depending on the severity of the ground shaking, which is related to the magnitude of the event. Most earthquakes occurring on land historically register in lower magnitudes and are much less likely to result in damaged property. However, stronger quakes can be expected to damage homes, public infrastructure (communications & utilities), and roadways and bridges while also causing spills of stored hazardous materials. A high-magnitude earthquake, such as an expected 8.0m or stronger CSZ earthquake, will likely cause bridges to collapse and the ground shaking will trigger landslides in the Coast and Cascade Ranges.

⁴⁵ Oregon Natural Hazard Mitigation Plan. (2020). "Earthquakes."; Eugene-Springfield Area Multi-Jurisdiction Natural Hazard Mitigation Plan. (2020). "Earthquakes."

Cascading Impacts and Secondary Hazards

Ground shaking of great enough severity can result in potential dam failures. With particularly strong ground shaking and liquefaction, dams in Lane County may collapse and result in destructive flooding in several areas throughout the county, including the Eugene-Springfield metropolitan area. Seismic assessments and hardening of these facilities are critical to safeguard communities and prevent compounding damage resulting from a CSZ earthquake. Additionally, a significant earthquake poses a risk to the release of stored hazardous materials. Though this risk is not characteristic for every community in Lane County, locations in the metropolitan area and close to Lowell in the Cascades region contain and store hazardous materials that pose significant risk to public health and life safety if released. This risk is compounded when hazardous material storage areas are in proximity to waterways. Though Dam Failures and Hazardous Materials are not profiled as hazard events within the update to this Plan (see Section 2.1 for Hazard Identification Summary), information about Fs in Lane County are included in Volume III: Appendix A.

Earthquakes can trigger other hazard events or result in cascading impacts depending on the type of quake and impact area.

Landslides and Debris Flows: Ground shaking is a driving factor that contributes to potential landslides and debris flows. In Lane County, the areas of most concern related to a high magnitude CSZ earthquake are the communities down slope in the Coast and Cascade Ranges. The potential for blocked roadways because of landslides also poses risk for access to critical infrastructure, such as communications towers, which can be damaged by ground shaking and soil liquefaction.

Tsunami: Offshore, oceanic earthquakes can produce local or distant tsunamis affecting the Oregon Coast. Included in the record of previous occurrences, Lane County issued a Tsunami warning in 2011 following the distant 9.0 magnitude earthquake that struck the Tōhoku region of Japan. A tsunami was detected moving towards the Oregon coast and arrived with limited wave height or force and resulted in varying damages along the coastline among communities throughout the state. Expectations are that a CSZ earthquake of any expected magnitude (at minimum an 8.0m) will produce a local tsunami that will strike the Oregon coast shortly after the ground stops shaking from the initial event (approximately 10 to 30 minutes). The size and severity of the tsunami will depend on the magnitude of the rupture but is expected to be large. For more specifics, refer to the Tsunami hazard profile in Section 2.2.6 of Volume I.

Geographic Location

The potential for earthquakes exists for all portions of Lane County, though the coastline is most vulnerable. In a statewide context, Lane County is as prone to earthquakes occurring compared to most western Oregon counties (considering both the CSZ and local faults).

The CSZ is a region of the ocean floor off the coast of Oregon and Washington where the North American, Pacific, Juan de Fuca, and Gorda Plates meet. Subduction refers to the Pacific Plate sinking beneath the North American Plate. The North American Plate is moving in a southwest direction, overriding the Pacific and Juan de Fuca Plates. The CSZ lies approximately 70 – 100 miles off Lane County’s coastline and extends approximately 600 miles north to south from British Columbia to northern California. Its presence creates higher earthquake (and tsunami) vulnerability for western portions of Lane County.

Figure 2.3 shows a cross-sectional view of the CSZ and demonstrates how the tectonic plates off the Pacific Coast interact to generate subterranean pressure. Included in the image are other prominent sources of earthquake activity in the Pacific Northwest as well as dates of notable past events.

Figure 2.3: Cross Section of Cascadia Subduction Zone and other Sources of Earthquakes in the Pacific Northwest

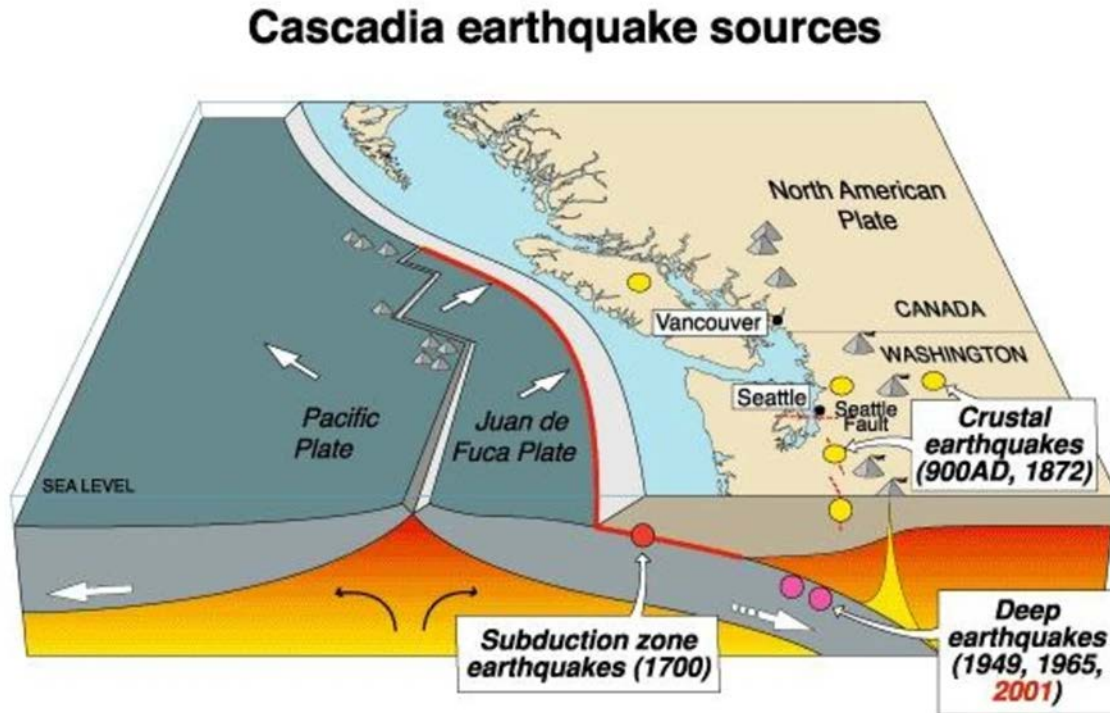

Source: U.S. Geological Survey

Coast Region: Coastal communities are most likely to experience (i.e., feel shaking or be directly impacted by) a moderate oceanic earthquake off the Oregon coastline. These earthquakes do occur with regularity, though most are of low magnitudes (less than 2.0 on the Richter scale, see Hazard Extent in this profile). A couple of faults active within the last 20,000 years exist close to coastal areas of Lane County.⁴⁶ The coast is in proximity to the eastern region of the Ring of Fire, a collection of active underwater volcanoes and seismic fault lines that extend along coastlines throughout the Pacific Ocean. These volcanoes exist in seismically active regions of the Pacific Basin. For example, major earthquakes in 1964 near Alaska and the 2011 earthquake that struck the Tōhoku region of Japan⁴⁷ caused widespread damage, loss of life, and produced tsunamis that struck the Oregon coast.

The risk of earthquake in the Coast region comes mainly from its exposure to a CSZ megathrust earthquake. The Oregon Department of Geology and Mineral Industries (DOGAMI) Statewide Geohazards Viewer tool, HazVu, projects that ground shaking in areas throughout western Lane County

⁴⁶ Lane County Emergency Management. (2018). "Multi-Jurisdiction Natural Hazard Mitigation Plan: Earthquake Hazard Profile." Lane County, p. 69.

⁴⁷ National Center of Environmental Information. (2021). "On this Day: The Great Tōhoku Earthquake." NOAA. <https://www.ncei.noaa.gov/news/day-2011-japan-earthquake-and-tsunami>.

will be severe to violent.⁴⁸ The immediate coastline will be destroyed by such an earthquake, both initially as the event begins and by the subsequent tsunami generated by the earthquake (see Section 2.2.6.). Areas around Florence, Dunes City, and west of Highway 101 also have “very high susceptibility” to liquefaction, which will further compound damage to structures and infrastructure during a CSZ earthquake (see specific impacts found in annexes provided by Dunes City and Florence in Volume II of this Plan).

Valley Region: Crustal earthquakes in the Willamette Valley within Lane County tend to be uncommon. The Eugene-Springfield metropolitan area noted that no earthquakes had occurred within either city’s limits in recent history, but three smaller earthquakes (each around 4.2 magnitude) occurred nearby in 2014 and 2015 (see Previous Occurrences).⁴⁹ Within the Valley, earthquakes historically occur in the eastern areas towards the Cascade foothills compared to the western valley floor at the base of the Coast Range. The 2015 event occurred approximately at the community Walterville along OR Highway 126 East.

The Willamette Valley is expected to experience strong to severe ground shaking in the event of a CSZ earthquake. A full rupture of the subduction zone is likely to produce an earthquake greater than a 9.0 magnitude, which will cause severe ground shaking in much of the Willamette Valley. Previous studies identified three areas of the Valley region with very high susceptibility to liquefaction that include east of Highway 99 around Junction City, along Highway 126 East between Springfield and Walterville, and southeast of the metropolitan area along Highway 58 and Interstate 5 near Pleasant Hill and east of Creswell.⁵⁰ Most of the remaining land is rated as moderate to low susceptibility to liquefaction. Areas prone to liquefaction are exposed to a higher potential of ground rupture and structural damage during a high-intensity earthquake.

Cascades Region: Lower magnitude crustal earthquakes occur in the Cascade foothills within Lane County. They are relatively infrequent and no recorded earthquake within Lane County in recent history has caused structural damage or resulted in injuries. The 2015 earthquake in Walterville is representative of the kind of events that do occur in this region of the county.

Communities in the Cascades will experience some of the effects such as ground shaking during a CSZ earthquake. Though the impacts from such an event are expected to be less severe at higher elevations of the Cascades, ground shaking could trigger landslides in the mountainous areas of the foothills and the McKenzie River Valley. There are also pockets of land with moderate to high susceptibility to liquefaction, but these areas are much more remote and away from developed areas.

Hazard Extent

Earthquakes are commonly described in terms of magnitude and intensity. A traditional measurement for seismic energy released by an earthquake is the **Richter** scale. The intensity of the shock at a particular location is measured by the **Modified Mercalli Intensity (MMI)** scale. The MMI scale quantifies effects on humans, objects of nature, and structures. A third method for measuring ground

⁴⁸ Oregon Department of Geology and Mineral Industries (DOGAMI), (n.d.). *HazVu Tool*.

⁴⁹ Eugene-Springfield Area MNHMP, (2020). “Earthquake.”

⁵⁰ DOGAMI. (2008). “IMS-24: Geologic hazards, earthquake and landslide hazard maps, and future earthquake damage estimates for six counties in the Mid/Southern Willamette Valley including Yamhill, Marion, Polk, Benton, Linn, and Lane Counties, and the City of Albany, Oregon.”

motion is expressed as **peak ground acceleration (PGA)**, which is the change in speed of ground surface horizontal motion. PGA is expressed as a percent of gravity, or “g”, with higher PGA values indicating a more violent event. Table 2.10 displays these measurements together for comparison.

Table 2.10: Summary Comparison of Earthquake Event Severity and Associated Impacts

Richter Magnitude	Mercalli Intensity (cm/s)	PGA (% g)	MMI Intensity (I - XII) and Description
1.0 - 3.0	less than 0.1	less than 0.17	I. Motion only noticed by humans in favorable conditions.
3.0 - 3.9	0.1 - 1.1	0.17 - 1.4	II. Felt only by persons at rest, especially upper floors of buildings. III. Felt quite noticeably by persons indoors, especially on upper floors of buildings. Many people do not recognize it as an earthquake. Standing motrocars may rock slightly. Vibrations similar to the passign of a truck.
4.0 - 4.9	1.1 - 3.4	1.4 - 9.2	IV. Felt indoors by many, outdoors by few. Dishes, windows, doors disturbed; walls make cracking sound. Sensation like heavy truck striking building. Parked cars rock noticeably. V. Felt by nearly everyone; many awakened. Some dishes and windows broken. Unstable objects overturned. Pendulum clocks may stop.
5.0 - 5.9	3.4 - 8.1	9.2 - 34	VI. Felt by all. Some heavy furniture moved. Damage slight. VII. Damage negligible in builidngs of good design and construction; slight to moderate in well-built ordinary structures; considerable damage in poorly built structures; some chimneys broken.
6.0 - 6.9	8.1 - 16	34 - 124	VIII. Damage slight in specially designed structures; considerable damage in ordinary substantial buildings with partial collapse. Major damage to poorly built structures. Chimneys, factory stacks, columns, and walls collapse. Heavy furniture overturned. IX. Considerable damage to structures; well-designed frame structures thrown out of plumb. Major damage to substantial buildings, with partial collapse. Buildings shifted off foundations.
7.0 and greater	16 - 31	124 and greater	X. Some well-built wooden structures destroyed; most masonry and frame structures destroyed with foundations. Rails bent. XI. Few structures remain standing. Bridges destroyed. XII. Damage total. Line of sight distorted. Objects thrown in the air.

Source: U.S. Geological Survey, Earthquake Hazards Program

PGA ranges for western Lane County are 0.6 to 0.8 as a percent of gravity and 0.2 to 0.3 for eastern portions of the county. These figures would indicate significantly higher intensity of shaking on the coast as described in the previous subsection and consistent with the findings of DOGAMI.

As shown in the map in Figure 2.4, potential earthquake intensity is highest in western Lane County along the coastline and Coast Range Mountains and somewhat lower along the Willamette Valley floor, Cascade foothills, and higher elevations of the Cascade Mountains.

Figure 2.4: Estimated Severity of Earthquake Amplification (Ground-Shaking) in Lane County

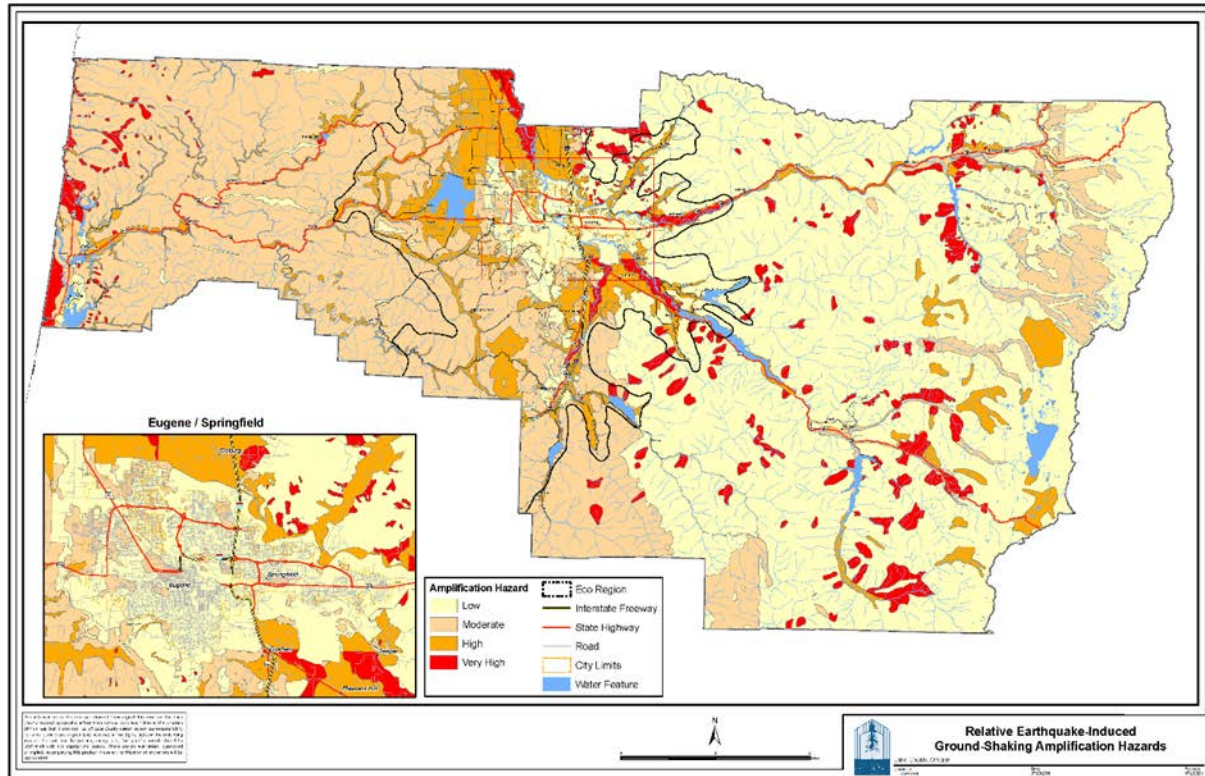

Source: Lane County GIS via DOGAMI Hazard Data

Based on assumptions for the most probable worst-case scenario, an 8.0 to 9.5 magnitude megathrust CSZ earthquake off the Oregon coast, and the impacts of previous earthquakes, a **Level 4 – Catastrophic** hazard extent classification is assigned for earthquake. This classification describes impacts and severity as affecting more than 25 percent (25%) of the county’s population and built environment. *This classification has not changed since the previous version of this Plan.*

Previous Occurrences

Earthquakes occur more frequently than many people realize. Since 2000, there have been approximately 141 registered earthquakes that exceeded a magnitude of 2.5 within a regional proximity to Lane County. Of these earthquakes, seven (7) exceeded a 4.0 magnitude, which may be felt by nearby communities. The strongest earthquake to occur onshore in proximity to Lane County in the twenty-first century happened near Sweet Home in Linn County on the morning of October 7, 2022. Though no damage was reported in Lane County,⁵¹ USGS received reports that the 4.4 magnitude earthquake had been felt in the Eugene-Springfield metropolitan area.

On July 4, 2015, a 4.1 magnitude earthquake occurred in central Lane County. The epicenter was located near the community of Walterville, approximately 10 miles east of downtown Springfield at a depth of six (6) miles below the surface. This earthquake produced minor to moderate shaking that was noticed

⁵¹ U.S. Geological Survey, (n.d.). “Earthquake Catalog.” <https://earthquake.usgs.gov/earthquakes/search/>.

by some residents in an approximate 20-mile radius from the epicenter. No injuries or significant damage was reported. Other earthquakes that have occurred close to Lane County include offshore events exceeding 4.0 in magnitude in July (4.9) and August (4.7) of 2004 along with a 5.2 magnitude offshore earthquake on July 28, 2010, approximately 80 miles west of the Pacific coast.⁵²

One of the most notable onshore earthquakes in Oregon occurred on September 21, 1993. A 6.0 magnitude earthquake near Klamath Falls caused two deaths as well as \$7.5 million in damaged property. More than 1,000 homes and commercial buildings were damaged. Three highways leading to Klamath Falls were temporarily closed because of rock falls and possible damage to bridges. Rock falls occurred in road cuts and on steep slopes throughout the epicenter region. Ground cracks in fill material were observed at several locations in the area. The earthquake was felt as far north as Eugene and as far south as Redding, California.

In addition to occurrences of crustal and intraplate earthquakes, 43 CSZ earthquakes have occurred in the last 10,000 years.⁵³ These CSZ earthquakes occurred at magnitudes ranging from 8.0 to 9.2, which is characterized as a disastrous or catastrophic event for much of the Pacific Northwest. Because the epicenter of these earthquakes is below the ocean surface, it is assumed that tsunamis accompanied each of these events. The most recent CSZ earthquake to occur happened in January of 1700, producing a strong enough earthquake to send tsunami waves towards both the Pacific Northwest and Japanese coastlines.⁵⁴ It has been 323 years since the last rupture of the CSZ. Table 2.5 displays a record of known ruptures of the CSZ over the past 10,000 years, distinguishing between earthquakes stronger or weaker than a 9.0 magnitude event.

Figure 2.5: Timeline of Identified Ruptures of the Cascadia Subduction Zone in the past 10,000 Years

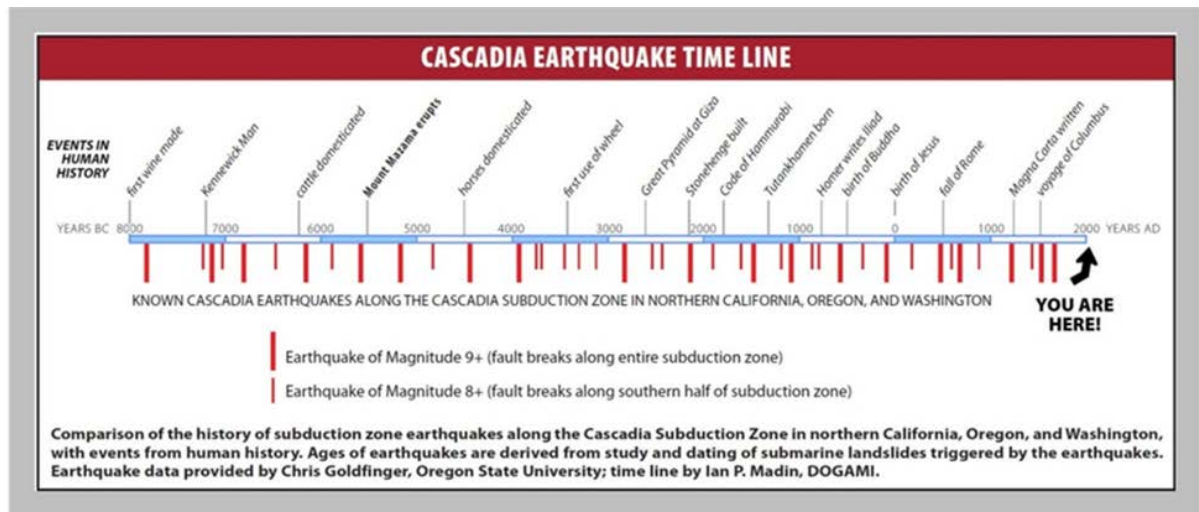

Source: Yu Q.-S., Wilson J., and Wang Y. Overview of the Oregon Resilience Plan for Next Cascadia Earthquake and Tsunami. Proceedings of the 10th National Conference in Earthquake Engineering, Earthquake Engineering Research Institute, Anchorage, AK, 2014.

⁵² Ibid.

⁵³ Goldfinger, C. (2016). "Subduction zone earthquakes off Oregon, Washington more frequent than previous estimates." Oregon State University, Corvallis, OR.

⁵⁴ Schulz, K. (2015). "The Really Big One." *Annals of Seismology*: The New Yorker. New York City, NY.

Probability of Future Occurrences

The most recent studies regarding a rupture of the CSZ provide varying conclusions about probabilities of when the next rupture will occur. As of this Plan's update, researchers estimate that in the next 50 years there is a 37 – 43 percent chance for a partial rupture that would mostly impact the southern Oregon and northern California coasts. Estimates state that there is a 16 – 22 percent chance of a partial rupture that would impact the entire Oregon and northern Californian coast. Lastly, estimates suggest a 7 – 12 percent chance for a complete rupture along the entire 600-mile fault zone, which would impact the southern British Columbian coast all the way to the northern California coastline along with all of Oregon and Washington's coastlines.⁵⁵

These estimates equate to a one percent (1%) probability of occurrence in any given year resulting in a classification of **low probability** of future occurrences (see classification definitions from Section 2.1.1). *This classification has not changed since the previous version of this Plan.*

Impacts Resulting from Climate Change

At this time, it is unknown how climate change will impact the extent or future occurrences of earthquakes in Lane County. Some research suggests that soil type and health could affect how earthquake effects take form during an event, but there is no consensus to this point. What limited research that has examined the relationships between seismic events and climate drivers only suggests there could be impacts along fault lines from changes in precipitation patterns and the severity of rainfall.⁵⁶ However, as with issues related to soil health and earthquake impacts, there is no broad consensus about these potential connections.

Overall Vulnerability

Despite estimates of a low probability of future occurrences, vulnerability to earthquake in Lane County is classified as **high** based on the catastrophic hazard extent and impact to critical systems. High vulnerability is characteristic for both the Coast and Valley regions while moderate vulnerability exists for the Cascades region, which will be further away from the source of the earthquake and experience less ground shaking and liquefaction potential. *The high vulnerability classification countywide has not changed since the previous plan.*

Liquefaction can amplify impacts of earthquakes, causing foundations to shift and damage buildings. The map in Figure 2.6 shows areas of liquefaction susceptibility in coastal areas in Florence, along Highway 101 west of Dunes City, east of Junction City, near Pleasant Hill, Lowell, and Walterville. The coastline faces the combined risk of liquefaction, potential for a high magnitude earthquake, and tsunami inundation. Considering these factors along with development in the Cities of Florence and Dunes City and along Highway 101, coastal areas are considered the most vulnerable in Lane County to a CSZ event.

⁵⁵ DOGAMI. (2022). "Cascadia Earthquake Knowledge Points for Emergency Managers and the Public."

⁵⁶ Buis, A. (2019). "Can Climate Affect Earthquakes, Or Are the Connections Shaky?" NASA Jet Propulsion Laboratory, California Institute of Technology. Pasadena, CA.

Figure 2.6: Relative Liquefaction Risk for Soils in Lane County

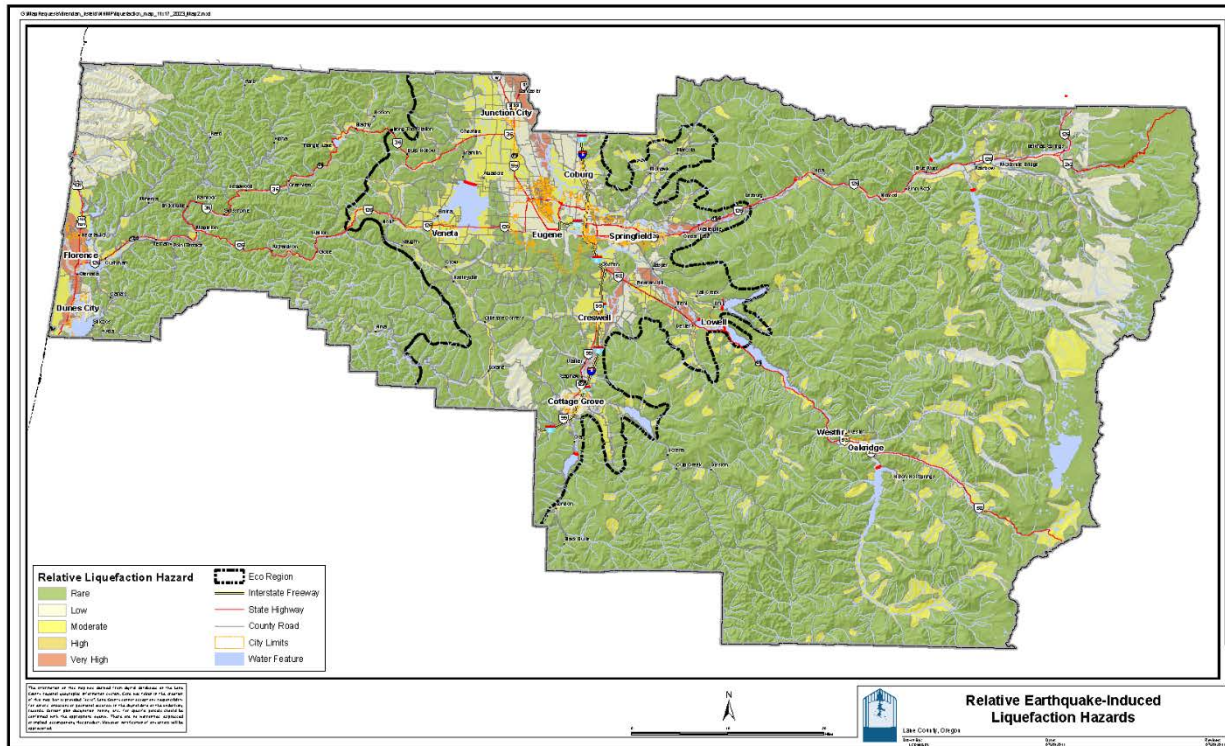

Source: Lane County GIS via DOGAMI Data

Section 2.2.3: Extreme Weather

The probability of extreme weather in Lane County is **high**. Extreme weather includes extreme temperatures (cold blasts, heat domes), thunderstorms that produce hail, and violent winds storm types such as tornados. A high probability of extreme weather will likely occur in the form of temperature driven events, particularly extreme heat during the summer months. The overall vulnerability of Lane County is classified as **moderate**. A moderate vulnerability indicates a high probability of future occurrences along with a **critical** hazard extent.

Extreme weather is a natural hazard included for the first time in the Lane County MNHMP. Recent occurrences of heat waves, freezing temperatures, and hailstorms demonstrate the potential for weather that creates hazardous conditions. Including extreme weather among hazards examined in this Plan is consistent with findings from the Lane County Climate Resilience Plan⁵⁷ and Oregon Natural Hazards Mitigation Plan, which included extreme heat for the first time in its most recent 2020 plan update.⁵⁸

⁵⁷ Lane County. (2022). "Climate Resilience Plan." County Administration Office. p. 15.

⁵⁸ Oregon NHMP. (2020). "Extreme Heat." pp. 237 – 254.

Hazard Description

Extreme weather is characterized by hazardous temperatures and powerful atmospheric-driven storms. Temperatures vary throughout the year and rise or fall to extremes that can pose risks to human health and potentially affect infrastructure operability.

Extreme heat describes either a singular instance of dangerous warm temperatures occurring on a given day or a prolonged period of high temperatures over several days. Heat waves generally describe consecutive days of higher temperatures and most often occur during summer. One approach to identifying hazardous heat is when temperatures in the area exceed a heat index of 90 degrees Fahrenheit. This threshold is when the human body begins to suffer adverse effects of prolonged exposure to heat.

Extreme heat is particularly hazardous due to its impact on people and systems. Prolonged exposure to heat can increase the likelihood of exhaustion, dehydration, heat cramps, and heat stroke. As a result of these public health risks, hospitals see a spike in heat-related illnesses, people working outdoors are at increased risk, and economic activities can be disrupted due to hazardous working conditions or reduced public attendance at outdoor events. In addition, extremely hot and consecutive days of high heat contribute to increased wildfire risk. Experiencing multiple heat waves in a season, and over several years, can also drive drought conditions, stressing wildlife such as trees and riverine species, such as salmon.

Extreme cold occurs when temperatures decrease below thresholds where risk to human health exists. When wind is also present during extreme cold days, the wind chill effect can intensify the effects cold has on people exposed to the air. At extreme low temperatures, pipes and other infrastructure can freeze and burst resulting in floods within buildings that cause extensive damage. During winter storms, freezing temperatures often create ice on roads and produce freezing rain that damage transmission lines leading to power outages. When people lose power, they may not have additional means for heating homes or powering medical devices.

In addition to extreme temperatures, atmospheric storms can produce severe weather events, such as thunderstorms. A thunderstorm is a rain-bearing cloud that produces lightning along with the acoustic effect on Earth's atmosphere, known as thunder. These storms can produce high winds, hail, and lightning. Thunderstorms occur both in winter and summer months. Dry thunderstorms, which are those clouds that do not produce rain but produce lightning, are more common in the western United States and can ignite wildfires. The effects of storms that generate powerful winds are covered in the Windstorm hazard profile (see Section 2.2.9). The effects of storms that produce heavy winter precipitation (such as snow and ice) are covered in the Winter Storms hazard profile (see Section 2.2.10).

Cascading Impacts and Secondary Hazards

Extreme weather triggers several cascading impacts to infrastructure and poses risks to public health and safety. Depending on the event type, extreme weather also contributes to the potential for inducing other natural hazards. For example, extreme temperatures cause an increase in energy demand for cooling or heating purposes. Water usage often increases during heat waves and extreme heat has the potential to damage roadways and airport runways when temperatures exceed 100 degrees. During thunderstorms, hail has the potential to damage buildings, vehicles, and poses safety risks for

unsheltered individuals as well as creating hazardous road conditions. Strong thunderstorms that bring hail and wind can potentially cause power outages and disrupt communications equipment operability.

Drought and Wildfire: Extreme heat most directly impacts the potential for an area to experience drought or wildfires. The warm air accelerates evaporation of water from the surface, drying the landscape and heightening the potential for the area to enter a period of drought. The warm air also dries out vegetation creating conditions favorable for wildfires to start. Furthermore, instances of thunderstorms during the warmer season often include lightning strikes that can ignite fires.

Windstorms: Thunderstorms often produce strong winds during the event and in rarer instances tornados. Recent impacts of thunderstorms to affect Lane County tend to occur in the Valley and Cascades regions. Straight-line winds characteristic of other types of windstorms in Lane County are addressed as part of the profile for Windstorms hazards (see Section 2.2.9).

Winter Storms: While extreme cold does not directly induce winter storms, when cold air meets a storm that brings high winds and heavy precipitation, the extreme cold compounds the impacts of the storm on infrastructure and people. Cold temperatures are most likely to result in snowfall or ice when there is precipitation. A large accumulation of either during a winter storm can lead to several system disruptions and failures, particularly hazardous driving conditions and impassable roadways, power outages, and risks to public health and safety. Heavy snowfall can also isolate residents in unincorporated communities, requiring the need to shelter in place for several hours or possibly days.

Geographic Location

Extreme weather happens regionally, affecting a wide area of Lane County. Extreme temperatures tend to cover one or more of the three planning regions with similar conditions. Given Lane County's geography, variations in temperature exist considering how the Coast region experiences fewer extreme temperature events compared to the Valley and Cascades regions. The Valley region is most likely to experience the highest temperatures countywide, with similar conditions experienced in the Coast and Cascade foothills. At higher elevations in the forested mountains, temperatures decrease. Temperatures also tend not to exceed hazardous conditions for areas along the Pacific coastline. Similarly, atmospheric storms can span across most of the valley floor in Lane County as well as the Coast and Cascade foothills.

Coast Region: Extreme temperatures are less frequent in the Coast region. The Pacific Ocean produces a cooling effect on the land area west of the Coast Range Mountains, which also regulates the temperature. This effect keeps temperatures from rising too high or falling too low in areas such as Florence, Dunes City, Cushman, and Heceta Beach. Further inland, temperatures in Coast Range communities such as Mapleton and Swisshome can be 5 to 7 degrees higher on average compared to the coastal areas but also remain under dangerous levels for most of the year. The Coast region is less susceptible to atmospheric storms compared to other regions of the county and mainly experience high winds when Pacific storms pass through.

Valley Region: The Willamette Valley floor can experience pronounced effects from extreme temperatures. Air settles on the valley floor between the Coast and Cascade ranges as it enters the region and then stagnates. Warmer air in the summer can raise temperatures above historical averages. In the Eugene-Springfield metropolitan area, July and August historically experience average highs of 80 degrees. During the most recent heat waves, the metropolitan area experienced temperatures higher than 90 degrees and at times over 100 degrees. These effects are consistent across the Valley region,

with similar averages and conditions experienced by cities such as Veneta to the west, Creswell and Cottage Grove to the south, and Coburg and Junction City to the north.

The Willamette Valley is less susceptible to frequent extreme cold blasts (temperatures 10 degrees or below) but experiences below-freezing days every year. However, the geography and climate extend the period of occurrence when temperatures can fall below freezing, which records show can happen anytime between September at the earliest through to May at the latest. Extreme cold is most likely and severe December through February. The coldest day recorded in the valley measured -12 degrees in December 1972.⁵⁹ More recently, the second coldest day recorded at -10 degrees occurred in December of 2013. Although temperatures rarely drop below 0 degrees, risk to public health for exposed individuals exists anytime temperatures drop below freezing and especially if there is sustained wind gusts and/or precipitation as well.

Thunderstorms pass over the valley floor affecting several of the cities located along Interstate 5. Thunderstorms can produce heavy rain, hail, and high winds. Transportation along the interstate and state highways is often disrupted during severe storms and may lead to some closures where there is flash flooding or a downed object from strong winds. When hail does form, it frequently is small posing less immediate risk of damage to property and buildings. Still, an intense, sustained spurt of hail can still threaten public safety to people caught outside without shelter, especially outside the metropolitan area where less infrastructure can provide temporary shelter from storms.

Cascades Region: Extreme heat is more likely to be experienced at lower elevations in the Cascade foothills. Annual averages in the summer months are similar to locations in the Willamette Valley, though these sites can be a couple of degrees higher during extreme events. For example, Oakridge has a historical average high temperature in August of 84 degrees compared to 81 degrees in Eugene. Average high temperatures are comparable in the McKenzie River Valley. Blue River for example experiences a historical average high in August of 79.5 degrees at an elevation of approximately 1040 feet. Both Blue River and Oakridge experienced temperatures greater than 100 degrees during the June 2021 heat dome demonstrating the wide area extreme heat events can cover. The areas also experience a comparable impact as the Valley region to extreme cold events. More information about winter season conditions that includes extreme cold events can be found in the Flood and Winter Storms hazard profiles.

Thunderstorms that produce high winds can be more impactful in creating transportation issues in the Cascades given the heavy forested land coverage and proximity to state highways. A thunderstorm producing heavy rains poses a heightened risk of flash flooding along the roadways and may induce landslides, particularly in the Holiday Farm Fire burn scar area that contains a major segment of OR Highway 126 East. The Cedar Creek Fire burn scar does not surround Highway 58 in the way that the Holiday Farm burned area contains a sizeable portion of Highway 126 east down slope from steep hillsides. Nevertheless, the area impacted should be monitored for any emerging risk that could affect Highway 58 past Oakridge in the next few years.

⁵⁹ National Weather Service, (2023). "ClimateBook, Historical Climate for Eugene, Oregon: Eugene Oregon Temperature Data, Period of Record 1892 through April 2022." NOAA website.

Hazard Extent

Extreme weather can be evaluated for severity based on the hazard type. Extreme weather characteristically in Lane County impacts infrastructure and can disrupt systems while posing a moderate risk to public safety and health. In recent years, events are showing that the risk to public health and safety is increasing.

Assessing the severity of extreme heat events include counting individual days where the daily high temperature exceeds 90 degrees or the number of consecutive days where temperatures exceed 90 degrees. Using the National Weather Service’s heat index is an even more effective tool to assess severity. This index identifies the temperature needed to produce conditions where the human body perceives temperature above 90 degrees, accounting for the relative humidity on that day and the actual temperature. Typically, the hottest part of the day occurs with lower humidity in Lane County and relative humidity averages 68 - 75% between June and September. However, were the humidity to coincide with high temperatures at a high of 86 degrees the heat index estimates that a person outside perceives the temperature to be 95 degrees when accounting for humidity. Therefore, with unusually high humidity during the hottest part of the day or unusually high overnight temperatures when relative humidity is typically high, even temperatures in the mid-80s can introduce health hazards for vulnerable individuals.

Table 2.11 displays the NWS Heat Index. In the summer months, particularly June through September, the Valley region in Lane County averages high temperatures ranging from 70 degrees (June & September) to 81 degrees (July & August).⁶⁰ Considering the historical humidity the area experiences during these months, high temperatures of 86 degrees begin creating hazardous conditions from heat. Dangerous conditions can occur from 90 to 92-degree days given humidity and extreme danger can occur from 96 to 100 degrees. Though less common, temperatures can exceed 100 degrees in the Valley and Cascade regions.

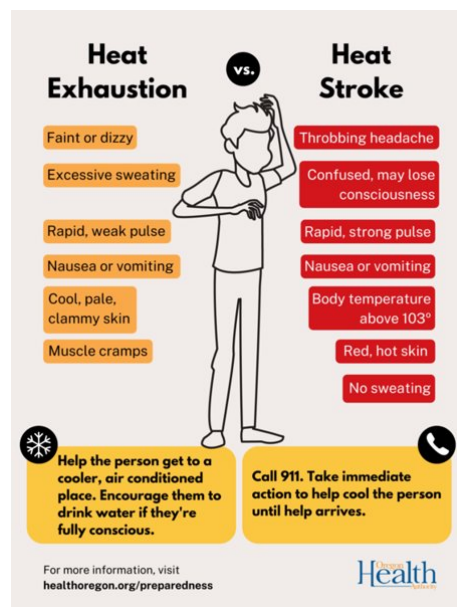

Heat exhaustion begins as the relative temperature exceeds the perception of 90 degrees and continues to deteriorate the longer a person is exposed to the heat or as the temperature rises. Heat exhaustion advances into heat stroke during prolonged exposure and particularly if the individual is dehydrated. Heat stroke poses serious health risks and can be fatal in extreme cases.

| Source: Oregon Health Authority

⁶⁰ NOAA. (n.d.). "U.S. Weather, Eugene, OR." Climate.gov.

Table 2.11: National Weather Service Heat Index, Air Temperature and Relative Humidity

		Air Temperature (°F)															
		80	82	84	86	88	90	92	94	96	98	100	102	104	106	108	110
Relative Humidity (%)	40	80	81	83	85	88	91	94	97	101	105	109	114	119	124	130	136
	45	80	82	84	87	89	93	96	100	104	109	114	119	124	130	137	
	50	81	83	85	88	91	95	99	103	108	113	118	124	131	137		
	55	81	84	86	89	93	97	101	106	112	117	124	130	137			
	60	82	84	88	91	95	100	105	110	116	123	129	137				
	65	82	85	89	93	98	103	108	114	121	128	136					
	70	83	86	90	95	100	105	112	119	126	134						
	75	84	88	92	97	103	109	116	124	132							
	80	84	89	94	100	106	113	121	129								
	85	85	90	96	102	110	117	126	135								
	90	86	91	98	105	113	122	131									
	95	86	93	100	108	117	127										
100	87	95	103	112	124	132											
		Likelihood of Heat Disorders with Prolonged Exposure or Strenuous Activity															
		Caution				Extreme Caution				Danger				Extreme Danger			

Source: National Weather Service

Wind chill can lower the body’s temperature when exposed to extreme cold. Lower temperatures and higher winds are common during the Willamette Valley’s winter season, creating the likelihood of risk resulting from extreme cold events for people exposed to the elements. Table 2.12 displays the wind chill index showing when the body begins to feel the effects of cold related impacts. Similar to how temperature and humidity interact to produce physical perceptions of heat, wind strength and air temperatures interact to make people feel colder than the actual temperature, which introduces a number of health risks such as frostbite, hypothermia, and in severe cases, death.

Table 2.12: Wind Chill Index for Effects of Extreme Cold

		Air Temperature (°F)															
		Calm	40	35	30	25	20	15	10	5	0	-5	-10	-15	-20	-25	-30
Wind Speed (mph)	5	36	31	25	19	13	7	1	-5	-11	-16	-22	-28	-34	-40	-46	-52
	10	34	27	21	15	9	3	-4	-10	-16	-22	-28	-35	-41	-47	-53	-59
	15	32	25	19	13	6	0	-7	-13	-19	-26	-32	-39	-45	-51	-58	-64
	20	30	24	17	11	4	-2	-9	-15	-22	-29	-35	-42	-48	-55	-61	-68
	25	29	23	16	9	3	-4	-11	-17	-24	-31	-37	-44	-51	-58	-64	-71
	30	28	22	15	8	1	-5	-12	-19	-26	-33	-39	-46	-53	-60	-67	-73
	35	28	21	14	7	0	-7	-14	-21	-27	-34	-41	-48	-55	-62	-69	-76
	40	27	20	13	6	-1	-8	-15	-22	-29	-36	-43	-50	-57	-64	-71	-78
	45	26	19	12	5	-2	-9	-16	-23	-30	-37	-44	-51	-58	-65	-72	-79
	50	26	19	12	4	-3	-10	-17	-24	-31	-38	-45	-52	-60	-67	-74	-81
	55	25	18	11	4	-3	-11	-18	-25	-32	-39	-46	-54	-61	-68	-75	-82
60	25	17	10	3	-4	-11	-19	-26	-33	-40	-48	-55	-62	-69	-76	-84	
Frostbite Times		30 minutes				10 minutes				5 minutes							

Source: National Weather Service

Thunderstorms generally are measured by the amount of rainfall during the storm. When thunderstorms produce tornados, the severity of the tornado is classified by the Enhanced Fujita Scale, ranging from EF0 events (40-72 mph fastest quarter-mile winds) through EF5 events (261-318 mph fastest quarter-mile winds). Lane County has not experienced a tornado greater than EF1 since 1950 according to the records available through NOAA's Storms Event database.

Taken as a whole, the types of extreme weather that can affect Lane County are most likely to disrupt transportation routes and impact infrastructure systems. Risks exist to public safety and health for individuals exposed to elements during an event or without a heating or cooling source in instances of extreme temperatures. Given the public health risk is most likely to lead to injuries and possibly fatalities, **extreme weather is classified at a Level 3 critical extent.** *Given that extreme weather is included for the first time in the Lane County MNHMP, this classification for extent is the first given for the hazard.*

Previous Occurrences

Lane County experiences various forms of extreme weather events, including a tornado during a 2015 windstorm. Heat waves and dangerously high temperatures have occurred on an annual basis over the past five (5) years. Periods of extreme cold have also occurred during the winter months presenting dangerous conditions for people caught outside. In both cases, community centers (as either warming or cooling shelters) open to provide a refuge for individuals without shelter or who have lost power without any source to heat or cool their homes. For more information about heating and cooling shelters in Lane County, refer to the Capability Assessment in Section 3.1.3 (Facilities).

Extreme Temperatures: According to the NCDC Storm Events database, 21 records appear since 2000 when searching for Lane County and the two event types, "Heat" and "Excessive Heat" contained in the records. These records identify 10 individual events of extreme heat.

In the last three (3) years, Lane County has experienced extreme heat most often between June and September. August 17, 2022, brought high temperatures of 97 degrees and on July 29, 2021, temperatures reached 99 degrees.⁶¹ The trend of past occurrences suggests there is a greater likelihood of heat events as many of the records set were within the past decade. The year 2021 is notable for having 42 days, or 11.5 percent of days all year, over 90 degrees that also included 12 consecutive days of temperatures exceeding 90 degrees. The year 2015 had seven (7) days where the temperature exceeded 100 degrees with four of those days occurring consecutively from July 29 – August 1.

The most extreme event to occur recently took place in late June 2021 when temperatures across the Pacific Northwest exceeded 110 degrees. A "heat dome" hovered atop the region producing dangerously high temperatures across Oregon. Eugene registered a high of 111 during this heat wave as temperatures remained elevated over 100 degrees for 2-3 days during the daytime. Approximately 123 people statewide died because of the event including one individual in Lane County.⁶² The governor's office has declared a state of emergency due to heat twice where Lane County has been included, each during 2021.⁶³

⁶¹ NCDC Storm Events Database.

⁶² Ibid.

⁶³ Office of Oregon Governor, EO 21-27 and 21-26, 2021.

Table 2.13 displays the dates of extreme heat events along with the recorded high temperature and the corresponding heat index at the time of the daily high (as calculated with the relative humidity of that day) that occurred in Lane County since 2000.

Table 2.13: Occurrences of Extreme Heat, Daily Highs Exceeding 90°F with Corresponding Heat Index in Lane County since 2000

Date of Event	Highs Measured (°F)	Heat Index (°F)
August 17 - 18, 2022	95	94
August 11, 2021	102	100
July 29, 2021	98	94
June 26 - 28, 2021	111	116
July 12 - 17, 2018	96	93
August 1 - 4, 2017	102	99
June 4 - 6, 2016	95	96
July 29 - Aug. 1, 2015	104	98
July 1 - 5, 2015	100	96
June 26 - 27, 2015	98	97
July 1, 2014	96	93
June 28, 2008	96	95
July 20 - 24, 2006	104	105
June 25 - 26, 2006	97	98

Source: NCDC Storm Events Database; Lane County Emergency Management; Oregon Natural Hazards Mitigation Plan, 2020

Each year has potential for experiencing extreme cold. The most recent instance of extreme cold occurred in December of 2013 when Eugene recorded air temperatures of -10 degrees Fahrenheit.⁶⁴ This temperature was the second coldest on record (since 1892) for Eugene, with the coldest day at -12 degrees Fahrenheit occurring in 1972. Though such extremes are rare for the area, extreme cold in February of 2022 and 2023 serve as reminders about how overnight low temperatures into the teens and low 20s can create threatening conditions for people exposed to the cold or struggle with heating their homes.

Atmospheric Storms: Pacific storms can produce strong thunderstorms capable of producing hail and storm patterns such as funnel clouds. The NCDC storms database contains six (6) records for “funnel clouds” occurring in Lane County dating back to 1996. A thunderstorm in 2010 near Creswell produced dime sized hail along with strong winds knocking over a few trees and branches.⁶⁵ Strong thunderstorms tend to occur in some fashion once or twice a year in Lane County and previous storms include both winter and summer season events. The storms can be characterized by numerous weather “types” within the NCDC Storms Event database, and this presents difficulty identifying all previous instances of severe storms (separate from those categorized as windstorms and winter storms).

⁶⁴ NCDC Storm Events, Database.

⁶⁵ Ibid.

There are documented occurrences of tornados occurring in Lane County. Most recently was an EF0 tornado that touched down at Lane Community College in April of 2015.⁶⁶ Though no injuries were reported, the tornado lifted two cars, including two people inside one of the vehicles, and resulting in approximately \$25,000 in property damage. Other instances of tornados have occurred near Creswell (1999), North Eugene (1996), the south hills of Eugene (1989), and south of Junction City (1984). The strongest of these tornados measured as an EF1. Tornados are uncommon and rarely form at magnitudes beyond EF0 in Lane County.



Impact of Tornado at Lane Community College, April 14, 2015 | Source: The Oregonian

Probability of Future Occurrences

The probability of extreme weather occurring in the future is **high** in Lane County. Extreme temperatures are likely to become more frequent during summer months and potentially in winter months as well. Other types of extreme weather, such as thunderstorms and tornados, are less frequently occurring, though instances of thunderstorms could become more severe (see the following subsection about impacts of climate change). Hail is moderately likely to be an effect of future thunderstorms when cold air is sufficient to produce hail from precipitation. Together, these events tend to present one to two hazard events per year under the extreme weather. Therefore, extreme weather has a high probability for future occurrences. *This classification of probability of future occurrences is the first assigned for extreme weather in this Plan.*

⁶⁶ Ibid.

Impacts Resulting from Climate Change

Instances of extreme heat are expected to be more common over the next decade as annual temperatures in Oregon continue to increase. OCCRI noted that consistent increases of the average annual temperature measured in the state is associated with an increase in recent heat events in the Pacific Northwest.⁶⁷ Locally, the Lane County Climate Resilience Plan (2022) estimated that the average number of days per year with temperatures above 90 degrees Fahrenheit would increase in all regions of the county, with averages totaling 32 – 34 days per year above 90 degrees in the Valley and Cascades by midcentury.⁶⁸ At these temperatures, above average summer heat can potentially produce nearly 6 – 7 weeks of days above 90 degrees, creating hazardous conditions for public health for nearly a quarter of the summer season. In the near-term, expectations will be that one (1) to three (3) dangerous heat waves are likely during the summer months, with high temperatures likely to exceed 90 degrees with the potential to break 100 degrees for two to three days.

Climate models estimate that winters in Oregon will become milder based on higher average temperatures compared to present day averages. For example, the Lane County Climate Resilience Plan estimates an increase of average low temperatures by approximately three degrees by mid-century in all of Lane County’s regions.⁶⁹ What is less understood is the potential for extreme cold events to occur with changes in seasonal winter climate patterns. Considering extreme temperatures, extreme heat events are more likely to create hazardous conditions compared to extreme cold events, though they do occur under the proper conditions.

Hail resulting from winter storms and thunderstorms in the summer months can be expected to occur with low frequency each year. Though these events occur infrequently enough at a severity that threatens people’s safety and causes property damage, changes in atmospheric conditions and overall climate may affect how often thunderstorms and hail occur in Lane County. There remains uncertainty about the form extreme storms will take, though it is expected that tornados will most likely be an uncommon to rare occurrence despite the potential for their forming in the Willamette Valley.

An increase in air moisture capacity that results from a warmer climate is also expected to increase the frequency of atmospheric rivers in the Pacific Northwest. The primary impact of these storms in Lane County is their potential for inducing flooding (see Section 2.2.4). It is worth noting that these types of events are expected to occur more frequently and bring greater volumes of rainfall to Lane County in the coming decades.

Overall Vulnerability

Given the documented effects of extreme temperatures in the Valley and Cascades regions along with a high probability of future occurrences, particularly extreme heat, vulnerability to extreme weather is classified as **moderate**. This classification for vulnerability is applicable for each region in the county though as previously noted, rural communities in the county are particularly vulnerable to extreme heat impacts on public health. The moderate classification is based on a high probability of future

⁶⁷ Fleishman, E., editor. (2023). *Sixth Oregon climate assessment: Heat*. Oregon Climate Change Research Institute, Oregon State University, Corvallis, OR. DOI: 10.5399/osu/1161.

⁶⁸ Lane County. (2022). “Climate Resilience Plan.” County Administration Office. pp. 30 & 34.

⁶⁹ Ibid.

occurrences and a critical hazard extent. *The moderate vulnerability classification for extreme weather is the **first designation** given for this hazard type in the Lane County MNHMP.*

Section 2.2.4: Flood

The probability of flood in Lane County is **high** and includes riverine, coastal, and storm water system type of events. Vulnerability of floods countywide is **high** with coastal communities facing risk from both coastal and riverine flooding. High vulnerability indicates a high probability of future occurrences and catastrophic severity (hazard extent). The hazard profile for flood in the Lane County MNHMP addresses the most common flood type countywide, which is riverine flooding. Coastal flooding is addressed within the annex for the City of Florence found in Volume II of this Plan.

Hazard Description

A flood is defined as the inundation of land by the rise and overflow of a body of water. Floods most commonly occur because of heavy rainfall causing a river or stream to exceed its normal carrying capacity. In Oregon, flooding can be exacerbated by “rain on snow” events that cause rapid snowmelt. Flooding potential in Lane County is most common from October through April due to winter-season Pacific storms. Flooding can be aggravated when human activity affects streams, such as through channelization of streams or loss of wetlands or dune structure along the coastline.

Riverine flooding is the most common type of flooding countywide and is affected by the intensity and distribution of rainfall, soil moisture, seasonal variation in vegetation, and water-resistance of the surface areas resulting from development. Flash flooding is a localized flood that results from a short duration of intense rainfall across a limited geographic area. During extended periods of intense rainfall, storm water conveyance systems can be overwhelmed and flood surrounding neighborhoods.

Floods severely damage property, pose high risk to life and safety, and are one of the most pervasive threats in Lane County. The experience of flooding is usually preceded by warnings from official sources encouraging the public to avoid flooded roadways, protect structures by sandbagging, and securing belongings in elevated positions. Table 2.14 provides definitions for National Weather Service flood announcements and warnings.

Table 2.14: Flood Stage and Stage Type Descriptions with Example Impacts

General Flood Categories	Description	Example Impacts
Major Flood Stage	Extensive inundation of structures and roads. Significant evacuations of people and/or transfer of property to higher elevations are necessary. A FLOOD WARNING should be issued if major flooding is expected during the event.	Many buildings flooded, some with substantial damage or destruction; infrastructure destroyed or rendered useless for an extended period of time; evacuations likely required.
Moderate Flood Stage	Some inundation of structures and roads near the stream. Some evacuations of people and/or transfer of property to higher elevations may be necessary. A FLOOD WARNING should be issued if moderate flooding is expected during the event.	Several buildings flooded with minor or moderate damage; some infrastructure rendered temporarily useless.
Minor Flood Stage	Minimal to no property damage, but possibly some public threat. A FLOOD ADVISORY product is issued to advise the public of flood events that are expected to not exceed the minor flood category.	Water over banks and in yards; some water under buildings on stilts; low lying areas will get wet.
Flood Stage	An established gauge height for a given location above which a rise in water surface level begins to create a hazard to lives, property, or commerce. The issuance of flood advisories or warnings is linked to flood stage.	NOTE: The severity of flooding at a given stage is not necessarily the same at all locations along a stream due to varying channel/bank characteristics on portions of the stream.

Source: National Weather Service

Cascading Impacts and Secondary Hazards

Floods can be induced beyond overflowing riverbanks. Several reservoirs exist throughout Lane County storing water at varying levels throughout the year. In the winter months, flood control dams lower water levels to ensure adequate storage capacity during the traditional wet months. Heavy rainfall, especially during atmospheric rivers, that occur at unusual periods (May or August for example) can catch reservoirs that are mostly, or completely, full. Weather alerts that include predictions for heavy rainfall should prompt a check of reservoir levels and the likelihood of overtopping and subsequent flooding. Reservoir storage levels can be accessed via the Willamette Valley “Teacup” map of the Willamette Basin.

Riverine and urban flooding can significantly impact critical infrastructure systems, blocking roadways and rendering bridges impassable. Power outages can occur depending on the location and extent of land flooded. Emergency response services may also be disrupted due to flooding directly impacting facilities and power sources used by first responders such as police, fire, and medical personnel. Lane County contains several low ground areas along roadways known to frequently flood during heavy rainfall. Refer to the Vulnerability Assessment in Section 2.3 for specific information about these locations.

Most notably is the impact of flooding, even in less severe events, on aging infrastructure. Heavy precipitation can turn rivers turbid, which presents challenges for older water and wastewater treatment plants to treat effluent from the water and keep flows at adequate levels. Rural, unincorporated communities in Lane County rely on infrastructure that in many cases is exceeding its functional lifespan and continues to age. Pipe leaks and reduced treatment capacity can cause facilities to operate at a limited capacity or outright fail, imperiling access to healthy drinking water and water for sanitation purposes.

Multiple types of flooding can also lead to levee or dam failure in instances where infrastructure is aging and in need of repair. Depending on the current water levels, leaks and eroded pipes within dam structures are more susceptible to water pressure and increasingly prone to leaks. Weakened segments of levees can break down and result in an opening for water to rush through and flood the land protected by the levee. Similar to reservoirs, levee failures can result from overtopping when water levels exceed the crest height of the levee.

Lane County contains many dams and levees designed for flood control and have functioned to contain the extent of some of the region’s most severe floods, such as the February 1996 event. Although there are many of these structures in Lane County, several of them continue to erode due to channel migration, burn scar areas, and additional run-off due to lack of vegetation. The 42nd Street Levee in Springfield continues to be an area of concern for both the City of Springfield and Lane County. The Eugene-Springfield Area Multi-Jurisdictional Natural Hazards Mitigation Plan (2020) outlines action items specific to maintain certification of the 42nd Street levee and other flood control structures within Springfield and surrounding Lane County.

Lastly, floods impacting locations where hazardous materials are stored result in these materials being carried downstream by flood waters. The polluted water can spread hazardous materials and waste to other areas that flood, further contaminating ground soils and water. As a result, the impact of a hazardous materials spill occurring during a flood presents significant public health risks, including lacking access to safe drinking water and soil contamination for agricultural operations that can also impact local food systems. The cost of cleanup increases significantly given the widespread spread of hazardous materials in the region. Lane County’s sites storing hazardous materials are in proximity to the incorporated cities and along the major transportation corridors in the county, particularly Interstate 5, Highway 58 near the metropolitan area, and along Highway 126 East through the McKenzie River Valley. Further information about the vulnerability of these sites to flooding can be found in the Vulnerability to Lifelines subsection within Volume I of this Plan (Section 2.3.3).

Ground Impacts and Landslides: In addition to cascading impacts, flooding may also induce other hazard events. Soils erosion and channel migration are among two secondary impacts that can further exacerbate flooding severity, extent of land inundated, and when occurring along sloped hillsides, can also induce landslides and flashing flooding in the area. Fast moving water exerts a significant force on ground materials and when strong enough, is likely to move earth even along relatively flat surfaces.

Geographic Location

Lane County experiences considerable variation in precipitation due to its geography. The average annual precipitation ranges from less than 40 inches in the Willamette Valley to over 100 inches at the highest elevations in the Coast Range and along the west slope of the Cascades. Using city locations as proxies for annual average precipitation, Florence receives approximately 69 inches of rainfall each year (period of record 1957-2022),⁷⁰ Eugene receives approximately 36 inches,⁷¹ and Oakridge receives approximately 85 inches each year.⁷²

⁷⁰ City of Florence. (2022). “Yearly Rainfall Report.”

⁷¹ Western Regional Climate Center.

⁷² NOAA.

FEMA’s definition for a floodplain, or Special Flood Hazard Area (SFHA), is the area inundated to a 1-foot depth by a flood with 1 percent annual probability of occurrence. According to common usage, this area is also referred to as the area inundated by the ‘100-year flood’, or ‘base-flood’. These terms describe the most severe flood that can be expected to occur during a 100-year timeframe. It is important to note that the geographic boundaries of the SFHA are estimated, based on various data inputs which may include topography, hydrology, climatology, and historic records. Flood inundation can and does occur in areas that are not mapped as SFHAs.

Lane County has more river miles of floodplain than any other county in Oregon. Over 136,000 acres of land is in SFHAs (212 square miles), and more than 20,000 individual parcels are partially or entirely located within SFHAs. Ongoing development along these rivers continues to displace natural areas that have historically functioned to store flood waters. Many rivers, tributaries, streams, and creeks are susceptible to annual flooding events. Flooding along these waterways threatens life and safety and can cause significant property damage.

Large rivers include the Willamette River (Main Stem, Middle and Coast Forks); McKenzie River (including the South Fork); Siuslaw River (including the North Fork); Row River; and Lake Creek. Smaller tributaries susceptible to frequent flooding include the Mohawk River, Long Tom River, Fall Creek, Little Fall Creek, Camp Creek, Mann Creek, Horse Creek, Coyote Creek, Mosby Creek, Poodle Creek, Siltcoos River, and Tenmile River.

The U.S. Army Corps of Engineers (USACE) operates nine (9) dams in Lane County that are primarily used for flood control. Constructed between 1941 and 1968, these dams control flooding on 50 percent of the tributaries in the Willamette Basin. The reservoirs behind the dams are drained throughout the summer and fall months to create storage capacity for water ahead of heavy winter and spring rains. Therefore, most flooding in Lane County occurs along waterways with no flood control devices, such as the Siuslaw and Mohawk Rivers.

Figure 2.7 displays the identified floodplain areas across Lane County. The map delineates Special Flood Hazard Areas (i.e., the 100-year floodplain). Also mapped is the area assumed to be inundated to at least a 1-foot depth by a flood with a 0.2 percent annual chance occurrence, also called the 500-year floodplain.

Note: Some FIRMs for Lane County are currently being updated such as for the Coast Fork and Middle Willamette Rivers and Amazon Creek. These maps would become effective in Summer of 2024 after this Plan’s promulgation. When the new maps become effective, this Plan will be updated within the hazard profile to accurately reflect the most recent data.

Figure 2.7: Floodplain Hazard Areas in Lane County

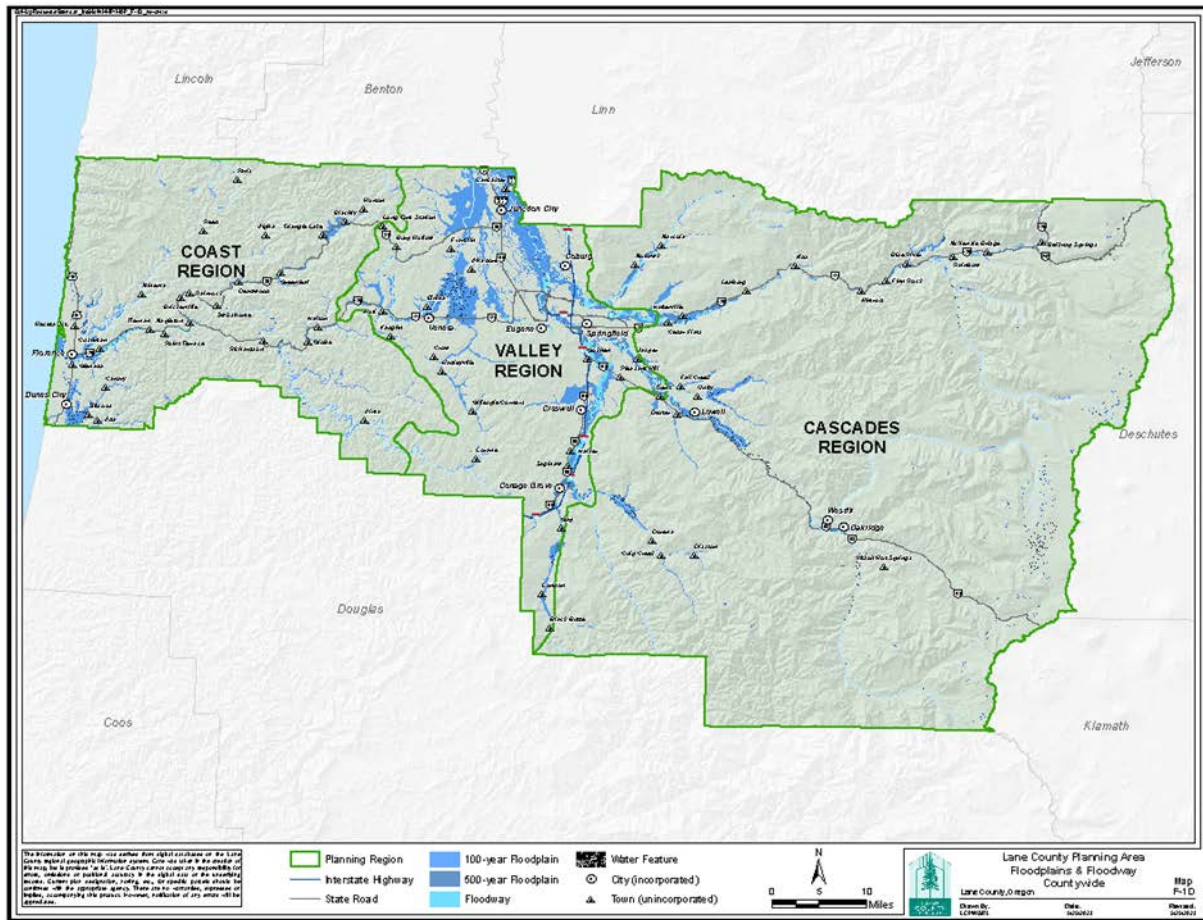

Source: Lane County GIS

Coast Region: Flood events in the Coast Region occur mainly from riverine flooding along the Siuslaw River and coastal flooding along the Pacific Coast. A number of communities along Highways 126 West and 36 include areas within the 100-year floodplain and floodway. Communities especially vulnerable to flood events include Mapleton, Florence, Glenada, and Dunes City. Swisshome, Deadwood, Triangle Lake, and Walton also exist close to floodplains. Figure 2.8 shows the areas in the Coast Region that are currently mapped within the 100-year floodplain and floodway.

Figure 2.8: Floodplain Hazard Areas in the Coast Region

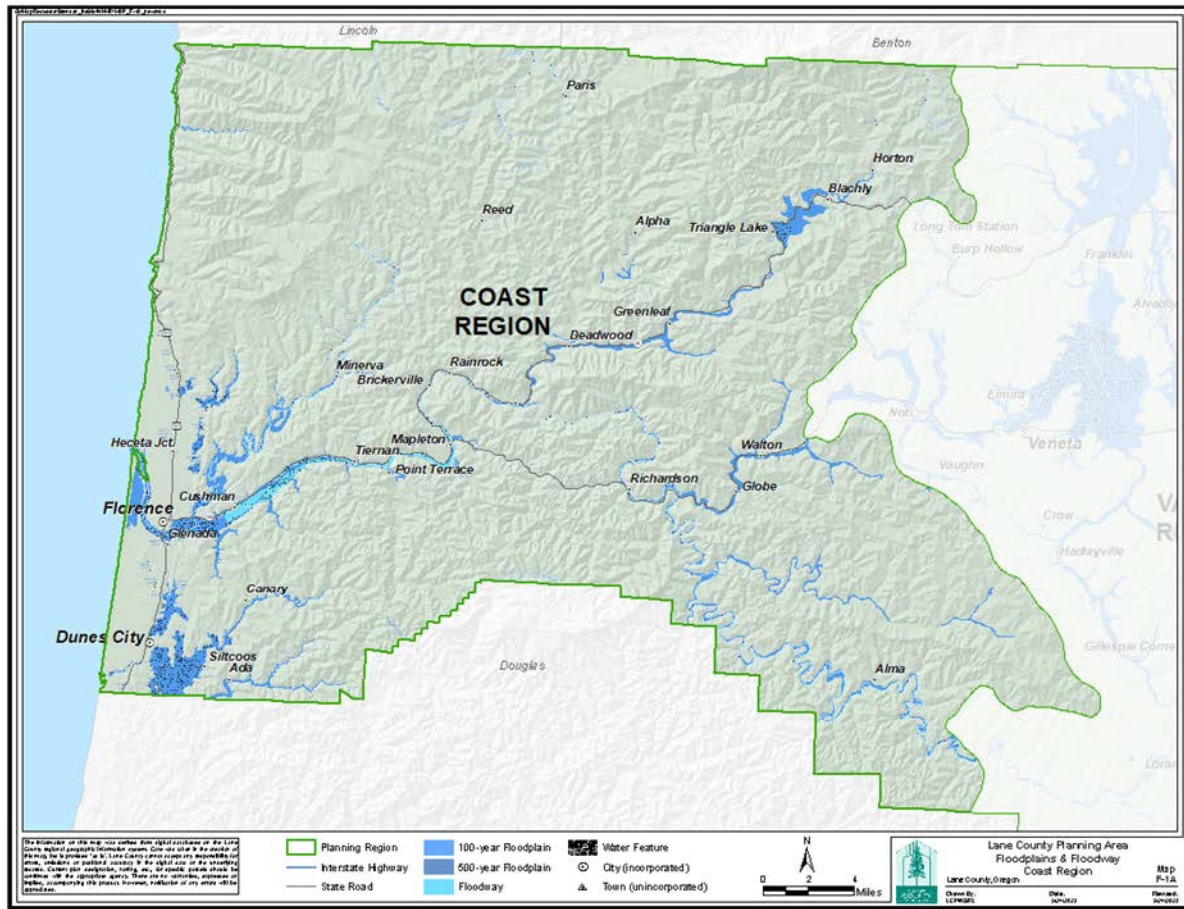

Source: Lane County GIS

Valley Region: Several communities exist within floodplains in the Willamette Valley region. The Willamette River, its tributaries, as well as the McKenzie River as it flows into the valley floor all present flood risk in this area. Much of Cottage Grove and Creswell exist in flood-prone areas. Specific portions of the Eugene-Springfield metropolitan area exist within the floodplains of the Willamette and McKenzie rivers. Both Coburg and Junction City reside in a wider covered area of floodplain (see Figure 2.8).

Veneta experiences exposure to floodplains to the north of Highway 126 West and on its eastern border. Flooding potential results from the city’s proximity to Fern Ridge Lake, but mainly impacts roadways and transportation rather than residences or other buildings. Figure 2.9 shows the areas in the Valley Region that are currently mapped within the 100- and 500-year floodplain along with those areas within the floodway.

Figure 2.9: Floodplain Hazard Areas in the Valley Region

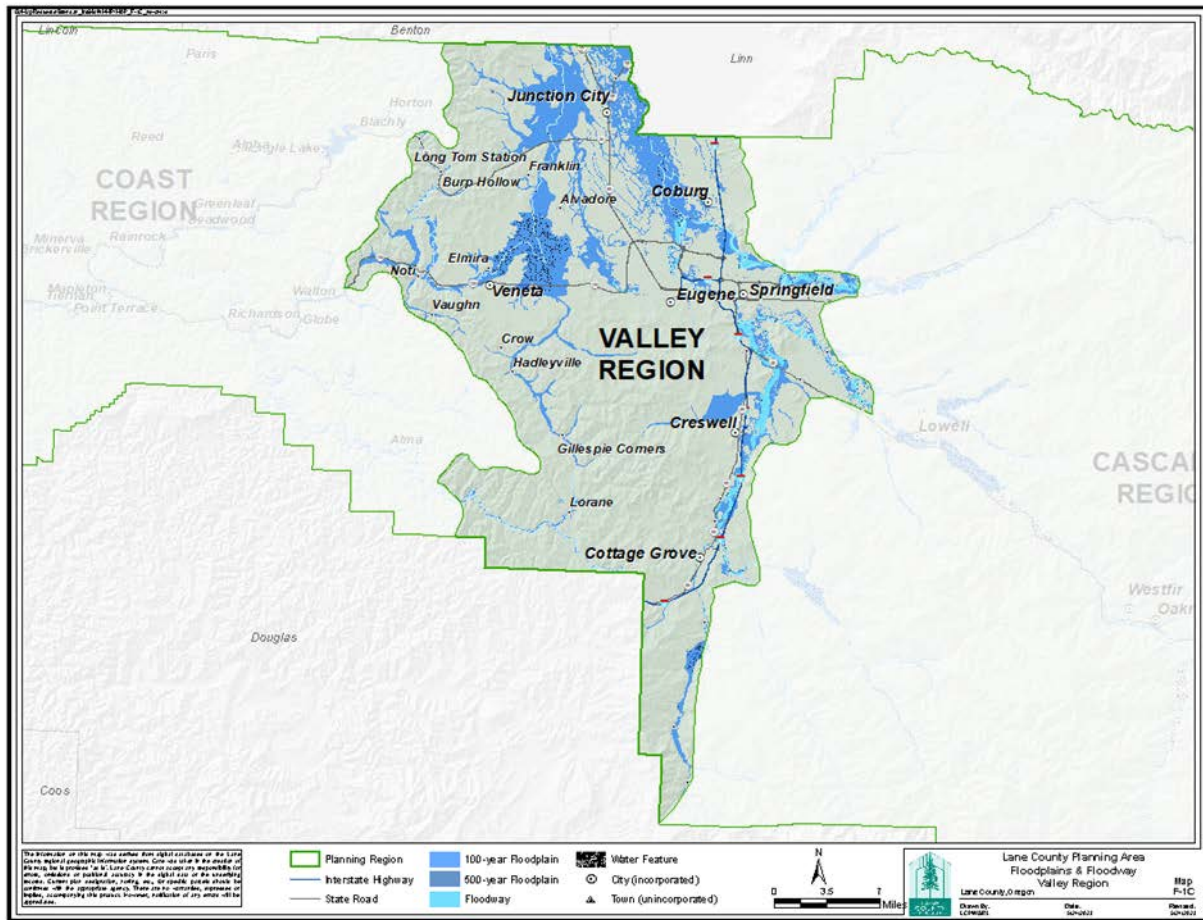

Source: Lane County GIS

Cascades Region: The Cascades Region contains two sub-areas: the McKenzie River Valley in the north and southeastern Lane. In the north, many of the unincorporated communities in proximity to the McKenzie River all include areas within floodplains, including Blue River, Rainbow, and McKenzie Bridge, as do portions of Nimrod, Vida, and Leaburg further west. In the south, Westfir and Oakridge each face flood risk from the Willamette River. Lowell also faces flood risk from its proximity to the Dexter Reservoir. On the border of the Valley and Cascades regions, the communities of Jasper, Pleasant Hill, Trent, and Fall Creek exist within floodplain areas. Figure 2.10 shows the areas in the Cascades region currently mapped within the 100- and 500-year floodplain along with those areas mapped to be within the floodway.

Figure 2.10: Floodplain Hazard Areas in Cascades Region

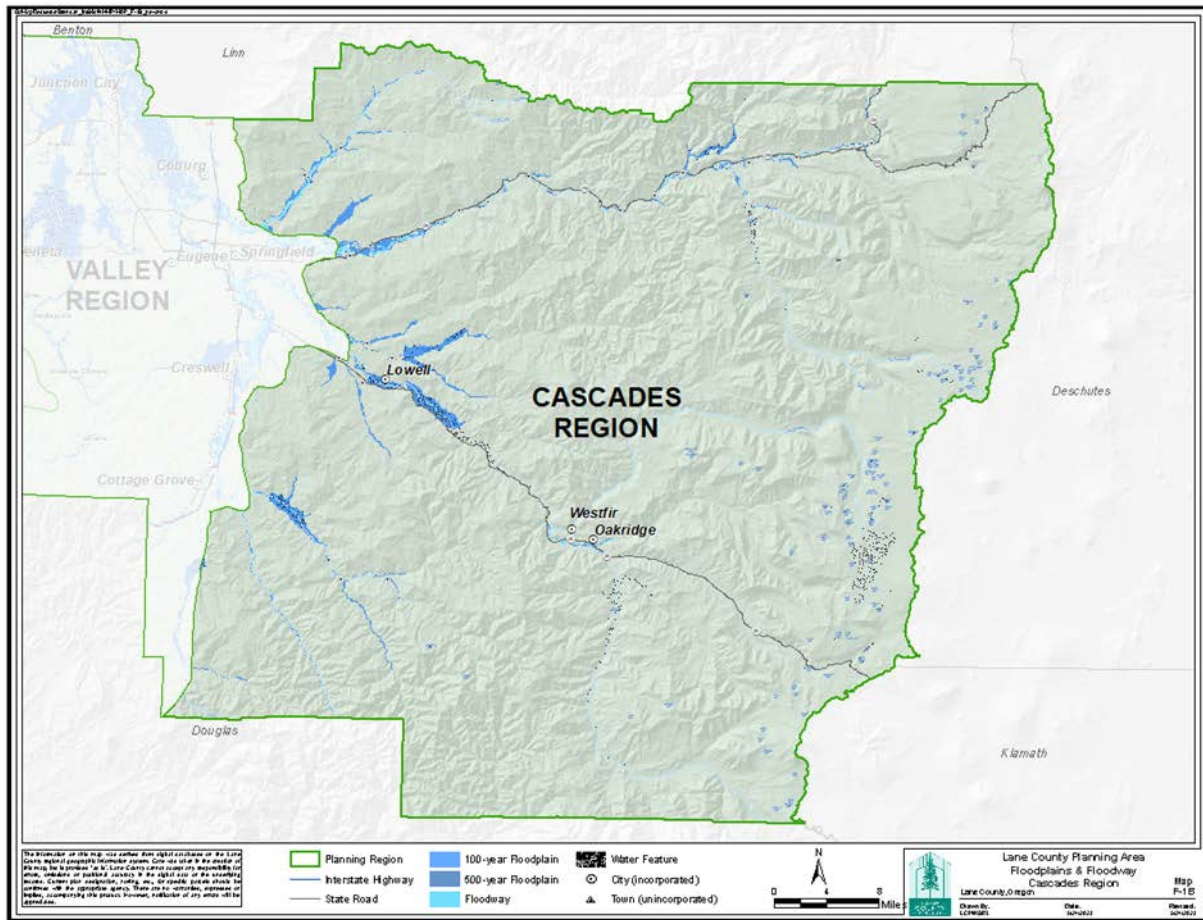

Source: Lane County GIS

Hazard Extent

Flooding extent can be described in several ways. One is to describe extent by acreage inundated. Version 3.0 of this Plan identified the amount of acreage inundated from four (4) historic flooding events in Lane County: 1861, 1945, 1964, and 1996. In these floods, approximately 150,000 to 195,000 acres were inundated, except for the 1861 flood which inundated approximately 320,300 acres, more than double the 1964, “Christmas Day” flooding extent. Table 2.15 shows the acreage inundated from those four (4) historic floods as a comparison of the potential maximum extent of area that can be flooded in Lane County based on the historical record.

Table 2.15: Extent of Historic Flooding Events in the Willamette Valley by Acres Inundated

Year	1861	1945	1964	1996
Acres Inundated	320,337	149,797	152,789	194,533

Source: Flood Inundations/FEMA Floodplains (Ashkenas, Wildman), PNW Ecosystem Research Consortium, Oregon State University; U.S. Geological Survey. Note: Inundation areas for 1861 may include areas from 1890; inundation areas for 1945 may include areas from 1943.

Another means for describing flooding extent is identifying the number of times that the river exceeds its banks. The U.S. Geological Survey operates stream gauges in Lane County that can measure when the water level exceeds flood stage. Table 2.16 summarizes instances in the historical record where river crests exceeded banks and were measured at flood stage or greater for three of the stream gauges in Lane County.

Table 2.16: Historic River Crests of Flooding Events for Three (3) Locations in Lane County, 1861 – 2012

Flood Stage	Impact Description	River Height Range	# of Events
General Location: Siuslaw at Mapleton (1964 - 2012) - Lat. 44.063333° N, Long. -123.882778° W			
Major Flood Stage	Expect major flooding of the Riverview Avenue area and numerous homes and businesses in Mapleton. Flooding of roads adjacent to the Siuslaw River in Mapleton is likely and flooding of Highways 126 and 36 will be significant.	28.00" - 30.21"	5
Moderate Flood Stage	Expect widespread flooding, including several homes and structures in low areas of Mapleton. Many sections of Highway 126 from Tiernane to Mapleton and Highway 36 north of Mapleton begin to flood and could be exacerbated during high tide.	22.68" - 25.79"	11
Flood Stage	Expect minor flooding of low lying dairy land along with some structures right along the banks of the Sisulaw River in the vicinity of Mapleton.	18.01" - 22.00"	1
General Location: Willamette River at Harrisburg (1861 - 2006) - Lat. 44.271389° N, Long. -123.173889° W			
Major Flood Stage	Flooding expected along the Willamette between Eugene and Albany, which include some parts of Highway 99E near Harrisburg. At 18", some homes and widespread lowland flooding expected. At 20", numerous small communities and developed areas from North Eugene to Harrisburg historically flood.	17.00" - 23.00"	12
Flood Stage	Expect minor flooding along the Willamette River concentrated to the western banks. At 15" low parts of Highway 99E have historically begun to flood. Expect widespread low land flooding along the Willamette River in the Harrisburg vicinity. At 16", expect widespread low land flooding mainly west of the river. More areas of Highway 99E can be flooded.	14.19-16.25"	9
General Location: Mohwak River at Springfield (1943 - 2012) - Lat. 44.092778° N, Long. -122.956667° W			
Moderate Flood Stage	At above 22", expect major widespread flooding of farmland and roads. Significant flooding in Marcola.	21.10" - 24.30"	5
Flood Stage	At above 15", expect flooding of low land areas and some rural roads near the river. At above 18", expected extensive flooding of farmland and local roads from the Confluence with the McKenzie River upstream to the Marcola area. Road closures are likely.	17.40" - 21.30"	15

Source: U.S. Geological Survey; National Climatic Data Center (NCDC), Storm Events Database; Lane County MNHMP 2018

A credible worst-case scenario for flood would involve conditions exceeding the 1861 flood event by 25 percent or more. Considering population and value of development within areas likely inundated by a major flood in Lane County (notably in the Willamette Valley), the hazard extent for flood in Lane County is classified as **Level 4 catastrophic severity**. *This classification of hazard extent has not changed since the previous plan.*

Previous Occurrences

The following subsection summarizes previous flood events for three time periods: since the previous plan update (2017 – 2023), between 2000 and 2016, and events that occurred prior to 2000.

Occurrences since Previous Plan Update (2017 – 2023): Over the past six (6) years, several flood events have occurred in Lane County. The NCDL Storm Events database identifies nine (9) total records, five (5) of which are separate events. Most of the records identify flood events in the Coast Region that resulted from heavy rains causing rivers to exceed flood stage. Most events reported no damage to property, or any injuries related to the event. Table 2.17 provides a list of flood events within the last six (6) years as recorded by both NOAA Storm Events database and Lane County sources.

Table 2.17: Recorded Flood Events at General Gauge Locations in Lane County, 2017 – 2023

General Location	Date	Cause	Flooding Type
Florence; Mapleton	December 20, 2021	Heavy Rains	Minor Flooding
Mapleton	January 12, 2021	Heavy Rains & Strong Winds	Minor Flooding
Mapleton	December 20, 2020	Heavy Rains & Strong Winds	Exceeded Flood Stage
*Mapleton; Cottage Grove; Jasper; Springfield; Goshen	April 7 - 11, 2019	Atmospheric River	Moderate Flood Stage
Mapleton	February 9, 2017	Heavy Rains	Exceeded Flood Stage

Source: National Climatic Data Center (NCDC), Storm Events Database; Lane County Emergency Management

*Event resulted in DR-4452 declaration for Oregon, though Lane County was not designated; Oregon Governor Kate Brown issued a State of Emergency declaration on May 6, 2019, for this event that included Lane County (EO 19-04)

One exception to these less impactful floods is the April 2019 event that occurred between the 7th and 11th. An atmospheric river slowly moved through the southern Willamette Valley over two days bringing heavy rains. Estimates of rainfall totals for areas south of Salem were between 2.5 to 5 inches of rain within the valley whereas some places in the Cascades and Cascade Foothills received 5 to 7 inches of rain.⁷³ Combined with snow melt, most of the rivers in the Willamette Valley Basin exceeded flood stage, including the Mohawk and Siuslaw.

Events between 2000 – 2016: Three (3) notable flood events occurred between 2000 and 2016: January 2006, January 2012, and December 2015.

The January 2006 event occurred because of heavy rains produced by a series of Pacific storms that moved across the region. Reports estimated that 2 – 3 inches of rain fell in the Willamette Valley and up to 4 – 5 inches of rain fell over parts of the Coast and Cascade Ranges at higher elevations. Over a dozen rivers in Oregon exceeded bank full levels and reached flood stage, including the Siuslaw at Mapleton and Mohawk at Springfield. Lane County was included in the resulting disaster declaration by then Governor Ted Kulongoski via Executive Order 06.01.⁷⁴

⁷³ NCDC Storm Events Database.

⁷⁴ NOTE: Executive Orders follow a naming convention of YEAR-ORDER #; therefore, EO-06.01 specifies the first executive order issued in the year 2006.

A series of storms in January 2012 resulted in a federal disaster declaration (DR-4055-OR). The storms caused flooding and landslides that impacted Lane County and other jurisdictions throughout western Oregon. The NWS reported areas of the Coast Range in Lincoln and Lane Counties received between 10 and 15 inches of rain during a 24-hour period between January 18 – 19, 2012. Numerous houses from the Willamette Valley to the west side of the Coast Range were inundated. Landslides, mudslides, and downed trees closed highways intermittently, trapping people either trying to escape the rising water or getting back home to safety. Lane County officials evacuated residents in Mapleton. The Mohawk Valley Fire District evacuated three families from their homes near Sunderman Road near the Mohawk River. Close to 2,000 Eugene Water & Electric Board (EWEB) customers lost power due to the storms.

In December 2015, over the course of about two weeks heavy rains triggered floods across the county resulting in property damage. On December 7, 2015, a moist pacific front produced heavy rain across Northwest Oregon, resulting in the Siuslaw River at Mapleton to exceed flood stage within Lane County. Approximately \$395,000 was reported in property damage.⁷⁵ Just about a week later, an atmospheric river resulted in more widespread flooding in Northwest Oregon, including the Siuslaw River at Mapleton and Mohawk at Springfield. Minor flooding of pastureland was reported in Swisshome resulting from flooding of Mann Creek. December 17, 2015, set a record at the time for daily rainfall in Eugene, recording 1.65 inches. Springfield reported approximately \$499,000 in property damage.⁷⁶

Table 2.18 provides a summary of flood events that occurred in Lane County between 2000 and 2016. Recorded flood events come from monitoring gauges along rivers and therefore reflect only reported instances. As noted in the Hazard Extent subsection of this profile, a lack of mapped area in several census tracts within the Cascades and Coast regions may underreport the number of events that have occurred since 2000. Of the 15 isolated events, 6 resulted in either a declared state of emergency by the Oregon governor or federally declared disaster.⁷⁷



Flooding resulting from the April 2019 atmospheric river. | Source: John Wooten, South Lane Fire District

⁷⁵ NCDC Storm Events Database.

⁷⁶ Ibid.

⁷⁷ Federal Emergency Management Agency.

Table 2.18: Recorded Floods at General Gauge Locations in Lane County, 2000 – 2016

General Location	Date	Cause	Flooding Type
*Mapleton; Springfield; Swisshome	December 17, 2015	Atmospheric River	Exceeded Flood Stage
*Mapleton; Alsea	December 7, 2015	Heavy Rains	Exceeded Flood Stage
Mapleton	December 20, 2014	Heavy Rains	Moderate Flood Stage
*Springfield	February 14, 2014	Heavy Rains	Exceeded Flood Stage
*Mapleton	February 12, 2014	Heavy Rains	Exceeded Flood Stage
Mapleton	November 19, 2012	Heavy Rains	Exceeded Flood Stage
Mapleton	March 30, 2012	Heavy Rains	Exceeded Flood Stage
*Mapleton; Marcola	January 18, 2012	Snowfall & Heavy Rains	Major Flood Stage
Mapleton	December 3, 2007	Pacific Storms & Heavy Rains	Exceeded Flood Stage
Mapleton	December 14, 2006	Heavy Rains	Exceeded Flood Stage
Mapleton	November 7, 2006	Heavy Rains	Exceeded Flood Stage
Springfield	January 17, 2006	Heavy Rains	Moderate Flood Stage
*Mapleton; Springfield	January 10, 2006	Pacific Storms & Heavy Rains	Exceeded Flood Stage
Mapleton; Springfield	December 28, 2005	Pacific Storms & Heavy Rains	Exceeded Flood Stage
Mapleton; Springfield	December 12, 2003	Heavy Rains	Exceeded Flood Stage

Source: National Climatic Data Center (NCDC), Storm Events Database; Federal Emergency Management Agency

*Indicates event included as part of a State of Emergency Declaration or Presidentially Declared Disaster

NOTE: General Location refers to gauge locations where river height is recorded and does not suggest that the listed place names of communities were the only areas in Lane County impacted by the event.

Events Prior to 2000: A report prepared by the U.S. Department of the Interior in 1956 identified eight (8) major floods that occurred in Lane County before 1900 and an additional nine (9) floods prior to the report’s publication. Aside from the stages reached by the 1861 flood, the two most significant and damaging flood events prior to 2000 in Lane County include the 1964 “Christmas Day” flood and the 1996 flood. The Lane County Land Management Division (LMD) Floodplain Administration Office maintains detailed information on previous flooding, including major events in 1964 and 1996.

The 1964 “Christmas Day” flood was caused by a preceding snowfall event that had frozen, followed by several days where temperatures rapidly rose and coupled with heavy rains. Over 210,000 acres of agricultural land was inundated in the Willamette Valley, most of it in Lane County.⁷⁸ In the basin, three (3) lives were lost to the flood, and it incurred more than \$65 million in local property damage. Stateside, estimates approximate damages to have reached \$157 million.⁷⁹

⁷⁸ Waananen, A.O., Harris, D.D., & Williams, R.C. (1971). *Floods of December 1964 and January 1965 in the Far Western States; Part 1 Description*. Oregon Water Science Center. U.S. Government Printing Office. DOI: 10.3133/wsp1866A.

⁷⁹ Ibid.

In February 1996, prolonged precipitation accompanied by early snowmelt caused by an atmospheric river, or “Pineapple Express,” caused many waterways in Oregon to rise to 100-year flood levels. In Lane County, flooding was particularly severe along the Siuslaw and Mohawk Rivers. President Clinton declared a major disaster for the state, DR-1099-OR, which included Lane County among the affected regions. Local damages were estimated at \$19 million.⁸⁰

Probability of Future Occurrences

Based on historical flooding occurrences as reported by federal sources, there were five (5) flooding events recorded by the NCDC during the most recent 6-year period. This rate equates to just over a one event per year average, resulting in a **High Probability** classification for future occurrences. The high probability classification applies for each of the Coast, Valley, and Cascades regions. *This classification for the probability of future occurrences has not changed since the previous version of this Plan.*

Impacts Resulting from Climate Change

Although uncertainty exists in determining how climate change will impact future floods in Lane County, recent research identifies some factors that will likely impact the probability of future flooding. First, though annual precipitation total is not expected to change much, it is possible that there will be fewer wet days (days with rainfall) when precipitation occurs, and that rainfall will be more extreme during fewer events. Heavy rain events are the leading cause of rivers exceeding flood stages and therefore, an increase in heavy rainstorms suggests flooding could occur more frequently.⁸¹ The Lane County Climate Resilience Plan also identified increased winter flood risk as a potential impact of climate change to each region in the county.⁸²

Future flood events may be impacted by the formation of El Niño or La Niña episodes. A La Niña episode has occurred during most months since 2020, though conditions are expected to return to normal by the spring of 2023.⁸³ During a La Niña, stronger trade winds blow west along the equator and push warm water towards Asia. The result is an increase in upwelling (or cold water rising to displace warm water at the surface) off the coast of the Americas. In the Pacific Northwest, La Niña episodes are most frequently associated with wetter winters that produce heavy rains and triggering flooding in the region. Changes to global climate patterns may impact the severity of La Niña events in the future.

The Oregon NHMP (2020) noted that the shorter historical record for precipitation and flood events for the Pacific coast presents uncertainty about the impacts of extreme events, such as atmospheric rivers. Since much of Lane County relies on dams for flood control, the state plan described how large precipitation volumes that surpass the historical record could exceed spillway capacity and cause dams to overtop.⁸⁴ In addition to an increase in winter Pacific storms, atmospheric rivers could become more frequent year-round in Lane County and western Oregon given the increased water vapor capacity a warmer atmosphere allows. The increased capacity results in a higher likelihood of these storms forming and bringing intense rain to the area.

⁸⁰ Lane County. (2018). “Multi-Jurisdiction Natural Hazard Mitigation Plan.” Lane County Emergency Management.

⁸¹ Fleishman, E., editor. (2023). *Sixth Oregon climate assessment*. Oregon Climate Change Research Institute, Oregon State University, Corvallis, OR. DOI: 10.5399/osu/1161.

⁸² Lane County. (2022). “Climate Resilience Plan.” County Administration Office.

⁸³ NOAA, (2023). “ENSO: Recent Evolution, Current Status and Predictions.”

⁸⁴ Oregon NHMP. (2020).

Overall Vulnerability

Based on the potentially catastrophic impacts of a severe flood, high probability of future occurrences, and exposure of people, infrastructure, and development in flood prone areas, Lane County has a **high vulnerability** classification for flood. The high vulnerability classification applies to each of the Coast, Valley, and Cascades regions. *This classification has not changed since the previous version of this Plan.*

Section 2.2.5: Landslide and Debris Flow

Within both the Coast and Cascade Mountain ranges, the probability of landslide in Lane County is **high**. Vulnerability to landslide is classified as **high**. High vulnerability indicates a high probability of future occurrences and critical severity for the hazard extent (see Table 2.4 for the definition of each classification rating).

Hazard Description

A landslide is a geologic phenomenon that includes a wide range of ground movement such as rock falls, debris flow, and earth down a slope.⁸⁵ Although gravity acts as the primary force causing a landslide to occur, there are typically other contributing factors. A change in the stability of a slope can be caused by many factors that at times act together or, in other instances, independently. Table 2.19 displays several contributing factors that cause landslides or debris flows, both factors that naturally occur and those resulting from human activity.

Table 2.19: Common Triggers of Landslides and Debris Flows, Natural and Human Causes

Natural Causes	Human Activity
Groundwater pressure acting to destabilize slope	Vibrations from machinery or traffic
Loss or absence of vegetation, root structure, and soil structure (burn scars)	Blasting of bedrock
Erosion or undercutting by river or ocean waves	Earthwork that alters the shape of a slope or imposes new loads on an existing slope
Heavy rain or snowmelt	Deforestation, cultivation, and road construction
Freeze and thaw cycles	Removal of deep-rooted vegetation that binds colluvium
Geological events	Activities that increase or concentrate the amount of water infiltration into the soil

Source: Lane County Emergency Management

As experienced by the public, the most common impacts of landslides are roadway blockages and, less frequently, damage to homes and structures. Categories of impacts include threats to public safety, economic impacts created by traffic delays and road closures, and environmental impacts related to increased sediment entering and polluting waterways. Landslides usually occur with little or no warning and, therefore, under conditions such as heavy rain in steep areas, curtailment of land altering activities should be considered.

⁸⁵ U.S. Geological Survey. (n.d.). "What is a landslide and what causes one?"

Cascading Impacts and Secondary Hazards

Landslides can contribute towards several cascading impacts depending on the location of the event and surrounding infrastructure and/or built environment. The most apparent impact is to transportation routes providing access to communities and critical infrastructure. If occurring during another hazard event where infrastructure failures occur, blocked roadways to remote sites can present additional challenges for response or recovery operations and compound the risk posed to vulnerable individuals. Additionally, landslides may impact water quality if they reach waterways, dumping more soil and debris into the channel. Water treatment plants may be unable to remove the full volume of excess sediment. The lack of treatment capacity can cause systems to fail and create blockages along the waterway in extreme cases.

Flooding: Landslides alone rarely trigger other hazards in the context of Lane County. However, depending on how soil and debris spills downslope, and the area affected, sedimentation or objects that create blockages in rivers, along roadways, and within sloped channels may create more favorable conditions for flooding to occur. As previously noted, in extreme cases landslides may result in blockages within waterways and contribute to increased flood risk when a high-precipitation event occurs following a recent landslide. The run-off created by an existing slide affecting areas that could typically absorb water into the ground can also heighten the potential for flooding along banks or flash flooding along roadways and paved surfaces.

Geographic Location

In general, landslides occur in areas with steep slopes. The most affected state highway is Highway 126. Sections of Highway 126 passing through mountainous areas in both eastern and western Lane County can experience blockages periodically throughout the year from smaller events such as rock falls and smaller landslides. Highway 58 from Lowell to the Willamette Pass is also susceptible to landslides, as is U.S. Highway 101 between Florence and Cape Perpetua. Rural county roads, and those serving as remote access roads, are also susceptible to landslides throughout the mountainous areas of Lane County. More detail about the regional distribution of landslides is the County follows.

Coast Region: Most landslides in western Lane County occur in the Coast Range mountains. Recent studies published by DOGAMI identify historical landslides points in the northern portion of the coastal areas close to Highway 101, signifying potential for road blockages and closures along the highway.⁸⁶ Most landslide activity south of the City of Florence is concentrated within the Coast Range foothills inland from the Pacific coastline. However, DOGAMI landslide mapping confirmed recent landslide activity in one concentrated area south of Dunes City. Lane County maintains data layers of identified landslides showing a number of instances nearby Siltcoos Lake. Further inland, identified landslides exist alongside segments of Highway 36 in the vicinity of Mapleton. Significant landslide activity and occurrences can potentially cut off access to much of the community.⁸⁷ Another identified landslide exists along Highway 36 close to Triangle Lake.

Valley Region: Most landslide risk in the Valley region exists in unincorporated Lane County west or east from the Interstate 5. Identified landslides exist in the southern part of the county as the valley floor reaches the base of the Cascade foothills as well as due east from Cottage Grove near Dorena Lake.

⁸⁶ DOGAMI. (2021). "Open-File Report O-21-11, Landslide Inventory Maps for the Coastal Portion of Lane County, Oregon."

⁸⁷ Lane County. (2023). "Identified Landslide DOGAMI Hazard Data." Emergency Management Mapping Application (EMMA).

Another notable concentration of landslide occurrences is just southeast of Coburg in the Coburg Hills and in the Cascade foothills to the west of Marcola and the Mohawk River.⁸⁸

Dozens of historic landslide points exist in the metropolitan area concentrated in the southern neighborhoods of Eugene in general proximity to the South Hills area as well as east of Springfield close to the Thurston Hills natural area.⁸⁹ The Thurston Hills area was also found to experience a high susceptibility to deep landslides, or those land movements that occur at depths of more than 15 feet.

Cascades Region: Landslides are common to the Cascades Region given the elevation of the mountains and deep channels created between peaks. The majority of identified landslides in the region exist far from most populated areas in remote sections within the mountains. Access roads leading to infrastructure can be at risk of blockages in the Cascades because of landslides. Infrastructure often includes communication towers and facility access for utility systems. Highway 126 East close to McKenzie Bridge and Highway 58 south of Oakridge also face higher risk from active landslide areas (heightened risk) and identified landslides in the region (post-event occurrence).

Where landslides exist in proximity to communities, the most notable risk area is developed, unincorporated communities close to McKenzie Bridge and Blue River. Identified landslides exist on both sides of Highway 126 East in this part of the McKenzie River Valley.⁹⁰ Though examinations of landslide risk exist for the broader Cascades region, ongoing studies are examining how landslide risk has been affected by burn scar resulting from the Holiday Farm Fire. The results from DOGAMI's study of the burn scar area are expected to be released in early 2024. Preliminary results presented to Lane County stakeholders suggest there is a high risk of landslides, debris flows, and rock falls for the communities of Blue River, Nimrod, and Vida, which also was the conclusion from studies of soil burn severity and emerging impacts resulting from the fire.⁹¹

This hazard profile will be updated once the results are finalized and published to accurately reflect the most recent analysis and exposure of people, property, and infrastructure to landslide risk in this northeastern region of Lane County. At this time, no known studies are active or expected to examine landslide risk in the wake of the Cedar Creek Fire that burned in 2022 just east of Oakridge. Similar to the aforementioned study examining the burn scar from Holiday Farm Fire, this hazard profile will be updated with the findings of any forthcoming landslide risk studies of the Cedar Creek burn scar.

Hazard Extent

Landslides, debris flows, and rock falls happen abruptly with little or no warning, and therefore are very dangerous to public safety. Vehicular travel on roadways is one element of public safety risk while another critical risk are structures situated close to the base of slopes where a landslide could occur and release earth and sediment as the slide reaches flat ground. According to DOGAMI Open-File Report O-02-05, average annual repair costs for landslides in Oregon exceed \$10 million, not including other direct and indirect economic impacts. Based on a credible worst-case scenario, the hazard extent of

⁸⁸ Ibid.

⁸⁹ Calhoun, N. C., Burns, W. J., Franczyk, J. J., and Monteverde, G. (2018). "IMS-60: Landslide hazard and risk study of Eugene-Springfield and Lane County, Oregon." Oregon Department of Geology and Mineral Industries.

⁹⁰ Lane County. (2023). "Identified Landslide DOGAMI Hazard Data." Emergency Management Mapping Application (EMMA).

⁹¹ Federal Emergency Management Agency. (2020). "Holiday Farm Fire: Erosion Threat Assessment/Reduction Team (ETART) Summary Report."

landslides is classified as **Level 3 critical severity**, with potential for some injuries or fatalities and temporary to extended disruptions of critical systems operability.

Previous Occurrences

Landslides have been a significant factor in recent disaster declarations in Lane County, the state of Oregon, and western United States. Notably, declaration DR-4258 in December 2015 included numerous landslides statewide that blocked highways, destroyed and/or imperiled homes, and resulted in public safety impacts. FEMA's preliminary damage assessment for DR-4258 notes 894 total residences impacted statewide, 11 of which were destroyed and 75 that sustained major damage.

Landslide damage within Lane County for DR-4258 involved two (2) destroyed homes and one (1) fatality. In addition, landslides damaged a main water line within a water district resulting in the need to truck in water to ensure uninterrupted delivery to approximately 100 residences. Approximately 10 percent of the residential damage totals for DR-4258 were attributed to landslides. Also notable during the 2012 – 2017 period were a number of landslides in western Lane County that damaged Highway 101 north of Florence and south of Yachats.

Highway 36, connecting Junction City to Mapleton, was closed by two (2) landslides for a 1 ½-week period from January 18 – 27, 2017. On January 18, 1,400 cubic yards of debris closed the highway three miles west of Triangle Lake. On January 22, road crews were nearly done clearing the dirt, rocks, and tress when a second 1,200 cubic yard slide blocked a nearby highway.

On January 19, 2008, a massive 60-acre landslide south of Oakridge occurred in the Willamette National Forest and closed the Union Pacific's main north-south railroad line for western Oregon as reported by the Register Guard. The landslide was the most serious natural disaster to hit Union Pacific's Oregon main railroad line in 40 years according to an industry spokesperson. The slide destroyed the rail bed, tore out the tracks, and scoured away another 30 to 40 feet of hillside composed of trees, mud, and boulders. It obliterated 1,500 feet of track in one spot and 150 feet in another location 150 feet below where the railroad switches back down the steep slope. The recovery effort was hampered by continuing instability of the hillside, downed trees, and storms that dumped approximately 10 feet of snow in the area.

In many parts of Lane County, weathering and the decomposition of geologic materials produces conditions conducive to landslides. Although landslides are a natural geological process, the incidence of landslides and their impacts on people can be exacerbated by human activities. Grading for road construction and development can increase slope steepness, decrease the stability of a hill slope (by adding weight to the top of the slope and removing support at the base of the slope), and increasing water content. For these reasons, landslides periodically affect county roadways, response efforts (debris removal), as well as slope stabilization, each of which are part of Lane County Public Works' routine work. Development coupled with natural processes such as heavy rainfall or rapid snowmelt can cause landslides or re-activate historical landslide sites.

Probability of Future Occurrences

Landslide information provided by DOGAMI notes that as population growth continues to push development into landslide susceptible terrain, greater losses are likely to result. To begin reducing losses from landslides, widespread endeavors are necessary at all community levels from state government to individual family homes. One successful way to reduce losses from landslides is building an inventory for the most impactful landslide events in recent history, associated with other hazard events that may have occurred or contributed to the slide.

Proceeding with a probability based on the best available data, and noted in the Previous Occurrences subsection, the approximate total number of active or geologically recent landslides in Lane County exceeds 3,000 instances. Using an assumption that the great majority of these occurred during the last 30 years, an average of 100 landslides have occurred per year in recent decades, though most of these instances occur in remote areas and forest lands. A rough estimate of landslides that immediately impact transportation routes or structures is about 1 – 3 each year. This equates to a **high** classification for the probability of future occurrences according to definitions for the Plan (see Section 2.1). *This classification for probability of future occurrences has not changed since the previous version of this Plan.*

Impacts Resulting from Climate Change

Climate change impacts may potentially increase the rate of landslides that occur as well expand the area at risk for landslides based on changes to precipitation patterns, effects of drought and extreme heat on soil health and vegetation stability, and the expectation for an increasing amount of acreage that will burn due to wildfires.⁹² Drought and extreme heat are both expected to become more common in the coming decades as global average temperatures warm. These hazard types can increase the rate at which soils dry out, compromising the stability of slopes as these soils lose the capacity for absorbing water. In addition, following wildfires, the burn scar area often produces a similar effect on soil health, creating new risk areas for landslides where these areas may have not previously existed.

With the expectation that precipitation patterns will change to be less frequent in occurrence but more intense during events that produce heavy rainfall, landslide risk can be expected to rise during these heavy rainfall events. Areas most susceptible to this increasing risk include existing high-risk areas for landslides identified in each of Lane’s regions as well as soils experiencing recurring severe to exceptional droughts and within burn scars.

Overall Vulnerability

Given a high probability for future occurrences, the cascading impacts to road access, structures, potential for environmental pollution, and the possibility for an expanding risk area due to drought and wildfire impacts, the overall vulnerability to landslides and debris flow in Lane County is classified **high**. The vulnerability rating applies similarly throughout the County’s three regions. However, risks may increase in the Cascades Region comparative to the other two regions given the connections between recent burn scars and landslide probability. *The high vulnerability classification for landslides and debris flows has not changed since the previous version of this Plan.*

⁹² Fleishman, E., editor. (2023). *Sixth Oregon climate assessment: Heat*. Oregon Climate Change Research Institute, Oregon State University, Corvallis, OR. DOI: 10.5399/osu/1161.

Section 2.2.6: Tsunami

The probability of tsunami in Lane County is **low**. Vulnerability to tsunami is classified as **moderate**, with tsunamis affecting the communities located closest to the Pacific coastline. Moderate vulnerability indicates a low probability of future occurrences and a critical hazard extent.

Hazard Description

A tsunami is a series of ocean waves generated by sudden displacements on the ocean floor, landslides, volcanic activity, or other large, abrupt disturbance of the sea-surface.⁹³ Tsunamis can reach heights exceeding than 100 feet. As the waves approach shallow coastal waters, they appear normal and the speed decreases. If the initial disturbance occurs close to the coastline, tsunamis can demolish coastal communities within minutes and large disturbances can cause inundation and destruction thousands of miles away from its epicenter. Figure 2.11 displays an infographic developed by DOGAMI explaining how tectonic plate movement in a marine environment generates a tsunami.

Figure 2.11: Infographic Explaining how Tectonic Plate Movement Generates Tsunamis

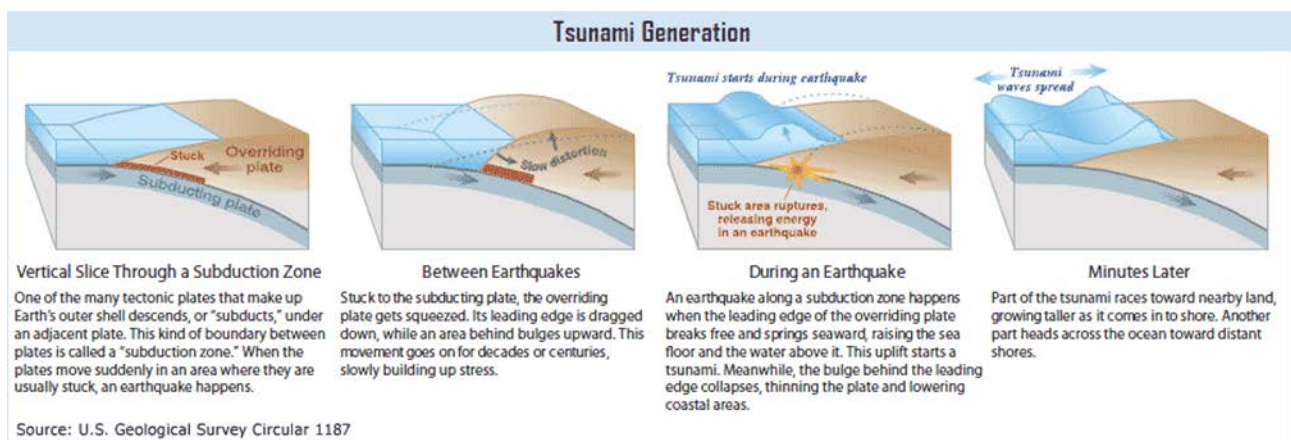

Source: U.S. Geological Survey via the Oregon Tsunami Information Clearinghouse

The destructive potential of tsunamis is enormous. In addition to property damage and fatalities, tsunamis cause disease and environmental damage. Areas near the coast get flooded with sea water, damaging infrastructure, such as drinking water supplies and water treatment plants. These effects result in water contamination that can cause the spread of diseases, such as malaria. Tsunamis also affect natural resources, animals, plants, and landscapes. They kill land and sea animals, uproot trees, and damage onshore habitats. Waste mixes with toxic substances and hazardous materials, contaminating soils and water.

Recent research suggests that tsunamis have struck the Oregon coast on a regular basis. They can occur any time of day or night. Typical wave heights from tsunamis occurring in the Pacific Ocean over the last 500 years have ranged between 20 – 65 feet at the shoreline. However, a few waves may have been much higher, as much as 100 feet, due to local conditions along the shoreline.

People experience tsunamis typically as an abruptly occurring phenomenon where warnings are often brief and urgent. A tsunami generated by a local offshore earthquake can arrive at the shoreline within

⁹³ National Oceanic and Atmospheric Administration.

10 to 25 minutes whereas a distant tsunami can take several hours to reach the coast. General evacuation protocol in coastal areas is to follow instructions, signage, and messaging and immediately proceed to high ground. The public is highly encouraged to make themselves aware of tsunami warning protocols, establish an evacuation plan, and participate in officially sponsored drills and educational workshops about tsunami risk and evacuations in their communities.

Cascading Impacts and Secondary Hazards

Tsunamis most directly act as a trigger of flooding when they reach land. Coastal flooding can result with the subsequent waves that form and travel towards the shoreline following the initial tsunami. Depending on the size of the wave and its force, riverine flooding is possible along waterways more inland from the coast. In Lane County, estimates suggest that a large local tsunami produced by a CSZ earthquake can trigger flooding along the Siuslaw as far inland as Mapleton.⁹⁴

Tsunamis' cascading impacts affect several essential services and systems within the estimated inundated area. These impacts include structural damage and destruction to buildings, power outages, hazardous materials spills (if present in the affected area), water contamination, transportation disruptions (road and maritime), and safety of first responders' entering the affected area after the initial event.

Geographic Location

Oceanic disturbances both above and below the water surface can generate tsunamis. The location of a seismic event that triggers a tsunami is a key indicator for the severity of the wave and amount of warning time. Given tsunamis' nature, they pose risk only to communities in the Coast Region of Lane County, mainly in closest proximity to the Pacific Ocean: Florence, Dunes City, Heceta Beach, Cushman, and Tiernan.

Recent inundation map studies conducted by DOGAMI show a range of potentially high hazard areas within a tsunami inundation zone. DOGAMI examined these risk areas for Florence, Dunes City, and the Siltcoos River Campgrounds.⁹⁵ Ranging from a small to extra-extra-large wave scenario, the studies approximate that much of the campground areas will be inundated by a local tsunami though the affected area does not quite reach Highway 101. However, as the road turns east to pass through Dunes City, it is possible areas along the banks of the Siltcoos River leading to Siltcoos Lake will be inundated, potentially affecting transportation in a CSZ earthquake event. In an extra-large wave scenario, areas east of 101 will be inundated affecting some areas of Dunes City within the city limits.

Areas directly along the Siuslaw River in Florence are most at risk of inundation from a moderate tsunami wave. The main area affected would be the businesses in the southern part of the city along the river, some residences in proximity to the projected inundation zone, as well as the Port of Siuslaw. As the tsunami wave intensity increases to large and extra-large, more of the southern neighborhood blocks become inundated, along with areas on the western edge of the city limits. An important aspect of tsunami risk in Florence is the inundation areas tend to be areas frequented by city residents and

⁹⁴ DOGAMI (2013). "TIM-Lane-07, Tsunami Inundation Maps for Dunes City, Lane County, Oregon."

⁹⁵ Allan, J.C., O'Brien, F.E. (2022). "Open-File Report O-22-06, Earthquake and tsunami impact analysis for coastal Lane, Douglas, and Coos Counties, Oregon." DOGAMI.

visitors (see Figure 2.12). Therefore, DOGAMI estimated a higher temporary population to occupy these inundation zones in Florence compared to the other study areas as part of its methodology.

Figure 2.12: Tsunami Inundation Zone Estimates based on a CSZ Earthquake Producing a Local Tsunami

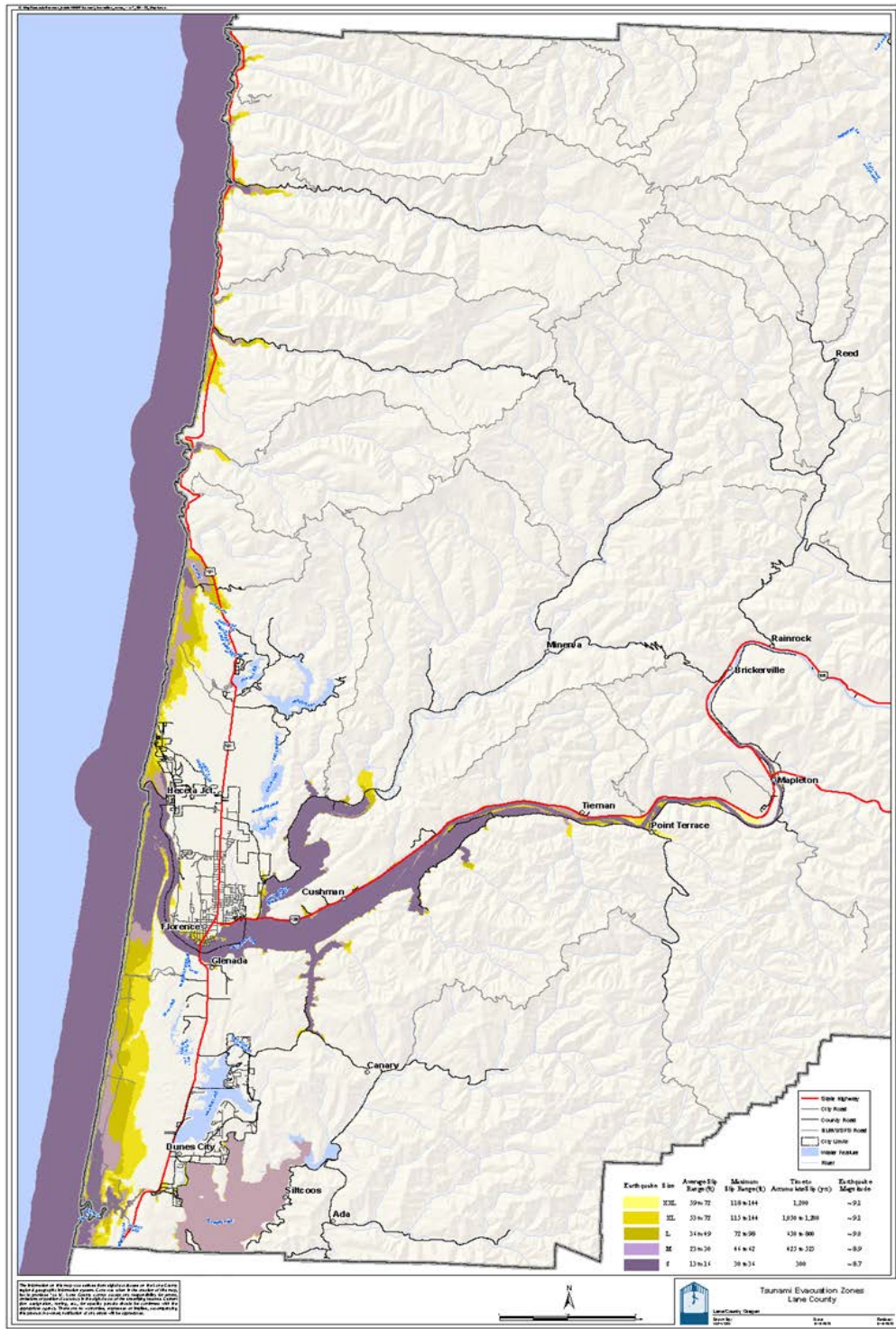

Source: DOGAMI Data adapted by Lane County GIS

Hazard Extent

Tsunami magnitude or severity can be defined by the speed at which they travel and wave height. As tsunamis approach land, the depth of the water decreases which reduces the tsunami's speed. The original speed depends on the epicenter of the triggering event, what type of event, and the amount of displacement in area that has occurred between the tectonic plates in contact. Tsunamis break onto land in different ways, influenced by both the speed of the wave, total energy in the wave, and the topography and bathymetry⁹⁶ of the shoreline area.

Considering a worst-case scenario, the magnitude and severity of a massive tsunami impacting the coastline of Lane County could be catastrophic for that area but impacting a relatively small percentage of the overall population. Severe property damage on the coast with multiple injuries and fatalities is a potential impact. However, the coastline in Lane County is less populated or developed compared to other coastal communities, reducing the potential impact of a large or extra-large tsunami. Because of the limited geographic area and development of the Lane County coastline, a **Level 3 critical severity** classification is assigned despite the severe impacts that can occur in this very localized area of the County.

Previous Occurrences

Western Lane County experienced tsunami advisories in 2011 and 2022.⁹⁷ Both events resulted from seismic activity in the Pacific Ocean. The Great Tōhoku earthquake in 2011 resulted in a tsunami warning along the Oregon coast that triggered evacuations from coastal communities including Florence. West Lane Emergency Operations Center (EOC) in Florence and Lane County Sheriff's Office EOC in Eugene were activated and the tsunami inundation zone in western Lane County was evacuated. At Heceta Beach, water receded and subsequently surged 50 – 150 feet at 7:30 AM, 8:00 AM, and 9:30 AM. No other impacts were recorded in Lane County, but a federal disaster was declared for Curry, Coos, and Lincoln Counties with damage estimated at over \$5 million.

In 2022, another tsunami advisory was issued after an undersea volcanic eruption near the Pacific nation of Tonga. At the outset of advisories, some waves were estimated to be four to six feet in height. Those estimates were later revised to one to three feet in height. When the waves did arrive along the Oregon coastline, they were mild near Florence and did not lead to significant coastal flooding or inundation. Some other coastal communities did experience stronger wave activity as a result.

Figure 2.13 repurposed from the Earthquake hazard profile displays the infographic of recorded Cascadia Subduction Zone (CSZ) earthquakes over the past 10,000 years, which also provides an estimate for the number of destructive tsunamis to strike the Oregon coast. The chart shows CSZ activity only; additional tsunamis caused by earthquakes in other regions of the world have occurred more frequently.

⁹⁶ Bathymetry refers to the study of landform elevations below sea level or more plainly, the depth of ocean, sea, lake, and river floors. In contrast, topography refers to measuring the elevation of landforms above sea level.

⁹⁷ Lane County Emergency Management. (2022).

Figure 2.13: Timeline of Identified Ruptures of the Cascadia Subduction Zone in the past 10,000 Years (Tsunami)

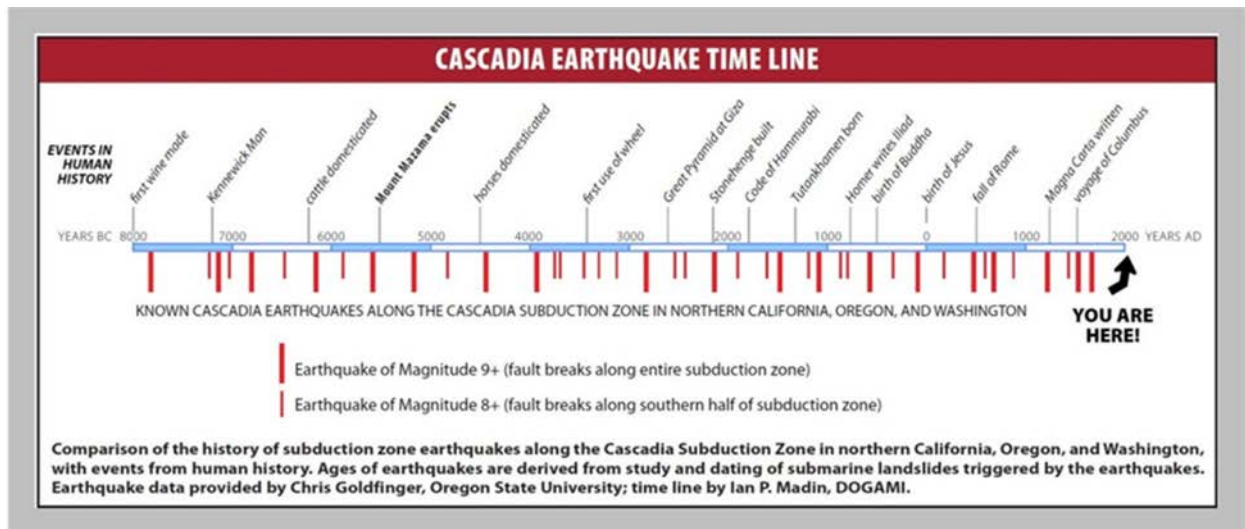

Source: Yu Q.-S., Wilson J., and Wang Y. Overview of the Oregon Resilience Plan for Next Cascadia Earthquake and Tsunami. Proceedings of the 10th National Conference in Earthquake Engineering, Earthquake Engineering Research Institute, Anchorage, AK, 2014.

Combining both local and distant earthquake sources, tsunamis from locations across the Pacific basin and CSZ off the Pacific Northwest Coast have hit coastal communities in 930, 1700, 1890, 1944, 1949, 1953, 1960, 1964, 1980, 2011, and 2022.

Probability of Future Occurrences

As noted in the earthquake hazard profile (see Section 2.2.2), it is difficult to precisely predict when great subduction zone earthquakes will occur. Similar to the chances of a CSZ earthquake, the probability of a distant tsunami striking the coast of Lane County is about 1 to 2 percent in any given year. Other deep ocean earthquakes along the Ring of Fire region may also produce distant tsunamis that impact the Oregon coast, yet these events also have extended number of years between events. Thus, the probability of future occurrences for tsunami hazards is classified as **low**. *The classification for the probability of future occurrences has not changed since the previous version of the plan.*

Impacts Resulting from Climate Change

Though there is a lack of consensus about connections between climate change and the frequency of earthquakes that produce distant-source tsunamis, emerging research suggests that sea-level rise could lead to an increase in the frequency of tsunami-induced flooding.⁹⁸ In the future, tsunamis of smaller sizes may be able to inundate and flood as much, or more, land area as large tsunamis can do in present day. Continuing work exploring the relationship between sea-level rise and tsunami hazards should be incorporated into future updates of this Plan as it becomes available.

⁹⁸ Switzer, A., and Federico, S. (2018). "Climate change sea-level rises could increase risk for more devastating tsunamis worldwide." Virginia Institute of Technology. Blacksburg, VA.

Overall Vulnerability

To the credit of many, tsunami detection, warning, and evacuation strategies have significantly advanced in recent decades. The result is a reduced (though existing) risk to public safety. Development in tsunami inundation areas remains a risk. Overall vulnerability to tsunami is classified as **moderate** for Lane County. A moderate vulnerability classification suggests a low probability of future occurrences with a critical hazard extent based on the number of people within the inundation zone, current evacuation strategy, and amount of development and infrastructure in potentially impacted areas if anything from a moderate to extra-large tsunami were to strike the Oregon coastline. *The moderate classification for vulnerability to tsunami has not changed since the previous version of the plan.*

Section 2.2.7: Volcano

The probability of a volcano hazard event impacting Lane County is **low**. Although Lane County is in proximity to a few volcanoes, most geological experts agree that the likelihood of one of these volcanoes erupting is very low. Vulnerability to an eruption is classified as **low**. A low vulnerability indicates a low probability of future occurrence and a negligible severity for hazard extent.

Hazard Description

As described by the U.S. Geological Survey Volcanic Hazards Program, volcanic eruptions are one of Earth's most dramatic and violent agents of change. Not only can explosive eruptions drastically alter land and water for tens of kilometers around a volcano, but sulfuric acid and other gases ejected into the stratosphere can change the planet's climate temporarily. Eruptions often force populations living near volcanoes to abandon their land and homes, sometimes forever. Those living farther away are likely to avoid physical danger and severe structural damage to homes, but cities and towns, crops, industrial plants, transportation systems, and electrical grids can still be indirectly damaged by tephra, ash fall, lahars, and flooding. Disrupted flight patterns are another notable impact from volcanic activity, as ash plumes present a significant risk to jet engines.

Volcanoes typically exhibit identifiable signals prior to eruption that, when detected and analyzed, allows eruptions to be anticipated and communities at risk to be forewarned. The warning time preceding volcanic events typically allows sufficient time for affected communities to implement response plans and mitigation measures. The USGS alert-level system for volcanic activity has two parts – 1) ranked terms to inform people on the ground about a volcano's status and 2) ranked colors to inform the aviation sector about airborne ash hazards (see Tables 2.20 and 2.21).

Table 2.20: Volcano Alert-Level Terms

Alert Term	Description
NORMAL	Volcano is in typical background, non-eruptive state or, <i>after a change from a higher level</i> , volcanic activity has ceased and volcano has returned to non-eruptive background state.
ADVISORY	Volcano is exhibiting signs of elevated unrest above known background level or, <i>after a change from a higher level</i> , volcanic activity has decreased significantly but continues to be closely monitored for possible renewed increase.
WATCH	Volcano is exhibiting heightened or escalating unrest with increased potential of eruption, timeframe uncertain, OR , eruption is underway but poses limited hazards.
WARNING	Hazardous eruption is imminent, underway, or suspected.

Source: U.S. Geological Survey, Cascades Volcano Observatory

NOTE: When the volcano alert-level is changed, a Volcano Activity Notice (VAN) is issued.

Table 2.21: Aviation Color Codes

Alert Term	Description
GREEN	Volcano is in typical background, non-eruptive state or, <i>after a change from a higher level</i> , volcanic activity has ceased and volcano has returned to non-eruptive background state.
YELLOW	Volcano is exhibiting signs of elevated unrest above known background level or, <i>after a change from a higher level</i> , volcanic activity has decreased significantly but continues to be closely monitored for possible renewed increase.
ORANGE	Volcano is exhibiting heightened or escalating unrest with increased potential of eruption, timeframe uncertain, OR , eruption is underway with no or minor volcanic-ash emissions [ash-plume height specified, if possible].
RED	Hazardous eruption is imminent with significant emissions of volcanic ash into the atmosphere likely, OR , eruption is underway or suspected with significant emission of volcanic ash into the atmosphere [ash-plume height specified, if possible].

Source: U.S. Geological Survey

Geographic Location

Geographic locations of volcanoes in the regional vicinity of Lane County are specific. The closest are located directly on Lane County’s eastern boundary, Diamond Peak in southeastern Lane County, and South, Middle, and North Sister (i.e., the Three Sisters) in northeastern Lane County. Other relatively nearby volcanos (previously active) include Crater Lake to the southeast and Belknap Crater/Mount Washington to the northeast.

Proximity has a direct relationship to volcanic impacts, though it should be noted various climatic and circumstantial factors including wind direction, snowpack, season of occurrence, etc., have a significant effect on how an eruption impacts an area. Table 2.22 displays locations and distances to populated areas of Lane County for proximate volcanos.

Table 2.22: Volcanoes in Proximity to Lane County

Volcano Name	Risk Factor	Latitude	Longitude	Distance to Closest Populated Area	Distance to Closest Metro Area
Diamond Peak	Low	43.52N	122.14W	22 miles (Oakridge)	55 miles (Eug/Spr)
South Sister	High	44.10N	121.76W	20 miles (McKenzie Bridge)	60 miles (Eug/Spr)

Source: U.S. Geological Survey

According to information from the Oregon NHMP, future eruptions at South Sister (and possibly Middle Sister) are likely to include lava flows, pyroclastic flows, and lahars, though no predictable timeframe for occurrence is available. Lahars could travel many miles down upper river valleys, dependent on snow/ice volume melted by the eruption. Ashfall would be expected to occur within 20 miles of the vent, though extraordinary wind conditions could alter ash plume drift to a moderate extent. Listed in Table 2.23 shows the threat potential for volcanos in Oregon.

Table 2.23: Threat Potential for Volcanoes in Oregon

Mountain	Threat Potential
Crater Lake	High to Very High
Mount Hood	High to Very High
Newberry	High to Very High
Three Sisters	High to Very High
Mount Bachelor	Moderate
Belknap	Low to Very Low
Black Butte Crater Lava Field	Low to Very Low
Davis Lake Volcanic Field	Low to Very Low
Mount Jefferson	Low to Very Low

Source: U.S. Geological Survey Volcano Hazards Program

Hazard Extent

According to a report entitled Modern Deformation and Uplift in the Sisters Region, in 2001, scientists discovered that a broad 6 x 12-mile area focused 3 – 4 miles west of the summit of South Sister had been rising at an average rate of 1 – 2 inches per year since late 1997. Rate of uplift decreased to about 0.5 inches per year between 2004 – 2006, and to less than 0.4 inches per year by 2013. According to these findings, since 1997, total uplift was approximately 1 foot.

Modeling of the uplift (inflation) suggests that it was caused either by the intrusion of about 26 million cubic yards of magma at about a 3-mile depth, or by rise of a hot, buoyant plume of water and gas to a similar level that caused heating and expansion of surrounding rock. The USGS considers an eruption unlikely in the near future if current trends continue. Similar inflation episodes have been recognized at many volcanos around the world, and others probably went unnoticed before the development of modern monitoring techniques.

The area most immediately at risk due to exposure to the Sisters is the McKenzie River Valley, which much less developed compared to places throughout Lane County. Highway 126 East provides an approximate outline for a defined moderate hazard zone while the remote, northeastern most area of Lane County in the Cascades includes part of a high hazard zone. Given the relative lack of homes, businesses, and public facilities along with a current low potential for an eruption, the hazard extent for volcano is classified as **Level 1 negligible severity**. *This classification for hazard extent has not changed since the previous version of this Plan.*

Previous Occurrences

There have been no volcanic eruptions in or affecting the state of Oregon in the preceding 35 years. In 1980, Mount Saint Helens erupted in southwestern Washington, resulting in indirect impacts in parts of Oregon. Approximately 1,300 years ago (715 CE), Belknap Crater erupted and created expansive lava flows at McKenzie Pass, also intersecting slightly older flows on the northern flank of North Sister. Table 2.24 denotes approximate timeframe for a series of recent volcanic activity affecting Oregon and/or Lane County.

Table 2.24: Volcanic Event History

Volcanic Event	Years since Event	Miles to Lane County Center	Magnitude at Source	Impact in Lane County
Mt. St. Helens	43	150	Major	Minor
Belknap/ Mt. Washington	1,300	60	Moderate	Moderate
North Sister	1,600	60	Moderate	Moderate
South Sister	2,000	60	Minor	Minor
Mt. Mazama/ Crater Lake	7,700	90	Major	Major

Source: U.S. Geological Survey Volcano Hazards Program

Probability of Future Occurrences

As a method to estimate probability of future occurrence over intermediate and long timeframes, approximate recurrence intervals can be developed by including previous timeframes for past volcanic activity that had a notable or measurable effect for Lane County.

Using this methodology, five (5) volcanic events with relatively significant magnitude have occurred in the previous 7,700 years, resulting in an average recurrence interval of 1,540 years. This corresponding frequency equates to classifying future occurrences of volcano eruptions as a **low probability**. *This classification has not changed since the previous version of the Plan.*

Impacts Resulting from Climate Change

The interactions between climate and volcanic activity continue to be studied and better understood. Often, it is volcanic eruptions that directly cause changes in the climate. When volcanoes erupt, they inject a combination of gases into the stratosphere, including sulfur dioxide and carbon dioxide. As sulfur dioxide coverts into sulfuric acid and condenses into sulfate aerosols, these aerosols reflect sunlight back into space resulting in a short-term cooling effect on regional climates. A relatively recent example of this phenomena occurred with the eruption of Mount Pinatubo in June 1991 (located in the

Philippines).⁹⁹ Though volcanic eruptions emit a large concentration of carbon dioxide, no recorded eruption on record has been connected to a detectable increase in global temperatures.

More recently, studies have proposed a linkage between heavy rainfall and an increasing likelihood of triggering a volcanic eruption. A 2018 study published in *Nature* presented evidence that prolonged heavy rainfall over several months triggered the eruption of the Kīlauea volcano in Hawai'i that year.¹⁰⁰ Other studies have also suggested a connection between periods of prolonged and intense rainfall with subsequent volcanic eruptions. These theories about how a warming climate can be expected to produce more intense precipitation during storms has resulted in calls to amplify this area of research to better understand volcanic activity around the globe in the context of climate change.

Of existing studies, most expect the potential impacts to affect the most volcano prone areas of the world, including South America, the Caribbean, and Indonesia. Few studies to date have examined how this connection could affect volcanic activity in North America's Pacific Northwest region and therefore, little is known about future volcanic hazard risk to communities in the Willamette Valley due to climate change.

Overall Vulnerability

According to information from the Oregon Natural Hazard Mitigation Plan, the Three Sisters region has a clear history of eruptions, but none noted in the last 15,000 years. North Sister has probably been inactive for at least 100,000 years. Middle Sister last erupted between 25,000 and 15,000 years ago. As previously noted, from 1996 to 2003, South Sister had minor but broad uplift of about one inch a year, indicating subsurface magma activity. There is no current indication that the previously active uplift will result in a volcanic eruption, but monitoring continues to quickly identify changes in condition.

Due to the low probability of future occurrences and negligible hazard extent, volcano is given a **low vulnerability** rating. *This rating has not changed for since the previous version of the Plan.*

Section 2.2.8: Wildfire

The probability of wildfire in Lane County is **high**. Vulnerability of wildfire countywide is **high**. A high vulnerability indicates a high probability of future occurrences and a critical severity for hazard extent. In 2020, Lane County adopted an updated version of its Community Wildfire Protection Plan (CWPP). This plan exists as the most current hazard-specific plan addressing wildfire risk in Lane County and prescribing mitigation action items for addressing that risk. To integrate the work and effort invested in the plan update, the CWPP will become a functional annex for the wildfire hazard in the 2023 update to the MNHMP. As a result, some of the action items listed in the current CWPP will be elevated as part of this Plan's update.

The CWPP operates under the CWPP Advisory Committee and Hazardous Fuel Subcommittee. These entities manage, update, and implement the plan's action items in coordination with stakeholder groups such as conservation and fire districts as well as individual property owners. Integrating the work of the

⁹⁹ Volcano Hazards Program. (n.d.). "Volcanoes Can Affect Climate." *United States Geological Survey*.

¹⁰⁰ Udel, D. (2020). "Excessive rain triggered 2018 Kilauea volcano eruption, study finds." *Rosenstiel School of Marine and Atmospheric Science*, University of Miami. Coral Gables, FL.

CWPP bodies in conjunction with the NHM-SC managing this Plan is intended to result in improved data collection about fuels reduction treatment areas, engagement with members of public about hazard risk, and restoring conditions in the natural environment that can provide further mitigation benefits addressing other hazards. Additionally, the CWPP also identifies additional funding sources and eligible activities for performing mitigation work in addition to the Hazard Mitigation Assistance programs managed by FEMA.

For more information about how plan integration supports the Mitigation Strategy contained within the updated Lane County MNHMP, see Section 3.1.1 in Volume I of this Plan. Table 2.25 displays five (5) action items from the 2020 CWPP designated as Priority Actions.

Table 2.25: Priority Action Items Identified in the 2020 Update of the Lane County Community Wildfire Protection Plan

Action Item Description	Designation	Coordinating Agency
Review and develop recommendations for the Lane County Board of County Commissioners for revisions to land use regulations, such as: Implementation of fire safety standards within rural residential zoning districts; Distribution of educational materials at the outset of the building permit review process; and conduct outreach services with neighborhood organizations and special interest groups.	2.1.1	Lane County Land Management
Identify and prioritize areas for local evacuation plan development across Lane County's Rural Fire Protection Districts, potentially including data from the CWPP Rural Response: Priorities for Fuel Reduction Map.	2.1.3	Lane County Emergency Management
Utilize maps in the CWPP risk assessment to guide and identify new partners and opportunities for cross-boundary collaboration. Coordinate the implementation of landscape-scale hazardous fuels projects.	2.3.1	Hazardous Fuel Subcommittee
Develop a coordinated multi-agency seasonal outreach campaign that includes county-specific educational materials to promote effective risk reduction practices and communicate landowner assistance programs in the wildland/urban interface.	3.1.1	Lane Fire Prevention Cooperative & Lane County Emergency Management
Implement landowner assistance for fuel reduction projects including cost-share incentives. Increase local capacity, establish incentive programs to support yard debris disposal to assist landowners with hazardous fuels removal. Create disposal opportunities using alternative methods to burning.	3.2.1	Oregon Department of Forestry

Source: Lane County Community Wildfire Protection Plan, 2020

Hazard Description

Fire is a natural and recurring ecological component of Oregon’s ecosystem. However, wildfires describe an uncontrolled fire spreading through vegetative fuels and potentially damaging or destroying structures. Wildfires often begin unnoticed, spread quickly, and are usually signaled by dense smoke from the fire that fills the air for miles. Causes include both human actions such as arson and careless accidents as well as natural occurrences such as lightning strikes. Wildfire risk is exacerbated by dry conditions, excessive heat, and high winds. Ninety percent (90%) of the wildfires in the United States are caused by human actions. Burning debris, unattended campfires, equipment failure/engine sparks, improperly discarded cigarettes, fireworks, and arson are some examples of human-caused sources of wildfire.

Communities can be classified into three categories based on the land use and development patterns present with respect to wildfire risk. **Interface communities** exist when development reaches and abuts natural areas. There is a clear boundary line between developed land and wildlands. **Intermix communities** exist where structures are intermingled with nonagricultural vegetation in wildland areas.

Occluded communities exist where structures abut an island of wildland fuels, such as a park or open space.¹⁰¹ The category typing can inform certain mitigation approaches to creating defensible space around structures. Structures in Lane County exist in all three community types.

Wildfires can result in people losing their homes, loss of vegetation, soil damage, death of wildlife, loss of food and habitat, and air pollution. People that work in the agricultural industry often experience economic losses and recreational areas become restricted or inaccessible to the public. Both vegetation and the built environment provide fuel for fires. Especially large fires can result in cascading impacts to important infrastructure, such as destroying communications equipment, blocking roadways, and causing systems failures both with respect to water availability and power distribution. Fire danger rating classifications as defined by the U.S. Forest Service are listed in Table 2.26.

Table 2.26: Adjective Class Rating Method under the Wildland Fire Assessment System

Danger Rating	Description
Low	Fuels do not ignite readily from small firebrands although a more intense heat source, such as lightning, may start fires in duff or punky wood. Fires in open cured grasslands may bum freely a few hours after rain, but woods fires spread slowly by creeping or smoldering, and burn in irregular fingers. There is little danger of spotting, destroyed or rendered useless for an extended period of time; evacuations likely required
Moderate	Fires can start from most accidental causes, but with the exception of lightning fires in some areas, the number of starts is generally low. Fires in open cured grasslands will burn briskly and spread rapidly on windy days. Timber fires spread slowly to moderately fast. The average fire is of moderate intensity, although heavy concentrations of fuel, especially draped fuel, may burn hot. Short-distance spotting may occur, but is not persistent. Fires are not likely to become serious and control is relatively easy.
High	All fine dead fuels ignite readily and fires start easily from most causes. Unattended brush and campfires are likely to escape. Fires spread rapidly and short-distance spotting is common. High-intensity burning may develop on slopes or in concentrations of fine fuels. Fires may become serious and their control difficult unless they are attacked successfully while small.
Very High	Fires start easily from all causes and, immediately after ignition, spread rapidly and increase quickly in intensity. Spot fires are a constant danger. Fires burning in light fuels may quickly develop high intensity characteristics such as long-distance spotting and fire whirlwinds when they burn into heavier fuels.
Extreme	Fires start quickly, spread furiously, and burn intensely. All fires are potentially serious. Development into high intensity burning will usually be faster and occur from smaller fires than in the very high fire danger class. Direct attack is rarely possible and may be dangerous except immediately after ignition. Fires that develop headway in heavy slash or in conifer stands may be unmanageable while the extreme burning condition lasts. Under these conditions the only effective and safe control action is on the flanks until the weather changes or the fuel supply lessens.

Source: U.S. Forest Service, Wildland Fire Assessment System

Cascading Impacts and Secondary Hazards

Beyond the threat to buildings that include residences and buildings, wildfires pose significant risk to community lifelines, causing power ages, communications failures, transportation disruptions, and destroying infrastructure (pipelines, pumping stations, substations, above-ground transmission lines, fuel depots). Wildfires that rapidly spread and expand the area burnt pose significant risk for damaging

¹⁰¹ Ferrell, R. (2020). "Wildfire Property Damage and the Growing Wildland-Urban Interface." WSRB. <https://www1.wsrb.com/blog/wildfire-property-damage-growing-wui>.

and contaminating natural environments, which includes polluting sources of drinking water, destroying habitats, and degrade air quality for miles surrounding the source of the fire. The resulting damage to soils creates conditions that increase the likelihood for triggering other types of natural hazards.

Smoke: Large wildfires produce a significant amount of polluted smoke that degrades air quality well beyond the vicinity of the fire. With the growth, spread, and length of large wildfires in recent years, particulate matter (PM) contained in wildfire smoke has significantly increased the days of poor air quality in Lane County.¹⁰² Smoke from wildfires poses health risks to people exposed to the particulate matter, causing irritation of the eyes, nose, and throat. Smaller sized PM can be inhaled into the lungs and impact respiratory function. People can be exposed to wildfire smoke both outside and inside their homes. Poorly ventilated homes and those with porous sealings can have smoke seep into the interior and degrade indoor air quality. Individuals with existing respiratory illnesses are at high risk to their health due to smoke. Frequent or prolonged exposure is a concern for vulnerable populations and those individuals that mostly work outdoors, which can experience heightened risk to their health from prolonged exposure to smoke-filled air.

Smoke impacts from wildfires can be especially hazardous for communities in the Willamette Valley due to the geography's effect on air flow. The valley floor nestled between the Coast and Cascade Ranges can experience slow moving and stagnate air flows when wind gusts are weak. Since wildfire smoke can travel great distances, the severity of polluted air can vary throughout the Willamette Valley. As a result, unhealthy air sinks, often to elevations beneath 1,500 feet onto the valley floor where people are most likely to be exposed. Without precipitation or gusty winds to move the smoke, the hazardous air lingers for multiple days, sometimes weeks.

Lane County has experienced a notable increase in hazardous air quality days during the past decade. Smoke most often impacts the Cascades and Valley regions but can reach areas in the Coast region under certain conditions. Table 2.27 displays the total number of days Lane County registered hazardous air quality and the number of those total days attributable to wildfire smoke. In addition to public health impacts, wildfire smoke also can be disruptive to local businesses and events operating during the summer months. For more information about these impacts, refer to the Vulnerability Assessment section of Volume I (Section 2.3).



Smoke filled air lingers in Springfield at Thurston Middle School | Photo: Lane County Emergency Management

¹⁰² Lane Regional Air Protection Agency, (2022).

Table 2.27: Number of Days in Lane County where AQI Exceeded 100 with Correlation to Days Attributable to Wildfire Smoke, 2010 – 2022

Year	Total # AQI +100 Days	% of Days in Year	Total # Days Caused by Wildfire	% of Total AQI +100 Days
2010	4	1.1%	0	0.0%
2011	13	3.6%	0	0.0%
2012	6	1.6%	0	0.0%
2013	27	7.4%	0	0.0%
2014	20	5.5%	4	20.0%
2015	13	3.6%	4	30.8%
2016	1	0.3%	0	0.0%
2017	28	7.7%	19	67.9%
2018	11	3.0%	4	36.4%
2019	5	1.4%	1	20.0%
2020	23	6.3%	22	95.7%
2021	19	5.2%	19	100.0%
2022	39	10.7%	37	94.9%
Totals	209	4.4%	110	52.63%

Source: Lane Regional Air Protection Agency

Flooding & Landslides: In the aftermath of wildfires, the impacts to the burned ground and soils also leaves the area in the burn scar less capable of absorbing water or stabilizing vegetation along slopes. Heavy rainfall on burned soils may not be absorbed into the ground and can runoff downhill and potentially trigger flooding. Furthermore, if rainfall is intense enough the water can also destabilize weakened soils along hillsides, inducing landslides or debris flows in mountainous areas. Given the seasonal context of natural hazards in western Oregon, large wildfires that burn during the summer months present a heightened risk over several years for flooding and landslides during the wet season, when precipitation is most frequent and intense.

In Lane County, two fires from 2020 and 2022 resulted in over 100,000 acres burned by each fire. Both fires occurred in the Cascades Region and the burn scars exist within the foothills and higher elevations of the Cascade Range, both in the McKenzie River Valley and southeastern Lane County just east of Oakridge. Assessing flood and landslide risk in these two areas of the Cascades region must account for the impact of these recent wildfires. Data examining the elevated risk or expected impacts is not currently available for the update to this Plan.

DOGAMI is currently completing a study examining landslide risk in the McKenzie River Valley following the Holiday Farm Fire and expects to publish its findings in 2024. As a living and dynamic plan, Version 4.0 of this Plan will update the hazard profile and risk assessment elements for landslide to include these findings when they become available. At this time, no known studies exist for the Cedar Creek Fire but should be pursued to further inform the county’s risk profile ahead of the 2027-28 plan update.

Geographic Location

Wildfire can occur in essentially any physiographic region of the county, though the risk of damage from wildfire is highest in the wildland-urban interface (WUI) of the Coast and Cascade Range foothills. The WUI is an area where development meets dense forest. Fires burning in the WUI are hard to contain, require concentrated firefighting resources, and are a primary concern from a mitigation standpoint. Significant fires either in or near the eastern portion of Lane County consistently occur at a comparable rate to the state average; about one (1) large wildfire every four (4) years.

Wildfire can occur in essentially any physiographic region of the county, though the risk of damage from wildfire is highest in the wildland-urban interface (WUI) of the Coast and Cascade Range foothills. The WUI is an area where development meets dense forest. Fires burning in the WUI are hard to contain, require concentrated firefighting resources, and are a primary concern from a mitigation standpoint. Significant fires either in or near the eastern portion of Lane County consistently occur at a comparable rate to the state average; about one (1) large wildfire every four (4) years.

The WUI in Lane County is large at approximately 1,481,400 acres (2,315 square miles) and results from a dispersed population developing near abundant vegetative fuels.¹⁰³ Nearly 2.5 million of the county's 2.9 million acres are zoned F1, non-impacted forestland.¹⁰⁴ The U.S. Forest Service and the Bureau of Land Management own and manage most of the property zoned F1. These forest lands contain extensive fuels comprised of flammable grasses, brush, slash, and timber. There are nearly 100,000 Lane County residents that live outside the metro area and near these forest lands. Figure 2.14 shows the most recent assessed wildfire risk for Lane County.



Burned trees along the slope collapse, blocking the roadway along Highway 126 East during the Holiday Farm Fire

*Photo: Lane County
Emergency Management*

¹⁰³ Lane County. (2020) *Lane County Community Wildfire Protection Plan*.

¹⁰⁴ Lane County Government, Zone & Plan Maps.

Figure 2.14: Overall Wildfire Risk in Lane County

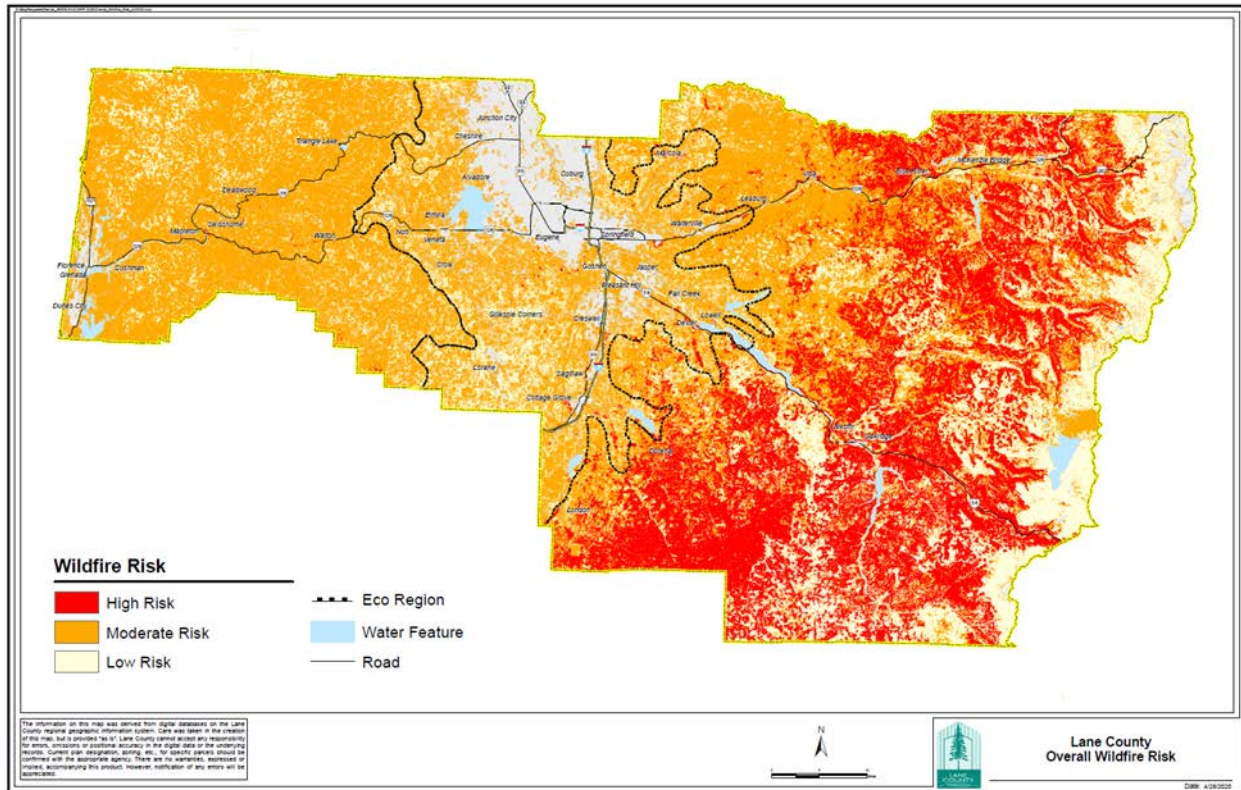

Source: Lane County Community Wildfire Protection Plan

Coast Region: The Lane County CWPP identified most areas as having moderate risk for wildfire. Small pockets of high-risk areas exist along Highway 126 West of Walton and at the junction of Highways 36 and 126 next to Mapleton along East Mapleton Road.¹⁰⁵ A portion of Highway 126 within the Coast Range was the site of a human-caused fire in 2020, which burned about 18 miles west of Veneta. In addition, the Coast Region contains five (5) communities at risk (CARs) identified in the Oregon Department of Forestry’s Communities at Risk Report (2020). Those communities are listed in Table 2.29 at the end of this hazard profile within the Overall Vulnerability subsection. Figure 2.15 shows the rated wildfire risk for the Coast Region.

¹⁰⁵ Lane County. (2020) Lane County Community Wildfire Protection Plan.

Figure 2.15: Overall Wildfire Risk in Coast Region of Lane County

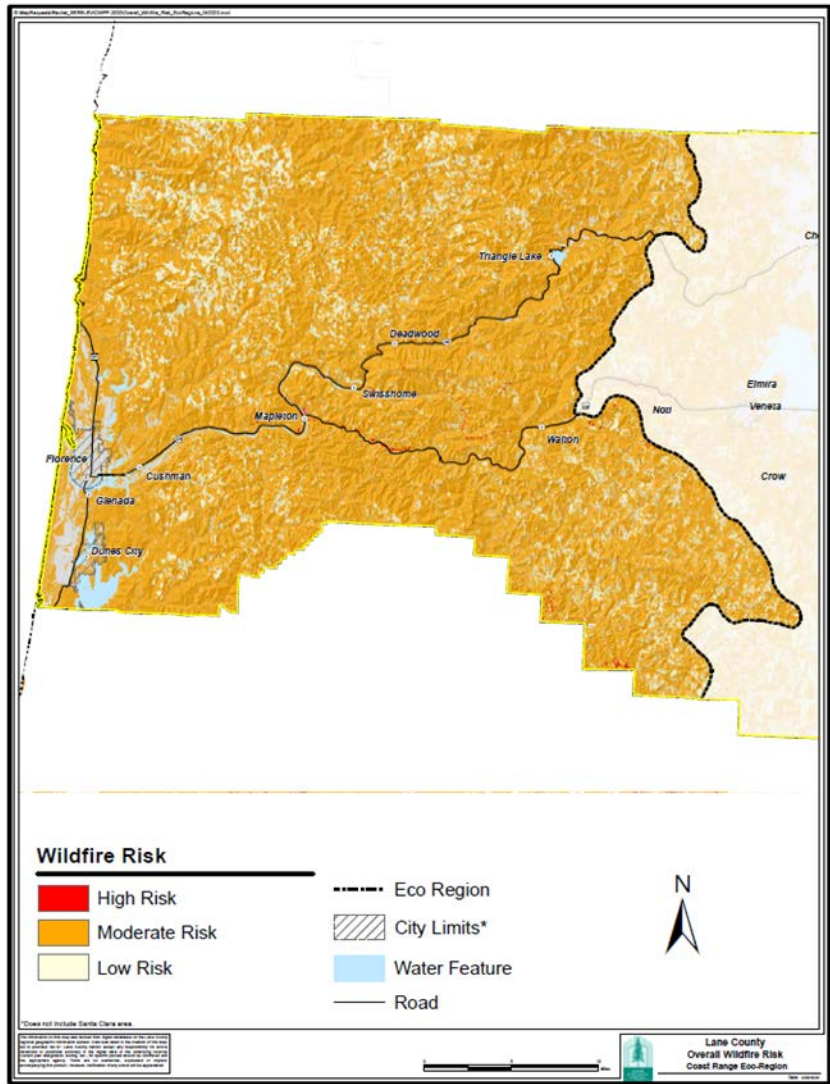

Source: Lane County Community Wildfire Protection Plan, 2020

Valley Region: Areas in the Willamette Valley mostly have a moderate risk for wildfire. Low-risk areas are concentrated in the northern part of the valley, including a sizeable part of the Eugene-Springfield metropolitan area, Coburg, and Junction City. Moderate risk areas are fewer but mixed with the low-risk areas of the northern part of the county. High risk areas do exist in the valley, dispersed among unincorporated areas south of Eugene and Creswell as well as west of Cottage Grove. Other high-risk areas include southeastern Springfield and areas north of the city, east of Interstate 5. The South Hills area of Eugene is also identified as a high-risk area for wildfire.¹⁰⁶ The Valley Region contains 14 communities at risk.¹⁰⁷ These communities are displayed in Table 2.29 contained in the Overall Vulnerability subsection of this profile. Figure 2.16 shows the rated wildfire risk for the Valley Region.

¹⁰⁶ Ibid.

¹⁰⁷ Trentadue, J.A., & Alcock, T.Z. (2020). *Communities at Risk Report*. Oregon Department of Forestry.

Figure 2.16: Overall Wildfire Risk for Valley Region of Lane County

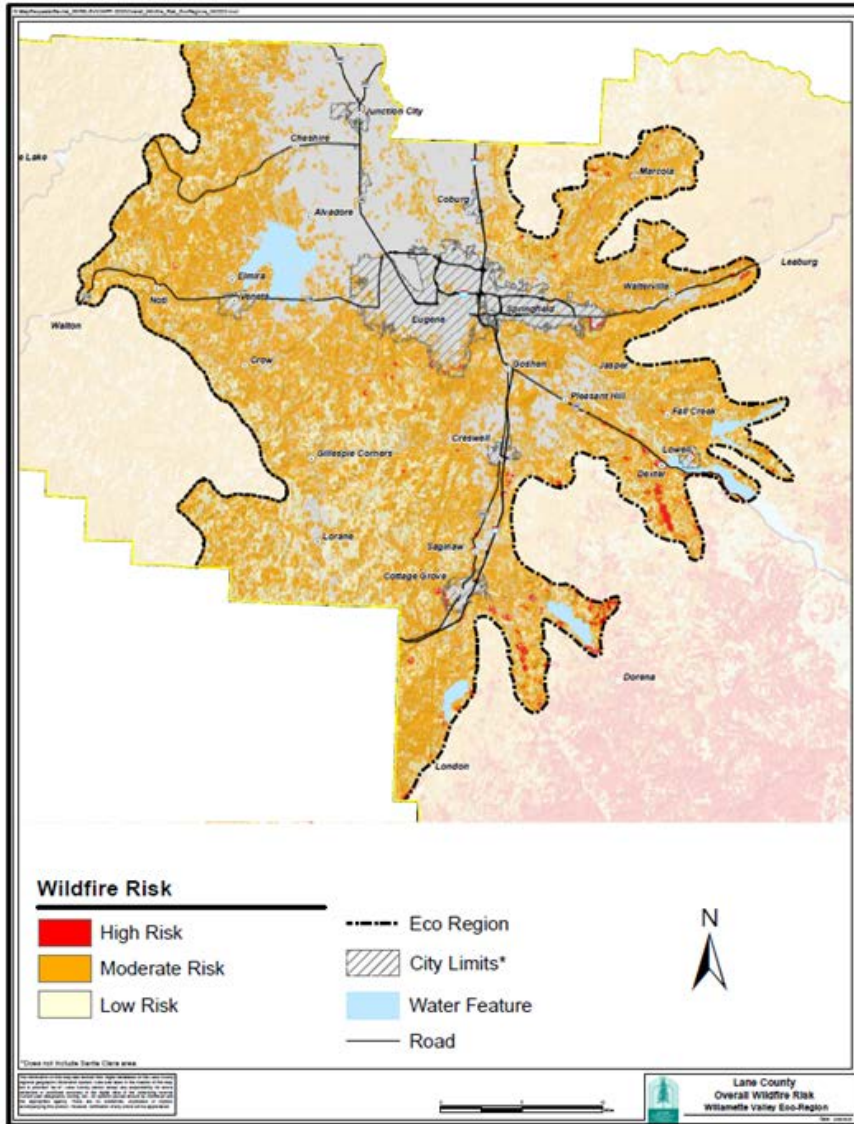

Source: Lane County Community Wildfire Protection Plan, 2020

Cascades Region: The majority of the area in the Cascades Region is rated as high risk for wildfires. Along Highway 126 in the McKenzie River Valley, moderate to high-risk areas surround many of the upriver communities, such as McKenzie Bridge, Blue River, and Vida. Further to the west, pockets of high-risk areas exist close to Marcola. Surrounding Highway 58, high risk areas exist along Lost Creek Road (south of Dexter) and are extensive around the cities of Lowell, Westfir, and Oakridge. In the southern portions of the Cascade foothills, the communities of Dorena and London also exist close to high-risk areas. The Cascades Region contains nine (9) communities at risk.¹⁰⁸ These communities are

¹⁰⁸ Ibid.

displayed in Table 2.29 contained in the Overall Vulnerability subsection of this profile. Figure 2.17 shows the rated wildfire risk for the Cascades Region.

Figure 2.17: Overall Wildfire Risk for Cascades Region of Lane County

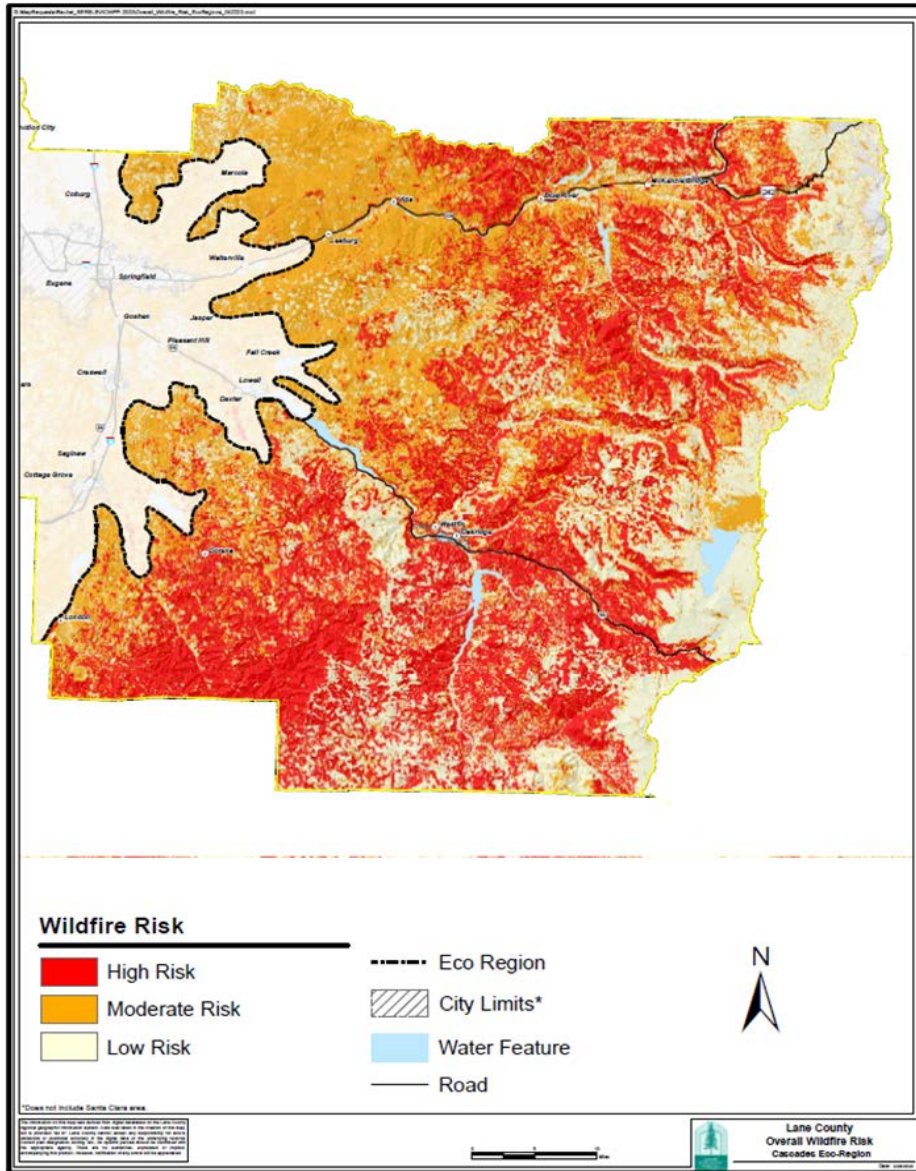

Source: Lane County Community Wildfire Protection Plan

Lane County contains a large quantity of privately owned valuable timber resources and these resources were a focus of the CWPP risk assessment. To assess the potential impact of losing timber resources, the CWPP visualizes the results using an impact map based on a low, moderate, and high scales of impact. Figure 2.18 displays the countywide impact map that highlights the large high-impact areas contained in the Coast and Cascade Ranges. For more information regarding vulnerability of structures to wildfire, see the Vulnerability Assessment in Section 2.3 of this Plan.

Figure 2.18: Overall Wildfire Impact for Lane County

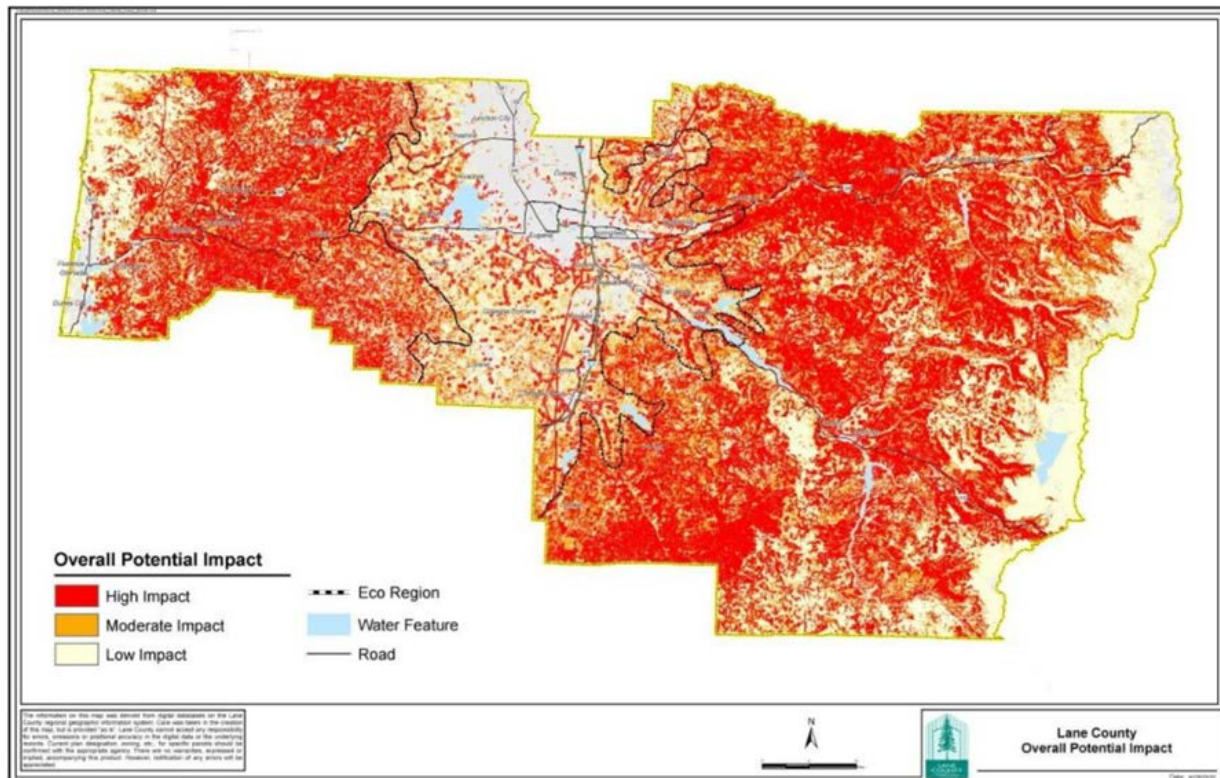

Source: Lane County Community Wildfire Protection Plan

Hazard Extent

Temporary shutdown of facilities can occur while economic and environmental losses are the most common impacts. Injuries and fatalities can occur, most often to wildland firefighters and first responders. A single event could cause structural damage on a neighborhood, community, or regional scale, involving anywhere from a dozen to a few hundred structures.

Over the past 20 years, wildfires have occurred as smaller, spot events ranging from 50 to 250 acres. Smaller regional fires can burn from 250 to 1,000 acres, such as the Sweet Creek Fire in 2020. Larger regional fires burn several thousand acres, especially when formed as fire complexes (multiple fires burning in proximity to each other). For example, the Deception Complex in 2014 burned approximately 7,800 acres while the Tumblebug Complex in 2009 burned approximately 13,000 acres. More extreme was the recent Middle Fork Complex in 2021, which burned nearly 31,000 acres.

Though rare in Lane County, smaller fires can grow rapidly to become megafires that burn an extensive amount of land. The threshold for classifying an event as a megafire is a fire that burnt 100,000 acres or more.¹⁰⁹ Two (2) fires within the last three (3) years were megafires, burning respectively 127,311 (Cedar Creek, 2022) and 173,400 (Holiday Farm, 2020) acres. The range of variation locally across the County makes it difficult to identify consistent and expected averages of acres burned.

¹⁰⁹ U.S. Interagency Fire Center. (2021).

Considering the most credible worst-case scenario, magnitude/severity of wildfire impacts in Lane County is classified as **Level 3 – Critical**. This classification indicates that wildfire potential in the county can cause significant property damage and temporary to prolonged shutdown of critical facilities. Wildfires can lead to injuries and in severe cases, fatalities. *The classification for hazard extent has not changed since the previous version of this Plan.*



Smoke filled air in downtown Eugene, OR during Holiday Farm Fire | Photo: Lane County Emergency Management

Previous Occurrences

There have been several large wildfires within the last five (5) years in Lane County. Within just the last three (3) years, two (2) megafires have occurred in the late summer and fall season: the Holiday Farm (2020) and Cedar Creek (2022) fires. The Holiday Farm Fire was the most destructive of these three events, burning approximately 173,439 acres in the McKenzie River Valley¹¹⁰ and about 500 structures, most of them residences. The Holiday Farm and Cedar Creek Fires triggered evacuations of people from the McKenzie River Valley in 2020 and the City of Oakridge in 2022.

¹¹⁰ USDA Willamette National Forest. (2020). “Burned Area Emergency Response Summary – Holiday Farm Fire.”

Large wildfires also occurred in the previous decade, noted in the 2018 version of this Plan. These events include the multiple fires that occurred in 2017, the Deception Complex Fire in 2014, and the Tumblebug Complex Fire in 2009. Since 2011, seven (7) of the 11 years included (up through 2021) exceed the 10-year average in acres burned (662,783 acres is the 10-YR average from 2011-2020).¹¹¹

Table 2.28 provides a summary of notable wildfires in Lane County over the past decade, including known data for acres burned and estimated suppression costs.

Table 2.28: List of Notable Fires in Lane County 2009 – 2022, Extent and Estimated Suppression Costs

Event Name	Year	Location	Acres Burned	Estimated Cost
Cedar Creek Fire	2022	15 mi E of Oakridge	127,311	\$57.9 million
Middle Fork Complex	2021	9 mi N of Oakridge	30,929	Not Available
Knoll Fire	2021	7 mi NE of McKenzie Bridge	544	Not Available
*Holiday Farm Fire	2020	3 mi W of McKenzie Bridge	173,393	\$42 million
Sweet Creek Fire	2020	1 mi S of Mapleton	307	Not Available
Terwilliger Fire	2018	5 mi SE of Blue River	11,555	\$40 million
Rebel Fire	2017	13 mi S of McKenzie Bridge	8,709	\$8.0 million
Staley Fire	2017	23 mi S of Oakridge	2,300	\$8.6 million
Jones Fire	2017	10 mi NE of Lowell	10,114	\$25.4 million
Horse Creek Complex	2017	7 mi S of Belknap Springs	33,780	\$9.7 million
Kelsey Creek	2017	10 mi W of Oakridge	441	\$2.5 million
Rigdon Point	2017	20 mi SW of Oakridge	206	\$500 thousand
High Pass 12.5	2016	10 mi W of Junction City	191	\$2.8 million
Bunker Hill Complex	2015	30 mi SE of Oakridge	388	\$5.5 million
DL Potter Mountain	2015	28 mi S of Oakridge	357	\$1.9 million
Deception Complex Fire	2014	2 mi W of Oakridge	7,801	\$33.6 million
Yellow Point	2014	25 mi W of Cottage Grove	790	\$5.1 million
Buckhead Complex	2012	2 miles N of Westfir	282	\$3.5 million
Scott Mountain	2010	14 mi NE of McKenzie Bridge	3,464	\$4.6 million
Tumblebug Complex Fire	2009	SE of Oakridge	14,560	\$14 million

Source: Northwest Interagency Coordination Center; NCDL Storm Events Database; State of Oregon NHMP, 2020; Lane County Community Wildfire Protection Plan, 2020; Lane County Emergency Management; Central Oregon Daily; the Register Guard; Federal Emergency Management Agency

*Disaster Declaration DR-4562

Previous Wildfire Events, early 20th Century: According to descriptions provided by the Oregon Department of Forestry (ODF), the Nelson Mountain Fire was one of many large fires in 1910 that burned most areas that are now state forestlands in western Lane County. Large fires burned again in western Lane County in 1917 and 1922. In 1929, several large fires burned most of the central Coast Range in Lane County, covering nearly 80,000 acres. With timber depleted, the Great Depression starting, and vast burned areas unsuitable for homesteading, many landowners allowed their land to revert to the county in place of back taxes. Lane County deeded its timberlands to the Board of Forestry in the mid-1940s.

¹¹¹ Northwest Annual Fire Report. (2021). Northwest Interagency Coordination Center, Portland, OR.

Probability of Future Occurrences

Based on historical wildfire occurrences reported by both state and federal sources, there were five (5) notable events in Lane County in the most recent 5-year period. This frequency equates to approximately one (1) event per year average, resulting in a **high probability** classification for future occurrences. The high probability classification applies to the Cascades region while the likelihood in the Coast and Valley regions is rated as a **moderate probability**. *The high probability classification for future occurrences countywide has not changed since the previous version of this Plan.*

The statewide average for Oregon counties experiencing a major wildfire is roughly once every four (4) years. However, a major wildfire occurs somewhere in the state at least once per year. Regarding wildfires of any size, the Oregon NHMP notes during a typical year, more than 2,500 wildland fires are started on forest lands in Oregon. ODF and USFS estimate 66 percent of these fires are caused by human activity (1,650); the remainder result from lightning (850).

These estimates and averages are in general agreement with data compiled by the National Interagency Coordination Center (NICC), which focuses on the most preventable and easily mitigated events; human caused hazards. According to NICC, the southern region of the United States records the most human caused fires in the nation. Historically, a much lower number of human caused fires occur in the northwest, less than 2,000 per year on average, and an even smaller number of human caused fires occur in Lane County. However, changing conditions and the occurrence of related hazards such as drought and extreme heat may contribute to a higher likelihood of ignitions from both sources but especially human activity.

Impacts Resulting from Climate Change

Projections for a warmer climate in the Pacific Northwest will impact the probability of future events, and severity, of wildfires in Lane County. The main drivers include less precipitation during spring, summer, and fall seasons and an increase in extreme heat events.¹¹² The long-term trends surrounding wildfire are difficult to project, but consensus estimates that wildfire seasons will be active in the coming 5 – 10 years burning a greater area of land compared to recent 10-year averages for the acres burned.¹¹³

Adding to challenges of future fire events is the source and pattern of growth of future wildfires. The Lane Climate Resilience Plan projects that while there is expected to be a small increase in the frequency and size of large wildfires, in the Coast Region these types of fires are more likely to develop as complexes.¹¹⁴ In contrast, already high-risk conditions in the Cascade Region are projected to increase in the number of days where risk is elevated to Very High. A warmer climate will create challenges for Lane County due to an expanding area susceptible to wildfire risk, particularly in eastern Lane.¹¹⁵

¹¹² Eugene-Springfield Area Multi-Jurisdiction Natural Hazard Mitigation Plan. (2020). "Wildfire."

¹¹³ Fleishman, E., editor. (2023). *Sixth Oregon climate assessment: Wildfire*. Oregon Climate Change Research Institute, Oregon State University, Corvallis, OR. DOI: 10.5399/osu/1161.

¹¹⁴ Lane County. (2022). "Climate Resilience Plan." County Administration Office.

¹¹⁵ Ibid.

Overall Vulnerability

Based on this data, combined with the large number of structures and populations existing in wildland-urban interface (WUI) zones, hazard vulnerability to wildfires is classified as **high**. This classification is applicable to the Cascades Region, while the Coast and Valley Regions classify as **moderate** vulnerability. The difference is a result of the higher probability of future events in the Cascades Region as well overall lower resilience in this region compared to the other two. *The classification of vulnerability for Lane County has not changed since the previous version of this Plan.*

Table 2.29 provides a list of the Communities at Risk (CARs) in Lane County organized by region. CARs are rated along a three-point scale of low (L), moderate (M), and high (H) risk.

Table 2.29: Communities at Risk (CAR) Identified in Lane County by Region

Coast	Rating	Valley	Rating	Cascades	Rating
Deadwood	L	Coburg	L	Dexter	M
Dunes City	L	Cottage Grove	M	Lowell	M
Mapleton	L	Creswell	M	Lower McKenzie	M
Siuslaw	L	Eugene	L	McKenzie	L
Swisshome	L	Glenwood	L	Mohawk	L
		Goshen	L	Oakridge	M
		Junction City	L	Rainbow	L
		Lorane	L	Upper McKenzie	M
		Pleasant Hill	H	Westfir	M
		Santa Clara, Eugene	L		
		Springfield	L		
		Veneta	L		
		Walker	M		
		Willakenzie	L		

Source: Oregon Department Forestry, 2020, "Communities at Risk Report."

Section 2.2.9: Windstorms

The geography created by the two mountain ranges that border the Willamette Valley, separating it from the low-lying areas adjacent to the Pacific coastline and Central Oregon, results in a **high** probability of windstorms occurring in Lane County. The vulnerability to windstorms countywide is high, with moderate vulnerability in the Valley and Cascades regions compared to the Coast region. Lane County’s vulnerability to windstorms results from the older housing stock, potential of downed branches and trees causing power outages, and blowing debris that can threaten people’s safety when they are caught outdoors. A **high** vulnerability indicates a high probability of future occurrences and a hazard extent of catastrophic under a credible worst-case scenario comparable to historic storms to occur in Lane County.

Hazard Description

Windstorms are often part of any storm system that produces sustained gusts of more than 45-50 mph. These storms can occur as sustained, high-wind weather or as part of winter storms or heavy rain events. In the Pacific Northwest, windstorms typically involve sustained winds in excess of 50 mph with less frequent events exceeding 80 mph. Most windstorms in the Willamette Valley occur as “straight-line” winds, differentiating this type of event from a tornado. Windstorms result from the low-pressure systems in the Pacific that most often occur from October through March. For more information on storm events such as tornados, see the Extreme Weather hazard profile found in Section 2.2.3.

The Coast and Cascades Ranges also create a specific wind effect called **Foehn winds**. These winds are defined as a “warm, dry and strong general wind that flows down into the valleys when stable, high-pressured air is forced across and then down the lee slopes of a mountain range. The descending air is warmed and dried due to adiabatic compression ...”¹¹⁶ When Foehn winds occur during the summer months, they can add to the risk for spreading wildfires.

Windstorms can down tree limbs and affect some infrastructure at less severe events (around 50 mph sustained winds). At higher wind speeds, trees can break and block roadways or damage structures, and above ground utility wires can be damaged and knock out power. Roof damage often occurs when windstorms are severe. On the coast, windstorms can also influence hazardous wave conditions and push water inland potentially triggering flooding along areas of Florence and Highway 126 West.

Cascading Impacts and Secondary Hazards

Windstorms cause several cascading impacts when producing gale force winds or stronger. Telecommunications equipment can be damaged, including towers and above-ground telephone lines. Communications failures directly impact the ability of first responders to coordinate and identify how to allocate personnel and resources during an emergency. Additionally, above-ground transmissions lines and substation sites can be damaged resulting in widespread power outages impact both responders and individual buildings.

Windstorms also pose risk directly to buildings not only by the sheer force of the wind on weakened building materials (roof tiles or window shutters) but also through knocking down branches, uprooting some trees that fall onto buildings or objects. Downed trees and vegetation can also result in transportation disruptions along roadways, damaging water and sewer systems, or falling into waterways such as rivers and creeks that can further cause failures of infrastructure systems.

Extreme Weather and Winter Storms: Windstorms can present conditions that exacerbate other natural hazards depending on the time of year and location in the county. Along the Coast Region, windstorms can intensify coastal flooding and high tides, particularly during the wetter, winter months. Lane County typically receives lower total amounts of snowfall compared to other areas of Oregon. However, a severe winter storm that includes high wind gusts and heavy snowfall can reduce visibility when traveling and disrupt transportation in the region.

Wildfire: During the dry, summer months, sustained high winds contribute to greater wildfire risk. Winds might blow embers of small camp or warming fires that ignite, starting wildfires. Fires already

¹¹⁶ National Wildfire Coordinating Group. (n.d.). “Glossary: Foehn Wind.”

burning can rapidly spread and grow when strong winds are present. A recent example of this occurrence was the Holiday Farm Fire in 2020 when strong east winds fueled a rapid growth in the fire during the initial days of its outbreak.

Geographic Location

The potential for severe windstorms is highest along the Pacific coast. It is uniform across the rest of the county on the eastern side of the Coast Range, experiencing wind speeds of about 10 – 20 mph less compared to the coast. In hilly areas, wind hazard is strongly determined by local conditions of topography and vegetation cover. Strong winds along the coast typically lose strength as they move inland due to the obstruction created by the Coast Range. Major windstorms that impact large areas of the state, like the Columbus Day windstorm of 1962, are relatively rare. It is not uncommon for Oregon to experience several windstorms during the winter months, particularly along the coast, yet major damage from these storms is infrequent.

Coast Region: Windstorms are most likely to affect coastal communities west of the Coast Range and near the Pacific Ocean. Florence, Dunes City, Glenada, Heceta Beach all exist as communities that can be susceptible to impacts from a strong windstorm. Coastal counties in Oregon typically record 60 – 80 mph winds at least once per year. A particularly strong windstorm can result in coastal flooding along Highway 101, downed tree limbs that block roads and damage buildings, and knock out power when infrastructure is damaged either from the force of the wind or because of downed objects.

Valley Region: Windstorms occur in the Willamette Valley often with less intensity compared to the coastal area. For example, storms with 60 – 80 mph winds in coastal Lane County typically create 40 – 60 mph winds in the Willamette Valley. Although windstorms tend to have a limited effect in the Valley region, downed tree limbs can cause disruptions to transportation through road closures and utilities can suffer damaged infrastructure leading to power outages for customers. Power outages remain a concern in the Valley region given the high concentration of the county’s population. In rare events, rotational windstorms, or tornados, can occur in the Valley Region as happened in April of 2015 at Lane Community College (see Section 2.2.3: Extreme Weather). The Valley Region’s greater vulnerability from windstorms is how they can influence wildfires in the summer months.

Cascades Region: Windstorms can affect both the Cascades foothills and at higher elevations. Similar to the Coast and Valley regions, windstorms can down tree limbs and move other debris to block roads, such as Highway 58, and disrupt utility systems. As many communities located in the Cascades region are more rural and contain older housing stock, windstorms also can cause property damage to residences, as documented with several events in the past 20 years, notably during a March 2006 storm.¹¹⁷ In addition to the potential damage windstorms can directly cause, the impacts from these events can affect other hazards, notably wildfires and smoke during the summer months, and snow during winter storms that tend to produce more snow in the Cascades region.

¹¹⁷ NCDCE Storm Events Database.

Hazard Extent

The severity of windstorms from straight-line winds can be measured in either knots or miles per hour (mph). A common reference of wind speed to impacts is the Beaufort Wind Scale. Table 2.30 provides a summary of wind speed effects from the low range of wind advisories (40 mph) to sustained gusts in excess of 75 mph.

Table 2.30: Modified Beaufort Wind Scale for Wind Speed Effects when Reaching Gale Force Winds or Above

Wind Force	Description	Wind Speed (mph)	Impacts
8	Gale	36 - 46	Twigs break off trees, cars veer on the road.
9	Strong Gale	47 - 54	Larger branches break off and some small trees blow over. Construction/temporary signs and barricades blow over. Damage to tents and canopies occurs.
10	Storm	55 - 63	Trees are broken off or uprooted, saplings bent and deformed, poorly attached and poor condition shingles peel off.
11	Violent Storm	64 - 72	Widespread vegetation damage. Damage occurs to most roofing surfaces.
12	Hurricane	73+	Considerable and widespread damage to vegetation, a few windows broken, structural damage to mobile homes and poorly constructed sheds and barns. Debris may be hurled about.

Source: National Weather Service

In Lane County, the strongest sustained winds occur in the Coast region and can reach 60 – 80 mph during a Pacific storm. These wind speeds can also occur in the Cascade foothills and higher elevations of the Cascades. The Valley region is more likely to experience wind gusts ranging from 40 – 60 mph during strong events.

According to damage related to previous storms, particularly the Columbus Day Storm of 1962, impacts from a credible worst case scenario windstorm can be classified as **Level 4 catastrophic severity**. Major damage on a regional scale is possible, with numerous injuries and fatalities along with extended disruption of infrastructure and facilities, most notably power distribution and transportation disruptions. *This classification for hazard extent has not changed since the previous the version of this Plan.*

Previous Occurrences

Since 2000, three (3) federal disaster declarations in Oregon that included Lane County cited windstorms as part of the event. Two (2) of these events were Pacific storms occurring during the winter months that included strong sustained winds causing widespread damage. In the February 2002 storm, peak gusts reached approximately 70 mph in Eugene and caused extensive power outages throughout the county. Across utilities, an estimated 120,930 customers lost power during the storm and over two dozen structures suffered damages.¹¹⁸ Similarly, the December 10, 2015, storm produced high winds along the coastline and Coast Range area. The event contributed to damaging thunderstorms in the Willamette Valley and Cascade foothills. High winds downed trees onto cars and buildings and damaged power lines causing extensive power outages in the Valley region.¹¹⁹

¹¹⁸ NOAA Storm Events Database, Event Details: High Wind Southern Willamette Valley, 02/07/2002.

¹¹⁹ NOAA Storm Events Database, Event Details: Thunderstorm Wind, LANE, 12/10/2015.

Most recently in September of 2020, strong straight-line winds coming from the east fueled the rapid spread of numerous wildfires around the state. This “east-wind” event contributed to the spread of the Holiday Farm Fire in Lane County and was included in disaster declaration DR-4562-OR.¹²⁰

Historically, the most severe windstorm to occur in Lane County is the October 1962 storm. The storm delivered sustained winds in excess of 85 mph across all regions of Lane County and resulted in widespread, destructive damage to buildings, trees, and infrastructure. In some parts of the county, such as coastal areas and higher elevations of the mountain ranges, winds were reported as hurricane force (reference speed). Statewide, the storm caused an estimated \$170-\$200 million in damage (\$1.7 to \$2.0 billion in 2023 dollars).¹²¹

Table 2.31 provides a summary of notable windstorms in Lane County from 2000 – 2022. These events produce conditions where the NWS characterizes a high to extreme threat to life and property from high wind.

Table 2.31: Notable Windstorms in Lane County since 2000

Date of Event	Region(s) Affected	Wind Speeds (mph)	Reported Power Outages	Reported Damages
5/28/2022	Valley	46	Yes	No
1/3/2022	Coast	40	No	Yes
12/11/2021	Coast & Valley	60 - 80	Yes	No
*9/7/2020	Countywide	50 - 70	Yes	Yes
12/14/2018	Coast & Valley	43	Yes	No
4/7/2018	Valley	45 - 49	No	Yes
4/22/2016	Valley	57	No	Yes
1/16/2016	Valley	63	Yes	Yes
*12/10/2015	Valley	47	Yes	Yes
4/14/2015	Valley	65 - 85	No	Yes
11/22/2014	Valley	60	No	Yes
3/13/2011	Countywide	60	Yes	No
10/24/2010	Valley & Cascades	59	No	Yes
12/19/2007	Coast & Cascades	59	No	Yes
12/3/2007	Cascades	87	Yes	No
6/30/2006	Cascades	58	No	Yes
3/7/2006	Coast & Cascades	43	No	Yes
2/3/2006	Countywide	63	Yes	Yes
1/27/2006	Coast	55 - 75	No	Yes
4/2/2004	Cascades	80	Yes	Yes
*2/7/2002	Countywide	50 - 70	Yes	Yes

Source: NCDC, Storm Events Database; Lane County Emergency Management

*Federally Declared Disaster

¹²⁰ Federal Emergency Management Agency, Declared Disasters, Oregon, Major Disaster Declaration 2000 – 2023.

¹²¹ Reed, W. (2001). “The 1962 Columbus Day Storm.” Oregon Climate Center, Oregon State University, Corvallis, OR.

Probability of Future Occurrences

Sustained wind speeds with two-year recurrence intervals range from about 37 to 47 mph in Lane County. These two-year interval wind speeds are generally too low to cause widespread substantial wind damage. However, significant local wind damage can occur at sites where local wind speeds are higher or, where there are especially exposed locations, such as at the boundary between clear cut and forested lands. The 50-year recurrence interval of wind speeds range from about 62 to 75 mph. These wind speeds are high enough to cause building and infrastructure damage.

Sustained wind speeds with two-year recurrence intervals range from about 37 to 47 mph in Lane County. These two-year interval wind speeds are generally too low to cause widespread substantial wind damage. However, significant local wind damage can occur at sites where local wind speeds are higher or, where there are especially exposed locations, such as at the boundary between clear cut and forested lands. The 50-year recurrence interval of wind speeds range from about 62 to 75 mph. These wind speeds are high enough to cause building and infrastructure damage.

Windstorms that can cause disruptions to power delivery and some minor property and vegetative damage can occur once or twice each year in Lane County. The trend over the past decade follows this general pattern estimating the occurrence of future hazardous windstorms. Future occurrences of high wind events can impact the area during winter storms but must also be considered during the latter summer months for the impact on creating or exacerbating wildfire-favorable conditions. Furthermore, strong windstorms that affect the coastal area of Lane County can also fuel coastal hazards such as high tides and flooding events.

Based on historical occurrences and recognized recurrence intervals, Lane County expects a significant windstorm about once every 10 years. This frequency equates to a **high probability** classification. *This classification was adjusted higher from the classification given in the previous version of this Plan.*

Impacts Resulting from Climate Change

Research continues to investigate how climate change can affect wind patterns and how they could affect the frequency and intensity of windstorms. Existing studies often address wind as a hazard in the context of hurricanes and typhoons. Researchers have acknowledged that surface wind patterns may be altered because of changes in large-scale free atmospheric circulation and storm systems.¹²² However, no consensus exists about how climate change may impact the frequency of occurrence or severity of windstorms in the Pacific Northwest.

Overall Vulnerability

Based on assessments of the magnitude of previous occurrences, disruptions of utilities' operability, and a high probability of future occurrences, a **high vulnerability** classification is assigned for windstorms. This classification is reflected for the Coast Range, while the Valley and Cascades regions classify as **moderate vulnerability**. The Valley and Cascades regions experience either less severe or less frequent events compared to the Coast region. *The high vulnerability classification countywide has not changed since the previous version this Plan.*

¹²² Oregon Office of Emergency Management. (2020). "Natural Hazards Mitigation Plan: Windstorms."

Section 2.2.10: Winter Storm

Lane County experiences winter storms each year and there is a **high** probability of at least one storm per year significantly impacting residents in Lane County. The vulnerability of winter storms countywide is **high**. High vulnerability indicates a high probability of future occurrences and critical severity. This determination resulted from the specific impacts to transportation throughout the county in either a heavy snow or ice scenario that both isolates rural residents from main transportation corridors and impedes access for first responders. Power outages also pose high risk for rural communities throughout the county, particularly for heating purposes and the need for powering medical devices when transportation is hazardous or cutoff.

Hazard Description

Winter storms can produce ice accumulation and freezing rain, heavy snowfall, and/or extreme cold and wind chill conditions. Impacts are determined by factors such as the amount and extent of snow or ice, air temperature, wind speed, event duration, and time of day. These hazard events typically create disruption of regional systems such as public utilities, telecommunications, and transportation routes. The public is generally advised to shelter in place and maintain adequate resources (emergency light, water, batteries, food, warm clothes, etc.).

An ice storm is used to describe occasions when ice accumulations damage trees, above ground utility lines, and affect travel surfaces. Heavy snowfall can cause extended periods of travel disruption and damage to structures. Exposure to extreme cold and wind chill associated with winter storms can be life-threatening, and pipes within structures can freeze or burst (see Section 2.2.3 for specific details about extreme cold impacts).

Cascading Impacts and Secondary Hazards

Winter storms can trigger other natural hazards in Lane County, notably flooding and to a lesser extent, landslides. Additionally, winter storms that occur in the presence of cold temperatures and wind can lower wind chill conditions and heighten public health risks for people exposed to cold.

Extreme Cold: Western Oregon typically experiences the coldest temperatures between December and February. Winter storms that occur in the presence of cold air settled in the Willamette Valley have the potential for amplifying wind chill during the event. Heavy snow and ice along with wind gusts resulting from winter storms create wet conditions that further decreases the temperature experienced through exposure, which compounds the risk for health and safety for people caught in the elements.

Flood: Winter storms mostly affect the potential for flooding when large amounts of snowfall cover the ground followed by a rapid snowmelt. Rapid snowmelt, if accompanied by precipitation after the winter storm, is likely to release copious amounts of water downstream, triggering flooding along areas prone to overflow. The combination of a winter storm that produces heavy snowfall followed by heavy rainfall and rapid snowmelt is the most likely scenario for producing the impacts of a 100-year flood affecting the county's Valley and Cascades regions. Most recently, the severe winter storm that occurred in 2019 created conditions for a potential significant flooding event shortly thereafter.

Landslides & Debris Flows: The excess water contained in snow can also trigger landslides or debris flows during rapid snowmelts. Excess water that seeps into already saturated soils can destabilize the earth along slopes and cause the movement of materials downhill. Landslides and debris flows may be triggered hours or several days after rapid snowmelt has occurred, which challenges alert and warning

capabilities for identifying hazardous events. Exploration into using snowmelt forecasts as proxy indicators for predicting potential landslides is one method under consideration for better identifying the relationship between heavy snowfall and subsequent landslides.

Geographic Location

Winter storms affect each region of Lane County. Snowfall and ice tend to accumulate in the eastern region of the county compared to the populated areas in the Coast Range. In the Coast Range and Coastal areas in western Lane County, snowfall is less common and winter storm impacts are more likely to be wind-related or take the form of coastal flooding and high tides. Some coastal cities north of Lane County may experience higher rates of snowfall, such as in Tillamook County.

Coast Region: Snowfall and extreme cold temperatures are uncommon if not rare events for the Oregon Coast.¹²³ Winter storms typically produce stronger winds, rain, and create risky coastal conditions as opposed to snow or heavy snowfall. Snowfall is more likely to occur within the Coast Range at higher elevations (more than 1,000 feet above sea level). When snowfall does occur, it mostly accumulates a couple of inches or fewer. Winter storms can bring heavy rains in addition to snowfall in the Coast region, which can trigger flooding along the Siuslaw River, Pacific coastline, and landslides in the Coast Range, creating blockages along roadways such as Highways 126 and 36.

Valley Region: Heavy snowfalls in the Willamette Valley are less frequent compared to highly elevated areas of the Coast or Cascade Ranges. For example, annual average snowfall measured at the Eugene Regional Airport is about 6.4 inches.¹²⁴ In the Valley region, the effects of winter storms are most likely to be experienced as strong winds and extreme cold. Ice accumulation can result from winter storms when enough cold air is present in the southern Willamette Valley, leading to hazardous traveling conditions along roadways and disrupting power delivery due to freezing of above-ground transmission lines. Winter storms also have the potential to trigger flooding events in the Valley region depending on the amount and type of precipitation that occurs during the storm as well as the water level in rivers. Although heavy snowfalls are less common in the Valley, the historical trend is that winter storms can produce heavy snowfall once every few years since 2000.

Given the higher concentration of population in the Valley region, power demand is more likely to increase during prolonged periods of cold temperatures and when winter storms occur. In addition, given the importance of Interstate 5 as a main transportation corridor for communities in the Valley region, large, wide-covering storms can create transportation disruptions in surrounding counties that can impact residents in Lane County (often through closures on I-5).

Cascades Regions: Snowfall from winter storms, as well as ice accumulation, is most frequent in the Cascades region. Areas at higher elevations can receive heavy snow, defined as 6 inches or more of snow in a 12-hour period or 8 inches or more of snowfall in a 24-hour period.¹²⁵ For example, historically

¹²³ Oregon Office of Emergency Management. (2020). "Natural Hazards Mitigation Plan: Winter Storms."

¹²⁴ Eugene-Springfield Area Multi-Jurisdiction Natural Hazard Mitigation Plan. (2020). "Winter Storms."

¹²⁵ National Weather Service.

McKenzie Bridge averages annual snowfall of approximately 42 inches.¹²⁶ At lower elevations, such as closer to Oakridge and Westfir, annual snowfall decreases to approximately 12 – 13 inches.¹²⁷

Highway 58 provides a low elevation pass through the Cascades foothills as it leaves the Willamette Pass section and runs through the communities of Westfir, Oakridge, Lowell, Dexter, and Pleasant Hill. Highway 58 closes three to four times per year for several hours at a time due to winter storms. The same is true for Highway 126 East, which runs along the McKenzie River through the communities of Walterville, Deerhorn, and Blue River.

Hazard Extent

Since winter storms can produce several different weather effects, the hazard extent of a storm can be described in multiple ways. Snowfall is frequently used for describing winter storm extent. Other indicators include accumulation of ice, total precipitation, low temperature of storm, or wind speed. In Lane County, the coastline communities most often experience winter storms through high winds and hazardous conditions along the shoreline. The Cascades region is most likely to accumulate snow during winter storms while the Valley typically does not receive significant accumulation of snow. Accumulation of ice is an effect of winter storms in the Valley and Cascade foothills.

National Centers for Environmental Information (NCEI) produces an index to measure winter storm severity through snowfall accumulation along a metric known as Regional Snowfall Index (RSI). Table 2.32 provides the RSI values that correspond to reported snowfall accumulations along with the Description value. Higher RSI-value events that have occurred in Lane County since 2016 typically characterize winter storms impacting the Cascades region. Significant and major winter storms tend to reflect impacts of an event affecting the Valley region.

Table 2.32: Regional Snowfall Index that includes Number of Winter Storms to Occur in Lane County since 2016

Category	RSI Value	# of Events	Description
1	1 - 3	0	Notable
2	3 - 6	2	Significant
3	6 - 10	3	Major
4	10 - 18	6	Crippling
5	18+	1	Extreme

Source: National Center for Environmental Information; NCDC Storm Events Database

NOTE: Values correspond to inches accumulated. The description category is defined based on impact observations of snowstorms historically on regions for the eastern two-thirds of the United States. They are approximate in terms of impact to people and systems and do not necessarily reflect the resulting effects of the winter storms that occurred in Lane County since 2016.

¹²⁶ Taylor, G. H. & Bartlett, A. (1993). "The Climate of Oregon: Climate Zone 4 Northern Cascades." *Oregon Climate Service*, Oregon State University, Corvallis, OR.

¹²⁷ Western Regional Climate Center. (n.d.). "Oakridge Fish Hatchery, Oregon (356213) Period of Record Monthly Climate Summary."

Impacts from winter storms include the following: 1) transportation safety and disruptions, 2) electricity and communications disruptions, 3) public safety risk for travelers, commuters, and special needs populations, and 4) economic losses due to lost production and wages, increased heating costs, and response costs. Disruptions are frequent and widespread while repair and response are expensive. Utility line damage is a major concern resulting from winter storms. Property damage due to falling trees is common and can pose risks to people inside their homes during winter storms. According to these factors, a **Level 3 critical severity** classification is assigned for winter storms given the risk to public safety and potential for causing infrastructure disruptions or failures for anywhere from several hours to several days. *This classification for hazard extent has not changed since the previous version of this Plan.*

Previous Occurrences

There have been four (4) federal disaster declarations related to winter storms over the past decade that included Lane County (since 2014). Additionally, eight (8) state of emergency declarations by the Oregon Governor’s office have occurred for winter storms for which Lane County was included in that same period. Table 2.33 lists the federal disaster declarations for winter storms where Lane County has been included since 2000. Table 2.34 lists the state of emergencies declared by the Governor due to winter storms since 2000.

Table 2.33: Federal Disaster Declarations for Winter Storms that included Lane County, 2000 – 2023

Event Declaration	Incident Period	Main Features	Accumulation Reported
DR-4432	Feb. 23 - 26, 2019	Heavy Snow	8-16" lower elevations; 18" in Lorane and Oakridge
DR-4296	Dec. 14 - 17, 2016	Freezing Rain & Heavy Snow	14" McKenzie SNOTEL
DR-4258	Dec. 6 - 23, 2015	Heavy Snow	12 - 18" at Cascades SNOTEL (both storms)
DR-4169	Feb. 6 - 10, 2014	Ice Storm & Heavy Snow	1" ice shown on EWEB power lines
DR-4055	Jan. 17 - 21, 2012	Heavy Snow and Ice	Lack of Reading at Gauge Site
DR-1510	Dec. 26, 2003 - Jan. 14, 2004	Heavy Snow	2-8" Valley & 14-27" in Cascades

Source: NCDC Storm Events Database; Federal Emergency Management Agency



Downed trees across a roadway during the February 2019 Winter Storm, DR-4432 | Photo: Lane County Emergency Management

Table 2.34: Executive Orders Issued by Oregon Governor for Winter Storms that included Lane County, 2000 – 2023

Executive Order	Incident Period	Main Features	Accumulation Reported
23-01	Dec. 22, 2022 - Jan. 6, 2023	Snow, Freezing Rain, & Strong Winds	Limited snowfall accumulation
22-01	Dec. 30, 2021 - Jan. 10, 2022	Heavy Snow	21-26" in Cascades
21-37	Dec. 24, 2021 - Continuing	Heavy Snow	13" Junction City; 2'-3' in Cascades
19-04	Mar. 24, 2019 - Continuing	Heavy Rains & Rapid Snowmelt	Accumulation not reported
19-02 (DR-4432)	Feb. 24, 2019 - Continuing	Heavy Snow	8-16" lower elevations; 18" in Lorane and Oakridge
17-06	Jan. 11 - Mar. 2017	Snowfall and Ice	2-4"; 4.5" at Eugene Airport
17-02	Jan. 17 2017 - Continuing	Snowfall and Ice	2-4"; 4.5" at Eugene Airport
16-02	Dec. 07, 2015 - Jan. 25, 2016	Snowfall and Freezing Rain	0.5-1" of ice
07-24	Dec. 01, 2007 - Continuing	Heavy Snow	17" at Willamette Pass

Source: NCDC Storm Events Database; Office of the Governor State of Oregon

Recently, heavy snowfall affected most of the Valley and Cascades region in February 2019. Reports indicated 9 – 12 inches of snowfall in Eugene and the South Hills with totals reported for the Cascades ranging from 2 – 3 feet over 24 hours. Transportation routes were significantly impacted due to the conditions, notably Highway 58 closing due to downed trees. The storm resulted in both a state of emergency (EO 19-02) and federally declared disaster (DR-4432). Another storm in early January 2022 brought heavy snow to the Cascades region producing approximately two (2) feet in most areas.¹²⁸ In the past year, freezing rain followed by high winds moved through Lane County in late December 2022, which mostly impacted road travel. However, the precipitation from this storm caused minor flooding and turbidity issues in the Siuslaw River that resulted in a leak and system failure of the Mapleton Water Plant.¹²⁹

Another recent winter storm worth noting is the February 2021 ice storm that caused widespread damage through much of the Willamette Valley, particularly Benton County.¹³⁰ The storm produced over an inch of ice accumulation and over an inch and a half in some areas, significantly disrupting road travel and damaging infrastructure. Approximately 400,000 people lost power, some for several days, as a result. Lane County did not experience most of the impacts produced by the storm as the furthest south it reached was in Albany and Salem. The event though is an apt reminder of the impacts that winter storms can have on areas in the Willamette Valley, especially when they take the form of ice storms.

¹²⁸ NCDC Storm Events Database, Events Details for 01/03/2022 Heavy Snow, Cascades in Lane County

¹²⁹ Lane County Emergency Management, 2023.

¹³⁰ NCDC Storm Events Database, Event Details for 02/12/2021 Ice Storm, Central Willamette Valley.

Probability of Future Occurrences

According to events reported by the National Weather Service and FEMA, for the period 2000 – 2022 Lane County experienced 15 winter storm events, for an average of 1.5 storm events per year. Furthermore, major winter storms have occurred four (4) times in the past decade, which equates to one (1) major winter storm every three (3) years. The frequency for winter storms equates to a **high probability** of future occurrences in Lane County. Winter storms are most likely to bring heavy snow to the Cascades region while having potential for less total snowfall or produce ice in the Valley region. Moderate to minor events occur several times annually with more impactful winter storms occurring every two (2) to three (3) years. In the Coast region, winter storms mainly occur as Pacific storms that produce high winds and create hazardous conditions along the coastline. *The high probability classification for future occurrences has not changed since the previous version of this Plan.*

Impacts Resulting from Climate Change

Uncertainty exists about whether climate change will have any significant influence on the frequency of future winter storms in Lane County. Consensus opinions estimate that winter storms will be less likely to produce snowfall as precipitation and forecasters will be less likely to predict when these storms occur.¹³¹ Fluctuations in extreme temperatures still poses the potential for sudden heavy snowfalls and ice storms when conditions warrant. Annual snowfall totals for the Cascades are expected to decrease over the next few decades with warming temperatures leading to reduced snowpack.¹³²

Overall, the number of winter storms may decrease in occurrence but become more severe during each event with a higher rate of precipitation falling in shorter timeframes compared to past winter storms. Depending on the form of precipitation, impacts could become more severe in the future during severe winter storms. However, most conclusions about the relationship between climate change and winter storms agree that precipitation is less likely to form as snow compared to rain.

Overall Vulnerability

Based on previous occurrences, a critical hazard extent, and high probability of future occurrences, a **high vulnerability** classification is assigned for winter storms. This classification is applicable to all regions of Lane County, though as noted in this profile, each region experiences winter storm impacts differently. Socially vulnerable populations, including the elderly, disabled, low-income households, and unsheltered persons are particularly at-risk during winter storms when power outages occur, and communication systems are disrupted. The physical layout of infrastructure, i.e., location of roads, power, and communications lines in relation to trees and mountains areas create a notable vulnerability to winter storm events. *The classification for overall vulnerability has not changed since the previous version of this Plan.*

¹³¹ Lane County. (2022). "Climate Resilience Plan" County Administration Office.

¹³² Fleishman, E., editor. (2023). *Sixth Oregon climate assessment: Wildfire*. Oregon Climate Change Research Institute, Oregon State University, Corvallis, OR. DOI: 10.5399/osu/1161.

Section 2.3: Vulnerability Assessment

The vulnerability assessment examines vulnerability through four categories: people, buildings, community lifelines, and the natural environment. The following subsections summarize Lane County's vulnerability to natural hazards based on a variety of factors that include social vulnerability, exposure to hazardous areas or extents, and the historical record of the impacts resulting from previous disasters.

Section 2.3.1: Vulnerability to People

People can be impacted by natural hazards in a variety of ways. Exposure to a hazardous area is one approach to assess people's vulnerability. Understanding exposure can be improved by reviewing the historical record of past hazard events and the impacts inflicted upon people. While injuries and deaths represent an important detail in assessing how severe and impactful past disasters have been on people's safety, understanding other outcomes such as property damage or destruction, financial damages that were incurred, and the cascading impacts that result from the disruption of normal life is equally as important. However, not all people experience these impacts in the same way. The NHMP update approaches vulnerability to people by assessing Lane County's characteristic social vulnerability, the public's exposure to hazard areas, and examining historical impacts of past events.

Social Vulnerability

Social vulnerability is an important factor to consider in natural hazard planning. Social vulnerability describes the characteristics or factors that can disproportionately affect a person during a hazard event. Being disproportionately affected can describe either a heightened risk factor during a hazard event or a characteristic that can affect a person or community's ability to recover from a disaster. Currently the federal government uses the social vulnerability index produced by the Centers for Disease Control (CDC). This data is used in a variety of federal tools to identify social vulnerability in the context of both climate change and natural hazards. Risk data is available at both the county and the census tract level.

For example, the National Risk Index as published by the Federal Emergency Management Agency (FEMA) lists Lane County as having a **relatively high** social vulnerability.¹³³ The Climate and Economic Justice screening tool identifies disadvantaged communities along social vulnerability criteria in Lane County at the census tract level. In Lane County, disadvantaged census tracts exist in the Coast Range, among several tracts within the western and southern portions of the Willamette Valley outside of the metropolitan area, and in southeastern Lane County, which includes unincorporated communities and the cities of Westfir and Oakridge.¹³⁴

Given that Lane County encompasses a large land area with a relatively spread-out population, it is important to use county level data in combination with city data and census tract data. The following tables present a series of indicators and estimates for social vulnerability characteristics amongst the cities of Lane County, the countywide total, and estimates of these totals among the unincorporated

¹³³ Federal Emergency Management Agency. (2023). *National Risk Index*. <https://www.fema.gov/flood-maps/products-tools/national-risk-index>.

¹³⁴ Council on Environmental Quality. (2022). *Climate and Economic Justice Screening Tool*. <https://screeningtool.geoplatform.gov/en/#3/33.47/-97.5>.

population. We then assess vulnerability according to traditional methods of exposure and historical analysis, comparing these results with the identified socially vulnerable areas.

Significant Factors: Among social vulnerability categories, Lane County is distinctly characterized by three of these categories. **Age, living with a disability, and cost-burdened households represent the most common social vulnerability factors for individuals living in Lane County.** The area currently contains a high proportion of young individuals (17 and under) and older individuals (65 and older). These populations can experience challenges in the context of advancing mitigation in terms of physical ability or possessing the necessary education, training, and experience. Medical needs also exist with respect to these populations. During a hazard event, these groups can be disproportionately impacted due to obstacles related to transportation (for evacuating without assistance), communications, and access to fuel or electricity. Nearly every city in Lane County contains a sizeable amount of these two age groups. Coburg and Florence have over half their population contained within the vulnerable age category while other cities range between approximately 33 and 50 percent (33% and 50%) of their populations contained in these two groups (see Table 2.36).

Cost-burdened households are those that spend 30 percent (30%) or more of their income on housing and utility costs, regardless of whether they own or rent. When households are cost burdened, they have less disposable income for other necessities such as food, medical supplies, fuel, and disposable income that would be available for an emergency expense. Cost-burden households are less likely to possess disposable income or savings that would allow them to pay for treatments or hardening on their property prior to a disaster or the available cost necessary to rebuild following a disaster. It is also less likely that these households would possess insurance policies, such as against damage from wildfire, earthquake, or wind damage. Lastly, it is less likely that these households would also carry affordable health insurance.

Most cities in Lane County contain households that are cost burdened ranging from about 14 percent (14%) on the lower end of the range up to as high as 27 percent (27%) (see Table 2.38). The exception within the county is Junction City, in which only five percent (5%) of households are estimated to be cost burdened. The most cost burden cities in the county are estimated to be Coburg, Florence, Oakridge, Veneta, and Westfir, each exceeding 20 percent (20%) of cost-burdened households. Furthermore, it is estimated that 18 percent (18%) of households in unincorporated Lane County are cost burdened.

A noticeable proportion of the population within each city in Lane County is living with a disability. These disabilities range from sensory, to cognitive, to mobility based. No matter the type of disability, individuals living with disabilities are disproportionately be impacted by hazard events due largely to the ability to evacuate an area, withstand hazard impacts, continue using medical devices that rely on electricity, or receive and process information that would alert or inform an individual prior or during a hazard event. People living with disabilities often need assistance and services adapted to their specific needs that results in mitigating their risk before a hazard event or aiding in their recovery immediately following an event. In Lane County the percentage of the population living with the disability ranges from approximately 14 percent (14%) on the low end of the range to as much as a quarter of the population. In unincorporated Lane County, it is estimated that nearly 22 percent (22%) of individuals are living with a disability (see Table 2.35). Among the cities these figures are highest in Dunes City, Florence, and Veneta.

Table 2.35: Social Vulnerability, Estimate Totals for Lane County, Incorporated Cities, and Unincorporated Communities based on Socioeconomic Factors

Jurisdiction	Area Median Income (2021 Inflation Adjusted Dollars)	# of people living below poverty level	% of population in poverty	% unemployed	% of population without HS Diploma	% living with a disability
Lane County	\$ 61,712	61,337	16.5%	7.2%	7.2%	17.6%
Unincorporated Lane	Not Available	12,531	4.6%	7.2%	5.7%	21.8%
Incorporated Cities						
Coburg	\$ 71,750	96	6.3%	10.9%	11.9%	15.3%
Cottage Grove	\$ 52,994	2,209	21.3%	8.2%	9.6%	19.8%
Creswell	\$ 78,974	333	6.0%	1.6%	6.4%	14.7%
Dunes City	\$ 68,906	45	3.9%	1.4%	7.9%	23.6%
Eugene	\$ 59,338	32,760	19.6%	7.4%	6.3%	14.0%
Florence	\$ 50,615	1,214	13.0%	5.6%	10.0%	24.9%
Junction City	\$ 58,017	828	12.6%	5.6%	6.5%	16.5%
Lowell	\$ 52,431	88	8.4%	1.8%	9.4%	18.7%
Oakridge	\$ 33,088	969	29.8%	20.3%	16.5%	18.1%
Springfield	\$ 54,503	9,855	16.0%	6.9%	10.3%	19.5%
Veneta	\$ 53,885	371	7.2%	4.3%	14.2%	23.4%
Westfir	\$ 56,250	38	9.6%	15.5%	14.3%	19.7%

Source: 2021 American Community Survey, 5-YR Estimates, Tables S1901, S1701, S1501, DP03

Table 2.36: Social Vulnerability, Estimate Totals for Lane County, Incorporated Cities, and Unincorporated Communities based on Household Composition Factors

Jurisdiction	# of people aged 65 and over	# of people 65 and over, living alone	# of people 17 and younger	% of population vulnerable by age (under 17 & older than 65)	# of single-parent households	# of single-parent, female households
Lane County	73,811	19,159	69,944	37.5%	9,345	7,191
Unincorporated Lane	25,520	4,390	18,293	44.1%	1,611	1,144
Incorporated Cities						
Coburg	352	42	437	60.4%	26	13
Cottage Grove	1,645	512	2,328	37.6%	353	321
Creswell	845	133	1,345	38.8%	125	103
Dunes City	561	165	127	48.2%	6	3
Eugene	28,509	9,285	29,241	32.7%	4,686	3,834
Florence	4,007	1,268	1,149	54.9%	171	166
Junction City	1,185	302	1,519	39.8%	135	124
Lowell	217	43	227	37.1%	30	15
Oakridge	643	106	657	40.5%	80	80
Springfield	9,220	2,720	13,348	36.5%	1,878	1,226
Veneta	1,028	163	1,167	42.1%	244	162
Westfir	79	30	106	46.8%	0	0

Source: 2021 American Community Survey, 5-YR Estimates, Tables S0101 & DP05

Table 2.37: Social Vulnerability, Estimate Totals for Lane County, Incorporated Cities, and Unincorporated Communities based on Minority Status & Language Factors

Jurisdiction	# of total BIPOC population	% of total population that is BIPOC	# persons that speak English less than "very well"	% of total population for persons that speak English less than "very well"
Lane County	59,151	15.4%	8,378	2.3%
Unincorporated Lane	10,194	10.2%	1,172	1.2%
Incorporated Cities				
Coburg	161	9.9%	0	0.0%
Cottage Grove	1,520	14.4%	396	3.9%
Creswell	552	9.8%	57	1.1%
Dunes City	151	13.1%	21	1.9%
Eugene	32,816	18.9%	5,107	3.1%
Florence	842	9.0%	162	1.8%
Junction City	551	8.2%	0	0.0%
Lowell	72	6.9%	0	0.0%
Oakridge	119	3.7%	0	0.0%
Springfield	10,967	17.6%	1,286	2.2%
Veneta	1,201	23.1%	168	3.4%
Westfir	5	1.3%	9	2.5%

Source: 2021 American Community Survey, 5-YR Estimates, Tables DP05 & S1601

Table 2.38: Social Vulnerability, Estimate Totals for Lane County, Incorporated Cities, and Unincorporated Communities based on Housing and Transportation Factors

Jurisdiction	# of mobile and vehicular homes	# households without access to a vehicle	# of total households that are cost burdened	# of households experiencing crowding
Lane County	5,013	11,898	24,552	4,240
Unincorporated Lane	1,172	1,446	7,228	671
Incorporated Cities				
Coburg	72	0	114	31
Cottage Grove	219	461	804	209
Creswell	30	53	360	30
Dunes City	3	23	94	0
Eugene	2,038	7,129	10,292	1,999
Florence	135	280	985	99
Junction City	20	209	137	20
Lowell	10	9	58	10
Oakridge	1,260	0	366	0
Springfield	37	2,223	3,499	1,117
Veneta	17	58	585	37
Westfir	0	7	30	17

Source: 2021 American Community Survey, 5-YR Estimates, Table DP04

Exposure Analysis

Lane County GIS analyzed the number of parcels that fell entirely or partially within five (5) hazard areas: the 100-year floodplain, 500-year floodplain, areas at high to very high risk of earthquake amplification (ground-shaking), areas at high to very high risk of earthquake-induced liquefaction, and within the wildland-urban interface (WUI).

Table 2.39 provides an estimate of the population exposure to high-hazard areas. The analysis estimates that nearly one in five Lane County residents live within or adjacent to the WUI. A little over 10 percent (10%) of residents live in the 100-year floodplain or a high to very high amplification risk area. Additional details about exposure to specific hazard types follows the table.

Table 2.39: Estimated Population Exposure to Floodplains, High Risk Amplification and Liquefaction Susceptibility, and Wildland-Urban Interface

Hazard Area Type	Parcel Count	Estimated Population	% of Total County Population
100-Year Floodplain	20,489	47,125	12.3%
500-Year Floodplain	9,680	22,264	5.8%
High-Very High Amplification Risk	18,878	43,419	11.3%
High-Very High Liquefaction Risk	8,460	19,458	5.1%
Wildland-Urban Interface (WUI)	33,155	76,257	19.9%

Source: Lane County GIS



A landslide washes out a section of road near the Siuslaw River in 2014

Photo: Lane County Public Works, Roads Division

Landslides: The entire population of people living in Lane County exposed to a high risk from landslides is unknown at present. Some studies have provided estimates for specific areas of the county. For example, DOGAMI IMS-60 report concluded within an area that included the Eugene-Springfield metropolitan area, Coburg UGB, and the immediate surrounding area of unincorporated Lane County in this extent, approximately 5,200 people live within a deep landslide high susceptibility zone and 4,600 people live within a shallow landslide high susceptibility zone.¹³⁵ Table 2.40 summarizes the exposure analysis results from IMS-60 for this study area. Future versions of this Plan will need to draw from any additional studies performed in other local areas within Lane County (e.g., the current study examining landslide risk in the McKenzie River Valley following Holiday Farm Fire).

Table 2.40: Population Exposure to High Susceptibility Landslide Risk, Valley-Central Region Study for Eugene-Springfield, Coburg, and Lane County

Geography	Shallow Landslides	Deep Landslides	% of Total Population
Lane County	505	744	3.0%
Eugene South	3,097	2,580	8.7%
Eugene Southwest	25	0	0.8%
Springfield East	393	1,904	11.4%
Eugene West	69	0	0.2%
Springfield West	246	4	0.7%
Coburg	2	0	0.4%
Eugene North	313	0	0.7%
Total in Study Area	4,650	5,232	3.9%

Source: DOGAMI IMS-60, 2018

Historical Analysis

Historically, the most significant vulnerability of people to natural hazards came from extreme weather, flood, landside and debris flows, and wildfire. Extreme temperatures represent an annual risk for vulnerable populations, especially unsheltered individuals that become directly exposed to these conditions. Floods, landslides, and wildfires most often pose life threatening risks for people when these events are especially severe. The 1996 flood killed eight (8) people in Oregon, and one (1) individual died during the Holiday Farm Fire (2020). Fortunately, many of the most significant hazard events in Lane County's history have not resulted in mass casualties and impacts are most likely to cause injury or displace individuals from their homes in addition to the financial losses to property and businesses that occur during these events.

Significant wildfires can displace individuals from their homes for anywhere to a few weeks to months and in extreme cases, even years. Displacement from residences because of the Holiday Farm Fire in 2020 were significant, requiring the need for temporary housing for individuals and families. Though less recent in the historical record, floods have also resulted in displacing people from their homes in the county.

¹³⁵ Calhoun, N.C., Burns, W.J., Franczyk, J.J., and Monteverde, G. (2018). "Interpretive Map Series 60, Landslide hazard and risk study of Eugene-Springfield and Lane County, Oregon." *Oregon Department of Geology and Mineral Industries*.

While the recent historical record does not contain an event of a powerful earthquake, this type of natural hazard would likely also displace a significant number of individuals, especially in western Lane County and in regions throughout the Willamette Valley. A CSZ earthquake and the resulting local tsunami also represents the most likely mass causality scenario from a natural disaster for Lane County.

Section 2.3.2: Vulnerability to Buildings

Certain hazards affect broad geographic regions, such as winter storms and windstorms, whereas other hazards have occurrence patterns that can be more geographically defined. Vulnerability of buildings is an examination of how natural hazards can cause damage to buildings, mainly residences and businesses. Specialty buildings such as police and fire stations are addressed in the following subsection examining vulnerability to **Community Lifelines and Critical Infrastructure**. To assess buildings' vulnerability, exposure analysis was used to identify the number of buildings partially, fully, or potentially depending on hazard type exposed to impacts resulting from an event.

Earthquake and tsunami are discussed in relation to each other given the potential for a CSZ earthquake that will affect Lane County. Parcels within the floodplain or wildland-urban interface (WUI) provide exposure data for buildings' risk from flood and wildfire. More geographically expansive natural hazards such as extreme weather, windstorms, and winter storms were addressed through a review of the housing stock age in Lane County for an understanding of how structure age is distributed based on the applicable building codes that existed during specific periods when housing was constructed. Drought may impact buildings directly through the weakening of soils causing subsidence and degrading the structural integrity of building foundations. However, this issue has not demonstrated posing existing risk to most buildings in Lane County.

Structures Exposed to Hazardous Areas

Exposure analysis provides an estimation of the potential risk for buildings located in or close to hazardous areas. These areas tend to be more localized based on risk factors compared to the geographic coverage of natural hazards that impact the entire county. The Planning Team drew from the most recent research and available data to determine building counts in hazardous areas for five (5) of the ten (10) natural hazardous included in this Plan. Lane County GIS and Land Management Division assisted and corroborated the estimates to be included in the vulnerability assessment.

Table 2.41 presents the results of analyzing parcel data in Lane County to determine the exposure of building assets to various high-hazard areas. Exposure in this assessment included parcels partially or entirely contained within the 100-year and 500-year floodplain, high to very-high liquefaction and amplification risk areas, and the urban-wildland interface (WUI). Included in the table is also a calculation as contained within the data of the total land value, improvement value, and total value exposed to hazardous areas.

Table 2.41: Exposure Analysis of Lane County Partially or Entirely within High-Hazard Areas

Hazard Area Type	Parcel Count	Total Land Value	Total Improvement Value	Total Value
100-Year Floodplain	20,489	\$ 5,582,720,918	\$ 9,614,654,106	\$ 15,198,193,847
500-Year Floodplain	9,681	\$ 2,482,054,946	\$ 6,646,239,518	\$ 9,129,403,158
High-Very High Amplification Risk	31,081	\$ 7,526,287,628	\$ 8,514,049,555	\$ 16,041,738,853
High-Very High Liquefaction Risk	11,777	\$ 1,926,673,953	\$ 3,107,390,698	\$ 5,034,447,675
Wildland-Urban Interface (WUI)	85,443	\$ 14,179,113,285	\$ 27,247,901,852	\$ 41,428,111,034

Source: Lane County GIS

NFIP & Repetitive Flood Claims

The National Flood Insurance Program (NFIP) has developed a strategy to mitigate repetitive flood insurance claims (RFIC) on individual properties (also called Repetitive Loss Properties). A Repetitive Loss Property (RLP) is defined as any insurable building with two (2) or more paid flood insurance claims exceeding \$1,000 within a ten-year period. A RLP property may or may not be currently insured by the NFIP.

A Severe Repetitive Loss property (SRL) is defined as having at least four (4) paid flood insurance claims each exceeding \$5,000, or when there are two (2) or more losses where the building payments exceed the property value. Loss history is determined by counting all flood claims paid on an insured property, regardless of any change(s) of ownership, since the building’s construction or back to 1978. States or communities may sponsor projects to mitigate flood losses to these properties or may be able to provide technical assistance on mitigation options.

Depending on individual circumstances, appropriate mitigation measures commonly include elevating buildings above the base flood elevation, demolishing buildings, and removing buildings from the Special Flood Hazard Area (SFHA). Occasionally, mitigation takes the form of a local drainage-improvement project that meets NFIP standards.

Local Repetitive Loss Information: There are 23 properties in Lane County that meet the NFIP definition for Repetitive Loss Properties. This number increased from 21 properties in the previous hazard mitigation plan cycle.

Flood Insurance Claim Information by Community: Based on NFIP data reported as of October 2014, unincorporated Lane County ranks 3rd among Oregon counties in total flood insurance claims (350) and 5th among Oregon counties in total flood insurance payments (\$3.17 million). Approximately 85 percent (85%) of overall flood insurance claims, 355 of the 420 claims, occurred in unincorporated Lane County.

Table 2.42: Repetitive Flood Loss Record for Lane County as of February 2023

Property Count	Community	# of Total Losses	Total Payments	NFIP Insured	Mitigated
1	SPRINGFIELD	4	\$ 185,471.06	SDF	NO
2	MAPLETON	4	\$ 44,615.38	NO	NO
3	SPRINGFIELD	2	\$ 25,042.80	NO	NO
4	SPRINGFIELD	4	\$ 21,999.28	NO	NO
5	MAPLETON	3	\$ 23,433.63	YES	NO
6	ELMIRA	2	\$ 19,112.45	NO	NO
7	MAPLETON	4	\$ 54,119.30	NO	NO
8	SPRINGFIELD	4	\$ 7,218.12	YES	NO
9	MAPLETON	3	\$ 40,672.66	NO	NO
10	COBURG	2	\$ 7,301.48	NO	NO
11	MAPLETON	2	\$ 13,408.97	NO	NO
12	MAPLETON	3	\$ 153,864.09	NO	NO
13	VIDA	3	\$ 28,719.58	NO	NO
14	SPRINGFIELD	2	\$ 24,123.04	NO	NO
15	SPRINGFIELD	2	\$ 53,662.36	YES	NO
16	SPRINGFIELD	2	\$ 52,307.62	YES	NO
17	SPRINGFIELD	3	\$ 41,142.13	YES	NO
18	MAPLETON	2	\$ 45,550.19	YES	NO
19	SPRINGFIELD	2	\$ 16,737.76	YES	NO
20	MAPLETON	3	\$ 88,009.16	NO	NO
21	FLORENCE	2	\$ 8,743.60	NO	NO
22	MAPLETON	2	\$ 9,037.82	NO	NO
23	MAPLETON	4	\$ 31,114.00	NO	NO
24	MAPLETON	4	\$ 43,588.60	NO	YES
25	MAPLETON	4	\$ 48,664.20	NO	NO
26	WALTON	2	\$ 38,926.68	NO	NO
27	COTTAGE GROVE	2	\$ 57,122.16	NO	NO
28	MAPLETON	2	\$ 32,994.40	YES	NO
29	FLORENCE	2	\$ 14,817.66	NO	NO
30	MAPLETON	2	\$ 5,288.24	YES	NO
31	MAPLETON	2	\$ 77,126.61	YES	NO
32	SIUSLAW RIVER	2	\$ 57,895.12	NO	NO
33	FLORENCE	2	\$ 35,541.85	NO	NO
34	MAPLETON	3	\$ 22,062.89	YES	NO
35	NOTI	2	\$ 63,778.46	YES	NO
36	COTTAGE GROVE	2	\$ 12,418.22	YES	NO
37	COTTAGE GROVE	2	\$ 32,219.83	YES	NO
38	COTTAGE GROVE	2	\$ 8,680.70	NO	NO
39	DEXTER	2	\$ 17,929.31	NO	NO
40	BLUE RIVER	2	\$ 4,670.93	NO	NO
Totals		103	\$ 1,569,132.34		

Source: Federal Emergency Management Agency; National Flood Insurance Program

Landslide Risk to Buildings: Buildings can be exposed to both shallow and deep landslides. Greater hazard risk comes from exposure to deep landslides and many of these do occur in the mountainous, remote regions of Lane County. While landslide occurrence has been monitored and documented extensively throughout the state of Oregon (refer to the Statewide Landslide Information Database for Oregon, SLIDO), fewer studies have focused on building exposure in the most populous area of the county. A DOGAMI study from 2018 explored landslide risk in the concentrated metropolitan area, Coburg UGB, and immediate surrounding area of unincorporated Lane County. The study identified building counts that were exposed to a high-susceptibility area for landslides, whether shallow or deep. Figure 2.19 shows the extent of the study area.

Figure 2.19: Study Area for IMS-60 Assessing Landslide Vulnerability

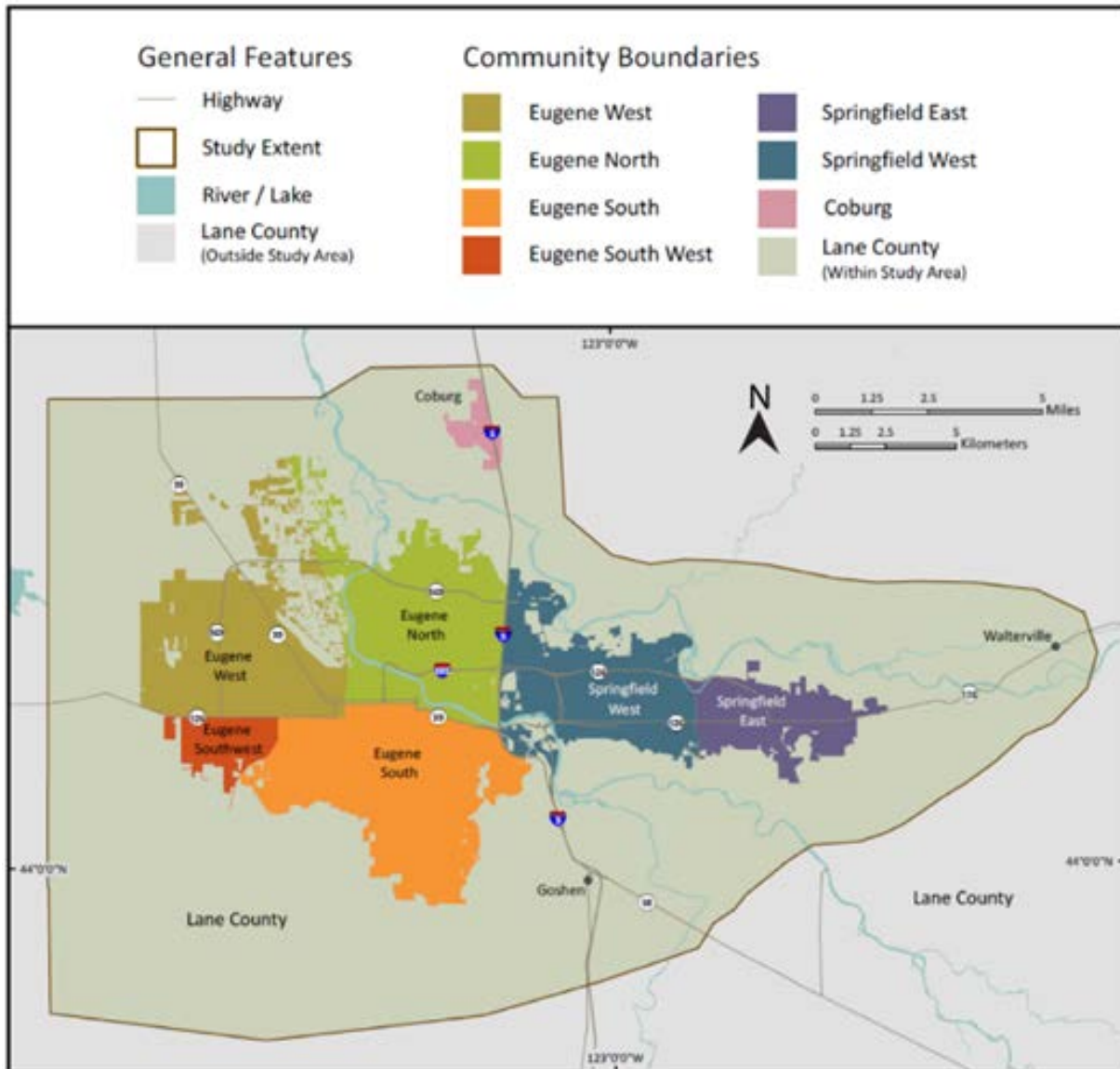

Source: DOGAMI IMS-60, 2018

Table 2.43 presents the results from this analysis to show counts for buildings exposed to landslide risk for the study. The estimated total building value in high-susceptibility areas within this study area is approximately \$5.12 billion.

Table 2.43: Building Exposure to High-Susceptibility Landslide Areas for Eugene-Springfield, Coburg, and Lane County

Geography	Shallow Landslides				Deep Landslides			
	Residential	Commercial	Public	Total	Residential	Commercial	Public	Total
Lane County	984	425	42	1,451	580	324	11	915
Eugene South	5,232	83	67	5,382	1,070	13	3	1,086
Eugene Southwest	9	7	4	20	-	-	-	-
Springfield East	549	24	1	574	978	3	2	983
Eugene West	40	74	1	115	-	-	-	-
Springfield West	291	66	10	367	3	-	2	5
Coburg	16	7	-	23	-	-	-	-
Eugene North	317	56	45	418	-	-	-	-
Total in Study Area	7,438	742	170	8,350	2,631	340	18	2,989

Source: DOGAMI IMS-60, 2018

DOGAMI is currently investigating the exposure of buildings to landslide and debris flows in the portion of the McKenzie River Valley contained within the Holiday Farm Fire burn scar. Results from this study are expected in 2024. Elements of this Plan will be updated for landslide risk in Lane County when these results are available.



Bridge Street bridge experiencing rising waters and debris during a December 2014 event. | Photo: Lane County Public Works, Roads Division

Tsunami Risk to Buildings: In 2008 DOGAMI published an extensive study on the primary geologic hazards of Yamhill, Marion, Polk, Benton, Linn, and Lane counties. Included in this report are earthquake and landslide hazard maps for each county along with future earthquakes damage estimates. This study is called *Interpretive Map Series, IMS-24, Geologic Hazards, Earthquake and Landslide Hazard Maps, and Future Earthquake Damage Estimates*.

The IMS-24 Maps discussed in this section show the coastline of Lane County and calculated areas likely to be inundated under various tsunami scenarios. The different scenarios followed a T-shirt sizing model ranging from small (an 8.7 magnitude earthquake) to extra extra large (a 9.1 magnitude earthquake). Refer to IMS-24 for further information about the methodology used to designate categories for different CSZ earthquake magnitudes. This study also calculated estimates for the impact of a distant tsunami caused by an earthquake within the Alaska-Aleutian Subduction Zone.

Table 2.44: Estimated Count of Buildings within the Tsunami Inundation Zone for Local and Distant Tsunamis, Coastal Lane County

Tsunami Size (Earthquake Mg.)	Unincorporated Areas	Dunes City	Florence	Entire Map Area
Cascadia Subduction Zone (Local Tsunami)				
Small (8.7)	59	0	53	112
Medium (8.9)	166	6	136	275
Large (9.0)	270	6	301	577
Extra Large (9.1)	396	46	716	1158
Extra Extra Large (9.1)	428	55	905	1388
Alaska-Aleutian Subduction Zone (Distant Tsunami)				
Alaska M9.2 (1964)	43	0	21	64
Alaska Maximum (9.2)	63	0	142	197

Source: DOGAMI Tsunami Inundation Maps, TIM-Lane Maps 01-08, 2013

Section 2.3.3: Vulnerability to Community Lifelines and Critical Infrastructure

Critical infrastructure is generally defined as facilities necessary for the basic functioning of communities and provide vital services to the public. Much of the critical infrastructure that supports communities can be categorized along the Community Lifelines model. A **community lifeline** enables the continuous operation of critical government and business functions and is essential to human health and safety or economic security. Lifelines are typified by structures and systems vital for the provision of energy, water, communications, and transportation to name a few. These lifelines are both local and regional networks that serve residents and businesses throughout Lane County and beyond. As a category, critical infrastructure and lifelines are different from “life support” systems, which include emergency services and public health, which have distinct characteristics and mission goals.

According to a report from the National Association of Counties, *Improving Lifelines: Protecting Critical Infrastructure for Resilient Counties*, in general there are four main factors that define lifelines:

- Lifelines provide necessary services and goods that support nearly every home, business, and county agency.
- Lifelines deliver services that are commonplace in everyday life, but disruption of the service has the potential to develop life-threatening situations.
- Lifelines involve complex physical and electronic networks that are interconnected within and across multiple sectors.
- Disrupting a lifeline has the potential to affect or disrupt other lifelines in a cascading effect.

Lane County identified four priority lifeline categories as follows:

- 1) Transportation (examples: roads, bridges, rail, airports and ports)
- 2) Energy (examples: fuel, oil, natural gas and electricity)
- 3) Communications (examples: telephone, satellite and internet infrastructure)
- 4) Food, Water, and Shelter (examples: drinking water and wastewater systems)

Transportation

Seismic vulnerability of proposed lifeline routes relative to projected ground shaking from a CSZ event is high despite the low probability of occurrence. Overall, very few bridges and overpasses in Lane County have been adequately retrofitted to date. Bridges on lifeline routes identified by the State of Oregon and other County/City owned roadways represent the most significant vulnerabilities of the roadway system. Seismic risk and the event impacts will significantly compromise the ability to move people, resources, and equipment following a CSZ earthquake. Long-term impacts to the local economy due to these transportation failures will further exacerbate the situation by reducing the ability of the industrial and agricultural sectors to provide services to the local population. The State Hazard Mitigation Plan goes on to explain, “Significant loss of life is likely in tsunami prone areas. Additional loss of life from untreated injuries and disease due to a fragmented response network could also be significant. Loss of life due to structural collapse could be widespread, exacerbating by the duration of ground shaking and the size of the event at the coast, in the Coast Range, along the Lower Columbia, in the Metro area and in the central valleys.”¹³⁶

The 2014 winter storm (DR – 4169) and 2016 ice storm (DR-4296) closed major corridors for several days, preventing the delivery of essential food supplies. Rural communities will be significantly impacted when transportation routes are compromised as demonstrated in the 2019 winter storm (DR-4432), where heavy snowfall impacted Highway 58 and others major corridors resulting in full closures for several days. Heavy snow, landslides, and fallen debris in the roadway caused these road closures.

Another related concern relates to flooding on county roadways. Certain sections of roads experience some degree of flooding nearly every year. Resulting impacts include impeded access/egress by emergency response vehicles as well as public safety risks and economic disruptions. A high proportion of flooding fatalities occur when vehicles attempt to travel on flooded roads. When inundated, it is difficult to judge vehicle alignment with the road surface and ditch location, as well as washouts or road

¹³⁶ State of Oregon. 2020. “Chapter 2: Risk Assessment, State Vulnerability.” *Natural Hazards Mitigation Plan*, Oregon Department of Emergency Management, p. 151.

hazards below the water surface. Adding to this danger, when water is running with velocity across a roadway, it exerts hydraulic force perpendicular to the direction of travel, which can sweep vehicles off the roadway and create life-threatening situations.

Table 2.45 provides a list of 10 high water locations that Lane County Public Works considers their highest mitigation priority.

Table 2.45: Highwater Locations along Frequently Flooded Roadways, Priority Areas

Road Number	Road Name	Begin M.P.	End M.P.	Average Daily Traffic (ADT)
3110	Love Lake Road	1.450		1,250
4335	Vaughn Road	8.350		750
1628	Coleman Road	0.090	0.370	500
6068	Edenvale Road	0.700	1.000	500
5070	North Fork Siuslaw Road	5.700		430
6122	Parvin Road	0.400		260
5036	Sweet Creek Road	4.570		200
1625	Herman Road	0.520	0.890	170
4093	Powell Road	0.139		60
4096	Simonsen Road	0.159		50

Source: Lane County Public Works, Roads Division

Additionally, nine (9) of the 23 covered bridges in Lane County are in Special Flood Hazard Areas as defined on the most current FEMA Flood Insurance Rate Maps:

- | | |
|-----------------------------|----------------------------|
| Coyote Creek Covered Bridge | Mosby Creek Covered Bridge |
| Dorena Covered Bridge | Parvin Covered Bridge |
| Lake Creek Covered Bridge | Stewart Covered Bridge |
| Lowell Covered Bridge | Wendling Covered Bridge |

Airports: Lane County contains six (6) airports, which three (3) are in the Valley region (Cottage Grove, Creswell, and Eugene), two (2) in the Cascades region (McKenzie Bridge, Oakridge), and one (1) in the Coast region (Florence). Airports face risks caused by earthquakes, extreme weather, flood, wildfire, windstorms, and winter storms. The Florence Airport is also potentially impacted by a local tsunami generated from a CSZ event, but impact would depend on the magnitude of the earthquake and the size the tsunami generated. This airport faces much greater risk from the seismic aspect of a CSZ earthquake compared to the tsunami.

Rail: A major segment of rail runs through southeastern and central-north Lane County. Operating trains and travel along railways can be impacted by seismic events, landslides, wildfires, and winter storms. During the update of this Plan, certain railway segments were identified by stakeholders as likely to be damaged moderately or significantly to the point as to render the rail segment inoperable. One of the action items included in this Plan’s update addresses one of the most vulnerable portions in Lane County at where the rails cross Jasper Lowell Road between the communities of Jasper and Lowell.

Communications

Communication infrastructure includes broadcast television, radio, landlines, cellular, two-way radio, internet, and ham radio. Much of the built infrastructure is vulnerable to many hazards, particularly wildfire and earthquake. Communication capabilities depend on fuel for backup power, staff to refuel, and open transportation routes for access. Most recently, radio towers on hilltops have lost power due to a large snowstorm (DR-4432, 2019) and the Labor Day fires in 2020 destroyed other sites (DR-4562, 2020), which impacted communications for the public, first responders, and private entities.

As copper wire becomes non-existent in Lane County, fiber is becoming the primary source of communications for the private citizen. Much like other lifelines, communications require energy and transportation to ensure it functions adequately. As noted in the 2014 Eugene/Springfield Vulnerability Assessment, “Extreme heat events are the biggest climate-related concern as most equipment requires cooling of some kind. Power loss during a heat event could result in equipment overheating and failure. While most service providers have backup generators, operating air conditioning units draws a lot of power and could draw more power than a generator can provide.”¹³⁷ As wildfire risk becomes more frequent, Public Safety Power Shut-Offs (PSPS) events will also become tools utilized to mitigate risk of fire starts. PSPS events impact the ability to communicate, cool, and limit fuel access.

A recent study of five (5) communications sites in Lane County operated by the Lane County Sheriff’s Office (LCSO) concluded that three (3) sites, which included the towers and buildings supporting the infrastructure, were at high risk of wildfire.¹³⁸ Nearly all buildings included in the study were found to have high seismic risk as well.

Energy

Currently, all fuel that comes into Lane County is piped in via one pipeline to West Eugene. Seismic retrofitting of the tank farm has not occurred making the site at risk of an earthquake. There are a limited number of fueling stations with backup power capabilities and even fewer in rural communities. Regarding wildfire risk and extreme weather conditions (heat), the ability to move, cool, and inform people is dependent on the ability to access fuel. First responders’ access to fuel is also compromised during power outages. Lane County has identified four (4) points of distribution in high-risk areas, such as Florence, which is an example of an area likely to become an island, or cut off, from the rest of the county after a significant seismic event.

Protecting electrical systems and transmission lines will become increasingly important as electrification of motor vehicles continues. Infrastructure at risk includes the existing electrical grid components as well as the increasing number of charging stations installed throughout Lane County. With more systems dependent on electricity as a power source, outages resulting from multiple natural hazards will compound the community’s annual risk as the result of multi-system failures following major power outages.

¹³⁷ Cities of Eugene and Springfield. (2014). “Regional Climate and Hazards Vulnerability Assessment.” p. 4-59.

¹³⁸ Haley & Aldrich, Inc. (2022). *Report on Lane County Sheriff’s Office Communications Sites All Hazards Assessment, Eugene, Oregon.*

Megafires, winter storms, a rare but powerful windstorm, and a CSZ earthquake all pose realistic threats for causing region-wide power outages. Emergency responders and government officials converting fleet vehicles to electric will require redundant backup power sources. The same is true for individuals dependent on electricity for home heating, cooling, or to power medical devices. Procuring backup power sources separate from the main grid is often financially inaccessible for socially vulnerable individuals and represents an expanding hazard risk in Lane County.

Food, Water, Shelter

The Oregon Resilience Plan (2013) estimates restoration of drinking water supply systems in Oregon after a seismic event to take one (1) to three (3) years for coastal communities and one (1) month to a year for places in the valley regions.¹³⁹ Lane County consists of many small and large drinking water systems. According to the Oregon Health Authority (OHA) water district database, there are over 325 drinking water systems in Lane County. These systems are either operated by federal or local government agencies or are privately owned and operated. Due largely to aging infrastructure, a number of these facilities are unable to make necessary repairs impacting their ability to maintain service delivery. For example, in unincorporated western Lane County, the Mapleton Water District provides drinking and wastewater capacity to over 600 people through 250 service connections. This district also provides water for the school fire sprinkler system, hydrant system, and the local rural fire district. Over the past several years, winter storms and flooding of the Siuslaw frequently impact the infrastructure of the district's water treatment plant causing leaks and compromising operability.

In addition to service providers operating drinking water systems, there are also a number of homes with wells installed on private property. Without access to power, most of these rural residents will possess limited access to water (potable & non-potable) for meeting basic human needs, but also for fire suppression.

Recent events have further identified gaps in Lane County's local shelter availability. At present, sheltering locations often are churches, schools, and the Lane County Fairgrounds site. Most buildings are not built to seismic standards necessary to withstand a large earthquake. Some sites are not ADA compliant and do not provide an adequate resource for individuals with accessibility and functional needs. Community Centers located in rural areas are working to become more resilient to disasters and provide resources to their residents in emergencies such as wildfires or snowstorms. The Upper McKenzie Community Center has undergone significant renovations to become more a storm hardened facility, equipped with backup power generation, alternate heating and air, and ADA compliant facilities to support their local community. This facility was instrumental in the community's recovery following the 2019 snowstorm and the 2020 Holiday Farm Fire.

¹³⁹ Oregon Seismic Safety Policy Advisory Committee. (2013). *The Oregon Resilience Plan: Reducing Risk and Improving Recovery for the Next Cascadia Earthquake and Tsunami*. Report to the 77th Legislative Assembly.



Upper McKenzie Community Center built post-Holiday Farm Fire | Source: Lane County Emergency Management

Health and Medical

Within Lane County, there are five (5) hospitals. One (1) hospital is in each of Cottage Grove, Florence, and Eugene with the remaining two (2) in Springfield. OHA conducted a hazard vulnerability assessment in 2013 concluding that local health and emergency facilities would be more significantly impacted by wildfire, winter storms, and riverine floods over the next 5 to 10 years.¹⁴⁰

Figure 2.20 is repurposed from this assessment, outlining the responses of emergency managers about priorities over the next five (5) years regarding public health and health systems consequences. Consequences were estimated on a five-point Likert scale ranging from minimal to catastrophic effects on the population’s health and health services.

Figure 2.20: Public Health Priority Graph of Natural Hazards and Cascading Impacts for State of Oregon

Figure 1 Oregon’s Public Health Hazard Vulnerability Assessment (PH-HVA)



Source: Oregon Health Authority, 2013

¹⁴⁰ Oregon Health Authority. (2013). “Public Health Hazard Vulnerability Assessment.”

Safety and Security

There are 11 law enforcement agencies represented in Lane County, including Oregon State Police. The County Office website identifies 84 fire stations serving a population of 363,471 people in an area of 4,553 square miles. There is one (1) fire department per 4,327 people, and one (1) fire department per 54 square miles. Most fire districts depend on volunteers especially rural fire departments. Unfortunately, a significant decrease in public volunteering in these rural areas continues to persist. The lack of capacity further incentives broad regional cooperation within and across counties, resulting in mutual aid agreements from other neighboring districts. A consequence though can be reduction in response call times.

In Oregon, Lane County is ranked 27th of 36 counties in fire departments per capita, and 13th of 36 counties in fire departments per square mile.

Hazardous Materials

The Emergency Planning and Community Right-to-Know Act of 1986 was authorized by Title III of the Superfund Amendments and Reauthorization Act to help communities plan for chemical emergencies. It requires industry to report on the storage, use, and releases of certain chemicals to federal, state, tribal, territorial, and/or local governments. It also requires these reports to be used to prepare for and protect their communities from potential risks. The Oregon State Fire Marshal's (OSFH) Office records hazmat incidents annually and publishes annual reports for the public. Lane County is most at risk from seismic and significant flood events when considering the release of hazardous materials. Additional information about local sites at risk is contained within the appropriate Annexes found in Volume II of this Plan.

Section 2.4: Summary of Natural Hazard Risk in Lane County

As part of conducting the risk assessment, OEM prescribes the implementation of a quantification method to assist local governments to examine the relative risk among multiple hazards. FEMA first developed the quantification methodology in 1983 and this original technique has been refined by OEM over the subsequent years. The hazard quantification categorizes components of risk into four buckets: *history*, *probability*, *vulnerability*, and *maximum threat*. Each bucket is scored along a 10-point scale depending upon the criteria met. Through this approach, a hazard can be "quantified" from a low value of 24 points to a high value of 240 points. These numbers represent increasing order of magnitude. For example, a hazard scored 240 is 10 times more severe in that area compared to a hazard scored 24.

The following sub-sections provide a detailed description of the hazard quantification methodology, definition of hazard classifications, and limitations in available data. The risk assessment concludes with a summarization of hazard vulnerability by planning region and then Lane County as a whole.

Section 2.4.1: Hazard Quantification for Lane County MNHMP Update, Version 4.0

Following the prescribe methodology described above, the project team worked with each jurisdiction to complete hazard quantifications for each participant of this Plan. The results were discussed at steering committees and during regional workshops held in each region of the county (see Section 6 for further details). Compared to Version 3.0 of this Plan, hazard quantification scores increased slightly, due to increases in either the history or vulnerability categories. Increases in total score elevated

wildfire in the order of relative impact on Lane County reflecting the events to occur in the past five (5) years. Table 2.46 displays the results from the quantification included in this Plan’s update.

Table 2.46: Hazard Quantification Results for Lane County

Hazard	History (WF x 2)	Sub-Total	Probability (WF x 7)	Sub-Total	Vulnerability (WF x 5)	Sub-Total	Max Threat (WF x 10)	Sub-Total	Total Risk Score
Winter Storm	10	20	10	70	8	40	7	70	200
Wildfire	10	20	8	56	8	40	8	80	196
Flood	10	20	9	63	8	40	7	70	193
Windstorm	9	18	7	49	8	40	8	80	187
Earthquake	3	6	4	28	9	45	10	100	179
Extreme Weather	8	16	9	63	6	30	7	70	179
Landslide	10	20	8	56	8	40	4	40	156
Tsunami	4	8	4	28	4	20	8	80	136
Drought	8	16	8	56	2	10	2	20	102
Volcano	2	4	2	14	2	10	4	40	68

Source: NHM-SC

Section 2.4.2: Data Limitations

Quality and availability of source data improved since previous versions of this Plan. National Climatic Data Center (NCDC) information is used extensively as a reporting mechanism for hazard events of various type. However, damage descriptions and totals provided by this source do not necessarily account for all local impacts, and further, damage totals for certain hazard events may cover multi-county regions that may or may not accurately reflect direct impacts in the planning area.

In addition, several studies are currently in progress that will enhance the ability of Lane County and its partners to accurately assess hazard risk at a local level. As additional studies are published, this Plan will be updated with the most current and vetted data produced from these efforts.

Additionally, this Plan update incorporated American Community Survey (ACS) data to estimate demographic characteristics of Lane County’s current population. When possible, the 5-Year ACS estimates were used to capture as an accurate a figure as possible that this dataset can provide. While helpful to generalize elements of community demographics, ACS data is limited as any survey tool when sample sizes are small. Cities in Lane County outside of the metropolitan area contain much smaller populations, as noted in the Community Profile. The margin of error that exists with small sample sizes makes it difficult to be precise in count, and therefore, determining the proportion of a subgroup within the entire population.

For determining social vulnerability within a county that is largely rural and splits jurisdiction among nearly a dozen small cities and two larger concentrated populations, these data limitations can hinder the ability of Lane County to effectively direct resources and projects towards the most vulnerable communities, which is especially challenging in unincorporated areas. These communities contain even fewer residents and further complicating analysis is that unincorporated Lane County exists in just a few geographically large census tracts. Estimates for unincorporated areas was calculated by subtracting the sum of all city counts from the Lane County counts. Aggregating data by census tract covering only the unincorporated communities suffered from inaccurate counts (i.e., the margin of error could exceed the total estimated population) given the sample size issue and expanded geographic extent.

Lane County will need to develop locally focused data collection strategies and public engagement efforts to determine and validate where its most vulnerable populations exist outside of incorporated cities. Efforts in this area have already occurred by Lane Public Health in response to the Covid-19 pandemic and rolling out vaccination clinics in rural Lane County. Advancing this work through other departmental efforts will yield benefits beyond the mitigation effort.

Section 2.4.3: Hazard Vulnerability Summary by Region and Countywide

Overall vulnerability to each hazard was based on assessments of previous and potential occurrences regarding the scale of geographic area affected, future probability, and severity of impact considering a credible worst-case scenario. Factors including risk exposure of special needs populations, medical needs of populations, the location of critical facilities, and key infrastructure were also considered.

Overall vulnerability to natural hazard impacts is substantial for Lane County, though it varies widely according to hazard type.

Based on factors and the definitions established in Section 2.1, Table 2.47 shows an assessment of overall vulnerability to each of the identified hazards and categories of primary impacts (classified as human, property, infrastructure, economy, and environment).

Table 2.47: Primary Hazard Impact Assessment for Natural Hazards, Lane County

Hazard Type	Overall Vulnerability	Primary Impact Categories
Winter Storm	High	Public Safety, Property, Infrastructure, Economy
Windstorm	High	Property, Infrastructure
Wildfire	High	Public Safety, Property, Infrastructure, Environment
Flood	High	Public Safety, Property, Infrastructure
Extreme Weather	High	Public Safety, Property, Infrastructure
Earthquake	High	Public Safety, Property, Infrastructure, Economy
Tsunami	High	Public Safety, Property, Infrastructure, Economy
Landslide	Moderate	Public Safety, Infrastructure, Economy
Drought	Low	Economy, Environment
Volcano	Low	Environment, Infrastructure

Source: NHM-SC

Lane County possesses a remarkable range of elevation, terrain types, climatic regimes, and potential natural hazards. It shares the distinction with Douglas County as the only counties in Oregon which range from the Pacific Ocean to the Cascade Crest.

Due to its proximity to the ocean, coastal headlands, and Cascadia Subduction Zone, Coastal Lane County has noticeable risk for windstorms, earthquake, and tsunami compared to other geographic regions. The Coast Range of Lane County has notable risk for landslide, earthquake, and wildfire. The Willamette Valley has heightened vulnerability to winter storms, flood, earthquake, and dam failure in relation to other regions of the county. The Cascade foothills and crest in eastern Lane County have relatively higher propensity for wildfire, winter storms, and windstorms.

Lastly, overall vulnerability can also be approximated through the estimated annual loss (EAL) metric. The statistic represents the dollar loss from building value, population, and/or agriculture exposure each year due to natural hazards.¹⁴¹ Table 2.48 provides the National Risk Index estimates for Lane County’s EAL for the hazards profile in this Plan, with inclusion of Coastal Hazards to account for the unique hazard exposure of Coastal Lane County.

Table 2.48: Expected Annual Loss (EAL) Estimates for Lane County Resulting from Natural Hazards

Natural Hazard	Expected Annual Loss (EAL)	Exposure Value (EV)
Coastal Flooding*	\$ 1,200,000	\$ 2,500,000,000
Drought	\$ 13,000	\$ 70,000,000
Earthquake	\$ 110,000,000	\$ 4,500,000,000,000
Extreme Weather**	\$ 420,000	\$ 4,500,000,000,000
Flood	\$ 3,800,000	\$ 280,000,000,000
Landslide and Debris Flow	\$ 2,900,000	\$ 1,200,000,000,000
Tsunami	\$ 3,900	\$ 21,000,000,000
Wildfire	\$ 31,000	\$ 150,000,000,000
Windstorm	\$ 13,000	\$ 4,500,000,000,000
Winter Storm***	\$ 1,060,000	\$ 4,500,000,000,000

Source: Federal Emergency Management Agency, 2023, National Risk Index

NOTES: For the table, an exposure value of \$4.5 trillion indicates a countywide exposure to the natural hazard

*Included given the impact to coastal areas of the county.

**Includes the cumulative values of EAL for Cold Wave, Hail, Heat, Lightning, and Tornado as categorized by the NRI

***Includes the cumulative values of EAL for Ice Storm and Winter Weather as categorized by the NRI

¹⁴¹ Federal Emergency Management Agency. (2023). *National Risk Index*. <https://www.fema.gov/flood-maps/products-tools/national-risk-index>.

Section 3: Capability Assessment

The Capability Assessment identifies and describes the ability of Lane County and plan participants to implement the mitigation strategy and associated action items. Capabilities can be evaluated through an examination of three broad categories: plans, regulations, and codes; personnel; and capital goods and financial resources. Sub-components exist within these categories that provide a comprehensive evaluation of the county's different regions' capabilities for implementing mitigation work.

This section is organized into four subsections, covering each of the three listed capability categories and concluding with a summarization of Lane County and plan participants' capabilities. As part of the summarization, this subsection highlights important findings from the capability assessment that informed the design of the Plan's mitigation strategy and aided in prioritizing action items.

Section 3.1: Capabilities via Planning, Structural Codes, and Land Use Regulations

Hazard mitigation can be executed at a local scale through three methods: integrating hazard mitigation actions into other local planning documents (i.e., plan integration), adopting the latest building codes that account for best practices in structural hardening, and codifying land use regulations and zoning designations that prescribe mitigation into development requirements. The extent to which a municipality or multi-jurisdictional effort leverages these approaches is an indicator of that community's capabilities.

Section 3.1.1: Plan Integration

According to the National Preparedness Goal, FEMA provides guidance outlining 32 core capabilities tied to the capabilities of local, state, and federal organizations within five (5) mission areas: Prevention, Protection, Mitigation, Response, and Recovery. Seven (7) core capabilities relate to the Mitigation Mission area are identified as: planning, public information & warning, operational coordination, community resilience, long term vulnerability reduction, risk & disaster resilience assessment, and threats & hazards identification. Though possessing the personnel necessary to carry forward core capabilities, such as public information & warning and operational coordination, executing capabilities such as community resilience and long-term vulnerability reduction can entail other actions beyond acquiring the necessary personnel and training. First and foremost is integrating hazard mitigation efforts into other planning documents. Plan integration is also a strategy for long-term climate adaptation and developing community resilience.¹⁴²

Lane County previously integrated natural hazard mitigation planning into the Rural Comprehensive Plan (RCP) during the last update in 2009. Currently, Lane County addresses Goal 7 by prescribing its agencies to be informed by a natural hazards inventory about specific and general land use decisions, that development should be commensurate with type of natural hazards present and affirms Lane County's continued participation in the National Flood Insurance Program (NFIP).¹⁴³ Any update to Goal 7 or the broader RCP should reflect the current data and analysis about natural hazards impacting Lane County

¹⁴² Missy Stults. (2016). "Integrating climate change into hazard mitigation planning: Opportunities and examples in practice." *Climate Risk Management*, 17, pp. 21-34.

¹⁴³ Lane County. (2009). Rural Comprehensive Plan. Land Management Division, Public Works.

as contained within this Plan. Furthermore, this Plan is meant to act as a technical resource informing future development, land use, and zoning decisions addressed in other statewide planning goals. Citing the MNHMP as a source among many adopts a hazard perspective with respect to land use and development strategies. Two versions of the local hazard mitigation plan have been adopted since most recent RCP update and should therefore be considered representative of Lane County’s accounting of statewide planning goal seven (7).

To enhance core capabilities and broaden the scope of treatment areas, this Plan also directs Lane County to explore integration into other planning documents and processes. As discussed in the Wildfire hazard profile found in Section 2.2.8, Lane County’s Community Wildfire Protection Plan (CWPP) will be incorporated into this plan as a functioning annex. The CWPP was last updated and adopted in 2020. The next plan update is expected to begin in either Winter 2023 or Spring 2024 and will remain a component of the broader natural hazard mitigation plan through updates after the most recent MNHMP is adopted. Integrating the CWPP with this Plan captures the efforts and expertise of the individuals that serve on the CWPP Advisory Committee and Hazardous Fuel Subcommittee. In addition, it provides a natural collaborative effort between Lane County’s Land Management and Emergency Management staff.

The MNHMP update reviewed projects included in Lane County’s Capital Improvement Plan (CIP) that could result in a significant mitigation benefit. Integrating the county’s CIP with this Plan allows Lane County to 1) recognize projects that have been scoped and included with a potential local funding source and 2) elevate projects that provide mitigation benefits by identifying opportunities for non-local funding sources to support the cost of implementation. Likewise, the planning team reviewed the recently adopted Climate Resilience Plan from 2022 for potential action items that could be carried forward and contained within the Plan’s update. This approach acknowledges overlapping efforts that advance both natural hazard mitigation and climate adaptation for Lane County’s communities.

Plan integration can occur among function-based plans (i.e., transportation plans) or area-based plans (e.g., a downtown development plan). The list below provides examples for further plan integration that should be explored as part of the implementation strategy for this Plan’s action items. Section 4 of Volume I of this plan contains the action items in Version 4.0. Within each action item “table” (see Section 4.1 for explanation of format), a Plan Integration cell identifies if the action item integrates the Plan with other Lane County planning documents.

Section 3.1.2: Structural Building Codes

The Oregon Legislature recently adopted updated building codes for both residential (2021 adoption) and commercial structures (2022) since the last update of this Plan. These two building codes are based on the 2021 version of the International Building Code, International Fire Code, and International Existing Building Code. As a result, both new residential and commercial structures will be required to build according to the latest seismic and wind standards in addition to requiring fire resistance building materials for those structures constructed in proximity or within the WUI. As a result, Lane County benefits by adopting these minimum standard building codes as established by the state to capture home hardening and building resilience during new construction.

Most structures in Lane County, however, residential, commercial, and public serving alike, were built prior to the adoption of strong hazard informed building codes, specifically prior to the mid-1970s and when the first seismic hardening building codes were introduced in Oregon. The current building codes now account for new but not existing structures. Older buildings and homes must be mitigated from hazard impacts through hardening or retrofitting, which often equates to expensive options and frequently results in a poor benefit cost ratio (BCR) an important element of funding consideration by FEMA hazard mitigation assistance grants. Areas containing a concentration of older buildings where such retrofitting efforts may exceed benefit-cost thresholds provide some indication for the need of other supportive measures to reduce long-term risk, such as priority and evacuation transportation routes connecting areas in the county, secondary energy or fuel sources when power systems fail, and mutual gathering places that can sustain response operations and provide immediate services to highly affected individuals in the initial stages of recovery (see Action Item O4.1 in Section 4.3.3 for proposed mitigation work related to these challenging areas).

New infrastructure is also subject to the most recent code adoptions and can be built using the most current best practices in mitigating hazard risk. Aging infrastructure may benefit from hardening and retrofitting system components and facilities, though, as with older existing homes, such work can quickly become very expensive. Large-scale capital projects that integrate mitigation actions, even when most effective, carry large price tags that can subsequently increase the required dollar total for local match dollars, which can equal anywhere from 10 to 25 percent of project’s cost.

Table 3.2 displays a list of applicable development codes adopted at the state level and incorporated into Lane County’s building codes. This list identifies the building codes in effect at the time of this plan update and represent a capability for ensuring that future development addresses hazard risk and potential impacts to new buildings and infrastructure.

Table 3.1: State Adopted Structural Building Codes as of 2022

Development Focus	Code Program	Effective Date
Commerical Buildings	2022 Oregon Structural Speciality Code (OSSC)	10/1/2022
Mechanical Systems	2022 Oregon Mechanical Specialty Code (OMSC)	10/1/2023
Commerical Buildings	2022 Oregon Commerical Reach Code (OCRC)	7/1/2022
Boilers and Pressure Vessels	2021 Oregon Boiler and Pressure Vessel Speciality Code (OBPVSC)	10/1/2021
Residential Buildings	2021 Oregon Residential Reach Code (ORRC)	8/6/2021
Residential Buildings	2021 Oregon Residential Speciality Code (ORSC)	4/1/2021
Electrical Systems	2021 Oregon Electrical Specialty Code (OESC)	4/1/2021
Plumbing Systems	2021 Oregon Plumbing Speciality Codes (OPSC)	4/1/2021
Amusement Rides and Devices	2015 Oregon Amusement Ride and Device Specialty Code (OARDSC)	4/1/2015
Elevators	2011 Oregon Elevator Speciality Code (OESC)	1/1/2012
Manufactured Dwellings	2010 Oregon Manufactured Dwelling Installation Speciality Code (OMDISC)	4/1/2010
Manufactured Dwelling Parks	2002 Oregon Manufactured Dweeling and Parks Speciality Code (OMD&PSC)	4/1/2005

Source: State of Oregon, State Building Code Programs, Building Codes Division, 2023

Section 3.1.3: Land Use Regulations – Zoning Codes and Hazard Overlays

Existing land use policies that define zoning and address hazardous overlays provide another source of mitigation capability for reducing long-term risk and making future development in Lane County resilient. These local planning elements represent deliberate efforts to codify hazard mitigation planning into the regulations that dictate land use decisions and permissible development. Though it is unknown if the entirety of the County’s land use code functions in congruency with the findings of this Plan’s risk assessment, these regulations and hazard overlays provide some degree of hazard mitigation capabilities with respect to development within the County’s jurisdictional authority.

Statewide measures applicable to Lane County prescribe hazard mitigation capability through a land use mechanism. Given the approximately 30 miles of coastline along the Pacific Ocean, Lane County is also subject to state and federal Coastal Management policies aimed at preventing coastal environmental degradation and mitigate the impacts of coastal hazards on communities built in these areas.

Table 3.3 displays a summary list of relevant statutes and zoning code organized by jurisdictional level that function as mitigation capabilities in Lane County.



Dunes City, Oregon, a community of the Coast Region where many Lane statutes address natural hazard risk | Photo: Lane County

Table 3.2: Local Land Use Regulations and Hazard Overlay Zones, Lane County, Oregon

Code Name	Hazards Addressed	Code Reference
Chapter 16: Land Use and Development Code		
Floodplain Combining Zone	Flood	§16.244
Beaches and Dunes Combining Zones	Coastal Erosion-Tidal	§16.243
Dredge Material/Mitigation Site Combining Zone	Coastal Erosion-Tidal	§16.242
Shorelands Mixed Development Combining	Coastal Erosion-Tidal	§16.241
Natural Resources Conservation Combining Zone	Coastal Erosion-Tidal	§16.239
Prime Wildlife Shorelands Combining Zone	Coastal Erosion-Tidal	§16.238
Significant Natural Shorelands Combining Zone	Coastal Erosion-Tidal	§16.237
Conservation Estuary Zone	Multiple Hazards	§16.235
Natural Estuary Zone	Multiple Hazards	§16.234
Chapter 13: Land Divisions and Property Line Adjustments		
Definition, Dangerous Areas	Multiple Hazards	§13.030 (3)(i)
Definition, Sensitive Areas	Multiple Hazards	§13.030 (3)(ee)
Tentative Partition Plan Submittal Requirements	Multiple Hazards	§13.050 (1)(b)(ii-hh)
Tentative Subdivision and Series Partition Plan Submittal Requirements	Multiple Hazards	§13.070 (1)(b)(ii-hh, ii)
Tentative Subdivision and Series Partition Plan Application Review Criteria: Dangerous and Sensitive Areas	Multiple Hazards	§13.080 (1)(f)
Chapter 10: Zoning		
Floodplain Combining District	Flood	§10.271
Beaches and Dunes Combining Zone	Coastal Erosion-Tidal	§10.270
Florence Beaches and Dunes Combining Zone Administration	Coastal Erosion-Tidal	§10.265
Dredge Material/Mitigation Site Combining Zone	Coastal Erosion-Tidal	§10.260
Natural Resources Conservation Combining Zone	Coastal Erosion-Tidal	§10.250
Prime Wildlife Shorelands Combining Zone	Coastal Erosion-Tidal	§10.245
Florence Coastal Shorelands Combining Zone Administration	Coastal Erosion-Tidal	§10.240
Conservation Estuary Zone	Multiple Hazards	§10.235
Natural Estuary Zone	Multiple Hazards	§10.230
Estuary District Administration	Multiple Hazards	§10.225
Forest Management District	Multiple Hazards	§10.102
Wildfire Hazard Severity Rates System	Wildfire	§10.103

Source: Lane County Code, Chapters 10, 13, and 16

Section 3.1.4: Mitigation-Focused Programs

Hazard mitigation implementation requires a concerted effort from a host of participants: governments, businesses, community organizations, nonprofits, and individuals. Over the years, numerous programs have been created to incentivize people to act and implement best practices on their property to promote hazard mitigation efforts. Two of the most relevant programs to reducing risk in Lane County include participation in the National Flood Insurance Program (NFIP), and subsequently the Community Rating System (CRS) process and managing a local Firewise incentive program. Details regarding Lane County's participation in each effort is documented in the following subsection.

National Flood Insurance Program & Community Rating System

In 1968, Congress passed the National Flood Insurance Act based on findings that: “(1) a program of flood insurance can promote the public interest by providing appropriate protection against the perils of flood losses and encouraging sound land use by minimizing exposure of property to flood losses; and (2) the objectives of a flood insurance program should be integrally related to a unified national program for floodplain management.”

The NFIP administers the requirements of Flood Insurance Act. The NFIP is a voluntary program based upon cooperative agreements between the federal government and local participating communities. The NFIP enables property owners within participating communities to purchase flood insurance and helps to provide an insurance alternative to the rising costs of federal flood disaster relief. In return, participating communities must properly manage their floodplains by adopting and enforcing floodplain management ordinances aimed at reducing the likelihood of future flood damage to new construction.

Lane County has participated in the NFIP since 1970. Participating in the NFIP requires the County to adopt and enforce floodplain management ordinances aimed at reducing the likelihood of future flood damage to new construction within the regulated floodplain, also known as the Special Flood Hazard Area (SFHA). The county must manage land within SFHA in ways that meet or exceed standards set by the Federal Emergency Management Agency (FEMA). The Land Management Division is responsible for administering the day-to-day activities of the County’s floodplain program, which are extensive. Specifically, the Land Management Division:

- maintains and administers Lane County’s floodplain regulations;
- reviews and issues floodplain development permits;
- maintains elevation certificates for all new and substantially improved structures (and maintains an extensive database of historic elevation certificates);
- ensures that encroachments do not occur within the regulated floodway;
- implements measures to ensure that new and substantially improved structures are protected from flood losses;
- maintains floodplain studies and maps and makes this information available to the public;
- maintains a flood information website with digital flood insurance rate map (DFIRM) data;
- conducts site visits to assess conditions and provide technical assistance to the public;
- maintains a library of historical flood related information;
- informs the public of flood insurance requirements; and
- conducts outreach and training about flood hazards and development within the floodplain.

In 1990, the National Flood Insurance Program’s Community Rating System (CRS) was implemented. The CRS is sub-program within the NFIP created to recognize and encourage floodplain management practices that exceed the minimum NFIP standards.

Under the CRS, flood insurance premium rates are lowered to reflect reduced flood risk resulting from community activities that meet the objectives of the CRS. Those objectives are:

1. Reduce flood losses, i.e.,
 - a. protect public health and safety,
 - b. reduce damage to buildings and contents,
 - c. prevent increases in flood damage from new construction,
 - d. reduce the risk of erosion damage, and
 - e. protect natural and beneficial floodplain functions.
2. Facilitate accurate insurance rating; and
3. Promote the awareness of flood insurance.

As part of the Lane County Land Management Division’s 2007 Long Range Planning Work Program, staff was formally directed to take actions necessary for the County to gain admittance into the CRS. Prior to applying, LMD was first required by FEMA to process updates to the County’s floodplain ordinances (LC 16.244 and LC 10.2.71) and to take measures necessary to address Lane County’s repetitive flood loss properties. These activities were carried out during 2007. On March 3, 2008, Lane County submitted its CRS application and accompanying documentation to FEMA for formal review.

On July 2, 2009, Lane County received official notification of admission into the CRS program and received a rating of “Class 7” on a scale of 10 (lowest) to 1 (highest), which results in a 15 percent discount of flood insurance premiums for homes located in the Special Flood Hazard Area (SFHA). FEMA re-verified Lane County as a participating member in the CRS program in September of 2022, a process that occurs every five (5) years. Staff worked with a CRS specialist to conduct a complete review of Lane County’s floodplain program, which resulted in an improved CRS rating of “Class 6” that becomes effective on October 1, 2023. Class 6 community members receive a 20 percent discount on flood insurance premiums for homes in the SFHA.

Local Firewise Incentive Program

The National Fire Protection Association’s Firewise USA® program is an interagency effort designed to encourage local solutions for wildfire safety by involving property owners, planners, community leaders, developers, firefighters, and others to protect people and property from the risk of wildfire – before a fire starts. The Firewise approach focuses on planning, landscaping, construction, and home maintenance to help protect people, property, and natural resources.

Lane County also manages a local Firewise program, which provides wildfire mitigation education and mitigation grant funding when available to rural Lane County residents. The mission of the Lane County Firewise Incentive Program is to promote home hardening and landscaping techniques intended to reduce the catastrophic loss of life, property, and natural resources from a wildland urban interface disaster. In 2009, Lane County adopted policies in Lane Manual Chapter 4.3 to establish a grant incentive program designed to mitigate the risk of wildfire to rural residents.

The program provides funding to reimburse the costs partially or wholly for rural homeowners for certain types of home and landscaping improvements. These improvements align with the National Fire Protection Association’s defensible space standards and, if implemented properly, have been shown to reduce the probability that a home will be damaged or destroyed in a wildfire.

Currently, grants are offered for the following types of improvements:

1. Replacement of a wood shake roof with a roof consisting of a Class-A covering or Class-A assembly (80 percent of costs up to \$4,000).
2. Installation of non-combustible exterior siding (80 percent of costs up to \$4,000).
3. Installation of fire resistant (and energy efficient) exterior windows and skylights made from tempered glass, multi-layered glazed panels or glass block (80 percent of costs up to \$1,500).
4. Installation of non-combustible exterior doors (80 percent of costs up to \$300).
5. Installation of spark arrestors on chimneys (\$100).
6. Installation of mesh screening on exterior ventilation or deck openings that will prevent the entry of firebrands and the accumulation of flammable debris (\$100).
7. Landscaping improvements that will create a defensible space around habitable structures. Under this category, funding is available for brush removal, tree pruning, chipping, vegetative driveway clearance, water catchment, irrigation, and placing noncombustible material or planting approved fire-resistant plants within a 100’ buffer around homes (up to \$5,500 depending on site specific conditions).

From June 2021 to June 2023, Lane County’s Firewise Incentive Program has dispersed over \$750,000 to property owners living in at risk areas to fund on risk reduction activities, with over 400 properties served.

In addition to the local incentive program, 14 communities in Lane County maintain Firewise Communities held in good standing by the national Firewise program. Table 3.3 displays these communities along with the designated planning region within Lane County.

Table 3.3: Communities in Lane County Participating in Firewise USA® in Good Standing

Community Name	Region	Place	Participation Date
Southview Homeowners Association	Coast	Florence	12/31/2020
Lakehills Homeowners Association	Valley	Inman Creek	6/14/2018
Upper Laughlin	Valley	Fox Hollow	7/23/2021
FoxWood	Valley	Camas Swale Creek	7/3/2019
Group 9	Valley	Camas Swale Creek	7/14/2021
Murdock Road Area	Valley	Camas Swale Creek	5/31/2022
Willamette St.	Valley	Spencer Butte	11/24/2019
Hidden Meadows Homeowners Association	Valley	Eugene South Hills	3/23/2021
Molitor Ranch Road Community	Valley	Cottage Grove	12/11/2018
Wallace Creek	Valley	Wallace Creek	6/26/2020
Fall Creek	Valley	Fall Creek	12/17/2021
SFCC	Cascades	Lowell	11/9/2021
Oakridge	Cascades	Oakridge	12/17/2021
Greater Oakridge-Westfir	Cascades	Westfir-Oakridge	12/17/2020

Source: National Fire Protection Association, Firewise USA® sites

Section 3.2: Capabilities via Personnel

Personnel provide capabilities via Lane County staff, City and Utility sub-plan holders staff and elected representatives, and the staff and volunteers of other organization types separate from the local municipal and utility participants (e.g., NGOs). This subsection details the capabilities that exist among the Plan participants through current staffing.

Section 3.2.1: Lane County Staff

Lane County staff include individuals qualified to execute mitigation action items, including its Emergency Management Department, Engineering Construction and Services, and Roads divisions within Public Works. A Policy division within County Administration staffs several grant management specialists responsible for acquisition, reporting, management, and closing of federal and state grants. A Public Information Officer (PIO) supports the County's communications regarding hazard risk, emergency alerting, and public education campaigns. Coordination between other divisions and the grants team provides further capacity to align mitigation projects with sources of funding both within FEMA's Hazard Mitigation Assistance (HMA) programs and other, separate federal programs. Examples of other programs include grants administered by the U.S. Housing and Urban Development (HUD) Department, the Small Business Association (SBA), Environmental Protection Agency (EPA), and the Federal Highway Administration (FHWA).

Within the Land Management division, Lane County staff administers participation in the NFIP and promotes a local Firewise program. These individuals address hazard mitigation to known risk areas and likely impacts when examining long-term (15 – 20 years) land use development strategies. Strengthening collaboration further between Land Management, Emergency Management, and Public Health staff should be a capability building objective for the next five (5) years in addition to executing the mitigation action items contained within this Plan.

Section 3.2.2: Plan Participants' Staff

Cities in Lane County vary in size and can be described comparatively small in terms of population. Outside of the metropolitan area, the largest city is Cottage Grove with just under 11,000 residents. Other cities range from several thousand residents to communities of a thousand people or fewer. Small cities often possess a limited staff in their departments, focusing most energy into managing day-to-day operations and responding to public questions and needs. People filling essential and critical roles are often delegated additional responsibilities outside of their work experience or technical training, particularly with respect to emergency management. Nevertheless, recent events have tested and developed capabilities of both the County and project participants with respect to hazard response and subsequently, mitigation work conducted during recovery efforts. Skills and experience exist amongst all participants and can be shared with those who are learning their role in hazard mitigation and/or emergency management on behalf of their communities.

Acknowledging the limited time and availability for individuals expected to assume the emergency management responsibilities must be incorporated into the implementation and maintenance strategy of the Plan. Coordinating and communicating efforts should adopt an approach that either prevents or limits additional time commitments. An area of focus for the next five (5) years will be how plan holders integrate their existing committees and build on these relationships to streamline efforts that intersect across jurisdictions and the responsibilities of departments to enhance mitigation capability.

Section 3.2.3: Partnerships with Special Districts, Nongovernmental Organizations, and Educational Institutions

Including public utilities as sub-holders to this Plan improves opportunities for communication and collaboration for regional mitigation efforts. Public utilities provide power and water systems for residents, businesses, and governments, and are essential partners for lowering hazard risk in Lane County. Though not every utility that operates in Lane County participated in the Plan update as a formal sub-plan holder, it is the intention of this Plan's mitigation strategy to strengthen relationships that support coordination and communication of hazard mitigation work with all power and water providers.

Nonprofits, community-based organizations, faith-based groups, land, soil, and water conservation organizations/districts, and philanthropic groups are among just some stakeholders advancing hazard mitigation work in Lane County. These groups often share objectives and strategies with those of mitigation planning and building community resiliency, such as restoring wetlands to support floodplain ecological capability to effectively soak up flood waters. Staff of Lane County possess connections to these organizations across numerous existing efforts and collaboratives. Building a resilient Lane County necessitates strengthening these partnerships and expanding their reach in a coordinated effort amongst the NHM-SC, county government, and local participants.

Lane County is home to several universities and colleges that partner with local government agencies to provide technical assistance and research capacity. The University of Oregon houses at least three (3) research bodies that investigate the latest hazard mitigation best practices, assist with conducting hazard risk assessments, and partner to assist local governments update and implement these types of planning documents or studies to inform ground-level projects. Assisting Lane County with the update to this Plan is the Oregon Partnership for Disaster Resilience (OPDR) and the Resource Assistance for Rural Environments (RARE) AmeriCorps program.

Deepening partnerships with Lane Community College, Bushnell University, and Oregon State University (including the extension facilities operating in the County) can expand the output and value derived from partnerships between educational institutions and local government efforts. This effort is another core objective of capability building over the lifespan of this Plan's updated version.

Section 3.3: Capabilities via Capital Goods and Financial Resources

Lane County mitigates impacts from natural hazards through deploying its inventory of capital goods (tools, equipment, systems, and facilities) and financial resources, both local and non-local.

Section 3.3.1: Capital Goods and Facilities

Lane County possesses capital goods and facilities that mitigate hazard risk for a number of the natural hazards identified in the risk assessment.

Tools and equipment provide redundancy of critical systems to mitigate the cascading impacts of infrastructure failures during hazard events. For example, mobile communication sites and the deployment of new technologies that use low orbiting satellites to establish two-way connections provide a redundant capability option available to the County when a communications tower fails or is destroyed. Two (2) communication towers were destroyed during the Holiday Farm Fire in 2020,

providing one example of the necessity to mitigate the impact to a community lifeline during a severe hazard event. Power generators with enough capacity to sustain buildings of varying sizes are also critical for public facilities, community centers, as well as medical facilities to effectively function. Adequate fuel to power these generators can mitigate the impacts of power outages resulting from failures of electrical systems.

Certain buildings in the county can shelter people for several days offering a protective environment from specific hazard impacts, often those impacts associated with extreme weather, windstorms, hazardous air quality (wildfire smoke), and winter storms. Throughout Lane County, there are nearly two dozen locations identified as warming shelters that activate when temperatures fall below freezing at 32 degrees Fahrenheit. Some shelters may activate at lower temperatures, but typically, anytime temperatures fall below 30 degrees warming shelters open in Lane County.

In addition to these buildings, which include libraries, places of worship, youth centers, shelters, food kitchens, and public buildings, Lane County also possesses a number of sites known as Egan Warming Centers. These sites are operated and maintained by St. Vincent de Paul, a non-profit organization. Egan warming centers can accommodate a total of up to 600 people on a given night and historically have served approximately 350 people at most on a given night.¹⁴⁴ Overtime, the Egan warming centers have also provided protection from extreme cold for nearly 1,500 individuals. Most of these buildings operate in the metropolitan area.

Many of the buildings used to shelter people from extreme cold also shelter people in the summer months during extreme heat events, acting as cooling centers. These buildings provide some level of protection and shelter for residents of Lane County including unsheltered individuals. However, limitations to their capabilities include having adequate staff to operate day-to-day activities while also handling the additional demand of services for an influx people ranging from several dozen to several hundred during an emergency. These places must also be outfitted with power and communication redundancies to remain operational during widespread systems failures. Lacking any of these components to operate the building and serve people can reduce the structure's capability and usefulness. These challenges often result in warming and cooling shelter locations being subject to change. Despite such obstacles, these facilities provide an important capability for the County and may represent an initial inventory of potential sites and structures suitable for conversion into rural community resilience hubs (see Action Item O4.1 in Section 4.3.1).

Section 3.3.2: Financial Resources

Lane County draws from its general fund to finance staff, acquire equipment, and advance capital projects. At a parcel/project scale, system development charges may be used to capture revenue during new development that can cover costs for hardening infrastructure or building hazard and climate resilient structures. The state of the County's financial health directly impacts mitigation capabilities and geographic reach. Much of the revenue supporting the County's general fund historically came from a robust timber industry that has significantly shrunk over the past three decades.

The eroding revenue stream has set the County along a process of adapting to how it generates revenue. Much like counties across the United States, shrinking industries based on extractive

¹⁴⁴ St. Vincent de Paul, (2023).

operations for natural resources is a familiar characteristic in explaining financial scarcity, which consequently increases the need to secure non-local funding for advancing hazard mitigation work. Additionally, emerging dependence on state and federal funding sources requires the leaders of Lane County and partner jurisdictions to explore and identify cost-effective solutions for reducing hazard impacts. For example, projects already included within CIPs often identify local funding sources or a portion of the funding needed to advance a project. Therefore, hazard mitigation plans can incorporate capital projects contained within the most recent CIP as an action item when that project demonstrates a clear mitigation benefit as a result.

Beyond local resources, federal and state programs provide funding for mitigation projects. FEMA's Hazard Mitigation Assistance (HMA) includes four grant programs: Building Resilient Infrastructure and Communities (BRIC), the Flood Mitigation Assistance (FMA), the Hazard Mitigation Grant Program (HMGP) and the HMGP-Post Fire. BRIC and FMA cycle annually initiated through a notice of funding opportunity (NOFO) published each year. The HMGP and HMGP Post-Fire become available following a federal disaster declaration. Though HMGP and HMGP-Post Fire serve as significant funding sources for supporting mitigation efforts during the recovery following a disaster, not every hazard event that impacts Lane County rises to the level of the federal disaster declaration. As a result, it is challenging to anticipate how available these funding sources would be when developing a 5-year mitigation strategy.

Other funding sources for mitigation projects include the Community Wildfire Defense Grant (CWDG), Community Development Block Grants (CDBG), and programs with specific objectives such as the Wildfire Smoke Preparedness in Community Buildings program. Potential sources of funding for mitigation activities at the state level include hazard-specific grants administered by state agencies, the Seismic Rehabilitation Grant Program administered by Business Oregon and programs administered through the Oregon Department of Forestry for the Office of the State Fire Marshal that resulted from Senate Bill 762 (2021). This list is not meant to be exhaustive, and Lane County should continue expanding knowledge of funding streams to recognize unique and creative opportunities to advance mitigation work. Effectively building this knowledge significantly depends on strengthening coordination between grant administrators, County staff from multiple divisions, and City and Utility Partners completing hazard mitigation projects.

Section 3.4: Findings from the Capability Assessment

As discussed in this section, Lane County and its partners possess capabilities that support advancing mitigation efforts through a variety of means. Leveraging these strengths and improving regional coordination of efforts is one of the central opportunities for achieving significant gains in reducing long-term risk from natural hazards in the County. Despite the progress over the past several years though, gaps remain with respect to certain capabilities and the area is not insulated from obstacles in the future. Through a SWOT analysis, Lane County can assess where the gaps and threats exist and how to address them along with highlighting areas where the County is already strong and capable. The basic components of a SWOT analysis are identifying strengths, weaknesses, opportunities, and threats. The following paragraphs provide a summary of conclusions about Lane County's hazard mitigation capabilities based on the SWOT model.

Section 3.4.1: Strengths

Lane County has enhanced existing capabilities locally during the current planning cycle (2018 – 2023) to better understand its natural hazard risk and what mitigation actions will most effectively reduce that risk. Collaborations between jurisdictions and regional stakeholders facilitates cross-organizational cooperation and expands capacity for research, analysis, grant acquisition and management, and project execution to complete mitigation work. One example includes the Lane Regional Resilience Collaborative (LRRC), a regional cross-agency/cross-jurisdictional collaborative focused on pre-event hazard mitigation and risk reduction and identifying opportunities for joint efforts among different public and private entities. Though the LRRC focuses on pre-event mitigation and risk reduction, its members recognize that by working collaboratively on resilience prior to events, Lane County will strengthen relationships and set in motion efforts that will make response and recovery more efficient when a disaster does occur.

The regional approach reflected in this Plan also demonstrates the ability of jurisdictions in Lane County to effectively share information and identify priority needs based on varied local conditions. Incorporating other planning documents within the Plan is one strategy for promoting mitigation efforts into land use decisions, future development designs, infrastructure usage, and emergency preparedness. As an example, the Community Wildfire Protection Plan and Climate Action Plan were created or recently updated to reflect how the County and its partners can consolidate priorities through incorporating elements of those plans into this hazard mitigation plan update. The integration and crosswalk of these plans' action items will ensure cross jurisdictional awareness and sustain a collaborative approach to mitigation activities in the future.

Section 3.4.2: Weaknesses

Weaknesses exist in the County's ability to safely shelter people, pets, and livestock during emergencies. Learning from recent events, while the Lane County Fairgrounds continues to serve as a resource to complete these missions, it lacks a facility with appropriate resources to meet the needs of the most vulnerable individuals that live in the community. The risk and vulnerability assessments revealed potential challenges in responding to an event where life safety of people is compromised based on different locations in the County given the wide area coverage and limited transportation routes beyond the network of state highways. Addressing the capability to effectively shelter people and animals along with sustaining a displaced population in severe events is one notable gap this Plans' holders will address in the upcoming planning cycle.

Though Lane County and its plan partners possess skills among its current workforce, staffing remains limited among many of the Plan holders. As previously mentioned, discussing strengths, Lane County Emergency Management was afforded the opportunity to hire staff focused exclusively on Mitigation and Recovery mission areas within the department. The position is funded through September 2024 as a limited duration staff and may or may not remain past this date. Limited and understaffing is a common shortfall of the emergency management departments of rural counties such as Lane. To address this challenge, LCEM benefitted from the assignment of an AmeriCorps volunteer position through the Resource Assistance for Rural Environments (RARE) program at the University of Oregon. Without the additional staff and volunteer adding technical capacity to the department, ensuring the inclusion of the special districts, other cities, and regional stakeholders into the planning process and maintaining this Plan will be challenging for the limited staffing at the County level.

Lastly, the limited number of locally source financial resources remains a weakness for the County and its plan participants. Hazard mitigation grants such as HMGP and BRIC require local funding match. As estimated project costs rise so does the local match requirement, which is anywhere from 10 to 25 percent of the total project cost. Cities with smaller tax bases already allocate most funds to the daily operability of their communities and are limited in how much funds are available to devote to local project match. This situation is true of Lane County's fiscal capabilities as well. Furthermore, the limited staff also reduces the capacity and expertise to navigate the application process or executing grants post award. Mitigation grants therefore are often seen as a barrier rather than a benefit. Until additional resources or support are provided at the local level, these funding opportunities will remain unattainable.

Section 3.4.3: Opportunities

Despite the existing weaknesses, Lane County and its partners can take advantage of opportunities to address capability shortfalls and improve its mitigation efforts regionwide.

Bodies such as the NHM-SC, the CWPP Advisory Committee, and Hazardous Fuels-Subcommittee each provide a forum for advancing regional collaboration among the participating municipalities. This collaborative effort extends to other groups such as the Lane Regional Resilience Collaborative and the Oakridge Area Fire Safe Council, which includes both staff and city officials from communities in Lane County. Further integrating the activities between these groups and bolstering coordination with other community-serving and volunteer groups remains a central opportunity for enhancing mitigation capabilities.

Adoption of the recent Lane County Climate Resilience Plan (2022) and the update to the Community Wildfire Protection Plan (2020) also afford Lane County to further integrate action items and priorities contained within the local hazard mitigation plan with other important planning processes. In addition to these plans, this Plan update sought to incorporate projects included in the county's Capital Improvements Plan that provided mitigation benefits into the action items of the MNHMP. Likewise, some of the planning study action items included in the Plan update should be advanced in other processes, particularly once the next comprehensive plan update occurs. The action items proposing completing the Resilience Hubs site analysis and Safe Growth Audit provide contributions to portions of comprehensive plan updates, which allows for assessing the congruency between land use and development strategies and hazard mitigation objectives.

Lastly, recent events have significantly impacted public awareness and interest into understand their risk of different hazards as well as what actions can be taken to reduce risk. Lane County and its partners already promote public awareness and provide educational materials via the County's Emergency Management webpage, public service announcements, and in conjunction with themed months associated with hazard risk topics (e.g., May is Wildfire Awareness Month prior to the traditional fire season in Western Oregon). Expanding the offerings for public interaction and discussion regarding the topic is an opportunity that can further enhance residents' individual capacity to respond and reduce risk directly to their properties. Part of expanding collaborative efforts between active participants in mitigating hazard risk in Lane County should incorporate this public interaction and discussion element as part of a complete strategy for communication information and directing people to resources.

Section 3.4.4: Threats

A constant threat is staff turnover. Experienced individuals with the necessary training to advance the County's mitigation work can depart their roles for a variety of reasons. People move onto different opportunities, funding for positions may be cut or depleted, or departments can merge and reorganize leading to the elimination of positions. Dozens of forces influence the staffing capabilities of municipalities and in regional efforts, such as is represented by this plan's multi-jurisdictional approach. The complexity of each participant's ability to staff trained and experienced people, or to train incoming people, represents a chronic threat to maintain an effective mitigation program across cities, the County, special interest groups, community-benefit groups, and individuals.

As profiled in the Risk Assessment, Lane County experiences a cyclical pattern between its wet and dry seasons for the likely natural hazards that will impact the area. A few of these hazards have the capability to trigger a local emergency response that escalates into a state of emergency. Aside from the implications of these declarations, given the limited staff among the County and participating cities, standing up an emergency operations center (EOC) immediately shifts personnel away from mitigation work into an active, emergency management function. Since the last update of this Plan, Lane County has activated EOCs for several events and a few of these events lasted three weeks or more. If natural hazard events elevate to emergency situations more often due to an increasing frequency and/or severity, the current limited staffing among this Plan's participants will be tested to maintain effective mitigation program work (e.g., grant management and acquisition) when devoting resources to increasing response needs.

In line with the threat of increasing disaster events is also expanding the resource need of recovery efforts. Lane County has experienced significant disruptions from severe storms and has come close to experiencing devastating disasters. As destructive as the Holiday Farm Fire was, the event did not result in a mass casualty situation. The McKenzie River community continues its recovery. The Cedar Creek Fire in 2022 approached the city limits of Oakridge requiring a full evacuation of the area but did not result in the destruction of the city. These recent events serve as a reminder of the disruption that can take place in a destructive and devastating event that included mass casualties, economic disruption to collapse, significant population displacement, destroyed buildings and infrastructure, and contamination of natural habitats. This present threat necessitates a discussion about how to sustain and maintain capabilities in mitigating the impacts of natural hazards in the event of a major disaster in a region of the County.

Section 4: Mitigation Strategy

44 CFR §201.6 (c)(3): Plan content. The plan **must** include the following: A *mitigation strategy* that provides the jurisdiction’s blueprint for reducing the potential losses identified in the risk assessment, based on existing authorities, policies, programs and resources, and its ability to expand on and improve these tools. This section **must** include:

- (i) A description of mitigation goals to reduce or avoid long-term vulnerabilities to the identified hazards.
- (ii) A section that identifies and analyzes a comprehensive range of specific mitigation actions and projects being considered to reduce the effects of each hazard, with particular emphasis on new and existing buildings and infrastructure. All plans approved by FEMA after October 1, 2008, must also address the jurisdiction’s participation in the NFIP, and continued compliance with NFIP requirements, as appropriate.
- (iii) An action plan describing how the actions identified in paragraph (c)(3)(ii) of this section will be prioritized, implemented, and administered by the local jurisdiction. Prioritization will include a special emphasis on the extent to which benefits are maximized according to a cost benefit review of the proposed projects and their associated costs.
- (iv) For multi-jurisdictional plans, there must be identified action items specific to the jurisdiction requesting FEMA approval or credit of the plan.

The Mitigation Strategy section describes Lane County’s approach for reducing the impacts of natural hazards identified in the risk assessment (Section 2 of Volume I). The strategy is informed by existing authorities, policies, programs and resources, and active projects. In addition, the conclusions drawn from the capability assessment, information gaps discussed during the planning process, and best practices identified through a review of the most recent applied research provided insight about how to structure the County’s mitigation approach and prioritize action items.

This section is organized into four sub-sections: Hazard Mitigation Strategy summary, mitigation action item identification and prioritization methodology, mitigation action items for Version 4.0 of the Plan, and lastly updates about Version 3.0 of the Plan’s action items and progress.

Section 4.1: Hazard Mitigation Strategy Summary

The Lane County MNHMP Version 4.0 follows the intent of the plan’s Mission Statement as presented in Section 1. The Mission Statement reads:

To promote and implement actions to eliminate or reduce long-term risk to human life and property from the effects of all types and sources of natural hazards, as well as to enhance capability to prepare, respond, and recover from such incidents.

The Natural Hazard Mitigation Steering Committee (NHM-SC) periodically reviews the Plan goals to consider adding, changing, or removing goals from the mitigation strategy. The goals presented for Version 4.0 consider the findings from the planning process in addition to goals stated in other planning documents (e.g., Community Wildfire Protection Plan and the Climate Resilience Plan). Additionally, these goals are vetted against the stated goals of the Oregon Natural Hazard Mitigation Plan. Table 4.1 presents a crosswalk between current the Lane County MNHMP goals along with those goals listed in the Oregon NHMP to show how they align.

Table 4.1: Mitigation Strategy Goals, Lane County MNHMP compared to Oregon NHMP Goals

Lane County Goals (2018)	State of Oregon Goals (2020)
#1: Prevent loss of life and reduce injuries and illness.	#1: Protect life and reduce injuries resulting from natural hazards.
#2: Minimize and prevent damage to buildings and infrastructure.	#2: Minimize property damage from natural hazards.
	#3: Minimize damage to critical or essential infrastructure and services from natural hazards.
	#13: Reduce repetitive and severe repetitive flood losses.
	#14: Minimize or eliminate potential impacts from dams posing the greatest risk to people, property, and infrastructure.
#3: Reduce recovery period and minimize economic losses for the community.	#4: Enhance the ability of Oregon's economies to rebound quickly from the effects of natural hazard events.
	#11: Mitigate the inequitable impacts of natural hazards by prioritizing and directing resources and investments to build resilience in the most vulnerable populations and communities least able to respond and recover.
#4: Maintain and improve ability of Lane County, municipal governments, and critical service providers to quickly resume operations.	#10: Enhance communication, collaboration, and coordination among agencies at all levels of government, sovereign tribal nations, and the private sector to mitigate natural hazards.
#5: Protect natural, historic, and cultural resources.	#5: Minimize project impacts to the environment and utilize natural solutions to protect people and property from natural hazards.
	#8: Eliminate development within mapped hazardous areas where the risks to people and property cannot be practically managed.
	#9: Minimize damage to historic and cultural resources from natural hazards.
#6: Increase awareness of hazards and understanding of mitigation methods.	#7: Motivate the "whole community" to build resilience and mitigate against the effects of natural hazards through engagement, listening, learning, information-sharing, and funding opportunities.
	#12: Develop, integrate, and align natural hazards mitigation and climate adaptation efforts based on the evolving understanding of the interrelationships between climate change and climate-related natural hazard events.
#7: Improve attractiveness to individuals and businesses by demonstrating effectiveness in dealing with a disaster.	#6: Enhance the state's capability to implement a comprehensive statewide natural hazards mitigation strategy.

Source: Lane County MNHMP (2018); Oregon Natural Hazards Mitigation Plan (2020)

The goals contained in this Plan remain the same and reflect the foundations of hazard mitigation as one of the five (5) mission areas of National Preparedness Framework. Above all, protecting people from injury and preventing loss of life is central to the outcomes of mitigation work. Critical as well is preventing damage to building structures, utilities, infrastructure, and the natural environment, which can all cascade into impacting human health and safety. New to Version 4.0 of this Plan is the addition of **Objectives** that ultimately tie goals to the specific action items contained in the Plan. **Goals** describe outcomes to be achieved while **objectives** describe the actions taken to achieve those outcomes. **Action items** describe the specific tasks needed to complete an objective. The mitigation strategy for Version 4.0 of this Plan contains seven (7) goals, five (5) objectives, and a total of 24 action items for the County Base Plan. Specific information about how the action items support goals can be found in Section 4.3 within each action item table. Additionally, the action items included within each sub-plan holder’s annex also describe how other local jurisdictions contribute to this regional mitigation strategy.

Section 4.2: Action Item Identification and Prioritization Methodology

Action items for Version 4.0 of the Plan were identified using six (6) approaches. The following paragraphs expand on how each approach contributed to identifying relevant action items and forming the goals and objectives. Table 4.2 displays how each strategy contributed to sections of this Plan update.

Table 4.2: Approaches for Action Item Identification and Prioritization Corresponding to Portions of the MNHMP Planning Process

Approach Description	Corresponding Part of the Planning Process
Reviewing current action items in Version 3.0	Risk Assessment & Mitigation Strategy
Identifying Current Action Items not included in Version 3.0	Risk Assessment & Capability Assessment
Aligning findings from risk assessment with mitigation best practices	Capability Assessment & Mitigation Strategy
Opportunities for plan integration	Capability Assessment
Exploratory Scenario Planning (XSP) workshops	Public Participation & Mitigation Strategy
Vetting action items and prioritization	Capability Assessment & Mitigation Strategy

Source: Lane County NHM-SC

Section 4.2.1: Reviewing Current Action Items from Version 3.0 (2018)

Part of assessing progress from the current version of the Plan includes assessing whether action items are still relevant to the mitigation strategy. Action items may remain relevant between versions of the Plan for a variety of reasons. Projects meant to implement action items may not be adequately funded or staffed to move forward since their identification. Progress made on action items may exist, but the overall action remains unfinished and should be sustained by being included in the next Plan update.

During the risk assessment, the planning team reviewed the action items from Version 3.0 of the Plan for their relevance to Lane County’s current mitigation efforts. The results from this review were incorporated into discussions about developing the mitigation strategy for the base plan (Volume I of this Plan) and for the strategy pursued by city and utility sub-plan holders (Volume II of this Plan).

The mitigation action items for Version 4.0 of this Plan are included in Section 4.3. Those action items carried forward from the current Plan into the updated Plan for 2023 are identified and distinguished from other action items.

Section 4.2.2: Identifying Current Mitigation Work Not Included in Version 3.0

Planning periods for local hazard mitigation plans cycle every five (5) years. Disasters can occur between plan updates that spur action from a variety of sources and levels of government. In Oregon, the destructive 2020 wildfire season was that most recent disaster. Following the fires, the Oregon Legislature passed Senate Bill 762 (SB 762) to direct resources towards wildfire mitigation action items, generally wildfire risk mapping, creating and maintaining defensible space around buildings and critical infrastructure, and fuels reduction treatments in high-risk areas.

In addition, House Bill 5006 (HB 5006) Section 282 set aside \$20 million to distribute as qualifying ‘matching funds’ for Hazard Mitigation Grant Projects (HMGP). Typically, state and local applicants must provide 25 percent (25%) of project costs under HMGP from non-federal funding sources. HB 5006 sought to provide financial resources for communities to pursue mitigation projects following a disaster and not be discouraged from applying due to a lack of cost-match. Lane County submitted over 23 applications for projects for DR-4562 (2020 Oregon wildfires) mitigation funds, of which eight (8) projects ultimately moved forward to be awarded funding (see Section 4.5: Success Stories).

Though mitigation work addresses multiple hazards, the wildfire example demonstrates how people respond to recent events and influences changes that should be captured between plan updates. The planning team in coordination with the NHM-SC reached out to departments within Lane County, participating cities, and utilities, as well as community-benefit organizations and nonprofits to identify current hazard mitigation actions that were not explicitly captured in Version 3.0 of this Plan. These discussions evaluated current mitigation activities for their potential to address high vulnerability and risk areas along with the eligibility of the work to be funded under several grant programs administered by both state and federal agencies. Action items included in this Plan update not included in Version 3.0 will be distinguished (see Section 4.3 of Volume I).

Section 4.2.3: Opportunities for Plan Integration

Plan integration is recognized as an important strategy for advancing hazard mitigation efforts into other planning efforts. The goal is to, “effectively integrate plans and policies across disciplines and agencies in [a] community by considering the potential hazards as one of the key factors in future development.”¹⁴⁵ The benefits of plan integration include improving coordination among government departments and their external partners, developing recommendations for inclusion in community-wide plans, and capturing existing planning activities that address hazard mitigation within the plan to document the sum of activities occurring in the region. Plan integration is an element FEMA considers for approving local mitigation plans.¹⁴⁶

Three (3) other County planning documents were prioritized for integration into Version 4.0 of the MNHMP. Lane County’s **Community Wildfire Protection Plan (CWPP)** will become a functioning annex

¹⁴⁵ Federal Emergency Management Agency. (2015). *Plan Integration: Linking Local Planning Efforts*, Department of Homeland Security, p. 2.

¹⁴⁶ Federal Emergency Management Agency. (2023). *Local Mitigation Planning Policy Guide*, FP 206-21-0002, Department of Homeland Security, Element Items A4, D3, & E2-c.

to this Plan, incorporating the action items identified in the CWPP into the all-hazards mitigation effort. Some action items from the CWPP were elevated to be included in this Plan based on priority and relevance while the remaining action items can be referenced through the CWPP directly as Lane County's effort to address wildfire risk.

Lane County adopted a **Climate Resilience Plan (CRP)** in December 2022. Though building resilience to climate change is a long-term effort, actions to progress Lane County towards climate resiliency exist that align well with the shorter-term planning period characteristic of local hazard mitigation plans. In addition, the work undertaken by the planning effort to complete the CRP (2020 – 2022) identified action items that Lane County can take that should be integrated into the MNHMP. Integrating local hazard mitigation with longer-term climate adaptation and resilience efforts also supports Lane County's Strategic Priority #3, which states the county should, "Maintain and invest in resilient infrastructure that creates the highest return for safety, community connectivity, enjoyment of life, and local economic success."¹⁴⁷

Identifying projects already contained within a jurisdiction's **capital improvement plan (CIP)** is another effective mechanism for advancing hazard mitigation work. Projects included in the CIP often have local funds previously identified to finance projects. Therefore, projects within the CIP that provide mitigation benefits should be captured within the local hazard mitigation plan to elevate these projects' priority value and provide a mechanism to support the project through other sources of state or federal funding. The action items found in Section 4.3 of Volume I include a reference to integration with other planning documents.

Further integration can occur during this Plan's upcoming active period (2023 – 2028). For example, the exposure analysis used in the risk assessment to update this Plan identifies hazardous areas in Lane County and can inform development and zoning policy included during the next update of Rural Comprehensive Plan. Local hazard mitigation plans are not regulatory documents though it is a requirement for eligibility under federal grant programs. However, insights from the work completed in a mitigation plan update can inform long-range land use and transportation planners within the county when updating regulatory plans so that each of these efforts are complimentary of each other. Oregon statewide planning Goal 7 addresses natural hazards within comprehensive plans but other statewide planning goals can incorporate the findings presented about hazardous areas and community vulnerability in Lane County into other statewide planning goals.

Two (2) current initiatives should be highlighted that exemplify the connection: the effort for addressing the housing affordability crisis (and within this the homelessness crisis) and the potential implementation of the Climate-Friendly and Equitable Communities (CFEC) rules, codified into Oregon Administrative Rules (OAR) Chapter 660. Both initiatives will impact development patterns and decisions for the rest of the decade and likely be incorporated into the next update of the county's and local cities' comprehensive plans. Therefore, integrating the information about hazard risk during the planning process for these regulatory plans is critical for developing communities in a resilient, sustainable, and most importantly, equitable manner.

¹⁴⁷ Lane County, (2022). *Lane County Strategic Plan (Three-Year Plan) 2022 – 2024*. County Administration Office. p. 8.

Action items that may contribute to the planning process of other plans is presented, when applicable, for each item presented in Section 4.3.

Section 4.2.4: Exploratory Scenario Planning (XSP) Workshops

Lane County Emergency Management (LCEM) facilitated six (6) regional workshop events with planning participants and stakeholders. Exploratory scenario planning (XSP) is a technique that aims to identify actions and outcomes that account for the implications of multiple futures.¹⁴⁸ Each planning region participated in two (2) workshops designed specifically based on the regional risk assessment for those areas and communities. As part of the second of these two workshops, each region evaluated multiple hazard event scenarios to identify significant impacts and then brainstormed the most relevant action items to address those impacts. LCEM distributed worksheets to attendees during the event and collected the notes that individuals provided to identify priority action items within each of Lane County's regions.

The XSP workshops served to not only brainstorm new action items to include in this Plan but also provided an opportunity to assess the importance of the action items in terms of the hazard impacts the actions addressed. More information about how XSP was used in the overall planning process can be found in Section 6 in Volume I of the Plan.

Section 4.3: Mitigation Action Items for Version 4.0

Action items listed here will carry through the upcoming 5-year planning cycle covered by Version 4.0 of the Lane County Multi-Jurisdictional Natural Hazard Mitigation Plan (2023 – 2028). These action items are presented in order based on the objectives they serve in the mitigation strategy in the form of an information table. Each table provides 11 details specific to the action. This subsection presents action items for Lane County. The action items specific to each sub-plan holder are included within the annexes comprising Volume II of this Plan.

Version 4.0 of the Lane County MNHMP contains five (5) objectives tied to the Plan goals and 24 action items associated with these objectives. Each action item table provides specific information about how the action fits into the broader county mitigation strategy.

Section 4.3.1: Seismic Hardening of Critical Infrastructure

Objective Statement: Harden critical facilities and essential systems from seismic and additional hazards (5 action items).

¹⁴⁸ Stapleton, J. (2020). "Chapter 1: Exploring Scenario Planning." *How to Use Exploratory Scenario Planning (XSP): Navigating an Uncertain Future*, Lincoln Institute of Land Policy.

Action Item		
ID#	Action Item Title	Goal(s) Addressed
O1.1	Seismic Assessment & Hardening of Lane County Delta Campus & Public Service Building	3; 4
Hazards Addressed	Purpose & Mitigation Outcome	
Earthquake	Phased project to conduct seismic assessment of Public Service Building (Law Enforcement, Dispatch Center, Emergency Operations Center - Primary location) as well as the secondary location at the Delta Campus housing Public Works. Based upon the assessment results, a second phase to seismically retrofit or renovate the County EOC, LE facilities, fleet fueling station, and other associated buildings to ensure they are functioning to a life safety standard following a Cascadia earthquake.	
Implementation Timeframe	Coordinating Agencies	Plan Integration
60 months	Lead Agency: Lane County Engineering and Construction Services Partners: Emergency Management, NHM-SC, Public Works Divisions, Lane County Courthouse	Climate Resilience Plan Capital Improvements Plan
Priority	Potential Funding Sources	Cost Estimate
High	BRIC	\$30,000,000

Action Item		
ID#	Action Item Title	Goal(s) Addressed
O1.2	Seismic Hardening of Railroad Tracks at Lowell & Jasper Road	2; 3; 4
Hazards Addressed	Purpose & Mitigation Outcome	
Earthquake; Flooding	In a seismic event the primary route for the community to evacuate or seek access to resources will be Jasper Lowell Road. This phased project will include a seismic assessment and seismic retrofit to ensure safe passage for people and commodities. Flooding is also a frequent event in this location preventing passage of vehicles. In a severe CSZ event, the tracks will most likely collapse. Complete a seismic assessment of the site and proceed with retrofit.	
Implementation Timeframe	Coordinating Agencies	Plan Integration
48 Months	Lead Agency: Lane County Engineering & Construction Services Partners: Lane County Roads Division; City of Lowell; Oregon Department of Transportation, Railroad Partners	Climate Resilience Plan Long-Range Transportation Plan Capital Improvements Plan
Priority	Potential Funding Sources	Cost Estimate
High	BRIC, FHWA	\$5,000,000

Action Item		
ID#	Action Item Title	Goal(s) Addressed
O1.3	Regional Seismic Resiliency Assessment for Bridges & Retrofit	1; 2; 3; 4; 7
Hazards Addressed	Purpose & Mitigation Outcome	
Earthquake	<p>Enhance safe transportation facilities and operations: The Oregon Department of Transportation (ODOT) identified priority routes (lifeline routes) that would be the most efficient routes for the movement of emergency services and supplies in the event of a major earthquake. Alternate routes around seismically vulnerable bridges along these lifeline routes have also been identified.</p> <p>Phase One: Assess all county owned bridges and overpass infrastructure; retrofit all facilities identified along lifeline priority routes in conjunction with city and state partners. To include seismic retrofit project identified in the Lane County Capital Improvement Plan 2020-2024.</p> <p>Phase Two: retrofit priority bridges as identified in the assessment results.</p>	
Implementation Timeframe	Coordinating Agencies	Plan Integration
24-48 months	<p>Lead Agency: Engineering & Construction Services</p> <p>Partners: Lane County Roads Division, Oregon Department of Transportation</p>	<p>Climate Resilience Plan</p> <p>Capital Improvements Plan</p>
Priority	Potential Funding Sources	Cost Estimate
High	BRIC	\$750,000

Action Item		
ID#	Action Item Title	Goal(s) Addressed
O1.4	Row River Road Bridge Retrofit	2; 3; 4; 7
Hazards Addressed	Purpose & Mitigation Outcome	
Earthquake; Flooding	<p>The project will enhance safe transportation facilities and operations. The Oregon Department of Transportation (ODOT) identified priority routes (lifeline routes) that would be the most efficient routes for the movement of emergency services and supplies in the event of a major earthquake. Further analysis on these deteriorating bridges assessed the feasibility and corrective costs of bridge improvements.</p> <p>The Row River Road Bridge emerged from the analysis as a priority for replacement/rehab work to remove seismic vulnerabilities along Row River Road lifeline route in a reasonable timeline. This project aligns well with the robust infrastructure mission of the Lane County Strategic Plan (CIP, Page 63 Action #35, 36).</p>	
Implementation Timeframe	Coordinating Agencies	Plan Integration
48 months (2023 - 2027)	<p>Lead Agency: Lane County Engineering & Construction Services</p> <p>Partners: Public Works, Roads Division; Transportation Division; Engineering & Construction Services</p>	<p>Climate Resilience Plan</p> <p>Capital Improvement Plan</p>
Priority	Potential Funding Sources	Cost Estimate
High	BRIC, HMGP, Local Funding	\$550,000

Action Item		
ID#	Action Item Title	Goal(s) Addressed
O1.5	Leachate Transport Pipeline	1; 2; 4; 5; 7
Hazards Addressed	Purpose & Mitigation Outcome	
Flooding	The Waste Management Division currently transports over 18 million gallons of leachate per year via tanker trucks from the landfill to the Glenwood Transfer Station discharge point. A pipeline that could convey the leachate from the landfill to the wastewater system would limit impacts to the environment, climate, and would also provide for sustainable conveyance in the case of a natural disaster or other event preventing tankers from operating. Leachate is required to be disposed of in the wastewater system. The current system is inefficient and does not allow for leachate disposal in the case of a natural disaster. Currently, tanker trucks haul the leachate from the landfill to the Glenwood Transfer Station, which takes up staff and equipment costs. In April 2019 Atmospheric River, the County barely kept up with transport, which put the public at risk for potential spillage/overflow into public waterways.	
Implementation Timeframe	Coordinating Agencies	Plan Integration
36 months	<p>Lead Agency: Public Works Waste Management Division</p> <p>Partners: Metropolitan Wastewater Management Commission</p>	<p>Climate Resilience Plan</p> <p>Capital Improvements Plan</p>
Priority	Potential Funding Sources	Cost Estimate
High	BRIC, HMGP	\$6,700,000

Section 4.3.2: Enhance Community Resiliency

Objective Statement: Limit cascading impacts on property and infrastructure resulting from natural hazards by enhancing community resiliency. (2 action items)

Action Item		
ID#	Action Item Title	Goal(s) Addressed
O2.1	Develop Renewable Energy Systems and Storage Capacity for County Facilities	1; 3; 4; 7
Hazards Addressed	Purpose & Mitigation Outcome	
All Hazards	<p>Develop renewable energy plus energy storage systems at County facilities that offer critical services, ensuring their function during a power outage. Conduct an assessment of facilities owned by Lane County to develop a priority lists, secure funding, and construct renewable and backup storage capabilities.</p> <p>Lane County will support other critical facilities, such as hospitals, fire stations, and others by partnering on grant applications or connecting</p>	
Implementation Timeframe	Coordinating Agencies	Plan Integration
24 - 30 months	<p>Lead Agency: Lane County Capital Improvement, Facilities</p> <p>Partners: Emergency Management, Fire Districts, Hospitals, Communications Partners (LRIG, LCSO)</p>	Climate Resilience Plan
Priority	Potential Funding Sources	Cost Estimate
High	BRIC	\$750,000

Action Item		
ID#	Action Item Title	Goal(s) Addressed
O2.2	Increase Water Quality Testing Assistance in Wells	1; 5; 6
Hazards Addressed	Purpose & Mitigation Outcome	
Drought	<p>Expand water quality testing programs for wells. Support community members by developing and providing information about the relevant programs countywide and the resources available to progress with the results of the tests.</p> <p>During implementation of this action item, support to the most vulnerable community members and assistance with creating regional solutions to water quality issues can help mitigate the worst impacts of the water quality issues resulting from drought.</p>	
Implementation Timeframe	Coordinating Agencies	Plan Integration
Ongoing	<p>Lead Agency: Oregon Health Authority Drinking Water Program</p> <p>Partners: Lane County Public Health, Community Organizations, Local Utilities</p>	<p>Climate Resilience Plan</p> <p>Capital Improvements Plan</p>
Priority	Potential Funding Sources	Cost Estimate
High	BRIC	\$250,000

Section 4.3.3: Construct a Regional Operating Picture of Hazard Risk and Impacts

Objective statement: Improve regional awareness of capabilities compared to hazard risk profile to advance strategic mitigation planning and long-term community resiliency. (4 action items)

Action Item		
ID#	Action Item Title	Goal(s) Addressed
O3.1	Regional Island Mapping Study	3; 4; 6; 7
Hazards Addressed	Purpose & Mitigation Outcome	
Earthquake; Flooding; Landslide; Tsunami; Wildfire	<p>Hazard events can impact transportation routes, whether temporary blockages that can be cleared in a couple of hours to more extensive shut downs that last a few days. Some of the maximum threat events for hazards that affect Lane County would likely render several key transportation routes impassable in the aftermath of the event (i.e., a CSZ earthquake). Due to Lane County's geography, communities will experience varying effects from these transportation disruptions and some places can become completely cutoff from the rest of the region.</p> <p>Assessing what areas will become "islands" with respect to different hazard scenarios will inform all parties about priorities for building resiliency among the areas most likely to become cutoff and develop plans with an understanding of the regional impact of the most severe hazard events that can affect Lane County.</p>	
Implementation Timeframe	Coordinating Agencies	Planning Integration
18 - 24 months	<p>Lead Agency: State Partners and Lane Emergency Management</p> <p>Partners: Lane County NHM-SC; GIS Division, Land Management Division, Engineering & Construction Services Division, University of Oregon, Oregon Department of Human Services</p>	<p>Community Wildfire Protection Plan</p> <p>Capital Improvement Plan</p> <p>Climate Resilience Plan</p>
Priority	Potential Funding Sources	Cost Estimate
Moderate	Staff Time; Local Budgets; State Funding; BRIC	\$500,000

Action Item		
ID#	Action Item Title	Goal(s) Addressed
O3.2	Fuel Supply & Distribution Analysis Study	3; 4; 7
Hazards Addressed	Purpose & Mitigation Outcome	
All Hazards	Functioning as a second phase to O3.1, regional island mapping project, phase two will identify fuel supply locations and distribution plan for public safety to include critical infrastructure, law enforcement, fire, hospitals, and Public Works across Lane County.	
Implementation Timeframe	Coordinating Agencies	Plan Integration
24 - 48 months	<p>Lead Agency: Lane County Roads Division</p> <p>Partners: Fleet Services, Emergency Management, City Partners, Special Districts, University of Oregon, Lane Regional Resilience Collaborative</p>	<p>Climate Resilience Plan</p> <p>Capial Improvements Plan</p>
Priority	Potential Funding Sources	Cost Estimate
High	BRIC	\$500,000

Action Item		
ID#	Action Item Title	Goal(s) Addressed
O3.3	Urban Heat Island Mapping Study	1; 6
Hazards Addressed	Purpose & Mitigation Outcome	
Extreme Weather (Heat)	<p>Recent extreme heat (summer months of 2020, 2021, and 2022) brought high temperatures to the Willamette Valley that exceeded 100 degrees Farenheit. The area also experienced more frequent heat waves where temperatures reached 95 degrees or more. Areas can experience heat effects differently based on a variety of factors. To better understand how extreme heat disproportionately affects areas of Lane County and its city partners, an urban heat island mapping study is the first step to identifying where the risk is greatest during the summer months.</p> <p>With an accurate urban heat island map, Lane County can better identify what areas should be prioritized within city and developed areas for actions that address the impacts of extreme heat. Through the process, Lane County can also improve its understanding of what communities lack access to in the form of existing services (i.e. cooling centers) during extreme heat events.</p>	
Implementation Timeframe	Coordinating Agencies	Planning Integration
12 - 15 months	<p>Lead Agency: Public Health and Land Management Division</p> <p>Partners: City Partners, Lane Council of Governments, Emergency Management</p>	Climate Resilience Plan
Priority	Potential Funding Sources	Cost Estimate
Moderate	Staff time, Local/State funding, BRIC, HMA, EMPG	\$250,000

Action Item		
ID#	Action Item Title	Goal(s) Addressed
O3.4	Identify strategic locations for water storage facilities in rural areas	1; 2; 4; 7
Hazards Addressed	Purpose & Mitigation Outcome	
Drought, Wildfire, Windstorm	<p>Continue to identify and establish private tanks & water resources, due to the lack of hydrants within our fire district, these may not always be the fastest, safest, or most efficient.</p> <p>There are many areas where river access is not close to the roadway, and the closest draft site for water supply may be miles away. There is also a number of areas that have one or more large commercial structures, with no immediate water supply on site or for the general surrounding area. Installing water storage facilities in the rural area.</p>	
Implementation Timeframe	Coordinating Agencies	Plan Integration
12 - 18 months	<p>Lead Agency: Oregon Health Authority Drinking Water Program</p> <p>Partners: Lane County Public Health, Community Organizations, Local Utilities, Fire Districts, Emergency Management</p>	<p>Climate Resilience Plan</p> <p>Capial Improvements Plan</p>
Priority	Potential Funding Sources	Cost Estimate
High	BRIC	\$250,000

Section 4.3.4: Establish Foundation Actions for Long-Term Climate Adaptation

Objective statement: Promote long-term community resilience through studies to generate recommendations for advancing long-term community resilience and climate adaption projects.

(3 action items)

Action Item		
ID#	Action Item Title	Goal(s) Addressed
O4.1	Resilience Hubs Site and Suitability Analysis Study	1; 3; 4; 7
Hazards Addressed	Purpose & Mitigation Outcome	
All-Hazards	<p>Mitigating the impacts of hazard events must account for how to hasten short and long-term recovery no matter if the event is disruptive or catastrophic. Resilience Hubs are, "community-serving facilities augmented to support residents, coordinate communication, distribute resources, and reduce carbon pollution while enhancing quality of life." (Urban Sustainability Directors Network). In order to identify where suitable locations and facilities exist for these community spaces, a countywide analysis must be completed. The results should facilitate a discussion among informed stakeholders and the public about which facilities are best suited for this purpose. For rural, unincorporated communities, resilience hubs can be exceptionally valuable community assets.</p> <p>This study would be the first step in a phased project approach to create a network of Resilience Hubs that serve the spectrum of community types in Lane County for a variety of hazard events and impacts.</p>	
Implementation Timeframe	Coordinating Agencies	Planning Integration
18 - 24 months	<p>Lead Agency: LC Emergency Management</p> <p>Partners: GIS Division, Land Management Division, Public Health, Transportation Division; Engineering & Construction Services, Capital Improvement Division, City & Utility Partners, Lane Council of Governments, University of Oregon</p>	Climate Resilience Plan
Priority	Potential Funding Sources	Cost Estimate
High	BRIC; Local Budgets; State Funding*	\$500,000

*NOTE: HB 2990 is currently working through the Oregon legislature; if signed into law, the bill provides state funding towards augmenting facilities for the purposes of creating resilience hubs.

Action Item		
ID#	Action Item Title	Goal(s) Addressed
O4.2	Conduct a Safe Growth Audit assessing hazard risk and future	1; 2; 3; 5; 6
Hazards Addressed	Purpose & Mitigation Outcome	
All-Hazards	<p>Lane County is expected to grow to 443,747 residents by 2045 (Population Research Center, Portland State University, 2021) about 70,000 more people than today. At the time of this Plan update, Oregon is embarking on an effort to construct affordable housing in response to chronic homeless in the state and increasing cost-burden on households, both renters and home owners. As communities in Lane County develop additional housing units, infrastructure, and gain more people, it will be critical to build resiliently and clear of hazardous areas.</p> <p>A safe growth audit analyses the impacts of current policies, ordinances, and plans on community from hazard risk due to growth. One of the initial steps in completing this process is to map existing hazard areas, which has been completed to a degree for some hazard types, are awaiting ongoing studies, or tie into some of the mapping studies included in this Plan (see O3.1 & O3.3). The process requires effective public engagement to capture local conditions and needs. It is therefore suitable to be incorporated into other planning processes, such as updates to comprehensive plans, zoning changes or overlays, and housing and economic development strategies.</p> <p>This information informs the public and decision makers about the trajectory of future growth and how to safe guard people's homes and lives. The results of this audit aim to include recommendations to the Board of County Commissioners about land use and development decisions for future growth in unincorporated Lane County and provide guidance for the City Participants to do so the same within their city limits.</p>	
Implementation Timeframe	Coordinating Agencies	Plan Integration
36 - 44 months	<p>Lead Agency: Land Management Division & Emergency Management</p> <p>Partners: Emergency Management, GIS Division, City and Utility Participants, City of Eugene, City of Springfield, Lane Council of Governments, University of Oregon, Community Organizations, Special Districts</p>	<p>Rural Comprehensive Plan</p> <p>Climate Resilience Plan</p> <p>Capital Improvement Plan</p> <p>Long-Range Transportation Plan</p>
Priority	Potential Funding Sources	Cost Estimate
High	Staff Time, Local/State Funding, BRIC, HMA, EMPG	\$250,000

Action Item		
ID#	Action Item Title	Goal(s) Addressed
O4.3	Develop Emergency Water Supply Plan	1; 3; 4; 6; 7
Hazards Addressed	Purpose & Mitigation Outcome	
Drought	In drought situations, identifying and establishing water distribution locations to provide potable water to general public can mitigate water restrictions and scarcity. Water shortages affect a number of community lifelines in addition to posing health risks to the public. This plan works in tandem with efforts contained in action items O2.2, O3.1, and O3.4.	
Implementation Timeframe	Coordinating Agencies	Plan Integration
18 - 24 months	<p>Lead Agency: Oregon Health Authority Drinking Water Program, Emergency Management, Water Districts</p> <p>Partners: Lane County Public Health, Community Organizations, Local Utilities, Watershed Conversation</p>	<p>Climate Resilience Plan</p> <p>Capial Improvements Plan</p>
Priority	Potential Funding Sources	Cost Estimate
Moderate	BRIC, HMGP, EMPG	\$100,000

Section 4.3.5: Promote Regional Collaboratives for Advancing Mitigation Efforts

Objective statement: Develop a regional coordination strategy for aligning mitigation efforts between the three (3) regions of Lane County, expanding participation in mitigation work beyond government and utility staff (3 action items).

Action Item		
ID#	Action Item Title	Goal(s) Addressed
O5.1	Sustain the Natural Hazard Mitigation Steering Committee (NHM-SC)	4
Hazards Addressed	Purpose & Mitigation Outcome	
All Hazards	Committee oversight of this plan will help prevent loss and maximize cost recovery after a disaster. Coordination and further integration/crosswalk with other existing plans and committees across the County will enhance the usefulness of mitigation efforts and regional collaboration. The NHM-SC will develop a process that can be supported by Lane County Emergency Management to progress efforts throughout the county that reduces hazard risk.	
Implementation Timeframe	Coordinating Agencies	Plan Integration
Ongoing	<p>Lead Agency: Lane County Emergency Management</p> <p>Partners: City and Utility Participants, Lane County Staff from other Divisions</p>	Community Wildfire Protection Plan
Priority	Potential Funding Sources	Cost Estimate
High	BRIC, EMPG, SHSP	Staff Time of Members

Action Item		
ID#	Action Item Title	Goal(s) Addressed
05.2	Conduct an assessment to identify Community Lifelines, supply management logistics, and mechanisms to re-establishing Lifelines during disruptions of supply chain on a countywide scale.	3; 4; 7
Hazards Addressed	Purpose & Mitigation Outcome	
All-Hazards	<p>Local disruptions are becoming increasingly unpredictable and have complex, cascading effects during hazard events given how the systems they affect are interconnected. FEMA's Community Lifelines approach focuses on logistical preparations to restore the key services that keep a community running, on both good and bad days. This assessment will identify issues and outline a practical approach to managing supply chain disruptions while building stakeholder partnerships.</p> <p>Aligning with FEMA's Community Lifelines with Supply Chain & Logistics techniques to keep supply chains running to expedite recovery after hazard events.</p>	
Implementation Timeframe	Coordinating Agencies	Plan Integration
12 - 15 months	<p>Lead Agency: Emergency Management, NHM-SC, & City Partners</p> <p>Partners: Businesses, Special Districts, Lane Regional Resilience Collaborative, Lane Council of Governments, University of Oregon, Community Benefit Organizations</p>	<p>Community Wildfire Protection Plan</p> <p>Capital Improvement Plan</p> <p>Climate Resilience Plan</p>
Priority	Potential Funding Sources	Cost Estimate
Moderate	Staff time, Local/State funding, BRIC, HMA, EMPG	\$500,000

Action Item		
ID#	Action Item Title	Goal(s) Addressed
05.3	Promote and implement the use of non-regulatory incentives to reduce structural ignitability	2; 3; 6
Hazards Addressed	Purpose & Mitigation Outcome	
Wildfire	Implement landowner assistance for fuel reduction projects including cost-share incentives. Increase local capacity, establish incentive programs to support yard debris disposal to assist landowners with hazardous fuels removal. Create disposal opportunities using alternative methods to burning (Action Item 3.2.1 in CWPP).	
Implementation Timeframe	Coordinating Agencies	Plan Integration
Ongoing	<p>Lead Agency: Land Management Division & Emergency Management</p> <p>Partners: City & Utility Participants; CWPP Advisory Committee; Hazardous Fuels Subcommittee; Lane County Public Works, Roads Division; Rural Fire Protection Districts; Community Based Organizations</p>	<p>Climate Resilience Plan</p> <p>Community Wildfire Protection Plan</p>
Priority	Potential Funding Sources	Cost Estimate
High	BRIC	\$500,000

Section 4.4: Previous Plan Action Items and Progress Report

To promote accountability and future implementation of mitigation action items, this subsection presents the action items included in Version 3.0 of this Plan (2018). Please find a list of action items from previous mitigation plan reporting progress and status in the mitigation strategy.

LANE COUNTY HAZARD MITIGATION ACTION ITEMS (2018-2022)

Action Item	Goals Addressed	Priority	Hazards Addressed	Status
Multi-Hazard				
Sustain Hazard Mitigation & Emergency Management Steering Committee	1,2,3,4,5,6,7	High	All	Move forward AI (sustain)
<i>Purpose:</i> Continuously review, update and facilitate implementation of Plan.	<i>Implementation Timeframe:</i> 16-12 months	<i>Coordinating Departments and Outside Agencies:</i> Emergency Mgmt.	<i>Potential Funding Source:</i> FEMA EMPG, Local Budgets	
<i>Benefits (loss avoidance):</i> Committee oversight of this Plan will help prevent loss and maximize cost recovery after a disaster.	<i>Cost Estimate:</i> Staff Time			
Include publicly owned utilities in 2022 Plan Update	1,2,3,4,6,7	High	All	Move forward AI (sustain)
<i>Purpose:</i> Incorporate Utility Planning into County efforts.	<i>Implementation Timeframe:</i> 12-18 months	<i>Coordinating Departments and Outside Agencies:</i> Emergency Mgmt. Utilities	<i>Potential Funding Source:</i> FEMA EMPG and HMGP	
<i>Benefits (loss avoidance):</i> Reduced infrastructure damage. Increased cooperation & information sharing decreases recovery time and costs.	<i>Cost Estimate:</i> \$40-50,000			
Enhance Public Education about natural hazards and preparedness	1,2,3,4,5,6,7	High	All	Ongoing
<i>Purpose:</i> Increase community resilience to disasters.	<i>Implementation Timeframe:</i> 1-6 months	<i>Coordinating Departments and Outside Agencies:</i> All Departments All Agencies	<i>Potential Funding Source:</i> Local Budgets, FEMA EMPG	
<i>Benefits (loss avoidance):</i> Improved community preparedness and resiliency	<i>Cost Estimate:</i> Staff Time			

Develop Emergency Water Supply Plan	1,3,4,6,7	High	All	Ongoing
<i>Purpose:</i>	<i>Implementation Timeframe:</i>	<i>Coordinating Departments and Outside Agencies:</i>	<i>Potential Funding Source</i>	
<i>Mitigate water shortages, prioritize needs, and establish protocols and triggers.</i>	6-12 months	<i>Emergency Mgmt.; County Public Works; City Emergency Mgmt.; City Public Works; Utilities; Water Districts</i>	<i>Local Budgets, FEMA EMPG</i>	
<i>Benefits (loss avoidance): Establishing triggers to activate plans reduces response and recovery time.</i>	<i>Cost Estimate:</i> <i>Staff Time</i>			
Action Item	Goals Addressed	Priority	Hazards Addressed	Status
Multi-Hazard (Cont.)				
Hazard Mapping	1,2,3,4,5,6,7	High	All	Ongoing
<i>Purpose:</i>	<i>Implementation Timeframe:</i>	<i>Coordinating Departments and Outside Agencies:</i>	<i>Potential Funding Source</i>	
<i>Identify hazards in specific locations in a usable, informative format.</i>	8-12 months	<i>Emergency Mgmt.; Technology Services (GIS)</i>	<i>Local Budgets</i>	
<i>Benefits (loss avoidance): Accurate mapping will allow for better land-use choices, decreasing potential losses due to ineffective mitigation planning.</i>	<i>Cost Estimate:</i> <i>Staff Time (GIS Analyst)</i>			
Maintain Vegetation Management Standards	2,3,4,5,6,7	High	Wildfire, Flood	Ongoing
<i>Purpose:</i>	<i>Implementation Timeframe:</i>	<i>Coordinating Departments and Outside Agencies:</i>	<i>Potential Funding Source</i>	
<i>Standards reduce wildfire fuels near structures and waterways.</i>	Ongoing	<i>County Public Works, Local Public Works Depts.</i>	<i>Local Budgets</i>	
<i>Benefits (loss avoidance): Decreased loss of structures due to wildfire hazard, decreased debris in waterways help prevent localized flooding</i>				
Storm-harden Grange Facilities	2,5	High	Flood, Windstorm,	

Action Item	Goals Addressed	Priority	Cost Estimate	Status
<p><i>Purpose:</i></p> <p>There are 22 granges in rural Lane County that serve difficult to reach communities and that are willing to open their facility if needed during a disaster. Storm hardening granges will give Lane County a resource for assembly of displaced persons.</p> <p><i>Benefits (loss avoidance)</i></p> <p>Provides nearby location for rural residents to receive emergency assistance. Reduces use of government services when resources are already spread thin and reduces cross-county vehicular travel when roads are most hazardous. Preserves cultural and historical resource</p>	<p><i>Implementation Timeframe:</i></p> <p>1 - 2 granges per year.</p>	<p><i>Coordinating Departments and Outside Agencies:</i></p> <p>Lane County Emergency Mgmt.</p>	<p>Winter Storm</p> <p><i>Potential Funding Source</i></p> <p>HMGP</p>	<p>Ongoing Included in Resilience Hubs</p>
<p>Dam Failure</p>				
<p>Load GIS layers of dam inundation areas into mass notification system</p> <p><i>Purpose:</i></p> <p>To accurately notify those in the path of dam inundation floodwaters in time to evacuate.</p> <p><i>Benefits (loss avoidance):</i></p> <p>Prevents loss of life, increases potential to decrease loss of property</p>	<p>1,2,3,4,5,6,7</p> <p><i>Implementation Timeframe:</i></p> <p>12-18 months</p>	<p>High</p> <p><i>Coordinating Departments and Outside Agencies:</i></p> <p>Emergency Mgmt.; Technology Services (GIS); Alerting System Vendor</p>	<p>\$ 45,000</p> <p><i>Potential Funding Source</i></p> <p>FEMA EMPG, Local Budgets</p>	<p>Completed</p>
<p>Make USACE Inundation maps available for public viewing</p> <p><i>Purpose:</i></p> <p>Inform the public on flood hazard.</p>	<p>1,2,3,4,5,6,7</p> <p><i>Implementation Timeframe:</i></p> <p>12-24 months</p>	<p>Medium</p> <p><i>Coordinating Departments and Outside Agencies:</i></p> <p>Emergency Mgmt.; US Army Corps of Engineers Depts.</p>	<p>Staff Time</p> <p><i>Potential Funding Source</i></p> <p>FEMA EMPG, Local Budgets</p>	

Benefits (loss avoidance):
Decrease loss of property.

Action Item	Goals Addressed	Priority	Cost Estimate	Status
Drought				
Drought Public Education and Outreach	3,4,5,6,7	Medium	Staff Time	All hazard action item - outreach materials project under DR-4562
<p><i>Purpose:</i></p> <p>Increase awareness of drought effects and provide mitigation actions for individuals.</p> <p><i>Benefits (loss avoidance):</i></p> <p>Improved water quality, reduced drought effects, reduced costs of water treatment and mandatory water restrictions.</p>	<p><i>Implementation Timeframe:</i></p> <p>12-18 Months</p>	<p><i>Coordinating Departments and Outside Agencies:</i></p> <p>Emergency Mgmt.; Fire Departments and Districts; Water Districts</p>	<p><i>Potential Funding Source</i></p> <p>FEMA EMPG, Local Budgets</p>	
Construct storm water detention / retention ponds	2,3,5,6,7	High	\$ 300,000	
<p><i>Purpose:</i></p> <p>Reduce localized Flooding</p> <p><i>Benefits (loss avoidance):</i></p> <p>Decrease damage to road infrastructure, increase natural watershed potential</p>	<p><i>Implementation Timeframe:</i></p> <p>18-24 months</p>	<p><i>Coordinating Departments and Outside Agencies:</i></p> <p>Emergency Mgmt.; County and City Public Works Depts.</p>	<p><i>Potential Funding Source</i></p> <p>Local Budgets, FEMA HMGP and PDM</p>	Reworded Action Item
Earthquake				
Harden Public Works Facilities	1,2,3,4,5,6,7	High	\$10-15 million	Some assessments have been completed but dated, ongoing.
<p><i>Purpose:</i></p> <p>Increase resilience to seismic forces.</p>	<p><i>Implementation Timeframe:</i></p> <p>18-36 months</p>	<p><i>Coordinating Departments and Outside Agencies:</i></p> <p>Emergency Mgmt.; County Public Works, local Public Works Depts.</p>	<p><i>Potential Funding Source</i></p> <p>EMPG, HMGP, PDM</p> <p>Local Budgets</p>	

<p><i>Benefits (loss avoidance):</i> Decrease damage due to shaking/liquefaction, ability to use structure in post event response/recovery.</p>				
<p>Participate in ODOT Bridge Seismic Resiliency Planning Project</p>	<p>1,2,3,4,5,6,7</p>	<p>High</p>	<p>Staff Time</p>	
<p><i>Purpose:</i> Increase bridge resiliency to seismic forces. <i>Benefits (loss avoidance):</i> Decreased loss of life, decrease loss of property. Increase resiliency of system, increase response capability.</p>	<p><i>Implementation Timeframe:</i> 18 months</p>	<p><i>Coordinating Departments and Outside Agencies:</i> Emergency Mgmt.; County Public Works, ODOT</p>	<p><i>Potential Funding Source</i> FEMA EMPG, Local Budgets</p>	<p>Row Rd: Bridges successful on HMGP grant; move forward as AI.</p>
<p>Action Item</p>	<p>Goals Addressed</p>	<p>Priority</p>	<p>Cost Estimate</p>	<p>Status</p>
<p>Flood</p>				
<p>Maintain and Enhance Community Rating System (CRS)</p>	<p>1,2,3,4,5,6,7</p>	<p>Medium</p>	<p>\$ 300,000</p>	
<p><i>Purpose:</i> Increase use of CRS to decrease costs of flood Insurance. <i>Benefits (loss avoidance):</i> Decrease cost of flood response, decrease loss of property.</p>	<p><i>Implementation Timeframe:</i> 12-36 months</p>	<p><i>Coordinating Departments and Outside Agencies:</i> Emergency Mgmt.; County Planning Dept., Local Planning Dept.'s.</p>	<p><i>Potential Funding Source</i> FEM EMPG, HMGP and PDM; Local budgets</p>	<p>Ongoing</p>
<p>Upgrade Culverts and Storm Water Drainage Systems</p>	<p>1,2,3,4,5,6,7</p>	<p>High</p>	<p>\$10 million</p>	
<p><i>Purpose:</i> Increase Stormwater drainage capacity.</p>	<p><i>Implementation Timeframe:</i> 24-36 months</p>	<p><i>Coordinating Departments and Outside Agencies:</i> Emergency Mgmt.; County Planning Dept., Local Planning Dept.'s.</p>		<p>Culvert upsizing projects due to HFF; application submitted for HMGP on County Roads.</p>

Benefits (loss avoidance):
 Decreased cost of maintenance, decreased damage to road infrastructure.

Action Item	Goals Addressed	Priority	Cost Estimate	Status
Hazardous Materials Incidents				
Promote proper use and storage of chemicals	1,2,3,4,5,6,7	High	\$ 40,000	Hazard removed
<p><i>Purpose:</i></p> <p>Reduce hazardous spills and releases.</p> <p><i>Benefits (loss avoidance):</i></p> <p>Lower costs for cleanup, lower damages to environment, less loss of property, lower threat to life.</p>	<p><i>Implementation</i></p> <p><i>Timeframe:</i></p> <p>12-18 months</p>	<p><i>Coordinating</i></p> <p><i>Departments and</i></p> <p><i>Outside</i></p> <p><i>Agencies:</i></p> <p>Emergency Mgmt.; Fire Departments and Districts; Local LEPC</p>	-	
Pre-identify collection sites and services for post-flood or earthquake cleanup	1,2,3,4,5,6,7	Medium	\$12,000 – 15,000	Completed
<p><i>Purpose:</i></p> <p>Preplan locations for debris removal/storage, consolidate debris disposal, and recycle where possible.</p> <p><i>Benefits (loss avoidance):</i></p> <p>Decreases recovery time, decreases cost of debris disposal.</p>	<p><i>Implementation</i></p> <p><i>Timeframe:</i></p> <p>12-18 months</p>	<p><i>Coordinating</i></p> <p><i>Departments and</i></p> <p><i>Outside</i></p> <p><i>Agencies:</i></p> <p>Emergency Mgmt.; County and City Public Works Depts.</p>		

Action Item	Goals Addressed	Priority	Cost Estimate	Status
Landslide				
Construct engineered walls at key locations for stabilizing slopes	1,2,3,4,5,6,7	High	\$30-50 Million	ODOT facilities; priority of different routes; difficult for Hwy 58 and 126
<p><i>Purpose:</i></p> <p>Decrease landslide potential.</p>	<p><i>Implementation</i></p> <p><i>Timeframe:</i></p> <p>24-48 months</p>	<p><i>Coordinating</i></p> <p><i>Departments and</i></p> <p><i>Outside</i></p> <p><i>Agencies:</i></p> <p>County Public Works</p>	<p><i>Potential</i></p> <p><i>Funding</i></p> <p><i>Source</i></p> <p>FEMA HMGP</p>	

		ODOT	FHA	
<u>Benefits (loss avoidance):</u> Reduce loss of property, life, and reduce cost of cleanup in time and funds.				
Public Awareness and Education	1,2,3,4,5,6,7	High	\$10,000 - 15,000	Moved forward Action Item
<u>Purpose:</u> Increase public awareness. <u>Benefits (loss avoidance):</u> <u>Reduce unintended damages by causing landslides through inappropriate land use.</u>	<u>Implementation Timeframe:</u> 12-24 months	<u>Coordinating Departments and Outside Agencies:</u> Emergency Mgmt.; County and City Planning and Public Works Depts..	<u>Potential Funding Source</u> FEMA EMPG, HMGP and PDM Local Budgets	
Action Item	Goals Addressed	Priority	Cost Estimate	
Tsunami				
Support community-based culture of tsunami awareness, preparedness and response	1,2,3,4,5,6,7	High	\$150,000 – 250,000	Moved forward Action Item
<u>Purpose:</u> Increase knowledge of the Hazard, and how to respond to it. <u>Benefits (loss avoidance):</u> Decreased loss of life.	<u>Implementation Timeframe:</u> 8-12 months	<u>Coordinating Departments and Outside Agencies:</u> Emergency Mgmt.; WLEOG DOGAMI	<u>Potential Funding Source</u> FEMA EMPG, HMGP and PDM Local budgets	
Continuously improve government proficiency in using multiple types of warning systems.	1,2,3,4,5,6,7	High	\$ 10,000	
<u>Purpose:</u> Increase effective use of the tools. <u>Benefits (loss avoidance):</u>	<u>Implementation Timeframe:</u> 12-18 months	<u>Coordinating Departments and Outside Agencies:</u> Emergency Mgmt.; PSAP's and Dispatch Centers	<u>Potential Funding Source</u> EMPG, HMGP, PDM Local budgets	Moved forward Action Item

<i>Decrease loss in live and property.</i>				
Action Item	Goals Addressed	Priority	Cost Estimate	Status
Wildfire				
Promote Firewise Communities Program offerings	1,2,3,4,5,6,7	High	\$ 5,000	Moved forward Action Item
<i>Purpose:</i> Increase public participation in Firewise program.	<i>Implementation Timeframe:</i> 6-18 months	<i>Coordinating Departments and Outside Agencies:</i> Emergency Mgmt.; County Planning Dept.	<i>Potential Funding Source</i> EMPG, HMGP, PDM Local budgets	
<i>Benefits (loss avoidance):</i> Decrease number of human caused fires, decrease loss of life and property, decrease cost of response				
Action Item	Goals Addressed	Priority	Cost Estimate	Status
Windstorm				
Reduce impact of tree damage from windstorms	1,2,3,4,5,6,7	High	\$75,000 - 100,000	Remove. Action item unclear who is lead and purpose/objective unclear
<i>Purpose:</i> To reduce damages caused by trees in windstorms.	<i>Implementation Timeframe:</i> 12-24 months	<i>Coordinating Departments and Outside Agencies:</i> Emergency Mgmt.; County Public Works, ODOT, Power Utilities	<i>Potential Funding Source</i> EMPG, HMGP, PDM Local budgets	
Provide local redundancy of windstorm warnings though local media on both traditional and social platforms	1,2,3,4,5,6,7	High	10000	Moved forward Action Item
<i>Purpose:</i> Increase imminent windstorm alerts.	<i>Implementation Timeframe:</i> 6-12 months	<i>Coordinating Departments and Outside Agencies:</i> Emergency Mgmt.; PIO Network	<i>Potential Funding Source</i> EMPG, HMGP, PDM Local Budgets	
<i>Benefits (loss avoidance):</i>				

Action Item	Goals Addressed	Priority	Cost Estimate	Status
Decrease injuries, decrease clean-up costs.				
Severe Winter Storm				
Develop emergency water supply plan for power outages caused by snow / ice storms	1,2,3,4,5,6,7	High	\$ 15,000	Moved forward Action Item Resilience Hubs Model
<i>Purpose:</i> Create a secondary water source for emergency use.	<i>Implementation Timeframe:</i> 12-18 months	<i>Coordinating Departments and Outside Agencies:</i> Emergency Mgmt.; NGO's; Water Districts; Local Emergency Management	<i>Potential Funding Source</i> EMPG, HMGP, PDM Local budgets	
<i>Benefits (loss avoidance):</i> Improved health and safety of local residences experiencing power outages.				
Develop emergency firewood supply plan for power outages caused by snow / ice storms	1,2,3,4,5,6,7	Medium	\$10,000	Moved forward Action Item Resilience Hubs Model
<i>Purpose:</i> Provide a plan to supply firewood to mitigate power loss from winter storms.	<i>Implementation Timeframe:</i> 12-18 months	<i>Coordinating Departments and Outside Agencies:</i> Emergency Mgmt.; NGO's; Water Districts; Local Emergency Management	<i>Potential Funding Source</i> EMPG, HMGP, PDM Local budgets	
<i>Benefits (loss avoidance):</i> Decrease use of shelters, decrease cost of shelters, decrease in illness.				

Success Stories

Lane County has submitted several applications for hazard mitigation grant projects to be considered for funding since the last update of this Plan. Notably, Lane County has several sub-applications under DR-4562 totaling 23 preapplications.

- 9 sub-applications were submitted, 1 sub-application was withdrawn after submission (4562-17-R-Lane County-Application Development AA)
- 8 sub-applications have either been awarded, or are still in pre-award phase:
 - **Awarded as of May 2023:**
 - 4562-36-R, Lane County PW- Holiday Farm Fire - Culvert Improvements AA
 - 4562-66-R, Lane County PW- Row River Rd - Bridges 14964B and 14965A Seismic Retrofit AA

- **Pre-award as of May 2023:**
 - 4562-15-R, Lane County PW-Hayden Bridge Seismic Retrofit
 - 4562-18-R, Lane County PW-Goodpasture Covered Bridge - Snow and Fire Mitigation and Seismic Retrofit AA
 - 4562-27-R, Lane County PW-Territorial Bridge Gillespie Corners Flood Mitigation and Reconstruction
 - 4562-34-R, Lane County-Right of Way Fuels Reduction
 - 4562-44-F, Lane County-Public Education and Warning
 - 4562-60-R, Lane County-McKenzie Schools Structural Retrofit Project

The Building Resilient Infrastructure and Communities (BRIC) program has been open for two (2) rounds prior to the update of this Plan. Lane County has submitted a handful of projects to be considered for funding with an emphasis on addressing electricity vulnerability.

A project that has continued to move forward from the 2019 round of funding opportunities under BRIC is the Alderwood Looped Power Transmissions Project. Lane County's partner Blachly-Lane Utility put forward \$2.7 million to this project. Lane County residents connected to the Blachly-Lane Electric Cooperative grid receive their power through a single transmission line, powered by the Bonneville Power Administration (BPA). Power is received from the power administration via transmission lines that connect to the District's Parker, Junction City, High Pass, Alderwood, Indian Creek, and Erb substations. The BPA-owned distribution substations at Walton and Mapleton also serve Blachly's distribution lines. The Emerald People's Utility District and the BPA were instrumental in developing the project and will be engaged in future aspects of project development and implementation.

In any instance where the BPA loses power to their transmission line, whether planned or by natural disaster, over 6,876 residents lose power. The consequences of the power outage can range from disruption of daily activities to severe medical impacts for individuals with access and functional needs. The electric cooperative serves a rural community, and many residents rely on well water. In the event of an outage, residents are unable to use their wells, cutting off their access to potable water. A nature-based solutions approach will be implemented to help solve the projects multi-faceted problems.

Since 2005, the transmission line has experienced a cumulative 3.16 days of outages. The longest outage, in 2011, due to wind damage to poles, lasted for nearly a full day. The project will use an existing distribution line plot to construct a new, dual transmission and distribution line. Since transmission lines carry higher voltage and use large gauge wire, construction requires additional building materials and a more resilient design.

Section 5: Plan Maintenance and Implementation

44 CFR §201.6(c)(4): [Plan content: The plan **must** include the following]: A *plan maintenance process* that includes:

- (i): A section describing the method and schedule for monitoring, evaluating, and updating the mitigation plan within a five-year cycle.
- (ii): A process by which local governments incorporate the requirements of the mitigation plan into other planning mechanisms such as comprehensive or capital improvement plans, when appropriate.
- (iii): Discussion on how the community will continue public participation in the plan maintenance process.

This section documents the plan maintenance and implementation process as required by 44 CFR 201.6(c)(4)(i-iii). Specifically, this section provides an overview of how Lane County and participating jurisdictions that submitted annexes to the Plan will execute the mitigation strategy, monitor and update the contents of the MNHMP document, and evaluate success. This section also outlines efforts to further plan integration between the MNHMP and other planning documents, enhance and sustain public engagement with the Plan, and prescribe when the next formal plan update will take place.

Section 5.1: Implementation, Monitoring, Evaluation, and Update

In accordance with 44 CFR 201.6(c)(4)(i), LCEM will convene the Natural Hazard Mitigation Steering Committee (NHM-SC) to continue to monitor and evaluate the action items set forth, ensure coordination and alignment with other planning initiatives such as the Climate Action Plan, Community Wildfire Protection Plan, and the Capital Improvements Plan. The following subsection describes the specific strategies Lane County and its partners will employ during the upcoming planning cycle (2023 – 2028).

Section 5.1.1: Plan Implementation and Monitoring

LCEM will support the NHM-SC's effort to implement the action items contained in this Plan. Other divisions of Lane County, as well as the city and utility participants that submitted annexes to this Plan, will contribute to implementation by participating in the NHM-SC to represent their communities' interests, coordinating with LCEM and Lane County staff on grant applications, and pursuing shovel-ready projects. The NHM-SC will meet quarterly to manage the Plan though may adjust the meeting frequency at the members' discretion.

During meetings, the NHM-SC will review progress on mitigation actions, discuss implementation challenges and opportunities, invite guest presenters to provide technical information and findings from relevant research studies, and annually review priorities (as detailed below under Annual Review and Update). The NHM-SC will use one of the quarterly meetings each year to review and maintain the MNHMP, including but not limited to the following tasks:

- Review progress toward mitigation goals made over the previous year;
- Review and re-evaluate priority of remaining mitigation actions;
- Review and adjust priorities, as needed;
- Consider new mitigation actions for inclusion within the Plan;
- Consider adjustments to existing mitigation actions to improve feasibility, add critical detail, or refocus the strategy;

- Consider additional implementation partners as necessary, and develop a plan for their inclusion;
- Review public outreach conducted over the previous year; and
- Identify opportunities for outreach over the coming year.

Lane County Emergency Management is a single resource assigned to convene and oversee this Plan. Given the limited staff within this department now, implementation of the action items will heavily rely on the responsiveness of County Action Item owners and stakeholders once the action items have been specified in detail (when necessary). LCEM staff will schedule at least two (2) meetings each year and coordinate with other Stakeholder Advisory Committees, such as CWPP, Climate Advisory, and including Plan Partners (cities, utilities) to address obstacles to advancing both items contained in the County base plan (Volume I) and the individual annexes (Volume II). The participating jurisdictions (cities, special districts, and utilities) are committed to utilizing this Plan to access mitigation grant funds to assist the implementation of action items set forth. Opportunities to partner and share costs with affiliated agencies and neighboring jurisdictions for multi-objective projects will be encouraged.

Two (2) working groups will support the NHM-SC's effort to monitor progress and report on the status of action items. These working groups will include staff from several divisions within Lane County and departments within participating cities and/or utilities. The intent of these working groups is to support plan implementation and aims to enhance the capability of this Plan's participants to successfully secure grant funds to finance mitigation projects but also streamline communication about project progress and needs. This Plan will encourage opportunities to partner and share costs with affiliated agencies and neighboring jurisdictions for multi-objective projects. Participants of this Plan will explore how to best form and deploy these working groups during the Summer and Fall of 2023. This section of the Plan will be updated to reflect these details and the Plan's most current implementation strategy.

Incorporating the Community Wildfire Protection Plan (CWPP) as a functioning annex to this Plan integrates existing wildfire risk reduction efforts into the broader, all-hazards mitigation effort. For example, the CWPP Advisory Committee monitors and manages the implementation of action items found in the CWPP and is further supported by the Hazardous Fuel Subcommittee. These two bodies direct and manage Lane County's wildfire mitigation efforts and include individuals representing local, state, and federal interests. These CWPP groups expand the connections members of the mitigation planning teams can access when addressing hazard risk, especially given this Plan's focus on cascading impacts and how natural hazards interact and can be triggered by one another.

Section 5.1.2: Plan Evaluation

To evaluate the effectiveness of the Plan at achieving its stated purpose and goals, LCEM will seek active participation by all relevant parties to conduct annual reviews of progress toward results by:

- Reviewing progress, issues, and trends in the achievement of desired results of action items;
- Making decisions on changes to the mitigation strategy or this Plan as needed;
- Reviewing the adequacy and efficiency of allocated resources; and
- Reviewing new information and data that could influence the tactics needed to implement action items

In addition, the incorporation of this Plan into other planning instruments will serve as an additional metric for success. This Plan will ultimately be evaluated based on implementation of action items, the

incorporation of mitigation principles into future public policy, improved public safety, and the overall reduction of financial losses for Lane County residents. An annual summary will be developed to document the review of progress made on Action Items and included in Lane County's records for implementing the MNHMP.

Section 5.1.3: Five-Year Plan Update for Version 5.0 (2027 – 2028)

In accordance with **44 CFR §201.6 (c)(4)(i)**, LCEM will convene the NHM-SC for a formal Plan update process in the Spring of 2027. Staff turnover and competing priorities can delay a plan update process from starting and leaving less time until the Plan's expiration to fully engage all aspects of mitigation planning regionwide as this Plan's update process attempted to accomplish over nine (9) months. Therefore, intentionality is necessary to identify when the update process should begin. Starting the next update during Spring 2027 should provide 18 months before expiration for the Plan to be updated.

The NHM-SC will invite stakeholders and members of each participants' staff to attend a broad kick off meeting to establish a regional, multi-jurisdictional approach for addressing hazard mitigation in Lane County and build upon the work completed for the 2023 – 2028 planning cycle. The operational capacity built during the upcoming planning period (2023-2028) will serve to better coordinate among multiple jurisdictional priorities, resources, and expand engagement with the public. At that time, new mitigation measures will be added to the Plan and accomplishments during the past five years will be documented.

Section 5.2: Integration with Existing and Future Plans

Mitigation is most successful when it is codified and incorporated into the functions and priorities of government, planning, and future development. Incorporating mitigation strategies into other planning documents is an effective way to leverage the support of affiliated agencies and departments while ensuring mutually supportive goals and policies. Likewise, the action items and strategies contained in other planning documents can be incorporated into the goals and objectives of this Plan.

The action items contained within this version of the plan incorporated action items from other planning documents such as adopting the CWPP as a functioning annex and drawing from the Climate Resilience Plan and the Capital Improvements Plan. Incorporating these plan elements within the MNHMP is a step towards bolstering integration across all of Lane County's planning documents.

Future opportunities for plan integration include using the results from the risk and vulnerability assessment to inform future land use decisions and zoning decisions. For example, promulgation of the latest version of this Plan will occur prior to an update of Lane County's Rural Comprehensive Plan (LCRCP). Natural hazard mitigation is addressed officially within the comprehensive plan via Goal 7 of the Oregon Statewide planning goals. Other planning goals can be informed by the MNHMP action items and integrated into future land use decisions. Action items contained in the previous version of this Plan (Version 3.0, 2018), the CWPP, and the Climate Resilience Plan all identify making recommendations to the Lane County Board of County Commissioners about land use reforms that can safeguard communities, property, infrastructure, and enhance quality of life as action items.

Completing a **safe growth audit** (see Action Item O4.2) is one example of how planning integration can occur and produce tangible outcomes informing the regulatory elements of the LCRCP. The safe growth audit assesses compatibility between land use and development practices and hazard mitigation efforts. The audit's mitigation benefit is to identify if certain land use practices or policies, which are regulatory

in nature, conflict and override the necessity to not build in the county's most hazardous areas. Please refer to the action item specifically contained within the mitigation strategy portion of this Plan (Section 4) for further details about how safe growth audits support guiding development from an all-hazards perspective and can safeguard future residents and businesses that come to make Lane County their home.

The MNHMP works in tandem with other planning documents within Lane County's Emergency Management program, including the Emergency Operations Plan (EOP) and Continuity of Operations Plan (COOP). This local hazard mitigation plan acknowledges where other regulatory codes support mitigation efforts such as within the most recently adopted commercial and residential building codes, county and city subdivision codes, erosion controls, hazard zoning overlays, and stormwater management policies (see Section 3 of Volume I: Capability Assessment). Accordingly, the goals and mitigation strategies of this Plan will be incorporated into other planning documents within the purview of participating jurisdictions as they are updated or are developed. Examples of such planning documents can be found in Section 4.4. Additional opportunities for incorporating the mitigation strategy into existing and future planning mechanisms include integration with Lane County's Community Health Improvement Plan (2021-2026), and associated principles of 'Health in All Policies'.

Section 5.3: Engaging the Public about Hazard Risk and Mitigation

Public awareness and engagement about hazard mitigation is exceptionally important for advancing the goals and objectives presented in this Plan. During this update, the public informed the plan and its action items through responding to a countywide survey, attending one of the regional workshops facilitated by LCEM for plan participants and stakeholders, and during a public comment period prior to sending the Plan draft for formal review at state and federal levels. These efforts are a foundation to build upon to develop a more robust and sustained public engagement process despite the staff limitations of Lane County and its partners. Furthermore, other planning processes adhering to statewide planning Goal 1: Citizen Involvement intersect with the addressing the risk and vulnerabilities identified in this Plan. It is important to incorporate public awareness and a willingness to engage in hazard mitigation efforts in conjunction with existing and effective planning processes.

Participants of this Plan will engage the public through a variety of strategies including but not limited to:

- tabling public events to discuss hazard risk and mitigation best practices;
- participating in exercises and trainings for volunteers and community-benefit and faith-based organizations; and
- conducting public awareness campaigns throughout the year that align with established messaging around natural hazard risk (e.g., May as Wildfire Awareness Month).

LCEM will design and publish a Storymap that consolidates the most important contents of this Plan for the public. Storymaps are an engaging and interactive way of communicating information to variety of audiences. The Storymap can also be used to collect comments from the public on an ongoing basis throughout the planning cycle. LCEM will maintain active links for the public to submit comment via the official Emergency Management page on Lane County's website in addition to supporting and managing an active Storymap detailing key elements of the County's regional mitigation effort.

Lastly, several of the action items included in the mitigation strategy will depend heavily on public participation and the engagement of communities throughout the region. For example, to adequately identify and assess locations and/or existing buildings most suitable for outfitting as Resilience Hubs, plan participants and staff will need to be informed of the specific needs of local communities. Plan participants will collaborate to establish a process for which to begin this discussion and establish the dialogue needed for these communities to convene, communicate, and prescribe the public’s interests to the individuals managing the hazard mitigation plan (see Action Item O4.1 for additional information).

Section 6: Planning Process

44 CFR §201.6(b): Planning Process. An open public involvement process is essential to the development of an effective plan. In order to develop a more comprehensive approach to reducing the effects of natural disasters, the planning process **must** include:

- 1) An opportunity for the public to comment on the plan during the drafting stage and prior to plan approval;
- 2) An opportunity for neighboring communities, local and regional agencies involved in hazard mitigation activities, and agencies that have the authority to regulate development, as well as businesses, academia and other private and nonprofit interests to be involved in the planning process; and
- 3) Review and incorporation, if appropriate, of existing plans, studies, reports, and technical information.

The Plan update followed the prescribed process for updating local hazard mitigation plans as expressed by FEMA¹⁴⁹ and established best practices. This section summarizes the planning process by describing who participated and what events took place to gather input from the public and key stakeholders. Lane County Emergency Management convened the Natural Hazard Mitigation Steering Committee (NHM-SC) to kick off the Plan update in October 2022. The project management team structured the process through four (4) strategies: meetings of the NHM-SC, planning team meetings, public outreach and participation, and facilitated regional workshops. Details demonstrating how these strategies contributed to the plan update is contained in the following subsections.

Section 6.1: Meetings of the NHM-SC

Lane County and participating city and utility staff compromised the members of the NHM-SC for this Plan update. The committee members represent this Plan's city and utility participants as well as Lane County staff responsible for mitigation activities in each of their jurisdictions. Table 6.1 displays the names and positions of the NHM-SC members during the 2023 plan update.

¹⁴⁹ Federal Emergency Management Agency. (2023). *Local Mitigation Planning Handbook*. U.S. Department of Homeland Security.

Table 6.1: Members of the 2023 Natural Hazards Mitigation Steering Committee

Name	Position	Jurisdiction/Organization
Burke Hansen	Public Works Supervisor	City of Coburg
Cole Haselip	Management Analyst	City of Veneta
Curtis Thomas	Planner	City of Creswell
Devon Ashbridge	Public Information Officer	Lane County Administration
D'Lynn Williams	Mayor	City of Westfir
Gary Luke	GIS Analyst	Lane County: GIS
James Cleavenger	City Manager	City of Oakridge
Jamie Mills	City Manager	City of Dunes City
Jeff Carlson	Safety, Compliance & Loss Control Specialist	Consumer Power, Inc.
Jeremy Caudle	City Manager	City of Lowell
Joanna Rodgers	Community Health Analyst	Lane County: Public Health
Matt McRae	Long-Term Recovery Manager	Lane County Administration
Matt Tarnoff	Roads Division Analyst	Lane County: Public Works, Roads
Megan Heurion	Senior Program Services Coordinator	Lane County Administration
Megan Messmer	Assistant City Manager	City of Florence
Patence Winningham-Melcher	Emergency Manager	Lane County Emergency Management
Rachel Serslev	Senior Planner (Floodplain Administrator)	Lane County: Public Works, Land Management
Sasha Vartanian	Transportation Planning Supervisor	Lane County: Public Works, Transportation
Selene Jaramillo	Emergency Program Coordinator	Lane County: Public Health

Source: Lane County

The NHM-SC met five (5) times between October 2022 and May 2023. Steering committee meetings focused attention on the progress made updating the county base plan (Volume I) and annexes from the sub-plan holders (Volume II) as well as an opportunity for LCEM to inform committee members about the process for updating local hazard mitigation plans. Some of the committee members had not previously participated in this kind of planning process and benefitted from understanding of state and federal requirements for updating and approving local hazard mitigation plans. LCEM also discussed the opportunities plan participants could exercise in acquiring funding for mitigation projects and the benefits of participating in a multi-jurisdictional plan. Table 6.2 displays meeting dates and the topics discussed among the steering committee members during this Plan update.

Table 6.2: NHM-SC Meeting Dates and Agenda Topics

Date	Main Topic	Secondary Topic(s)
October 17, 2022	Local Hazard Mitigation Planning Process	Project Schedule, NHM-SC Members and Roles
November 28, 2022	Risk and Vulnerability Assessment	Identifying Capabilities and Gaps
January 23, 2023	Mitigation Strategy & Action Item Updates	XSP Regional Workshops; Annex Requirements
March 13, 2023	New Action Items & Implementation	HMA Funding Programs and Action Item Eligibility
May 8, 2023	Mitigation Strategy & Plan Review Cycle	Adoption Requirements, Next NHM-SC Meeting

Source: Lane County NHM-SC

The first steering committee meeting formally kicked off the update to the Lane County MNHMP. LCEM introduced the process for updating local hazard mitigation plans to the steering committee members. Part of the discussion highlighted the eligibility requirements for sub-plan holders to meet for an approved, multi-jurisdictional plan. The NHM-SC reviewed a project timeline developed to bring a FEMA-approved plan before the governing bodies of each plan participant for adoption in October 2023 and how Lane County would work with its plan partners to conduct the risk assessment, identify capabilities, and develop priority mitigation actions.

The NHM-SC met in November 2022 to begin the updated risk assessment. LCEM presented a walk-through for steering committee members about the components included in the risk and vulnerability assessment. Steering committee members discussed and identified the hazards to be included within the plan and those hazards to remove from the plan. The committee also endorsed the regional approach for evaluating risk countywide, which included conducting the risk assessment and developing a mitigation strategy by examining Lane County as three (3) distinct regions: Coast, Valley, and Cascades.

During the third meeting of the NHM-SC in January 2023, members reported on progress with completing the risk assessment for each local jurisdictions participating in the plan as well as the countywide base plan. LCEM also presented a summary of the Exploratory Scenario Planning (XSP) process that was being incorporated into the regional approach to prepare plan participants for workshops scheduled to provide an opportunity for stakeholder and public input on the Plan (see Section 6.4). The presentation allowed members of the committee time to ask questions, explore which stakeholders would benefit from participating in the regional workshops, and identifying how the workshops would assist with developing mitigation action items.

The fourth meeting of the NHM-SC took place in March of 2023. The topic of this meeting was to update steering committee members about the progress of the plan update, review results from the risk assessments, advance the conversation regarding priorities within the mitigation strategy, and update the progress of existing action items. Committee members discussed completed projects, ongoing work, or projects that had yet to move forward and how these varying statuses had addressed mitigation priorities from the 2018 version of the Plan. As a result, the NHM-SC could assess where gaps remained and should be addressed in new action items included in the Plan update.

The NHM-SC met for a fifth time in May 2023. The meeting brought together the results of the regional workshops and city and utility annexes to evaluate an initial list of action items and vet priority actions. The committee discussed the upcoming public comment period and a distribution strategy to capture feedback from the public ahead of the plan's first review at the state level. Also, during this meeting members discussed the cumulative mitigation strategy and how the action items addressed reducing risk for natural hazards both on annual basis and considering those with low probability but a high and catastrophic potential impact on the community. LCEM engaged with the committee members to discuss suitable formats for collaborative work to sustain the plan and begin to execute action items upon the plan's adoption in October 2023.

The steering committee plans to meet over the summer at least once, tentatively scheduled for August 2023, to discuss which of the action items to advance heading into 2024 and the plan's first year of the five-year cycle. A meeting date will be set to take place shortly after the adoption of the plan occurs to begin executing the implementation strategy. One agenda item for August 2023 will be to discuss whether this committee should meet on a quarterly or biannual basis during plan implementation and maintenance and in what format to convene the steering committee meetings. To sustain regional engagement, an active steering committee will be essential for coordinating actions among stakeholders and multiple jurisdictions across Lane County's three (3) regions. The agenda items and minutes from the NHM-SC meetings will be documented and included in the next update of this Plan.

Section 6.2: Planning Team Meetings

LCEM conducted individual meetings with each of the city and utility partners throughout the process. These meetings explored the unique characteristics and hazard profiles to complete the hazard quantification for risk areas that fell under the jurisdiction of plan participant (see Volume II: Annexes). These meetings also identified high priority actions and potential mitigation projects to meet those objectives. Table 6.3 lists the meetings that took place between the project management team and city partners’ planning teams. LCEM also coordinated with staff throughout the County’s different divisions and stakeholder groups to inform the risk assessment and mitigation priorities associated with specific hazards. These meetings are also included in Table 6.3.

Table 6.3: Lane County MNHMP Update Planning Team Meetings, County and Plan Participants

Date of Meeting	Participants	Discussion Topic
November 3, 2022	Emergency Management; Land Management	Risk Assessment
November 3, 2022	Emergency Management; Public Health	Risk Assessment
November 8, 2022	Lane County Planning Team	Risk Assessment
November 9, 2022	Emergency Management, Transportation Division	Risk Assessment
December 1, 2022	Emergency Management, Oregon Partnership for Disaster Resilience	Risk Assessment
December 5, 2022	Emergency Management, Mapleton Water District	Annex & Participation
December 7, 2022	Emergency Management, Willamalane Park District	Stakeholder Collaboration
December 20, 2022	Emergency Management, Policy Division & County Administration	Climate Integration & Public Outreach
January 11, 2023	Emergency Management, Oregon Partnership for Disaster Resilience	Mitigation Strategy
January 31, 2023	Emergency Management, Mapleton Water District	Annex & Participation
January 31, 2023	Emergency Management, Public Health, Lane Regional Air Protection Agency	Smoke Impact
February 22, 2023	Emergency Management, City of Coburg	Annex & Participation
February 27, 2023	Emergency Management, City of Lowell	Annex & Participation
February 28, 2023	Emergency Management, City of Dunes City	Annex & Participation
March 2, 2023	Emergency Management, City of Creswell	Annex & Participation
March 2, 2023	Emergency Management, City of Veneta	Annex & Participation
March 6, 2023	Emergency Management, Public Health, Lane Regional Air Protection Agency	Smoke Impact
March 6, 2023	Emergency Management, City of Oakridge	Annex & Participation
March 8, 2023	Lane County Planning Team	Mitigation Strategy
March 14, 2023	Emergency Management, City of Florence	Annex & Participation
March 17, 2023	Lane County Planning Team	XSP Workshop Meeting
March 29, 2023	Emergency Management, Consumer Power Inc.	Annex & Participation
April 7, 2023	Lane County Planning Team	XSP Workshop Meeting
April 12, 2023	Emergency Management, City of Veneta	Hazard Quantification & Risk Assessment
May 4, 2023	Emergency Management, City of Coburg	Mitigation Action Items
May 8, 2023	Lane County Planning Team	Mitigation Action Items

Source: Lane County

Section 6.3: Public Outreach and Input

The planning team conducted public outreach during the update to solicit perspectives and feedback about hazard risk and mitigation capabilities in Lane County. This effort is important for keeping the public aware and attentive to their individual hazard risk and necessary to empower people to be proactive in reducing their risk or assisting others that struggle to do so. The public outreach strategy included: a survey distributed to residents of Lane County, hosting a live comment page on the LCEM webpage through the Plan update, releasing a Plan draft for a public comment period and incorporating the results into the plan’s elements, and designing interactive products to better convey the information contained in this Plan to communities across the county.

Section 6.3.1: Summary of the Rural Lane County Survey Results

The planning team released a public survey for residents of Lane County and residents of the participating cities. The survey remained open for five (5) weeks from March 6 through April 7, 2023. LCEM coordinated with county staff, city, and utility participants to distribute mailings containing the survey as well as promote access to an online version.

Survey respondents were balanced between the Valley, Cascades, and those living outside of city limits, with a smaller proportion responding from the Coast. A total of 380 responses were received. For a detailed version of the survey responses, see Appendix B in Volume III of this Plan.

Respondents indicated that they were most concerned about wildfire and its secondary impact of smoke. Approximately one third of respondents also mentioned being very concerned by drought, earthquakes, and windstorms. About a quarter responded that they were very concerned about extreme heat and winter storms. The only hazards that stood out as not as significant a concern to most respondents were tsunami and volcano, though about a fifth of respondents also indicated not being concerned with landslides.

Respondents indicated that they felt that infrastructure and environmental damage were amongst the most likely and vulnerable community assets to natural hazards. Over a third of respondents also rated that human loss of life and injuries along with economic impacts were also very vulnerable in Lane County. Many respondents indicated that these areas were somewhat vulnerable as the response rate for community assets rated as not very vulnerable was low amongst all categories. In terms of the community assets most important to individuals, hospitals, major bridges, and fire and police stations stood out as very important amongst most respondents. Also notable was schools and small businesses, which over half of respondents selected as very important. More than half of respondents indicated that each community asset category was either somewhat or very important (see Questions 3 & 4 included in Appendix B of Volume III).

A majority of respondents indicated that a lot of the goals and objectives in the hazard mitigation strategy were very important to them including protecting private property, critical facilities, networks, utilities, and emergency services. Over half of respondents indicated it was very important to disclose natural hazard risk during real estate transactions and promoting cooperation among public agencies, citizens, nonprofits, and private businesses. While nearly half of respondents indicated it was somewhat important to protect cultural and historical landmarks only 17 percent indicated that this was very important to them.

Overall, respondents indicated that they believed Lane County is somewhat to not very prepared for most hazards profiled in this plan. Only eight percent (8%) of respondents indicated that Lane County was very prepared for winter storms, which was the highest rating of any natural hazard. The most common response indicated that Lane County is somewhat prepared for wildfire and winter storms. Respondents indicated that Lane County is not very prepared or not prepared at all for drought, earthquake, and extreme heat.

Most respondents indicated that their primary residence was at risk from wildfire, windstorms, winter storms, and smoke. Nearly three quarters of respondents also indicated that drought, earthquake, and extreme heat would impact their primary residence. The majority of respondents indicated that they did not have flood insurance and that it was not required. 43 percent (43%) of

respondents indicated that they had insurance for another natural hazard aside from flood with the most likely response being fire insurance.

Among secondary homes, which may be used as rental or investment properties or as a vacation or seasonal home, respondents indicated that these properties were most at risk from winter storms, wildfire, smoke, earthquakes, and windstorms. Most of the responses indicated that these secondary residences did not have flood insurance, with two-thirds of respondents indicating that flood insurance is not required. Similar to primary residences, fire was most likely type of insurance other than flood for respondents' secondary residence.

Section 6.3.2: Public Comments

Throughout the planning process, LCEM hosted a space for the public to submit comments on the Emergency Management department page of Lane County's website. The website provided status updates about the mitigation plan, allowed people to sign up for notifications about items related to the plan's development, notice of steering committee meetings, contact information for LCEM staff, and encouraged the public to submit comments about mitigation priorities in their communities.

Upon completing the initial draft of the Lane County MNHMP Version 4.0, LCEM released the plan for a public comment period as specified in FEMA requirements for plan approval and Oregon state requirements for public participation in planning processes. The comment period remained open for three (3) weeks from June 1 through June 23. During this time, the planning team monitored submitted comments and incorporated comments as appropriate to refining the risk assessment or mitigation strategy action items. A summary of the public comments content follows. A collection of submitted comment is included as part of Volume III: Appendix B.

In addition to survey responses, residents of Lane County submitted comments detailing their feedback about the contents of the Plan. Notable comments included expanding the opportunity to funnel FireWise grants to rural residents in Lane County and assessing local priority routes resiliency from a major seismic event in coordination with ODOT. Other comments highlighted the addition of the expanded social vulnerability section and inquired about a providing an accurate count of houseless individuals throughout Lane County, both those sheltered and unsheltered. Lane County Human Services Division publishes updates about the counts of individuals experiencing houselessness in the County and this Plan will review most recent counts provided to update the social vulnerability assessment to better understand the location of need related to this element of social vulnerability.

Section 6.3.3: Ongoing Public Engagement

As noted in Section 5: Plan Maintenance and Implementation, sustaining public outreach and developing engagement strategies with the public for discussing mitigation actions will be critical for advancing risk reduction in Lane County during the upcoming planning period. While LCEM will maintain an active web presence for the MNHMP allowing for the public to submit questions or comments while the Plan is active, other tools can be used to capture and cultivate public interest in mitigation efforts throughout the county and how they can directly participate in shaping a resilient community.



Project Manager and RARE AmeriCorps Member Hannah Shafer (pictured to the center) encourages people to review and comment on the Lane County MNHMP | Photo: Patence Winningham

LCEM is developing a Storymap that consolidates the contents of this Plan through visualization and interactive features. Storymaps are digital tools that present information in both a narrative and visual format. Rather than expect people to read through the entire Plan, the planning team strives to provide a product that packages the analysis, effort, and collective work of participants of this Plan into a consumable and engaging format. This work will take place during the Summer of 2023 as the Plan draft is reviewed at the state and federal levels. It will be rolled out to the public in completed segments with a target for completion by the time of the Plan's adoption in October 2023.

Public engagement must also incorporate approaches that do not solely rely on digital tools. Sustaining motivation across the county requires active planning and facilitation of community events. The participants of this Plan will discuss and develop a comprehensive public engagement campaign that aims to standardize how mitigation efforts can be promoted year-round. Elements of this campaign are likely to include organized events by LCEM and its partners, public festivals and fairs, safety awareness events periodically hosted throughout the County, tabling at partner events, and public service announcements about the ongoing and successfully completed mitigation projects.

Elements of this Plan reflecting the planning process will be updated as this concept evolves from identified opportunities into a structured and strategic campaign.

Section 6.4: Exploratory Scenario Planning (XSP) Regional Workshops

To regionally assess Lane County’s hazard risk and promote coordination between the three (3) regions, LCEM organized and facilitated six (6) workshops that included both plan participants and key stakeholders within the Coast, Valley, and Cascades regions. The workshops were designed based on a process known as Exploratory Scenario Planning (XSP). XSP is often used for long-range land use and transportation planning processes. The process leads its participants through a series of thought exercises that explore the outcomes of several potential futures in comparison to better understand how to address uncertainty of future conditions. XSP aims to assess the elements of multiple futures to devise robust strategies, or those strategies that can account for multiple potential outcomes. Since XSP addresses the uncertainty inherent in future conditions, the process offers an opportunity to be applied to hazard mitigation planning. Uncertainty in the context of hazard mitigation planning results from the impacts of climate change in tandem with future growth and land development trends.

Each region in Lane County participated separately in two (2) workshops, for a total of six (6) workshops. The workshops were designed specifically for the context and unique characteristics of hazard risk in each region. LCEM facilitated the first of these regional workshops in February 2023 and followed up with the second workshop in April 2023. The following section summarizes the activities, participation, and outcomes resulting from these workshops and how they contributed to the update of the mitigation plan. In total, 68 people participated and contributed to the plan update. Note that the attendee count for all six (6) workshops is 90 since some individuals attended multiple workshops. This fact was most likely if the person worked for Lane County and/or had an interest in connecting individuals in each of the county’s three regions. Table 6.4 summarizes the attendance and dates that the workshops took place.

Table 6.4: Dates of Regional XSP Workshops with Attendee Count

Workshop Date	Region	Attendees
February 7, 2023	Valley	23
February 8, 2023	Coast	13
February 9, 2023	Cascades	11
April 17, 2023	Cascades	27
April 20, 2023	Coast	26
April 26, 2023	Valley	10

Source: Lane County
Emergency Management

Section 6.4.1: Pre-Planning Prior to Workshops

Prior to the first workshops, LCEM spoke with the NHM-SC to establish a baseline for operating and organizing the structure of the regional workshops. This meant drafting a **focal question**, which would guide the thinking of plan participants throughout the XSP process. The NHM-SC discussed an appropriate focal question that would apply to all three (3) planning regions during the January 2023 steering committee meeting. After discussing the objectives of committee members, the NHM-SC produced a statement that served as the focal question:

What strategies can residents and public officials in Lane County implement to protect life and property, safeguard public and private investments, and strengthen community resilience against multiple natural hazards?

Section 6.4.2: Workshop 1 (Identifying Trends and Mitigation Capabilities)

The first of two workshops presented the XSP process to attendees to establish expectations for everyone's time and the objectives in the exercise. LCEM facilitated this workshop with each region and after explaining the process and answering questions about the exercises, presented the focal question to facilitate a discussion about relevant trends affecting Lane County's ability to achieve the three (3) stated objectives in the focal question: 1) protecting life and property, 2) safeguarding private and public investments in development, and 3) becoming resilient against multiple natural hazard types.

Each group first discussed and brainstormed what trends were changing conditions and impacting people's ability to reduce risk long-term in Lane County through mitigation. These trends are referred to as **driving forces of change** (DFCs) and each region identified approximately 14 to 15 DFCs during the workshop. Some trends were similar between regional groups while others were unique to one group. In total, the three (3) regions produced a total of 33 unique trends that were examined along a spectrum of how certain or uncertain participants felt about describing future conditions. Table 6.5 lists the complete DFCs by each group during the three events designated as Workshop 1.



Coast Region Workshop 1 in MNHMP Update Process, February 8, 2023 | Photo: Brendan J. Irsfeld

Table 6.5: Lane County MNHMP Regional Workshop 1, Driving Forces of Change Identified by Regions

Driving Force of Change (DFCs)	Region(s)
Aging Population	All Regions
Limited Transportation Routes	Coast; Cascades
Sheltering Location of Homeless Individuals and Size of Population	All Regions
Decreasing Rate of Vegetation Treatment	Coast
Location of New Development	Coast; Valley
Changing Living Arrangements	Coast
Housing Affordability	Coast; Valley
Net Population Growth	Coast
Dispersing of Population	Coast
Declining Capabilities due to Workforce Skill Drain	Coast; Cascades
Changes in the Natural Environment; Climate Drivers	Coast; Valley
Mandates for Natural Landscape Treatments	Coast
Funding Priorities of Federal Programs; Regulatory Environment	Coast; Valley
Implications of Past Decisions for Placing Infrastructure	Coast
Possession of Precise Measurement Tools for Conditions in Environment	Valley
Unfunded PFAS Mandates	Valley
Habitat Loss, Fragmentation of Landscapes and Ecosystems	Valley
Political Culture Regarding Hazard Mitigation Actions	Valley
Aging Infrastructure and Built Environment	Valley; Cascades
Emphasis of Seismic Retrofitting Projects and Funding Priority	Valley
Self-Generating Electricity	Valley
Increasing Isolation of Residents and Community	Valley
Electricity Dependence	Valley
Alert Capability and Tools	Cascades
Increasing System Dependency	Cascades
Difficulty in Acquiring Materials, Equipment, and Goods	Cascades
Supply Chain Disruptions	Cascades
Cultural Attitudes between Generations	Cascades
Landscape Changes Resulting from Burn Scars	Cascades
State of the Insurance Market with Respect to Covering Hazard Losses	Cascades
State of Community Resiliency	Cascades
Expanding Area Affected by Natural Hazard Events	Cascades
Degree of Burden in Applying and Managing Federal Mitigation Grants	Cascades
Local Fiscal Health and Grant Dependency	Cascades

Source: Lane County Emergency Management

From the trends identified by each group, participants then examined which trends were most critical to advancing mitigation work in the future as well as which trends participants felt most uncertain about estimating future conditions. For example, during the Valley region’s workshop participants identified electricity dependence as driving force of change. They acknowledged this trend to be critically important for mitigating risk from natural hazards in the future but were somewhat uncertain about the overall demand for electricity and the implications of becoming a more electric-dependent society. Through the discussion of the trends identified, each group selected a few trends labeled as either **critical certainties** or **critical uncertainties**. Critical certainties provided insight into the immediate issues facing the region that were often already known trends in the community. Critical uncertainties highlighted the “what if” questions about how future conditions would affect the risk facing Lane County from natural hazards. Table 6.6 lists the trends selected as critically certain or uncertain by each group.

Table 6.6: Lane County MNHMP Workshop 1, Critical Certainties and Uncertainties by Region

	Critical Certainty	Critical Uncertainty
Coast	<ul style="list-style-type: none"> Implications of Past Decisions for Placing Infrastructure Declining Capabilities due to Workforce Skill Drain Aging Population 	<ul style="list-style-type: none"> Funding Priorities of Federal Programs; Regulatory Environment Changes in the Natural Environment; Climate Drivers Sheltering Location of Homeless Individuals and Size of Population Housing Affordability
Valley	<ul style="list-style-type: none"> Net Population Growth Aging Infrastructure and Built Environment 	<ul style="list-style-type: none"> Sheltering Location of Homeless Individuals and Size of Population Political Culture Regarding Hazard Mitigation Actions Changes in the Natural Environment; Climate Drivers Electricity Dependence
Cascades	<ul style="list-style-type: none"> Expanding Area Affected by Natural Hazard Events Supply Chain Disruptions Declining Capabilities due to Workforce Skill Drain Increasing System Interdependency 	<ul style="list-style-type: none"> Long-Term Health Impacts Sheltering Location of Homeless Individuals and Size of Population Local Fiscal Health and Grant Dependency Degree of Burden in Applying and Managing Federal Mitigation Grants State of Community Resiliency

Source: Lane County Emergency Management

To conclude the first workshop participants examined the trends tagged as critical uncertainties and explored how to express them in a way that would help inform the potential future conditions related to hazard risk. A simple example is to take a trend such as **climate drivers** and assign the trend a question with two potential answers: will changes in global climate result in more frequent and severe natural hazards? Using a straightforward yes/no model to organize the details of a potential future allows participants to construct an operating picture to evaluate future conditions.

Though this segment of the workshop was intended to select trends that would be incorporated as a basis for designing scenario narratives used in the second workshop, the resulting outcome of workshop one contributed significantly to vetting the capabilities of both regional partners and Lane County, the findings of which are referenced in the Capability Assessment (see Section 3 in Volume I of this Plan).

Section 6.4.3: Workshop 2 (Identifying Mitigation Priorities and Action Items)

In April 2023, LCEM facilitated a second workshop for each planning region. Traditionally, XSP takes the selected critical uncertainties from the previous workshop and uses them to develop scenario narratives that describe the conditions associated with a potential future. In evaluating this approach for hazard mitigation planning, as well as the time restrictions available in facilitating three (3) individual workshops, LCEM chose to adapt the process and organize the second workshop around examining a few potential natural hazard events rather than potential futures.

Scenario narratives of a credible, severe hazard event were constructed using information from the critical certainties and uncertainties identified in Workshop 1, including the capabilities available in carrying forward mitigation work and initial response. Three (3) scenarios were developed for each planning region. The scenarios were similar in that each covered a likely worst-case situation for the different seasons and geologic hazards that can impact Lane County. Addressing the hazard event rather than simply the natural hazard type allowed LCEM to include cascading impacts and secondary hazards within a single narrative and cover a wider spectrum of impacts identified in the risk assessment.

The scenarios presented were: 1) the impacts of a severe atmospheric river that produces heavy rainfall or snowfall in Lane County during the winter, 2) the outbreak of a wildfire that corresponds to areas of high risk in Lane County as identified in the risk assessment maps of the Community Wildfire Protection Plan (CWPP), and 3) the rupture of the CSZ producing a 9.0 magnitude earthquake.

In groups, participants read the scenario narratives, identified the details that explained existing capabilities and what community lifelines would likely be impacted, as well as other important details such as time of day and time of year the event occurs. After reading the narratives, participants discussed the likely impacts to the region and people to understand what problems would emerge threatening public safety and causing property damage or destruction. Using the list of impacts, participants then discussed what mitigation actions addressed the most severe and cascading impacts produced by each scenario. The second workshop permitted enough time for participants to engage two (2) of the three (3) hazard scenarios.

Workshop handouts were used to capture discussion notes about the impacts likely to occur during each scenario as well as the appropriate mitigation action. The worksheets helped LCEM and the planning team identify priority mitigation needs and address capability gaps through action items. Workshop 2 most contributed to the mitigation strategy through identifying action items specific to both City and Utility partners but also Lane County from a regional perspective. Table 6.7 provides a few examples of mitigation action items included in the update of this Plan that resulted from Workshop 2.

Table 6.7: Examples of Action Items Resulting from XSP Workshop 2

Action Item	Region
O1.2: Seismic Hardening of Railroad Tracks at Lowell & Jasper Road	Cascades
O1.4: Row River Road Bridge Retrofit	Valley
O2.1: Develop Renewable Energy Systems and Storage Capacity for County Facilities	All Regions
O3.1: Regional Island Mapping Study	Coast
O4.1: Resilience Hub Site and Suitability Analysis Study	All Regions

Source: Lane County Emergency Management

Through the XSP approach and designing a process centering the unique characteristics of each region allowed participants to recognize mitigation actions that would produce the most widespread benefit. Additionally, specific, localized needs with respect to hardening infrastructure were also identified through the regional approach. LCEM and plan participants will also explore how this technique can be further adapted and deployed as part of a broader public engagement effort.

VOLUME II: CITY AND UTILITY PARTICIPANT ANNEXES

Table of Contents

- Section 1: City of Coburg 7
 - Section 1.1: City of Coburg: Natural Hazard Mitigation Meetings and Work Sessions..... 8
 - Section 1.2: City of Coburg: Hazard Quantification..... 9
 - Section 1.2.1: Individual Hazard Discussions..... 9
 - Section 1.3: City of Coburg: Mitigation Action Items 13
 - Section 1.4: Plan Implementation and Maintenance..... 15
- Section 2: City of Creswell 17
 - Section 2.1: City of Creswell: Natural Hazard Mitigation Meetings and Work Sessions..... 18
 - Section 2.2: City of Creswell: Hazard Quantification Results 19
 - Section 2.2.1: Individual Hazard Discussions..... 19
 - Section 2.3: City of Creswell: Mitigation Projects 24
 - Section 2.4: Plan Implementation and Maintenance..... 29
- Section 3: City of Dunes City..... 30
 - Section 3.1: Dunes City: Natural Hazard Mitigation Meetings and Work Sessions 31
 - Section 3.2: Dunes City: Hazard Quantification 32
 - Section 3.2.1: Individual Hazard Discussion 32
 - Section 3.2.2: Dunes City: Mitigation Projects 37
 - Section 3.3: Plan Implementation and Maintenance..... 42
- Section 4: City of Florence..... 43
 - Section 4.1: City of Florence: Natural Hazard Mitigation Meetings and Work Sessions 44
 - Section 4.2: Florence Hazard Quantification Results 45
 - Section 4.2.1: Individual Hazard Discussions..... 45
 - Section 4.3: City of Florence: Mitigation Projects 53
 - Section 4.4: Plan Implementation and Maintenance..... 59
- Section 5: City of Lowell 60
 - Section 5.1: City of Lowell: Natural Hazard Mitigation Meetings and Work Sessions 61
 - Section 5.2: City of Lowell: Hazard Quantification 62
 - Section 5.2.1: Individual Hazard Discussions..... 62
 - Section 5.3: City of Lowell: Mitigation Projects..... 65
 - Section 5.4: Plan Implementation and Maintenance..... 67

Section 6: City of Oakridge 68

 Section 6.1: City of Oakridge: Natural Hazard Mitigation Meetings and Work Sessions..... 69

 Section 6.2: City of Oakridge: Hazard Quantification..... 71

 Section 6.2.1: Individual Hazard Discussions..... 71

 Section 6.3: City of Oakridge: Mitigation Projects 75

 Section 6.4: Plan Implementation and Maintenance..... 83

Section 7: City of Veneta 84

 Section 7.1: City of Veneta: Natural Hazard Mitigation Meetings and Work Sessions..... 85

 Section 7.2: City of Veneta: Hazard Quantification..... 86

 Section 7.2.1: Individual Hazard Discussions..... 86

 Section 7.3: City of Veneta: Mitigation Projects 90

 Section 7.4: City of Veneta: Plan Implementation and Maintenance..... 90

Section 8: City of Westfir..... 91

 Section 8.1: City of Westfir: Natural Hazard Mitigation Meetings and Work Sessions 92

 Section 8.2: City of Westfir: Hazard Quantification 93

 Section 8.2.1: Individual Hazard Discussions..... 93

 Section 8.3: City of Westfir: Mitigation Projects 97

 Section 8.4: City of Westfir: Plan Implementation and Maintenance..... 99

Section 9: Blachly-Lane Electric Co-op 100

 Section 9.1: Profile of Blachly Lane-Electric Co-op..... 101

 Section 9.2: Applicable Regulations, Plans..... 103

 Section 9.3: Natural Hazard Mitigation Meetings and Work Sessions..... 104

 Section 9.4: Jurisdiction Specific Natural Hazard History..... 105

 Section 9.4.1: Individual Hazard Discussions..... 105

 Section 9.5: Mitigation Projects 106

 Section 9.6: Plan Implementation and Maintenance..... 108

 Section 9.6.1: Future Needs 109

Section 10: Consumers Power Inc. 110

 Section 10.1: Consumers Power, Inc. Jurisdictional Profile 111

 Section 10.2: Natural Hazard Mitigation Meetings and Work Sessions..... 112

 Section 10.3: Consumers Power, Inc. Hazard Quantification..... 112

 Section 10.3.1: Individual Hazard Discussions..... 113

 Section 10.4: Consumers Power, Inc. Mitigation Projects 115

Section 11: Emerald People’s Utility District 118

 Section 11.1: Emerald People’s Utility District Jurisdictional Profile 119

 Section 11.2: Applicable Regulations, Plans 121

 Section 11.3: Natural Hazard Mitigation Meetings and Work Sessions 122

 Section 11.4: Emerald People’s Utility District Hazard Quantification 123

 Section 11.4.1: Individual Hazard Discussions 123

 Section 11.5: Mitigation Projects 126

 Section 11.6: Progress on Mitigation Actions 127

List of Tables

Table 1.1: Planning Team for City of Coburg	8
Table 1.2: Individual Work Sessions for City of Coburg.....	8
Table 1.3: Coburg Hazard Quantification Results, Local Risk Assessment	9
Table 2.1: City of Creswell Planning Team	18
Table 2.2: City of Creswell Work Sessions	18
Table 2.3: City of Creswell Hazard Quantification Results	19
Table 2.4: Land Use Designations per Flood Zone, City of Creswell	20
Table 3.1: City of Dunes City Planning Team	31
Table 3.2: City of Dunes City Work Sessions	31
Table 3.3: Dunes City Hazard Quantification Results	32
Table 4.1: City of Florence Planning Team.....	44
Table 4.2: City of Florence Work Sessions	44
Table 4.3: Florence Hazard Quantification Results.....	45
Table 5.1: City of Lowell Planning Team	61
Table 5.2: City of Lowell Work Sessions.....	61
Table 5.3: Lowell Hazard Quantification Results	62
Table 6.1: City of Oakridge Planning Team	69
Table 6.2: City of Oakridge Work Sessions	69
Table 6.3: Oakridge Hazard Quantification Results.....	71
Table 7.1: City of Veneta Planning Team	85
Table 7.2: City of Veneta Work Sessions.....	85
Table 7.3: Veneta Hazard Quantification Results.....	86
Table 8.1: City of Westfir Planning Team.....	92
Table 8.2: City of Westfir Work Sessions	92
Table 8.3: Westfir Hazard Quantification Results.....	93
Table 9.1: Blachly-Lane Electric Co-op Planning Team	104
Table 9.2: Blachly-Lane Electric Co-op Work Sessions.....	104
Table 9.3: Blachly-Lane Electric Co-op Hazard Quantification Results	105
Table 10.1: Major Assets owned by Consumers Power, Inc.	111
Table 10.2: Consumers Power, Inc. Planning Team.....	112
Table 10.3: Consumers Power, Inc. Work Sessions	112
Table 10.4: Consumers Power, Inc. Hazard Quantification Results	112
Table 11.1: Emerald People’s Utility District Summary Statistics with changes since 2016	119
Table 11.2: District Owned Facilities, EPUD.....	120
Table 11.3: Emerald People’s Utility District Planning Team	122
Table 11.4: Emerald People’s Utility District Work Sessions	122
Table 11.5: Emerald People’s Utility District Hazard Quantification Results	123

List of Figures

Figure 9.1: Blachly-Lane Service Territory, Transmission, and Primary Feeder Map 101
Figure 11.1: Substations and District Owned Buildings in Service Area 120

Section 1: City of Coburg



Version 4.0 (October 2023 – October 2028)

Developed as an annex to the Lane County Multi-Jurisdictional
Natural Hazard Mitigation Plan

Section 1.1: City of Coburg: Natural Hazard Mitigation Meetings and Work Sessions

Development of the City of Coburg’s materials for the Natural Hazard Mitigation Plan involved participation by city staff, public works, school district, county emergency management, fire district, and law enforcement. The process followed FEMA’s prescribed model for organizing resources, identifying hazards, evaluating risk, identifying mitigation options, and prioritizing mitigation projects. For additional details regarding the planning process, please refer to Section 6 of Volume I.

Table 1.1: Planning Team for City of Coburg

Title	Contact number	Agency
Mayor	541-682-7850	City of Coburg
City Administrator	541-682-7871	City of Coburg
Chief of Police	541-682-7853	City of Coburg
Coburg Rural Fire District Chief	541-686-1573	Coburg Rural Fire District
Coburg Public Works Director	541-682-7857	City of Coburg
Emergency Management Coordinator	541-682-7850	City of Coburg

Individual City Work Sessions

Work sessions with individual cities were conducted following the initial project orientation meeting and intervening months between general planning group meetings. These individual work sessions are outlined below.

Table 1.2: Individual Work Sessions for City of Coburg

Date	Location	Meeting/Work Session
02/22/2023	City Hall	Distribute existing Annex plan to group for input
03/13/2023	City Hall	Group reviewed and updated project scopes.
05/04/2023	City Hall	Meeting with Hannah Shafer for hazard quantification process

Subject matter discussed during work sessions included an overview of the plan and projects that are in the existing plan. This resulted in the evaluation and removal of some projects on the original plan. It also allowed the group to decide what remaining projects would be updated with the new cost associated with them. Systems and concepts considered included infrastructure resiliency, transportation network, city planning, floodplain management, public safety, public and private facilities.

Section 1.2: City of Coburg: Hazard Quantification

The following table summarizes hazard quantification results, followed by a discussion of Coburg’s local risk profile for each hazard.

Table 1.3: Coburg Hazard Quantification Results, Local Risk Assessment

Hazard Type / Weight Factor (WF)	History WF x 2	Probability WF x 7	Vulnerability WF x 5	Maximum Threat WF x 10	Raw Score	Weighted Score	Weighted Score Rank
Winter Storm	8	9	8	10	35	219	1
Extreme Weather	8	9	8	8	33	199	2
Earthquake	3	4	10	10	27	184	3
Windstorm	8	8	8	5	29	162	4
Flood	2	4	8	5	19	122	5
Drought	0	5	3	7	15	120	6
Volcano	0	2	2	1	5	34	7
Landslide	0	1	3	2	4	30	8
Wildfire	0	0	2	1	3	20	9

Source: City of Coburg Natural Hazard Mitigation Team

Section 1.2.1: Individual Hazard Discussions

Nine (9) natural hazards were elevated posing some degree of risk to the City of Coburg.

Winter Storm

December 5, 2016, a localized sleet storm resulted in 14 traffic accidents on I-5 near Coburg. The series of individual incidents unfolded over a 45-minute timeframe resulting in virtual closure of the interstate for approximately 2 hours. Minor injuries reported. Winter storms resulting in snow or ice storms on the floor of the Willamette Valley in Lane County have occurred in 1950, 1968, 1969, 1971, 1989, 1993, 1996, 1997, 2001, 2003, 2004, 2005, 2008, and 2010, and 2019. These events generally fall into two categories, events of snow and ice at low elevation due to very cold air trapped at the surface, and regional cold air systems. Most events seeing snow and ice on the valley floor are created by cold air trapped at the surface, with warmer, moister air at elevation. These events often occur as rain events at higher elevations.

Like most cities Coburg contains an extensive network of above ground electrical lines vulnerable to damage from falling limbs and trees during winter storms. Recent history has been frequent including notable damage and power loss in 2014 and 2015. The February 2014 storm caused a power outage that lasted three days. Wind is often a contributing factor in winter storms. A warming center has been established in Eugene to provide shelter for vulnerable populations in cold weather. Probability is considered high that patterns of previous occurrence will continue. Overall

population potentially affected by winter storm is high since effects are not geographically contained. Transportation and roadways are vulnerable to closure during winter storms, though the city benefits from primarily level terrain. Maximum threat is high however due to threat of structural damage directly related to winter weather (cold, snow, ice), and difficulty in accessing needed public services. See also winter storm hazard profile in Section 3 of the main document.

Extreme Weather

Extreme weather is a new natural hazard included in the Lane County MNHMP. Recent occurrences of heat waves in Coburg demonstrate the potential for it to be a reoccurring and life-threatening hazard. Extreme heat describes either a singular instance of dangerous temperatures occurring on a given day or a prolonged period of high temperatures over several days, typically if temperatures exceed a heat index of 90 degrees Fahrenheit. Coburg presents increased risk of extreme heat due to its geographic location in the Willamette Valley, where air settles between the Coast and the Cascade ranges and becomes stagnant. In recent years, the valley region experienced temperatures between 90 and 100 degrees. History, probability, vulnerability, and maximum threat are all high due to these factors. See Section 3 of the main document for detailed history of extreme heat.

Earthquake

Earthquake is somewhat unique as it occurs much less frequently but has potential for significant damage and disruption. From a geographic standpoint, occurrence would presumably affect the entire city uniformly. History of occurrence dates back over long-time scales, with the most recent (minor) event occurring in Sweet Home, which is 37 miles northeast of Coburg. On October 5th, 2022, a 4.4 magnitude earthquake occurred in Sweet Home. Only a few residents in the Coburg/Eugene area felt shaking and no damage or injuries were reported. Considered at a different scale, a Cascadia Subduction Zone Earthquake event is a very large, Pacific Northwest Region event, due to a 600-mile-long subduction zone fault line approximately 70 miles off the Oregon Coast. While the source of this earthquake is quite distant to Coburg, the magnitude and scope of this hazard will impact the entire State of Oregon from the Coast to the Cascades.

Probability is low in any given year. Vulnerability is complex to assess due to varying standards of construction, but newer construction is considered relatively sound. Maximum threat is expected to involve minor-moderate damage to numerous structures. Importance of resiliency of infrastructure is notable. See also earthquake profile in Section 3 of the main document.

Windstorm

Like winter storms, windstorms can frequently impact above ground electrical lines vulnerable to damage from falling limbs and trees. For Lane County at large, the two-year interval sustained wind speeds range from about 37 to 47 miles per hour, generally too low to cause significant damages. The 50-year occurrence wind speeds range from 62 to 75 miles per hour. These more damaging windstorms can be expected in intervals averaging a few decades. The windstorm in February 2002 snapped 30 to 40 powerlines, impacting residents and businesses in the city.

Probability is considered high that patterns of previous occurrence will continue. Overall vulnerability is considered high; roadways are notably vulnerable to closure, like winter storms due to falling limbs, trees, and snapped powerlines. The Columbus Day storm of 1962 can serve as an example for maximum threat, with winds measured at 86 mph in Eugene and presumably similar in

Coburg. A windstorm of similar magnitude to the Columbus Day Storm could potentially damage numerous of homes and businesses in city, either by direct structural damage, falling trees, or wind-blown debris. Due to its location on eastern slope of the Coburg foothills the city may have a slight protective factor from extreme wind as compared to fully exposed areas. See also windstorm hazard profile in Section 2 of the main document.

Flood

Flood is a geographically contained hazard and widespread impacts in Coburg are unlikely. Neighborhood flooding issues can be found to the south and southwest of the city, though most of the potentially affected land is primarily used as agricultural land. History of flooding is low, future probability is moderate. Overall vulnerability is high as the floodplain boundary is within the corporate city boundary in the SW corner of the city. This includes the area of Abby Road where several residential homes have been built. Maximum threat scores are somewhat lower than the vulnerability due to elevation changes moving to the north and west, and the land is currently being used for agricultural purposes with fewer impacts to residents. Coburg Bottom Loop Road is frequently inundated per reports from local Police and Fire departments. This, and other anecdotal reporting, leads to the conclusion that the current (1999) Flood Maps of the area may be inaccurate and in need of updating. See also flood hazard profile in Section 2 of Volume I.

National Flood Insurance Program

The City of Coburg is a formal program participant in good standing and considers continued participation as integral to future flood mitigation efforts. Participation consists of adoption and maintenance of Flood Insurance Rate Maps (FIRMs) which define Special Flood Hazard Areas (SFHAs) and maintenance of an ordinance regulating future development in SFHAs. The Flood Insurance Rate Map Community Number for Coburg is 410119. Compliance with the program is pursuant to the City of Coburg's floodplain ordinance.

Statistics as reported by FEMA on the NFIP Bureau Net for the period of January 1, 1978, through January 1, 2023, are as follows:

NFIP Policies in Force

Policies in Force: **9**

Insurance in Force: **\$ 3,280,000**

Premium in Force: **\$ 4,661**

Insurance Claim Data

Total Losses: 3

Closed Losses: 3

Open Losses: 0

CWOP Losses: 0

Total Payments: \$ 7,301

Data Definitions

Policies in Force – Policies in force on the "as of" date of the report.

Insurance in Force – The coverage amounts for policies in force.

Written Premium in Force – The premium paid for policies in force.

Total losses – All losses submitted regardless of the status.

Closed losses – Losses that have been paid.

Open losses – Losses that have not been paid in full.

CWOP losses – Losses that have been closed without payment.

Total Payments – Total amount paid on losses.

Drought

Drought is neither life threatening nor presents a direct risk to structures but does involve potential for significant disruption if dramatic water shortage were to develop. Drought can exacerbate wildfire risk as related hazards, and a water shortage would likely affect the entire city uniformly. History and probability are considered relatively low. Vulnerability is relatively low as Coburg is close to two major sources of water, the Willamette and McKenzie Rivers, helping to maintain redundancy to its water supply network. Maximum threat is moderate if an event occurred where all water supply systems go were to become inoperable or water supply unexpectedly ran short. See also drought profile in Section 3 of the main document.

Volcano

Volcano is like earthquake in that it occurs very infrequently. Coburg is situated approximately 60 miles from the closest volcano source, far enough to minimize probable impacts to minor ash-fall across the city if wind patterns allow. History, probability, and vulnerability are relatively low, maximum threat is also considered low. See also volcano profile in Section 2 of the main document.

Landslide

Landslide is considered to have very low history, probability, and vulnerability rankings, as the majority of Coburg is situated on level terrain. Maximum threat is similarly low. Coburg, due to its flat terrain, may be susceptible to liquefaction hazard in the event of an earthquake centered nearby, or more potentially in a Cascadia Earthquake event. See also landslide profile in Section 2 of Volume I.

Wildfire

Coburg is home to the Coburg Fire Department, a member of the Lane County Fire Defense Board. The Urban Wildfire interface is not significant in the city due to the fact it is situated in an agricultural farmland use area. Grassfires do occur, and orchards area located near the city. However, this has not been a significant hazard in the past, leading to the very low historical scoring. Probability, vulnerability, and maximum threat are all similarly low. It must be noted however, there is currently no fire suppression east of I-5, east of the city. See also wildfire hazard profile in Section 2 of Volume I.

New Development in Hazard Areas



There was significant growth in housing units for the period. Areas on west side of the city are designated as Special Flood Hazard Areas and there was no development in these areas. Much of the newest construction is in urbanized areas with adequate drainage and floor elevations to mitigate potential flooding impacts. Recent development is also located away from steep slopes with proper construction techniques to mitigate seismic and landslide factors. For new development the potential for wildfire impacts is relatively low, and enforcement of building codes makes major wind impacts a generally negligible concern.

Section 1.3: City of Coburg: Mitigation Action Items

This section describes mitigation projects identified by Coburg during the planning process. See Section 4 of Volume I for additional information regarding mitigation action item methodology and prioritization.

Mitigation Action Item (a)	Retrofit or replace existing 500,000-gallon water supply tanks for seismic and flood mitigation. Install additional 750,000-gallon elevated reservoir for fire suppression and general resiliency.
Location	TBD
Coordinating Agencies	Coburg Public Works
Implementation Timeframe	18-24 months
Estimated Cost	est. \$10.2 million (Tank Rehabilitation \$2.2 million, 750K Gallon Elevated Reservoir \$8 million)
Potential Funding Sources	HUD-CDBG, OR-SRGP, HMGP, PDM, FEMA PA-106,
Hazards Mitigated	Earthquake, Urban Fire
Comments	Seismic rehabilitation – Existing Water Tanks Installation of new elevated reservoir
Current Site Photos	

Mitigation Action Item (b)	City Hall Seismic Assessment
Location	City Hall
Coordinating Agencies	Coburg Public Works, City Council
Implementation Timeframe	12-months
Estimated Cost	\$45,000 - \$75,000
Potential Funding Sources	HUD-CDBG, OR-SRGP, HMGP, PDM, FEMA PA-106
Hazards Mitigated	Structural damage prevention
Comments	Assessment for Seismic rating
Current Site Photos	

Mitigation Action Item (c)	Enhancements for Community Emergency Center
Location	City Hall
Coordinating Agencies	Coburg Public Works, City Council
Implementation Timeframe	12-18 months
Estimated Cost	\$200,000
Potential Funding Sources	HUD-CDBG, OR-SRGP, HMGP, PDM, FEMA PA-106
Hazards Mitigated	Public safety, heating/cooling center, clean air center
Comments	Upgrade the air handling units and facility to provide a reliable heating/cooling center, clean air center, and shelter during extreme weather events.
Current Site Photos	 

Mitigation Action Item (d)	Storm hardening for a community staging area/shelter. City Park upgrades, installation of a restroom to serve as sheltering/staging area in the park.
Location	Coburg City Park (Pavilion Park)
Coordinating Agencies	Coburg Public Works
Implementation Timeframe	12 – 18 Months
Estimated Cost	\$185,000
Potential Funding Sources	HUD-CDBG, OR-SRGP, HMGP, PDM, FEMA PA-106,
Hazards Mitigated	Earthquake, flood, winter storm, windstorm. dam failure, hazmat incident
Comments	Installation of a restroom and providing a staging/shelter area for community.
Current Site Photos	 

Mitigation Action Item (f)	Stormwater Master Plan
Location	City of Coburg
Coordinating Agencies	Coburg Public Works
Implementation Timeframe	12 months
Estimated Cost	\$60,000
Potential Funding Sources	FEMA HMA
Hazards Mitigated	Flood, earthquake, HazMat incident
Comments	Deliberate planning enables funding and project opportunities that will help to check Stormwater runoff and treat it before it enters nearby waterways. Promotes innovative land use practices and city programs that over time improve water quality. Planning to increase the planting of appropriate trees, open spaces, wetlands, and vegetated planters benefits the community through cost-effective practices, increasing property values, and increasing revenues from tourism.

Section 1.4: Plan Implementation and Maintenance

In keeping with standard practices to ensure incorporation of overall goals and strategies of the Natural Hazard Mitigation Plan, the City of Coburg natural hazard mitigation team members will be invited to participate in future plan development or existing plan update committees. Additionally, this Natural Hazard Mitigation Plan will be cited as a technical reference for future plan update processes. Planning documents and mechanisms applicable to this process may include the following:

City of Coburg Comprehensive Plan

Capital Improvement Plans

Emergency Management Plan**City of Coburg Floodplain Development Ordinance****Building Code****Subdivision Code****Erosion Control****Stormwater Management Plan**

Additionally, progress to implement this plan will be monitored on an ongoing basis by city staff and administration. The planning process is essential in identifying weaknesses and strengths inherent in the community, and cooperatively enables coordination with various agencies and jurisdictions that might not otherwise occur. Continuing this cooperative and interactive process is exemplified by the planning process. Annual reviews and updates under a 5-year cycle will be pursued. Using these methods, the overarching goal of a stronger, safer, more resilient community can be attained.

Section 2: City of Creswell

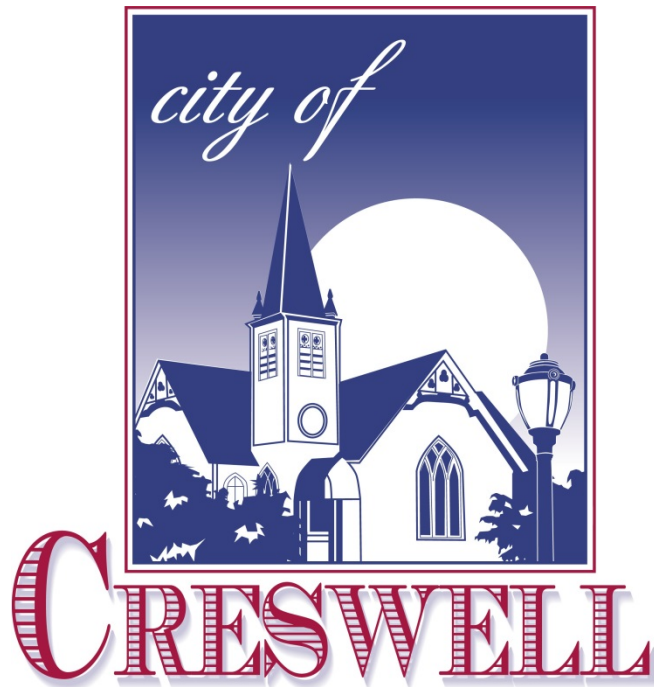

Version 4.0 (October 2023 – October 2028)

Developed as an annex to the Lane County Multi-Jurisdictional
Natural Hazard Mitigation Plan

Section 2.1: City of Creswell: Natural Hazard Mitigation Meetings and Work Sessions

Development of the City of Creswell’s materials for the Natural Hazard Mitigation Plan involved participation by city staff, public works, airport, school district, library, county emergency management, fire district, and law enforcement. The process followed FEMA’s prescribed model for organizing resources, identifying hazards, evaluating risk, identifying mitigation options, and prioritizing mitigation projects. For additional details regarding the planning process, please refer to Section 6 of Volume I.

Table 2.1: City of Creswell Planning Team

Name	Title	Agency
Curtis Thomas	Planner	City of Creswell
Cliff Bellew	Public Works Director	City of Creswell
Michelle Amberg	City Manager	City of Creswell
Shelley Humble	Airport Manager	City of Creswell
Danny Solesbee	Fire Marshal	South Lane Fire & Rescue
Joel Higdon	Director of Facilities	Creswell School District 40

Individual City Work Sessions

Work sessions with individual cities were conducted following the initial project orientation meeting and intervening months between general planning group meetings. These individual work sessions are outlined below.

Table 2.2: City of Creswell Work Sessions

Date	Location	Meeting/Work Session
11/28/2022	Remote	Lane County Steering Committee Meeting
01/23/2023	Remote	Lane County Steering Committee Meeting
02/07/2023	Eugene, LC Office	XSP Valley Region Workshop 1
03/02/2023	Remote	Meeting – Hannah Shafer & Curtis Thomas
03/13/2023	Remote	Lane County Steering Committee Meeting
04/26/2023	Eugene, LC Office	XSP Valley Region Workshop 2

Subject matter discussed included an overview of FEMA grant programs, discussion of common mitigation ideas, and specific project ideas for the City of Creswell. The result of this overall process was a thorough evaluation of risk factors and mitigation solutions. Certain hazards were highlighted with notable significance for Creswell, others found to be less relevant in a direct context. Systems and concepts considered included infrastructure resiliency, transportation network, city planning, floodplain management, public safety, and public and private facilities. A range of both general and specific mitigation ideas and projects were identified and scoped in the field.

Section 2.2: City of Creswell: Hazard Quantification Results

The Creswell planning team determined that winter storms and windstorms represent the most relatively high-risk natural hazards to the community. Flood, earthquake, landslides, and wildfires rated as moderate hazards while drought and volcano were rated lowest risk.

Table 2.3: City of Creswell Hazard Quantification Results

Hazard Type / Weight Factor (WF)	History WF x 2	Probability WF x 7	Vulnerability WF x 5	Maximum Threat WF x 10	Raw Score	Weighted Score	Weighted Score Rank
Winter Storm	9	10	10	10	39	238	1
Windstorm	10	10	8	10	38	230	2
Flood	5	6	7	7	25	157	3
Earthquake	0	2	6	10	18	144	4
Landslide	1	3	3	10	17	138	5
Wildfire	10	10	2	3	25	130	6
Drought	3	5	2	6	16	111	7
Volcano	2	2	2	4	10	68	8

Source: Creswell Natural Hazard Mitigation Team

Section 2.2.1: Individual Hazard Discussions

The City of Creswell evaluated eight (8) natural hazards that can impact the community. Details about specific risk areas or vulnerabilities is contained in the following sections.

Winter Storm

Winter storm involves a relatively frequent pattern of occurrence and produces transportation disruptions and electrical grid impacts. Icy roads, falling limbs and trees during winter storms are most common impacts. Probability is considered high that patterns of previous occurrence will continue.

Winter storm affects broad geographic regions and therefore population numbers potentially affected by winter storm. Creswell benefits from primarily level terrain with exception of southern portion of the city. Maximum threat is considered high, based on potential damage to roof structures resulting from heavy snow, falling trees, extended travel and power disruption, and severe cold which could pose public safety risk. See also winter storm hazard profile in Section 2 of Volume I.

Windstorm

Creswell is in a semi-exposed valley south of Camas Swale where winds can be channeled between Coast Range foothills to the west and Cascade Range foothills to the east. Many of the windstorm events described in the main document profile affected central Lane County including Creswell, with the most severe event occurring in October 1962 (Columbus Day Storm), which carried +85mph winds across the general area and resulted in widespread damage.

In addition to windstorm events described in the main document profile, rotational winds (tornados) have occurred in Creswell and in surrounding area.

Notably on December 2, 1999, eyewitnesses reported shingles and other debris lifted 200 feet into the air by a tornado. Four roofs were damaged, one tree uprooted, and a mill slash burner was tipped over according to a report by the National Weather Service. There was one unconfirmed injury and damages estimated at over \$10,000. Other rotational windstorms in the general Creswell vicinity include events in 2015 (LCC area), and 1989.

Windstorm frequently impacts above ground electrical lines vulnerable to damage from falling limbs and trees. Probability is considered high based on patterns of previous occurrence. Overall vulnerability is considered moderate-high, according to assessments of total population potentially affected.

In the intervening period since the Columbus Day Storm of 1962 overall strength and wind resilience of building stock has improved in general terms. Wind driven debris is another potential hazard related to windstorm, particularly sheet metal and tree limbs, and therefore areas surrounding industrial and agricultural operations, as well as areas of forest fringe have somewhat higher vulnerability of impact.

Overall maximum threat assessment for windstorm is considered in the upper tier of potential hazards along with winter storm and hazardous materials incident. See also windstorm hazard profile in Section 2 of Volume I.

Flood

Flooding received the 3rd highest weighted hazard quantification score, with moderate-high scores for history, probability, vulnerability, and maximum threat. Eastern portions of the city are in mapped floodplains of the Coast Fork Willamette River based on Flood Insurance Rate Maps for Creswell (FIRM 410421-1661F). Residential areas and a golf course are in this proximity. According to analysis by LCOG in 2007 Natural Hazards Mitigation Study for Creswell, over 26.8 acres of land was located in areas defined as Floodway on FEMA Flood Insurance Rate Maps, and 211.4 acres defined as 100-Year Floodplain. The following table excerpted from the Natural Hazards Mitigation Study shows a breakdown of various land use designations per flood zone.

Table 2.4: Land Use Designations per Flood Zone, City of Creswell

Plan Designation	Acres in Floodway	Acres in 100-Year Floodplain
Undesignated	0	10.2
Commercial	8.1	96
Industrial	0	109.7
Park, Open Space	0.5	36.4
Public Facilities/Government	0	2.2
Residential	18.2	46.9
TOTAL	26.8	211.4

Source: LCOG, City of Creswell Natural Hazards Mitigation Study (2007) Note: Acreage totals reported above do not account for LOMR 15-10-1143P effective 1/15/2016 and LOMR 16-10-041 5X effective 7/5/2016.

Notably, in January and July of 2016 Letters of Map Revision (LOMRs) modified regulatory floodplain designations for residential neighborhoods in eastern Creswell. The vicinity of Hill Creek at Park Drive is designated 100-year floodplain, and to the north of the city Camas Swale Creek is another potential flooding source which can disrupt travel to and from the city on Hwy 99. Overall vulnerability for Creswell and maximum threat scores are moderated by central and western portions with lower susceptibility to flooding. See also flood hazard profile in Section 2 of Volume I.

National Flood Insurance Program

The City of Creswell is a formal program participant in good standing and considers continued participation as integral to future flood mitigation efforts. Participation consists of adoption and maintenance of Flood Insurance Rate Maps (FIRMs) which define Special Flood Hazard Areas (SFHAs) and maintenance of an ordinance regulating future development in SFHAs. The Flood Insurance Rate Map Community Number for Creswell is 410121. Compliance with the program is pursuant to the City of Creswell's floodplain ordinance.

Statistics as reported by FEMA on the NFIP Bureau Net for the period of January 1, 1978, through January 1, 2023, are as follows:

NFIP Policies in Force

Policies in Force: **25**

Insurance in Force: **\$ 7,160,500**

Premium in Force: **\$ 12,022**

Insurance Claim Data

There are no reported claims for the City of Creswell

Data Definitions

Policies In Force – Policies in force on the "as of" date of the report.

Insurance In Force – The coverage amount for policies in force.

Written Premium in Force – The premium paid for policies in force.

Earthquake

Earthquake is somewhat unique as it occurs much less frequently but has potential for significant damage and disruption. History of occurrence dates back over long time scales, and therefore probability is low in any given year. From a geographic standpoint occurrence would presumably affect the entire city uniformly. Oregon Department of Geology and Mineral Industries assessed seismic vulnerability in 2006-2007 for public buildings in Creswell. The project entailed visual observation, basic analysis of structures and soil types. Findings included 'High' and 'Very High' collapse potential for certain structures based on FEMA-154 classifications. Newer buildings and constructed to buildings codes is considered comparatively sound.

Maximum threat is expected to involve significant damage to some structures and minor-moderate damage to numerous structures. See also earthquake profile in Section 2 of Volume I.

Landslide

Weighted hazard quantification score for landslide was 5th highest out of 8 hazard types evaluated. Landslide risk for Creswell is primarily contained to the southern portion of the city on slopes of Creswell Butte. The remainder of the city benefits from primarily level terrain. Infrastructure could be affected in the event of landslide at Creswell Butte, which is most likely to occur in potential combined scenario initiated by earthquake. See also landslide profile in Section 2 of Volume I.

Wildfire

Creswell benefits from relatively small proportion of assets in forested wildland-urban interface. Primary risk factors for wildfire are forested areas in the southern portion of Creswell near Creswell Butte. Grass fire potential is also present in urban-agricultural transition areas primarily west and north of city limits.

The hazard mitigation team notes wildfires have occurred and are retain probability for future occurrence. Vulnerability is moderated by response capability, and maximum threat is relatively low. Smoke from distant wildfires is a notable factor. See also wildfire hazard profile in Section 2 of Volume I.

Drought

Drought is neither life threatening nor presents a direct risk to structures but does involve potential for significant disruption if dramatic water shortage were to develop. Drought can exacerbate wildfire risk as related hazards, and a water shortage would likely affect the entire city uniformly. History and probability are considered relatively low. Vulnerability is relatively low. Maximum threat is moderate. See also drought profile in Section 2 of Volume I.

Volcano

Volcano is similar to earthquake in that it occurs very infrequently. Creswell is situated approximately 50-60 miles from the closest volcano source, far enough to limit potential impacts to minor ash-fall across the city if wind patterns allow. History, probability, and vulnerability are relatively low, maximum threat considered moderate. See also volcano profile in Section 2 of Volume I.

New Development in Hazard Areas

Compared to other small cities in Lane County, Creswell has experienced a high amount of growth. Creswell has been informally designated as a bedroom community to Eugene and Springfield as 75% of Creswell residents commute north every day. The Metro's pressure for housing is shared in Creswell. Within Hazard areas, Creswell has seen growth on the East side of the city, which is also within the floodplain. As FEMA remaps the flood hazards, some of the homes will be redesignated for being in the 100-year floodway. In addition, there is a subdivision proposed North of the Creswell Butte, and the homes are vulnerable to landslide risk.

Critical Facilities: Those facilities and infrastructure necessary for emergency response efforts.

- City Hall
- Creswell Community Center
- Creswell Fire Station
- City Public Works Shop
- Creswell Airport
- Water Treatment Facility
- Wastewater Treatment Plant
- Sheriff's Office
- Recreation Center (note: currently the building is vacant)

Essential Facilities: Those facilities and infrastructure that supplement response efforts.

- Creswell High School
- Creslane Elementary School
- Creswell Middle School
- LTD Park and Ride
- Creswell Recreation Center
- Creswell Library
- Creswell Clinic (PeaceHealth)
- Creswell Post Office

Vulnerable Populations: Locations serving populations that have special needs or require special consideration.

- South Willamette Veterinary Clinic
- Creswell Veterinary Hospital
- Creswell Care Center
- Creswell Christian Child Care Center
- Growing Place Pre-School and Child Center
- Head Start of Lane County
- Over in the Meadow Child Care Center
- Cresview Villa
- Awesome Care Inc. (outside Urban Growth Boundary)
- Class 2 Adult Foster Care: Mi Casa es Su Casa, Kilwien Residential Care Home, Porch Sitters Manor, Luthe's Adult Foster Care, Avalon House

Section 2.3: City of Creswell: Mitigation Projects

This section describes mitigation projects identified by the City of Creswell during the planning process. See section four of the main document for additional information regarding mitigation action item methodology and prioritization.

Mitigation Action Item (a)	Water Tank Anchoring
Location	43.9110N, -123.0255W
Coordinating Agencies	Creswell Public Works Department
Implementation Timeframe	36 months
Estimated Cost	est. \$400,000
Potential Funding Sources	BRIC, HUD-CDBG, OR-SRGP, HMGP, PDM, FEMA PA-106,
Hazards Mitigated	Earthquake, Landslide
Comments	FEMA is currently reviewing Creswell’s 2022 application.



Mitigation Action Item (b)	Connection to Transmission Line
Location	43.9110000; -123.0255000
Coordinating Agencies	Creswell Public Works Department
Implementation Timeframe	36 months
Estimated Cost	est. \$200,000
Potential Funding Sources	BRIC, HUD-CDBG, OR-SRGP, HMGP, PDM, FEMA PA-106,
Hazards Mitigated	Earthquake, Landslide
Comments	FEMA is currently reviewing Creswell’s 2022 application.

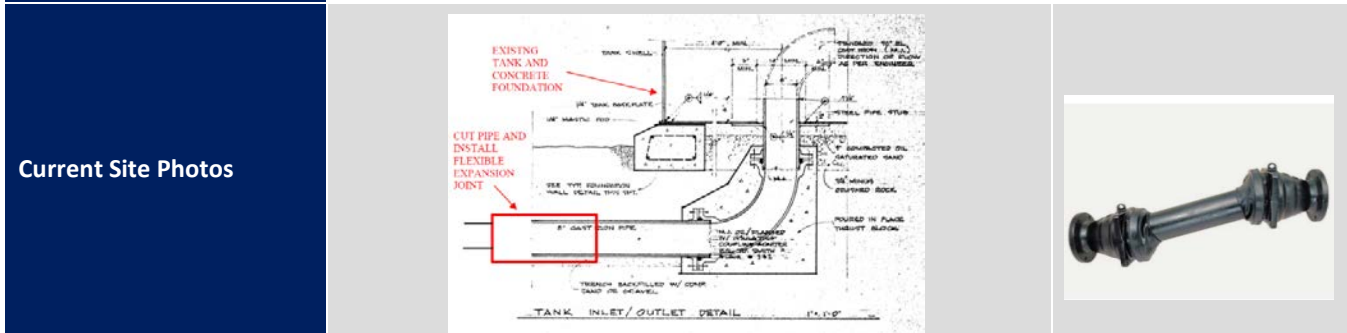



Mitigation Action Item (f)	Resiliency Analysis of Wastewater System
Location	City Wide
Coordinating Agencies	Creswell Public Works Department
Implementation Timeframe	1 – 5 years
Estimated Cost	est. \$100,000
Potential Funding Sources	BRIC, HMGP
Hazards Mitigated	All Hazards
Comments	N/A
Current Site Photos	

Mitigation Action Item (g)	Resiliency Analysis of Transportation System
Location	City Wide
Coordinating Agencies	Creswell Public Works Department
Implementation Timeframe	1 – 5 years
Estimated Cost	est. \$100,000
Potential Funding Sources	BRIC, HMGP
Hazards Mitigated	All Hazards

Mitigation Action Item (h)	Creslane High School Main Gym Retrofit
Location	43.92482913036689, -123.02934109503957
Coordinating Agencies	Creswell School District, Building Department
Implementation Timeframe	Completed 2024
Estimated Cost	est. \$1,000,000
Potential Funding Sources	BRIC, HMGP
Hazards Mitigated	Earthquake
Current Site Photos	

Mitigation Action Item (i)	Seismic Evaluation of Creswell High School
Location	43.92482913036689, -123.02934109503957
Coordinating Agencies	Creswell School District
Implementation Timeframe	Completed 2025
Estimated Cost	est. \$50,000
Potential Funding Sources	BRIC, HMGP
Hazards Mitigated	Earthquake
Current Site Photos	

Mitigation Action Item (j)	South Lane Fire Creswell Station. Critical facility seismic retrofit/mitigation reconstruction. Address structural issues including non-reinforced concrete block (lacking steel re-bar), bay-door dimensions.
Location	43.9174N, -123.0202W
Coordinating Agencies	South Lane Fire District, City of Creswell
Implementation Timeframe	24-36 months
Estimated Cost	est. \$2-3M
Potential Funding Sources	OR-SRGP, HMGP, FEMA PA-106, PDM
Hazards Mitigated	Earthquake, Multi-Hazard
Comments	DOGAMI Rapid Visual Seismic Assessment Risk Rating 0.7, FEMA-154 Collapse Potential 'High'. The City's Community Center will be torn down.
Current Site Photos	 

Mitigation Action Item (k)	Storm-hardening retrofit for airport including but not limited to structural, windows, bay doors, generator, upgrades to serve as back-up EOC.
Location	43.930N, -123.008W
Coordinating Agencies	City of Creswell, Airport
Implementation Timeframe	Ongoing
Estimated Cost	est. \$500,000
Potential Funding Sources	HMGP, FEMA PA-106, PDM
Hazards Mitigated	Windstorm, Multi-Hazard
Comments	The roof has been replaced and generators have been installed



Mitigation Action Item (l)	Install new backup generator at City Hall
Location	43.91761028083751, -123.02016680137821
Coordinating Agencies	Creswell Public Works Department
Implementation Timeframe	Immediate
Estimated Cost	est. \$75,000
Potential Funding Sources	HMGP, FDM
Hazards Mitigated	Multi-Hazard
Comments	The current generator only runs a few lights and a few workstations

Section 2.4: Plan Implementation and Maintenance

In keeping with standard practices to ensure incorporation of overall goals and strategies of the Natural Hazard Mitigation Plan, the City of Creswell hazard mitigation team members will be invited to participate in plan development or existing plan update committees. Additionally, this Natural Hazard Mitigation Plan will be cited as a technical reference for plan update processes. Planning documents and mechanisms applicable to this process may include the following:

City of Creswell Comprehensive Plan

Capital Improvement Plans

Emergency Management Plan

Local Community Wildfire Protection Plans

City of Creswell Floodplain Development Ordinance

Building Code

Development Code

Stormwater Management Plan

Wastewater Systems Plan

Water Systems Plan

Additionally, progress to implement this plan will be monitored on an ongoing basis by city staff and administration. The planning process is essential in identifying weaknesses and strengths inherent in the community and cooperatively enables coordination with various agencies and jurisdictions that might not otherwise occur. Continuing this cooperative and interactive process is exemplified by the planning process. Annual reviews and updates under a 5-year cycle will be pursued. Using these methods, the overarching goal of a stronger, safer, more resilient community can be attained.

Section 3: City of Dunes City



Version 4.0 (October 2023 – October 2028)

Developed as an annex to the Lane County Multi-Jurisdictional
Natural Hazard Mitigation Plan

Section 3.1: Dunes City: Natural Hazard Mitigation Meetings and Work Sessions

Development of Dunes City’s materials for the Natural Hazard Mitigation Plan involved participation by city staff, county emergency management, fire district, and law enforcement. The process followed FEMA’s prescribed model for organizing resources, identifying hazards, evaluating risk, identifying mitigation options, and prioritizing mitigation projects. For additional details regarding the planning process, please refer to Section 6 of the main document. Specific participants are listed as follows.

Table 3.1: City of Dunes City Planning Team

Name	Title	Agency
Jamie Mills	City Administrator	City of Dunes City
Pamela Palmer	Permit Tech	City of Dunes City
Lani Naroña	Planning Tech	City of Dunes City

Individual City Work Sessions

Work sessions with individual cities were conducted following the initial project orientation meeting and intervening months between general planning group meetings. These individual work sessions are outlined below.

Table 3.2: City of Dunes City Work Sessions

Date	Location	Meeting/Work Session
February 7 th , 2023	Florence Events Center	XSP Coast Region Workshop #1
April 26 th , 2023	Florence Events Center	XSP Coast Region Workshop #2
May 15, 2023	City Hall	Dunes City Council Regular Session
May 23, 2023	City Hall	Dunes City Planning Commission Regular Session

Matters discussed during work sessions included an overview of FEMA grant programs, discussion of common mitigation ideas, and specific project ideas for Dunes City. The result of this overall process was a thorough evaluation of risk factors and mitigation solutions. Certain hazards were highlighted with notable significance for Dunes City, others found to be less relevant in a direct context. Systems and concepts considered included infrastructure resiliency, transportation network, city planning, floodplain management, public safety, public and private facilities. A range of both general and specific mitigation ideas and projects were identified and scoped in the field.

Section 3.2: Dunes City: Hazard Quantification

Dunes City rated windstorms as its highest hazard risk and at the highest possible weighted score. Earthquake and winter storms were also notable hazards posing risk to Dunes City. The community faces moderate risk from drought, landslides and a tsunami. A hazardous materials incident is also of concern and Dunes City’s planning team decided to include this hazard with its annex despite the hazard type being removed from the county base plan (see Section 2.1 in Volume I).

Table 3.3: Dunes City Hazard Quantification Results

Hazard Type / Weight Factor (WF)	History WF x 2	Probability WF x 7	Vulnerability WF x 5	Maximum Threat WF x 10	Raw Score	Weighted Score	Weighted Score Rank
Windstorm	10	10	10	10	40	240	1
Earthquake	2	9	7	10	28	202	2
Winter Storm	8	8	9	8	33	197	3
Drought	1	4	8	8	21	150	5
HazMat Incident	8	8	4	5	25	142	6
Landslide	10	8	4	4	26	136	7
Tsunami	1	3	3	7	14	108	8
Wildfire	1	3	5	5	14	98	9
Flood	2	2	4	4	12	78	10
Dam Failure	0	2	3	3	8	59	11

Source: Dunes City Natural Hazard Mitigation Team

Section 3.2.1: Individual Hazard Discussion

Dunes City evaluated 11 hazard types. Given its proximity to the Pacific Ocean, tsunami is included in the local risk assessment. Dunes City also evaluated the risk of dam failure as a realistic local hazard risk.

Windstorm

Windstorms are a yearly and familiar hazard to all coastal communities, including Dunes City, which justifies the high rating this hazard received. Windstorms often impact above ground electrical lines that are vulnerable to damage from falling limbs and trees. Recent history includes notable damage and power loss in 2021, 2022 and 2023. A winter storm in 2022 caused trees to fall on private homes due to wind and saturated ground from rain. Probability is also considered high, patterns of previous occurrence of windstorms on the Oregon Coast will continue.

Overall vulnerability is again considered high as more than 10% of residents are often affected; roadways are vulnerable to closure due to downed trees, powerlines, and landslides which often accompany these events. The Columbus Day storm of 1962 can serve as an example for maximum threat, with winds measured at well over hurricane strength up and down the Oregon Coast. A windstorm of similar magnitude to the Columbus Day Storm could potentially damage numerous of homes in city, either by direct structural damage, falling trees, or wind-blown debris. Due to its location on the Oregon Coast, Dunes City can expect damaging windstorms in the future. Best practices for new construction are to utilize underground utilities wherever possible. See also windstorm hazard profile in Section 3 in the main document.

Earthquake

Earthquake is somewhat unique as it occurs much less frequently but has potential for significant damage and disruption. From a geographic standpoint occurrence will affect the entire city uniformly. History of occurrence dates back over long-time scales and so must be considered low. Probability is however high, DOGAMI and the State of Oregon consider a Cascadia earthquake in the future a certainty. The only question is whether the event will be a full unzipping of the 600-mile-long fault line off the coast, a southern centric event near the Oregon and California border, or a mid-zone event which would center the rupture west of Dune City and Florence. Additionally, there is a crustal earthquake fault north of Dunes City, approximately five miles directly east of Florence. Closer to Dunes City, another crustal fault lies offshore slightly to the south and west of the city. Due to the proximity of the dunes, and coupled with a liquefaction hazard, shifting sands have the potential to change the course of rivers, causing the potential for flooding.

Vulnerability is complex to assess due to varying standards of construction, but newer (after 1996) construction is considered relatively sound. It is expected that 1 to 10% of the population would be affected by an average occurrence of the event – which must be taken into context depending on the type of earthquake. A local crustal earthquake is not as likely to cause widespread impacts – magnitude ranges are generally in the range of 3 to 4 in magnitude. A Cascadia event will cause a tremendous amount of destruction and very significant disruption to the entire community. Maximum threat is expected to be high, with damage to numerous structures. In this worst-case scenario, a full unzipping of Cascadia will cause widespread destruction on the coastline from Northern California into British Columbia, Canada. Importance for increasing the resiliency of the community, infrastructure, water supply, and healthcare is notable. Retrofitting existing homes for earthquake would increase the resilience of the community. Liquefaction of dunes could cause river channel changes, and cause flooding. Dam failure due to earthquake could cause loss of city water supply from Woahink Lake. See also the earthquake hazard profile in Section 2 of Volume I.

Winter Storm

Like most cities Dunes City contains a network of above ground electrical lines vulnerable to damage from falling limbs and trees during winter storms. Recent history has been frequent including notable damage and power loss on a yearly basis, leading to this hazards classification of high. Wind is nearly always a contributing factor. During the winter of 2016 and 2017, ice and snow were also factors causing downed tree branches, and slick dangerous roads. Probability is considered high that patterns of previous occurrence will continue. Overall population potentially affected by winter

storm is high since effects are not geographically contained. Transportation and roadways are vulnerable to closure during winter storms. Maximum threat is also high due to the high threat of structural damage directly related to winter weather (cold, snow, ice, and wind). Best practices in this area lead to placing utilities such as power, telephone, and cable lines underground. See also winter storm hazard profile in Section 2 of Volume I.

Drought

Drought is neither life threatening nor presents a direct risk to structures but does involve potential for significant disruption if dramatic water shortage were to develop. Drought can exacerbate wildfire risk as related hazards, and a water shortage would likely affect the entire city uniformly. History is considered low in a region that sees 80 inches of rain a year. Probability is considered moderate with a potential event within 35 to 75 years possible. Vulnerability higher as Dune City is accustomed to dealing with too much water as opposed to too little. Should the nearby lakes be significantly affected by a long drought, water supply to the city could be impacted, affecting 1 – 10% of the population. Maximum threat is relatively high if an event occurred where all water supply systems were to become inoperable, or water supply unexpectedly ran short. See also drought profile in Section 2 of Volume I.

Hazardous Materials Incident

Hazardous materials incident is considered a technical hazard and involves different characteristics than natural hazards. Proximity to transport corridors and particularly intersections are significant geographic factor. Highway 101 runs north to south just to the west of Dunes City. Underground gas lines serve various neighborhoods. History is high with more than 4 incidents over history. Probability is similarly high with another incident expected within the next 35 years. Vulnerability is moderate relative to other hazard types with the expectation that 1 to 10% of the population potentially affected. Maximum threat is similarly considered moderate, with the expectation that 5 to 25% of the population might be affected. Rupture of underground gas lines is also possible. In the event of occurrence, prevailing wind and proximity to waterways are important factors relating to public safety risk and environmental impacts.

Landslide

Landslide is considered a high probability event on the Oregon coast. This common hazard is one with a high history and probability for reoccurrence. Due to proactive mitigation efforts in the past, the vulnerability to this hazard is considered moderate, as 1 to 10% of the population might be affected. Maximum threat would likely involve a slide in areas where deforestation has occurred to create views of the lake. When combined with record rainfall, roads and homes were put in some danger. Redrafting slope requirements for roads and housing has been discussed. See also landslide profile in Section 2 of Volume I.

Tsunami

The importance of Tsunami to the Oregon Coast is of the highest order. Not all areas on the coast will be inside the expected Tsunami inundation zone; however, this does not mean that areas outside that immediate impact zone will remain unaffected. Located between Woahink Lake to the north and Siltcoos Lake to the south, Dunes City is above the Tsunami Inundation zone expected by DOGAMI and the state of Oregon. In the event of a catastrophic event, the Department of Geology and Mineral Industries has identified a portion of the Westlake area as being in the tsunami inundation zone in the event of localized earthquake. Likewise, Highway 101 and the western portion of Pacific Avenue, is also in the inundation zone. This means that the people who live in the areas of Westlake that are in the inundation zone have no way to evacuate, other than to walk to City Hall. The proposed hiking and biking connectivity trail would provide an alternative escape route for these residents to get to higher ground, should the need arise.

The Siltcoos Dam, which is located west and south of the city on the Siltcoos River, is either very close to or inside the Tsunami Inundation Zone. Damage from either a Cascadia Event or the Tsunami certain to follow may have a significant negative impact on the ability of Dunes City to obtain fresh water. Woahink Lake is also a source of fresh water and is not expected to be impacted by Tsunami. As mentioned in the Earthquake notes, shifting sands and liquefaction that accompany a tsunami generating Cascadia event may lead to changes in water level in the Woahink Lake. The probability of a Tsunami in Dunes City is low, as is the vulnerability of the city. The maximum threat this hazard presents lay in the potential damage to infrastructure and Highway 101. Like much of the Oregon Coast, Dunes City will be isolated due to the damage caused by a large tsunami expected with a Cascadia Event. Travel will be correspondingly difficult. See also tsunami hazard profile in Section 2 of Volume I.

Wildfire

Dunes City is surrounded by urban wildland interface. The coastal forest and the city's integration with it are a major attractive quality of the community. However, the history of wildfire in the area is generally low. Similarly, future probability is also considered low, due in part to the mild and generally wet climate most of the year. The vulnerability of the community is moderate, as 1 to 10% of Dunes City could be affected by Wildfire. In a worst-case scenario, the maximum threat is also moderate with 5 to 25% of residents and property might be impacted. See also wildfire hazard profile in Section 2 of Volume I.

Flood

Flood is a geographically contained hazard and widespread impacts in Dunes City are unlikely. Though not considered a severe hazard, there is a history of flooding at North Pioneer. Additionally, Clear Lake Rd. has experienced inundations of the roadway and the history of flooding is well noted. Probability of a future event disrupting the community to a significant degree is low. It should be noted however that drainage issues in the area have occurred. Overall vulnerability and maximum threat scores are moderate as widespread severe damage from flooding might affect as much as 25% of population and property. Flood vulnerability exists for City Hall, which has had to deploy sandbags in the past. City Hall is a major resource for the community and needs to be available when other resources are not. See also flood hazard profile in Section 2 of Volume I.

National Flood Insurance Program

Dunes City is a formal program participant in good standing and considers continued participation as integral to future flood mitigation efforts. Participation consists of adoption and maintenance of Flood Insurance Rate Maps (FIRMs) which define Special Flood Hazard Areas (SFHAs) and maintenance of an ordinance regulating future development in SFHAs. The Flood Insurance Rate Map Community Number for Creswell is 410262. Compliance with the program is pursuant to the City of Creswell's floodplain ordinance.

Statistics as reported by FEMA on the NFIP Bureau Net for the period of January 1, 1978, through January 1, 2023, are as follows:

NFIP Policies in Force

Policies in Force: **9**

Insurance in Force: **\$ 2,177,000**

Premium in Force: **\$ 10,201**

Insurance Claim Data

There are no reported claims.

Data Definitions

Policies In Force – Policies in force on the "as of" date of the report.

Insurance In Force – The coverage amounts for policies in force.

Written Premium in Force – The premium paid for policies in force.

Dam Failure

There is no history of dam failure affecting either dam in Dunes City, the Woahink or Siltcoos Dams. Vulnerability and maximum threat are correspondingly low. The maximum hazard this presents is also low, as the city itself is not in the path of floodwaters. Instead, the hazard presents itself in the loss of fresh water supply to the city from Woahink Lake.

New Development in Hazard Areas

For the City of Dunes City there was a moderate increase in housing unit data with moderate residential development occurring during the planning period. Areas on east side of the city are located near steep slopes and forested areas. The potential for development in relation to flood zones is for the most part negligible and future developable areas would be reasonably well protected from direct impacts of tsunamis. Future development may be potentially vulnerable to wildfire impacts due to proximity of forest canopy within and surrounding annexed areas but can be mitigated by adequate defensible space around structure perimeter. Relative to certain other parts of the county & nation future development in Dunes City is reasonably well protected from winter storm impacts due to low elevation in relation to sea level and overall moderate winter climate. The city has taken steps to acquire most of the land known vulnerable to flooding.

Section 3.2.2: Dunes City: Mitigation Projects

This section describes mitigation projects identified by Dunes City during the planning process. See Volume I, Section 4 for additional information regarding mitigation action item methodology and prioritization.

Mitigation Action Item (a)	Storm-hardening and seismic retrofit for City Hall. Reinforce roof, windows, building veneer to withstand high-winds and general hazards.
Location	City Hall
Coordinating Agencies	City Hall, Dunes City Public Works
Implementation Timeframe	Three Phases (Inspection, Plans, and Construction) 12 – 18 months
Estimated Cost	\$750,000
Potential Funding Sources	HMGP, FEMA PA-106, PDM
Hazards Mitigated	Windstorm, Winter Storm
Comments	Seismic rehabilitation and storm hardening for this city structure has great importance for the community following a disaster. It may be the main source of shelter for many town residents for some time.
Current Site Photos	

Mitigation Action Item (b)	Connectivity trail for west shore Woahink Lake. Aka Chet’s Trail to Westlake. Assist evacuation, supply, and emergency response.
Location	Trail from Westlake Shore to the area on North Shore (Darling’s Resort)
Coordinating Agencies	Dunes City Public Works
Implementation Timeframe	2-4 years
Estimated Cost	\$1.7 million
Potential Funding Sources	TGMP, HMGP
Hazards Mitigated	Earthquake, Tsunami, Winter Storm, Windstorm, Haz-Mat Incident, Flood, Wildfire
Comments	Dunes City is a bifurcated community. A solid trail will offer residents a secondary means of reaching assistance that will be centered upon Dunes City Hall. An easement might be sought from property owner(s). The City has acquired the land to construct the ADA compliant trail, has completed a wetland delineation that resulted in the finding of an endangered plant species on the property. The City is seeking grant funding from FEMA, elsewhere to finalize the project.
Current Site Photos	

Mitigation Action Item (c)	Flood-proofing for City Hall. Door seals, siding reinforcement, electrical retrofit. Drainage/grading improvements for grounds and parking area.
Location	City Hall
Coordinating Agencies	Dunes City Public Works
Implementation Timeframe	12-18 months
Estimated Cost	\$65,000
Potential Funding Sources	HMGP, FEMA PA-106, PDM, FMA
Hazards Mitigated	Flood, Winter Storm
Comments	Past flooding events have required sandbagging at City Hall, which is a major resource for the community when private resources have been exceeded. This project could run concurrent with the Seismic Retrofitting of the structure. While the City has installed a bullet proof glass window at its counter, no flooding retrofitting has been done.
Current Site Photos	

Mitigation Action Item (d)	Water flow and quality monitoring for Woahink Lake.
Location	North of City Hall where Woahink Creek drains into Siltcoos Lake.
Coordinating Agencies	Dunes City Public Works
Implementation Timeframe	6 – 12 months
Estimated Cost	\$75,000
Potential Funding Sources	HMGP, FEMA PA-106, PDM, FMA
Hazards Mitigated	Flooding, Winter Storm, Earthquake, Drought, Haz-Mat Incident
Comments	Woahink Creek supplies Siltcoos lake with fresh water, currently under private ownership with access easement granted to the City. Outlet Control Structure is currently failing and leaking. A doppler meter was installed on the bottom of the Creek providing readings for a few months, but then a beaver ate through the lines, rendering the meter useless. Will need to measure at the out take at Woahink (Staff Gauge in place) and at the confluence of Woahink Creek as it enters Siltcoos Lake for reporting requirements to the State. During summer months, both Siltcoos and Woahink Lakes are monitored under the requirements and direction of the Oregon Department of Environmental Quality, Quality Assurance Project Plan.
Current Site Photos	

Mitigation Action Item (e)	Slope stabilization for landslide mitigation
Location	Dunes City UGB
Coordinating Agencies	Dunes City Public Works
Implementation Timeframe	6 -18 months
Estimated Cost	\$185,000
Potential Funding Sources	HMGP, FEMA PA-106, PDM
Hazards Mitigated	Landslide, Earthquake
Comments	Slopes have been rendered unstable due to logging on private lands. There are three homes at risk if a landslide were to occur, two of which are short-term rentals and have many people residing in them.
Current Site Photos	

Mitigation Action Item (f)	Stormwater catch basin and culvert upgrades for North Pioneer Road
Location	North Pioneer Road
Coordinating Agencies	Dunes City Public Works
Implementation Timeframe	6 – 12 Months
Estimated Cost	\$85,000
Potential Funding Sources	FEMA PA-106, PDM, HMGP, FMA, SRGP
Hazards Mitigated	Flooding, Winter Storm
Comments	This is a frequent location of flooding, and over a long period of time. Lack of proper drainage or a stormwater catch basin, and an undersized culvert need to be addressed. This roadway is a private roadway owned by the residents of the Siltcoos Lake Club Plat, so the City had to abandon the project due to lack of interest on the part of the residents, except the one that was seriously damaged.

Mitigation Action Item (h)	Vision clearance upgrades for Hwy 101 intersections
Location	Highway 101 roadsides
Coordinating Agencies	ODOT, Dunes City Public Works
Implementation Timeframe	6 – 12 months
Estimated Cost	\$10,000
Potential Funding Sources	ODOT
Hazards Mitigated	Windstorm, Winter Storm, Haz-Mat Incident
Comments	Lower the likelihood of fallen trees and branches blocking Hwy 101.

Mitigation Action Item (i)	Re-drafting slope requirements for new construction on slopes
Location	City Hall
Coordinating Agencies	Dunes City Public Works, City Council
Implementation Timeframe	3 – 6 months
Estimated Cost	\$3,000
Potential Funding Sources	N/A
Hazards Mitigated	Landslide, Winter Storm, Windstorm
Comments	Re-writing existing City Code will not incur a cost. However, there may be a cost associated with a Survey Team/Engineers needed to evaluate slopes and water drainage and recommend an appropriate set of degrees of slope for specific areas at increased risk of landslide upon development.

Mitigation Action Item (k)	Obtain assured access to water outlet control structure
Location	City Hall
Coordinating Agencies	Dunes City Public Works
Implementation Timeframe	unknown
Estimated Cost	TBD
Potential Funding Sources	HMGP, FEMA PA-106, PDM, FMA
Hazards Mitigated	Flooding, Earthquake, Haz-Mat incident
Comments	This may be a negotiating process with the owner of the outlet control structure to increase community access to water resources. Currently the structure is privately owned and maintained. Negotiations failed and owners refuse to allow the City to purchase the property. At this time the City operates the dam via recorded easement.

Completed Projects from 2018 NHMP

Mitigation Action Item	Remove waterway obstructions for boating safety
Location	Siltcoos and Woahink Lakes, Woahink Creek and Siltcoos River
Coordinating Agencies	Dunes City Public Works, Oregon Department of Forestry
Implementation Timeframe	6-12 Months
Estimated Cost	\$1,000 – 3,000
Potential Funding Sources	Community Volunteers, City of Dunes City, USACE
Hazards Mitigated	Haz-Mat impact on Water quality, Winter Storm, Flooding
Comments	Removal of snags likely to decrease flooding potential. Removal of obstructions to the waterway will improve the response capability in the event of a Haz-Mat incident impacting the lakes or creek. It also removes obstacles from the water that have the potential to cause boating accidents which have the potential to impact the water quality.

Section 3.3: Plan Implementation and Maintenance

In keeping with standard practices to ensure incorporation of overall goals and strategies of the Natural Hazard Mitigation Plan, Dunes City hazard mitigation team members will be invited to participate in future development or existing plan update committees. Additionally, this NHMP will be cited as a technical reference for future update processes. Planning documents and mechanisms applicable to this process may include the following:

Dunes City Comprehensive Plan

Capital Improvement Plans

Emergency Management Plan

Dunes City Floodplain Development Ordinance

Building Code

Subdivision Code

Erosion Control

Stormwater Management Plan

Additionally, progress to implement this plan will be monitored on an ongoing basis by city staff and administration. The planning process is essential in identifying weaknesses and strengths inherent in the community, and cooperatively enables coordination with various agencies and jurisdictions that might not otherwise occur. Continuing this cooperative and interactive process is exemplified by the planning process. Annual reviews and update under a 5-year cycle will be pursued. Using these methods, the overarching goal of a stronger, safer, more resilient community can be attained.

Section 4: City of Florence



Version 4.0 (October 2023 – October 2028)

Developed as an annex to the Lane County Multi-Jurisdictional
Natural Hazard Mitigation Plan

Section 4.1: City of Florence: Natural Hazard Mitigation Meetings and Work Sessions

Development of Florence’s materials for the Natural Hazard Mitigation Plan involved participation by city staff, public works, airport, school district, county emergency management, fire district, and law enforcement. The process followed FEMA’s prescribed model for organizing resources, identifying hazards, evaluating risk, identifying mitigation options, and prioritizing mitigation projects. For additional details regarding the planning process, please refer to section six of the main document. Specific participants are listed as follows.

Table 4.1: City of Florence Planning Team

Name	Title	Agency
Erin Reynolds	City Manager	City of Florence
Megan Messmer	Assistant City Manager	City of Florence
John Pitcher	Police Chief	City of Florence
Brandon Ott	Police Sergeant	City of Florence
Mike Miller	Public Works Director	City of Florence
August Murphy	Assistant Public Works Director	City of Florence
Wendy FarleyCampbell	Community Development Director	City of Florence
Michael Schick	Fire & EMS Chief	Western Lane Fire & EMS Authority
Matt House	Deputy Chief	Western Lane Fire & EMS Authority

Individual City Work Sessions

Work sessions with individual cities were conducted following the initial project orientation meeting and intervening months between general planning group meetings. The individual work sessions that the City of Florence took part are outlined below.

Table 4.2: City of Florence Work Sessions

Date	Location	Meeting/Work Session
Wednesday, February 8, 2023	Florence Events Center	XSP Coast Region Workshop 1
Tuesday, March 14, 2023	Virtual	Florence Check-In with Lane County
Friday, April 7, 2023	Florence City Hall	Florence Planning Team Hazard Rating
Thursday, April 20, 2023	Florence Events Center	XSP Coast Region Workshop 2

Subject matter discussed during work sessions included an overview of FEMA grant programs, discussion of common mitigation ideas, and specific project ideas for the City of Florence. The result of this overall process was a thorough evaluation of risk factors and mitigation solutions. Certain hazards such as windstorms, wildfire, winter storms, and tsunami were highlighted with notable significance for Florence, while other hazards like dam failure and volcano were found to be less relevant in a direct context. Systems and concepts considered included infrastructure resiliency, transportation network, city planning, floodplain management, public safety, and public and private

facilities. A range of both general and specific mitigation ideas and projects were identified and scoped in the field.

Section 4.2: Florence Hazard Quantification Results

Table 4.3 provides the results from the hazard quantification for the City of Florence.

Table 4.3: Florence Hazard Quantification Results

Hazard Type / Weight Factor (WF)	History	Probability	Vulnerability	Maximum Threat	Raw Score	Weighted Score	Weighted Score Rank
	WF x 2	WF x 7	WF x 5	WF x 10			
Windstorm	9	10	6	10	35	218	1
Wildfire	6	7	8	10	31	201	2
Tsunami	10	7	5	10	32	194	3
Winter Storm	8	8	6	7	29	172	4
Earthquake	2	3	7	10	22	160	5
Landslide	10	6	5	4	25	127	6
Tidal Impacts	8	8	6	2	24	122	7
Coastal Erosion	8	9	4	2	24	119	8
Drought	4	2	1	7	14	97	9
Flood	8	3	2	2	15	67	10

Source: Florence Hazard Mitigation Team

Section 4.2.1: Individual Hazard Discussions

The City of Florence evaluated 10 natural hazard types in its risk assessment. This includes the unique hazards of tidal impacts and coastal erosion.

Windstorm

Windstorms are a normal and regular event on the Oregon Coast. Due to its location, the City of Florence is exposed to extreme wind as compared to more sheltered areas. Coordinated response is multi-jurisdictional in addressing the impacts of windstorms of all sizes but is most notable during and after large windstorms with widespread impacts. In addition, the City and partner agencies have worked to mitigate potential impacts of frequent storms through tree trimming, securing infrastructure, and requiring undergrounding of power and telecommunications lines for new development and, when possible, during redevelopment.

They can, and frequently do, impact above ground power and telecommunications lines vulnerable to damage from falling limbs and trees. Notable damage and power loss occurs nearly every year. Numerous trees and tree branches fall and are a regular expectation in the region about damage from windstorms.

Probability and history are considered high with the expectation that the patterns of previous occurrence will continue. Overall vulnerability is moderate with roadways being notably vulnerable to closure on the Oregon Coast and are a regularly encountered hazard in the region. The Columbus

Day storm of 1962 can serve as an example for maximum threat, with winds measured the neighborhood of 170 miles per hour at Florence. A windstorm of similar magnitude to the Columbus Day Storm could potentially damage numerous residential and commercial structures in the city, either by direct structural damage, falling trees, or by wind-blown debris.

Wildfire

Florence is surrounded to the north and east by significant forest lands in the Siuslaw National Forest, and privately owned lands. The city is bounded to the south by the Siuslaw River, with little in the way of direct threat from that direction, but the area south of the river is also heavily forested.

Major wildfires have occurred in the past in the Siuslaw National Forest. Its proximity to the city and the few roadways leading in and out of the city make this a hazard during dry summer months. The hazard is mitigated by generally mild temperatures and moisture from the Pacific Ocean; however, it can be exacerbated by the often-constant winds and the greater prominence of red flag warnings during the extended dry months. The Oregon Department of Forestry monitors the fire conditions in the area closely.

The history of this hazard has seen 3 to 4 events in area in the last 100 years, with the addition of the Sweet Creek Fire east of town during late summer of 2020. Probability is moderate, with the expectation of another wildfire in the area in the next 35 to 75 years. Vulnerability is considered high, with the potential for severe property damage on a regional level. Maximum threat involves the potential for over 50% of the community being impacted either directly by wildfire or more indirectly by evacuations and smoke from a wildfire.

Tsunami

The importance of tsunamis to the Oregon Coast is a large threat that needs to be prepared for. Not all areas on the coast will be inside the expected tsunami inundation zone; however, this does not mean that areas outside that immediate impact zone will remain unaffected. The directly impacted tsunami inundation zones are split in two, with consideration for local tsunamis and distant tsunamis. In the past fifteen years there have been approximately 10 occurrences that have resulted in at least a tsunami watch, with two resulting a higher level of classification, and many more information statements where no threat was indicated. These have come from distant earthquakes.

Florence is moderately vulnerable to tsunami. Areas to the south of the city may be isolated due to damage to the Highway 101 Bridge crossing the Siuslaw River. The tsunami inundation zones, according to DOGAMI and the State of Oregon Office of Emergency Management (OEM), run from the coast inland along the shores of the Siuslaw River, flooding areas south of Rhododendron Drive inundating Bay and Laurel Streets east of Hwy 101. Full tsunami inundation zone and evacuation maps can be found at <https://www.ci.florence.or.us/em>. See also the map in the Tsunami Hazard profile found in Volume I: Section 2.2.6 of this Plan.

A *distant tsunami* will take 4 hours or more to reach the shore. Residents will not feel the earthquake, and the tsunami will generally be smaller than that from a local earthquake. Typically, there is time for an official warning and evacuation to safety. Evacuation for a distant tsunami will

generally be indicated by an announcement over NOAA weather radio that the local area has been put into an official TSUNAMI WARNING. Even if there is no announcement, a sudden change of sea level should prompt people to move immediately to high ground.

A *local tsunami* can come onshore within 15 to 20 minutes after the earthquake — before there is time for an official warning from the national warning system. Ground shaking from the earthquake may be the only warning you have. The local inundation zone has the larger impact area.

The Cascadia earthquake and resulting tsunami may cause damage to the Hwy 126 Bridge as it crosses the north fork of the Siuslaw River, the city will be isolated from the inland east. Tsunami waters are expected to cover the Florence-Eugene Highway (Hwy 126) east of the city, blocking the only road east to the Coast Range Mountains and the Willamette Valley. North of the city, the Siuslaw North Jetty Park will be inundated north of North Jetty Road; the South Jetty area will be inundated well east of Sand Dune Road. Shoreline beach areas can expect to be inundated. Areas close to the water in Heceta Beach will also be impacted. Siuslaw Valley Fire and Rescue Station #2 is also located in the local inundation zone and consideration for its relocation outside the inundation zone should be made.

Like much of the Oregon Coast, Florence will become isolated due to the damage caused by a large tsunami expected with a Cascadia event and the resulting damage to transportation infrastructure. Travel and commerce dependent on travel of all types will be correspondingly difficult and services of all types will be difficult to obtain. Proximity of the railroad line, which travels for extended lengths along the north and then east shores of the Siuslaw River east of Florence, is anticipated to be impacted by a local event due to the reliance on bridges and tunnels for travel.

Winter Storm

Winter storms are characterized by ice accumulation and freezing rain, heavy snowfall, and/or extreme cold and wind chill conditions. These hazard events typically create disruption of regional systems such as public utilities, telecommunications, and transportation routes. Cities on the Oregon Coast are familiar with high levels of rainfall during the winter month and throughout the year. Like most cities on the Oregon Coast, Florence is not fully equipped to address snowfall and/or ice, nor is the community fully prepared for long periods of cold weather.

Florence contains a network of above ground electrical lines vulnerable to damage from falling limbs and trees during winter storms. Early winter storms that occur before the trees lose needles result in a greater likelihood for downed trees and limbs. This is also amplified when storms bring in large amounts of rain and are followed/accompanied by windstorms, making the trees more vulnerable to being blown down with saturated ground.

Recent history has included frequent/notable damage and power loss on a yearly basis, leading to this hazard classification of high. Wind and rain are nearly always contributing factors. Periodically over the past decade and most recently for an extended time in early 2023, ice and snow were also factors causing downed tree branches, and slick dangerous roads, especially in the outlying areas that impact the ability to get to and from town, as well as emergency response in those areas. Probability is considered high that patterns of previous occurrence will continue.

Overall population potentially affected by winter storm is moderate since effects are not geographically contained. Transportation and roadways are vulnerable to closure during winter storms. Especially vulnerable populations will be impacted by extended winter storms and cold weather, creating the need for community resources to address cold weather sheltering. Maximum threat is high due to the high

threat of structural damage directly related to winter weather (cold, snow, ice, and wind). Best practices in this area lead to placing utilities such as power and telecommunications lines underground.

Earthquake

Earthquakes are somewhat unique as it occurs much less frequently than other hazards but has the potential for significant damage and disruption. This is particularly true on the Oregon Coast, where the region is subject to both Crustal earthquakes, and a far larger Cascadia Subduction Zone Earthquake. From a geographic standpoint occurrence, an earthquake will impact the entire city uniformly, with a resulting tsunami from a local earthquake adding on to the impact in general and higher within the inundation zone.

History of occurrence dates back over long-time scales and so must be considered low. Probability is however high, DOGAMI and the State of Oregon consider a Cascadia earthquake in the future a certainty. The only question is whether the event will be a full unzipping of the 600-mile-long fault line off the coast, a southern centric event near the Oregon and California border, or a mid-zone event which would center the rupture generally west of Florence. There are 2 crustal earthquake faults nearby, approximately five miles directly east of Florence. The second is closer to Dunes City to the south and west. Due to the prevalence of sand in the geology a high liquefaction hazard exists beneath the city which will be a factor in an earthquake in the resulting damages to the community and infrastructure. The probability for an earthquake event affecting Florence is on the high end of medium, with an event expected within the next 35 to 50 years.

Vulnerability is complex to assess due to varying standards of construction, but newer (after 1996) construction is considered relatively sound. A local crustal earthquake is not as likely to cause widespread impacts – magnitude ranges are generally in the range of 3 to 5 in magnitude. A Cascadia event is on a different order of magnitude in the range of 8.0 to 9.0, will result in a tremendous amount of destruction, and cause significant disruptions to the entire community. A Cascadia event is not an average occurrence of earthquake in the region; however, it cannot be discounted due to the fact it has not reoccurred in over 300 years and would result in a corresponding tsunami.

Maximum threat is expected to be high, with damage to numerous structures. In this worst-case scenario, a full unzipping of Cascadia will cause widespread destruction on the coastline from Northern California into British Columbia, Canada. Importance for increasing the resiliency of the community, infrastructure, water supply, and healthcare is notable. Retrofitting existing homes for earthquake would increase the resilience of the community. With Florence's prominence of sand, liquefaction could cause river channel changes, potentially leading to flooding.

Seismic assessments for the Siuslaw High School, and the Siuslaw Valley Fire and Rescue Station #2 are indicated by both age, current condition of the structures, and their potential vulnerability to either earthquake and/or tsunami. Following assessment, consideration for the relocation or replacement of these structures may be indicated.

Landslide

Landslides are one of the characteristics of living on the Oregon Coast, and the City of Florence is no exception. Landslides are common yearly events in the region; a hazard that residents, public works officials, transportation departments, and local utilities are well rehearsed in responding to.

Historical occurrences of landslides are high. Probability of a future event is also high, with at least one event in the next 10-35 years; however, the City is prepared for yearly events. Vulnerability within the city is moderate, more often landslides impact the limited number of roads and highways leading in and out of the City. These events impact commerce, individual travel, tourism, and recreational activities. For these reasons, Maximum Threat is considered moderate with the potential to impact with 5% to 25% of the population.

Tidal Impacts/High-Tide Flooding

Tidal impacts on the Oregon Coastline are a general result of high tide flooding, versus general flooding due to high rainfall or storm events. High tide flooding is described by NOAA as follows (<https://oceanservice.noaa.gov/facts/high-tide-flooding.html>):

As relative sea level rises, it no longer takes a strong storm or a hurricane to cause coastal flooding. High tide flooding occurs when sea level rise combines with local factors to push water levels above the normal high tide mark. Changes in prevailing winds, shifts in ocean currents, and strong tidal forces (which occur during full or new moon) can all cause high tide flooding, inundating streets even on sunny days.

High tide flooding falls into three levels of severity: minor, moderate, and major. The classifications measure how much water levels exceed average high tide for that location.

- Minor high tide flooding is when water levels reach 0.55 meters (1.8 feet) above average high tide. This minor flooding is mostly disruptive, causing stormwater backups and road closures.
- Moderate high tide flooding is 0.85 meters (2.8 feet) above average high tide. This can cause more disruption and can damage homes and businesses.
- Major flooding is flooding 1.20 meters (3.9 feet) above average high tide. Floods of this severity are quite destructive, may lead to evacuations, and often require repairs to infrastructure and property.

Because of rising seas, land subsidence, and the loss of natural barriers, high tide flooding is now twice as frequent in U.S. coastal communities as it was 20 years ago. Predictions from the latest interagency Sea Level Rise Technical Report show that high tide flooding will become more common and more severe over the coming decades. As sea levels continue to rise, conditions that cause

minor and moderate high tide flooding today will cause moderate and major high tide flooding by 2050.

The occurrences of extreme high tides, with the added King Tide occurrences several times per year, have had impacts on the coastlines and the riverbanks in Florence. These events have caused severe damage to infrastructure and have caused failures of slopes and bulkheads. Due to the ongoing, daily impacts of high tides and the more severe King Tides this hazard is weighted high for history and probability, moderate on the vulnerability scale, and low on the maximum threat.

Coastal Erosion

Florence and the beaches which bring so many visitors to the city year-round have experienced significant coastal erosion in the past. The Oregon Sand Dunes (south of Florence) are a significant draw for tourists and residents alike. These areas offer significant assets to wildlife, and to coastal vegetation and are considered a vulnerable habitat. Healthy beaches protect coastline properties, and infrastructure that leads to beach access. Often a result of winter storms, waves, and tides move sand out, and waves as a result climb higher. This can cause rapid changes in beaches.

History of coastal erosion is high; the characteristics of beaches often change on a frequent if not constant basis. The probability of this continuing is also high. Vulnerability is considered moderate in this area of the Coast, with a lower number of residential, commercial, and infrastructure structures directly impacted by coastal erosion than is seen in other coastal communities. The maximum threat the hazard presents is also low, with <5% of population and property impacted by a worst-case scenario event of coastal erosion.

Drought

Drought is neither life threatening nor presents a direct risk to structures but does involve potential for significant disruption if dramatic water shortage were to develop. Drought can exacerbate wildfire risk as related hazards, and a water shortage could impact the entire city uniformly. Average annual rainfall dating back to 1957 is 68.85 inches per year. Long-term, below average rainfall years could impact the water supply in the two water sources used in the Florence area.

The City of Florence's water source is the North Florence Sole Source Dunal Aquifer, designated as a "sole source" aquifer from the EPA in 1987. It continues to be the only "sole source" aquifer in the State of Oregon. The EPA defines a sole source aquifer as "an underground water source that supplies at least 50% of the drinking water consumed in the area overlying the aquifer. These areas have no alternative drinking water source(s) that could physically, legally and economically supply all those who depend upon the aquifer for drinking water." All streams, creeks, lakes, and wetlands (surface waters) in the aquifer boundary are "hydrologically connected" with the groundwater system.

Heceta Water People's Utility District (HWPDU) provides water to some residents within the northern City of Florence city limits, the northern Florence Urban Growth Boundary, and the area north of Florence within Lane County. HWPUD's water source is Clear Lake north of Florence, and it draws directly from the lake. Clear Lake is one of a string of lakes on the central Oregon coast that

lies on the 50 mile long North Florence Dunal Aquifer, an important ground water body supplying water for domestic needs in the Florence area.

History is considered moderate in the region. The area averages about 70 inches of rain a year. Over the recorded history, there have been several years that have seen significantly lower rainfall. Probability is considered low with as events have historically been spread out with several years in between. Vulnerability is also low in an area that is balanced with years that see above or significantly above average rainfall to replenish the aquifer and lakes. Maximum threat is moderate due to the city's reliance on the sole source aquifer and the connectivity of the lakes to the aquifer. Should a long duration drought impact the region, it may potentially impact most of the population.

Flood

Flood is a geographically contained hazard with potentially widespread impacts. The area of Florence has a moderate history of flooding, with several instances in the last 100 years. The geology of the coast allows for drainage of floodwaters with relative ease compared with inland areas. The probability of future occurrences is low, with the expectation of future events in the range of 35 to 75 years. Overall vulnerability and maximum threat scores are low as widespread damage from flooding is not considered likely.

National Flood Insurance Program (Program): The City of Florence is a formal program participant in good standing and considers continued participation as integral to future flood mitigation efforts. Participation consists of adoption and maintenance of Flood Insurance Rate Maps (FIRMs) which define Special Flood Hazard Areas (SFHAs) and maintenance of an ordinance regulating future development in SFHAs. The Flood Insurance Rate Map Community Number for Florence is XXXX. Compliance with the program is pursuant to the City of Florence's floodplain ordinance.

Statistics as reported by FEMA on the NFIP Bureau Net for the period of January 1, 1978, through January 1, 2023, are as follows:

NFIP Policies in Force

Policies in Force: **157**
 Insurance in Force: **\$ 44,861,200**
 Premium in Force: **\$ 82,890**

Insurance Claim Data

Total Losses: 8
 Closed Losses: 3
 Open Losses: 1
 CWOP Losses: 4
 Total Payments: **\$59,527.08**

Data Definitions

Policies In Force – Policies in force on the "as of" date of the report.
 Insurance In Force – The coverage amounts for policies in force.
 Written Premium in Force – The premium paid for policies in force.
 Total losses – All losses submitted regardless of the status.

Closed losses – Losses that have been paid.

Open losses – Losses that have not been paid in full.

New Development in Hazard Areas

Development in Florence in the main hazard specific areas, such as tsunami or tidal influence has not substantially increased since the previous plan. Development throughout town, where hazards are equally impactful to all areas such as earthquakes, wildfire, and storm damage, has increased related to multi-family and single-family housing. These developments are not any more prone to hazards than if they were located elsewhere in town.

There are areas near the updated flood plains and the tsunami hazard overlay zone that are available for redevelopment in the Old Town area of Florence. The City provides this information to prospective developers and has updated code related to floodplain and tsunami hazard zone. Information on the City's efforts can be found at:

- <https://www.ci.florence.or.us/planning/fema-coastal-floodplain-map-update>
- <https://www.ci.florence.or.us/planning/tsunami-hazard-overlay-zone-completed-oct-2018>

Section 4.3: City of Florence: Mitigation Projects

This subsection describes mitigation projects identified by the City of Florence during the planning process. See Volume I, Section 4 for additional information regarding the methodology for developing of the overall mitigation strategy, identifying action items, and prioritizing action items and projects.

Mitigation Action Item (a)	Regional Public Agency and Emergency Fueling Facility
Location	City of Florence Public Works Operations Center
Coordinating Agencies	City of Florence, Lane County, Various First Responding Agencies
Implementation Timeframe	Estimated Completion in 2024
Estimated Cost	\$550,000
Potential Funding Sources	HB 5202 provided \$250,000, City Match of \$300,000
Hazards Mitigated	Windstorm, Winter Storm, Various Hazards
Comments	The fueling facility will allow the City and our other emergency agency partners to have a fueling source (unleaded and diesel fuel) on both ‘blue sky’ days for normal operations but more importantly ability to supply fuel when a major (and extended) disaster strikes. The site will be secured and lit, as well as have emergency backup power to utilize during power outages and times where there is also high demand from the public on the commercially operated fueling facilities.
Progress Since Last Plan	New Item, In Process

Current Site Photos

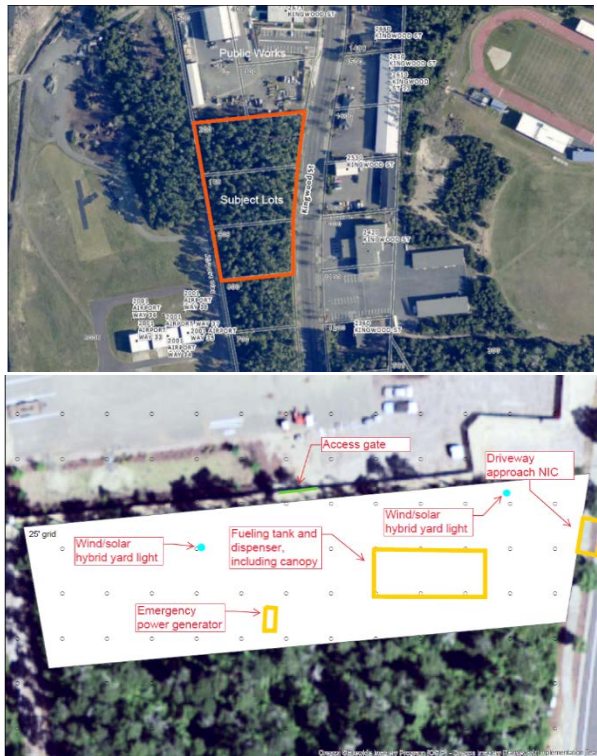

Mitigation Action Item (b)	Siuslaw River/Coast Guard Road Slope Stabilization Project
Location	Coast Guard Road
Coordinating Agencies	City of Florence, State of Oregon, Lane County, Federal/Coast Guard
Implementation Timeframe	Unknown, ASAP
Estimated Cost	\$1+ million
Potential Funding Sources	Seeking Funding -- In March 2023, City submitted a congressionally directed spending (CDS) requests for Fiscal the Year 2024 appropriations process.
Hazards Mitigated	Erosion, Tidal Impact
Comments	The project is located along the top of the slope to the Siuslaw River near the US Coast Guard Station Siuslaw River. A portion of the steep slope has begun to actively slide. From the City’s evaluation the slope movement resulted in the formation of a scarp (a long steep slope or cliff at the edge of a plateau or ridge that is formed by erosion). Our design team is in the process of developing a concept design consisting of a retaining wall above the scarp to prevent it from progressing north toward the Coast Guard Station parking lot; south toward a private residence; west to the Siuslaw River; as well as storm drainage system modifications to potentially eliminate the stormwater outfall at the scarp location. Our design consists of a secant pile retaining wall system.
Progress Since Last Plan	New Project
Current Site Photos	

Mitigation Action Item (c)	Tsunami Siren Updates
Location	Various - Four locations in Florence
Coordinating Agencies	West Lane Emergency Operations Group
Implementation Timeframe	TBD
Estimated Cost	TBD
Potential Funding Sources	Grant Funding, WLEOG Partner Agencies
Hazards Mitigated	Tsunami
Comments	There are currently four sirens located in the Florence area utilized to provide emergency notification to community members and visitors of tsunami threats. Due to the harsh coastal climate, they are in need of repair and maintenance. They are being evaluated for repair and possible replacement of at least one siren that is not currently working.
Progress Since Last Plan	New project

Mitigation Action Item (d)	Port of Siuslaw Bulkhead
Location	Port of Siuslaw
Coordinating Agencies	Port of Siuslaw, State of Oregon, Federal
Implementation Timeframe	Unknown
Estimated Cost	Unknown
Potential Funding Sources	Unknown
Hazards Mitigated	Erosion, Flood, Tidal Influence, Storms
Comments	Port of Siuslaw needs to repair the failing bulkhead and install approximately 900’ of sheet pile wall at the damaged side bank along the Siuslaw River, adjacent and south along the Port of Siuslaw Campground. Property is located on the Siuslaw River.
Progress Since Last Plan	New Item

Current Site Photos



Mitigation Action Item (e)	Utility Line Undergrounding
Location	Various
Coordinating Agencies	City of Florence, Central Lincoln PUD
Implementation Timeframe	Various
Estimated Cost	Varied
Potential Funding Sources	Grants, City, PUD
Hazards Mitigated	Windstorms, Winter Storms, Various
Comments	Continued efforts to underground utilities to harden them against storm hazards throughout the community. Most of the existing power and communications lines are above ground and vulnerable to storms. New development and services are generally installed underground unless the area is aerial currently. Continued efforts towards undergrounding will assist the community in hazard resiliency.
Progress Since Last Plan	New Item

Mitigation Action Item (f)	Firewise Education and Programs in North UGB
Location	City of Florence North Urban Growth Boundary
Coordinating Agencies	City of Florence, Siuslaw Valley Fire & Rescue, Oregon State Fire Marshal
Implementation Timeframe	Ongoing
Estimated Cost	Ongoing
Potential Funding Sources	City, SVFR, State
Hazards Mitigated	Wildfires
Comments	The City of Florence's northern UGB area is relatively developed for being outside of the City limits. Due to fewer codes related to landscaping and vegetation, the area is more wooded in nature and has a high amount of vegetation that could become fuel for fires in dry months. Education on Firewise programs and best practices to the residents is ongoing to mitigate the hazard in the area.
Progress Since Last Plan	Ongoing item, new to plan

Mitigation Items in Previous Plan

Mitigation Action Item	Mitigation reconstruction for Public Works facility. Storm hardening and seismic resiliency.
Location	Florence Public Works Facility – Airport facility
Coordinating Agencies	City of Florence Public Works
Implementation Timeframe	6 to 18 months
Estimated Cost	\$5.5 to 6 million
Potential Funding Sources	HUD-CDBG, OR-SRGP, HMGP, PDM, FEMA PA-106,
Hazards Mitigated	Windstorm, winter storm, tsunami hazard, earthquake, flood
Comments	Equipment & bays from west of Administration to the eastside. 2.5 acres of land, \$20 Million lease to the city.
Progress Since Last Plan	Florence Public Works Operating Facility was completed in 2018. Additional phases to build out the site have been completed and/or are planned in future fiscal years to expand the capabilities of the site.

Current Site Photos	
----------------------------	--

Mitigation Action Item	Seismic retrofit for water supply tanks and foundation reinforcements
Location	City Reservoirs
Coordinating Agencies	City of Florence Public Works, Water Department
Implementation Timeframe	18-24 months
Estimated Cost	\$2 million
Potential Funding Sources	HUD-CDBG, OR-SRGP, HMGP, PDM, FEMA PA-106
Hazards Mitigated	Earthquake, drought
Comments	Cribbing, foundation control; seismic lateral stability; ball joints & auto-shut off valve. Tanks located at 35th Street and 31st Street.
Progress Since Last Plan	Not in the current capital improvement plan or budget forecasts.
Current Site Photos	

Mitigation Action Item	Erosion control measures for Rhododendron Drive, structural reinforcements
Location	Rhododendron Drive near New Hope Ln.
Coordinating Agencies	City of Florence Public Works Department
Implementation Timeframe	24 months
Estimated Cost	\$7-8 million
Potential Funding Sources	HUD-CDBG, OR-SRGP, HMGP, PDM, FEMA PA-106, USACE
Hazards Mitigated	Tsunami, flood, winter storm, windstorm, coastal erosion, tidal impacts
Comments	2000+ homes served by this road; ore drillings show decaying organics and wing dams have shifted the flow of the river, cutting into the bank adjacent to the roadway. This has caused a significant undercut below the compacted sand shelf.
Progress Since Last Plan	The City has completed design and engineering for the full reconstruction and shifting of this section of Rhododendron Drive. Construction is anticipated to begin in late 2023 and last two years.
Current Site Photos	

Mitigation Action Item	Seismic reinforcements or relocation for WLFEA Fire Station #2
Location	2nd St. Siuslaw Valley Fire Station #2
Coordinating Agencies	City of Florence, Western Lane Fire & EMS Authority (WLFEA)
Implementation Timeframe	Unknown
Estimated Cost	\$5 million for relocation, Just deconstruction would be less
Potential Funding Sources	HUD-CDBG, OR-SRGP, HMGP, PDM, FEMA PA-106
Hazards Mitigated	Earthquake, Tsunami,
Comments	Station #2 is in the Tsunami Inundation zone.
Progress Since Last Plan	WLFEA has executed seismic upgrades on their other fire stations. With Station #2 in the inundation zone, it did not qualify for the grants that funded the projects on the other stations. There have been discussions of relocation of the station and/or simply deconstructing that station. WLFEA currently does not respond out of Station #2, with it mainly storing items.
Current Site Photos	

Mitigation Item	Highway 126 trestle overpass at Cushman
Location	East Florence, Cushman on Hwy 126
Coordinating Agencies	City of Florence, ODOT, Railroad
Implementation Timeframe	36 Months
Estimated Cost	\$20-30 million
Potential Funding Sources	HUD-CDBG, OR-SRGP, HMGP, PDM, FEMA PA-106, ODOT
Hazards Mitigated	Tsunami, earthquake, flooding
Comments	Highway overpass at Cushman Rd., over railroad trestle.
Progress Since Last Plan	No progress has been made on this project as it is outside of the Florence jurisdiction. The current conditions cause the highway to close at extreme high tides several times of the year. Progress would need participation from the railroad and ODOT.

Section 4.4: Plan Implementation and Maintenance

In keeping with standard practices to ensure incorporation of overall goals and strategies of the NHMP, the City of Florence Natural Hazard Mitigation Planning Team members will be invited to participate in future plan development or existing plan update committees. Additionally, this NHMP will be cited as a technical reference for plan update processes. Planning documents and mechanisms applicable to this process may include the following:

- City of Florence Comprehensive Plan**
- Capital Improvement Plans**
- Emergency Management Plan**
- Local Community Wildfire Protection Plan**
- City of Florence Floodplain Development Code**
- Building Code**
- Subdivision Code**
- Erosion Control**
- Stormwater Management Plan**
- Tsunami Hazard Overlay Zone**
- Transportation System Plan**
- North Florence Dunal Aquifer Study, Aquifer Protection Plan, Drinking Water Protection Plan**

Additionally, progress to implement this plan will be monitored on an ongoing basis by city staff and administration. The planning process is essential in identifying weaknesses and strengths inherent in the community and cooperatively enables coordination with various agencies and jurisdictions that might not otherwise occur. Continuing this cooperative and interactive process is exemplified by the planning process. Annual reviews and updates under a 5-year cycle will be pursued. Using these methods, the overarching goal of a stronger, safer, more resilient community can be attained.

Section 5: City of Lowell



Version 4.0 (October 2023 – October 2028)

Developed as an annex to the Lane County Multi-Jurisdictional
Natural Hazard Mitigation Plan

Section 5.1: City of Lowell: Natural Hazard Mitigation Meetings and Work Sessions

Development of Lowell’s materials for the Natural Hazard Mitigation Plan involved participation by city staff, public works, school district, county emergency management, fire district, and law enforcement. The process followed FEMA’s prescribed model for organizing resources, identifying hazards, evaluating risk, identifying mitigation options, and prioritizing mitigation projects. For additional details regarding the planning process, please refer to Section 6 of the main document.

Table 5.1: City of Lowell Planning Team

Name	Title	Agency
Jeremy Caudle	City Administrator	City of Lowell
Max Baker	Public Works Director	City of Lowell
Don Bennett	Mayor	City of Lowell
Lon Dragt	Fire Chief	Lowell Rural Fire Protection District
Jason Pickett	Facilities Manager	Lowell School District

Individual City Work Sessions

Work sessions with individual cities were conducted following the initial project orientation meeting and intervening months between general planning group meetings. These individual work sessions are outlined below.

Table 5.2: City of Lowell Work Sessions

Date	Location	Meeting/Work Session
January 17, 2023	Lowell Rural Fire Protection District Station 1	City Council Regular Meeting
February 7, 2023	Lowell Rural Fire Protection District Station 1	City Council Regular Meeting
March 20, 2023	Lowell City Hall	Hazard Mitigation Team meeting
April 18, 2023	Lowell Rural Fire Protection District Station 1	City Council Regular Meeting

Subject matter discussed during work sessions included an overview of FEMA grant programs, discussion of common mitigation ideas, and specific project ideas for the City of Lowell. The result of this overall process was a thorough evaluation of risk factors and mitigation solutions. Certain hazards were highlighted with notable significance for Lowell, others found to be less relevant in a direct context.

Section 5.2: City of Lowell: Hazard Quantification

The City of Lowell faces high risk from the impacts of wildfire smoke, extreme heat, wildfires, and winter storms. There is also a local hazardous materials concern that is accounted for in the risk profile for this annex.

Table 5.3: Lowell Hazard Quantification Results

Hazard Type / Weight Factor (WF)	History WF x 2	Probability WF x 7	Vulnerability WF x 5	Maximum Threat WF x 10	Raw Score	Weighted Score	Weighted Score Rank
Smoke	16	70	25	90	201	240	1
Extreme Heat	16	56	40	100	212	236	2
Wildfire	16	56	25	80	177	226	3
Winter Storm	2	28	15	100	145	212	4
HazMat Incident	14	56	15	40	125	201	5
Windstorm	2	49	5	80	136	177	6
Pandemic	16	56	15	90	177	177	7
Dam Failure	2	14	15	30	61	149	8
Earthquake	16	70	40	100	226	145	9
Drought	20	70	50	100	240	136	10
Flood	16	70	50	100	236	125	11
Landslide	6	28	20	100	154	61	12

Section 5.2.1: Individual Hazard Discussions

The City of Lowell evaluated 12 natural hazards for its local risk assessment. In addition to the hazard types included in Volume I: County Base Plan, Lowell also chose to assess hazard types treated as secondary hazards or cascading impacts of those hazards evaluated countywide, namely Smoke as a component of Wildfire and Extreme Heat as a component of Extreme Weather. Lastly, Lowell addresses Pandemic and Dam Failure as hazard types although they were removed from evaluation in the County Base Plan (see Section 2.1 in Volume I for further explanation).

Smoke

Smoke from surrounding forest fires have affected the city for weeks at a time, resulting in hazardous air quality. Hazardous air quality results in canceling outdoor activity and work. Citizens with poor health conditions experience negative health effects from poor air quality.

Extreme heat

This area is experiencing a higher frequency of extreme heat events in the summer, which includes temperatures in the 90-to-100-degree range. Many residents don't have central air conditioning, which results in dangerous conditions and risk of heat exhaustion or heat stroke. Extreme heat increases the risk of wildfire.

Wildfire

Nearly every 2 years for the past 6 years, significant wildfires have threatened the city. The city has been under a Level 1 evacuation notice twice in the past 6 years. The frequency of these threats has increased in recent years. Nearby Disappointment Butte poses a risk due to heavily forested areas. Recent housing developments have been built in forested areas. The eastern section of the city is bordered by National Forest. The embers and ash from wildfires in these areas could cause spot firing within the city.

Winter Storm

A winter storm would result in city-wide power outages. Roads would be impassable and the ability to commute to the Eugene/Springfield area, 20 miles away, for supplies or medical assistance would be difficult or impossible. Downed trees could result in damage to property, blocked roadways, and downed power lines. A winter storm involving abnormally low temperatures would cause water lines to freeze and burst, in turn affecting water service to residents.

Hazardous Materials Incident

A railroad passes by the city and Dexter Reservoir. A derailment involving hazardous materials could cause pollution to Dexter Reservoir, which provides drinking water to the city. Highway 58 also passes by the city and reservoir. A wreck involving hazardous materials could have the same effect. The city's water and sewer plants use hazardous materials such as sodium hypochlorite. A spill involving these chemicals could lead to evacuation of the southern area of the city, including the school campus, as well as the reservoir. A gas station exists in the city, which receives frequent deliveries of gasoline and propane. A wreck involving the delivery trucks could result in spills that would have localized effects. Under the worst-case scenario involving hazardous material spill in the reservoir, water service would be discontinued until the spill is cleaned up.

Windstorm

An estimated 80% of electric service in the city is above ground. The main distribution system is 100% above ground. Around 2008 or 2009, a windstorm event involving 90 mile per hour winds occurred in the system, which damaged roofs and other property. In 2022, 60 mile per hour gusts existed in the city. When these events occur, the electric utilities turn off electric service as a precaution. In the summer, when temperatures are dangerously high, the lack of electric service effects citizens' ability to use air conditioning. The preventative electric turn-offs can last for several days at a time.

Pandemic

The Lowell community, like the rest of the world, recently experienced the COVID-19 pandemic. Due to the isolated nature of Lowell, the community didn't experience as high a transmission rate compared to surrounding urban areas at the outset of the pandemic. Future pandemics could result in illness or isolation of critical staff in the community, which would result in inability to respond to public health or other emergencies. Future pandemics could also cause high rates of illness or death among city residents.

Dam Failure

If the two dams near the City of Lowell fail, then a risk exists that water from a dam failure could cause extensive damage to property. Lookout Point Dam is located to the east of the city, and Dexter Dam is located to the west. The two dams are earthen and concrete structures. Abnormally high rains could cause flood water to top the dams, causing structural damage resulting in dam failure. The structures of the dams haven't been upgraded since their construction in the 1950s. Failure to Fall Creek Dam, located about 4 miles north of city limits, could possibly affect the city, as well as access into the city.

Earthquake

Compared to other areas on the west coast, the Lowell area has a low risk for earthquakes that are likely to cause property damage, though lower magnitude earthquakes do occur. A Cascadia subduction event, however, would cause catastrophic damage to property and utilities. Transportation into the city depends on the causeway leading to Pioneer Street, as well as numerous bridges in Jasper for Jasper-Lowell Road. Connection to Eugene/Springfield along Highway 58 also depends on bridges. A severe earthquake that damages bridges and connectivity would isolate Lowell for weeks. This would limit the ability of supplies and medical assistance to enter the community. A Cascadia subduction event likely would damage the dams near the city, in turn causing flooding. For that reason, the maximum threat scenario would also cause two other hazards identified in this annex—dam failure and flooding—to occur.

Drought

The city is fortunate to be located next to Dexter Reservoir, which provides drinking water for the city. Summers have become increasingly dry, which increases the risk of wildfire. The impacts to drought will be low if Dexter Reservoir continues to be a reliable source of water for the city. The city also has 3 deep wells that it can use as back-up water sources in case of prolonged drought.

Flood

The US Army Corps of Engineers operates the 3 dams in our vicinity for flood control, which minimizes the risk of flooding. Atmospheric river events and other heavy rains tend to drain into the reservoir, so risks of standing water are low. FEMA's flood maps show that some residences are in a flood plain around Dexter Reservoir. A risk does exist that the city's water treatment system cannot absorb abnormally high rain, which would result in overflows and discharges into the reservoir.

National Flood Insurance Program

The City of Lowell is a formal program participant in good standing and considers continued participation as integral to future flood mitigation efforts. Participation consists of adoption and maintenance of Flood Insurance Rate Maps (FIRMs) which define Special Flood Hazard Areas (SFHAs) and maintenance of an ordinance regulating future development in SFHAs. Compliance with the program is pursuant to the City of Lowell's floodplain ordinance.

Landslide

Landslides can occur on Highway 58 and Jasper-Lowell Road, which connect the city of urban areas. Landslides along these highways would affect ability to get supplies and assistance into the city. Hillside developments exist and are planned in the city. A risk exists that high rains or earthquakes could cause structural instability for these developments. The city's hillside development

regulations, however, mitigate the risks of structural failure on hillsides. The slopes surrounding the city tend to be gradual.

New Development in Hazard Areas

There was significant growth in housing units for the period. Areas on southern side of the city are designated as Flood Hazard Areas, and there was no development in these areas. Recent development has been located near steep slopes. Examples include the recent Crestview Estates subdivision, which is also in a wildfire hazard area. The Sunset Hills subdivision (currently under construction as of April 2023) is also located on a hillside. Finally, the Lake Town Subdivision (approved but not under construction as of April 2023) is on a hillside, too. Hillside development is subject to engineering controls and review, under the City’s hillside development ordinances. This mitigates risk of landslides and structural failure on hillsides.

Section 5.3: City of Lowell: Mitigation Projects

This section describes mitigation projects identified by Lowell during the planning process. See Volume I, Section 4 for additional information regarding mitigation action item methodology and prioritization.

Mitigation Action Item (a)	Complete backbone pipeline and water storage mitigation projects from 2022 Seismic Risk Assessment and Mitigation Plan.
Location	City-wide
Coordinating Agencies	Lowell Public Works
Implementation Timeframe	Over next 50 years
Estimated Cost	\$5,876,825
Potential Funding Sources	Infrastructure Finance Authority, USDA, general obligation, or revenue bonds
Hazards Mitigated	Earthquake, Wildfire
Comments	The existing backbone has several significant risks. The existing backbone is constructed of AC and PVC pipe, which are both known to be very susceptible to damage in a seismic event. The sole water storage tanks are constructed in or downslope of an area that has been identified as having a high risk of landslide. In addition, the core of the town has a high risk of liquefaction, leading to increased risk and severity of ground displacement, pipe breakage, and general damage.

Mitigation Action Item (b)	Complete generator and electrical service improvements at Lowell School District and Lowell Rural Fire Protection Districts to allow community warming and cooling centers.
Location	Lowell High School or Elementary School cafeteria or gym; Lowell Fire Department conference room
Coordinating Agencies	Lowell Rural Fire Protection District; Lowell School District, City of Lowell
Implementation Timeframe	By the end of 2024
Estimated Cost	School district – \$1,000,000+ to increase power sustainability to operate a community cooling or warming center. Lowell Rural Fire Protection District -- \$45,000 to install emergency generators.
Potential Funding Sources	Community Renewable Energy Project grant from Lowell School District. Application is pending.
Hazards Mitigated	Smoke; wildfire; power outages; winter storm
Comments	This project will allow the Lowell Rural Fire Protection District and Lowell School District to operate cooling or warming centers for the public.

Mitigation Action Item (c)	Explore reactivating city wells as back-up water sources to respond to hazmat, drought, or earthquake risks.
Location	Lowell Water Plant
Coordinating Agencies	Lowell Public Works Department
Implementation Timeframe	24 to 36 months
Estimated Cost	\$20,000 in engineering fees/studies
Potential Funding Sources	Water Fund budget
Hazards Mitigated	Drought, hazmat incident
Comments	Explore reactivating city wells as back-up water sources to respond to hazmat or drought. Lowell has two groundwater rights. Due to water quality concerns, these wells are held in reserve for emergency use. This action item would involve analyzing the feasibility of diluting well water with surface water from the reservoir. This would apply in cases where severe drought, poor water quality from upstream wildfire ash, or hazmat emergencies reduce how much water the city could use from the reservoir.

Mitigation Action Item (d)	Prepare city-wide evacuation plan to respond to dam failure, wildfire, and “go now” orders
Location	City-wide
Coordinating Agencies	City of Lowell, Lowell Rural Fire Protection District, Lowell School District
Implementation Timeframe	24 to 36 months
Estimated Cost	Budget staff time if done in-house; \$20,000 to \$50,000 if hiring a consultant
Potential Funding Sources	General fund budget from the 3 agencies listed above
Hazards Mitigated	Dam failure, wildfire
Comments	Prepare evacuation plan to respond to dam failure, wildfire “go now,” and so on.

Mitigation Action Item (e)	Wildfire mitigation planning and fuels reduction for areas surrounding the city
Location	City-wide
Coordinating Agencies	City of Lowell; Oregon Department of Forestry; Sunridge FireWise group
Implementation Timeframe	24 to 36 months
Estimated Cost	Wildfire mitigation - \$25,000 estimate; wildfire mitigation planning - \$25,000 to \$50,000 estimate to hire a consultant
Potential Funding Sources	Oregon Department of Forestry; FEMA; USDA; Community Wildfire Defense Grant (CWDG);
Hazards Mitigated	Wildfire
Comments	The SunRidge FireWise group is a resource for this item. The FireWise group has been active in seeking grant funding on behalf of the city to fund fuels mitigation projects. This group would also be interested in participating in the planning, and they have established a working relationship with ODF foresters.

Section 5.4: Plan Implementation and Maintenance

In keeping with standard practices to ensure incorporation of overall goals and strategy of the NHMP, the City of Lowell hazard mitigation team members will be invited to participate in future plan development or existing plan update committees. Additionally, this NHMP will be cited as a technical reference for plan update processes. Planning documents and mechanisms applicable to this process may include the following:

City of Lowell Comprehensive Plan

City of Lowell Development Code (including hillside development standards and floodplain development standards)

Building Code

Water Master Plan

Sewer Master Plan (update in progress as of April 2023)

Additionally, progress to implement this plan will be monitored on an ongoing basis by city staff and administration. The planning process is essential in identifying weaknesses and strengths inherent in the community, and cooperatively enables coordination with various agencies and jurisdictions that might not otherwise occur. Continuing this cooperative and interactive process is exemplified by the planning process. Annual reviews and update under a 5-year cycle will be pursued. Using these methods, the overarching goal of a stronger, safer, more resilient community can be attained.

Section 6: City of Oakridge



Version 4.0 (October 2023 – October 2028)

Developed as an annex to the Lane County Multi-Jurisdictional
Natural Hazard Mitigation Plan

Section 6.1: City of Oakridge: Natural Hazard Mitigation Meetings and Work Sessions

Development of the City of Oakridge’s materials for the Natural Hazard Mitigation Plan involved participation by city, county, fire district, law enforcement, community partners, and project assistants. The process followed FEMA’s prescribed model for organizing resources, identifying hazards, evaluating risk, identifying mitigation options, and prioritizing mitigation projects. For additional details regarding the planning process, please refer to Volume I, Section 6. Specific participants are listed as follows.

Table 6.1: City of Oakridge Planning Team

Name	Title	Agency
James Cleavenger	City Administrator	City of Oakridge
Bryan Cutchen	Mayor	City of Oakridge
Kevin Martin	Police Chief	City of Oakridge
Scott Hollett	Fire Chief	City of Oakridge
Rick Zylstra	Community Development Director	City of Oakridge
Robeart Chrisman	Public Works Supervisor	City of Oakridge
Sarah Altemus-Pope	Coordinator	Southern Willamette Forest Collaborative
Dustin Rymph	Projects Manager	Southern Willamette Forest Collaborative

Individual City Work Sessions

Work sessions with individual cities were conducted following the initial project orientation meeting and intervening months between general planning group meetings. These individual work sessions are outlined below.

Table 6.2: City of Oakridge Work Sessions

Date	Location	Meeting/Work Session
2/9/23	Lowell Library	Lane County NHMP Regional Workshop 1
4/17/23	Lowell Fire Station	Lane County NHMP Regional Workshop 2
3/13/23	Virtual	NHMP Steering Committee Meeting 4
4/24/23, 5/1-4/23	Virtual	Meetings with City of Westfir, the Southern Willamette Forest Collaborative (“SWFC”), and the City of Oakridge Hazard Mitigation Team (which includes SWFC staff) to discuss mitigation strategies and the NHMP Oakridge Annex.
9/1/22	Oakridge City Hall	City Council adopts the 2020 Lane County Community Wildfire Protection Plan (“CWPP”) through Resolution 05-2022
5/4/23	Oakridge City Hall	City Council adopts the 2021 Oakridge Smoke Safety and Community Response Plan through Resolution 06-2023.
4/6/23, 5/25/23	Oakridge	Community Disaster Readiness Group planning meetings
8/1/22, 9/5/22, 10/3/22, 11/7/22, 12/5/22, 1/1/23,	Oakridge	Oakridge Fire Safe Council Meetings

2/6/23, 3/5/23, 4/2/23, 5/2/23		
2/28/23, 3/28/23, 4/25/23, 5/23/23	Oakridge	Oakridge Public Safety Advisory Committee Meetings
Every 4th Thursday of the month (too many to list)	Oakridge Fire Station	Hazeldell Rural Fire District Meetings
8/25/22, 9/22/22, 10/27/22, 11/22/22, 1/26/23, 2/23/23, 3/23/23, 5/25/23	Oakridge Fire Station	Oakridge/Westfir/Hazeldell Special Fire District Joint Subcommittee Meetings
10/20/22, 12/5/22	Oakridge	Cedar Creek Fire Debriefings & After-Action Review Workshops
8/4/22, 9/23/22, 10/28/22, 2/23/23, 1/27/23, 3/29/23, 4/20/23, 4/27/23	Oakridge	Oakridge Willamette Activities Center (“WAC”) Funding Committee Meetings
12/5/22	Oakridge	Cedar Creek Fire Internal After-Action Review Released
7/7/22, 8/15/22, 10/3/22, 11/15/22, 2/6/23, 4/3/23, 5/1/23	Oakridge City Hall	Oakridge Willamette Activities Center (“WAC”) Advisory Subcommittee Meetings
5/8/23	Virtual	NHMP Steering Committee Meeting 5
3/6/23, 4/5/23, 4/20/23, 4/24/23, 5/1/23	Virtual	Oakridge NHMP Annex Planning Meetings
2/9/23	Virtual	Lane County NHMP Kick-Off Meeting
11/28/22	Virtual	Lane County NHMP Risk Assessment Meeting
1/23/23	Virtual	Lane County NHMP Mitigation Strategy Meeting
5/1/23	Virtual	FEMA Fire Management Assistance Grant (FMAG) FM-5457 Briefing for 2022 Cedar Creek Fire
5/21/21	Oakridge	Oakridge-Westfir Community Wildfire Safety Night 2021
7/14/22	Oakridge	Oakridge-Westfir Community Wildfire Safety Night 2022
7/14/23	Oakridge	Oakridge-Westfir Community Wildfire Safety Night 2023
Sept. 2023-Present	Oakridge	Air Purifier distribution after Cedar Creek Fire
1/27/23	N/A	Cedar Creek Fire FEMA Disaster Declaration FM-5457-OR

Section 6.2: City of Oakridge: Hazard Quantification

Table 6.3 provides the results for the hazard quantification process for the City of Oakridge.

Table 6.3: Oakridge Hazard Quantification Results

Hazard Type / Weight Factor (WF)	History WF x 2	Probability WF x 7	Vulnerability WF x 5	Maximum Threat WF x 10	Raw Score	Weighted Score	Weighted Score Rank
Wildfire	10	10	8	10	38	230	1
Flood	8	8	10	10	36	222	2
Winter Storm	8	10	8	9	34	216	3
Windstorm	8	8	7	7	30	177	4
Drought	5	8	7	7	27	171	5
Earthquake	2	3	4	10	19	145	6
Dam Failure	0	1	6	9	16	127	7
Extreme Weather	5	5	3	5	18	110	8
Landslide	5	4	4	4	17	98	9

Source: City of Oakridge Hazard Mitigation Team

Section 6.2.1: Individual Hazard Discussions

Wildfire

Oakridge is surrounded by the Willamette National Forest. While the valley floor is relatively clear of the tall pine trees on the mountain slopes, the community is nonetheless surrounded by country susceptible to wildfire. History of wildfire in the area of Oakridge is high, with more several instances of nearby wildfires impacting the city. The probability of this continuing in the future is high that a similar pattern will continue. Vulnerability is moderated by response capability, and the removal of vegetation from the urban-wildland interface for fire protection. Maximum threat involves potential for damage to numerous structures and forest tracts, and the potential for a rapidly moving fire to sweep through or over the city under the right conditions. See also wildfire hazard profile in Section 2 of Volume I.

Flood

Flood is a geographically contained hazard, which in the Oakridge valley, is one with real potential for occurrence. The Oakridge area is a sloped valley in the foothills of the Cascade Range surrounded by the Willamette National Forest. Five streams pass through this relatively small area between mountain ridges: Salmon Creek, Salt Creek, Hills Creek, and the Middle and North forks of the Willamette River. These five tributaries join to create the Middle fork of the Willamette River, which flows Northwest into Lookout Point Lake, a U.S. Corps of Engineers Willamette Valley Project Dam. Oakridge is less than 5 miles west of the Hills Creek Dam, another U.S. Army Corps of Engineer’s project, which was installed to control seasonal flooding down in the larger Willamette Valley.

The history of flooding in Oakridge is high as the geography the city is built upon is created from repeated floods in the past. It is a significant egress for melting winter snows from the surrounding mountains. The future probability for flooding is relatively high, primarily due to the weakening and near

complete breach of the Salmon Creek levy during the 2019 winter storm (AKA “Snowmagedon”), the severity of which was 2nd only to the 1964 winter flood. The Salmon Creek levy is located inside city limits and next to Hwy 58, which is the *only* route in and out of the city. The entire levy, for which the city is responsible for upkeep, is approximately 1 mile long and it abuts 2 mobile home parks. It has been continuously eroding and is estimated to cost \$5-10m to permanently fix. Flash flood warnings are also quite common for Oakridge. Overall vulnerability and maximum threat scores are very high, widespread severe damage from flooding is likely in the future, as reflected in the National Flood Insurance Program.

National Flood Insurance Program: The City of Oakridge is a formal program participant in good standing and considers continued participation as integral to future flood mitigation efforts. Participation consists of adoption and maintenance of Flood Insurance Rate Maps (FIRMs) which define Special Flood Hazard Areas (SFHAs) and maintenance of an ordinance regulating future development in SFHAs. Oakridge has 2 Flood Insurance Rate Map Community Numbers: **41039C2476F** for the west side of the city and **41039C2477F** for the east side. Compliance with the program is pursuant to the City of Oakridge’s floodplain ordinance (#939). The southern part of the city is designated a “Special Flood Hazard Area.”

Winter Storm

Oakridge, like many cities in Oregon, face winter storms at least once a year. In Oakridge, winter conditions including significant snowfall are regular occurrences due to the city’s elevation (1200’-1600’). The city contains a network of above ground electrical lines vulnerable to damage from falling trees during winter storms. Recent history has seen storms causing damage and power loss nearly every year, with wind usually being a contributing factor.

Probability is high that patterns of previous occurrence will continue. The percentage of population potentially affected by winter storm is also high, since effects are not geographically contained and the city itself is situated on the western side of the Cascade Mountains, where weather can intensify due to the forced uplift of air caused by the mountains surrounding the city on all sides, resulting in a high vulnerability level. Transportation and roadways are also vulnerable to closure during winter storms, with Oregon State Hwy 58 being the *only* viable route in and out of the city. And as you travel east out of Oakridge, Hwy 58 quickly gains additional elevation until it reaches 5100’ at Willamette Pass.

Maximum threat is also high, due primarily to the 2019 “Snowmagedon” winter storm, which cut-off the cities of Oakridge and Westfir* for almost a week, after nearly 3 feet of snow fell in 3 days, leaving the cities totally isolated and without power. The cities’ water and sewer plants remained functional thanks to generators (but they *nearly* ran out of fuel). See the City of Oakridge’s After-Action Report for the 2019 winter storm for more details. Like many other parts of the western US, the winter of 2022-2023 has seen snowpacks well above average as well, the impacts of which are not yet known at the time of writing this annex.

**The City of Oakridge provides police and fire protection services to the City of Westfir through an Intergovernmental Agreement that has been renewed annually.*

Windstorm

Like winter storms, windstorms frequently impact above-ground electrical lines vulnerable to damage from falling limbs and trees. Recent history includes damage caused by windstorms on a nearly yearly basis, which is reflected in the high Probability score. Overall vulnerability is also high, with roadways vulnerable to closure due to downed trees, and loss of power due to damage to powerlines, such as during the 2019 winter storm as further described in the winter storm section. The Columbus Day storm of 1962 was another severe example for maximum threat, wherein reports noted that 40 trees were downed on Hwy 58, in just a single mile of roadway, trapping 19 vehicles. A windstorm of severe magnitude could potentially damage numerous homes in city, either by direct structural damage, falling trees, or blown debris.

Drought

Drought is neither life threatening nor presents a direct risk to structures but does involve potential for some disruption if dramatic water shortage were to develop. Drought can exacerbate wildfire risk as related hazards, and a water shortage may affect the entire city uniformly. History is considered moderate, with 2 to 3 events occurring over the last 100 years. The probability of this reoccurring is high, part of a normal cycle over time. Vulnerability is medium as Oakridge has access to five sources of river water, and two large reservoirs. Maximum threat is moderately high, particularly when combined with an active fire season.

Earthquake

Earthquake is unique, in that it occurs much less frequently, but has the potential to cause more catastrophic damage. Oakridge is located near three crustal earthquake faults. Small (1-3 in magnitude) earthquakes have occurred in the area, causing little damage and often going unfelt by residents. From a geographic standpoint, occurrence would presumably affect the entire city uniformly, should a higher magnitude event occur. Probability of a larger earthquake is low in any given year, but eventually the Cascadia Subduction Zone will give way. Vulnerability is complex to assess due to varying standards of construction. While most new construction is relatively sound, most the older construction, which accounts for most of the city, is not.

When the Cascadia Subduction Zone off the Oregon Coast does finally give, Oakridge can expect to feel very strong shaking according to DOGAMI and the State of Oregon Office of Emergency Management. Minor to moderate damage to numerous structures, roadways, and bridges is also expected. The city's aging water & sewer system, much of which is from before the 1950's, is also extremely vulnerable to earthquakes and needs to be upgraded.

Dam Failure

There is no history of dam failure affecting Oakridge, so probability is low. But vulnerability & maximum threat are higher considering the Hills Creek Dam is located less than 5 miles east of the city and is at a higher elevation, which would result in people having almost no warning if the dam failed. The damages would also be catastrophic, as the water would have nowhere to go except towards Oakridge. The dam can generate power, but it is not currently utilized.

Extreme Weather

This is a new category in our NHMP Annex. Extreme weather events which could and have affected Oakridge include thunderstorms, hail, extreme cold, and extreme heat. Dry thunderstorms pose the greatest risk when coupled with extreme heat, leading to the very real possibility of large wildfires, including the 2022 Cedar Creek Fire. Wet thunderstorms which often occur during the summer can include hail, affecting crops and animals located outdoors.

Landslide

Oakridge and the surrounding area are susceptible to landslides at any time of year and they occur frequently. However, the probability is higher in the surrounding hillsides after rain & snow events. Vulnerability is moderate due to potential closures of Hwy 58, which is the *only* viable route in and out of Oakridge. Although most landslides are usually minor in severity, their maximum threat level in Oakridge is a high medium due to the city's isolated location. During the 2019 winter storm, multiple landslides on Hwy 58 *completely* cut-off access to the city for almost a week, making it impossible for emergency services to get to the city and no one could get out. A landslide could also alter the course of one of the many rivers and creeks which flow through Oakridge, which could cause potential flooding.

New Development in Hazard Areas

There was no new development in the City of Oakridge during the planning period. It is noted that areas on south side of the city are designated as Special Flood Hazard Areas and areas to the north and east are steeper, forested slopes, which are more vulnerable to wildfires.

Section 6.3: City of Oakridge: Mitigation Projects

This section describes mitigation projects identified by the City of Oakridge during the planning process. To see a more detailed description of Lane County’s planning process, please see Volume I, Section 6.

Mitigation Action Item (a)	Retrofit/mitigation remodeling of the Willamette Activity Center to serve as an Emergency Operations Center, community disaster shelter, recovery center, and clean air space. Electrical, structural, communications, power (backup generator and solar power), and ADA upgrades.
Location	Willamette Activity Center, downtown Oakridge
Coordinating Agencies	City of Oakridge
Implementation Timeframe	12-18 Months
Estimated Cost	\$3-6 million (additional)
Potential Funding Sources	HUD-CDBG, OR-SRGP, HMGP, PDM, FEMA, PA-106, Fed/State Gov
Hazards Mitigated	Earthquake, flood, winter storm, windstorm, dam failure, wildfire
Comments	The Willamette Activity Center is currently condemned but has received \$1.5 million from the Oregon State Legislature to start remodeling it as a community center. It is estimated that an additional \$3-6 million will be needed to remodel and upgrade the building to serve as an Emergency Operation Center and disaster shelter & recovery center and additional funding is currently being sought. The EOC will be a separate portal housing a JIC and press/community briefing room.
Current Site Photos	

Mitigation Action Item (b)	Seismic, flood-proofing, storm-hardening retrofitting, as well as electrical, communications, plumbing, structural, and roofing upgrades for the Oakridge City Hall and Police Department building.
Location	Oakridge Police Department, uptown Oakridge
Coordinating Agencies	Oakridge City Council, Oakridge Police Department and Public Works
Implementation Timeframe	12-18 months
Estimated Cost	\$1-2 million
Potential Funding Sources	HUD-CDBG, OR-SRGP, HMGP, PDM, FEMA, PA-106
Hazards Mitigated	Earthquake, flood, winter storm, windstorm, wildfire, extreme weather
Comments	The Police Department is the lower floor/basement of City Hall. This project would create a protected & contained space for city employees for continuity of government in the event of a disaster.
Current Site Photos	

Mitigation Action Item (c)	Water intake upgrades for a secondary surface water source as back-up to the aging ground water system.
Location	Oakridge wellfields and Salt Creek canal rehab adding micro-hydro
Coordinating Agencies	Oakridge Public Works
Implementation Timeframe	12-18 months
Estimated Cost	\$5-7 million
Potential Funding Sources	HUD-CDBG-DR, HMGP, PDM, FEMA, PA-406
Hazards Mitigated	Drought, wildfire, hazardous materials contamination, earthquake
Comments	This project would also rehabilitate the Salt Creek Canal, adding additional water storage, treatment, and transmission capabilities (including micro-hydro), and for which a 2012 feasibility study was done. A 2015 Wellfield and Storage Reservoir Feasibility Study was also done. Secondary water source needed as backup for existing surface water system that is currently not functioning. The City of Oakridge holds water rights to two rivers, but rehab is needed to utilize either source. The Canal can be piped, and micro-hydro generation added at multiple sites to create a backup power source.
Current Site Photos	

Mitigation Action Item (d)	Emergency supply storage building and purchase and installation of a fuel storage tanks for the Oakridge Fire Station and Oakridge Public Works Shop.
Location	Oakridge Fire Department
Coordinating Agencies	City of Oakridge, Oakridge Public Works, Oakridge Fire Department
Implementation Timeframe	12-18 months
Estimated Cost	\$750,000-1,500,000
Potential Funding Sources	FEMA, HMGP
Hazards Mitigated	Earthquake, wildfire, windstorm, flood, winter storm
Comments	The Oakridge Fire Department’s fire district service area is 28 square miles, and its ambulance service district area is 2,200 square miles (2,200 is not a typo). The next nearest fire department is 30 miles away in Dexter, and the next nearest ambulance service is 45 miles away in Springfield. Due to more frequent events resulting in Hwy 58 being closed, shutting off all outside access to Oakridge, including the 2019 winter storm, it is vital that the city has its own fuel stores and emergency supplies, since outside help after a disaster may not be possible. The Oakridge Public Works Department is also in need of additional fuel storage. Each fuel storage tank is estimated to cost around \$250,000 to purchase and install. A photo of the existing tank at the Oakridge Public Works Shop is below.
Current Site Photos	

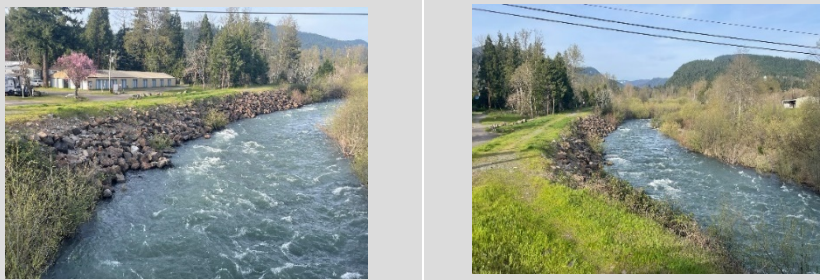
Mitigation Action Item (e)	Repair and harden the Salmon Creek levy to withstand earthquakes, storms, and more frequent flood events, including the 2019 winter storm.
Location	Salmon Creek Levy
Coordinating Agencies	Oakridge City Council, Oakridge Public Works
Implementation Timeframe	12-18 Months
Estimated Cost	\$5-10 million
Potential Funding Sources	HUD-CDBG, OR-SRGP, HMGP, PDM, FEMA, PA-106
Hazards Mitigated	Earthquake, flood, winter storm, landslide, extreme weather
Comments	The approximately 1-mile-long levy protects the Oregon Department of Fish and Wildlife’s Willamette Fish Hatchery, 2 RV parks, the Roaring Rapids neighborhood, and a major bridge on Oregon State Highway 58. The levy broke and nearly flooded the city in 2019 and 2022. The first photo below is of the levy almost breaching during the 2019 winter storm and the next two photos are of the same part of the levy today.
Current Site Photos	

Mitigation Action Item (f)	Repair and harden the City’s aging stormwater and wastewater systems to withstand major storms and other natural hazard events.
Location	Stormwater system upgrades
Coordinating Agencies	Oakridge City Council, Oakridge Public Works
Implementation Timeframe	1-2 years
Estimated Cost	\$5-6 million
Potential Funding Sources	HUD-CDBG, OR-SRGP, HMGP, PDM, FEMA, PA-106
Hazards Mitigated	Earthquake, flood, winter storm, extreme weather
Comments	During the 2019 winter storm, the city nearly ran out of fuel for the generators to operate the water system, and during the 2022 Cedar Creek Fire a mainline pipe broke causing an estimated \$500,000 in damages to the system (see photos below).
Current Site Photos	

Mitigation Action Item (g)	Repair, upgrade, and fire-harden the City owned emergency communications system (radio tower and building) located on Dead Mountain (land leased from USFS). Adding a secondary system on nearby Wolf Mountain could also be considered but is <i>not</i> included in cost estimates.
Location	Emergency communications tower at Dead Mountain
Coordinating Agencies	Oakridge Police, Fire, and Public Works, USFS, ODOT, LCSO, OSP
Implementation Timeframe	12-18 Months
Estimated Cost	\$1-1.5 million
Potential Funding Sources	HUD-CDBG, OR-SRGP, HMGP, PDM, FEMA, PA-106, ODOT
Hazards Mitigated	Earthquake, wildfire, flood, winter storm
Current Site Photos	

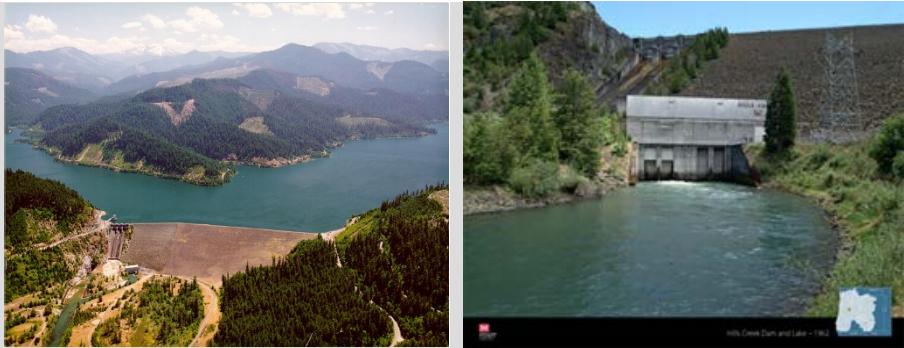
Mitigation Action Item (h)	Automating power from the Hills Creek Dam to provide an additional source of power to the Oakridge area during power outages.
Location	Hills Creek Dam, 5 miles east of Oakridge
Coordinating Agencies	City of Oakridge Public Works, US Army Corp of Engineers, Bonneville Power Administration (“BPA”)
Implementation Timeframe	UNK
Estimated Cost	UNK
Potential Funding Sources	HUD-CDBG, OR-SRGP, HMGP, PDM, FEMA, PA-106, BPA, USACE
Hazards Mitigated	winter storm, extreme weather, wildfire
Comments	Automating power from the Hills Creek Dam (photos below) to provide an additional source of power to the Oakridge area during power outages. The dam was reenergized during the 2019 winter storm, but it took almost a week for the US Army Corps of Engineers to do this due to the system not being automated.
Current Site Photos	

Mitigation Action Item (i)	Increase community awareness and education regarding natural hazards by funding the recently created “Community Disaster Readiness Group,” organized and managed by Southern Willamette Forest Collaborative (SWFC).
Location	City of Oakridge
Coordinating Agencies	City of Oakridge and Southern Willamette Forest Collaborative
Implementation Timeframe	Already started but need additional funding to continue
Estimated Cost	\$50,000-\$250,000
Potential Funding Sources	HUD-CDBG, OR-SRGP, HMGP, PDM, FEMA, PA-106, CWDG
Hazards Mitigated	All
Comments	<p>SWFC, which started the “Community Disaster Readiness Group,” is also the umbrella organization for South Willamette Solutions (SWS) and Oakridge Air, two additional NGO’s which work closely with the cities of Oakridge and Westfir on natural hazard mitigation projects. After the 2022 Cedar Creek Fire, SWFC was able to procure over 1,000 air purifiers, which they then distributed to Oakridge & Westfir citizens, who endured 37 days of unhealth air quality (AQI) in 2 months (September 1, 2022 to October 31, 2022), including 9 days in the “Hazardous” range (over 300 AQI – see the photos below of the 533 AQI reading on 10/8/22, smoke during this time period, and SWFC giving out purifiers in response). SWFC also created the Oakridge Fire Safe Council. Oakridge Air has been producing the annual “Community Wildfire Safety Night” since 2021. SWFC Coordinator & Founder Sarah Altemus-Pope and SWFC Projects Manager Dustin Rymph are both members of the City of Oakridge’s Hazard Mitigation Team.</p>
Current Site Photos	

Mitigation Action Item (j)	Repair the Oakridge State Airport (5SO) runway to keep it operational.
Location	Oakridge Airport
Coordinating Agencies	State of Oregon, Oregon Dept of Aviation
Implementation Timeframe	12-18 Months
Estimated Cost	\$2,642,000
Potential Funding Sources	HUD-CDBG, OR-SRGP, HMGP, PDM, FEMA, PA-106, State Legislature
Hazards Mitigated	All
Comments	<p>The Oakridge State Airport (pictured below, airport identifier 5SO) has been the home to firefighting air assets (planes and helicopters) <i>every fire season since 2019</i>. Without these assets, it is highly likely that the 2020, 2021, and 2022 wildfires would have entered Oakridge and/or Westfir.</p> <p>But the condition of the runway has deteriorated to the point it may soon be closed by the state. The airport is vital to the citizens of Oakridge, not only for firefighting efforts, but also for landing Life Flight helicopters for hospital transports (the nearest hospital is 50 miles away and Oakridge only has 1 health clinic, which is only open weekdays 9-5). The current estimated cost to fix the runway is 2,642,000 (based on a 2022 estimate prepared by Precision Approach Engineering).</p>
Current Site Photos	

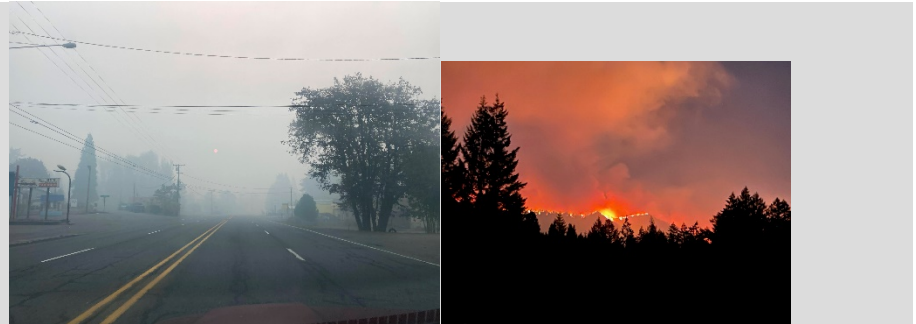
Mitigation Action Item (k)	Increase defensible space and wildfire fuels reduction efforts.
Location	Oakridge and surrounding areas
Coordinating Agencies	Cities of Oakridge & Westfir, USFS, SWFC
Implementation Timeframe	Already started
Estimated Cost	\$20-30 million in additional funding
Potential Funding Sources	HUD-CDBG, OR-SRGP, HMGP, PDM, FEMA, PA-106
Hazards Mitigated	Wildfire
Comments	<p>Reduction of fuels around structures to reduce wildfire risks is critical to the very survival of the cities of Oakridge and Westfir. This was most apparent last year during the 2022 Cedar Creek Fire, which burned nearly 130,000 acres of the Willamette National Forest and came within less than 8 miles of the outskirts of both cities, causing a Level-3 evacuation of both cities for almost 3 days. Some areas remained at a Level-2 evacuation notice for an additional <i>2 months</i>.</p> <p>Thanks to a \$225,350 Community Wildfire Risk Reduction Grant from the Oregon State Fire Marshal’s Office just granted to the City of Oakridge on 5/1/23, as well as another \$484,950 grant to the SWFC, work on wildfire fuels reduction in and around Oakridge will begin this spring (2023). However, it is estimated that an <i>additional</i> \$20-30 million would be required to fully mitigate wildfire danger in the surrounding area, including land owned by the US Forest Service (the Willamette National Forest), Lane County, and private property. Additional grants are being sought by the City of Oakridge and the SWFC.</p> <p>The photos below are from the 2022 Cedar Creek Fire and current wildfire fuels reduction efforts. The Oakridge Fire Department was also recently awarded a Wildland Firefighting Type III Engine. However, due to lack of funding, most Oakridge firefighters are not yet wildland fire certified/trained.</p>
Current Site Photos	

Items for Lane County to Consider

Oakridge Airport repairs, automate power switchover between Hills Creek Reservoir/Dam and Lookout Reservoir/Dam, help fund the Oakridge Fire Department’s 28 square mile fire district service area and its **2,200 square mile** (2,200 is not a typo) ambulance service district area.

Section 6.4: Plan Implementation and Maintenance

In keeping with standard practices to ensure incorporation of overall goals and strategy of the NHMP, the City of Oakridge hazard mitigation team members will be invited to participate in future development or existing plan update committees. Additionally, this NHMP will be cited as a technical reference for future update processes. Planning documents and mechanisms applicable to this process may include the following:

- City of Oakridge Comprehensive Plan**
- Oakridge Capital Improvement Plans**
- 2020 City of Oakridge Emergency Operations Plan**
- 2018 Oakridge Fire Department Staffing Needs Assessment**
- 2019 Winter Storm Internal After-Action Report**
- 2020 Lane County Community Wildfire Protection Plan (“CWPP”)**
- 2021 Oakridge Smoke Safety and Community Response Plan**
- 2022 Cedar Creek Fire Internal After-Action Report**
- 2022 Lane County Climate Action Plan**
- 2021 City of Oakridge Community Evacuation Plan**
- 2012 Salt Creek Canal Rehabilitation Feasibility Study**
- 2015 Wellfield and Storage Reservoir Feasibility Study**
- City of Oakridge Strategic Plan 2020-2025**
- City of Oakridge Floodplain Development Ordinance**
- City of Oakridge Building, Planning, Erosion Control, and Subdivision Codes**
- City of Oakridge Stormwater Management Plan**
- City of Oakridge Ordinance 939 (Floodplain Subdistrict Ord.)**

Additionally, progress to implement this plan will be monitored on an ongoing basis by city staff and administration. Annual reviews and updates under a 5-year cycle will be pursued. By using these methods, the goal of a stronger, safer, more resilient community can be attained.

Section 7: City of Veneta



Version 4.0 (October 2023 – October 2028)

Developed as an annex to the Lane County Multi-Jurisdictional
Natural Hazard Mitigation Plan

Section 7.1: City of Veneta: Natural Hazard Mitigation Meetings and Work Sessions

Development of the City of Veneta’s materials for the Natural Hazard Mitigation Plan involved participation by city, county, fire district, law enforcement, and project assistants. The process followed FEMA’s prescribed model for organizing resources, identifying hazards, evaluating risk, identifying mitigation options, and prioritizing mitigation projects. For additional details regarding the planning process, please refer to Volume I, Section 6. Specific participants are listed as follows.

Table 7.1: City of Veneta Planning Team

Name	Title	Agency
Cole Haselip	Management Analyst	City of Veneta
Kyle Schauer	Public Works Director	City of Veneta
Matt Laird	Community Development Director	City of Veneta

Individual City Work Sessions

Work sessions with individual cities were conducted following the initial project orientation meeting and intervening months between general planning group meetings. These individual work sessions are outlined below.

Table 7.2: City of Veneta Work Sessions

Date	Location	Meeting/Work Session
02/07/2023	Eugene EM office	XSP Valley Region Workshop 1
04/12/2023	88184 8 th St. Veneta, OR 97487	Natural Hazards Risk Assessment Work Session
04/26/2023	Eugene EM office	XSP Valley Region Workshop 2

The result of this overall process was a thorough evaluation of risk factors and mitigation solutions. Certain hazards were highlighted with notable significance for the City of Veneta, others found to be less relevant in a direct context. Systems and concepts considered included infrastructure resiliency, transportation network, public safety, public and private facilities. A range of both general and specific mitigation ideas and projects were identified and scoped in the field.

Section 7.2: City of Veneta: Hazard Quantification

Table 7.3 provides the results of the hazard quantification process for the City of Veneta.

Table 7.3: Veneta Hazard Quantification Results

Hazard Type / Weight Factor (WF)	History WF x 2	Probability WF x 7	Vulnerability WF x 5	Maximum Threat WF x 10	Raw Score	Weighted Score	Weighted Score Rank
Winter Storm	10	10	7	6	33	185	1
Wildfire	6	8	7	7	28	173	2
Windstorm	10	8	5	7	30	171	3
Extreme Weather	10	10	5	3	28	145	4
Flood	8	7	4	5	24	135	5
Earthquake	2	2	5	7	16	113	6
Drought	2	2	2	7	13	98	7
Volcano	1	1	2	4	8	59	8
Landslide	0	1	2	3	6	47	9

Source: City of Veneta Hazard Mitigation Team

Section 7.2.1: Individual Hazard Discussions

Winter Storm

Like most cities Veneta contains an extensive network of above ground electrical lines vulnerable to damage from falling limbs and trees during winter storms. Recent history has been frequent including notable damage and power loss in recent winter seasons such as the 2019 “Snowmageddon” event. Wind has been a contributing factor in recent winter storms. A volunteer operated warming center has been established a local church to provide shelter for vulnerable populations in cold weather. Probability is considered high that patterns of previous occurrence will continue. Overall population potentially affected by winter storm is high since effects are not geographically contained. Transportation and roadways are vulnerable to closure during winter storms, though the city benefits from primarily level terrain with exception of western outskirts. Maximum threat is more moderate however due to somewhat limited threat of structural damage directly related to winter weather (cold, snow, ice).

Wildfire

Veneta benefits from excellent response capability (Lane Fire Authority headquarters and ODF station). A significant number of structures/properties exist near wildland-urban interface, particularly west and south quadrant. The City of Veneta partnered with ODF to complete a wildfire fuels reduction project in the southwestern quadrant of the City 2021-2022. There are also some wildfire vulnerable areas in the eastern portion of the City, along the railroad, and the City public works headquarters. The 2021-22 wildfire fuels reduction project mitigated some of the threat along the railroad at Territorial Hwy. and Brooker and significantly reduced the threat surrounding the City public works yard. Moderate drought conditions in recent years have caused tree death and an associated increase in wildfire fuels. The City has not experienced a history of wildfire within or near City limits. However, small spot fires have

occurred within and surrounding the City. Vulnerability is moderated by response capability and relatively new and safely constructed housing in the wildland urban interface. Some homes in the Territorial Hwy/Cheney and Territorial Hwy./E. Bolton areas of the City are concerning due to a high percentage of wooden exterior features. However, these homes are relatively distanced from wildfire-prone areas. Maximum threat does involve the potential for damage to numerous structures and forest tracts.

Windstorm

Similar to winter storm, windstorm can and frequently does impact above ground electrical lines vulnerable to damage from falling limbs and trees. Recent history includes notable damage and power loss in 2014 and 2015. Numerous large trees fell at the city park in December 2015 windstorm, also damaging roof of city library. Emergency measures were taken to fall a tree threatening the city library. This same event resulted in residential structure damage in western portion of city. Probability is considered moderate-high that patterns of previous occurrence will continue. Overall vulnerability is considered moderate, roadways are notably vulnerable to closure similar to winter storms. The Columbus Day storm of 1962 can serve as an example for maximum threat, with winds measured at 86 mph in Eugene and presumably similar in Veneta. A windstorm of similar magnitude to the Columbus Day Storm could potentially damage numerous of homes in city, either by direct structural damage, falling trees, or windblown debris. Due to its location on eastern slope of Coast Range foothills the city may have a slight protective factor from extreme wind as compared to fully exposed areas.

Extreme Weather

Extreme weather events, such as extremely high or extremely low temperatures, have occurred frequently and seasonally in the City of Veneta. Normally, extremely high temperatures occur in summer months and extremely low temperatures occur in winter months. Every recent year has at least one occurrence of both extremely high and extremely low temperatures. Extreme temperatures may have been particularly worse in recent years due to the occurrence of a prolonged “La Nina” event in the Southern Pacific. “La Nina” is often associated with extreme temperatures. Extreme temperature events may also become more often due to climate change. A volunteer operated warming center has been established a local church to provide shelter for vulnerable populations in cold weather. A volunteer operated cooling center has been established at the Fern Ridge Service Center in Veneta, OR. Overall vulnerability and maximum threat scores are low because most structures in the City of Veneta can withstand extreme temperatures.

Flood

Flood is a geographically contained hazard and widespread impacts in Veneta are unlikely. Neighborhood flooding issues at Cherry Lane-Oak Island Drive, and Territorial Hwy-Cheney Drive are notable. Though located just outside city limits, road inundation on Territorial Hwy north of the city is relatively frequent concern and Long Tom River floodplain in similar vicinity. History of flooding is well noted, future probability relatively high. Overall vulnerability and maximum threat scores are somewhat lower as widespread severe damage from flooding has relatively low probability.

National Flood Insurance Program

The City of Veneta is a formal program participant in good standing and considers continued participation as integral to future flood mitigation efforts. Participation consists of adoption and maintenance of Flood Insurance Rate Maps (FIRMs) which define Special Flood Hazard Areas (SFHAs) and maintenance of an ordinance regulating future development in SFHAs. The Flood Insurance Rate Map Community Number for Veneta is **410128**. Compliance with the program is pursuant to the City of Veneta's floodplain ordinance.

Statistics as reported by FEMA on the NFIP Bureau Net for the period of January 1, 1978, through January 1, 2023, are as follows:

NFIP Policies in Force

Policies in Force: **8**

Insurance in Force: **\$ 2,415,000**

Premium in Force: **\$ 2,865**

Insurance Claim Data

Total Losses: 3

Closed Losses: 3

Open Losses: 0

CWOP Losses: 0

Total Payments: **\$7,301.48**

Data Definitions

Policies In Force – Policies in force on the "as of" date of the report.

Insurance In Force – The coverage amounts for policies in force.

Written Premium in Force – The premium paid for policies in force.

Total losses – All losses submitted regardless of the status.

Closed losses – Losses that have been paid.

Open losses – Losses that have not been paid in full.

CWOP losses – Losses that have been closed without payment.

Total Payments – Total amount paid on losses.

Earthquake

Earthquake is somewhat unique as it occurs much less frequently but has potential for significant damage and disruption. From a geographic standpoint occurrence would presumably affect the entire city uniformly. History of occurrence dates back over long-time scales. Probability is low in any given year. Vulnerability is complex to assess due to varying standards of construction, but newer construction is considered relatively sound. Maximum threat is expected to involve minor-moderate damage to numerous structures. Importance of resiliency of infrastructure is notable.

Drought

Drought is neither life threatening nor presents a direct risk to structures but does involve potential for significant disruption if dramatic water shortage were to develop. Drought can exacerbate wildfire risk as related hazards, and a water shortage would likely affect the entire city uniformly. History and probability are considered relatively low. Vulnerability is relatively low as Veneta maintains redundancy to its water supply network. Maximum threat is relatively high if an event occurred where all water supply systems were to become inoperable or water supply unexpectedly ran short.

Volcano

Volcano is like earthquake in that it occurs very infrequently. Veneta is situated approximately 80 miles from the closest volcano source, far enough to minimize probable impacts to minor ash-fall across the city if wind patterns allow. History, probability, and vulnerability are relatively low, maximum threat considered moderate.

Landslide

Landslide is considered to have very low history, probability, and vulnerability rankings, as the majority of Veneta is situated on level terrain. Maximum threat would likely involve a slide in Bolton Hill area on south-western portion of city. Infrastructure could be affected, but most likely in combined scenario initiated by earthquake.

New Development in Hazard Areas

For the City of Veneta there was significant growth in housing units for the period. Areas on north side of the city are designated as Special Flood Hazard Areas and there was no development in these areas. Areas to the west are steeper, forested slopes. There was one (1) single-family dwelling built at the base of a steep slope at 24674 Bolton Hill Rd., Veneta, OR 97487. Although Aspen Heights Subdivision has many vacant lots adjacent to steep slopes, none have been constructed after 2012.

Development in the urban-wildland interface (abutting heavily forested areas) is as follows: 43 single-family dwellings “in the urban wildfire interface” Applegate Landing Phase 3 lots (42 total) were the only ones developed in 2012 next to vacant land. The only other dwelling that was built in that period is the house at 24674 Bolton Hill Rd., Veneta, OR 97487 that was previously mentioned in the City’s steep slope area. Wildfire risk can be mitigated by adequate defensible space around structure perimeters.

Section 7.3: City of Veneta: Mitigation Projects

This section describes mitigation projects identified by the City of Veneta specific to its local context during the planning process. See Volume I, Section 4 for additional information regarding mitigation action item methodology and prioritization.

Mitigation Action Item (a)	All hazards threat assessment of City facilities
Location	Several sites within the City of Veneta. All Veneta lift stations, water/sewer treatment plant, Veneta City Hall, Veneta Public Works Yard, Bolton Hill Water Tower, and Veneta Parks and Recreational Facilities
Coordinating Agencies	City of Veneta
Implementation Timeframe	12-24 months
Estimated Cost	est. \$50,000-\$100,000
Potential Funding Sources	FEMA and State Grants
Hazards Mitigated	All Hazards
Comments	The goal of this project is to assess the threat that all hazards could pose to each City facility. Once City facilities are assessed, the City can develop plans to improve them to mitigate the threat of worrisome natural hazards.

Section 7.4: City of Veneta: Plan Implementation and Maintenance

To ensure the incorporation of the overall goals and strategies of the NHMP, the City of Veneta hazard mitigation team members will be invited to participate in future plan development or existing plan update committees. Additionally, this NHMP will be cited as a technical reference for plan update processes. Planning documents and mechanisms applicable to this process may include the following:

City of Veneta Comprehensive Plan

Capital Improvement Plans

Emergency Management Plan

Land Development Ordinance(s)

- Floodplain
- Stormwater
- Erosion Control

Additionally, progress to implement this plan will be monitored on an ongoing basis by city administration. Annual reviews and updates under a five-year cycle will be pursued. Using these methods, the overarching goal of a stronger, safer, more resilient community can be attained.

Section 8: City of Westfir

City of Westfir



A quiet little town in a beautiful place

Version 4.0 (October 2023 – October 2028)

Developed as an annex to the Lane County Multi-Jurisdictional
Natural Hazard Mitigation Plan

Section 8.1: City of Westfir: Natural Hazard Mitigation Meetings and Work Sessions

Development of the City of Westfir’s materials for the Natural Hazard Mitigation Plan involved participation by city, county, fire district, law enforcement, and project assistants. The process followed FEMA’s prescribed model for organizing resources, identifying hazards, evaluating risk, identifying mitigation options, and prioritizing mitigation projects. For additional details regarding the planning process, please refer to Volume I, Section 6. Specific participants are listed as follows.

Table 8.1: City of Westfir Planning Team

Name	Title	Agency
Nichole Tritten	City Recorder	City of Westfir
Robert McClafin	Relief City Recorder	City of Westfir
Bobby Archer	City Operator	City of Westfir
D'Lynn Williams	Mayor	City of Westfir
Jim McKee	Volunteer Fire Chief	City of Westfir

Individual City Work Sessions

Work sessions with individual cities were conducted following the initial project orientation meeting and intervening months between general planning group meetings. These individual work sessions are outlined below.

Table 8.2: City of Westfir Work Sessions

Date	Location	Meeting/Work Session
11/07/2022	Westfir City Hall	City Council discussed changing hazard priorities
12/12/2022	Westfir City Hall	City Council discussed/modified the Index content
02/07/2023	Lowell City Hall	XSP Cascades Region Workshop 1
03/21/2023	Westfir City Hall	City Council work session discussion mitigation methods
04/26/2023	Lowell Rural Fire Protection District Station	XSP Cascades Region Workshop 2

The result of this process was a thorough evaluation of risk factors and mitigation solutions. Certain hazards were highlighted with notable significance for the City of Westfir, others found to be less relevant in a direct context. Systems and concepts considered included infrastructure resiliency, transportation network, public safety, public and private facilities. A range of both general and specific mitigation ideas and projects were identified and scoped in the field.

Section 8.2: City of Westfir: Hazard Quantification

Table 8.3 provides the results of the hazard quantification process for the City of Westfir.

Table 8.3: Westfir Hazard Quantification Results

Hazard Type / Weight Factor (WF)	History WF x 2	Probability WF x 7	Vulnerability WF x 5	Maximum Threat WF x 10	Raw Score	Weighted Score	Weighted Score Rank
Wildfire	10	10	8	10	38	230	1
Winter Storm	7	10	8	9	34	214	2
Drought	5	8	9	9	31	201	3
Windstorm	8	8	7	7	30	177	4
Flood	6	8	4	8	26	168	5
Haz Mat Incident	4	2	9	9	24	157	6
Volcano	1	1	3	6	11	84	7
Landslide	1	3	4	4	12	83	8
Earthquake	1	1	2	5	9	69	9

Source: City of Westfir Hazard Mitigation Team

Section 8.2.1: Individual Hazard Discussions

Wildfire

Wildfire is a significant risk to the City of Westfir, which is largely bounded by the urban wildland interface, and exposed to wildfire. A significant number of structures and properties lay near this wildland-urban interface, particularly along Westfir Rd. and Westfir Oakridge Rd. History of wildfires in the area is high with several events occurring over time. Probability is high that conditions for wildfires will reoccur in the future. Vulnerability is also high, with a significant percentage of structures in the city on the urban-wildland interface. Maximum threat is high, involving potential for damage to numerous structures and forest tracts. See also wildfire hazard profile in Section 2 of Volume I.

The Cedar Creek Fire began August 1, 2022, when a lightning storm caused 20 to 30 new fires on the Willamette National Forest. The fire grew to 127,311 acres and threatened the entire Oakridge/Westfir community. The community was evacuated for three (3) days and engulfed in wildfire smoke until after Fall rains arrived.

Winter Storm

Westfir, like most cities in Oregon, faces a regular occurrence of winter storms, which occur at least once in most years. This is undoubtedly true for Westfir where the city is regularly impacted by snow due to the city’s elevation, making it something of a normal occurrence, with a moderate history of occurrence. The city contains a network of above ground electrical lines vulnerable to damage from falling limbs and trees during winter storms. Recent history has seen storms causing some damage and power loss in 2014, 2015, and 2016. Wind is nearly always a contributing factor in winter storms. Probability is considered high that patterns of previous occurrence will continue. The percentage of population vulnerable to winter storm is high as the effects are not geographically contained, and the city itself is situated in a geographic area where weather can intensify.

Transportation and roadways are also vulnerable to closure during winter storms. Maximum threat is also high due to the threat of structural damage directly related to winter weather (cold, snow, ice). See also winter storm hazard profile in Section 2 of Volume I.

2019 Snowstorm – DR 4432

Starting on February 23, 2019, rain and snow fell along a frontal boundary that stretched from the south - central Oregon coast to the northeastern part of Oregon. The heaviest snow fell east of the Cascades with 6 to 18 inches of accumulation during the late afternoon of February 23rd. The heavy snow continued through February 26 in many locations across the state with Lane, Douglas, and Jefferson counties being the most severely impacted by this hazard. The amount of heavy snow in Lane County was up to 22 inches. Douglas County received 4 to 12 inches on top of saturated soils, the biggest snow event since 1965.

The closure of Highway 58 from mile posts 13 to 86 impacted residents of Westfir and the City of Oakridge (est. population 4,200), with many being cut off from critical services and without power for three (3) days.

Drought

Drought is neither life threatening nor presents a direct risk to structures but does involve potential for some disruption if dramatic water shortage were to develop. Drought can exacerbate wildfire risk as related hazards, and a water shortage may affect the entire city uniformly. History is considered moderate, with 2 to 3 events occurring over the last 100 years. The probability of this re-occurring is high, part of a normal cycle over time. Vulnerability is high, in part due to the sensitivity of the surrounding forests to drought and the potential for increased fire hazards and the proximity of the urban-wildland interface all around the city. Maximum threat is high, particularly when combined with an active fire season. See also drought profile in Section 2 of Volume I.

Windstorm

Like winter storm, windstorm can and frequently does impact above ground electrical lines vulnerable to damage from falling limbs and trees. Recent history includes damage caused by storms in a nearly yearly basis. Probability is similarly considered high that patterns of previous occurrence will continue. Overall vulnerability is moderate with fewer structures fully exposed to extremely high winds. It should be noted that roadways are vulnerable to closure due to downed trees, and loss of power from damaged powerlines which in some cases traverse terrain difficult to access. The Columbus Day storm of 1962 can serve as an example for maximum threat, reports at the time noted 40 trees downed over Hwy 58, in just a single mile of roadway, trapping 19 vehicles. A windstorm of similar magnitude to the Columbus Day Storm could potentially damage numerous of homes in city, either by direct structural damage, falling trees, or wind-blown debris. The access routes the city is dependent upon, both by road and rail, are more exposed. See also windstorm hazard profile in Section 2 of Volume I.

Flood

Flood is a geographically contained hazard, which in the valley that is home to Westfir, is one with real potential for occurrence. The area is a sloped valley in the foothills of the Cascade Range surrounded by the Willamette National Forest. Five streams pass through this relatively small area between mountain ridges: Salmon Creek, Salt Creek, Hills Creek, and the Middle and North forks of

the Willamette River. These five tributaries join to create the Middle fork of the Willamette River, Northwest into Lookout Point Lake, a U.S. Corps of Engineers Willamette Valley Project Dam. The North Fork of the Willamette River flows through Westfir, to join with the Middle Fork of the Willamette River in the middle of town. Westfir is within 10 miles of the Hills Creek Dam to the southeast, another U.S. Army Corps of Engineer’s project, controlling seasonal flooding in the larger Willamette Valley.

The history of flooding in Westfir is moderate as the geography the city is built upon is created from repeated floods in the past over great lengths of time. It is a significant egress for melting winter snows out of the surrounding mountainside. The future probability for flooding is relatively high. Vulnerability is moderate with 1 to 10% of the population vulnerable to flood. Maximum threat is high, with significant damage from flooding possible in a worst-case scenario. See also flood hazard profile in Section 2 of Volume I.

National Flood Insurance Program

The City of Westfir is a formal program participant in good standing and considers continued participation as integral to future flood mitigation efforts. Participation consists of adoption and maintenance of Flood Insurance Rate Maps (FIRMs) which define Special Flood Hazard Areas (SFHAs) and maintenance of an ordinance regulating future development in SFHAs. The Flood Insurance Rate Map Community Number for Westfir is 410289. Compliance with the program is pursuant to the City of Westfir’s floodplain ordinance.

Statistics as reported by FEMA on the NFIP Bureau Net for the period of January 1, 1978, through January 31, 2023, are as follows:

NFIP Policies in Force

Policies in Force: **6**

Insurance in Force: **\$ 1,214,000**

Premium in Force: **\$ 6,314**

Insurance Claim Data

There are no reported claims.

Data Definitions

Policies In Force – Policies in force on the "as of" date of the report.

Insurance In Force – The coverage amounts for policies in force.

Written Premium in Force – The premium paid for policies in force.

Total losses – All losses submitted regardless of the status.

Closed losses – Losses that have been paid.

Open losses – Losses that have not been paid in full.

CWOP losses – Losses that have been closed without payment.

Total Payments – Total amount paid on losses.

Hazardous Materials Incident

Hazardous materials incident is considered a technical hazard and involves different characteristics than natural hazards. Nearby Oakridge is historically a railroad town, at one time one of the major routes between eastern Oregon and the Willamette Valley. Northern Pacific Railroad still utilizes this route for commerce and transport – including transport of hazardous materials. The Northern Pacific runs adjacent to the Westfir urban growth boundary on the north and east sides of Westfir, north of the North Fork Willamette and east of the Middle Fork Willamette north of the confluence of the rivers. Highway 58 is a major transport thoroughfare from Eastern Oregon to the Willamette Valley, which of course includes the road transport of hazardous materials.

History of Hazardous Materials incidents is moderate, two to three incidents in recent history requiring a response. The probability is low another incident soon. Vulnerability is considered high, potentially affecting 10% of the population. Maximum threat could involve such events as railroad or truck accident involving toxic release and is high. Rupture of underground gas lines is also possible. In the event of occurrence, prevailing wind and proximity to waterways are important factors relating to public safety risk and environmental impacts. See also hazardous materials incident profile in Section 2 of Volume I.

Volcano

Volcano is like earthquake in that it occurs very infrequently. Westfir is situated in the foothills of the Cascade Mountain Range, placing it in closer proximity to dormant Volcanos, the closest being Diamond Peak, a shield volcano approximately 35 miles from the city to the southeast. History and probability are relatively low, vulnerability is low, maximum threat considered moderate should it occur nearby. The last eruption at Diamond Peak occurred over 11,000 years ago. See also volcano profile in Section 2 of Volume I.

Landslide

Landslide is considered to have very low history and probability in Westfir itself, though it is higher in the surrounding hillsides. Vulnerability is moderate due to the potential for closures of Hwy 58. Maximum threat is also moderate for the same reason - transportation infrastructure could be affected. See also landslide profile in Section 2 of Volume I.

Earthquake

Earthquake is somewhat unique as it occurs much less frequently but has potential for significant damage and disruption. Westfir, like Oakridge, is located near three crustal earthquake faults, and small (1-3 in magnitude) have occurred in the area, doing little damage and often going unfelt by residents. From a geographic standpoint occurrence would presumably affect the entire city uniformly, should a higher magnitude event occur.

History of occurrence dates back over long-time scales, and in the short term is considered low. Probability is low in any given year. Vulnerability is complex to assess due to varying standards of construction, but most new and newer construction is considered relatively sound. Maximum threat is moderate in awareness of the Cascadia Subduction Zone off the Oregon Coast; Westfir can expect to feel the shaking associated with that event, causing very strong shaking according to DOGAMI and the State of Oregon Office of Emergency Management. Minor to moderate damage to numerous structures can be expected in an event of that magnitude and scope. Importance of resiliency of infrastructure is notable. See also earthquake profile in Section 2 of Volume I.

New Development in Hazard Areas

There were no new developments in the City of Westfir during the planning period. However, a new development called the Transcascadia RV Plan was approved in March 2022, with a time extension until September 2023. This potential RV Park will be located on the eastern edge of the City adjacent to the North Fork of the Middle Fork Willamette River and the mainline of the Northern Pacific railroad tracks.

Owners of the Westfir Mill Site property are also renewing interest in development of their property located in the heart of Westfir and will present a plan to the City in spring 2023. The Housing Needs Analysis for the period 2022-2042 states the need for 33 additional homes within Westfir city limits. The buildable land inventory identified approximately 50 acres of vacant land within the City limits, with most of this property located on the mill site.

The Urban Growth Boundary follows the narrow valley of lower North Middle Fork Willamette River to confluence with Middle Fork west of the city. Surrounding areas are relatively steep, forested slopes with negligible potential for development.

Section 8.3: City of Westfir: Mitigation Projects

This section describes mitigation projects identified by the City of Westfir during the planning process. See Volume I, Section 4 for additional information regarding mitigation action item methodology and prioritization.

Mitigation Action Item (a)	New Fire Station Building
Location	West side of mill site property (1.27ac donated)
Coordinating Agencies	Westfir City Hall, Westfir Public Works, City of Oakridge
Implementation Timeframe	24-36 month
Estimated Cost	\$450,000 – 500,000
Potential Funding Sources	HUD-CDBG, OR-SRGP, HMGP, PDM, FEMA PA-106, Ford Family grant
Hazards Mitigated	Wildfire, hazard materials, winter storm, windstorm, earthquake
Comments	The City of Westfir is pursuing funding to build a new fire station to house our engine (currently at Oakridge fire hall) and other equipment; we’re recruiting volunteers to respond in a more efficient manner to events with the boundaries of Westfir, and to provide additional resources for the entire community.

Mitigation Action Item (b)	New Building to House City Hall
Location	City Hall
Coordinating Agencies	Westfir City Hall, Westfir Public Works
Implementation Timeframe	24-36 month
Estimated Cost	\$450,000 – 500,000
Potential Funding Sources	HUD-CDBG, OR-SRGP, HMGP, PDM, FEMA PA-106
Hazards Mitigated	Wildfire, Winter storm, windstorm, earthquake
Comments	<p>Current location vulnerable to hazmat incident due to proximity to railroad line. Current structure is additionally vulnerable to wildfire, windstorm, earthquake and winter storm impacts.</p> <p>2023 update: The current building is past its maintenance life and would be more expensive to remodel to meet current standards than to replace with a modular building.</p>

Mitigation Action Item (c)	Defensible Space Fuels Reduction
Location	Various – reduction of wildfire fuels
Coordinating Agencies	Westfir Public Works, ODF
Implementation Timeframe	12 – 24 months
Estimated Cost	\$40,000
Potential Funding Sources	ODFW, HUD-CDBG, OR-SRGP, HMGP, PDM, FEMA PA-106, ODF
Hazards Mitigated	Wildfire
Comments	<p>Reduction of fuels around structures in the city to reduce fire hazards. On-going; ODF removed fuels around city hall 2021. Volunteers have been removing fuels in the Westfir Portal.</p> <p>The Southern Willamette Forest Collaborative is pursuing funding to treat individual properties with the community 2023.</p>

Mitigation Action Item (d)	Develop additional storage capability for water supply and fire suppression
Location	TBD
Coordinating Agencies	Westfir Public Works
Implementation Timeframe	24-36 months
Estimated Cost	\$300,000
Potential Funding Sources	OR-SRGP, HMGP, PDM, FEMA, PA-106
Hazards Mitigated	Wildfire, drought
Comments	Current storage capacity is inadequate, upgrades needed. Additional 250,000-gallon storage tank needed to support future capacity.

Mitigation Action Item (e)	Structure elevation, mitigation reconstruction, and/or acquisition relocation for flood prone properties.
Location	City of Westfir Special Flood Hazard Area (SFHA)
Coordinating Agencies	Westfir, OEM, FEMA, NFIP
Implementation Timeframe	12-18 months
Estimated Cost	\$750,000
Potential Funding Sources	FEMA HMA, FMA
Hazards Mitigated	Flooding
Comments	N/A

Mitigation Action Item (f)	Drainage improvements for 1st/2nd Street Loop
Location	Central Westfir
Coordinating Agencies	OEM, Westfir, Lane County Public Works
Implementation Timeframe	12-18 months
Estimated Cost	\$80,000
Potential Funding Sources	OR-SRGP, HMGP, PDM, FEMA PA-106
Hazards Mitigated	Flood
Comments	Neighborhood in central Westfir experiences frequent flooding of certain homes due to elevation of structures and surrounding terrain. Streets are privately owned.

Section 8.4: City of Westfir: Plan Implementation and Maintenance

To ensure the incorporation of the overall goals and strategies of the NHMP, the City of Westfir hazard mitigation team members will be invited to participate in future development or existing plan update committees. Additionally, this NHMP will be cited as a technical reference for future update processes. Planning documents and mechanisms applicable to this process may include the following:

- City of Westfir Comprehensive Plan**
- Emergency Operations Plan**
- Local Community Wildfire Protection Plans**
- City of Westfir Floodplain Development Regulations**
- Building Code**
- Westfir Land Development Code**

Additionally, progress to implement this plan will be monitored on an ongoing basis by city administration. Annual reviews and updates under a five-year cycle will be pursued. Using these methods, the overarching goal of a stronger, safer, more resilient community can be attained.

Section 9: Blachly-Lane Electric Co-op



Version 4.0 (October 2023 – October 2028)

Developed as an annex to the Lane County Multi-Jurisdictional
Natural Hazard Mitigation Plan

Section 9.1: Profile of Blachly Lane-Electric Co-op

Introduction

On April 28, 1934, Blachly-Lane County Cooperative Electric Association was formed and became the first REA financed cooperative to operate in Oregon. Blachly-Lane is an Electric Cooperative operating according to its Bylaws. These Bylaws outline the procedures under which the Cooperative serves its members and the responsibilities of its members to the Cooperative.

Blachly-Lane Electric Coop’s service territory lies within Lane County, West of I-5. The Blachly-Lane Electric Coop District service area includes the city limit areas of the City of Eugene and the City of Junction City along with the surrounding unincorporated areas.

Blachly is governed by a five-member board of directors. Each director is elected to serve a 3-year term. These directors represent Blachly-Lane’s members’ best interests when making important decisions. Being a member of the Board of Directors is an incredibly important position in the community. A director’s decisions will impact issues, such as service rates, right-of-way, and work plans. The board is a democratically elected body nominated by members of the cooperatives five districts and voted into position by any member who chooses to participate in the cooperatives open election.

- The cooperative has on average, 7 members per line mile.
- 492 miles of distribution line.
- Blachly-Lane serves approximately 2865 owner-members.
- 83 years in operation
- 21 employees run the Cooperative.

- **Population Served:** 2,865
- **Land area served:** 492 miles of distribution line

Figure 9.1: Blachly-Lane Service Territory, Transmission, and Primary Feeder Map

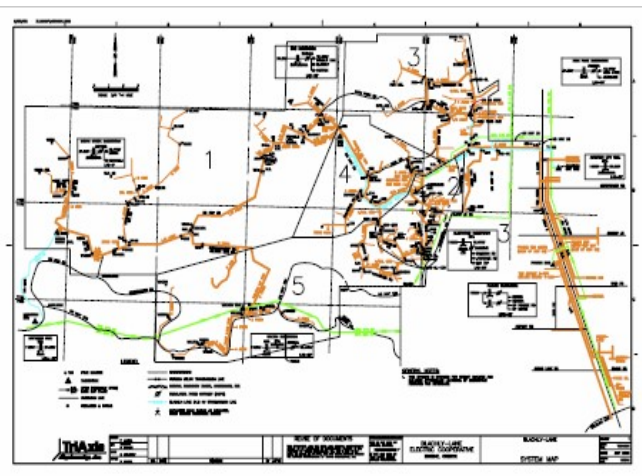

This annex notes Blachly-Lane specific variances from the Lane County NHMP base plan. Variances arise due to differing risks faced by Blachly-Lane compared to Lane County. The different risks are due to utility specific regulations, infrastructure, and locations. Unless explicitly expressed by this annex, Blachly-Lane complies with the 2023 NHMP.

Electric System

Blachly-Lane purchases 100% of its power through the Bonneville Power Administration, approximately 82% of that power, on average, is hydroelectric and the other percentage is a mesh of nuclear and other means to produce electricity. Power is received from the Bonneville Power Administration via their Eugene-Alderwood and Albany-Eugene 115 kV transmission lines, which connect to the District's Parker, Junction City, High Pass, Alderwood, Indian Creek, and Erb substations, as well as the BPA owned distribution substations at Walton and Mapleton that serve Blachly's distribution lines from those stations.

Blachly-lane owns and operates its own medium-voltage distribution system with two separate voltages; 34.5kV and 12.47kV. The 7 substations in Blachly's system provide electricity to all its members, and the ability to loop feed, alternate feed, back feed, and by-pass certain parts of the distribution system depending on the needs and conditions of the system.

To date, the value of Blachly-Lane's system assets and capital goods total \$28,417,000.00.

In 2019 Blachly-Lane went through the process of an Electric System Planning Study and one of the considerations was load forecasting. Specifically, a ten-year forecast. BLEC provided estimated load forecast, system peak information, metering data, PNUCC load forecast projections, weather data from NOAA, Portland State University Population Research Center, and the OPUC.

System planning and system capacity must be based on serving peak demand. This peak demand is strongly dependent on weather and temperature extremes. Blachly's recent largest system peaks correlated with the two coldest days in the last ten years. One occurring in January of 2017, the other in December of 2013.

With a significant portion of BLEC's load being residential and commercial, peak electricity demands are typically observed during the coldest weather conditions. Peak demand during extreme warm weather events does appear to be starting to grow but remain much lower than that for cold weather events.

BLEC's customer count and commercial/ industrial loads are at an all-time high, meaning weather like that experienced in 2013 and 2017 could feasibly produce a higher peak demand event.

The system peak in 2013 was scaled up by 1% each year to provide a conservative estimate of what the 1 in 10-year peak could be in 2019. BLEC utility statistics show there was no customer growth between 2013 and 2019 however, there was significant spot loads added and significant industrial growth. The 1% increase is a way of recognizing this and providing a conservative base case for analysis.

Between 2006 and 2018, energy sales grew by 16.7% and the customer count by 3.6%. Several factors on BLEC's system effect energy use and similar utilities, though in general there is a direct proportional linear relationship between customer count growth and growth in energy use. This

trend holds true for Blachly-Lane as well; as customer counts have increased, so has total energy use.

Section 9.2: Applicable Regulations, Plans

Wildfire Mitigation Plan

As a result of this increased wildfire danger the Oregon legislature passed Senate Bill 762 which Gov. Kate Brown signed into law in 2021. SB 762 establishes new programs to fight and mitigate wildfires, bolster recovery, help communities adapt to smoke, and implement changes to the state's building code for structures within high-risk areas in the wildland-urban interface (WUI). It also requires consumer owned electric utilities develop risk-based wildfire mitigation plans and submit them to the Oregon Public Utility Commission (OPUC) by June 30, 2022.

The Wildfire Mitigation Plan describes strategies, programs, and procedures to mitigate the threat of electrical equipment ignited wildfires, and addresses the unique features of its service territory, such as topography, weather, infrastructure, grid configuration, and areas most prone to wildfire risks. This includes the maintenance of its transmission and distribution (T&D) assets as well as the management of vegetation in the ROWs that contain these assets. Blachly-Lane Electric Coop's Board of Directors reviews, and approves the plan as needed, while the Manager of Operations is responsible for its implementation. Primary accountability for plan implementation resides with the General Manager.

Natural Hazard Mitigation Plan

The Blachly-Lane Electric Coop District Hazard Mitigation Plan Annex covers each of the major natural hazards that pose significant threats to the District.

The mission statement of the Blachly-Lane Electric Coop District Hazard Mitigation Plan Annex is to:

Proactively facilitate and support district-wide policies, practices, and programs that make the Blachly-Lane Electric Coop District more disaster resistant and disaster resilient.

Making the Blachly-Lane Electric Coop District more disaster resistant and disaster resilient means taking proactive steps and actions to protect life safety, reduce damage, minimize service outages, and shorten the recovery period from future disasters.

Completely eliminating the risk of future disasters in the Blachly-Lane Electric Coop District is neither technologically possible nor economically feasible. However, substantially reducing the negative consequences of future disasters is achievable with the implementation of a pragmatic mitigation measures that reduce the likelihood of damages to the electric system in future disaster events.

The 2016-current Blachly-Lane Electric Coop District Hazard Mitigation Plan Annex is a living document which will be reviewed and updated periodically.

Capital Improvement Plan

The Blachly-Lane Electric Coop District capital improvement planning includes extension of existing lines to serve new customers and replacement/upgrade of existing infrastructure that has reached the end of its useful lifetime and upgrading infrastructure with history of repetitive failures and/or identified high vulnerability to failure in natural hazard events.

Section 9.3: Natural Hazard Mitigation Meetings and Work Sessions

This sub-section of the Blachly-Lane NHMP Annex provides a detailed account of the local hazard mitigation planning team and the individual work sessions that contributed to the Lane County Multi-Jurisdiction Hazard Mitigation Plan update.

Table 9.1: Blachly-Lane Electric Co-op Planning Team

Name	Title	Agency
Cody Smith	Engineering Supervisor	Blachly-Lane Electric Cooperative
Jeff Jones	Operations Manager	Blachly-Lane Electric Cooperative

Individual Utility Work Sessions

Work sessions with individual utilities were conducted following the initial project orientation meeting and intervening months between general planning group meetings. These individual work sessions are outlined below.

Table 9.2: Blachly-Lane Electric Co-op Work Sessions

Date	Location	Meeting/Work Session
03/15/2023	Microsoft Teams	Cody Smith, Jeff Jones & Hannah Shafer meeting to discuss annex details, and completion timeline
03/13/2023	Microsoft Teams	Cody Smith Steering Committee Meeting
02/07/2023	Microsoft Teams	XSP Coast Region Workshop 1
10/17/2022	Microsoft Teams	Cody Smith NHMP Overview and Introduction

The result of this overall process was a thorough evaluation of risk factors and mitigation solutions. Certain hazards were highlighted with notable significance for Blachly-Lane, others found to be less relevant in a direct context. Systems and concepts considered included infrastructure resiliency, transportation network, public safety, public and private facilities. A range of both general and specific mitigation ideas and projects were identified and scoped in the field.

Section 9.4: Jurisdiction Specific Natural Hazard History

Table 9.3 displays the results from the hazard quantification process for the Blachly-Lane Electric Co-op.

Table 9.3: Blachly-Lane Electric Co-op Hazard Quantification Results

Hazard Type / Weight Factor (WF)	History WF x 2	Probability WF x 7	Vulnerability WF x 5	Maximum Threat WF x 10	Raw Score	Weighted Score	Weighted Score Rank
Winter Storm	10	10	10	10	40	240	1
Wildfire	9	10	8	10	37	228	2
Windstorm	8	10	8	10	36	226	3
Drought	9	10	7	10	36	223	4
Earthquake	5	3	8	10	26	171	5
Volcano	2	1	8	10	21	151	6

Source: Blachly-Lane Natural Hazard Mitigation Planning Team

Section 9.4.1: Individual Hazard Discussions

Winter Storm

For Blachly-Lane, winter storms are the predominant natural hazard. Major storms can result in widespread damage and power outages from tree falls on overhead power lines. Power outages from winter storms occur frequently with the severity ranging from minor damage at only a few locations with quick restoration of service to major with widespread, long duration outages.

Wildfire

Wildfires also cause localized damage from burn down of poles and overhead power lines. Historically the risk from wildfires was low due to rainfall in the area but has increased in the past decades for Blachly-Lane because of the higher temperatures and sustained drought. In 2016 a wildfire broke out in the Low Pass area in the Cooperative’s service area. That fire had the potential to threaten our Erb substation and required neighbors in the area to evacuate. Since then, there has been a trend of an increased number, size, and severity of wildfires in our area. We expect this trend to continue and focus efforts on wildfire prevention and mitigation in our region.

Windstorm

Windstorms are the predominant natural hazard in our territory. Like winter storms, major windstorms can result in widespread damage and power outages from tree falls on overhead power lines, or from direct wind loading. Power outages from windstorms occur frequently with severity ranging from minor damage at only a few locations with quick restoration of service to major with widespread, long duration outages. Blachly-Lane expects these events to increase in occurrence and severity in the coming years due to climate change.

Drought

Drought conditions have occurred frequently in Oregon in recent years, and droughts are predicted to be even worse as climate change effects escalate. Blachly-Lane expects these events to increase in occurrence and severity in the coming years and the effect of that will be an impact on the forested areas that surround our territory. Weakened trees and dead trees increase our risk of wildfire due to increased fuel and compound the effects of winter storms and windstorms due to trees falling into the lines.

Earthquake

Earthquakes with strong ground shaking can cause major damage to electric power systems, especially for high voltage transformers and other essential substation equipment. Earthquakes with high enough levels of ground shaking have long return periods. However, major events such as a M9 earthquake on the Cascadia Subduction Zone can result in very high levels of damage, with service restoration times measured in weeks or months, rather than hours or days.

Volcano

Volcanic events pose minimal risk for the Blachly-Lane Electric Coop District. The district’s only exposure to volcanic events is from volcanic ash. This risk is minimal because of the location of active volcanoes in Oregon and the prevailing westerly winds.

Section 9.5: Mitigation Projects

This section describes mitigation projects identified by Blachly-Lane during the planning process. See Volume I, Section 4 for additional information regarding mitigation action item methodology and prioritization.

Mitigation Action Item (a)	System Hardening
Location	System wide
Coordinating Agencies	Blachly-Lane
Implementation Timeframe	Ongoing
Estimated Cost	TBD
Potential Funding Sources	Blachly-Lane capital budget, government grants from the state and federal levels.
Hazards Mitigated	Wildfire, Windstorm, Winter storm, Earthquake
Comments	System hardening consists of building new infrastructure and retrofitting legacy infrastructure with more resilient materials and improved design standards. These materials stand up to damage better than traditional wooden system components. System hardening components include metal power poles, composite crossarms, covered conductors, system undergrounding, and increasing minimum standard pole classes for wood poles. The pictures below depict metal power poles and covered overhead conductor waiting for installation in the Blachly-Lane storage yard.

Current Site Photos



Mitigation Action Item (b)	System Protection
Location	System wide
Coordinating Agencies	Blachly-Lane
Implementation Timeframe	Ongoing
Estimated Cost	TBD
Potential Funding Sources	Blachly-Lane capital budget, government grants from the state and federal levels.
Hazards Mitigated	Wildfire, Windstorm, Winter storm, Earthquake
Comments	System Protection refers to efforts to increase system protection and sensitivity systemwide. In the past, system components such as reclosers were exclusively hydraulically operated. Blachly-Lane is investing in newer technologies that allow our system to better deal with transient outages in a major storm and to be able to respond better during fire weather. This gives Blachly-Lane better operational control to change settings on the system to response to threats. This effort involves starting replacement at the substations and working downstream from there to replace legacy devices. The pictures below depict the Blachly-Lane updated system protection devices.

Current Site Photos

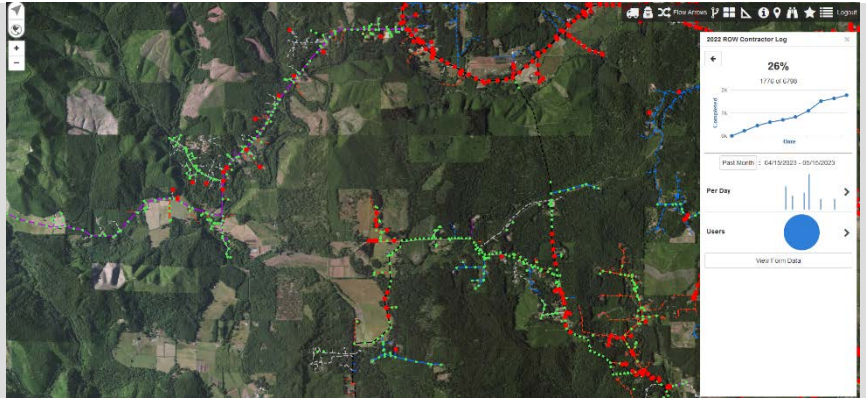

Mitigation Action Item (c)	Enhanced Vegetation Management
Location	Systemwide
Coordinating Agencies	Blachly-Lane
Implementation Timeframe	2021-2023
Estimated Cost	\$600,000
Potential Funding Sources	Blachly-Lane Operating Budget
Hazards Mitigated	Wildfire, Windstorm, Winter Storm
Comments	A right of way audit in 2021 indicated Blachly-Lane needed to move away from managed hotspotting to maintain the trees and vegetation on their system and go to a cycle maintenance program. Based on the tree growth rates and the recommended clearance specifications in the study, the recommended cycle length is 4 years with interim pruning of cycle buster trees at mid-cycle (2 years). To achieve that, Blachly-Lane has needed to greatly increase its Vegetation Management budget. After this project is complete and we can achieve a 4-year trim cycle, maintenance of that system will help mitigate the risk of wildfires and lessen the impact of storms by increasing the clearances from vegetation to energized conductor and by the removal of hazard trees. Below is an image from our GIS system now being used to track clearance trimming on a cycle basis.
Current Site Photos	

Section 9.6: Plan Implementation and Maintenance

In keeping with standard practices to ensure incorporation of overall goals and strategy of the hazard mitigation plan, Blachly-Lane Natural Hazard Mitigation Planning Team members will be invited to participate in future development or existing plan update committees. Additionally, this Natural Hazard Mitigation Action Plan will be cited as a technical reference for future update processes.

Additionally, progress to implement this plan will be monitored on an ongoing basis by Cody Smith and administration. The planning process is essential in identifying weaknesses and strengths inherent in the community and cooperatively enables coordination with various agencies and jurisdictions that might not otherwise occur. Continuing this cooperative and interactive process is exemplified by the planning process. Annual reviews and updates under a 5-year cycle will be pursued. Using these methods, the overarching goal of a stronger, safer, more resilient community can be attained.

Section 9.6.1: Future Needs

Based on current trends and predictions, it is likely that Blachly-Lane will continue to face natural hazards such as wildfires, storms, and earthquakes in the future. To mitigate the impact of these hazards, the cooperative may need to seek grant funding for projects such as vegetation management, infrastructure upgrades, and new technology to enhance response and situational awareness. Additionally, as climate change continues to exacerbate extreme weather events, the cooperative may need to prioritize resilience and adaptation measures in their grant proposals.

Section 10: Consumers Power Inc.



Version 4.0 (October 2023 – October 2028)

Developed as an annex to the Lane County Multi-Jurisdictional
Natural Hazard Mitigation Plan

Section 10.1: Consumers Power, Inc. Jurisdictional Profile

Introduction

Consumers Power Inc. (CPI) incorporated in 1939, is a privately owned not-for-profit rural electric cooperative serving over 23,000 members in parts of six counties in Oregon: Benton, Lane, Lincoln, Linn, Marion, and Polk. CPI’s service territory covers more than 3,500 square miles and is divided into nine zones containing approximately the same number of members in each. CPI is governed by a nine-member board of directors, one from each zone, elected by the members to serve a three-year term. Elections for directors take place each year at the Cooperative’s annual meeting, which is usually held at CPI Philomath headquarters in September. CPI has more than 3,000 miles of transmission and distribution line with approximately 7.2 customers per mile.

- **Population Served: 25,500 Meters**
- **Land area served: 3,500 Square Miles**
- **Land area owned: 40 acres**

Electric System

The electric system supplies service to 88 meters within Lane County.

CPI does not directly produce any power for distribution. Instead, CPI purchases power from the Bonneville Power Administration (BPA). The primary power supply sources are hydroelectric dams operated by BPA. Other smaller power sources include wind, landfill gas regeneration, and solar power facilities. The electric utility’s operating budget is \$45.3M. The budget for capital improvements is \$9.5M and the budget for debt services is \$3.2M.

- **Total Electric System Service Area: 3,500 square miles**
- **Transmission and distribution lines: 3,161-line miles**
- **Substations: 26**
- **Utility-owned hydroelectric facilities: 0**
- **Utility-owned wind facilities: 0**

The estimated values of major electric assets are listed in Table 10.1.

Table 10.1: Major Assets owned by Consumers Power, Inc.

Major Electric Asset	Historical Cost (as of April 2023)
Land	\$3,008,000
Transmission	\$13,134,000
Distribution	\$155,810,000
Construction Work in Progress	\$10,435,000
Completed Construction, not yet classified	N/A
TOTAL:	\$182,387,000

Section 10.2: Natural Hazard Mitigation Meetings and Work Sessions

This sub-section of the CPI MNHMP Annex provides a detailed account of the local hazard mitigation planning team and the individual work sessions that contributed to the Lane County Multi-Jurisdiction Hazard Mitigation Plan update.

Table 10.2: Consumers Power, Inc. Planning Team

Name	Title	Agency
Jeff Carlson	Safety, Compliance & Loss Control Specialist	Consumers Power Inc.
Billy Terry	Chief Operations Officer	Consumers Power Inc.

Individual Work Sessions

Work sessions with individual utilities were conducted following the initial project orientation meeting and intervening months between general planning group meetings. These individual work sessions are outlined below.

Table 10.3: Consumers Power, Inc. Work Sessions

Date	Location	Meeting/Work Session
03/30/2023	3040 N Delta Hwy, Eugene, OR	Jeff Carlson & Hannah Shafer meeting to discuss annex details, and completion timeline

The result of this overall process was a thorough evaluation of risk factors and mitigation solutions. Certain hazards were highlighted with notable significance for CPI, others found to be less relevant in a direct context. Systems and concepts considered included infrastructure resiliency, transportation network, public safety, public and private facilities. A range of both general and specific mitigation ideas and projects were identified and scoped in the field.

Section 10.3: Consumers Power, Inc. Hazard Quantification

Table 10.4 displays the results of the hazard quantification process for Consumers Power, Inc.

Table 10.4: Consumers Power, Inc. Hazard Quantification Results

Hazard Type / Weight Factor (WF)	History WF x 2	Probability WF x 7	Vulnerability WF x 5	Maximum Threat WF x 10	Raw Score	Weighted Score	Weighted Score Rank
Winter Storm	10	10	10	10	40	240	1
Drought	10	10	10	10	40	240	2
Wildfire	10	10	8	10	38	230	3
Windstorm	8	10	8	10	36	226	4
Earthquake	5	3	8	10	21	171	5
Volcano	2	1	8	10	21	151	6

Source: Consumers Power INC Natural Hazard Mitigation Team

Section 10.3.1: Individual Hazard Discussions

Winter Storm

CPI primarily operates in rural areas of our served counties. This is especially true in Lane County where CPI serves no cities or towns. Because CPI operates in a rural and heavily timbered part of Lane County, winter storms can be extremely damaging to the CPI system in Lane County. Snow and ice loading typically break limbs and tree trunks when enough weight accumulates to cause failure. If the ground is saturated, then it is common for entire trees including root systems, to topple over under snow and ice loads. When this occurs in the vicinity of CPI powerlines the resulting damage can cause outages that last for many days and incur very high repair costs on CPI. Due to the likelihood of occurrence, the fact that citizens are without power during the coldest part of the year, and the very high costs associated with repairs, CPI considers major winter storms as being among our most concerning natural disaster scenarios.

Drought

Drought conditions have occurred frequently in Oregon in recent years, and droughts are predicted to be even worse as climate change effects escalate. The main danger posed by drought is the increased risk of wildfires caused by dead and dying vegetation providing ready fuel to burn. Another serious but lesser hazard is the stress that drought causes to timberlands. A bad drought year can kill or weaken trees that then fall more easily during subsequent storm events. CPI scored drought very highly on this matrix because of the likelihood of extreme drought in coming years and the expected knock-on effects that will endanger our electrical system in Lane County.

Wildfire

CPI's electrical system was partially destroyed during the Santiam Canyon Fires in 2020. The damage to electrical power systems during that fire is still being remedied. Associated recovery and prevention work will continue for several years as CPI endeavors to build a system that is more fire safe and fire resistant in that area. Much like several other of the hazards listed here wildfires will become more frequent and more serious as climate change effects escalate. In their 6th Climate Assessment released in January of 2023 the Oregon Department of Energy states that wildfires have increased in size and are occurring at higher elevations over the past 35 years. Additionally, the number of days with extreme wildfire danger have more than doubled since 1979. This trend will continue and worsen in coming years. CPI takes this threat very seriously and expects that wildfires will cause major property damage and significant loss of life in the coming years. Consequently, much of CPI's construction and maintenance efforts are focused on wildfire prevention and mitigation year-round to stay ahead of an escalating threat.

Windstorm

Windstorms can cause enormous damage to electrical systems due to broken and toppled trees. This damage is more likely when the wind is accompanied by rain and/or the ground is saturated. Damaging wind events occur with some regularity but CPI expects these events to worsen in coming

years due to climate change. Increased heat and reduced rainfall associated with our changing climate will weaken trees and make them more susceptible to damage. This will occur while our region can expect to experience extreme weather events (including windstorms) caused by climate change itself at a higher frequency than climatology would otherwise suggest is likely.

Earthquake

Oregon Emergency Management (OEM) states that there is a 37% likelihood of a major earthquake at the Cascadia Subduction Zone within the next 50 years. A major earthquake would severely damage the CPI electrical system in every county we serve, and Lane County is no different. The fallout from a large earthquake would be catastrophic and it may take many months to fully restore power to all the areas CPI serves. Trees toppling over, landslides, and liquefaction of soil during the earthquake would damage or destroy almost every pole and transformer that CPI owns in Lane County. Recovery from such an event would be extremely slow and CPI along with other utilities in the region would certainly need to call on utility construction crews from other regions to help with repairs.

Volcano

A major volcanic eruption can be catastrophic for people living in the vicinity of the eruption. The nearest volcanoes to Lane County will probably not directly kill people or damage infrastructure in the county during an eruption but the associated ashfall will cause widespread disruption to the region. The most direct impact to the CPI system in Lane County would be from ash accumulating on transformers and causing electrical shorts. This would cause widespread outages that would be difficult to address. Additionally volcanic ash is very heavy, and it is expected that ash building up on trees will cause limb and tree failures akin to snow loading. A heavy ashfall would therefore cause widespread electrical outages, and shortly after falling trees would cause extensive damage to electrical power systems throughout the region. In the aftermath of a major volcanic eruption CPI and the other utilities in the region would most certainly need to call for aid crews from unaffected areas to help repair the damage and restore power.

Section 10.4: Consumers Power, Inc. Mitigation Projects

This section describes mitigation projects identified by CPI during the planning process. See Volume I, Section 4 for additional information regarding mitigation action item methodology and prioritization.

Mitigation Action Item (a)	System Hardening
Location	System wide including Lane County
Coordinating Agencies	CPI
Implementation Timeframe	Ongoing
Estimated Cost	TBD
Potential Funding Sources	CPI operating budget, government grants from the state and federal levels.
Hazards Mitigated	Wildfire, Windstorm, Winter storm, Earthquake,
Comments	System hardening consists of building new infrastructure and retrofitting legacy infrastructure with more resilient materials. These materials stand up to damage better than traditional wooden system components. System hardening components include metal & fiberglass power poles, composite crossarms, covered conductors, system undergrounding, and protective fireproof wraps around wooden poles. The pictures below depict fiberglass power poles and composite crossarms waiting for installation in the CPI storage yard.
Current Site Photos	 

Mitigation Action Item (b)	System Intelligence
Location	System wide including Lane County
Coordinating Agencies	CPI
Implementation Timeframe	Ongoing
Estimated Cost	TBD
Potential Funding Sources	CPI operating budget, government grants from the state and federal levels.
Hazards Mitigated	Wildfire
Comments	System intelligence refers to efforts to increase system control and automation through the CPI SCADA system. In the past, system components such as reclosers were exclusively manually operated by linemen in the field. CPI is investing in newer technologies that allow greater command and control of the system via our SCADA system. This means that CPI dispatchers can change system settings very quickly in response to threats. Compared to older technologies the difference in control allows changes to be made in minutes instead of hours or days. This effort involves running fiberoptic communication cables to new system components so that CPI can communicate with them. The pictures below depict

Current Site Photos

the CPI SCADA interface and remotely operated reclosers waiting for installation in the CPI warehouse.

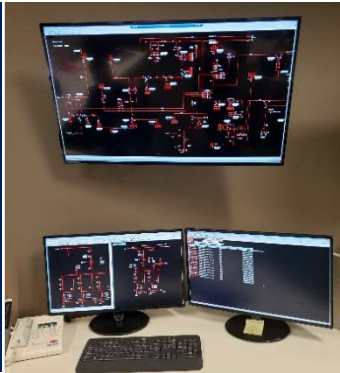

Mitigation Action Item (c)	Environmental Intelligence
Location	Systemwide including Lane County
Coordinating Agencies	CPI
Implementation Timeframe	2023-2025
Estimated Cost	\$6,000-\$12,000 depending on number of sensors purchased and deployed.
Potential Funding Sources	CPI Operating Budget
Hazards Mitigated	Wildfire
Comments	Environmental Intelligence refers to CPI efforts to characterize the current state of the lower levels of the atmosphere and analyze the potential effects to CPI system operations. Knowledge of current weather conditions is a key part of CPI’s wildfire mitigation plan. Current weather conditions play a significant part in decisions about protective measures that CPI takes to prevent our system from starting fires. The rural nature of CPI’s system means that existing publicly owned weather stations are often far from critical system components. The weather stations that do exist in CPI areas are often installed at an altitude that makes them unrepresentative of the conditions at the altitude of CPI’s electrical system components. To remedy this CPI is going to buy and install Tempest Weatherflow systems over the next couple of years. Currently the Tempest Weatherflow only works on Wi-fi, but Tempest will release a cellular communication enabled model in 2023. After that cellular communication model is available CPI will purchase and deploy roughly 20-40 Weatherflow sensors throughout our system to provide environmental intelligence. The pictures below depict a Weatherflow sensor and its information output.

Current Site Photos

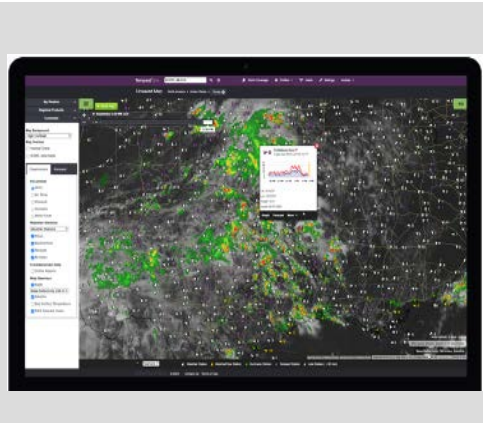

Future Needs

CPI's system footprint in Lane County is quite limited so our future needs in Lane County are modest. CPI will continue to implement the hazard mitigation solutions outlined above over the next several years. In the future newer technologies and practices will likely emerge that provide greater hazard mitigation effects. CPI stays abreast of such developments and will implement them when available and appropriate. In the meantime, what CPI needs from officials in Lane County is to simply maintain robust lines of communication vis-à-vis possible hazards and appropriate responses so we can respond to them effectively for our members.

Section 11: Emerald People's Utility District



Version 4.0 (October 2023 – October 2028)

Developed as an annex to the Lane County Multi-Jurisdictional
Natural Hazard Mitigation Plan

Section 11.1: Emerald People’s Utility District Jurisdictional Profile

Introduction

Emerald People’s Utility District (EPUD) is one of the six Public Utility Districts in the State of Oregon. EPUD was formally indoctrinated in 1983. EPUD’s area consists of 550 square miles, including a portion of the incorporated city of Veneta, and the unincorporated communities of Alvadore, Cheshire, Dexter, Elmira, Jasper, Marcola, Pleasant Hill, Noti, and Vaughn, as well as portions of Goshen, Springfield and Eugene. The municipalities of Junction City, Cottage Grove, Creswell and Coburg are surrounded by the District, but are not part of the District (except areas annexed after the boundaries of the District were corrected).

- **Population Served:** 22,353
- **Land area served:** 550 square miles

This annex notes Emerald People’s Utility District (EPUD) specific variances from the Lane County NHMP base plan (sections XX). Variances arise due to differing risks faced by EPUD compared to Lane County, Veneta, Alvadore, Cheshire, Dexter, Elmira, Jasper, Marcola, Pleasant Hill, Noti, and Vaughn, as well as portions of Goshen, Springfield and Eugene. The different risks are due to utility specific regulations, infrastructure, and locations. Unless explicitly expressed by this annex, EPUD complies with the 2023 NHMP. Public outreach activities are outlined in Appendix X.

Electric System

The electric system supplies service to 22,353 residential, commercial, and industrial customers within Lane County. The District’s physical plant is comprised of utility infrastructure and buildings and is summarized in Table 11.1 below.

Table 11.1: Emerald People’s Utility District Summary Statistics with changes since 2016

Summary of EPUD Utility Infrastructure Data	2016	2021	Change
Customers	21,076	22,353	+6.05 %
Residential meters	18,451	19,558	+5.99 %
Commercial and public meters	2,558	2,795	+9.26 %
Substations	9	9	0 %
Overhead primary line (miles)	813	813	0 %
Underground primary line (miles)	345	345	0 %
Transmission line miles	21.5	21.5	0 %

Table 11.2: District Owned Facilities, EPUD

Facilities Owned by EPUD Description	Location
Buildings	
Headquarters	Eugene
Short Mountain (Methane Gas Plant)	Eugene
Substations	
Cheshire	Junction City
Creswell	Creswell
Elmira	Elmira
Halsey	Halsey
Latham	Cottage Grove
Marcola	Springfield
Noti Creek	Eugene
Pleasant Hill	Pleasant Hill
Infrastructure	
Powerline	Eugene

Figure 11.1: Substations and District Owned Buildings in Service Area

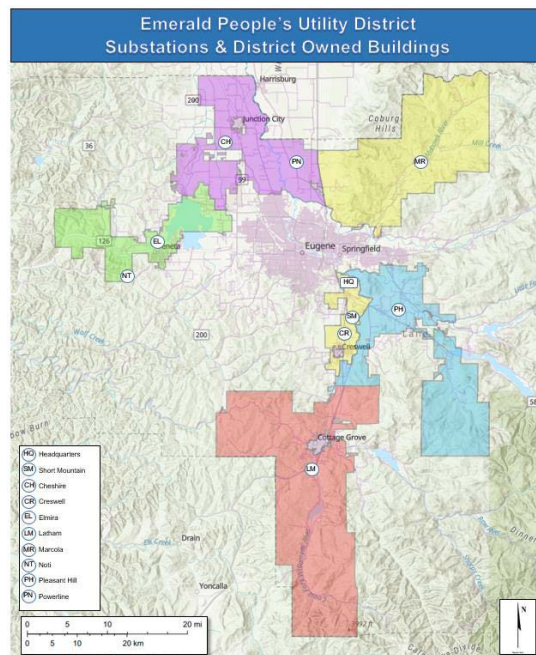

Section 11.2: Applicable Regulations, Plans

As discussed elsewhere in the original EPUD hazard mitigation plan and this update, the District has a very specific and somewhat narrow function in providing power to a defined geographic area, so the opportunity to cross-integrate plans studies, report, etc. is limited. The following lists of regulations, plans, tools, etc. were carried over from the original version of the mitigation plan and updated as appropriate by EPUD. Except for the EPUD Capital Improvement Plan, Long-Term Strategic Plan, and the first set of resources, the District has only limited authority and opportunity to integrate its actions and procedures into other plans and processes.

As part of the 2022 HMP update, EPUD reviewed the Oregon and Lane County hazard mitigation plans to identify any potential areas where there is opportunity for cross-integration. There are many obvious overlaps with both State and County mitigation plans, particularly regarding the types of hazards that affect the region, as well as the general categories of mitigation actions and priorities.

Because EPUD has its own mitigation plan, it was not part of the process to develop and update the Lane County Plan, but the County intends to incorporate EPUD in its mitigation document as part of the upcoming update in 2023 (see page 16 of the County mitigation plan).

Pertinent Federal and State Regulators:

- Oregon Public Utility Commission
- Federal Energy Regulatory Commission

Plans and Agreements:

- Oregon Natural Hazards Mitigation Plan
- Lane County Emergency Response Plan
- Lane County Natural Hazard Mitigation Plan
- Mutual Aid Agreements
- EPUD Capital Improvement Plan
- EPUD Long-Term Strategic Plan
- Mutual Aid Agreements with multiple power companies Statewide

Section 11.3: Natural Hazard Mitigation Meetings and Work Sessions

Table 11.3: Emerald People’s Utility District Planning Team

Name	Title	Agency
Kyle Roadman	General Manager	EPUD
Sara Cline	CFO	EPUD
Mark Raimer	Operations Manager	EPUD
Will Burks	Engineering Supervisor	EPUD
Jeff Wasson	Tree Crew Supervisor	EPUD
MeriAnne Moore	Accounting Technician II	EPUD
Matt Mills	Business Intelligence Analyst	EPUD
Christopher Silva	Staking Supervisor	EPUD

Individual Utility Work Sessions

Work sessions with individual utilities were conducted following the initial project orientation meeting and intervening months between general planning group meetings. These individual work sessions are outlined below.

Table 11.4: Emerald People’s Utility District Work Sessions

Date	Location	Meeting/Work Session
02/07/2023	Eugene	XSP Valley Region Workshop 1
04/26/2023	Eugene	XSP Valley Region Workshop 2

The result of this overall process was a thorough evaluation of risk factors and mitigation solutions. Certain hazards were highlighted with notable significance for EPUD, others found to be less relevant in a direct context. Systems and concepts considered included infrastructure resiliency, transportation network, public safety, public and private facilities. A range of both general and specific mitigation ideas and projects were identified and scoped in the field.

Section 11.4: Emerald People’s Utility District Hazard Quantification

Table 11.5 displays the results of the hazard quantification process for Emerald People’s Utility District.

Table 11.5: Emerald People’s Utility District Hazard Quantification Results

Hazard Type / Weight Factor (WF)	History WF x 2	Probability WF x 7	Vulnerability WF x 5	Maximum Threat WF x 10	Raw Score	Weighted Score	Weighted Score Rank
Windstorm	10	10	10	10	40	240	1
Winter Storm	10	9	8	10	37	223	2
Earthquake	1	8	8	10	27	198	3
Landslide	1	3	3	6	13	98	4
Wildfire	1	3	3	6	13	98	5
Flood	1	2	2	3	8	56	6

Source: EPUD’s Natural Hazard Mitigation Team

Section 11.4.1: Individual Hazard Discussions

Windstorm

Windstorms are the predominant natural hazard for EPUD. **(Location)** They affect the entire geographic area of the organization and all its powerline infrastructure. Windstorms can result in both direct physical and power outages from tree falls on overhead power lines or from direct wind loading on power infrastructure. **(Extent)** Windstorms have the potential to affect the entire EPUD customer service area/population. The severity of power outages is related to their duration, which varies greatly depending on the specific nature and physical extent of damages. When only a single or a few locations are damaged, then power is usually restored in hours or less, whereas with major events that significantly damage multiple locations, such outages can be days long in rare cases. **(Previous occurrences)** EPUD experiences multiple windstorms every year, with wide variations in severity, which is based almost entirely on wind speed.

For windstorms, the most common small to medium events with return periods from less than 1 year to 10 years, result in damages from approximately \$5,000 to \$50,000, predominantly to overhead power lines. Larger windstorm events, such as October 1962 Columbus Day windstorm would likely result in damages of \$500,000 or more. **(Probability of future occurrences)** There is a 100% annual probability of windstorms in the planning area. However, the term windstorm is only vaguely defined, so a better measure of probability is to use engineering or meteorology sources that relate wind speeds to probabilities. The Applied Technology Council website indicates that for the planning area, a 10-year storm approximates a 66-mph wind, a 25-year event is 71 mph, a 50-year event is 76 mph, and a 100-year event is 81 mph. Note there is not a significant difference among these wind speeds, and a 66-mph wind is highly likely to cause damages to EPUD infrastructure. Note further that the figures are three-

second sustained winds, and gust speeds (which are often the cause of power line damage) may be much higher.

Winter Storm

Winter storms, or snow and ice storms, can cause impacts like those related to windstorms. While snow and ice storms do occur in the planning area, they are infrequent and generally not as significant as windstorms, although the two hazards may exacerbate each other. Because of its proximity to the coast, the planning area typically experiences snow of only about 5 inches per year, and infrequent freezes.

(Extent) Snow and ice have the potential to affect the entire EPUD customer service area/population, when power is interrupted due to tree limbs falling on power lines or direct physical damage to infrastructure due to ice loading. Snow alone is generally not problematic. Ice storms have the potential to cause widespread power outages, but this depends entirely on the severity of an event. Outages do have the potential to last days, but this is very unusual because of the relatively low probability.

(Previous occurrences)

As part of the 2022 HMP update process, the EPUD lead developed a summary of recent snow and ice events. These include a December 2016 winter storm that created very significant ice loads due to freezing rain. There were numerous pole and wire failures across the EPUD system, and many customers were without power for two to six days depending on location. A 2017 winter storm had similar though less significant effects, as ice accumulations again caused pole and wire failures. In this event, however, most customers lost power for about 24 hours, though some experienced longer outages. High wind events in 2017 – 2020 downed trees and stresses power infrastructure, again causing service interruptions on the order of 245 hours, with longer outages in some localized areas. The most recent events that caused system damage and service interruptions were winter storms, both of which occurred in 2019.

The February 8 event was relatively minor, primarily affecting two feeders. About 500 customers were without power for about 24 hours. The second event was on February 23 and was much more significant in terms of physical damage, although power was restored to most customers within 48 hours.

(Probability of future occurrences) Based on history, EPUD estimates the annual probability of damaging snow or ice storms at about 10 to 20 percent.

Earthquake

Most of the west coast of the U.S. has at least some exposure to earthquake risks, particularly from the Cascadia Subduction Zone (CSZ). The source of CSZ event is off the coast, but the nature of the fault means that it may produce an earthquake or earthquakes of very high magnitude and affect a very large geographic area. Strong ground shaking can cause major damage to electric power systems, especially for high voltage transformers and other essential substation equipment. **(Extent)** The physical extent of earthquake effects is the entire planning area, although levels of ground shaking are related to distance from the fault and soil characteristics, among other factors. A major CSZ event would likely result in extreme damage, with service restoration times measured in weeks or months, rather than hours or days. A major event would likely result in more than \$1M in damages. **(Previous occurrences)**

The CSZ has not experienced a major earthquake in recent history. Like most places, the planning area experiences small earthquakes periodically, but most of them are not severe enough to be felt or cause damage. **(Probability of future occurrences)** The probability of very small events is high, but the

probability of a major CSZ event is generally thought to be on the order of 1,500- to 2,500-year return interval.

Landslide

Landslides can cause localized damage to overhead or underground power lines. Most landslides occur during winter storms with high rainfall, but earthquakes may also cause widespread landslides. **(Extent)** The physical extent of landslides is limited to those areas with slopes and soil characteristics that may cause instability when an area is subjected to high rainfall or earthquakes, or both. Damages from a landslide would depend on the specific location and facility that was impacted. EPUD has not studied this hazard in detail, as it is not considered significant. **(Previous occurrences)** There have been no significant landslides during EPUD's history. **(Probability of future occurrences)** The likelihood of future landslides can only be generally estimated. EPUD has determined that the probability of a landslide occurring somewhere in the planning area is on the order of a 10- to 50-year event, although this is not specific to any EPUD facility or location.

Wildfire

Wildfires also cause localized damage when poles and overhead power lines burn. **(Extent)** Wildfires can occur throughout most of the planning area because of the presence of so much vegetation. If the area was to burn, most of the District's overhead infrastructure would be at risk, and the results of a significant fire would be days to weeks of interrupted power while the infrastructure was inspected and repaired. **(Previous occurrences)** While Oregon has experienced significant wildfires over the past decade, these have not affected the planning area, in large part because of the high rainfall and lack of antecedent conditions. **(Probability of future occurrences)** The probability of future occurrences is very low, likely on the order of a 50-year recurrence interval for any event that would cause significant damage. The FEMA benefit-cost analysis software was consulted because it incorporates USGS wildfire history data. The software indicated that the burn return probability for the planning area is 32 years.

Flood

Floods occur in the planning area, but only in isolated locations. **(Extent)** The physical extent of floods in EPUD's area is very limited. If a substation was to flood, this could cause potential outages to parts of the service area for a matter of days. It is also possible for floods to wash out poles, which would likely cause outages of a day or so if such an event was localized. **(Previous occurrences)** No significant flood damage has occurred to EPUD's facilities during the District's history. **(Probability of future occurrences)** Flood recurrence intervals in the planning area are on the order of 10 to 25 years.

Section 11.5: Mitigation Projects

This section describes mitigation projects identified by EPUD during the planning process. See Volume I, Section 4 for additional information regarding mitigation action item methodology and prioritization.

Mitigation Action Item (a)	Upgrading and/or undergrounding when replacing poles and lines damaged in wind/snow/ice storm events
Location	All service locations
Coordinating Agencies	EPUD Engineering
Implementation Timeframe	Ongoing
Estimated Cost	TBD
Potential Funding Sources	EPUD, HMGP, BRIC
Hazards Mitigated	Multi-Hazard (Wildfire, Winter Storms, Windstorm)
Comments	New standards of poles have been enacted to include class 2 poles, which are of greater strength than necessary in most cases throughout the operating system. Winter storms are becoming more frequent, which necessitated the need for more resilient infrastructure, one being poles. EPUD has implemented additional engineering tools to properly design for greater loading within the district, making it so the system can reasonably withstand greater loads caused by storms. Additionally, spans have been recalculated, and distances decreased, to add additional support structures to heavier, loaded wire. This is an ongoing process and will constantly be evolving as standards change, and storms strengthen.

Mitigation Action Item (b)	Map system infrastructure locations subject to flood damages
Location	All service locations
Coordinating Agencies	EPUD Engineering
Implementation Timeframe	Ongoing
Estimated Cost	TBD
Potential Funding Sources	EPUD, HMGP, BRIC
Hazards Mitigated	Flood
Comments	Floodway mapping has been utilized in relation to new projects to determine mitigation methods in relation to flood hazard zones as dictated by FEMA National Flood Hazard Layers. New build practices are being utilized, as well as utilities being relocated outside of designated flood zones. Current impact is minimal, but floodway can change in the future, necessitating the need for an ongoing plan.

Mitigation Action Item (c)	Map system infrastructure locations subject to wildland or wildland/urban interface fire damage
Location	All service locations
Coordinating Agencies	EPUD Engineering
Implementation Timeframe	Ongoing
Estimated Cost	TBD
Potential Funding Sources	EPUD, HMGP, BRIC
Hazards Mitigated	Wildfire
Comments	Due to extreme droughts, the need for wildland fire damage layers is actively being pursued. Currently, EPUD is in the process of migrating to new mapping system. Additional layers for hazards in relation to infrastructure will be added as the system enhances.

Section 11.6: Progress on Mitigation Actions

Recent Progress on Mitigation Planning Efforts

This subsection of the Plan update briefly summarizes various EPUD mitigation efforts since the original version of the document was reviewed by the State and approved by FEMA.

Overhead to Underground Conversions

- 09/2021 - Cottage Grove Lorane Road Overhead to Underground Conversion:
 - 4.3 Miles of aged overhead electric through heavy vegetation that was continually impacted by wind and winter storms. Converted to underground and relocated to right of way.
 - Activity / Mitigation Type: Reduced need for vegetation management, fire mitigation, winter storms.
- 8/2021 – Jasper Lowell Road Overhead to Underground Conversion & Reroute
 - 1700’ of inaccessible cross country overhead wire, rerouted to right of way and placed underground in new conduit system.
 - Reconductored 3000’ of overhead wire to enhance system reliability.
 - Activity / Mitigation Type: Reduced need for vegetation management, fire mitigation, storm hardening.
- 4/2021 – Longview Land Overhead to Underground Conversion & Reroute
 - 3500’ Removal of cross-country overhead wire through heavy vegetation
 - 3200’ of underground placement in existing right of way via new source
 - Activity / Mitigation Type: Reduced need for vegetation management, fire mitigation, Storm Hardening.
- 5/2021 – Kensington Overhead to Underground Conversion & Reroute
 - Relocated existing overhead wire to right of way and converted to underground. Undergrounded 2000’ of primary and 1000’ of secondary.

- Removed 2700' of existing overhead wire that is inaccessible and frequently impacted by winter storms.
- Activity / Mitigation Type: Reduced need for vegetation management, fire mitigation, storm hardening.

Transmission Rebuilds

- 12/2016 – Vogt Road New Transmission Line and Distribution Rebuild
 - Rebuilt 8000' of distribution line and overbuilt with transmission to create additional feed to substation.
 - Activity / Mitigation Type: New feed, system enhancement, storm hardening
- 1/2018 – Elmira Substation Transmission Reroute
 - Reroute existing transmission line 2,500' up Fountain Road due to heavy vegetation on Suttle and runaway vehicle hazards.
 - Activity / Mitigation Type: Reroute feed, reduced need for vegetation management, fire mitigation, storm hardening

Feeder Tie Projects

- 10/2017 – Highway 36 New Feeder Tie o Relocated and rebuilt 8800' of feeder tie to get off foreign owned poles and increase wire size.
 - Activity / Mitigation Type: New feed, system enhancement, storm hardening
- 6/2020 – Add new tie at end of Lost Valley Land to have additional feed
 - Placed 1700' of new single phase underground tie line to create alternate feed to heavily vegetated area which is frequently impacted by vegetation and storms.
 - Activity / Mitigation Type: Additional feed, storm hardening
- 12/2017 – River Road Reconductor o Reconductor 10,000' of overhead wire. Increase size due to high wind and ice loading
 - Activity / Mitigation Type: System enhancement, storm Hardening
- 8/2020 – Old Marcola Road Reconductor o Reconductor 8,000' of overhead wire. Increase size due to faults caused by vegetation, winter storms.
 - Activity / Mitigation Type: System enhancement, storm hardening

System Enhancement

- 1/2021 – Matthews Road Reconductor o Reconductor 11,000' of overhead wire. Increase size due to loads and faults caused by vegetation and winter storms.
 - Activity / Mitigation Type: System enhancement, storm hardening

Substation

- 2020 & 2021 – Seismic Retrofit at All Substations
 - Added seismic retrofit to all substations to secure transformers

VOLUME III: APPENDICES

Table of Contents

Appendix A: Dam Failure and Risk Context in Lane County 3

 Dam Failure 3

 Risk Assessment 4

Appendix B: Public Input and Participation 6

 Public Survey Results 6

Appendix C: Meeting Notes from Version 3.0 Planning Cycle (2018 - 2023)..... 28

Appendix A: Dam Failure and Risk Context in Lane County

Dam Failure

The probability of dam failure in Lane County is low; vulnerability to a dam failure is high. According to the Army Corps of Engineers National Dam Inventory Website, there are 29 total dams in Lane County, with an average age of 60 years, 100% of all High hazard dams have an emergency action plan in place, 31% of dams are hydropower; 55% are federally regulated, while 59% are state regulated.

Table 1: List of Dams within Lane County with Material Type

Dam Name	Primary Dam Type	Core Types	Foundation
Blue River Dam	Earth	Earth	Rock; Soil
Booth Kelly Lumber Pond (Lagoon)	Earth		
Carroll Reservoir	Earth		
Cottage Grove Dam	Earth	Earth	Rock; Soil
Cougar Dam	Rockfill	Earth	Rock; Soil
Dexter Dam	Earth	Earth	Rock; Soil
Dorena Dam	Earth	Earth	Rock; Soil
East Basin, Cell 1 and 2	Earth		
Fall Creek Dam	Rockfill	Earth	Rock; Soil
Farnam Creek Reservoir	Earth		
Fern Ridge Dam	Earth	Earth	Soil
Fern Ridge Dam - Dike 1			
Fern Ridge Dam - Dike 2			
Forcia and Larsen Log Pond	Other		
Ford Farms Reservoir	Earth		
Hills Creek Dam	Earth	Earth	Rock ;Soil
Hult Pond Dam	Gravity	Earth; Unlisted/Unknown	Unlisted/Unknown
Konyn Dairy Lagoon	Earth		
Leaburg	Concrete	Concrete	Rock
Leaburg Canal and Forebay	Earth	Concrete	Rock
Lookout Point Dam	Earth	Earth	Rock ;Soil
Metropolitan Sludge Ponds (Lagoon)	Earth		
Oakridge Mill Log Pond	Earth		
Santa Clara	Earth		

Schwartz Reservoir	Earth		
Siltcoos Lake	Gravity		
Vaughn Log Pond	Earth		
Walterville Forebay	Concrete	Concrete	Rock
Walterville Storage Pond	Earth	Earth	Rock

Risk Assessment

Although the likelihood of failure is very low, all dams upstream from the Eugene-Springfield area have the potential of causing widespread flooding should they fail. All dams in the Eugene-Springfield area have been inventoried by the Army Corps of Engineers in the National Inventory of Dams (NID). The NID lists 26,983 dams in the US that have significant or high hazard potential. The NID rates each dam as either high, significant, or low hazard potential depending on the probable impacts if a dam fails. High hazard potential indicates loss of human life is likely if the dam fails.

In Lane County, there are 14 high hazard potential dams which are listed below in Table 2. All dams, except Fern Ridge and Santa Clara, are upstream from the major metropolitan area of Eugene-Springfield.

Table 2: List Dams in Lane County with Ownership Identified

Dam Name	Owner Names	Primary Owner Type	Primary Purpose	Primary Dam Type	Hazard Potential Classification
Santa Clara	EUGENE WATER & ELECTRIC BOARD	Public Utility	Other	Earth	High
Walterville Forebay	Eugene Water and Electric Board	Public Utility	Hydroelectric	Concrete	High
Leaburg Canal and Forebay	Eugene Water and Electric Board	Public Utility	Hydroelectric	Earth	High
Walterville Storage Pond	Eugene Water and Electric Board	Public Utility	Hydroelectric	Earth	High
Hult Pond Dam	DOI BLM	Federal	Recreation	Gravity	High
Blue River Dam	USACE - Portland District	Federal	Flood Risk Reduction	Earth	High
Cottage Grove Dam	USACE - Portland District	Federal	Flood Risk Reduction	Earth	High
Dexter Dam	USACE - Portland District	Federal	Flood Risk Reduction	Earth	High
Dorena Dam	USACE - Portland District	Federal	Flood Risk Reduction	Earth	High

Hills Creek Dam	USACE - Portland District	Federal	Flood Risk Reduction	Earth	High
Cougar Dam	USACE - Portland District	Federal	Flood Risk Reduction	Rockfill	High
Fall Creek Dam	USACE - Portland District	Federal	Flood Risk Reduction	Rockfill	High
Lookout Point Dam	USACE - Portland District	Federal	Flood Risk Reduction	Earth	High
Fern Ridge Dam	USACE - Portland District	Federal	Flood Risk Reduction	Earth	High
Metropolitan Sludge Ponds (Lagoon)	METROPOLITAN WASTEWATER MGMT COMMISSION	Local Government	Other	Earth	Low
Carroll Reservoir	BLACK BERRY HILLS RANCH LLC	Private	Irrigation	Earth	Low
Siltcoos Lake	INDUSTRIAL HARBOR USA	Private	Other	Gravity	Low
Konyn Dairy Lagoon	JACK P KONYN SURVIVORS TRUST	Private	Other	Earth	Low
Booth Kelly Lumber Pond (Lagoon)	WEYERHAEUSER COMPANY	Private	Other	Earth	Low
Oakridge Mill Log Pond	CITY OF OAKRIDGE	Private	Other	Earth	Low
East Basin, Cell 1 and 2	INTERNATIONAL PAPER COMPANY	Private	Other	Earth	Low
Leaburg	Eugene Water and Electric Board	Public Utility	Hydroelectric	Concrete	Low
Fern Ridge Dam - Dike 1	USACE - Portland District	Federal			Low
Fern Ridge Dam - Dike 2	USACE - Portland District	Federal			Low
Vaughn Log Pond	ROSBORO, LLC	Private	Other	Earth	Significant
Forcia and Larsen Log Pond	PEGGY KRAFT, DON MERKLE	Private	Other	Other	Significant
Farnam Creek Reservoir	LINDE KESTER	Private	Recreation	Earth	Significant
Ford Farms Reservoir	FORD FARMS, INC.	Private	Irrigation	Earth	Significant
Schwartz Reservoir	JOHN INDA	Private	Irrigation	Earth	Significant

Source: Army Corps of Engineers, 'National Inventory of Dams, Interactive Map & Charts, 2018, <https://nid.sec.usace.army.mil/>, (accessed 1 August 2019).

Appendix B: Public Input and Participation

Public Survey Results

The purpose of the NHMP Community Survey was to gain information about how residents in Lane County perceive the potential hazard risks presented in this Plan. This appendix shows the survey questions and the data associated with those questions.

1. Where in Lane County do you live?

29% Cascades

16% Coast

34% Valley

22% Outside City Limits

2. Please indicate your level of concern regarding the following natural hazards affecting your community:

	Very Concerned	Somewhat Concerned	Not Very Concerned	Not Concerned	Unsure
Drought	32%	37%	17%	11%	0%
Earthquake	30%	40%	20%	8%	1%
Extreme Heat	27%	40%	21%	11%	1%
Flood	17%	40%	29%	13%	1%
Landslide	10%	38%	31%	20%	1%
Smoke	45%	34%	15%	6%	0%
Tsunami	11%	12%	20%	55%	3%
Volcano	1%	12%	28%	57%	3%
Wildfire	68%	24%	6%	2%	0%
Windstorm	29%	44%	18%	9%	0%
Winter Storm	22%	46%	23%	9%	0%

3. From your perspective, how vulnerable are each of the following community assets?

	Very Vulnerable	Somewhat Vulnerable	Neutral	Not Very Vulnerable	Not Vulnerable
Human – Loss of life and/or injuries	39%	48%	6%	6%	1%
Economic – Business closures and/or job losses	36%	44%	13%	6%	1%
Infrastructure – Damage or loss of bridges, utilities, schools, etc.	58%	34%	5%	2%	1%
Cultural/Historic – Damage or loss of libraries, museums, fairgrounds, etc.	14%	40%	26%	14%	6%
Environmental – Damage or loss of forests, rangeland, waterways, etc.	62%	28%	5%	4%	1%
Governance – Ability to maintain order and/or provide public amenities and services	38%	37%	17%	7%	2%

4. What types of community assets are most important to you?

	Very Important	Somewhat Important	Neutral	Not Very Important	Not Important
Assisted Living Facilities	24%	37%	24%	11%	5%
Schools (K-12)	54%	23%	16%	4%	3%
Hospitals	78%	15%	5%	1%	2%
Major Bridges	76%	21%	2%	1%	0%
Fire/Police Stations	79%	18%	2%	1%	0%
Museums/Historic Buildings	11%	62%	38%	18%	7%
Major Employers	17%	38%	29%	11%	4%
Small Businesses	46%	36%	13%	3%	2%
University	13%	34%	31%	13%	8%
City Hall/Courthouse	14%	40%	29%	12%	5%
Parks	24%	38%	23%	10%	6%

5. How important is each of the following to you?

	Very Important	Somewhat Important	Neutral	Not Very Important	Not Important
Protecting Private Property	55%	34%	8%	2%	1%
Protecting Critical Facilities	76%	19%	4%	1%	0%
Networks	86%	11%	2%	1%	0%
Preventing development in hazard areas	48%	31%	16%	4%	1%
Enhancing the function of natural features	48%	33%	12%	6%	2%
Protecting historical and cultural landmarks	17%	47%	23%	9%	4%
Protecting and reducing damage to utilities	74%	23%	3%	0%	0%
Strengthening emergency services	69%	24%	6%	1%	0%
Disclosing natural hazard risks during real estate transactions	56%	29%	12%	3%	1%
Promoting cooperating among public agencies, citizens, non-profit organizations, and businesses	59%	25%	12%	3%	1%

6. In your opinion, how prepared is Lane County to respond to these hazard events?

	Very Prepared	Somewhat Prepared	Not Very Prepared	Not Prepared	Unsure
Drought	2%	21%	37%	19%	21%
Earthquake	1%	26%	31%	22%	20%
Extreme Heat	3%	28%	32%	21%	16%
Flood	3%	34%	30%	16%	17%
Landslide	5%	36%	24%	12%	23%
Smoke	3%	34%	29%	21%	13%
Tsunami	4%	31%	22%	14%	29%
Volcano	1%	11%	20%	30%	38%
Wildfire	7%	45%	24%	17%	8%
Windstorm	6%	39%	26%	13%	16%
Winter Storm	8%	50%	22%	11%	9%

7. What are the top three things Lane County should do to reduce risk from natural hazards?

- 26% Strengthen infrastructure
- 19% Help citizens reduce their individual risk to natural hazards
- 14% Reduce development in known hazard areas
- 10% Restore natural floodplains and open space
- 10% Provide more information to the public about risks to natural hazards
- 8% Build or improve man-made protections (i.e., levees)
- 5% Strengthen public buildings
- 5% Collect more data and information about hazard areas
- 4% Increase safety requirements for building permits

8. How long have you lived in Lane County?

- 2% Less than one year
- 21% 1 to 5 years
- 18% 6 to 10 years
- 19% 11 to 20 years
- 40% More than 20 years

9. Is your primary residence at risk of any of the following hazards?

	Yes	No	Unsure
Drought	71%	19%	11%
Earthquake	74%	9%	18%
Extreme Heat	69%	21%	11%
Flood	40%	44%	16%
Landslide	31%	71%	14%
Smoke	89%	11%	4%
Tsunami	12%	79%	12%
Volcano	26%	43%	35%
Wildfire	90%	8%	10%
Windstorm	90%	10%	7%
Winter Storm	90%	11%	6%

10. Do you have flood insurance for your primary residence?

- 16% Yes
- 73% No
- 11% Unsure

11. Are you required to have flood insurance for your primary residence?

- 8% Yes, it's required
- 7% No, I purchased it voluntarily
- 71% No, it's not required, and I don't have insurance
- 14% Unsure

12. Do you have insurance for any other natural hazard?

- 43% Yes
- 24% No
- 34% Unsure

13. For which other natural hazard(s) do you have insurance for your primary residence?

- 28% Earthquake
- 72% Fire

14. Do you own or rent one or more secondary residences (a dwelling unit that you own or rent that is not your primary residence) in Lane County?

- 9% Yes, one secondary residence
- 6% Yes, multiple secondary residences
- 85% No

15. How long have you owned a secondary residence in Lane County?

- 1% Less than one year
- 42% 1 to 5 years
- 14% 6 to 10 years
- 16% 11 to 20 years
- 26% More than 20 years

16. Please indicate the purpose of your secondary residence:

- 58% Rental or investment residence(s)
- 10% Vacation or seasonal(s)
- 32% Other

17. Is one or more of your secondary residences at risk of any of the following natural hazards?

	Yes	No	Unsure
Drought	73%	20%	7%
Earthquake	80%	7%	13%
Extreme Heat	69%	22%	9%
Flood	45%	44%	11%
Landslide	24%	64%	13%
Smoke	82%	11%	7%
Tsunami	16%	75%	9%
Volcano	40%	36%	24%
Wildfire	73%	22%	5%
Windstorm	85%	11%	4%
Winter Storm	91%	5%	4%

18. Do you have flood insurance for one or more secondary residences in Lane County?

- 18% Yes
- 75% No
- 7% Unsure

19. Are you required to have flood insurance for one or more of your secondary residences?
- 9% Yes, it's required
 - 11% No, I purchase flood insurance voluntarily
 - 67% No, I am not required, and I don't have flood insurance
 - 13% Unsure
20. Do you have flood insurance for one or more of your secondary residences for any other natural hazard?
- 38% Yes
 - 52% No
 - 10% Unsure
21. For which other natural hazard(s) do you have insurance for your secondary residence(s)?
- 62% Fire
 - 38% Earthquake
22. What is your gender?
- 33% Male
 - 62% Female
 - 1% Non-binary
 - 4% I prefer not to answer
23. What age group best describes you?
- 1% Under 18
 - 1% 18 - 24
 - 5% 24 - 35
 - 11% 35 – 44
 - 10% 45 – 54
 - 26% 55 – 64
 - 35% 65 – 74
 - 10% 75 – 84
 - 1% 85 or older

24. Which best describes the combined annual income of all members of your household?

- 10% \$15,000 - \$29,000
- 11% \$30,000 - \$44,000
- 8% \$45,000 - \$59,000
- 16% \$60,000 - \$74,000
- 11% \$75,000 - \$99,000
- 24% 100,000 - \$199,000
- 5% \$200,000 or more
- 15% I prefer not to answer

25. Which best describes your race or ethnic background? Select all that apply.

- 79% White
- 3% Black or African American
- 3% American Indian or Alaska Native
- 2% Asian or Pacific Islander
- 2% Hispanic or Latinx
- 11% I prefer not to answer

26. Please feel free to provide any additional comments in the space provided:

NOTE: The following table contains all survey responses that provided a response to this open-ended question.

Entry #	Date Submitted	Responses
378	4/5/2023 10:39 AM	The blackberry bushes are a fire hazard.
377	4/5/2023 10:25 AM	Dorena needs a fire district. We are trying, please help us!!
375	3/28/2023 9:46 PM	Very limited resources for health and wellness programs, no control of water usage from hemp growers.
369	3/22/2023 6:23 AM	We live where we live, we know the risks. When mother nature decides to strike not much you can do to mitigate it.
358	3/20/2023 1:09 PM	Please repaint all lane dividers and install lane reflectors on highway 126! Reflectors needed especially on the side edges of the road. When it rains all painted surfaces are impossible to see at night. Very dangerous and frightening.

355	3/20/2023 11:18 AM	While Lane County government is doing a fairly good job of education on natural hazard risks, there still needs to be more of this type of outreach for homeowners/citizens to understand and to assess hazard risks in there local areas. Establishing funds, not overly burdened in red tape, to help people owning property in these hazard areas to have incentives and means to help mitigate these risks (such as the wildfire fuel reduction programs underway) will go far in getting people onboard towards making meaningful changes to your efforts to reduce these types of hazards. Here I'm thinking floodway overflow channel improvements and stream/river side vegetation improvement grants that aren't so difficult to obtain and administer. I purchased a property in the floodway with Zone X designation which was reclassified to the Floodway designation after the latest Fema Flood maps were revised. This was a huge financial loss to me as my whole property is now listed in this Floodway designation. If government wants folks to accept these changes in designations the taxable values and perhaps some other type of mitigation incentives of these properties needs to be reduced or created in a manner that realistically corresponds to the loss of value these designations create whatever that hazard risk be. Otherwise folks will continue to bend the rules and to continue foster the "us and them" attitudes around what many will say is Government Overreach.
351	3/18/2023 8:59 AM	What do we do if we have a tsunami I wouldn't even know what to do where do we go
349	3/16/2023 9:45 AM	Loss of natural resources due to development is a primary cause of many of the risks listed in this questionnaire.
348	3/16/2023 7:19 AM	Do more for our unhoused neighbors pls
346	3/15/2023 8:36 PM	I highly value fire and EMS but not police. They should not be grouped together for this survey.
344	3/15/2023 2:07 PM	Tired of smelling chemicals released from industry along Roosevelt and Danebo and very concerned about the railway through there; what it transports and the maintenance of the rail lines and other infrastructure. Are there designated locations in each community to gather in the event of a sustained catastrophe for supplies, information/direction, first aid, etc.? If so, we need more public education to reiterate these places exist and where they are...and yes generally more prolific information on what to do if "the stuff hits the fan" so to speak. Also please, shore up the transportation infrastructure ASAP and intensely, bridges, roads and rails and the airport.

<p>341</p>	<p>3/13/2023 10:02 PM</p>	<p>I live between Creswell and Cottage Grove several miles up Lynx Hollow Road (a long road going west off Highway 99), and more people live further west. The road dead ends to the west into miles of private timber tracts that are gated. It's not an escape option right now. This dead-end road has several side roads that also have no exit. I'm guessing we have more than 200 residents here, but it's only a guess.</p> <p>As far as I know, we only have one way to escape or for emergency vehicles to get into the neighborhood if a fire spreads or another disaster occurs. We aren't the only isolated community that has no escape route if their road is blocked.</p> <p>We really need escape/access plans in an emergency, preferably with some roads on the private timber land or other land connecting to any road that would give connection to a road going north, south or west out of the neighborhood. In the meantime, some planning on what trapped residents could do if we could not leave (maybe create some sort of spot to shelter together in place with some protection from fire).</p> <p>We also need adjacent private timber lots thinned or with fire breaks. Individuals can create defensible spaces, but it's not enough if the community itself doesn't have fire breaks in a fast-moving wildfire.</p> <p>Communication during any emergency is also an issue. Evacuation alerts may be difficult to get to all residents. Cell service is spotty at best.</p> <p>If nothing else, it would be helpful if a Lane County representative could coordinate planning with our unincorporated neighborhood. We don't know what resources are available or what plans Lane County or nearby communities might already have. We could use help with planning and brainstorming on what we can do to prepare in advance of a disaster.</p>
<p>325</p>	<p>3/9/2023 8:09 PM</p>	<p>First we need cell service and reliable internet connections. Then fire services.</p>
<p>324</p>	<p>3/9/2023 5:31 PM</p>	<p>The two most important improvements I would like to see are extending the grooves on the centerline in winding roads, and undergrounding utilities. Underground utilities are not at risk from damage due to wind or snow storms. After the 2020 fire, it was 7 weeks before power was restored to my neighborhood, and 8 months for other utilities.</p>
<p>322</p>	<p>3/9/2023 3:51 PM</p>	<p>My level of concern about parks relates to the trails and undeveloped areas. Recently, I noticed that some brush has been cut back, but the trailside is still full of blackberry vines and other brush. I smell marijuana smoke along the trails, and there are encampments nearby. The fire risk seems little deterred by the minimal brush removal that was done, and there are a lot of dead fir trees mixed among the brush. I recently saw that our area is at about 17" of rain where 27" is normal. Another risky year for wildfire. I live on the east side of Eugene and dread a fire coming from an encampment or a careless hiker.</p>
<p>319</p>	<p>3/9/2023 10:11 AM</p>	<p>We have a post office and a school in Dorena, there is no reason we shouldn't also have a fire/police station as well to protect our very large community. There is a lot of people that live out here and we're all at risk of crime and fires, especially since all of the homeless people have moved up here.</p>

318	3/9/2023 10:03 AM	Firewise was very helpful this year in helping us reduce our risk of wildfire damage. I think they should also offer yearly inspections and certification (i.e. certify a home as "Firewise") annually, as well as neighborhood wide certifications if everyone in a given area participates.
317	3/9/2023 5:49 AM	No mention of cleaning up our towns and getting rid of the homeless and filth. Not to mention the corrupt political bs in Oregon. Done with this state and leaving as soon as we possibly can.
315	3/8/2023 5:13 PM	Hire more employees and train them to adequately do their jobs. Prepare in advance for unexpected hazards.
314	3/8/2023 2:53 PM	I believe the way we handle natural occurrences is under par for the amount we face annually, we seldom have means to protect citizens from smoke or snow and I am constantly hearing comments from people living in other states that we are "scaredy cats about all weather... a little bit (1/2 inch) of snow will block off roads and stop traffic and businesses constantly!" I can't help but feel if we had better preparations or even had distributed filters for air systems, we would be able to maintain a much higher standard and be able to hold much more productive capacity.
312	3/8/2023 12:00 PM	We need to keep the reservoirs filled up to provide water to put out wildfires and provide emergency power generation if the rest of the power grid fails. In the past there was water available for these important issues, but now the reservoirs are nearly empty. This seems to be a very shortsighted way to manage this resource!!! We also need to keep our dams operating to generate clean, green electricity, especially as more people switch to electric vehicles and move away from gas appliances.
307	3/7/2023 6:49 PM	Dorena needs some kind of fire protection. We as a community have worked on smaller water tanks but we need more help establishing EMS and an active and trained fire department. We have had 3 larger fires and dozens of small ones in the past 5 years, without thinking ahead we are only putting ourselves in a position where the big one comes and we are at risk of losing our houses, animals, homes and lives.
303	3/7/2023 2:48 PM	There are two genders. Stop this woke crap.
300	3/7/2023 10:04 AM	Do not prioritize corporations and business/residential development when what we have isn't sustainable to begin with. People and our planet should be prioritized first.
299	3/7/2023 9:58 AM	Thank you for creating this survey...
298	3/7/2023 8:16 AM	Seniors who live in rural areas need assistance maintaining their property to minimize risks of fire. Some of my neighbors can't afford to pay to have grass and dead trees removed.
293	3/6/2023 3:21 PM	Our medical services ambulance, helicopter, and clinic services need more economical help!!

287	3/5/2023 4:58 PM	The most major concern in my area South of Eugene is emergency egress. Both Willamette Street and Fox Hollow have "choke points" where fire could close the road to both first responders and emergency egress. These choke points are adjoining private property areas and county owned right of way areas (to the roadways) which contain ladder fuel. During a wildfire event those areas could potentially cause the fire to crown which would threaten the roadways by causing blockage due to fire and falling burning trees and debris.
285	3/5/2023 4:02 PM	To have an early warning system active we need improved cell service for mountain areas. We are also in dire need of fire and police services. We have to be constantly vigil to catch fires so our neighborhood volunteers can control them. There are too many incidents where cars are abandoned and set on fire.
281	3/5/2023 1:49 PM	Biggest concern is earthquake, and fires due to dryness (including smoke, increased heat).
280	3/5/2023 12:41 PM	Forest management should be a top priority but does not appear on the list of options presented for choosing the top three.
278	3/5/2023 11:15 AM	I believe the most relevant disaster to prepare for is an earthquake and the subsequent consequences on the availability of clean water, food and services, followed by other extreme natural events. We should have a coordinated plan in place to address the consequences of these types of events that impact large numbers of people at once. If there is such a plan in place, I am not aware of it and there could be more public information.
274	3/5/2023 8:36 AM	Dorena needs HOME fire protection.
273	3/5/2023 8:11 AM	We have to prepare for the dams to fail in case of the cascade earthquake
272	3/5/2023 8:09 AM	We need a survey and database of insurance denials/non-renewals of community residences in high wildfire or other high hazard areas. This information needs to be tracked. Lack of the ability to get affordable home insurance perpetuates poverty, reduces community resiliency, and reduces LC revenue while lowering property values.
268	3/5/2023 6:18 AM	Radio was our lifeline during Snowmagedden. (12 day Power outage) There was very little info on the 1 station we could get. Said radio station receives awards for news coverage, yet informed me that they are an entertainment station, not a news source. Could there be funding for this, or a mandatory requirement during disasters?
265	3/4/2023 6:04 PM	Weyerhaeuser forest land is overgrown, unthinned (like a bamboo forest) and not maintained creating a huge fire hazard in the Walterville, Camp Creek and Upper Camp Creek neighborhoods.
261	3/4/2023 3:51 PM	Last summer our area experienced severe danger from Forest Fire and heavy smoke in our area. We were required to evacuate which we did for a few days. Returning home was difficult and

		finding care also difficult. I felt The Amercian Red Cross should have done much more for our folks living out of the city as well with in the cities of Oakridge and Westfir.
258	3/4/2023 1:43 PM	We are both CERT trained
257	3/4/2023 1:37 PM	People need to be prepared to take care of themselves for an extended time after disaster. Most are not.
251	3/4/2023 11:56 AM	Lane County was well prepared and without a doubt, saved numerous lives during the Holiday Farm fire. The 911 alert system, the rapid law enforcement response, the mutual aid who responded to help. I am a volunteer firefighter with McKenzie fire. Exceptional leadership from the County.
240	3/3/2023 3:16 PM	Except for Police, fire, emergency services is what we need. Government wastes sooooo much money on the above survey questions already and what we are getting, Nothing. Lane County follows the wims of Eugene and does not understand the citizens of the outline areas.
238	3/3/2023 12:21 PM	We need a fire dept in Dorena!
237	3/3/2023 5:15 AM	The drug problem needs to be addressed people that are on drugs are distorting our community's
236	3/2/2023 8:58 PM	I saw this video on YouTube and appreciate the value of good date, so I took it. However, I think this survey will have some sample size issues.
229	3/2/2023 11:32 AM	Smoke is a serious problem in Oakridge, and wildfires. We should have been made a FEMA disaster area during the last wildfire and smoke
227	3/2/2023 10:41 AM	After the Holiday Farm Fire, I recognized several areas with room for improvement. There is already poor cellular and internet service and the fire cut all of that off for weeks. The communication portion of this plan needs more emphasis and support to assure redundancy covering rural areas. Since the fire several caches of emergency supplies have been established. Support for keeping them current needs to be included in plans with support to fire departments to maintain them. Fuel was also a problem as the few gas and propane supplies needed electricity to function. Another point to consider is coordination on the ground for all the initial relief responders is needed. Several local groups formed to coordinate efforts of volunteers to limit redundant actions and share what was being done, who was doing it, and share volunteers to best effect. The McKenzie River Long Term Recovery Group is being very successful in helping recovery and standing up their model structure at the beginning of an emergency should be considered. Thanks for your hard work in keeping this mitigation plan current and useful.
226	3/2/2023 9:48 AM	When we had the extreme ice storm a few years back and many residents lost power I was disappointed and

		concerned at how long it took the city and Lane County to figure out how to help the residents. Recommending they go to the Egan Warming Centers was an awful idea!
221	3/1/2023 7:04 PM	Thank you for asking these questions.
220	3/1/2023 6:52 PM	If how lane county plows snow on marcola road compared to linn county on brush creek. I have no faith in timely response to any event in lane county.
219	3/1/2023 5:37 PM	I very much encourage considerations of population limits. TO THAT EXTENT, I believe and immediate moratorium on any further development be suspended pending completion of an analysis to include "impact" statements. Simply stated we have reached and/or exceeded our growth capabilities!!!!
215	3/1/2023 2:40 PM	I wish you had separated fire, ambulance, and police services into their own lines. I feel very differently about these things.
213	3/1/2023 1:30 PM	Lane County is slacking on county road safety during ice/snow events. Need to be proactive to have safe driving conditions by at least 7 am please.
209	3/1/2023 12:21 PM	School air quality should be a priority.
196	2/28/2023 9:25 PM	I would like to see a concerted effort, not including FEMA, to develop a plan communities hit by natural disasters knew they could depend on for sustainable redevelopment, even if we are required to pay a tax into a fund to support it. The comprehensive plan for sustainable development after our fire has been dismal, at best, and is only now beginning to emerge, too late because so many residents are entrenched in their own ignorance and warfare over how to rebuild, and it's a mess.
191	2/28/2023 6:10 PM	Additional bridges to cross the McKenzie River would save lives in a wildfire, flood, earthquake or snow/ice storm.
187	2/28/2023 3:47 PM	Why does the age group category not have "prefer not to answer" as a selection
186	2/28/2023 3:39 PM	It would be nice to know what the risks Lane County thinks my property or community has and what I could do as a resident to mitigate them. It would be nice to know how I could assist in the event of a natural disaster in my area or in general.
185	2/28/2023 3:34 PM	Based on the last 3 years, I am most worried about climate/drought/wildfires. So far even if the fire isn't very close, we have suffered badly from smoke, and I am concerned that wildfire could sweep through parts of Eugene itself if we are not very careful. I live in South Eugene in a neighborhood built in the 1950s and 60s, & it seems quite safe but if we continue having drought our yard is going to die completely and be more vulnerable to wildfire.

183	2/28/2023 2:18 PM	<p>I'm hopeful that wildfire smoke will be prioritized here. It's been disheartening to see Lane County commissioners and Eugene's mayor and city council give such lip service around wildfire smoke back during the weeks-long smoke across the state in Fall 2020. Two and a half years later, I'm still not aware of any concrete efforts either jurisdiction has made to open clean air shelters or provide any other smoke-related resources.</p> <p>Wildfire smoke is certainly not the scariest concern (considering the devastation some other hazards can cause), but from my perspective, I at least have some faith in our first responders (especially fire departments across the county) that they will do everything they can to respond effectively, but I do not have faith that policymakers will take the simple actions to protect people (like opening clean air shelters during smoke events).</p> <p>Thanks for all the work you're doing! Super important topic and I really appreciate what county staff are doing here!</p>
181	2/28/2023 1:55 PM	<p>I am the Secretary of the Elmira Grange, and I would be interested in finding our how our facility could be included as an Emergency asset.</p>
180	2/28/2023 1:42 PM	<p>The greatest threat to the Oakridge/Westfir is wildfire due to miss management by the Forest Service in regards to thinning and clearing down timber as well as not promptly putting out wildfires regardless of whether they are in a wilderness area or not. Highway 58 needs to be maintained for wildfire in that brush needs to be Removed at least 20 yards from ODOT right of way where Forest Service lands abut the right of way. On the west side of Oakridge between mile markers 34 to 30 the forest service land is full of dead and down timber which a wildfire would burn through there so quickly Endangering the town and closing the highway. While there are ways to get through the mountains out of Oakridge there is only one paved major arterial to escape a wild fire i& go either east or west and that is Highway 58. Many citizens in the area do not have a vehicle appropriate for traveling over gravel roads that aren't well-maintained to escape a wild fire. We had a lucky escape this last summer. We have much less green Timberland as a buffer now due to the fire for the way they fought this last forest fire i.e. creating a perimeter acres and acres away from where the fire was actually burning. If the remaining forest isn't cleaned up and prepped for wild fire prevention Oakridge may not be that lucky again.</p>
179	2/28/2023 1:29 PM	<p>Homeless people are unprotected against natural hazards & should be prioritized. I am a fan of CERT & found it extremely useful for community & personal preparedness. County did a great job with Covid, supporting vaccination.</p> <p>I'm disabled & asthmatic. Smoke might drive us out of Oregon.</p>
176	2/28/2023 1:12 PM	<p>Local insufficient response to recent wildfire evacuations indicate that Lane County and it's municipalities are woefully unprepared to deal with major disasters. I strongly recommend that governmental bodies, NGOs develop a volunteer structure to better prepare for the inevitable next big crisis. People want to get involved and y'all are unresponsive to their offers!</p>

174	2/28/2023 12:55 PM	Thank you for asking the public to share their preferences and concerns.
170	2/28/2023 10:58 AM	The federal government needs to manage the forests around us with logging and replanting to lessen the risks of fires that we have had the last 3 years
168	2/28/2023 10:40 AM	Oakridge has had two summers of catastrophic wildfire events. We need MORE HELP and resources so that we aren't the next OR community (Detroit and McKenzie) to be obliterated by forest fires. Epecially with people in the woods in the summer in the National Forest. We see/hear people illegally chainsawing and burning fires during restrictions.
167	2/28/2023 10:24 AM	Stop clearing underbrush. It just dries out the ground & makes the trees even more vulnerable to fire!
165	2/28/2023 10:07 AM	I answered these questions with strictly my community in mind. We do not have schools, hospitals, etc.
160	2/28/2023 9:15 AM	Poverty is an issue out here, and is relative. But many people out here have chainsaws, some have real trucks, and a few have tractors. Most look out for one another but there are things that are too big for us, like bridges and floodplains v roads. Also, many exits through the forest have been gated off to our danger in fires and floods--not good. Thank you for this opportunity to inform you.
154	2/28/2023 8:19 AM	Building permits are ridiculously difficult in this county especially for those who have lost homes to fires. They have suffered enough, dont add to the problem. In the event of a larger natural disaster lane county will become a ghost town because nobody will be able to rebuild.
152	2/28/2023 4:32 AM	More resources and information for local / neighborhood citizen emergency response groups would be wonderful. Florence has many elderly residents -- many of us relatively young newcomers would like to organize to discuss preparedness and develop specific action plans to help our neighbors.
150	2/27/2023 9:23 PM	Lc has improved the local drainage to the reservoir in the past year than odot has in the past 5, thank you!
144	2/27/2023 3:32 PM	I believe that the people of Far west Lane County are willing and able to participate in community preparedness activities. Educational flyers and seminars could be effective means of getting knowledge out there.
143	2/27/2023 3:11 PM	Thank you for helping our community become more resilient :)
136	2/27/2023 9:27 AM	I am concerned that this plan will increase my homeowners insurance.
132	2/27/2023 8:59 AM	Thank you for this opportunity to participate in this survey and for all you are doing to make sure we are prepared for natural disasters. A majority on city government has taken a position to deny climate change despite considerable effort on the part of the community to support preparedness to prevent loss. It's sad and short-sighted.

128	2/27/2023 8:49 AM	<p>Here are some actions I have seen in our area that help prepare for natural hazards. EPUD working year around to keep overhead lines clear of brush and trees on public right-aways and when requested by home owners, EPUD clears brush and overhanging tree branches affecting lines to residences. Public and private groups worked together to improve Cedar Creek's flow to Cottage Grove Lake. Crews clear brush on rural bridges. Several years ago, South Lane Fire provided free address markers to residences in order to clearly mark private lanes.</p> <p>One concern during a natural disaster is that the only road to town could be unusable. Could the county work with granges to help rural communities designate/mark a 2nd route that takes a different direction? For instance, London Road might be impassable but heading the other direction over Shoestring to I 5, south of Curtain might be open.</p>
126	2/27/2023 7:56 AM	<p>Over the 20+ years I have lived here, Lane County has started an Emergency Planning Effort several times and they have NEVER yielded anything substantive. Hopefully this latest effort will be different. Since rural communities will likely be on their own for several days/weeks, I think it's important for the County to facilitate an inventory of each community's assets (backhoes, airstrips/helipads, public buildings for community shelters, etc.) as well as a "phone tree" type document that would be helpful prior to and in the initial phases of an emergency. That way, for instance, if there's a landslide blocking a remote, but important road, we would know who has the equipment to open the road since the County's assets might not be readily available or able to reach the site at all. Or, if a tanker spills chemicals into a waterway, who has boats closest to the incident that could help install booms to contain the spill quickly. There is a private airstrip and a separate helipad in the area that I'm not sure very many people know about that could be very helpful here and county-wide. Thanks for the opportunity to participate in this survey.</p>
125	2/27/2023 7:52 AM	<p>The county should require owners of undeveloped land to clear fire hazard overgrowth if their land borders developed areas. Penalties for not doing so should be severe.</p>
124	2/27/2023 7:50 AM	<p>Clean health mature natural forests are our best protection against many of the fire risks we face. This require we reduce the forest industries hold on these lands. 2. Clean and healthy rivers and streams are our life blood. We must remove invisible contaminants from seeping in to them. One huge problem is that economically disadvantaged cant afford so dont have garbage pickup so they dump, burn, or pile up. We need to de- privatize garbage services and put a sliding scale on garbage pick up, paying for those who can not. It effects us all.</p>
120	2/27/2023 6:19 AM	<p>I'm always concerned about the dams breaking having gone to school at the UofO 20 years ago and now living in Lane County.</p>
118	2/27/2023 5:36 AM	<p>I suggest a set of questions or future survey to ask the respondent what they have done personally to prepare for natural hazards e.g go kits, meetup plans, extra food, water, heat etc. After Snowmageddon we shared a lot because neighbors were not prepared which in turn made us less resilient.</p>

117	2/27/2023 5:28 AM	The local/state governments lack of support for all of the law enforcement agencies will allow the significant numbers of transients to act as they wish. The amount of looting, riots and sheer anarchy will completely over run Eugene and most of Springfield in the event of a significant disaster. The inability of many of the cities residents to take care of themselves in a simple snow storm is evidence that the loss of life will be high and due to the significant numbers of transients allowed to live within this community, many people will be attacked/killed for any asset they possess. We simply do not have the necessary amount of law enforcement to keep order.
105	2/26/2023 9:46 AM	Public schools on the coast are not adequately supplied for any disaster and most of the schools are not earthquake safe.
104	2/26/2023 9:24 AM	Thank you!!! Please keep the Siuslaw Region in your plans please!!!! West of the tunnel matters!!! Thank you :)
102	2/25/2023 8:17 PM	I really wish Lane County could work with the US Army Corp of Engineers to rethink the filling of Fern Ridge and opt for a management plan that would help the lake be full for recreational use. The current plan is outdated and does not take into effect tge changing climate in the Willamette Valley.
99	2/25/2023 5:07 PM	Need Police service and code inforcement
96	2/25/2023 10:59 AM	We need sheriffs,troopers up the McKenzie, ridiculous that they have to come from 50 miles+ ...if tgey come at all! We pay taxes too yet get NOTHING!
95	2/25/2023 10:01 AM	Reduce fire/windstorm/emergency response risk etc. by burying electric lines in the McKenzie River Valley! Do not herbicide roadsides in fire-prone areas! Dead vegetation is far more flammable than live vegetation! Replace the River Crossing over the Leaburg Dam once the dam is removed! Otherwise the escape routes for residents to the south of the river will be very vulnerable. Restrict freight traffic more on highway 126, and reduce speed limits on more dangerous areas.
94	2/25/2023 9:15 AM	Could use help clearing brush under the forest canopy.
88	2/24/2023 6:23 PM	County should inventory all water sources for wildfire supression
87	2/24/2023 6:12 PM	Since the train incident in OH I have been very worried. Here in Oakridge we are so vulnerable to the UP trains hauling oil tankers and who knows what else through here 24 x7. I live 100 or so feet from the tracks. No one ever talks about it. I called my congressperson and feel that this is extremely important. UP functions with total imperviousness.
86	2/24/2023 5:46 PM	We're not sure what lane county has done for preparedness. Information dissemination would be helpful.

76	2/24/2023 2:26 PM	Example issue: The only access to my home is via a county wooden covered bridge, that is vulnerable to flood, fire, wind, and snow/ice. The weight limit prevents emergency vehicles from legally crossing the bridge to provide life saving services. County should consider a solution, such as that at Lowell to provide a parallel concrete bridge for traffic and close off the covered bridge for historic purposes or upgrade the suspension structure so that the school buses, fire trucks, etc can legally cross the bridge.
67	2/24/2023 6:46 AM	I feel adequate assistance for future major disasters is not available for the population. Not enough attention is given for future disasters like, earthquakes an fire. To much under growth an dead timber in our forests. None of this removed in Willamette Nat Forrest from Snowmeggdon between Lowell an around Oakridge areas, fodder for fires. Very concerning!
65	2/24/2023 5:24 AM	Thank You.
61	2/23/2023 7:40 PM	I did not know when I bought the house that usable internet service or any cell service was non-existant here. I didn't know there was no fire department coverage in this area or any emergency response that was timely. We're basically on our own and at the whim of a private water company that charges a fortune. I didn't know I am not even allowed free library service here. I almost feel I live in a 3rd world area even though I'm only 10 miles from a city. Its crazy. I pay property taxes but what value do I have from that? Any wind takes out the power and Dorena area is always the last to be restored. I have to have flood insurance even though this house has never flooded and neighbors right on the river don't have to have it. All of this is unsettling. Its a beautigul area but lacks basic services.
59	2/23/2023 7:28 PM	The less government intervention the better. This year around poor air quality due to mismanagement of our forests is ridiculous and dangerous. If we aren't having to breathe the foul air from a "managed" forest fire, we have yard burning, wood stoves, or "controlled" burns. Since I live with pulmonary fibrosis agitated by this disgusting air—I am personally invested in air quality.
56	2/23/2023 6:11 PM	My partner, 44f, and our 6year old daughter live in our primary home.
55	2/23/2023 5:49 PM	I do not feel in general that Lane County has a good approach to dealing with civilians. The building department in particular is extremely toxic. They have terrible skills when it comes to interacting with citizens. Based on all my experiences with Lane County government, I feel that it is full of bullies who use their power to abuse citizens and make their lives worse by being focused more on punishments, fines and penalties than on being a collaborative government partner. My interactions with Lane County government have previously all be terrible and I am filling out this survey with more hope than optimism that the actual needs of citizens are important to the government officials who oversee the institutional culture of the Lane County offices. Until there is a huge paradigm shift in how lane county officials interact with the public, our ability as a community to improve resilience will remain limited. Lane county public health is the only trustworthy department and they should be the ones helping set the standards for how to protect the public. The building department is a disaster.

48	2/23/2023 1:21 PM	The biggest problem is climate change and you have no questions that DIRECTLY address climate change. With the exception of volcanoes and earthquakes and worn out infrastructure, your questions are about the effects of climate change and not actual climate change or solutions in mitigating climate change. The # 1 recommendation I could suggest for Lane Co. residences is a program that would pay, at least in part for wild fire mitigation. Then on a local level, set goals and ways to achieve those goals for atmospheric carbon reduction.
43	2/23/2023 11:53 AM	I think this is a waste of time. I think you should also be concerned about wildlife and the reasons many species are dwindling and disappearing. In the long run, it could certainly affect humans.
41	2/23/2023 11:33 AM	Thank you for doing and allowing participation in this survey!
40	2/23/2023 11:08 AM	With all do respect! You really need to stop attacking private residence with your regulations! If we need your help we will ask for it!
38	2/23/2023 10:21 AM	Mostly wildfire is our main worry.
27	2/22/2023 6:48 PM	Our community lacks in depth of services, particularly when we experience being isolated by a natural disaster ie snow storm, flood, hazadous material incident. Having a CERT group would provide depth of knowledge and skills to respond to local incidents. This should be an emphasis item for all rural areas in Lane Couty.
25	2/22/2023 4:55 PM	The poorest communities in Lane County which includes Glenwood where I reside will be the most impacted and is least prepared for natural and man made disasters. A train derailment and chemical spill/explosion is the most likely but there is not contingency plans for addressing by the county or Oregon for such. Why? Instead Lane County, the State of Oregon and Federal Gov't diddle while giving away \$ billions of corporate welfare for paving, timber industry, real estate development, etc) instead of addressing the myriad of looming disaster scenarios all Oregonians face but especially the poorest communities. Where is the leadership from our so called leaders and policy makers like Gov Kotek, Sen. Merkley, Sen. Wyden, Rep. Hoyle, and County Commissioners?
22	2/22/2023 2:47 PM	Did my best to answer but I hope your policy is based on your best judgment and good staff research, rather than guesses from citizens about what priorities should be. It was easy to say "very important" to several priorities. You have a difficult job to make the hard choices about how to allocate scarce resources. Thank you for your efforts.
20	2/22/2023 1:26 PM	We live in the Row River Valley. Our biggest concern is Wildfire.
15	2/22/2023 12:30 PM	Tsunami is misspelled a few times. Moving Emergency Management out of LCSO has been a very positive change, especially in terms of community engagement.

14	2/22/2023 12:28 PM	Need more fire fighters, police, and sheriff to decrease response time during disaster. *holiday farm fire survivor*
13	2/22/2023 12:24 PM	Rural residents need more financial assistance for defensible space and creating fire-resistant homes.
10	2/22/2023 12:03 PM	Limiting flood plain development, restoring and protecting riparian areas and enforcing code violations in floodplains is most important to me right now.
4	2/19/2023 8:43 AM	The unhoused of Lane County are at greatest risk from natural hazards. More attention and effort should be made to remedy the issue and provide positive model for national resolutions for safe & affordable housing. Be solution oriented.

Appendix C: Meeting Notes from Version 3.0 Planning Cycle (2018 - 2023)

M E E T I N G M I N U T E S

Attendees: Eli Davis, Maya Buelow, Mary Vuksich-Shafer, Shawn Waite, Rachel Serslev, Mike Dapkus, Jared Bauder, John Roche, Steve McGuire, Mike Cowles, Ray Wooth, Cody Kleinsmith, Matt Tarnoff, Dan Hurley, Peggy Keppler, Orin S., Mike Finch, Pete Z., Brian Greig, Matt McRae, and Chanelle Moody.

1. **Welcome:**

Welcome Cody Kleinsmith.

2. **Cody Kleinsmith Presentation:**

Cody is the Climate Resiliency Analyst for Lane County, and an Americorp Service member. He is currently working on Stage 3 - Greenhouse Gas Mitigation Plan which includes looking at externally facing issues and dividing these into topics such as wildfire, droughts, and other risks.

Being proactive and looking to do progressive planning for such topics as solar ray, battery storage, and modeling codes. In early stages including the vulnerabilities assessment, and feedback from stakeholders and citizens in community for what we want to pursue. Looking at how we may incorporate into NHMP plan and not duplicating efforts with Emergency Mgmt.

3. **Recent Projects:**

Maya Buelow: Looking to secure two permanent backup generators for Waste whether approved in this FEMA grant cycle or not.

Are there current tax incentives for electricity and solar? Looking into battery storage as well. Would like to explore the potential of non-fossil based fuels planning.

Matt Tarnoff: PW Rds is seeking an HMGP grant, waiting for approval from OEM. Also have Spire Grant application in for reader board and lights.

Looking at Federal infrastructure BIL funding. (Maya)This pot is \$55 mil. and for funding in 2022-2026. County currently has an RFP open. Consider get this for future funding and planning.

Mike Finch: Working on cybersecurity grant with Kim Morgan. Also, a position for a Regional Broadband Coordinator. This could optimize all funding opportunities and provide connectivity for communities with a need.

On a personal note, has recently taken IC training to support committee.

4. **Review Action Items**

Action items updates and notes were directly taken in the NHMP tracking sheet in Teams.

5. **Potential Projects/Grant Funding**

No updates

6. **Next Steps**

Determine if there is a need to re-evaluate the 2 hr. timeframe for quarterly meetings.

Possibly determine speaker or POC for each category/action item to provide updates to committee.

Adjourn: 3:45

M E E T I N G M I N U T E S

Attendees: Steve McGuire, Mike Cowles, Ray Wooth, Bill Burns, Matt Tarnoff, Tim Chase, Dan Hurley, Peggy K., Cody Kleinsmith, Orin S. Aariah Thompson, Patence W., Mike Finch, Selene J., Pete Z., Andrew Cooke, Brian Greig, Matt McRae, Lance Englet, and Chanelle Moody

1. **Welcome:**

Welcome Bill Burns from DOGAMI.

2. **Bill Burn Presentation:**

Presentation from Bill Burns. This included the components of; reducing landslide risk in Lane County; types of slides; Lidar data (this will be put on Lido on web); funding to complete projects in Eugene area, HFF, and proposition to do I-5 corridor; community outreach and awareness; and geotechnical reports witch are 100% free – available to everyone (Possibly mapping is already uploaded into Transmaps).

Brian Greig suggested potential project of mapping remote hill top communications infrastructure.

The new Open file Report published last week.

<https://www.oregongeology.org/pubs/ofr/O-21-12/O-21-12.htm>

New SLIDO web map viewer

<https://gis.dogami.oregon.gov/maps/slido/>

SLIDO data and story map

<https://www.oregongeology.org/pubs/dds/p-slido4.htm>

Homeowners guide to landslides

https://www.oregongeology.org/Landslide/ger_homeowners_guide_landslides.pdf

Land Use Guide for Landslides

https://www.oregongeology.org/Landslide/Landslide_Hazards_Land_Use_Guide_2019.pdf

3. **Recent Projects:**

NHMP Plan – U of O update of plan will go forward.

- a. HMGP – PW Roads (Tarnoff) – Closing LCOG agreement to lead process of \$1.5 mil. for removal of hazardous trees and fuels ID through fire dist. Closing soon and looking favorable. The U of O Road Access Review of alternate routes is coming to a close.

HFF Recovery (McCrae) – Working on two projects; McKenzie River school seismic retrofit, which includes replacing the windows, \$2 mil. project; and McKenzie Fire project for Firewise landscaping on 45 individual properties. This involves hiring people for hazardous fuels removal, (\$500,000 project) with legislature putting aside the funds to cover the 25% portion.

ECS Projects (Peggy) – Projects include: Hayden Bridge, Territorial Bridge, HFF culverts, E. King Rd., Row River Rd., and the Goodpasture Bridge.

ICF – PW contractor can be utilized again once grants close to work with upcoming COVID dollars.

Emergency Mgmt. (Patence) – Wildfire Risk Project (\$725,000) involves distributing emergency alert radios. Will leverage brochure based on CWPP, including website tools with the three ecoregion concept, and defensible space around homes. This project has 100% funding.

Wildfire Evacuation Plan project will entail assessments for each fire dist. with consideration to vulnerable population. Areas include Row River Rd., Swisshome, Marcola, and other areas. The CWPP was updated in August, ties into mitigation plan.

PW Roads (Orin) – HFF building happening. We are at stage 2 cleanup, there is significant impact happening to the road system do to projects. When all settled out will have to think about future road restoration (Hwy 126). Consider potential request to legislature for CBDR funding. Other counties are in same situation.

4. **Potential Projects/Grant Funding**

- a. Public Works (Dan) – Building Back Better – Not a lot of funding available here, getting sucked back up at Sate level.

5. **Next Steps**

- a. Next meeting we will go through NHMP action items to prepare for the contractor.

Adjourn: 4:20PM

M E E T I N G M I N U T E S

Meeting: Natural Hazards Mitigation Steering Committee Meeting

Date: August 9th, 2021

Time: 1400-1600

Room: Virtual Meeting

Attendees: Steve McGuire (PW, Land Management), Matt Tarnoff (RDS), Peggy Kepler (PW), Pete Zugelder (Safety), Keir Miller (LMD), Dan Hurley (PW), Mike Cowles (A&T), Orin Schumacher (RDS), Patence Winningham (EM), Elijah Davis (EM), Matt McRae (HFF Recovery), Amber Bell (LMD), and Matt Dapkus (CAO).

Notes:

Reviewed funding breakdown of NHMP dollars (75/25% match), money brought forward as a result of Umatilla flooding. Several projects put in by LC: EWEB, Rainbow Water Dist., Emergency Mgmt. and emergency alerting radios.

We are using CWPP (Community Wildfire Protection Plan) committee to build out portion of the NHMP to make more applicable to our eco-regions.

NHMP set to expire October 2023. U of O will facilitate update.

The group reviewed all Action Items outlined in the 2018 NHMP, itemized below:

Multi-Hazard

Mitigation Action item 1: Sustain Hazard Mitigation & Emergency Management Steering Committee. Continuously review, update and facilitate implementation of Plan. Committee oversight of this Plan will help prevent loss and maximize cost recovery after a disaster.

- *Coordinating Departments:* Emergency Mgmt.
- *Timeline:* 12-16 months
- *Progress/Update:* Standing quarterly meetings scheduled beginning April 2021.

Mitigation Action item 2: Include publicly owned utilities in 2022 Plan Update.

Incorporate Utility Planning into County efforts. Reduced infrastructure damage. Increased cooperation & information sharing decreases recovery time and costs.

- *Coordinating Departments:* Emergency Mgmt. /Utilities.
- *Timeline:* 12-18 months
- *Progress/Update:* EWEB and Lane Electric moving forward. EWEB to participate in fuels reduction and chip in money for match.
- *PSPS shutoff for utilities. Put into place guidance by November.*

Mitigation Action item 3: Enhance Public Education about natural hazards and preparedness. Increase community resilience to disasters. Improved community preparedness and resiliency.

- *Coordinating Departments:* All Departments/ All Agencies
- *Timeline:* 1-6 months
- *Progress/Update:* Radio System, Starlink is not available yet, something coming. We are in a holding pattern for now.
- *DR 4562 Project being developed.*

Mitigation Action item 4: Develop Emergency Water Supply Plan.

Mitigate water shortages, prioritize needs, and establish protocols and triggers. Establishing triggers to activate plans reduces response and recovery time.

- *Coordinating Departments:* Emergency Mgmt. /County Public Works/City Emergency Mgmt./City Public Works/Utilities/Water Districts.
- *Timeline:* 6-12 months
- *Progress/Update:* Storage containers at sites, possible at granges and schools? Problem – How to filter the water. When no electricity how to supply homes. Use of hand wells/hand pumps. Florence filtering water. Public Outreach. At this time, EWEB plan is not focusing on rural communities. Firewise Stationary Water Towers (response for fire events)-not potable waters. Water source to keep defensible space green. May consider outreach materials to those with wells, help understand back up power, hand pump solutions. Kier M reminded us that there are 55-gallon tanks from Glory Bee, additional costs for pump/chemicals, provide resources to make useable system.
- *Canned water? Stored water supply for staff, possibility of using local vendor.*

Mitigation Action item 5: Hazard Mapping. Identify hazards in specific locations in a usable, informative format. Accurate mapping will allow for better land-use choices, decreasing potential losses due to ineffective mitigation planning.

- *Coordinating Departments:* Emergency Mgmt./ GIS/ Technology Services
- *Timeline:* 8-12 months
- *Progress/Update:* County employees have access to EMMA. <https://www.emma-toolkit.org/market-system-mapping-tool>

- EMMA is being built out, including fire zones, inundation, and EWEB provided mapping including Trailbridge. Possibility of Eugene GIS and file sharing.

Mitigation Action item 6: Maintain Vegetation Management Standards.

Standards reduce wildfire fuels near structures and waterways. Decreased loss of structures due to wildfire hazard, decreased debris in waterways help prevent localized flooding

- *Coordinating Departments:* County Public Works, Local Public Works Depts.
- *Timeline:* Ongoing
- *Progress/Update:* No update. Fire wise and WF Safety Standards as assigned. Presenting to BCC in summer, changes to Lane Code that require land management vegetation reduction requirements. (Forest zones) CWPP Adopted, identified 3 eco regions high hazards fuels reductions projects.
- Senate 7862 overlaps somewhat. Need to research best practices. Going to put on pause till can digest and implement.

Mitigation Action item 7: Storm-harden Grange Facilities. There are 22 granges in rural Lane County that serve difficult to reach communities and that are willing to open their facility if needed during a disaster. Storm hardening granges will give Lane County a resource for assembly of displaced persons. Provides nearby location for rural residents to receive emergency assistance. Reduces use of government services when resources are already spread thin and reduces cross-county vehicular travel when roads are most hazardous. Preserves cultural and historical resources.

- *Coordinating Departments:* Lane County Emergency Mgmt.
- *Timeline:* 1 - 2 granges per year.
- *Progress/Update:* Consideration in McKenzie area, and utilizing libraries. Will this be recovery or respite site. Oregon Community Foundation and school district funds to utilize H.S gym as recovery center.

Dam Failure

Mitigation Action item 8: Load GIS layers of dam inundation areas into mass notification system. To accurately notify those in the path of dam inundation floodwaters in time to evacuate. Prevents loss of life, increases potential to decrease loss of property.

- *Coordinating Departments:* Lane County Emergency Mgmt./ Technology Services (GIS)/ Alerting System Vendor
- *Timeline:* 12-18 months
- *Progress/Update:* EWEB info will be upcoming.
- USACE to review work completed.

Mitigation Action item 9: Make USACE Inundation maps available for public viewing. Inform the public of flood hazard. Decrease loss of property.

- *Coordinating Departments:* Emergency Mgmt./ US Army Corps of Engineering.

- *Timeline:* 12-24 months
- *Progress/Update:* Dispatch has maps if needed.

Drought

Mitigation Action item 10: Drought Public Education and Outreach. Increase awareness of drought effects and provide mitigation actions for individuals. Improved water quality, reduced drought effects, reduced costs of water treatment and mandatory water restrictions.

- *Coordinating Departments:* Emergency Mgmt./Fire Depts. and districts/Water Districts.
- *Timeline:* 12-18 months
- *Progress/Update:* No movement. Not a huge threat, fire suppression. Educate newer ranch owners. Spencer Creek Watershed, including new homeowners.
- Drought Emergency declared 2021.

Mitigation Action item 11: Construct storm water detention/retention ponds. Reduce localized Flooding. Decrease damage to road infrastructure, increase natural watershed potential.

- *Coordinating Departments:* Emergency Mgmt./ County and City Public Works Depts.
- *Timeline:* 18-24 months
- *Progress/Update:* (who is the lead POC for PW Dept?) Roads knows of frequent flooding areas, but does not track. DEQ stormwater tracks. Maybe follow with Watershed Task Force from HFF--

Earthquake

Mitigation Action item 12: Harden Public Works Facilities. Increase resilience to seismic forces. Decrease damage due to shaking/liquefaction, ability to use structure in post event response/recovery.

- *Coordinating Departments:* Emergency Mgmt./County Public Works, local Public Works Depts.
- *Timeline:* 18-36 months
- *Progress/Update:* Seismic eval for PSB. Nothing changed or suspect.
- Good time to update seismic assessment, possibly by structural engineering.

Mitigation Action item 13: Participate in ODOT Bridge Seismic Resiliency Planning Project. Increase bridge resiliency to seismic forces. Decreased loss of life, decrease loss of property. Increase resiliency of system, increase response capability.

- *Coordinating Departments:* Emergency Mgmt./County Public Works/ ODOT.
- *Timeline:* 18 months
- *Progress/Update:* Peggy K.
- Goodpasture covered bridge as possible seismic project, more study needed.

Flood

Mitigation Action item 14: Maintain and Enhance Community Rating System (CRS) .Increase use of CRS to decrease costs of flood insurance. Decrease cost of flood response, decrease loss of property.

- *Coordinating Departments:* Emergency Mgmt./County Planning Dept./Local Planning Depts.
- *Timeline:* 12-36 months
- *Progress/Update:* Unsure of 5 yr. audit status. Addition amendment being completed by Deanne Wright, Amber will follow up.

Mitigation Action item 15: Upgrade Culverts and Storm Water Drainage Systems. Increase Stormwater drainage capacity. Decreased cost of maintenance, decreased damage to road infrastructure.

- *Coordinating Departments:* Emergency Mgmt. / County Planning Dept./ Local Planning Depts.
- *Timeline:* 24-36 months
- *Progress/Update:* HFF- ECS is currently working on.

Hazardous Materials Incidents

Mitigation Action item 16: Promote proper use and storage of chemicals.

Reduce hazardous spills and releases. Lower costs for cleanup, lower damages to environment, less loss of property, lower threat to life.

- *Coordinating Departments:* Emergency Mgmt./Fire Depts. And Districts./Local LEPC.
- *Timeline:* 12-18 months
- *Progress/Update:* LEPC just met. Review alert tool, subscription lists, and preplans of each facilities. Currently 40 EHS facilities.

Mitigation Action item 17: Pre-identify collection sites and services for post-flood or earthquake cleanup. Preplan locations for debris removal/storage, consolidate debris, disposal, and recycle where possible. Decreases recovery time, decreases cost of debris disposal.

- *Coordinating Departments:* Emergency Mgmt./ County and City Public Works Depts.
- *Timeline:* 12-18 months
- *Progress/Update:* Review Debris Management Plan update sites and protocol. Debris Management Plan has been updated is included in ESF 3; sites still need to be identified across Lane County for debris (waste vs. Debris) stockpiling rather than waste Consider broader use with partners State, Federal. (Dan H. suggested Jeff Orlandini to look into this). Pre-approved permits/standards with community partners prior to an event.

Landslide

Mitigation Action item 18: Construct engineered walls at key locations for stabilizing slopes. Decrease landslide potential. Reduce loss of property, life, and reduce cost of cleanup in time and funds.

- *Coordinating Departments:* County Public Works/ODOT
- *Timeline:* 24-48 months
- *Progress/Update:* Stew M. from EWEB in processing Lidar next year.

Mitigation Action item 19: Public Awareness and Education. Increase public awareness. Reduce unintended damages by causing landslides through inappropriate land use.

- *Coordinating Departments:* Coordinating Depts.: Emergency Mgmt./County and City Planning and Public Works Depts.
- *Timeline:* 12-24 months
- *Progress/Update:* Flooding and runoff will be an issue. Need to develop floodplain language. Amber will talk to DFM's. Letter was sent out.

Tsunami

Mitigation Action item 20: Support community-based culture of tsunami awareness, preparedness and response. Increase knowledge of the Hazard, and how to respond to it. Decreased loss of life.

- *Coordinating Departments:* Emergency Mgmt./ WLEOG/ DOGAMI
- *Timeline:* 8-12 months
- *Progress/Update:* Patence will contact City of Florence.

Mitigation Action item 21: Continuously improve government proficiency in using multiple types of warning systems. Increase effective use of the tools.

Decrease loss in live and property.

- *Coordinating Departments:* Emergency Mgmt./PSAP's and Dispatch Centers.
- *Timeline:* 12-18 months
- *Progress/Update:* Gov. Brown signed bill to allow critical infrastructure below tsunami level. Utilizing state tool that 34 out of 36 Counties are concurrently implementing.

Wildfire

Mitigation Action item 22: Promote Firewise Communities Program offerings.

Increase public participation in Firewise program. Decrease number of human caused fires, decrease loss of life and property, decrease cost of response.

- *Coordinating Departments:* Emergency Mgmt./County Planning Dept.
- *Timeline:* 6-18 months
- *Progress/Update:* OSU Extension webinars-Fire ready Fire Alert being offered every 2 weeks; CWPP was formerly adopted by BOC on 8/2020; Working with COOP Lane Fire COOP connection with Firewise.
- *HMPG DR4562-Public Outreach campaign CWPP.*

Windstorm

Mitigation Action item 23: To reduce damages caused by trees in windstorms.

To reduce damages caused by trees in windstorms. Reduced cost in loss of property, cleanup, decrease disruptions in power and transportation.

- *Coordinating Departments:* Emergency Mgmt.; County Public Works, ODOT, Power Utilities
- *Timeline:* 12-24 months
- *Progress/Update:* No change.

Mitigation Action item 24: Provide local redundancy of windstorm warnings through local media on both traditional and social platforms. Increase imminent windstorm alerts.

- *Coordinating Departments:* Emergency Mgmt./ PIO networks. County Public Works/ODOT
- *Timeline:* 6-12 months
- *Progress/Update:* Regional PIO Network; working out mutual aid agreements with other local government entities to utilize when assets are taxed.

Severe Winter Storm

Mitigation Action item 25: Develop emergency water supply plan for power outages caused by snow/ice storms. Create a secondary water source for emergency use. Improved health and safety of local residences experiencing power outages.

- *Coordinating Departments:* Emergency Mgmt./ NGO's/ Water districts/ Local Emergency management.
- *Timeline:* 12-18 months

- *Progress/Update:* City of Florence and local hospital working to install backup power supply for well water system. SPIRE Generator housed at Fairgrounds supplies to EWEB Well system.

Mitigation Action item 26: Develop emergency firewood supply plan for power outages caused by snow/ice storms. Provide a plan to supply firewood to mitigate power loss from winter storms. Decrease use of shelters, decrease cost of shelters, decrease in illness.

- *Coordinating Departments:* Emergency Mgmt./ NGO's/ Water districts/ Local Emergency management.
 - *Timeline:* 12-18 months
 - *Progress/Update:* Most suburban/city have gas. Rural community is generally heated by wood. Stockpile wood for use of others, areas needed to be identified to community, for future use. (add to debris sites)
-
- Fuel (west side) Cottage Grove, Dexter, backup generators installed.
 - Damage Assessment (OSFM) working on project, what is our authority, what is the hazard and caused the damage and what is the damage assessment, impacts from specific hazards wildfire, flood, could be different for each. Oregon SAP program using evaluator coordinator aspect. Executive direction and authority and level of expectation.
 - Connect with Sarah SWCS – Oakridge
 - Matt Tarnoff-Roads Project Wildfire fuels reduction in the ROW for 2 years of funding/contract to prevent spread.
 - EM-Priority routes identified connections to move people, in pinch point areas/routes for moving people/livestock.

M E E T I N G M I N U T E S

Meeting: Natural Hazards Mitigation Steering Committee Meeting

Date: April 19th, 2021

Time: 1400-1600

Room: Virtual Meeting

Attendees: Steve McGuire (PW, Land Management), Matt Mcrae (PW), Peggy Kepler (PW), Pete Zugelder (Safety), Keir Miller (LMD), Dan Hurley (PW), Mike Cowles (A&T), Orin Schumacher (PW), Patence Winningham (EM), Elijah Davis (EM).

Notes:

Subcommittee agreed to meet twice a year to review action items outlined in the current 2018 NHMP for Lane County. These action items will be posted on the Emergency Management website for the group to review and track to ensure this plan is a living document – striving to complete action items “bolded” in the plan as action items we can achieve before the next update of the plan in 2023.

The group reviewed all Action Items outlined in the 2018 NHMP, itemized below:

Multi-Hazard

Mitigation Action item 1: Sustain Hazard Mitigation & Emergency Management Steering Committee. Continuously review, update and facilitate implementation of Plan. Committee oversight of this Plan will help prevent loss and maximize cost recovery after a disaster.

- *Coordinating Departments:* Emergency Mgmt.
- *Timeline:* 12-16 months
- *Progress/Update:* How often did this group meet in the past? Possibly schedule regular meetings of twice a year. ODF Funding will be awarded and spent by June 2021. Cities annexes;

Mitigation Action item 2: Include publicly owned utilities in 2022 Plan Update.

Incorporate Utility Planning into County efforts. Reduced infrastructure damage. Increased cooperation & information sharing decreases recovery time and costs.

- *Coordinating Departments:* Emergency Mgmt. /Utilities.
- *Timeline:* 12-18 months
- *Progress/Update:* EWEB plan doesn't focus on rural communities. Consider reaching out to smaller utilities to assist in their planning efforts for mitigation. Under 4562, U of O will review and update.

Mitigation Action item 3: Enhance Public Education about natural hazards and preparedness. Increase community resilience to disasters. Improved community preparedness and resiliency.

- *Coordinating Departments:* All Departments/ All Agencies
- *Timeline:* 1-6 months
- *Progress/Update:* Continuation by all, hand out flyers, inform community. Emergency Alert Radio program, Firewise, Website Flooding annual mailer flood hazards CRS Flooding. Starlink-Beta (not mobile), communities could review/investigate option to maintained in area for community or POD for station solution. Kier M. Spoke about CRS flooding documentation that could be helpful. Mike F. suggested that Starlink must be Geolocated but is still a strong possible solution to pursue.

Mitigation Action item 4: Develop Emergency Water Supply Plan.

Mitigate water shortages, prioritize needs, and establish protocols and triggers. Establishing triggers to activate plans reduces response and recovery time.

- *Coordinating Departments:* Emergency Mgmt. /County Public Works/City Emergency Mgmt./City Public Works/Utilities/Water Districts.
- *Timeline:* 6-12 months
- *Progress/Update:* Storage containers at sites, possible at granges and schools? Problem – How to filter the water. When no electricity how to supply homes. Use of hand wells/hand pumps. Florence filtering water. Public Outreach. At this time, EWEB plan is not focusing on rural communities. Firewise Stationary Water Towers (response for fire events)-not potable waters. Water source to keep defensible space green. May consider outreach materials to those with wells, help understand back up power, hand pump solutions. Kier M reminded us that there are 55-gallon tanks from Glory Bee, additional costs for pump/chemicals, provide resources to make useable system.

Mitigation Action item 5: Hazard Mapping. Identify hazards in specific locations in a usable, informative format. Accurate mapping will allow for better land-use choices, decreasing potential losses due to ineffective mitigation planning.

- *Coordinating Departments:* Emergency Mgmt./ GIS/ Technology Services
- *Timeline:* 8-12 months
- *Progress/Update:* GIS adding layers to minimize mistakes. Making EMMA and other tools more efficient. Adding in layers for 1996 and 2019 flooding. Add Kier to EMMA. Wildfire Evacuations need to be looked at throughout the County. ESRI and State program of Raptor are now connected.

Mitigation Action item 6: Maintain Vegetation Management Standards.

Standards reduce wildfire fuels near structures and waterways. Decreased loss of structures due to wildfire hazard, decreased debris in waterways help prevent localized flooding

- *Coordinating Departments:* County Public Works, Local Public Works Depts.
- *Timeline:* Ongoing
- *Progress/Update:* Fire wise and WF Safety Standards as assigned. Presenting to BCC in summer, changes to Lane Code that require land management vegetation reduction requirements. (Forest zones) CWPP Adopted, identified 3 eco regions high hazards fuels reductions projects.

Mitigation Action item 7: Storm-harden Grange Facilities. There are 22 granges in rural Lane County that serve difficult to reach communities and that are willing to open their facility if needed during a disaster. Storm hardening granges will give Lane County a resource for assembly of displace persons. Provides nearby location for rural residents to receive emergency assistance. Reduces use of government services when resources are already spread thin and reduces cross-

county vehicular travel when roads are most hazardous. Preserves cultural and historical resources.

- *Coordinating Departments:* Lane County Emergency Mgmt.
- *Timeline:* 1 - 2 granges per year.
- *Progress/Update:* Consideration (given recent snow event) community centers to equip for Emergency shelters, cost prohibitive, and possibly equip 2 shelters a year. Co-op generators/ Fuel capacity/ diesel (Riverstone). Building code standards will need to be reviewed, for emergency occupancy. Facilities could be used as cleaner air spaces, evaluate locations to meet standard to include Merv-A or HEPA Filters (13). Specifically Upper McKenzie Community Center, McKenzie High School, Oakridge High School. Included Red Cross Shelter Assessment to evaluate cleaner air facility requirements. 70 filters distributed Fire Departments, Public Health Staff for cleaner air facilities during wildfire events. **4 Connex boxes - distro around County for use-permanent use with building permit/issue of accessibility. Fire Marshal Discovery Center Permit use for higher occupancy? Change of use? Land use requirements; Propane cook top, produce heat/warm food portable tanks (100 lbs) instead of permanent install at Community Centers potential outdoors.**

Dam Failure

Mitigation Action item 8: Load GIS layers of dam inundation areas into mass notification system. To accurately notify those in the path of dam inundation floodwaters in time to evacuate. Prevents loss of life, increases potential to decrease loss of property.

- *Coordinating Departments:* Lane County Emergency Mgmt./ Technology Services (GIS)/ Alerting System Vendor
- *Timeline:* 12-18 months
- *Progress/Update:* Patence met with ACOE. Potential flooding data effected areas into layers. Include livestock/animals, fly areas impacted-using eagle view pictometry (ask Brad Welch). 2019/1996 layered in EMMA, Collector – shared platform between SAR, GIS, OEM, ACOE, EWEB build Raptor/Sartopo.

Mitigation Action item 9: Make USACE Inundation maps available for public viewing. Inform the public of flood hazard. Decrease loss of property.

- *Coordinating Departments:* Emergency Mgmt./ US Army Corps of Engineering.
- *Timeline:* 12-24 months
- *Progress/Update:* Difficult to implement for public.

Drought

Mitigation Action item 10: Drought Public Education and Outreach. Increase awareness of drought effects and provide mitigation actions for individuals. Improved water quality, reduced drought effects, reduced costs of water treatment and mandatory water restrictions.

- *Coordinating Departments:* Emergency Mgmt./Fire Depts. and districts/Water Districts.
- *Timeline:* 12-18 months
- *Progress/Update:* Not a huge threat, fire suppression. Educate newer ranch owners. Spencer Creek Watershed, including new homeowners.

Mitigation Action item 11: Construct storm water detention/retention ponds. Reduce localized Flooding. Decrease damage to road infrastructure, increase natural watershed potential.

- *Coordinating Departments:* Emergency Mgmt./ County and City Public Works Depts.
- *Timeline:* 18-24 months
- *Progress/Update:* (who is the lead POC for PW Dept?) Roads knows of frequent flooding areas, but does not track. DEQ stormwater tracks. Maybe follow with Watershed Task Force from HFF--

Earthquake

Mitigation Action item 12: Harden Public Works Facilities. Increase resilience to seismic forces. Decrease damage due to shaking/liquefaction, ability to use structure in post event response/recovery.

- *Coordinating Departments:* Emergency Mgmt./County Public Works, local Public Works Depts.
- *Timeline:* 18-36 months
- *Progress/Update:* Do we have seismic evaluation for Lane Co. Delta Campus? Pete Z. communicated no and that PSB is about 25 years old, (1996). There is interest for a survey being done for PSB and Delta. This could be a planning project? Delta is a Secondary site for data center; EOC Primary location; The Courthouse upgrade project looked into seismic considerations? Pete Z is responsible for full COOP Plan, and tying all departments together.

Mitigation Action item 13: Participate in ODOT Bridge Seismic Resiliency Planning Project. Increase bridge resiliency to seismic forces. Decreased loss of life, decrease loss of property. Increase resiliency of system, increase response capability.

- *Coordinating Departments:* Emergency Mgmt./County Public Works/ ODOT.
- *Timeline:* 18 months
- *Progress/Update:* Peggy K. informed the group that there was a completed resiliency planning project in 2017, most were ODOT owned. 5 LC bridges on priority routes, 1 requested construction dollars, 2 on Row River Rd.-looking for funding for design. Roads seismic training for all staff in roads division; Coordinated effort in past; interest in

reconnecting on coordinate effort; two temporary bridges in event of bridge failure. There are a number of bridges that ODOT is putting load restrictions on-NHMP should be looking at restricted bridges have capacity; Peggy K. is looking for up to date list.

Flood

Mitigation Action item 14: Maintain and Enhance Community Rating System (CRS) .Increase use of CRS to decrease costs of flood insurance. Decrease cost of flood response, decrease loss of property.

- *Coordinating Departments:* Emergency Mgmt./County Planning Dept./Local Planning Depts.
- *Timeline:* 12-36 months
- *Progress/Update:* 5 year Audit FPM CRS Code update-Development no longer allowing CR2K; Kier M. communicated that the (Follow up with Deanne Wright) 12 year of program; Also looking at seismic survey done for repeater sites that the County owns.

Mitigation Action item 15: Upgrade Culverts and Storm Water Drainage Systems. Increase Stormwater drainage capacity. Decreased cost of maintenance, decreased damage to road infrastructure.

- *Coordinating Departments:* Emergency Mgmt. / County Planning Dept./ Local Planning Depts.
- *Timeline:* 24-36 months
- *Progress/Update:* Check with Keith and Deanna-this is happening currently. Is a list of sites being maintained (as upgraded or due for upgrade)?

Hazardous Materials Incidents

Mitigation Action item 16: Promote proper use and storage of chemicals.

Reduce hazardous spills and releases. Lower costs for cleanup, lower damages to environment, less loss of property, lower threat to life.

- *Coordinating Departments:* Emergency Mgmt./Fire Depts. And Districts./Local LEPC.
- *Timeline:* 12-18 months
- *Progress/Update:* 41? High Hazard Sites. Fire Authority outreach to each site to equip with knowledge. Conducted two TTX, meeting July 2021.

Mitigation Action item 17: Pre-identify collection sites and services for post-flood or earthquake cleanup. Preplan locations for debris removal/storage, consolidate debris, disposal, and recycle where possible. Decreases recovery time, decreases cost of debris disposal.

- *Coordinating Departments:* Emergency Mgmt./ County and City Public Works Depts.
- *Timeline:* 12-18 months

- *Progress/Update:* Review Debris Management Plan update sites and protocol. Debris Management Plan has been updated is included in ESF 3; sites still need to be identified across Lane County for debris stockpiling rather than waste Consider broader use with partners State, Federal. (Dan H. suggested Jeff Orlandini to look into this).

Landslide

Mitigation Action item 18: Construct engineered walls at key locations for stabilizing slopes. Decrease landslide potential. Reduce loss of property, life, and reduce cost of cleanup in time and funds.

- *Coordinating Departments:* County Public Works/ODOT
- *Timeline:* 24-48 months
- *Progress/Update:* Hwy 58 & 126. Mapleton Area of concern, GIS Layer available? Holiday Farm Fire; Sweet Creek Fire impacts; look at options revegetation in areas of concern (Hydroseeding for roads, past practice). Contracted out for other areas, Planning project for contractor to identify hazards with DOGAMI information, implement projects. EWEB Lidar approved. Orin to represent-bring back information. University of Oregon;

Mitigation Action item 19: Public Awareness and Education. Increase public awareness. Reduce unintended damages by causing landslides through inappropriate land use.

- *Coordinating Departments:* Coordinating Depts.: Emergency Mgmt./County and City Planning and Public Works Depts.
- *Timeline:* 12-24 months
- *Progress/Update:* Requiring folks to get Geotech report before building in risk areas, to ensure slope is adequate/setback is adequate. Outreach/education due to HFF impacts, GIS map to show areas that are more susceptible to earthquakes or higher risk to landslide/slope in liquefiable soils.

Tsunami

Mitigation Action item 20: Support community-based culture of tsunami awareness, preparedness and response. Increase knowledge of the Hazard, and how to respond to it. Decreased loss of life.

- *Coordinating Departments:* Emergency Mgmt./ WLEOG/ DOGAMI
- *Timeline:* 8-12 months
- *Progress/Update:* Provided materials to community for preparedness and response outreach, attended two events this year (Prep Fair, and National Night Out Event 2019); No update.

Mitigation Action item 21: Continuously improve government proficiency in using multiple types of warning systems. Increase effective use of the tools.

Decrease loss in live and property.

- *Coordinating Departments:* Emergency Mgmt./PSAP's and Dispatch Centers.
- *Timeline:* 12-18 months
- *Progress/Update:* Gov. Brown signed bill to allow critical infrastructure below tsunami level. Utilizing state tool that 34 out of 36 Counties are concurrently implementing.

Wildfire

Mitigation Action item 22: Promote Firewise Communities Program offerings.

Increase public participation in Firewise program. Decrease number of human caused fires, decrease loss of life and property, decrease cost of response.

- *Coordinating Departments:* Emergency Mgmt./County Planning Dept.
- *Timeline:* 6-18 months
- *Progress/Update:* OSU Extension webinars-Fire ready Fire Alert being offered every 2 weeks; CWPP was formerly adopted by BOC on 8/2020; Working with COOP Lane Fire COOP connection with Firewise.

Windstorm

Mitigation Action item 23: To reduce damages caused by trees in windstorms.

To reduce damages caused by trees in windstorms. Reduced cost in loss of property, cleanup, decrease disruptions in power and transportation.

- *Coordinating Departments:* Emergency Mgmt.; County Public Works, ODOT, Power Utilities
- *Timeline:* 12-24 months
- *Progress/Update:*

Mitigation Action item 24: Provide local redundancy of windstorm warnings through local media on both traditional and social platforms. Increase imminent windstorm alerts.

- *Coordinating Departments:* Emergency Mgmt./ PIO networks. County Public Works/ODOT
- *Timeline:* 6-12 months
- *Progress/Update:* Regional PIO Network; working out mutual aid agreements with other local government entities to utilize when assets are taxed.

Severe Winter Storm

Mitigation Action item 25: Develop emergency water supply plan for power outages caused by snow/ice storms. Create a secondary water source for emergency use. Improved health and safety of local residences experiencing power outages.

- *Coordinating Departments:* Emergency Mgmt./ NGO's/ Water districts/ Local Emergency management.
- *Timeline:* 12-18 months

- *Progress/Update:* City of Florence and local hospital working to install backup power supply for well water system. SPIRE Generator housed at Fairgrounds supplies to EWEB Well system.

Mitigation Action item 26: Develop emergency firewood supply plan for power outages caused by snow/ice storms. Provide a plan to supply firewood to mitigate power loss from winter storms. Decrease use of shelters, decrease cost of shelters, decrease in illness.

- *Coordinating Departments:* Emergency Mgmt./ NGO's/ Water districts/ Local Emergency management.
- *Timeline:* 12-18 months
- *Progress/Update:* Most suburban/city have gas. Rural community is generally heated by wood. Stockpile wood for use of others, areas needed to be identified to community, for future use. (add to debris sites)
- Fuel (west side) Cottage Grove, Dexter, backup generators installed.
- Damage Assessment (OSFM) working on project, what is our authority, what is the hazard and caused the damage and what is the damage assessment, impacts from specific hazards wildfire, flood, could be different for each. Oregon SAP program using evaluator coordinator aspect. Executive direction and authority and level of expectation.
- **Connect with Sarah SWCS - Oakridge**

M E E T I N G M I N U T E S

Meeting: Natural Hazards Mitigation Steering Committee Meeting

Date: December 14, 2020

Time: 1400-1500

Room: Virtual

Attendees: Patence Winningham, Eli Davis, Chanelle Moody, Linda Cook, Dan Hurley, Steve Sieczkowski, Mike Cowles, Gary Luke, Amber Bell, Carrie Carver, Tim Chase, Matt Dapkus, Chris Doyle, Debby Haller, Jonna Hill, Selene' Jaramillo, Michael Johns, Lisa Lacey, DJ Mann, Steve McGuire, Keir Miller, Orrin Schumacher, Ray Wooth, and Pete Zuegelder.

Minutes

1. **Welcome**
Overview of grant funding availability due to Holiday Farm Fire.
2. **Recent Projects:**

Lane County submitted two plans that have been approved:

Community Wildfire Protection Plan (CWPP)- (Wildfire evacuation planning) Approved amount of \$130,000.

Lane Regional Resilience Collaborative (LRRC) – Goal is to bring partners together in a common goal. Works with resilience at a community level, a mitigation project as a community approach. In process of writing by-laws, forming a committee, writing a charter, and marketing.

3. Potential Projects

There are two funding options currently available for hazard mitigation assistance HMA funding:

- a. **HMGP-PF-FM-5327** (pre-applications due to SHMO no later than 15 January 2021; sub applications due to SHMO no later than 19 February 2021)-1 funding stream 8 projects currently submitted.
- b. **HMGP-DR-4562-OR** (pre-applications due to SHMO no later than 1 April 2021; sub applications due to SHMO no later than 25 August 2021)- 1 funding stream 13 projects.

A letter of intent will need to be submitted to determine eligibility.

Some currently proposed projects include EWEB and McKenzie flood plain and watershed, fire recovery and restoration for McKenzie Hwy., alerting capabilities for U of O for earthquake/wildfire, and Rainbow Water District backup power.

Lane County Emergency Mgmt. also plans on applying for grant to upgrade NHMP plan, which will be due in 2023.

Mike Finch – Previously submitted letter of intent for microwave DA update. Can we re-submit same proposal?-Yes.

The state will offer more training on how to complete applications (three day course). Eli took this class, and can send out recorded session. We can also connect you to the state to assist. We took advantage of funding that became available due to Snowmageddon and the flooding in Hermiston. Take advantage of dollars that may work for you.

Steve S.- (LCSO) – Natural hazard of debris in in waterways, and mudslides, we have authority to deal with life safety. Should this go to state or NHMP grant? Can you get reimbursed twice?

Linda Cook – Tricky due to question of who own waterways? If hazard could bring in contractor and could get reimbursed by state.

EWEB is restoring bank, and conducting watershed restoration which can be difficult to show investment in LC.

Amie Bashant from the State can give examples of funded projects.

Other potential projects could include: Territorial Hwy, Parks projects for future mitigation strategies for erosion, Firewise and fuel reduction (funding can be utilized in incorporated and un-incorporated areas).

Orin - BEARS and ETART data which contain data for low level bridges, culvert, etc. as well as for Archie Creek and Lionshead could be utilized as a starting point for project submission, as they have already been identified as potential projects. Orin will reach out to Steve S., Jeanine Parisi, and Carl Morgan and get looped into meetings.

4. Next Steps:

Do projects need to be spec. ready? No.

Could potentially match some of these projects to coincide with our CIP projects.

Linda Cook - Sticking with BEAR/ETART data, is there someone who could notate and put a check mark by what is critical in these reports?

Gary Luke - EWEB and LIDAR data from flyover could potentially show hazard areas in the river (logs and vegetation). Carl Morgan from EWEB paid for the data.

Orin – Other ongoing projects also include East King, which is outside of Holiday Farm area which lacks funding. Environment and survey work is done. Can we initiate projects that are outside of burn area – Yes.

Linda – Work with Amie Bashant to determine benefit cost analysis for rural areas. Who has jurisdictional authority, it will make it our responsibility.

Other counties are looking at surveyor expenses as PA eligible.

CIP list, we can align HMA assistance with these CIP projects. Post fire there are 13 projects.

Adjourn: 1555

M E E T I N G M I N U T E S

Meeting: Natural Hazards Mitigation Steering Committee Meeting

Date: June 30th, 2020

Time: 1100-1200

Room: Virtual

Attendees: Steve McGuire (PW, Land Management), Gary Luke (GIS), Jocelyn Warren(HHS), Mike Harman (TS), Keir Miller (LMD), Lisa Lacey (Risk), Orin Schumacher (RDS), Ray Wooth (PW), Devon Ashbridge (LC), Mike Cowles (A&T), Patence Winningham (EM), Chanelle Moody (EM), Eli Davis (EM), and Tim Chase (SAR).

Minutes

1. Welcome Eli Davis, NEW Management Analyst:

Eli worked in the private sector as the Emergency Management Coordinator for the hospital system. Upon joining Emergency Management at week one he was moved into the Liaison role for the COVID response.

2. COVID – 19 Update:

LC Public Health has filled multiple roles (Refer to Org Chart) from Policy and Liaison roles to answering questions from Lane County Board of Commissioners. This didn't bog down response. The Call Center was opened as we did in the Winter Storm, as well as setting up the Joint Information Center that works to dispel rumor control. Public Info Officers included: Devon Ashbridge, Carrie Carver, and Jason Davis.

This is an unprecedented event. The State is capable to call in assistance. They release assets to assist including; Kristina Deschaine (State Fire Marshall), as well as Mark Boren (FDB) to assist in the Operations Section and Planning, and to train additional staff. Lane County Public Works staff have assisted in Planning, Finance, Operations, and Logistics.

Key Component – PPE shortage. How to take in donations, how to manage, and how to receive and disperse.

The Finance Section is working on the Corona Fund Relief (CARES ACT). This effort will be composed of how to track funds and requests. The EOC model currently has: Department Operations, HHS Contract Tracing, and public outreach. The Recovery effort is running at the Incident command level. To keep on track we are having weekly check in's with Steve Mo., and completing weekly full Incident Action Plans.

How we are tracking other Operations include: Call Center (what questions are coming in from the community), testing inventory, Logistics, and meeting the seven bench marks. We have a 30 day PPE supply and filling needs, and also have supply chain connections.

HHS Planning – Initially produced IAP once a day with an operational period on 24 hour basis. They are now producing plans on a weekly basis with a 1 week operational period.

Finance: Composed of County Admin (Robert Tintle and Shawn Waite). Worked with securing contracts and writing on the fly including; respite shelters at LEC and Memorial in Springfield, St. Vincent DePaul, and security with DPI for example.

Recovery effort: Patence is the Recovery Branch Director and Ops Chief, Judy Williams is Liaison, Devon Ashbridge is PIO, Eli Davis is Planning Chief (producing full IAP's), Austin Ramirez is Economic Recovery, Steve Manela is Finance, and Housing is Sarai Johnson.

The 204 documents are large and include contact numbers and work assignments, these have been used in wildfire and for Olympic Trials (Eli's role)

3. **HMA Grant Funding Projects:**

- a. (HMGP 4432) Funding source.
Application is for \$100,000 and working in coordination with U of O. The plan is focused on wildfire evacuation planning. Those assisting include: fire chiefs with high hazard areas, LMD, GIS, Forest Service, and Emergency Mgmt.
 - b. (HMGP 4452) Funding (Flooding).
Lane Regional Resilience Collaborative (LRRC) – Works with our resilience at a community level, a mitigation project as a community approach. This will leverage more money to meet goals as a community. Similar to EWEB and the 2nd well source. The first meeting had 110 people attending. The U of O Policy has the framework and will work collaboratively as a committee. The next charter will be focusing on by-laws. The LRRC could model the Regional Disaster Preparedness Organization (RDPO) - An organization in Portland in which all jurisdictions pay into program. Potentially, we could apply for grants as a group, creating a powerhouse as a tool. As a tool this could be used to create flood map studies focused on different areas and their impact to public infrastructure reducing mitigation risks. Another example could be used for Territorial Hwy. as a way to continue funding.
 - c. BRIC Funding – Guidance was sent out in an email. Brian Greggs from the Sheriff's Office was able to utilize funds as a way to mitigate risks.
4. **Community Wildfire Protection Plan (CWPP) Update-** This plan is updated and finished, it was on the shelf for 10 years. It contains 5 top areas/action items. The formal adoption will be next week. The committee adopted to re-incorporate as an annex into 2023 NHMP. The areas covered are from the Coast Range to the Cascades, including the Willamette Valley. It contains new maps, as well as a wildfire extraction for high density areas. The plan was adopted and written with help from Alex Rahmlow from the OR Dept of Forestry, Fire Defense Board, and LC Emergency Mgmt.
5. **National Preparedness Month-** Does staff see an interest in continuing program? – YES. We would like ideas of how to streamline process. Potentially push out pick up date a week due to receiving orders on time. Also, find financial billing platform to make payment easier. Tim Chase potentially having SAR volunteer assist with distribution.
6. **Other items:** Last Fall we had the EM Mgmt. Kickoff. We have since built up teams (Red, White, and Blue) in order to build depth and are penciling in names as we go. Jocelyn Warren reached out to want to train folks from HHS. When Eli is up to speed he will be coordinating and conducting training here at Lane County. TEEX Training is also planning on hosting an event here

in the Fall. We would like to have them do Logistics training. How to track, when, where, and how supplies move.

Emergency Management Performance Grant is due tomorrow.

Eli is working to update 8 of our ESF's as part of this years' goal.

Jocelyn- Spoke briefly of standup needed and the Recovery in COVID response, may be used as type/model for wildfire, appreciate model. Is Tim's Search and Rescue still a resource to be used in contact tracing?

Tim - Technology is an issue as many levels of knowledge.

Jocelyn - Documentation for tracing is a challenge. Need system created. Currently using paper. State is 2 months behind in guidance

Currently updating AlertSense contract. Used by dispatch for staff and public. Working with Janet Labonte. Used to issue wireless emergency alerts. Eugene issued WEAA alerts to people concerning rioting. Notified people to shelter in place, and of a curfew. It was used for Mt. Pisgah fire. Alerts went from McKenzie Bridge to Junction City. It has evolved and improved. It can be used with all cellular devices. Seven jurisdiction's currently use, including Tim Chase with SAR and 911 Dispatch. It can be used with an app on your phone. Let us know if you want to use as a way to poll employees through email or text.

Adjourn: 11:50

M E E T I N G M I N U T E S

Meeting: Natural Hazards Mitigation Steering Committee Meeting

Date: June 25th, 2019

Time: 0830-1000

Room: Lowell Conference Room

Attendees: Steve McGuire (PW, Land Management), Gary Luke (GIS), Selene Jaramillo (HHS), Lorren Blythe (TS), Michael Johns (Fleet), Keir Miller (LMD), Matt Dapkus (COA), Mike Cowles (A&T), Patence Winningham (EM), Chanelle Moody (EM).

Notes:

Subcommittee agreed to meet twice a year to review action items outlined in the current 2018 NHMP for Lane County. These action items will be posted on the Emergency Management website for the group to review and track to ensure this plan is a living document – striving to complete action items “bolded” in the plan as action items we can achieve before the next update of the plan in 2023.

The group reviewed all Action Items outlined in the 2018 NHMP, itemized below:

Multi-Hazard

Mitigation Action item 1: Sustain Hazard Mitigation & Emergency Management Steering Committee. Continuously review, update and facilitate implementation of Plan. Committee oversight of this Plan will help prevent loss and maximize cost recovery after a disaster.

- *Coordinating Departments:* Emergency Mgmt.
- *Timeline:* 12-16 months
- *Progress/Update:* **How often did this group meet in the past? Possibly schedule regular meetings of twice a year.**

Mitigation Action item 2: Include publicly owned utilities in 2022 Plan Update.

Incorporate Utility Planning into County efforts. Reduced infrastructure damage. Increased cooperation & information sharing decreases recovery time and costs.

- *Coordinating Departments:* Emergency Mgmt. /Utilities.
- *Timeline:* 12-18 months
- *Progress/Update:* **EWEB plan doesn't focus on rural communities. Consider reaching out to smaller utilities to assist in their planning efforts for mitigation.**

Mitigation Action item 3: Enhance Public Education about natural hazards and preparedness. Increase community resilience to disasters. Improved community preparedness and resiliency.

- *Coordinating Departments:* All Departments/ All Agencies
- *Timeline:* 1-6 months
- *Progress/Update:* **Continuation by all, hand out flyers, inform community.**

Mitigation Action item 4: Develop Emergency Water Supply Plan.

Mitigate water shortages, prioritize needs, and establish protocols and triggers. Establishing triggers to activate plans reduces response and recovery time.

- *Coordinating Departments:* Emergency Mgmt. /County Public Works/City Emergency Mgmt./City Public Works/Utilities/Water Districts.
- *Timeline:* 6-12 months
- *Progress/Update:* **Storage containers at sites, possible at granges and schools? Problem – How to filter the water. When no electricity how to supply homes. Use of hand wells/hand pumps. Florence filtering water. Public Outreach. At this time, EWEB plan is not focusing on rural communities.**

Mitigation Action item 5: Hazard Mapping. Identify hazards in specific locations in a usable, informative format. Accurate mapping will allow for better land-use choices, decreasing potential losses due to ineffective mitigation planning.

- *Coordinating Departments:* Emergency Mgmt./ GIS/ Technology Services
- *Timeline:* 8-12 months
- *Progress/Update:* GIS adding layers to minimize mistakes. Making EMMA and other tools more efficient.

Mitigation Action item 6: Maintain Vegetation Management Standards.

Standards reduce wildfire fuels near structures and waterways. Decreased loss of structures due to wildfire hazard, decreased debris in waterways help prevent localized flooding

- *Coordinating Departments:* County Public Works, Local Public Works Depts.
- *Timeline:* Ongoing
- *Progress/Update:* Fire wise and WF Safety Standards as assigned.

Mitigation Action item 7: Storm-harden Grange Facilities. There are 22 granges in rural Lane County that serve difficult to reach communities and that are willing to open their facility if needed during a disaster. Storm hardening granges will give Lane County a resource for assembly of displaced persons. Provides nearby location for rural residents to receive emergency assistance. Reduces use of government services when resources are already spread thin and reduces cross-county vehicular travel when roads are most hazardous. Preserves cultural and historical resources.

- *Coordinating Departments:* Lane County Emergency Mgmt.
- *Timeline:* 1 - 2 granges per year.
- *Progress/Update:* Consideration (given recent snow event) community centers to equip for Emergency shelters, cost prohibitive, and possibly equip 2 shelters a year. Co-op generators/ Fuel capacity/ diesel (Riverstone). Building code standards will need to be reviewed, for emergency occupancy. Facilities could be used as cleaner air spaces, evaluate locations to meet standard to include Merv-A or HEPA Filters (13). Specifically Upper McKenzie Community Center, McKenzie High School, Oakridge High School. Included Red Cross Shelter Assessment to evaluate cleaner air facility requirements.

Dam Failure

Mitigation Action item 8: Load GIS layers of dam inundation areas into mass notification system. To accurately notify those in the path of dam inundation floodwaters in time to evacuate. Prevents loss of life, increases potential to decrease loss of property.

- *Coordinating Departments:* Lane County Emergency Mgmt./ Technology Services (GIS)/ Alerting System Vendor
- *Timeline:* 12-18 months
- *Progress/Update:* Patence met with ACOE. Potential flooding data effected areas into layers. Include livestock/animals, fly areas impacted-using eagle view pictometry (ask Brad Welch).

Mitigation Action item 9: Make USACE Inundation maps available for public viewing. Inform the public of flood hazard. Decrease loss of property.

- *Coordinating Departments:* Emergency Mgmt./ US Army Corps of Engineering.
- *Timeline:* 12-24 months
- *Progress/Update:* Difficult to implement for public.

Drought

Mitigation Action item 10: Drought Public Education and Outreach. Increase awareness of drought effects and provide mitigation actions for individuals. Improved water quality, reduced drought effects, reduced costs of water treatment and mandatory water restrictions.

- *Coordinating Departments:* Emergency Mgmt./Fire Depts. and districts/Water Districts.
- *Timeline:* 12-18 months
- *Progress/Update:* Not a huge threat, fire suppression. Educate newer ranch owners. Spencer Creek Watershed, including new homeowners.

Mitigation Action item 11: Construct storm water detention/retention ponds. Reduce localized Flooding. Decrease damage to road infrastructure, increase natural watershed potential.

- *Coordinating Departments:* Emergency Mgmt./ County and City Public Works Depts.
- *Timeline:* 18-24 months
- *Progress/Update:* (who is the lead POC for PW Dept?)

Earthquake

Mitigation Action item 12: Harden Public Works Facilities. Increase resilience to seismic forces. Decrease damage due to shaking/liquefaction, ability to use structure in post event response/recovery.

- *Coordinating Departments:* Emergency Mgmt./County Public Works, local Public Works Depts.
- *Timeline:* 18-36 months
- *Progress/Update:* Do we have seismic evaluation for Lane Co. Campus? No

Mitigation Action item 13: Participate in ODOT Bridge Seismic Resiliency Planning Project. Increase bridge resiliency to seismic forces. Decreased loss of life, decrease loss of property. Increase resiliency of system, increase response capability.

- *Coordinating Departments:* Emergency Mgmt./County Public Works/ ODOT.
- *Timeline:* 18 months
- *Progress/Update:*

Flood

Mitigation Action item 14: Maintain and Enhance Community Rating System (CRS) .Increase use of CRS to decrease costs of flood insurance. Decrease cost of flood response, decrease loss of property.

- *Coordinating Departments:* Emergency Mgmt./County Planning Dept./Local Planning Depts.
- *Timeline:* 12-36 months
- *Progress/Update:* 5 year Audit FPM CRS Code update-Development no longer allowing CR2K

Mitigation Action item 15: Upgrade Culverts and Storm Water Drainage Systems. Increase Stormwater drainage capacity. Decreased cost of maintenance, decreased damage to road infrastructure.

- *Coordinating Departments:* Emergency Mgmt. / County Planning Dept./ Local Planning Depts.
- *Timeline:* 24-36 months
- *Progress/Update:* Check with Keith and Deanna-this is happening currently. Is a list of sites being maintained (as upgraded or due for upgrade)?

Hazardous Materials Incidents

Mitigation Action item 16: Promote proper use and storage of chemicals.

Reduce hazardous spills and releases. Lower costs for cleanup, lower damages to environment, less loss of property, lower threat to life.

- *Coordinating Departments:* Emergency Mgmt./Fire Depts. And Districts./Local LEPC.
- *Timeline:* 12-18 months
- *Progress/Update:* 41? High Hazard Sites. Fire Authority outreach to each site to equip with knowledge.

Mitigation Action item 17: Pre-identify collection sites and services for post-flood or earthquake cleanup. Preplan locations for debris removal/storage, consolidate debris, disposal, and recycle where possible. Decreases recovery time, decreases cost of debris disposal.

- *Coordinating Departments:* Emergency Mgmt./ County and City Public Works Depts.
- *Timeline:* 12-18 months
- *Progress/Update:* Review Debris Management Plan update sites and protocol.

Landslide

Mitigation Action item 18: Construct engineered walls at key locations for stabilizing slopes. Decrease landslide potential. Reduce loss of property, life, and reduce cost of cleanup in time and funds.

- *Coordinating Departments:* County Public Works/ODOT
- *Timeline:* 24-48 months
- *Progress/Update:* Hwy 58 & 126. Mapleton Area of concern, GIS Layer available?

Mitigation Action item 19: Public Awareness and Education. Increase public awareness. Reduce unintended damages by causing landslides through inappropriate land use.

- *Coordinating Departments:* Coordinating Depts.: Emergency Mgmt./County and City Planning and Public Works Depts.
- *Timeline:* 12-24 months
- *Progress/Update:*

Tsunami

Mitigation Action item 20: Support community-based culture of tsunami awareness, preparedness and response. Increase knowledge of the Hazard, and how to respond to it. Decreased loss of life.

- *Coordinating Departments:* Emergency Mgmt./ WLEOG/ DOGAMI
- *Timeline:* 8-12 months
- *Progress/Update:* Provided outreach materials to community for outreach, attended two events this year (Prep Fair, and National Night Out Event 2019)

Mitigation Action item 21: Continuously improve government proficiency in using multiple types of warning systems. Increase effective use of the tools.

Decrease loss in live and property.

- *Coordinating Departments:* Emergency Mgmt./PSAP's and Dispatch Centers.
- *Timeline:* 12-18 months
- *Progress/Update:* Gov. Brown signed bill to allow critical infrastructure below tsunami level.

Wildfire

Mitigation Action item 22: Promote Firewise Communities Program offerings.

Increase public participation in Firewise program. Decrease number of human caused fires, decrease loss of life and property, decrease cost of response.

- *Coordinating Departments:* Emergency Mgmt./County Planning Dept.
- *Timeline:* 6-18 months
- *Progress/Update:*

Windstorm

Mitigation Action item 23: To reduce damages caused by trees in windstorms.

To reduce damages caused by trees in windstorms. Reduced cost in loss of property, cleanup, decrease disruptions in power and transportation.

- *Coordinating Departments:* Emergency Mgmt.; County Public Works, ODOT, Power Utilities
- *Timeline:* 12-24 months
- *Progress/Update:*

Mitigation Action item 24: Provide local redundancy of windstorm warnings through local media on both traditional and social platforms. Increase imminent windstorm alerts.

- *Coordinating Departments:* Emergency Mgmt./ PIO networks. County Public Works/ODOT
- *Timeline:* 6-12 months
- *Progress/Update:*

Severe Winter Storm

Mitigation Action item 25: Develop emergency water supply plan for power outages caused by snow/ice storms. Create a secondary water source for emergency use. Improved health and safety of local residences experiencing power outages.

- *Coordinating Departments:* Emergency Mgmt./ NGO's/ Water districts/ Local Emergency management.
- *Timeline:* 12-18 months
- *Progress/Update:* City of Florence and local hospital working to install backup power supply for well water system.

Mitigation Action item 26: Develop emergency firewood supply plan for power outages caused by snow/ice storms. Provide a plan to supply firewood to mitigate power loss from winter storms. Decrease use of shelters, decrease cost of shelters, decrease in illness.

- *Coordinating Departments:* Emergency Mgmt./ NGO's/ Water districts/ Local Emergency management.
- *Timeline:* 12-18 months
- *Progress/Update:* Most suburban/city have gas. Rural community is generally heated by wood.

Section 1: City of Coburg



Version 4.0 (October 2023 – October 2028)

Developed as an annex to the Lane County Multi-Jurisdictional
Natural Hazard Mitigation Plan

Section 1.1: City of Coburg: Natural Hazard Mitigation Meetings and Work Sessions

Development of the City of Coburg’s materials for the Natural Hazard Mitigation Plan involved participation by city staff, public works, school district, county emergency management, fire district, and law enforcement. The process followed FEMA’s prescribed model for organizing resources, identifying hazards, evaluating risk, identifying mitigation options, and prioritizing mitigation projects. For additional details regarding the planning process, please refer to Section 6 of Volume I.

Table 1.1: Planning Team for City of Coburg

Title	Contact number	Agency
Mayor	541-682-7850	City of Coburg
City Administrator	541-682-7871	City of Coburg
Chief of Police	541-682-7853	City of Coburg
Coburg Rural Fire District Chief	541-686-1573	Coburg Rural Fire District
Coburg Public Works Director	541-682-7857	City of Coburg
Emergency Management Coordinator	541-682-7850	City of Coburg

Individual City Work Sessions

Work sessions with individual cities were conducted following the initial project orientation meeting and intervening months between general planning group meetings. These individual work sessions are outlined below.

Table 1.2: Individual Work Sessions for City of Coburg

Date	Location	Meeting/Work Session
02/22/2023	City Hall	Distribute existing Annex plan to group for input
03/13/2023	City Hall	Group reviewed and updated project scopes.
05/04/2023	City Hall	Meeting with Hannah Shafer for hazard quantification process

Subject matter discussed during work sessions included an overview of the plan and projects that are in the existing plan. This resulted in the evaluation and removal of some projects on the original plan. It also allowed the group to decide what remaining projects would be updated with the new cost associated with them. Systems and concepts considered included infrastructure resiliency, transportation network, city planning, floodplain management, public safety, public and private facilities.

Section 1.2: City of Coburg: Hazard Quantification

The following table summarizes hazard quantification results, followed by a discussion of Coburg’s local risk profile for each hazard.

Table 1.3: Coburg Hazard Quantification Results, Local Risk Assessment

Hazard Type / Weight Factor (WF)	History WF x 2	Probability WF x 7	Vulnerability WF x 5	Maximum Threat WF x 10	Raw Score	Weighted Score	Weighted Score Rank
Winter Storm	8	9	8	10	35	219	1
Extreme Weather	8	9	8	8	33	199	2
Earthquake	3	4	10	10	27	184	3
Windstorm	8	8	8	5	29	162	4
Flood	2	4	8	5	19	122	5
Drought	0	5	3	7	15	120	6
Volcano	0	2	2	1	5	34	7
Landslide	0	1	3	2	4	30	8
Wildfire	0	0	2	1	3	20	9

Source: City of Coburg Natural Hazard Mitigation Team

Section 1.2.1: Individual Hazard Discussions

Nine (9) natural hazards were elevated posing some degree of risk to the City of Coburg.

Winter Storm

December 5, 2016, a localized sleet storm resulted in 14 traffic accidents on I-5 near Coburg. The series of individual incidents unfolded over a 45-minute timeframe resulting in virtual closure of the interstate for approximately 2 hours. Minor injuries reported. Winter storms resulting in snow or ice storms on the floor of the Willamette Valley in Lane County have occurred in 1950, 1968, 1969, 1971, 1989, 1993, 1996, 1997, 2001, 2003, 2004, 2005, 2008, and 2010, and 2019. These events generally fall into two categories, events of snow and ice at low elevation due to very cold air trapped at the surface, and regional cold air systems. Most events seeing snow and ice on the valley floor are created by cold air trapped at the surface, with warmer, moister air at elevation. These events often occur as rain events at higher elevations.

Like most cities Coburg contains an extensive network of above ground electrical lines vulnerable to damage from falling limbs and trees during winter storms. Recent history has been frequent including notable damage and power loss in 2014 and 2015. The February 2014 storm caused a power outage that lasted three days. Wind is often a contributing factor in winter storms. A warming center has been established in Eugene to provide shelter for vulnerable populations in cold weather. Probability is considered high that patterns of previous occurrence will continue. Overall

population potentially affected by winter storm is high since effects are not geographically contained. Transportation and roadways are vulnerable to closure during winter storms, though the city benefits from primarily level terrain. Maximum threat is high however due to threat of structural damage directly related to winter weather (cold, snow, ice), and difficulty in accessing needed public services. See also winter storm hazard profile in Section 3 of the main document.

Extreme Weather

Extreme weather is a new natural hazard included in the Lane County MNHMP. Recent occurrences of heat waves in Coburg demonstrate the potential for it to be a reoccurring and life-threatening hazard. Extreme heat describes either a singular instance of dangerous temperatures occurring on a given day or a prolonged period of high temperatures over several days, typically if temperatures exceed a heat index of 90 degrees Fahrenheit. Coburg presents increased risk of extreme heat due to its geographic location in the Willamette Valley, where air settles between the Coast and the Cascade ranges and becomes stagnant. In recent years, the valley region experienced temperatures between 90 and 100 degrees. History, probability, vulnerability, and maximum threat are all high due to these factors. See Section 3 of the main document for detailed history of extreme heat.

Earthquake

Earthquake is somewhat unique as it occurs much less frequently but has potential for significant damage and disruption. From a geographic standpoint, occurrence would presumably affect the entire city uniformly. History of occurrence dates back over long-time scales, with the most recent (minor) event occurring in Sweet Home, which is 37 miles northeast of Coburg. On October 5th, 2022, a 4.4 magnitude earthquake occurred in Sweet Home. Only a few residents in the Coburg/Eugene area felt shaking and no damage or injuries were reported. Considered at a different scale, a Cascadia Subduction Zone Earthquake event is a very large, Pacific Northwest Region event, due to a 600-mile-long subduction zone fault line approximately 70 miles off the Oregon Coast. While the source of this earthquake is quite distant to Coburg, the magnitude and scope of this hazard will impact the entire State of Oregon from the Coast to the Cascades.

Probability is low in any given year. Vulnerability is complex to assess due to varying standards of construction, but newer construction is considered relatively sound. Maximum threat is expected to involve minor-moderate damage to numerous structures. Importance of resiliency of infrastructure is notable. See also earthquake profile in Section 3 of the main document.

Windstorm

Like winter storms, windstorms can frequently impact above ground electrical lines vulnerable to damage from falling limbs and trees. For Lane County at large, the two-year interval sustained wind speeds range from about 37 to 47 miles per hour, generally too low to cause significant damages. The 50-year occurrence wind speeds range from 62 to 75 miles per hour. These more damaging windstorms can be expected in intervals averaging a few decades. The windstorm in February 2002 snapped 30 to 40 powerlines, impacting residents and businesses in the city.

Probability is considered high that patterns of previous occurrence will continue. Overall vulnerability is considered high; roadways are notably vulnerable to closure, like winter storms due to falling limbs, trees, and snapped powerlines. The Columbus Day storm of 1962 can serve as an example for maximum threat, with winds measured at 86 mph in Eugene and presumably similar in

Coburg. A windstorm of similar magnitude to the Columbus Day Storm could potentially damage numerous of homes and businesses in city, either by direct structural damage, falling trees, or wind-blown debris. Due to its location on eastern slope of the Coburg foothills the city may have a slight protective factor from extreme wind as compared to fully exposed areas. See also windstorm hazard profile in Section 2 of the main document.

Flood

Flood is a geographically contained hazard and widespread impacts in Coburg are unlikely. Neighborhood flooding issues can be found to the south and southwest of the city, though most of the potentially affected land is primarily used as agricultural land. History of flooding is low, future probability is moderate. Overall vulnerability is high as the floodplain boundary is within the corporate city boundary in the SW corner of the city. This includes the area of Abby Road where several residential homes have been built. Maximum threat scores are somewhat lower than the vulnerability due to elevation changes moving to the north and west, and the land is currently being used for agricultural purposes with fewer impacts to residents. Coburg Bottom Loop Road is frequently inundated per reports from local Police and Fire departments. This, and other anecdotal reporting, leads to the conclusion that the current (1999) Flood Maps of the area may be inaccurate and in need of updating. See also flood hazard profile in Section 2 of Volume I.

National Flood Insurance Program

The City of Coburg is a formal program participant in good standing and considers continued participation as integral to future flood mitigation efforts. Participation consists of adoption and maintenance of Flood Insurance Rate Maps (FIRMs) which define Special Flood Hazard Areas (SFHAs) and maintenance of an ordinance regulating future development in SFHAs. The Flood Insurance Rate Map Community Number for Coburg is 410119. Compliance with the program is pursuant to the City of Coburg's floodplain ordinance.

Statistics as reported by FEMA on the NFIP Bureau Net for the period of January 1, 1978, through January 1, 2023, are as follows:

NFIP Policies in Force

Policies in Force: **9**

Insurance in Force: **\$ 3,280,000**

Premium in Force: **\$ 4,661**

Insurance Claim Data

Total Losses: 3

Closed Losses: 3

Open Losses: 0

CWOP Losses: 0

Total Payments: \$ 7,301

Data Definitions

Policies in Force – Policies in force on the "as of" date of the report.

Insurance in Force – The coverage amounts for policies in force.

Written Premium in Force – The premium paid for policies in force.

Total losses – All losses submitted regardless of the status.

Closed losses – Losses that have been paid.

Open losses – Losses that have not been paid in full.

CWOP losses – Losses that have been closed without payment.

Total Payments – Total amount paid on losses.

Drought

Drought is neither life threatening nor presents a direct risk to structures but does involve potential for significant disruption if dramatic water shortage were to develop. Drought can exacerbate wildfire risk as related hazards, and a water shortage would likely affect the entire city uniformly. History and probability are considered relatively low. Vulnerability is relatively low as Coburg is close to two major sources of water, the Willamette and McKenzie Rivers, helping to maintain redundancy to its water supply network. Maximum threat is moderate if an event occurred where all water supply systems go were to become inoperable or water supply unexpectedly ran short. See also drought profile in Section 3 of the main document.

Volcano

Volcano is like earthquake in that it occurs very infrequently. Coburg is situated approximately 60 miles from the closest volcano source, far enough to minimize probable impacts to minor ash-fall across the city if wind patterns allow. History, probability, and vulnerability are relatively low, maximum threat is also considered low. See also volcano profile in Section 2 of the main document.

Landslide

Landslide is considered to have very low history, probability, and vulnerability rankings, as the majority of Coburg is situated on level terrain. Maximum threat is similarly low. Coburg, due to its flat terrain, may be susceptible to liquefaction hazard in the event of an earthquake centered nearby, or more potentially in a Cascadia Earthquake event. See also landslide profile in Section 2 of Volume I.

Wildfire

Coburg is home to the Coburg Fire Department, a member of the Lane County Fire Defense Board. The Urban Wildfire interface is not significant in the city due to the fact it is situated in an agricultural farmland use area. Grassfires do occur, and orchards area located near the city. However, this has not been a significant hazard in the past, leading to the very low historical scoring. Probability, vulnerability, and maximum threat are all similarly low. It must be noted however, there is currently no fire suppression east of I-5, east of the city. See also wildfire hazard profile in Section 2 of Volume I.

New Development in Hazard Areas

There was significant growth in housing units for the period. Areas on west side of the city are designated as Special Flood Hazard Areas and there was no development in these areas. Much of the newest construction is in urbanized areas with adequate drainage and floor elevations to mitigate potential flooding impacts. Recent development is also located away from steep slopes with proper construction techniques to mitigate seismic and landslide factors. For new development the potential for wildfire impacts is relatively low, and enforcement of building codes makes major wind impacts a generally negligible concern.

Section 1.3: City of Coburg: Mitigation Action Items

This section describes mitigation projects identified by Coburg during the planning process. See Section 4 of Volume I for additional information regarding mitigation action item methodology and prioritization.

Mitigation Action Item (a)	Retrofit or replace existing 500,000-gallon water supply tanks for seismic and flood mitigation. Install additional 750,000-gallon elevated reservoir for fire suppression and general resiliency.	
Location	TBD	
Coordinating Agencies	Coburg Public Works	
Implementation Timeframe	18-24 months	
Estimated Cost	est. \$10.2 million (Tank Rehabilitation \$2.2 million, 750K Gallon Elevated Reservoir \$8 million)	
Potential Funding Sources	HUD-CDBG, OR-SRGP, HMGP, PDM, FEMA PA-106,	
Hazards Mitigated	Earthquake, Urban Fire	
Comments	Seismic rehabilitation – Existing Water Tanks Installation of new elevated reservoir	
Current Site Photos		

Mitigation Action Item (b)	City Hall Seismic Assessment
Location	City Hall
Coordinating Agencies	Coburg Public Works, City Council
Implementation Timeframe	12-months
Estimated Cost	\$45,000 - \$75,000
Potential Funding Sources	HUD-CDBG, OR-SRGP, HMGP, PDM, FEMA PA-106
Hazards Mitigated	Structural damage prevention
Comments	Assessment for Seismic rating
Current Site Photos	

Mitigation Action Item (c)	Enhancements for Community Emergency Center
Location	City Hall
Coordinating Agencies	Coburg Public Works, City Council
Implementation Timeframe	12-18 months
Estimated Cost	\$200,000
Potential Funding Sources	HUD-CDBG, OR-SRGP, HMGP, PDM, FEMA PA-106
Hazards Mitigated	Public safety, heating/cooling center, clean air center
Comments	Upgrade the air handling units and facility to provide a reliable heating/cooling center, clean air center, and shelter during extreme weather events.
Current Site Photos	 

Mitigation Action Item (d)	Storm hardening for a community staging area/shelter. City Park upgrades, installation of a restroom to serve as sheltering/staging area in the park.
Location	Coburg City Park (Pavilion Park)
Coordinating Agencies	Coburg Public Works
Implementation Timeframe	12 – 18 Months
Estimated Cost	\$185,000
Potential Funding Sources	HUD-CDBG, OR-SRGP, HMGP, PDM, FEMA PA-106,
Hazards Mitigated	Earthquake, flood, winter storm, windstorm. dam failure, hazmat incident
Comments	Installation of a restroom and providing a staging/shelter area for community.
Current Site Photos	

Mitigation Action Item (f)	Stormwater Master Plan
Location	City of Coburg
Coordinating Agencies	Coburg Public Works
Implementation Timeframe	12 months
Estimated Cost	\$60,000
Potential Funding Sources	FEMA HMA
Hazards Mitigated	Flood, earthquake, HazMat incident
Comments	Deliberate planning enables funding and project opportunities that will help to check Stormwater runoff and treat it before it enters nearby waterways. Promotes innovative land use practices and city programs that over time improve water quality. Planning to increase the planting of appropriate trees, open spaces, wetlands, and vegetated planters benefits the community through cost-effective practices, increasing property values, and increasing revenues from tourism.

Section 1.4: Plan Implementation and Maintenance

In keeping with standard practices to ensure incorporation of overall goals and strategies of the Natural Hazard Mitigation Plan, the City of Coburg natural hazard mitigation team members will be invited to participate in future plan development or existing plan update committees. Additionally, this Natural Hazard Mitigation Plan will be cited as a technical reference for future plan update processes. Planning documents and mechanisms applicable to this process may include the following:

City of Coburg Comprehensive Plan

Capital Improvement Plans

Emergency Management Plan**City of Coburg Floodplain Development Ordinance****Building Code****Subdivision Code****Erosion Control****Stormwater Management Plan**

Additionally, progress to implement this plan will be monitored on an ongoing basis by city staff and administration. The planning process is essential in identifying weaknesses and strengths inherent in the community, and cooperatively enables coordination with various agencies and jurisdictions that might not otherwise occur. Continuing this cooperative and interactive process is exemplified by the planning process. Annual reviews and updates under a 5-year cycle will be pursued. Using these methods, the overarching goal of a stronger, safer, more resilient community can be attained.



COBURG CITY COUNCIL ACTION/ISSUE ITEM

TOPIC: Adoption of State Statutes as Coburg Violations

Meeting Date: July 11th, 2023
 Staff Contact: Larry Larson, Chief of Police
 Contact: 541-682-7855, larry.larson@ci.coburg.or.us

REQUESTED COUNCIL ACTION:

First Reading and Public Hearing on Ordinance A-163-U.

Suggested Motion: None at this time

The Second Reading of Ordinance A-163U will be at the August 8, 2023 City Council Meeting

CITY COUNCIL GOAL

None. This item is operational.

BACKGROUND

Coburg Police can only issue summons to appear in Coburg's Municipal Court for violations of a Coburg Ordinance. By adopting certain state statutes as also being violations of Coburg's ordinances, the Coburg Police are able to issue summons for these violations into the Coburg Municipal Court. The alternative would be that all summons for these violations would be to the Lane County Circuit Court.

Ordinance A-163-U is the latest in a regular series of ordinances accomplishing this purpose. It makes violations of the traffic laws, similar violations and minor criminal offenses violations of the City ordinance.

BUDGET / FINANCIAL IMPACT

There is no immediate budget impact if the Ordinance is adopted. Failure to act would mean an increasing number of offenses for which summons to Coburg Municipal Court could not be issued.

RECOMMENDATION AND ALTERNATIVES

The adoption of Ordinance A-163-U is recommended.

The alternative is to not adopt the updated Ordinance. This would mean that changes in the law since 2022 would not be included and it would be improper to issue summons for those offenses.

PUBLIC INVOLVEMENT

Public Hearing and First Reading July 11th 2023 City Council Meeting.

NEXT STEPS

Second reading of Ordinance A-163-U at the August City Council Meeting

Ordinance A-163-U would become effective 30 days after adoption.

ATTACHMENTS

- A. Draft Ordinance A-163-U.
-

REVIEWED THROUGH:

Anne Heath, City Administrator
Sammy Egbert, City Recorder

**ATTACHMENT A
DRAFT
ORDINANCE A-163-U**

AN ORDINANCE ADOPTING THE OREGON CRIMINAL CODE, OREGON UNIFORM CONTROLLED SUBSTANCES ACT, OREGON LIQUOR CONTROL ACT, AND THE OREGON MOTOR VEHICLE CODE; REPEALING CONFLICTING ORDINANCES.

THE CITY OF COBURG ORDAINS AS FOLLOWS:

Section 1. Oregon Criminal Code Adopted. Violation of any provision of Oregon Revised Statutes chapters 161 through 167, as now constituted, is an offense against this city.

Section 2. Oregon Uniform Controlled Substances Act Adopted. Violation of any provision of Oregon Revised Statutes chapter 475, as now constituted, is an offense against this city.

Section 3. Oregon Liquor Control Act Adopted. Violation of any provision of Oregon Revised Statutes chapter 471 and 472, as now constituted, is an offense against this city.

Section 4. Oregon Motor Vehicle Code Adopted. Except for Oregon Revised Statute 813.170, violation of provisions of Oregon Revised Statutes chapter 153 and chapters 801 through 822, as now constituted, is an offense against this city.

Section 5. Jurisdiction. In the above Acts, Codes, and laws of the State of Oregon which are adopted hereby, the City shall have jurisdiction over infractions, violations, offenses, and misdemeanors only.

Section 6. Severability. Should any section or provision of this ordinance or the laws adopted hereby be declared unconstitutional or invalid, such decision shall not affect the validity of this ordinance as a whole, or any part hereof, except that part so declared to be unconstitutional or invalid.

Section 7. Repeal. Ordinance No. A-163-S of the City of Coburg is hereby repealed in its entirety. All other ordinances in conflict herewith are hereby repealed to the extent of such conflicts.

This ordinance was read as required by the City of Coburg Charter at the July 11th, 2023 regular meeting of the City Council, and, at the August 8th, 2023 City Council. It was put to a vote.

ADOPTED by the City Council of the City of Coburg this ____ day of _____, 2023, by a vote of ____ for and ____ against.

APPROVED by Mayor of City of Coburg this ___ day of _____, 2023.

Nancy Bell, Mayor

ATTEST: _____
Sammy Egbert, City Recorder



COBURG CITY COUNCIL ACTION/ISSUE ITEM

TOPIC: Resolution 2023-14 Authorizing Grant Funding Application to the Oregon Department of Transportation for the Small City Allotment Program

Meeting Date: July 11th 2023
 Staff Contact: Brian Harmon
 Contact: 541-682-7857
brian.harmon@ci.coburg.or.us

REQUESTED COUNCIL ACTION

Approval of Resolution 2023-14, a resolution authorizing the application to the Oregon Department of Transportation for the Small City Allotment Program Grant for the N Willamette St. in the amount of \$250,000.

Suggested motion:

I move to approve resolution 2023-14, a resolution authorizing the application to the Oregon Department of Transportation for the Small City Allotment Program Grant for an amount up to \$250,000.

POLICIES OR CITY COUNCIL GOAL(S) ADDRESSED

Utilities and Infrastructure
 Livability, Health, and Vitality
 Capacity

BACKGROUND

The City Council has designated that the repairs and maintenance of Coburg streets as a priority in the budget. The SCA Grant allows small cities to apply for grants up to \$250,000. Applications are accepted June 1st through July 31st. This project will be a replacement of N. Willamette Street, add sidewalks on the west side of N Willamette, install stormwater management to improve water quality in the groundwater, and improve off street parking. It will increase capacity, and add a safe and usable pedestrian "safe route to school". Engineers estimate for this project is \$384,745.67

BUDGET

This project will also use some SDC Funds as well as Transportation Utility Fee funds.

PUBLIC INVOLVEMENT

None at this time.

NEXT STEPS

- Completion and submittal of grant applications
-

ATTACHMENTS

- A. Resolution 2023-14
 - B. Small City Allotment Program Information Page
 - C. Engineers Estimate
-

REVIEWED BY:

Anne Heath, City Administrator

RESOLUTION 2023-14

A RESOLUTION AUTHORIZING THE CITY TO SEEK STATE TRANSPORTATION FUNDS THROUGH THE 2023 SMALL CITY ALLOTMENT GRANT PROGRAM

WHEREAS, Under the provisions of ORS 366.800 and 366.805, there has been withdrawn from state highway funds appropriated for allocation to the small cities of the State of Oregon. As provided in ORS 366.805, said sums have been set up in a separate account to be administrated by the Oregon Transportation Commission and to be allotted each year by said commission to be spent within cities of 5,000 or fewer persons, upon streets not a part of the state highway system that are inadequate for the capacity they serve, or are in a condition detrimental to safety. No one project can receive more than \$250,000;

WHEREAS, the City of Coburg is an incorporated City of the State of Oregon and has a population of less than 5,000 as given by the latest official federal census;

WHEREAS, North Willamette Street meets the conditions required in ORS 366.805.

NOW, THEREFORE, BE IT RESOLVED by the City Council of the City of Coburg

1. That the aforementioned named street of Coburg is inadequate for the capacity it serves and is in a condition detrimental to safety.
2. That said street in Coburg is in need of repair, reconstruction, or other major improvement.
3. That said street is not a part of the state highway system, and is under the jurisdiction and control of the City.
4. That the Oregon Transportation Commission hereby is respectfully requested to consider and declare said street as qualified for reconstruction, repair, or other improvements out of funds allocated and made available by and through the said appropriation of revenues which is to be administered and spent by the Transportation Commission.
5. That the City of Coburg does hereby offer to Transportation Commission and does hereby pledge complete cooperation and assistance to the end, that Coburg may share and participate in the use and benefit of said special fund and appropriation; and therefore does designate the City Administrator as the official representative of the City in all negotiations resulting from this request.
6. This Resolution is effective immediately upon passage.

Adopted by the **City Council** of the **City of Coburg**, Oregon, by a vote of ___ for and ___ against, this 11th day of July, 2023.

Nancy Bell, Mayor

ATTEST: _____
Sammy L. Egbert, City Recorder

Small Cities Allotment Program

A Dedicated Funding Option for Oregon's Smallest Communities



Program Overview

Small City Allotment (SCA) program funding comes from an annual allocation of state funds for local transportation projects. Through Oregon Revised Statute (ORS) 366.805, ODOT sets aside \$5,000,000 each year to provide funding for cities with under 5,000 residents. Awarded projects are selected per competitive process by region. Applications are accepted June 1 through July 31st each year.

Project funding is limited to \$100,000 per project with cities able to request an advance of up to \$50,000 upon execution of project agreement. Final payment is made at project completion.

Eligible applicants are cities with less than 5,000 in population. Cities are allowed two active projects though only one application may be submitted for each funding cycle.

Eligible projects are those

1. On streets that are not part of the state highway system
2. Streets that are inadequate for the capacity they serve, or
3. Streets that are in a condition detrimental to safety

*Funds may be used as match on an existing federally or state funded project as long as the project work meets the intent of the Small City Allotment Program.

*Funds may be used on a county road though a written agreement between city & county will be required prior to entering into project agreement with ODOT.

Examples of Ineligible Projects Include those:

1. That do not meet the criteria listed above
2. Where SCA funds have already been expended in the past 7-10 years
3. That would construct new roads to planned developments
4. That cannot be completed in 2 years' time

Small City Allotment Contacts

For project level questions or to discuss delivery options please contact your Regional ODOT Transportation Project Manager listed below:

Region 1: Matthew Novak • 503-731-3247 • matthew.c.novak@odot.state.or.us

Region 2: Shelly White-Robinson • 503-986-6925 • shelly.white-robinson@odot.state.or.us

Region 3: Jeanette Denn • 541-957-3508 • jeanette.m.denn@odot.state.or.us

Region 4: Paul Singer • 541-410-2993 • paul.singer@odot.state.or.us

Region 5: Mike Barry • 541-963-1353 • michael.p.barry@odot.state.or.us

Program Manager: Deanna Edgar • 503-986-3441 • deanna.edgar@odot.state.or.us

PRELIMINARY ENGINEER'S COST ESTIMATE, MARCH 31, 2021 PROJECT 21-004A: E. MCKENZIE STREET RECONSTRUCT					
ITEM NO.	ITEM DESCRIPTION	QTY	Unit	UNIT COST	TOTAL BID PRICE
1 210	Mobilization, Bonds, And Insurance	1	Lump Sum	\$16,750.00	\$16,750.00
2 225	Temporary Work Zone Traffic Control, Complete	1	Lump Sum	\$7,500.00	\$7,500.00
3 280	Erosion Control	1	Lump Sum	\$2,500.00	\$2,500.00
4 490	Pothole Utility Conflicts	1	Lump Sum	\$1,500.00	\$1,500.00
5 310	Site Layout, Complete	1	Lump Sum	\$2,750.00	\$2,750.00
6 310	Saw Cutting	175	Lineal Feet	\$3.00	\$525.00
7 310	Removal of Structures and Obstructions	1	Lump Sum	\$2,500.00	\$2,500.00
8 759	Flag Pole Sleeve In Concrete	2	Each	\$2,200.00	\$4,400.00
9 310	General Excavation	325	Cubic Yards	\$32.00	\$10,400.00
10 350	Subgrade Geotextile	865	Square Yards	\$1.25	\$831.25
11 445	6 Inch PVC Storm Sewer Pipe	65	Lineal Feet	\$85.00	\$5,525.00
12 445	12 Inch Storm Sewer Pipe	265	Lineal Feet	\$120.00	\$31,800.00
13 470	Concrete Storm Sewer Manhole	2	Each	\$3,500.00	\$7,000.00
14 470	24 Inch Concrete Inlet Manhole with Beehive Grate	4	Each	\$2,000.00	\$8,000.00
15 490	Connection to Existing Structures	1	Each	\$1,000.00	\$1,000.00
16 490	Adjusting Boxes to Finish Grade	4	Each	\$250.00	\$1,000.00
17 1140	Relocate/Adjust Water Meters and Services, As Needed	2	Each	\$500.00	\$1,000.00
18 841	Aggregate Base - 1 1/2" Minus Quarry Rock	550	Ton	\$30.00	\$18,500.00
19 744	Level 2, 1/2 Inch Dense HMA, 4 Inch Depth	155	Ton	\$100.00	\$15,500.00
20 759	Concrete Curb and Gutter	475	Lineal Feet	\$30.00	\$14,250.00
21 759	Concrete Driveways	290	Square Feet	\$9.50	\$2,755.00
22 759	Concrete Walks	1825	Square Feet	\$12.00	\$21,900.00
23 759	Truncated Dome Panel Texturing	20	Square Feet	\$25.00	\$500.00
24 759	Concrete Curb Cut Spillway	4	Each	\$400.00	\$1,600.00
25 865	Striping	1	Lump Sum	\$750.00	\$750.00
26 900	Remove and Reinstall Existing Sign on 2" 12 Gage PSST Post, Complete	1	Lump Sum	\$500.00	\$500.00
27 970	Electrical Conduit for Future Street Lights and Fiber	400	Lineal Feet	\$30.00	\$12,000.00
28 1050	Removing and Rebuilding Fence	95	Lineal Feet	\$40.00	\$3,800.00
29 1160	Landscaping	1	Lump Sum	\$3,500.00	\$3,500.00
30 1160	Deciduous Street Trees, 2.5 Inch Caliper	2	Each	\$1,500.00	\$3,000.00
				Project Subtotal	\$201,536.25
				Engineering, Survey, Permitting, and Inspection @ 20%	\$40,307.25
				Project Contingency @ 20%	\$48,368.70
				Project Total	\$290,212.20

PRELIMINARY ENGINEER'S COST ESTIMATE, JUNE 2023
PROJECT 21-004B.3: N. WILLAMETTE SCA GRANT STREET IMPROVEMENTS

ITEM NO.	ITEM DESCRIPTION	QTY	Unit	UNIT COST	TOTAL BID PRICE
1 210	Mobilization, Bonds, And Insurance	1	Lump Sum	\$22,061.11	\$22,061.11
2 225	Temporary Work Zone Traffic Control, Complete	1	Lump Sum	\$12,000.00	\$12,000.00
3 280	Erosion Control	1	Lump Sum	\$3,500.00	\$3,500.00
4 490	Pothole Utility Conflicts	1	Lump Sum	\$1,500.00	\$1,500.00
5 305	Site Layout, Complete	1	Lump Sum	\$10,000.00	\$10,000.00
6 310	Saw Cutting	140	Lineal Feet	\$6.00	\$840.00
7 320	Tree Removal	1	Each	\$5,000.00	\$5,000.00
8 330	General Excavation	775	Cubic Yards	\$38.50	\$29,855.32
9 350	Subgrade Geotextile	1226	Square Yards	\$1.50	\$1,838.31
10 490	Adjusting SS Boxes to Finish Grade	2	Each	\$400.00	\$800.00
11 490	Relocate/Adjust Water Meters and Services, As Needed	1	Each	\$400.00	\$400.00
12 641	Aggregate Base – ¾" Minus Quarry Rock	350	Ton	\$56.00	\$19,600.00
13 745	Level 2, ½ Inch Dense HMA, 4 Inch Depth	225	Ton	\$165.50	\$37,237.50
14 759	Concrete Driveways	310	Square Feet	\$15.75	\$4,882.50
15 759	Concrete Walks, 4-inch Thick Concrete	3550	Square Feet	\$13.00	\$46,150.00
16 759	Truncated Dome Panel Texturing	57	Square Feet	\$36.00	\$2,052.00
17 760	Straight/Standard Curb, "H" = 16"	78	Lineal Feet	\$45.00	\$3,510.00
18 860	Permanent Pavement Markings: 4" White Longitudinal Striping for On-Street Parking Stalls "Tee Stripe" (non-ADA Spaces)	11	Lineal Feet	\$5.00	\$55.00
19 867	Permanent Pavement Markings: 1.0' Transverse Stop Bars, Type B-HS	20	Lineal Feet	\$25.00	\$500.00
20 905	Remove Existing Signs, Posts, and Foundations	1	Lump Sum	\$1,950.00	\$1,950.00
21 905	Install Existing Sign on New PSST Post and New Anchor Foundation - Complete	1	Lump Sum	\$1,100.00	\$1,100.00
22 905	Install New Sign on New PSST Post and New Anchor Foundation - Complete	1	Lump Sum	\$3,000.00	\$3,000.00
23 970	Electrical Conduit for Future Street Lights and Fiber	60	Lineal Feet	\$30.00	\$1,800.00
24 1010	Water Quality Swale, Grassy Swale, Per City of Coburg Std Dwg SS-001	1	Lump Sum	\$50,552.75	\$50,552.75
25 1030	Site Restoration, Permanent Seeding and Topsoil	1	Lump Sum	\$7,000.00	\$7,000.00
Project Subtotal					\$267,184.49
Engineering, Survey, Permitting, and Inspection @ 20%					\$53,436.90
Project Contingency @ 20%					\$64,124.28
Project Total					\$384,745.67

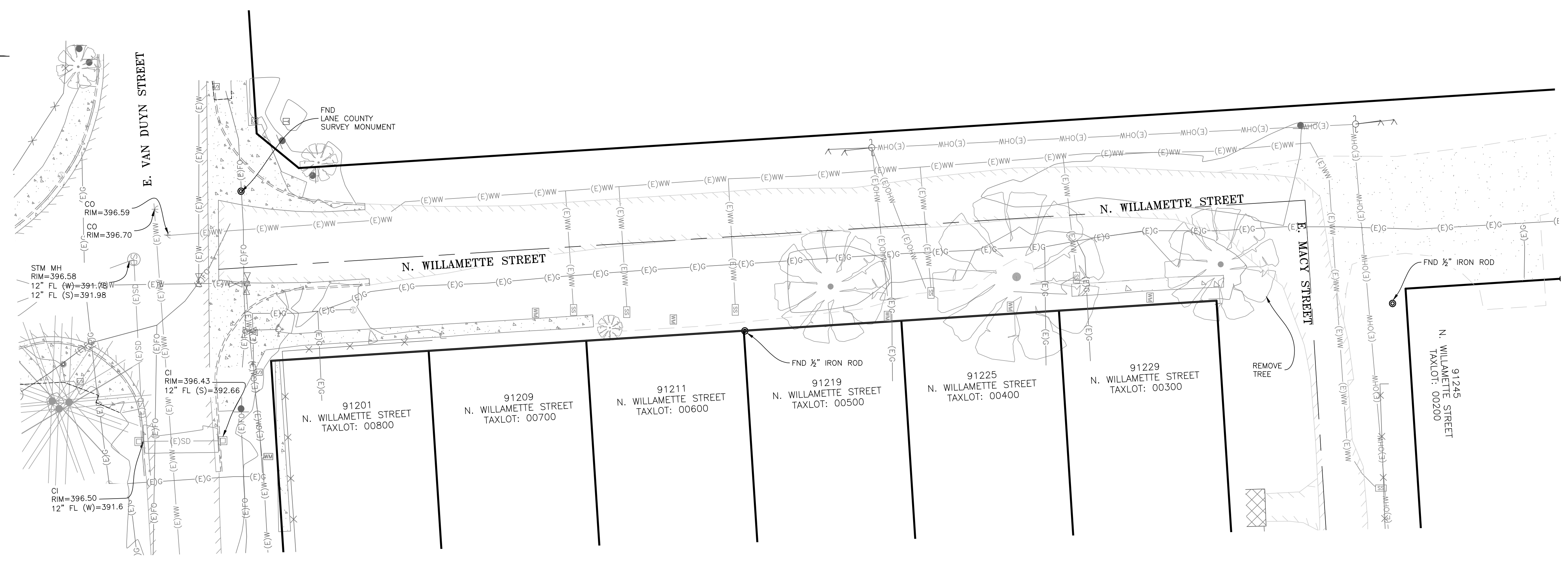
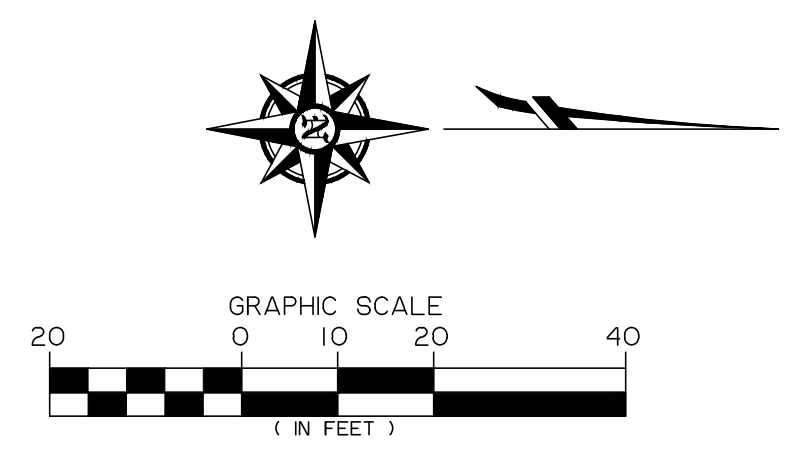

LEGEND

EXISTING

	PROPERTY LINE		WASTEWATER BOX		WASTEWATER LINE
	EDGE OF ASPHALT		GAS LINE		OVERHEAD WIRE
	CONCRETE		SIGN		FIBER OPTIC
	BUILDING		CURB INLET		WW CLEANOUT
	STORM DRAIN MANHOLE		SURVEY MONUMENT		
	CURB		ANCHOR		
	WATER METER		UTILITY POLE		
	WATER VALVE		FIRE HYDRANT		
	STORM DRAIN LINE		TELEPHONE PEDESTAL		
	WATER LINE		GAS VALVE		
	DECIDUOUS TREE		SIGNAL BOX		
	EVERGREEN TREE		FENCE		

project title:

N. WILLAMETTE STREET PUBLIC IMPROVEMENTS E. VAN DUYN STREET TO E. MACY ST.

CITY OF COBURG
91136 N. WILLAMETTE STREET
COBURG, OREGON

revisions:

date: June 12, 2023
drawn by: ZZ
designer: JLB
project no: 21-0048.3

EXISTING CONDITIONS

sheet:

C1

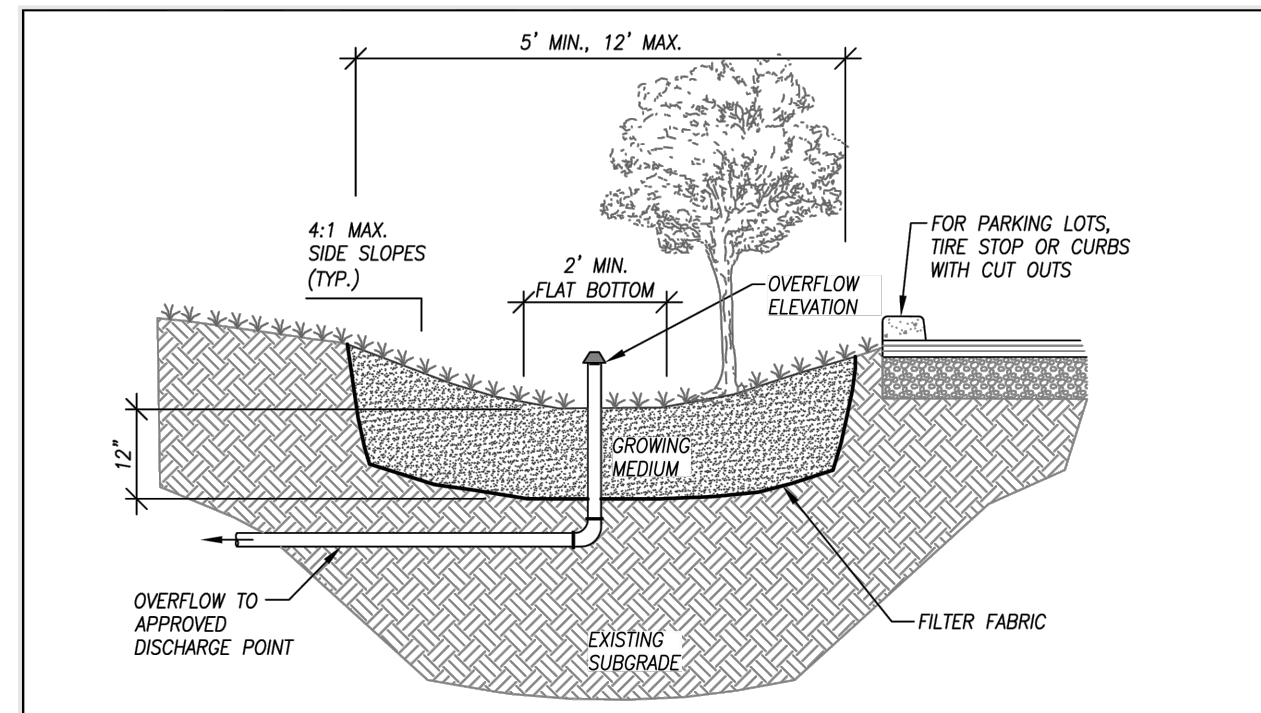

- PROVIDE PROTECTION FROM ALL VEHICLE TRAFFIC, EQUIPMENT STAGING, AND FOOT TRAFFIC IN PROPOSED INFILTRATION AREAS PRIOR TO, DURING, AND AFTER CONSTRUCTION.
- DIMENSIONS:
 - WIDTH OF SWALE: 5' - 12'.
 - DEPTH OF SWALE: 12"
 - LONGITUDINAL SLOPE OF SWALE: 0.5% MIN. AND 6% MAX.
 - FLAT BOTTOM WIDTH: 2' MIN.
 - SIDE SLOPES OF SWALE: 3:1 MAX. FOR VEGETATIVE AND 4:1 FOR GRASSY.
- SETBACKS (FROM CENTERLINE OF FACILITY):
 - INFILTRATION SWALES MUST BE 10' FROM FOUNDATIONS AND 5' FROM PROPERTY LINES.
 - FILTRATION SWALES MUST HAVE A WATERPROOF LINER WHEN WITHIN 10' FROM FOUNDATION AND 5' FROM PROPERTY LINES.
- OVERFLOW:
 - OVERFLOWS ARE REQUIRED TO AN APPROVED POINT DISCHARGE POINT UNLESS SIZED TO FULLY INFILTRATE THE FLOOD CONTROL DESIGN STORM.
 - INLET ELEVATION MUST ALLOW FOR 2" OF FREEBOARD, MINIMUM.
- PIPING: MINIMUM 4" PIPE REQUIRED FOR UP TO 1,500 SQ. FT. OF IMPERVIOUS AREA. PIPING MATERIAL, SLOPES AND INSTALLATION SHALL FOLLOW THE UNIFORM PLUMBING CODE WHEN ON PRIVATE PROPERTY OR BE ENGINEERED WHEN IN THE RIGHT-OF-WAY.
- GROWING MEDIUM:
 - 12" MINIMUM
 - IMPORT TOPSOIL OR AMENDED NATIVE SOIL.
- VEGETATION: FOLLOWING LANDSCAPE PLANS OTHERWISE REFER TO PLANT LIST IN CITY OF EUGENE'S STORMWATER MANAGEMENT MANUAL, APPENDIX F. GRASSY SWALES MUST HAVE 100% COVERAGE. VEGETATIVE SWALES MUST HAVE FOLLOWING PLANTINGS PER 100 SF OF FACILITY AREA:
 - 100 GROUND COVERS, OR
 - 80 GROUND COVERS, 2 SMALL SHRUBS, 4 LARGE SHRUBS, AND 1 TREE (DECIDUOUS OR EVERGREEN)
- WATERPROOF LINER: SHALL BE 30 MIL PVC OR EQUIVALENT WHERE REQUIRED.
- INSTALL WASHED PEA GRAVEL OR RIVER ROCK TO TRANSITION FROM INLETS AND SPLASH PAD TO GROWING MEDIUM.
- CHECK DAMS: SHALL BE PLACED AT 12' INTERVALS ALONG THE LENGTH OF THE SWALE.

CITY OF COBURG STANDARD DRAWING
GRASSY SWALE
DATE: JANUARY 2017 DRAWING NO: SS-001

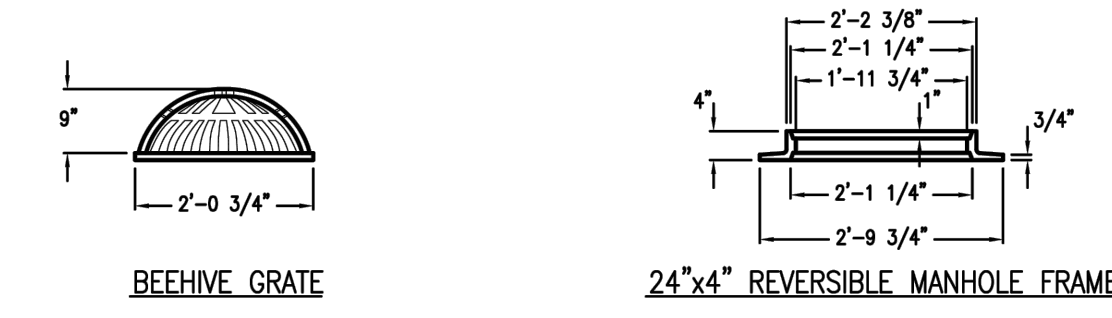
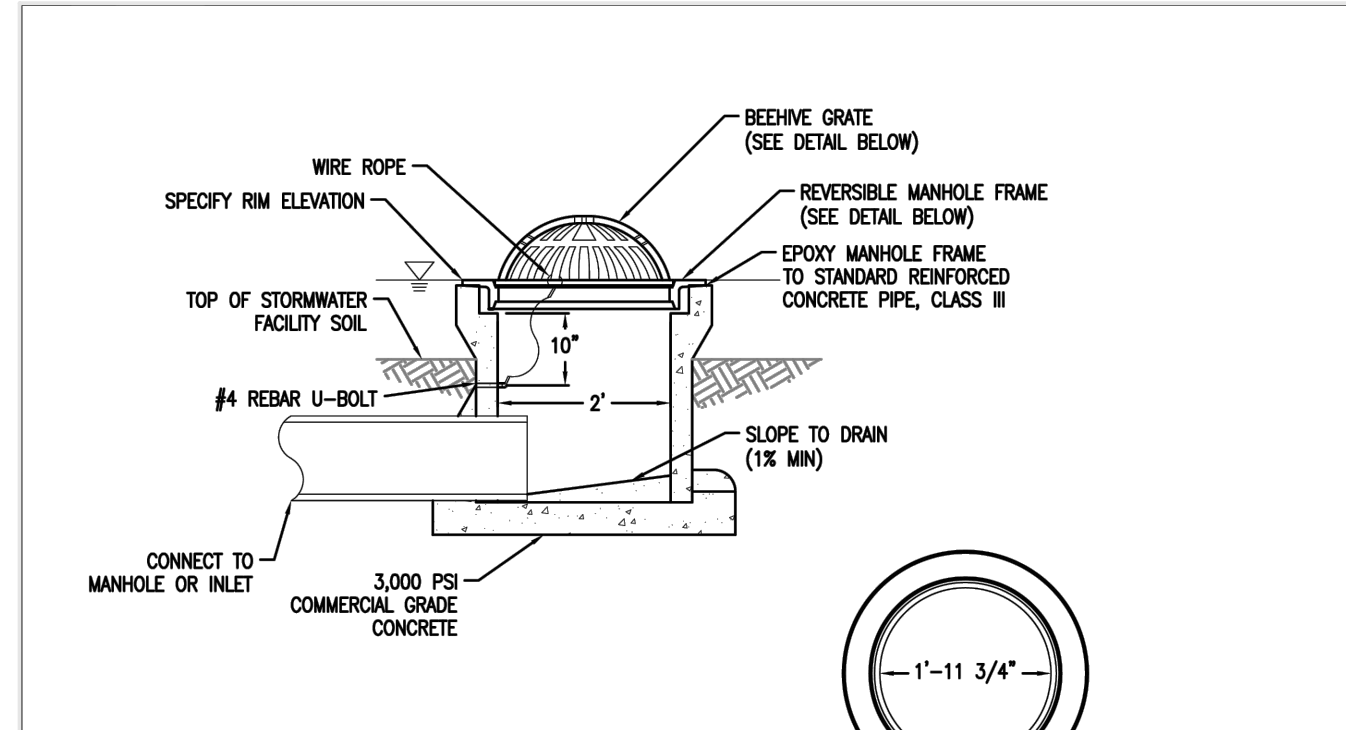

- DESIGNER INFORMATION**
- If connecting to a combination sewer manhole installation of a "wing-check type backwater valve" or approved equal is required to prevent odor emissions.
 - Size inlet based on calculated flows & manufacturers recommendations.
- CONSTRUCTION NOTES**
- Secure grate in place with 5/4" of wire rope. Loop ends of wire rope around U-bolt and grate. Crimp each end of wire rope with ferrule.
 - Drill 2" deep holes into pipe and epoxy #4 rebar U-bolt (2"x 4") in holes.
 - Grate to be cast iron, ASTM A48 CL30.
 - Beehive rim elevation to be 1" lower than sidewalk notches, top of planter wall, top of slope, outlet notch or upstream notch, whichever is lowest.
 - Wire rope between 1/8"-3/16" diameter, stainless steel, 7 strands of 19 wires.

CITY OF COBURG STANDARD DRAWING
Stormwater Management Manual Typical Details
Green Streets
Beehive Inlet Grate
Overflow Inlets
DATE: JANUARY 2017 DRAWING NO: SW-350
Bureau of Environmental Services

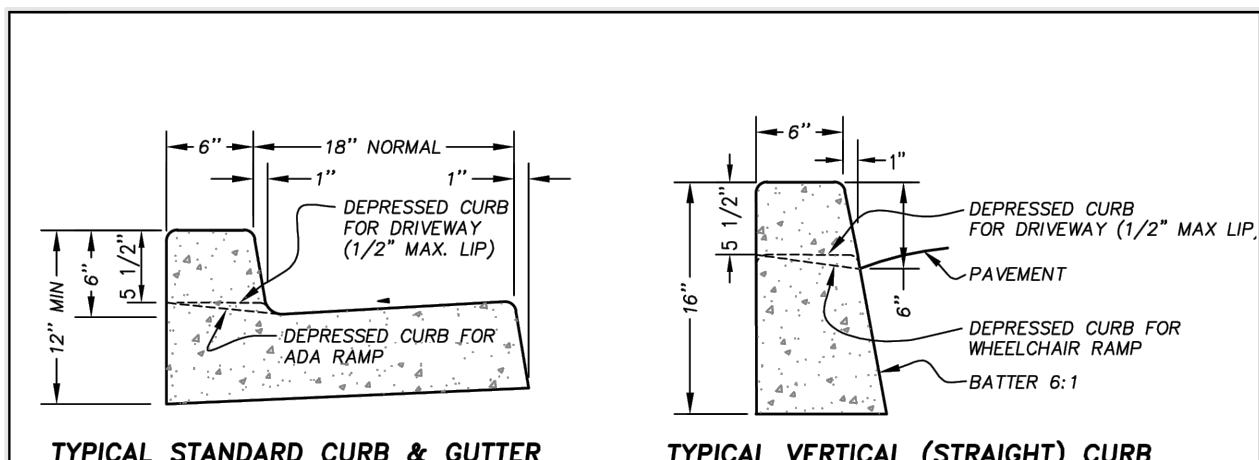

TYPICAL STANDARD CURB & GUTTER **TYPICAL VERTICAL (STRAIGHT) CURB**

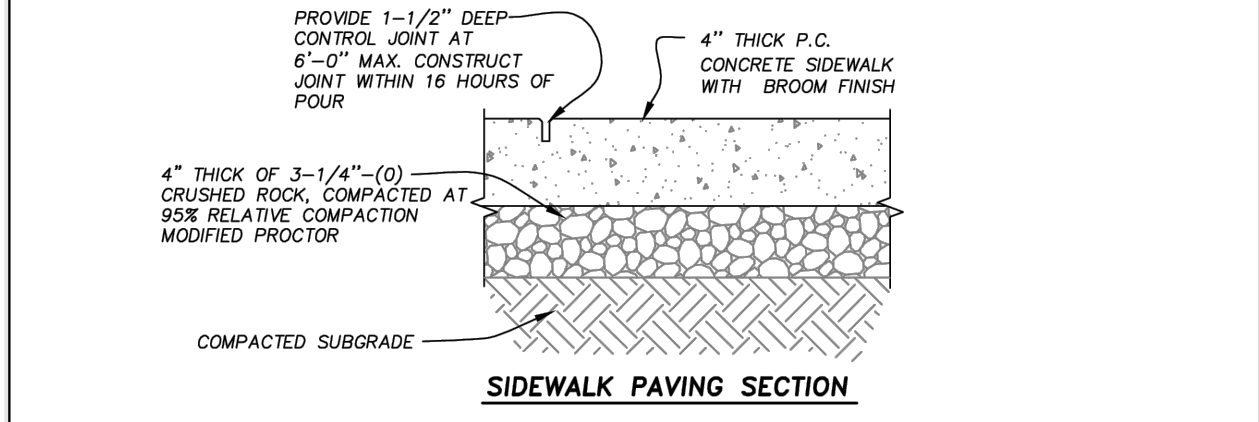

SIDEWALK PAVING SECTION

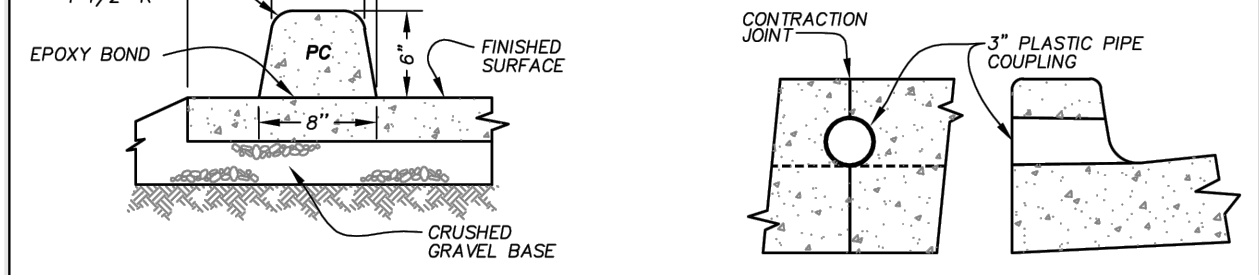

EXTRUDED PC CONCRETE BONDED CURB



WEEP HOLE THROUGH CURB

CITY OF COBURG STANDARD DRAWING
CURB AND GUTTER, CURB, SIDEWALK, AND WEEP HOLE
DATE: JANUARY 2017 DRAWING NO: ST-001

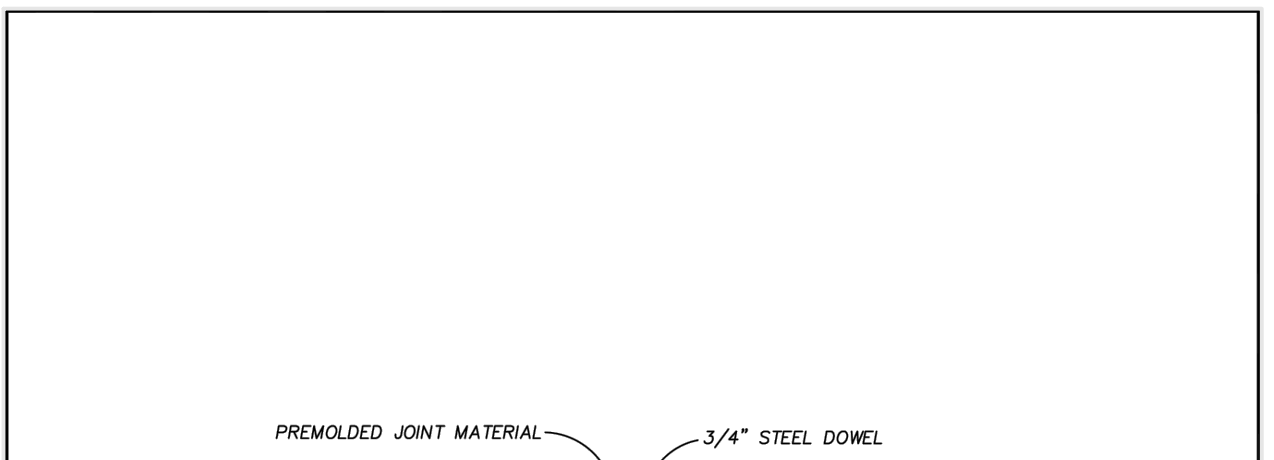

TYPICAL ISOLATION (COLD) JOINT WITH DOWEL

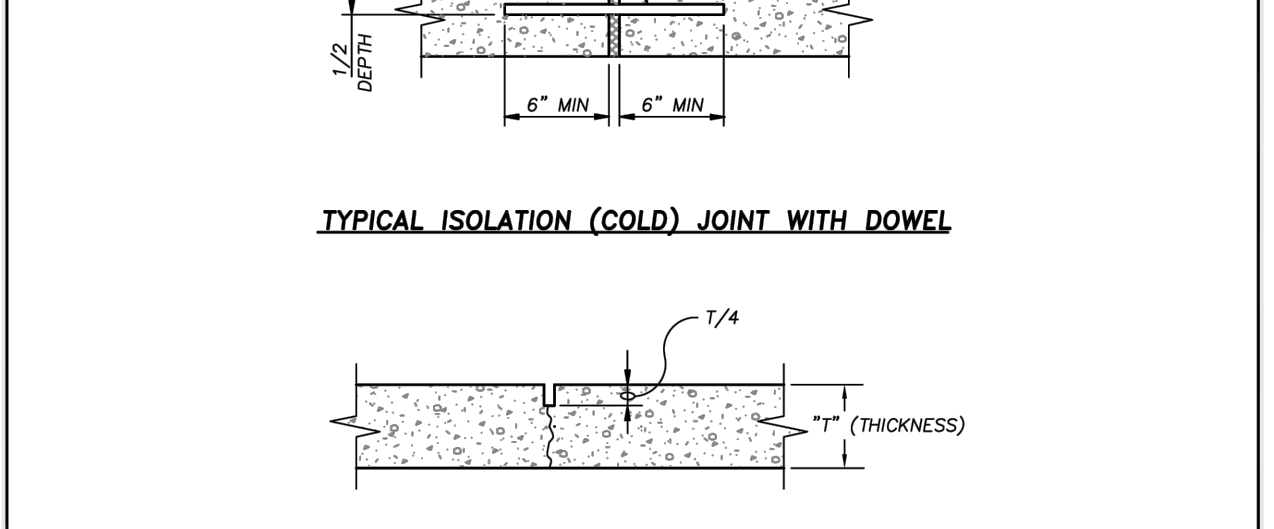

TYPICAL CONTRACTION JOINT

CITY OF COBURG STANDARD DRAWING
PC CONCRETE PAVEMENT JOINTS
NOTE: ALL JOINTS TO BE TOOLED WITH 1/2" RADIUS UNLESS SAWCUT
DATE: JANUARY 2017 DRAWING NO: ST-002

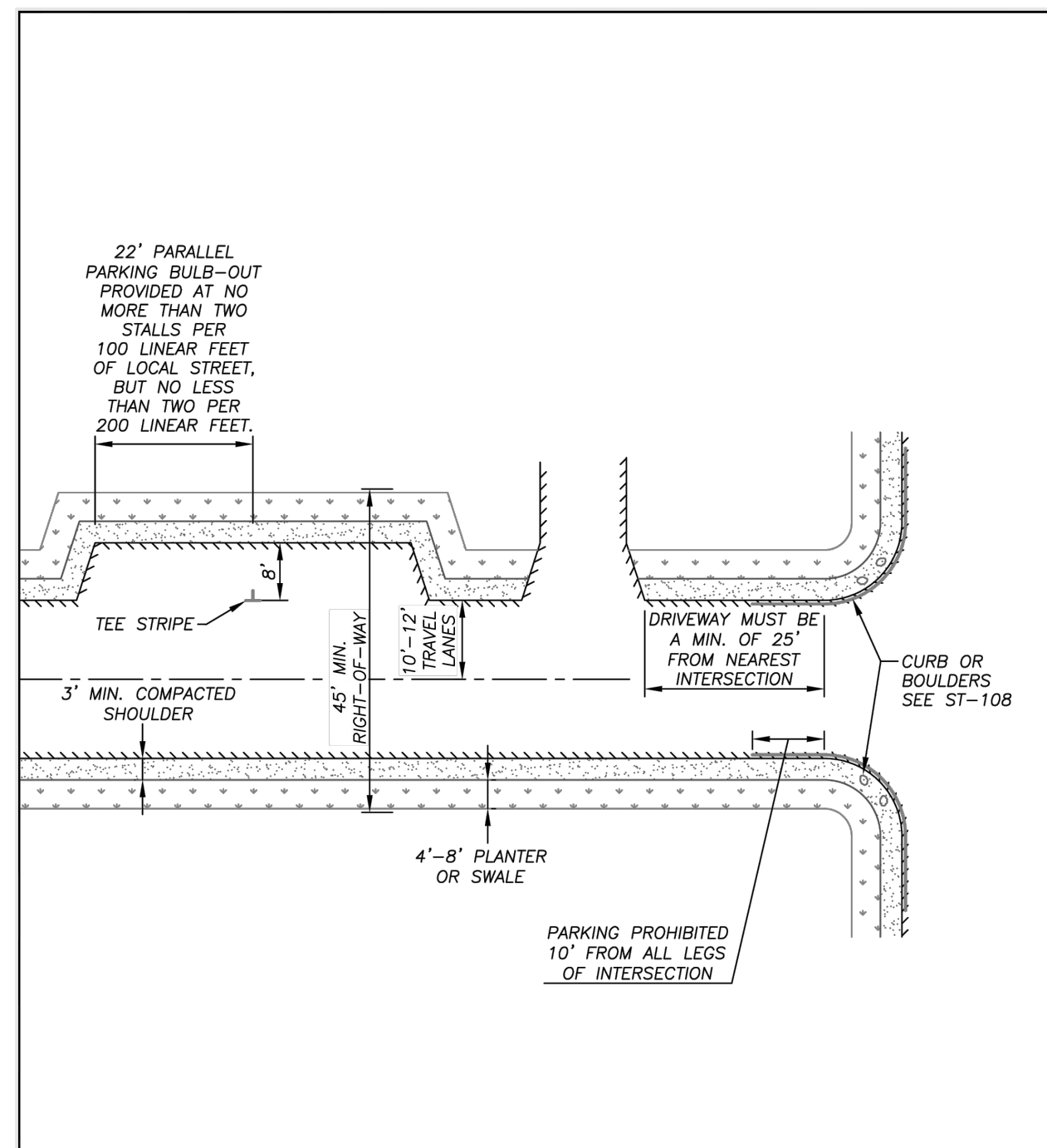

CITY OF COBURG STANDARD DRAWING
LOCAL STREET DETAILED STANDARDS
DATE: JANUARY 2017 DRAWING NO: ST-102

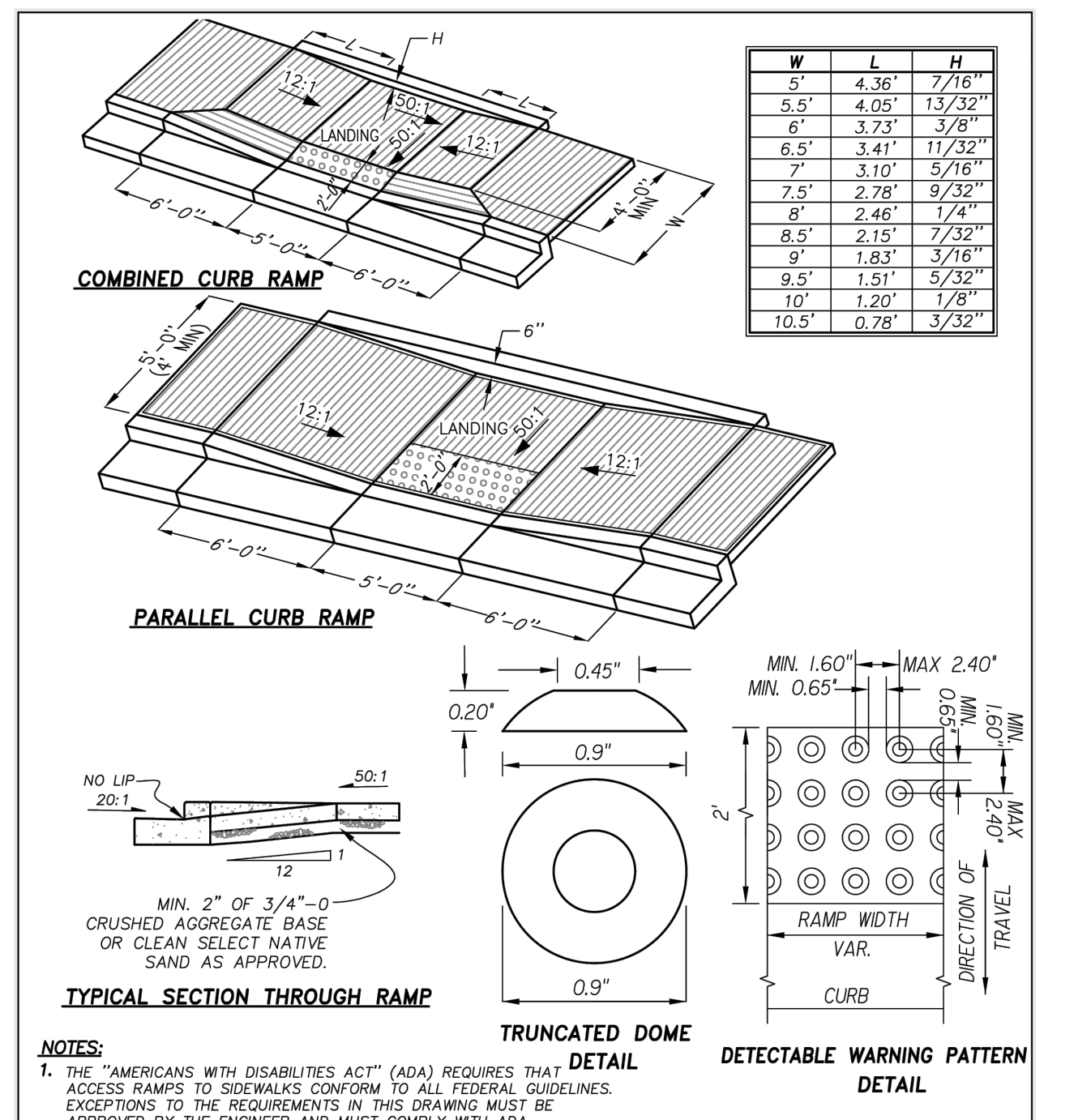

CITY OF COBURG STANDARD DRAWING
SIDEWALK ACCESS RAMP
DATE: MARCH 2022 DRAWING NO: ST-105

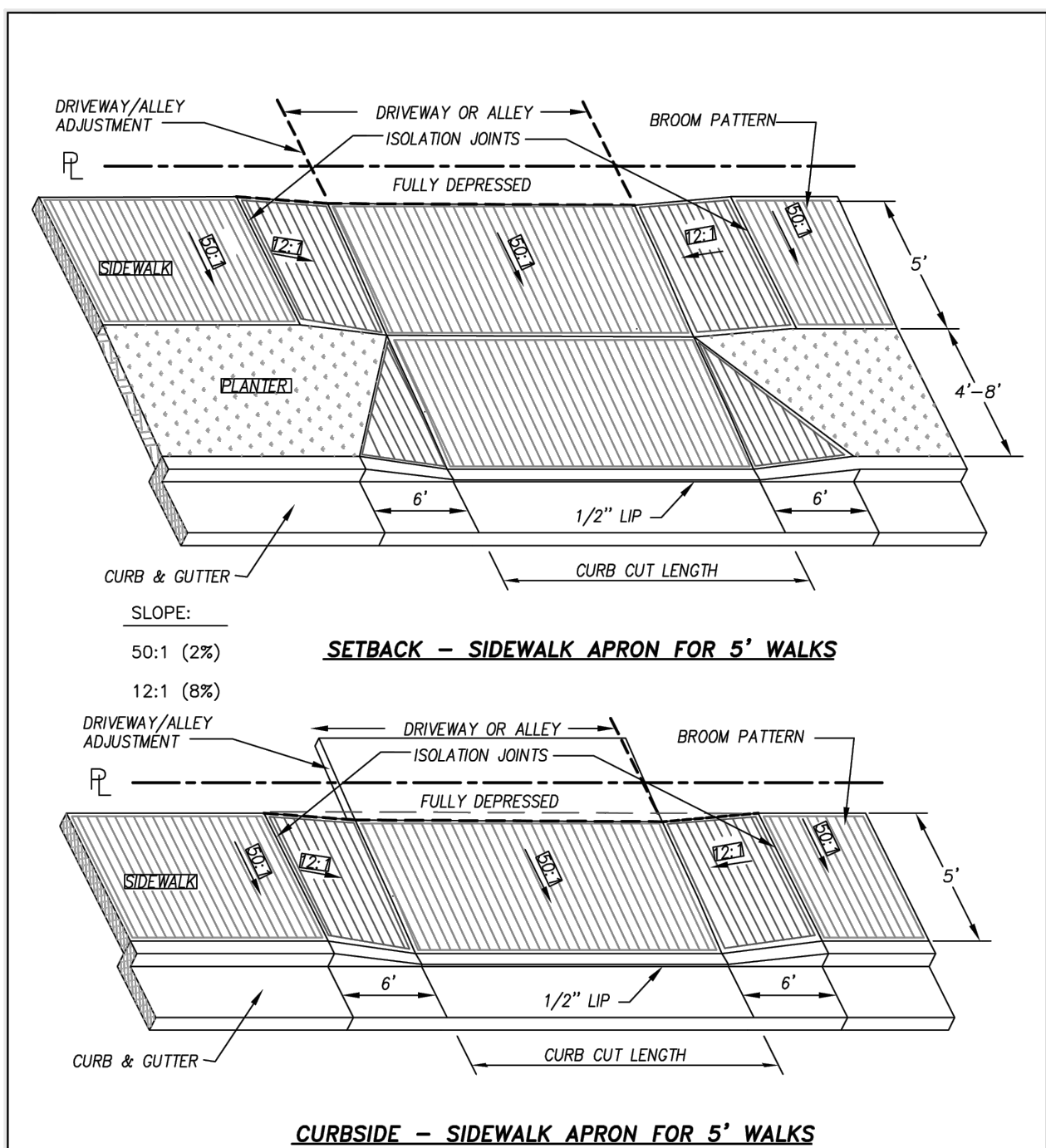

CITY OF COBURG STANDARD DRAWING
DRIVEWAY AND ALLEY APRON 5' CURBSIDE SIDEWALK
DATE: JANUARY 2017 DRAWING NO: ST-106

project title:

N. WILLAMETTE STREET PUBLIC IMPROVEMENTS
E. VAN DUYN STREET TO E. MACY ST.
CITY OF COBURG
91136 N. WILLAMETTE STREET
COBURG, OREGON

revisions:

date: June 12, 2023
drawn by: ZZ
designer: JLB
project no: 21-0048.3

CIVIL DETAILS

sheet: **C3**



COBURG CITY COUNCIL ACTION/ISSUE ITEM

TOPIC: Pavement Preservation Sealcoating Project Agreement

Meeting Date: July 11th 2023

Staff Contact: Brian Harmon, Public Works Director

Contact: 541-682-7857 brian.harmon@ci.coburg.or.us

REQUESTED COUNCIL ACTION

RECOMMENDED MOTION: *"I move to approve the agreement with Paverite USA for pavement preservation Seal coating project in the amount of \$38,500."*

BACKGROUND

As part of the pavement preservation plan, the staff identified the west side of Coburg for the seal coating portion of the preservation work. The project includes the contractor installing a commercial-grade slurry pavement sealer. They will secure the area of slurry seal with safety barricades, secure and cover drains per requirements, and set up a staging area. Contractor will clean the affected asphalt areas with blowers and powered brooms, and they will sweep with a vacuum truck to remove remaining debris. They then will install a slurry coat and supervise the drying process to ensure proper curing. Only one company returned a proposal to the RFQ that was sent out in June of 2023. Paverite USA presented a proposal for \$38,500. Paverite USA has until September 29, 2023, to finish all preservation projects.

This Crack Sealing Project will help preserve the integrity of the older asphalt streets and prevent major cracking in the future. **However, the** project does have the potential for medium to heavy traffic impact. We will work with the contractor and the residents that will be impacted by the activity.

BUDGET

The engineers estimated cost of the total preservation work is \$50,000. Paverite USA's proposal is for \$38,500 for the Crack Sealing portion of the project.

RECOMMENDATIONS AND ALTERNATIVES

The alternatives for City Council include:

1. Approve the contract as drafted. The contract will become effective immediately, and

- end with final completion of the project.
2. Adopt an amended contract. Council may make suggestions for contract changes.
 3. Do not accept the proposal.
-

PUBLIC INVOLVEMENT

Once proposal is approved staff will start the public involvement process by letting residents know what to expect during the sealcoating process.

RECOMMENDATIONS:

NEXT STEPS

- The next step would be to implement the project.
-

ATTACHMENTS

A. Paverite Agreement draft

Reviewed by:

Sammy Egbert, City Recorder

Anne Heath, City Administrator



PROPOSAL NUMBER

#0187-4

JOB NAME AND ADDRESS

**Julie leland
310 5th st
Springfield , OR, 97477**

CLIENT

**Julie leland
310 5th st
Springfield , OR**

CONTACT

Julie Leland

PROJECT PROPOSAL

6/28/2023

ADDRESS

P.O. BOX 70401
SPRINGFIELD, OR
97475

TELEPHONE

(541)-241-7283 office

EMAIL

COMPANY: PAVERITEUSA@GMAIL.COM
SALESPERSON: PAVERITEUSA@GMAIL.COM



PROPOSAL

Dear Julie Leland ,

Thank you for the opportunity to provide you with a proposal.



Per your request, we propose to supply the following to complete the indicated job: Labor, Materials, Equipment

Exclusions: Testing, Towing, Permits, 3rd Party Inspections, Stake Out, Removal Or Relocation Of Utilities, Any Other Items As Listed On The Terms And Conditions Page.

Please review the proposal and feel free to call with any questions.

CCB#225125



PROPOSAL

SEALCOATING ABBEY RD AND AUSTIN STREET

mobilization fee : \$5500
price per sq foot: \$0.55
streets included:
all streets on bid sheet
completion time 4 days

Sealcoating - We will apply slurry seal.

We will install a commercial-grade slurry pavement sealer. We will secure area of slurry seal with safety barricades. We will secure and cover drains per requirements. We will set up staging area. We will clean the affected asphalt areas with blowers and powered brooms. we will have area sweeper with a vacuum truck to remove remaining debris . we will install slurry coat and supervise drying process to ensure proper curing.

Price: \$38,500.00

TOTAL PRICE OF THIS PROPOSAL AS PRESENTED:

\$38,500.00



AGREEMENT

Paverite USA proposes to furnish material and labor to perform the work outlined herein for the sum of:

\$38,500.00, THIRTY-EIGHT THOUSAND, FIVE HUNDRED DOLLARS AND ZERO CENTS

Payment is to be made as follows: • 100% upon completion

This proposal is valid for ninety (90) days from the date written above. The proposal is subject to the terms and conditions enclosed, attached and/or on the backside of the proposal.

This proposal contains confidential information belonging to the sender, which is legally privileged. The information is intended only for the use of the individual or entity named above. If you are not the intended recipient, you are hereby notified that any disclosure, copying, distribution or the taking of any action in reliance on the contents of this proposal is strictly prohibited. If you have received this proposal in error, please immediately notify us by telephone to arrange for return of the original documents to us.

Sincerely,

Paverite USA,
paveriteusa@gmail.com

Accepted: The above proposed terms and conditions, including price and payment terms are satisfactory and hereby accepted. **{Company}** is hereby authorized to proceed with the work specified.

Purchaser: _____ Title: _____

Printed Name: _____ Date: _____



TERMS & CONDITIONS

- These Terms and Conditions are by and between {Company} (hereinafter the "Contractor"), and the front-side "Purchaser", (hereinafter the "Purchaser").
- Unit prices, if specified, shall apply to all extra work performed beyond the original scope, if such work can be performed at the same time Contractor is working at the site on original items of work. Contractor reserves the right to renegotiate the terms and conditions, including price if it must move any equipment back to the site to perform additional work. Contractor will be under no obligation to perform any extra work.
- Purchaser shall not prematurely subject the work to any type of traffic; loads in excess of the design capacity before proper cure, or in a manner which may damage the work. Contractor is not responsible for graffiti, tire tracks, animal or human footprints, etc., on finished concrete/asphalt.
- Contractor shall not be bound to any construction schedules unless agreed to in writing by Contractor. If no schedule is established, Contractor will undertake the work in the course of its normal operating schedule.
- Contractor will not be responsible for construction or material failures or delays in construction caused by any factor beyond its control, including, but not limited to, delays or failures caused by weather, acts of God, delays in transportation, acts of suppliers and subcontractors, acts of the Purchaser, Owner or its separate contractors, fuel or raw material shortages, plant failures, or any other cause beyond its control.



COBURG CITY COUNCIL ACTION/ISSUE ITEM

TOPIC: Pavement Preservation Crack Sealing Project Agreement

Meeting Date: July 11th 2023

Staff Contact: Brian Harmon Public Works Director

Contact: 541-682-7857 brian.harmon@ci.coburg.or.us

REQUESTED COUNCIL ACTION

RECOMMENDED MOTION: *"I move to approve the agreement with Paverite USA for pavement preservation Crack Sealing Project in the amount of \$21,250."*

BACKGROUND

As part of the pavement preservation plan, the staff identified the eastside of Coburg for crack sealing preservation work. The crack sealing project includes cleaning the streets, then the cracks will be cleaned of inorganic material, and then hot rubber crack sealant will be injected into all the cracks. Paverite USA is the only company who returned a proposal to the RFQ that was sent out in June of 2023. Their proposal is for \$21,250. Paverite USA has until September 29th 2023, to finish all preservation projects.

This Crack Sealing Project will help preserve the integrity of the older asphalt street and prevent major cracking in the future. However, the project does have the potential for mild traffic impact. We will work with the Contractor and the residents that will be impacted by the activity.

BUDGET

The engineers estimated cost of the total preservation work is \$50,000. Paverite USA's proposal for the crack sealing portion is \$21,250.

RECOMMENDATIONS AND ALTERNATIVES

The alternatives for City Council include:

1. Approve the contract as drafted. The contract will become effective immediately and end with final completion of the project.
2. Adopt an amended contract. Council may make suggestions for contract changes.

However, Council should consider that this contract language is the approved and required language of the City of Coburg's Capital Projects.

PUBLIC INVOLVEMENT

Once proposal is approved, staff will start the Public involvement phase by letting residents know what to expect during the crack sealing process.

RECOMMENDATIONS:

NEXT STEPS

- The next step would be to implement the project.
-

ATTACHMENTS

- A. Paverite USA Agreement draft
-

Reviewed by:

Anne Heath, City Administrator



PROPOSAL NUMBER

#0187-5

JOB NAME AND ADDRESS

**Julie leland
310 5th st
Springfield , OR, 97477**

CLIENT

**Julie leland
310 5th st
Springfield , OR**

CONTACT

Julie Leland

PROJECT PROPOSAL

6/28/2023

ADDRESS

P.O. BOX 70401
SPRINGFIELD, OR
97475

TELEPHONE

(541)-241-7283 office

EMAIL

COMPANY: PAVERITEUSA@GMAIL.COM
SALESPERSON: PAVERITEUSA@GMAIL.COM



PROPOSAL

Dear Julie Leland ,

Thank you for the opportunity to provide you with a proposal.



Per your request, we propose to supply the following to complete the indicated job: Labor, Materials, Equipment

Exclusions: Testing, Towing, Permits, 3rd Party Inspections, Stake Out, Removal Or Relocation Of Utilities, Any Other Items As Listed On The Terms And Conditions Page.

Please review the proposal and feel free to call with any questions.

CCB#225125



PROPOSAL

CRACK FILL

Price: \$21,250.00

TOTAL PRICE OF THIS PROPOSAL AS PRESENTED:

\$21,250.00



AGREEMENT

Paverite USA proposes to furnish material and labor to perform the work outlined herein for the sum of:

\$21,250.00, TWENTY-ONE THOUSAND, TWO HUNDRED FIFTY DOLLARS AND ZERO CENTS

Payment is to be made as follows: • 100% upon completion

This proposal is valid for ninety (90) days from the date written above. The proposal is subject to the terms and conditions enclosed, attached and/or on the backside of the proposal.

This proposal contains confidential information belonging to the sender, which is legally privileged. The information is intended only for the use of the individual or entity named above. If you are not the intended recipient, you are hereby notified that any disclosure, copying, distribution or the taking of any action in reliance on the contents of this proposal is strictly prohibited. If you have received this proposal in error, please immediately notify us by telephone to arrange for return of the original documents to us.

Sincerely,

Paverite USA,
paveriteusa@gmail.com

Accepted: The above proposed terms and conditions, including price and payment terms are satisfactory and hereby accepted. **{Company}** is hereby authorized to proceed with the work specified.

Purchaser: _____ Title: _____

Printed Name: _____ Date: _____



TERMS & CONDITIONS

- These Terms and Conditions are by and between {Company} (hereinafter the "Contractor"), and the front-side "Purchaser", (hereinafter the "Purchaser").
- Unit prices, if specified, shall apply to all extra work performed beyond the original scope, if such work can be performed at the same time Contractor is working at the site on original items of work. Contractor reserves the right to renegotiate the terms and conditions, including price if it must move any equipment back to the site to perform additional work. Contractor will be under no obligation to perform any extra work.
- Purchaser shall not prematurely subject the work to any type of traffic; loads in excess of the design capacity before proper cure, or in a manner which may damage the work. Contractor is not responsible for graffiti, tire tracks, animal or human footprints, etc., on finished concrete/asphalt.
- Contractor shall not be bound to any construction schedules unless agreed to in writing by Contractor. If no schedule is established, Contractor will undertake the work in the course of its normal operating schedule.
- Contractor will not be responsible for construction or material failures or delays in construction caused by any factor beyond its control, including, but not limited to, delays or failures caused by weather, acts of God, delays in transportation, acts of suppliers and subcontractors, acts of the Purchaser, Owner or its separate contractors, fuel or raw material shortages, plant failures, or any other cause beyond its control.



COBURG CITY COUNCIL MONTHLY REPORTS

TOPIC: Citizen Inquiry Quarterly Report

Meeting Date: July 11, 2023
Staff Contact: Sammy Egbert, City Recorder
Contact: 541-682-7852, sammy.egbert@ci.coburg.or.us

REQUESTED COUNCIL ACTION:

This is a quarterly report to City Council and is presented as information only on the Citizen Inquiry requests received by the City.

CITY COUNCIL GOAL

Citizen Communication

BACKGROUND

Council requested a summary on Citizen Inquires be provided quarterly. The purpose is to provided accountability and consistency on following up with citizens questions and concerns.

Citizen Inquires process -

1. Administration intake at front desk. Inquiry is date stamped, logged and emailed to the City Administrator and department heads who will handle the response.
 2. Departments print working copy and follow up on inquiry.
 3. When complete the department signs off on Citizen Inquiry form. Summarizing any actions taken, correspondence, etc. Attach all supporting documentation.
 4. Department follows up with citizen who submitted the Inquiry by letter, email or phone call. Update them on how the inquiry has been handled and letting them know that it is closed. **(N/A if Anonymous)**
 5. Route completed inquiry to City Administrator for final review and sign off.
 6. Return to administration staff to log, close and retain.
-

NEXT STEPS

Quarterly report covering July, August, September is scheduled for the October 10, 2023 City Council Meeting.

ATTACHMENTS

Quarterly Citizen Inquiry summary

REVIEWED THROUGH:

Anne Heath, City Administrator

Citizen Inquires April, May & June 2023

Recieved	Inquiry by	Citizens Inquiry	Closed	City Response
4/19/2023	Ryan Cunningham	6:23am metal material being dropped/thrown onto asphalt	5/11/2023	Property owner & Plant manager agreed to change the start time to 7:00 am to be in compliance with Noise ORD.
4/20/2023	Ryan Cunningham	6:27am forklift activity hauling materials	5/11/2023	Anne emailed me to log
4/24/2023	Ryan Cunningham	6:19am forklift activity loud horn dragging materials on road	5/11/2023	Anne emailed me to log
4/26/2023	Ryan Cunningham	6:11 am nonstop hammering on metal material	5/11/2023	Anne emailed me to log
4/27/2023	Ryan Cunningham	6:28am Forklift activity loud hammering	5/11/2023	Anne emailed me to log
5/11/2023	Marl Carter	32639 Vintage Way - Noxious Vegetation	6/15/2023	In compliance
5/15/2023	Jeff Gratreak	alley behind 32776 E Dixon Blackberry bushes in alley are overtaking the right a way	5/16/2023	Public Works cleared the alley
6/2/2023	Leanna Gilderhus	91193 N Skinner - Noxious Vegetation	6/15/2023	In compliance
6/5/2023	Multiple	(15) inquires regarding the post office	PENDING	
6/5/2023	Marl Carter	32639 Vinatge way Noxious Vegetation	6/15/2023	In compliance
6/19/2023	Nick Blickfeldt	91155 N Emerald St excessive loud stereo grey/white suv	PENDING	
6/20/2023	Marl Carter	Trees along Christian way being an issue for people hauling boat\trailers on the road	PENDING	
6/27/2023	Ginger Payevr	Would like a speed bump in driveway between industrial road	PENDING	
6/29/2023	Admin	32800 E Dixon St Noxious Vegetation	PENDING	10 Day letter Sent
6/29/2023	Admin	31225 N Willamette St Noxious Vegetation	PENDING	10 Day letter Sent
6/29/2023	Admin	Vacant Lot Van Duyn St and Skinner - Noxious Vegetation	PENDING	10 Day letter Sent
6/29/2023	Admin	91125 N Willamette St - Noxious Vegetation	PENDING	10 Day letter sent

COBURG CITY COUNCIL MONTHLY REPORTS



TOPIC: City Administration Report

Meeting Date: July 11, 2023

Staff Contact: Anne Heath, City Administrator

Contact: 541-682-7871, anne.heath@ci.coburg.or.us

The following is an overview of important activities during the month of June, general administration, and upcoming work to be done. The City Administrator and Department Directors compiled the information in this report.

City Administrator

Adam Hanks will report to work on July 31. It is anticipated that Anne Heath's last day will be the week of August 31.

Water Project

- Well is under construction.
- SKADA design is in process. However, it appears the cost will come in much higher than expected. This is still in a preliminary design discussion stage.
- East-side line to Premier RV is still waiting wetland permit approval by the state and federal authorities. City staff have continued to be engaged and provide any and all information requested. There seems to be confusion on the DEQ level as to what kind of permit needs to be issued. City Administrator reached out to our Regional Solutions Representative at DEQ to let them know that this is a huge concern to our community and we are very uncomfortable with how long this is taking. She agreed to try to reach out to the other agencies and try to move it along.
- North Willamette and Van Duyn Water Line replacement is behind schedule due to the contractor's inability to acquire necessary supplies. They are moving it forward as fast as they can.

Street Projects

- **Macy/Harrison/North Willamette** – Design is in process
- **North Willamette Intersection** – The engineer is working on a couple of designs depicting how the intersection could be improved. Engineering staff will attend the July 12th Transportation Discussion Group meeting to discuss this topic.
- **Transportation Group** – will meet on July 12th. Invited to this meeting is ODOT, Lane County Transportation staff, Commissioner Heather Buch, Jae Pudewell, and members of the Regional Solutions Team. Topics of discussion at this meeting will be the I-5 Interchange, and North Willamette and Van Duyn Intersection.

Park Projects

- **Pavilion Park Planning** – Park|Tree have met with designer to forward final design requests. In the process of final design being completed by engineers.

Coburg Mainstreet

Tracey Pugh left the City on June 29th as the City will no longer pay the salary of the Main Street employee. The City budget was approved to forward funds to Coburg Mainstreet for 2023-24 budget year.

Auditor Recommendation for Change in Cash Basis

City Administrator did reach out to our funder for the majority of the loans at the City and it does not appear that the City has a choice to move to this basis as our agreement with the bank requires that the City retain a GAAP cash basis. I have let the auditor know and he will not be coming to address the Council on this subject. Therefore, our basis will remain Modified Accrual Basis.

Zoning Code Update Consideration

Councilor Engebretson has provided the Council with valuable information regarding zoning code concerns and consideration. Updating zoning code is a costly and time consuming project. However, it is also very important that the City does provide updates when needed. The Council chose to discuss this in work session at their retreat. Therefore, there is a scheduled work Session on September 26th to look at options for updating the zoning code. Most importantly, consideration should be for a comprehensive update to the code with enough time to apply for funding to support it and budget it. Please mark the work session date on your calendar.

Promotion of Accountant to Finance Director

After a probationary period of employment as accountant, Gregory Peck has been promoted to Finance Director at the City. This was planned and budgeted. Greg has hit the ground running and brings excellent business work experience to the position and contributes excellently to the team . He will providing the quarterly finance report to the Council in August.

Upcoming Meetings

- July 18 Park Tree Committee
- July 19 Planning Commission
- July 25 Finance Audit Committee

DEPARTMENTS AND OPERATIONS

Administration Front Office - Prepared by Sammy Egbert

- 4 Citizen Inquiries
- 6 Noxious Vegetation enforcement (3 Incompliance | 3 pending)

- 6 Park Rentals
- 1 Special Event Application
- (0) IOOF Rentals

Utility Billing – Prepared by Sammy Egbert

- **Utility Bills for service period 5/9/2023 to 6/9/2023.**
 - Billed Water \$70,400 | Sewer \$71,000 | Transportation Utility Fee \$12,526
 - Cash Receipts or Payments Received \$143,000
 - Past dues charged - 81
 - 3 new utility accounts set up
 - 4 Change in accounts - In & Outs – Final bill and set up new account.
 - 8 Door Hangers
 - Fire Hydrant Meter application and billing.
- Limited income assistance enrollment was open through June 31, 2023. Information was included in the May utility bills, and renewal applications were mailed to all who participated in the FY 22/23.
- Set up and billing for 2 new commercial accounts.

Finance

- A complete report for the year ended June 30, 2023 will be included in the August City Council packet.

Next Steps

- Year-end planning
- Continued training of Finance Director
- Audit preparation

Planning – Prepared by Megan Winner

- SUB 02-20 & SUB 01-22: Construction continues in the Coburg Creek Subdivision. Application for final plat approval has been submitted by the applicant and is being prepared for signature;
- SR 04-22: Building permits issued for ADA compliant picnic area at food truck plaza at 91070 N. Willamette St.;
- Seven Structural/Plumbing/Mechanical/Electrical permits issued in June;
- Attended regional transportation meetings including Transportation Planning Committee, Safe Lane Transportation Coalition, Transportation Options Advisory

Committee and Technical Advisory Sub-Committee (of MPC), Climate Friendly and Equitable Communities (CFEC) partner meetings with other MPO members;

- Safe Lane Transportation Coalition is rescheduling an Oregon Friendly Driver course at the IOOF for some time in August for the Slow Down in Coburg! campaign;

Coburg Main Street – Prepared by Tracey Pugh

- Completed Our Town newsletter for July/August 2022
- Obtained nonprofit status for Coburg Main Street
- Finalizing Coburg Business Map/Directory
- Finalized logo for Coburg Main Street
- Working on City of Coburg website - updating information, fixing broken links
- Created poster for Concerts in the Park and Coburg Market
- Held a Business After Hours mixer with Oregon RAIN
- Redesigning Chamber website for Coburg Main Street
- Working on cleaning up Visitor Kiosk and Bike Hub
- Coordinating vendors for Coburg Market on Thursdays (July 21-August 25)
- Coordinated/attended monthly meeting with Main Street Executive Committee
- Coordinated/attended monthly Coburg Main Street committee meeting
- Assisting Coburg Antique Fair Director
- Participated in weekly Oregon Main Street zoom meetings

Public Works – Prepared by Brian Harmon

- **Streets and ROW.**
 - **Street**
 - **Repairs**
 - Hot patched three trenches
 - Pot hole repairs
 - Replaced stop sign on Roberts Ct
 - **Mowing**
 - Right of Way mowing
 - Mowed all Bio swales
- **Water Utility**
 - **Callouts**
 - Leak was called in on Christian Way
 - **Flow Testing**
 - Crews flow tested 12 fire hydrants around town and worked with the Fire Department on report to ISO for insurance.
- **Sewer Utility**
 - **Collections**
 - **Inspections**
 - 12
 - **Callouts**
 - 7

- **Tanks Pumped**
 - 6
 - **Treatment Plant**
 - **Projects**
 - We planted 102 Oregon Ash Trees for the DEQ Project
- **Parks Dept**
 - **Parks and Tree Committee**
 - Work Party worked at Johnny Diamond Park
 - **Park Maintenance**
 - Reese Landscaping went through all the flowerbeds at Johnny Diamond Park
 - Removed two tree that blew over in the wind.
 - Cleaned up Diamond St Island
- **Misc.**
 - **Locates** 15
 - **Work Orders** 60
 - 45
 - **Work Orders**
 - 97

Municipal Court – Prepared by Mandy Balcom

- **June 2023 Activity Measures:**
 - **Citations (Crimes and Violations)**
 - New Citations for June 7, 2022 Court Date: 55
 - **June 2023 Receipts Including Collections,**
 - **Total Fines:** \$11,776.44 (total monies taken in for the month, nothing deducted), *compared to \$14,979.87 in June of 2021*
 - **Net Fines:** \$7,833.00 (City share only, NOT including collections), *compared to \$9,000.00 in June of 2021*
 - **June 2023 Professional Credit Service Collections:**
 - **Total Collection Revenue:** \$ 3,943.44 *compared to \$5,979.87 in June of 2021*
 - **Turned over to collection:** \$ 20,140.00 *compared to \$17,337.00 in June of 2021*

Comparisons should only be considered when viewing the year-to-date amounts as court dates are not consistently held on the same dates each month, nor is there consistent cases presented to the court.

Other Information:

- **Upcoming Court Date: July 12, 2022 Regular Court Session**
August 2, 2022 Regular Court Session

Police Department – Prepared by Chief Larry Larson

- Officers cited a male for initiating a false report and improper use of 911.
- Officer arrested a male for resisting arrest and trespassing.
- Officer investigated stolen vehicle and other stolen items.
- Officer received ammunition from a citizen.
- Officer arrested a male for a warrant on a traffic stop.
- Officer investigated multiple aggravated thefts from the same location.
- Officer investigated a burglary and stolen vehicle from the same location.
- Officer investigated extensive damage to a property.
- Officer investigated burglary and thefts from several locations.
- Officer took a report of a stolen firearm.
- Officer investigated a physical dispute and determined a crime was not committed.
- Officer investigated a hit and run.
- Officer investigated a vehicle crash at the school.
- Officers responded to an ongoing dispute between brothers; no crime was reported.
- Officer returned a loose dog to the owner.
- Officer participated in the Ribbon Cutting Ceremony for the pickle ball court.
- Officers cited a male for stealing items out of a citizen's backyard.
- Officers conducted safety vacation residence patrol checks as requested by community.
- CIS conducted a Best Practices review of the Police Department and Evidence Room.
- Officers conducted an Evidence Room audit.
- Officers participated in an Ice Cream Social at the school.
- Officers gave away over 25 bicycles to local children from the school.
- Officers posted tow notices on boats.
- Officers contacted citizens regarding tall grass.
- Officers attended investigative training from an EPD Detective.
- Officers participated in a crosswalk.
- Officers completed a death investigation and determined it was a drug overdose.

Upcoming Events:

We have two Reserve Police applicants in backgrounds.
Officers are scheduled for the range.





MINUTES

Coburg Finance/Audit Committee Meeting

May 2, 2023 at 5:30 P.M.

91136 N Willamette Street

In-person meeting

PRESENT: Chair Elise Landry, Vice Chair Terry Dawson, Coleen Marshall

STAFF PRESENT: Anne Heath, City Administrator; Gregory Peck, Accountant; City Council Liaison Claire Smith; Bobbi Bengston, LCOG Finance and Operations Specialist

RECORDED BY: Angela Kern, Lane Council of Governments (LCOG)

1. CALL TO ORDER

Chair Landry called the meeting to order at 5:30 pm.

2. ROLL CALL

A quorum was present.

3. MINUTES REVIEW: January 31st, 2023

Mr. Dawson requested that Ms. Engebretson's name be moved from Committee to Staff.

MOTION: Mr. Dawson moved to accept the Coburg Finance/Audit January 31st, 2023 minutes as amended, seconded by Ms. Marshall. The motion passed unanimously – 3:0:0.

4. Introductions of Gregory Peck and Bobbi Bengston

Anne Heath introduced accountant Gregory Peck and Finance and Operations Specialist Bobbi Bengston, explaining their roles.

5. Review of 1st Qtr, 2023 Financials

Anne Heath presented, stating that the city was doing fine, as of the current numbers.

Ms. Marshall pointed out an error, which was noted by Ms. Heath.

Chair Landry inquired about the fuel tax source. Ms. Heath offered the information. Ms. Marshall wondered if that would increase with summer driving. Ms. Heath responded in the affirmative.

Ms. Heath explained the expenses and gave an overview of the General Fund sheet.

6. Discuss Fiscal Policies and Accounting Procedures

Anne Heath led the discussion. The Committee requested copies of the whole document. The decision by consensus was to continue from page 20 with the goal of completing the document by July, before the new fiscal year.

7. Council Reporting

There was discussion of how restructuring the Finance/Audit Committee as a subcommittee of the Budget Committee would work and whether there were any bylaws to consider.

Council reporting options were discussed.

It was decided by consensus that Chair Landry would write a report and email it to the Committee members for review before submitting it to the Coburg City Council by May 25th.

The report would provide an overview of the Committee's:

- Review of the City Financials
- Ongoing review of financial policies
- Staff Introductions
- Discussion of merging Budget and Finance Committees

8. ADJOURNMENT

Chair Landry adjourned at 6:15 pm.

APPROVED by the City Council of the City of Coburg on this ____ day of _____, 2023.

Elise Landry, Finance Audit Chair

ATTEST:

Sammy L. Egbert, City Recorder



MINUTES

Coburg Parks | Tree Committee

Coburg City Hall, 91136 N. Willamette Street

May 18, 2023 - 6:00 p.m.

MEMBERS PRESENT: Mary Mosier, Chair; Tom Beatty, Lonna Metson, Colleen Marshall, Joe Morneau

MEMBERS ABSENT: Karen Coury

GUESTS/STAFF PRESENT: Nancy Bell, Mayor; Claire Smith, Coburg City Council; Anne Heath, City Administrator; Brian Harmon, Public Works Director

CALL TO ORDER

Ms. Mosier called the meeting to order at 6:00 p.m.

ROLL CALL

A quorum was established.

AGENDA REVIEW

Ms. Mosier said the agenda item City Updates/Reports would be taken up prior to regular committee business and minute's approval.

CITY UPDATES/CITY ADMINISTRATOR REPORT

Ms. Heath provided an overview of the recent circuit court rulings on cases related to the right to sit or rest and presence on public property. She said that a person could not be asked to leave public property, such as Pavilion Park, unless the City had an alternative location for them to be and a person could not be asked to leave the city limits or transported outside of the city limits, although the City could provide transportation to another location if the person requested it. An attorney with expertise in those matters had been hired to review city ordinances and recommend any changes that were required to be in compliance.

Ms. Heath said that simple modifications to two ordinances were identified and would be addressed by the City Council, along with giving the city administrator the authority to identify a location where camping was permitted. She said that did not mean that a permanent camp

would be established as there were limited options. Any location would need to include a restroom and trash receptacle. She said people had a right to shelter, including in their car. Cars could be parked in residential areas for up to 72 hours unless the City provided an alternative parking location. The amendments to ordinances did not specify locations; city staff would make those determinations as needed. She stressed that the City needed to adopt its own rules or would be required to follow state mandates. One location under consideration was a portion of Wetland Park, but other options were also being explored.

Committee members and staff discussed issues the City would need to address, including amenities required for a camping location, conditions under which dogs would be allowed, potential use of private property within the city limits with the owner's agreement, panhandling and lack of some services in the community such as medical clinics and public transit.

Mr. Harmon pointed out that a private citizen or business agreeing to let their property be used for camping could opt out of that agreement, leaving the City without a backup location. Ms. Heath noted that a person could not be required to leave public property and move to private property; they could only be directed to another public location.

Committee members expressed appreciation for the City's proactive approach and the need to address homelessness with empathy and respect.

APPROVE MINUTES FROM APRIL 18, 2023, WORK SESSION AND REGULAR MEETING

MOTION: Ms. Marshall, seconded by Ms. Metson, moved to approve the minutes of the April 18, 2023, work session and regular meeting. The motion passed 4:1, Mr. Morneau abstaining.

COMMITTEE BUSINESS

Memorial Bench

Mr. Harmon reported that a local family wished to donate a memorial bench to Pavilion Park in honor of their son. He said the bench would be constructed of redwood and made by Steve Bowers. He would do further research on the proposed bench and plaque design and report back to the committee at its June meeting.

Arbor Day Follow-up

Ms. Mosier said Arbor Day had been a success and many trees were planted. Mr. Harmon said the Coburg Pizza Company has sponsored the event, providing food and t-shirts for participants; the City had purchased trees. Other business would be asked to be a sponsor in future years.

Volunteer for Newsletter

Ms. Metson reported that a volunteer for the newsletter had been found.

Pickleball Grand Opening

Mr. Harmon said the afternoon of June 15 was being considered for the date of the grand opening. He said the Emerald Valley Pickleball Club was interested in being involved in the event and possibly providing a clinic for players.

Work Party Johnny Diamond Park/Pavilion Weeding

Ms. Marshall said that a crew comprised of Ms. Mosier, Ms. Metson, Mr. Beatty and she had weeded the area; the next work party would focus on the flag pole and playground on June 19.

Johnny Diamond Grass Update

Mr. Harmon said that the grass was not growing. He would try another method to enjoy growth and if that did not work he would consider using a cultivator. If those efforts were not successful, the infill would be removed.

Candidate for Committee

Mr. Harmon announced that the open position on the committee had been posed and the application period would close June 19, the day before the committee's next meeting. No applications had been received to date and encouraged committee members to recruit candidates. The committee would interview applicants and make a recommendation to the City Council on an appointment.

Veterans Memorial Update

Mr. Harmon said he would provide an update at the committee's June meeting. He hoped to get work done in June in order to spend funds, some of which would expire on June 30, 2023.

Ms. Mosier asked if any parks budget funds would carry over into the next fiscal year. Mr. Harmon said that the capital funds would not carry over. He said the Veterans Memorial was on the City Council's work plan.

Mr. Harmon said based on current financial forecasts, the parks budget could be tight in the coming year.

Ms. Smith said that parks funding comprised a large percentage of the City's General Fund without generating revenue; there could be a future discussion of how parks could provide some revenue to the City through fees or other options.

Mr. Harmon said one option the City Council could explore might be establishing a parks district. Some hard decisions could be required in the future.

Other Items

Mr. Beatty said there might be an opportunity to obtain a seedling from the ginkgo tree that survived ground zero at Hiroshima. He said several communities in Oregon had planted the seedlings. He asked if the committee agreed with obtaining a seedling that could be planted at the Veterans Memorial.

There was consensus among committee members to pursue a gingko seeding for Coburg.

In response to a question from Ms. Mosier, Mr. Harmon said there was a sign at Trail's End requiring dogs to be on a leash.

Ms. Mosier said there did not appear to be a need for another work session.

Mr. Harmon announced that Public Works had moved to a 4-10 schedule for the summer time. Staff would work Monday through Thursday, with a person on call for four hours on Friday mornings.

ADJOURNMENT

Ms. Mosier adjourned the meeting at 7:00 p.m.

(Minutes recorded by Lynn Taylor, LCOG)

APPROVED by the Coburg Parks | Tree Committee on this ____ day of _____, 2023.

Nancy Bell, Mayor of Coburg

ATTEST:

Sammy L. Egbert, City Recorder



MINUTES

Coburg Parks | Tree Committee

Coburg City Hall, 91136 N. Willamette Street

May 18, 2023 - 6:00 p.m.

MEMBERS PRESENT: Mary Mosier, Chair; Tom Beatty, Lonna Metson, Colleen Marshall, Joe Morneau

MEMBERS ABSENT: Karen Coury

GUESTS/STAFF PRESENT: Nancy Bell, Mayor; Claire Smith, Coburg City Council; Anne Heath, City Administrator; Brian Harmon, Public Works Director

CALL TO ORDER

Ms. Mosier called the meeting to order at 6:00 p.m.

ROLL CALL

A quorum was established.

AGENDA REVIEW

Ms. Mosier said the agenda item City Updates/Reports would be taken up prior to regular committee business and minute's approval.

CITY UPDATES/CITY ADMINISTRATOR REPORT

Ms. Heath provided an overview of the recent circuit court rulings on cases related to the right to sit or rest and presence on public property. She said that a person could not be asked to leave public property, such as Pavilion Park, unless the City had an alternative location for them to be and a person could not be asked to leave the city limits or transported outside of the city limits, although the City could provide transportation to another location if the person requested it. An attorney with expertise in those matters had been hired to review city ordinances and recommend any changes that were required to be in compliance.

Ms. Heath said that simple modifications to two ordinances were identified and would be addressed by the City Council, along with giving the city administrator the authority to identify a location where camping was permitted. She said that did not mean that a permanent camp

would be established as there were limited options. Any location would need to include a restroom and trash receptacle. She said people had a right to shelter, including in their car. Cars could be parked in residential areas for up to 72 hours unless the City provided an alternative parking location. The amendments to ordinances did not specify locations; city staff would make those determinations as needed. She stressed that the City needed to adopt its own rules or would be required to follow state mandates. One location under consideration was a portion of Wetland Park, but other options were also being explored.

Committee members and staff discussed issues the City would need to address, including amenities required for a camping location, conditions under which dogs would be allowed, potential use of private property within the city limits with the owner's agreement, panhandling and lack of some services in the community such as medical clinics and public transit.

Mr. Harmon pointed out that a private citizen or business agreeing to let their property be used for camping could opt out of that agreement, leaving the City without a backup location. Ms. Heath noted that a person could not be required to leave public property and move to private property; they could only be directed to another public location.

Committee members expressed appreciation for the City's proactive approach and the need to address homelessness with empathy and respect.

APPROVE MINUTES FROM APRIL 18, 2023, WORK SESSION AND REGULAR MEETING

MOTION: Ms. Marshall, seconded by Ms. Metson, moved to approve the minutes of the April 18, 2023, work session and regular meeting. The motion passed 4:1, Mr. Morneau abstaining.

COMMITTEE BUSINESS

Memorial Bench

Mr. Harmon reported that a local family wished to donate a memorial bench to Pavilion Park in honor of their son. He said the bench would be constructed of redwood and made by Steve Bowers. He would do further research on the proposed bench and plaque design and report back to the committee at its June meeting.

Arbor Day Follow-up

Ms. Mosier said Arbor Day had been a success and many trees were planted. Mr. Harmon said the Coburg Pizza Company has sponsored the event, providing food and t-shirts for participants; the City had purchased trees. Other business would be asked to be a sponsor in future years.

Volunteer for Newsletter

Ms. Metson reported that a volunteer for the newsletter had been found.

Pickleball Grand Opening

Mr. Harmon said the afternoon of June 15 was being considered for the date of the grand opening. He said the Emerald Valley Pickleball Club was interested in being involved in the event and possibly providing a clinic for players.

Work Party Johnny Diamond Park/Pavilion Weeding

Ms. Marshall said that a crew comprised of Ms. Mosier, Ms. Metson, Mr. Beatty and she had weeded the area; the next work party would focus on the flag pole and playground on June 19.

Johnny Diamond Grass Update

Mr. Harmon said that the grass was not growing. He would try another method to enjoy growth and if that did not work he would consider using a cultivator. If those efforts were not successful, the infill would be removed.

Candidate for Committee

Mr. Harmon announced that the open position on the committee had been posed and the application period would close June 19, the day before the committee's next meeting. No applications had been received to date and encouraged committee members to recruit candidates. The committee would interview applicants and make a recommendation to the City Council on an appointment.

Veterans Memorial Update

Mr. Harmon said he would provide an update at the committee's June meeting. He hoped to get work done in June in order to spend funds, some of which would expire on June 30, 2023.

Ms. Mosier asked if any parks budget funds would carry over into the next fiscal year. Mr. Harmon said that the capital funds would not carry over. He said the Veterans Memorial was on the City Council's work plan.

Mr. Harmon said based on current financial forecasts, the parks budget could be tight in the coming year.

Ms. Smith said that parks funding comprised a large percentage of the City's General Fund without generating revenue; there could be a future discussion of how parks could provide some revenue to the City through fees or other options.

Mr. Harmon said one option the City Council could explore might be establishing a parks district. Some hard decisions could be required in the future.

Other Items

Mr. Beatty said there might be an opportunity to obtain a seedling from the ginkgo tree that survived ground zero at Hiroshima. He said several communities in Oregon had planted the seedlings. He asked if the committee agreed with obtaining a seedling that could be planted at the Veterans Memorial.

There was consensus among committee members to pursue a gingko seeding for Coburg.

In response to a question from Ms. Mosier, Mr. Harmon said there was a sign at Trail's End requiring dogs to be on a leash.

Ms. Mosier said there did not appear to be a need for another work session.

Mr. Harmon announced that Public Works had moved to a 4-10 schedule for the summer time. Staff would work Monday through Thursday, with a person on call for four hours on Friday mornings.

ADJOURNMENT

Ms. Mosier adjourned the meeting at 7:00 p.m.

(Minutes recorded by Lynn Taylor, LCOG)

APPROVED by the Coburg Parks | Tree Committee on this ____ day of _____, 2023.

Nancy Bell, Mayor of Coburg

ATTEST:

Sammy L. Egbert, City Recorder