



CITY OF CLEWISTON
115 West Ventura Avenue
Clewiston, Florida 33440

PARKS, RECREATION & LEISURE SERVICES
ADVISORY BOARD SPECIAL MEETING AGENDA

Thursday, April 2, 2026 – 4:00 p.m.

Call meeting to order

Prayer and Pledge of Allegiance

Additions/Deletions/Changes and Approval of the Agenda

Public Comments – At this time, any person will be allowed to speak.

Special Meeting Agenda:

- 1. Discussion regarding field fees**
 - a. Resolution No. 2025-85 update**
- 2. Discussion regarding fields lights on field 1 (used by CHS Baseball)**
- 3. Board member comments.**

Adjournment

The City of Clewiston is an equal opportunity provider and employer.

City Hall is wheelchair accessible and accessible parking spaces are available. Accommodation requests or interpretive services must be made 48 hours prior to the meeting. Please contact the City Clerk's office at (863) 983-1484, extension 104, or FAX (863) 983-4055 for information or assistance.

If a person decides to appeal any decision made by the City Commission with respect to any matter considered at this meeting, the person will need a record of the proceedings, and that, for such purpose, the person may need to ensure a verbatim record of the proceedings is made, which record includes the testimony and evidence upon which the appeal is to be based.

I, the undersigned authority, hereby certify that the foregoing Notice of Meeting of the City Commission of the City of Clewiston is a true and correct copy of said Notice and that I have posted a true and correct copy on the city's official website at www.clewiston-fl.gov, a location convenient and readily accessible to the general public at all times.

Fransheska Berrios

Fransheska Berrios, City Clerk

CITY OF CLEWISTON PARKS & RECREATION DEPARTMENT



SUGARLAND PARK FIELD RESERVATION

League/Organization Information (Please print all information)

Organization Name _____ Address _____ City/State/Zip _____

Contact Person _____ Phone Number _____ Fax Number _____

Description of Facility	Date Time *Attach schedule, if available
-------------------------	--

<p align="center">Fees</p> <p>(ALL payments are due at time of booking. Make check payable to the City of Clewiston)</p> <p>*Rental fee can be waived for local non-profits (501c3) only by the City Commission</p>	*Rental - \$1,000 for season	\$ _____
	\$500 Security Deposit	\$ _____
	TOTAL	\$ _____
	Requesting fees to be waived by City Commission? (Yes or No)	_____

Team Insurance: Yes No Attach copy of Certificate of Insurance to this form.

All field use is by permit only unless an exception is made by the Director of Recreation & Leisure Services. Coaches are responsible for leaving fields, dugouts, and spectators' areas clean. Extra field maintenance for any play, tournament, or special event is considered a "billable" event. It is the responsibility of the user group to maintain a clean and safe concession. The Director of Recreation & Leisure Services is to be notified of all accidents/incidents requiring medical attention. Athletic fields can be used only when field conditions are deemed safe and when use will not create conditions which may cause damage to the fields. If field conditions change during the permit period, the Director of Recreation & Leisure Services reserves the right to close the fields. Security deposit is fully refundable upon cancellation or no damage to the fields.

AGREEMENT OF UNDERSTANDING

I understand the rules and policies of the City of Clewiston and agree to abide by the stated guidelines. I understand any non-compliance may result in the revocation of existing permits, the loss of permits in the future, and loss of security deposit. I also understand non-compliance may result in the revocation of field privileges and/or a fee assessment for damages.

Signature of Organization Representative

Organization

Date

Director of Recreation & Leisure Services

CITY OF CLEWISTON PARKS & RECREATION DEPARTMENT



SUGARLAND PARK FIELD RESERVATION

Field Playability, Rules and Regulations

The Park Personnel will decide if the field is playable. This person will use common sense and good judgment in the decision to play. The soil must be firm and free of obstacles that could cause personal injury or field damage before play begins. Water can be broom-dried to remove puddles from infield to expedite play.

- All persons, if given permission to use a field, will abide by all and any directives from the City of Clewiston & Parks and Recreation Personnel.
- All teams and individuals given permission to use a field assume all responsibilities in regards to injury and/or accident and all liabilities, as per insurance requirements listed on Page 1 & 3.
- Permits must be kept with team while using field at all times.
- Teams and individuals given permission to use a field must use the field assigned.
- No exchanging of field permits with another team or individual is allowed.

Rain-outs Rescheduling Procedures

If you are rained out on a given night, you must contact Parks & Recreation Department within 24 hours or the next business day in order to receive a rain-date. A failure to contact this office within the allotted time will result in forfeiture of the rain-date. Rain dates will be scheduled on the same day of the week and the same time period, as your regularly scheduled play dates, unless a mutually agreed upon time and date is reserved. It will be added to your schedules accordingly. All attempts to schedule your rain-date for the earliest possible time will be made.

Parking

All parking must be in designated areas. No vehicles are permitted to park on grassy areas, behind backstops or along the side of fields. Any vehicle parked illegally will be tagged and/or towed at the discretion of the City Police Department.

By signing below, I agree to comply with the above stated rules and regulations concerning the use of the Ball Park Fields.

Signature: _____

Date: _____

CITY OF CLEWISTON PARKS & RECREATION DEPARTMENT



SUGARLAND PARK FIELD RESERVATION

HOLD HARMLESS AGREEMENT

(Please type or print)

BETWEEN THE CITY OF CLEWISTON, FLORIDA AND _____
(Applicant)

WITNESSETH:

1. In consideration of permission to use the public facility described below on the ____ day of, _____ 20____, the application does hereby covenant and agree to save and hold the City of Clewiston, its agents, servants and employees harmless from any and all liabilities of costs arising out of the described premises by the applicant, the applicant's invitees or other persons.
2. The facilities will be used for the following purpose and no other _____.
Number of persons expected to attend: _____
3. The applicant is: (check one) _____ An Individual _____ Non-profit Organization
_____ A Profit Organization _____ Other (describe) _____.

If applicant is an Association or Corporation, the undersigned certifies that the execution of the HOLD HARMLESS AGREEMENT has been duly authorized.

4. The applicant acknowledges that the permission to utilize the facilities is limited to the portion of the premises herein described (if applicable) and the permission to use the facility is valid only for the activity herein described. Notwithstanding the foregoing, however, this HOLD HARMLESS AGREEMENT shall be applicable to any claim asserted against the City of Clewiston or any loss incurred arising out of the applicant's activity whether or not the same extends beyond the permitted type or locale of activity or occurs on a different date out of the applicant's activity whether or not the same extends beyond the permitted type or locale of activity or occurs on a different date than specified. The applicant further HOLDS HARMLESS, the City of Clewiston and its agents, from all liability or costs arising from any interaction or contact between the applicant and other applicants/activities taking place on municipal property, or arising from adjoining private property.
5. The applicant specifically agrees that this Indemnification and Hold Harmless Agreement shall include the responsibility to provide legal defense for the City of Clewiston for any suit arising out of the applicant's use of premises, and that should the applicant or the applicant's insurance carrier fail or refuse to provide such a defense, the applicant will reimburse the City of Clewiston for any costs incurred by it for any person or organization acting on its behalf.

CITY OF CLEWISTON PARKS & RECREATION DEPARTMENT



SUGARLAND PARK FIELD RESERVATION

6. The undersigned is authorized to execute this HOLD HARMLESS AGREEMENT as the binding act of the applicant.

X _____

Signature of Applicant

_____ Date

X _____

Signature of Witness

_____ Date

If you (the applicant) are a Corporation, Association or Company carrying Insurance, please complete the information below. The applicant has furnished the Certificate of Insurance described below as an additional inducement for the permission to use of the premises.

NAME OF INSURANCE CARRIER: _____

CERTIFICATE NUMBER: _____

LIMITS OF LIABILITY: Property Damage _____

Public Liability _____

A true copy of the Certificate of Insurance is attached. NOTE: Requires \$1,000,000 per loss liability insurance for Special Events, subject to review and approval by the City of Clewiston. The following additional documents form a part of the agreement:

- ✓ Rental Application Forms

CITY OF CLEWISTON PARKS & RECREATION DEPARTMENT



SUGARLAND PARK FIELD RESERVATION

Travel/Private Team Information (Please print all information)

Organization Name	Address	City/State/Zip
<hr/>		

Contact Person	Phone Number	Fax Number
<hr/>		

Description of Facility	Date Time *Attach schedule, if available
-------------------------	--

<p style="text-align: center;">Fees</p> <p>(ALL payments are due at time of booking. Make check payable to the City of Clewiston)</p>	Rental - \$100 per day/per field	\$ _____
	Light Fee - \$25 per hour	\$ _____
	Maintenance Fee - \$50 per day	\$ _____
	Sales Tax 7%	\$ _____
	Subtotal	\$ _____
	\$50 Security Deposit (Refundable)	\$ _____
	TOTAL	\$ _____

Team Insurance: Yes No Attach copy of Certificate of Insurance to this form.

All field use is by permit only unless an exception is made by the Director of Recreation & Leisure Services. Coaches are responsible for leaving fields, dugouts, and spectators' areas clean. Extra field maintenance for any play, tournament, or special event is considered a "billable" event. It is the responsibility of the user group to maintain a clean and safe concession. The Director of Recreation & Leisure Services is to be notified of all accidents/incidents requiring medical attention. Athletic fields can be used only when field conditions are deemed safe and when use will not create conditions which may cause damage to the fields. If field conditions change during the permit period, the Director of Recreation & Leisure Services reserves the right to close the fields. Security deposit is fully refundable upon cancellation or no damage to the fields.

AGREEMENT OF UNDERSTANDING

I understand the rules and policies of the City of Clewiston and agree to abide by the stated guidelines. I understand any non-compliance may result in the revocation of existing permits, the loss of permits in the future, and loss of security deposit. I also understand non-compliance may result in the revocation of field privileges and/or a fee assessment for damages.

<hr/> Signature of Organization Representative	<hr/> Organization
--	--------------------

<hr/> Date	<hr/> Director of Recreation & Leisure Services
------------	---

CITY OF CLEWISTON PARKS & RECREATION DEPARTMENT



SUGARLAND PARK FIELD RESERVATION

Field Playability, Rules and Regulations

The Park Personnel will decide if the field is playable. This person will use common sense and good judgment in the decision to play. The soil must be firm and free of obstacles that could cause personal injury or field damage before play begins. Water can be broom-dried to remove puddles from infield to expedite play.

- All persons, if given permission to use a field, will abide by all and any directives from the City of Clewiston & Parks and Recreation Personnel.
- All teams and individuals given permission to use a field assume all responsibilities in regards to injury and/or accident and all liabilities, as per insurance requirements listed on Page 1 & 3.
- Permits must be kept with team while using field at all times.
- Teams and individuals given permission to use a field must use the field assigned.
- No exchanging of field permits with another team or individual is allowed.

Rain-outs Rescheduling Procedures

If you are rained out on a given night, you must contact Parks & Recreation Department within 24 hours or the next business day in order to receive a rain-date. A failure to contact this office within the allotted time will result in forfeiture of the rain-date. Rain dates will be scheduled on the same day of the week and the same time period, as your regularly scheduled play dates, unless a mutually agreed upon time and date is reserved. It will be added to your schedules accordingly. All attempts to schedule your rain-date for the earliest possible time will be made.

Parking

All parking must be in designated areas. No vehicles are permitted to park on grassy areas, behind backstops or along the side of fields. Any vehicle parked illegally will be tagged and/or towed at the discretion of the City Police Department.

By signing below, I agree to comply with the above stated rules and regulations concerning the use of the Ball Park Fields.

Signature: _____

Date: _____

CITY OF CLEWISTON PARKS & RECREATION DEPARTMENT



SUGARLAND PARK FIELD RESERVATION

HOLD HARMLESS AGREEMENT

(Please type or print)

BETWEEN THE CITY OF CLEWISTON, FLORIDA AND _____
(Applicant)

WITNESSETH:

1. In consideration of permission to use the public facility described below on the ____ day of, _____ 20 ____, the application does hereby covenant and agree to save and hold the City of Clewiston, its agents, servants and employees harmless from any and all liabilities of costs arising out of the described premises by the applicant, the applicant's invitees or other persons.
2. The facilities will be used for the following purpose and no other _____.
Number of persons expected to attend: _____
3. The applicant is: (check one) _____ An Individual _____ Non-profit Organization
_____ A Profit Organization _____ Other (describe) _____.

If applicant is an Association or Corporation, the undersigned certifies that the execution of the HOLD HARMLESS AGREEMENT has been duly authorized.

4. The applicant acknowledges that the permission to utilize the facilities is limited to the portion of the premises herein described (if applicable) and the permission to use the facility is valid only for the activity herein described. Notwithstanding the foregoing, however, this HOLD HARMLESS AGREEMENT shall be applicable to any claim asserted against the City of Clewiston or any loss incurred arising out of the applicant's activity whether or not the same extends beyond the permitted type or locale of activity or occurs on a different date out of the applicant's activity whether or not the same extends beyond the permitted type or locale of activity or occurs on a different date than specified. The applicant further HOLDS HARMLESS, the City of Clewiston and its agents, from all liability or costs arising from any interaction or contact between the applicant and other applicants/activities taking place on municipal property, or arising from adjoining private property.
5. The applicant specifically agrees that this Indemnification and Hold Harmless Agreement shall include the responsibility to provide legal defense for the City of Clewiston for any suit arising out of the applicant's use of premises, and that should the applicant or the applicant's insurance carrier fail or refuse to provide such a defense, the applicant will reimburse the City of Clewiston for any costs incurred by it for any person or organization acting on its behalf.

CITY OF CLEWISTON PARKS & RECREATION DEPARTMENT



SUGARLAND PARK FIELD RESERVATION

6. The undersigned is authorized to execute this HOLD HARMLESS AGREEMENT as the binding act of the applicant.

X _____

Signature of Applicant

Date

X _____

Signature of Witness

Date

If you (the applicant) are a Corporation, Association or Company carrying Insurance, please complete the information below. The applicant has furnished the Certificate of Insurance described below as an additional inducement for the permission to use of the premises.

NAME OF INSURANCE CARRIER: _____

CERTIFICATE NUMBER: _____

LIMITS OF LIABILITY: Property Damage _____

Public Liability _____

A true copy of the Certificate of Insurance is attached. NOTE: Requires \$1,000,000 per loss liability insurance for Special Events, subject to review and approval by the City of Clewiston. The following additional documents form a part of the agreement:

- ✓ Rental Application Forms

Evolve®



CUSTOMER NAME _____

PROJECT NAME _____

DATE _____ TYPE 57,186.-

CATALOG NUMBER _____

ESPL Series Need 54 @ \$1,059.- each

Sports Lighter LED Floodlight

- The Evolve ESPL LED sports lighter is designed to replace legacy 1500W HID systems one-for-one, with better uniformity and superior lumen maintenance, providing over 50% energy savings with improved light levels
- Ideal for municipal sports fields, large area lighting, and other applications requiring high light levels
- Superior efficacy ranging from 135 to 153 LPW
- Available in three beam spreads - NEMA 3x3, 4x4, 5x5

CONSTRUCTION

- Housing:** Die Cast Aluminum Housing
- Lens:** UV Stabilized polycarbonate outer lens protects LED's
- Paint:** Light Gray
- Weight:** 54.4lbs. (24.7kg)

OPTICAL SYSTEM

- Lumens:** 99,500 - 113,000
- Distribution:** NEMA 3x3, 4x4, 5x5
- Efficacy:** 135-153 LPW
- CCT:** 4000K
- CRI (Min):** 70

ELECTRICAL

- Input Voltage:** 120-277V, 277-480V
- Input Frequency:** 50/60Hz
- Power Factor:** 90%
- Total Harmonic Distortion:** >20%
- Cord:** SOOW Cord is 30 inches long with five 18AWG conductors (line, neutral, ground, dim+ and dim-)

SURGE PROTECTION*

*Per ANSI C136.2-2015

Standard

6kA

WARRANTY

5 Year (Standard)

LUMEN MAINTENANCE

Projected Lxx per IES TM-21 at 25°C

SKU	LXX 10K @ HOURS		
	25,000 HR	50,000 HR	100,000 HR
ESPL	L96	L91	L81

Note: Projected LXX based on LM80 (> 10,000 hour testing). Accepted industry tolerances apply to initial luminous flux and lumen maintenance measurements.

AMBIENT TEMPERATURE FACTOR

AMBIENT TEMP °C

-40°C to 40°C

RATINGS

Operating Temperature: -40°C to 40°C

Vibration: 3G Vibration Rating

CONTROLS

Dimming: 0-10V Dimming Driver available for use with control devices (provided by others). Dimming leads contained in driver housing.

CUSTOMER NAME _____
 PROJECT NAME _____
 DATE _____ TYPE _____
 CATALOG NUMBER _____

E S P L 01 10 7 40 S N T1 GRAY

PROD. ID	GEN	VOLTAGE	LUMEN OUTPUT	DIST.	CRI	CCT	DIMMING	CONTROLS	MOUNTING	COLOR
E = Evolve	01 = 1st Gen	0 = 120-277V	10 = 100,000	33 = NEMA 3x3	7 = 70	40 = 4000K	S = 0-10V dimming (leads in driver housing)	N = No Control	T1 = Trunnion	GRAY = Light Gray
SP = Sports		E = 277-480V		44 = NEMA 4x4						
L = Light				55 = NEMA 5x5						

ACCESSORIES

CATALOG 93 NUMBER	CATALOG NUMBER	DESCRIPTION
93157414	VISOR-TSL SINGLE PACK	Single Visor for field installation
93147872	VISOR-TSL 10 PACK	Visor 10 pack for field installation
4024SLS	4024SLS	Laser Aiming Device. Only one needed per job
LASER-TSL	LASER-TSL AIMING GUIDE	Slipfitter for 2" (2 3/8" OD) tenon for integral luminaires

ELECTRICAL DATA		
NOMINAL WATTAGE	INPUT VOLTAGE V	OPERATING CURRENT AMPS
720W	120	6.0
	240	3.0
	277	2.6
	347	2.2
	480	1.6

BEAM	OUTPUT LUMENS
NEMA 3x3	99,500
NEMA 4x4	108,000
NEMA 5x5	113,000

CUSTOMER NAME _____

PROJECT NAME _____

DATE _____ TYPE _____

CATALOG NUMBER _____

ESPL 01 0 33 70 40
NEMA 3x3

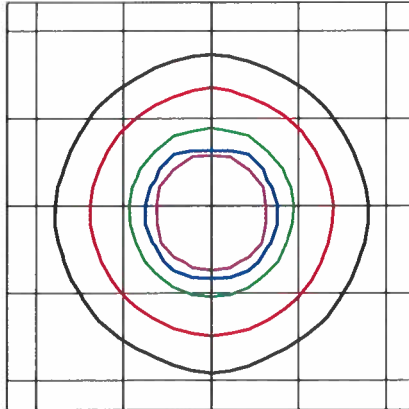

Beam Pattern: NEMA 3x3, Beam Angle: 19° x 19° Mounting Height: 60ft

ESPL 01 0 44 70 40
NEMA 4x4

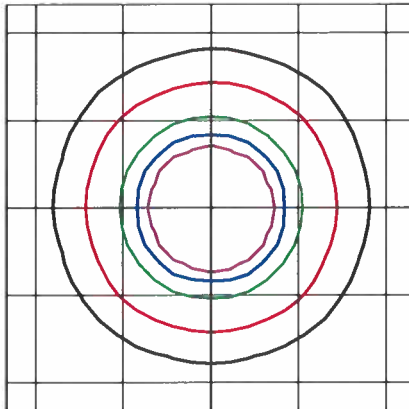

Beam Pattern: NEMA 4x4, Beam Angle: 30° x 30° Mounting Height: 60ft

ESPL 01 0 55 70 40
NEMA 5x5

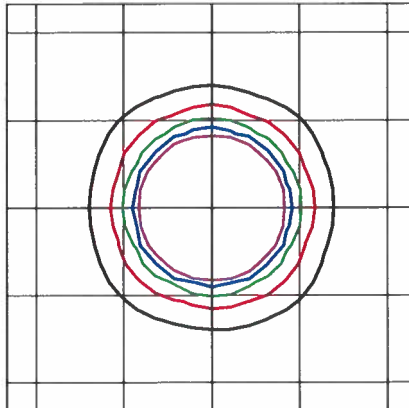

Beam Pattern: NEMA 5x5, Beam Angle: 56° x 56° Mounting Height: 60ft

CUSTOMER NAME _____
 PROJECT NAME _____
 DATE _____ TYPE _____
 CATALOG NUMBER _____

Dimensions

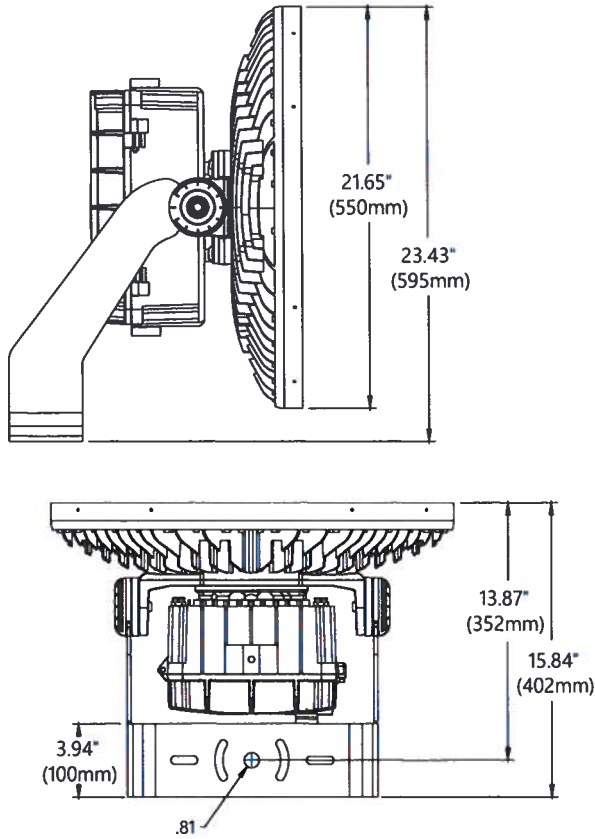

EPA	
90°	40° (downward)
3.1 EPA	2.5 EPA

VISOR

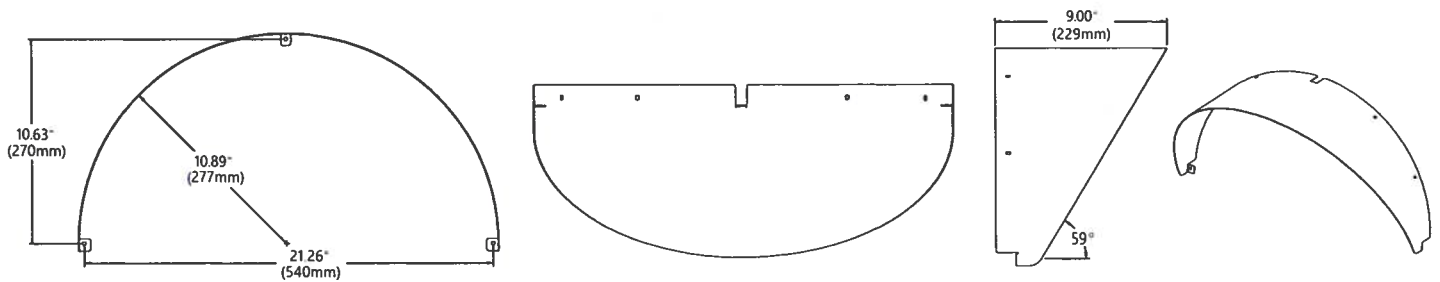

LASER AIMING

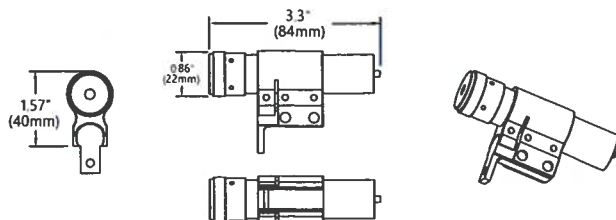



BUDGETARY ONLY

Project Name: Sugarland Park
Project City, State: Clewiston, FL

Issued On: 2/6/2026
Expires On: 4/6/2026

Field and Design Specifications

- Sugarcane Field (320'/360'/320'), 50/30 light levels per High School Standards
- (2) 300' Softball Fields, 50/30 light levels

System Description – Lumasport System – Fixture Retrofit

Sugarcane Field

- (~56) Ephesus Lumasport 8 680W light fixtures
- Aiming Diagrams, aiming laser included
- 10 year parts warranty reference version 04092020

\$91,666.67

- Ephesus AirMesh hub including 5 pre-programmed dynamic lighting scenes and 10 year remote access/cloud control plan via app

\$20,000.00

300' Fields

- (~38) Ephesus Lumasport 8 680W light fixtures per field
- Aiming Diagrams, aiming laser included
- 10 year parts warranty reference version 04092020

\$124,444.44

- Ephesus AirMesh hub including 5 pre-programmed dynamic lighting scenes

\$20,000.00

Scope of Services

Ephesus Responsibilities

- Provide required fixtures, new power whips from fixture to cross-arm, and wireless control system.
- Provide design layout, aiming diagrams, and remote installation assistance.
- Remotely commission controls (with subcontractor assistance) and train staff.

Terms and Conditions

- Prices are in US dollars
- Customer shall pay all taxes, duties, levies, or fees
- Payment terms are subject to credit approval
- Standard Incoterms of FOB Origin will apply
- This estimate is non-contractual
- Existing poles and cross-arms are to be reused and are assumed to be in good, working condition. Ephesus does not take responsibility for existing poles and cross-arms, their structural integrity, or any structural certifications.
- Leadtime for product to be determined at time of official quote
- Third party vendors extend their respective warranties, terms & conditions and exclusions apply
- Estimate assumes that lighting circuit voltages are within 3% of nominal. Any sag or surge outside of that voltage range must be corrected before fixtures are installed.
- Estimate assumes existing electrical distribution system is properly grounded/bonded in accordance with NEC (NFPA 70) and for electronics as specified in IEEE Emerald Book
- Metallic conduits are not acceptable grounding methods for LED lighting systems. Improper grounding may affect fixture warranty.
- Budget is subject to change based on design revisions and/or technical scope review.
- Cooper Lighting LLC reserves the right to take exception to any specification, drawing, or detail that has not been communicated through the RFP. Purchaser assumes all liability for specification, drawing, or detail not communicated at time of quotation.
- Budget assumes standard transportation methods and carriers are used.
- Reference Cooper Lighting's terms and conditions on our website for all product freight line allowances. All other standard terms and conditions apply – see website for details.



BUDGETARY ONLY

Project Name: Sugarland Park
Project City, State: Clewiston, FL

Issued On: 2/6/2026
Expires On: 4/6/2026

Field and Design Specifications

- Sugarcane Field (320'/360'/320'), 50/30 light levels per High School Standards
- (2) 300' Softball Fields, 50/30 light levels

System Description – Lumasport System – Remote Power Supply – New Poles

Sugarcane Field

- (~56) Ephesus Lumasport 8 680W light fixtures
- (6 – 70') Pre-wired concrete encased sectional steel poles
- Pre-wired remote power supply enclosures
- Pre-wired fused disconnect enclosures
- Pole length wire harnesses
- Aiming Diagrams, aiming laser included
- 10 year product warranty
- Existing pole removal, new pole install, aiming, and wiring from top to bottom

\$327,777.78

- Ephesus AirMesh hub including 5 pre-programmed dynamic lighting scenes and 10 year remote access/cloud control plan via app

\$20,000.00

300' Fields

- (~38) Ephesus Lumasport 8 680W light fixtures per field
- (10 – 70') Pre-wired concrete encased sectional steel poles
- Pre-wired remote power supply enclosures
- Pre-wired fused disconnect enclosures
- Pole length wire harnesses
- Aiming Diagrams, aiming laser included
- 10 year product warranty
- Existing pole removal, new pole install, aiming, and wiring from top to bottom

\$488,888.89

- Ephesus AirMesh hub including 5 pre-programmed dynamic lighting scenes and 10 year remote access/cloud control plan via app

\$20,000.00

Scope of Services

Customer Responsibilities

General:

- Complete access to the site for construction using standard 2 wheel drive rubber tire equipment
- Locate existing underground utilities not covered by local utilities, i.e. water lines, electrical lines, irrigation systems, and sprinkler heads. Ephesus or Ephesus' subcontractor will not be responsible for repairs to unmarked utilities.
- Locate and mark field reference points per Ephesus supplied layout. (i.e. home plate, center of FB/SO field)
- Mark and confirm pole locations per the aiming/installation diagram provided. If there are any issues or changes immediately notify Ephesus project manager.
- Pay for extra costs associated with foundation excavation in non-standard soils (rock, caliche, high water table, collapsing holes, etc). Standard soils are defined as soils that can be excavated using standard earth auguring equipment.
- Customer responsible for any necessary power company fees and requirements.
- Customer responsible for all permitting fees. Subcontractor will obtain the required permitting.
- Provide any existing as-built documents or drawings (if available).
- Provide area on site for disposal of spoils from foundation excavation
- Provide area on site for pole lay down, dumpsters, etc.

Electrical:

- Provide labor, equipment, and materials to extend existing conduit and wire to new pole locations.
- Wiring to poles shall be terminated at the Ephesus disconnect enclosure.
- Provide as-built drawings on completion of installation (if required).
- Provide dedicated 120V circuit to Ephesus AirMesh hub at owner designated location.
- Mount and power up Ephesus AirMesh hub.

Ephesus Responsibilities

- Provide required fixtures, cross-arm assemblies, poles, wire harnesses, disconnect enclosures, and control system.
- Provide design layout, aiming diagrams, and remote installation assistance.
- Provide sign and sealed foundation designs based on standard soils or based on owner provided Geotech report (if available).
- Remotely commission controls (with subcontractor assistance) and train staff.
- Assist our installing subcontractor and ensure our responsibilities are satisfied.

Ephesus Subcontractor Responsibilities

General:

- Provide equipment and materials to off load equipment at jobsite and/or subcontractor's facility per scheduled delivery.
- Provide on-site storage containers and adequate security to protect Ephesus products from theft, vandalism, or damage during installation (if necessary)
- Obtain any required permitting
- Provide necessary waste disposal and daily cleanup
- Confirm existing underground utilities and irrigation systems have been located and are clearly marked so as to avoid damage from construction equipment. Repair any such damage during construction.
- Keep all heavy equipment off playing fields when possible. Repair damage to grounds

which exceeds that which would be expected. Indentations caused by heavy equipment traveling over dry ground would be an example of expected damage. Ruts and sod damage caused by equipment traveling over wet grounds would be an example of damage requiring repair.

- Provide startup and aiming as required to provide complete and operating sports lighting system.
- Remove and dispose of existing lighting equipment. This will include recycling of lamps, aluminum reflectors, ballast, and steel as necessary. Existing concrete poles to be demo'd and laid down on-site.

Foundations, Poles, and Light Fixtures:

- Provide labor, materials, and equipment to install Ephesus provided poles and light fixtures specified on layout and per the sign and sealed foundation designs.
- Provide labor, materials, and equipment to install Ephesus provided wire harness and fused disconnect enclosure on each pole, aim light fixtures per provided diagram, and make all electrical connections and top of pole and into disconnect enclosure.
- Upon mounting of light fixtures to cross-arms remove two MAC address stickers (one will be permanent on the fixture, remove the other 2) from driver enclosure. Sticker to be affixed to installation drawing or provided tracking sheet to assist in remote controls commissioning.
- Place spoils to owner designated location on site.

Terms and Conditions

- Prices are in US dollars
- Customer shall pay all taxes, duties, levies, or fees
- Payment terms are subject to credit approval
- Standard Incoterms of FOB Origin will apply
- This estimate is non-contractual
- Leadtime for product to be determined at time of official quote
- Third party vendors extend their respective warranties, terms & conditions and exclusions apply
- Estimate assumes that lighting circuit voltages are within 3% of nominal. Any sag or surge outside of that voltage range must be corrected before fixtures are installed.
- Estimate assumes existing electrical distribution system is properly grounded/bonded in accordance with NEC (NFPA 70) and for electronics as specified in IEEE Emerald Book
- Metallic conduits are not acceptable grounding methods for LED lighting systems. Improper grounding may affect fixture warranty.
- Budget is subject to change based on design revisions and/or technical scope review.
- Cooper Lighting LLC reserves the right to take exception to any specification, drawing, or detail that has not been communicated through the RFP. Purchaser assumes all liability for specification, drawing, or detail not communicated at time of quotation.
- Budget assumes standard transportation methods and carriers are used.
- Reference Cooper Lighting's terms and conditions on our website for all product freight line allowances. All other standard terms and conditions apply – see website for details.

