



CITY COUNCIL REGULAR MEETING

Clearlake City Hall Council Chambers

14050 Olympic Dr, Clearlake, CA

Thursday, June 15, 2023

Budget Workshop 5:00 PM

Regular Meeting 6:00 PM

The City Council meetings are viewable in person in the Council Chambers, via livestreaming on the City's YouTube Channel (https://www.youtube.com/channel/UCTyifT_nKS-3woxEu1ilBXA) or "Lake County PEG TV Live Stream" at <https://www.youtube.com/user/LakeCountyPegTV/featured> and the public may participate through Zoom at the link listed below. The public can submit comments and questions in writing for City Council consideration by sending them to the Administrative Services Director/City Clerk at mswanson@clearlake.ca.us. To give the City Council adequate time to review your questions and comments, please submit your written comments prior to 4:00 p.m. on the day of the meeting.

AGENDA

MEETING PROCEDURES: *All items on agenda will be open for public comments before final action is taken. Citizens wishing to introduce written material into the record at the public meeting on any item are requested to provide a copy of the written material to the Administrative Services Director/City Clerk prior to the meeting date so that the material may be distributed to the City Council prior to the meeting. Speakers must restrict comments to the item as it appears on the agenda and stay within a three minutes time limit. The Mayor has the discretion of limiting the total discussion time for an item.*

AMERICANS WITH DISABILITY ACT (ADA) REQUESTS

If you need disability related modification, including auxiliary aids or services, to participate in this meeting, please contact Melissa Swanson, Administrative Services Director/City Clerk at the Clearlake City Hall, 14050 Olympic Drive, Clearlake, California 95422, phone (707) 994-8201, ext 106, or via email at mswanson@clearlake.ca.us at least 72 hours prior to the meeting, to allow time to provide for special accommodations.

AGENDA REPORTS

Staff reports for each agenda item are available for review at www.clearlake.ca.us. Any writings or documents pertaining to an open session item provided to a majority of the City Council less than 72 hours prior to the meeting, shall be made available for public inspection on the City's website at www.clearlake.ca.us.

Zoom Link: <https://clearlakeca.zoom.us/j/81575241629>

Join from a PC, Mac, iPad, iPhone or Android device:

Please click this URL to join. <https://clearlakeca.zoom.us/j/81575241629>

Or One tap mobile:

+16694449171,,81575241629# US

+12532158782,,81575241629# US (Tacoma)

Or join by phone:

Dial (for higher quality, dial a number based on your current location):

US: +1 669 444 9171 or +1 253 215 8782 or +1 346 248 7799 or +1 719 359 4580 or +1 720 707 2699 or +1 253 205 0468 or +1 646 931 3860 or +1 689 278 1000 or +1 301 715 8592 or +1 305 224 1968 or +1 309 205 3325 or +1 312 626 6799 or +1 360 209 5623 or +1 386 347 5053 or +1 507 473 4847 or +1 564 217 2000 or +1 646 558 8656

Webinar ID: 815 7524 1629

International numbers available: <https://clearlakeca.zoom.us/j/81575241629>

5:00 PM

A. ROLL CALL

B. FY 2023/24 BUDGET WORKSHOP

6:00 PM REGULAR MEETING

C. PLEDGE OF ALLEGIANCE

D. INVOCATION/MOMENT OF SILENCE: *The City Council invites members of the clergy, as well as interested members of the public in the City of Clearlake, to voluntarily offer an invocation before the beginning of its meetings for the benefit and blessing of the City Council. This opportunity is voluntary and invocations are to be less than three minutes, offered in a solemn and respectful tone, and directed at the City Council. Invocational speakers who do not abide by these simple rules of respect and brevity shall be given a warning and/or not invited back to provide a subsequent invocation for a reasonable period of time, as determined appropriate by the City. This policy is not intended, and shall not be implemented or construed in any way, to affiliate the City Council with, nor express the City Council's preference for, any faith or religious denomination. Rather, this policy is intended to acknowledge and express the City Council's respect for the diversity of religious denominations and faith represented and practiced among the citizens of Clearlake. If a scheduled invocational speaker does not appear at the scheduled meeting, the Mayor will ask that the City Council observe a moment of silence in lieu of the invocation. More information about the City's invocation policy is available upon request by contacting the Administrative Services Director/City Clerk at (707) 994-8201x106 or via email at mswanson@clearlake.ca.us.*

E. ADOPTION OF THE AGENDA *(This is the time for agenda modifications.)*

F. PRESENTATIONS

1. Presentation of June's Adoptable Dogs

G. PUBLIC COMMENT: *This is the time for any member of the public to address the City Council on any matter not on the agenda that is within the subject matter jurisdiction of the City. **The Brown Act, with limited exceptions, does not allow the Council or staff to discuss issues brought forth under Public Comment.** The Council cannot take action on non-agenda items. Concerns may be referred to staff or placed on the next available agenda. Please note that comments from the public will also be taken on each agenda item. Comments shall be limited to three (3) minutes per person.*

H. CONSENT AGENDA: *All items listed under the Consent Agenda are considered to be routine in nature and will be approved by one motion. There will be no separate discussion of these items unless a member of the Council requests otherwise, or if staff has requested a change under Adoption of the Agenda, in which case the item will be removed for separate consideration. Any item so removed will be taken up following the motion to approve the Consent Agenda.*

2. Warrants

Recommended Action: Receive and file

3. Approval of an Amendment to the Agreement with Operating Engineers Public and Miscellaneous Employees Health and Welfare Trust Fund

Recommended Action: Approve the amendment to the agreement and authorize the City Manager to sign

4. Minutes of the May 10, 2023 Lake County Vector Control District Board Meeting

Recommended Action: Review and file

I. PUBLIC HEARING

5. Public Hearing to Consider the Appeal of the Planning Commission's decision of April 25th, 2023, for the approval of the Environmental Analysis (CEQA IS 2022-05) in accordance with the California Environmental Quality Act and Conditional Use Permit (CUP 2022-16) for the Burns Valley Development Project located at 14885 Burns Valley Road, Clearlake, CA 95422 further described as Assessor's Parcel Number 010-026-40 (Continued from June 1st, 2023 and June 7th, 2023)

Recommendation: Move to Adopt Resolution 2023-03, A Resolution of the City Council of the City of Clearlake denying Appeal Application, APCC 2023-01 and upholding the Planning decisions of April 25th, 2023, approving the referenced projects

6. Adoption of the City of Clearlake's Budget for Fiscal Year 2023-24

Recommended Action: Adopt Resolution No 2023-27

7. Adoption of Appropriations Limit (Gann Limit) for FY 2023-24 and designating the formula to be used for calculation of same

Recommended Action: Adopt Resolution No. 2023-28

8. Adoption of the City of Clearlake's Fee Schedule

Recommended Action: Adopt Resolution No. 2023-29

J. BUSINESS

9. Consideration of Memorandum of Understanding between the City of Clearlake and Clearlake Middle Management Association from July 1, 2023 to June 30, 2024.

Recommended Action: Approve MOU and Authorize the City Manager to sign.

10. Award of contract to Case Excavating in the amount of \$113,800.00 for demolition of structure(s) and abatement of properties located at 3191 6th Street, 3662 Cottonwood Street, 16272 32nd Avenue, 14870 Clement Drive, 3556 Madrone Street, 14081 Woodland Drive,

3628 Johnson Avenue, 16052 19th Avenue, 3287 3rd Street and 15582 Sharpe Lane Clearlake, CA 95422.

K. CITY MANAGER AND COUNCILMEMBER REPORTS

L. FUTURE AGENDA ITEMS

M. CLOSED SESSION

(11) Liability Claims Pursuant to Government Code Section 54961: Claimant: Joseph Barrios; Agency Claimed Against: City of Clearlake

(12) Conference with Legal Counsel: Existing Litigation: Pursuant to Government Code Section 54956.9(d)(1): Case No. CV-423786; Koi Nation of Northern California v. City of Clearlake, et al., Lake County Superior Court

N. ANNOUNCEMENT OF ACTION FROM CLOSED SESSION

O. ADJOURNMENT

POSTED: June 9, 2023

BY:



Melissa Swanson, Administrative Services Director/City Clerk



Clearlake, CA

By Check Number

Vendor Number	Vendor Name	Payment Date	Payment Type	Discount Amount	Payment Amount	Number
Bank Code: AP-Accounts Payable						
VEN01085	ACC BUSINESS	06/07/2023	Regular	0.00	608.66	14822
000703	ACME RIGGING & SUPPLY	06/07/2023	Regular	0.00	51.93	14823
000591	ACTION SANITARY	06/07/2023	Regular	0.00	143.55	14824
VEN01168	ADAM J GIORDANO	06/07/2023	Regular	0.00	400.00	14825
002131	AIRCON ENERGY INC	06/07/2023	Regular	0.00	7,339.28	14826
001897	AIRMEDCARE NETWORK	06/07/2023	Regular	0.00	48.00	14827
002353	ALL IN ONE AUTO	06/07/2023	Regular	0.00	10,300.00	14828
000085	ARAMARK UNIFORM SERVICES	06/07/2023	Regular	0.00	98.62	14829
001397	AT&T CALNET 3	06/07/2023	Regular	0.00	115.33	14830
001397	AT&T CALNET 3	06/07/2023	Regular	0.00	606.30	14831
001397	AT&T CALNET 3	06/07/2023	Regular	0.00	331.11	14832
001397	AT&T CALNET 3	06/07/2023	Regular	0.00	59.82	14833
001397	AT&T CALNET 3	06/07/2023	Regular	0.00	201.61	14834
001397	AT&T CALNET 3	06/07/2023	Regular	0.00	24.22	14835
001397	AT&T CALNET 3	06/07/2023	Regular	0.00	24.81	14836
001397	AT&T CALNET 3	06/07/2023	Regular	0.00	24.29	14837
VEN01057	BASIC PACIFIC	06/07/2023	Regular	0.00	452.37	14838
000068	BOB'S JANITORIAL	06/07/2023	Regular	0.00	167.48	14839
002060	CALPELRA	06/07/2023	Regular	0.00	650.00	14840
2404	CALTRONICS	06/07/2023	Regular	0.00	868.76	14841
VEN01393	CHRISTOPHER WILLIAM INGLIS	06/07/2023	Regular	0.00	75.00	14842
002295	CI TECHNOLOGIES INC	06/07/2023	Regular	0.00	3,366.00	14843
001645	CIVIC PLUS	06/07/2023	Regular	0.00	8,681.75	14844
000024	CLEARLAKE POLICE ASSOCIATION	06/07/2023	Regular	0.00	1,752.00	14845
000548	COMPUTER LOGISTICS	06/07/2023	Regular	0.00	3,171.04	14846
001698	CPCA	06/07/2023	Regular	0.00	617.00	14847
001744	DC ELECTRIC	06/07/2023	Regular	0.00	59,715.00	14848
002392	DE LAGE LANDEN PUBLIC FINANCE	06/07/2023	Regular	0.00	829.68	14849
000774	DEEP VALLEY SECURITY	06/07/2023	Regular	0.00	390.50	14850
000073	EASTLAKE SANITARY LANDFILL	06/07/2023	Regular	0.00	98.52	14851
000851	ENTERPRISE TOWING	06/07/2023	Regular	0.00	197.00	14852
000633	ESRI, INC	06/07/2023	Regular	0.00	4,285.00	14853
001199	EUREKA OXYGEN CO	06/07/2023	Regular	0.00	85.98	14854
VEN01108	FAWN CHRISTINE WILLIAMS	06/07/2023	Regular	0.00	75.00	14855
VEN01053	HIGH COUNTRY SECURITY	06/07/2023	Regular	0.00	7,153.33	14856
000121	HIGHLANDS WATER COMPANY	06/07/2023	Regular	0.00	98.50	14857
000121	HIGHLANDS WATER COMPANY	06/07/2023	Regular	0.00	57.34	14858
000121	HIGHLANDS WATER COMPANY	06/07/2023	Regular	0.00	81.76	14859
000121	HIGHLANDS WATER COMPANY	06/07/2023	Regular	0.00	276.10	14860
000121	HIGHLANDS WATER COMPANY	06/07/2023	Regular	0.00	282.91	14861
000121	HIGHLANDS WATER COMPANY	06/07/2023	Regular	0.00	138.00	14862
000121	HIGHLANDS WATER COMPANY	06/07/2023	Regular	0.00	57.52	14863
000121	HIGHLANDS WATER COMPANY	06/07/2023	Regular	0.00	21.00	14864
001949	ICE WATER DISTRIBUTORS INC	06/07/2023	Regular	0.00	67.50	14865
001866	LACO ASSOCIATES	06/07/2023	Regular	0.00	262.50	14866
000108	LAKE COUNTY RECORD BEE	06/07/2023	Regular	0.00	397.02	14867
001995	LANGUAGE TESTING INTERNATIONAL	06/07/2023	Regular	0.00	438.00	14868
000277	LAYNE PAVING	06/07/2023	Regular	0.00	587.26	14869
VEN01123	LOOMIS	06/07/2023	Regular	0.00	583.48	14870
001434	LYN DISTRIBUTING	06/07/2023	Regular	0.00	1,074.82	14871
002176	MANAGEMENT CONNECTIONS	06/07/2023	Regular	0.00	1,131.38	14872
000793	MEDIACOM	06/07/2023	Regular	0.00	650.00	14873
VEN01344	MICHAEL PESONEN - COMFORTABLE	06/07/2023	Regular	0.00	1,625.00	14874
001489	NAPA AUTO PARTS	06/07/2023	Regular	0.00	264.10	14875

Check Register

Vendor Number	Vendor Name	Payment Date	Payment Type	Discount Amount	Payment Amount	Number
000026	NATIONWIDE RETIREMENT SOLUTIO	06/07/2023	Regular	0.00	1,193.04	14876
001392	OFFICE DEPOT	06/07/2023	Regular	0.00	1,446.63	14877
000027	OPERATING ENGINEERS PUBLIC EMF	06/07/2023	Regular	0.00	78,243.00	14878
000387	PACE SUPPLY CORP	06/07/2023	Regular	0.00	487.17	14879
001286	PAPE MACHINERY	06/07/2023	Regular	0.00	32.32	14880
001536	PRECISION WIRELESS SERVICES	06/07/2023	Regular	0.00	500.00	14881
VEN01283	PROFORCE MARKETING, INC	06/07/2023	Regular	0.00	4,326.08	14882
002031	REDWOOD COAST PETROLEUM & N	06/07/2023	Regular	0.00	1,645.96	14883
002215	ROBERT COKER	06/07/2023	Regular	0.00	75.00	14884
001513	SAN DIEGO POLICE EQUIPMENT	06/07/2023	Regular	0.00	1,518.89	14885
VEN01222	TERRY LEE STEWART	06/07/2023	Regular	0.00	75.00	14886
002375	THOMAS DEWALT	06/07/2023	Regular	0.00	1,000.00	14887
001540	US BANK CORPORATE PMT. SYSTEM	06/07/2023	Regular	0.00	18,458.01	14888
	Void	06/07/2023	Regular	0.00	0.00	14889
	Void	06/07/2023	Regular	0.00	0.00	14890
	Void	06/07/2023	Regular	0.00	0.00	14891
	Void	06/07/2023	Regular	0.00	0.00	14892
	Void	06/07/2023	Regular	0.00	0.00	14893
	Void	06/07/2023	Regular	0.00	0.00	14894
	Void	06/07/2023	Regular	0.00	0.00	14895
000708	VALIC LOCKBOX	06/07/2023	Regular	0.00	445.00	14896
001723	VALLEY TOXICOLOGY SERVICE	06/07/2023	Regular	0.00	85.00	14897
002069	WATER'S EDGE CLEANERS	06/07/2023	Regular	0.00	178.00	14898
001214	WEST ALERT SECURITY SER INC	06/07/2023	Regular	0.00	200.00	14899
VEN01221	WINE COUNTRY VENTURES, INC	06/07/2023	Regular	0.00	1,190.00	14900
002191	ENTERPRISE FM TRUST	06/03/2023	Bank Draft	0.00	23,331.52	DFT0002199

Bank Code AP Summary

Payment Type	Payable Count	Payment Count	Discount	Payment
Regular Checks	213	72	0.00	232,202.23
Manual Checks	0	0	0.00	0.00
Voided Checks	0	7	0.00	0.00
Bank Drafts	1	1	0.00	23,331.52
EFT's	0	0	0.00	0.00
	214	80	0.00	255,533.75

Fund Summary

Fund	Name	Period	Amount
999	Pooled Cash	6/2023	255,533.75
			<hr/> 255,533.75

CITY OF CLEARLAKE

City Council



STAFF REPORT	
SUBJECT: Approval of an Amendment to the Agreement with Operating Engineers Public and Miscellaneous Employees Health and Welfare Trust Fund	MEETING DATE: June 1, 2023
SUBMITTED BY: Melissa Swanson, Administrative Services Director/City Clerk	
PURPOSE OF REPORT: <input type="checkbox"/> Information only <input type="checkbox"/> Discussion <input checked="" type="checkbox"/> Action Item	

WHAT IS BEING ASKED OF THE CITY COUNCIL/BOARD:

The City Council is being asked to approve an amendment to the agreement with Operating Engineers Public and Miscellaneous Employees Health and Welfare Trust Fund and authorize the City Manager to sign.

BACKGROUND/DISCUSSION:

The Operating Engineers Public and Miscellaneous Employees Health and Welfare Trust Fund has provided health benefits for City employees and Council Members for many years. During a recent review of the contract, it was determined that the City needed to amend the contract to memorialize coverage for non-represented employees and Council Members. While this coverage has been provided to non-represented employees and Council Members for decades, there is no formalized agreement for these services. Because of this, staff is recommending adoption of the Participation Agreement.

OPTIONS:

1. Move to approve the amendment to the agreement and authorize the City Manager to sign.
2. Other direction

FISCAL IMPACT:

None \$ Budgeted Item? Yes No

Budget Adjustment Needed? Yes No If yes, amount of appropriation increase: \$

Affected fund(s): General Fund Measure P Fund Measure V Fund Other:

Comments:

STRATEGIC PLAN IMPACT:

Goal #1: Make Clearlake a Visibly Cleaner City

- Goal #2: Make Clearlake a Statistically Safer City
- Goal #3: Improve the Quality of Life in Clearlake with Improved Public Facilities
- Goal #4: Improve the Image of Clearlake
- Goal #5: Ensure Fiscal Sustainability of City
- Goal #6: Update Policies and Procedures to Current Government Standards
- Goal #7: Support Economic Development

SUGGESTED MOTIONS:

Move to approve an amendment to the agreement with Operating Engineers Public and Miscellaneous Employees Health and Welfare Trust Fund.

- Attachments:**
 - 1) Participation Agreement
 - 2) Original Trust Agreement

+Participation Agreement
Operating Engineers Public and Miscellaneous Employees Health and Welfare Trust Fund

WHEREAS, City of Clearlake (hereinafter “Employer”) signatory hereto desires to be a contributing Employer in the Operating Engineers Public and Miscellaneous Employees Health and Welfare Fund (hereinafter “Trust Fund”);

WHEREAS, the Employer and Trust Fund hereby memorialize the Employer’s participation effective (Date);

THEREFORE, the Employer and Trust Fund hereby agree as follows:

- 1. The Employer has accepted and agreed to the terms and provisions of the Trust Agreement creating the Trust Fund, and agrees to pay the following monthly amounts established by the Board of Trustees effective November 1, 2022:

Anthem A	Single	\$1,029.00
(includes dental and vision)	Two-Party	\$2,057.00
	Family	\$2,777.00

Kaiser A	Single	\$947.00
(includes dental and vision)	Two-Party	\$1,894.00
	Family	\$2,470.00

as selected by and for each non-bargained Eligible Employee of the Employer as defined by this Agreement and to be bound by all the rules and regulations adopted by the Board of Trustees, as currently in effect and as may be amended by the Board of Trustees from time to time.

- 2. In the event that the Board of Trustees determine that the current contribution amount or the amount referred to in this Agreement is insufficient to provide the benefits then in effect, the Employer herein agrees to pay such further amount as may be necessary in the decision of the Trustees to maintain the then current level of benefits for the life of the Agreement as determined by the Board of Trustees
- 3. Eligible employees may enroll in the Employer’s medical, dental, and vision plan in accordance with Section 53201 through 53205 of the California Government Code. Eligible employees are current permanent full-time employees and eligible elected officials. Eligible elected officials are City Council Members while they are sworn in and presently hold office.
- 4. The Employer agrees that, as long as it is bound to this agreement, it will remit contributions on behalf of all Eligible Employees of the Employer,

5. The Employer further agrees that he or it does irrevocably designate and appoint the employers mentioned in said Trust Agreement document as his or its attorney in fact for the selection, removal and substitution of Trustees as provided for in such Trust Agreement as may be hereinafter provided or pursuant to said Trust Agreement,
6. The Employer agrees to submit contributions in a timely manner and agrees that it is bound to all delinquency provisions of the Trust Agreement and all procedures, policies, rules and regulations related thereto.
7. The Employer hereby acknowledges receipt of copies of the Summary Plan Description/Rules and Regulations, Trust Agreement, Collection Procedures and Mistaken Contribution Policy
8. This Agreement may be terminated by either the Fund or the Employer at any time by giving at least thirty (30) days advance written notice to the other party of such termination.

For Employer:

For Trust Fund

Participation Agreement

Operating Engineers Public and Miscellaneous Employees Health and Welfare Trust Fund

WHEREAS, City of Clearlake (hereinafter “Employer”) signatory hereto desires to be a contributing Employer in the Operating Engineers Public and Miscellaneous Employees Health and Welfare Fund (hereinafter “Trust Fund”);

WHEREAS, the Employer and Trust Fund hereby memorialize the Employer’s participation effective (Date);

THEREFORE, the Employer and Trust Fund hereby agree as follows:

1. The Employer has accepted and agreed to the terms and provisions of the Trust Agreement creating the Trust Fund, and agrees to pay the following monthly amounts established by the Board of Trustees effective November 1, 2022:

Anthem A	Single	\$1,029.00
(includes dental and vision)	Two-Party	\$2,057.00
	Family	\$2,777.00

Kaiser A	Single	\$947.00
(includes dental and vision)	Two-Party	\$1,894.00
	Family	\$2,470.00

as selected by and for each non-bargained Eligible Employee of the Employer as defined by this Agreement and to be bound by all the rules and regulations adopted by the Board of Trustees, as currently in effect and as may be amended by the Board of Trustees from time to time.

2. In the event that the Board of Trustees determine that the current contribution amount or the amount referred to in this Agreement is insufficient to provide the benefits then in effect, the Employer herein agrees to pay such further amount as may be necessary in the decision of the Trustees to maintain the then current level of benefits for the life of the Agreement as determined by the Board of Trustees
3. Eligible Employee is a permanent, full-time employee that is employed by the Employer,
4. The Employer agrees that, as long as it is bound to this agreement, it will remit contributions on behalf of all Eligible Employees of the Employer,
5. The Employer further agrees that he or it does irrevocably designate and appoint the employers mentioned in said Trust Agreement document as his or its attorney in fact for

the selection, removal and substitution of Trustees as provided for in such Trust Agreement as may be hereinafter provided or pursuant to said Trust Agreement,

6. The Employer agrees to submit contributions in a timely manner and agrees that it is bound to all delinquency provisions of the Trust Agreement and all procedures, policies, rules and regulations related thereto.
7. The Employer hereby acknowledges receipt of copies of the Summary Plan Description/Rules and Regulations, Trust Agreement, Collection Procedures and Mistaken Contribution Policy
8. This Agreement may be terminated by either the Fund or the Employer at any time by giving at least thirty (30) days advance written notice to the other party of such termination.

For Employer:

For Trust Fund

MINUTES OF PREVIOUS MEETING

May 10, 2023

Prior to the Board Meeting, starting at 11:00 A.M., an AB 1234 Ethics Training for Local Officials Webinar was held for the Trustees in the District Board Room. The training was open to the public.

The regular monthly meeting of the Board of Trustees of the Lake County Vector Control District was called to order at 1:30 P.M. by President Giambruno.

Board Present: Rob Bostock, Curt Giambruno, Ron Nagy, and George Spurr.

Absent: Chuck Leonard (excused).

District Personnel: Jamesina Scott, Ph.D., Manager and Research Director and Ms. Jacinda Franusich, Office Manager.

Guests: None

Citizen's Input: None.

Agenda additions/Deletions: None.

Approve Minutes of April 12, 2023 Regular Meeting

Mr. Nagy moved to approve the minutes of the April 12, 2023 Regular Meeting with a correction to the check numbers to include checks 21685-21701 in the amount of \$56,025.21 making the total expenditures for April \$112,007.86. Mr. Bostock seconded the motion. Motion carried unanimously.

Research Report for April 2023

Dr. Scott reported on arbovirus activity. No West Nile virus (WNV) activity has been reported in Lake County in 2023.

For the rest of California, two mosquito samples from Alameda and Los Angeles counties have tested positive for WNV in 2023. One dead bird from Santa Clara County has tested positive for WNV as well.

Dr. Scott reported on adult biting fly activity. Carbon dioxide-baited traps were set in Kelseyville, Lakeport, Lower Lake, and Upper Lake. Among the mosquito species collected were *Aedes sierrensis* and *Culiseta inornata*.

New Jersey light traps were set near Borax Lake and in the Reclamation in April. Among the mosquito species collected were *Culiseta incidens* and *Culiseta inornata*. In addition, biting black gnats were collected from the Borax Lake trap.

Dr. Scott reported on tick testing. Four *Ixodes pacificus* ticks that Lake County residents removed from themselves have been submitted to the Sonoma County Public Health Laboratory for testing for *Borrelia burgdorferi*. All the samples were negative.

Dr. Scott reported on Clear Lake Gnat, Chironominae, and Tanypodinae Surveillance in Clear Lake. Lake checks were not completed in April due to staff availability and weather.

Operation Report for April 2023

The rain gauge at the LCVCD office in Lakeport received 0.40 inches of rain in April. Total rainfall for the season is 35.02 inches.

On April 1, the level of Clear Lake was 8.04 feet on the Rumsey Gauge. The lake level was 7.63 feet by the end of April.

District Vector Control Technicians completed 108 service requests in April, with 96 requests received online.

During April, Vector Control Technicians Brad Hayes and Porter Anderson worked with Lake County Water Resources to minimize mosquito habitat in the Reclamation District near Upper Lake. The County provided equipment and an operator and District Vector Control Technicians found the problem sites and manually cleared some boxes and pulled boards to move the water along.

Vector Biologist Michelle Koschik will be the featured speaker at the Senior Day at Anderson Marsh State Historic Park on June 3.

On April 4, an article about mosquitoes appeared in the Lake County Record-Bee. The District's services were referenced in the article.

Dr. Scott has been working with Austris Rungis of Industrial Employers Distributors Association (IEDA) to finalize the Participation Agreement as stipulated by the Memorandum of Understanding (MOU) that the Board approved at the March 8, 2023 regular meeting. The trustees of the Operating Engineers Local 3 Health and Welfare Fund approved the Participation Agreement at their April 18 meeting. The Participation Agreement has been signed by all parties, and the process has begun to return District employees to regular health coverage.

Dr. Scott attended the Vector Control Joint Powers Agency (VCJPA) Board of Directors meeting in Sacramento. Dr. Scott serves as the VCJPA Alternate Representative to ERMA.

Dr. Scott attended two webinars offered through the California Special Districts Association (CSDA) on March 21, and March 28.

Dr. Scott participated in two CalSurv Gateway Training Webinars held on April 18 and 27.

Consideration of Resolution No. 23-01 A Resolution Establishing the 2023-2024 Proposition 4 Appropriations Limit

After some discussion, Mr. Bostock moved to approve Resolution 23-01 A Resolution Establishing the 2023-2024 Proposition 4 Appropriations Limit. Mr. Nagy seconded the motion. Motion carried by roll call vote as follows: 4 in favor (Mr. Bostock, Mr. Giambruno, Mr. Nagy, and Mr. Spurr), and 1 absent (Mr. Leonard).

Adopt a Proposed Lake County Vector Control District Budget for FY 2023-2024

After some discussion, Mr. Spurr moved to approve the Proposed Lake County Vector Control District Budget for FY 2023-2024. Mr. Nagy seconded to motion. Motion carried unanimously.

Approve Budget Transfers

Mr. Spurr moved to approve the budget transfer from 796.90-91 Contingencies, in the amount of \$2,500 to 796.22-70 Office Supplies in the amount of \$2,500. Mr. Nagy seconded the motion. Motion carried unanimously.

Approval of Checks for the Months of May 2023

Mr. Nagy moved to approve Check Nos. 21702-21745 for the month of May 2023 in the amount of \$43,282.43. Mr. Spurr seconded the motion. Motion carried unanimously.

Other Business

No Other Business was discussed.

Announcement of Next Regular Board Meeting

The next regular meeting of the Board of Trustees of the Lake County Vector Control District will be at 1:30 P.M. on June 14, 2023 in the LCVCD Board Room, 410 Esplanade, Lakeport, CA 95453.

Mr. Nagy moved to adjourn the meeting. Mr. Spurr seconded the motion. Motion carried unanimously. There being no other business the meeting was adjourned by President Giamb Bruno at 2:12 P.M.

Respectfully submitted,

Ronald Nagy
Secretary



STAFF REPORT	
SUBJECT: Appeal (APCC 2023-01) – KOI Nation of Northern California is appealing the Planning Commission’s decision of April 25 th , 2023 for the approval of the Burns Valley Development Project.	MEETING DATE: June 7th, 2023
SUBMITTED BY: Community Development Department – Planning	
PURPOSE OF REPORT: <input type="checkbox"/> Information only <input type="checkbox"/> Discussion <input checked="" type="checkbox"/> Action Item	

WHAT IS BEING ASKED OF THE CITY COUNCIL/BOARD:

The appellant, KOI Nation of Northern California is appealing the Planning Commission’s decision of April 25th, 2023, for the approval of the Environmental Analysis (CEQA IS 2022-05) in accordance with the California Environmental Quality Act and Conditional Use Permit (CUP 2022-16) for the Burns Valley Development Project located at 14885 Burns Valley Road, Clearlake, CA 95422 further described as Assessor’s Parcel Number 010-026-40.

BACKGROUND/DISCUSSION

The project parcel is approximately 25.46 acres in size and located in the Burns Valley Area, north of Olympic Drive and South of Burns Valley Drive, behind the Safeway Shopping Center. The Burns Valley Development Project includes but is not limited:

One full size baseball field	Multi-Sport Field (i.e., Soccer, etc.)	ADA Accessible Playground
One little league baseball field	Dugouts, Batting/Pitching area	Four Permeable Walkable Areas
One T-Ball Field	Fitness Equipment Area	Native Plant Demonstration Area
One Softball Field	Central Gathering/Picnic Areas	Recreation Facility

Recreation Facility: The project would involve the development of a 15,000 to 20,000 square foot recreation center building to be used for public events and activities. This building would contain sports features, such as basketball and volleyball courts.

Access/Parking: The project would be accessible from Olympic Drive and Burns Valley Road. There would be approximately 334 parking spaces throughout the development. Additional improvements would include sidewalks, fencing, lighting features, sport field protective netting and restroom facilities. All sport fields will include lighting to allow for night operations.

ENVIRONMENTAL DETERMINATION:

Pursuant to California Environmental Quality Act (CEQA) Guidelines, staff prepared an Initial Study (*Mitigated Negative Declaration based on Initial Study, IS 2022-05*) to assess the potential adverse environmental effects of the proposed Project. The study concludes that any potentially significant adverse environmental impacts from the project would be reduced to a level of non-significance with the incorporated Mitigation Measures and Conditions of Approval.

Additional mitigation measures have been added to reconfirm the protocols for avoidance and capping of the sensitive sites. These mitigation measures do not create new significant environmental effects and are not

necessary to mitigate an avoidable significant effect. Thus, pursuant to CEQA Guidelines Section 15073 Guidelines, recirculation of the MND is not required.

The Mitigated Negative Declaration based on Initial Study, IS 2022-05, were noticed and circulated in accordance with California Environmental Quality Act (CEQA), and in compliance with Section 15070-15075 of the CEQA State Guidelines, by:

- ❖ *Circulation of the Notice of Intent (NOI) for the environmental analysis/proposed Mitigated Negative Declaration (CEQA Initial Study, IS 2022-05) was published in the Lake County Record Bee and sent to the State Clearinghouse; Various Federal, State, and local agencies/organizations for the minimum of a 30-day commenting period from July 19th, 2022, through August 19th, 2022. The document was also uploaded onto the City's Website and made available upon request. The following agencies commented on the project during the appropriate review period.*
 - *Lake County Fire Protection District dated July 20th, 2022.*
 - *Lake County Environmental Health Department dated July 22nd, 2022.*
 - *California Department of Transportation dated August 2nd, 2022.*
 - *Requested a copy of the Traffic Analysis on August 2, 2022, and on August 4, 2022, a copy was emailed to Caltrans for their review. No further comments were received from Caltrans.*
 - *Lake County Special Districts dated August 9th, 2022.*
 - *Central Valley Regional Water Quality Control Board dated August 19th, 2022.*
 - *Koi Nation of Northern California dated September 2nd, 2022.*
- ❖ *A Notice of Intent (NOI) was mailed (via USPS) to the surrounding parcels owners within 300 feet of the subject property informing them of the City's decision to adopt a Mitigated Negative Declaration for the proposed use and that there is a 30-day commenting period on the environmental document from July 19th, 2022, through August 19th, 2022.*
 - *The city did not receive any comments from the public.*

TRIBAL CONSULTATION SUMMARY:

In receipt of the Koi Nation of Northern California comments dated September 2, 2023, the city met with tribal representatives on October 12th and 20th, 2022 and subsequently exchanged ideas, comments, and information. During the consultation process, the city revised the Mitigated Negative Declarations Tribal/Cultural Mitigation Measures, in coordination with the tribe. The revised Mitigation Measures are as follows:

- *TCR-1: Requirement to develop a tribal cultural resources preservation plan that delineates the boundary of CCL-21-01 and CCL-21-02, describes the appropriate combination of materials and culturally sterile fill in capping, provides landscaping specifications that favor culturally important plants, and restricts certain types of post-project activities in or on the cap.*
- *TCR-2: Requirement to designate a project reburial area in advance of ground disturbing activities in the event that materials are discovered during construction.*
- *TCR-3: Requirement for contractors to receive meaningful training on cultural sensitivity and tribal cultural resources from a tribal representative.*
- *TCR-4: Requirement for tribal monitoring during ground disturbing activities in sensitive areas of the project area.*
- *TCR-5: Procedures for compliance with existing state law in the event of the discovery of human remains during construction.*
- *TCR-6: A prohibition on the removal of cultural soils from the project area.*

The city has maintained consultation since September 2022, which resulted in significant modifications to the mitigation measures, and the design of the project was carried out in good faith with reasonable effort. As indicated in the letter dated March 21, 2023, to tribal representatives, the city formally concluded tribal consultation under CEQA and AB 52 per Section 21080.3.2(b)(2) of the Government Code.

OPTIONS:

1. Move to Adopt Resolution 2023-03, A Resolution of the City Council of the City of Clearlake deny Application, APCC 2023-01 and upholding the Planning decisions of April 25th, 2023, approving the referenced projects.
2. Move to Adopt Resolution 2023-03, A Resolution of the City Council of the City of Clearlake approving the Appeal Application, APCC 2023-01 and denying the referenced projects.
3. Move to continue the item and provide alternate direction to staff.

Attachments:

- 1) Resolution 2023- 03 with Conditions of Approval
- 2) Appeal Application Packet dated May 4th, 2023.
- 3) Staff Report Packet from April 25, 2023, PC Meeting
- 4) Proposed Concept Master Plan
- 5) Amended CEQA Initial Study, IS 2022-05 (Approved by PC)
- 6) CEQA Attachments "A through G"
- 7) Geotechnical Report
- 8) Agency Comments
- 9) Public Comment
- 10) Mitigation Monitoring Reporting Program (MMRP)
- 11) Tribal Consultation Conclusion Letter

RESOLUTION NO. 2023-03

A RESOLUTION OF THE CITY COUNCIL OF THE CITY OF CLEARLAKE, CALIFORNIA DENYING APPEAL APCC 2023-01 AND UPHOLDING THE PLANNING COMMISSION APPROVAL OF APRIL 25TH, 2023 ADOPTING MITIGATED NEGATIVE DECLARATION (BASED ON ENVIRONMENTAL ANALYSIS - INITIAL STUDY, IS 2022-05) AND CONDITIONAL USE PERMIT, CUP 2022-16 FOR THE DEVELOPMENT AND OPERATION OF THE BURNS VALLEY DEVELOPMENT PROJECT LOCATED AT 14885 BURNS VALLEY ROAD, CLEARLAKE, CALIFORNIA, APN: 010-026-40-000.

WHEREAS, City of Clearlake, California (*Owner/Developer/Operator*), applied for approval of a Mitigated Negative Declaration (Based on Environmental Analysis, IS 2022-05) and Conditional Use Permit (CUP 2022-16) for the development of the Burns Valley Development located at 14885 Burns Valley Road, further described as Assessor Parcel Number 010-048-40-000: and

WHEREAS, Appeal Application APCC 2023-01, KOI Nation of Northern California contesting the determination of the Planning Commission approval on April 25th, 2023 of a Mitigated Negative Declaration (Based on Environmental Analysis, IS 2022-05) and Conditional Use Permit (CUP 2022-16) has been processed in accordance with the City Municipal Codes/Regulations, and

WHEREAS, the land use zoning designation is “MUX” Mixed Use. As conditioned, the proposed use would be consistent with the allowable uses in the MUX Zoning Designation; and

WHEREAS, the General Plan Designates the project site as “MDR” Medium Density. As conditioned, the proposed use would be consistent with the General Plan; and

WHEREAS, the incorporated Mitigation Measures and Conditions of Approval, the project is found to comply with the Zoning Codes (*Refer to Enclosed Exhibit A*) and

WHEREAS, the Conditional Use Permit, CUP 2022-16 would allow Public Assemblies, Outdoor Recreation, and a Impound Yard, Pursuant to Section 18.18.030 of the City Municipal Code; and

WHEREAS, in accordance with Section 18.14.445 (b) of the Zoning Code the use as proposed will not be detrimental to the health, safety, convenience, or general welfare of persons residing or working in the vicinity, or injurious to the property, improvements or potential development in the vicinity with respect to aspects including, but not limited to, the following:

- (a) *The nature of the proposed site, including its size and shape, and the proposed size, shape, and arrangement of structures.*
- (b) *The accessibility and traffic patterns for persons and vehicles, the type and volume of such traffic and the adequacy of proposed off-street parking and loading.*
- (c) *The safeguards afforded to prevent noxious or offensive emissions such as noise, glare, dust and odor;*
- (d) *Treatment given, as appropriate, to such aspects as landscaping, screening, open spaces, parking areas, loading areas, service areas, lighting, and signs; and*

WHEREAS, the City has completed Tribal Consultation in accordance with CEQA and AB 52 and per Section 21080.3.2(b)(2), and formally concluded tribal consultation per Section 21080.3.2(b)(2) of the Government Code as indicated in the letter to tribal representative on March 21st, 2023, and

WHEREAS, the Mitigated Negative Declaration (Initial Study, IS 2022-05) and Conditional Use Permit, CUP 2022-16 has been processed in accordance with the City’s Environmental Review Guidelines; and

WHEREAS, the project underwent environmental review (Initial Study, IS 2022-05) subject to the California State Environmental Quality Act (CEQA) Guidelines, and a Mitigated Negative Declaration has been prepared, and adopted; and as evidenced by the following:

1. The initial study and Mitigated Negative Declaration were properly noticed and circulated in compliance with the California Environmental Quality Act of 1970, and in compliance with Section 15070-15075 of the CEQA State Guidelines, by:
 - *Circulation of the Notice of Intent (NOI) for the environmental analysis/proposed Mitigated Negative Declaration (CEQA Initial Study, IS 2022-05) was published in the Lake County Record Bee and sent to the State Clearinghouse; Various Federal, State, and local agencies/organizations for the minimum of a 30-day commenting period from July 19th, 2022, through August 19th, 2022. The document was also uploaded onto the City’s Website and made available upon request.*
 - *A Notice of Intent (NOI) was mailed (via USPS) to the surrounding parcels owners within 300 feet of the subject property informing them of the City’s decision to adopt a Mitigated Negative Declaration for the proposed use and that there is a 30-day commenting period on the environmental document from July 19th, 2022, through August 19th, 2022.*
 - *Additional mitigation measures have been added in order to reconfirm the protocols for avoidance and capping of the sensitive sites. These mitigation measures do not create new significant environmental effects and are not necessary to mitigate an avoidable significant effect. Thus, pursuant to CEQA Guidelines section 15073.5, recirculation of the MND is not required.*

WHEREAS, environmental review (Initial Study, IS 2022-05) was prepared in accordance with the California Environmental Quality Act (CEQA), which shows substantial evidence, in light of the whole record, that the project will not result in a significant environmental impact with the incorporated Mitigation Measures/Conditions of Approval and, hereby adopts a Mitigated Negative Declaration (MND) and authorizes staff to file a Notice of Determination in compliance with CEQA.

WHEREAS, if any section, division, sentence, clause, phrase, or portion of this resolution is for any reason held to be invalid or unconstitutional by a decision of any court of competent jurisdiction, such decision shall not affect the validity of the remaining provisions.

WHEREAS, on April 25th, 2023, the Planning Commission of the City of Clearlake held a duly noticed public hearing at which interested persons had the opportunity to testify and at which the Planning Commission considered the proposed development; and

WHEREAS, adequate public noticing was made for the project in accordance with the Municipal Code; and

WHEREAS, the City Council has considered this project, the staff report, public testimony, on this date (June 7th, 2023) at a duly noticed public hearing, and found that the project is compatible with the surrounding area, and will not be detrimental to adjacent property owners or the public at large, and approval of the Mitigated Negative Declaration (Based on Environmental Analysis, IS 2022-05) and Conditional Use Permit (CUP 2022-16) is in the public interest; and;

NOW, THEREFORE, BE IT RESOLVED by the City Council of the City of Clearlake that Appeal Application APCC 2023-01 contesting the Planning Commission’s decision of April 25th, 2023, is hereby **denied** and Mitigated Negative Declaration (Based on Environmental Analysis, IS 2022-05) and Conditional Use Permit (CUP 2022-16) is approved.

PASSED AND ADOPTED on this 7th day of June 2023, by the following vote:

- AYES:
- NOES:
- ABSENT:
- ABSTAIN:

Mayor – City of Clearlake

ATTEST:

City/Deputy Clerk, City Council

EXHIBIT A

**CONDITIONS OF APPROVAL
CONDITIONAL USE PERMIT, CUP 2022-16
INITIAL STUDY, IS 2022-05**

Burns Valley Development Project

Pursuant to the approval of the Planning Commission on **April 25th, 2023 and the City Council on _____, 2023**), is hereby granted to the City of Clearlake, a Mitigated Negative Declaration (based on CEQA Analysis IS 2022-05) and Conditional Use Permit, CUP 2022-16 to allow the development and operation of the Burns Valley Development located at 14885 Burns Valley Road, Clearlake, CA 95422 further described as APN: 010-026-40-000 is subject to the following terms and mitigation measures/conditions of approval.

SECTION A: GENERAL CONDITIONS:

1. The use hereby permitted shall substantially conform to the Site Plan(s), and Project Description and any conditions of approval/mitigation measures imposed by the above project as shown on the approved project plan for this action dated April 25th, 2023 (Planning Commission) and on _____, **2023 by City Council.**
2. All handicap parking areas, routes of travel, building access and bathrooms shall meet American with Disabilities Act (ADA) requirements and be subject to review and approval of a Certified Accessibility Access Specialist (CASP).
3. **Prior to operation**, the permit holder shall meet and operate in full compliance with fire safety rules and regulations of the Lake County Fire District.
4. The operation shall not exceed the maximum occupancy as prescribed by the California Building Code.
5. Any modifications and/or additions to a use requiring use permit approval shall itself be subject to use permit approval. The addition of an allowed use to a premise occupied by a conditionally allowed use shall require use permit approval of the type required for the existing use. The Community Development Director shall determine when such an addition and/or change is of such a minor or incidental nature that the intent of these regulations can be met without further use permit control
6. The California Department of Fish & Wildlife filing fee shall be submitted as required by California Environmental Quality Act (CEQA) statute, Section 21089(b) and Fish and Game Code Section 711.4. **The fee should be paid within five (5) days of approval of the mitigated negative declaration at the Lake County Clerk's Office.** Once fees have been paid, the applicant shall submit a copy of all documentation to the City of Clearlake, verifying the fees have been paid. **Said permit shall not become valid, vested or operative until the fee has been paid, including the issuance of any permits.**

SECTION B. AESTHETICS:

1. (*Mitigation Measure AES-1*) All outdoor lighting shall be directed downwards and shielded onto the project site and not onto adjacent properties. All lighting shall comply and adhere to all federal, state and local agency requirements, including all requirements in darksky.org. (Refer to the City's Design Standards).

2. *(Mitigation Measure AES-2)* A final lighting design plan shall be submitted for review and approval by the Community Development Department. Lighting levels shall not exceed lighting levels beyond those referenced in Attachment A, Lighting Analysis for this project. Lighting shall be installed in accordance with the final approved lighting plan.
3. *(Mitigation Measure AES-2)* All nighttime ball field lighting shall be operated no later than 10 pm.
4. **Prior to operation**, the applicant shall install a Trash enclosure in accordance with City of Clearlake Municipal Codes and Trash Enclosure Design Standards. The plans shall show that the enclosure will be constructed of block with an attractive cap and the gates should incorporate solid metal materials painted to match the building colors. The gates should be mounted on separate posts mounted inside the enclosure. A hose bib should be located next to the enclosure for maintenance.

SECTION C. AIR QUALITY:

1. *(Mitigation Measure AIR 1)* Construction activities shall be conducted with adequate dust suppression methods, including watering during grading and construction activities to limit the generation of fugitive dust or other methods approved by the Lake County Air Quality Management District. Prior to initiating soil removing activities for construction purposes, the applicant shall pre-wet affected areas with at least 0.5 gallons of water per square yard of ground area to control dust.
2. *(Mitigation Measure AIR 2)* Driveways, access roads and parking areas shall be surfaced in a manner so as to minimize dust. The applicant shall obtain all necessary encroachment permits for any work within the right-of-way. All improvement shall adhere to all applicable federal, State and local agency requirements.
3. *(Mitigation Measure AIR 3)* Any disposal of vegetation removed as a result of lot clearing shall be lawfully disposed of, preferably by chipping and composting, or as authorized by the Lake County Air Quality Management District and the Lake County Fire Protection District.
4. *(Mitigation Measure AIR-4)* During construction activities, the applicant shall remove daily accumulation of mud and dirt from any roads adjacent to the site.
5. *(Mitigation Measure AIR-5)* Grading permits shall be secured for any applicable activity from the Community Development Department, Building Division. Applicable activities shall adhere to all grading permit conditions, including Best Management Practices. All areas disturbed by grading shall be either surfaced in manner to minimize dust, landscaped or hydro seeded. All BMPs shall be routinely inspected and maintained for life of the project.
6. *(Mitigation Measure AIR-6)* All refuse generated by the facility shall be stored in approved disposal/storage containers, and appropriately covered. Removal of waste shall be on a weekly basis so as to avoid excess waste. All trash receptacles/containers shall remain covered at all times to prevent fugitive odors and rodent infestation. An odor control plan shall be submitted for review and approval by the City in accordance with the Zoning Code. Odor control shall be maintained to an acceptable level at all times.
7. *(Mitigation Measure AIR-7)* Construction activities that involve pavement, masonry, sand, gravel, grading, and other activities that could produce airborne particulate should be conducted with adequate dust controls to minimize airborne emissions. A dust mitigation plan may be required should the applicant fail to maintain adequate dust controls.

8. *(Mitigation Measure AIR-8)* If construction or site activities are conducted within Serpentine soils, a Serpentine Control Plan may be required. Any parcel with Serpentine soils must obtain proper approvals from LCAQMD prior to beginning any construction activities. Contact LCAQMD for more details.
9. *(Mitigation Measure AIR-9)* All engines must notify LCAQMD prior to beginning construction activities and prior to engine Use. Mobile diesel equipment used for construction and/or maintenance must be in compliance with State registration requirements. All equipment units must meet Federal, State and local requirements. All equipment units must meet RICE NESHAP/ NSPS requirements including proper maintenance to minimize airborne emissions and proper record-keeping of all activities, all units must meet the State Air Toxic Control Measures for CI engines and must meet local regulations.
10. *(Mitigation Measure AIR-10)* Site development, vegetation disposal, and site operation shall not create nuisance odors or dust. During the site preparation phase, the District recommends that any removed vegetation be chipped and spread for ground cover and erosion control. Burning of debris/construction material is not allowed on commercial property, materials generated from the commercial operation, and waste material from construction debris, must not be burned as a means of disposal.
11. *(Mitigation Measure AIR-11)* Significant dust may be generated from increase vehicle traffic if driveways and parking areas are not adequately surfaced. Surfacing standards should be included as a requirement in the use permit to minimize dust impacts to the public, visitors, and road traffic. At a minimum, the district recommends chip seal as a temporary measure for primary access roads and parking. Paving with asphaltic concrete is preferred and should be required for long term occupancy. All areas subject to semi-truck / trailer traffic should require asphaltic concrete paving or equivalent to prevent fugitive dust generation. Gravel surfacing may be adequate for low use driveways and overflow parking areas; however, gravel surfaces require more maintenance to achieve dust control, and permit conditions should require regular palliative treatment if gravel is utilized. White rock is not suitable for surfacing (and should be prohibited in the permit) because of its tendency to break down and create excessive dust. Grading and re-graveling roads should utilizing water trucks, if necessary, reduce travel times through efficient time management and consolidating solid waste removal/supply deliveries, and speed limits.
12. Construction activities that involve pavement, masonry, sand, gravel, grading, and other activities that could produce airborne particulate should be conducted with adequate dust controls to minimize airborne emissions. A dust mitigation plan may be required should the applicant fail to maintain adequate dust controls.

SECTION D - BIOLOGICAL RESOURCES:

1. *(Mitigation Measure BIO-1)* The project should implement erosion control measures and BMPs to reduce the potential for sediment or pollutants at the Project site.
2. *(Mitigation Measure BIO-2)* A qualified biologist shall conduct a mandatory Worker Environmental Awareness Program for all contractors, work crews, and any onsite personnel to aid workers in recognizing special status species and sensitive biological resources that may occur on-site. The program shall include identification of the special status species and their habitats, a description of the regulatory status and general ecological characteristics of sensitive resources, and review of the limits of construction and Mitigation Measures required to reduce impacts to biological resources within the work area.

3. *(Mitigation Measure BIO-3)* Conduct a pre-construction northwestern pond turtle survey in Project impact and staging areas within 48 hours prior to construction activities. Any northwestern pond turtle individuals discovered in the Project work area immediately prior to or during Project activities shall be allowed to move out of the work area of their own volition. If this is not feasible, they shall be captured by a qualified biologist and relocated out of harm's way to the nearest suitable habitat at least 100 feet from the Project work area where they were found.
4. *(Mitigation Measure BIO-4)* If construction is to occur during the nesting season (generally February 1 - August 31), conduct a pre-construction nesting bird survey of all suitable nesting habitat on the Project within 14 days of the commencement of construction. The survey shall be conducted within a 500-foot radius of Project work areas for raptors and within a 100-foot radius for other nesting birds. If any active nests are observed, these nests shall be designated a sensitive area and protected by an avoidance buffer established in coordination with CDFW until the breeding season has ended or until a qualified biologist has determined that the young have fledged and are no longer reliant upon the nest or parental care for survival. Pre-construction nesting surveys are not required for construction activity outside the nesting season.
5. *(Mitigation Measure BIO-5)* Within 14 days prior to Project activities that may impact bat roosting habitat (e.g., removal of manmade structures or trees), a qualified biologist will survey for all suitable roosting habitat within the Project impact limits. If suitable roosting habitat is not identified, no further measures are necessary. If suitable roosting habitat is identified, a qualified biologist will conduct an evening bat emergence survey that may include acoustic monitoring to determine whether or not bats are present. If roosting bats are determined to be present within the Project site, consultation with CDFW prior to initiation of construction activities and/or preparation of a Bat Management Plan outlining avoidance and minimization measures specific to the roost(s) potentially affected may be required.
6. *(Mitigation Measure BIO-6)* To minimize potential impacts to the ephemeral drainage on the project site during construction activity, a qualified biologist shall map the extent of the riparian habitat on the project site. Avoidance buffers for riparian habitat shall be applied in compliance with City of Clearlake requirements. The riparian habitat and avoidance buffer shall be demarcated prior to construction and shall be maintained until the completion of construction. A qualified biologist/biological monitor shall be present if work must occur within the avoidance buffer to ensure riparian habitat is not impacted by the construction activity.
7. *(Mitigation Measure BIO-7)* A native tree protection and removal permit, waiver, or similar approval shall be secured prior to impacting trees protected under the City ordinance. Avoidance buffers for protected trees shall be consistent with the City requirements, shall be clearly demarcated prior to construction, and should be maintained until the completion of construction. A qualified biologist/biological monitor should be present if work must occur within the avoidance buffer to ensure avoided protected trees are not impacted by the work.

SECTION E - CULTURAL/TRIBAL RESOURCES:

1. *(Mitigation Measure CUL-1)* During construction activities, if any subsurface archaeological remains are uncovered, all work shall be halted within 100 feet of the find and the owner shall utilize a qualified cultural resources consultant to identify and investigate any subsurface historic remains and define their physical extent and the nature of any built features or artifact-bearing deposits.

2. *(Mitigation Measure CUL-2)* The cultural resource consultant's investigation shall proceed into formal evaluation to determine their eligibility for the California Register of Historical Resources. This shall include, at a minimum, additional exposure of the feature(s), photo-documentation and recordation, and analysis of the artifact assemblage(s). If the evaluation determines that the features and artifacts do not have sufficient data potential to be eligible for the California Register, additional work shall not be required. However, if data potential exists – e.g., there is an intact feature with a large and varied artifact assemblage – it will be necessary to mitigate any Project impacts. Mitigation of impacts might include avoidance of further disturbance to the resources through Project redesign. If avoidance is determined to be infeasible, pursuant to CEQA Guidelines Section 15126.4(b)(3)(C), a data recovery plan, which makes provisions for adequately recovering the scientifically consequential information from and about the historical resource, shall be prepared and adopted prior to any excavation being undertaken. Such studies shall be deposited with the California Historical Resources Regional Information Center. Archeological sites known to contain human remains shall be treated in accordance with the provisions of Section 7050.5 Health and Safety Code. If an artifact must be removed during Project excavation or testing, curation may be an appropriate mitigation. This language of this mitigation measure shall be included on any future grading plans and utility plans approved by the City for the Project.
3. *(Mitigation Measure CUL-3)* If human remains are encountered, no further disturbance shall occur within 100 feet of the vicinity of the find(s) until the Lake County Coroner has made the necessary findings as to origin (California Health and Safety Code Section 7050.5). Further, pursuant to California Public Resources Code Section 5097.98(b) remains shall be left in place and free from disturbance until a final decision as to the treatment and disposition has been made. If the Lake County Coroner determines the remains to be Native American, the Native American Heritage Commission must be contacted within 24 hours. The Native American Heritage Commission must then identify the “most likely descendant(s)”. The landowner shall engage in consultations with the most likely descendant (MLD). The MLD will make recommendations concerning the treatment of the remains within 48 hours as provided in Public Resources Code 5097.98.
4. *(Mitigation Measure CUL-4)* The sensitive site section noted on the project site plan shall not be disturbed during construction and/or maintenance of the park. This sensitive site is identified as investigation resulted in the discovery of two intact, buried, archaeological sites, CCL-21-01 and CCL-21-02 (Figure 7, yellow polygons), both of the sites can be considered significant cultural resources. Both of the sites occupy relatively small areas and are buried at depths of 16–32 inches below grade. The project as currently designed, will not impact sites CCL-21-01 or CCL-21-02. If avoidance and/or preservation in place is not possible, the owner will consider re-design or other measures to avoid impacting resources consistent with CEQA. The owner will contract with tribal monitors for ground disturbance within 100 feet of sites CCL-21-01 and CCL-21-02. The owner and contract archeologist will consult with tribal representatives regarding ground disturbing work within these areas including the designation of a “reburial” location, if needed.
5. (Mitigation Measure CUL-5) On or prior to the first day of construction the owner shall organize cultural sensitivity training for contractors involved in ground disturbing activities.
6. (Mitigation Measure CUL-6) The southern two-thirds of site CCL-21-01 is contained within APN010-026-400-000 and the Burns Valley Development Project area. The area occupied by the site has been slated for a paved parking area serving planned playing fields nearby (Figure 2). This portion of the site is situated on the sloping bank of an extinct section of upper Miller Creek, an area marked by an overstory of mixed native oak and introduced conifer and hardwood trees. Because this part of the site is situated on a bank, the land surface is sloped and drops 10–15 feet

in elevation. Current engineering plan calls for vegetation and tree removal as well as application of remote fill materials to bring it to a level grade, with installation of landscaping, drains, and underground utility lines in the area. Project revisions in design, location, and operations should be implemented in the area occupied by the footprint of site CCL-21-01, inclusive to a 15-foot (4.5-meter) buffer around the site perimeter. Limitations to disturbance in this area shall be as follows:

(1) *Fill Cap*. Because CCL-21-01 is a buried archaeological deposit contained in a dense clay loam likely to resist compaction impacts, avoidance can be achieved by placing fill on the site surface;

(2) *Flush Cut Vegetation*. Existing vegetation including shrubs and trees should be flush-cut, i.e., cut flush with the ground at a point not to exceed 10-inches below grade;

(3) *Landscaping Fabric and Fill*. Once the flush cut is complete and surface cleared of debris, landscaping fabric should be laid over the area of the site to create a boundary between intact soils and remote fill. With respect to the fill, drainage, safety, and operational concerns may prevent adding a lot of elevation; however, an additional minimum 6–12-inches (15–30 centimeters) of fill should be added to the site area to provide a construction and compaction buffer to protect the deposit. This would result in an overburden of 21–27 inches (53–71 centimeters) of capping material;

(4) *Avoid Installation of Subsurface Features*. Avoid placement of pier supports, subsurface landscaping features, subsurface drains, and utility lines in the site area.

(5) *Avoid New Overstory Plantings*. Avoid placement of new overstory trees in the site area.

7. (Mitigation Measure CUL-7) Site CCL-21-02 is contained within APN010-026-400-000 and the Burns Valley Development Project area. The area occupied by the site has been slated for open space. Project revisions in design, location, and operations should be implemented in the area occupied by the footprint of site CCL-21-02, inclusive to a 15-foot (4.5-meter) buffer around the site perimeter. Limitations to disturbance in this area shall be as follows:

(1) *Fill Cap*. Because CCL-21-01 is a buried archaeological deposit contained in a dense clay loam likely to resist compaction impacts, avoidance can be achieved by placing fill on the site/buffer surface;

(2) *Landscaping Fabric and Fill*. Prior to site prep and construction in the area, landscaping fabric should be laid over the area of the site to create a boundary between intact soils and remote fill. With respect to the fill, drainage, safety, and operational concerns may prevent adding a lot of elevation; however, an additional minimum 6–12-inches (15–30 centimeters) of fill should be added to the site area to provide a construction and compaction buffer to protect the deposit. This would result in an overburden of 21–27 inches (53–71 centimeters) of capping material;

(3) *Avoid Installation of Subsurface Features*. Avoid placement of pier supports, subsurface landscaping features, subsurface drains, and utility lines in the site area.

(4) *Avoid New Overstory Plantings*. Avoid placement of new overstory trees in the site area.

SECTION F - GEOLOGY AND SOILS:

1. (*Mitigation Measure GEO-1*) Prior to any ground disturbance and/or operation, the applicant shall submit Erosion Control and Sediment Plans to the Community Development Department for review and approval.
 - *The project shall incorporate Best Management Practices (BMPs) consistent with the City Code and the State Storm Water Drainage Regulations to the maximum extent practicable to prevent and/or reduce discharge of all construction or post-construction pollutants into the local storm drainage system.*
2. (*Mitigation Measure GEO-2*) Prior to any ground disturbance, (if applicable), the applicant shall submit and obtain a Grading Permit from the Community Development in accordance with the City of Clearlake Municipal code(s).
3. (*Mitigation Measure GEO-3*) The applicant shall monitor the site during the rainy season including post-installation, application of BMPs, erosion control maintenance, and other improvements as needed. Said measures shall be maintained for life of the project and replace/repared when necessary.

SECTION G- HAZARD/HAZARDOUS MATERIALS:

1. All hazardous waste shall not be disposed of on-site without review or permits from Environmental Health Department, the California Regional Water Control Board, and/or the Air Quality Board. Collected hazardous or toxic waste materials shall be recycled or disposed of through a registered waste hauler to an approved site legally authorized to accept such material.
2. The storage of potentially hazardous materials shall be located at least 100 feet from any existing water well. These materials shall not be allowed to leak into the ground or contaminate surface waters. Collected hazardous or toxic materials shall be recycled or disposed of through a registered waste hauler to an approved site legally authorized to accept such materials.
3. Any spills of oils, fluids, fuel, concrete, or other hazardous construction material shall be immediately cleaned up. All equipment and materials shall be stored in the staging areas away from all known waterways.
4. The storage of hazardous materials equals to or greater than fifty-five (55) gallons of a liquid, 500 pounds of a solid, or 200 cubic feet of compressed gas, then a Hazardous Materials Inventory Disclosure Statement/Business Plan shall be submitted and maintained in compliance with requirements of Lake County Environmental Health Division. Industrial waste shall not be disposed of on site without review or permit from Lake County Environmental Health Division or the California Regional Water Quality Control Board. The permit holder shall comply with petroleum fuel storage tank regulations if fuel is to be stored on site.
5. All equipment shall be maintained and operated in a manner that minimizes any spill or leak of hazardous materials. Hazardous materials and contaminated soil shall be stored, transported, and disposed of consistent with applicable local, state, and federal regulations
6. Hazardous Waste must be handled according to all Hazardous Waste Control Laws. Any generation of a hazardous waste must be reported to Lake County Environmental Health within thirty days.
7. All employees and/or staff members shall be properly trained in and utilize Personnel Protective Equipment in accordance with all federal, state and local regulations regarding handling any biological and/or chemical agents.

8. Hazardous waste must be handled according to all Hazardous Waste Control and Generator regulations. Waste shall not be disposed of onsite without review or permits from EHD, the California Regional Water Control Board, and/or the Air Quality Board. Collected hazardous or toxic waste materials shall be recycled or disposed of through a registered waste hauler to an approved site legally authorized to accept such material.

SECTION H -NOISE/VIBRATIONS:

1. *(Mitigation Measure NOI-1)* All construction activities including engine warm-up shall be limited to weekdays and Saturday, between the hours of 7:00am and 7:00pm to minimize noise impacts on nearby residents.
2. *(Mitigation Measure NOI-2)* Permanent potential noise sources such as, generators used for power shall be designed and located to minimize noise impacts to surrounding properties.
3. *(Mitigation Measure NOI-3)* During construction noise levels shall not exceed 65 decibels within fifty (50) feet of any dwellings or transient accommodations between the hours of 7:00 AM and 6:00 PM. This threshold can be increased by the Building Inspector or City Engineer have approved an exception in accordance with Section 5-4.4(b)(1) of the City Code. An exception of up to 80 decibels may be approved within one hundred (100) feet from the source during daylight hours. Project is expected to result in less than significant impacts with regard to noise and vibration.
4. *(Mitigation Measure NOI-4)* Park operations, including baseball at the northeasterly ballpark shall be shall be restricted to not later than 10 pm.

SECTION I - TRANSPORTATION/TRAFFIC:

1. All handicap parking areas, routes of travel, building access and bathrooms shall meet American with Disabilities Act (ADA) requirements and be subject to review and approval of a Certified Accessibility Access Specialist (CASP).

SECTION J – TRIBAL CULTURAL RESOURCES

1. *(Mitigation Measure TCR-1):* Requirement to develop a tribal cultural resources preservation plan that delineates the boundary of CCL-21-01 and CCL-21-02, describes the appropriate combination of materials and culturally sterile fill in capping, provides landscaping specifications that favor culturally important plants, and restricts certain types of post-project activities in or on the cap.
2. *(Mitigation Measure TCR-2):* Requirement to designate a project reburial area in advance of ground disturbing activities in the event that materials are discovered during construction.
3. *(Mitigation Measure TCR-3):* Requirement for contractors to receive meaningful training on cultural sensitivity and tribal cultural resources from a tribal representative.
4. *(Mitigation Measure TCR-4):* Requirement for tribal monitoring during ground disturbing activities in sensitive areas of the project area.
5. *(Mitigation Measure TCR-5):* Procedures for compliance with existing state law in the event of the discovery of human remains during construction.
6. *(Mitigation Measure TCR-6):* A prohibition on the removal of cultural soils from the project area.
7. Requirement for City staff to organize a discussion with the City Council to exercise its independent

discretion on naming part or all of the facility with an appropriate tribal name, if it so chooses.

8. Requirement to develop and install culturally appropriate interpretive signage to educate the public about the cultural significance of the area.
9. Requirement to allow free access to the facilities for tribal cultural events up to four times per year, pursuant to the same application process of other events at City facilities.
10. Commitment by the City to meaningful consultation as a consulting party under Section 106 of the National Historic Preservation Act or National Environmental Policy Act, if applicable.

SECTION K -TIMING AND MONITORING

1. The applicant shall agree to indemnify, defend, and hold harmless the City or its agents, officers and employees from and against any and all claims, actions, demands or proceeding (*including damage, attorney fees, and court cost awards*) against the City or its agents, officers, or employees to attach, set aside, void, or annul an approval of the City, advisory agency, appeal board, or legislative body concerning the permit or entitlement when such action is brought within the applicable statute of limitations. In providing any defense under this Paragraph, the applicant shall use counsel reasonably acceptable to the City. The City shall promptly notify the applicant of any claim, action, demands or proceeding and the City shall cooperate fully in the defense. If the City fails to promptly notify the applicant of any claim, action, or proceeding, or if the City fails to cooperate fully in the defense, the applicant shall not thereafter be responsible to defend, indemnify, or hold the City harmless as to that action. The City may require that the applicant post a bond, in an amount determined to be sufficient, to satisfy the above indemnification and defense obligation. Applicant understands and acknowledges that City is under no obligation to defend any claim, action, demand or proceeding challenging the City's actions with respect to the permit or entitlement.
2. Upon written request received prior to expiration, the Community Development Director may grant renewals of use permit approval for successive periods of not more than one (1) year each.
 - *Approvals of such renewals shall be in writing and for a specific period.*
 - *Renewals may be approved with new or modified conditions upon a finding that the circumstances under which the use permit was originally approved have substantially changed.*
 - *Renewal of a use permit shall not require public notice or hearing unless the renewal is subject to new or modified conditions. In order to approve a renewal, the Community Development Director must make the findings required for initial approval.*
3. The Planning Commission may revoke or modify the use permit in the future if the Commission finds that the use to which the permit allows is detrimental to health, safety, comfort, general welfare of the public; constitutes a public nuisance; if the permit was obtained or is being used by fraud; and/or if one or more the conditions upon which a permit was granted are in noncompliance or have been violated. Applicant shall be notified of potential violations of the use permit prior to action taken by the Planning Commission.
4. Said Use Permits shall be subject to revocation or modification by the Planning Commission if the Commission finds that there has been:
 - a) *Noncompliance with any of the foregoing conditions of approval; or*
 - b) *The Planning Commission finds that the use for which this permit is hereby granted is so exercised as to be substantially detrimental to persons or property in the neighborhood of*

the use. Any such revocation shall be preceded by a public hearing noticed and heard pursuant to the City of Clearlake Municipal Code. 15.

ACCEPTANCE

I have read and understand the foregoing approved project and agree to each term and condition of approval and/or mitigation measure(s) thereof.

Date: _____

Applicant or Authorized Agent Signature

Printed Name of Authorized Agent

To be Completed by Authorized Staff Only:	
_____ Staff Name	_____ Staff Signature
Date Project Approved: _____	



City of Clearlake
14050 Olympic Drive, Clearlake, California 95422
(707) 994-8201 Fax (707) 995-2653

**Planning Application
Appeal to CC**

OFFICE USE ONLY		INITIAL FEES
Clearance Fee		880.00
Categorical Exemption Fee		N.A.
General Plan Maintenance Fee		25.00
Technology Fee (2%)		18.10
	Subtotal	923.10
	3% CC/DC Processing Fee (\$27.69)	
	Total	
Received By:	<i>M. [Signature]</i>	
Date:	May 4 2023	
Receipt Number:		
File Number:	AP CC 20 23 -- 01	

APPLICANT

NAME: Appellant - Koi Nation of Northern California

MAILING ADDRESS: P. O. Box 3162

CITY: Santa Rosa

STATE: CA ZIP CODE: 95402

PRIMARY PHONE: 707-572-5586

EMAIL: kn@koination.com

SIGNATURE: [Signature]

I declare under penalty of perjury that I am the owner of said property or have written authority from the property owner to file this application. I certify that all the submitted information is true and correct to the best of my knowledge and belief. I understand that any misrepresentation of submitted data may invalidate any approval of this application.

PROPERTY OWNER (IF NOT APPLICANT)

NAME: _____

MAILING ADDRESS: _____

CITY: _____

STATE: _____ ZIP CODE: _____

PRIMARY PHONE: _____

EMAIL: _____

SIGNATURE: _____

I declare under penalty of perjury that I am the owner of said property or have written authority from the property owner to file this application. I certify that all the submitted information is true and correct to the best of my knowledge and belief. I understand that any misrepresentation of submitted data may invalidate any approval of this application.

PROJECT LOCATION

ADDRESS: 14885 Burns Valley Road

ASSESSOR PARCEL NUMBERS: 010-026-40

PRESENT USE OF LAND: Mixed use

WATER SUPPLY: PUBLIC GROUNDWATER WELL

SANITATION: PUBLIC SEWER SEPTIC SYSTEM

FLOOD ZONE: _____

OFFICE USE ONLY

ZONING DISTRICT: _____

GENERAL PLAN DESIGNATION: _____

RELATED FILE NUMBERS: _____

NOTES: _____

APPROVED: _____ DATE: _____

Detailed Reason for Appeal (All material must be submitted as a complete application)

See attached letter to Mayor and City Councilmembers.

RECEIVED

MAY 04 2023

CITY OF CLEARLAKE

Rec'd: May 4 2023 @



KOI NATION OF NORTHERN CALIFORNIA

RECEIVED

MAY 04 2023

CITY OF CLEARLAKE

May 4, 2023

VIA EMAIL AND U.S. MAIL

Hon. Russell Perdock, Mayor
and City Councilmembers
City of Clearlake
14050 Olympic Drive
Clearlake, CA 95422
ATTN: Melissa Swanson, City Clerk
Email: mswanson@clearlake.ca.us

Re: Appeal of April 25, 2023 Planning Commission Decision
Approval of Burns Valley Development Project MND and CUP

Dear Mayor Perdock and Councilmembers:

While the Koi Nation of Northern California ("Koi Nation" or "Tribe") continues to support responsible development within the City of Clearlake ("City"), we are writing to you regarding an appeal from the City Planning Commission's April 25, 2023, adoption of a Mitigated Negative Declaration (IS-2022-05) ("MND") and approval of a Conditional Use Permit Application (CUP 2022-16) ("CUP") to authorize the Burns Valley Development Project ("Project"). Notwithstanding this appeal, the Tribe does appreciate the time taken by City staff to re-engage in consultation pursuant to AB 52 (Gatto, 2015) after the Planning Commission's initial September 27, 2022, hearing on this matter. The parties did make good progress in seeking to address the crucial issues raised by the Tribe, and the mitigation for significant impacts to tribal cultural resources ("TCR") has been improved. Thank you.

Unfortunately, the mitigation in the MND still does not reach the level of reducing the impact on TCRs to below a level of significance. The parties have not reached an agreement due to the City declaring an impasse over the extent of necessary tribal monitoring for the Project, which is necessary because of extensive TCRs present or likely to be present throughout the entire Project footprint. The record contains a lot of substantial evidence to support this fact. The City and the Tribe met for consultation twice, then exchanged a series of letters via email. The Tribe asked the City to meet again to consult on or about February 15, 2023, but the City unilaterally closed consultation in its March 23, 2023, letter to the Tribe.

The City must follow the law in approving this development. However, despite numerous warnings by the Tribe, the City continues to ignore its legal responsibilities. Unfortunately, the Commission's action is an example of the City approving a project based upon faulty environmental compliance documents in disregard of its obligations under the California Environmental Quality Act, Public Resources Code section 21000, et seq. ("CEQA"). The Commission specifically erred in adopting the faulty MND rather than directing the preparation of an Environmental Impact Report ("EIR") as required by CEQA.

Mayor and City Council
 May 4, 2023
 Page 2

Through this appeal, the Tribe requests that the City Council correct the Commission's error and direct the preparation of an EIR. The City's Municipal Code, at section 18-36.030, provides for appeals to the City Council of decisions by the City Planning Commission, and Code section 18-36.010 instructs that any person may appeal the decision of any official body. The Tribe has previously submitted comments to the Planning Commission on the Project including written comments in advance of the Commission's September 27, 2022 and April 25, 2023, hearings. Those comments, and any other documents submitted to the Commission by the Tribe related to this Project, are expressly incorporated herein by reference. Please note that these comments apply to the entire Burns Valley Master Plan including the Burns Valley Development Project and the Oak Valley Villas Senior Residential Development (collectively, "Project").

CONTINUANCE FOR FURTHER CONSULTATION

As an initial matter, the Tribe requests that the City Council continue this matter and direct staff to further consult with the Tribe in an effort to reach a mutually agreeable resolution as to remaining TCR protocol issues. The Tribe has attached to this letter, at Attachment 1, a redlined version of the mitigation measures needed to resolve this matter and remains optimistic that the parties can resolve any remaining differences if the City returns to the table.

To be clear, the Tribe is not trying to take away the City's decision-making authority as a lead agency under CEQA. Rather, the Tribe needs the City to fully consider the substantial evidence provided by the Tribe in consultation, in making its determinations about TCRs present on the Project site, and how to avoid, preserve, or mitigate them. The Tribe's concern is about the City's privileging archeological knowledge over the Tribe's cultural knowledge about the Tribe's own cultural resources, not the City's decision-making authority. The Tribe wants to be able to speak for its own cultural resources, not have an archeologist say that they do not matter because they are not part of an intact site useful for scientific research.

THIS PROJECT REQUIRES AN EIR RATHER THAN AN MND

If the City opts to proceed with the current MND, it places the Project at risk due to the document's many deficiencies. Of foremost concern is the MND's failure to properly consider and mitigate TCR impacts which can only be remedied by the preparation of an EIR. Under CEQA, all lead agencies must prepare an EIR for projects "which may have a significant effect on the environment." (Pub. Resources Code § 21151(a).) In *Laurel Heights Improvement Association v. Regents of the University of California* (1988) 47 Cal.3d 376, the California Supreme Court explained the role an EIR plays in the CEQA process, and instructed that: "The EIR is the primary means of achieving the Legislature's considered declaration that it is the policy of this state to 'take all action necessary to protect, rehabilitate, and enhance the environmental quality of the state.' [Citation.] The EIR is therefore the 'heart of CEQA.' [Citation]." (*Id.* at 392; *see also Friends of College of San Mateo Gardens v. San Mateo County Community College Dist.* (2016) 1 Cal.5th 937, 944 ["At the 'heart of CEQA' [citation] is the requirement that public agencies prepare an EIR for any 'project' that 'may have a significant effect on the environment.' [Citation.].") "When the informational requirements of CEQA are not complied with, an agency has failed to proceed in a manner required by law and has therefore abused its discretion." (*Save our Peninsula Committee v. Monterey County Board of Supervisors* (2001) 87 Cal.App.4th 99, 118.)

Since an EIR is the "heart of CEQA," it is not surprising that CEQA "creates a low threshold requirement for an initial preparation of an EIR and reflects a preference for resolving doubts in favor of environmental review when the question is whether any such review is warranted." (*Sierra Club v. County of Sonoma* (1992) 6 Cal.App.4th 1307, 1316-1317). Accordingly, "if a lead agency

is presented with a fair argument that a project may have a significant effect on the environment, the lead agency shall prepare an EIR even though it may also be presented with other substantial evidence that the project will not have a significant effect.' " (*Berkeley Hillside Preservation v. City of Berkeley* (2015) 60 Cal.4th 1086, 1111.) To the extent there is a conflict in the evidence, the City should not "weigh" the conflicting evidence to determine whether an EIR should be prepared. It should simply prepare an EIR. It is the function of an EIR, not an MND, to resolve conflicting claims based on substantial evidence, as to the environmental effects of a project. (See Pub. Resources Code § 21064.5.) Substantial evidence is "enough relevant information and reasonable inferences from this information that a fair argument can be made to support a conclusion, even though other conclusions might also be reached." (Cal. Code of Regs., tit.14, § 15384(a).) "The fair argument standard thus creates a low threshold for requiring an EIR, reflecting the legislative preference for resolving doubts in favor of environmental review. [Citations.]" (*Covina Residents for Responsible Development v. City of Covina* (2018) 21 Cal.App.5th 712, 723.) As explained in this comment letter, numerous aspects of the Project present a fair argument of significant environmental effects requiring the City to prepare an EIR rather than rely on a defective and inadequate MND for the Project.

THE MND FAILS TO ANALYZE AND MITIGATE IMPACTS TO TRIBAL CULTURAL RESOURCES

The Tribe is comprised of people whose Ancestors have lived in this area since time immemorial and who are survivors of state-sponsored genocide and the forceable removal of their Ancestors. The Project site, including the Burns Valley Creek and an identified Village Site, was inhabited and was an important source of food and cultural materials for Tribal Ancestors. Multiple TCRs have been discovered both within and without the City's identified monitoring area despite previous ground-disturbing activities, and all this information points to a very high likelihood of finding more TCRs throughout the Project.

Public Resources Code section 21082.3(b) sets forth the City's responsibilities under CEQA in regards to TCR and mandates:

If a project may have a significant impact on a tribal cultural resource, the lead agency's environmental document shall discuss both of the following:

- (1) Whether the proposed project has a significant impact on an identified tribal cultural resource.
- (2) Whether feasible alternatives or mitigation measures, including those measures that may be agreed to pursuant to subdivision (a), avoid or substantially lessen the impact on the identified tribal cultural resource.

The presence of TCRs and the unmitigated handling of them is one of the primary reasons that the City must prepare an EIR. (See *Protect Niles v. City of Fremont* (2016) 25 Cal.App.5th 1129, 1134 [holding that an EIR is required rather than an MND when evidence supports a fair argument that there will be adverse environmental impacts from a project]; see also *Berkeley Hillside Preservation v. City of Berkeley, supra*, 60 Cal.4th at 1111 ["if a lead agency is presented with a fair argument that a project may have a significant effect on the environment, the lead agency shall prepare an EIR even though it may also be presented with other substantial evidence that the project will not have a significant effect."].) As courts have instructed,

to the extent there was a conflict in the evidence, ' "neither the lead agency nor a court may "weigh" conflicting substantial evidence to determine whether an EIR must be prepared in the first instance.' " (*Citizens for Responsible & Open Government v. City of Grand Terrace* (2008) 160 Cal.App.4th 1323, 1340 [73 Cal.Rptr.3d 202]; see also CEQA Guidelines, § 15064, subd. (f)(1).) "It is the function of an EIR, not a negative declaration, to resolve conflicting claims, based on substantial evidence, as to the environmental effects of a project." (*Pocket Protectors v. City of Sacramento, supra*, 124 Cal.App.4th at p. 935.) Because the record contains substantial evidence supporting a fair argument that the MND's measures are inadequate to avoid or mitigate the impacts to CA-LAN-1352 "to a point where clearly no significant effect on the environment would occur," an EIR is required to consider the project's impacts on cultural resources. (§ 21064.5.)

(*Save the Agoura Cornell Knoll v. City of Agoura Hills* (2020) 46 Cal.App.5th 665, 690 (hereafter *Agoura Hills*); emphasis added.)

Throughout the proceedings before the Commission, the Tribe has presented substantial evidence of on-site TCRs, which have not been fully analyzed in the MND. (See AB 52, § 1 ["California Native American tribes may have expertise with regard to their tribal history and practices, which concern the tribal cultural resources with which they are traditionally and culturally affiliated.]; *Confederated Tribes and Bands of Yakama Nation v. Klichitat County* (9th Cir. 2021) 1 F.4th 673, 682 fn. 9 [noting the importance of tribal oral history and traditions in interpreting information].) The Tribe will again present to the Council confidential maps of TCRs on the Project site and near the Project site. Additionally, the Tribe presented evidence of a water source on or near the Project which by itself is important culturally and also because it contains the Clearlake Hitch/Chi – a very important food source. The Tribe also references the confidential email previously submitted in support of the Tribe by Tribal Historic Preservation Officer Robert Geary, dated August 20, 2022, identifying numerous pre-historic archeological sites and waterways next to and/or inside the Project site. The cultural importance of the entire site, not just the two limited areas identified in the MND, has now been further bolstered by the previously presented report prepared by archeologist John Parker, Ph.D. Dr. Parker examined three sites identified by the City's archeologist and "confirmed and expanded the site boundaries." Dr. Parker "found no break in surface artifact scatter between the two site areas reported by White" and "that these two sites are in fact a single site with areas of artifact concentration." This report undercuts the City's findings limited to only the two sites it believes are impacted by the Project. Fundamentally, it is not culturally appropriate to build a recreational facility on a Village site as identified by the Tribe. Nevertheless, the Tribe has decided not to oppose this Project so long as the TCRs on site are appropriately mitigated. Requiring tribal monitoring on the whole Project site so that the Tribe can move its TCRs out of the way of the bulldozers during construction is the bare minimum needed to move forward respectfully.

The archeologist retained by the City, Dr. White, prepared a Cultural Resources report dated August 30, 2022. Although the City and Tribe re-engaged in consultation during the October 2022 to March 2023, timeframe, to the best of our knowledge the City did not update the Cultural Resources report to include and analyze any of the new substantial evidence the Tribe provided during the period of renewed consultation including information about the tribal cultural landscape, new TCRs found, the sites identified in the email from Robert Geary on August 29, 2022, or the tribal cultural significance of Burns Valley Creek, which is mentioned only in passing in the report. The Tribe has provided the City with substantial evidence of impacts to TCRs, but the City is not even updating its documents to address such evidence. (See *Save our Peninsula Committee v. Monterey County Board of Supervisors, supra*, 87 Cal.App.4th at 118 ["When the informational

requirements of CEQA are not complied with, an agency has failed to proceed in a manner required by law and has therefore abused its discretion.".)

To be sure, and to give the City the benefit of the doubt, we asked the City on May 2, 2023, to provide a copy of the confidential TCR appendix for this Project, if one was prepared, so that we could see if the City did in fact analyze the new information and update the record. As of the date of this letter, we have not received a confidential TCR appendix.

It is impermissible under CEQA for the City to make an impact determination without first determining the extent of the resource, and whether avoidance of the resource is feasible. (See *Agoura Hills, supra*, 46 Cal.App.5th at 684-690.) In *Agoura Hills*, similar to this Project, the City of Agoura Hills failed to identify and analyze a prehistoric archaeological site which was also a tribal cultural resource, as a TCR, despite being notified by public comments that fairly apprised the City of the concern that it had failed to adequately address project alternatives or mitigation measures that could preserve TCRs. As a result, the City was sued, and it lost. After considerable expense and a lengthy delay of the project, the City was required by the Court of Appeal to prepare an EIR.

The failure to analyze the Project's impacts to the identified TCRs violates CEQA's mandate to analyze all of the Project's direct and indirect impacts. (See Pub. Resources Code § 21065.3; see also CEQA Guidelines §§ 15064(d), 15065(a)(4) & 15358(a); *Protect the Historic Amador Waterways v. Amador Water Agency* (2004) 116 Cal.App.4th 1099, 1109 ["the agency must . . . consider any fair argument that a certain environmental effect may be significant"].) Without a doubt, the Tribe has raised a fair argument that from a tribal cultural resources perspective there is valuable information available about the TCR landscape as informed by the presence of TCRs on the site, and present on adjacent sites. To the extent that there is a conflict in the evidence, the City should not "weigh" the conflicting evidence to determine whether an EIR should be prepared. It should simply prepare an EIR. It is the function of an EIR, not an MND, to resolve conflicting claims based on substantial evidence, as to the environmental effects of a project. (*Agoura Hills, supra*, 46 Cal.App.5th at 690.)

THE MND FAILS TO ANALYZE CUMULATIVE IMPACTS ON TRIBAL CULTURAL RESOURCES

In enacting AB 52 (Gatto, 2015), the Legislature acknowledged that "a substantial adverse change to a tribal cultural resource has a significant effect on the environment," and consequently it sought to "[r]ecognize the unique history of California Native American tribes and uphold existing rights of all California Native American tribes to participate in, and contribute their knowledge to, the environmental review process pursuant to [CEQA]." The substantial change to TCRs and the need for tribal participation in the environmental review process for projects involving artifacts, remains, and ancestral lands is significant as to one project and this significance is amplified when numerous projects within the relatively small municipal boundaries of the City involve the same or similar TCR impacts. As courts recognize,

[c]umulative impact analysis is necessary because the full environmental impact of a proposed project cannot be gauged in a vacuum. One of the most important environmental lessons that has been learned is that environmental damage often occurs incrementally from a variety of small sources. These sources appear insignificant when considered individually, but assume threatening dimensions when considered collectively with other sources with which they interact.

(*Communities for a Better Environment v. California Resources Agency* (2002) 103 Cal.App.4th 98, 114, disapproved on other grounds in *Berkeley Hillside Preservation v. City of Berkeley* (2015) 60 Cal.4th 1086.) Impacts are cumulatively considerable if the effects of a project are significant when viewed in connection with the effect of past projects, other current projects, and probable future projects. (Pub. Resources Code § 21083(b)(2).) An EIR is required if a project will involve cumulatively significant impacts. (Pub. Resources Code § 21083(b).)

The City is located within the aboriginal territory of the Tribe, and it contains numerous documented and undocumented sites used and inhabited by Ancestors of Tribal members. Some of these sites are the oldest in California. Lake County in general, and the City of Clearlake area in particular, are incredibly archaeologically, historically, culturally, and tribal culturally significant. The City's own Cultural Resources report notes that there is a national monument which is a TCR only 0.6 miles away from the Project site, as well as multiple other TCRs within 0.5 miles from the Project site, yet there is no cumulative impact analysis of TCRs in the Project record. Many of these TCR sites have been, are currently, or will be subject to City projects including the present Project. These projects have resulted in, and will likely continue to result in, the discovery of Native American human remains and a significant number of TCRs and cultural artifacts associated with the Tribe such as occurred at the recent Austin Park Splash Pad project. The City's pattern and practice of engaging in development projects without full environmental analysis is creating a cumulative impact to TCRs which violates CEQA, and which is unethical and disrespectful to the Ancestors of people who are part of the Clearlake community. Thus, the City must fully examine such cumulatively considerable cultural impacts within the context of an EIR for this Project. Yet, contrary to the dictates of CEQA, the MND improperly lacks any cumulative impacts analysis, and such analysis must be included within the EIR's scope.

THE MND FAILS TO ANALYZE TURF IMPACTS

One significant aspect of the Project is the development of several sport fields. Initially, the City indicated these fields would use artificial turf. Such use raised a host of unaddressed impact issues as explained in detail in the Tribe's September 2, 2022, comment letter which is incorporated herein by reference. Rather than address such impacts, the current MND fails to acknowledge or discuss the surface areas of the sport fields. If the City intends to proceed with artificial turf, the significant impacts raised by the Tribe remain unaddressed. If the City intends to proceed with natural turf, it must address the significant water supply, drainage, and potential toxicity consequences of its revised plan and recirculate any environmental document. Additionally, there is Clearlake Hitch/Chi habitat in the Project area that is occupied habitat for this species, a rare and culturally significant fish which is presently being considered by the U.S. Fish and Wildlife Service for listing under the Endangered Species Act,¹ and which could be impacted by the Project including drainage from irrigation and surface areas into waterways and groundwater. Thus, deferred analysis is not appropriate, and an EIR is required to fully analyze and address these significant health and safety issues with impacts on both humans and wildlife. (See *Golden Door Properties, LLC v. County of San Diego* (2020) 50 Cal.App.5th 467, 520-521 [deferral of mitigation without objective and measurable standards or reasonable assurance an impact will be reduced is an error].)

¹ <https://biologicaldiversity.org/w/news/press-releases/californias-clear-lake-hitch-back-on-track-for-endangered-species-protections-2022-04-14/>

THE MND FAILS TO PROPERLY ANALYZE IMPACTS TO WATER RESOURCES

The MND indicates summarily that the Project would be served by Highland Mutual Water Company, but it contains no indication the Water Company has the capacity to serve Project needs. (MND, at 42.) This contrasts with the MND's statement as to sewage indicating the Project "would be served by Lake County Special Districts which has sufficient wastewater treatment capacity to service the project. (MND, at 42, emphasis added.) The MND simply states in bare conclusionary language, without any supporting analysis, that "[t]he project would have sufficient water supplies available to serve the project and [sic] reasonably foreseeable future." (MND, at 42.) The lack of water availability analysis renders any conclusions about water service incomplete and requires further analysis.² This is especially important since the MND fails to identify, discuss or analyze the sport fields surface areas which could have a significant demand on water use and availability. This vital issue requires analysis through an EIR.

THE MND FAILS TO PROPERLY ANALYZE TRAFFIC IMPACTS

The Project description indicates it will include "[d]evelopment of a public park (sports complex), community center, public works yard with public works building facility and combined police department office and maintenance facilities, vehicle and equipment storage areas, public access and parking facilities" (MND, at 3, emphasis added.) The traffic analysis section relies upon a Transportation Impact Study for the Burns Valley Development prepared by W Trans on June 22, 2022, and attached as Attachment E to the MND. The Study's "Project Profile" indicates: "[t]he project includes a public works corporation yard, a drive-through coffee shop, various recreational uses such as baseball, softball, and soccer fields as well as a 15,000 square-foot recreational center and a separate affordable multi-family residential project." Notably absent from the Study's project profile description is any indication that the Project includes a "police department office and maintenance facilities." Given this omission, it is unclear whether the Study includes traffic impacts arising from the police station and maintenance facilities. Absent a full analysis, the accuracy of the MND's traffic impact conclusions is called into doubt especially its conclusion that access and circulation are anticipated to function acceptably which are based upon the incomplete traffic study. (MND, at 40.) Additionally, the traffic study did not consider the traffic and public service impacts of having a police facility adjacent to a sports complex which potentially impacts the ability of first responders to provide emergency services when they must first navigate in and around a potentially crowded sports complex. Thus, the MND is incomplete. It has safety and traffic issues that are unaddressed, and it does not satisfy the City's CEQA obligations.

THE MND FAILS TO PROPERLY ANALYZE LIGHTING IMPACTS

The MND acknowledges that "[o]ne building [of the Oak Valley Villas housing complex] would be impacted by lighting during nighttime use of the sport field." (MND, at 19-20.) AES-1 simply directs that the Project shall comply with all federal, state, and local agency requirements. (MND, at 20.) However, the MND acknowledges that the "City does not have a threshold of significance for lighting levels." (MND, at 20.) Thus, the MND acknowledges the lighting will cause an impact, and directs, in part, that the Project must mitigate such impact by following an unspecified and

² While the subject to variables which would be analyzed in an EIR, turfgrasses can require one inch of water for irrigation per week. (<https://hgic.clemson.edu/how-often-should-a-lawn-be-watered>.) Since a baseball field and a soccer field will be at least five acres, this could require a significant amount of acre-feet of water annually for the playing fields alone.

undefined local requirement. Such a vague and ambiguous requirement for addressing this impact is meaningless and cannot support a valid MND. Mitigation measures must be specific enough to be implemented, and not deferred.

THE MND FAILS TO PROPERLY ANALYZE AIR QUALITY IMPACTS

The MND includes a finding that "unpaved roads were the largest source of particulate matter (PM) in the County" and "[m]ore than half of the area wide PM emissions come from travel on unpaved roads within the City." (MND, at 21.) AIR – 11 states that "[s]ignificant dust may be generated from increase vehicle traffic if driveways and parking areas are not adequately surfaced." (MND, at 24) AIR - 2 states "[d]riveways, access roads and parking areas shall be surfaced in a manner so as to minimize dust." (MND, at 23.) Based upon this mitigation, the MND concludes that "[o]nce fully operational, the proposed project would not generate volumes of criteria pollutants which may exceed thresholds of significance disclosed in the Bay Area Air Quality Management District Guidelines . . ." (MND, at 23.) As an initial matter, the MND fails to explain why it is appropriate to rely upon BAAQMD Guidelines for Lake County, which is outside of the BAAQMD's jurisdiction and inapplicable to a rural area such as Clearlake. Instead, the environmental review for this Project should focus on criteria considering the unique characteristics of the City. Additionally, while acknowledging the air quality impacts of unpaved roads, driveways, and other surfaces, the MND also states that driveways and parking lots will not be paved until 2024. (MND, at 63.) To the extent this encompasses the operational rather than the construction stage of the Project, the MND fails to address the impacts on air quality caused by these unpaved surfaces which will not be eliminated until at least 2024. The MND must address the air quality impacts of unpaved surfaces once the Project becomes operational.

THE MND FAILS TO PROPERLY ANALYZE WILDLIFE IMPACTS

The MND acknowledges that within the Project site "two special-status bats have potential or low potential to occur within the Study area" as well as "one special-status turtle." (MND, at 25.) BIO-1 simply indicates the Project will use BMP to reduce the potential for sediment or pollutants at the Project site. BIO-5 generally references a "Bat Management Plan outlining avoidance and minimization measures specific to the roost(s) potentially affected." Other mitigation measures deal with construction but not operational activities. Importantly, the Project admittedly contains large light installations to illuminate the sports fields. As the abstract of one journal noted, "[b]eing nocturnal, bats are among the taxa most likely to be affected by light pollution" and "[l]ight pollution affects the ecological interactions across a range of taxa, and has adverse effects on behaviors such as foraging, reproduction and communication." (80 Mammalian Biology (2015) Impacts of artificial lighting on bats: a review of challenges and solutions.) The MND is silent as to the impact of the lighting on the bat population. Additionally, as discussed above, the Project's multiple playing fields potentially comprised of artificial turf could generate toxic runoff, but the MND is silent on the impact of such toxic runoff on the special status turtle, let alone the Clearlake Hitch/Chi. The City must fully analyze these potential wildlife impacts within the scope of an EIR.

THE MND FAILS TO PROPERLY ANALYZE MIGRATION IMPACTS

According to the MND, "[t]he Study Area provides limited migratory opportunities for terrestrial wildlife. Project construction is likely to temporarily disturb and displace most wildlife from the Study Area. Some wildlife such as birds or nocturnal species are likely to continue to use the habitats opportunistically for the duration of construction. Once construction is complete, wildlife movements are expected to resume but will likely be more limited through the developed areas of the Study Area. The Project is not expected to substantially interfere with wildlife movement."

(MND, at 27.) However, the MND also purports to show a "perimeter fencing concept" for the Project with high chain link fencing topped by barbed wire. (MND, at 14.) Surrounding the Project perimeter with high barbed wire-topped fencing contradicts the statement that wildlife migration will face only minimal impacts once construction ends. The perimeter fence indicates a significant impact on terrestrial mitigation since wildlife will presumably no longer have access to a significant portion of the Project site. The City must fully explain and mitigate this impact through appropriate mitigation measures.

THE MND FAILS TO PROPERLY ANALYZE HAZARDS AND HAZARDOUS MATERIALS IMPACTS

The MND focuses on materials used during construction but also admits that "[s]mall quantities of hazardous materials would likely be routinely used on the site, primarily fertilizers, herbicides and pesticides." (MND, at 33.) However, the MND indicates the Project will include "[d]evelopments of a public park (sports complex), community center, public works yard with public works building facility and combined police department office and maintenance facilities, vehicle and equipment storage areas, public access and parking facilities" (MND, at 3, emphasis added.) Similarly, the police building on the Project site "would include a vehicle wash station, and sections for equipment repair . . . [t]his public works yard would be used to store and maintain city public vehicles including public works and police department cars, trucks and heavy equipment." (*Ibid.*) A public works yard and maintenance facilities will certainly use chemicals and potentially hazardous materials other than "fertilizers, herbicides and pesticides," and the City must analyze the use and disposal of these other potentially hazardous substances. These concerns coupled with hazardous substance concerns related to the potential artificial turf usage necessitate thorough analysis through an EIR.

THE MND FAILS TO PROPERLY ANALYZE NOISE IMPACTS

The MND attempts to limit noise impacts through NOI – 4 which restricts park operations to no later than 10 pm. (MND, at 37.) However, the noise study underlying the City's findings explains that "[a]t the time of the creation of this report and assessment the City of Clearlake has not sufficiently programmed the site nor provided the author of this report with any specific information on speaker location, mounting height, orientation, nor amplification metrics." (MND, at 81.) Lacking specific information, the Study relied upon assumptions and generalities to conclude that "[b]ased upon the anticipated duration of sporting events, e.g. summer weekends and evenings, and shoulder season (March through May) high school level sporting events, it can safely be stated that when averaged over a twenty-hour (24) hour period, the noise levels within these units would safely remain below HUD's required 45 dBA DNL standard." (MND, at 82, emphasis added.) Despite purporting to establish a mitigation measure, the City's consultant lacked concrete information on actual sound systems for the Project including speaker location, mounting height, orientation, and amplification metrics. Such information is necessary to establish a meaningful analysis rather than having to rely upon guesses, estimates, and assumptions as to the sound system's actual design. Additionally, listing noise based upon a 24-hour average is similarly meaningless since the noise level will be at or near zero at least during late night and early morning hours. Thus, a meaningful noise analysis requires information as to actual system design and must consider noise impacts throughout the day rather than rely on a 24-hour average.

At a minimum, a fair argument exists that there are substantial environmental impacts to each of these resource categories which lack any analysis or need further analysis, so the City must proceed to an EIR rather than adopt a defective MND. (*See Berkeley Hillside Preservation v. City of Berkeley, supra*, 60 Cal.4th at 1111.)

THE CITY FAILS TO COMPLY WITH ITS NEPA OBLIGATIONS

There is no apparent coordination of the City's CEQA process with the required National Environmental Policy Act ("NEPA") and Section 106 of the National Historic Preservation Act ("NHPA") process. Additionally, it is currently unclear which federal agency will be the lead agency for NEPA and NHPA purposes. The NEPA regulations provide that until the lead NEPA agency issues a Finding of No Significant Impact ("FONSI") or record of decision, "no action concerning the proposal may be taken that would: ... (2) Limit the choice of reasonable alternatives." (40 C.F.R. § 1506.1(a)(2).) Similar to NEPA, Section 106 of the NHPA prohibits an agency from "restrict[ing] the subsequent consideration of alternatives to avoid, minimize or mitigate the undertaking's adverse effects on historic properties." (36 C.F.R. § 800.1(c).) Likewise, "[t]he agency official shall ensure that the section 106 process is initiated early in the undertaking's planning, so that a broad range of alternatives may be considered during the planning process for the undertaking." (36 C.F.R. § 800.1(c).)

CEQA Guidelines instruct that CEQA and NEPA should be coordinated: "local agencies should cooperate with federal agencies to the fullest extent possible to reduce duplication between [CEQA] and [NEPA,]" including joint planning, joint environmental research and studies, joint public hearings, and joint environmental documents. (Cal. Code of Regs., tit.14, § 15226.) If a lead agency finds that NEPA review documents would not be prepared by the time the lead agency will need to consider CEQA review documents, "the lead agency should try to prepare a combined EIR-EIS or negative declaration-finding of no significant impact." (Cal. Code of Regs., tit.14, § 15222.) To do that, "the lead agency must involve the federal agency in the preparation of the joint document." (*Ibid.*) CEQA requires that if the City plans to prepare a joint document with a federal agency, it must consult with the federal agency as soon as possible. (Cal. Code of Regs., tit.14, § 15223.)

Adopting an MND and/or a Conditional Use Permit ("CUP") without coordinating review under NEPA and Section 106 of the NHPA could limit the choice of reasonable alternatives under NEPA and prevent the City from considering a broad range of alternatives under the NHPA. Adopting an MND/CUP under CEQA limits the City to one path forward for the Project and prevents the City from considering other alternative options under NEPA or the NHPA. The City is required to undertake the Section 106 process early in its project planning so that the Section 106 findings can inform the environmental review process and decisions. Committing the City to a particular project without any Section 106 input forecloses that possibility. Adopting an MND and CUP now constrains the City's ability to keep its options open, which is a violation of NEPA and NHPA.

Coordination between the CEQA process and the NEPA and NHPA processes is so crucial to project planning that the CEQA Guidelines emphasize the importance and instruct on how to coordinate. Under CEQA, coordination with federal agencies should be to the fullest extent possible throughout the entire process. To reduce duplication, CEQA encourages lead agencies like the City to prepare combined CEQA-NEPA documents if the federal agency will not prepare the NEPA review documents in time. If a joint document is prepared, CEQA requires the CEQA lead agency to consult with the federal agency as soon as possible. The City has made no apparent effort to reduce duplication between the CEQA and NEPA processes or to consult with the federal agency, as the proper agency under NEPA has not even been identified yet.

The Commission inappropriately rushed to adopt an MND/CUP, putting the City at risk of violating CEQA, NEPA, and NHPA. Violating these laws, even at this early procedural stage, can result in invalidation of the Project approvals. The Tribe therefore requests that the Council rescind the Commission's decision to adopt the MND/CUP, and instead instruct its staff to take the proper

Mayor and City Council
May 4, 2023
Page 11

steps to coordinate its CEQA, NEPA, and NHPA review in order to properly evaluate the Project in conjunction with its preparation of an EIR.

CONCLUSION

As set forth above, the City's proposed MND is defective and fails to comply with CEQA in numerous respects, and such defects can only be cured if the City Council rejects the Commission's MND approval and directs preparation of an EIR.

Please enter this letter into the administrative record for this Project. We also request that the City notify us via email to kn@koination.com, rgeary@hpultribe-nsn.com, and hroberson@kmtg.com and mail of the public hearing for this Project, so that the Tribe and its Tribal Historic Preservation Officer and Tribal Cultural Resources Counsel can submit further and updated comments on the record and can arrange for submission of the confidential information for the Council's consideration.

Thank you for your anticipated consideration of these matters. Again, we remain willing to engage in further good faith, meaningful consultations with the City. Please also feel free to reach out to the Tribal representatives, Robert Geary or Holly Roberson, at the emails noted above, if you have questions or wish to discuss this matter prior to the City Council appeal hearing.

Respectfully,



Chairman Darin Beltran
Koi Nation of Northern California

Attachment
cc w/attach.:

- Merri Lopez-Keifer, Director of the Attorney General's Office of Native American Affairs
- Raymond Hitchcock, Native American Heritage Commission Executive Director
- Mario Pallari, Native American Heritage Commission Counsel
- Julianne Polcano, State Historic Preservation Officer
- Mathew Brady, Caltrans District 1 Director
- Leslie Hartzell, Chief of the Cultural Resources Division, California State Parks
- Ryan Jones, City Attorney
- Andrew Skanchy, City CEQA Attorney
- Holly Roberson, KOI Nation Tribal Cultural Resources Counsel

RECEIVED

MAY 04 2023

CITY OF CLEARLAKE

ATTACHMENT 1

04/23/2023

Koi Nation of Northern California's Proposal to City of Clearlake Planning Commission
Revisions to Burns Valley Sports Complex Project Conditions of Approval/Mitigation Measures

Section E- CULTURAL/~~Tribal Resources~~:

1. *(Mitigation Measure CUL-1)* During construction activities, if any subsurface archaeological remains are uncovered, all work shall be halted within 100 feet of the find and the owner shall utilize a qualified cultural resources consultant to identify and investigate any subsurface historic remains and define their physical extent and the nature of any built features or artifact-bearing deposits.
2. *(Mitigation Measure CUL-2)* The cultural resource consultant's investigation shall proceed into formal evaluation to determine their eligibility for the California Register of Historical Resources. This shall include, at a minimum, additional exposure of the feature(s), photo-documentation and recordation, and analysis of the artifact assemblage(s). If the evaluation determines that the features and artifacts do not have sufficient data potential to be eligible for the California Register, additional work shall not be required. However, if data potential exists – e.g., there is an intact feature with a large and varied artifact assemblage – it will be necessary to mitigate any Project impacts. Mitigation of impacts might include avoidance of further disturbance to the resources through Project redesign. If avoidance is determined to be infeasible, pursuant to CEQA Guidelines Section 15126.4(b)(3)(C), a data recovery plan, which makes provisions for adequately recovering the scientifically consequential information from and about the historical resource, shall be prepared and adopted prior to any excavation being undertaken. Under no circumstances will destructive data testing be allowed on a tribal cultural resource. Such studies shall be deposited with the California Historical Resources Regional Information Center within 90 days of completion of the Project. Archeological sites known to contain human remains shall be treated in accordance with the provisions of Section 7050.5 Health and Safety Code. If a historic ~~n~~-artifact must be removed during Project excavation or testing, curation may be an appropriate mitigation. Under no circumstances will curation be allowed on a tribal cultural resource. This language of this mitigation measure shall be included on any future grading plans and utility plans approved by the City for the Project.
3. *(Mitigation Measure CUL-3)* If human remains are encountered, no further disturbance shall occur within 100 feet of the vicinity of the find(s) until the Lake County Coroner has made the necessary findings as to origin (California Health and Safety Code Section 7050.5). Further, pursuant to California Public Resources Code Section 5097.98(b) remains shall be left in place and free from disturbance until a final decision as to the treatment and disposition has been made. If the Lake County Coroner determines the remains to be Native American, the Native American Heritage Commission must be contacted within 24 hours. The Native American Heritage Commission must then identify the “most likely descendant(s)”. The landowner shall engage in consultations with the most likely descendant (MLD). The MLD will make recommendations concerning the treatment of the remains within 48 hours as provided in Public Resources Code 5097.98.]
4. *(Mitigation Measure CUL-4)* The sensitive site section noted on the project site plan shall not be disturbed during construction and/or maintenance of the park. This sensitive site

04/23/2023

Koi Nation of Northern California's Proposal to City of Clearlake Planning Commission

Revisions to Burns Valley Sports Complex Project Conditions of Approval/Mitigation Measures

is identified as investigation resulted in the discovery of two intact, buried, archaeological sites, CCL-21-01 and CCL-21-02 (Figure 7, yellow polygons), both of the sites can be considered significant cultural resources. Both of the sites occupy relatively small areas and are buried at depths of 16–32 inches below grade. The project as currently designed, will not impact sites CCL-21-01 or CCL-21-02. If avoidance and/or preservation in place is not possible, the owner will consider re-design or other measures to avoid impacting resources consistent with CEQA. The owner will contract with tribal monitors designated by the Consulting Tribe for ground disturbance within 100 feet of sites CCL-21-01 and CCL-21-02. The owner and contract archeologist will consult with tribal representatives from the Consulting Tribe regarding ground disturbing work within these areas including the designation before construction begins of a “reburial” location on site, if needed.

5. (Mitigation Measure CUL-5) On or prior to the first day of construction the owner shall organize cultural sensitivity training for contractors involved in ground disturbing activities.
6. (Mitigation Measure CUL-6) The southern two-thirds of site CCL-21-01 is contained within APN010-026-400-000 and the Burns Valley Development Project area. The area occupied by the site has been slated for a paved parking area serving planned playing fields nearby (Figure 2). This portion of the site is situated on the sloping bank of an extinct section of upper Miller Creek, an area marked by an overstory of mixed native oak and introduced conifer and hardwood trees. Because this part of the site is situated on a bank, the land surface is sloped and drops 10–15 feet in elevation. Current engineering plan calls for vegetation and tree removal as well as application of remote fill materials to bring it to a level grade, with installation of landscaping, drains, and underground utility lines in the area. Project revisions in design, location, and operations should be implemented in the area occupied by the footprint of site CCL-21-01, inclusive to a 15-foot (4.5- meter) buffer around the site perimeter. Limitations to disturbance in this area shall be as follows:
 - *Fill Cap.* Because CCL-21-01 is a buried archaeological deposit contained in a dense clay loam likely to resist compaction impacts, avoidance can be achieved by placing fill on the site surface;
 - *Flush Cut Vegetation.* Existing vegetation including shrubs and trees should be flush- cut, i.e., cut flush with the ground at a point not to exceed 10-inches below grade;
 - *Landscaping Fabric and Fill.* Once the flush cut is complete and surface cleared of debris, landscaping fabric should be laid over the area of the site to create a boundary between intact soils and remote fill. With respect to the fill, drainage, safety, and operational concerns may prevent adding a lot of elevation; however, an additional minimum 6–12-inches (15–30 centimeters) of fill should be added to the site area to provide a construction and compaction buffer to protect the deposit. This would result in an overburden of 21–27 inches (53–71 centimeters) of capping material. Only culturally sterile fill will be used on the Project;
 - *Avoid Installation of Subsurface Features.* Avoid placement of pier supports, subsurface landscaping features, subsurface drains, and utility lines in the site area.

04/23/2023

Koi Nation of Northern California's Proposal to City of Clearlake Planning Commission
Revisions to Burns Valley Sports Complex Project Conditions of Approval/Mitigation Measures

- *Avoid New Overstory Plantings.* Avoid placement of new overstory trees in the site area.

7. (Mitigation Measure CUL-7) Site CCL-21-02 is contained within APN010-026-400-000 and the Burns Valley Development Project area. The area occupied by the site has been slated for open space. Project revisions in design, location, and operations should be implemented in the area occupied by the footprint of site CCL-21-02, inclusive to a 15-foot (4.5-meter) buffer around the site perimeter. Limitations to disturbance in this area shall be as follows:

1. *Fill Cap.* Because CCL-21-01 is a buried archaeological deposit contained in a dense clay loam likely to resist compaction impacts, avoidance can be achieved by placing fill on the site/buffer surface;

2. *Landscaping Fabric and Fill.* Prior to site prep and construction in the area, landscaping fabric should be laid over the area of the site to create a boundary between intact soils and remote fill. With respect to the fill, drainage, safety, and operational concerns may prevent adding a lot of elevation; however, an additional minimum 6–12-inches (15–30 centimeters) of fill should be added to the site area to provide a construction and compaction buffer to protect the deposit. This would result in an overburden of 21–27 inches (53–71 centimeters) of capping material;

3. *Avoid Installation of Subsurface Features.* Avoid placement of pier supports, subsurface landscaping features, subsurface drains, and utility lines in the site area.

4. *Avoid New Overstory Plantings.* Avoid placement of new overstory trees in the site area.

8. (Mitigation Measure CUL-8) For resources which are both a tribal cultural resource and a cultural resource, the tribal cultural resource mitigation measures shall control. The Consulting Tribe will determine which resources are tribal cultural resources.

Section J- TRIBAL CULTURAL RESOURCES

1. (Mitigation Measure TCR-1): Requirement to develop a tribal cultural resources preservation plan that applies to all tribal cultural resources on the Project site, including resources which are also a cultural resource, and delineates the boundary of CCL-21-01 and CCL-21-02 without further disturbance, describes the appropriate combination of materials and culturally sterile fill in capping, provides landscaping specifications that favor culturally important plants, and ~~restricts-prohibits certain-any~~ types of post-project activities in or on the cap that intrude past the cap. The tribal cultural resources preservation plan must be agreed to in writing by the Koi Nation of Northern California ("Consulting Tribe") and the City and completed before any permit is issued.

04/23/2023

Koi Nation of Northern California's Proposal to City of Clearlake Planning Commission
Revisions to Burns Valley Sports Complex Project Conditions of Approval/Mitigation Measures

2. *(Mitigation Measure TCR-2):* Requirement to designate a project reburial area on the Project site in advance of ground disturbing activities, in the event that tribal cultural resources materials are discovered during construction. The reburial area shall be in a mutually agreed upon location with the Consulting Tribe and capped after ground disturbance is complete.
3. *(Mitigation Measure TCR-3):* Requirement for each contractors engaged in ground disturbing activities to receive meaningful training on tribal cultural sensitivity and tribal cultural resources one time and prior to the beginning of work, from a tribal representative designated by the Consulting Tribe.
4. *(Mitigation Measure TCR-4):* Requirement for tribal monitoring during ground disturbing activities in sensitive areas of the project area. The Tribal Monitoring Agreement must be agreed to by the Consulting Tribe and the City in writing and completed before any permits are issued.
5. *(Mitigation Measure TCR-5):* ~~Procedures for compliance~~ The Project shall comply with existing state law in the event of the discovery of Native American human remains during ~~construction~~ ground disturbance.
6. *(Mitigation Measure TCR-6):* ~~A prohibition on the R~~ removal of tribal cultural soils from the project area is prohibited. Tribal cultural soils shall be designated by the Consulting Tribe in consultation with the Project Archeologist.

CONDITIONS OF APPROVAL

7. Requirement for City staff to organize a discussion within 10 days of project approval with the Consulting Tribe and the City Council to exercise its independent discretion on naming part or all of the facility with an appropriate tribal name, such as Kula'i, if it so chooses.
8. Requirement to develop and install tribal culturally appropriate interpretive signage to educate the public about the tribal cultural significance of the area. The culturally appropriate verbiage of the signage shall be provided by the Consulting Tribe.
9. Requirement to allow free access to the Project facilities for tribal cultural events by the Consulting Tribe up to four times per year, pursuant to the same application process of other events at City facilities.
10. Commitment by the City to meaningful consultation with any requesting federally recognized Southeastern Pomo Tribe as a consulting party under Section 106 of the National Historic Preservation Act or National Environmental Policy Act, if applicable.



Receipt Number:

R00

Section 1, Item 5.

Cashier Name:

Register Operator

Terminal Number:

2

Receipt Date: 5/4/2023 5:40:23 PM

RECEIVED

MAY 04 2023

APCC 2023-01

CITY OF CLEARLAKE

Trans Code: 106 - Planning/Zoning **Name: PLANNING COMISSION APPEAL 2023-01** **\$880.00**
 Product: PLANNING/ZONING Units: 0.00 Amount: 880.00
 PLANNING COMISSION APPEAL 2023-01 880.00
 PLANNING/ZONING 880.00
 100-414-510 -880.00

Trans Code: 224 - CREDIT CARD PROCESSING FEE **Name: CC Processing Fee** **\$27.69**
 Product: CREDIT CARD PROCESSING FEE Units: 0.00 Amount: 27.69
 224 27.69

Trans Code: 226 - GENERAL PLAN MAINTENANCE **Name: Miscellaneous Receipt** **\$25.00**
 Product: GENERAL PLAN MAINTENANCE Units: 0.00 Amount: 25.00
 Miscellaneous Receipt 25.00
 GENERAL PLAN MAINTENANCE 25.00
 100-417-895 -25.00

Trans Code: 225 - TECH FEE **Name: Miscellaneous Receipt** **\$18.10**
 Product: TECH FEE Units: 0.00 Amount: 18.10
 Miscellaneous Receipt 18.10
 TECH FEE 18.10
 100-416-895 -18.10

Total Balance Due: \$950.79

Payment Method: CREDIT CAF Payor: APCC 2023-01 Reference: Visa-Authorized Amount: \$950.79

Total Payment Received: \$950.79

Change: \$0.00

Cardmember acknowledges receipt of goods and/or services in the amount of the total shown hereon and agrees to perform the obligations set forth by the cardmember's agreement with the issuer.

X _____

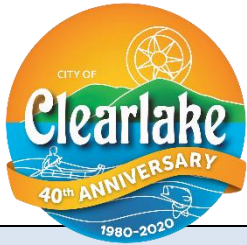

STAFF REPORT	
SUBJECT: Burns Valley Development Complex <ul style="list-style-type: none"> Environmental Analysis (CEQA-IS 2022-05) Conditional Use Permit (CUP 2022-16) 	MEETING DATE: April 25th, 2023
SUBMITTED BY: Mark Roberts, Senior Planner	
PURPOSE OF REPORT: <input type="checkbox"/> Information only <input type="checkbox"/> Discussion <input checked="" type="checkbox"/> Action Item	

WHAT IS BEING ASKED OF THE CITY COUNCIL/BOARD:

The Planning Commission is being asked to consider Mitigated Negative Declaration based on Environmental Analysis, IS 2022-05 (in accordance with CEQA) and Conditional Use Permit, CUP 2022-16 to allow the Burns Valley Sports Complex located at 14885 Burns Valley Road; Clearlake, CA 95422 further described as Assessor Parcel Number 010-026-40-000.

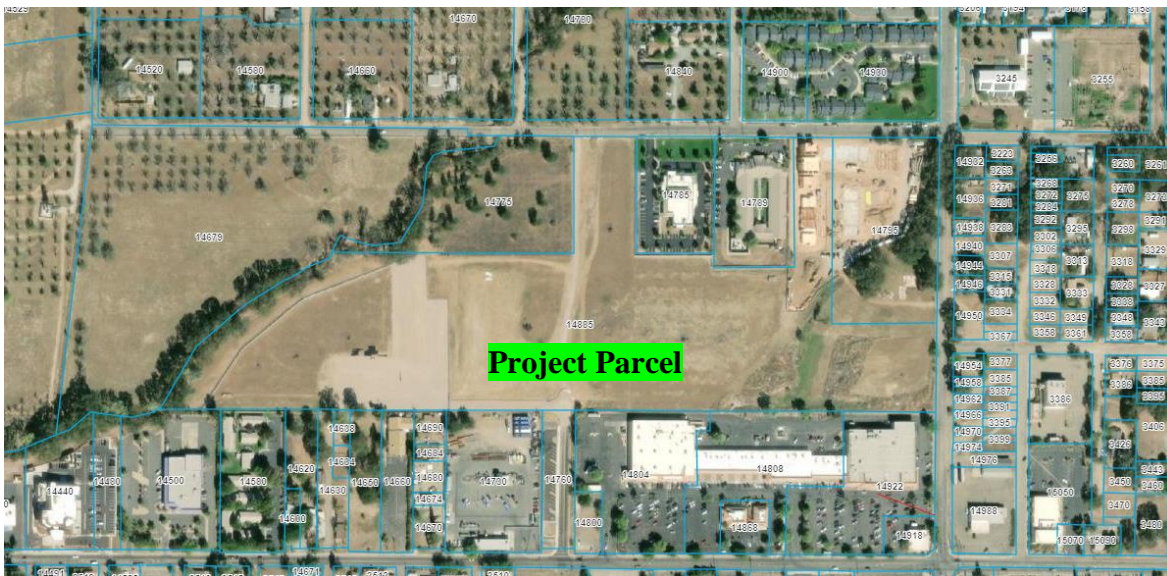

BACKGROUND/DISCUSSION:

The project parcel is approximately 25.46 acres in size and located in the Burns Valley Area, north of Olympic Drive and South of Burns Valley Drive, behind the Safeway Shopping Center. The Burns Valley Sports Complex Project includes but is not limited:

- One full size baseball field
- One little league baseball field
- One tee-ball field
- One softball field
- A multi-sport field (i.e. soccer)

- Fitness equipment area
- Picnic areas
- Central community gathering area
- Indoor recreation center
- ADA accessible playground
- Walking paths/trails
- Native plant demonstration area

The project would involve the development of a 15,000 to 20,000 square foot recreation center building to be used for public events/activities. This building would contain sports features, such as basketball and volleyball courts. There would be approximately 334 parking spaces throughout the development. Additional improvements would include sidewalks, fencing, lighting features, sport field protective netting and restroom facilities. All play fields will include lighting to allow for night operations.

Access to the project would be from Olympic Drive and Burns Valley Road.

Environmental Setting:

The project area is relatively flat with gently rolling terrain situated at an elevational range of approximately 1,350 to 1,365 feet above mean sea level (MSL) in the Inner North Coast Ranges District of the California Floristic Province (Baldwin et al. 2012).

The parcel is an irregularly shaped 25.46-acre parcel generally composed of open landscape, existing tree orchard and grasses. A drainage channel transects the eastern portion of the parcel in the southwest direction. The property is surrounded by vacant parcels to the north and northeast; there is a multifamily residential development located to the south and southeast; there is retail (Rite Aid) to the southwest, and professional offices (Bank of the West) and [Shopping Plaza – Grocery Outlet, Safeway Plaza, Coffee Shop, Pet Store, etc.] to the West.

GENERAL PLAN CONSISTENCY, AND ZONING AND DESIGN STANDARDS COMPLIANCE:

General Plan Consistency: The General Plan identifies the project site for Medium Density Residential

GOAL LU 1: Grow a Sustainable Community:

- Objective LU 1.1: Maintain an appropriate mix of land uses.
 - *Policy LU 1.1.1: The City should grow contiguously to manage the efficiency of public services and municipal infrastructure provision, to maintain a compact and well-defined community form, and to oblige its fiscal responsibility.*
 - *Policy LU 1.1.3: Future development and redevelopment should be planned and implemented with appreciation for the physical environment and natural features of the community and with recognition of potential physical constraints to ensure appropriate siting of various types of development.*
 - *Policy LU 1.1.4: Walkability and good connectivity should be promoted through continuity of the street and pedestrian system, together with a compact community form.*
 - *Policy LU 1.1.10: Schools, parks, golf courses and community facilities should be located close to or within residential neighborhoods for accessibility and to provide a focal point for effective and cohesive neighborhood design.*

Zoning Ordinance Consistency/Regulations:

The proposed operation would involve Public Assemblies, Outdoor Recreation, and a Impound Yard, which requires a Conditional Use Permit Pursuant to Section 18.18.030 of the City Municipal Code. Upon review of the submitted application, including the environmental analysis, staff has determined the proposed development to be in conformance with all applicable regulations with the incorporated Mitigation Measures and Conditions of Approval.

To grant a discretionary permit, the Director, Planning Commission, or City Council, the review authority find that the proposed use will not be detrimental to the health, safety or welfare of persons working or living at the site or within the vicinity. The Director, Planning Commission or Council may deny the proposal or attach conditions as deemed necessary to secure the purposes of these regulations. Actions on use permits shall be justified by written findings, based on substantial evidence in view of the whole record (Section 18-28.040, Findings).

ENVIRONMENTAL REVIEW (CEQA):

Mitigated Negative Declaration based on Initial Study, IS 2022-05.

Pursuant to California Environmental Quality Act (CEQA) Guidelines, staff prepared an Initial Study to assess the potential adverse environmental effects of the proposed Project. The study concludes that any potentially significant adverse environmental impacts from the project would be reduced to a level of non-significance with the incorporated Mitigation Measures and Conditions of Approval.

Note: Additional mitigation measures have been added to reconfirm the protocols for avoidance and capping of the sensitive sites. These mitigation measures do not create new significant environmental effects and are not necessary to mitigate an avoidable significant effect. Thus, pursuant to CEQA Guidelines Section 15073.5, of CEQA Guidelines, recirculation of the MND is not required.

The Mitigated Negative Declaration based on Initial Study, IS 2022-05, were noticed and circulated in accordance with CEQA, and in compliance with Section 15070-15075 of the CEQA State Guidelines, by:

- ❖ *Circulation of the Notice of Intent (NOI) for the environmental analysis/proposed Mitigated Negative Declaration (CEQA Initial Study, IS 2022-05) was published in the Lake County Record Bee and sent to the State Clearinghouse; Various Federal, State, and local agencies/organizations for the minimum of a 30-day commenting period from July 19th, 2022, through August 19th, 2022. The document was also uploaded onto the City's Website and made available upon request. The following agencies commented on the project during the appropriate review period.*
 - *Lake County Fire Protection District dated July 20th, 2022.*
 - *Lake County Environmental Health Department dated July 22nd, 2022.*
 - *California Department of Transportation dated August 2nd, 2022.*
 - *Requested a copy of the Traffic Analysis on August 2, 2022, and on August 4, 2022, a copy was emailed to Caltrans for their review. No further comments were received from Caltrans.*
 - *Lake County Special Districts dated August 9th, 2022.*
 - *Central Valley Regional Water Quality Control Board dated August 19th, 2022.*
 - *Koi Nation of Northern California dated September 2nd, 2022.*
- ❖ *A Notice of Intent (NOI) was mailed (via USPS) to the surrounding parcels owners within 300 feet of the subject property informing them of the City's decision to adopt a Mitigated Negative Declaration for the proposed use and that there is a 30-day commenting period on the environmental document from July 19th, 2022, through August 19th, 2022.*

PLANNING COMMISSION SUMMARY:

This project was initially reviewed by the Planning Commission on September 27, 2022. November 16, 2022. At this meeting the Planning Commission directed staff to perform additional tribal consultation with the Koi Nation related to their concerns over the project. Staff as well as the Mayor and Chair of the Planning Commission met with tribal representatives on two occasions, October 12, 2022 and October 20, 2022. The City and tribe agreed to a new Planning Commission hearing date of November 16, 2022. However agreement on mitigation measures was not reached and that hearing was cancelled. After much back and forth on March 21, 2023 the City notified the tribe of the conclusion of consultation without agreement. However, as part of the consultation process, the

City revised the Tribal and Cultural Resource Mitigation Measures. The revised Mitigation Measures follows:

- *TCR-1: Requirement to develop a tribal cultural resources preservation plan that delineates the boundary of CCL-21-01 and CCL-21-02, describes the appropriate combination of materials and culturally sterile fill in capping, provides landscaping specifications that favor culturally important plants, and restricts certain types of post-project activities in or on the cap.*
- *TCR-2: Requirement to designate a project reburial area in advance of ground disturbing activities in the event that materials are discovered during construction.*
- *TCR-3: Requirement for contractors to receive meaningful training on cultural sensitivity and tribal cultural resources from a tribal representative.*
- *TCR-4: Requirement for tribal monitoring during ground disturbing activities in sensitive areas of the project area.*
- *TCR-5: Procedures for compliance with existing state law in the event of the discovery of human remains during construction.*
- *TCR-6: A prohibition on the removal of cultural soils from the project area.*

On December 2nd, 2022, the City sent the revised Mitigation Measures/Conditions of Approval for tribal representatives for review and received comments from Tribal Representatives on February 15th, 2023.

The extended consultation process resulted in significant modifications to the mitigation measures, and the design of the project, was carried out in good faith with reasonable effort. As indicated in the letter dated March 21, 2023, to tribal representatives, the City formally concluded tribal consultation under CEQA and AB 52 per Section 21080.3.2(b)(2) of the Government Code.

PUBLIC HEARING LEGAL NOTICE

The public hearing was noticed at least ten (10) days in advance in an electronic publication with the Lake County Record Bee on **Saturday, April 15th, 2023**; and mailed (via USPS) to all surrounding property owners within 300 feet of the subject parcel(s) as required pursuant to the Clearlake Municipal Code.

- *All mailing address are drawn from the electronic database supplied by the Lake County Assessor/Recorders Office Database.*
- *The City did not receive any written public concerns regarding the project and/or legal notice.*

MOTION/OPTIONS:

1. Move to Adopt Resolution PC 2023-01, A Resolution of the Planning Commission of the City of Clearlake Adopting a Mitigated Negative Declaration based on Environmental Analysis, IS 2022-05 and approving Conditional Use Permit Application, CUP 2022-16 to authorize the development of the Burns Valley Development Project located at 14885 Burns Valley Road, Clearlake, CA 95422, further described as Assessor Parcel Number 010-026-40-000.
2. Move to Deny Resolution PC 2023-01 and direct staff to prepare appropriate findings.
3. Move to continue the item and provide alternate direction to staff.

ATTACHMENTS:

- 1) PC Resolution PC 2023-01 with Conditions of Approval
- 2) Proposed Concept Master Plan
- 3) CEQA Initial Study, IS 2022-05
- 4) CEQA Attachments "A through G"
- 5) CEQA Attachment Geotechnical Report
- 6) Agency Comments
- 7) Public Comment

8) Mitigation Monitoring Reporting Program (MMRP)

Section I, Item 5.

RESOLUTION NO. PC 2023-01

**A RESOLUTION OF THE PLANNING COMMISSION OF THE CITY OF CLEARLAKE,
CALIFORNIA ADOPTING MITIGATED NEGATIVE DECLARATION (BASED ON
ENVIRONMENTAL ANALYSIS - INITIAL STUDY, IS 2022-05) AND CONDITIONAL USE
PERMIT, CUP 2022-16 FOR THE DEVELOPMENT OF THE BURNS VALLEY
DEVELOPMENT LOCATED AT 14885 BURNS VALLEY ROAD, CLEARLAKE,
CALIFORNIA, APN: 010-026-40-000.**

WHEREAS, City of Clearlake, California (*Owner/Developer/Operator*), applied for approval of a Mitigated Negative Declaration (Based on Environmental Analysis, IS 2022-05) and Conditional Use Permit (CUP 2022-16) for the development of the Burns Valley Development located at 14885 Burns Valley Road, further described as Assessor Parcel Number 010-048-40-000: and

WHEREAS, the zoning designation is “MUX” Mixed Use. As conditioned, the proposed use would be consistent with the allowable uses in the MUX Zoning Designation; and

WHEREAS, the General Plan Designates the project site as “MDR” Medium Density. As conditioned, the proposed use would be consistent with the General Plan; and

WHEREAS, the project is found to comply with the Zoning Codes as conditioned (*Refer to Enclosed Exhibit A*) by this use permit; and

WHEREAS, the Conditional Use Permit, CUP 2022-16 would allow Public Assemblies, Outdoor Recreation, and a Impound Yard, Pursuant to Section 18.18.030 of the City Municipal Code; and

WHEREAS, in accordance with Section 18.14.445 (b) of the Zoning Code the use as proposed will not be detrimental to the health, safety, convenience, or general welfare of persons residing or working in the vicinity, or injurious to the property, improvements or potential development in the vicinity with respect to aspects including, but not limited to, the following:

- (a) *The nature of the proposed site, including its size and shape, and the proposed size, shape, and arrangement of structures.*
- (b) *The accessibility and traffic patterns for persons and vehicles, the type and volume of such traffic and the adequacy of proposed off-street parking and loading.*
- (c) *The safeguards afforded to prevent noxious or offensive emissions such as noise, glare, dust and odor;*
- (d) *Treatment given, as appropriate, to such aspects as landscaping, screening, open spaces, parking areas, loading areas, service areas, lighting, and signs; and*

WHEREAS, the City has completed Tribal Consultation in accordance with CEQA and AB 52 and per Section 21080.3.2(b)(2), and formally concluded tribal consultation per Section 21080.3.2(b)(2) of the Government Code as indicated in the letter to tribal representative on March 21st, 2023, and

WHEREAS, the project underwent environmental review (Initial Study, IS 2022-05) subject to the California State Environmental Quality Act (CEQA) Guidelines, and a Mitigated Negative Declaration has been prepared, and adopted; and as evidenced by the following:

1. The initial study and Mitigated Negative Declaration were properly noticed and circulated in compliance with the California Environmental Quality Act of 1970, and in compliance with Section 15070-15075 of the CEQA State Guidelines, by:

- *Circulation of the Notice of Intent (NOI) for the environmental analysis/proposed Mitigated Negative Declaration (CEQA Initial Study, IS 2022-05) was published in the Lake County Record Bee and sent to the State Clearinghouse; Various Federal, State, and local agencies/organizations for the minimum of a 30-day commenting period from July 19th, 2022, through August 19th, 2022. The document was also uploaded onto the City’s Website and made available upon request.*
- *A Notice of Intent (NOI) was mailed (via USPS) to the surrounding parcels owners within 300 feet of the subject property informing them of the City’s decision to adopt a Mitigated Negative Declaration for the proposed use and that there is a 30-day commenting period on the environmental document from July 19th, 2022, through August 19th, 2022.*
- *Additional mitigation measures have been added in order to reconfirm the protocols for avoidance and capping of the sensitive sites. These mitigation measures do not create new significant environmental effects and are not necessary to mitigate an avoidable significant effect. Thus, pursuant to CEQA Guidelines section 15073.5, recirculation of the MND is not required*

WHEREAS, environmental review (Initial Study, IS 2022-05) was prepared in accordance with the California Environmental Quality Act (CEQA), which shows substantial evidence, in light of the whole record, that the project will not result in a significant environmental impact with the incorporated Mitigation Measures/Conditions of Approval and, hereby adopts a Mitigated Negative Declaration (MND) and authorizes staff to file a Notice of Determination in compliance with CEQA.

WHEREAS, if any section, division, sentence, clause, phrase, or portion of this resolution is for any reason held to be invalid or unconstitutional by a decision of any court of competent jurisdiction, such decision shall not affect the validity of the remaining provisions.

WHEREAS, on **April 25th, 2023**, the Planning Commission of the City of Clearlake held a duly noticed public hearing at which interested persons had the opportunity to testify and at which the Planning Commission considered the proposed development; and

WHEREAS, adequate public noticing was made for the project in accordance with the Municipal Code; and

NOW, THEREFORE, BE IT RESOLVED by the Planning Commission of the City of Clearlake that the project is hereby approved, subject to the following conditions being satisfied:

PASSED AND ADOPTED on this **25th day of April 2023**, by the following vote:

- AYES:
- NOES:
- ABSENT:
- ABSTAIN:

Chairperson, Planning Commission

ATTEST:

City/Deputy Clerk, Planning Commission

EXHIBIT A

CONDITIONS OF APPROVAL CONDITIONAL USE PERMIT, CUP 2022-16 INITIAL STUDY, IS 2022-05

Burns Valley Development Project

Pursuant to the approval of the Planning Commission on **April 25th, 2023**, there is hereby granted to **City of Clearlake**, a **Mitigated Negative Declaration (based on CEQA Analysis IS 2022-05) and Conditional Use Permit CUP 2022-16 with the following conditions of approval to allow the Burns Valley Development** located at **14885 Burns Valley Road, Clearlake, CA 95422 further described as APN: 010-026-40-000** is subject to the following terms and conditions of approval.

SECTION A: GENERAL CONDITIONS:

1. The use hereby permitted shall substantially conform to the Site Plan(s), and Project Description and any conditions of approval imposed by the above Conditional Use Permit as shown on the approved site plan for this action dated **April 25th, 2023**.
2. All handicap parking areas, routes of travel, building access and bathrooms shall meet American with Disabilities Act (ADA) requirements and be subject to review and approval of a Certified Accessibility Access Specialist (CASP).
3. **Prior to operation**, the permit holder shall meet and operate in full compliance with fire safety rules and regulations of the Lake County Fire District.
4. The operation shall not exceed the maximum occupancy as prescribed by the California Building Code.
5. Any modifications and/or additions to a use requiring use permit approval shall itself be subject to use permit approval. The addition of an allowed use to a premise occupied by a conditionally allowed use shall require use permit approval of the type required for the existing use. The Community Development Director shall determine when such an addition and/or change is of such a minor or incidental nature that the intent of these regulations can be met without further use permit control
6. The California Department of Fish & Wildlife filing fee shall be submitted as required by California Environmental Quality Act (CEQA) statute, Section 21089(b) and Fish and Game Code Section 711.4. **The fee should be paid within five (5) days of approval of the mitigated negative declaration at the Lake County Clerk's Office.** Once fees have been paid, the applicant shall submit a copy of all documentation to the City of Clearlake, verifying the fees have been paid. **Said permit shall not become valid, vested or operative until the fee has been paid, including the issuance of any permits.**

SECTION B. AESTHETICS:

1. *(Mitigation Measure AES-1)* All outdoor lighting shall be directed downwards and shielded onto the project site and not onto adjacent properties. All lighting shall comply and adhere to all federal, state and local agency requirements, including all requirements in darksky.org. (Refer to the City's Design Standards).
2. *(Mitigation Measure AES-2)* A final lighting design plan shall be submitted for review and approval by the Community Development Department. Lighting levels shall not exceed lighting levels beyond those referenced in Attachment A, Lighting Analysis for this project. Lighting shall be installed in accordance with the final approved lighting plan.
3. *(Mitigation Measure AES-2)* All nighttime ball field lighting shall be operated no later than 10 pm.
4. **Prior to operation**, the applicant shall install a Trash enclosure in accordance with City of Clearlake Municipal Codes and Trash Enclosure Design Standards. The plans shall show that the enclosure will be constructed of block with an attractive cap and the gates should incorporate solid metal materials painted to match the building colors. The gates should be mounted on separate posts mounted inside the enclosure. A hose bib should be located next to the enclosure for maintenance.

SECTION C. AIR QUALITY:

1. *(Mitigation Measure AIR 1)* Construction activities shall be conducted with adequate dust suppression methods, including watering during grading and construction activities to limit the generation of fugitive dust or other methods approved by the Lake County Air Quality Management District. Prior to initiating soil removing activities for construction purposes, the applicant shall pre-wet affected areas with at least 0.5 gallons of water per square yard of ground area to control dust.
2. *(Mitigation Measure AIR 2)* Driveways, access roads and parking areas shall be surfaced in a manner so as to minimize dust. The applicant shall obtain all necessary encroachment permits for any work within the right-of-way. All improvement shall adhere to all applicable federal, State and local agency requirements.
3. *(Mitigation Measure AIR 3)* Any disposal of vegetation removed as a result of lot clearing shall be lawfully disposed of, preferably by chipping and composting, or as authorized by the Lake County Air Quality Management District and the Lake County Fire Protection District.
4. *(Mitigation Measure AIR-4)* During construction activities, the applicant shall remove daily accumulation of mud and dirt from any roads adjacent to the site.
5. *(Mitigation Measure AIR-5)* Grading permits shall be secured for any applicable activity from the Community Development Department, Building Division. Applicable activities shall adhere to all grading permit conditions, including Best Management Practices. All areas disturbed by grading shall be either surfaced in manner to minimize dust, landscaped or hydro seeded. All BMPs shall be routinely inspected and maintained for life of the project.
6. *(Mitigation Measure AIR-6)* All refuse generated by the facility shall be stored in approved disposal/storage containers, and appropriately covered. Removal of waste shall be on a weekly basis so as to avoid excess waste. All trash receptacles/containers shall remain covered at all times to prevent fugitive odors and rodent infestation. An odor control plan shall be submitted for review

and approval by the City In accordance with the Zoning Code. Odor control shall be maintained to an acceptable level at all times.

7. *(Mitigation Measure AIR-7)* Construction activities that involve pavement, masonry, sand, gravel, grading, and other activities that could produce airborne particulate should be conducted with adequate dust controls to minimize airborne emissions. A dust mitigation plan may be required should the applicant fail to maintain adequate dust controls.
8. *(Mitigation Measure AIR-8)* If construction or site activities are conducted within Serpentine soils, a Serpentine Control Plan may be required. Any parcel with Serpentine soils must obtain proper approvals from LCAQMD prior to beginning any construction activities. Contact LCAQMD for more details.
9. *(Mitigation Measure AIR-9)* All engines must notify LCAQMD prior to beginning construction activities and prior to engine Use. Mobile diesel equipment used for construction and/or maintenance must be in compliance with State registration requirements. All equipment units must meet Federal, State and local requirements. All equipment units must meet RICE NESHAP/ NSPS requirements including proper maintenance to minimize airborne emissions and proper record-keeping of all activities, all units must meet the State Air Toxic Control Measures for CI engines and must meet local regulations.
10. *(Mitigation Measure AIR-10)* Site development, vegetation disposal, and site operation shall not create nuisance odors or dust. During the site preparation phase, the District recommends that any removed vegetation be chipped and spread for ground cover and erosion control. Burning of debris/construction material is not allowed on commercial property, materials generated from the commercial operation, and waste material from construction debris, must not be burned as a means of disposal.
11. *(Mitigation Measure AIR-11)* Significant dust may be generated from increase vehicle traffic if driveways and parking areas are not adequately surfaced. Surfacing standards should be included as a requirement in the use permit to minimize dust impacts to the public, visitors, and road traffic. At a minimum, the district recommends chip seal as a temporary measure for primary access roads and parking. Paving with asphaltic concrete is preferred and should be required for long term occupancy. All areas subject to semi-truck / trailer traffic should require asphaltic concrete paving or equivalent to prevent fugitive dust generation. Gravel surfacing may be adequate for low use driveways and overflow parking areas; however, gravel surfaces require more maintenance to achieve dust control, and permit conditions should require regular palliative treatment if gravel is utilized. White rock is not suitable for surfacing (and should be prohibited in the permit) because of its tendency to break down and create excessive dust. Grading and re-graveling roads should utilizing water trucks, if necessary, reduce travel times through efficient time management and consolidating solid waste removal/supply deliveries, and speed limits.
12. Construction activities that involve pavement, masonry, sand, gravel, grading, and other activities that could produce airborne particulate should be conducted with adequate dust controls to minimize airborne emissions. A dust mitigation plan may be required should the applicant fail to maintain adequate dust controls.

SECTION D - BIOLOGICAL RESOURCES:

1. *(Mitigation Measure BIO-1)* The project should implement erosion control measures and BMPs to reduce the potential for sediment or pollutants at the Project site.
2. *(Mitigation Measure BIO-2)* A qualified biologist shall conduct a mandatory Worker Environmental Awareness Program for all contractors, work crews, and any onsite personnel to aid workers in recognizing special status species and sensitive biological resources that may occur on-site. The program shall include identification of the special status species and their habitats, a description of the regulatory status and general ecological characteristics of sensitive resources, and review of the limits of construction and Mitigation Measures required to reduce impacts to biological resources within the work area.
3. *(Mitigation Measure BIO-3)* Conduct a pre-construction northwestern pond turtle survey in Project impact and staging areas within 48 hours prior to construction activities. Any northwestern pond turtle individuals discovered in the Project work area immediately prior to or during Project activities shall be allowed to move out of the work area of their own volition. If this is not feasible, they shall be captured by a qualified biologist and relocated out of harm's way to the nearest suitable habitat at least 100 feet from the Project work area where they were found.
4. *(Mitigation Measure BIO-4)* If construction is to occur during the nesting season (generally February 1 - August 31), conduct a pre-construction nesting bird survey of all suitable nesting habitat on the Project within 14 days of the commencement of construction. The survey shall be conducted within a 500-foot radius of Project work areas for raptors and within a 100-foot radius for other nesting birds. If any active nests are observed, these nests shall be designated a sensitive area and protected by an avoidance buffer established in coordination with CDFW until the breeding season has ended or until a qualified biologist has determined that the young have fledged and are no longer reliant upon the nest or parental care for survival. Pre-construction nesting surveys are not required for construction activity outside the nesting season.
5. *(Mitigation Measure BIO-5)* Within 14 days prior to Project activities that may impact bat roosting habitat (e.g., removal of manmade structures or trees), a qualified biologist will survey for all suitable roosting habitat within the Project impact limits. If suitable roosting habitat is not identified, no further measures are necessary. If suitable roosting habitat is identified, a qualified biologist will conduct an evening bat emergence survey that may include acoustic monitoring to determine whether or not bats are present. If roosting bats are determined to be present within the Project site, consultation with CDFW prior to initiation of construction activities and/or preparation of a Bat Management Plan outlining avoidance and minimization measures specific to the roost(s) potentially affected may be required
6. *(Mitigation Measure BIO-6)* To minimize potential impacts to the ephemeral drainage on the project site during construction activity, a qualified biologist shall map the extent of the riparian habitat on the project site. Avoidance buffers for riparian habitat shall be applied in compliance with City of Clearlake requirements. The riparian habitat and avoidance buffer shall be demarcated prior to construction and shall be maintained until the completion of construction. A qualified biologist/biological monitor shall be present if work must occur within the avoidance buffer to ensure riparian habitat is not impacted by the construction activity.

7. (*Mitigation Measure BIO-7*) A native tree protection and removal permit, waiver, or similar approval shall be secured prior to impacting trees protected under the City ordinance. Avoidance buffers for protected trees shall be consistent with the City requirements, shall be clearly demarcated prior to construction, and should be maintained until the completion of construction. A qualified biologist/biological monitor should be present if work must occur within the avoidance buffer to ensure avoided protected trees are not impacted by the work.

SECTION E - CULTURAL/TRIBAL RESOURCES:

1. (*Mitigation Measure CUL-1*) During construction activities, if any subsurface archaeological remains are uncovered, all work shall be halted within 100 feet of the find and the owner shall utilize a qualified cultural resources consultant to identify and investigate any subsurface historic remains and define their physical extent and the nature of any built features or artifact-bearing deposits.
2. (*Mitigation Measure CUL-2*) The cultural resource consultant's investigation shall proceed into formal evaluation to determine their eligibility for the California Register of Historical Resources. This shall include, at a minimum, additional exposure of the feature(s), photo-documentation and recordation, and analysis of the artifact assemblage(s). If the evaluation determines that the features and artifacts do not have sufficient data potential to be eligible for the California Register, additional work shall not be required. However, if data potential exists – e.g., there is an intact feature with a large and varied artifact assemblage – it will be necessary to mitigate any Project impacts. Mitigation of impacts might include avoidance of further disturbance to the resources through Project redesign. If avoidance is determined to be infeasible, pursuant to CEQA Guidelines Section 15126.4(b)(3)(C), a data recovery plan, which makes provisions for adequately recovering the scientifically consequential information from and about the historical resource, shall be prepared and adopted prior to any excavation being undertaken. Such studies shall be deposited with the California Historical Resources Regional Information Center. Archeological sites known to contain human remains shall be treated in accordance with the provisions of Section 7050.5 Health and Safety Code. If an artifact must be removed during Project excavation or testing, curation may be an appropriate mitigation. This language of this mitigation measure shall be included on any future grading plans and utility plans approved by the City for the Project.
3. (*Mitigation Measure CUL-3*) If human remains are encountered, no further disturbance shall occur within 100 feet of the vicinity of the find(s) until the Lake County Coroner has made the necessary findings as to origin (California Health and Safety Code Section 7050.5). Further, pursuant to California Public Resources Code Section 5097.98(b) remains shall be left in place and free from disturbance until a final decision as to the treatment and disposition has been made. If the Lake County Coroner determines the remains to be Native American, the Native American Heritage Commission must be contacted within 24 hours. The Native American Heritage Commission must then identify the “most likely descendant(s)”. The landowner shall engage in consultations with the most likely descendant (MLD). The MLD will make recommendations concerning the treatment of the remains within 48 hours as provided in Public Resources Code 5097.98.
4. (*Mitigation Measure CUL-4*) The sensitive site section noted on the project site plan shall not be disturbed during construction and/or maintenance of the park. This sensitive site is identified as investigation resulted in the discovery of two intact, buried, archaeological sites, CCL-21-01 and CCL-21-02 (Figure 7, yellow polygons), both of the sites can be considered significant cultural resources. Both of the sites occupy relatively small areas and are buried at depths of 16–32 inches below grade. The project as currently designed, will not impact sites CCL-21-01 or CCL-21-02. If avoidance and/or preservation in place is not possible, the owner will consider re-design or other

measures to avoid impacting resources consistent with CEQA. The owner will contract with tribal monitors for ground disturbance within 100 feet of sites CCL-21-01 and CCL-21-02. The owner and contract archeologist will consult with tribal representatives regarding ground disturbing work within these areas including the designation of a “reburial” location, if needed.

5. (Mitigation Measure CUL-5) On or prior to the first day of construction the owner shall organize cultural sensitivity training for contractors involved in ground disturbing activities.

6. (Mitigation Measure CUL-6) The southern two-thirds of site CCL-21-01 is contained within APN010-026-400-000 and the Burns Valley Development Project area. The area occupied by the site has been slated for a paved parking area serving planned playing fields nearby (Figure 2). This portion of the site is situated on the sloping bank of an extinct section of upper Miller Creek, an area marked by an overstory of mixed native oak and introduced conifer and hardwood trees. Because this part of the site is situated on a bank, the land surface is sloped and drops 10–15 feet in elevation. Current engineering plan calls for vegetation and tree removal as well as application of remote fill materials to bring it to a level grade, with installation of landscaping, drains, and underground utility lines in the area. Project revisions in design, location, and operations should be implemented in the area occupied by the footprint of site CCL-21-01, inclusive to a 15-foot (4.5-meter) buffer around the site perimeter. Limitations to disturbance in this area shall be as follows:
 - (1) *Fill Cap*. Because CCL-21-01 is a buried archaeological deposit contained in a dense clay loam likely to resist compaction impacts, avoidance can be achieved by placing fill on the site surface;

 - (2) *Flush Cut Vegetation*. Existing vegetation including shrubs and trees should be flush-cut, i.e., cut flush with the ground at a point not to exceed 10-inches below grade;

 - (3) *Landscaping Fabric and Fill*. Once the flush cut is complete and surface cleared of debris, landscaping fabric should be laid over the area of the site to create a boundary between intact soils and remote fill. With respect to the fill, drainage, safety, and operational concerns may prevent adding a lot of elevation; however, an additional minimum 6–12-inches (15–30 centimeters) of fill should be added to the site area to provide a construction and compaction buffer to protect the deposit. This would result in an overburden of 21–27 inches (53–71 centimeters) of capping material;

 - (4) *Avoid Installation of Subsurface Features*. Avoid placement of pier supports, subsurface landscaping features, subsurface drains, and utility lines in the site area.

 - (5) *Avoid New Overstory Plantings*. Avoid placement of new overstory trees in the site area.

7. (Mitigation Measure CUL-7) Site CCL-21-02 is contained within APN010-026-400-000 and the Burns Valley Development Project area. The area occupied by the site has been slated for open space. Project revisions in design, location, and operations should be implemented in the area occupied by the footprint of site CCL-21-02, inclusive to a 15-foot (4.5-meter) buffer around the site perimeter. Limitations to disturbance in this area shall be as follows:
 - (1) *Fill Cap*. Because CCL-21-01 is a buried archaeological deposit contained in a dense clay loam likely to resist compaction impacts, avoidance can be achieved by placing fill on the site/buffer surface;

(2) *Landscaping Fabric and Fill.* Prior to site prep and construction in the area, landscaping fabric should be laid over the area of the site to create a boundary between intact soils and remote fill. With respect to the fill, drainage, safety, and operational concerns may prevent adding a lot of elevation; however, an additional minimum 6–12-inches (15–30 centimeters) of fill should be added to the site area to provide a construction and compaction buffer to protect the deposit. This would result in an overburden of 21–27 inches (53–71 centimeters) of capping material;

(3) *Avoid Installation of Subsurface Features.* Avoid placement of pier supports, subsurface landscaping features, subsurface drains, and utility lines in the site area.

(4) *Avoid New Overstory Plantings.* Avoid placement of new overstory trees in the site area.

SECTION F - GEOLOGY AND SOILS:

1. (*Mitigation Measure GEO-1*) Prior to any ground disturbance and/or operation, the applicant shall submit Erosion Control and Sediment Plans to the Community Development Department for review and approval.
 - *The project shall incorporate Best Management Practices (BMPs) consistent with the City Code and the State Storm Water Drainage Regulations to the maximum extent practicable to prevent and/or reduce discharge of all construction or post-construction pollutants into the local storm drainage system.*
2. (*Mitigation Measure GEO-2*) Prior to any ground disturbance, (if applicable), the applicant shall submit and obtain a Grading Permit from the Community Development in accordance with the City of Clearlake Municipal code(s).
3. (*Mitigation Measure GEO-3*) The applicant shall monitor the site during the rainy season including post-installation, application of BMPs, erosion control maintenance, and other improvements as needed. Said measures shall be maintained for life of the project and replace/repared when necessary.

SECTION G- HAZARD/HAZARDOUS MATERIALS:

1. All hazardous waste shall not be disposed of on-site without review or permits from Environmental Health Department, the California Regional Water Control Board, and/or the Air Quality Board. Collected hazardous or toxic waste materials shall be recycled or disposed of through a registered waste hauler to an approved site legally authorized to accept such material.
2. The storage of potentially hazardous materials shall be located at least 100 feet from any existing water well. These materials shall not be allowed to leak into the ground or contaminate surface waters. Collected hazardous or toxic materials shall be recycled or disposed of through a registered waste hauler to an approved site legally authorized to accept such materials.
3. Any spills of oils, fluids, fuel, concrete, or other hazardous construction material shall be immediately cleaned up. All equipment and materials shall be stored in the staging areas away from all known waterways.
4. The storage of hazardous materials equals to or greater than fifty-five (55) gallons of a liquid, 500 pounds of a solid, or 200 cubic feet of compressed gas, then a Hazardous Materials Inventory Disclosure Statement/Business Plan shall be submitted and maintained in compliance with requirements of Lake County Environmental Health Division. Industrial waste shall not be

disposed of on site without review or permit from Lake County Environmental Health Division or the California Regional Water Quality Control Board. The permit holder shall comply with petroleum fuel storage tank regulations if fuel is to be stored on site.

5. All equipment shall be maintained and operated in a manner that minimizes any spill or leak of hazardous materials. Hazardous materials and contaminated soil shall be stored, transported, and disposed of consistent with applicable local, state, and federal regulations
6. Hazardous Waste must be handled according to all Hazardous Waste Control Laws. Any generation of a hazardous waste must be reported to Lake County Environmental Health within thirty days.
7. All employees and/or staff members shall be properly trained in and utilize Personnel Protective Equipment in accordance with all federal, state and local regulations regarding handling any biological and/or chemical agents.
8. Hazardous waste must be handled according to all Hazardous Waste Control and Generator regulations. Waste shall not be disposed of onsite without review or permits from EHD, the California Regional Water Control Board, and/or the Air Quality Board. Collected hazardous or toxic waste materials shall be recycled or disposed of through a registered waste hauler to an approved site legally authorized to accept such material.

SECTION H -NOISE/VIBRATIONS:

1. *(Mitigation Measure NOI-1)* All construction activities including engine warm-up shall be limited to weekdays and Saturday, between the hours of 7:00am and 7:00pm to minimize noise impacts on nearby residents.
2. *(Mitigation Measure NOI-2)* Permanent potential noise sources such as, generators used for power shall be designed and located to minimize noise impacts to surrounding properties.
3. *(Mitigation Measure NOI-3)* During construction noise levels shall not exceed 65 decibels within fifty (50) feet of any dwellings or transient accommodations between the hours of 7:00 AM and 6:00 PM. This threshold can be increased by the Building Inspector or City Engineer have approved an exception in accordance with Section 5-4.4(b)(1) of the City Code. An exception of up to 80 decibels may be approved within one hundred (100) feet from the source during daylight hours. Project is expected to result in less than significant impacts with regard to noise and vibration.
4. *(Mitigation Measure NOI-4)* Park operations, including baseball at the northeasterly ballpark shall be shall be restricted to not later than 10 pm.

SECTION I - TRANSPORTATION/TRAFFIC:

1. All handicap parking areas, routes of travel, building access and bathrooms shall meet American with Disabilities Act (ADA) requirements and be subject to review and approval of a Certified Accessibility Access Specialist (CASP).

SECTION J – TRIBAL CULTURAL RESOURCES

1. *(Mitigation Measure TCR-1):* Requirement to develop a tribal cultural resources preservation plan that delineates the boundary of CCL-21-01 and CCL-21-02, describes the appropriate combination of materials and culturally sterile fill in capping, provides landscaping specifications that favor culturally important plants, and restricts certain types of post-project activities in or on the cap.

2. (*Mitigation Measure TCR-2*): Requirement to designate a project reburial area in advance of ground disturbing activities in the event that materials are discovered during construction.
3. (*Mitigation Measure TCR-3*): Requirement for contractors to receive meaningful training on cultural sensitivity and tribal cultural resources from a tribal representative.
4. (*Mitigation Measure TCR-4*): Requirement for tribal monitoring during ground disturbing activities in sensitive areas of the project area.
5. (*Mitigation Measure TCR-5*): Procedures for compliance with existing state law in the event of the discovery of human remains during construction.
6. (*Mitigation Measure TCR-6*): A prohibition on the removal of cultural soils from the project area.
7. Requirement for City staff to organize a discussion with the City Council to exercise its independent discretion on naming part or all of the facility with an appropriate tribal name, if it so chooses.
8. Requirement to develop and install culturally appropriate interpretive signage to educate the public about the cultural significance of the area.
9. Requirement to allow free access to the facilities for tribal cultural events up to four times per year, pursuant to the same application process of other events at City facilities.
10. Commitment by the City to meaningful consultation as a consulting party under Section 106 of the National Historic Preservation Act or National Environmental Policy Act, if applicable.

SECTION K -TIMING AND MONITORING

1. The applicant shall agree to indemnify, defend, and hold harmless the City or its agents, officers and employees from and against any and all claims, actions, demands or proceeding (*including damage, attorney fees, and court cost awards*) against the City or its agents, officers, or employees to attach, set aside, void, or annul an approval of the City, advisory agency, appeal board, or legislative body concerning the permit or entitlement when such action is brought within the applicable statute of limitations. In providing any defense under this Paragraph, the applicant shall use counsel reasonably acceptable to the City. The City shall promptly notify the applicant of any claim, action, demands or proceeding and the City shall cooperate fully in the defense. If the City fails to promptly notify the applicant of any claim, action, or proceeding, or if the City fails to cooperate fully in the defense, the applicant shall not thereafter be responsible to defend, indemnify, or hold the City harmless as to that action. The City may require that the applicant post a bond, in an amount determined to be sufficient, to satisfy the above indemnification and defense obligation. Applicant understands and acknowledges that City is under no obligation to defend any claim, action, demand or proceeding challenging the City's actions with respect to the permit or entitlement.
2. Upon written request received prior to expiration, the Community Development Director may grant renewals of use permit approval for successive periods of not more than one (1) year each.
 - *Approvals of such renewals shall be in writing and for a specific period.*
 - *Renewals may be approved with new or modified conditions upon a finding that the circumstances under which the use permit was originally approved have substantially changed.*

- *Renewal of a use permit shall not require public notice or hearing unless the renewal is subject to new or modified conditions. In order to approve a renewal, the Community Development Director must make the findings required for initial approval.*
3. The Planning Commission may revoke or modify the use permit in the future if the Commission finds that the use to which the permit allows is detrimental to health, safety, comfort, general welfare of the public; constitutes a public nuisance; if the permit was obtained or is being used by fraud; and/or if one or more the conditions upon which a permit was granted are in noncompliance or have been violated. Applicant shall be notified of potential violations of the use permit prior to action taken by the Planning Commission.
 4. Said Use Permits shall be subject to revocation or modification by the Planning Commission if the Commission finds that there has been:
 - a) *Noncompliance with any of the foregoing conditions of approval; or*
 - b) *The Planning Commission finds that the use for which this permit is hereby granted is so exercised as to be substantially detrimental to persons or property in the neighborhood of the use. Any such revocation shall be preceded by a public hearing noticed and heard pursuant to the City of Clearlake Municipal Code. 15.*

ACCEPTANCE

I have read and understand the foregoing Conditional Use Permit and agree to each term and condition of approval and/or mitigation measure(s) thereof.

Date: _____

Applicant or Authorized Agent Signature

Printed Name of Authorized Agent

To be Completed by Authorized Staff Only:	
_____ Staff Name	_____ Staff Signature
Date Project Approved: _____	

BURNS VALLEY ROAD

ELEMENTS

- 1 RECREATION CENTER - 15,000 SF
- 2 RESTROOM/ CONCESSION BUILDING
- 3 RESTROOM BUILDING
- 4 MULTI-SPORT TURF FIELD WITH LIGHTS - (1) U12 SOCCER, (3) U10 SOCCER, (8) U8 SOCCER
- 5 (1) BASEBALL FIELD - 300' FENCES & LIGHTS
- 6 (1) LITTLE LEAGUE BASEBALL FIELD - 200' FENCES & LIGHTS
- 7 (1) SOFTBALL FIELD - 200' FENCES & LIGHTS
- 8 (1) T-BALL FIELDS
- 9 (3) FITNESS EQUIPMENT AREA
- 10 ADA ACCESSIBLE PLAYGROUND WITH FENCE - APPROX. 4,600SF
- 11 CENTRAL COMMUNITY GATHERING AREA (22 TABLES)
- 12 DISPLAY PANELS UNDER ARBOR (ANNOUNCEMENTS/ PUBLIC ART/ WALL OF CHAMPIONS)
- 13 (2) SHADE STRUCTURE PICNIC AREA (5 TABLES TOTAL)
- 14 PICNIC AREA (6 TABLES TOTAL)
- 15 DUGOUT
- 16 BATTING/PITCHING CAGE
- 17 BLEACHERS
- 18 BENCHES
- 19 (4) PERMEABLE WALKING TRAILS SURROUNDING LARGER FIELDS WITH INTERPRETIVE SIGNS. (PERMEABLE SURFACE = 30% TOTAL HARDSCAPE)
- 20 NATIVE PLANT DEMONSTRATION AREA
- 21 STORMWATER BIOSWALE & INTERPRETIVE SIGN



CONCEPT MASTERPLAN

BURNS VALLEY SPORTS COMPLEX

14885 BURNS VALLEY ROAD
CITY OF CLEARLAKE, CA

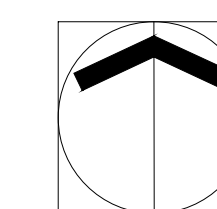



CITY OF CLEARLAKE

MITIGATED NEGATIVE DECLARATION

ENVIRONMENTAL ANALYSIS (CEQA)

INITIAL STUDY

Burns Valley Development Complex

~~BURNS VALLEY PARK AND PUBLIC WORKS YARD MASTER PLAN~~

June 16, 2022

Amended April 4, 2023

CALIFORNIA ENVIRONMENTAL QUALITY ACT

ENVIRONMENTAL CHECKLIST FORM

INITIAL STUDY

- 1. Project Title:** Burns valley Development Project
~~Burns Valley Park and Public Works Yard Master Plan~~
- 2. Permit Numbers:** Initial Study, IS 2022-05
Conditional Use Permit, CUP 2022-16
- 3. Lead Agency Name/Address:** City of Clearlake 14050 Olympic Drive
Clearlake, CA 95422
- 4. Contact Person:** Mark Roberts – Senior Planner
Phone: (707) 994-8201
Email: mroberts@clearlake.ca.us
- 5. Project Location(s):** 14885 Burns Valley Road
Clearlake, CA 95422
- 6. Parcel Numbers(s):** 010-026-40
- 7. Project Sponsor's Name/Address:** City of Clearlake 14050 Olympic Drive
Clearlake, CA 95422
- 8. Property Owner(s) Name/Address:** City of Clearlake 14050 Olympic Drive
Clearlake, CA 95422
- 9. Zoning Designations:** Mix Use
- 10. General Plan Designation:** Mixed Use
- 11. Supervisor District:** District Two (2)
- 12. Average Cross Slope:** Less than 10% cross slope
- 13. Earthquake Fault Zone:** Not within a fault zone
- 14. Dam Failure Inundation Area:** Not within a Dam Failure Inundation Zone
- 15. Flood Zone:** Partially located within Flood Zone AO
- 16. Waste Management:** Clearlake Waste Solutions
- 17. Water Access:** Highlands Mutual Water Company

18. Fire Department: Lake County Fire Protection District

19. School District: Konocti Unified School District

20. Description of Project: *(Describe the whole action involved, including but not limited to later phases of the project and any secondary, support, or off-site features necessary for its implementation. Attach additional pages if necessary.)*

Development of a public park (sports complex), community center, public works yard with public works building facility and combined police department office and maintenance facilities, vehicle and equipment storage areas, public access and parking facilities on approximately 26 acres.

The project is proposed to be located in the Burns Valley Area, north of Olympic Drive and South of Burns Valley Drive, behind the Safeway Shopping Center, Clearlake, CA (Accessors Parcel No. 010-026-40). Also, see Figures 1, 2, and 3 (location maps).

The park would include one full size baseball field, two smaller little league baseball fields, two small Tee-Ball Fields, a full-size soccer field (see Figure 6, Site and Preliminary Grading Plan). The project would include development of an approximately 15,000 to 20,000 square foot recreation center building for use for public events and activities (see Figure 7-concept building elevations). This building would contain sports features, such as basketball and volleyball courts. Being located next to the baseball area, a concession building/stand would be constructed next to or as part of this larger building. These combined facilities would be located on the east side of the project site.

On the west side is proposed an approximate 12,000 square foot public works building, including a Police Department investigation facility (see Figure 8). This building would include a vehicle wash station, and sections for equipment repair. This public works yard would be used to store and maintain city public vehicles, including public works and police department cars, trucks, and heavy equipment.

Access to the project would be from a number of driveways/streets including access from Olympic Drive and Burns Valley Road. Approximately 365 parking spaces would be developed along access roads through the park (including 20 for the public works/police facility). Other related improvements would include sidewalks, fencing (see Figure 11), lighting features (see figures 12. 13. And 14), baseball field protective netting (see Figure 10) and restroom facilities. All play fields will include lighting to allow for night operations.

Project development is envisioned to be constructed in two development phasing depending on funding availability and City priority. The first phase, as shown in Figure 6, is to develop the sports complex components, with the recreation center building and public works hop building to come later.

21. Environmental Setting:

The project area is relatively flat with gently rolling terrain situated at an elevational range of approximately 1,350 to 1,365 feet above mean sea level (MSL) in the Inner North Coast Ranges District of the California floristic province (Baldwin et al. 2012). Please refer to site photos (Figure 5). The parcel is an irregularly shaped 25.46-acre parcel generally composed of

open landscape, existing tree orchard and grasses. A drainage channel transects the eastern portion of the parcel in the southwest direction.

22. Surrounding Land Uses and Setting: Briefly describe the project's surroundings:

- The parcels to the **North** – Library and senior residential care center, vacant ag land
- The parcels to the **South** – Commercial Retail
- The parcels to the **West** – Vacant land
- The parcels to the **East** – Rural residential

20. Other Public Agencies Whose Approval is Required: Local Agencies: City of Clearlake - Community Development (Planning, Building, Public Works); Clearlake Police Department, Lake County Fire Protection, Lake County Department of Environmental Health, Lake County Air Quality Management District, Lake County Special Districts, Highlands Water Districts, Local Tribal Organizations.

21. Federal and State Agencies: Central Valley Regional Water Quality Control Board, CA Department of Fish and Wildlife, California Department of Transportation (Caltrans); California Department of Public Health.

22. Have California Native American tribes traditionally and culturally affiliated with the project area requested consultation pursuant to Public Resources Code section 21080.3.1? If so, is there a plan for consultation that includes, for example, the determination of significance of impacts to tribal cultural resources, procedures regarding confidentiality, etc.? Note: Conducting consultation early in the CEQA process allows tribal governments, lead agencies, and project proponents to discuss the level of environmental review, identify and address potential adverse impacts to tribal cultural resources, and reduce the potential for delay and conflict in the environmental review process. (See Public Resources Code section 21080.3.2.) Information may also be available from the California Native American Heritage Commission's Sacred Lands File per Public Resources Code section 5097.96 and the California Historical Resources Information System administered by the California Office of Historic Preservation. Please also note that Public Resources Code section 21082.3 (c) contains provisions specific to confidentiality.

Notification of the project was sent to local tribes for "AB 52" Notification, which allows interested Tribes to request tribal consultation within 30 days of receipt of notice. The Cultural Study documents all consultation conducted.

23. Impact Categories defined by CEQA: The following documents are referenced information sources and are incorporated by reference into this document and are available for review upon request of the Community Development Department if they have not already been incorporated by reference into this report:

- City of Clearlake General Plan
- City of Clearlake Zoning Code
- U.S.D.A. Lake County Soil Survey
- Important Farmland Map <https://maps.conservation.ca.gov/agriculture/>
- Lake County Serpentine Soil Mapping
- California Natural Diversity Database (<https://www.wildlife.ca.gov/Data/CNDDDB>)
- U.S. Fish and Wildlife Service National Wetlands Inventory
- U.S.G.S. Geologic Map and Structure Sections of the Clear Lake Volcanic, Northern California, Miscellaneous Investigation Series, 1995

- Official Alquist-Priolo Earthquake Fault Zone maps for Lake County
- Landslide Hazards in the Eastern Clear Lake Area, Lake County, California, Landslide Hazard Identification Map No. 16, California Department of Conservation, Division of Mines and Geology, DMG Open –File Report 89-27, 1990
- Hazardous Waste and Substances Sites List: www.envirostor.dtsc.ca.gov/public
- California Department of Forestry and Fire Protection - Fire Hazard Mapping
- National Pollution Discharge Elimination System (NPDES)
- Cal Recycle Solid Waste Information System
<http://www.calrecycle.ca.gov/SWFacilities/Directory/Search.aspx>
- Written comments received from public agencies.
- Site visits

Figures

- Figure 1 – Regional Map
- Figure 2 – Vicinity Map
- Figure 3 – USGS Map
- Figure 4 – Zoning Map
- Figure 5 – Site Photos
- Figure 6 – Master Site and Preliminary Grading Plan
- Figure 7– Burns Valley Sports Complex Park Project 15,000 square foot Community Center Building Concept and Example of Buildings
- Figure 8 – City Public Works Yard, Building Design Concepts/Example
- Figure 10 – Baseball Field Protective Netting Concept/Example
- Figure 11 – Perimeter Fencing Concept/Example
- Figure 12 – Exterior Lighting Concept/Example
- Figure 13 – Typical Street Lighting Design
- Figure 14 – Baseball Field Lighting Example

Attachments

- Attachment A – Lighting Impact Analysis
- Attachment B – Air Quality Impact Analysis
- Attachment C – Biological Impact Report
- Attachment E – Traffic Impact Study
- Attachment F – Noise Study for Oak Valley Villas Apartments
- Attachment G – Flood Hazards Map

24. Figures

Figure 1: Regional Map



Figure 2: Vicinity Map

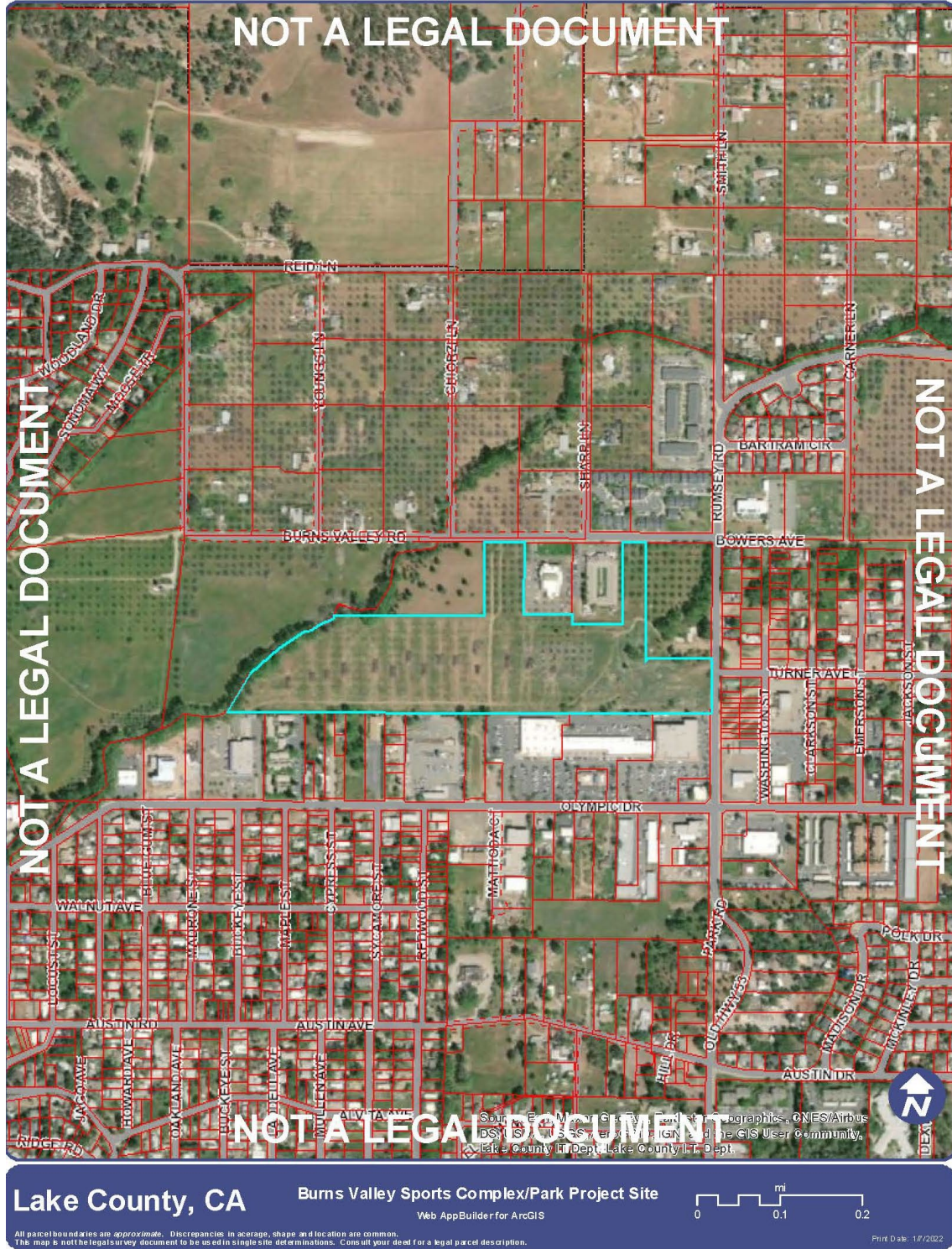

Figure 3: USGS Map

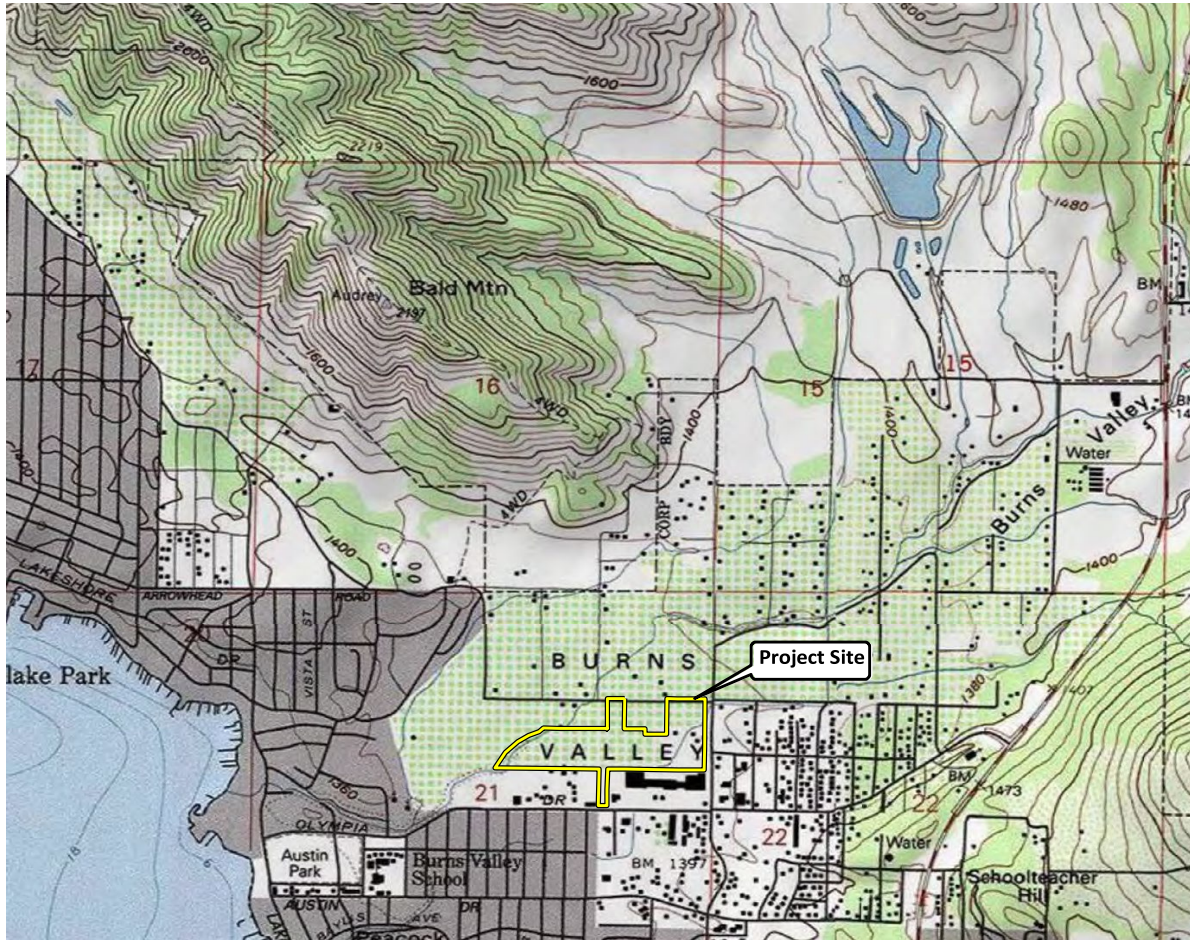

Figure 4: Zoning Map (MUX – Mix Use)

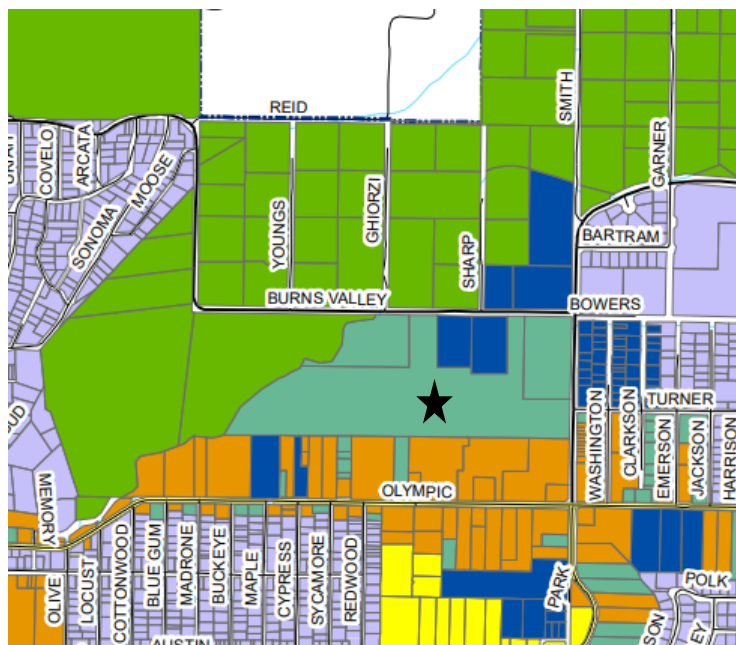

Figure 5: Site Photos



Easterly view from south side and central on site



Southerly view from north center of site



Easterly view from center of site



Westerly view from north side of site

Figure 6: Master Site and Preliminary Grading Plan (larger plan available by request of the City)

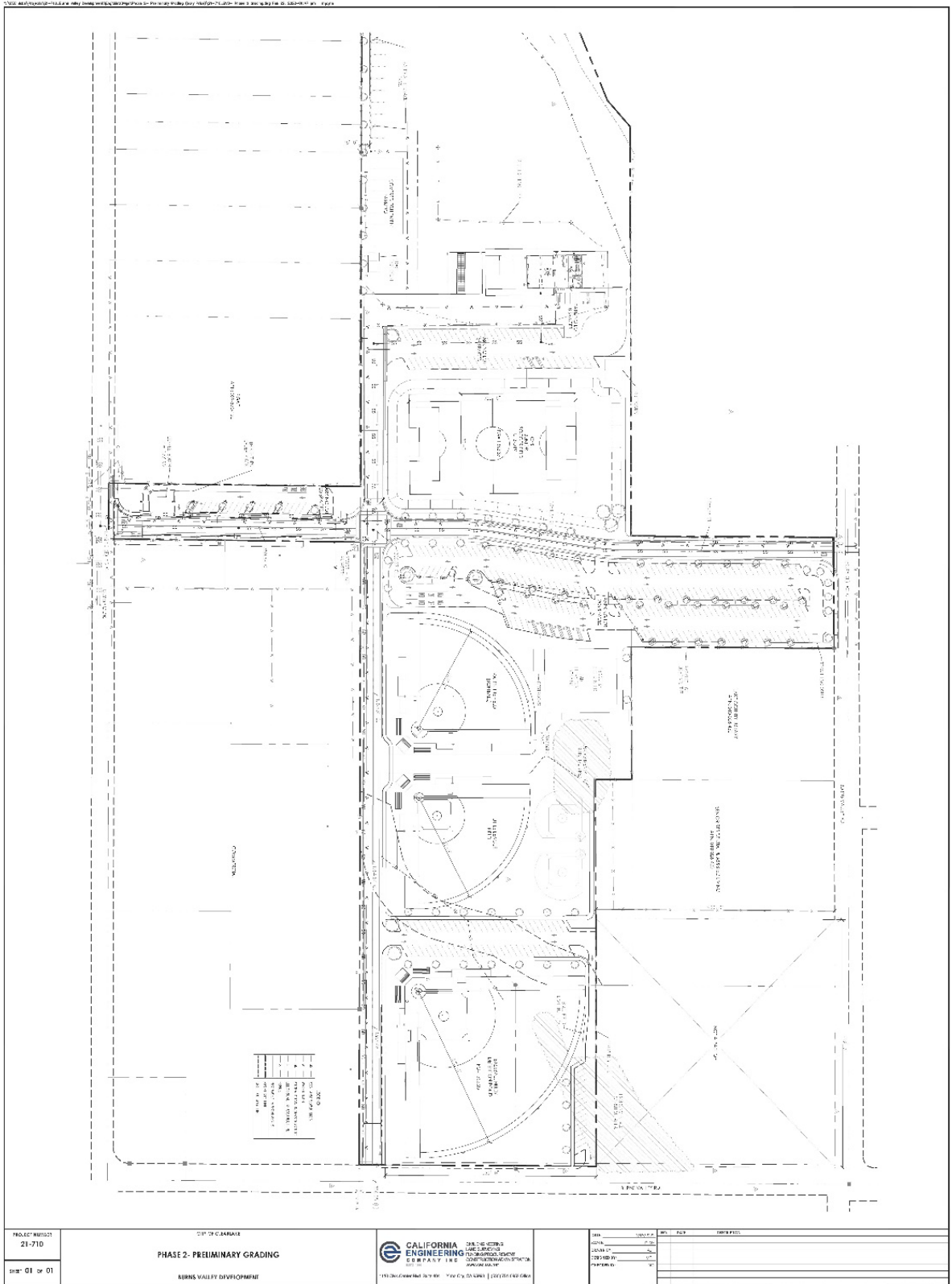

Figure 7: Burns Valley Sports Complex Park Project 15,000 square foot Community Center Building Concept and Example of Buildings



Figure 8: City Public Works Yard, Building Design Concepts/Example



Figure 9: Baseball Field Protective Netting Concept/Example



Figure 10: Perimeter Fencing Concept/Example



Figure 11: Exterior Lighting Concept/Example



Figure 12: Typical Street Lighting Design

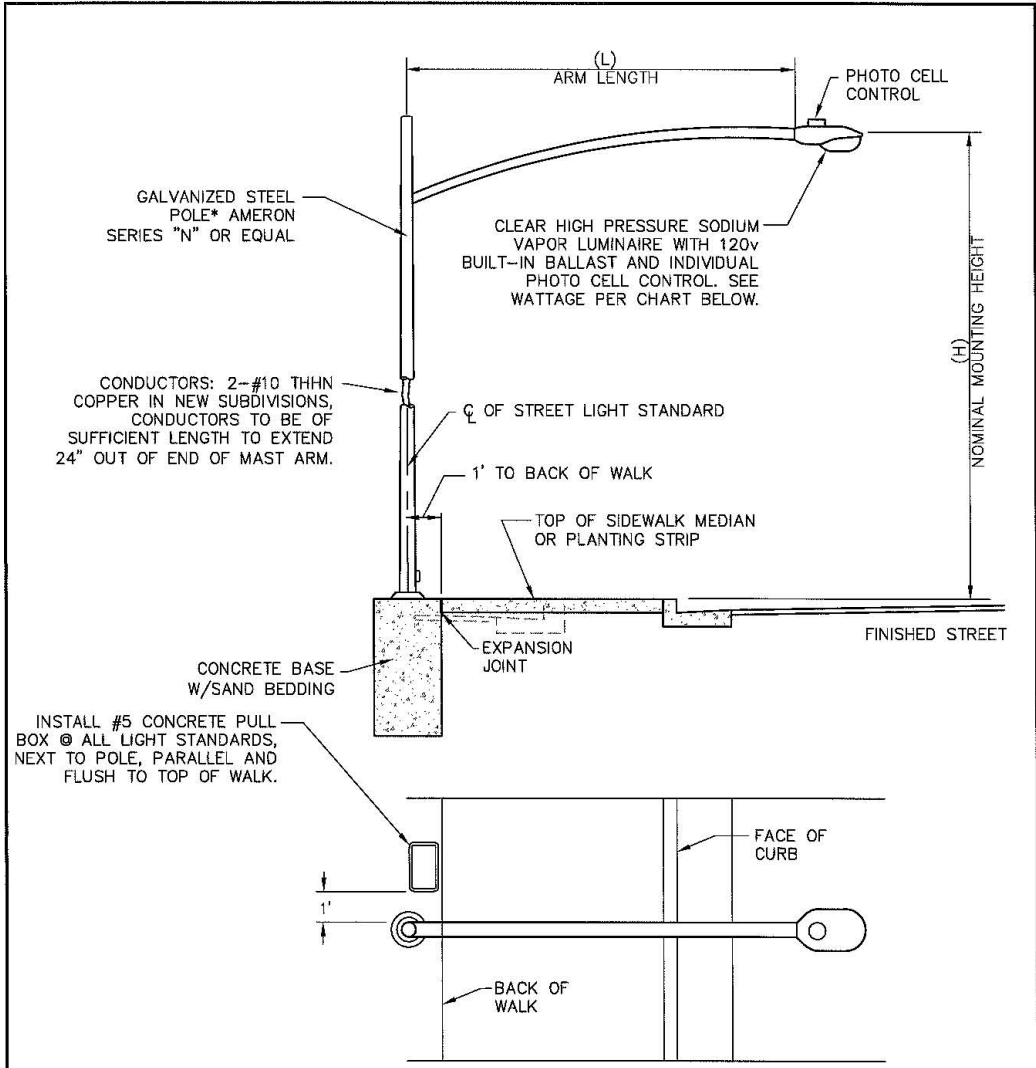

*ALTERNATES TO BE SPECIFICALLY APPROVED BY THE CITY ENGINEER.

STREET CLASSIFICATION	MOUNTING HEIGHT(H)	ARM LENGTH(L)	MAXIMUM SPACING	WATTAGE
ARTERIAL	32'-3"	12'-0"	100'	150
COLLECTOR & INDUSTRIAL	27'-6"	10'-0"	200'	100
RESIDENTIAL	27'-3"	8'-0"	200'	70



STANDARD STREET LIGHT

STD. NO.
401

SCALE: NONE | DRAWN: CLG | CHK: PWV | APPVD: JLW | DATE: APR. 2012

Figure 13: Baseball Field Lighting Example



31. Environmental Factors Effected: The environmental sections checked below would be potentially affected by this project in an adverse manner, including at least one environmental issue/significance criteria that is “potentially significant impacts” as indicated by the analysis in the following evaluation of environmental impacts.

<input checked="" type="checkbox"/>	Aesthetics	<input type="checkbox"/>	Greenhouse Gas Emissions	<input type="checkbox"/>	Public Services
<input type="checkbox"/>	Agriculture & Forestry Resources	<input checked="" type="checkbox"/>	Hazards & Hazardous Materials	<input type="checkbox"/>	Recreation
<input checked="" type="checkbox"/>	Air Quality	<input type="checkbox"/>	Hydrology / Water Quality	<input checked="" type="checkbox"/>	Transportation
<input checked="" type="checkbox"/>	Biological Resources	<input type="checkbox"/>	Land Use / Planning	<input checked="" type="checkbox"/>	Tribal Cultural Resources
<input checked="" type="checkbox"/>	Cultural Resources	<input type="checkbox"/>	Mineral Resources	<input type="checkbox"/>	Utilities / Service Systems
<input type="checkbox"/>	Energy	<input checked="" type="checkbox"/>	Noise & Vibration	<input type="checkbox"/>	Wildfire
<input checked="" type="checkbox"/>	Geology / Soils	<input type="checkbox"/>	Population / Housing	<input checked="" type="checkbox"/>	Mandatory Findings of Significance

DETERMINATION: (To be completed by the lead Agency)

On the basis of this initial evaluation:

- I find that the proposed project COULD NOT have a significant effect on the environment, and a NEGATIVE DECLARATION will be prepared.
- I find that although the proposed project could have a significant effect on the environment, there will not be a significant effect in this case because revisions in the project have been made by or agreed to by the project proponent. A MITIGATED NEGATIVE DECLARATION will be prepared.**
- I find that the proposed project MAY have a significant effect on the environment, and an ENVIRONMENTAL IMPACT REPORT is required.
- I find that the proposed project MAY have a “potentially significant impact” or “potentially significant unless mitigated” impact on the environment, but at least one effect 1) has been adequately analyzed in an earlier document pursuant to applicable legal standards, and 2) has been addressed by mitigation measures based on the earlier analysis as described on attached sheets. An ENVIRONMENTAL IMPACT REPORT is required, but it must analyze only the effects that remain to be addressed.
- I find that although the proposed project could have a significant effect on the environment, because all potentially significant effects (a) have been analyzed adequately in an earlier EIR or NEGATIVE DECLARATION pursuant to applicable standards and (b) have been avoided or mitigated pursuant to that earlier EIR or NEGATIVE DECLARATION, including revisions or mitigation measures that are imposed upon the proposed project, nothing further is required.

Prepared By: Mark Roberts

Title: Senior Planner

Signature: 

Date: July 19, 2022 / Amended April 4th, 2023

Alan Flora – City Manager
City of Clearlake, California

SECTION 1 - EVALUATION OF ENVIRONMENTAL IMPACTS:

- 1) A brief explanation is required for all answers except "No Impact" answers that are adequately supported by the information sources a lead agency cites in the parentheses following each question. A "No Impact" answer is adequately supported if the referenced information sources show that the impact simply does not apply to projects like the one involved (e.g., the project falls outside a fault rupture zone). A "No Impact" answer should be explained where it is based on project-specific factors as well as general standards (e.g., the project will not expose sensitive receptors to pollutants, based on a project-specific screening analysis).
- 2) All answers must take account of the whole action involved, including off-site as well as on-site, cumulative as well as project-level, indirect as well as direct, and construction as well as operational impacts.
- 3) Once the lead agency has determined that a particular physical impact may occur, and then the checklist answers must indicate whether the impact is potentially significant, less than significant with mitigation, or less than significant. "Potentially Significant Impact" is appropriate if there is substantial evidence that an effect may be significant. If there are one or more "Potentially Significant Impact" entries when the determination is made, an EIR is required.
- 4) "Negative Declaration: Less Than Significant with Mitigation Incorporated" applies where the incorporation of mitigation measures has reduced an effect from "Potentially Significant Impact" to a "Less Than Significant Impact." The lead agency must describe the mitigation measures, and briefly explain how they reduce the effect to a less than significant level (mitigation measures from Section XVII, "Earlier Analyses," may be cross-referenced).
- 5) Earlier analyses may be used where, pursuant to the tiering, program EIR, or other CEQA process, an effect has been adequately analyzed in an earlier EIR or negative declaration. Section 15063(c)(3)(D). In this case, a brief discussion should identify the following:
 - a) Earlier Analysis Used. Identify and state where they are available for review.
 - b) Impacts Adequately Addressed. Identify which effects from the above checklist were within the scope of and adequately analyzed in an earlier document pursuant to applicable legal standards, and state whether such effects were addressed by mitigation measures based on the earlier analysis.
 - c) Mitigation Measures. For effects that are "Less than Significant with Mitigation Measures Incorporated," describe the mitigation measures, which were incorporated or refined from the earlier document and the extent to which they address site-specific conditions for the project.

- 6) Lead agencies are encouraged to incorporate into the checklist references to information sources for potential impacts (e.g., general plans, zoning ordinances). Reference to a previously prepared or outside document should, where appropriate, include a reference to the page or pages where the statement is substantiated.
- 7) Supporting Information Sources: A source list should be attached, and other sources used or individuals contacted should be cited in the discussion.
- 8) This is only a suggested form, and lead agencies are free to use different formats; however, lead agencies should normally address the questions from this checklist that are relevant to a project's environmental effects in whatever format is selected.
- 9) The explanation of each issue should identify:
 - a) the significance criteria or threshold, if any, used to evaluate each question; and
 - b) the mitigation measure identified, if any, to reduce the impact to less than significance

IMACT CATEGORIES KEY:

- **1 = Potentially Significant Impact**
- **2 = Less Than Significant with Mitigation Incorporation**
- **3 = Analyzed in Prior EIR**
- **4 = Substantially Mitigated by Uniformly Applicable Development Policies/Standards**
- **5 = Less Than Significant Impact**
- **6 = No Impact**

IMPACT CATEGORIES*	1	2	3	4	5	6	All determinations need explanation. Reference to documentation, sources, notes and correspondence.
SECTION I. AESTHETICS							
<i>Except as provided in Public Resources Code Section 21099, would the project:</i>							
a) Have a substantial adverse effect on a scenic vista that is visible from a City scenic corridor?	<input type="checkbox"/>	<input type="checkbox"/>	<input type="checkbox"/>	<input type="checkbox"/>	<input type="checkbox"/>	<input checked="" type="checkbox"/>	The project parcel(s) are not located within and/or near scenic vistas. Therefore, the project will not have a substantial adverse effect one a scenic vista that is visible from a city scenic corridor. No Impact.
b) Substantially damage scenic resources that is visible from a City Corridor, including, but not limited to, trees, rock outcroppings, and historic buildings within a state scenic highway?	<input type="checkbox"/>	<input type="checkbox"/>	<input type="checkbox"/>	<input type="checkbox"/>	<input type="checkbox"/>	<input checked="" type="checkbox"/>	The project will not substantially damage scenic resources that may be visible from a City Corridor, including, but not limited to, trees, rock outcroppings, and historic buildings within a state scenic highway. There are no known rock outcroppings, historic buildings, and/or scenic highways on the project site and no scenic highways with views of the project site. No Impact.
c) Conflict with applicable General Plan policies or zoning regulations governing scenic quality.	<input type="checkbox"/>	<input type="checkbox"/>	<input type="checkbox"/>	<input type="checkbox"/>	<input type="checkbox"/>	<input checked="" type="checkbox"/>	The project will not conflict with applicable any General Plan policies and/or zoning regulations governing scenic quality within the City of Clearlake. No impact.
d) Create a new source of substantial light or glare which would adversely affect day or nighttime views in the area?	<input type="checkbox"/>	<input checked="" type="checkbox"/>	<input type="checkbox"/>	<input type="checkbox"/>	<input type="checkbox"/>	<input type="checkbox"/>	The proposed lighting for the project will increase lighting levels in the area that may impact nighttime views and may result in substantial light glare, particularly from the new sport field lighting (see Figures 12, 13, and 14). The sport field lighting would consist of a series of maximum 70-foot-tall poles with LED glare resistant lighting fixtures directed/shielded downward. Lighting height and design may change as a result of final design plans, but will not exceed parameters in this analysis/document. A

IMPACT CATEGORIES*	1	2	3	4	5	6	All determinations need explanation. Reference to documentation, sources, notes and correspondence.
							<p>lighting analysis was conducted to determine the extent of glare impacts on adjoining properties/uses (see Attachment A). It shows lighting levels of about 15-foot candles at the property line of a proposed apartment project; Oak Valley Villas. One building in particular would be impacted by lighting during nighttime use of the sport field. The City does not have a threshold of significance for lighting levels. However, major efforts have been made to address lighting glare levels with the use of this type of lighting. Several mitigation measures have been developed to lessen the significant of lighting impacts from the project to a level of less than significant.</p> <p>AES-1 All outdoor lighting shall be directed downwards and shielded onto the project site and not onto adjacent properties. All lighting shall comply and adhere to all federal, state and local agency requirements, including all requirements in darksky.org. (Refer to the City’s Design Standards).</p> <p>AES-2. A final lighting design plan shall be submitted for review and approval by the Community Development Department. Lighting levels shall not exceed lighting levels beyond those referenced in Attachment A, Lighting Analysis for this project. Lighting shall be installed in accordance with the final approved lighting plan.</p> <p>AES-2 All nighttime ball field lighting shall be operated no later than 10 pm.</p>
<p>SECTION II. AGRICULTURE AND FORESTRY RESOURCES</p> <p><i>In determining whether impacts to agricultural resources are significant environmental effects, lead agencies may refer to the California Agricultural Land Evaluation and Site Assessment Model (1997) prepared by the California Dept. of Conservation as an optional model to use in assessing impacts on agriculture and farmland. In determining whether impacts to forest resources, including timberland, are significant environmental effects, lead agencies may refer to information compiled by the California Department of Forestry and Fire Protection regarding the state’s inventory of forest land, including the Forest and Range Assessment Project and the Forest Legacy Assessment Project; and forest carbon measurement methodology provided in Forest protocols adopted by the California Air Resources Board.</i></p> <p><i>Would the project</i></p>							
<p>a) Convert Prime Farmland, Unique Farmland, or Farmland of Statewide Importance (Farmland), as shown on the maps prepared pursuant to the Farmland Mapping and Monitoring Program of the California Resources Agency, to non-agricultural use?</p>	<input type="checkbox"/>	<input type="checkbox"/>	<input type="checkbox"/>	<input type="checkbox"/>	<input type="checkbox"/>	<input checked="" type="checkbox"/>	<p>There is no Prime Farmland, Unique Farmland, and/or Farmland of Statewide Importance on or adjacent to the proposed project; therefore, there will be no impact.</p>
<p>b) Conflict with existing zoning for agricultural use, or a Williamson Act contract?</p>	<input type="checkbox"/>	<input type="checkbox"/>	<input type="checkbox"/>	<input type="checkbox"/>	<input type="checkbox"/>	<input checked="" type="checkbox"/>	<p>The project site is not zoned for agricultural use and is not under contract for agricultural land use therefore, there will be no impact.</p>

IMPACT CATEGORIES*	1	2	3	4	5	6	All determinations need explanation. Reference to documentation, sources, notes and correspondence.
c) Conflict with existing zoning for, or cause rezoning of, forest land (as defined in Public Resources Code section 12220(g)), timberland (as defined by Public Resources Code section 4526), or timberland zoned Timberland Production (as defined by Government Code section 51104(g))?	<input type="checkbox"/>	<input type="checkbox"/>	<input type="checkbox"/>	<input type="checkbox"/>	<input type="checkbox"/>	<input checked="" type="checkbox"/>	The project will not conflict with existing zoning for, or cause the rezoning of, forest land (as defined in Public Resources Code section 12220(g)), timberland (as defined by Public Resources Code section 4526), or timberland zoned Timberland Production (as defined by Government Code section 51104(g)). No Impact
d) Involve other changes in the existing environment which, due to their location or nature, could result in conversion of Farmland, to non-agricultural use or conversion of forest land to non-forest use?	<input type="checkbox"/>	<input type="checkbox"/>	<input type="checkbox"/>	<input type="checkbox"/>	<input type="checkbox"/>	<input checked="" type="checkbox"/>	The project will not involve other changes in the existing environment which, due to their location or nature, could result in conversion of Farmland, to non-agricultural use or conversion of forest land to non-forest use. Refer to 2a and 2b, above. No Impact

SECTION III. AIR QUALITY

Where available, the significance criteria established by the applicable air quality management district or air pollution control district may be relied upon to make the following determinations.

Would the project:

a) Conflict with or obstruct implementation of the applicable air quality plan?	<input type="checkbox"/>	<input checked="" type="checkbox"/>	<input type="checkbox"/>	<input type="checkbox"/>	<input type="checkbox"/>	<input type="checkbox"/>	<p>The project is located in the Lake County Air Basin (LCAB). The State and Federal Clean Air Acts mandate the reduction and control of certain air pollutants. Under these Acts, the U.S. Environmental Protection Agency (USEPA) and the California Air Resources Board (CARB) have established ambient air quality standards for certain “criteria pollutants.” As shown in Table 1, the LCAB is in attainment status for each criteria pollutant, meaning that the LCAB is in compliance with the established ambient air quality standards for the criteria pollutants. Lake County Air Basin is one of only nine regions in California to have never exceeded the maximum ozone standard, and the only air basin to meet the standard for visibility reducing particles. Clearlake, located in LCAB, is currently in attainment of all State and Federal Ambient Air Quality Standards. The project will not result in air quality impacts that exceed the Bay Area Air Quality Management District (BAAQMD).</p> <p>In 2008, the California Air Resource Board released a summary of the estimated annual average emissions rates in the Lake County Air Basin, including stationary, area wide, and mobile source emissions. The main stationary source of total organic gas (TOG) emissions is electric fuel combustion. Carbon Monoxide (CO) is mostly coming from mobile emissions sources. Motorized boats and light duty passenger vehicles and trucks make up two-thirds of the mobile source CO emissions, and one half of the total CO emissions in the Air Basin. Finally, unpaved roads were the largest source of particulate matter (PM) in the County. According to the report, the main stationary source of total organic gas (TOG) emissions is electric fuel combustion. The main mobile source was recreational boats, and the main area-wide source was solvent evaporation from consumer products. More than half of area wide PM emissions come from travel on unpaved roads within the City (General Plan Background report, 2013).</p> <p>Table 1 presents Federal and State Air Quality Attainment Status, 2011 Pollutant State Standard Federal Standards for criteria air quality pollutants.</p>
---	--------------------------	-------------------------------------	--------------------------	--------------------------	--------------------------	--------------------------	--

IMPACT CATEGORIES*	1	2	3	4	5	6	<p style="text-align: center;">All determinations need explanation. Reference to documentation, sources, notes and correspondence.</p>																																																																							
							<p>Table 1. Clearlake Federal and State Air Quality Attainment Status, 2011</p> <table border="1" data-bbox="716 262 1531 510"> <thead> <tr> <th>Pollutant</th> <th>State Standard</th> <th>Federal Standard</th> </tr> </thead> <tbody> <tr> <td>PM 2.5</td> <td>Attainment</td> <td>Unclassified/ Attainment</td> </tr> <tr> <td>Carbon Monoxide</td> <td>Attainment</td> <td>Unclassified/ Attainment</td> </tr> <tr> <td>Nitrogen Monoxide</td> <td>Attainment</td> <td>Unclassified/ Attainment</td> </tr> <tr> <td>Sulfur Dioxide</td> <td>Attainment</td> <td>Unclassified/ Attainment</td> </tr> <tr> <td>Sulfates</td> <td>Attainment</td> <td></td> </tr> <tr> <td>Lead</td> <td>Attainment</td> <td>Unclassified/ Attainment</td> </tr> <tr> <td>Hydrogen Sulfide</td> <td>Attainment</td> <td></td> </tr> <tr> <td>Visibility Reducing Particles</td> <td>Attainment</td> <td></td> </tr> </tbody> </table> <p>Local air districts and CARB monitor ambient air quality to assure that air quality standards are met, and if they are not met, to develop strategies to meet the standards. LAAQMD regulates air quality in the LCAB and is responsible for attainment planning related to criteria air pollutants. While the LCAQMD does not have an air quality management plan, the LCAQMD refers to the Bay Area Air Quality Management District (BAAQMD) guidelines to evaluate thresholds of significance for general guidance. It is noted, however, that the District has not formally adopted these as the area's threshold of significance, and leaves the determination of level of significance to each local agency for determination.</p> <p>Table 2. BAAQMD Guidelines for Evaluating Air Quality Impacts.</p> <table border="1" data-bbox="732 846 1531 1066"> <thead> <tr> <th>Pollutant</th> <th>Construction Phase lb./ day</th> <th>Operation Phase lbs./ day</th> <th>Operation Phase tons/yr.</th> </tr> </thead> <tbody> <tr> <td>ROG</td> <td>54</td> <td>54</td> <td>10</td> </tr> <tr> <td>NOx</td> <td>54</td> <td>54</td> <td>10</td> </tr> <tr> <td>PM-10 (Exhaust</td> <td>82</td> <td>82</td> <td>15</td> </tr> <tr> <td>PM-2.5 (Exhaust</td> <td>54</td> <td>54</td> <td>10</td> </tr> <tr> <td>GHG</td> <td>None</td> <td>None</td> <td>1,100 MTCO₂ (e) or 4.6 MTCO₂ (e) / SP/ Yr.</td> </tr> </tbody> </table> <p>Air quality impacts from new projects consider both construction-related and operation-related activities (refer to Attachment B). Construction-related activities could result in the generation of dust, Toxic Air Contaminants (TAC) and other emissions from on-road haul trucks and off-road equipment exhaust emissions. However, construction is temporary and occurs over a relatively short duration in comparison to the operational lifetime of the proposed project. Project construction will also be required to comply with all applicable LCAQMD rules and regulations. Health risks associated with TACs are a function of both the concentration of emissions and the duration of exposure, where the higher the concentration and/or the longer the period of time can result in greater health risks.</p> <p>The analysis of air quality impacts conforms to the methodologies recommended in the BAAQMD Guidelines; therefore, construction and operational emissions generated by the proposed project are analyzed separately. Project air pollutant emissions were quantified using the California Emissions Estimator Model (CalEEMod, Version 2020.40) and are summarized in Tables 3 and 4. CalEEMod worksheets showing model inputs and results are provided in Attachment B).</p> <p>As shown in Table 3, criteria pollutant volumes generated during project construction would not exceed thresholds of significance disclosed in the BAAQMD Guidelines for any of the pollutant categories listed above.</p> <p>Table 3. Maximum Unmitigated Project Construction-Related Emissions (lbs./day)</p> <table border="1" data-bbox="789 1732 1531 1869"> <thead> <tr> <th>Pollutant</th> <th>Proposed Project Emissions</th> <th>Threshold of Significance</th> <th>Exceeds Threshold?</th> </tr> </thead> <tbody> <tr> <td>ROG</td> <td>3.65</td> <td>54</td> <td>NO</td> </tr> <tr> <td>NOx</td> <td>20.00</td> <td>54</td> <td>NO</td> </tr> <tr> <td>PM₁₀</td> <td>0.71</td> <td>82</td> <td>NO</td> </tr> <tr> <td>PM_{2.5}</td> <td>3.89</td> <td>54</td> <td>NO</td> </tr> </tbody> </table> <p><i>Source: CalEEMod Version 2020.40. Emission results in the model are in tons and then converted to pounds for the purpose of this table.</i></p>	Pollutant	State Standard	Federal Standard	PM 2.5	Attainment	Unclassified/ Attainment	Carbon Monoxide	Attainment	Unclassified/ Attainment	Nitrogen Monoxide	Attainment	Unclassified/ Attainment	Sulfur Dioxide	Attainment	Unclassified/ Attainment	Sulfates	Attainment		Lead	Attainment	Unclassified/ Attainment	Hydrogen Sulfide	Attainment		Visibility Reducing Particles	Attainment		Pollutant	Construction Phase lb./ day	Operation Phase lbs./ day	Operation Phase tons/yr.	ROG	54	54	10	NOx	54	54	10	PM-10 (Exhaust	82	82	15	PM-2.5 (Exhaust	54	54	10	GHG	None	None	1,100 MTCO ₂ (e) or 4.6 MTCO ₂ (e) / SP/ Yr.	Pollutant	Proposed Project Emissions	Threshold of Significance	Exceeds Threshold?	ROG	3.65	54	NO	NOx	20.00	54	NO	PM ₁₀	0.71	82	NO	PM _{2.5}	3.89	54	NO
Pollutant	State Standard	Federal Standard																																																																												
PM 2.5	Attainment	Unclassified/ Attainment																																																																												
Carbon Monoxide	Attainment	Unclassified/ Attainment																																																																												
Nitrogen Monoxide	Attainment	Unclassified/ Attainment																																																																												
Sulfur Dioxide	Attainment	Unclassified/ Attainment																																																																												
Sulfates	Attainment																																																																													
Lead	Attainment	Unclassified/ Attainment																																																																												
Hydrogen Sulfide	Attainment																																																																													
Visibility Reducing Particles	Attainment																																																																													
Pollutant	Construction Phase lb./ day	Operation Phase lbs./ day	Operation Phase tons/yr.																																																																											
ROG	54	54	10																																																																											
NOx	54	54	10																																																																											
PM-10 (Exhaust	82	82	15																																																																											
PM-2.5 (Exhaust	54	54	10																																																																											
GHG	None	None	1,100 MTCO ₂ (e) or 4.6 MTCO ₂ (e) / SP/ Yr.																																																																											
Pollutant	Proposed Project Emissions	Threshold of Significance	Exceeds Threshold?																																																																											
ROG	3.65	54	NO																																																																											
NOx	20.00	54	NO																																																																											
PM ₁₀	0.71	82	NO																																																																											
PM _{2.5}	3.89	54	NO																																																																											

IMPACT CATEGORIES*	1	2	3	4	5	6	<p style="text-align: center;">All determinations need explanation. Reference to documentation, sources, notes and correspondence.</p>																				
							<p>Table 4. Maximum Operational-Related Emissions (lbs./day)</p> <table border="1" data-bbox="792 258 1536 436"> <thead> <tr> <th>Pollutant</th> <th>Proposed Project Emissions</th> <th>Threshold of Significance</th> <th>Exceeds Threshold?</th> </tr> </thead> <tbody> <tr> <td>ROG</td> <td>0.93</td> <td>54</td> <td>NO</td> </tr> <tr> <td>NO_x</td> <td>0.16</td> <td>54</td> <td>NO</td> </tr> <tr> <td>PM₁₀</td> <td>17.86</td> <td>82</td> <td>NO</td> </tr> <tr> <td>PM_{2.5}</td> <td>36.21</td> <td>54</td> <td>NO</td> </tr> </tbody> </table> <p><i>Source: CalEEMod Version 2020.40. Emission results in the model are in tons and then converted to pounds for the purpose of this table.</i></p> <p>Once fully operational, the proposed project would not generate volumes of criteria pollutants which may exceed thresholds of significance disclosed in the BAAQMD Guidelines for any of the pollutant categories listed above.</p> <p>On the basis of the air modeling conducted, the project will not exceed the Bay Area Air Quality Management District (BAAQMD) air quality impact thresholds the criteria pollutants. Although the City has not adopted specific air quality impact thresholds of significance, using the BAAQMD criteria and threshold, the project will not result in a significant adverse air quality impact. To ensure impacts related to the Air Quality are less than significant, the following mitigation measures have been implemented.</p> <p><u>Mitigation measures:</u></p> <p>AIR 1: Construction activities shall be conducted with adequate dust suppression methods, including watering during grading and construction activities to limit the generation of fugitive dust or other methods approved by the Lake County Air Quality Management District. Prior to initiating soil removing activities for construction purposes, the applicant shall pre-wet affected areas with at least 0.5 gallons of water per square yard of ground area to control dust.</p> <p>AIR 2: Driveways, access roads and parking areas shall be surfaced in a manner so as to minimize dust. The applicant shall obtain all necessary encroachment permits for any work within the right-of-way. All improvement shall adhere to all applicable federal, State and local agency requirements.</p> <p>AIR 3: Any disposal of vegetation removed as a result of lot clearing shall be lawfully disposed of, preferably by chipping and composting, or as authorized by the Lake County Air Quality Management District and the Lake County Fire Protection District.</p> <p>AIR-4. During construction activities, the applicant shall remove daily accumulation of mud and dirt from any roads adjacent to the site.</p> <p>AIR-5. Grading permits shall be secured for any applicable activity from the Community Development Department, Building Division. Applicable activities shall adhere to all grading permit conditions, including Best Management Practices. All areas disturbed by grading shall be either surfaced in manner to minimize dust, landscaped or hydro seeded. All BMPs shall be routinely inspected and maintained for life of the project.</p> <p>AIR-6 All refuse generated by the facility shall be stored in approved disposal/storage containers, and appropriately covered. Removal of waste shall be on a weekly basis so as to avoid excess waste. All trash receptacles/containers shall remain covered at all times to prevent fugitive odors and rodent infestation. An odor control plan shall be submitted for review and approval by the City in accordance with the Zoning Code. Odor control shall be maintained to an acceptable level at all times.</p> <p>AIR-7 Construction activities that involve pavement, masonry, sand, gravel, grading, and other activities that could produce airborne particulate should be conducted with adequate dust controls to minimize airborne emissions. A dust mitigation plan may be required should the applicant fail to maintain adequate dust controls.</p>	Pollutant	Proposed Project Emissions	Threshold of Significance	Exceeds Threshold?	ROG	0.93	54	NO	NO _x	0.16	54	NO	PM ₁₀	17.86	82	NO	PM _{2.5}	36.21	54	NO
Pollutant	Proposed Project Emissions	Threshold of Significance	Exceeds Threshold?																								
ROG	0.93	54	NO																								
NO _x	0.16	54	NO																								
PM ₁₀	17.86	82	NO																								
PM _{2.5}	36.21	54	NO																								

IMPACT CATEGORIES*	1	2	3	4	5	6	All determinations need explanation. Reference to documentation, sources, notes and correspondence.
							<p>AIR-8 If construction or site activities are conducted within Serpentine soils, a Serpentine Control Plan may be required. Any parcel with Serpentine soils must obtain proper approvals from LCAQMD prior to beginning any construction activities. Contact LCAQMD for more details.</p> <p>AIR-9. All engines must notify LCAQMD prior to beginning construction activities and prior to engine Use. Mobile diesel equipment used for construction and/or maintenance must be in compliance with State registration requirements. All equipment units must meet Federal, State and local requirements. All equipment units must meet RICE NESHAP/ NSPS requirements including proper maintenance to minimize airborne emissions and proper record-keeping of all activities, all units must meet the State Air Toxic Control Measures for CI engines and must meet local regulations.</p> <p>AIR-10. Site development, vegetation disposal, and site operation shall not create nuisance odors or dust. During the site preparation phase, the District recommends that any removed vegetation be chipped and spread for ground cover and erosion control. Burning of debris/construction material is not allowed on commercial property, materials generated from the commercial operation, and waste material from construction debris, must not be burned as a means of disposal.</p> <p>AIR-11. Significant dust may be generated from increase vehicle traffic if driveways and parking areas are not adequately surfaced. Surfacing standards should be included as a requirement in the use permit to minimize dust impacts to the public, visitors, and road traffic. At a minimum, the district recommends chip seal as a temporary measure for primary access roads and parking. Paving with asphaltic concrete is preferred and should be required for long term occupancy. All areas subject to semi-truck / trailer traffic should require asphaltic concrete paving or equivalent to prevent fugitive dust generation. Gravel surfacing may be adequate for low use driveways and overflow parking areas; however, gravel surfaces require more maintenance to achieve dust control, and permit conditions should require regular palliative treatment if gravel is utilized. White rock is not suitable for surfacing (and should be prohibited in the permit) because of its tendency to break down and create excessive dust. Grading and re-graveling roads should utilizing water trucks, if necessary, reduce travel times through efficient time management and consolidating solid waste removal/supply deliveries, and speed limits.</p>
b) Result in a cumulatively considerable net increase of ROC and/or NOx emissions??	<input type="checkbox"/>	<input checked="" type="checkbox"/>	<input type="checkbox"/>	<input type="checkbox"/>	<input type="checkbox"/>	<input type="checkbox"/>	See Response to Section III(a). Therefore, all potential impacts have been reduced to less than Significant Impacts with the incorporated Mitigation Measures AIR-1 through AIR-11.

IMPACT CATEGORIES*	1	2	3	4	5	6	All determinations need explanation. Reference to documentation, sources, notes and correspondence.
c) Expose sensitive receptors to substantial pollutant concentrations?	<input type="checkbox"/>	<input checked="" type="checkbox"/>	<input type="checkbox"/>	<input type="checkbox"/>	<input type="checkbox"/>	<input type="checkbox"/>	<p>Sensitive receptors are defined as facilities or land uses that include members of the population who are particularly sensitive to the effects of air pollutants, such as children, the elderly, and people with illnesses. CARB has identified the following groups of individuals as the most likely to be affected by air pollution: the elderly over 65, children under 14, athletes, and persons with cardiovascular and chronic respiratory diseases such as asthma, emphysema, and bronchitis. Operation of the proposed project would not result in the development of any substantial sources of air toxics. There are no stationary sources associated with the operations of the project; nor would the project attract additional mobile sources that spend long periods queuing and idling at the site. Onsite project emissions would not result in significant concentrations of pollutants at nearby sensitive receptors.</p> <p>Another potential air quality issue associated with construction-related activities is the airborne entrainment of asbestos due to the disturbance of naturally-occurring asbestos-containing soils. The proposed project is not located within an area designated by the State of California as likely to contain naturally-occurring asbestos (Department of Conservation [DOC] 2000). As a result, construction-related activities would not be anticipated to result in increased exposure of sensitive land uses to asbestos. A carbon monoxide (CO) "hot spot" would occur if an exceedance of the state one-hour standard of 20 parts per million (ppm) or the eight-hour standard of 9 ppm were to occur. Based on the project's anticipated generation of 1,332 daily trips on average, localized air quality impacts related to mobile source emissions would not be a concern as there is no likelihood of the project traffic exceeding CO significant threshold values.</p> <p>See Response to Section III(a). Therefore, all potential impacts have been reduced to less than Significant Impacts with the incorporated Mitigation Measures AIR-1 through AIR-11.</p>
d) Result in other emissions that create objectionable odors adversely affecting a substantial number of people?	<input type="checkbox"/>	<input checked="" type="checkbox"/>	<input type="checkbox"/>	<input type="checkbox"/>	<input type="checkbox"/>	<input type="checkbox"/>	<p>During construction, the proposed project presents the potential for generation of objectionable odors in the form of diesel exhaust in the immediate vicinity of the site. However, these emissions are short-term in nature and will rapidly dissipate and be diluted by the atmosphere downwind of the emission sources. Additionally, odors would be localized and generally confined to the construction area. Given that there are no natural topographic features (e.g., canyon walls) or manmade structures (e.g., tall buildings) that would potentially trap such emissions, construction-related odors would occur at magnitudes that would not affect substantial numbers of people.</p> <p>The project could produce some odors from outdoor trash containment. However, if properly managed, these odors should not result in significant adverse odors, however, most trash and recycling activities will be conducted within the buildings so odors are not expected to result, or create any objectionable concerns from nearby residences.</p> <p>See Response to Section III(a). Therefore, all potential impacts have been reduced to less than Significant Impacts with the incorporated Mitigation Measures AIR-1 through AIR-11.</p>
SECTION IV. BIOLOGICAL RESOURCES							
<i>Would the project:</i>							
a) Have a substantial adverse effect, either directly or through habitat modifications, on any species identified as a candidate, sensitive, or special status species in local or regional plans, policies, or regulations, or by the California Department of Fish and Game or U.S. Fish and Wildlife Service?	<input type="checkbox"/>	<input checked="" type="checkbox"/>	<input type="checkbox"/>	<input type="checkbox"/>	<input type="checkbox"/>	<input type="checkbox"/>	<p>According to the Biological Assessment prepared for the project by ECORP Consulting dated March 11, 2021 (Attachment C) no federal or State listed species have potential to occur within the Study Area. However, 21 non-listed special-status plants, one special-status turtle, three special-status birds, various birds protected under the MBTA and the California Fish and Game Code, and two special-status bats have potential or low potential to occur within the Study Area. One drainage channel located within the Study Area may be considered a Water of the U.S. and State. Individual oak trees within the Study Area are protected under City ordinance are located within the Study Area, and the oak woodlands onsite may be considered a sensitive natural community by CDFW. To ensure impacts related to the Biological Resources are less than significant, the following mitigation measures have been implemented.</p>

IMPACT CATEGORIES*	1	2	3	4	5	6	All determinations need explanation. Reference to documentation, sources, notes and correspondence.
							<p>BIO-1: The project should implement erosion control measures and BMPs to reduce the potential for sediment or pollutants at the Project site.</p> <p>BIO-2: A qualified biologist shall conduct a mandatory Worker Environmental Awareness Program for all contractors, work crews, and any onsite personnel to aid workers in recognizing special status species and sensitive biological resources that may occur on-site. The program shall include identification of the special status species and their habitats, a description of the regulatory status and general ecological characteristics of sensitive resources, and review of the limits of construction and Mitigation Measures required to reduce impacts to biological resources within the work area.</p> <p>BIO-3: Conduct a pre-construction northwestern pond turtle survey in Project impact and staging areas within 48 hours prior to construction activities. Any northwestern pond turtle individuals discovered in the Project work area immediately prior to or during Project activities shall be allowed to move out of the work area of their own volition. If this is not feasible, they shall be captured by a qualified biologist and relocated out of harm's way to the nearest suitable habitat at least 100 feet from the Project work area where they were found.</p> <p>BIO-4: If construction is to occur during the nesting season (generally February 1 - August 31), conduct a pre-construction nesting bird survey of all suitable nesting habitat on the Project within 14 days of the commencement of construction. The survey shall be conducted within a 500-foot radius of Project work areas for raptors and within a 100-foot radius for other nesting birds. If any active nests are observed, these nests shall be designated a sensitive area and protected by an avoidance buffer established in coordination with CDFW until the breeding season has ended or until a qualified biologist has determined that the young have fledged and are no longer reliant upon the nest or parental care for survival. Pre-construction nesting surveys are not required for construction activity outside the nesting season.</p> <p>BIO-5: Within 14 days prior to Project activities that may impact bat roosting habitat (e.g., removal of manmade structures or trees), a qualified biologist will survey for all suitable roosting habitat within the Project impact limits. If suitable roosting habitat is not identified, no further measures are necessary. If suitable roosting habitat is identified, a qualified biologist will conduct an evening bat emergence survey that may include acoustic monitoring to determine whether or not bats are present. If roosting bats are determined to be present within the Project site, consultation with CDFW prior to initiation of construction activities and/or preparation of a Bat Management Plan outlining avoidance and minimization measures specific to the roost(s) potentially affected may be required</p>
<p>b) Have a substantial adverse effect on any riparian habitat or other sensitive natural community identified in local or regional plans, policies, and regulations or by the California Department of Fish and Game or U.S. Fish and Wildlife Service?</p>	<input type="checkbox"/>	<input type="checkbox"/>	<input type="checkbox"/>	<input type="checkbox"/>	<input checked="" type="checkbox"/>	<input type="checkbox"/>	<p>The Study Area supports a small amount of valley oak woodland, which may be considered a sensitive natural community. The project will require the removal of a several trees on the site, but most of these were identified in the Biological Report as being English Walnut trees. However, there is some potential oak trees on the site, such as along the Burns Valley Creek area. Prior to vegetation/tree removal, the applicant shall obtain a Tree Removal Permit from the City of Clearlake and if Oak Trees are to be removed, they shall be replaced in accordance with Section 18-40.050 of the City Code (see Mitigation Measure BIO-6 regarding tree removal). The Biological Study also identified the potential for wetlands. The Project does not propose impacts to riparian habitat or valley oak woodland that is adjacent to Burns Valley Creek. Less than Significant impact.</p>

IMPACT CATEGORIES*	1	2	3	4	5	6	All determinations need explanation. Reference to documentation, sources, notes and correspondence.
c) Have a substantial adverse effect on state or federally protected wetlands (including, not limited to, marsh, vernal pool, coastal, etc.) through direct removal, filling, hydrological interruption, or other means?	<input type="checkbox"/>	<input checked="" type="checkbox"/>	<input type="checkbox"/>	<input type="checkbox"/>	<input type="checkbox"/>	<input type="checkbox"/>	As discussed in Response a), the Biological Assessment identified a narrow (one to three-feet in width) drainage channel that occurs along the western property line which may or may not be a Waters of the U.S./Streambed. Compliance with Mitigation Measure outlined in Response a) above along with City ordinances and state water quality permit requirements for construction and post-construction scenarios would entail the installation of construction and post-development BMPs to prevent erosion and siltation within the drainage channel. As recommended in the Biological Assessment Mitigation Measure BIO-6 will reduce potential impacts to wetlands to a level of non-significance. Less than Significant Impact with Mitigation Measures. BIO-6: To minimize potential impacts to the ephemeral drainage on the project site during construction activity, a qualified biologist shall map the extent of the riparian habitat on the project site. Avoidance buffers for riparian habitat shall be applied in compliance with City of Clearlake requirements. The riparian habitat and avoidance buffer shall be demarcated prior to construction and shall be maintained until the completion of construction. A qualified biologist/biological monitor shall be present if work must occur within the avoidance buffer to ensure riparian habitat is not impacted by the construction activity.
d) Interfere substantially with the movement of any native resident or migratory fish or wildlife species or with established native resident or migratory wildlife corridors, or impede the use of native wildlife nursery sites?	<input type="checkbox"/>	<input type="checkbox"/>	<input type="checkbox"/>	<input type="checkbox"/>	<input checked="" type="checkbox"/>	<input type="checkbox"/>	The Study Area provides limited migratory opportunities for terrestrial wildlife. Project construction is likely to temporarily disturb and displace most wildlife from the Study Area. Some wildlife such as birds or nocturnal species are likely to continue to use the habitats opportunistically for the duration of construction. Once construction is complete, wildlife movements are expected to resume but will likely be more limited through the developed areas of the Study Area. The Project is not expected to substantially interfere with wildlife movement. There are no documented nursery sites and no nursey sites were observed within the Study Area during the site reconnaissance. Therefore, the Project is not expected to impact wildlife nursery sites. Less than Significant
e) Conflict with any local policies or ordinances protecting biological resources, such as a tree preservation policy or ordinance?	<input type="checkbox"/>	<input checked="" type="checkbox"/>	<input type="checkbox"/>	<input type="checkbox"/>	<input type="checkbox"/>	<input type="checkbox"/>	The project will have minimal to no conflict with any local policies or ordinances protecting biological resources, such as a tree preservation policy or ordinance. However, the project will require the removal of a several trees on the site, several which are Oak trees. Prior to vegetation/tree removal, the applicant shall obtain a Tree Removal Permit from the City of Clearlake and if Oak Trees are to be removed, they shall be replaced in accordance with Section 18-40.050 of the City Code. To ensure impacts related to the Tree Preservation are less than significant, the following mitigation measure have been implemented. BIO-7: A native tree protection and removal permit, waiver, or similar approval shall be secured prior to impacting trees protected under the City ordinance. Avoidance buffers for protected trees shall be consistent with the City requirements, shall be clearly demarcated prior to construction, and should be maintained until the completion of construction. A qualified biologist/biological monitor should be present if work must occur within the avoidance buffer to ensure avoided protected trees are not impacted by the work.
f) Conflict with the provisions of an adopted Habitat Conservation Plan, Natural Community Conservation Plan, or other approved local, regional, or state habitat conservation plan?	<input type="checkbox"/>	<input type="checkbox"/>	<input type="checkbox"/>	<input type="checkbox"/>	<input checked="" type="checkbox"/>	<input type="checkbox"/>	The project will not conflict with any adopted Habitat Conservation Plan, Natural Community Conservation Plan, or other approved local, regional, or state habitat conservation plan. However, the project may require the removal of Oak Trees. Less Than Significant Impact
SECTION V. CULTURAL RESOURCES							
<i>Would the project:</i>							
a) Cause a substantial adverse change in the significance of a	<input type="checkbox"/>	<input checked="" type="checkbox"/>	<input type="checkbox"/>	<input type="checkbox"/>	<input type="checkbox"/>	<input type="checkbox"/>	An evaluation of the potential for historical, cultural, tribal, or paleontological resources on the project site and in the vicinity of the project a cultural resource investigation was conducted by Gregory G. White, PhD, RPA of Sub Terra Heritage Resource

IMPACT CATEGORIES*	1	2	3	4	5	6	<p style="text-align: center;">All determinations need explanation. Reference to documentation, sources, notes and correspondence.</p>
<p>historical resource pursuant to §15064.5?</p>							<p>Investigations. This investigation included records searches, consultation with Native American tribes, and a site reconnaissance.</p> <p>The investigation resulted in the discovery of two intact, buried, archaeological sites CCL-21-01 and CCL-21-02. Both sites can be considered significant cultural resources:</p> <p><i>Site CCL-21-01.</i> CCL-21-01 is a prehistoric Native American non-midden lithic site encountered in five trenches located in the east-center of the Project area. Closely spaced trench probes established well-defined site limits indicating that the site occupies an area of 3,046 square yards (2,547 square meters). The site continues to the east outside the Project area and across Burns Valley Road. The archaeological deposit is not evident on the surface and throughout its extent was found buried at depths of 16–32 inches below surface. The archaeological deposit was contained in non-midden Cole Bt1 soils and characterized by low-diversity, moderate-density (50–250 items per cubic meter) artifact assemblages. Associated artifacts were dominated by Borax Lake obsidian including many large and medium-sized flakes indicative of early-stage biface production. In addition to an evident tool production function, the presence of possible fire-cracked rock and a few basalt spalls probably derived from basalt cores and core-tools suggests that the site also served a temporary residential function.</p> <p><i>Site CCL-21-02.</i> CCL-21-02 is a prehistoric Native American non-midden lithic site encountered in two trenches located in the center of the Project area immediately south of the Redbud Library Annex boundary fence. Dispersed trench probes established well-defined east-west site limits indicating that the site occupies an area of 2,190 square yards. The archaeological deposit is not evident on the surface and in both trenches was found buried at a depth of 20–28 inches below surface. Similar to site CCL-21-01, the archaeological deposit was contained in non-midden Cole Bt1 soils and characterized by low-diversity, low- to moderate-density (20–150 items per cubic meter) artifact assemblages. Associated artifacts were dominated by Borax Lake obsidian including many large and medium-sized flakes indicative of early-stage biface production.</p> <p>Obsidian artifacts were found in association with the remote fill dumped in the southeast quadrant and south-center of the Project area. These re-deposits do not constitute cultural resources and no further management measures are necessary.</p> <p><i>Intact, Buried Archaeological Sites.</i> The investigation resulted in the discovery of two intact, buried, archaeological sites, CCL-21-01 and CCL-21-02 (Figure 7, yellow polygons), both of the sites can be considered significant cultural resources. Both of the sites occupy relatively small areas and are buried at depths of 16–32 inches below grade. No further management measures will be necessary if potential impacts to these sites can be eliminated by means of avoidance or placement of fill.</p> <p>To ensure impacts related to the Cultural Resources are minimized, the following mitigation measures have been implemented.</p> <p><u>Mitigation Measures:</u></p> <p>CUL-1 During construction activities, if any subsurface archaeological remains are uncovered, all work shall be halted within 100 feet of the find and the owner shall utilize a qualified cultural resources consultant to identify and investigate any subsurface historic remains and define their physical extent and the nature of any built features or artifact-bearing deposits.</p> <p>CUL-2 The cultural resource consultant’s investigation shall proceed into formal evaluation to determine their eligibility for the California Register of Historical Resources. This shall include, at a minimum, additional exposure of the feature(s), photo-documentation and recordation, and analysis of the artifact assemblage(s). If the evaluation determines that the features and artifacts do not have sufficient data potential to be eligible for the California Register, additional work shall not be required. However, if data potential exists – e.g., there is an intact feature with a large and varied artifact assemblage – it will be necessary to mitigate any Project impacts. Mitigation of impacts might include avoidance of further disturbance to the resources through Project redesign. If avoidance is determined</p>

IMPACT CATEGORIES*	1	2	3	4	5	6	<p style="text-align: center;">All determinations need explanation. Reference to documentation, sources, notes and correspondence.</p>
							<p>to be infeasible, pursuant to CEQA Guidelines Section 15126.4(b)(3)(C), a data recovery plan, which makes provisions for adequately recovering the scientifically consequential information from and about the historical resource, shall be prepared and adopted prior to any excavation being undertaken. Such studies shall be deposited with the California Historical Resources Regional Information Center. Archeological sites known to contain human remains shall be treated in accordance with the provisions of Section 7050.5 Health and Safety Code. If an artifact must be removed during Project excavation or testing, curation may be an appropriate mitigation. This language of this mitigation measure shall be included on any future grading plans and utility plans approved by the City for the Project.</p> <p>CUL-3 If human remains are encountered, no further disturbance shall occur within 100 feet of the vicinity of the find(s) until the Lake County Coroner has made the necessary findings as to origin (California Health and Safety Code Section 7050.5). Further, pursuant to California Public Resources Code Section 5097.98(b) remains shall be left in place and free from disturbance until a final decision as to the treatment and disposition has been made. If the Lake County Coroner determines the remains to be Native American, the Native American Heritage Commission must be contacted within 24 hours. The Native American Heritage Commission must then identify the “most likely descendant(s)”, The landowner shall engage in consultations with the most likely descendant (MLD). The MLD will make recommendations concerning the treatment of the remains within 48 hours as provided in Public Resources Code 5097.98.</p> <p>CUL-4 The sensitive site section noted on the project site plan shall not be disturbed during construction and/or maintenance of the park. This sensitive site is identified as investigation resulted in the discovery of two intact, buried, archaeological sites, CCL-21-01 and CCL-21-02 (Figure 7, yellow polygons), both of the sites can be considered significant cultural resources. Both of the sites occupy relatively small areas and are buried at depths of 16–32 inches below grade. The project as currently designed, will not impact sites CCL-21-01 or CCL-21-02. If avoidance and/or preservation in place is not possible, the owner will consider re-design or other measures to avoid impacting resources consistent with CEQA. The owner will contract with tribal monitors for ground disturbance within 100 feet of sites CCL-21-01 and CCL-21-02. The owner and contract archeologist will consult with tribal representatives regarding ground disturbing work within these areas including the designation of a “reburial” location, if needed.</p> <p>CUL-5: On or prior to the first day of construction the owner shall organize cultural sensitivity training for contractors involved in ground disturbing activities.</p> <p>CUL-6: The southern two-thirds of site CCL-21-01 is contained within APN010-026-400-000 and the Burns Valley Development Project area. The area occupied by the site has been slated for a paved parking area serving planned playing fields nearby (Figure 2). This portion of the site is situated on the sloping bank of an extinct section of upper Miller Creek, an area marked by an overstory of mixed native oak and introduced conifer and hardwood trees. Because this part of the site is situated on a bank, the land surface is sloped and drops 10–15 feet in elevation. Current engineering plan calls for vegetation and tree removal as well as application of remote fill materials to bring it to a level grade, with installation of landscaping, drains, and underground utility lines in the area. Project revisions in design, location, and operations should be implemented in the area occupied by the footprint of site CCL-21-01, inclusive to a 15-foot (4.5-meter) buffer around the site perimeter. Limitations to disturbance in this area shall be as follows:</p> <ol style="list-style-type: none"> 1. <i>Fill Cap.</i> Because CCL-21-01 is a buried archaeological deposit contained in a dense clay loam likely to resist compaction impacts, avoidance can be achieved by placing fill on the site surface; 2. <i>Flush Cut Vegetation.</i> Existing vegetation including shrubs and trees should be flush-cut, i.e., cut flush with the ground at a point not to exceed 10-inches below grade;

IMPACT CATEGORIES*	1	2	3	4	5	6	All determinations need explanation. Reference to documentation, sources, notes and correspondence.
							<p>3. <i>Landscaping Fabric and Fill.</i> Once the flush cut is complete and surface cleared of debris, landscaping fabric should be laid over the area of the site to create a boundary between intact soils and remote fill. With respect to the fill, drainage, safety, and operational concerns may prevent adding a lot of elevation; however, an additional minimum 6–12-inches (15–30 centimeters) of fill should be added to the site area to provide a construction and compaction buffer to protect the deposit. This would result in an overburden of 21–27 inches (53–71 centimeters) of capping material;</p> <p>4. <i>Avoid Installation of Subsurface Features.</i> Avoid placement of pier supports, subsurface landscaping features, subsurface drains, and utility lines in the site area.</p> <p>5. <i>Avoid New Overstory Plantings.</i> Avoid placement of new overstory trees in the site area.</p> <p>CUL-7: Site CCL-21-02 is contained within APN010-026-400-000 and the Burns Valley Development Project area. The area occupied by the site has been slated for open space. Project revisions in design, location, and operations should be implemented in the area occupied by the footprint of site CCL-21-02, inclusive to a 15-foot (4.5-meter) buffer around the site perimeter. Limitations to disturbance in this area shall be as follows:</p> <p>1. <i>Fill Cap.</i> Because CCL-21-01 is a buried archaeological deposit contained in a dense clay loam likely to resist compaction impacts, avoidance can be achieved by placing fill on the site/buffer surface;</p> <p>2. <i>Landscaping Fabric and Fill.</i> Prior to site prep and construction in the area, landscaping fabric should be laid over the area of the site to create a boundary between intact soils and remote fill. With respect to the fill, drainage, safety, and operational concerns may prevent adding a lot of elevation; however, an additional minimum 6–12-inches (15–30 centimeters) of fill should be added to the site area to provide a construction and compaction buffer to protect the deposit. This would result in an overburden of 21–27 inches (53–71 centimeters) of capping material;</p> <p>3. <i>Avoid Installation of Subsurface Features.</i> Avoid placement of pier supports, subsurface landscaping features, subsurface drains, and utility lines in the site area.</p> <p>4. <i>Avoid New Overstory Plantings.</i> Avoid placement of new overstory trees in the site area.</p>
b) Cause a substantial adverse change in the significance of an archeological resource pursuant to §15064.5?	<input type="checkbox"/>	<input checked="" type="checkbox"/>	<input type="checkbox"/>	<input type="checkbox"/>	<input type="checkbox"/>	<input type="checkbox"/>	See Response to Section V(a): Less than Significant Impact with the incorporated mitigation measure CUL-1 through CUL-3.
c) Disturb any human remains, including those interred outside of formal cemeteries?	<input type="checkbox"/>	<input checked="" type="checkbox"/>	<input type="checkbox"/>	<input type="checkbox"/>	<input type="checkbox"/>	<input type="checkbox"/>	See Response to Section V(a): Less than Significant Impact with the incorporated mitigation measure CUL-1 through CUL-3.
SECTION VI. ENERGY							
<i>Would the project:</i>							
a) Consume energy resources in a wasteful, inefficient, or unnecessary amount during project	<input type="checkbox"/>	<input type="checkbox"/>	<input type="checkbox"/>	<input type="checkbox"/>	<input checked="" type="checkbox"/>	<input type="checkbox"/>	The project would not result in wasteful, inefficient, or unnecessary consumption of energy, given project installation of outdoor lighting and public systems are compliant with State of California energy conservation regulations. Therefore, this impact would be less than significant.

IMPACT CATEGORIES*	1	2	3	4	5	6	All determinations need explanation. Reference to documentation, sources, notes and correspondence.
construction and/or operation?							
b) Conflict with or obstruct a state or local plan for renewable energy or energy efficiency?	<input type="checkbox"/>	<input type="checkbox"/>	<input type="checkbox"/>	<input type="checkbox"/>	<input checked="" type="checkbox"/>	<input type="checkbox"/>	The California State Building Standards Commission adopted updates to the California Green Building Standards Code (CALGreen). CALGreen contains requirements for construction site selection, storm water control during construction, construction waste reduction, indoor water use reduction, material selection, natural resource conservation, and site irrigation conservation. CALGreen is intended to (1) reduce GHG emissions; (2) promote environmentally responsible, cost-effective, healthier places to live and work; and (3) reduce energy and water consumption. The project would-be built in accord with CALGreen standards and reduce water use by the installation of artificial turf athletic fields. Therefore, this impact would be less than significant.
SECTION VII. GEOLOGY AND SOILS							
<i>Would the project:</i>							
<p>a) Directly or indirectly cause potential substantial adverse effects, including the risk of loss, injury, or death involving:</p> <p>i) Rupture of a known earthquake fault, as delineated on the most recent Alquist- Priolo Earthquake Fault Zoning Map issued by the State Geologist for the area or based on other substantial evidence of a known fault? Refer to Division of Mines and Geology Special Publication 42.</p> <p>ii) Strong seismic ground shaking?</p> <p>iii) Seismic-related ground failure, including liquefaction?</p> <p>iv) Landslides?</p>	<input type="checkbox"/>	<input type="checkbox"/>	<input type="checkbox"/>	<input type="checkbox"/>	<input checked="" type="checkbox"/>	<input type="checkbox"/>	<p>Topography on the project site is generally flat (<10%) and the site is situated at an elevation of approximately 1,350 feet above mean sea level. The site is located in an area that was historically used for agricultural and residential purposes. The Geotechnical Engineering Investigation Report prepared for the Proposed Burns Valley Development project, prepared by NV5, February 26, 2021, includes the following recommendations (Refer to Attachment D):</p> <ol style="list-style-type: none"> 1. The existing foundation remnants and exterior slab-on-grade within the proposed building areas should be razed and disposed off-site. It may be possible to use some of this demolition material to construct engineered fills provided they meet the gradation requirements specified for “testable fill” materials presented in this report. The project geotechnical engineer should approve the use of both asphalt concrete (AC) and aggregate base (AB) rock demolition materials for use on constructing engineering fills. 2. All foundations, underground utilities and other existing site improvements that are encountered during construction with the proposed building area should be demolished and removed from the site, these demolition materials should be disposed off site in compliance with applicable regulatory requirements <p><u>i) Earthquake Faults</u> There are no mapped earthquake faults on or adjacent to the subject site.</p> <p><u>ii-iii) Seismic Ground Shaking and Seismic-Related Ground Failure, including liquefaction.</u> The mapping of the site’s soil indicates that the soil is stable and not prone to liquefaction.</p> <p><u>iv) Landslides</u> According to the Landslide Hazard Identification Map prepared by the California Department of Conservation, Division of Mines and Geology, the project parcel soil is considered “generally stable” and not located within and/or adjacent to an existing known “landslide area”.</p> <p>Project design shall incorporate Best Management Practices (BMPs) to the maximum extent practicable to prevent or reduce discharge of all construction or post construction pollutants into the County storm drainage system. BMPs include scheduling of activities, erosion and sediment control, operation and maintenance procedures and other measures in accordance City of Clearlake Municipal Code(s). Less Than Significant Impact</p>
b) Result in substantial soil erosion or the loss of topsoil?	<input type="checkbox"/>	<input checked="" type="checkbox"/>	<input type="checkbox"/>	<input type="checkbox"/>	<input type="checkbox"/>	<input type="checkbox"/>	The project is not anticipated to result in substantial soil erosion or the loss of topsoil.. All disturbance will occur onsite, and no soil will be exported and/or imported. The applicant shall incorporate Best Management Practices (BMPs) consistent with the City Code and the State Storm Water Drainage Regulations to the maximum extent practicable to prevent and/or reduce discharge of all construction or post-construction pollutants into the local storm drainage system. All grading measure shall adhere to all Federal, State and local agency requirements. The project shall adhere to all Federal, State, and local agencies requirements. Therefore, to ensure impacts related to the

IMPACT CATEGORIES*	1	2	3	4	5	6	All determinations need explanation. Reference to documentation, sources, notes and correspondence.
							<p>Geology and Soils are minimized, the following mitigation measures have been implemented.</p> <p>Mitigation Measures: GEO-1: Prior to any ground disturbance and/or operation, the applicant shall submit <u>Erosion Control and Sediment Plans</u> to the Community Development Department for review and approval.</p> <ul style="list-style-type: none"> The project shall incorporate Best Management Practices (BMPs) consistent with the City Code and the State Storm Water Drainage Regulations to the maximum extent practicable to prevent and/or reduce discharge of all construction or post-construction pollutants into the local storm drainage system. <p>GEO-2: Prior to any ground disturbance, (if applicable), the applicant shall submit and obtain a Grading Permit from the Community Development in accordance with the City of Clearlake Municipal code(s).</p> <p>GEO-3: The applicant shall monitor the site during the rainy season including post-installation, application of BMPs, erosion control maintenance, and other improvements as needed. Said measures shall be maintained for life of the project and replace/repaired when necessary.</p>
c) Be located on a geologic unit or soil that is unstable, or that would become unstable as a result of the project, and potentially result in on-site or off-site landslide, lateral spreading, subsidence, liquefaction or collapse?	<input type="checkbox"/>	<input type="checkbox"/>	<input type="checkbox"/>	<input type="checkbox"/>	<input checked="" type="checkbox"/>	<input type="checkbox"/>	<p>According to the Geotechnical Report prepared for the project, undocumented fills were observed on site and are not considered suitable for support of the proposed structural improvements without the following recommendations (refer to Attachment D).</p> <p>According to the soil survey of Lake County, prepared by the U.S.D.A., the soil at the site is considered “generally stable” and there is little to no potential for landslide, subsidence, debris flows, liquefaction or collapse. The project shall incorporate Best Management Practices (BMPs) consistent with the City Code and the State Storm Water Drainage Regulations to the maximum extent practicable to prevent and/or reduce discharge of all construction or post-construction pollutants into the local storm drainage system. Less Than Significant Impact</p>
d) Be located on expansive soil, as defined in Table 18-1-B of the Uniform Building Code (1994), creating substantial direct or indirect risks to life or property?	<input type="checkbox"/>	<input type="checkbox"/>	<input type="checkbox"/>	<input type="checkbox"/>	<input type="checkbox"/>	<input type="checkbox"/>	<p>The Geotechnical Report did not identify any expansive soils on the site. The project will adhere to all Federal, State and local agency requirements, including all requirements in the City of Clearlake’s Municipal Code(s). Less Than Significant Impact</p>
e) Have soils incapable of adequately supporting the use of septic tanks or alternative wastewater disposal systems where sewers are not available for the disposal of wastewater?	<input type="checkbox"/>	<input type="checkbox"/>	<input type="checkbox"/>	<input type="checkbox"/>	<input type="checkbox"/>	<input type="checkbox"/>	<p>The project parcel is currently vacant, when development occurs, the project shall adhere to all applicable Federal, State and local agency requirements regarding wastewater disposal systems, (i.e connecting to public/private sewer facilities and/or onsite waste management systems (septic). Less Than Significant Impact</p>
f) Directly or indirectly destroy a unique paleontological resource or site or unique geologic feature?	<input type="checkbox"/>	<input type="checkbox"/>	<input type="checkbox"/>	<input type="checkbox"/>	<input type="checkbox"/>	<input type="checkbox"/>	<p>Disturbance of paleontological resources or unique geologic features is not anticipated, but mitigation measures are in place to assure that in the event any artifacts are found. All potential impacts have been reduced to less than significant levels with the incorporated mitigation measures CUL-1 and CUL-5.</p>
SECTION VIII. GREENHOUSE GAS EMISSIONS							
<i>Would the project:</i>							
a) Generate greenhouse gas emissions, either directly or indirectly, that may have a significant impact on the environment?	<input type="checkbox"/>	<input type="checkbox"/>	<input type="checkbox"/>	<input type="checkbox"/>	<input checked="" type="checkbox"/>	<input type="checkbox"/>	<p>Air quality impacts, including Carbon Dioxide emissions from the project, which contribute to global warming, need to be analyzed using the current guidelines or procedures specified by the local air district or the Air Resources Board. Calculations of CO₂, CH₄, and N₂O emissions are provided to identify the magnitude of potential project effects. This analysis focuses on CO₂, CH₄, and N₂O since these comprise 98.9 percent of all GHG emissions by volume (IPCC 2007) and are the GHG emissions that the project</p>

IMPACT CATEGORIES*	1	2	3	4	5	6	<p style="text-align: center;">All determinations need explanation. Reference to documentation, sources, notes and correspondence.</p>
							<p>would emit in the greatest quantities. Fluorinated gases, such as HFC, PFCs, and SF6 were not used in this analysis, as they are primarily associated with industrial processes and the proposed project involves retail development and does not include an industrial component. Emissions of all GHGs are converted into metric tons of carbon dioxide equivalent (MT of CO₂e), which presents the volume of GHGs equivalent to the global warming effect of CO₂. While minimal amounts of other GHGs, such as chlorofluorocarbons (CFC), would be emitted, they would not substantially add to the calculated CO₂e quantities. Calculations are based on the California Air Pollution Control Officers Association (CAPCOA) CEQA & Climate Change white paper (CAPCOA 2008).</p> <p>The Lake County Air Quality Management District does not have an air quality management plan. However, the LCAQMD refers to the Bay Area Air Quality Management District (BAAQMD) guidelines to evaluate thresholds of significance for general guidance (refer excerpts from this document in Attachment B). It is noted, however, that the LCAQMD has not formally adopted these as the area's threshold of significance and leaves the determination of level of significance to each local agency for determination.</p> <p>Air impact modeling was conducted using CalEEMod.2020.40 Modeling which indicates that the project's construction will result in about 52 metric tons of CO₂e during construction (2 years) and about 34 metric tons of CO₂e annually during operation. Construction and operational estimates fall below the BAAQMD levels of significance of GHG which is 1,100 metric tons annually (see Attachment B). Therefore, the impact is less than significant.</p>
b) Conflict with an applicable plan, policy or regulation adopted for the purpose of reducing the emissions of greenhouse gases?	<input type="checkbox"/>	<input type="checkbox"/>	<input type="checkbox"/>	<input type="checkbox"/>	<input checked="" type="checkbox"/>	<input type="checkbox"/>	<p>This project will not conflict with any adopted plans or policies for the reduction of greenhouse gas emissions. The City of Clearlake is within an 'air attainment' basin. In accordance with the requirements of the Lake County Air Quality Management District, an air permit will be required as a condition of the use permit, prior to issuance of a building permit for the project. Refer to response in Section VIII(a). Less Than Significant Impact</p>
<h2 style="margin: 0;">SECTION IX. HAZARDS AND HAZARDOUS MATERIALS</h2> <p style="margin: 0;"><i>Would the project:</i></p>							
a) Create a significant hazard to the public or the environment through the routine transport, use, or disposal of hazardous materials?	<input type="checkbox"/>	<input type="checkbox"/>	<input type="checkbox"/>	<input type="checkbox"/>	<input checked="" type="checkbox"/>	<input type="checkbox"/>	<p>Project construction activities may involve the use and transport of hazardous materials. These materials may include fuels, oils, mechanical fluids, and other chemicals used during construction. Transportation, storage, use, and disposal of hazardous materials during construction activities would be required to comply with applicable federal, state, and local statutes and regulations. Compliance would ensure that human health and the environment are not exposed to hazardous materials. In addition, the construction contractor would be required to implement a Stormwater Pollution Prevention Plan during construction activities to prevent contaminated runoff from leaving the project site. Therefore, no significant impacts would occur during construction activities. In addition, the proposed project would not be a large-quantity user of hazardous materials. Small quantities of hazardous materials would likely routinely be used on site, primarily fertilizers, herbicides, and pesticides. The potential risks posed by the use and storage of these hazardous materials are limited primarily to the immediate vicinity of the materials. Any transport of these materials would be required to comply with various federal and state laws regarding hazardous materials transportation. In summary, the proposed project would not create a significant hazard to the public or the environment from routine transport, use, or disposal of hazardous materials and impacts would be less than significant.</p>
b) Create a significant hazard to the public or the environment through reasonably foreseeable upset and accident conditions involving the release of hazardous materials into the environment?	<input type="checkbox"/>	<input type="checkbox"/>	<input type="checkbox"/>	<input type="checkbox"/>	<input checked="" type="checkbox"/>	<input type="checkbox"/>	<p>The project will not create a significant hazard to the public or the environment through reasonably foreseeable upset and accident conditions involving the release of hazardous materials into the environment. All chemicals, pesticides, fertilizer, and other materials associated with the operation shall adhere to all Federal, State, and local agency requirements. Less than Significant.</p>

IMPACT CATEGORIES*	1	2	3	4	5	6	All determinations need explanation. Reference to documentation, sources, notes and correspondence.
c) Emit hazardous emissions or handle hazardous or acutely hazardous materials, substances, or waste within one-quarter mile of an existing or proposed school?	<input type="checkbox"/>	<input type="checkbox"/>	<input type="checkbox"/>	<input type="checkbox"/>	<input type="checkbox"/>	<input checked="" type="checkbox"/>	The proposed project is not located within one-quarter mile of an existing or proposed school. No Impact
d) Be located on a site which is included on a list of hazardous materials sites compiled pursuant to Government Code Section 65962.5 and, as a result, would it create a significant hazard to the public or the environment?	<input type="checkbox"/>	<input type="checkbox"/>	<input type="checkbox"/>	<input type="checkbox"/>	<input type="checkbox"/>	<input checked="" type="checkbox"/>	The project site is not located on or within 2,000 feet of an NPL ("Superfund") site or a CERCLIS site (CA DTSC, 2022). The project site is not listed as a site containing hazardous materials in the databases maintained by the Environmental Protection Agency (EPA), California Department of Toxic Substance, and Control State Resources Water Control Board. No Impact
e) For a project located within an airport land use plan or, where such a plan has not been adopted, within two miles of a public airport or public use airport, would the project result in a safety hazard or excessive noise for people residing or working in the project area?	<input type="checkbox"/>	<input type="checkbox"/>	<input type="checkbox"/>	<input type="checkbox"/>	<input type="checkbox"/>	<input checked="" type="checkbox"/>	The project is not located within two (2) miles of an airport and/or within an Airport Land Use Plan. No Impact
f) Impair implementation of or physically interfere with an adopted emergency response plan or emergency evacuation plan?	<input type="checkbox"/>	<input type="checkbox"/>	<input type="checkbox"/>	<input type="checkbox"/>	<input checked="" type="checkbox"/>	<input type="checkbox"/>	The project would not impair or interfere with an adopted emergency response or evacuation plan. The project has been reviewed by the Lake County Department of Environmental Health, Lake County Special Districts, City of Clearlake Police Department, City of Clearlake's Community Development Department (Building, Public Works, Planning), and the Local Fire Protection District/CalFire for consistency with access and safety standards. The City of Clearlake did not receive any adverse comments. Less Than Significant Impact
g) Expose people or structures, either directly or indirectly, to a significant risk of loss, injury or death involving wildland fires?	<input type="checkbox"/>	<input type="checkbox"/>	<input type="checkbox"/>	<input type="checkbox"/>	<input checked="" type="checkbox"/>	<input type="checkbox"/>	The project will not expose people or structures, either directly or indirectly, to a significant risk of loss, injury or death involving wildland fires as it is located in a "Low to Moderate" Fire Hazard Severity Zone and within the Lake County Fire Protection District. The project was circulated for review to various agencies, include but not limited to City Engineer, City of Clearlake Police Department, City of Clearlake Building Official/Inspection, Lake County Fire Protection District and the California Department of Transportation (Caltrans). During the project review, no adverse comments were received. The application shall adhere to all current Federal, State and local agency requirements, including all mitigation measures and conditions of approval imposed on such use. Less Than Significant Impact

SECTION X. HYDROLOGY AND WATER QUALITY

Would the project:

a) Violate any water quality standards or waste discharge requirements or otherwise substantially degrade surface or ground water quality?	<input type="checkbox"/>	<input type="checkbox"/>	<input type="checkbox"/>	<input type="checkbox"/>	<input checked="" type="checkbox"/>	<input type="checkbox"/>	The North Coast Regional Water Quality Control Board (RWQCB) administers the National Pollutant Discharge Elimination System (NPDES) stormwater permitting program for construction activities. Construction activities disturbing one acre or more of land are subject to the permitting requirements of the NPDES General Permit for Discharges of Storm Water Runoff Associated with Construction Activity. Since the project site involves more than one acre in size the City, as the applicant is required to submit a NOI to the RWQCB that covers the General Construction Permit (GCP) prior to the beginning of construction. The GCP requires the preparation and implementation of a Water Quality Management Plan (WQMP) and a Storm Water Pollution Prevention Plan (SWPPP) both of which
--	--------------------------	--------------------------	--------------------------	--------------------------	-------------------------------------	--------------------------	--

IMPACT CATEGORIES*	1	2	3	4	5	6	All determinations need explanation. Reference to documentation, sources, notes and correspondence.
							must be prepared before construction can begin. The SWPPP outlines all activities to prevent stormwater contamination, control sedimentation and erosion, and compliance with Clean Water Act (CWA) requirements during construction. Implementation of the SWPPP starts with the commencement of construction and continues through to the completion of the project. The WQMP outlines the project site design, source control and treatment control of BMPs utilized throughout the life of the project. Upon completion of project construction, the City, as the applicant must submit a Notice of Termination (NOT) to the RWQCB to indicate that construction is completed. Therefore, with implementation of NPDES and the SWPPP in compliance with the RWQCB, impacts to water quality and discharge requirements will be a less than significant impact.
b) Substantially decrease groundwater supplies or interfere substantially with groundwater recharge such that the project may impede sustainable groundwater management of the basin?	<input type="checkbox"/>	<input type="checkbox"/>	<input type="checkbox"/>	<input type="checkbox"/>	<input checked="" type="checkbox"/>	<input type="checkbox"/>	The operation would not substantially decrease groundwater supplies or interfere substantially with groundwater recharge such that the project may impede sustainable groundwater management of the basin. Less than significant impact.
c) Substantially alter the existing drainage pattern of the site or area, including through the alteration of the course of a stream or river or through the addition of impervious surfaces, in a manner that would: i) result in substantial erosion or siltation on-site or off-site; ii) substantially increase the rate or amount of surface runoff in a manner which would result in flooding on- or off-site; iii) create or contribute runoff water which would exceed the capacity of existing or planned stormwater drainage systems or provide substantial additional sources of polluted run-off; or iv) impede or redirect flood flows?	<input type="checkbox"/>	<input checked="" type="checkbox"/>	<input type="checkbox"/>	<input type="checkbox"/>	<input type="checkbox"/>	<input type="checkbox"/>	The project would not substantially alter the existing drainage pattern of the site or area, or add impervious surfaces, in a manner which would (i) result in substantial erosion or siltation on- or off-site; (ii) substantially increase the rate or amount of surface runoff in a manner which would result in flooding on- or offsite; (iii) create or contribute runoff water which would exceed the capacity of existing or planned stormwater drainage systems or provide substantial additional sources of polluted runoff; or (iv) impede or redirect flows. Therefore, impacts would be less than significant.
d) In flood hazard, tsunami, or seiche zones, risk release of pollutants due to project inundation?	<input type="checkbox"/>	<input type="checkbox"/>	<input type="checkbox"/>	<input type="checkbox"/>	<input type="checkbox"/>	<input checked="" type="checkbox"/>	Based on the 2005 Flood Insurance Rate Map (Panel 06033C0684D, eff. 9/30/2005), the project site is shown as being in a special flood hazard area (Zone AE and AO) associated with the ephemeral drainage on the eastern boundary of the site (FEMA, 2005). Refer to Attachment G. As determined by the City Engineer, who is also the City's Floodplain Administrator, the FEMA mapping for this area of the City has a datum problem, as stated in a letter from the City Engineer (dated 1/5/22).. It appears that the 1929 datum was assumed, however the elevations shown on the flood mapping, seem to align with the 1988 vertical datum. The City Engineer has outlined this with the FEMA representative and submitted a request for map revision. "Based on my research of the historical

IMPACT CATEGORIES*	1	2	3	4	5	6	All determinations need explanation. Reference to documentation, sources, notes and correspondence.
							<p>characterization of the flows in this area, coupled with the potential datum matter, I believe that the project would be able to reasonably file a Letter of Map Revision with FEMA at the end of the project and would meet the criteria to receive approval."</p> <p>As required by the Chapter XVII (Floodplain Management) of the City's Municipal Code, flood elevation certificates have been prepared for the proposed project based on the 1929 vertical datum, which demonstrates that the finished floor elevations of the proposed structures would be located a minimum of 1-foot above the base flood elevation. Less than Significant.</p>
e) Conflict with or obstruct implementation of a water quality control plan or sustainable groundwater management plan?	<input type="checkbox"/>	<input type="checkbox"/>	<input type="checkbox"/>	<input type="checkbox"/>	<input checked="" type="checkbox"/>	<input type="checkbox"/>	<p>The project would not conflict with or obstruct any water quality or management plans. Additionally, to control runoff, the operation will incorporate appropriate Best Management Practices (BMPs) consistent with City code and State Storm Water Drainage Regulations to the maximum extent practicable to prevent or reduce discharge of all construction or post-construction pollutants into the local storm drainage system. All grading measure shall adhere to all Federal, State and local agency requirements. Less than Significant.</p>
SECTION XI. LAND USE AND PLANNING							
<i>Would the project:</i>							
a) Physically divide an established community?	<input type="checkbox"/>	<input type="checkbox"/>	<input type="checkbox"/>	<input type="checkbox"/>	<input type="checkbox"/>	<input checked="" type="checkbox"/>	<p>The project is intended to attract and accommodate residents from around the city to participate in athletic events including the +/- 15,000 square foot indoor sports facility, soccer fields, and baseball/softball fields. Therefore, the project will not divide an established community. No impact.</p>
b) Cause a significant environmental impact due to a conflict with any land use plan, policy, or regulation adopted for the purpose of avoiding or mitigating an environmental effect?	<input type="checkbox"/>	<input type="checkbox"/>	<input type="checkbox"/>	<input type="checkbox"/>	<input type="checkbox"/>	<input checked="" type="checkbox"/>	<p>The project site is designated for Medium Density Residential in the General Plan with a Land Use Designation of MUX, Mixed Use. Section 18-02.040 of the Zoning Code references that MUX Zoning is consistent with the Medium Density Residential General Plan Land Use Designation. The Mixed-Use Zoning District is intended to allow a mixture of residential and commercial uses which can be made compatible with each other. This District provides a balanced mix of residential and employment opportunities to create focal points of activity in the form of mixed-use centers, nodes, or corridors. The Mixed-Use Districts support service commercial, employment, and housing needs of a growing community. The maximum allowed density in the MUX Zone is 25 units per acre.</p> <p>The project proposes a public park and public works yard. Although these uses will not produce residential or commercial uses envisioned in the General Plan or Zoning Map, it will create employment and recreational opportunities that would be generally consistent with both the General Plan and Zoning Code.</p> <p>The following uses are identified as requiring a use permit from the planning commission in the MUX Zone:</p> <ul style="list-style-type: none"> • Public Assembly • Outdoor and Indoor Recreation • Impound Yard <p>Also, Section 18-19.370 of the Zoning Code indicates that other uses otherwise not identified in the use table would be subject to a use permit, such as public and quasi-public uses of an administrative, public services or cultural type including special district, City, County, State or Federal facilities. Less than Significant.</p>
SECTION XII. MINERAL RESOURCES							
<i>Would the project:</i>							
a) Result in the loss of availability of a known mineral resource that would be of value to the region and the residents of the state?	<input type="checkbox"/>	<input type="checkbox"/>	<input type="checkbox"/>	<input type="checkbox"/>	<input type="checkbox"/>	<input checked="" type="checkbox"/>	<p>The operation would not result in the loss of availability of a known mineral resource that would be of value to the region and the residents of the state. No Impact</p>

IMPACT CATEGORIES*	1	2	3	4	5	6	All determinations need explanation. Reference to documentation, sources, notes and correspondence.
b) Result in the loss of availability of a locally important mineral resource recovery site delineated on a local general plan, specific plan, or other land use plan?	<input type="checkbox"/>	<input type="checkbox"/>	<input type="checkbox"/>	<input type="checkbox"/>	<input type="checkbox"/>	<input checked="" type="checkbox"/>	The operations would not result in the loss of availability of a locally important mineral resource recovery site delineated on a local general plan, specific plan, or other land use plan. No Impact

SECTION XIII. NOISE & VIBRATIONS

Would the project:

a) Generate construction noise levels that exceed the Noise Ordinance exterior or interior noise standards at residential properties during the hours that are specified in the City's General Plan Noise Element?	<input type="checkbox"/>	<input checked="" type="checkbox"/>	<input type="checkbox"/>	<input type="checkbox"/>	<input type="checkbox"/>	<input type="checkbox"/>	<p>Sound is produced by the vibration of sound pressure waves in the air. Sound pressure levels are used to measure the intensity of sound and are described in terms of decibels. The decibel (dB) is a logarithmic unit that expresses the ratio of the sound pressure level being measured to a standard reference level. A-weighted decibels (dBA) approximate the subjective response of the human ear to a broad frequency noise source by discriminating against very low and very high frequencies of the audible spectrum. They are adjusted to reflect only those frequencies that are audible to the human ear.</p> <p><u>Community Noise Equivalent Level</u> Community Noise Equivalent Level (CNEL) is the predominant rating scale now in use in California for land use compatibility assessment. The CNEL scale represents a time weighted 24- hour average noise level based on the A-weighted decibel. Time weighted refers to the fact that noise occurrences during certain sensitive time periods are penalized. The evening time period (7 p.m. to 10 p.m.) penalizes noises by 5 dBA, while nighttime (10 p.m. to 7 a.m.) noises are penalized by 10 dBA. These time periods and penalties were selected to reflect people's increased sensitivity to noise during these time periods. A CNEL noise level may be reported as a "CNEL of 60 dB(A)," "60 dBA CNEL," or simply "60 CNEL."</p> <p>Short-term increases in ambient noise levels to uncomfortable levels may be expected during project construction. There will be vehicles entering and exiting the project premises primarily from Burns Valley Road. Construction shall adhere to all Federal, State and local agency requirements regarding noise standards.</p> <p>Activities in the park, such as nighttime baseball games could impact adjoining residential uses. The Oak Valley Villas project, an 80 units apartment development that is being planned for construction adjacent to and to the northeast of one of the lighted baseball fields will receive noise impacts from park activities. A Noise study was conducted for this project concerning impacts from the park project (refer to Attachment F). The study identifies three types of noise impacts from surrounding activities, such as noise from vehicles in surrounding parking lots, noise from amplified sound from public address systems, and noise from spectators during a baseball game. Of particular focus of the study, noise from spectators during a ball game seemed to be most concern. However, the project will include interior mitigation sound attenuation when constructed to reduce potential interior noise levels for the building adjoining the park.</p> <p>Therefore, to ensure impacts related to the Noise are minimized, the following mitigation measures have been implemented. Impacts would be less than significant.</p> <p><u>Mitigation Measures:</u> NOI-1: All construction activities including engine warm-up shall be limited to weekdays and Saturday, between the hours of 7:00am and 7:00pm to minimize noise impacts on nearby residents.</p> <p>NOI-2: Permanent potential noise sources such as, generators used for power shall be designed and located to minimize noise impacts to surrounding properties.</p>
--	--------------------------	-------------------------------------	--------------------------	--------------------------	--------------------------	--------------------------	---

IMPACT CATEGORIES*	1	2	3	4	5	6	All determinations need explanation. Reference to documentation, sources, notes and correspondence.
							<p>NOI-3: During construction noise levels shall not exceed 65 decibels within fifty (50) feet of any dwellings or transient accommodations between the hours of 7:00 AM and 6:00 PM. This threshold can be increased by the Building Inspector or City Engineer have approved an exception in accordance with Section 5-4.4(b)(1) of the City Code. An exception of up to 80 decibels may be approved within one hundred (100) feet from the source during daylight hours. Project is expected to result in less than significant impacts with regard to noise and vibration.</p> <p>NOI-4: Park operations, including baseball at the northeasterly ball park shall be shall be restricted to not later than 10 pm.</p>
b) Generate a substantial temporary (non- construction) or permanent increase in noise levels at existing sensitive receptors in the vicinity of the project site?	<input type="checkbox"/>	<input type="checkbox"/>	<input type="checkbox"/>	<input type="checkbox"/>	<input type="checkbox"/>	<input checked="" type="checkbox"/>	The project is not expected to create unusual groundborne vibration due to site development or operation. The low-level truck traffic would create a minimal amount of groundborne vibration. No Impact
c) For a project located within the vicinity of a private airstrip or an airport land use plan or, where such a plan has not been adopted, within two miles of a public airport or public use airport, would the project expose people residing or working in the project area to excessive noise levels and generate excessive ground borne vibration?	<input type="checkbox"/>	<input type="checkbox"/>	<input type="checkbox"/>	<input type="checkbox"/>	<input type="checkbox"/>	<input checked="" type="checkbox"/>	The project is not located within an airport land use plan or within two (2) miles of a public airport. No Impact
SECTION XIV. POPULATION AND HOUSING							
<i>Would the project:</i>							
a) Induce substantial unplanned population growth in an area, either directly or indirectly?	<input type="checkbox"/>	<input type="checkbox"/>	<input type="checkbox"/>	<input type="checkbox"/>	<input type="checkbox"/>	<input checked="" type="checkbox"/>	The proposed project is for a public park (sports complex), community center, public works yard with public works building facility and combined police department office and maintenance facilities, vehicle and equipment storage areas, public access and parking facilities on approximately 26 acres and will not create population growth in the area. No Impact
b) Displace substantial numbers of existing people or housing, necessitating the construction of replacement housing elsewhere?	<input type="checkbox"/>	<input type="checkbox"/>	<input type="checkbox"/>	<input type="checkbox"/>	<input type="checkbox"/>	<input checked="" type="checkbox"/>	The operation will not displace a substantial number(s) of existing people or housing, necessitating the construction of replacement housing elsewhere. No Impact

IMPACT CATEGORIES*	1	2	3	4	5	6	All determinations need explanation. Reference to documentation, sources, notes and correspondence.
--------------------	---	---	---	---	---	---	--

SECTION XV. PUBLIC SERVICES
Would the project:

Result in substantial adverse physical impacts associated with the provision of new or physically altered government facilities, need for new or physically altered government facilities, the construction of which could cause significant environmental impacts, in order to maintain acceptable service ratios, response times, or other performance objectives for any of the following public services: a) Fire Protection? b) Police Protection? c) Schools? d) Parks? e) Other public facility?	<input type="checkbox"/>	<input type="checkbox"/>	<input type="checkbox"/>	<input type="checkbox"/>	<input checked="" type="checkbox"/>	<input type="checkbox"/>	a) - e) The project does not propose housing or other uses that would necessitate the need for new or altered government facilities. There will not be a need to increase fire or police protection, schools, parks or other public facilities as a result of the project's implementation. Less Than Significant Impact
--	--------------------------	--------------------------	--------------------------	--------------------------	-------------------------------------	--------------------------	---

SECTION XVI. RECREATION
Would the project:

a) Increase the use of existing neighborhood and regional parks or other recreational facilities such that substantial physical deterioration of the facility would occur or be accelerated?	<input type="checkbox"/>	<input type="checkbox"/>	<input type="checkbox"/>	<input type="checkbox"/>	<input type="checkbox"/>	<input checked="" type="checkbox"/>	The project site is of non-residential development that will provide a variety of recreational activities to serve the City residents. Therefore, the project will not cause a population increase that will impact existing parks or recreational facilities.
--	--------------------------	--------------------------	--------------------------	--------------------------	--------------------------	-------------------------------------	--

IMPACT CATEGORIES*	1	2	3	4	5	6	All determinations need explanation. Reference to documentation, sources, notes and correspondence.
b) Does the project include recreational facilities or require the construction or expansion of recreational facilities which might have an adverse physical effect on the environment? <ul style="list-style-type: none"> • Fire Protection • Police Protection • Schools • Parks • Other Public Services 	<input type="checkbox"/>	<input type="checkbox"/>	<input type="checkbox"/>	<input type="checkbox"/>	<input type="checkbox"/>	<input checked="" type="checkbox"/>	The project would not require the construction or expansion of other recreational facilities. Because the project does not include features that would result in additional adverse impacts to recreational facilities beyond that addressed herein, no impacts would occur that are not already addressed elsewhere in this IS.
SECTION XVII. TRANSPORTATION							
<i>Would the project:</i>							
a) Conflict with a program plan, ordinance or policy addressing the circulation system, including transit, roadway, bicycle, and pedestrian facilities?	<input type="checkbox"/>	<input type="checkbox"/>	<input type="checkbox"/>	<input type="checkbox"/>	<input checked="" type="checkbox"/>	<input type="checkbox"/>	A traffic impact study was prepared for the project by W-Trans, Traffic Engineers (see Attachment F). It indicates that this project would result in an increase in 1,332 average daily vehicle trips, with a peak hour increase in 182 trips. This study also references coincidental development of an 80-unit apartment project located at the southeast corner on Burns Valley Road and Bowers Avenue, adjacent and to the north and east of the project. The study concludes that the project (including this apartment project) would not result in a significant traffic impact, nor conflict with ordinances or policies addressing the City's circulation system. The project will obtain all the necessary Federal, State, and local agency permits for any works that occurs with the right-of-way and will be subject to the City's traffic impact fee program. Participation in this program will mitigate any cumulative impacts on the City's transportation system. Less Than Significant Impact
b) Would the project conflict or be inconsistent with CEQA Guidelines section 15064.3, subdivision (b)?	<input type="checkbox"/>	<input type="checkbox"/>	<input type="checkbox"/>	<input type="checkbox"/>	<input type="checkbox"/>	<input type="checkbox"/>	Regarding CEQA Section 15064.3, Vehicles Miles Traveled (VMT), the traffic study indicates that the project, would have a less than significant impacts based on the California Governor's Office of Planning and Research (OPR) in the publication Transportation Impacts (SB 743) CEQA Guidelines Update and Technical Advisory, 2018 as well as information contained within Senate Bill 743 Vehicle Miles Traveled Regional Baseline Study (RBS). Less Than Significant Impact
c) Substantially increase hazards due to a geometric design feature (e.g., sharp curves or dangerous intersections) or incompatible uses (e.g., farm equipment)?	<input type="checkbox"/>	<input type="checkbox"/>	<input type="checkbox"/>	<input type="checkbox"/>	<input type="checkbox"/>	<input checked="" type="checkbox"/>	The traffic study included a comprehensive analysis of safety hazards in relation to geometric design and concluded that as long as proper sight distance is maintained at intersection corners (vision triangles), the it would not result in a significant circulation safety impact. The study recommended that these intersections be maintained with minimal obstructions, such as signs and shrubs. Less Than Significant Impact
d) Result in inadequate emergency access?	<input type="checkbox"/>	<input type="checkbox"/>	<input type="checkbox"/>	<input type="checkbox"/>	<input checked="" type="checkbox"/>	<input type="checkbox"/>	The traffic study concludes that emergency access and circulation are anticipated to function acceptably with incorporation of applicable design standards into the site layout and traffic from the proposed development would be expected to have a less-than-significant impact on emergency response times. Less Than Significant Impact

IMPACT CATEGORIES*	1	2	3	4	5	6	All determinations need explanation. Reference to documentation, sources, notes and correspondence.
SECTION XVIII. TRIBAL CULTURAL RESOURCES							
<i>Would the project cause a substantial adverse change in the significance of a tribal cultural resource, defined in Public Resources Code section 21074 as either a site, feature, place, cultural landscape that is geographically defined in terms of the size and scope of the landscape, sacred place, or object with cultural value to a California Native American tribe, and that is:</i>							
a) Listed or eligible for listing in the California Register of Historical Resources, or in a local register of historical resources as defined in Public Resources Code section 5020.1(k), or	<input type="checkbox"/>	<input checked="" type="checkbox"/>	<input type="checkbox"/>	<input type="checkbox"/>	<input type="checkbox"/>	<input type="checkbox"/>	<p>See Response to Section V(a): Less than Significant Impact with the incorporated mitigation measure CUL-1 through CUL-3, including the mitigation measures.</p> <p>Mitigation Measures:</p> <p>TCR-1: Requirement to develop a tribal cultural resources preservation plan that delineates the boundary of CCL-21-01 and CCL-21-02, describes the appropriate combination of materials and culturally sterile fill in capping, provides landscaping specifications that favor culturally important plants, and restricts certain types of post-project activities in or on the cap.</p> <p>TCR-2: Requirement to designate a project reburial area in advance of ground disturbing activities in the event that materials are discovered during construction.</p> <p>TCR-3: Requirement for contractors to receive meaningful training on cultural sensitivity and tribal cultural resources from a tribal representative.</p> <p>TCR-4: Requirement for tribal monitoring during ground disturbing activities in sensitive areas of the project area.</p> <p>TCR-5: Procedures for compliance with existing state law in the event of the discovery of human remains during construction.</p> <p>TCR-6: A prohibition on the removal of cultural soils from the project area.</p>
b) A resource determined by the lead agency, in its discretion and supported by substantial evidence, to be significant pursuant to criteria set forth in subdivision (c) of Public Resources Code section 5024.1. In applying the criteria set forth in subdivision (c) of Public Resources Code 5024.1, the lead agency shall consider the significance of the resource to a California Native American tribe.	<input type="checkbox"/>	<input checked="" type="checkbox"/>	<input type="checkbox"/>	<input type="checkbox"/>	<input type="checkbox"/>	<input type="checkbox"/>	<p>See Response to Section V(a): Less than Significant Impact with the incorporated mitigation measure CUL-1 through CUL-3, and TCR-1 through TCR-6.</p>
SECTION XIX. UTILITIES AND SERVICE SYSTEMS							
<i>Would the project:</i>							
a) Require the relocation or construction of new or expanded water, wastewater treatment, or storm water drainage, electric power, or natural gas, or telecommunications facilities, the construction or relocation of which	<input type="checkbox"/>	<input type="checkbox"/>	<input type="checkbox"/>	<input type="checkbox"/>	<input checked="" type="checkbox"/>	<input type="checkbox"/>	<p>The project would not require or result in the relocation or construction of new or expanded water or, wastewater treatment facilities or expansion of existing storm water drainage, electric power, natural gas or telecommunications facilities, the construction or relocations of which could cause significant environmental effects.</p> <p>The project would be served by the Highlands Mutual Water Company The project will require compliance with all rules, regulations, policies, resolutions, costs and specifications that are in effect at the time service is requested. Therefore, less than significant impact related to these utilities and service systems would occur.</p>

IMPACT CATEGORIES*	1	2	3	4	5	6	All determinations need explanation. Reference to documentation, sources, notes and correspondence.
could cause significant environmental effects?							
b) Due to slope, prevailing winds, and other factors, exacerbate wildfire risks, and thereby expose project occupants to pollutant concentrations from a wildfire or the uncontrolled spread of a wildfire?	<input type="checkbox"/>	<input type="checkbox"/>	<input type="checkbox"/>	<input type="checkbox"/>	<input type="checkbox"/>	<input checked="" type="checkbox"/>	The project would have sufficient water supplies available to serve the project and reasonably foreseeable future. Therefore, no impact related to these utilities and service systems would occur.
c) Result in a determination by the wastewater treatment provider which serves or may serve the project that it has inadequate capacity to serve the project's projected demand in addition to the provider's existing commitments?	<input type="checkbox"/>	<input type="checkbox"/>	<input type="checkbox"/>	<input type="checkbox"/>	<input type="checkbox"/>	<input type="checkbox"/>	The project site is located next to sewer lines and would be served by Lake County Special Districts which has sufficient wastewater treatment capacity to serve the project. Less than significant impact.
d) Generate solid waste in excess of State or local standards, or in excess of the capacity of local infrastructure, or otherwise impair the attainment of solid waste reduction goals?	<input type="checkbox"/>	<input type="checkbox"/>	<input type="checkbox"/>	<input type="checkbox"/>	<input checked="" type="checkbox"/>	<input type="checkbox"/>	The project would generate a minimal amount of construction waste. Additionally, the project would not generate solid waste in excess of State or local standards, or in excess of the capacity of local infrastructure, or otherwise impair the attainment of solid waste reduction goals. The project would be served by Clearlake Waste Solutions which has sufficient capacity to accommodate the project's solid waste disposal needs. In addition, the proposed project would comply with federal, state, and local regulations regarding solid waste. Impacts would be less than significant .
e) Comply with federal, state, and local management and reduction statutes and regulations related to solid waste?	<input type="checkbox"/>	<input type="checkbox"/>	<input type="checkbox"/>	<input type="checkbox"/>	<input checked="" type="checkbox"/>	<input type="checkbox"/>	The project would comply with Federal, State, and local management and reduction statutes and regulations related to solid waste. The proposed project would be required to comply with applicable elements of AB 1327, Chapter 18 (California Solid Waste Reuse and Recycling Access Act of 1991) and other local, state, and federal waste disposal standards. Impacts would be less than significant .
SECTION XX. WILDFIRE							
<i>If located in or near state responsibility areas or lands classified as very high fire hazard severity zones, would the project:</i>							
a) Substantially impair an adopted emergency response plan or emergency evacuation plan?	<input type="checkbox"/>	<input type="checkbox"/>	<input type="checkbox"/>	<input type="checkbox"/>	<input checked="" type="checkbox"/>	<input type="checkbox"/>	<p>According to the Office of the State Fire Marshal Online Portal (https://egis.fire.ca.gov/FHSZ/) and the County of Lake, CA GIS Fire Hazard Zone (https://gispublic.co.lake.ca.us/portal/apps/webappviewer/index.html?id=e68893fda34e495ab5f053f6a96b305c), the project parcel is not located within a known Fire Hazard Severity Zone.</p> <p>According to the above databases, the project is located within a "Non-Wildland/Non-Urban Area. Additionally, the project will adhere to all applicable Federal, State, and local agency requirements, including the CA Building Code and the Lake County Fire Protection Districts requirements. Therefore, the project will not substantially impair an adopted emergency response plan or emergency evacuation plan. Less Than Significant Impact</p>

IMPACT CATEGORIES*	1	2	3	4	5	6	All determinations need explanation. Reference to documentation, sources, notes and correspondence.
b) Due to slope, prevailing winds, and other factors, exacerbate wildfire risks, and thereby expose project occupants to, pollutant concentrations from a wildfire or the uncontrolled spread of a wildfire?	<input type="checkbox"/>	<input type="checkbox"/>	<input checked="" type="checkbox"/>	<input type="checkbox"/>	<input checked="" type="checkbox"/>	<input type="checkbox"/>	The project will not exacerbate wildfire risks and/or expose persons to pollutant concentrations in the event of a wildfire in the area. Additionally, the applicant will adhere to all Federal, State, and local fire requirements/regulations, including all mitigation measure and/or conditions of approval imposed on such use. Less than Significant Impact
c) Require the installation or maintenance of associated infrastructure (such as roads, fuel breaks, emergency water sources, power lines or other utilities) that may exacerbate fire risk or that may result in temporary or ongoing impacts to the environment?	<input type="checkbox"/>	<input type="checkbox"/>	<input type="checkbox"/>	<input type="checkbox"/>	<input checked="" type="checkbox"/>	<input type="checkbox"/>	All infrastructure will be routinely maintained to ensure all Federal, State, and local agency requirements are being satisfied, including all necessary City Codes and/or regulations. Additionally, prior to operation the applicant(s) will make all necessary improvements to the project site, such as access/roadways, fuels breaks, and emergency water source/water tanks. Less than Significant Impact
d) Expose people or structures to significant risks, including downslope or downstream flooding or landslides, as a result of runoff, post-fire slope instability, or drainage changes?	<input type="checkbox"/>	<input type="checkbox"/>	<input type="checkbox"/>	<input type="checkbox"/>	<input checked="" type="checkbox"/>	<input type="checkbox"/>	The project area to be developed is not located within the vicinity of known waterways nor is it located within a designated flood zone. Therefore, the risk of flooding/runoff, landslides, slope instability, or drainage changes would not be increased due to this project. Less Than Significant Impact

IMPACT CATEGORIES*	1	2	3	4	5	6	All determinations need explanation. Reference to documentation, sources, notes and correspondence.
SECTION XXI. MANDATORY FINDINGS OF SIGNIFICANCE							
a) Does the project have the potential to substantially degrade the quality of the environment, substantially reduce the habitat of a fish or wildlife species, cause a fish or wildlife population to drop below self-sustaining levels, threaten to eliminate a plant or animal community, substantially reduce the number or restrict the range of rare or endangered plant or animal or eliminate important examples of the major periods of California history or prehistory?	<input type="checkbox"/>	<input checked="" type="checkbox"/>	<input type="checkbox"/>	<input type="checkbox"/>	<input type="checkbox"/>	<input type="checkbox"/>	This project is not anticipated to significantly impact habitat of fish and/or wildlife species or cultural/tribal resources with the incorporated mitigation measures described above. Therefore, there is minimal risk of degradation, and mitigation measures are proposed that would alleviate most or all of the project-related impacts. The implementation of and compliance with all mitigation measures identified in each section as project conditions of approval would avoid or reduce all potential impacts to less than significant levels and would not result in cumulatively considerable environmental impacts on habitat of fish and/or wildlife species or cultural resources, nor will the project contribute to factors that would harm the environment or add to any wildfire risk.
b) Does the project have impacts that are individually limited, but cumulatively considerable? (“Cumulatively considerable” means that the incremental effects of a project are considerable when viewed in connection with the effects of past projects, the effects of other current projects, and the effects of probable future projects.)	<input type="checkbox"/>	<input checked="" type="checkbox"/>	<input type="checkbox"/>	<input type="checkbox"/>	<input type="checkbox"/>	<input type="checkbox"/>	All potentially significant impacts have been identified related to, Aesthetics, Air Quality, Biological Resources; Cultural/Tribal Resources; Geology & Soil; Noise & Vibration; and Hazards & Hazardous Materials. These impacts in combination with the impacts of other past, present, and reasonably foreseeable future projects in the vicinity could cumulatively contribute to significant effects on the environment if proper mitigation measures are not put in place. The implementation of and compliance with all mitigation measures identified in each section as project conditions of approval would avoid or reduce all potential impacts to less than significant levels and would not result in cumulatively considerable environmental impacts.
c) Does the project have environmental effects which will cause substantial adverse effects on human beings, either directly or indirectly?	<input type="checkbox"/>	<input checked="" type="checkbox"/>	<input type="checkbox"/>	<input type="checkbox"/>	<input type="checkbox"/>	<input type="checkbox"/>	The proposed project has potential to result in adverse indirect or direct effects on human beings. In particular, risks associated with, Aesthetics, Air Quality, Biological Resources; Cultural/Tribal Resources; Geology & Soil; Noise & Vibration; Hazards & Hazardous Materials and have the potential to impact human beings. Implementation of and compliance with mitigation measures identified in each section would reduce adverse indirect or direct effects on human beings and impacts to less than significant impact levels.

INITIAL STUDY SUMMARY: Based on the review of the proposed project site and surrounding area, appropriate mitigation measures were identified to mitigate potentially significant impacts to a level below adversity for Air Quality, Cultural Resources, Hazards & Hazardous Materials, Hydrology/ Water Quality, Traffic Circulation, and Tribal Cultural Resources. Assuming implementation of the identified measures and standard conditions of project approval of the City of Clearlake and other pertinent agencies, no adverse impacts are anticipated.

Attachment A

Lighting Impact Analysis

Maximum 70' tall poles
 Max spill and glare control (30/20 Light levels)

SPILL HORIZONTAL	0.11	0.4	0.0	N.A.	145	30	N.A.	0.75	N.A.
LL	20.80	28.7	11.4	2.52	40	20	20	0.23	1.61
SOCCER	31.96	44.6	18.0	2.48	60	30	30	0.20	1.72
SPILL VERTICAL EAST	0.40	0.6	0.1	6.00	22	30	N.A.	0.35	N.A.
SPILL VERTICAL NORTH	0.41	0.8	0.1	8.00	48	30	N.A.	0.56	N.A.
SPILL VERTICAL SOUTH	0.37	0.7	0.1	7.00	55	30	N.A.	0.49	N.A.
SPILL VERTICAL WEST	0.29	0.5	0.1	5.00	20	30	N.A.	0.58	N.A.

Photo-Metric Diagram

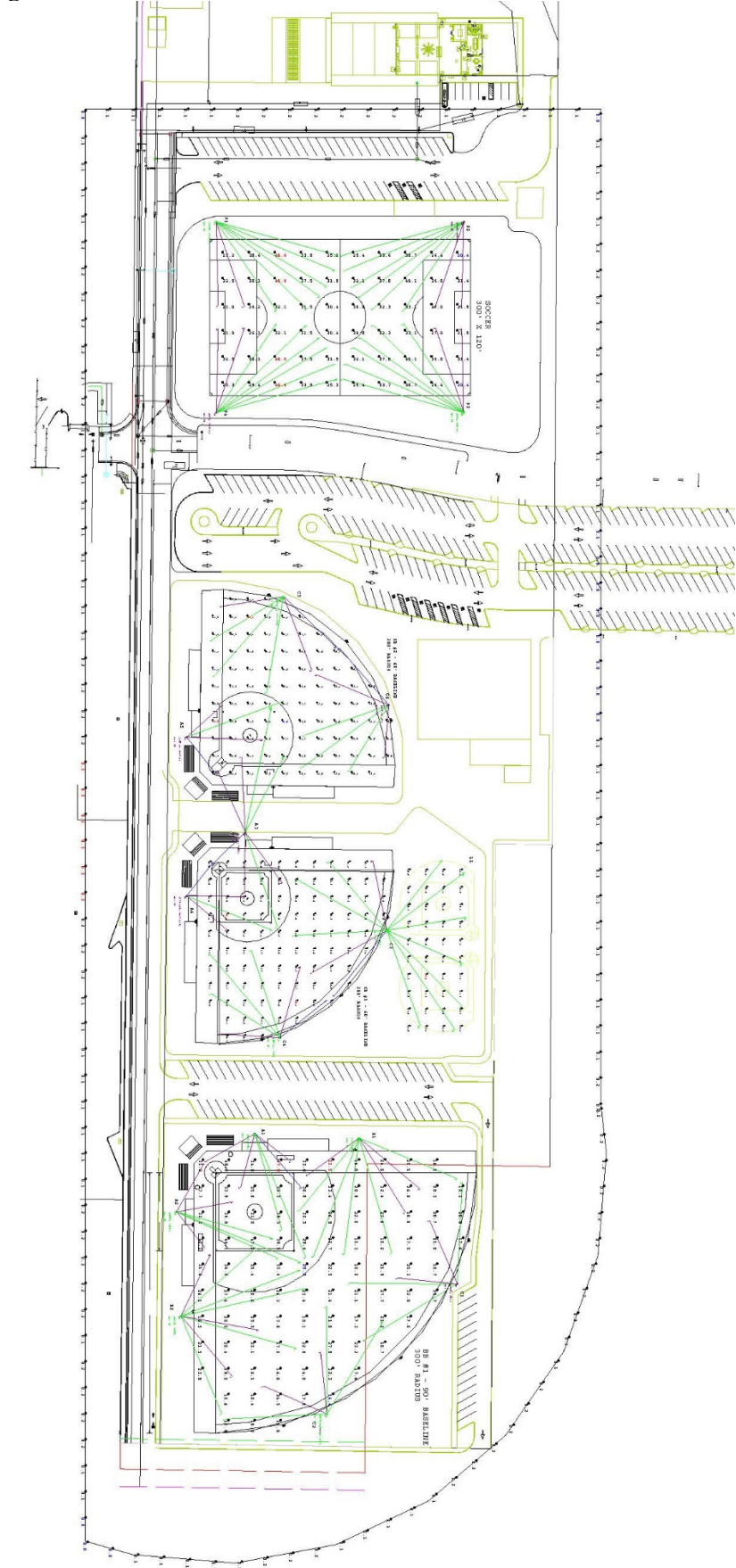

Burns Valley City Recreation and Public Works Complex
Lake County Air Basin, Annual

1.0 Project Characteristics

1.1 Land Usage

Land Uses	Size	Metric	Lot Acreage	Floor Surface Area	Population
City Park	26.00	Acre	26.00	1,132,560.00	0

1.2 Other Project Characteristics

Urbanization	Urban	Wind Speed (m/s)	2.2	Precipitation Freq (Days)	67
Climate Zone	1			Operational Year	2024
Utility Company	Pacific Gas and Electric Company				
CO2 Intensity (lb/MW hr)	203.98	CH4 Intensity (lb/MW hr)	0.033	N2O Intensity (lb/MW hr)	0.004

1.3 User Entered Comments & Non-Default Data

- Project Characteristics -
- Land Use -
- Grading -
- Demolition -

Table Name	Column Name	Default Value	New Value
------------	-------------	---------------	-----------

2.0 Emissions Summary

2.1 Overall Construction

Unmitigated Construction

	ROG	NOx	CO	SO2	Fugitive PM10	Exhaust PM10	PM10 Total	Fugitive PM2.5	Exhaust PM2.5	PM2.5 Total	Bio-CO2	NBio-CO2	Total CO2	CH4	N2O	CO2e
Year	tons/yr										MT/yr					
2022	0.4949	3.5014	3.6443	8.6800e-003	0.7073	0.1298	0.8371	0.2656	0.1209	0.3865	0.0000	787.9748	787.9748	0.1108	0.0443	803.9563
2023	0.6523	3.6480	4.9631	0.0134	0.6462	0.1036	0.7498	0.1756	0.0975	0.2731	0.0000	1,226.7790	1,226.7790	0.0952	0.0918	1,256.5241
2024	0.4873	1.0057	1.4571	3.6800e-003	0.1668	0.0309	0.1977	0.0452	0.0290	0.0742	0.0000	335.5406	335.5406	0.0339	0.0215	342.7819
Maximum	0.6523	3.6480	4.9631	0.0134	0.7073	0.1298	0.8371	0.2656	0.1209	0.3865	0.0000	1,226.7790	1,226.7790	0.1108	0.0918	1,256.5241

Mitigated Construction

	ROG	NOx	CO	SO2	Fugitive PM10	Exhaust PM10	PM10 Total	Fugitive PM2.5	Exhaust PM2.5	PM2.5 Total	Bio-CO2	NBio-CO2	Total CO2	CH4	N2O	CO2e
Year	tons/yr										MT/yr					
2022	0.4949	3.5014	3.6443	8.6800e-003	0.7073	0.1298	0.8371	0.2656	0.1209	0.3865	0.0000	787.9744	787.9744	0.1108	0.0443	803.9559
2023	0.6523	3.6480	4.9631	0.0134	0.6462	0.1036	0.7498	0.1756	0.0975	0.2731	0.0000	1,226.7787	1,226.7787	0.0952	0.0918	1,256.5237
2024	0.4873	1.0057	1.4571	3.6800e-003	0.1668	0.0309	0.1977	0.0452	0.0290	0.0742	0.0000	335.5404	335.5404	0.0339	0.0215	342.7818
Maximum	0.6523	3.6480	4.9631	0.0134	0.7073	0.1298	0.8371	0.2656	0.1209	0.3865	0.0000	1,226.7787	1,226.7787	0.1108	0.0918	1,256.5237

	ROG	NOx	CO	SO2	Fugitive PM10	Exhaust PM10	PM10 Total	Fugitive PM2.5	Exhaust PM2.5	PM2.5 Total	Bio-CO2	NBio-CO2	Total CO2	CH4	N2O	CO2e
Percent Reduction	0.00	0.00	0.00	0.00	0.00	0.00	0.00	0.00	0.00	0.00	0.00	0.00	0.00	0.00	0.00	0.00

Quarter	Start Date	End Date	Maximum Unmitigated ROG + NOX (tons/quarter)	Maximum Mitigated ROG + NOX (tons/quarter)
1	3-8-2022	6-7-2022	1.1295	1.1295
2	6-8-2022	9-7-2022	1.3022	1.3022

3	9-8-2022	12-7-2022	1.2304	1.2304
4	12-8-2022	3-7-2023	1.1172	1.1172
5	3-8-2023	6-7-2023	1.0809	1.0809
6	6-8-2023	9-7-2023	1.0734	1.0734
7	9-8-2023	12-7-2023	1.0830	1.0830
8	12-8-2023	3-7-2024	1.0458	1.0458
9	3-8-2024	6-7-2024	0.5705	0.5705
10	6-8-2024	9-7-2024	0.1730	0.1730
		Highest	1.3022	1.3022

2.2 Overall Operational

Unmitigated Operational

	ROG	NOx	CO	SO2	Fugitive PM10	Exhaust PM10	PM10 Total	Fugitive PM2.5	Exhaust PM2.5	PM2.5 Total	Bio-CO2	NBio-CO2	Total CO2	CH4	N2O	CO2e
Category	tons/yr										MT/yr					
Area	0.1472	0.0000	2.4000e-004	0.0000		0.0000	0.0000		0.0000	0.0000	0.0000	4.6000e-004	4.6000e-004	0.0000	0.0000	4.9000e-004
Energy	0.0000	0.0000	0.0000	0.0000		0.0000	0.0000		0.0000	0.0000	0.0000	0.0000	0.0000	0.0000	0.0000	0.0000
Mobile	0.0241	0.0296	0.1751	2.6000e-004	0.0236	3.1000e-004	0.0239	6.3200e-003	2.9000e-004	6.6100e-003	0.0000	23.6320	23.6320	2.1900e-003	1.4900e-003	24.1300
Waste						0.0000	0.0000		0.0000	0.0000	0.4547	0.0000	0.4547	0.0269	0.0000	1.1265
Water						0.0000	0.0000		0.0000	0.0000	0.0000	10.0319	10.0319	1.6200e-003	2.0000e-004	10.1311
Total	0.1713	0.0296	0.1753	2.6000e-004	0.0236	3.1000e-004	0.0239	6.3200e-003	2.9000e-004	6.6100e-003	0.4547	33.6643	34.1190	0.0307	1.6900e-003	35.3881

Mitigated Operational

	ROG	NOx	CO	SO2	Fugitive PM10	Exhaust PM10	PM10 Total	Fugitive PM2.5	Exhaust PM2.5	PM2.5 Total	Bio-CO2	NBio-CO2	Total CO2	CH4	N2O	CO2e
Category	tons/yr										MT/yr					
Area	0.1472	0.0000	2.4000e-004	0.0000		0.0000	0.0000		0.0000	0.0000	0.0000	4.6000e-004	4.6000e-004	0.0000	0.0000	4.9000e-004
Energy	0.0000	0.0000	0.0000	0.0000		0.0000	0.0000		0.0000	0.0000	0.0000	0.0000	0.0000	0.0000	0.0000	0.0000
Mobile	0.0241	0.0296	0.1751	2.6000e-004	0.0236	3.1000e-004	0.0239	6.3200e-003	2.9000e-004	6.6100e-003	0.0000	23.6320	23.6320	2.1900e-003	1.4900e-003	24.1300
Waste						0.0000	0.0000		0.0000	0.0000	0.4547	0.0000	0.4547	0.0269	0.0000	1.1265
Water						0.0000	0.0000		0.0000	0.0000	0.0000	10.0319	10.0319	1.6200e-003	2.0000e-004	10.1311
Total	0.1713	0.0296	0.1753	2.6000e-004	0.0236	3.1000e-004	0.0239	6.3200e-003	2.9000e-004	6.6100e-003	0.4547	33.6643	34.1190	0.0307	1.6900e-003	35.3881

	ROG	NOx	CO	SO2	Fugitive PM10	Exhaust PM10	PM10 Total	Fugitive PM2.5	Exhaust PM2.5	PM2.5 Total	Bio-CO2	NBio-CO2	Total CO2	CH4	N2O	CO2e
Percent Reduction	0.00	0.00	0.00	0.00	0.00	0.00	0.00	0.00	0.00	0.00	0.00	0.00	0.00	0.00	0.00	0.00

3.0 Construction Detail

Construction Phase

Phase Number	Phase Name	Phase Type	Start Date	End Date	Num Days Week	Num Days	Phase Description
1	Demolition	Demolition	3/8/2022	4/18/2022	5	30	
2	Site Preparation	Site Preparation	4/19/2022	5/16/2022	5	20	
3	Grading	Grading	5/17/2022	7/18/2022	5	45	
4	Building Construction	Building Construction	7/19/2022	3/25/2024	5	440	
5	Paving	Paving	3/26/2024	5/13/2024	5	35	
6	Architectural Coating	Architectural Coating	5/14/2024	7/1/2024	5	35	

Acres of Grading (Site Preparation Phase): 30

Acres of Grading (Grading Phase): 135

Acres of Paving: 0

Residential Indoor: 0; Residential Outdoor: 0; Non-Residential Indoor: 40,500; Non-Residential Outdoor: 13,500; Striped Parking Area: 0 (Architectural Coating – sqft)

OffRoad Equipment

Phase Name	Offroad Equipment Type	Amount	Usage Hours	Horse Power	Load Factor
Architectural Coating	Air Compressors	1	6.00	78	0.48
Demolition	Concrete/Industrial Saws	1	8.00	81	0.73
Building Construction	Cranes	1	7.00	231	0.29
Demolition	Excavators	3	8.00	158	0.38
Grading	Excavators	2	8.00	158	0.38
Building Construction	Forklifts	3	8.00	89	0.20
Building Construction	Generator Sets	1	8.00	84	0.74
Grading	Graders	1	8.00	187	0.41
Paving	Pavers	2	8.00	130	0.42
Paving	Paving Equipment	2	8.00	132	0.36
Paving	Rollers	2	8.00	80	0.38
Demolition	Rubber Tired Dozers	2	8.00	247	0.40
Grading	Rubber Tired Dozers	1	8.00	247	0.40
Site Preparation	Rubber Tired Dozers	3	8.00	247	0.40
Grading	Scrapers	2	8.00	367	0.48
Building Construction	Tractors/Loaders/Backhoes	3	7.00	97	0.37
Grading	Tractors/Loaders/Backhoes	2	8.00	97	0.37
Site Preparation	Tractors/Loaders/Backhoes	4	8.00	97	0.37
Building Construction	Welders	1	8.00	46	0.45

Trips and VMT

Phase Name	Offroad Equipment Count	Worker Trip Number	Vendor Trip Number	Hauling Trip Number	Worker Trip Length	Vendor Trip Length	Hauling Trip Length	Worker Vehicle Class	Vendor Vehicle Class	Hauling Vehicle Class
Demolition	6	15.00	0.00	10.00	10.80	7.30	20.00	LD_Mix	HDT_Mix	HHDT
Site Preparation	7	18.00	0.00	0.00	10.80	7.30	20.00	LD_Mix	HDT_Mix	HHDT
Grading	8	20.00	0.00	0.00	10.80	7.30	20.00	LD_Mix	HDT_Mix	HHDT
Building Construction	9	476.00	186.00	0.00	10.80	7.30	20.00	LD_Mix	HDT_Mix	HHDT
Paving	6	15.00	0.00	0.00	10.80	7.30	20.00	LD_Mix	HDT_Mix	HHDT

Architectural Contingency	1	95.00	0.00	0.00	10.80	7.30	20.00	LD_Mix	HDT_Mix	HHDT
------------------------------	---	-------	------	------	-------	------	-------	--------	---------	------

3.1 Mitigation Measures Construction

3.2 Demolition - 2022

Unmitigated Construction On-Site

	ROG	NOx	CO	SO2	Fugitive PM10	Exhaust PM10	PM10 Total	Fugitive PM2.5	Exhaust PM2.5	PM2.5 Total	Bio-CO2	NBio-CO2	Total CO2	CH4	N2O	CO2e
Category	tons/yr										MT/yr					
Fugitive Dust					1.0700e-003	0.0000	1.0700e-003	1.6000e-004	0.0000	1.6000e-004	0.0000	0.0000	0.0000	0.0000	0.0000	0.0000
Off-Road	0.0396	0.3858	0.3089	5.8000e-004		0.0186	0.0186		0.0173	0.0173	0.0000	50.9853	50.9853	0.0143	0.0000	51.3434
Total	0.0396	0.3858	0.3089	5.8000e-004	1.0700e-003	0.0186	0.0197	1.6000e-004	0.0173	0.0175	0.0000	50.9853	50.9853	0.0143	0.0000	51.3434

Unmitigated Construction Off-Site

	ROG	NOx	CO	SO2	Fugitive PM10	Exhaust PM10	PM10 Total	Fugitive PM2.5	Exhaust PM2.5	PM2.5 Total	Bio-CO2	NBio-CO2	Total CO2	CH4	N2O	CO2e
Category	tons/yr										MT/yr					
Hauling	3.0000e-005	1.2100e-003	1.7000e-004	0.0000	8.0000e-005	1.0000e-005	9.0000e-005	2.0000e-005	1.0000e-005	3.0000e-005	0.0000	0.3244	0.3244	0.0000	5.0000e-005	0.3397
Vendor	0.0000	0.0000	0.0000	0.0000	0.0000	0.0000	0.0000	0.0000	0.0000	0.0000	0.0000	0.0000	0.0000	0.0000	0.0000	0.0000
Worker	1.5600e-003	1.0400e-003	0.0100	2.0000e-005	1.7700e-003	1.0000e-005	1.7900e-003	4.7000e-004	1.0000e-005	4.9000e-004	0.0000	1.5649	1.5649	9.0000e-005	7.0000e-005	1.5881
Total	1.5900e-003	2.2500e-003	0.0102	2.0000e-005	1.8500e-003	2.0000e-005	1.8800e-003	4.9000e-004	2.0000e-005	5.2000e-004	0.0000	1.8893	1.8893	9.0000e-005	1.2000e-004	1.9278

Mitigated Construction On-Site

	ROG	NOx	CO	SO2	Fugitive PM10	Exhaust PM10	PM10 Total	Fugitive PM2.5	Exhaust PM2.5	PM2.5 Total	Bio-CO2	NBio-CO2	Total CO2	CH4	N2O	CO2e	
Category	tons/yr										MT/yr						
Fugitive Dust					1.0700e-003	0.0000	1.0700e-003	1.6000e-004	0.0000	1.6000e-004	0.0000	0.0000	0.0000	0.0000	0.0000	0.0000	0.0000
Off-Road	0.0396	0.3858	0.3089	5.8000e-004		0.0186	0.0186		0.0173	0.0173	0.0000	50.9853	50.9853	0.0143	0.0000	51.3433	
Total	0.0396	0.3858	0.3089	5.8000e-004	1.0700e-003	0.0186	0.0197	1.6000e-004	0.0173	0.0175	0.0000	50.9853	50.9853	0.0143	0.0000	51.3433	

Mitigated Construction Off-Site

	ROG	NOx	CO	SO2	Fugitive PM10	Exhaust PM10	PM10 Total	Fugitive PM2.5	Exhaust PM2.5	PM2.5 Total	Bio-CO2	NBio-CO2	Total CO2	CH4	N2O	CO2e
Category	tons/yr										MT/yr					
Hauling	3.0000e-005	1.2100e-003	1.7000e-004	0.0000	8.0000e-005	1.0000e-005	9.0000e-005	2.0000e-005	1.0000e-005	3.0000e-005	0.0000	0.3244	0.3244	0.0000	5.0000e-005	0.3397
Vendor	0.0000	0.0000	0.0000	0.0000	0.0000	0.0000	0.0000	0.0000	0.0000	0.0000	0.0000	0.0000	0.0000	0.0000	0.0000	0.0000
Worker	1.5600e-003	1.0400e-003	0.0100	2.0000e-005	1.7700e-003	1.0000e-005	1.7900e-003	4.7000e-004	1.0000e-005	4.9000e-004	0.0000	1.5649	1.5649	9.0000e-005	7.0000e-005	1.5881
Total	1.5900e-003	2.2500e-003	0.0102	2.0000e-005	1.8500e-003	2.0000e-005	1.8800e-003	4.9000e-004	2.0000e-005	5.2000e-004	0.0000	1.8893	1.8893	9.0000e-005	1.2000e-004	1.9278

3.3 Site Preparation - 2022

Unmitigated Construction On-Site

	ROG	NOx	CO	SO2	Fugitive PM10	Exhaust PM10	PM10 Total	Fugitive PM2.5	Exhaust PM2.5	PM2.5 Total	Bio-CO2	NBio-CO2	Total CO2	CH4	N2O	CO2e
Category	tons/yr										MT/yr					
Fugitive Dust					0.1966	0.0000	0.1966	0.1010	0.0000	0.1010	0.0000	0.0000	0.0000	0.0000	0.0000	0.0000
Off-Road	0.0317	0.3308	0.1970	3.8000e-004		0.0161	0.0161		0.0148	0.0148	0.0000	33.4394	33.4394	0.0108	0.0000	33.7098
Total	0.0317	0.3308	0.1970	3.8000e-004	0.1966	0.0161	0.2127	0.1010	0.0148	0.1159	0.0000	33.4394	33.4394	0.0108	0.0000	33.7098

Unmitigated Construction Off-Site

	ROG	NOx	CO	SO2	Fugitive PM10	Exhaust PM10	PM10 Total	Fugitive PM2.5	Exhaust PM2.5	PM2.5 Total	Bio-CO2	NBio-CO2	Total CO2	CH4	N2O	CO2e
Category	tons/yr										MT/yr					
Hauling	0.0000	0.0000	0.0000	0.0000	0.0000	0.0000	0.0000	0.0000	0.0000	0.0000	0.0000	0.0000	0.0000	0.0000	0.0000	0.0000
Vendor	0.0000	0.0000	0.0000	0.0000	0.0000	0.0000	0.0000	0.0000	0.0000	0.0000	0.0000	0.0000	0.0000	0.0000	0.0000	0.0000
Worker	1.2500e-003	8.3000e-004	8.0000e-003	1.0000e-005	1.4200e-003	1.0000e-005	1.4300e-003	3.8000e-004	1.0000e-005	3.9000e-004	0.0000	1.2519	1.2519	7.0000e-005	6.0000e-005	1.2705
Total	1.2500e-003	8.3000e-004	8.0000e-003	1.0000e-005	1.4200e-003	1.0000e-005	1.4300e-003	3.8000e-004	1.0000e-005	3.9000e-004	0.0000	1.2519	1.2519	7.0000e-005	6.0000e-005	1.2705

Mitigated Construction On-Site

	ROG	NOx	CO	SO2	Fugitive PM10	Exhaust PM10	PM10 Total	Fugitive PM2.5	Exhaust PM2.5	PM2.5 Total	Bio-CO2	NBio-CO2	Total CO2	CH4	N2O	CO2e
Category	tons/yr										MT/yr					
Fugitive Dust					0.1966	0.0000	0.1966	0.1010	0.0000	0.1010	0.0000	0.0000	0.0000	0.0000	0.0000	0.0000
Off-Road	0.0317	0.3308	0.1970	3.8000e-004		0.0161	0.0161		0.0148	0.0148	0.0000	33.4394	33.4394	0.0108	0.0000	33.7097
Total	0.0317	0.3308	0.1970	3.8000e-004	0.1966	0.0161	0.2127	0.1010	0.0148	0.1159	0.0000	33.4394	33.4394	0.0108	0.0000	33.7097

Mitigated Construction Off-Site

	ROG	NOx	CO	SO2	Fugitive PM10	Exhaust PM10	PM10 Total	Fugitive PM2.5	Exhaust PM2.5	PM2.5 Total	Bio-CO2	NBio-CO2	Total CO2	CH4	N2O	CO2e
Category	tons/yr										MT/yr					
Hauling	0.0000	0.0000	0.0000	0.0000	0.0000	0.0000	0.0000	0.0000	0.0000	0.0000	0.0000	0.0000	0.0000	0.0000	0.0000	0.0000
Vendor	0.0000	0.0000	0.0000	0.0000	0.0000	0.0000	0.0000	0.0000	0.0000	0.0000	0.0000	0.0000	0.0000	0.0000	0.0000	0.0000
Worker	1.2500e-003	8.3000e-004	8.0000e-003	1.0000e-005	1.4200e-003	1.0000e-005	1.4300e-003	3.8000e-004	1.0000e-005	3.9000e-004	0.0000	1.2519	1.2519	7.0000e-005	6.0000e-005	1.2705
Total	1.2500e-003	8.3000e-004	8.0000e-003	1.0000e-005	1.4200e-003	1.0000e-005	1.4300e-003	3.8000e-004	1.0000e-005	3.9000e-004	0.0000	1.2519	1.2519	7.0000e-005	6.0000e-005	1.2705

3.4 Grading - 2022

Unmitigated Construction On-Site

	ROG	NOx	CO	SO2	Fugitive PM10	Exhaust PM10	PM10 Total	Fugitive PM2.5	Exhaust PM2.5	PM2.5 Total	Bio-CO2	NBio-CO2	Total CO2	CH4	N2O	CO2e
Category	tons/yr										MT/yr					
Fugitive Dust					0.2071	0.0000	0.2071	0.0822	0.0000	0.0822	0.0000	0.0000	0.0000	0.0000	0.0000	0.0000
Off-Road	0.0816	0.8740	0.6534	1.4000e-003		0.0368	0.0368		0.0338	0.0338	0.0000	122.7029	122.7029	0.0397	0.0000	123.6950
Total	0.0816	0.8740	0.6534	1.4000e-003	0.2071	0.0368	0.2439	0.0822	0.0338	0.1161	0.0000	122.7029	122.7029	0.0397	0.0000	123.6950

Unmitigated Construction Off-Site

	ROG	NOx	CO	SO2	Fugitive PM10	Exhaust PM10	PM10 Total	Fugitive PM2.5	Exhaust PM2.5	PM2.5 Total	Bio-CO2	NBio-CO2	Total CO2	CH4	N2O	CO2e
Category	tons/yr										MT/yr					
Hauling	0.0000	0.0000	0.0000	0.0000	0.0000	0.0000	0.0000	0.0000	0.0000	0.0000	0.0000	0.0000	0.0000	0.0000	0.0000	0.0000
Vendor	0.0000	0.0000	0.0000	0.0000	0.0000	0.0000	0.0000	0.0000	0.0000	0.0000	0.0000	0.0000	0.0000	0.0000	0.0000	0.0000
Worker	3.1200e-003	2.0900e-003	0.0200	3.0000e-005	3.5500e-003	3.0000e-005	3.5800e-003	9.4000e-004	3.0000e-005	9.7000e-004	0.0000	3.1297	3.1297	1.7000e-004	1.4000e-004	3.1763
Total	3.1200e-003	2.0900e-003	0.0200	3.0000e-005	3.5500e-003	3.0000e-005	3.5800e-003	9.4000e-004	3.0000e-005	9.7000e-004	0.0000	3.1297	3.1297	1.7000e-004	1.4000e-004	3.1763

Mitigated Construction On-Site

	ROG	NOx	CO	SO2	Fugitive PM10	Exhaust PM10	PM10 Total	Fugitive PM2.5	Exhaust PM2.5	PM2.5 Total	Bio-CO2	NBio-CO2	Total CO2	CH4	N2O	CO2e
Category	tons/yr										MT/yr					
Fugitive Dust					0.2071	0.0000	0.2071	0.0822	0.0000	0.0822	0.0000	0.0000	0.0000	0.0000	0.0000	0.0000
Off-Road	0.0816	0.8740	0.6534	1.4000e-003		0.0368	0.0368		0.0338	0.0338	0.0000	122.7027	122.7027	0.0397	0.0000	123.6948
Total	0.0816	0.8740	0.6534	1.4000e-003	0.2071	0.0368	0.2439	0.0822	0.0338	0.1161	0.0000	122.7027	122.7027	0.0397	0.0000	123.6948

Mitigated Construction Off-Site

	ROG	NOx	CO	SO2	Fugitive PM10	Exhaust PM10	PM10 Total	Fugitive PM2.5	Exhaust PM2.5	PM2.5 Total	Bio-CO2	NBio-CO2	Total CO2	CH4	N2O	CO2e
Category	tons/yr										MT/yr					
Hauling	0.0000	0.0000	0.0000	0.0000	0.0000	0.0000	0.0000	0.0000	0.0000	0.0000	0.0000	0.0000	0.0000	0.0000	0.0000	0.0000
Vendor	0.0000	0.0000	0.0000	0.0000	0.0000	0.0000	0.0000	0.0000	0.0000	0.0000	0.0000	0.0000	0.0000	0.0000	0.0000	0.0000
Worker	3.1200e-003	2.0900e-003	0.0200	3.0000e-005	3.5500e-003	3.0000e-005	3.5800e-003	9.4000e-004	3.0000e-005	9.7000e-004	0.0000	3.1297	3.1297	1.7000e-004	1.4000e-004	3.1763
Total	3.1200e-003	2.0900e-003	0.0200	3.0000e-005	3.5500e-003	3.0000e-005	3.5800e-003	9.4000e-004	3.0000e-005	9.7000e-004	0.0000	3.1297	3.1297	1.7000e-004	1.4000e-004	3.1763

3.5 Building Construction - 2022

Unmitigated Construction On-Site

	ROG	NOx	CO	SO2	Fugitive PM10	Exhaust PM10	PM10 Total	Fugitive PM2.5	Exhaust PM2.5	PM2.5 Total	Bio-CO2	NBio-CO2	Total CO2	CH4	N2O	CO2e
Category	tons/yr										MT/yr					
Off-Road	0.1015	0.9291	0.9736	1.6000e-003		0.0481	0.0481		0.0453	0.0453	0.0000	137.8765	137.8765	0.0330	0.0000	138.7023
Total	0.1015	0.9291	0.9736	1.6000e-003		0.0481	0.0481		0.0453	0.0453	0.0000	137.8765	137.8765	0.0330	0.0000	138.7023

Unmitigated Construction Off-Site

	ROG	NOx	CO	SO2	Fugitive PM10	Exhaust PM10	PM10 Total	Fugitive PM2.5	Exhaust PM2.5	PM2.5 Total	Bio-CO2	NBio-CO2	Total CO2	CH4	N2O	CO2e
Category	tons/yr										MT/yr					
Hauling	0.0000	0.0000	0.0000	0.0000	0.0000	0.0000	0.0000	0.0000	0.0000	0.0000	0.0000	0.0000	0.0000	0.0000	0.0000	0.0000
Vendor	0.0384	0.8453	0.2138	2.5100e-003	0.0724	8.2700e-003	0.0807	0.0209	7.9100e-003	0.0288	0.0000	239.7212	239.7212	1.6400e-003	0.0351	250.2228
Worker	0.1962	0.1313	1.2594	2.1500e-003	0.2234	1.8000e-003	0.2252	0.0594	1.6600e-003	0.0611	0.0000	196.9785	196.9785	0.0109	8.9100e-003	199.9085
Total	0.2346	0.9765	1.4732	4.6600e-003	0.2958	0.0101	0.3058	0.0804	9.5700e-003	0.0899	0.0000	436.6997	436.6997	0.0126	0.0440	450.1313

Mitigated Construction On-Site

	ROG	NOx	CO	SO2	Fugitive PM10	Exhaust PM10	PM10 Total	Fugitive PM2.5	Exhaust PM2.5	PM2.5 Total	Bio-CO2	NBio-CO2	Total CO2	CH4	N2O	CO2e
Category	tons/yr										MT/yr					
Off-Road	0.1015	0.9291	0.9736	1.6000e-003		0.0481	0.0481		0.0453	0.0453	0.0000	137.8764	137.8764	0.0330	0.0000	138.7021
Total	0.1015	0.9291	0.9736	1.6000e-003		0.0481	0.0481		0.0453	0.0453	0.0000	137.8764	137.8764	0.0330	0.0000	138.7021

Mitigated Construction Off-Site

	ROG	NOx	CO	SO2	Fugitive PM10	Exhaust PM10	PM10 Total	Fugitive PM2.5	Exhaust PM2.5	PM2.5 Total	Bio-CO2	NBio-CO2	Total CO2	CH4	N2O	CO2e
Category	tons/yr										MT/yr					
Hauling	0.0000	0.0000	0.0000	0.0000	0.0000	0.0000	0.0000	0.0000	0.0000	0.0000	0.0000	0.0000	0.0000	0.0000	0.0000	0.0000
Vendor	0.0384	0.8453	0.2138	2.5100e-003	0.0724	8.2700e-003	0.0807	0.0209	7.9100e-003	0.0288	0.0000	239.7212	239.7212	1.6400e-003	0.0351	250.2228
Worker	0.1962	0.1313	1.2594	2.1500e-003	0.2234	1.8000e-003	0.2252	0.0594	1.6600e-003	0.0611	0.0000	196.9785	196.9785	0.0109	8.9100e-003	199.9085
Total	0.2346	0.9765	1.4732	4.6600e-003	0.2958	0.0101	0.3058	0.0804	9.5700e-003	0.0899	0.0000	436.6997	436.6997	0.0126	0.0440	450.1313

3.5 Building Construction - 2023

Unmitigated Construction On-Site

	ROG	NOx	CO	SO2	Fugitive PM10	Exhaust PM10	PM10 Total	Fugitive PM2.5	Exhaust PM2.5	PM2.5 Total	Bio-CO2	NBio-CO2	Total CO2	CH4	N2O	CO2e
Category	tons/yr										MT/yr					
Off-Road	0.2045	1.8700	2.1117	3.5000e-003		0.0910	0.0910		0.0856	0.0856	0.0000	301.3462	301.3462	0.0717	0.0000	303.1383
Total	0.2045	1.8700	2.1117	3.5000e-003		0.0910	0.0910		0.0856	0.0856	0.0000	301.3462	301.3462	0.0717	0.0000	303.1383

Unmitigated Construction Off-Site

	ROG	NOx	CO	SO2	Fugitive PM10	Exhaust PM10	PM10 Total	Fugitive PM2.5	Exhaust PM2.5	PM2.5 Total	Bio-CO2	NBio-CO2	Total CO2	CH4	N2O	CO2e
Category	tons/yr										MT/yr					
Hauling	0.0000	0.0000	0.0000	0.0000	0.0000	0.0000	0.0000	0.0000	0.0000	0.0000	0.0000	0.0000	0.0000	0.0000	0.0000	0.0000
Vendor	0.0491	1.5260	0.3838	5.3100e-003	0.1581	8.9600e-003	0.1671	0.0457	8.5700e-003	0.0543	0.0000	507.8532	507.8532	2.1100e-003	0.0741	529.9898
Worker	0.3988	0.2520	2.4675	4.5500e-003	0.4881	3.6300e-003	0.4917	0.1299	3.3400e-003	0.1332	0.0000	417.5797	417.5797	0.0214	0.0177	423.3959
Total	0.4478	1.7780	2.8513	9.8600e-003	0.6462	0.0126	0.6588	0.1756	0.0119	0.1875	0.0000	925.4329	925.4329	0.0235	0.0918	953.3858

Mitigated Construction On-Site

	ROG	NOx	CO	SO2	Fugitive PM10	Exhaust PM10	PM10 Total	Fugitive PM2.5	Exhaust PM2.5	PM2.5 Total	Bio-CO2	NBio-CO2	Total CO2	CH4	N2O	CO2e
Category	tons/yr										MT/yr					
Off-Road	0.2045	1.8700	2.1117	3.5000e-003		0.0910	0.0910		0.0856	0.0856	0.0000	301.3458	301.3458	0.0717	0.0000	303.1380
Total	0.2045	1.8700	2.1117	3.5000e-003		0.0910	0.0910		0.0856	0.0856	0.0000	301.3458	301.3458	0.0717	0.0000	303.1380

Mitigated Construction Off-Site

	ROG	NOx	CO	SO2	Fugitive PM10	Exhaust PM10	PM10 Total	Fugitive PM2.5	Exhaust PM2.5	PM2.5 Total	Bio-CO2	NBio-CO2	Total CO2	CH4	N2O	CO2e
Category	tons/yr										MT/yr					
Hauling	0.0000	0.0000	0.0000	0.0000	0.0000	0.0000	0.0000	0.0000	0.0000	0.0000	0.0000	0.0000	0.0000	0.0000	0.0000	0.0000
Vendor	0.0491	1.5260	0.3838	5.3100e-003	0.1581	8.9600e-003	0.1671	0.0457	8.5700e-003	0.0543	0.0000	507.8532	507.8532	2.1100e-003	0.0741	529.9898
Worker	0.3988	0.2520	2.4675	4.5500e-003	0.4881	3.6300e-003	0.4917	0.1299	3.3400e-003	0.1332	0.0000	417.5797	417.5797	0.0214	0.0177	423.3959
Total	0.4478	1.7780	2.8513	9.8600e-003	0.6462	0.0126	0.6588	0.1756	0.0119	0.1875	0.0000	925.4329	925.4329	0.0235	0.0918	953.3858

3.5 Building Construction - 2024

Unmitigated Construction On-Site

	ROG	NOx	CO	SO2	Fugitive PM10	Exhaust PM10	PM10 Total	Fugitive PM2.5	Exhaust PM2.5	PM2.5 Total	Bio-CO2	NBio-CO2	Total CO2	CH4	N2O	CO2e
Category	tons/yr										MT/yr					
Off-Road	0.0449	0.4100	0.4931	8.2000e-004		0.0187	0.0187		0.0176	0.0176	0.0000	70.7140	70.7140	0.0167	0.0000	71.1320
Total	0.0449	0.4100	0.4931	8.2000e-004		0.0187	0.0187		0.0176	0.0176	0.0000	70.7140	70.7140	0.0167	0.0000	71.1320

Unmitigated Construction Off-Site

	ROG	NOx	CO	SO2	Fugitive PM10	Exhaust PM10	PM10 Total	Fugitive PM2.5	Exhaust PM2.5	PM2.5 Total	Bio-CO2	NBio-CO2	Total CO2	CH4	N2O	CO2e
Category	tons/yr										MT/yr					
Hauling	0.0000	0.0000	0.0000	0.0000	0.0000	0.0000	0.0000	0.0000	0.0000	0.0000	0.0000	0.0000	0.0000	0.0000	0.0000	0.0000
Vendor	0.0106	0.3488	0.0851	1.2300e-003	0.0371	2.0200e-003	0.0391	0.0107	1.9300e-003	0.0127	0.0000	117.7819	117.7819	4.5000e-004	0.0172	122.9083
Worker	0.0870	0.0520	0.5221	1.0400e-003	0.1145	7.8000e-004	0.1153	0.0305	7.2000e-004	0.0312	0.0000	94.9414	94.9414	4.5100e-003	3.7900e-003	96.1838
Total	0.0976	0.4008	0.6071	2.2700e-003	0.1516	2.8000e-003	0.1544	0.0412	2.6500e-003	0.0439	0.0000	212.7233	212.7233	4.9600e-003	0.0210	219.0922

Mitigated Construction On-Site

	ROG	NOx	CO	SO2	Fugitive PM10	Exhaust PM10	PM10 Total	Fugitive PM2.5	Exhaust PM2.5	PM2.5 Total	Bio-CO2	NBio-CO2	Total CO2	CH4	N2O	CO2e
Category	tons/yr										MT/yr					
Off-Road	0.0449	0.4100	0.4931	8.2000e-004		0.0187	0.0187		0.0176	0.0176	0.0000	70.7139	70.7139	0.0167	0.0000	71.1319
Total	0.0449	0.4100	0.4931	8.2000e-004		0.0187	0.0187		0.0176	0.0176	0.0000	70.7139	70.7139	0.0167	0.0000	71.1319

Mitigated Construction Off-Site

	ROG	NOx	CO	SO2	Fugitive PM10	Exhaust PM10	PM10 Total	Fugitive PM2.5	Exhaust PM2.5	PM2.5 Total	Bio-CO2	NBio-CO2	Total CO2	CH4	N2O	CO2e
Category	tons/yr										MT/yr					
Hauling	0.0000	0.0000	0.0000	0.0000	0.0000	0.0000	0.0000	0.0000	0.0000	0.0000	0.0000	0.0000	0.0000	0.0000	0.0000	0.0000
Vendor	0.0106	0.3488	0.0851	1.2300e-003	0.0371	2.0200e-003	0.0391	0.0107	1.9300e-003	0.0127	0.0000	117.7819	117.7819	4.5000e-004	0.0172	122.9083
Worker	0.0870	0.0520	0.5221	1.0400e-003	0.1145	7.8000e-004	0.1153	0.0305	7.2000e-004	0.0312	0.0000	94.9414	94.9414	4.5100e-003	3.7900e-003	96.1838
Total	0.0976	0.4008	0.6071	2.2700e-003	0.1516	2.8000e-003	0.1544	0.0412	2.6500e-003	0.0439	0.0000	212.7233	212.7233	4.9600e-003	0.0210	219.0922

3.6 Paving - 2024

Unmitigated Construction On-Site

	ROG	NOx	CO	SO2	Fugitive PM10	Exhaust PM10	PM10 Total	Fugitive PM2.5	Exhaust PM2.5	PM2.5 Total	Bio-CO2	NBio-CO2	Total CO2	CH4	N2O	CO2e
Category	tons/yr										MT/yr					
Off-Road	0.0173	0.1667	0.2560	4.0000e-004		8.2000e-003	8.2000e-003		7.5400e-003	7.5400e-003	0.0000	35.0464	35.0464	0.0113	0.0000	35.3298
Paving	0.0000					0.0000	0.0000		0.0000	0.0000	0.0000	0.0000	0.0000	0.0000	0.0000	0.0000
Total	0.0173	0.1667	0.2560	4.0000e-004		8.2000e-003	8.2000e-003		7.5400e-003	7.5400e-003	0.0000	35.0464	35.0464	0.0113	0.0000	35.3298

Unmitigated Construction Off-Site

	ROG	NOx	CO	SO2	Fugitive PM10	Exhaust PM10	PM10 Total	Fugitive PM2.5	Exhaust PM2.5	PM2.5 Total	Bio-CO2	NBio-CO2	Total CO2	CH4	N2O	CO2e
Category	tons/yr										MT/yr					
Hauling	0.0000	0.0000	0.0000	0.0000	0.0000	0.0000	0.0000	0.0000	0.0000	0.0000	0.0000	0.0000	0.0000	0.0000	0.0000	0.0000
Vendor	0.0000	0.0000	0.0000	0.0000	0.0000	0.0000	0.0000	0.0000	0.0000	0.0000	0.0000	0.0000	0.0000	0.0000	0.0000	0.0000
Worker	1.5700e-003	9.4000e-004	9.4400e-003	2.0000e-005	2.0700e-003	1.0000e-005	2.0800e-003	5.5000e-004	1.0000e-005	5.6000e-004	0.0000	1.7166	1.7166	8.0000e-005	7.0000e-005	1.7391
Total	1.5700e-003	9.4000e-004	9.4400e-003	2.0000e-005	2.0700e-003	1.0000e-005	2.0800e-003	5.5000e-004	1.0000e-005	5.6000e-004	0.0000	1.7166	1.7166	8.0000e-005	7.0000e-005	1.7391

Mitigated Construction On-Site

	ROG	NOx	CO	SO2	Fugitive PM10	Exhaust PM10	PM10 Total	Fugitive PM2.5	Exhaust PM2.5	PM2.5 Total	Bio-CO2	NBio-CO2	Total CO2	CH4	N2O	CO2e
Category	tons/yr										MT/yr					
Off-Road	0.0173	0.1667	0.2560	4.0000e-004		8.2000e-003	8.2000e-003		7.5400e-003	7.5400e-003	0.0000	35.0464	35.0464	0.0113	0.0000	35.3298
Paving	0.0000					0.0000	0.0000		0.0000	0.0000	0.0000	0.0000	0.0000	0.0000	0.0000	0.0000
Total	0.0173	0.1667	0.2560	4.0000e-004		8.2000e-003	8.2000e-003		7.5400e-003	7.5400e-003	0.0000	35.0464	35.0464	0.0113	0.0000	35.3298

Mitigated Construction Off-Site

	ROG	NOx	CO	SO2	Fugitive PM10	Exhaust PM10	PM10 Total	Fugitive PM2.5	Exhaust PM2.5	PM2.5 Total	Bio-CO2	NBio-CO2	Total CO2	CH4	N2O	CO2e
Category	tons/yr										MT/yr					
Hauling	0.0000	0.0000	0.0000	0.0000	0.0000	0.0000	0.0000	0.0000	0.0000	0.0000	0.0000	0.0000	0.0000	0.0000	0.0000	0.0000
Vendor	0.0000	0.0000	0.0000	0.0000	0.0000	0.0000	0.0000	0.0000	0.0000	0.0000	0.0000	0.0000	0.0000	0.0000	0.0000	0.0000
Worker	1.5700e-003	9.4000e-004	9.4400e-003	2.0000e-005	2.0700e-003	1.0000e-005	2.0800e-003	5.5000e-004	1.0000e-005	5.6000e-004	0.0000	1.7166	1.7166	8.0000e-005	7.0000e-005	1.7391
Total	1.5700e-003	9.4000e-004	9.4400e-003	2.0000e-005	2.0700e-003	1.0000e-005	2.0800e-003	5.5000e-004	1.0000e-005	5.6000e-004	0.0000	1.7166	1.7166	8.0000e-005	7.0000e-005	1.7391

3.7 Architectural Coating - 2024

Unmitigated Construction On-Site

	ROG	NOx	CO	SO2	Fugitive PM10	Exhaust PM10	PM10 Total	Fugitive PM2.5	Exhaust PM2.5	PM2.5 Total	Bio-CO2	NBio-CO2	Total CO2	CH4	N2O	CO2e
Category	tons/yr										MT/yr					
Archit. Coating	0.3129					0.0000	0.0000		0.0000	0.0000	0.0000	0.0000	0.0000	0.0000	0.0000	0.0000
Off-Road	3.1600e-003	0.0213	0.0317	5.0000e-005		1.0700e-003	1.0700e-003		1.0700e-003	1.0700e-003	0.0000	4.4682	4.4682	2.5000e-004	0.0000	4.4745
Total	0.3160	0.0213	0.0317	5.0000e-005		1.0700e-003	1.0700e-003		1.0700e-003	1.0700e-003	0.0000	4.4682	4.4682	2.5000e-004	0.0000	4.4745

Unmitigated Construction Off-Site

	ROG	NOx	CO	SO2	Fugitive PM10	Exhaust PM10	PM10 Total	Fugitive PM2.5	Exhaust PM2.5	PM2.5 Total	Bio-CO2	NBio-CO2	Total CO2	CH4	N2O	CO2e
Category	tons/yr										MT/yr					
Hauling	0.0000	0.0000	0.0000	0.0000	0.0000	0.0000	0.0000	0.0000	0.0000	0.0000	0.0000	0.0000	0.0000	0.0000	0.0000	0.0000
Vendor	0.0000	0.0000	0.0000	0.0000	0.0000	0.0000	0.0000	0.0000	0.0000	0.0000	0.0000	0.0000	0.0000	0.0000	0.0000	0.0000
Worker	9.9600e-003	5.9500e-003	0.0598	1.2000e-004	0.0131	9.0000e-005	0.0132	3.4900e-003	8.0000e-005	3.5700e-003	0.0000	10.8720	10.8720	5.2000e-004	4.3000e-004	11.0143
Total	9.9600e-003	5.9500e-003	0.0598	1.2000e-004	0.0131	9.0000e-005	0.0132	3.4900e-003	8.0000e-005	3.5700e-003	0.0000	10.8720	10.8720	5.2000e-004	4.3000e-004	11.0143

Mitigated Construction On-Site

	ROG	NOx	CO	SO2	Fugitive PM10	Exhaust PM10	PM10 Total	Fugitive PM2.5	Exhaust PM2.5	PM2.5 Total	Bio-CO2	NBio-CO2	Total CO2	CH4	N2O	CO2e
Category	tons/yr										MT/yr					
Archit. Coating	0.3129					0.0000	0.0000		0.0000	0.0000	0.0000	0.0000	0.0000	0.0000	0.0000	0.0000
Off-Road	3.1600e-003	0.0213	0.0317	5.0000e-005		1.0700e-003	1.0700e-003		1.0700e-003	1.0700e-003	0.0000	4.4682	4.4682	2.5000e-004	0.0000	4.4745
Total	0.3160	0.0213	0.0317	5.0000e-005		1.0700e-003	1.0700e-003		1.0700e-003	1.0700e-003	0.0000	4.4682	4.4682	2.5000e-004	0.0000	4.4745

Mitigated Construction Off-Site

	ROG	NOx	CO	SO2	Fugitive PM10	Exhaust PM10	PM10 Total	Fugitive PM2.5	Exhaust PM2.5	PM2.5 Total	Bio-CO2	NBio-CO2	Total CO2	CH4	N2O	CO2e
Category	tons/yr										MT/yr					
Hauling	0.0000	0.0000	0.0000	0.0000	0.0000	0.0000	0.0000	0.0000	0.0000	0.0000	0.0000	0.0000	0.0000	0.0000	0.0000	0.0000
Vendor	0.0000	0.0000	0.0000	0.0000	0.0000	0.0000	0.0000	0.0000	0.0000	0.0000	0.0000	0.0000	0.0000	0.0000	0.0000	0.0000
Worker	9.9600e-003	5.9500e-003	0.0598	1.2000e-004	0.0131	9.0000e-005	0.0132	3.4900e-003	8.0000e-005	3.5700e-003	0.0000	10.8720	10.8720	5.2000e-004	4.3000e-004	11.0143
Total	9.9600e-003	5.9500e-003	0.0598	1.2000e-004	0.0131	9.0000e-005	0.0132	3.4900e-003	8.0000e-005	3.5700e-003	0.0000	10.8720	10.8720	5.2000e-004	4.3000e-004	11.0143

4.0 Operational Detail - Mobile**4.1 Mitigation Measures Mobile**

	ROG	NOx	CO	SO2	Fugitive PM10	Exhaust PM10	PM10 Total	Fugitive PM2.5	Exhaust PM2.5	PM2.5 Total	Bio-CO2	NBio-CO2	Total CO2	CH4	N2O	CO2e
Category	tons/yr										MT/yr					
Mitigated	0.0241	0.0296	0.1751	2.6000e-004	0.0236	3.1000e-004	0.0239	6.3200e-003	2.9000e-004	6.6100e-003	0.0000	23.6320	23.6320	2.1900e-003	1.4900e-003	24.1300
Unmitigated	0.0241	0.0296	0.1751	2.6000e-004	0.0236	3.1000e-004	0.0239	6.3200e-003	2.9000e-004	6.6100e-003	0.0000	23.6320	23.6320	2.1900e-003	1.4900e-003	24.1300

4.2 Trip Summary Information

Land Use	Average Daily Trip Rate			Unmitigated	Mitigated
	Weekday	Saturday	Sunday	Annual VMT	Annual VMT
City Park	20.28	50.96	56.94	63,832	63,832
Total	20.28	50.96	56.94	63,832	63,832

4.3 Trip Type Information

Land Use	Miles			Trip %			Trip Purpose %		
	H-W or C-W	H-S or C-C	H-O or C-NW	H-W or C-W	H-S or C-C	H-O or C-NW	Primary	Diverted	Pass-by
City Park	9.50	7.30	7.30	33.00	48.00	19.00	66	28	6

4.4 Fleet Mix

Land Use	LDA	LDT1	LDT2	MDV	LHD1	LHD2	MHD	HHD	OBUS	UBUS	MCY	SBUS	MH
City Park	0.464659	0.064863	0.191817	0.155973	0.051760	0.009603	0.008536	0.006240	0.000416	0.000000	0.037661	0.001217	0.007255

5.0 Energy Detail

Historical Energy Use: N

5.1 Mitigation Measures Energy

	ROG	NOx	CO	SO2	Fugitive PM10	Exhaust PM10	PM10 Total	Fugitive PM2.5	Exhaust PM2.5	PM2.5 Total	Bio-CO2	NBio-CO2	Total CO2	CH4	N2O	CO2e
Category	tons/yr										MT/yr					
Electricity Mitigated						0.0000	0.0000		0.0000	0.0000	0.0000	0.0000	0.0000	0.0000	0.0000	0.0000
Electricity Unmitigated						0.0000	0.0000		0.0000	0.0000	0.0000	0.0000	0.0000	0.0000	0.0000	0.0000
NaturalGas Mitigated	0.0000	0.0000	0.0000	0.0000		0.0000	0.0000		0.0000	0.0000	0.0000	0.0000	0.0000	0.0000	0.0000	0.0000
NaturalGas Unmitigated	0.0000	0.0000	0.0000	0.0000		0.0000	0.0000		0.0000	0.0000	0.0000	0.0000	0.0000	0.0000	0.0000	0.0000

5.2 Energy by Land Use - NaturalGas

Unmitigated

	NaturalGas Use	ROG	NOx	CO	SO2	Fugitive PM10	Exhaust PM10	PM10 Total	Fugitive PM2.5	Exhaust PM2.5	PM2.5 Total	Bio-CO2	NBio-CO2	Total CO2	CH4	N2O	CO2e
Land Use	kBTU/yr	tons/yr										MT/yr					
City Park	0	0.0000	0.0000	0.0000	0.0000		0.0000	0.0000		0.0000	0.0000	0.0000	0.0000	0.0000	0.0000	0.0000	0.0000
Total		0.0000	0.0000	0.0000	0.0000		0.0000	0.0000		0.0000	0.0000	0.0000	0.0000	0.0000	0.0000	0.0000	0.0000

Mitigated

	Natural Gas Use	ROG	NOx	CO	SO2	Fugitive PM10	Exhaust PM10	PM10 Total	Fugitive PM2.5	Exhaust PM2.5	PM2.5 Total	Bio-CO2	NBio-CO2	Total CO2	CH4	N2O	CO2e
Land Use	kBTU/yr	tons/yr										MT/yr					
City Park	0	0.0000	0.0000	0.0000	0.0000		0.0000	0.0000		0.0000	0.0000	0.0000	0.0000	0.0000	0.0000	0.0000	0.0000
Total		0.0000	0.0000	0.0000	0.0000		0.0000	0.0000		0.0000	0.0000	0.0000	0.0000	0.0000	0.0000	0.0000	0.0000

5.3 Energy by Land Use - Electricity

Unmitigated

	Electricity Use		Total CO2	CH4	N2O	CO2e
Land Use	kWh/yr	tons/yr	MT/yr			
City Park	0		0.0000	0.0000	0.0000	0.0000
Total			0.0000	0.0000	0.0000	0.0000

Mitigated

	Electricity Use		Total CO2	CH4	N2O	CO2e
Land Use	kWh/yr	tons/yr	MT/yr			
City Park	0		0.0000	0.0000	0.0000	0.0000
Total			0.0000	0.0000	0.0000	0.0000

6.0 Area Detail

6.1 Mitigation Measures Area

	ROG	NOx	CO	SO2	Fugitive PM10	Exhaust PM10	PM10 Total	Fugitive PM2.5	Exhaust PM2.5	PM2.5 Total	Bio-CO2	NBio-CO2	Total CO2	CH4	N2O	CO2e
Category	tons/yr										MT/yr					
Mitigated	0.1472	0.0000	2.4000e-004	0.0000		0.0000	0.0000		0.0000	0.0000	0.0000	4.6000e-004	4.6000e-004	0.0000	0.0000	4.9000e-004
Unmitigated	0.1472	0.0000	2.4000e-004	0.0000		0.0000	0.0000		0.0000	0.0000	0.0000	4.6000e-004	4.6000e-004	0.0000	0.0000	4.9000e-004

6.2 Area by SubCategory

Unmitigated

	ROG	NOx	CO	SO2	Fugitive PM10	Exhaust PM10	PM10 Total	Fugitive PM2.5	Exhaust PM2.5	PM2.5 Total	Bio-CO2	NBio-CO2	Total CO2	CH4	N2O	CO2e
SubCategory	tons/yr										MT/yr					
Architectural Coating	0.0313					0.0000	0.0000		0.0000	0.0000	0.0000	0.0000	0.0000	0.0000	0.0000	0.0000
Consumer Products	0.1158					0.0000	0.0000		0.0000	0.0000	0.0000	0.0000	0.0000	0.0000	0.0000	0.0000
Landscaping	2.0000e-005	0.0000	2.4000e-004	0.0000		0.0000	0.0000		0.0000	0.0000	0.0000	4.6000e-004	4.6000e-004	0.0000	0.0000	4.9000e-004
Total	0.1472	0.0000	2.4000e-004	0.0000		0.0000	0.0000		0.0000	0.0000	0.0000	4.6000e-004	4.6000e-004	0.0000	0.0000	4.9000e-004

Mitigated

	ROG	NOx	CO	SO2	Fugitive PM10	Exhaust PM10	PM10 Total	Fugitive PM2.5	Exhaust PM2.5	PM2.5 Total	Bio-CO2	NBio-CO2	Total CO2	CH4	N2O	CO2e
SubCategory	tons/yr										MT/yr					
Architectural Coating	0.0313					0.0000	0.0000		0.0000	0.0000	0.0000	0.0000	0.0000	0.0000	0.0000	0.0000
Consumer Products	0.1158					0.0000	0.0000		0.0000	0.0000	0.0000	0.0000	0.0000	0.0000	0.0000	0.0000
Landscaping	2.0000e-005	0.0000	2.4000e-004	0.0000		0.0000	0.0000		0.0000	0.0000	0.0000	4.6000e-004	4.6000e-004	0.0000	0.0000	4.9000e-004
Total	0.1472	0.0000	2.4000e-004	0.0000		0.0000	0.0000		0.0000	0.0000	0.0000	4.6000e-004	4.6000e-004	0.0000	0.0000	4.9000e-004

7.0 Water Detail

7.1 Mitigation Measures Water

		Total CO2	CH4	N2O	CO2e
Category	tons/yr	MT/yr			
Mitigated		10.0319	1.6200e-003	2.0000e-004	10.1311
Unmitigated		10.0319	1.6200e-003	2.0000e-004	10.1311

7.2 Water by Land Use

Unmitigated

	Indoor/Outdoor Use		Total CO2	CH4	N2O	CO2e
Land Use	Mgal	tons/yr	MT/yr			
City Park	0 / 30.9785		10.0319	1.6200e-003	2.0000e-004	10.1311
Total			10.0319	1.6200e-003	2.0000e-004	10.1311

Mitigated

	Indoor/Outdoor Use		Total CO2	CH4	N2O	CO2e
Land Use	Mgal	tons/yr	MT/yr			
City Park	0 / 30.9785		10.0319	1.6200e-003	2.0000e-004	10.1311
Total			10.0319	1.6200e-003	2.0000e-004	10.1311

8.0 Waste Detail

8.1 Mitigation Measures Waste

Category/Year

		Total CO2	CH4	N2O	CO2e
	tons/yr	MT/yr			
Mitigated		0.4547	0.0269	0.0000	1.1265
Unmitigated		0.4547	0.0269	0.0000	1.1265

8.2 Waste by Land Use

Unmitigated

	Waste Disposed		Total CO2	CH4	N2O	CO2e
Land Use	tons	tons/yr	MT/yr			
City Park	2.24		0.4547	0.0269	0.0000	1.1265
Total			0.4547	0.0269	0.0000	1.1265

Mitigated

	Waste Disposed		Total CO2	CH4	N2O	CO2e
Land Use	tons	tons/yr	MT/yr			
City Park	2.24		0.4547	0.0269	0.0000	1.1265
Total			0.4547	0.0269	0.0000	1.1265

9.0 Operational Offroad

Equipment Type	Number	Hours/Day	Days/Year	Horse Power	Load Factor	Fuel Type
----------------	--------	-----------	-----------	-------------	-------------	-----------

10.0 Stationary Equipment

Fire Pumps and Emergency Generators

Equipment Type	Number	Hours/Day	Hours/Year	Horse Power	Load Factor	Fuel Type
----------------	--------	-----------	------------	-------------	-------------	-----------

Boilers

Equipment Type	Number	Heat Input/Day	Heat Input/Year	Boiler Rating	Fuel Type
----------------	--------	----------------	-----------------	---------------	-----------

User Defined Equipment

Equipment Type	Number
----------------	--------

11.0 Vegetation

Attachment C
Biological Report

Insert March 11, 2022 Biological Resource Assessment document from ECORP here

Biological Resources Assessment

Burns Valley Development Project

Lake County, California

March 11, 2021

CONTENTS

1.0 INTRODUCTION 1

 1.1 Project Location 1

 1.2 Project Description 1

 1.3 Purpose of this Biological Resources Assessment 3

2.0 REGULATORY SETTING 3

 2.1 Federal Regulations 3

 2.1.1 Federal Endangered Species Act 3

 2.1.2 Migratory Bird Treaty Act 5

 2.1.3 Federal Clean Water Act 5

 2.1.4 Rivers and Harbors Act 6

 2.2 State Regulations 6

 2.2.1 California Endangered Species Act 6

 2.2.2 Fully Protected Species 6

 2.2.3 Native Plant Protection Act 7

 2.2.4 California Fish and Game Code Special Protections for Birds 7

 2.2.5 Lake or Streambed Alteration Agreements 8

 2.2.6 Porter-Cologne Water Quality Act 8

 2.2.7 California Environmental Quality Act 8

 2.3 Local Plans and Ordinances 11

 2.3.1 City of Clearlake General Plan 11

 2.3.2 City of Clearlake Municipal Code 11

3.0 METHODS 12

 3.1 Literature Review 12

 3.2 Field Surveys Conducted 12

 3.3 Special-Status Species Considered for the Study Area 13

4.0 RESULTS 13

 4.1 Existing Condition 13

 4.1.1 Site Characteristics and Land Use 13

 4.1.2 Soils 14

 4.1.3 Vegetation Communities and Land Cover Types 14

 4.1.4 Aquatic Resources 18

 4.1.5 Wildlife Observations 18

 4.2 Evaluation of Species Identified in the Literature Search 20

 4.2.1 Fish 43

4.2.2 Amphibians 44

4.2.3 Reptiles 44

4.2.4 Birds 45

4.2.5 Mammals 46

4.3 Critical Habitat and Essential Fish Habitat..... 47

4.4 Riparian Habitats and Sensitive Natural Communities 47

4.5 Wildlife Movement/Corridors and Nursery Sites 47

5.0 IMPACT ANALYSIS..... 48

5.1 Special Status Species 48

5.1.1 Special-Status Plants 48

5.1.2 Northwestern Pond Turtle 48

5.1.3 Special-Status and Other Protected Birds 49

5.1.4 Special-Status Mammals 49

5.2 Riparian Habitat and Sensitive Natural Communities 49

5.3 Aquatic Resources, Including Waters the U.S. and State 50

5.4 Wildlife Movement/Corridors 50

5.5 Local Policies, Ordinances, and Other Plans..... 50

6.0 RECOMMENDATIONS..... 51

6.1 General Recommendations..... 51

6.2 Special-Status Species..... 51

6.2.1 Plants 51

6.2.2 Northwestern Pond Turtle 52

6.2.3 Special-Status Birds and MBTA-Protected Birds (including nesting raptors)..... 52

6.2.4 Special-Status Bats..... 53

6.3 Riparian and Sensitive Natural Communities 53

6.4 Waters of the U.S./State 53

6.5 Wildlife Movement Corridors 54

6.6 Trees 54

7.0 SUMMARY 54

8.0 REFERENCES..... 56

LIST OF TABLES

Table 1. Special-Status Species Evaluated for the Study Area 20

LIST OF FIGURES

Figure 1. Study Area Location and Vicinity2
 Figure 2. Natural Resources Conservation Service Soil Types..... 15
 Figure 3. Vegetation Communities and Land Cover Types 16
 Figure 4. Preliminary Wetland Assessment..... 19

LIST OF ATTACHMENTS

- Attachment A – Results of Database Queries
 Attachment B – Representative Site Photographs

LIST OF ACRONYMS AND ABBREVIATIONS

°F	Degrees Fahrenheit
BA	Biological Assessment
BCC	Birds of Conservation Concern
BIOS	Biogeographic Information and Observation System
BO	Biological Opinion
BRA	Biological Resources Assessment
CDFW	California Department of Fish and Wildlife
CEQA	California Environmental Quality Act
CFR	Code of Federal Regulations
City	City of Clearlake
CNDDB	California Natural Diversity Database
CNPS	California Native Plant Society
CRPR	California Rare Plant Rank
CWA	Clean Water Act
DPS	Distinct population segment
ESA	Endangered Species Act
HCP	Habitat conservation plan
ITP	Incidental Take Permit
LSA	Lake or Streambed Alteration
MBTA	Migratory Bird Treaty Act
MSL	Mean sea level
NMFS	National Marine Fisheries Service
NOAA	National Oceanic and Atmospheric Administration
NPDES	National Pollutant Discharge Elimination System
NPPA	Native Plant Protection Act
NRCS	Natural Resources Conservation Service
Plan	City of Clearlake 2040 General Plan Update
Project	Burns Valley Development Project
RPZ	Root Protection Zone
RWQCB	Regional Water Quality Control Board
SAA	Streambed Alteration Agreement

LIST OF ACRONYMS AND ABBREVIATIONS

SSC	Species of Special Concern
SWRCB	State Water Resources Control Board
USACE	U.S. Army Corps of Engineers
USC	U.S. Code
USFWS	U.S. Fish and Wildlife Service
USGS	U.S. Geological Survey
WBWG	Western Bat Working Group

1.0 INTRODUCTION

On behalf of the City of Clearlake (City), ECORP Consulting, Inc. conducted a Biological Resources Assessment (BRA) for the Burns Valley Development Project (Project) located in Lake County, California. The purpose of the assessment was to collect information on the biological resources present and evaluate the potential for special-status species and their habitats to occur in the Study Area; assess potential biological impacts related to Project activities; and identify potential mitigation measures to inform the Project's California Environmental Quality Act (CEQA) documentation for biological resources.

1.1 Project Location

The approximately 30.65-acre Study Area includes the impact limits of the Project and is located southwest of the intersection of Burns Valley Road and Rumsey Road, in the city of Clearlake in Lake County, California (Figure 1. *Study Area Location and Vicinity*). The Study Area corresponds to a portion of Section 21, Township 13 North, Range 07 West (Mount Diablo Base and Meridian) within the "Clearlake Highlands, California" 7.5-minute quadrangle (U.S. Geological Survey [USGS] 1993). The approximate center of the Study Area is located at latitude 38.96391 ° and longitude -122.634884° (NAD83) within the Upper Cache watershed (Hydrologic Unit Code #18020116) (Natural Resources Conservation Service [NRCS] et al. 2016).

1.2 Project Description

The Project proposes a multi-use land plan for approximately 29 acres of property with Accessor's Parcel Numbers 010-026-290, 010-026-400, and 039-570-180.

The eastern section of the property will be dedicated to a multi-family development of approximately 4.4 acres and a continuation of commercial-retail development of approximately 1.7 acres. The multi-family development will be located at the northeast corner of the property and the commercial-retail development will be located adjacently to the south along Burns Valley Road.

The mid-portion of the property is dedicated public use and will be active recreational uses such as Little League® Baseball, softball, and soccer fields. These facilities will be served with standard support services such as restrooms, concessions, and parking.

The western portion of the property is dedicated to the development of a public works facility, which includes a large graded area, covered equipment parking, public works shop, material storage bays, and a covered fuel and wash island.

Access and circulation will be provided to the development from three locations: Burns Valley Road traveling east-west, Burns Valley Road traveling north-south, and Olympic Drive.

The Project will not impact Burns Valley Creek or its riparian corridor.

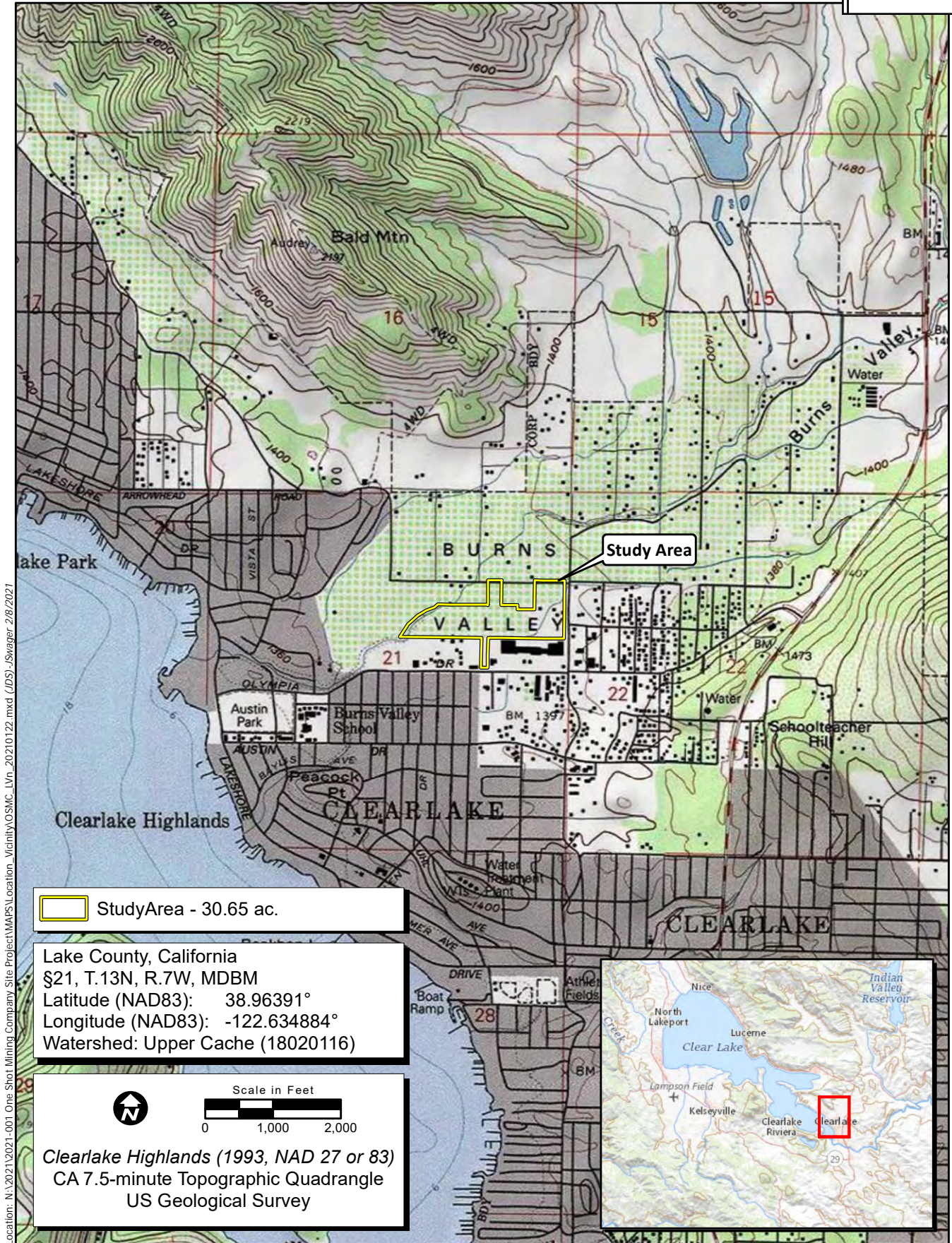

Map Date: 2/8/2021
Sources:

Figure 1. Study Area Location and Vicinity

1.3 Purpose of this Biological Resources Assessment

The purpose of this BRA is to assess the potential for occurrence of special-status plant and animal species or their habitat, and sensitive habitats such as wetlands within the Study Area. This assessment does not include determinate field surveys conducted according to agency-promulgated protocols. The conclusions and recommendations presented in this report are based upon a review of the available literature and site reconnaissance.

For the purposes of this assessment, special-status species are defined as plants or animals that:

- are listed, proposed for listing, or candidates for future listing as threatened or endangered under the federal Endangered Species Act (ESA);
- are listed or candidates for future listing as threatened or endangered under the California ESA;
- meet the definitions of endangered or rare under Section 15380 of CEQA Guidelines;
- are identified as a Species of Special Concern (SSC) by the California Department of Fish and Wildlife (CDFW);
- are birds identified as Birds of Conservation Concern (BCC) by the U.S. Fish and Wildlife Service (USFWS);
- are plants considered by the California Native Plant Society (CNPS) to be "rare, threatened, or endangered in California" (California Rare Plant Rank [CRPR] 1 and 2), plants listed by CNPS as species about which more information is needed to determine their status (CRPR 3), and plants of limited distribution (CRPR 4);
- are plants listed as rare under the California Native Plant Protection Act (NPPA; California Fish and Game Code, § 1900 et seq.); or
- are fully protected in California in accordance with the California Fish and Game Code, §§ 3511 (birds), 4700 (mammals), 5050 (amphibians and reptiles), and 5515 (fishes).

Only species that fall into one of the above-listed groups were considered for this assessment. Other species without special status that are sometimes found in database or literature searches were not included in this analysis.

2.0 REGULATORY SETTING

2.1 Federal Regulations

2.1.1 *Federal Endangered Species Act*

The federal ESA protects plants and animals that are listed as endangered or threatened by the USFWS and the National Marine Fisheries Service (NMFS). Section 9 of the ESA prohibits the taking of listed wildlife, where take is defined as "harass, harm, pursue, hunt, shoot, wound, kill, trap, capture, collect, or attempt to engage in such conduct" (50 Code of Federal Regulations [CFR] 17.3). For plants, this statute

governs removing, possessing, maliciously damaging, or destroying any listed plant on federal land and removing, cutting, digging up, damaging, or destroying any listed plant on non-federal land in knowing violation of state law (16 U.S. Code [USC] 1538). Under Section 7 of the ESA, federal agencies are required to consult with the USFWS if their actions, including permit approvals or funding, could adversely affect a listed (or proposed) species (including plants) or its critical habitat. Section 10 of the ESA provides for issuance of incidental take permits where no other federal actions are necessary provided a habitat conservation plan (HCP) is developed.

Section 7

Section 7 of the ESA mandates that all federal agencies consult with USFWS and/or NMFS to ensure that federal agencies' actions do not jeopardize the continued existence of a listed species or adversely modify Critical Habitat for listed species. If adverse effects to a species or its Critical Habitat are likely, the applicant must conduct a biological assessment (BA) for the purpose of analyzing the potential effects of the project on listed species and critical habitat to establish and justify an "effect determination." The federal agency reviews the BA; if it concludes that the project may adversely affect a listed species or its habitat, it prepares a biological opinion (BO). Through consultation and the issuance of a BO, the USFWS may issue an incidental take statement allowing take of the species that is incidental to an otherwise authorized activity provided the activity will not jeopardize the continued existence of the species. The BO may recommend "reasonable and prudent alternatives" to the project to avoid jeopardizing or adversely modifying habitat. If direct and/or indirect effects will occur to Critical Habitat that appreciably diminish the value of Critical Habitat for both the survival and recovery of a species, the adverse modifications will require formal consultation with USFWS or NMFS.

Section 10

When no discretionary action is being taken by a federal agency but a project may result in the take of listed species, an incidental take permit (ITP) under Section 10 of the ESA is necessary. The purpose of the ITP is to authorize the take of federally listed species that may result from an otherwise lawful activity, not to authorize the activities themselves. In order to obtain an ITP under Section 10, an application must be submitted that includes an HCP. In some instances, applicants, USFWS, and/or NMFS may determine that an HCP is necessary or prudent, even if a discretionary federal action will occur. The purpose of the HCP planning process associated with the permit application is to ensure that adequate minimization and mitigation for impacts to listed species and/or their habitat will occur.

Critical Habitat

Critical Habitat is defined in Section 3 of the ESA as:

1. the specific areas within the geographical area occupied by a species, at the time it is listed in accordance with the ESA, on which are found those physical or biological features essential to the conservation of the species and that may require special management considerations or protection; and
- (2. specific areas outside the geographical area occupied by a species at the time it is listed, upon a determination that such areas are essential for the conservation of the species.

For inclusion in a Critical Habitat designation, habitat within the geographical area occupied by the species at the time it was listed must first have features that are essential to the conservation of the species. Critical Habitat designations identify, to the extent known and using the best scientific data available, the physical or biological features needed for life processes. Physical and biological features that are essential to the conservation of the species may require special management considerations or protection. These include but are not limited to:

- space for individual and population growth and for normal behavior;
- food, water, air, light, minerals, or other nutritional or physiological requirements;
- cover or shelter;
- sites for breeding, reproduction, or rearing (or development) of offspring; or
- habitats that are protected from disturbance or are representative of the historic, geographical, and ecological distributions of a species.

2.1.2 Migratory Bird Treaty Act

The Migratory Bird Treaty Act (MBTA) implements international treaties between the U.S. and other nations devised to protect migratory birds, any of their parts, eggs, and nests from activities such as hunting, pursuing, capturing, killing, selling, and shipping, unless expressly authorized in the regulations or by permit. As authorized by the MBTA, the USFWS issues permits to qualified applicants for the following types of activities: falconry, raptor propagation, scientific collecting, special purposes (rehabilitation, education, migratory game bird propagation, and salvage), take of depredating birds, taxidermy, and waterfowl sale and disposal. The regulations governing migratory bird permits can be found in 50 CFR part 13 General Permit Procedures and 50 CFR part 21 Migratory Bird Permits. The State of California has incorporated the protection of birds of prey in Sections 3800, 3513, and 3503.5 of the California Fish and Game Code.

2.1.3 Federal Clean Water Act

The purpose of the federal Clean Water Act (CWA) is to "...restore and maintain the chemical, physical, and biological integrity of the nation's waters." Section 404 of the CWA prohibits the discharge of dredged or fill material into Waters of the U.S. without a permit from the U.S. Army Corps of Engineers (USACE). "Discharges of fill material" is defined as the addition of fill material into Waters of the U.S., including, but not limited to the following: placement of fill that is necessary for the construction of any structure, or impoundment requiring rock, sand, dirt, or other material for its construction; site-development fills for recreational, industrial, commercial, residential, and other uses; causeways or road fills; and fill for intake and outfall pipes, and subaqueous utility lines [33 CFR § 328.2(f)]. In addition, Section 401 of the CWA (33 USC 1341) requires any applicant for a federal license or permit to conduct any activity that may result in a discharge of a pollutant into Waters of the U.S. to obtain a certification that the discharge will comply with the applicable effluent limitations and water quality standards.

Substantial impacts to Waters of the U.S. (more than 0.5 acre of impact) may require an individual permit. Projects that only minimally affect Waters of the U.S. (less than 0.5 acre of impact) may meet the conditions of one of the existing Nationwide Permits. A Water Quality Certification or waiver pursuant to Section 401 of the CWA is required for Section 404 permit actions; this certification or waiver is issued by the Regional Water Quality Control Board (RWQCB).

2.1.4 Rivers and Harbors Act

Section 10 of the Rivers and Harbors Act of 1899 requires authorization from the Secretary of the Army, acting through the USACE, for the construction of any structure in or over any navigable Waters of the U.S. Structures or work outside the limits defined for navigable Waters of the U.S. require a Section 10 permit if the structure or work affects the course, location, or condition of the water body. The law applies to any dredging or disposal of dredged materials, excavation, filling, re-channelization, or any other modification of a navigable Water of the U.S., and applies to all structures, from the smallest floating dock to the largest commercial undertaking. It further includes, without limitation, any wharf, dolphin, weir, boom breakwater, jetty, groin, bank protection (e.g., riprap, revetment, bulkhead), mooring structures such as pilings, aerial or subaqueous power transmission lines, intake or outfall pipes, permanently moored floating vessel, tunnel, artificial canal, boat ramp, aids to navigation, and any other permanent, or semi-permanent obstacle or obstruction. The alteration of a USACE-federally authorized civil works project requires a permit pursuant to Section 14 of the Act, as amended and codified in 33 USC 408. Projects with minimal impacts require approval by the USACE Sacramento District Construction Operations Group; however, projects with more substantial impacts may require USACE Headquarters review. Coordination with the Central Valley Flood Protection Board, who serve as the Non-Federal Sponsor, is required as a part of the process of obtaining a Section 408 permit.

2.2 State Regulations

2.2.1 California Endangered Species Act

The California ESA (California Fish and Game Code §§ 2050-2116) protects species of fish, wildlife, and plants listed by the State as endangered or threatened. Species identified as candidates for listing may also receive protection. Section 2080 of the California ESA prohibits the taking, possession, purchase, sale, and import or export of endangered, threatened, or candidate species, unless otherwise authorized by permit. Take is defined in Section 86 of the California Fish and Game Code as “hunt, pursue, catch, capture, or kill, or attempt to hunt, pursue, catch, capture, or kill.” The California ESA allows for take incidental to otherwise lawful projects under permits issued by CDFW.

2.2.2 Fully Protected Species

The State of California first began to designate species as “fully protected” prior to the creation of the federal and California ESAs. Lists of fully protected species were initially developed to provide protection to those animals that were rare or faced possible extinction and included fish, amphibians and reptiles, birds, and mammals. Most fully protected species have since been listed as threatened or endangered

under the federal and/or California ESAs. Fully protected species are identified in the California Fish and Game Code § 4700 for mammals, § 3511 for birds, § 5050 for reptiles and amphibians, and § 5515 for fish.

These sections of the California Fish and Game Code provide that fully protected species may not be taken or possessed at any time, including prohibition of CDFW from issuing incidental take permits for fully protected species under the California ESA. CDFW will issue licenses or permits for take of these species for necessary scientific research or live capture and relocation pursuant to the permit and may allow incidental take for lawful activities carried out under an approved Natural Community Conservation Plan within which such species are covered.

2.2.3 Native Plant Protection Act

The NPPA of 1977 (California Fish and Game Code §§ 1900-1913) was established with the intent to “preserve, protect and enhance rare and endangered plants in this state.” The NPPA is administered by CDFW. The Fish and Game Commission has the authority to designate native plants as “endangered” or “rare.” The NPPA prohibits the take of plants listed under the NPPA, though the NPPA contains exemptions to this prohibition that have not been clarified by regulation or judicial rule. In 1984, the California ESA brought under its protection all plants previously listed as endangered under NPPA. Plants listed as rare under NPPA are not protected under the California ESA but are still protected under the provisions of NPPA. The Fish and Game Commission no longer lists plants under NPPA, reserving all listings to the California ESA.

2.2.4 California Fish and Game Code Special Protections for Birds

In addition to protections contained within the California ESA and California Fish and Game Code § 3511 described above, the California Fish and Game Code includes a several sections that specifically protect certain birds:

- Section 3800 states that it is unlawful to take nongame birds, such as those occurring naturally in California that are not resident game birds, migratory game birds, or fully protected birds, except when in accordance with regulations of the California Fish and Game Commission or a mitigation plan approved by CDFW for mining operations.
- Section 3503 prohibits the take, possession, or needless destruction of the nest or eggs of any bird.
- Section 3503.5 protects birds of prey (which includes eagles, hawks, falcons, kites, ospreys, and owls) and prohibits the take, possession, or destruction of any birds and their nests.
- Section 3505 makes it unlawful to take, sell, or purchase egrets, ospreys, and several exotic nonnative species, or any part of these birds.
- Section 3513 specifically prohibits the take or possession of any migratory nongame bird as designated in the MBTA.

2.2.5 Lake or Streambed Alteration Agreements

Section 1602 of the California Fish and Game Code requires individuals or agencies to provide a Notification of Lake or Streambed Alteration (LSA) to CDFW for “any activity that may substantially divert or obstruct the natural flow or substantially change the bed, channel, or bank of any river, stream, or lake.” CDFW reviews the proposed actions and, if necessary, proposed measures to protect affected fish and wildlife resources. The final proposal mutually agreed upon by CDFW and the applicant is the Lake or Streambed Alteration Agreement (SAA).

2.2.6 Porter-Cologne Water Quality Act

The RWQCB implements water quality regulations under the federal CWA and the State Porter-Cologne Water Quality Act. These regulations require compliance with the National Pollutant Discharge Elimination System (NPDES), including compliance with the California Storm Water NPDES General Construction Permit for discharges of storm water runoff associated with construction activities. General Construction Permits for projects that disturb one or more acres of land require development and implementation of a Storm Water Pollution Prevention Plan. Under the Porter-Cologne Water Quality Act, the RWQCB regulates actions that would involve “discharging waste, or proposing to discharge waste, with any region that could affect the water of the state” (Water Code 13260(a)). Waters of the State are defined as “any surface water or groundwater, including saline waters, within the boundaries of the state” (Water Code 13050 (e)). The RWQCB regulates all such activities, as well as dredging, filling, or discharging materials into Waters of the State that are not regulated by the USACE due to a lack of connectivity with a navigable water body. The RWQCB may require issuance of Waste Discharge Requirements for these activities.

2.2.7 California Environmental Quality Act

In accordance with CEQA Guidelines § 15380, a species or subspecies not specifically protected under the federal or California ESAs or NPPA may be considered endangered, rare, or threatened for CEQA review purposes if the species meets certain criteria specified in the Guidelines. These criteria parallel the definitions used in the ESA, California ESA, and NPPA. Section 15380 was included in the CEQA Guidelines primarily to address situations in which a project under review may have a significant effect on a species that has not been listed under the ESA, California ESA, or NPPA, but that may meet the definition of endangered, rare, or threatened. Animal species identified as SSC by CDFW, birds identified as BCC by USFWS, and plants identified by the CNPS as rare, threatened, or endangered may meet the CEQA definition of rare or endangered.

Species of Special Concern

SSC are defined by CDFW as a species, subspecies, or distinct population of an animal native to California that are not legally protected under the federal ESA, California ESA, or California Fish and Game Code, but currently satisfies one or more of the following criteria:

- The species has been completely extirpated from the state or, as in the case of birds, it has been extirpated from its primary seasonal or breeding role.
- The species is listed as federally (but not State) threatened or endangered or meets the State definition of threatened or endangered but has not formally been listed.
- The species has or is experiencing serious (noncyclical) population declines or range retractions (not reversed) that, if continued or resumed, could qualify it for State threatened or endangered status.
- The species has naturally small populations that exhibit high susceptibility to risk from any factor that if realized, could lead to declines that would qualify it for State threatened or endangered status.
- SSC are typically associated with habitats that are threatened.

Depending on the policy of the lead agency, projects that result in substantial impacts to SSC may be considered significant under CEQA.

USFWS Birds of Conservation Concern

The 1988 amendment to the Fish and Wildlife Conservation Act mandates USFWS “identify species, subspecies, and populations of all migratory nongame birds that, without additional conservation actions, are likely to become candidates for listing under ESA.” To meet this requirement, USFWS published a list of BCC (USFWS 2008) for the U.S. The list identifies the migratory and nonmigratory bird species (beyond those already designated as federally threatened or endangered) that represent USFWS’ highest conservation priorities. Depending on the policy of the lead agency, projects that result in substantial impacts to BCC may be considered significant under CEQA.

Sensitive Natural Communities

The CDFW maintains the *California Natural Community List* (CDFW 2021a), which provides a list of vegetation alliances, associations, and special stands as defined in the *Manual of California Vegetation* (Sawyer et al. 2009), along with their respective state and global rarity ranks. Natural communities with a state rarity rank of S1, S2, or S3 are considered sensitive natural communities. Depending on the policy of the lead agency, impacts to sensitive natural communities may be considered significant under CEQA.

California Rare Plant Ranks

The CNPS maintains the Inventory of Rare and Endangered Plants of California (CNPS 2021), which provides a list of plant species native to California that are threatened with extinction, have limited distributions, and/or low populations. Plant species meeting one of these criteria are assigned to one of six CRPRs. The rank system was developed in collaboration with government, academia, non-governmental organizations, and private-sector botanists, and is jointly managed by CDFW and the CNPS. The CRPRs are currently recognized in the California Natural Diversity Database (CNDDB). The following are definitions of the CNPS CRPRs:

- Rare Plant Rank 1A – presumed extirpated in California and either rare or extinct elsewhere.
- Rare Plant Rank 1B – rare, threatened, or endangered in California and elsewhere.
- Rare Plant Rank 2A – presumed extirpated in California, but more common elsewhere.
- Rare Plant Rank 2B – rare, threatened, or endangered in California but more common elsewhere.
- Rare Plant Rank 3 – a review list of plants about which more information is needed.
- Rare Plant Rank 4 – a watch list of plants of limited distribution.

Additionally, CNPS has defined Threat Ranks that are added to the CRPR as an extension. Threat Ranks designate the level of threat on a scale of 1 through 3, with 1 being the most threatened and 3 being the least threatened. Threat Ranks are generally present for all plants ranked 1B, 2B, or 4, and for the majority of plants ranked 3. Plant species ranked 1A and 2A (presumed extirpated in California), and some species ranked 3, which lack threat information, do not typically have a Threat Rank extension. The following are definitions of the CNPS Threat Ranks:

- Threat Rank 0.1 – Seriously threatened in California (more than 80 percent of occurrences threatened/high degree and immediacy of threat).
- Threat Rank 0.2 – Moderately threatened in California (20 to 80 percent occurrences threatened/moderate degree and immediacy of threat).
- Threat Rank 0.3 – Not very threatened in California (less than 20 percent of occurrences threatened/low degree and immediacy of threat or no current threats known).

Factors such as habitat vulnerability and specificity, distribution, and condition of occurrences are considered in setting the Threat Rank; and differences in Threat Ranks do not constitute additional or different protection (CNPS 2021).

Depending on the policy of the lead agency, substantial impacts to plants ranked 1A, 1B, 2, and 3 are typically considered significant under CEQA Guidelines § 15380. Significance under CEQA is typically evaluated on a case-by-case basis for plants ranked 4 and at the discretion of the CEQA lead agency.

CEQA Significance Criteria

Sections 15063-15065 of the CEQA Guidelines address how an impact is identified as significant. Generally, impacts to listed (rare, threatened, or endangered) species are considered significant. Assessment of "impact significance" to populations of non-listed species (e.g., SSC) usually considers the proportion of the species' range that will be affected by a project, impacts to habitat, and the regional and population level effects.

Specifically, § 15064.7 of the CEQA Guidelines encourages local agencies to develop and publish the thresholds that the agency uses in determining the significance of environmental effects caused by projects under its review. However, agencies may also rely upon the guidance provided by the expanded

Initial Study checklist contained in Appendix G of the CEQA Guidelines, which provides examples of impacts that would normally be considered significant.

An evaluation of whether an impact on biological resources would be substantial must consider both the resource itself and how that resource fits into a regional or local context. Substantial impacts would be those that would diminish, or result in the loss of, an important biological resource, or those that would obviously conflict with local, State, or federal resource conservation plans, goals, or regulations. Impacts are sometimes locally important but not significant under CEQA. The reason for this is that although the impacts would result in an adverse alteration of existing conditions, they would not substantially diminish or result in the permanent loss of an important resource on a population-wide or region-wide basis.

2.3 Local Plans and Ordinances

2.3.1 City of Clearlake General Plan

The City of Clearlake 2040 General Plan Update (Plan) is the governing document for all planning and development related decisions within City limits (City of Clearlake 2016a). The Environmental Impact Report for the Plan (City of Clearlake 2016b) summarizes mitigation measures for biological resources the City must follow when implementing the Plan.

The Conservation Element of the Plan generally outlines goals, objectives, policies, and programs related to the protection of water quality, listed species, sensitive habitats, and wildlife movement.

2.3.2 City of Clearlake Municipal Code

Subsection 18-1.4.435 (Native Tree Protection and Removal Permits) of the City of Clearlake Municipal Code (City of Clearlake 2020) establishes the procedures for protecting certain native trees, and requires a native tree protection and removal permit for the following:

- Blue oak (*Quercus douglasii*),
- Valley oak (*Quercus lobata*),
- Interior live oak (*Quercus wislizeni*),
- California black oak (*Quercus kelloggii*),
- Canyon live oak (*Quercus chrysolepis*),
- Oregon white oak (*Quercus garryana*), and
- Any other tree designated by the City Council as a "Heritage Tree".

As described in Subsection 18-51404 (Tree Protection Regulations) any disturbances which might cause harm to a protected tree, are strictly prohibited within the root protection zone (RPZ) of that tree. The RPZ is defined as a circular area around the trunk of the tree with the radius equal to the largest radius of the tree's drip line. Any activities within the RPZ of a protected tree requires a tree removal permit.

As described in Subsection 18-5.1405 (Removal Regulations), tree removal permits require preparation of a Tree Replacement Plan. Mitigation or compensation for protected trees that are felled and/or removed includes either onsite or offsite planting or an equivalent compensatory payment into a fund established by the City to plant and maintain trees.

3.0 METHODS

3.1 Literature Review

The following resources were reviewed to determine the special-status species that have been documented within or in the vicinity of the Study Area.

- CDFW CNDDDB data for the "Clearlake Highlands, California" 7.5-minute USGS quadrangle and the nine surrounding USGS quadrangles (CDFW 2021a).
- USFWS Information, Planning, and Consultation System Resource Report List for the Study Area (USFWS 2021a).
- CNPS' electronic Inventory of Rare and Endangered Plants of California was queried for the "Clearlake Highlands, California" 7.5-minute USGS quadrangles and the nine surrounding quadrangles (CNPS 2021).
- NMFS Resources data for the "Clearlake Highlands, California" 7.5-minute USGS quadrangle (National Oceanic and Atmospheric Administration [NOAA] 2021a).

The results of the database queries are included in Attachment A.

Aerial imagery and site or species-specific background information, as cited throughout this document, were reviewed to determine the potential for occurrence of sensitive biological resources within or in the vicinity of the Study Area.

3.2 Field Surveys Conducted

ECORP Biologist Hannah Stone conducted a reconnaissance-level field survey for the Study Area on January 29, 2021. The Study Area was systematically surveyed on foot using an Eos Arrow Global Positioning System unit with sub-meter accuracy, topographic maps, and aerial imagery to ensure total site coverage. Special attention was given to identifying those portions of the Study Area with the potential to support special-status species and sensitive habitats. During the field survey, biological communities occurring onsite were characterized and the following biological resource information was collected:

- Potential aquatic resources.
- Vegetation communities.
- Plant and animal species directly observed.
- Animal evidence (e.g., scat, tracks).

- Existing active raptor nest locations.
- Special habitat features.
- Representative photographs.

3.3 Special-Status Species Considered for the Study Area

Based on database queries, a list of special-status species that are considered to have the potential to occur within the vicinity of the Study Area was generated (Table 1). Each of the species was evaluated for its potential to occur within the Study Area through the literature review and field observations, and categorized based on the following criteria:

- **Present** - Species was observed during the site visit or is known to occur within the Study Area based on documented occurrences within the CNDDDB or other literature.
- **Potential to Occur** - Habitat (including soils and elevation requirements) for the species occurs within the Study Area.
- **Low Potential to Occur** - Marginal or limited amounts of habitat occurs and/or the species is not known to occur within the vicinity of the Study Area based on CNDDDB records and other available documentation.
- **Absent** - No suitable habitat (including soils and elevation requirements) and/or the species is not known to occur within the vicinity of the Study Area based on CNDDDB records and other documentation.

4.0 RESULTS

4.1 Existing Condition

4.1.1 Site Characteristics and Land Use

The Study Area is located within relatively flat to gently rolling terrain situated at an elevational range of approximately 1,350 to 1,365 feet above mean sea level (MSL) in the Inner North Coast Ranges District of the California floristic province (Baldwin et al. 2012). The average winter low temperature in the vicinity of the Study Area is 44.2 degrees Fahrenheit (°F) and the average summer high temperature is 70.9°F. Average annual precipitation is approximately 31.42 inches, which falls as rain (NOAA 2021b).

The majority of the Study Area is an English walnut (*Juglans regia*) orchard that appears to be nonoperational and unmaintained except for occasional discing. A residential structure was located near the middle of the eastern Study Area boundary, but has since been mostly demolished. Building foundations, portions of the driveway and parking areas, and cultivated vegetation including a small pomegranate (*Punica granatum*) orchard, are remnant of the old residence. The eastern portion of the Study Area appears to receive regular use by the neighboring community. Native surface trails are common throughout this area and appear to be used mostly by pedestrians, although a dirt biker was observed using the trails during the site reconnaissance. Bags of trash and other miscellaneous materials

are dumped and scattered throughout this portion of the Study Area, and there are signs of abandoned encampments. A few small areas of the Study Area were observed to be recently burned.

Representative photographs of the Study Area are included in Attachment B.

4.1.2 Soils

According to the Web Soil Survey (NRCS 2021a), two soil units, or types, have been mapped within the Study Area (Figure 2. *Natural Resources Conservation Service Soils Types*):

- 124 – Cole variant clay loam
- 158 – Lupoyoma silt loam, protected

The Cole series consists of very deep, somewhat poorly drained soils that formed in alluvium from mixed sources. Cole soils are on stream terraces, flood-plain steps, and alluvial fans with slopes of 0 to 5 percent (NRCS 2021a).

The Lupoyoma series consists of very deep, moderately well drained soils formed in alluvium derived from mixed rock sources, dominantly sandstone and shale. Lupoyoma soils are on floodplains and have slopes of 0 to 2 percent (NRCS 2021a).

The Cole variant clay loam map unit and the Lupoyoma silt loam, protected map unit each contain one minor component listed as hydric: Clear Lake and Xerofluvents, respectively (NRCS 2021b).

No soil units derived from serpentinite or other ultramafic parent materials have been reported to occur within the Study Area or its immediate vicinity (NRCS 2021a; Jennings et al. 1977; Horton 2017).

4.1.3 Vegetation Communities and Land Cover Types

Vegetation communities or land cover types observed within the Study Area include English walnut orchard, valley oak woodland, Harding grass (*Phalaris aquatica*) sward, yellow star-thistle (*Centaurea solstitialis*) field, and developed/disturbed areas.

Figure 3. *Vegetation Communities and Land Cover Types* generally depicts the locations of the land cover types and vegetation communities; descriptions are provided in the following sections. The reconnaissance site visit was not conducted during the optimum identifiable period for most plant species. However, many plants commonly present within the Study Area were identifiable from characteristics of dead vegetation from the previous growing season.

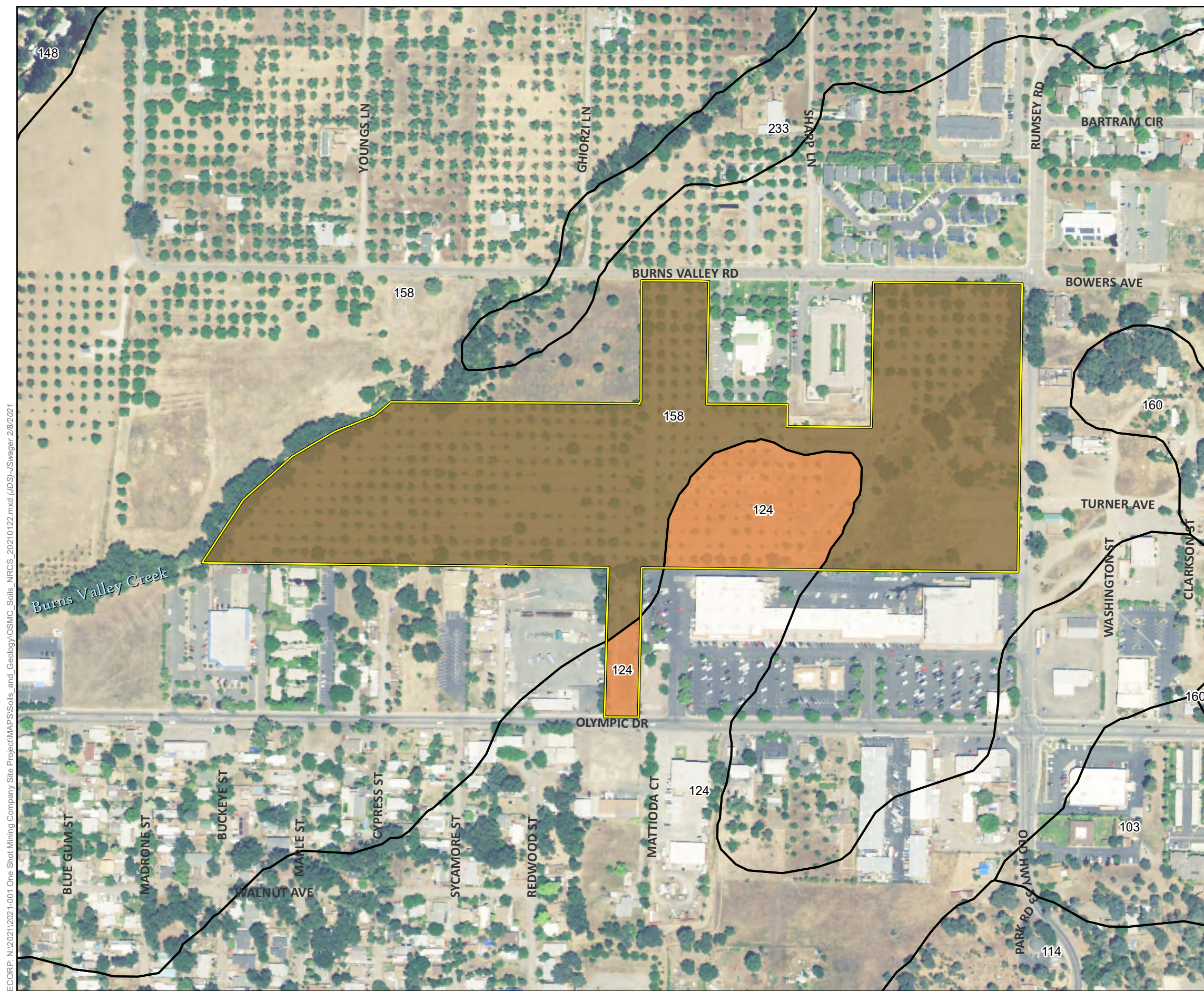

Map Features

- Study Area - 30.65 ac.

NRCS Soils

Series Number - Series Name

- 124 - Cole variant clay loam
- 158 - Lupoyoma silt loam, protected

Natural Resources Conservation Service (NRCS) Soil Survey Geographic (SSURGO) Database for Lake County, CA

ECORP: N:\2021\2021-001 One Shot Mining Company Site Project\MAPS\Soils_and_Geology\OSMC_Soils_NRCS_20210122.mxd (JDS)-JSwager 2/8/2021

Sources: ESRI, USGS, NAIP (2020), CEC

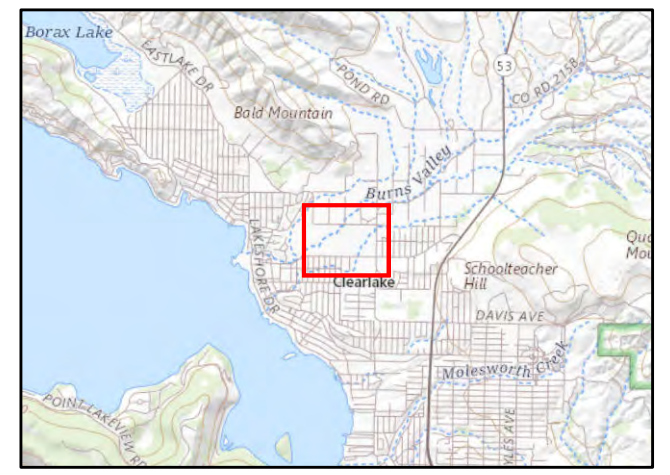
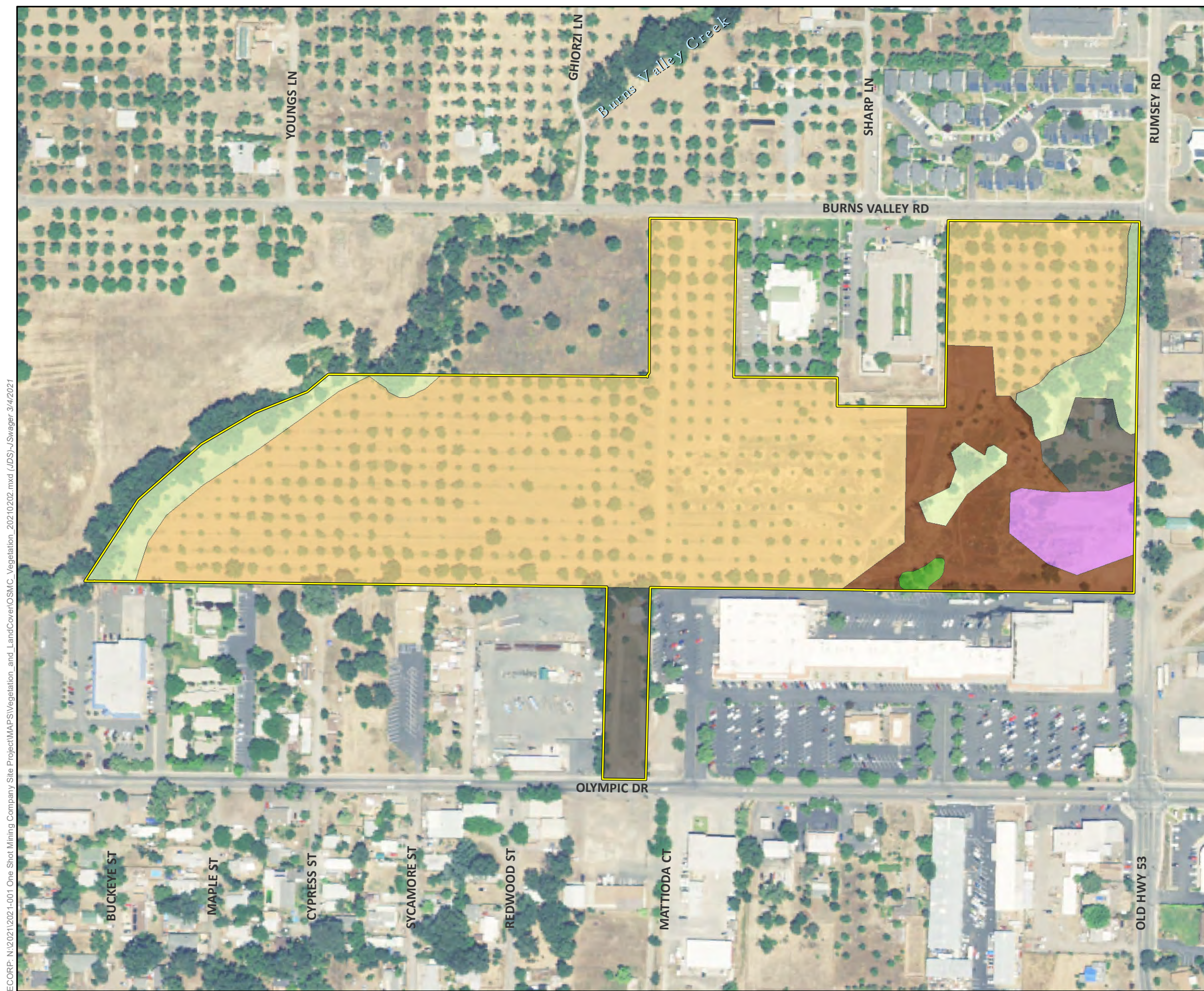

Figure 2. Natural Resources Conservation Service Soil Type
2021-001 Burns Valley Development Project





- Map Features**
- Study Area - 30.65 ac.
- Vegetation Communities and Land Cover Types**
- Fremont Cottonwood Patch - 0.11 ac.
 - Valley Oak Woodland - 2.74 ac.
 - Harding Grass Grassland - 3.26 ac.
 - English Walnut Orchard - 21.63 ac.
 - Yellow Star-thistle Field - 1.09 ac.
 - Developed/Disturbed - 1.81 ac.

Sources: ESRI, USGS, NAIP (2020), CEC

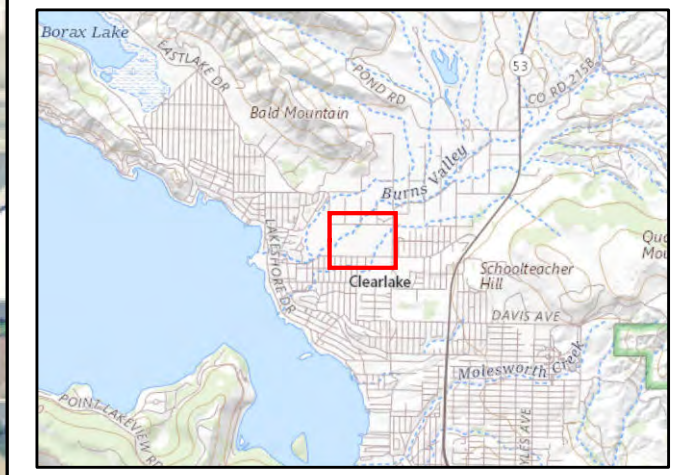

ECORP: N:\2021\2021-001 One Shot Mining Company Site Project\WAPS\Vegetation_and_LandCover\OSMC_Vegetation_20210202.mxd (JDS)-\Swagger_3/4/2021

Map Date: 3/4/2021

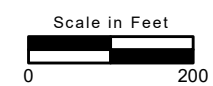

Figure 3. Vegetation Communities and Land Cover Types

English Walnut Orchard

An English walnut orchard makes up most of the Study Area, covering the majority of land west of the unnamed stream which runs northeast-southwest through the eastern portion of the Study Area. The orchards are characterized by evenly spaced rows of black walnuts with patchy ruderal vegetation growing on mechanically tilled soils between the walnuts. At the time of the reconnaissance field survey, yellow star-thistle was dominant in the understory, patches of short-pod mustard (*Hirschfeldia incana*) were scattered throughout and seedlings of unidentifiable annual grasses and annual herbs including red-stemmed filaree (*Erodium cicutarium*), hairy hawkbit (*Leontodon saxatilis*), and miner's lettuce (*Claytonia* sp.) carpeted the soils.

Valley Oak Woodland

Strips of valley oak woodland are located along Burns Valley Creek, which borders the western Study Area boundary, and along the unnamed stream that runs northeast-southwest through the eastern portion of the Study Area. At the time of the reconnaissance field survey, valley oak was dominant in the canopy, and the understory included patches of rush (*Carex* sp.), Himalayan blackberry (*Rubus armeniacus*) and rose (*Rosa* sp.) near the stream, and oats (*Avena* sp.) and vetch (*Vicia* sp.) in upland areas.

Valley oak woodland within the Study Area is consistent with the Valley Oak Forest and Woodland Alliance (Sawyer et al. 2009), which has a state rarity ranking of S3 and is considered a sensitive natural community.

Harding Grass Grassland

The majority of the non-riparian areas that are not planted as orchards are characterized as Harding Grass grasslands. At the time of the reconnaissance field survey, Harding grass was dominant and prickly lettuce (*Lactuca serriola*) and curly dock (*Rumex crispus*) were scattered throughout. A small patch of Fremont cottonwood was located within the Harding Grass Grassland.

This vegetation type is consistent with the Harding grass – Reed Canary grass (*Phalaris arundinacea*) swards Semi-Natural Alliance (Sawyer et al. 2009).

Yellow Star-Thistle Field

A yellow star-thistle field is located between the Harding grass grassland and Burns Valley Road in the southeastern portion of the Study Area. This area appears to have been disturbed in the past by vehicle traffic and potentially grading. At the time of the reconnaissance field survey, yellow star-thistle was dominant and short-pod mustard and vetch were scattered throughout.

This vegetation type is consistent with the Yellow Star-thistle Herbaceous Semi Natural Alliance (Sawyer et al. 2009).

Developed/Disturbed

The developed/disturbed land cover type within the Study Area was observed in two areas bordering Burns Valley Road on the east side of the Study Area. One area is a former residential development that

has been demolished. Remnants of that development include foundations for structures, driveways, parking areas, and cultivated vegetation including a small pomegranate orchard, a Coast redwood (*Sequoia sempervirens*), and a European olive (*Olea europaea*). Large valley oaks are also located within this area near the foundations.

4.1.4 Aquatic Resources

A preliminary aquatic resources assessment to identify potential Waters of the U.S./State was conducted within the Study Area concurrent with the reconnaissance-level field survey. The Study Area does not include any portion of Burns Valley Creek, which is directly adjacent to the western boundary of the Study Area. However, the current mapped boundary for the Study Area may inadvertently include a portion of the creek (Figure 4. *Preliminary Aquatic Assessment*). An aquatic resources delineation would be necessary to determine the boundary for Burns Valley Creek in order to completely exclude it from the Study Area.

One aquatic resource was identified, a drainage channel which enters the Study Area through a culvert in the northeast corner of the site and flows southwest to another culvert located near the southern boundary of the Study Area (Figure 4). At the time of the site reconnaissance, the majority of the channel was dry despite recent storms. Some ponding was observed along segments of the channel. An area of ponding caused by human disturbance to the channel was observed approximately midway between the inlet and outlet culverts. The channel was no longer distinctly incised south of this location. Small constructed earthen berms and walking trails appear to have affected the flow path beyond this point and little indication of hydrology or an ordinary high water mark (OHWM) was observed beyond the berms. However, the drainage was mapped to the outlet culvert following the most likely flow path. An aquatic resources delineation would be required to determine the actual extent and location of the drainage, especially in the southern portion where hydrology was not clear. The drainage appears to be ephemeral, and likely only flows during larger storm events.

In the current definition of Waters of the U.S. under the Navigable Waters Protection Rule, ephemeral features and features that are not adjacent to existing Waters of the U.S. are generally not jurisdictional. Based on anecdotal observations, the channel onsite appears to be ephemeral, but this would need to be analyzed using historic precipitation data and verified by the USACE. Regardless of federal jurisdictional, the channel could be considered a Water of the State under the State Wetland Definition and Procedures for Discharges of Dredged or Fill Material to Waters of the State (State Water Resources Control Board [SWRCB] 2019).

4.1.5 Wildlife Observations

Wildlife observed within or flying over the Study Area during the site reconnaissance includes American crow (*Corvus brachyrhynchos*), Brewer's blackbird (*Euphagus cyanocephalus*), Eurasian collared-dove (*Streptopelia decaocto*), red-shouldered hawk (*Buteo lineatus*), Anna's hummingbird (*Calypte anna*), white-crowned sparrow (*Zonotrichia leucophrys*), American goldfinch (*Spinus tristis*), California scrub-jay (*Aphelocoma californica*), and Nuttall's woodpecker (*Dryobates nuttallii*).

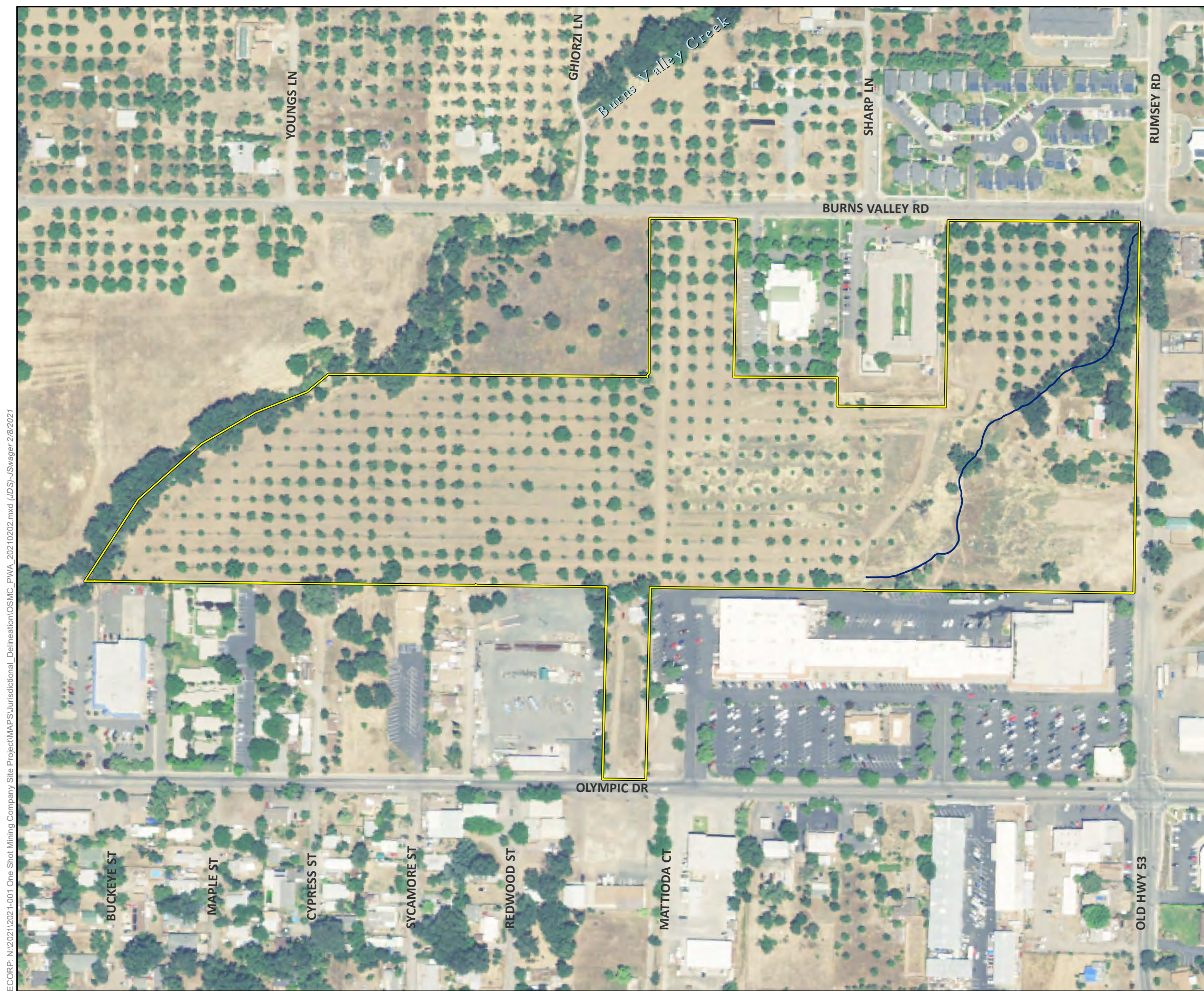

Map Features

Study Area - 30.65 ac.

Potential Aquatic Resources*

Drainage - 0.06 ac.

* The information depicted on this graphic represents a preliminary wetland assessment. The assessment was not conducted in accordance with the Corps of Engineers Wetland Delineation Manual and San Francisco District Minimum Standards. The project boundaries, wetland boundaries, and acreage values are approximate.
 * The acreage value for each feature has been rounded to the nearest 1/100 decimal. Summation of these values may not equal the total potential Waters of the U.S. acreage reported.

ECORP: N:\2021\2021-001 One Shot Mining Company Site Project\WAPS\jurisdictional_Delineation\OSMC_PWA_20210202.mxd (JDS)-Jsvager 2/8/2021

Sources: ESRI, USGS, NAIP (2020), CEC

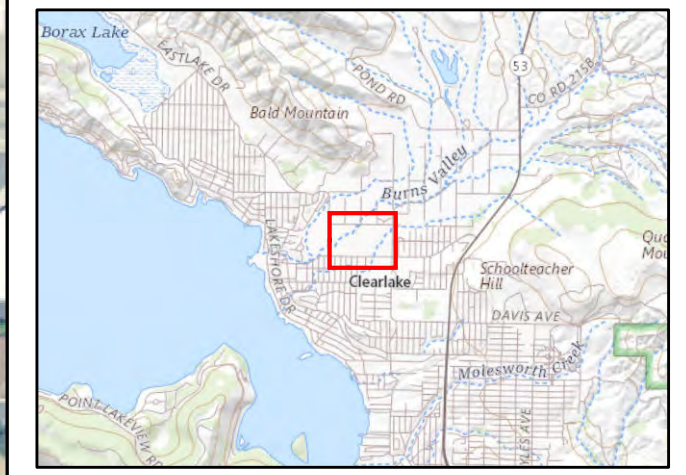
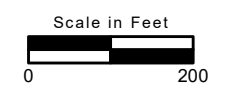

Figure 4. Preliminary Wetland Assessment



4.2 Evaluation of Species Identified in the Literature Search

Table 1 lists all the special-status plant and wildlife species (as defined in Section 1.3) identified in the literature review as potentially occurring within the vicinity of the Study Area. Included in this table are the listing status for each species, a brief habitat description, and an evaluation on the potential for each species to occur within the Study Area.

Following the table is a brief description and discussion of each special-status species that was determined to have potential to occur onsite.

Common Name (<i>Scientific Name</i>)	Status			Habitat Description ¹	Survey Period	Potential to Occur Onsite
	ESA	CESA	Other			
Plants						
Bent-flowered fiddleneck (<i>Amsinckia lunaris</i>)	-	-	1B.2	Cismontane woodland, coastal bluff scrub, and valley and foothill grasslands (10'-1,640').	March-June	Potential to occur. Suitable habitat within Study Area.
Dimorphic snapdragon (<i>Antirrhinum subcordatum</i>)	-	-	4.3	Chaparral and lower montane coniferous forest; sometimes on serpentine substrates (606'-2,625')	April-July	Absent. No suitable habitat within Study Area.
Twig-like snapdragon (<i>Antirrhinum virga</i>)	-	-	4.3	Rocky soils, openings, and often serpentine in chaparral and lower montane coniferous forest (328'-6,611').	June-July	Absent. No suitable habitat within Study Area.
Coast rockcress (<i>Arabis blepharophylla</i>)	-	-	4.3	Rocky soils in broadleaf upland forest, coastal bluff scrub, coastal prairie, and coastal scrub (10'-3,609').	February-May	Low potential to occur. Marginally suitable habitat (woodland) within Study Area.
Konocti manzanita (<i>Arctostaphylos manzanita</i> ssp. <i>elegans</i>)	-	-	1B.3	Volcanic substrates of chaparral, cismontane woodland, and lower montane coniferous forest (1,295'-5,299').	March-May	Absent. No suitable habitat within Study Area.
Raiche's manzanita (<i>Arctostaphylos stanfordiana</i> ssp. <i>raichei</i>)	-	-	1B.1	Rocky, often serpentine soils of chaparral and lower montane coniferous forest openings (1,476'-3,396').	February-April	Absent. No suitable habitat within Study Area.
Serpentine milkweed (<i>Asclepias solanoana</i>)	-	-	4.2	Serpentine substrates of chaparral, cismontane woodland, and lower montane coniferous forest (754'-6,103').	May-July	Absent. No suitable habitat within Study Area.

Table 1. Special-Status Species Evaluated for the Study Area

Common Name (<i>Scientific Name</i>)	Status			Habitat Description ¹	Survey Period	Potential to Occur Onsite
	ESA	CESA	Other			
Brewer's milk-vetch (<i>Astragalus breweri</i>)	–	–	4.2	Often serpentine and volcanic substrates of chaparral, cismontane woodland, meadows and seeps, and open gravelly openings of valley and foothill grassland (295'–2,395').	April–June	Low potential to occur. Marginally suitable habitat (woodland and grassland) within Study Area.
Cleveland's milk-vetch (<i>Astragalus clevelandii</i>)	–	–	4.3	Serpentine seeps of chaparral, cismontane woodland, and riparian forest (656'–4,922').	June–September	Absent. No suitable habitat within Study Area.
Jepson's milk-vetch (<i>Astragalus rattanii</i> var. <i>jepsonianus</i>)	–	–	1B.2	Chaparral, cismontane woodland, and valley and foothill grassland; often on serpentine substrates (968'–2,297').	March–June	Low potential to occur. Marginally suitable habitat (non-serpentine woodland and grassland) within Study Area.
Mexican mosquito fern (<i>Azolla microphylla</i>)	–	–	4.2	Marshes and swamps, ponds or slow-moving bodies of water (98'–328').	August	Absent. No suitable habitat within Study Area.
Watershield (<i>Brasenia schreberi</i>)	–	–	2B.3	Freshwater marshes and swamps (98'–7,218').	June–September	Absent. No suitable habitat within Study Area.
Indian Valley brodiaea (<i>Brodiaea rosea</i> ssp. <i>rosea</i>)	–	CE	3.1	Serpentinite substrates of closed-cone coniferous forest, chaparral, cismontane woodland, and valley and foothill grassland (1,099'–4,758').	May–June	Absent. No suitable habitat within Study Area.
Serpentine reed grass (<i>Calamagrostis ophitidis</i>)	–	–	4.3	Rocky, serpentinite substrates of chaparral (open, often north-facing slopes), lower montane coniferous forest, meadows and seeps, and valley and foothill grassland (295'–3,495').	April–July	Absent. No suitable habitat within Study Area.
Pink star-tulip (<i>Calochortus uniflorus</i>)	–	–	4.2	Coastal prairie, coastal scrub, meadows and seeps, and North Coast coniferous forest (32'–3,511').	April–June	Absent. No suitable habitat within Study Area.

Table 1. Special-Status Species Evaluated for the Study Area

Common Name (Scientific Name)	Status			Habitat Description ¹	Survey Period	Potential to Occur Onsite
	ESA	CESA	Other			
Four-petaled pussypaws (<i>Calyptridium quadripetalum</i>)	-	-	4.3	Sandy or gravelly soils of chaparral and lower montane coniferous forest; often on serpentinite substrates (1,033'-6,693').	April-June	Absent. No suitable habitat within Study Area.
Mt. Saint Helena morning-glory (<i>Calystegia collina</i> ssp. <i>oxyphylla</i>)	-	-	4.2	Serpentinite substrates of chaparral, lower montane coniferous forest, and valley and foothill grassland (915'-3,314').	April-June	Absent. No suitable habitat within Study Area.
Three-fingered morning-glory (<i>Calystegia collina</i> ssp. <i>tridactylosa</i>)	-	-	1B.2	Rocky, gravelly openings on serpentine substrates of chaparral and cismontane woodland (0'-1,969').	April-June	Absent. No suitable habitat within Study Area.
Northern meadow sedge (<i>Carex praticola</i>)	-	-	2B.2	Mesic meadows and seeps (0'-10,499').	May-July	Absent. No suitable habitat within Study Area.
Pink creamsacs (<i>Castilleja rubicundula</i> var. <i>rubicundula</i>)	-	-	1B.2	Serpentinite substrates in chaparral openings, cismontane woodland, meadows and seeps, and valley and foothill grassland (66'-2,986').	April-June	Absent. No suitable habitat within Study Area.
Rincon Ridge ceanothus (<i>Ceanothus confusus</i>)	-	-	1B.1	Volcanic or serpentine soils in closed-cone coniferous forest, chaparral, and cismontane woodland communities (246'-3,494').	February-June	Absent. No suitable habitat within Study Area.
Calistoga ceanothus (<i>Ceanothus divergens</i>)	-	-	1B.2	Serpentinite or rocky volcanic substrates in chaparral (558'-3,117').	February-April	Absent. No suitable habitat within Study Area.
Dwarf soaproot (<i>Chlorogalum pomeridianum</i> var. <i>minus</i>)	-	-	1B.2	Serpentine soils within chaparral (1,001'-3,281').	May-August	Absent. No suitable habitat within Study Area.
Tracy's clarkia (<i>Clarkia gracilis</i> ssp. <i>tracyi</i>)	-	-	4.2	Openings, usually with serpentine soils, in chaparral (213'-2,132').	April-July	Absent. No suitable habitat within Study Area.
Serpentine collomia (<i>Collomia diversifolia</i>)	-	-	4.3	Rocky or gravelly serpentinite substrates (Safford and Miller 2020) in chaparral and cismontane woodland (656'-1,969').	May-June	Absent. No suitable habitat within Study Area.

Table 1. Special-Status Species Evaluated for the Study Area

Common Name (Scientific Name)	Status			Habitat Description ¹	Survey Period	Potential to Occur Onsite
	ESA	CESA	Other			
Serpentine bird's-beak (<i>Cordylanthus tenuis</i> ssp. <i>brunneus</i>)	-	-	4.3	Usually serpentinite soils of closed-cone coniferous forest, chaparral, and cismontane woodland (1,001'-3,002').	July–August	Low potential to occur. Marginally suitable habitat (woodland) within Study Area
Serpentine cryptantha (<i>Cryptantha dissita</i>)	-	-	1B.2	Serpentine in chaparral (1,295'-1,903').	April–June	Absent. No suitable habitat within Study Area.
Swamp larkspur (<i>Delphinium uliginosum</i>)	-	-	4.2	Serpentinite seeps in chaparral and valley and foothill grassland (1,115'-2,001').	May–June	Absent. No suitable habitat within Study Area.
Cascade downingia (<i>Downingia willamettensis</i>)	-	-	2B.2	Lake margins of cismontane woodland and valley and foothill grassland; vernal pools (49'-3,642').	June–July	Absent. No suitable habitat within Study Area.
Brandegee's eriastrum (<i>Eriastrum brandegeeeae</i>)	-	-	1B.1	Volcanic, sandy substrates of chaparral and cismontane woodland (1,394'-2,756').	April–August	Absent. No suitable habitat within Study Area.
Greene's narrow-leaved daisy (<i>Erigeron greenei</i>)	-	-	1B.2	Serpentine or volcanic soils in chaparral (262'-3,298').	May–September	Absent. No suitable habitat within Study Area.
Snow Mountain buckwheat (<i>Eriogonum nervulosum</i>)	-	-	1B.2	Serpentine chaparral communities (984'-6,906').	June–September	Absent. No suitable habitat within Study Area.
Loch Lomond button-celery (<i>Eryngium constancei</i>)	FE	CE	1B.1	Vernal pools (1,509'-2,805').	April–June	Absent. No suitable habitat within Study Area.
Adobe lily (<i>Fritillaria pluriflora</i>)	-	-	1B.2	Adobe soils in chaparral, cismontane woodland, and valley and foothill grassland (197'-2,313').	February–April	Absent. No suitable habitat within Study Area.
Boggs Lake hedge-hyssop (<i>Gratiola heterosepala</i>)	-	CE	1B.2	Marshes, swamps, lake margins, and vernal pools (33'-7,792').	April–August	Absent. No suitable habitat within Study Area.
Toren's grimmia (<i>Grimmia torenii</i>)	-	-	1B.3	Openings, rocky substrates, boulder and rock walls, carbonate substrates, and volcanic substrates in chaparral, cismontane woodland, and lower montane coniferous forest (1,066'-3,806').	Any season	Absent. No suitable habitat within Study Area.

Table 1. Special-Status Species Evaluated for the Study Area

Common Name (<i>Scientific Name</i>)	Status			Habitat Description ¹	Survey Period	Potential to Occur Onsite
	ESA	CESA	Other			
Hall's harmonia (<i>Harmonia hallii</i>)	–	–	1B.2	Serpentinite substrates of chaparral (1,000'–3,199').	April–June	Absent. No suitable habitat within Study Area.
Congested-headed hayfield tarplant (<i>Hemizonia congesta</i> ssp. <i>congesta</i>)	–	–	1B.2	Valley and foothill grassland; sometimes roadsides (66'–1,837').	April–November	Potential to occur. Suitable habitat within Study Area.
Glandular western flax (<i>Hesperolinon adenophyllum</i>)	–	–	1B.2	Serpentinite soils (Safford and Miller 2020) in chaparral, cismontane woodland, and valley and foothill grassland (492'–4,314').	May–August	Absent. No suitable habitat within Study Area.
Two-carpellate western flax (<i>Hesperolinon bicarpellatum</i>)	–	–	1B.2	Serpentinite soils of chaparral (196'–3,298').	May–July	Absent. No suitable habitat within Study Area.
Lake County western flax (<i>Hesperolinon didymocarpum</i>)	–	CE	1B.2	Serpentinite substrates of chaparral, cismontane woodland, and valley and foothill grassland (1,082'–1,198').	May–July	Absent. No suitable habitat within Study Area.
Sharsmith western flax (<i>Hesperolinon sharsmithiae</i>)	–	–	1B.2	Serpentinite soils of chaparral (885'–985').	May–July	Absent. No suitable habitat within Study Area.
Bolander's horkelia (<i>Horkelia bolanderi</i>)	–	–	1B.2	Within and on edges of vernal mesic areas in chaparral, lower montane coniferous forest, meadows and seeps, and valley and foothill grassland (1,476'–3,938').	June–August	Low potential to occur. Marginally suitable habitat (drainage) within Study Area.
California satintail (<i>Imperata brevifolia</i>)	–	–	2B.1	Mesic areas in chaparral, coastal scrub, Mojavean desert scrub, meadows and seeps (often alkali) and riparian scrub (0'–3,986').	September–May	Absent. No suitable habitat within Study Area.
Burke's goldfields (<i>Lasthenia burkei</i>)	FE	CE	1B.1	Mesic sites within meadows and seeps and vernal pools (49'–1,969').	April–June	Absent. No suitable habitat within Study Area.

Table 1. Special-Status Species Evaluated for the Study Area

Common Name (Scientific Name)	Status			Habitat Description ¹	Survey Period	Potential to Occur Onsite
	ESA	CESA	Other			
Colusa layia (<i>Layia septentrionalis</i>)	-	-	1B.2	Sandy or serpentinite soils in chaparral, cismontane woodland, and valley and foothill grasslands (328'-3,593').	April-May	Low potential to occur. Marginally suitable habitat (woodland and grassland without sandy or serpentinite substrates) within Study Area.
Legenere (<i>Legenere limosa</i>)	-	-	1B.1	Various seasonally inundated areas including wetlands, wetland swales, marshes, vernal pools, artificial ponds, and floodplains of intermittent drainages (USFWS 2005) (3'-2,887').	April-June	Low potential to occur. Marginally suitable habitat (drainage) within Study Area.
Bristly leptosiphon (<i>Leptosiphon acicularis</i>)	-	-	4.2	Chaparral, cismontane woodland, coastal prairie, valley and foothill grassland (180'-4,921').	April-July	Potential to occur. Suitable habitat within Study Area.
Jepson's leptosiphon (<i>Leptosiphon jepsonii</i>)	-	-	1B.2	Usually volcanic soils of chaparral, cismontane woodland, valley and foothill grasslands (328'-1,640').	March-May	Low potential to occur. Marginally suitable habitat (non-volcanic woodland and grassland) within Study Area.
Woolly meadowfoam (<i>Limnanthes floccosa</i> ssp. <i>floccosa</i>)	-	-	4.2	Vernally mesic areas in chaparral, cismontane woodland, valley and foothill grassland, and vernal pools (197'-4,380').	March-May	Low potential to occur. Marginally suitable habitat (drainage) within Study Area.
Napa lomatium (<i>Lomatium repostum</i>)	-	-	4.3	Serpentinite soils of chaparral and cismontane woodland (295'-2,724').	March-June	Absent. No suitable habitat within Study Area.
Anthony Peak lupine (<i>Lupinus antoninus</i>)	-	-	1B.2	Rocky substrates in lower montane and upper montane coniferous forest (4,002'-7,497').	May-July	Absent. No suitable habitat within Study Area.
Cobb Mountain lupine (<i>Lupinus sericatus</i>)	-	-	1B.2	Broadleaf upland forest, chaparral, cismontane woodland, and lower montane coniferous forest (902'-5,004').	May-June	Potential to occur. Suitable habitat within Study Area.

Table 1. Special-Status Species Evaluated for the Study Area

Common Name (<i>Scientific Name</i>)	Status			Habitat Description ¹	Survey Period	Potential to Occur Onsite
	ESA	CESA	Other			
Heller's bush-mallow (<i>Malacothamnus helleri</i>)	-	-	3.3	Sandstone substrates of chaparral and gravelly substrates of riparian woodland (1,000'-2,084').	May-July	Low potential to occur. Marginally suitable habitat (woodland without sandstone or gravelly substrates) within Study Area.
Mt. Diablo cottonweed (<i>Micropus amphibolus</i>)	-	-	3.2	Rocky soils in broad-leaved upland forest, chaparral, cismontane woodland, valley and foothill grassland (148'-2,707').	March-May	Low potential to occur. Marginally suitable habitat (woodland without rocky soils) within Study Area.
Elongate copper moss (<i>Mielichhoferia elongata</i>)	-	-	4.3	Metamorphic rock, usually acidic, usually vernal mesic, often roadsides, sometimes carbonate in broadleaf upland forest, chaparral, cismontane woodland, coastal scrub, lower montane coniferous forest, meadows and seeps, and subalpine coniferous forest (0'-6,430').	Any Season	Absent. No suitable habitat within Study Area.
Little mousetail (<i>Myosurus minimus</i> ssp. <i>apus</i>)	-	-	3.1	Mesic areas (USACE 2020) of valley and foothill grassland and alkaline vernal pools (66'-2,100').	March-June	Low potential to occur. Marginally suitable habitat (drainage) within Study Area.
Cotula navarretia (<i>Navarretia cotulifolia</i>)	-	-	4.2	Adobe soils of chaparral, cismontane woodland, and valley and foothill grassland (13'-6,004').	May-June	Absent. No suitable habitat within Study Area.
Jepson's navarretia (<i>Navarretia jepsonii</i>)	-	-	4.3	Serpentine substrates of chaparral, cismontane woodland, and valley and foothill grassland (574'-2,806').	April-June	Absent. No suitable habitat within Study Area.
Baker's navarretia (<i>Navarretia leucocephala</i> ssp. <i>bakeri</i>)	-	-	1B.1	Vernal pools and mesic areas within cismontane woodlands, lower montane coniferous forests, meadows and seeps, and valley and foothill grasslands (16'-5,709').	April-July	Low potential to occur. Marginally suitable habitat (drainage) within Study Area.

Table 1. Special-Status Species Evaluated for the Study Area

Common Name (<i>Scientific Name</i>)	Status			Habitat Description ¹	Survey Period	Potential to Occur Onsite
	ESA	CESA	Other			
Few-flowered navarretia (<i>Navarretia leucocephala</i> ssp. <i>pauciflora</i>)	FE	CT	1B.1	Volcanic ash flow vernal pools (1,312'–2,805').	May–June	Absent. No suitable habitat within Study Area.
Many-flowered navarretia (<i>Navarretia leucocephala</i> ssp. <i>plieantha</i>)	FE	CE	1B.2	Volcanic ash flow vernal pools (98'–3,117').	May–June	Absent. No suitable habitat within Study Area.
Porter's navarretia (<i>Navarretia paradoxinota</i>)	–	–	1B.3	Vernally mesic openings and drainages on serpentine substrates in meadows and seeps (541'–2,756').	May–June	Absent. No suitable habitat within Study Area.
Slender Orcutt grass (<i>Orcuttia tenuis</i>)	FT	CE	1B.1	Vernal pools, often gravelly (115'–5,774').	May–September	Absent. No suitable habitat within Study Area.
Geysers panicum (<i>Panicum acuminatum</i> var. <i>thermale</i>)	–	CE	1B.2	Geothermally-altered soils and sometimes streamsides of closed-cone coniferous forest, riparian forest, and valley and foothill grassland (1,000'–8,104').	June–August	Absent. No suitable habitat within Study Area.
Lake County stonecrop (<i>Parvisedum leiocarpum</i>)	FE	CE	1B.1	Vernally mesic depressions in volcanic outcrops of cismontane woodland, valley and foothill grassland, and vernal pools (1,197'–2,592').	April–May	Absent. No suitable habitat within Study Area.
Sonoma beardtongue (<i>Penstemon newberryi</i> var. <i>sonomensis</i>)	–	–	1B.3	Rocky substrates of chaparral (2,296'–4,495').	April–August	Absent. No suitable habitat within Study Area.
Michael's rein orchid (<i>Piperia michaelii</i>)	–	–	4.2	Coastal bluff scrub, closed-cone coniferous forest, chaparral, cismontane woodland, coastal scrub, and lower montane coniferous forest (10'–3,002').	April–August	Potential to occur. Suitable habitat within Study Area.
Eel-grass pondweed (<i>Potamogeton zosteriformis</i>)	–	–	2B.2	Assorted freshwater marshes and swamps (0'–6,102').	June–July	Absent. No suitable habitat within Study Area.

Table 1. Special-Status Species Evaluated for the Study Area

Common Name (Scientific Name)	Status			Habitat Description ¹	Survey Period	Potential to Occur Onsite
	ESA	CESA	Other			
Lake County stonecrop (<i>Sedella leiocarpa</i>)	FE	CE	1B.1	Vernally mesic depressions in volcanic outcrops in cismontane woodland, valley and foothill grasslands, and vernal pools (1,198'-2,592').	April–May	Absent. No suitable habitat within Study Area.
Cleveland's ragwort (<i>Senecio clevelandii</i> var. <i>clevelandii</i>)	–	–	4.3	Serpentine seeps of chaparral (1,197'–2,953').	June–July	Absent. No suitable habitat within Study Area.
Marsh checkerbloom (<i>Sidalcea oregana</i> ssp. <i>hydrophila</i>)	–	–	1B.2	Mesic areas of meadows and seeps and riparian forest communities (3,608'–7,545').	July–August	Absent. Study Area is outside of the known elevational range for this species.
Bearded jewelflower (<i>Streptanthus barbiger</i>)	–	–	4.2	Serpentinite substrates of chaparral (492'–3,511').	May–July	Absent. No suitable habitat within Study Area.
Socrates Mine jewelflower (<i>Streptanthus brachiatus</i> ssp. <i>brachiatus</i>)	–	–	1B.2	Closed-cone coniferous forest and chaparral; usually on serpentinite substrates (1,788'–3,281').	May–June	Absent. No suitable habitat within Study Area.
Freed's jewelflower (<i>Streptanthus brachiatus</i> ssp. <i>hoffmanii</i>)	–	–	1B.2	Serpentinite substrates of chaparral and cismontane woodland (1,608'–4,003').	May–July	Absent. No suitable habitat within Study Area.
Hoffman's bristly jewelflower (<i>Streptanthus glandulosus</i> ssp. <i>hoffmanii</i>)	–	–	1B.3	Rocky substrates in chaparral, cismontane woodland, and often serpentinite substrates in valley and foothill grassland (393'–1,592').	March–July	Absent. No suitable habitat within Study Area.
Green jewelflower (<i>Streptanthus hesperidis</i>)	–	–	1B.2	Rocky, serpentinite substrates of chaparral openings and cismontane woodland (426'–2,494').	May–July	Absent. No suitable habitat within Study Area.
Three Peaks jewelflower (<i>Streptanthus morrisonii</i> ssp. <i>elatus</i>)	–	–	1B.2	Serpentinite substrates of chaparral (295'–2,674').	June–September	Absent. No suitable habitat within Study Area.
Kruckeberg's jewel flower (<i>Streptanthus morrisonii</i> ssp. <i>kruckebergii</i>)	–	–	1B.2	Serpentinite substrates of cismontane woodland (705'–3,396').	April–July	Absent. No suitable habitat within Study Area.

Table 1. Special-Status Species Evaluated for the Study Area						
Common Name (Scientific Name)	Status			Habitat Description ¹	Survey Period	Potential to Occur Onsite
	ESA	CESA	Other			
Marsh zigadenus (<i>Toxicoscordion fontanum</i>)	-	-	4.2	Vernally mesic chaparral, cismontane woodland, lower montane coniferous forest, meadows and seeps, and marshes and swamps; often on serpentinite substrates (49'-3,281').	April-July	Low potential to occur. Marginally suitable habitat (drainage) within Study Area.
Napa bluecurls (<i>Trichostema ruygtii</i>)	-	-	1B.2	Chaparral, cismontane woodland, lower montane coniferous forest, valley and foothill grassland, and vernal pools (98'-2,231').	June-October	Potential to occur. Suitable habitat within Study Area.
Saline clover (<i>Trifolium hydrophilum</i>)	-	-	1B.2	Marshes and swamps, vernal pools, and mesic alkaline areas in valley and foothill grassland (0'-984').	April-June	Absent. No suitable habitat within Study Area.
Oval-leaved viburnum (<i>Viburnum ellipticum</i>)	-	-	2B.3	Chaparral, cismontane woodland, and lower montane coniferous forest communities (705'-4,593').	May-June	Potential to occur. Suitable habitat within Study Area.
Fish						
Sacramento perch (<i>Archoplites interruptus</i>)	-	-	SSC	Ponds, rivers, backwaters, and lakes.	N/A	Absent. No suitable habitat within Study Area.
Clear Lake tule perch (<i>Hysterocarpus traskii lagunae</i>)	-	-	SSC	Endemic to Clear Lake, Lower Blue Lake, and Upper Blue Lake in Lake County. Requires cover and are usually found in small shoals in deep tule beds, among rocks, or among branches of fallen leaves (Moyle et al. 2015).	N/A	Absent. No suitable habitat within Study Area.

Table 1. Special-Status Species Evaluated for the Study Area

Common Name (<i>Scientific Name</i>)	Status			Habitat Description ¹	Survey Period	Potential to Occur Onsite
	ESA	CESA	Other			
Clear Lake hitch (<i>Lavinia exilicauda chi</i>)	-	CT	-	Found only in Clear Lake and associated ponds and streams in Lake County. Adults found in the limnetic zone. Juveniles found in the shallow-water habitat hiding in vegetation. Spawning occurs in streams flowing into Clear Lake (CDFW 2021a).	N/A	Absent. No suitable habitat within Study Area. Burns Valley Creek, which is directly adjacent to the Study Area to the west, represents marginally suitable spawning habitat for this species. However, the Study Area does not include Burns Valley Creek and the Project does not propose impacts to the creek or riparian corridor for the creek.
Delta smelt (<i>Hypomesus transpacificus</i>)	FT	CE	-	Sacramento-San Joaquin Delta.	N/A	Absent. Outside of geographic range and no suitable habitat within Study Area.
Steelhead (California Central Coast distinct population segment [DPS]) (<i>Oncorhynchus mykiss</i>)	FT	-	-	Undammed rivers, streams, creeks.	N/A	Absent. No suitable habitat within Study Area.
Amphibians						
Red-bellied newt (<i>Taricha rivularis</i>)	-	-	SSC	Terrestrial habitat. Juveniles generally stay underground, adults active at surface in moist environments. Will migrate over 1 km to breed, typically in streams with moderate flow and clean, rocky substrate. Found in coastal drainages from Humboldt County south to Sonoma County, inland to Lake County with an isolated population in Santa Clara County.	January – April	Absent. Study Area is outside of the known geographical range for this species.

Table 1. Special-Status Species Evaluated for the Study Area

Common Name (<i>Scientific Name</i>)	Status			Habitat Description ¹	Survey Period	Potential to Occur Onsite
	ESA	CESA	Other			
California giant salamander (<i>Dicamptodon ensatus</i>)	-	-	SSC	Aquatic larvae found in cold, clear streams, occasionally in lakes and ponds. Adults known from wet forests under rocks and logs near streams and lakes. Known from wet coastal forests near streams and seeps from Mendocino County south to Monterey County and east to Napa County.	Year round	Absent. No suitable habitat and Study Area is outside of the known geographical range for this species.
Foothill yellow-legged frog (<i>Northwest/North Coast Clade</i>) (<i>Rana boylei</i>)	-	-	SSC	Foothill yellow-legged frogs can be active all year in warmer locations but may become inactive or hibernate in colder climates. At lower elevations, foothill yellow-legged frogs likely spend most of the year in or near streams. Adult frogs, primarily males, will gather along main-stem rivers during spring to breed.	May - October	Absent. No suitable habitat within Study Area.
California red-legged frog (<i>Rana draytonii</i>)	FT	-	SSC	Lowlands or foothills at waters with dense shrubby or emergent riparian vegetation. Adults must have aestivation habitat to endure summer dry down.	May 1 - November 1	Absent. No suitable upland habitat within Study Area and species unlikely to occur in onsite aquatic habitat. There are no known occurrences or potential breeding ponds nearby and the site is within an urban/agricultural setting with a long history of disturbance.

Table 1. Special-Status Species Evaluated for the Study Area

Common Name (Scientific Name)	Status			Habitat Description ¹	Survey Period	Potential to Occur Onsite
	ESA	CESA	Other			
Reptiles						
Northwestern pond turtle (<i>Actinemys marmorata</i>)	-	-	SSC	Requires basking sites and upland habitats up to 0.5 km from water for egg laying. Uses ponds, streams, detention basins, and irrigation ditches.	April-September	Low potential to occur. Marginally suitable upland habitat within Study Area. The site is within an urban/agricultural setting with a long history of disturbance.
Birds						
Clark's grebe (<i>Aechmophorus clarkii</i>)	-	-	BCC	Winters on salt or brackish bays, estuaries, sheltered sea coasts, freshwater lakes, and rivers. Breeds on freshwater to brackish marshes, lakes, reservoirs and ponds, with a preference for large stretches of open water fringed with emergent vegetation.	June-August (breeding)	Absent. No suitable habitat within Study Area.
Yellow-billed cuckoo (<i>Coccyzus americanus</i>)	FT	CE	BCC	Breeds in California, Arizona, Utah, Colorado, and Wyoming. In California, they nest along the upper Sacramento River and the South Fork Kern River from Isabella Reservoir to Canebrake Ecological Reserve. Other known nesting locations include Feather River (Butte, Yuba, Sutter counties), Prado Flood Control Basin (San Bernardino and Riverside counties), Amargosa River and Owens Valley (Inyo County), Santa Clara River (Los Angeles County), Mojave River and Colorado River (San Bernardino County). Nests in riparian woodland. Winters in South America.	June 15-August 15	Absent. Study Area is outside of geographic range for this species.

Table 1. Special-Status Species Evaluated for the Study Area

Common Name (Scientific Name)	Status			Habitat Description ¹	Survey Period	Potential to Occur Onsite
	ESA	CESA	Other			
Osprey (<i>Pandion haliaetus</i>)	-	-	CDFW WL	Nesting habitat requires close proximity to accessible fish, open nest site free of mammalian predators, and extended ice-free season. The nest in large trees, snags, cliffs, transmission/communication towers, artificial nest platforms, channel markers/buoys.	April-September	Absent. No suitable habitat within Study Area.
Golden eagle (<i>Aquila chrysaetos</i>)	-	-	BCC, CFP	Nesting habitat includes mountainous canyon land, rimrock terrain of open desert and grasslands, riparian, oak woodland/savannah, and chaparral. Nesting occurs on cliff ledges, river banks, trees, and human-made structures (e.g., windmills, platforms, and transmission towers). Breeding occurs throughout California, except the immediate coast, Central Valley floor, Salton Sea region, and the Colorado River region, where they can be found during Winter.	Nest (February-August); winter CV (October-February)	Absent. No suitable habitat within Study Area.
Bald eagle (<i>Haliaeetus leucocephalus</i>)	Delisted	CE	CFP, BCC	Typically nests in forested areas near large bodies of water in the northern half of California; nest in trees and rarely on cliffs; wintering habitat includes forest and woodland communities near water bodies (e.g., rivers, lakes), wetlands, flooded agricultural fields, open grasslands	February – September (nesting); October-March (wintering)	Absent. No suitable habitat within Study Area.
Northern spotted owl (<i>Strix occidentalis caurina</i>)	FT	CC	SSC	Found from Marin County through coastal ranges north to British Columbia; breeds in old growth mature forest. They use forests with greater complexity and structure.	March-June	Absent. No suitable habitat within Study Area.

Table 1. Special-Status Species Evaluated for the Study Area

Common Name (<i>Scientific Name</i>)	Status			Habitat Description ¹	Survey Period	Potential to Occur Onsite
	ESA	CESA	Other			
Nuttall's woodpecker (<i>Dryobates nuttalli</i>)	-	-	BCC	Resident from northern California south to Baja California. Nests in tree cavities in oak woodlands and riparian woodlands.	April-July	Potential to occur. Suitable nesting habitat within Study Area. Observed during reconnaissance site visit.
Purple martin (<i>Progne subis</i>)	-	-	SSC	In California, breeds along coast range, Cascade-northern Sierra Nevada region and isolated population in Sacramento. Nesting habitat includes montane forests, Pacific lowlands with dead snags; the isolated Sacramento population nests in weep holes under elevated highways/bridges. Winters in South America.	May-August	Absent. No suitable habitat within Study Area.
Oak titmouse (<i>Baeolophus inornatus</i>)	-	-	BCC	Nests in tree cavities within dry oak or oak-pine woodland and riparian; where oaks aren't absent, they nest in juniper woodland and open forests (gray, Jeffrey, Coulter, pinyon pines and Joshua tree).	March-July	Potential to occur. Suitable nesting habitat within Study Area.
Wrentit (<i>Chamaea fasciata</i>)	-	-	BCC	Coastal sage scrub, northern coastal scrub, chaparral, dense understory of riparian woodlands, riparian scrub, coyote brush and blackberry thickets, and dense thickets in suburban parks and gardens.	March-August	Absent. No suitable habitat within Study Area.

Table 1. Special-Status Species Evaluated for the Study Area

Common Name (<i>Scientific Name</i>)	Status			Habitat Description ¹	Survey Period	Potential to Occur Onsite
	ESA	CESA	Other			
Lawrence's goldfinch (<i>Spinus lawrencei</i>)	-	-	BCC	Breeds in Sierra Nevada and inner Coast Range foothills surrounding the Central Valley and the southern Coast Range to Santa Barbara County east through southern California to the Mojave Desert and Colorado Desert into the Peninsular Range. Nests in arid and open woodlands with chaparral or other brushy areas, tall annual weed fields, and a water source (e.g., small stream, pond, lake), and to a lesser extent riparian woodland, coastal scrub, evergreen forests, pinyon-juniper woodland, planted conifers, and ranches or rural residences near weedy fields and water.	March-September	Potential to occur. Suitable nesting habitat within Study Area.
Song sparrow "Modesto" (<i>Melospiza melodia heermanni</i>)	-	-	BCC, SSC	Resident in central and southwest California, including Central Valley; nests in marsh, scrub habitat.	April-June	Absent. No suitable habitat within Study Area.
Tricolored blackbird (<i>Agelaius tricolor</i>)	-	CT	BCC, SSC	Breeds locally west of Cascade-Sierra Nevada and southeastern deserts from Humboldt and Shasta counties south to San Bernardino, Riverside and San Diego counties. Central California, Sierra Nevada foothills and Central Valley, Siskiyou, Modoc and Lassen counties. Nests colonially in freshwater marsh, blackberry bramble, milk thistle, triticale fields, weedy (mustard, mallow) fields, giant cane, safflower, stinging nettles, tamarisk, riparian scrublands and forests, fiddleneck and fava bean fields.	March-August	Absent. No suitable habitat within Study Area.

Table 1. Special-Status Species Evaluated for the Study Area						
Common Name (<i>Scientific Name</i>)	Status			Habitat Description ¹	Survey Period	Potential to Occur Onsite
	ESA	CESA	Other			
San Clemente spotted towhee (<i>Pipilo maculatus clementae</i>)	-	-	BCC, SSC	Resident on Santa Catalina and Santa Rosa islands; extirpated on San Clemente Island, California. Breeds in dense, broadleaf shrubby brush, thickets, and tangles in chaparral, oak woodland, island woodland, and Bishop pine forest.	Year-round resident; breeding season is April-July	Absent. Study Area is outside of the geographic range for this subspecies.
Saltmarsh common yellowthroat (<i>Geothlypis trichas sinuosa</i>)	-	-	BCC, SSC	Breeds in salt marshes of San Francisco Bay; winters San Francisco south along coast to San Diego County.	March-July	Absent. No suitable habitat within Study Area.
Mammals						
Townsend's big-eared bat (<i>Corynorhinus townsendii</i>)	-	-	SSC	Caves, mines, buildings, rock crevices, trees.	April-September	Potential to occur. Suitable roosting and foraging habitat within Study Area.
Pallid bat (<i>Antrozous pallidus</i>)	-	-	SSC	Crevices in rocky outcrops and cliffs, caves, mines, trees (e.g., basal hollows of redwoods, cavities of oaks, exfoliating pine and oak bark, deciduous trees in riparian areas, and fruit trees in orchards). Also roosts in various human structures such as bridges, barns, porches, bat boxes, and human-occupied as well as vacant buildings (Western Bat Working Group [WBWG] 2021).	April-September	Potential to occur. Suitable roosting and foraging habitat within Study Area.
¹ Habitat descriptions for plant species are from the CNPS Inventory of Rare and Endangered Plants (CNPS 2021), unless otherwise stated.						
Status Codes:						

- FESA Federal Endangered Species Act
- CESA California Endangered Species Act
- FE FESA listed, Endangered.
- FT FESA listed, Threatened.
- BCC USFWS Bird of Conservation Concern
- CE CESA or NPPA listed, Endangered.
- CT CESA- or NPPA-listed, Threatened.
- CC Candidate for CESA listing as Endangered or Threatened.
- CFP California Fish and Game Code Fully Protected Species (§ 3511-birds, § 4700-mammals, §5 050-reptiles/amphibians).
- CDFW WL CDFW Watch List
- SSC CDFW Species of Special Concern (CDFW, updated July 2017).
- 1B CRPR/Rare or Endangered in California and elsewhere.
- 2B Plants rare, threatened, or endangered in California but more common elsewhere.

Common Name (Scientific Name)	Status			Habitat Description ¹	Survey Period	Potential to Occur Onsite
	ESA	CESA	Other			
3	CRPR/Plants About Which More Information is Needed – A Review List.					
4	CRPR/Plants of Limited Distribution – A Watch List.					
0.1	Threat Rank/Seriously threatened in California (over 80% of occurrences threatened / high degree and immediacy of threat)					
0.2	Threat Rank/Moderately threatened in California (20-80% occurrences threatened / moderate degree and immediacy of threat)					
0.3	Threat Rank/Not very threatened in California (<20% of occurrences threatened / low degree and immediacy of threat or no current threats known)					
Delisted	Formally Delisted (delisted species are monitored for 5 years).					

Plants

A total of 83 special-status plant species were identified as having the potential to occur in the vicinity of the Study Area based on the literature review (Table 1). Of those, 62 species were determined to be absent from the Study Area due to the lack of suitable habitat or due to the Study Area being outside of the known elevational range for the species (Table 1). No further discussion of those species is provided in this assessment. A brief description of the remaining 21 species that have the potential to occur within the Study Area is presented below.

Bent-Flowered Fiddleneck

Bent-flowered fiddleneck (*Amsinckia lunaris*) is not listed pursuant to the federal or California ESAs, but is designated as a CRPR 1B.2 species. This species is an herbaceous annual that occurs in cismontane woodland, coastal bluff scrub, and valley and foothill grasslands (CNPS 2021). Bent-flowered fiddleneck blooms from March through June and is known to occur at elevations ranging from 10 to 1,640 feet above MSL (CNPS 2021). This species is endemic to California; its current range includes Alameda, Contra Costa, Colusa, Lake, Marin, Napa, San Benito, Santa Clara, Santa Cruz, San Mateo, Sonoma, Sutter, and Yolo counties (CNPS 2021).

There is one CNDDDB occurrence of bent-flowered fiddleneck within five miles of the Study Area (CDFW 2021a). The oak woodlands and grassland within the Study Area may provide suitable habitat for this species. Bent-flowered fiddleneck has potential to occur within the Study Area.

Coast Rockcress

Coast rockcress (*Arabis blepharophylla*) is not listed pursuant to either the federal or California ESAs, but is designated as a CRPR 4.3 species. This species is an herbaceous perennial that occurs in rocky soils in broadleaf upland forest, coastal bluff scrub, coastal prairie, and coastal scrub (CNPS 2021). Coast rockcress blooms from February through May and is known to occur at elevations ranging from 10 to 3,609 feet above MSL (CNPS 2021). Coast rockcress is endemic to California; its current range includes Contra Costa, Lake, Monterey, Marin, Santa Cruz, San Francisco, San Mateo, and Sonoma counties; however, its presence is uncertain in Santa Cruz County (CNPS 2021).

The CNDDDB does not often publish occurrence records for CRPR 4 species, and there are no published occurrences of coast rockcress. The oak woodlands within the Study Area may provide marginally suitable habitat for this species. Coast rockcress has low potential to occur within the Study Area.

Brewer's Milk-Vetch

Brewer's milk-vetch (*Astragalus breweri*) is not listed pursuant to either the federal or California ESAs, but is designated as a CRPR 4.2 species (CNPS 2021). This species is an herbaceous annual that occurs on volcanic and often serpentinite substrates in chaparral, cismontane woodland, meadows and seeps, and open, often gravelly areas of valley and foothill grassland. Brewer's milk-vetch blooms from April through June and is known to occur at elevations ranging from 295 to 2,395 feet above MSL (CNPS 2021). Brewer's milk-vetch is endemic to California; its current range includes Colusa, Lake, Mendocino, Marin, Napa, Sonoma, and Yolo counties (CNPS 2021).

The CNDDDB does not often publish occurrence records for CRPR 4 species, and there are no published occurrences of Brewer's milk-vetch. The oak woodlands and grassland within the Study Area may provide marginally suitable habitat for this species. Brewer's milk-vetch has low potential to occur within the Study Area.

Jepson's Milk-Vetch

Jepson's milk-vetch (*Astragalus rattanii* var. *jepsonianus*) is not listed pursuant to either the federal or California ESAs, but is designated as a CRPR 1B.2 species. This species is an herbaceous annual that often occurs on serpentinite substrates in chaparral, cismontane woodland, and valley and foothill grassland (CNPS 2021). Jepson's milk-vetch blooms from March through June and is known to occur at elevations ranging from 968 to 2,297 feet above MSL (CNPS 2021). Jepson's milk-vetch is endemic to California; its current range includes Colusa, Glenn, Lake, Mendocino, Napa, San Benito, Sonoma, Tehama, and Yolo counties (CNPS 2021).

There are no CNDDDB occurrences of Jepson's milk-vetch within five miles of the Study Area (CDFW 2021a). However, the grassland within the Study Area may provide marginally suitable habitat for this species. Jepson's milk-vetch has low potential to occur within the Study Area.

Serpentine Bird's-Beak

Serpentine bird's-beak (*Cordylanthus tenuis* ssp. *brunneus*) is not listed pursuant to either the federal or California ESAs, but is designated as a CRPR 4.3 species. This species is a hemiparasitic herbaceous annual that occurs usually in serpentinite soil within closed-cone coniferous forest, chaparral, and cismontane woodland (CNPS 2021). Serpentine bird's-beak blooms from July through August and is known to occur at elevations ranging from 1,001 to 3,002 feet above MSL (CNPS 2021). Serpentine bird's-beak is endemic to California; its current range includes Lake, Napa, and Sonoma counties (CNPS 2021).

There are no CNDDDB occurrences of serpentine bird's-beak within five miles of the Study Area (CDFW 2021a). However, the oak woodlands within the Study Area may provide marginally suitable habitat for this species. Serpentine bird's-beak has low potential to occur within the Study Area.

Congested-Headed Hayfield Tarplant

Congested-headed hayfield tarplant (*Hemizonia congesta* ssp. *congesta*) is not listed pursuant to either the federal or California ESAs, but is designated as a CRPR 1B.2 species. This species is an annual herb that occurs in valley and foothill grassland and sometimes roadsides (CNPS 2021). Congested-headed hayfield tarplant blooms from April through November and is known to occur at elevations ranging from 66 to 1,837 feet above MSL (CNPS 2021). Congested-headed hayfield tarplant is endemic to California; the current range of this species includes Lake, Mendocino, Marin, San Francisco, San Mateo, and Sonoma counties (CNPS 2021).

There are no CNDDDB occurrences of congested-headed hayfield tarplant within five miles of the Study Area (CDFW 2021a). However, the developed/disturbed areas and grassland within the Study Area may provide suitable habitat for this species. Congested-headed hayfield tarplant has potential to occur within the Study Area.

Bolander's Horkelia

Bolander's horkelia (*Horkelia bolanderi*) is not listed pursuant to either the federal or California ESAs, but is designated as a CRPR 1B.2 species. This species is an herbaceous perennial that occurs in and on edges of vernal mesic areas in chaparral, lower montane coniferous forest, meadows and seeps, and valley and foothill grassland (CNPS 2021). Bolander's horkelia blooms from June through August and is known to occur at elevations ranging from 1,476 to 3,938 feet above MSL (CNPS 2021). Bolander's horkelia is endemic to California; its current range includes Colusa, Lake, and Mendocino counties; however, it is presumed extirpated in Colusa County (CNPS 2021).

There are four CNDDDB occurrences of Bolander's horkelia within five miles of the Study Area (CDFW 2021a). The drainage corridor within the Study Area may provide marginally suitable habitat for this species. Bolander's horkelia has low potential to occur within the Study Area.

Colusa Layia

Colusa layia (*Layia septentrionalis*) is not listed pursuant to either the federal or California ESAs, but is designated as a CRPR 1B.2 species. This species is an herbaceous annual that occurs in sandy or serpentinite soils in chaparral, cismontane woodland, and valley and foothill grasslands (CNPS 2021). Colusa layia blooms from April through May and is known to occur at elevations ranging from 328 to 3,593 feet above MSL (CNPS 2021). Colusa layia is endemic to California; the current range of this species includes Butte, Colusa, Glenn, Lake, Mendocino, Napa, Sonoma, Sutter, Tehama, and Yolo counties (CNPS 2021).

There is one CNDDDB occurrence of Colusa layia within five miles of the Study Area (CDFW 2021a). The woodland and grassland within the Study Area may provide marginally suitable habitat for this species. Colusa layia has low potential to occur within the Study Area.

Legenere

Legenere (*Legenere limosa*) is not listed pursuant to either the federal or California ESAs, but is designated as a CRPR 1B.1 species (CNPS 2021). This species is an herbaceous annual that occurs in a variety of

seasonally inundated environments including wetlands, wetland swales, marshes, vernal pools, artificial ponds, and floodplains of intermittent drainages (USFWS 2005). *Legenere* blooms from April through June and is known to occur at elevations ranging from three feet to 2,887 feet above MSL (CNPS 2021). *Legenere* is endemic to California; the current range of this species includes Alameda, Lake, Monterey, Napa, Placer, Sacramento, Santa Clara, San Joaquin, Shasta, San Mateo, Solano, Sonoma, Stanislaus, Tehama, and Yuba counties; is believed to be extirpated from Stanislaus County (CNPS 2021).

There are no CNDDDB occurrences of *legenere* within five miles of the Study Area (CDFW 2021a). However, the drainage corridor within the Study Area may provide marginally suitable habitat for this species. *Legenere* has low potential to occur within the Study Area.

Bristly Leptosiphon

Bristly leptosiphon (*Leptosiphon acicularis*) is not listed pursuant to either the federal or California ESAs, but is designated as a CRPR 4.2 species. This species is an annual herb that occurs in chaparral, cismontane woodland, coastal prairie, and valley and foothill grassland (CNPS 2021). Bristly leptosiphon blooms from April through July and is known to occur at elevations ranging from 180 to 4,921 feet above MSL (CNPS 2021). Bristly leptosiphon is endemic to California; the current range of this species includes Alameda, Butte, Contra Costa (distribution and presence is uncertain), Fresno, Humboldt, Lake, Mendocino, Marin, Napa, Santa Clara, San Mateo, and Sonoma counties (CNPS 2021).

There are no CNDDDB occurrences of bristly leptosiphon within five miles of the Study Area (CDFW 2021a). However, the oak woodlands and grassland within the Study Area may provide suitable habitat for this species. Bristly leptosiphon has potential to occur within the Study Area.

Jepson's Leptosiphon

Jepson's leptosiphon (*Leptosiphon jepsonii*) is not listed pursuant to either the federal or California ESAs, but is designated as a CRPR 1B.2 species. This species is an annual herb that usually occurs in volcanic soils of chaparral, cismontane woodland, and valley and foothill grasslands (CNPS 2021). Jepson's leptosiphon blooms from March through May and is known to occur at elevations ranging from 328 to 1,640 feet above MSL (CNPS 2021). Jepson's leptosiphon is endemic to California; the current range of this species includes Lake, Napa, Sonoma, and Yolo counties (CNPS 2021).

There are no CNDDDB occurrences of Jepson's leptosiphon within five miles of the Study Area (CDFW 2021a). However, the oak woodlands and grassland within the Study Area may provide marginally suitable habitat for this species. Jepson's leptosiphon has low potential to occur within the Study Area.

Woolly Meadowfoam

Woolly meadowfoam (*Limnanthes floccosa* ssp. *floccosa*) is not listed pursuant to either the federal or California ESAs, but is designated as a CRPR 4.2 species. This species is an herbaceous annual that occurs in vernal mesic chaparral, cismontane woodland, valley and foothill grassland, and vernal pools (CNPS 2021). Woolly meadowfoam blooms from March through May and is known to occur at elevations ranging from 196 to 4,380 feet above MSL (CNPS 2021). The current known range for this species in California includes Butte, Lake, Lassen, Napa, Shasta, Siskiyou, Tehama, and Trinity counties (CNPS 2021).

There are no CNDDDB occurrences of woolly meadowfoam within five miles of the Study Area (CDFW 2021a). However, the drainage corridor within the Study Area may provide marginally suitable habitat for this species. Woolly meadowfoam has low potential to occur within the Study Area.

Cobb Mountain Lupine

Cobb Mountain lupine (*Lupinus sericatus*) is not listed pursuant to either the federal or California ESAs, but is designated as a CRPR 1B.2 species. This species is an herbaceous perennial that occurs in broadleaved upland forest, chaparral, cismontane woodland, and lower montane coniferous forest (CNPS 2021). Cobb Mountain lupine blooms from March through June and is known to occur at elevations ranging from 902 to 5,004 feet above MSL (CNPS 2021). Cobb Mountain lupine is endemic to California; its current range includes Colusa, Lake, Napa, and Sonoma counties (CNPS 2021).

There are no CNDDDB occurrences of Cobb Mountain lupine within five miles of the Study Area (CDFW 2021a). However, the oak woodland within the Study Area may provide marginally suitable habitat for this species. Cobb Mountain lupine has low potential to occur within the Study Area.

Heller's Bush-Mallow

Heller's bush-mallow (*Malacothamnus helleri*) is not listed pursuant to either the federal or California ESAs, but is designated as a CRPR 3.3 species. This species is a perennial deciduous shrub that occurs in sandstone substrates in chaparral and gravel substrates of riparian woodland (CNPS 2021). Heller's bush-mallow blooms from May through July and is known to occur at elevations ranging from 1,000 to 2,084 feet above MSL (CNPS 2021). Heller's bush-mallow is endemic to California; its current range includes Colusa, Glenn, Lake, Napa, Tehama, and Yolo counties; however, its distribution or identity is uncertain in Glenn County (CNPS 2021).

There are no CNDDDB occurrences of Heller's bush-mallow within five miles of the Study Area (CDFW 2021a). However, the oak woodland within the Study Area may provide marginally suitable habitat for this species. Heller's bush-mallow has low potential to occur within the Study Area.

Mt. Diablo Cottonweed

Mt. Diablo cottonweed (*Micropus amphibolus*) is not listed pursuant to either the federal or California ESAs, but is designated as a CRPR 3.2 species. This species is an herbaceous annual that occurs in rocky soils in broadleaved upland forest, chaparral, cismontane woodland, and valley and foothill grassland (CNPS 2021). Mt. Diablo cottonweed blooms from March through May and is known to occur at elevations ranging from 148 to 2,707 feet above MSL (CNPS 2021). Mt. Diablo cottonweed is endemic to California; the current range of this species includes Alameda, Contra Costa, Colusa, Lake, Monterey, Marin, Napa, Santa Barbara, Santa Clara, Santa Cruz, San Joaquin, Solano, and Sonoma counties (CNPS 2021).

The CNDDDB does not often publish occurrence records for CRPR 3 species, and there are no published occurrences of Mt. Diablo cottonweed. The oak woodlands and grassland within the Study Area may provide marginally suitable habitat for this species. Mt. Diablo cottonweed has low potential to occur within the Study Area.

Little Mouseltail

Little mouseltail (*Myosurus minimus* ssp. *apus*) is not listed pursuant to either the federal or California ESAs, but is designated as a CRPR 3.1 species. This species is an herbaceous annual that occurs in mesic areas (USACE 2020) of valley and foothill grassland and alkaline vernal pools (CNPS 2021). Little mouseltail blooms between March and June and is known to occur at elevations ranging from 66 to 2,100 feet above MSL (CNPS 2021). The current range for little mouseltail in California includes Alameda, Contra Costa, Colusa, Lake, Merced, Riverside, San Bernardino, San Diego, Solano, Tulare, and Yolo counties (CNPS 2021).

There are no CNDDDB occurrences of little mouseltail within five miles of the Study Area (CDFW 2021a). However, the drainage corridor within the Study Area may provide marginally suitable habitat for this species. Little mouseltail has low potential to occur within the Study Area.

Baker's Navarretia

Baker's navarretia (*Navarretia leucocephala* ssp. *bakeri*) is not listed pursuant to either the federal or California ESAs, but is designated as a CRPR 1B.1 species. This species is an herbaceous annual that occurs in vernal pools and mesic areas within cismontane woodlands, lower montane coniferous forests, meadows and seeps, and valley and foothill grasslands (CNPS 2021). Baker's navarretia blooms from April through July and is known to occur at elevations ranging from 16 to 5,709 feet above MSL (CNPS 2021). Baker's navarretia is endemic to California; the current range of this species includes Colusa, Glenn, Lake, Lassen, Mendocino, Marin, Napa, Solano, Sonoma, Sutter, Tehama, and Yolo counties (CNPS 2021).

There are three CNDDDB occurrences of Baker's navarretia within five miles of the Study Area (CDFW 2021a). The drainage corridor within the Study Area may provide marginally suitable habitat for this species. Baker's navarretia has low potential to occur within the Study Area.

Michael's Rein Orchid

Michael's rein orchid (*Piperia michaelii*) is not listed pursuant to either the federal or California ESAs, but is designated as a CRPR 4.2 species. This species is an herbaceous perennial that occurs in coastal bluff scrub, closed-cone coniferous forest, chaparral, cismontane woodland, coastal scrub, and lower montane coniferous forest (CNPS 2021). Michael's rein orchid blooms from April through August and is known to occur at elevations ranging from 10 to 3,002 feet above MSL (CNPS 2021). Michael's rein orchid is endemic to California; its current range includes Alameda, Amador, Butte, Contra Costa, Fresno, Humboldt, Los Angeles Monterey, Marin, Santa Barbara, San Benito, Santa Clara, Santa Cruz, Santa Cruz Island, San Francisco, San Luis Obispo, San Mateo, Stanislaus, Tulare, Tuolumne, Ventura, and Yuba counties. It is presumed extirpated in Los Angeles County, and distribution is uncertain, but presumed extirpated if once present in Ventura County (CNPS 2021).

The CNDDDB does not often publish occurrence records for CRPR 4 species, and there are no published occurrences of Michael's rein orchid. The oak woodlands within the Study Area may provide suitable habitat for this species. Michael's rein orchid has potential to occur within the Study Area.

Marsh Zigadenus

Marsh zigadenus (*Toxicoscordion fontanum*) is not listed pursuant to either the federal or California ESAs, but is designated as a CRPR 4.2 species. This species is an herbaceous bulbiferous perennial that occurs in vernal mesic and often on serpentinite substrates in chaparral, cismontane woodland, lower montane coniferous forest, meadows and seeps, and marshes and swamps (CNPS 2021). Marsh zigadenus is known to occur at elevations ranging from 49 to 3,281 feet above MSL (CNPS 2021). Marsh zigadenus is endemic to California; its current range includes Lake, Mendocino, Monterey, Marin, Napa, San Benito, Santa Cruz, San Luis Obispo, San Mateo, and Sonoma counties (CNPS 2021).

The CNDDDB does not often publish occurrence records for CRPR 4 species, and there are no published occurrences of marsh zigadenus. The drainage corridor within the Study Area may provide marginally suitable habitat for this species. Marsh zigadenus has low potential to occur within the Study Area.

Napa Bluecurls

Napa bluecurls (*Trichostema ruygtii*) is not listed pursuant to either the federal or California ESAs, but is designated as a CRPR 1B.2 species. This species is an herbaceous annual that occurs in chaparral, cismontane woodland, lower montane coniferous forest, valley and foothill grassland, and vernal pools (CNPS 2021). Napa bluecurls blooms from June through October and is known to occur at elevations ranging from 98 to 2,231 feet above MSL (CNPS 2021). Napa bluecurls is endemic to California; the current range of this species includes Lake, Napa, and Solano counties; however, it is possibly extirpated from Lake County (CNPS 2021).

There are no CNDDDB occurrences of Napa bluecurls within five miles of the Study Area (CDFW 2021a). However, the oaks woodlands and grasslands within the Study Area may provide suitable habitat for this species. Napa bluecurls has potential to occur within the Study Area.

Oval-Leaved Viburnum

Oval-leaved viburnum (*Viburnum ellipticum*) is not listed pursuant to either the federal or California ESAs, but is designated as a CRPR 2B.3 species. This species is a perennial deciduous shrub that occurs in chaparral, cismontane woodland, and lower montane coniferous forest communities. Oval-leaved viburnum blooms from May through June and is known to occur at elevations ranging from 705 to 4,593 feet above MSL (CNPS 2021). The current range of this species in California includes Alameda, Contra Costa, El Dorado, Fresno, Glenn, Humboldt, Lake, Mendocino, Mariposa, Napa, Placer, Shasta, Solano, Sonoma, and Tehama counties (CNPS 2021).

There is one CNDDDB occurrence of oval-leaved viburnum within five miles of the Study Area (CDFW 2021a). The oak woodlands and grassland within the Study Area may provide suitable habitat for this species. Oval-leaved viburnum has potential to occur within the Study Area.

4.2.1 Fish

Five special-status fish species were identified as having potential to occur in the vicinity of the Study Area based on the literature review (Table 1). However, upon further analysis and after the site visit, all five

species were considered to be absent from the Study Area due to the lack of suitable habitat and/or because the Study Area is outside of the known geographic range for these species. No further discussion of these species is provided within this assessment.

4.2.2 Amphibians

Four special-status amphibian species were identified as having potential to occur in the vicinity of the Study Area based on the literature review (Table 1). However, upon further analysis and after the site visit, all four species were considered to be absent from the Study Area due to the lack of suitable habitat and/or because the Study Area is outside of the known geographic range for these species. No further discussion of these species is provided within this assessment.

4.2.3 Reptiles

One special-status reptile species, northwestern pond turtle (*Actinemys marmorata*), was identified as having potential to occur in the vicinity of the Study Area based on the literature review (Table 1). Upon further analysis and after the reconnaissance site visit, Northwestern pond turtle was identified to have potential to occur in the Study Area. A brief description of this species is presented below.

Northwestern Pond Turtle

The northwestern pond turtle is not listed pursuant to either the federal or California ESAs; however, it is designated as a CDFW SSC. Northwestern pond turtles occur in a variety of fresh and brackish water habitats including marshes, lakes, ponds, and slow-moving streams (Jennings and Hayes 1994). This species is primarily aquatic; however, they typically leave aquatic habitats in the fall to reproduce and to overwinter (Jennings and Hayes 1994). Deep, still water with abundant emergent woody debris, overhanging vegetation, and rock outcrops is optimal for basking and thermoregulation. Although adults are habitat generalists, hatchlings and juveniles and hatchlings require shallow edgewater with relatively dense submergent or short emergent vegetation in which to forage. Northwestern pond turtles are typically active between March and November. Mating generally occurs during late April and early May and eggs are deposited between late April and early August (Jennings and Hayes 1994). Eggs are deposited within excavated nests in upland areas, with substrates that typically have high clay or silt fractions (Jennings and Hayes 1994). The majority of nesting sites are located within 650 feet (200 meters) of aquatic sites; however, nests have been documented as far as 1,310 feet (400 meters) from aquatic habitat.

There are no CNDDDB occurrences of northwestern pond turtle within five miles of the Study Area (CDFW 2021a). However, the Study Area may provide marginally suitable upland habitat for this species. Habitat suitability is likely diminished by the long history of disturbance to the aquatic features and uplands within and adjacent to the Study Area, the urban/agricultural setting, and the frequency of public use of the site. Northwestern pond turtle has low potential to occur within the Study Area.

4.2.4 Birds

A total of 15 special-status bird species were identified as having the potential to occur within the Study Area based on the literature review (Table 1). Of those, 12 species were determined to be absent from the Study Area due to the lack of suitable habitat and/or due to the Study Area being outside of the known geographic range of the species. No further discussion of those species is provided in this assessment. A brief description of the remaining three species that have the potential to occur within the Study Area is presented below.

Nuttall's Woodpecker

The Nuttall's woodpecker (*Dryobates nuttallii*) is not listed pursuant to either the federal or California ESAs but is designated as a USFWS BCC. They are resident from Siskiyou County south to Baja California. Nuttall's woodpeckers nest in tree cavities primarily within oak woodlands, but also can be found in riparian woodlands (Lowther et al. 2020). Breeding occurs during April through July.

The CNDDDB does not track Nuttall's woodpecker. Nuttall's woodpecker was observed foraging within the oak woodland in the Study Area during the site reconnaissance. The trees in the oak woodlands within and adjacent to the Study Area may also provide suitable nesting habitat for this species. Nuttall's woodpecker has potential to nest onsite.

Oak Titmouse

Oak titmouse (*Baeolophus inornatus*) is not listed pursuant to either the federal or California ESAs but is designated as a USFWS BCC. Oak titmouse breeding range includes southwestern Oregon south through California's Coast, Transverse and Peninsular ranges, western foothills of the Sierra Nevada, into Baja California; they are absent from the humid northwestern coastal region and the San Joaquin Valley (Cicero et al. 2020). They are found in dry oak or oak-pine woodlands but may also use scrub oaks or other brush near woodlands (Cicero et al. 2020). Nesting occurs during March through July.

The CNDDDB does not track oak titmouse. The trees and brush in and near the oak woodlands within and adjacent to the Study Area may provide suitable nesting and foraging habitat for this species. Oak titmouse has potential to nest onsite.

Lawrence's Goldfinch

The Lawrence's goldfinch (*Spinus lawrencei*) is not listed pursuant to either the federal or California ESAs but is designated as a USFWS BCC. Lawrence's goldfinch breed west of the Sierra Nevada-Cascade axis from Tehama, Shasta, and Trinity counties south into the foothills surrounding the Central Valley to Kern County; and on the Coast Range from Contra Costa County to Santa Barbara County (Watt et al. 2020). Lawrence's goldfinch nest in arid woodlands usually with brushy areas, tall annual weeds and a local water source (Watt et al. 2020). Nesting occurs during March through September.

There are no CNDDDB occurrences of Lawrence's goldfinch within five miles of the Study Area (CDFW 2021a). However, the trees and other vegetation within and adjacent to the Study Area may provide suitable nesting and foraging habitat for this species. Lawrence's goldfinch has potential to nest onsite.

Other Protected Birds

In addition to the above-listed special-status birds, all native or naturally occurring birds and their occupied nests/eggs are protected under the California Fish and Game Code and the MBTA. The Study Area supports potential nesting habitat for a variety of native birds protected under these regulations.

4.2.5 Mammals

Two special-status mammal species were identified as having potential to occur in the vicinity of the Study Area based on the literature review (Table 1). Upon further analysis and after the reconnaissance site visit, both species were identified to have potential to occur in the Study Area as described below. A brief description of both species is presented in the following sections.

Townsend's Big-Eared Bat

The Townsend's big-eared bat (*Corynorhinus townsendii*) is not listed pursuant to either the California or federal ESAs; however, this species is considered an SSC by CDFW. Townsend's big-eared bat is a fairly large bat with prominent bilateral nose lumps and large "rabbit-like" ears. This species occurs throughout the west and ranges from the southern portion of British Columbia south along the Pacific coast to central Mexico and east into the Great Plains. This species has been reported from a wide variety of habitat types and elevations from sea level to 10,827 feet. Habitats include coniferous forests, mixed meso-phytic forests, deserts, native prairies, riparian communities, active agricultural areas, and coastal habitat types. Its distribution is strongly associated with the availability of caves and cave-like roosting habitat including abandoned mines, buildings, bridges, rock crevices, and hollow trees. Townsend's big-eared bat primarily forages on moths. Foraging habitat is generally edge habitats along streams adjacent to and within a variety of wooded habitats. This species often travels long distances when foraging and large home ranges have been documented in California (WBWG 2021).

There are two CNDDDB occurrences of Townsend's big-eared bat within five miles of the Study Area (CDFW 2021a). The structures and trees within the Study Area may provide suitable roosting habitat and the entire Study Area may provide suitable foraging habitat for this species. Townsend's big-eared bat has potential to occur within the Study Area.

Pallid Bat

The pallid bat (*Antrozous pallidus*) is not listed pursuant to either the California or federal ESAs; however, this species is considered an SSC by CDFW. The pallid bat is a large, light-colored bat with long, prominent ears and pink, brown, or grey wing and tail membranes. This species ranges throughout North America from the interior of British Columbia, south to Mexico, and east to Texas. The pallid bat inhabits low elevation (below 6,000 feet) rocky arid deserts and canyonlands, shrub-steppe grasslands, karst formations, and higher elevation coniferous forest (above 7,000 feet). This species roosts alone or in groups in the crevices of rocky outcrops and cliffs, caves, mines, trees, and in various human structures such as bridges and barns. Pallid bats are feeding generalists that glean a variety of arthropod prey from surfaces as well as capturing insects on the wing. Foraging occurs over grasslands, oak savannahs,

ponderosa pine forests, talus slopes, gravel roads, lava flows, fruit orchards, and vineyards. This species is not thought to migrate long distances between summer and winter sites (WBWG 2021).

There is one CNDDDB occurrence of pallid bat within five miles of the Study Area (CDFW 2021a). The structures and trees within the Study Area may provide suitable roosting habitat and the entire Study Area may provide suitable foraging habitat for this species. Pallid bat has potential to occur within the Study Area.

4.3 Critical Habitat and Essential Fish Habitat

There are no Critical Habitats mapped within the Study Area (USFWS 2021b). The Study Area is not EFH (NOAA 2021a).

4.4 Riparian Habitats and Sensitive Natural Communities

Riparian habitats are present within the Study Area. Two narrow strips of valley oak woodland and a small patch of Fremont cottonwood are located along the riparian corridors for the onsite drainage and for Burns Valley Creek which is adjacent to the Study Area to the west (See Section 4.1.3 and Figure 3). Only a portion of the valley oak woodland depicted on Figure 3 is considered to be riparian habitat.

The valley oak woodland is representative of the Valley Oak Forest and Woodland Alliance, a sensitive natural community with a state rarity rank of S3. The patch of Fremont cottonwood within the Study Area is too limited in extent to be considered a stand or a separate vegetation community and is not representative of a sensitive alliance.

Four other sensitive natural communities were identified as having potential to occur within the vicinity of the Study Area based on the literature review (CDFW 2021a). These include Coastal and Valley Freshwater Marsh, Great Valley Cottonwood Riparian Forest, Northern Basalt Flow Vernal Pool, and Northern Volcanic Ash Vernal Pool. Upon further analysis and site reconnaissance, these four sensitive natural communities were determined to be absent from the Study Area.

4.5 Wildlife Movement/Corridors and Nursery Sites

The Study Area is subject to disturbance from the presence of people, has a history of disturbance due to agricultural use, and is surrounded entirely by either agricultural, commercial, or residential development. The Study Area does not fall within an Essential Habitat Connectivity area mapped by the CDFW and is not identified as a critical and non-critical winter and summer range, fall holding areas, fawning grounds, or migration corridors for mule deer (*Odocoileus hemionus*) (CDFW 2021b). Therefore, the Study Area is not expected to support critical wildlife movement corridors or potential nursery sites. However, a variety of common bird species were observed within the Study Area during the site reconnaissance and other wildlife species also likely move through the Study Area.

For the purposes of this analysis, nursery sites include but are not limited to concentrations of nest or den sites such as heron rookeries or bat maternity roosts. This data is available through CDFW's Biogeographic Information and Observation System (BIOS) database or as occurrence records in the CNDDDB and is

supplemented with the results of the site reconnaissance. No nursery sites have been documented within the Study Area (CDFW 2021a) and none were observed during the site reconnaissance.

5.0 IMPACT ANALYSIS

This section specifically addresses the questions raised by the CEQA - Appendix G Environmental Checklist Form, IV. Biological Resources. This impact analysis assumes the Project will implement measures that fulfill the intent of recommended measures described in Section 6.0.

5.1 Special Status Species

Would the Project result in effects, either directly or through habitat modifications, to species identified as a candidate, sensitive, or special-status species in local or regional plans, policies, or regulations, or by the CDFW or USFWS?

No special-status species are known to occur within the Study Area; however, plant and wildlife surveys have not been conducted. The Study Area includes potential habitat for special-status species within the impact area. Potential effects to special-status species are summarized in the following sections by taxonomic group or species.

5.1.1 Special-Status Plants

There is no potential habitat for federally or State-listed plant species in the Study Area, but there is potential or low potential for 21 non-listed special-status plant species to occur. Project development would permanently remove or alter a minimal amount of marginally suitable or suitable potential habitat for special-status plants, and in the unlikely chance that special-status plant populations occur onsite they may be directly or indirectly impacted by development.

Implementation of recommendations BIO2, PLANT1, and PLANT2 described in Section 6.0 would avoid, minimize, and/or compensate for potential effects to special-status plants. With implementation of these measures, the Project is not expected to significantly impact special-status plants.

5.1.2 Northwestern Pond Turtles

Northwestern pond turtles have low potential to occur within the Study Area due to the historic degradation of the aquatic features near the project, the urban/agricultural setting, and the extent of disturbance and public use. Should Northwestern pond turtles utilize the site and/or be present onsite before and during construction, a minimal amount of marginal potential upland habitat would be permanently removed or altered, and turtles may be temporarily displaced from upland habitats during construction. Removal or alteration of marginal habitat and displacement of turtles which may incidentally occur during construction is not expected to significantly impact Northwestern pond turtles.

Implementation of recommendations BIO1, BIO2, and NPT1 described in Section 6.0 would avoid or minimize potential effects to Northwestern pond turtles.

5.1.3 *Special-Status and Other Protected Birds*

There is no potential habitat for federally or State-listed bird species in the Study Area, but there is potential for three non-listed special-status bird species and a variety of other birds that are protected under the MBTA and the California Fish and Game Code. Project development would permanently remove or alter a minimal amount of nesting and foraging habitat in the development area, and Project construction would generate a temporary disturbance that would likely displace foraging birds from the Study Area during construction. Permanent removal or alteration of a minimal amount of habitat and displacement of foraging birds during construction is not expected to significantly impact special-status birds.

Implementation of recommendations BIO2 and BIRD1 described in Section 6.0 would avoid or minimize potential effects to special-status birds and other protected birds.

5.1.4 *Special-Status Mammals*

Two special-status bats have potential to occur in the Study Area. Removal of trees and structures may directly impact roosting habitat. Project development would permanently remove a minimal amount of potential roosting and foraging habitat in the development area, and Project construction would generate a temporary disturbance during the day that would likely displace day-roosting bats from the Study Area. Permanent removal of a minimal amount of potential roosting or foraging habitat and displacement of day-roosting bats during construction is not expected to significantly impact special-status bats.

Implementation of recommendations BIO2 and BAT1 described in Section 6.0 would avoid and/or minimize potential effects to special-status bats.

5.2 Riparian Habitat and Sensitive Natural Communities

Would the Project have a substantial adverse effect on any riparian habitat or other sensitive natural community identified in local or regional plans, policies, regulations or by the California Department of Fish and Game or US Fish and Wildlife Service?

The Study Area supports a small amount of valley oak woodland, which may be considered a sensitive natural community. Portions of the valley oak woodland and a patch of Fremont cottonwood located riparian along the Burns Valley Creek and the unnamed drainage represent riparian habitat (Figure 3). The Project does not propose impacts to riparian habitat or valley oak woodland that is adjacent to Burns Valley Creek.

The Project is located within an urban and agricultural area, and the valley oak woodland that is not associated with Burns Valley Creek is a small patch on the edge of a complex of scattered oak woodland patches that are remnant of historical clearing for development of the surrounding areas. Impacts to this small patch of remnant valley oak woodland within the Study Area is not expected to be a significant impact to the sensitive natural community.

The Project may directly or indirectly impact riparian habitat and valley oak woodland along the unnamed drainage due to removal for development or due to alteration of hydrology.

Implementation of recommendations BIO2, RIP1, RIP2, and TREE1 as described in Section 6.0 would avoid, minimize, and/or compensate for potential effects to riparian habitat and individual oak trees.

5.3 Aquatic Resources, Including Waters the U.S. and State

Would the Project have a substantial adverse effect on federally protected wetlands as defined by Section 404 of the Clean Water Act CWA (including, but not limited to, marsh, vernal pool, coastal, etc.) through direct removal, filling, hydrological interruption, or other means?

Based on the preliminary aquatic resources assessment, the Project would have no direct impact on federally protected wetlands; however, the drainage channel within the Study Area may be considered a Water of the U.S. and/or State. Project implementation may result in fill of this drainage within the development area.

The Project is adjacent to Burns Valley Creek, which may also be considered a Water of the U.S. and State. The Project does not propose impacts Burns Valley Creek.

Implementation of recommendations WATER1 through WATER5 described in Section 6.0 would avoid, minimize, and/or compensate for potential effects to Waters of the U.S. and State.

5.4 Wildlife Movement/Corridors

Would the Project interfere substantially with the movement of any native resident or migratory fish or wildlife species or with established native resident or migratory wildlife corridors, or impede the use of native wildlife nursery sites?

The Study Area provides limited migratory opportunities for terrestrial wildlife. Project construction is likely to temporarily disturb and displace most wildlife from the Study Area. Some wildlife such as birds or nocturnal species are likely to continue to use the habitats opportunistically for the duration of construction. Once construction is complete, wildlife movements are expected to resume but will likely be more limited through the developed areas of the Study Area. The Project is not expected to substantially interfere with wildlife movement.

There are no documented nursery sites and no nursery sites were observed within the Study Area during the site reconnaissance. Therefore, the Project is not expected to impact wildlife nursery sites.

5.5 Local Policies, Ordinances, and Other Plans

Does the Project conflict with any local policies or ordinances protecting biological resources, such as a tree preservation policy or ordinance?

The Project may impact trees protected under the City's Tree Ordinance. Implementation of recommendations BIO2 and TREE1 would prevent conflicts with the local tree ordinance.

Does the Project conflict with the provisions of an adopted Habitat Conservation Plan, Natural Community Conservation Plan, or other approved local, regional, or state habitat conservation plan?

The Study Area is not covered by any local, regional, or State conservation plan. Therefore, the Project would not conflict with a local, regional, or State conservation plan.

6.0 RECOMMENDATIONS

This section summarizes recommended measures to avoid, minimize, or compensate for potential impacts to biological resources from the proposed Project.

6.1 General Recommendations

The following general measures are recommended to avoid impacts to offsite and onsite biological resources:

- **BIO1:** The project should implement erosion control measures and BMPs to reduce the potential for sediment or pollutants at the Project site. Examples of appropriate measures are included below.
 - Avoided aquatic resources (including Burns Valley Creek) should be clearly demarcated prior to construction. Avoidance buffers should be consistent with the City of Clearlake requirements and/or requirements of regulatory permits. Erosion control measures should be placed between avoided aquatic resources and the outer edge of the impact limits prior to commencement of construction activities. Such identification and erosion control measures should be properly maintained until construction is completed and the soils have been stabilized.
 - Any fueling in the Study Area should use appropriate secondary containment techniques to prevent spills.
- **BIO2:** A qualified biologist should conduct a mandatory Worker Environmental Awareness Program for all contractors, work crews, and any onsite personnel to aid workers in recognizing special status species and sensitive biological resources that may occur on-site. The program shall include identification of the special status species and their habitats, a description of the regulatory status and general ecological characteristics of sensitive resources, and review of the limits of construction and Mitigation Measures required to reduce impacts to biological resources within the work area.

6.2 Special-Status Species

Recommendations to minimize impacts to special status species or habitats are summarized below by species or taxonomic group.

6.2.1 Plants

There is potential or low potential for 20 special-status plants to occur within the Study Area. The following measures are recommended to minimize potential impacts to special-status plants:

- **PLANT1:** Perform floristic plant surveys according to USFWS, CDFW, and CNPS protocols prior to construction. Surveys should be conducted by a qualified biologist and timed according to the appropriate phenological stage for identifying target species. Known reference populations should be visited and/or local herbaria records should be reviewed, if available, prior to surveys to confirm the phenological stage of the target species. If no special-status plants are found within the Project site, no further measures pertaining to special-status plants are necessary.
- **PLANT2:** If special-status plants are identified within 25-feet of the Project impact area, implement the following measures:
 - If avoidance of special-status plants is feasible, establish and clearly demarcate avoidance zones for special-status plant occurrences prior to construction. Avoidance zones should include the extent of the special-status plants plus a 25-foot buffer, unless otherwise determined by a qualified biologist, and should be maintained until the completion of construction. A qualified biologist/biological monitor should be present must occur within the avoidance buffer to ensure special-status plants are not impacted by the work.
 - If avoidance of special-status plants is not feasible, mitigate for significant impacts to special-status plants. Mitigation measures should be developed in consultation with CDFW. Mitigation measures may include permanent preservation of onsite or offsite habitat for special-status plants and/or translocation of plants or seeds from impacted areas to unaffected habitats.

6.2.2 *Northwestern Pond Turtle*

Northwestern pond turtles have low potential to incidentally occur within the Study Area. Implementation of recommendation BIO1, BIO2, and the following measure would avoid and/or minimize potential adverse effects to northwestern pond turtles:

- **NPT1:** Conduct a pre-construction northwestern pond turtle survey in Project impact and staging areas within 48 hours prior to construction activities. Any northwestern pond turtle individuals discovered in the Project work area immediately prior to or during Project activities shall be allowed to move out of the work area of their own volition. If this is not feasible, they shall be captured by a qualified biologist and relocated out of harm's way to the nearest suitable habitat at least 100 feet from the Project work area where they were found.

6.2.3 *Special-Status Birds and MBTA-Protected Birds (including nesting raptors)*

Three special-status birds and various other protected birds have the potential to nest within the Study Area. The following measures are recommended to minimize potential impacts to nesting birds:

- **BIRD1:** If construction is to occur during the nesting season (generally February 1 - August 31), conduct a pre-construction nesting bird survey of all suitable nesting habitat on the Project within 14 days of the commencement of construction. The survey shall be conducted within a 500-foot radius of Project work areas for raptors and within a 100-foot radius for other nesting birds. If any

active nests are observed, these nests shall be designated a sensitive area and protected by an avoidance buffer established in coordination with CDFW until the breeding season has ended or until a qualified biologist has determined that the young have fledged and are no longer reliant upon the nest or parental care for survival. Pre-construction nesting surveys are not required for construction activity outside the nesting season.

6.2.4 Special-Status Bats

There is potential for two special-status bats to occur within the Study Area, and the majority of the Study Area is planned for impact. The following measure is recommended to minimize potential impacts to special-status bats.

- **BAT1:** Within 14 days prior to Project activities that may impact bat roosting habitat (e.g., removal of manmade structures or trees), a qualified biologist will survey for all suitable roosting habitat within the Project impact limits. If suitable roosting habitat is not identified, no further measures are necessary. If suitable roosting habitat is identified, a qualified biologist will conduct an evening bat emergence survey that may include acoustic monitoring to determine whether or not bats are present. If roosting bats are determined to be present within the Project site, consultation with CDFW prior to initiation of construction activities and/or preparation of a Bat Management Plan outlining avoidance and minimization measures specific to the roost(s) potentially affected may be required.

6.3 Riparian and Sensitive Natural Communities

Valley oak woodland and riparian habitat is located within the Study Area. Measure TREE1 in Section 6.6 would avoid and/or minimize potential impacts to individual oak trees. The following measures are recommended to minimize potential impacts to riparian habitat:

- **RIP1:** Map the extent of riparian areas within the Study Area. Avoidance buffers for avoided riparian habitats (including riparian habitat for Burns Valley Creek) should be consistent with the City of Clearlake requirements and/or requirements of regulatory permits, should be clearly demarcated prior to construction, and should be maintained until the completion of construction. A qualified biologist/biological monitor should be present if work must occur within the avoidance buffer to ensure riparian habitat is not impacted by the work.
- **RIP2:** An SAA, pursuant to Section 1602 of the California Fish and Game Code, should be secured for any activity that will impact riparian habitats. Minimization measures will be developed during consultation with CDFW as part of the SAA agreement process to ensure protections for affected fish and wildlife resources.

6.4 Waters of the U.S./State

The Project site supports potential Waters of the U.S. and State. In addition to BIO1, the following measure is recommended if impacts are proposed to aquatic resources:

- **WATER1:** Prepare and submit an aquatic resources delineation for the Project to the USACE and obtain an Approved Jurisdictional Determination.
- **WATER2:** If necessary, file a request for authorization to fill wetlands and other Waters of the U.S. under the Section 404 of the federal CWA (Section 404 Permit) prior to discharging any dredged or fill materials into any Waters of the U.S. Mitigation measures will be developed as part of the Section 404 Permit process to ensure no net loss of wetland function and values. To facilitate such authorization, an application for a Section 404 Nationwide Permit for the Project should be prepared and submitted to USACE. Mitigation for impacts to Waters of the U.S. typically consists of a minimum of a 1:1 ratio for direct impacts; however final mitigation requirements will be developed in consultation with USACE.
- **WATER3:** If necessary, file a request for a Water Quality Certification or waiver pursuant to Section 401 of the CWA must be obtained from the RWQCB for Section 404 permit actions.
- **WATER4:** Pursuant to the Porter-Cologne Water Quality Act, a permit authorization from the RWQCB is required prior to the discharge of material in an area that could affect Waters of the State. Mitigation requirements for discharge to Waters of the State within the Project site will be developed in consultation with the RWQCB.
- **WATER5:** If necessary, prepare an LSA Notification to CDFW under California Fish and Game Code Section 1602 to request authorization to impact regulated aquatic features.

6.5 Wildlife Movement Corridors

No impacts to wildlife movement, corridors, or nursery sites are expected.

6.6 Trees

Oak trees are present within the Study Area and are protected under the City tree ordinance. The following measure is recommended to prevent conflicts with the local tree ordinance:

- **TREE1:** A native tree protection and removal permit, waiver, or similar approval should be secured prior to impacting trees protected under the City ordinance. Avoidance buffers for protected trees should be consistent with the City requirements, should be clearly demarcated prior to construction, and should be maintained until the completion of construction. A qualified biologist/biological monitor should be present if work must occur within the avoidance buffer to ensure avoided protected trees are not impacted by the work.

7.0 SUMMARY

No federal or State listed species have potential to occur within the Study Area. However, 21 non-listed special-status plants, one special-status turtle, three special-status birds, various birds protected under the MBTA and the California Fish and Game Code, and two special-status bats have potential or low potential to occur within the Study Area. One drainage channel located within the Study Area may be considered a Water of the U.S. and State. Individual oak trees within the Study Area are protected under the City

ordinance are located within the Study Area, and the oak woodlands onsite may be considered a sensitive natural community by CDFW.

With implementation of recommendations described in Section 6.0, the Project is not expected to have a significant effect on biological resources.

8.0 REFERENCES

- Baldwin, B.G., D.H. Goldman, D.J. Keil, R. Patterson, T.J. Rosatti, and D.H. Wilken, editors. 2012. *The Jepson Manual; Vascular Plants of California*, Second Edition. University of California Press, Berkeley, California.
- CDFW. 2021a. Rarefind 5. Online Version, commercial version dated February 28, 2021. California Natural Diversity Database. The Resources Agency, Sacramento.
- _____. 2021b. Biogeographic Information and Observation System (BIOS). Available <https://wildlife.ca.gov/data/BIOS>. Accessed February and March 2021.
- Cicero, C., P. Pyle, and M. A. Patten. 2020. Oak Titmouse (*Baeolophus inornatus*), version 1.0. In *Birds of the World* (P. G. Rodewald, Editor). Cornell Lab of Ornithology, Ithaca, NY, USA. <https://doi.org/10.2173/bow.oaktit.01>.
- City of Clearlake. 2020. City of Clearlake Municipal Code. Chapter XVIII (Zoning), Article 18-1 (Administration). Available <https://clearlake.municipal.codes/>. Accessed March 2021.
- _____. 2016a. *City of Clearlake 2040 General Plan Update*. Available https://clearlake.ca.us/DocumentCenter/View/608/A_Clearlake_2040_General_Planpdf. Accessed March 5, 2021.
- _____. 2016b. *City of Clearlake California 2040 General Plan Update Draft EIR*. November 2016. State Clearinghouse No. 2014012023. Available https://clearlake.ca.us/DocumentCenter/View/608/A_Clearlake_2040_General_Planpdf. Accessed March 5, 2021.
- CNPS. 2021. Inventory of Rare and Endangered Plants in California (online edition, v8-03 0.39). California Native Plant Society. Sacramento, CA. Available online: February and March 2021.
- Horton, John D., 2017. 0818, The State Geologic Map Compilation (SGMC) Geodatabase of the Conterminous United States: U.S. Geological Survey data release DOI: 10.5066/F7WH2N65, U.S. Geological Survey, Denver, CO. Available <https://doi.org/10.5066/F7WH2N65>
- Jennings, C.W., R.G. Strand, and T.H. Rogers. 1977. Geologic map of California: California Division of Mines and Geology, scale 1:750,000. Available <https://mrdata.usgs.gov/geology/state/sgmc-lith.php?code=5.14#California>. Accessed December 2020.
- Jennings, M. R. and M. P. Hayes. 1994. Amphibian and Reptile Species of Special Concern in California. Final report to California Department of Fish and Game, Inland Fisheries Branch. Rancho Cordova, CA.
- Lowther, P. E., P. Pyle, and M. A. Patten. 2020. Nuttall's Woodpecker (*Dryobates nuttallii*), version 1.0. In *Birds of the World* (P. G. Rodewald, Editor). Cornell Lab of Ornithology, Ithaca, NY, USA. <https://doi.org/10.2173/bow.nutwoo.01>.

- Moyle, P.B., R. M. Quiñones, J. V. Katz and J. Weaver. 2015. Fish Species of Special Concern in California. Sacramento: California Department of Fish and Wildlife. Available <https://wildlife.ca.gov/Conservation/SSC/Fishes>. Accessed March 2021.
- NOAA. 2021a. NOAA Fisheries West Coast Region California Species List Tools. Available online: https://archive.fisheries.noaa.gov/wcr/maps_data/california_species_list_tools.html. Accessed March 4, 2021.
- _____. 2021b. National Climatic Data Center 1981-2010 Climate Normals for Clearlake 4 SE, California. <https://www.ncdc.noaa.gov/cdo-web/datatools/normal>. Accessed March 2, 2021.
- NRCS. 2021a. Web Soil Survey. <http://websoilsurvey.nrcs.usda.gov/>. Accessed December 2020.
- _____. 2021b. State Soil Data Access Hydric Soils List. <https://www.nrcs.usda.gov/wps/portal/nrcs/main/soils/use/hydric/>. Accessed February 2, 2021.
- NRCS, USGS, and U.S. Environmental Protection Agency. 2016. Watershed Boundary Dataset for California. <http://datagateway.nrcs.usda.gov>.
- Safford, H. and Miller J.E.D. 2020. An updated database of serpentine endemism in the California flora. *Madroño* 67(2), 85-104, (October 16, 2020). <https://doi.org/10.3120/0024-9637-67.2.85>
- Sawyer, J., Keeler-Wolf T., Evens J. M. 2009. *A Manual of California Vegetation, Second Edition*. Sacramento, California: California Native Plant Society.
- SWRCB. State Wetland Definition and Procedures for Discharges of Dredged or Fill Material to Waters of the State. Adopted April 2, 2019. Available https://www.waterboards.ca.gov/water_issues/programs/cwa401/wrapp.html#officialdocuments. Accessed March 8, 2021.
- USACE. 2020. National Wetland Plant List. Document Number 2020-10630. Published May 18, 2020. Available <https://www.federalregister.gov/documents/2020/05/18/2020-10630/national-wetland-plant-list#citation-1-p29690>.
- USFWS. 2021a. USFWS Resource Report List. Information for Planning and Conservation. Available <https://ecos.fws.gov/ipac>. Accessed February 2021.
- _____. 2021b. Online Critical Habitat Mapper. Available <https://fws.maps.arcgis.com/home/webmap/viewer.html?webmap=9d8de5e265ad4fe09893cf75b8dbfb77>. Accessed February 2021.
- _____. 2008. Birds of Conservation Concern 2008. U.S. Fish and Wildlife Service, Division of Migratory Bird Management, Arlington, Virginia. Arlington, Virginia. <http://www.fws.gov/migratorybirds/>. Accessed March 2021.
- _____. 2005. Vernal Pool Recovery Plan: Species Account for Legenere. United States Department of the Interior, USFWS. Sacramento, California. Available Online:

<http://www.fws.gov/sacramento/ES/Recovery-Planning/Vernal-Pool/Documents/legenera.pdf>.
[Accessed 2 October 2015.]

USGS. 1993. "Clearlake Highlands, California" 7.5-minute Quadrangle. U.S. Department of the Interior. Denver, Colorado.

Watt, D. J., P. Pyle, M. A. Patten, and J. N. Davis. 2020. Lawrence's Goldfinch (*Spinus lawrencei*), version 1.0. In *Birds of the World* (P. G. Rodewald, Editor). Cornell Lab of Ornithology, Ithaca, NY, USA. <https://doi.org/10.2173/bow.lawgol.01>.

WBWG. 2021. Western Bat Species Accounts. Available <http://wbwg.org/western-bat-species/>. Accessed March 2021.

LIST OF ATTACHMENTS

Attachment A – Results of Database Queries

Attachment B – Representative Site Photographs

ATTACHMENT A

Results of Database Searches

IPaC resource list

This report is an automatically generated list of species and other resources such as critical habitat (collectively referred to as *trust resources*) under the U.S. Fish and Wildlife Service's (USFWS) jurisdiction that are known or expected to be on or near the project area referenced below. The list may also include trust resources that occur outside of the project area, but that could potentially be directly or indirectly affected by activities in the project area. However, determining the likelihood and extent of effects a project may have on trust resources typically requires gathering additional site-specific (e.g., vegetation/species surveys) and project-specific (e.g., magnitude and timing of proposed activities) information.

Below is a summary of the project information you provided and contact information for the USFWS office(s) with jurisdiction in the defined project area. Please read the introduction to each section that follows (Endangered Species, Migratory Birds, USFWS Facilities, and NWI Wetlands) for additional information applicable to the trust resources addressed in that section.

Location

Lake County, California



Local offices

Red Bluff Fish And Wildlife Office

☎ (530) 527-3043

📠 (530) 529-0292

10950 Tyler Road
Red Bluff, CA 96080-7762

Sacramento Fish And Wildlife Office

☎ (916) 414-6600

📞 (916) 414-6713

Federal Building
2800 Cottage Way, Room W-2605
Sacramento, CA 95825-1846

NOT FOR CONSULTATION

Endangered species

This resource list is for informational purposes only and does not constitute an analysis of project level impacts.

The primary information used to generate this list is the known or expected range of each species. Additional areas of influence (AOI) for species are also considered. An AOI includes areas outside of the species range if the species could be indirectly affected by activities in that area (e.g., placing a dam upstream of a fish population even if that fish does not occur at the dam site, may indirectly impact the species by reducing or eliminating water flow downstream). Because species can move, and site conditions can change, the species on this list are not guaranteed to be found on or near the project area. To fully determine any potential effects to species, additional site-specific and project-specific information is often required.

Section 7 of the Endangered Species Act **requires** Federal agencies to "request of the Secretary information whether any species which is listed or proposed to be listed may be present in the area of such proposed action" for any project that is conducted, permitted, funded, or licensed by any Federal agency. A letter from the local office and a species list which fulfills this requirement can **only** be obtained by requesting an official species list from either the Regulatory Review section in IPaC (see directions below) or from the local field office directly.

For project evaluations that require USFWS concurrence/review, please return to the IPaC website and request an official species list by doing the following:

1. Draw the project location and click CONTINUE.
2. Click DEFINE PROJECT.
3. Log in (if directed to do so).
4. Provide a name and description for your project.
5. Click REQUEST SPECIES LIST.

Listed species¹ and their critical habitats are managed by the [Ecological Services Program](#) of the U.S. Fish and Wildlife Service (USFWS) and the fisheries division of the National Oceanic and Atmospheric Administration (NOAA Fisheries²).

Species and critical habitats under the sole responsibility of NOAA Fisheries are **not** shown on this list. Please contact [NOAA Fisheries](#) for [species under their jurisdiction](#).

1. Species listed under the [Endangered Species Act](#) are threatened or endangered; IPaC also shows species that are candidates, or proposed, for listing. See the [listing status page](#) for more information. IPaC only shows species that are regulated by USFWS (see FAQ).
2. [NOAA Fisheries](#), also known as the National Marine Fisheries Service (NMFS), is an office of the National Oceanic and Atmospheric Administration within the Department of Commerce.

The Red Bluff Fish And Wildlife Office has not enabled species list delivery through IPaC. Please contact them directly to determine which endangered species need to be considered as part of your project.

Red Bluff Fish And Wildlife Office

☎ (530) 527-3043

📠 (530) 529-0292

10950 Tyler Road
Red Bluff, CA 96080-7762

The following species are potentially affected by activities in this location:

Birds

NAME	STATUS
<p>Northern Spotted Owl <i>Strix occidentalis caurina</i></p> <p>Wherever found</p> <p>There is final critical habitat for this species. The location of the critical habitat is not available.</p> <p>https://ecos.fws.gov/ecp/species/1123</p>	Threatened
<p>Yellow-billed Cuckoo <i>Coccyzus americanus</i></p> <p>There is proposed critical habitat for this species. The location of the critical habitat is not available.</p> <p>https://ecos.fws.gov/ecp/species/3911</p>	Threatened

Amphibians

NAME	STATUS
<p>California Red-legged Frog <i>Rana draytonii</i></p> <p>Wherever found</p> <p>There is final critical habitat for this species. The location of the critical habitat is not available.</p> <p>https://ecos.fws.gov/ecp/species/2891</p>	Threatened

Fishes

NAME	STATUS
<p>Delta Smelt <i>Hypomesus transpacificus</i></p> <p>Wherever found</p> <p>There is final critical habitat for this species. The location of the critical habitat is not available.</p> <p>https://ecos.fws.gov/ecp/species/321</p>	Threatened

Flowering Plants

NAME	STATUS
------	--------

Burke's Goldfields *Lasthenia burkei* **Endangered**

Wherever found

No critical habitat has been designated for this species.

<https://ecos.fws.gov/ecp/species/4338>

Few-flowered Navarretia *Navarretia leucocephala* ssp. *pauciflora* **Endangered**

(=N. *pauciflora*)

Wherever found

No critical habitat has been designated for this species.

<https://ecos.fws.gov/ecp/species/8242>

Lake County Stonecrop *Parvisedum leiocarpum* **Endangered**

Wherever found

No critical habitat has been designated for this species.

<https://ecos.fws.gov/ecp/species/2263>

Loch Lomond Coyote Thistle *Eryngium constancei* **Endangered**

Wherever found

No critical habitat has been designated for this species.

<https://ecos.fws.gov/ecp/species/5106>

Many-flowered Navarretia *Navarretia leucocephala* ssp. *plieantha* **Endangered**

plieantha

Wherever found

No critical habitat has been designated for this species.

<https://ecos.fws.gov/ecp/species/2491>

Slender Orcutt Grass *Orcuttia tenuis* **Threatened**

Wherever found

There is **final** critical habitat for this species. The location of the critical habitat is not available.

<https://ecos.fws.gov/ecp/species/1063>

Critical habitats

Potential effects to critical habitat(s) in this location must be analyzed along with the endangered species themselves.

THERE ARE NO CRITICAL HABITATS AT THIS LOCATION.

Migratory birds

Certain birds are protected under the Migratory Bird Treaty Act¹ and the Bald and Golden Eagle Protection Act².

Any person or organization who plans or conducts activities that may result in impacts to birds, eagles, and their habitats should follow appropriate regulations and consider implementing appropriate conservation measures, as described [below](#).

1. The [Migratory Birds Treaty Act](#) of 1918.
2. The [Bald and Golden Eagle Protection Act](#) of 1940.

Additional information can be found using the following links:

- Birds of Conservation Concern <http://www.fws.gov/birds/management/managed-species/birds-of-conservation-concern.php>
- Measures for avoiding and minimizing impacts to birds <http://www.fws.gov/birds/management/project-assessment-tools-and-guidance/conservation-measures.php>
- Nationwide conservation measures for birds <http://www.fws.gov/migratorybirds/pdf/management/nationwidestandardconservationmeasures.pdf>

The birds listed below are birds of particular concern either because they occur on the [USFWS Birds of Conservation Concern](#) (BCC) list or warrant special attention in your project location. To learn more about the levels of concern for birds on your list and how this list is generated, see the FAQ [below](#). This is not a list of every bird you may find in this location, nor a guarantee that every bird on this list will be found in your project area. To see exact locations of where birders and the general public have sighted birds in and around your project area, visit the [E-bird data mapping tool](#) (Tip: enter your location, desired date range and a species on your list). For projects that occur off the Atlantic Coast, additional maps and models detailing the relative occurrence and abundance of bird species on your list are available. Links to additional information about Atlantic Coast birds, and other important information about your migratory bird list, including how to properly interpret and use your migratory bird report, can be found [below](#).

For guidance on when to schedule activities or implement avoidance and minimization measures to reduce impacts to migratory birds on your list, click on the PROBABILITY OF PRESENCE SUMMARY at the top of your list to see when these birds are most likely to be present and breeding in your project area.

NAME

BREEDING SEASON (IF A BREEDING SEASON IS INDICATED FOR A BIRD ON YOUR LIST, THE BIRD MAY BREED IN YOUR PROJECT AREA SOMETIME WITHIN THE TIMEFRAME SPECIFIED, WHICH IS A VERY LIBERAL ESTIMATE OF THE DATES INSIDE WHICH THE BIRD BREEDS ACROSS ITS ENTIRE RANGE. "BREEDS ELSEWHERE" INDICATES THAT THE BIRD DOES NOT LIKELY BREED IN YOUR PROJECT AREA.)

- Bald Eagle** *Haliaeetus leucocephalus*
Breeds Jan 1 to Aug 31
This is not a Bird of Conservation Concern (BCC) in this area, but warrants attention because of the Eagle Act or for potential susceptibilities in offshore areas from certain types of development or activities.
<https://ecos.fws.gov/ecp/species/1626>
- Clark's Grebe** *Aechmophorus clarkii*
Breeds Jan 1 to Dec 31
This is a Bird of Conservation Concern (BCC) throughout its range in the continental USA and Alaska.
- Common Yellowthroat** *Geothlypis trichas sinuosa*
Breeds May 20 to Jul 31
This is a Bird of Conservation Concern (BCC) only in particular Bird Conservation Regions (BCRs) in the continental USA
<https://ecos.fws.gov/ecp/species/2084>
- Golden Eagle** *Aquila chrysaetos*
Breeds Jan 1 to Aug 31
This is not a Bird of Conservation Concern (BCC) in this area, but warrants attention because of the Eagle Act or for potential susceptibilities in offshore areas from certain types of development or activities.
<https://ecos.fws.gov/ecp/species/1680>
- Lawrence's Goldfinch** *Carduelis lawrencei*
Breeds Mar 20 to Sep 20
This is a Bird of Conservation Concern (BCC) throughout its range in the continental USA and Alaska.
<https://ecos.fws.gov/ecp/species/9464>
- Nuttall's Woodpecker** *Picoides nuttallii*
Breeds Apr 1 to Jul 20
This is a Bird of Conservation Concern (BCC) only in particular Bird Conservation Regions (BCRs) in the continental USA
<https://ecos.fws.gov/ecp/species/9410>
- Oak Titmouse** *Baeolophus inornatus*
Breeds Mar 15 to Jul 15
This is a Bird of Conservation Concern (BCC) throughout its range in the continental USA and Alaska.
<https://ecos.fws.gov/ecp/species/9656>
- Song Sparrow** *Melospiza melodia*
Breeds Feb 20 to Sep 5
This is a Bird of Conservation Concern (BCC) only in particular Bird Conservation Regions (BCRs) in the continental USA
- Spotted Towhee** *Pipilo maculatus clementae*
Breeds Apr 15 to Jul 20
This is a Bird of Conservation Concern (BCC) only in particular Bird Conservation Regions (BCRs) in the continental USA
<https://ecos.fws.gov/ecp/species/4243>

Tricolored Blackbird *Agelaius tricolor*

Breeds Mar 15 to Aug 10

This is a Bird of Conservation Concern (BCC) throughout its range in the continental USA and Alaska.

<https://ecos.fws.gov/ecp/species/3910>

Wrentit *Chamaea fasciata*

Breeds Mar 15 to Aug 10

This is a Bird of Conservation Concern (BCC) throughout its range in the continental USA and Alaska.

Probability of Presence Summary

The graphs below provide our best understanding of when birds of concern are most likely to be present in your project area. This information can be used to tailor and schedule your project activities to avoid or minimize impacts to birds. Please make sure you read and understand the FAQ "Proper Interpretation and Use of Your Migratory Bird Report" before using or attempting to interpret this report.

Probability of Presence (■)

Each green bar represents the bird's relative probability of presence in the 10km grid cell(s) your project overlaps during a particular week of the year. (A year is represented as 12 4-week months.) A taller bar indicates a higher probability of species presence. The survey effort (see below) can be used to establish a level of confidence in the presence score. One can have higher confidence in the presence score if the corresponding survey effort is also high.

How is the probability of presence score calculated? The calculation is done in three steps:

1. The probability of presence for each week is calculated as the number of survey events in the week where the species was detected divided by the total number of survey events for that week. For example, if in week 12 there were 20 survey events and the Spotted Towhee was found in 5 of them, the probability of presence of the Spotted Towhee in week 12 is 0.25.
2. To properly present the pattern of presence across the year, the relative probability of presence is calculated. This is the probability of presence divided by the maximum probability of presence across all weeks. For example, imagine the probability of presence in week 20 for the Spotted Towhee is 0.05, and that the probability of presence at week 12 (0.25) is the maximum of any week of the year. The relative probability of presence on week 12 is $0.25/0.25 = 1$; at week 20 it is $0.05/0.25 = 0.2$.
3. The relative probability of presence calculated in the previous step undergoes a statistical conversion so that all possible values fall between 0 and 10, inclusive. This is the probability of presence score.

To see a bar's probability of presence score, simply hover your mouse cursor over the bar.

Breeding Season (■)

Yellow bars denote a very liberal estimate of the time-frame inside which the bird breeds across its entire range. If there are no yellow bars shown for a bird, it does not breed in your project area.

Survey Effort (I)

Vertical black lines superimposed on probability of presence bars indicate the number of surveys performed for that species in the 10km grid cell(s) your project area overlaps. The number of surveys is expressed as a range, for example, 33 to 64 surveys.

To see a bar's survey effort range, simply hover your mouse cursor over the bar.

No Data (–)

A week is marked as having no data if there were no survey events for that week.

Survey Timeframe

Surveys from only the last 10 years are used in order to ensure delivery of currently relevant information. The exception to this is areas off the Atlantic coast, where bird returns are based on all years of available data, since data in these areas is currently much more sparse.

Tell me more about conservation measures I can implement to avoid or minimize impacts to migratory birds.

[Nationwide Conservation Measures](#) describes measures that can help avoid and minimize impacts to all birds at any location year round. Implementation of these measures is particularly important when birds are most likely to occur in the project area. When birds may be breeding in the area, identifying the locations of any active nests and avoiding their destruction is a very helpful impact minimization measure. To see when birds are most likely to occur and be breeding in your project area, view the Probability of Presence Summary. [Additional measures](#) or [permits](#) may be advisable depending on the type of activity you are conducting and the type of infrastructure or bird species present on your project site.

What does IPaC use to generate the migratory birds potentially occurring in my specified location?

The Migratory Bird Resource List is comprised of USFWS [Birds of Conservation Concern \(BCC\)](#) and other species that may warrant special attention in your project location.

The migratory bird list generated for your project is derived from data provided by the [Avian Knowledge Network \(AKN\)](#). The AKN data is based on a growing collection of [survey, banding, and citizen science datasets](#) and is queried and filtered to return a list of those birds reported as occurring in the 10km grid cell(s) which your project intersects, and that have been identified as warranting special attention because they are a BCC species in that area, an eagle ([Eagle Act](#) requirements may apply), or a species that has a particular vulnerability to offshore activities or development.

Again, the Migratory Bird Resource list includes only a subset of birds that may occur in your project area. It is not representative of all birds that may occur in your project area. To get a list of all birds potentially present in your project area, please visit the [AKN Phenology Tool](#).

What does IPaC use to generate the probability of presence graphs for the migratory birds potentially occurring in my specified location?

The probability of presence graphs associated with your migratory bird list are based on data provided by the [Avian Knowledge Network \(AKN\)](#). This data is derived from a growing collection of [survey, banding, and citizen science datasets](#).

Probability of presence data is continuously being updated as new and better information becomes available. To learn more about how the probability of presence graphs are produced and how to interpret them, go the Probability of Presence Summary and then click on the "Tell me about these graphs" link.

How do I know if a bird is breeding, wintering, migrating or present year-round in my project area?

To see what part of a particular bird's range your project area falls within (i.e. breeding, wintering, migratory year-round), you may refer to the following resources: [The Cornell Lab of Ornithology All About Birds Bird Guide](#), or (if you are unsuccessful in locating the bird of interest there), the [Cornell Lab of Ornithology Neotropical Birds guide](#). If a bird on your migratory bird species list has a breeding season associated with it, if that bird does occur in your project area, there may be nests present at some point within the timeframe specified. If "Breeds elsewhere" is indicated, then the bird likely does not breed in your project area.

What are the levels of concern for migratory birds?

Migratory birds delivered through IPaC fall into the following distinct categories of concern:

1. "BCC Rangewide" birds are [Birds of Conservation Concern](#) (BCC) that are of concern throughout their range anywhere within the USA (including Hawaii, the Pacific Islands, Puerto Rico, and the Virgin Islands);
2. "BCC - BCR" birds are BCCs that are of concern only in particular Bird Conservation Regions (BCRs) in the continental USA; and
3. "Non-BCC - Vulnerable" birds are not BCC species in your project area, but appear on your list either because of the [Eagle Act](#) requirements (for eagles) or (for non-eagles) potential susceptibilities in offshore areas from certain types of development or activities (e.g. offshore energy development or longline fishing).

Although it is important to try to avoid and minimize impacts to all birds, efforts should be made, in particular, to avoid and minimize impacts to the birds on this list, especially eagles and BCC species of rangewide concern. For more information on conservation measures you can implement to help avoid and minimize migratory bird impacts and requirements for eagles, please see the FAQs for these topics.

Details about birds that are potentially affected by offshore projects

For additional details about the relative occurrence and abundance of both individual bird species and groups of bird species within your project area off the Atlantic Coast, please visit the [Northeast Ocean Data Portal](#). The Portal also offers data and information about other taxa besides birds that may be helpful to you in your project review. Alternately, you may download the bird model results files underlying the portal maps through the [NOAA NCCOS Integrative Statistical Modeling and Predictive Mapping of Marine Bird Distributions and Abundance on the Atlantic Outer Continental Shelf](#) project webpage.

Bird tracking data can also provide additional details about occurrence and habitat use throughout the year, including migration. Models relying on survey data may not include this information. For additional information on marine bird tracking data, see the [Diving Bird Study](#) and the [nanotag studies](#) or contact [Caleb Spiegel](#) or [Pam Loring](#).

What if I have eagles on my list?

If your project has the potential to disturb or kill eagles, you may need to [obtain a permit](#) to avoid violating the Eagle Act should such impacts occur.

Proper Interpretation and Use of Your Migratory Bird Report

The migratory bird list generated is not a list of all birds in your project area, only a subset of birds of priority concern. To learn more about how your list is generated, and see options for identifying what other birds may be in your project area, please see the FAQ "What does IPaC use to generate the migratory birds potentially occurring in my specified location". Please be aware this report provides the "probability of presence" of birds within the 10 km grid cell(s) that overlap your project; not your exact project footprint. On the graphs provided, please also look carefully at the survey effort (indicated by the black vertical bar) and for the existence of the "no data" indicator (a red horizontal bar). A high survey effort is the key component. If the survey effort is high, then the probability of presence score can be viewed as more dependable. In contrast, a low survey effort bar or no data bar means a lack of data and, therefore, a lack of certainty about presence of the species. This list is not perfect; it is simply a starting point for identifying what birds of concern have the potential to be in your project area, when they might be there, and if they might be breeding (which means nests might be present). The list helps you know what to look for to

confirm presence, and helps guide you in knowing when to implement conservation measures to avoid minimize potential impacts from your project activities, should presence be confirmed. To learn more about conservation measures, visit the FAQ "Tell me about conservation measures I can implement to avoid or minimize impacts to migratory birds" at the bottom of your migratory bird trust resources page.

Facilities

Wildlife refuges and fish hatcheries

REFUGE AND FISH HATCHERY INFORMATION IS NOT AVAILABLE AT THIS TIME

Wetlands in the National Wetlands Inventory

Impacts to [NWI wetlands](#) and other aquatic habitats may be subject to regulation under Section 404 of the Clean Water Act, or other State/Federal statutes.

For more information please contact the Regulatory Program of the local [U.S. Army Corps of Engineers District](#).

Please note that the NWI data being shown may be out of date. We are currently working to update our NWI data set. We recommend you verify these results with a site visit to determine the actual extent of wetlands on site.

This location overlaps the following wetlands:

RIVERINE

[R4SBC](#)

A description for each wetland code can be found at the [National Wetlands Inventory website](#)

Data limitations

The Service's objective of mapping wetlands and deepwater habitats is to produce reconnaissance level information on the location, type and size of these resources. The maps are prepared from the analysis of high altitude imagery. Wetlands are identified based on vegetation, visible hydrology and geography. A margin of error is inherent in the use of imagery; thus, detailed on-the-ground inspection of any particular site may result in revision of the wetland boundaries or classification established through image analysis.

The accuracy of image interpretation depends on the quality of the imagery, the experience of the image analysts, the amount and quality of the collateral data and the amount of ground truth verification work conducted. Metadata should be consulted to determine the date of the source imagery used and any mapping problems.

Wetlands or other mapped features may have changed since the date of the imagery or field work. There may be occasional differences in polygon boundaries or classifications between the information depicted on the map and the actual conditions on site.

Data exclusions

Certain wetland habitats are excluded from the National mapping program because of the limitations of aerial imagery as the primary data source used to detect wetlands. These habitats include seagrasses or submerged aquatic vegetation that are found in the intertidal and subtidal zones of estuaries and nearshore coastal waters. Some deepwater reef communities (coral or tubercid worm reefs) have also been excluded from the inventory. These habitats, because of their depth, go undetected by aerial imagery.

Data precautions

Federal, state, and local regulatory agencies with jurisdiction over wetlands may define and describe wetlands in a different manner than that used in this inventory. There is no attempt, in either the design or products of this inventory, to define the limits of proprietary jurisdiction of any Federal, state, or local government or to establish the geographical scope of the regulatory programs of government agencies. Persons intending to engage in activities involving modifications within or adjacent to wetland areas should seek the advice of appropriate federal, state, or local agencies concerning specified agency regulatory programs and proprietary jurisdictions that may affect such activities.

NOT FOR CONSULTATION

*The database used to provide updates to the Online Inventory is under construction. [View updates and changes made since May 2019 here.](#)

Plant List

81 matches found. [Click on scientific name for details](#)

Search Criteria

Found in Quads 3912217, 3912216, 3912215, 3812287, 3812286, 3812285, 3812277 3812276 and 3812275;

[Modify Search Criteria](#) [Export to Excel](#) [Modify Columns](#) [Modify Sort](#) [Display Photos](#)

Scientific Name	Common Name	Family	Lifeform	Blooming Period	CA Rare Plant Rank	State Rank	Global Rank
Amsinckia lunaris	bent-flowered fiddleneck	Boraginaceae	annual herb	Mar-Jun	1B.2	S3	G3
Antirrhinum subcordatum	dimorphic snapdragon	Plantaginaceae	annual herb	Apr-Jul	4.3	S3	G3
Antirrhinum virga	twig-like snapdragon	Plantaginaceae	perennial herb	Jun-Jul	4.3	S3?	G3?
Arabis blepharophylla	coast rockcress	Brassicaceae	perennial herb	Feb-May	4.3	S4	G4
Arctostaphylos manzanita ssp. elegans	Konocti manzanita	Ericaceae	perennial evergreen shrub	(Jan)Mar-May(Jul)	1B.3	S3	G5T3
Arctostaphylos stanfordiana ssp. raichei	Raiche's manzanita	Ericaceae	perennial evergreen shrub	Feb-Apr	1B.1	S2	G3T2
Asclepias solanoana	serpentine milkweed	Apocynaceae	perennial herb	May-Jul(Aug)	4.2	S3	G3
Astragalus breweri	Brewer's milk-vetch	Fabaceae	annual herb	Apr-Jun	4.2	S3	G3
Astragalus clevelandii	Cleveland's milk-vetch	Fabaceae	perennial herb	Jun-Sep	4.3	S4	G4
Astragalus rattanii var. jepsonianus	Jepson's milk-vetch	Fabaceae	annual herb	Mar-Jun	1B.2	S3	G4T3
Azolla microphylla	Mexican mosquito fern	Azollaceae	annual / perennial herb	Aug	4.2	S4	G5
Brasenia schreberi	watershield	Cabombaceae	perennial rhizomatous herb (aquatic)	Jun-Sep	2B.3	S3	G5
Brodiaea rosea ssp. rosea	Indian Valley brodiaea	Themidaceae	perennial bulbiferous herb	May-Jun	3.1	S2	G2
Calamagrostis ophitidis	serpentine reed grass	Poaceae	perennial herb	Apr-Jul	4.3	S3	G3
Calochortus uniflorus	pink star-tulip	Liliaceae	perennial bulbiferous herb	Apr-Jun	4.2	S4	G4
Calyptridium quadripetalum	four-petaled pussypaws	Montiaceae	annual herb	Apr-Jun	4.3	S4	G4
	Mt. Saint Helena	Convolvulaceae	perennial	Apr-Jun	4.2	S3	G4

<u>Calystegia collina ssp. oxyphylla</u>	morning-glory		rhizomatous herb					
<u>Calystegia collina ssp. tridactylosa</u>	three-fingered morning-glory	Convolvulaceae	perennial rhizomatous herb	Apr-Jun	1B.2	S1	G4T1	
<u>Carex praticola</u>	northern meadow sedge	Cyperaceae	perennial herb	May-Jul	2B.2	S2	G5	
<u>Castilleja rubicundula var. rubicundula</u>	pink creamsacs	Orobanchaceae	annual herb (hemiparasitic)	Apr-Jun	1B.2	S2	G5T2	
<u>Ceanothus confusus</u>	Rincon Ridge ceanothus	Rhamnaceae	perennial evergreen shrub	Feb-Jun	1B.1	S1	G1	
<u>Ceanothus divergens</u>	Calistoga ceanothus	Rhamnaceae	perennial evergreen shrub	Feb-Apr	1B.2	S2	G2	
<u>Chlorogalum pomeridianum var. minus</u>	dwarf soaproot	Agavaceae	perennial bulbiferous herb	May-Aug	1B.2	S3	G5T3	
<u>Clarkia gracilis ssp. tracyi</u>	Tracy's clarkia	Onagraceae	annual herb	Apr-Jul	4.2	S3	G5T3	
<u>Collomia diversifolia</u>	serpentine collomia	Polemoniaceae	annual herb	May-Jun	4.3	S4	G4	
<u>Cordylanthus tenuis ssp. brunneus</u>	serpentine bird's-beak	Orobanchaceae	annual herb (hemiparasitic)	Jul-Aug	4.3	S3	G4G5T3	
<u>Cryptantha dissita</u>	serpentine cryptantha	Boraginaceae	annual herb	Apr-Jun	1B.2	S2	G2	
<u>Delphinium uliginosum</u>	swamp larkspur	Ranunculaceae	perennial herb	May-Jun	4.2	S3	G3	
<u>Downingia willamettensis</u>	Cascade downingia	Campanulaceae	annual herb	Jun-Jul(Sep)	2B.2	S2	G4	
<u>Eriastrum brandegeae</u>	Brandegee's eriastrum	Polemoniaceae	annual herb	Apr-Aug	1B.1	S1	G1Q	
<u>Erigeron greenei</u>	Greene's narrow-leaved daisy	Asteraceae	perennial herb	May-Sep	1B.2	S3	G3	
<u>Eriogonum nervulosum</u>	Snow Mountain buckwheat	Polygonaceae	perennial rhizomatous herb	Jun-Sep	1B.2	S2	G2	
<u>Eryngium constancei</u>	Loch Lomond button-celery	Apiaceae	annual / perennial herb	Apr-Jun	1B.1	S1	G1	
<u>Fritillaria pluriflora</u>	adobe-lily	Liliaceae	perennial bulbiferous herb	Feb-Apr	1B.2	S2S3	G2G3	
<u>Gratiola heterosepala</u>	Boggs Lake hedge-hyssop	Plantaginaceae	annual herb	Apr-Aug	1B.2	S2	G2	
<u>Grimmia torenii</u>	Toren's grimmia	Grimmiaceae	moss		1B.3	S2	G2	
<u>Harmonia hallii</u>	Hall's harmonia	Asteraceae	annual herb	Apr-Jun	1B.2	S2?	G2?	
<u>Hemizonia congesta ssp. congesta</u>	congested-headed hayfield tarplant	Asteraceae	annual herb	Apr-Nov	1B.2	S2	G5T2	
<u>Hesperolinon adenophyllum</u>	glandular western flax	Linaceae	annual herb	May-Aug	1B.2	S2S3	G2G3	
<u>Hesperolinon bicarpellatum</u>	two-carpellate western flax	Linaceae	annual herb	May-Jul	1B.2	S2	G2	
<u>Hesperolinon didymocarpum</u>	Lake County western flax	Linaceae	annual herb	May-Jul	1B.2	S1	G1	
<u>Hesperolinon sharsmithiae</u>	Sharsmith's western flax	Linaceae	annual herb	May-Jul	1B.2	S2	G2Q	
<u>Horkelia bolanderi</u>	Bolander's horkelia	Rosaceae	perennial herb	(May)Jun-Aug	1B.2	S1	G1	
<u>Imperata brevifolia</u>	California satintail	Poaceae	perennial	Sep-May	2B.1	S3	G4	

			rhizomatous herb				Section I, Item 5.	
<u>Lasthenia burkei</u>	Burke's goldfields	Asteraceae	annual herb	Apr-Jun	1B.1		S1	G1
<u>Layia septentrionalis</u>	Colusa layia	Asteraceae	annual herb	Apr-May	1B.2		S2	G2
<u>Legenere limosa</u>	legenere	Campanulaceae	annual herb	Apr-Jun	1B.1		S2	G2
<u>Leptosiphon acicularis</u>	bristly leptosiphon	Polemoniaceae	annual herb	Apr-Jul	4.2		S4?	G4?
<u>Leptosiphon jepsonii</u>	Jepson's leptosiphon	Polemoniaceae	annual herb	Mar-May	1B.2		S2S3	G2G3
<u>Limnanthes floccosa</u> <u>ssp. floccosa</u>	woolly meadowfoam	Limnanthaceae	annual herb	Mar-May(Jun)	4.2		S3	G4T4
<u>Lomatium repostum</u>	Napa lomatium	Apiaceae	perennial herb	Mar-Jun	4.3		S3	G3
<u>Lupinus sericatus</u>	Cobb Mountain lupine	Fabaceae	perennial herb	Mar-Jun	1B.2		S2?	G2?
<u>Malacothamnus helleri</u>	Heller's bush-mallow	Malvaceae	perennial deciduous shrub	May-Jul	3.3		S3	G3Q
<u>Micropus amphibolus</u>	Mt. Diablo cottonweed	Asteraceae	annual herb	Mar-May	3.2		S3S4	G3G4
<u>Mielichhoferia elongata</u>	elongate copper moss	Mielichhoferiaceae	moss		4.3		S4	G5
<u>Myosurus minimus ssp. apus</u>	little mouse-tail	Ranunculaceae	annual herb	Mar-Jun	3.1		S2	G5T2Q
<u>Navarretia cotulifolia</u>	cotula navarretia	Polemoniaceae	annual herb	May-Jun	4.2		S4	G4
<u>Navarretia jepsonii</u>	Jepson's navarretia	Polemoniaceae	annual herb	Apr-Jun	4.3		S4	G4
<u>Navarretia leucocephala ssp. bakeri</u>	Baker's navarretia	Polemoniaceae	annual herb	Apr-Jul	1B.1		S2	G4T2
<u>Navarretia leucocephala ssp. pauciflora</u>	few-flowered navarretia	Polemoniaceae	annual herb	May-Jun	1B.1		S1	G4T1
<u>Navarretia leucocephala ssp. plieantha</u>	many-flowered navarretia	Polemoniaceae	annual herb	May-Jun	1B.2		S1	G4T1
<u>Navarretia paradoxinota</u>	Porter's navarretia	Polemoniaceae	annual herb	May-Jun(Jul)	1B.3		S2	G2
<u>Orcuttia tenuis</u>	slender Orcutt grass	Poaceae	annual herb	May-Sep(Oct)	1B.1		S2	G2
<u>Panicum acuminatum var. thermale</u>	Geysers panicum	Poaceae	annual / perennial herb	Jun-Aug	1B.2		S2	G5T2Q
<u>Penstemon newberryi var. sonomensis</u>	Sonoma beardtongue	Plantaginaceae	perennial herb	Apr-Aug	1B.3		S2	G4T2
<u>Piperia michaelii</u>	Michael's rein orchid	Orchidaceae	perennial herb	Apr-Aug	4.2		S3	G3
<u>Potamogeton zosteriformis</u>	eel-grass pondweed	Potamogetonaceae	annual herb (aquatic)	Jun-Jul	2B.2		S3	G5
<u>Sedella leiocarpa</u>	Lake County stonecrop	Crassulaceae	annual herb	Apr-May	1B.1		S1	G1
<u>Senecio clevelandii var. clevelandii</u>	Cleveland's ragwort	Asteraceae	perennial herb	Jun-Jul	4.3		S3	G4?T3Q
<u>Sidalcea oregana ssp. hydrophila</u>	marsh checkerbloom	Malvaceae	perennial herb	(Jun)Jul-Aug	1B.2		S2	G5T2
<u>Streptanthus barbiger</u>	bearded jewelflower	Brassicaceae	annual herb	May-Jul	4.2		S3	G3
<u>Streptanthus brachiatus ssp. brachiatus</u>	Socrates Mine jewelflower	Brassicaceae	perennial herb	May-Jun	1B.2		S1	G2T1
<u>Streptanthus brachiatus ssp. hoffmanii</u>	Freed's jewelflower	Brassicaceae	perennial herb	May-Jul	1B.2		S2	G2

Streptanthus glandulosus ssp. hoffmanii	Hoffman's bristly jewelflower	Brassicaceae	annual herb	Mar-Jul	1B.3	Section I, Item 5.	
Streptanthus hesperidis	green jewelflower	Brassicaceae	annual herb	May-Jul	1B.2	S2	G2
Streptanthus morrisonii ssp. elatus	Three Peaks jewelflower	Brassicaceae	perennial herb	Jun-Sep	1B.2	S1	G2T1
Streptanthus morrisonii ssp. kruckebergii	Kruckeberg's jewelflower	Brassicaceae	perennial herb	Apr-Jul	1B.2	S1	G2T1
Toxicoscordion fontanum	marsh zigadenus	Melanthiaceae	perennial bulbiferous herb	Apr-Jul	4.2	S3	G3
Trichostema ruygtii	Napa bluecurls	Lamiaceae	annual herb	Jun-Oct	1B.2	S1S2	G1G2
Trifolium hydrophilum	saline clover	Fabaceae	annual herb	Apr-Jun	1B.2	S2	G2
Viburnum ellipticum	oval-leaved viburnum	Adoxaceae	perennial deciduous shrub	May-Jun	2B.3	S3?	G4G5

Suggested Citation

California Native Plant Society, Rare Plant Program. 2021. Inventory of Rare and Endangered Plants of California (online edition, v8-03 0.39). Website <http://www.rareplants.cnps.org> [accessed 27 January 2021].

Search the Inventory

[Simple Search](#)

[Advanced Search](#)

[Glossary](#)

Information

[About the Inventory](#)

[About the Rare Plant Program](#)

[CNPS Home Page](#)

[About CNPS](#)

[Join CNPS](#)

Contributors

[The Calflora Database](#)

[The California Lichen Society](#)

[California Natural Diversity Database](#)

[The Jepson Flora Project](#)

[The Consortium of California Herbaria](#)

[CalPhotos](#)

Questions and Comments

rareplants@cnps.org



Selected Elements by Element Code
California Department of Fish and Wildlife
California Natural Diversity Database

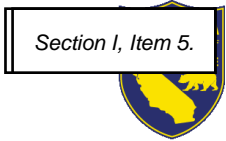

Query Criteria: Quad (Lucerne (3912217) OR Clearlake Highlands (3812286) OR Clearlake Oaks (3912216) OR Benmore Canyon (3912215) OR Kelseyville (3812287) OR Lower Lake (3812285) OR The Geysers (3812277) OR Whispering Pines (3812276) OR Middletown (3812275))

Element Code	Species	Federal Status	State Status	Global Rank	State Rank	Rare Plant Rank/CDFW SSC or FP
AAAAF02020	<i>Taricha rivularis</i> red-bellied newt	None	None	G4	S2	SSC
AAAAH01020	<i>Dicamptodon ensatus</i> California giant salamander	None	None	G3	S2S3	SSC
AAABH01022	<i>Rana draytonii</i> California red-legged frog	Threatened	None	G2G3	S2S3	SSC
AAABH01050	<i>Rana boylei</i> foothill yellow-legged frog	None	Endangered	G3	S3	SSC
ABNKC01010	<i>Pandion haliaetus</i> osprey	None	None	G5	S4	WL
ABNKC10010	<i>Haliaeetus leucocephalus</i> bald eagle	Delisted	Endangered	G5	S3	FP
ABNKC22010	<i>Aquila chrysaetos</i> golden eagle	None	None	G5	S3	FP
ABNRB02022	<i>Coccyzus americanus occidentalis</i> western yellow-billed cuckoo	Threatened	Endangered	G5T2T3	S1	
ABPAU01010	<i>Progne subis</i> purple martin	None	None	G5	S3	SSC
AFCHA0209G	<i>Oncorhynchus mykiss irideus pop. 8</i> steelhead - central California coast DPS	Threatened	None	G5T2T3Q	S2S3	
AFCJB19011	<i>Lavinia exilicauda chi</i> Clear Lake hitch	None	Threatened	G4T1	S1	
AFCQB07010	<i>Archoplites interruptus</i> Sacramento perch	None	None	G2G3	S1	SSC
AFCQK02013	<i>Hysterocarpus traskii lagunae</i> Clear Lake tule perch	None	None	G5T2T3	S2S3	SSC
AMACC01070	<i>Myotis evotis</i> long-eared myotis	None	None	G5	S3	
AMACC01090	<i>Myotis thysanodes</i> fringed myotis	None	None	G4	S3	
AMACC02010	<i>Lasionycteris noctivagans</i> silver-haired bat	None	None	G5	S3S4	
AMACC05030	<i>Lasiurus cinereus</i> hoary bat	None	None	G5	S4	
AMACC05060	<i>Lasiurus blossevillii</i> western red bat	None	None	G5	S3	SSC
AMACC08010	<i>Corynorhinus townsendii</i> Townsend's big-eared bat	None	None	G3G4	S2	SSC



Selected Elements by Element Code
California Department of Fish and Wildlife
California Natural Diversity Database

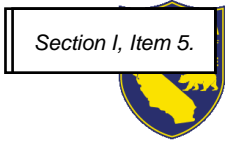

Element Code	Species	Federal Status	State Status	Global Rank	State Rank	Rare Plant Rank/CDFW SSC or FP
AMACC10010	<i>Antrozous pallidus</i> pallid bat	None	None	G5	S3	SSC
AMAFJ01010	<i>Erethizon dorsatum</i> North American porcupine	None	None	G5	S3	
ARAAD02030	<i>Emys marmorata</i> western pond turtle	None	None	G3G4	S3	SSC
CARA2422CA	Central Valley Drainage Rainbow Trout/Cyprinid Stream Central Valley Drainage Rainbow Trout/Cyprinid Stream	None	None	GNR	SNR	
CARA2520CA	Clear Lake Drainage Resident Trout Stream Clear Lake Drainage Resident Trout Stream	None	None	GNR	SNR	
CARA2530CA	Clear Lake Drainage Cyprinid/Catostomid Stream Clear Lake Drainage Cyprinid/Catostomid Stream	None	None	GNR	SNR	
CARA2550CA	Clear Lake Drainage Seasonal Lakefish Spawning Stream Clear Lake Drainage Seasonal Lakefish Spawning Stream	None	None	GNR	SNR	
CTT44131CA	Northern Basalt Flow Vernal Pool Northern Basalt Flow Vernal Pool	None	None	G3	S2.2	
CTT44133CA	Northern Volcanic Ash Vernal Pool Northern Volcanic Ash Vernal Pool	None	None	G1	S1.1	
CTT52410CA	Coastal and Valley Freshwater Marsh Coastal and Valley Freshwater Marsh	None	None	G3	S2.1	
CTT61420CA	Great Valley Mixed Riparian Forest Great Valley Mixed Riparian Forest	None	None	G2	S2.2	
ICBRA06010	<i>Lindleriella occidentalis</i> California linderiella	None	None	G2G3	S2S3	
ICMAL34010	<i>Calasellus californicus</i> An isopod	None	None	G2	S2	
IICOL5A010	<i>Dubiraphia brunnescens</i> brownish dubiraphian riffle beetle	None	None	G1	S1	
IICOL5V010	<i>Hydrochara rickseckeri</i> Ricksecker's water scavenger beetle	None	None	G2?	S2?	
IIHEM07010	<i>Saldula usingeri</i> Wilbur Springs shorebug	None	None	G1	S1	
IIHYM24250	<i>Bombus occidentalis</i> western bumble bee	None	Candidate Endangered	G2G3	S1	
IIHYM24380	<i>Bombus caliginosus</i> obscure bumble bee	None	None	G4?	S1S2	
IIHYM68020	<i>Hedychridium milleri</i> Borax Lake cuckoo wasp	None	None	G1	S1	
IMBIV19010	<i>Gonidea angulata</i> western ridged mussel	None	None	G3	S1S2	



Selected Elements by Element Code
California Department of Fish and Wildlife
California Natural Diversity Database

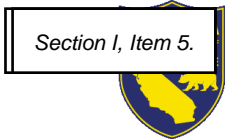

Element Code	Species	Federal Status	State Status	Global Rank	State Rank	Rare Plant Rank/CDFW SSC or FP
IMGASJ0F40	<i>Pyrgulopsis ventricosa</i> Clear Lake pyrg	None	None	G1	S1	
NBMUS32330	<i>Grimmia torenii</i> Toren's grimmia	None	None	G2	S2	1B.3
NBMUS4Q022	<i>Mielichhoferia elongata</i> elongate copper moss	None	None	G5	S3S4	4.3
PDAP10Z0W0	<i>Eryngium constancei</i> Loch Lomond button-celery	Endangered	Endangered	G1	S1	1B.1
PDAST3M5G0	<i>Erigeron greenii</i> Greene's narrow-leaved daisy	None	None	G3	S3	1B.2
PDAST4R065	<i>Hemizonia congesta ssp. congesta</i> congested-headed hayfield tarplant	None	None	G5T2	S2	1B.2
PDAST5L010	<i>Lasthenia burkei</i> Burke's goldfields	Endangered	Endangered	G1	S1	1B.1
PDAST5N0F0	<i>Layia septentrionalis</i> Colusa layia	None	None	G2	S2	1B.2
PDAST650A0	<i>Harmonia hallii</i> Hall's harmonia	None	None	G2?	S2?	1B.2
PDBOR01070	<i>Amsinckia lunaris</i> bent-flowered fiddleneck	None	None	G3	S3	1B.2
PDBRA2G071	<i>Streptanthus brachiatus ssp. hoffmanii</i> Freed's jewelflower	None	None	G2T2	S2	1B.2
PDBRA2G072	<i>Streptanthus brachiatus ssp. brachiatus</i> Socrates Mine jewelflower	None	None	G2T1	S1	1B.2
PDBRA2G0J4	<i>Streptanthus glandulosus ssp. hoffmanii</i> Hoffman's bristly jewelflower	None	None	G4T2	S2	1B.3
PDBRA2G510	<i>Streptanthus hesperidis</i> green jewelflower	None	None	G2G3	S2S3	1B.2
PDCAB01010	<i>Brasenia schreberi</i> watershield	None	None	G5	S3	2B.3
PDCAM060E0	<i>Downingia willamettensis</i> Cascade downingia	None	None	G4	S2	2B.2
PDCAM0C010	<i>Legenere limosa</i> legenere	None	None	G2	S2	1B.1
PDCON04032	<i>Calystegia collina ssp. oxyphylla</i> Mt. Saint Helena morning-glory	None	None	G4T3	S3	4.2
PDCON04036	<i>Calystegia collina ssp. tridactylosa</i> three-fingered morning-glory	None	None	G4T1	S1	1B.2
PDCPR07080	<i>Viburnum ellipticum</i> oval-leaved viburnum	None	None	G4G5	S3?	2B.3
PDCRA0F020	<i>Sedella leiocarpa</i> Lake County stonecrop	Endangered	Endangered	G1	S1	1B.1



Selected Elements by Element Code
California Department of Fish and Wildlife
California Natural Diversity Database

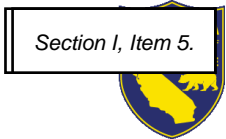

Element Code	Species	Federal Status	State Status	Global Rank	State Rank	Rare Plant Rank/CDFW SSC or FP
PDERI041G2	<i>Arctostaphylos stanfordiana ssp. raichei</i> Raiche's manzanita	None	None	G3T2	S2	1B.1
PDERI04271	<i>Arctostaphylos manzanita ssp. elegans</i> Konocti manzanita	None	None	G5T3	S3	1B.3
PDFAB0F7E1	<i>Astragalus rattanii var. jepsonianus</i> Jepson's milk-vetch	None	None	G4T3	S3	1B.2
PDFAB2B0C0	<i>Lupinus antoninus</i> Anthony Peak lupine	None	None	G2	S2	1B.2
PDFAB2B3J0	<i>Lupinus sericatus</i> Cobb Mountain lupine	None	None	G2?	S2?	1B.2
PDFAB400R5	<i>Trifolium hydrophilum</i> saline clover	None	None	G2	S2	1B.2
PDLAM220H0	<i>Trichostema ruygtii</i> Napa bluecurls	None	None	G1G2	S1S2	1B.2
PDLIM02043	<i>Limnanthes floccosa ssp. floccosa</i> woolly meadowfoam	None	None	G4T4	S3	4.2
PDLIN01010	<i>Hesperolinon adenophyllum</i> glandular western flax	None	None	G2G3	S2S3	1B.2
PDLIN01020	<i>Hesperolinon bicarpellatum</i> two-carpellate western flax	None	None	G2	S2	1B.2
PDLIN01070	<i>Hesperolinon didymocarpum</i> Lake County western flax	None	Endangered	G1	S1	1B.2
PDLIN010E0	<i>Hesperolinon sharsmithiae</i> Sharsmith's western flax	None	None	G2Q	S2	1B.2
PDMAL110K2	<i>Sidalcea oregana ssp. hydrophila</i> marsh checkerbloom	None	None	G5T2	S2	1B.2
PDPGN08440	<i>Eriogonum nervulosum</i> Snow Mountain buckwheat	None	None	G2	S2	1B.2
PDPLM03020	<i>Eriastrum brandegeae</i> Brandegee's eriastrum	None	None	G1Q	S1	1B.1
PDPLM09140	<i>Leptosiphon jepsonii</i> Jepson's leptosiphon	None	None	G2G3	S2S3	1B.2
PDPLM0C0E1	<i>Navarretia leucocephala ssp. bakeri</i> Baker's navarretia	None	None	G4T2	S2	1B.1
PDPLM0C0E4	<i>Navarretia leucocephala ssp. pauciflora</i> few-flowered navarretia	Endangered	Threatened	G4T1	S1	1B.1
PDPLM0C0E5	<i>Navarretia leucocephala ssp. plieantha</i> many-flowered navarretia	Endangered	Endangered	G4T1	S1	1B.2
PDPLM0C160	<i>Navarretia paradoxinota</i> Porter's navarretia	None	None	G2	S2	1B.3
PDRHA04220	<i>Ceanothus confusus</i> Rincon Ridge ceanothus	None	None	G1	S1	1B.1



Selected Elements by Element Code
California Department of Fish and Wildlife
California Natural Diversity Database

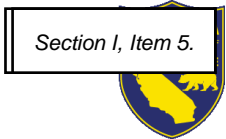

Element Code	Species	Federal Status	State Status	Global Rank	State Rank	Rare Plant Rank/CDFW SSC or FP
PDRHA04240	<i>Ceanothus divergens</i> Calistoga ceanothus	None	None	G2	S2	1B.2
PDROS0W011	<i>Horkelia bolanderi</i> Bolander's horkelia	None	None	G1	S1	1B.2
PDSCR0D482	<i>Castilleja rubicundula var. rubicundula</i> pink creamsacs	None	None	G5T2	S2	1B.2
PDSCR0R060	<i>Gratiola heterosepala</i> Boggs Lake hedge-hyssop	None	Endangered	G2	S2	1B.2
PDSCR1L483	<i>Penstemon newberryi var. sonomensis</i> Sonoma beardtongue	None	None	G4T3	S3	1B.3
PDSCR2S070	<i>Antirrhinum subcordatum</i> dimorphic snapdragon	None	None	G3	S3	4.3
PMCYP03B20	<i>Carex praticola</i> northern meadow sedge	None	None	G5	S2	2B.2
PMLIL0G042	<i>Chlorogalum pomeridianum var. minus</i> dwarf soaproot	None	None	G5T3	S3	1B.2
PMLIL0V0F0	<i>Fritillaria pluriflora</i> adobe-lily	None	None	G2G3	S2S3	1B.2
PMPOA24028	<i>Panicum acuminatum var. thermale</i> Geysers panicum	None	Endangered	G5T2Q	S2	1B.2
PMPOA3D020	<i>Imperata brevifolia</i> California satintail	None	None	G4	S3	2B.1
PMPOA4G050	<i>Orcuttia tenuis</i> slender Orcutt grass	Threatened	Endangered	G2	S2	1B.1
PMPOA03160	<i>Potamogeton zosteriformis</i> eel-grass pondweed	None	None	G5	S3	2B.2

Record Count: 94

Quad Name **Clearlake Highlands**

Quad Number **38122-H6**

ESA Anadromous Fish

SONCC Coho ESU (T) - None

CCC Coho ESU (E) - None

CC Chinook Salmon ESU (T) - None

CVSR Chinook Salmon ESU (T) - None

SRWR Chinook Salmon ESU (E) - None

NC Steelhead DPS (T) - None

CCC Steelhead DPS (T) - None

SCCC Steelhead DPS (T) - None

SC Steelhead DPS (E) - None

CCV Steelhead DPS (T) - None

Eulachon (T) - None

sDPS Green Sturgeon (T) - None

ESA Anadromous Fish Critical Habitat

SONCC Coho Critical Habitat - None

CCC Coho Critical Habitat - None

CC Chinook Salmon Critical Habitat - None

CVSR Chinook Salmon Critical Habitat - None

SRWR Chinook Salmon Critical Habitat - None

NC Steelhead Critical Habitat - None

CCC Steelhead Critical Habitat - None

SCCC Steelhead Critical Habitat - None

SC Steelhead Critical Habitat - None

CCV Steelhead Critical Habitat - None

Eulachon Critical Habitat - None

sDPS Green Sturgeon Critical Habitat - None

ESA Marine Invertebrates

Range Black Abalone (E) - None

Range White Abalone (E) - None

ESA Marine Invertebrates Critical Habitat

Black Abalone Critical Habitat - None

ESA Sea Turtles

East Pacific Green Sea Turtle (T) - None
Olive Ridley Sea Turtle (T/E) - None
Leatherback Sea Turtle (E) - None
North Pacific Loggerhead Sea Turtle (E) - None

ESA Whales

Blue Whale (E) - None
Fin Whale (E) - None
Humpback Whale (E) - None
Southern Resident Killer Whale (E) - None
North Pacific Right Whale (E) - None
Sei Whale (E) - None
Sperm Whale (E) - None

ESA Pinnipeds

Guadalupe Fur Seal (T) - None
Steller Sea Lion Critical Habitat - None

Essential Fish Habitat

Coho EFH - None
Chinook Salmon EFH - None
Groundfish EFH - None
Coastal Pelagics EFH - None
Highly Migratory Species EFH - None

MMPA Species (See list at left)

ESA and MMPA Cetaceans/Pinnipeds

**See list at left and consult the NMFS Long Beach office
562-980-4000**

MMPA Cetaceans - None
MMPA Pinnipeds - None

ATTACHMENT B

Representative Site Photographs



Photo 1. Representative photo of the walnut orchard that makes up the majority of the site. Photo taken January 29, 2021, facing north.



Photo 2. Culverted inlet for the onsite drainage located in the northeast corner of the Study Area. Photo taken January 29, 2021, facing west.



Photo 3. Representative photo of the vegetation along the drainage. Photo taken January 29, 2021, facing west.



Photo 4. Harding grass grassland and large oak trees in the southeast portion of the Study Area. Photo taken January 29, 2021, facing west-northwest



Photo 5. Representative photo of oak woodland riparian vegetation along Burns Valley Creek. Photo taken January 29, 2021, facing west.



Photo 6. Patch of Fremont cottonwood near the southern portion of the mapped drainage. Photo taken January 29, 2021, facing southwest.



Photo 7. A structure within the walnut orchard may provide roosting habitat for bats. Photo taken January 29, 2021, facing northeast.



Photo 8. Photo of foundations from old residential development and large oak trees. Photo taken January 29, 2021, facing west-northwest.

Attachment E
Geotechnical Report

Insert February 26, 2021 Geotechnical Report by NV5 here

Attachment E

Traffic Impact Study

Insert Traffic Impact Study for the Burns Valley Development by W-Trans here



Transportation Impact Study for the Burns Valley Development

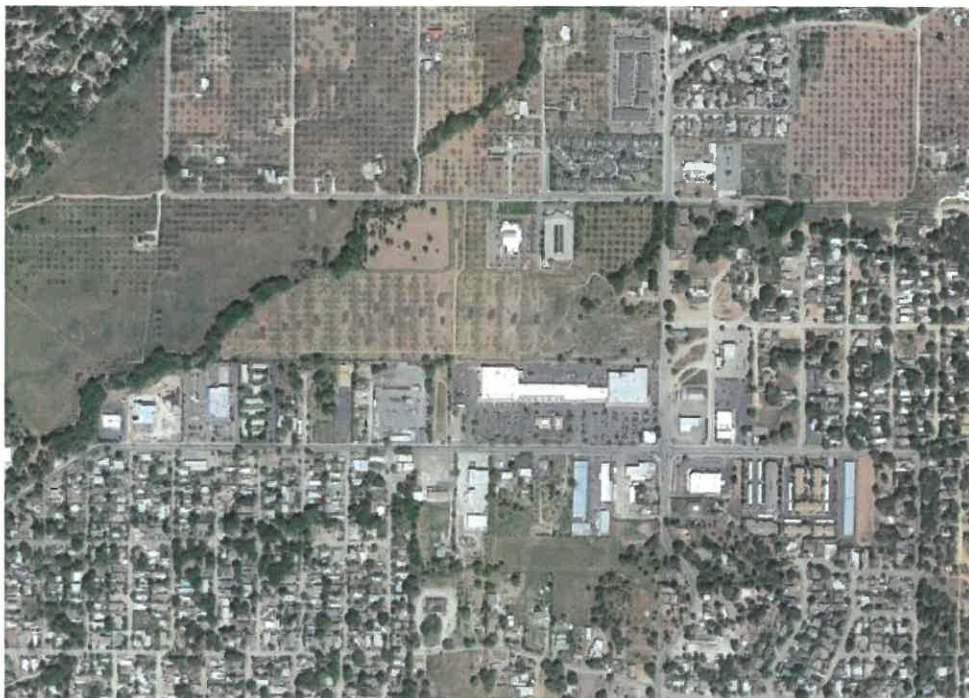

Prepared for the City of Clearlake

Submitted by
W-Trans

June 20, 2022



**TRAFFIC ENGINEERING
TRANSPORTATION PLANNING**
Balancing Functionality and Livability since 1995
w-trans.com



This page intentionally left blank

Table of Contents

Executive Summary	1
Introduction.....	2
Transportation Setting.....	5
Project Data	8
Circulation System	12
Vehicle Miles Traveled (VMT).....	16
Safety Issues.....	19
Emergency Access.....	23
Capacity Analysis	24
Parking.....	39
Conclusions and Recommendations.....	40
Study Participants and References	42

Figures

1. Study Area and Existing Lane Configurations	4
2. Site Plan	9
3. Existing Traffic Volumes	27
4. Baseline Traffic Volumes	29
5. Future Traffic Volumes.....	31
6. Project Traffic Volumes and Trip Distribution	32
7. Existing plus Project Traffic Volumes	33
8. Baseline plus Project Traffic Volumes	35
9. Future plus Project Traffic Volumes.....	37

Tables

1. Collision Rates at the Study Intersections	7
2. Trip Generation Summary (Weekdays)	10
3. Trip Generation Summary (Saturday)	11
4. Trip Distribution Assumptions.....	11
5. Bicycle Facility Summary	14
6. Employee Vehicle Miles Traveled Analysis Summary	17
7. 95 th Percentile Queues (Weekday)	22
8. 95 th Percentile Queues (Weekend).....	22
9. Intersection Level of Service Criteria.....	25
10. Existing Peak Hour Intersection Levels of Service.....	26



11. Baseline Peak Hour Intersection Levels of Service..... 28
12. Future Peak Hour Intersection Levels of Service 30
13. Existing and Existing plus Project Peak Hour Intersection Levels of Service..... 34
14. Baseline plus Project Peak Hour Intersection Levels of Service..... 36
15. Future plus Project Peak Hour Intersection Levels of Service 38
16. Parking Analysis Summary 39

Plates

1. Vision Triangle Graphic..... 20

Appendices

- A. Collision Rate Calculations
- B. NCHRP Pedestrian Crossing Treatment Worksheet
- C. VMT Screening Tool Output
- D. Turn Lane Warrant Spreadsheets
- E. Maximum Left-Turn Queue Length Calculations
- F. Intersection Level of Service and Queuing Calculations

Executive Summary

The proposed Burns Valley Development would occupy approximately 29 acres of vacant land between Burns Valley Road and Olympic Drive in the City of Clearlake. The development includes a public works corporation yard, a drive-through coffee shop, six athletic fields, a 15,000 square-foot recreational center, and a separate affordable multi-family residential project. The development would be expected to generate an average of 1,332 new daily trips, with 77 new trips during the weekday a.m. peak hour, 182 new trips during the weekday p.m. peak hour, and 353 new trips during the Saturday p.m. peak hour.

A new crosswalk with high-visibility continental crosswalk markings would be provided on Olympic Drive at the North-South Project Street intersection, along with ADA-compliant curb ramps, pedestrian crossing signage, and advance yield line markings. Crosswalks would also be provided on the project street legs of the new street connections to Burns Valley Road and Olympic Drive. The long-term bicycle storage supply for the Oak Valley Villas should be increased from the proposed four spaces to seven spaces. A total supply of 19 bicycle parking spaces should be provided throughout the non-residential portions of the development site. With the construction of these facilities in addition to sidewalks, crosswalks, and bike lanes within the development site, access for pedestrians, bicyclists, and transit riders would be adequate.

Under guidance provided by the California Governor's Office of Planning and Research (OPR) as well as data contained in the *Senate Bill 743 Vehicle Miles Traveled Regional Baseline Study* for Lake County, all components of the proposed development would be expected to have a less-than-significant transportation impact on vehicle miles traveled (VMT), including the residential, coffee shop, corporation yard, and recreational uses.

The development site would be accessed via a new north-south street extending from Olympic Drive on the south to Burns Valley Road on the north, as well as a new east-west street to be constructed north of the Safeway commercial property and extending from the proposed City corporation yard on the west to Burns Valley Road on the east. The new project streets would provide full access to the parking lots and driveways throughout the development site. The Oak Valley Villas project would also be accessed via a new driveway on Burns Valley Road. Sight lines on Burns Valley Road and Olympic Drive are adequate to accommodate all turns into and out of the proposed intersections and driveways. To maintain clear sight lines, vision triangles at the access points should be kept free of obstructions. The planting of tall vegetation should be avoided at the northeast corner of the site near the intersection of Burns Valley Road/Bowers Avenue-Rumsey Road.

A left-turn lane would be warranted on Olympic Drive at the intersection with the project street. Therefore, it is recommended that the existing two-way left-turn lane (TWLTL) on Olympic Drive be extended to provide 75 feet west of stacking space at the proposed Olympic Drive/North-South Project Street Intersection; this improvement has been added to the site plan. The projected 95th percentile queues in turn pockets at the study intersections would remain within existing storage capacity at each location under all scenarios.

To assess the project's compliance with General Plan policies, operations were evaluated at intersections along Burns Valley Road and Olympic Drive, as well as at new intersections with project streets. For Future Conditions, operations with a roundabout at Olympic Drive/Lakeshore Drive were analyzed. Analysis indicates that all study intersections operate acceptably under Existing Conditions and would continue to do so under Baseline and Future Conditions, with and without project traffic added.

The proposed parking supply would be more than sufficient to meet City and State Density Bonus requirements.

Introduction

This report presents an analysis of the potential transportation impacts and operational effects that would be associated with the proposed Burns Valley Development to be located between Burns Valley Road and Olympic Drive in the City of Clearlake. The transportation study was completed in accordance with the criteria established by the City of Clearlake, reflects a scope of work approved by City staff, and is consistent with standard traffic engineering techniques.

Prelude

The purpose of a transportation impact study (TIS) is to provide City staff and policy makers with data that they can use to make an informed decision regarding the potential transportation impacts of a proposed project, and any associated improvements that would be required to mitigate these impacts to an acceptable level under CEQA, the City's General Plan, or other policies. This report provides an analysis of those items that are identified as areas of environmental concern under the California Environmental Quality Act (CEQA) and that, if significant, require an EIR. Impacts associated with access for pedestrians, bicyclists, and to transit; the vehicle miles traveled (VMT) generated by the project; potential safety concerns such as increased queuing in dedicated turn lanes, adequacy of sight distance, need for turn lanes, and need for additional right-of-way controls; and emergency access are addressed in the context of the CEQA criteria.

While no longer a part of the CEQA review process, vehicular traffic service levels at key intersections were evaluated for consistency with General Plan policies by determining the number of new trips that the proposed uses would be expected to generate, distributing these trips to the surrounding street system based on anticipated travel patterns specific to the proposed project, then analyzing the effect the new traffic would be expected to have on the study intersections and need for improvements to maintain acceptable operation. Adequacy of parking is also addressed as a policy issue. It is noted that while the transportation impacts and traffic effects of the proposed affordable housing project are being presented in this study, for the purposes of environmental clearance the Oak Valley Villas is being entitled separately from the rest of the Burns Valley Development.

Applied Standards and Criteria

The report is organized to provide background data that supports the various aspects of the analysis, followed by the assessment of CEQA issues and then evaluation of policy-related issues. The CEQA criteria evaluated are as follows.

Would the project:

- a. Conflict with a program, plan, ordinance, or policy addressing the circulation system, including transit, roadway, bicycle, and pedestrian facilities?
- b. Conflict or be inconsistent with CEQA Guidelines § 15064.3, subdivision (b)?
- c. Substantially increase hazards due to a geometric design feature (e.g., sharp curves or dangerous intersections) or incompatible uses (e.g., farm equipment)?
- d. Result in inadequate emergency access?

Project Profile

The project includes a public works corporation yard, a drive-through coffee shop, various recreational uses such as baseball, softball, and soccer fields as well as a 15,000 square-foot recreational center and a separate affordable multi-family residential project. As part of the development, a new north-south street would be constructed that

would extend from Olympic Drive to Burns Valley Road west of the Lake County Library. Additionally, an east-west street would be constructed north of the Safeway commercial property and would extend from the proposed City corporation yard on the west to Burns Valley Road on the east.

The project site is located on approximately 29 acres of vacant land between Burns Valley Road and Olympic Drive in the City of Clearlake, as shown in Figure 1.

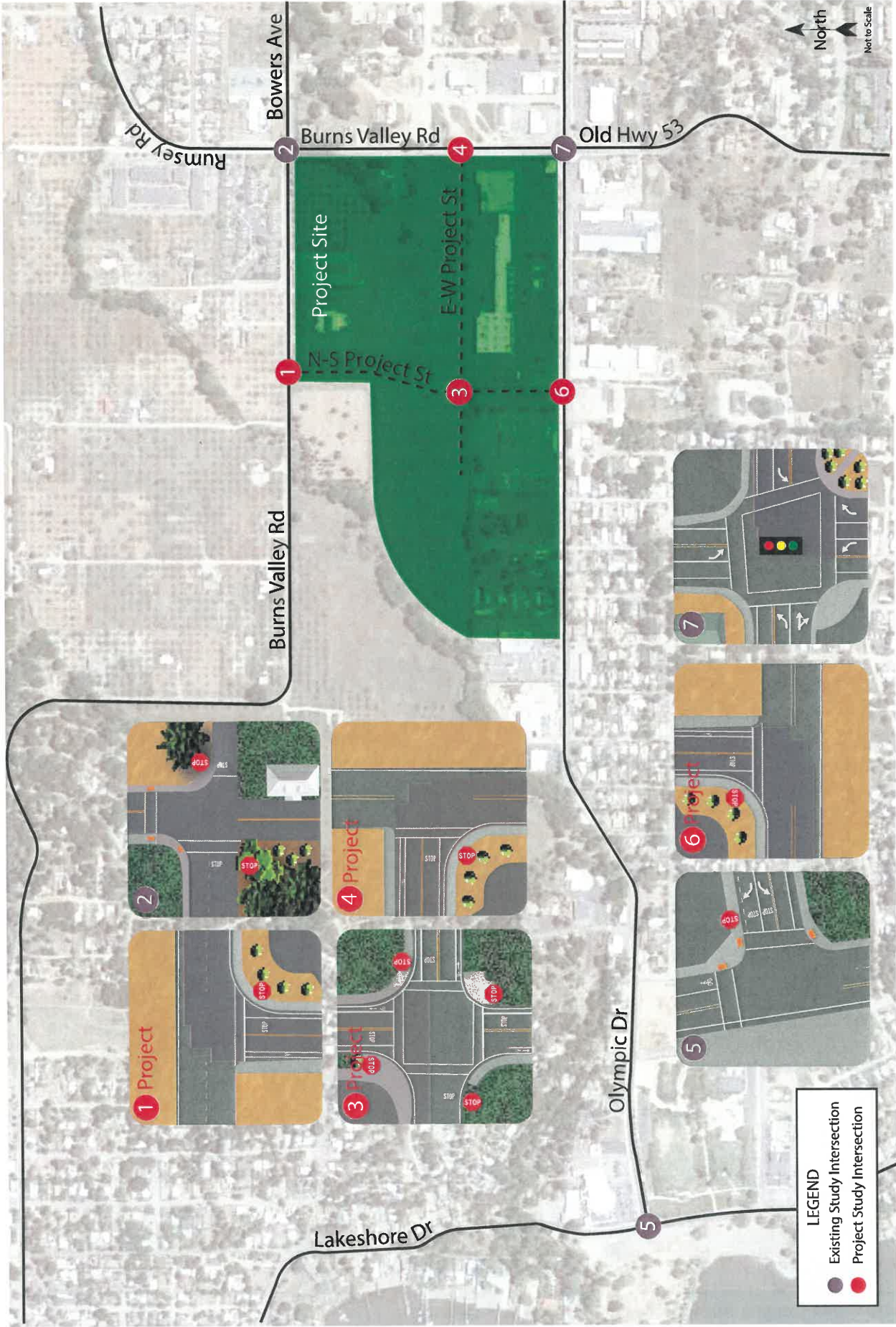

cle029.at 4/22



Transportation Impact Study for the Burns Valley Development
Figure 1 – Study Area, Existing and Proposed Lane Configurations

Transportation Setting

Study Area and Periods

The study area varies depending on the topic. For pedestrian trips it consists of all streets within a half-mile of the project site that would lie along primary routes of pedestrian travel, or those leading to nearby generators or attractors. For bicycle trips it consists of all streets within one mile of the project site that would lie along primary routes of bicycle travel. For the safety and operational analyses, the study area was selected with input from City staff and consists of the following intersections, three of which are existing and four that would be new intersections constructed by the proposed development:

1. Burns Valley Road/North-South Project Street (New)
2. Burns Valley Road/Bowers Avenue-Rumsey Road (Existing)
3. North-South Project Street/East-West Project Street (New)
4. Burns Valley Road/East-West Project Street (New)
5. Olympic Drive/Lakeshore Drive (Existing)
6. Olympic Drive/North-South Project Street (New)
7. Olympic Drive/Burns Valley Road-Old Highway 53 (Existing)

Operating conditions during the weekday a.m. and p.m. peak periods as well as the Saturday afternoon peak period were evaluated to capture the highest trip generation potential for the proposed uses as well as the highest volumes on the local transportation network. The weekday morning peak hour occurs between 7:00 and 9:00 a.m. and reflects conditions during the home to work or school commute, while the weekday p.m. peak hour occurs between 4:00 and 6:00 p.m. and typically reflects the highest level of congestion during the homeward bound commute. The Saturday afternoon peak hour generally occurs between 1:00 and 3:00 p.m. and reflects the highest level of activity associated with the recreational components of the development. New turning movement counts were obtained for the existing study intersections in January 2022.

Study Intersections

Burns Valley Road/North-South Project Street is a proposed tee intersection that would be created by the development and be located approximately 400 feet west of Sharp Lane. The intersection would be stop-controlled on the northbound terminating project street approach and a crosswalk would be provided on the south leg.

Burns Valley Road/Bowers Avenue-Rumsey Road is a four-legged existing intersection with stop controls on the eastbound and westbound Burns Valley Road and Bowers Avenue approaches, which are offset by approximately 20 feet. The south leg of the intersection is also Burns Valley Road, while the north leg is Rumsey Road. A marked crosswalk is provided on the north leg, about 30 feet north of the intersection.

North-South Project Street/East-West Project Street is a proposed four-legged intersection that would be stop-controlled on all approaches. Crosswalks would be provided on all legs.

Burns Valley Road/East-West Project Street is a tee intersection proposed to be located approximately 500 feet north of Olympic Drive. The intersection would be stop-controlled on the terminating eastbound project street approach.

Olympic Drive/Lakeshore Drive is an existing tee intersection with stop control and dedicated left- and right-turn lanes on the westbound terminating Olympic Drive approach. Crosswalks are marked on the north and east legs and the crossing on the north leg has a pedestrian-activated flashing beacon system.

Olympic Drive/North-South Project Street is a proposed tee intersection that would be located approximately 150 feet west of the westernmost driveway to the Safeway commercial center. The intersection would be stop-controlled on the southbound terminating project street approach. A crosswalk would be provided on the north leg.

Olympic Drive/Burns Valley Road-Old Highway 53 is an existing four-legged signalized intersection with left-turn lanes and protected left-turn phasing on all approaches. Crosswalks with pedestrian phasing are provided on all four legs.

The locations of the study intersections along with the existing and proposed lane configurations and controls are shown in Figure 1.

Study Roadways

Burns Valley Road has two travel lanes in each direction and bounds the development site on the eastern and northern boundaries as the roadway changes orientation from north-south to east-west at the intersection with Bowers Avenue-Rumsey Road. The north-south section of the roadway has a posted speed limit of 30 miles per hour (mph), while the east-west section has a posted speed limit of 35 mph. Based on count data collected in January 2022, the roadway has an average daily traffic (ADT) volume of approximately 2,100 vehicles to the west of Sharp Lane and 3,540 vehicles south of Turner Avenue.

Olympic Drive runs mostly east-west between Lakeshore Drive on the west and SR 53 on the east and has two travel lanes in each direction with a posted speed limit of 35 mph. A center two-way left-turn lane (TWLTL) is provided along the Safeway commercial center frontage, which extends to Emerson Street. Based on count data collected in January 2022, the roadway has an ADT volume of approximately 7,100 vehicles adjacent to the project site.

Vehicle Collision History

The collision history for the study area was reviewed to determine any trends or patterns that may indicate a safety issue for motorists in the project vicinity. Collision rates were calculated based on records available from the California Highway Patrol (CHP) as published in their Statewide Integrated Traffic Records System (SWITRS) reports. The most current five-year period available is August 1, 2016, through July 31, 2021.

As presented in Table 1, the calculated collision rates for the three existing study intersections were compared to average collision rates for similar facilities statewide, as indicated in *2018 Collision Data on California State Highways*, California Department of Transportation (Caltrans). These average rates statewide are for intersections in the same environment (urban, suburban, or rural), with the same number of approaches (three or four), and the same controls (all-way stop, two-way stop, or traffic signal). Calculated collision rates for the study intersections were all determined to be lower than the statewide average rates, indicating that the intersections are performing within normal safety parameters. The collision rate calculations are provided in Appendix A.

Table 1 – Collision Rates for the Study Intersections

Study Intersection	Number of Collisions (2016–2021)	Calculated Collision Rate (c/mve)	Statewide Average Collision Rate (c/mve)
2. Burns Valley Rd/Bowers Ave-Rumsey Rd	1	0.13	0.14
5. Olympic Dr/Lakeshore Dr	1	0.07	0.09
7. Olympic Dr/Burns Valley Rd-Old Hwy 53	4	0.21	0.24

Note: c/mve = collisions per million vehicles entering

Project Data

The proposed development consists of the following uses:

- A city corporation yard consisting of a 12,000 square-foot industrial building;
- Six sports fields consisting of full-size baseball, little league, and softball fields, two tee-ball fields, and one youth soccer field;
- A 15,000 square-foot community recreation center with sports features such as basketball and volleyball courts; and
- A 160 square-foot drive-through coffee shop; and
- A separate project with 80 multi-family apartment units dedicated as “affordable” housing known as the Oak Valley Villas.

Approximately 507 on-site parking spaces would be provided, with 144 of these spaces in a separate lot dedicated to the Oak Valley Villas.

The proposed project site plan is shown in Figure 2.

Trip Generation

The anticipated trip generation for the Burns Valley Development, including the Oak Valley Villas, was estimated using standard rates published by the Institute of Transportation Engineers (ITE) in *Trip Generation Manual*, 11th Edition, 2021. Rates for “Affordable Housing – Income Limits” (Land Use #223) were applied to the apartments, rates for “Soccer Complex” (Land Use #488) were applied to the sports field, rates for “Recreational Community Center” (Land Use #495) were applied to the recreation building, rates for “Coffee/Donut Shop with Drive-Through Window and No Indoor Seating” (Land Use #938) were applied to the coffee shop, and rates for “General Light Industrial” (Land Use #110) were applied to the City corporation yard. It is noted that rates for “Soccer Complex” were applied to all sports fields including the baseball, softball, and tee-ball fields as soccer fields and ball fields can be expected to generate similar numbers of trips. To estimate trips during the Saturday p.m. peak hour, standard ITE rates for the “Saturday Peak Hour of the Generator” were applied where available, though the Manual does not include Saturday data for industrial or coffee shop land uses so weekday p.m. peak hour rates were retained for these two uses for the Saturday peak. Further, it is noted that the trip generation calculations for the coffee shop were based on a floor area of 1,000 square feet upon reviewing the anticipated trip generation based on 160 square feet and determination that it would likely underestimate the number of trips that would be generated.

Internal Trips

Internal trips occur at mixed-use developments, and in this case, could consist of residents patronizing the coffee shop and recreational uses or guests visiting more than one establishment in a single round trip to the site, such as someone visiting the sports fields and the recreation center. If these facilities were located on separate sites these trips would occur on the streets between the facilities; however, since the entire development would be connected internally, these trips could occur without affecting operation of the adjacent street network and would therefore be considered internal. However, given the limited published standard internal trip data available for the proposed uses of the development and to result in a conservative analysis no trip deductions were taken for internal trips.



4/72
4/22
cfe029.al

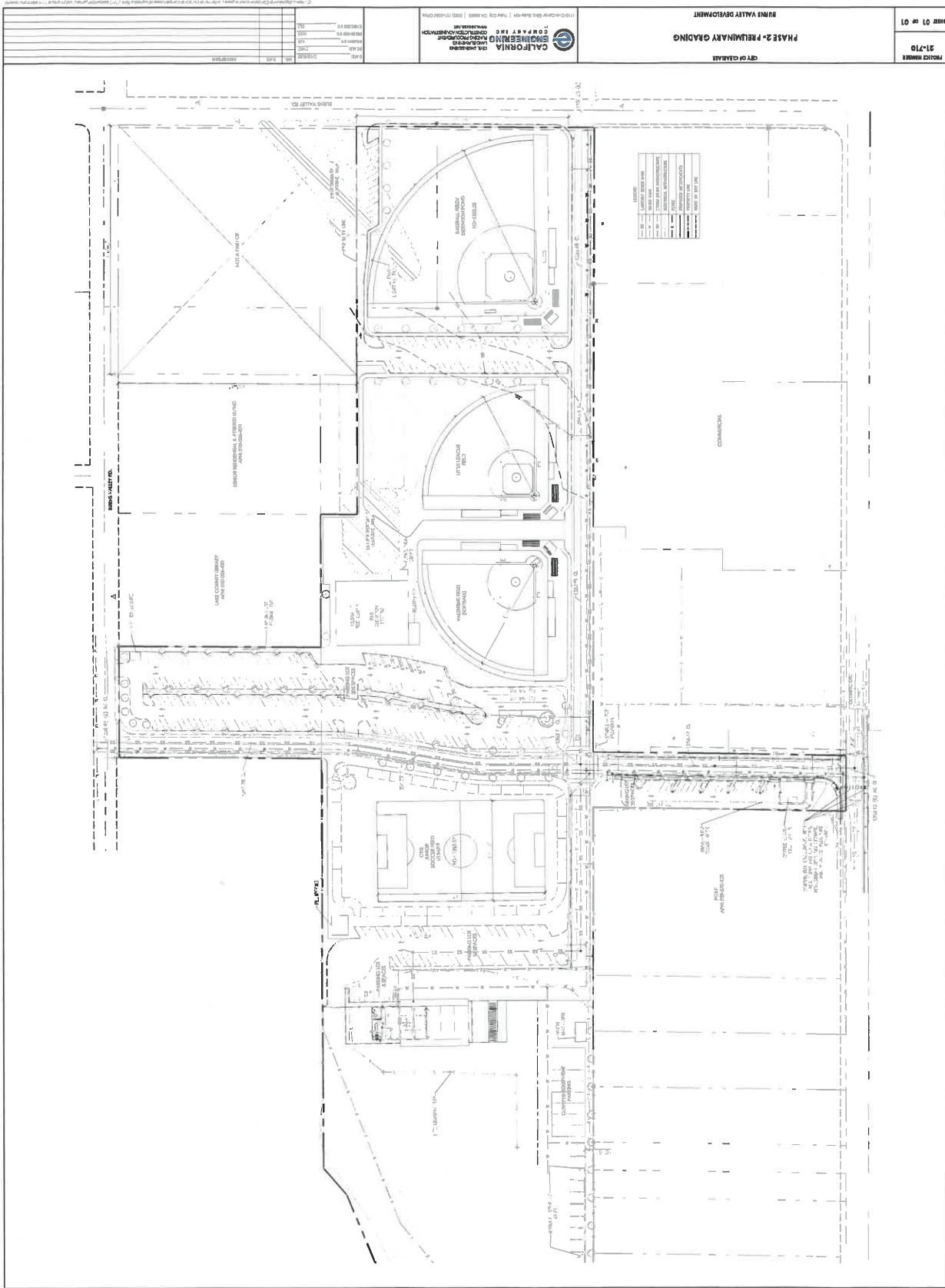

Source: California Engineering Company Inc. 4/72

Transportation Impact Study for the Burns Valley Development
Figure 2 – Site Plan

Pass-by Trips

As is typical of most retail uses, especially drive-through restaurant uses, a portion of the trips associated with the coffee shop would be drawn from existing traffic on nearby streets. These vehicle trips, known as pass-by trips, are not considered new trips since they consist of drivers who are already driving on the adjacent street and choose to make an interim stop. In the case of the proposed coffee shop which would not have indoor seating, most trips would be diverted from traffic already passing by the site on Olympic Drive. Data published in the *Trip Generation Manual* indicates pass-by percentages for a “Coffee/Donut Shop with Drive-Through Window and no Indoor Seating” (ITE LU 938) of 90 and 98 percent during the morning and evening peak hours, respectively, along with a pass-by rate of 84 percent during the weekday afternoon peak hour, which was applied to the Saturday p.m. peak hour. To estimate the number of daily trips that would be pass-by, the lower peak hour rate of 84 percent was applied for informational purposes.

Total Development Trip Generation

The expected trip generation potential for the proposed development is shown in Table 2 for weekdays and Table 3 for Saturdays, with deductions taken for pass-by trips. The development has the potential to result in an average of 1,332 new trips on local streets per day, with 77 new trips during the weekday a.m. peak hour, 182 new trips during the weekday p.m. peak hour, and 353 new trips during the Saturday p.m. peak hour.

Table 2 – Trip Generation Summary (Weekdays)											
Land Use	Units	Daily		Weekday AM Peak Hour				Weekday PM Peak Hour			
		Rate	Trips	Rate	Trips	In	Out	Rate	Trips	In	Out
Affordable Housing	80 du	4.81	385	0.36	29	8	21	0.46	37	22	15
Soccer Complex	6 fields	71.33	428	0.99	6	4	2	16.43	99	65	34
Recreation Center	15 ksf	28.82	432	1.91	29	19	10	2.50	38	18	20
General Light Ind'l	12 ksf	4.87	58	0.74	9	8	1	0.65	8	1	7
Coffee Shop	1 ksf*	179.00	179	39.81	40	20	20	15.08	15	8	7
<i>Pass-by Deduction</i>		-84%	-150	-90%	-36	-18	-18	-98%	-15	-8	-7
Total New Project Trips			1,332		77	41	36		182	106	76

Note: du = dwelling unit; ksf = 1,000 square feet; * = actual floor area is 160 sf

Table 3 – Trip Generation Summary (Saturday)

Land Use	Units	Saturday PM Peak Hour			
		Rate	Trips	In	Out
Affordable Housing	80 du	1.28	102	60	42
Soccer Complex	6 fields	37.48	225	108	117
Recreational Center	15 ksf	1.07	16	9	7
General Light Ind'l	12 ksf	0.65	8	1	7
Coffee Shop	1 ksf	15.08	15	8	7
<i>Pass-by Deduction</i>		<i>-84%</i>	<i>-13</i>	<i>-7</i>	<i>-6</i>
Total New Project Trips			353	179	174

Note: du = dwelling unit; ksf = 1,000 square feet

Trip Distribution

The pattern used to allocate new project trips to the surrounding street network was determined by reviewing existing turning movements at the study intersections, applying knowledge of the area and surrounding region, and considering anticipated travel patterns for patrons of the development. The applied trip distribution assumptions and resulting daily trips are shown in Table 4.

Table 4 – Trip Distribution Assumptions

Route	Percent	Daily Trips
To/from Rumsey Rd North of Bowers Ave	5%	67
To/from Burns Valley Rd West of Project Site	10%	133
To/from Lakeshore Dr North of Olympic Dr	10%	133
To/from Lakeshore Dr South of Olympic Dr	20%	266
To/from Old Hwy 53 South of Olympic Dr	25%	334
To/from Olympic Dr East of Old Hwy 53	20%	266
To/from Local Streets Accessed from Olympic Dr to the West of Project Site	10%	133
TOTAL	100%	1332

Circulation System

This section addresses the first bullet point on the CEQA checklist, which relates to the potential for a project to conflict with a program, plan, ordinance, or policy addressing the circulation system, including transit, roadway, bicycle, and pedestrian facilities.

Pedestrian Facilities

Existing and Planned Pedestrian Facilities

Pedestrian facilities include sidewalks, crosswalks, pedestrian signal phases, curb ramps, curb extensions, and various streetscape amenities such as lighting, benches, etc. In general, a network of sidewalks is provided on developed frontages surrounding the project site but is missing from undeveloped frontages.

- **Burns Valley Road** – Sidewalk coverage is provided on Burns Valley Road along developed property frontages but is missing from undeveloped parcels including the proposed project site. Existing sections of sidewalk are provided on the west side of Burns Valley Road between Olympic Drive and the northern boundary of the Safeway commercial center, the north side of Burns Valley Road between the project site and Rumsey Road, and on the south side of Burns Valley Road along the library and Orchard Park Senior Living Community frontages. Curb ramps and crosswalks are present at the intersection of Burns Valley Road/Rumsey Road/Bowers Avenue. Lighting is provided by overhead streetlights where sidewalks exist.
- **Olympic Drive** – Continuous sidewalks are provided on the northern side of Olympic Drive between Lakeshore Drive and Old Highway 53, while coverage on the southern side is sporadic. Lighting is provided by overhead streetlights. Crossing opportunities exist at the uncontrolled intersection at Madrone Street and at the signalized intersection with Old Highway 53-Burns Valley Road, which has pedestrian phasing.

Pedestrian Safety

The collision history for the study area was reviewed to determine any trends or patterns that may indicate a safety issue for pedestrians in the vicinity of the project site. For the same five-year study period used for the vehicle collision analysis of August 1, 2016 through July 31, 2021, there were no reported collisions involving pedestrians at the study intersections indicating that there are no readily apparent existing safety issues for pedestrians.

Project Impacts on Pedestrian Facilities

Given the proximity of residential and commercial uses surrounding the site, it is reasonable to assume that some project residents and patrons would want to walk, bicycle, and/or use transit to travel between the project site and surrounding areas. Upon construction of sidewalks along the project frontages with the north-south and east-west sections of Burns Valley Road, as shown on the project site plan, and upon construction of sidewalks along the new streets that would be constructed within the Burns Valley Development, the project site would be connected to the surrounding pedestrian network. A network of sidewalks and crosswalks would be provided throughout the Oak Valley Villas project site, resulting in connected on-site pedestrian circulation.

For the type of uses proposed, including athletic fields and a recreational center, the proposed development has the potential to generate high amounts of active transportation trips such as those made by walking and bicycling. Many of these trips would result in pedestrians needing to cross Olympic Drive when walking between the site and the residential neighborhoods on the south side of the street. The nearest existing pedestrian crossing opportunity on Olympic Drive to the west of the project site is at Madrone Street, approximately 1,400 feet away. Between Madrone Street and the development site, there are five residential streets (Buckeye Street, Maple Street,

Cypress Street, Sycamore Street, and Redwood Street) that intersect Olympic Drive and provide access to numerous homes; these residential streets also connect through to Austin Road, which provides access to even more homes further south. Pedestrians walking between residences located on these streets would not be expected to walk west in the opposite direction of the project site to use the existing crosswalk at Madrone Street to cross Olympic Drive; therefore, consideration was given to the need for a new crosswalk at the intersection that the North-South Project Street would form with Olympic Drive.

The National Cooperative Highway Research Program (NCHRP) Report 562 *Improving Pedestrian Safety at Unsignalized Intersections* Pedestrian Crossing Treatment Worksheet was completed to help determine if installation of a crosswalk or other pedestrian crossing measures would be appropriate at the new project street connection to Olympic Drive. The NCHRP worksheet recommends pedestrian treatment devices such as crosswalks, Rectangular Rapid Flashing Beacons (RRFBs), In-Roadway Warning Lights (IRWLs), High Visibility markings, and signage depending on pedestrian and vehicle volumes and geometrics of the crosswalk.

Based on vehicle counts collected in January 2022, approximately 20 pedestrian crossings would be needed within a single hour for a crosswalk to be warranted, while approximately 100 pedestrian crossings would be needed to warrant installation of a pedestrian-activated crossing device such as an RRFB. Between the demand for new crossings associated with the proposed development and existing demand associated with the Safeway commercial center, it would be reasonable to expect 20 peak hour pedestrian crossings at this location, though 100 pedestrian crossings are unlikely to be achieved; therefore, it is recommended that a crosswalk be striped on Olympic Drive at the North-South Project Street along with provision of ADA-compliant curb ramps and pedestrian crossing signage. A copy of the NCHRP Pedestrian Crossing Treatment Worksheet is contained in Appendix B.

Additionally, it is recommended that crosswalks be striped on the project street legs of the new street connections to Burns Valley Road and Olympic Drive.

Finding – Upon constructing sidewalks along the project frontages with Burns Valley Road and along the new project streets and with provision of a new crosswalk on Olympic Drive at the North-South Project Street intersection, the development would be connected to the existing pedestrian network and circulation for pedestrians would be adequate.

Recommendation – To ensure adequate connectivity for pedestrians traveling between the project site and the residential neighborhoods south of Olympic Drive, the new crosswalk with high visibility continental crosswalk markings proposed to be provided on Olympic Drive at the North-South Project Street intersection along with provision of ADA-compliant curb ramps, pedestrian crossing signage, and advanced yield line markings should be installed. Additionally, crosswalks on the project street legs of the new street connections to Burns Valley Road and Olympic Drive should be provided as proposed. These improvements are indicated on the site plan.

Bicycle Facilities

Existing and Planned Bicycle Facilities

The *Highway Design Manual*, Caltrans, 2017, classifies bikeways into four categories:

- **Class I Multi-Use Path** – a completely separated right-of-way for the exclusive use of bicycles and pedestrians with cross flows of motorized traffic minimized.
- **Class II Bike Lane** – a striped and signed lane for one-way bike travel on a street or highway.
- **Class III Bike Route** – signing only for shared use with motor vehicles within the same travel lane on a street or highway.

- **Class IV Bikeway** – also known as a separated bikeway, a Class IV Bikeway is for the exclusive use of bicycles and includes a separation between the bikeway and the motor vehicle traffic lane. The separation may include, but is not limited to, grade separation, flexible posts, inflexible physical barriers, or on-street parking.

In the project area, Class II bike lanes exist on Olympic Drive, Lakeshore Drive, Old Highway 53, and Burns Valley Road. Additional Class II bike lanes are planned on Burns Valley Road and Lakeshore Drive. Bicyclists ride in the roadway and/or on sidewalks along all other streets within the project study area. Table 5 summarizes the existing and planned bicycle facilities in the project vicinity, as contained in the *Active Transportation Plan for Lake County, 2016*.

Table 5 – Bicycle Facility Summary				
Status Facility	Class	Length (miles)	Begin Point	End Point
Existing				
Olympic Dr	II	1.7	Lakeshore Dr	SR 53
Lakeshore Dr	II	1.4	Olympic Dr	Old Hwy 53
Burns Valley Rd (SB only)	II	0.25	Bowers Ave	Olympic Dr
Old Hwy 53	II	0.25	Olympic Dr	Austin Rd
Planned				
Lakeshore Dr	II	0.57	Arrowhead Rd	Olympic Dr
Burns Valley Rd (NB only)	II	0.25	Bowers Ave	Olympic Dr

Source: *Active Transportation Plan for Lake County, Lake County/City Area Planning Council, 2016*

Bicyclist Safety

Collision records for the study area were reviewed to determine if any bicyclist-involved crashes were reported. During the five-year study period between August 1, 2016, and July 31, 2021, there were no reported collisions involving bicyclists at any of the study intersections indicating that there are no readily apparent safety issues for cyclists.

Project Impacts on Bicycle Facilities

As part of the project, Class II bike lanes would be provided on the proposed north-south and east-west project streets. These improvements together with the existing bicycle lanes on Olympic Drive, Burns Valley Road, Old Highway 53, and Lakeshore Drive and the planned facilities outlined in the County's *Active Transportation Plan* would provide adequate access for bicyclists.

Bicycle Storage

According to the Clearlake Municipal Code, bicycle parking shall be provided at a rate of five percent of the required vehicle parking spaces. For the Oak Valley Villas' proposed supply of 144 vehicle parking spaces, seven bicycle parking spaces would need to be supplied. According to the site plan, 40 short-term bicycle parking spaces would be provided in the form of bike racks throughout the residential project site along with four long-term bicycle lockers. To accommodate residents who own bicycles and since residents would not have private garages, it is recommended that the City Code requirements be applied to long-term bicycle lockers, meaning seven long-term bicycle parking spaces should be provided.

For the other development uses which would share 363 parking spaces, a supply of 19 bicycle parking spaces would need to be provided.

Finding – Bicycle facilities serving the project site would be adequate with the planned provision of Class II bike lanes on the new project streets.

Recommendation – The long-term bicycle storage supply for the Oak Valley Villas should be increased from four spaces to seven spaces. A total supply of 19 bicycle parking spaces should be provided throughout the non-residential portions of the development site.

Transit Facilities

Existing Transit Facilities

Lake Transit provides fixed route bus service in the City of Clearlake and throughout Lake County. Lake Transit Route 10 provides loop service in the northern part of the City and stops on Olympic Drive west of Old Highway 53. Route 10 operates Monday through Friday with approximately one-hour headways between 5:10 a.m. and 7:10 p.m. Route 11 provides loop service in the central portion of the City and stops on Burns Valley Road north of Olympic Drive and Rumsey Road north of Bowers Avenue. Route 11 operates Monday through Friday between 7:20 a.m. and 5:20 p.m.

Two bicycles can be carried on most Lake Transit buses. Bike rack space is on a first come, first served basis. Additional bicycles are allowed on Lake Transit buses at the discretion of the driver.

Dial-a-ride, also known as paratransit, or door-to-door service, is available for those who are unable to independently use the transit system due to a physical or mental disability. Lake Transit Dial-A-Ride and Flex Stops are designed to serve the needs of individuals with disabilities within Clearlake.

Impact on Transit Facilities

Existing stops are within an acceptable walking distance of the site and would be reachable upon completion of the proposed sidewalk improvements. Nothing proposed by the project would be expected to negatively impact Lake Transit operations; therefore, existing transit routes are adequate to accommodate project-generated transit trips.

Finding – Existing transit facilities serving the project site are adequate.

Vehicle Miles Traveled (VMT)

The potential for the project to conflict or be inconsistent with CEQA Guidelines § 15064.3, subdivision (b) was evaluated based the project's anticipated Vehicle Miles Traveled (VMT).

Background and Guidance

Senate Bill (SB) 743 established VMT as the metric to be applied in determining transportation impacts associated with development projects. As of the date of this analysis, the City of Clearlake has not yet adopted a policy or thresholds of significance regarding VMT so the project-related VMT impacts were assessed based on guidance provided by the California Governor's Office of Planning and Research (OPR) in the publication *Transportation Impacts (SB 743) CEQA Guidelines Update and Technical Advisory*, 2018 as well as information contained within the *Senate Bill 743 Vehicle Miles Traveled Regional Baseline Study (RBS)*, Fehr & Peers, 2020, prepared for the Lake Area Planning Council (LAPC). Many of the recommendations in the RBS are consistent with the OPR Technical Advisory. As allowed by CEQA, each component of the proposed development was assessed individually considering the residential, employee-based, retail, and recreational uses separately.

Residential VMT (Oak Valley Villas)

The OPR *Technical Advisory* notes that "a project consisting of a high percentage of affordable housing may be a basis for the lead agency to find a less-than-significant impact on VMT. Evidence supports a presumption of less-than-significant impact for a 100 percent affordable residential development (or the residential component of a mixed-use development) in infill locations." Because the residential component of the proposed development is a 100 percent affordable housing project within a developed area of the City of Clearlake, the screening guidance provided by OPR would apply, and it is reasonable to conclude that the project would have a less-than-significant impact on VMT.

Finding – The Oak Valley Villas residential component of the proposed development would be expected to have a less-than-significant transportation impact on vehicle miles traveled.

Employee VMT

VMT impacts associated with employees of the proposed development, including those for the coffee shop, corporation yard, and recreational facilities, were assessed based on guidance contained in the both the *Technical Advisory* and the County's RBS, which indicate that an employee-based project generating vehicle travel that is 15 or more percent below the existing average countywide VMT per worker may indicate a less-than-significant VMT impact. OPR encourages the use of screening maps to establish geographic areas that achieve the 15 percent below regional average thresholds, allowing jurisdictions to "screen" projects in those areas from quantitative VMT analysis since impacts can be presumed to be less than significant.

The RBS includes a link to a web-based VMT screening tool in the appendix of the document that can be used to screen employment-based projects that are located in low VMT-generating areas. The tool uses data from the Wine Country Travel Demand Model (WCTDM) to compare the home-based VMT per worker for the Traffic Analysis Zone (TAZ) in which a study parcel is located to the same measure for the County as a whole. The tool projects the Countywide average baseline VMT per worker to be 12.3 miles per day in 2022. A project generating a VMT that is 15 percent or more below this value, or 10.5 miles per employee or less per day, would have a less-than-significant VMT impact.

The development site is located within TAZ 1908, which is bounded by Burns Valley Road on the east and north, Olympic Drive on the south, and Lakeshore Drive on the west and has a baseline VMT per employee of 7.6 miles

per day. Because this per capita VMT ratio is below the significance threshold of 10.5 miles per day, the VMT generated by employees of the proposed development would be considered to have a less-than-significant VMT impact. A copy of the VMT screening tool output is provided in Appendix C and the VMT calculations are summarized in Table 6.

Proposed Development VMT for TAZ 1908	7.6
Countywide Average VMT	12.3
Significance Threshold VMT	10.5
Result	Less than Significant

Note: TAZ = Traffic Analysis Zone, VMT is measured in daily miles driven per employee

Finding – Employees of the proposed development including those for the coffee shop, City corporation yard, and the recreational facilities would be expected to have a less-than-significant transportation impact on vehicle miles traveled.

Retail VMT

The OPR *Technical Advisory* indicates that retail projects should generally be analyzed by examining total VMT, with an increase in total regional VMT being considered a significant impact. The *Technical Advisory* also indicates that local-serving retail uses may generally be presumed by lead agencies to have a less-than-significant VMT impact (see *Technical Advisory* pages 16-17). OPR based this presumption on substantial evidence and research demonstrating that adding local-serving retail uses typically improves destination accessibility to customers. The theory behind this criterion is that while a larger retail project may generate interregional trips that increase a region's total VMT, small retail establishments do not necessarily add new trips to a region, but change where existing customers shop within the region, and often shorten trip lengths. OPR cites a size of 50,000 square feet or greater as being a potential indicator of regional-serving retail (versus local-serving) that would typically require a quantitative VMT analysis.

The retail component of the proposed development is a 160 square-foot coffee shop, which is well below the local-serving retail screening threshold of 50,000 square feet; therefore, it is reasonable to conclude that the coffee shop would have a less-than-significant transportation impact on VMT. This conclusion is further supported by the notion that approximately 84 percent of the total daily coffee shops are anticipated to be pulled from traffic already passing by the site on Olympic Drive.

Finding – The proposed coffee shop would be expected to have a less-than-significant transportation impact on vehicle miles traveled as a local-serving retail use.

Recreational Facilities VMT

The OPR *Technical Advisory* does not specifically address recreational uses such as the proposed sports fields and recreation center, indicating that lead agencies may develop their own thresholds for other land use types, and also allowing assessment on a case-by-case basis. For land uses not addressed in the *Technical Advisory*, it is common practice to consider whether the land use of interest has travel characteristics that are similar to the residential, employment-based, or retail land use types that are addressed. If so, similar VMT assessment methodologies can often be used. In some cases, recreation-based uses have similarities to retail, in that the total demand for services (shopping trips, or in this case recreation visits) tends to remain steady at a regional level and customers/visitors often choose to visit a store/facility based on convenience and its proximity to their home. The use of retail-based methods for assessing recreational uses is also consistent with opinions offered by OPR staff

during VMT “office hours” – informational sessions during the summer of 2020 – during which it was suggested that the analysis could be based on whether the recreational use would draw visitors from the wider region or whether it would be more local-serving.

In order to determine if the proposed recreation uses would have the potential to generate interregional trips, consideration was given to the project’s intended visitor base and whether or not it would include any notable components that would potentially draw new visitors to the region. The proposed recreation uses consist of various athletic fields and sports courts including a soccer field, softball field, little league field, two tee ball fields, and a baseball field; the recreation center building would include basketball and volleyball courts. These recreation facilities would be public facilities intended to serve the local residents of the City of Clearlake, as is the intent for most public recreation facilities to serve local residents. It is further noted that the proposed athletic fields and sports courts are common facilities that are typically provided in most cities so it is unlikely that they will draw new recreation visits to the City, but rather redistribute where existing residents choose to recreate. It is likely that the proposed recreation uses would redistribute trips within the City of Clearlake from other public parks such as Austin Park and Redbud Park, rather than generate new regional trips to the City. Therefore, it was determined that it would be appropriate to evaluate the recreation component of the development as a local-serving use.

Applying the aforementioned logic behind the screening of local-serving retail uses to the proposed recreation uses, adding new recreational facilities to the urban fabric of a City can be expected to shift automobile travel patterns within the City but would be unlikely to increase the region’s total VMT, and in fact may result in a reduction in total VMT by improving destination proximity. Since the public recreational uses are intending to be primarily local-serving, as opposed to a private athletic club which may have more of a tendency to draw recreation trips from a wider region, it is reasonable to conclude that the proposed uses would have a less-than-significant impact on VMT.

Finding – The proposed recreation uses would reasonably be classified as local-serving uses with a less-than-significant transportation impact on vehicle miles traveled.

Safety Issues

The potential for the project to impact safety was evaluated in terms of the adequacy of sight distance and need for turn lanes at the project accesses as well as the adequacy of stacking space in dedicated turn lanes at the study intersections to accommodate additional queuing due to adding project-generated trips and need for additional right-of-way controls. This section addresses the third bullet on the CEQA checklist which is whether or not the project would substantially increase hazards due to a geometric design feature (e.g., sharp curves or dangerous intersections) or incompatible uses (e.g., farm equipment).

Site Access

The development site would be accessed via a new north-south street that would extend from Olympic Drive on the south to Burns Valley Road on the north and a new east-west street would be constructed to the north of the Safeway commercial property and would extend from the proposed City corporation yard on the west to Burns Valley Road on the east. Both new streets would be public streets with one lane of vehicle travel in each direction along with Class II bike lanes. Within the development site, the project streets would provide full access to the various components of the development, including parking lots and associated driveways.

The Oak Valley Villas project would be accessed via a new driveway on Burns Valley Road approximately 125 feet west of the intersection with Rumsey Road and a connection to the proposed east-west project street. The driveway on the new east-west street would be positioned approximately 450 feet west of its intersection with Burns Valley Road.

Sight Distance

Sight distances along Burns Valley Road and Olympic Drive at the proposed intersections and driveways were evaluated based on sight distance criteria contained in the *Highway Design Manual* published by Caltrans. The recommended sight distance at intersections of public streets is based on corner sight distances, while recommended sight distances for minor street approaches that are either a private road or a driveway are based on stopping sight distance. Both use the approach travel speeds as the basis for determining the recommended sight distance. Additionally, the stopping sight distance needed for a following driver to stop if there is a vehicle waiting to turn into a side street or driveway is evaluated based on stopping sight distance criterion and the approach speed on the major street.

Field measurements were obtained at the locations of the proposed intersections and driveways.

Burns Valley Road/North-South Project Street Intersection

For the posted speed limit of 35 mph on the east-west segment of Burns Valley Road, the minimum corner sight distance needed at the proposed intersection is 385 feet. Sight lines were field measured to extend more than 400 feet in each direction, which is adequate to accommodate the anticipated travel speeds.

Oak Valley Villas Driveway

For the posted speed limit of 35 mph, the minimum stopping sight distance needed is 250 feet. Based on a review of field conditions, sight lines to and from the project driveway location were measured to extend more than 300 feet to the west, which would be more than adequate for the posted speed limit. While the project driveway would be located within about 125 feet of the intersection with Rumsey Road, clear sight lines of more than 300 feet are available from the driveway to the southbound and westbound approaches of the intersection and sight lines of approximately 150 feet would be available between a motorist on the driveway and a northbound motorist turning left onto the east-west section of Burns Valley Road. Those completing this turning movement

would likely be traveling in the 15 to 20 mph range for which only 100 to 125 feet of stopping sight distance would be needed and is available. Therefore, existing sight lines are adequate.

To preserve existing adequate sight lines, it is recommended that any new signage or other structures to be installed along the Oak Valley Villas project frontage be placed outside of the vision triangle of a driver waiting on the driveway. Additionally, it is recommended that planting of trees be avoided near the northeast corner of the project site near the intersection of Burns Valley Road/Rumsey Road.

Burns Valley Road/East-West Project Street Intersection

For the posted speed limit of 30 mph on the north-south segment of Burns Valley Road, the minimum corner sight distance needed is 330 feet. Sight lines were field measured to extend more than 400 feet in each direction, which is more than adequate for the posted speed limit.

Olympic Drive/North-South Project Street Intersection

For the posted speed limit of 35 mph on Olympic Drive, the minimum corner sight distance needed at the proposed intersection is 385 feet. Based on a review of field conditions, sight lines extend more than 400 feet in each direction, which is adequate for the posted speed limit.

Additionally, given the straight and flat alignments of Burns Valley Road and Olympic Drive adjacent to the proposed intersections and driveways, adequate stopping sight distances are available for following drivers to notice and react to a preceding motorist slowing to turn right or stopped waiting to turn left into any of the access points. While sight lines are currently clear, care should be taken to maintain unobstructed sight lines during the design and construction of the proposed development and placement of signage, monuments, or other structures should be avoided within the sight triangles at the access points, which are denoted graphically in Plate 1. The Intersection Sight Distance (ISD) lengths should be based on corner sight distance for the new intersections and stopping sight distance for the Oak Valley Villas driveway.

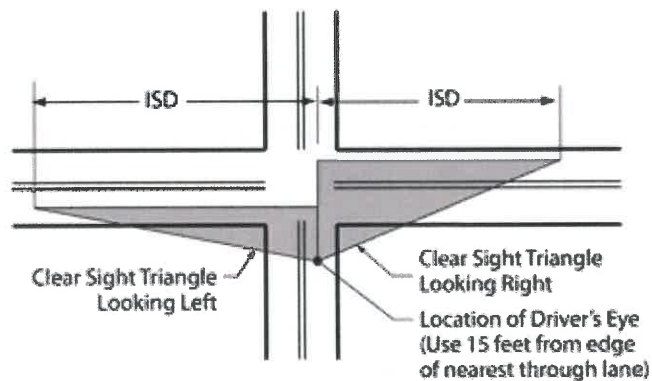

Plate 1 Vision Triangle Graphic

Finding – Sight lines on Burns Valley Road and Olympic Drive are adequate to accommodate all turns into and out of the proposed intersections and driveways.

Recommendation – To maintain adequate sight lines, any new signage, monuments, or other structures should be kept out of the vision triangles at the access points. Additionally, the planting of trees should be avoided near the northeast corner of the project site near the intersection of Burns Valley Road/Bowers Avenue-Rumsey Road.

Access Analysis

Left-Turn Lane Warrants

The need for left-turn lanes on Burns Valley Road and Olympic Drive at the proposed intersections and Oak Valley Villas driveway were evaluated based on criteria contained in the *Intersection Channelization Design Guide*, National Cooperative Highway Research Program (NCHRP) Report No. 279, Transportation Research Board, 1985, as well as an update of the methodology developed by the Washington State Department of Transportation and published in the *Method for Prioritizing Intersection Improvements*, January 1997. The NCHRP report references a methodology developed by M. D. Harmelink that includes equations that can be applied to expected or actual traffic volumes to determine the need for a left-turn pocket based on safety issues.

Using Future plus Project volumes, which represents worst-case conditions, it was determined that left-turn lanes would not be warranted on Burns Valley Road at any of the intersections with the project streets or the Oak Valley Villas driveway. However, a left-turn lane would be warranted under Baseline plus Project and Future plus Project volumes on Olympic Drive at the intersection with the project street. Copies of the turn lane warrant spreadsheets are provided in Appendix D.

There is an existing two-way left-turn lane (TWLTL) on Olympic Drive to the east of the proposed intersection along the commercial shopping center frontage so it is recommended that the TWLTL be extended to the west to facilitate left-turn movements into and out of the development site. In order to determine how far the existing TWLTL would need to be extended to the west, the projected maximum left-turn queue length was determined using a methodology contained in "Estimating Maximum Queue Length at Unsignalized Intersections," John T. Gard, *ITE Journal*, November 2001. Using Future plus Project volumes, the maximum eastbound left-turn queue on Olympic Drive would be no more than three vehicles. Therefore, it is recommended that the storage be based on three passenger cars, or 75 feet. Copies of the queue length calculations are contained in Appendix E.

Finding – Volumes would not be sufficient to warrant installation of a left-turn lane on Burns Valley Road at any of the access points to the development; however, volumes would be sufficient to meet the warrant at the Olympic Drive/North-South Project Street intersection.

Recommendation – The existing TWLTL on Olympic Drive which terminates east of the proposed intersection with the North-South Project Street should be extended to the west to provide a minimum of 75 feet of storage on the west leg of the proposed intersection, as is currently proposed and shown on the site plan.

Queuing

The City of Clearlake does not prescribe thresholds of significance regarding queue lengths. However, an increase in queue length due to project traffic was considered a potentially significant impact if the increase would cause the queue to extend out of a dedicated turn lane into a through traffic lane where moving traffic would be impeded, or the back of queue into a visually restricted area, such as a blind corner.

Unsignalized Intersections

The only existing unsignalized study intersection with a dedicated turn lane is Lakeshore Drive/Olympic Drive, which has a left-turn lane on the westbound approach. However, this approach terminates at the intersection so all traffic is slowing to be able to stop. Hence there is not a safety concern associated with the back of a queue potentially extending into the adjacent travel lane.

Signalized Intersection

Under each scenario, the projected 95th percentile queues in dedicated turn lanes at the signalized intersection of Olympic Drive/Burns Valley Road-Old Highway 53 were determined using the Vistro software. As summarized in

Table 7 and Table 8, the existing turn lanes are expected to have adequate storage capacity to accommodate queuing under all scenarios. It should be noted that while the southbound left-turn lane channelizing line is only 55 feet in length, the turn lane is preceded by a two-way left-turn lane (TWLTL) so the effective storage capacity would extend to the driveway to the commercial center before creating safety concerns; therefore, the storage length was considered to be 160 feet. Copies of the queuing projections are contained in Appendix F in the Vistro output.

Table 7 – 95th Percentile Queues (Weekday)

Study Intersection Turn Lane	Available Storage	95 th Percentile Queues											
		Weekday AM Peak Hour						Weekday PM Peak Hour					
		E	E+P	B	B+P	F	F+P	E	E+P	B	B+P	F	F+P
Olympic Dr/Burns Valley Rd- Old Hwy 53													
Northbound Left Turn	95	11	12	15	17	33	35	32	36	41	52	75	86
Northbound Right Turn	95	4	5	8	8	12	13	8	9	19	25	35	38
Eastbound Left Turn	50	7	7	8	8	12	13	8	8	11	12	23	26
Southbound Left Turn	160*	18	19	20	22	48	51	35	40	38	48	80	93
Westbound Left Turn	105	11	12	16	17	27	28	19	21	36	42	47	51

Notes: Maximum Queue based on Vistro output; all distances are measured in feet; E = Existing Conditions; E+P = Existing plus Project Conditions; B = Baseline Conditions; B+P = Baseline plus Project Conditions; F = Future Conditions; F+P = Future plus Project Conditions; * turn lane length includes adjacent TWLTL

Table 8 – 95th Percentile Queues (Weekend)

Study Intersection Turn Lane	Available Storage	95 th Percentile Queues					
		Weekend PM Peak Hour					
		E	E+P	B	B+P	F	F+P
Olympic Dr/Burns Valley Rd-Old Hwy 53							
Northbound Left Turn	96	19	26	41	46	46	55
Northbound Right Turn	96	5	5	22	19	14	16
Eastbound Left Turn	48	6	7	11	11	13	16
Southbound Left Turn	160*	23	5	36	44	51	65
Westbound Left Turn	106	9	10	37	39	20	23

Notes: Maximum Queue based on Vistro output; all distances are measured in feet; E = Existing Conditions; E+P = Existing plus Project Conditions; B = Baseline Conditions; B+P = Baseline plus Project Conditions; F = Future Conditions; F+P = Future plus Project Conditions; * turn lane length includes adjacent TWLTL

Finding – The project would not be expected to cause any queues to exceed available storage or extend into an adjacent intersection, so the impact is considered less than significant.

Emergency Access

The final bullet on the CEQA checklist requires an evaluation as to whether the project would result in inadequate emergency access or not.

Adequacy of Site Access

Access to the Oak Valley Villas project site for emergency response vehicles would be facilitated via the northern driveway on Burns Valley Road and southern driveway along the new east-west street, both of which would have a width of 26 feet; this would be adequate to satisfy the required minimum driveway width of 24 feet set forth in the City of Clearlake's *Design and Construction Standards*. On-site circulation includes a 26-foot drive aisle, which also exceeds the minimum width of 24 feet.

While the site plan for the rest of the Burns Valley Development is still preliminary, it is anticipated that all aspects of the site including street and driveway widths and parking lot circulation would be designed in accordance with applicable standards; therefore, access would be expected to function acceptably for emergency response vehicles. It should also be noted that the development site would have multiple access points so should one means of access be compromised during an emergency, responders would be able to use another access point to reach the various aspects of the development.

Off-Site Impacts

While the development would be expected to result in a minor increase in delay for traffic on Burns Valley Road and Olympic Drive, emergency response vehicles can claim the right-of-way by using their lights and sirens; therefore, the project would be expected to have a nominal effect on emergency response times.

Finding – Emergency access and circulation are anticipated to function acceptably with incorporation of applicable design standards into the site layout and traffic from the proposed development would be expected to have a less-than-significant impact on emergency response times.

Capacity Analysis

Though not relevant to the CEQA review process, in keeping with General Plan policies, the potential for the project to effect traffic operation was evaluated.

Intersection Level of Service Methodologies

Level of Service (LOS) is used to rank traffic operation on various types of facilities based on traffic volumes and roadway capacity using a series of letter designations ranging from A to F. Generally, Level of Service A represents free flow conditions and Level of Service F represents forced flow or breakdown conditions. A unit of measure that indicates a level of delay generally accompanies the LOS designation.

The study intersections were analyzed using methodologies published in the *Highway Capacity Manual (HCM)*, Transportation Research Board, 2018. This source contains methodologies for various types of intersection control, all of which are related to a measurement of delay in average number of seconds per vehicle.

The Levels of Service for the existing and proposed intersections with side street stop controls, or those which are unsignalized and have one or two approaches stop controlled, were analyzed using the “Two-Way Stop-Controlled” intersection capacity method from the HCM. This methodology determines a level of service for each minor turning movement by estimating the level of average delay in seconds per vehicle. Results are presented for individual movements together with the weighted overall average delay for the intersection.

The study intersection of the East-West and North-South Project Streets is proposed to have stop signs on all approaches so was analyzed using the “All-Way Stop-Controlled” Intersection methodology from the HCM. This methodology evaluates delay for each approach based on turning movements, opposing and conflicting traffic volumes, and the number of lanes. Average vehicle delay is computed for the intersection as a whole, and is then related to a Level of Service.

The study intersection of Olympic Drive/Burns Valley Road-Old Highway 53 is controlled by a traffic signal so was evaluated using the signalized methodology from the HCM. This methodology is based on factors including traffic volumes, green time for each movement, phasing, whether the signals are coordinated or not, truck traffic, and pedestrian activity. Average stopped delay per vehicle in seconds is used as the basis for evaluation in this LOS methodology. For purposes of this study, delays were calculated using optimized signal timing.

The study intersection of Lakeshore Drive/Olympic Drive is programmed to be controlled by a modern roundabout in the future according to the City’s Development Impact Fee Program so was evaluated using the Federal Highway Administration (FHWA) Roundabout Method, also contained within the Unsignalized Methodology of the HCM 6th Edition, Transportation Research Board, 2016. This methodology determines intersection operation using a gap acceptance method along with basic geometric and volume data to calculate entering and circulating flows. This information is then translated to average vehicle delays, with LOS break points at the same delays as used in the two-way stop-controlled methodology.

The ranges of delay associated with the various levels of service are indicated in Table 9.

Table 9 – Intersection Level of Service Criteria

LOS	Two-Way Stop-Controlled	All-Way Stop-Controlled	Signalized	Roundabout
A	Delay of 0 to 10 seconds. Gaps in traffic are readily available for drivers exiting the minor street.	Delay of 0 to 10 seconds. Upon stopping, drivers are immediately able to proceed.	Delay of 0 to 10 seconds. Most vehicles arrive during the green phase, so do not stop at all.	Delay of 0 to 10 seconds.
B	Delay of 10 to 15 seconds. Gaps in traffic are somewhat less readily available than with LOS A, but no queuing occurs on the minor street.	Delay of 10 to 15 seconds. Drivers may wait for one or two vehicles to clear the intersection before proceeding from a stop.	Delay of 10 to 20 seconds. More vehicles stop than with LOS A, but many drivers still do not have to stop.	Delay of 10 to 15 seconds.
C	Delay of 15 to 25 seconds. Acceptable gaps in traffic are less frequent, and drivers may approach while another vehicle is already waiting to exit the side street.	Delay of 15 to 25 seconds. Drivers will enter a queue of one or two vehicles on the same approach, and wait for vehicle to clear from one or more approaches prior to entering the intersection.	Delay of 20 to 35 seconds. The number of vehicles stopping is significant, although many still pass through without stopping.	Delay of 15 to 25 seconds.
D	Delay of 25 to 35 seconds. There are fewer acceptable gaps in traffic, and drivers may enter a queue of one or two vehicles on the side street.	Delay of 25 to 35 seconds. Queues of more than two vehicles are encountered on one or more approaches.	Delay of 35 to 55 seconds. The influence of congestion is noticeable, and most vehicles have to stop.	Delay of 25 to 35 seconds.
E	Delay of 35 to 50 seconds. Few acceptable gaps in traffic are available, and longer queues may form on the side street.	Delay of 35 to 50 seconds. Longer queues are encountered on more than one approach to the intersection.	Delay of 55 to 80 seconds. Most, if not all, vehicles must stop and drivers consider the delay excessive.	Delay of 35 to 50 seconds.
F	Delay of more than 50 seconds. Drivers may wait for long periods before there is an acceptable gap in traffic for exiting the side streets, creating long queues.	Delay of more than 50 seconds. Drivers enter long queues on all approaches.	Delay of more than 80 seconds. Vehicles may wait through more than one cycle to clear the intersection.	Delay of more than 50 seconds.

Reference: *Highway Capacity Manual*, Transportation Research Board, 2018

Traffic Operation Standards

City of Clearlake

The City of Clearlake established a standard of LOS D for all intersections and roadways in Policy CI 1.3.4 of *City of Clearlake 2040 General Plan Update*, City of Clearlake, 2017. Exceptions to this may be considered by the City Council when an unacceptable LOS (E or F) would result in clear public benefit. Such circumstances may include when improvements to achieve the LOS standard would result in impacts to unique historic resources or highly sensitive environmental areas; if right-of-way acquisition is infeasible; and/or if there are overriding economic or social circumstances.

Existing Conditions

The Existing Conditions scenario provides an evaluation of current operation based on existing traffic volumes during the weekday a.m., weekday p.m., and weekend p.m. peak periods. This condition does not include project-generated traffic volumes. Volume data was collected in January 2022 during typical traffic conditions and while local schools were in session. Peak hour factors (PHFs) were calculated based on the counts obtained and used in the analysis.

The three existing study intersections are currently operating acceptably at LOS A or B overall and on the minor street approaches. The existing traffic volumes are shown in Figure 3. A summary of the intersection Level of Service calculations is contained in Table 10, and copies of the calculations for all evaluated scenarios are provided in Appendix F.

Table 10 – Existing Peak Hour Intersection Levels of Service

Study Intersection Approach	Weekday AM Peak		Weekday PM Peak		Weekend PM Peak	
	Delay	LOS	Delay	LOS	Delay	LOS
2. Burns Valley Rd/Bowers Ave-Rumsey Rd	6.8	A	5.7	A	6.1	A
<i>Eastbound (Burns Valley Rd) Approach</i>	9.4	A	9.3	A	9.2	A
<i>Westbound (Bowers Ave) Approach</i>	13.4	B	12.6	B	11.5	B
5. Olympic Dr/Lakeshore Dr	2.8	A	4.8	A	4.3	A
<i>Westbound (Olympic Dr) Approach</i>	12.5	B	13.2	B	13.8	B
7. Olympic Dr/Burns Valley Rd-Old Hwy 53	11.2	B	13.3	B	11.7	B

Notes: Delay is measured in average seconds per vehicle; LOS = Level of Service; Results for minor approaches to two-way stop-controlled intersections are indicated in *italics*.

Baseline Conditions

Baseline (Existing plus Approved) operating conditions were determined with traffic from approved or pending projects in the study area that could be operational within the next five-year horizon added to the existing volumes. The following projects were identified for inclusion in the Baseline scenario through coordination with City staff.

- Konocti Gardens is a 102-unit multi-family affordable housing project that would be located at 3930 Old Highway 53. Based on standard rates published by the Institute of Transportation Engineers (ITE) in the *Trip Generation Manual*, 11th Edition, 2021, the project would be expected to generate an average of 491 daily trips on weekdays and 1,224 daily trips on weekend days, including 37 trips during the weekday a.m. peak hour, 47 trips during the weekday p.m. peak hour, and 131 trips during the weekend p.m. peak hour.
- A tribal health clinic of approximately 24,000 square feet is approved and will be located at 14440 and 14480 Olympic Drive. As evaluated in the *Traffic Impact Study for the Lake County Tribal Health Clinic*, W-Trans, 2019, the project is expected to generate 906 daily trips on average, including 88 trips during the weekday a.m. peak hour and 78 trips during the weekday p.m. peak hour. Trip rates for the weekday p.m. peak period were applied to the weekend p.m. peak hour. The same trip distribution assumptions as were applied in the project's traffic study were also applied in this analysis.
- Four Corners is an approved cannabis project consisting of 8,000 square feet of dispensary retail space, 4,300 square feet of storage space, and 20,000 square feet of cultivation and processing space to be located on the southwest corner of the Olympic Drive/Old Highway 53-Burns Valley Road intersection. Over the last three

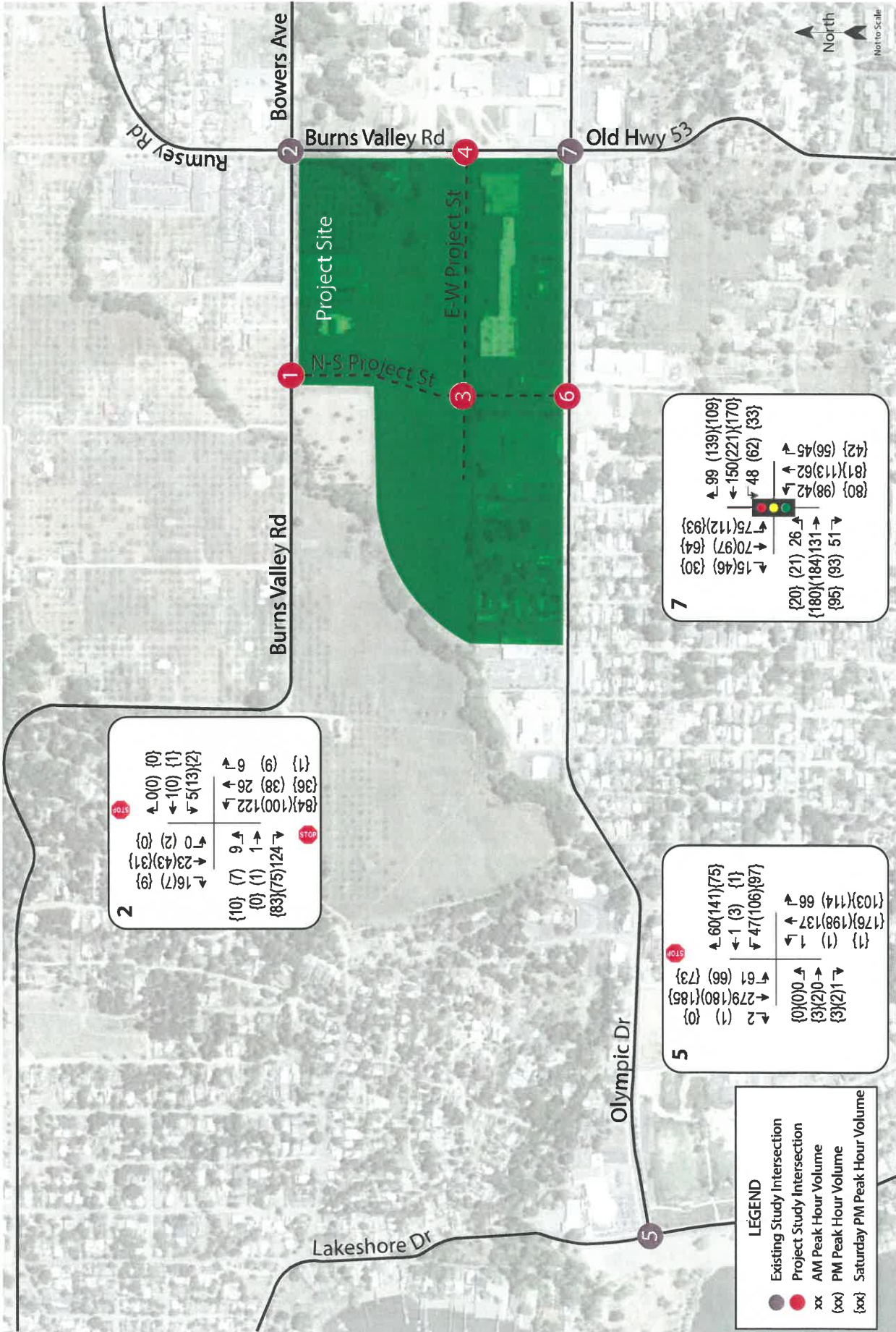

Transportation Impact Study for the Burns Valley Development
Figure 3 – Existing Traffic Volumes

years, W-Trans has collected data at several dispensaries in the North Bay Area, which was used to estimate the trip generation potential of the retail portion of the project. This data collection effort has identified that local dispensaries are expected to generate about 95 vehicle trips per day per 1,000 square feet of gross floor area, including two trips per 1,000 square feet during the weekday a.m. peak hour and 22 trips per 1,000 square feet during the weekday p.m. peak hour. Standard ITE rates for “Warehousing” and “Marijuana Cultivation and Processing Facility” were applied to the non-retail components of the project. Trip rates for the weekday p.m. peak period were applied to the weekend p.m. peak hour. Based on these rates, the project would be expected to generate an average of 32 trips during the weekday a.m. peak hour, 190 trips during the weekday p.m. peak hour, and 190 trips during the weekend p.m. peak hour.

- The addition of a drive-through window to an existing 1,600 square-foot Subway restaurant located at 15060 Lakeshore Drive has been approved. Based on standard ITE rates, the addition would be expected to generate an average of three new trips during the weekday a.m. peak hour, 10 new trips during the weekday p.m. peak hour, and one new trip during the weekend p.m. peak hour.
- The remodel and expansion of an existing Shell gasoline service station located at 15105 Lakeshore Drive has been approved. Based on standard ITE rates with pass-by trips deducted, the project would be expected to generate an average of 15 new trips during the weekday a.m. peak hour, 24 new trips during the weekday p.m. peak hour, and 26 new trips during the weekend p.m. peak hour.

Upon adding trips from approved or pending projects in the study area to existing volumes, all existing study intersections would continue to operate acceptably. These results are summarized in Table 11, and Baseline volumes are shown in Figure 4.

Table 11 – Baseline Peak Hour Intersection Levels of Service						
Study Intersection <i>Approach</i>	Weekday AM Peak		Weekday PM Peak		Weekend PM Peak	
	Delay	LOS	Delay	LOS	Delay	LOS
2. Burns Valley Rd/Bowers Ave-Rumsey Rd <i>Eastbound (Burns Valley Rd) Approach</i> <i>Westbound (Bowers Ave) Approach</i>	6.8	A	5.9	A	6.3	A
	<i>9.5</i>	<i>A</i>	<i>9.3</i>	<i>A</i>	<i>9.3</i>	<i>A</i>
	<i>13.7</i>	<i>B</i>	<i>13.2</i>	<i>B</i>	<i>12.1</i>	<i>B</i>
5. Olympic Dr/Lakeshore Dr <i>Westbound (Olympic Dr) Approach</i>	3.1	A	5.5	A	5.7	A
	<i>13.0</i>	<i>B</i>	<i>13.9</i>	<i>B</i>	<i>16.1</i>	<i>C</i>
7. Olympic Dr/Burns Valley Rd-Old Hwy 53	11.8	B	14.3	B	14.2	B

Notes: Delay is measured in average seconds per vehicle; LOS = Level of Service; Results for minor approaches to two-way stop-controlled intersections are indicated in *italics*.

Future Conditions

Future volumes for the horizon year 2040, as developed for the traffic analysis that was prepared for the *City of Clearlake 2040 General Plan Update*, were used to project future operating conditions at the study intersections. For the study intersections that were not evaluated in the General Plan Update a growth factor was calculated based on the increase between existing and future volume projections for the nearest intersection that was analyzed in the General Plan analysis and then applied to the existing volumes at the study intersection in order to project likely future volumes. This same methodology was used to project future turning movement volumes for the Saturday afternoon peak hour since this period was not analyzed for the General Plan. The City’s Development Impact Fee program includes funding for installation of a single-lane modern roundabout at the intersection of Lakeshore Drive/Olympic Drive so this improvement was assumed to be in place for the evaluation of future operating conditions.

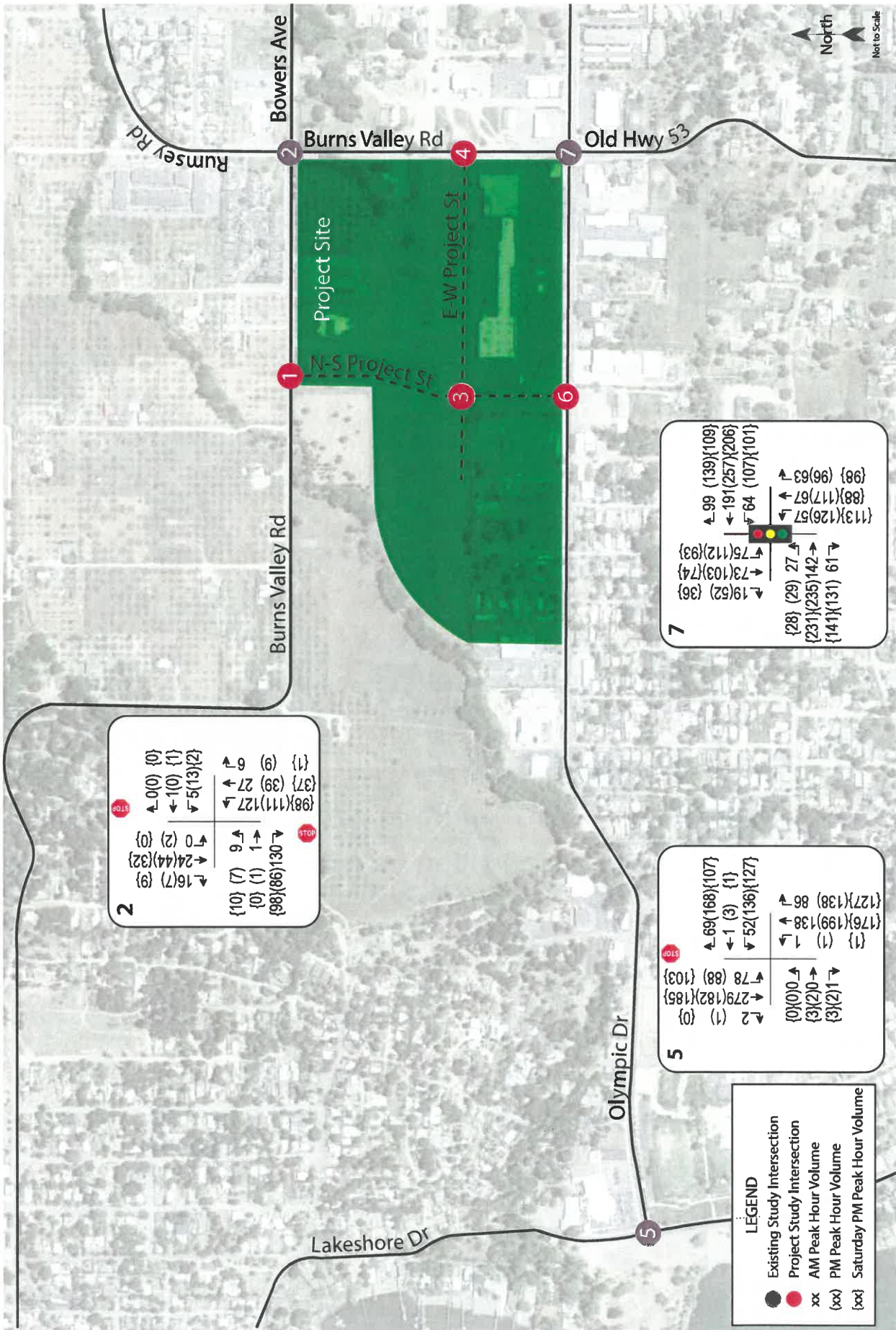

Transportation Impact Study for the Burns Valley Development
Figure 4 – Baseline Traffic Volumes

cle029.al 4/22



Under the anticipated future volumes that would be expected upon buildout of the City's General Plan, and with installation of a roundabout at the Lakeshore Drive/Olympic Drive intersection, the study intersections are expected to operate acceptably overall as well as on the minor street approaches.

Future volumes are shown in Figure 5 and operating conditions are summarized in Table 12.

Table 12 – Future Peak Hour Intersection Levels of Service						
Study Intersection <i>Approach</i>	Weekday AM Peak		Weekday PM Peak		Weekend PM Peak	
	Delay	LOS	Delay	LOS	Delay	LOS
2. Burns Valley Rd/Bowers Ave-Rumsey Rd	7.3	A	6.1	A	6.1	A
<i>Eastbound (Burns Valley Rd) Approach</i>	<i>10.4</i>	<i>A</i>	<i>9.8</i>	<i>A</i>	<i>9.7</i>	<i>A</i>
<i>Westbound (Bowers Ave) Approach</i>	<i>18.3</i>	<i>C</i>	<i>15.6</i>	<i>C</i>	<i>13.3</i>	<i>B</i>
5. Olympic Dr/Lakeshore Dr (Roundabout)	5.7	A	4.9	A	4.6	A
7. Olympic Dr/Burns Valley Rd-Old Hwy 53	14.4	B	19.4	B	14.8	B

Notes: Delay is measured in average seconds per vehicle; LOS = Level of Service; Results for minor approaches to two-way stop-controlled intersections are indicated in *italics*.

Project Conditions

Existing plus Project Conditions

The new North-South Project Street would be expected to redistribute some of the existing traffic in the area by allowing motorists to pass through the Burns Valley Development site, which would likely result in a faster route than traveling around the site using the north-south segment of Burns Valley Road for trips between the northwestern part of the City and the Safeway shopping center. Therefore, for Project Conditions, it was assumed that 10 percent of the existing traffic traveling along the north-south segment of Burns Valley Road would be redistributed to the North-South Project Street. To result in a conservative analysis, rerouted traffic was not deducted from the volumes at the north-south Burns Valley Road study intersections.

Upon the addition of trips associated with the entire Burns Valley Development, including the proposed Oak Valley Villas, the study intersections would be expected to continue operating acceptably during all three peak hours. These results are summarized in Table 13. Project-only traffic volumes are shown in Figure 6, and Existing plus Project volumes are shown in Figure 7.

cle029.ai 4/22

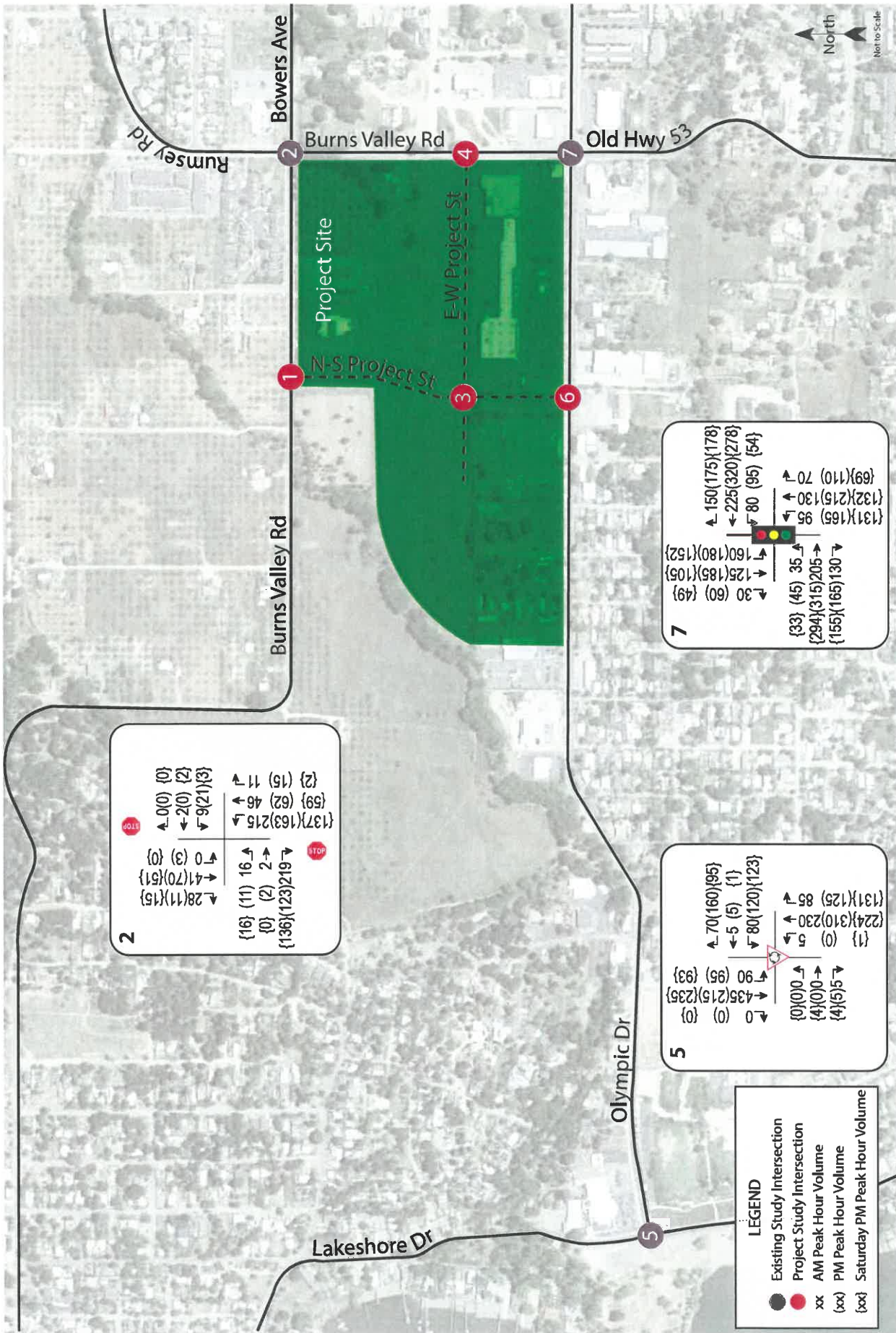

Transportation Impact Study for the Burns Valley Development
Figure 5 – Future Traffic Volumes

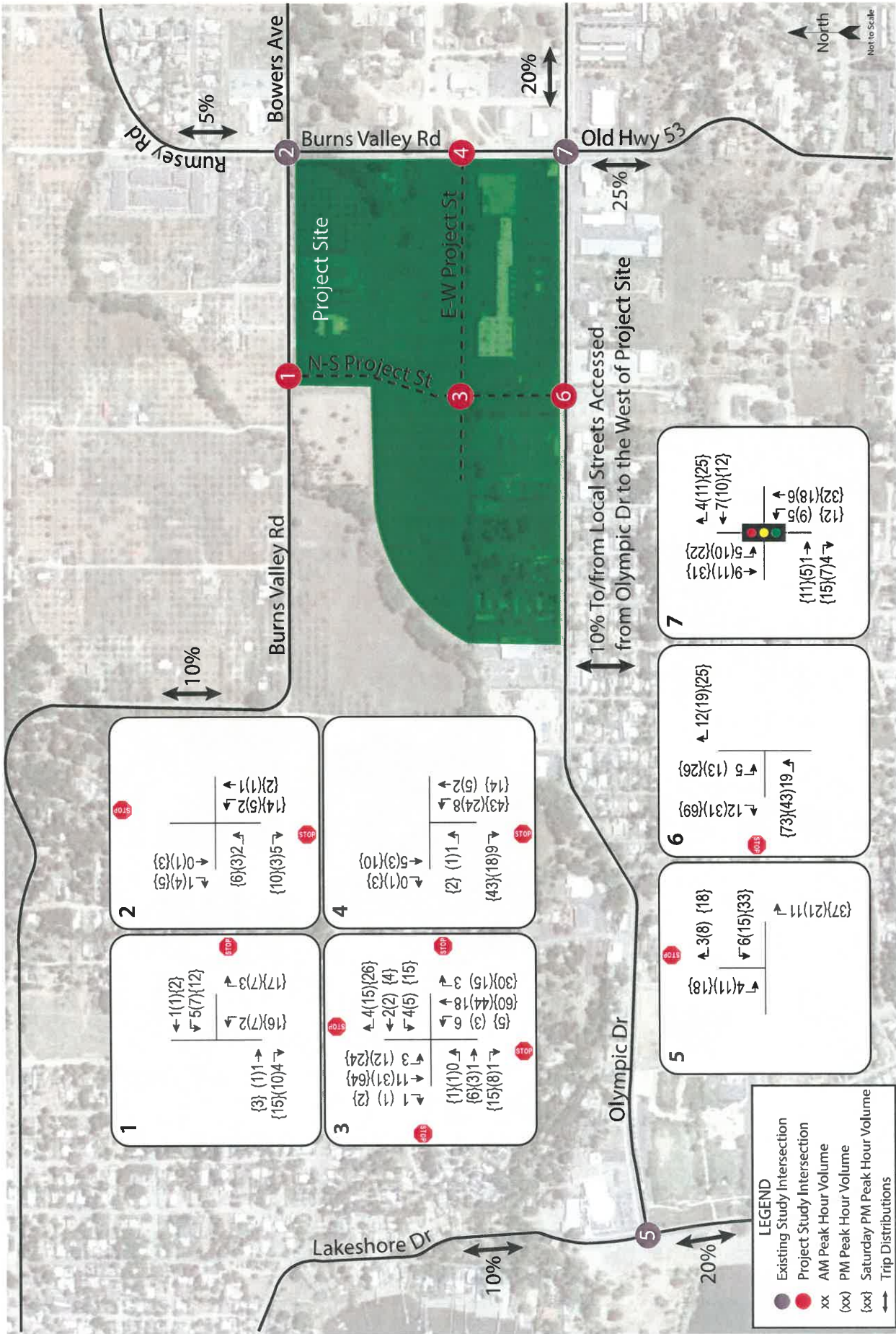

Transportation Impact Study for the Burns Valley Development
Figure 6 – Project Traffic Volumes and Trip Distributions

cle029.al 4/72

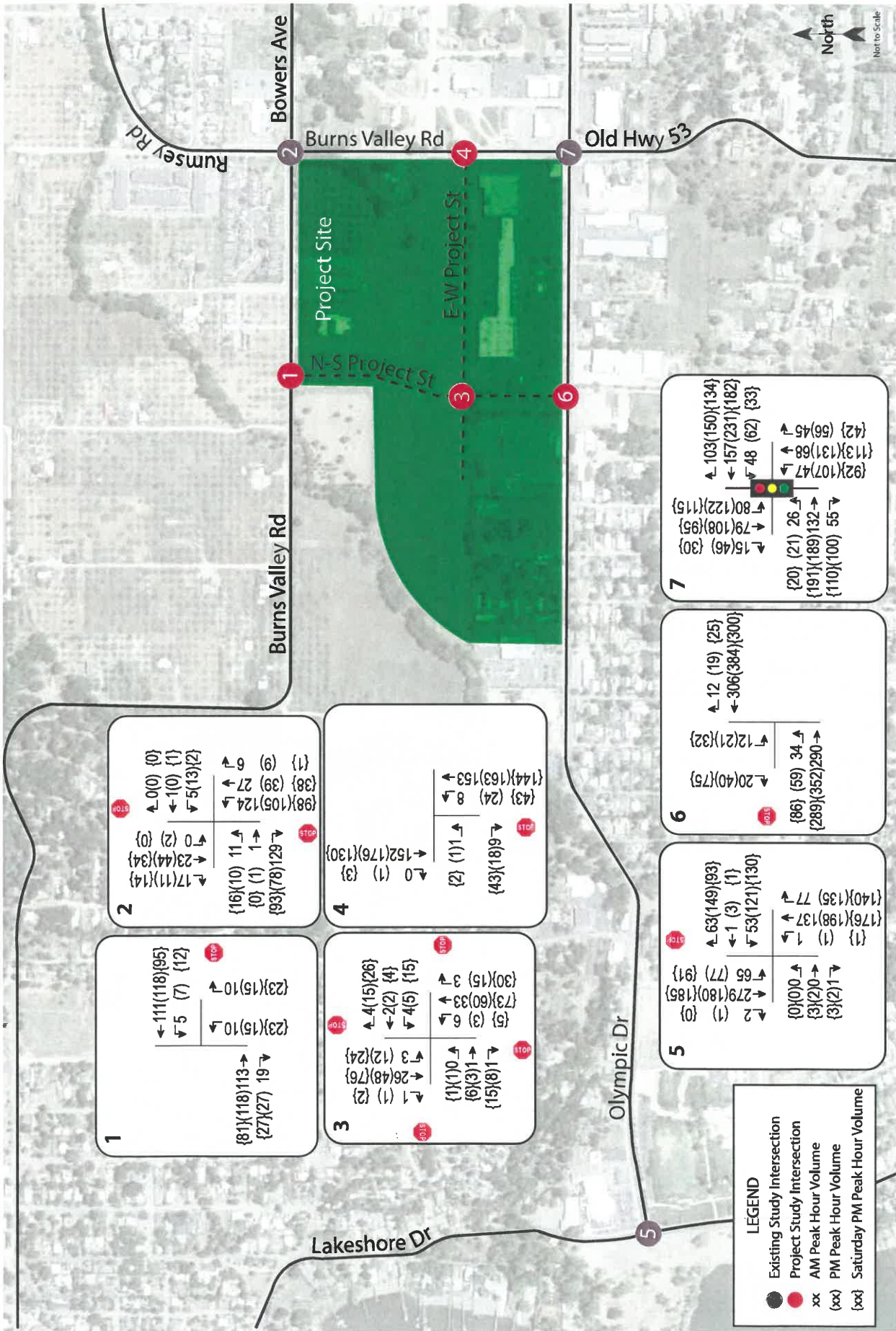

Transportation Impact Study for the Burns Valley Development
Figure 7 – Existing plus Project Traffic Volumes

Table 13 – Existing plus Project Peak Hour Intersection Levels of Service

Study Intersection Approach	Weekday AM		Weekday PM		Weekend PM	
	Delay	LOS	Delay	LOS	Delay	LOS
1. Burns Valley Rd/N-S Project St <i>NB (Project St) Approach</i>	0.9 <i>9.6</i>	A <i>A</i>	1.2 <i>9.8</i>	A <i>A</i>	2.0 <i>9.6</i>	A <i>A</i>
2. Burns Valley Rd/Bowers Ave-Rumsey Rd <i>EB (Burns Valley Rd) Approach</i> <i>WB (Bowers Ave) Approach</i>	6.9 <i>9.5</i> <i>13.6</i>	A <i>A</i> <i>B</i>	5.8 <i>9.5</i> <i>12.9</i>	A <i>A</i> <i>B</i>	6.3 <i>9.5</i> <i>12.1</i>	A <i>A</i> <i>B</i>
3. N-S Project St/E-W Project St	7.2	A	7.4	A	7.6	A
4. Burns Valley Rd/E-W Project St <i>EB (Project St) Approach</i>	0.5 <i>9.4</i>	A <i>A</i>	0.9 <i>9.5</i>	A <i>A</i>	2.0 <i>9.3</i>	A <i>A</i>
5. Olympic Dr/Lakeshore Dr <i>WB (Olympic Dr) Approach</i>	3.0 <i>12.9</i>	A <i>B</i>	5.2 <i>14.0</i>	A <i>B</i>	5.3 <i>15.9</i>	A <i>C</i>
6. Olympic Dr/N-S Project St <i>SB (Project St) Approach</i>	1.0 <i>12.8</i>	A <i>B</i>	1.7 <i>16.1</i>	A <i>C</i>	2.1 <i>15.5</i>	A <i>C</i>
7. Olympic Dr/Burns Valley Rd-Old Hwy 53	11.4	B	13.8	B	12.7	B

Notes: Delay is measured in average seconds per vehicle; LOS = Level of Service; Results for minor approaches to two-way stop-controlled intersections are indicated in italics.

Finding – The study intersections would continue to operate acceptably upon the addition of traffic associated with the Burns Valley Development (including the Oak Valley Villas) to existing volumes; therefore, the project would have an acceptable effect on operation of the surrounding roadway network.

Baseline plus Project Conditions

With project-related traffic added to the near-term Baseline volumes and including the redistribution of trips along the new North-South Project Street as detailed above, the study intersections are expected to operate acceptably. Baseline plus Project volumes are shown in Figure 8 and these results are summarized in Table 14.

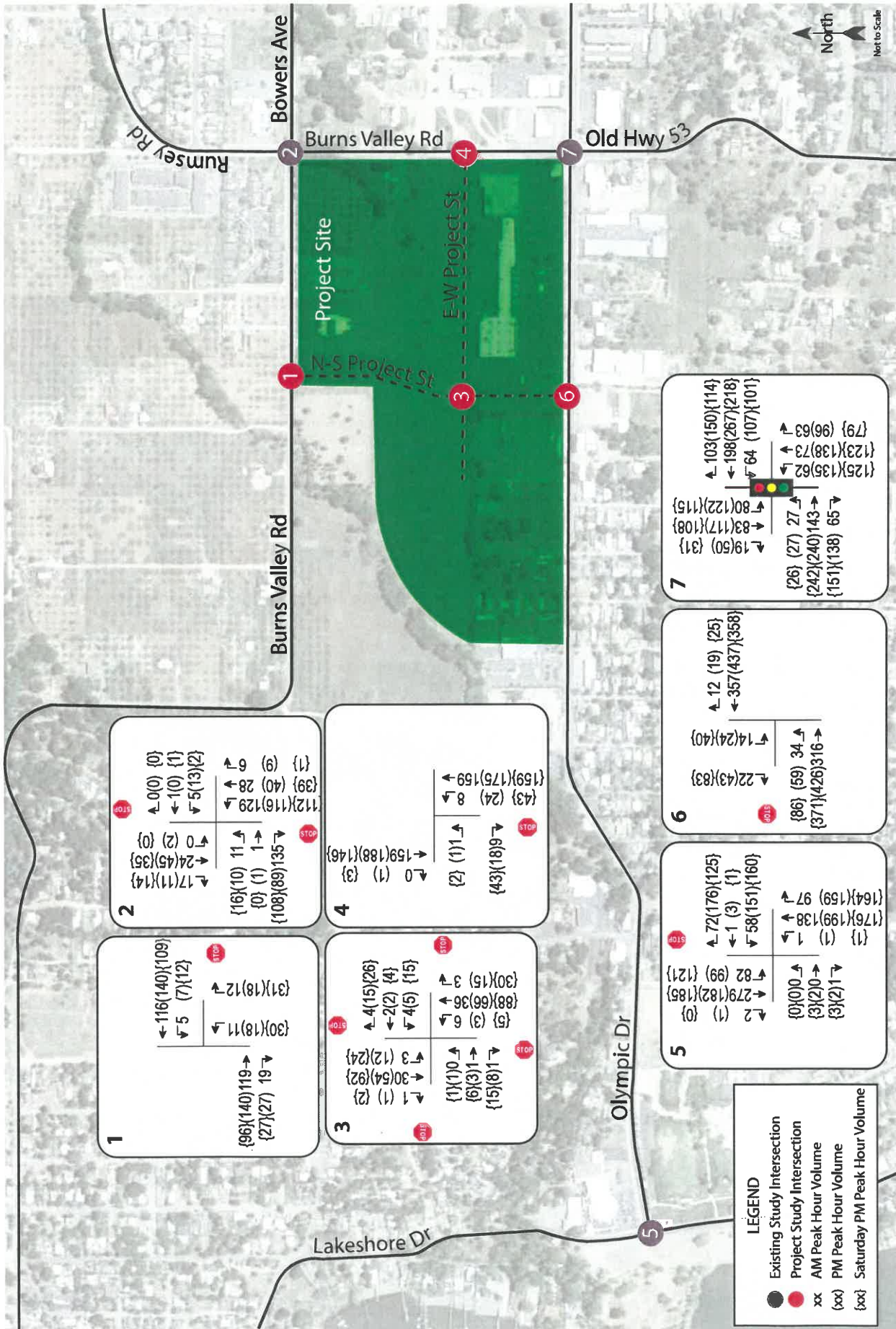

Transportation Impact Study for the Burns Valley Development
Figure 8 – Baseline plus Project Traffic Volumes

Table 14 – Baseline plus Project Peak Hour Intersection Levels of Service

Study Intersection Approach	Weekday AM		Weekday PM		Weekend PM	
	Delay	LOS	Delay	LOS	Delay	LOS
1. Burns Valley Rd/N-S Project St <i>NB (Project St) Approach</i>	0.9 9.7	A A	1.2 10.1	A B	2.3 9.8	A A
2. Burns Valley Rd/Bowers Ave-Rumsey Rd <i>EB (Burns Valley Rd) Approach</i> <i>WB (Bowers Ave) Approach</i>	6.9 9.6 13.9	A A B	6.0 9.5 13.5	A A B	6.5 9.6 12.7	A A B
3. N-S Project St/E-W Project St	7.2	A	7.4	A	7.8	A
4. Burns Valley Rd/E-W Project St <i>EB (Project St) Approach</i>	0.5 9.4	A A	0.9 9.6	A A	1.9 9.4	A A
5. Olympic Dr/Lakeshore Dr <i>WB (Olympic Dr) Approach</i>	3.3 13.4	A B	6.4 16.3	A C	7.3 19.9	A C
6. Olympic Dr/N-S Project St <i>SB (Project St) Approach</i>	1.0 13.9	A B	1.8 19.0	A C	3.3 19.9	A C
7. Olympic Dr/Burns Valley Rd-Old Hwy 53	12.1	B	15.4	B	14.8	B

Notes: Delay is measured in average seconds per vehicle; LOS = Level of Service; Results for minor approaches to two-way stop-controlled intersections are indicated in italics.

Finding – The study intersections are expected to continue operating acceptably overall upon the addition of traffic from the Burns Valley Development (including the Oak Valley Villas) to near-term Baseline volumes; therefore, the project’s near-term effect on operation of the surrounding roadway network would be considered acceptable.

Future plus Project Conditions

Upon the addition of project-generated traffic to the anticipated future volumes, and with the planned roundabout at Olympic Drive/Lakeshore Drive, the study intersections are expected to operate acceptably. It should be noted that the land use assumptions developed for the General Plan Update analysis included some level of development on the proposed site so at least a portion of project trips would reasonably be expected to be included in the buildout volumes, though project trips were added to the projected future volumes to result in a conservative assessment of the project’s potential effect on operations. The Future plus Project volumes are shown in Figure 9 and operating conditions are summarized in Table 15.

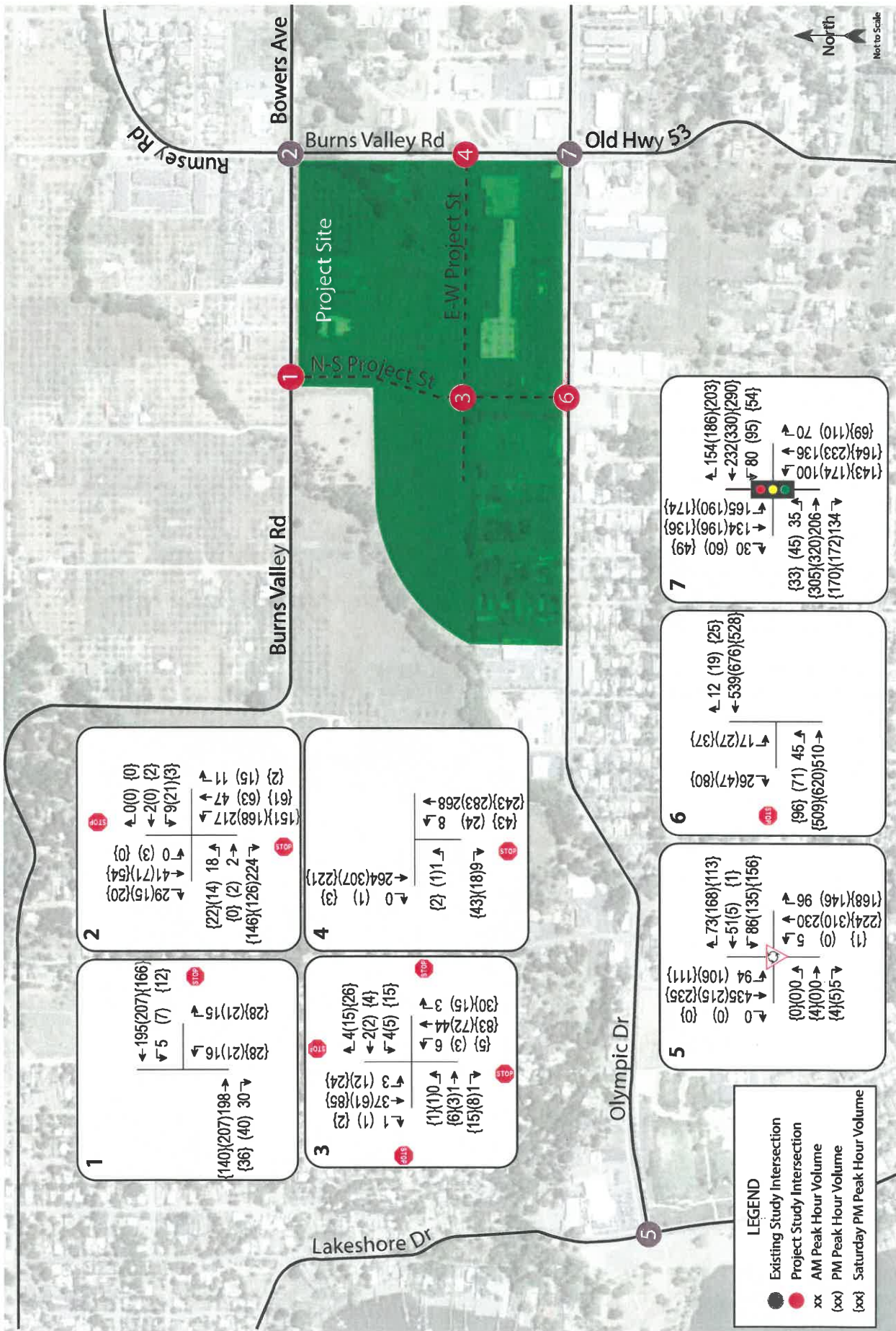

Transportation Impact Study for the Burns Valley Development
Figure 9 – Future plus Project Traffic Volumes

Table 15 – Future plus Project Peak Hour Intersection Levels of Service

Study Intersection Approach	Weekday AM		Weekday PM		Weekend PM	
	Delay	LOS	Delay	LOS	Delay	LOS
1. Burns Valley Rd/N-S Project St <i>NB (Project St) Approach</i>	0.8 <i>10.5</i>	A <i>B</i>	1.0 <i>10.8</i>	A <i>B</i>	1.6 <i>10.2</i>	A <i>B</i>
2. Burns Valley Rd/Bowers Ave-Rumsey Rd <i>EB (Burns Valley Rd) Approach</i> <i>WB (Bowers Ave) Approach</i>	7.4 <i>10.5</i> <i>18.6</i>	A <i>B</i> <i>C</i>	6.2 <i>10.0</i> <i>16.0</i>	A <i>B</i> <i>C</i>	6.3 <i>10.0</i> <i>14.0</i>	A <i>B</i> <i>B</i>
3. N-S Project St/E-W Project St	7.2	A	7.4	A	7.7	A
4. Burns Valley Rd/E-W Project St <i>EB (Project St) Approach</i>	0.3 <i>10.0</i>	A <i>B</i>	0.6 <i>10.2</i>	A <i>B</i>	1.4 <i>9.8</i>	A <i>A</i>
5. Olympic Dr/Lakeshore Dr (Roundabout) <i>WB (Olympic Dr) Approach</i>	5.7 <i>1.6</i>	A <i>A</i>	5.0 <i>2.4</i>	A <i>A</i>	4.8 <i>3.8</i>	A <i>A</i>
6. Olympic Dr/N-S Project St <i>SB (Project St) Approach</i>	1.0 <i>17.6</i>	A <i>C</i>	1.8 <i>27.4</i>	A <i>D</i>	2.8 <i>22.8</i>	B <i>C</i>
7. Olympic Dr/Burns Valley Rd-Old Hwy 53	0.5	A	0.7	A	1.0	A

Notes: Delay is measured in average seconds per vehicle; LOS = Level of Service; Results for minor approaches to two-way stop-controlled intersections are indicated in italics.

Finding – The study intersections are expected to operate acceptably under Future plus Project conditions; therefore, the project’s cumulative effect on operation of the surrounding roadway network would be considered acceptable.

Parking

The proposed development was analyzed to determine whether the proposed parking supply would be sufficient to satisfy applicable requirements. The project site as proposed would provide a total of 507 parking spaces. Of these 507 spaces, 144 would be dedicated to the Oak Valley Villas.

Jurisdiction parking supply requirements are based on the City of Clearlake Municipal Code, Chapter 18-20.090; Parking Space Requirements. Vehicle parking for multifamily housing is required at a rate of one and one-half spaces for each one- or two-bedroom unit and two spaces for each unit with three or more bedrooms. The Oak Valley Villas project is also expected to qualify for a Density Bonus due to 100 percent of the units being affordable housing units, resulting in a reduction of required on-site parking for the residential project. Vehicle parking is required at a rate of one space per 750 square feet for light industrial uses, which was applied to the corporation yard, one space per 400 square feet for a community recreation center, 30 spaces per athletic field, and one space per 60 square feet for a drive-through restaurant.

The proposed parking supply and City and State requirements are shown in Table 16.

Land Use	Units	Supply (spaces)	City Requirements		Density Bonus Requirements	
			Rate	Spaces Required	Rate	Spaces Required
Affordable Housing	20 1-bdr	144	1.5 for 1-2 bdr	84	1 for 1 bdr	20
	36 2-bdr			48	1.5 for 2-3 bdr	81
	18 3-bdr			2.5 for 4+ bdr	15	
	6 4-bdr					
<i>Oak Valley Villas Total</i>			<i>132</i>		<i>116</i>	
Corporation Yard	12,000 sf	363	1 per 750 sf	16	n/a	-
Recreation Center	15,000 sf		1 per 400 sf	38	n/a	-
Athletic Fields	6 fields		30 per field	180	n/a	-
Drive-Through Coffee Shop	160 sf		1 per 60 sf	3	n/a	-
<i>Non-Residential Total</i>				<i>237</i>		
Development Total		507		369		116

Notes: bdr = bedrooms; sf = square feet; n/a = not applicable.

For the Oak Valley Villas, the City requires one covered parking space per dwelling unit. The residential site plan indicates provision of 80 covered parking spaces, meeting the City requirements. The site plan also shows that out of the 144 spaces proposed, there are ten accessible stalls with two of those accessible stalls being van accessible. Based on requirements stipulated by the Federal Accessibility Guidelines, the required number of accessible stalls is five stalls, so the proposed supply is adequate. For the non-residential uses, eight accessible stalls are required, and a total of 12 accessible stalls would be provided, including five van accessible stalls.

Finding – The proposed parking supply would be more than sufficient to meet the applicable requirements.

Conclusions and Recommendations

Conclusions

CEQA Issues

- The proposed development (including the Oak Valley Villas) has the potential to result in an average of 1,332 new trips on local streets per day, with 77 new trips during the weekday a.m. peak hour, 182 new trips during the weekday p.m. peak hour, and 353 new trips during the Saturday p.m. peak hour.
- Calculated collision rates for the existing study intersections were all determined to be lower than the statewide average rates, indicating that there are no readily apparent safety issues for motorists in the vicinity of the development site. Nor were there any collisions reported involving a pedestrian or bicyclist.
- Upon constructing sidewalks along the project frontages with Burns Valley Road and along the new project streets, and the provision of a new crossing on Olympic Drive and the North-South Project Street, the development would be connected to the existing pedestrian network and circulation for pedestrians would be acceptable.
- Access for bicyclists would be adequate with the planned Class II bike lanes on the new project streets. Existing transit facilities are adequate.
- The entire Burns Valley Development, including the Oak Valley Villas, is anticipated to result in a less-than-significant transportation impact on VMT.
 - The Oak Valley Villas can be presumed to result in a less-than-significant impact as it would consist of 100 percent affordable housing.
 - Employees of the development, including those for the coffee shop, City corporation yard, and recreational facilities would be expected to have a less-than-significant impact on VMT based on data contained within the Lake County *Senate Bill 743 Vehicle Miles Traveled Regional Baseline Study* and the Wine Country Travel Demand Model.
 - The retail and recreational land uses would be expected to have less-than-significant impacts on VMT as local-serving uses.
- Sight lines on Burns Valley Road and Olympic Drive are adequate to accommodate all turns into and out of the proposed intersections and driveways.
- A left-turn lane would be warranted on Olympic Drive at the intersection with the North-South Project Street.
- The project would have a less-than-significant impact on queues in dedicated turn lanes at the existing study intersections.
- Emergency access and circulation are anticipated to function acceptably with incorporation of applicable design standards into the site layout and traffic from the proposed development would be expected to have a less-than-significant impact on emergency response times.

Policy Issues

- All existing and proposed study intersections are expected to operate at acceptable Levels of Service under Existing, near-term Baseline, and Future buildout volumes without and with the addition of trips from the proposed development. This evaluation was based on implementation of side-street stop controls at the intersections that the project streets would form with Olympic Drive and Burns Valley Road and all-way stop controls at the intersection of the north-south and east-west project streets, as shown on the preliminary site plan.
- The proposed parking supply satisfies City and State requirements.

Recommendations

CEQA Issues

- As proposed and indicated on the site plan, a crosswalk with high-visibility continental crosswalk markings, ADA-compliant curb ramps, pedestrian crossing signage, and advance yield line markings should be provided on Olympic Drive at the North-South Project Street intersection. Crosswalks should also be striped on the project street legs of the new street connections to Burns Valley Road and Olympic Drive.
- Long-term bicycle storage supply in the Oak Valley Villas should be increased from four spaces to seven spaces. A supply of 19 bicycle parking spaces should be provided throughout the non-residential portions of the project site.
- Sight lines at driveways and project street intersections should be clear of obstructions such as vegetation and signing within the vision triangles. The planting of tall vegetation should be avoided near the northeast corner of the project site near the intersection of Burns Valley Road/Bowers Avenue-Rumsey Road.
- Consistent with the site plan, the existing two-way left-turn lane which terminates east of the proposed Olympic Drive/North-South Project Street intersection should be extended to provide 75 feet of stacking at the proposed intersection.

Study Participants and References

Study Participants

Principal in Charge	Dalene J. Whitlock, PE, PTOE
Transportation Planner	Zack Matley, AICP
Associate Engineer	Cameron Nye, EIT
Assistant Engineer	Siddharth Gangrade
Graphics	Cameron Wong
Editing/Formatting	Hannah Yung-Boxdell
Quality Control	Dalene J. Whitlock, PE, PTOE

References

- 2018 Collision Data on California State Highways*, California Department of Transportation, 2020
- Active Transportation Plan for Lake County*, Lake County/City Area Planning Council, 2016
- City of Clearlake 2040 General Plan Update*, City of Clearlake, 2017
- Guide for the Preparation of Traffic Impact Studies*, California Department of Transportation, 2002
- Highway Capacity Manual*, Transportation Research Board, 2018
- Highway Design Manual*, 6th Edition, California Department of Transportation, 2017
- Intersection Channelization Design Guide*, National Cooperative Highway Research Program (NCHRP) Report No. 279, Transportation Research Board, 1985
- Lake Transit Authority, <http://www.laketransit.org>
- Method for Prioritizing Intersection Improvements*, Washington State Transportation Center, 1997
- Municipal Code of the City of Clearlake*, Coded Systems LLC, 2017
- Senate Bill 743 Vehicle Miles Traveled Regional Baseline Study (RBS)*, Fehr & Peers, 2020
- Statewide Integrated Traffic Records System (SWITRS)*, California Highway Patrol, 2016-2021
- Technical Advisory on Evaluating Transportation Impacts in CEQA*, Governor's Office of Planning and Research, 2018
- Traffic Impact Study for the Lake County Tribal Health Clinic*, W-Trans, 2019
- Trip Generation Manual*, 11th Edition, Institute of Transportation Engineers, 2021

CLE029



Appendix A

Collision Rate Calculations





This page intentionally left blank

Intersection Collision Rate Worksheet															
Burns Valley Development															
Intersection # 2: Burns Valley Rd & Bowers Ave-Rumsey Rd															
Date of Count: Thursday, January 20, 2022															
Number of Collisions: 1															
Number of Injuries: 1															
Number of Fatalities: 0															
Average Daily Traffic (ADT): 4200															
Start Date: August 1, 2016															
End Date: July 31, 2021															
Number of Years: 5															
Intersection Type: Four-Legged															
Control Type: Stop & Yield Controls															
Area: Urban															
Collision Rate = $\frac{\text{Number of Collisions} \times 1 \text{ Million}}{\text{ADT} \times \text{Days per Year} \times \text{Number of Years}}$															
Collision Rate = $\frac{1}{4,200} \times \frac{1,000,000}{365 \times 5}$															
<table border="1" style="width: 100%; border-collapse: collapse;"> <thead> <tr> <th style="width: 33%;">Study Intersection</th> <th style="width: 16.5%;">Collision Rate</th> <th style="width: 16.5%;">Fatality Rate</th> <th style="width: 16.5%;">Injury Rate</th> </tr> </thead> <tbody> <tr> <td></td> <td style="text-align: center;">0.13 c/mve</td> <td style="text-align: center;">0.0%</td> <td style="text-align: center;">100.0%</td> </tr> <tr> <td>Statewide Average*</td> <td style="text-align: center;">0.14 c/mve</td> <td style="text-align: center;">1.1%</td> <td style="text-align: center;">46.2%</td> </tr> </tbody> </table>				Study Intersection	Collision Rate	Fatality Rate	Injury Rate		0.13 c/mve	0.0%	100.0%	Statewide Average*	0.14 c/mve	1.1%	46.2%
Study Intersection	Collision Rate	Fatality Rate	Injury Rate												
	0.13 c/mve	0.0%	100.0%												
Statewide Average*	0.14 c/mve	1.1%	46.2%												
Notes															
ADT = average daily total vehicles entering intersection															
c/mve = collisions per million vehicles entering intersection															
* 2018 Collision Data on California State Highways, Caltrans															
Intersection # 5: Olympic Dr & Lakeshore Dr															
Date of Count: Thursday, January 20, 2022															
Number of Collisions: 1															
Number of Injuries: 0															
Number of Fatalities: 0															
Average Daily Traffic (ADT): 8200															
Start Date: August 1, 2016															
End Date: July 31, 2021															
Number of Years: 5															
Intersection Type: Tee															
Control Type: Stop & Yield Controls															
Area: Urban															
Collision Rate = $\frac{\text{Number of Collisions} \times 1 \text{ Million}}{\text{ADT} \times \text{Days per Year} \times \text{Number of Years}}$															
Collision Rate = $\frac{1}{8,200} \times \frac{1,000,000}{365 \times 5}$															
<table border="1" style="width: 100%; border-collapse: collapse;"> <thead> <tr> <th style="width: 33%;">Study Intersection</th> <th style="width: 16.5%;">Collision Rate</th> <th style="width: 16.5%;">Fatality Rate</th> <th style="width: 16.5%;">Injury Rate</th> </tr> </thead> <tbody> <tr> <td></td> <td style="text-align: center;">0.07 c/mve</td> <td style="text-align: center;">0.0%</td> <td style="text-align: center;">0.0%</td> </tr> <tr> <td>Statewide Average*</td> <td style="text-align: center;">0.09 c/mve</td> <td style="text-align: center;">1.2%</td> <td style="text-align: center;">46.9%</td> </tr> </tbody> </table>				Study Intersection	Collision Rate	Fatality Rate	Injury Rate		0.07 c/mve	0.0%	0.0%	Statewide Average*	0.09 c/mve	1.2%	46.9%
Study Intersection	Collision Rate	Fatality Rate	Injury Rate												
	0.07 c/mve	0.0%	0.0%												
Statewide Average*	0.09 c/mve	1.2%	46.9%												
Notes															
ADT = average daily total vehicles entering intersection															
c/mve = collisions per million vehicles entering intersection															
* 2018 Collision Data on California State Highways, Caltrans															

Intersection Collision Rate Worksheet															
Burns Valley Development															
Intersection # 7: Olympic Dr & Burns Valley Rd-Old Hwy 53															
Date of Count: Thursday, January 20, 2022															
Number of Collisions: 4															
Number of Injuries: 3															
Number of Fatalities: 0															
Average Daily Traffic (ADT): 10200															
Start Date: August 1, 2016															
End Date: July 31, 2021															
Number of Years: 5															
Intersection Type: Four-Legged															
Control Type: Signals															
Area: Urban															
Collision Rate = $\frac{\text{Number of Collisions} \times 1 \text{ Million}}{\text{ADT} \times \text{Days per Year} \times \text{Number of Years}}$															
Collision Rate = $\frac{4}{10,200} \times \frac{1,000,000}{365 \times 5}$															
<table border="1" style="width: 100%; border-collapse: collapse; text-align: center;"> <thead> <tr> <th></th> <th>Collision Rate</th> <th>Fatality Rate</th> <th>Injury Rate</th> </tr> </thead> <tbody> <tr> <td>Study Intersection</td> <td>0.21 c/mve</td> <td>0.0%</td> <td>75.0%</td> </tr> <tr> <td>Statewide Average*</td> <td>0.24 c/mve</td> <td>0.5%</td> <td>46.9%</td> </tr> </tbody> </table>					Collision Rate	Fatality Rate	Injury Rate	Study Intersection	0.21 c/mve	0.0%	75.0%	Statewide Average*	0.24 c/mve	0.5%	46.9%
	Collision Rate	Fatality Rate	Injury Rate												
Study Intersection	0.21 c/mve	0.0%	75.0%												
Statewide Average*	0.24 c/mve	0.5%	46.9%												
Notes															
ADT = average daily total vehicles entering intersection															
c/mve = collisions per million vehicles entering intersection															
* 2018 Collision Data on California State Highways, Caltrans															

Appendix B

NCHRP Pedestrian Crossing Treatment Worksheet





This page intentionally left blank

GUIDELINES FOR PEDESTRIAN CROSSING TREATMENTS

This spreadsheet combines Worksheet 1 and Worksheet 2 (Appendix A, pages 69-70) of TCRP Report 112/NCHRP Report 562 (*Improving Pedestrian Safety at Unsignalized Intersections*) into an electronic format. This spreadsheet should be used in conjunction with, and not independent of, Appendix A documentation.

Key	
	Blue fields contain descriptive information.
	Green fields are required and must be completed.
	Tan fields are adjustments that are filled out only under certain conditions (follow instructions to the left of the cell).
	Gray fields are automatically calculated and should not be edited.

Analyst and Site Information			
Analyst	W-Trans	Major Street	Olympic Drive
Analysis Date	April 26, 2022	Minor Street or Location	North-South Project Street
Data Collection Date	January 20, 2022	Peak Hour	Weekday PM
Step 1: Select worksheet:			
Posted or statutory speed limit (or 85th percentile speed) on the major street (mph)		1a	30
Is the population of the surrounding area <10,000? (enter YES or NO)		1b	NO
Step 2: Does the crossing meet minimum pedestrian volumes to be considered for a traffic control device?			
Peak-hour pedestrian volume (ped/h), V_p		2a	20
Result: Go to step 3.			
Step 3: Does the crossing meet the pedestrian warrant for a traffic signal?			
Major road volume, total of both approaches during peak hour (veh/h), V_{major}		3a	700
[Calculated automatically] Preliminary (before min. threshold) peak hour pedestrian volume to meet warrant		3b	425
[Calculated automatically] Minimum required peak hour pedestrian volume to meet traffic signal warrant		3c	425
Is 15th percentile crossing speed of pedestrians less than 3.5 ft/s (1.1 m/s)? (enter YES or NO)		3d	NO
If 15th percentile crossing speed of pedestrians is less than 3.5 ft/s (1.1 m/s), then reduce 3c by up to 50%.	% rate of reduction for 3c (up to 50%)	3e	
	Reduced value or 3c	3f	425
Result: The signal warrant is not met. Go to step 4.			
Step 4: Estimate pedestrian delay.			
Pedestrian crossing distance, curb to curb (ft), L		4a	36
Pedestrian walking speed (ft/s), S_p (suggested speed = 3.5 ft/s)		4b	3.5
Pedestrian start-up time and end clearance time (s), t_s (suggested start-up time = 3 sec)		4c	3
[Calculated automatically] Critical gap required for crossing pedestrian (s), t_c		4d	13.2
Major road volume, total both approaches OR approach being crossed if raised median island is present, during peak hour (veh/h), V_{major}		4e	700
Major road flow rate (veh/s), v		4f	0.19
Average pedestrian delay (s/person), d_p		4g	46
Total pedestrian delay (h), D_p The value in 4h is the calculated estimated delay for all pedestrians crossing the major roadway without a crossing treatment (assumes 0% compliance). If the actual total pedestrian delay has been measured at the site, that value can be entered in 4i to replace the calculated value in 4h.		4h	0.3
		4i	
Step 5: Select treatment based up on total pedestrian delay and expected motorist compliance.			
Expected motorist compliance at pedestrian crossings in region: enter HIGH for High Compliance or LOW for Low Compliance		5a	LOW
Treatment Category:		CROSSWALK	

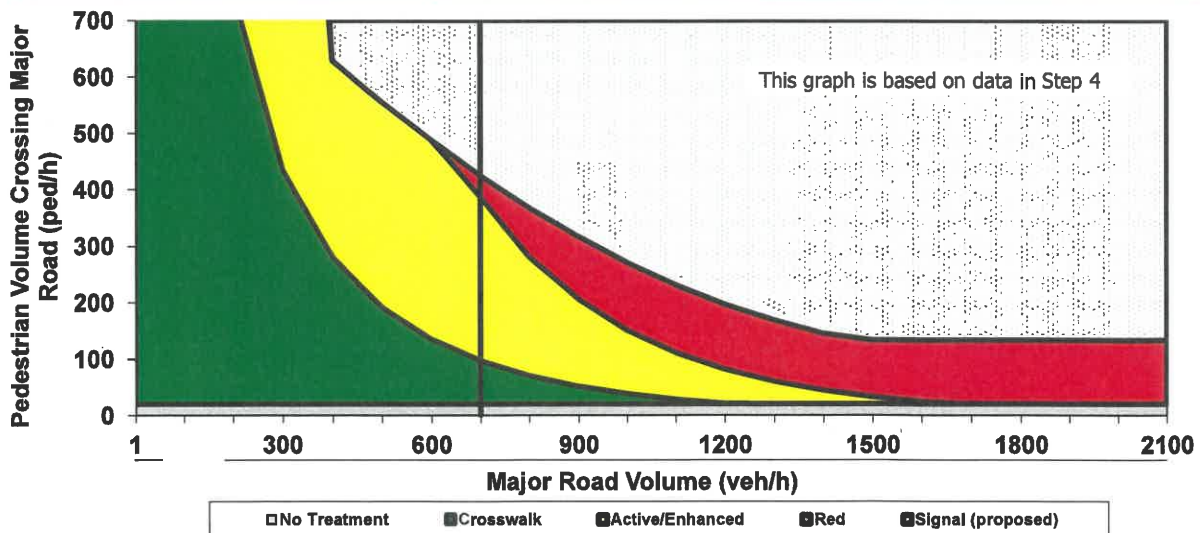

This worksheet provides general recommendations on pedestrian crossing treatments to consider at unsignalized intersections; in all cases, engineering judgment should be used in selecting a specific treatment for installation. This worksheet does not apply to school crossings. In addition to the results provided by this worksheet, users should consider whether a pedestrian treatment could present an increased safety risk to pedestrians, such as where there is poor sight distance, complex geometrics, or nearby traffic signals.



This page intentionally left blank

Appendix C

VMT Screening Tool Output







This page intentionally left blank

Screening Results

Screening Inputs

Criteria	Input
VMT Metric	Home-based Work VMT per Worker
Baseline Year	2022
Threshold (% reduction from Baseline Year)	Countywide Benchmark (-15%)

Legend

Category	Color
Selected Project Area	
Traffic Analysis Zone ID	
Low VMT Generating TAZs	

Project Location



Project Proximity to Output Low VMT Generating TAZs

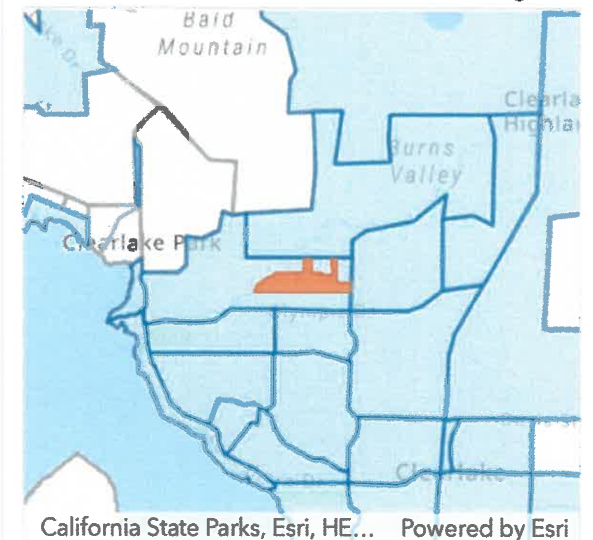

 **Passed**

Screening Questions	Results
Within a low VMT generating TAZ?	Yes (Pass) 

Screening results are based on location of parcel centroids. If results are desired considering the full parcel, please refer to the associated map layers to visually review parcel and TAZ boundary relationship.

Traffic Analysis Zone (TAZ) Details

TAZ Questions	TAZ ID: 1908
Jurisdiction	Clearlake
TAZ VMT	7.6
Countywide Average VMT	12.3
% Difference	-38.2%
VMT Metric	Home-based Work VMT per Worker
Threshold	10.5

Threshold Evaluation

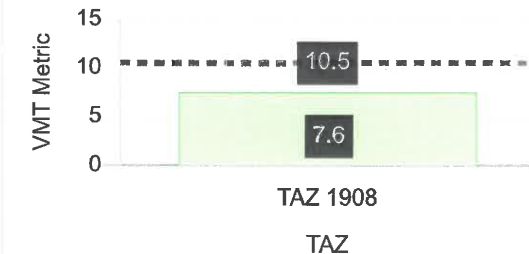



This page intentionally left blank

Appendix D

Turn Lane Warrant Spreadsheets



This page intentionally left blank

Turn Lane Warrant Analysis - Tee Intersections

Study Intersection: Olympic Dr/N-S Project St
 Study Scenario: E+P Weekday AM

Direction of Analysis Street: East/West

Cross Street Intersects: From the North

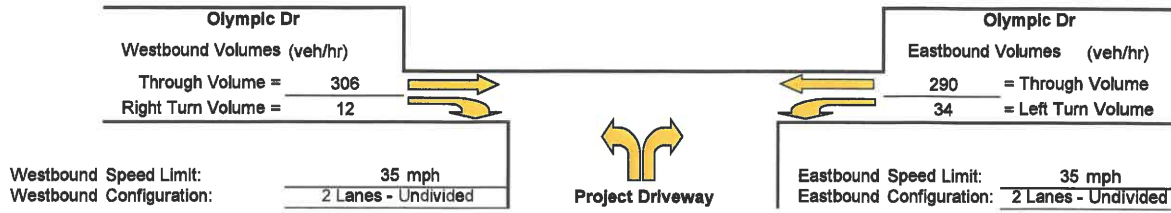

Westbound Right Turn Lane Warrants

1. Check for right turn volume criteria

Thresholds not met, continue to next step

2. Check advance volume threshold criteria for turn lane

Advancing Volume Threshold	AV =	960.1
Advancing Volume	Va =	318
If $AV < Va$ then warrant is met		No

Right Turn Lane Warranted: NO

Westbound Right Turn Taper Warrants (evaluate if right turn lane is unwarranted)

1. Check taper volume criteria

NOT WARRANTED - Less than 20 vehicles

2. Check advance volume threshold criteria for taper

Advancing Volume Threshold	AV =	-
Advancing Volume	Va =	318
If $AV < Va$ then warrant is met		-

Right Turn Taper Warranted: NO

Eastbound Left Turn Lane Warrants

Percentage Left Turns %lt	10.5 %
Advancing Volume Threshold AV	566 veh/hr
If $AV < Va$ then warrant is met	

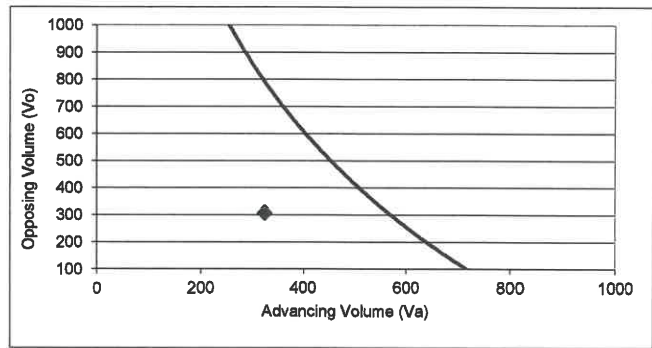

◆ Study Intersection
 Two lane roadway warrant threshold for: 35 mph
 Turn lane warranted if point falls to right of warrant threshold line

Left Turn Lane Warranted: NO

Methodology based on Washington State Transportation Center Research Report *Method For Prioritizing Intersection Improvements*, January 1997.
 The right turn lane and taper analysis is based on work conducted by Cottrell in 1981.
 The left turn lane analysis is based on work conducted by M.D. Harmelink in 1967, and modified by Kikuchi and Chakroborty in 1991.

Turn Lane Warrant Analysis - Tee Intersections

Study Intersection: Olympic Dr/N-S Project St
 Study Scenario: E+P Weekday PM

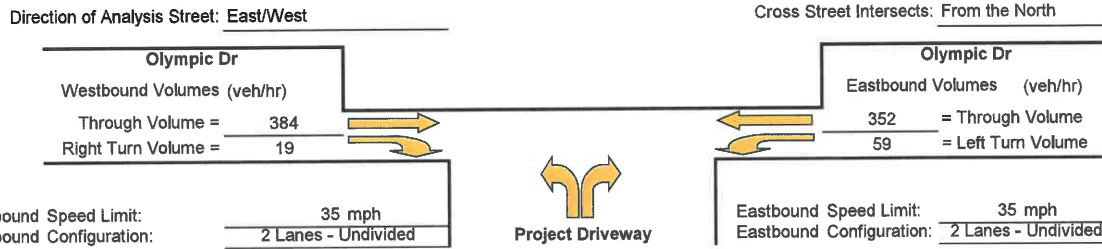

Westbound Right Turn Lane Warrants

1. Check for right turn volume criteria

Thresholds not met, continue to next step

2. Check advance volume threshold criteria for turn lane

Advancing Volume Threshold	AV =	907.6
Advancing Volume	Va =	403
If AV < Va then warrant is met		

Right Turn Lane Warranted: NO

Westbound Right Turn Taper Warrants
(evaluate if right turn lane is unwarranted)

1. Check taper volume criteria

NOT WARRANTED - Less than 20 vehicles

2. Check advance volume threshold criteria for taper

Advancing Volume Threshold	AV =	-
Advancing Volume	Va =	403
If AV < Va then warrant is met		

Right Turn Taper Warranted: NO

Eastbound Left Turn Lane Warrants

Percentage Left Turns %lt	14.4 %
Advancing Volume Threshold AV	443 veh/hr
If AV < Va then warrant is met	

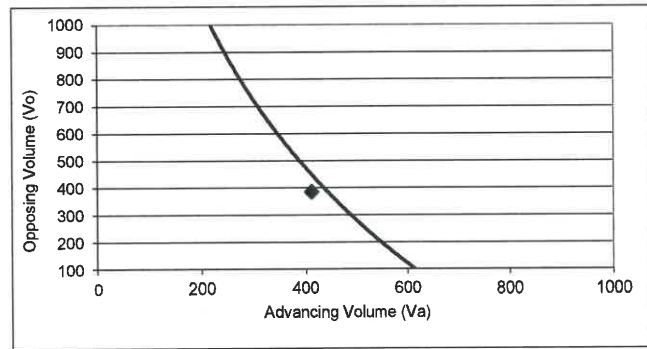

◆ Study Intersection
 Two lane roadway warrant threshold for: 35 mph
 Turn lane warranted if point falls to right of warrant threshold line

Left Turn Lane Warranted: NO

Methodology based on Washington State Transportation Center Research Report *Method For Prioritizing Intersection Improvements*, January 1997.
 The right turn lane and taper analysis is based on work conducted by Cottrell in 1981.
 The left turn lane analysis is based on work conducted by M.D. Harmelink in 1967, and modified by Kikuchi and Chakroborty in 1991.

Turn Lane Warrant Analysis - Tee Intersections

Study Intersection: Olympic Dr/N-S Project St
 Study Scenario: E+P Weekend PM

Direction of Analysis Street: East/West

Cross Street Intersects: From the North

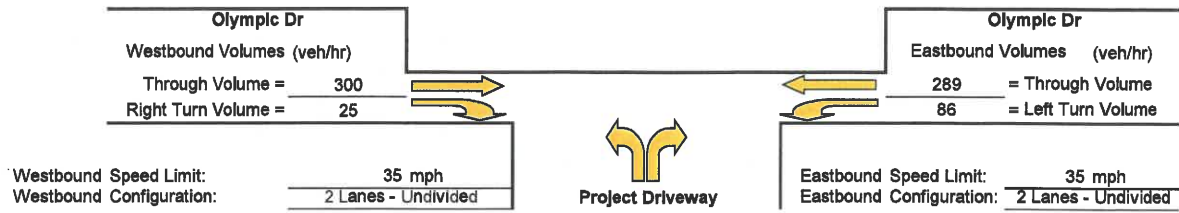

Westbound Right Turn Lane Warrants

1. Check for right turn volume criteria

Thresholds not met, continue to next step

2. Check advance volume threshold criteria for turn lane

Advancing Volume Threshold	AV =	862.6
Advancing Volume	Va =	325
If $AV < Va$ then warrant is met		No

Right Turn Lane Warranted: NO

Westbound Right Turn Taper Warrants (evaluate if right turn lane is unwarranted)

1. Check taper volume criteria

Thresholds not met, continue to next step

2. Check advance volume threshold criteria for taper

Advancing Volume Threshold	AV =	650
Advancing Volume	Va =	325
If $AV < Va$ then warrant is met		No

Right Turn Taper Warranted: NO

Eastbound Left Turn Lane Warrants

Percentage Left Turns %lt	22.9 %
Advancing Volume Threshold AV	411 veh/hr
If $AV < Va$ then warrant is met	

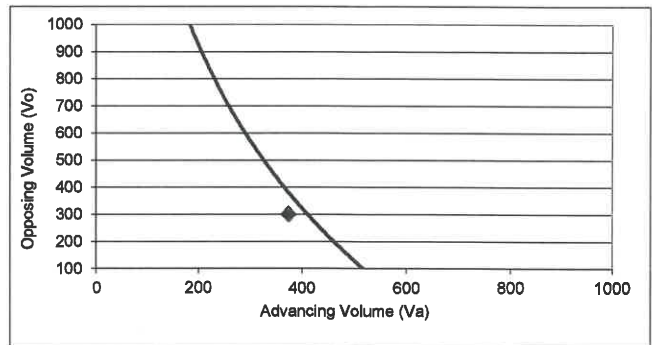

◆ Study Intersection
 Two lane roadway warrant threshold for: 35 mph
 Turn lane warranted if point falls to right of warrant threshold line

Left Turn Lane Warranted: NO

Methodology based on Washington State Transportation Center Research Report *Method For Prioritizing Intersection Improvements*, January 1997.
 The right turn lane and taper analysis is based on work conducted by Cottrell in 1981.
 The left turn lane analysis is based on work conducted by M.D. Harmelink in 1967, and modified by Kikuchi and Chakroborty in 1991.

Turn Lane Warrant Analysis - Tee Intersections

Study Intersection: Olympic Dr/N-S Project St
 Study Scenario: B+P Weekday AM

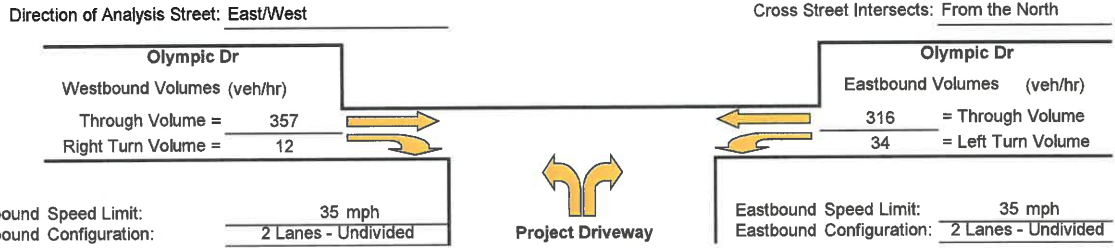

Westbound Right Turn Lane Warrants

1. Check for right turn volume criteria

Thresholds not met, continue to next step

2. Check advance volume threshold criteria for turn lane

Advancing Volume Threshold	AV = 960.1
Advancing Volume	Va = 369
If AV < Va then warrant is met	
	No

Right Turn Lane Warranted: NO

Westbound Right Turn Taper Warrants
(evaluate if right turn lane is unwarranted)

1. Check taper volume criteria

NOT WARRANTED - Less than 20 vehicles

2. Check advance volume threshold criteria for taper

Advancing Volume Threshold	AV = -
Advancing Volume	Va = 369
If AV < Va then warrant is met	
	-

Right Turn Taper Warranted: NO

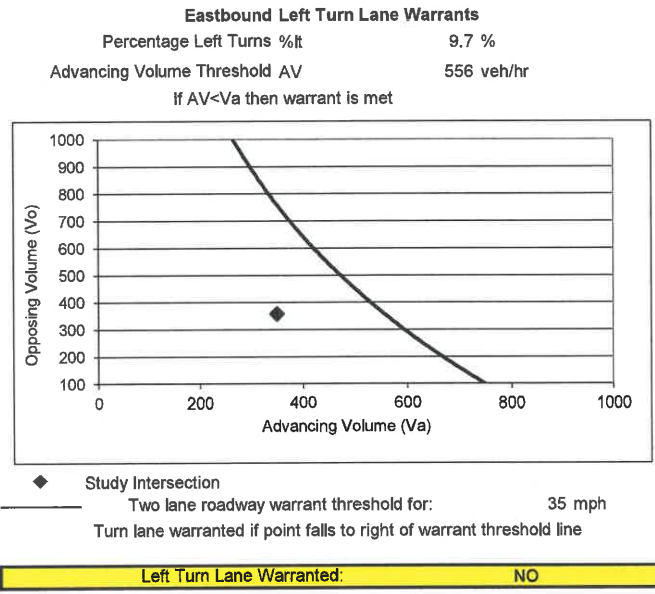

Methodology based on Washington State Transportation Center Research Report *Method For Prioritizing Intersection Improvements*, January 1997.
 The right turn lane and taper analysis is based on work conducted by Cottrell in 1981.
 The left turn lane analysis is based on work conducted by M.D. Harmelink in 1967, and modified by Kikuchi and Chakroborty in 1991.

Turn Lane Warrant Analysis - Tee Intersections

Study Intersection: Olympic Dr/N-S Project St
 Study Scenario: B+P Weekday PM

Direction of Analysis Street: East/West

Cross Street Intersects: From the North

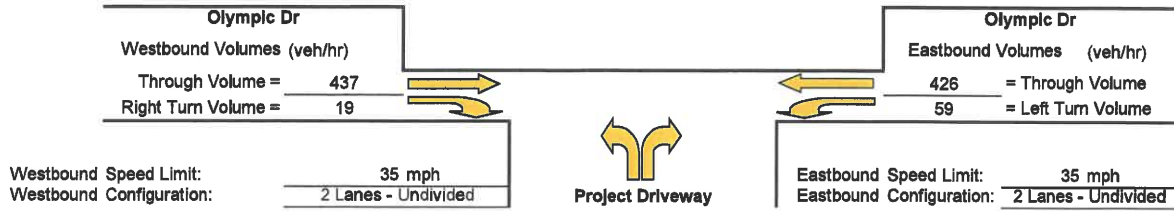

Westbound Right Turn Lane Warrants

1. Check for right turn volume criteria

Thresholds not met, continue to next step

2. Check advance volume threshold criteria for turn lane

Advancing Volume Threshold AV = 907.6
 Advancing Volume Va = 456
 If $AV < Va$ then warrant is met No

Right Turn Lane Warranted: NO

Westbound Right Turn Taper Warrants (evaluate if right turn lane is unwarranted)

1. Check taper volume criteria

NOT WARRANTED - Less than 20 vehicles

2. Check advance volume threshold criteria for taper

Advancing Volume Threshold AV = -
 Advancing Volume Va = 456
 If $AV < Va$ then warrant is met -

Right Turn Taper Warranted: NO

Eastbound Left Turn Lane Warrants

Percentage Left Turns %lt 12.2 %
 Advancing Volume Threshold AV 451 veh/hr
 If $AV < Va$ then warrant is met

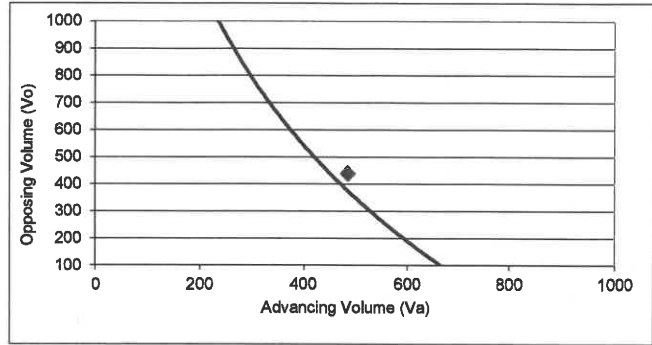

◆ Study Intersection
 Two lane roadway warrant threshold for: 35 mph
 Turn lane warranted if point falls to right of warrant threshold line

Left Turn Lane Warranted: YES

Methodology based on Washington State Transportation Center Research Report *Method For Prioritizing Intersection Improvements*, January 1997.
 The right turn lane and taper analysis is based on work conducted by Cottrell in 1981.
 The left turn lane analysis is based on work conducted by M.D. Harmelink in 1967, and modified by Kikuchi and Chakroborty in 1991.

Turn Lane Warrant Analysis - Tee Intersections

Study Intersection: Olympic Dr/N-S Project St
 Study Scenario: B+P Weekend PM

Direction of Analysis Street: East/West

Cross Street Intersects: From the North

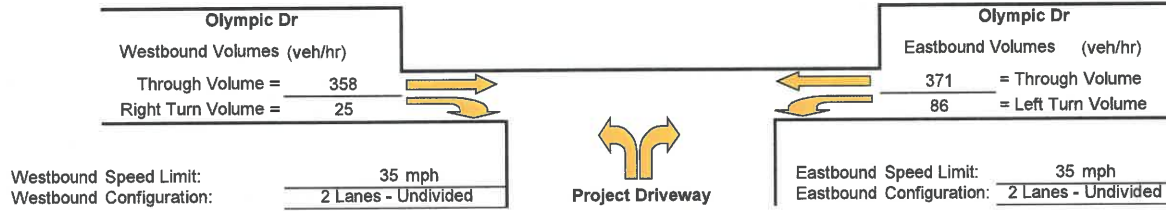

Westbound Right Turn Lane Warrants

1. Check for right turn volume criteria

Thresholds not met, continue to next step

2. Check advance volume threshold criteria for turn lane

Advancing Volume Threshold	AV =	862.6
Advancing Volume	Va =	383
If $AV < Va$ then warrant is met		No

Right Turn Lane Warranted: NO

Westbound Right Turn Taper Warrants (evaluate if right turn lane is unwarranted)

1. Check taper volume criteria

Thresholds not met, continue to next step

2. Check advance volume threshold criteria for taper

Advancing Volume Threshold	AV =	650
Advancing Volume	Va =	383
If $AV < Va$ then warrant is met		No

Right Turn Taper Warranted: NO

Eastbound Left Turn Lane Warrants

Percentage Left Turns %lt	18.8 %
Advancing Volume Threshold AV	409 veh/hr
If $AV < Va$ then warrant is met	

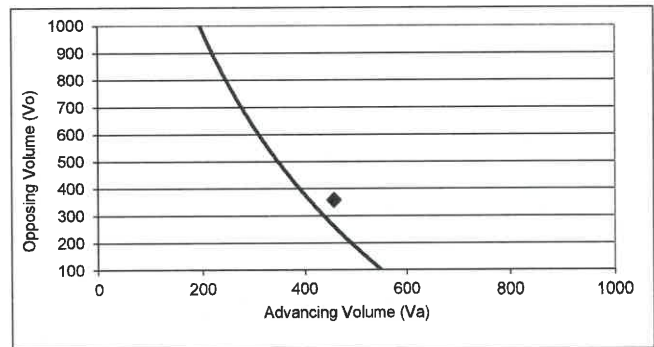

◆ Study Intersection
 — Two lane roadway warrant threshold for: 35 mph
 Turn lane warranted if point falls to right of warrant threshold line

Left Turn Lane Warranted: YES

Methodology based on Washington State Transportation Center Research Report *Method For Prioritizing Intersection Improvements*, January 1997.
 The right turn lane and taper analysis is based on work conducted by Cottrell in 1981.
 The left turn lane analysis is based on work conducted by M.D. Harmelink in 1967, and modified by Kikuchi and Chakrobrty in 1991.

Turn Lane Warrant Analysis - Tee Intersections

Study Intersection: Burns Valley Rd/N-S Project St
 Study Scenario: Weekday AM F+P

Direction of Analysis Street: East/West

Cross Street Intersects: From the South



Eastbound Right Turn Lane Warrants

1. Check for right turn volume criteria

Thresholds not met, continue to next step

2. Check advance volume threshold criteria for turn lane

Advancing Volume Threshold	AV =	825.1
Advancing Volume	Va =	228
If $AV < Va$ then warrant is met		No

Right Turn Lane Warranted: NO

Eastbound Right Turn Taper Warrants (evaluate if right turn lane is unwarranted)

1. Check taper volume criteria

Thresholds not met, continue to next step

2. Check advance volume threshold criteria for taper

Advancing Volume Threshold	AV =	600
Advancing Volume	Va =	228
If $AV < Va$ then warrant is met		No

Right Turn Taper Warranted: NO

Westbound Left Turn Lane Warrants

Percentage Left Turns %lt 2.5 %

Advancing Volume Threshold AV 1249 veh/hr

If $AV < Va$ then warrant is met

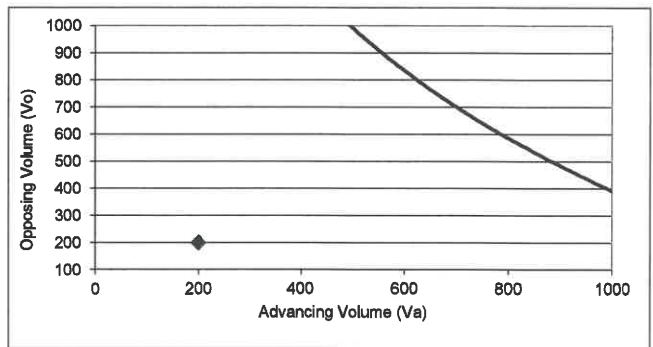

◆ Study Intersection
 Two lane roadway warrant threshold for: 35 mph
 Turn lane warranted if point falls to right of warrant threshold line

Left Turn Lane Warranted: NO

Methodology based on Washington State Transportation Center Research Report *Method For Prioritizing Intersection Improvements*, January 1997.
 The right turn lane and taper analysis is based on work conducted by Cottrell in 1981.
 The left turn lane analysis is based on work conducted by M.D. Harmelink in 1967, and modified by Kikuchi and Chakroborty in 1991.

Turn Lane Warrant Analysis - Tee Intersections

Study Intersection: Burns Valley Rd / Oak Valley Villas Northern Driveway
 Study Scenario: Weekday AM F+P

Direction of Analysis Street: East/West

Cross Street Intersects: From the South

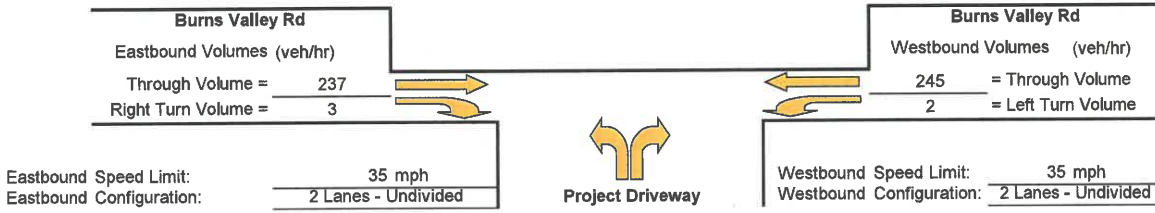

Eastbound Right Turn Lane Warrants

1. Check for right turn volume criteria

Thresholds not met, continue to next step

2. Check advance volume threshold criteria for turn lane

Advancing Volume Threshold	AV =	1027.6
Advancing Volume	Va =	240
If AV < Va then warrant is met		No

Right Turn Lane Warranted: NO

Eastbound Right Turn Taper Warrants (evaluate if right turn lane is unwarranted)

1. Check taper volume criteria

NOT WARRANTED - Less than 20 vehicles

2. Check advance volume threshold criteria for taper

Advancing Volume Threshold	AV =	-
Advancing Volume	Va =	240
If AV < Va then warrant is met		-

Right Turn Taper Warranted: NO

Westbound Left Turn Lane Warrants

Percentage Left Turns %lt	0.8 %
Advancing Volume Threshold AV	1520 veh/hr
If AV < Va then warrant is met	

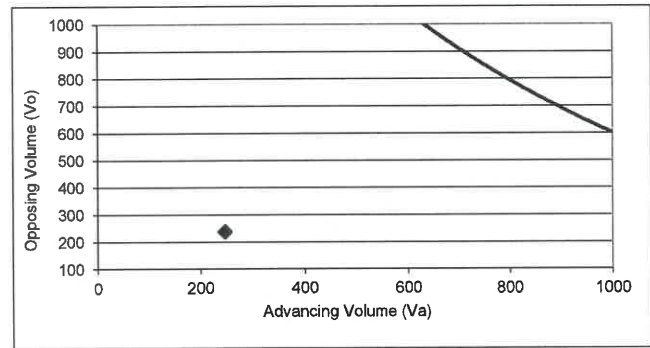

◆ Study Intersection
 Two lane roadway warrant threshold for: 35 mph
 Turn lane warranted if point falls to right of warrant threshold line

Left Turn Lane Warranted: NO

Methodology based on Washington State Transportation Center Research Report *Method For Prioritizing Intersection Improvements*, January 1997.
 The right turn lane and taper analysis is based on work conducted by Cottrell in 1981.
 The left turn lane analysis is based on work conducted by M.D. Harmelink in 1967, and modified by Kikuchi and Chakroborty in 1991.

Turn Lane Warrant Analysis - Tee Intersections

Study Intersection: Burns Valley Rd/E-W Project St
 Study Scenario: F+P Weekday PM

Direction of Analysis Street: North/South

Cross Street Intersects: From the West

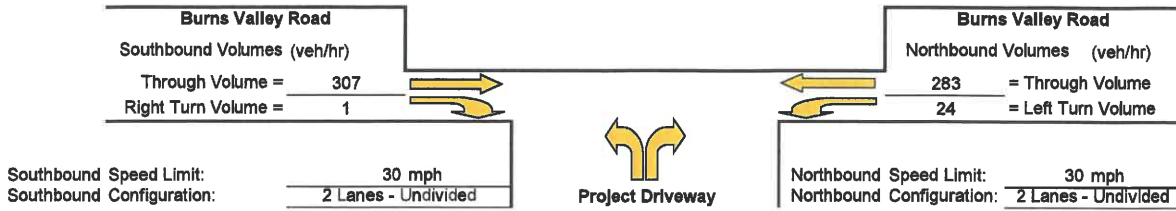

Southbound Right Turn Lane Warrants

1. Check for right turn volume criteria

Thresholds not met, continue to next step

2. Check advance volume threshold criteria for turn lane

Advancing Volume Threshold	AV = 1042.6
Advancing Volume	Va = 308
If AV < Va then warrant is met	No

Right Turn Lane Warranted: NO

Southbound Right Turn Taper Warrants
 (evaluate if right turn lane is unwarranted)

1. Check taper volume criteria

NOT WARRANTED - Less than 20 vehicles

2. Check advance volume threshold criteria for taper

Advancing Volume Threshold	AV = -
Advancing Volume	Va = 308
If AV < Va then warrant is met	-

Right Turn Taper Warranted: NO

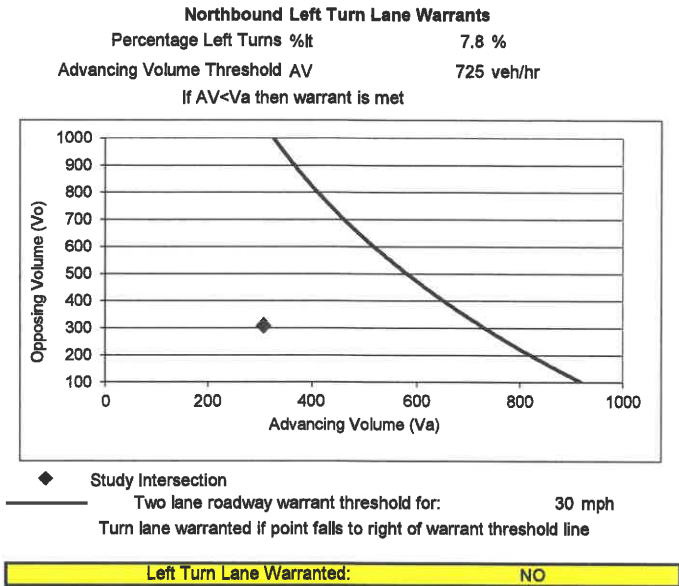

Methodology based on Washington State Transportation Center Research Report *Method For Prioritizing Intersection Improvements*, January 1997.
 The right turn lane and taper analysis is based on work conducted by Cottrell in 1981.
 The left turn lane analysis is based on work conducted by M.D. Harmelink in 1967, and modified by Kikuchi and Chakroborty in 1991.

Turn Lane Warrant Analysis - Tee Intersections

Study Intersection: Olympic Dr/N-S Project St
 Study Scenario: F+P Weekday AM

Direction of Analysis Street: East/West

Cross Street Intersects: From the North

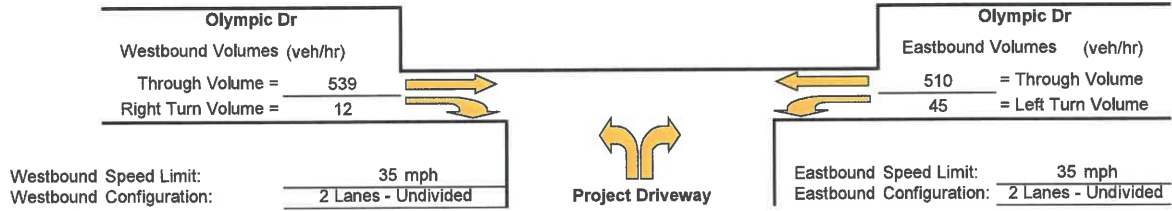

Westbound Right Turn Lane Warrants

1. Check for right turn volume criteria

Thresholds not met, continue to next step

2. Check advance volume threshold criteria for turn lane

Advancing Volume Threshold	AV =	960.1
Advancing Volume	Va =	551
If $AV < Va$ then warrant is met		No

Right Turn Lane Warranted: NO

Westbound Right Turn Taper Warrants (evaluate if right turn lane is unwarranted)

1. Check taper volume criteria

NOT WARRANTED - Less than 20 vehicles

2. Check advance volume threshold criteria for taper

Advancing Volume Threshold	AV =	-
Advancing Volume	Va =	551
If $AV < Va$ then warrant is met		-

Right Turn Taper Warranted: NO

Eastbound Left Turn Lane Warrants

Percentage Left Turns %lt	8.1 %
Advancing Volume Threshold AV	497 veh/hr
If $AV < Va$ then warrant is met	

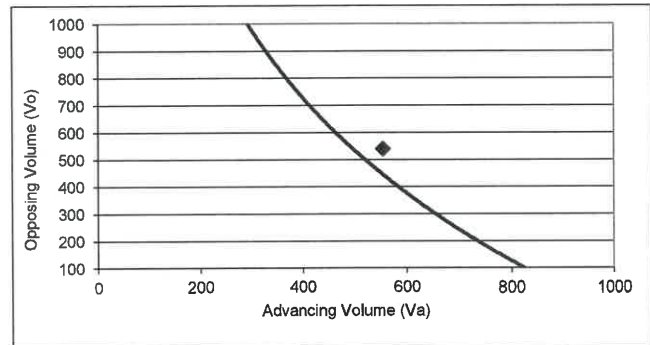

◆ Study Intersection
 — Two lane roadway warrant threshold for: 35 mph
 Turn lane warranted if point falls to right of warrant threshold line

Left Turn Lane Warranted: YES

Methodology based on Washington State Transportation Center Research Report *Method For Prioritizing Intersection Improvements*, January 1997.
 The right turn lane and taper analysis is based on work conducted by Cottrell in 1981.
 The left turn lane analysis is based on work conducted by M.D. Harmelink in 1967, and modified by Kikuchi and Chakroborty in 1991.

Turn Lane Warrant Analysis - Tee Intersections

Study Intersection: Burns Valley Rd/N-S Project St
 Study Scenario: Weekday PM F+P

Direction of Analysis Street: East/West

Cross Street Intersects: From the South

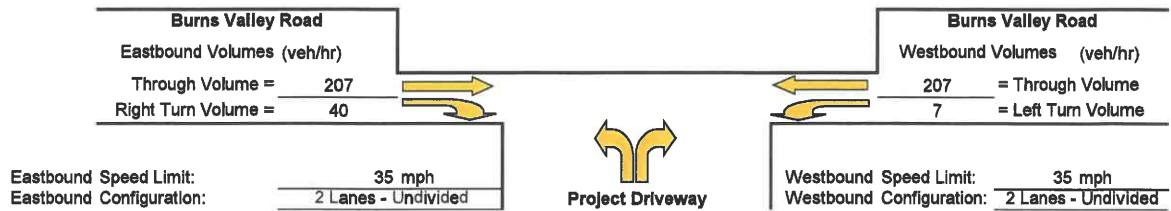

Eastbound Right Turn Lane Warrants

1. Check for right turn volume criteria

Thresholds not met, continue to next step

2. Check advance volume threshold criteria for turn lane

Advancing Volume Threshold	AV =	750
Advancing Volume	Va =	247
If $AV < Va$ then warrant is met		No

Right Turn Lane Warranted: NO

Eastbound Right Turn Taper Warrants (evaluate if right turn lane is unwarranted)

1. Check taper volume criteria

Thresholds not met, continue to next step

2. Check advance volume threshold criteria for taper

Advancing Volume Threshold	AV =	500
Advancing Volume	Va =	247
If $AV < Va$ then warrant is met		No

Right Turn Taper Warranted: NO

Westbound Left Turn Lane Warrants

Percentage Left Turns %t 3.3 %
 Advancing Volume Threshold AV 1124 veh/hr
 If $AV < Va$ then warrant is met

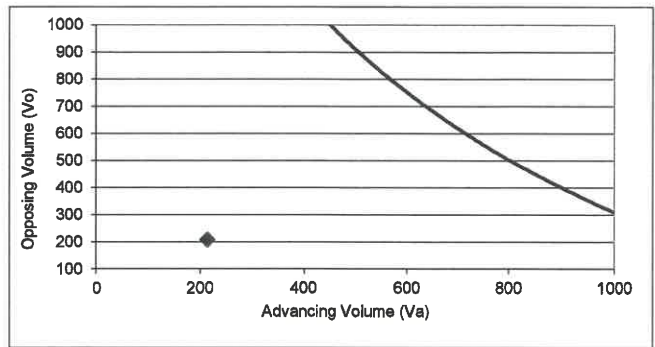

◆ Study Intersection
 Two lane roadway warrant threshold for: 35 mph
 Turn lane warranted if point falls to right of warrant threshold line

Left Turn Lane Warranted: NO

Methodology based on Washington State Transportation Center Research Report *Method For Prioritizing Intersection Improvements*, January 1997.
 The right turn lane and taper analysis is based on work conducted by Cottrell in 1981.
 The left turn lane analysis is based on work conducted by M.D. Harmelink in 1967, and modified by Kikuchi and Chakroborty in 1991.

Turn Lane Warrant Analysis - Tee Intersections

Study Intersection: Burns Valley Rd / Oak Valley Villas Northern Driveway
 Study Scenario: Weekday PM F+P

Direction of Analysis Street: East/West

Cross Street Intersects: From the South

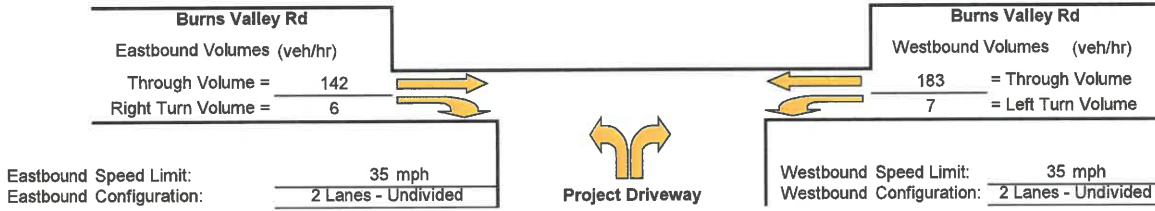

Eastbound Right Turn Lane Warrants

1. Check for right turn volume criteria

Thresholds not met, continue to next step

2. Check advance volume threshold criteria for turn lane

Advancing Volume Threshold	AV =	1005.1
Advancing Volume	Va =	148
If $AV < Va$ then warrant is met		No

Right Turn Lane Warranted: NO

Eastbound Right Turn Taper Warrants (evaluate if right turn lane is unwarranted)

1. Check taper volume criteria

NOT WARRANTED - Less than 20 vehicles

2. Check advance volume threshold criteria for taper

Advancing Volume Threshold	AV =	-
Advancing Volume	Va =	148
If $AV < Va$ then warrant is met		-

Right Turn Taper Warranted: NO

Westbound Left Turn Lane Warrants

Percentage Left Turns %lt	3.7 %
Advancing Volume Threshold AV	1155 veh/hr
If $AV < Va$ then warrant is met	

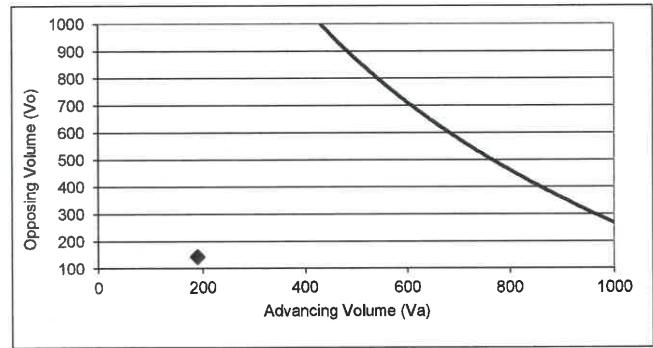

◆ Study Intersection
 — Two lane roadway warrant threshold for: 35 mph
 Turn lane warranted if point falls to right of warrant threshold line

Left Turn Lane Warranted: NO

Methodology based on Washington State Transportation Center Research Report *Method For Prioritizing Intersection Improvements*, January 1997.
 The right turn lane and taper analysis is based on work conducted by Cottrell in 1981.
 The left turn lane analysis is based on work conducted by M.D. Harmelink in 1967, and modified by Kikuchi and Chakroborty in 1991.

Turn Lane Warrant Analysis - Tee Intersections

Study Intersection: Burns Valley Rd/E-W Project St
 Study Scenario: F+P Weekday PM

Direction of Analysis Street: North/South

Cross Street Intersects: From the West

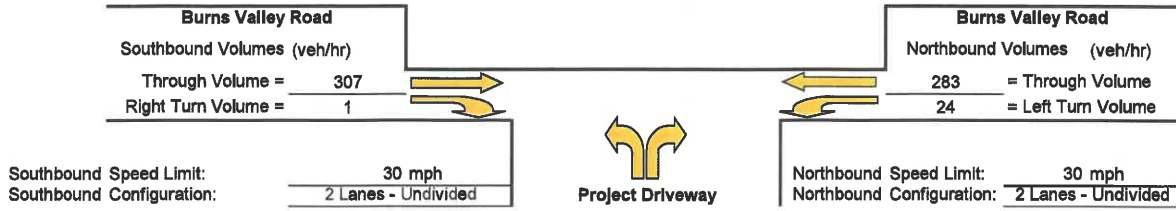

Southbound Right Turn Lane Warrants

1. Check for right turn volume criteria

Thresholds not met, continue to next step

2. Check advance volume threshold criteria for turn lane

Advancing Volume Threshold	AV =	1042.6
Advancing Volume	Va =	308
If $AV < Va$ then warrant is met		No

Right Turn Lane Warranted: NO

Southbound Right Turn Taper Warrants (evaluate if right turn lane is unwarranted)

1. Check taper volume criteria

NOT WARRANTED - Less than 20 vehicles

2. Check advance volume threshold criteria for taper

Advancing Volume Threshold	AV =	-
Advancing Volume	Va =	308
If $AV < Va$ then warrant is met		-

Right Turn Taper Warranted: NO

Northbound Left Turn Lane Warrants

Percentage Left Turns %lt	7.8 %
Advancing Volume Threshold AV	725 veh/hr
If $AV < Va$ then warrant is met	

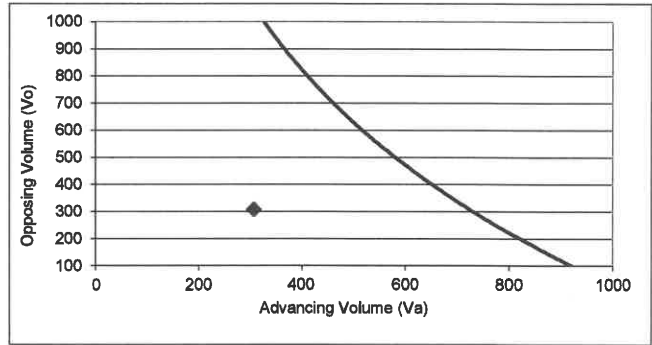

◆ Study Intersection
 Two lane roadway warrant threshold for: 30 mph
 Turn lane warranted if point falls to right of warrant threshold line

Left Turn Lane Warranted: NO

Methodology based on Washington State Transportation Center Research Report *Method For Prioritizing Intersection Improvements*, January 1997.
 The right turn lane and taper analysis is based on work conducted by Cottrell in 1981.
 The left turn lane analysis is based on work conducted by M.D. Harmelink in 1967, and modified by Kikuchi and Chakroborty in 1991.

Turn Lane Warrant Analysis - Tee Intersections

Study Intersection: Olympic Dr/N-S Project St
 Study Scenario: F+P Weekday PM

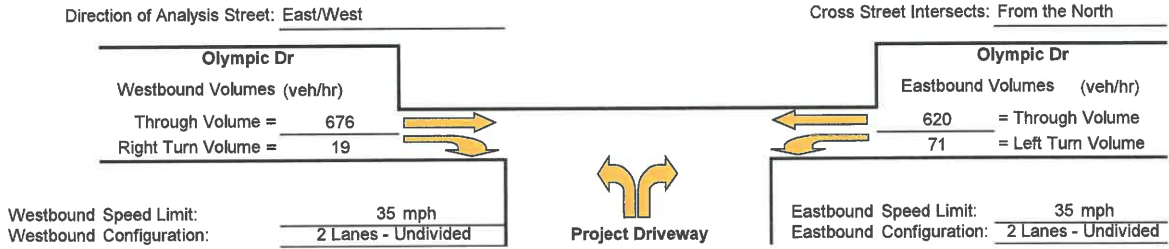

Westbound Right Turn Lane Warrants

1. Check for right turn volume criteria

Thresholds not met, continue to next step

2. Check advance volume threshold criteria for turn lane

Advancing Volume Threshold	AV =	907.6
Advancing Volume	Va =	695
If AV < Va then warrant is met		

Right Turn Lane Warranted: NO

Westbound Right Turn Taper Warrants (evaluate if right turn lane is unwarranted)

1. Check taper volume criteria

NOT WARRANTED - Less than 20 vehicles

2. Check advance volume threshold criteria for taper

Advancing Volume Threshold	AV =	-
Advancing Volume	Va =	695
If AV < Va then warrant is met		

Right Turn Taper Warranted: NO

Eastbound Left Turn Lane Warrants

Percentage Left Turns %lt	10.3 %
Advancing Volume Threshold AV	374 veh/hr

If AV < Va then warrant is met

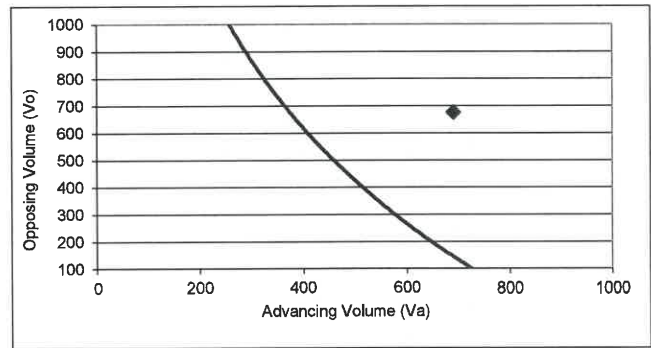

◆ Study Intersection
 — Two lane roadway warrant threshold for: 35 mph
 Turn lane warranted if point falls to right of warrant threshold line

Left Turn Lane Warranted: YES

Methodology based on Washington State Transportation Center Research Report *Method For Prioritizing Intersection Improvements*, January 1997.
 The right turn lane and taper analysis is based on work conducted by Cottrell in 1981.
 The left turn lane analysis is based on work conducted by M.D. Harmelink in 1967, and modified by Kikuchi and Chakroborty in 1991.

Turn Lane Warrant Analysis - Tee Intersections

Study Intersection: Burns Valley Rd/N-S Project St
 Study Scenario: Weekend PM F+P

Direction of Analysis Street: East/West

Cross Street Intersects: From the South

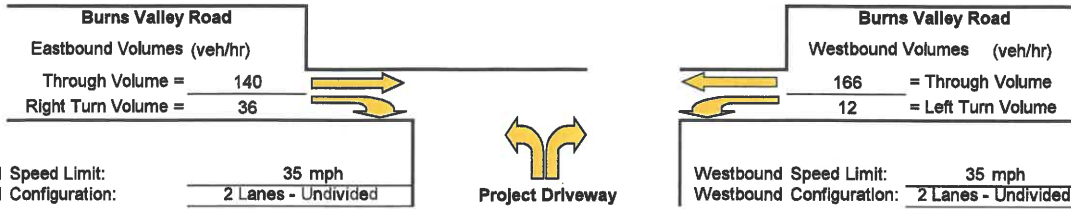

Eastbound Right Turn Lane Warrants

1. Check for right turn volume criteria

Thresholds not met, continue to next step

2. Check advance volume threshold criteria for turn lane

Advancing Volume Threshold	AV =	780
Advancing Volume	Va =	176
If $AV < Va$ then warrant is met		No

Right Turn Lane Warranted: NO

Eastbound Right Turn Taper Warrants (evaluate if right turn lane is unwarranted)

1. Check taper volume criteria

Thresholds not met, continue to next step

2. Check advance volume threshold criteria for taper

Advancing Volume Threshold	AV =	540
Advancing Volume	Va =	176
If $AV < Va$ then warrant is met		No

Right Turn Taper Warranted: NO

Westbound Left Turn Lane Warrants

Percentage Left Turns %lt	6.7 %
Advancing Volume Threshold AV	869 veh/hr
If $AV < Va$ then warrant is met	

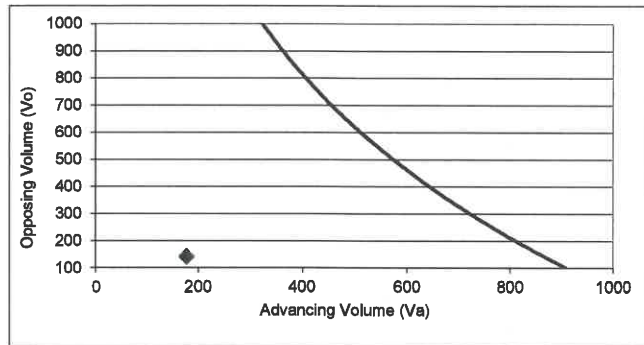

◆ Study Intersection
 Two lane roadway warrant threshold for: 35 mph
 Turn lane warranted if point falls to right of warrant threshold line

Left Turn Lane Warranted: NO

Methodology based on Washington State Transportation Center Research Report *Method For Prioritizing Intersection Improvements*, January 1997.
 The right turn lane and taper analysis is based on work conducted by Cottrell in 1981.
 The left turn lane analysis is based on work conducted by M.D. Harmelink in 1967, and modified by Kikuchi and Chakroborty in 1991.

Turn Lane Warrant Analysis - Tee Intersections

Study Intersection: Burns Valley Rd / Oak Valley Villas Northern Driveway
 Study Scenario: Weekend PM F+P

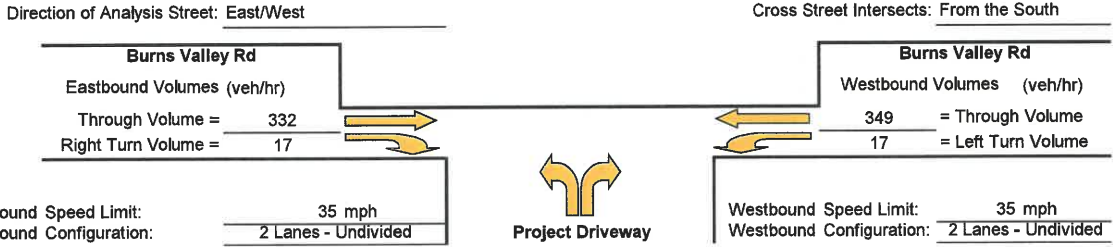

Eastbound Right Turn Lane Warrants

1. Check for right turn volume criteria

Thresholds not met, continue to next step

2. Check advance volume threshold criteria for turn lane

Advancing Volume Threshold	AV =	922.6
Advancing Volume	Va =	349
If AV < Va then warrant is met		No

Right Turn Lane Warranted: NO

Eastbound Right Turn Taper Warrants (evaluate if right turn lane is unwarranted)

1. Check taper volume criteria

NOT WARRANTED - Less than 20 vehicles

2. Check advance volume threshold criteria for taper

Advancing Volume Threshold	AV =	-
Advancing Volume	Va =	349
If AV < Va then warrant is met		-

Right Turn Taper Warranted: NO

Westbound Left Turn Lane Warrants

Percentage Left Turns %lt 4.6 %
 Advancing Volume Threshold AV 839 veh/hr
 If AV < Va then warrant is met

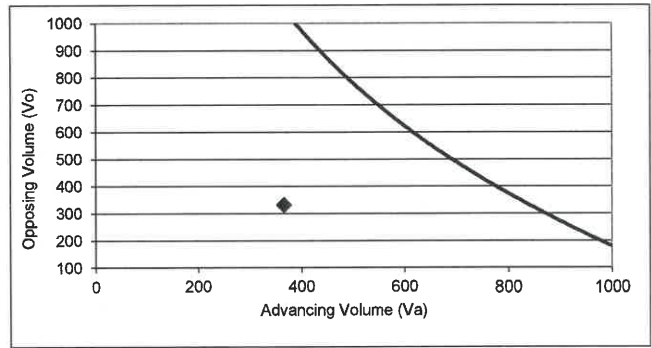

◆ Study Intersection
 Two lane roadway warrant threshold for: 35 mph
 Turn lane warranted if point falls to right of warrant threshold line

Left Turn Lane Warranted: NO

Methodology based on Washington State Transportation Center Research Report *Method For Prioritizing Intersection Improvements*, January 1997.
 The right turn lane and taper analysis is based on work conducted by Cottrell in 1981.
 The left turn lane analysis is based on work conducted by M.D. Harmelink in 1967, and modified by Kikuchi and Chakroborty in 1991.

Turn Lane Warrant Analysis - Tee Intersections

Study Intersection: Burns Valley Rd/E-W Project St
 Study Scenario: F+P Weekend PM

Direction of Analysis Street: North/South

Cross Street Intersects: From the West

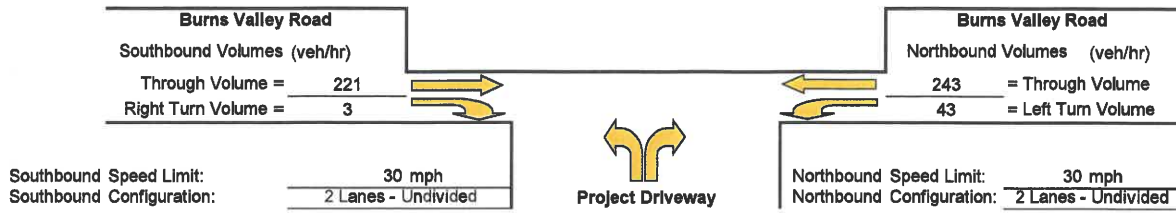

Southbound Right Turn Lane Warrants

1. Check for right turn volume criteria

Thresholds not met, continue to next step

2. Check advance volume threshold criteria for turn lane

Advancing Volume Threshold	AV = 1027.6
Advancing Volume	Va = 224
If $AV < Va$ then warrant is met	
	No

Right Turn Lane Warranted: NO

Southbound Right Turn Taper Warrants
 (evaluate if right turn lane is unwarranted)

1. Check taper volume criteria

NOT WARRANTED - Less than 20 vehicles

2. Check advance volume threshold criteria for taper

Advancing Volume Threshold	AV = -
Advancing Volume	Va = 224
If $AV < Va$ then warrant is met	
	-

Right Turn Taper Warranted: NO

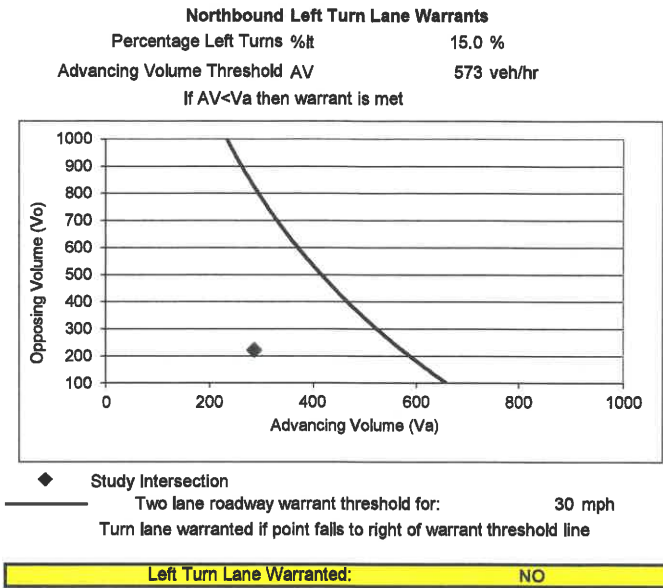

Methodology based on Washington State Transportation Center Research Report *Method For Prioritizing Intersection Improvements*, January 1997.
 The right turn lane and taper analysis is based on work conducted by Cottrell in 1981.
 The left turn lane analysis is based on work conducted by M.D. Harmelink in 1967, and modified by Kikuchi and Chakroborty in 1991.

Turn Lane Warrant Analysis - Tee Intersections

Study Intersection: Olympic Dr/N-S Project St
 Study Scenario: F+P Weekend PM

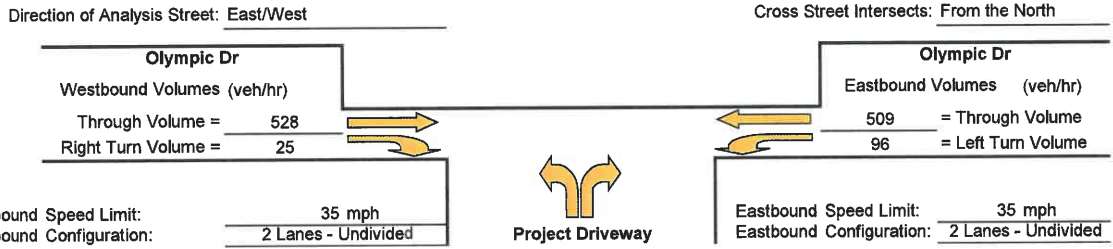

Westbound Right Turn Lane Warrants

1. Check for right turn volume criteria

Thresholds not met, continue to next step

2. Check advance volume threshold criteria for turn lane

Advancing Volume Threshold	AV =	862.6
Advancing Volume	Va =	553

If $AV < Va$ then warrant is met No

Right Turn Lane Warranted: NO

Westbound Right Turn Taper Warrants
(evaluate if right turn lane is unwarranted)

1. Check taper volume criteria

Thresholds not met, continue to next step

2. Check advance volume threshold criteria for taper

Advancing Volume Threshold	AV =	650
Advancing Volume	Va =	553

If $AV < Va$ then warrant is met No

Right Turn Taper Warranted: NO

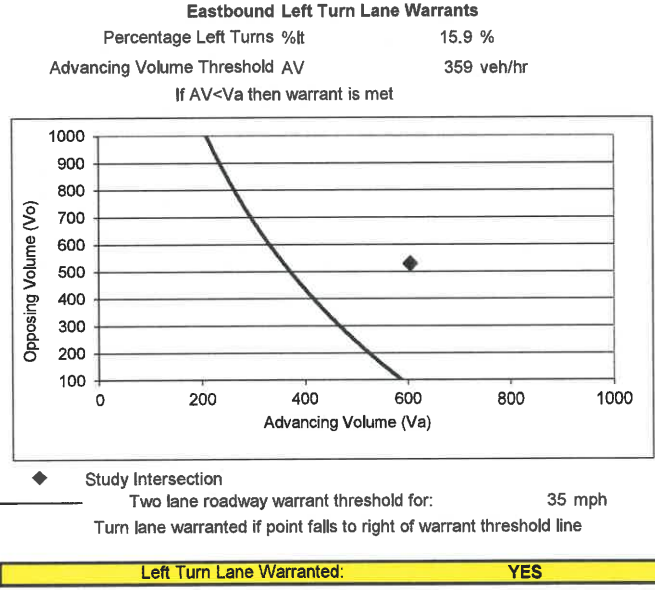

Methodology based on Washington State Transportation Center Research Report *Method For Prioritizing Intersection Improvements*, January 1997.
 The right turn lane and taper analysis is based on work conducted by Cottrell in 1981.
 The left turn lane analysis is based on work conducted by M.D. Harmelink in 1967, and modified by Kikuchi and Chakroborty in 1991.

Appendix E

Maximum Left-Turn Queue Length Calculations



This page intentionally left blank

Maximum Queue Length Two-Way Stop-Controlled Intersections

Through Street: Olympic Dr
Side Street: North-South Project St

Scenario: F+P Weekday AM
Stop Controlled Legs: North/South

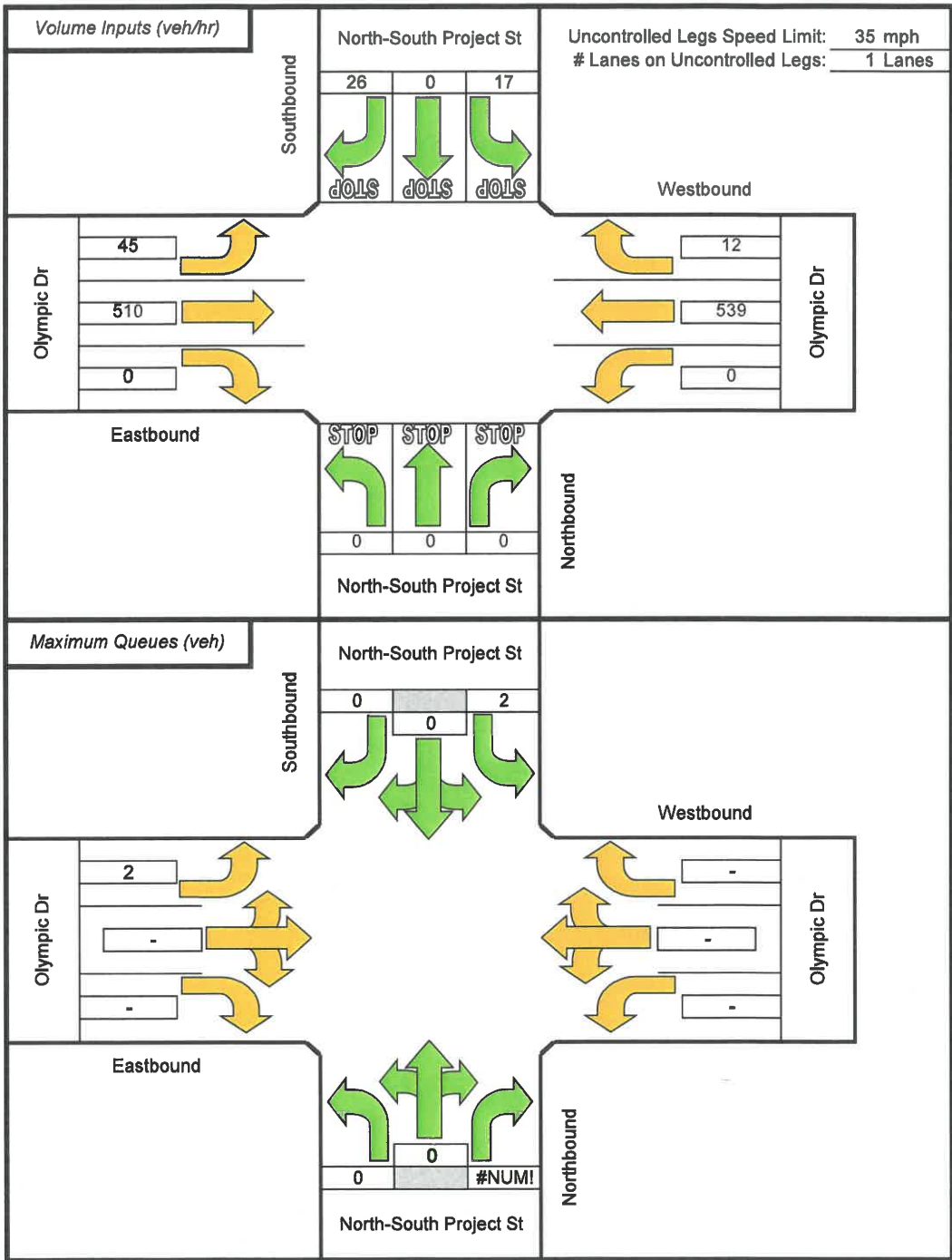

Source: John T. Gard, ITE Journal, November 2001, "Estimating Maximum Queue Length at Unsignalized Intersections"

Maximum Queue Length Two-Way Stop-Controlled Intersections

Through Street: Olympic Dr
Side Street: North-South Project St

Scenario: F+P Weekday PM
Stop Controlled Legs: North/South

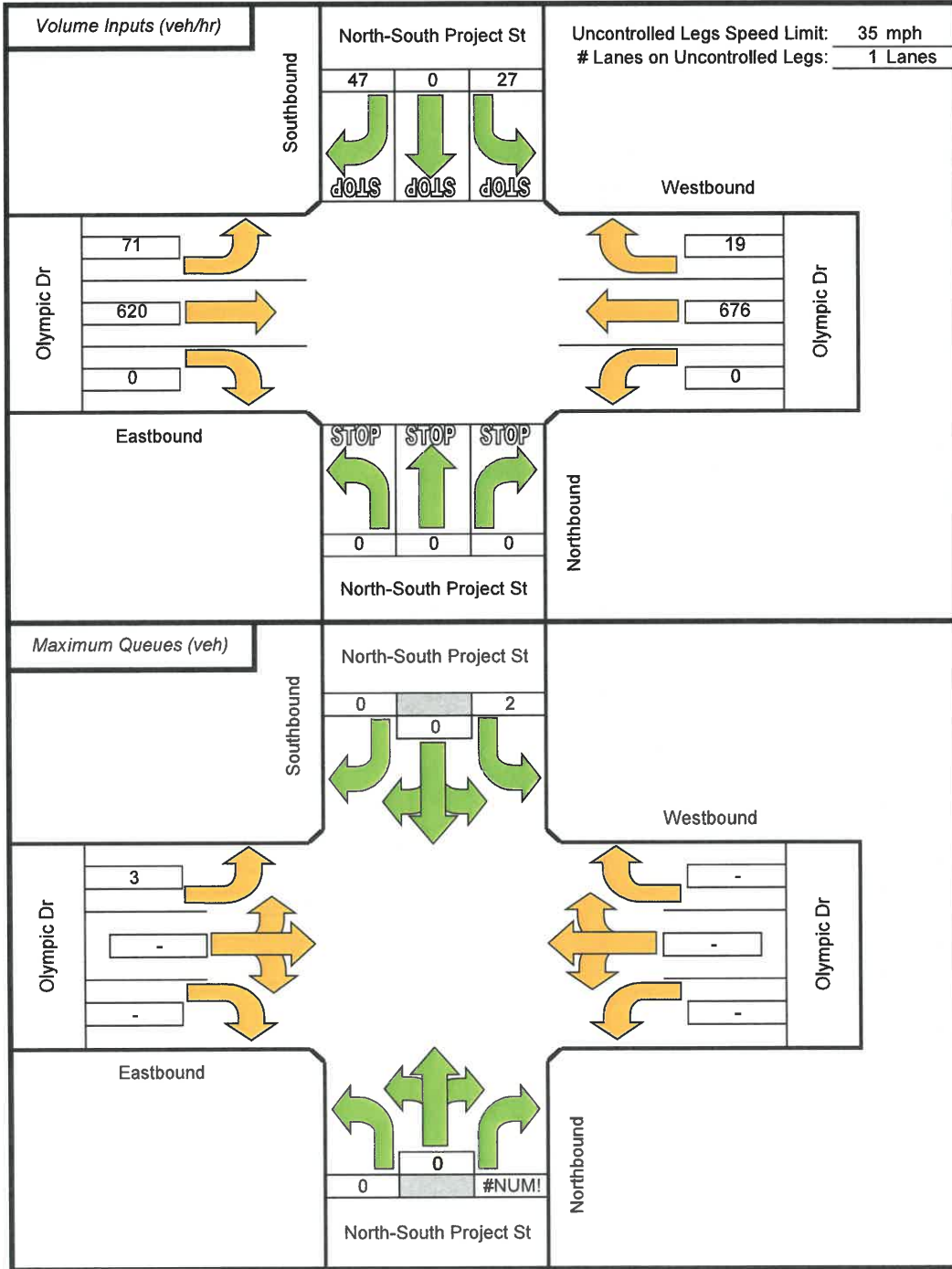

Source: John T. Gard, ITE Journal, November 2001, "Estimating Maximum Queue Length at Unsignalized Intersections"

Maximum Queue Length Two-Way Stop-Controlled Intersections

Through Street: Olympic Dr
Side Street: North-South Project St

Scenario: F+P Weekend PM
Stop Controlled Legs: North/South

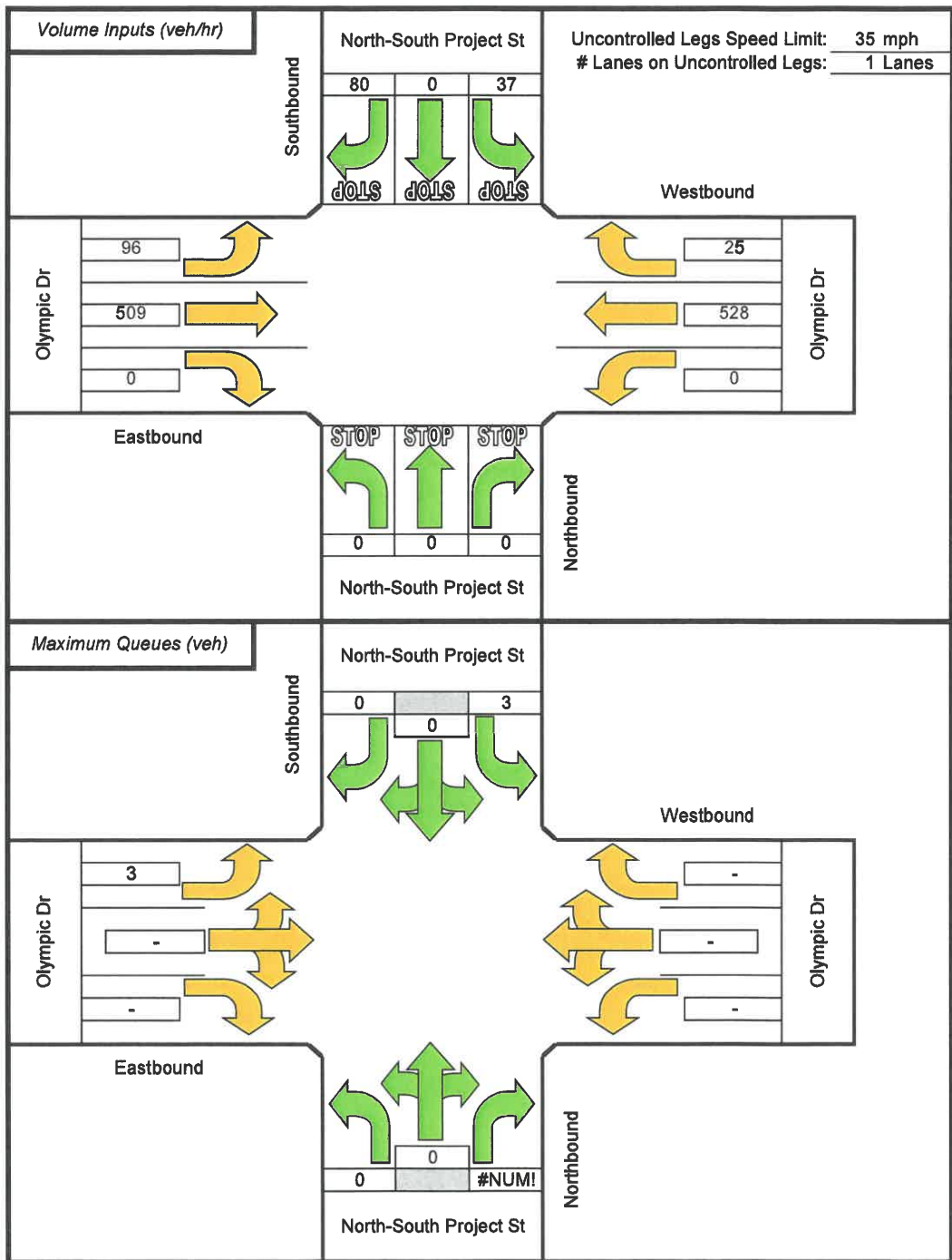

Source: John T. Gard, ITE Journal, November 2001, "Estimating Maximum Queue Length at Unsignalized Intersections"



This page intentionally left blank

Appendix F

Intersection Level of Service and Queuing Calculations



This page intentionally left blank

Intersection Level Of Service Report
Intersection 2: Burns Valley Rd/Bowers Ave-Runsey Rd

Control Type: Two-way stop
Analysis Method: HCM 6th Edition
Analysis Period: 15 minutes
Delay (sec / veh): 13.6
Level Of Service: B
Volume to Capacity (v/c): 0.014

Intersection Setup

Name	Burns Valley Rd			Runsey Rd			Burns Valley Rd			Bowers Ave		
Approach	Northbound			Southbound			Eastbound			Westbound		
Lane Configuration	+			+			+			+		
Turning Movement	Left	Thru	Right	Left	Thru	Right	Left	Thru	Right	Left	Thru	Right
Lane Width [ft]	12.00	12.00	12.00	12.00	12.00	12.00	12.00	12.00	12.00	12.00	12.00	12.00
No. of Lanes in Entry Pocket	0	0	0	0	0	0	0	0	0	0	0	0
Entry Pocket Length [ft]	100.00	100.00	100.00	100.00	100.00	100.00	100.00	100.00	100.00	100.00	100.00	100.00
No. of Lanes in Exit Pocket	0	0	0	0	0	0	0	0	0	0	0	0
Exit Pocket Length [ft]	0.00	0.00	0.00	0.00	0.00	0.00	0.00	0.00	0.00	0.00	0.00	0.00
Speed [mph]	30.00			30.00			35.00			25.00		
Grade [%]	0.00			0.00			0.00			0.00		
Crosswalk	No			Yes			Yes			No		

Volumes

Name	Burns Valley Rd			Runsey Rd			Burns Valley Rd			Bowers Ave		
Base Volume Input [veh/h]	122	26	6	0	23	16	9	1	124	5	1	0
Base Volume Adjustment Factor	1.0000	1.0000	1.0000	1.0000	1.0000	1.0000	1.0000	1.0000	1.0000	1.0000	1.0000	1.0000
Heavy Vehicles Percentage [%]	2.00	2.00	2.00	2.00	2.00	2.00	2.00	2.00	2.00	2.00	2.00	2.00
Growth Factor	1.0000	1.0000	1.0000	1.0000	1.0000	1.0000	1.0000	1.0000	1.0000	1.0000	1.0000	1.0000
In-Process Volume [veh/h]	0	0	0	0	0	0	0	0	0	0	0	0
Site-Generated Trips [veh/h]	0	0	0	0	0	0	0	0	0	0	0	0
Diverted Trips [veh/h]	0	0	0	0	0	0	0	0	0	0	0	0
Pass-by Trips [veh/h]	0	0	0	0	0	0	0	0	0	0	0	0
Existing Site Adjustment Volume [veh/h]	0	0	0	0	0	0	0	0	0	0	0	0
Other Volume [veh/h]	0	0	0	0	0	0	0	0	0	0	0	0
Total Hourly Volume [veh/h]	122	26	6	0	23	16	9	1	124	5	1	0
Peak Hour Factor	0.8500	0.8500	0.8500	0.8500	0.8500	0.8500	0.8500	0.8500	0.8500	0.8500	0.8500	0.8500
Other Adjustment Factor	1.0000	1.0000	1.0000	1.0000	1.0000	1.0000	1.0000	1.0000	1.0000	1.0000	1.0000	1.0000
Total 15-Minute Volume [veh/h]	36	8	2	0	7	5	3	0	36	1	0	0
Total Analysis Volume [veh/h]	144	31	7	0	27	19	11	1	146	6	1	0
Pedestrian Volume [ped/h]	0	0	0	0	0	0	0	0	0	0	0	0



Intersection Settings

Priority Scheme	Free	Free	Stop	Stop
Flared Lane			No	No
Storage Area [veh]	0	0	0	0
Two-Stage Gap Acceptance			No	No
Number of Storage Spaces in Median	0	0	0	0

Movement, Approach, & Intersection Results

V/C, Movement V/C Ratio	0.09	0.30	0.00	0.00	0.00	0.00	0.02	0.00	0.14	0.01	0.00	0.00
d_M, Delay for Movement [s/veh]	7.54	9.30	0.00	7.29	0.00	0.00	12.24	12.75	9.20	13.62	12.22	8.86
Movement LOS	A	A	A	A	A	A	B	B	A	B	B	A
95th-Percentile Queue Length [veh/h]	0.30	0.30	0.30	0.00	0.00	0.00	0.58	0.58	0.58	0.05	0.05	0.05
95th-Percentile Queue Length [ft/h]	7.60	7.60	7.60	0.00	0.00	0.00	14.50	14.50	14.50	1.23	1.23	1.23
d_A, Approach Delay [s/veh]	5.96			0.00			9.43			13.42		
Approach LOS	A			A			A			B		
d_I, Intersection Delay [s/veh]							6.79					
Intersection LOS	B											



Intersection Level Of Service Report
Intersection 5: Olympic Dr/Lakeshore Dr

Control Type: Two-way stop
 Analysis Method: HCM 6th Edition
 Analysis Period: 15 minutes
 Delay (sec / veh): 16.3
 Level Of Service: C
 Volume to Capacity (v/c): 0.147

Intersection Setup

Name	Lakeshore Dr			Lakeshore Dr			Olympic Dr					
Approach	Northbound			Southbound			Eastbound			Westbound		
Lane Configuration	[Diagram]			[Diagram]			[Diagram]			[Diagram]		
Turning Movement	Left	Thru	Right	Left	Thru	Right	Left	Thru	Right	Left	Thru	Right
Lane Width [ft]	12.00	12.00	12.00	12.00	12.00	12.00	12.00	12.00	12.00	12.00	12.00	12.00
No. of Lanes in Entry Pocket	0	0	1	0	0	0	0	0	0	0	0	1
Entry Pocket Length [ft]	100.00	100.00	120.00	100.00	100.00	100.00	100.00	100.00	100.00	100.00	100.00	250.00
No. of Lanes in Exit Pocket	0	0	0	0	0	0	0	0	0	0	0	0
Exit Pocket Length [ft]	0.00	0.00	0.00	0.00	0.00	0.00	0.00	0.00	0.00	0.00	0.00	0.00
Speed [mph]	25.00			25.00			30.00			30.00		
Grade [%]	0.00			0.00			0.00			0.00		
Crosswalk	No			Yes			No			Yes		

Volumes

Name	Lakeshore Dr			Lakeshore Dr			Olympic Dr					
Base Volume Input [veh/h]	1	137	66	81	279	2	0	0	1	47	1	60
Base Volume Adjustment Factor	1.0000	1.0000	1.0000	1.0000	1.0000	1.0000	1.0000	1.0000	1.0000	1.0000	1.0000	1.0000
Heavy Vehicles Percentage [%]	2.00	2.00	2.00	2.00	2.00	2.00	2.00	2.00	2.00	2.00	2.00	2.00
Growth Factor	1.0000	1.0000	1.0000	1.0000	1.0000	1.0000	1.0000	1.0000	1.0000	1.0000	1.0000	1.0000
In-Process Volume [veh/h]	0	0	0	0	0	0	0	0	0	0	0	0
Site-Generated Trips [veh/h]	0	0	0	0	0	0	0	0	0	0	0	0
Diverted Trips [veh/h]	0	0	0	0	0	0	0	0	0	0	0	0
Pass-by Trips [veh/h]	0	0	0	0	0	0	0	0	0	0	0	0
Existing Site Adjustment Volume [veh/h]	0	0	0	0	0	0	0	0	0	0	0	0
Other Volume [veh/h]	0	0	0	0	0	0	0	0	0	0	0	0
Total Hourly Volume [veh/h]	1	137	66	81	279	2	0	0	1	47	1	60
Peak Hour Factor	0.8600	0.8600	0.8600	0.8600	0.8600	0.8600	0.8600	0.8600	0.8600	0.8600	0.8600	0.8600
Other Adjustment Factor	1.0000	1.0000	1.0000	1.0000	1.0000	1.0000	1.0000	1.0000	1.0000	1.0000	1.0000	1.0000
Total 15-Minute Volume [veh/h]	0	40	19	18	81	1	0	0	0	14	0	17
Total Analysis Volume [veh/h]	1	159	77	71	324	2	0	0	1	55	1	70
Pedestrian Volume [ped/h]	0			0			0			1		



Intersection Settings

Priority Scheme	Free	Free	Stop	Stop
Flared Lane			No	No
Storage Area [veh]	0	0	0	0
Two-Stage Gap Acceptance			No	No
Number of Storage Spaces in Median	0	0	0	0

Movement, Approach, & Intersection Results

V/C, Movement V/C Ratio	0.00	0.00	0.00	0.05	0.00	0.00	0.00	0.00	0.00	0.15	0.00	0.08
d_M, Delay for Movement [s/veh]	7.92	0.79	0.00	7.86	0.03	0.00	10.70	15.71	10.03	16.29	15.05	9.44
Movement LOS	A	A	A	A	A	A	C	C	B	C	C	A
95th-Percentile Queue Length [veh/ln]	0.00	0.00	0.00	0.17	0.17	0.00	0.00	0.00	0.00	0.51	0.27	0.27
95th-Percentile Queue Length [ft/ln]	0.06	0.06	0.00	4.23	4.23	4.23	3.10	0.10	0.10	12.78	6.67	6.67
d_A, Approach Delay [s/veh]	0.03		1.41		10.03		12.47					
Approach LOS	A		A		B		B					
d_I, Intersection Delay [s/veh]	2.82											
Intersection LOS	C											



Intersection Level Of Service Report
Intersection 7: Olympic Dr/Burns Valley Rd-Old Hwy 53

Control Type: Signalized Delay (sec / veh): 11.2
 Analysis Method: HCM 6th Edition Level Of Service: B
 Analysis Period: 15 minutes Volume to Capacity (v/c): 0.655

Intersection Setup

Name	Old Hwy 53			Burns Valley Rd			Olympic Dr			Old Hwy 53		
	Northbound			Southbound			Eastbound			Westbound		
Approach	Northbound			Southbound			Eastbound			Westbound		
Lane Configuration	[Diagram]			[Diagram]			[Diagram]			[Diagram]		
Turning Movement	Left	Thru	Right	Left	Thru	Right	Left	Thru	Right	Left	Thru	Right
Lane Width [ft]	12.00	12.00	12.00	12.00	12.00	12.00	12.00	12.00	12.00	12.00	12.00	12.00
No. of Lanes in Entry Pocket	1	0	1	1	0	0	1	0	0	1	0	0
Entry Pocket Length [ft]	100.00	100.00	100.00	56.00	100.00	100.00	48.00	100.00	100.00	100.00	100.00	100.00
No. of Lanes in Exit Pocket	0	0	0	0	0	0	0	0	0	0	0	0
Exit Pocket Length [ft]	0.00	0.00	0.00	0.00	0.00	0.00	0.00	0.00	0.00	0.00	0.00	0.00
Speed [mph]	30.00			30.00			35.00			35.00		
Grade [%]	0.00			0.00			0.00			0.00		
Curb Present	No			No			No			No		
Crosswalk	Yes			Yes			Yes			Yes		

Volumes

Name	Old Hwy 53			Burns Valley Rd			Olympic Dr			Old Hwy 53		
Base Volume Input [veh/h]	42	62	45	75	70	15	26	131	51	48	150	99
Base Volume Adjustment Factor	1.0000	1.0000	1.0000	1.0000	1.0000	1.0000	1.0000	1.0000	1.0000	1.0000	1.0000	1.0000
Heavy Vehicles Percentage [%]	2.00	2.00	2.00	2.00	2.00	2.00	2.00	2.00	2.00	2.00	2.00	2.00
Growth Factor	1.0000	1.0000	1.0000	1.0000	1.0000	1.0000	1.0000	1.0000	1.0000	1.0000	1.0000	1.0000
In-Process Volume [veh/h]	0	0	0	0	0	0	0	0	0	0	0	0
Site-Generated Trips [veh/h]	0	0	0	0	0	0	0	0	0	0	0	0
Diverted Trips [veh/h]	0	0	0	0	0	0	0	0	0	0	0	0
Pass-by Trips [veh/h]	0	0	0	0	0	0	0	0	0	0	0	0
Existing Site Adjustment Volume [veh/h]	0	0	0	0	0	0	0	0	0	0	0	0
Other Volume [veh/h]	0	0	0	0	0	0	0	0	0	0	0	0
Right Turn on Red Volume [veh/h]	0	0	19	0	0	3	0	0	5	0	0	20
Total Hourly Volume [veh/h]	42	62	26	75	70	12	26	131	46	48	150	79
Peak Hour Factor	0.8900	0.8900	0.8900	0.8900	0.8900	0.8900	0.8900	0.8900	0.8900	0.8900	0.8900	0.8900
Other Adjustment Factor	1.0000	1.0000	1.0000	1.0000	1.0000	1.0000	1.0000	1.0000	1.0000	1.0000	1.0000	1.0000
Total 15-Minute Volume [veh/h]	12	17	7	21	20	3	7	37	13	13	42	22
Total Analysis Volume [veh/h]	47	70	29	84	79	13	29	147	52	54	169	89
Presence of On-Street Parking	No	No	No	No	No	No	No	No	No	No	No	No
On-Street Parking Maneuver Rate [h]	0	0	0	0	0	0	0	0	0	0	0	0
Local Bus Stopping Rate [h]	0	0	0	0	0	0	0	0	0	0	0	0
v_do, Outbound Pedestrian Volume crossing major street	1			0			1			1		
v_di, Inbound Pedestrian Volume crossing major street	1			1			0			1		
v_co, Outbound Pedestrian Volume crossing minor street	1			0			0			0		
v_ci, Inbound Pedestrian Volume crossing minor street	0			0			1			0		
v_ab, Corner Pedestrian Volume [ped/h]	0			0			0			0		
Bicycle Volume [bicycles/h]	0			0			0			1		



Intersection Settings

Located in CBD	Yes
Signal Coordination Group	-
Cycle Length [s]	109
Coordination Type	Time of Day Pattern Isolated
Actuation Type	Fully actuated
Offset [s]	0.0
Offset Reference	Lead Green - Beginning of First Green
Permissive Mode	SingleBand
Last time [s]	14.00

Phasing & Timing

Control Type	Protect	Permis	Permis	Protect	Permis	Permis	Protect	Permis	Permis	Protect	Permis	Permis
Signal Group	3	8	0	7	4	0	5	2	0	1	6	0
Auxiliary Signal Groups												
Lead / Lag	Lead	-	-	Lead	-	-	Lead	-	-	Lead	-	-
Minimum Green [s]	4	6	0	4	6	0	4	6	0	4	6	0
Maximum Green [s]	20	25	0	20	25	0	20	30	0	20	20	0
Amber [s]	3.0	3.3	0.0	3.0	3.3	0.0	3.0	3.6	0.0	3.0	3.6	0.0
All red [s]	0.0	0.3	0.0	0.0	0.3	0.0	0.0	0.3	0.0	0.0	0.3	0.0
Split [s]	23	29	0	23	29	0	23	34	0	23	34	0
Vehicle Extension [s]	0.0	0.0	0.0	0.0	0.0	0.0	0.0	0.0	0.0	0.0	0.0	0.0
Walk [s]	0	7	0	0	7	0	0	7	0	0	7	0
Pedestrian Clearance [s]	0	11	0	0	9	0	0	14	0	0	9	0
Delayed Vehicle Green [s]	0.0	0.0	0.0	0.0	0.0	0.0	0.0	0.0	0.0	0.0	0.0	0.0
Rest In Walk		No			No			No			No	
I1, Start-Up Lost Time [s]	2.0	2.0	0.0	2.0	2.0	0.0	2.0	2.0	0.0	2.0	2.0	0.0
I2, Clearance Lost Time [s]	1.0	1.6	0.0	1.0	1.6	0.0	1.0	1.9	0.0	1.0	1.9	0.0
Minimum Recall	No	No		No	No		No	No		No	No	
Maximum Recall	No	No		No	No		No	No		No	No	
Pedestrian Recall	No	No		No	No		No	No		No	No	
Detector Location [ft]	3.0	0.0	0.0	0.0	0.0	0.0	0.0	0.0	0.0	0.0	0.0	0.0
Detector Length [ft]	0.0	0.0	0.0	0.0	0.0	0.0	0.0	0.0	0.0	0.0	0.0	0.0
I, Upstream Filtering Factor	1.00	1.00	1.00	1.00	1.00	1.00	1.00	1.00	1.00	1.00	1.00	1.00

Exclusive Pedestrian Phase

Pedestrian Signal Group	0
Pedestrian Walk [s]	0
Pedestrian Clearance [s]	0

Lane Group Calculations

Lane Group	L	C	R	L	C	L	C	L	C
C, Cycle Length [s]	24	24	24	24	24	24	24	24	24
L, Total Lost Time per Cycle [s]	3.00	3.60	3.60	3.00	3.60	3.00	3.60	3.00	3.60
I1_p, Permitted Start-Up Lost Time [s]	0.00	0.30	0.00	0.00	0.00	0.00	0.00	0.00	0.00
I2, Clearance Lost Time [s]	1.00	1.60	1.60	1.00	1.60	1.00	1.60	1.00	1.60
g_l, Effective Green Time [s]	1	3	3	2	4	1	5	1	5
g / C, Green / Cycle	0.05	0.13	0.13	0.07	0.16	0.03	0.19	0.05	0.21
(v / s)_ Volume / Saturation Flow Rate	0.03	0.04	0.02	0.05	0.06	0.02	0.12	0.03	0.16
s, saturation flow rate [veh/h]	1603	1683	1419	1603	1641	1603	1608	1603	1573
c, Capacity [veh/h]	76	218	184	119	257	50	306	85	334
d1, Uniform Delay [s]	11.42	9.55	9.44	11.04	9.20	11.67	9.13	11.33	9.06
k, delay calibration	0.04	0.04	0.04	0.04	0.04	0.04	0.04	0.04	0.04
I, Upstream Filtering Factor	1.00	1.00	1.00	1.00	1.00	1.00	1.00	1.00	1.00
d2, Incremental Delay [s]	3.08	0.31	0.15	2.82	0.31	3.94	0.87	2.94	1.45
d3, Initial Queue Delay [s]	0.00	0.00	0.00	0.00	0.00	0.00	0.00	0.00	0.00
Rp, platoon ratio	1.00	1.00	1.00	1.00	1.00	1.00	1.00	1.00	1.00
PF, progression factor	1.00	1.00	1.00	1.00	1.00	1.00	1.00	1.00	1.00

Lane Group Results

X, volume / capacity	0.62	0.32	0.16	0.70	0.36	0.58	0.65	0.64	0.77
d, Delay for Lane Group [s/veh]	14.50	9.97	9.59	13.85	9.51	15.61	10.00	14.27	10.51
Lane Group LOS	B	A	A	B	A	B	A	B	B
Critical Lane Group	No	Yes	No	Yes	No	Yes	No	No	Yes
50th-Percentile Queue Length [veh/ln]	0.24	0.24	0.10	0.39	0.29	0.16	0.81	0.25	0.81
50th-Percentile Queue Length [ft/ln]	5.89	5.91	2.39	9.75	7.37	3.88	15.15	6.29	20.31
95th-Percentile Queue Length [veh/ln]	0.42	0.43	0.17	0.70	0.53	0.28	1.09	0.45	1.46
95th-Percentile Queue Length [ft/ln]	10.60	10.65	4.31	17.55	13.27	6.99	27.27	11.32	35.57

Movement, Approach, & Intersection Results

d_M, Delay for Movement [s/veh]	14,50	9,97	9,59	13,85	9,51	9,51	15,61	10,00	10,00	14,27	10,51	10,51
Movement LOS	B	A	A	B	A	A	B	A	A	B	B	B
d_A, Approach Delay [s/veh]	11,35		11,58		10,71		11,16					
Approach LOS	B		B		B		B					
d_I, Intersection Delay [s/veh]	11,16											
Intersection LOS	B											
Intersection V/C	0,655											

Other Modes

g_Walk,mi, Effective Walk Time [s]	11,0	11,0	11,0	11,0
M_corner, Corner Circulation Area [ft²/ped]	0,00	0,00	0,00	0,00
M_CW, Crosswalk Circulation Area [ft²/ped]	0,00	0,00	0,00	0,00
d_p, Pedestrian Delay [s]	3,60	3,60	3,60	3,60
I_p,int, Pedestrian LOS Score for Intersection	2,153	1,979	2,032	2,109
Crosswalk LOS	B	A	B	B
s_b, Saturation Flow Rate of the bicycle lane [bicycles/h]	2000	2000	2000	2000
c_b, Capacity of the bicycle lane [bicycles/h]	2098	2098	2487	2487
d_b, Bicycle Delay [s]	0,03	0,03	0,72	0,72
I_b,int, Bicycle LOS Score for Intersection	1,832	1,855	1,944	2,107
Bicycle LOS	A	A	A	B

Sequence

Ring 1	1	2	3	4	-	-	-	-	-	-	-	-	-	-
Ring 2	5	6	7	8	-	-	-	-	-	-	-	-	-	-
Ring 3	-	-	-	-	-	-	-	-	-	-	-	-	-	-
Ring 4	-	-	-	-	-	-	-	-	-	-	-	-	-	-

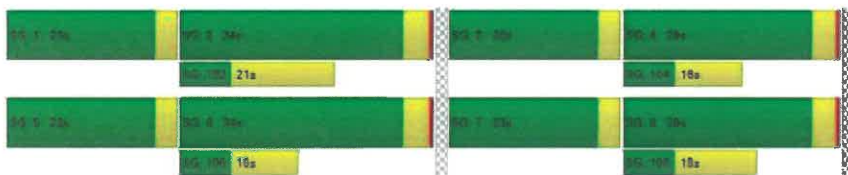

Intersection Level Of Service Report

Intersection 2: Burns Valley Rd/Bowers Ave-Rumsey Rd

Control Type:	Two-way stop	Delay (sec / veh):	12,8
Analysis Method:	HCM 6th Edition	Level Of Service:	B
Analysis Period:	15 minutes	Volume to Capacity (v/c):	0,031

Intersection Setup

Name	Burns Valley Rd			Rumsey Rd			Burns Valley Rd			Bowers Ave		
Approach	Northbound			Southbound			Eastbound			Westbound		
Lane Configuration	+			+			+			+		
Turning Movement	Left	Thru	Right	Left	Thru	Right	Left	Thru	Right	Left	Thru	Right
Lane Width [ft]	12,00	12,00	12,00	12,00	12,00	12,00	12,00	12,00	12,00	12,00	12,00	12,00
No. of Lanes in Entry Pocket	0	0	0	0	0	0	0	0	0	0	0	0
Entry Pocket Length [ft]	100,00	100,00	100,00	100,00	100,00	100,00	100,00	100,00	100,00	100,00	100,00	100,00
No. of Lanes in Exit Pocket	0	0	0	0	0	0	0	0	0	0	0	0
Exit Pocket Length [ft]	0,00	0,00	0,00	0,00	0,00	0,00	0,00	0,00	0,00	0,00	0,00	0,00
Speed [mph]	30,00			30,00			35,00			25,00		
Grade [%]	0,00			0,00			0,00			0,00		
Crosswalk	No			Yes			Yes			No		

Volumes

Name	Burns Valley Rd			Rumsey Rd			Burns Valley Rd			Bowers Ave		
Base Volume Input [veh/h]	100	38	9	2	43	7	7	1	75	13	0	0
Base Volume Adjustment Factor	1,0000	1,0000	1,0000	1,0000	1,0000	1,0000	1,0000	1,0000	1,0000	1,0000	1,0000	1,0000
Heavy Vehicles Percentage [%]	2,00	2,00	2,00	2,00	2,00	2,00	2,00	2,00	2,00	2,00	2,00	2,00
Growth Factor	1,0000	1,0000	1,0000	1,0000	1,0000	1,0000	1,0000	1,0000	1,0000	1,0000	1,0000	1,0000
In-Process Volume [veh/h]	0	0	0	0	0	0	0	0	0	0	0	0
Site-Generated Trips [veh/h]	0	0	0	0	0	0	0	0	0	0	0	0
Diverted Trips [veh/h]	0	0	0	0	0	0	0	0	0	0	0	0
Pass-by Trips [veh/h]	0	0	0	0	0	0	0	0	0	0	0	0
Existing Site Adjustment Volume [veh/h]	0	0	0	0	0	0	0	0	0	0	0	0
Other Volume [veh/h]	0	0	0	0	0	0	0	0	0	0	0	0
Total Hourly Volume [veh/h]	100	38	9	2	43	7	7	1	75	13	0	0
Peak Hour Factor	0,8500	0,8500	0,8500	0,8500	0,8500	0,8500	0,8500	0,8500	0,8500	0,8500	0,8500	0,8500
Other Adjustment Factor	1,0000	1,0000	1,0000	1,0000	1,0000	1,0000	1,0000	1,0000	1,0000	1,0000	1,0000	1,0000
Total 15-Minute Volume [veh/h]	29	11	3	1	13	2	2	0	22	4	0	0
Total Analysis Volume [veh/h]	118	45	11	2	51	8	8	1	88	15	0	0
Pedestrian Volume [ped/h]	0			0			0			0		



Intersection Settings

Priority Scheme	Free	Free	Stop	Stop
Flared Lane			No	No
Storage Area [veh]	0	0	0	0
Two-Stage Gap Acceptance			No	No
Number of Storage Spaces in Median	0	0	0	0

Movement, Approach, & Intersection Results

V/C, Movement V/C Ratio	0.08	0.00	0.00	0.00	0.00	0.00	0.01	0.00	0.09	0.03	0.00	0.00
d_M, Delay for Movement [s/veh]	7.52	0.00	0.00	7.33	0.00	0.00	11.74	12.26	9.00	12.63	12.05	8.77
Movement LOS	A	A	A	A	A	A	B	B	A	B	B	A
95th-Percentile Queue Length [veh/h]	0.25	0.25	0.25	0.00	0.00	0.00	0.34	0.34	0.34	0.10	0.10	0.10
95th-Percentile Queue Length [ft/in]	6.19	6.19	6.19	0.10	0.10	0.10	8.57	8.57	8.57	2.38	2.38	2.38
d_A, Approach Delay [s/veh]	5.10			0.24			9.25			12.63		
Approach LOS	A			A			A			B		
d_I, Intersection Delay [s/veh]							5.73					
Intersection LOS	B											



Intersection Level Of Service Report
Intersection 5: Olympic Dr/Lakeshore Dr

Control Type:	Two-way stop	Delay (sec / veh):	16.8
Analysis Method:	HCM 6th Edition	Level Of Service:	C
Analysis Period:	15 minutes	Volume to Capacity (v/c):	0.273

Intersection Setup

Name	Lakeshore Dr			Lakeshore Dr			Olympic Dr					
Approach	Northbound			Southbound			Eastbound			Westbound		
Lane Configuration	←→			←→			←→			←→		
Turning Movement	Left	Thru	Right	Left	Thru	Right	Left	Thru	Right	Left	Thru	Right
Lane Width [ft]	12.00	12.00	12.00	12.00	12.00	12.00	12.00	12.00	12.00	12.00	12.00	12.00
No. of Lanes in Entry Pocket	0	0	1	0	0	0	0	0	0	0	0	1
Entry Pocket Length [ft]	100.00	100.00	120.00	100.00	100.00	100.00	100.00	100.00	100.00	100.00	100.00	250.00
No. of Lanes in Exit Pocket	0	0	0	0	0	0	0	0	0	0	0	0
Exit Pocket Length [ft]	0.00	0.00	0.00	0.00	0.00	0.00	0.00	0.00	0.00	0.00	0.00	0.00
Speed [mph]	25.00			25.00			30.00			30.00		
Grade [%]	0.00			0.00			0.00			0.00		
Crosswalk	No			Yes			No			Yes		

Volumes

Name	Lakeshore Dr			Lakeshore Dr			Olympic Dr					
Base Volume Input [veh/h]	1	198	114	66	180	1	0	2	2	106	3	141
Base Volume Adjustment Factor	1.0000	1.0000	1.0000	1.0000	1.0000	1.0000	1.0000	1.0000	1.0000	1.0000	1.0000	1.0000
Heavy Vehicles Percentage [%]	2.00	2.00	2.00	2.00	2.00	2.00	2.00	2.00	2.00	2.00	2.00	2.00
Growth Factor	1.0000	1.0000	1.0000	1.0000	1.0000	1.0000	1.0000	1.0000	1.0000	1.0000	1.0000	1.0000
In-Process Volume [veh/h]	0	0	0	0	0	0	0	0	0	0	0	0
Site-Generated Trips [veh/h]	0	0	0	0	0	0	0	0	0	0	0	0
Diverted Trips [veh/h]	0	0	0	0	0	0	0	0	0	0	0	0
Pass-by Trips [veh/h]	0	0	0	0	0	0	0	0	0	0	0	0
Existing Site Adjustment Volume [veh/h]	0	0	0	0	0	0	0	0	0	0	0	0
Other Volume [veh/h]	0	0	0	0	0	0	0	0	0	0	0	0
Total Hourly Volume [veh/h]	1	198	114	66	180	1	0	2	2	106	3	141
Peak Hour Factor	0.9300	0.9300	0.9300	0.9300	0.9300	0.9300	0.9300	0.9300	0.9300	0.9300	0.9300	0.9300
Other Adjustment Factor	1.0000	1.0000	1.0000	1.0000	1.0000	1.0000	1.0000	1.0000	1.0000	1.0000	1.0000	1.0000
Total 15-Minute Volume [veh/h]	0	53	31	18	48	0	0	1	1	28	1	38
Total Analysis Volume [veh/h]	1	213	123	71	194	1	0	2	2	114	3	152
Pedestrian Volume [ped/h]	0				0			0				1



Intersection Settings

Priority Scheme	Free	Free	Stop	Stop
Flared Lane			No	No
Storage Area [veh]	0	0	0	0
Two-Stage Gap Acceptance			No	No
Number of Storage Spaces in Median	0	0	0	0

Movement, Approach, & Intersection Results

V/C, Movement V/C Ratio	0.00	0.00	0.00	0.06	0.00	0.00	0.00	0.01	0.00	0.27	0.01	0.18
d_M, Delay for Movement [s/veh]	7.61	0.00	0.00	8.13	0.00	0.00	18.07	15.34	9.31	16.84	14.80	10.41
Movement LOS	A	A	A	A	A	C	C	A	C	B	B	B
95th-Percentile Queue Length [veh/ln]	0.00	0.00	0.00	0.18	0.18	0.18	0.02	0.02	1.10	0.70	0.70	0.70
95th-Percentile Queue Length [ft/ln]	0.05	0.05	0.00	4.62	4.62	4.62	0.81	0.81	27.41	17.61	17.61	17.61
d_A, Approach Delay [s/veh]	0.02			2.17			12.32			13.19		
Approach LOS	A			A			B			B		
d_I, Intersection Delay [s/veh]	4.77											
Intersection LOS	C											



Intersection Level Of Service Report

Intersection 7: Olympic Dr/Burns Valley Rd-Old Hwy 53

Control Type:	Signalized	Delay (sec / veh):	13.3
Analysis Method:	HCM 6th Edition	Level Of Service:	B
Analysis Period:	15 minutes	Volume to Capacity (v/c):	0.759

Intersection Setup

Name	Old Hwy 53			Burns Valley Rd			Olympic Dr			Old Hwy 53		
Approach	Northbound			Southbound			Eastbound			Westbound		
Lane Configuration	T T T			T T			T T			T T		
Turning Movement	Left	Thru	Right	Left	Thru	Right	Left	Thru	Right	Left	Thru	Right
Lane Width [ft]	12.00	12.00	12.00	12.00	12.00	12.00	12.00	12.00	12.00	12.00	12.00	12.00
No. of Lanes in Entry Pocket	1	0	1	1	0	0	1	0	0	1	0	0
Entry Pocket Length [ft]	100.00	100.00	100.00	58.00	100.00	100.00	48.00	100.00	100.00	100.00	100.00	100.00
No. of Lanes in Exit Pocket	0	0	0	0	0	0	0	0	0	0	0	0
Exit Pocket Length [ft]	0.00	0.00	0.00	0.00	0.00	0.00	0.00	0.00	0.00	0.00	0.00	0.00
Speed [mph]	30.00			30.00			35.00			35.00		
Grade [%]	0.00			0.00			0.00			0.00		
Curb Present	No			No			No			No		
Crosswalk	Yes			Yes			Yes			Yes		



Volumes

Name	Old Hwy 53			Burns Valley Rd			Olympic Dr			Old Hwy 53		
Base Volume Input [veh/h]	98	113	56	112	97	46	21	184	93	62	221	139
Base Volume Adjustment Factor	1.0000	1.0000	1.0000	1.0000	1.0000	1.0000	1.0000	1.0000	1.0000	1.0000	1.0000	1.0000
Heavy Vehicles Percentage [%]	2.00	2.00	2.00	2.00	2.00	2.00	2.00	2.00	2.00	2.00	2.00	2.00
Growth Factor	1.0000	1.0000	1.0000	1.0000	1.0000	1.0000	1.0000	1.0000	1.0000	1.0000	1.0000	1.0000
In-Process Volume [veh/h]	0	0	0	0	0	0	0	0	0	0	0	0
Site-Generated Trips [veh/h]	0	0	0	0	0	0	0	0	0	0	0	0
Diverted Trips [veh/h]	0	0	0	0	0	0	0	0	0	0	0	0
Pass-by Trips [veh/h]	0	0	0	0	0	0	0	0	0	0	0	0
Existing Site Adjustment Volume [veh/h]	0	0	0	0	0	0	0	0	0	0	0	0
Other Volume [veh/h]	0	0	0	0	0	0	0	0	0	0	0	0
Right Turn on Red Volume [veh/h]	0	0	18	0	0	11	0	0	14	0	0	25
Total Hourly Volume [veh/h]	98	113	38	112	97	35	21	184	79	62	221	114
Peak Hour Factor	0.9200	0.9200	0.9200	0.9200	0.9200	0.9200	0.9200	0.9200	0.9200	0.9200	0.9200	0.9200
Other Adjustment Factor	1.0000	1.0000	1.0000	1.0000	1.0000	1.0000	1.0000	1.0000	1.0000	1.0000	1.0000	1.0000
Total 15-Minute Volume [veh/h]	27	31	10	30	26	10	6	50	21	17	60	31
Total Analysis Volume [veh/h]	107	123	41	122	105	38	23	200	86	67	240	124
Presence of On-Street Parking	No	No	No	No	No	No	No	No	No	No	No	No
On-Street Parking Maneuver Rate [h]	0	0	0	0	0	0	0	0	0	0	0	0
Local Bus Stopping Rate [h]	0	0	0	0	0	0	0	0	0	0	0	0
v_do, Outbound Pedestrian Volume crossing major street	1			0			1			1		
v_di, Inbound Pedestrian Volume crossing major street	1			1			0			1		
v_co, Outbound Pedestrian Volume crossing minor street	1			0			0			0		
v_ci, Inbound Pedestrian Volume crossing minor street	0			0			1			0		
v_ab, Corner Pedestrian Volume [ped/h]	0			0			0			0		
Bicycle Volume [bicycles/h]	0			0			0			1		

Intersection Settings

Located in CBD	Yes
Signal Coordination Group	-
Cycle Length [s]	109
Coordination Type	Time of Day Pattern Isolated
Actuation Type	Fully actuated
Offset [s]	0.0
Offset Reference	Lead Green - Beginning of First Green
Permissive Mode	SingleBand
Lost time [s]	14.00

Phasing & Timing

Control Type	Protect	Permis	Permis	Protect	Permis	Permis	Protect	Permis	Permis	Protect	Permis	Permis
Signal Group	3	8	0	7	4	0	5	2	0	1	6	0
Auxiliary Signal Groups												
Lead / Lag	Lead	-	-	Lead	-	-	Lead	-	-	Lead	-	-
Minimum Green [s]	4	6	0	4	6	0	4	6	0	4	6	0
Maximum Green [s]	20	25	0	20	25	0	20	30	0	20	20	0
Amber [s]	3.0	3.3	0.0	3.0	3.3	0.0	3.0	3.6	0.0	3.0	3.6	0.0
All red [s]	0.0	0.3	0.0	0.0	0.3	0.0	0.0	0.3	0.0	0.0	0.3	0.0
Split [s]	23	29	0	23	29	0	23	34	0	23	34	0
Vehicle Extension [s]	0.0	0.0	0.0	0.0	0.0	0.0	0.0	0.0	0.0	0.0	0.0	0.0
Walk [s]	7	7	0	7	7	0	7	7	0	7	7	0
Pedestrian Clearance [s]	0	11	0	0	9	0	0	14	0	0	9	0
Delayed Vehicle Green [s]	0.0	0.0	0.0	0.0	0.0	0.0	0.0	0.0	0.0	0.0	0.0	0.0
Rest In Walk	No	No	No	No	No	No	No	No	No	No	No	No
I1, Start-Up Lost Time [s]	2.0	2.0	0.0	2.0	2.0	0.0	2.0	2.0	0.0	2.0	2.0	0.0
I2, Clearance Lost Time [s]	1.0	1.6	0.0	1.0	1.6	0.0	1.0	1.9	0.0	1.0	1.9	0.0
Minimum Recall	No	No	No	No	No	No	No	No	No	No	No	No
Maximum Recall	No	No	No	No	No	No	No	No	No	No	No	No
Pedestrian Recall	No	No	No	No	No	No	No	No	No	No	No	No
Detector Location [ft]	0.0	0.0	0.0	0.0	0.0	0.0	0.0	0.0	0.0	0.0	0.0	0.0
Detector Length [ft]	0.0	0.0	0.0	0.0	0.0	0.0	0.0	0.0	0.0	0.0	0.0	0.0
I, Upstream Filtering Factor	1.00	1.00	1.00	1.00	1.00	1.00	1.00	1.00	1.00	1.00	1.00	1.00

Exclusive Pedestrian Phase

Pedestrian Signal Group	0
Pedestrian Walk [s]	0
Pedestrian Clearance [s]	0



Lane Group Calculations

Lane Group	L	C	R	L	C	L	C	L	C
C, Cycle Length [s]	30	30	30	30	30	30	30	30	30
L, Total Lost Time per Cycle [s]	3.00	3.60	3.60	3.00	3.60	3.00	3.90	3.00	3.90
l1_p, Permitted Start-Up Lost Time [s]	0.00	0.00	0.00	0.00	0.00	0.00	0.00	0.00	0.00
l2, Clearance Lost Time [s]	1.00	1.60	1.60	1.00	1.60	1.00	1.90	1.00	1.90
g_l, Effective Green Time [s]	2	5	5	3	5	1	7	2	8
g / C, Green / Cycle	0.08	0.16	0.16	0.09	0.17	0.02	0.24	0.06	0.27
(v / s)_j Volume / Saturation Flow Rate	0.07	0.07	0.03	0.08	0.09	0.01	0.18	0.04	0.23
s, saturation flow rate [veh/h]	1603	1683	1421	1603	1606	1603	1597	1603	1575
c, Capacity [veh/h]	129	261	221	149	269	38	386	94	435
d1, Uniform Delay [s]	13.52	11.50	10.97	13.30	11.37	14.44	10.46	13.82	10.18
k, delay calibration	0.04	0.04	0.04	0.04	0.04	0.04	0.04	0.04	0.04
l, Upstream Filtering Factor	1.00	1.00	1.00	1.00	1.00	1.00	1.00	1.00	1.00
d2, Incremental Delay [s]	5.00	0.49	0.15	4.18	0.61	5.45	1.06	3.77	1.67
d3, Initial Queue Delay [s]	0.00	0.00	0.00	0.00	0.00	0.00	0.00	0.00	0.00
Rp, platoon ratio	1.00	1.00	1.00	1.00	1.00	1.00	1.00	1.00	1.00
PF, progression factor	1.00	1.00	1.00	1.00	1.00	1.00	1.00	1.00	1.00

Lane Group Results

X, volume / capacity	0.83	0.47	0.19	0.82	0.53	0.80	0.74	0.72	0.84
d, Delay for Lane Group [s/veh]	18.53	11.99	11.12	17.49	11.97	19.89	11.52	17.59	11.85
Lane Group LOS	B	B	B	B	B	B	B	B	B
Critical Lane Group	Yes	No	No	No	Yes	Yes	No	No	Yes
50th-Percentile Queue Length [veh/ln]	0.72	0.58	0.18	0.78	0.67	0.17	1.21	0.42	1.56
50th-Percentile Queue Length [ft/ln]	17.99	14.46	4.54	19.54	16.80	4.34	30.33	10.60	39.05
95th-Percentile Queue Length [veh/ln]	1.30	1.04	0.33	1.41	1.21	0.31	2.18	0.76	2.81
95th-Percentile Queue Length [ft/ln]	32.38	26.02	8.16	35.17	30.24	7.81	54.60	19.08	70.29



Movement, Approach, & Intersection Results

d_M, Delay for Movement [s/veh]	18.53	11.99	11.12	17.49	11.97	11.97	19.89	11.52	11.52	17.59	11.85	11.85
Movement LOS	B	B	B	B	B	B	B	B	B	B	B	B
d_A, Approach Delay [s/veh]	14.44			14.51			12.14			12.74		
Approach LOS	B			B			B			B		
d_I, Intersection Delay [s/veh]	13.33											
Intersection LOS	B											
Intersection V/C	0.759											

Other Modes

g_Walk,mi, Effective Walk Time [s]	11.0	11.0	11.0	11.0
M_corner, Corner Circulation Area [ft²/ped]	0.00	0.00	0.00	0.00
M_CW, Crosswalk Circulation Area [ft²/ped]	0.00	0.00	0.00	0.00
d_p, Pedestrian Delay [s]	5.89	5.89	5.89	5.89
L_p,int, Pedestrian LOS Score for Intersection	2.222	2.070	2.161	2.222
Crosswalk LOS	B	B	B	B
s_b, Saturation Flow Rate of the bicycle lane [bicycles/h]	2000	2000	2000	2000
c_b, Capacity of the bicycle lane [bicycles/h]	1710	1710	2026	2026
d_b, Bicycle Delay [s]	0.31	0.31	0.00	0.00
L_b,int, Bicycle LOS Score for Intersection	2.036	2.015	2.093	2.312
Bicycle LOS	B	B	B	B

Sequence

Ring 1	1	2	3	4	-	-	-	-	-	-	-	-	-	-	-
Ring 2	5	6	7	8	-	-	-	-	-	-	-	-	-	-	-
Ring 3	-	-	-	-	-	-	-	-	-	-	-	-	-	-	-
Ring 4	-	-	-	-	-	-	-	-	-	-	-	-	-	-	-

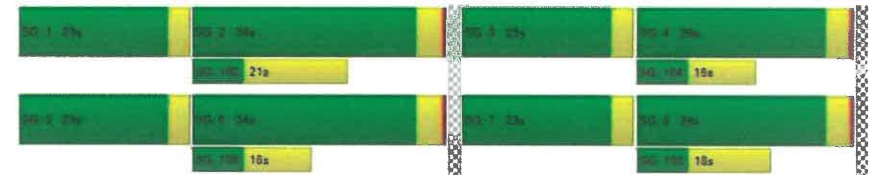

Intersection Level Of Service Report

Intersection 2: Burns Valley Rd/Bowers Ave-Rumsey Rd

Control Type: Two-way stop
Analysis Method: HCM 6th Edition
Analysis Period: 15 minutes
Delay (sec / veh): 11.7
Level Of Service: B
Volume to Capacity (v/c): 0.004

Intersection Setup

Name	Burns Valley Rd			Rumsey Rd			Burns Valley Rd			Bowers Ave		
Approach	Northbound			Southbound			Eastbound			Westbound		
Lane Configuration	+			+			+			+		
Turning Movement	Left	Thru	Right	Left	Thru	Right	Left	Thru	Right	Left	Thru	Right
Lane Width [ft]	12.00	12.00	12.00	12.00	12.00	12.00	12.00	12.00	12.00	12.00	12.00	12.00
No. of Lanes in Entry Pocket	0	0	0	0	0	0	0	0	0	0	0	0
Entry Pocket Length [ft]	100.00	100.00	100.00	100.00	100.00	100.00	100.00	100.00	100.00	100.00	100.00	100.00
No. of Lanes in Exit Pocket	0	0	0	0	0	0	0	0	0	0	0	0
Exit Pocket Length [ft]	0.00	0.00	0.00	0.00	0.00	0.00	0.00	0.00	0.00	0.00	0.00	0.00
Speed [mph]	30.00			30.00			35.00			25.00		
Grade [%]	0.00			0.00			0.00			0.00		
Crosswalk	No			Yes			Yes			No		

Volumes

Name	Burns Valley Rd			Rumsey Rd			Burns Valley Rd			Bowers Ave		
Base Volume Input [veh/h]	84	36	1	0	31	9	10	0	83	2	1	0
Base Volume Adjustment Factor	1.0000	1.0000	1.0000	1.0000	1.0000	1.0000	1.0000	1.0000	1.0000	1.0000	1.0000	1.0000
Heavy Vehicles Percentage [%]	2.00	2.00	2.00	2.00	2.00	2.00	2.00	2.00	2.00	2.00	2.00	2.00
Growth Factor	1.0000	1.0000	1.0000	1.0000	1.0000	1.0000	1.0000	1.0000	1.0000	1.0000	1.0000	1.0000
In-Process Volume [veh/h]	0	0	0	0	0	0	0	0	0	0	0	0
Site-Generated Trips [veh/h]	0	0	0	0	0	0	0	0	0	0	0	0
Diverted Trips [veh/h]	0	0	0	0	0	0	0	0	0	0	0	0
Pass-by Trips [veh/h]	0	0	0	0	0	0	0	0	0	0	0	0
Existing Site Adjustment Volume [veh/h]	0	0	0	0	0	0	0	0	0	0	0	0
Other Volume [veh/h]	0	0	0	0	0	0	0	0	0	0	0	0
Total Hourly Volume [veh/h]	84	36	1	0	31	9	10	0	83	2	1	0
Peak Hour Factor	0.8500	0.9600	0.9600	0.9600	0.9600	0.8500	0.8500	0.8500	0.8500	0.9600	0.8500	0.9600
Other Adjustment Factor	1.0000	1.0000	1.0000	1.0000	1.0000	1.0000	1.0000	1.0000	1.0000	1.0000	1.0000	1.0000
Total 15-Minute Volume [veh/h]	25	9	0	0	8	3	3	0	24	1	0	0
Total Analysis Volume [veh/h]	99	38	1	0	32	11	12	0	98	2	1	0
Pedestrian Volume [ped/h]	0	0	0	0	0	0	0	0	0	0	0	0

Intersection Settings

Priority Scheme	Free	Free	Stop	Stop
Flared Lane			No	No
Storage Area [veh]	0	0	0	0
Two-Stage Gap Acceptance			No	No
Number of Storage Spaces in Median	0	0	0	0

Movement, Approach, & Intersection Results

V/C, Movement V/C Ratio	0.06	0.00	0.00	0.00	0.00	0.00	0.02	0.00	0.09	0.00	0.00	0.00
d_M, Delay for Movement [s/veh]	7.45	0.30	0.00	7.22	0.00	0.00	11.07	11.59	8.95	11.68	11.16	8.02
Movement LOS	A	A	A	A	A	A	B	B	A	B	B	A
95th-Percentile Queue Length [veh/ln]	0.20	0.20	0.20	0.00	0.00	0.00	0.38	0.38	0.38	0.02	0.02	0.02
95th-Percentile Queue Length [ft/ln]	5.06	5.06	5.06	0.00	0.00	0.00	9.56	9.56	9.56	0.41	0.41	0.41
d_A, Approach Delay [s/veh]	5.35			0.00			9.18			11.50		
Approach LOS	A			A			A			B		
d_I, Intersection Delay [s/veh]	6.06											
Intersection LOS	B											



Intersection Level Of Service Report
Intersection 5: Olympic Dr/Lakeshore Dr

Control Type: Two-way stop
 Analysis Method: HCM 8th Edition
 Analysis Period: 15 minutes
 Delay (sec / veh): 16.9
 Level Of Service: C
 Volume to Capacity (v/c): 0.282

Intersection Setup

Name	Lakeshore Dr			Lakeshore Dr			Olympic Dr		
	Northbound			Southbound			Westbound		
Lane Configuration	[Diagram]			[Diagram]			[Diagram]		
Turning Movement	Left	Thru	Right	Left	Thru	Right	Left	Thru	Right
Lane Width [ft]	12.00	12.00	12.00	12.00	12.00	12.00	12.00	12.00	12.00
No. of Lanes in Entry Pocket	0	0	1	0	0	0	0	0	1
Entry Pocket Length [ft]	100.00	100.00	120.00	100.00	100.00	100.00	100.00	100.00	250.00
No. of Lanes in Exit Pocket	0	0	0	0	0	0	0	0	0
Exit Pocket Length [ft]	0.00	0.00	0.00	0.00	0.00	0.00	0.00	0.00	0.00
Speed [mph]	25.00			25.00			30.00		
Grade [%]	0.00			0.00			0.00		
Crosswalk	No			Yes			Yes		

Volumes

Name	Lakeshore Dr			Lakeshore Dr			Olympic Dr		
	1	176	103	73	185	0	3	3	97
Base Volume Input [veh/h]	1	176	103	73	185	0	3	3	97
Base Volume Adjustment Factor	1.0000	1.0000	1.0000	1.0000	1.0000	1.0000	1.0000	1.0000	1.0000
Heavy Vehicles Percentage [%]	2.00	2.00	2.00	2.00	2.00	2.00	2.00	2.00	2.00
Growth Factor	1.0000	1.0000	1.0000	1.0000	1.0000	1.0000	1.0000	1.0000	1.0000
In-Process Volume [veh/h]	0	0	0	0	0	0	0	0	0
Site-Generated Trips [veh/h]	0	0	0	0	0	0	0	0	0
Diverted Trips [veh/h]	0	0	0	0	0	0	0	0	0
Pass-by Trips [veh/h]	0	0	0	0	0	0	0	0	0
Existing Site Adjustment Volume [veh/h]	0	0	0	0	0	0	0	0	0
Other Volume [veh/h]	0	0	0	0	0	0	0	0	0
Total Hourly Volume [veh/h]	1	176	103	73	185	0	3	3	97
Peak Hour Factor	0.9100	0.9100	0.9100	0.9100	0.9100	0.9100	0.9100	0.9100	0.9100
Other Adjustment Factor	1.0000	1.0000	1.0000	1.0000	1.0000	1.0000	1.0000	1.0000	1.0000
Total 15-Minute Volume [veh/h]	0	48	28	20	51	0	1	1	27
Total Analysis Volume [veh/h]	1	193	113	80	203	0	3	3	107
Pedestrian Volume [ped/h]									1



Intersection Settings

Priority Scheme	Free	Free	Stop	Stop
Flared Lane			No	No
Storage Area [veh]	0	0	0	0
Two-Stage Gap Acceptance			No	No
Number of Storage Spaces in Median	0	0	0	0

Movement, Approach, & Intersection Results

V/C, Movement V/C Ratio	0.00	0.00	0.00	0.06	0.00	0.00	0.00	0.01	0.00	0.26	0.00	0.10
d_M, Delay for Movement [s/veh]	7.63	0.00	0.00	8.07	0.00	0.00	16.29	15.40	9.39	16.90	14.36	9.73
Movement LOS	A	A	A	A	A	C	C	A	C	B	A	A
95th-Percentile Queue Length [veh/ln]	0.00	0.00	0.00	0.20	0.20	0.04	0.04	0.04	1.04	0.33	0.33	0.33
95th-Percentile Queue Length [ft/ln]	0.05	0.05	0.00	5.11	5.11	0.52	0.92	0.92	25.89	8.24	8.24	8.24
d_A, Approach Delay [s/veh]	0.02			2.28			12.39			13.79		
Approach LOS	A			A			B			B		
d_I, Intersection Delay [s/veh]	4.26											
Intersection LOS	C											



Intersection Level Of Service Report

Intersection 7: Olympic Dr/Burns Valley Rd-Old Hwy 53

Control Type: Signalized
Analysis Method: HCM 6th Edition
Analysis Period: 15 minutes
Delay (sec / veh): 11.7
Level Of Service: B
Volume to Capacity (v/c): 0.682

Intersection Setup

Name	Old Hwy 53			Burns Valley Rd			Olympic Dr			Old Hwy 53		
	Northbound			Southbound			Eastbound			Westbound		
Lane Configuration	T T T			T T T			T T T			T T T		
Turning Movement	Left	Thru	Right	Left	Thru	Right	Left	Thru	Right	Left	Thru	Right
Lane Width [ft]	12.00	12.00	12.00	12.00	12.00	12.00	12.00	12.00	12.00	12.00	12.00	12.00
No. of Lanes in Entry Pocket	1	0	1	1	0	0	1	0	0	1	0	0
Entry Pocket Length [ft]	100.00	100.00	100.00	56.00	100.00	100.00	48.00	100.00	100.00	100.00	100.00	100.00
No. of Lanes in Exit Pocket	0	0	0	0	0	0	0	0	0	0	0	0
Exit Pocket Length [ft]	0.00	0.00	0.00	0.00	0.00	0.00	0.00	0.00	0.00	0.00	0.00	0.00
Speed [mph]	30.00			30.00			35.00			35.00		
Grade [%]	0.00			0.00			0.00			0.00		
Curb Present	No			No			No			No		
Crosswalk	Yes			Yes			Yes			Yes		

Volumes

Name	Old Hwy 53			Burns Valley Rd			Olympic Dr			Old Hwy 53		
Base Volume Input [veh/h]	80	81	42	93	64	30	20	180	95	33	170	109
Base Volume Adjustment Factor	1.0000	1.0000	1.0000	1.0000	1.0000	1.0000	1.0000	1.0000	1.0000	1.0000	1.0000	1.0000
Heavy Vehicles Percentage [%]	2.00	2.00	2.00	2.00	2.00	2.00	2.00	2.00	2.00	2.00	2.00	2.00
Growth Factor	1.0000	1.0000	1.0000	1.0000	1.0000	1.0000	1.0000	1.0000	1.0000	1.0000	1.0000	1.0000
In-Process Volume [veh/h]	0	0	0	0	0	0	0	0	0	0	0	0
Site-Generated Trips [veh/h]	0	0	0	0	0	0	0	0	0	0	0	0
Diverted Trips [veh/h]	0	0	0	0	0	0	0	0	0	0	0	0
Pass-by Trips [veh/h]	0	0	0	0	0	0	0	0	0	0	0	0
Existing Site Adjustment Volume [veh/h]	0	0	0	0	0	0	0	0	0	0	0	0
Other Volume [veh/h]	0	0	0	0	0	0	0	0	0	0	0	0
Right Turn on Red Volume [veh/h]	0	0	16	0	0	12	0	0	25	0	0	29
Total Hourly Volume [veh/h]	80	81	27	93	64	18	20	180	70	33	170	80
Peak Hour Factor	0.9300	0.9300	0.9300	0.9300	0.9300	0.9300	0.9300	0.9300	0.9300	0.9300	0.9300	0.9300
Other Adjustment Factor	1.0000	1.0000	1.0000	1.0000	1.0000	1.0000	1.0000	1.0000	1.0000	1.0000	1.0000	1.0000
Total 15-Minute Volume [veh/h]	22	22	7	25	17	5	5	48	19	9	46	22
Total Analysis Volume [veh/h]	86	87	29	100	69	19	22	194	75	35	183	86
Presence of On-Street Parking	No	No	No	No	No	No	No	No	No	No	No	No
On-Street Parking Maneuver Rate [h]	0	0	0	0	0	0	0	0	0	0	0	0
Local Bus Stopping Rate [h]	0	0	0	0	0	0	0	0	0	0	0	0
v_do, Outbound Pedestrian Volume crossing major street	1			0			1			1		
v_di, Inbound Pedestrian Volume crossing major street	1			1			0			1		
v_co, Outbound Pedestrian Volume crossing minor street	1			0			0			0		
v_ci, Inbound Pedestrian Volume crossing minor street	0			0			1			0		
v_ab, Corner Pedestrian Volume [ped/h]	0			0			0			0		
Bicycle Volume [bicycles/h]	0			0			0			1		



Intersection Settings	
Located In CBD	Yes
Signal Coordination Group	-
Cycle Length [s]	109
Coordination Type	Time of Day Pattern Isolated
Actuation Type	Fully actuated
Offset [s]	0.0
Offset Reference	Lead Green - Beginning of Red Green
Permissive Mode	SingleBand
Last time [s]	14.00

Phasing & Timing													
Control Type	Protect	Permis	Permis	Protect	Permis	Permis	Protect	Permis	Permis	Protect	Permis	Permis	Protect
Signal Group	3	8	0	7	4	0	5	2	0	1	6	0	
Auxiliary Signal Groups													
Lead / Lag	Lead	-	-	Lead	-	-	Lead	-	-	Lead	-	-	
Minimum Green [s]	4	6	0	4	6	0	4	6	0	4	6	0	
Maximum Green [s]	20	25	0	20	25	0	20	30	0	20	20	0	
Amber [s]	3.0	3.3	0.0	3.0	3.3	0.0	3.0	3.6	0.0	3.0	3.6	0.0	
All red [s]	0.0	0.3	0.0	0.0	0.3	0.0	0.0	0.3	0.0	0.0	0.3	0.0	
Split [s]	23	29	0	23	29	0	23	34	0	23	34	0	
Vehicle Extension [s]	0.0	0.0	0.0	0.0	0.0	0.0	0.0	0.0	0.0	0.0	0.0	0.0	
Walk [s]	0	7	0	0	7	0	0	7	0	0	7	0	
Pedestrian Clearance [s]	0	11	0	0	9	0	0	14	0	0	9	0	
Delayed Vehicle Green [s]	0.0	0.0	0.0	0.0	0.0	0.0	0.0	0.0	0.0	0.0	0.0	0.0	
Rest in Walk		No			No			No			No		
I1, Start-Up Lost Time [s]	2.0	2.0	0.0	2.0	2.0	0.0	2.0	2.0	0.0	2.0	2.0	0.0	
I2, Clearance Lost Time [s]	1.0	1.6	0.0	1.0	1.6	0.0	1.0	1.9	0.0	1.0	1.9	0.0	
Minimum Recall	No	No		No	No		No	No		No	No		
Maximum Recall	No	No		No	No		No	No		No	No		
Pedestrian Recall	No	No		No	No		No	No		No	No		
Detector Location [ft]	0.0	0.0	0.0	0.0	0.0	0.0	0.0	0.0	0.0	0.0	0.0	0.0	
Detector Length [ft]	0.0	0.0	0.0	0.0	0.0	0.0	0.0	0.0	0.0	0.0	0.0	0.0	
I, Upstream Filtering Factor	1.00	1.00	1.00	1.00	1.00	1.00	1.00	1.00	1.00	1.00	1.00	1.00	

Exclusive Pedestrian Phase	
Pedestrian Signal Group	0
Pedestrian Walk [s]	0
Pedestrian Clearance [s]	0

Lane Group Calculations									
Lane Group	L	C	R	L	C	L	C	L	C
C, Cycle Length [s]	25	25	25	25	25	25	25	25	25
L, Total Lost Time per Cycle [s]	3.00	3.60	3.60	3.00	3.60	3.00	3.60	3.00	3.60
I1, Permitted Start-Up Lost Time [s]	0.00	0.00	0.00	0.00	0.00	0.00	0.00	0.00	0.00
I2, Clearance Lost Time [s]	1.00	1.60	1.60	1.00	1.60	1.00	1.60	1.00	1.60
g, Effective Green Time [s]	2	4	4	2	4	1	5	1	6
g / C, Green / Cycle	0.07	0.14	0.14	0.08	0.15	0.02	0.21	0.04	0.22
(v / s) Volume / Saturation Flow Rate	0.05	0.05	0.02	0.05	0.05	0.01	0.17	0.02	0.17
s, saturation flow rate [veh/h]	1603	1683	1420	1603	1620	1603	1603	1603	1581
c, Capacity [veh/h]	118	235	198	132	240	38	338	57	353
d1, Uniform Delay [s]	11.52	9.92	9.60	11.42	9.76	12.28	9.50	12.07	9.24
k, delay calibration	0.04	0.04	0.04	0.04	0.04	0.04	0.04	0.04	0.04
I, Upstream Filtering Factor	1.00	1.00	1.00	1.00	1.00	1.00	1.00	1.00	1.00
d2, Incremental Delay [s]	3.14	0.36	0.12	3.35	0.35	5.10	1.62	3.82	1.29
d3, Initial Queue Delay [s]	0.00	0.00	0.00	0.00	0.00	0.00	0.00	0.00	0.00
Rp, platoon ratio	1.00	1.00	1.00	1.00	1.00	1.00	1.00	1.00	1.00
PF, progression factor	1.00	1.00	1.00	1.00	1.00	1.00	1.00	1.00	1.00

Lane Group Results									
X, volume / capacity	0.73	0.37	0.15	0.76	0.37	0.58	0.79	0.61	0.76
d, Delay for Lane Group [s/veh]	14.86	10.26	9.72	14.77	10.10	17.38	11.12	15.90	10.53
Lane Group LOS	B	B	A	B	B	B	B	B	B
Critical Lane Group	No	Yes	No	Yes	No	No	Yes	Yes	No
50th-Percentile Queue Length [veh/m]	0.43	0.31	0.10	0.50	0.31	0.14	0.94	0.19	0.69
50th-Percentile Queue Length [ft/m]	10.79	7.82	2.50	12.54	7.78	3.43	23.46	4.79	22.19
95th-Percentile Queue Length [veh/m]	0.78	0.56	0.18	0.90	0.58	0.25	1.69	0.34	1.60
95th-Percentile Queue Length [ft/m]	19.42	14.07	4.51	22.57	14.00	6.17	42.24	8.62	39.94



Movement, Approach, & Intersection Results

d_M, Delay for Movement [s/veh]	14.66	10.28	9.72	14.77	10.10	10.10	17.38	11.12	11.12	15.90	10.53	10.53
Movement LOS	B	B	A	B	B	B	B	B	B	B	B	B
d_A, Approach Delay [s/veh]	12.06		12.59		11.60		11.15					
Approach LOS	B		B		B		B					
d_I, Intersection Delay [s/veh]	11.74											
Intersection LOS	B											
Intersection V/C	0.682											

Other Modes

g_Walk,mi, Effective Walk Time [s]	11.0	11.0	11.0	11.0
M_corner, Corner Circulation Area [ft²/ped]	0.00	0.00	0.00	0.00
M_CW, Crosswalk Circulation Area [ft²/ped]	0.00	0.00	0.00	0.00
d_p, Pedestrian Delay [s]	4.01	4.01	4.01	4.01
L_p,int, Pedestrian LOS Score for Intersection	2.168	2.008	2.122	2.149
Crosswalk LOS	B	B	B	B
s_b, Saturation Flow Rate of the bicycle lane [bicycles/h]	2000	2000	2000	2000
c_b, Capacity of the bicycle lane [bicycles/h]	2013	2013	2388	2388
d_b, Bicycle Delay [s]	0.00	0.00	0.47	0.47
L_b,int, Bicycle LOS Score for Intersection	1.918	1.890	2.081	2.109
Bicycle LOS	A	A	B	B

Sequence

Ring 1	1	2	3	4	-	-	-	-	-	-	-	-	-	-	-
Ring 2	5	6	7	8	-	-	-	-	-	-	-	-	-	-	-
Ring 3	-	-	-	-	-	-	-	-	-	-	-	-	-	-	-
Ring 4	-	-	-	-	-	-	-	-	-	-	-	-	-	-	-

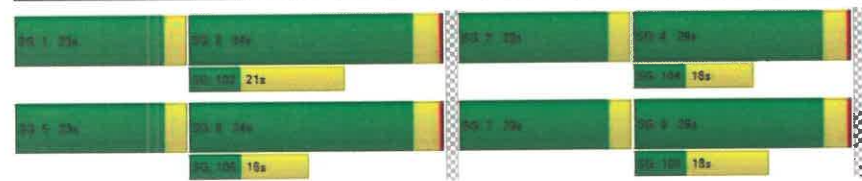

Intersection Level Of Service Report

Intersection 2: Burns Valley Rd/Bowers Ave-Rumsey Rd

Control Type:	Two-way stop	Delay (sec / veh):	13.9
Analysis Method:	HCM 6th Edition	Level Of Service:	B
Analysis Period:	15 minutes	Volume to Capacity (v/c):	0.015

Intersection Setup

Name	Burns Valley Rd			Rumsey Rd			Burns Valley Rd			Bowers Ave		
Approach	Northbound			Southbound			Eastbound			Westbound		
Lane Configuration	+			+			+			+		
Turning Movement	Left	Thru	Right	Left	Thru	Right	Left	Thru	Right	Left	Thru	Right
Lane Width [ft]	12.00	12.00	12.00	12.00	12.00	12.00	12.00	12.00	12.00	12.00	12.00	12.00
No. of Lanes in Entry Pocket	0	0	0	0	0	0	0	0	0	0	0	0
Entry Pocket Length [ft]	100.00	100.00	100.00	100.00	100.00	100.00	100.00	100.00	100.00	100.00	100.00	100.00
No. of Lanes in Exit Pocket	0	0	0	0	0	0	0	0	0	0	0	0
Exit Pocket Length [ft]	0.00	0.00	0.00	0.00	0.00	0.00	0.00	0.00	0.00	0.00	0.00	0.00
Speed [mph]	30.00			30.00			35.00			25.00		
Grade [%]	0.00			0.00			0.00			0.00		
Crosswalk	No			Yes			Yes			No		

Volumes

Name	Burns Valley Rd			Rumsey Rd			Burns Valley Rd			Bowers Ave		
Base Volume Input [veh/h]	122	26	6	0	23	16	9	1	124	5	1	0
Base Volume Adjustment Factor	1.0000	1.0000	1.0000	1.0000	1.0000	1.0000	1.0000	1.0000	1.0000	1.0000	1.0000	1.0000
Heavy Vehicles Percentage [%]	2.00	2.00	2.00	2.00	2.00	2.00	2.00	2.00	2.00	2.00	2.00	2.00
Growth Factor	1.0000	1.0000	1.0000	1.0000	1.0000	1.0000	1.0000	1.0000	1.0000	1.0000	1.0000	1.0000
In-Process Volume [veh/h]	0	0	0	0	0	0	0	0	0	0	0	0
Site-Generated Trips [veh/h]	5	1	0	0	1	0	0	0	6	0	0	0
Diverted Trips [veh/h]	0	0	0	0	0	0	0	0	0	0	0	0
Pass-by Trips [veh/h]	0	0	0	0	0	0	0	0	0	0	0	0
Existing Site Adjustment Volume [veh/h]	0	0	0	0	0	0	0	0	0	0	0	0
Other Volume [veh/h]	0	0	0	0	0	0	0	0	0	0	0	0
Total Hourly Volume [veh/h]	127	27	6	0	24	16	9	1	130	5	1	0
Peak Hour Factor	0.8500	0.8500	0.8500	0.8500	0.8500	0.8500	0.8500	0.8500	0.8500	0.8500	0.8500	0.8500
Other Adjustment Factor	1.0000	1.0000	1.0000	1.0000	1.0000	1.0000	1.0000	1.0000	1.0000	1.0000	1.0000	1.0000
Total 15-Minute Volume [veh/h]	37	8	2	0	7	5	3	0	38	1	0	0
Total Analysis Volume [veh/h]	149	32	7	0	28	19	11	1	153	6	1	0
Pedestrian Volume [ped/h]	0			0			0			0		

Intersection Settings				
Priority Scheme	Free	Free	Stop	Stop
Flared Lane			No	No
Storage Area [veh]	0	0	0	0
Two-Stage Gap Acceptance			No	No
Number of Storage Spaces in Median	0	0	0	0

Movement, Approach, & Intersection Results												
V/C, Movement V/C Ratio	0.10	0.00	0.00	0.00	0.00	0.00	0.02	0.00	0.15	0.01	0.00	0.00
d_M, Delay for Movement [s/veh]	7.55	0.00	0.00	0.00	0.00	0.00	12.42	12.93	9.24	13.92	12.37	6.52
Movement LOS	A	A	A	A	A	A	B	B	A	B	B	A
95th-Percentile Queue Length [veh/ln]	0.32	0.32	0.32	0.00	0.00	0.00	0.61	0.61	0.61	0.05	0.05	0.05
95th-Percentile Queue Length [ft/ln]	7.90	7.90	7.90	0.00	0.00	0.00	15.29	15.29	15.29	1.27	1.27	1.27
d_A, Approach Delay [s/veh]	5.88			0.00			9.47			13.70		
Approach LOS	A			A			A			B		
d_J, Intersection Delay [s/veh]	6.84											
Intersection LOS	B											

Intersection Level Of Service Report			
Intersection 5: Olympic Dr/Lakeshore Dr			
Control Type:	Two-way stop	Delay (sec / veh):	17.6
Analysis Method:	HCM 6th Edition	Level Of Service:	C
Analysis Period:	15 minutes	Volume to Capacity (v/c):	0.174

Intersection Setup												
Name	Lakeshore Dr			Lakeshore Dr			Eastbound			Olympic Dr		
Approach	Northbound			Southbound						Westbound		
Lane Configuration	TT			TT			TT			TT		
Turning Movement	Left	Thru	Right	Left	Thru	Right	Left	Thru	Right	Left	Thru	Right
Lane Width [ft]	12.00	12.00	12.00	12.00	12.00	12.00	12.00	12.00	12.00	12.00	12.00	12.00
No. of Lanes in Entry Pocket	0	0	1	0	0	0	0	0	0	0	0	1
Entry Pocket Length [ft]	105.00	100.00	120.00	105.00	100.00	100.00	100.00	100.00	100.00	100.00	100.00	250.00
No. of Lanes in Exit Pocket	0	0	0	0	0	0	0	0	0	0	0	0
Exit Pocket Length [ft]	0.00	0.00	0.00	0.00	0.00	0.00	0.00	0.00	0.00	0.00	0.00	0.00
Speed [mph]	25.00			25.00			30.00			30.00		
Grade [%]	0.00			0.00			0.00			0.00		
Crosswalk	No			Yes			No			Yes		

Volumes												
Name	Lakeshore Dr			Lakeshore Dr						Olympic Dr		
Base Volume Input [veh/h]	1	137	66	61	279	2	0	0	1	47	1	60
Base Volume Adjustment Factor	1.0000	1.0000	1.0000	1.0000	1.0000	1.0000	1.0000	1.0000	1.0000	1.0000	1.0000	1.0000
Heavy Vehicles Percentage [%]	2.00	2.00	2.00	2.00	2.00	2.00	2.00	2.00	2.00	2.00	2.00	2.00
Growth Factor	1.0000	1.0000	1.0000	1.0000	1.0000	1.0000	1.0000	1.0000	1.0000	1.0000	1.0000	1.0000
In-Process Volume [veh/h]	0	0	0	0	0	0	0	0	0	0	0	0
Site-Generated Trips [veh/h]	0	1	20	17	0	0	0	0	0	0	5	9
Diverted Trips [veh/h]	0	0	0	0	0	0	0	0	0	0	0	0
Pass-by Trips [veh/h]	0	0	0	0	0	0	0	0	0	0	0	0
Existing Site Adjustment Volume [veh/h]	0	0	0	0	0	0	0	0	0	0	0	0
Other Volume [veh/h]	0	0	0	0	0	0	0	0	0	0	0	0
Total Hourly Volume [veh/h]	1	138	66	78	279	2	0	0	1	52	1	69
Peak Hour Factor	0.8600	0.8600	0.8600	0.8600	0.8600	0.8600	0.8600	0.8600	0.8600	0.8600	0.8600	0.8600
Other Adjustment Factor	1.0000	1.0000	1.0000	1.0000	1.0000	1.0000	1.0000	1.0000	1.0000	1.0000	1.0000	1.0000
Total 15-Minute Volume [veh/h]	0	40	25	23	81	1	0	0	0	15	0	20
Total Analysis Volume [veh/h]	1	160	100	91	324	2	0	0	1	60	1	80
Pedestrian Volume [ped/h]	0			0			0			1		

Intersection Settings

Priority Scheme	Free	Free	Stop	Stop
Flared Lane			No	No
Storage Area [veh]	0	0	0	0
Two-Stage Gap Acceptance			No	No
Number of Storage Spaces in Median	0	0	0	0

Movement, Approach, & Intersection Results

V/C, Movement V/C Ratio	0.00	0.00	0.00	0.07	0.00	0.00	0.00	0.00	0.17	0.00	0.09	
d_M, Delay for Movement [s/veh]	7.92	0.00	0.00	7.97	0.00	0.00	18.17	16.92	10.03	17.61	15.87	9.50
Movement LOS	A	A	A	A	A	A	C	B	C	C	A	
95th-Percentile Queue Length [veh/ln]	0.00	0.00	0.00	0.23	0.23	0.23	3.00	0.00	0.00	0.62	0.31	0.31
95th-Percentile Queue Length [ft/ln]	0.06	0.06	0.00	5.63	5.63	5.63	0.10	0.10	0.10	15.51	7.71	7.71
d_A, Approach Delay [s/veh]	0.03			1.74			10.03			13.00		
Approach LOS	A			A			B			B		
d_I, Intersection Delay [s/veh]	3.14											
Intersection LOS	C											

Intersection Level Of Service Report

Intersection 7: Olympic Dr/Burns Valley Rd-Old Hwy 53

Control Type:	Signalized	Delay (sec / veh):	11.8
Analysis Method:	HCM 6th Edition	Level Of Service:	B
Analysis Period:	15 minutes	Volume to Capacity (v/c):	0.677

Intersection Setup

Name	Old Hwy 53			Burns Valley Rd			Olympic Dr			Old Hwy 53		
Approach	Northbound			Southbound			Eastbound			Westbound		
Lane Configuration	T T T			T T			T T			T T		
Turning Movement	Left	Thru	Right	Left	Thru	Right	Left	Thru	Right	Left	Thru	Right
Lane Width [ft]	12.00	12.00	12.00	12.00	12.00	12.00	12.00	12.00	12.00	12.00	12.00	12.00
No. of Lanes in Entry Pocket	1	0	1	1	0	0	1	0	0	1	0	0
Entry Pocket Length [ft]	100.00	100.00	100.00	56.00	100.00	100.00	48.00	100.00	100.00	100.00	100.00	100.00
No. of Lanes in Exit Pocket	0	0	0	0	0	0	0	0	0	0	0	0
Exit Pocket Length [ft]	0.00	0.00	0.00	0.00	0.00	0.00	0.00	0.00	0.00	0.00	0.00	0.00
Speed [mph]	30.00			30.00			35.00			35.00		
Grade [%]	0.00			0.00			0.00			0.00		
Curb Present	No			No			No			No		
Crosswalk	Yes			Yes			Yes			Yes		



Volumes	Old Hwy 53			Burns Valley Rd			Olympic Dr			Old Hwy 53		
Base Volume Input [veh/h]	42	62	45	75	70	15	26	131	51	48	150	99
Base Volume Adjustment Factor	1.0000	1.0000	1.0000	1.0000	1.0000	1.0000	1.0000	1.0000	1.0000	1.0000	1.0000	1.0000
Heavy Vehicles Percentage [%]	2.00	2.00	2.00	2.00	2.00	2.00	2.00	2.00	2.00	2.00	2.00	2.00
Growth Factor	1.0000	1.0000	1.0000	1.0000	1.0000	1.0000	1.0000	1.0000	1.0000	1.0000	1.0000	1.0000
In-Process Volume [veh/h]	0	0	0	0	0	0	0	0	0	0	0	0
Site-Generated Trips [veh/h]	15	5	18	0	3	4	1	11	10	16	41	0
Diverted Trips [veh/h]	0	0	0	0	0	0	0	0	0	0	0	0
Pass-by Trips [veh/h]	0	0	0	0	0	0	0	0	0	0	0	0
Existing Site Adjustment Volume [veh/h]	0	0	0	0	0	0	0	0	0	0	0	0
Other Volume [veh/h]	0	0	0	0	0	0	0	0	0	0	0	0
Right Turn on Red Volume [veh/h]	0	0	19	0	0	3	0	0	5	0	0	20
Total Hourly Volume [veh/h]	57	67	44	75	73	16	27	142	56	64	191	79
Peak Hour Factor	0.8900	0.8900	0.8900	0.8900	0.8900	0.8900	0.8900	0.8900	0.8900	0.8900	0.8900	0.8900
Other Adjustment Factor	1.0000	1.0000	1.0000	1.0000	1.0000	1.0000	1.0000	1.0000	1.0000	1.0000	1.0000	1.0000
Total 15-Minute Volume [veh/h]	16	19	12	21	21	4	8	40	16	18	54	22
Total Analysis Volume [veh/h]	64	75	49	84	82	18	30	160	63	72	215	89
Presence of On-Street Parking	No	No	No	No	No	No	No	No	No	No	No	No
On-Street Parking Maneuver Rate [1/h]	0	0	0	0	0	0	0	0	0	0	0	0
Local Bus Stopping Rate [1/h]	0	0	0	0	0	0	0	0	0	0	0	0
v_do, Outbound Pedestrian Volume crossing major street	1			0			1			1		
v_di, Inbound Pedestrian Volume crossing major street	1			1			0			1		
v_co, Outbound Pedestrian Volume crossing minor street	1			0			0			0		
v_ci, Inbound Pedestrian Volume crossing minor street	0			0			1			0		
v_ab, Corner Pedestrian Volume [ped/h]	0			0			0			0		
Bicycle Volume [bicycles/h]	0			0			0			1		



Intersection Settings	
Located in CBD	Yes
Signal Coordination Group	-
Cycle Length [s]	109
Coordination Type	Time of Day Pattern Isolated
Actuation Type	Fully actuated
Offset [s]	0.5
Offset Reference	Lead Green - Beginning of First Green
Permissive Mode	SingleBand
Lost time [s]	14.00

Phasing & Timing		Protect	Permis	Permis	Protect	Permis	Permis	Protect	Permis	Permis	Protect	Permis	Permis
Control Type													
Signal Group		3	8	0	7	4	0	5	2	0	1	6	0
Auxiliary Signal Groups													
Lead / Lag		Lead	-	-	Lead	-	-	Lead	-	-	Lead	-	-
Minimum Green [s]		4	6	0	4	6	0	4	6	0	4	6	0
Maximum Green [s]		20	25	0	20	25	0	20	30	0	20	20	0
Amber [s]		3.0	3.3	0.0	3.0	3.3	0.0	3.0	3.6	0.0	3.0	3.6	0.0
All red [s]		0.0	0.3	0.0	0.0	0.3	0.0	0.0	0.3	0.0	0.0	0.3	0.0
Split [s]		23	29	0	23	29	0	23	34	0	23	34	0
Vehicle Extension [s]		0.0	0.0	0.0	0.0	0.0	0.0	0.0	0.0	0.0	0.0	0.0	0.0
Walk [s]		7	7	0	7	7	0	7	7	0	7	7	0
Pedestrian Clearance [s]		0	11	0	9	0	0	14	0	0	9	0	0
Delayed Vehicle Green [s]		0.0	0.0	0.0	0.0	0.0	0.0	0.0	0.0	0.0	0.0	0.0	0.0
Rest In Walk		No			No			No			No		
I1, Start-Up Lost Time [s]		2.0	2.0	0.0	2.0	2.0	0.0	2.0	2.0	0.0	2.0	2.0	0.0
I2, Clearance Lost Time [s]		1.0	1.6	0.0	1.0	1.6	0.0	1.0	1.9	0.0	1.0	1.9	0.0
Minimum Recall		No	No		No	No		No	No		No	No	
Maximum Recall		No	No		No	No		No	No		No	No	
Pedestrian Recall		No	No		No	No		No	No		No	No	
Detector Location [ft]		0.0	0.0	0.0	0.0	0.0	0.0	0.0	0.0	0.0	0.0	0.0	0.0
Detector Length [ft]		0.0	0.0	0.0	0.0	0.0	0.0	0.0	0.0	0.0	0.0	0.0	0.0
I, Upstream Filtering Factor		1.00	1.00	1.00	1.00	1.00	1.00	1.00	1.00	1.00	1.00	1.00	1.00

Exclusive Pedestrian Phase	
Pedestrian Signal Group	0
Pedestrian Walk [s]	0
Pedestrian Clearance [s]	0



Lane Group Calculations

Lane Group	L	C	R	L	C	L	C	L	C
C, Cycle Length [s]	26	26	26	26	26	26	26	26	26
L, Total Lost Time per Cycle [s]	3.00	3.60	3.60	3.00	3.60	3.00	3.90	3.00	3.90
H1_p, Permitted Start-Up Lost Time [s]	0.00	0.00	0.00	0.00	0.00	0.00	0.30	0.00	0.00
H2, Clearance Lost Time [s]	1.00	1.60	1.60	1.00	1.60	1.00	1.90	1.00	1.90
g_i, Effective Green Time [s]	2	4	4	2	4	1	5	2	6
g / C, Green / Cycle	0.06	0.14	0.14	0.07	0.16	0.03	0.20	0.06	0.23
(v / s)_i Volume / Saturation Flow Rate	0.04	0.04	0.03	0.05	0.06	0.02	0.14	0.04	0.19
s, saturation flow rate [veh/h]	1603	1683	1421	1603	1630	1603	1602	1603	1589
c, Capacity [veh/h]	94	242	204	115	256	50	324	103	374
d1, Uniform Delay [s]	12.04	10.01	9.90	11.86	9.88	12.48	9.64	11.96	9.42
k, delay calibration	0.04	0.04	0.04	0.04	0.04	0.04	0.04	0.04	0.04
I, Upstream Filtering Factor	1.00	1.00	1.00	1.00	1.00	1.00	1.00	1.00	1.00
d2, Incremental Delay [s]	3.18	0.27	0.22	3.25	0.36	4.24	0.97	3.17	1.63
d3, Initial Queue Delay [s]	0.00	0.00	0.00	0.00	0.00	0.00	0.00	0.00	0.00
Rp, platoon ratio	1.00	1.00	1.00	1.00	1.00	1.00	1.00	1.00	1.00
PF, progression factor	1.00	1.00	1.00	1.00	1.00	1.00	1.00	1.00	1.00

Lane Group Results

X, volume / capacity	0.68	0.31	0.24	0.73	0.39	0.60	0.89	0.70	0.81
d, Delay for Lane Group [s/veh]	15.21	10.28	10.13	15.11	10.24	16.72	10.61	15.13	11.05
Lane Group LOS	B	B	B	B	B	B	B	B	B
Critical Lane Group	Yes	No	No	No	Yes	Yes	No	No	Yes
50th-Percentile Queue Length [veh/ln]	0.34	0.28	0.18	0.44	0.37	0.18	0.77	0.36	1.07
50th-Percentile Queue Length [ft/ln]	8.57	6.80	4.48	11.03	9.14	4.43	19.29	9.11	28.83
95th-Percentile Queue Length [veh/ln]	0.62	0.50	0.32	0.79	0.66	0.32	1.39	0.66	1.93
95th-Percentile Queue Length [ft/ln]	15.43	12.41	8.07	19.85	16.45	7.97	34.73	16.39	48.30

Movement, Approach, & Intersection Results

d_M, Delay for Movement [s/veh]	15.21	10.28	10.13	15.11	10.24	10.24	16.72	10.61	10.61	15.13	11.05	11.05
Movement LOS	B	B	B	B	B	B	B	B	B	B	B	B
d_A, Approach Delay [s/veh]	11.92			12.46			11.33			11.83		
Approach LOS	B			B			B			B		
d_I, Intersection Delay [s/veh]	11.84											
Intersection LOS	B											
Intersection V/C	0.677											

Other Modes

g_Walk,mi, Effective Walk Time [s]	11.0	11.0	11.0	11.0
M_corner, Corner Circulation Area [ft²/pe/d]	0.00	0.00	0.00	0.00
M_CW, Crosswalk Circulation Area [ft²/pe/d]	0.00	0.00	0.00	0.00
d_p, Pedestrian Delay [s]	4.29	4.29	4.29	4.29
I_p,int, Pedestrian LOS Score for Intersection	2.178	1.991	2.075	2.153
Crosswalk LOS	B	A	B	B
s_b, Saturation Flow Rate of the bicycle lane [bicycles/h]	2000	2000	2000	2000
c_b, Capacity of the bicycle lane [bicycles/h]	1960	1960	2323	2323
d_b, Bicycle Delay [s]	0.01	0.01	0.34	0.34
I_b,int, Bicycle LOS Score for Intersection	1.901	1.868	1.985	2.213
Bicycle LOS	A	A	A	B

Sequence

Ring	1	2	3	4	-	-	-	-	-	-	-	-	-	-	-
Ring 1	1	2	3	4	-	-	-	-	-	-	-	-	-	-	-
Ring 2	5	6	7	8	-	-	-	-	-	-	-	-	-	-	-
Ring 3	-	-	-	-	-	-	-	-	-	-	-	-	-	-	-
Ring 4	-	-	-	-	-	-	-	-	-	-	-	-	-	-	-

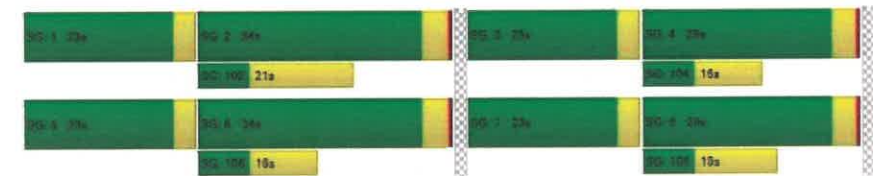

Intersection Level Of Service Report
Intersection 2: Burns Valley Rd/Bowers Ave-Rumsey Rd

Control Type: Two-way stop Delay (sec / veh): 13.2
Analysis Method: HCM 6th Edition Level Of Service: B
Analysis Period: 15 minutes Volume to Capacity (v/c): 0.033

Intersection Setup

Name	Burns Valley Rd			Rumsey Rd			Burns Valley Rd			Bowers Ave		
Approach	Northbound			Southbound			Eastbound			Westbound		
Lane Configuration	+			+			+			+		
Turning Movement	Left	Thru	Right	Left	Thru	Right	Left	Thru	Right	Left	Thru	Right
Lane Width [ft]	12.00	12.00	12.00	12.00	12.00	12.00	12.00	12.00	12.00	12.00	12.00	12.00
No. of Lanes in Entry Pocket	0	0	0	0	0	0	0	0	0	0	0	0
Entry Pocket Length [ft]	100.00	100.00	100.00	100.00	100.00	100.00	100.00	100.00	100.00	100.00	100.00	100.00
No. of Lanes in Exit Pocket	0	0	0	0	0	0	0	0	0	0	0	0
Exit Pocket Length [ft]	0.00	0.00	0.00	0.00	0.00	0.00	0.00	0.00	0.00	0.00	0.00	0.00
Speed [mph]	30.00			30.00			35.00			25.00		
Grade [%]	0.00			0.00			0.00			0.00		
Crosswalk	No			Yes			Yes			No		

Volumes

Name	Burns Valley Rd			Rumsey Rd			Burns Valley Rd			Bowers Ave		
Base Volume Input [veh/h]	100	38	9	2	43	7	7	1	75	13	0	0
Base Volume Adjustment Factor	1.0000	1.0000	1.0000	1.0000	1.0000	1.0000	1.0000	1.0000	1.0000	1.0000	1.0000	1.0000
Heavy Vehicles Percentage [%]	2.00	2.00	2.00	2.00	2.00	2.00	2.00	2.00	2.00	2.00	2.00	2.00
Growth Factor	1.0000	1.0000	1.0000	1.0000	1.0000	1.0000	1.0000	1.0000	1.0000	1.0000	1.0000	1.0000
In-Process Volume [veh/h]	0	0	0	0	0	0	0	0	0	0	0	0
Site-Generated Trips [veh/h]	11	1	0	0	1	0	0	0	11	0	0	0
Diverted Trips [veh/h]	0	0	0	0	0	0	0	0	0	0	0	0
Pass-by Trips [veh/h]	0	0	0	0	0	0	0	0	0	0	0	0
Existing Site Adjustment Volume [veh/h]	0	0	0	0	0	0	0	0	0	0	0	0
Other Volume [veh/h]	0	0	0	0	0	0	0	0	0	0	0	0
Total Hourly Volume [veh/h]	111	39	9	2	44	7	7	1	86	13	0	0
Peak Hour Factor	0.8500	0.8500	0.8500	0.8500	0.8500	0.8500	0.8500	0.8500	0.8500	0.8500	0.8500	0.8500
Other Adjustment Factor	1.0000	1.0000	1.0000	1.0000	1.0000	1.0000	1.0000	1.0000	1.0000	1.0000	1.0000	1.0000
Total 15-Minute Volume [veh/h]	33	11	3	1	13	2	2	2	25	4	0	0
Total Analysis Volume [veh/h]	131	46	11	2	52	8	8	1	101	15	0	0
Pedestrian Volume [ped/h]	0			0			0			0		



Intersection Settings

Priority Scheme	Free	Free	Stop	Stop
Flared Lane			No	No
Storage Area [veh]	0	0	C	C
Two-Stage Gap Acceptance			No	No
Number of Storage Spaces in Median	0	0	0	C

Movement, Approach, & Intersection Results

V/C, Movement V/C Ratio	0.08	0.00	0.00	0.00	0.00	0.00	0.01	0.00	0.10	0.03	0.00	0.00
d_M, Delay for Movement [s/veh]	7.55	0.00	0.00	7.33	0.00	0.00	12.12	12.65	9.07	13.23	12.49	8.81
Movement LOS	A	A	A	A	A	A	B	B	A	B	B	A
95th-Percentile Queue Length [veh/ln]	0.28	0.28	0.28	0.00	0.00	0.00	0.39	0.39	0.39	0.10	0.10	0.10
95th-Percentile Queue Length [ft/ln]	6.94	6.94	6.94	0.10	0.10	0.10	9.87	9.87	9.87	2.57	2.57	2.57
d_A, Approach Delay [s/veh]	5.28			0.24			9.32			13.23		
Approach LOS	A			A			A			B		
d_I, Intersection Delay [s/veh]							5.94					
Intersection LOS	B											



Intersection Level Of Service Report
Intersection 5: Olympic Dr/Lakeshore Dr

Control Type: Two-way stop
 Analysis Method: HCM 6th Edition
 Analysis Period: 15 minutes
 Delay (sec / veh): 18.2
 Level Of Service: C
 Volume to Capacity (v/c): 0.334

Intersection Setup

Name	Lakeshore Dr			Lakeshore Dr			Eastbound			Olympic Dr		
	Northbound			Southbound			Eastbound			Westbound		
Approach	←←←			→→→			→→→			←←←		
Lane Configuration	←←←			→→→			→→→			←←←		
Turning Movement	Left	Thru	Right	Left	Thru	Right	Left	Thru	Right	Left	Thru	Right
Lane Width [ft]	12.00	12.00	12.00	12.00	12.00	12.00	12.00	12.00	12.00	12.00	12.00	12.00
No. of Lanes in Entry Pocket	0	0	1	0	0	0	0	0	0	0	0	1
Entry Pocket Length [ft]	100.00	100.00	120.00	100.00	100.00	100.00	100.00	100.00	100.00	100.00	100.00	250.00
No. of Lanes in Exit Pocket	0	0	0	0	0	0	0	0	0	0	0	0
Exit Pocket Length [ft]	0.00	0.00	0.00	0.00	0.00	0.00	0.00	0.00	0.00	0.00	0.00	0.00
Speed [mph]	25.00			25.00			30.00			30.00		
Grade [%]	0.00			0.00			0.00			0.00		
Crosswalk	No			Yes			No			Yes		

Volumes

Name	Lakeshore Dr			Lakeshore Dr			Eastbound			Olympic Dr		
	1	198	114	66	180	1	0	2	2	108	3	141
Base Volume Input [veh/h]	1	198	114	66	180	1	0	2	2	108	3	141
Base Volume Adjustment Factor	1.0000	1.0000	1.0000	1.0000	1.0000	1.0000	1.0000	1.0000	1.0000	1.0000	1.0000	1.0000
Heavy Vehicles Percentage [%]	2.00	2.00	2.00	2.00	2.00	2.00	2.00	2.00	2.00	2.00	2.00	2.00
Growth Factor	1.0000	1.0000	1.0000	1.0000	1.0000	1.0000	1.0000	1.0000	1.0000	1.0000	1.0000	1.0000
In-Process Volume [veh/h]	0	0	0	0	0	0	0	0	0	0	0	0
Site-Generated Trips [veh/h]	0	1	24	22	2	0	0	0	0	30	0	27
Diverted Trips [veh/h]	0	0	0	0	0	0	0	0	0	0	0	0
Pass-by Trips [veh/h]	0	0	0	0	0	0	0	0	0	0	0	0
Existing Site Adjustment Volume [veh/h]	0	0	0	0	0	0	0	0	0	0	0	0
Other Volume [veh/h]	0	0	0	0	0	0	0	0	0	0	0	0
Total Hourly Volume [veh/h]	1	199	138	88	182	1	0	2	2	136	3	168
Peak Hour Factor	1.0000	1.0000	1.0000	1.0000	1.0000	1.0000	1.0000	1.0000	1.0000	1.0000	1.0000	1.0000
Other Adjustment Factor	1.0000	1.0000	1.0000	1.0000	1.0000	1.0000	1.0000	1.0000	1.0000	1.0000	1.0000	1.0000
Total 15-Minute Volume [veh/h]	0	50	35	22	46	0	0	1	1	34	1	42
Total Analysis Volume [veh/h]	1	199	138	88	182	1	0	2	2	136	3	168
Pedestrian Volume [ped/h]		0		0			0			1		



Intersection Settings

Priority Scheme	Free	Free	Stop	Stop
Flared Lane			No	No
Storage Area [veh]	0	0	0	0
Two-Stage Gap Acceptance			No	No
Number of Storage Spaces in Median	0	0	0	0

Movement, Approach, & Intersection Results

V/C, Movement V/C Ratio	0.00	0.30	0.00	0.07	0.00	0.00	0.00	0.01	0.00	0.33	0.01	0.20
d_M, Delay for Movement [s/veh]	7.59	0.00	0.00	8.18	0.00	0.00	18.89	15.83	9.25	18.22	15.12	10.42
Movement LOS	A	A	A	A	A	C	C	A	C	C	B	B
95th-Percentile Queue Length [veh/ln]	0.00	0.00	0.00	0.23	0.23	0.23	0.03	0.03	0.03	1.44	0.78	0.78
95th-Percentile Queue Length [ft/ln]	0.05	0.05	0.00	5.82	5.82	5.82	3.53	0.63	0.63	36.10	19.45	19.45
d_A, Approach Delay [s/veh]	0.02		2.66		12.54		13.92					
Approach LOS	A		A		B		B					
d_I, Intersection Delay [s/veh]	5.49											
Intersection LOS	C											



Intersection Level Of Service Report
Intersection 7: Olympic Dr/Burns Valley Rd-Old Hwy 53

Control Type: Signalized Delay (sec / veh): 14.3
Analysis Method: HCM 6th Edition Level Of Service: B
Analysis Period: 15 minutes Volume to Capacity (v/c): 0.815

Intersection Setup

Name	Old Hwy 53			Burns Valley Rd			Olympic Dr			Old Hwy 53		
Approach	Northbound			Southbound			Eastbound			Westbound		
Lane Configuration	[Diagram]			[Diagram]			[Diagram]			[Diagram]		
Turning Movement	Left	Thru	Right	Left	Thru	Right	Left	Thru	Right	Left	Thru	Right
Lane Width [ft]	12.00	12.00	12.00	12.00	12.00	12.00	12.00	12.00	12.00	12.00	12.00	12.00
No. of Lanes in Entry Pocket	1	0	1	1	0	0	1	0	0	1	0	0
Entry Pocket Length [ft]	100.00	100.00	100.00	56.00	100.00	100.00	48.00	100.00	100.00	100.00	100.00	100.00
No. of Lanes in Exit Pocket	0	0	0	0	0	0	0	0	0	0	0	0
Exit Pocket Length [ft]	0.00	0.00	0.00	0.00	0.00	0.00	0.00	0.00	0.00	0.00	0.00	0.00
Speed [mph]	30.00			30.00			35.00			35.00		
Grade [%]	0.00			0.00			0.00			0.00		
Curb Present	No			No			No			No		
Crosswalk	Yes			Yes			Yes			Yes		



Volumes

Name	Old Hwy 53			Burns Valley Rd			Olympic Dr			Old Hwy 53		
Base Volume Input [veh/h]	98	113	58	112	97	46	21	184	93	62	221	139
Base Volume Adjustment Factor	1.0000	1.0000	1.0000	1.0000	1.0000	1.0000	1.0000	1.0000	1.0000	1.0000	1.0000	1.0000
Heavy Vehicles Percentage [%]	2.00	2.00	2.00	2.00	2.00	2.00	2.00	2.00	2.00	2.00	2.00	2.00
Growth Factor	1.0000	1.0000	1.0000	1.0000	1.0000	1.0000	1.0000	1.0000	1.0000	1.0000	1.0000	1.0000
In-Process Volume [veh/h]	0	0	0	0	0	0	0	0	0	0	0	0
Site-Generated Trips [veh/h]	28	4	40	0	6	6	8	51	38	45	36	0
Diverted Trips [veh/h]	0	0	0	0	0	0	0	0	0	0	0	0
Pass-by Trips [veh/h]	0	0	0	0	0	0	0	0	0	0	0	0
Existing Site Adjustment Volume [veh/h]	0	0	0	0	0	0	0	0	0	0	0	0
Other Volume [veh/h]	0	0	0	0	0	0	0	0	0	0	0	0
Right Turn on Red Volume [veh/h]	0	0	19	0	0	3	0	0	5	0	0	20
Total Hourly Volume [veh/h]	126	117	77	112	103	49	29	235	126	107	257	119
Peak Hour Factor	1.0000	1.0000	1.0000	1.0000	1.0000	1.0000	1.0000	1.0000	1.0000	1.0000	1.0000	1.0000
Other Adjustment Factor	1.0000	1.0000	1.0000	1.0000	1.0000	1.0000	1.0000	1.0000	1.0000	1.0000	1.0000	1.0000
Total 15-Minute Volume [veh/h]	32	29	19	28	26	12	7	59	32	27	64	30
Total Analysis Volume [veh/h]	126	117	77	112	103	49	29	235	126	107	257	119
Presence of On-Street Parking	No	No	No	No	No	No	No	No	No	No	No	No
On-Street Parking Maneuver Rate [1/h]	0	0	0	0	0	0	0	0	0	0	0	0
Local Bus Stopping Rate [1/h]	0	0	0	0	0	0	0	0	0	0	0	0
v_do, Outbound Pedestrian Volume crossing major street	1			0			1			1		
v_di, Inbound Pedestrian Volume crossing major street	1			1			0			1		
v_oo, Outbound Pedestrian Volume crossing minor street	1			0			0			0		
v_oi, Inbound Pedestrian Volume crossing minor street	0			0			1			0		
v_ab, Corner Pedestrian Volume [ped/h]	0			0			0			0		
Bicycle Volume [bicycles/h]	0			0			0			0		1



Intersection Settings

Located in CBD	Yes
Signal Coordination Group	-
Cycle Length [s]	109
Coordination Type	Time of Day Pattern Isolated
Actuation Type	Fully actuated
Offset [s]	0.0
Offset Reference	Lead Green - Beginning of First Green
Permissive Mode	SingleBand
Lost time [s]	14.00

Phasing & Timing

Control Type	Protect	Permis	Permis	Protect	Permis	Permis	Protect	Permis	Permis	Protect	Permis	Permis
Signal Group	3	8	0	7	4	0	5	2	0	1	6	0
Auxiliary Signal Groups												
Lead / Lag	Lead	-	-	Lead	-	-	Lead	-	-	Lead	-	-
Minimum Green [s]	4	6	0	4	6	0	4	6	0	4	6	0
Maximum Green [s]	20	25	0	20	25	0	20	30	0	20	20	0
Amber [s]	3.0	3.3	0.0	3.0	3.3	0.0	3.0	3.6	0.0	3.0	3.6	0.0
All red [s]	0.0	0.3	0.0	0.0	0.3	0.0	0.0	0.3	0.0	0.0	0.3	0.0
Split [s]	23	29	0	23	29	0	23	34	0	23	34	0
Vehicle Extension [s]	0.0	0.0	0.0	0.0	0.0	0.0	0.0	0.0	0.0	0.0	0.0	0.0
Walk [s]	0	7	0	0	7	0	0	7	0	0	7	0
Pedestrian Clearance [s]	0	11	0	0	9	0	0	14	0	0	9	0
Delayed Vehicle Green [s]	0.0	0.0	0.0	0.0	0.0	0.0	0.0	0.0	0.0	0.0	0.0	0.0
Rest In Walk		No			No			No			No	
I1, Start-Up Lost Time [s]	2.0	2.0	0.0	2.0	2.0	0.0	2.0	2.0	0.0	2.0	2.0	0.0
I2, Clearance Lost Time [s]	1.0	1.6	0.0	1.0	1.6	0.0	1.0	1.9	0.0	1.0	1.9	0.0
Minimum Recall	No	No		No	No		No	No		No	No	
Maximum Recall	No	No		No	No		No	No		No	No	
Pedestrian Recall	No	No		No	No		No	No		No	No	
Detector Location [ft]	0.0	0.0	0.0	0.0	0.0	0.0	0.0	0.0	0.0	0.0	0.0	0.0
Detector Length [ft]	0.0	0.0	0.0	0.0	0.0	0.0	0.0	0.0	0.0	0.0	0.0	0.0
I, Upstream Filtering Factor	1.00	1.00	1.00	1.00	1.00	1.00	1.00	1.00	1.00	1.00	1.00	1.00

Exclusive Pedestrian Phase

Pedestrian Signal Group	0
Pedestrian Walk [s]	0
Pedestrian Clearance [s]	0



Lane Group Calculations

Lane Group	L	C	R	L	C	L	C	L	C
C, Cycle Length [s]	33	33	33	33	33	33	33	33	33
L, Total Lost Time per Cycle [s]	3.00	3.60	3.60	3.00	3.60	3.00	3.90	3.00	3.90
I1_p, Permitted Start-Up Lost Time [s]	0.00	0.00	0.00	0.00	0.00	0.00	0.00	0.00	0.00
I2, Clearance Lost Time [s]	1.00	1.60	1.60	1.00	1.60	1.00	1.90	1.00	1.90
g, Effective Green Time [s]	3	5	5	3	5	1	9	3	11
g / C, Green / Cycle	0.10	0.16	0.16	0.08	0.14	0.03	0.27	0.08	0.32
(v / s)_ Volume / Saturation Flow Rate	0.08	0.07	0.05	0.07	0.10	0.02	0.23	0.07	0.24
s, saturation flow rate [veh/h]	1603	1683	1421	1603	1590	1603	1584	1603	1582
c, Capacity [veh/h]	154	262	221	136	229	46	429	129	511
d1, Uniform Delay [s]	14.66	12.67	12.46	14.90	13.39	15.89	11.38	14.98	9.95
k, delay calibration	0.04	0.04	0.04	0.04	0.04	0.04	0.04	0.04	0.04
I, Upstream Filtering Factor	1.00	1.00	1.00	1.00	1.00	1.00	1.00	1.00	1.00
d2, Incremental Delay [s]	3.99	0.44	0.35	4.72	1.23	5.14	1.73	5.05	0.78
d3, Initial Queue Delay [s]	0.00	0.00	0.00	0.00	0.00	0.00	0.00	0.00	0.00
Rp, platoon ratio	1.00	1.00	1.00	1.00	1.00	1.00	1.00	1.00	1.00
PF, progression factor	1.00	1.00	1.00	1.00	1.00	1.00	1.00	1.00	1.00

Lane Group Results

X, volume / capacity	0.82	0.45	0.35	0.83	0.66	0.63	0.84	0.83	0.74
d, Delay for Lane Group [s/veh]	18.66	13.11	12.81	19.62	14.62	21.02	13.12	20.04	10.73
Lane Group LOS	B	B	B	B	B	C	B	C	B
Critical Lane Group	Yes	No	No	No	Yes	No	Yes	Yes	No
50th-Percentile Queue Length [veh/ln]	0.91	0.64	0.42	0.84	0.91	0.24	1.87	0.79	1.64
50th-Percentile Queue Length [ft/ln]	22.71	16.03	10.39	21.00	22.74	5.91	46.87	19.75	40.96
95th-Percentile Queue Length [veh/ln]	1.63	1.15	0.75	1.51	1.64	0.43	3.37	1.42	2.95
95th-Percentile Queue Length [ft/ln]	40.87	28.85	18.89	37.80	40.93	10.64	84.36	35.55	73.73



Movement, Approach, & Intersection Results

d_M, Delay for Movement [s/veh]	18.65	13.11	12.81	19.62	14.62	14.62	21.02	13.12	13.12	20.04	10.73	10.73
Movement LOS	B	B	B	B	B	B	C	B	B	C	B	B
d_A, Approach Delay [s/veh]	15.22			16.74			13.71			12.79		
Approach LOS	B			B			B			B		
d_I, Intersection Delay [s/veh]							14.29					
Intersection LOS							B					
Intersection V/C							0.815					

Other Modes

g_Walk, Effective Walk Time [s]	11.0	11.0	11.0	11.0
M_corner, Corner Circulation Area [ft²/ped]	0.00	0.00	0.00	0.00
M_CW, Crosswalk Circulation Area [ft²/ped]	0.00	0.00	0.00	0.00
d_p, Pedestrian Delay [s]	7.31	7.31	7.31	7.31
L_p,int, Pedestrian LOS Score for Intersection	2.261	2.061	2.199	2.264
Crosswalk LOS	B	B	B	B
s_b, Saturation Flow Rate of the bicycle lane [bicycles/s]	2000	2000	2000	2000
c_b, Capacity of the bicycle lane [bicycles/h]	1542	1542	1827	1827
d_b, Bicycle Delay [s]	0.86	0.86	0.12	0.12
L_b,int, Bicycle LOS Score for Intersection	2.119	2.000	2.211	2.390
Bicycle LOS	B	B	B	B

Sequence

Ring 1	1	2	3	4	-	-	-	-	-	-	-	-	-	-
Ring 2	5	6	7	8	-	-	-	-	-	-	-	-	-	-
Ring 3	-	-	-	-	-	-	-	-	-	-	-	-	-	-
Ring 4	-	-	-	-	-	-	-	-	-	-	-	-	-	-

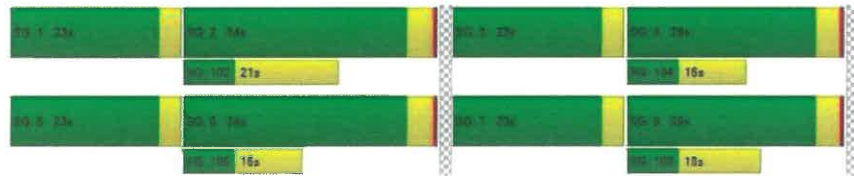

Intersection Level Of Service Report
Intersection 2: Burns Valley Rd/Bowers Ave-Rumsey Rd

Control Type:	Two-way stop	Delay (sec / veh):	12.3
Analysis Method:	HCM 6th Edition	Level Of Service:	B
Analysis Period:	15 minutes	Volume to Capacity (v/c):	0.004

Intersection Setup

Name	Burns Valley Rd			Rumsey Rd			Burns Valley Rd			Bowers Ave		
Approach	Northbound			Southbound			Eastbound			Westbound		
Lane Configuration	+			+			+			+		
Turning Movement	Left	Thru	Right	Left	Thru	Right	Left	Thru	Right	Left	Thru	Right
Lane Width [ft]	12.00	12.00	12.00	12.00	12.00	12.00	12.00	12.00	12.00	12.00	12.00	12.00
No. of Lanes in Entry Pocket	0	0	0	0	0	0	0	0	0	0	0	0
Entry Pocket Length [ft]	100.00	100.00	100.00	100.00	100.00	100.00	100.00	100.00	100.00	100.00	100.00	100.00
No. of Lanes in Exit Pocket	0	0	0	0	0	0	0	0	0	0	0	0
Exit Pocket Length [ft]	0.00	0.00	0.00	0.00	0.00	0.00	0.00	0.00	0.00	0.00	0.00	0.00
Speed [mph]	30.00			30.00			35.00			25.00		
Grade [%]	0.00			0.00			0.00			0.00		
Crosswalk	No			Yes			Yes			No		

Volumes

Name	Burns Valley Rd			Rumsey Rd			Burns Valley Rd			Bowers Ave		
Base Volume Input [veh/h]	84	36	1	0	31	9	10	0	83	2	1	0
Base Volume Adjustment Factor	1.0000	1.0000	1.0000	1.0000	1.0000	1.0000	1.0000	1.0000	1.0000	1.0000	1.0000	1.0000
Heavy Vehicles Percentage [%]	2.00	2.00	2.00	2.00	2.00	2.00	2.00	2.00	2.00	2.00	2.00	2.00
Growth Factor	1.0000	1.0000	1.0000	1.0000	1.0000	1.0000	1.0000	1.0000	1.0000	1.0000	1.0000	1.0000
In-Process Volume [veh/h]	0	0	0	0	0	0	0	0	0	0	0	0
Site-Generated Trips [veh/h]	14	1	0	0	1	0	0	0	15	0	0	0
Diverted Trips [veh/h]	0	0	0	0	0	0	0	0	0	0	0	0
Pass-by Trips [veh/h]	0	0	0	0	0	0	0	0	0	0	0	0
Existing Site Adjustment Volume [veh/h]	0	0	0	0	0	0	0	0	0	0	0	0
Other Volume [veh/h]	0	0	0	0	0	0	0	0	0	0	0	0
Total Hourly Volume [veh/h]	98	37	1	0	32	9	10	0	98	2	1	0
Peak Hour Factor	0.8500	0.9500	0.9600	0.9600	0.9600	0.8500	0.8500	0.8500	0.8500	0.9600	0.8500	0.9600
Other Adjustment Factor	1.0000	1.0000	1.0000	1.0000	1.0000	1.0000	1.0000	1.0000	1.0000	1.0000	1.0000	1.0000
Total 15-Minute Volume [veh/h]	29	10	0	0	8	3	3	0	29	1	0	0
Total Analysis Volume [veh/h]	115	39	1	0	33	11	12	0	115	2	1	0
Pedestrian Volume [ped/h]	0			0			0			0		



Intersection Settings

	Free	Free	Stop	Stop
Priority Scheme				
Flared Lane			No	No
Storage Area [veh]	0	0	0	0
Two-Stage Gap Acceptance			No	No
Number of Storage Spaces in Median	0	0	0	0

Movement, Approach, & Intersection Results

V/C, Movement V/C Ratio	0.07	0.06	0.00	0.00	0.00	0.02	0.00	0.11	0.00	0.00	0.00
d_M, Delay for Movement [s/veh]	7.48	0.00	0.00	7.29	0.00	0.00	11.50	11.99	9.04	12.32	11.51
Movement LOS	A	A	A	A	A	B	B	A	B	B	A
95th-Percentile Queue Length [veh/ln]	0.24	0.24	0.24	0.00	0.00	0.45	0.45	0.45	0.02	0.02	0.92
95th-Percentile Queue Length [ft/ln]	5.94	5.94	5.94	0.00	0.00	11.27	11.27	11.27	0.44	0.44	0.44
d_A, Approach Delay [s/veh]	5.55			0.00			9.28			12.05	
Approach LOS	A			A			A			B	
d_I, Intersection Delay [s/veh]	6.31										
Intersection LOS	B										



Intersection Level Of Service Report
Intersection 5: Olympic Dr/Lakeshore Dr

Control Type:	Two-way stop	Delay (sec / veh):	21.3
Analysis Method:	HCM 6th Edition	Level Of Service:	C
Analysis Period:	15 minutes	Volume to Capacity (v/c):	0.390

Intersection Setup

Name	Lakeshore Dr			Lakeshore Dr			Olympic Dr		
Approach	Northbound			Southbound			Westbound		
Lane Configuration	+			+			+		
Turning Movement	Left	Thru	Right	Left	Thru	Right	Left	Thru	Right
Lane Width [ft]	12.00	12.00	12.00	12.00	12.00	12.00	12.00	12.00	12.00
No. of Lanes in Entry Pocket	0	0	1	0	0	0	0	0	1
Entry Pocket Length [ft]	100.00	100.00	120.00	100.00	100.00	100.00	100.00	100.00	250.00
No. of Lanes in Exit Pocket	0	0	0	0	0	0	0	0	0
Exit Pocket Length [ft]	0.00	0.00	0.00	0.00	0.00	0.00	0.00	0.00	0.00
Speed [mph]	25.00			25.00			30.00		
Grade [%]	0.00			0.00			0.00		
Crosswalk	No			Yes			No		

Volumes

Name	Lakeshore Dr			Lakeshore Dr			Olympic Dr					
Base Volume Input [veh/h]	1	176	103	73	185	0	0	3	3	97	1	75
Base Volume Adjustment Factor	1.0000	1.0000	1.0000	1.0000	1.0000	1.0000	1.0000	1.0000	1.0000	1.0000	1.0000	1.0000
Heavy Vehicles Percentage [%]	2.00	2.00	2.00	2.00	2.00	2.00	2.00	2.00	2.00	2.00	2.00	2.00
Growth Factor	1.0000	1.0000	1.0000	1.0000	1.0000	1.0000	1.0000	1.0000	1.0000	1.0000	1.0000	1.0000
In-Process Volume [veh/h]	0	0	0	0	0	0	0	0	0	0	0	0
Site-Generated Trips [veh/h]	0	0	24	30	0	0	0	0	0	30	0	32
Diverted Trips [veh/h]	0	0	0	0	0	0	0	0	0	0	0	0
Pass-by Trips [veh/h]	0	0	0	0	0	0	0	0	0	0	0	0
Existing Site Adjustment Volume [veh/h]	0	0	0	0	0	0	0	0	0	0	0	0
Other Volume [veh/h]	0	0	0	0	0	0	0	0	0	0	0	0
Total Hourly Volume [veh/h]	1	176	127	103	185	0	0	3	3	127	1	107
Peak Hour Factor	0.9100	0.9100	0.9100	0.9100	0.9100	0.9100	0.9100	0.9100	0.9100	0.9100	0.9100	0.9100
Other Adjustment Factor	1.0000	1.0000	1.0000	1.0000	1.0000	1.0000	1.0000	1.0000	1.0000	1.0000	1.0000	1.0000
Total 15-Minute Volume [veh/h]	0	48	35	28	51	0	0	1	1	35	0	29
Total Analysis Volume [veh/h]	1	193	140	113	203	0	0	3	3	140	1	118
Pedestrian Volume [ped/h]	0	0	0	0	0	0	0	0	0	0	0	1



Generated with **PTV VISTRO** Burns Valley Development 4/22/2022
Version 2021 (SP 0-6)

Intersection Settings

Priority Scheme	Free	Free	Stop	Stop
Flared Lane			No	No
Storage Area [veh]	0	0	0	0
Two-Stage Gap Acceptance			No	No
Number of Storage Spaces in Median	0	0	0	0

Movement, Approach, & Intersection Results

VIC, Movement V/C Ratio	0.00	0.07	0.06	0.09	0.03	0.06	0.00	0.01	0.00	0.39	0.00	0.14
d_M, Delay for Movement [s/veh]	7.63	0.00	0.06	8.24	0.03	0.00	16.10	17.19	9.41	21.27	15.74	9.96
Movement LOS	A	A	A	A	A	C	C	A	C	C	C	A
95th-Percentile Queue Length [veh/ln]	0.00	0.00	0.00	0.30	0.30	0.30	0.04	0.04	1.80	0.49	0.49	
95th-Percentile Queue Length [ft/ln]	0.05	0.05	0.00	7.61	7.61	7.61	1.04	1.04	44.83	12.36	12.36	
d_A, Approach Delay [s/veh]	0.02			2.95			13.30			16.10		
Approach LOS	A			A			B			C		
d_I, Intersection Delay [s/veh]	5.67											
Intersection LOS	C											



Generated with **PTV VISTRO** Burns Valley Development 4/22/2022
Version 2021 (SP 0-6)

Intersection Level Of Service Report

Intersection 7: Olympic Dr/Burns Valley Rd-Old Hwy 53

Control Type:	Signalized	Delay (sec / veh):	14.2
Analysis Method:	HCM 6th Edition	Level Of Service:	B
Analysis Period:	15 minutes	Volume to Capacity (v/c):	0.799

Intersection Setup

Name	Old Hwy 53			Burns Valley Rd			Olympic Dr			Old Hwy 53		
Approach	Northbound			Southbound			Eastbound			Westbound		
Lane Configuration	T T T			T T			T T			T T		
Turning Movement	Left	Thru	Right	Left	Thru	Right	Left	Thru	Right	Left	Thru	Right
Lane Width [ft]	12.00	12.00	12.00	12.00	12.00	12.00	12.00	12.00	12.00	12.00	12.00	12.00
No. of Lanes in Entry Pocket	1	0	1	1	0	0	1	0	0	1	0	0
Entry Pocket Length [ft]	100.00	100.00	100.00	56.00	100.00	100.00	48.00	100.00	100.00	100.00	100.00	100.00
No. of Lanes in Exit Pocket	0	0	0	0	0	0	0	0	0	0	0	0
Exit Pocket Length [ft]	0.00	0.00	0.00	0.00	0.00	0.00	0.00	0.00	0.00	0.00	0.00	0.00
Speed [mph]	30.00			30.00			35.00			35.00		
Grade [%]	0.00			0.00			0.00			0.00		
Curb Present	No			No			No			No		
Crosswalk	Yes			Yes			Yes			Yes		



Volumes

Name	Old Hwy 53			Burns Valley Rd			Olympic Dr			Old Hwy 53		
Base Volume Input [veh/h]	80	81	42	93	64	30	20	180	95	33	170	109
Base Volume Adjustment Factor	1.0000	1.0000	1.0000	1.0000	1.0000	1.0000	1.0000	1.0000	1.0000	1.0000	1.0000	1.0000
Heavy Vehicles Percentage [%]	2.00	2.00	2.00	2.00	2.00	2.00	2.00	2.00	2.00	2.00	2.00	2.00
Growth Factor	1.0000	1.0000	1.0000	1.0000	1.0000	1.0000	1.0000	1.0000	1.0000	1.0000	1.0000	1.0000
In-Process Volume [veh/h]	0	0	0	0	0	0	0	0	0	0	0	0
Site-Generated Trips [veh/h]	33	7	56	0	10	6	8	51	46	68	36	0
Diverted Trips [veh/h]	0	0	0	0	0	0	0	0	0	0	0	0
Pass-by Trips [veh/h]	0	0	0	0	0	0	0	0	0	0	0	0
Existing Site Adjustment Volume [veh/h]	0	0	0	0	0	0	0	0	0	0	0	0
Other Volume [veh/h]	0	0	0	0	0	0	0	0	0	0	0	0
Right Turn on Red Volume [veh/h]	0	0	19	0	0	3	0	0	0	5	0	20
Total Hourly Volume [veh/h]	113	88	79	93	74	33	28	231	136	101	206	89
Peak Hour Factor	0.9300	0.9300	0.9300	0.9300	0.9300	0.9300	0.9300	0.9300	0.9300	0.9300	0.9300	0.9300
Other Adjustment Factor	1.0000	1.0000	1.0000	1.0000	1.0000	1.0000	1.0000	1.0000	1.0000	1.0000	1.0000	1.0000
Total 15-Minute Volume [veh/h]	30	24	21	25	20	9	8	62	37	27	55	24
Total Analysis Volume [veh/h]	122	95	85	100	80	35	30	248	146	109	222	96
Presence of On-Street Parking	No	No	No	No	No	No	No	No	No	No	No	No
On-Street Parking Maneuver Rate [1/h]	0	0	0	0	0	0	0	0	0	0	0	0
Local Bus Stopping Rate [1/h]	0	0	0	0	0	0	0	0	0	0	0	0
v_do, Outbound Pedestrian Volume crossing major street [ped/h]	1			0			1			1		
v_di, Inbound Pedestrian Volume crossing major street [ped/h]	1			1			0			0		
v_co, Outbound Pedestrian Volume crossing minor street [ped/h]	1			0			0			0		
v_ci, Inbound Pedestrian Volume crossing minor street [ped/h]	0			0			1			0		
v_ab, Corner Pedestrian Volume [ped/h]	0			0			0			0		
Bicycle Volume [bicycles/h]	0			0			0			1		



Intersection Settings

Located in CBD	Yes
Signal Coordination Group	-
Cycle Length [s]	109
Coordination Type	Time of Day Pattern Isolated
Actuation Type	Fully actuated
Offset [s]	0.0
Offset Reference	Lead Green - Beginning of First Green
Permissive Mode	SingleBand
Lost time [s]	14.00

Phasing & Timing

Control Type	Protect	Perms	Perms	Protect	Perms	Perms	Protect	Perms	Perms	Protect	Perms	Perms
Signal Group	3	8	0	7	4	0	5	2	0	1	6	0
Auxiliary Signal Groups												
Lead / Lag	Lead	-	-	Lead	-	-	Lead	-	-	Lead	-	-
Minimum Green [s]	4	6	0	4	6	0	4	6	0	4	6	0
Maximum Green [s]	20	25	0	20	25	0	20	30	0	20	20	0
Amber [s]	3.0	3.3	0.0	3.0	3.3	0.0	3.0	3.6	0.0	3.0	3.6	0.0
All red [s]	0.0	0.3	0.0	0.0	0.3	0.0	0.0	0.3	0.0	0.0	0.3	0.0
Split [s]	23	29	0	23	29	0	23	34	0	23	34	0
Vehicle Extension [s]	0.0	0.0	0.0	0.0	0.0	0.0	0.0	0.0	0.0	0.0	0.0	0.0
Walk [s]	0	7	0	0	7	0	0	7	0	0	7	0
Pedestrian Clearance [s]	0	11	0	0	9	0	0	14	0	0	9	0
Delayed Vehicle Green [s]	0.0	0.0	0.0	0.0	0.0	0.0	0.0	0.0	0.0	0.0	0.0	0.0
Rest In Walk	No			No			No			No		
I1, Start-Up Lost Time [s]	2.0	2.0	0.0	2.0	2.0	0.0	2.0	2.0	0.0	2.0	2.0	0.0
I2, Clearance Lost Time [s]	1.0	1.6	0.0	1.0	1.6	0.0	1.0	1.9	0.0	1.0	1.9	0.0
Minimum Recall	No	No		No	No		No	No		No	No	
Maximum Recall	No	No		No	No		No	No		No	No	
Pedestrian Recall	No	No		No	No		No	No		No	No	
Detector Location [ft]	0.0	0.0	0.0	0.0	0.0	0.0	0.0	0.0	0.0	0.0	0.0	0.0
Detector Length [ft]	0.0	0.0	0.0	0.0	0.0	0.0	0.0	0.0	0.0	0.0	0.0	0.0
I, Upstream Filtering Factor	1.00	1.00	1.00	1.00	1.00	1.00	1.00	1.00	1.00	1.00	1.00	1.00

Exclusive Pedestrian Phase

Pedestrian Signal Group	0
Pedestrian Walk [s]	0
Pedestrian Clearance [s]	0



Lane Group Calculations

Lane Group	L	C	R	L	C	L	C	L	C
C, Cycle Length [s]	34	34	34	34	34	34	34	34	34
L, Total Lost Time per Cycle [s]	3.00	3.00	3.00	3.00	3.00	3.00	3.00	3.00	3.00
M _p , Permitted Start-Up Lost Time [s]	0.00	0.00	0.00	0.00	0.00	0.00	0.00	0.00	0.00
l ₂ , Clearance Lost Time [s]	1.00	1.00	1.00	1.00	1.00	1.00	1.00	1.00	1.00
g _i , Effective Green Time [s]	3	5	5	2	4	1	10	3	12
g / C, Green / Cycle	0.09	0.15	0.15	0.07	0.13	0.03	0.29	0.08	0.34
(v / s) _i Volume / Saturation Flow Rate	0.08	0.06	0.06	0.06	0.07	0.02	0.25	0.07	0.20
s, saturation flow rate [veh/h]	1603	1683	1421	1603	1595	1603	1579	1603	1586
c, Capacity [veh/h]	149	252	213	120	210	47	461	132	547
d1, Uniform Delay [s]	15.00	12.90	12.94	15.37	13.68	16.16	11.24	15.22	9.03
k, delay calibration	0.04	0.04	0.04	0.04	0.04	0.04	0.04	0.04	0.04
l, Upstream Filtering Factor	1.00	1.00	1.00	1.00	1.00	1.00	1.00	1.00	1.00
d2, Incremental Delay [s]	4.18	0.35	0.45	5.61	0.83	5.12	1.77	4.92	0.36
d3, Initial Queue Delay [s]	0.00	0.00	0.00	0.00	0.00	0.00	0.00	0.00	0.00
R _p , platoon ratio	1.00	1.00	1.00	1.00	1.00	1.00	1.00	1.00	1.00
PF, progression factor	1.00	1.00	1.00	1.00	1.00	1.00	1.00	1.00	1.00

Lane Group Results

X, volume / capacity	0.82	0.38	0.40	0.83	0.55	0.63	0.85	0.83	0.58
d, Delay for Lane Group [s/veh]	19.18	13.25	13.39	20.98	14.51	21.29	13.01	20.14	9.40
Lane Group LOS	B	B	B	C	B	C	B	C	A
Critical Lane Group	Yes	No	No	No	Yes	No	Yes	Yes	No
50th-Percentile Queue Length [veh/ln]	0.91	0.53	0.48	0.80	0.69	0.25	2.06	0.82	1.25
50th-Percentile Queue Length [ft/ln]	22.73	13.29	12.05	19.98	17.34	6.22	51.52	20.43	31.25
95th-Percentile Queue Length [veh/ln]	1.64	0.96	0.87	1.44	1.25	0.45	3.71	1.47	2.25
95th-Percentile Queue Length [ft/ln]	40.91	23.93	21.69	35.97	31.22	11.20	92.73	36.78	56.24

Movement, Approach, & Intersection Results

d _M , Delay for Movement [s/veh]	19.18	13.25	13.39	20.98	14.51	14.51	21.29	13.01	13.01	20.14	9.40	9.40
Movement LOS	B	B	B	C	B	B	C	B	B	C	A	A
d _A , Approach Delay [s/veh]	15.68			17.52			13.60			12.14		
Approach LOS	B			B			B			B		
d _I , Intersection Delay [s/veh]	14.22											
Intersection LOS	B											
Intersection V/C	0.799											

Other Modes

g _{Walk} , mi, Effective Walk Time [s]	11.0		11.0		11.0		11.0	
M _{corner} , Corner Circulation Area [ft ² /ped]	0.00		0.00		0.00		0.00	
M _{CW} , Crosswalk Circulation Area [ft ² /ped]	0.00		0.00		0.00		0.00	
d _p , Pedestrian Delay [s]	7.58		7.58		7.58		7.58	
l _{p,int} , Pedestrian LOS Score for Intersection	2.258		2.032		2.193		2.248	
Crosswalk LOS	B		B		B		B	
s _b , Saturation Flow Rate of the bicycle lane [bicycles/h]	2000		2000		2000		2000	
c _b , Capacity of the bicycle lane [bicycles/h]	1514		1514		1794		1794	
d _b , Bicycle Delay [s]	0.99		0.99		0.18		0.18	
l _{b,int} , Bicycle LOS Score for Intersection	2.089		1.919		2.267		2.287	
Bicycle LOS	B		A		B		B	

Sequence

Ring 1	1	2	3	4	-	-	-	-	-	-	-	-	-	-	-
Ring 2	5	6	7	8	-	-	-	-	-	-	-	-	-	-	-
Ring 3	-	-	-	-	-	-	-	-	-	-	-	-	-	-	-
Ring 4	-	-	-	-	-	-	-	-	-	-	-	-	-	-	-

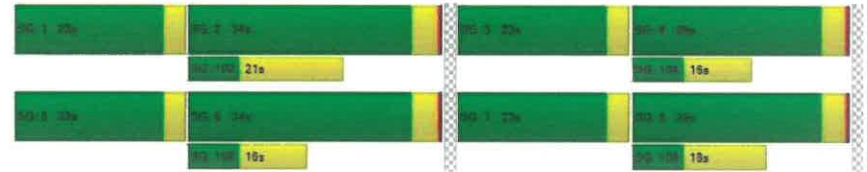

Intersection Level Of Service Report

Intersection 2: Burns Valley Rd/Bowers Ave-Rumsey Rd

Control Type: Two-way stop
Analysis Method: HCM 6th Edition
Analysis Period: 15 minutes
Delay (sec / veh): 19.0
Level Of Service: C
Volume to Capacity (v/c): 0.034

Intersection Setup

Name	Burns Valley Rd			Rumsey Rd			Burns Valley Rd			Bowers Ave		
Approach	Northbound			Southbound			Eastbound			Westbound		
Lane Configuration	+			+			+			+		
Turning Movement	Left	Thru	Right	Left	Thru	Right	Left	Thru	Right	Left	Thru	Right
Lane Width [ft]	12.00	12.00	12.00	12.00	12.00	12.00	12.00	12.00	12.00	12.00	12.00	12.00
No. of Lanes in Entry Pocket	0	0	0	0	0	0	0	0	0	0	0	0
Entry Pocket Length [ft]	100.00	100.00	100.00	100.00	100.00	100.00	100.00	100.00	100.00	100.00	100.00	100.00
No. of Lanes in Exit Pocket	0	0	0	0	0	0	0	0	0	0	0	0
Exit Pocket Length [ft]	0.00	0.00	0.00	0.00	0.00	0.00	0.00	0.00	0.00	0.00	0.00	0.00
Speed [mph]	30.00			30.00			35.00			25.00		
Grade [%]	0.00			0.00			0.00			0.00		
Crosswalk	No			Yes			Yes			No		

Volumes

Name	Burns Valley Rd			Rumsey Rd			Burns Valley Rd			Bowers Ave		
Base Volume Input [veh/h]	215	46	11	0	41	28	16	2	219	9	2	0
Base Volume Adjustment Factor	1.0000	1.0000	1.0000	1.0000	1.0000	1.0000	1.0000	1.0000	1.0000	1.0000	1.0000	1.0000
Heavy Vehicles Percentage [%]	2.00	2.00	2.00	2.00	2.00	2.00	2.00	2.00	2.00	2.00	2.00	2.00
Growth Factor	1.0000	1.0000	1.0000	1.0000	1.0000	1.0000	1.0000	1.0000	1.0000	1.0000	1.0000	1.0000
In-Process Volume [veh/h]	0	0	0	0	0	0	0	0	0	0	0	0
Site-Generated Trips [veh/h]	0	0	0	0	0	0	0	0	0	0	0	0
Diverted Trips [veh/h]	0	0	0	0	0	0	0	0	0	0	0	0
Pass-by Trips [veh/h]	0	0	0	0	0	0	0	0	0	0	0	0
Existing Site Adjustment Volume [veh/h]	0	0	0	0	0	0	0	0	0	0	0	0
Other Volume [veh/h]	0	0	0	0	0	0	0	0	0	0	0	0
Total Hourly Volume [veh/h]	215	46	11	0	41	28	16	2	219	9	2	0
Peak Hour Factor	1.0000	1.0000	1.0000	1.0000	1.0000	1.0000	1.0000	1.0000	1.0000	1.0000	1.0000	1.0000
Other Adjustment Factor	1.0000	1.0000	1.0000	1.0000	1.0000	1.0000	1.0000	1.0000	1.0000	1.0000	1.0000	1.0000
Total 15-Minute Volume [veh/h]	54	12	3	0	10	7	4	1	55	2	1	0
Total Analysis Volume [veh/h]	215	46	11	0	41	28	16	2	219	9	2	0
Pedestrian Volume [ped/h]	0	0	0	0	0	0	0	0	0	0	0	0



Intersection Settings

Priority Scheme	Free	Free	Stop	Stop
Flared Lane			No	No
Storage Area [veh]	0	0	0	C
Two-Stage Gap Acceptance			No	No
Number of Storage Spaces in Median	0	0	0	0

Movement, Approach, & Intersection Results

V/C, Movement V/C Ratio	0.14	0.30	0.00	0.00	0.00	0.00	0.04	0.01	0.22	0.03	0.01	0.00
d_M, Delay for Movement [s/veh]	7.73	0.00	0.00	7.35	0.00	0.00	15.35	15.81	9.96	19.03	15.04	5.00
Movement LOS	A	A	A	A	A	A	C	C	A	C	C	A
95th-Percentile Queue Length [veh/ln]	0.49	0.49	0.49	0.00	0.00	0.00	1.05	1.05	1.05	0.12	0.12	0.12
95th-Percentile Queue Length [ft/ln]	12.21	12.21	12.21	0.00	0.00	0.00	26.22	26.22	26.22	3.04	3.04	3.04
d_A, Approach Delay [s/veh]	6.11		0.00		10.37		18.31					
Approach LOS	A		A		B		C					
d_I, Intersection Delay [s/veh]	7.34											
Intersection LOS	C											



Intersection Level Of Service Report
Intersection 5: Olympic Dr/Lakeshore Dr

Control Type: Roundabout Delay (sec / veh): 5.7
Analysis Method: HCM 6th Edition Level Of Service: A
Analysis Period: 15 minutes

Intersection Setup

Name	Lakeshore Dr			Lakeshore Dr			Olympic Dr		
	Northbound			Southbound			Westbound		
Approach	←→			←→			←→		
Lane Configuration	←→			←→			←→		
Turning Movement	Left	Thru	Right	Left	Thru	Right	Left	Thru	Right
Lane Width [ft]	12.00	12.00	12.00	12.00	12.00	12.00	12.00	12.00	12.00
No. of Lanes in Entry Pocket	0	1	0	0	1	0	0	1	0
Entry Pocket Length [ft]	100.00	100.00	120.00	100.00	100.00	100.00	100.00	100.00	250.00
No. of Lanes in Exit Pocket	0	0	0	0	0	0	0	0	0
Exit Pocket Length [ft]	0.00	0.00	0.00	0.00	0.00	0.00	0.00	0.00	0.00
Speed [mph]	25.00			25.00			30.00		
Grade [%]	0.00			0.00			0.00		
Crosswalk	No			Yes			No		

Volumes

Name	Lakeshore Dr			Lakeshore Dr			Olympic Dr					
Base Volume Input [veh/h]	5	230	85	90	435	0	0	0	5	80	5	70
Base Volume Adjustment Factor	1.0000	1.0000	1.0000	1.0000	1.0000	1.0000	1.0000	1.0000	1.0000	1.0000	1.0000	1.0000
Heavy Vehicles Percentage [%]	2.00	2.00	2.00	2.00	2.00	2.00	2.00	2.00	2.00	2.00	2.00	2.00
Growth Factor	1.0000	1.0000	1.0000	1.0000	1.0000	1.0000	1.0000	1.0000	1.0000	1.0000	1.0000	1.0000
In-Process Volume [veh/h]	0	0	0	0	0	0	0	0	0	0	0	0
Site-Generated Trips [veh/h]	0	0	0	0	0	0	0	0	0	0	0	0
Diverted Trips [veh/h]	0	0	0	0	0	0	0	0	0	0	0	0
Pass-by Trips [veh/h]	0	0	0	0	0	0	0	0	0	0	0	0
Existing Site Adjustment Volume [veh/h]	0	0	0	0	0	0	0	0	0	0	0	0
Other Volume [veh/h]	0	0	0	0	0	0	0	0	0	0	0	0
Total Hourly Volume [veh/h]	5	230	85	90	435	0	0	0	5	80	5	70
Peak Hour Factor	1.0000	1.0000	1.0000	1.0000	1.0000	1.0000	1.0000	1.0000	1.0000	1.0000	1.0000	1.0000
Other Adjustment Factor	1.0000	1.0000	1.0000	1.0000	1.0000	1.0000	1.0000	1.0000	1.0000	1.0000	1.0000	1.0000
Total 15-Minute Volume [veh/h]	1	58	21	23	109	0	0	1	20	1	18	
Total Analysis Volume [veh/h]	5	230	85	90	435	0	0	5	80	5	70	
Pedestrian Volume [ped/h]	0			0			0			1		

Intersection Settings

Number of Conflicting Circulating Lanes	1			1			1			1		
Circulating Flow Rate [veh/h]	92			92			617			240		
Exiting Flow Rate [veh/h]	530			306			10			179		
Demand Flow Rate [veh/h]	5	230	85	90	435	0	0	0	5	80	5	70
Adjusted Demand Flow Rate [veh/h]	5	230	85	90	435	0	0	0	5	80	5	70

Lanes

Overwrite Calculated Critical Headway	No	No	No	No	No	No
User-Defined Critical Headway [s]	4.00	4.00	4.00	4.00	4.00	4.00
Overwrite Calculated Follow-Up Time	No	No	No	No	No	No
User-Defined Follow-Up Time [s]	3.00	3.00	3.00	3.00	3.00	3.00
A (intercept)	1420.00	1420.00	1380.00	1380.00	1420.00	1420.00
B (coefficient)	0.00091	0.00091	0.00102	0.00102	0.00091	0.00091
HV Adjustment Factor	0.98	0.98	0.98	0.98	0.98	0.98
Entry Flow Rate [veh/h]	240	87	536	6	82	77
Capacity of Entry and Bypass Lanes [veh/h]	1307	1307	1257	736	1142	1142
Pedestrian Impedance	1.00	1.00	1.00	1.00	1.00	1.00
Capacity per Entry Lane [veh/h]	1281	1281	1233	721	1119	1119
X, volume / capacity	0.18	0.07	0.43	0.01	0.07	0.07

Movement, Approach, & Intersection Results

Lane LOS	A	A	A	A	A	A
95th-Percentile Queue Length [veh]	0.67	0.21	2.17	0.02	0.23	0.22
95th-Percentile Queue Length [ft]	16.77	5.32	54.36	0.52	5.77	5.38
Approach Delay [s/veh]	4.09		7.20	5.06		3.81
Approach LOS	A		A	A		A
Intersection Delay [s/veh]	5.68					
Intersection LOS	A					



Intersection Level Of Service Report
Intersection 7: Olympic Dr/Burns Valley Rd-Old Hwy 53

Control Type: Signalized
 Analysis Method: HCM 6th Edition
 Analysis Period: 15 minutes
 Delay (sec / veh): 14.4
 Level Of Service: B
 Volume to Capacity (v/c): 0.757

Intersection Setup

Name	Old Hwy 53			Burns Valley Rd			Olympic Dr			Old Hwy 53		
	Northbound			Southbound			Eastbound			Westbound		
Approach	Northbound			Southbound			Eastbound			Westbound		
Lane Configuration	[Diagram]			[Diagram]			[Diagram]			[Diagram]		
Turning Movement	Left	Thru	Right	Left	Thru	Right	Left	Thru	Right	Left	Thru	Right
Lane Width [ft]	12.00	12.00	12.00	12.00	12.00	12.00	12.00	12.00	12.00	12.00	12.00	12.00
No. of Lanes in Entry Pocket	1	0	1	1	0	1	0	1	0	0	1	0
Entry Pocket Length [ft]	100.00	100.00	100.00	56.00	100.00	100.00	48.00	100.00	100.00	100.00	100.00	100.00
No. of Lanes in Exit Pocket	0	0	0	0	0	0	0	0	0	0	0	0
Exit Pocket Length [ft]	0.00	0.00	0.00	0.00	0.00	0.00	0.00	0.00	0.00	0.00	0.00	0.00
Speed [mph]	30.00			30.00			35.00			35.00		
Grade [%]	0.00			0.00			0.00			0.00		
Curb Present	No			No			No			No		
Crosswalk	Yes			Yes			Yes			Yes		

Volumes

Name	Old Hwy 53			Burns Valley Rd			Olympic Dr			Old Hwy 53		
Base Volume Input [veh/h]	95	130	70	160	125	30	35	205	130	80	225	150
Base Volume Adjustment Factor	1.0000	1.0000	1.0000	1.0000	1.0000	1.0000	1.0000	1.0000	1.0000	1.0000	1.0000	1.0000
Heavy Vehicles Percentage [%]	2.00	2.00	2.00	2.00	2.00	2.00	2.00	2.00	2.00	2.00	2.00	2.00
Growth Factor	1.0000	1.0000	1.0000	1.0000	1.0000	1.0000	1.0000	1.0000	1.0000	1.0000	1.0000	1.0000
In-Process Volume [veh/h]	0	0	0	0	0	0	0	0	0	0	0	0
Site-Generated Trips [veh/h]	0	0	0	0	0	0	0	0	0	0	0	0
Diverted Trips [veh/h]	0	0	0	0	0	0	0	0	0	0	0	0
Pass-by Trips [veh/h]	0	0	0	0	0	0	0	0	0	0	0	0
Existing Site Adjustment Volume [veh/h]	0	0	0	0	0	0	0	0	0	0	0	0
Other Volume [veh/h]	0	0	0	0	0	0	0	0	0	0	0	0
Right Turn on Red Volume [veh/h]	0	0	19	0	0	3	0	0	5	0	0	20
Total Hourly Volume [veh/h]	95	130	51	160	125	27	35	205	125	80	225	130
Peak Hour Factor	1.0000	1.0000	1.0000	1.0000	1.0000	1.0000	1.0000	1.0000	1.0000	1.0000	1.0000	1.0000
Other Adjustment Factor	1.0000	1.0000	1.0000	1.0000	1.0000	1.0000	1.0000	1.0000	1.0000	1.0000	1.0000	1.0000
Total 15-Minute Volume [veh/h]	24	33	13	40	31	7	9	51	31	20	56	33
Total Analysis Volume [veh/h]	95	130	51	160	125	27	35	205	125	80	225	130
Presence of On-Street Parking	No	No	No	No	No	No	No	No	No	No	No	No
On-Street Parking Maneuver Rate [h]	0	0	0	0	0	0	0	0	0	0	0	0
Local Bus Stopping Rate [h]	0	0	0	0	0	0	0	0	0	0	0	0
v_do, Outbound Pedestrian Volume crossing major street	1			0			1			1		
v_di, Inbound Pedestrian Volume crossing major street	1			1			0			1		
v_co, Outbound Pedestrian Volume crossing minor street	1			0			0			0		
v_ci, Inbound Pedestrian Volume crossing minor street	0			0			1			0		
v_ab, Corner Pedestrian Volume [ped/h]	0			0			0			0		
Bicycle Volume [bicycles/h]	0			0			0			1		



Intersection Settings	
Located in CBD	Yes
Signal Coordination Group	-
Cycle Length [s]	109
Coordination Type	Time of Day Pattern Isolated
Actuation Type	Fully actuated
Offset [s]	0.0
Offset Reference	Lead Green - Beginning of First Green
Permissive Mode	SingleBand
Lost time [s]	14.00

Phasing & Timing														
Control Type	Protect	Permis	Permis	Protect	Permis	Permis	Protect	Permis	Permis	Protect	Permis	Permis	Protect	Permis
Signal Group	3	8	0	7	4	0	5	2	0	1	6	0		
Auxiliary Signal Groups														
Lead / Lag	Lead	-	-	Lead	-	-	Lead	-	-	Lead	-	-		
Minimum Green [s]	4	6	0	4	6	0	4	6	0	4	6	0		
Maximum Green [s]	20	25	0	20	25	0	20	30	0	20	20	0		
Amber [s]	3.0	3.3	0.0	3.0	3.3	0.0	3.0	3.6	0.0	3.0	3.6	0.0		
All red [s]	0.0	0.3	0.0	0.0	0.3	0.0	0.0	0.3	0.0	0.0	0.3	0.0		
Split [s]	23	29	0	23	29	0	23	34	0	23	34	0		
Vehicle Extension [s]	0.0	0.0	0.0	0.0	0.0	0.0	0.0	0.0	0.0	0.0	0.0	0.0		
Walk [s]	0	7	0	0	7	0	0	7	0	0	7	0		
Pedestrian Clearance [s]	0	11	0	0	9	0	0	14	0	0	9	0		
Delayed Vehicle Green [s]	0.0	0.0	0.0	0.0	0.0	0.0	0.0	0.0	0.0	0.0	0.0	0.0		
Rest In Walk	No	No		No	No		No	No		No	No			
I1, Start-Up Lost Time [s]	2.0	2.0	0.0	2.0	2.0	0.0	2.0	2.0	0.0	2.0	2.0	0.0		
I2, Clearance Lost Time [s]	1.0	1.6	0.0	1.0	1.6	0.0	1.0	1.9	0.0	1.0	1.9	0.0		
Minimum Recall	No	No		No	No		No	No		No	No			
Maximum Recall	No	No		No	No		No	No		No	No			
Pedestrian Recall	No	No		No	No		No	No		No	No			
Detector Location [ft]	0.0	0.0	0.0	0.0	0.0	0.0	0.0	0.0	0.0	0.0	0.0	0.0		
Detector Length [ft]	0.0	0.0	0.0	0.0	0.0	0.0	0.0	0.0	0.0	0.0	0.0	0.0		
I Upstream Filtering Factor	1.00	1.00	1.00	1.00	1.00	1.00	1.00	1.00	1.00	1.00	1.00	1.00		

Exclusive Pedestrian Phase	
Pedestrian Signal Group	0
Pedestrian Walk [s]	0
Pedestrian Clearance [s]	0



Lane Group Calculations										
Lane Group	L	C	R	L	C	L	C	L	C	C
C, Cycle Length [s]	33	33	33	33	33	33	33	33	33	33
L, Total Lost Time per Cycle [s]	3.00	3.60	3.60	3.00	3.60	3.00	3.60	3.00	3.60	3.00
I1_p, Permitted Start-Up Lost Time [s]	0.00	0.30	0.30	0.00	0.30	0.00	0.30	0.00	0.30	0.00
I2, Clearance Lost Time [s]	1.00	1.60	1.60	1.00	1.60	1.00	1.60	1.00	1.60	1.00
g_i, Effective Green Time [s]	2	5	5	4	7	1	8	2	9	9
g / C, Green / Cycle	0.07	0.15	0.15	0.12	0.20	0.03	0.25	0.06	0.28	0.28
(v / s)_j Volume / Saturation Flow Rate	0.06	0.08	0.04	0.10	0.09	0.02	0.21	0.05	0.23	0.23
s, saturation flow rate [veh/h]	1603	1683	1421	1603	1631	1603	1576	1603	1567	1567
c, Capacity [veh/h]	115	256	216	200	334	55	399	103	443	443
d1, Uniform Delay [s]	15.21	12.95	12.39	14.14	11.59	15.85	11.73	15.32	11.05	11.05
k, delay calibration	0.04	0.04	0.04	0.04	0.04	0.04	0.04	0.04	0.04	0.04
I, Upstream Filtering Factor	1.00	1.00	1.00	1.00	1.00	1.00	1.00	1.00	1.00	1.00
d2, Incremental Delay [s]	5.44	0.58	0.21	2.79	0.36	4.55	1.70	4.67	1.29	1.29
d3, Initial Queue Delay [s]	0.00	0.00	0.00	0.00	0.00	0.00	0.00	0.00	0.00	0.00
Rp, platoon ratio	1.00	1.00	1.00	1.00	1.00	1.00	1.00	1.00	1.00	1.00
PF, progression factor	1.00	1.00	1.00	1.00	1.00	1.00	1.00	1.00	1.00	1.00

Lane Group Results										
X, volume / capacity	0.82	0.51	0.24	0.80	0.46	0.64	0.83	0.78	0.80	0.80
d, Delay for Lane Group [s/veh]	20.65	13.53	12.60	16.94	11.95	20.40	13.43	19.99	12.33	12.33
Lane Group LOS	C	B	B	B	B	C	B	B	B	B
Critical Lane Group	No	Yes	No	Yes	No	No	Yes	Yes	No	No
50th-Percentile Queue Length [veh/m]	0.74	0.73	0.27	1.07	0.77	0.28	1.76	0.60	1.76	1.76
50th-Percentile Queue Length [ft/m]	18.59	18.28	6.79	26.80	19.35	6.88	43.91	14.88	43.91	43.91
95th-Percentile Queue Length [veh/m]	1.34	1.32	0.49	1.93	1.39	0.50	3.16	1.07	3.16	3.16
95th-Percentile Queue Length [ft/m]	33.46	32.91	12.21	48.24	34.84	12.38	79.04	26.78	79.04	79.04



Movement, Approach, & Intersection Results

d_M, Delay for Movement [s/veh]	20.65	13.53	12.60	16.94	11.95	11.95	20.40	13.43	13.43	19.99	12.33	12.33
Movement LOS	C	B	B	B	B	B	C	B	B	B	B	B
d_A, Approach Delay [s/veh]	15.81		14.51		14.10		13.74					
Approach LOS	B		B		B		B					
d_I, Intersection Delay [s/veh]	14.42											
Intersection LOS	B											
Intersection VIC	0.757											

Other Modes

g_Walk, mi, Effective Walk Time [s]	11.0	11.0	11.0	11.0
M_corner, Corner Circulation Area [ft²/ped]	0.00	0.00	0.00	0.00
M_CW, Crosswalk Circulation Area [ft²/ped]	0.00	0.00	0.00	0.00
d_p, Pedestrian Delay [s]	7.35	7.35	7.35	7.35
L_p,int, Pedestrian LOS Score for Intersection	2.249	2.087	2.158	2.243
Crosswalk LOS	B	B	B	B
s_b, Saturation Flow Rate of the bicycle lane [bicycles/h]	2000	2000	2000	2000
c_b, Capacity of the bicycle lane [bicycles/h]	1537	1537	1822	1822
d_b, Bicycle Delay [s]	0.88	0.88	0.13	0.13
I_b,int, Bicycle LOS Score for Intersection	2.048	2.079	2.170	2.310
Bicycle LOS	B	B	B	B

Sequence

Ring 1	1	2	3	4	-	-	-	-	-	-	-	-	-	-	-
Ring 2	5	6	7	8	-	-	-	-	-	-	-	-	-	-	-
Ring 3	-	-	-	-	-	-	-	-	-	-	-	-	-	-	-
Ring 4	-	-	-	-	-	-	-	-	-	-	-	-	-	-	-

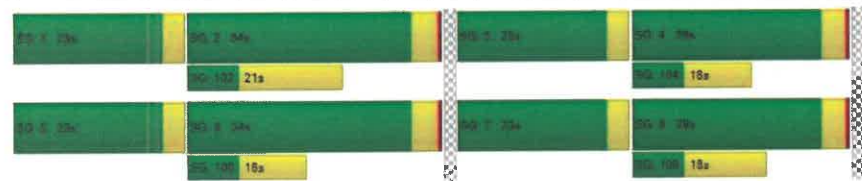

Intersection Level Of Service Report
Intersection 2: Burns Valley Rd/Bowers Ave-Rumsey Rd

Control Type:	Two-way stop	Delay (sec / veh):	15.6
Analysis Method:	HCM 6th Edition	Level Of Service:	C
Analysis Period:	15 minutes	Volume to Capacity (v/c):	0.058

Intersection Setup

Name	Burns Valley Rd			Rumsey Rd			Burns Valley Rd			Bowers Ave		
Approach	Northbound			Southbound			Eastbound			Westbound		
Lane Configuration	+			+			+			+		
Turning Movement	Left	Thru	Right	Left	Thru	Right	Left	Thru	Right	Left	Thru	Right
Lane Width [ft]	12.00	12.00	12.00	12.00	12.00	12.00	12.00	12.00	12.00	12.00	12.00	12.00
No. of Lanes in Entry Pocket	0	6	0	0	0	0	0	0	0	0	0	0
Entry Pocket Length [ft]	100.00	100.00	100.00	100.00	100.00	100.00	100.00	100.00	100.00	100.00	100.00	100.00
No. of Lanes in Exit Pocket	0	0	0	0	0	0	0	0	0	0	0	0
Exit Pocket Length [ft]	0.00	0.00	0.00	0.00	0.00	0.00	0.00	0.00	0.00	0.00	0.00	0.00
Speed [mph]	30.00			30.00			35.00			25.00		
Grade [%]	0.00			0.00			0.00			0.00		
Crosswalk	No			Yes			Yes			No		

Volumes

Name	Burns Valley Rd			Rumsey Rd			Burns Valley Rd			Bowers Ave		
Base Volume Input [veh/h]	163	62	15	3	70	11	11	2	123	21	0	0
Base Volume Adjustment Factor	1.0000	1.0000	1.0000	1.0000	1.0000	1.0000	1.0000	1.0000	1.0000	1.0000	1.0000	1.0000
Heavy Vehicles Percentage [%]	2.00	2.00	2.00	2.00	2.00	2.00	2.00	2.00	2.00	2.00	2.00	2.00
Growth Factor	1.0000	1.0000	1.0000	1.0000	1.0000	1.0000	1.0000	1.0000	1.0000	1.0000	1.0000	1.0000
In-Process Volume [veh/h]	0	0	0	0	0	0	0	0	0	0	0	0
Site-Generated Trips [veh/h]	0	0	0	0	0	0	0	0	0	0	0	0
Diverted Trips [veh/h]	0	0	0	0	0	0	0	0	0	0	0	0
Pass-by Trips [veh/h]	0	0	0	0	0	0	0	0	0	0	0	0
Existing Site Adjustment Volume [veh/h]	0	0	0	0	0	0	0	0	0	0	0	0
Other Volume [veh/h]	0	0	0	0	0	0	0	0	0	0	0	0
Total Hourly Volume [veh/h]	163	62	15	3	70	11	11	2	123	21	0	0
Peak Hour Factor	1.0000	1.0000	1.0000	1.0000	1.0000	1.0000	1.0000	1.0000	1.0000	1.0000	1.0000	1.0000
Other Adjustment Factor	1.0000	1.0000	1.0000	1.0000	1.0000	1.0000	1.0000	1.0000	1.0000	1.0000	1.0000	1.0000
Total 15-Minute Volume [veh/h]	41	16	4	1	18	3	3	1	31	5	0	0
Total Analysis Volume [veh/h]	163	62	15	3	70	11	11	2	123	21	0	0
Pedestrian Volume [ped/h]	0			0			0			0		

Intersection Settings

Priority Scheme	Free	Free	Stop	Stop
Flared Lane			No	No
Storage Area [veh]	0	0	0	0
Two-Stage Gap Acceptance			No	No
Number of Storage Spaces in Median	0	0	0	0

Movement, Approach, & Intersection Results

VC, Movement V/C Ratio	0.11	0.00	0.00	0.00	0.00	0.00	0.02	0.00	0.12	0.06	0.00	0.00
d_M, Delay for Movement [s/veh]	7.66	0.00	0.00	7.37	0.00	0.00	13.65	14.16	9.39	15.60	14.02	9.24
Movement LOS	A	A	A	A	A	A	B	B	A	C	B	A
95th-Percentile Queue Length [veh/m]	0.36	0.36	0.36	0.01	0.01	0.01	0.54	0.54	0.54	0.18	0.14	0.18
95th-Percentile Queue Length [ft/m]	9.01	9.01	9.01	0.15	0.15	0.15	13.54	13.54	13.54	4.62	4.62	4.62
d_A, Approach Delay [s/veh]	5.20			0.26			9.80			15.60		
Approach LOS	A			A			A			C		
d_I, Intersection Delay [s/veh]							6.09					
Intersection LOS	C											



Intersection Level of Service Report
Intersection 5: Olympic Dr/Lakeshore Dr

Control Type:	Roundabout	Delay (sec / veh):	4.9
Analysis Method:	HCM 6th Edition	Level of Service:	A
Analysis Period:	15 minutes		

Intersection Setup

Name	Lakeshore Dr			Lakeshore Dr			Olympic Dr					
Approach	Northbound			Southbound			Eastbound			Westbound		
Lane Configuration												
Turning Movement	Left	Thru	Right	Left	Thru	Right	Left	Thru	Right	Left	Thru	Right
Lane Width [ft]	12.00	12.00	12.00	12.00	12.00	12.00	12.00	12.00	12.00	12.00	12.00	12.00
No. of Lanes in Entry Pocket	0	0	1	0	0	0	0	0	0	0	0	1
Entry Pocket Length [ft]	100.00	100.00	120.00	100.00	100.00	100.00	100.00	100.00	100.00	100.00	100.00	250.00
No. of Lanes in Exit Pocket	0	0	0	0	0	0	0	0	0	0	0	0
Exit Pocket Length [ft]	0.00	0.00	0.00	0.00	0.00	0.00	0.00	0.00	0.00	0.00	0.00	0.00
Speed [mph]	25.00			25.00			30.00			30.00		
Grade [%]	0.00			0.00			0.00			0.00		
Crosswalk	No			Yes			No			Yes		

Volumes

Name	Lakeshore Dr			Lakeshore Dr			Olympic Dr					
Base Volume Input [veh/h]	0	310	125	95	215	0	0	0	5	120	5	160
Base Volume Adjustment Factor	1.0000	1.0000	1.0000	1.0000	1.0000	1.0000	1.0000	1.0000	1.0000	1.0000	1.0000	1.0000
Heavy Vehicles Percentage [%]	2.00	2.00	2.00	2.00	2.00	2.00	2.00	2.00	2.00	2.00	2.00	2.00
Growth Factor	1.0000	1.0000	1.0000	1.0000	1.0000	1.0000	1.0000	1.0000	1.0000	1.0000	1.0000	1.0000
In-Process Volume [veh/h]	0	0	0	0	0	0	0	0	0	0	0	0
Site-Generated Trips [veh/h]	0	0	0	0	0	0	0	0	0	0	0	0
Diverted Trips [veh/h]	0	0	0	0	0	0	0	0	0	0	0	0
Pass-by Trips [veh/h]	0	0	0	0	0	0	0	0	0	0	0	0
Existing Site Adjustment Volume [veh/h]	0	0	0	0	0	0	0	0	0	0	0	0
Other Volume [veh/h]	0	0	0	0	0	0	0	0	0	0	0	0
Total Hourly Volume [veh/h]	0	310	125	95	215	0	0	0	5	120	5	160
Peak Hour Factor	1.0000	1.0000	1.0000	1.0000	1.0000	1.0000	1.0000	1.0000	1.0000	1.0000	1.0000	1.0000
Other Adjustment Factor	1.0000	1.0000	1.0000	1.0000	1.0000	1.0000	1.0000	1.0000	1.0000	1.0000	1.0000	1.0000
Total 15-Minute Volume [veh/h]	0	78	31	24	54	0	0	0	1	30	1	40
Total Analysis Volume [veh/h]	0	310	125	95	215	0	0	0	5	120	5	160
Pedestrian Volume [ped/h]	0			0			0			1		



Intersection Settings

Number of Conflicting Circulating Lanes	1			1			1			1		
Circulating Flow Rate [veh/h]	97			128			439			316		
Exiting Flow Rate [veh/h]	347			479			5			224		
Demand Flow Rate [veh/h]	0	310	125	95	215	0	0	0	5	120	5	160
Adjusted Demand Flow Rate [veh/h]	0	310	125	95	215	0	0	0	5	120	5	160

Lanes

Overwrite Calculated Critical Headway	No	No	No	No	No	No
User-Defined Critical Headway [s]	4.00	4.00	4.00	4.00	4.00	4.00
Overwrite Calculated Follow-Up Time	No	No	No	No	No	No
User-Defined Follow-Up Time [s]	3.00	3.00	3.00	3.00	3.00	3.00
A (intercept)	1420.00	1420.00	1380.00	1380.00	1420.00	1420.00
B (coefficient)	0.00091	0.00091	0.00102	0.00102	0.00091	0.00091
HV Adjustment Factor	0.98	0.98	0.98	0.98	0.98	0.98
Entry Flow Rate [veh/h]	317	128	317	6	123	169
Capacity of Entry and Bypass Lanes [veh/h]	1301	1301	1212	883	1065	1065
Pedestrian Impedance	1.00	1.00	1.00	1.00	1.00	1.00
Capacity per Entry Lane [veh/h]	1275	1275	1188	885	1044	1044
X, volume / capacity	0.24	0.10	0.26	0.01	0.12	0.16

Movement, Approach, & Intersection Results

Lane LOS	A	A	A	A	A	A
95th-Percentile Queue Length [veh]	0.96	0.33	1.05	0.02	0.39	0.56
95th-Percentile Queue Length [ft]	23.91	8.14	26.23	0.44	9.72	14.02
Approach Delay [s/veh]	4.57		5.40	4.22	4.71	
Approach LOS	A		A	A	A	
Intersection Delay [s/veh]	4.86					
Intersection LOS	A					

Intersection Level Of Service Report

Intersection 7: Olympic Dr/Burns Valley Rd-Old Hwy 53

Control Type:	Signalized	Delay (sec / veh):	19.4
Analysis Method:	HCM 6th Edition	Level Of Service:	B
Analysis Period:	15 minutes	Volume to Capacity (v/c):	0.866

Intersection Setup

Name	Old Hwy 53			Burns Valley Rd			Olympic Dr			Old Hwy 53		
Approach	Northbound			Southbound			Eastbound			Westbound		
Lane Configuration	T T T			T T			T T			T T		
Turning Movement	Left	Thru	Right	Left	Thru	Right	Left	Thru	Right	Left	Thru	Right
Lane Width [ft]	12.00	12.00	12.00	12.00	12.00	12.00	12.00	12.00	12.00	12.00	12.00	12.00
No. of Lanes in Entry Pocket	1	2	1	1	2	0	1	0	0	1	0	0
Entry Pocket Length [ft]	100.00	100.00	100.00	56.00	100.00	100.00	48.00	100.00	100.00	100.00	100.00	100.00
No. of Lanes in Exit Pocket	0	0	0	0	0	0	0	0	0	0	0	0
Exit Pocket Length [ft]	0.00	0.00	0.00	0.00	0.00	0.00	0.00	0.00	0.00	0.00	0.00	0.00
Speed [mph]	30.00			30.00			35.00			35.00		
Grade [%]	0.00			0.00			0.00			0.00		
Curb Present	No			No			No			No		
Crosswalk	Yes			Yes			Yes			Yes		



Volumes												
Name	Old Hwy 53			Burns Valley Rd			Olympic Dr			Old Hwy 53		
Base Volume Input [veh/h]	165	215	110	180	185	80	45	315	165	95	320	175
Base Volume Adjustment Factor	1.0000	1.0000	1.0000	1.0000	1.0000	1.0000	1.0000	1.0000	1.0000	1.0000	1.0000	1.0000
Heavy Vehicles Percentage [%]	2.00	2.00	2.00	2.00	2.00	2.00	2.00	2.00	2.00	2.00	2.00	2.00
Growth Factor	1.0000	1.0000	1.0000	1.0000	1.0000	1.0000	1.0000	1.0000	1.0000	1.0000	1.0000	1.0000
In-Process Volume [veh/h]	0	0	0	0	0	0	0	0	0	0	0	0
Site-Generated Trips [veh/h]	0	0	0	0	0	0	0	0	0	0	0	0
Diverted Trips [veh/h]	0	0	0	0	0	0	0	0	0	0	0	0
Pass-by Trips [veh/h]	0	0	0	0	0	0	0	0	0	0	0	0
Existing Site Adjustment Volume [veh/h]	0	0	0	0	0	0	0	0	0	0	0	0
Other Volume [veh/h]	0	0	0	0	0	0	0	0	0	0	0	0
Right Turn on Red Volume [veh/h]	0	0	18	0	0	11	0	0	14	0	0	25
Total Hourly Volume [veh/h]	165	215	92	180	185	49	45	315	151	95	320	150
Peak Hour Factor	1.0000	1.0000	1.0000	1.0000	1.0000	1.0000	1.0000	1.0000	1.0000	1.0000	1.0000	1.0000
Other Adjustment Factor	1.0000	1.0000	1.0000	1.0000	1.0000	1.0000	1.0000	1.0000	1.0000	1.0000	1.0000	1.0000
Total 15-Minute Volume [veh/h]	41	54	23	45	46	12	11	79	38	24	80	38
Total Analysis Volume [veh/h]	165	215	92	180	185	49	45	315	151	95	320	150
Presence of On-Street Parking	No	No	No	No	No	No	No	No	No	No	No	No
On-Street Parking Maneuver Rate [h]	0	0	0	0	0	0	0	0	0	0	0	0
Local Bus Stopping Rate [h]	0	0	0	0	0	0	0	0	0	0	0	0
v_do, Outbound Pedestrian Volume crossing major street	1			0			1			1		
v_di, Inbound Pedestrian Volume crossing major street	1			1			0			1		
v_co, Outbound Pedestrian Volume crossing minor street	1			0			0			0		
v_ci, Inbound Pedestrian Volume crossing minor street	0			0			1			0		
v_ab, Corner Pedestrian Volume [ped/h]	0			0			0			0		
Bicycle Volume [bicycles/h]	0			0			0			0		1



Intersection Settings	
Located in CBD	Yes
Signal Coordination Group	-
Cycle Length [s]	109
Coordination Type	Time of Day Pattern Isolated
Actuation Type	Fully actuated
Offset [s]	0.0
Offset Reference	Lead Green - Beginning of First Green
Permissive Mode	SingleBand
Lost time [s]	14.00

Phasing & Timing												
Control Type	Protect	Permis	Permis	Protect	Permis	Permis	Protect	Permis	Permis	Protect	Permis	Permis
Signal Group	3	8	0	7	4	0	5	2	0	1	6	0
Auxiliary Signal Groups												
Lead / Lag	Lead	-	-	Lead	-	-	Lead	-	-	Lead	-	-
Minimum Green [s]	4	6	0	4	6	0	4	6	0	4	6	0
Maximum Green [s]	20	25	0	20	25	0	20	30	0	20	20	0
Amber [s]	3.0	3.3	0.0	3.0	3.3	0.0	3.0	3.6	0.0	3.0	3.6	0.0
All red [s]	0.0	0.3	0.0	0.0	0.3	0.0	0.0	0.3	0.0	0.0	0.3	0.0
Split [s]	23	29	0	23	29	0	23	34	0	23	34	0
Vehicle Extension [s]	0.0	0.0	0.0	0.0	0.0	0.0	0.0	0.0	0.0	0.0	0.0	0.0
Walk [s]	3	7	0	0	7	0	0	7	0	0	7	0
Pedestrian Clearance [s]	0	11	0	0	9	0	0	14	0	0	9	0
Delayed Vehicle Green [s]	0.0	0.0	0.0	0.0	0.0	0.0	0.0	0.0	0.0	0.0	0.0	0.0
Rest In Walk	No	No	No	No	No	No	No	No	No	No	No	No
I1, Start-Up Lost Time [s]	2.0	2.0	0.0	2.0	2.0	0.0	2.0	2.0	0.0	2.0	2.0	0.0
I2, Clearance Lost Time [s]	1.0	1.6	0.0	1.0	1.6	0.0	1.0	1.9	0.0	1.0	1.9	0.0
Minimum Recall	No	No	No	No	No	No	No	No	No	No	No	No
Maximum Recall	No	No	No	No	No	No	No	No	No	No	No	No
Pedestrian Recall	No	No	No	No	No	No	No	No	No	No	No	No
Detector Location [ft]	0.0	0.0	0.0	0.0	0.0	0.0	0.0	0.0	0.0	0.0	0.0	0.0
Detector Length [ft]	0.0	0.0	0.0	0.0	0.0	0.0	0.0	0.0	0.0	0.0	0.0	0.0
I, Upstream Filtering Factor	1.00	1.00	1.00	1.00	1.00	1.00	1.00	1.00	1.00	1.00	1.00	1.00

Exclusive Pedestrian Phase	
Pedestrian Signal Group	0
Pedestrian Walk [s]	0
Pedestrian Clearance [s]	0



Lane Group Calculations

Lane Group	L	C	R	L	C	L	C	L	C
C, Cycle Length [s]	45	45	45	45	45	45	45	45	45
L, Total Lost Time per Cycle [s]	3.00	3.60	3.60	3.00	3.60	3.00	3.90	3.00	3.90
l1_p, Permitted Start-Up Lost Time [s]	0.00	0.00	0.00	0.00	0.00	0.00	0.00	0.00	0.00
l2, Clearance Lost Time [s]	1.00	1.60	1.60	1.00	1.60	1.00	1.90	1.00	1.90
g_u, Effective Green Time [s]	6	8	8	6	8	2	15	3	16
g / C, Green / Cycle	0.13	0.17	0.17	0.14	0.18	0.04	0.33	0.07	0.36
(v / s)_j Volume / Saturation Flow Rate	0.10	0.13	0.06	0.11	0.14	0.03	0.29	0.06	0.30
s, saturation flow rate [veh/h]	1603	1683	1422	1603	1622	1603	1591	1603	1581
c, Capacity [veh/h]	205	281	237	222	289	62	519	116	569
d1, Uniform Delay [s]	19.37	18.16	16.93	19.08	18.02	21.72	14.67	20.88	13.30
k, delay calibration	0.04	0.04	0.04	0.04	0.04	0.04	0.04	0.04	0.15
l, Upstream Filtering Factor	1.00	1.00	1.00	1.00	1.00	1.00	1.00	1.00	1.00
d2, Incremental Delay [s]	2.84	1.64	0.38	2.67	2.07	6.02	2.33	5.20	4.26
d3, Initial Queue Delay [s]	0.00	0.00	0.00	0.00	0.00	0.00	0.00	0.00	0.00
Rp, progression ratio	1.00	1.00	1.00	1.00	1.00	1.00	1.00	1.00	1.00
PF, progression factor	1.00	1.00	1.00	1.00	1.00	1.00	1.00	1.00	1.00

Lane Group Results

X, volume / capacity	0.81	0.76	0.39	0.81	0.81	0.73	0.90	0.82	0.83
d, Delay for Lane Group [s/veh]	22.21	19.80	17.31	21.74	20.10	27.74	17.00	26.07	17.56
Lane Group LOS	C	B	B	C	C	C	B	C	B
Critical Lane Group	Yes	No	No	No	Yes	No	Yes	Yes	No
50th-Percentile Queue Length [veh/ln]	1.66	2.01	0.78	1.79	2.22	0.52	3.90	1.04	4.01
50th-Percentile Queue Length [ft/m]	41.49	50.32	19.43	44.69	55.47	13.04	97.56	25.94	100.15
95th-Percentile Queue Length [veh/ln]	2.99	3.62	1.40	3.22	3.99	0.94	7.02	1.87	7.21
95th-Percentile Queue Length [ft/m]	74.68	90.58	34.97	80.44	99.85	23.48	175.61	46.70	180.26



Movement, Approach, & Intersection Results

d_M, Delay for Movement [s/veh]	22.21	19.80	17.31	21.74	20.10	20.10	27.74	17.00	17.00	26.07	17.56	17.56
Movement LOS	C	B	B	C	C	C	C	B	B	C	B	B
d_A, Approach Delay [s/veh]	20.16			20.81			17.94			18.99		
Approach LOS	C			C			B			B		
d_I, Intersection Delay [s/veh]	19.38											
Intersection LOS	B											
Intersection V/C	0.866											

Other Modes

g_Walk,mi, Effective Walk Time [s]	11.0	11.0	11.0	11.0
M_corner, Corner Circulation Area [ft²/ped]	0.00	0.00	0.00	0.00
M_CW, Crosswalk Circulation Area [ft²/ped]	0.00	0.00	0.00	0.00
d_p, Pedestrian Delay [s]	13.08	13.08	13.08	13.08
l_p.int, Pedestrian LOS Score for Intersection	2,345	2,196	2,326	2,389
Crosswalk LOS	B	B	B	B
s_b, Saturation Flow Rate of the bicycle lane [bicycles/h]	2000	2000	2000	2000
c_b, Capacity of the bicycle lane [bicycles/h]	1117	1117	1323	1323
d_b, Bicycle Delay [s]	4.44	4.44	2.61	2.61
l_b.int, Bicycle LOS Score for Intersection	2,368	2,261	2,426	2,533
Bicycle LOS	B	B	B	B

Sequence

Ring	1	2	3	4	-	-	-	-	-	-	-	-	-	-
Ring 1	1	2	3	4	-	-	-	-	-	-	-	-	-	-
Ring 2	5	6	7	8	-	-	-	-	-	-	-	-	-	-
Ring 3	-	-	-	-	-	-	-	-	-	-	-	-	-	-
Ring 4	-	-	-	-	-	-	-	-	-	-	-	-	-	-

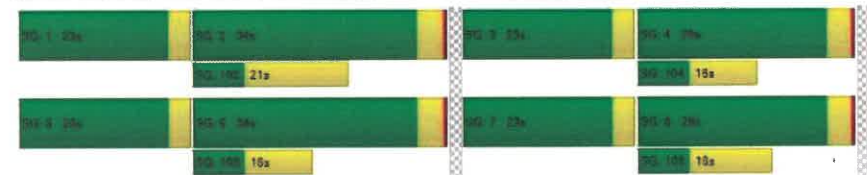

Intersection Level Of Service Report
Intersection 2: Burns Valley Rd/Bowers Ave-Rumsey Rd
Control Type: Two-way stop Delay (sec / veh): 13.9
Analysis Method: HCM 6th Edition Level Of Service: B
Analysis Period: 15 minutes Volume to Capacity (v/c): 0.007

Intersection Settings

Priority Scheme	Free	Free	Stop	Stop
Flared Lane			No	No
Storage Area [veh]	0	0	0	0
Two-Stage Gap Acceptance			No	No
Number of Storage Spaces in Median	0	0	0	0

Intersection Setup

Movement, Approach, & Intersection Results

Name	Burns Valley Rd			Rumsey Rd			Burns Valley Rd			Bowers Ave		
Approach	Northbound			Southbound			Eastbound			Westbound		
Lane Configuration	+			+			+			+		
Turning Movement	Left	Thru	Right	Left	Thru	Right	Left	Thru	Right	Left	Thru	Right
Lane Width [ft]	12.00	12.00	12.00	12.00	12.00	12.00	12.00	12.00	12.00	12.00	12.00	12.00
No. of Lanes in Entry Pocket	0	0	0	0	0	0	0	0	0	0	0	0
Entry Pocket Length [ft]	100.00	100.00	100.00	100.00	100.00	100.00	100.00	100.00	100.00	100.00	100.00	100.00
No. of Lanes in Exit Pocket	0	0	0	0	0	0	0	0	0	0	0	0
Exit Pocket Length [ft]	0.00	0.00	0.00	0.00	0.00	0.00	0.00	0.00	0.00	0.00	0.00	0.00
Speed [mph]	30.00			30.00			35.00			25.00		
Grade [%]	0.00			0.00			0.00			0.00		
Crosswalk	No			Yes			Yes			No		

V/C, Movement V/C Ratio	0.09	0.00	0.03	0.00	0.00	0.00	0.03	0.00	0.14	0.01	0.00	0.00
d_M, Delay for Movement [s/veh]	7.57	0.00	0.00	7.33	0.00	0.00	12.64	15.08	9.35	13.86	12.46	7.98
Movement LOS	A	A	A	A	A	A	B	B	A	B	B	A
95th-Percentile Queue Length [veh/m]	0.29	0.29	0.29	0.00	0.00	0.00	0.59	0.59	0.59	0.03	0.03	0.03
95th-Percentile Queue Length [ft/m]	7.33	7.33	7.33	0.00	0.00	0.00	14.78	14.78	14.78	0.86	0.86	0.86
d_A, Approach Delay [s/veh]	5.24			0.00			9.70			13.30		
Approach LOS	A			A			A			B		
d_I, Intersection Delay [s/veh]	6.12											
Intersection LOS	B											

Volumes

Name	Burns Valley Rd			Rumsey Rd			Burns Valley Rd			Bowers Ave		
Base Volume Input [veh/h]	137	59	2	0	51	15	16	0	136	3	2	0
Base Volume Adjustment Factor	1.0000	1.0000	1.0000	1.0000	1.0000	1.0000	1.0000	1.0000	1.0000	1.0000	1.0000	1.0000
Heavy Vehicles Percentage [%]	2.00	2.00	2.00	2.00	2.00	2.00	2.00	2.00	2.00	2.00	2.00	2.00
Growth Factor	1.0000	1.0000	1.0000	1.0000	1.0000	1.0000	1.0000	1.0000	1.0000	1.0000	1.0000	1.0000
In-Process Volume [veh/h]	0	0	0	0	0	0	0	0	0	0	0	0
Site-Generated Trips [veh/h]	0	0	0	0	0	0	0	0	0	0	0	0
Diverted Trips [veh/h]	0	0	0	0	0	0	0	0	0	0	0	0
Pass-by Trips [veh/h]	0	0	0	0	0	0	0	0	0	0	0	0
Existing Site Adjustment Volume [veh/h]	0	0	0	0	0	0	0	0	0	0	0	0
Other Volume [veh/h]	0	0	0	0	0	0	0	0	0	0	0	0
Total Hourly Volume [veh/h]	137	59	2	0	51	15	16	0	136	3	2	0
Peak Hour Factor	1.0000	1.0000	1.0000	1.0000	1.0000	1.0000	1.0000	1.0000	1.0000	1.0000	1.0000	1.0000
Other Adjustment Factor	1.0000	1.0000	1.0000	1.0000	1.0000	1.0000	1.0000	1.0000	1.0000	1.0000	1.0000	1.0000
Total 15-Minute Volume [veh/h]	34	15	1	0	13	4	4	0	34	1	1	0
Total Analysis Volume [veh/h]	137	59	2	0	51	15	16	0	136	3	2	0
Pedestrian Volume [ped/h]	0			0			0			0		



Intersection Level Of Service Report
Intersection 5: Olympic Dr/Lakeshore Dr

Control Type: Roundabout
Analysis Method: HCM 6th Edition
Analysis Period: 15 minutes
Delay (sec / veh): 4.6
Level Of Service: A

Intersection Setup

Name	Lakeshore Dr			Lakeshore Dr			Olympic Dr					
	Northbound			Southbound			Eastbound			Westbound		
Approach	←←			→→			→→			←←		
Lane Configuration	←←			→→			→→			←←		
Turning Movement	Left	Thru	Right	Left	Thru	Right	Left	Thru	Right	Left	Thru	Right
Lane Width [ft]	12.00	12.00	12.00	12.00	12.00	12.00	12.00	12.00	12.00	12.00	12.00	12.00
No. of Lanes in Entry Pocket	0	0	1	0	0	0	0	0	0	0	0	1
Entry Pocket Length [ft]	100.00	100.00	120.00	100.00	100.00	100.00	100.00	100.00	100.00	100.00	100.00	250.00
No. of Lanes in Exit Pocket	0	0	0	0	0	0	0	0	0	0	0	0
Exit Pocket Length [ft]	0.00	0.00	0.00	0.00	0.00	0.00	0.00	0.00	0.00	0.00	0.00	0.00
Speed [mph]	25.00			25.00			30.00			30.00		
Grade [%]	0.00			0.00			0.00			0.00		
Crosswalk	No			Yes			No			Yes		

Volumes

Name	Lakeshore Dr			Lakeshore Dr			Olympic Dr					
	1	224	131	93	235	0	0	4	4	123	1	95
Base Volume Input [veh/h]	1	224	131	93	235	0	0	4	4	123	1	95
Base Volume Adjustment Factor	1.0000	1.0000	1.0000	1.0000	1.0000	1.0000	1.0000	1.0000	1.0000	1.0000	1.0000	1.0000
Heavy Vehicles Percentage [%]	2.00	2.00	2.00	2.00	2.00	2.00	2.00	2.00	2.00	2.00	2.00	2.00
Growth Factor	1.0000	1.0000	1.0000	1.0000	1.0000	1.0000	1.0000	1.0000	1.0000	1.0000	1.0000	1.0000
In-Process Volume [veh/h]	0	0	0	0	0	0	0	0	0	0	0	0
Site-Generated Trips [veh/h]	0	0	0	0	0	0	0	0	0	0	0	0
Diverted Trips [veh/h]	0	0	0	0	0	0	0	0	0	0	0	0
Pass-by Trips [veh/h]	0	0	0	0	0	0	0	0	0	0	0	0
Existing Site Adjustment Volume [veh/h]	0	0	0	0	0	0	0	0	0	0	0	0
Other Volume [veh/h]	0	0	0	0	0	0	0	0	0	0	0	0
Total Hourly Volume [veh/h]	1	224	131	93	235	0	4	4	4	123	1	95
Peak Hour Factor	1.0000	1.0000	1.0000	1.0000	1.0000	1.0000	1.0000	1.0000	1.0000	1.0000	1.0000	1.0000
Other Adjustment Factor	1.0000	1.0000	1.0000	1.0000	1.0000	1.0000	1.0000	1.0000	1.0000	1.0000	1.0000	1.0000
Total 15-Minute Volume [veh/h]	0	56	33	23	59	0	1	1	1	31	0	24
Total Analysis Volume [veh/h]	1	224	131	93	235	0	4	4	4	123	1	95
Pedestrian Volume [ped/h]	0			0			0			1		

Intersection Settings

Number of Conflicting Circulating Lanes	1			1			1			1		
Circulating Flow Rate [veh/h]	99			128			460			230		
Exiting Flow Rate [veh/h]	369			325			2			233		
Demand Flow Rate [veh/h]	1	224	131	93	235	0	0	4	4	123	1	95
Adjusted Demand Flow Rate [veh/h]	1	224	131	93	235	0	0	4	4	123	1	95

Lanes

Parameter	No	No	No	No	No	No
Override Calculated Critical Headway	No	No	No	No	No	No
User-Defined Critical Headway [s]	4.00	4.00	4.00	4.00	4.00	4.00
Override Calculated Follow-Up Time	No	No	No	No	No	No
User-Defined Follow-Up Time [s]	3.00	3.00	3.00	3.00	3.00	3.00
A (intercept)	1420.00	1420.00	1380.00	1380.00	1420.00	1420.00
B (coefficient)	0.00091	0.00091	0.00102	0.00102	0.00091	0.00091
HV Adjustment Factor	0.98	0.98	0.98	0.98	0.98	0.98
Entry Flow Rate [veh/h]	230	134	335	9	126	98
Capacity of Entry and Bypass Lanes [veh/h]	1298	1298	1212	864	1153	1153
Pedestrian Impedance	1.00	1.00	1.00	1.00	1.00	1.00
Capacity per Entry Lane [veh/h]	1273	1273	1188	847	1129	1129
X, volume / capacity	0.18	0.10	0.28	0.01	0.11	0.09

Movement, Approach, & Intersection Results

Parameter	A	A	A	A	A	A
Lane LOS	A	A	A	A	A	A
95th-Percentile Queue Length [veh]	0.64	0.34	1.13	0.03	0.37	0.28
95th-Percentile Queue Length [ft]	16.03	8.59	28.31	0.72	9.15	6.96
Approach Delay [s/veh]	4.08		5.56	4.34	4.03	
Approach LOS	A		A	A	A	
Intersection Delay [s/veh]	4.60					
Intersection LOS	A					



Intersection Level Of Service Report
Intersection 7: Olympic Dr/Burns Valley Rd-Old Hwy 53

Control Type: Signalized
Analysis Method: HCM 6th Edition
Analysis Period: 15 minutes

Delay (sec / veh): 14.8
Level Of Service: B
Volume to Capacity (v/c): 0.783

Intersection Setup

Name	Old Hwy 53			Burns Valley Rd			Olympic Dr			Old Hwy 53		
	Northbound			Southbound			Eastbound			Westbound		
Lane Configuration												
Turning Movement	Left	Thru	Right	Left	Thru	Right	Left	Thru	Right	Left	Thru	Right
Lane Width [ft]	12.00	12.00	12.00	12.00	12.00	12.00	12.00	12.00	12.00	12.00	12.00	12.00
No. of Lanes in Entry Pocket	1	0	1	1	0	0	1	0	0	1	0	0
Entry Pocket Length [ft]	100.00	100.00	100.00	56.00	100.00	100.00	48.00	100.00	100.00	100.00	100.00	100.00
No. of Lanes in Exit Pocket	0	0	0	0	0	0	0	0	0	0	0	0
Exit Pocket Length [ft]	0.00	0.00	0.00	0.00	0.00	0.00	0.00	0.00	0.00	0.00	0.00	0.00
Speed [mph]	30.00			30.00			35.00			35.00		
Grade [%]	0.00			0.00			0.00			0.00		
Curb Present	No			No			No			No		
Crosswalk	Yes			Yes			Yes			Yes		



Volumes

Name	Old Hwy 53			Burns Valley Rd			Olympic Dr			Old Hwy 53		
Base Volume Input [veh/h]	131	132	69	152	105	49	33	294	155	54	278	178
Base Volume Adjustment Factor	1.0000	1.0000	1.0000	1.0000	1.0000	1.0000	1.0000	1.0000	1.0000	1.0000	1.0000	1.0000
Heavy Vehicles Percentage [%]	2.00	2.00	2.00	2.00	2.00	2.00	2.00	2.00	2.00	2.00	2.00	2.00
Growth Factor	1.0000	1.0000	1.0000	1.0000	1.0000	1.0000	1.0000	1.0000	1.0000	1.0000	1.0000	1.0000
In-Process Volume [veh/h]	0	0	0	0	0	0	0	0	0	0	0	0
Site-Generated Trips [veh/h]	0	0	0	0	0	0	0	0	0	0	0	0
Diverted Trips [veh/h]	0	0	0	0	0	0	0	0	0	0	0	0
Pass-by Trips [veh/h]	0	0	0	0	0	0	0	0	0	0	0	0
Existing Site Adjustment Volume [veh/h]	0	0	0	0	0	0	0	0	0	0	0	0
Other Volume [veh/h]	0	0	0	0	0	0	0	0	0	0	0	0
Right Turn on Red Volume [veh/h]	0	0	15	0	0	12	0	0	25	0	0	28
Total Hourly Volume [veh/h]	131	132	54	152	105	37	33	294	130	54	278	149
Peak Hour Factor	1.0000	1.0000	1.0000	1.0000	1.0000	1.0000	1.0000	1.0000	1.0000	1.0000	1.0000	1.0000
Other Adjustment Factor	1.0000	1.0000	1.0000	1.0000	1.0000	1.0000	1.0000	1.0000	1.0000	1.0000	1.0000	1.0000
Total 15-Minute Volume [veh/h]	33	33	14	38	26	9	8	74	33	14	70	37
Total Analysis Volume [veh/h]	131	132	54	152	105	37	33	294	130	54	278	149
Presence of On-Street Parking	No	No	No	No	No	No	No	No	No	No	No	No
On-Street Parking Maneuver Rate [h]	0	0	0	0	0	0	0	0	0	0	0	0
Local Bus Stopping Rate [h]	0	0	0	0	0	0	0	0	0	0	0	0
v_do, Outbound Pedestrian Volume crossing major street	1			0			1			1		
v_di, Inbound Pedestrian Volume crossing major street	1			1			0			1		
v_co, Outbound Pedestrian Volume crossing minor street	1						0			0		
v_ci, Inbound Pedestrian Volume crossing minor street	0			0			1			0		
v_ab, Corner Pedestrian Volume [ped/h]	0			0			0			0		
Bicycle Volume [bicycles/h]	0			0			0			0		1



Intersection Settings

Located in CBD	Yes
Signal Coordination Group	-
Cycle Length [s]	109
Coordination Type	Time of Day Pattern Isolated
Actuation Type	Fully actuated
Offset [s]	0.0
Offset Reference	Lead Green - Beginning of First Green
Permissive Mode	SingleBand
Lost time [s]	14.00

Phasing & Timing

Control Type	Protect	Permis	Permis	Protect	Permis	Permis	Protect	Permis	Permis	Protect	Permis	Permis
Signal Group	3	8	0	7	4	0	5	2	0	1	6	0
Auxiliary Signal Groups												
Lead / Lag	Lead	-	-	Lead	-	-	Lead	-	-	Lead	-	-
Minimum Green [s]	4	6	0	4	6	0	4	6	0	4	6	0
Maximum Green [s]	20	25	0	20	25	0	20	30	0	20	20	0
Amber [s]	3.0	3.3	0.0	3.0	3.3	0.0	3.0	3.6	0.0	3.0	3.6	0.0
All red [s]	0.0	0.3	0.0	0.0	0.3	0.0	0.0	0.3	0.0	0.0	0.3	0.0
Split [s]	23	29	0	23	29	0	23	34	0	23	34	0
Vehicle Extension [s]	0.0	0.0	0.0	0.0	0.0	0.0	0.0	0.0	0.0	0.0	0.0	0.0
Walk [s]	0	7	0	0	7	0	0	7	0	0	7	0
Pedestrian Clearance [s]	0	11	0	0	9	0	0	14	0	0	9	0
Delayed Vehicle Green [s]	0.0	0.0	0.0	0.0	0.0	0.0	0.0	0.0	0.0	0.0	0.0	0.0
Rest In Walk		No		No			No			No		No
I1, Start-Up Lost Time [s]	2.0	2.0	0.0	2.0	2.0	0.0	2.0	2.0	0.0	2.0	2.0	0.0
I2, Clearance Lost Time [s]	1.0	1.5	0.0	1.0	1.6	0.0	1.0	1.9	0.0	1.0	1.9	0.0
Minimum Recall	No	No		No	No		No	No		No	No	
Maximum Recall	No	No		No	No		No	No		No	No	
Pedestrian Recall	No	No		No	No		No	No		No	No	
Detector Location [ft]	0.0	0.0	0.0	0.0	0.0	0.0	0.0	0.0	0.0	0.0	0.0	0.0
Detector Length [ft]	0.0	0.0	0.0	0.0	0.0	0.0	0.0	0.0	0.0	0.0	0.0	0.0
I, Upstream Filtering Factor	1.00	1.00	1.00	1.00	1.00	1.00	1.00	1.00	1.00	1.00	1.00	1.00

Exclusive Pedestrian Phase

Pedestrian Signal Group	0
Pedestrian Walk [s]	0
Pedestrian Clearance [s]	0



Lane Group Calculations

Lane Group	L	C	R	L	C	L	C	L	C
C, Cycle Length [s]	35	35	35	35	35	35	35	35	35
L, Total Lost Time per Cycle [s]	3.00	3.50	3.50	3.00	3.50	3.00	3.90	3.00	3.90
I1_p, Permitted Start-Up Lost Time [s]	0.00	0.00	0.00	0.00	0.00	0.00	0.00	0.00	0.00
I2, Clearance Lost Time [s]	1.00	1.60	1.60	1.00	1.60	1.00	1.90	1.00	1.90
g_i, Effective Green Time [s]	4	5	5	4	6	1	11	2	11
g / C, Green / Cycle	0.10	0.15	0.15	0.12	0.16	0.03	0.31	0.05	0.32
(v / s)_j Volume / Saturation Flow Rate	0.08	0.08	0.04	0.09	0.09	0.02	0.27	0.03	0.27
s, saturation flow rate [veh/h]	1603	1683	1421	1603	1608	1503	1596	1603	1572
c, Capacity [veh/h]	162	247	209	189	263	51	491	76	508
d1, Uniform Delay [s]	15.62	14.01	13.42	15.25	13.61	16.97	11.58	16.66	11.16
k, delay calibration	0.04	0.04	0.04	0.04	0.04	0.04	0.04	0.04	0.04
I, Upstream Filtering Factor	1.00	1.00	1.00	1.00	1.00	1.00	1.00	1.00	1.00
d2, Incremental Delay [s]	3.65	0.67	0.24	3.05	0.64	4.99	1.80	4.56	1.47
d3, Initial Queue Delay [s]	0.00	0.00	0.00	0.00	0.00	0.00	0.00	0.00	0.00
Rp, platoon ratio	1.00	1.00	1.00	1.00	1.00	1.00	1.00	1.00	1.00
PF, progression factor	1.00	1.00	1.00	1.00	1.00	1.00	1.00	1.00	1.00

Lane Group Results

X, volume / capacity	0.81	0.53	0.26	0.81	0.54	0.65	0.86	0.71	0.84
d, Delay for Lane Group [s/veh]	19.26	14.68	13.66	18.30	14.25	21.97	13.38	21.22	12.62
Lane Group LOS	B	B	B	B	B	C	B	C	B
Critical Lane Group	No	Yes	No	Yes	No	No	Yes	Yes	No
50th-Percentile Queue Length [veh/m]	1.01	0.83	0.32	1.13	0.88	0.29	2.38	0.44	2.28
50th-Percentile Queue Length [ft/m]	25.30	20.80	8.05	28.27	21.90	7.16	59.45	11.12	57.06
95th-Percentile Queue Length [veh/m]	1.82	1.50	0.58	2.04	1.58	0.52	4.28	0.80	4.11
95th-Percentile Queue Length [ft/m]	45.55	37.44	14.49	50.89	39.42	12.88	107.00	20.01	102.72



Movement, Approach, & Intersection Results

d_M, Delay for Movement [s/veh]	19.25	14.68	13.66	18.30	14.25	14.25	21.97	13.38	13.38	21.22	12.62	12.62
Movement LOS	B	B	B	B	B	B	C	B	B	C	B	B
d_A, Approach Delay [s/veh]	16.40		16.35		14.00		13.59					
Approach LOS	B		B		B		B					
d_I, Intersection Delay [s/veh]	14.81											
Intersection LOS	B											
Intersection V/C	0.783											

Other Modes

g_Walk,mi, Effective Walk Time [s]	11.0	11.0	11.0	11.0
M_corner, Corner Circulation Area [ft ² /ped]	0.00	0.00	0.00	0.00
M_CW, Crosswalk Circulation Area [ft ² /ped]	0.00	0.00	0.00	0.00
d_p, Pedestrian Delay [s]	8.38	8.38	8.38	8.38
L_p,int, Pedestrian LOS Score for Intersection	2.252	2.111	2.275	2.313
Crosswalk LOS	B	B	B	B
s_b, Saturation Flow Rate of the bicycle lane [bicycles/s]	2000	2000	2000	2000
c_b, Capacity of the bicycle lane [bicycles/h]	1438	1438	1704	1704
d_b, Bicycle Delay [s]	1.40	1.40	0.39	0.39
L_b,int, Bicycle LOS Score for Intersection	2.107	2.065	2.355	2.401
Bicycle LOS	B	B	B	B

Sequence

Ring 1	1	2	3	4	-	-	-	-	-	-	-	-	-	-
Ring 2	5	6	7	8	-	-	-	-	-	-	-	-	-	-
Ring 3	-	-	-	-	-	-	-	-	-	-	-	-	-	-
Ring 4	-	-	-	-	-	-	-	-	-	-	-	-	-	-

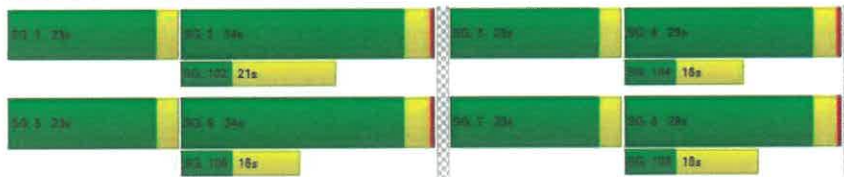

Intersection Level of Service Report

Intersection 1: Burns Valley Rd/N-S Project Street

Control Type:	Two-way stop	Delay (sec / veh):	10.2
Analysis Method:	HCM 6th Edition	Level of Service:	B
Analysis Period:	15 minutes	Volume to Capacity (v/c):	0.015

Intersection Setup

Name	N-S Project Street		Burns Valley Rd		Burns Valley Rd	
	Northbound		Eastbound		Westbound	
Approach	Northbound		Eastbound		Westbound	
Lane Configuration	T		T		T	
Turning Movement	Left	Right	Thru	Right	Left	Thru
Lane Width [ft]	12.00	12.00	12.00	12.00	12.00	12.00
No. of Lanes in Entry Pocket	0	0	0	0	0	0
Entry Pocket Length [ft]	100.00	100.00	100.00	100.00	100.00	100.00
No. of Lanes in Exit Pocket	0	0	0	0	0	0
Exit Pocket Length [ft]	0.00	0.00	0.00	0.00	0.00	0.00
Speed [mph]	25.00		35.00		35.00	
Grade [%]	0.00		0.00		0.00	
Crosswalk	No		No		No	

Volumes

Name	N-S Project Street		Burns Valley Rd		Burns Valley Rd	
Base Volume Input [veh/h]	8	7	112	15	0	110
Base Volume Adjustment Factor	1.0000	1.0000	1.0000	1.0000	1.0000	1.0000
Heavy Vehicles Percentage [%]	2.00	2.00	2.00	2.00	2.00	2.00
Growth Factor	1.0000	1.0000	1.0000	1.0000	1.0000	1.0000
In-Process Volume [veh/h]	0	0	0	0	0	0
Site-Generated Trips [veh/h]	2	3	1	4	5	1
Diverted Trips [veh/h]	0	0	0	0	0	0
Pass-by Trips [veh/h]	0	0	0	0	0	0
Existing Site Adjustment Volume [veh/h]	0	0	0	0	0	0
Other Volume [veh/h]	0	0	0	0	0	0
Total Hourly Volume [veh/h]	10	10	113	19	5	111
Peak Hour Factor	0.8890	0.8890	0.8890	0.8890	0.8890	0.8890
Other Adjustment Factor	1.0000	1.0000	1.0000	1.0000	1.0000	1.0000
Total 15-Minute Volume [veh/h]	3	3	32	5	1	31
Total Analysis Volume [veh/h]	11	11	127	21	6	125
Pedestrian Volume [ped/h]	0		0		0	



Generated with **PTV VISTRO**
Version 2021 (SP 0-6)

Burns Valley Development

5/2/2022

Intersection Settings

Priority Scheme	Stop	Free	Free
Flared Lane	No		
Storage Area [veh]	0	0	0
Two-Stage Gap Acceptance	No		
Number of Storage Spaces in Median	0	0	0

Movement, Approach, & Intersection Results

V/C, Movement V/C Ratio	0.02	0.01	0.00	0.00	0.00	0.00
d_M, Delay for Movement [s/veh]	10.18	9.08	0.00	0.00	7.52	0.00
Movement LOS	B	A	A	A	A	A
95th-Percentile Queue Length [veh/ln]	0.08	0.08	0.00	0.00	0.01	0.01
95th-Percentile Queue Length [ft/ln]	2.12	2.12	0.00	0.00	0.32	0.32
d_A, Approach Delay [s/veh]	9.63		0.00		0.34	
Approach LOS	A		A		A	
d_I, Intersection Delay [s/veh]			0.85			
Intersection LOS			B			

Weekday AM E+P



Generated with **PTV VISTRO**
Version 2021 (SP 0-6)

Burns Valley Development

5/2/2022

Intersection Level Of Service Report

Intersection 2: Burns Valley Rd/Bowers Ave-Rumsey Rd

Control Type:	Two-way stop	Delay (sec / veh):	13.8
Analysis Method:	HCM 6th Edition	Level Of Service:	B
Analysis Period:	15 minutes	Volume to Capacity (v/c):	0.014

Intersection Setup

Name	Burns Valley Rd			Rumsey Rd			Burns Valley Rd			Bowers Ave		
Approach	Northbound			Southbound			Eastbound			Westbound		
Lane Configuration	+			+			+			+		
Turning Movement	Left	Thru	Right	Left	Thru	Right	Left	Thru	Right	Left	Thru	Right
Lane Width [ft]	12.00	12.00	12.00	12.00	12.00	12.00	12.00	12.00	12.00	12.00	12.00	12.00
No. of Lanes in Entry Pocket	0	0	0	0	0	0	0	0	0	0	0	0
Entry Pocket Length [ft]	100.00	100.00	100.00	100.00	100.00	100.00	100.00	100.00	100.00	100.00	100.00	100.00
No. of Lanes in Exit Pocket	0	0	0	0	0	0	0	0	0	0	0	0
Exit Pocket Length [ft]	3.00	0.00	0.00	0.00	0.00	0.00	0.00	0.00	0.00	0.00	0.00	0.00
Speed [mph]	30.00			30.00			35.00			25.00		
Grade [%]	0.00			0.00			0.00			0.00		
Crosswalk	No			Yes			Yes			No		

Volumes

Name	Burns Valley Rd			Rumsey Rd			Burns Valley Rd			Bowers Ave		
Base Volume Input [veh/h]	122	26	6	0	23	16	9	1	124	5	1	0
Base Volume Adjustment Factor	1.0000	1.0000	1.0000	1.0000	1.0000	1.0000	1.0000	1.0000	1.0000	1.0000	1.0000	1.0000
Heavy Vehicles Percentage [%]	2.00	2.00	2.00	2.00	2.00	2.00	2.00	2.00	2.00	2.00	2.00	2.00
Growth Factor	1.0000	1.0000	1.0000	1.0000	1.0000	1.0000	1.0000	1.0000	1.0000	1.0000	1.0000	1.0000
In-Process Volume [veh/h]	0	0	0	0	0	0	0	0	0	0	0	0
Site-Generated Trips [veh/h]	2	1	0	0	0	1	2	0	5	0	0	0
Diverted Trips [veh/h]	0	0	0	0	0	0	0	0	0	0	0	0
Pass-by Trips [veh/h]	0	0	0	0	0	0	0	0	0	0	0	0
Existing Site Adjustment Volume [veh/h]	0	0	0	0	0	0	0	0	0	0	0	0
Other Volume [veh/h]	0	0	0	0	0	0	0	0	0	0	0	0
Total Hourly Volume [veh/h]	124	27	6	0	23	17	11	1	129	5	1	0
Peak Hour Factor	0.8500	0.8500	0.8500	0.8500	0.8500	0.8500	0.8500	0.8500	0.8500	0.8500	0.8500	0.8500
Other Adjustment Factor	1.0000	1.0000	1.0000	1.0000	1.0000	1.0000	1.0000	1.0000	1.0000	1.0000	1.0000	1.0000
Total 15-Minute Volume [veh/h]	36	8	2	0	7	5	3	0	38	1	0	0
Total Analysis Volume [veh/h]	146	32	7	0	27	20	13	1	152	6	1	0
Pedestrian Volume [ped/h]	0			0			0			0		

Weekday AM E+P



Intersection Settings

Priority Scheme	Free	Free	Stop	Stop
Flared Lane			No	No
Storage Area [veh]	0	0	0	0
Two-Stage Gap Acceptance			No	No
Number of Storage Spaces in Median	0	0	0	0

Movement, Approach, & Intersection Results

V/C, Movement V/C Ratio	0.09	0.00	0.00	0.00	0.00	0.02	0.00	0.15	0.01	0.00	0.00	
d_M, Delay for Movement [s/veh]	7.54	0.00	0.00	7.29	0.00	0.00	12.36	12.87	0.26	13.80	12.30	
Movement LOS	A	A	A	A	A	B	B	A	B	B	A	
95th-Percentile Queue Length [veh/ln]	0.31	0.31	0.31	0.00	0.00	0.62	0.62	0.62	0.05	0.05	0.05	
95th-Percentile Queue Length [ft/ln]	7.73	7.73	7.73	0.00	0.00	15.54	15.54	15.54	1.25	1.25	1.25	
d_A, Approach Delay [s/veh]	5.95			0.00			9.52			13.59		
Approach LOS	A			A			A			B		
d_I, Intersection Delay [s/veh]	6.86											
Intersection LOS	B											



Intersection Level Of Service Report

Intersection 3: N-S Project Street/E-W Project Street

Control Type:	All-way stop	Delay (sec / veh):	7.2
Analysis Method:	HCM 6th Edition	Level Of Service:	A
Analysis Period:	15 minutes	Volume to Capacity (v/c):	0.055

Intersection Setup

Name	N-S Project Street			N-S Project Street			E-W Project Street			E-W Project Street		
Approach	Northbound			Southbound			Eastbound			Westbound		
Lane Configuration	+			+			+			+		
Turning Movement	Left	Thru	Right	Left	Thru	Right	Left	Thru	Right	Left	Thru	Right
Lane Width [ft]	12.00	12.00	12.00	12.00	12.00	12.00	12.00	12.00	12.00	12.00	12.00	12.00
No. of Lanes in Entry Pocket	0	0	0	0	0	0	0	0	0	0	0	0
Entry Pocket Length [ft]	100.00	100.00	100.00	100.00	100.00	100.00	100.00	100.00	100.00	100.00	100.00	100.00
No. of Lanes in Exit Pocket	0	0	0	0	0	0	0	0	0	0	0	0
Exit Pocket Length [ft]	0.00	0.00	0.00	0.00	0.00	0.00	0.00	0.00	0.00	0.00	0.00	0.00
Speed [mph]	25.00			25.00			25.00			25.00		
Grade [%]	0.00			0.00			0.00			0.00		
Crosswalk	Yes			Yes			Yes			Yes		

Volumes

Name	N-S Project Street			N-S Project Street			E-W Project Street			E-W Project Street		
Base Volume Input [veh/h]	0	15	0	0	15	0	0	0	0	0	0	0
Base Volume Adjustment Factor	1.0000	1.0000	1.0000	1.0000	1.0000	1.0000	1.0000	1.0000	1.0000	1.0000	1.0000	1.0000
Heavy Vehicles Percentage [%]	2.00	2.00	2.00	2.00	2.00	2.00	2.00	2.00	2.00	2.00	2.00	2.00
Growth Factor	1.0000	1.0000	1.0000	1.0000	1.0000	1.0000	1.0000	1.0000	1.0000	1.0000	1.0000	1.0000
In-Process Volume [veh/h]	0	0	0	0	0	0	0	0	0	0	0	0
Site-Generated Trips [veh/h]	8	18	3	3	11	1	0	1	1	4	2	4
Diverted Trips [veh/h]	0	0	0	0	0	0	0	0	0	0	0	0
Pass-by Trips [veh/h]	0	0	0	0	0	0	0	0	0	0	0	0
Existing Site Adjustment Volume [veh/h]	0	0	0	0	0	0	0	0	0	0	0	0
Other Volume [veh/h]	0	0	0	0	0	0	0	0	0	0	0	0
Total Hourly Volume [veh/h]	6	33	3	3	26	1	0	1	1	4	2	4
Peak Hour Factor	0.8500	0.8500	0.8500	0.8500	0.8500	0.8500	0.8500	0.8500	0.8500	0.8500	0.8500	0.8500
Other Adjustment Factor	1.0000	1.0000	1.0000	1.0000	1.0000	1.0000	1.0000	1.0000	1.0000	1.0000	1.0000	1.0000
Total 15-Minute Volume [veh/h]	2	10	1	1	8	0	0	0	0	1	1	1
Total Analysis Volume [veh/h]	7	39	4	4	31	1	0	1	1	5	2	5
Pedestrian Volume [ped/h]	0			0			0			0		



Intersection Settings

Lanes				
Capacity per Entry Lane [veh/h]	906	896	941	911
Degree of Utilization, x	0.06	0.04	0.00	0.01

Movement, Approach, & Intersection Results

95th-Percentile Queue Length [veh]	0.18	0.13	0.01	0.04
95th-Percentile Queue Length [ft]	4.38	3.13	0.16	1.00
Approach Delay [s/veh]	7.21	7.18	6.84	7.00
Approach LOS	A	A	A	A
Intersection Delay [s/veh]	7.17			
Intersection LOS	A			



Intersection Level Of Service Report

Intersection 4: Burns Valley Rd/E-W Project Street

Control Type:	Two-way stop	Delay (sec / veh):	10.9
Analysis Method:	HCM 6th Edition	Level Of Service:	B
Analysis Period:	15 minutes	Volume to Capacity (v/c):	0.002

Intersection Setup

Name	Burns Valley Rd		Burns Valley Rd		E-W Project Street	
	Northbound		Southbound		Eastbound	
Approach	←		→		←	
Lane Configuration	←		→		←	
Turning Movement	Left	Thru	Thru	Right	Left	Right
Lane Width [ft]	12.00	12.00	12.00	12.00	12.00	12.00
No. of Lanes in Entry Pocket	0	0	0	0	0	0
Entry Pocket Length [ft]	100.00	100.00	100.00	100.00	100.00	100.00
No. of Lanes in Exit Pocket	0	0	0	0	0	0
Exit Pocket Length [ft]	0.00	0.00	0.00	0.00	0.00	0.00
Speed [mph]	30.00		30.00		25.00	
Grade [%]	0.00		0.00		0.00	
Crosswalk	No		No		Yes	

Volumes

Name	Burns Valley Rd		Burns Valley Rd		E-W Project Street	
	Northbound	Southbound	Northbound	Southbound	Eastbound	Westbound
Base Volume Input [veh/h]	0	151	147	0	0	0
Base Volume Adjustment Factor	1.0000	1.0000	1.0000	1.0000	1.0000	1.0000
Heavy Vehicles Percentage [%]	2.00	2.00	2.00	2.00	2.00	2.00
Growth Factor	1.0000	1.0000	1.0000	1.0000	1.0000	1.0000
In-Process Volume [veh/h]	0	0	0	0	0	0
Site-Generated Trips [veh/h]	8	2	5	0	1	9
Diverted Trips [veh/h]	0	0	0	0	0	0
Pass-by Trips [veh/h]	0	0	0	0	0	0
Existing Site Adjustment Volume [veh/h]	0	0	0	0	0	0
Other Volume [veh/h]	0	0	0	0	0	0
Total Hourly Volume [veh/h]	8	153	152	0	1	9
Peak Hour Factor	0.8500	0.8500	0.8500	0.8500	0.8500	0.8500
Other Adjustment Factor	1.0000	1.0000	1.0000	1.0000	1.0000	1.0000
Total 15-Minute Volume [veh/h]	2	45	45	0	0	3
Total Analysis Volume [veh/h]	9	180	179	0	1	11
Pedestrian Volume [ped/h]	0	0	0	0	0	0



Intersection Settings

Priority Scheme	Free	Free	Stop
Flared Lane			No
Storage Area [veh]	0	0	0
Two-Stage Gap Acceptance			No
Number of Storage Spaces in Median	0	0	0

Movement, Approach, & Intersection Results

V/C, Movement V/C Ratio	0.01	0.01	0.00	0.00	0.00	0.01
d_M, Delay for Movement [s/veh]	7.59	0.00	0.00	0.00	10.87	9.23
Movement LOS	A	A	A	A	B	A
95th-Percentile Queue Length [veh/ln]	0.02	0.02	0.00	0.00	0.04	0.04
95th-Percentile Queue Length [ft/ln]	0.49	0.49	0.00	0.00	1.09	1.09
d_A, Approach Delay [s/veh]	0.36		0.00		9.37	
Approach LOS	A		A		A	
d_I, Intersection Delay [s/veh]			0.46			
Intersection LOS			B			



Intersection Level Of Service Report
Intersection 5: Olympic Dr/Lakeshore Dr

Control Type: Two-way stop
Analysis Method: HCM 6th Edition
Analysis Period: 15 minutes

Delay (sec / veh): 16.8
Level Of Service: C
Volume to Capacity (v/c): 0.169

Intersection Setup

Name	Lakeshore Dr			Lakeshore Dr			Olympic Dr					
Approach	Northbound			Southbound			Eastbound			Westbound		
Lane Configuration	+			+			+			+		
Turning Movement	LeR	Thru	Right	Left	Thru	Right	Left	Thru	Right	Left	Thru	Right
Lane Width [ft]	12.00	12.00	12.00	12.00	12.00	12.00	12.00	12.00	12.00	12.00	12.00	12.00
No. of Lanes in Entry Pocket	0	0	1	0	0	0	0	0	0	0	0	1
Entry Pocket Length [ft]	100.00	100.00	120.00	100.00	100.00	100.00	100.00	100.00	100.00	100.00	100.00	250.00
No. of Lanes in Exit Pocket	0	0	0	0	0	0	0	0	0	0	0	0
Exit Pocket Length [ft]	0.00	0.00	0.00	0.00	0.00	0.00	0.00	0.00	0.00	0.00	0.00	0.00
Speed [mph]	25.00			25.00			30.00			30.00		
Grade [%]	0.00			0.00			0.00			0.00		
Crosswalk	No			Yes			No			Yes		

Volumes

Name	Lakeshore Dr			Lakeshore Dr			Olympic Dr					
Base Volume Input [veh/h]	1	137	66	81	279	2	0	0	1	47	1	60
Base Volume Adjustment Factor	1.0000	1.0000	1.0000	1.0000	1.0000	1.0000	1.0000	1.0000	1.0000	1.0000	1.0000	1.0000
Heavy Vehicles Percentage [%]	2.00	2.00	2.00	2.00	2.00	2.00	2.00	2.00	2.00	2.00	2.00	2.00
Growth Factor	1.0000	1.0000	1.0000	1.0000	1.0000	1.0000	1.0000	1.0000	1.0000	1.0000	1.0000	1.0000
In-Process Volume [veh/h]	0	0	0	0	0	0	0	0	0	0	0	0
Site-Generated Trips [veh/h]	0	0	11	4	0	0	0	0	0	6	0	3
Diverted Trips [veh/h]	0	0	0	0	0	0	0	0	0	0	0	0
Pass-by Trips [veh/h]	0	0	0	0	0	0	0	0	0	0	0	0
Existing Site Adjustment Volume [veh/h]	0	0	0	0	0	0	0	0	0	0	0	0
Other Volume [veh/h]	0	0	0	0	0	0	0	0	0	0	0	0
Total Hourly Volume [veh/h]	1	137	77	85	279	2	0	0	1	53	1	63
Peak Hour Factor	0.8600	0.8600	0.8600	0.8600	0.8600	0.8600	0.8600	0.8600	0.8600	0.8600	0.8600	0.8600
Other Adjustment Factor	1.0000	1.0000	1.0000	1.0000	1.0000	1.0000	1.0000	1.0000	1.0000	1.0000	1.0000	1.0000
Total 15-Minute Volume [veh/h]	0	40	22	19	81	1	0	0	0	15	0	18
Total Analysis Volume [veh/h]	1	159	90	76	324	2	0	0	1	62	1	73
Pedestrian Volume [ped/h]												1



Intersection Settings

	Free	Free	Stop	Stop
Priority Scheme				
Flared Lane			No	No
Storage Area [veh]	0	0	0	0
Two-Stage Gap Acceptance			No	No
Number of Storage Spaces in Median	0	0	0	0

Movement, Approach, & Intersection Results

V/C, Movement V/C Ratio	0.00	0.00	0.00	0.05	0.05	0.05	0.00	0.00	0.00	0.17	0.00	0.08
d_M, Delay for Movement [s/veh]	7.92	0.00	0.00	7.91	0.00	0.00	17.13	0.11	10.03	16.82	15.25	9.46
Movement LOS	A	A	A	A	A	A	C	B	C	C	C	A
95th-Percentile Queue Length [veh/ln]	0.00	0.00	0.00	0.18	0.18	0.18	0.00	0.00	0.60	0.28	0.28	0.28
95th-Percentile Queue Length [ft/ln]	0.05	0.05	0.00	4.60	4.60	4.60	0.18	0.10	15.04	6.97	6.97	6.97
d_A, Approach Delay [s/veh]		0.03			1.49			10.03			12.85	
Approach LOS		A			A			B			B	
d_I, Intersection Delay [s/veh]							3.00					
Intersection LOS							C					

Intersection Level Of Service Report
Intersection 6: Olympic Dr/N-S Project Street

Control Type:	Two-way stop	Delay (sec / veh):	16.0
Analysis Method:	HCM 6th Edition	Level Of Service:	C
Analysis Period:	15 minutes	Volume to Capacity (v/c):	0.041

Intersection Setup

Name	N-S Project Street		Olympic Dr		Olympic Dr	
Approach	Southbound		Eastbound		Westbound	
Lane Configuration	T		↑		↑	
Turning Movement	Left	Right	Left	Thru	Thru	Right
Lane Width [ft]	12.00	12.00	12.00	12.00	12.00	12.00
No. of Lanes in Entry Pocket	0	0	0	0	0	0
Entry Pocket Length [ft]	100.00	100.00	100.00	100.00	100.00	100.00
No. of Lanes in Exit Pocket	0	0	0	0	0	0
Exit Pocket Length [ft]	0.00	0.00	0.00	0.00	0.00	0.00
Speed [mph]	25.00		30.00		30.00	
Grade [%]	0.00		0.00		0.00	
Crosswalk	Yes		No		No	

Volumes

Name	N-S Project Street		Olympic Dr		Olympic Dr	
Base Volume Input [veh/h]	7	8	15	290	306	0
Base Volume Adjustment Factor	1.0000	1.0000	1.0000	1.0000	1.0000	1.0000
Heavy Vehicles Percentage [%]	2.00	2.00	2.00	2.00	2.00	2.00
Growth Factor	1.0000	1.0000	1.0000	1.0000	1.0000	1.0000
In-Process Volume [veh/h]	0	0	0	0	0	0
Site-Generated Trips [veh/h]	5	12	19	0	0	12
Diverted Trips [veh/h]	0	0	0	0	0	0
Pass-by Trips [veh/h]	0	0	0	0	0	0
Existing Site Adjustment Volume [veh/h]	0	0	0	0	0	0
Other Volume [veh/h]	0	0	0	0	0	0
Total Hourly Volume [veh/h]	12	20	34	290	306	12
Peak Hour Factor	0.8500	0.8500	0.8500	0.8500	0.8500	0.8500
Other Adjustment Factor	1.0000	1.0000	1.0000	1.0000	1.0000	1.0000
Total 15-Minute Volume [veh/h]	4	6	10	85	90	4
Total Analysis Volume [veh/h]	14	24	40	341	360	14
Pedestrian Volume [ped/h]	0		0		0	



Intersection Settings

Priority Scheme	Stop	Free	Free
Flared Lane	No		
Storage Area [veh]	0	0	0
Two-Stage Gap Acceptance	No		
Number of Storage Spaces in Median	0	0	0

Movement, Approach, & Intersection Results

V/C, Movement V/C Ratio	0.04	0.04	0.03	0.03	0.03	0.03
d_M, Delay for Movement [s/veh]	16.03	10.90	8.15	0.68	0.59	0.00
Movement LOS	C	B	A	A	A	A
95th-Percentile Queue Length [veh/ln]	0.25	0.25	0.10	0.10	0.00	0.00
95th-Percentile Queue Length [Min]	6.14	6.14	2.62	2.62	0.00	0.00
d_A, Approach Delay [s/veh]	12.79		0.86		0.00	
Approach LOS	B		A		A	
d_I, Intersection Delay [s/veh]			1.02			
Intersection LOS			C			



Intersection Level Of Service Report

Intersection 7: Olympic Dr/Burns Valley Rd-Old Hwy 53

Control Type:	Signalized	Delay (sec / veh):	11.4
Analysis Method:	HCM 6th Edition	Level Of Service:	B
Analysis Period:	15 minutes	Volume to Capacity (v/c):	0.668

Intersection Setup

Name	Old Hwy 53			Burns Valley Rd			Olympic Dr			Old Hwy 53		
Approach	Northbound			Southbound			Eastbound			Westbound		
Lane Configuration	T			T			T			T		
Turning Movement	Left	Thru	Right	Left	Thru	Right	Left	Thru	Right	Left	Thru	Right
Lane Width [ft]	12.00	12.00	12.00	12.00	12.00	12.00	12.00	12.00	12.00	12.00	12.00	12.00
No. of Lanes in Entry Pocket	1	0	1	1	0	0	1	0	0	1	0	0
Entry Pocket Length [ft]	100.00	100.00	100.00	56.00	100.00	100.00	48.00	100.00	100.00	100.00	100.00	100.00
No. of Lanes in Exit Pocket	0	0	0	0	0	0	0	0	0	0	0	0
Exit Pocket Length [ft]	0.00	0.00	0.00	0.00	0.00	0.00	0.00	0.00	0.00	0.00	0.00	0.00
Speed [mph]	30.00			30.00			35.00			35.00		
Grade [%]	0.00			0.00			0.00			0.00		
Curb Present	No			No			No			No		
Crosswalk	Yes			Yes			Yes			Yes		



Volumes

Name	Old Hwy 53			Burns Valley Rd			Olympic Dr			Old Hwy 53		
Base Volume Input [veh/h]	42	62	45	75	70	15	26	131	51	48	150	99
Base Volume Adjustment Factor	1.0000	1.0000	1.0000	1.0000	1.0000	1.0000	1.0000	1.0000	1.0000	1.0000	1.0000	1.0000
Heavy Vehicles Percentage [%]	2.00	2.00	2.00	2.00	2.00	2.00	2.00	2.00	2.00	2.00	2.00	2.00
Growth Factor	1.0000	1.0000	1.0000	1.0000	1.0000	1.0000	1.0000	1.0000	1.0000	1.0000	1.0000	1.0000
In-Process Volume [veh/h]	0	0	0	0	0	0	0	0	0	0	0	0
Site-Generated Trips [veh/h]	5	6	0	5	9	0	0	1	4	0	7	4
Diverted Trips [veh/h]	0	0	0	0	0	0	0	0	0	0	0	0
Pass-by Trips [veh/h]	0	0	0	0	0	0	0	0	0	0	0	0
Existing Site Adjustment Volume [veh/h]	0	0	0	0	0	0	0	0	0	0	0	0
Other Volume [veh/h]	0	0	0	0	0	0	0	0	0	0	0	0
Right Turn on Red Volume [veh/h]	0	0	18	0	0	11	0	0	14	0	0	25
Total Hourly Volume [veh/h]	47	68	27	80	79	4	26	132	41	48	157	78
Peak Hour Factor	0.8900	0.8900	0.8900	0.8900	0.8900	0.8900	0.8900	0.8900	0.8900	0.8900	0.8900	0.8900
Other Adjustment Factor	1.0000	1.0000	1.0000	1.0000	1.0000	1.0000	1.0000	1.0000	1.0000	1.0000	1.0000	1.0000
Total 15-Minute Volume [veh/h]	13	19	8	22	22	1	7	37	12	13	44	22
Total Analysis Volume [veh/h]	53	78	30	90	89	4	29	148	46	54	176	88
Presence of On-Street Parking	No	No	No	No	No	No	No	No	No	No	No	No
On-Street Parking Maneuver Rate [/h]	0	0	0	0	0	0	0	0	0	0	0	0
Local Bus Stopping Rate [/h]	0	0	0	0	0	0	0	0	0	0	0	0
v_do, Outbound Pedestrian Volume crossing major street	1			0			1			1		
v_di, Inbound Pedestrian Volume crossing major street	1			1			0			1		
v_co, Outbound Pedestrian Volume crossing minor street	1			0			0			0		
v_ci, Inbound Pedestrian Volume crossing minor street	0			0			1			0		
v_ab, Corner Pedestrian Volume [ped/h]	0			0			0			0		
Bicycle Volume [bicycles/h]	0			0			0			1		



Intersection Settings

Located in CBD	Yes
Signal Coordination Group	-
Cycle Length [s]	109
Coordination Type	Time of Day Pattern Isolated
Actuation Type	Fully actuated
Offset [s]	0.0
Offset Reference	Lead Green - Beginning of First Green
Permissive Mode	SingleBand
Lost time [s]	14.00

Phasing & Timing

Control Type	Protect	Permis	Permis	Protect	Permis	Permis	Protect	Permis	Permis	Protect	Permis	Permis
Signal Group	3	8	0	7	4	0	5	2	0	1	6	0
Auxiliary Signal Groups												
Lead / Lag	Lead	-	-	Lead	-	-	Lead	-	-	Lead	-	-
Minimum Green [s]	4	6	0	4	6	0	4	6	0	4	6	0
Maximum Green [s]	20	25	0	20	25	0	20	30	0	20	20	0
Amber [s]	3.0	3.3	0.0	3.0	3.3	0.0	3.0	3.6	0.0	3.0	3.6	0.0
All red [s]	0.0	0.3	0.0	0.0	0.3	0.0	0.0	0.3	0.0	0.0	0.3	0.0
Split [s]	23	29	0	23	29	0	23	34	0	23	34	0
Vehicle Extension [s]	0.0	0.0	0.0	0.0	0.0	0.0	0.0	0.0	0.0	0.0	0.0	0.0
Walk [s]	0	7	0	0	7	0	0	7	0	0	7	0
Pedestrian Clearance [s]	0	11	0	0	9	0	0	14	0	0	9	0
Delayed Vehicle Green [s]	0.0	0.0	0.0	0.0	0.0	0.0	0.0	0.0	0.0	0.0	0.0	0.0
Rest In Walk	No	No	No	No	No	No	No	No	No	No	No	No
I1, Start-Up Lost Time [s]	2.0	2.0	0.0	2.0	2.0	0.0	2.0	2.0	0.0	2.0	2.0	0.0
I2, Clearance Lost Time [s]	1.0	1.6	0.0	1.0	1.6	0.0	1.0	1.9	0.0	1.0	1.9	0.0
Minimum Recall	No	No	No	No	No	No	No	No	No	No	No	No
Maximum Recall	No	No	No	No	No	No	No	No	No	No	No	No
Pedestrian Recall	No	No	No	No	No	No	No	No	No	No	No	No
Detector Location [ft]	0.0	0.0	0.0	0.0	0.0	0.0	0.0	0.0	0.0	0.0	0.0	0.0
Detector Length [ft]	0.0	0.0	0.0	0.0	0.0	0.0	0.0	0.0	0.0	0.0	0.0	0.0
I, Upstream Filtering Factor	1.00	1.00	1.00	1.00	1.00	1.00	1.00	1.00	1.00	1.00	1.00	1.00

Exclusive Pedestrian Phase

Pedestrian Signal Group	0
Pedestrian Walk [s]	0
Pedestrian Clearance [s]	0



Lane Group Calculations

Lane Group	L	C	R	L	C	L	C	L	C
C, Cycle Length [s]	25	25	25	25	25	25	25	25	25
L, Total Lost Time per Cycle [s]	3.00	3.60	3.60	3.00	3.60	3.00	3.90	3.00	3.90
H_p, Permitted Start-Up Lost Time [s]	0.00	0.00	0.00	0.00	0.00	0.00	0.00	0.00	0.00
I2, Clearance Lost Time [s]	1.00	1.60	1.60	1.00	1.60	1.00	1.90	1.00	1.90
g_i, Effective Green Time [s]	1	3	3	2	4	1	5	1	5
g / C, Green / Cycle	0.05	0.13	0.13	0.08	0.16	0.03	0.19	0.05	0.21
(v / s)_j Volume / Saturation Flow Rate	0.03	0.05	0.02	0.06	0.06	0.02	0.12	0.03	0.17
s, saturation flow rate [veh/h]	1603	1683	1420	1603	1670	1603	1614	1603	1576
c, Capacity [veh/h]	83	227	191	125	269	50	305	85	332
d1, Uniform Delay [s]	11.51	9.71	9.47	11.15	9.23	11.84	9.25	11.50	9.26
k, delay calibration	0.04	0.04	0.04	0.04	0.04	0.04	0.04	0.04	0.04
I, Upstream Filtering Factor	1.00	1.00	1.00	1.00	1.00	1.00	1.00	1.00	1.00
d2, Incremental Delay [s]	2.95	0.32	0.14	2.88	0.28	3.92	0.82	2.94	1.64
d3, Initial Queue Delay [s]	0.00	0.00	0.00	0.00	0.00	0.00	0.00	0.00	0.00
Rp, platoon ratio	1.00	1.00	1.00	1.00	1.00	1.00	1.00	1.00	1.00
PF, progression factor	1.00	1.00	1.00	1.00	1.00	1.00	1.00	1.00	1.00

Lane Group Results

X, volume / capacity	0.64	0.33	0.16	0.72	0.35	0.58	0.64	0.64	0.79
d, Delay for Lane Group [s/veh]	14.46	10.03	9.61	14.03	9.52	15.76	10.07	14.43	10.90
Lane Group LOS	B	B	A	B	A	B	B	B	B
Critical Lane Group	No	Yes	No	Yes	No	Yes	No	No	Yes
50th-Percentile Queue Length [veh/ln]	0.26	0.26	0.10	0.43	0.30	0.16	0.60	0.26	0.86
50th-Percentile Queue Length [ft/ln]	6.62	6.52	2.50	10.63	7.53	3.94	15.12	6.41	21.88
95th-Percentile Queue Length [veh/ln]	0.48	0.47	0.18	0.77	0.54	0.26	1.09	0.46	1.58
95th-Percentile Queue Length [ft/ln]	11.92	11.73	4.50	19.13	13.56	7.10	27.22	11.53	39.38



Movement, Approach, & Intersection Results

d_M, Delay for Movement [s/veh]	14.46	10.03	9.61	14.03	9.52	9.52	15.76	10.07	10.07	14.43	10.90	10.90
Movement LOS	B	B	A	B	A	A	B	B	B	B	B	B
d_A, Approach Delay [s/veh]	11.43			11.74			10.81			11.50		
Approach LOS	B			B			B			B		
d_I, Intersection Delay [s/veh]	11.36											
Intersection LOS	B											
Intersection V/C	0.868											

Other Modes

g_Walk,mi, Effective Walk Time [s]	11.0	11.0	11.0	11.0
M_comer, Corner Circulation Area [ft ² /ped]	0.00	0.00	0.00	0.00
M_CW, Crosswalk Circulation Area [ft ² /ped]	0.00	0.00	0.00	0.00
d_p, Pedestrian Delay [s]	3.73	3.73	3.73	3.73
I_p,int, Pedestrian LOS Score for Intersection	2.159	2.000	2.053	2.124
Crosswalk LOS	B	A	B	B
s_b, Saturation Flow Rate of the bicycle lane [bicycles/h]	2000	2000	2000	2000
c_b, Capacity of the bicycle lane [bicycles/h]	2070	2070	2453	2453
d_b, Bicycle Delay [s]	0.02	0.02	0.63	0.63
I_b,int, Bicycle LOS Score for Intersection	1.852	1.880	1.951	2.126
Bicycle LOS	A	A	A	B

Sequence

Ring 1	1	2	3	4	-	-	-	-	-	-	-	-	-	-	-
Ring 2	5	6	7	8	-	-	-	-	-	-	-	-	-	-	-
Ring 3	-	-	-	-	-	-	-	-	-	-	-	-	-	-	-
Ring 4	-	-	-	-	-	-	-	-	-	-	-	-	-	-	-

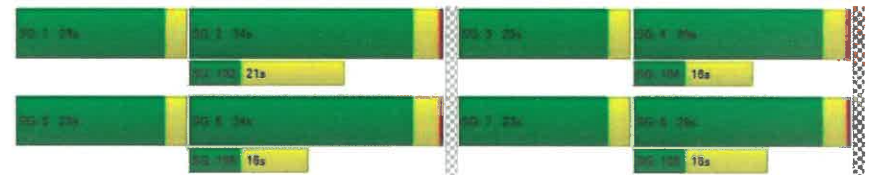

Intersection Level Of Service Report
Intersection 1: Burns Valley Rd/N-S Project Street

Control Type: Two-way stop
Analysis Method: HCM 6th Edition
Analysis Period: 15 minutes
Delay (sec / veh): 10.4
Level Of Service: B
Volume to Capacity (v/c): 0.025

Intersection Setup

Name	N-S Project Street		Burns Valley Rd		Burns Valley Rd	
	Northbound		Eastbound		Westbound	
Approach	←		→		←	
Lane Configuration	←		→		←	
Turning Movement	Left	Right	Thru	Right	Left	Thru
Lane Width [ft]	12.00	12.00	12.00	12.00	12.00	12.00
No. of Lanes in Entry Pocket	0	0	0	0	0	0
Entry Pocket Length [ft]	100.00	100.00	100.00	100.00	100.00	100.00
No. of Lanes in Exit Pocket	0	0	0	0	0	0
Exit Pocket Length [ft]	0.00	0.00	0.00	0.00	0.00	0.00
Speed [mph]	25.00		35.00		35.00	
Grade [%]	0.00		0.00		0.00	
Crosswalk	No		No		No	

Volumes

Name	N-S Project Street		Burns Valley Rd		Burns Valley Rd	
	Base Volume Input [veh/h]	8	8	117	17	0
Base Volume Adjustment Factor	1.0000	1.0000	1.0000	1.0000	1.0000	1.0000
Heavy Vehicles Percentage [%]	2.00	2.00	2.00	2.00	2.00	2.00
Growth Factor	1.0000	1.0000	1.0000	1.0000	1.0000	1.0000
In-Process Volume [veh/h]	0	0	0	0	0	0
Site-Generated Trips [veh/h]	7	7	1	10	7	1
Diverted Trips [veh/h]	0	0	0	0	0	0
Pass-by Trips [veh/h]	0	0	0	0	0	0
Existing Site Adjustment Volume [veh/h]	0	0	0	0	0	0
Other Volume [veh/h]	0	0	0	0	0	0
Total Hourly Volume [veh/h]	15	15	118	27	7	118
Peak Hour Factor	0.8930	0.8930	0.8930	0.8930	0.8930	0.8930
Other Adjustment Factor	1.0000	1.0000	1.0000	1.0000	1.0000	1.0000
Total 15-Minute Volume [veh/h]	4	4	33	8	2	33
Total Analysis Volume [veh/h]	17	17	132	30	8	132
Pedestrian Volume [ped/h]	0	0	0	0	0	0



Intersection Settings

Priority Scheme	Stop	Free	Free
Flared Lane	No		
Storage Area [veh]	0	0	0
Two-Stage Gap Acceptance	No		
Number of Storage Spaces in Median	0	0	0

Movement, Approach, & Intersection Results

V/C, Movement V/C Ratio	0.02	0.02	0.00	0.00	0.01	0.00
d_M, Delay for Movement [s/veh]	10.41	9.21	0.00	0.00	7.56	0.00
Movement LOS	B	A	A	A	A	A
95th-Percentile Queue Length [veh/ln]	0.14	0.14	0.00	0.00	0.02	0.02
95th-Percentile Queue Length [ft/ln]	3.40	3.40	0.00	0.00	0.43	0.43
d_A, Approach Delay [s/veh]	9.81		0.00		0.43	
Approach LOS	A		A		A	
d_I, Intersection Delay [s/veh]				1.17		
Intersection LOS	B					



Intersection Level Of Service Report

Intersection 2: Burns Valley Rd/Bowers Ave-Rumsey Rd

Control Type: Two-way stop
 Analysis Method: HCM 6th Edition
 Analysis Period: 15 minutes
 Delay (sec / veh): 12.9
 Level Of Service: B
 Volume to Capacity (v/c): 0.032

Intersection Setup

Name	Burns Valley Rd			Rumsey Rd			Burns Valley Rd			Bowers Ave		
Approach	Northbound			Southbound			Eastbound			Westbound		
Lane Configuration	+			+			+			+		
Turning Movement	Left	Thru	Right	Left	Thru	Right	Left	Thru	Right	Left	Thru	Right
Lane Width [ft]	12.00	12.00	12.00	12.00	12.00	12.00	12.00	12.00	12.00	12.00	12.00	12.00
No. of Lanes in Entry Pocket	0	0	0	0	0	0	0	0	0	0	0	0
Entry Pocket Length [ft]	100.00	100.00	100.00	100.00	100.00	100.00	100.00	100.00	100.00	100.00	100.00	100.00
No. of Lanes in Exit Pocket	0	0	0	0	0	0	0	0	0	0	0	0
Exit Pocket Length [ft]	0.00	0.00	0.00	0.00	0.00	0.00	0.00	0.00	0.00	0.00	0.00	0.00
Speed [mph]	30.00			30.00			35.00			25.00		
Grade [%]	0.00			0.00			0.00			0.00		
Crosswalk	No			Yes			Yes			No		

Volumes

Name	Burns Valley Rd			Rumsey Rd			Burns Valley Rd			Bowers Ave		
Base Volume Input [veh/h]	100	38	9	2	43	7	7	1	75	13	0	0
Base Volume Adjustment Factor	1.0000	1.0000	1.0000	1.0000	1.0000	1.0000	1.0000	1.0000	1.0000	1.0000	1.0000	1.0000
Heavy Vehicles Percentage [%]	2.00	2.00	2.00	2.00	2.00	2.00	2.00	2.00	2.00	2.00	2.00	2.00
Growth Factor	1.0000	1.0000	1.0000	1.0000	1.0000	1.0000	1.0000	1.0000	1.0000	1.0000	1.0000	1.0000
In-Process Volume [veh/h]	0	0	0	0	0	0	0	0	0	0	0	0
Site-Generated Trips [veh/h]	5	1	0	0	1	4	3	0	3	0	0	0
Diverted Trips [veh/h]	0	0	0	0	0	0	0	0	0	0	0	0
Pass-by Trips [veh/h]	0	0	0	0	0	0	0	0	0	0	0	0
Existing Site Adjustment Volume [veh/h]	0	0	0	0	0	0	0	0	0	0	0	0
Other Volume [veh/h]	0	0	0	0	0	0	0	0	0	0	0	0
Total Hourly Volume [veh/h]	105	39	9	2	44	11	10	1	78	13	0	0
Peak Hour Factor	0.8500	0.8500	0.8500	0.8500	0.8500	0.8500	0.8500	0.8500	0.8500	0.8500	0.8500	0.8500
Other Adjustment Factor	1.0000	1.0000	1.0000	1.0000	1.0000	1.0000	1.0000	1.0000	1.0000	1.0000	1.0000	1.0000
Total 15-Minute Volume [veh/h]	31	11	3	1	13	3	3	0	23	4	0	0
Total Analysis Volume [veh/h]	124	46	11	2	52	13	12	1	92	15	0	0
Pedestrian Volume [ped/h]	0			0			0			0		



Intersection Settings

Priority Scheme	Free	Free	Stop	Stop
Flared Lane			No	No
Storage Area [veh]	0	0	0	0
Two-Stage Gap Acceptance			No	No
Number of Storage Spaces in Median	0	0	0	0

Movement, Approach, & Intersection Results

V/C, Movement V/C Ratio	0.08	0.00	0.00	0.00	0.00	0.00	0.02	0.00	0.09	0.03	0.00	0.00
d_M, Delay for Movement [s/veh]	7.55	0.00	0.00	7.33	0.00	0.00	11.99	12.52	9.08	12.92	12.27	8.75
Movement LOS	A	A	A	A	A	A	B	B	A	B	B	A
95th-Percentile Queue Length [veh/m]	0.26	0.26	0.26	0.00	0.00	0.00	0.39	0.39	0.39	0.10	0.10	0.10
95th-Percentile Queue Length [ft/m]	6.57	6.57	6.57	0.10	0.10	0.10	9.70	9.70	9.70	2.47	2.47	2.47
d_A, Approach Delay [s/veh]	5.17			0.22			9.45			12.92		
Approach LOS	A			A			A			B		
d_I, Intersection Delay [s/veh]							5.81					
Intersection LOS	B											



Intersection Level Of Service Report

Intersection 3: N-S Project Street/E-W Project Street

Control Type: All-way stop
 Analysis Method: HCM 6th Edition
 Analysis Period: 15 minutes
 Delay (sec / veh): 7.4
 Level Of Service: A
 Volume to Capacity (v/c): 0.097

Intersection Setup

Name	N-S Project Street			N-S Project Street			E-W Project Street			E-W Project Street		
Approach	Northbound			Southbound			Eastbound			Westbound		
Lane Configuration	+			+			+			+		
Turning Movement	Left	Thru	Right	Left	Thru	Right	Left	Thru	Right	Left	Thru	Right
Lane Width [ft]	12.00	12.00	12.00	12.00	12.00	12.00	12.00	12.00	12.00	12.00	12.00	12.00
No. of Lanes in Entry Pocket	0	0	0	0	0	0	0	0	0	0	0	0
Entry Pocket Length [ft]	100.00	100.00	100.00	100.00	100.00	100.00	100.00	100.00	100.00	100.00	100.00	100.00
No. of Lanes in Exit Pocket	0	0	0	0	0	0	0	0	0	0	0	0
Exit Pocket Length [ft]	0.00	0.00	0.00	0.00	0.00	0.00	0.00	0.00	0.00	0.00	0.00	0.00
Speed [mph]	25.00			25.00			25.00			25.00		
Grade [%]	0.00			0.00			0.00			0.00		
Crosswalk	Yes			Yes			Yes			Yes		

Volumes

Name	N-S Project Street			N-S Project Street			E-W Project Street			E-W Project Street		
Base Volume Input [veh/h]	0	16	0	0	17	0	0	0	0	0	0	0
Base Volume Adjustment Factor	1.0000	1.0000	1.0000	1.0000	1.0000	1.0000	1.0000	1.0000	1.0000	1.0000	1.0000	1.0000
Heavy Vehicles Percentage [%]	2.00	2.00	2.00	2.00	2.00	2.00	2.00	2.00	2.00	2.00	2.00	2.00
Growth Factor	1.0000	1.0000	1.0000	1.0000	1.0000	1.0000	1.0000	1.0000	1.0000	1.0000	1.0000	1.0000
In-Process Volume [veh/h]	0	0	0	0	0	0	0	0	0	0	0	0
Site-Generated Trips [veh/h]	3	44	15	12	31	1	1	3	8	5	2	15
Diverted Trips [veh/h]	0	0	0	0	0	0	0	0	0	0	0	0
Pass-by Trips [veh/h]	0	0	0	0	0	0	0	0	0	0	0	0
Existing Site Adjustment Volume [veh/h]	0	0	0	0	0	0	0	0	0	0	0	0
Other Volume [veh/h]	0	0	0	0	0	0	0	0	0	0	0	0
Total Hourly Volume [veh/h]	3	60	15	12	48	1	1	3	8	5	2	15
Peak Hour Factor	0.8800	0.8800	0.8800	0.8800	0.8800	0.8800	0.8800	0.8800	0.8800	0.8800	0.8800	0.8800
Other Adjustment Factor	1.0000	1.0000	1.0000	1.0000	1.0000	1.0000	1.0000	1.0000	1.0000	1.0000	1.0000	1.0000
Total 15-Minute Volume [veh/h]	1	17	4	3	14	0	0	1	2	1	1	4
Total Analysis Volume [veh/h]	3	68	17	14	55	1	1	3	9	6	2	17
Pedestrian Volume [ped/h]	0			0			0			0		



Intersection Settings

Lanes	Capacity per Entry Lane [veh/h]	907	872	924	918
Degree of Utilization, x	0.10	0.08	0.01	0.03	

Movement, Approach, & Intersection Results

95th-Percentile Queue Length [veh]	0.32	0.26	0.04	0.08
95th-Percentile Queue Length [ft]	8.04	6.52	1.07	2.10
Approach Delay [s/veh]	7.40	7.48	6.95	7.03
Approach LOS	A	A	A	A
Intersection Delay [s/veh]	7.35			
Intersection LOS	A			



Intersection Level Of Service Report
Intersection 4: Burns Valley Rd/E-W Project Street

Control Type: Two-way stop Delay (sec / veh): 11.5
 Analysis Method: HCM 6th Edition Level Of Service: B
 Analysis Period: 15 minutes Volume to Capacity (v/c): 0.002

Intersection Setup

Name	Burns Valley Rd		Burns Valley Rd		E-W Project Street	
	Northbound		Southbound		Eastbound	
Approach	←		→		→	
Lane Configuration	← →		← →		← →	
Turning Movement	Left	Thru	Thru	Right	Left	Right
Lane Width [ft]	12.00	12.00	12.00	12.00	12.00	12.00
No. of Lanes in Entry Pocket	0	0	0	0	0	0
Entry Pocket Length [ft]	100.00	100.00	100.00	100.00	100.00	100.00
No. of Lanes in Exit Pocket	0	0	0	0	0	0
Exit Pocket Length [ft]	0.00	0.00	0.00	0.00	0.00	0.00
Speed [mph]	30.00		30.00		25.00	
Grade [%]	0.00		0.00		0.00	
Crosswalk	No		No		Yes	

Volumes

Name	Burns Valley Rd		Burns Valley Rd		E-W Project Street	
	Northbound	Southbound	Northbound	Southbound	Eastbound	Westbound
Base Volume Input [veh/h]	0	158	173	0	0	0
Base Volume Adjustment Factor	1.0000	1.0000	1.0000	1.0000	1.0000	1.0000
Heavy Vehicles Percentage [%]	2.00	2.00	2.00	2.00	2.00	2.00
Growth Factor	1.0000	1.0000	1.0000	1.0000	1.0000	1.0000
In-Process Volume [veh/h]	0	0	0	0	0	0
Site-Generated Trips [veh/h]	24	5	3	1	1	18
Diverted Trips [veh/h]	0	0	0	0	0	0
Pass-by Trips [veh/h]	0	0	0	0	0	0
Existing Site Adjustment Volume [veh/h]	0	0	0	0	0	0
Other Volume [veh/h]	0	0	0	0	0	0
Total Hourly Volume [veh/h]	24	163	176	1	1	18
Peak Hour Factor	0.8800	0.8800	0.8800	0.8800	0.8800	0.8800
Other Adjustment Factor	1.0000	1.0000	1.0000	1.0000	1.0000	1.0000
Total 15-Minute Volume [veh/h]	7	46	50	0	0	5
Total Analysis Volume [veh/h]	27	185	200	1	1	20
Pedestrian Volume [ped/h]	0		0		0	



Intersection Settings

Priority Scheme	Free	Free	Stop
Flared Lane			No
Storage Area [veh]	0	0	0
Two-Stage Gap Acceptance			No
Number of Storage Spaces in Median	0	0	0

Movement, Approach, & Intersection Results

V/C, Movement V/C Ratio	0.02	0.00	0.00	0.00	0.00	0.02
d_M, Delay for Movement [s/veh]	7.68	0.00	0.00	0.00	11.52	9.40
Movement LOS	A	A	A	A	B	A
95th-Percentile Queue Length [veh/ln]	0.06	0.06	0.00	0.00	0.08	0.08
95th-Percentile Queue Length [ft/ln]	1.51	1.51	0.00	0.00	1.97	1.97
d_A, Approach Delay [s/veh]	0.98		0.00		9.50	
Approach LOS	A		A		A	
d_I, Intersection Delay [s/veh]					0.94	
Intersection LOS	B					



Intersection Level Of Service Report
Intersection 5: Olympic Dr/Lakeshore Dr

Control Type: Two-way stop
Analysis Method: HCM 6th Edition
Analysis Period: 15 minutes
Delay (sec / veh): 18.4
Level Of Service: C
Volume to Capacity (v/c): 0.327

Intersection Setup

Name	Lakeshore Dr			Lakeshore Dr			Olympic Dr					
Approach	Northbound			Southbound			Eastbound			Westbound		
Lane Configuration	[Diagram]			[Diagram]			[Diagram]			[Diagram]		
Turning Movement	Left	Thru	Right	Left	Thru	Right	LeR	Thru	Right	Left	Thru	Right
Lane Width [ft]	12.00	12.00	12.00	12.00	12.00	12.00	12.00	12.00	12.00	12.00	12.00	12.00
No. of Lanes in Entry Pocket	0	0	1	0	0	0	0	0	0	0	0	1
Entry Pocket Length [ft]	100.00	100.00	120.00	100.00	100.00	100.00	100.00	100.00	100.00	100.00	100.00	250.00
No. of Lanes in Exit Pocket	0	0	0	0	0	0	0	0	0	0	0	0
Exit Pocket Length [ft]	0.00	0.00	0.00	0.00	0.00	0.00	0.00	0.00	0.00	0.00	0.00	0.00
Speed [mph]	25.00			25.00			30.00			30.00		
Grade [%]	0.00			0.00			0.00			0.00		
Crosswalk	No			Yes			No			Yes		

Volumes

Name	Lakeshore Dr			Lakeshore Dr			Olympic Dr					
Base Volume Input [veh/h]	1	198	114	66	180	1	0	2	2	106	3	141
Base Volume Adjustment Factor	1.0000	1.0000	1.0000	1.0000	1.0000	1.0000	1.0000	1.0000	1.0000	1.0000	1.0000	1.0000
Heavy Vehicles Percentage [%]	2.00	2.00	2.00	2.00	2.00	2.00	2.00	2.00	2.00	2.00	2.00	2.00
Growth Factor	1.0000	1.0000	1.0000	1.0000	1.0000	1.0000	1.0000	1.0000	1.0000	1.0000	1.0000	1.0000
In-Process Volume [veh/h]	0	0	0	0	0	0	0	0	0	0	0	0
Site-Generated Trips [veh/h]	0	0	21	11	0	0	0	0	0	15	0	8
Diverted Trips [veh/h]	0	0	0	0	0	0	0	0	0	0	0	0
Pass-by Trips [veh/h]	0	0	0	0	0	0	0	0	0	0	0	0
Existing Site Adjustment Volume [veh/h]	0	0	0	0	0	0	0	0	0	0	0	0
Other Volume [veh/h]	0	0	0	0	0	0	0	0	0	0	0	0
Total Hourly Volume [veh/h]	1	198	135	77	180	1	0	2	2	121	3	149
Peak Hour Factor	0.9300	0.9300	0.9300	0.9300	0.9300	0.9300	0.9300	0.9300	0.9300	0.9300	0.9300	0.9300
Other Adjustment Factor	1.0000	1.0000	1.0000	1.0000	1.0000	1.0000	1.0000	1.0000	1.0000	1.0000	1.0000	1.0000
Total 15-Minute Volume [veh/h]	0	53	36	21	48	0	0	1	1	33	1	40
Total Analysis Volume [veh/h]	1	213	145	83	194	1	0	2	2	130	3	160
Pedestrian Volume [ped/h]	0			0			0			1		



Intersection Settings

Priority Scheme	Free	Free	Stop	Stop
Flared Lane			No	No
Storage Area [veh]	0	0	0	0
Two-Stage Gap Acceptance			No	No
Number of Storage Spaces in Median	0	0	0	0

Movement, Approach, & Intersection Results



V/C, Movement V/C Ratio	0.00	0.30	0.00	0.07	0.00	0.00	0.00	0.01	0.00	0.33	0.01	0.19
d_M, Delay for Movement [s/veh]	7.61	0.30	0.00	8.23	0.00	0.00	16.20	16.14	9.32	18.38	15.27	10.48
Movement LOS	A	A	A	A	A	C	C	A	C	C	C	B
95th-Percentile Queue Length [veh/m]	0.00	0.00	0.00	0.22	0.22	0.22	0.00	0.03	0.03	1.40	0.75	0.75
95th-Percentile Queue Length [ft/m]	0.05	0.05	0.00	5.57	5.57	5.57	0.64	0.64	0.64	34.94	18.75	18.75
d_A, Approach Delay [s/veh]	0.02		2.46		12.73		14.03					
Approach LOS	A		A		B		B					
d_I, Intersection Delay [s/veh]	5.20											
Intersection LOS	C											



Intersection Level Of Service Report
Intersection 6: Olympic Dr/N-S Project Street

Control Type: Two-way stop Delay (sec / veh): 21.9
Analysis Method: HCM 6th Edition Level Of Service: C
Analysis Period: 15 minutes Volume to Capacity (v/c): 0.103

Intersection Setup

Name	N-S Project Street		Olympic Dr		Olympic Dr	
	Southbound		Eastbound		Westbound	
Approach						
Lane Configuration						
Turning Movement	Left	Right	Left	Thru	Thru	Right
Lane Width [ft]	12.00	12.00	12.00	12.00	12.00	12.00
No. of Lanes in Entry Pocket	0	0	0	0	0	0
Entry Pocket Length [ft]	100.00	100.00	100.00	100.00	100.00	100.00
No. of Lanes in Exit Pocket	0	0	0	0	0	0
Exit Pocket Length [ft]	0.00	0.00	0.00	0.00	0.00	0.00
Speed [mph]	25.00		30.00		30.00	
Grade [%]	0.00		0.00		0.00	
Crosswalk	Yes		No		No	

Volumes

Name	N-S Project Street		Olympic Dr		Olympic Dr	
	Base Volume Input [veh/h]	8	9	16	352	384
Base Volume Adjustment Factor	1.0000	1.0000	1.0000	1.0000	1.0000	1.0000
Heavy Vehicles Percentage [%]	2.00	2.00	2.00	2.00	2.00	2.00
Growth Factor	1.0000	1.0000	1.0000	1.0000	1.0000	1.0000
In-Process Volume [veh/h]	0	0	0	0	0	0
Site-Generated Trips [veh/h]	13	31	43	0	0	19
Diverted Trips [veh/h]	0	0	0	0	0	0
Pass-by Trips [veh/h]	0	0	0	0	0	0
Existing Site Adjustment Volume [veh/h]	0	0	0	0	0	0
Other Volume [veh/h]	0	0	0	0	0	0
Total Hourly Volume [veh/h]	21	40	59	352	384	19
Peak Hour Factor	0.8500	0.8500	0.8500	0.8500	0.8500	0.8500
Other Adjustment Factor	1.0000	1.0000	1.0000	1.0000	1.0000	1.0000
Total 15-Minute Volume [veh/h]	6	12	17	104	113	6
Total Analysis Volume [veh/h]	25	47	69	414	452	22
Pedestrian Volume [ped/h]	0		0		0	



Intersection Settings

Priority Scheme	Stop	Free	Free
Flared Lane	No		
Storage Area [veh]	0	0	0
Two-Stage Gap Acceptance	No		
Number of Storage Spaces in Median	0	0	0

Movement, Approach, & Intersection Results

V/C, Movement V/C Ratio	0.10	0.08	0.06	0.03	0.05	0.00
d_M, Delay for Movement [s/veh]	21.87	13.02	8.53	0.00	0.00	0.00
Movement LOS	C	B	A	A	A	A
95th-Percentile Queue Length [veh/ln]	0.66	0.66	0.20	0.20	0.00	0.00
95th-Percentile Queue Length [ft/ln]	16.38	16.38	5.07	5.07	0.00	0.00
d_A, Approach Delay [s/veh]	16.09		1.22		0.00	
Approach LOS	C		A		A	
d_I, Intersection Delay [s/veh]	1.70					
Intersection LOS	C					



Intersection Level Of Service Report

Intersection 7: Olympic Dr/Burns Valley Rd-Old Hwy 53

Control Type: Signalized
 Analysis Method: HCM 6th Edition
 Analysis Period: 15 minutes
 Delay (sec / veh): 13.8
 Level Of Service: B
 Volume to Capacity (v/c): 0.772

Intersection Setup

Name	Old Hwy 53			Burns Valley Rd			Olympic Dr			Old Hwy 53		
Approach	Northbound			Southbound			Eastbound			Westbound		
Lane Configuration	[Diagram]			[Diagram]			[Diagram]			[Diagram]		
Turning Movement	Left	Thru	Right	Left	Thru	Right	Left	Thru	Right	Left	Thru	Right
Lane Width [ft]	12.00	12.00	12.00	12.00	12.00	12.00	12.00	12.00	12.00	12.00	12.00	12.00
No. of Lanes in Entry Pocket	1	0	1	1	0	1	0	1	0	1	0	0
Entry Pocket Length [ft]	100.00	100.00	100.00	56.00	100.00	100.00	48.00	100.00	100.00	100.00	100.00	100.00
No. of Lanes in Exit Pocket	0	0	0	0	0	0	0	0	0	0	0	0
Exit Pocket Length [ft]	0.00	0.00	0.00	0.00	0.00	0.00	0.00	0.00	0.00	0.00	0.00	0.00
Speed [mph]	30.00			30.00			35.00			35.00		
Grade [%]	0.00			0.00			0.00			0.00		
Curb Present	No			No			No			No		
Crosswalk	Yes			Yes			Yes			Yes		

Volumes

Name	Old Hwy 53			Burns Valley Rd			Olympic Dr			Old Hwy 53		
Base Volume Input [veh/h]	98	113	56	112	97	46	21	184	93	62	221	139
Base Volume Adjustment Factor	1.0000	1.0000	1.0000	1.0000	1.0000	1.0000	1.0000	1.0000	1.0000	1.0000	1.0000	1.0000
Heavy Vehicles Percentage [%]	2.00	2.00	2.00	2.00	2.00	2.00	2.00	2.00	2.00	2.00	2.00	2.00
Growth Factor	1.0000	1.0000	1.0000	1.0000	1.0000	1.0000	1.0000	1.0000	1.0000	1.0000	1.0000	1.0000
In-Process Volume [veh/h]	0	0	0	0	0	0	0	0	0	0	0	0
Site-Generated Trips [veh/h]	9	18	0	10	11	0	0	5	7	0	10	11
Diverted Trips [veh/h]	0	0	0	0	0	0	0	0	0	0	0	0
Pass-by Trips [veh/h]	0	0	0	0	0	0	0	0	0	0	0	0
Existing Site Adjustment Volume [veh/h]	0	0	0	0	0	0	0	0	0	0	0	0
Other Volume [veh/h]	0	0	0	0	0	0	0	0	0	0	0	0
Right Turn on Red Volume [veh/h]	0	0	18	0	0	11	0	0	14	0	0	25
Total Hourly Volume [veh/h]	107	131	38	122	108	35	21	189	86	62	231	125
Peak Hour Factor	0.9200	0.9200	0.9200	0.9200	0.9200	0.9200	0.9200	0.9200	0.9200	0.9200	0.9200	0.9200
Other Adjustment Factor	1.0000	1.0000	1.0000	1.0000	1.0000	1.0000	1.0000	1.0000	1.0000	1.0000	1.0000	1.0000
Total 15-Minute Volume [veh/h]	29	36	10	33	29	10	6	51	23	17	63	34
Total Analysis Volume [veh/h]	116	142	41	133	117	38	23	205	93	67	251	136
Presence of On-Street Parking	No	No	No	No	No	No	No	No	No	No	No	No
On-Street Parking Maneuver Rate [h]	0	0	0	0	0	0	0	0	0	0	0	0
Local Bus Stopping Rate [h]	0	0	0	0	0	0	0	0	0	0	0	0
v_do, Outbound Pedestrian Volume crossing major street	1							1			1	
v_di, Inbound Pedestrian Volume crossing major street	1				1			0			1	
v_co, Outbound Pedestrian Volume crossing minor street	1				0			0			0	
v_ci, Inbound Pedestrian Volume crossing minor street	0				0			1			0	
v_ab, Corner Pedestrian Volume [ped/h]	0				0			0			0	
Bicycle Volume [bicycles/h]	0				0			0			1	



Intersection Settings

Located in CBD	Yes
Signal Coordination Group	-
Cycle Length [s]	109
Coordination Type	Time of Day Pattern Isolated
Actuation Type	Fully actuated
Offset [s]	0.0
Offset Reference	Lead Green - Beginning of First Green
Permissive Mode	SingleBand
Lost time [s]	14.00

Phasing & Timing

Control Type	Protect	Permis	Permis	Protect	Permis	Permis	Protect	Permis	Permis	Protect	Permis	Permis
Signal Group	3	8	0	7	4	0	5	2	0	1	6	0
Auxiliary Signal Groups												
Lead / Lag	Lead	-	-	Lead	-	-	Lead	-	-	Lead	-	-
Minimum Green [s]	4	6	0	4	6	0	4	6	0	4	6	0
Maximum Green [s]	20	25	0	20	25	0	20	30	0	20	20	0
Amber [s]	3.0	3.3	0.0	3.0	3.3	0.0	3.0	3.6	0.0	3.0	3.6	0.0
All red [s]	0.0	0.3	0.0	0.0	0.3	0.0	0.0	0.3	0.0	0.0	0.3	0.0
Split [s]	23	29	0	23	29	0	23	34	0	23	34	0
Vehicle Extension [s]	0.0	0.0	0.0	0.0	0.0	0.0	0.0	0.0	0.0	0.0	0.0	0.0
Walk [s]	0	7	0	0	7	0	0	7	0	0	7	0
Pedestrian Clearance [s]	0	11	0	0	9	0	0	14	0	0	9	0
Delayed Vehicle Green [s]	0.0	0.0	0.0	0.0	0.0	0.0	0.0	0.0	0.0	0.0	0.0	0.0
Rest In Walk	No			No			No			No		
M, Start-Up Lost Time [s]	2.0	2.0	0.0	2.0	2.0	0.0	2.0	2.0	0.0	2.0	2.0	0.0
I2, Clearance Lost Time [s]	1.0	1.6	0.0	1.0	1.6	0.0	1.0	1.9	0.0	1.0	1.9	0.0
Minimum Recall	No	No		No	No		No	No		No	No	
Maximum Recall	No	No		No	No		No	No		No	No	
Pedestrian Recall	No	No		No	No		No	No		No	No	
Detector Location [ft]	0.0	0.0	0.0	0.0	0.0	0.0	0.0	0.0	0.0	0.0	0.0	0.0
Detector Length [ft]	3.0	0.0	0.0	0.0	0.0	0.0	0.0	0.0	0.0	0.0	0.0	0.0
I, Upstream Filtering Factor	1.00	1.00	1.00	1.00	1.00	1.00	1.00	1.00	1.00	1.00	1.00	1.00

Exclusive Pedestrian Phase

Pedestrian Signal Group	0
Pedestrian Walk [s]	0
Pedestrian Clearance [s]	0



Lane Group Calculations

Lane Group	L	C	R	L	C	L	C	L	C
C, Cycle Length [s]	32	32	32	32	32	32	32	32	32
L, Total Lost Time per Cycle [s]	3.00	3.60	3.60	3.00	3.60	3.00	3.90	3.00	3.90
M_p, Permitted Start-Up Lost Time [s]	0.00	0.00	0.00	0.00	0.00	0.00	0.00	0.00	0.00
I2, Clearance Lost Time [s]	1.00	1.60	1.60	1.00	1.60	1.00	1.90	1.00	1.90
g_l, Effective Green Time [s]	3	5	5	3	5	1	8	2	9
g / C, Green / Cycle	0.09	0.16	0.16	0.10	0.17	0.02	0.26	0.06	0.29
(v / s)_j Volume / Saturation Flow Rate	0.07	0.08	0.03	0.08	0.10	0.01	0.19	0.04	0.25
s, saturation flow rate [veh/h]	1603	1683	1421	1603	1612	1603	1594	1603	1571
c, Capacity [veh/h]	142	264	223	164	276	38	410	92	457
d1, Uniform Delay [s]	14.19	12.29	11.59	13.92	12.04	15.31	10.76	14.68	10.58
k, delay calibration	0.04	0.04	0.04	0.04	0.04	0.04	0.04	0.04	0.04
I, Upstream Filtering Factor	1.00	1.00	1.00	1.00	1.00	1.00	1.00	1.00	1.00
d2, Incremental Delay [s]	4.35	0.63	0.15	3.60	0.67	5.57	0.93	4.04	1.71
d3, Initial Queue Delay [s]	0.00	0.00	0.00	0.00	0.00	0.00	0.00	0.00	0.00
Rp, platoon ratio	1.00	1.00	1.00	1.00	1.00	1.00	1.00	1.00	1.00
PF, progression factor	1.00	1.00	1.00	1.00	1.00	1.00	1.00	1.00	1.00

Lane Group Results

X, volume / capacity	0.82	0.54	0.18	0.81	0.56	0.60	0.73	0.73	0.85
d, Delay for Lane Group [s/veh]	18.54	12.62	11.73	17.51	12.71	20.88	11.89	18.73	12.29
Lane Group LOS	B	B	B	B	B	C	B	B	B
Critical Lane Group	Yes	No	No	No	Yes	Yes	No	No	Yes
50th-Percentile Queue Length [veh/m]	0.81	0.74	0.20	0.89	0.80	0.19	1.35	0.46	1.81
50th-Percentile Queue Length [ft/m]	20.23	18.58	4.97	22.15	20.02	4.84	33.83	11.57	45.33
95th-Percentile Queue Length [veh/m]	1.46	1.34	0.36	1.60	1.44	0.33	2.44	0.83	3.26
95th-Percentile Queue Length [ft/m]	36.42	33.44	8.94	39.88	36.04	8.36	60.89	20.63	81.59



Movement, Approach, & Intersection Results												
d_M, Delay for Movement [s/veh]	18.54	12.92	11.73	17.51	12.71	12.71	20.88	11.69	11.69	18.73	12.29	12.29
Movement LOS	B	B	B	B	B	B	C	B	B	B	B	B
d_A, Approach Delay [s/veh]	14.94		14.93		12.35		13.24					
Approach LOS	B		B		B		B					
d_I, Intersection Delay [s/veh]	13.76											
Intersection LOS	B											
Intersection V/C	0.772											

Other Modes				
g_Walk,mi, Effective Walk Time [s]	11.0	11.0	11.0	11.0
M_corner, Corner Circulation Area [ft²/ped]	0.00	0.00	0.00	0.00
M_CW, Crosswalk Circulation Area [ft²/ped]	0.00	0.00	0.00	0.00
d_p, Pedestrian Delay [s]	6.67	6.67	6.67	6.67
I_p,int, Pedestrian LOS Score for Intersection	2.238	2.092	2.178	2.241
Crosswalk LOS	B	B	B	B
s_b, Saturation Flow Rate of the bicycle lane [bicycles/h]	2000	2000	2000	2000
c_b, Capacity of the bicycle lane [bicycles/h]	1612	1612	1911	1911
d_b, Bicycle Delay [s]	0.59	0.59	0.03	0.03
I_b,int, Bicycle LOS Score for Intersection	2.083	2.053	2.112	2.350
Bicycle LOS	B	B	B	B

Sequence

Ring 1	1	2	3	4	-	-	-	-	-	-	-	-	-	-
Ring 2	5	6	7	8	-	-	-	-	-	-	-	-	-	-
Ring 3	-	-	-	-	-	-	-	-	-	-	-	-	-	-
Ring 4	-	-	-	-	-	-	-	-	-	-	-	-	-	-

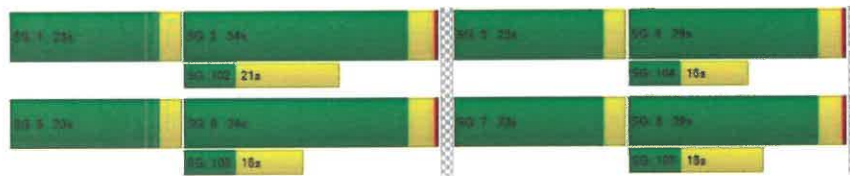

Intersection Level Of Service Report			
Intersection 1: Burns Valley Rd/N-S Project Street			
Control Type:	Two-way stop	Delay (sec / veh):	10.1
Analysis Method:	HCM 6th Edition	Level Of Service:	B
Analysis Period:	15 minutes	Volume to Capacity (v/c):	0.033

Intersection Setup

Name	N-S Project Street		Burns Valley Rd		Burns Valley Rd	
	Northbound		Eastbound		Westbound	
Approach						
Lane Configuration	T		T		T	
Turning Movement	Left	Right	Thru	Right	Left	Thru
Lane Width [ft]	12.00	12.00	12.00	12.00	12.00	12.00
No. of Lanes in Entry Pocket	0	0	0	0	0	0
Entry Pocket Length [ft]	109.00	100.00	100.00	100.00	100.00	100.00
No. of Lanes in Exit Pocket	0	0	0	0	0	0
Exit Pocket Length [ft]	0.00	0.00	0.00	0.00	0.00	0.00
Speed [mph]	25.00		35.00		35.00	
Grade [%]	0.00		0.00		0.00	
Crosswalk	No		No		No	

Volumes

Name	N-S Project Street		Burns Valley Rd		Burns Valley Rd	
	7	8	78	12	0	93
Base Volume Input [veh/h]	7	8	78	12	0	93
Base Volume Adjustment Factor	1,0000	1,0000	1,0000	1,0000	1,0000	1,0000
Heavy Vehicles Percentage [%]	2.00	2.00	2.00	2.00	2.00	2.00
Growth Factor	1,0000	1,0000	1,0000	1,0000	1,0000	1,0000
In-Process Volume [veh/h]	0	0	0	0	0	0
Site-Generated Trips [veh/h]	16	17	3	15	12	2
Diverted Trips [veh/h]	0	0	0	0	0	0
Pass-by Trips [veh/h]	0	0	0	0	0	0
Existing Site Adjustment Volume [veh/h]	0	0	0	0	0	0
Other Volume [veh/h]	0	0	0	0	0	0
Total Hourly Volume [veh/h]	23	23	81	27	12	95
Peak Hour Factor	0.9130	0.9130	0.9130	0.9130	0.9130	0.9130
Other Adjustment Factor	1,0000	1,0000	1,0000	1,0000	1,0000	1,0000
Total 15-Minute Volume [veh/h]	6	6	22	7	3	26
Total Analysis Volume [veh/h]	25	25	89	30	13	104
Pedestrian Volume [ped/h]	0		0		0	



Intersection Settings			
Priority Scheme	Stop	Free	Free
Flared Lane	No		
Storage Area [veh]	0	0	0
Two-Stage Gap Acceptance	No		
Number of Storage Spaces in Median	0	0	0

Movement, Approach, & Intersection Results						
V/C, Movement V/C Ratio	0.03	0.03	0.03	0.03	0.01	0.03
d_M, Delay for Movement [s/veh]	10.09	9.06	0.03	0.03	7.47	0.03
Movement LOS	B	A	A	A	A	A
95th-Percentile Queue Length [veh/ln]	0.19	0.19	0.00	0.00	0.03	0.03
95th-Percentile Queue Length [ft/ln]	4.76	4.76	0.00	0.00	0.67	0.67
d_A, Approach Delay [s/veh]	9.58		0.00		0.83	
Approach LOS	A		A		A	
d_I, Intersection Delay [s/veh]	2.01					
Intersection LOS	B					

Intersection Level Of Service Report			
Intersection 2: Burns Valley Rd/Bowers Ave-Rumsey Rd			
Control Type:	Two-way stop	Delay (sec / veh):	12.3
Analysis Method:	HCM 6th Edition	Level Of Service:	B
Analysis Period:	15 minutes	Volume to Capacity (v/c):	0.004

Intersection Setup												
Name	Burns Valley Rd			Rumsey Rd			Burns Valley Rd			Bowers Ave		
Approach	Northbound			Southbound			Eastbound			Westbound		
Lane Configuration	+			+			+			+		
Turning Movement	Left	Thru	Right	Left	Thru	Right	Left	Thru	Right	Left	Thru	Right
Lane Width [ft]	12.00	12.00	12.00	12.00	12.00	12.00	12.00	12.00	12.00	12.00	12.00	12.00
No. of Lanes in Entry Pocket	0	0	0	0	0	0	0	0	0	0	0	0
Entry Pocket Length [ft]	100.00	100.00	100.00	100.00	100.00	100.00	100.00	100.00	100.00	100.00	100.00	100.00
No. of Lanes in Exit Pocket	0	0	0	0	0	0	0	0	0	0	0	0
Exit Pocket Length [ft]	0.00	0.00	0.00	0.00	0.00	0.00	0.00	0.00	0.00	0.00	0.00	0.00
Speed [mph]	30.00			30.00			35.00			25.00		
Grade [%]	0.00			0.00			0.00			0.00		
Crosswalk	No			Yes			Yes			No		

Volumes												
Name	Burns Valley Rd			Rumsey Rd			Burns Valley Rd			Bowers Ave		
Base Volume Input [veh/h]	84	36	1	0	31	9	10	0	83	2	1	0
Base Volume Adjustment Factor	1.0000	1.0000	1.0000	1.0000	1.0000	1.0000	1.0000	1.0000	1.0000	1.0000	1.0000	1.0000
Heavy Vehicles Percentage [%]	2.00	2.00	2.00	2.00	2.00	2.00	2.00	2.00	2.00	2.00	2.00	2.00
Growth Factor	1.0000	1.0000	1.0000	1.0000	1.0000	1.0000	1.0000	1.0000	1.0000	1.0000	1.0000	1.0000
In-Process Volume [veh/h]	0	0	0	0	0	0	0	0	0	0	0	0
Site-Generated Trips [veh/h]	14	2	0	0	3	5	6	0	10	0	0	0
Diverted Trips [veh/h]	0	0	0	0	0	0	0	0	0	0	0	0
Pass-by Trips [veh/h]	0	0	0	0	0	0	0	0	0	0	0	0
Existing Site Adjustment Volume [veh/h]	0	0	0	0	0	0	0	0	0	0	0	0
Other Volume [veh/h]	0	0	0	0	0	0	0	0	0	0	0	0
Total Hourly Volume [veh/h]	86	38	1	0	34	14	16	0	93	2	1	0
Peak Hour Factor	0.8500	0.9500	0.9600	0.9600	0.8600	0.8500	0.8500	0.8500	0.8500	0.9600	0.8500	0.9600
Other Adjustment Factor	1.0000	1.0000	1.0000	1.0000	1.0000	1.0000	1.0000	1.0000	1.0000	1.0000	1.0000	1.0000
Total 15-Minute Volume [veh/h]	29	10	0	0	9	4	5	0	27	1	0	0
Total Analysis Volume [veh/h]	115	40	1	0	35	16	19	0	109	2	1	0
Pedestrian Volume [ped/h]	0	0	0	0	0	0	0	0	0	0	0	0



Intersection Settings

	Free	Free	Stop	Stop
Priority Scheme			Stop	Stop
Flared Lane			No	No
Storage Area [veh]	0	0	0	0
Two-Stage Gap Acceptance			No	No
Number of Storage Spaces in Median	0	0	0	0

Movement, Approach, & Intersection Results

V/C, Movement V/C Ratio	0.07	0.00	0.00	0.00	0.00	0.00	0.03	0.00	0.11	0.00	0.00	0.00
d_M, Delay for Movement [s/veh]	7.50	0.00	0.00	7.20	0.00	0.00	11.61	12.00	9.12	12.31	11.58	8.55
Movement LOS	A	A	A	A	A	A	B	B	A	B	B	A
95th-Percentile Queue Length [veh/ln]	0.24	0.24	0.24	0.00	0.00	0.00	0.48	0.48	0.48	0.02	0.02	0.00
95th-Percentile Queue Length [ft/ln]	5.98	5.98	5.98	0.00	0.00	0.00	11.92	11.92	11.92	0.44	0.44	0.44
d_A, Approach Delay [s/veh]	5.53			0.00			9.49			12.06		
Approach LOS	A			A			A			B		
d_I, Intersection Delay [s/veh]	6.25											
Intersection LOS	B											



Intersection Level Of Service Report

Intersection 3: N-S Project Street/E-W Project Street

Control Type:	All-way stop	Delay (sec / veh):	7.6
Analysis Method:	HCM 6th Edition	Level Of Service:	A
Analysis Period:	15 minutes	Volume to Capacity (v/c):	0.124

Intersection Setup

Name	N-S Project Street			N-S Project Street			E-W Project Street			E-W Project Street		
Approach	Northbound			Southbound			Eastbound			Westbound		
Lane Configuration	+			+			+			+		
Turning Movement	Left	Thru	Right	Left	Thru	Right	Left	Thru	Right	Left	Thru	Right
Lane Width [ft]	12.00	12.00	12.00	12.00	12.00	12.00	12.00	12.00	12.00	12.00	12.00	12.00
No. of Lanes in Entry Pocket	0	0	0	0	0	0	0	0	0	0	0	0
Entry Pocket Length [ft]	100.00	100.00	100.00	100.00	100.00	100.00	100.00	100.00	100.00	100.00	100.00	100.00
No. of Lanes in Exit Pocket	0	0	0	0	0	0	0	0	0	0	0	0
Exit Pocket Length [ft]	0.00	0.00	0.00	0.00	0.00	0.00	0.00	0.00	0.00	0.00	0.00	0.00
Speed [mph]	25.00			25.00			25.00			25.00		
Grade [%]	0.00			0.00			0.00			0.00		
Crosswalk	Yes			Yes			Yes			Yes		

Volumes

Name	N-S Project Street			N-S Project Street			E-W Project Street			E-W Project Street		
Base Volume Input [veh/h]	0	13	0	0	12	0	0	0	0	0	0	0
Base Volume Adjustment Factor	1.0000	1.0000	1.0000	1.0000	1.0000	1.0000	1.0000	1.0000	1.0000	1.0000	1.0000	1.0000
Heavy Vehicles Percentage [%]	2.00	2.00	2.00	2.00	2.00	2.00	2.00	2.00	2.00	2.00	2.00	2.00
Growth Factor	1.0000	1.0000	1.0000	1.0000	1.0000	1.0000	1.0000	1.0000	1.0000	1.0000	1.0000	1.0000
In-Process Volume [veh/h]	0	0	0	0	0	0	0	0	0	0	0	0
Site-Generated Trips [veh/h]	5	60	30	24	64	2	1	6	15	15	4	26
Diverted Trips [veh/h]	0	0	0	0	0	0	0	0	0	0	0	0
Pass-by Trips [veh/h]	0	0	0	0	0	0	0	0	0	0	0	0
Existing Site Adjustment Volume [veh/h]	0	0	0	0	0	0	0	0	0	0	0	0
Other Volume [veh/h]	0	0	0	0	0	0	0	0	0	0	0	0
Total Hourly Volume [veh/h]	5	73	30	24	76	2	1	6	15	15	4	26
Peak Hour Factor	0.9720	0.9720	0.9720	0.9720	0.9720	0.9720	0.9720	0.9720	0.9720	0.9720	0.9720	0.9720
Other Adjustment Factor	1.0000	1.0000	1.0000	1.0000	1.0000	1.0000	1.0000	1.0000	1.0000	1.0000	1.0000	1.0000
Total 15-Minute Volume [veh/h]	1	19	8	6	20	1	0	2	4	4	1	7
Total Analysis Volume [veh/h]	5	75	31	25	78	2	1	6	15	15	4	27
Pedestrian Volume [ped/h]	0			0			0			0		



Intersection Settings				
Lanes				
Capacity per Entry Lane [veh/h]	894	852	889	870
Degree of Utilization, x	0.12	0.12	0.02	0.05
Movement, Approach, & Intersection Results				
95th-Percentile Queue Length [veh]	0.42	0.42	0.08	0.17
95th-Percentile Queue Length [ft]	10.60	10.50	1.90	4.18
Approach Delay [s/veh]	7.60	7.82	7.15	7.37
Approach LOS	A	A	A	A
Intersection Delay [s/veh]	7.61			
Intersection LOS	A			



Intersection Level Of Service Report						
Intersection 4: Burns Valley Rd/E-W Project Street						
Control Type:	Two-way stop	Delay (sec / veh):	11.1			
Analysis Method:	HCM 6th Edition	Level Of Service:	B			
Analysis Period:	15 minutes	Volume to Capacity (v/c):	0.003			
Intersection Setup						
Name	Burns Valley Rd		Burns Valley Rd		E-W Project Street	
Approach	Northbound		Southbound		Eastbound	
Lane Configuration	← →		← →		← →	
Turning Movement	Left	Thru	Thru	Right	Left	Right
Lane Width [ft]	12.00	12.00	12.00	12.00	12.00	12.00
No. of Lanes in Entry Pocket	0	0	0	0	0	0
Entry Pocket Length [ft]	100.00	100.00	100.00	100.00	100.00	100.00
No. of Lanes in Exit Pocket	0	0	0	0	0	0
Exit Pocket Length [ft]	0.00	0.00	0.00	0.00	0.00	0.00
Speed [mph]	30.00		30.00		25.00	
Grade [%]	0.00		0.00		0.00	
Crosswalk	No		No		Yes	
Volumes						
Name	Burns Valley Rd		Burns Valley Rd		E-W Project Street	
Base Volume Input [veh/h]	0	130	120	0	0	0
Base Volume Adjustment Factor	1.0000	1.0000	1.0000	1.0000	1.0000	1.0000
Heavy Vehicles Percentage [%]	2.00	2.00	2.00	2.00	2.00	2.00
Growth Factor	1.0000	1.0000	1.0000	1.0000	1.0000	1.0000
In-Process Volume [veh/h]	0	0	0	0	0	0
Site-Generated Trips [veh/h]	43	14	10	3	2	43
Diverted Trips [veh/h]	0	0	0	0	0	0
Pass-by Trips [veh/h]	0	0	0	0	0	0
Existing Site Adjustment Volume [veh/h]	0	0	0	0	0	0
Other Volume [veh/h]	0	0	0	0	0	0
Total Hourly Volume [veh/h]	43	144	130	3	2	43
Peak Hour Factor	0.9720	0.9720	0.9720	0.9720	0.9720	0.9720
Other Adjustment Factor	1.0000	1.0000	1.0000	1.0000	1.0000	1.0000
Total 15-Minute Volume [veh/h]	11	37	33	1	1	11
Total Analysis Volume [veh/h]	44	148	134	3	2	44
Pedestrian Volume [ped/h]	0		0		0	



Intersection Settings

Priority Scheme	Free	Free	Stop
Flared Lane			No
Storage Area [veh]	3	0	0
Two-Stage Gap Acceptance			No
Number of Storage Spaces in Median	0	0	0

Movement, Approach, & Intersection Results

V/C, Movement V/C Ratio	0.03	0.00	0.00	0.00	0.00	0.05
d_M, Delay for Movement [s/veh]	7.57	0.00	0.00	0.00	11.14	9.16
Movement LOS	A	A	A	A	B	A
95th-Percentile Queue Length [veh/ln]	0.09	0.09	0.00	0.00	0.16	0.16
95th-Percentile Queue Length [ft/ln]	2.35	2.35	0.00	0.00	4.06	4.06
d_A, Approach Delay [s/veh]	1.73		0.00		9.25	
Approach LOS	A		A		A	
d_I, Intersection Delay [s/veh]			2.02			
Intersection LOS			B			



Intersection Level Of Service Report
Intersection 5: Olympic Dr/Lakeshore Dr

Control Type:	Two-way stop	Delay (sec / veh):	20.2
Analysis Method:	HCM 6th Edition	Level Of Service:	C
Analysis Period:	15 minutes	Volume to Capacity (v/c):	0.379

Intersection Setup

Name	Lakeshore Dr			Lakeshore Dr			Eastbound			Olympic Dr		
Approach	Northbound			Southbound			Eastbound			Westbound		
Lane Configuration	←→			↑			↑			←→		
Turning Movement	Left	Thru	Right	Left	Thru	Right	Left	Thru	Right	Left	Thru	Right
Lane Width [ft]	12.00	12.00	12.00	12.00	12.00	12.00	12.00	12.00	12.00	12.00	12.00	12.00
No. of Lanes in Entry Pocket	0	0	1	0	0	0	0	0	0	0	0	1
Entry Pocket Length [ft]	100.00	100.00	120.00	100.00	100.00	100.00	100.00	100.00	100.00	100.00	100.00	250.00
No. of Lanes in Exit Pocket	0	0	0	0	0	0	0	0	0	0	0	0
Exit Pocket Length [ft]	0.00	0.00	0.00	0.00	0.00	0.00	0.00	0.00	0.00	0.00	0.00	0.00
Speed [mph]	25.00			25.00			30.00			30.00		
Grade [%]	0.00			0.00			0.00			0.00		
Crosswalk	No			Yes			No			Yes		

Volumes

Name	Lakeshore Dr			Lakeshore Dr			Olympic Dr						
Base Volume Input [veh/h]	1	176	103	78	185	0	0	0	3	3	97	1	75
Base Volume Adjustment Factor	1.0000	1.0000	1.0000	1.0000	1.0000	1.0000	1.0000	1.0000	1.0000	1.0000	1.0000	1.0000	1.0000
Heavy Vehicles Percentage [%]	2.00	2.00	2.00	2.00	2.00	2.00	2.00	2.00	2.00	2.00	2.00	2.00	2.00
Growth Factor	1.0000	1.0000	1.0000	1.0000	1.0000	1.0000	1.0000	1.0000	1.0000	1.0000	1.0000	1.0000	1.0000
In-Process Volume [veh/h]	0	0	0	0	0	0	0	0	0	0	0	0	0
Site-Generated Trips [veh/h]	0	0	37	18	0	0	0	0	0	0	33	0	18
Diverted Trips [veh/h]	0	0	0	0	0	0	0	0	0	0	0	0	0
Pass-by Trips [veh/h]	0	0	0	0	0	0	0	0	0	0	0	0	0
Existing Site Adjustment Volume [veh/h]	0	0	0	0	0	0	0	0	0	0	0	0	0
Other Volume [veh/h]	0	0	0	0	0	0	0	0	0	0	0	0	0
Total Hourly Volume [veh/h]	1	176	140	91	185	0	0	0	3	3	130	1	93
Peak Hour Factor	0.9100	0.9100	0.9100	0.9100	0.9100	0.9100	0.9100	0.9100	0.9100	0.9100	0.9100	0.9100	0.9100
Other Adjustment Factor	1.0000	1.0000	1.0000	1.0000	1.0000	1.0000	1.0000	1.0000	1.0000	1.0000	1.0000	1.0000	1.0000
Total 15-Minute Volume [veh/h]	0	48	38	25	51	0	0	0	1	1	36	0	26
Total Analysis Volume [veh/h]	1	193	154	100	203	0	0	0	3	3	143	1	102
Pedestrian Volume [ped/h]		0			0			0				1	



Intersection Settings				
Priority Scheme	Free	Free	Stop	Stop
Flared Lane			No	No
Storage Area [veh]	0	0	0	0
Two-Stage Gap Acceptance			No	No
Number of Storage Spaces in Median	0	0	0	0

Movement, Approach, & Intersection Results												
V/C, Movement V/C Ratio	0.00	0.00	0.00	0.08	0.00	0.00	0.00	0.01	0.00	0.38	0.00	0.12
d_M, Delay for Movement [s/veh]	7.63	0.00	0.00	8.24	0.00	0.00	18.12	16.85	9.41	20.24	15.18	9.86
Movement LOS	A	A	A	A	A	C	C	A	C	C	C	A
95th-Percentile Queue Length [veh/ln]	0.00	0.00	0.00	0.27	0.27	0.27	0.04	0.04	1.73	0.42	0.42	0.42
95th-Percentile Queue Length [ft/ln]	0.05	0.05	0.00	6.75	6.75	6.75	1.02	1.02	43.20	10.48	10.48	10.48
d_A, Approach Delay [s/veh]	0.02			2.72			13.13			15.91		
Approach LOS	A			A			B			C		
d_I, Intersection Delay [s/veh]	5.34											
Intersection LOS	C											

Intersection Level Of Service Report Intersection 6: Olympic Dr/N-S Project Street			
Control Type:	Two-way stop	Delay (sec / veh):	21.0
Analysis Method:	HCM 6th Edition	Level Of Service:	C
Analysis Period:	15 minutes	Volume to Capacity (v/c):	0.139

Intersection Setup						
Name	N-S Project Street		Olympic Dr		Olympic Dr	
Approach	Southbound		Eastbound		Westbound	
Lane Configuration	T		T		T	
Turning Movement	Left	Right	Left	Thru	Thru	Right
Lane Width [ft]	12.00	12.00	12.00	12.00	12.00	12.00
No. of Lanes in Entry Pocket	0	0	0	0	0	0
Entry Pocket Length [ft]	100.00	100.00	100.00	100.00	100.00	100.00
No. of Lanes in Exit Pocket	0	0	0	0	0	0
Exit Pocket Length [ft]	0.00	0.00	0.00	0.00	0.00	0.00
Speed [mph]	25.00		30.00		30.00	
Grade [%]	0.00		0.00		0.00	
Crosswalk	Yes		No		No	

Volumes						
Name	N-S Project Street		Olympic Dr		Olympic Dr	
Base Volume Input [veh/h]	6	8	13	289	300	0
Base Volume Adjustment Factor	1.0000	1.0000	1.0000	1.0000	1.0000	1.0000
Heavy Vehicles Percentage [%]	2.00	2.00	2.00	2.00	2.00	2.00
Growth Factor	1.0000	1.0000	1.0000	1.0000	1.0000	1.0000
In-Process Volume [veh/h]	0	0	0	0	0	0
Site-Generated Trips [veh/h]	26	69	73	0	0	25
Diverted Trips [veh/h]	0	0	0	0	0	0
Pass-by Trips [veh/h]	0	0	0	0	0	0
Existing Site Adjustment Volume [veh/h]	0	0	0	0	0	0
Other Volume [veh/h]	0	0	0	0	0	0
Total Hourly Volume [veh/h]	32	75	86	289	300	25
Peak Hour Factor	0.8500	0.8500	0.8500	0.8500	0.8500	0.8500
Other Adjustment Factor	1.0000	1.0000	1.0000	1.0000	1.0000	1.0000
Total 15-Minute Volume [veh/h]	9	22	25	85	88	7
Total Analysis Volume [veh/h]	38	88	101	340	353	29
Pedestrian Volume [ped/h]	0		0		0	



Intersection Settings

Priority Scheme	Stop	Free	Free
Flared Lane	No		
Storage Area [veh]	?	0	0
Two-Stage Gap Acceptance	No		
Number of Storage Spaces in Median	0	0	?

Movement, Approach, & Intersection Results

V/C, Movement V/C Ratio	0.14	0.13	0.09	0.00	0.00	0.00
d_M, Delay for Movement [s/veh]	21.00	13.12	8.35	0.00	0.00	0.00
Movement LOS	C	B	A	A	A	A
95th-Percentile Queue Length [veh/ln]	1.08	1.08	0.28	0.28	0.00	0.00
95th-Percentile Queue Length [ft/ln]	26.94	26.94	7.03	7.03	0.00	0.00
d_A, Approach Delay [s/veh]	15.50		1.91		0.00	
Approach LOS	C		A		A	
d_I, Intersection Delay [s/veh]	2.95					
Intersection LOS	C					



Intersection Level Of Service Report

Intersection 7: Olympic Dr/Burns Valley Rd-Old Hwy 53

Control Type:	Signalized	Delay (sec / veh):	12.7
Analysis Method:	HCM 6th Edition	Level Of Service:	B
Analysis Period:	15 minutes	Volume to Capacity (v/c):	0.732

Intersection Setup

Name	Old Hwy 53			Burns Valley Rd			Olympic Dr			Old Hwy 53		
Approach	Northbound			Southbound			Eastbound			Westbound		
Lane Configuration	T T T			T T			T T			T T		
Turning Movement	Left	Thru	Right	Left	Thru	Right	Left	Thru	Right	Left	Thru	Right
Lane Width [ft]	12.00	12.00	12.00	12.00	12.00	12.00	12.00	12.00	12.00	12.00	12.00	12.00
No. of Lanes in Entry Pocket	1	0	1	1	0	0	1	0	0	1	0	0
Entry Pocket Length [ft]	100.00	100.00	100.00	58.00	100.00	100.00	48.00	100.00	100.00	100.00	100.00	100.00
No. of Lanes in Exit Pocket	0	0	0	0	0	0	0	0	0	0	0	0
Exit Pocket Length [ft]	0.00	0.00	0.00	0.00	0.00	0.00	0.00	0.00	0.00	0.00	0.00	0.00
Speed [mph]	30.00			30.00			35.00			35.00		
Grade [%]	0.00			0.00			0.00			0.00		
Curb Present	No			No			No			No		
Crosswalk	Yes			Yes			Yes			Yes		



Volumes												
Name	Old Hwy 53			Burns Valley Rd			Olympic Dr			Old Hwy 53		
Base Volume Input [veh/h]	80	81	42	93	64	30	20	180	95	33	170	109
Base Volume Adjustment Factor	1.0000	1.0000	1.0000	1.0000	1.0000	1.0000	1.0000	1.0000	1.0000	1.0000	1.0000	1.0000
Heavy Vehicles Percentage [%]	2.00	2.00	2.00	2.00	2.00	2.00	2.00	2.00	2.00	2.00	2.00	2.00
Growth Factor	1.0000	1.0000	1.0000	1.0000	1.0000	1.0000	1.0000	1.0000	1.0000	1.0000	1.0000	1.0000
In-Process Volume [veh/h]	0	0	0	0	0	0	0	0	0	0	0	0
Site-Generated Trips [veh/h]	12	32	0	22	31	0	0	11	15	0	12	25
Diverted Trips [veh/h]	0	0	0	0	0	0	0	0	0	0	0	0
Pass-by Trips [veh/h]	0	0	0	0	0	0	0	0	0	0	0	0
Existing Site Adjustment Volume [veh/h]	0	0	0	0	0	0	0	0	0	0	0	0
Other Volume [veh/h]	0	0	0	0	0	0	0	0	0	0	0	0
Right Turn on Red Volume [veh/h]	0	0	15	0	0	12	0	0	25	0	0	29
Total Hourly Volume [veh/h]	92	113	27	115	95	18	20	191	95	33	182	105
Peak Hour Factor	0.9300	0.9300	0.9300	0.9300	0.9300	0.9300	0.9300	0.9300	0.9300	0.9300	0.9300	0.9300
Other Adjustment Factor	1.0000	1.0000	1.0000	1.0000	1.0000	1.0000	1.0000	1.0000	1.0000	1.0000	1.0000	1.0000
Total 15-Minute Volume [veh/h]	25	30	7	31	26	5	5	51	23	9	49	28
Total Analysis Volume [veh/h]	99	122	29	124	102	19	22	205	91	35	196	113
Presence of On-Street Parking	No	No	No	No	No	No	No	No	No	No	No	No
On-Street Parking Maneuver Rate [1/h]	0	0	0	0	0	0	0	0	0	0	0	0
Local Bus Stopping Rate [1/h]	0	0	0	0	0	0	0	0	0	0	0	0
v_do, Outbound Pedestrian Volume crossing major street	1			0			1			1		
v_di, Inbound Pedestrian Volume crossing major street	1			1			0			1		
v_co, Outbound Pedestrian Volume crossing minor street	1			0			0			0		
v_ci, Inbound Pedestrian Volume crossing minor street	0			0			1			0		
v_ab, Corner Pedestrian Volume [ped/h]	0			0			0			0		
Bicycle Volume [bicycles/h]	0			0			0			0		1



Intersection Settings	
Located in CBD	Yes
Signal Coordination Group	-
Cycle Length [s]	109
Coordination Type	Time of Day Pattern Isolated
Actuation Type	Fully actuated
Offset [s]	0.0
Offset Reference	Lead Green - Beginning of First Green
Permissive Mode	SingleBand
Lost time [s]	14.00

Phasing & Timing												
Control Type	Protect	Permis	Permis	Protect	Permis	Permis	Protect	Permis	Permis	Protect	Permis	Permis
Signal Group	3	8	0	7	4	0	5	2	0	1	6	0
Auxiliary Signal Groups												
Lead / Lag	Lead	-	-	Lead	-	-	Lead	-	-	Lead	-	-
Minimum Green [s]	4	6	0	4	6	0	4	6	0	4	6	0
Maximum Green [s]	20	25	0	20	25	0	20	30	0	20	20	0
Amber [s]	3.0	3.3	0.0	3.0	3.3	0.0	3.0	3.6	0.0	3.0	3.6	0.0
All red [s]	0.0	0.3	0.0	0.0	0.3	0.0	0.0	0.3	0.0	0.0	0.3	0.0
Split [s]	23	29	0	23	29	0	23	34	0	23	34	0
Vehicle Extension [s]	0.0	0.0	0.0	0.0	0.0	0.0	0.0	0.0	0.0	0.0	0.0	0.0
Walk [s]	0	7	0	0	7	0	0	7	0	0	7	0
Pedestrian Clearance [s]	0	11	0	0	9	0	0	14	0	0	9	0
Delayed Vehicle Green [s]	0.0	0.0	0.0	0.0	0.0	0.0	0.0	0.0	0.0	0.0	0.0	0.0
Rest In Walk	No			No			No			No		
I1, Start-Up Lost Time [s]	2.0	2.0	0.0	2.0	2.0	0.0	2.0	2.0	0.0	2.0	2.0	0.0
I2, Clearance Lost Time [s]	1.0	1.6	0.0	1.0	1.6	0.0	1.0	1.9	0.0	1.0	1.9	0.0
Minimum Recall	No	No		No	No		No	No		No	No	
Maximum Recall	No	No		No	No		No	No		No	No	
Pedestrian Recall	No	No		No	No		No	No		No	No	
Detector Location [ft]	0.0	0.0	0.0	0.0	0.0	0.0	0.0	0.0	0.0	0.0	0.0	0.0
Detector Length [ft]	0.0	0.0	0.0	0.0	0.0	0.0	0.0	0.0	0.0	0.0	0.0	0.0
I, Upstream Filtering Factor	1.00	1.00	1.00	1.00	1.00	1.00	1.00	1.00	1.00	1.00	1.00	1.00

Exclusive Pedestrian Phase	
Pedestrian Signal Group	0
Pedestrian Walk [s]	0
Pedestrian Clearance [s]	0



Lane Group Calculations

Lane Group	L	C	R	L	C	L	C	L	C
C, Cycle Length [s]	28	28	28	28	28	28	28	28	28
L, Total Lost Time per Cycle [s]	3.00	3.60	3.60	3.00	3.60	3.00	3.90	3.00	3.90
l1_p, Permitted Start-Up Lost Time [s]	0.00	0.00	0.00	0.00	0.00	0.00	0.00	0.00	0.00
l2, Clearance Lost Time [s]	1.00	1.60	1.60	1.00	1.60	1.00	1.90	1.00	1.90
g_i, Effective Green Time [s]	2	4	4	3	5	1	6	1	7
g / C, Green / Cycle	0.08	0.15	0.15	0.09	0.17	0.02	0.23	0.03	0.24
(v / s)_i Volume / Saturation Flow Rate	0.06	0.07	0.02	0.06	0.07	0.01	0.19	0.02	0.20
s, saturation flow rate [veh/h]	1603	1683	1421	1603	1637	1603	1595	1603	1567
c, Capacity [veh/h]	126	261	220	151	279	37	366	56	378
d1, Uniform Delay [s]	12.56	10.68	10.11	12.35	10.31	13.42	10.11	13.21	9.95
k, delay calibration	0.04	0.04	0.04	0.04	0.04	0.04	0.04	0.04	0.04
l, Upstream Filtering Factor	1.00	1.00	1.00	1.00	1.00	1.00	1.00	1.00	1.00
d2, Incremental Delay [s]	4.03	0.48	0.10	4.23	0.40	5.47	1.63	4.14	1.66
d3, Initial Queue Delay [s]	0.00	0.00	0.00	0.00	0.00	0.00	0.00	0.00	0.00
Rp, platoon ratio	1.00	1.00	1.00	1.00	1.00	1.00	1.00	1.00	1.00
PF, progression factor	1.00	1.00	1.00	1.00	1.00	1.00	1.00	1.00	1.00

Lane Group Results

X, volume / capacity	0.79	0.47	0.13	0.82	0.43	0.59	0.81	0.62	0.82
d, Delay for Lane Group [s/veh]	16.58	11.17	10.21	16.58	10.71	18.89	11.74	17.35	11.61
Lane Group LOS	B	B	B	B	B	B	B	B	B
Critical Lane Group	No	Yes	No	Yes	No	Yes	No	No	Yes
50th-Percentile Queue Length [veh/m]	0.58	0.51	0.11	0.72	0.49	0.15	1.18	0.22	1.22
50th-Percentile Queue Length [ft/m]	14.55	12.70	2.81	18.09	12.14	3.85	29.62	5.46	30.49
95th-Percentile Queue Length [veh/m]	1.05	0.91	0.20	1.30	0.87	0.28	2.13	0.39	2.20
95th-Percentile Queue Length [ft/m]	26.20	22.86	5.06	32.57	21.85	6.93	53.32	9.81	54.88



Movement, Approach, & Intersection Results

d_M, Delay for Movement [s/veh]	16.58	11.17	10.21	16.58	10.71	10.71	18.89	11.74	11.74	17.35	11.61	11.61
Movement LOS	B	B	B	B	B	B	B	B	B	B	B	B
d_A, Approach Delay [s/veh]	13.20			13.66			12.24			12.19		
Approach LOS	B			B			B			B		
d_I, Intersection Delay [s/veh]	12.74											
Intersection LOS	B											
Intersection V/C	0.732											

Other Modes

g_Walk,mi, Effective Walk Time [s]	11.0	11.0	11.0	11.0
M_corner, Corner Circulation Area [FF/ped]	0.00	0.00	0.00	0.00
M_CW, Crosswalk Circulation Area [FF/ped]	0.00	0.00	0.00	0.00
d_p, Pedestrian Delay [s]	4.99	4.99	4.99	4.99
l_p,int, Pedestrian LOS Score for Intersection	2.200	2.056	2.151	2.186
Crosswalk LOS	B	B	B	B
s_b, Saturation Flow Rate of the bicycle lane [bicycles/h]	2000	2000	2000	2000
c_b, Capacity of the bicycle lane [bicycles/h]	1841	1841	2182	2182
d_b, Bicycle Delay [s]	0.09	0.09	0.11	0.11
l_b,int, Bicycle LOS Score for Intersection	1.997	1.984	2.126	2.175
Bicycle LOS	A	A	B	B

Sequence

Ring 1	1	2	3	4	-	-	-	-	-	-	-	-	-	-
Ring 2	5	6	7	8	-	-	-	-	-	-	-	-	-	-
Ring 3	-	-	-	-	-	-	-	-	-	-	-	-	-	-
Ring 4	-	-	-	-	-	-	-	-	-	-	-	-	-	-

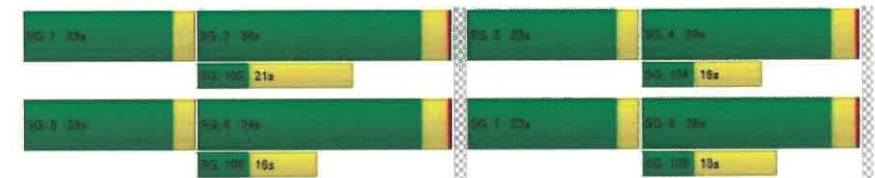

Intersection Level Of Service Report
Intersection 1: Burns Valley Rd/N-S Project Street

Control Type: Two-way stop Delay (sec / veh): 10.3
 Analysis Method: HCM 6th Edition Level Of Service: B
 Analysis Period: 15 minutes Volume to Capacity (v/c): 0.017

Intersection Setup

Name	N-S Project Street		Burns Valley Rd		Burns Valley Rd	
	Northbound		Eastbound		Westbound	
Approach	Northbound		Eastbound		Westbound	
Lane Configuration	T		T		T	
Turning Movement	Left	Right	Thru	Right	Left	Thru
Lane Width [ft]	12.00	12.00	12.00	12.00	12.00	12.00
No. of Lanes in Entry Pocket	0	0	0	0	0	0
Entry Pocket Length [ft]	100.00	100.00	100.00	100.00	100.00	100.00
No. of Lanes in Exit Pocket	0	0	0	0	0	0
Exit Pocket Length [ft]	0.00	0.00	0.00	0.00	0.00	0.00
Speed [mph]	25.00		35.00		35.00	
Grade [%]	0.00		0.00		0.00	
Crosswalk	No		No		No	

Volumes

Name	N-S Project Street		Burns Valley Rd		Burns Valley Rd	
	Base Volume Input [veh/h]	8	7	112	15	0
Base Volume Adjustment Factor	1.0000	1.0000	1.0000	1.0000	1.0000	1.0000
Heavy Vehicles Percentage [%]	2.00	2.00	2.00	2.00	2.00	2.00
Growth Factor	1.0000	1.0000	1.0000	1.0000	1.0000	1.0000
In-Process Volume [veh/h]	1	2	6	0	0	5
Site-Generated Trips [veh/h]	2	3	1	4	5	1
Diverted Trips [veh/h]	0	0	0	0	0	0
Pass-by Trips [veh/h]	0	0	0	0	0	0
Existing Site Adjustment Volume [veh/h]	0	0	0	0	0	0
Other Volume [veh/h]	0	0	0	0	0	0
Total Hourly Volume [veh/h]	11	12	119	19	5	116
Peak Hour Factor	0.8890	0.8890	0.8890	0.8890	0.8890	0.8890
Other Adjustment Factor	1.0000	1.0000	1.0000	1.0000	1.0000	1.0000
Total 15-Minute Volume [veh/h]	3	3	33	5	1	33
Total Analysis Volume [veh/h]	12	13	134	21	6	130
Pedestrian Volume [ped/h]	0	0	0	0	0	0



Intersection Settings

Priority Scheme	Stop	Free	Free
Flared Lane	No		
Storage Area [veh]	0	0	0
Two-Stage Gap Acceptance	No		
Number of Storage Spaces in Median	0	0	0

Movement, Approach, & Intersection Results

V/C, Movement V/C Ratio	0.02	0.01	0.00	0.00	0.00	0.00
d_M, Delay for Movement [s/veh]	10.29	9.14	0.00	0.00	7.54	0.00
Movement LOS	B	A	A	A	A	A
95th-Percentile Queue Length [veh/m]	0.10	0.10	0.00	0.00	0.01	0.01
95th-Percentile Queue Length [ft/m]	2.44	2.44	0.00	0.00	0.32	0.32
d_A, Approach Delay [s/veh]	9.69		0.00		0.33	
Approach LOS	A		A		- A	
d_I, Intersection Delay [s/veh]			0.91			
Intersection LOS			B			



Intersection Level Of Service Report

Intersection 2: Burns Valley Rd/Bowers Ave-Rumsey Rd

Control Type: Two-way stop
Analysis Method: HCM 6th Edition
Analysis Period: 15 minutes
Delay (sec / veh): 14.1
Level Of Service: B
Volume to Capacity (v/c): 0.015

Intersection Setup

Name	Burns Valley Rd			Rumsey Rd			Burns Valley Rd			Bowers Ave		
Approach	Northbound			Southbound			Eastbound			Westbound		
Lane Configuration	+			+			+			+		
Turning Movement	Left	Thru	Right	Left	Thru	Right	Left	Thru	Right	Left	Thru	Right
Lane Width [ft]	12.00	12.00	12.00	12.00	12.00	12.00	12.00	12.00	12.00	12.00	12.00	12.00
No. of Lanes in Entry Pocket	0	0	0	0	0	0	0	0	0	0	0	0
Entry Pocket Length [ft]	100.00	100.00	100.00	100.00	100.00	100.00	100.00	100.00	100.00	100.00	100.00	100.00
No. of Lanes in Exit Pocket	0	0	0	0	0	0	0	0	0	0	0	0
Exit Pocket Length [ft]	0.00	0.00	0.00	0.00	0.00	0.00	0.00	0.00	0.00	0.00	0.00	0.00
Speed [mph]	30.00			30.00			35.00			25.00		
Grade [%]	0.00			0.00			0.00			0.00		
Crosswalk	No			Yes			Yes			No		

Volumes

Name	Burns Valley Rd			Rumsey Rd			Burns Valley Rd			Bowers Ave		
Base Volume Input [veh/h]	127	27	6	0	24	16	9	1	130	5	1	0
Base Volume Adjustment Factor	1.0000	1.0000	1.0000	1.0000	1.0000	1.0000	1.0000	1.0000	1.0000	1.0000	1.0000	1.0000
Heavy Vehicles Percentage [%]	2.00	2.00	2.00	2.00	2.00	2.00	2.00	2.00	2.00	2.00	2.00	2.00
Growth Factor	1.0000	1.0000	1.0000	1.0000	1.0000	1.0000	1.0000	1.0000	1.0000	1.0000	1.0000	1.0000
In-Process Volume [veh/h]	0	0	0	0	0	0	0	0	0	0	0	0
Site-Generated Trips [veh/h]	2	1	0	0	0	1	2	0	5	0	0	0
Diverted Trips [veh/h]	0	0	0	0	0	0	0	0	0	0	0	0
Pass-by Trips [veh/h]	0	0	0	0	0	0	0	0	0	0	0	0
Existing Site Adjustment Volume [veh/h]	0	0	0	0	0	0	0	0	0	0	0	0
Other Volume [veh/h]	0	0	0	0	0	0	0	0	0	0	0	0
Total Hourly Volume [veh/h]	129	28	6	0	24	17	11	1	135	5	1	0
Peak Hour Factor	0.8500	0.8500	0.8500	0.8500	0.8500	0.8500	0.8500	0.8500	0.8500	0.8500	0.8500	0.8500
Other Adjustment Factor	1.0000	1.0000	1.0000	1.0000	1.0000	1.0000	1.0000	1.0000	1.0000	1.0000	1.0000	1.0000
Total 15-Minute Volume [veh/h]	38	8	2	0	7	5	3	0	40	1	0	0
Total Analysis Volume [veh/h]	152	33	7	0	28	20	13	1	159	6	1	0
Pedestrian Volume [ped/h]	0	0	0	0	0	0	0	0	0	0	0	0



Intersection Settings

Priority Scheme	Free	Free	Stop	Stop
Flared Lane			No	No
Storage Area [veh]	0	0	0	0
Two-Stage Gap Acceptance			No	No
Number of Storage Spaces in Median	0	0	0	0

Movement, Approach, & Intersection Results

V/C, Movement V/C Ratio	0.10	0.30	0.50	0.00	0.50	3.00	0.02	0.00	0.15	0.01	0.00	0.00
d_M, Delay for Movement [s/veh]	7.56	0.30	0.00	7.20	0.00	0.00	12.57	13.08	9.30	14.15	12.47	8.53
Movement LOS	A	A	A	A	A	A	B	B	A	B	B	A
95th-Percentile Queue Length [veh/ln]	0.32	0.32	0.32	0.00	0.00	0.00	0.65	0.65	0.65	0.05	0.05	0.05
95th-Percentile Queue Length [ft/ln]	8.09	8.09	8.09	0.00	0.00	0.00	16.37	16.37	16.37	1.30	1.30	1.30
d_A, Approach Delay [s/veh]	5.98			0.00			9.57			13.91		
Approach LOS	A			A			A			B		
d_I, Intersection Delay [s/veh]	6.91											
Intersection LOS	B											



Intersection Level Of Service Report
Intersection 3: N-S Project Street/E-W Project Street

Control Type: All-way stop Delay (sec / veh): 7.2
Analysis Method: HCM 6th Edition Level Of Service: A
Analysis Period: 15 minutes Volume to Capacity (v/c): 0.059

Intersection Setup

Name	N-S Project Street			N-S Project Street			E-W Project Street			E-W Project Street		
	Northbound			Southbound			Eastbound			Westbound		
Approach	+			+			+			+		
Lane Configuration	+			+			+			+		
Turning Movement	Left	Thru	Right	Left	Thru	Right	Left	Thru	Right	Left	Thru	Right
Lane Width [ft]	12.00	12.00	12.00	12.00	12.00	12.00	12.00	12.00	12.00	12.00	12.00	12.00
No. of Lanes in Entry Pocket	0	0	0	0	0	0	0	0	0	0	0	0
Entry Pocket Length [ft]	100.00	100.00	100.00	100.00	100.00	100.00	100.00	100.00	100.00	100.00	100.00	100.00
No. of Lanes in Exit Pocket	0	0	0	0	0	0	0	0	0	0	0	0
Exit Pocket Length [ft]	0.00	0.00	0.00	0.00	0.00	0.00	0.00	0.00	0.00	0.00	0.00	0.00
Speed [mph]	25.00			25.00			25.00			25.00		
Grade [%]	0.00			0.00			0.00			0.00		
Crosswalk	Yes			Yes			Yes			Yes		

Volumes

Name	N-S Project Street			N-S Project Street			E-W Project Street			E-W Project Street		
	Base Volume Input [veh/h]	0	18	0	0	19	0	0	0	0	0	0
Base Volume Adjustment Factor	1.0000	1.0000	1.0000	1.0000	1.0000	1.0000	1.0000	1.0000	1.0000	1.0000	1.0000	1.0000
Heavy Vehicles Percentage [%]	2.00	2.00	2.00	2.00	2.00	2.00	2.00	2.00	2.00	2.00	2.00	2.00
Growth Factor	1.0000	1.0000	1.0000	1.0000	1.0000	1.0000	1.0000	1.0000	1.0000	1.0000	1.0000	1.0000
In-Process Volume [veh/h]	0	0	0	0	0	0	0	0	0	0	0	0
Site-Generated Trips [veh/h]	6	18	3	3	11	1	0	1	1	4	2	4
Diverted Trips [veh/h]	0	0	0	0	0	0	0	0	0	0	0	0
Pass-by Trips [veh/h]	0	0	0	0	0	0	0	0	0	0	0	0
Existing Site Adjustment Volume [veh/h]	0	0	0	0	0	0	0	0	0	0	0	0
Other Volume [veh/h]	0	0	0	0	0	0	0	0	0	0	0	0
Total Hourly Volume [veh/h]	6	36	3	3	30	1	0	1	1	4	2	4
Peak Hour Factor	0.8500	0.8500	0.8500	0.8500	0.8500	0.8500	0.8500	0.8500	0.8500	0.8500	0.8500	0.8500
Other Adjustment Factor	1.0000	1.0000	1.0000	1.0000	1.0000	1.0000	1.0000	1.0000	1.0000	1.0000	1.0000	1.0000
Total 15-Minute Volume [veh/h]	2	11	1	1	9	0	0	0	0	1	1	1
Total Analysis Volume [veh/h]	7	42	4	4	35	1	0	1	1	5	2	5
Pedestrian Volume [ped/h]	0			0			0			0		



Intersection Settings

Lanes				
Capacity per Entry Lane [veh/h]	905	897	937	908
Degree of Utilization, x	0.06	0.04	0.00	0.01

Movement, Approach, & Intersection Results

95th-Percentile Queue Length [veh]	0.19	0.14	0.01	0.04
95th-Percentile Queue Length [ft]	4.86	3.50	0.16	1.00
Approach Delay [s/veh]	7.23	7.20	6.85	7.02
Approach LOS	A	A	A	A
Intersection Delay [s/veh]	7.19			
Intersection LOS	A			



Intersection Level Of Service Report
Intersection 4: Burns Valley Rd/E-W Project Street

Control Type: Two-way stop
Analysis Method: HCM 6th Edition
Analysis Period: 15 minutes
Delay (sec / veh): 11.0
Level Of Service: B
Volume to Capacity (v/c): 0.002

Intersection Setup

Name	Burns Valley Rd		Burns Valley Rd		E-W Project Street	
Approach	Northbound		Southbound		Eastbound	
Lane Configuration	←		→		←	
Turning Movement	Left	Thru	Thru	Right	Left	Right
Lane Width [ft]	12.00	12.00	12.00	12.00	12.00	12.00
No. of Lanes in Entry Pocket	0	0	0	0	0	0
Entry Pocket Length [ft]	100.00	100.00	100.00	100.00	100.00	100.00
No. of Lanes in Exit Pocket	0	0	0	0	0	0
Exit Pocket Length [ft]	0.00	0.00	0.00	0.00	0.00	0.00
Speed [mph]	30.00		30.00		25.00	
Grade [%]	0.00		0.00		0.00	
Crosswalk	No		No		Yes	

Volumes

Name	Burns Valley Rd		Burns Valley Rd		E-W Project Street	
Base Volume Input [veh/h]	0	157	154	0	0	0
Base Volume Adjustment Factor	1.0000	1.0000	1.0000	1.0000	1.0000	1.0000
Heavy Vehicles Percentage [%]	2.00	2.00	2.00	2.00	2.00	2.00
Growth Factor	1.0000	1.0000	1.0000	1.0000	1.0000	1.0000
In-Process Volume [veh/h]	0	0	0	0	0	0
Site-Generated Trips [veh/h]	8	2	5	0	1	9
Diverted Trips [veh/h]	0	0	0	0	0	0
Pass-by Trips [veh/h]	0	0	0	0	0	0
Existing Site Adjustment Volume [veh/h]	0	0	0	0	0	0
Other Volume [veh/h]	0	0	0	0	0	0
Total Hourly Volume [veh/h]	8	159	159	0	1	9
Peak Hour Factor	0.8500	0.8500	0.8500	0.8500	0.8500	0.8500
Other Adjustment Factor	1.0000	1.0000	1.0000	1.0000	1.0000	1.0000
Total 15-Minute Volume [veh/h]	2	47	47	0	0	3
Total Analysis Volume [veh/h]	9	187	187	0	1	11
Pedestrian Volume [ped/h]	0	0	0	0	0	0



Intersection Settings

Priority Scheme	Free	Free	Stop
Flared Lane			No
Storage Area [veh]	0	0	0
Two-Stage Gap Acceptance			No
Number of Storage Spaces in Median	0	0	0

Movement, Approach, & Intersection Results

V/C, Movement V/C Ratio	0.01	0.00	0.00	0.00	0.00	0.01
d_M, Delay for Movement [s/veh]	7.61	0.00	0.00	0.00	10.99	9.27
Movement LOS	A	A	A	A	B	A
95th-Percentile Queue Length [veh/ln]	0.02	0.02	0.00	0.00	0.04	0.04
95th-Percentile Queue Length [ft/ln]	0.49	0.49	0.00	0.00	1.10	1.10
d_A, Approach Delay [s/veh]	0.35		0.00		9.42	
Approach LOS	A		A		A	
d_I, Intersection Delay [s/veh]				0.46		
Intersection LOS	B					



Control Type: Two-way stop
Analysis Method: HCM 6th Edition
Analysis Period: 15 minutes
Intersection Level Of Service Report
Intersection 5: Olympic Dr/Lakeshore Dr
Delay (sec / veh): 18.2
Level Of Service: C
Volume to Capacity (v/c): 0.197

Intersection Setup

Name	Lakeshore Dr			Lakeshore Dr			Eastbound			Olympic Dr		
Approach	Northbound			Southbound			Eastbound			Westbound		
Lane Configuration	← →			← →			← →			← →		
Turning Movement	Left	Thru	Right	Left	Thru	Right	Left	Thru	Right	Left	Thru	Right
Lane Width [ft]	12.00	12.00	12.00	12.00	12.00	12.00	12.00	12.00	12.00	12.00	12.00	12.00
No. of Lanes in Entry Pocket	0	0	1	0	0	0	0	0	0	0	0	1
Entry Pocket Length [ft]	100.00	100.00	120.00	100.00	100.00	100.00	100.00	100.00	100.00	100.00	100.00	250.00
No. of Lanes in Exit Pocket	0	0	0	0	0	0	0	0	0	0	0	0
Exit Pocket Length [ft]	0.00	0.00	0.00	0.00	0.00	0.00	0.00	0.00	0.00	0.00	0.00	0.00
Speed [mph]	25.00			25.00			30.00			30.00		
Grade [%]	0.00			0.00			0.00			0.00		
Crosswalk	No			Yes			No			Yes		

Volumes

Name	Lakeshore Dr			Lakeshore Dr			Eastbound			Olympic Dr		
Base Volume Input [veh/h]	1	138	86	78	279	2	0	0	1	52	1	69
Base Volume Adjustment Factor	1.0000	1.0000	1.0000	1.0000	1.0000	1.0000	1.0000	1.0000	1.0000	1.0000	1.0000	1.0000
Heavy Vehicles Percentage [%]	2.00	2.00	2.00	2.00	2.00	2.00	2.00	2.00	2.00	2.00	2.00	2.00
Growth Factor	1.0000	1.0000	1.0000	1.0000	1.0000	1.0000	1.0000	1.0000	1.0000	1.0000	1.0000	1.0000
In-Process Volume [veh/h]	0	0	0	0	0	0	0	0	0	0	0	0
Site-Generated Trips [veh/h]	0	0	11	4	0	0	0	0	0	6	0	3
Diverted Trips [veh/h]	0	0	0	0	0	0	0	0	0	0	0	0
Pass-by Trips [veh/h]	0	0	0	0	0	0	0	0	0	0	0	0
Existing Site Adjustment Volume [veh/h]	0	0	0	0	0	0	0	0	0	0	0	0
Other Volume [veh/h]	0	0	0	0	0	0	0	0	0	0	0	0
Total Hourly Volume [veh/h]	1	138	97	82	279	2	0	0	1	58	1	72
Peak Hour Factor	0.8600	0.8600	0.8600	0.8600	0.8600	0.8600	0.8600	0.8600	0.8600	0.8600	0.8600	0.8600
Other Adjustment Factor	1.0000	1.0000	1.0000	1.0000	1.0000	1.0000	1.0000	1.0000	1.0000	1.0000	1.0000	1.0000
Total 15-Minute Volume [veh/h]	0	40	28	24	81	1	0	0	0	17	0	21
Total Analysis Volume [veh/h]	1	180	113	95	324	2	0	0	1	67	1	84
Pedestrian Volume [ped/h]	0			0			0			1		



Intersection Settings

Priority Scheme	Free	Free	Stop	Stop
Flared Lane			No	No
Storage Area [veh]	0	0	0	0
Two-Stage Gap Acceptance			No	No
Number of Storage Spaces in Median	0	0	0	0

Movement, Approach, & Intersection Results

V/C, Movement V/C Ratio	0.00	0.00	0.00	0.07	0.00	0.00	0.00	0.00	0.00	0.20	0.00	0.10
d_M, Delay for Movement [s/veh]	7.92	0.00	0.00	8.02	0.00	0.00	18.63	17.30	10.03	18.19	16.06	9.53
Movement LOS	A	A	A	A	A	A	C	C	B	C	C	A
95th-Percentile Queue Length [veh/m]	0.00	0.00	0.00	0.24	0.24	0.24	0.00	0.00	0.00	0.72	0.33	0.33
95th-Percentile Queue Length [ft/m]	0.06	0.06	0.00	5.96	5.96	5.96	0.00	0.00	0.10	18.05	8.13	8.13
d_A, Approach Delay [s/veh]	0.03			1.81			10.03			13.39		
Approach LOS	A			A			B			B		
d_I, Intersection Delay [s/veh]	3.32											
Intersection LOS	C											



Intersection Level Of Service Report
Intersection 6: Olympic Dr/N-S Project Street

Control Type: Two-way stop
Analysis Method: HCM 6th Edition
Analysis Period: 15 minutes
Delay (sec / veh): 17.7
Level Of Service: C
Volume to Capacity (v/c): 0.053

Intersection Setup

Name	N-S Project Street		Olympic Dr		Olympic Dr	
	Southbound		Eastbound		Westbound	
Approach	T		T		T	
Lane Configuration	T		T		T	
Turning Movement	Left	Right	Left	Thru	Thru	Right
Lane Width [ft]	12.00	12.00	12.00	12.00	12.00	12.00
No. of Lanes in Entry Pocket	0	0	0	0	0	0
Entry Pocket Length [ft]	100.00	100.00	100.00	100.00	100.00	100.00
No. of Lanes in Exit Pocket	0	0	0	0	0	0
Exit Pocket Length [ft]	6.00	0.00	0.00	0.00	0.00	0.00
Speed [mph]	25.00		30.00		30.00	
Grade [%]	0.00		0.00		0.00	
Crosswalk	Yes		No		No	

Volumes

Name	N-S Project Street		Olympic Dr		Olympic Dr	
	Base Volume Input [veh/h]	7	8	15	290	306
Base Volume Adjustment Factor	1.0000	1.0000	1.0000	1.0000	1.0000	1.0000
Heavy Vehicles Percentage [%]	2.00	2.00	2.00	2.00	2.00	2.00
Growth Factor	1.0000	1.0000	1.0000	1.0000	1.0000	1.0000
In-Process Volume [veh/h]	2	2	0	26	51	0
Site-Generated Trips [veh/h]	5	12	19	0	0	12
Diverted Trips [veh/h]	0	0	0	0	0	0
Pass-by Trips [veh/h]	0	0	0	0	0	0
Existing Site Adjustment Volume [veh/h]	0	0	0	0	0	0
Other Volume [veh/h]	0	0	0	0	0	0
Total Hourly Volume [veh/h]	14	22	34	316	357	12
Peak Hour Factor	0.8500	0.8500	0.8500	0.8500	0.8500	0.8500
Other Adjustment Factor	1.0000	1.0000	1.0000	1.0000	1.0000	1.0000
Total 15-Minute Volume [veh/h]	4	6	10	93	105	4
Total Analysis Volume [veh/h]	16	26	40	372	420	14
Pedestrian Volume [ped/h]	0		0		0	



Intersection Settings

Priority Scheme	Stop	Free	Free
Flared Lane	No		
Storage Area [veh]	0	0	0
Two-Stage Gap Acceptance	No		
Number of Storage Spaces in Median	C	0	0

Movement, Approach, & Intersection Results

V/C, Movement V/C Ratio	0.05	0.04	0.04	0.00	0.00	0.00
d_M, Delay for Movement [s/veh]	17.69	11.57	8.32	0.00	0.00	0.00
Movement LOS	C	B	A	A	A	A
95th-Percentile Queue Length [veh/m]	0.31	0.31	0.11	0.11	0.00	0.00
95th-Percentile Queue Length [ft/m]	7.74	7.74	2.76	2.78	0.00	0.00
d_A, Approach Delay [s/veh]	13.90		0.81		0.00	
Approach LOS	B		A		A	
d_I, Intersection Delay [s/veh]				1.03		
Intersection LOS	C					



Intersection Level Of Service Report

Intersection 7: Olympic Dr/Burns Valley Rd-Old Hwy 53

Control Type: Signalized
 Analysis Method: HCM 6th Edition
 Analysis Period: 15 minutes
 Delay (sec / veh): 12.0
 Level Of Service: B
 Volume to Capacity (v/c): 0.693

Intersection Setup

Name	Old Hwy 53			Burns Valley Rd			Olympic Dr			Old Hwy 53		
Approach	Northbound			Southbound			Eastbound			Westbound		
Lane Configuration	[Diagram]			[Diagram]			[Diagram]			[Diagram]		
Turning Movement	Left	Thru	Right	Left	Thru	Right	Left	Thru	Right	Left	Thru	Right
Lane Width [ft]	12.00	12.00	12.00	12.00	12.00	12.00	12.00	12.00	12.00	12.00	12.00	12.00
No. of Lanes in Entry Pocket	1	0	1	1	0	0	1	0	0	1	0	0
Entry Pocket Length [ft]	100.00	100.00	100.00	55.00	100.00	100.00	48.00	100.00	100.00	100.00	100.00	100.00
No. of Lanes in Exit Pocket	0	0	0	0	0	0	0	0	0	0	0	0
Exit Pocket Length [ft]	0.00	0.00	0.00	0.00	0.00	0.00	0.00	0.00	0.00	0.00	0.00	0.00
Speed [mph]	30.00			30.00			35.00			35.00		
Grade [%]	0.00			0.00			0.00			0.00		
Curb Present	No			No			No			No		
Crosswalk	Yes			Yes			Yes			Yes		



Volumes

Name	Old Hwy 53			Burns Valley Rd			Olympic Dr			Old Hwy 53		
Base Volume Input [veh/h]	57	67	63	75	74	19	27	142	61	84	191	99
Base Volume Adjustment Factor	1.0000	1.0000	1.0000	1.0000	1.0000	1.0000	1.0000	1.0000	1.0000	1.0000	1.0000	1.0000
Heavy Vehicles Percentage [%]	2.00	2.00	2.00	2.00	2.00	2.00	2.00	2.00	2.00	2.00	2.00	2.00
Growth Factor	1.0000	1.0000	1.0000	1.0000	1.0000	1.0000	1.0000	1.0000	1.0000	1.0000	1.0000	1.0000
In-Process Volume [veh/h]	0	0	0	0	0	0	0	0	0	0	0	0
Site-Generated Trips [veh/h]	5	6	0	5	9	0	0	1	4	0	7	4
Diverted Trips [veh/h]	0	0	0	0	0	0	0	0	0	0	0	0
Pass-by Trips [veh/h]	0	0	0	0	0	0	0	0	0	0	0	0
Existing Site Adjustment Volume [veh/h]	0	0	0	0	0	0	0	0	0	0	0	0
Other Volume [veh/h]	0	0	0	0	0	0	0	0	0	0	0	0
Right Turn on Red Volume [veh/h]	0	0	19	0	0	3	0	0	5	0	0	20
Total Hourly Volume [veh/h]	62	73	44	80	83	16	27	143	60	84	198	83
Peak Hour Factor	0.8900	0.8900	0.8900	0.8900	0.8900	0.8900	0.8900	0.8900	0.8900	0.8900	0.8900	0.8900
Other Adjustment Factor	1.0000	1.0000	1.0000	1.0000	1.0000	1.0000	1.0000	1.0000	1.0000	1.0000	1.0000	1.0000
Total 15-Minute Volume [veh/h]	17	21	12	22	23	4	8	40	17	18	56	23
Total Analysis Volume [veh/h]	70	82	49	90	93	18	30	161	67	72	222	93
Presence of On-Street Parking	No	No	No	No	No	No	No	No	No	No	No	No
On-Street Parking Maneuver Rate [h]	0	0	0	0	0	0	0	0	0	0	0	0
Local Bus Stopping Rate [h]	0	0	0	0	0	0	0	0	0	0	0	0
v_do, Outbound Pedestrian Volume crossing major street	1			0			1			1		
v_di, Inbound Pedestrian Volume crossing major street	1			1			0			1		
v_co, Outbound Pedestrian Volume crossing minor street	1			0			0			0		
v_ci, Inbound Pedestrian Volume crossing minor street	0			0			1			0		
v_ab, Corner Pedestrian Volume [ped/h]	0			0			0			0		
Bicycle Volume [bicycles/h]	0			0			0			0		1



Intersection Settings	
Located In CBD	Yes
Signal Coordination Group	-
Cycle Length [s]	109
Coordination Type	Time of Day Pattern Isolated
Actuation Type	Fully actuated
Offset [s]	0.0
Offset Reference	Lead Green - Beginning of First Green
Permissive Mode	SingleBand
Lost time [s]	14.00

Phasing & Timing													
Control Type	Protect	Permis	Permis	Protect	Permis	Permis	Protect	Permis	Permis	Protect	Permis	Permis	Protect
Signal Group	3	8	0	7	4	0	5	2	0	1	6	0	
Auxiliary Signal Groups													
Lead / Lag	Lead	-	-	Lead	-	-	Lead	-	-	Lead	-	-	
Minimum Green [s]	4	6	0	4	6	0	4	6	0	4	6	0	
Maximum Green [s]	20	25	0	20	25	0	20	30	0	20	20	0	
Amber [s]	3.0	3.3	0.0	3.0	3.3	0.0	3.0	3.6	0.0	3.0	3.6	0.0	
All red [s]	0.0	0.3	0.0	0.0	0.3	0.0	0.0	0.3	0.0	0.0	0.3	0.0	
Split [s]	23	29	0	23	29	0	23	34	0	23	34	0	
Vehicle Extension [s]	0.0	0.0	0.0	0.0	0.0	0.0	0.0	0.0	0.0	0.0	0.0	0.0	
Walk [s]	7	7	0	7	7	0	7	7	0	7	7	0	
Pedestrian Clearance [s]	9	11	0	9	9	0	14	0	0	9	9	0	
Delayed Vehicle Green [s]	0.0	0.0	0.0	0.0	0.0	0.0	0.0	0.0	0.0	0.0	0.0	0.0	
Rest in Walk		No		No	No		No	No		No	No		
I1, Start-Up Lost Time [s]	2.0	2.0	0.0	2.0	2.0	0.0	2.0	0.0	0.0	2.0	2.0	0.0	
I2, Clearance Lost Time [s]	1.0	1.6	0.0	1.0	1.6	0.0	1.0	1.9	0.0	1.0	1.9	0.0	
Minimum Recall	No	No		No	No		No	No		No	No		
Maximum Recall	No	No		No	No		No	No		No	No		
Pedestrian Recall	No	No		No	No		No	No		No	No		
Detector Location [ft]	0.0	0.0	0.0	0.0	0.0	0.0	0.0	0.0	0.0	0.0	0.0	0.0	
Detector Length [ft]	0.0	0.0	0.0	0.0	0.0	0.0	0.0	0.0	0.0	0.0	0.0	0.0	
I, Upstream Filtering Factor	1.00	1.00	1.00	1.00	1.00	1.00	1.00	1.00	1.00	1.00	1.00	1.00	

Exclusive Pedestrian Phase	
Pedestrian Signal Group	0
Pedestrian Walk [s]	0
Pedestrian Clearance [s]	0



Lane Group Calculations										
Lane Group	L	C	R	L	C	L	C	L	C	
C, Cycle Length [s]	27	27	27	27	27	27	27	27	27	
L, Total Lost Time per Cycle [s]	3.00	3.60	3.60	3.00	3.60	3.00	3.60	3.00	3.60	
I1_p, Permitted Start-Up Lost Time [s]	0.00	0.00	0.00	0.00	0.00	0.00	0.00	0.00	0.00	
I2, Clearance Lost Time [s]	1.00	1.60	1.60	1.00	1.60	1.00	1.60	1.00	1.60	
g_j, Effective Green Time [s]	2	4	4	2	4	1	6	2	6	
g / C, Green / Cycle	0.06	0.15	0.15	0.07	0.16	0.03	0.21	0.06	0.24	
(v / s)_j Volume / Saturation Flow Rate	0.04	0.05	0.03	0.06	0.07	0.02	0.14	0.04	0.20	
s, saturation flow rate [veh/h]	1603	1683	1421	1603	1635	1603	1599	1603	1588	
c, Capacity [veh/h]	100	247	208	120	260	50	337	102	387	
d1, Uniform Delay [s]	12.31	10.25	10.10	12.14	10.16	12.82	9.74	12.29	9.57	
k, delay calibration	0.04	0.04	0.04	0.04	0.04	0.04	0.04	0.04	0.04	
I, Upstream Filtering Factor	1.00	1.00	1.00	1.00	1.00	1.00	1.00	1.00	1.00	
d2, Incremental Delay [s]	3.26	0.29	0.21	3.46	0.41	4.29	0.89	3.26	1.61	
d3, Initial Queue Delay [s]	0.00	0.00	0.00	0.00	0.00	0.00	0.00	0.00	0.00	
Rp, platoon ratio	1.00	1.00	1.00	1.00	1.00	1.00	1.00	1.00	1.00	
PF, progression factor	1.00	1.00	1.00	1.00	1.00	1.00	1.00	1.00	1.00	

Lane Group Results										
X, volume / capacity	0.70	0.33	0.24	0.75	0.43	0.60	0.68	0.70	0.81	
d, Delay for Lane Group [s/veh]	15.57	10.64	10.31	15.61	10.57	17.11	10.63	15.55	11.18	
Lane Group LOS	B	B	B	B	B	B	B	B	B	
Critical Lane Group	Yes	No	No	No	Yes	Yes	No	No	Yes	
50th-Percentile Queue Length [veh/m]	0.39	0.32	0.19	0.49	0.43	0.18	0.61	0.38	1.15	
50th-Percentile Queue Length [ft/m]	9.68	7.89	4.66	12.33	10.66	4.58	20.28	9.51	28.84	
95th-Percentile Queue Length [veh/m]	0.70	0.57	0.34	0.89	0.77	0.33	1.46	0.68	2.08	
95th-Percentile Queue Length [ft/m]	17.42	14.20	8.38	22.19	19.22	8.25	36.51	17.11	51.91	



Movement, Approach, & Intersection Results

d_M, Delay for Movement [s/veh]	15.57	10.54	10.31	15.61	10.57	10.57	17.11	10.63	10.63	15.55	11.18	11.18
Movement LOS	B	B	B	B	B	B	B	B	B	B	B	B
d_A, Approach Delay [s/veh]	12.24			12.83			11.38			11.99		
Approach LOS	B			B			B			B		
d_I, Intersection Delay [s/veh]	12.05											
Intersection LOS	B											
Intersection V/C	0.693											

Other Modes

g_Walk,mi, Effective Walk Time [s]	11.0	11.0	11.0	11.0
M_corner, Corner Circulation Area [ft²/ped]	0.00	0.00	0.00	0.00
M_CW, Crosswalk Circulation Area [ft²/ped]	0.00	0.00	0.00	0.00
d_p, Pedestrian Delay [s]	4.58	4.58	4.58	4.58
L_p,int, Pedestrian LOS Score for Intersection	2.188	2.002	2.084	2.162
Crosswalk LOS	B	B	B	B
s_b, Saturation Flow Rate of the bicycle lane [bicycles/h]	2000	2000	2000	2000
c_b, Capacity of the bicycle lane [bicycles/h]	1909	1909	2262	2262
d_b, Bicycle Delay [s]	0.03	0.03	0.23	0.23
L_b,int, Bicycle LOS Score for Intersection	1.923	1.898	1.994	2.231
Bicycle LOS	A	A	A	B

Sequence

Ring 1	1	2	3	4	-	-	-	-	-	-	-	-	-	-
Ring 2	5	6	7	8	-	-	-	-	-	-	-	-	-	-
Ring 3	-	-	-	-	-	-	-	-	-	-	-	-	-	-
Ring 4	-	-	-	-	-	-	-	-	-	-	-	-	-	-

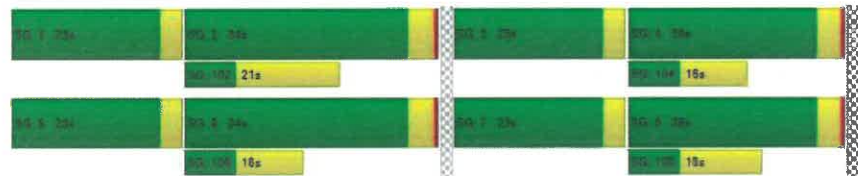

Intersection Level Of Service Report
Intersection 1: Burns Valley Rd/N-S Project Street

Control Type:	Two-way stop	Delay (sec / veh):	10.8
Analysis Method:	HCM 6th Edition	Level Of Service:	B
Analysis Period:	15 minutes	Volume to Capacity (v/c):	0.031

Intersection Setup

Name	N-S Project Street		Burns Valley Rd		Burns Valley Rd	
	Northbound		Eastbound		Westbound	
Approach	Northbound		Eastbound		Westbound	
Lane Configuration	T		T		T	
Turning Movement	Left	Right	Thru	Right	Left	Thru
Lane Width [ft]	12.00	12.00	12.00	12.00	12.00	12.00
No. of Lanes in Entry Pocket	0	0	0	0	0	0
Entry Pocket Length [ft]	100.00	100.00	100.00	100.00	100.00	100.00
No. of Lanes in Exit Pocket	0	0	0	0	0	0
Exit Pocket Length [ft]	0.00	0.00	0.00	0.00	0.00	0.00
Speed [mph]	25.00		35.00		35.00	
Grade [%]	0.00		0.00		0.00	
Crosswalk	No		No		No	

Volumes

Name	N-S Project Street		Burns Valley Rd		Burns Valley Rd	
	Northbound		Eastbound		Westbound	
Base Volume Input [veh/h]	8	8	117	17	0	117
Base Volume Adjustment Factor	1.0000	1.0000	1.0000	1.0000	1.0000	1.0000
Heavy Vehicles Percentage [%]	2.00	2.00	2.00	2.00	2.00	2.00
Growth Factor	1.0000	1.0000	1.0000	1.0000	1.0000	1.0000
In-Process Volume [veh/h]	3	3	11	0	0	11
Site-Generated Trips [veh/h]	7	7	1	10	7	1
Diverted Trips [veh/h]	0	0	0	0	0	0
Pass-by Trips [veh/h]	0	0	0	0	0	0
Existing Site Adjustment Volume [veh/h]	0	0	0	0	0	0
Other Volume [veh/h]	0	0	11	0	0	11
Total Hourly Volume [veh/h]	18	18	140	27	7	140
Peak Hour Factor	0.8930	0.8930	0.8930	0.8930	0.8930	0.8930
Other Adjustment Factor	1.0000	1.0000	1.0000	1.0000	1.0000	1.0000
Total 15-Minute Volume [veh/h]	5	5	39	8	2	39
Total Analysis Volume [veh/h]	20	20	157	30	8	157
Pedestrian Volume [ped/h]	0		0		0	



Intersection Settings

Priority Scheme	Stop	Free	Free
Flared Lane	No		
Storage Area [veh]	0	0	0
Two-Stage Gap Acceptance	No		
Number of Storage Spaces in Median	0	0	0

Movement, Approach, & Intersection Results

V/C, Movement V/C Ratio	0.03	0.02	0.00	0.00	0.01	0.00
d_M, Delay for Movement [s/veh]	10.84	9.41	0.00	0.00	7.81	0.00
Movement LOS	B	A	A	A	A	A
95th-Percentile Queue Length [veh/ln]	0.17	0.17	0.00	0.00	0.02	0.02
95th-Percentile Queue Length [ft/ln]	4.26	4.26	0.00	0.00	0.43	0.43
d_A, Approach Delay [s/veh]	10.12		0.00		0.37	
Approach LOS	B		A		A	
d_I, Intersection Delay [s/veh]			1.19			
Intersection LOS			B			



Intersection Level Of Service Report

Intersection 2: Burns Valley Rd/Bowers Ave-Rumsey Rd

Control Type:	Two-way stop	Delay (sec / veh):	13.5
Analysis Method:	HCM 6th Edition	Level Of Service:	B
Analysis Period:	15 minutes	Volume to Capacity (v/c):	0.034

Intersection Setup

Name	Burns Valley Rd			Rumsey Rd			Burns Valley Rd			Bowers Ave		
Approach	Northbound			Southbound			Eastbound			Westbound		
Lane Configuration	+			+			+			+		
Turning Movement	Left	Thru	Right	Left	Thru	Right	Left	Thru	Right	Left	Thru	Right
Lane Width [ft]	12.00	12.00	12.00	12.00	12.00	12.00	12.00	12.00	12.00	12.00	12.00	12.00
No. of Lanes in Entry Pocket	0	0	0	0	0	0	0	0	0	0	0	0
Entry Pocket Length [ft]	100.00	100.00	100.00	100.00	100.00	100.00	100.00	100.00	100.00	100.00	100.00	100.00
No. of Lanes in Exit Pocket	0	0	0	0	0	0	0	0	0	0	0	0
Exit Pocket Length [ft]	0.00	0.00	0.00	0.00	0.00	0.00	0.00	0.00	0.00	0.00	0.00	0.00
Speed [mph]	30.00			30.00			35.00			25.00		
Grade [%]	0.00			0.00			0.00			0.00		
Crosswalk	No			Yes			Yes			No		

Volumes

Name	Burns Valley Rd			Rumsey Rd			Burns Valley Rd			Bowers Ave		
Base Volume Input [veh/h]	111	39	9	2	44	7	7	1	86	13	0	0
Base Volume Adjustment Factor	1.0000	1.0000	1.0000	1.0000	1.0000	1.0000	1.0000	1.0000	1.0000	1.0000	1.0000	1.0000
Heavy Vehicles Percentage [%]	2.00	2.00	2.00	2.00	2.00	2.00	2.00	2.00	2.00	2.00	2.00	2.00
Growth Factor	1.0000	1.0000	1.0000	1.0000	1.0000	1.0000	1.0000	1.0000	1.0000	1.0000	1.0000	1.0000
In-Process Volume [veh/h]	0	0	0	0	0	0	0	0	0	0	0	0
Site-Generated Trips [veh/h]	5	1	0	0	1	4	3	0	3	0	0	0
Diverted Trips [veh/h]	0	0	0	0	0	0	0	0	0	0	0	0
Pass-by Trips [veh/h]	0	0	0	0	0	0	0	0	0	0	0	0
Existing Site Adjustment Volume [veh/h]	0	0	0	0	0	0	0	0	0	0	0	0
Other Volume [veh/h]	0	0	0	0	0	0	0	0	0	0	0	0
Total Hourly Volume [veh/h]	116	40	9	2	45	11	10	1	89	13	0	0
Peak Hour Factor	0.8500	0.8500	0.8500	0.8500	0.8500	0.8500	0.8500	0.8500	0.8500	0.8500	0.8500	0.8500
Other Adjustment Factor	1.0000	1.0000	1.0000	1.0000	1.0000	1.0000	1.0000	1.0000	1.0000	1.0000	1.0000	1.0000
Total 15-Minute Volume [veh/h]	34	12	3	1	13	3	3	0	26	4	0	0
Total Analysis Volume [veh/h]	136	47	11	2	53	13	12	1	105	15	0	0
Pedestrian Volume [ped/h]	0			0			0			0		



Intersection Settings				
Priority Scheme	Free	Free	Stop	Stop
Flared Lane			No	No
Storage Area [veh]	0	0	0	0
Two-Stage Gap Acceptance			No	No
Number of Storage Spaces in Median	0	0	0	0

Movement, Approach, & Intersection Results												
V/C, Movement V/C Ratio	0.09	0.00	0.00	0.00	0.00	0.00	0.02	0.00	0.10	0.03	0.00	
d_M, Delay for Movement [s/veh]	7.57	0.00	0.00	7.33	0.00	0.00	12.37	12.89	9.16	13.52	12.01	
Movement LOS	A	A	A	A	A	A	B	B	A	B	A	
95th-Percentile Queue Length [veh/ln]	0.29	0.29	0.29	0.00	0.00	0.00	0.44	0.44	0.44	0.11	0.11	
95th-Percentile Queue Length [ft/ln]	7.27	7.27	7.27	0.10	0.10	0.10	11.06	11.06	11.06	2.86	2.86	
d_A, Approach Delay [s/veh]	5.31			0.22			9.52			13.52		
Approach LOS	A			A			A			B		
d_I, Intersection Delay [s/veh]							6.00					
Intersection LOS							B					



Intersection Level of Service Report			
Intersection 3: N-S Project Street/E-W Project Street			
Control Type:	All-way stop	Delay (sec / veh):	7.4
Analysis Method:	HCM 6th Edition	Level of Service:	A
Analysis Period:	15 minutes	Volume to Capacity (v/c):	0.105

Intersection Setup												
Name	N-S Project Street			N-S Project Street			E-W Project Street			E-W Project Street		
Approach	Northbound			Southbound			Eastbound			Westbound		
Lane Configuration	+			+			+			+		
Turning Movement	Left	Thru	Right	Left	Thru	Right	Left	Thru	Right	Left	Thru	Right
Lane Width [ft]	12.00	12.00	12.00	12.00	12.00	12.00	12.00	12.00	12.00	12.00	12.00	12.00
No. of Lanes in Entry Pocket	0	0	0	0	0	0	0	0	0	0	0	0
Entry Pocket Length [ft]	100.00	100.00	100.00	100.00	100.00	100.00	100.00	100.00	100.00	100.00	100.00	100.00
No. of Lanes in Exit Pocket	0	0	0	0	0	0	0	0	0	0	0	0
Exit Pocket Length [ft]	0.00	0.00	0.00	0.00	0.00	0.00	0.00	0.00	0.00	0.00	0.00	0.00
Speed [mph]	25.00			25.00			25.00			25.00		
Grade [%]	0.00			0.00			0.00			0.00		
Crosswalk	Yes			Yes			Yes			Yes		

Volumes												
Name	N-S Project Street			N-S Project Street			E-W Project Street			E-W Project Street		
Base Volume Input [veh/h]	0	22	0	0	23	0	0	0	0	0	0	0
Base Volume Adjustment Factor	1.0000	1.0000	1.0000	1.0000	1.0000	1.0000	1.0000	1.0000	1.0000	1.0000	1.0000	1.0000
Heavy Vehicles Percentage [%]	2.00	2.00	2.00	2.00	2.00	2.00	2.00	2.00	2.00	2.00	2.00	2.00
Growth Factor	1.0000	1.0000	1.0000	1.0000	1.0000	1.0000	1.0000	1.0000	1.0000	1.0000	1.0000	1.0000
In-Process Volume [veh/h]	0	0	0	0	0	0	0	0	0	0	0	0
Site-Generated Trips [veh/h]	3	44	15	12	31	1	1	3	8	5	2	15
Diverted Trips [veh/h]	0	0	0	0	0	0	0	0	0	0	0	0
Pass-by Trips [veh/h]	0	0	0	0	0	0	0	0	0	0	0	0
Existing Site Adjustment Volume [veh/h]	0	0	0	0	0	0	0	0	0	0	0	0
Other Volume [veh/h]	0	0	0	0	0	0	0	0	0	0	0	0
Total Hourly Volume [veh/h]	3	66	15	12	54	1	1	3	8	5	2	15
Peak Hour Factor	0.8800	0.8800	0.8800	0.8800	0.8800	0.8800	0.8800	0.8800	0.8800	0.8800	0.8800	0.8800
Other Adjustment Factor	1.0000	1.0000	1.0000	1.0000	1.0000	1.0000	1.0000	1.0000	1.0000	1.0000	1.0000	1.0000
Total 15-Minute Volume [veh/h]	1	19	4	3	15	0	0	1	2	1	1	4
Total Analysis Volume [veh/h]	3	75	17	14	61	1	1	3	9	6	2	17
Pedestrian Volume [ped/h]	0			0			0			0		



Intersection Settings

Lanes				
Capacity per Entry Lane [veh/h]	903	872	918	911
Degree of Utilization, x	0.11	0.09	0.01	0.03

Movement, Approach, & Intersection Results

95th-Percentile Queue Length [veh]	0.35	0.29	0.04	0.08
95th-Percentile Queue Length [ft]	8.78	7.14	1.08	2.11
Approach Delay [s/veh]	7.46	7.52	6.98	7.06
Approach LOS	A	A	A	A
Intersection Delay [s/veh]	7.40			
Intersection LOS	A			



Intersection Level Of Service Report
Intersection 4: Burns Valley Rd/E-W Project Street

Control Type:	Two-way stop	Delay (sec / veh):	11.8
Analysis Method:	HCM 6th Edition	Level Of Service:	B
Analysis Period:	15 minutes	Volume to Capacity (v/c):	0.002

Intersection Setup

Name	Burns Valley Rd		Burns Valley Rd		E-W Project Street	
	Northbound		Southbound		Eastbound	
Approach	Northbound		Southbound		Eastbound	
Lane Configuration	←		→		← →	
Turning Movement	Left	Thru	Thru	Right	Left	Right
Lane Width [ft]	12.00	12.00	12.00	12.00	12.00	12.00
No. of Lanes in Entry Pocket	0	0	0	0	0	0
Entry Pocket Length [ft]	100.00	100.00	100.00	100.00	100.00	100.00
No. of Lanes in Exit Pocket	0	0	0	0	0	0
Exit Pocket Length [ft]	0.00	0.00	0.00	0.00	0.00	0.00
Speed [mph]	30.00		30.00		25.00	
Grade [%]	0.00		0.00		0.00	
Crosswalk	No		No		Yes	

Volumes

Name	Burns Valley Rd		Burns Valley Rd		E-W Project Street	
	0	170	185	0	0	0
Base Volume Input [veh/h]	0	170	185	0	0	0
Base Volume Adjustment Factor	1.0000	1.0000	1.0000	1.0000	1.0000	1.0000
Heavy Vehicles Percentage [%]	2.00	2.00	2.00	2.00	2.00	2.00
Growth Factor	1.0000	1.0000	1.0000	1.0000	1.0000	1.0000
In-Process Volume [veh/h]	0	0	0	0	0	0
Site-Generated Trips [veh/h]	24	5	3	1	1	18
Diverted Trips [veh/h]	0	0	0	0	0	0
Pass-by Trips [veh/h]	0	0	0	0	0	0
Existing Site Adjustment Volume [veh/h]	0	0	0	0	0	0
Other Volume [veh/h]	0	0	0	0	0	0
Total Hourly Volume [veh/h]	24	175	188	1	1	18
Peak Hour Factor	0.8800	0.8800	0.8800	0.8800	0.8800	0.8800
Other Adjustment Factor	1.0000	1.0000	1.0000	1.0000	1.0000	1.0000
Total 15-Minute Volume [veh/h]	7	50	53	0	0	5
Total Analysis Volume [veh/h]	27	199	214	1	1	20
Pedestrian Volume [ped/h]	0	0	0	0	0	0



Intersection Settings			
Priority Scheme	Free	Free	Stop
Flared Lane			No
Storage Area [veh]	0	0	0
Two-Stage Gap Acceptance			No
Number of Storage Spaces in Median	0	0	0

Movement, Approach, & Intersection Results						
V/C, Movement V/C Ratio	0.02	0.00	0.00	0.00	0.00	0.02
d_M, Delay for Movement [s/veh]	7.71	0.00	0.00	0.00	11.77	9.48
Movement LOS	A	A	A	A	B	A
95th-Percentile Queue Length [veh/ln]	0.05	0.05	0.00	0.00	0.08	0.08
95th-Percentile Queue Length [ft/ln]	1.52	1.52	0.00	0.00	2.01	2.01
d_A, Approach Delay [s/veh]	0.92		0.00		9.59	
Approach LOS	A		A		A	
d_I, Intersection Delay [s/veh]			0.89			
Intersection LOS			B			

Intersection Level Of Service Report			
Intersection 5: Olympic Dr/Lakeshore Dr			
Control Type:	Two-way stop	Delay (sec / veh):	22.8
Analysis Method:	HCM 6th Edition	Level Of Service:	C
Analysis Period:	15 minutes	Volume to Capacity (v/c):	0.448

Intersection Setup												
Name	Lakeshore Dr			Lakeshore Dr			Olympic Dr			Olympic Dr		
Approach	Northbound			Southbound			Eastbound			Westbound		
Lane Configuration	+ + +			+ + +			+ + +			+ + +		
Turning Movement	Left	Thru	Right	Left	Thru	Right	Left	Thru	Right	Left	Thru	Right
Lane Width [ft]	12.00	12.00	12.00	12.00	12.00	12.00	12.00	12.00	12.00	12.00	12.00	12.00
No. of Lanes in Entry Pocket	0	0	1	0	0	0	0	0	0	0	0	1
Entry Pocket Length [ft]	100.00	100.00	120.00	100.00	100.00	100.00	100.00	100.00	100.00	100.00	100.00	250.00
No. of Lanes in Exit Pocket	0	0	0	0	0	0	0	0	0	0	0	0
Exit Pocket Length [ft]	0.00	0.00	0.00	0.00	0.00	0.00	0.00	0.00	0.00	0.00	0.00	0.00
Speed [mph]	25.00			25.00			30.00			30.00		
Grade [%]	0.00			0.00			0.00			0.00		
Crosswalk	No			Yes			No			Yes		

Volumes												
Name	Lakeshore Dr			Lakeshore Dr			Olympic Dr			Olympic Dr		
Base Volume Input [veh/h]	1	199	138	88	182	1	0	2	2	136	3	168
Base Volume Adjustment Factor	1.0000	1.0000	1.0000	1.0000	1.0000	1.0000	1.0000	1.0000	1.0000	1.0000	1.0000	1.0000
Heavy Vehicles Percentage [%]	2.00	2.00	2.00	2.00	2.00	2.00	2.00	2.00	2.00	2.00	2.00	2.00
Growth Factor	1.0000	1.0000	1.0000	1.0000	1.0000	1.0000	1.0000	1.0000	1.0000	1.0000	1.0000	1.0000
In-Process Volume [veh/h]	0	0	0	0	0	0	0	0	0	0	0	0
Site-Generated Trips [veh/h]	0	0	21	11	0	0	0	0	0	15	0	8
Diverted Trips [veh/h]	0	0	0	0	0	0	0	0	0	0	0	0
Pass-by Trips [veh/h]	0	0	0	0	0	0	0	0	0	0	0	0
Existing Site Adjustment Volume [veh/h]	0	0	0	0	0	0	0	0	0	0	0	0
Other Volume [veh/h]	0	0	0	0	0	0	0	0	0	0	0	0
Total Hourly Volume [veh/h]	1	199	159	99	182	1	0	2	2	151	3	176
Peak Hour Factor	0.9300	0.9300	0.9300	0.9300	0.9300	0.9300	0.9300	0.9300	0.9300	0.9300	0.9300	0.9300
Other Adjustment Factor	1.0000	1.0000	1.0000	1.0000	1.0000	1.0000	1.0000	1.0000	1.0000	1.0000	1.0000	1.0000
Total 15-Minute Volume [veh/h]	0	53	43	27	49	0	0	1	1	41	1	47
Total Analysis Volume [veh/h]	1	214	171	106	186	1	0	2	2	162	3	189
Pedestrian Volume [ped/h]		0			0			0			1	



Intersection Settings

	Free	Free	Stop	Stop
Priority Scheme				
Flared Lane			No	No
Storage Area [veh]	0	0	0	0
Two-Stage Gap Acceptance			No	No
Number of Storage Spaces in Median	0	0	0	0

Movement, Approach, & Intersection Results

V/C, Movement V/C Ratio	0.00	0.00	0.00	0.09	0.00	0.00	0.00	0.01	0.00	0.45	0.01	0.23
d_M, Delay for Movement [s/veh]	7.62	0.00	0.00	8.38	0.00	0.00	22.09	17.64	9.34	22.79	16.40	10.75
Movement LOS	A	A	A	A	A	A	C	C	A	C	C	B
95th-Percentile Queue Length [veh/ln]	0.00	0.00	0.00	0.30	0.30	0.30	0.03	0.03	0.03	2.23	0.82	0.92
95th-Percentile Queue Length [ft/ln]	0.05	0.05	0.00	7.45	7.45	7.45	0.71	0.71	0.71	55.87	23.11	23.11
d_A, Approach Delay [s/veh]	0.02			2.93			13.49			16.31		
Approach LOS	A			A			B			C		
d_I, Intersection Delay [s/veh]	6.42											
Intersection LOS	C											



Intersection Level Of Service Report
Intersection 6: Olympic Dr/N-S Project Street

Control Type:	Two-way stop	Delay (sec / veh):	26.7
Analysis Method:	HCM 6th Edition	Level Of Service:	D
Analysis Period:	15 minutes	Volume to Capacity (v/c):	0.144

Intersection Setup

Name	N-S Project Street		Olympic Dr		Olympic Dr	
Approach	Southbound		Eastbound		Westbound	
Lane Configuration	T		T		T	
Turning Movement	Left	Right	Left	Thru	Thru	Right
Lane Width [ft]	12.00	12.00	12.00	12.00	12.00	12.00
No. of Lanes in Entry Pocket	0	0	0	0	0	0
Entry Pocket Length [ft]	100.00	100.00	100.00	100.00	100.00	100.00
No. of Lanes in Exit Pocket	0	0	0	0	0	0
Exit Pocket Length [ft]	0.00	0.00	0.00	0.00	0.00	0.00
Speed [mph]	25.00		30.00		30.00	
Grade [%]	0.00		0.00		0.00	
Crosswalk	Yes		No		No	

Volumes

Name	N-S Project Street		Olympic Dr		Olympic Dr	
Base Volume Input [veh/h]	8	9	16	352	384	0
Base Volume Adjustment Factor	1.0000	1.0000	1.0000	1.0000	1.0000	1.0000
Heavy Vehicles Percentage [%]	2.00	2.00	2.00	2.00	2.00	2.00
Growth Factor	1.0000	1.0000	1.0000	1.0000	1.0000	1.0000
In-Process Volume [veh/h]	3	3	0	74	53	0
Site-Generated Trips [veh/h]	13	31	43	0	0	19
Diverted Trips [veh/h]	0	0	0	0	0	0
Pass-by Trips [veh/h]	0	0	0	0	0	0
Existing Site Adjustment Volume [veh/h]	0	0	0	0	0	0
Other Volume [veh/h]	0	0	0	0	0	0
Total Hourly Volume [veh/h]	24	43	59	426	437	19
Peak Hour Factor	0.8500	0.8500	0.8500	0.8500	0.8500	0.8500
Other Adjustment Factor	1.0000	1.0000	1.0000	1.0000	1.0000	1.0000
Total 15-Minute Volume [veh/h]	7	13	17	125	129	6
Total Analysis Volume [veh/h]	28	51	69	501	514	22
Pedestrian Volume [ped/h]	0		0		0	



Generated with **PTV VISTRO**
Version 2021 (SP 0-6)

Burns Valley Development

5/2/2022

Intersection Settings

Priority Scheme	Stop	Free	Free
Flared Lane	No		
Storage Area [veh]	∞	0	0
Two-Stage Gap Acceptance	No		
Number of Storage Spaces in Median	∞	0	0

Movement, Approach, & Intersection Results

VIC, Movement VIC Ratio	0.14	0.09	0.07	0.01	0.01	3.00
d_M, Delay for Movement [s/veh]	26.74	14.80	8.74	0.00	0.00	0.00
Movement LOS	D	B	A	A	A	A
95th-Percentile Queue Length [veh/ln]	0.90	0.90	0.21	0.21	0.00	0.00
95th-Percentile Queue Length [ft/ln]	22.52	22.52	5.36	5.36	0.00	0.00
d_A, Approach Delay [s/veh]	19.04		1.06		0.00	
Approach LOS	C		A		A	
d_I, Intersection Delay [s/veh]	1.78					
Intersection LOS	D					

Weekday PM B+P



Generated with **PTV VISTRO**
Version 2021 (SP 0-6)

Burns Valley Development

5/2/2022

Intersection Level Of Service Report

Intersection 7: Olympic Dr/Burns Valley Rd-Old Hwy 53

Control Type: Signalized
Analysis Method: HCM 6th Edition
Analysis Period: 15 minutes
Delay (sec / veh): 15.4
Level Of Service: B
Volume to Capacity (v/c): 0.838

Intersection Setup

Name	Old Hwy 53			Burns Valley Rd			Olympic Dr			Old Hwy 53		
Approach	Northbound			Southbound			Eastbound			Westbound		
Lane Configuration	T T T			T T			T T			T T		
Turning Movement	Left	Thru	Right	Left	Thru	Right	Left	Thru	Right	Left	Thru	Right
Lane Width [ft]	12.00	12.00	12.00	12.00	12.00	12.00	12.00	12.00	12.00	12.00	12.00	12.00
No. of Lanes in Entry Pocket	1	0	1	1	0	0	1	0	0	1	0	0
Entry Pocket Length [ft]	100.00	100.00	100.00	56.00	100.00	100.00	48.00	100.00	100.00	100.00	100.00	100.00
No. of Lanes in Exit Pocket	0	0	0	0	0	0	0	0	0	0	0	0
Exit Pocket Length [ft]	0.00	0.00	0.00	0.00	0.00	0.00	0.00	0.00	0.00	0.00	0.00	0.00
Speed [mph]	30.00			30.00			35.00			35.00		
Grade [%]	0.00			0.00			0.00			0.00		
Curb Present	No			No			No			No		
Crosswalk	Yes			Yes			Yes			Yes		

Weekday PM B+P



Volumes

Name	Old Hwy 53			Burns Valley Rd			Olympic Dr			Old Hwy 53		
Base Volume Input [veh/h]	126	120	96	112	106	50	27	235	131	107	257	139
Base Volume Adjustment Factor	1.0000	1.0000	1.0000	1.0000	1.0000	1.0000	1.0000	1.0000	1.0000	1.0000	1.0000	1.0000
Heavy Vehicles Percentage [%]	2.00	2.00	2.00	2.00	2.00	2.00	2.00	2.00	2.00	2.00	2.00	2.00
Growth Factor	1.0000	1.0000	1.0000	1.0000	1.0000	1.0000	1.0000	1.0000	1.0000	1.0000	1.0000	1.0000
In-Process Volume [veh/h]	0	0	0	0	0	0	0	0	0	0	0	0
Site-Generated Trips [veh/h]	9	18	0	10	11	0	0	5	7	0	10	11
Diverted Trips [veh/h]	0	0	0	0	0	0	0	0	0	0	0	0
Pass-by Trips [veh/h]	0	0	0	0	0	0	0	0	0	0	0	0
Existing Site Adjustment Volume [veh/h]	0	0	0	0	0	0	0	0	0	0	0	0
Other Volume [veh/h]	0	0	0	0	0	0	0	0	0	0	0	0
Right Turn on Red Volume [veh/h]	0	0	18	0	0	11	0	0	14	0	0	25
Total Hourly Volume [veh/h]	135	138	78	122	117	39	27	240	124	107	267	125
Peak Hour Factor	0.9200	0.9200	0.9200	0.9200	0.9200	0.9200	0.9200	0.9200	0.9200	0.9200	0.9200	0.9200
Other Adjustment Factor	1.0000	1.0000	1.0000	1.0000	1.0000	1.0000	1.0000	1.0000	1.0000	1.0000	1.0000	1.0000
Total 15-Minute Volume [veh/h]	37	38	21	33	32	11	7	65	34	29	73	34
Total Analysis Volume [veh/h]	147	150	85	133	127	42	29	261	135	116	290	136
Presence of On-Street Parking	No		No	No		No	No		No	No		No
On-Street Parking Maneuver Rate [/h]	0	0	0	0	0	0	0	0	0	0	0	0
Local Bus Stopping Rate [/h]	0	0	0	0	0	0	0	0	0	0	0	0
v_do, Outbound Pedestrian Volume crossing major street	1			0			1			1		
v_di, Inbound Pedestrian Volume crossing major street	1			1			0			1		
v_co, Outbound Pedestrian Volume crossing minor street	1			0			0			0		
v_ci, Inbound Pedestrian Volume crossing minor street	0			0			1			0		
v_ab, Corner Pedestrian Volume [ped/h]	0			0			0			0		
Bicycle Volume [bicycles/h]	0			0			0			1		



Intersection Settings

Located in CBD	Yes
Signal Coordination Group	-
Cycle Length [s]	109
Coordination Type	Time of Day Pattern Isolated
Actuation Type	Fully actuated
Offset [s]	0.0
Offset Reference	Lead Green - Beginning of First Green
Permissive Mode	SingleBand
Lost time [s]	14.00

Phasing & Timing

Control Type	Protect	Permis	Permis	Protect	Permis	Permis	Protect	Permis	Permis	Protect	Permis	Permis
Signal Group	3	8	0	7	4	0	5	2	0	1	6	0
Auxiliary Signal Groups												
Lead / Lag	Lead	-	-	Lead	-	-	Lead	-	-	Lead	-	-
Minimum Green [s]	4	6	0	4	6	0	4	6	0	4	6	0
Maximum Green [s]	20	25	0	20	25	0	20	30	0	20	20	0
Amber [s]	3.0	3.3	0.0	3.0	3.3	0.0	3.0	3.6	0.0	3.0	3.6	0.0
All red [s]	0.0	0.3	0.0	0.0	0.3	0.0	0.0	0.3	0.0	0.0	0.3	0.0
Split [s]	23	29	0	23	29	0	23	34	0	23	34	0
Vehicle Extension [s]	0.0	0.0	0.0	0.0	0.0	0.0	0.0	0.0	0.0	0.0	0.0	0.0
Walk [s]	0	7	0	0	7	0	0	7	0	0	7	0
Pedestrian Clearance [s]	0	11	0	0	9	0	0	14	0	0	9	0
Delayed Vehicle Green [s]	0.0	0.0	0.0	0.0	0.0	0.0	0.0	0.0	0.0	0.0	0.0	0.0
Rest In Walk		No			No			No			No	
I1, Start-Up Lost Time [s]	2.0	2.0	0.0	2.0	2.0	0.0	2.0	2.0	0.0	2.0	2.0	0.0
I2, Clearance Lost Time [s]	1.0	1.6	0.0	1.0	1.6	0.0	1.0	1.9	0.0	1.0	1.9	0.0
Minimum Recall	No	No		No	No		No	No		No	No	
Maximum Recall	No	No		No	No		No	No		No	No	
Pedestrian Recall	No	No		No	No		No	No		No	No	
Detector Location [ft]	0.0	0.0	0.0	0.0	0.0	0.0	0.0	0.0	0.0	0.0	0.0	0.0
Detector Length [ft]	0.0	0.0	0.0	0.0	0.0	0.0	0.0	0.0	0.0	0.0	0.0	0.0
I, Upstream Filtering Factor	1.00	1.00	1.00	1.00	1.00	1.00	1.00	1.00	1.00	1.00	1.00	1.00

Exclusive Pedestrian Phase

Pedestrian Signal Group	0
Pedestrian Walk [s]	0
Pedestrian Clearance [s]	0



Lane Group Calculations

Lane Group	L	C	R	L	C	L	C	L	C
C, Cycle Length [s]	37	37	37	37	37	37	37	37	37
L, Total Lost Time per Cycle [s]	3.00	3.60	3.60	3.00	3.60	3.00	3.90	3.00	3.90
l _{1,p} , Permitted Start-Up Lost Time [s]	0.00	0.00	0.00	0.00	0.00	0.00	0.00	0.00	0.00
l ₂ , Clearance Lost Time [s]	1.00	1.60	1.60	1.00	1.60	1.00	1.90	1.00	1.90
g _i , Effective Green Time [s]	4	6	6	4	5	1	11	3	13
g / C, Green / Cycle	0.11	0.15	0.15	0.10	0.14	0.03	0.29	0.09	0.35
(v / s) _i Volume / Saturation Flow Rate	0.09	0.09	0.08	0.08	0.10	0.02	0.25	0.07	0.27
s, saturation flow rate [veh/h]	1603	1683	1421	1603	1611	1603	1586	1603	1581
c, Capacity [veh/h]	182	256	217	164	227	45	460	142	554
d ₁ , Uniform Delay [s]	15.94	14.54	14.08	16.19	15.19	17.72	12.37	16.50	10.84
k, delay calibration	0.04	0.04	0.04	0.04	0.04	0.04	0.04	0.04	0.04
l, Upstream Filtering Factor	1.00	1.00	1.00	1.00	1.00	1.00	1.00	1.00	1.00
d ₂ , Incremental Delay [s]	3.18	0.79	0.43	3.58	1.80	5.45	1.87	4.28	0.86
d ₃ , Initial Queue Delay [s]	0.00	0.00	0.00	0.00	0.00	0.00	0.00	0.00	0.00
R _p , platoon ratio	1.00	1.00	1.00	1.00	1.00	1.00	1.00	1.00	1.00
PF, progression factor	1.00	1.00	1.00	1.00	1.00	1.00	1.00	1.00	1.00

Lane Group Results

X, volume / capacity	0.81	0.58	0.39	0.81	0.74	0.64	0.86	0.82	0.77
d, Delay for Lane Group [s/veh]	19.12	15.32	14.51	19.77	16.99	23.17	14.24	20.78	11.49
Lane Group LOS	B	B	B	B	B	C	B	C	B
Critical Lane Group	Yes	No	No	No	Yes	No	Yes	Yes	No
50th-Percentile Queue Length [veh/in]	1.16	1.00	0.55	1.07	1.22	0.27	2.42	0.94	2.19
50th-Percentile Queue Length [ft/in]	28.95	25.12	13.66	26.84	30.58	6.74	60.54	23.58	54.66
95th-Percentile Queue Length [veh/in]	2.09	1.81	0.98	1.93	2.20	0.49	4.36	1.70	3.94
95th-Percentile Queue Length [ft/in]	52.13	45.21	24.59	48.32	55.04	12.13	108.97	42.44	98.39



Movement, Approach, & Intersection Results

d _M , Delay for Movement [s/veh]	19,12	15,32	14,51	19,77	16,99	16,99	23,17	14,24	14,24	20,78	11,49	11,49
Movement LOS	B	B	B	B	B	B	C	B	B	C	B	B
d _A , Approach Delay [s/veh]	16.60			18.22			14.85			13.48		
Approach LOS	B			B			B			B		
d _I , Intersection Delay [s/veh]	15.42											
Intersection LOS	B											
Intersection V/C	0.838											

Other Modes

g _{Walk} , mi, Effective Walk Time [s]	11.0	11.0	11.0	11.0
M _{corner} , Corner Circulation Area [ft ² /ped]	0.00	0.00	0.00	0.00
M _{CW} , Crosswalk Circulation Area [ft ² /ped]	0.00	0.00	0.00	0.00
d _p , Pedestrian Delay [s]	9.01	9.01	9.01	9.01
l _{p,int} , Pedestrian LOS Score for Intersection	2.295	2.114	2.258	2.325
Crosswalk LOS	B	B	B	B
s _b , Saturation Flow Rate of the bicycle lane [bicycles/h]	2000	2000	2000	2000
c _b , Capacity of the bicycle lane [bicycles/h]	1383	1383	1639	1639
d _b , Bicycle Delay [s]	1.75	1.75	0.80	0.60
l _{b,int} , Bicycle LOS Score for Intersection	2.220	2.076	2.284	2.495
Bicycle LOS	B	B	B	B

Sequence

Ring 1	1	2	3	4	-	-	-	-	-	-	-	-
Ring 2	5	6	7	8	-	-	-	-	-	-	-	-
Ring 3	-	-	-	-	-	-	-	-	-	-	-	-
Ring 4	-	-	-	-	-	-	-	-	-	-	-	-

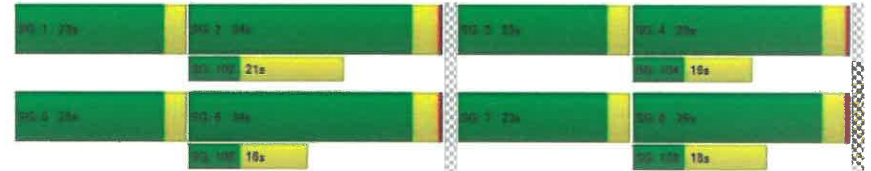

Intersection Level Of Service Report

Intersection 1: Burns Valley Rd/N-S Project Street

Control Type: Two-way stop
Analysis Method: HCM 6th Edition
Analysis Period: 15 minutes
Delay (sec / veh): 10.4
Level Of Service: B
Volume to Capacity (v/c): 0.046

Intersection Setup

Name	N-S Project Street		Burns Valley Rd		Burns Valley Rd	
Approach	Northbound		Eastbound		Westbound	
Lane Configuration	T		T		T	
Turning Movement	Left	Right	Thru	Right	Left	Thru
Lane Width [ft]	12.00	12.00	12.00	12.00	12.00	12.00
No. of Lanes in Entry Pocket	0	0	0	0	0	0
Entry Pocket Length [ft]	100.00	100.00	100.00	100.00	100.00	100.00
No. of Lanes in Exit Pocket	0	0	0	0	0	0
Exit Pocket Length [ft]	0.00	0.00	0.00	0.00	0.00	0.00
Speed [mph]	25.00		35.00		35.00	
Grade [%]	0.00		0.00		0.00	
Crosswalk	No		No		No	

Volumes

Name	N-S Project Street		Burns Valley Rd		Burns Valley Rd	
Base Volume Input [veh/h]	7	6	78	12	0	93
Base Volume Adjustment Factor	1.0000	1.0000	1.0000	1.0000	1.0000	1.0000
Heavy Vehicles Percentage [%]	2.00	2.00	2.00	2.00	2.00	2.00
Growth Factor	1.0000	1.0000	1.0000	1.0000	1.0000	1.0000
In-Process Volume [veh/h]	7	8	15	0	0	14
Site-Generated Trips [veh/h]	16	17	3	15	12	2
Diverted Trips [veh/h]	0	0	0	0	0	0
Pass-by Trips [veh/h]	0	0	0	0	0	0
Existing Site Adjustment Volume [veh/h]	0	0	0	0	0	0
Other Volume [veh/h]	0	0	0	0	0	0
Total Hourly Volume [veh/h]	30	31	96	27	12	109
Peak Hour Factor	0.9130	0.9130	0.9130	0.9130	0.9130	0.9130
Other Adjustment Factor	1.0000	1.0000	1.0000	1.0000	1.0000	1.0000
Total 15-Minute Volume [veh/h]	8	8	26	7	3	30
Total Analysis Volume [veh/h]	33	34	105	30	13	119
Pedestrian Volume [ped/h]	0	0	0	0	0	0



Intersection Settings

Priority Scheme	Stop	Free	Free
Flared Lane	No		
Storage Area [veh]	0	C	0
Two-Stage Gap Acceptance	No		
Number of Storage Spaces in Median	0	0	0

Movement, Approach, & Intersection Results

V/C, Movement V/C Ratio	0.05	0.04	0.00	0.00	0.01	0.00
d_M, Delay for Movement [s/veh]	10.42	9.26	0.00	0.00	7.51	0.00
Movement LOS	B	A	A	A	A	A
95th-Percentile Queue Length [veh/ln]	0.27	0.27	0.00	0.00	0.03	0.03
95th-Percentile Queue Length [ft/ln]	6.73	6.73	0.00	0.00	0.68	0.68
d_A, Approach Delay [s/veh]	9.83		0.00		0.74	
Approach LOS	A		A		A	
d_I, Intersection Delay [s/veh]				2.26		
Intersection LOS	B					



Generated with **PTV VISTRO**
Version 2021 (SP 0-6)

Burns Valley Development

5/2/2022

Intersection Level Of Service Report

Intersection 2: Burns Valley Rd/Bowers Ave-Rumsey Rd

Control Type: Two-way stop
Analysis Method: HCM 6th Edition
Analysis Period: 15 minutes
Delay (sec / veh): 13.1
Level Of Service: B
Volume to Capacity (v/c): 0.004

Intersection Setup

Name	Burns Valley Rd			Rumsey Rd			Burns Valley Rd			Bowers Ave		
Approach	Northbound			Southbound			Eastbound			Westbound		
Lane Configuration	+			+			+			+		
Turning Movement	Left	Thru	Right	Left	Thru	Right	Left	Thru	Right	Left	Thru	Right
Lane Width [ft]	12.00	12.00	12.00	12.00	12.00	12.00	12.00	12.00	12.00	12.00	12.00	12.00
No. of Lanes in Entry Pocket	0	0	0	0	0	0	0	0	0	0	0	0
Entry Pocket Length [ft]	100.00	100.00	100.00	100.00	100.00	100.00	100.00	100.00	100.00	100.00	100.00	100.00
No. of Lanes in Exit Pocket	0	0	0	0	0	0	0	0	0	0	0	0
Exit Pocket Length [ft]	0.00	0.00	0.00	0.00	0.00	0.00	0.00	0.00	0.00	0.00	0.00	0.00
Speed [mph]	30.00			30.00			35.00			25.00		
Grade [%]	0.00			0.00			0.00			0.00		
Crosswalk	No			Yes			Yes			No		

Volumes

Name	Burns Valley Rd			Rumsey Rd			Burns Valley Rd			Bowers Ave		
Base Volume Input [veh/h]	98	37	1	0	32	9	10	0	98	2	1	0
Base Volume Adjustment Factor	1.0000	1.0000	1.0000	1.0000	1.0000	1.0000	1.0000	1.0000	1.0000	1.0000	1.0000	1.0000
Heavy Vehicles Percentage [%]	2.00	2.00	2.00	2.00	2.00	2.00	2.00	2.00	2.00	2.00	2.00	2.00
Growth Factor	1.0000	1.0000	1.0000	1.0000	1.0000	1.0000	1.0000	1.0000	1.0000	1.0000	1.0000	1.0000
In-Process Volume [veh/h]	0	0	0	0	0	0	0	0	0	0	0	0
Site-Generated Trips [veh/h]	14	2	0	0	3	5	6	0	10	0	0	0
Diverted Trips [veh/h]	0	0	0	0	0	0	0	0	0	0	0	0
Pass-by Trips [veh/h]	0	0	0	0	0	0	0	0	0	0	0	0
Existing Site Adjustment Volume [veh/h]	0	0	0	0	0	0	0	0	0	0	0	0
Other Volume [veh/h]	0	0	0	0	0	0	0	0	0	0	0	0
Total Hourly Volume [veh/h]	112	39	1	0	35	14	16	0	108	2	1	0
Peak Hour Factor	0.8500	0.9600	0.9600	0.9600	0.9600	0.8500	0.8500	0.8500	0.9600	0.8500	0.9600	
Other Adjustment Factor	1.0000	1.0000	1.0000	1.0000	1.0000	1.0000	1.0000	1.0000	1.0000	1.0000	1.0000	
Total 15-Minute Volume [veh/h]	33	10	0	0	9	4	5	0	32	1	0	0
Total Analysis Volume [veh/h]	132	41	1	0	36	16	19	0	127	2	1	0
Pedestrian Volume [ped/h]	0			0			0			0		

Weekend PM B+P



Generated with **PTV VISTRO**
Version 2021 (SP 0-6)

Burns Valley Development

5/2/2022

Intersection Settings

Priority Scheme	Free	Free	Stop	Stop
Flared Lane			No	No
Storage Area [veh]	0	0	0	0
Two-Stage Gap Acceptance			No	No
Number of Storage Spaces in Median	0	0	0	0

Movement, Approach, & Intersection Results

VC, Movement V/C Ratio	0.08	0.00	0.00	0.00	0.00	0.00	0.03	0.00	0.12	0.00	0.00	0.00
d_M, Delay for Movement [s/veh]	7.53	0.30	0.00	7.35	0.50	0.00	12.11	12.69	9.23	13.06	11.98	8.55
Movement LOS	A	A	A	A	A	A	B	B	A	B	B	A
95th-Percentile Queue Length [veh/ln]	0.28	0.28	0.28	0.00	0.00	0.00	0.56	0.56	0.56	0.02	0.02	0.02
95th-Percentile Queue Length [ft/ln]	6.95	6.95	6.95	0.00	0.00	0.00	13.94	13.94	13.94	0.48	0.48	0.48
d_A, Approach Delay [s/veh]	5.71			0.00			9.61			12.70		
Approach LOS	A			A			A			B		
d_I, Intersection Delay [s/veh]							6.49					
Intersection LOS	B											

Weekend PM B+P



Intersection Level Of Service Report
Intersection 3: N-S Project Street/E-W Project Street

Control Type: All-way stop
Analysis Method: HCM 6th Edition
Analysis Period: 15 minutes
Delay (sec / veh): 7.7
Level Of Service: A
Volume to Capacity (v/c): 0.144

Intersection Setup

Name	N-S Project Street			N-S Project Street			E-W Project Street			E-W Project Street		
Approach	Northbound			Southbound			Eastbound			Westbound		
Lane Configuration	+			+			+			+		
Turning Movement	Left	Thru	Right	Left	Thru	Right	Left	Thru	Right	Left	Thru	Right
Lane Width [ft]	12.00	12.00	12.00	12.00	12.00	12.00	12.00	12.00	12.00	12.00	12.00	12.00
No. of Lanes in Entry Pocket	0	0	0	0	0	0	0	0	0	0	0	0
Entry Pocket Length [ft]	100.00	100.00	100.00	100.00	100.00	100.00	100.00	100.00	100.00	100.00	100.00	100.00
No. of Lanes in Exit Pocket	0	0	0	0	0	0	0	0	0	0	0	0
Exit Pocket Length [ft]	0.00	0.00	0.00	0.00	0.00	0.00	0.00	0.00	0.00	0.00	0.00	0.00
Speed [mph]	25.00			25.00			25.00			25.00		
Grade [%]	0.00			0.00			0.00			0.00		
Crosswalk	Yes			Yes			Yes			Yes		

Volumes

Name	N-S Project Street			N-S Project Street			E-W Project Street			E-W Project Street		
Base Volume Input [veh/h]	0	28	0	0	28	0	0	0	0	0	0	0
Base Volume Adjustment Factor	1.0000	1.0000	1.0000	1.0000	1.0000	1.0000	1.0000	1.0000	1.0000	1.0000	1.0000	1.0000
Heavy Vehicles Percentage [%]	2.00	2.00	2.00	2.00	2.00	2.00	2.00	2.00	2.00	2.00	2.00	2.00
Growth Factor	1.0000	1.0000	1.0000	1.0000	1.0000	1.0000	1.0000	1.0000	1.0000	1.0000	1.0000	1.0000
In-Process Volume [veh/h]	0	0	0	0	0	0	0	0	0	0	0	0
Site-Generated Trips [veh/h]	5	60	30	24	64	2	1	6	15	15	4	26
Diverted Trips [veh/h]	0	0	0	0	0	0	0	0	0	0	0	0
Pass-by Trips [veh/h]	0	0	0	0	0	0	0	0	0	0	0	0
Existing Site Adjustment Volume [veh/h]	0	0	0	0	0	0	0	0	0	0	0	0
Other Volume [veh/h]	0	0	0	0	0	0	0	0	0	0	0	0
Total Hourly Volume [veh/h]	5	88	30	24	92	2	1	6	15	15	4	26
Peak Hour Factor	0.9720	0.9720	0.9720	0.9720	0.9720	0.9720	0.9720	0.9720	0.9720	0.9720	0.9720	0.9720
Other Adjustment Factor	1.0000	1.0000	1.0000	1.0000	1.0000	1.0000	1.0000	1.0000	1.0000	1.0000	1.0000	1.0000
Total 15-Minute Volume [veh/h]	1	23	8	6	24	1	0	2	4	4	1	7
Total Analysis Volume [veh/h]	5	91	31	25	95	2	1	6	15	15	4	27
Pedestrian Volume [ped/h]	0			0			0			0		



Intersection Settings

Lanes	Capacity per Entry Lane [veh/h]	885	848	873	855
Degree of Utilization, x	0.14	0.14	0.03	0.05	

Movement, Approach, & Intersection Results

95th-Percentile Queue Length [veh]	0.50	0.50	0.08	0.17
95th-Percentile Queue Length [ft]	12.51	12.52	1.94	4.26
Approach Delay [s/veh]	7.75	7.95	7.23	7.45
Approach LOS	A	A	A	A
Intersection Delay [s/veh]	7.75			
Intersection LOS	A			



Intersection Level Of Service Report
Intersection 4: Burns Valley Rd/E-W Project Street

Control Type: Two-way stop
Analysis Method: HCM 6th Edition
Analysis Period: 15 minutes
Delay (sec / veh): 11.4
Level Of Service: B
Volume to Capacity (v/c): 0.003

Intersection Setup

Name	Burns Valley Rd		Burns Valley Rd		E-W Project Street	
	Northbound		Southbound		Eastbound	
Approach	←		→		←	
Lane Configuration	←		→		←	
Turning Movement	Left	Thru	Thru	Right	Left	Right
Lane Width [ft]	12.00	12.00	12.00	12.00	12.00	12.00
No. of Lanes in Entry Pocket	0	0	0	0	0	0
Entry Pocket Length [ft]	100.00	100.00	100.00	100.00	100.00	100.00
No. of Lanes in Exit Pocket	0	0	0	0	0	0
Exit Pocket Length [ft]	0.00	0.00	0.00	0.00	0.00	0.00
Speed [mph]	30.00		30.00		25.00	
Grade [%]	0.00		0.00		0.00	
Crosswalk	No		No		Yes	

Volumes

Name	Burns Valley Rd		Burns Valley Rd		E-W Project Street	
	Northbound	Southbound	Northbound	Southbound	Eastbound	Westbound
Base Volume Input [veh/h]	0	145	136	0	0	0
Base Volume Adjustment Factor	1.0000	1.0000	1.0000	1.0000	1.0000	1.0000
Heavy Vehicles Percentage [%]	2.00	2.00	2.00	2.00	2.00	2.00
Growth Factor	1.0000	1.0000	1.0000	1.0000	1.0000	1.0000
In-Process Volume [veh/h]	0	0	0	0	0	0
Site-Generated Trips [veh/h]	43	14	10	3	2	43
Diverted Trips [veh/h]	0	0	0	0	0	0
Pass-by Trips [veh/h]	0	0	0	0	0	0
Existing Site Adjustment Volume [veh/h]	0	0	0	0	0	0
Other Volume [veh/h]	0	0	0	0	0	0
Total Hourly Volume [veh/h]	43	159	146	3	2	43
Peak Hour Factor	0.9720	0.9720	0.9720	0.9720	0.9720	0.9720
Other Adjustment Factor	1.0000	1.0000	1.0000	1.0000	1.0000	1.0000
Total 15-Minute Volume [veh/h]	11	41	38	1	1	11
Total Analysis Volume [veh/h]	44	164	150	3	2	44
Pedestrian Volume [ped/h]	0	0	0	0	0	0



Intersection Settings

Priority Scheme	Free	Free	Stop
Flared Lane			No
Storage Area [veh]	0	0	0
Two-Stage Gap Acceptance			No
Number of Storage Spaces in Median	0	0	0

Movement, Approach, & Intersection Results

V/C, Movement V/C Ratio	0.03	0.00	0.00	0.00	0.00	0.05
d_M, Delay for Movement [s/veh]	7.60	0.00	0.00	0.00	11.41	9.25
Movement LOS	A	A	A	A	B	A
95th-Percentile Queue Length [veh/ln]	0.10	0.10	0.00	0.00	0.17	0.17
95th-Percentile Queue Length [ft/ln]	2.38	2.38	0.00	0.00	4.16	4.16
d_A, Approach Delay [s/veh]	1.61		0.00		9.35	
Approach LOS	A		A		A	
d_I, Intersection Delay [s/veh]			1.88			
Intersection LOS			B			



Intersection Level Of Service Report
Intersection 5: Olympic Dr/Lakeshore Dr

Control Type: Two-way stop
Analysis Method: HCM 6th Edition
Analysis Period: 15 minutes
Delay (sec / veh): 27.6
Level Of Service: D
Volume to Capacity (v/c): 0.532

Intersection Setup

Name	Lakeshore Dr			Lakeshore Dr			Olympic Dr					
Approach	Northbound			Southbound			Eastbound			Westbound		
Lane Configuration	TT			+			+			TT		
Turning Movement	Left	Thru	Right	Left	Thru	Right	Left	Thru	Right	Left	Thru	Right
Lane Width [ft]	12.00	12.00	12.00	12.00	12.00	12.00	12.00	12.00	12.00	12.00	12.00	12.00
No. of Lanes in Entry Pocket	0	0	1	0	0	0	0	0	0	0	0	1
Entry Pocket Length [ft]	120.00	120.00	120.00	100.00	100.00	100.00	100.00	100.00	100.00	100.00	100.00	250.00
No. of Lanes in Exit Pocket	0	0	0	0	0	0	0	0	0	0	0	0
Exit Pocket Length [ft]	0.00	0.00	0.00	0.00	0.00	0.00	0.00	0.00	0.00	0.00	0.00	0.00
Speed [mph]	25.00			25.00			30.00			30.00		
Grade [%]	0.00			0.00			0.00			0.00		
Crosswalk	No			Yes			No			Yes		

Volumes

Name	Lakeshore Dr			Lakeshore Dr			Olympic Dr					
Base Volume Input [veh/h]	1	176	127	103	185	0	0	3	3	127	1	107
Base Volume Adjustment Factor	1.0000	1.0000	1.0000	1.0000	1.0000	1.0000	1.0000	1.0000	1.0000	1.0000	1.0000	1.0000
Heavy Vehicles Percentage [%]	2.00	2.00	2.00	2.00	2.00	2.00	2.00	2.00	2.00	2.00	2.00	2.00
Growth Factor	1.0000	1.0000	1.0000	1.0000	1.0000	1.0000	1.0000	1.0000	1.0000	1.0000	1.0000	1.0000
In-Process Volume [veh/h]	0	0	0	0	0	0	0	0	0	0	0	0
Site-Generated Trips [veh/h]	0	0	37	18	0	0	0	0	0	33	0	18
Diverted Trips [veh/h]	0	0	0	0	0	0	0	0	0	0	0	0
Pass-by Trips [veh/h]	0	0	0	0	0	0	0	0	0	0	0	0
Existing Site Adjustment Volume [veh/h]	0	0	0	0	0	0	0	0	0	0	0	0
Other Volume [veh/h]	0	0	0	0	0	0	0	0	0	0	0	0
Total Hourly Volume [veh/h]	1	176	164	121	185	0	0	3	3	160	1	125
Peak Hour Factor	0.9100	0.9100	0.9100	0.9100	0.9100	0.9100	0.9100	0.9100	0.9100	0.9100	0.9100	0.9100
Other Adjustment Factor	1.0000	1.0000	1.0000	1.0000	1.0000	1.0000	1.0000	1.0000	1.0000	1.0000	1.0000	1.0000
Total 15-Minute Volume [veh/h]	0	48	45	33	51	0	0	1	1	44	0	34
Total Analysis Volume [veh/h]	1	193	180	133	203	0	0	3	3	176	1	137
Pedestrian Volume [ped/h]	0			0			0			1		



Intersection Settings

Priority Scheme	Free	Free	Stop	Stop
Flared Lane			No	No
Storage Area [veh]	0	0	0	0
Two-Stage Gap Acceptance			No	No
Number of Storage Spaces in Median	0	0	0	0

Movement, Approach, & Intersection Results

V/C, Movement V/C Ratio	0.00	0.00	0.00	0.11	0.00	0.00	0.00	0.01	0.00	0.53	0.00	0.16
d_M, Delay for Movement [s/veh]	7.63	0.00	0.00	8.43	0.00	0.00	21.45	18.92	9.44	27.56	16.70	10.10
Movement LOS	A	A	A	A	A	A	C	C	A	D	C	B
95th-Percentile Queue Length [veh/ln]	0.00	0.00	0.00	0.38	0.38	0.38	0.05	0.05	0.05	2.95	0.59	0.59
95th-Percentile Queue Length [ft/ln]	0.05	0.05	0.00	9.47	9.47	9.47	1.15	1.15	1.15	73.85	14.70	14.70
d_A, Approach Delay [s/veh]	0.02			3.34			14.18			19.91		
Approach LOS	A			A			B			C		
d_I, Intersection Delay [s/veh]	7.25											
Intersection LOS	D											



**Intersection Level Of Service Report
 Intersection 6: Olympic Dr/N-S Project Street**

Control Type: Two-way stop Delay (sec / veh): 27.4
 Analysis Method: HCM 6th Edition Level Of Service: D
 Analysis Period: 15 minutes Volume to Capacity (v/c): 0.219

Intersection Setup

Name	N-S Project Street		Olympic Dr		Olympic Dr	
Approach	Southbound		Eastbound		Westbound	
Lane Configuration	T		T		T	
Turning Movement	Left	Right	Left	Thru	Thru	Right
Lane Width [ft]	12.00	12.00	12.00	12.00	12.00	12.00
No. of Lanes in Entry Pocket	0	0	0	0	0	0
Entry Pocket Length [ft]	100.00	100.00	100.00	100.00	100.00	100.00
No. of Lanes in Exit Pocket	0	0	0	0	0	0
Exit Pocket Length [ft]	0.00	0.00	0.00	0.00	0.00	0.00
Speed [mph]	25.00		30.00		30.00	
Grade [%]	0.00		0.00		0.00	
Crosswalk	Yes		No		No	

Volumes

Name	N-S Project Street		Olympic Dr		Olympic Dr	
Base Volume Input [veh/h]	6	6	13	288	300	0
Base Volume Adjustment Factor	1.0000	1.0000	1.0000	1.0000	1.0000	1.0000
Heavy Vehicles Percentage [%]	2.00	2.00	2.00	2.00	2.00	2.00
Growth Factor	1.0000	1.0000	1.0000	1.0000	1.0000	1.0000
In-Process Volume [veh/h]	8	8	0	82	58	0
Site-Generated Trips [veh/h]	26	89	73	0	0	25
Diverted Trips [veh/h]	0	0	0	0	0	0
Pass-by Trips [veh/h]	0	0	0	0	0	0
Existing Site Adjustment Volume [veh/h]	0	0	0	0	0	0
Other Volume [veh/h]	0	0	0	0	0	0
Total Hourly Volume [veh/h]	40	83	86	371	358	25
Peak Hour Factor	0.8500	0.8500	0.8500	0.8500	0.8500	0.8500
Other Adjustment Factor	1.0000	1.0000	1.0000	1.0000	1.0000	1.0000
Total 15-Minute Volume [veh/h]	12	24	25	109	105	7
Total Analysis Volume [veh/h]	47	98	101	436	421	29
Pedestrian Volume [ped/h]	0		0		0	



Intersection Settings

Priority Scheme	Stop	Free	Free
Flared Lane	No		
Storage Area [veh]	C	0	0
Two-Stage Gap Acceptance	No		
Number of Storage Spaces in Median	0	0	0

Movement, Approach, & Intersection Results

V/C, Movement V/C Ratio	0.22	0.16	0.09	0.00	0.00	0.00
d_M, Delay for Movement [s/veh]	27.35	16.36	8.57	0.00	0.00	0.00
Movement LOS	D	C	A	A	A	A
95th-Percentile Queue Length [veh/ln]	1.72	1.72	0.30	0.30	0.00	0.00
95th-Percentile Queue Length [ft/ln]	42.95	42.95	7.49	7.49	0.00	0.00
d_A, Approach Delay [s/veh]	19.92		1.61		0.00	
Approach LOS	C		A		A	
d_I, Intersection Delay [s/veh]			3.32			
Intersection LOS			D			



Intersection Level Of Service Report
Intersection 7: Olympic Dr/Burns Valley Rd-Old Hwy 53

Control Type: Signalized
Analysis Method: HCM 6th Edition
Analysis Period: 15 minutes
Delay (sec / veh): 14.8
Level Of Service: B
Volume to Capacity (v/c): 0.802

Intersection Setup

Name	Old Hwy 53			Burns Valley Rd			Olympic Dr			Old Hwy 53		
	Northbound			Southbound			Eastbound			Westbound		
Approach	Northbound			Southbound			Eastbound			Westbound		
Lane Configuration	[Diagram]			[Diagram]			[Diagram]			[Diagram]		
Turning Movement	Left	Thru	Right	Left	Thru	Right	Left	Thru	Right	Left	Thru	Right
Lane Width [ft]	12.00	12.00	12.00	12.00	12.00	12.00	12.00	12.00	12.00	12.00	12.00	12.00
No. of Lanes in Entry Pocket	1	0	1	1	0	0	1	0	0	1	0	0
Entry Pocket Length [ft]	100.00	100.00	100.00	56.00	100.00	100.00	48.00	100.00	100.00	100.00	100.00	100.00
No. of Lanes in Exit Pocket	0	0	0	0	0	0	0	0	0	0	0	0
Exit Pocket Length [ft]	0.00	0.00	0.00	0.00	0.00	0.00	0.00	0.00	0.00	0.00	0.00	0.00
Speed [mph]	30.00			30.00			35.00			35.00		
Grade [%]	0.00			0.00			0.00			0.00		
Curb Present	No			No			No			No		
Crosswalk	Yes			Yes			Yes			Yes		



Volumes

Name	Old Hwy 53			Burns Valley Rd			Olympic Dr			Old Hwy 53		
Base Volume Input [veh/h]	113	91	79	93	77	31	26	231	136	101	206	89
Base Volume Adjustment Factor	1.0000	1.0000	1.0000	1.0000	1.0000	1.0000	1.0000	1.0000	1.0000	1.0000	1.0000	1.0000
Heavy Vehicles Percentage [%]	2.00	2.00	2.00	2.00	2.00	2.00	2.00	2.00	2.00	2.00	2.00	2.00
Growth Factor	1.0000	1.0000	1.0000	1.0000	1.0000	1.0000	1.0000	1.0000	1.0000	1.0000	1.0000	1.0000
In-Process Volume [veh/h]	0	0	0	0	0	0	0	0	0	0	0	0
Site-Generated Trips [veh/h]	12	32	0	22	31	0	0	11	15	0	12	25
Diverted Trips [veh/h]	0	0	0	0	0	0	0	0	0	0	0	0
Pass-by Trips [veh/h]	0	0	0	0	0	0	0	0	0	0	0	0
Existing Site Adjustment Volume [veh/h]	0	0	0	0	0	0	0	0	0	0	0	0
Other Volume [veh/h]	0	0	0	0	0	0	0	0	0	0	0	0
Right Turn on Red Volume [veh/h]	0	0	16	0	0	12	0	25	0	0	0	29
Total Hourly Volume [veh/h]	125	123	64	115	108	19	26	242	126	101	218	85
Peak Hour Factor	0.9300	0.9300	0.9300	0.9300	0.9300	0.9300	0.9300	0.9300	0.9300	0.9300	0.9300	0.9300
Other Adjustment Factor	1.0000	1.0000	1.0000	1.0000	1.0000	1.0000	1.0000	1.0000	1.0000	1.0000	1.0000	1.0000
Total 15-Minute Volume [veh/h]	34	33	17	31	29	5	7	65	34	27	59	23
Total Analysis Volume [veh/h]	134	132	69	124	116	20	28	260	135	109	234	91
Presence of On-Street Parking	No	No	No	No	No	No	No	No	No	No	No	No
On-Street Parking Maneuver Rate [h]	0	0	0	0	0	0	0	0	0	0	0	0
Local Bus Stopping Rate [h]	0	0	0	0	0	0	0	0	0	0	0	0
v_do, Outbound Pedestrian Volume crossing major street	1			0			1			1		
v_di, Inbound Pedestrian Volume crossing major street	1			1			0			1		
v_co, Outbound Pedestrian Volume crossing minor street	1			0			0			0		
v_ci, Inbound Pedestrian Volume crossing minor street	0			0			1			0		
v_ab, Corner Pedestrian Volume [ped/h]	0			0			0			0		
Bicycle Volume [bicycles/h]	0			0			0			1		



Intersection Settings	
Located in CBD	Yes
Signal Coordination Group	
Cycle Length [s]	109
Coordination Type	Time of Day Pattern Isolated
Actuation Type	Fully actuated
Offset [s]	0.0
Offset Reference	Left Green - Beginning of First Green
Permissive Mode	SingleBand
Last time [s]	14.00

Phasing & Timing													
Control Type	Protect	Permis	Permis	Protect	Permis	Permis	Protect	Permis	Permis	Protect	Permis	Permis	Protect
Signal Group	3	8	0	7	4	0	5	2	0	1	6	0	
Auxiliary Signal Groups													
Lead / Lag	Lead	-	-	Lead	-	-	Lead	-	-	Lead	-	-	
Minimum Green [s]	4	6	0	4	6	0	4	6	0	4	6	0	
Maximum Green [s]	20	25	0	20	25	0	20	30	0	20	20	0	
Amber [s]	3.0	3.3	0.0	3.0	3.3	0.0	3.0	3.6	0.0	3.0	3.6	0.0	
All red [s]	0.0	0.3	0.0	0.0	0.3	0.0	0.0	0.3	0.0	0.0	0.3	0.0	
Split [s]	23	29	0	23	29	0	23	34	0	23	34	0	
Vehicle Extension [s]	0.0	0.0	0.0	0.0	0.0	0.0	0.0	0.0	0.0	0.0	0.0	0.0	
Walk [s]	0	7	0	0	7	0	0	7	0	0	7	0	
Pedestrian Clearance [s]	0	11	0	0	9	0	0	14	0	0	9	0	
Delayed Vehicle Green [s]	0.0	0.0	0.0	0.0	0.0	0.0	0.0	0.0	0.0	0.0	0.0	0.0	
Rest in Walk	No			No			No			No			
I1, Start-Up Lost Time [s]	2.0	2.0	0.0	2.0	2.0	0.0	2.0	2.0	0.0	2.0	2.0	0.0	
I2, Clearance Lost Time [s]	1.0	1.6	0.0	1.0	1.6	0.0	1.0	1.9	0.0	1.0	1.9	0.0	
Minimum Recall	No	No		No	No		No	No		No	No		
Maximum Recall	No	No		No	No		No	No		No	No		
Pedestrian Recall	No	No		No	No		No	No		No	No		
Detector Location [ft]	0.0	0.0	0.0	0.0	0.0	0.0	0.0	0.0	0.0	0.0	0.0	0.0	
Detector Length [ft]	0.0	0.0	0.0	0.0	0.0	0.0	0.0	0.0	0.0	0.0	0.0	0.0	
I, Upstream Filtering Factor	1.00	1.00	1.00	1.00	1.00	1.00	1.00	1.00	1.00	1.00	1.00	1.00	

Exclusive Pedestrian Phase	
Pedestrian Signal Group	0
Pedestrian Walk [s]	0
Pedestrian Clearance [s]	0



Lane Group Calculations										
Lane Group	L	C	R	L	C	L	C	L	C	C
C, Cycle Length [s]	35	35	35	35	35	35	35	35	35	35
L, Total Lost Time per Cycle [s]	3.00	3.60	3.60	3.00	3.60	3.00	3.60	3.00	3.60	3.00
I1_p, Permitted Start-Up Lost Time [s]	0.00	0.00	0.00	0.00	0.00	0.00	0.00	0.00	0.00	0.00
I2, Clearance Lost Time [s]	1.00	1.60	1.60	1.00	1.60	1.00	1.60	1.00	1.60	1.00
g_L, Effective Green Time [s]	4	5	5	3	5	1	10	3	12	
g / C, Green / Cycle	0.10	0.15	0.15	0.09	0.14	0.03	0.29	0.08	0.34	
(v / s)_j Volume / Saturation Flow Rate	0.08	0.08	0.05	0.08	0.08	0.02	0.25	0.07	0.20	
s, saturation flow rate [veh/h]	1603	1683	1421	1603	1639	1603	1586	1603	1593	
c, Capacity [veh/h]	165	253	214	152	233	44	461	132	551	
d1, Uniform Delay [s]	15.54	13.86	13.42	15.71	14.20	17.03	11.86	15.98	9.52	
k, delay calibration	0.04	0.04	0.04	0.04	0.04	0.04	0.04	0.04	0.04	
I, Upstream Filtering Factor	1.00	1.00	1.00	1.00	1.00	1.00	1.00	1.00	1.00	
d2, Incremental Delay [s]	3.61	0.62	0.32	3.99	0.86	5.43	1.82	4.78	0.38	
d3, Initial Queue Delay [s]	0.00	0.00	0.00	0.00	0.00	0.00	0.00	0.00	0.00	
Rp, platoon ratio	1.00	1.00	1.00	1.00	1.00	1.00	1.00	1.00	1.00	
PF, progression factor	1.00	1.00	1.00	1.00	1.00	1.00	1.00	1.00	1.00	

Lane Group Results										
X, volume / capacity	0.81	0.52	0.32	0.82	0.58	0.63	0.86	0.82	0.59	
d, Delay for Lane Group [s/veh]	19.15	14.48	13.74	19.70	15.05	22.46	13.68	20.76	9.90	
Lane Group LOS	B	B	B	B	B	C	B	C	A	
Critical Lane Group	Yes	No	No	No	Yes	No	Yes	Yes	No	
50th-Percentile Queue Length [veh/m]	1.03	0.82	0.41	0.97	0.87	0.25	2.26	0.86	1.41	
50th-Percentile Queue Length [ft/m]	25.73	20.55	10.33	24.33	21.84	6.24	56.38	21.59	35.21	
95th-Percentile Queue Length [veh/m]	1.85	1.48	0.74	1.75	1.57	0.45	4.06	1.55	2.54	
95th-Percentile Queue Length [ft/m]	46.32	37.00	18.59	43.79	39.31	11.23	101.48	38.85	63.39	



Movement, Approach, & Intersection Results

d_M, Delay for Movement [s/veh]	19.15	14.48	13.74	19.70	15.05	15.05	22.46	13.68	13.68	20.76	9.90	9.90
Movement LOS	B	B	B	B	B	B	C	B	B	C	A	A
d_A, Approach Delay [s/veh]	16.19			17.27			14.26			12.62		
Approach LOS	B			B			B			B		
d_I, Intersection Delay [s/veh]	14.76											
Intersection LOS	B											
Intersection V/C	0.602											

Other Modes

g_Walk,mi, Effective Walk Time [s]	11.0	11.0	11.0	11.0
M_corner, Corner Circulation Area [ft²/ped]	0.00	0.00	0.00	0.00
M_CW, Crosswalk Circulation Area [ft²/ped]	0.00	0.00	0.00	0.00
d_p, Pedestrian Delay [s]	8.35	8.35	8.35	8.35
L_p,int, Pedestrian LOS Score for Intersection	2.274	2.079	2.240	2.277
Crosswalk LOS	B	B	B	B
s_b, Saturation Flow Rate of the bicycle lane [bicycles/h]	2000	2000	2000	2000
c_b, Capacity of the bicycle lane [bicycles/h]	1440	1440	1707	1707
d_b, Bicycle Delay [s]	1.38	1.38	0.38	0.38
L_b,int, Bicycle LOS Score for Intersection	2.137	2.008	2.299	2.324
Bicycle LOS	B	B	B	B

Sequence

Ring 1	1	2	3	4	-	-	-	-	-	-	-	-	-	-	-
Ring 2	5	6	7	8	-	-	-	-	-	-	-	-	-	-	-
Ring 3	-	-	-	-	-	-	-	-	-	-	-	-	-	-	-
Ring 4	-	-	-	-	-	-	-	-	-	-	-	-	-	-	-

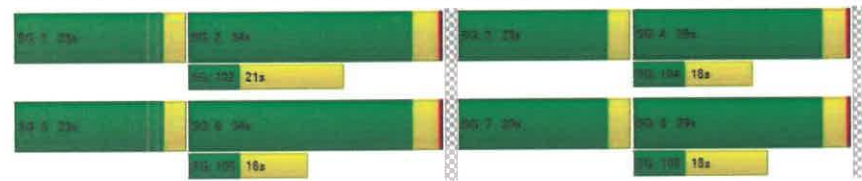

Intersection Level Of Service Report
Intersection 1: Burns Valley Rd/N-S Project Street

Control Type:	Two-way stop	Delay (sec / veh):	11.4
Analysis Method:	HCM 6th Edition	Level Of Service:	B
Analysis Period:	15 minutes	Volume to Capacity (v/c):	0.027

Intersection Setup

Name	N-S Project Street		Burns Valley Rd		Burns Valley Rd	
Approach	Northbound		Eastbound		Westbound	
Lane Configuration	T		T		T	
Turning Movement	Left	Right	Thru	Right	Left	Thru
Lane Width [ft]	12.00	12.00	12.00	12.00	12.00	12.00
No. of Lanes in Entry Pocket	0	0	0	0	0	0
Entry Pocket Length [ft]	100.00	100.00	100.00	100.00	100.00	100.00
No. of Lanes in Exit Pocket	0	0	0	0	0	0
Exit Pocket Length [ft]	0.00	0.00	0.00	0.00	0.00	0.00
Speed [mph]	25.00		35.00		35.00	
Grade [%]	0.00		0.00		0.00	
Crosswalk	No		No		No	

Volumes

Name	N-S Project Street		Burns Valley Rd		Burns Valley Rd	
Base Volume Input [veh/h]	8	7	112	15	0	110
Base Volume Adjustment Factor	1.0000	1.0000	1.0000	1.0000	1.0000	1.0000
Heavy Vehicles Percentage [%]	2.00	2.00	2.00	2.00	2.00	2.00
Growth Factor	1.7600	1.7600	1.7600	1.7600	1.7600	1.7600
In-Process Volume [veh/h]	0	0	0	0	0	0
Site-Generated Trips [veh/h]	2	3	1	4	5	1
Diverted Trips [veh/h]	0	0	0	0	0	0
Pass-by Trips [veh/h]	0	0	0	0	0	0
Existing Site Adjustment Volume [veh/h]	0	0	0	0	0	0
Other Volume [veh/h]	0	0	0	0	0	0
Total Hourly Volume [veh/h]	16	15	198	30	5	195
Peak Hour Factor	1.0000	1.0000	1.0000	1.0000	1.0000	1.0000
Other Adjustment Factor	1.0000	1.0000	1.0000	1.0000	1.0000	1.0000
Total 15-Minute Volume [veh/h]	4	4	50	8	1	49
Total Analysis Volume [veh/h]	16	15	198	30	5	195
Pedestrian Volume [ped/h]	0		0		0	



Intersection Settings

Priority Scheme	Stop	Free	Free
Flared Lane	No		
Storage Area [veh]	0	0	0
Two-Stage Gap Acceptance	No		
Number of Storage Spaces in Median	0	0	0

Movement, Approach, & Intersection Results

V/C, Movement V/C Ratio	0.03	0.02	0.00	0.00	0.00	0.00
d_M, Delay for Movement [s/Veh]	11.36	9.60	0.00	0.00	7.70	0.00
Movement LOS	B	A	A	A	A	A
95th-Percentile Queue Length [veh/ln]	0.14	0.14	0.00	0.00	0.01	0.01
95th-Percentile Queue Length [ft/ln]	3.55	3.55	0.00	0.00	0.28	0.28
d_A, Approach Delay [s/Veh]	10.51		0.00		0.19	
Approach LOS	B		A		A	
d_I, Intersection Delay [s/Veh]			0.79			
Intersection LOS			B			



Intersection Level Of Service Report

Intersection 2: Burns Valley Rd/Bowers Ave-Rumsey Rd

Control Type:	Two-way stop	Delay (sec / veh):	19.3
Analysis Method:	HCM 6th Edition	Level Of Service:	C
Analysis Period:	15 minutes	Volume to Capacity (v/c):	0.034

Intersection Setup

Name	Burns Valley Rd			Rumsey Rd			Burns Valley Rd			Bowers Ave		
Approach	Northbound			Southbound			Eastbound			Westbound		
Lane Configuration	+			+			+			+		
Turning Movement	Left	Thru	Right	Left	Thru	Right	Left	Thru	Right	Left	Thru	Right
Lane Width [ft]	12.00	12.00	12.00	12.00	12.00	12.00	12.00	12.00	12.00	12.00	12.00	12.00
No. of Lanes in Entry Pocket	0	0	0	0	0	0	0	0	0	0	0	0
Entry Pocket Length [ft]	100.00	100.00	100.00	100.00	100.00	100.00	100.00	100.00	100.00	100.00	100.00	100.00
No. of Lanes in Exit Pocket	0	0	0	0	0	0	0	0	0	0	0	0
Exit Pocket Length [ft]	0.00	0.00	0.00	0.00	0.00	0.00	0.00	0.00	0.00	0.00	0.00	0.00
Speed [mph]	30.00			30.00			35.00			25.00		
Grade [%]	0.00			0.00			0.00			0.00		
Crosswalk	No			Yes			Yes			No		

Volumes

Name	Burns Valley Rd			Rumsey Rd			Burns Valley Rd			Bowers Ave		
Base Volume Input [veh/h]	215	46	11	0	41	28	16	2	219	9	2	0
Base Volume Adjustment Factor	1.0000	1.0000	1.0000	1.0000	1.0000	1.0000	1.0000	1.0000	1.0000	1.0000	1.0000	1.0000
Heavy Vehicles Percentage [%]	2.00	2.00	2.00	2.00	2.00	2.00	2.00	2.00	2.00	2.00	2.00	2.00
Growth Factor	1.0000	1.0000	1.0000	1.0000	1.0000	1.0000	1.0000	1.0000	1.0000	1.0000	1.0000	1.0000
In-Process Volume [veh/h]	0	0	0	0	0	0	0	0	0	0	0	0
Site-Generated Trips [veh/h]	2	1	0	0	0	1	2	0	5	0	0	0
Diverted Trips [veh/h]	0	0	0	0	0	0	0	0	0	0	0	0
Pass-by Trips [veh/h]	0	0	0	0	0	0	0	0	0	0	0	0
Existing Site Adjustment Volume [veh/h]	0	0	0	0	0	0	0	0	0	0	0	0
Other Volume [veh/h]	0	0	0	0	0	0	0	0	0	0	0	0
Total Hourly Volume [veh/h]	217	47	11	0	41	29	18	2	224	9	2	0
Peak Hour Factor	1.0000	1.0000	1.0000	1.0000	1.0000	1.0000	1.0000	1.0000	1.0000	1.0000	1.0000	1.0000
Other Adjustment Factor	1.0000	1.0000	1.0000	1.0000	1.0000	1.0000	1.0000	1.0000	1.0000	1.0000	1.0000	1.0000
Total 15-Minute Volume [veh/h]	54	12	3	0	10	7	5	1	56	2	1	0
Total Analysis Volume [veh/h]	217	47	11	0	41	29	18	2	224	9	2	0
Pedestrian Volume [ped/h]	0			0			0			0		



Intersection Settings

Priority Scheme	Free	Free	Stop	Stop
Flared Lane			No	No
Storage Area [veh]	0	0	0	0
Two-Stage Gap Acceptance			No	No
Number of Storage Spaces in Median	0	0	0	0

Movement, Approach, & Intersection Results

V/C, Movement V/C Ratio	0.14	0.00	0.00	0.00	0.00	0.00	0.05	0.01	0.22	0.03	0.01	0.00
d_M, Delay for Movement [s/veh]	7.74	0.00	0.00	7.33	0.00	0.00	15.53	15.99	10.05	19.33	15.15	9.09
Movement LOS	A	A	A	A	A	A	C	C	B	C	C	A
95th-Percentile Queue Length [veh/ln]	0.49	0.49	0.49	0.00	0.00	0.00	1.11	1.11	1.11	0.12	0.12	0.12
95th-Percentile Queue Length [ft/ln]	12.35	12.35	12.35	0.00	0.00	0.00	27.65	27.65	27.65	3.10	3.10	3.10
d_A, Approach Delay [s/veh]	6.11			0.00			10.51			18.57		
Approach LOS	A			A			B			C		
d_I, Intersection Delay [s/veh]	7.41											
Intersection LOS	C											



Intersection Level Of Service Report

Intersection 3: N-S Project Street/E-W Project Street

Control Type:	All-way stop	Delay (sec / veh):	7.2
Analysis Method:	HCM 6th Edition	Level Of Service:	A
Analysis Period:	15 minutes	Volume to Capacity (v/c):	0.059

Intersection Setup

Name	N-S Project Street			N-S Project Street			E-W Project Street			E-W Project Street		
Approach	Northbound			Southbound			Eastbound			Westbound		
Lane Configuration	+			+			+			+		
Turning Movement	Left	Thru	Right	Left	Thru	Right	Left	Thru	Right	Left	Thru	Right
Lane Width [ft]	12.00	12.00	12.00	12.00	12.00	12.00	12.00	12.00	12.00	12.00	12.00	12.00
No. of Lanes in Entry Pocket	0	0	0	0	0	0	0	0	0	0	0	0
Entry Pocket Length [ft]	100.00	100.00	100.00	100.00	100.00	100.00	100.00	100.00	100.00	100.00	100.00	100.00
No. of Lanes in Exit Pocket	0	0	0	0	0	0	0	0	0	0	0	0
Exit Pocket Length [ft]	0.00	0.00	0.00	0.00	0.00	0.00	0.00	0.00	0.00	0.00	0.00	0.00
Speed [mph]	25.00			25.00			25.00			25.00		
Grade [%]	0.00			0.00			0.00			0.00		
Crosswalk	Yes			Yes			Yes			Yes		

Volumes

Name	N-S Project Street			N-S Project Street			E-W Project Street			E-W Project Street		
Base Volume Input [veh/h]	0	15	0	0	15	0	0	0	0	0	0	0
Base Volume Adjustment Factor	1.0000	1.0000	1.0000	1.0000	1.0000	1.0000	1.0000	1.0000	1.0000	1.0000	1.0000	1.0000
Heavy Vehicles Percentage [%]	2.00	2.00	2.00	2.00	2.00	2.00	2.00	2.00	2.00	2.00	2.00	2.00
Growth Factor	1.7600	1.7600	1.7600	1.7600	1.7600	1.7600	1.7600	1.7600	1.7600	1.7600	1.7600	1.7600
In-Process Volume [veh/h]	0	0	0	0	0	0	0	0	0	0	0	0
Site-Generated Trips [veh/h]	6	18	3	3	11	1	0	1	1	4	2	4
Diverted Trips [veh/h]	0	0	0	0	0	0	0	0	0	0	0	0
Pass-by Trips [veh/h]	0	0	0	0	0	0	0	0	0	0	0	0
Existing Site Adjustment Volume [veh/h]	0	0	0	0	0	0	0	0	0	0	0	0
Other Volume [veh/h]	0	0	0	0	0	0	0	0	0	0	0	0
Total Hourly Volume [veh/h]	6	44	3	3	37	1	0	1	1	4	2	4
Peak Hour Factor	1.0000	1.0000	1.0000	1.0000	1.0000	1.0000	1.0000	1.0000	1.0000	1.0000	1.0000	1.0000
Other Adjustment Factor	1.0000	1.0000	1.0000	1.0000	1.0000	1.0000	1.0000	1.0000	1.0000	1.0000	1.0000	1.0000
Total 15-Minute Volume [veh/h]	2	11	1	1	9	0	0	0	0	1	1	1
Total Analysis Volume [veh/h]	6	44	3	3	37	1	0	1	1	4	2	4
Pedestrian Volume [ped/h]	0			0			0			0		



Intersection Settings

Lanes				
Capacity per Entry Lane [veh/h]	903	899	937	906
Degree of Utilization, x	0.06	0.05	0.00	0.01

Movement, Approach, & Intersection Results

95th-Percentile Queue Length [veh]	0.19	0.14	0.01	0.03
95th-Percentile Queue Length [ft]	4.67	3.58	0.16	0.84
Approach Delay [s/veh]	7.23	7.20	6.85	7.02
Approach LOS	A	A	A	A
Intersection Delay [s/veh]	7.19			
Intersection LOS	A			



Intersection Level Of Service Report
Intersection 4: Burns Valley Rd/E-W Project Street

Control Type:	Two-way stop	Delay (sec / veh):	12.4
Analysis Method:	HCM 6th Edition	Level Of Service:	B
Analysis Period:	15 minutes	Volume to Capacity (v/c):	0.002

Intersection Setup

Name	Burns Valley Rd		Burns Valley Rd		E-W Project Street	
	Northbound		Southbound		Eastbound	
Approach	←		→		↑	
Lane Configuration	←		→		↑	
Turning Movement	Left	Thru	Thru	Right	Left	Right
Lane Width [ft]	12.00	12.00	12.00	12.00	12.00	12.00
No. of Lanes in Entry Pocket	0	0	0	0	0	0
Entry Pocket Length [ft]	100.00	100.00	100.00	100.00	100.00	100.00
No. of Lanes in Exit Pocket	0	0	0	0	0	0
Exit Pocket Length [ft]	0.00	0.00	0.00	0.00	0.00	0.00
Speed [mph]	30.00		30.00		25.00	
Grade [%]	0.00		0.00		0.00	
Crosswalk	No		No		Yes	

Volumes

Name	Burns Valley Rd		Burns Valley Rd		E-W Project Street	
	Northbound		Southbound		Eastbound	
Base Volume Input [veh/h]	0	151	147	0	0	0
Base Volume Adjustment Factor	1.0000	1.0000	1.0000	1.0000	1.0000	1.0000
Heavy Vehicles Percentage [%]	2.00	2.00	2.00	2.00	2.00	2.00
Growth Factor	1.7600	1.7600	1.7600	1.7600	1.7600	1.7600
In-Process Volume [veh/h]	0	0	0	0	0	0
Site-Generated Trips [veh/h]	8	2	5	0	1	9
Diverted Trips [veh/h]	0	0	0	0	0	0
Pass-by Trips [veh/h]	0	0	0	0	0	0
Existing Site Adjustment Volume [veh/h]	0	0	0	0	0	0
Other Volume [veh/h]	0	0	0	0	0	0
Total Hourly Volume [veh/h]	8	268	264	0	1	9
Peak Hour Factor	1.0000	1.0000	1.0000	1.0000	1.0000	1.0000
Other Adjustment Factor	1.0000	1.0000	1.0000	1.0000	1.0000	1.0000
Total 15-Minute Volume [veh/h]	2	67	66	0	0	2
Total Analysis Volume [veh/h]	8	288	264	0	1	9
Pedestrian Volume [ped/h]	0		0		0	



Intersection Settings

Priority Scheme	Free	Free	Stop
Flared Lane			No
Storage Area [veh]	0	0	0
Two-Stage Gap Acceptance			No
Number of Storage Spaces in Median	0	0	0

Movement, Approach, & Intersection Results

V/C, Movement V/C Ratio	0.01	0.01	0.03	0.00	0.00	0.01
d_M, Delay for Movement [s/veh]	7.79	0.00	0.03	0.00	12.36	9.72
Movement LOS	A	A	A	A	B	A
95th-Percentile Queue Length [veh/ln]	0.02	0.02	0.00	0.00	0.04	0.04
95th-Percentile Queue Length [ft/ln]	0.46	0.46	0.00	0.00	1.04	1.04
d_A, Approach Delay [s/veh]	0.23		0.00		9.98	
Approach LOS	A		A		A	
d_I, Intersection Delay [s/veh]				0.29		
Intersection LOS				B		



Intersection Level Of Service Report
Intersection 5: Olympic Dr/Lakeshore Dr

Control Type: Roundabout
Analysis Method: HCM 6th Edition
Analysis Period: 15 minutes
Delay (sec / veh): 5.7
Level Of Service: A

Intersection Setup

Name	Lakeshore Dr			Lakeshore Dr			Olympic Dr		
	Northbound			Southbound			Westbound		
Approach	Northbound			Southbound			Westbound		
Lane Configuration	T T			+			+		
Turning Movement	Left	Thru	Right	Left	Thru	Right	Left	Thru	Right
Lane Width [ft]	12.00	12.00	12.00	12.00	12.00	12.00	12.00	12.00	12.00
No. of Lanes in Entry Pocket	0	0	1	0	0	0	0	0	1
Entry Pocket Length [ft]	100.00	100.00	120.00	100.00	100.00	100.00	100.00	100.00	250.00
No. of Lanes in Exit Pocket	0	0	0	0	0	0	0	0	0
Exit Pocket Length [ft]	0.00	0.00	0.00	0.00	0.00	0.00	0.00	0.00	0.00
Speed [mph]	25.00			25.00			30.00		
Grade [%]	0.00			0.00			0.00		
Crosswalk	No			Yes			No		

Volumes

Name	Lakeshore Dr			Lakeshore Dr			Olympic Dr				
	5	230	85	90	435	0	0	5	80	5	70
Base Volume Input [veh/h]	5	230	85	90	435	0	0	5	80	5	70
Base Volume Adjustment Factor	1.0000	1.0000	1.0000	1.0000	1.0000	1.0000	1.0000	1.0000	1.0000	1.0000	1.0000
Heavy Vehicles Percentage [%]	2.00	2.00	2.00	2.00	2.00	2.00	2.00	2.00	2.00	2.00	2.00
Growth Factor	1.0000	1.0000	1.0000	1.0000	1.0000	1.0000	1.0000	1.0000	1.0000	1.0000	1.0000
In-Process Volume [veh/h]	0	0	0	0	0	0	0	0	0	0	0
Site-Generated Trips [veh/h]	0	0	11	4	0	0	0	0	6	0	3
Diverted Trips [veh/h]	0	0	0	0	0	0	0	0	0	0	0
Pass-by Trips [veh/h]	0	0	0	0	0	0	0	0	0	0	0
Existing Site Adjustment Volume [veh/h]	0	0	0	0	0	0	0	0	0	0	0
Other Volume [veh/h]	0	0	0	0	0	0	0	0	0	0	0
Total Hourly Volume [veh/h]	5	230	96	94	435	0	0	5	86	5	73
Peak Hour Factor	1.0000	1.0000	1.0000	1.0000	1.0000	1.0000	1.0000	1.0000	1.0000	1.0000	1.0000
Other Adjustment Factor	1.0000	1.0000	1.0000	1.0000	1.0000	1.0000	1.0000	1.0000	1.0000	1.0000	1.0000
Total 15-Minute Volume [veh/h]	1	58	24	24	109	0	0	1	22	1	18
Total Analysis Volume [veh/h]	5	230	96	94	435	0	0	5	86	5	73
Pedestrian Volume [ped/h]	0	0	0	0	0	0	0	0	0	0	1



Intersection Settings

Number of Conflicting Circulating Lanes	1		1		1		1					
Circulating Flow Rate [veh/h]	96		98		627		240					
Exiting Flow Rate [veh/h]	537		309		10		194					
Demand Flow Rate [veh/h]	5	230	96	94	435	0	0	0	5	86	5	73
Adjusted Demand Flow Rate [veh/h]	5	230	96	94	435	0	0	0	5	86	5	73

Lanes

Overwrite Calculated Critical Headway	No	No	No	No	No	No
User-Defined Critical Headway [s]	4.00	4.00	4.00	4.00	4.00	4.00
Overwrite Calculated Follow-Up Time	No	No	No	No	No	No
User-Defined Follow-Up Time [s]	3.00	3.00	3.00	3.00	3.00	3.00
A (intercept)	1420.00	1420.00	1380.00	1380.00	1420.00	1420.00
B (coefficient)	0.00091	0.00091	0.00102	0.00102	0.00091	0.00091
HV Adjustment Factor	0.98	0.98	0.98	0.98	0.98	0.98
Entry Flow Rate [veh/h]	240	98	540	6	88	80
Capacity of Entry and Bypass Lanes [veh/h]	1302	1302	1249	728	1142	1142
Pedestrian Impedance	1.00	1.00	1.00	1.00	1.00	1.00
Capacity per Entry Lane [veh/h]	1276	1276	1225	714	1119	1119
X, volume / capacity	0.18	0.08	0.43	0.01	0.08	0.07

Movement, Approach, & Intersection Results

Lane LOS	A	A	A	A	A	A
95th-Percentile Queue Length [veh]	0.67	0.24	2.23	0.02	0.25	0.22
95th-Percentile Queue Length [ft]	16.85	6.09	55.63	0.53	6.24	5.61
Approach Delay [s/veh]	4.10		7.32	5.12	3.84	
Approach LOS	A		A	A	A	
Intersection Delay [s/veh]	5.72					
Intersection LOS	A					



Intersection Level Of Service Report
Intersection 6: Olympic Dr/N-S Project Street

Control Type:	Two-way stop	Delay (sec / veh):	24.0
Analysis Method:	HCM 6th Edition	Level Of Service:	C
Analysis Period:	15 minutes	Volume to Capacity (v/c):	0.082

Intersection Setup

Name	N-S Project Street		Olympic Dr		Olympic Dr	
	Southbound		Eastbound		Westbound	
Lane Configuration	←		↑		↑	
Turning Movement	Left	Right	Left	Thru	Thru	Right
Lane Width [ft]	12.00	12.00	12.00	12.00	12.00	12.00
No. of Lanes in Entry Pocket	0	0	0	0	0	0
Entry Pocket Length [ft]	100.00	100.00	100.00	100.00	100.00	100.00
No. of Lanes in Exit Pocket	0	0	0	0	0	0
Exit Pocket Length [ft]	0.00	0.00	0.00	0.00	0.00	0.00
Speed [mph]	25.00		30.00		30.00	
Grade [%]	0.00		0.00		0.00	
Crosswalk	Yes		No		No	

Volumes

Name	N-S Project Street		Olympic Dr		Olympic Dr	
Base Volume Input [veh/h]	7	8	15	290	306	0
Base Volume Adjustment Factor	1.0000	1.0000	1.0000	1.0000	1.0000	1.0000
Heavy Vehicles Percentage [%]	2.00	2.00	2.00	2.00	2.00	2.00
Growth Factor	1.7600	1.7600	1.7600	1.7600	1.7600	1.7600
In-Process Volume [veh/h]	0	0	0	0	0	0
Site-Generated Trips [veh/h]	5	12	19	0	0	12
Diverted Trips [veh/h]	0	0	0	0	0	0
Pass-by Trips [veh/h]	0	0	0	0	0	0
Existing Site Adjustment Volume [veh/h]	0	0	0	0	0	0
Other Volume [veh/h]	0	0	0	0	0	0
Total Hourly Volume [veh/h]	17	28	45	510	539	12
Peak Hour Factor	1.0000	1.0000	1.0000	1.0000	1.0000	1.0000
Other Adjustment Factor	1.0000	1.0000	1.0000	1.0000	1.0000	1.0000
Total 15-Minute Volume [veh/h]	4	7	11	128	135	3
Total Analysis Volume [veh/h]	17	28	45	510	539	12
Pedestrian Volume [ped/h]	0		0		0	



Intersection Settings

Priority Scheme	Stop	Free	Free
Flared Lane	No		
Storage Area [veh]	0	0	0
Two-Stage Gap Acceptance	No		
Number of Storage Spaces in Median	0	0	1

Movement, Approach, & Intersection Results

V/C, Movement V/C Ratio	0.08	0.05	0.04	0.01	0.01	0.00
d_M, Delay for Movement [s/veh]	24.01	13.32	8.70	0.00	0.00	0.00
Movement LOS	C	B	A	A	A	A
95th-Percentile Queue Length [veh/ln]	0.44	0.44	0.14	0.14	0.00	0.00
95th-Percentile Queue Length [ft/ln]	11.11	11.11	3.46	3.46	0.00	0.00
d_A, Approach Delay [s/veh]	17.55		0.71		0.00	
Approach LOS	C		A		A	
d_I, Intersection Delay [s/veh]	1.00					
Intersection LOS	C					



Intersection Level Of Service Report

Intersection 7: Olympic Dr/Burns Valley Rd-Old Hwy 53

Control Type:	Signalized	Delay (sec / veh):	14.6
Analysis Method:	HCM 6th Edition	Level Of Service:	B
Analysis Period:	15 minutes	Volume to Capacity (v/c):	0.765

Intersection Setup

Name	Old Hwy 53			Burns Valley Rd			Olympic Dr			Old Hwy 53		
Approach	Northbound			Southbound			Eastbound			Westbound		
Lane Configuration	T T T			T T			T T			T T		
Turning Movement	Left	Thru	Right	Left	Thru	Right	Left	Thru	Right	Left	Thru	Right
Lane Width [ft]	12.00	12.00	12.00	12.00	12.00	12.00	12.00	12.00	12.00	12.00	12.00	12.00
No. of Lanes in Entry Pocket	1	0	1	1	0	0	1	0	0	1	0	0
Entry Pocket Length [ft]	100.00	100.00	100.00	56.00	100.00	100.00	48.00	100.00	100.00	100.00	100.00	100.00
No. of Lanes in Exit Pocket	0	0	0	0	0	0	0	0	0	0	0	0
Exit Pocket Length [ft]	0.00	0.00	0.00	0.00	0.00	0.00	0.00	0.00	0.00	0.00	0.00	0.00
Speed [mph]	30.00			30.00			35.00			35.00		
Grade [%]	0.00			0.00			0.00			0.00		
Curb Present	No			No			No			No		
Crosswalk	Yes			Yes			Yes			Yes		



Volumes	Name											
	Old Hwy 53			Burns Valley Rd			Olympic Dr			Old Hwy 53		
Base Volume Input [veh/h]	95	130	70	160	125	30	35	205	130	80	225	150
Base Volume Adjustment Factor	1.0000	1.0000	1.0000	1.0000	1.0000	1.0000	1.0000	1.0000	1.0000	1.0000	1.0000	1.0000
Heavy Vehicles Percentage [%]	2.00	2.00	2.00	2.00	2.00	2.00	2.00	2.00	2.00	2.00	2.00	2.00
Growth Factor	1.0000	1.0000	1.0000	1.0000	1.0000	1.0000	1.0000	1.0000	1.0000	1.0000	1.0000	1.0000
In-Process Volume [veh/h]	0	0	0	0	0	0	0	0	0	0	0	0
Site-Generated Trips [veh/h]	5	6	0	5	9	0	0	1	4	0	7	4
Diverted Trips [veh/h]	0	0	0	0	0	0	0	0	0	0	0	0
Pass-by Trips [veh/h]	0	0	0	0	0	0	0	0	0	0	0	0
Existing Site Adjustment Volume [veh/h]	0	0	0	0	0	0	0	0	0	0	0	0
Other Volume [veh/h]	0	0	0	0	0	0	0	0	0	0	0	0
Right Turn on Red Volume [veh/h]	0	0	19	0	0	3	0	0	5	0	0	20
Total Hourly Volume [veh/h]	100	136	51	165	134	27	35	206	129	80	232	134
Peak Hour Factor	1.0000	1.0000	1.0000	1.0000	1.0000	1.0000	1.0000	1.0000	1.0000	1.0000	1.0000	1.0000
Other Adjustment Factor	1.0000	1.0000	1.0000	1.0000	1.0000	1.0000	1.0000	1.0000	1.0000	1.0000	1.0000	1.0000
Total 15-Minute Volume [veh/h]	25	34	13	41	34	7	9	52	32	20	58	34
Total Analysis Volume [veh/h]	100	136	51	165	134	27	35	206	129	80	232	134
Presence of On-Street Parking	No	No	No	No	No	No	No	No	No	No	No	No
On-Street Parking Maneuver Rate [/h]	0	0	0	0	0	0	0	0	0	0	0	0
Local Bus Stopping Rate [/h]	0	0	0	0	0	0	0	0	0	0	0	0
v_do, Outbound Pedestrian Volume crossing major street	1			0				1			1	
v_di, Inbound Pedestrian Volume crossing major street	1			1				0			1	
v_co, Outbound Pedestrian Volume crossing minor street	1			0				0			0	
v_ci, Inbound Pedestrian Volume crossing minor street	0			0				1			0	
v_ab, Corner Pedestrian Volume [ped/h]	0			0				0			0	
Bicycle Volume [bicycles/h]	0			0				0			1	



Intersection Settings	Yes
Located in CBD	
Signal Coordination Group	-
Cycle Length [s]	109
Coordination Type	Time of Day Pattern Isolated
Actuation Type	Fully actuated
Offset [s]	0.0
Offset Reference	Lead Green - Beginning of First Green
Permissive Mode	SingleBand
Lost time [s]	14.00

Phasing & Timing	Protect	Permis	Permis	Protect	Permis	Permis	Protect	Permis	Permis	Protect	Permis	Permis
Control Type	Protect	Permis	Permis	Protect	Permis	Permis	Protect	Permis	Permis	Protect	Permis	Permis
Signal Group	3	8	0	7	4	0	5	2	0	1	6	0
Auxiliary Signal Groups												
Lead / Lag	Lead	-	-	Lead	-	-	Lead	-	-	Lead	-	-
Minimum Green [s]	4	6	0	4	6	0	4	6	0	4	6	0
Maximum Green [s]	20	25	0	20	25	0	20	30	0	20	20	0
Amber [s]	3.0	3.3	0.0	3.0	3.3	0.0	3.0	3.6	0.0	3.0	3.6	0.0
All red [s]	0.0	0.3	0.0	0.0	0.3	0.0	0.0	0.3	0.0	0.0	0.3	0.0
Split [s]	23	29	0	23	29	0	23	34	0	23	34	0
Vehicle Extension [s]	0.0	0.0	0.0	0.0	0.0	0.0	0.0	0.0	0.0	0.0	0.0	0.0
Walk [s]	0	7	0	0	7	0	0	7	0	0	7	0
Pedestrian Clearance [s]	0	11	0	0	9	0	0	14	0	0	9	0
Delayed Vehicle Green [s]	0.0	0.0	0.0	0.0	0.0	0.0	0.0	0.0	0.0	0.0	0.0	0.0
Rest In Walk	No	No	No	No	No	No	No	No	No	No	No	No
I1, Start-Up Lost Time [s]	2.0	2.0	0.0	2.0	2.0	0.0	2.0	2.0	0.0	2.0	2.0	0.0
I2, Clearance Lost Time [s]	1.0	1.6	0.0	1.0	1.6	0.0	1.0	1.9	0.0	1.0	1.9	0.0
Minimum Recall	No	No	No	No	No	No	No	No	No	No	No	No
Maximum Recall	No	No	No	No	No	No	No	No	No	No	No	No
Pedestrian Recall	No	No	No	No	No	No	No	No	No	No	No	No
Detector Location [ft]	0.0	0.0	0.0	0.0	0.0	0.0	0.0	0.0	0.0	0.0	0.0	0.0
Detector Length [ft]	0.0	0.0	0.0	0.0	0.0	0.0	0.0	0.0	0.0	0.0	0.0	0.0
I, Upstream Filtering Factor	1.00	1.00	1.00	1.00	1.00	1.00	1.00	1.00	1.00	1.00	1.00	1.00

Exclusive Pedestrian Phase	
Pedestrian Signal Group	0
Pedestrian Walk [s]	0
Pedestrian Clearance [s]	0



Lane Group Calculations

Lane Group	L	C	R	L	C	L	C	L	C
C, Cycle Length [s]	34	34	34	34	34	34	34	34	34
L, Total Lost Time per Cycle [s]	3.00	3.60	3.60	3.00	3.60	3.00	3.90	3.00	3.90
l1_p, Permitted Start-Up Lost Time [s]	0.00	0.00	0.00	0.00	0.00	0.00	0.00	0.00	0.00
l2, Clearance Lost Time [s]	1.00	1.60	1.60	1.00	1.60	1.00	1.90	1.00	1.90
g_l, Effective Green Time [s]	3	5	5	4	7	1	9	2	10
g / C, Green / Cycle	0.08	0.15	0.15	0.13	0.20	0.03	0.25	0.06	0.28
(v / s)_l Volume / Saturation Flow Rate	0.06	0.08	0.04	0.10	0.10	0.02	0.21	0.05	0.23
s, saturation flow rate [veh/h]	1603	1683	1421	1603	1634	1603	1575	1603	1567
c, Capacity [veh/h]	122	256	216	207	335	55	403	102	448
d1, Uniform Delay [s]	15.41	13.23	12.61	14.31	11.86	16.14	11.89	15.60	11.25
k, delay calibration	0.04	0.04	0.04	0.04	0.04	0.04	0.04	0.04	0.04
l, Upstream Filtering Factor	1.00	1.00	1.00	1.00	1.00	1.00	1.00	1.00	1.00
d2, Incremental Delay [s]	5.15	0.64	0.21	2.69	0.40	4.59	1.71	4.81	1.41
d3, Initial Queue Delay [s]	0.00	0.00	0.00	0.00	0.00	0.00	0.00	0.00	0.00
Rp, platoon ratio	1.00	1.00	1.00	1.00	1.00	1.00	1.00	1.00	1.00
PF, progression factor	1.00	1.00	1.00	1.00	1.00	1.00	1.00	1.00	1.00

Lane Group Results

X, volume / capacity	0.82	0.53	0.24	0.80	0.48	0.64	0.83	0.78	0.82
d, Delay for Lane Group [s/veh]	20.56	13.87	12.82	17.00	12.25	20.73	13.60	20.41	12.66
Lane Group LOS	C	B	B	B	B	C	B	C	B
Critical Lane Group	No	Yes	No	Yes	No	No	Yes	Yes	No
50th-Percentile Queue Length [veh/m]	0.79	0.79	0.28	1.12	0.85	0.28	1.83	0.61	1.88
50th-Percentile Queue Length [ft/m]	19.70	19.76	6.97	28.06	21.21	7.03	45.74	15.28	47.01
95th-Percentile Queue Length [veh/m]	1.42	1.42	0.50	2.02	1.53	0.51	3.29	1.10	3.39
95th-Percentile Queue Length [ft/m]	35.46	35.56	12.54	50.50	38.18	12.66	82.33	27.51	84.63



Movement, Approach, & Intersection Results

d_M, Delay for Movement [s/veh]	20.56	13.87	12.82	17.00	12.25	12.25	20.73	13.60	13.60	20.41	12.66	12.66
Movement LOS	C	B	B	B	B	B	C	B	B	C	B	B
d_A, Approach Delay [s/veh]	16.01			14.65			14.27			14.05		
Approach LOS	B			B			B			B		
d_I, Intersection Delay [s/veh]	14.64											
Intersection LOS	B											
Intersection V/C	0.765											

Other Modes

g_Walk,mi, Effective Walk Time [s]	11.0	11.0	11.0	11.0
M_corner, Corner Circulation Area [ft²/ped]	0.00	0.00	0.00	0.00
M_CW, Crosswalk Circulation Area [ft²/ped]	0.00	0.00	0.00	0.00
d_p, Pedestrian Delay [s]	7.61	7.61	7.61	7.61
l_p,int, Pedestrian LOS Score for Intersection	2.256	2.096	2.165	2.251
Crosswalk LOS	B	B	B	B
s_b, Saturation Flow Rate of the bicycle lane [bicycles/h]	2000	2000	2000	2000
c_b, Capacity of the bicycle lane [bicycles/h]	1511	1511	1790	1790
d_b, Bicycle Delay [s]	1.01	1.01	0.19	0.19
l_b,int, Bicycle LOS Score for Intersection	2.065	2.102	2.178	2.329
Bicycle LOS	B	B	B	B

Sequence

Ring 1	1	2	3	4	-	-	-	-	-	-	-	-	-	-	-
Ring 2	5	6	7	8	-	-	-	-	-	-	-	-	-	-	-
Ring 3	-	-	-	-	-	-	-	-	-	-	-	-	-	-	-
Ring 4	-	-	-	-	-	-	-	-	-	-	-	-	-	-	-

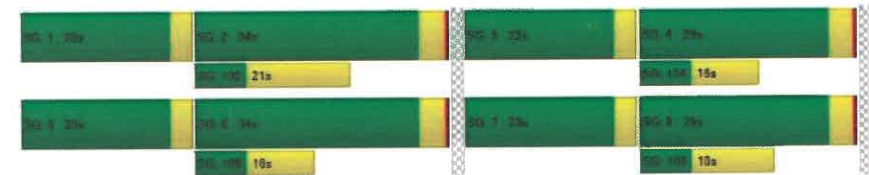

Intersection Level Of Service Report
Intersection 1: Burns Valley Rd/N-S Project Street

Control Type: Two-way stop Delay (sec / veh): 11.7
Analysis Method: HCM 6th Edition Level Of Service: B
Analysis Period: 15 minutes Volume to Capacity (v/c): 0.037

Intersection Setup

Name	N-S Project Street		Burns Valley Rd		Burns Valley Rd	
	Northbound		Eastbound		Westbound	
Approach						
Lane Configuration	←		→		←	
Turning Movement	Left	Right	Thru	Right	Left	Thru
Lane Width [ft]	12.00	12.00	12.00	12.00	12.00	12.00
No. of Lanes in Entry Pocket	0	0	0	0	0	0
Entry Pocket Length [ft]	100.00	100.00	100.00	100.00	100.00	100.00
No. of Lanes in Exit Pocket	0	0	0	0	0	0
Exit Pocket Length [ft]	0.00	0.00	0.00	0.00	0.00	0.00
Speed [mph]	25.00		35.00		35.00	
Grade [%]	0.00		0.00		0.00	
Crosswalk	No		No		No	

Volumes

Name	N-S Project Street		Burns Valley Rd		Burns Valley Rd	
	Base Volume Input [veh/h]	8	8	117	17	0
Base Volume Adjustment Factor	1.0000	1.0000	1.0000	1.0000	1.0000	1.0000
Heavy Vehicles Percentage [%]	2.00	2.00	2.00	2.00	2.00	2.00
Growth Factor	1.7600	1.7600	1.7600	1.7600	1.7600	1.7600
In-Process Volume [veh/h]	0	0	0	0	0	0
Site-Generated Trips [veh/h]	7	7	1	10	7	1
Diverted Trips [veh/h]	0	0	0	0	0	0
Pass-by Trips [veh/h]	0	0	0	0	0	0
Existing Site Adjustment Volume [veh/h]	0	0	0	0	0	0
Other Volume [veh/h]	0	0	0	0	0	0
Total Hourly Volume [veh/h]	21	21	207	40	7	207
Peak Hour Factor	1.0000	1.0000	1.0000	1.0000	1.0000	1.0000
Other Adjustment Factor	1.0000	1.0000	1.0000	1.0000	1.0000	1.0000
Total 15-Minute Volume [veh/h]	5	5	52	10	2	52
Total Analysis Volume [veh/h]	21	21	207	40	7	207
Pedestrian Volume [ped/h]	0	0	0	0	0	0



Intersection Settings

Priority Scheme	Stop	Free	Free
Flared Lane	No		
Storage Area [veh]	0	0	0
Two-Stage Gap Acceptance	No		
Number of Storage Spaces in Median	0	0	0

Movement, Approach, & Intersection Results

V/C, Movement V/C Ratio	0.04	0.03	0.00	0.00	0.01	0.00
d_M, Delay for Movement [s/veh]	11.74	9.79	0.00	0.00	7.74	5.85
Movement LOS	B	A	A	A	A	A
95th-Percentile Queue Length [veh/ln]	0.20	0.20	0.00	0.00	0.02	0.02
95th-Percentile Queue Length [ft/ln]	5.03	5.03	0.00	0.00	0.40	0.40
d_A, Approach Delay [s/veh]	10.76		0.00		0.25	
Approach LOS	B		A		A	
d_I, Intersection Delay [s/veh]			1.01			
Intersection LOS			B			



Intersection Level Of Service Report

Intersection 2: Burns Valley Rd/Bowers Ave-Rumsey Rd

Control Type: Two-way stop
 Analysis Method: HCM 6th Edition
 Analysis Period: 15 minutes
 Delay (sec / veh): 16.0
 Level Of Service: C
 Volume to Capacity (v/c): 0.060

Intersection Setup

Name	Burns Valley Rd			Rumsey Rd			Burns Valley Rd			Bowers Ave		
Approach	Northbound			Southbound			Eastbound			Westbound		
Lane Configuration	+			+			+			+		
Turning Movement	Left	Thru	Right	Left	Thru	Right	Left	Thru	Right	Left	Thru	Right
Lane Width [ft]	12.00	12.00	12.00	12.00	12.00	12.00	12.00	12.00	12.00	12.00	12.00	12.00
No. of Lanes in Entry Pocket	0	0	0	0	0	0	0	0	0	0	0	0
Entry Pocket Length [ft]	100.00	100.00	100.00	100.00	100.00	100.00	100.00	100.00	100.00	100.00	100.00	100.00
No. of Lanes in Exit Pocket	0	0	0	0	0	0	0	0	0	0	0	0
Exit Pocket Length [ft]	0.00	0.00	0.00	0.00	0.00	0.00	0.00	0.00	0.00	0.00	0.00	0.00
Speed [mph]	30.00			30.00			35.00			25.00		
Grade [%]	0.00			0.00			0.00			0.00		
Crosswalk	No			Yes			Yes			No		

Volumes

Name	Burns Valley Rd			Rumsey Rd			Burns Valley Rd			Bowers Ave		
Base Volume Input [veh/h]	163	62	15	3	70	11	11	2	123	21	0	0
Base Volume Adjustment Factor	1.0000	1.0000	1.0000	1.0000	1.0000	1.0000	1.0000	1.0000	1.0000	1.0000	1.0000	1.0000
Heavy Vehicles Percentage [%]	2.00	2.00	2.00	2.00	2.00	2.00	2.00	2.00	2.00	2.00	2.00	2.00
Growth Factor	1.0000	1.0000	1.0000	1.0000	1.0000	1.0000	1.0000	1.0000	1.0000	1.0000	1.0000	1.0000
In-Process Volume [veh/h]	0	0	0	0	0	0	0	0	0	0	0	0
Site-Generated Trips [veh/h]	5	1	0	0	1	4	3	0	3	0	0	0
Diverted Trips [veh/h]	0	0	0	0	0	0	0	0	0	0	0	0
Pass-by Trips [veh/h]	0	0	0	0	0	0	0	0	0	0	0	0
Existing Site Adjustment Volume [veh/h]	0	0	0	0	0	0	0	0	0	0	0	0
Other Volume [veh/h]	0	0	0	0	0	0	0	0	0	0	0	0
Total Hourly Volume [veh/h]	168	63	15	3	71	15	14	2	126	21	0	0
Peak Hour Factor	1.0000	1.0000	1.0000	1.0000	1.0000	1.0000	1.0000	1.0000	1.0000	1.0000	1.0000	1.0000
Other Adjustment Factor	1.0000	1.0000	1.0000	1.0000	1.0000	1.0000	1.0000	1.0000	1.0000	1.0000	1.0000	1.0000
Total 15-Minute Volume [veh/h]	42	16	4	1	18	4	4	1	32	5	0	0
Total Analysis Volume [veh/h]	168	63	15	3	71	15	14	2	126	21	0	0
Pedestrian Volume [ped/h]												



Intersection Settings

Priority Scheme	Free	Free	Stop	Stop
Flared Lane			No	No
Storage Area [veh]	0	0	0	0
Two-Stage Gap Acceptance			No	No
Number of Storage Spaces in Median	0	0	0	0

Movement, Approach, & Intersection Results

V/C, Movement V/C Ratio	0.11	0.30	0.06	0.00	0.00	0.00	0.03	0.00	0.13	0.06	0.00	0.00
d_M, Delay for Movement [s/veh]	7.68	0.00	0.00	7.37	0.00	0.00	13.94	14.44	9.49	15.96	14.28	3.29
Movement LOS	A	A	A	A	A	A	B	B	A	C	B	A
95th-Percentile Queue Length [veh/ln]	0.37	0.37	0.37	0.01	0.01	0.01	0.59	0.59	0.59	0.19	0.19	0.19
95th-Percentile Queue Length [ft/ln]	9.37	9.37	9.37	0.15	0.15	0.15	14.69	14.69	14.69	4.77	4.77	4.77
d_A, Approach Delay [s/veh]	5.25			0.25			10.00			15.96		
Approach LOS	A			A			A			C		
d_I, Intersection Delay [s/veh]							6.16					
Intersection LOS	C											



Intersection Level Of Service Report
Intersection 3: N-S Project Street/E-W Project Street

Control Type: All-way stop Delay (sec / veh): 7.4
Analysis Method: HCM 6th Edition Level Of Service: A
Analysis Period: 15 minutes Volume to Capacity (v/c): 0.100

Intersection Setup

Name	N-S Project Street			N-S Project Street			E-W Project Street			E-W Project Street		
Approach	Northbound			Southbound			Eastbound			Westbound		
Lane Configuration	+			+			+			+		
Turning Movement	Left	Thru	Right	Left	Thru	Right	Left	Thru	Right	Left	Thru	Right
Lane Width [ft]	12.00	12.00	12.00	12.00	12.00	12.00	12.00	12.00	12.00	12.00	12.00	12.00
No. of Lanes in Entry Pocket	0	3	0	0	0	0	0	0	0	0	0	0
Entry Pocket Length [ft]	100.00	100.00	137.00	100.00	100.00	100.00	100.00	100.00	100.00	130.00	100.00	100.00
No. of Lanes in Exit Pocket	0	0	0	0	0	0	0	0	0	0	0	0
Exit Pocket Length [ft]	0.00	0.00	0.00	0.00	0.00	0.00	0.00	0.00	0.00	0.00	0.00	0.00
Speed [mph]	25.00			25.00			25.00			25.00		
Grade [%]	0.00			0.00			0.00			0.00		
Crosswalk	Yes			Yes			Yes			Yes		

Volumes

Name	N-S Project Street			N-S Project Street			E-W Project Street			E-W Project Street		
Base Volume Input [veh/h]	0	16	0	0	17	0	0	0	0	0	0	0
Base Volume Adjustment Factor	1.0000	1.0000	1.0000	1.0000	1.0000	1.0000	1.0000	1.0000	1.0000	1.0000	1.0000	1.0000
Heavy Vehicles Percentage [%]	2.00	2.00	2.00	2.00	2.00	2.00	2.00	2.00	2.00	2.00	2.00	2.00
Growth Factor	1.7600	1.7600	1.7600	1.7600	1.7600	1.7600	1.7600	1.7600	1.7600	1.7600	1.7600	1.7600
In-Process Volume [veh/h]	0	0	0	0	0	0	0	0	0	0	0	0
Site-Generated Trips [veh/h]	3	44	15	12	31	1	1	3	8	5	2	15
Diverted Trips [veh/h]	0	0	0	0	0	0	0	0	0	0	0	0
Pass-by Trips [veh/h]	0	0	0	0	0	0	0	0	0	0	0	0
Existing Site Adjustment Volume [veh/h]	0	0	0	0	0	0	0	0	0	0	0	0
Other Volume [veh/h]	0	0	0	0	0	0	0	0	0	0	0	0
Total Hourly Volume [veh/h]	3	72	15	12	61	1	1	3	8	5	2	15
Peak Hour Factor	1.0000	1.0000	1.0000	1.0000	1.0000	1.0000	1.0000	1.0000	1.0000	1.0000	1.0000	1.0000
Other Adjustment Factor	1.0000	1.0000	1.0000	1.0000	1.0000	1.0000	1.0000	1.0000	1.0000	1.0000	1.0000	1.0000
Total 15-Minute Volume [veh/h]	1	18	4	3	15	0	0	1	2	1	1	4
Total Analysis Volume [veh/h]	3	72	15	12	61	1	1	3	8	5	2	15
Pedestrian Volume [ped/h]	0			0			0			0		



Intersection Settings

Lanes	1	2	3	4
Capacity per Entry Lane [veh/h]	905	876	919	916
Degree of Utilization, x	0.10	0.08	0.01	0.02

Movement, Approach, & Intersection Results

95th-Percentile Queue Length [veh]	0.33	0.28	0.04	0.07
95th-Percentile Queue Length [ft]	8.26	6.91	0.99	1.84
Approach Delay [s/veh]	7.42	7.49	6.97	7.03
Approach LOS	A	A	A	A
Intersection Delay [s/veh]	7.38			
Intersection LOS	A			



Intersection Level Of Service Report
Intersection 4: Burns Valley Rd/E-W Project Street

Control Type: Two-way stop
Analysis Method: HCM 6th Edition
Analysis Period: 15 minutes
Delay (sec / veh): 13.5
Level Of Service: B
Volume to Capacity (v/c): 0.002

Intersection Setup

Name	Burns Valley Rd		Burns Valley Rd		E-W Project Street	
	Northbound		Southbound		Eastbound	
Approach	←		→		←	
Lane Configuration	←		→		←	
Turning Movement	Left	Thru	Thru	Right	Left	Right
Lane Width [ft]	12.00	12.00	12.00	12.00	12.00	12.00
No. of Lanes in Entry Pocket	0	0	0	0	0	0
Entry Pocket Length [ft]	100.00	100.00	100.00	100.00	100.00	100.00
No. of Lanes in Exit Pocket	0	0	0	0	0	0
Exit Pocket Length [ft]	0.00	0.00	0.00	0.00	0.00	0.00
Speed [mph]	30.00		30.00		25.00	
Grade [%]	0.00		0.00		0.00	
Crosswalk	No		No		Yes	

Volumes

Name	Burns Valley Rd		Burns Valley Rd		E-W Project Street	
	Northbound	Southbound	Northbound	Southbound	Eastbound	Westbound
Base Volume Input [veh/h]	0	168	173	0	0	0
Base Volume Adjustment Factor	1.0000	1.0000	1.0000	1.0000	1.0000	1.0000
Heavy Vehicles Percentage [%]	2.00	2.00	2.00	2.00	2.00	2.00
Growth Factor	1.7600	1.7600	1.7600	1.7600	1.7600	1.7600
In-Process Volume [veh/h]	0	0	0	0	0	0
Site-Generated Trips [veh/h]	24	5	3	1	1	18
Diverted Trips [veh/h]	0	0	0	0	0	0
Pass-by Trips [veh/h]	0	0	0	0	0	0
Existing Site Adjustment Volume [veh/h]	0	0	0	0	0	0
Other Volume [veh/h]	0	0	0	0	0	0
Total Hourly Volume [veh/h]	24	283	307	1	1	18
Peak Hour Factor	1.0000	1.0000	1.0000	1.0000	1.0000	1.0000
Other Adjustment Factor	1.0000	1.0000	1.0000	1.0000	1.0000	1.0000
Total 15-Minute Volume [veh/h]	6	71	77	0	0	5
Total Analysis Volume [veh/h]	24	283	307	1	1	18
Pedestrian Volume [ped/h]	0	0	0	0	0	0



Intersection Settings

Priority Scheme	Free	Free	Stop
Flared Lane			No
Storage Area [veh]	0	0	0
Two-Stage Gap Acceptance			No
Number of Storage Spaces in Median	0	0	0

Movement, Approach, & Intersection Results

V/C, Movement V/C Ratio	0.02	0.00	0.00	0.00	0.00	0.02
d_M, Delay for Movement [s/veh]	7.93	0.00	0.00	0.00	13.50	10.06
Movement LOS	A	A	A	A	B	B
95th-Percentile Queue Length [veh/ln]	0.06	0.06	0.00	0.00	0.08	0.08
95th-Percentile Queue Length [ft/ln]	1.46	1.46	0.00	0.00	2.07	2.07
d_A, Approach Delay [s/veh]	0.62		0.00		10.24	
Approach LOS	A		A		B	
d_I, Intersection Delay [s/veh]					0.61	
Intersection LOS	B					



Intersection Level Of Service Report
Intersection 5: Olympic Dr/Lakeshore Dr

Control Type: Roundabout
Analysis Method: HCM 6th Edition
Analysis Period: 15 minutes
Delay (sec / veh): 5.0
Level Of Service: A

Intersection Setup

Name	Lakeshore Dr			Lakeshore Dr			Eastbound			Olympic Dr		
	Northbound			Southbound			Eastbound			Westbound		
Approach	Northbound			Southbound			Eastbound			Westbound		
Lane Configuration	[Diagram]			[Diagram]			[Diagram]			[Diagram]		
Turning Movement	Left	Thru	Right	Left	Thru	Right	Left	Thru	Right	Left	Thru	Right
Lane Width [ft]	12.00	12.00	12.00	12.00	12.00	12.00	12.00	12.00	12.00	12.00	12.00	12.00
No. of Lanes in Entry Pocket	0	0	1	0	0	0	0	0	0	0	0	1
Entry Pocket Length [ft]	100.00	100.00	120.00	100.00	100.00	100.00	100.00	100.00	100.00	100.00	100.00	250.00
No. of Lanes in Exit Pocket	0	0	0	0	0	0	0	0	0	0	0	0
Exit Pocket Length [ft]	0.00	0.00	0.00	0.00	0.00	0.00	0.00	0.00	0.00	0.00	0.00	0.00
Speed [mph]	25.00			25.00			30.00			30.00		
Grade [%]	0.00			0.00			0.00			0.00		
Crosswalk	No			Yes			No			Yes		

Volumes

Name	Lakeshore Dr			Lakeshore Dr			Eastbound			Olympic Dr		
	0	310	125	95	215	0	0	0	5	120	5	160
Base Volume Input [veh/h]	0	310	125	95	215	0	0	0	5	120	5	160
Base Volume Adjustment Factor	1.0000	1.0000	1.0000	1.0000	1.0000	1.0000	1.0000	1.0000	1.0000	1.0000	1.0000	1.0000
Heavy Vehicles Percentage [%]	2.00	2.00	2.00	2.00	2.00	2.00	2.00	2.00	2.00	2.00	2.00	2.00
Growth Factor	1.0000	1.0000	1.0000	1.0000	1.0000	1.0000	1.0000	1.0000	1.0000	1.0000	1.0000	1.0000
In-Process Volume [veh/h]	0	0	0	0	0	0	0	0	0	0	0	0
Site-Generated Trips [veh/h]	0	0	21	11	0	0	0	0	0	15	0	8
Diverted Trips [veh/h]	0	0	0	0	0	0	0	0	0	0	0	0
Pass-by Trips [veh/h]	0	0	0	0	0	0	0	0	0	0	0	0
Existing Site Adjustment Volume [veh/h]	0	0	0	0	0	0	0	0	0	0	0	0
Other Volume [veh/h]	0	0	0	0	0	0	0	0	0	0	0	0
Total Hourly Volume [veh/h]	0	310	146	106	215	0	0	0	5	135	5	168
Peak Hour Factor	1.0000	1.0000	1.0000	1.0000	1.0000	1.0000	1.0000	1.0000	1.0000	1.0000	1.0000	1.0000
Other Adjustment Factor	1.0000	1.0000	1.0000	1.0000	1.0000	1.0000	1.0000	1.0000	1.0000	1.0000	1.0000	1.0000
Total 15-Minute Volume [veh/h]	0	78	37	27	54	0	0	0	1	34	1	42
Total Analysis Volume [veh/h]	0	310	146	106	215	0	0	0	5	135	5	168
Pedestrian Volume [ped/h]	0			0			0			1		



Intersection Settings

	1	1	1	1								
Number of Conflicting Circulating Lanes	1	1	1	1								
Circulating Flow Rate [veh/h]	108	143	465	316								
Exiting Flow Rate [veh/h]	362	488	5	257								
Demand Flow Rate [veh/h]	0	310	146	108	215	0	0	0	5	135	5	168
Adjusted Demand Flow Rate [veh/h]	0	310	146	108	215	0	0	0	5	135	5	168

Lanes

	No	No	No	No	No	No
Override Calculated Critical Headway	No	No	No	No	No	No
User-Defined Critical Headway [s]	4.00	4.00	4.00	4.00	4.00	4.00
Override Calculated Follow-Up Time	No	No	No	No	No	No
User-Defined Follow-Up Time [s]	3.00	3.00	3.00	3.00	3.00	3.00
A (intercept)	1420.00	1420.00	1380.00	1380.00	1420.00	1420.00
B (coefficient)	0.00091	0.00091	0.00102	0.00102	0.00091	0.00091
HV Adjustment Factor	0.98	0.98	0.98	0.98	0.98	0.98
Entry Flow Rate [veh/h]	317	149	328	6	138	177
Capacity of Entry and Bypass Lanes [veh/h]	1287	1287	1193	859	1065	1065
Pedestrian Impedance	1.00	1.00	1.00	1.00	1.00	1.00
Capacity per Entry Lane [veh/h]	1262	1262	1170	842	1044	1044
X, volume / capacity	0.25	0.12	0.27	0.01	0.13	0.17

Movement, Approach, & Intersection Results

	A	A	A	A	A	A
Lane LOS	A	A	A	A	A	A
95th-Percentile Queue Length [veh]	0.97	0.39	1.12	0.02	0.44	0.59
95th-Percentile Queue Length [ft]	24.23	9.79	28.07	0.45	11.11	14.83
Approach Delay [s/veh]	4.62		5.61	4.33		4.81
Approach LOS	A		A	A		A
Intersection Delay [s/veh]	4.97					
Intersection LOS	A					



Intersection Level Of Service Report
Intersection 6: Olympic Dr/N-S Project Street

Control Type: Two-way stop Delay (sec / veh): 40.3
 Analysis Method: HCM 6th Edition Level Of Service: E
 Analysis Period: 15 minutes Volume to Capacity (v/c): 0.212

Intersection Setup

Name	N-S Project Street		Olympic Dr		Olympic Dr	
Approach	Southbound		Eastbound		Westbound	
Lane Configuration	T		T		T	
Turning Movement	Left	Right	Left	Thru	Thru	Right
Lane Width [ft]	12.00	12.00	12.00	12.00	12.00	12.00
No. of Lanes in Entry Pocket	0	0	0	0	0	0
Entry Pocket Length [ft]	100.00	100.00	100.00	100.00	100.00	100.00
No. of Lanes in Exit Pocket	0	0	0	0	0	0
Exit Pocket Length [ft]	0.00	0.00	0.00	0.00	0.00	0.00
Speed [mph]	25.00		30.00		30.00	
Grade [%]	0.00		0.00		0.00	
Crosswalk	Yes		No		No	

Volumes

Name	N-S Project Street		Olympic Dr		Olympic Dr	
Base Volume Input [veh/h]	8	9	16	352	384	0
Base Volume Adjustment Factor	1.0000	1.0000	1.0000	1.0000	1.0000	1.0000
Heavy Vehicles Percentage [%]	2.00	2.00	2.00	2.00	2.00	2.00
Growth Factor	1.7600	1.7600	1.7600	1.7600	1.7600	1.7600
In-Process Volume [veh/h]	0	0	0	0	0	0
Site-Generated Trips [veh/h]	13	31	43	0	0	19
Diverted Trips [veh/h]	0	0	0	0	0	0
Pass-by Trips [veh/h]	0	0	0	0	0	0
Existing Site Adjustment Volume [veh/h]	0	0	0	0	0	0
Other Volume [veh/h]	0	0	0	0	0	0
Total Hourly Volume [veh/h]	27	47	71	620	676	19
Peak Hour Factor	1.0000	1.0000	1.0000	1.0000	1.0000	1.0000
Other Adjustment Factor	1.0000	1.0000	1.0000	1.0000	1.0000	1.0000
Total 15-Minute Volume [veh/h]	7	12	18	155	169	5
Total Analysis Volume [veh/h]	27	47	71	620	676	19
Pedestrian Volume [ped/h]	0	0	0	0	0	0



Intersection Settings

Priority Scheme	Stop	Free	Free
Flared Lane	No		
Storage Area [veh]	0	0	0
Two-Stage Gap Acceptance	No		
Number of Storage Spaces in Median	0	0	0

Movement, Approach, & Intersection Results

V/C, Movement V/C Ratio	0.21	0.10	0.08	0.01	0.31	0.00
d_M, Delay for Movement [s/veh]	40.28	20.04	9.34	0.00	0.00	0.00
Movement LOS	E	C	A	A	A	A
95th-Percentile Queue Length [veh/ln]	1.31	1.31	0.26	0.26	0.00	0.00
95th-Percentile Queue Length [ft/ln]	32.68	32.68	6.40	6.40	0.00	0.00
d_A, Approach Delay [s/veh]	27.43		0.96		0.00	
Approach LOS	D		A		A	
d_I, Intersection Delay [s/veh]				1.84		
Intersection LOS	E					



Intersection Level Of Service Report
Intersection 7: Olympic Dr/Burns Valley Rd-Old Hwy 53

Control Type: Signalized
Analysis Method: HCM 6th Edition
Analysis Period: 15 minutes
Delay (sec / veh): 21.2
Level Of Service: C
Volume to Capacity (v/c): 0.867

Intersection Setup

Name	Old Hwy 53			Burns Valley Rd			Olympic Dr			Old Hwy 53		
Approach	Northbound			Southbound			Eastbound			Westbound		
Lane Configuration	T T T			T T T			T T T			T T T		
Turning Movement	Left	Thru	Right	Left	Thru	Right	Left	Thru	Right	Left	Thru	Right
Lane Width [ft]	12.00	12.00	12.00	12.00	12.00	12.00	12.00	12.00	12.00	12.00	12.00	12.00
No. of Lanes in Entry Pocket	1	0	1	1	0	0	1	0	0	1	0	0
Entry Pocket Length [ft]	100.00	100.00	100.00	56.00	100.00	100.00	48.00	100.00	100.00	100.00	100.00	100.00
No. of Lanes in Exit Pocket	0	0	0	0	0	0	0	0	0	0	0	0
Exit Pocket Length [ft]	0.00	0.00	0.00	0.00	0.00	0.00	0.00	0.00	0.00	0.00	0.00	0.00
Speed [mph]	30.00			30.00			35.00			35.00		
Grade [%]	0.00			0.00			0.00			0.00		
Curb Present	No			No			No			No		
Crosswalk	Yes			Yes			Yes			Yes		



Volumes

Name	Old Hwy 53			Burns Valley Rd			Olympic Dr			Old Hwy 53		
Base Volume Input [veh/h]	185	215	110	180	185	60	45	315	165	95	320	175
Base Volume Adjustment Factor	1.0000	1.0000	1.0000	1.0000	1.0000	1.0000	1.0000	1.0000	1.0000	1.0000	1.0000	1.0000
Heavy Vehicles Percentage [%]	2.00	2.00	2.00	2.00	2.00	2.00	2.00	2.00	2.00	2.00	2.00	2.00
Growth Factor	1.0000	1.0000	1.0000	1.0000	1.0000	1.0000	1.0000	1.0000	1.0000	1.0000	1.0000	1.0000
In-Process Volume [veh/h]	0	0	0	0	0	0	0	0	0	0	0	0
Site-Generated Trips [veh/h]	9	18	0	10	11	0	0	5	7	0	10	11
Diverted Trips [veh/h]	0	0	0	0	0	0	0	0	0	0	0	0
Pass-by Trips [veh/h]	0	0	0	0	0	0	0	0	0	0	0	0
Existing Site Adjustment Volume [veh/h]	0	0	0	0	0	0	0	0	0	0	0	0
Other Volume [veh/h]	0	0	0	0	0	0	0	0	0	0	0	0
Right Turn on Red Volume [veh/h]	0	0	18	0	0	11	0	14	0	0	0	25
Total Hourly Volume [veh/h]	174	233	92	190	196	49	45	320	158	95	330	161
Peak Hour Factor	1.0000	1.0000	1.0000	1.0000	1.0000	1.0000	1.0000	1.0000	1.0000	1.0000	1.0000	1.0000
Other Adjustment Factor	1.0000	1.0000	1.0000	1.0000	1.0000	1.0000	1.0000	1.0000	1.0000	1.0000	1.0000	1.0000
Total 15-Minute Volume [veh/h]	44	58	23	48	49	12	11	80	40	24	83	40
Total Analysis Volume [veh/h]	174	233	92	190	196	49	45	320	158	95	330	161
Presence of On-Street Parking	No	No	No	No	No	No	No	No	No	No	No	No
On-Street Parking Maneuver Rate [h]	0	0	0	0	0	0	0	0	0	0	0	0
Local Bus Stopping Rate [h]	0	0	0	0	0	0	0	0	0	0	0	0
v_do, Outbound Pedestrian Volume crossing major street	1			0			1			1		
v_di, Inbound Pedestrian Volume crossing major street	1			1			0			1		
v_co, Outbound Pedestrian Volume crossing minor street	1			0			0			0		
v_ci, Inbound Pedestrian Volume crossing minor street	0			0			1			0		
v_ab, Corner Pedestrian Volume [ped/h]	0			0			0			0		
Bicycle Volume [bicycles/h]	0			0			0			0		1



Intersection Settings	
Located in CBD	Yes
Signal Coordination Group	-
Cycle Length [s]	109
Coordination Type	Time of Day Pattern Isolated
Actuation Type	Fully actuated
Offset [s]	0,0
Offset Reference	Lead Green - Segments of First Green
Permissive Mode	SingleBand
Lost time [s]	14,00

Phasing & Timing													
Control Type	Protect	Permiss	Permiss	Protect	Permiss	Permiss	Protect	Permiss	Permiss	Protect	Permiss	Permiss	Permiss
Signal Group	3	8	0	7	4	0	5	2	0	1	6	0	
Auxiliary Signal Groups													
Lead / Lag	Lead	-	-	Lead	-	-	Lead	-	-	Lead	-	-	
Minimum Green [s]	4	6	0	4	6	0	4	6	0	4	6	0	
Maximum Green [s]	20	25	0	20	25	0	20	30	0	20	20	0	
Amber [s]	3,0	3,3	0,0	3,0	3,3	0,0	3,0	3,6	0,0	3,0	3,6	0,0	
All red [s]	0,0	0,3	0,0	0,0	0,3	0,0	0,0	0,3	0,0	0,0	0,3	0,0	
Split [s]	23	29	0	23	29	0	23	34	0	23	34	0	
Vehicle Extension [s]	0,0	0,0	0,0	0,0	0,0	0,0	0,0	0,0	0,0	0,0	0,0	0,0	
Walk [s]	0	7	0	0	7	0	0	7	0	0	7	0	
Pedestrian Clearance [s]	0	11	0	0	9	0	0	14	0	0	9	0	
Delayed Vehicle Green [s]	0,0	0,0	0,0	0,0	0,0	0,0	0,0	0,0	0,0	0,0	0,0	0,0	
Rest In Walk		No		No	No		No	No		No	No		
I1, Start-Up Lost Time [s]	2,0	2,0	0,0	2,0	2,0	0,0	2,0	2,0	0,0	2,0	2,0	0,0	
I2, Clearance Lost Time [s]	1,0	1,6	0,0	1,0	1,6	0,0	1,0	1,9	0,0	1,0	1,9	0,0	
Minimum Recall	No	No		No	No		No	No		No	No		
Maximum Recall	No	No		No	No		No	No		No	No		
Pedestrian Recall	No	No		No	No		No	No		No	No		
Detector Location [ft]	0,0	0,0	0,0	0,0	0,0	0,0	0,0	0,0	0,0	0,0	0,0	0,0	
Detector Length [ft]	0,0	0,0	0,0	0,0	0,0	0,0	0,0	0,0	0,0	0,0	0,0	0,0	
I, Upstream Filtering Factor	1,00	1,00	1,00	1,00	1,00	1,00	1,00	1,00	1,00	1,00	1,00	1,00	

Exclusive Pedestrian Phase	
Pedestrian Signal Group	0
Pedestrian Walk [s]	0
Pedestrian Clearance [s]	0



Lane Group Calculations										
Lane Group	L	C	R	L	C	L	C	L	C	
C, Cycle Length [s]	49	49	49	49	49	49	49	49	49	49
L, Total Lost Time per Cycle [s]	3,00	3,60	3,60	3,00	3,60	3,00	3,60	3,00	3,60	3,90
I1_p, Permitted Start-Up Lost Time [s]	0,00	0,00	0,00	0,00	0,00	0,00	0,00	0,00	0,00	0,00
I2, Clearance Lost Time [s]	1,00	1,60	1,60	1,00	1,60	1,00	1,60	1,00	1,60	1,90
g_l, Effective Green Time [s]	7	9	9	7	9	2	16	4	18	
g / C, Green / Cycle	0,13	0,18	0,18	0,15	0,19	0,04	0,33	0,07	0,37	
(v / s)_j Volume / Saturation Flow Rate	0,11	0,14	0,06	0,12	0,15	0,03	0,30	0,06	0,31	
s, saturation flow rate [veh/h]	1603	1683	1422	1603	1625	1603	1589	1603	1579	
c, Capacity [veh/h]	215	295	250	233	304	60	527	117	579	
d1, Uniform Delay [s]	20,68	19,40	17,86	20,36	19,13	23,42	15,71	22,46	14,31	
k, delay calibration	0,04	0,04	0,04	0,04	0,04	0,04	0,04	0,04	0,22	
I, Upstream Filtering Factor	1,00	1,00	1,00	1,00	1,00	1,00	1,00	1,00	1,00	
d2, Incremental Delay [s]	2,77	1,79	0,34	2,63	1,93	6,59	2,52	5,04	7,01	
d3, Initial Queue Delay [s]	0,00	0,00	0,00	0,00	0,00	0,00	0,00	0,00	0,00	
Rp, platoon ratio	1,00	1,00	1,00	1,00	1,00	1,00	1,00	1,00	1,00	
PF, progression factor	1,00	1,00	1,00	1,00	1,00	1,00	1,00	1,00	1,00	

Lane Group Results										
X, volume / capacity	0,81	0,79	0,37	0,81	0,81	0,75	0,91	0,81	0,85	
d, Delay for Lane Group [s/veh]	23,44	21,19	18,20	22,99	21,07	30,01	18,23	27,50	21,31	
Lane Group LOS	C	C	B	C	C	C	B	C	C	
Critical Lane Group	Yes	No	No	No	Yes	No	Yes	Yes	No	
50th-Percentile Queue Length [veh/h]	1,90	2,40	0,84	2,06	2,52	0,57	4,46	1,12	5,06	
50th-Percentile Queue Length [ft/h]	47,57	60,04	21,08	51,39	63,09	14,32	111,60	28,09	126,39	
95th-Percentile Queue Length [veh/h]	3,42	4,32	1,52	3,70	4,54	1,03	7,93	2,02	8,74	
95th-Percentile Queue Length [ft/h]	85,62	108,07	37,94	92,50	113,56	26,77	198,23	50,57	218,57	



Movement, Approach, & Intersection Results

d_M, Delay for Movement [s/veh]	23.44	21.19	18.20	22.99	21.07	21.07	30.01	18.23	18.23	27.50	21.31	21.31
Movement LOS	C	C	B	C	C	C	C	B	B	C	C	C
d_A, Approach Delay [s/veh]	21.42				21.81				18.25		22.32	
Approach LOS	C				C				B		C	
d_I, Intersection Delay [s/veh]							21.22					
Intersection LOS							C					
Intersection VIC							0.867					

Other Modes

g_Walk,mi, Effective Walk Time [s]	11.0	11.0	11.0	11.0
M_corner, Corner Circulation Area [ft²/ped]	0.00	0.00	0.00	0.00
M_CW, Crosswalk Circulation Area [ft²/ped]	0.00	0.00	0.00	0.00
d_p, Pedestrian Delay [s]	14.73	14.73	14.73	14.73
I_p,int, Pedestrian LOS Score for Intersection	2.361	2.217	2.343	2.408
Crosswalk LOS	B	B	B	B
s_b, Saturation Flow Rate of the bicycle lane [bicycles/h]	2000	2000	2000	2000
c_b, Capacity of the bicycle lane [bicycles/h]	1037	1037	1229	1229
d_b, Bicycle Delay [s]	5.68	5.68	3.64	3.64
I_b,int, Bicycle LOS Score for Intersection	2.413	2.298	2.448	2.598
Bicycle LOS	B	B	B	B

Sequence

Ring 1	1	2	3	4	-	-	-	-	-	-	-	-	-	-
Ring 2	5	6	7	8	-	-	-	-	-	-	-	-	-	-
Ring 3	-	-	-	-	-	-	-	-	-	-	-	-	-	-
Ring 4	-	-	-	-	-	-	-	-	-	-	-	-	-	-

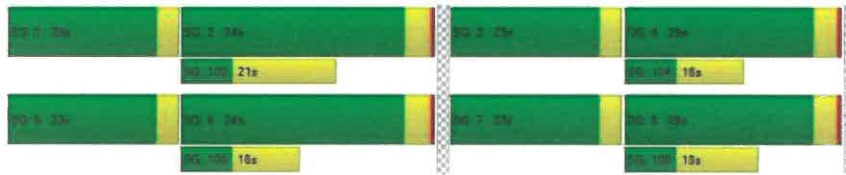

Intersection Level Of Service Report

Intersection 1: Burns Valley Rd/N-S Project Street

Control Type:	Two-way stop	Delay (sec / veh):	11.0
Analysis Method:	HCM 6th Edition	Level Of Service:	B
Analysis Period:	15 minutes	Volume to Capacity (v/c):	0.044

Intersection Setup

Name	N-S Project Street		Burns Valley Rd		Burns Valley Rd	
	Northbound		Eastbound		Westbound	
Approach	←		→		←	
Lane Configuration	T		T		T	
Turning Movement	Left	Right	Thru	Right	Left	Thru
Lane Width [ft]	12.00	12.00	12.00	12.00	12.00	12.00
No. of Lanes in Entry Pocket	0	0	0	0	0	0
Entry Pocket Length [ft]	100.00	100.00	100.00	100.00	100.00	100.00
No. of Lanes in Exit Pocket	0	0	0	0	0	0
Exit Pocket Length [ft]	0.00	0.00	0.00	0.00	0.00	0.00
Speed [mph]	25.00		35.00		35.00	
Grade [%]	0.00		0.00		0.00	
Crosswalk	No		No		No	

Volumes

Name	N-S Project Street		Burns Valley Rd		Burns Valley Rd	
	7	6	78	12	0	93
Base Volume Input [veh/h]	7	6	78	12	0	93
Base Volume Adjustment Factor	1.0000	1.0000	1.0000	1.0000	1.0000	1.0000
Heavy Vehicles Percentage [%]	2.00	2.00	2.00	2.00	2.00	2.00
Growth Factor	1.7600	1.7600	1.7600	1.7600	1.7600	1.7600
In-Process Volume [veh/h]	0	0	0	0	0	0
Site-Generated Trips [veh/h]	16	17	3	15	12	2
Diverted Trips [veh/h]	0	0	0	0	0	0
Pass-by Trips [veh/h]	0	0	0	0	0	0
Existing Site Adjustment Volume [veh/h]	0	0	0	0	0	0
Other Volume [veh/h]	0	0	0	0	0	0
Total Hourly Volume [veh/h]	28	28	140	36	12	166
Peak Hour Factor	1.0000	1.0000	1.0000	1.0000	1.0000	1.0000
Other Adjustment Factor	1.0000	1.0000	1.0000	1.0000	1.0000	1.0000
Total 15-Minute Volume [veh/h]	7	7	35	9	3	42
Total Analysis Volume [veh/h]	28	28	140	36	12	166
Pedestrian Volume [ped/h]	0		0		0	



Intersection Settings

Priority Scheme	Stop	Free	Free
Flared Lane	No		
Storage Area [veh]	0	0	0
Two-Stage Gap Acceptance	No		
Number of Storage Spaces in Median	0	0	0

Movement, Approach, & Intersection Results

V/C, Movement V/C Ratio	0.04	0.03	0.00	0.00	0.01	0.00
d_M, Delay for Movement [s/veh]	10.99	9.45	0.00	0.00	7.59	0.00
Movement LOS	B	A	A	A	A	A
95th-Percentile Queue Length [veh/ln]	0.24	0.24	0.00	0.00	0.03	0.03
95th-Percentile Queue Length [ft/ln]	6.07	6.07	0.00	0.00	0.65	0.65
d_A, Approach Delay [s/veh]	10.22		0.00		0.51	
Approach LOS	B		A		A	
d_I, Intersection Delay [s/veh]			1.62			
Intersection LOS			B			



Intersection Level Of Service Report

Intersection 2: Burns Valley Rd/Bowers Ave-Rumsey Rd

Control Type:	Two-way stop	Delay (sec / veh):	14.6
Analysis Method:	HCM 6th Edition	Level Of Service:	B
Analysis Period:	15 minutes	Volume to Capacity (v/c):	0.008

Intersection Setup

Name	Burns Valley Rd			Rumsey Rd			Burns Valley Rd			Bowers Ave		
Approach	Northbound			Southbound			Eastbound			Westbound		
Lane Configuration	+			+			+			+		
Turning Movement	Left	Thru	Right	Left	Thru	Right	Left	Thru	Right	Left	Thru	Right
Lane Width [ft]	12.00	12.00	12.00	12.00	12.00	12.00	12.00	12.00	12.00	12.00	12.00	12.00
No. of Lanes in Entry Pocket	0	0	0	0	0	0	0	0	0	0	0	0
Entry Pocket Length [ft]	100.00	100.00	100.00	100.00	100.00	100.00	100.00	100.00	100.00	100.00	100.00	100.00
No. of Lanes in Exit Pocket	0	0	0	0	0	0	0	0	0	0	0	0
Exit Pocket Length [ft]	0.00	0.00	0.00	0.00	0.00	0.00	0.00	0.00	0.00	0.00	0.00	0.00
Speed [mph]	30.00			30.00			35.00			25.00		
Grade [%]	0.00			0.00			0.00			0.00		
Crosswalk	No			Yes			Yes			No		

Volumes

Name	Burns Valley Rd			Rumsey Rd			Burns Valley Rd			Bowers Ave		
Base Volume Input [veh/h]	137	59	2	0	51	15	16	0	136	3	2	0
Base Volume Adjustment Factor	1.0000	1.0000	1.0000	1.0000	1.0000	1.0000	1.0000	1.0000	1.0000	1.0000	1.0000	1.0000
Heavy Vehicles Percentage [%]	2.00	2.00	2.00	2.00	2.00	2.00	2.00	2.00	2.00	2.00	2.00	2.00
Growth Factor	1.0000	1.0000	1.0000	1.0000	1.0000	1.0000	1.0000	1.0000	1.0000	1.0000	1.0000	1.0000
In-Process Volume [veh/h]	0	0	0	0	0	0	0	0	0	0	0	0
Site-Generated Trips [veh/h]	14	2	0	0	3	5	6	0	10	0	0	0
Diverted Trips [veh/h]	0	0	0	0	0	0	0	0	0	0	0	0
Pass-by Trips [veh/h]	0	0	0	0	0	0	0	0	0	0	0	0
Existing Site Adjustment Volume [veh/h]	0	0	0	0	0	0	0	0	0	0	0	0
Other Volume [veh/h]	0	0	0	0	0	0	0	0	0	0	0	0
Total Hourly Volume [veh/h]	151	61	2	0	54	20	22	0	146	3	2	0
Peak Hour Factor	1.0000	1.0000	1.0000	1.0000	1.0000	1.0000	1.0000	1.0000	1.0000	1.0000	1.0000	1.0000
Other Adjustment Factor	1.0000	1.0000	1.0000	1.0000	1.0000	1.0000	1.0000	1.0000	1.0000	1.0000	1.0000	1.0000
Total 15-Minute Volume [veh/h]	38	15	1	0	14	5	6	0	37	1	1	0
Total Analysis Volume [veh/h]	151	61	2	0	54	20	22	0	146	3	2	0
Pedestrian Volume [ped/h]	0			0			0			0		



Intersection Settings

Priority Scheme	Free	Free	Stop	Stop
Flared Lane			No	No
Storage Area [veh]	0	0	C	C
Two-Stage Gap Acceptance			No	No
Number of Storage Spaces in Median	0	0	0	0

Movement, Approach, & Intersection Results

V/C, Movement V/C Ratio	0.10	0.05	0.00	0.00	0.05	0.05	0.04	0.00	0.15	0.01	0.00	0.00
d_M, Delay for Movement [s/veh]	7.62	0.00	0.00	7.33	0.00	0.00	13.27	13.70	9.56	14.63	12.94	8.70
Movement LOS	A	A	A	A	A	A	B	B	A	B	B	A
95th-Percentile Queue Length [veh/ln]	0.33	0.33	0.33	0.00	0.00	0.00	0.70	0.70	0.70	0.04	0.04	0.04
95th-Percentile Queue Length [ft/ln]	8.22	8.22	8.22	0.00	0.00	0.00	17.53	17.53	17.53	0.93	0.93	0.93
d_A, Approach Delay [s/veh]	5.38			0.00			10.04			13.95		
Approach LOS	A			A			B			B		
d_I, Intersection Delay [s/veh]	8.31											
Intersection LOS	B											



Intersection Level Of Service Report

Intersection 3: N-S Project Street/E-W Project Street

Control Type:	All-way stop	Delay (sec / veh):	7.7
Analysis Method:	HCM 6th Edition	Level Of Service:	A
Analysis Period:	15 minutes	Volume to Capacity (v/c):	0.133

Intersection Setup

Name	N-S Project Street			N-S Project Street			E-W Project Street			E-W Project Street		
	Northbound			Southbound			Eastbound			Westbound		
Approach	+			+			+			+		
Lane Configuration	+			+			+			+		
Turning Movement	Left	Thru	Right	Left	Thru	Right	Left	Thru	Right	Left	Thru	Right
Lane Width [ft]	12.00	12.00	12.00	12.00	12.00	12.00	12.00	12.00	12.00	12.00	12.00	12.00
No. of Lanes in Entry Pocket	0	0	0	0	0	0	0	0	0	0	0	0
Entry Pocket Length [ft]	100.00	100.00	100.00	100.00	100.00	100.00	100.00	100.00	100.00	100.00	100.00	100.00
No. of Lanes in Exit Pocket	0	0	0	0	0	0	0	0	0	0	0	0
Exit Pocket Length [ft]	0.00	0.00	0.00	0.00	0.00	0.00	0.00	0.00	0.00	0.00	0.00	0.00
Speed [mph]	25.00			25.00			25.00			25.00		
Grade [%]	0.00			0.00			0.00			0.00		
Crosswalk	Yes			Yes			Yes			Yes		

Volumes

Name	N-S Project Street			N-S Project Street			E-W Project Street			E-W Project Street		
Base Volume Input [veh/h]	0	13	0	0	12	0	0	0	0	0	0	0
Base Volume Adjustment Factor	1.0000	1.0000	1.0000	1.0000	1.0000	1.0000	1.0000	1.0000	1.0000	1.0000	1.0000	1.0000
Heavy Vehicles Percentage [%]	2.00	2.00	2.00	2.00	2.00	2.00	2.00	2.00	2.00	2.00	2.00	2.00
Growth Factor	1.7600	1.7600	1.7600	1.7600	1.7600	1.7600	1.7600	1.7600	1.7600	1.7600	1.7600	1.7600
In-Process Volume [veh/h]	0	0	0	0	0	0	0	0	0	0	0	0
Site-Generated Trips [veh/h]	5	60	30	24	64	2	1	6	15	15	4	26
Diverted Trips [veh/h]	0	0	0	0	0	0	0	0	0	0	0	0
Pass-by Trips [veh/h]	0	0	0	0	0	0	0	0	0	0	0	0
Existing Site Adjustment Volume [veh/h]	0	0	0	0	0	0	0	0	0	0	0	0
Other Volume [veh/h]	0	0	0	0	0	0	0	0	0	0	0	0
Total Hourly Volume [veh/h]	5	83	30	24	85	2	1	6	15	15	4	26
Peak Hour Factor	1.0000	1.0000	1.0000	1.0000	1.0000	1.0000	1.0000	1.0000	1.0000	1.0000	1.0000	1.0000
Other Adjustment Factor	1.0000	1.0000	1.0000	1.0000	1.0000	1.0000	1.0000	1.0000	1.0000	1.0000	1.0000	1.0000
Total 15-Minute Volume [veh/h]	1	21	8	6	21	1	0	2	4	4	1	7
Total Analysis Volume [veh/h]	5	83	30	24	85	2	1	6	15	15	4	26
Pedestrian Volume [ped/h]	0			0			0			0		



Intersection Settings

Lanes				
Capacity per Entry Lane [veh/h]	889	851	883	863
Degree of Utilization, x	0.13	0.13	0.02	0.05

Movement, Approach, & Intersection Results

95th-Percentile Queue Length [veh]	0.46	0.45	0.08	0.16
95th-Percentile Queue Length [ft]	11.43	11.19	1.92	4.12
Approach Delay [s/veh]	7.87	7.86	7.18	7.40
Approach LOS	A	A	A	A
Intersection Delay [s/veh]	7.86			
Intersection LOS	A			



Intersection Level Of Service Report

Intersection 4: Burns Valley Rd/E-W Project Street

Control Type:	Two-way stop	Delay (sec / veh):	12.8
Analysis Method:	HCM 6th Edition	Level Of Service:	B
Analysis Period:	15 minutes	Volume to Capacity (v/c):	0.004

Intersection Setup

Name	Burns Valley Rd		Burns Valley Rd		E-W Project Street	
	Northbound		Southbound		Eastbound	
Approach	←		→		←	
Lane Configuration	←		→		←	
Turning Movement	Left	Thru	Thru	Right	Left	Right
Lane Width [ft]	12.00	12.00	12.00	12.00	12.00	12.00
No. of Lanes in Entry Pocket	0	0	0	0	0	0
Entry Pocket Length [ft]	100.00	100.00	100.00	100.00	100.00	100.00
No. of Lanes in Exit Pocket	0	0	0	0	0	0
Exit Pocket Length [ft]	0.00	0.00	0.00	0.00	0.00	0.00
Speed [mph]	30.00		30.00		25.00	
Grade [%]	0.00		0.00		0.00	
Crosswalk	No		No		Yes	

Volumes

Name	Burns Valley Rd		Burns Valley Rd		E-W Project Street	
	0	130	120	0	0	0
Base Volume Input [veh/h]	0	130	120	0	0	0
Base Volume Adjustment Factor	1.0000	1.0000	1.0000	1.0000	1.0000	1.0000
Heavy Vehicles Percentage [%]	2.00	2.00	2.00	2.00	2.00	2.00
Growth Factor	1.7600	1.7600	1.7600	1.7600	1.7600	1.7600
In-Process Volume [veh/h]	0	0	0	0	0	0
Site-Generated Trips [veh/h]	43	14	10	3	2	43
Diverted Trips [veh/h]	0	0	0	0	0	0
Pass-by Trips [veh/h]	0	0	0	0	0	0
Existing Site Adjustment Volume [veh/h]	0	0	0	0	0	0
Other Volume [veh/h]	0	0	0	0	0	0
Total Hourly Volume [veh/h]	43	243	221	3	2	43
Peak Hour Factor	1.0000	1.0000	1.0000	1.0000	1.0000	1.0000
Other Adjustment Factor	1.0000	1.0000	1.0000	1.0000	1.0000	1.0000
Total 15-Minute Volume [veh/h]	11	61	55	1	1	11
Total Analysis Volume [veh/h]	43	243	221	3	2	43
Pedestrian Volume [ped/h]	0		0		0	



Generated with **PTV VISTRO**
Version 2021 (SP 0-5)

Burns Valley Development

5/2/2022

Intersection Settings

Priority Scheme	Free	Free	Stop
Flared Lane			No
Storage Area [veh]	0	0	0
Two-Stage Gap Acceptance			No
Number of Storage Spaces in Median	0	0	0

Movement, Approach, & Intersection Results

V/C, Movement V/C Ratio	0.03	0.00	0.03	0.00	0.00	0.05
d_M, Delay for Movement [s/veh]	7.77	0.00	6.82	0.00	12.82	9.68
Movement LOS	A	A	A	A	B	A
95th-Percentile Queue Length [veh/ln]	0.10	0.10	0.00	0.00	0.18	0.18
95th-Percentile Queue Length [ft/ln]	2.48	2.48	0.00	0.00	4.51	4.51
d_A, Approach Delay [s/veh]	1.17		0.00		9.82	
Approach LOS	A		A		A	
d_I, Intersection Delay [s/veh]			1.40			
Intersection LOS			B			

Weekend PM F+P



Generated with **PTV VISTRO**
Version 2021 (SP 0-6)

Burns Valley Development

5/2/2022

Intersection Level Of Service Report
Intersection 5: Olympic Dr/Lakeshore Dr

Control Type: Roundabout
Analysis Method: HCM 6th Edition
Analysis Period: 15 minutes

Delay (sec / veh): 4.8
Level Of Service: A

Intersection Setup

Name	Lakeshore Dr			Lakeshore Dr			Eastbound			Olympic Dr		
Approach	Northbound			Southbound			Eastbound			Westbound		
Lane Configuration	← →			← →			← →			← →		
Turning Movement	Left	Thru	Right	Left	Thru	Right	Left	Thru	Right	Left	Thru	Right
Lane Width [ft]	12.00	12.00	12.00	12.00	12.00	12.00	12.00	12.00	12.00	12.00	12.00	12.00
No. of Lanes in Entry Pocket	0	0	1	0	0	0	0	0	0	0	0	1
Entry Pocket Length [ft]	100.00	100.00	120.00	100.00	100.00	100.00	100.00	100.00	100.00	100.00	100.00	250.00
No. of Lanes in Exit Pocket	0	0	0	0	0	0	0	0	0	0	0	0
Exit Pocket Length [ft]	0.00	0.00	0.00	0.00	0.00	0.00	0.00	0.00	0.00	0.00	0.00	0.00
Speed [mph]	25.00			25.00			30.00			30.00		
Grade [%]	0.00			0.00			0.00			0.00		
Crosswalk	No			Yes			No			Yes		

Volumes

Name	Lakeshore Dr			Lakeshore Dr			Eastbound			Olympic Dr		
Base Volume Input [veh/h]	1	224	131	93	235	0	0	4	4	123	1	96
Base Volume Adjustment Factor	1.0000	1.0000	1.0000	1.0000	1.0000	1.0000	1.0000	1.0000	1.0000	1.0000	1.0000	1.0000
Heavy Vehicles Percentage [%]	2.00	2.00	2.00	2.00	2.00	2.00	2.00	2.00	2.00	2.00	2.00	2.00
Growth Factor	1.0000	1.0000	1.0000	1.0000	1.0000	1.0000	1.0000	1.0000	1.0000	1.0000	1.0000	1.0000
In-Process Volume [veh/h]	0	0	0	0	0	0	0	0	0	0	0	0
Site-Generated Trips [veh/h]	0	0	37	18	0	0	0	0	0	33	0	18
Diverted Trips [veh/h]	0	0	0	0	0	0	0	0	0	0	0	0
Pass-by Trips [veh/h]	0	0	0	0	0	0	0	0	0	0	0	0
Existing Site Adjustment Volume [veh/h]	0	0	0	0	0	0	0	0	0	0	0	0
Other Volume [veh/h]	0	0	0	0	0	0	0	0	0	0	0	0
Total Hourly Volume [veh/h]	1	224	168	111	235	0	0	4	4	156	1	113
Peak Hour Factor	1.0000	1.0000	1.0000	1.0000	1.0000	1.0000	1.0000	1.0000	1.0000	1.0000	1.0000	1.0000
Other Adjustment Factor	1.0000	1.0000	1.0000	1.0000	1.0000	1.0000	1.0000	1.0000	1.0000	1.0000	1.0000	1.0000
Total 15-Minute Volume [veh/h]	0	55	42	28	59	0	0	1	1	39	0	28
Total Analysis Volume [veh/h]	1	224	168	111	235	0	0	4	4	156	1	113
Pedestrian Volume [ped/h]	0			0			0			0		1

Weekend PM F+P



Intersection Settings

Number of Conflicting Circulating Lanes	1		1		1		1					
Circulating Flow Rate [veh/h]	117		161		512		230					
Exiting Flow Rate [veh/h]	403		344		2		289					
Demand Flow Rate [veh/h]	1	224	168	111	235	0	0	4	4	156	1	113
Adjusted Demand Flow Rate [veh/h]	1	224	168	111	235	0	0	4	4	156	1	113

Lanes

Override Calculated Critical Headway	No	No	No	No	No	No
User-Defined Critical Headway [s]	4.00	4.00	4.00	4.00	4.00	4.00
Override Calculated Follow-Up Time	No	No	No	No	No	No
User-Defined Follow-Up Time [s]	3.00	3.00	3.00	3.00	3.00	3.00
A (intercept)	1420.00	1420.00	1380.00	1380.00	1420.00	1420.00
B (coefficient)	0.00091	0.00091	0.00102	0.00102	0.00091	0.00091
HV Adjustment Factor	0.98	0.98	0.98	0.98	0.98	0.98
Entry Flow Rate [veh/h]	230	172	353	9	160	117
Capacity of Entry and Bypass Lanes [veh/h]	1277	1277	1171	819	1153	1153
Pedestrian Impedance	1.00	1.00	1.00	1.00	1.00	1.00
Capacity per Entry Lane [veh/h]	1252	1252	1148	803	1129	1129
X, volume / capacity	0.18	0.13	0.30	0.01	0.14	0.10

Movement, Approach, & Intersection Results

Lane LOS	A	A	A	A	A	A
95th-Percentile Queue Length [veh]	0.65	0.46	1.28	0.03	0.48	0.34
95th-Percentile Queue Length [ft]	16.36	11.59	31.95	0.75	11.98	8.40
Approach Delay [s/veh]	4.23		5.99	4.58	4.25	
Approach LOS	A		A	A	A	
Intersection Delay [s/veh]	4.84					
Intersection LOS	A					



Intersection Level Of Service Report

Intersection 6: Olympic Dr/N-S Project Street

Control Type:	Two-way stop	Delay (sec / veh):	32.9
Analysis Method:	HCM 6th Edition	Level Of Service:	D
Analysis Period:	15 minutes	Volume to Capacity (v/c):	0.221

Intersection Setup

Name	N-S Project Street		Olympic Dr		Olympic Dr	
Approach	Southbound		Eastbound		Westbound	
Lane Configuration	T		↑		↑	
Turning Movement	Left	Right	Left	Thru	Thru	Right
Lane Width [ft]	12.00	12.00	12.00	12.00	12.00	12.00
No. of Lanes in Entry Pocket	0	0	0	0	0	0
Entry Pocket Length [ft]	100.00	100.00	100.00	100.00	100.00	100.00
No. of Lanes in Exit Pocket	0	0	0	0	0	0
Exit Pocket Length [ft]	0.00	0.00	0.00	0.00	0.00	0.00
Speed [mph]	25.00		30.00		30.00	
Grade [%]	0.00		0.00		0.00	
Crosswalk	Yes		No		No	

Volumes

Name	N-S Project Street		Olympic Dr		Olympic Dr	
Base Volume Input [veh/h]	6	6	13	288	300	0
Base Volume Adjustment Factor	1.0000	1.0000	1.0000	1.0000	1.0000	1.0000
Heavy Vehicles Percentage [%]	2.00	2.00	2.00	2.00	2.00	2.00
Growth Factor	1.7600	1.7600	1.7600	1.7600	1.7600	1.7600
In-Process Volume [veh/h]	0	0	0	0	0	0
Site-Generated Trips [veh/h]	26	69	73	0	0	25
Diverted Trips [veh/h]	0	0	0	0	0	0
Pass-by Trips [veh/h]	0	0	0	0	0	0
Existing Site Adjustment Volume [veh/h]	0	0	0	0	0	0
Other Volume [veh/h]	0	0	0	0	0	0
Total Hourly Volume [veh/h]	37	80	96	509	528	25
Peak Hour Factor	1.0000	1.0000	1.0000	1.0000	1.0000	1.0000
Other Adjustment Factor	1.0000	1.0000	1.0000	1.0000	1.0000	1.0000
Total 15-Minute Volume [veh/h]	9	20	24	127	132	6
Total Analysis Volume [veh/h]	37	80	96	509	528	25
Pedestrian Volume [ped/h]	0		0		0	



Generated with **PTV VISTRO** Burns Valley Development 5/2/2022
Version 2021 (SP 0-6)

Intersection Settings

Priority Scheme	Stop	Free	Free
Flared Lane	No		
Storage Area [veh]	0	0	0
Two-Stage Gap Acceptance	No		
Number of Storage Spaces in Median	0	0	0

Movement, Approach, & Intersection Results

V/C, Movement V/C Ratio	0.22	0.15	0.09	0.01	0.01	0.00
d_M, Delay for Movement [s/veh]	32.95	18.12	8.91	0.00	0.00	0.00
Movement LOS	D	C	A	A	A	A
95th-Percentile Queue Length [veh/ln]	1.64	1.64	0.31	0.31	0.00	0.00
95th-Percentile Queue Length [ft/ln]	41.07	41.07	7.80	7.80	0.00	0.00
d_A, Approach Delay [s/veh]	22.81		1.41		0.00	
Approach LOS	C		A		A	
d_I, Intersection Delay [s/veh]	2.78					
Intersection LOS	D					

Weekend PM F+P



Generated with **PTV VISTRO** Burns Valley Development 5/2/2022
Version 2021 (SP 0-6)

Intersection Level Of Service Report

Intersection 7: Olympic Dr/Burns Valley Rd-Old Hwy 53

Control Type:	Signalized	Delay (sec / veh):	16.6
Analysis Method:	HCM 6th Edition	Level Of Service:	B
Analysis Period:	15 minutes	Volume to Capacity (v/c):	0.834

Intersection Setup

Name	Old Hwy 53			Burns Valley Rd			Olympic Dr			Old Hwy 53		
Approach	Northbound			Southbound			Eastbound			Westbound		
Lane Configuration	T T T			T T			T T			T T		
Turning Movement	Left	Thru	Right	Left	Thru	Right	Left	Thru	Right	Left	Thru	Right
Lane Width [ft]	12.00	12.00	12.00	12.00	12.00	12.00	12.00	12.00	12.00	12.00	12.00	12.00
No. of Lanes in Entry Pocket	1	0	1	1	0	0	1	0	0	1	0	0
Entry Pocket Length [ft]	100.00	100.00	100.00	56.00	100.00	100.00	48.00	100.00	100.00	100.00	100.00	100.00
No. of Lanes in Exit Pocket	0	0	0	0	0	0	0	0	0	0	0	0
Exit Pocket Length [ft]	0.00	0.00	0.00	0.00	0.00	0.00	0.00	0.00	0.00	0.00	0.00	0.00
Speed [mph]	30.00			30.00			35.00			35.00		
Grade [%]	0.00			0.00			0.00			0.00		
Curb Present	No			No			No			No		
Crosswalk	Yes			Yes			Yes			Yes		

Weekend PM F+P



Volumes

Name	Old Hwy 53			Burns Valley Rd			Olympic Dr			Old Hwy 53		
Base Volume Input [veh/h]	131	132	69	152	106	49	33	294	165	54	278	178
Base Volume Adjustment Factor	1.0000	1.0000	1.0000	1.0000	1.0000	1.0000	1.0000	1.0000	1.0000	1.0000	1.0000	1.0000
Heavy Vehicles Percentage [%]	2.00	2.00	2.00	2.00	2.00	2.00	2.00	2.00	2.00	2.00	2.00	2.00
Growth Factor	1.0000	1.0000	1.0000	1.0000	1.0000	1.0000	1.0000	1.0000	1.0000	1.0000	1.0000	1.0000
In-Process Volume [veh/h]	0	0	0	0	0	0	0	0	0	0	0	0
Site-Generated Trips [veh/h]	12	32	0	22	31	0	0	11	15	0	12	25
Diverted Trips [veh/h]	0	0	0	0	0	0	0	0	0	0	0	0
Pass-by Trips [veh/h]	0	0	0	0	0	0	0	0	0	0	0	0
Existing Site Adjustment Volume [veh/h]	0	0	0	0	0	0	0	0	0	0	0	0
Other Volume [veh/h]	0	0	0	0	0	0	0	0	0	0	0	0
Right Turn on Red Volume [veh/h]	0	0	19	0	0	3	0	0	5	0	0	20
Total Hourly Volume [veh/h]	143	164	50	174	136	46	33	305	165	54	290	183
Peak Hour Factor	1.0000	1.0000	1.0000	1.0000	1.0000	1.0000	1.0000	1.0000	1.0000	1.0000	1.0000	1.0000
Other Adjustment Factor	1.0000	1.0000	1.0000	1.0000	1.0000	1.0000	1.0000	1.0000	1.0000	1.0000	1.0000	1.0000
Total 15-Minute Volume [veh/h]	36	41	13	44	34	12	8	76	41	14	73	46
Total Analysis Volume [veh/h]	143	164	50	174	136	46	33	305	165	54	290	183
Presence of On-Street Parking	No		No	No		No	No		No	No		No
On-Street Parking Maneuver Rate [1/h]	0	0	0	0	0	0	0	0	0	0	0	0
Local Bus Stopping Rate [1/h]	0	0	0	0	0	0	0	0	0	0	0	0
v_do, Outbound Pedestrian Volume crossing major street	1			0			1			1		
v_di, Inbound Pedestrian Volume crossing major street	1			1			0			1		
v_co, Outbound Pedestrian Volume crossing minor street	1			0			0			0		
v_ci, Inbound Pedestrian Volume crossing minor street	0			0			1			0		
v_ab, Corner Pedestrian Volume [ped/h]	0			0			0			0		
Bicycle Volume [bicycles/h]	0			0			0			1		



Intersection Settings

Located in CBD	Yes
Signal Coordination Group	-
Cycle Length [s]	109
Coordination Type	Time of Day Pattern Isolated
Actuation Type	Fully actuated
Offset [s]	0.0
Offset Reference	Lead Green - Beginning of First Green
Permissive Mode	SingleBand
Lost time [s]	14.00

Phasing & Timing

Control Type	Protect	Permis	Permis	Protect	Permis	Permis	Protect	Permis	Permis	Protect	Permis	Permis
Signal Group	3	8	0	7	4	0	5	2	0	1	6	0
Auxiliary Signal Groups												
Lead / Lag	Lead	-	-	Lead	-	-	Lead	-	-	Lead	-	-
Minimum Green [s]	4	6	0	4	6	0	4	6	0	4	6	0
Maximum Green [s]	20	25	0	20	25	0	20	30	0	20	20	0
Amber [s]	3.0	3.3	0.0	3.0	3.3	0.0	3.0	3.6	0.0	3.0	3.6	0.0
All red [s]	0.0	0.3	0.0	0.0	0.3	0.0	0.0	0.3	0.0	0.0	0.3	0.0
Split [s]	23	29	0	23	29	0	23	34	0	23	34	0
Vehicle Extension [s]	0.0	0.0	0.0	0.0	0.0	0.0	0.0	0.0	0.0	0.0	0.0	0.0
Walk [s]	0	7	0	0	7	0	0	7	0	0	7	0
Pedestrian Clearance [s]	0	11	0	0	9	0	0	14	0	0	9	0
Delayed Vehicle Green [s]	0.0	0.0	0.0	0.0	0.0	0.0	0.0	0.0	0.0	0.0	0.0	0.0
Rest In Walk		No			No			No			No	
I1, Start-Up Lost Time [s]	2.0	2.0	0.0	2.0	2.0	0.0	2.0	2.0	0.0	2.0	2.0	0.0
I2, Clearance Lost Time [s]	1.0	1.6	0.0	1.0	1.6	0.0	1.0	1.9	0.0	1.0	1.9	0.0
Minimum Recall	No	No		No	No		No	No		No	No	
Maximum Recall	No	No		No	No		No	No		No	No	
Pedestrian Recall	No	No		No	No		No	No		No	No	
Detector Location [ft]	0.0	0.0	0.0	0.0	0.0	0.0	0.0	0.0	0.0	0.0	0.0	0.0
Detector Length [ft]	0.0	0.0	0.0	0.0	0.0	0.0	0.0	0.0	0.0	0.0	0.0	0.0
I, Upstream Filtering Factor	1.00	1.00	1.00	1.00	1.00	1.00	1.00	1.00	1.00	1.00	1.00	1.00

Exclusive Pedestrian Phase

Pedestrian Signal Group	0
Pedestrian Walk [s]	0
Pedestrian Clearance [s]	0



Lane Group Calculations

Lane Group	L	C	R	L	C	L	C	L	C
C, Cycle Length [s]	39	39	39	39	39	39	39	39	39
L, Total Lost Time per Cycle [s]	3.00	3.60	3.60	3.00	3.60	3.00	3.90	3.00	3.90
H1_p, Permitted Start-Up Lost Time [s]	1.00	1.60	1.60	1.00	1.60	1.00	1.90	1.00	1.90
H2, Clearance Lost Time [s]	1.00	1.60	1.60	1.00	1.60	1.00	1.90	1.00	1.90
g_i, Effective Green Time [s]	4	6	6	5	7	1	13	2	14
g / C, Green / Cycle	0.11	0.14	0.14	0.13	0.17	0.03	0.33	0.05	0.35
(v / s)_j, Volume / Saturation Flow Rate	0.09	0.10	0.04	0.11	0.11	0.02	0.30	0.03	0.30
s, saturation flow rate [veh/h]	1603	1683	1420	1603	1610	1603	1584	1603	1561
c, Capacity [veh/h]	178	239	202	216	267	50	530	74	545
d1, Uniform Delay [s]	17.10	16.08	15.04	16.54	15.46	18.89	12.41	18.57	11.97
k, delay calibration	0.04	0.04	0.04	0.04	0.04	0.04	0.04	0.04	0.08
I, Upstream Filtering Factor	1.00	1.00	1.00	1.00	1.00	1.00	1.00	1.00	1.00
d2, Incremental Delay [s]	3.21	1.31	0.24	2.65	1.14	5.37	2.05	5.17	3.34
d3, Initial Queue Delay [s]	0.00	0.00	0.00	0.00	0.00	0.00	0.00	0.00	0.00
Rp, platoon ratio	1.00	1.00	1.00	1.00	1.00	1.00	1.00	1.00	1.00
PF, progression factor	1.00	1.00	1.00	1.00	1.00	1.00	1.00	1.00	1.00

Lane Group Results

X, volume / capacity	0.80	0.89	0.25	0.80	0.68	0.66	0.89	0.73	0.87
d, Delay for Lane Group [s/veh]	20.31	17.39	15.27	19.19	16.60	24.25	14.45	23.74	15.32
Lane Group LOS	C	B	B	B	B	C	B	C	B
Critical Lane Group	No	Yes	No	Yes	No	No	Yes	Yes	No
50th-Percentile Queue Length [veh/m]	1.23	1.26	0.35	1.44	1.36	0.33	3.08	0.51	3.22
50th-Percentile Queue Length [ft/m]	30.73	31.58	8.72	36.98	33.98	8.15	76.95	12.84	80.44
95th-Percentile Queue Length [veh/m]	2.21	2.27	0.63	2.59	2.45	0.59	5.54	0.92	5.79
95th-Percentile Queue Length [ft/m]	55.32	56.84	15.69	64.76	61.17	14.67	138.51	23.11	144.79



Movement, Approach, & Intersection Results

d_M, Delay for Movement [s/veh]	20.31	17.39	15.27	19.19	16.60	16.60	24.25	14.45	14.45	23.74	15.32	15.32
Movement LOS	C	B	B	B	B	B	C	B	B	C	B	B
d_A, Approach Delay [s/veh]	18.26			17.86			15.09			16.18		
Approach LOS	B			B			B			B		
d_I, Intersection Delay [s/veh]	16.64											
Intersection LOS	B											
Intersection V/C	0.834											

Other Modes

g_Walk,mi, Effective Walk Time [s]	11.0	11.0	11.0	11.0
M_corner, Corner Circulation Area [ft ² /ped]	0.00	0.00	0.00	0.00
M_CW, Crosswalk Circulation Area [ft ² /ped]	0.00	0.00	0.00	0.00
d_p, Pedestrian Delay [s]	10.18	10.18	10.18	10.18
L_p,int, Pedestrian LOS Score for Intersection	2.288	2.141	2.273	2.334
Crosswalk LOS	B	B	B	B
s_b, Saturation Flow Rate of the bicycle lane [bicycles/h]	2000	2000	2000	2000
c_b, Capacity of the bicycle lane [bicycles/h]	1294	1294	1533	1533
d_b, Bicycle Delay [s]	2.45	2.45	1.07	1.07
L_b,int, Bicycle LOS Score for Intersection	2.160	2.152	2.398	2.462
Bicycle LOS	B	B	B	B

Sequence

Ring	1	2	3	4	-	-	-	-	-	-	-	-	-	-
Ring 1	1	2	3	4	-	-	-	-	-	-	-	-	-	-
Ring 2	5	6	7	8	-	-	-	-	-	-	-	-	-	-
Ring 3	-	-	-	-	-	-	-	-	-	-	-	-	-	-
Ring 4	-	-	-	-	-	-	-	-	-	-	-	-	-	-

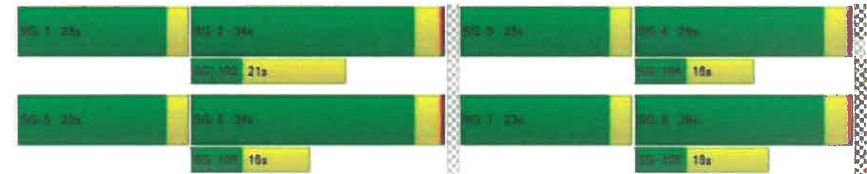

**Attachment F
Noise Study for Oak Valley Villas Apartments**



Oak Valley Villas Apartments Acoustic Mitigation Summary Report

By Douglas L. Gibson, A.I.A., California Architect C29792

2 March 2022

The Oak Valley Villas Apartment project is located in the northerly portion of the City of Clearlake, in what could best be described as a semi-rural, suburban area of impact. Nearby uses include multifamily residential to the north and west with farmland, orchards and vineyards to the north. To the south of the project is the more urban, developed center of town, for the city, along with commercial uses, and existing residential uses and zoning designations as well. As proposed, Oak Valley Villas Apartments, is to be located at the Southwest Corner of Burns Valley Road and Rumsey Road, a non-signalized intersection with traffic control by use of stop signs. Neither Burns Valley Road nor Rumsey Road are considered arterial or high-speed vehicular thoroughfares, both in width of roadway, posted allowable speeds and profiles of intersection. As these two roads are considered residential collector roads servicing a limited geographic area, the acoustical noise impact to the proposed development will be nominal, and within acceptable limitations per state statute and HUD standards at 24CFR Part 51B, averaging between 38 to 45 dBA (background) but no greater than an anticipated 65 dBA day night average. This assessment is based upon current traffic patterns, adjacent uses and the semi-rural nature of the primary frontage for the project, Burns Valley Road.

Secondary acoustical consideration for the development is specific to the future installation of a municipal sports field directly to the south of the apartment development by the City of Clearlake. The following summary report is based upon a Masterplan Format Document provided by the City of Clearlake to the Architect of Record, Douglas L. Gibson, on or about October 29, 2021. Physical dimensions of the proposed sports complex have been verified with the Owner provided ALTA document and reconciled with the approved site plan for the apartment complex, recorded by the City of Clearlake Planning Department. The architectural site plan used for this assessment was dated February 12, 2022, and noted as "Delta 2 Coordination Revisions" submitted to the city for permitting. All dimensions noted are approximate, but should be within less than 12" in accuracy. Final site plan dimensions for both the proposed apartment complex and the city owned sports facility will not be confirmed, in situ, until such time as a final ALTA is recorded for both properties.

For any sports complex of the proposed design, there are commonly noted or recorded three major sources of noise energy production (*Noise-Con 90, Jack B. Evans, P.E., "Community Annoyance with Sports Crowd Noise – A Case Study of the Facts in a Jury Decision"*). These three major sources of noise are the following: 1.) Vehicular automobile, private truck and limited commercial truck engine noise; 2.) Amplified Public Announcement sounds, including both voice and music energy; and 3.) Spontaneous sound energy created by multiple voices, sound emissions and collective human generated sound energy of random sources, areas, zones and magnitude. Of the three recognized sound energy sources, the third is recognized as the most intrusive and acoustically difficult to address on account of various pitch, sound wave lengths and energy. Recent professional and collegiate football stadiums have had

430 E. State St., Ste. 100 • Eagle, ID 83616 • 208-908-4871 • 208-392-1269 Fax
Licensed Architect: Idaho • Utah • Nevada • Wyoming • Montana • Washington • Oregon • California • Hawaii • Alaska Arizona • Colorado • South Dakota • Louisiana • Nebraska • North Dakota • New Mexico



acoustical energy recordings in excess of 110 dB, for limited durations. Spectator noise is of serious concern for large and small sports venues, however, there is also a significant reduction in the production of sound energy from a group of 100 spectators, compared to 100,000 spectators. It is this smaller group of spectators that are to be addressed in this summary as the primary source of acoustical energy.

However, before addressing spectator noise, the first and second sources of anticipated sound energy will be reviewed, assessed and then noted for any anticipated mitigation measures. The first source of sound energy is proposed as vehicular sound created at the sports complex as participants, fans, officials and ancillary staff park cars, drive around the parking lot looking for a parking spot, or idle, waiting for a spot to clear. Anticipated sound production for the larger of the two parking lots in the sports complex are anticipated to be between 54 dBA and 59 dBA. The larger of the two parking lots, to the west of the proposed sports complex is approximately 500 linear feet from the western wall of Buildings 3 and 4 of Oak Valley Villas. In addition, this direct line of site sound source is buffered from the apartment project development by two existing single story structures, a municipal library that is approximately 25' tall and a single story senior living project which is contiguous to the western property line of Oak Valley Villas. Based upon distance from the two structures on site, physical obstacles that will prevent direct sound acquisition and which will deflect and refract sound energy, it is presumed that any sound energy reaching the interior of the units will be less than 40 to 45 dBA from these sources at the westerly parking lot.

A second parking lot for the sports field, proposed at the easterly portion of the facility is planned to be contiguous to the southern parcel line of the apartment complex. This fifty six (56) parking stall lot is directly adjacent to the primary baseball field at the easterly portion of the sports complex and is approximately 140' from the closest residential structure within the apartment development, Building 4 and approximately 290' from Building 5. Similar to the above calculation, it is anticipated that noise generation of this secondary lot will be in the 54 to 59 dBA range, with bursts associated with diesel engine rev up and bass sound production from vehicular stereo systems in excess of 65 decibels, for limited duration and magnitude. The closest structure to this source of noise, Building 4, has primary deck and patio openings parallel to the source of noise energy, and presents in the general direction of this noise source, a wall consisting of approximately 95% solid surface. There are six individual, fixed windows, facing south on this elevation. For these six windows, elevating the acoustical mitigation or STC rating from the standard STC 30 to STC 33 will result in sound level energy within the respective unit interiors of less than 45 dBA DNL (day night average) on standard days when the parking lot is utilized for sporting events or similar activities.

Similarly, Building 5, the second closest structure to this parking lot has approximately 60 to 65% of the facade designed as an opaque surface with three smaller, fixed windows and three larger bedroom egress windows at this south elevation. In addition, based upon the unit interior floor plans each unit in the three story structure at the south end of the building is provided with an approximately 80 square foot exterior private space, patio or balcony. Access to this patio and balcony is through a full light

430 E. State St., Ste. 100 • Eagle, ID 83616 • 208-908-4871 • 208-392-1269 Fax
 Licensed Architect: Idaho • Utah • Nevada • Wyoming • Montana • Washington • Oregon • California • Hawaii • Alaska Arizona • Colorado • South Dakota • Louisiana • Nebraska • North Dakota • New Mexico



French door (swinging) with a side light and window which provide natural daylighting into the interior of the unit. The windows on this portion of the structure will receive the majority of sound energy and will be provided with a higher acoustical rating of STC 33. Based upon the distance from the source of sound energy (parking lot and drive aisles) it is anticipated that maximum sound readings within this unit's living room and the bedrooms with direct exposure to the source of sound energy, would experience internal acoustic readings of approximately 45 to 50 dBA, for short durations as sporting activities occurred on an irregular basis. By providing for a more rigorous acoustical mitigation response in the project's construction document package, as permitted and approved for construction by local authorities having jurisdiction, it can be summarized that the interior of the residential units, upon completion, will have sound levels less than 45 dBA DNL. This analysis is based upon the design and construction of the exterior walls, that is, 2x6 wood construction with wood sheathing, sound absorptive stucco or EIFS siding, R-21 rated batt insulation, and acoustical dampening gypsum drywall within the unit interiors. From time to time resident use of their exterior patio may be compromised by the creation of sound energy at the parking lot, with sound levels in excess of 65 dBA. To fully address this sound source the only acceptable means of addressing mitigation at the exterior patios would be the introduction of solid half walls (currently shown as transparent railing to 4" AFF) and construction of such half walls to a minimum height of approximately 52". Based upon the limited events or occurrences of excessive sound levels generated by the sports complex the architect is of the professional opinion that retaining the current patio design is acceptable without additional mitigation being required.

The next source of noise energy to be addressed is that energy produced by both electrical amplification of voice and musical soundtracks over an energized audio system. At the time of the creation of this report and assessment the City of Clearlake had not sufficiently programmed the site nor provided the author of this report with any specific information on speaker location, mounting height, orientation, nor amplification metrics. Based upon the understanding that the baseball diamond anticipated to be built directly to the south of the proposed apartment complex, Oak Valley Villas, will be the largest of the five baseball diamonds, the other two being little league fields and T-ball fields, this diamond will be the only one to potentially contain an amplified sound system. Based upon the Master Plan Format document provided to the design team, the closest bleacher section to Building 4 is approximately 420' from the south face of that structure, and from Building 5 to this bleacher seating is approximately 440'. Based upon the prior cited source, Noise-Con 90 proceedings, Jack B. Evans, P.E., the anticipated noise energy production from these amplifications can range from 75 to 80 dBA, with high loads of over 85 dBA, when sound amplification energy is overlaid with organic noise production from spectators and players. This level of energy production (highest yield of 85 dBA) would occur approximately less than 15% of the time of total play or participant attendance of a baseball event. Anticipated noise levels of the combined amplified and crowd noise could be estimated to be between 60 to 65 dBA, for more than half of the time of attendance, but more generally within the 55 to 60 dBA for more than seventy percent of the time, when both physically active participants, spectators, and amplification are used.

As noted previously, the sound 'face' of the two closest buildings to this source of energy are Buildings 4 and 5, and by design, both structures present their smallest profile to the south, or that direction

430 E. State St., Ste. 100 • Eagle, ID 83616 • 208-908-4871 • 208-392-1269 Fax
 Licensed Architect: Idaho • Utah • Nevada • Wyoming • Montana • Washington • Oregon • California • Hawaii • Alaska Arizona • Colorado • South Dakota • Louisiana • Nebraska • North Dakota • New Mexico



specifically facing the proposed sports complex. By providing upgraded STC ratings for the fixed windows, Building 4 primarily, and the three fixed windows, six operable windows and three French patio doors, it will be possible to reduce the sound energy reception within these spaces to less than 52 dBA during peak energy events. Construction documents will note the installation of acoustical sealant or caulking at these two structures south elevations, upgraded STC ratings for vinyl windows from industry standard 30 to an upgraded STC 33 minimum, as all as the utilization of acoustic dampening gypsum wall board on these south facing unit interior walls. Combining the sound mitigation effects of these built components, and considering the distance from the source of sound energy, it is proposed that ambient sound energy within these residential units will remain less than 45 dBA, on average, and would be estimated in the 57 to 59 dBA range during most times when active sporting events are occurring. Based upon the anticipated duration of sporting events, e.g. summer weekends and evenings, and shoulder season (March through May) high school level sporting events, it can safely be stated that when averaged over a twenty four (24) hour period, the noise levels within these units would safely remain below HUD's required 45 dBA DNL standard.

430 E. State St., Ste. 100 • Eagle, ID 83616 • 208-908-4871 • 208-392-1269 Fax
Licensed Architect: Idaho • Utah • Nevada • Wyoming • Montana • Washington • Oregon • California • Hawaii • Alaska Arizona •
Colorado • South Dakota • Louisiana • Nebraska • North Dakota • New Mexico

Attachment G
Flood Hazards Map

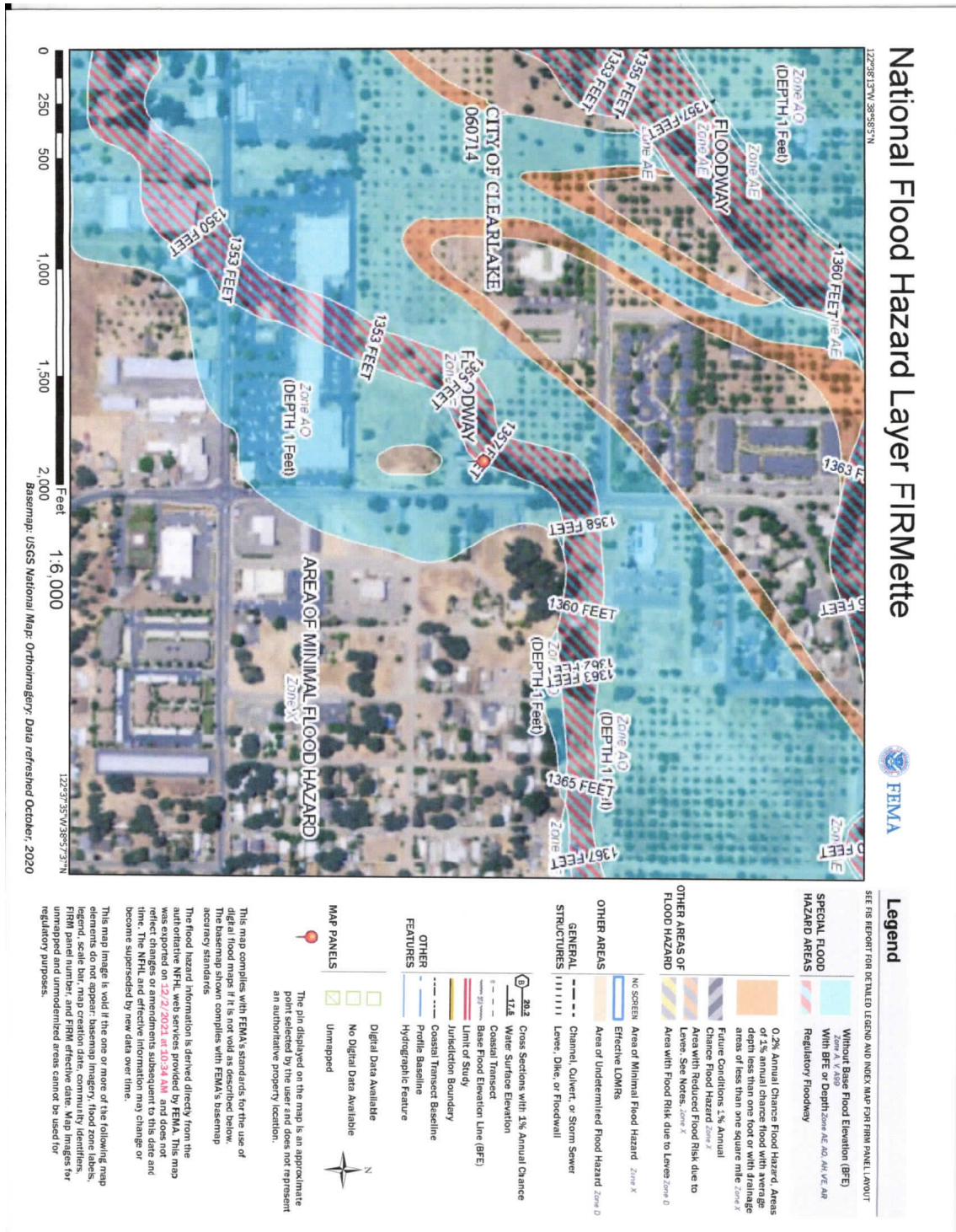

**GEOTECHNICAL ENGINEERING INVESTIGATION REPORT
PROPOSED BURNS VALLEY DEVELOPMENT
BURNS VALLEY ROAD
CLEARLAKE, LAKE COUNTY, CALIFORNIA**
February 26, 2021

Prepared For:

CITY OF CLEARLAKE
14050 Olympic Drive
Clearlake, California 95422

Ms. Adeline Brown, Engineering Tech/Construction Manager



N | V | 5

48 Bellarmine Court
Suite 40
Chico, CA 95928

125620-0071075.00.001



February 26, 2021
Project No. 71075.00.001

Ms. Adeline Brown,
Engineering Tech/Construction Manager
City of Clearlake
14050 Olympic Drive
Clearlake, California 95422

**Reference: Geotechnical Engineering Investigation Report
Proposed Burns Valley Development
Burns Valley Road, Clearlake, Lake County, California**

Dear Ms. Brown,

NV5 conducted a geotechnical engineering investigation for the proposed Burns Valley Development located at Burns Valley Road, Clearlake, California. NV5's geotechnical engineering investigation of the site was performed consistent with the scope of services presented in the November 6, 2020 proposal (PC20.230).

The findings, conclusions and recommendations presented in this report are based on the following relevant information collected and evaluated by NV5: literature review, surface observations, subsurface exploration, laboratory test results, and previous experience with similar projects, sites and conditions in the area. The approximately 25-acre parcel is proposed for mixed-use development including multi-story apartment buildings, a single-story commercial building, and a City of Clearlake Public Works (CCPW) Yard with an approximately 20,000-square-foot (sf) shop utilizing conventional design and construction practices. There were no seismic hazards identified on the site or in the immediate area that require design mitigation. Portions of the site support loose undocumented fills that are not considered suitable for support of the proposed improvements. Therefore, it is NV5's opinion that the site is suitable for the proposed construction provided the geotechnical engineering recommendations presented in this report are incorporated into the earthwork and structural improvements. This report should not be relied upon without review by NV5 if a period of 24 months elapses between the issuance report date shown above and the date when construction commences.

NV5 appreciates the opportunity to provide geotechnical engineering services for this important project. If you have questions or need additional information, please do not hesitate to contact the undersigned at 530-894-2487.

Sincerely,
NV5

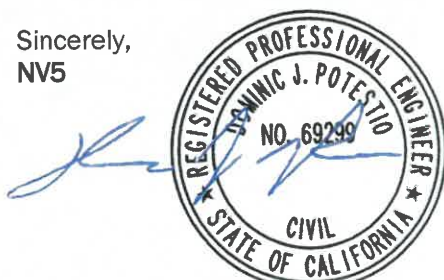

Dominic J. Potestio, PE 69299
Senior Engineer



Shane D. Cummings, CEG 2492
Senior Engineering Geologist

Title Sheet	i
Transmittal Letter with Engineer's/Geologist's Signature and Seal.....	ii
Table of Contents.....	iii
Acronyms	vi

TABLE OF CONTENTS

1.0 INTRODUCTION.....	1
1.1 SCOPE-OF-SERVICES.....	1
1.2 SITE LOCATION AND DESCRIPTION.....	1
1.3 PROPOSED IMPROVEMENTS.....	4
1.4 INVESTIGATION PURPOSE.....	4
2.0 SITE INVESTIGATION.....	6
2.1 LITERATURE REVIEW	6
2.1.1 Site Improvement Plans	6
2.1.2 Previous Site Investigation Reports.....	6
2.2 REGIONAL GEOLOGY.....	6
2.3 SITE GEOLOGY	7
2.4 REGIONAL FAULTING AND SEISMIC SOURCES.....	7
2.5 FIELD INVESTIGATION.....	7
2.5.1 Surface Conditions.....	8
2.5.2 Subsurface Conditions	8
3.0 LABORATORY TESTING	12
4.0 HISTORICAL SEISMICITY	14
5.0 LIQUEFACTION AND SEISMIC SETTLEMENT.....	15
5.1 LIQUEFACTION	15
5.2 SEISMIC SETTLEMENT AND LATERAL SPREADING.....	16
6.0 CONCLUSIONS	17
7.0 RECOMMENDATIONS	19
7.1 EARTHWORK GRADING.....	19
7.1.1 Demolition and Abandonment of Existing Site Improvements	19
7.1.2 Import Fill Soil	19
7.1.3 Temporary Excavations.....	20
7.1.4 Stripping and Grubbing.....	20
7.1.5 Native Soil Preparation for Engineered Fill Placement	20
7.1.6 Engineered Fill Construction with Testable Earth Materials	21
7.1.7 Cut and Fill Slope Grading.....	23
7.1.8 Erosion Controls	23
7.1.9 Underground Utility Trenches.....	24
7.1.10 Construction Dewatering.....	27
7.1.11 Soil Corrosion Potential	28

7.1.12	Subsurface Groundwater Drainage.....	28
7.1.13	Surface Water Drainage	28
7.1.14	Grading Plan Review and Construction Monitoring.....	29
7.2	STRUCTURAL IMPROVEMENTS	29
7.2.1	Seismic Design Parameters.....	29
7.2.2	Shallow Foundations.....	32
7.2.3	Retaining Walls Entirely Above the Groundwater Table	33
7.2.4	Retaining Wall Backfill.....	35
7.2.5	Concrete Slab-On-Grade Interior Floors, Sidewalk and Patio Construction.....	37
7.2.6	Rigid Concrete Pavement for Heavy Truck Traffic Areas and Fire Lanes	42
7.2.7	Flexible Pavement	43
8.0	REFERENCES	46
9.0	LIMITATIONS.....	47

LIST OF TABLES

Table 3.0-1, Laboratory Test Results	13
Table 5.1-1, Liquefaction Potential Calculated From Borings	16
Table 7.1.5-1, Minimum Testing Frequencies	21
Table 7.1.6.1-1, Minimum Testing Frequencies for Non-Expansive Soil	23
Table 7.1.9-1, Minimum Testing Frequencies for Utility Trench Backfill.....	27
Table 7.2.1-1 2019 CBC Seismic Design Parameters	31
Table 7.2.2-1, Foundation Bearing Pressures for Shallow Foundations	32
Table 7.2.3-1, Design Parameters for Retaining Walls.....	35
Table 7.2.7-1, Flexible Pavement Design.....	44

LIST OF FIGURES

Figure 1, Site Location Map.....	2
Figure 2, Site Plan and Exploratory Boring Location Map	5

APPENDICES

A	Important Information about This Geotechnical Engineering Report (Included with permission of GBA, Copyright 2019)
B	Exploratory Boring Logs
C	Soil Laboratory Test Results
D	Liquefaction Analysis Results
E	Seismic Design Parameters

ACRONYMS

°F	degrees Fahrenheit
AB	aggregate base
AC	asphalt concrete
ACI	American Concrete Institute
ASCE	American Society of Civil Engineers
ASTM	ASTM International
bgs	below ground surface
Cal/EPA	California Environmental Protection Agency
CAT	Caterpillar
CBC	California Building Code
CCPW	City of Clearlake Public Works
CEC	California Engineering Company
CGS	California Geological Survey
CQA	Construction Quality Assurance
DTSC	Department of Toxic Substances Control
DWR	Department of Water Resources
EERI	Earthquake Engineering Research Institute
EFP	equivalent fluid pressure
FS	factor of safety
ft/s	feet per second
GBA	Geoprofessional Business Association
H:V	horizontal to vertical slope ratio
IBC	International Building Code
km	kilometer
MCE	maximum considered earthquake
M _L	local magnitude earthquake
msl	mean sea level
M _w	modal magnitude
NEIC	National Earthquake Information Center
OSHA	Occupational Safety and Hazards Administration
oz/sy	ounce per square yard
P-wave	seismic compression wave
PCA	Portland Cement Association
pcf	pounds per cubic foot
PGA _m	peak ground acceleration
PG&E	Pacific Gas & Electric
PI	plasticity index
psf	pounds per square foot
psi	pounds per square inch
PVC	polyvinylchloride
Q _{al}	Quaternary Alluvium
S-wave	shear-wave
SEAOC	Structural Engineers Association of California
sf	square foot
SPT	standard penetration test
SRMS	Seismic Refraction Microtremor Survey

ACRONYMS (CONCLUDED)

SSD	saturated surface dry
TI	traffic index
USCS	Unified Soils Classification System
USGS	United States Geological Survey

1.0 INTRODUCTION

NV5 performed a geotechnical engineering investigation and prepared a geotechnical engineering investigation report for the proposed Burns Valley Development mixed-use project at Burns Valley Road in Clearlake, California, consistent with the scope of services presented in NV5's *Proposal for Geotechnical Engineering Services* (PC20.230), dated November 6, 2020. NV5's findings, conclusions and recommendations are presented herein.

For your review, Appendix A presents a document prepared by the Geoprofessional Business Association (GBA) entitled "*Important Information about This Geotechnical Engineering Report.*" This document summarizes project specific factors, limitations, content interpretation, responsibilities and other pertinent information.

1.1 SCOPE-OF-SERVICES

NV5 performed a specific scope-of-services to develop geotechnical engineering design recommendations for earthwork and structural improvements. Brief descriptions of each work scope task are presented below. A detailed description of each work scope task is presented in Section 2 (Site Investigation) of this report.

- **Task 1 Site Investigation:** NV5 performed a site investigation to characterize the existing surface and subsurface soil, rock and groundwater conditions encountered to the maximum depth excavated. NV5's field engineer/geologist made observations, took representative soil samples, and performed field tests at a limited number of subsurface exploratory locations. NV5 performed laboratory tests on selected soil samples to evaluate their engineering material properties.
- **Task 2 Data Analysis and Engineering Design:** NV5 evaluated the field and laboratory site data and the proposed site improvements and used this information to develop geotechnical engineering design recommendations for earthwork and structural improvements. NV5 used engineering judgment to extrapolate NV5's observations and conclusions regarding the field and laboratory data to other onsite areas located between and beyond the locations of NV5's subsurface exploratory excavations.
- **Task 3 Report Preparation:** NV5 prepared this report to present the findings, conclusions and recommendations for this geotechnical engineering investigation.

1.2 SITE LOCATION AND DESCRIPTION

The proposed Burns Valley Development are located at Burns Valley Road, in Clearlake, California, identified as Lake County Assessor's Parcel Numbers 010-026-40, 010-026-29 and 039-570-18. The proposed development is located at the southwest corner of Burns Valley Road and Rumsey Road. The site is centered at about latitude 38.9638 north and longitude -122.6349 west on the United States Geological Survey's (USGS), 7.5 minute Clearlake Highlands Quadrangle topographic map. The property elevation is approximately 1360 feet above mean sea level (msl), based on review of the USGS 7.5-minute Clearlake Highlands Quadrangle topographic map, and is generally flat with a gentle downgrade slope from east to west. Figure 1 shows the approximate site location and vicinity.



SITE LOCATION

T13N R7W

CLEARLAKE

Clearlake Highlands



SITE LOCATION MAP

CITY OF CLEARLAKE BURNS VALLEY DEVELOPMENT
 BURNS VALLEY ROAD, CLEARLAKE, LAKE COUNTY, CALIFORNIA

DRAWN BY:	SC
CHECKED BY:	DJP
PROJECT:	71075.01.001
DATE:	FEBRUARY 2021

FIGURE

1

455



At the time the site investigation was performed on January 12 and 13, 2021, the following conditions were observed and are shown in the inset image:

The area of the proposed Burns Valley Development is comprised of Lake County Assessor's Parcel Numbers 010-026-40, 010-026-29 and 039-570-18. Each of the three parcels is described respectively.

- Parcel 010-026-40 is an irregular-shaped property generally comprised of an existing tree orchard and high concentrations of weeds and grasses. The terrain was relatively flat with a gentle downward slope from the east to the west. A drainage channel transected the east portion of the property in the southwest direction. To the east of the drainage channel the surface topography was relatively higher in elevation than the rest of the site. Large stockpiles consisting of soils, concrete and asphalt rubble, boulders, and other deleterious debris were present. Overhead power poles and power lines were present along the north and east boundaries of the property. The property was bounded to the east and north by Burns Valley Road; to the west by Burns Valley Creek; and, to the south by apartments, commercial buildings and a retail shopping center.
- Parcel 010-026-29 is a rectangular shaped property supporting a large number of mature oak trees, agricultural tress, and high concentrations of weeds and grasses. Concrete foundation remnants of a former structure and a large construction crane were present in the southern portion of the property. A drainage channel transected the center of the site and extended in the southwest direction. A California Department of Water Recourses (DWR) monitoring well was present in the northeast portion of the site. A water well pump house was present in the north half of the property. The site was bounded to the north and east by Burns Valley Road, to the south by fallow land and stockpiles; and, to the west by a senior living community.

- Parcel 039-570-18 is a rectangular shaped property comprised of fallow land supporting low to moderate concentrations of weeds and grasses. Sparse mature trees and fence posts were present throughout the site. Numerous utility markings were present indicating the presence of underground utilities. The property is bounded to the north by existing tree orchards; to the west by an existing Pacific Gas & Electric (PG&E) facility; to the south by Olympic Drive; and, to the east by a retail shopping center. Evidence of a former structure was observed in the northern portion of the parcel.

1.3 PROPOSED IMPROVEMENTS

Based on the preliminary project information provided by representatives of California Engineering Company (CEC), NV5 understands the approximately 30-acre parcel is proposed for mixed-use development including multi-story apartment buildings, a single-story commercial building, and a City of Clearlake Public Works (CCPW) Yard with an approximately 20,000-square-foot (sf) shop. The proposed residential and commercial structures are anticipated to be constructed with wood or light-metal framing and supported on shallow concrete foundations with interior concrete slab-on-grade floors. The proposed CCPW shop is anticipated to consist of a metal, prefabricated building, or constructed with light-metal framing, and supported on shallow concrete foundations with an interior concrete slab-on-grade floor.

Associated development is indicated to include construction of an asphalt concrete paved police department parking lot, recreational fields (baseball/softball, soccer, etc.), underground utilities, exterior slab-on-grade concrete flatwork, rigid concrete and asphalt concrete pavements, and landscaping. Earthwork grading may include general site preparation, and minor cuts and fills to balance the site to meet the proposed building grades. Figure 2 shows the proposed site location and approximate exploratory boring locations.

1.4 INVESTIGATION PURPOSE

The purpose of the geotechnical investigation was to obtain sufficient on-site information about the soil, rock and groundwater conditions to provide geotechnical engineering recommendations for the proposed earthwork and structural improvements. As part of this contract, NV5 did not evaluate the site for the presence of hazardous waste, mold, asbestos and radon gas. Therefore, the presence and removal of these materials are not discussed in this report.

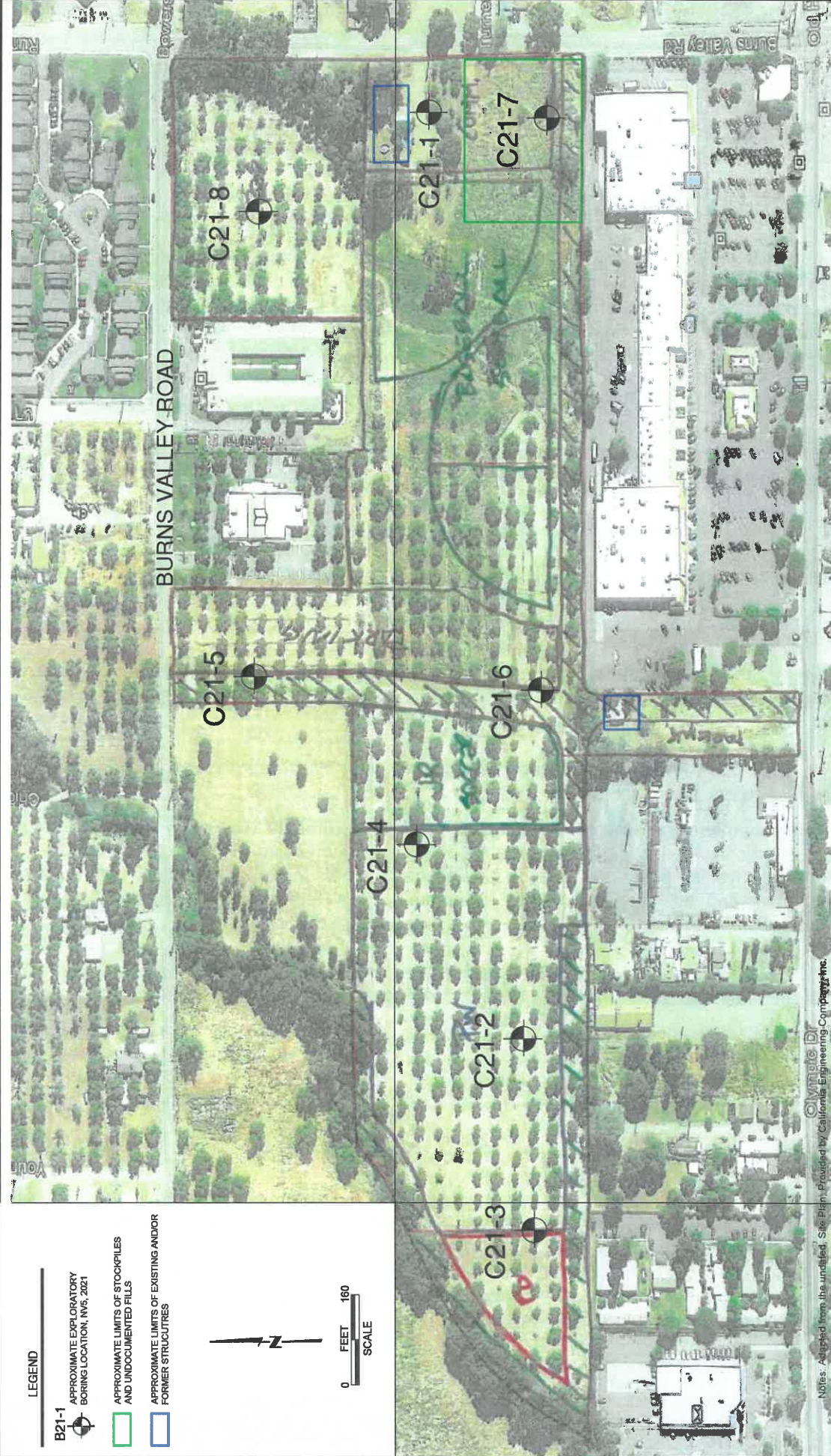

LEGEND

- B21-1 APPROXIMATE EXPLORATORY BORING LOCATION, NV5, 2021
- APPROXIMATE LIMITS OF STOCKPILES AND UNDOCUMENTED FILLS
- APPROXIMATE LIMITS OF EXISTING AND/OR FORMER STRUCTURES



DRAWN BY:	SC
CHECKED BY:	DJP
PROJECT:	71075.01.001
DATE:	FEBRUARY 2021

SITE PLAN AND EXPLORATORY CORE LOCATION MAP
 CITY OF CLEARLAKE BURNS VALLEY DEVELOPMENT
 BURNS VALLEY ROAD, CLEARLAKE, LAKE COUNTY, CALIFORNIA

Notes: Adapted from the untitle... Site Plan. Provided by California Engineering Company, Inc.



2.0 SITE INVESTIGATION

NV5 performed a site investigation to characterize the existing surface and subsurface conditions beneath the proposed improvements. The site investigation included a literature review of published and unpublished geologic documents and maps, a surface reconnaissance investigation, and a subsurface exploratory investigation using a track-mounted drill rig to excavate exploratory borings. Each component of the site investigation is presented below.

2.1 LITERATURE REVIEW

NV5 performed a limited review of available literature that was pertinent to the project site. The following summarizes NV5's findings:

2.1.1 Site Improvement Plans

Improvement plans were not available for review at the time this report was prepared.

2.1.2 Previous Site Investigation Reports

NV5 reviewed the following reports associated with the project site area. The following identifies each report and summarizes the findings, conclusions and recommendations presented in each report:

- NV5, 2021, *Field Investigation Summary Report, Sulphur Fire Road Rehabilitation Project, Various Streets, Clearlake, California*, prepared by NV5, February XX.

The investigation consisted of evaluating various streets within the City of Clearlake. The evaluation consisted of logging the existing pavement conditions and thickness, collecting representative sample of the underlying subgrade materials for subgrade quality testing. Based on the field and laboratory information recommendations were provided for roadway rehabilitation with asphalt concrete overlay or full depth reconstruction.

- NV5, 2021, *Reconnaissance Geotechnical Engineering Report, City of Clearlake Sulphur Fire Cuts Rehabilitation Assessments, Clearlake, California*, prepared by NV5, January 11.

The investigation consisted of evaluating seven existing damaged road cuts for slope stability failure modes. The cuts only showed evidence of shallow erosion caused by surface water runoff, shallow sloughing and/or shallow soil creep. Recommendations for standard soil erosion prevention rehabilitation practices were provided to mitigate the erosion concerns.

2.2 REGIONAL GEOLOGY

The proposed Burns Valley Development is situated in the Coast Range Geomorphic Province of California. The Coast Range Geomorphic Province is characterized as northwest-trending mountain ranges and valleys that are subparallel to the San Andreas Fault. Strata of the Coast Range dip beneath alluvium of the Great Valley to the east and rise above the Pacific Ocean to the west. The Coast Range is comprised of thick Mesozoic and Cenozoic sedimentary rocks that were uplifted by the San Andreas Fault, terraced, and wave-cut. In the northern region, the Coast Range is dominated

by irregular and knobby topography of the Franciscan Complex. Locally, the Franciscan rocks are overlain by volcanic cones and flows of the Clearlake volcanic field.

In the Clearlake area, the geology is dominated by the late Pliocene to early Holocene Clearlake volcanic field. The volcanic field consists of lava domes, cinder cones, and maars comprised of basalt and rhyolite. Cobb Mountain and Mount Konocti are the two highest peaks in the volcanic field. The Geysers, which host the largest complex of geothermal plants in the world, are located within the volcanic field.

2.3 SITE GEOLOGY

Based on review of the *Geologic Map of the Santa Rosa Quadrangle*, published by the California Division of Mines and Geology (Wagner and Bortugno, 1982), the geology immediately underlying the subject site is comprised of Quaternary Alluvium. Quaternary Alluvium is comprised of Pleistocene to Holocene Age alluvial deposits of sand, gravel, silt, and clay.

2.4 REGIONAL FAULTING AND SEISMIC SOURCES

Regional faulting is associated with the Maacama Fault Zone and Konocti Bay Fault Zone to the west, the Bartlett Springs Fault Zone to the north and east and the Hunting Creek-Berryessa Fault Zone to the south. NV5 reviewed the Official Maps of Earthquake Fault Zones delineated by the California Geological Survey through December 2010, on the internet at <http://maps.conservation.ca.gov/cgs/informationwarehouse/index.html?map=regulatorymaps>. These maps are updates to Special Publication 42, Interim Revision 2007 edition *Fault Rupture Hazard Zones in California*, which describes active faults and fault zones (activity within 11,000 years), as part of the Alquist-Priolo Earthquake Fault Zoning Act. Special Publication 42 and the 2010 on-line update indicate that the site is not located within an Alquist-Priolo active fault zone. However, the Clearlake Highlands Alquist-Priolo active fault zone is located approximately 3 miles to the west of the site.

According to the Fault Activity Map of California (2010) by the California Geological Survey, Geologic Data Map No. 6 (<http://maps.conservation.ca.gov/cgs/fam/>), the closest known active fault which has surface displacement within Holocene time (about the last 11,000 years) is the Konocti Bay Fault Zone. The mapped fault zone is located approximately 3 miles west of the subject site. The Fault Activity Map of California (2010) also shows the Bartlett Springs Fault Zone located 6 miles (13 kilometer [km]) northeast of the site and the Hunting Creek-Berryessa Fault Zone located 10 miles (15 km) east of the site to be known active faults with surface displacement within Holocene time.

2.5 FIELD INVESTIGATION

NV5 performed a field investigation of the site on January 12 and 13, 2021. NV5's field engineer/geologist described the surface and subsurface soil, rock and groundwater conditions observed at the site using the procedures cited in the ASTM International, Inc. (ASTM), Volume 04.08, *Soil and Rock (I)* as general guidelines. The field engineer/geologist described the soil color using the general guideline procedures presented in the Munsell® Soil-Color Chart. Engineering judgment was used to extrapolate the observed surface and subsurface soil, rock and groundwater conditions to areas located between and beyond the subsurface exploratory locations.

The surface, subsurface and groundwater conditions observed during the field investigation are summarized below.

2.5.1 Surface Conditions

NV5 observed the following surface conditions during the field investigation of the property. Figure 2 shows the existing building footprint, surrounding improvements and the approximate exploratory boring locations. The area of the proposed Burns Valley Development is comprised of Lake County Assessor's Parcel Numbers 010-026-40, 010-026-29 and 039-570-18. Each of the three parcels is described respectively.

Parcel 010-026-40 is an irregular-shaped property generally comprised of an existing tree orchard and high concentrations of weeds and grasses. The terrain was relatively flat with a gentle downward slope from the east to the west. A drainage channel transected the east portion of the property in the southwest direction. To the east of the drainage channel the surface topography was relatively higher in elevation than the rest of the site. Large stockpiles consisting of soils, concrete and asphalt rubble, boulders, and other deleterious debris were present. Overhead power poles and power lines were present along the north and east boundaries of the property. The property was bounded to the east and north by Burns Valley Road; to the west by Burns Valley Creek; and, to the south by apartments, commercial buildings and a retail shopping center.

Parcel 010-026-29 is a rectangular shaped property supporting a large number of mature oak trees, agricultural tress, and high concentrations of weeds and grasses. Concrete foundation remnants of a former structure and a large construction crane were present in the southern portion of the property. A drainage channel transected the center of the site and extended in the southwest direction. A California DWR monitoring well was present in the northeast portion of the site. A water well pump house was present in the north half of the property. The site was bounded to the north and east by Burns Valley Road, to the south by fallow land and stockpiles; and, to the west by a senior living community.

Parcel 039-570-18 is a rectangular shaped property comprised of fallow land supporting low to moderate concentrations of weeds and grasses. Sparse mature trees and fence posts were present throughout the site. Numerous utility markings were present indicating the presence of underground utilities. The property is bounded to the north by existing tree orchards; to the west by an existing PG&E facility; to the south by Olympic Drive; and, to the east by a retail shopping center. Evidence of a former structure was observed in the northern portion of the parcel.

2.5.2 Subsurface Conditions

The subsurface soil, rock and groundwater conditions were investigated by drilling exploratory borings. The subsurface information obtained from this investigation method is described in the following subsections.

2.5.2.1 Exploratory Boring Information

NV5 provided engineering oversight for the excavation of 8 exploratory soil borings at the project site. The borings were advanced with a track-mounted CME-55 drill rig equipped with 8-inch outside diameter, continuous flight, hollow stem augers. Figure 2 shows the approximate locations of the

subsurface exploratory excavations. The borings were excavated to a maximum depth of 51.5 feet below ground surface (bgs). Engineering judgment was used to extrapolate the observed soil, rock and groundwater conditions to areas located between and beyond the subsurface exploratory excavations.

NV5's field engineer/geologist logged each exploratory boring using the ASTM D2487 USCS as guidelines for soil descriptions and the American Geophysical Union guidelines for rock descriptions. Relatively undisturbed soil samples were collected with an unlined standard penetration test (SPT) split-spoon sampler and 2.5-inch-inside-diameter, split-spoon sampler equipped with stainless steel liner sampler tubes. The samplers were driven into the soil using an overshot cathead hammer weighing 140 pounds with a 30-inch free-fall. The stainless-steel liner samples were sealed with labeled plastic caps. The samples collected with the SPT sampler were sealed in labeled plastic bags. Representative bulk samples of the near-surface soil materials generated from drilling the exploratory borings also were collected and placed in labeled sample bags. The soil samples collected in the exploratory borings were transported to NV5's Chico soil laboratory facility.

Detailed descriptions of the soil, rock and groundwater conditions that were encountered in each subsurface exploratory location are presented on the exploratory boring logs included in Appendix B. The soil and rock descriptions include: visual field estimates of the particle size percentages (by dry weight), color, relative density or consistency, moisture content and cementation that comprise each soil material encountered.

A generalized profile of the soil, rock and groundwater conditions encountered to the maximum depth excavated (51.5 feet) for the proposed building area is presented below. The soil and/or rock units encountered in the subsurface exploratory excavations were generally stratigraphically continuous across the site with some variations in gradations and thicknesses. The units encountered in general stratigraphic sequence during the subsurface investigation of the site are described below.

- **ML, Low Plasticity Silt Soil:** This soil is considered to be a native soil consisting of the following field estimated particle size percentages 70 percent low plasticity silt and clay fines and 30 percent fine sand. This soil is predominantly dark yellowish brown with a Munsell® Soil-Color Chart designation of (10YR, 4/4). This soil was stiff and damp at the time of the subsurface investigation.
- **SC, Clayey Sand Soil:** This soil is considered to be a native soil consisting of the following field estimated particle size percentages: 55 percent fine sand, 20 percent low plasticity silt and clay fines, and 25% Gravel. This soil is predominantly dark yellowish brown with a Munsell® Soil-Color Chart designation of (10YR, 4/6). This soil was medium dense and moist to damp at the time of the subsurface investigation
- **CL, Low Plasticity Clay Soil:** This soil is considered to be a native soil consisting of the following field estimated particle size percentages 85 percent low plasticity silt and clay fines and 15 percent fine sand. This soil is predominantly brown with a Munsell® Soil-Color Chart designation of (10YR, 4/3). This soil was stiff and moist at the time of the subsurface investigation.
- **GM, Silty Gravel Soil:** This soil is considered to be a native soil consisting of the following field estimated particle size percentages: 60 percent gravel, 30 percent fine sand and 10 percent low plasticity silt and clay fines. This soil is predominantly light gray with a Munsell® Soil-Color Chart

designation of (10YR, 7/1). This soil was medium dense and wet at the time of the subsurface investigation.

- **CH, High Plasticity Clay Soil:** This soil is considered to be a native soil consisting of the following field estimated particle size percentages 85 percent high plasticity silt and clay fines and 15 percent fine sand. This soil is predominantly dark greenish gray with a Munsell® Soil-Color Chart designation of (GLEY 1, 4/1). This soil was firm and wet at the time of the subsurface investigation.
- **GP, Poorly Graded Gravel Soil:** This soil is considered to be a native soil consisting of the following field estimated particle size percentages: 80 percent gravel, 10 percent fine sand and 10 percent low plasticity silt and clay fines. This soil is predominantly gray with a Munsell® Soil-Color Chart designation of (10YR, 5/1). This soil was dense and very moist at the time of the subsurface investigation.
- **SM, Silty Sand Soil:** This soil is considered to be a native soil consisting of the following field estimated particle size percentages: 55 percent fine sand and 45 percent low plasticity silt and clay fines. This soil is predominantly dark grayish brown with a Munsell® Soil-Color Chart designation of (2.5YR, 4/2). This soil was medium dense and wet at the time of the subsurface investigation.

2.5.2.2 Seismic Refraction Microtremor Survey

A Seismic Refraction Microtremor Survey (SRMS) was performed at a nearby site, approximately ½-mile southeast of the subject property, using the SeisOpt® ReMi™ Vs30 method to determine the in-situ shear-wave (S-wave) velocity profile (Vs Model) of the uppermost 100 feet (30 meters) of soil beneath the site. The measured S-wave profile is used to determine the California Building Code (CBC) Site Class in accordance with Chapter 16, Section 1613.3.2 and Chapter 20 of ASCE 7-16.

The SRMS method is performed at the surface using a conventional seismograph equipped with geophones that record both seismic compression waves (P-waves) and S-waves. The P-wave and S-wave sources consist of ambient seismic microtremors which are constantly being generated by cultural activities and natural noise in the area. The data was collected in a series of twenty-one, 30-second-long, continuous recording periods. The inset image shows the Vs Model subsurface shear-wave

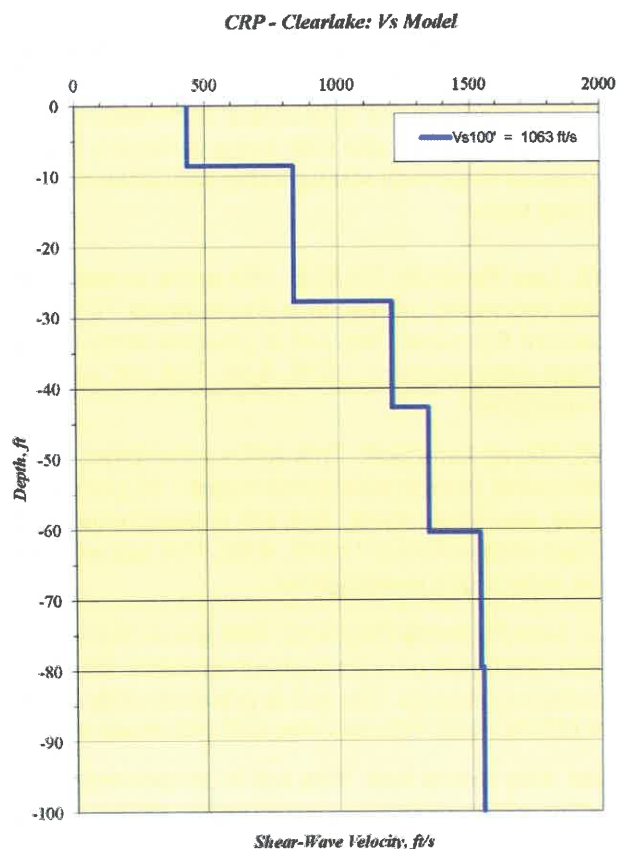

velocity profile for the site that was developed from the SeisOpt® ReMi™ data.

The Vs Model developed for the site indicates that the harmonic mean seismic shear wave velocity for the upper 100 feet of the subsurface is approximately 1063 feet per second (ft/s). This weighted shear wave velocity corresponds to the higher range of Site Class D, as described in Chapter 20, Table 20.3-1 Site Classification of ASCE 7-16.

2.5.2.3 Groundwater Conditions

The groundwater table was encountered at depths ranging between 19 to 30 feet below ground surface in exploratory borings B21-1, B21-2, B21-4, B21-6, and B21-8. The moisture content of each soil unit described on the exploratory boring logs is considered the natural moisture within the vadose soil zone (soil situated above the groundwater table).

NV5 used the Department of Water Resources Water Data Library database (wdl.water.ca.gov/waterdatalibrary) to review historical groundwater elevation data in the immediate area. Based on review of groundwater elevation data generated from a monitoring well located in the northeast portion of the project site, NV5 estimates that the historically high groundwater occurs at a depth of approximately 10 to 20 feet bgs in the late winter or spring during periods of above average and prolonged rainfall.

Fluctuations in groundwater elevation may also occur from agricultural irrigation in the area and the adjacent Burns Valley Creek

3.0 LABORATORY TESTING

NV5 performed laboratory tests on selected soil samples taken from the subsurface exploratory excavations to determine their geotechnical engineering material properties. These engineering material properties were used to develop geotechnical engineering design recommendations for earthwork and structural improvements. The following laboratory tests were performed using the cited ASTM guideline procedures:

- ASTM D422 Particle Size Gradation (Sieve Only)
- ASTM D2216 Soil Moisture Content
- ASTM D2487 Soil Classification by the USCS
- ASTM D2844 Resistance Value (R-Value)
- ASTM D2850 Unconsolidated-Undrained Triaxial Compression Test
- ASTM D2937 In Place Density of Soil
- ASTM D4318 Atterberg Limits (Dry Method)

Table 3.0-1 presents a summary of the geotechnical engineering laboratory test results. Appendix C presents the laboratory test data sheets.

Table 3.0-1, Laboratory Test Results

Boring No.	Sample		ASTM Test Results ⁽¹⁾								
	No.	Depth	D2487 D2488	D2216	D2937	D422		D4318		D2850	D2844
		(ft)	USCS (sym)	Moisture Content (%)	Dry Density (pcf)	Passing No. 4 Mesh Sieve (%)	Passing No. 200 Mesh Sieve (%)	Plasticity Index (%)	Liquid Limit (%)	UU Triaxial Compressive Strength (psf)	Resistance Value (R-Value) (dim)
B21-1	BK-1	0-3	SC	–	–	61.4	20.1	11	30	–	–
B21-1	B2-1-1	31.0	CH	–	–	–	–	31	54	–	–
B21-2	BK-2	1-3	CL	–	–	89.1	57.1	18	39	–	–
B21-2	L2-1-2	6.0	CL	16.1	100.8	–	–	–	–	–	–
B21-5	BK-4	0-4	ML	–	–	–	–	–	–	–	22
B21-8	L1-1-2	1.0	CL	18.5	101.6	–	–	–	–	1,538.51	–

Notes: (1) Laboratory test forms are presented in Appendix C
 % percent
 ASTM ASTM International
 dim dimensionless
 ft feet
 No. Number
 Pcf pounds per cubic foot
 psf pounds per square foot
 sym symbol
 UU Unconsolidated-Undrained
 USCS Unified Soils Classification System

4.0 HISTORICAL SEISMICITY

The regional geology and faulting are discussed in Section 2 of this report. NV5 used the USGS National Earthquake Information Center (NEIC) Earthquake Search Results on-line database (<http://earthquake.usgs.gov/earthquakes/search>) to identify historical seismic activity within a 100 km (62 miles) radial distance of the subject site. A search for earthquakes was limited to moderate to strong events with a minimum magnitude of 5.0 local magnitude [M_L]. The results produced three recent events that occurred within 100 km of the site since 2014. These earthquakes include the following events:

- August 24, 2014, 6.0 M_L South Napa earthquake main shock occurred at approximately 03:20 hours in the Napa Valley. The earthquake epicenter was approximately 87 km (54 miles) south of the subject site. The earthquake damaged many structures in the Napa County and Sonoma County surrounding areas. The mean intensity estimated at the distance of the subject property ranged from 2.9 to 3.4, which indicates weak to light shaking and no damage.
- December 14, 2016, 5.0 M_L earthquake occurred approximately 8 km northwest of The Geysers, approximately 26 km (16 miles) southwest of the subject site. The event recorded a mean intensity of 4.1 at the distance to the subject site, which indicates light shaking and no damage.
- August 10, 2016, 5.1 M_L earthquake occurred approximately 20 km northeast of Upper Lake, approximately 34 km (21 miles) north-northwest of the subject site. The event recorded a mean intensity of 3.4 at the distance to the subject site, which indicates light shaking and no damage.

Additionally, a number of moderate to strong earthquakes were recorded within the past 150 years, although many of them occurred more than 100 years ago.

- 1962 and 1869, a 5.2 M_L (1969) earthquake and a 5.0 M_L (1869) earthquake occurred approximately 40km (25 miles) northwest of the subject site, near Ukiah.
- 1969 and 1893, 5.1 M_L earthquakes occurred approximately 58 km (36 miles) south of the site, near Santa Rosa.
- 1898 and 1891, a 6.2 M_L (1898) earthquake and a 5.5 M_L (1891) earthquake occurred approximately 84 km (52 miles) south-southeast of the site, near Sonoma.
- 1968, a 5.0 M_L earthquake occurred approximately 80 km (50 miles) from the site, in Glenn County.
- April 1892, three earthquakes (5.5 M_L , 6.2 M_L , and 6.4 M_L) occurred approximately 89 km (55 miles) southeast of the site, near Vacaville.
- 1902, a 5.4 M_L earthquake occurred approximately 100 km (62 miles) southeast of the site, near Fairfield.

The Geysers area, located approximately 24 km (15 miles) from the site, also is very active and produces dozens of small earthquakes, below magnitude of 4.0 M_L , on a daily to weekly basis.

5.0 LIQUEFACTION AND SEISMIC SETTLEMENT

NV5 did not perform a detailed evaluation of the potential for seismically induced soil liquefaction at the site. However, NV5 believes that the site has a low potential for soil liquefaction. The following supports our assessment.

5.1 LIQUEFACTION

Soil liquefaction results when the shear strength of a saturated soil decreases to zero during cyclic loading that is generally caused by machine vibrations or earthquake shaking. Generally, saturated, clean, loose, uniformly graded sand and loose, silty sand soils of Holocene age are the most prone to undergo liquefaction. However, saturated, gravelly soil and some silt and clay-rich soil may be prone to liquefaction under certain conditions. The onsite soil is Pleistocene to Holocene age soil consisting of Quaternary Alluvium (Q_{al}) primarily composed of stiff, damp to wet, cohesive soil and dense to very dense, damp to moist, sandy and silty gravels. Groundwater was encountered in exploratory borings B20-1 through B20-3 at depths of approximately 19 to 30 feet bgs. Groundwater data collected from nearby groundwater monitoring wells indicate the historical high groundwater table in the area may be encountered as shallow as approximately 10 feet bgs. NV5 considers 10 feet bgs to be the historical high groundwater elevation and used this data in the liquefaction analysis.

NV5 evaluated the liquefaction potential of the site using the procedures presented in the 2008 Earthquake Engineering Research Institute (EERI) Monograph publication *Soil Liquefaction During Earthquakes* by I. M. Idriss and R. W. Boulanger (Idriss, I. M. & Boulanger, R. W., 2008). It should be noted that NV5 used the maximum considered earthquake (MCE) modal magnitude $9M_w$ from a Cascadian subduction zone event. The shear stress reduction coefficient currently established does not use historical data from model magnitude $9M_w$, however current evaluations using recent magnitude 9M events are being evaluated. The determination of a shear stress reduction coefficient for a $9M_w$ earthquake exceeds the current model computations, therefore, NV5 conservatively assumed no stress reductions which is represented by an r_d value of 1 for all depths. This is a very conservative approach for liquefaction analyses.

The California Geological Society (CGS) Special Publication 117A suggests a minimum factor of safety (FS) of 1.3 for liquefaction analyses when using their ground motion maps. NV5 used a computed FS of less than 1.3 to indicate the occurrence of liquefaction at the site. The computed liquefaction FS for the project site soils ranged from 0.13 to greater than 2.0 for the soil layer intervals evaluated. The calculation spreadsheet of this analysis is included in Appendix D. Table 5.1-1 summarizes the findings of each borehole analyses using a depth to groundwater of 10 ft bgs.

Table 5.1-1, Liquefaction Potential Calculated From Borings

Assumed Groundwater Level (ft bgs)	Earthquake Magnitude (Mm)	Deterministic PGA (g)	Boring ID (No.)	Liquefaction Interval FS<1.3 (ft bgs)	Seismically Induced Settlement (inches)	Expected Manifestation (Yes/No)
10.0	9.0	0.628	B21-1	25 to 30	0.75	No
			B21-2	N/A	0.0	No
Notes ft = feet bgs = below ground surface Mm = Moment Magnitude g = gravitational acceleration						

The liquefaction evaluation is a simplified procedure that has a number of limitations that cause it to produce conservative results. These limitations include the lack of a stress reduction coefficient (r_d) value for earthquake magnitudes over 8M, as well as the assumption that penetration resistance is a good indicator for liquefaction; however, other factors such as over consolidation and age of the deposit can influence the liquefaction potential. The procedure used does not take into account the age and over consolidation of the units.

Based on the subsurface exploratory boring 2.5-inch diameter California Modified split spoon sampler and standard penetration test (SPT) sampler blow counts, field data, expected seismic peak ground acceleration and literature review, NV5 believes the probability of liquefaction occurring during ground shaking caused by a maximum considered earthquake to be low at the site.

5.2 SEISMIC SETTLEMENT AND LATERAL SPREADING

The results of the liquefaction analysis performed for this investigation indicate a calculated seismic settlement of less than 1.0 inches. These settlement estimates represent ground settlement within the soil layers prone to liquefaction, not settlement at the ground surface.

Based on the relative flat terrain across the site and adjacent to the site and the existing development surrounding the site, NV5 considers there to be a low probability for the occurrence of lateral spreading that would be detrimental to the proposed site improvements.

6.0 CONCLUSIONS

The conclusions presented in this section are based on information developed from the field and laboratory investigations.

1. It is NV5's opinion that the site is suitable for the proposed improvements provided that the geotechnical engineering design recommendations presented in this report are incorporated into the earthwork and structural improvement project plans. Prior to construction, NV5 should be allowed to review the proposed final earthwork grading plan and structural improvement plans to determine if the geotechnical engineering recommendations were properly incorporated, are still applicable or need modifications.
2. Undocumented fills were observed in the southeastern portion of the site that extended to at least 36 inches feet bgs. These undocumented fills cannot be relied upon for support of the proposed improvements, due to their unknown quality, unknown method of placement, and potential for settlement. Recommendations for mitigating the undocumented fills are presented in Section 7.1 of this report.
3. Based on the site geology, the observations within the exploratory borings, the site soil profile can be modeled, according to the 2019 CBC, Chapter 16, and ASCE 7-16, Chapter 20, as a Site Class D (Stiff Soil Profile) designation for the purposes of establishing seismic design loads for the proposed improvements.
4. Based on the results of the liquefaction analyses, the subsurface exploratory boring blow counts, other field data, and literature review, NV5 believes that the probability of liquefaction occurring during a nearby earthquake to be low.
5. The site is comprised of Lake County Assessor's Parcel Numbers 010-026-40, 010-026-29 and 039-570-18. Each of the three parcels is described respectively.

Parcel 010-026-40 is an irregular-shaped property generally comprised of an existing tree orchard and high concentrations of weeds and grasses. The terrain was relatively flat with a gentle downward slope from the east to the west. A drainage channel transected the east portion of the property in the southwest direction. To the east of the drainage channel the surface topography was relatively higher in elevation than the rest of the site. Large stockpiles consisting of soils, concrete and asphalt rubble, boulders, and other deleterious debris were present. Overhead power poles and power lines were present along the north and east boundaries of the property. The property was bounded to the east and north by Burns Valley Road; to the west by Burns Valley Creek; and, to the south by apartments, commercial buildings and a retail shopping center.

Parcel 010-026-29 is a rectangular shaped property supporting a large number of mature oak trees, agricultural tress, and high concentrations of weeds and grasses. Concrete foundation remnants of a former structure and a large construction crane were present in the southern portion of the property. A drainage channel transected the center of the site and extended in the southwest direction. A California DWR monitoring well was present in the northeast portion of the site. A water well pump house was present in the northern half of the property. The site was bounded to the north and east by Burns Valley Road, to the south by fallow land and stockpiles; and, to the west by a senior living community.

Parcel 039-570-18 is a rectangular shaped property comprised of fallow land supporting low to moderate concentrations of weeds and grasses. Sparse mature trees and fence posts were present throughout the site. Numerous utility markings were present indicating the presence of underground utilities. The property is bounded to the north by existing tree orchards; to the west by an existing Pacific Gas & Electric (PG&E) facility; to the south by Olympic Drive; and, to the east by a retail shopping center. Evidence of a former structure was observed in the northern portion of the parcel.

6. The soil conditions observed to a maximum depth of 51.5 feet below the existing ground surface in our subsurface exploratory excavations (described relative to the existing ground surface) generally consisted of: dark yellowish brown, stiff, damp, sandy silt (ML); dark yellowish brown, medium dense, moist to damp, clayey sand (SC); brown, stiff to very stiff, moist, lean clay (CL); light gray, medium dense, wet, silty gravel (GM); dark greenish gray, firm, wet, fat clay (CH); gray, dense, very moist, poorly graded gravel (GP); and, dark grayish brown, medium dense, damp, silty sand.
7. NV5's field and laboratory test data indicates that the clayey sand (SC), lean clay (CL) and silt (ML) soil units encountered beneath the site has the following general geotechnical engineering properties: medium dense/stiff to very stiff, low plasticity and low to moderate bearing capacity that is suitable for supporting shallow foundations.
8. The groundwater table was encountered at depths ranging between 19 to 30 feet below ground surface in the exploratory borings B21-1, B21-2, B21-4, B21-6 and B21-8. Based on the above average rainfall, subsurface geologic conditions and review of monitoring well data near the site, NV5 assumes that for design and evaluation purposes, the historically high groundwater table will probably be encountered at a depth of approximately 10 to 20 feet bgs.

7.0 RECOMMENDATIONS

Undocumented fills were observed on the site and are not considered suitable for support of the proposed structural improvements. NV5 developed geotechnical engineering design recommendations for earthwork and structural improvements from the field and laboratory investigation data. Subsequent to earthwork and site preparation, it is anticipated that the proposed apartment building may be founded on conventional continuous and/or spread footings founded in undisturbed native soils or properly compacted fill. NV5's recommendations are presented below.

7.1 EARTHWORK GRADING

NV5's earthwork grading recommendations include: demolition and abandonment of existing site improvements, import fill soil, temporary excavations, stripping and grubbing, native soil preparation for engineered fill placement, engineered fill construction with testable earth materials, cut-fill transitions, cut and fill slope grading, erosion controls, underground utility trenches, construction dewatering, soil corrosion potential, subsurface groundwater drainage, surface water drainage, grading plan review and construction monitoring.

7.1.1 Demolition and Abandonment of Existing Site Improvements

NV5 anticipates that the existing site improvements within the proposed building areas will need to be demolished and removed from the site as described below.

1. The existing foundation remnants and exterior concrete slab-on-grade within the proposed building areas should be razed and disposed off-site. However, it may be possible to use some of this demolition material to construct engineered fills provided they meet the gradation requirements specified for "testable fill" materials presented in this report. The project geotechnical engineer should approve the use of both asphalt concrete (AC) and aggregate base (AB) rock demolition materials for use in constructing engineered fills.
2. All foundations, underground utilities and other existing site improvements that are encountered during construction within the proposed building area should be demolished and removed from the site. These demolition materials should be disposed off-site in compliance with applicable regulatory requirements.
3. Abandonment of any underground utilities within the construction area that will not interfere with the proposed site improvements should be plugged with cement grout to reduce migration of soil and/or water.

7.1.2 Import Fill Soil

Import fill soil should meet the geotechnical engineering material properties described in Section 7.1.6.1 (Engineered Fill Construction with Non-Expansive Soil) of this report. Prior to importation to the site, the source generator should document that the import fill meets the guidelines set forth by the California Environmental Protection Agency (CalEPA) Department of Toxic Substances Control (DTSC) in their 2001 "Information Advisory, Clean Imported Fill Material." This advisory represents the best practice for characterization of soil prior to import for use as engineered fill. The project engineer should approve all proposed import fill soil for use in constructing engineered fills at the site.

7.1.3 Temporary Excavations

All temporary excavations must comply with applicable local, state and federal safety regulations, including the current Occupational Safety and Hazards Administration (OSHA) excavation and trench safety standards. Construction site safety is the responsibility of the contractor, who is solely responsible for the means, methods and sequencing of construction operations. Under no circumstances should the findings, conclusions and recommendations presented herein be inferred to mean that NV5 is assuming any responsibility for temporary excavations, or for the design, installation, maintenance and performance of any temporary shoring, bracing, underpinning or other similar systems. NV5 could provide temporary cut slope gradients, if required.

7.1.4 Stripping and Grubbing

The site should be stripped and grubbed of vegetation and other deleterious materials, as described below.

1. Strip and remove the top 4 to 6 inches of organic-laden topsoil and other deleterious materials from the building area. Remove all existing trees within the proposed building pad areas. Grub the underlying 6 to 8 inches of soil to remove any large vegetation roots or other deleterious material while leaving the soil in place. The project geotechnical engineer or their representative should approve the use of any soil materials generated from the clearing and grubbing activities.
2. Completely remove all existing stockpiles, undocumented fill materials, concrete rubble, and other deleterious debris from the site. Excavate the remaining cavities or holes to a sufficient width so that an approved backfill soil can be placed and compacted in the cavities or holes. Enough backfill soil should be placed and compacted in order to match the surrounding elevations and grades. The project geotechnical engineer or their representative should observe and approve the preparation of the cavities and holes prior to placing and compacting engineered fill soil in the cavities and holes.
3. Excessively large amounts of vegetation, other deleterious materials and oversized rock materials should be removed from the site.

7.1.5 Native Soil Preparation for Engineered Fill Placement

After completing site stripping and grubbing activities, the exposed native soil should be prepared for placement and compaction of engineered fills, as described below.

1. The native soil should be scarified to a minimum depth of 8 inches below the existing land surface or stripped and grubbed surface and then uniformly moisture conditioned. If the soil is classified as a coarse-grained soil by the Unified Soils Classification System (USCS) (i.e., GP, GW, GC, GM, SP, SW, SC or SM) then it should be moisture conditioned to within ± 3 percentage points of the ASTM D1557 optimum moisture content. If the soil is classified as a low plasticity fine-grained soil by the USCS (i.e., CL, ML), then it should be moisture conditioned to between 2 and 4 percentage points greater than the ASTM D1557 optimum moisture content. If soil is classified as a high plasticity fine-grained soil by the USCS (i.e., CH, MH), the soil should be removed from the building pad area or contact NV5 for further recommendations.
2. The native soil should then be compacted to achieve a minimum relative compaction of 90 percent of the ASTM D1557 maximum dry unit weight (density). The moisture content, density

and relative percent compaction should be tested by the project engineer or his/her field representative to evaluate whether the compacted soil meets or exceeds the minimum percent compaction and moisture content requirements. The earthwork contractor shall assist the project engineer or his/her field representative by excavating test pads with the on-site earth moving equipment. Native soil preparation beneath concrete slab-on-grade structures (i.e., floors, sidewalks, patios, etc.) and AC pavement should be prepared as specified in Section 7.2 (Structural Improvements).

3. The prepared native soil surface should be proof-rolled with a fully loaded 4,000-gallon-capacity water truck with the rear of the truck supported on a double-axle, tandem-wheel undercarriage or approved equivalent. The proof-rolled surface should be visually observed by the project engineer or his/her field representative to be firm, competent and relatively unyielding. The project engineer or his/her field representative may also evaluate the surface material by hand probing with a ¼-inch-diameter steel probe; however, this evaluation method should not be performed in place of proof rolling as described above.
4. Construction Quality Assurance (CQA) tests should be performed using the minimum testing frequencies presented in Table 7.1.5-1 or as modified by the project engineer to better suit the site conditions.
5. The native soil surface should be graded to minimize ponding of water and to drain surface water away from the building foundations and associated structures. Where possible, surface water should be collected, conveyed and discharged into natural drainage courses, storm sewer inlet structures, permanent engineered storm water runoff percolation/evaporation basins or engineered infiltration subdrain systems.

Table 7.1.5-1, Minimum Testing Frequencies

ASTM No.	Test Description	Minimum Test Frequency ⁽¹⁾
D1557	Modified Proctor Compaction Curve	1 per 1,500 CY or Material Change ⁽²⁾
D6938	Nuclear Density and Nuclear Moisture Content	1 per 250 CY
Notes:		
(1)	These are minimum testing frequencies that may be increased or decreased at the project engineer's discretion based on the site conditions encountered during grading.	
(2)	Whichever criteria provide the greatest number of tests.	
ASTM	= ASTM International	
CY	= cubic yards	
No.	= number	

7.1.6 Engineered Fill Construction with Testable Earth Materials

Engineered fills are constructed to support structural improvements. Engineered fills should be constructed using non-expansive soil as described in Section 7.1.6.1. If possible, the use of expansive soil for constructing engineered fills should be avoided. If the use of expansive soil cannot be avoided, then engineered fills should be constructed as described in Section 7.1.6.2 or as modified by the project engineer. If soil is to be imported to the site for constructing engineered fills, then NV5 should be allowed to evaluate the suitability of the borrowed soil source by taking representative soil samples for laboratory testing. Testable earth materials are generally considered to be soils with gravel and larger particle sizes retained on the No. 4 mesh sieve that make up less

than 30 percent by dry weight of the total mass. The relative percent compaction of testable earth materials can readily be determined by the following ASTM test procedures: laboratory compaction curve (D1557), field moisture and density (D6938). Construction of engineered fills with non-expansive and expansive testable earth materials is described below.

7.1.6.1 Engineered Fill Construction with Non-Expansive Soil

Construction of engineered fills with non-expansive soil should be performed as described below.

1. Non-expansive soil used to construct engineered fills should consist predominantly of materials less than ½-inch in greatest dimension and should not contain rocks greater than 3 inches in greatest dimension (oversized material). Non-expansive soil should have a plasticity index (PI) of less than or equal to 15, as determined by ASTM D4318 Atterberg Indices testing. Oversized materials should be spread apart to prevent clustering so that void spaces are not created. The project engineer or his/her field representative should approve the use of oversized materials for constructing engineered fills.
2. Non-expansive soil used to construct engineered fills should be uniformly moisture conditioned. If the soil is classified by the USCS as coarse grained (i.e., GP, GW, GC, GM, SP, SW, SC or SM), then it should be moisture conditioned to within ± 3 percentage points of the ASTM D1557 optimum moisture content. If the soil is classified by the USCS as fine grained (i.e., CL, ML), then it should be moisture conditioned to between 2 and 4 percentage points greater than the ASTM D1557 optimum moisture content.
3. Engineered fills should be constructed by placing uniformly moisture conditioned soil in maximum 8-inch-thick loose lifts (layers) prior to compacting.
4. The soil should then be compacted to achieve a minimum relative compaction of 90 percent of the ASTM D1557 maximum dry density.
5. The earthwork contractor should compact each loose soil lift with a tamping foot compactor such as a Caterpillar (CAT) 815 Compactor or equivalent as approved by NV5's project engineer or his/her field representative. A smooth steel drum roller compactor should not be used to compact loose soil lifts for construction of engineered fills.
6. The field and laboratory CQA tests should be performed consistent with the testing frequencies presented in Table 7.1.6.1-1 or as modified by the project engineer to better suit the site conditions.

Table 7.1.6.1-1, Minimum Testing Frequencies for Non-Expansive Soil

ASTM No.	Test Description	Minimum Test Frequency ⁽¹⁾
D1557	Modified Proctor Compaction Curve	1 per 1,500 CY or Material Change ⁽²⁾
D6983	Nuclear Moisture and Density	1 per 250 CY
Notes:		
(1)	These are minimum testing frequencies that may be increased or decreased at the project engineer's discretion based on the site conditions encountered during grading.	
(2)	Whichever criteria provide the greatest number of tests.	
ASTM	=	ASTM International
CY	=	cubic yards
No.	=	number

7. The moisture content, density and relative percent compaction of all engineered fills should be tested by the project engineer's field representative during construction to evaluate whether the compacted soil meets or exceeds the minimum compaction and moisture content requirements. The earthwork contractor shall assist the project engineer's field representative by excavating test pads with the on-site earth-moving equipment.
8. The prepared finished grade or finished subgrade soil surface should be proof-rolled as mentioned above in Section 7.1.5, Paragraph 3.

7.1.6.2 Engineered Fill Construction with Expansive Soil

NV5 did not encounter highly expansive soil within the shallow soil or zone that would be influenced by the foundation loads at the site during the subsurface investigation. If expansive soils are encountered during grading of the site, and if the property owner desires to use expansive soil to construct engineered fills, then NV5 should be notified to prepare recommendation options for constructing fills with potentially expansive soil.

7.1.7 Cut and Fill Slope Grading

NV5 does not anticipate that grading of cut and fill slopes will have vertical heights greater than 3 feet at the site. In general, both cut and fill slopes should be graded at a maximum slope gradient of 2H:1V (horizontal to vertical slope ratio). Surface water should not be allowed to flow over the cut and fill slopes graded at the site. If steeper cut and/or fill slopes are designed, then NV5 should be allowed to review the proposed cuts and provide additional recommendations as appropriate.

7.1.8 Erosion Controls

Erosion controls should be installed as described below.

1. Erosion controls should be installed on all cut and fill slopes to minimize erosion caused by surface water runoff.
2. Install on all slopes either an appropriate hydroseed mixture compatible with the soil and climate conditions of the site, as determined by the local United States Soil Conservation District or apply an appropriate manufactured erosion control mat.

3. Install surface water drainage ditches at the top of cut and fill slopes (as necessary) to collect and convey both sheet flow and concentrated flow away from the slope face.
4. The intercepted surface water should be discharged into a natural drainage course or into other collection and disposal structures.

7.1.9 Underground Utility Trenches

Underground utility trenches should be excavated and backfilled as described below for each trench zone shown in the figure below.

1. **Trench Excavation Equipment:** NV5 anticipates that the contractor will be able to excavate all underground utility trenches with a Case 580 Backhoe or equivalent, however, deeper utility trenches (10-feet or greater) may require larger equipment.
2. **Trench Shoring:** All utility trenches that are excavated deeper than 5 feet bgs are required by California OSHA to be shored with bracing equipment or sloped back to an appropriate slope gradient prior to being entered by any individuals.
3. **Trench Dewatering:** NV5 does not anticipate that the proposed underground utility trenches will encounter shallow groundwater. However, if the utility trenches are excavated during the winter rainy season, then shallow or perched groundwater may be encountered. The earthwork contractor may need to employ dewatering methods as discussed in Section 7.1.10 in order to excavate, place and compact the trench backfill materials.
4. **Pipe Zone Backfill Type and Compaction Requirements:** The backfill material type and compaction requirements for the pipe zone, which includes the bedding zone, the shading zone and the cover zone, are described in Detail 7.1.9-1 below.

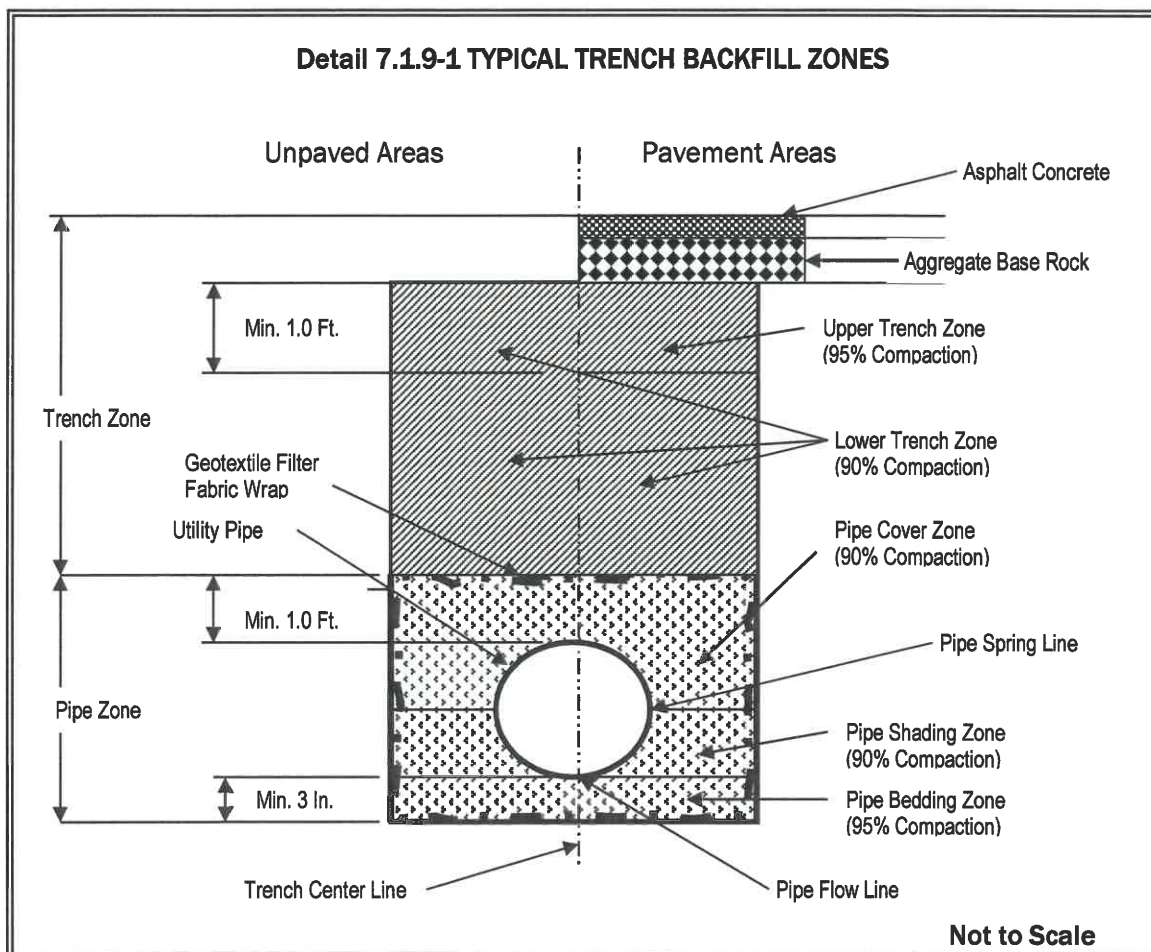

- Pipe Zone Backfill Material Type:** Trench backfill used within the pipe zone, which includes the bedding zone, the shading zone and the cover zone, should consist of $\frac{3}{4}$ -inch-minus, washed, crushed rock, imported sand, or Class 2 AB. The crushed rock particle size gradation should meet the following requirements (percentages are expressed as dry weights using ASTM D422 test method): 100 percent passing the $\frac{3}{4}$ -inch sieve, 80 to 100 percent passing the $\frac{1}{2}$ -inch sieve, 60 to 100 percent passing the $\frac{3}{8}$ -inch sieve, 0 to 30 percent passing the No. 4 sieve, 0 to 10 percent passing the No. 8 sieve, and 0 to 3 percent passing the No. 200 sieve. If groundwater is encountered within the trench during construction, or if groundwater is expected to rise during the rainy season to an elevation that will infiltrate the pipe zone within the trench, then the pipe zone material should be wrapped with a minimum 6 ounce per square yard, non-woven geotextile filter fabric such as TenCate® Mirafi N140 or an approved equivalent. The geotextile seam should be located along the trench centerline and have a minimum 1-foot overlap. If the utility pipes are coated with a corrosion protection material, then the pipes should be wrapped with a minimum 6 ounce per square yard, non-woven, geotextile cushion fabric such as TenCate® Mirafi N140 or an approved equivalent. The geotextile cushion fabric should have a minimum 6-inch seam overlap. The geotextile cushion fabric will protect the pipe from being scratched by the crushed rock backfill material.

- **Pipe Bedding Zone Compaction:** Crushed rock placed in the pipe bedding zone (beneath the utilities) should be consolidated using mechanical equipment to a firm unyielding condition. Imported sand or Class II AB placed in the pipe bedding zone (beneath the utilities) should be a minimum of 3 inches thick, moisture conditioned to within ± 3 percentage points of the ASTM D1557 optimum moisture content and compacted to achieve a minimum relative compaction of 95 percent of the ASTM D1557 maximum dry density. Crushed rock should be mechanically consolidated under the observation of NV5.
 - **Pipe Shading Zone Compaction:** Crushed rock placed within the pipe shading zone should be consolidated using mechanical equipment to a firm unyielding condition, shovel slicing material to support the pipe bells or haunches. Imported sand or Class II AB placed within the pipe shading zone (above the bedding zone and to a height of one pipe radius above the pipe spring line) should be moisture conditioned to within ± 3 percentage points of the ASTM D1557 optimum moisture content and compacted to achieve a minimum relative compaction of 90 percent of the ASTM D1557 maximum dry density. Crushed rock should be mechanically consolidated under the observation of NV5. The pipe shading zone backfill material should be shovel-sliced to remove voids, support the pipe bells or haunches and to promote compaction.
 - **Pipe Cover Zone Compaction:** Crushed rock placed within the pipe cover zone should be consolidated using mechanical equipment to a firm unyielding condition. Native soils, imported sand, and Class II AB placed within the pipe cover zone (above the pipe shading zone to 1 foot over the pipe top surface) should be moisture conditioned to within ± 3 percentage points of the ASTM D1557 optimum moisture content and compacted to achieve a minimum relative compaction of 90 percent of the ASTM D1557 maximum dry density. Crushed rock should be mechanically consolidated under the observation of NV5.
5. **Trench Zone Backfill and Compaction Requirements:** The trench zone backfill materials consist of both lower and upper zones, as discussed below.
- **Trench Zone Backfill Material Type:** Soil used as trench backfill within the lower and upper intermediate zones, as shown on the preceding figure, should consist of non-expansive soil with a PI of less than or equal to 15 (based on ASTM D4318) and should not contain rocks greater than 3 inches in greatest dimension.
 - **Lower Trench Zone Compaction:** Crushed rock placed within the lower trench zone should be consolidated using mechanical equipment to a firm unyielding condition. Soils, including imported sand and Class 2 AB, used to construct the lower trench zone backfills should be uniformly moisture conditioned to within 0 and 4 percentage points of the ASTM D1557 optimum moisture content, placed in maximum 12-inch-thick loose lifts prior to compacting and compacted to achieve a minimum relative compaction of 90 percent of the ASTM D1557 maximum dry density.
 - **Upper Trench Zone Compaction (Road and Parking Lot Areas):** Crushed rock placed within the upper trench zone should be consolidated using mechanical equipment to a firm unyielding condition. Soils, including imported sand and Class 2 AB, used to construct the upper trench zone backfills should be uniformly moisture conditioned to within 0 and 4 percentage points greater than the ASTM D1557 optimum moisture content, placed in maximum 8-inch-thick loose lifts (layers) prior to compacting and compacted to achieve a minimum relative compaction of 95 percent of the ASTM D1557 maximum dry density.

- **Upper Trench Zone Compaction (Non-Road and Non-Parking Lot Areas):** Crushed rock placed within the upper trench zone should be consolidated using mechanical equipment to a firm unyielding condition. Soils, including imported sand and Class 2 AB, used to construct the upper trench zone backfills should be uniformly moisture conditioned to within 0 and 2 percentage points greater than the ASTM D1557 optimum moisture content, placed in maximum 6-inch-thick loose lifts (layers) prior to compacting and compacted to achieve a minimum relative compaction of 90 percent of the ASTM D1557 maximum dry density.
6. **CQA Testing and Observation Engineering Services:** The moisture content, dry density and relative percent compaction of all engineered utility trench backfills should be tested by the project geotechnical engineer's field representative during construction to evaluate whether the compacted trench backfill materials meet or exceed the minimum compaction and moisture content requirements presented in this report. The earthwork contractor shall assist the project geotechnical engineer's field representative by excavating test pads with the on-site earth moving equipment.
- **Compaction Testing Frequencies:** The field and laboratory CQA tests should be performed consistent with the testing frequencies presented in Table 7.1.9-1 or as modified by the project engineer to better suit the site conditions.

Table 7.1.9-1, Minimum Testing Frequencies for Utility Trench Backfill

ASTM No.	Test Description	Minimum Test Frequency ⁽¹⁾
D1557	Modified Proctor Compaction Curve	1 per 500 CY ⁽²⁾ Or Material Change
D6983	Nuclear Moisture and Density	1 per 100 LF per 24-Inch-Thick Compacted Backfill Layer ⁽²⁾ The maximum loose lift thickness shall not exceed 12-inches prior to compacting.
Notes:		
(1)	These are minimum testing frequencies that may be increased or decreased at the project engineer's discretion based on the site conditions encountered during grading.	
(2)	Whichever criteria provide the greatest number of tests.	
ASTM	= ASTM International	
CY	= cubic yards	
No.	= number	

- **Final Proof Rolling:** The prepared finished grade AB rock surface and/or finished subgrade soil surface of utility trench backfills should be proof-rolled as mentioned above in Section 7.1.5, Paragraph 3.

7.1.10 Construction Dewatering

NV5 does not anticipate the need to perform dewatering of the site during earthwork grading however, the earthwork contractor should be prepared to dewater the utility trench excavations and any other excavations if perched water or the groundwater table is encountered during winter or spring grading. The following recommendations are preliminary and are not based on performing a groundwater flow analysis. A detailed dewatering analysis was not a part of the proposed work scope. It should be understood that it is the earthwork contractor's sole responsibility to select and employ a satisfactory dewatering method for each excavation.

1. NV5 anticipates that dewatering of utility trenches can be performed by constructing sumps to depths below the trench bottom and removing the water with sump pumps.
2. Additional sump excavations and pumps should be added as necessary to keep the excavation bottom free of standing water and relatively dry when placing and compacting the trench backfill materials.
3. If groundwater enters the trench faster than it can be removed by the dewatering system, thereby allowing the underlying compacted soil to become unstable while compacting successive soil lifts, then it may be necessary to remove the unstable soil and replace it with free-draining, granular drain rock. Native backfill soil can again be used after placing the granular rock to an elevation that is higher than the groundwater table.
4. If granular rock is used, it should be wrapped in a non-woven geotextile fabric, such as TenCate® Mirafi® N140 or an approved equivalent. The geotextile filter fabric should have minimum 1-foot overlapped seams. The granular rock should meet or exceed the following gradation specifications (all percentages are expressed as dry weights using ASTM D422 test method): 100 percent passing the 3/4-inch sieve, 80 to 100 percent passing the 1/2-inch sieve, 60 to 100 percent passing the 3/8-inch sieve, 0 to 30 percent passing the No. 4 sieve, 0 to 10 percent passing the No. 8 sieve, and 0 to 3 percent passing the No. 200 sieve.
5. NV5 recommends that the utility trench excavations be performed as late in the summer months as possible to allow the groundwater table to reach its lowest seasonal elevation.

7.1.11 Soil Corrosion Potential

The selected materials used for constructing underground utilities should be evaluated by a corrosion engineer for compatibility with the on-site soil and groundwater conditions. NV5 did not perform any testing to determine the corrosion potential of the shallow soils that are anticipated to be in contact with the underground pipes and concrete structures associated with the improvements. NV5's experience with soil encountered in the Clearlake area is that their corrosion potential is moderately corrosive. Buried iron, steel, cast iron, ductile iron, galvanized steel, and dielectric coated steel or iron should be properly protected against corrosion depending on the critical nature of the structure.

7.1.12 Subsurface Groundwater Drainage

NV5 does anticipate encountering perched groundwater or a shallow local groundwater table during the wet weather construction season. If groundwater is encountered during grading, then NV5 should be allowed to observe the conditions and provide site-specific dewatering recommendations.

7.1.13 Surface Water Drainage

NV5 recommends the following surface water drainage mitigation measures:

1. Grade all slopes to drain away from building areas with a minimum 4 percent slope for a distance of not less than 10 feet from the building foundations.
2. Grade all landscape areas near and adjacent to buildings to prevent ponding of water.

3. Direct all building downspouts to solid pipe collectors which discharge to natural drainage courses, storm sewers, catchment basins, infiltration subdrains or other drainage facilities.

7.1.14 Grading Plan Review and Construction Monitoring

CQA includes review of plans and specifications and performing construction monitoring, as described below.

1. NV5 should be allowed to review the final earthwork grading improvement plans prior to commencement of construction to determine whether the recommendations were implemented and, if necessary, to provide additional and/or modified recommendations.
2. NV5 should be allowed to perform CQA monitoring of all earthwork grading performed by the contractor to determine whether the recommendations have been implemented and, if necessary, to provide additional and/or modified recommendations.
3. NV5's experience, and that of the engineering profession, clearly indicates that during the construction phase of a project the risks of costly design, construction and maintenance problems can be significantly reduced by retaining a design geotechnical engineering firm to review the project plans and specifications and to provide geotechnical engineering observation and CQA testing services. Upon your request we will prepare a CQA geotechnical engineering services proposal that will present a work scope, a tentative schedule and a fee estimate for your consideration and authorization. If NV5 is not retained to provide geotechnical engineering CQA services during the construction phase of the project, then NV5 will not be responsible for geotechnical engineering CQA services provided by others nor any aspect of the project that fails to meet your or a third party's expectations in the future.

7.2 STRUCTURAL IMPROVEMENTS

NV5's structural improvement design criteria recommendations include seismic design parameters, shallow foundations, retaining walls entirely above the groundwater table, retaining wall backfill, concrete slab-on-grade interior floors, sidewalk and patio construction, rigid concrete pavement for heavy truck traffic areas and fire lanes, and flexible pavement. These recommendations are presented hereafter.

7.2.1 Seismic Design Parameters

NV5 developed the code-based seismic design parameters in accordance with Section 1613 of the 2019 CBC and the Structural Engineers Association of California (SEAOC), *Seismic Design Maps* web application. The internet based application (www.seismicmaps.org) is used for determining seismic design values from the 2016 ASCE-7 Standard (erratum released February 2019) and the 2018 International Building Code (IBC). The spectral acceleration, site class, site coefficients and adjusted maximum considered earthquake spectral response acceleration, and design spectral acceleration parameters are presented in Table 7.2.1-1. The Seismic Design Parameter detailed report from the SEAOC analysis is provided in Appendix E.

7.2.1.1 Long-Period Seismic Site Coefficient (F_v)

Using Table 1613.2.3(2) of the 2019 CBC, NV5 calculated the long-period site coefficient (F_v) using $S_1=0.541$ and linear interpolation of the values presented in the table. Linear interpolating the values resulted in the following equations for calculating F_v :

- $F_v = (-2 \times S_1) + 2.6$ (S_1 is less than 0.3)
- $F_v = (-1 \times S_1) + 2.3$ (S_1 is greater than 0.3)

$$F_v = (-1 \times S_1) + 2.3 = (-1 \times 0.541) + 2.3 = 1.759$$

7.2.1.2 Seismic Design Category

Based on the short period response acceleration ground motion parameters ($S_{DS} = 1.2$), the 1-S period response acceleration ground motion parameters ($S_{D1} = .634$), and the Risk Category of I through III, the Seismic Design Category is D.

7.2.1.3 Geometric Mean Peak Ground Acceleration

NV5 used the SEAOC *Seismic Design Maps* web application to determine the seismic design parameters for the site, including the geometric mean peak ground acceleration (PGA_M). The PGA_M is calculated by using the Site Coefficient (F_{PGA}) multiplied by the PGA mapped values found on Figure 22-9 from ASCE 7-16. The PGA_M was calculated using the following equation:

$$PGA_M = F_{PGA}PGA = 1.2 \times 0.523 = 0.628 \text{ g}$$

The Seismic Design Maps report from the SEAOC analysis is provided in Appendix E.

7.2.1.4 Site-Specific Ground Motion Hazard Analysis

Based on the preliminary information provided to NV5 on the proposed building sizes and types, NV5 understands a ground motion hazard analysis is not required for the site provided the seismic response coefficient (C_s) is determined in accordance with Exception 2 found in Section 11.4.8 of ASCE 7-16.

Table 7.2.1-1 2019 CBC Seismic Design Parameters

Description	Value	Reference
Latitude North (degrees)	39.9638	Google Earth
Longitude West (degrees)	-121.6349	Google Earth
Site Coefficient, F_A	1.2	2019 CBC, Table 1613.2.3(1), SEAOC Seismic Design Maps
Site Coefficient, F_V	1.759	2019 CBC, Table 1613.2.3(2), SEAOC Seismic Design Maps
Site Class	D = Stiff Soil	ASCE 7-16 Chapter 20, Table 20.3-1
Short (0.2 sec) Spectral Response, S_S (g)	1.5	ASCE 7-16, Section 11.4.2, SEAOC Seismic Design Maps
Long (1.0 sec) Spectral Response, S_1 (g)	0.541	ASCE 7-16, Section 11.4.2, SEAOC Seismic Design Maps
Short (0.2 sec) MCE Spectral Response, S_{MS} (g)	1.8	ASCE 7-16, Section 11.4.4, SEAOC Seismic Design Maps
Long (1.0 sec) MCE Spectral Response, S_{M1} (g)	0.952	ASCE 7-16, Section 11.4.4, SEAOC Seismic Design Maps
Short (0.2 sec) Design Spectral Response, S_{DS} (g)	1.2	ASCE 7-16, Section 11.4.5, SEAOC Seismic Design Maps
Long (1.0 sec) Design Spectral Response, S_{D1} (g)	0.634	ASCE 7-16, Section 11.4.5, SEAOC Seismic Design Maps
Seismic Design Category (Risk Category I, II or III)	D	ASCE 7-16, Section 11.6, SEAOC Seismic Design Maps
Geometric Mean Peak Ground Acceleration (PGA_M) (g)	0.628	ASCE 7-16, Section 11.8.3, SEAOC Seismic Design Maps
CBC = California Building Code MCE = Maximum Considered Earthquake g = gravitational acceleration (9.81 meters per second ² = 32.2 feet per second ²) sec = second		

7.2.2 Shallow Foundations

Shallow continuous and isolated spread foundations that will support load bearing walls shall be designed as follows:

1. The base of all shallow foundations should bear on firm, competent non-expansive native soil, or non-expansive engineered fill compacted consistent with the earthwork recommendations of Section 7.1.
2. Continuous strip foundations should be constructed with the following dimensions:
 - a. Minimum Width = 12 Inches
 - b. Minimum Embedment Depth below the lowest adjacent exterior surface grade as shown in Table 7.2.2-1.
3. The bearing capacities to be used for structural design of shallow foundations embedded in either non-expansive native soil or non-expansive engineered fill are presented in Table 7.2.2-1.
 - The calculated factor of safety for allowable bearing pressures including live plus dead loads is 3.0 for all foundation embedment depths.
 - The allowable bearing pressure capacities were increased by a factor of 1.33 to include wind or seismic short-term loads.
 - The project structural engineer of record should review the FS and confirm that it is not less than the over-strength factor for this structure.

Table 7.2.2-1, Foundation Bearing Pressures for Shallow Foundations

Minimum Foundation Embedment Depth	Maximum Ultimate Bearing Pressures For Live + Dead Loads	Maximum Allowable Bearing Pressures For Live + Dead Loads	Maximum Allowable Bearing Pressures For Live + Dead + Wind or Seismic Loads	Allowable Safety Factor (Ultimate/Total)
(in)	(psf)	(psf)	(psf)	(dim.)
12	6,000	2,000	2,660	3.0
18	7,500	2,500	3,325	3.0
24	9,000	3,000	3,990	3.0

psf = pounds per square foot
in = inches
dim = dimensionless

4. Foundation lateral resistance may be computed from passive pressure along the side of the foundation and sliding friction/cohesion resistance along the foundation base; however, the larger of the two resistance forces should be reduced by 50 percent when combining these two forces. The passive pressure can be assumed to be equal to an equivalent fluid pressure (EFP) per foot of depth. The passive pressure force and sliding friction coefficient for computing lateral resistance are as follows:
 - a. Passive pressure = 225 (H), pounds per square foot (psf), where H = foundation embedment depth (feet) below lowest adjacent soil surface.
 - b. Foundation bottom sliding friction coefficient = 0.30 (dimensionless).

5. Minimum steel reinforcement for continuous strip foundations should consist of four No. 4 bars with two bar placed near the top and two bar placed near the bottom of each foundation or as designated by a California licensed structural engineer.
6. The concrete should have a minimum 3,000 pounds per square inch (psi) compressive break strength after 28 days of curing, have a water-to-cement ratio from 0.40 to 0.50, and should be placed with minimum and maximum slumps of 4 and 6 inches, respectively. Since water is often added to uncured concrete to increase workability, it is important that strict quality control measures be employed during placement of the foundation concrete to ensure that the water-to-cement ratio is not altered prior to or during placement.
7. Concrete coverage over steel reinforcements should be a minimum of 3 inches as recommended by the American Concrete Institute (ACI).
8. Prior to placing concrete in any foundation excavations, the contractor shall remove all loose soil, rock, wood debris or other deleterious materials from the foundation excavations.
9. Foundation excavations should be saturated prior to placing concrete to aid the concrete curing process; however, concrete should not be placed in standing water.
10. Total settlement of individual foundations will vary depending on the plan dimensions of the foundation and actual structural loading. Based on the anticipated foundation dimensions and loads, we estimate that the total post-construction settlement of foundations designed and constructed in accordance with the recommendations will be on the order of 1/2 inch. Differential settlement between similarly loaded, adjacent foundations is expected to be about 1/4 inch, provided the foundations are founded into similar materials (e.g., all on competent and firm engineered fill, native soil, or rock).
11. Prior to placing concrete in any foundation excavation, the project geotechnical engineer or his/her field representative should observe the excavations to document that the following requirements are achieved: minimum foundation dimensions, minimum reinforcement steel placement and dimensions, removal of all loose soil, rock, wood debris or other deleterious materials, and that firm and competent native or engineered fill soil is exposed along the entire foundation excavation bottom. Strict adherence to these requirements is paramount to the satisfactory behavior of a building foundation. Minor deviations from these requirements can cause the foundations to undergo minor to severe amounts of settlement which can result in cracks developing in the foundation and adjacent structural members, such as concrete slab-on-grade floors.

7.2.3 Retaining Walls Entirely Above the Groundwater Table

A California licensed professional engineer should design all retaining walls situated above the groundwater table with drained backfill using the following geotechnical engineering design criteria:

1. The retaining wall recommendations for static loading conditions are based on Rankine earth pressure theory published by W.J.M. Rankine (1857). The retaining wall recommendations for seismic loading conditions are based on the published work by Gerall and Sitar, *Seismic Earth Pressures on Retaining Structures in Cohesionless Soils*, (2013).
2. Retaining walls should be founded on firm native soils or engineered fill consistent with the requirements of Section 7.1.

3. The retaining wall should be designed using the geotechnical engineering design parameters presented in Table 7.2.3-1.
4. The retaining wall backfill soil should be free draining material that meets or exceeds the material requirements of and is placed and compacted consistent with the requirements of Section 7.2.4.
5. The static lateral earth pressures exerted on the retaining walls may be assumed to be equal to an equivalent fluid pressure per foot of depth below the top of the wall. The lateral pressures presented in the table below are ultimate values and, therefore, do not include a safety factor, and assumes a free draining backfill (no hydrostatic forces acting on the wall) and no surcharge loads applied within a distance of $0.50H$, where H equals the total vertical wall height.
6. The retaining wall backfill slope shall have a horizontal slope gradient for a minimum horizontal distance of $0.50H$, where H equals the total vertical wall height. If a steeper backfill slope ratio is desired, then NV5 should be notified and contracted to perform additional retaining wall designs.
7. The retaining wall foundation excavations should be saturated prior to placing concrete to aid the concrete curing process. However, concrete should not be placed in standing water.

Table 7.2.3-1, Design Parameters for Retaining Walls

Design Parameters for Retaining Walls		
Loading Conditions	Static Loads On Retaining Wall With Horizontal Backfill Slope	Seismic Load On Retaining Wall With Horizontal Backfill Slope
Wall Active Condition Pressures (psf)/ft ⁽¹⁾	50 (H) ⁽⁵⁾	9 (H ²)
Wall Passive Condition Pressures (psf)/ft ⁽²⁾	225 (H)	9 (H ²)
Wall At-Rest Condition Pressure (psf)/ft ⁽³⁾	70 (H)	21 (H ²)
P _{active} Force Located Above Foundation Base	0.33 (H)	Not Applicable
P _{passive} Force Located Above Foundation Base	0.33 (H)	Not Applicable
P _{at-rest} Force Located Above Foundation Base	0.33 (H)	Not Applicable
P _{earthquake} Force Located Above Foundation Base	Not Applicable	0.33(H)
Maximum Allowable Foundation Bearing Capacity (psf), (Live + Dead Loads)	2,000	2,000
Maximum Allowable Foundation Bearing Capacity (psf) (Live + Dead + Wind or Seismic Loads)	2,660	2,660
Minimum Foundation Embedment Depth (in)	12	12
Foundation Bottom Friction Coefficient (dim.) ⁽⁴⁾	0.30	0.30

Notes:

- (1) The active pressure condition applies to a retaining wall with an unrestrained top (deflection allowed).
- (2) The passive pressure condition applies to a retaining wall with soil resistance at the base. If passive pressures are used, then NV5 recommends that the top 1.0 feet of soil weight be ignored.
- (3) The At-Rest pressure condition applies to a retaining wall with the top restrained (no deflection allowed).
- (4) If the design horizontal resistance force acting on the wall foundation is computed by combining both the sliding friction force and passive soil pressure force, then the larger of the two forces should be reduced by 50 percent.
- (5) H = The distance to a point in the backfill soil where the pressure is desired. The H distance is measured from the top of the wall for active and at-rest conditions and from one foot below the soil height at the toe of the wall for the passive condition (See Note 2 for passive condition).

7.2.4 Retaining Wall Backfill

Place and compact all retaining wall backfill and drainage layer materials as described below. NV5 did not review the final improvement plans for the site. If sub-structure retaining walls for below grade rooms, basements, garages, etc., are designed for this project, then these structures should also incorporate a water proofing sealant as described below. The water proofing sealant products should be installed by a qualified waterproofing contractor according to the manufacturer's directions. A typical retaining wall and backfill material zones figure is shown below.

TYPICAL CANTILEVER RETAINING WALL AND BACKFILL MATERIALS

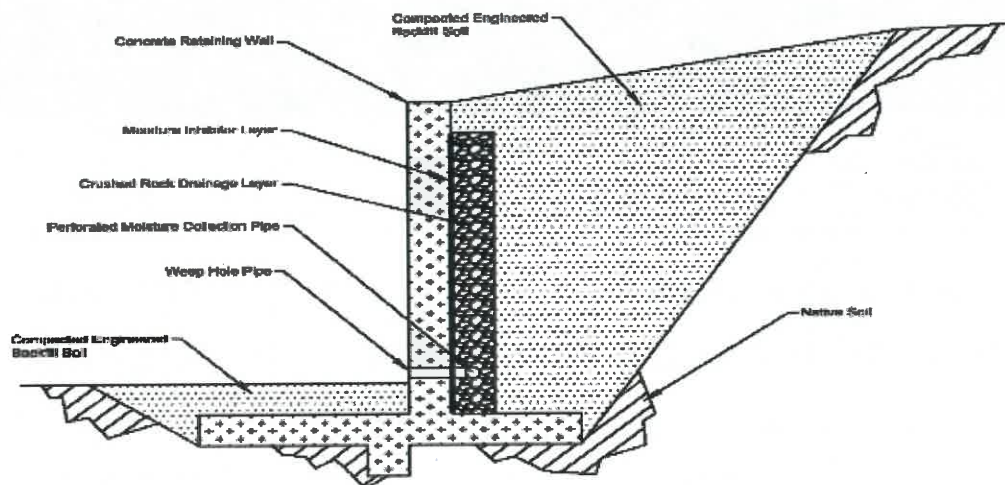

1. **Waterproofing:** Waterproofing materials should be installed behind retaining walls prior to backfilling if retaining walls will be constructed for below grade rooms, basements, garages, elevator shafts, etc. The waterproofing materials should be installed by a qualified waterproofing contractor according to the manufacturer's directions.
2. **Drainage Layer:** A drainage layer should be placed between the wall and backfill material to prevent buildup of hydrostatic pressures behind the wall. Additionally, care should be taken during placement of the drainage layer materials so as not to crush, tear, or damage the waterproofing materials. The drainage layer can be constructed from drain rock, geosynthetic drain nets or a combination of both as described below.
 - a. **Caltrans Class II Permeable Material Method:** Place a minimum 12-inch thick layer of Caltrans Class II Permeable Material directly against the wall or waterproofing system (as described below) without a geotextile wrapping to separate the backfill soil from the wall. The drainage material should extend from the wall bottom to within 12 inches of the wall top.
 - b. **Geotextile Wrapped Drain Rock Method:** Place a minimum 12-inch-thick layer of drain rock wrapped in a geotextile filter fabric directly against the wall or waterproofing system (as described below) to separate the backfill soil from the wall. The drain rock should extend from the wall bottom to within 12 inches of the wall top. A minimum 6-ounce per square yard (oz/sy) non-woven geotextile fabric, such as Mirafi 140N manufactured by Tencate Geosynthetics or equivalent should be used.
 - c. **Geosynthetic Composite Drainnet (Geonet) Method:** Place a geosynthetic composite drain-net (geonet) directly against the wall or waterproofing system (as described below) to separate the backfill soil from the wall. The composite geonet should extend from the wall bottom to within 12 inches of the wall top. A geosynthetic composite drainnet such as Hydroduct 200 or Hydroduct 220 distributed by Grace Construction Products or equivalent should be used.

3. **Drainage Layer Collection and Discharge Pipes:** A minimum 4-inch diameter schedule 40, polyvinylchloride (PVC) perforated drainpipe should be placed at the wall base inside the geotextile wrapped drain rock or wrapped by the composite geonet. ¼-inch diameter perforations should be drilled into the pipe. The perforations should be oriented in cross section view at 90 degrees to one another and along the pipe length on 6-inch centers. The pipe should be placed such that the perforations are oriented 45 degrees from the vertical. A minimum of 3 inches of drain rock should be placed below the perforated PVC pipe. The pipe should direct water away from the wall by gravity with a minimum 1 percent slope. The pipe should collect groundwater collected by the drainage layer discharged to the surface at the end of the wall or through weep-hole penetrations through the wall.
4. **Backfill Placement and Compaction Equipment:** Heavy conventional motorized compaction equipment should not be used directly adjacent to a retaining wall unless the wall is designed with sufficient steel reinforcements and/or bracing to resist the additional lateral pressures. Compaction of backfill materials within 5 feet of the retaining wall should be accomplished by lightweight, hand-operated, walk-behind, vibratory equipment. Additionally, care should be taken during placement of the general backfill materials so as not to crush, tear or damage the waterproofing and/or drainage layer materials.
5. **Backfill Materials and Compaction:** The backfill material should be free draining and classified by the USCS as a coarse-grained material (i.e., GP, GW, GC, GM, SP, SW, SC, and SM). Materials classified by the USCS as a fine-grained material (i.e., CL, CH, ML, or MH) should not be used as retaining wall backfill. The retaining wall backfill material placed between the drainage layer and temporary cut-slope should be moisture conditioned to between ± 3 percentage points of the ASTM D1557 optimum moisture content and then compacted to a minimum of 90 percent and a maximum of 95 percent of the ASTM D1557 maximum dry density.

7.2.5 Concrete Slab-On-Grade Interior Floors, Sidewalk and Patio Construction

In general, NV5 recommends that subgrade elevations on which the concrete slab-on-grade floors are constructed be a minimum of 6 inches above the elevation of the surrounding parking lots, driveways, and landscaped areas. Elevating the building will reduce the potential for subsurface water to enter beneath the concrete slab-on-grade floors and exterior surfaces and underground utility trenches.

The concrete slab-on-grade building floors, patios, and sidewalk areas should be evaluated by a California-licensed professional engineer for expected live and dead loads to determine if the minimum slab thickness and steel reinforcement recommendations presented in this report should be increased or redesigned.

NV5 recommends using the guideline procedures, methods and material properties that are presented in the following ASTM and ACI documents for construction of concrete slab-on-grade floors:

- ACI 302.1R-15, Guide for Concrete Floor and Slab Construction, reported by ACI Committee 302.
- ASTM E1643-18a, Standard Practice for Installation of Water Vapor Retarders Used in Contact with Earth or Granular Fill Under Concrete Slabs.

- ASTM E1745-17, Standard Specifications for Plastic Water Vapor Retarders Used in Contact with Soil or Granular Fill under Concrete Slabs.
- ASTM F710-19, Standard Practice for Preparing Concrete Floors to Receive Resilient Flooring.

The interior building concrete slab-on-grade floor and exterior slab-on-grade concrete components are described below from top to bottom. If static or intermittent live floor loads greater than 250 psf are anticipated, then a California-licensed professional engineer should design the necessary concrete slab-on-grade floor thickness and steel reinforcements.

7.2.5.1 Interior Office Floors

1. **Minimum 4-Inch-Thick Concrete Slab:** The concrete slab should be installed with a minimum 3,000 psi compressive strength after 28 days of curing. NV5 recommends that the concrete design use a water-to-cement ratio between 0.40 and 0.45 and should be placed with minimum and maximum slumps of 3 and 5 inches, respectively. The concrete mix design is the responsibility of the concrete supplier.
2. **Steel Reinforcement:** Reinforcement should be used to improve the load-carrying capacity, to reduce cracking caused by shrinkage during curing and from both differential and repeated loadings. It should be understood that it is nearly impossible to prevent all cracks from development in concrete slabs; in other words, it should be expected that some cracking will occur in all concrete slabs no matter how well they are reinforced. Concrete slabs that will be subjected to heavy loads should be designed with steel reinforcements by a California-licensed professional engineer.

Rebar: As a minimum, use No. 3 rebar (ASTM A615/A 615M-18e1 Grade 60), tied and placed with 18-inch centers in both directions (perpendicular) and supported on concrete “dobies” to position the rebar in the center of the slab during concrete pouring. NV5 does not recommend that the steel reinforcements of the concrete slab-on-grade floor be tied into the perimeter or interior continuous strip foundations or interior isolated column foundations. In other words, we recommend that the concrete slab-on-grade floors be constructed as independent structural members so that they can move (float) independently from the foundation structures.

3. **Underslab Vapor-Moisture Retarder Membrane:** The underslab retarder membrane should be placed in areas with moisture sensitive floor coverings as a floor component that will minimize transmission of both liquid water and water vapor transmission through the concrete slab-on-grade floor. NV5 recommends using at a minimum a Class A (ASTM E1745-17), minimum 10-mil-thick, plastic, vapor-moisture, retarder membrane material such as Stego Wrap® underslab vapor retarder membranes or equivalents. Additionally, the following materials are recommended: Stego® Tape and Stego® Mastic or equivalents to seal membrane joints and any utility penetrations.

Regardless of the type of moisture-vapor retarder membrane used moisture can wick up through a concrete slab-on-grade floor. Excessive moisture transmission through a concrete slab floor can cause adhesion loss, warping and peeling of resilient floor coverings, deterioration of adhesive, seam separation, formation of air pockets, mineral deposition beneath flooring, odor and both fungi and mold growth. Slabs can be tested for water transmissivity in areas that are moisture sensitive. Commercial sealants, polymer additives to the concrete at the batch plant, entrained air, flyash, and a reduced water-to-content ratio can be incorporated into the concrete

slab-on-grade floor mix design to reduce its permeability and water-vapor transmissivity properties. A waterproofing consultant should be contacted to provide detailed recommendations if moisture sensitive flooring materials will be installed on the concrete slab-on-grade floors.

4. **Minimum 4-Inch-Thick Crushed Rock or Class II Aggregate Base Rock Layer:** Interior floors should be underlain by clean crushed rock. Crushed rock should be mechanically consolidated under the observation of NV5. The crushed rock should be washed to produce a particle size distribution of 100 percent (by dry weight) passing the ¾ inch sieve and 5 percent passing the No. 4 sieve and 0 to 3 percent passing the No. 200 sieve. An alternative rock material for slab-on-grade concrete surfaces would include AB rock meeting the specification of Caltrans Class II AB. AB rock layers should be placed and compacted to a minimum of 95 percent of the ASTM D1557 dry density with a moisture content of ± 3 percentage points of the ASTM D1557 optimum moisture content. Just prior to pouring the concrete slab, the rock layer should be moistened to a saturated surface dry (SSD) condition. This measure will reduce the potential for water to be withdrawn from the bottom of the concrete slab while it is curing and will help minimize the development of shrinkage cracks.

If the current property owner elects to eliminate the crushed rock or AB rock layer beneath the interior concrete slabs-on-grade for economic reasons, then there will be an inherent greater risk assumed by the developer for the development of both shrinkage and bearing-related cracks in the associated slabs.

5. **Subgrade Soil Preparation:** All concrete slab-on-grade subgrade soil should be prepared and compacted consistent with the recommendations of Section 7.1. The top 12 inches of the non-expansive soil should be compacted to a minimum of 90 percent of the ASTM D1557 dry density with a moisture content within ± 3 percentage points of the ASTM D1557 optimum moisture content.
6. **Crack Control:** Crack control grooves should be installed during placement or saw cuts should be made in accordance with the ACI and Portland Cement Association (PCA) specifications. Generally, NV5 recommends that expansion joints be provided between the slab and perimeter footings, and that crack control grooves or saw cuts are installed on 10-foot-centers in both directions (perpendicular).
7. **Field Observations:** All concrete slab-on-grade surfaces and installed steel reinforcements should be observed and inspected by an NV5 construction monitor prior to pouring concrete.
8. **Field Curing of Concrete:** Prior to applying construction loads, all exposed concrete slab-on-grade floors should be moisture cured for a minimum of 7 days following placement of the concrete. If concrete is placed during the hot summer months when the ambient air temperatures may be as low as 50 to 60 degrees Fahrenheit ($^{\circ}$ F) in the early morning and in excess of 90 $^{\circ}$ F in the afternoon, then the contractor may need to implement special curing measures to reduce the development of shrinkage cracks. The concrete contractor is responsible for determining the appropriate curing process to be applied to the slab-on-grade floor.

7.2.5.2 Interior Floors with Vehicle Traffic

1. **Minimum 6-Inch-Thick Concrete Slab:** should be installed with a minimum 3,500 psi compressive strength after 28 days of curing. NV5 recommends that the concrete design uses a water to

cement ratio between 0.40 and 0.50 and should be placed with minimum and maximum slumps of 4 and 6 inches, respectively. The concrete mix design is the responsibility of the concrete supplier.

2. Concrete Slabs in Contact With Isolated Concrete Foundations: We do not recommend that concrete slab-on-grade floors be placed in direct contact with the top surface of isolated column concrete foundations. Our experience is that during curing period of the concrete slab-on-grade floors a significant thermal gradient may develop between the portions of the slab placed directly on the typically more massive isolated column concrete foundations and the portions of the slab placed over the vapor-moisture retarder membrane and crushed rock of the slab support layers. The development of adverse thermal gradients may cause the development of significant orthogonal and/or circular shrinkage cracks around the isolated column foundations.
3. Steel Reinforcement: should be used to improve the load carrying capacity and to reduce cracking caused by shrinkage during curing and from both differential and repeated loadings. It should be understood that it is nearly impossible to prevent all cracks from development in concrete slabs; in other words, it should be expected that some cracking will occur in all concrete slabs no matter how well they are reinforced. Concrete slabs that will be subjected to heavy loads should be designed with steel reinforcements by a California licensed professional engineer.

Steel Rebar: As a minimum, use No. 4 ribbed steel rebar (ASTM A615/A615M-18e1 Grade 60 deformed for reinforcement in concrete), tied and placed with 12-inch centers in both directions (perpendicular) and supported on concrete “dobies” to position the rebar in the center of the slab during concrete pouring.

4. Underslab Vapor-Moisture Retarder Membrane: should be placed as a floor component that will minimize transmission of both liquid water and water vapor transmission through the concrete slab-on-grade floor. NV5 recommends using at a minimum a Class A (ASTM E1745-17), minimum 10-mil-thick, plastic, vapor-moisture, retarder membrane material such as: Stego Wrap® underslab vapor retarder membranes or equivalents. Additionally, the following materials are recommended: Stego® Tape and Stego® Mastic or equivalents to seal membrane joints and any utility penetrations.

Regardless of the type of moisture-vapor retarder membrane used, moisture can wick up through a concrete slab-on-grade floor. Excessive moisture transmission through a concrete slab floor can cause adhesion loss, warping, and peeling of resilient floor coverings, deterioration of adhesive, seam separation, formation of air pockets, mineral deposition beneath flooring, odor and both fungi and mold growth. Slabs can be tested for water transmissivity in areas that are moisture sensitive. Commercial sealants, polymer additives to the concrete at the batch plant, entrained air, flyash, and reduced water to content ratio can be incorporated into the concrete slab-on-grade floor mix design to reduce its permeability and water-vapor transmissivity properties. A waterproofing consultant should be contacted to provide detailed recommendations if moisture sensitive flooring materials will be installed on the concrete slab-on-grade floors.

5. Minimum 6-Inch-Thick Crushed Rock Layer or Class II Aggregate Base Rock Layer: Interior floors should be underlain by clean crushed rock. Crushed rock should be mechanically consolidated under the observation of NV5. The crushed rock should be washed to produce a particle size distribution of 100 percent (by dry weight) passing the $\frac{3}{4}$ inch sieve and 5 percent passing the No. 4 sieve and 0 to 3 percent passing the No. 200 sieve. An alternative rock material for slab-

on-grade concrete surfaces would include AB rock meeting the specification of Caltrans Class II AB. AB rock layers should be placed and compacted to a minimum of 95 percent of the ASTM D1557 dry density with a moisture content of ± 3 percentage points of the ASTM D1557 optimum moisture content. Just prior to pouring the concrete slab, the rock layer should be moistened to a SSD condition. This measure will reduce the potential for water to be withdrawn from the bottom of the concrete slab while it is curing and will help minimize the development of shrinkage cracks.

If the current property owner elects to eliminate the crushed rock or AB rock layer beneath the interior concrete slabs-on-grade for economic reasons, then there will be an inherent greater risk assumed by the developer for the development of both shrinkage and bearing-related cracks in the associated slabs.

6. **Subgrade Soil Preparation:** All concrete slab-on-grade subgrade soil should be prepared and compacted consistent with the recommendations of Section 7.1. The top 12 inches of the non-expansive soil should be compacted to a minimum of 95 percent of the ASTM D1557 dry density with a moisture content within ± 3 percentage points of the ASTM D1557 optimum moisture content.
7. **Crack Control:** Crack control grooves should be installed during placement or saw cuts should be made in accordance with the ACI and PCA specifications. Generally, NV5 recommends that expansion joints be provided between the slab and perimeter footings, and that crack control grooves or saw cuts are installed on 10-foot-centers in both directions (perpendicular).
8. **Field Observations:** All concrete slab-on-grade surfaces and installed steel reinforcements should be observed and inspected by an NV5 construction monitor prior to pouring concrete.
9. **Field Curing of Concrete:** Prior to applying construction loads, all exposed concrete slab-on-grade floors should be moisture cured for a minimum of 7 days following placement of the concrete. If concrete is placed during the hot summer months when the ambient air temperatures may be as low as 50 to 60 °F in the early morning and in excess of 90 °F in the afternoon, then the contractor may need to implement special curing measures to reduce the development of shrinkage cracks. The concrete contractor is responsible for determining the appropriate curing process to be applied to the slab-on-grade floor.

7.2.5.3 Exterior Sidewalks and Patios

1. **Minimum 4-Inch-Thick Concrete Slab:** should be installed with a minimum 2,500 psi compressive strength after 28 days of curing. NV5 recommends that the concrete design uses a water to cement ratio between 0.40 and 0.45 and should be placed with minimum and maximum slumps of 4 and 6 inches, respectively. The concrete mix design is the responsibility of the concrete supplier.
2. **Concrete Slabs in Contact With Isolated Concrete Foundations:** NV5 does not recommend that concrete slab-on-grade floors be placed in direct contact with the top surface of isolated column concrete foundations. Our experience is that during curing period of the concrete slab-on-grade floor a significant thermal gradient may develop between the portions of the slab placed directly on the typically more massive isolated column concrete foundations and the portions of the slab placed over a vapor-moisture retarder membrane and crushed rock layers. The development of adverse thermal gradients may cause the development of significant orthogonal and/or circular shrinkage cracks around the isolated column foundations.

3. **Steel Reinforcement:** should be used to improve the load carrying capacity and to reduce cracking caused by shrinkage during curing and from both differential and repeated loadings. It should be understood that it is nearly impossible to prevent all cracks from development in concrete slabs; in other words, it should be expected that some cracking will occur in all concrete slabs no matter how well they are reinforced or cured. Concrete slabs that will be subjected to heavy loads should be designed with steel reinforcements by a California licensed professional engineer.

If the current property owner (developer) elects to eliminate the steel reinforcements from the exterior concrete slabs-on-grade for economic reasons, then there will be an inherent greater risk assumed by the developer for the development of both shrinkage and bearing related cracks in the associated slabs.

4. **Minimum 4-Inch-Thick Crushed Rock Layer:** Exterior concrete slabs-on-grade should be underlain by clean crushed rock. Crushed rock should be mechanically consolidated under the observation of NV5. The crushed rock should be washed to produce a particle size distribution of 100 percent (by dry weight) passing the $\frac{3}{4}$ inch sieve and 5 percent passing the No. 4 sieve and 0 to 3 percent passing the No. 200 sieve. An alternative rock material for slab-on-grade concrete surfaces would include AB rock meeting the specification of Caltrans Class II AB. AB rock layers should be placed and compacted to a minimum of 95 percent of the ASTM D1557 dry density with a moisture content of ± 3 percentage points of the ASTM D1557 optimum moisture content. Just prior to pouring the concrete slab, the rock layer should be moistened to a SSD condition. This measure will reduce the potential for water to be withdrawn from the bottom of the concrete slab while it is curing and will help minimize the development of shrinkage cracks.

If the current property owner elects to eliminate the crushed rock or AB rock layer beneath the interior concrete slabs-on-grade for economic reasons, then there will be an inherent greater risk assumed by the developer for the development of both shrinkage and bearing-related cracks in the associated slabs.

5. **Subgrade Soil Preparation:** All concrete slab-on-grade subgrade soil should be prepared and compacted consistent with the recommendations of Section 7.1. The top 12 inches of the non-expansive soil should be compacted to a minimum of 90 percent of the ASTM D1557 dry density with a moisture content within ± 3 percentage points of the ASTM D1557 optimum moisture content.
6. **Crack Control:** Crack control grooves should be installed during placement or saw cuts should be made in accordance with the ACI and PCA specifications. Generally, NV5 recommends that expansion joints be provided between the slab and perimeter footings, and that crack control grooves or saw cuts are installed on 10-foot-centers in both directions (perpendicular).
7. **Field Observations:** All concrete slab-on-grade surfaces and installed steel reinforcements should be observed and inspected by an NV5 construction monitor prior to pouring concrete.

7.2.6 Rigid Concrete Pavement for Heavy Truck Traffic Areas and Fire Lanes

The rigid concrete pavement components are described below from top to bottom. If static or intermittent live floor loads greater than 250 psf are anticipated, then a California-licensed professional engineer should design the necessary concrete slab-on-grade floor thickness and steel reinforcements.

1. The recommended modulus of subgrade value of 150 kips/cubic foot should be used if the site subgrade is prepared in accordance with the recommendations presented in Section 7.1 above.
2. **Minimum 6-Inch-Thick Concrete Slab:** The rigid concrete pavement should be installed with a minimum 3,500 pounds psi compressive strength after 28 days of curing. NV5 recommends that the concrete design uses a water-to-cement ratio between 0.40 and 0.45 and should be placed with minimum and maximum slumps of 4 and 6 inches, respectively. The concrete mix design is the responsibility of the concrete supplier.
3. **Steel Reinforcements:** The rigid concrete pavement sections should include steel reinforcement to improve the load carrying capacity and to minimize cracking caused by shrinkage during curing and from both differential and repeated loadings. It should be understood that it is nearly impossible to prevent all cracks from development in concrete slabs; in other words, it should be expected that some cracking will occur in all concrete slabs no matter how well they are reinforced. Rigid concrete pavement that will be subjected to heavy loads should be designed with steel reinforcements by a California-licensed professional engineer.

If the owner elects to eliminate the steel reinforcements from the exterior concrete slabs-on-grade for economic reasons, then there will be an inherent greater risk assumed by the developer for the development of both shrinkage and bearing related cracks in the associated slabs.

4. **Steel Rebar:** Use No. 4 steel rebar (ASTM A615/A615M-18e1 Grade 60 reinforcement), tied and placed with 18-inch centers in both directions (perpendicular) and supported on concrete “dobies” to position the rebar in the center of the slab during concrete pouring.
5. **Minimum 6-Inch Caltrans Class II AB Layer:** The rigid concrete pavement should be underlain by Class II AB placed and compacted to a minimum of 95 percent of the ASTM D1557 dry density with a moisture content of ± 3 percentage points of the ASTM D1557 optimum moisture content.
6. **Subgrade Soil Preparation:** The subgrade soil below the rigid concrete pavement sections designed for vehicle traffic should be prepared and compacted consistent with the recommendations of Section 7.1. The top 12 inches of the non-expansive soil should be compacted to a minimum of 95 percent of the ASTM D1557 dry density with a relatively uniform moisture content of 0 to 4 percentage points greater than the ASTM D1557 optimum moisture content.
7. **Crack Control Grooves:** The rigid concrete pavement should include crack control and expansion joint grooves installed during placement or saw cuts should be made in accordance with the ACI and PCA specifications. Generally, NV5 recommends that expansion joints be provided between the slab and perimeter footings, and that crack control grooves or saw cuts are installed on no greater than 10-foot-centers in both directions (perpendicular).
8. **Field Observations:** Field observations should be made by an NV5 construction monitor of all concrete slab-on-grade subgrade surfaces and installed steel reinforcements prior to placing concrete.

7.2.7 Flexible Pavement

NV5 used the Caltrans Highway Design Manual to develop several AC and AB rock pavement design alternatives to allow for different traffic loading conditions. NV5 used a Traffic Index (TI) of 4 to 8 which represents typical vehicle traffic for residential streets, collector streets, industrial/commercial

streets, minor arterial streets, major arterial streets, and truck route arterial streets. The actual TI for the project pavement areas should be determined in accordance with Chapter 600 of the Caltrans Highway Design Manual.

Laboratory test results performed on a representative sample of the anticipated pavement subgrade soils within the proposed pavement improvements indicate these materials generally possess an R-Value of 22. Based on the fair quality near-surface soils encountered an R-Value of 20 should be considered for design purposes. The actual subsurface soil conditions exposed at the finished subgrade surface of the proposed pavement areas may be different from this R-Value based on site grades, or the use of imported fill materials. The actual finished subgrade materials should be evaluated during construction to confirm the design recommendations below. Please note that the Caltrans design method requires that the maximum R-Value of the subgrade soil not exceed 50.

NV5 assumed that the pavement layers will be constructed with Class 2 Aggregate Base Rock (Minimum R-Value = 78) and Type A Asphalt Concrete in accordance with the requirements of Section 26 of the Caltrans Standard Specifications. Table 7.2.7-1 presents the AC pavement design sections for varying TI's. NV5 recommends that the AB rock layer be constructed with a minimum thickness of 6-inches for constructability issues and to achieve a higher level of confidence that the road will achieve the expected service life.

Table 7.2.7-1, Flexible Pavement Design

Parameters	Design Values				
Traffic Description (approximate)	Light Automobiles	Light to Medium Autos and Trucks	Medium to Heavy Trucks	Heavy Trucks	Very Heavy Trucks
Traffic Index (TI)	4	5	6	7	8
Design R-Values					
Class II AB Rock	78	78	78	78	78
Subgrade Soil	20	20	20	20	20
AC Thickness (inch) ⁽¹⁾	2.5	3.0	3.5	4.0	5.0
AB Rock Thickness (inch) ⁽²⁾ (95% Relative Compaction)	6.0	8.0	10.0	12.0	14.0
Subgrade Soil Thickness (inch) (95% Relative Compaction)	12.0	12.0	12.0	12.0	12.0
Notes:					
(1) The asphalt concrete thickness includes the Caltrans safety factor.					
(2) NV5 recommends that the minimum thickness of AB rock should be 6 inches regardless of what the Caltrans design method indicates. This minimum thickness is necessary for constructability issues and will increase the level of confidence that the roads will achieve the expected service life.					

The subgrade soil and AB rock should be placed and compacted as described below.

1. The subgrade soil to a depth of 12 inches from the finished grade surface should be compacted to a minimum relative compaction of 95 percent of the ASTM D1557 maximum dry density with a moisture content of 2 to 4 percentage points of the ASTM D1557 optimum moisture content. The compacted sub-grade soil shall be graded to achieve the design grades and tolerances.
2. The stability of the compacted subgrade soil should be evaluated by wheel rolling prior to placing the overlying AB rock layer. Wheel rolling should be performed with a fully loaded water truck with tire pressures between 60 and 95 psi. The subgrade soil surface should exhibit only minor deflections as the wheel load passes by. Any unstable areas should be reworked and then retested for percent relative compaction and percent moisture content and then proof rolled again. This process should be repeated until the area appears to be relatively stable.
3. The Caltrans Class II AB rock should be compacted to a minimum relative compaction of 95 percent of the ASTM D1557 maximum dry density with a moisture content of ± 3 percentage points of the ASTM D1557 optimum moisture content.
4. The stability of the compacted AB rock should be evaluated by wheel rolling prior to placing the overlying AC layer. Wheel rolling should be performed with a fully loaded water truck with tire pressures between 60 and 95 psi. The AB rock surface should exhibit only minor deflections as the wheel load passes by. Any unstable areas should be reworked and then retested for percent relative compaction and percent moisture content and then proof rolled again. This process should be repeated until the area appears to be relatively stable.
5. Concrete cut-off curbs should be constructed around all landscaped areas that are adjacent to AC paved driveways and parking areas. The curbs should extend to a minimum depth of 8 inches into the underlying subgrade soil. The extended curbs will reduce migration of irrigation and rain waters originating in the landscaped areas from entering the AB rock materials underlying the AC pavement material. This design is intended to minimize failures of the paved areas due to saturation of the underlying AB rock and subgrade soils.

8.0 REFERENCES

- American Society of Civil Engineers, 2016. *Minimum Design Loads for Buildings and Other Structures* (ASCE 7-16).
- ASTM International, Inc. (ASTM), 2019. *Soil and Rock (I)*. Volume 04.08.
- California Geological Survey (CGS), 1997. *Fault Rupture Hazard Zones in California, Alquist-Priolo Earthquake Fault Zoning Act with Index to Earthquake Fault Zones Maps*. Special Publication 42. Interim Revision.
- GBA 2019. *Important Information about Your Geotechnical Engineering Report*.
- Geraili and Sitar, *Seismic Earth Pressures on Retaining Structures in Cohesionless Soils*, (2013)
- Rankine, W.J.M., 1857, *On the Stability of Loose Earth*, Philosophical Transactions of the Royal Society, London, Vol. 147.
- United States Geological Survey, 2018. *Clearlake Highlands Quadrangle, California-Lake Co.* 7.5 Minute Series (Topographic).
- Wagner, D.L., and Bortugno, E.J., 1982. *Geologic Map of the Santa Rosa quadrangle Sheet, 1:250,000*. California Division of Mines and Geology, Regional Geologic Map 2A.

9.0 LIMITATIONS

The following limitations apply to the findings, conclusions and recommendations presented in this report:

1. This report should not be relied upon without review by NV5 if a period of 24 months elapses between the issuance report date shown above and the date when construction commences.
2. NV5's professional services were performed consistent with the generally accepted geotechnical engineering principles and practices employed in Northern California. No warranties are either expressed or implied.
3. NV5 provided engineering services for the site project consistent with the work scope and contract agreement presented in the proposal and agreed to by the client. The findings, conclusions and recommendations presented in this report apply to the conditions existing when NV5 performed the services and are intended only for the client, purposes, locations, timeframes and project parameters described herein. NV5 is not responsible for the impacts of any changes in environmental standards, practices or regulations subsequent to completing the services. NV5 does not warrant the accuracy of information supplied by others, or the use of segregated portions of this report. This report is solely for the use of the client unless noted otherwise. Any reliance on this report by a third party is at the party's sole risk.
4. If changes are made to the nature or design of the project as described in this report, then the conclusions and recommendations presented in this report should be considered invalid by all parties. The validity of the conclusions and recommendations presented in this report can only be made by NV5; therefore, NV5 should be allowed to review all project changes and prepare written responses with regards to their impacts on the conclusions and recommendations. However, additional fieldwork and laboratory testing may be required for NV5 to develop any modifications to the recommendations. The cost to review project changes and perform additional fieldwork and laboratory testing necessary to modify the recommendations is beyond the scope-of-services presented in this report. Any additional work will be performed only after receipt of an approved scope-of-work, budget and written authorization to proceed.
5. The analyses, conclusions and recommendations presented in this report are based on the site conditions as they existed at the time NV5 performed the surface and subsurface field investigations. NV5 has assumed that the subsurface soil and groundwater conditions encountered at the location of the exploratory borings are generally representative of the subsurface conditions throughout the entire project site; however, if the actual subsurface conditions encountered during construction are different than those described in this report, then NV5 should be notified immediately so that we can review these differences and, if necessary, modify the recommendations.
6. The elevation or depth to the groundwater table underlying the project site may differ with time and location; therefore, the depth to the groundwater table encountered in the exploratory borings is only representative of the specific time and location where it was observed.
7. The project site map shows approximate exploratory excavation locations as determined by pacing distances from identifiable site features; therefore, their locations should not be relied upon as being exact nor located with the accuracy of a California-licensed land surveyor.
8. NV5's geotechnical investigation scope-of-services did not include an evaluation of the project site for the presence of hazardous materials. Although NV5 did not observe the presence of

hazardous materials at the time of the field investigation, all project personnel should be careful and take the necessary precautions in the event hazardous materials are encountered during construction.

9. NV5's geotechnical investigation scope-of-services did not include an evaluation of the project site for the presence of mold nor for the future potential development of mold at the project site. If an evaluation of the presence of mold and/or for the future potential development of mold at the site is desired, then the property owner should contact a consulting firm specializing in these types of investigations. NV5 does not perform mold evaluation investigations.
10. NV5's experience and that of the civil engineering profession clearly indicates that during the construction phase of a project the risks of costly design, construction and maintenance problems can be significantly reduced by retaining a design geotechnical engineering firm to review the project plans and specifications and to provide geotechnical engineering CQA observation and testing services. Upon your request NV5 will prepare a CQA geotechnical engineering services proposal that will present a work scope, a tentative schedule and fee estimate for your consideration and authorization. If NV5 is not retained to provide geotechnical engineering CQA services during the construction phase of the project, then NV5 will not be responsible for geotechnical engineering CQA services provided by others nor any aspect of the project that fails to meet your or a third party's expectations in the future.

APPENDIX A:

Important Information about This Geotechnical Engineering Report (Included with permission of GBA, Copyright 2019)

Important Information about This Geotechnical-Engineering Report

Subsurface problems are a principal cause of construction delays, cost overruns, claims, and disputes.

While you cannot eliminate all such risks, you can manage them. The following information is provided to help.

The Geoprofessional Business Association (GBA) has prepared this advisory to help you – assumedly a client representative – interpret and apply this geotechnical-engineering report as effectively as possible. In that way, you can benefit from a lowered exposure to problems associated with subsurface conditions at project sites and development of them that, for decades, have been a principal cause of construction delays, cost overruns, claims, and disputes. If you have questions or want more information about any of the issues discussed herein, contact your GBA-member geotechnical engineer. Active engagement in GBA exposes geotechnical engineers to a wide array of risk-confrontation techniques that can be of genuine benefit for everyone involved with a construction project.

Understand the Geotechnical-Engineering Services Provided for this Report

Geotechnical-engineering services typically include the planning, collection, interpretation, and analysis of exploratory data from widely spaced borings and/or test pits. Field data are combined with results from laboratory tests of soil and rock samples obtained from field exploration (if applicable), observations made during site reconnaissance, and historical information to form one or more models of the expected subsurface conditions beneath the site. Local geology and alterations of the site surface and subsurface by previous and proposed construction are also important considerations. Geotechnical engineers apply their engineering training, experience, and judgment to adapt the requirements of the prospective project to the subsurface model(s). Estimates are made of the subsurface conditions that will likely be exposed during construction as well as the expected performance of foundations and other structures being planned and/or affected by construction activities.

The culmination of these geotechnical-engineering services is typically a geotechnical-engineering report providing the data obtained, a discussion of the subsurface model(s), the engineering and geologic engineering assessments and analyses made, and the recommendations developed to satisfy the given requirements of the project. These reports may be titled investigations, explorations, studies, assessments, or evaluations. Regardless of the title used, the geotechnical-engineering report is an engineering interpretation of the subsurface conditions within the context of the project and does not represent a close examination, systematic inquiry, or thorough investigation of all site and subsurface conditions.

Geotechnical-Engineering Services are Performed for Specific Purposes, Persons, and Projects, and At Specific Times

Geotechnical engineers structure their services to meet the specific needs, goals, and risk management preferences of their clients. A geotechnical-engineering study conducted for a given civil engineer

will not likely meet the needs of a civil-works constructor or even a different civil engineer. Because each geotechnical-engineering study is unique, each geotechnical-engineering report is unique, prepared *solely* for the client.

Likewise, geotechnical-engineering services are performed for a specific project and purpose. For example, it is unlikely that a geotechnical-engineering study for a refrigerated warehouse will be the same as one prepared for a parking garage; and a few borings drilled during a preliminary study to evaluate site feasibility will not be adequate to develop geotechnical design recommendations for the project.

Do not rely on this report if your geotechnical engineer prepared it:

- for a different client;
- for a different project or purpose;
- for a different site (that may or may not include all or a portion of the original site); or
- before important events occurred at the site or adjacent to it; e.g., man-made events like construction or environmental remediation, or natural events like floods, droughts, earthquakes, or groundwater fluctuations.

Note, too, the reliability of a geotechnical-engineering report can be affected by the passage of time, because of factors like changed subsurface conditions; new or modified codes, standards, or regulations; or new techniques or tools. *If you are the least bit uncertain about the continued reliability of this report, contact your geotechnical engineer before applying the recommendations in it. A minor amount of additional testing or analysis after the passage of time – if any is required at all – could prevent major problems.*

Read this Report in Full

Costly problems have occurred because those relying on a geotechnical-engineering report did not read the report in its entirety. Do not rely on an executive summary. Do not read selective elements only. *Read and refer to the report in full.*

You Need to Inform Your Geotechnical Engineer About Change

Your geotechnical engineer considered unique, project-specific factors when developing the scope of study behind this report and developing the confirmation-dependent recommendations the report conveys.

Typical changes that could erode the reliability of this report include those that affect:

- the site's size or shape;
- the elevation, configuration, location, orientation, function or weight of the proposed structure and the desired performance criteria;
- the composition of the design team; or
- project ownership.

As a general rule, *always* inform your geotechnical engineer of project or site changes – even minor ones – and request an assessment of their impact. *The geotechnical engineer who prepared this report cannot accept*

responsibility or liability for problems that arise because the geotechnical engineer was not informed about developments the engineer otherwise would have considered.

Most of the “Findings” Related in This Report Are Professional Opinions

Before construction begins, geotechnical engineers explore a site’s subsurface using various sampling and testing procedures. *Geotechnical engineers can observe actual subsurface conditions only at those specific locations where sampling and testing is performed.* The data derived from that sampling and testing were reviewed by your geotechnical engineer, who then applied professional judgement to form opinions about subsurface conditions throughout the site. Actual sitewide-subsurface conditions may differ – maybe significantly – from those indicated in this report. Confront that risk by retaining your geotechnical engineer to serve on the design team through project completion to obtain informed guidance quickly, whenever needed.

This Report’s Recommendations Are Confirmation-Dependent

The recommendations included in this report – including any options or alternatives – are confirmation-dependent. In other words, they are not final, because the geotechnical engineer who developed them relied heavily on judgement and opinion to do so. Your geotechnical engineer can finalize the recommendations *only after observing actual subsurface conditions* exposed during construction. If through observation your geotechnical engineer confirms that the conditions assumed to exist actually do exist, the recommendations can be relied upon, assuming no other changes have occurred. *The geotechnical engineer who prepared this report cannot assume responsibility or liability for confirmation-dependent recommendations if you fail to retain that engineer to perform construction observation.*

This Report Could Be Misinterpreted

Other design professionals’ misinterpretation of geotechnical-engineering reports has resulted in costly problems. Confront that risk by having your geotechnical engineer serve as a continuing member of the design team, to:

- confer with other design-team members;
- help develop specifications;
- review pertinent elements of other design professionals’ plans and specifications; and
- be available whenever geotechnical-engineering guidance is needed.

You should also confront the risk of constructors misinterpreting this report. Do so by retaining your geotechnical engineer to participate in prebid and preconstruction conferences and to perform construction-phase observations.

Give Constructors a Complete Report and Guidance

Some owners and design professionals mistakenly believe they can shift unanticipated-subsurface-conditions liability to constructors by limiting the information they provide for bid preparation. To help prevent the costly, contentious problems this practice has caused, include the complete geotechnical-engineering report, along with any attachments or appendices, with your contract documents, *but be certain to note*

conspicuously that you’ve included the material for information purposes only. To avoid misunderstanding, you may also want to note that “informational purposes” means constructors have no right to rely on the interpretations, opinions, conclusions, or recommendations in the report. Be certain that constructors know they may learn about specific project requirements, including options selected from the report, *only* from the design drawings and specifications. Remind constructors that they may perform their own studies if they want to, and *be sure to allow enough time* to permit them to do so. Only then might you be in a position to give constructors the information available to you, while requiring them to at least share some of the financial responsibilities stemming from unanticipated conditions. Conducting prebid and preconstruction conferences can also be valuable in this respect.

Read Responsibility Provisions Closely

Some client representatives, design professionals, and constructors do not realize that geotechnical engineering is far less exact than other engineering disciplines. This happens in part because soil and rock on project sites are typically heterogeneous and not manufactured materials with well-defined engineering properties like steel and concrete. That lack of understanding has nurtured unrealistic expectations that have resulted in disappointments, delays, cost overruns, claims, and disputes. To confront that risk, geotechnical engineers commonly include explanatory provisions in their reports. Sometimes labeled “limitations,” many of these provisions indicate where geotechnical engineers’ responsibilities begin and end, to help others recognize their own responsibilities and risks. *Read these provisions closely.* Ask questions. Your geotechnical engineer should respond fully and frankly.

Geoenvironmental Concerns Are Not Covered

The personnel, equipment, and techniques used to perform an environmental study – e.g., a “phase-one” or “phase-two” environmental site assessment – differ significantly from those used to perform a geotechnical-engineering study. For that reason, a geotechnical-engineering report does not usually provide environmental findings, conclusions, or recommendations; e.g., about the likelihood of encountering underground storage tanks or regulated contaminants. *Unanticipated subsurface environmental problems have led to project failures.* If you have not obtained your own environmental information about the project site, ask your geotechnical consultant for a recommendation on how to find environmental risk-management guidance.

Obtain Professional Assistance to Deal with Moisture Infiltration and Mold

While your geotechnical engineer may have addressed groundwater, water infiltration, or similar issues in this report, the engineer’s services were not designed, conducted, or intended to prevent migration of moisture – including water vapor – from the soil through building slabs and walls and into the building interior, where it can cause mold growth and material-performance deficiencies. Accordingly, *proper implementation of the geotechnical engineer’s recommendations will not of itself be sufficient to prevent moisture infiltration.* Confront the risk of moisture infiltration by including building-envelope or mold specialists on the design team. *Geotechnical engineers are not building-envelope or mold specialists.*



Telephone: 301/565-2733

e-mail: info@geoprofessional.org www.geoprofessional.org

Copyright 2019 by Geoprofessional Business Association (GBA). Duplication, reproduction, or copying of this document, in whole or in part, by any means whatsoever, is strictly prohibited, except with GBA’s specific written permission. Excerpting, quoting, or otherwise extracting wording from this document is permitted only with the express written permission of GBA, and only for purposes of scholarly research or book review. Only members of GBA may use this document or its wording as a complement to or as an element of a report of any kind. Any other firm, individual, or other entity that so uses this document without being a GBA member could be committing negligence.

APPENDIX B:

Exploratory Boring Logs

NV5

EXPLORATORY BORING LOG

48 BELLARMINE COURT, SUITE 40, CHICO, CA. 95928
 PHONE: 530-894-2487, FAX: 530-894-2437

Boring No.

B21-1

Project Name: Proposed Burns Valley Development

Project No.: 71075.00.001

Task: 001

Start Date: 1-12-21

Location: Burns Valley Road, Clearlake, California

Estimated Ground Surface

Elevation (Ft. AMSL): 1360.00

Finish Date: 1-12-21

Sheet: 1 Of 3

Logged By: Santiago Carrillo

Drilling Cmpny: Taber Drilling

Drill Rig Type: CME-55

Driller: Toby Baldazo

Drilling Method: Hollow Stem Auger (HSA)

Hammer Type: 140 Pound Auto Trip Hammer

Boring Dia. (In.): 8.00

Total Depth (Ft.): 51.5

Backfill or Well Design: Neat Cement Grout

24 Hour Clock Time (HH:MM)	Pocket Penetrometer (TSF)	Uncorrected Blow Counts (Blows / 6-inch)	Drilling Method and/or Sampler Type	Sample Recovery (Ft./Ft.)	Sample No.	Depth B.G.S. (Ft.)	Sample Interval And Symbol	Graphic Log	Ground Water Information				
									Date	1-12-21			
									Time (24 Hour)	11:10			
									Soil And/O Rock Material Descriptions				
SOIL: USCS Symbol; Name; Particle Size Gradation %; Munsell Color; Density/Consistency; Moisture; Odor; Organics; Cementation; Texture; Refuse; Etc. ROCK: Unit Name; Lithology; Munsell Color; Cementation; Weathering; Competency; Bedding/Foliation; Fracture/Joint Spacing & Roughness; RQD; Moisture.													
8:55			HSA			0			(SC) CLAYEY SAND WITH GRAVEL, fld. Est.: 50% Fine to Medium Sand, 30% Gravel, and 20% Low Plastic Clay-Silt Fines; Dark Yellowish Brown (10YR, 4/4); Medium Dense; Damp.				
					BK-1	1							
8:56		6	2.5SS			2							
		6			L1-2-2	3							
	3.0	10		0.75/1.5	L1-1-2	4							
			HSA			5							
9:04		7	2.5SS			6			Roots Encountered				
		14			L2-2-2	7							
	4.5	19		0.8/1.5	L2-1-2	8							
			HSA			9							
						10			(CL) SANDY CLAY, FLD. EST: 60% Low Plastic Clay-Silt Fines, 30% Fine Sand, and 10% Gravel; Light Olive Brown (2.5YR, 5/4); Hard; Damp.				
9:15		6	2.5SS			11							
		19			L3-2-2	12							
	4.5	29		0.9/1.5	L3-1-2	13			Increased Drill Effort				
			HSA			14							
						15							
9:24		9	2.5SS			16			Yellowish Brown (10YR, 5/6); Stiff; Damp; Reddish Brown Mottling				
		8			L4-2-2	17							
	2.75	8		1.2/1.5	L4-1-2	18							
			HSA			19							
						20							

NOTES: SPT - Standard Penetration Test
 HSA - Hollow Stem Augers
 2.5SS - 2.5" Split Spoon Sampler

N|V|5

EXPLORATORY BORING

Section 1, Item 5.

48 BELLARMINE COURT, SUITE 40, CHICO, CA., 95928
PHONE: 530-894-2487, FAX: 530-894-2437

Boring No.

B21-1

Project Name: Proposed Burns Valley Development

Project No.: 71075.00.001

Task: 001

Start Date: 1-12-21

Location: Burns Valley Road, Clearlake, California

Estimated Ground Surface Elevation (Ft. AMSL):

1360.00

Finish Date: 1-12-21

Sheet: 2 Of 3

Logged By: Santiago Carrillo

Drilling Cmpny: Taber Drilling

Drill Rig Type: CME-55

Driller: Toby Baldazo

Drilling Method: Hollow Stem Auger (HSA)

Hammer Type: 140 Pound Auto Trip Hammer

Boring Dia. (In.): 8.00

Total Depth (Ft.): 51.5

Backfill or Well Design: Neat Cement Grout

Ground Water Information

Date	1-12-21		
Time (24 Hour)	11:10		
Depth (Ft.)	23.0		

Soil And/OR Rock Material Descriptions

SOIL: USCS Symbol; Name; Particle Size Gradation %; Munsel Color; Density/Consistency; Moisture; Odor; Organics; Cementation; Texture; Refuse; Etc.
ROCK: Unit Name; Lithology; Munsel Color; Cementation; Weathering; Competency; Bedding/Foliation; Fracture/Joint Spacing & Roughness; RGD; Moisture.

24 Hour Clock Time (HH:MM)	Pocket Penetrometer (TSF)	Uncorrected Blow Counts (Blows / 6-inch)	Drilling Method and/or Sampler Type	Sample Recovery (Ft./Ft.)	Sample No.	Depth B.G.S. (Ft.)	Sample Interval And Symbol	Graphic Log	Soil And/OR Rock Material Descriptions
9:39		2	2.5SS			20			(CL) SANDY CLAY, FLD. EST: 60% Low Plastic Clay-Silt Fines, 30% Fine Sand, and 10% Gravel; Light Olive Brown (2.5Y, 5/4); Hard; Moist; Weakly Cemented.
		23			L5-2-2	21			
	1.5	43	HSA	1.5/1.5	L5-1-2	22			
						23		Hard Drilling	
						24			
9:58		15	SPT			25			(GM) SILTY GRAVEL WITH SAND, Fld. Est.: 60% Gravel; 20% Fine Sand; and 20% Low Plastic Clay-Silt Fines; Light Gray (10YR, 7/1); Medium Dense; Wet.
		10		0.3/1.5	B1-1-1	26			
		3	HSA			27			
						28			
						29			
10:11		2	SPT			30			(CH) FAT CLAY WITH SAND, FLD. EST: 85% High Plastic Clay-Silt Fines and 15% Fine Sand; Dark Greenish Gray (GLEYS 1, 4/1); Firm; Wet.
		2				31			
	1.5	3	HSA	1.5/1.5	B2-1-1	32			
						33			
						34			
10:21		7	SPT			35			Hard
		15				36			
	3.0	20	HSA	1.5/1.5	B3-1-1	37			
						38			
						39			
						40			

NOTES: SPT - Standard Penetration Test
HSA - Hollow Stem Augers
2.5SS - 2.5" Split Spoon Sampler



EXPLORATORY BORING LOG

Section 1, Item 5.

48 BELLARMINE COURT, SUITE 40, CHICO, CA., 95928
PHONE: 530-894-2487, FAX: 530-894-2437

Boring No.
B21-1

Project Name: Proposed Burns Valley Development

Project No.: 71075.00.001

Task: 001

Start Date: 1-12-21

Location: Burns Valley Road, Clearlake, California

Estimated Ground Surface

Elevation (Ft. AMSL): 1360.00

Finish Date: 1-12-21

Sheet: 3 Of 3

Logged By: Santiago Carrillo

Drilling Cmpny: Taber Drilling

Drill Rig Type: CME-55

Driller: Toby Baldazo

Drilling Method: Hollow Stem Auger (HSA)

Hammer Type: 140 Pound Auto Trip Hammer

Boring Dia. (In.): 8.00

Total Depth (Ft.): 51.5

Backfill or Well Design: Neat Cement Grout

24 Hour Clock Time (HH:MM)	Pocket Penetrometer (TSF)	Uncorrected Blow Counts (Blows / 6-inch)	Drilling Method and/or Sampler Type	Sample Recovery (Fu/Ft)	Sample No.	Depth B.G.S. (Ft.)	Sample Interval And Symbol	Graphic Log	Ground Water Information			
									Date	1-12-21		
									Time (24 Hour)	11:10		
									Soil And/Or Rock Material Descriptions			
									SOIL: USCS Symbol; Name; Particle Size Gradation %; Munsel Color; Density/Consistency; Moisture; Odor; Organics; Cementation; Texture; Refuse; Etc. ROCK: Unit Name; Lithology; Munsel Color; Cementation; Weathering; Competency; Bedding/Foliation; Fracture/Joint Spacing & Roughness; RGD; Moisture.			
10:37		5	SPT			40			(CH) FAT CLAY WITH SAND, FLD. EST: 85% High Plastic Clay-Silt Fines and 15% Fine Sand; Dark Greenish Gray (GLEYS 1, 4/1); Very Stiff; Wet.			
		9				41						
	1.5	9	HSA	1.5/1.5	B4-1-1	42						
						43			Stiff			
						44						
						45						
10:52		4	SPT			46			Stiff			
		6				47						
	1.0	10	HSA	1.5/1.5	B5-1-1	48						
						49			Increase in Sand Content; Very Stiff			
						50						
						51						
11:10		5	SPT			52						
		10				53						
11:10	2.0	12		1.0/1.5	B6-1-1	54						
						55						
						56						
						57						
						58						
						59						
						60						

NOTES: SPT - Standard Penetration Test
HSA - Hollow Stem Augers
2.5SS - 2.5" Split Spoon Sampler

NV5

EXPLORATORY BORING LOG

48 BELLARMINE COURT, SUITE 40, CHICO, CA., 95928
 PHONE: 530-894-2487, FAX: 530-894-2437

Boring No.
B21-2

Project Name: Proposed Burns Valley Development		Project No.: 71075.00.001	Task: 001	Start Date: 1-12-21
Location: Burns Valley Road, Clearlake, California		Estimated Ground Surface Elevation (Ft. AMSL): 1352.00	Finish Date: 1-12-21	
Logged By: Santiago Carrillo		Drilling Cmpny: Taber Drilling		Drill Rig Type: CME-55
Driller: Toby Baldazo		Drilling Method: Hollow Stem Auger (HSA)		Hammer Type: 140 Pound Auto Trip Hammer
Boring Dia. (In.): 8.00	Total Depth (Ft.): 51.5	Backfill or Well Design: Neat Cement Grout		

24 Hour Clock Time (HH:MM)	Pocket Penetrometer (TSF)	Uncorrected Blow Counts (Blows / 6-inch)	Drilling Method and/or Sampler Type	Sample Recovery (Ft./Ft.)	Sample No.	Depth B.G.S. (Ft.)	Sample Interval And Symbol	Graphic Log	Ground Water Information				
									Date	1-12-21			
									Time (24 Hour)	15:38			
									Depth (Ft.)	30.0			
										Soil And/Or Rock Material Descriptions			
<small>SOIL: USCS Symbol; Name; Particle Size Gradation %; Munsell Color; Density/Consistency; Moisture; Odor; Organics; Cementation; Texture; Refuse; Etc. ROCK: Unit Name; Lithology; Munsell Color; Cementation; Weathering; Competency; Bedding/Foliation; Fracture/Joint Spacing & Roughness; RQD; Moisture.</small>													
13:56			HSA			0			(CL) SANDY CLAY, fld. Est.: 60% Low Plastic Clay-Silt Fines, 30% Fine Sand, and 10% Gravel; Dark Yellowish Brown (10YR, 3/6); Very Stiff; Moist. Weakly Cemented Black Mottling				
					BK-2	1							
14:04		7	2.5SS			2							
		11			L1-2-2	3							
	4.5	12		0.8/1.5	L1-1-2	3							
			HSA			4							
						5							
14:10		6	2.5SS			5							
		12			L2-2-2	6							
	4.5	16		1.0/1.5	L2-1-2	6							
			HSA			7							
						8							
						9							
						10							
14:17		5	2.5SS			10							
		11			L3-2-2	11							
	4.5	18		1.0/1.5	L3-1-2	11							
			HSA			12							
						13							
						14							
						15							
14:23		3	2.5SS			15							
		7			L4-2-2	16							
	2.0	11		1.2/1.5	L4-1-2	16							
			HSA			17							
						18							
						19							
						20							

NOTES: SPT - Standard Penetration Test
 HSA - Hollow Stem Augers
 2.5SS - 2.5" Split Spoon Sampler



EXPLORATORY BORING LOG

48 BELLARMINE COURT, SUITE 40, CHICO, CA., 95928
 PHONE: 530-894-2487, FAX: 530-894-2437

Boring No.
B21-2

Project Name: Proposed Burns Valley Development **Project No.:** 71075.00.001 **Task:** 001 **Start Date:** 1-12-21
Location: Burns Valley Road, Clearlake, California **Estimated Ground Surface Elevation (Ft. AMSL):** 1352.00 **Finish Date:** 1-12-21 **Sheet:** 2 Of 3

Logged By: Santiago Carrillo **Drilling Cmpny:** Taber Drilling **Drill Rig Type:** CME-55
Driller: Toby Baldazo **Drilling Method:** Hollow Stem Auger (HSA) **Hammer Type:** 140 Pound Auto Trip Hammer
Boring Dia. (In.): 8.00 **Total Depth (Ft.):** 51.5 **Backfill or Well Design:** Neat Cement Grout

24 Hour Clock Time (HH:MM)	Pocket Penetrometer (TSF)	Uncorrected Blow Counts (Blows / 6-inch)	Drilling Method and/or Sampler Type	Sample Recovery (FL/FL)	Sample No.	Depth B.G.S. (FL)	Sample Interval And Symbol	Graphic Log	Ground Water Information				
									Date	1-12-21			
									Time (24 Hour)	15:38			
Depth (Ft.)	30.0												
Soil And/Or Rock Material Descriptions													
<small>SOIL: USCS Symbol; Name; Particle Size Gradation %; Munsell Color; Density/Consistency; Moisture; Odor; Organics; Cementation; Texture; Refuse; Etc. ROCK: Unit Name; Lithology; Munsell Color; Cementation; Weathering; Competency; Bedding/Foliation; Fracture/Joint Spacing & Roughness; RQD; Moisture.</small>													
14:31		2	2.5SS			20			(CL) SANDY CLAY, Fld. Est.: 60% Low Plastic Clay-Silt Fines, 30% Fine Sand, and 10% Gravel; Dark Yellowish Brown (10YR, 3/6); Firm; Moist to Very Moist.				
		4			L5-2-2	21							
	0.5	6		1.4/1.5	L5-1-2	22							
			HSA			23							
						24							
						25							
14:46		7	SPT			25			(GP) POORLY GRADED GRAVELS, Fld. Est.: 80% Gravel; 10% Fine Sand; and 10% Low Plastic Clay-Silt Fines; Gray (10YR, 5/1); Dense; Very Moist.				
		9				26							
	2.0	9		1.5/1.5	B1-1-1	27							
			HSA			28							
						29							
						30							
14:49		2	SPT			30			(CL) LEAN CLAY WITH SAND, FLD. EST: 85% Low Plastic Clay-Silt Fines and 15% Fine Sand; Dark Greenish Gray (GLEY 1, 4/1); Soft; Wet.				
		2				31							
	.5	2		1.5/1.5	B2-1-1	32							
			HSA			33							
						34							
						35							
15:00		6	SPT			35			(SM) SILTY SAND, FLD. EST: 55% Fine Sand and 45% Low Plastic Clay-Silt Fines; Dark Grayish Brown (2.5YR, 4/2); Medium Dense; Wet.				
		9				36							
		10		1.5/1.5	B3-1-1	37							
			HSA			38							
						39							
						40							
									(CH) FAT CLAY, FLD. EST: 95% High Plastic Clay-Silt Fines and 5% Fine Sand; Dark Greenish Gray (GLEY 1, 4/1); Stiff; Wet.				

NOTES: SPT - Standard Penetration Test
 HSA - Hollow Stem Augers
 2.5SS - 2.5" Split Spoon Sampler



EXPLORATORY BORING LOG

48 BELLARMINE COURT, SUITE 40, CHICO, CA., 95928
PHONE: 530-894-2487, FAX: 530-894-2437

Boring No.
B21-2

Project Name: Proposed Burns Valley Development

Project No.: 71075.00.001

Task: 001

Start Date: 1-12-21

Location: Burns Valley Road, Clearlake, California

Estimated Ground Surface Elevation (Ft. AMSL):

1352.00

Finish Date: 1-12-21

Sheet: 3 Of 3

Logged By: Santiago Carrillo

Drilling Cmpny: Taber Drilling

Drill Rig Type: CME-55

Driller: Toby Baldazo

Drilling Method: Hollow Stem Auger (HSA)

Hammer Type: 140 Pound Auto Trip Hammer

Boring Dia. (In.): 8.00

Total Depth (Ft.): 51.5

Backfill or Well Design: Neat Cement Grout

24 Hour Clock Time (HH:MM)	Pocket Penetrometer (TSF)	Uncorrected Blow Counts (Blows / 6-inch)	Drilling Method and/or Sampler Type	Sample Recovery (Ft./Ft.)	Sample No.	Depth B.G.S. (Ft.)	Sample Interval And Symbol	Graphic Log	Ground Water Information			
									Date	1-12-21		
									Time (24 Hour)	15:38		
									Soil And/OR Rock Material Descriptions			
									SOIL: USCS Symbol; Name; Particle Size Gradation %; Munsell Color; Density/Consistency; Moisture; Odor; Organics; Cementation; Texture; Refuse; Etc. ROCK: Unit Name; Lithology; Munsell Color; Cementation; Weathering; Competency; Bedding/Foliation; Fracture/Joint Spacing & Roughness; RQD; Moisture.			
15:13		3 6	SPT			40			(CH) FAT CLAY, FLD. EST: 95% High Plastic Clay-Silt Fines and 5% Fine Sand; Dark Greenish Gray (GLE 1, 4/1); Stiff; Wet.			
	1.75	8	HSA	1.5/1.5	B4-1-1	41						
						42						
						43						
						44						
15:25		3 5	SPT			45						
	1.0	7	HSA	1.5/1.5	B5-1-1	46						
						47						
						48						
						49						
15:37		6 6	SPT			50						
15:38	1.5	10		1.5/1.5	B6-1-1	51		Increase in Sand Content				
						52						
						53						
						54						
						55						
						56						
						57						
						58						
						59						
						60						

NOTES: SPT - Standard Penetration Test
HSA - Hollow Stem Augers
2.5SS - 2.5" Split Spoon Sampler

NV5

EXPLORATORY BORING LOG

48 BELLARMINE COURT, SUITE 40, CHICO, CA., 95928
PHONE: 530-894-2487, FAX: 530-894-2437

Boring No.

B21-3

Project Name: Proposed Burns Valley Development	Project No.: 71075.00.001	Task: 001	Start Date: 1-13-21
Location: Burns Valley Road, Clearlake, California	Estimated Ground Surface Elevation (Ft. AMSL): 1352.00		Finish Date: 1-13-21
Logged By: Santiago Carrillo	Drilling Cmpny: Taber Drilling		Drill Rig Type: CME-55
Driller: Toby Baldazo	Drilling Method: Hollow Stem Auger (HSA)		Hammer Type: 140 Pound Auto Trip Hammer
Boring Dia. (In.): 8.00	Total Depth (Ft.): 15.0	Backfill or Well Design: Neat Cement Grout	

24 Hour Clock Time (HH:MM)	Pocket Penetrometer (TSF)	Uncorrected Blow Counts (Blows / 6-inch)	Drilling Method and/or Sampler Type	Sample Recovery (FL/FT)	Sample No.	Depth B.G.S. (Ft.)	Sample Interval And Symbol	Graphic Log	Ground Water Information			
									Date	1-13-21		
									Time (24 Hour)	9:00		
									Depth (Ft.)	None		
Soil And/Or Rock Material Descriptions												
<small>SOIL: USCS Symbol; Name; Particle Size Gradation %; Munsell Color; Density/Consistency; Moisture; Odor; Organics; Cementation; Texture; Refuse; Etc. ROCK: Unit Name; Lithology; Munsell Color; Cementation; Weathering; Competency; Bedding/Foliation; Fracture/Joint Spacing & Roughness; RGD; Moisture.</small>												
8:28			HSA			0			(SC) CLAYEY SAND WITH GRAVEL, fld. Est.: 55% Fine Sand, 20% Low Plastic Clay-Silt Fines, and 25% Gravel; Dark Yellowish Brown (10YR, 4/6); Medium Dense; Moist to Damp.			
8:31		5	2.5SS		BK-3	1						
		5			L1-2-2	2						
		8		0.9/1.5	L1-1-2	3						
			HSA			4						
8:40		5	2.5SS			5						
		7			L2-2-2	6						
		6		0.75/1.5	L2-1-2	7						
			HSA			8						
						9						
						10						
						11						
						12						
						13						
						14						
8:50		5	2.5SS			15			(CL) LEAN CLAY WITH SAND, fld. Est.: 90% Low Plastic Clay-Silt Fines and 10% Fine Sand; Dark Brown (10YR, 5/3); Very Stiff; Moist.			
		9			L3-2-2	16						
	4.25	11		1.25/1.5	L3-1-2	17						
			HSA			18						
						19						
						20						
						21						
						22						
						23						
						24						
						25						
						26						
						27						
						28						
						29						
						30						
						31						
						32						
						33						
						34						
						35						
						36						
						37						
						38						
						39						
						40						
						41						
						42						
						43						
						44						
						45						
						46						
						47						
						48						
						49						
						50						
						51						
						52						
						53						
						54						
						55						
						56						
						57						
						58						
						59						
						60						
						61						
						62						
						63						
						64						
						65						
						66						
						67						
						68						
						69						
						70						
						71						
						72						
						73						
						74						
						75						
						76						
						77						
						78						
						79						
						80						
						81						
						82						
						83						
						84						
						85						
						86						
						87						
						88						
						89						
						90						
						91						
						92						
						93						
						94						
						95						
						96						
						97						
						98						
						99						
						100						

NOTES: HSA - Hollow Stem Augers
2.5SS - 2.5" Split Spoon Sampler



EXPLORATORY BORING LOG

48 BELLARMINE COURT, SUITE 40, CHICO, CA., 95928
 PHONE: 530-894-2487, FAX: 530-894-2437

Boring No.
B21-4

Project Name: Proposed Burns Valley Development		Project No.: 71075.00.001	Task: 001	Start Date: 1-13-21
Location: Burns Valley Road, Clearlake, California		Estimated Ground Surface Elevation (Ft. AMSL): 1355.00	Finish Date: 1-13-21	
Logged By: Santiago Carrillo		Drilling Cmpny: Taber Drilling		Drill Rig Type: CME-55
Driller: Toby Baldazo		Drilling Method: Hollow Stem Auger (HSA)		Hammer Type: 140 Pound Auto Trip Hammer
Boring Dia. (In.): 8.00	Total Depth (Ft.): 21.5	Backfill or Well Design: Neat Cement Grout		

24 Hour Clock Time (HH:MM)	Pocket Penetrometer (TSF)	Uncorrected Blow Counts (Blows / 6-inch)	Drilling Method and/or Sampler Type	Sample Recovery (Ft./Ft.)	Sample No.	Depth B.G.S. (Ft.)	Sample Interval And Symbol	Graphic Log	Ground Water Information			
									Date	1-13-21		
									Time (24 Hour)	10:06		
									Soil And/Or Rock Material Descriptions			
									SOIL: USCS Symbol; Name; Particle Size Gradation %; Munsell Color; Density/Consistency; Moisture; Odor; Organics; Cementation; Texture; Refuse; Etc. ROCK: Unit Name; Lithology; Munsell Color; Cementation; Weathering; Competency; Bedding/Foliation; Fracture/Joint Spacing & Roughness; RQD; Moisture.			
9:24			HSA			0			(CL) LEAN CLAY WITH SAND, fld. Est.: 85% Low Plastic Clay-Silt Fines and 15% Fine Sand; Brown (10YR, 4/3); Stiff; Moist.			
						1						
9:26		5	2.5SS		L1-2-2	2						
		9				3			Very Stiff			
	4.5	10		1.2/1.5	L1-1-2	3						
			HSA			4						
						5						
9:31		14	2.5SS		L2-2-2	5						
		27				6			Hard			
	4.5+	38		1.3/1.5	L2-1-2	6						
			HSA			7						
						8						
						9						
						10			(SC) CLAYEY SAND WITH GRAVEL, fld. Est.: 65% Fine Sand, 25% Low Plastic Clay-Silt Fines, and 10% Gravel; Strong Brown (7.5YR, 4/6); Medium Dense; Moist.			
9:41		10	2.5SS		L3-2-2	10						
		12				11						
	4.5+	17		.8/1.5	L3-1-2	11						
			HSA			12						
						13						
						14						
						15						
9:52		9	2.5SS		L4-2-2	15						
		5				16						
	1.5	7		1.1/1.5	L4-1-2	16			(CL) LEAN CLAY, fld. Est.: 90% Low Plastic Clay-Silt Fines and 10% Fine Sand; Dark Grayish Brown (10YR, 4/2); Firm; Moist; Orange Mottling.			
			HSA			17						
						18						
						19						
						20						
10:04		16	2.5SS		L5-2-2	20			(SM) SILTY SAND, fld. Est.: 80% Fine Sand and 15% Low Plastic Clay-Silt Fines, and, 5% Gravel; Brown (10YR, 4/3); Dense; Wet.			
		29				21						
10:06		16		.8/1.5	L5-1-2	21						

NOTES: HSA - Hollow Stem Augers
 2.5SS - 2.5" Split Spoon Sampler

N/V5

EXPLORATORY BORING LOG

48 BELLARMINA COURT, SUITE 40, CHICO, CA., 95928
PHONE: 530-894-2487, FAX: 530-894-2437

Boring No.
B21-5
Sheet: 1 Of 1

Project Name: Proposed Burns Valley Development **Project No.:** 71075.00.001 **Task:** 001 **Start Date:** 1-13-21
Location: Burns Valley Road, Clearlake, California **Estimated Ground Surface Elevation (Ft. AMSL):** 1360.00 **Finish Date:** 1-13-21

Logged By: Santiago Carrillo **Drilling Cmpny:** Taber Drilling **Drill Rig Type:** CME-55
Driller: Toby Baldazo **Drilling Method:** Hollow Stem Auger (HSA) **Hammer Type:** 140 Pound Auto Trip Hammer

Boring Dia. (In.): 8.00 **Total Depth (Ft.):** 21.5 **Backfill or Well Design:** Neat Cement Grout

24 Hour Clock Time (HH:MM)	Pocket Penetrometer (TSF)	Uncorrected Blow Counts (Blows / 6-inch)	Drilling Method and/or Sampler Type	Sample Recovery (F/U/L)	Sample No.	Depth B.G.S. (Ft.)	Sample Interval And Symbol	Graphic Log	Ground Water Information				
									Date	1-13-21			
									Time (24 Hour)	11:07			
									Depth (Ft.)	None			
Soil And/Or Rock Material Descriptions													
<small>SOIL: USCS Symbol; Name; Particle Size Gradation %; Munsell Color; Density/Consistency; Moisture; Odor; Organics; Cementation; Texture; Refuse; Etc. ROCK: Unit Name; Lithology; Munsell Color; Cementation; Weathering; Competency; Bedding/Foliation; Fracture/Joint Spacing & Roughness; RQD; Moisture.</small>													
10:30			HSA			0			(ML) SANDY SILT, FLD. EST: 70% Low Plastic Clay-Silt Fines and 30% Fine Sand; Dark Yellowish Brown; (10YR, 4/4); Stiff; Damp.				
					BK-4	1							
10:32		4	2.5SS			2							
		6			L1-2-2	3							
	4.25	8		.9/1.5	L1-1-2	4							
			HSA			5			(CL) LEAN CLAY WITH SAND, Fld. Est.: 80% Low Plastic Clay-Silt Fines and 20% Fine Sand; Brown (10YR, 4/4); Very Stiff; Damp to Moist.				
10:36		8	2.5SS			6							
		10		.9/1.5	L2-2-2	7							
	4.5+	17			L2-1-2	8							
			HSA			9							
						10							
10:45		10	2.5SS			11							
		16		.7/1.5	L3-2-2	12							
		19			L3-1-2	13							
			HSA			14							
						15							
10:56		3	2.5SS			16			Firm				
		6		1.4/1.5	L4-2-2	17							
	.75	6			L4-1-2	18							
			HSA			19							
						20							
11:07		4	2.5SS			21			Firm to Stiff				
		6			L5-2-2	22							
11:07	1.75	8		1.5/1.5	L5-1-2	23							

NOTES: HSA - Hollow Stem Augers
2.5SS - 2.5" Split Spoon Sampler



EXPLORATORY BORING LOG

48 BELLARMINE COURT, SUITE 40, CHICO, CA., 95928
PHONE: 530-894-2487, FAX: 530-894-2437

Boring No.
B21-6
Sheet: 1 Of 2

Project Name: Proposed Burns Valley Development		Project No.: 71075.00.001	Task: 001	Start Date: 1-13-21
Location: Burns Valley Road, Clearlake, California		Estimated Ground Surface Elevation (Ft. AMSL): 1356.00		Finish Date: 1-13-21
Logged By: Santiago Carrillo		Drilling Cmpny: Taber Drilling		Drill Rig Type: CME-55
Driller: Toby Baldazo		Drilling Method: Hollow Stem Auger (HSA)		Hammer Type: 140 Pound Auto Trip Hammer
Boring Dia. (In.): 8.00		Total Depth (Ft.): 25.0	Backfill or Well Design: Neat Cement Grout	

24 Hour Clock Time (HH:MM)	Pocket Penetrometer (TSF)	Uncorrected Blow Counts (Blows / 6-inch)	Drilling Method and/or Sampler Type	Sample Recovery (Ft./Ft.)	Sample No.	Depth B.G.S. (Ft.)	Sample Interval And Symbol	Graphic Log	Ground Water Information				
									Date	1-13-21			
									Time (24 Hour)	12:10			
									Depth (Ft.)	18.0			
										Soil And/Or Rock Material Descriptions			
										SOIL: USCS Symbol, Name; Particle Size Gradation %, Munsell Color; Density/Consistency, Moisture, Odor; Organics; Cementation; Texture; Refuse; Etc. ROCK: Unit Name, Lithology, Munsell Color; Cementation; Weathering; Competency; Bedding/Foliation; Fracture/Joint Spacing & Roughness; RQD; Moisture.			
11:30			HSA			0			(CL) LEAN CLAY WITH SAND, fld. Est.: 90% Low Plastic Clay-Silt Fines and 10% Fine Sand; Dark Brown (10YR, 5/3); Very Stiff; Moist.				
11:32		6	2.5SS		L1-2-2	1							
		11		1.2/1.5	L1-1-2	2							
	4.5	12				3							
11:36		8	2.5SS		L2-2-2	4							
	4.5	16		1.5/1.5	L2-1-2	5							
			HSA			6							
						7							
						8							
11:45		5	2.5SS		L3-2-2	9							
	4.5	16		1.4/1.5	L3-1-2	10							
			HSA			11							
						12							
						13							
11:52		16	2.5SS		L4-2-2	14		(SC) CLAYEY SAND WITH GRAVEL, fld. Est.: 45% Fine Sand, 35% Low Plastic Clay-Silt Fines, and 20% Gravel; Brown (10YR, 4/3); Medium Dense; Moist.					
	4.5+	12		1.0/1.5	L4-1-2	15							
			HSA			16							
						17							
11:59		5	2.5SS		L5-2-2	19		Dense; Wet					
		26		1.0/1.5	L5-1-2	20							

NOTES: HSA - Hollow Stem Augers
2.5SS - 2.5" Split Spoon Sampler



EXPLORATORY BORING LOG

48 BELLARMINE COURT, SUITE 40, CHICO, CA., 95928
 PHONE: 530-894-2487, FAX: 530-894-2437

Boring No.
B21-6

Project Name: Proposed Burns Valley Development

Project No.: 71075.00.001

Task: 001

Start Date: 1-13-21

Location: Burns Valley Road, Clearlake, California

Estimated Ground Surface

Elevation (Ft. AMSL): 1357.00

Finish Date: 1-13-21

Sheet: 2 Of 2

Logged By: Santiago Carrillo

Drilling Cmpny: Taber Drilling

Drill Rig Type: CME-55

Driller: Toby Baldazo

Drilling Method: Hollow Stem Auger (HSA)

Hammer Type: 140 Pound Auto Trip Hammer

Boring Dia. (In.): 8.00

Total Depth (Ft.): 25.0

Backfill or Well Design: Neat Cement Grout

24 Hour Clock Time (HH:MM)	Pocket Penetrometer (TSF)	Uncorrected Blow Counts (Blows / 6-inch)	Drilling Method and/or Sampler Type	Sample Recovery (FL/Ft.)	Sample No.	Depth B.G.S. (Ft.)	Sample Interval And Symbol	Graphic Log	Ground Water Information				
									Date	1-13-21			
									Time (24 Hour)	12:10			
									Depth (Ft.)	18.0			
									Soil And/Or Rock Material Descriptions				
									<small>SOIL: USCS Symbol Name; Particle Size Gradation %; Munsell Color; Density/Consistency; Moisture; Odor; Organics; Cementation; Texture; Refuse; Etc. ROCK: Unit Name; Lithology; Munsell Color; Cementation; Weathering; Competency; Bedding/Foliation; Fracture/Joint Spacing & Roughness; RQD; Moisture.</small>				
			HSA			20		<p>(SC) CLAYEY SAND WITH GRAVEL, fld. Est.: 45% Fine Sand, 35% Low Plastic Clay-Silt Fines, and 20% Gravel; Brown (10YR, 4/3); Dense; Moist.</p>					
						21							
						22							
						23		<p>(CH) FAT CLAY, FLD. EST: 90% High Plastic Clay-Silt Fines and 10% Fine Sand; Dark Greenish Gray (GLEYS 1, 4/1); Stiff; Wet.</p>					
12:10		3	2.5SS			24							
		4			L6-2-2								
12:10	1.75	6		1.5/1.5	L6-1-2	25							
						26							
						27							
						28							
						29							
						30							
						31							
						32							
						33							
						34							
						35							
						36							
						37							
						38							
						39							
						40							

NOTES: HSA - Hollow Stem Augers
 2.5SS - 2.5" Split Spoon Sampler



EXPLORATORY BORING LOG

Section I, Item 5.

48 BELLARMINE COURT, SUITE 40, CHICO, CA., 95928
PHONE: 530-894-2487, FAX: 530-894-2437

Boring No.

B21-7

Sheet: 1 Of 1

Project Name: Proposed Burns Valley Development	Project No.: 71075.00.001	Task: 001	Start Date: 1-13-21
Location: Burns Valley Road, Clearlake, California	Estimated Ground Surface Elevation (Ft. AMSL): 1365.00	Finish Date: 1-13-21	
Logged By: Santiago Carrillo	Drilling Cmpny: Taber Drilling	Drill Rig Type: CME-55	
Driller: Toby Baldazo	Drilling Method: Hollow Stem Auger (HSA)	Hammer Type: 140 Pound Auto Trip Hammer	
Boring Dia. (In.): 8.00	Total Depth (Ft.): 21.5	Backfill or Well Design: Neat Cement Grout	

24 Hour Clock Time (HH:MM)	Pocket Penetrometer (TSF)	Uncorrected Blow Counts (Blows / 6-inch)	Drilling Method and/or Sampler Type	Sample Recovery (Ft./Ft.)	Sample No.	Depth B.G.S. (Ft.)	Sample Interval And Symbol	Graphic Log	Ground Water Information			
									Date	1-13-21		
									Time (24 Hour)	13:33		
									Soil And/Or Rock Material Descriptions			
									SOIL: USCS Symbol, Name, Particle Size Gradation %, Munsell Color, Density/Consistency, Moisture, Odor, Organics, Cementation, Texture, Refuse, Etc. ROCK: Unit Name, Lithology, Munsell Color, Cementation, Weathering, Competency, Bedding/Foliation, Fracture/Joint Spacing & Roughness, RQD, Moisture.			
12:56			HSA			0			(FILL) Undocumented Fill; Rocks; Garbage; Organics.			
						1						
						2						
						3						
						4						
13:01		9	2.5SS		L1-2-2	5						
		9			L1-1-2	6						
	4.5	8	HSA	.6/1.5		7						
						8						
						9						
						10						
13:09		8	2.5SS		L2-2-2	11			Very Stiff			
		12			L2-1-2	12						
	4.5	15	HSA	.8/1.5		13						
						14						
						15						
13:19		14	2.5SS		L3-2-2	16			Increase Gravels; Hard; Moist			
		25			L3-1-2	17						
		30	HSA	.9/1.5		18						
						19						
						20						
13:32		4	2.5SS		L4-2-2				Light Olive Brown (2.5Y, 5/6); Stiff			
		7										
13:33		10		1.5/1.5	L4-1-2							

NOTES: HSA - Hollow Stem Augers
2.5SS - 2.5" Split Spoon Sampler

NV5

EXPLORATORY BORING LOG

48 BELLARMINE COURT, SUITE 40, CHICO, CA., 95928
PHONE: 530-894-2487, FAX: 530-894-2437

Boring No.
B21-8

Project Name: Proposed Burns Valley Development

Project No.: 71075.00.001

Task: 001

Start Date: 1-13-21

Location: Burns Valley Road, Clearlake, California

Estimated Ground Surface Elevation (Ft. AMSL):

1363.00

Finish Date: 1-13-21

Sheet: 1 Of 1

Logged By: Santiago Carrillo

Drilling Cmpny: Taber Drilling

Drill Rig Type: CME-55

Driller: Toby Baldazo

Drilling Method: Hollow Stem Auger (HSA)

Hammer Type: 140 Pound Auto Trip Hammer

Boring Dia. (In.): 8.00

Total Depth (Ft.): 20.0

Backfill or Well Design: Neat Cement Grout

24 Hour Clock Time (HH:MM)	Pocket Penetrometer (TSF)	Uncorrected Blow Counts (Blows / 6-inch)	Drilling Method and/or Sampler Type	Sample Recovery (Ft./Ft.)	Sample No.	Depth B.G.S. (Ft.)	Sample Interval And Symbol	Graphic Log	Ground Water Information				
									Date	1-13-21			
									Time (24 Hour)	14:41			
									Soil And/Or Rock Material Descriptions				
										<small>SOIL: USCS Symbol; Name; Particle Size Gradation %; Munsell Color; Density/Consistency; Moisture; Odor; Organics; Cementation; Texture; Refuse; Etc. ROCK: Unit Name; Lithology; Munsell Color; Cementation; Weathering; Competency; Bedding/Foliation; Fracture/Joint Spacing & Roughness; RGD; Moisture.</small>			
14:05			HSA			0			(CL) LEAN CLAY WITH SAND, fld. Est.:85% Low Plastic Clay-Silt Fines and 15% Fine Sand; Dark Yellowish Brown (10YR, 4/4); Stiff; Damp.				
14:08		4	2.5SS		BK-5	1							
		9			L1-2-2	2							
	4.5+	14		1.1/1.5	L1-1-2	3							
			HSA			4							
14:11		13	2.5SS			5			Hard				
		17			L2-2-2	6							
	4.5+	21		1.5/1.5	L2-1-2	7							
			HSA			8							
						9							
14:22		8	2.5SS			10			Dark Brown (10YR, 3/3); Very Stiff; White Mottling				
		14			L3-2-2	11							
	4.25	18		1.5/1.5	L3-1-2	12							
			HSA			13							
						14							
14:32		4	2.5SS			15			Stiff; Black Mottling				
		7			L4-2-2	16							
	3.5+	8		1.5/1.5	L4-1-2	17							
			HSA			18							
						19							
14:41		3	2.5SS			20			Increase Sand Content; Brown (10YR, 4/4)				
		6			L5-2-2								
14:41		11		1.2/1.5	L5-1-2								

NOTES:HSA - Hollow Stem Augers
2.5SS - 2.5" Split Spoon Sampler

APPENDIX C:

Soil Laboratory Test Results



ATTERBERG INDICES

ASTM D4318

DSA LEA No. 284

DSA File No. N/A
 DSA App No. N/A

Project No.	71075.00.001	Project Name	City of Clearlake Burns Valley Development	Date:	01/20/21	
Sample No.	BK-1	Boring/Trench	B21-1	Depth, (ft.):	0-3	
Description:	(SC) CLAYEY SAND WITH GRAVEL; Yellowish Brown (10YR, 4/4)				Tested By:	LGH
Sample Location:					Checked By:	DJP
					Lab. No.	C21-014

Estimated % of Sample Retained on No. 40 Sieve: _____ Sample Air Dried: _____
 Test Method A or B: A

Sample No.:	LIQUID LIMIT:					PLASTIC LIMIT:		
	1	2	3	4	5	1	2	3
Pan ID:	C	X	E			Z	W	
Wt. Pan (gr)	38.48	38.20	36.46			37.46	37.79	
Wt. Wet Soil + Pan	46.96	49.42	48.06			46.75	45.34	
Wt. Dry Soil + Pan	45.07	46.82	43.70			45.28	44.15	
Wt. Water (gr)	1.89	2.60	4.36			1.47	1.19	
Wt. Dry Soil (gr)	6.59	8.62	7.24			7.82	6.36	
Water Content (%)	28.7	30.2	60.2			18.8	18.7	
Number of Blows, N	35	25	15					

LIQUID LIMIT = 30 PLASTIC LIMIT = 19

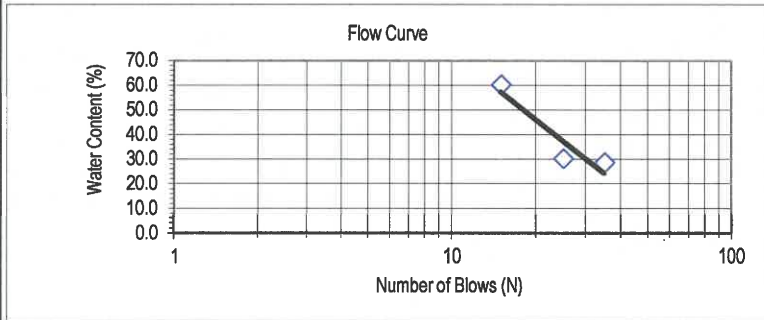

Plasticity Index = 11

Group Symbol = CL

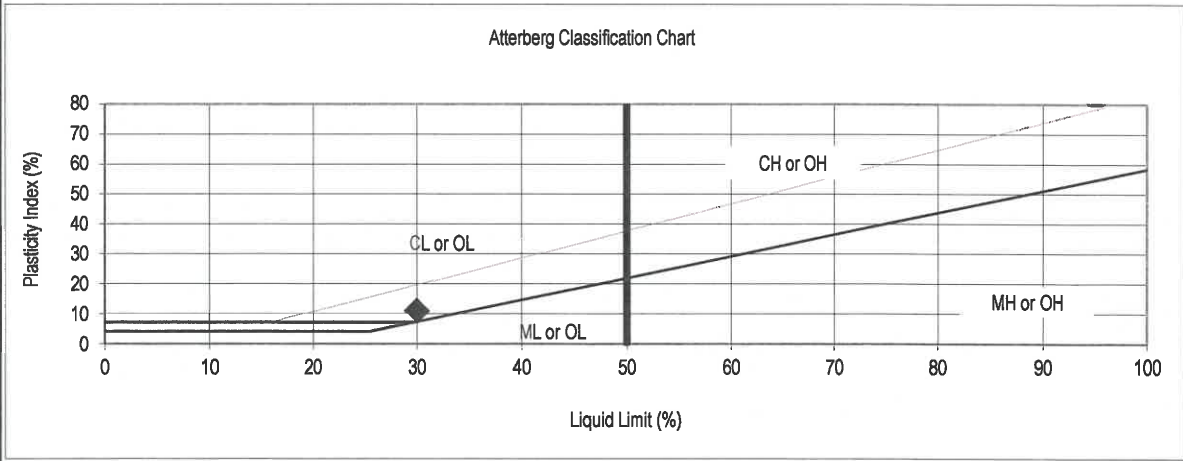



DSA LEA No. 284

PARTICLE SIZE DISTRIBUTION TEST WORK SHEET

ASTM D422, C136

DSA File No. N/A
DSA App No. N/A

Sieve Only Analysis Worksheet

Project No. 71075.00.001 Project Name: City of Clearlake Burns Valley Development Date: 01/20/21
 Sample No. BK-1 Boring/Trench: B21-1 Depth, (ft.): 0-3 Tested By: LGH
 Description: (SC) CLAYEY SAND WITH GRAVEL; Yellowish Brown (10YR, 4/4) Checked By: DJP
 Sample Location: Lab. No. C21-014

Moisture Content Data:		Total Material Sample Data:	
Pan ID		Pan ID	
Pan Weight	(gm)	Pan Weight	(gm)
Wet Soil + Pan	(gm)	Wet Soil + Pan Wt.	3,065.00 (gm)
Dry Soil + Pan	(gm)	Total Wet Weight	3,065.00 (gm)
Water Weight	0.00 (gm)	Total Dry Weight	3,065.00 (gm)
Dry Soil Weight	0.00 (gm)	Total Dry Wt. >#4 Sieve	1,183.20 (gm)
Moisture Content	0.0 (%)	Total Dry Wt. <#4 Sieve	1,881.80 (gm)
		Total Dry Wt. <#200 Sieve	614.73 (gm)
		Total Percent <#200 Sieve	20.06 (%)

GRAVEL PORTION SIEVE ANALYSIS (Portion Retained On > #4 Sieve)

Sieve Size	Particle Diameter		Wet Weight Retained On Sieve (gm)	Dry Weight			
	Inches (in.)	Millimeter (mm)		Retained On Sieve (gm)	Accum. On Sieve (gm)	Passing Sieve (gm)	Percent Passing (%)
6 Inch	6.0000	152.40		0.00	0.00	3,065.00	100.0
3 Inch	3.0000	76.20		0.00	0.00	3,065.00	100.0
2 Inch	2.0000	50.80		0.00	0.00	3,065.00	100.0
1.5 Inch	1.5000	38.10		0.00	0.00	3,065.00	100.0
1.0 Inch	1.0000	25.40	26.10	26.10	26.10	3,038.90	99.1
3/4 Inch	0.7500	19.05	66.10	66.10	92.20	2,972.80	97.0
1/2 Inch	0.5000	12.70	239.00	239.00	331.20	2,733.80	89.2
3/8 Inch	0.3750	9.53	235.60	235.60	566.80	2,498.20	81.5
#4	0.1870	4.75	616.40	616.40	1,183.20	1,881.80	61.4
PAN			1,881.80	1,881.80			

SAND PORTION SIEVE ANALYSIS (Portion Retained On < #4 Sieves)

Representative Sample Data:		#200 Wash Data:	
Pan ID		Portion >#200 Sieve:	222.40 (gm)
Pan Weight	(gm)	Portion <#200 Sieve:	107.90 (gm)
Wet Soil + Pan	330.30 (gm)	Percent <#200 Sieve	32.67 (%)
Wet Soil	330.30 (gm)	Total Wt. <#200 Sieve	614.73 (gm)
Dry Soil	330.30 (gm)		

Sieve Size	Particle Diameter		Dry Weight Rep. Sample		Total Sample Weight Retained (gm)	Accum. Grand Total On Sieve (gm)	Total Percent Passing (%)
	Inches (in.)	Millimeter (mm)	Retained On Sieve (gm)	Percent Retained (%)			
#10	0.079	2.000	91.8	27.79	523.01	1,705.21	44.3
#20	0.033	0.850	48.50	14.68	276.32	1,982.52	35.3
#40	0.017	0.425	27.60	8.36	157.24	2,139.77	30.2
#60	0.010	0.250	16.50	5.00	94.00	2,233.77	27.1
#100	0.006	0.150	17.80	5.39	101.41	2,335.18	23.8
#200	0.003	0.075	20.20	6.12	115.08	2,450.27	20.1
PAN			Discard				



PARTICLE SIZE DISTRIBUTION

ASTM D422, C136

DSA LEA No.: 284

Project No. 71075.00.001	Project Name: City of Clearlake Burns Valley Development	Date: 1/20/2021
Sample No. BK-1	Boring/Trench: B21-1	Depth, (ft.): 0-3
Description: (SC) CLAYEY SAND WITH GRAVEL; Yellowish Brown (10YR, 4/4)	Tested By: LGH	Checked By: DJP
Sample Location:		Lab. No. C21-014

Sieve Size (U.S. Standard)	Particle Diameter		Dry Weight on Sieve			Percent Passing (%)
	Inches (in.)	Millimeter (mm)	Retained On Sieve (gm)	Accumulated On Sieve (gm)	Passing Sieve (gm)	
6 Inch	6.0000	152.4	0.00	0.0	3,065.0	100.0
3 Inch	3.0000	76.2	0.00	0.0	3,065.0	100.0
2 Inch	2.0000	50.8	0.00	0.0	3,065.0	100.0
1.5 Inch	1.5000	38.1	0.00	0.0	3,065.0	100.0
1.0 Inch	1.0000	25.4	26.10	26.1	3,038.9	99.1
3/4 Inch	0.7500	19.1	66.10	92.2	2,972.8	97.0
1/2 Inch	0.5000	12.7	239.00	331.2	2,733.8	89.2
3/8 Inch	0.3750	9.5	235.60	566.8	2,498.2	81.5
#4	0.1870	4.7500	616.40	1,183.2	1,881.8	61.4
#10	0.0790	2.0066	523.01	1,706.2	1,358.8	44.3
#20	0.0335	0.8500	276.32	1,982.5	1,082.5	35.3
#40	0.0167	0.4250	157.24	2,139.8	925.2	30.2
#60	0.0098	0.2500	94.00	2,233.8	831.2	27.1
#100	0.0059	0.1500	101.41	2,335.2	729.8	23.8
#200	0.0030	0.0750	115.08	2,450.3	614.7	20.1

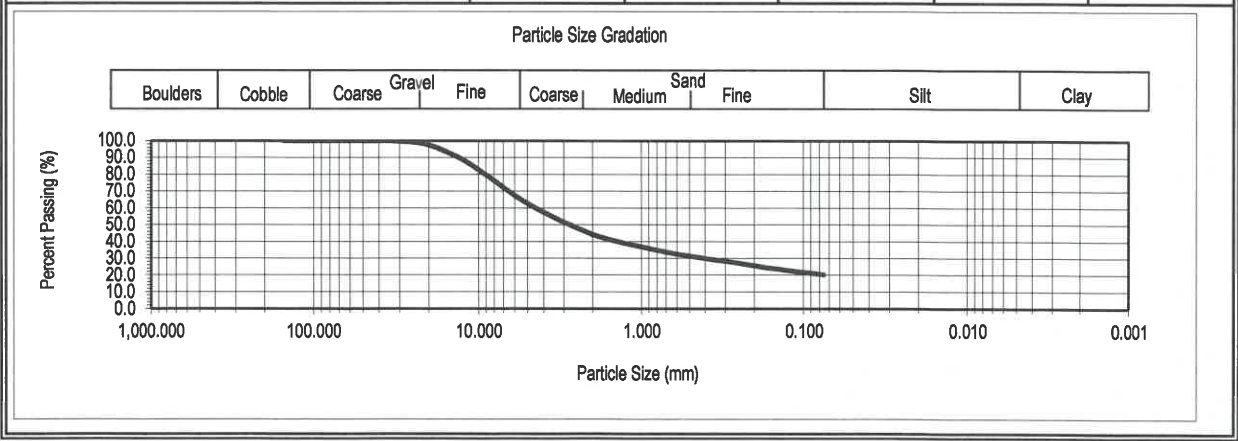



ATTERBERG INDICES

ASTM D4318

DSA LEA No. 284

DSA File No. N/A
 DSA App No. N/A

Project No.	71075.00.001	Project Name	City of Clearlake Burns Valley Development	Date:	01/20/21	
Sample No.	B2-1-1	Boring/Trench	B21-1	Depth, (ft.):	31.0	
Description:	(CH) FAT CLAY, Dark Greenish Gray (GLEYS 1, 4/1)				Tested By:	LGH
Sample Location:					Checked By:	DJP
					Lab. No.	C21-014

Estimated % of Sample Retained on No. 40 Sieve: _____ Sample Air Dried: _____
 Test Method A or B: A

Sample No.:	LIQUID LIMIT:					PLASTIC LIMIT:			
	1	2	3	4	5	1	2	3	
Pan ID:	E	C	X			D	Z		
Wt. Pan (gr)	36.45	38.47	38.20			38.29	37.46		
Wt. Wet Soil + Pan	44.43	48.24	47.42			44.50	43.55		
Wt. Dry Soil + Pan	41.69	44.81	44.07			43.31	42.43		
Wt. Water (gr)	2.74	3.43	3.35			1.19	1.12		
Wt. Dry Soil (gr)	5.24	6.34	5.87			5.02	4.97		
Water Content (%)	52.3	54.1	57.1			23.7	22.5		
Number of Blows, N	33	25	15						
LIQUID LIMIT =					54	PLASTIC LIMIT =			23

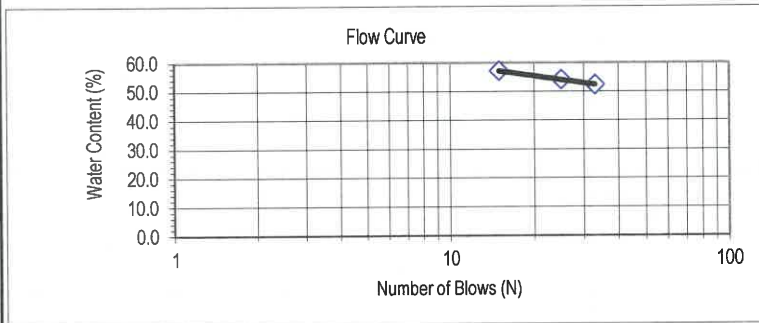

Plasticity Index = 31
 Group Symbol = CH

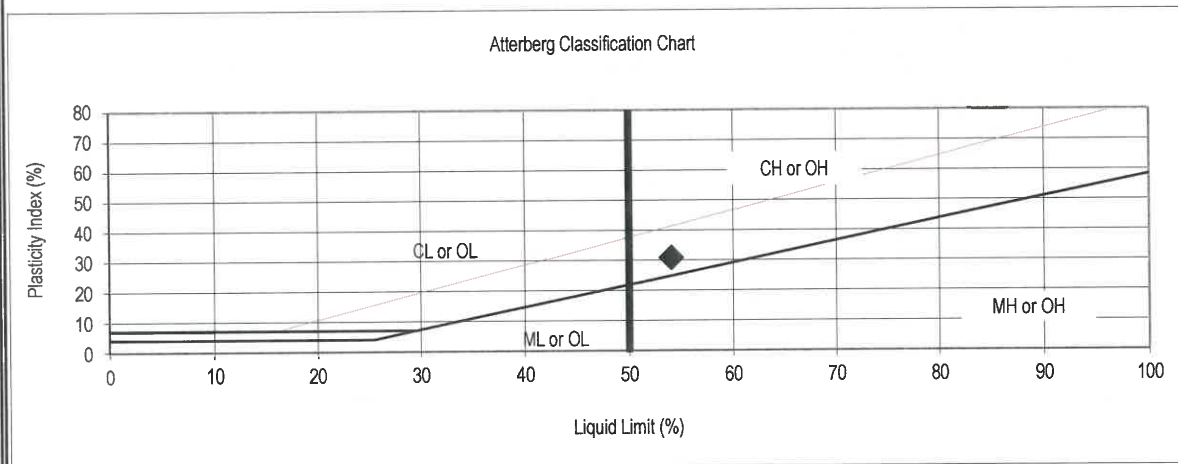



ATTERBERG INDICES

ASTM D4318

DSA LEA No. 284

DSA File No. N/A
 DSA App No. N/A

Project No.	71075.00.001	Project Name	City of Clearlake Burns Valley Development			Date:	01/20/21
Sample No.	BK-2	Boring/Trench	B21-2	Depth, (ft.):	1-3	Tested By:	LGH
Description:	(CL) SANDY CLAY; Dark Yellowish Brown (10YR, 3/6)					Checked By:	0
Sample Location:						Lab. No.	C21-014

Estimated % of Sample Retained on No. 40 Sieve: _____ Sample Air Dried: _____
 Test Method A or B: A

Sample No.:	LIQUID LIMIT:					PLASTIC LIMIT:		
	1	2	3	4	5	1	2	3
Pan ID:	D	A	B			V	Y	
Wt. Pan (gr)	38.30	38.47	38.98			37.35	37.12	
Wt. Wet Soil + Pan	47.47	50.22	48.41			44.65	43.20	
Wt. Dry Soil + Pan	44.97	46.90	45.71			43.37	42.17	
Wt. Water (gr)	2.50	3.32	2.70			1.28	1.03	
Wt. Dry Soil (gr)	6.67	8.43	6.73			6.02	5.05	
Water Content (%)	37.5	39.4	40.1			21.3	20.4	
Number of Blows, N	35	22	15					

LIQUID LIMIT = 39 PLASTIC LIMIT = 21

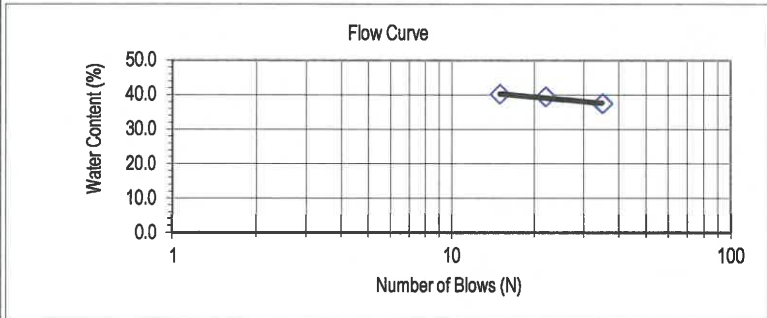

Plasticity Index = 18
 Group Symbol = CL

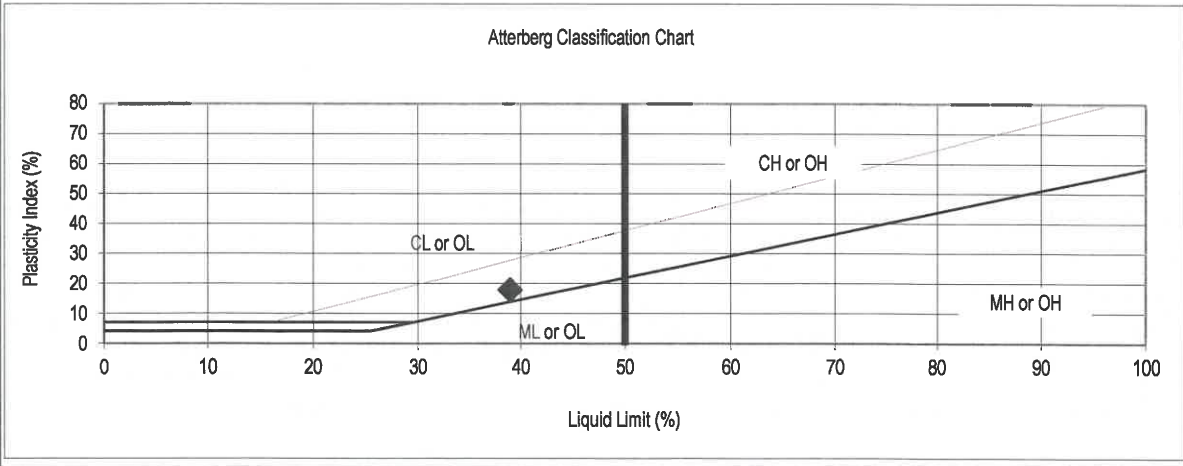



DSA LEA No. 284

PARTICLE SIZE DISTRIBUTION TEST WORK SHEET

ASTM D422, C136

DSA File No. N/A
DSA App No. N/A

Sieve Only Analysis Worksheet

Project No. 71075.00.001 Project Name: City of Clearlake Burns Valley Development Date: 01/20/21
 Sample No. BK-2 Boring/Trench: B21-2 Depth, (ft.): 1-3 Tested By: LGH
 Description: (CL) SANDY CLAY; Dark Yellowish Brown (10YR, 3/6) Checked By: 0
 Sample Location: Lab. No. C21-014

Moisture Content Data:		Total Material Sample Data:	
Pan ID		Pan ID	
Pan Weight	(gm)	Pan Weight	(gm)
Wet Soil + Pan	(gm)	Wet Soil + Pan Wt.	2,048.70 (gm)
Dry Soil + Pan	(gm)	Total Wet Weight	2,048.70 (gm)
Water Weight	0.00 (gm)	Total Dry Weight	2,048.70 (gm)
Dry Soil Weight	0.00 (gm)	Total Dry Wt. >#4 Sieve	224.20 (gm)
Moisture Content	0.0 (%)	Total Dry Wt. <#4 Sieve	1,824.50 (gm)
		Total Dry Wt. <#200 Sieve	1,169.67 (gm)
		Total Percent <#200 Sieve	57.09 (%)

GRAVEL PORTION SIEVE ANALYSIS (Portion Retained On > #4 Sieve)

Sieve Size	Particle Diameter		Wet Weight Retained On Sieve (gm)	Dry Weight			
	Inches (in.)	Millimeter (mm)		Retained On Sieve (gm)	Accum. On Sieve (gm)	Passing Sieve (gm)	Percent Passing (%)
6 Inch	6.0000	152.40		0.00	0.00	2,048.70	100.0
3 Inch	3.0000	76.20		0.00	0.00	2,048.70	100.0
2 Inch	2.0000	50.80		0.00	0.00	2,048.70	100.0
1.5 Inch	1.5000	38.10		0.00	0.00	2,048.70	100.0
1.0 Inch	1.0000	25.40		0.00	0.00	2,048.70	100.0
3/4 Inch	0.7500	19.05		0.00	0.00	2,048.70	100.0
1/2 Inch	0.5000	12.70		0.00	0.00	2,048.70	100.0
3/8 Inch	0.3750	9.53	28.20	28.20	28.20	2,020.50	98.6
#4	0.1870	4.75	196.00	196.00	224.20	1,824.50	89.1
PAN			1,824.50	1,824.50			

SAND PORTION SIEVE ANALYSIS (Portion Retained On < #4 Sieves)

Representative Sample Data:

Pan Data		#200 Wash Data:	
Pan ID		Portion >#200 Sieve:	117.40 (gm)
Pan Weight	(gm)	Portion <#200 Sieve:	209.70 (gm)
Wet Soil + Pan	327.10 (gm)	Percent <#200 Sieve	64.11 (%)
Wet Soil	327.10 (gm)	Total Wt. <#200 Sieve	1169.67 (gm)
Dry Soil	327.10 (gm)		

Sieve Size	Particle Diameter		Dry Weight Rep. Sample		Total Sample Weight Retained (gm)	Accum. Grand Total On Sieve (gm)	Total Percent Passing (%)
	Inches (in.)	Millimeter (mm)	Retained On Sieve (gm)	Percent Retained (%)			
#10	0.079	2.000	23.8	7.28	132.75	356.95	82.6
#20	0.033	0.850	17.10	5.23	95.38	452.33	77.9
#40	0.017	0.425	15.50	4.74	86.46	538.79	73.7
#60	0.010	0.250	13.70	4.19	76.42	615.20	70.0
#100	0.006	0.150	19.10	5.84	106.54	721.74	64.8
#200	0.003	0.075	28.20	8.62	157.29	879.03	57.1
PAN			Discard				



PARTICLE SIZE DISTRIBUTION

ASTM D422, C136

DSA LEA No.: 284

Project No. **71075.00.001** Project Name: **City of Clearlake Burns Valley Development** Date: **1/20/2021**
 Sample No. **BK-2** Boring/Trench: **B21-2** Depth, (ft.): **1-3** Tested By: **LGH**
 Description: **(CL) SANDY CLAY; Dark Yellowish Brown (10YR, 3/6)** Checked By: **0**
 Sample Location: Lab. No. **C21-014**

Sieve Size (U.S. Standard)	Particle Diameter		Dry Weight on Sieve			Percent Passing (%)
	Inches (in.)	Millimeter (mm)	Retained On Sieve (gm)	Accumulated On Sieve (gm)	Passing Sieve (gm)	
6 Inch	6.0000	152.4	0.00	0.0	2,048.7	100.0
3 Inch	3.0000	76.2	0.00	0.0	2,048.7	100.0
2 Inch	2.0000	50.8	0.00	0.0	2,048.7	100.0
1.5 Inch	1.5000	38.1	0.00	0.0	2,048.7	100.0
1.0 Inch	1.0000	25.4	0.00	0.0	2,048.7	100.0
3/4 Inch	0.7500	19.1	0.00	0.0	2,048.7	100.0
1/2 Inch	0.5000	12.7	0.00	0.0	2,048.7	100.0
3/8 Inch	0.3750	9.5	28.20	28.2	2,020.5	98.6
#4	0.1875	4.7500	196.00	224.2	1,824.5	89.1
#10	0.0750	2.0066	132.75	357.0	1,691.7	82.6
#20	0.0335	0.8500	95.38	452.3	1,596.4	77.9
#40	0.0167	0.4250	86.46	538.8	1,509.9	73.7
#60	0.0098	0.2500	76.42	615.2	1,433.5	70.0
#100	0.0059	0.1500	106.54	721.7	1,327.0	64.8
#200	0.0030	0.0750	157.29	879.0	1,169.7	57.1

Hydrometer

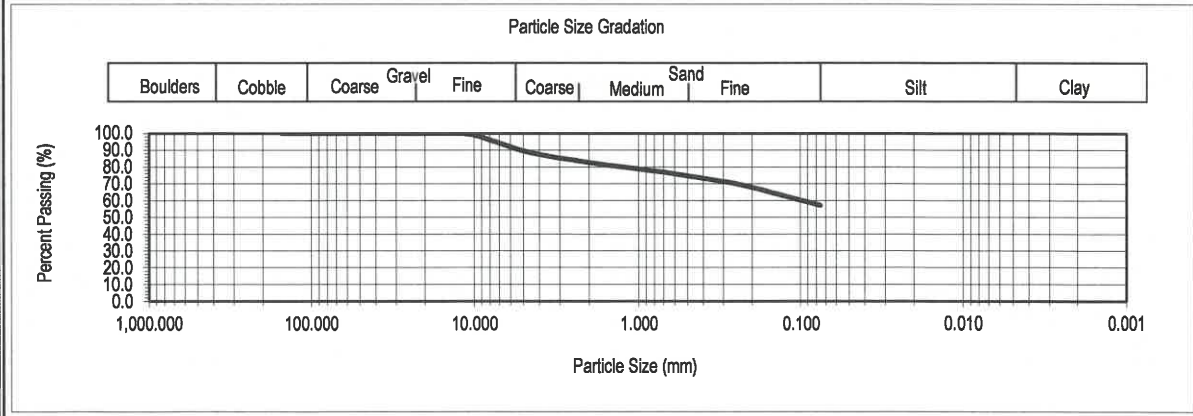



MOISTURE & DENSITY
ASTM D2216, D2937, C566

DSA File No. N/A
DSA App No. N/A

Project No. 71075.00.001 Project Name: City of Clearlake Burns Valley Development Date: 01/20/21
 Tested By: LGH
 Checked By: DJP
 Lab. No. C21-014

SAMPLE LOCATION DATA

Boring/Trench No.	Units	B21-2							
Sample No.		L2-1-2							
Depth Interval	(ft.)	6.0							
Sample Description		(CL) Sandy Clay; Dark Yellowish Brown (10YR,3/6)							
USCS Symbol		CL							

SAMPLE DIMENSION AND WEIGHT DATA

Sample Length	(in)	6.043							
Sample Diameter	(in)	2.367							
Sample Volume	(cf)	0.0154							
Wet Soil + Tube Wt.	(gr)	817.20							
Tube Wt.	(gr)	0.00							
Wet Soil Wt.	(gr)	817.20							

MOISTURE CONTENT DATA

Tare No.		ZZ-2							
Tare Wt.	(gr)	0.00							
Wet Soil + Tare Wt.	(gr)	817.20							
Dry Soil + Tare Wt.	(gr)	703.70							
Water Wt.	(gr)	113.50							
Dry Soil Wt.	(gr)	703.70							
Moisture Content	(%)	16.1							

TEST RESULTS

Wet Unit Wt.	(pcf)	117.1							
Moisture Content	(%)	16.1							
Dry Unit Wt.	(pcf)	100.8							

MOISTURE CORRECTION DATA

Gauge Moisture	(%)								
K Value Correction Factor									

COMPACTION CURVE DATA (ASTM D698, ASTM D1557, or CAL216)

Test Method									
Curve No.									
Max Wet Unit Wt.	(pcf)								
Max Dry Unit Wt.	(pcf)								
Optimum Moisture	(%)								
Wet Relative Comp.	(%)								
Dry Relative Comp.	(%)								



NV5
48 Bellarmine Court, Suite 40
Chico, CA 95928
530-894-2487

Unconsolidated Undrained Test

ASTM D2850

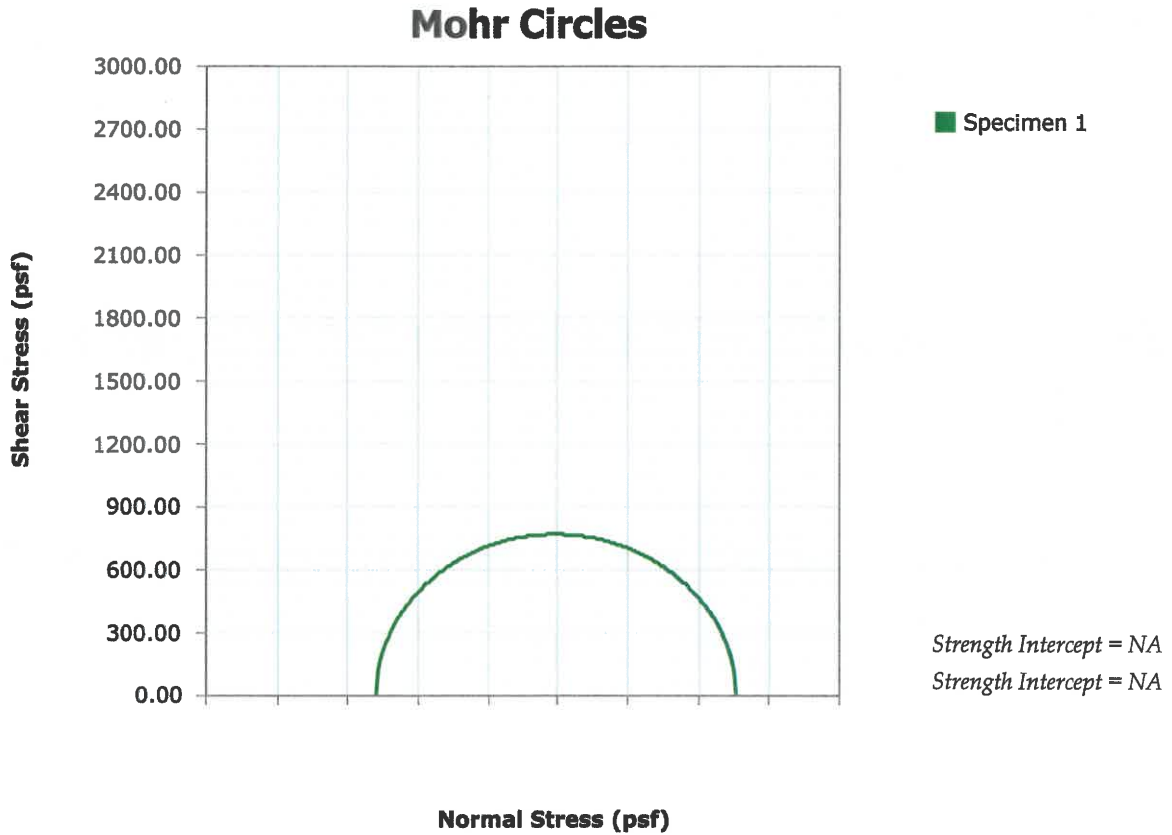

Project:	City of Clearlake Burns Valley Development
Project Number:	71075.00.001
Sampling Date:	
Sample Number:	L1-2-2
Sample Depth:	1.5 ft
Location:	B21-8
Client Name:	City of Clearlake
Remarks:	

Unconsolidated Undrained Test

ASTM D2850

Before Test	Specimen Number							
	1	2	3	4	5	6	7	8
Membrane Thickness (in)	0.001							
Initial Cell Pressure (psi)	5.0							
Height (in)	5.680							
Diameter (in)	2.375							
Water Content (%)	18.5							
Wet Density (Units)	120.4							
Dry Density (pcf)	101.6							
Degree of Saturation (%)	78.0							
Void Ratio	0.628							
Height To Diameter Ratio	2.392							
Test Data	1	2	3	4	5	6	7	8
Comp. Strength at Failure (psf)	1538.51							
σ_1 at Failure (psf)	2258.51							
σ_3 at Failure (psf)	720.00							
Rate of Strain (in/min)	0.085200							
Axial Strain at Failure (%)	20.44							
After Test	1	2	3	4	5	6	7	8
Final Water Content (%)	22.3							

Project:	City of Clearlake Burns Valley Development
Project Number:	71075.00.001
Sampling Date:	
Sample Number:	L1-2-2
Sample Depth:	1.5 ft
Location:	B21-8
Client Name:	City of Clearlake
Project Remarks:	

Specimen 1	Specimen 2	Specimen 3	Specimen 4	Specimen 5	Specimen 6	Specimen 7	Specimen 8
Failure Sketch	Failure Sketch	Failure Sketch	Failure Sketch	Failure Sketch	Failure Sketch	Failure Sketch	Failure Sketch
							



Unconsolidated Undrained Test

ASTM D2850

Specimen 1	
Test Description:	D2850
Other Associated Tests:	
Device Details:	
Test Specification:	
Test Time:	2/3/2021
Technician:	DJP
Specimen Code:	
Sampling Method:	
Specimen Lab #:	
Specimen Description:	
Specific Gravity:	2.650
Plastic Limit:	0
Liquid Limit:	0
Height (in):	5.680
Diameter (in):	2.375
Area (in ²):	4.430
Volume (in ³):	25.16
Large Particle:	
Moisture Material:	Specimen
Moist Weight (g):	795.4
Test Remarks:	



NV5

48 Bellarmine Court, Suite 40
Chico, CA 95928
530-894-2487

Mohr Circles (Total Stress) Graph

ASTM D2850

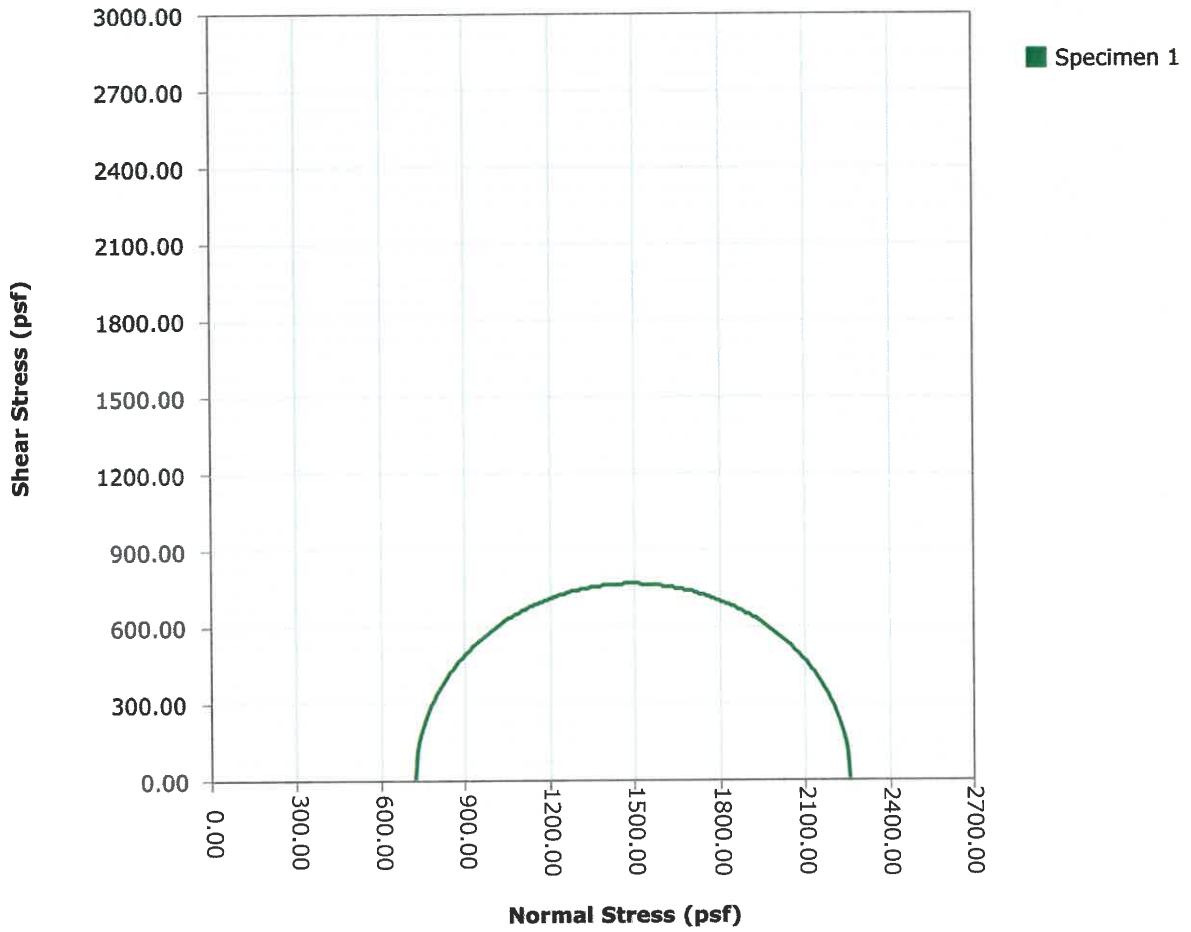

Tangent Results	
Strength Intercept (psi)	NA
Friction Angle (°)	NA



NV5
48 Bellarmine Court, Suite 40
Chico, CA 95928
530-894-2487

Stress-Strain Graph

ASTM D2850

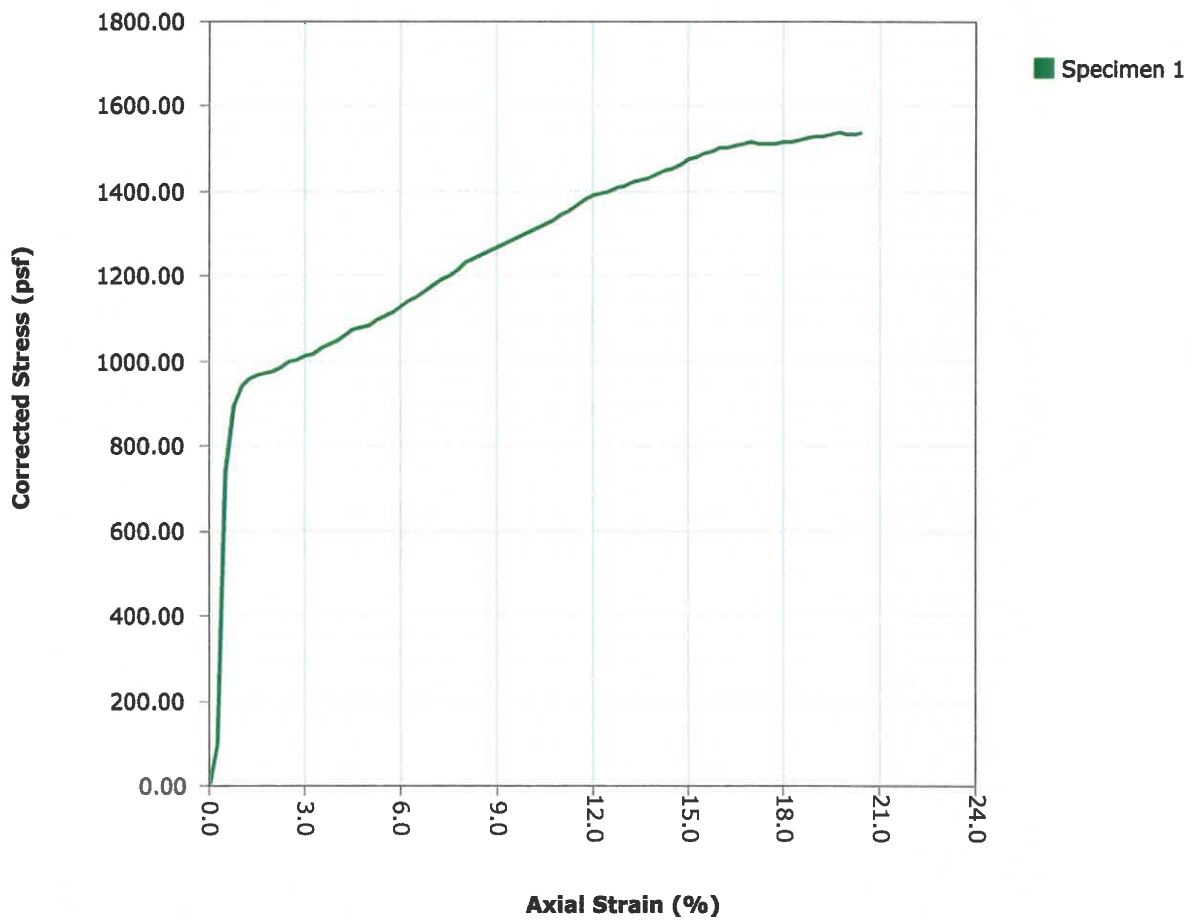

Unconsolidated Undrained Test - Tabulated Data - Specimen 1

ASTM D2850

Index	Elapsed Time (hh:mm:ss)	Load (Lbf)	Disp. (in)	Corrected			Axial Strain (%)	Stress (psf)	Corrected			σ ₁ - σ ₃ (psf)	P (psf)	q (psf)
				Load (Lbf)	Disp. (in)	Area (in ²)			Stress (psf)	Stress (psf)	σ ₁ (psf)			
0	00:00:00	2.1	0.0007	0.0	0.000	4.430	0.0	0.00	0.00	720.00	720.00	1.000	720.00	0.00
1	00:00:10	5.2	0.0151	3.0	0.014	4.441	0.3	97.84	97.47	817.47	720.00	1.135	768.74	48.74
2	00:00:20	24.9	0.0293	22.8	0.029	4.453	0.5	739.77	735.79	1,455.79	720.00	2.022	1,087.90	367.90
3	00:00:30	29.9	0.0439	27.7	0.043	4.464	0.8	901.70	894.48	1,614.48	720.00	2.242	1,167.24	447.24
4	00:00:40	31.4	0.0582	29.2	0.057	4.475	1.0	950.21	940.11	1,660.11	720.00	2.306	1,190.05	470.05
5	00:00:50	32.1	0.0723	29.9	0.072	4.487	1.3	972.86	960.59	1,680.59	720.00	2.334	1,200.30	480.30
6	00:01:00	32.4	0.0865	30.3	0.086	4.498	1.5	984.54	969.67	1,689.67	720.00	2.347	1,204.83	484.83
7	00:01:10	32.6	0.1006	30.4	0.100	4.509	1.8	988.69	971.30	1,691.30	720.00	2.349	1,205.65	485.65
8	00:01:20	32.8	0.1147	30.7	0.114	4.521	2.0	997.82	977.79	1,697.79	720.00	2.358	1,208.90	488.90
9	00:01:30	33.2	0.1288	31.1	0.128	4.532	2.3	1,009.64	986.88	1,706.88	720.00	2.371	1,213.44	493.44
10	00:01:40	33.6	0.1428	31.5	0.142	4.544	2.5	1,022.67	997.09	1,717.09	720.00	2.385	1,218.54	498.54
11	00:01:50	34.0	0.1569	31.8	0.156	4.555	2.8	1,034.12	1,005.68	1,725.68	720.00	2.397	1,222.84	502.84
12	00:02:00	34.2	0.1712	32.1	0.170	4.567	3.0	1,042.13	1,010.85	1,730.85	720.00	2.404	1,225.43	505.43
13	00:02:10	34.5	0.1854	32.4	0.185	4.579	3.3	1,052.95	1,018.71	1,738.71	720.00	2.415	1,229.35	509.35
14	00:02:20	35.0	0.1998	32.9	0.199	4.591	3.5	1,067.99	1,030.56	1,750.56	720.00	2.431	1,235.28	515.28
15	00:02:30	35.4	0.2141	33.2	0.213	4.603	3.8	1,079.56	1,039.01	1,759.01	720.00	2.443	1,239.50	519.50
16	00:02:40	35.7	0.2286	33.6	0.228	4.615	4.0	1,091.94	1,048.12	1,768.12	720.00	2.456	1,244.06	524.06
17	00:02:50	36.3	0.2431	34.1	0.242	4.628	4.3	1,109.38	1,062.04	1,782.04	720.00	2.475	1,251.02	531.02
18	00:03:00	36.7	0.2575	34.6	0.257	4.640	4.5	1,124.44	1,073.59	1,793.59	720.00	2.491	1,256.80	536.80
19	00:03:10	37.1	0.2716	34.9	0.271	4.652	4.8	1,135.74	1,081.57	1,801.57	720.00	2.502	1,260.78	540.78
20	00:03:20	37.3	0.2861	35.2	0.285	4.664	5.0	1,143.83	1,086.36	1,806.36	720.00	2.509	1,263.18	543.18
21	00:03:30	37.7	0.3001	35.6	0.299	4.677	5.3	1,156.95	1,095.97	1,815.97	720.00	2.522	1,267.98	547.98
22	00:03:40	38.1	0.3142	36.0	0.313	4.689	5.5	1,170.11	1,105.53	1,825.53	720.00	2.535	1,272.76	552.76
23	00:03:50	38.6	0.3283	36.5	0.328	4.701	5.8	1,186.37	1,117.94	1,837.94	720.00	2.553	1,278.97	558.97
24	00:04:00	39.2	0.3425	37.0	0.342	4.714	6.0	1,203.35	1,130.94	1,850.94	720.00	2.571	1,285.47	565.47
25	00:04:10	39.7	0.3567	37.5	0.356	4.726	6.3	1,219.44	1,143.02	1,863.02	720.00	2.588	1,291.51	571.51

Unconsolidated Undrained Test - Tabulated Data - Specimen 1

ASTM D2850

Index	Elapsed Time (hh:mm:ss)	Load (Lbf)	Disp. (in)	Corrected			Corrected			Corrected				
				Load (Lbf)	Disp. (in)	Area (in ²)	Area (in ²)	Disp. (in)	Axial Strain (%)	Stress (psf)	Stress (psf)	Stress (psf)	σ ₁ - σ ₃ (psf)	σ ₃ (psf)
26	00:04:20	40.1	0.3709	38.0	0.370	4.739	6.5	1,234.29	1,153.85	1,873.85	2.603	720.00	1,296.92	576.92
27	00:04:30	40.6	0.3850	38.5	0.384	4.752	6.8	1,249.92	1,165.35	1,885.35	2.619	720.00	1,302.67	582.67
28	00:04:40	41.1	0.3993	39.0	0.399	4.764	7.0	1,266.67	1,177.78	1,897.78	2.636	720.00	1,308.89	588.89
29	00:04:50	41.6	0.4137	39.5	0.413	4.778	7.3	1,283.95	1,190.58	1,910.58	2.654	720.00	1,315.29	595.29
30	00:05:00	42.2	0.4281	40.0	0.427	4.791	7.5	1,300.99	1,203.09	1,923.09	2.671	720.00	1,321.54	601.54
31	00:05:10	42.7	0.4424	40.6	0.442	4.804	7.8	1,319.49	1,216.87	1,936.87	2.690	720.00	1,328.43	608.43
32	00:05:20	43.4	0.4566	41.2	0.456	4.817	8.0	1,340.32	1,232.72	1,952.72	2.712	720.00	1,336.36	616.36
33	00:05:30	43.8	0.4707	41.6	0.470	4.830	8.3	1,353.01	1,241.05	1,961.05	2.724	720.00	1,340.53	620.53
34	00:05:40	44.2	0.4849	42.0	0.484	4.843	8.5	1,366.64	1,250.14	1,970.14	2.736	720.00	1,345.07	625.07
35	00:05:50	44.6	0.4989	42.5	0.498	4.856	8.8	1,380.45	1,259.36	1,979.36	2.749	720.00	1,349.68	629.68
36	00:06:00	45.0	0.5130	42.9	0.512	4.869	9.0	1,394.23	1,268.48	1,988.48	2.762	720.00	1,354.24	634.24
37	00:06:10	45.5	0.5270	43.3	0.526	4.883	9.3	1,408.09	1,277.61	1,997.61	2.774	720.00	1,358.80	638.80
38	00:06:20	45.9	0.5411	43.7	0.540	4.896	9.5	1,421.24	1,286.01	2,006.01	2.786	720.00	1,363.00	643.00
39	00:06:30	46.3	0.5552	44.1	0.554	4.909	9.8	1,434.51	1,294.48	2,014.48	2.798	720.00	1,367.24	647.24
40	00:06:40	46.7	0.5693	44.6	0.569	4.923	10.0	1,449.54	1,304.42	2,024.42	2.812	720.00	1,372.21	652.21
41	00:06:50	47.2	0.5835	45.1	0.583	4.937	10.3	1,465.35	1,315.00	2,035.00	2.826	720.00	1,377.50	657.50
42	00:07:00	47.6	0.5977	45.5	0.597	4.950	10.5	1,478.52	1,323.11	2,043.11	2.838	720.00	1,381.56	661.56
43	00:07:10	48.1	0.6122	45.9	0.611	4.965	10.8	1,493.14	1,332.40	2,052.40	2.851	720.00	1,386.20	666.20
44	00:07:20	48.6	0.6265	46.5	0.626	4.979	11.0	1,510.09	1,343.72	2,063.72	2.866	720.00	1,391.86	671.86
45	00:07:30	49.1	0.6410	47.0	0.640	4.993	11.3	1,527.66	1,355.46	2,075.46	2.883	720.00	1,397.73	677.73
46	00:07:40	49.8	0.6551	47.6	0.654	5.007	11.5	1,547.62	1,369.32	2,089.32	2.902	720.00	1,404.66	684.66
47	00:07:50	50.3	0.6693	48.1	0.669	5.021	11.8	1,564.00	1,379.91	2,099.91	2.917	720.00	1,409.95	689.95
48	00:08:00	50.7	0.6833	48.6	0.683	5.035	12.0	1,578.67	1,388.95	2,108.95	2.929	720.00	1,414.48	694.48
49	00:08:10	51.1	0.6974	48.9	0.697	5.050	12.3	1,589.90	1,394.88	2,114.88	2.937	720.00	1,417.44	697.44
50	00:08:20	51.4	0.7114	49.3	0.711	5.064	12.5	1,601.17	1,400.84	2,120.84	2.946	720.00	1,420.42	700.42
51	00:08:30	51.8	0.7256	49.6	0.725	5.078	12.8	1,613.14	1,407.27	2,127.27	2.955	720.00	1,423.64	703.64

Section I, Item 5.

Unconsolidated Undrained Test - Tabulated Data - Specimen 1

ASTM D2850

Index	Elapsed Time (hh:mm:ss)	Load (Lbf)	Disp. (in)	Corrected		Axial Strain (%)	Stress (psf)	Corrected		o1 - o3 (psf)	p (psf)	q (psf)		
				Load (Lbf)	Disp. (in)			Area (in ²)	Stress (psf)				o1 (psf)	o3 (psf)
52	00:08:40	52.1	0.7396	50.0	0.739	5.093	13.0	1,625.06	1,413.65	2,133.65	720.00	2.963	1,426.82	706.82
53	00:08:50	52.5	0.7536	50.4	0.753	5.107	13.3	1,637.06	1,420.06	2,140.06	720.00	2.972	1,430.03	710.03
54	00:09:00	52.8	0.7676	50.7	0.767	5.122	13.5	1,647.90	1,425.40	2,145.40	720.00	2.980	1,432.70	712.70
55	00:09:10	53.2	0.7817	51.1	0.781	5.136	13.8	1,660.51	1,432.18	2,152.18	720.00	2.989	1,436.09	716.09
56	00:09:20	53.7	0.7959	51.5	0.795	5.151	14.0	1,674.91	1,440.42	2,160.42	720.00	3.001	1,440.21	720.21
57	00:09:30	54.1	0.8103	51.9	0.810	5.167	14.3	1,687.55	1,447.00	2,167.00	720.00	3.010	1,443.50	723.50
58	00:09:40	54.5	0.8249	52.3	0.824	5.182	14.5	1,701.37	1,454.47	2,174.48	720.00	3.020	1,447.24	727.24
59	00:09:50	54.9	0.8393	52.8	0.839	5.197	14.8	1,715.53	1,462.25	2,182.25	720.00	3.031	1,451.13	731.13
60	00:10:00	55.5	0.8536	53.4	0.853	5.213	15.0	1,734.54	1,474.08	2,194.08	720.00	3.047	1,457.04	737.04
61	00:10:10	56.0	0.8677	53.8	0.867	5.228	15.3	1,749.72	1,482.63	2,202.63	720.00	3.059	1,461.31	741.31
62	00:10:20	56.3	0.8818	54.2	0.881	5.243	15.5	1,760.92	1,487.77	2,207.77	720.00	3.066	1,463.89	743.89
63	00:10:30	56.7	0.8956	54.6	0.895	5.259	15.8	1,773.36	1,493.95	2,213.95	720.00	3.075	1,466.98	746.98
64	00:10:40	57.1	0.9096	55.0	0.909	5.274	16.0	1,787.19	1,501.20	2,221.20	720.00	3.085	1,470.60	750.60
65	00:10:50	57.4	0.9236	55.3	0.923	5.290	16.2	1,797.26	1,505.23	2,225.23	720.00	3.091	1,472.61	752.61
66	00:11:00	57.7	0.9378	55.6	0.937	5.305	16.5	1,806.11	1,508.13	2,228.13	720.00	3.095	1,474.07	754.07
67	00:11:10	58.0	0.9518	55.8	0.951	5.321	16.7	1,813.88	1,510.15	2,230.15	720.00	3.097	1,475.08	755.08
68	00:11:20	58.3	0.9660	56.1	0.965	5.337	17.0	1,824.36	1,514.30	2,234.30	720.00	3.103	1,477.15	757.15
69	00:11:30	58.3	0.9802	56.1	0.979	5.353	17.2	1,824.55	1,509.92	2,229.92	720.00	3.097	1,474.96	754.96
70	00:11:40	58.5	0.9945	56.3	0.994	5.370	17.5	1,830.85	1,510.50	2,230.50	720.00	3.098	1,475.25	755.25
71	00:11:50	58.7	1.0088	56.6	1.008	5.386	17.7	1,839.20	1,512.77	2,232.77	720.00	3.101	1,476.39	756.39
72	00:12:00	59.0	1.0232	56.9	1.023	5.403	18.0	1,849.09	1,516.20	2,236.20	720.00	3.106	1,478.10	758.10
73	00:12:10	59.2	1.0376	57.1	1.037	5.419	18.3	1,855.67	1,516.91	2,236.91	720.00	3.107	1,478.46	758.46
74	00:12:20	59.5	1.0519	57.4	1.051	5.436	18.5	1,865.59	1,520.31	2,240.31	720.00	3.112	1,480.16	760.16
75	00:12:30	59.9	1.0663	57.8	1.066	5.453	18.8	1,877.79	1,525.51	2,245.51	720.00	3.119	1,482.76	762.76
76	00:12:40	60.3	1.0804	58.1	1.080	5.470	19.0	1,888.87	1,529.81	2,249.81	720.00	3.125	1,484.91	764.90
77	00:12:50	60.5	1.0943	58.4	1.094	5.487	19.3	1,897.28	1,531.97	2,251.97	720.00	3.128	1,485.99	765.99

Unconsolidated Undrained Test - Tabulated Data - Specimen 1

ASTM D2850

Index	Elapsed Time (hh:mm:ss)	Load (Lbf)	Disp. (in)	Corrected		Axial Strain (%)	Stress (psf)	Corrected Compressive		$\sigma_1 - \sigma_3$	p (psf)	q (psf)	
				Load (Lbf)	Disp. (in)			Area (in ²)	Stress (psf)				σ_1 (psf)
78	00:13:00	60.8	1.1081	58.6	1.107	5.503	1,906.28	1,534.61	2,254.61	720.00	3.131	1,487.31	767.31
79	00:13:10	61.1	1.1223	58.9	1.122	5.520	1,915.23	1,537.04	2,257.04	720.00	3.135	1,488.52	768.52
80	00:13:20	61.2	1.1364	59.1	1.136	5.537	1,920.64	1,536.60	2,256.60	720.00	3.134	1,488.30	768.30
81	00:13:30	61.4	1.1505	59.3	1.150	5.555	1,926.08	1,536.16	2,256.16	720.00	3.134	1,488.08	768.08
82	00:13:37	61.6	1.1615	59.5	1.161	5.568	1,933.71	1,538.51	2,258.51	720.00	3.137	1,489.25	769.25

APPENDIX D:

Liquefaction Analysis Results

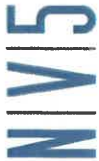

Appendix D: SPT-Based Liquefaction Triggering Analysis for a Single Boring

Project Name: Proposed Burns Valley Development

Project No.: 71075.00

Boring No.: BZ1-1

Input parameters:

Peak ground accel (g) = 0.628 PGA_w

Earthquake magnitude, M = 9

Water table depth (m) = 3.048

Average Y above water table (kN/m²) = 17.6

Average Y below water table (kN/m²) = 16.0

Borehole Diameter (mm) = 203.2

Requires correction for sampler liners (YES/NO) YES

Rod lengths assumed equal to the depth plus 1.5m (for the above ground extension).

*multiply unit weight in pcf by 0.16026 to obtain metric units

Liquefaction Potential and Triggering

SPT Sample Number	Depth (m)	Measured N	Soil Type (USCS)	Flag "Clay" "Unsaturated" "Unreliable"	Fines Content (%)	Energy Ratio, ER (%)	C _E	C _B	C _R	C _S	N ₆₀	α _{cs} (kPa)	α _{cs} ' (kPa)	C _N	(N) ₆₀	Δn for fines content (N) _{60cs}	Stress Reduct. Coefficient i _r	CSR	MSF for sand	K _s for sand	crit FOR m=7.5 & α _{cs} '=1aim	CRR	Factor of Safety
1	1.524	23	SC	unsaturated	20	75	1.25	1.15	0.8	1.3	34.4	27	27	1.42	48.7	4.5	1.00	0.410	0.87	1.10	2.000	n.a.	n.a.
2	3.048	34	CL	clay	60	75	1.25	1.15	0.85	1.3	54.0	54	54	1.18	63.8	5.6	1.00	0.410	0.87	1.10	2.000	n.a.	n.a.
3	4.572	11	CL	clay	60	75	1.25	1.15	0.95	1.3	19.5	78	63	1.13	n.a.	n.a.	1.01	0.507	0.67	1.10	n.a.	n.a.	n.a.
4	6.096	46	CL	clay	90	75	1.25	1.15	0.95	1.3	81.7	103	73	1.09	n.a.	n.a.	1.01	0.579	0.67	1.10	n.a.	n.a.	n.a.
5	7.620	13	GM	clay	20	75	1.25	1.15	0.95	1.2374	22.0	127	82	1.08	23.7	4.5	1.01	0.635	0.67	1.10	0.393	0.273	0.43
6	9.144	5	CH	clay	85	75	1.25	1.15	1	1.3	9.3	151	92	1.03	n.a.	n.a.	1.01	0.678	0.67	1.03	n.a.	n.a.	n.a.
7	10.668	35	CH	clay	85	75	1.25	1.15	1	1.3	65.4	176	101	1.00	n.a.	n.a.	1.00	0.713	0.67	1.00	n.a.	n.a.	n.a.
8	12.192	18	CH	clay	85	75	1.25	1.15	1	1.3	33.6	200	111	1.00	n.a.	n.a.	1.00	0.741	0.67	0.97	n.a.	n.a.	n.a.
9	13.716	16	CH	clay	85	75	1.25	1.15	1	1.3	29.9	225	120	0.96	n.a.	n.a.	1.00	0.764	0.67	0.95	n.a.	n.a.	n.a.
10	15.240	22	CH	clay	85	75	1.25	1.15	1	1.3	41.1	249	130	0.94	n.a.	n.a.	1.00	0.782	0.67	0.93	n.a.	n.a.	n.a.

Seismically Induced Settlement

SPT Sample Number	Depth (m)	Measured N	Soil Type (USCS)	Limiting shear strain γ _{lim}	Parameter F _{sr}	Maximum shear strain γ _{max}	ΔL _{Di} (m)	Vertical reconsol. Strain ε _v	ΔS _i (m)	ΔS _i (m)	ΔS _i (m)
1	1.524	23	SC	0.000	-1.851	0.000	1.524	0.000	0.000	0.000	0.000
2	3.048	34	CL	0.000	-3.239	0.000	1.524	0.000	0.000	0.000	0.000
3	4.572	11	CL	0.000	0.000	0.000	1.524	0.000	0.000	0.000	0.000
4	6.096	46	CL	0.000	0.000	0.000	1.524	0.000	0.000	0.000	0.000
5	7.620	13	GM	0.059	0.029	0.059	1.524	0.012	0.012	0.012	0.012
6	9.144	5	CH	0.000	0.000	0.000	1.524	0.000	0.000	0.000	0.000
7	10.668	35	CH	0.000	0.000	0.000	1.524	0.000	0.000	0.000	0.000
8	12.192	18	CH	0.000	0.000	0.000	1.524	0.000	0.000	0.000	0.000
9	13.716	16	CH	0.000	0.000	0.000	1.524	0.000	0.000	0.000	0.000
10	15.240	22	CH	0.000	0.000	0.000	1.524	0.000	0.000	0.000	0.000
							LDI=	0.090	Total S=	0.039	0.749

Field Data for Conversion

Sample Number	Sample Depth (ft)	Strata Δh (ft)	Depth to GW (ft)	Historic High Depth to GW (ft)	Ave. Unit Wt Above GW (pcf)	Ave. Unit Wt Below GW (pcf)	Borehole Dia. (in)
1	5	1.524	19	10	110	100	8
2	10	1.524					
3	15	1.524					
4	20	1.524					
5	25	1.524					
6	30	1.524					
7	35	1.524					
8	40	1.524					
9	45	1.524					
10	50	1.524					

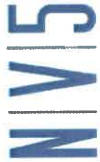

Appendix D: SPT-Based Liquefaction Triggering Analysis for a Single Boring

Project Name: Proposed Burns Valley Development
Project No.: 71075-00
Boring No.: B21-2

Input parameters:
 Peak ground accel (g) = 0.628 PG_A
 Earthquake magnitude, M = 9
 Water table depth (m) = 3.048
 Average γ above water table (kN/m³) = 17.6
 Average γ below water table (kN/m³) = 16.0

*Multiply unit weight in pcf by 0.16026 to obtain metric units

Borehole Diameter (mm) = 203.2

Requires correction for sampler liners (YES/NO) Yes

Rod lengths assumed equal to the depth plus 1.5m (for the above ground extension).

Liquefaction Potential and Triggering

SPT Sample Number	Depth (m)	Measured N	Soil Type	Flag "Clay" "Unsaturated" "Unreliable"	Fines Content (%)	Energy Ratio, ER (%)	C _E	C _B	C _R	C _S	N ₆₀	q _{cs} ' (kPa)	q _{cs} (kPa)	C _N	(N ₁) ₆₀	Δn for fines content	(N ₁) ₆₀₋₃	Stress Reduct. Coefficient f _d	CSR	MSF for sand	K _{cs} for sand	crit FOR m=7.5 & q _{cs} =1atm	CRR	Factor of Safety
1	1.524	28	SC	unsaturated	60	75	1.25	1.15	0.8	1.3	41.9	27	27	1.42	59.3	5.6	64.91	1.00	0.410	0.67	1.10	2.000	n.a.	n.a.
2	3.048	29	CL	unsaturated	60	75	1.25	1.15	0.85	1.3	46.1	54	54	1.18	54.4	5.6	59.99	1.00	0.410	0.67	1.10	2.000	n.a.	n.a.
3	4.572	18	CL	clay	60	75	1.25	1.15	0.95	1.3	32.0	78	63	1.13	n.a.	n.a.	n.a.	1.01	0.507	0.67	1.10	n.a.	n.a.	n.a.
4	6.096	10	CL	clay	60	75	1.25	1.15	0.95	1.3	17.8	103	73	1.09	n.a.	n.a.	n.a.	1.01	0.579	0.67	1.10	n.a.	n.a.	n.a.
5	7.620	18	CL	clay	60	75	1.25	1.15	0.95	1.3	32.0	127	82	1.06	n.a.	n.a.	n.a.	1.01	0.635	0.67	1.06	n.a.	n.a.	n.a.
6	9.144	4	CL	clay	85	75	1.25	1.15	1	1.3	7.5	151	151	1.03	n.a.	n.a.	n.a.	1.01	0.678	0.67	1.03	n.a.	n.a.	n.a.
7	10.668	19	SM	clay	45	75	1.25	1.15	1	1.3	35.5	176	101	1.00	35.5	5.6	41.10	1.00	0.741	0.67	1.00	2.000	1.338	1.88
8	12.192	14	CH	clay	85	75	1.25	1.15	1	1.3	26.2	200	111	0.98	n.a.	n.a.	n.a.	1.00	0.764	0.67	0.97	n.a.	n.a.	n.a.
9	13.716	12	CH	clay	85	75	1.25	1.15	1	1.3	22.4	225	120	0.96	n.a.	n.a.	n.a.	1.00	0.782	0.67	0.95	n.a.	n.a.	n.a.
10	15.240	15	CH	clay	85	75	1.25	1.15	1	1.3	29.9	249	130	0.94	n.a.	n.a.	n.a.	1.00	0.782	0.67	0.93	n.a.	n.a.	n.a.

Seismically Induced Settlement

SPT Sample Number	Depth (m)	Measured N	Soil Type	Limiting shear strain γ _{lim}	Parameter F _r	Maximum shear strain γ _{max}	Δh _i (m)	ΔLD _i	Vertical reconsol. Strain ε _v	ΔS _i	ΔS _i (m)	ΔS _i (in)		
1	1.524	28	SC	0.000	-2.847	0.000	1.524	0.000	0.000	0.000	0.000	0.000		
2	3.048	29	CL	0.000	-2.422	0.000	1.524	0.000	0.000	0.000	0.000	0.000		
3	4.572	18	CL	0.000	0.000	0.000	1.524	0.000	0.000	0.000	0.000	0.000		
4	6.096	10	CL	0.000	0.000	0.000	1.524	0.000	0.000	0.000	0.000	0.000		
5	7.620	18	CL	0.000	0.000	0.000	1.524	0.000	0.000	0.000	0.000	0.000		
6	9.144	4	CL	0.000	0.000	0.000	1.524	0.000	0.000	0.000	0.000	0.000		
7	10.668	19	SM	0.007	-0.888	0.000	1.524	0.000	0.000	0.000	0.000	0.000		
8	12.192	14	CH	0.000	0.000	0.000	1.524	0.000	0.000	0.000	0.000	0.000		
9	13.716	12	CH	0.000	0.000	0.000	1.524	0.000	0.000	0.000	0.000	0.000		
10	15.240	16	CH	0.000	0.000	0.000	1.524	0.000	0.000	0.000	0.000	0.000		
										LDI=	0.000	Total S=	0.000	0.000

Field Data for Conversion

Sample Number	Sample Depth (ft)	Strata Δh	Depth to GW (ft)	Historic High Depth to GW (ft)	Ave. Unit Above (pcf)	Unit Wt Below (pcf)	Ave. Unit Wt (pcf)	Borehole Dia. (m)
1	5	1.524	19	10	11.0	100	100	8
2	10	1.524						
3	15	1.524						
4	20	1.524						
5	25	1.524						
6	30	1.524						
7	35	1.524						
8	40	1.524						
9	45	1.524						
10	50	1.524						

APPENDIX E:

Seismic Design Parameters



City of Clearlake - Burns Valley Development

Latitude, Longitude: 38.9638, -122.6349

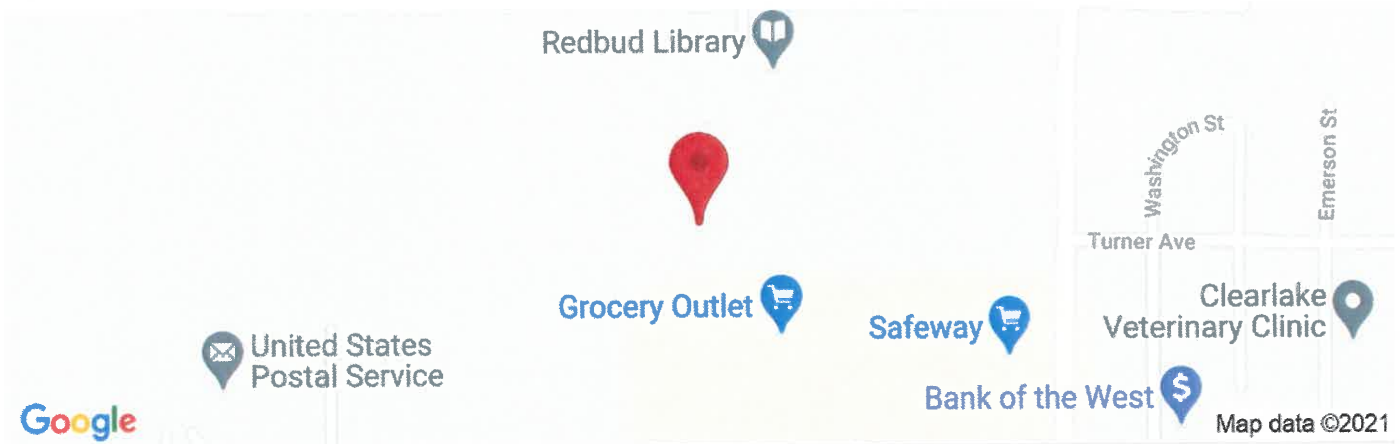

Date	2/19/2021, 12:14:23 PM
Design Code Reference Document	ASCE7-16
Risk Category	II
Site Class	D - Default (See Section 11.4.3)

Type	Value	Description
S_s	1.5	MCE_R ground motion. (for 0.2 second period)
S_1	0.541	MCE_R ground motion. (for 1.0s period)
S_{MS}	1.8	Site-modified spectral acceleration value
S_{M1}	null -See Section 11.4.8	Site-modified spectral acceleration value
S_{DS}	1.2	Numeric seismic design value at 0.2 second SA
S_{D1}	null -See Section 11.4.8	Numeric seismic design value at 1.0 second SA

Type	Value	Description
SDC	null -See Section 11.4.8	Seismic design category
F_a	1.2	Site amplification factor at 0.2 second
F_v	null -See Section 11.4.8	Site amplification factor at 1.0 second
PGA	0.523	MCE_G peak ground acceleration
F_{PGA}	1.2	Site amplification factor at PGA
PGA_M	0.628	Site modified peak ground acceleration
T_L	8	Long-period transition period in seconds
S_{sRT}	1.567	Probabilistic risk-targeted ground motion. (0.2 second)
S_{sUH}	1.672	Factored uniform-hazard (2% probability of exceedance in 50 years) spectral acceleration
S_{sD}	1.5	Factored deterministic acceleration value. (0.2 second)
S_{1RT}	0.541	Probabilistic risk-targeted ground motion. (1.0 second)
S_{1UH}	0.586	Factored uniform-hazard (2% probability of exceedance in 50 years) spectral acceleration.
S_{1D}	0.6	Factored deterministic acceleration value. (1.0 second)
PGA_d	0.523	Factored deterministic acceleration value. (Peak Ground Acceleration)
C_{RS}	0.937	Mapped value of the risk coefficient at short periods
C_{R1}	0.923	Mapped value of the risk coefficient at a period of 1 s

Agency Comments

From: [Alexandra Owens](#)
To: [Mark Roberts](#)
Subject: SCH Number 2022070344
Date: Tuesday, July 19, 2022 3:40:44 PM

CAUTION: This email originated from outside of the organization. Do not click links or open attachments unless you recognize the sender and know the content is safe.

Hello,

Your project is published and is available for review. Please note the State/Local review 'start' and 'end' period.

You can click "Navigation" and select "Published Document" to view your project and any attachments on CEQAnet.

Closing Letters: The State Clearinghouse (SCH) will not provide a close of review period acknowledgement on your CEQA environmental document, at this time. Comments submitted by a state agency at the close of review period (and after) are available on CEQAnet.

Please visit: <https://ceqanet.opr.ca.gov/Search/Advanced>

- Type in the SCH# of your project
 - If filtering by "Lead Agency"
 - Select the correct project
- Only State agency comments will be available in the "attachments" section **labeled "State Comment Letters"**; the SCH does not post comments received from non-State entities.

Thank you,

Alexandra Owens

SCH Student Assistant
Governor's Office of Planning and Research
alexandra.owens@opr.ca.gov

To view your submission, use the following link.

<https://ceqasubmit.opr.ca.gov/Document/Index/280258/1>

From: [Willie Sapeta](#)
To: [Mark Roberts](#)
Cc: [Miasha Rivas](#); [Tiffany Franklin](#); [Autumn Lancaster](#)
Subject: RE: Notice of Intent to Adopt a Mitigated Negative Declaration
Date: Wednesday, July 20, 2022 12:48:07 PM
Attachments: [image001.png](#)
[image003.png](#)

CAUTION: This email originated from outside of the organization. Do not click links or open attachments unless you recognize the sender and know the content is safe.

In my review I concur with the documents supplied, but I would like for our new Fire Marshal to take a quick review and respond with her comments if warranted.

Thank you

Chief Sapeta

From: Mark Roberts
Sent: Tuesday, July 19, 2022 3:49 PM
Subject: Notice of Intent to Adopt a Mitigated Negative Declaration
Importance: High

Good Afternoon,

City of Clearlake –Notice of Intent to Adopt a Mitigated Negative Declaration

Notice is hereby given that the City of Clearlake has tentatively determined that the project described below will not result in a significant adverse impact on the environment and that, in accordance with the California Environmental Quality Act, the City is prepared to issue a “mitigated negative declaration” in accordance with the California Environmental Quality Act (CEQA).

Project Title: BV Sports Complex

Project Location: 14885 Burns Valley Road; Clearlake, CA 95422. Assessor Parcel Number (APN): 010-026-40.

Summary: Development of a public park (sports complex), community center, public works yard with public works building facility and combined police department office and maintenance facilities, vehicle and equipment storage areas, public access and parking facilities on approximately 26 acres. The project is proposed to be located in the Burns Valley Area, north of Olympic Drive and South of Burns Valley Drive, behind the Safeway Shopping

Center, Clearlake, CA (Accessors Parcel No. 010-026-40). The park would include one full size baseball field, two smaller little league baseball fields, two small Tee-Ball Fields, a full-size soccer field. The project would include development of an approximately 15,000 to 20,000 square foot recreation center building for use for public events and activities. This building would contain sports features, such as basketball and volleyball courts. Being located next to the baseball area, a concession building/stand would be constructed next to or as part of this larger building. These combined facilities would be located on the east side of the project site. On the west side is proposed an approximate 12,000 square foot public works building, including a Police Department investigation facility. This building would include a vehicle wash station, and sections for equipment repair. This public works yard would be used to store and maintain city public vehicles, including public works and police department cars, trucks, and heavy equipment. Access to the project would be from a number of driveways/streets including access from Olympic Drive and Burns Valley Road. Approximately 365 parking spaces would be developed along access roads through the park (including 20 for the public works/police facility). Other related improvements would include sidewalks, fencing lighting features, baseball field protective netting and restroom facilities. All play fields will include lighting to allow for night operations. Project development is envisioned to be constructed in two development phasing depending on funding availability and City priority. The first phase is to develop the sports complex components, with the recreation center building and public works hop building to come later.

This tentative determination is based on an environmental study that assesses the project's potential environmental impacts and those potential impacts have been reduced to less than significant levels with the incorporated mitigation measures. Anyone can review this study at Clearlake City Hall, 14050 Olympic Drive, Clearlake, CA 95901, during normal business hours or by downloading from the State Clearinghouse Website at: I have also attached a Complete Initial Packet above for your convenience.

- <https://ceqanet.opr.ca.gov/>

Final environmental determinations are made by the decision-making body, which, in this case would be the City of Clearlake, Planning Commission. The public review period for this notice will remain open for a period of at least 30 days from the publication of this **Notice (07/19/2022), until (08/19/2022)**. For more information, please call (707) 994-8201 during normal business hours of City Hall (Monday through Thursday – 8am to 5pm).

During this period written comments on the project and the proposed mitigated negative declaration may be addressed. You may also submit comments via email at mroberts@clearlake.ca.us **(All comments must be received no later than August 19th, 2022, by 5pm).**

City of Clearlake
 Planning Department
 Attn: Mark Roberts
 14050 Olympic Drive
 Clearlake, CA 95422



COUNTY OF LAKE
Health Services Department
Environmental Health Division
922 Bevins Court
Lakeport, California 95453-9739
Telephone 707/263-1164
FAX 707/263-1681

Jonathan Portney
Health Services Director

Jennifer Baker
Deputy Health Services Director

Craig Wetherbee
Environmental Health Director

MEMORANDUM

DATE: July 22, 2022
TO: Mark Roberts, Senior Planner
FROM: Tina Dawn-Rubin, Environmental Health Aide
RE: BV Sports Complex
Notice of Intent
APN: 010-026-40 14885 Burns Valley Rd, Clearlake

If the applicant stores hazardous materials (defined as either virgin or waste materials) equal to or greater than 55 gallons of a liquid, 500 pounds of a solid or 200 cubic feet of compressed gas, the applicant will be required to submit a Hazardous Materials Business Plan to the Environmental Health Division via the California Electronic Reporting system (CERS) and it shall be renewed and updated annually or if quantities increase. If the amount of hazardous materials is less than the above quantities, the applicant will need to complete and submit a Hazardous Materials/Waste Declaration stating the name of the material and the quantity to be stored on site.

If the applicant increases hazardous material storage, they will need to update their Hazardous Materials Business Plan.

All wells shall be located an adequate horizontal distance from potential sources of contamination and pollution. The storage of hazardous materials shall be located a safe distance from any water well to prevent contamination. The applicant is required to implement measures to prevent contamination of the well(s).

Hazardous materials shall not be allowed to leak onto the ground or contaminate surface waters. Any release of a hazardous material must immediately be reported to Lake County Environmental Health (LCEH).

Collected hazardous or toxic materials shall be recycled or disposed of through a registered waste hauler to an approved site authorized to accept such materials.

Industrial Waste shall not be disposed of on-site without review or permit from the Environmental Health Division or the Regional Water Quality Control Board.

Promoting an Optimal State of Wellness in Lake County

Hazardous Waste must be handled according to all Hazardous Waste Control Laws. Any generation of a hazardous waste must be reported to Lake County Environmental Health (LCEH) within thirty (30) days.

If applicable, the applicant must comply with the California Health and Safety Code 25280 et seq. Underground Storage Tank Laws. The applicant will need to apply and pay for an Underground Storage Tank System installation permit and submit three (3) sets of full plans to the Environmental Health Division for review and approval.

The applicant shall comply with all Above Ground Petroleum Storage Tank Regulations if applicable.

The applicant must comply with the California Retail Food Code Regulations and applicant must have a potable water supply.

The applicant must apply and pay for plan check application: submit three sets of complete plans and supporting documents for review of any proposed retail food facility and must obtain approval from the Division of Environmental Health for construction before obtaining any building permits. Food facilities must be permitted and inspected prior to opening to the public.

If in the future the applicant proposes to install a public pool, spa or water feature such as a water slide, the applicant must comply with the California Health and Safety Code for the construction and operation of a public swimming pool and/or spa or water features. The applicant must submit complete sets of plans to this Division for approval, before obtaining any building permits. The pool/spa/water feature must be permitted and inspected by this Division.

From: [Lori Baca](#)
To: [Mark Roberts](#)
Subject: RE: Notice of Intent to Adopt a Mitigated Negative Declaration
Date: Tuesday, August 9, 2022 11:01:38 AM
Attachments: [image004.png](#)
[image001.png](#)

CAUTION: This email originated from outside of the organization. Do not click links or open attachments unless you recognize the sender and know the content is safe.

Mark,

I see they listed Clearlake Waste Solutions as waste management but I do not see Lake County Sanitation District listed for public sewer.

Lori A. Baca
Customer Service Supervisor
Lori.Baca@lakecountyca.gov
Office Number (707) 263-0119
Fax (707) 263-3836



From: Mark Roberts [mailto:mroberts@clearlake.ca.us]
Sent: Tuesday, July 19, 2022 3:49 PM
Subject: Notice of Intent to Adopt a Mitigated Negative Declaration
Importance: High

Good Afternoon,

City of Clearlake –Notice of Intent to Adopt a Mitigated Negative Declaration

Notice is hereby given that the City of Clearlake has tentatively determined that the project described below will not result in a significant adverse impact on the environment and that, in accordance with the California Environmental Quality Act, the City is prepared to issue a “mitigated negative declaration” in accordance with the California Environmental Quality Act (CEQA).

Project Title: BV Sports Complex

From: [Rightnar, Jacob@DOT](mailto:Rightnar.Jacob@DOT)
To: [Mark Roberts](mailto:Mark.Roberts)
Subject: RE: Notice of Intent to Adopt a Mitigated Negative Declaration
Date: Tuesday, August 2, 2022 3:27:52 PM
Attachments: [image001.png](#)
[image003.png](#)

CAUTION: This email originated from outside of the organization. Do not click links or open attachments unless you recognize the sender and know the content is safe.

Good Afternoon,

Thank you for providing Caltrans D1 the opportunity to review the BV Sports Complex project. We are still in the review process, however we could not seem to locate the traffic impact report in the project documents. Does the City of Clearlake have this document available or any other information regarding the traffic impact of this project? Your help is much appreciated.

Sincerely,
Jacob Rightnar
Caltrans District 1
Transportation Planning
Cell: (707)684-6895

From: Mark Roberts <mroberts@clearlake.ca.us>
Sent: Tuesday, July 19, 2022 3:49 PM
Subject: Notice of Intent to Adopt a Mitigated Negative Declaration
Importance: High

EXTERNAL EMAIL. Links/attachments may not be safe.

Good Afternoon,

City of Clearlake –Notice of Intent to Adopt a Mitigated Negative Declaration

Notice is hereby given that the City of Clearlake has tentatively determined that the project described below will not result in a significant adverse impact on the environment and that, in accordance with the California Environmental Quality Act, the City is prepared to issue a “mitigated negative declaration” in accordance with the California Environmental Quality Act (CEQA).

Project Title: BV Sports Complex

From: [Mark Roberts](#)
To: Rightnar, Jacob@DOT
Subject: FW: Notice of Intent to Adopt a Mitigated Negative Declaration
Date: Thursday, August 4, 2022 8:59:00 AM
Attachments: [Transportation Impact Study for the Burns Valley Development \(1\).pdf](#)
[image001.png](#)
[image003.png](#)
Importance: High

Hi Jacob,

Quick follow up, besides the Traffic Study attached above. Due to the size of the CEQA file, we were unable to attached it to the NOI email. If you click on the link below, you can review the entire CEQA packet from the State Clearing House Website.

Mark

From: Mark Roberts
Sent: Wednesday, August 3, 2022 10:48 AM
To: Rightnar, Jacob@DOT <Jacob.Rightnar@dot.ca.gov>
Subject: RE: Notice of Intent to Adopt a Mitigated Negative Declaration
Importance: High

Hi Jacob,

Please see the above attachment.

Mark

From: Rightnar, Jacob@DOT <Jacob.Rightnar@dot.ca.gov>
Sent: Tuesday, August 2, 2022 3:28 PM
To: Mark Roberts <mroberts@clearlake.ca.us>
Subject: RE: Notice of Intent to Adopt a Mitigated Negative Declaration

CAUTION: This email originated from outside of the organization. Do not click links or open attachments unless you recognize the sender and know the content is safe.

Good Afternoon,

Thank you for providing Caltrans D1 the opportunity to review the BV Sports Complex project. We are still in the review process, however we could not seem to locate the traffic impact report in the project documents. Does the City of Clearlake have this document available or any other information regarding the traffic impact of this project? Your help is much appreciated.

Sincerely,

Jacob Rightnar
 Caltrans District 1
 Transportation Planning
 Cell: (707)684-6895

From: Mark Roberts <mroberts@clearlake.ca.us>
Sent: Tuesday, July 19, 2022 3:49 PM
Subject: Notice of Intent to Adopt a Mitigated Negative Declaration
Importance: High

EXTERNAL EMAIL. Links/attachments may not be safe.

Good Afternoon,

City of Clearlake –Notice of Intent to Adopt a Mitigated Negative Declaration

Notice is hereby given that the City of Clearlake has tentatively determined that the project described below will not result in a significant adverse impact on the environment and that, in accordance with the California Environmental Quality Act, the City is prepared to issue a “mitigated negative declaration” in accordance with the California Environmental Quality Act (CEQA).

Project Title: BV Sports Complex

Project Location: 14885 Burns Valley Road; Clearlake, CA 95422. Assessor Parcel Number (APN): 010-026-40.

Summary: Development of a public park (sports complex), community center, public works yard with public works building facility and combined police department office and maintenance facilities, vehicle and equipment storage areas, public access and parking facilities on approximately 26 acres. The project is proposed to be located in the Burns Valley Area, north of Olympic Drive and South of Burns Valley Drive, behind the Safeway Shopping Center, Clearlake, CA (Accessors Parcel No. 010-026-40). The park would include one full size baseball field, two smaller little league baseball fields, two small Tee-Ball Fields, a full-size soccer field. The project would include development of an approximately 15,000 to 20,000 square foot recreation center building for use for public events and activities. This building would contain sports features, such as basketball and volleyball courts. Being located next to the baseball area, a concession building/stand would be constructed next to or as part of this larger building. These combined facilities would be located on the east side of the project site. On the west side is proposed an approximate 12,000 square foot public works building, including a Police Department investigation facility. This building would include a vehicle wash station, and sections for equipment repair. This public works yard would be used to store and maintain city public vehicles, including public works and police department cars, trucks, and heavy equipment. Access to the project would be from a number of

driveways/streets including access from Olympic Drive and Burns Valley Road. Approximately 365 parking spaces would be developed along access roads through the park (including 20 for the public works/police facility). Other related improvements would include sidewalks, fencing lighting features, baseball field protective netting and restroom facilities. All play fields will include lighting to allow for night operations. Project development is envisioned to be constructed in two development phasing depending on funding availability and City priority. The first phase is to develop the sports complex components, with the recreation center building and public works hop building to come later.

This tentative determination is based on an environmental study that assesses the project's potential environmental impacts and those potential impacts have been reduced to less than significant levels with the incorporated mitigation measures. Anyone can review this study at Clearlake City Hall, 14050 Olympic Drive, Clearlake, CA 95901, during normal business hours or by downloading from the State Clearinghouse Website at: I have also attached a Complete Initial Packet above for your convenience.

- <https://ceqanet.opr.ca.gov/>

Final environmental determinations are made by the decision-making body, which, in this case would be the City of Clearlake, Planning Commission. The public review period for this notice will remain open for a period of at least 30 days from the publication of this **Notice (07/19/2022), until (08/19/2022)**. For more information, please call (707) 994-8201 during normal business hours of City Hall (Monday through Thursday – 8am to 5pm).

During this period written comments on the project and the proposed mitigated negative declaration may be addressed. You may also submit comments via email at mroberts@clearlake.ca.us (**All comments must be received no later than August 19th, 2022, by 5pm**).

City of Clearlake
Planning Department
Attn: Mark Roberts
14050 Olympic Drive
Clearlake, CA 95422

Published Date: **July 19, 2022**

Sincerely,

Mark Roberts
Senior Planner

Mark Roberts

From: Whitman, Terri <TWhitman@kmtg.com>
Sent: Friday, September 2, 2022 3:22 PM
To: Mark Roberts
Cc: Roberson, Holly; Kn@koination.com; rgeary@hpultribe-nsn.gov
Subject: Comments of Koi Nation of Northern California to BV Sports Complex Project Mitigated Negative Declaration
Attachments: 2022-09-02 FINAL Koi Nation Comment Letter.pdf

CAUTION: This email originated from outside of the organization. Do not click links or open attachments unless you recognize the sender and know the content is safe.

Good afternoon ~

Please find attached the Comments of Koi Nation of Northern California to BV Sports Complex Project Mitigated Negative Declaration. Thank you.

Terri Whitman

Assistant to Daniel J. O'Hanlon, Eric N. Robinson, Holly A. Roberson and Lauren Bernadett



Kronick Moskovitz Tiedemann & Girard
1331 Garden Hwy, 2nd Floor
Sacramento, CA 95833

916.321.4500 | T
916.321.4555 | F

kmtg.com | [vCard](#) | [map](#) | twhitman@kmtg.com



CONFIDENTIALITY: This communication may contain confidential information. If you are not the intended recipient, or believe that you have received this communication in error, please do not print, copy, retransmit, disseminate, or otherwise use the information. Also, please indicate to the sender that you have received this email in error, and delete the copy you received.

Mark Roberts

From: Whitman, Terri <TWhitman@kmtg.com>
Sent: Thursday, September 1, 2022 9:38 AM
To: Mark Roberts
Cc: Roberson, Holly
Subject: RE: Question regarding Comment Letter Re: BV Sports Complex Project

CAUTION: This email originated from outside of the organization. Do not click links or open attachments unless you recognize the sender and know the content is safe.

Thank you!

Terri Whitman

Assistant to Daniel J. O'Hanlon, Eric N. Robinson, Holly A. Roberson and Lauren Bernadett



Kronick Moskovitz Tiedemann & Girard
1331 Garden Hwy, 2nd Floor
Sacramento, CA 95833

916.321.4500 | T
916.321.4555 | F

kmtg.com | [vCard](#) | [map](#) | twhitman@kmtg.com



CONFIDENTIALITY: This communication may contain confidential information. If you are not the intended recipient, or believe that you have received this communication in error, please do not print, copy, retransmit, disseminate, or otherwise use the information. Also, please indicate to the sender that you have received this email in error, and delete the copy you received.

From: Mark Roberts <mroberts@clearlake.ca.us>
Sent: Thursday, September 1, 2022 9:33 AM
To: Whitman, Terri <TWhitman@kmtg.com>
Cc: Roberson, Holly <hroberson@kmtg.com>
Subject: RE: Question regarding Comment Letter Re: BV Sports Complex Project

Good Morning,

Thank you for your email and I hope you are well. Yes, either format is acceptable but we prefer to receive written comments via email. If you have any questions, please let me know.

Mark

From: Whitman, Terri <TWhitman@kmtg.com>
Sent: Wednesday, August 31, 2022 3:34 PM
To: Mark Roberts <mroberts@clearlake.ca.us>
Cc: Roberson, Holly <hroberson@kmtg.com>; Whitman, Terri <TWhitman@kmtg.com>
Subject: Question regarding Comment Letter Re: BV Sports Complex Project

CAUTION: This email originated from outside of the organization. Do not click links or open attachments unless you recognize the sender and know the content is safe.

Good afternoon ~

Can you tell me if Comment Letters regarding BV Sports Complex Project will be accepted by email and US Mail?

Thank you for your assistance in this regard.

Terri Whitman

Assistant to Daniel J. O'Hanlon, Eric N. Robinson, Holly A. Roberson and Lauren Bernadett



Kronick Moskowitz Tiedemann & Girard
1331 Garden Hwy, 2nd Floor
Sacramento, CA 95833

916.321.4500 | T
916.321.4555 | F

kmtg.com | [vCard](#) | [map](#) | twitman@kmtg.com



CONFIDENTIALITY: This communication may contain confidential information. If you are not the intended recipient, or believe that you have received this communication in error, please do not print, copy, retransmit, disseminate, or otherwise use the information. Also, please indicate to the sender that you have received this email in error, and delete the copy you received.



September 2, 2022

VIA E-MAIL AND U.S. MAIL

Mark Roberts
Senior Planner
City of Clearlake
14050 Olympic Drive
Clearlake, CA 95422
E-Mail: mroberts@clearlake.ca.us

Re: Comments of Koi Nation of Northern CA to BV Sports Complex Project Mitigated Negative Declaration

Dear Mr. Roberts:

Thank you for the opportunity to provide comments on the City of Clearlake's ("City") Notice of Intent ("NOI") to Adopt a Mitigated Negative Declaration ("MND") related to the proposed BV Sports Complex Project ("Project"). The Project is within the aboriginal territories of the Koi Nation of Northern California ("Koi Nation" or "Tribe"), and the Tribe has a cultural interest and authority in the proposed Project area. The Tribe offers these comments, consistent with the September 2, 2022, comment deadline, for the City's consideration, and we encourage the City to proceed with a more rigorous environmental review process than has been conducted to date.

As explained in this letter, the proposed MND is inadequate and does not adequately consider and remediate the adverse impacts of the Project on the environment. Substantial evidence provided in this letter demonstrates a fair argument exists that the Project will have substantial impacts on the environment. Therefore, the City should prepare an Environmental Impact Report ("EIR") including a meaningful consideration of project alternatives and adoption of feasible mitigation measures to reduce the impacts of the Project on the environment. (*See Protect Niles v. City of Fremont* (2016) 25 Cal.App.5th 1129, 1134 [holding that an EIR is required rather than a MND when substantial evidence supports a fair argument that there will be adverse environmental impacts from a project].)

APPLICABLE CEQA STANDARDS

Under the California Environmental Quality Act ("CEQA"), all lead agencies must prepare an EIR for projects "which may have a significant effect on the environment." (Pub. Res. Code §§ 21151(a) & 21060.5.) *In Laurel Heights Improvement Association v. Regents of the University of California* (1988) 47 Cal.3d 376, the California Supreme Court explained the role an EIR plays in the CEQA process, and instructed that: "The EIR is the primary means of achieving the Legislature's considered declaration that it is the policy of this state to 'take all action necessary to protect, rehabilitate, and enhance the environmental quality of the state.' [Citation.] The EIR is therefore the 'heart of CEQA.' [Citation]." (*Id.* at 392; *see also Friends of College of San Mateo Gardens v. San Mateo County Community College Dist.* (2016) 1 Cal.5th 937, 944 ["At the 'heart of CEQA' [citation] is the requirement that public agencies prepare an EIR for any 'project' that 'may have a significant effect on the environment.' [Citation]."]) "When the informational requirements of CEQA

Mark Roberts
 September 2, 2022
 Page 2

are not complied with, an agency has failed to proceed in a manner required by law and has therefore abused its discretion.” (*Save our Peninsula Committee v. Monterey County Board of Supervisors* (2001) 87 Cal.App.4th 99, 118.)

CEQA “creates a low threshold requirement for an initial preparation of an EIR and reflects a preference for resolving doubts in favor of environmental review when the question is whether any such review is warranted.” (*Sierra Club v. County of Sonoma* (1992) 6 Cal.App.4th 1307, 1316-1317). Accordingly, “if a lead agency is presented with a fair argument that a project may have a significant effect on the environment, the lead agency shall prepare an EIR even though it may also be presented with other substantial evidence that the project will not have a significant effect.” (*Berkeley Hillside Preservation v. City of Berkeley* (2015) 60 Cal.4th 1086, 1111.) When, as here, there is an argument that the lead agency, in this case the City, should have prepared an EIR rather than the proposed MND, a reviewing court reviews the administrative record to determine whether “it can be fairly argued on the basis of substantial evidence that the project may have significant environmental impacts.” (*Ibid.*) Substantial evidence is “enough relevant information and reasonable inferences from this information that a fair argument can be made to support a conclusion, even though other conclusions might also be reached.” (Cal. Code of Regs., tit.14, § 15384(a).) “The fair argument standard thus creates a low threshold for requiring an EIR, reflecting the legislative preference for resolving doubts in favor of environmental review. [Citations.]” (*Covina Residents for Responsible Development v. City of Covina* (2018) 21 Cal.App.5th 712, 723.) As explained in this comment letter, numerous aspects of the Project present a fair argument of significant environmental effects requiring the City to prepare an EIR rather than rely on a defective and inadequate MND for the Project.

CULTURAL RESOURCES AND TRIBAL CULTURAL RESOURCES

In the proposed MND, the City purports to address the category of Cultural Resources together with the distinct category of Tribal Cultural Resources by simply cross-referencing its prior cultural resources analysis. This has been illegal since July 1, 2015, when Assembly Bill 52 (“AB 52”) (2014 Stats, ch. 532.) went into effect. The City purports to rely on a Cultural Resource Investigation by Greg White, Ph.D., as attached to the MND at Attachment D. The proposed MND posted on the State’s CEQA website¹ indicates Attachment D is to be attached. However, the document listed on the website at Attachment D is a Geotechnical Report. It is difficult for any interested party to provide meaningful commentary on a document that is not posted.

Based on the proposed MND, it is apparent that the information developed by and relied upon by the City for purposes of cultural resources does not satisfy requirements applicable to an adequate tribal cultural resources analysis. Archaeological information may inform a tribal cultural resources assessment as a starting point, but it is no substitute for input from the California Native American Tribal government which is traditionally and culturally affiliated with the area. Such input can include both written and oral tradition information and must also recognize the need to maintain confidentiality of relevant data. (See AB 52, § 1 [“California Native American tribes may have expertise with regard to their tribal history and practices, which concern the tribal cultural resources with which they are traditionally and culturally affiliated.”]; *Confederated Tribes and Bands of Yakama Nation v. Klichitat County* (9th Cir. 2021) 1 F.4th 673, 682 fn. 9 [noting the importance of tribal oral history and traditions in interpreting information]; Gov. Code § 65352.4 [acknowledging the need to maintain confidentiality with respect to places that have traditional tribal cultural significance].) Although the City did initially reach out during the AB 52 process, and the City and Tribe met, this limited attempt at engagement does not satisfy the on-going and robust statutory requirements for consultation under AB 52 applicable to CEQA review for projects involving tribal lands.

¹ <https://ceqanet.opr.ca.gov/2022070344>

Mark Roberts
September 2, 2022
Page 3

The Koi Nation reached out and asked the City to continue to engage in tribal consultation on this Project, and the City Manager Alan Flora responded that the City was done consulting because the City met with the Tribe once, therefore consultation was done. Tribal consultation is not a box checking exercise. The Tribe's concerns were not given the full consideration that they deserve for this important tribal cultural resource site.

According to Public Resources Code section 21080.3.1, as enacted through AB 52,

(a) The Legislature finds and declares that California Native American tribes traditionally and culturally affiliated with a geographic area may have expertise concerning their tribal cultural resources.

(b) Prior to the release of a negative declaration, mitigated negative declaration, or environmental impact report for a project, the lead agency shall begin consultation with a California Native American tribe that is traditionally and culturally affiliated with the geographic area of the proposed project if: (1) the California Native American tribe requested to the lead agency, in writing, to be informed by the lead agency through formal notification of proposed projects in the geographic area that is traditionally and culturally affiliated with the tribe, and (2) the California Native American tribe responds, in writing, within 30 days of receipt of the formal notification, and requests the consultation.

Government Code section 65352.4 provides that:

"consultation" means the meaningful and timely process of seeking, discussing, and considering carefully the views of others, in a manner that is cognizant of all parties' cultural values and, where feasible, seeking agreement. Consultation between government agencies and Native American tribes shall be conducted in a way that is mutually respectful of each party's sovereignty. Consultation shall also recognize the tribes' potential needs for confidentiality with respect to places that have traditional tribal cultural significance.

Public Resources Code section 21080.3.2(b) provides that consultation is concluded if: "(1) The parties agree to measures to mitigate or avoid a significant effect, if a significant effect exists, on a tribal cultural resource" or "(2) A party, acting in good faith and after reasonable effort, concludes that mutual agreement cannot be reached."

According to Public Resources Code section 21082.3(d),

. . . the lead agency may certify an environmental impact report or adopt a mitigated negative declaration for a project with a significant impact on an identified tribal cultural resource only if one of the following occurs:

(1) The consultation process between the California Native American tribe and the lead agency has occurred as provided in Sections 21080.3.1 and 21080.3.2 and concluded pursuant to subdivision (b) of Section 21080.3.2.

(2) The California Native American tribe has requested consultation pursuant to Section 21080.3.1 and has failed to provide comments to the lead agency, or otherwise failed to engage, in the consultation process.

(3) The lead agency has complied with subdivision (d) of Section 21080.3.1 and the California Native American tribe has failed to request consultation within 30 days.

In the present case, the consultation has begun but is not complete according to the statutory criteria, and therefore adoption of a EIR or MND is premature under section 21082.3. There has certainly been no agreement on culturally appropriate mitigation measures to avoid, preserve, or mitigate impacts to tribal cultural resources for the Project. Full and complete consultation is required in order to fully understand the tribal cultural resources impacted by the Project and to develop meaningful and culturally appropriate mitigation measures. The Koi Nation wrote the City asking it to re-engage in tribal consultation on this project on August 30, 2022. The City's response was that the required AB 52 consultation occurred on March 9, 2022, no further consultation was required unless requested by the Tribe, and any obligation to consult terminated upon issuance of the draft MND. Once a MND issues, the City apparently believes that the Tribe is limited to submitting comments to the City and the time for any consultation has passed. False. The City also stated that the Tribe failed to produce substantial evidence of an impact, and it discounted and dismissed the Tribal Historic Preservation Officer Robert Geary's "verbal testimony." That is unacceptable. The City also appears focused solely on whether "intact cultural resources" were found on the site. Whether or not a resource is intact is not relevant from a tribal cultural resources perspective. That may matter for archaeology, but that is a different category of resource under CEQA. Here, the City can avoid the mistake that other public entities have made by taking these public comments and tribal consultation seriously, reaching out to the tribal government again for information, and properly analyzing the cultural and archaeological sites as tribal cultural resources prior to the adoption of an EIR or MND. (See Pub. Res. Code § 21074(a), 21082.3(b).)

Mr. Geary provided substantial evidence in consultation, including a detailed map of registered and significant tribal cultural resources in the project area. The City dismissed this evidence because the Tribe did not leave the map with the City, but the Tribe could not because of the California Historic Resource Information Center's (CHRIS) tribal access policies. The City's own archaeologist has access to the same information through the CHRIS center. Once presented with this evidence, the City's due diligence in the CEQA process should have included follow-up on these important sites. The City knew there was evidence of an environmental resource, and failed to analyze it. That is a clear CEQA violation.

Meaningful consultation will ultimately inform the local agency's CEQA determinations. According to Public Resources Code section 21082.3(b)

If a project may have a significant impact on a tribal cultural resource, the lead agency's environmental document shall discuss both of the following:

(1) Whether the proposed project has a significant impact on an identified tribal cultural resource.

(2) Whether feasible alternatives or mitigation measures, including those measures that may be agreed to pursuant to subdivision (a), avoid or substantially lessen the impact on the identified tribal cultural resource.

In an attempt to address these criteria, the City retained an archaeologist who conducted an investigation, and “[the investigation resulted in the discovery of two intact, buried, archeological sites . . . Both sites can be considered significant cultural resources.” (MND, at 28.) The archeologist also found moderate density artifact assemblages and noted the artifacts “suggests that the site also served as a temporary residential function.” (MND, at 28) The MND concludes that no further management measures are necessary “if potential impacts to these sites can be eliminated by means of avoidance or placement of fill.” (MND, at 28.)

The City may argue that the Archaeologist’s report indicates that the cultural resources are not significant because, from an archaeological perspective, they lack context and would not yield information that is important to California’s history. As demonstrated by the City’s August 30, 2022, email, the City appears focused, for example, on whether “intact cultural resources” were discovered, but the text of AB 52 clearly indicates its protections and procedures are broadly applicable to tribal cultural concerns and are not limited simply to instances in which an intact cultural resource is discovered on a site. The lack of an archaeological finding of significance does not mean that these tribal cultural resources are insignificant to the Tribe, or to the people of California. The relevant tribal government and tribal cultural practitioners can shed more light on these tribal cultural resources beyond simply an archeological analysis. Appropriate tribal consultation would elucidate the tribal cultural landscape and specific cultural context in which the known artifacts and other tribal cultural resources on the Project site exist.

Without a doubt, the Tribe has raised a fair argument that from a tribal cultural resources perspective there is valuable information available about the tribal cultural resources landscape and specific tribal cultural resources as informed by the presence of the tribal cultural resources on the site, and present on adjacent sites. To the extent that there is a conflict in the evidence, the City should not “weigh” the conflicting evidence to determine whether an EIR should be prepared. It should simply prepare an EIR. It is the function of an EIR, not a MND, to resolve conflicting claims based on substantial evidence, as to the environmental effects of a project. (See Pub. Res. Code § 21064.5)

Even if the City were to ignore its obligation to prepare an EIR, which it should not, the MND as drafted fails to satisfy the applicable standards of the law by improperly deferring to a later date the formulation of a plan, if further resources are found, rather than proactively developing culturally appropriate mitigation measures including alternatives, avoidance, and preservation in place, or potentially tribal monitoring, as required by AB 52. This impacts analysis in the MND is inaccurate, and the mitigation measures are inadequate. The City needs to continue the consultation process and include the Tribe’s reasonable and modest recommendations that will help protect these tribal cultural resources from damage during the construction process. During the consultation thus far, the Tribe has raised numerous such concerns that the City needs to address including:

- (1) Lack of appropriate inclusion and analysis of Archeological and Tribal Cultural Resources sites in and near the Project Area of Potential Effect;
- (2) Lack of incorporation of the Tribe’s Tribal Cultural Resources Treatment Protocols into project Mitigation Measures;
- (3) Lack of inclusion of a Tribal Monitor for all ground disturbance activities based upon a signed tribal monitoring agreement; and
- (4) Absence of necessary Cultural Sensitivity Training for all project personnel on the first day of construction prior to work starting.

This MND must be revised to be adequate by including the following avoidance, preservation in place, and mitigation measures for tribal cultural resources:

- (1) Avoidance: Change the Project design to avoid sensitive areas, to the extent feasible and if avoidance is not feasible, the environmental documentation must explain what options were considered and why they were rejected;
- (2) Preservation in Place: Use capping with culturally appropriate materials to cover and protect Tribal Cultural Resources and leave them in place;
- (3) Decisions about Tribal Cultural Resources must be made by the Koi Nation Tribal Historic Preservation Officer, in consultation with the Project Archaeologist;
- (4) A signed Tribal Cultural Resources Treatment Protocol must be in place before construction begins, which includes a Tribal Monitoring agreement;
- (5) A reburial location for Tribal Cultural Resources on site must be identified in advance of project construction, in a place not subject to further disturbance; and
- (6) All Tribal Cultural Resources must be recorded on the appropriate DPR forms and submitted to the CHRIS center within 90 days of project completion.

Thus, the City must analyze potential impacts of the proposed Project for their significance and assess whether there may be a culturally significant impact. If there is, then robust mitigation measures are required. Fully utilizing the consultation process with the Tribe which is traditionally and culturally affiliated with the area is key to avoiding impacts to these environmental resources to the extent feasible, as CEQA requires. This will allow the City to obtain more relevant information about the impacts of the Project on Tribal Cultural Resources and allow the City to set in place culturally appropriate mitigation measures for those impacts. It is impermissible under CEQA for the City to make an impact determination without first determining the extent of the resource, and whether avoidance of the resource is feasible. (See *Save the Agoura Cornell Knoll v. City of Agoura Hills* (2020) 46 Cal.App.5th 665 (“*Agoura Hills*”).)

In *Agoura Hills*, just like in this project, the City of Agoura Hills failed to identify and analyze a prehistoric archaeological site which was also a tribal cultural resource, as a tribal cultural resources, despite being notified by public comments that fairly apprised the City of Agoura Hills of the concern that it had failed to adequately address project alternatives or mitigation measures that could preserve tribal cultural resources. As a result, the City was sued, and it lost. After considerable expense and a lengthy delay of the project, the City was required by the Court of Appeal to prepare an EIR. The better course for this Project is to proceed immediately with the required EIR and avoid unnecessary expense and delay.

Additionally, if this Project moves forward at this location, and the Koi Nation or the Archaeologist indicates that Native American Human remains may be present on the Project site, then a reburial and repatriation plan should be developed with the Tribe since it is traditionally and culturally affiliated with the Project prior to any ground disturbance. The Koi Nation is also concerned that there may be inadvertent discoveries of Native American Human Remains during Project construction, which would

trigger the application of both the Native American Graves Protection and Repatriation Act (“NAGPRA”) and California NAGPRA. The MND for this project does address the potential for NAGPRA issues to arise on this project, but there is no viable plan in place to avoid impacts on Native American Human remains through appropriate tribal monitoring to avoid or preserve the Ancestors before they are disturbed, or worse, destroyed, during construction.

Aside from the impacts discussed above, the City is required to analyze environmental impacts which are cumulatively considerable. Impacts are cumulatively considerable if the effects of a project are significant when viewed in connection with the effect of past projects, other current projects and probable future projects. (Pub. Res. Code § 21083(b)(2).) An EIR is required if a Project will involve cumulatively significant impacts. (Pub. Res. Code § 21083(b).) The City is located within the aboriginal territory of the Tribe, and it contains numerous documented and undocumented sites used and inhabited by ancestral Tribal members. Some of these sites are the oldest in California. Lake County in general, and the City of Clearlake area in particular, are incredibly archaeologically, historically, culturally, and tribal culturally significant. Many of these sites have been, are currently, or will be subject to City projects including the present Project. These projects have resulted in, and will likely continue to result in, the discovery of human remains and a significant number of artifacts associated with the Tribe such as occurred at the recent Austin Park Splash Pad project. The City’s pattern and practice of engaging in development projects without meaningful good faith tribal consultation is creating a cumulative impact to tribal cultural resources which violates CEQA, and which is unethical and disrespectful to the Ancestors of people who are part of the Clearlake community.

In enacting AB 52, the Legislature acknowledged that “a substantial adverse change to a tribal cultural resource has a significant effect on the environment,” and consequently it sought to “[r]ecognize the unique history of California Native American tribes and uphold existing rights of all California Native American tribes to participate in, and contribute their knowledge to, the environmental review process pursuant to [CEQA].” The substantial change to tribal cultural resources and need for tribal participation in the environmental review process for projects involving artifacts, remains and ancestral lands is significant as to one project and this significance is amplified when numerous projects within the relatively small municipal boundaries of the City involve the same or similar cultural impacts. The City must fully examine such cumulatively considerable cultural impacts within the context of an EIR for this Project.

More broadly, the MND’s inadequate analysis and mitigation of tribal cultural concerns is part of a board pattern and practice of the City proceeding with projects without following applicable AB 52 CEQA procedures. This failure relating to tribal cultural concerns causes permanent and long-lasting impacts to the Tribe and their religious and cultural practices in a manner that the Legislature sought to avoid through its enactment of AB 52. Recent examples of this pattern and practice include the egregious situation in 2020 where, after soil containing Native American human remains was excavated, the City simply placed the soil containing the human remains in an unprotected location on the airport site. The City, to its credit, disclosed this situation to the Tribe and worked with the Tribe to come up with an appropriate plan. The Tribe appreciated that engagement. While the mutually agreed on plan was pending, the City had a duty to protect this cultural soil. It failed. The City’s negligence allowed a developer to take the soil, and the Native American human remains within it, and use it as fill for a housing development. The City did not engage in meaningful consultation as to the appropriate storage and reinternment of the remains, and the Native American human remains are now interned in the housing development without the Tribe being allowed to first conduct culturally appropriate reinternment or relocation practices.

Because of terrible and traumatic experiences like that, the Koi Nation now has to forcefully advocate for having tribal cultural resources treatment protocols and a tribal monitoring agreement in place for projects on sensitive sites such as this one, to avoid a repeat of that situation. For example, the treatment protocol would require that the City not remove cultural soils from the project site, which is a standard practice throughout the state which the City ignores.

Another example is that when over 1,500 tribal cultural resources and stone artifacts were revealed during one day of trenching on a nearby park project, the City again refused to engage in meaningful consultation with the Tribe as to the culturally appropriate way to handle such artifacts and tribal cultural resources. Instead, the City deemed it appropriate to simply re-use the soil containing the artifacts as fill for project trenches without sorting them out and reburying them in a respectful way.

Most recently, a set forth in an August 30, 2022, email from the City Manager to Tribal leaders, the City appears to take the position that AB 52 imposes a mere pro forma obligation to engage in one "consultation". The City is mistaken. AB 52 expressly establishes a consultation process rather a single meet and confer session. Also, this process does not end simply because the agency issues a draft MND. Public Resources Code section 21082.3(d) mandates that consultation must occur until: (1) The parties agree to measures to mitigate or avoid a significant effect, if a significant effect exists, on a tribal cultural resource; or (2) A party, acting in good faith and after reasonable effort, concludes that mutual agreement cannot be reached. Certainly no agreement has been reached as to the current Project, and the City fails to explain how no agreement is possible if the parties engaged in a reasonable and good faith effort, which the Tribe is willing to do. Each of these incidents demonstrates a pattern and practice by the City of ignoring the processes mandated by the Legislature through AB 52 as part of CEQA.

Thus, before proceeding, the relevant Koi Nation should be consulted about opportunities for avoidance, preservation in place, or mitigation of tribal cultural resources if avoidance and preservation in place is infeasible. Any development in tribal culturally sensitive areas, such as this site, must be done in a way that is respectful of tribal cultural resources and seeks to avoid, protect, preserve in place, or mitigate impacts to those resources as required by CEQA and AB 52. The Tribe is willing to consult and collaborate with the City to accomplish both goals. The tribal cultural heritage of Lake County is rich and diverse. Impacting and damaging these important tribal cultural resources impacts the Tribe's cultural practices and its religious practices, as well as the cultural, archaeological, and historic heritage of the Koi Nation and California. (*See, e.g., American Indian Religious Freedom Act.*) Such impacts are significant and the City must address them through the CEQA process including the processes of AB 52. In any event, a mitigated negative declaration is inappropriate given the significant tribal cultural impacts at stake. (*See Agoura Hills, supra, 46 Cal.App.5th at 690.*)

Finally, the City should keep in mind that the Koi Nation continues to support responsible development in the City. The Tribe merely asks that the City do so in a respectful manner that is cognizant of the original people of this land who have been here since time immemorial. Development to improve the community can continue, it just needs prudent mitigation measures in place so that new development does not destroy tribal cultural resources.

TURF IMPACTS

One significant aspect of the Project is the development of several sport fields which will utilize artificial turf rather than natural grass. The MND notes the use of such artificial turf in passing without analysis and simply states the Project will “reduce water use by the installation of artificial turf athletic fields.” (MND, at 30.) This use of artificial turf, and the associated impacts, is an important factor with significant impacts that the MND fails to consider.

Contrary to the MND’s representation, artificial turf does require irrigation as well as related drainage facilities. One commentator noted that in arid and semi-arid climate zones the surface temperature of the artificial turf fields can exceed 80°C during the summer, requiring irrigation and drainage systems to keep them cool enough for use. (Journal of Irrigation and Drainage Engineering (2020) Water Requirements for Cooling Artificial Turf.) As another commentator noted, “[s]urface temperatures of artificial grass are about 20-50°F higher than natural grass and typically reach the same temperature as asphalt pavement. . . . The Synthetic Turf Council has even published guidelines for minimizing risk of heat-related illness.” (Water Use It Wisely (2022) 10 Reasons Why Artificial Turf May Not Be What You’re Looking For.)² As the Sierra Club noted in a June 20, 2022, comment letter to a City of Burbank artificial turf project, “[s]ynthetic turf causes a heat island effect. Plastic Grass absorbs heat from the sun all day and stays hot at night for several hours after the sun sets. They radiate heat and increase the ambient temperature causing a giant heat island in the immediate area and the surrounding neighborhood.”³ Related to the heat island, the Sierra Club’s letter also noted that “[t]he entire surface area of heated plastic constantly off-gasses the greenhouse gasses methane and ethylene.”⁴

Water can temporarily reduce this heat impact, but one New Mexico State University study found that the amount of water required to maintain artificial turf at temperatures similar to irrigated natural turfgrass is comparable. (Journal of Irrigation and Drainage Engineering (2020) Water Requirements for Cooling Artificial Turf.) Aside from heat reduction, another commentator notes that irrigation is required “to flush contaminants such a dust, dirt, bodily fluids, etc., through the system.” (Parks and Rec Business (2016) Watering Synthetic Turf – Really?)⁵ The MND is completely silent as to the heat, greenhouse gas and water usage required by the artificial turf.

This necessary turf irrigation also requires drainage. The MND appears to recognize drainage is required since the Project will purportedly not increase impervious surface area impacting erosion or surface flows. (MND, at 34.) Whether not artificial turf is impervious depends upon how it is installed,

² <https://wateruseitwisely.com/saving-water-outdoors/grass-artificial-turf/10-reasons-why-artificial-turf-may-not-be-what-youre-looking-for/>

³ <https://drive.google.com/file/d/1bIDdJ365eyo5Nx7b6Pjo9hV62UYfXaKG/view?usp=sharing>

⁴ In support of its comments, the Sierra Club cited an extensive list of supporting materials at: [Docs.google.com/document/d/1ABYr6x7cGllhywuPmTtECm65CayA18N9fKK4k9vlxXLM/edit?usp=sharing](https://docs.google.com/document/d/1ABYr6x7cGllhywuPmTtECm65CayA18N9fKK4k9vlxXLM/edit?usp=sharing). These citations are incorporated by reference in support of the comments set forth in this letter.

⁵ <https://www.parksandrecbusiness.com/articles/2016/8/watering-synthetic-turfreally-part-1>

but the MND fails to delineate installation or drainage standards for the artificial turf. Assuming the Project will provide for drainage, such drainage from the artificial turf⁶ may contain potentially harmful chemicals such as: toxic metals including zinc, lead, arsenic, cadmium, and chromium which have many harmful effects on humans and the environment; Carcinogens including polycyclic aromatic hydrocarbons (PAHs); Latex and other rubbers which can cause allergic reactions; and Phthalates which have adverse effects on reproductive organs, lungs, kidneys and liver. (New Jersey Work Environment Council, Be Aware of Artificial Turf Hazards.)⁷ As a July 2010 Artificial Turf Study by the Connecticut Department of Environment Protection concludes: “The DEP concludes that there is a potential risk to surface waters and aquatic organisms associated with whole effluent and zinc toxicity of stormwater runoff from artificial turf fields. Zinc concentrations in the stormwater may cause exceedences of the acute aquatic toxicity criteria for receiving surface waters, especially smaller watercourses.”⁸ Another study noted the presence of PFAS in artificial turf of 190 to 300 parts per trillion, but the EPA advises that anything over 70 parts per trillion in drinking water can be hazardous to health, and can cause birth defects and hormonal problems. (WUSA9 (2022) DC Artificial turf fields tested as possible source of cancer-causing chemicals.)⁹

The MND fails to discuss the heat inducing impact, the water supply impacts, the drainage impacts and the toxicity impacts of the Project’s use of artificial turf. It also fails to discuss the impact of these substances on wildlife, such as special status turtle species, which will face potential exposure as the toxic chemicals drain from the sports complex into surface waterways and groundwater basins. Drainage into waterways and groundwater is especially important in Clearlake given the sensitivity of the Clearlake Hitch, a rare and culturally important fish which is presently being considered by the U.S. Environmental Protection Agency for listing under the Endangered Species Act.¹⁰ Thus, an EIR is required to fully analyze and address these significant health and safety issues with impacts on both humans and wildlife.

The Project description indicates it will include “[d]evelopment of a public park (sports complex), community center, public works yard with public works building facility and combined police department office and maintenance facilities, vehicle and equipment storage areas, public access and parking facilities . . .” (MND, at 3, emphasis added.) The traffic analysis section relies upon a Transportation Impact Study for the Burns Valley Development prepared by W Trans on June 22, 2022, and attached as Attachment E. The Study’s “Project Profile” indicates: “[t]he project includes a public works corporation yard, a drive-through coffee shop, various recreational uses such as baseball, softball, and soccer fields as well as a 15,000 square-foot recreational center and a separate affordable multi-family residential project.” Notably absent from the Study’s project profile description is any indication that the Project includes a “police department office and maintenance facilities.” Given this omission, it is unclear whether the Study includes traffic impacts arising from the

⁶ <https://www.installitdirect.com/learn/is-artificial-grass-permeable/>

⁷ <https://njwec.org/PDF/Factsheets/fact-artificialterf.pdf>

⁸ <https://portal.ct.gov/-/media/DEEP/artificialturf/DEPArtificialTurfReportpdf.pdf>

⁹ <https://www.wusa9.com/article/news/health/health-alert/hormone-changing-chemicals-found-in-artificial-turf/65-4783ea96-f407-4c88-b0de-0887b6a74bb8>

¹⁰ <https://biologicaldiversity.org/w/news/press-releases/californias-clear-lake-hitch-back-on-track-for-endangered-species-protections-2022-04-14/>

police station and maintenance facilities. Absent a full analysis, the accuracy of the MND's traffic impact conclusions is called into doubt especially its conclusion that access and circulation are anticipated to function acceptably which are based upon the incomplete traffic study. (MND, at 39.) Additionally, the traffic study necessarily did not consider the traffic and public service impacts of having a police facility adjacent to a sports complex which potentially impacts the ability of first responders to provide emergency services when they must first navigate in and around a potentially crowded sports complex. Thus, the MND is incomplete. It has safety and traffic issues that are unaddressed, and it does not satisfy the City's CEQA obligations.

LIGHTING

The MND acknowledges that "[o]ne building [of the Oak Valley Villas housing complex] would be impacted by lighting during nighttime use of the sport field." (MND, at 20.) AES-1 simply directs that the Project shall comply with all federal, state, and local agency requirements. (MND, at 20.) However, the MND acknowledges that the "City does not have a threshold of significance for lighting levels." (MND, at 20.) Thus, the MND acknowledges the lighting will cause an impact, and directs, in part, that the Project must mitigate such impact by following an unspecified and undefined local requirement. Such a vague and ambiguous requirement for addressing this impact is meaningless and cannot support a valid MND. Mitigation measures must be specific enough to be implemented, and not deferred.

AGRICULTURE

The introduction of the agriculture section of the MND directs that: "[i]n determining whether impacts to agricultural resources are significant environmental effects, lead agencies may refer to the California Agricultural Land Evaluation and Site Assessment Model (1997) prepared by the California Dept. of Conservation as an optional model to use in assessing impacts on agriculture and farmland." (MND, at 20.) However, the Lake County information on the Department's website was last updated in 2018. The Project property presently contains an orchard on at least part of site, so the Project will potentially impact farmland. In order to accurately address current impacts on agriculture, the MND should not rely on farmland classification information that is already four years old.

AIR QUALITY

The MND includes a finding that "unpaved roads were the largest source of particulate matter (PM) in the County" and "[m]ore than half of the area wide PM emissions come from travel on unpaved roads within the City." (MND, at 21.) AIR – 11 states that "[s]ignificant dust may be generated from increase vehicle traffic if driveways and parking areas are not adequately surfaced." (MND, at 24) AIR - 2 states "[d]riveways, access roads and parking areas shall be surfaced in a manner so as to minimize dust." (MND, at 23.) Based upon this mitigation, the MND concludes that "[o]nce fully operational, the proposed project would not generate volumes of criteria pollutants which may exceed thresholds of significance disclosed in the Bay Area Air Quality Management District Guidelines , , ,," (MND, at 23.) As an initial matter, the MND fails to explain why it is appropriate to rely upon BAAQMD Guidelines for Lake County, which is outside of the BAAQMD's jurisdiction and inapplicable to a rural area such as Clearlake. Instead, the environmental review for this project should focus on criteria considering the unique characteristics of the City. Additionally, while acknowledging the air quality impacts of unpaved roads, driveways and other surfaces, the MND also states that driveways and parking lots will not be paved until 2024. (MND, at 49.) To the extent this encompasses the operational rather

than the construction stage of the Project, the MND fails to address the impacts on air quality caused by these unpaved surfaces which will not be eliminated until at least 2024. The MND must address the air quality impacts of unpaved surfaces once the Project becomes operational.

WILDLIFE

The MND acknowledges that within the Project site “two special-status bats have potential or low potential to occur within the Study area” as well as “one special-status turtle.” (MND, at 25.) BIO-1 simply indicates the Project will use BMP to reduce the potential for sediment or pollutants at the Project site. BIO-5 generally references a “Bat Management Plan outlining avoidance and minimization measures specific to the roost(s) potentially affected.” Other mitigation measures deal with construction but not operational activities. Importantly, the Project will admittedly contains large light installations to illuminate the sports fields. As the abstract of one journal noted, “[b]eing nocturnal, bats are among the taxa most likely to be affected by light pollution” and “[l]ight pollution affects the ecological interactions across a range of taxa, and has adverse effects on behaviors such as foraging, reproduction and communication.” (80 Mammalian Biology (2015) Impacts of artificial lighting on bats: a review of challenges and solutions.) The MND is silent as to the impact of the lighting on the bat population. Additionally, as discussed above, the Project’s multiple playing fields with artificial turf will potentially generate toxic runoff, but the MND is silent on the impact of such toxic runoff on the special status turtle, let alone the Clearlake Hitch. The City must fully analyze these potentially catastrophic wildlife impacts within the scope of an EIR.

MIGRATION

According to the MND, “[t]he Study Area provides limited migratory opportunities for terrestrial wildlife. Project construction is likely to temporarily disturb and displace most wildlife from the Study Area. Some wildlife such as birds or nocturnal species are likely to continue to use the habitats opportunistically for the duration of construction. Once construction is complete, wildlife movements are expected to resume but will likely be more limited through the developed areas of the Study Area. The Project is not expected to substantially interfere with wildlife movement” (MND, at 27.) However, the MND also purports to show a “perimeter fencing concept” for the Project with high chain link fencing topped by barbed wire. (MND, at 14.) Surrounding the Project perimeter with high barbed wire topped fencing contradicts the statement that wildlife migration will face only minimal impacts once construction ends. The perimeter fence indicates a significant impact on terrestrial migration since wildlife will presumably no longer have access to a significant portion of the Project site. The City must fully explain and mitigate this impact through appropriate mitigation measures.

HAZARDS AND HAZAROUS MATERIALS

The MND focuses on materials used during construction but also admits that “[s]mall quantities of hazardous materials would likely be routinely used on the site, primarily fertilizers, herbicides and pesticides.” (MND, at 32.) However, the MND indicates the Project will include “[d]evelopments of a public park (sports complex), community center, public works yard with public works building facility and combined police department office and maintenance facilities, vehicle and equipment storage areas, public access and parking facilities” (Emphasis added.) A public works yard and maintenance facilities will certainly use chemicals and potentially hazardous materials other than “fertilizers, herbicides and pesticides,” and the City must analyze the use and disposal of these other potentially hazardous substances. These concerns coupled with hazardous substance concerns related to the artificial turf necessitate thorough analysis through an EIR.

NOISE

The MND attempts to limit noise impacts through NOI – 4 which restricts park operations to no later than 10 pm. (MND, at 37.) However, the noise study underlying the City’s findings explains that “[a]t the time of the creation of this report and assessment the City of Clearlake has not sufficiently programmed the site nor provided the author of this report with any specific information on speaker location, mounting height, orientation, nor amplification metrics.” (MND, at 81.) Lacking specific information, the Study relied upon assumptions and generalities to conclude that “[b]ased upon the anticipated duration of sporting events, e.g. summer weekends and evenings, and shoulder season (March through May) high school level sporting events, it can safely be stated that when averaged over a twenty-hour (24) hour period, the noise levels within these units would safely remain below HUD’s required 45 dBA DNL standard.” (MND, at 82, emphasis added.) Despite purporting to establish a mitigation measure, the City’s consultant lacked concrete information on actual sound systems for the Project including speaker location, mounting height, orientation and amplification metrics. Such information is necessary to establish a meaningful analysis rather than having to rely upon guesses, estimates and assumptions as to the sound system’s actual design. Additionally, listing noise based upon a 24-hour average is similarly meaningless since the noise level will be at or near zero at least during late night and early morning hours. Thus, a meaningful noise analysis requires information as to actual system design and must consider noise impacts throughout the day rather than rely on a 24-hour average.

WATER

The MND indicates summarily that the Project would be served by Highland Mutual Water Company, but it contains no indication the Water Company has the capacity to serve Project needs. (MND, at 40.) This contrasts with the MND’s statement as to sewage indicating the Project “would be served by Lake County Special Districts which has sufficient wastewater treatment capacity to service the project. (MND, at 40, emphasis added.) The lack of water availability analysis renders any conclusions about water service incomplete and requires further analysis. This is especially important since the MND purports to minimize the water requirements of the artificial turf, which as discussed above, is not accurate and requires analysis through an EIR.

WILDFIRE

The MND inconsistently reports the Project fire risk based upon both “Moderate to High Fire Hazard Severity Zone” (MND, at 41) and “Low to Moderate Fire Hazard Severity Zone” (MND, at 38.) The fire hazard zone is therefore unclear, and could impact appropriate wildfire mitigation. The City must clarify this important designation.

The issues raised in this letter show that the MND’s “Findings of Significance as to impact of fish and/or wildlife habitat or cultural tribal resources” are inaccurate. (MND, at 42.) One cannot reasonably conclude that the mitigation measures are sufficient due to the lack of complete analysis and tribal consultation. At a minimum, a fair argument exists that there are substantial environmental impacts which need further analysis, so the City must proceed to an EIR rather than adopt a defective MND.

Mark Roberts
September 2, 2022
Page 14

Please enter this letter into the administrative record for this Project. We also request that the City notify us via email to both kn@koination.com and hroberson@kmtg.com and mail of the public hearing for this Project, so that the Tribe and its Tribal Cultural Resources Counsel can submit further comments on the record.

Thank you for your anticipated consideration of these matters. Again, we remain willing to engage in further good faith, meaningful consultations with the City.

Very truly yours,

A handwritten signature in black ink, appearing to read "Darin F. Beltran". The signature is fluid and cursive, with a large initial "D" and "B".

Darin Beltran
Chairman
Koi Nation of Northern California



Central Valley Regional Water Quality Control Board

19 August 2022

Mark Roberts
 City of Clearlake
 14050 Olympic Drive
 Clearlake, CA 95422
 mroberts@clearlake.ca.us

COMMENTS TO REQUEST FOR REVIEW FOR THE MITIGATED NEGATIVE DECLARATION, BV SPORTS COMPLEX PROJECT, SCH#2022070344, LAKE COUNTY

Pursuant to the State Clearinghouse's 19 July 2022 request, the Central Valley Regional Water Quality Control Board (Central Valley Water Board) has reviewed the *Request for Review for the Mitigated Negative Declaration* for the BV Sports Complex Project, located in Lake County.

Our agency is delegated with the responsibility of protecting the quality of surface and groundwaters of the state; therefore, our comments will address concerns surrounding those issues.

I. Regulatory Setting

Basin Plan

The Central Valley Water Board is required to formulate and adopt Basin Plans for all areas within the Central Valley region under Section 13240 of the Porter-Cologne Water Quality Control Act. Each Basin Plan must contain water quality objectives to ensure the reasonable protection of beneficial uses, as well as a program of implementation for achieving water quality objectives with the Basin Plans. Federal regulations require each state to adopt water quality standards to protect the public health or welfare, enhance the quality of water and serve the purposes of the Clean Water Act. In California, the beneficial uses, water quality objectives, and the Antidegradation Policy are the State's water quality standards. Water quality standards are also contained in the National Toxics Rule, 40 CFR Section 131.36, and the California Toxics Rule, 40 CFR Section 131.38.

The Basin Plan is subject to modification as necessary, considering applicable laws, policies, technologies, water quality conditions and priorities. The original Basin Plans were adopted in 1975, and have been updated and revised periodically as required, using Basin Plan amendments. Once the Central Valley Water Board has adopted a Basin Plan amendment in noticed public hearings, it must be approved by the State Water Resources Control Board (State Water Board), Office of

MARK BRADFORD, CHAIR | PATRICK PULUPA, ESQ., EXECUTIVE OFFICER

Administrative Law (OAL) and in some cases, the United States Environmental Protection Agency (USEPA). Basin Plan amendments only become effective after they have been approved by the OAL and in some cases, the USEPA. Every three (3) years, a review of the Basin Plan is completed that assesses the appropriateness of existing standards and evaluates and prioritizes Basin Planning issues. For more information on the *Water Quality Control Plan for the Sacramento and San Joaquin River Basins*, please visit our website:

http://www.waterboards.ca.gov/centralvalley/water_issues/basin_plans/

Antidegradation Considerations

All wastewater discharges must comply with the Antidegradation Policy (State Water Board Resolution 68-16) and the Antidegradation Implementation Policy contained in the Basin Plan. The Antidegradation Implementation Policy is available on page 74 at:

https://www.waterboards.ca.gov/centralvalley/water_issues/basin_plans/sacsjr_2018_05.pdf

In part it states:

Any discharge of waste to high quality waters must apply best practicable treatment or control not only to prevent a condition of pollution or nuisance from occurring, but also to maintain the highest water quality possible consistent with the maximum benefit to the people of the State.

This information must be presented as an analysis of the impacts and potential impacts of the discharge on water quality, as measured by background concentrations and applicable water quality objectives.

The antidegradation analysis is a mandatory element in the National Pollutant Discharge Elimination System and land discharge Waste Discharge Requirements (WDRs) permitting processes. The environmental review document should evaluate potential impacts to both surface and groundwater quality.

II. Permitting Requirements

Construction Storm Water General Permit

Dischargers whose project disturb one or more acres of soil or where projects disturb less than one acre but are part of a larger common plan of development that in total disturbs one or more acres, are required to obtain coverage under the General Permit for Storm Water Discharges Associated with Construction and Land Disturbance Activities (Construction General Permit), Construction General Permit Order No. 2009-0009-DWQ. Construction activity subject to this permit includes clearing, grading, grubbing, disturbances to the ground, such as stockpiling, or excavation, but does not include regular maintenance activities performed to restore the original line, grade, or capacity of the facility. The Construction General Permit requires the development and implementation of a Storm Water Pollution Prevention Plan (SWPPP). For more information on the Construction General Permit, visit the State Water Resources Control Board website at:

http://www.waterboards.ca.gov/water_issues/programs/stormwater/constpermits.shtml

Phase I and II Municipal Separate Storm Sewer System (MS4) Permits¹

The Phase I and II MS4 permits require the Permittees reduce pollutants and runoff flows from new development and redevelopment using Best Management Practices (BMPs) to the maximum extent practicable (MEP). MS4 Permittees have their own development standards, also known as Low Impact Development (LID)/post-construction standards that include a hydromodification component. The MS4 permits also require specific design concepts for LID/post-construction BMPs in the early stages of a project during the entitlement and CEQA process and the development plan review process.

For more information on which Phase I MS4 Permit this project applies to, visit the Central Valley Water Board website at:

http://www.waterboards.ca.gov/centralvalley/water_issues/storm_water/municipal_permits/

For more information on the Phase II MS4 permit and who it applies to, visit the State Water Resources Control Board at:

http://www.waterboards.ca.gov/water_issues/programs/stormwater/phase_ii_municipal.shtml

Clean Water Act Section 404 Permit

If the project will involve the discharge of dredged or fill material in navigable waters or wetlands, a permit pursuant to Section 404 of the Clean Water Act may be needed from the United States Army Corps of Engineers (USACE). If a Section 404 permit is required by the USACE, the Central Valley Water Board will review the permit application to ensure that discharge will not violate water quality standards. If the project requires surface water drainage realignment, the applicant is advised to contact the Department of Fish and Game for information on Streambed Alteration Permit requirements. If you have any questions regarding the Clean Water Act Section 404 permits, please contact the Regulatory Division of the Sacramento District of USACE at (916) 557-5250.

Clean Water Act Section 401 Permit – Water Quality Certification

If an USACE permit (e.g., Non-Reporting Nationwide Permit, Nationwide Permit, Letter of Permission, Individual Permit, Regional General Permit, Programmatic General Permit), or any other federal permit (e.g., Section 10 of the Rivers and Harbors Act or Section 9 from the United States Coast Guard), is required for this project due to the disturbance of waters of the United States (such as streams and wetlands), then a Water Quality Certification must be obtained from the Central Valley Water Board prior to initiation of project activities. There are no waivers for 401 Water Quality Certifications. For more information on the Water Quality Certification, visit the Central Valley Water Board website at:

¹ Municipal Permits = The Phase I Municipal Separate Storm Water System (MS4) Permit covers medium sized Municipalities (serving between 100,000 and 250,000 people) and large sized municipalities (serving over 250,000 people). The Phase II MS4 provides coverage for small municipalities, including non-traditional Small MS4s, which include military bases, public campuses, prisons and hospitals.

https://www.waterboards.ca.gov/centralvalley/water_issues/water_quality_certification/

Waste Discharge Requirements – Discharges to Waters of the State

If USACE determines that only non-jurisdictional waters of the State (i.e., “non-federal” waters of the State) are present in the proposed project area, the proposed project may require a Waste Discharge Requirement (WDR) permit to be issued by Central Valley Water Board. Under the California Porter-Cologne Water Quality Control Act, discharges to all waters of the State, including all wetlands and other waters of the State including, but not limited to, isolated wetlands, are subject to State regulation. For more information on the Waste Discharges to Surface Water NPDES Program and WDR processes, visit the Central Valley Water Board website at: [https://www.waterboards.ca.gov/centralvalley/water_issues/waste to surface water/](https://www.waterboards.ca.gov/centralvalley/water_issues/waste_to_surface_water/)

Projects involving excavation or fill activities impacting less than 0.2 acre or 400 linear feet of non-jurisdictional waters of the state and projects involving dredging activities impacting less than 50 cubic yards of non-jurisdictional waters of the state may be eligible for coverage under the State Water Resources Control Board Water Quality Order No. 2004-0004-DWQ (General Order 2004-0004). For more information on the General Order 2004-0004, visit the State Water Resources Control Board website at:

https://www.waterboards.ca.gov/board_decisions/adopted_orders/water_quality/2004/wqo/wqo2004-0004.pdf

Dewatering Permit

If the proposed project includes construction or groundwater dewatering to be discharged to land, the proponent may apply for coverage under State Water Board General Water Quality Order (Low Threat General Order) 2003-0003 or the Central Valley Water Board’s Waiver of Report of Waste Discharge and Waste Discharge Requirements (Low Threat Waiver) R5-2018-0085. Small temporary construction dewatering projects are projects that discharge groundwater to land from excavation activities or dewatering of underground utility vaults. Dischargers seeking coverage under the General Order or Waiver must file a Notice of Intent with the Central Valley Water Board prior to beginning discharge.

For more information regarding the Low Threat General Order and the application process, visit the Central Valley Water Board website at:

http://www.waterboards.ca.gov/board_decisions/adopted_orders/water_quality/2003/wqo/wqo2003-0003.pdf

For more information regarding the Low Threat Waiver and the application process, visit the Central Valley Water Board website at:

https://www.waterboards.ca.gov/centralvalley/board_decisions/adopted_orders/waivers/r5-2018-0085.pdf

Limited Threat General NPDES Permit

If the proposed project includes construction dewatering and it is necessary to discharge the groundwater to waters of the United States, the proposed project will

BV Sports Complex Project
Lake County

- 5 -

xx August 2022

require coverage under a National Pollutant Discharge Elimination System (NPDES) permit. Dewatering discharges are typically considered a low or limited threat to water quality and may be covered under the General Order for *Limited Threat Discharges to Surface Water* (Limited Threat General Order). A complete Notice of Intent must be submitted to the Central Valley Water Board to obtain coverage under the Limited Threat General Order. For more information regarding the Limited Threat General Order and the application process, visit the Central Valley Water Board website at:

https://www.waterboards.ca.gov/centralvalley/board_decisions/adopted_orders/general_orders/r5-2016-0076-01.pdf

NPDES Permit

If the proposed project discharges waste that could affect the quality of surface waters of the State, other than into a community sewer system, the proposed project will require coverage under a National Pollutant Discharge Elimination System (NPDES) permit. A complete Report of Waste Discharge must be submitted with the Central Valley Water Board to obtain a NPDES Permit. For more information regarding the NPDES Permit and the application process, visit the Central Valley Water Board website at: <https://www.waterboards.ca.gov/centralvalley/help/permit/>

If you have questions regarding these comments, please contact me at (916) 464-4684 or Peter.Minkel2@waterboards.ca.gov.

Peter Minkel

Peter Minkel
Engineering Geologist

cc: State Clearinghouse unit, Governor's Office of Planning and Research,
Sacramento



KOI NATION OF NORTHERN CALIFORNIA

August 18, 2022

VIA E-MAIL AND U.S. MAIL

Mr. Dirk Slooten
 Mayor
 City of Clearlake
 14050 Olympic Drive
 Clear Lake, CA 95422
 E-Mail: dslooten@clearlake.ca.us

Re: Burns Valley Park and Public Works Yard Master Plan, Mitigated Negative Declaration

Dear Mayor Slooten:

I am the Chairman of the Koi Nation of Northern California ("Tribe"). I am writing to you with respect to the Tribe's interest in protecting tribal cultural resources that are impacted by various projects in Clearlake, including the Burns Valley Park and Public Works Yard Master Plan ("Project"). We have reviewed the Mitigated Negative Declaration ("MND") for the Project, which was circulated June 16, 2022. We have serious concerns that we would like to discuss with you before potentially filing a formal comment on the MND pursuant to the California Environmental Quality Act ("CEQA"). I understand that our Vice Chair Dino Beltran would like to meet you as soon as possible. To discuss this and other issues with the City's treatment of tribal cultural resources. I further understand that the City has extended the comment period for the MND by two weeks until Friday, September 2nd, thank you. Please include this letter in the administrative record for the Project.

First, we are appreciative of the City's efforts to reach out and consult with the Tribe pursuant to AB 52 (Gatto, 2014), hereafter "AB 52". The City met with the Tribe for government-to-government consultation on March 2, March 30, and April 11, 2022. At the March 2, 2022, consultation, seven representatives from the City met with Yolanda Tovar, leadership from the Koi Nation, and Robert Geary, our Tribal Historic Preservation Officer. (Burns Valley Development Project, Pre-Job Sign In Sheet [March 2, 2022]; see also Pre-Construction Meeting Agenda Minutes.) Unfortunately, the tribal cultural resources information shared through the consultation process is not reflected in the MND. The MND says simply that "[t]he Cultural Study documents all consultation conducted." (MND at p.4.) The Cultural Study, however, was not attached to the circulated MND. (MND at p. 76.) The MND does provide a placeholder for an Attachment D, Cultural Report, however, Attachment D uploaded to CEQANET.opr.gov is a Geotechnical Investigation Report, which contains no discussion of the consultation. (MND at p. 76; see also Attachment D, Geotechnical Engineering Investigation Report [Feb. 26, 2021].)

In any event, it is well known that the Project site includes several significant recorded archaeological and tribal cultural resources sites. The MND continues to confirm discovery of "intact, buried, archaeological sites . . . [that] can be considered significant cultural resources." (MND at pp. 27-29.)

Mr. Dirk Slooten
 August 18, 2022
 Page 2

Problematically, further description of these resources in the MND and the corresponding mitigation measures do not reflect any of the substantial evidence provided by the Tribe through the consultation process. (*Ibid.*) A confidential map of significant tribal cultural resources and archaeological sites on or near this area is attached.

We note further that pursuant to CEQA and AB 52, consultation shall only be considered concluded when either: (1) the parties agree to measures that mitigate or avoid significant effects on tribal cultural resources, or (2) a party, acting in good faith and after reasonable effort, concludes that mutual agreement cannot be reached. (Guidelines, § 21080.3.2(b).) Neither circumstance has occurred here, and the consultation is continuing. The City should include measures in the MND to avoid tribal cultural resources, preserve them in place, or mitigate them to the extent feasible. The current level of analysis of tribal cultural resources in the MND is inadequate because it focuses solely on archaeological resources and does not include the Tribe's perspective, which was shared in consultation. In addition, the cumulative impact analysis is sorely lacking, as there are a number of adjacent projects with impacts to significant tribal cultural resources. The Project is within a tribal cultural landscape, which is itself a tribal cultural resource.

Second, the City has requested, and the Tribe has provided, tribal monitoring at the Burns Valley I project site on at least two occasions- May 19 and June 29, 2022. Currently the Tribe's tribal monitors are working without a signed agreement, which is not appropriate, and which should be remedied immediately. A proposed agreement was provided to the City on March 1, 2022, and on August 5, 2022, the City Manager Alan Flora said that he would review it but he has not responded as of the date of this letter. (See Email from H. Roberson to R. Jones [Aug. 10, 2022], based on consultation debrief from R. Geary.) The Koi Nation's tribal monitors have already discovered intact arrowheads, stone tools, and lithics, all of which are tribal cultural resources. (See, e.g., Email from H. Roberson to R. Jones [Aug. 10, 2022] based on information received from R. Geary.) These finds confirm the fact that there are tribal cultural resources on the Burns Valley I project site and increase the likelihood of finding additional tribal cultural resources on the Burns Valley II project site. Again, this information is not reflected in the MND, and it should be included in the cumulative impacts analysis. It also appears that City has a pattern and practice of not promptly recording the discovery of tribal cultural resources and archaeological resources and thus sensitive sites so as to avoid future harm. All finds must be appropriately reported to the California Historical Resources Information Center within 90 days so that the City and other lead agencies have an opportunity to avoid tribal cultural resources in their project planning. The City is responsible for the compliance of its contractors, including archaeological consultants, with standard professional practices. It is clear that, without appropriate tribal cultural resources treatment protocol and mitigation measures, the Project will have significant impacts on tribal cultural resources. In fact, we are deeply concerned that such irreversible impacts may have already occurred on the Burns Valley I project site.

As you know, CEQA requires environmental review to be completed prior to approval of a project so that environmental damage can be considered and minimized. (Guidelines §§ 15004, 15061.) An EIR, rather than a negative declaration, must be prepared if it can be fairly argued on the basis of substantial evidence in light of the whole record that the project may have significant environmental effect, even though the agency has other substantial evidence that the project will not have a significant effect. (Pub. Res. Code, §§ 21080(d), 21082.2(d); Guidelines § 15064 (g)(1); *Protect Niles v. City of Fremont* (2018) 25 Cal.App.5th 1129, 1139.) "A project with an effect that may cause a substantial adverse change in the significance of a tribal cultural resource is a project that may have a significant effect on the environment." (Pub. Res. Code, § 21084.2.) Public agencies must mitigate such impacts. (Pub. Res. Code, § 21084.3.)

Mr. Dirk Slooten
 August 18, 2022
 Page 3

A mitigation measure brought to the attention of the lead agency should not be omitted unless infeasible on its face; and in that case, the infeasibility must be explained. (*Los Angeles Unified School Dist. v. City of Los Angeles* (1997) 58 Cal.App.4th 1019, 1029.)

As set forth in *Save the Agoura Cornell Knoll v. City of Agoura Hills*, where "the record contains substantial evidence supporting a fair argument that the MND's measures are inadequate to avoid or mitigate the impacts to [tribal cultural resources] 'to a point where clearly no significant effect on the environment would occur,' an EIR is required to consider the project's impacts on cultural resources." (*Save the Agoura Cornell Knoll v. City of Agoura Hills* (2020) 46 Cal.App.5th 665, 690.) In *Save the Agoura Cornell Knoll*, there was evidence that the City of Agoura Hills ("City") did not adequately consult with relevant tribes or properly identify and analyze tribal cultural resources in the project mitigated negative declaration. (*Id.* at 684.) The City responded that mitigation measures in the project MND ensured the resources would be avoided and undisturbed. (*Id.* at 686.) The court disagreed and found that there was substantial evidence the measures improperly deferred mitigation and were insufficient to avoid or reduce impacts to less than significant. (*Id.* at 686.) More specifically, the court found that measures providing for monitoring with allowances for work stoppage for "appropriate actions" were inadequate. (*Id.* at 687.) The project MND did not completely define the boundaries of the project site or the tribal cultural resources on the project site so as to determine the feasibility of avoidance. (*Id.* at 687.) Contrastingly, there was evidence in the record that avoidance of tribal cultural resources was not feasible given the project footprint. (*Id.* at 688.) Accordingly, there was substantial evidence supporting a fair argument that the project MND's measures were inadequate to avoid or mitigate the impacts to tribal cultural resources to less than significant, and hence, an EIR was required. (*Id.* at 690.) Likewise, the MND here fails to reflect evidence received during the ongoing tribal consultation or provide meaningful measures to mitigate potential impacts to tribal cultural resources to less than significant. Instead, the MND's mitigation measures provide for the same work stoppage found inadequate by the Court and include further investigation by the cultural resource consultant. (See MND, pp. 28-29, CUL-1 -CUL-2.)

Based on the ongoing consultation and the tribal monitoring performed to date, there is substantial evidence in the record to support a fair argument that the Project, even with the mitigation measures currently described in the MND, will have a significant effect on tribal cultural resources, and hence the environment. Therefore, if we cannot resolve this matter voluntarily during consultation, and if the City does not take proper steps to protect, avoid, and mitigate tribal cultural resources in the MND, then the Tribe is prepared to assert in its comment letter on the MND that an EIR should be prepared for this Project. Legally, the City cannot simply ignore the information received through the government-to-government tribal consultation process and proceed with the Project without adequate environmental analysis and appropriate mitigation. Through consultation, and our work with the City on other Projects, including the Austin Park Splash Pad, the Tribe has presented a tribal cultural resources agreement and treatment protocol, which would be the building blocks for appropriate avoidance and mitigation measures. We strongly urge you to consider that information and work with the Tribe to adequately address impacts to tribal cultural resources in a revised MND.

My Tribal Council was therefore shocked and disappointed that immediately after reaching an agreement for appropriate avoidance, preservation in place, and mitigation of tribal cultural resources on the Austin Park Splash Pad project site, the City issued such an inadequate MND for another culturally significant site without proper consideration of tribal cultural resources.

Mr. Dirk Slooten
August 18, 2022
Page 4

Despite disappointment in the inadequacy of the MND, the Tribe remains committed to consulting with the City and working to develop a tribal cultural resources agreement and treatment protocol as well as appropriate mitigation to lessen the impacts of the Project on tribal cultural resources to less than significant. If, however, the City fails to address these issues voluntarily through the consultation process, the Tribe will be required to submit its comment on the MND, alert the Attorney General's office and the Native American Heritage Commission to the City's pattern and practice of bad faith tribal consultation, and challenge any resulting project approval on the basis that the environmental analysis is insufficient.

Respectfully,



Darin Beltran
Chairman
Koi Nation of Northern California

Cc: Koi Nation Tribal Council
Robert Geary, Director of Cultural Resources/Tribal Historic Preservation Officer
Ryan Jones, City Attorney
Alan Flora, City Manager
Holly Roberson, Tribal Cultural Resources Counsel to the Koi Nation of Northern California

Enclosures:

(1) Confidential map of tribal cultural resources associated with the Project area. Note: This map contains sensitive tribal cultural resources information. It may only be shared with the Mayor, the City Manager, the City Attorney, and the Project Manager for the Project as part of the confidential AB 52 consultation process. This map is not for distribution in the public facing MND.

From: [Brian Hanson](#)
To: [Mark Roberts](#)
Subject: Sports complex
Date: Tuesday, September 27, 2022 6:41:14 PM

CAUTION: This email originated from outside of the organization. Do not click links or open attachments unless you recognize the sender and know the content is safe.

I love that the City of Clearlake is trying to be progressive in the development of resources for our community and youth through the advancement of sports in Lake County. This will bring people from inside and outside Lake County to the City of Clearlake.

As a former Lake County athlete/collegiate athlete, and now father and coach of local youth athletes, I am continually left shaking my head at our counties lack of clean, safe, and well maintained sports resources. Our children deserve better.

Sports brings people together. They instill life long skills such as discipline, teamwork, and a sense of community pride to name a few.

Thank you for bringing this project forward, it is absolutely supported by the community and surrounding communities.

Sincerely,
Brian Hanson

Sent from my iPhone



City of Clearlake

Draft Mitigation Monitoring Reporting Program (MMRP) Checklist

Project Name: Burns Valley Development Project (Environmental Analysis, CEQA IS 2022-05 and Conditional Use Permit, CUP 2022-16)

Location: 14885 Burns Valley Road, Clearlake, CA 95422; further described as Assessor parcel Number (APN) 010-026-40-000.

File Numbers:

- Environmental Analysis, CEQA IS 2022-05
- Conditional Use Permit, CUP 2022-16

Approval Date: _____ Neg. Dec.: Mitigated Negative Declaration

The mitigation measures outlined below were incorporated into the approval for this project in order to reduce potentially significant environmental impacts to a level of insignificance. A completed and signed checklist for each mitigation measure indicates that this mitigation measure has been complied with and implemented and fulfills the City's monitoring pursuant to Section 15097 of the CEQA Guidelines.

Additional mitigation measures have been added in order to reconfirm the protocols for avoidance and capping of the sensitive sites. These mitigation measures do not create new significant environmental effects and are not necessary to mitigate an avoidable significant effect. Thus, pursuant to CEQA Guidelines section 15073.5, recirculation of the MND is not required.

Mitigation Measure	Type	Monitoring Shown on Department Plans	Verified Implementation	Remarks
AES-1	Aesthetics	All outdoor lighting shall be directed downwards and shielded onto the project site and not onto adjacent properties. All lighting shall comply and adhere to all federal, state and local agency requirements, including all requirements in darksky.org. (Refer to the City’s Design Standards).		
AES-2	Aesthetics	A final lighting design plan shall be submitted for review and approval by the Community Development Department. Lighting levels shall not exceed lighting levels beyond those referenced in Attachment A, Lighting Analysis for this project. Lighting shall be installed in accordance with the final approved lighting plan.		
AES-3	Aesthetics	All nighttime ball field lighting shall be operated no later than 10 pm.		
AIR-1	Air Quality	Construction activities shall be conducted with adequate dust suppression methods, including watering during grading and construction activities to limit the generation of fugitive dust or other methods approved by the Lake County Air Quality Management District. Prior to initiating soil removing activities for construction purposes, the applicant shall pre-wet affected areas with at least 0.5 gallons of water per square yard of ground area to control dust.		
AIR-2	Air Quality	Driveways, access roads and parking areas shall be surfaced in a manner so as to minimize dust. The applicant shall obtain all necessary encroachment permits for any work within the right-of-way. All improvement shall adhere to all applicable federal, State and local agency requirements.		

Mitigation Measure	Type	Monitoring Shown on Department Plans	Verified Implementation	Remarks
AIR-3.	Air Quality	Any disposal of vegetation removed as a result of lot clearing shall be lawfully disposed of, preferably by chipping and composting, or as authorized by the Lake County Air Quality Management District and the Lake County Fire Protection District..		
AIR 4.	Air Quality	During construction activities, the applicant shall remove daily accumulation of mud and dirt from any roads adjacent to the site.		
AIR 5.	Air Quality	Grading permits shall be secured for any applicable activity from the Community Development Department, Building Division. Applicable activities shall adhere to all grading permit conditions, including Best Management Practices. All areas disturbed by grading shall be either surfaced in manner to minimize dust, landscaped or hydro seeded. All BMPs shall be routinely inspected and maintained for lifer of the project.		
AIR-6.	Air Quality	All refuse generated by the facility shall be stored in approved disposal/storage containers, and appropriately covered. Removal of waste shall be on a weekly basis so as to avoid excess waste. All trash receptacles/containers shall remain covered at all times to prevent fugitive odors and rodent infestation. An odor control plan shall be submitted for review and approval by the City In accordance with the Zoning Code. Odor control shall be maintained to an acceptable level at all times.		
AIR-7.	Air Quality	Construction activities that involve pavement, masonry, sand, gravel, grading, and other activities that could produce airborne particulate should be conducted with adequate dust controls to minimize airborne emissions. A dust mitigation plan may be required should the applicant fail to maintain adequate dust controls.		

Mitigation Measure	Type	Monitoring Shown on Department Plans	Verified Implementation	Remarks
AIR-8.	Air Quality	If construction or site activities are conducted within Serpentine soils, a Serpentine Control Plan may be required. Any parcel with Serpentine soils must obtain proper approvals from LCAQMD prior to beginning any construction activities. Contact LCAQMD for more details.		
AIR-9.	Air Quality	All engines must notify LCAQMD prior to beginning construction activities and prior to engine Use. Mobile diesel equipment used for construction and/or maintenance must be in compliance with State registration requirements. All equipment units must meet Federal, State and local requirements. All equipment units must meet RICE NESHAP/ NSPS requirements including proper maintenance to minimize airborne emissions and proper record-keeping of all activities, all units must meet the State Air Toxic Control Measures for CI engines and must meet local regulations.		
AIR-10.	Air Quality	Site development, vegetation disposal, and site operation shall not create nuisance odors or dust. During the site preparation phase, the District recommends that any removed vegetation be chipped and spread for ground cover and erosion control. Burning of debris/construction material is not allowed on commercial property, materials generated from the commercial operation, and waste material from construction debris, must not be burned as a means of disposal.		

Mitigation Measure	Type	Monitoring Shown on Department Plans	Verified Implementation	Remarks
AIR-11.	Air Quality	<p>Significant dust may be generated from increase vehicle traffic if driveways and parking areas are not adequately surfaced. Surfacing standards should be included as a requirement in the use permit to minimize dust impacts to the public, visitors, and road traffic. At a minimum, the district recommends chip seal as a temporary measure for primary access roads and parking. Paving with asphaltic concrete is preferred and should be required for long term occupancy. All areas subject to semi-truck / trailer traffic should require asphaltic concrete paving or equivalent to prevent fugitive dust generation. Gravel surfacing may be adequate for low use driveways and overflow parking areas; however, gravel surfaces require more maintenance to achieve dust control, and permit conditions should require regular palliative treatment if gravel is utilized. White rock is not suitable for surfacing (and should be prohibited in the permit) because of its tendency to break down and create excessive dust. Grading and re-graveling roads should utilize water trucks, if necessary, reduce travel times through efficient time management and consolidating solid waste removal/supply deliveries, and speed limits</p>		
BIO-1.	Biological Resources	<p>The project should implement erosion control measures and BMPs to reduce the potential for sediment or pollutants at the Project site.</p>		

Mitigation Measure	Type	Monitoring Shown on Department Plans	Verified Implementation	Remarks
BIO-2.	Biological Resources	A qualified biologist shall conduct a mandatory Worker Environmental Awareness Program for all contractors, work crews, and any onsite personnel to aid workers in recognizing special status species and sensitive biological resources that may occur on-site. The program shall include identification of the special status species and their habitats, a description of the regulatory status and general ecological characteristics of sensitive resources, and review of the limits of construction and Mitigation Measures required to reduce impacts to biological resources within the work area.		
BIO-3.	Biological Resources	Conduct a pre-construction northwestern pond turtle survey in Project impact and staging areas within 48 hours prior to construction activities. Any northwestern pond turtle individuals discovered in the Project work area immediately prior to or during Project activities shall be allowed to move out of the work area of their own volition. If this is not feasible, they shall be captured by a qualified biologist and relocated out of harm's way to the nearest suitable habitat at least 100 feet from the Project work area where they were found.		

Mitigation Measure	Type	Monitoring Shown on Department Plans	Verified Implementation	Remarks
BIO-4.	Biological Resources	<p>If construction is to occur during the nesting season (generally February 1 - August 31), conduct a pre-construction nesting bird survey of all suitable nesting habitat on the Project within 14 days of the commencement of construction. The survey shall be conducted within a 500-foot radius of Project work areas for raptors and within a 100-foot radius for other nesting birds. If any active nests are observed, these nests shall be designated a sensitive area and protected by an avoidance buffer established in coordination with CDFW until the breeding season has ended or until a qualified biologist has determined that the young have fledged and are no longer reliant upon the nest or parental care for survival. Pre-construction nesting surveys are not required for construction activity outside the nesting season</p>		
BIO-5.	Biological Resources	<p>Within 14 days prior to Project activities that may impact bat roosting habitat (e.g., removal of manmade structures or trees), a qualified biologist will survey for all suitable roosting habitat within the Project impact limits. If suitable roosting habitat is not identified, no further measures are necessary. If suitable roosting habitat is identified, a qualified biologist will conduct an evening bat emergence survey that may include acoustic monitoring to determine whether or not bats are present. If roosting bats are determined to be present within the Project site, consultation with CDFW prior to initiation of construction activities and/or preparation of a Bat Management Plan outlining avoidance and minimization measures specific to the roost(s) potentially affected may be required</p>		

Mitigation Measure	Type	Monitoring Shown on Department Plans	Verified Implementation	Remarks
BIO-6	Biological Resources	To minimize potential impacts to the ephemeral drainage on the project site during construction activity, a qualified biologist shall map the extent of the riparian habitat on the project site. Avoidance buffers for riparian habitat shall be applied in compliance with City of Clearlake requirements. The riparian habitat and avoidance buffer shall be demarcated prior to construction and shall be maintained until the completion of construction. A qualified biologist/biological monitor shall be present if work must occur within the avoidance buffer to ensure riparian habitat is not impacted by the construction activity.		
BIO-7	Biological Resources	A native tree protection and removal permit, waiver, or similar approval shall be secured prior to impacting trees protected under the City ordinance. Avoidance buffers for protected trees shall be consistent with the City requirements, shall be clearly demarcated prior to construction, and should be maintained until the completion of construction. A qualified biologist/biological monitor should be present if work must occur within the avoidance buffer to ensure avoided protected trees are not impacted by the work		
CUL-1.	Cultural Resources	During construction activities, if any subsurface archaeological remains are uncovered, all work shall be halted within 100 feet of the find and the owner shall utilize a qualified cultural resources consultant to identify and investigate any subsurface historic remains and define their physical extent and the nature of any built features or artifact-bearing deposits.		
CUL-2.	Cultural Resources	The cultural resource consultant's investigation shall proceed into formal evaluation to determine their eligibility for the California Register of Historical Resources. This shall include, at a minimum, additional exposure of the feature(s), photo-documentation and recordation, and analysis of the artifact		

Mitigation Measure	Type	Monitoring Shown on Department Plans	Verified Implementation	Remarks
		<p>assemblage(s). If the evaluation determines that the features and artifacts do not have sufficient data potential to be eligible for the California Register, additional work shall not be required. However, if data potential exists – e.g., there is an intact feature with a large and varied artifact assemblage – it will be necessary to mitigate any Project impacts. Mitigation of impacts might include avoidance of further disturbance to the resources through Project redesign. If avoidance is determined to be infeasible, pursuant to CEQA Guidelines Section 15126.4(b)(3)(C), a data recovery plan, which makes provisions for adequately recovering the scientifically consequential information from and about the historical resource, shall be prepared and adopted prior to any excavation being undertaken. Such studies shall be deposited with the California Historical Resources Regional Information Center. Archeological sites known to contain human remains shall be treated in accordance with the provisions of Section 7050.5 Health and Safety Code. If an artifact must be removed during Project excavation or testing, curation may be an appropriate mitigation. This language of this mitigation measure shall be included on any future grading plans and utility plans approved by the City for the Project.</p>		
CUL-3.	Cultural Resources	<p>If human remains are encountered, no further disturbance shall occur within 100 feet of the vicinity of the find(s) until the Lake County Coroner has made the necessary findings as to origin (California Health and Safety Code Section 7050.5). Further, pursuant to California Public Resources Code Section 5097.98(b) remains shall be left in place and free from disturbance until a final decision as to the treatment and disposition has been made. If the Lake County Coroner determines the remains to be Native American, the Native American Heritage Commission must be contacted within 24 hours. The Native American Heritage Commission must then</p>		

Mitigation Measure	Type	Monitoring Shown on Department Plans	Verified Implementation	Remarks
		identify the “most likely descendant(s)”. The landowner shall engage in consultations with the most likely descendant (MLD). The MLD will make recommendations concerning the treatment of the remains within 48 hours as provided in Public Resources Code 5097.98.		
CUL-4.	Cultural Resources	The sensitive site section noted on the project site plan shall not be disturbed during construction and/or maintenance of the park. This sensitive site is identified as investigation resulted in the discovery of two intact, buried, archaeological sites, CCL-21-01 and CCL-21-02 (Figure 7, yellow polygons), both of the sites can be considered significant cultural resources. Both of the sites occupy relatively small areas and are buried at depths of 16–32 inches below grade. The project as currently designed, will not impact sites CCL-21-01 or CCL-21-02. If avoidance and/or preservation in place is not possible, the owner will consider re-design or other measures to avoid impacting resources consistent with CEQA. The owner will contract with tribal monitors for ground disturbance within 100 feet of sites CCL-21-01 and CCL-21-02. The owner and contract archeologist will consult with tribal representatives regarding ground disturbing work within these areas including the designation of a “reburial” location, if needed.		
CUL-5	Cultural Resources	On or prior to the first day of construction the owner shall organize cultural sensitivity training for contractors involved in ground disturbing activities.		
CUL-6	Cultural Resources	The southern two-thirds of site CCL-21-01 is contained within APN010-026-400-000 and the Burns Valley Development Project area. The area occupied by the site has been slated for a paved parking area serving planned playing fields nearby (Figure 2). This portion of the site is situated on the sloping bank of an extinct section of upper Miller Creek, an area marked by an overstory of mixed native oak and		

Mitigation Measure	Type	Monitoring Shown on Department Plans	Verified Implementation	Remarks
		<p>introduced conifer and hardwood trees. Because this part of the site is situated on a bank, the land surface is sloped and drops 10–15 feet in elevation. Current engineering plan calls for vegetation and tree removal as well as application of remote fill materials to bring it to a level grade, with installation of landscaping, drains, and underground utility lines in the area. Project revisions in design, location, and operations should be implemented in the area occupied by the footprint of site CCL-21-01, inclusive to a 15-foot (4.5-meter) buffer around the site perimeter. Limitations to disturbance in this area shall be as follows:</p> <ol style="list-style-type: none"> 1. <i>Fill Cap.</i> Because CCL-21-01 is a buried archaeological deposit contained in a dense clay loam likely to resist compaction impacts, avoidance can be achieved by placing fill on the site surface; 2. <i>Flush Cut Vegetation.</i> Existing vegetation including shrubs and trees should be flush-cut, i.e., cut flush with the ground at a point not to exceed 10-inches below grade; 3. <i>Landscaping Fabric and Fill.</i> Once the flush cut is complete and surface cleared of debris, landscaping fabric should be laid over the area of the site to create a boundary between intact soils and remote fill. With respect to the fill, drainage, safety, and operational concerns may prevent adding a lot of elevation; however, an additional minimum 6–12-inches (15–30 centimeters) of fill should be added to the site area to provide a construction and compaction buffer to protect the deposit. This would result in an overburden of 21–27 inches (53–71 centimeters) of capping material; 4. <i>Avoid Installation of Subsurface Features.</i> Avoid placement of pier 		

Mitigation Measure	Type	Monitoring Shown on Department Plans	Verified Implementation	Remarks
		<p>supports, subsurface landscaping features, subsurface drains, and utility lines in the site area.</p> <p>5. <i>Avoid New Overstory Plantings.</i> Avoid placement of new overstory trees in the site area</p>		
CUL-7	Cultural Resources	<p>Site CCL-21-02 is contained within APN010-026-400-000 and the Burns Valley Development Project area. The area occupied by the site has been slated for open space. Project revisions in design, location, and operations should be implemented in the area occupied by the footprint of site CCL-21-02, inclusive to a 15-foot (4.5-meter) buffer around the site perimeter. Limitations to disturbance in this area shall be as follows:</p> <ol style="list-style-type: none"> 1. <i>Fill Cap.</i> Because CCL-21-01 is a buried archaeological deposit contained in a dense clay loam likely to resist compaction impacts, avoidance can be achieved by placing fill on the site/buffer surface; 2. <i>Landscaping Fabric and Fill.</i> Prior to site prep and construction in the area, landscaping fabric should be laid over the area of the site to create a boundary between intact soils and remote fill. With respect to the fill, drainage, safety, and operational concerns may prevent adding a lot of elevation; however, an additional minimum 6–12-inches (15–30 centimeters) of fill should be added to the site area to provide a construction and compaction buffer to protect the deposit. This would result in an overburden of 21–27 inches (53–71 centimeters) of capping material; 3. <i>Avoid Installation of Subsurface Features.</i> Avoid placement of pier supports, subsurface landscaping features, subsurface drains, and 		

Mitigation Measure	Type	Monitoring Shown on Department Plans	Verified Implementation	Remarks
		<p>utility lines in the site area.</p> <p>4. <i>Avoid New Overstory Plantings.</i> Avoid placement of new overstory trees in the site area.</p>		
GEO-1	Geology and Soils	<p>GEO-1: Prior to any ground disturbance and/or operation, the applicant shall submit <u>Erosion Control and Sediment Plans</u> to the Community Development Department for review and approval.</p> <ul style="list-style-type: none"> <i>The project shall incorporate Best Management Practices (BMPs) consistent with the City Code and the State Storm Water Drainage Regulations to the maximum extent practicable to prevent and/or reduce discharge of all construction or post-construction pollutants into the local storm drainage system.</i> 		
GEO-2	Geology and Soils	<p>Prior to any ground disturbance, (if applicable), the applicant shall submit and obtain a Grading Permit from the Community Development in accordance with the City of Clearlake Municipal code(s).</p>		
GEO-3	Geology and Soils	<p>The applicant shall monitor the site during the rainy season including post-installation, application of BMPs, erosion control maintenance, and other improvements as needed. Said measures shall be maintained for life of the project and replace/repared when necessary</p>		
NOI-1.	Noise	<p>All construction activities including engine warm-up shall be limited to weekdays and Saturday, between the hours of 7:00am and 7:00pm to minimize noise impacts on nearby residents.</p>		
NOI-2.	Noise	<p>Permanent potential noise sources such as, generators used for power shall be designed and located to minimize noise impacts to surrounding properties.</p>		

Mitigation Measure	Type	Monitoring Shown on Department Plans	Verified Implementation	Remarks
NOI-3.	Noise	During construction noise levels shall not exceed 65 decibels within fifty (50) feet of any dwellings or transient accommodations between the hours of 7:00 AM and 6:00 PM. This threshold can be increased by the Building Inspector or City Engineer have approved an exception in accordance with Section 5-4.4(b)(1) of the City Code. An exception of up to 80 decibels may be approved within one hundred (100) feet from the source during daylight hours. Project is expected to result in less than significant impacts with regard to noise and vibration.		
NOI-4	Noise	Park operations, including baseball at the northeasterly ball park shall be shall be restricted to not later than 10 pm.		
TCR-1	Tribal Cultural Resource	Requirement to develop a tribal cultural resources preservation plan that delineates the boundary of CCL-21-01 and CCL-21-02, describes the appropriate combination of materials and culturally sterile fill in capping, provides landscaping specifications that favor culturally important plants, and restricts certain types of post-project activities in or on the cap.		
TCR-2	Tribal Cultural Resource	Requirement to designate a project reburial area in advance of ground disturbing activities in the event that materials are discovered during construction.		
TCR-3	Tribal Cultural Resource	Requirement for contractors to receive meaningful training on cultural sensitivity and tribal cultural resources from a tribal representative.		
TCR-4	Tribal Cultural Resource	Requirement for tribal monitoring during ground disturbing activities in sensitive areas of the project area.		
TCR-5	Tribal Cultural Resource	Procedures for compliance with existing state law in the event of the discovery of human remains during construction.		
TCR-6	Tribal Cultural Resource	A prohibition on the removal of cultural soils from the project area.		

Explanation of Headings

Type = Project (mitigation for this specific project), ongoing, and/or cumulative.

Monitoring Department = Department or agency responsible for monitoring a particular mitigation measure.

Shown on Plans = When a mitigation measure is shown on the construction plans, this column must be initialed and dated.

Verified Implementation = When mitigation measure has been implemented, this column must be initialed and dated.

Remarks = Area for describing status of ongoing mitigation measure, or other information.

BURNS VALLEY ROAD

ELEMENTS

- 1 RECREATION CENTER - 15,000 SF
- 2 RESTROOM/ CONCESSION BUILDING
- 3 RESTROOM BUILDING
- 4 MULTI-SPORT TURF FIELD WITH LIGHTS - (1) U12 SOCCER, (3) U10 SOCCER, (8) U8 SOCCER
- 5 (1) BASEBALL FIELD - 300' FENCES & LIGHTS
- 6 (1) LITTLE LEAGUE BASEBALL FIELD - 200' FENCES & LIGHTS
- 7 (1) SOFTBALL FIELD - 200' FENCES & LIGHTS
- 8 (1) T-BALL FIELDS
- 9 (3) FITNESS EQUIPMENT AREA
- 10 ADA ACCESSIBLE PLAYGROUND WITH FENCE - APPROX. 4,600SF
- 11 CENTRAL COMMUNITY GATHERING AREA (22 TABLES)
- 12 DISPLAY PANELS UNDER ARBOR (ANNOUNCEMENTS/ PUBLIC ART/ WALL OF CHAMPIONS)
- 13 (2) SHADE STRUCTURE PICNIC AREA (5 TABLES TOTAL)
- 14 PICNIC AREA (6 TABLES TOTAL)
- 15 DUGOUT
- 16 BATTING/PITCHING CAGE
- 17 BLEACHERS
- 18 BENCHES
- 19 (4) PERMEABLE WALKING TRAILS SURROUNDING LARGER FIELDS WITH INTERPRETIVE SIGNS. (PERMEABLE SURFACE = 30% TOTAL HARDSCAPE)
- 20 NATIVE PLANT DEMONSTRATION AREA
- 21 STORMWATER BIOSWALE & INTERPRETIVE SIGN



CONCEPT MASTERPLAN

BURNS VALLEY SPORTS COMPLEX

14885 BURNS VALLEY ROAD
CITY OF CLEARLAKE, CA

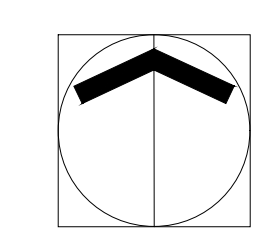

- 1" = 50'-0"
- 12.02.2022
- 01 OF 09



CITY OF CLEARLAKE

MITIGATED NEGATIVE DECLARATION

ENVIRONMENTAL ANALYSIS (CEQA)

INITIAL STUDY

Burns Valley Development Complex
~~BURNS VALLEY PARK AND PUBLIC WORKS YARD~~
~~MASTER PLAN~~

June 16, 2022

Amended April 4, 2023

CALIFORNIA ENVIRONMENTAL QUALITY ACT

ENVIRONMENTAL CHECKLIST FORM

INITIAL STUDY

- 1. Project Title:** Burns valley Development Project
~~Burns Valley Park and Public Works Yard Master Plan~~
- 2. Permit Numbers:** Initial Study, IS 2022-05
Conditional Use Permit, CUP 2022-16
- 3. Lead Agency Name/Address:** City of Clearlake 14050 Olympic Drive
Clearlake, CA 95422
- 4. Contact Person:** Mark Roberts – Senior Planner
Phone: (707) 994-8201
Email: mroberts@clearlake.ca.us
- 5. Project Location(s):** 14885 Burns Valley Road
Clearlake, CA 95422
- 6. Parcel Numbers(s):** 010-026-40
- 7. Project Sponsor's Name/Address:** City of Clearlake 14050 Olympic Drive
Clearlake, CA 95422
- 8. Property Owner(s) Name/Address:** City of Clearlake 14050 Olympic Drive
Clearlake, CA 95422
- 9. Zoning Designations:** Mix Use
- 10. General Plan Designation:** Mixed Use
- 11. Supervisor District:** District Two (2)
- 12. Average Cross Slope:** Less than 10% cross slope
- 13. Earthquake Fault Zone:** Not within a fault zone
- 14. Dam Failure Inundation Area:** Not within a Dam Failure Inundation Zone
- 15. Flood Zone:** Partially located within Flood Zone AO
- 16. Waste Management:** Clearlake Waste Solutions
- 17. Water Access:** Highlands Mutual Water Company

18. Fire Department: Lake County Fire Protection District

19. School District: Konocti Unified School District

20. Description of Project: *(Describe the whole action involved, including but not limited to later phases of the project and any secondary, support, or off-site features necessary for its implementation. Attach additional pages if necessary.)*

Development of a public park (sports complex), community center, public works yard with public works building facility and combined police department office and maintenance facilities, vehicle and equipment storage areas, public access and parking facilities on approximately 26 acres.

The project is proposed to be located in the Burns Valley Area, north of Olympic Drive and South of Burns Valley Drive, behind the Safeway Shopping Center, Clearlake, CA (Accessors Parcel No. 010-026-40). Also, see Figures 1, 2, and 3 (location maps).

The park would include one full size baseball field, two smaller little league baseball fields, two small Tee-Ball Fields, a full-size soccer field (see Figure 6, Site and Preliminary Grading Plan). The project would include development of an approximately 15,000 to 20,000 square foot recreation center building for use for public events and activities (see Figure 7-concept building elevations). This building would contain sports features, such as basketball and volleyball courts. Being located next to the baseball area, a concession building/stand would be constructed next to or as part of this larger building. These combined facilities would be located on the east side of the project site.

On the west side is proposed an approximate 12,000 square foot public works building, including a Police Department investigation facility (see Figure 8). This building would include a vehicle wash station, and sections for equipment repair. This public works yard would be used to store and maintain city public vehicles, including public works and police department cars, trucks, and heavy equipment.

Access to the project would be from a number of driveways/streets including access from Olympic Drive and Burns Valley Road. Approximately 365 parking spaces would be developed along access roads through the park (including 20 for the public works/police facility). Other related improvements would include sidewalks, fencing (see Figure 11), lighting features (see figures 12. 13. And 14), baseball field protective netting (see Figure 10) and restroom facilities. All play fields will include lighting to allow for night operations.

Project development is envisioned to be constructed in two development phasing depending on funding availability and City priority. The first phase, as shown in Figure 6, is to develop the sports complex components, with the recreation center building and public works hop building to come later.

21. Environmental Setting:

The project area is relatively flat with gently rolling terrain situated at an elevational range of approximately 1,350 to 1,365 feet above mean sea level (MSL) in the Inner North Coast Ranges District of the California floristic province (Baldwin et al. 2012). Please refer to site photos (Figure 5). The parcel is an irregularly shaped 25.46-acre parcel generally composed of

open landscape, existing tree orchard and grasses. A drainage channel transects the eastern portion of the parcel in the southwest direction.

22. Surrounding Land Uses and Setting: Briefly describe the project's surroundings:

- The parcels to the **North** – Library and senior residential care center, vacant ag land
- The parcels to the **South** – Commercial Retail
- The parcels to the **West** – Vacant land
- The parcels to the **East** – Rural residential

20. Other Public Agencies Whose Approval is Required: Local Agencies: City of Clearlake - Community Development (Planning, Building, Public Works); Clearlake Police Department, Lake County Fire Protection, Lake County Department of Environmental Health, Lake County Air Quality Management District, Lake County Special Districts, Highlands Water Districts, Local Tribal Organizations.

21. Federal and State Agencies: Central Valley Regional Water Quality Control Board, CA Department of Fish and Wildlife, California Department of Transportation (Caltrans); California Department of Public Health.

22. Have California Native American tribes traditionally and culturally affiliated with the project area requested consultation pursuant to Public Resources Code section 21080.3.1? If so, is there a plan for consultation that includes, for example, the determination of significance of impacts to tribal cultural resources, procedures regarding confidentiality, etc.? Note: Conducting consultation early in the CEQA process allows tribal governments, lead agencies, and project proponents to discuss the level of environmental review, identify and address potential adverse impacts to tribal cultural resources, and reduce the potential for delay and conflict in the environmental review process. (See Public Resources Code section 21080.3.2.) Information may also be available from the California Native American Heritage Commission's Sacred Lands File per Public Resources Code section 5097.96 and the California Historical Resources Information System administered by the California Office of Historic Preservation. Please also note that Public Resources Code section 21082.3 (c) contains provisions specific to confidentiality.

Notification of the project was sent to local tribes for "AB 52" Notification, which allows interested Tribes to request tribal consultation within 30 days of receipt of notice. The Cultural Study documents all consultation conducted.

23. Impact Categories defined by CEQA: The following documents are referenced information sources and are incorporated by reference into this document and are available for review upon request of the Community Development Department if they have not already been incorporated by reference into this report:

- City of Clearlake General Plan
- City of Clearlake Zoning Code
- U.S.D.A. Lake County Soil Survey
- Important Farmland Map <https://maps.conservation.ca.gov/agriculture/>
- Lake County Serpentine Soil Mapping
- California Natural Diversity Database (<https://www.wildlife.ca.gov/Data/CNDDDB>)
- U.S. Fish and Wildlife Service National Wetlands Inventory
- U.S.G.S. Geologic Map and Structure Sections of the Clear Lake Volcanic, Northern California, Miscellaneous Investigation Series, 1995

- Official Alquist-Priolo Earthquake Fault Zone maps for Lake County
- Landslide Hazards in the Eastern Clear Lake Area, Lake County, California, Landslide Hazard Identification Map No. 16, California Department of Conservation, Division of Mines and Geology, DMG Open –File Report 89-27, 1990
- Hazardous Waste and Substances Sites List: www.envirostor.dtsc.ca.gov/public
- California Department of Forestry and Fire Protection - Fire Hazard Mapping
- National Pollution Discharge Elimination System (NPDES)
- Cal Recycle Solid Waste Information System
<http://www.calrecycle.ca.gov/SWFacilities/Directory/Search.aspx>
- Written comments received from public agencies.
- Site visits

Figures

- Figure 1 – Regional Map
- Figure 2 – Vicinity Map
- Figure 3 – USGS Map
- Figure 4 – Zoning Map
- Figure 5 – Site Photos
- Figure 6 – Master Site and Preliminary Grading Plan
- Figure 7– Burns Valley Sports Complex Park Project 15,000 square foot Community Center Building Concept and Example of Buildings
- Figure 8 – City Public Works Yard, Building Design Concepts/Example
- Figure 10 – Baseball Field Protective Netting Concept/Example
- Figure 11 – Perimeter Fencing Concept/Example
- Figure 12 – Exterior Lighting Concept/Example
- Figure 13 – Typical Street Lighting Design
- Figure 14 – Baseball Field Lighting Example

Attachments

- Attachment A – Lighting Impact Analysis
- Attachment B – Air Quality Impact Analysis
- Attachment C – Biological Impact Report
- Attachment E – Traffic Impact Study
- Attachment F – Noise Study for Oak Valley Villas Apartments
- Attachment G – Flood Hazards Map

24. Figures

Figure 1: Regional Map



Figure 2: Vicinity Map

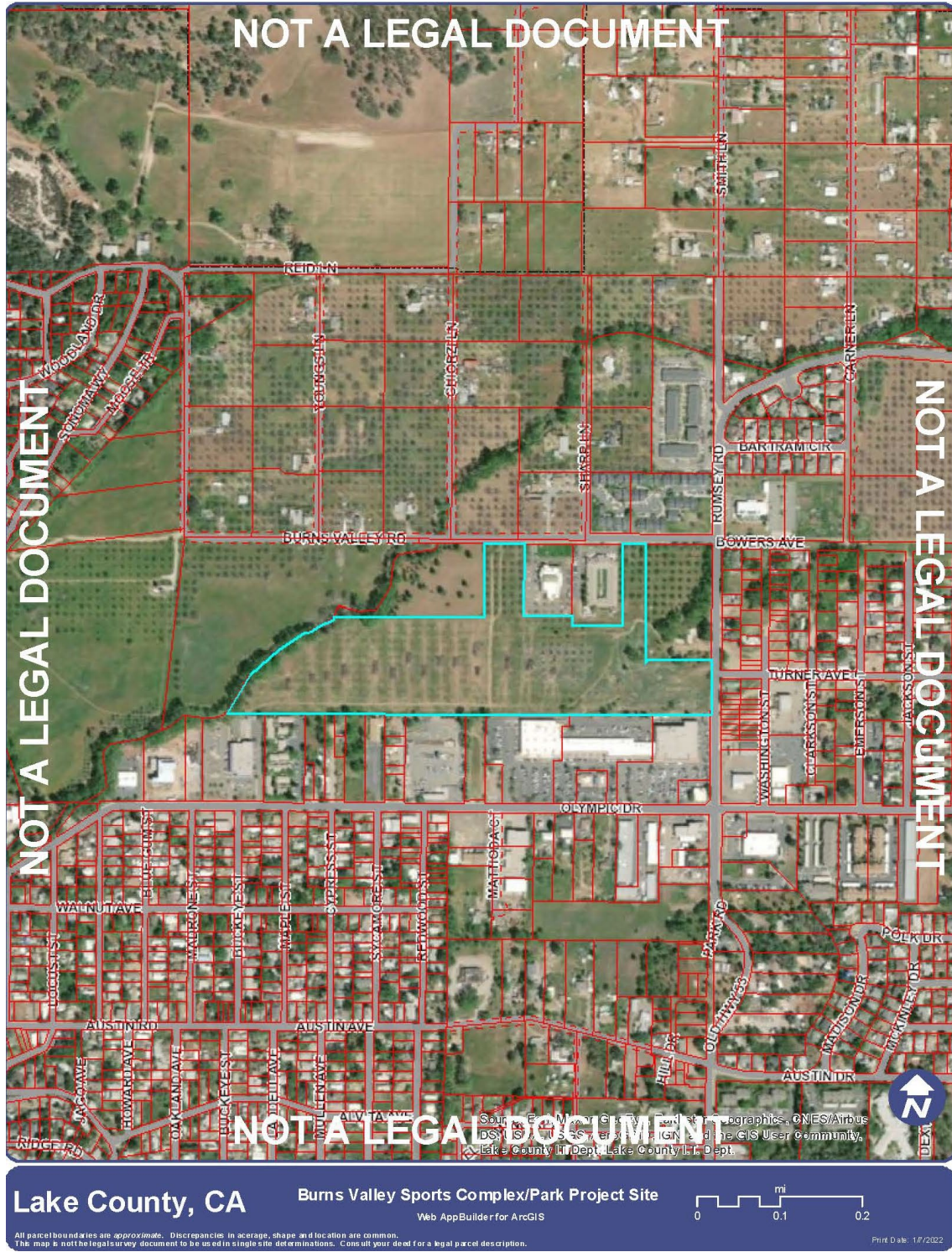

Figure 3: USGS Map

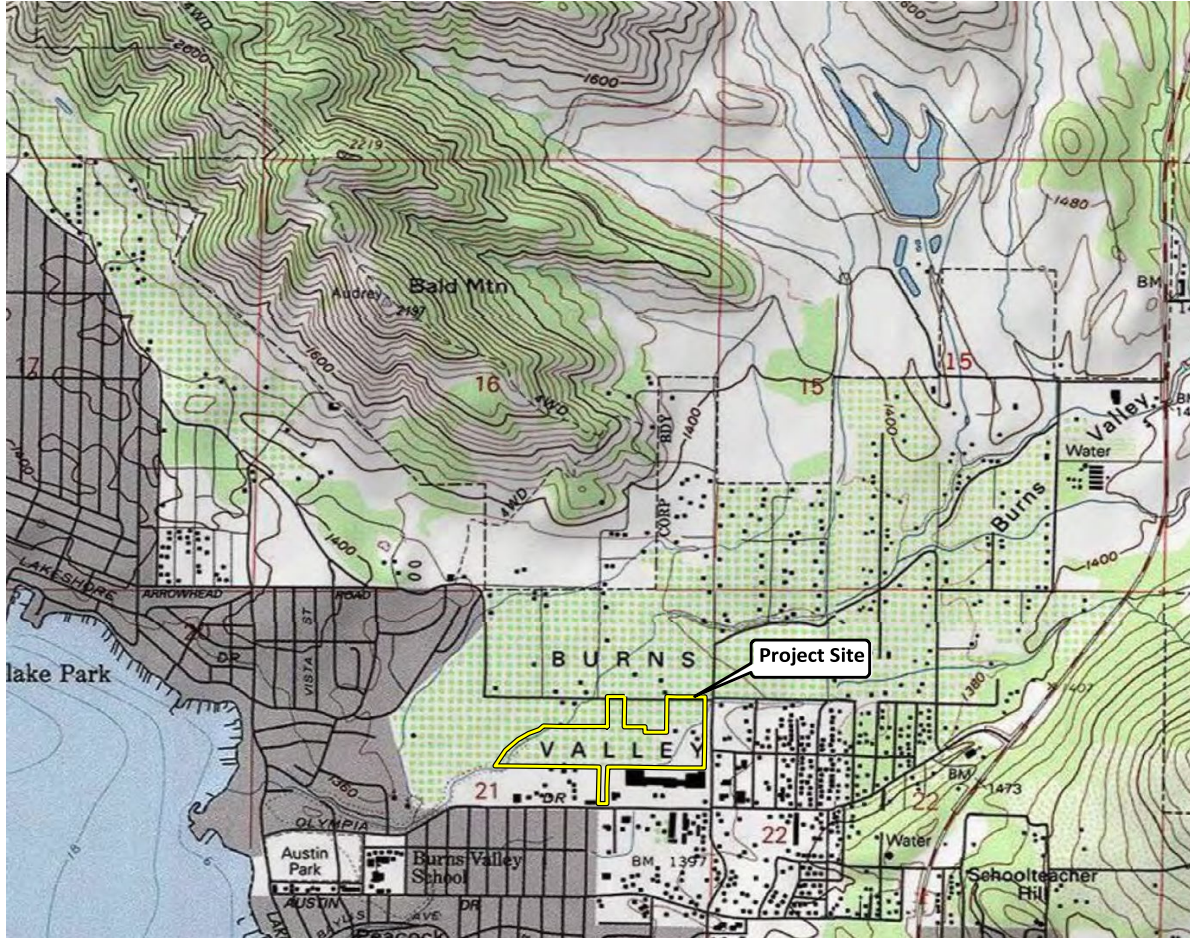

Figure 4: Zoning Map (MUX – Mix Use)

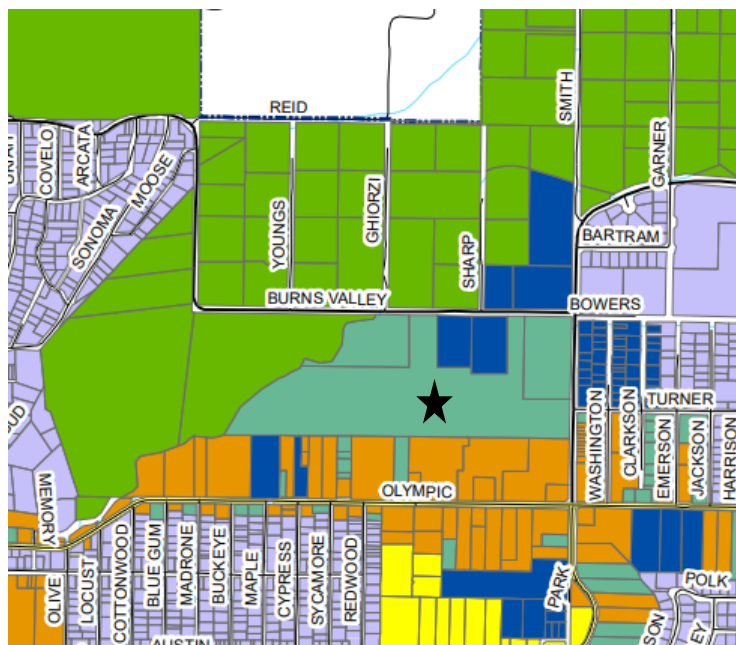

Figure 5: Site Photos



Easterly view from south side and central on site



Southerly view from north center of site



Easterly view from center of site



Westerly view from north side of site

Figure 6: Master Site and Preliminary Grading Plan (larger plan available by request of the City)

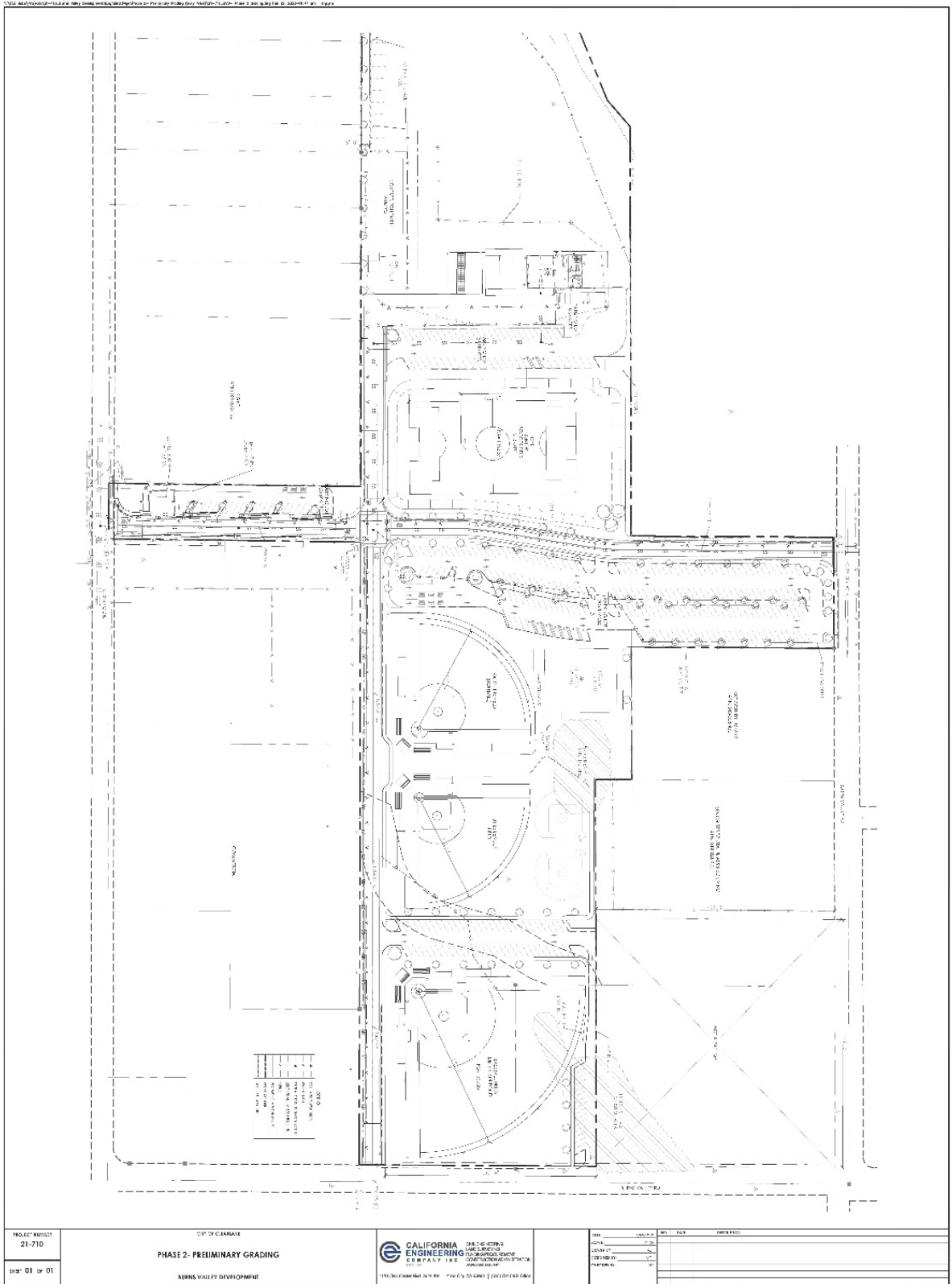

Figure 7: Burns Valley Sports Complex Park Project 15,000 square foot Community Center Building Concept and Example of Buildings



Figure 8: City Public Works Yard, Building Design Concepts/Example



Figure 9: Baseball Field Protective Netting Concept/Example



Figure 10: Perimeter Fencing Concept/Example



Figure 11: Exterior Lighting Concept/Example



Figure 12: Typical Street Lighting Design

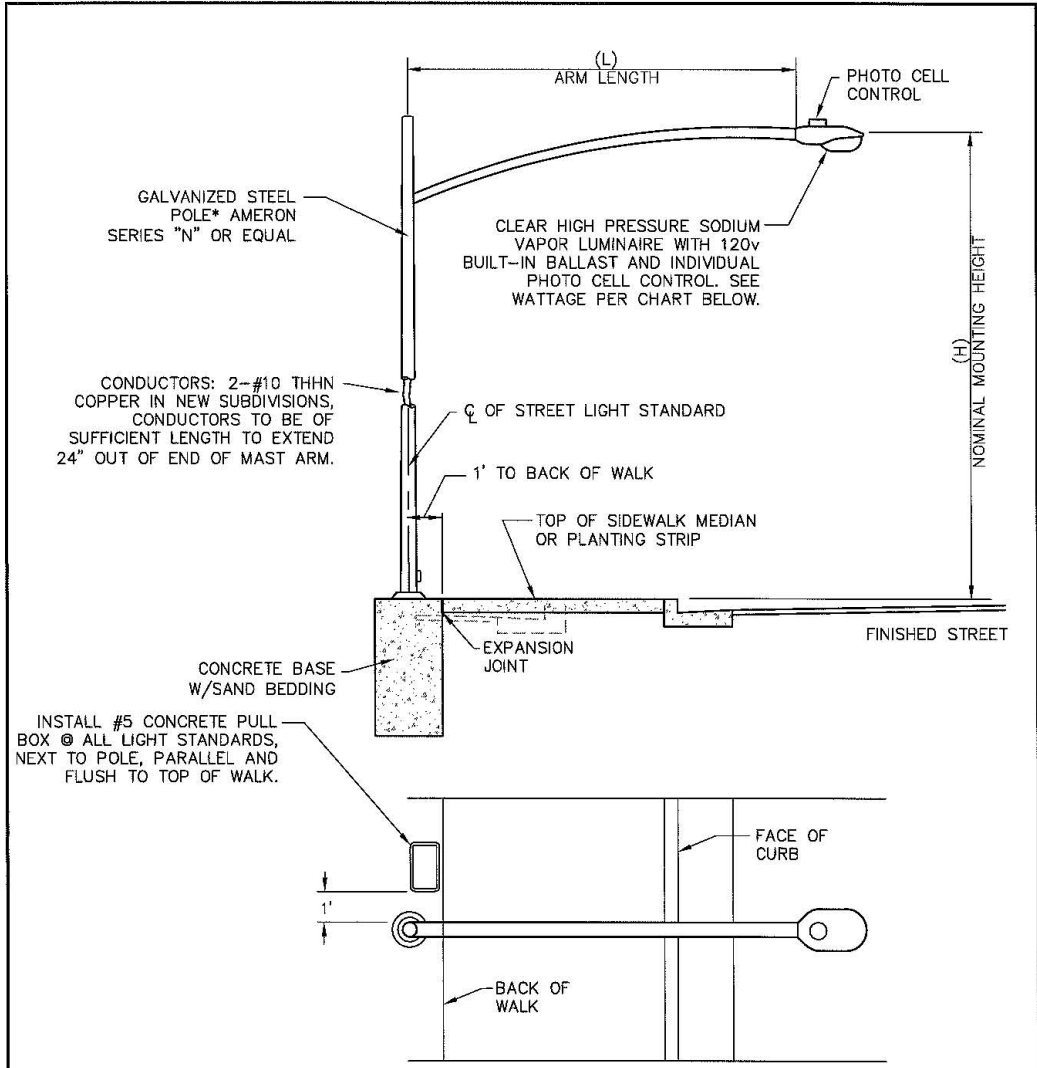

*ALTERNATES TO BE SPECIFICALLY APPROVED BY THE CITY ENGINEER.

STREET CLASSIFICATION	MOUNTING HEIGHT(H)	ARM LENGTH(L)	MAXIMUM SPACING	WATTAGE
ARTERIAL	32'-3"	12'-0"	100'	150
COLLECTOR & INDUSTRIAL	27'-6"	10'-0"	200'	100
RESIDENTIAL	27'-3"	8'-0"	200'	70



STANDARD STREET LIGHT

STD. NO.
401

SCALE: NONE | DRAWN: CLG | CHK: PWV | APPVD: JLW | DATE: APR. 2012

Figure 13: Baseball Field Lighting Example



31. Environmental Factors Effected: The environmental sections checked below would be potentially affected by this project in an adverse manner, including at least one environmental issue/significance criteria that is “potentially significant impacts” as indicated by the analysis in the following evaluation of environmental impacts.

<input checked="" type="checkbox"/>	Aesthetics	<input type="checkbox"/>	Greenhouse Gas Emissions	<input type="checkbox"/>	Public Services
<input type="checkbox"/>	Agriculture & Forestry Resources	<input checked="" type="checkbox"/>	Hazards & Hazardous Materials	<input type="checkbox"/>	Recreation
<input checked="" type="checkbox"/>	Air Quality	<input type="checkbox"/>	Hydrology / Water Quality	<input checked="" type="checkbox"/>	Transportation
<input checked="" type="checkbox"/>	Biological Resources	<input type="checkbox"/>	Land Use / Planning	<input checked="" type="checkbox"/>	Tribal Cultural Resources
<input checked="" type="checkbox"/>	Cultural Resources	<input type="checkbox"/>	Mineral Resources	<input type="checkbox"/>	Utilities / Service Systems
<input type="checkbox"/>	Energy	<input checked="" type="checkbox"/>	Noise & Vibration	<input type="checkbox"/>	Wildfire
<input checked="" type="checkbox"/>	Geology / Soils	<input type="checkbox"/>	Population / Housing	<input checked="" type="checkbox"/>	Mandatory Findings of Significance

DETERMINATION: (To be completed by the lead Agency)

On the basis of this initial evaluation:

- I find that the proposed project COULD NOT have a significant effect on the environment, and a NEGATIVE DECLARATION will be prepared.
- I find that although the proposed project could have a significant effect on the environment, there will not be a significant effect in this case because revisions in the project have been made by or agreed to by the project proponent. A MITIGATED NEGATIVE DECLARATION will be prepared.**
- I find that the proposed project MAY have a significant effect on the environment, and an ENVIRONMENTAL IMPACT REPORT is required.
- I find that the proposed project MAY have a “potentially significant impact” or “potentially significant unless mitigated” impact on the environment, but at least one effect 1) has been adequately analyzed in an earlier document pursuant to applicable legal standards, and 2) has been addressed by mitigation measures based on the earlier analysis as described on attached sheets. An ENVIRONMENTAL IMPACT REPORT is required, but it must analyze only the effects that remain to be addressed.
- I find that although the proposed project could have a significant effect on the environment, because all potentially significant effects (a) have been analyzed adequately in an earlier EIR or NEGATIVE DECLARATION pursuant to applicable standards and (b) have been avoided or mitigated pursuant to that earlier EIR or NEGATIVE DECLARATION, including revisions or mitigation measures that are imposed upon the proposed project, nothing further is required.

Prepared By: Mark Roberts

Title: Senior Planner

Signature: 

Date: July 19, 2022 / Amended April 4th, 2023

Alan Flora – City Manager
City of Clearlake, California

SECTION 1 - EVALUATION OF ENVIRONMENTAL IMPACTS:

- 1) A brief explanation is required for all answers except "No Impact" answers that are adequately supported by the information sources a lead agency cites in the parentheses following each question. A "No Impact" answer is adequately supported if the referenced information sources show that the impact simply does not apply to projects like the one involved (e.g., the project falls outside a fault rupture zone). A "No Impact" answer should be explained where it is based on project-specific factors as well as general standards (e.g., the project will not expose sensitive receptors to pollutants, based on a project-specific screening analysis).
- 2) All answers must take account of the whole action involved, including off-site as well as on-site, cumulative as well as project-level, indirect as well as direct, and construction as well as operational impacts.
- 3) Once the lead agency has determined that a particular physical impact may occur, and then the checklist answers must indicate whether the impact is potentially significant, less than significant with mitigation, or less than significant. "Potentially Significant Impact" is appropriate if there is substantial evidence that an effect may be significant. If there are one or more "Potentially Significant Impact" entries when the determination is made, an EIR is required.
- 4) "Negative Declaration: Less Than Significant with Mitigation Incorporated" applies where the incorporation of mitigation measures has reduced an effect from "Potentially Significant Impact" to a "Less Than Significant Impact." The lead agency must describe the mitigation measures, and briefly explain how they reduce the effect to a less than significant level (mitigation measures from Section XVII, "Earlier Analyses," may be cross-referenced).
- 5) Earlier analyses may be used where, pursuant to the tiering, program EIR, or other CEQA process, an effect has been adequately analyzed in an earlier EIR or negative declaration. Section 15063(c)(3)(D). In this case, a brief discussion should identify the following:
 - a) Earlier Analysis Used. Identify and state where they are available for review.
 - b) Impacts Adequately Addressed. Identify which effects from the above checklist were within the scope of and adequately analyzed in an earlier document pursuant to applicable legal standards, and state whether such effects were addressed by mitigation measures based on the earlier analysis.
 - c) Mitigation Measures. For effects that are "Less than Significant with Mitigation Measures Incorporated," describe the mitigation measures, which were incorporated or refined from the earlier document and the extent to which they address site-specific conditions for the project.

- 6) Lead agencies are encouraged to incorporate into the checklist references to information sources for potential impacts (e.g., general plans, zoning ordinances). Reference to a previously prepared or outside document should, where appropriate, include a reference to the page or pages where the statement is substantiated.
- 7) Supporting Information Sources: A source list should be attached, and other sources used or individuals contacted should be cited in the discussion.
- 8) This is only a suggested form, and lead agencies are free to use different formats; however, lead agencies should normally address the questions from this checklist that are relevant to a project's environmental effects in whatever format is selected.
- 9) The explanation of each issue should identify:
 - a) the significance criteria or threshold, if any, used to evaluate each question; and
 - b) the mitigation measure identified, if any, to reduce the impact to less than significance

IMACT CATEGORIES KEY:

- **1 = Potentially Significant Impact**
- **2 = Less Than Significant with Mitigation Incorporation**
- **3 = Analyzed in Prior EIR**
- **4 = Substantially Mitigated by Uniformly Applicable Development Policies/Standards**
- **5 = Less Than Significant Impact**
- **6 = No Impact**

IMPACT CATEGORIES*	1	2	3	4	5	6	All determinations need explanation. Reference to documentation, sources, notes and correspondence.
SECTION I. AESTHETICS							
<i>Except as provided in Public Resources Code Section 21099, would the project:</i>							
a) Have a substantial adverse effect on a scenic vista that is visible from a City scenic corridor?	<input type="checkbox"/>	<input type="checkbox"/>	<input type="checkbox"/>	<input type="checkbox"/>	<input type="checkbox"/>	<input checked="" type="checkbox"/>	The project parcel(s) are not located within and/or near scenic vistas. Therefore, the project will not have a substantial adverse effect one a scenic vista that is visible from a city scenic corridor. No Impact.
b) Substantially damage scenic resources that is visible from a City Corridor, including, but not limited to, trees, rock outcroppings, and historic buildings within a state scenic highway?	<input type="checkbox"/>	<input type="checkbox"/>	<input type="checkbox"/>	<input type="checkbox"/>	<input type="checkbox"/>	<input checked="" type="checkbox"/>	The project will not substantially damage scenic resources that may be visible from a City Corridor, including, but not limited to, trees, rock outcroppings, and historic buildings within a state scenic highway. There are no known rock outcroppings, historic buildings, and/or scenic highways on the project site and no scenic highways with views of the project site. No Impact.
c) Conflict with applicable General Plan policies or zoning regulations governing scenic quality.	<input type="checkbox"/>	<input type="checkbox"/>	<input type="checkbox"/>	<input type="checkbox"/>	<input type="checkbox"/>	<input checked="" type="checkbox"/>	The project will not conflict with applicable any General Plan policies and/or zoning regulations governing scenic quality within the City of Clearlake. No impact.
d) Create a new source of substantial light or glare which would adversely affect day or nighttime views in the area?	<input type="checkbox"/>	<input checked="" type="checkbox"/>	<input type="checkbox"/>	<input type="checkbox"/>	<input type="checkbox"/>	<input type="checkbox"/>	The proposed lighting for the project will increase lighting levels in the area that may impact nighttime views and may result in substantial light glare, particularly from the new sport field lighting (see Figures 12, 13, and 14). The sport field lighting would consist of a series of maximum 70-foot-tall poles with LED glare resistant lighting fixtures directed/shielded downward. Lighting height and design may change as a result of final design plans, but will not exceed parameters in this analysis/document. A

IMPACT CATEGORIES*	1	2	3	4	5	6	<p style="text-align: center;">All determinations need explanation. Reference to documentation, sources, notes and correspondence.</p>
							<p>lighting analysis was conducted to determine the extent of glare impacts on adjoining properties/uses (see Attachment A). It shows lighting levels of about 15-foot candles at the property line of a proposed apartment project; Oak Valley Villas. One building in particular would be impacted by lighting during nighttime use of the sport field. The City does not have a threshold of significance for lighting levels. However, major efforts have been made to address lighting glare levels with the use of this type of lighting. Several mitigation measures have been developed to lessen the significant of lighting impacts from the project to a level of less than significant.</p> <p>AES-1 All outdoor lighting shall be directed downwards and shielded onto the project site and not onto adjacent properties. All lighting shall comply and adhere to all federal, state and local agency requirements, including all requirements in darksky.org. (Refer to the City’s Design Standards).</p> <p>AES-2. A final lighting design plan shall be submitted for review and approval by the Community Development Department. Lighting levels shall not exceed lighting levels beyond those referenced in Attachment A, Lighting Analysis for this project. Lighting shall be installed in accordance with the final approved lighting plan.</p> <p>AES-2 All nighttime ball field lighting shall be operated no later than 10 pm.</p>
<p>SECTION II. AGRICULTURE AND FORESTRY RESOURCES</p> <p><i>In determining whether impacts to agricultural resources are significant environmental effects, lead agencies may refer to the California Agricultural Land Evaluation and Site Assessment Model (1997) prepared by the California Dept. of Conservation as an optional model to use in assessing impacts on agriculture and farmland. In determining whether impacts to forest resources, including timberland, are significant environmental effects, lead agencies may refer to information compiled by the California Department of Forestry and Fire Protection regarding the state’s inventory of forest land, including the Forest and Range Assessment Project and the Forest Legacy Assessment Project; and forest carbon measurement methodology provided in Forest protocols adopted by the California Air Resources Board.</i></p> <p><i>Would the project</i></p>							
<p>a) Convert Prime Farmland, Unique Farmland, or Farmland of Statewide Importance (Farmland), as shown on the maps prepared pursuant to the Farmland Mapping and Monitoring Program of the California Resources Agency, to non-agricultural use?</p>	<input type="checkbox"/>	<input type="checkbox"/>	<input type="checkbox"/>	<input type="checkbox"/>	<input type="checkbox"/>	<input checked="" type="checkbox"/>	<p>There is no Prime Farmland, Unique Farmland, and/or Farmland of Statewide Importance on or adjacent to the proposed project; therefore, there will be no impact.</p>
<p>b) Conflict with existing zoning for agricultural use, or a Williamson Act contract?</p>	<input type="checkbox"/>	<input type="checkbox"/>	<input type="checkbox"/>	<input type="checkbox"/>	<input type="checkbox"/>	<input checked="" type="checkbox"/>	<p>The project site is not zoned for agricultural use and is not under contract for agricultural land use therefore, there will be no impact.</p>

IMPACT CATEGORIES*	1	2	3	4	5	6	All determinations need explanation. Reference to documentation, sources, notes and correspondence.
c) Conflict with existing zoning for, or cause rezoning of, forest land (as defined in Public Resources Code section 12220(g)), timberland (as defined by Public Resources Code section 4526), or timberland zoned Timberland Production (as defined by Government Code section 51104(g))?	<input type="checkbox"/>	<input type="checkbox"/>	<input type="checkbox"/>	<input type="checkbox"/>	<input type="checkbox"/>	<input checked="" type="checkbox"/>	The project will not conflict with existing zoning for, or cause the rezoning of, forest land (as defined in Public Resources Code section 12220(g)), timberland (as defined by Public Resources Code section 4526), or timberland zoned Timberland Production (as defined by Government Code section 51104(g)). No Impact
d) Involve other changes in the existing environment which, due to their location or nature, could result in conversion of Farmland, to non-agricultural use or conversion of forest land to non-forest use?	<input type="checkbox"/>	<input type="checkbox"/>	<input type="checkbox"/>	<input type="checkbox"/>	<input type="checkbox"/>	<input checked="" type="checkbox"/>	The project will not involve other changes in the existing environment which, due to their location or nature, could result in conversion of Farmland, to non-agricultural use or conversion of forest land to non-forest use. Refer to 2a and 2b, above. No Impact

SECTION III. AIR QUALITY

Where available, the significance criteria established by the applicable air quality management district or air pollution control district may be relied upon to make the following determinations.

Would the project:

a) Conflict with or obstruct implementation of the applicable air quality plan?	<input type="checkbox"/>	<input checked="" type="checkbox"/>	<input type="checkbox"/>	<input type="checkbox"/>	<input type="checkbox"/>	<input type="checkbox"/>	<p>The project is located in the Lake County Air Basin (LCAB). The State and Federal Clean Air Acts mandate the reduction and control of certain air pollutants. Under these Acts, the U.S. Environmental Protection Agency (USEPA) and the California Air Resources Board (CARB) have established ambient air quality standards for certain “criteria pollutants.” As shown in Table 1, the LCAB is in attainment status for each criteria pollutant, meaning that the LCAB is in compliance with the established ambient air quality standards for the criteria pollutants. Lake County Air Basin is one of only nine regions in California to have never exceeded the maximum ozone standard, and the only air basin to meet the standard for visibility reducing particles. Clearlake, located in LCAB, is currently in attainment of all State and Federal Ambient Air Quality Standards. The project will not result in air quality impacts that exceed the Bay Area Air Quality Management District (BAAQMD).</p> <p>In 2008, the California Air Resource Board released a summary of the estimated annual average emissions rates in the Lake County Air Basin, including stationary, area wide, and mobile source emissions. The main stationary source of total organic gas (TOG) emissions is electric fuel combustion. Carbon Monoxide (CO) is mostly coming from mobile emissions sources. Motorized boats and light duty passenger vehicles and trucks make up two-thirds of the mobile source CO emissions, and one half of the total CO emissions in the Air Basin. Finally, unpaved roads were the largest source of particulate matter (PM) in the County. According to the report, the main stationary source of total organic gas (TOG) emissions is electric fuel combustion. The main mobile source was recreational boats, and the main area-wide source was solvent evaporation from consumer products. More than half of area wide PM emissions come from travel on unpaved roads within the City (General Plan Background report, 2013).</p> <p>Table 1 presents Federal and State Air Quality Attainment Status, 2011 Pollutant State Standard Federal Standards for criteria air quality pollutants.</p>
---	--------------------------	-------------------------------------	--------------------------	--------------------------	--------------------------	--------------------------	--

IMPACT CATEGORIES*	1	2	3	4	5	6	<p align="center">All determinations need explanation. Reference to documentation, sources, notes and correspondence.</p>																																																																							
							<p>Table 1. Clearlake Federal and State Air Quality Attainment Status, 2011</p> <table border="1" data-bbox="714 262 1526 514"> <thead> <tr> <th>Pollutant</th> <th>State Standard</th> <th>Federal Standard</th> </tr> </thead> <tbody> <tr> <td>PM 2.5</td> <td>Attainment</td> <td>Unclassified/ Attainment</td> </tr> <tr> <td>Carbon Monoxide</td> <td>Attainment</td> <td>Unclassified/ Attainment</td> </tr> <tr> <td>Nitrogen Monoxide</td> <td>Attainment</td> <td>Unclassified/ Attainment</td> </tr> <tr> <td>Sulfur Dioxide</td> <td>Attainment</td> <td>Unclassified/ Attainment</td> </tr> <tr> <td>Sulfates</td> <td>Attainment</td> <td></td> </tr> <tr> <td>Lead</td> <td>Attainment</td> <td>Unclassified/ Attainment</td> </tr> <tr> <td>Hydrogen Sulfide</td> <td>Attainment</td> <td></td> </tr> <tr> <td>Visibility Reducing Particles</td> <td>Attainment</td> <td></td> </tr> </tbody> </table> <p>Local air districts and CARB monitor ambient air quality to assure that air quality standards are met, and if they are not met, to develop strategies to meet the standards. LAAQMD regulates air quality in the LCAB and is responsible for attainment planning related to criteria air pollutants. While the LCAQMD does not have an air quality management plan, the LCAQMD refers to the Bay Area Air Quality Management District (BAAQMD) guidelines to evaluate thresholds of significance for general guidance. It is noted, however, that the District has not formally adopted these as the area's threshold of significance, and leaves the determination of level of significance to each local agency for determination.</p> <p>Table 2. BAAQMD Guidelines for Evaluating Air Quality Impacts.</p> <table border="1" data-bbox="730 850 1526 1060"> <thead> <tr> <th>Pollutant</th> <th>Construction Phase lb./ day</th> <th>Operation Phase lbs./ day</th> <th>Operation Phase tons/yr.</th> </tr> </thead> <tbody> <tr> <td>ROG</td> <td>54</td> <td>54</td> <td>10</td> </tr> <tr> <td>NOx</td> <td>54</td> <td>54</td> <td>10</td> </tr> <tr> <td>PM-10 (Exhaust</td> <td>82</td> <td>82</td> <td>15</td> </tr> <tr> <td>PM-2.5 (Exhaust</td> <td>54</td> <td>54</td> <td>10</td> </tr> <tr> <td>GHG</td> <td>None</td> <td>None</td> <td>1,100 MTCO₂ (e) or 4.6 MTCO₂ (e) / SP/ Yr.</td> </tr> </tbody> </table> <p>Air quality impacts from new projects consider both construction-related and operation-related activities (refer to Attachment B). Construction-related activities could result in the generation of dust, Toxic Air Contaminants (TAC) and other emissions from on-road haul trucks and off-road equipment exhaust emissions. However, construction is temporary and occurs over a relatively short duration in comparison to the operational lifetime of the proposed project. Project construction will also be required to comply with all applicable LCAQMD rules and regulations. Health risks associated with TACs are a function of both the concentration of emissions and the duration of exposure, where the higher the concentration and/or the longer the period of time can result in greater health risks.</p> <p>The analysis of air quality impacts conforms to the methodologies recommended in the BAAQMD Guidelines; therefore, construction and operational emissions generated by the proposed project are analyzed separately. Project air pollutant emissions were quantified using the California Emissions Estimator Model (CalEEMod, Version 2020.40) and are summarized in Tables 3 and 4. CalEEMod worksheets showing model inputs and results are provided in Attachment B).</p> <p>As shown in Table 3, criteria pollutant volumes generated during project construction would not exceed thresholds of significance disclosed in the BAAQMD Guidelines for any of the pollutant categories listed above.</p> <p>Table 3. Maximum Unmitigated Project Construction-Related Emissions (lbs./day)</p> <table border="1" data-bbox="787 1732 1534 1869"> <thead> <tr> <th>Pollutant</th> <th>Proposed Project Emissions</th> <th>Threshold of Significance</th> <th>Exceeds Threshold?</th> </tr> </thead> <tbody> <tr> <td>ROG</td> <td>3.65</td> <td>54</td> <td>NO</td> </tr> <tr> <td>NOx</td> <td>20.00</td> <td>54</td> <td>NO</td> </tr> <tr> <td>PM₁₀</td> <td>0.71</td> <td>82</td> <td>NO</td> </tr> <tr> <td>PM_{2.5}</td> <td>3.89</td> <td>54</td> <td>NO</td> </tr> </tbody> </table> <p><i>Source: CalEEMod Version 2020.40. Emission results in the model are in tons and then converted to pounds for the purpose of this table.</i></p>	Pollutant	State Standard	Federal Standard	PM 2.5	Attainment	Unclassified/ Attainment	Carbon Monoxide	Attainment	Unclassified/ Attainment	Nitrogen Monoxide	Attainment	Unclassified/ Attainment	Sulfur Dioxide	Attainment	Unclassified/ Attainment	Sulfates	Attainment		Lead	Attainment	Unclassified/ Attainment	Hydrogen Sulfide	Attainment		Visibility Reducing Particles	Attainment		Pollutant	Construction Phase lb./ day	Operation Phase lbs./ day	Operation Phase tons/yr.	ROG	54	54	10	NOx	54	54	10	PM-10 (Exhaust	82	82	15	PM-2.5 (Exhaust	54	54	10	GHG	None	None	1,100 MTCO ₂ (e) or 4.6 MTCO ₂ (e) / SP/ Yr.	Pollutant	Proposed Project Emissions	Threshold of Significance	Exceeds Threshold?	ROG	3.65	54	NO	NOx	20.00	54	NO	PM ₁₀	0.71	82	NO	PM _{2.5}	3.89	54	NO
Pollutant	State Standard	Federal Standard																																																																												
PM 2.5	Attainment	Unclassified/ Attainment																																																																												
Carbon Monoxide	Attainment	Unclassified/ Attainment																																																																												
Nitrogen Monoxide	Attainment	Unclassified/ Attainment																																																																												
Sulfur Dioxide	Attainment	Unclassified/ Attainment																																																																												
Sulfates	Attainment																																																																													
Lead	Attainment	Unclassified/ Attainment																																																																												
Hydrogen Sulfide	Attainment																																																																													
Visibility Reducing Particles	Attainment																																																																													
Pollutant	Construction Phase lb./ day	Operation Phase lbs./ day	Operation Phase tons/yr.																																																																											
ROG	54	54	10																																																																											
NOx	54	54	10																																																																											
PM-10 (Exhaust	82	82	15																																																																											
PM-2.5 (Exhaust	54	54	10																																																																											
GHG	None	None	1,100 MTCO ₂ (e) or 4.6 MTCO ₂ (e) / SP/ Yr.																																																																											
Pollutant	Proposed Project Emissions	Threshold of Significance	Exceeds Threshold?																																																																											
ROG	3.65	54	NO																																																																											
NOx	20.00	54	NO																																																																											
PM ₁₀	0.71	82	NO																																																																											
PM _{2.5}	3.89	54	NO																																																																											

IMPACT CATEGORIES*	1	2	3	4	5	6	<p style="text-align: center;">All determinations need explanation. Reference to documentation, sources, notes and correspondence.</p>																				
							<p>Table 4. Maximum Operational-Related Emissions (lbs./day)</p> <table border="1" data-bbox="792 258 1539 436"> <thead> <tr> <th>Pollutant</th> <th>Proposed Project Emissions</th> <th>Threshold of Significance</th> <th>Exceeds Threshold?</th> </tr> </thead> <tbody> <tr> <td>ROG</td> <td>0.93</td> <td>54</td> <td>NO</td> </tr> <tr> <td>NO_x</td> <td>0.16</td> <td>54</td> <td>NO</td> </tr> <tr> <td>PM₁₀</td> <td>17.86</td> <td>82</td> <td>NO</td> </tr> <tr> <td>PM_{2.5}</td> <td>36.21</td> <td>54</td> <td>NO</td> </tr> </tbody> </table> <p><i>Source: CalEEMod Version 2020.40. Emission results in the model are in tons and then converted to pounds for the purpose of this table.</i></p> <p>Once fully operational, the proposed project would not generate volumes of criteria pollutants which may exceed thresholds of significance disclosed in the BAAQMD Guidelines for any of the pollutant categories listed above.</p> <p>On the basis of the air modeling conducted, the project will not exceed the Bay Area Air Quality Management District (BAAQMD) air quality impact thresholds the criteria pollutants. Although the City has not adopted specific air quality impact thresholds of significance, using the BAAQMD criteria and threshold, the project will not result in a significant adverse air quality impact. To ensure impacts related to the Air Quality are less than significant, the following mitigation measures have been implemented.</p> <p><u>Mitigation measures:</u></p> <p>AIR 1: Construction activities shall be conducted with adequate dust suppression methods, including watering during grading and construction activities to limit the generation of fugitive dust or other methods approved by the Lake County Air Quality Management District. Prior to initiating soil removing activities for construction purposes, the applicant shall pre-wet affected areas with at least 0.5 gallons of water per square yard of ground area to control dust.</p> <p>AIR 2: Driveways, access roads and parking areas shall be surfaced in a manner so as to minimize dust. The applicant shall obtain all necessary encroachment permits for any work within the right-of-way. All improvement shall adhere to all applicable federal, State and local agency requirements.</p> <p>AIR 3: Any disposal of vegetation removed as a result of lot clearing shall be lawfully disposed of, preferably by chipping and composting, or as authorized by the Lake County Air Quality Management District and the Lake County Fire Protection District.</p> <p>AIR-4. During construction activities, the applicant shall remove daily accumulation of mud and dirt from any roads adjacent to the site.</p> <p>AIR-5. Grading permits shall be secured for any applicable activity from the Community Development Department, Building Division. Applicable activities shall adhere to all grading permit conditions, including Best Management Practices. All areas disturbed by grading shall be either surfaced in manner to minimize dust, landscaped or hydro seeded. All BMPs shall be routinely inspected and maintained for life of the project.</p> <p>AIR-6 All refuse generated by the facility shall be stored in approved disposal/storage containers, and appropriately covered. Removal of waste shall be on a weekly basis so as to avoid excess waste. All trash receptacles/containers shall remain covered at all times to prevent fugitive odors and rodent infestation. An odor control plan shall be submitted for review and approval by the City in accordance with the Zoning Code. Odor control shall be maintained to an acceptable level at all times.</p> <p>AIR-7 Construction activities that involve pavement, masonry, sand, gravel, grading, and other activities that could produce airborne particulate should be conducted with adequate dust controls to minimize airborne emissions. A dust mitigation plan may be required should the applicant fail to maintain adequate dust controls.</p>	Pollutant	Proposed Project Emissions	Threshold of Significance	Exceeds Threshold?	ROG	0.93	54	NO	NO _x	0.16	54	NO	PM ₁₀	17.86	82	NO	PM _{2.5}	36.21	54	NO
Pollutant	Proposed Project Emissions	Threshold of Significance	Exceeds Threshold?																								
ROG	0.93	54	NO																								
NO _x	0.16	54	NO																								
PM ₁₀	17.86	82	NO																								
PM _{2.5}	36.21	54	NO																								

IMPACT CATEGORIES*	1	2	3	4	5	6	All determinations need explanation. Reference to documentation, sources, notes and correspondence.
							<p>AIR-8 If construction or site activities are conducted within Serpentine soils, a Serpentine Control Plan may be required. Any parcel with Serpentine soils must obtain proper approvals from LCAQMD prior to beginning any construction activities. Contact LCAQMD for more details.</p> <p>AIR-9. All engines must notify LCAQMD prior to beginning construction activities and prior to engine Use. Mobile diesel equipment used for construction and/or maintenance must be in compliance with State registration requirements. All equipment units must meet Federal, State and local requirements. All equipment units must meet RICE NESHAP/ NSPS requirements including proper maintenance to minimize airborne emissions and proper record-keeping of all activities, all units must meet the State Air Toxic Control Measures for CI engines and must meet local regulations.</p> <p>AIR-10. Site development, vegetation disposal, and site operation shall not create nuisance odors or dust. During the site preparation phase, the District recommends that any removed vegetation be chipped and spread for ground cover and erosion control. Burning of debris/construction material is not allowed on commercial property, materials generated from the commercial operation, and waste material from construction debris, must not be burned as a means of disposal.</p> <p>AIR-11. Significant dust may be generated from increase vehicle traffic if driveways and parking areas are not adequately surfaced. Surfacing standards should be included as a requirement in the use permit to minimize dust impacts to the public, visitors, and road traffic. At a minimum, the district recommends chip seal as a temporary measure for primary access roads and parking. Paving with asphaltic concrete is preferred and should be required for long term occupancy. All areas subject to semi-truck / trailer traffic should require asphaltic concrete paving or equivalent to prevent fugitive dust generation. Gravel surfacing may be adequate for low use driveways and overflow parking areas; however, gravel surfaces require more maintenance to achieve dust control, and permit conditions should require regular palliative treatment if gravel is utilized. White rock is not suitable for surfacing (and should be prohibited in the permit) because of its tendency to break down and create excessive dust. Grading and re-graveling roads should utilizing water trucks, if necessary, reduce travel times through efficient time management and consolidating solid waste removal/supply deliveries, and speed limits.</p>
b) Result in a cumulatively considerable net increase of ROC and/or NOx emissions??	<input type="checkbox"/>	<input checked="" type="checkbox"/>	<input type="checkbox"/>	<input type="checkbox"/>	<input type="checkbox"/>	<input type="checkbox"/>	See Response to Section III(a). Therefore, all potential impacts have been reduced to less than Significant Impacts with the incorporated Mitigation Measures AIR-1 through AIR-11.

IMPACT CATEGORIES*	1	2	3	4	5	6	All determinations need explanation. Reference to documentation, sources, notes and correspondence.
c) Expose sensitive receptors to substantial pollutant concentrations?	<input type="checkbox"/>	<input checked="" type="checkbox"/>	<input type="checkbox"/>	<input type="checkbox"/>	<input type="checkbox"/>	<input type="checkbox"/>	<p>Sensitive receptors are defined as facilities or land uses that include members of the population who are particularly sensitive to the effects of air pollutants, such as children, the elderly, and people with illnesses. CARB has identified the following groups of individuals as the most likely to be affected by air pollution: the elderly over 65, children under 14, athletes, and persons with cardiovascular and chronic respiratory diseases such as asthma, emphysema, and bronchitis. Operation of the proposed project would not result in the development of any substantial sources of air toxics. There are no stationary sources associated with the operations of the project; nor would the project attract additional mobile sources that spend long periods queuing and idling at the site. Onsite project emissions would not result in significant concentrations of pollutants at nearby sensitive receptors.</p> <p>Another potential air quality issue associated with construction-related activities is the airborne entrainment of asbestos due to the disturbance of naturally-occurring asbestos-containing soils. The proposed project is not located within an area designated by the State of California as likely to contain naturally-occurring asbestos (Department of Conservation [DOC] 2000). As a result, construction-related activities would not be anticipated to result in increased exposure of sensitive land uses to asbestos. A carbon monoxide (CO) "hot spot" would occur if an exceedance of the state one-hour standard of 20 parts per million (ppm) or the eight-hour standard of 9 ppm were to occur. Based on the project's anticipated generation of 1,332 daily trips on average, localized air quality impacts related to mobile source emissions would not be a concern as there is no likelihood of the project traffic exceeding CO significant threshold values.</p> <p>See Response to Section III(a). Therefore, all potential impacts have been reduced to less than Significant Impacts with the incorporated Mitigation Measures AIR-1 through AIR-11.</p>
d) Result in other emissions that create objectionable odors adversely affecting a substantial number of people?	<input type="checkbox"/>	<input checked="" type="checkbox"/>	<input type="checkbox"/>	<input type="checkbox"/>	<input type="checkbox"/>	<input type="checkbox"/>	<p>During construction, the proposed project presents the potential for generation of objectionable odors in the form of diesel exhaust in the immediate vicinity of the site. However, these emissions are short-term in nature and will rapidly dissipate and be diluted by the atmosphere downwind of the emission sources. Additionally, odors would be localized and generally confined to the construction area. Given that there are no natural topographic features (e.g., canyon walls) or manmade structures (e.g., tall buildings) that would potentially trap such emissions, construction-related odors would occur at magnitudes that would not affect substantial numbers of people.</p> <p>The project could produce some odors from outdoor trash containment. However, if properly managed, these odors should not result in significant adverse odors, however, most trash and recycling activities will be conducted within the buildings so odors are not expected to result, or create any objectionable concerns from nearby residences.</p> <p>See Response to Section III(a). Therefore, all potential impacts have been reduced to less than Significant Impacts with the incorporated Mitigation Measures AIR-1 through AIR-11.</p>

SECTION IV. BIOLOGICAL RESOURCES

Would the project:

a) Have a substantial adverse effect, either directly or through habitat modifications, on any species identified as a candidate, sensitive, or special status species in local or regional plans, policies, or regulations, or by the California Department of Fish and Game or U.S. Fish and Wildlife Service?	<input type="checkbox"/>	<input checked="" type="checkbox"/>	<input type="checkbox"/>	<input type="checkbox"/>	<input type="checkbox"/>	<input type="checkbox"/>	<p>According to the Biological Assessment prepared for the project by ECORP Consulting dated March 11, 2021 (Attachment C) no federal or State listed species have potential to occur within the Study Area. However, 21 non-listed special-status plants, one special-status turtle, three special-status birds, various birds protected under the MBTA and the California Fish and Game Code, and two special-status bats have potential or low potential to occur within the Study Area. One drainage channel located within the Study Area may be considered a Water of the U.S. and State. Individual oak trees within the Study Area are protected under City ordinance are located within the Study Area, and the oak woodlands onsite may be considered a sensitive natural community by CDFW. To ensure impacts related to the Biological Resources are less than significant, the following mitigation measures have been implemented.</p>
--	--------------------------	-------------------------------------	--------------------------	--------------------------	--------------------------	--------------------------	---

IMPACT CATEGORIES*	1	2	3	4	5	6	All determinations need explanation. Reference to documentation, sources, notes and correspondence.
							<p>BIO-1: The project should implement erosion control measures and BMPs to reduce the potential for sediment or pollutants at the Project site.</p> <p>BIO-2: A qualified biologist shall conduct a mandatory Worker Environmental Awareness Program for all contractors, work crews, and any onsite personnel to aid workers in recognizing special status species and sensitive biological resources that may occur on-site. The program shall include identification of the special status species and their habitats, a description of the regulatory status and general ecological characteristics of sensitive resources, and review of the limits of construction and Mitigation Measures required to reduce impacts to biological resources within the work area.</p> <p>BIO-3: Conduct a pre-construction northwestern pond turtle survey in Project impact and staging areas within 48 hours prior to construction activities. Any northwestern pond turtle individuals discovered in the Project work area immediately prior to or during Project activities shall be allowed to move out of the work area of their own volition. If this is not feasible, they shall be captured by a qualified biologist and relocated out of harm's way to the nearest suitable habitat at least 100 feet from the Project work area where they were found.</p> <p>BIO-4: If construction is to occur during the nesting season (generally February 1 - August 31), conduct a pre-construction nesting bird survey of all suitable nesting habitat on the Project within 14 days of the commencement of construction. The survey shall be conducted within a 500-foot radius of Project work areas for raptors and within a 100-foot radius for other nesting birds. If any active nests are observed, these nests shall be designated a sensitive area and protected by an avoidance buffer established in coordination with CDFW until the breeding season has ended or until a qualified biologist has determined that the young have fledged and are no longer reliant upon the nest or parental care for survival. Pre-construction nesting surveys are not required for construction activity outside the nesting season.</p> <p>BIO-5: Within 14 days prior to Project activities that may impact bat roosting habitat (e.g., removal of manmade structures or trees), a qualified biologist will survey for all suitable roosting habitat within the Project impact limits. If suitable roosting habitat is not identified, no further measures are necessary. If suitable roosting habitat is identified, a qualified biologist will conduct an evening bat emergence survey that may include acoustic monitoring to determine whether or not bats are present. If roosting bats are determined to be present within the Project site, consultation with CDFW prior to initiation of construction activities and/or preparation of a Bat Management Plan outlining avoidance and minimization measures specific to the roost(s) potentially affected may be required</p>
b) Have a substantial adverse effect on any riparian habitat or other sensitive natural community identified in local or regional plans, policies, and regulations or by the California Department of Fish and Game or U.S. Fish and Wildlife Service?	<input type="checkbox"/>	<input type="checkbox"/>	<input type="checkbox"/>	<input type="checkbox"/>	<input checked="" type="checkbox"/>	<input type="checkbox"/>	<p>The Study Area supports a small amount of valley oak woodland, which may be considered a sensitive natural community. The project will require the removal of a several trees on the site, but most of these were identified in the Biological Report as being English Walnut trees. However, there is some potential oak trees on the site, such as along the Burns Valley Creek area. Prior to vegetation/tree removal, the applicant shall obtain a Tree Removal Permit from the City of Clearlake and if Oak Trees are to be removed, they shall be replaced in accordance with Section 18-40.050 of the City Code (see Mitigation Measure BIO-6 regarding tree removal). The Biological Study also identified the potential for wetlands. The Project does not propose impacts to riparian habitat or valley oak woodland that is adjacent to Burns Valley Creek. Less than Significant impact.</p>

IMPACT CATEGORIES*	1	2	3	4	5	6	<p style="text-align: center;">All determinations need explanation. Reference to documentation, sources, notes and correspondence.</p>
<p>c) Have a substantial adverse effect on state or federally protected wetlands (including, not limited to, marsh, vernal pool, coastal, etc.) through direct removal, filling, hydrological interruption, or other means?</p>	<input type="checkbox"/>	<input checked="" type="checkbox"/>	<input type="checkbox"/>	<input type="checkbox"/>	<input type="checkbox"/>	<input type="checkbox"/>	<p>As discussed in Response a), the Biological Assessment identified a narrow (one to three-feet in width) drainage channel that occurs along the western property line which may or may not be a Waters of the U.S./Streambed. Compliance with Mitigation Measure outlined in Response a) above along with City ordinances and state water quality permit requirements for construction and post-construction scenarios would entail the installation of construction and post-development BMPs to prevent erosion and siltation within the drainage channel. As recommended in the Biological Assessment Mitigation Measure BIO-6 will reduce potential impacts to wetlands to a level of non-significance. Less than Significant Impact with Mitigation Measures.</p> <p>BIO-6: To minimize potential impacts to the ephemeral drainage on the project site during construction activity, a qualified biologist shall map the extent of the riparian habitat on the project site. Avoidance buffers for riparian habitat shall be applied in compliance with City of Clearlake requirements. The riparian habitat and avoidance buffer shall be demarcated prior to construction and shall be maintained until the completion of construction. A qualified biologist/biological monitor shall be present if work must occur within the avoidance buffer to ensure riparian habitat is not impacted by the construction activity.</p>
<p>d) Interfere substantially with the movement of any native resident or migratory fish or wildlife species or with established native resident or migratory wildlife corridors, or impede the use of native wildlife nursery sites?</p>	<input type="checkbox"/>	<input type="checkbox"/>	<input type="checkbox"/>	<input type="checkbox"/>	<input checked="" type="checkbox"/>	<input type="checkbox"/>	<p>The Study Area provides limited migratory opportunities for terrestrial wildlife. Project construction is likely to temporarily disturb and displace most wildlife from the Study Area. Some wildlife such as birds or nocturnal species are likely to continue to use the habitats opportunistically for the duration of construction. Once construction is complete, wildlife movements are expected to resume but will likely be more limited through the developed areas of the Study Area. The Project is not expected to substantially interfere with wildlife movement.</p> <p>There are no documented nursery sites and no nurse sites were observed within the Study Area during the site reconnaissance. Therefore, the Project is not expected to impact wildlife nursery sites. Less than Significant</p>
<p>e) Conflict with any local policies or ordinances protecting biological resources, such as a tree preservation policy or ordinance?</p>	<input type="checkbox"/>	<input checked="" type="checkbox"/>	<input type="checkbox"/>	<input type="checkbox"/>	<input type="checkbox"/>	<input type="checkbox"/>	<p>The project will have minimal to no conflict with any local policies or ordinances protecting biological resources, such as a tree preservation policy or ordinance. However, the project will require the removal of a several trees on the site, several which are Oak trees. Prior to vegetation/tree removal, the applicant shall obtain a Tree Removal Permit from the City of Clearlake and if Oak Trees are to be removed, they shall be replaced in accordance with Section 18-40.050 of the City Code. To ensure impacts related to the Tree Preservation are less than significant, the following mitigation measure have been implemented.</p> <p>BIO-7: A native tree protection and removal permit, waiver, or similar approval shall be secured prior to impacting trees protected under the City ordinance. Avoidance buffers for protected trees shall be consistent with the City requirements, shall be clearly demarcated prior to construction, and should be maintained until the completion of construction. A qualified biologist/biological monitor should be present if work must occur within the avoidance buffer to ensure avoided protected trees are not impacted by the work.</p>
<p>f) Conflict with the provisions of an adopted Habitat Conservation Plan, Natural Community Conservation Plan, or other approved local, regional, or state habitat conservation plan?</p>	<input type="checkbox"/>	<input type="checkbox"/>	<input type="checkbox"/>	<input type="checkbox"/>	<input checked="" type="checkbox"/>	<input type="checkbox"/>	<p>The project will not conflict with any adopted Habitat Conservation Plan, Natural Community Conservation Plan, or other approved local, regional, or state habitat conservation plan. However, the project may require the removal of Oak Trees. Less Than Significant Impact</p>
<p>SECTION V. CULTURAL RESOURCES</p>							
<p><i>Would the project:</i></p>							
<p>a) Cause a substantial adverse change in the significance of a</p>	<input type="checkbox"/>	<input checked="" type="checkbox"/>	<input type="checkbox"/>	<input type="checkbox"/>	<input type="checkbox"/>	<input type="checkbox"/>	<p>An evaluation of the potential for historical, cultural, tribal, or paleontological resources on the project site and in the vicinity of the project a cultural resource investigation was conducted by Gregory G. White, PhD, RPA of Sub Terra Heritage Resource</p>

IMPACT CATEGORIES*	1	2	3	4	5	6	<p style="text-align: center;">All determinations need explanation. Reference to documentation, sources, notes and correspondence.</p>
<p>historical resource pursuant to §15064.5?</p>							<p>Investigations. This investigation included records searches, consultation with Native American tribes, and a site reconnaissance.</p> <p>The investigation resulted in the discovery of two intact, buried, archaeological sites CCL-21-01 and CCL-21-02. Both sites can be considered significant cultural resources:</p> <p><i>Site CCL-21-01.</i> CCL-21-01 is a prehistoric Native American non-midden lithic site encountered in five trenches located in the east-center of the Project area. Closely spaced trench probes established well-defined site limits indicating that the site occupies an area of 3,046 square yards (2,547 square meters). The site continues to the east outside the Project area and across Burns Valley Road. The archaeological deposit is not evident on the surface and throughout its extent was found buried at depths of 16–32 inches below surface. The archaeological deposit was contained in non-midden Cole Bt1 soils and characterized by low-diversity, moderate-density (50–250 items per cubic meter) artifact assemblages. Associated artifacts were dominated by Borax Lake obsidian including many large and medium-sized flakes indicative of early-stage biface production. In addition to an evident tool production function, the presence of possible fire-cracked rock and a few basalt spalls probably derived from basalt cores and core-tools suggests that the site also served a temporary residential function.</p> <p><i>Site CCL-21-02.</i> CCL-21-02 is a prehistoric Native American non-midden lithic site encountered in two trenches located in the center of the Project area immediately south of the Redbud Library Annex boundary fence. Dispersed trench probes established well-defined east-west site limits indicating that the site occupies an area of 2,190 square yards. The archaeological deposit is not evident on the surface and in both trenches was found buried at a depth of 20–28 inches below surface. Similar to site CCL-21-01, the archaeological deposit was contained in non-midden Cole Bt1 soils and characterized by low-diversity, low- to moderate-density (20–150 items per cubic meter) artifact assemblages. Associated artifacts were dominated by Borax Lake obsidian including many large and medium-sized flakes indicative of early-stage biface production.</p> <p>Obsidian artifacts were found in association with the remote fill dumped in the southeast quadrant and south-center of the Project area. These re-deposits do not constitute cultural resources and no further management measures are necessary.</p> <p><i>Intact, Buried Archaeological Sites.</i> The investigation resulted in the discovery of two intact, buried, archaeological sites, CCL-21-01 and CCL-21-02 (Figure 7, yellow polygons), both of the sites can be considered significant cultural resources. Both of the sites occupy relatively small areas and are buried at depths of 16–32 inches below grade. No further management measures will be necessary if potential impacts to these sites can be eliminated by means of avoidance or placement of fill.</p> <p>To ensure impacts related to the Cultural Resources are minimized, the following mitigation measures have been implemented.</p> <p><u>Mitigation Measures:</u></p> <p>CUL-1 During construction activities, if any subsurface archaeological remains are uncovered, all work shall be halted within 100 feet of the find and the owner shall utilize a qualified cultural resources consultant to identify and investigate any subsurface historic remains and define their physical extent and the nature of any built features or artifact-bearing deposits.</p> <p>CUL-2 The cultural resource consultant’s investigation shall proceed into formal evaluation to determine their eligibility for the California Register of Historical Resources. This shall include, at a minimum, additional exposure of the feature(s), photo-documentation and recordation, and analysis of the artifact assemblage(s). If the evaluation determines that the features and artifacts do not have sufficient data potential to be eligible for the California Register, additional work shall not be required. However, if data potential exists – e.g., there is an intact feature with a large and varied artifact assemblage – it will be necessary to mitigate any Project impacts. Mitigation of impacts might include avoidance of further disturbance to the resources through Project redesign. If avoidance is determined</p>

IMPACT CATEGORIES*	1	2	3	4	5	6	<p style="text-align: center;">All determinations need explanation. Reference to documentation, sources, notes and correspondence.</p>
							<p>to be infeasible, pursuant to CEQA Guidelines Section 15126.4(b)(3)(C), a data recovery plan, which makes provisions for adequately recovering the scientifically consequential information from and about the historical resource, shall be prepared and adopted prior to any excavation being undertaken. Such studies shall be deposited with the California Historical Resources Regional Information Center. Archeological sites known to contain human remains shall be treated in accordance with the provisions of Section 7050.5 Health and Safety Code. If an artifact must be removed during Project excavation or testing, curation may be an appropriate mitigation. This language of this mitigation measure shall be included on any future grading plans and utility plans approved by the City for the Project.</p> <p>CUL-3 If human remains are encountered, no further disturbance shall occur within 100 feet of the vicinity of the find(s) until the Lake County Coroner has made the necessary findings as to origin (California Health and Safety Code Section 7050.5). Further, pursuant to California Public Resources Code Section 5097.98(b) remains shall be left in place and free from disturbance until a final decision as to the treatment and disposition has been made. If the Lake County Coroner determines the remains to be Native American, the Native American Heritage Commission must be contacted within 24 hours. The Native American Heritage Commission must then identify the “most likely descendant(s)”, The landowner shall engage in consultations with the most likely descendant (MLD). The MLD will make recommendations concerning the treatment of the remains within 48 hours as provided in Public Resources Code 5097.98.</p> <p>CUL-4 The sensitive site section noted on the project site plan shall not be disturbed during construction and/or maintenance of the park. This sensitive site is identified as investigation resulted in the discovery of two intact, buried, archaeological sites, CCL-21-01 and CCL-21-02 (Figure 7, yellow polygons), both of the sites can be considered significant cultural resources. Both of the sites occupy relatively small areas and are buried at depths of 16–32 inches below grade. The project as currently designed, will not impact sites CCL-21-01 or CCL-21-02. If avoidance and/or preservation in place is not possible, the owner will consider re-design or other measures to avoid impacting resources consistent with CEQA. The owner will contract with tribal monitors for ground disturbance within 100 feet of sites CCL-21-01 and CCL-21-02. The owner and contract archeologist will consult with tribal representatives regarding ground disturbing work within these areas including the designation of a “reburial” location, if needed.</p> <p>CUL-5: On or prior to the first day of construction the owner shall organize cultural sensitivity training for contractors involved in ground disturbing activities.</p> <p>CUL-6: The southern two-thirds of site CCL-21-01 is contained within APN010-026-400-000 and the Burns Valley Development Project area. The area occupied by the site has been slated for a paved parking area serving planned playing fields nearby (Figure 2). This portion of the site is situated on the sloping bank of an extinct section of upper Miller Creek, an area marked by an overstory of mixed native oak and introduced conifer and hardwood trees. Because this part of the site is situated on a bank, the land surface is sloped and drops 10–15 feet in elevation. Current engineering plan calls for vegetation and tree removal as well as application of remote fill materials to bring it to a level grade, with installation of landscaping, drains, and underground utility lines in the area. Project revisions in design, location, and operations should be implemented in the area occupied by the footprint of site CCL-21-01, inclusive to a 15-foot (4.5-meter) buffer around the site perimeter. Limitations to disturbance in this area shall be as follows:</p> <ol style="list-style-type: none"> 1. <i>Fill Cap.</i> Because CCL-21-01 is a buried archaeological deposit contained in a dense clay loam likely to resist compaction impacts, avoidance can be achieved by placing fill on the site surface; 2. <i>Flush Cut Vegetation.</i> Existing vegetation including shrubs and trees should be flush-cut, i.e., cut flush with the ground at a point not to exceed 10-inches below grade;

IMPACT CATEGORIES*	1	2	3	4	5	6	All determinations need explanation. Reference to documentation, sources, notes and correspondence.
							<p>3. <i>Landscaping Fabric and Fill.</i> Once the flush cut is complete and surface cleared of debris, landscaping fabric should be laid over the area of the site to create a boundary between intact soils and remote fill. With respect to the fill, drainage, safety, and operational concerns may prevent adding a lot of elevation; however, an additional minimum 6–12-inches (15–30 centimeters) of fill should be added to the site area to provide a construction and compaction buffer to protect the deposit. This would result in an overburden of 21–27 inches (53–71 centimeters) of capping material;</p> <p>4. <i>Avoid Installation of Subsurface Features.</i> Avoid placement of pier supports, subsurface landscaping features, subsurface drains, and utility lines in the site area.</p> <p>5. <i>Avoid New Overstory Plantings.</i> Avoid placement of new overstory trees in the site area.</p> <p>CUL-7: Site CCL-21-02 is contained within APN010-026-400-000 and the Burns Valley Development Project area. The area occupied by the site has been slated for open space. Project revisions in design, location, and operations should be implemented in the area occupied by the footprint of site CCL-21-02, inclusive to a 15-foot (4.5-meter) buffer around the site perimeter. Limitations to disturbance in this area shall be as follows:</p> <p>1. <i>Fill Cap.</i> Because CCL-21-01 is a buried archaeological deposit contained in a dense clay loam likely to resist compaction impacts, avoidance can be achieved by placing fill on the site/buffer surface;</p> <p>2. <i>Landscaping Fabric and Fill.</i> Prior to site prep and construction in the area, landscaping fabric should be laid over the area of the site to create a boundary between intact soils and remote fill. With respect to the fill, drainage, safety, and operational concerns may prevent adding a lot of elevation; however, an additional minimum 6–12-inches (15–30 centimeters) of fill should be added to the site area to provide a construction and compaction buffer to protect the deposit. This would result in an overburden of 21–27 inches (53–71 centimeters) of capping material;</p> <p>3. <i>Avoid Installation of Subsurface Features.</i> Avoid placement of pier supports, subsurface landscaping features, subsurface drains, and utility lines in the site area.</p> <p>4. <i>Avoid New Overstory Plantings.</i> Avoid placement of new overstory trees in the site area.</p>
b) Cause a substantial adverse change in the significance of an archeological resource pursuant to §15064.5?	<input type="checkbox"/>	<input checked="" type="checkbox"/>	<input type="checkbox"/>	<input type="checkbox"/>	<input type="checkbox"/>	<input type="checkbox"/>	See Response to Section V(a): Less than Significant Impact with the incorporated mitigation measure CUL-1 through CUL-3.
c) Disturb any human remains, including those interred outside of formal cemeteries?	<input type="checkbox"/>	<input checked="" type="checkbox"/>	<input type="checkbox"/>	<input type="checkbox"/>	<input type="checkbox"/>	<input type="checkbox"/>	See Response to Section V(a): Less than Significant Impact with the incorporated mitigation measure CUL-1 through CUL-3.
SECTION VI. ENERGY							
<i>Would the project:</i>							
a) Consume energy resources in a wasteful, inefficient, or unnecessary amount during project	<input type="checkbox"/>	<input type="checkbox"/>	<input type="checkbox"/>	<input type="checkbox"/>	<input checked="" type="checkbox"/>	<input type="checkbox"/>	The project would not result in wasteful, inefficient, or unnecessary consumption of energy, given project installation of outdoor lighting and public systems are compliant with State of California energy conservation regulations. Therefore, this impact would be less than significant.

IMPACT CATEGORIES*	1	2	3	4	5	6	All determinations need explanation. Reference to documentation, sources, notes and correspondence.
construction and/or operation?							
b) Conflict with or obstruct a state or local plan for renewable energy or energy efficiency?	<input type="checkbox"/>	<input type="checkbox"/>	<input type="checkbox"/>	<input type="checkbox"/>	<input checked="" type="checkbox"/>	<input type="checkbox"/>	The California State Building Standards Commission adopted updates to the California Green Building Standards Code (CALGreen). CALGreen contains requirements for construction site selection, storm water control during construction, construction waste reduction, indoor water use reduction, material selection, natural resource conservation, and site irrigation conservation. CALGreen is intended to (1) reduce GHG emissions; (2) promote environmentally responsible, cost-effective, healthier places to live and work; and (3) reduce energy and water consumption. The project would-be built in accord with CALGreen standards and reduce water use by the installation of artificial turf athletic fields. Therefore, this impact would be less than significant.

SECTION VII. GEOLOGY AND SOILS

Would the project:

a) Directly or indirectly cause potential substantial adverse effects, including the risk of loss, injury, or death involving: i) Rupture of a known earthquake fault, as delineated on the most recent Alquist- Priolo Earthquake Fault Zoning Map issued by the State Geologist for the area or based on other substantial evidence of a known fault? Refer to Division of Mines and Geology Special Publication 42. ii) Strong seismic ground shaking? iii) Seismic-related ground failure, including liquefaction? iv) Landslides?	<input type="checkbox"/>	<input type="checkbox"/>	<input type="checkbox"/>	<input type="checkbox"/>	<input checked="" type="checkbox"/>	<input type="checkbox"/>	<p>Topography on the project site is generally flat (<10%) and the site is situated at an elevation of approximately 1,350 feet above mean sea level. The site is located in an area that was historically used for agricultural and residential purposes. The Geotechnical Engineering Investigation Report prepared for the Proposed Burns Valley Development project, prepared by NV5, February 26, 2021, includes the following recommendations (Refer to Attachment D):</p> <ol style="list-style-type: none"> The existing foundation remnants and exterior slab-on-grade within the proposed building areas should be razed and disposed off-site. It may be possible to use some of this demolition material to construct engineered fills provided they meet the gradation requirements specified for “testable fill” materials presented in this report. The project geotechnical engineer should approve the use of both asphalt concrete (AC) and aggregate base (AB) rock demolition materials for use on constructing engineering fills. All foundations, underground utilities and other existing site improvements that are encountered during construction with the proposed building area should be demolished and removed from the site, these demolition materials should be disposed off site in compliance with applicable regulatory requirements <p><u>i) Earthquake Faults</u> There are no mapped earthquake faults on or adjacent to the subject site.</p> <p><u>ii-iii) Seismic Ground Shaking and Seismic-Related Ground Failure, including liquefaction.</u> The mapping of the site’s soil indicates that the soil is stable and not prone to liquefaction.</p> <p><u>iv) Landslides</u> According to the Landslide Hazard Identification Map prepared by the California Department of Conservation, Division of Mines and Geology, the project parcel soil is considered “generally stable” and not located within and/or adjacent to an existing known “landslide area”.</p> <p>Project design shall incorporate Best Management Practices (BMPs) to the maximum extent practicable to prevent or reduce discharge of all construction or post construction pollutants into the County storm drainage system. BMPs include scheduling of activities, erosion and sediment control, operation and maintenance procedures and other measures in accordance City of Clearlake Municipal Code(s). Less Than Significant Impact</p>
b) Result in substantial soil erosion or the loss of topsoil?	<input type="checkbox"/>	<input checked="" type="checkbox"/>	<input type="checkbox"/>	<input type="checkbox"/>	<input type="checkbox"/>	<input type="checkbox"/>	The project is not anticipated to result in substantial soil erosion or the loss of topsoil.. All disturbance will occur onsite, and no soil will be exported and/or imported. The applicant shall incorporate Best Management Practices (BMPs) consistent with the City Code and the State Storm Water Drainage Regulations to the maximum extent practicable to prevent and/or reduce discharge of all construction or post-construction pollutants into the local storm drainage system. All grading measure shall adhere to all Federal, State and local agency requirements. The project shall adhere to all Federal, State, and local agencies requirements. Therefore, to ensure impacts related to the

IMPACT CATEGORIES*	1	2	3	4	5	6	All determinations need explanation. Reference to documentation, sources, notes and correspondence.
							<p>Geology and Soils are minimized, the following mitigation measures have been implemented.</p> <p>Mitigation Measures: GEO-1: Prior to any ground disturbance and/or operation, the applicant shall submit <u>Erosion Control and Sediment Plans</u> to the Community Development Department for review and approval.</p> <ul style="list-style-type: none"> • <i>The project shall incorporate Best Management Practices (BMPs) consistent with the City Code and the State Storm Water Drainage Regulations to the maximum extent practicable to prevent and/or reduce discharge of all construction or post-construction pollutants into the local storm drainage system.</i> <p>GEO-2: Prior to any ground disturbance, (if applicable), the applicant shall submit and obtain a Grading Permit from the Community Development in accordance with the City of Clearlake Municipal code(s).</p> <p>GEO-3: The applicant shall monitor the site during the rainy season including post-installation, application of BMPs, erosion control maintenance, and other improvements as needed. Said measures shall be maintained for life of the project and replace/repaired when necessary.</p>
c) Be located on a geologic unit or soil that is unstable, or that would become unstable as a result of the project, and potentially result in on-site or off-site landslide, lateral spreading, subsidence, liquefaction or collapse?	<input type="checkbox"/>	<input type="checkbox"/>	<input type="checkbox"/>	<input type="checkbox"/>	<input checked="" type="checkbox"/>	<input type="checkbox"/>	<p>According to the Geotechnical Report prepared for the project, undocumented fills were observed on site and are not considered suitable for support of the proposed structural improvements without the following recommendations (refer to Attachment D).</p> <p>According to the soil survey of Lake County, prepared by the U.S.D.A., the soil at the site is considered “generally stable” and there is little to no potential for landslide, subsidence, debris flows, liquefaction or collapse. The project shall incorporate Best Management Practices (BMPs) consistent with the City Code and the State Storm Water Drainage Regulations to the maximum extent practicable to prevent and/or reduce discharge of all construction or post-construction pollutants into the local storm drainage system. Less Than Significant Impact</p>
d) Be located on expansive soil, as defined in Table 18-1-B of the Uniform Building Code (1994), creating substantial direct or indirect risks to life or property?	<input type="checkbox"/>	<input type="checkbox"/>	<input type="checkbox"/>	<input type="checkbox"/>	<input type="checkbox"/>	<input type="checkbox"/>	<p>The Geotechnical Report did not identify any expansive soils on the site. The project will adhere to all Federal, State and local agency requirements, including all requirements in the City of Clearlake’s Municipal Code(s). Less Than Significant Impact</p>
e) Have soils incapable of adequately supporting the use of septic tanks or alternative wastewater disposal systems where sewers are not available for the disposal of wastewater?	<input type="checkbox"/>	<input type="checkbox"/>	<input type="checkbox"/>	<input type="checkbox"/>	<input type="checkbox"/>	<input type="checkbox"/>	<p>The project parcel is currently vacant, when development occurs, the project shall adhere to all applicable Federal, State and local agency requirements regarding wastewater disposal systems, (i.e connecting to public/private sewer facilities and/or onsite waste management systems (septic). Less Than Significant Impact</p>
f) Directly or indirectly destroy a unique paleontological resource or site or unique geologic feature?	<input type="checkbox"/>	<input type="checkbox"/>	<input type="checkbox"/>	<input type="checkbox"/>	<input type="checkbox"/>	<input type="checkbox"/>	<p>Disturbance of paleontological resources or unique geologic features is not anticipated, but mitigation measures are in place to assure that in the event any artifacts are found. All potential impacts have been reduced to less than significant levels with the incorporated mitigation measures CUL-1 and CUL-5.</p>
SECTION VIII. GREENHOUSE GAS EMISSIONS							
<i>Would the project:</i>							
a) Generate greenhouse gas emissions, either directly or indirectly, that may have a significant impact on the environment?	<input type="checkbox"/>	<input type="checkbox"/>	<input type="checkbox"/>	<input type="checkbox"/>	<input checked="" type="checkbox"/>	<input type="checkbox"/>	<p>Air quality impacts, including Carbon Dioxide emissions from the project, which contribute to global warming, need to be analyzed using the current guidelines or procedures specified by the local air district or the Air Resources Board. Calculations of CO₂, CH₄, and N₂O emissions are provided to identify the magnitude of potential project effects. This analysis focuses on CO₂, CH₄, and N₂O since these comprise 98.9 percent of all GHG emissions by volume (IPCC 2007) and are the GHG emissions that the project</p>

IMPACT CATEGORIES*	1	2	3	4	5	6	<p align="center">All determinations need explanation. Reference to documentation, sources, notes and correspondence.</p>
							<p>would emit in the greatest quantities. Fluorinated gases, such as HFC, PFCs, and SF6 were not used in this analysis, as they are primarily associated with industrial processes and the proposed project involves retail development and does not include an industrial component. Emissions of all GHGs are converted into metric tons of carbon dioxide equivalent (MT of CO2e), which presents the volume of GHGs equivalent to the global warming effect of CO2. While minimal amounts of other GHGs, such as chlorofluorocarbons (CFC), would be emitted, they would not substantially add to the calculated CO2e quantities. Calculations are based on the California Air Pollution Control Officers Association (CAPCOA) CEQA & Climate Change white paper (CAPCOA 2008).</p> <p>The Lake County Air Quality Management District does not have an air quality management plan. However, the LCAQMD refers to the Bay Area Air Quality Management District (BAAQMD) guidelines to evaluate thresholds of significance for general guidance (refer excerpts from this document in Attachment B). It is noted, however, that the LCAQMD has not formally adopted these as the area's threshold of significance and leaves the determination of level of significance to each local agency for determination.</p> <p>Air impact modeling was conducted using CalEEMod.2020.40 Modeling which indicates that the project's construction will result in about 52 metric tons of CO2e during construction (2 years) and about 34 metric tons of CO2e annually during operation. Construction and operational estimates fall below the BAAQMD levels of significance of GHG which is 1,100 metric tons annually (see Attachment B). Therefore, the impact is less than significant.</p>
b) Conflict with an applicable plan, policy or regulation adopted for the purpose of reducing the emissions of greenhouse gases?	<input type="checkbox"/>	<input type="checkbox"/>	<input type="checkbox"/>	<input type="checkbox"/>	<input checked="" type="checkbox"/>	<input type="checkbox"/>	This project will not conflict with any adopted plans or policies for the reduction of greenhouse gas emissions. The City of Clearlake is within an 'air attainment' basin. In accordance with the requirements of the Lake County Air Quality Management District, an air permit will be required as a condition of the use permit, prior to issuance of a building permit for the project. Refer to response in Section VIII(a). Less Than Significant Impact
<h2 style="margin: 0;">SECTION IX. HAZARDS AND HAZARDOUS MATERIALS</h2> <p style="margin: 0;"><i>Would the project:</i></p>							
a) Create a significant hazard to the public or the environment through the routine transport, use, or disposal of hazardous materials?	<input type="checkbox"/>	<input type="checkbox"/>	<input type="checkbox"/>	<input type="checkbox"/>	<input checked="" type="checkbox"/>	<input type="checkbox"/>	Project construction activities may involve the use and transport of hazardous materials. These materials may include fuels, oils, mechanical fluids, and other chemicals used during construction. Transportation, storage, use, and disposal of hazardous materials during construction activities would be required to comply with applicable federal, state, and local statutes and regulations. Compliance would ensure that human health and the environment are not exposed to hazardous materials. In addition, the construction contractor would be required to implement a Stormwater Pollution Prevention Plan during construction activities to prevent contaminated runoff from leaving the project site. Therefore, no significant impacts would occur during construction activities. In addition, the proposed project would not be a large-quantity user of hazardous materials. Small quantities of hazardous materials would likely routinely be used on site, primarily fertilizers, herbicides, and pesticides. The potential risks posed by the use and storage of these hazardous materials are limited primarily to the immediate vicinity of the materials. Any transport of these materials would be required to comply with various federal and state laws regarding hazardous materials transportation. In summary, the proposed project would not create a significant hazard to the public or the environment from routine transport, use, or disposal of hazardous materials and impacts would be less than significant.
b) Create a significant hazard to the public or the environment through reasonably foreseeable upset and accident conditions involving the release of hazardous materials into the environment?	<input type="checkbox"/>	<input type="checkbox"/>	<input type="checkbox"/>	<input type="checkbox"/>	<input checked="" type="checkbox"/>	<input type="checkbox"/>	The project will not create a significant hazard to the public or the environment through reasonably foreseeable upset and accident conditions involving the release of hazardous materials into the environment. All chemicals, pesticides, fertilizer, and other materials associated with the operation shall adhere to all Federal, State, and local agency requirements. Less than Significant.

IMPACT CATEGORIES*	1	2	3	4	5	6	All determinations need explanation. Reference to documentation, sources, notes and correspondence.
c) Emit hazardous emissions or handle hazardous or acutely hazardous materials, substances, or waste within one-quarter mile of an existing or proposed school?	<input type="checkbox"/>	<input type="checkbox"/>	<input type="checkbox"/>	<input type="checkbox"/>	<input type="checkbox"/>	<input checked="" type="checkbox"/>	The proposed project is not located within one-quarter mile of an existing or proposed school. No Impact
d) Be located on a site which is included on a list of hazardous materials sites compiled pursuant to Government Code Section 65962.5 and, as a result, would it create a significant hazard to the public or the environment?	<input type="checkbox"/>	<input type="checkbox"/>	<input type="checkbox"/>	<input type="checkbox"/>	<input type="checkbox"/>	<input checked="" type="checkbox"/>	The project site is not located on or within 2,000 feet of an NPL ("Superfund") site or a CERCLIS site (CA DTSC, 2022). The project site is not listed as a site containing hazardous materials in the databases maintained by the Environmental Protection Agency (EPA), California Department of Toxic Substance, and Control State Resources Water Control Board. No Impact
e) For a project located within an airport land use plan or, where such a plan has not been adopted, within two miles of a public airport or public use airport, would the project result in a safety hazard or excessive noise for people residing or working in the project area?	<input type="checkbox"/>	<input type="checkbox"/>	<input type="checkbox"/>	<input type="checkbox"/>	<input type="checkbox"/>	<input checked="" type="checkbox"/>	The project is not located within two (2) miles of an airport and/or within an Airport Land Use Plan. No Impact
f) Impair implementation of or physically interfere with an adopted emergency response plan or emergency evacuation plan?	<input type="checkbox"/>	<input type="checkbox"/>	<input type="checkbox"/>	<input type="checkbox"/>	<input checked="" type="checkbox"/>	<input type="checkbox"/>	The project would not impair or interfere with an adopted emergency response or evacuation plan. The project has been reviewed by the Lake County Department of Environmental Health, Lake County Special Districts, City of Clearlake Police Department, City of Clearlake's Community Development Department (Building, Public Works, Planning), and the Local Fire Protection District/CalFire for consistency with access and safety standards. The City of Clearlake did not receive any adverse comments. Less Than Significant Impact
g) Expose people or structures, either directly or indirectly, to a significant risk of loss, injury or death involving wildland fires?	<input type="checkbox"/>	<input type="checkbox"/>	<input type="checkbox"/>	<input type="checkbox"/>	<input checked="" type="checkbox"/>	<input type="checkbox"/>	The project will not expose people or structures, either directly or indirectly, to a significant risk of loss, injury or death involving wildland fires as it is located in a "Low to Moderate" Fire Hazard Severity Zone and within the Lake County Fire Protection District. The project was circulated for review to various agencies, include but not limited to City Engineer, City of Clearlake Police Department, City of Clearlake Building Official/Inspection, Lake County Fire Protection District and the California Department of Transportation (Caltrans). During the project review, no adverse comments were received. The application shall adhere to all current Federal, State and local agency requirements, including all mitigation measures and conditions of approval imposed on such use. Less Than Significant Impact

SECTION X. HYDROLOGY AND WATER QUALITY

Would the project:

a) Violate any water quality standards or waste discharge requirements or otherwise substantially degrade surface or ground water quality?	<input type="checkbox"/>	<input type="checkbox"/>	<input type="checkbox"/>	<input type="checkbox"/>	<input checked="" type="checkbox"/>	<input type="checkbox"/>	<p>The North Coast Regional Water Quality Control Board (RWQCB) administers the National Pollutant Discharge Elimination System (NPDES) stormwater permitting program for construction activities.</p> <p>Construction activities disturbing one acre or more of land are subject to the permitting requirements of the NPDES General Permit for Discharges of Storm Water Runoff Associated with Construction Activity. Since the project site involves more than one acre in size the City, as the applicant is required to submit a NOI to the RWQCB that covers the General Construction Permit (GCP) prior to the beginning of construction. The GCP requires the preparation and implementation of a Water Quality Management Plan (WQMP) and a Storm Water Pollution Prevention Plan (SWPPP) both of which</p>
--	--------------------------	--------------------------	--------------------------	--------------------------	-------------------------------------	--------------------------	---

IMPACT CATEGORIES*	1	2	3	4	5	6	All determinations need explanation. Reference to documentation, sources, notes and correspondence.
							must be prepared before construction can begin. The SWPPP outlines all activities to prevent stormwater contamination, control sedimentation and erosion, and compliance with Clean Water Act (CWA) requirements during construction. Implementation of the SWPPP starts with the commencement of construction and continues through to the completion of the project. The WQMP outlines the project site design, source control and treatment control of BMPs utilized throughout the life of the project. Upon completion of project construction, the City, as the applicant must submit a Notice of Termination (NOT) to the RWQCB to indicate that construction is completed. Therefore, with implementation of NPDES and the SWPPP in compliance with the RWQCB, impacts to water quality and discharge requirements will be a less than significant impact.
b) Substantially decrease groundwater supplies or interfere substantially with groundwater recharge such that the project may impede sustainable groundwater management of the basin?	<input type="checkbox"/>	<input type="checkbox"/>	<input type="checkbox"/>	<input type="checkbox"/>	<input checked="" type="checkbox"/>	<input type="checkbox"/>	The operation would not substantially decrease groundwater supplies or interfere substantially with groundwater recharge such that the project may impede sustainable groundwater management of the basin. Less than significant impact.
c) Substantially alter the existing drainage pattern of the site or area, including through the alteration of the course of a stream or river or through the addition of impervious surfaces, in a manner that would: i) result in substantial erosion or siltation on-site or off-site; ii) substantially increase the rate or amount of surface runoff in a manner which would result in flooding on- or off-site; iii) create or contribute runoff water which would exceed the capacity of existing or planned stormwater drainage systems or provide substantial additional sources of polluted run-off; or iv) impede or redirect flood flows?	<input type="checkbox"/>	<input checked="" type="checkbox"/>	<input type="checkbox"/>	<input type="checkbox"/>	<input type="checkbox"/>	<input type="checkbox"/>	The project would not substantially alter the existing drainage pattern of the site or area, or add impervious surfaces, in a manner which would (i) result in substantial erosion or siltation on- or off-site; (ii) substantially increase the rate or amount of surface runoff in a manner which would result in flooding on- or offsite; (iii) create or contribute runoff water which would exceed the capacity of existing or planned stormwater drainage systems or provide substantial additional sources of polluted runoff; or (iv) impede or redirect flows. Therefore, impacts would be less than significant.
d) In flood hazard, tsunami, or seiche zones, risk release of pollutants due to project inundation?	<input type="checkbox"/>	<input type="checkbox"/>	<input type="checkbox"/>	<input type="checkbox"/>	<input type="checkbox"/>	<input checked="" type="checkbox"/>	Based on the 2005 Flood Insurance Rate Map (Panel 06033C0684D, eff. 9/30/2005), the project site is shown as being in a special flood hazard area (Zone AE and AO) associated with the ephemeral drainage on the eastern boundary of the site (FEMA, 2005). Refer to Attachment G. As determined by the City Engineer, who is also the City's Floodplain Administrator, the FEMA mapping for this area of the City has a datum problem, as stated in a letter from the City Engineer (dated 1/5/22).. It appears that the 1929 datum was assumed, however the elevations shown on the flood mapping, seem to align with the 1988 vertical datum. The City Engineer has outlined this with the FEMA representative and submitted a request for map revision. "Based on my research of the historical

IMPACT CATEGORIES*	1	2	3	4	5	6	All determinations need explanation. Reference to documentation, sources, notes and correspondence.
							characterization of the flows in this area, coupled with the potential datum matter, I believe that the project would be able to reasonably file a Letter of Map Revision with FEMA at the end of the project and would meet the criteria to receive approval." As required by the Chapter XVII (Floodplain Management) of the City's Municipal Code, flood elevation certificates have been prepared for the proposed project based on the 1929 vertical datum, which demonstrates that the finished floor elevations of the proposed structures would be located a minimum of 1-foot above the base flood elevation. Less than Significant.
e) Conflict with or obstruct implementation of a water quality control plan or sustainable groundwater management plan?	<input type="checkbox"/>	<input type="checkbox"/>	<input type="checkbox"/>	<input type="checkbox"/>	<input checked="" type="checkbox"/>	<input type="checkbox"/>	The project would not conflict with or obstruct any water quality or management plans. Additionally, to control runoff, the operation will incorporate appropriate Best Management Practices (BMPs) consistent with City code and State Storm Water Drainage Regulations to the maximum extent practicable to prevent or reduce discharge of all construction or post-construction pollutants into the local storm drainage system. All grading measure shall adhere to all Federal, State and local agency requirements. Less than Significant.
SECTION XI. LAND USE AND PLANNING <i>Would the project:</i>							
a) Physically divide an established community?	<input type="checkbox"/>	<input type="checkbox"/>	<input type="checkbox"/>	<input type="checkbox"/>	<input type="checkbox"/>	<input checked="" type="checkbox"/>	The project is intended to attract and accommodate residents from around the city to participate in athletic events including the +/- 15,000 square foot indoor sports facility, soccer fields, and baseball/softball fields. Therefore, the project will not divide an established community. No impact.
b) Cause a significant environmental impact due to a conflict with any land use plan, policy, or regulation adopted for the purpose of avoiding or mitigating an environmental effect?	<input type="checkbox"/>	<input type="checkbox"/>	<input type="checkbox"/>	<input type="checkbox"/>	<input type="checkbox"/>	<input checked="" type="checkbox"/>	The project site is designated for Medium Density Residential in the General Plan with a Land Use Designation of MUX, Mixed Use. Section 18-02.040 of the Zoning Code references that MUX Zoning is consistent with the Medium Density Residential General Plan Land Use Designation. The Mixed-Use Zoning District is intended to allow a mixture of residential and commercial uses which can be made compatible with each other. This District provides a balanced mix of residential and employment opportunities to create focal points of activity in the form of mixed-use centers, nodes, or corridors. The Mixed-Use Districts support service commercial, employment, and housing needs of a growing community. The maximum allowed density in the MUX Zone is 25 units per acre. The project proposes a public park and public works yard. Although these uses will not produce residential or commercial uses envisioned in the General Plan or Zoning Map, it will create employment and recreational opportunities that would be generally consistent with both the General Plan and Zoning Code. The following uses are identified as requiring a use permit from the planning commission in the MUX Zone: <ul style="list-style-type: none"> • Public Assembly • Outdoor and Indoor Recreation • Impound Yard Also, Section 18-19.370 of the Zoning Code indicates that other uses otherwise not identified in the use table would be subject to a use permit, such as public and quasi-public uses of an administrative, public services or cultural type including special district, City, County, State or Federal facilities. Less than Significant.
SECTION XII. MINERAL RESOURCES <i>Would the project:</i>							
a) Result in the loss of availability of a known mineral resource that would be of value to the region and the residents of the state?	<input type="checkbox"/>	<input type="checkbox"/>	<input type="checkbox"/>	<input type="checkbox"/>	<input type="checkbox"/>	<input checked="" type="checkbox"/>	The operation would not result is the loss of availability of a known mineral resource that would be of value to the region and the residents of the state. No Impact

IMPACT CATEGORIES*	1	2	3	4	5	6	All determinations need explanation. Reference to documentation, sources, notes and correspondence.
b) Result in the loss of availability of a locally important mineral resource recovery site delineated on a local general plan, specific plan, or other land use plan?	<input type="checkbox"/>	<input type="checkbox"/>	<input type="checkbox"/>	<input type="checkbox"/>	<input type="checkbox"/>	<input checked="" type="checkbox"/>	The operations would not result in the loss of availability of a locally important mineral resource recovery site delineated on a local general plan, specific plan, or other land use plan. No Impact

SECTION XIII. NOISE & VIBRATIONS

Would the project:

a) Generate construction noise levels that exceed the Noise Ordinance exterior or interior noise standards at residential properties during the hours that are specified in the City's General Plan Noise Element?	<input type="checkbox"/>	<input checked="" type="checkbox"/>	<input type="checkbox"/>	<input type="checkbox"/>	<input type="checkbox"/>	<input type="checkbox"/>	<p>Sound is produced by the vibration of sound pressure waves in the air. Sound pressure levels are used to measure the intensity of sound and are described in terms of decibels. The decibel (dB) is a logarithmic unit that expresses the ratio of the sound pressure level being measured to a standard reference level. A-weighted decibels (dBA) approximate the subjective response of the human ear to a broad frequency noise source by discriminating against very low and very high frequencies of the audible spectrum. They are adjusted to reflect only those frequencies that are audible to the human ear.</p> <p><u>Community Noise Equivalent Level</u> Community Noise Equivalent Level (CNEL) is the predominant rating scale now in use in California for land use compatibility assessment. The CNEL scale represents a time weighted 24- hour average noise level based on the A-weighted decibel. Time weighted refers to the fact that noise occurrences during certain sensitive time periods are penalized. The evening time period (7 p.m. to 10 p.m.) penalizes noises by 5 dBA, while nighttime (10 p.m. to 7 a.m.) noises are penalized by 10 dBA. These time periods and penalties were selected to reflect people's increased sensitivity to noise during these time periods. A CNEL noise level may be reported as a "CNEL of 60 dB(A)," "60 dBA CNEL," or simply "60 CNEL."</p> <p>Short-term increases in ambient noise levels to uncomfortable levels may be expected during project construction. There will be vehicles entering and exiting the project premises primarily from Burns Valley Road. Construction shall adhere to all Federal, State and local agency requirements regarding noise standards.</p> <p>Activities in the park, such as nighttime baseball games could impact adjoining residential uses. The Oak Valley Villas project, an 80 units apartment development that is being planned for construction adjacent to and to the northeast of one of the lighted baseball fields will receive noise impacts from park activities. A Noise study was conducted for this project concerning impacts from the park project (refer to Attachment F). The study identifies three types of noise impacts from surrounding activities, such as noise from vehicles in surrounding parking lots, noise from amplified sound from public address systems, and noise from spectators during a baseball game. Of particular focus of the study, noise from spectators during a ball game seemed to be most concern. However, the project will include interior mitigation sound attenuation when constructed to reduce potential interior noise levels for the building adjoining the park.</p> <p>Therefore, to ensure impacts related to the Noise are minimized, the following mitigation measures have been implemented. Impacts would be less than significant.</p> <p><u>Mitigation Measures:</u> NOI-1: All construction activities including engine warm-up shall be limited to weekdays and Saturday, between the hours of 7:00am and 7:00pm to minimize noise impacts on nearby residents. NOI-2: Permanent potential noise sources such as, generators used for power shall be designed and located to minimize noise impacts to surrounding properties.</p>
--	--------------------------	-------------------------------------	--------------------------	--------------------------	--------------------------	--------------------------	--

IMPACT CATEGORIES*	1	2	3	4	5	6	All determinations need explanation. Reference to documentation, sources, notes and correspondence.
							<p>NOI-3: During construction noise levels shall not exceed 65 decibels within fifty (50) feet of any dwellings or transient accommodations between the hours of 7:00 AM and 6:00 PM. This threshold can be increased by the Building Inspector or City Engineer have approved an exception in accordance with Section 5-4.4(b)(1) of the City Code. An exception of up to 80 decibels may be approved within one hundred (100) feet from the source during daylight hours. Project is expected to result in less than significant impacts with regard to noise and vibration.</p> <p>NOI-4: Park operations, including baseball at the northeasterly ball park shall be shall be restricted to not later than 10 pm.</p>
b) Generate a substantial temporary (non- construction) or permanent increase in noise levels at existing sensitive receptors in the vicinity of the project site?	<input type="checkbox"/>	<input type="checkbox"/>	<input type="checkbox"/>	<input type="checkbox"/>	<input type="checkbox"/>	<input checked="" type="checkbox"/>	The project is not expected to create unusual groundborne vibration due to site development or operation. The low-level truck traffic would create a minimal amount of groundborne vibration. No Impact
c) For a project located within the vicinity of a private airstrip or an airport land use plan or, where such a plan has not been adopted, within two miles of a public airport or public use airport, would the project expose people residing or working in the project area to excessive noise levels and generate excessive ground borne vibration?	<input type="checkbox"/>	<input type="checkbox"/>	<input type="checkbox"/>	<input type="checkbox"/>	<input type="checkbox"/>	<input checked="" type="checkbox"/>	The project is not located within an airport land use plan or within two (2) miles of a public airport. No Impact
SECTION XIV. POPULATION AND HOUSING							
<i>Would the project:</i>							
a) Induce substantial unplanned population growth in an area, either directly or indirectly?	<input type="checkbox"/>	<input type="checkbox"/>	<input type="checkbox"/>	<input type="checkbox"/>	<input type="checkbox"/>	<input checked="" type="checkbox"/>	The proposed project is for a public park (sports complex), community center, public works yard with public works building facility and combined police department office and maintenance facilities, vehicle and equipment storage areas, public access and parking facilities on approximately 26 acres and will not create population growth in the area. No Impact
b) Displace substantial numbers of existing people or housing, necessitating the construction of replacement housing elsewhere?	<input type="checkbox"/>	<input type="checkbox"/>	<input type="checkbox"/>	<input type="checkbox"/>	<input type="checkbox"/>	<input checked="" type="checkbox"/>	The operation will not displace a substantial number(s) of existing people or housing, necessitating the construction of replacement housing elsewhere. No Impact

IMPACT CATEGORIES*	1	2	3	4	5	6	All determinations need explanation. Reference to documentation, sources, notes and correspondence.
SECTION XV. PUBLIC SERVICES							
<i>Would the project:</i>							
Result in substantial adverse physical impacts associated with the provision of new or physically altered government facilities, need for new or physically altered government facilities, the construction of which could cause significant environmental impacts, in order to maintain acceptable service ratios, response times, or other performance objectives for any of the following public services: a) Fire Protection? b) Police Protection? c) Schools? d) Parks? e) Other public facility?	<input type="checkbox"/>	<input type="checkbox"/>	<input type="checkbox"/>	<input type="checkbox"/>	<input checked="" type="checkbox"/>	<input type="checkbox"/>	a) - e) The project does not propose housing or other uses that would necessitate the need for new or altered government facilities. There will not be a need to increase fire or police protection, schools, parks or other public facilities as a result of the project's implementation. Less Than Significant Impact
SECTION XVI. RECREATION							
<i>Would the project:</i>							
a) Increase the use of existing neighborhood and regional parks or other recreational facilities such that substantial physical deterioration of the facility would occur or be accelerated?	<input type="checkbox"/>	<input type="checkbox"/>	<input type="checkbox"/>	<input type="checkbox"/>	<input type="checkbox"/>	<input checked="" type="checkbox"/>	The project site is of non-residential development that will provide a variety of recreational activities to serve the City residents. Therefore, the project will not cause a population increase that will impact existing parks or recreational facilities.

IMPACT CATEGORIES*	1	2	3	4	5	6	All determinations need explanation. Reference to documentation, sources, notes and correspondence.
b) Does the project include recreational facilities or require the construction or expansion of recreational facilities which might have an adverse physical effect on the environment? <ul style="list-style-type: none"> • Fire Protection • Police Protection • Schools • Parks • Other Public Services 	<input type="checkbox"/>	<input type="checkbox"/>	<input type="checkbox"/>	<input type="checkbox"/>	<input type="checkbox"/>	<input checked="" type="checkbox"/>	The project would not require the construction or expansion of other recreational facilities. Because the project does not include features that would result in additional adverse impacts to recreational facilities beyond that addressed herein, no impacts would occur that are not already addressed elsewhere in this IS.

SECTION XVII. TRANSPORTATION

Would the project:

a) Conflict with a program plan, ordinance or policy addressing the circulation system, including transit, roadway, bicycle, and pedestrian facilities?	<input type="checkbox"/>	<input type="checkbox"/>	<input type="checkbox"/>	<input type="checkbox"/>	<input checked="" type="checkbox"/>	<input type="checkbox"/>	A traffic impact study was prepared for the project by W-Trans, Traffic Engineers (see Attachment F). It indicates that this project would result in an increase in 1,332 average daily vehicle trips, with a peak hour increase in 182 trips. This study also references coincidental development of an 80-unit apartment project located at the southeast corner on Burns Valley Road and Bowers Avenue, adjacent and to the north and east of the project. The study concludes that the project (including this apartment project) would not result in a significant traffic impact, nor conflict with ordinances or policies addressing the City's circulation system. The project will obtain all the necessary Federal, State, and local agency permits for any works that occurs with the right-of-way and will be subject to the City's traffic impact fee program. Participation in this program will mitigate any cumulative impacts on the City's transportation system. Less Than Significant Impact
b) Would the project conflict or be inconsistent with CEQA Guidelines section 15064.3, subdivision (b)?	<input type="checkbox"/>	<input type="checkbox"/>	<input type="checkbox"/>	<input type="checkbox"/>	<input type="checkbox"/>	<input type="checkbox"/>	Regarding CEQA Section 15064.3, Vehicles Miles Traveled (VMT), the traffic study indicates that the project, would have a less than significant impacts based on the California Governor's Office of Planning and Research (OPR) in the publication Transportation Impacts (SB 743) CEQA Guidelines Update and Technical Advisory, 2018 as well as information contained within Senate Bill 743 Vehicle Miles Traveled Regional Baseline Study (RBS). Less Than Significant Impact
c) Substantially increase hazards due to a geometric design feature (e.g., sharp curves or dangerous intersections) or incompatible uses (e.g., farm equipment)?	<input type="checkbox"/>	<input type="checkbox"/>	<input type="checkbox"/>	<input type="checkbox"/>	<input type="checkbox"/>	<input checked="" type="checkbox"/>	The traffic study included a comprehensive analysis of safety hazards in relation to geometric design and concluded that as long as proper sight distance is maintained at intersection corners (vision triangles), the it would not result in a significant circulation safety impact. The study recommended that these intersections be maintained with minimal obstructions, such as signs and shrubs. Less Than Significant Impact
d) Result in inadequate emergency access?	<input type="checkbox"/>	<input type="checkbox"/>	<input type="checkbox"/>	<input type="checkbox"/>	<input checked="" type="checkbox"/>	<input type="checkbox"/>	The traffic study concludes that emergency access and circulation are anticipated to function acceptably with incorporation of applicable design standards into the site layout and traffic from the proposed development would be expected to have a less-than-significant impact on emergency response times. Less Than Significant Impact

IMPACT CATEGORIES*	1	2	3	4	5	6	All determinations need explanation. Reference to documentation, sources, notes and correspondence.
SECTION XVIII. TRIBAL CULTURAL RESOURCES							
<i>Would the project cause a substantial adverse change in the significance of a tribal cultural resource, defined in Public Resources Code section 21074 as either a site, feature, place, cultural landscape that is geographically defined in terms of the size and scope of the landscape, sacred place, or object with cultural value to a California Native American tribe, and that is:</i>							
a) Listed or eligible for listing in the California Register of Historical Resources, or in a local register of historical resources as defined in Public Resources Code section 5020.1(k), or	<input type="checkbox"/>	<input checked="" type="checkbox"/>	<input type="checkbox"/>	<input type="checkbox"/>	<input type="checkbox"/>	<input type="checkbox"/>	<p>See Response to Section V(a): Less than Significant Impact with the incorporated mitigation measure CUL-1 through CUL-3, including the mitigation measures.</p> <p>Mitigation Measures:</p> <p>TCR-1: Requirement to develop a tribal cultural resources preservation plan that delineates the boundary of CCL-21-01 and CCL-21-02, describes the appropriate combination of materials and culturally sterile fill in capping, provides landscaping specifications that favor culturally important plants, and restricts certain types of post-project activities in or on the cap.</p> <p>TCR-2: Requirement to designate a project reburial area in advance of ground disturbing activities in the event that materials are discovered during construction.</p> <p>TCR-3: Requirement for contractors to receive meaningful training on cultural sensitivity and tribal cultural resources from a tribal representative.</p> <p>TCR-4: Requirement for tribal monitoring during ground disturbing activities in sensitive areas of the project area.</p> <p>TCR-5: Procedures for compliance with existing state law in the event of the discovery of human remains during construction.</p> <p>TCR-6: A prohibition on the removal of cultural soils from the project area.</p>
b) A resource determined by the lead agency, in its discretion and supported by substantial evidence, to be significant pursuant to criteria set forth in subdivision (c) of Public Resources Code section 5024.1. In applying the criteria set forth in subdivision (c) of Public Resources Code 5024.1, the lead agency shall consider the significance of the resource to a California Native American tribe.	<input type="checkbox"/>	<input checked="" type="checkbox"/>	<input type="checkbox"/>	<input type="checkbox"/>	<input type="checkbox"/>	<input type="checkbox"/>	<p>See Response to Section V(a): Less than Significant Impact with the incorporated mitigation measure CUL-1 through CUL-3, and TCR-1 through TCR-6.</p>
SECTION XIX. UTILITIES AND SERVICE SYSTEMS							
<i>Would the project:</i>							
a) Require the relocation or construction of new or expanded water, wastewater treatment, or storm water drainage, electric power, or natural gas, or telecommunications facilities, the construction or relocation of which	<input type="checkbox"/>	<input type="checkbox"/>	<input type="checkbox"/>	<input type="checkbox"/>	<input checked="" type="checkbox"/>	<input type="checkbox"/>	<p>The project would not require or result in the relocation or construction of new or expanded water or, wastewater treatment facilities or expansion of existing storm water drainage, electric power, natural gas or telecommunications facilities, the construction or relocations of which could cause significant environmental effects.</p> <p>The project would be served by the Highlands Mutual Water Company The project will require compliance with all rules, regulations, policies, resolutions, costs and specifications that are in effect at the time service is requested. Therefore, less than significant impact related to these utilities and service systems would occur.</p>

IMPACT CATEGORIES*	1	2	3	4	5	6	All determinations need explanation. Reference to documentation, sources, notes and correspondence.
could cause significant environmental effects?							
b) Due to slope, prevailing winds, and other factors, exacerbate wildfire risks, and thereby expose project occupants to pollutant concentrations from a wildfire or the uncontrolled spread of a wildfire?	<input type="checkbox"/>	<input type="checkbox"/>	<input type="checkbox"/>	<input type="checkbox"/>	<input type="checkbox"/>	<input checked="" type="checkbox"/>	The project would have sufficient water supplies available to serve the project and reasonably foreseeable future. Therefore, no impact related to these utilities and service systems would occur.
c) Result in a determination by the wastewater treatment provider which serves or may serve the project that it has inadequate capacity to serve the project's projected demand in addition to the provider's existing commitments?	<input type="checkbox"/>	<input type="checkbox"/>	<input type="checkbox"/>	<input type="checkbox"/>	<input type="checkbox"/>	<input type="checkbox"/>	The project site is located next to sewer lines and would be served by Lake County Special Districts which has sufficient wastewater treatment capacity to serve the project. Less than significant impact.
d) Generate solid waste in excess of State or local standards, or in excess of the capacity of local infrastructure, or otherwise impair the attainment of solid waste reduction goals?	<input type="checkbox"/>	<input type="checkbox"/>	<input type="checkbox"/>	<input type="checkbox"/>	<input checked="" type="checkbox"/>	<input type="checkbox"/>	The project would generate a minimal amount of construction waste. Additionally, the project would not generate solid waste in excess of State or local standards, or in excess of the capacity of local infrastructure, or otherwise impair the attainment of solid waste reduction goals. The project would be served by Clearlake Waste Solutions which has sufficient capacity to accommodate the project's solid waste disposal needs. In addition, the proposed project would comply with federal, state, and local regulations regarding solid waste. Impacts would be less than significant .
e) Comply with federal, state, and local management and reduction statutes and regulations related to solid waste?	<input type="checkbox"/>	<input type="checkbox"/>	<input type="checkbox"/>	<input type="checkbox"/>	<input checked="" type="checkbox"/>	<input type="checkbox"/>	The project would comply with Federal, State, and local management and reduction statutes and regulations related to solid waste. The proposed project would be required to comply with applicable elements of AB 1327, Chapter 18 (California Solid Waste Reuse and Recycling Access Act of 1991) and other local, state, and federal waste disposal standards. Impacts would be less than significant .
SECTION XX. WILDFIRE							
<i>If located in or near state responsibility areas or lands classified as very high fire hazard severity zones, would the project:</i>							
a) Substantially impair an adopted emergency response plan or emergency evacuation plan?	<input type="checkbox"/>	<input type="checkbox"/>	<input type="checkbox"/>	<input type="checkbox"/>	<input checked="" type="checkbox"/>	<input type="checkbox"/>	<p>According to the Office of the State Fire Marshal Online Portal (https://egis.fire.ca.gov/FHSZ/) and the County of Lake, CA GIS Fire Hazard Zone (https://gispublic.co.lake.ca.us/portal/apps/webappviewer/index.html?id=e68893fda34e495ab5f053f6a96b305c), the project parcel is not located within a known Fire Hazard Severity Zone.</p> <p>According to the above databases, the project is located within a "Non-Wildland/Non-Urban Area. Additionally, the project will adhere to all applicable Federal, State, and local agency requirements, including the CA Building Code and the Lake County Fire Protection Districts requirements. Therefore, the project will not substantially impair an adopted emergency response plan or emergency evacuation plan. Less Than Significant Impact</p>

IMPACT CATEGORIES*	1	2	3	4	5	6	All determinations need explanation. Reference to documentation, sources, notes and correspondence.
b) Due to slope, prevailing winds, and other factors, exacerbate wildfire risks, and thereby expose project occupants to, pollutant concentrations from a wildfire or the uncontrolled spread of a wildfire?	<input type="checkbox"/>	<input type="checkbox"/>	<input checked="" type="checkbox"/>	<input type="checkbox"/>	<input checked="" type="checkbox"/>	<input type="checkbox"/>	The project will not exacerbate wildfire risks and/or expose persons to pollutant concentrations in the event of a wildfire in the area. Additionally, the applicant will adhere to all Federal, State, and local fire requirements/regulations, including all mitigation measure and/or conditions of approval imposed on such use. Less than Significant Impact
c) Require the installation or maintenance of associated infrastructure (such as roads, fuel breaks, emergency water sources, power lines or other utilities) that may exacerbate fire risk or that may result in temporary or ongoing impacts to the environment?	<input type="checkbox"/>	<input type="checkbox"/>	<input type="checkbox"/>	<input type="checkbox"/>	<input checked="" type="checkbox"/>	<input type="checkbox"/>	All infrastructure will be routinely maintained to ensure all Federal, State, and local agency requirements are being satisfied, including all necessary City Codes and/or regulations. Additionally, prior to operation the applicant(s) will make all necessary improvements to the project site, such as access/roadways, fuels breaks, and emergency water source/water tanks. Less than Significant Impact
d) Expose people or structures to significant risks, including downslope or downstream flooding or landslides, as a result of runoff, post-fire slope instability, or drainage changes?	<input type="checkbox"/>	<input type="checkbox"/>	<input type="checkbox"/>	<input type="checkbox"/>	<input checked="" type="checkbox"/>	<input type="checkbox"/>	The project area to be developed is not located within the vicinity of known waterways nor is it located within a designated flood zone. Therefore, the risk of flooding/runoff, landslides, slope instability, or drainage changes would not be increased due to this project. Less Than Significant Impact

IMPACT CATEGORIES*	1	2	3	4	5	6	All determinations need explanation. Reference to documentation, sources, notes and correspondence.
SECTION XXI. MANDATORY FINDINGS OF SIGNIFICANCE							
a) Does the project have the potential to substantially degrade the quality of the environment, substantially reduce the habitat of a fish or wildlife species, cause a fish or wildlife population to drop below self-sustaining levels, threaten to eliminate a plant or animal community, substantially reduce the number or restrict the range of rare or endangered plant or animal or eliminate important examples of the major periods of California history or prehistory?	<input type="checkbox"/>	<input checked="" type="checkbox"/>	<input type="checkbox"/>	<input type="checkbox"/>	<input type="checkbox"/>	<input type="checkbox"/>	This project is not anticipated to significantly impact habitat of fish and/or wildlife species or cultural/tribal resources with the incorporated mitigation measures described above. Therefore, there is minimal risk of degradation, and mitigation measures are proposed that would alleviate most or all of the project-related impacts. The implementation of and compliance with all mitigation measures identified in each section as project conditions of approval would avoid or reduce all potential impacts to less than significant levels and would not result in cumulatively considerable environmental impacts on habitat of fish and/or wildlife species or cultural resources, nor will the project contribute to factors that would harm the environment or add to any wildfire risk.
b) Does the project have impacts that are individually limited, but cumulatively considerable? (“Cumulatively considerable” means that the incremental effects of a project are considerable when viewed in connection with the effects of past projects, the effects of other current projects, and the effects of probable future projects.)	<input type="checkbox"/>	<input checked="" type="checkbox"/>	<input type="checkbox"/>	<input type="checkbox"/>	<input type="checkbox"/>	<input type="checkbox"/>	All potentially significant impacts have been identified related to, Aesthetics, Air Quality, Biological Resources; Cultural/Tribal Resources; Geology & Soil; Noise & Vibration; and Hazards & Hazardous Materials. These impacts in combination with the impacts of other past, present, and reasonably foreseeable future projects in the vicinity could cumulatively contribute to significant effects on the environment if proper mitigation measures are not put in place. The implementation of and compliance with all mitigation measures identified in each section as project conditions of approval would avoid or reduce all potential impacts to less than significant levels and would not result in cumulatively considerable environmental impacts.
c) Does the project have environmental effects which will cause substantial adverse effects on human beings, either directly or indirectly?	<input type="checkbox"/>	<input checked="" type="checkbox"/>	<input type="checkbox"/>	<input type="checkbox"/>	<input type="checkbox"/>	<input type="checkbox"/>	The proposed project has potential to result in adverse indirect or direct effects on human beings. In particular, risks associated with, Aesthetics, Air Quality, Biological Resources; Cultural/Tribal Resources; Geology & Soil; Noise & Vibration; Hazards & Hazardous Materials and have the potential to impact human beings. Implementation of and compliance with mitigation measures identified in each section would reduce adverse indirect or direct effects on human beings and impacts to less than significant impact levels.

INITIAL STUDY SUMMARY: Based on the review of the proposed project site and surrounding area, appropriate mitigation measures were identified to mitigate potentially significant impacts to a level below adversity for Air Quality, Cultural Resources, Hazards & Hazardous Materials, Hydrology/ Water Quality, Traffic Circulation, and Tribal Cultural Resources. Assuming implementation of the identified measures and standard conditions of project approval of the City of Clearlake and other pertinent agencies, no adverse impacts are anticipated.

Attachment A

Lighting Impact Analysis

Maximum 70' tall poles
 Max spill and glare control (30/20 Light levels)

SPILL HORIZONTAL	0.11	0.4	0.0	N.A.	145	30	N.A.	0.75	N.A.
LL	20.80	28.7	11.4	2.52	40	20	20	0.23	1.61
SOCCER	31.96	44.6	18.0	2.48	60	30	30	0.20	1.72
SPILL VERTICAL EAST	0.40	0.6	0.1	6.00	22	30	N.A.	0.35	N.A.
SPILL VERTICAL NORTH	0.41	0.8	0.1	8.00	48	30	N.A.	0.56	N.A.
SPILL VERTICAL SOUTH	0.37	0.7	0.1	7.00	55	30	N.A.	0.49	N.A.
SPILL VERTICAL WEST	0.29	0.5	0.1	5.00	20	30	N.A.	0.58	N.A.

Photo-Metric Diagram

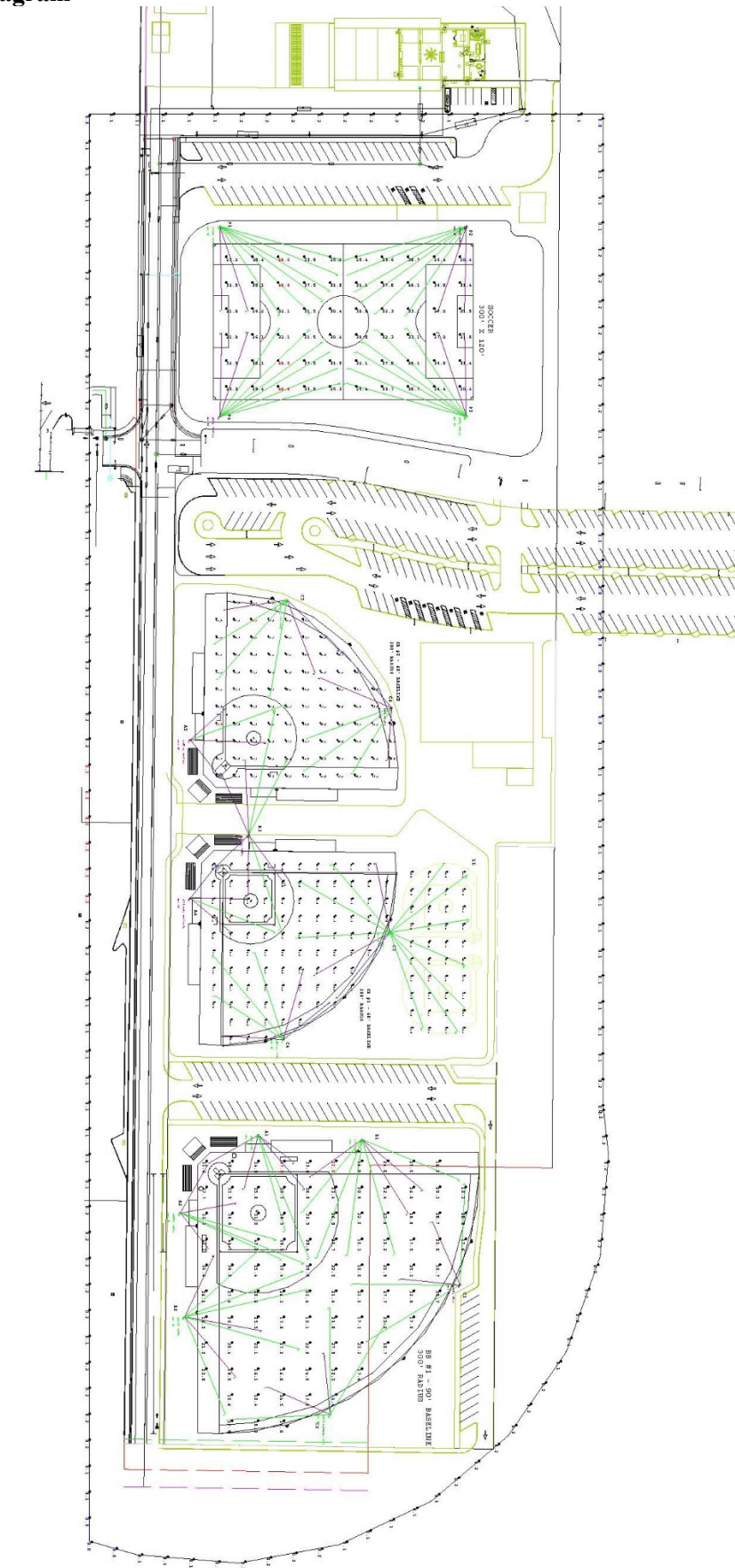

Burns Valley City Recreation and Public Works Complex
Lake County Air Basin, Annual

1.0 Project Characteristics

1.1 Land Usage

Land Uses	Size	Metric	Lot Acreage	Floor Surface Area	Population
City Park	26.00	Acre	26.00	1,132,560.00	0

1.2 Other Project Characteristics

Urbanization	Urban	Wind Speed (m/s)	2.2	Precipitation Freq (Days)	67
Climate Zone	1			Operational Year	2024
Utility Company	Pacific Gas and Electric Company				
CO2 Intensity (lb/MW hr)	203.98	CH4 Intensity (lb/MW hr)	0.033	N2O Intensity (lb/MW hr)	0.004

1.3 User Entered Comments & Non-Default Data

- Project Characteristics -
- Land Use -
- Grading -
- Demolition -

Table Name	Column Name	Default Value	New Value
------------	-------------	---------------	-----------

2.0 Emissions Summary

2.1 Overall Construction

Unmitigated Construction

	ROG	NOx	CO	SO2	Fugitive PM10	Exhaust PM10	PM10 Total	Fugitive PM2.5	Exhaust PM2.5	PM2.5 Total	Bio-CO2	NBio-CO2	Total CO2	CH4	N2O	CO2e
Year	tons/yr										MT/yr					
2022	0.4949	3.5014	3.6443	8.6800e-003	0.7073	0.1298	0.8371	0.2656	0.1209	0.3865	0.0000	787.9748	787.9748	0.1108	0.0443	803.9563
2023	0.6523	3.6480	4.9631	0.0134	0.6462	0.1036	0.7498	0.1756	0.0975	0.2731	0.0000	1,226.7790	1,226.7790	0.0952	0.0918	1,256.5241
2024	0.4873	1.0057	1.4571	3.6800e-003	0.1668	0.0309	0.1977	0.0452	0.0290	0.0742	0.0000	335.5406	335.5406	0.0339	0.0215	342.7819
Maximum	0.6523	3.6480	4.9631	0.0134	0.7073	0.1298	0.8371	0.2656	0.1209	0.3865	0.0000	1,226.7790	1,226.7790	0.1108	0.0918	1,256.5241

Mitigated Construction

	ROG	NOx	CO	SO2	Fugitive PM10	Exhaust PM10	PM10 Total	Fugitive PM2.5	Exhaust PM2.5	PM2.5 Total	Bio-CO2	NBio-CO2	Total CO2	CH4	N2O	CO2e
Year	tons/yr										MT/yr					
2022	0.4949	3.5014	3.6443	8.6800e-003	0.7073	0.1298	0.8371	0.2656	0.1209	0.3865	0.0000	787.9744	787.9744	0.1108	0.0443	803.9559
2023	0.6523	3.6480	4.9631	0.0134	0.6462	0.1036	0.7498	0.1756	0.0975	0.2731	0.0000	1,226.7787	1,226.7787	0.0952	0.0918	1,256.5237
2024	0.4873	1.0057	1.4571	3.6800e-003	0.1668	0.0309	0.1977	0.0452	0.0290	0.0742	0.0000	335.5404	335.5404	0.0339	0.0215	342.7818
Maximum	0.6523	3.6480	4.9631	0.0134	0.7073	0.1298	0.8371	0.2656	0.1209	0.3865	0.0000	1,226.7787	1,226.7787	0.1108	0.0918	1,256.5237

	ROG	NOx	CO	SO2	Fugitive PM10	Exhaust PM10	PM10 Total	Fugitive PM2.5	Exhaust PM2.5	PM2.5 Total	Bio-CO2	NBio-CO2	Total CO2	CH4	N2O	CO2e
Percent Reduction	0.00	0.00	0.00	0.00	0.00	0.00	0.00	0.00	0.00	0.00	0.00	0.00	0.00	0.00	0.00	0.00

Quarter	Start Date	End Date	Maximum Unmitigated ROG + NOX (tons/quarter)	Maximum Mitigated ROG + NOX (tons/quarter)
1	3-8-2022	6-7-2022	1.1295	1.1295
2	6-8-2022	9-7-2022	1.3022	1.3022

3	9-8-2022	12-7-2022	1.2304	1.2304
4	12-8-2022	3-7-2023	1.1172	1.1172
5	3-8-2023	6-7-2023	1.0809	1.0809
6	6-8-2023	9-7-2023	1.0734	1.0734
7	9-8-2023	12-7-2023	1.0830	1.0830
8	12-8-2023	3-7-2024	1.0458	1.0458
9	3-8-2024	6-7-2024	0.5705	0.5705
10	6-8-2024	9-7-2024	0.1730	0.1730
		Highest	1.3022	1.3022

2.2 Overall Operational

Unmitigated Operational

	ROG	NOx	CO	SO2	Fugitive PM10	Exhaust PM10	PM10 Total	Fugitive PM2.5	Exhaust PM2.5	PM2.5 Total	Bio-CO2	NBio-CO2	Total CO2	CH4	N2O	CO2e
Category	tons/yr										MT/yr					
Area	0.1472	0.0000	2.4000e-004	0.0000		0.0000	0.0000		0.0000	0.0000	0.0000	4.6000e-004	4.6000e-004	0.0000	0.0000	4.9000e-004
Energy	0.0000	0.0000	0.0000	0.0000		0.0000	0.0000		0.0000	0.0000	0.0000	0.0000	0.0000	0.0000	0.0000	0.0000
Mobile	0.0241	0.0296	0.1751	2.6000e-004	0.0236	3.1000e-004	0.0239	6.3200e-003	2.9000e-004	6.6100e-003	0.0000	23.6320	23.6320	2.1900e-003	1.4900e-003	24.1300
Waste						0.0000	0.0000		0.0000	0.0000	0.4547	0.0000	0.4547	0.0269	0.0000	1.1265
Water						0.0000	0.0000		0.0000	0.0000	0.0000	10.0319	10.0319	1.6200e-003	2.0000e-004	10.1311
Total	0.1713	0.0296	0.1753	2.6000e-004	0.0236	3.1000e-004	0.0239	6.3200e-003	2.9000e-004	6.6100e-003	0.4547	33.6643	34.1190	0.0307	1.6900e-003	35.3881

Mitigated Operational

	ROG	NOx	CO	SO2	Fugitive PM10	Exhaust PM10	PM10 Total	Fugitive PM2.5	Exhaust PM2.5	PM2.5 Total	Bio-CO2	NBio-CO2	Total CO2	CH4	N2O	CO2e
Category	tons/yr										MT/yr					
Area	0.1472	0.0000	2.4000e-004	0.0000		0.0000	0.0000		0.0000	0.0000	0.0000	4.6000e-004	4.6000e-004	0.0000	0.0000	4.9000e-004
Energy	0.0000	0.0000	0.0000	0.0000		0.0000	0.0000		0.0000	0.0000	0.0000	0.0000	0.0000	0.0000	0.0000	0.0000
Mobile	0.0241	0.0296	0.1751	2.6000e-004	0.0236	3.1000e-004	0.0239	6.3200e-003	2.9000e-004	6.6100e-003	0.0000	23.6320	23.6320	2.1900e-003	1.4900e-003	24.1300
Waste						0.0000	0.0000		0.0000	0.0000	0.4547	0.0000	0.4547	0.0269	0.0000	1.1265
Water						0.0000	0.0000		0.0000	0.0000	0.0000	10.0319	10.0319	1.6200e-003	2.0000e-004	10.1311
Total	0.1713	0.0296	0.1753	2.6000e-004	0.0236	3.1000e-004	0.0239	6.3200e-003	2.9000e-004	6.6100e-003	0.4547	33.6643	34.1190	0.0307	1.6900e-003	35.3881

	ROG	NOx	CO	SO2	Fugitive PM10	Exhaust PM10	PM10 Total	Fugitive PM2.5	Exhaust PM2.5	PM2.5 Total	Bio-CO2	NBio-CO2	Total CO2	CH4	N2O	CO2e
Percent Reduction	0.00	0.00	0.00	0.00	0.00	0.00	0.00	0.00	0.00	0.00	0.00	0.00	0.00	0.00	0.00	0.00

3.0 Construction Detail

Construction Phase

Phase Number	Phase Name	Phase Type	Start Date	End Date	Num Days Week	Num Days	Phase Description
1	Demolition	Demolition	3/8/2022	4/18/2022	5	30	
2	Site Preparation	Site Preparation	4/19/2022	5/16/2022	5	20	
3	Grading	Grading	5/17/2022	7/18/2022	5	45	
4	Building Construction	Building Construction	7/19/2022	3/25/2024	5	440	
5	Paving	Paving	3/26/2024	5/13/2024	5	35	
6	Architectural Coating	Architectural Coating	5/14/2024	7/1/2024	5	35	

Acres of Grading (Site Preparation Phase): 30

Acres of Grading (Grading Phase): 135

Acres of Paving: 0

Residential Indoor: 0; Residential Outdoor: 0; Non-Residential Indoor: 40,500; Non-Residential Outdoor: 13,500; Striped Parking Area: 0 (Architectural Coating – sqft)

OffRoad Equipment

Phase Name	Offroad Equipment Type	Amount	Usage Hours	Horse Power	Load Factor
Architectural Coating	Air Compressors	1	6.00	78	0.48
Demolition	Concrete/Industrial Saws	1	8.00	81	0.73
Building Construction	Cranes	1	7.00	231	0.29
Demolition	Excavators	3	8.00	158	0.38
Grading	Excavators	2	8.00	158	0.38
Building Construction	Forklifts	3	8.00	89	0.20
Building Construction	Generator Sets	1	8.00	84	0.74
Grading	Graders	1	8.00	187	0.41
Paving	Pavers	2	8.00	130	0.42
Paving	Paving Equipment	2	8.00	132	0.36
Paving	Rollers	2	8.00	80	0.38
Demolition	Rubber Tired Dozers	2	8.00	247	0.40
Grading	Rubber Tired Dozers	1	8.00	247	0.40
Site Preparation	Rubber Tired Dozers	3	8.00	247	0.40
Grading	Scrapers	2	8.00	367	0.48
Building Construction	Tractors/Loaders/Backhoes	3	7.00	97	0.37
Grading	Tractors/Loaders/Backhoes	2	8.00	97	0.37
Site Preparation	Tractors/Loaders/Backhoes	4	8.00	97	0.37
Building Construction	Welders	1	8.00	46	0.45

Trips and VMT

Phase Name	Offroad Equipment Count	Worker Trip Number	Vendor Trip Number	Hauling Trip Number	Worker Trip Length	Vendor Trip Length	Hauling Trip Length	Worker Vehicle Class	Vendor Vehicle Class	Hauling Vehicle Class
Demolition	6	15.00	0.00	10.00	10.80	7.30	20.00	LD_Mix	HDT_Mix	HHDT
Site Preparation	7	18.00	0.00	0.00	10.80	7.30	20.00	LD_Mix	HDT_Mix	HHDT
Grading	8	20.00	0.00	0.00	10.80	7.30	20.00	LD_Mix	HDT_Mix	HHDT
Building Construction	9	476.00	186.00	0.00	10.80	7.30	20.00	LD_Mix	HDT_Mix	HHDT
Paving	6	15.00	0.00	0.00	10.80	7.30	20.00	LD_Mix	HDT_Mix	HHDT

Architectural Continue	1	95.00	0.00	0.00	10.80	7.30	20.00	LD_Mix	HDT_Mix	HHDT
---------------------------	---	-------	------	------	-------	------	-------	--------	---------	------

3.1 Mitigation Measures Construction

3.2 Demolition - 2022

Unmitigated Construction On-Site

	ROG	NOx	CO	SO2	Fugitive PM10	Exhaust PM10	PM10 Total	Fugitive PM2.5	Exhaust PM2.5	PM2.5 Total	Bio-CO2	NBio-CO2	Total CO2	CH4	N2O	CO2e
Category	tons/yr										MT/yr					
Fugitive Dust					1.0700e-003	0.0000	1.0700e-003	1.6000e-004	0.0000	1.6000e-004	0.0000	0.0000	0.0000	0.0000	0.0000	0.0000
Off-Road	0.0396	0.3858	0.3089	5.8000e-004		0.0186	0.0186		0.0173	0.0173	0.0000	50.9853	50.9853	0.0143	0.0000	51.3434
Total	0.0396	0.3858	0.3089	5.8000e-004	1.0700e-003	0.0186	0.0197	1.6000e-004	0.0173	0.0175	0.0000	50.9853	50.9853	0.0143	0.0000	51.3434

Unmitigated Construction Off-Site

	ROG	NOx	CO	SO2	Fugitive PM10	Exhaust PM10	PM10 Total	Fugitive PM2.5	Exhaust PM2.5	PM2.5 Total	Bio-CO2	NBio-CO2	Total CO2	CH4	N2O	CO2e
Category	tons/yr										MT/yr					
Hauling	3.0000e-005	1.2100e-003	1.7000e-004	0.0000	8.0000e-005	1.0000e-005	9.0000e-005	2.0000e-005	1.0000e-005	3.0000e-005	0.0000	0.3244	0.3244	0.0000	5.0000e-005	0.3397
Vendor	0.0000	0.0000	0.0000	0.0000	0.0000	0.0000	0.0000	0.0000	0.0000	0.0000	0.0000	0.0000	0.0000	0.0000	0.0000	0.0000
Worker	1.5600e-003	1.0400e-003	0.0100	2.0000e-005	1.7700e-003	1.0000e-005	1.7900e-003	4.7000e-004	1.0000e-005	4.9000e-004	0.0000	1.5649	1.5649	9.0000e-005	7.0000e-005	1.5881
Total	1.5900e-003	2.2500e-003	0.0102	2.0000e-005	1.8500e-003	2.0000e-005	1.8800e-003	4.9000e-004	2.0000e-005	5.2000e-004	0.0000	1.8893	1.8893	9.0000e-005	1.2000e-004	1.9278

Mitigated Construction On-Site

	ROG	NOx	CO	SO2	Fugitive PM10	Exhaust PM10	PM10 Total	Fugitive PM2.5	Exhaust PM2.5	PM2.5 Total	Bio-CO2	NBio-CO2	Total CO2	CH4	N2O	CO2e
Category	tons/yr										MT/yr					
Fugitive Dust					1.0700e-003	0.0000	1.0700e-003	1.6000e-004	0.0000	1.6000e-004	0.0000	0.0000	0.0000	0.0000	0.0000	0.0000
Off-Road	0.0396	0.3858	0.3089	5.8000e-004		0.0186	0.0186		0.0173	0.0173	0.0000	50.9853	50.9853	0.0143	0.0000	51.3433
Total	0.0396	0.3858	0.3089	5.8000e-004	1.0700e-003	0.0186	0.0197	1.6000e-004	0.0173	0.0175	0.0000	50.9853	50.9853	0.0143	0.0000	51.3433

Mitigated Construction Off-Site

	ROG	NOx	CO	SO2	Fugitive PM10	Exhaust PM10	PM10 Total	Fugitive PM2.5	Exhaust PM2.5	PM2.5 Total	Bio-CO2	NBio-CO2	Total CO2	CH4	N2O	CO2e
Category	tons/yr										MT/yr					
Hauling	3.0000e-005	1.2100e-003	1.7000e-004	0.0000	8.0000e-005	1.0000e-005	9.0000e-005	2.0000e-005	1.0000e-005	3.0000e-005	0.0000	0.3244	0.3244	0.0000	5.0000e-005	0.3397
Vendor	0.0000	0.0000	0.0000	0.0000	0.0000	0.0000	0.0000	0.0000	0.0000	0.0000	0.0000	0.0000	0.0000	0.0000	0.0000	0.0000
Worker	1.5600e-003	1.0400e-003	0.0100	2.0000e-005	1.7700e-003	1.0000e-005	1.7900e-003	4.7000e-004	1.0000e-005	4.9000e-004	0.0000	1.5649	1.5649	9.0000e-005	7.0000e-005	1.5881
Total	1.5900e-003	2.2500e-003	0.0102	2.0000e-005	1.8500e-003	2.0000e-005	1.8800e-003	4.9000e-004	2.0000e-005	5.2000e-004	0.0000	1.8893	1.8893	9.0000e-005	1.2000e-004	1.9278

3.3 Site Preparation - 2022

Unmitigated Construction On-Site

	ROG	NOx	CO	SO2	Fugitive PM10	Exhaust PM10	PM10 Total	Fugitive PM2.5	Exhaust PM2.5	PM2.5 Total	Bio-CO2	NBio-CO2	Total CO2	CH4	N2O	CO2e
Category	tons/yr										MT/yr					
Fugitive Dust					0.1966	0.0000	0.1966	0.1010	0.0000	0.1010	0.0000	0.0000	0.0000	0.0000	0.0000	0.0000
Off-Road	0.0317	0.3308	0.1970	3.8000e-004		0.0161	0.0161		0.0148	0.0148	0.0000	33.4394	33.4394	0.0108	0.0000	33.7098
Total	0.0317	0.3308	0.1970	3.8000e-004	0.1966	0.0161	0.2127	0.1010	0.0148	0.1159	0.0000	33.4394	33.4394	0.0108	0.0000	33.7098

Unmitigated Construction Off-Site

	ROG	NOx	CO	SO2	Fugitive PM10	Exhaust PM10	PM10 Total	Fugitive PM2.5	Exhaust PM2.5	PM2.5 Total	Bio-CO2	NBio-CO2	Total CO2	CH4	N2O	CO2e
Category	tons/yr										MT/yr					
Hauling	0.0000	0.0000	0.0000	0.0000	0.0000	0.0000	0.0000	0.0000	0.0000	0.0000	0.0000	0.0000	0.0000	0.0000	0.0000	0.0000
Vendor	0.0000	0.0000	0.0000	0.0000	0.0000	0.0000	0.0000	0.0000	0.0000	0.0000	0.0000	0.0000	0.0000	0.0000	0.0000	0.0000
Worker	1.2500e-003	8.3000e-004	8.0000e-003	1.0000e-005	1.4200e-003	1.0000e-005	1.4300e-003	3.8000e-004	1.0000e-005	3.9000e-004	0.0000	1.2519	1.2519	7.0000e-005	6.0000e-005	1.2705
Total	1.2500e-003	8.3000e-004	8.0000e-003	1.0000e-005	1.4200e-003	1.0000e-005	1.4300e-003	3.8000e-004	1.0000e-005	3.9000e-004	0.0000	1.2519	1.2519	7.0000e-005	6.0000e-005	1.2705

Mitigated Construction On-Site

	ROG	NOx	CO	SO2	Fugitive PM10	Exhaust PM10	PM10 Total	Fugitive PM2.5	Exhaust PM2.5	PM2.5 Total	Bio-CO2	NBio-CO2	Total CO2	CH4	N2O	CO2e
Category	tons/yr										MT/yr					
Fugitive Dust					0.1966	0.0000	0.1966	0.1010	0.0000	0.1010	0.0000	0.0000	0.0000	0.0000	0.0000	0.0000
Off-Road	0.0317	0.3308	0.1970	3.8000e-004		0.0161	0.0161		0.0148	0.0148	0.0000	33.4394	33.4394	0.0108	0.0000	33.7097
Total	0.0317	0.3308	0.1970	3.8000e-004	0.1966	0.0161	0.2127	0.1010	0.0148	0.1159	0.0000	33.4394	33.4394	0.0108	0.0000	33.7097

Mitigated Construction Off-Site

	ROG	NOx	CO	SO2	Fugitive PM10	Exhaust PM10	PM10 Total	Fugitive PM2.5	Exhaust PM2.5	PM2.5 Total	Bio-CO2	NBio-CO2	Total CO2	CH4	N2O	CO2e
Category	tons/yr										MT/yr					
Hauling	0.0000	0.0000	0.0000	0.0000	0.0000	0.0000	0.0000	0.0000	0.0000	0.0000	0.0000	0.0000	0.0000	0.0000	0.0000	0.0000
Vendor	0.0000	0.0000	0.0000	0.0000	0.0000	0.0000	0.0000	0.0000	0.0000	0.0000	0.0000	0.0000	0.0000	0.0000	0.0000	0.0000
Worker	1.2500e-003	8.3000e-004	8.0000e-003	1.0000e-005	1.4200e-003	1.0000e-005	1.4300e-003	3.8000e-004	1.0000e-005	3.9000e-004	0.0000	1.2519	1.2519	7.0000e-005	6.0000e-005	1.2705
Total	1.2500e-003	8.3000e-004	8.0000e-003	1.0000e-005	1.4200e-003	1.0000e-005	1.4300e-003	3.8000e-004	1.0000e-005	3.9000e-004	0.0000	1.2519	1.2519	7.0000e-005	6.0000e-005	1.2705

3.4 Grading - 2022

Unmitigated Construction On-Site

	ROG	NOx	CO	SO2	Fugitive PM10	Exhaust PM10	PM10 Total	Fugitive PM2.5	Exhaust PM2.5	PM2.5 Total	Bio-CO2	NBio-CO2	Total CO2	CH4	N2O	CO2e
Category	tons/yr										MT/yr					
Fugitive Dust					0.2071	0.0000	0.2071	0.0822	0.0000	0.0822	0.0000	0.0000	0.0000	0.0000	0.0000	0.0000
Off-Road	0.0816	0.8740	0.6534	1.4000e-003		0.0368	0.0368		0.0338	0.0338	0.0000	122.7029	122.7029	0.0397	0.0000	123.6950
Total	0.0816	0.8740	0.6534	1.4000e-003	0.2071	0.0368	0.2439	0.0822	0.0338	0.1161	0.0000	122.7029	122.7029	0.0397	0.0000	123.6950

Unmitigated Construction Off-Site

	ROG	NOx	CO	SO2	Fugitive PM10	Exhaust PM10	PM10 Total	Fugitive PM2.5	Exhaust PM2.5	PM2.5 Total	Bio-CO2	NBio-CO2	Total CO2	CH4	N2O	CO2e
Category	tons/yr										MT/yr					
Hauling	0.0000	0.0000	0.0000	0.0000	0.0000	0.0000	0.0000	0.0000	0.0000	0.0000	0.0000	0.0000	0.0000	0.0000	0.0000	0.0000
Vendor	0.0000	0.0000	0.0000	0.0000	0.0000	0.0000	0.0000	0.0000	0.0000	0.0000	0.0000	0.0000	0.0000	0.0000	0.0000	0.0000
Worker	3.1200e-003	2.0900e-003	0.0200	3.0000e-005	3.5500e-003	3.0000e-005	3.5800e-003	9.4000e-004	3.0000e-005	9.7000e-004	0.0000	3.1297	3.1297	1.7000e-004	1.4000e-004	3.1763
Total	3.1200e-003	2.0900e-003	0.0200	3.0000e-005	3.5500e-003	3.0000e-005	3.5800e-003	9.4000e-004	3.0000e-005	9.7000e-004	0.0000	3.1297	3.1297	1.7000e-004	1.4000e-004	3.1763

Mitigated Construction On-Site

	ROG	NOx	CO	SO2	Fugitive PM10	Exhaust PM10	PM10 Total	Fugitive PM2.5	Exhaust PM2.5	PM2.5 Total	Bio-CO2	NBio-CO2	Total CO2	CH4	N2O	CO2e
Category	tons/yr										MT/yr					
Fugitive Dust					0.2071	0.0000	0.2071	0.0822	0.0000	0.0822	0.0000	0.0000	0.0000	0.0000	0.0000	0.0000
Off-Road	0.0816	0.8740	0.6534	1.4000e-003		0.0368	0.0368		0.0338	0.0338	0.0000	122.7027	122.7027	0.0397	0.0000	123.6948
Total	0.0816	0.8740	0.6534	1.4000e-003	0.2071	0.0368	0.2439	0.0822	0.0338	0.1161	0.0000	122.7027	122.7027	0.0397	0.0000	123.6948

Mitigated Construction Off-Site

	ROG	NOx	CO	SO2	Fugitive PM10	Exhaust PM10	PM10 Total	Fugitive PM2.5	Exhaust PM2.5	PM2.5 Total	Bio-CO2	NBio-CO2	Total CO2	CH4	N2O	CO2e
Category	tons/yr										MT/yr					
Hauling	0.0000	0.0000	0.0000	0.0000	0.0000	0.0000	0.0000	0.0000	0.0000	0.0000	0.0000	0.0000	0.0000	0.0000	0.0000	0.0000
Vendor	0.0000	0.0000	0.0000	0.0000	0.0000	0.0000	0.0000	0.0000	0.0000	0.0000	0.0000	0.0000	0.0000	0.0000	0.0000	0.0000
Worker	3.1200e-003	2.0900e-003	0.0200	3.0000e-005	3.5500e-003	3.0000e-005	3.5800e-003	9.4000e-004	3.0000e-005	9.7000e-004	0.0000	3.1297	3.1297	1.7000e-004	1.4000e-004	3.1763
Total	3.1200e-003	2.0900e-003	0.0200	3.0000e-005	3.5500e-003	3.0000e-005	3.5800e-003	9.4000e-004	3.0000e-005	9.7000e-004	0.0000	3.1297	3.1297	1.7000e-004	1.4000e-004	3.1763

3.5 Building Construction - 2022

Unmitigated Construction On-Site

	ROG	NOx	CO	SO2	Fugitive PM10	Exhaust PM10	PM10 Total	Fugitive PM2.5	Exhaust PM2.5	PM2.5 Total	Bio-CO2	NBio-CO2	Total CO2	CH4	N2O	CO2e
Category	tons/yr										MT/yr					
Off-Road	0.1015	0.9291	0.9736	1.6000e-003		0.0481	0.0481		0.0453	0.0453	0.0000	137.8765	137.8765	0.0330	0.0000	138.7023
Total	0.1015	0.9291	0.9736	1.6000e-003		0.0481	0.0481		0.0453	0.0453	0.0000	137.8765	137.8765	0.0330	0.0000	138.7023

Unmitigated Construction Off-Site

	ROG	NOx	CO	SO2	Fugitive PM10	Exhaust PM10	PM10 Total	Fugitive PM2.5	Exhaust PM2.5	PM2.5 Total	Bio-CO2	NBio-CO2	Total CO2	CH4	N2O	CO2e
Category	tons/yr										MT/yr					
Hauling	0.0000	0.0000	0.0000	0.0000	0.0000	0.0000	0.0000	0.0000	0.0000	0.0000	0.0000	0.0000	0.0000	0.0000	0.0000	0.0000
Vendor	0.0384	0.8453	0.2138	2.5100e-003	0.0724	8.2700e-003	0.0807	0.0209	7.9100e-003	0.0288	0.0000	239.7212	239.7212	1.6400e-003	0.0351	250.2228
Worker	0.1962	0.1313	1.2594	2.1500e-003	0.2234	1.8000e-003	0.2252	0.0594	1.6600e-003	0.0611	0.0000	196.9785	196.9785	0.0109	8.9100e-003	199.9085
Total	0.2346	0.9765	1.4732	4.6600e-003	0.2958	0.0101	0.3058	0.0804	9.5700e-003	0.0899	0.0000	436.6997	436.6997	0.0126	0.0440	450.1313

Mitigated Construction On-Site

	ROG	NOx	CO	SO2	Fugitive PM10	Exhaust PM10	PM10 Total	Fugitive PM2.5	Exhaust PM2.5	PM2.5 Total	Bio-CO2	NBio-CO2	Total CO2	CH4	N2O	CO2e
Category	tons/yr										MT/yr					
Off-Road	0.1015	0.9291	0.9736	1.6000e-003		0.0481	0.0481		0.0453	0.0453	0.0000	137.8764	137.8764	0.0330	0.0000	138.7021
Total	0.1015	0.9291	0.9736	1.6000e-003		0.0481	0.0481		0.0453	0.0453	0.0000	137.8764	137.8764	0.0330	0.0000	138.7021

Mitigated Construction Off-Site

	ROG	NOx	CO	SO2	Fugitive PM10	Exhaust PM10	PM10 Total	Fugitive PM2.5	Exhaust PM2.5	PM2.5 Total	Bio-CO2	NBio-CO2	Total CO2	CH4	N2O	CO2e
Category	tons/yr										MT/yr					
Hauling	0.0000	0.0000	0.0000	0.0000	0.0000	0.0000	0.0000	0.0000	0.0000	0.0000	0.0000	0.0000	0.0000	0.0000	0.0000	0.0000
Vendor	0.0384	0.8453	0.2138	2.5100e-003	0.0724	8.2700e-003	0.0807	0.0209	7.9100e-003	0.0288	0.0000	239.7212	239.7212	1.6400e-003	0.0351	250.2228
Worker	0.1962	0.1313	1.2594	2.1500e-003	0.2234	1.8000e-003	0.2252	0.0594	1.6600e-003	0.0611	0.0000	196.9785	196.9785	0.0109	8.9100e-003	199.9085
Total	0.2346	0.9765	1.4732	4.6600e-003	0.2958	0.0101	0.3058	0.0804	9.5700e-003	0.0899	0.0000	436.6997	436.6997	0.0126	0.0440	450.1313

3.5 Building Construction - 2023

Unmitigated Construction On-Site

	ROG	NOx	CO	SO2	Fugitive PM10	Exhaust PM10	PM10 Total	Fugitive PM2.5	Exhaust PM2.5	PM2.5 Total	Bio-CO2	NBio-CO2	Total CO2	CH4	N2O	CO2e
Category	tons/yr										MT/yr					
Off-Road	0.2045	1.8700	2.1117	3.5000e-003		0.0910	0.0910		0.0856	0.0856	0.0000	301.3462	301.3462	0.0717	0.0000	303.1383
Total	0.2045	1.8700	2.1117	3.5000e-003		0.0910	0.0910		0.0856	0.0856	0.0000	301.3462	301.3462	0.0717	0.0000	303.1383

Unmitigated Construction Off-Site

	ROG	NOx	CO	SO2	Fugitive PM10	Exhaust PM10	PM10 Total	Fugitive PM2.5	Exhaust PM2.5	PM2.5 Total	Bio-CO2	NBio-CO2	Total CO2	CH4	N2O	CO2e
Category	tons/yr										MT/yr					
Hauling	0.0000	0.0000	0.0000	0.0000	0.0000	0.0000	0.0000	0.0000	0.0000	0.0000	0.0000	0.0000	0.0000	0.0000	0.0000	0.0000
Vendor	0.0491	1.5260	0.3838	5.3100e-003	0.1581	8.9600e-003	0.1671	0.0457	8.5700e-003	0.0543	0.0000	507.8532	507.8532	2.1100e-003	0.0741	529.9898
Worker	0.3988	0.2520	2.4675	4.5500e-003	0.4881	3.6300e-003	0.4917	0.1299	3.3400e-003	0.1332	0.0000	417.5797	417.5797	0.0214	0.0177	423.3959
Total	0.4478	1.7780	2.8513	9.8600e-003	0.6462	0.0126	0.6588	0.1756	0.0119	0.1875	0.0000	925.4329	925.4329	0.0235	0.0918	953.3858

Mitigated Construction On-Site

	ROG	NOx	CO	SO2	Fugitive PM10	Exhaust PM10	PM10 Total	Fugitive PM2.5	Exhaust PM2.5	PM2.5 Total	Bio-CO2	NBio-CO2	Total CO2	CH4	N2O	CO2e
Category	tons/yr										MT/yr					
Off-Road	0.2045	1.8700	2.1117	3.5000e-003		0.0910	0.0910		0.0856	0.0856	0.0000	301.3458	301.3458	0.0717	0.0000	303.1380
Total	0.2045	1.8700	2.1117	3.5000e-003		0.0910	0.0910		0.0856	0.0856	0.0000	301.3458	301.3458	0.0717	0.0000	303.1380

Mitigated Construction Off-Site

	ROG	NOx	CO	SO2	Fugitive PM10	Exhaust PM10	PM10 Total	Fugitive PM2.5	Exhaust PM2.5	PM2.5 Total	Bio-CO2	NBio-CO2	Total CO2	CH4	N2O	CO2e
Category	tons/yr										MT/yr					
Hauling	0.0000	0.0000	0.0000	0.0000	0.0000	0.0000	0.0000	0.0000	0.0000	0.0000	0.0000	0.0000	0.0000	0.0000	0.0000	0.0000
Vendor	0.0491	1.5260	0.3838	5.3100e-003	0.1581	8.9600e-003	0.1671	0.0457	8.5700e-003	0.0543	0.0000	507.8532	507.8532	2.1100e-003	0.0741	529.9898
Worker	0.3988	0.2520	2.4675	4.5500e-003	0.4881	3.6300e-003	0.4917	0.1299	3.3400e-003	0.1332	0.0000	417.5797	417.5797	0.0214	0.0177	423.3959
Total	0.4478	1.7780	2.8513	9.8600e-003	0.6462	0.0126	0.6588	0.1756	0.0119	0.1875	0.0000	925.4329	925.4329	0.0235	0.0918	953.3858

3.5 Building Construction - 2024

Unmitigated Construction On-Site

	ROG	NOx	CO	SO2	Fugitive PM10	Exhaust PM10	PM10 Total	Fugitive PM2.5	Exhaust PM2.5	PM2.5 Total	Bio-CO2	NBio-CO2	Total CO2	CH4	N2O	CO2e
Category	tons/yr										MT/yr					
Off-Road	0.0449	0.4100	0.4931	8.2000e-004		0.0187	0.0187		0.0176	0.0176	0.0000	70.7140	70.7140	0.0167	0.0000	71.1320
Total	0.0449	0.4100	0.4931	8.2000e-004		0.0187	0.0187		0.0176	0.0176	0.0000	70.7140	70.7140	0.0167	0.0000	71.1320

Unmitigated Construction Off-Site

	ROG	NOx	CO	SO2	Fugitive PM10	Exhaust PM10	PM10 Total	Fugitive PM2.5	Exhaust PM2.5	PM2.5 Total	Bio-CO2	NBio-CO2	Total CO2	CH4	N2O	CO2e
Category	tons/yr										MT/yr					
Hauling	0.0000	0.0000	0.0000	0.0000	0.0000	0.0000	0.0000	0.0000	0.0000	0.0000	0.0000	0.0000	0.0000	0.0000	0.0000	0.0000
Vendor	0.0106	0.3488	0.0851	1.2300e-003	0.0371	2.0200e-003	0.0391	0.0107	1.9300e-003	0.0127	0.0000	117.7819	117.7819	4.5000e-004	0.0172	122.9083
Worker	0.0870	0.0520	0.5221	1.0400e-003	0.1145	7.8000e-004	0.1153	0.0305	7.2000e-004	0.0312	0.0000	94.9414	94.9414	4.5100e-003	3.7900e-003	96.1838
Total	0.0976	0.4008	0.6071	2.2700e-003	0.1516	2.8000e-003	0.1544	0.0412	2.6500e-003	0.0439	0.0000	212.7233	212.7233	4.9600e-003	0.0210	219.0922

Mitigated Construction On-Site

	ROG	NOx	CO	SO2	Fugitive PM10	Exhaust PM10	PM10 Total	Fugitive PM2.5	Exhaust PM2.5	PM2.5 Total	Bio-CO2	NBio-CO2	Total CO2	CH4	N2O	CO2e
Category	tons/yr										MT/yr					
Off-Road	0.0449	0.4100	0.4931	8.2000e-004		0.0187	0.0187		0.0176	0.0176	0.0000	70.7139	70.7139	0.0167	0.0000	71.1319
Total	0.0449	0.4100	0.4931	8.2000e-004		0.0187	0.0187		0.0176	0.0176	0.0000	70.7139	70.7139	0.0167	0.0000	71.1319

Mitigated Construction Off-Site

	ROG	NOx	CO	SO2	Fugitive PM10	Exhaust PM10	PM10 Total	Fugitive PM2.5	Exhaust PM2.5	PM2.5 Total	Bio-CO2	NBio-CO2	Total CO2	CH4	N2O	CO2e
Category	tons/yr										MT/yr					
Hauling	0.0000	0.0000	0.0000	0.0000	0.0000	0.0000	0.0000	0.0000	0.0000	0.0000	0.0000	0.0000	0.0000	0.0000	0.0000	0.0000
Vendor	0.0106	0.3488	0.0851	1.2300e-003	0.0371	2.0200e-003	0.0391	0.0107	1.9300e-003	0.0127	0.0000	117.7819	117.7819	4.5000e-004	0.0172	122.9083
Worker	0.0870	0.0520	0.5221	1.0400e-003	0.1145	7.8000e-004	0.1153	0.0305	7.2000e-004	0.0312	0.0000	94.9414	94.9414	4.5100e-003	3.7900e-003	96.1838
Total	0.0976	0.4008	0.6071	2.2700e-003	0.1516	2.8000e-003	0.1544	0.0412	2.6500e-003	0.0439	0.0000	212.7233	212.7233	4.9600e-003	0.0210	219.0922

3.6 Paving - 2024

Unmitigated Construction On-Site

	ROG	NOx	CO	SO2	Fugitive PM10	Exhaust PM10	PM10 Total	Fugitive PM2.5	Exhaust PM2.5	PM2.5 Total	Bio-CO2	NBio-CO2	Total CO2	CH4	N2O	CO2e
Category	tons/yr										MT/yr					
Off-Road	0.0173	0.1667	0.2560	4.0000e-004		8.2000e-003	8.2000e-003		7.5400e-003	7.5400e-003	0.0000	35.0464	35.0464	0.0113	0.0000	35.3298
Paving	0.0000					0.0000	0.0000		0.0000	0.0000	0.0000	0.0000	0.0000	0.0000	0.0000	0.0000
Total	0.0173	0.1667	0.2560	4.0000e-004		8.2000e-003	8.2000e-003		7.5400e-003	7.5400e-003	0.0000	35.0464	35.0464	0.0113	0.0000	35.3298

Unmitigated Construction Off-Site

	ROG	NOx	CO	SO2	Fugitive PM10	Exhaust PM10	PM10 Total	Fugitive PM2.5	Exhaust PM2.5	PM2.5 Total	Bio-CO2	NBio-CO2	Total CO2	CH4	N2O	CO2e
Category	tons/yr										MT/yr					
Hauling	0.0000	0.0000	0.0000	0.0000	0.0000	0.0000	0.0000	0.0000	0.0000	0.0000	0.0000	0.0000	0.0000	0.0000	0.0000	0.0000
Vendor	0.0000	0.0000	0.0000	0.0000	0.0000	0.0000	0.0000	0.0000	0.0000	0.0000	0.0000	0.0000	0.0000	0.0000	0.0000	0.0000
Worker	1.5700e-003	9.4000e-004	9.4400e-003	2.0000e-005	2.0700e-003	1.0000e-005	2.0800e-003	5.5000e-004	1.0000e-005	5.6000e-004	0.0000	1.7166	1.7166	8.0000e-005	7.0000e-005	1.7391
Total	1.5700e-003	9.4000e-004	9.4400e-003	2.0000e-005	2.0700e-003	1.0000e-005	2.0800e-003	5.5000e-004	1.0000e-005	5.6000e-004	0.0000	1.7166	1.7166	8.0000e-005	7.0000e-005	1.7391

Mitigated Construction On-Site

	ROG	NOx	CO	SO2	Fugitive PM10	Exhaust PM10	PM10 Total	Fugitive PM2.5	Exhaust PM2.5	PM2.5 Total	Bio-CO2	NBio-CO2	Total CO2	CH4	N2O	CO2e
Category	tons/yr										MT/yr					
Off-Road	0.0173	0.1667	0.2560	4.0000e-004		8.2000e-003	8.2000e-003		7.5400e-003	7.5400e-003	0.0000	35.0464	35.0464	0.0113	0.0000	35.3298
Paving	0.0000					0.0000	0.0000		0.0000	0.0000	0.0000	0.0000	0.0000	0.0000	0.0000	0.0000
Total	0.0173	0.1667	0.2560	4.0000e-004		8.2000e-003	8.2000e-003		7.5400e-003	7.5400e-003	0.0000	35.0464	35.0464	0.0113	0.0000	35.3298

Mitigated Construction Off-Site

	ROG	NOx	CO	SO2	Fugitive PM10	Exhaust PM10	PM10 Total	Fugitive PM2.5	Exhaust PM2.5	PM2.5 Total	Bio-CO2	NBio-CO2	Total CO2	CH4	N2O	CO2e
Category	tons/yr										MT/yr					
Hauling	0.0000	0.0000	0.0000	0.0000	0.0000	0.0000	0.0000	0.0000	0.0000	0.0000	0.0000	0.0000	0.0000	0.0000	0.0000	0.0000
Vendor	0.0000	0.0000	0.0000	0.0000	0.0000	0.0000	0.0000	0.0000	0.0000	0.0000	0.0000	0.0000	0.0000	0.0000	0.0000	0.0000
Worker	1.5700e-003	9.4000e-004	9.4400e-003	2.0000e-005	2.0700e-003	1.0000e-005	2.0800e-003	5.5000e-004	1.0000e-005	5.6000e-004	0.0000	1.7166	1.7166	8.0000e-005	7.0000e-005	1.7391
Total	1.5700e-003	9.4000e-004	9.4400e-003	2.0000e-005	2.0700e-003	1.0000e-005	2.0800e-003	5.5000e-004	1.0000e-005	5.6000e-004	0.0000	1.7166	1.7166	8.0000e-005	7.0000e-005	1.7391

3.7 Architectural Coating - 2024

Unmitigated Construction On-Site

	ROG	NOx	CO	SO2	Fugitive PM10	Exhaust PM10	PM10 Total	Fugitive PM2.5	Exhaust PM2.5	PM2.5 Total	Bio-CO2	NBio-CO2	Total CO2	CH4	N2O	CO2e
Category	tons/yr										MT/yr					
Archit. Coating	0.3129					0.0000	0.0000		0.0000	0.0000	0.0000	0.0000	0.0000	0.0000	0.0000	0.0000
Off-Road	3.1600e-003	0.0213	0.0317	5.0000e-005		1.0700e-003	1.0700e-003		1.0700e-003	1.0700e-003	0.0000	4.4682	4.4682	2.5000e-004	0.0000	4.4745
Total	0.3160	0.0213	0.0317	5.0000e-005		1.0700e-003	1.0700e-003		1.0700e-003	1.0700e-003	0.0000	4.4682	4.4682	2.5000e-004	0.0000	4.4745

Unmitigated Construction Off-Site

	ROG	NOx	CO	SO2	Fugitive PM10	Exhaust PM10	PM10 Total	Fugitive PM2.5	Exhaust PM2.5	PM2.5 Total	Bio-CO2	NBio-CO2	Total CO2	CH4	N2O	CO2e
Category	tons/yr										MT/yr					
Hauling	0.0000	0.0000	0.0000	0.0000	0.0000	0.0000	0.0000	0.0000	0.0000	0.0000	0.0000	0.0000	0.0000	0.0000	0.0000	0.0000
Vendor	0.0000	0.0000	0.0000	0.0000	0.0000	0.0000	0.0000	0.0000	0.0000	0.0000	0.0000	0.0000	0.0000	0.0000	0.0000	0.0000
Worker	9.9600e-003	5.9500e-003	0.0598	1.2000e-004	0.0131	9.0000e-005	0.0132	3.4900e-003	8.0000e-005	3.5700e-003	0.0000	10.8720	10.8720	5.2000e-004	4.3000e-004	11.0143
Total	9.9600e-003	5.9500e-003	0.0598	1.2000e-004	0.0131	9.0000e-005	0.0132	3.4900e-003	8.0000e-005	3.5700e-003	0.0000	10.8720	10.8720	5.2000e-004	4.3000e-004	11.0143

Mitigated Construction On-Site

	ROG	NOx	CO	SO2	Fugitive PM10	Exhaust PM10	PM10 Total	Fugitive PM2.5	Exhaust PM2.5	PM2.5 Total	Bio-CO2	NBio-CO2	Total CO2	CH4	N2O	CO2e
Category	tons/yr										MT/yr					
Archit. Coating	0.3129					0.0000	0.0000		0.0000	0.0000	0.0000	0.0000	0.0000	0.0000	0.0000	0.0000
Off-Road	3.1600e-003	0.0213	0.0317	5.0000e-005		1.0700e-003	1.0700e-003		1.0700e-003	1.0700e-003	0.0000	4.4682	4.4682	2.5000e-004	0.0000	4.4745
Total	0.3160	0.0213	0.0317	5.0000e-005		1.0700e-003	1.0700e-003		1.0700e-003	1.0700e-003	0.0000	4.4682	4.4682	2.5000e-004	0.0000	4.4745

Mitigated Construction Off-Site

	ROG	NOx	CO	SO2	Fugitive PM10	Exhaust PM10	PM10 Total	Fugitive PM2.5	Exhaust PM2.5	PM2.5 Total	Bio-CO2	NBio-CO2	Total CO2	CH4	N2O	CO2e
Category	tons/yr										MT/yr					
Hauling	0.0000	0.0000	0.0000	0.0000	0.0000	0.0000	0.0000	0.0000	0.0000	0.0000	0.0000	0.0000	0.0000	0.0000	0.0000	0.0000
Vendor	0.0000	0.0000	0.0000	0.0000	0.0000	0.0000	0.0000	0.0000	0.0000	0.0000	0.0000	0.0000	0.0000	0.0000	0.0000	0.0000
Worker	9.9600e-003	5.9500e-003	0.0598	1.2000e-004	0.0131	9.0000e-005	0.0132	3.4900e-003	8.0000e-005	3.5700e-003	0.0000	10.8720	10.8720	5.2000e-004	4.3000e-004	11.0143
Total	9.9600e-003	5.9500e-003	0.0598	1.2000e-004	0.0131	9.0000e-005	0.0132	3.4900e-003	8.0000e-005	3.5700e-003	0.0000	10.8720	10.8720	5.2000e-004	4.3000e-004	11.0143

4.0 Operational Detail - Mobile

4.1 Mitigation Measures Mobile

	ROG	NOx	CO	SO2	Fugitive PM10	Exhaust PM10	PM10 Total	Fugitive PM2.5	Exhaust PM2.5	PM2.5 Total	Bio-CO2	NBio-CO2	Total CO2	CH4	N2O	CO2e
Category	tons/yr										MT/yr					
Mitigated	0.0241	0.0296	0.1751	2.6000e-004	0.0236	3.1000e-004	0.0239	6.3200e-003	2.9000e-004	6.6100e-003	0.0000	23.6320	23.6320	2.1900e-003	1.4900e-003	24.1300
Unmitigated	0.0241	0.0296	0.1751	2.6000e-004	0.0236	3.1000e-004	0.0239	6.3200e-003	2.9000e-004	6.6100e-003	0.0000	23.6320	23.6320	2.1900e-003	1.4900e-003	24.1300

4.2 Trip Summary Information

Land Use	Average Daily Trip Rate			Unmitigated	Mitigated
	Weekday	Saturday	Sunday	Annual VMT	Annual VMT
City Park	20.28	50.96	56.94	63,832	63,832
Total	20.28	50.96	56.94	63,832	63,832

4.3 Trip Type Information

Land Use	Miles			Trip %			Trip Purpose %		
	H-W or C-W	H-S or C-C	H-O or C-NW	H-W or C-W	H-S or C-C	H-O or C-NW	Primary	Diverted	Pass-by
City Park	9.50	7.30	7.30	33.00	48.00	19.00	66	28	6

4.4 Fleet Mix

Land Use	LDA	LDT1	LDT2	MDV	LHD1	LHD2	MHD	HHD	OBUS	UBUS	MCY	SBUS	MH
City Park	0.464659	0.064863	0.191817	0.155973	0.051760	0.009603	0.008536	0.006240	0.000416	0.000000	0.037661	0.001217	0.007255

5.0 Energy Detail

Historical Energy Use: N

5.1 Mitigation Measures Energy

	ROG	NOx	CO	SO2	Fugitive PM10	Exhaust PM10	PM10 Total	Fugitive PM2.5	Exhaust PM2.5	PM2.5 Total	Bio-CO2	NBio-CO2	Total CO2	CH4	N2O	CO2e
Category	tons/yr										MT/yr					
Electricity Mitigated						0.0000	0.0000		0.0000	0.0000	0.0000	0.0000	0.0000	0.0000	0.0000	0.0000
Electricity Unmitigated						0.0000	0.0000		0.0000	0.0000	0.0000	0.0000	0.0000	0.0000	0.0000	0.0000
NaturalGas Mitigated	0.0000	0.0000	0.0000	0.0000		0.0000	0.0000		0.0000	0.0000	0.0000	0.0000	0.0000	0.0000	0.0000	0.0000
NaturalGas Unmitigated	0.0000	0.0000	0.0000	0.0000		0.0000	0.0000		0.0000	0.0000	0.0000	0.0000	0.0000	0.0000	0.0000	0.0000

5.2 Energy by Land Use - NaturalGas

Unmitigated

	NaturalGas Use	ROG	NOx	CO	SO2	Fugitive PM10	Exhaust PM10	PM10 Total	Fugitive PM2.5	Exhaust PM2.5	PM2.5 Total	Bio-CO2	NBio-CO2	Total CO2	CH4	N2O	CO2e
Land Use	kBTU/yr	tons/yr										MT/yr					
City Park	0	0.0000	0.0000	0.0000	0.0000		0.0000	0.0000		0.0000	0.0000	0.0000	0.0000	0.0000	0.0000	0.0000	0.0000
Total		0.0000	0.0000	0.0000	0.0000		0.0000	0.0000		0.0000	0.0000	0.0000	0.0000	0.0000	0.0000	0.0000	0.0000

Mitigated

	Natural Gas Use	ROG	NOx	CO	SO2	Fugitive PM10	Exhaust PM10	PM10 Total	Fugitive PM2.5	Exhaust PM2.5	PM2.5 Total	Bio-CO2	NBio-CO2	Total CO2	CH4	N2O	CO2e
Land Use	kBTU/yr	tons/yr										MT/yr					
City Park	0	0.0000	0.0000	0.0000	0.0000		0.0000	0.0000		0.0000	0.0000	0.0000	0.0000	0.0000	0.0000	0.0000	0.0000
Total		0.0000	0.0000	0.0000	0.0000		0.0000	0.0000		0.0000	0.0000	0.0000	0.0000	0.0000	0.0000	0.0000	0.0000

5.3 Energy by Land Use - Electricity

Unmitigated

	Electricity Use		Total CO2	CH4	N2O	CO2e
Land Use	kWh/yr	tons/yr	MT/yr			
City Park	0		0.0000	0.0000	0.0000	0.0000
Total			0.0000	0.0000	0.0000	0.0000

Mitigated

	Electricity Use		Total CO2	CH4	N2O	CO2e
Land Use	kWh/yr	tons/yr	MT/yr			
City Park	0		0.0000	0.0000	0.0000	0.0000
Total			0.0000	0.0000	0.0000	0.0000

6.0 Area Detail

6.1 Mitigation Measures Area

	ROG	NOx	CO	SO2	Fugitive PM10	Exhaust PM10	PM10 Total	Fugitive PM2.5	Exhaust PM2.5	PM2.5 Total	Bio-CO2	NBio-CO2	Total CO2	CH4	N2O	CO2e
Category	tons/yr										MT/yr					
Mitigated	0.1472	0.0000	2.4000e-004	0.0000		0.0000	0.0000		0.0000	0.0000	0.0000	4.6000e-004	4.6000e-004	0.0000	0.0000	4.9000e-004
Unmitigated	0.1472	0.0000	2.4000e-004	0.0000		0.0000	0.0000		0.0000	0.0000	0.0000	4.6000e-004	4.6000e-004	0.0000	0.0000	4.9000e-004

6.2 Area by SubCategory

Unmitigated

	ROG	NOx	CO	SO2	Fugitive PM10	Exhaust PM10	PM10 Total	Fugitive PM2.5	Exhaust PM2.5	PM2.5 Total	Bio-CO2	NBio-CO2	Total CO2	CH4	N2O	CO2e
SubCategory	tons/yr										MT/yr					
Architectural Coating	0.0313					0.0000	0.0000		0.0000	0.0000	0.0000	0.0000	0.0000	0.0000	0.0000	0.0000
Consumer Products	0.1158					0.0000	0.0000		0.0000	0.0000	0.0000	0.0000	0.0000	0.0000	0.0000	0.0000
Landscaping	2.0000e-005	0.0000	2.4000e-004	0.0000		0.0000	0.0000		0.0000	0.0000	0.0000	4.6000e-004	4.6000e-004	0.0000	0.0000	4.9000e-004
Total	0.1472	0.0000	2.4000e-004	0.0000		0.0000	0.0000		0.0000	0.0000	0.0000	4.6000e-004	4.6000e-004	0.0000	0.0000	4.9000e-004

Mitigated

	ROG	NOx	CO	SO2	Fugitive PM10	Exhaust PM10	PM10 Total	Fugitive PM2.5	Exhaust PM2.5	PM2.5 Total	Bio-CO2	NBio-CO2	Total CO2	CH4	N2O	CO2e
SubCategory	tons/yr										MT/yr					
Architectural Coating	0.0313					0.0000	0.0000		0.0000	0.0000	0.0000	0.0000	0.0000	0.0000	0.0000	0.0000
Consumer Products	0.1158					0.0000	0.0000		0.0000	0.0000	0.0000	0.0000	0.0000	0.0000	0.0000	0.0000
Landscaping	2.0000e-005	0.0000	2.4000e-004	0.0000		0.0000	0.0000		0.0000	0.0000	0.0000	4.6000e-004	4.6000e-004	0.0000	0.0000	4.9000e-004
Total	0.1472	0.0000	2.4000e-004	0.0000		0.0000	0.0000		0.0000	0.0000	0.0000	4.6000e-004	4.6000e-004	0.0000	0.0000	4.9000e-004

7.0 Water Detail

7.1 Mitigation Measures Water

		Total CO2	CH4	N2O	CO2e
Category	tons/yr	MT/yr			
Mitigated		10.0319	1.6200e-003	2.0000e-004	10.1311
Unmitigated		10.0319	1.6200e-003	2.0000e-004	10.1311

7.2 Water by Land Use

Unmitigated

	Indoor/Outdoor Use		Total CO2	CH4	N2O	CO2e
Land Use	Mgal	tons/yr	MT/yr			
City Park	0 / 30.9785		10.0319	1.6200e-003	2.0000e-004	10.1311
Total			10.0319	1.6200e-003	2.0000e-004	10.1311

Mitigated

	Indoor/Outdoor Use		Total CO2	CH4	N2O	CO2e
Land Use	Mgal	tons/yr	MT/yr			
City Park	0 / 30.9785		10.0319	1.6200e-003	2.0000e-004	10.1311
Total			10.0319	1.6200e-003	2.0000e-004	10.1311

8.0 Waste Detail

8.1 Mitigation Measures Waste

Category/Year

		Total CO2	CH4	N2O	CO2e
	tons/yr	MT/yr			
Mitigated		0.4547	0.0269	0.0000	1.1265
Unmitigated		0.4547	0.0269	0.0000	1.1265

8.2 Waste by Land Use

Unmitigated

	Waste Disposed		Total CO2	CH4	N2O	CO2e
Land Use	tons	tons/yr	MT/yr			
City Park	2.24		0.4547	0.0269	0.0000	1.1265
Total			0.4547	0.0269	0.0000	1.1265

Mitigated

	Waste Disposed		Total CO2	CH4	N2O	CO2e
Land Use	tons	tons/yr	MT/yr			
City Park	2.24		0.4547	0.0269	0.0000	1.1265
Total			0.4547	0.0269	0.0000	1.1265

9.0 Operational Offroad

Equipment Type	Number	Hours/Day	Days/Year	Horse Power	Load Factor	Fuel Type
----------------	--------	-----------	-----------	-------------	-------------	-----------

10.0 Stationary Equipment

Fire Pumps and Emergency Generators

Equipment Type	Number	Hours/Day	Hours/Year	Horse Power	Load Factor	Fuel Type
----------------	--------	-----------	------------	-------------	-------------	-----------

Boilers

Equipment Type	Number	Heat Input/Day	Heat Input/Year	Boiler Rating	Fuel Type
----------------	--------	----------------	-----------------	---------------	-----------

User Defined Equipment

Equipment Type	Number
----------------	--------

11.0 Vegetation

Attachment C
Biological Report

Insert March 11, 2022 Biological Resource Assessment document from ECORP here

Biological Resources Assessment

Burns Valley Development Project

Lake County, California

March 11, 2021

CONTENTS

1.0 INTRODUCTION 1

 1.1 Project Location 1

 1.2 Project Description 1

 1.3 Purpose of this Biological Resources Assessment 3

2.0 REGULATORY SETTING 3

 2.1 Federal Regulations 3

 2.1.1 Federal Endangered Species Act 3

 2.1.2 Migratory Bird Treaty Act 5

 2.1.3 Federal Clean Water Act 5

 2.1.4 Rivers and Harbors Act 6

 2.2 State Regulations 6

 2.2.1 California Endangered Species Act 6

 2.2.2 Fully Protected Species 6

 2.2.3 Native Plant Protection Act 7

 2.2.4 California Fish and Game Code Special Protections for Birds 7

 2.2.5 Lake or Streambed Alteration Agreements 8

 2.2.6 Porter-Cologne Water Quality Act 8

 2.2.7 California Environmental Quality Act 8

 2.3 Local Plans and Ordinances 11

 2.3.1 City of Clearlake General Plan 11

 2.3.2 City of Clearlake Municipal Code 11

3.0 METHODS 12

 3.1 Literature Review 12

 3.2 Field Surveys Conducted 12

 3.3 Special-Status Species Considered for the Study Area 13

4.0 RESULTS 13

 4.1 Existing Condition 13

 4.1.1 Site Characteristics and Land Use 13

 4.1.2 Soils 14

 4.1.3 Vegetation Communities and Land Cover Types 14

 4.1.4 Aquatic Resources 18

 4.1.5 Wildlife Observations 18

 4.2 Evaluation of Species Identified in the Literature Search 20

 4.2.1 Fish 43

4.2.2 Amphibians 44

4.2.3 Reptiles 44

4.2.4 Birds 45

4.2.5 Mammals 46

4.3 Critical Habitat and Essential Fish Habitat..... 47

4.4 Riparian Habitats and Sensitive Natural Communities 47

4.5 Wildlife Movement/Corridors and Nursery Sites 47

5.0 IMPACT ANALYSIS..... 48

5.1 Special Status Species 48

5.1.1 Special-Status Plants 48

5.1.2 Northwestern Pond Turtle 48

5.1.3 Special-Status and Other Protected Birds 49

5.1.4 Special-Status Mammals 49

5.2 Riparian Habitat and Sensitive Natural Communities 49

5.3 Aquatic Resources, Including Waters the U.S. and State 50

5.4 Wildlife Movement/Corridors 50

5.5 Local Policies, Ordinances, and Other Plans..... 50

6.0 RECOMMENDATIONS..... 51

6.1 General Recommendations..... 51

6.2 Special-Status Species..... 51

6.2.1 Plants 51

6.2.2 Northwestern Pond Turtle 52

6.2.3 Special-Status Birds and MBTA-Protected Birds (including nesting raptors)..... 52

6.2.4 Special-Status Bats..... 53

6.3 Riparian and Sensitive Natural Communities 53

6.4 Waters of the U.S./State 53

6.5 Wildlife Movement Corridors 54

6.6 Trees 54

7.0 SUMMARY 54

8.0 REFERENCES..... 56

LIST OF TABLES

Table 1. Special-Status Species Evaluated for the Study Area 20

LIST OF FIGURES

Figure 1. Study Area Location and Vicinity2
 Figure 2. Natural Resources Conservation Service Soil Types..... 15
 Figure 3. Vegetation Communities and Land Cover Types 16
 Figure 4. Preliminary Wetland Assessment..... 19

LIST OF ATTACHMENTS

- Attachment A – Results of Database Queries
 Attachment B – Representative Site Photographs

LIST OF ACRONYMS AND ABBREVIATIONS

°F	Degrees Fahrenheit
BA	Biological Assessment
BCC	Birds of Conservation Concern
BIOS	Biogeographic Information and Observation System
BO	Biological Opinion
BRA	Biological Resources Assessment
CDFW	California Department of Fish and Wildlife
CEQA	California Environmental Quality Act
CFR	Code of Federal Regulations
City	City of Clearlake
CNDDB	California Natural Diversity Database
CNPS	California Native Plant Society
CRPR	California Rare Plant Rank
CWA	Clean Water Act
DPS	Distinct population segment
ESA	Endangered Species Act
HCP	Habitat conservation plan
ITP	Incidental Take Permit
LSA	Lake or Streambed Alteration
MBTA	Migratory Bird Treaty Act
MSL	Mean sea level
NMFS	National Marine Fisheries Service
NOAA	National Oceanic and Atmospheric Administration
NPDES	National Pollutant Discharge Elimination System
NPPA	Native Plant Protection Act
NRCS	Natural Resources Conservation Service
Plan	City of Clearlake 2040 General Plan Update
Project	Burns Valley Development Project
RPZ	Root Protection Zone
RWQCB	Regional Water Quality Control Board
SAA	Streambed Alteration Agreement

LIST OF ACRONYMS AND ABBREVIATIONS

SSC	Species of Special Concern
SWRCB	State Water Resources Control Board
USACE	U.S. Army Corps of Engineers
USC	U.S. Code
USFWS	U.S. Fish and Wildlife Service
USGS	U.S. Geological Survey
WBWG	Western Bat Working Group

1.0 INTRODUCTION

On behalf of the City of Clearlake (City), ECORP Consulting, Inc. conducted a Biological Resources Assessment (BRA) for the Burns Valley Development Project (Project) located in Lake County, California. The purpose of the assessment was to collect information on the biological resources present and evaluate the potential for special-status species and their habitats to occur in the Study Area; assess potential biological impacts related to Project activities; and identify potential mitigation measures to inform the Project's California Environmental Quality Act (CEQA) documentation for biological resources.

1.1 Project Location

The approximately 30.65-acre Study Area includes the impact limits of the Project and is located southwest of the intersection of Burns Valley Road and Rumsey Road, in the city of Clearlake in Lake County, California (Figure 1. *Study Area Location and Vicinity*). The Study Area corresponds to a portion of Section 21, Township 13 North, Range 07 West (Mount Diablo Base and Meridian) within the "Clearlake Highlands, California" 7.5-minute quadrangle (U.S. Geological Survey [USGS] 1993). The approximate center of the Study Area is located at latitude 38.96391 ° and longitude -122.634884° (NAD83) within the Upper Cache watershed (Hydrologic Unit Code #18020116) (Natural Resources Conservation Service [NRCS] et al. 2016).

1.2 Project Description

The Project proposes a multi-use land plan for approximately 29 acres of property with Accessor's Parcel Numbers 010-026-290, 010-026-400, and 039-570-180.

The eastern section of the property will be dedicated to a multi-family development of approximately 4.4 acres and a continuation of commercial-retail development of approximately 1.7 acres. The multi-family development will be located at the northeast corner of the property and the commercial-retail development will be located adjacently to the south along Burns Valley Road.

The mid-portion of the property is dedicated public use and will be active recreational uses such as Little League® Baseball, softball, and soccer fields. These facilities will be served with standard support services such as restrooms, concessions, and parking.

The western portion of the property is dedicated to the development of a public works facility, which includes a large graded area, covered equipment parking, public works shop, material storage bays, and a covered fuel and wash island.

Access and circulation will be provided to the development from three locations: Burns Valley Road traveling east-west, Burns Valley Road traveling north-south, and Olympic Drive.

The Project will not impact Burns Valley Creek or its riparian corridor.

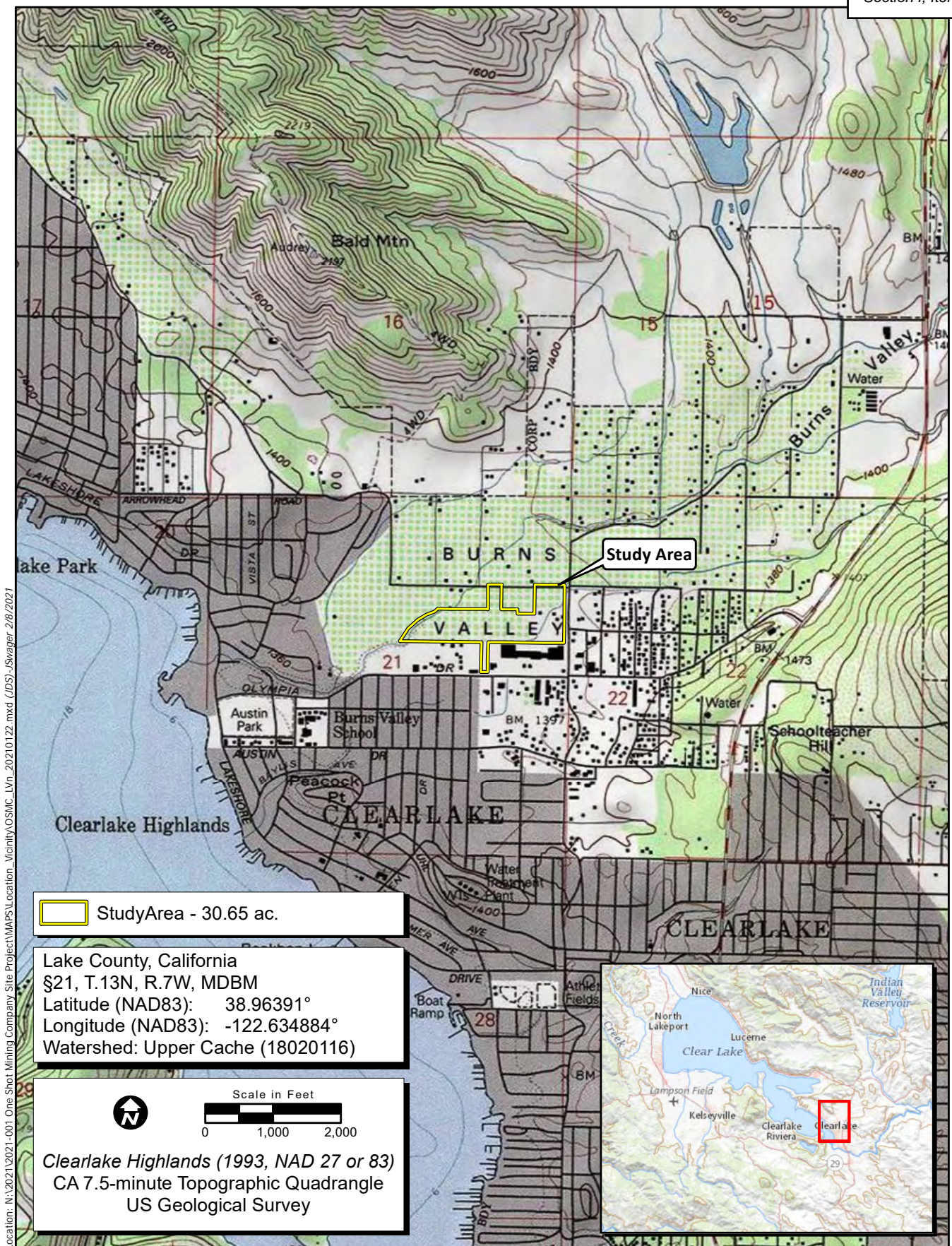

Location: N:\2021\2021-001 One Shot Mining Company Site Project\WAPS\Location_Vicinity\OSMC_LVn_20210122.mxd (JDS)_Swager 2/8/2021

Map Date: 2/8/2021
Sources:

Figure 1. Study Area Location and Vicinity

1.3 Purpose of this Biological Resources Assessment

The purpose of this BRA is to assess the potential for occurrence of special-status plant and animal species or their habitat, and sensitive habitats such as wetlands within the Study Area. This assessment does not include determinate field surveys conducted according to agency-promulgated protocols. The conclusions and recommendations presented in this report are based upon a review of the available literature and site reconnaissance.

For the purposes of this assessment, special-status species are defined as plants or animals that:

- are listed, proposed for listing, or candidates for future listing as threatened or endangered under the federal Endangered Species Act (ESA);
- are listed or candidates for future listing as threatened or endangered under the California ESA;
- meet the definitions of endangered or rare under Section 15380 of CEQA Guidelines;
- are identified as a Species of Special Concern (SSC) by the California Department of Fish and Wildlife (CDFW);
- are birds identified as Birds of Conservation Concern (BCC) by the U.S. Fish and Wildlife Service (USFWS);
- are plants considered by the California Native Plant Society (CNPS) to be "rare, threatened, or endangered in California" (California Rare Plant Rank [CRPR] 1 and 2), plants listed by CNPS as species about which more information is needed to determine their status (CRPR 3), and plants of limited distribution (CRPR 4);
- are plants listed as rare under the California Native Plant Protection Act (NPPA; California Fish and Game Code, § 1900 et seq.); or
- are fully protected in California in accordance with the California Fish and Game Code, §§ 3511 (birds), 4700 (mammals), 5050 (amphibians and reptiles), and 5515 (fishes).

Only species that fall into one of the above-listed groups were considered for this assessment. Other species without special status that are sometimes found in database or literature searches were not included in this analysis.

2.0 REGULATORY SETTING

2.1 Federal Regulations

2.1.1 *Federal Endangered Species Act*

The federal ESA protects plants and animals that are listed as endangered or threatened by the USFWS and the National Marine Fisheries Service (NMFS). Section 9 of the ESA prohibits the taking of listed wildlife, where take is defined as "harass, harm, pursue, hunt, shoot, wound, kill, trap, capture, collect, or attempt to engage in such conduct" (50 Code of Federal Regulations [CFR] 17.3). For plants, this statute

governs removing, possessing, maliciously damaging, or destroying any listed plant on federal land and removing, cutting, digging up, damaging, or destroying any listed plant on non-federal land in knowing violation of state law (16 U.S. Code [USC] 1538). Under Section 7 of the ESA, federal agencies are required to consult with the USFWS if their actions, including permit approvals or funding, could adversely affect a listed (or proposed) species (including plants) or its critical habitat. Section 10 of the ESA provides for issuance of incidental take permits where no other federal actions are necessary provided a habitat conservation plan (HCP) is developed.

Section 7

Section 7 of the ESA mandates that all federal agencies consult with USFWS and/or NMFS to ensure that federal agencies' actions do not jeopardize the continued existence of a listed species or adversely modify Critical Habitat for listed species. If adverse effects to a species or its Critical Habitat are likely, the applicant must conduct a biological assessment (BA) for the purpose of analyzing the potential effects of the project on listed species and critical habitat to establish and justify an "effect determination." The federal agency reviews the BA; if it concludes that the project may adversely affect a listed species or its habitat, it prepares a biological opinion (BO). Through consultation and the issuance of a BO, the USFWS may issue an incidental take statement allowing take of the species that is incidental to an otherwise authorized activity provided the activity will not jeopardize the continued existence of the species. The BO may recommend "reasonable and prudent alternatives" to the project to avoid jeopardizing or adversely modifying habitat. If direct and/or indirect effects will occur to Critical Habitat that appreciably diminish the value of Critical Habitat for both the survival and recovery of a species, the adverse modifications will require formal consultation with USFWS or NMFS.

Section 10

When no discretionary action is being taken by a federal agency but a project may result in the take of listed species, an incidental take permit (ITP) under Section 10 of the ESA is necessary. The purpose of the ITP is to authorize the take of federally listed species that may result from an otherwise lawful activity, not to authorize the activities themselves. In order to obtain an ITP under Section 10, an application must be submitted that includes an HCP. In some instances, applicants, USFWS, and/or NMFS may determine that an HCP is necessary or prudent, even if a discretionary federal action will occur. The purpose of the HCP planning process associated with the permit application is to ensure that adequate minimization and mitigation for impacts to listed species and/or their habitat will occur.

Critical Habitat

Critical Habitat is defined in Section 3 of the ESA as:

1. the specific areas within the geographical area occupied by a species, at the time it is listed in accordance with the ESA, on which are found those physical or biological features essential to the conservation of the species and that may require special management considerations or protection; and
- (2. specific areas outside the geographical area occupied by a species at the time it is listed, upon a determination that such areas are essential for the conservation of the species.

For inclusion in a Critical Habitat designation, habitat within the geographical area occupied by the species at the time it was listed must first have features that are essential to the conservation of the species. Critical Habitat designations identify, to the extent known and using the best scientific data available, the physical or biological features needed for life processes. Physical and biological features that are essential to the conservation of the species may require special management considerations or protection. These include but are not limited to:

- space for individual and population growth and for normal behavior;
- food, water, air, light, minerals, or other nutritional or physiological requirements;
- cover or shelter;
- sites for breeding, reproduction, or rearing (or development) of offspring; or
- habitats that are protected from disturbance or are representative of the historic, geographical, and ecological distributions of a species.

2.1.2 Migratory Bird Treaty Act

The Migratory Bird Treaty Act (MBTA) implements international treaties between the U.S. and other nations devised to protect migratory birds, any of their parts, eggs, and nests from activities such as hunting, pursuing, capturing, killing, selling, and shipping, unless expressly authorized in the regulations or by permit. As authorized by the MBTA, the USFWS issues permits to qualified applicants for the following types of activities: falconry, raptor propagation, scientific collecting, special purposes (rehabilitation, education, migratory game bird propagation, and salvage), take of depredated birds, taxidermy, and waterfowl sale and disposal. The regulations governing migratory bird permits can be found in 50 CFR part 13 General Permit Procedures and 50 CFR part 21 Migratory Bird Permits. The State of California has incorporated the protection of birds of prey in Sections 3800, 3513, and 3503.5 of the California Fish and Game Code.

2.1.3 Federal Clean Water Act

The purpose of the federal Clean Water Act (CWA) is to "...restore and maintain the chemical, physical, and biological integrity of the nation's waters." Section 404 of the CWA prohibits the discharge of dredged or fill material into Waters of the U.S. without a permit from the U.S. Army Corps of Engineers (USACE). "Discharges of fill material" is defined as the addition of fill material into Waters of the U.S., including, but not limited to the following: placement of fill that is necessary for the construction of any structure, or impoundment requiring rock, sand, dirt, or other material for its construction; site-development fills for recreational, industrial, commercial, residential, and other uses; causeways or road fills; and fill for intake and outfall pipes, and subaqueous utility lines [33 CFR § 328.2(f)]. In addition, Section 401 of the CWA (33 USC 1341) requires any applicant for a federal license or permit to conduct any activity that may result in a discharge of a pollutant into Waters of the U.S. to obtain a certification that the discharge will comply with the applicable effluent limitations and water quality standards.

Substantial impacts to Waters of the U.S. (more than 0.5 acre of impact) may require an individual permit. Projects that only minimally affect Waters of the U.S. (less than 0.5 acre of impact) may meet the conditions of one of the existing Nationwide Permits. A Water Quality Certification or waiver pursuant to Section 401 of the CWA is required for Section 404 permit actions; this certification or waiver is issued by the Regional Water Quality Control Board (RWQCB).

2.1.4 Rivers and Harbors Act

Section 10 of the Rivers and Harbors Act of 1899 requires authorization from the Secretary of the Army, acting through the USACE, for the construction of any structure in or over any navigable Waters of the U.S. Structures or work outside the limits defined for navigable Waters of the U.S. require a Section 10 permit if the structure or work affects the course, location, or condition of the water body. The law applies to any dredging or disposal of dredged materials, excavation, filling, re-channelization, or any other modification of a navigable Water of the U.S., and applies to all structures, from the smallest floating dock to the largest commercial undertaking. It further includes, without limitation, any wharf, dolphin, weir, boom breakwater, jetty, groin, bank protection (e.g., riprap, revetment, bulkhead), mooring structures such as pilings, aerial or subaqueous power transmission lines, intake or outfall pipes, permanently moored floating vessel, tunnel, artificial canal, boat ramp, aids to navigation, and any other permanent, or semi-permanent obstacle or obstruction. The alteration of a USACE-federally authorized civil works project requires a permit pursuant to Section 14 of the Act, as amended and codified in 33 USC 408. Projects with minimal impacts require approval by the USACE Sacramento District Construction Operations Group; however, projects with more substantial impacts may require USACE Headquarters review. Coordination with the Central Valley Flood Protection Board, who serve as the Non-Federal Sponsor, is required as a part of the process of obtaining a Section 408 permit.

2.2 State Regulations

2.2.1 California Endangered Species Act

The California ESA (California Fish and Game Code §§ 2050-2116) protects species of fish, wildlife, and plants listed by the State as endangered or threatened. Species identified as candidates for listing may also receive protection. Section 2080 of the California ESA prohibits the taking, possession, purchase, sale, and import or export of endangered, threatened, or candidate species, unless otherwise authorized by permit. Take is defined in Section 86 of the California Fish and Game Code as “hunt, pursue, catch, capture, or kill, or attempt to hunt, pursue, catch, capture, or kill.” The California ESA allows for take incidental to otherwise lawful projects under permits issued by CDFW.

2.2.2 Fully Protected Species

The State of California first began to designate species as “fully protected” prior to the creation of the federal and California ESAs. Lists of fully protected species were initially developed to provide protection to those animals that were rare or faced possible extinction and included fish, amphibians and reptiles, birds, and mammals. Most fully protected species have since been listed as threatened or endangered

under the federal and/or California ESAs. Fully protected species are identified in the California Fish and Game Code § 4700 for mammals, § 3511 for birds, § 5050 for reptiles and amphibians, and § 5515 for fish.

These sections of the California Fish and Game Code provide that fully protected species may not be taken or possessed at any time, including prohibition of CDFW from issuing incidental take permits for fully protected species under the California ESA. CDFW will issue licenses or permits for take of these species for necessary scientific research or live capture and relocation pursuant to the permit and may allow incidental take for lawful activities carried out under an approved Natural Community Conservation Plan within which such species are covered.

2.2.3 Native Plant Protection Act

The NPPA of 1977 (California Fish and Game Code §§ 1900-1913) was established with the intent to “preserve, protect and enhance rare and endangered plants in this state.” The NPPA is administered by CDFW. The Fish and Game Commission has the authority to designate native plants as “endangered” or “rare.” The NPPA prohibits the take of plants listed under the NPPA, though the NPPA contains exemptions to this prohibition that have not been clarified by regulation or judicial rule. In 1984, the California ESA brought under its protection all plants previously listed as endangered under NPPA. Plants listed as rare under NPPA are not protected under the California ESA but are still protected under the provisions of NPPA. The Fish and Game Commission no longer lists plants under NPPA, reserving all listings to the California ESA.

2.2.4 California Fish and Game Code Special Protections for Birds

In addition to protections contained within the California ESA and California Fish and Game Code § 3511 described above, the California Fish and Game Code includes a several sections that specifically protect certain birds:

- Section 3800 states that it is unlawful to take nongame birds, such as those occurring naturally in California that are not resident game birds, migratory game birds, or fully protected birds, except when in accordance with regulations of the California Fish and Game Commission or a mitigation plan approved by CDFW for mining operations.
- Section 3503 prohibits the take, possession, or needless destruction of the nest or eggs of any bird.
- Section 3503.5 protects birds of prey (which includes eagles, hawks, falcons, kites, ospreys, and owls) and prohibits the take, possession, or destruction of any birds and their nests.
- Section 3505 makes it unlawful to take, sell, or purchase egrets, ospreys, and several exotic nonnative species, or any part of these birds.
- Section 3513 specifically prohibits the take or possession of any migratory nongame bird as designated in the MBTA.

2.2.5 Lake or Streambed Alteration Agreements

Section 1602 of the California Fish and Game Code requires individuals or agencies to provide a Notification of Lake or Streambed Alteration (LSA) to CDFW for “any activity that may substantially divert or obstruct the natural flow or substantially change the bed, channel, or bank of any river, stream, or lake.” CDFW reviews the proposed actions and, if necessary, proposed measures to protect affected fish and wildlife resources. The final proposal mutually agreed upon by CDFW and the applicant is the Lake or Streambed Alteration Agreement (SAA).

2.2.6 Porter-Cologne Water Quality Act

The RWQCB implements water quality regulations under the federal CWA and the State Porter-Cologne Water Quality Act. These regulations require compliance with the National Pollutant Discharge Elimination System (NPDES), including compliance with the California Storm Water NPDES General Construction Permit for discharges of storm water runoff associated with construction activities. General Construction Permits for projects that disturb one or more acres of land require development and implementation of a Storm Water Pollution Prevention Plan. Under the Porter-Cologne Water Quality Act, the RWQCB regulates actions that would involve “discharging waste, or proposing to discharge waste, with any region that could affect the water of the state” (Water Code 13260(a)). Waters of the State are defined as “any surface water or groundwater, including saline waters, within the boundaries of the state” (Water Code 13050 (e)). The RWQCB regulates all such activities, as well as dredging, filling, or discharging materials into Waters of the State that are not regulated by the USACE due to a lack of connectivity with a navigable water body. The RWQCB may require issuance of Waste Discharge Requirements for these activities.

2.2.7 California Environmental Quality Act

In accordance with CEQA Guidelines § 15380, a species or subspecies not specifically protected under the federal or California ESAs or NPPA may be considered endangered, rare, or threatened for CEQA review purposes if the species meets certain criteria specified in the Guidelines. These criteria parallel the definitions used in the ESA, California ESA, and NPPA. Section 15380 was included in the CEQA Guidelines primarily to address situations in which a project under review may have a significant effect on a species that has not been listed under the ESA, California ESA, or NPPA, but that may meet the definition of endangered, rare, or threatened. Animal species identified as SSC by CDFW, birds identified as BCC by USFWS, and plants identified by the CNPS as rare, threatened, or endangered may meet the CEQA definition of rare or endangered.

Species of Special Concern

SSC are defined by CDFW as a species, subspecies, or distinct population of an animal native to California that are not legally protected under the federal ESA, California ESA, or California Fish and Game Code, but currently satisfies one or more of the following criteria:

- The species has been completely extirpated from the state or, as in the case of birds, it has been extirpated from its primary seasonal or breeding role.
- The species is listed as federally (but not State) threatened or endangered or meets the State definition of threatened or endangered but has not formally been listed.
- The species has or is experiencing serious (noncyclical) population declines or range retractions (not reversed) that, if continued or resumed, could qualify it for State threatened or endangered status.
- The species has naturally small populations that exhibit high susceptibility to risk from any factor that if realized, could lead to declines that would qualify it for State threatened or endangered status.
- SSC are typically associated with habitats that are threatened.

Depending on the policy of the lead agency, projects that result in substantial impacts to SSC may be considered significant under CEQA.

USFWS Birds of Conservation Concern

The 1988 amendment to the Fish and Wildlife Conservation Act mandates USFWS “identify species, subspecies, and populations of all migratory nongame birds that, without additional conservation actions, are likely to become candidates for listing under ESA.” To meet this requirement, USFWS published a list of BCC (USFWS 2008) for the U.S. The list identifies the migratory and nonmigratory bird species (beyond those already designated as federally threatened or endangered) that represent USFWS’ highest conservation priorities. Depending on the policy of the lead agency, projects that result in substantial impacts to BCC may be considered significant under CEQA.

Sensitive Natural Communities

The CDFW maintains the *California Natural Community List* (CDFW 2021a), which provides a list of vegetation alliances, associations, and special stands as defined in the *Manual of California Vegetation* (Sawyer et al. 2009), along with their respective state and global rarity ranks. Natural communities with a state rarity rank of S1, S2, or S3 are considered sensitive natural communities. Depending on the policy of the lead agency, impacts to sensitive natural communities may be considered significant under CEQA.

California Rare Plant Ranks

The CNPS maintains the Inventory of Rare and Endangered Plants of California (CNPS 2021), which provides a list of plant species native to California that are threatened with extinction, have limited distributions, and/or low populations. Plant species meeting one of these criteria are assigned to one of six CRPRs. The rank system was developed in collaboration with government, academia, non-governmental organizations, and private-sector botanists, and is jointly managed by CDFW and the CNPS. The CRPRs are currently recognized in the California Natural Diversity Database (CNDDB). The following are definitions of the CNPS CRPRs:

- Rare Plant Rank 1A – presumed extirpated in California and either rare or extinct elsewhere.
- Rare Plant Rank 1B – rare, threatened, or endangered in California and elsewhere.
- Rare Plant Rank 2A – presumed extirpated in California, but more common elsewhere.
- Rare Plant Rank 2B – rare, threatened, or endangered in California but more common elsewhere.
- Rare Plant Rank 3 – a review list of plants about which more information is needed.
- Rare Plant Rank 4 – a watch list of plants of limited distribution.

Additionally, CNPS has defined Threat Ranks that are added to the CRPR as an extension. Threat Ranks designate the level of threat on a scale of 1 through 3, with 1 being the most threatened and 3 being the least threatened. Threat Ranks are generally present for all plants ranked 1B, 2B, or 4, and for the majority of plants ranked 3. Plant species ranked 1A and 2A (presumed extirpated in California), and some species ranked 3, which lack threat information, do not typically have a Threat Rank extension. The following are definitions of the CNPS Threat Ranks:

- Threat Rank 0.1 – Seriously threatened in California (more than 80 percent of occurrences threatened/high degree and immediacy of threat).
- Threat Rank 0.2 – Moderately threatened in California (20 to 80 percent occurrences threatened/moderate degree and immediacy of threat).
- Threat Rank 0.3 – Not very threatened in California (less than 20 percent of occurrences threatened/low degree and immediacy of threat or no current threats known).

Factors such as habitat vulnerability and specificity, distribution, and condition of occurrences are considered in setting the Threat Rank; and differences in Threat Ranks do not constitute additional or different protection (CNPS 2021).

Depending on the policy of the lead agency, substantial impacts to plants ranked 1A, 1B, 2, and 3 are typically considered significant under CEQA Guidelines § 15380. Significance under CEQA is typically evaluated on a case-by-case basis for plants ranked 4 and at the discretion of the CEQA lead agency.

CEQA Significance Criteria

Sections 15063-15065 of the CEQA Guidelines address how an impact is identified as significant. Generally, impacts to listed (rare, threatened, or endangered) species are considered significant. Assessment of "impact significance" to populations of non-listed species (e.g., SSC) usually considers the proportion of the species' range that will be affected by a project, impacts to habitat, and the regional and population level effects.

Specifically, § 15064.7 of the CEQA Guidelines encourages local agencies to develop and publish the thresholds that the agency uses in determining the significance of environmental effects caused by projects under its review. However, agencies may also rely upon the guidance provided by the expanded

Initial Study checklist contained in Appendix G of the CEQA Guidelines, which provides examples of impacts that would normally be considered significant.

An evaluation of whether an impact on biological resources would be substantial must consider both the resource itself and how that resource fits into a regional or local context. Substantial impacts would be those that would diminish, or result in the loss of, an important biological resource, or those that would obviously conflict with local, State, or federal resource conservation plans, goals, or regulations. Impacts are sometimes locally important but not significant under CEQA. The reason for this is that although the impacts would result in an adverse alteration of existing conditions, they would not substantially diminish or result in the permanent loss of an important resource on a population-wide or region-wide basis.

2.3 Local Plans and Ordinances

2.3.1 City of Clearlake General Plan

The City of Clearlake 2040 General Plan Update (Plan) is the governing document for all planning and development related decisions within City limits (City of Clearlake 2016a). The Environmental Impact Report for the Plan (City of Clearlake 2016b) summarizes mitigation measures for biological resources the City must follow when implementing the Plan.

The Conservation Element of the Plan generally outlines goals, objectives, policies, and programs related to the protection of water quality, listed species, sensitive habitats, and wildlife movement.

2.3.2 City of Clearlake Municipal Code

Subsection 18-1.4.435 (Native Tree Protection and Removal Permits) of the City of Clearlake Municipal Code (City of Clearlake 2020) establishes the procedures for protecting certain native trees, and requires a native tree protection and removal permit for the following:

- Blue oak (*Quercus douglasii*),
- Valley oak (*Quercus lobata*),
- Interior live oak (*Quercus wislizeni*),
- California black oak (*Quercus kelloggii*),
- Canyon live oak (*Quercus chrysolepis*),
- Oregon white oak (*Quercus garryana*), and
- Any other tree designated by the City Council as a "Heritage Tree".

As described in Subsection 18-51404 (Tree Protection Regulations) any disturbances which might cause harm to a protected tree, are strictly prohibited within the root protection zone (RPZ) of that tree. The RPZ is defined as a circular area around the trunk of the tree with the radius equal to the largest radius of the tree's drip line. Any activities within the RPZ of a protected tree requires a tree removal permit.

As described in Subsection 18-5.1405 (Removal Regulations), tree removal permits require preparation of a Tree Replacement Plan. Mitigation or compensation for protected trees that are felled and/or removed includes either onsite or offsite planting or an equivalent compensatory payment into a fund established by the City to plant and maintain trees.

3.0 METHODS

3.1 Literature Review

The following resources were reviewed to determine the special-status species that have been documented within or in the vicinity of the Study Area.

- CDFW CNDDDB data for the "Clearlake Highlands, California" 7.5-minute USGS quadrangle and the nine surrounding USGS quadrangles (CDFW 2021a).
- USFWS Information, Planning, and Consultation System Resource Report List for the Study Area (USFWS 2021a).
- CNPS' electronic Inventory of Rare and Endangered Plants of California was queried for the "Clearlake Highlands, California" 7.5-minute USGS quadrangles and the nine surrounding quadrangles (CNPS 2021).
- NMFS Resources data for the "Clearlake Highlands, California" 7.5-minute USGS quadrangle (National Oceanic and Atmospheric Administration [NOAA] 2021a).

The results of the database queries are included in Attachment A.

Aerial imagery and site or species-specific background information, as cited throughout this document, were reviewed to determine the potential for occurrence of sensitive biological resources within or in the vicinity of the Study Area.

3.2 Field Surveys Conducted

ECORP Biologist Hannah Stone conducted a reconnaissance-level field survey for the Study Area on January 29, 2021. The Study Area was systematically surveyed on foot using an Eos Arrow Global Positioning System unit with sub-meter accuracy, topographic maps, and aerial imagery to ensure total site coverage. Special attention was given to identifying those portions of the Study Area with the potential to support special-status species and sensitive habitats. During the field survey, biological communities occurring onsite were characterized and the following biological resource information was collected:

- Potential aquatic resources.
- Vegetation communities.
- Plant and animal species directly observed.
- Animal evidence (e.g., scat, tracks).

- Existing active raptor nest locations.
- Special habitat features.
- Representative photographs.

3.3 Special-Status Species Considered for the Study Area

Based on database queries, a list of special-status species that are considered to have the potential to occur within the vicinity of the Study Area was generated (Table 1). Each of the species was evaluated for its potential to occur within the Study Area through the literature review and field observations, and categorized based on the following criteria:

- **Present** - Species was observed during the site visit or is known to occur within the Study Area based on documented occurrences within the CNDDDB or other literature.
- **Potential to Occur** - Habitat (including soils and elevation requirements) for the species occurs within the Study Area.
- **Low Potential to Occur** - Marginal or limited amounts of habitat occurs and/or the species is not known to occur within the vicinity of the Study Area based on CNDDDB records and other available documentation.
- **Absent** - No suitable habitat (including soils and elevation requirements) and/or the species is not known to occur within the vicinity of the Study Area based on CNDDDB records and other documentation.

4.0 RESULTS

4.1 Existing Condition

4.1.1 Site Characteristics and Land Use

The Study Area is located within relatively flat to gently rolling terrain situated at an elevational range of approximately 1,350 to 1,365 feet above mean sea level (MSL) in the Inner North Coast Ranges District of the California floristic province (Baldwin et al. 2012). The average winter low temperature in the vicinity of the Study Area is 44.2 degrees Fahrenheit (°F) and the average summer high temperature is 70.9°F. Average annual precipitation is approximately 31.42 inches, which falls as rain (NOAA 2021b).

The majority of the Study Area is an English walnut (*Juglans regia*) orchard that appears to be nonoperational and unmaintained except for occasional discing. A residential structure was located near the middle of the eastern Study Area boundary, but has since been mostly demolished. Building foundations, portions of the driveway and parking areas, and cultivated vegetation including a small pomegranate (*Punica granatum*) orchard, are remnant of the old residence. The eastern portion of the Study Area appears to receive regular use by the neighboring community. Native surface trails are common throughout this area and appear to be used mostly by pedestrians, although a dirt biker was observed using the trails during the site reconnaissance. Bags of trash and other miscellaneous materials

are dumped and scattered throughout this portion of the Study Area, and there are signs of abandoned encampments. A few small areas of the Study Area were observed to be recently burned.

Representative photographs of the Study Area are included in Attachment B.

4.1.2 Soils

According to the Web Soil Survey (NRCS 2021a), two soil units, or types, have been mapped within the Study Area (Figure 2. *Natural Resources Conservation Service Soils Types*):

- 124 – Cole variant clay loam
- 158 – Lupoyoma silt loam, protected

The Cole series consists of very deep, somewhat poorly drained soils that formed in alluvium from mixed sources. Cole soils are on stream terraces, flood-plain steps, and alluvial fans with slopes of 0 to 5 percent (NRCS 2021a).

The Lupoyoma series consists of very deep, moderately well drained soils formed in alluvium derived from mixed rock sources, dominantly sandstone and shale. Lupoyoma soils are on floodplains and have slopes of 0 to 2 percent (NRCS 2021a).

The Cole variant clay loam map unit and the Lupoyoma silt loam, protected map unit each contain one minor component listed as hydric: Clear Lake and Xerofluvents, respectively (NRCS 2021b).

No soil units derived from serpentinite or other ultramafic parent materials have been reported to occur within the Study Area or its immediate vicinity (NRCS 2021a; Jennings et al. 1977; Horton 2017).

4.1.3 Vegetation Communities and Land Cover Types

Vegetation communities or land cover types observed within the Study Area include English walnut orchard, valley oak woodland, Harding grass (*Phalaris aquatica*) sward, yellow star-thistle (*Centaurea solstitialis*) field, and developed/disturbed areas.

Figure 3. *Vegetation Communities and Land Cover Types* generally depicts the locations of the land cover types and vegetation communities; descriptions are provided in the following sections. The reconnaissance site visit was not conducted during the optimum identifiable period for most plant species. However, many plants commonly present within the Study Area were identifiable from characteristics of dead vegetation from the previous growing season.

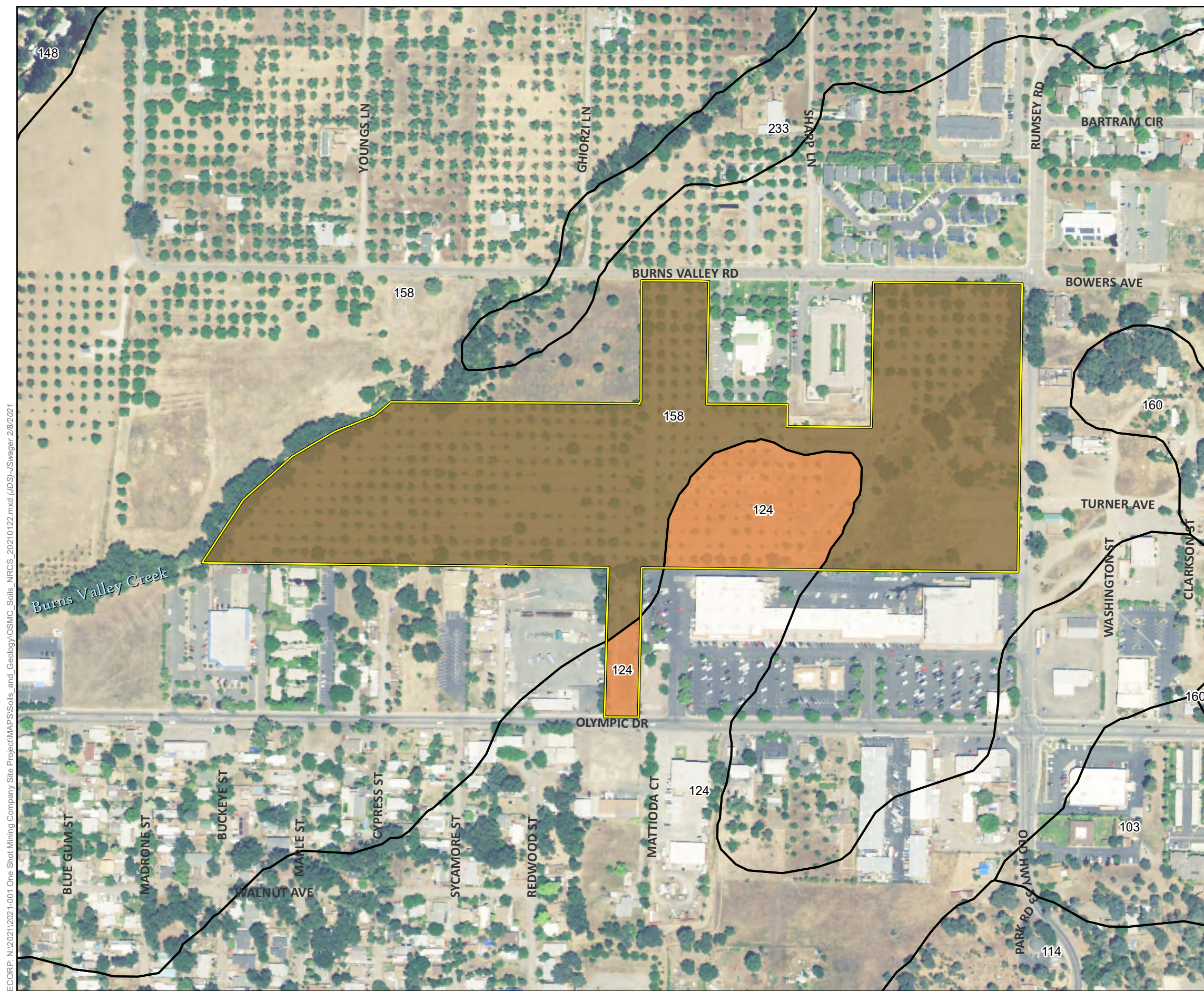

Map Features

- Study Area - 30.65 ac.

NRCS Soils

Series Number - Series Name

- 124 - Cole variant clay loam
- 158 - Lupoyoma silt loam, protected

Natural Resources Conservation Service (NRCS) Soil Survey Geographic (SSURGO) Database for Lake County, CA

ECORP: N:\2021\2021-001 One Shot Mining Company Site Project\MAPS\Soils_and_Geology\OSMC_Soils_NRCS_20210122.mxd (JDS)-JSwager 2/8/2021

Sources: ESRI, USGS, NAIP (2020), CEC

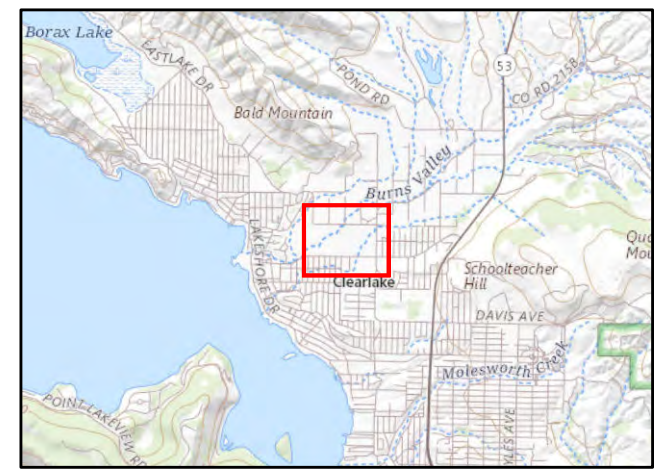
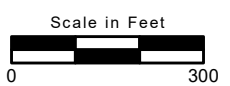
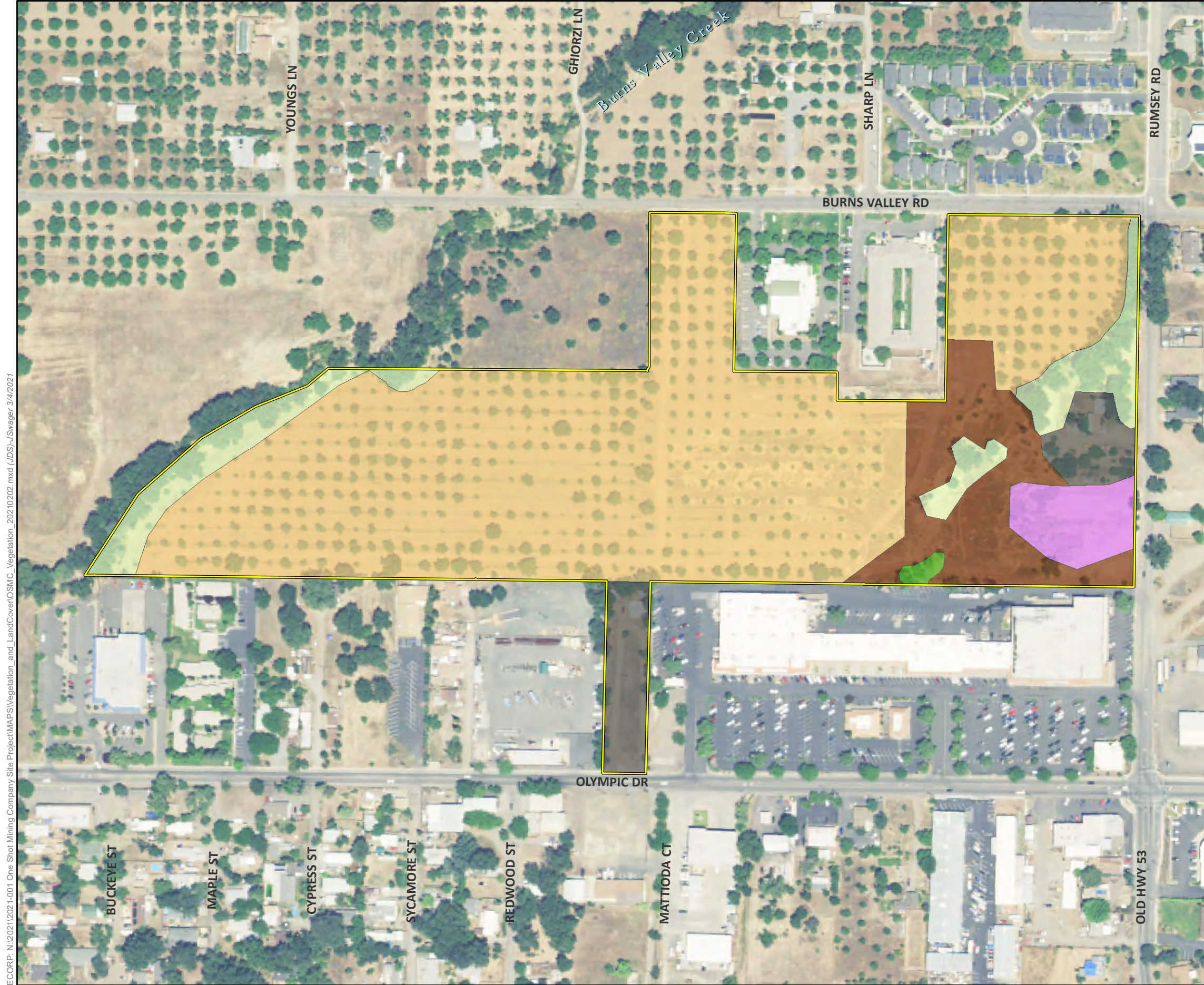

Figure 2. Natural Resources Conservation Service Soil Type
2021-001 Burns Valley Development Project





Map Features

Study Area - 30.65 ac.

Vegetation Communities and Land Cover Types

- Fremont Cottonwood Patch - 0.11 ac.
- Valley Oak Woodland - 2.74 ac.
- Harding Grass Grassland - 3.26 ac.
- English Walnut Orchard - 21.63 ac.
- Yellow Star-thistle Field - 1.09 ac.
- Developed/Disturbed - 1.81 ac.

ECORP: N:\2021\2021-001 One Shot Mining Company Site Project\WAPS\Vegetation_and_LandCover\OSMC_Vegetation_20210202.mxd (JDS)-\Swagger_3/4/2021

Sources: ESRI, USGS, NAIP (2020), CEC

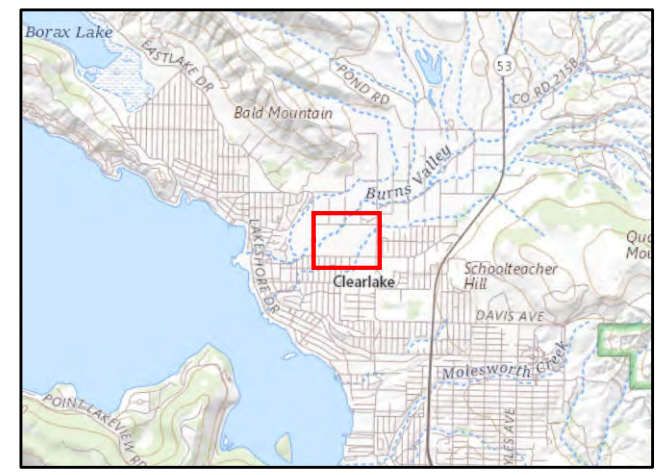

Figure 3. Vegetation Communities and Land Cover Types

English Walnut Orchard

An English walnut orchard makes up most of the Study Area, covering the majority of land west of the unnamed stream which runs northeast-southwest through the eastern portion of the Study Area. The orchards are characterized by evenly spaced rows of black walnuts with patchy ruderal vegetation growing on mechanically tilled soils between the walnuts. At the time of the reconnaissance field survey, yellow star-thistle was dominant in the understory, patches of short-pod mustard (*Hirschfeldia incana*) were scattered throughout and seedlings of unidentifiable annual grasses and annual herbs including red-stemmed filaree (*Erodium cicutarium*), hairy hawkbit (*Leontodon saxatilis*), and miner's lettuce (*Claytonia* sp.) carpeted the soils.

Valley Oak Woodland

Strips of valley oak woodland are located along Burns Valley Creek, which borders the western Study Area boundary, and along the unnamed stream that runs northeast-southwest through the eastern portion of the Study Area. At the time of the reconnaissance field survey, valley oak was dominant in the canopy, and the understory included patches of rush (*Carex* sp.), Himalayan blackberry (*Rubus armeniacus*) and rose (*Rosa* sp.) near the stream, and oats (*Avena* sp.) and vetch (*Vicia* sp.) in upland areas.

Valley oak woodland within the Study Area is consistent with the Valley Oak Forest and Woodland Alliance (Sawyer et al. 2009), which has a state rarity ranking of S3 and is considered a sensitive natural community.

Harding Grass Grassland

The majority of the non-riparian areas that are not planted as orchards are characterized as Harding Grass grasslands. At the time of the reconnaissance field survey, Harding grass was dominant and prickly lettuce (*Lactuca serriola*) and curly dock (*Rumex crispus*) were scattered throughout. A small patch of Fremont cottonwood was located within the Harding Grass Grassland.

This vegetation type is consistent with the Harding grass – Reed Canary grass (*Phalaris arundinacea*) swards Semi-Natural Alliance (Sawyer et al. 2009).

Yellow Star-Thistle Field

A yellow star-thistle field is located between the Harding grass grassland and Burns Valley Road in the southeastern portion of the Study Area. This area appears to have been disturbed in the past by vehicle traffic and potentially grading. At the time of the reconnaissance field survey, yellow star-thistle was dominant and short-pod mustard and vetch were scattered throughout.

This vegetation type is consistent with the Yellow Star-thistle Herbaceous Semi Natural Alliance (Sawyer et al. 2009).

Developed/Disturbed

The developed/disturbed land cover type within the Study Area was observed in two areas bordering Burns Valley Road on the east side of the Study Area. One area is a former residential development that

has been demolished. Remnants of that development include foundations for structures, driveways, parking areas, and cultivated vegetation including a small pomegranate orchard, a Coast redwood (*Sequoia sempervirens*), and a European olive (*Olea europaea*). Large valley oaks are also located within this area near the foundations.

4.1.4 Aquatic Resources

A preliminary aquatic resources assessment to identify potential Waters of the U.S./State was conducted within the Study Area concurrent with the reconnaissance-level field survey. The Study Area does not include any portion of Burns Valley Creek, which is directly adjacent to the western boundary of the Study Area. However, the current mapped boundary for the Study Area may inadvertently include a portion of the creek (Figure 4. *Preliminary Aquatic Assessment*). An aquatic resources delineation would be necessary to determine the boundary for Burns Valley Creek in order to completely exclude it from the Study Area.

One aquatic resource was identified, a drainage channel which enters the Study Area through a culvert in the northeast corner of the site and flows southwest to another culvert located near the southern boundary of the Study Area (Figure 4). At the time of the site reconnaissance, the majority of the channel was dry despite recent storms. Some ponding was observed along segments of the channel. An area of ponding caused by human disturbance to the channel was observed approximately midway between the inlet and outlet culverts. The channel was no longer distinctly incised south of this location. Small constructed earthen berms and walking trails appear to have affected the flow path beyond this point and little indication of hydrology or an ordinary high water mark (OHWM) was observed beyond the berms. However, the drainage was mapped to the outlet culvert following the most likely flow path. An aquatic resources delineation would be required to determine the actual extent and location of the drainage, especially in the southern portion where hydrology was not clear. The drainage appears to be ephemeral, and likely only flows during larger storm events.

In the current definition of Waters of the U.S. under the Navigable Waters Protection Rule, ephemeral features and features that are not adjacent to existing Waters of the U.S. are generally not jurisdictional. Based on anecdotal observations, the channel onsite appears to be ephemeral, but this would need to be analyzed using historic precipitation data and verified by the USACE. Regardless of federal jurisdictional, the channel could be considered a Water of the State under the State Wetland Definition and Procedures for Discharges of Dredged or Fill Material to Waters of the State (State Water Resources Control Board [SWRCB] 2019).

4.1.5 Wildlife Observations

Wildlife observed within or flying over the Study Area during the site reconnaissance includes American crow (*Corvus brachyrhynchos*), Brewer's blackbird (*Euphagus cyanocephalus*), Eurasian collared-dove (*Streptopelia decaocto*), red-shouldered hawk (*Buteo lineatus*), Anna's hummingbird (*Calypte anna*), white-crowned sparrow (*Zonotrichia leucophrys*), American goldfinch (*Spinus tristis*), California scrub-jay (*Aphelocoma californica*), and Nuttall's woodpecker (*Dryobates nuttallii*).



Map Features

Study Area - 30.65 ac.

Potential Aquatic Resources*

Drainage - 0.06 ac.

* The information depicted on this graphic represents a preliminary wetland assessment. The assessment was not conducted in accordance with the Corps of Engineers Wetland Delineation Manual and San Francisco District Minimum Standards. The project boundaries, wetland boundaries, and acreage values are approximate.
 * The acreage value for each feature has been rounded to the nearest 1/100 decimal. Summation of these values may not equal the total potential Waters of the U.S. acreage reported.

ECORP: N:\2021\2021-001 One Shot Mining Company Site Project\WAPS\jurisdictional_Delineation\OSMC_PWA_20210202.mxd (JDS)-Jsvager 2/8/2021

Sources: ESRI, USGS, NAIP (2020), CEC

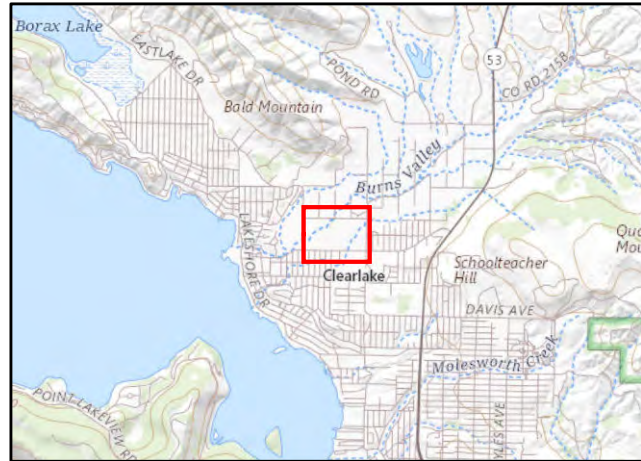

Figure 4. Preliminary Wetland Assessment



4.2 Evaluation of Species Identified in the Literature Search

Table 1 lists all the special-status plant and wildlife species (as defined in Section 1.3) identified in the literature review as potentially occurring within the vicinity of the Study Area. Included in this table are the listing status for each species, a brief habitat description, and an evaluation on the potential for each species to occur within the Study Area.

Following the table is a brief description and discussion of each special-status species that was determined to have potential to occur onsite.

Table 1. Special-Status Species Evaluated for the Study Area						
Common Name (Scientific Name)	Status			Habitat Description ¹	Survey Period	Potential to Occur Onsite
	ESA	CESA	Other			
Plants						
Bent-flowered fiddleneck (<i>Amsinckia lunaris</i>)	-	-	1B.2	Cismontane woodland, coastal bluff scrub, and valley and foothill grasslands (10'-1,640').	March-June	Potential to occur. Suitable habitat within Study Area.
Dimorphic snapdragon (<i>Antirrhinum subcordatum</i>)	-	-	4.3	Chaparral and lower montane coniferous forest; sometimes on serpentine substrates (606'-2,625')	April-July	Absent. No suitable habitat within Study Area.
Twig-like snapdragon (<i>Antirrhinum virga</i>)	-	-	4.3	Rocky soils, openings, and often serpentine in chaparral and lower montane coniferous forest (328'-6,611').	June-July	Absent. No suitable habitat within Study Area.
Coast rockcress (<i>Arabis blepharophylla</i>)	-	-	4.3	Rocky soils in broadleaf upland forest, coastal bluff scrub, coastal prairie, and coastal scrub (10'-3,609').	February-May	Low potential to occur. Marginally suitable habitat (woodland) within Study Area.
Konocti manzanita (<i>Arctostaphylos manzanita</i> ssp. <i>elegans</i>)	-	-	1B.3	Volcanic substrates of chaparral, cismontane woodland, and lower montane coniferous forest (1,295'-5,299').	March-May	Absent. No suitable habitat within Study Area.
Raiche's manzanita (<i>Arctostaphylos stanfordiana</i> ssp. <i>raichei</i>)	-	-	1B.1	Rocky, often serpentine soils of chaparral and lower montane coniferous forest openings (1,476'-3,396').	February-April	Absent. No suitable habitat within Study Area.
Serpentine milkweed (<i>Asclepias solanoana</i>)	-	-	4.2	Serpentine substrates of chaparral, cismontane woodland, and lower montane coniferous forest (754'-6,103').	May-July	Absent. No suitable habitat within Study Area.

Table 1. Special-Status Species Evaluated for the Study Area

Common Name (<i>Scientific Name</i>)	Status			Habitat Description ¹	Survey Period	Potential to Occur Onsite
	ESA	CESA	Other			
Brewer's milk-vetch (<i>Astragalus breweri</i>)	–	–	4.2	Often serpentine and volcanic substrates of chaparral, cismontane woodland, meadows and seeps, and open gravelly openings of valley and foothill grassland (295'–2,395').	April–June	Low potential to occur. Marginally suitable habitat (woodland and grassland) within Study Area.
Cleveland's milk-vetch (<i>Astragalus clevelandii</i>)	–	–	4.3	Serpentine seeps of chaparral, cismontane woodland, and riparian forest (656'–4,922').	June–September	Absent. No suitable habitat within Study Area.
Jepson's milk-vetch (<i>Astragalus rattanii</i> var. <i>jepsonianus</i>)	–	–	1B.2	Chaparral, cismontane woodland, and valley and foothill grassland; often on serpentine substrates (968'–2,297').	March–June	Low potential to occur. Marginally suitable habitat (non-serpentine woodland and grassland) within Study Area.
Mexican mosquito fern (<i>Azolla microphylla</i>)	–	–	4.2	Marshes and swamps, ponds or slow-moving bodies of water (98'–328').	August	Absent. No suitable habitat within Study Area.
Watershield (<i>Brasenia schreberi</i>)	–	–	2B.3	Freshwater marshes and swamps (98'–7,218').	June–September	Absent. No suitable habitat within Study Area.
Indian Valley brodiaea (<i>Brodiaea rosea</i> ssp. <i>rosea</i>)	–	CE	3.1	Serpentinite substrates of closed-cone coniferous forest, chaparral, cismontane woodland, and valley and foothill grassland (1,099'–4,758').	May–June	Absent. No suitable habitat within Study Area.
Serpentine reed grass (<i>Calamagrostis ophitidis</i>)	–	–	4.3	Rocky, serpentinite substrates of chaparral (open, often north-facing slopes), lower montane coniferous forest, meadows and seeps, and valley and foothill grassland (295'–3,495').	April–July	Absent. No suitable habitat within Study Area.
Pink star-tulip (<i>Calochortus uniflorus</i>)	–	–	4.2	Coastal prairie, coastal scrub, meadows and seeps, and North Coast coniferous forest (32'–3,511').	April–June	Absent. No suitable habitat within Study Area.

Table 1. Special-Status Species Evaluated for the Study Area

Common Name (Scientific Name)	Status			Habitat Description ¹	Survey Period	Potential to Occur Onsite
	ESA	CESA	Other			
Four-petaled pussypaws (<i>Calyptridium quadripetalum</i>)	-	-	4.3	Sandy or gravelly soils of chaparral and lower montane coniferous forest; often on serpentinite substrates (1,033'-6,693').	April-June	Absent. No suitable habitat within Study Area.
Mt. Saint Helena morning-glory (<i>Calystegia collina</i> ssp. <i>oxyphylla</i>)	-	-	4.2	Serpentinite substrates of chaparral, lower montane coniferous forest, and valley and foothill grassland (915'-3,314').	April-June	Absent. No suitable habitat within Study Area.
Three-fingered morning-glory (<i>Calystegia collina</i> ssp. <i>tridactylosa</i>)	-	-	1B.2	Rocky, gravelly openings on serpentine substrates of chaparral and cismontane woodland (0'-1,969').	April-June	Absent. No suitable habitat within Study Area.
Northern meadow sedge (<i>Carex praticola</i>)	-	-	2B.2	Mesic meadows and seeps (0'-10,499').	May-July	Absent. No suitable habitat within Study Area.
Pink creamsacs (<i>Castilleja rubicundula</i> var. <i>rubicundula</i>)	-	-	1B.2	Serpentinite substrates in chaparral openings, cismontane woodland, meadows and seeps, and valley and foothill grassland (66'-2,986').	April-June	Absent. No suitable habitat within Study Area.
Rincon Ridge ceanothus (<i>Ceanothus confusus</i>)	-	-	1B.1	Volcanic or serpentine soils in closed-cone coniferous forest, chaparral, and cismontane woodland communities (246'-3,494').	February-June	Absent. No suitable habitat within Study Area.
Calistoga ceanothus (<i>Ceanothus divergens</i>)	-	-	1B.2	Serpentinite or rocky volcanic substrates in chaparral (558'-3,117').	February-April	Absent. No suitable habitat within Study Area.
Dwarf soaproot (<i>Chlorogalum pomeridianum</i> var. <i>minus</i>)	-	-	1B.2	Serpentine soils within chaparral (1,001'-3,281').	May-August	Absent. No suitable habitat within Study Area.
Tracy's clarkia (<i>Clarkia gracilis</i> ssp. <i>tracyi</i>)	-	-	4.2	Openings, usually with serpentine soils, in chaparral (213'-2,132').	April-July	Absent. No suitable habitat within Study Area.
Serpentine collomia (<i>Collomia diversifolia</i>)	-	-	4.3	Rocky or gravelly serpentinite substrates (Safford and Miller 2020) in chaparral and cismontane woodland (656'-1,969').	May-June	Absent. No suitable habitat within Study Area.

Common Name (Scientific Name)	Status			Habitat Description ¹	Survey Period	Potential to Occur Onsite
	ESA	CESA	Other			
Serpentine bird's-beak (<i>Cordylanthus tenuis</i> ssp. <i>brunneus</i>)	–	–	4.3	Usually serpentinite soils of closed-cone coniferous forest, chaparral, and cismontane woodland (1,001'–3,002').	July–August	Low potential to occur. Marginally suitable habitat (woodland) within Study Area
Serpentine cryptantha (<i>Cryptantha dissita</i>)	–	–	1B.2	Serpentine in chaparral (1,295'–1,903').	April–June	Absent. No suitable habitat within Study Area.
Swamp larkspur (<i>Delphinium uliginosum</i>)	–	–	4.2	Serpentinite seeps in chaparral and valley and foothill grassland (1,115'–2,001').	May–June	Absent. No suitable habitat within Study Area.
Cascade downingia (<i>Downingia willamettensis</i>)	–	–	2B.2	Lake margins of cismontane woodland and valley and foothill grassland; vernal pools (49'–3,642').	June–July	Absent. No suitable habitat within Study Area.
Brandegee's eriastrum (<i>Eriastrum brandegeeeae</i>)	–	–	1B.1	Volcanic, sandy substrates of chaparral and cismontane woodland (1,394'–2,756').	April–August	Absent. No suitable habitat within Study Area.
Greene's narrow-leaved daisy (<i>Erigeron greenei</i>)	–	–	1B.2	Serpentine or volcanic soils in chaparral (262'–3,298').	May–September	Absent. No suitable habitat within Study Area.
Snow Mountain buckwheat (<i>Eriogonum nervulosum</i>)	–	–	1B.2	Serpentine chaparral communities (984'–6,906').	June–September	Absent. No suitable habitat within Study Area.
Loch Lomond button-celery (<i>Eryngium constancei</i>)	FE	CE	1B.1	Vernal pools (1,509'–2,805').	April–June	Absent. No suitable habitat within Study Area.
Adobe lily (<i>Fritillaria pluriflora</i>)	–	–	1B.2	Adobe soils in chaparral, cismontane woodland, and valley and foothill grassland (197'–2,313').	February–April	Absent. No suitable habitat within Study Area.
Boggs Lake hedge-hyssop (<i>Gratiola heterosepala</i>)	–	CE	1B.2	Marshes, swamps, lake margins, and vernal pools (33'–7,792').	April–August	Absent. No suitable habitat within Study Area.
Toren's grimmia (<i>Grimmia torenii</i>)	–	–	1B.3	Openings, rocky substrates, boulder and rock walls, carbonate substrates, and volcanic substrates in chaparral, cismontane woodland, and lower montane coniferous forest (1,066'–3,806').	Any season	Absent. No suitable habitat within Study Area.

Table 1. Special-Status Species Evaluated for the Study Area

Common Name (<i>Scientific Name</i>)	Status			Habitat Description ¹	Survey Period	Potential to Occur Onsite
	ESA	CESA	Other			
Hall's harmonia (<i>Harmonia hallii</i>)	-	-	1B.2	Serpentine substrates of chaparral (1,000'-3,199').	April-June	Absent. No suitable habitat within Study Area.
Congested-headed hayfield tarplant (<i>Hemizonia congesta</i> ssp. <i>congesta</i>)	-	-	1B.2	Valley and foothill grassland; sometimes roadsides (66'-1,837').	April-November	Potential to occur. Suitable habitat within Study Area.
Glandular western flax (<i>Hesperolinon adenophyllum</i>)	-	-	1B.2	Serpentine soils (Safford and Miller 2020) in chaparral, cismontane woodland, and valley and foothill grassland (492'-4,314').	May-August	Absent. No suitable habitat within Study Area.
Two-carpellate western flax (<i>Hesperolinon bicarpellatum</i>)	-	-	1B.2	Serpentine soils of chaparral (196'-3,298').	May-July	Absent. No suitable habitat within Study Area.
Lake County western flax (<i>Hesperolinon didymocarpum</i>)	-	CE	1B.2	Serpentine substrates of chaparral, cismontane woodland, and valley and foothill grassland (1,082'-1,198').	May-July	Absent. No suitable habitat within Study Area.
Sharsmith western flax (<i>Hesperolinon sharsmithiae</i>)	-	-	1B.2	Serpentine soils of chaparral (885'-985').	May-July	Absent. No suitable habitat within Study Area.
Bolander's horkelia (<i>Horkelia bolanderi</i>)	-	-	1B.2	Within and on edges of vernal mesic areas in chaparral, lower montane coniferous forest, meadows and seeps, and valley and foothill grassland (1,476'-3,938').	June-August	Low potential to occur. Marginally suitable habitat (drainage) within Study Area.
California satintail (<i>Imperata brevifolia</i>)	-	-	2B.1	Mesic areas in chaparral, coastal scrub, Mojavean desert scrub, meadows and seeps (often alkali) and riparian scrub (0'-3,986').	September-May	Absent. No suitable habitat within Study Area.
Burke's goldfields (<i>Lasthenia burkei</i>)	FE	CE	1B.1	Mesic sites within meadows and seeps and vernal pools (49'-1,969').	April-June	Absent. No suitable habitat within Study Area.

Table 1. Special-Status Species Evaluated for the Study Area

Common Name (Scientific Name)	Status			Habitat Description ¹	Survey Period	Potential to Occur Onsite
	ESA	CESA	Other			
Colusa layia (<i>Layia septentrionalis</i>)	-	-	1B.2	Sandy or serpentinite soils in chaparral, cismontane woodland, and valley and foothill grasslands (328'-3,593').	April-May	Low potential to occur. Marginally suitable habitat (woodland and grassland without sandy or serpentinite substrates) within Study Area.
Legenere (<i>Legenere limosa</i>)	-	-	1B.1	Various seasonally inundated areas including wetlands, wetland swales, marshes, vernal pools, artificial ponds, and floodplains of intermittent drainages (USFWS 2005) (3'-2,887').	April-June	Low potential to occur. Marginally suitable habitat (drainage) within Study Area.
Bristly leptosiphon (<i>Leptosiphon acicularis</i>)	-	-	4.2	Chaparral, cismontane woodland, coastal prairie, valley and foothill grassland (180'-4,921').	April-July	Potential to occur. Suitable habitat within Study Area.
Jepson's leptosiphon (<i>Leptosiphon jepsonii</i>)	-	-	1B.2	Usually volcanic soils of chaparral, cismontane woodland, valley and foothill grasslands (328'-1,640').	March-May	Low potential to occur. Marginally suitable habitat (non-volcanic woodland and grassland) within Study Area.
Woolly meadowfoam (<i>Limnanthes floccosa</i> ssp. <i>floccosa</i>)	-	-	4.2	Vernally mesic areas in chaparral, cismontane woodland, valley and foothill grassland, and vernal pools (197'-4,380').	March-May	Low potential to occur. Marginally suitable habitat (drainage) within Study Area.
Napa lomatium (<i>Lomatium repostum</i>)	-	-	4.3	Serpentinite soils of chaparral and cismontane woodland (295'-2,724').	March-June	Absent. No suitable habitat within Study Area.
Anthony Peak lupine (<i>Lupinus antoninus</i>)	-	-	1B.2	Rocky substrates in lower montane and upper montane coniferous forest (4,002'-7,497').	May-July	Absent. No suitable habitat within Study Area.
Cobb Mountain lupine (<i>Lupinus sericatus</i>)	-	-	1B.2	Broadleaf upland forest, chaparral, cismontane woodland, and lower montane coniferous forest (902'-5,004').	May-June	Potential to occur. Suitable habitat within Study Area.

Table 1. Special-Status Species Evaluated for the Study Area

Common Name (<i>Scientific Name</i>)	Status			Habitat Description ¹	Survey Period	Potential to Occur Onsite
	ESA	CESA	Other			
Heller's bush-mallow (<i>Malacothamnus helleri</i>)	–	–	3.3	Sandstone substrates of chaparral and gravelly substrates of riparian woodland (1,000'–2,084').	May–July	Low potential to occur. Marginally suitable habitat (woodland without sandstone or gravelly substrates) within Study Area.
Mt. Diablo cottonweed (<i>Micropus amphibolus</i>)	–	–	3.2	Rocky soils in broad-leaved upland forest, chaparral, cismontane woodland, valley and foothill grassland (148'–2,707').	March–May	Low potential to occur. Marginally suitable habitat (woodland without rocky soils) within Study Area.
Elongate copper moss (<i>Mielichhoferia elongata</i>)	–	–	4.3	Metamorphic rock, usually acidic, usually vernal mesic, often roadsides, sometimes carbonate in broadleaf upland forest, chaparral, cismontane woodland, coastal scrub, lower montane coniferous forest, meadows and seeps, and subalpine coniferous forest (0'–6,430').	Any Season	Absent. No suitable habitat within Study Area.
Little mousetail (<i>Myosurus minimus</i> ssp. <i>apus</i>)	–	–	3.1	Mesic areas (USACE 2020) of valley and foothill grassland and alkaline vernal pools (66'–2,100').	March–June	Low potential to occur. Marginally suitable habitat (drainage) within Study Area.
Cotula navarretia (<i>Navarretia cotulifolia</i>)	–	–	4.2	Adobe soils of chaparral, cismontane woodland, and valley and foothill grassland (13'–6,004').	May–June	Absent. No suitable habitat within Study Area.
Jepson's navarretia (<i>Navarretia jepsonii</i>)	–	–	4.3	Serpentine substrates of chaparral, cismontane woodland, and valley and foothill grassland (574'–2,806').	April–June	Absent. No suitable habitat within Study Area.
Baker's navarretia (<i>Navarretia leucocephala</i> ssp. <i>bakeri</i>)	–	–	1B.1	Vernal pools and mesic areas within cismontane woodlands, lower montane coniferous forests, meadows and seeps, and valley and foothill grasslands (16'–5,709').	April–July	Low potential to occur. Marginally suitable habitat (drainage) within Study Area.

Table 1. Special-Status Species Evaluated for the Study Area

Common Name (<i>Scientific Name</i>)	Status			Habitat Description ¹	Survey Period	Potential to Occur Onsite
	ESA	CESA	Other			
Few-flowered navarretia (<i>Navarretia leucocephala</i> ssp. <i>pauciflora</i>)	FE	CT	1B.1	Volcanic ash flow vernal pools (1,312'–2,805').	May–June	Absent. No suitable habitat within Study Area.
Many-flowered navarretia (<i>Navarretia leucocephala</i> ssp. <i>plieantha</i>)	FE	CE	1B.2	Volcanic ash flow vernal pools (98'–3,117').	May–June	Absent. No suitable habitat within Study Area.
Porter's navarretia (<i>Navarretia paradoxinota</i>)	–	–	1B.3	Vernally mesic openings and drainages on serpentine substrates in meadows and seeps (541'–2,756').	May–June	Absent. No suitable habitat within Study Area.
Slender Orcutt grass (<i>Orcuttia tenuis</i>)	FT	CE	1B.1	Vernal pools, often gravelly (115'–5,774').	May–September	Absent. No suitable habitat within Study Area.
Geysers panicum (<i>Panicum acuminatum</i> var. <i>thermale</i>)	–	CE	1B.2	Geothermally-altered soils and sometimes streamsides of closed-cone coniferous forest, riparian forest, and valley and foothill grassland (1,000'–8,104').	June–August	Absent. No suitable habitat within Study Area.
Lake County stonecrop (<i>Parvisedum leiocarpum</i>)	FE	CE	1B.1	Vernally mesic depressions in volcanic outcrops of cismontane woodland, valley and foothill grassland, and vernal pools (1,197'–2,592').	April–May	Absent. No suitable habitat within Study Area.
Sonoma beardtongue (<i>Penstemon newberryi</i> var. <i>sonomensis</i>)	–	–	1B.3	Rocky substrates of chaparral (2,296'–4,495').	April–August	Absent. No suitable habitat within Study Area.
Michael's rein orchid (<i>Piperia michaelii</i>)	–	–	4.2	Coastal bluff scrub, closed-cone coniferous forest, chaparral, cismontane woodland, coastal scrub, and lower montane coniferous forest (10'–3,002').	April–August	Potential to occur. Suitable habitat within Study Area.
Eel-grass pondweed (<i>Potamogeton zosteriformis</i>)	–	–	2B.2	Assorted freshwater marshes and swamps (0'–6,102').	June–July	Absent. No suitable habitat within Study Area.

Table 1. Special-Status Species Evaluated for the Study Area

Common Name (<i>Scientific Name</i>)	Status			Habitat Description ¹	Survey Period	Potential to Occur Onsite
	ESA	CESA	Other			
Lake County stonecrop (<i>Sedella leiocarpa</i>)	FE	CE	1B.1	Vernally mesic depressions in volcanic outcrops in cismontane woodland, valley and foothill grasslands, and vernal pools (1,198'–2,592').	April–May	Absent. No suitable habitat within Study Area.
Cleveland's ragwort (<i>Senecio clevelandii</i> var. <i>clevelandii</i>)	–	–	4.3	Serpentine seeps of chaparral (1,197'–2,953').	June–July	Absent. No suitable habitat within Study Area.
Marsh checkerbloom (<i>Sidalcea oregana</i> ssp. <i>hydrophila</i>)	–	–	1B.2	Mesic areas of meadows and seeps and riparian forest communities (3,608'–7,545').	July–August	Absent. Study Area is outside of the known elevational range for this species.
Bearded jewelflower (<i>Streptanthus barbiger</i>)	–	–	4.2	Serpentine substrates of chaparral (492'–3,511').	May–July	Absent. No suitable habitat within Study Area.
Socrates Mine jewelflower (<i>Streptanthus brachiatus</i> ssp. <i>brachiatus</i>)	–	–	1B.2	Closed-cone coniferous forest and chaparral; usually on serpentine substrates (1,788'–3,281').	May–June	Absent. No suitable habitat within Study Area.
Freed's jewelflower (<i>Streptanthus brachiatus</i> ssp. <i>hoffmanii</i>)	–	–	1B.2	Serpentine substrates of chaparral and cismontane woodland (1,608'–4,003').	May–July	Absent. No suitable habitat within Study Area.
Hoffman's bristly jewelflower (<i>Streptanthus glandulosus</i> ssp. <i>hoffmanii</i>)	–	–	1B.3	Rocky substrates in chaparral, cismontane woodland, and often serpentine substrates in valley and foothill grassland (393'–1,592').	March–July	Absent. No suitable habitat within Study Area.
Green jewelflower (<i>Streptanthus hesperidis</i>)	–	–	1B.2	Rocky, serpentine substrates of chaparral openings and cismontane woodland (426'–2,494').	May–July	Absent. No suitable habitat within Study Area.
Three Peaks jewelflower (<i>Streptanthus morrisonii</i> ssp. <i>elatus</i>)	–	–	1B.2	Serpentine substrates of chaparral (295'–2,674').	June–September	Absent. No suitable habitat within Study Area.
Kruckeberg's jewel flower (<i>Streptanthus morrisonii</i> ssp. <i>kruckebergii</i>)	–	–	1B.2	Serpentine substrates of cismontane woodland (705'–3,396').	April–July	Absent. No suitable habitat within Study Area.

Table 1. Special-Status Species Evaluated for the Study Area						
Common Name (Scientific Name)	Status			Habitat Description ¹	Survey Period	Potential to Occur Onsite
	ESA	CESA	Other			
Marsh zigadenus (<i>Toxicoscordion fontanum</i>)	-	-	4.2	Vernally mesic chaparral, cismontane woodland, lower montane coniferous forest, meadows and seeps, and marshes and swamps; often on serpentinite substrates (49'-3,281').	April-July	Low potential to occur. Marginally suitable habitat (drainage) within Study Area.
Napa bluecurls (<i>Trichostema ruygtii</i>)	-	-	1B.2	Chaparral, cismontane woodland, lower montane coniferous forest, valley and foothill grassland, and vernal pools (98'-2,231').	June-October	Potential to occur. Suitable habitat within Study Area.
Saline clover (<i>Trifolium hydrophilum</i>)	-	-	1B.2	Marshes and swamps, vernal pools, and mesic alkaline areas in valley and foothill grassland (0'-984').	April-June	Absent. No suitable habitat within Study Area.
Oval-leaved viburnum (<i>Viburnum ellipticum</i>)	-	-	2B.3	Chaparral, cismontane woodland, and lower montane coniferous forest communities (705'-4,593').	May-June	Potential to occur. Suitable habitat within Study Area.
Fish						
Sacramento perch (<i>Archoplites interruptus</i>)	-	-	SSC	Ponds, rivers, backwaters, and lakes.	N/A	Absent. No suitable habitat within Study Area.
Clear Lake tule perch (<i>Hysterocarpus traskii lagunae</i>)	-	-	SSC	Endemic to Clear Lake, Lower Blue Lake, and Upper Blue Lake in Lake County. Requires cover and are usually found in small shoals in deep tule beds, among rocks, or among branches of fallen leaves (Moyle et al. 2015).	N/A	Absent. No suitable habitat within Study Area.

Table 1. Special-Status Species Evaluated for the Study Area

Common Name (<i>Scientific Name</i>)	Status			Habitat Description ¹	Survey Period	Potential to Occur Onsite
	ESA	CESA	Other			
Clear Lake hitch (<i>Lavinia exilicauda chi</i>)	-	CT	-	Found only in Clear Lake and associated ponds and streams in Lake County. Adults found in the limnetic zone. Juveniles found in the shallow-water habitat hiding in vegetation. Spawning occurs in streams flowing into Clear Lake (CDFW 2021a).	N/A	Absent. No suitable habitat within Study Area. Burns Valley Creek, which is directly adjacent to the Study Area to the west, represents marginally suitable spawning habitat for this species. However, the Study Area does not include Burns Valley Creek and the Project does not propose impacts to the creek or riparian corridor for the creek.
Delta smelt (<i>Hypomesus transpacificus</i>)	FT	CE	-	Sacramento-San Joaquin Delta.	N/A	Absent. Outside of geographic range and no suitable habitat within Study Area.
Steelhead (California Central Coast distinct population segment [DPS]) (<i>Oncorhynchus mykiss</i>)	FT	-	-	Undammed rivers, streams, creeks.	N/A	Absent. No suitable habitat within Study Area.
Amphibians						
Red-bellied newt (<i>Taricha rivularis</i>)	-	-	SSC	Terrestrial habitat. Juveniles generally stay underground, adults active at surface in moist environments. Will migrate over 1 km to breed, typically in streams with moderate flow and clean, rocky substrate. Found in coastal drainages from Humboldt County south to Sonoma County, inland to Lake County with an isolated population in Santa Clara County.	January – April	Absent. Study Area is outside of the known geographical range for this species.

Table 1. Special-Status Species Evaluated for the Study Area

Common Name (<i>Scientific Name</i>)	Status			Habitat Description ¹	Survey Period	Potential to Occur Onsite
	ESA	CESA	Other			
California giant salamander (<i>Dicamptodon ensatus</i>)	-	-	SSC	Aquatic larvae found in cold, clear streams, occasionally in lakes and ponds. Adults known from wet forests under rocks and logs near streams and lakes. Known from wet coastal forests near streams and seeps from Mendocino County south to Monterey County and east to Napa County.	Year round	Absent. No suitable habitat and Study Area is outside of the known geographical range for this species.
Foothill yellow-legged frog (<i>Northwest/North Coast Clade</i>) (<i>Rana boylei</i>)	-	-	SSC	Foothill yellow-legged frogs can be active all year in warmer locations but may become inactive or hibernate in colder climates. At lower elevations, foothill yellow-legged frogs likely spend most of the year in or near streams. Adult frogs, primarily males, will gather along main-stem rivers during spring to breed.	May - October	Absent. No suitable habitat within Study Area.
California red-legged frog (<i>Rana draytonii</i>)	FT	-	SSC	Lowlands or foothills at waters with dense shrubby or emergent riparian vegetation. Adults must have aestivation habitat to endure summer dry down.	May 1 - November 1	Absent. No suitable upland habitat within Study Area and species unlikely to occur in onsite aquatic habitat. There are no known occurrences or potential breeding ponds nearby and the site is within an urban/agricultural setting with a long history of disturbance.

Table 1. Special-Status Species Evaluated for the Study Area						
Common Name (Scientific Name)	Status			Habitat Description ¹	Survey Period	Potential to Occur Onsite
	ESA	CESA	Other			
Reptiles						
Northwestern pond turtle (<i>Actinemys marmorata</i>)	-	-	SSC	Requires basking sites and upland habitats up to 0.5 km from water for egg laying. Uses ponds, streams, detention basins, and irrigation ditches.	April-September	Low potential to occur. Marginally suitable upland habitat within Study Area. The site is within an urban/agricultural setting with a long history of disturbance.
Birds						
Clark's grebe (<i>Aechmophorus clarkii</i>)	-	-	BCC	Winters on salt or brackish bays, estuaries, sheltered sea coasts, freshwater lakes, and rivers. Breeds on freshwater to brackish marshes, lakes, reservoirs and ponds, with a preference for large stretches of open water fringed with emergent vegetation.	June-August (breeding)	Absent. No suitable habitat within Study Area.
Yellow-billed cuckoo (<i>Coccyzus americanus</i>)	FT	CE	BCC	Breeds in California, Arizona, Utah, Colorado, and Wyoming. In California, they nest along the upper Sacramento River and the South Fork Kern River from Isabella Reservoir to Canebrake Ecological Reserve. Other known nesting locations include Feather River (Butte, Yuba, Sutter counties), Prado Flood Control Basin (San Bernardino and Riverside counties), Amargosa River and Owens Valley (Inyo County), Santa Clara River (Los Angeles County), Mojave River and Colorado River (San Bernardino County). Nests in riparian woodland. Winters in South America.	June 15-August 15	Absent. Study Area is outside of geographic range for this species.

Table 1. Special-Status Species Evaluated for the Study Area

Common Name (Scientific Name)	Status			Habitat Description ¹	Survey Period	Potential to Occur Onsite
	ESA	CESA	Other			
Osprey (<i>Pandion haliaetus</i>)	-	-	CDFW WL	Nesting habitat requires close proximity to accessible fish, open nest site free of mammalian predators, and extended ice-free season. The nest in large trees, snags, cliffs, transmission/communication towers, artificial nest platforms, channel markers/buoys.	April-September	Absent. No suitable habitat within Study Area.
Golden eagle (<i>Aquila chrysaetos</i>)	-	-	BCC, CFP	Nesting habitat includes mountainous canyon land, rimrock terrain of open desert and grasslands, riparian, oak woodland/savannah, and chaparral. Nesting occurs on cliff ledges, river banks, trees, and human-made structures (e.g., windmills, platforms, and transmission towers). Breeding occurs throughout California, except the immediate coast, Central Valley floor, Salton Sea region, and the Colorado River region, where they can be found during Winter.	Nest (February-August); winter CV (October-February)	Absent. No suitable habitat within Study Area.
Bald eagle (<i>Haliaeetus leucocephalus</i>)	Delisted	CE	CFP, BCC	Typically nests in forested areas near large bodies of water in the northern half of California; nest in trees and rarely on cliffs; wintering habitat includes forest and woodland communities near water bodies (e.g., rivers, lakes), wetlands, flooded agricultural fields, open grasslands	February – September (nesting); October-March (wintering)	Absent. No suitable habitat within Study Area.
Northern spotted owl (<i>Strix occidentalis caurina</i>)	FT	CC	SSC	Found from Marin County through coastal ranges north to British Columbia; breeds in old growth mature forest. They use forests with greater complexity and structure.	March-June	Absent. No suitable habitat within Study Area.

Common Name (<i>Scientific Name</i>)	Status			Habitat Description ¹	Survey Period	Potential to Occur Onsite
	ESA	CESA	Other			
Nuttall's woodpecker (<i>Dryobates nuttalli</i>)	-	-	BCC	Resident from northern California south to Baja California. Nests in tree cavities in oak woodlands and riparian woodlands.	April-July	Potential to occur. Suitable nesting habitat within Study Area. Observed during reconnaissance site visit.
Purple martin (<i>Progne subis</i>)	-	-	SSC	In California, breeds along coast range, Cascade-northern Sierra Nevada region and isolated population in Sacramento. Nesting habitat includes montane forests, Pacific lowlands with dead snags; the isolated Sacramento population nests in weep holes under elevated highways/bridges. Winters in South America.	May-August	Absent. No suitable habitat within Study Area.
Oak titmouse (<i>Baeolophus inornatus</i>)	-	-	BCC	Nests in tree cavities within dry oak or oak-pine woodland and riparian; where oaks aren't absent, they nest in juniper woodland and open forests (gray, Jeffrey, Coulter, pinyon pines and Joshua tree).	March-July	Potential to occur. Suitable nesting habitat within Study Area.
Wrentit (<i>Chamaea fasciata</i>)	-	-	BCC	Coastal sage scrub, northern coastal scrub, chaparral, dense understory of riparian woodlands, riparian scrub, coyote brush and blackberry thickets, and dense thickets in suburban parks and gardens.	March-August	Absent. No suitable habitat within Study Area.

Table 1. Special-Status Species Evaluated for the Study Area

Common Name (<i>Scientific Name</i>)	Status			Habitat Description ¹	Survey Period	Potential to Occur Onsite
	ESA	CESA	Other			
Lawrence's goldfinch (<i>Spinus lawrencei</i>)	-	-	BCC	Breeds in Sierra Nevada and inner Coast Range foothills surrounding the Central Valley and the southern Coast Range to Santa Barbara County east through southern California to the Mojave Desert and Colorado Desert into the Peninsular Range. Nests in arid and open woodlands with chaparral or other brushy areas, tall annual weed fields, and a water source (e.g., small stream, pond, lake), and to a lesser extent riparian woodland, coastal scrub, evergreen forests, pinyon-juniper woodland, planted conifers, and ranches or rural residences near weedy fields and water.	March-September	Potential to occur. Suitable nesting habitat within Study Area.
Song sparrow "Modesto" (<i>Melospiza melodia heermanni</i>)	-	-	BCC, SSC	Resident in central and southwest California, including Central Valley; nests in marsh, scrub habitat.	April-June	Absent. No suitable habitat within Study Area.
Tricolored blackbird (<i>Agelaius tricolor</i>)	-	CT	BCC, SSC	Breeds locally west of Cascade-Sierra Nevada and southeastern deserts from Humboldt and Shasta counties south to San Bernardino, Riverside and San Diego counties. Central California, Sierra Nevada foothills and Central Valley, Siskiyou, Modoc and Lassen counties. Nests colonially in freshwater marsh, blackberry bramble, milk thistle, triticale fields, weedy (mustard, mallow) fields, giant cane, safflower, stinging nettles, tamarisk, riparian scrublands and forests, fiddleneck and fava bean fields.	March-August	Absent. No suitable habitat within Study Area.

Table 1. Special-Status Species Evaluated for the Study Area						
Common Name (<i>Scientific Name</i>)	Status			Habitat Description ¹	Survey Period	Potential to Occur Onsite
	ESA	CESA	Other			
San Clemente spotted towhee (<i>Pipilo maculatus clementae</i>)	-	-	BCC, SSC	Resident on Santa Catalina and Santa Rosa islands; extirpated on San Clemente Island, California. Breeds in dense, broadleaf shrubby brush, thickets, and tangles in chaparral, oak woodland, island woodland, and Bishop pine forest.	Year-round resident; breeding season is April-July	Absent. Study Area is outside of the geographic range for this subspecies.
Saltmarsh common yellowthroat (<i>Geothlypis trichas sinuosa</i>)	-	-	BCC, SSC	Breeds in salt marshes of San Francisco Bay; winters San Francisco south along coast to San Diego County.	March-July	Absent. No suitable habitat within Study Area.
Mammals						
Townsend's big-eared bat (<i>Corynorhinus townsendii</i>)	-	-	SSC	Caves, mines, buildings, rock crevices, trees.	April-September	Potential to occur. Suitable roosting and foraging habitat within Study Area.
Pallid bat (<i>Antrozous pallidus</i>)	-	-	SSC	Crevices in rocky outcrops and cliffs, caves, mines, trees (e.g., basal hollows of redwoods, cavities of oaks, exfoliating pine and oak bark, deciduous trees in riparian areas, and fruit trees in orchards). Also roosts in various human structures such as bridges, barns, porches, bat boxes, and human-occupied as well as vacant buildings (Western Bat Working Group [WBWG] 2021).	April-September	Potential to occur. Suitable roosting and foraging habitat within Study Area.
¹ Habitat descriptions for plant species are from the CNPS Inventory of Rare and Endangered Plants (CNPS 2021), unless otherwise stated.						
Status Codes:						

- FESA Federal Endangered Species Act
- CESA California Endangered Species Act
- FE FESA listed, Endangered.
- FT FESA listed, Threatened.
- BCC USFWS Bird of Conservation Concern
- CE CESA or NPPA listed, Endangered.
- CT CESA- or NPPA-listed, Threatened.
- CC Candidate for CESA listing as Endangered or Threatened.
- CFP California Fish and Game Code Fully Protected Species (§ 3511-birds, § 4700-mammals, §5 050-reptiles/amphibians).
- CDFW WL CDFW Watch List
- SSC CDFW Species of Special Concern (CDFW, updated July 2017).
- 1B CRPR/Rare or Endangered in California and elsewhere.
- 2B Plants rare, threatened, or endangered in California but more common elsewhere.

Common Name (Scientific Name)	Status			Habitat Description ¹	Survey Period	Potential to Occur Onsite
	ESA	CESA	Other			
3	CRPR/Plants About Which More Information is Needed – A Review List.					
4	CRPR/Plants of Limited Distribution – A Watch List.					
0.1	Threat Rank/Seriously threatened in California (over 80% of occurrences threatened / high degree and immediacy of threat)					
0.2	Threat Rank/Moderately threatened in California (20-80% occurrences threatened / moderate degree and immediacy of threat)					
0.3	Threat Rank/Not very threatened in California (<20% of occurrences threatened / low degree and immediacy of threat or no current threats known)					
Delisted	Formally Delisted (delisted species are monitored for 5 years).					

Plants

A total of 83 special-status plant species were identified as having the potential to occur in the vicinity of the Study Area based on the literature review (Table 1). Of those, 62 species were determined to be absent from the Study Area due to the lack of suitable habitat or due to the Study Area being outside of the known elevational range for the species (Table 1). No further discussion of those species is provided in this assessment. A brief description of the remaining 21 species that have the potential to occur within the Study Area is presented below.

Bent-Flowered Fiddleneck

Bent-flowered fiddleneck (*Amsinckia lunaris*) is not listed pursuant to the federal or California ESAs, but is designated as a CRPR 1B.2 species. This species is an herbaceous annual that occurs in cismontane woodland, coastal bluff scrub, and valley and foothill grasslands (CNPS 2021). Bent-flowered fiddleneck blooms from March through June and is known to occur at elevations ranging from 10 to 1,640 feet above MSL (CNPS 2021). This species is endemic to California; its current range includes Alameda, Contra Costa, Colusa, Lake, Marin, Napa, San Benito, Santa Clara, Santa Cruz, San Mateo, Sonoma, Sutter, and Yolo counties (CNPS 2021).

There is one CNDDDB occurrence of bent-flowered fiddleneck within five miles of the Study Area (CDFW 2021a). The oak woodlands and grassland within the Study Area may provide suitable habitat for this species. Bent-flowered fiddleneck has potential to occur within the Study Area.

Coast Rockcress

Coast rockcress (*Arabis blepharophylla*) is not listed pursuant to either the federal or California ESAs, but is designated as a CRPR 4.3 species. This species is an herbaceous perennial that occurs in rocky soils in broadleaf upland forest, coastal bluff scrub, coastal prairie, and coastal scrub (CNPS 2021). Coast rockcress blooms from February through May and is known to occur at elevations ranging from 10 to 3,609 feet above MSL (CNPS 2021). Coast rockcress is endemic to California; its current range includes Contra Costa, Lake, Monterey, Marin, Santa Cruz, San Francisco, San Mateo, and Sonoma counties; however, its presence is uncertain in Santa Cruz County (CNPS 2021).

The CNDDDB does not often publish occurrence records for CRPR 4 species, and there are no published occurrences of coast rockcress. The oak woodlands within the Study Area may provide marginally suitable habitat for this species. Coast rockcress has low potential to occur within the Study Area.

Brewer's Milk-Vetch

Brewer's milk-vetch (*Astragalus breweri*) is not listed pursuant to either the federal or California ESAs, but is designated as a CRPR 4.2 species (CNPS 2021). This species is an herbaceous annual that occurs on volcanic and often serpentinite substrates in chaparral, cismontane woodland, meadows and seeps, and open, often gravelly areas of valley and foothill grassland. Brewer's milk-vetch blooms from April through June and is known to occur at elevations ranging from 295 to 2,395 feet above MSL (CNPS 2021). Brewer's milk-vetch is endemic to California; its current range includes Colusa, Lake, Mendocino, Marin, Napa, Sonoma, and Yolo counties (CNPS 2021).

The CNDDDB does not often publish occurrence records for CRPR 4 species, and there are no published occurrences of Brewer's milk-vetch. The oak woodlands and grassland within the Study Area may provide marginally suitable habitat for this species. Brewer's milk-vetch has low potential to occur within the Study Area.

Jepson's Milk-Vetch

Jepson's milk-vetch (*Astragalus rattanii* var. *jepsonianus*) is not listed pursuant to either the federal or California ESAs, but is designated as a CRPR 1B.2 species. This species is an herbaceous annual that often occurs on serpentinite substrates in chaparral, cismontane woodland, and valley and foothill grassland (CNPS 2021). Jepson's milk-vetch blooms from March through June and is known to occur at elevations ranging from 968 to 2,297 feet above MSL (CNPS 2021). Jepson's milk-vetch is endemic to California; its current range includes Colusa, Glenn, Lake, Mendocino, Napa, San Benito, Sonoma, Tehama, and Yolo counties (CNPS 2021).

There are no CNDDDB occurrences of Jepson's milk-vetch within five miles of the Study Area (CDFW 2021a). However, the grassland within the Study Area may provide marginally suitable habitat for this species. Jepson's milk-vetch has low potential to occur within the Study Area.

Serpentine Bird's-Beak

Serpentine bird's-beak (*Cordylanthus tenuis* ssp. *brunneus*) is not listed pursuant to either the federal or California ESAs, but is designated as a CRPR 4.3 species. This species is a hemiparasitic herbaceous annual that occurs usually in serpentinite soil within closed-cone coniferous forest, chaparral, and cismontane woodland (CNPS 2021). Serpentine bird's-beak blooms from July through August and is known to occur at elevations ranging from 1,001 to 3,002 feet above MSL (CNPS 2021). Serpentine bird's-beak is endemic to California; its current range includes Lake, Napa, and Sonoma counties (CNPS 2021).

There are no CNDDDB occurrences of serpentine bird's-beak within five miles of the Study Area (CDFW 2021a). However, the oak woodlands within the Study Area may provide marginally suitable habitat for this species. Serpentine bird's-beak has low potential to occur within the Study Area.

Congested-Headed Hayfield Tarplant

Congested-headed hayfield tarplant (*Hemizonia congesta* ssp. *congesta*) is not listed pursuant to either the federal or California ESAs, but is designated as a CRPR 1B.2 species. This species is an annual herb that occurs in valley and foothill grassland and sometimes roadsides (CNPS 2021). Congested-headed hayfield tarplant blooms from April through November and is known to occur at elevations ranging from 66 to 1,837 feet above MSL (CNPS 2021). Congested-headed hayfield tarplant is endemic to California; the current range of this species includes Lake, Mendocino, Marin, San Francisco, San Mateo, and Sonoma counties (CNPS 2021).

There are no CNDDDB occurrences of congested-headed hayfield tarplant within five miles of the Study Area (CDFW 2021a). However, the developed/disturbed areas and grassland within the Study Area may provide suitable habitat for this species. Congested-headed hayfield tarplant has potential to occur within the Study Area.

Bolander's Horkelia

Bolander's horkelia (*Horkelia bolanderi*) is not listed pursuant to either the federal or California ESAs, but is designated as a CRPR 1B.2 species. This species is an herbaceous perennial that occurs in and on edges of vernal mesic areas in chaparral, lower montane coniferous forest, meadows and seeps, and valley and foothill grassland (CNPS 2021). Bolander's horkelia blooms from June through August and is known to occur at elevations ranging from 1,476 to 3,938 feet above MSL (CNPS 2021). Bolander's horkelia is endemic to California; its current range includes Colusa, Lake, and Mendocino counties; however, it is presumed extirpated in Colusa County (CNPS 2021).

There are four CNDDDB occurrences of Bolander's horkelia within five miles of the Study Area (CDFW 2021a). The drainage corridor within the Study Area may provide marginally suitable habitat for this species. Bolander's horkelia has low potential to occur within the Study Area.

Colusa Layia

Colusa layia (*Layia septentrionalis*) is not listed pursuant to either the federal or California ESAs, but is designated as a CRPR 1B.2 species. This species is an herbaceous annual that occurs in sandy or serpentinite soils in chaparral, cismontane woodland, and valley and foothill grasslands (CNPS 2021). Colusa layia blooms from April through May and is known to occur at elevations ranging from 328 to 3,593 feet above MSL (CNPS 2021). Colusa layia is endemic to California; the current range of this species includes Butte, Colusa, Glenn, Lake, Mendocino, Napa, Sonoma, Sutter, Tehama, and Yolo counties (CNPS 2021).

There is one CNDDDB occurrence of Colusa layia within five miles of the Study Area (CDFW 2021a). The woodland and grassland within the Study Area may provide marginally suitable habitat for this species. Colusa layia has low potential to occur within the Study Area.

Legenere

Legenere (*Legenere limosa*) is not listed pursuant to either the federal or California ESAs, but is designated as a CRPR 1B.1 species (CNPS 2021). This species is an herbaceous annual that occurs in a variety of

seasonally inundated environments including wetlands, wetland swales, marshes, vernal pools, artificial ponds, and floodplains of intermittent drainages (USFWS 2005). *Legenere* blooms from April through June and is known to occur at elevations ranging from three feet to 2,887 feet above MSL (CNPS 2021). *Legenere* is endemic to California; the current range of this species includes Alameda, Lake, Monterey, Napa, Placer, Sacramento, Santa Clara, San Joaquin, Shasta, San Mateo, Solano, Sonoma, Stanislaus, Tehama, and Yuba counties; is believed to be extirpated from Stanislaus County (CNPS 2021).

There are no CNDDDB occurrences of *legenere* within five miles of the Study Area (CDFW 2021a). However, the drainage corridor within the Study Area may provide marginally suitable habitat for this species. *Legenere* has low potential to occur within the Study Area.

Bristly Leptosiphon

Bristly leptosiphon (*Leptosiphon acicularis*) is not listed pursuant to either the federal or California ESAs, but is designated as a CRPR 4.2 species. This species is an annual herb that occurs in chaparral, cismontane woodland, coastal prairie, and valley and foothill grassland (CNPS 2021). Bristly leptosiphon blooms from April through July and is known to occur at elevations ranging from 180 to 4,921 feet above MSL (CNPS 2021). Bristly leptosiphon is endemic to California; the current range of this species includes Alameda, Butte, Contra Costa (distribution and presence is uncertain), Fresno, Humboldt, Lake, Mendocino, Marin, Napa, Santa Clara, San Mateo, and Sonoma counties (CNPS 2021).

There are no CNDDDB occurrences of bristly leptosiphon within five miles of the Study Area (CDFW 2021a). However, the oak woodlands and grassland within the Study Area may provide suitable habitat for this species. Bristly leptosiphon has potential to occur within the Study Area.

Jepson's Leptosiphon

Jepson's leptosiphon (*Leptosiphon jepsonii*) is not listed pursuant to either the federal or California ESAs, but is designated as a CRPR 1B.2 species. This species is an annual herb that usually occurs in volcanic soils of chaparral, cismontane woodland, and valley and foothill grasslands (CNPS 2021). Jepson's leptosiphon blooms from March through May and is known to occur at elevations ranging from 328 to 1,640 feet above MSL (CNPS 2021). Jepson's leptosiphon is endemic to California; the current range of this species includes Lake, Napa, Sonoma, and Yolo counties (CNPS 2021).

There are no CNDDDB occurrences of Jepson's leptosiphon within five miles of the Study Area (CDFW 2021a). However, the oak woodlands and grassland within the Study Area may provide marginally suitable habitat for this species. Jepson's leptosiphon has low potential to occur within the Study Area.

Woolly Meadowfoam

Woolly meadowfoam (*Limnanthes floccosa* ssp. *floccosa*) is not listed pursuant to either the federal or California ESAs, but is designated as a CRPR 4.2 species. This species is an herbaceous annual that occurs in vernal mesic chaparral, cismontane woodland, valley and foothill grassland, and vernal pools (CNPS 2021). Woolly meadowfoam blooms from March through May and is known to occur at elevations ranging from 196 to 4,380 feet above MSL (CNPS 2021). The current known range for this species in California includes Butte, Lake, Lassen, Napa, Shasta, Siskiyou, Tehama, and Trinity counties (CNPS 2021).

There are no CNDDDB occurrences of woolly meadowfoam within five miles of the Study Area (CDFW 2021a). However, the drainage corridor within the Study Area may provide marginally suitable habitat for this species. Woolly meadowfoam has low potential to occur within the Study Area.

Cobb Mountain Lupine

Cobb Mountain lupine (*Lupinus sericatus*) is not listed pursuant to either the federal or California ESAs, but is designated as a CRPR 1B.2 species. This species is an herbaceous perennial that occurs in broadleaved upland forest, chaparral, cismontane woodland, and lower montane coniferous forest (CNPS 2021). Cobb Mountain lupine blooms from March through June and is known to occur at elevations ranging from 902 to 5,004 feet above MSL (CNPS 2021). Cobb Mountain lupine is endemic to California; its current range includes Colusa, Lake, Napa, and Sonoma counties (CNPS 2021).

There are no CNDDDB occurrences of Cobb Mountain lupine within five miles of the Study Area (CDFW 2021a). However, the oak woodland within the Study Area may provide marginally suitable habitat for this species. Cobb Mountain lupine has low potential to occur within the Study Area.

Heller's Bush-Mallow

Heller's bush-mallow (*Malacothamnus helleri*) is not listed pursuant to either the federal or California ESAs, but is designated as a CRPR 3.3 species. This species is a perennial deciduous shrub that occurs in sandstone substrates in chaparral and gravel substrates of riparian woodland (CNPS 2021). Heller's bush-mallow blooms from May through July and is known to occur at elevations ranging from 1,000 to 2,084 feet above MSL (CNPS 2021). Heller's bush-mallow is endemic to California; its current range includes Colusa, Glenn, Lake, Napa, Tehama, and Yolo counties; however, its distribution or identity is uncertain in Glenn County (CNPS 2021).

There are no CNDDDB occurrences of Heller's bush-mallow within five miles of the Study Area (CDFW 2021a). However, the oak woodland within the Study Area may provide marginally suitable habitat for this species. Heller's bush-mallow has low potential to occur within the Study Area.

Mt. Diablo Cottonweed

Mt. Diablo cottonweed (*Micropus amphibolus*) is not listed pursuant to either the federal or California ESAs, but is designated as a CRPR 3.2 species. This species is an herbaceous annual that occurs in rocky soils in broadleaved upland forest, chaparral, cismontane woodland, and valley and foothill grassland (CNPS 2021). Mt. Diablo cottonweed blooms from March through May and is known to occur at elevations ranging from 148 to 2,707 feet above MSL (CNPS 2021). Mt. Diablo cottonweed is endemic to California; the current range of this species includes Alameda, Contra Costa, Colusa, Lake, Monterey, Marin, Napa, Santa Barbara, Santa Clara, Santa Cruz, San Joaquin, Solano, and Sonoma counties (CNPS 2021).

The CNDDDB does not often publish occurrence records for CRPR 3 species, and there are no published occurrences of Mt. Diablo cottonweed. The oak woodlands and grassland within the Study Area may provide marginally suitable habitat for this species. Mt. Diablo cottonweed has low potential to occur within the Study Area.

Little Mousetail

Little mousetail (*Myosurus minimus* ssp. *apus*) is not listed pursuant to either the federal or California ESAs, but is designated as a CRPR 3.1 species. This species is an herbaceous annual that occurs in mesic areas (USACE 2020) of valley and foothill grassland and alkaline vernal pools (CNPS 2021). Little mousetail blooms between March and June and is known to occur at elevations ranging from 66 to 2,100 feet above MSL (CNPS 2021). The current range for little mousetail in California includes Alameda, Contra Costa, Colusa, Lake, Merced, Riverside, San Bernardino, San Diego, Solano, Tulare, and Yolo counties (CNPS 2021).

There are no CNDDDB occurrences of little mousetail within five miles of the Study Area (CDFW 2021a). However, the drainage corridor within the Study Area may provide marginally suitable habitat for this species. Little mousetail has low potential to occur within the Study Area.

Baker's Navarretia

Baker's navarretia (*Navarretia leucocephala* ssp. *bakeri*) is not listed pursuant to either the federal or California ESAs, but is designated as a CRPR 1B.1 species. This species is an herbaceous annual that occurs in vernal pools and mesic areas within cismontane woodlands, lower montane coniferous forests, meadows and seeps, and valley and foothill grasslands (CNPS 2021). Baker's navarretia blooms from April through July and is known to occur at elevations ranging from 16 to 5,709 feet above MSL (CNPS 2021). Baker's navarretia is endemic to California; the current range of this species includes Colusa, Glenn, Lake, Lassen, Mendocino, Marin, Napa, Solano, Sonoma, Sutter, Tehama, and Yolo counties (CNPS 2021).

There are three CNDDDB occurrences of Baker's navarretia within five miles of the Study Area (CDFW 2021a). The drainage corridor within the Study Area may provide marginally suitable habitat for this species. Baker's navarretia has low potential to occur within the Study Area.

Michael's Rein Orchid

Michael's rein orchid (*Piperia michaelii*) is not listed pursuant to either the federal or California ESAs, but is designated as a CRPR 4.2 species. This species is an herbaceous perennial that occurs in coastal bluff scrub, closed-cone coniferous forest, chaparral, cismontane woodland, coastal scrub, and lower montane coniferous forest (CNPS 2021). Michael's rein orchid blooms from April through August and is known to occur at elevations ranging from 10 to 3,002 feet above MSL (CNPS 2021). Michael's rein orchid is endemic to California; its current range includes Alameda, Amador, Butte, Contra Costa, Fresno, Humboldt, Los Angeles Monterey, Marin, Santa Barbara, San Benito, Santa Clara, Santa Cruz, Santa Cruz Island, San Francisco, San Luis Obispo, San Mateo, Stanislaus, Tulare, Tuolumne, Ventura, and Yuba counties. It is presumed extirpated in Los Angeles County, and distribution is uncertain, but presumed extirpated if once present in Ventura County (CNPS 2021).

The CNDDDB does not often publish occurrence records for CRPR 4 species, and there are no published occurrences of Michael's rein orchid. The oak woodlands within the Study Area may provide suitable habitat for this species. Michael's rein orchid has potential to occur within the Study Area.

Marsh Zigadenus

Marsh zigadenus (*Toxicoscordion fontanum*) is not listed pursuant to either the federal or California ESAs, but is designated as a CRPR 4.2 species. This species is an herbaceous bulbiferous perennial that occurs in vernal mesic and often on serpentinite substrates in chaparral, cismontane woodland, lower montane coniferous forest, meadows and seeps, and marshes and swamps (CNPS 2021). Marsh zigadenus is known to occur at elevations ranging from 49 to 3,281 feet above MSL (CNPS 2021). Marsh zigadenus is endemic to California; its current range includes Lake, Mendocino, Monterey, Marin, Napa, San Benito, Santa Cruz, San Luis Obispo, San Mateo, and Sonoma counties (CNPS 2021).

The CNDDDB does not often publish occurrence records for CRPR 4 species, and there are no published occurrences of marsh zigadenus. The drainage corridor within the Study Area may provide marginally suitable habitat for this species. Marsh zigadenus has low potential to occur within the Study Area.

Napa Bluecurls

Napa bluecurls (*Trichostema ruygtii*) is not listed pursuant to either the federal or California ESAs, but is designated as a CRPR 1B.2 species. This species is an herbaceous annual that occurs in chaparral, cismontane woodland, lower montane coniferous forest, valley and foothill grassland, and vernal pools (CNPS 2021). Napa bluecurls blooms from June through October and is known to occur at elevations ranging from 98 to 2,231 feet above MSL (CNPS 2021). Napa bluecurls is endemic to California; the current range of this species includes Lake, Napa, and Solano counties; however, it is possibly extirpated from Lake County (CNPS 2021).

There are no CNDDDB occurrences of Napa bluecurls within five miles of the Study Area (CDFW 2021a). However, the oaks woodlands and grasslands within the Study Area may provide suitable habitat for this species. Napa bluecurls has potential to occur within the Study Area.

Oval-Leaved Viburnum

Oval-leaved viburnum (*Viburnum ellipticum*) is not listed pursuant to either the federal or California ESAs, but is designated as a CRPR 2B.3 species. This species is a perennial deciduous shrub that occurs in chaparral, cismontane woodland, and lower montane coniferous forest communities. Oval-leaved viburnum blooms from May through June and is known to occur at elevations ranging from 705 to 4,593 feet above MSL (CNPS 2021). The current range of this species in California includes Alameda, Contra Costa, El Dorado, Fresno, Glenn, Humboldt, Lake, Mendocino, Mariposa, Napa, Placer, Shasta, Solano, Sonoma, and Tehama counties (CNPS 2021).

There is one CNDDDB occurrence of oval-leaved viburnum within five miles of the Study Area (CDFW 2021a). The oak woodlands and grassland within the Study Area may provide suitable habitat for this species. Oval-leaved viburnum has potential to occur within the Study Area.

4.2.1 Fish

Five special-status fish species were identified as having potential to occur in the vicinity of the Study Area based on the literature review (Table 1). However, upon further analysis and after the site visit, all five

species were considered to be absent from the Study Area due to the lack of suitable habitat and/or because the Study Area is outside of the known geographic range for these species. No further discussion of these species is provided within this assessment.

4.2.2 Amphibians

Four special-status amphibian species were identified as having potential to occur in the vicinity of the Study Area based on the literature review (Table 1). However, upon further analysis and after the site visit, all four species were considered to be absent from the Study Area due to the lack of suitable habitat and/or because the Study Area is outside of the known geographic range for these species. No further discussion of these species is provided within this assessment.

4.2.3 Reptiles

One special-status reptile species, northwestern pond turtle (*Actinemys marmorata*), was identified as having potential to occur in the vicinity of the Study Area based on the literature review (Table 1). Upon further analysis and after the reconnaissance site visit, Northwestern pond turtle was identified to have potential to occur in the Study Area. A brief description of this species is presented below.

Northwestern Pond Turtle

The northwestern pond turtle is not listed pursuant to either the federal or California ESAs; however, it is designated as a CDFW SSC. Northwestern pond turtles occur in a variety of fresh and brackish water habitats including marshes, lakes, ponds, and slow-moving streams (Jennings and Hayes 1994). This species is primarily aquatic; however, they typically leave aquatic habitats in the fall to reproduce and to overwinter (Jennings and Hayes 1994). Deep, still water with abundant emergent woody debris, overhanging vegetation, and rock outcrops is optimal for basking and thermoregulation. Although adults are habitat generalists, hatchlings and juveniles and hatchlings require shallow edgewater with relatively dense submergent or short emergent vegetation in which to forage. Northwestern pond turtles are typically active between March and November. Mating generally occurs during late April and early May and eggs are deposited between late April and early August (Jennings and Hayes 1994). Eggs are deposited within excavated nests in upland areas, with substrates that typically have high clay or silt fractions (Jennings and Hayes 1994). The majority of nesting sites are located within 650 feet (200 meters) of aquatic sites; however, nests have been documented as far as 1,310 feet (400 meters) from aquatic habitat.

There are no CNDDDB occurrences of northwestern pond turtle within five miles of the Study Area (CDFW 2021a). However, the Study Area may provide marginally suitable upland habitat for this species. Habitat suitability is likely diminished by the long history of disturbance to the aquatic features and uplands within and adjacent to the Study Area, the urban/agricultural setting, and the frequency of public use of the site. Northwestern pond turtle has low potential to occur within the Study Area.

4.2.4 Birds

A total of 15 special-status bird species were identified as having the potential to occur within the Study Area based on the literature review (Table 1). Of those, 12 species were determined to be absent from the Study Area due to the lack of suitable habitat and/or due to the Study Area being outside of the known geographic range of the species. No further discussion of those species is provided in this assessment. A brief description of the remaining three species that have the potential to occur within the Study Area is presented below.

Nuttall's Woodpecker

The Nuttall's woodpecker (*Dryobates nuttallii*) is not listed pursuant to either the federal or California ESAs but is designated as a USFWS BCC. They are resident from Siskiyou County south to Baja California. Nuttall's woodpeckers nest in tree cavities primarily within oak woodlands, but also can be found in riparian woodlands (Lowther et al. 2020). Breeding occurs during April through July.

The CNDDDB does not track Nuttall's woodpecker. Nuttall's woodpecker was observed foraging within the oak woodland in the Study Area during the site reconnaissance. The trees in the oak woodlands within and adjacent to the Study Area may also provide suitable nesting habitat for this species. Nuttall's woodpecker has potential to nest onsite.

Oak Titmouse

Oak titmouse (*Baeolophus inornatus*) is not listed pursuant to either the federal or California ESAs but is designated as a USFWS BCC. Oak titmouse breeding range includes southwestern Oregon south through California's Coast, Transverse and Peninsular ranges, western foothills of the Sierra Nevada, into Baja California; they are absent from the humid northwestern coastal region and the San Joaquin Valley (Cicero et al. 2020). They are found in dry oak or oak-pine woodlands but may also use scrub oaks or other brush near woodlands (Cicero et al. 2020). Nesting occurs during March through July.

The CNDDDB does not track oak titmouse. The trees and brush in and near the oak woodlands within and adjacent to the Study Area may provide suitable nesting and foraging habitat for this species. Oak titmouse has potential to nest onsite.

Lawrence's Goldfinch

The Lawrence's goldfinch (*Spinus lawrencei*) is not listed pursuant to either the federal or California ESAs but is designated as a USFWS BCC. Lawrence's goldfinch breed west of the Sierra Nevada-Cascade axis from Tehama, Shasta, and Trinity counties south into the foothills surrounding the Central Valley to Kern County; and on the Coast Range from Contra Costa County to Santa Barbara County (Watt et al. 2020). Lawrence's goldfinch nest in arid woodlands usually with brushy areas, tall annual weeds and a local water source (Watt et al. 2020). Nesting occurs during March through September.

There are no CNDDDB occurrences of Lawrence's goldfinch within five miles of the Study Area (CDFW 2021a). However, the trees and other vegetation within and adjacent to the Study Area may provide suitable nesting and foraging habitat for this species. Lawrence's goldfinch has potential to nest onsite.

Other Protected Birds

In addition to the above-listed special-status birds, all native or naturally occurring birds and their occupied nests/eggs are protected under the California Fish and Game Code and the MBTA. The Study Area supports potential nesting habitat for a variety of native birds protected under these regulations.

4.2.5 Mammals

Two special-status mammal species were identified as having potential to occur in the vicinity of the Study Area based on the literature review (Table 1). Upon further analysis and after the reconnaissance site visit, both species were identified to have potential to occur in the Study Area as described below. A brief description of both species is presented in the following sections.

Townsend's Big-Eared Bat

The Townsend's big-eared bat (*Corynorhinus townsendii*) is not listed pursuant to either the California or federal ESAs; however, this species is considered an SSC by CDFW. Townsend's big-eared bat is a fairly large bat with prominent bilateral nose lumps and large "rabbit-like" ears. This species occurs throughout the west and ranges from the southern portion of British Columbia south along the Pacific coast to central Mexico and east into the Great Plains. This species has been reported from a wide variety of habitat types and elevations from sea level to 10,827 feet. Habitats include coniferous forests, mixed meso-phytic forests, deserts, native prairies, riparian communities, active agricultural areas, and coastal habitat types. Its distribution is strongly associated with the availability of caves and cave-like roosting habitat including abandoned mines, buildings, bridges, rock crevices, and hollow trees. Townsend's big-eared bat primarily forages on moths. Foraging habitat is generally edge habitats along streams adjacent to and within a variety of wooded habitats. This species often travels long distances when foraging and large home ranges have been documented in California (WBWG 2021).

There are two CNDDDB occurrences of Townsend's big-eared bat within five miles of the Study Area (CDFW 2021a). The structures and trees within the Study Area may provide suitable roosting habitat and the entire Study Area may provide suitable foraging habitat for this species. Townsend's big-eared bat has potential to occur within the Study Area.

Pallid Bat

The pallid bat (*Antrozous pallidus*) is not listed pursuant to either the California or federal ESAs; however, this species is considered an SSC by CDFW. The pallid bat is a large, light-colored bat with long, prominent ears and pink, brown, or grey wing and tail membranes. This species ranges throughout North America from the interior of British Columbia, south to Mexico, and east to Texas. The pallid bat inhabits low elevation (below 6,000 feet) rocky arid deserts and canyonlands, shrub-steppe grasslands, karst formations, and higher elevation coniferous forest (above 7,000 feet). This species roosts alone or in groups in the crevices of rocky outcrops and cliffs, caves, mines, trees, and in various human structures such as bridges and barns. Pallid bats are feeding generalists that glean a variety of arthropod prey from surfaces as well as capturing insects on the wing. Foraging occurs over grasslands, oak savannahs,

ponderosa pine forests, talus slopes, gravel roads, lava flows, fruit orchards, and vineyards. This species is not thought to migrate long distances between summer and winter sites (WBWG 2021).

There is one CNDDDB occurrence of pallid bat within five miles of the Study Area (CDFW 2021a). The structures and trees within the Study Area may provide suitable roosting habitat and the entire Study Area may provide suitable foraging habitat for this species. Pallid bat has potential to occur within the Study Area.

4.3 Critical Habitat and Essential Fish Habitat

There are no Critical Habitats mapped within the Study Area (USFWS 2021b). The Study Area is not EFH (NOAA 2021a).

4.4 Riparian Habitats and Sensitive Natural Communities

Riparian habitats are present within the Study Area. Two narrow strips of valley oak woodland and a small patch of Fremont cottonwood are located along the riparian corridors for the onsite drainage and for Burns Valley Creek which is adjacent to the Study Area to the west (See Section 4.1.3 and Figure 3). Only a portion of the valley oak woodland depicted on Figure 3 is considered to be riparian habitat.

The valley oak woodland is representative of the Valley Oak Forest and Woodland Alliance, a sensitive natural community with a state rarity rank of S3. The patch of Fremont cottonwood within the Study Area is too limited in extent to be considered a stand or a separate vegetation community and is not representative of a sensitive alliance.

Four other sensitive natural communities were identified as having potential to occur within the vicinity of the Study Area based on the literature review (CDFW 2021a). These include Coastal and Valley Freshwater Marsh, Great Valley Cottonwood Riparian Forest, Northern Basalt Flow Vernal Pool, and Northern Volcanic Ash Vernal Pool. Upon further analysis and site reconnaissance, these four sensitive natural communities were determined to be absent from the Study Area.

4.5 Wildlife Movement/Corridors and Nursery Sites

The Study Area is subject to disturbance from the presence of people, has a history of disturbance due to agricultural use, and is surrounded entirely by either agricultural, commercial, or residential development. The Study Area does not fall within an Essential Habitat Connectivity area mapped by the CDFW and is not identified as a critical and non-critical winter and summer range, fall holding areas, fawning grounds, or migration corridors for mule deer (*Odocoileus hemionus*) (CDFW 2021b). Therefore, the Study Area is not expected to support critical wildlife movement corridors or potential nursery sites. However, a variety of common bird species were observed within the Study Area during the site reconnaissance and other wildlife species also likely move through the Study Area.

For the purposes of this analysis, nursery sites include but are not limited to concentrations of nest or den sites such as heron rookeries or bat maternity roosts. This data is available through CDFW's Biogeographic Information and Observation System (BIOS) database or as occurrence records in the CNDDDB and is

supplemented with the results of the site reconnaissance. No nursery sites have been documented within the Study Area (CDFW 2021a) and none were observed during the site reconnaissance.

5.0 IMPACT ANALYSIS

This section specifically addresses the questions raised by the CEQA - Appendix G Environmental Checklist Form, IV. Biological Resources. This impact analysis assumes the Project will implement measures that fulfill the intent of recommended measures described in Section 6.0.

5.1 Special Status Species

Would the Project result in effects, either directly or through habitat modifications, to species identified as a candidate, sensitive, or special-status species in local or regional plans, policies, or regulations, or by the CDFW or USFWS?

No special-status species are known to occur within the Study Area; however, plant and wildlife surveys have not been conducted. The Study Area includes potential habitat for special-status species within the impact area. Potential effects to special-status species are summarized in the following sections by taxonomic group or species.

5.1.1 Special-Status Plants

There is no potential habitat for federally or State-listed plant species in the Study Area, but there is potential or low potential for 21 non-listed special-status plant species to occur. Project development would permanently remove or alter a minimal amount of marginally suitable or suitable potential habitat for special-status plants, and in the unlikely chance that special-status plant populations occur onsite they may be directly or indirectly impacted by development.

Implementation of recommendations BIO2, PLANT1, and PLANT2 described in Section 6.0 would avoid, minimize, and/or compensate for potential effects to special-status plants. With implementation of these measures, the Project is not expected to significantly impact special-status plants.

5.1.2 Northwestern Pond Turtles

Northwestern pond turtles have low potential to occur within the Study Area due to the historic degradation of the aquatic features near the project, the urban/agricultural setting, and the extent of disturbance and public use. Should Northwestern pond turtles utilize the site and/or be present onsite before and during construction, a minimal amount of marginal potential upland habitat would be permanently removed or altered, and turtles may be temporarily displaced from upland habitats during construction. Removal or alteration of marginal habitat and displacement of turtles which may incidentally occur during construction is not expected to significantly impact Northwestern pond turtles.

Implementation of recommendations BIO1, BIO2, and NPT1 described in Section 6.0 would avoid or minimize potential effects to Northwestern pond turtles.

5.1.3 *Special-Status and Other Protected Birds*

There is no potential habitat for federally or State-listed bird species in the Study Area, but there is potential for three non-listed special-status bird species and a variety of other birds that are protected under the MBTA and the California Fish and Game Code. Project development would permanently remove or alter a minimal amount of nesting and foraging habitat in the development area, and Project construction would generate a temporary disturbance that would likely displace foraging birds from the Study Area during construction. Permanent removal or alteration of a minimal amount of habitat and displacement of foraging birds during construction is not expected to significantly impact special-status birds.

Implementation of recommendations BIO2 and BIRD1 described in Section 6.0 would avoid or minimize potential effects to special-status birds and other protected birds.

5.1.4 *Special-Status Mammals*

Two special-status bats have potential to occur in the Study Area. Removal of trees and structures may directly impact roosting habitat. Project development would permanently remove a minimal amount of potential roosting and foraging habitat in the development area, and Project construction would generate a temporary disturbance during the day that would likely displace day-roosting bats from the Study Area. Permanent removal of a minimal amount of potential roosting or foraging habitat and displacement of day-roosting bats during construction is not expected to significantly impact special-status bats.

Implementation of recommendations BIO2 and BAT1 described in Section 6.0 would avoid and/or minimize potential effects to special-status bats.

5.2 Riparian Habitat and Sensitive Natural Communities

Would the Project have a substantial adverse effect on any riparian habitat or other sensitive natural community identified in local or regional plans, policies, regulations or by the California Department of Fish and Game or US Fish and Wildlife Service?

The Study Area supports a small amount of valley oak woodland, which may be considered a sensitive natural community. Portions of the valley oak woodland and a patch of Fremont cottonwood located riparian along the Burns Valley Creek and the unnamed drainage represent riparian habitat (Figure 3). The Project does not propose impacts to riparian habitat or valley oak woodland that is adjacent to Burns Valley Creek.

The Project is located within an urban and agricultural area, and the valley oak woodland that is not associated with Burns Valley Creek is a small patch on the edge of a complex of scattered oak woodland patches that are remnant of historical clearing for development of the surrounding areas. Impacts to this small patch of remnant valley oak woodland within the Study Area is not expected to be a significant impact to the sensitive natural community.

The Project may directly or indirectly impact riparian habitat and valley oak woodland along the unnamed drainage due to removal for development or due to alteration of hydrology.

Implementation of recommendations BIO2, RIP1, RIP2, and TREE1 as described in Section 6.0 would avoid, minimize, and/or compensate for potential effects to riparian habitat and individual oak trees.

5.3 Aquatic Resources, Including Waters the U.S. and State

Would the Project have a substantial adverse effect on federally protected wetlands as defined by Section 404 of the Clean Water Act CWA (including, but not limited to, marsh, vernal pool, coastal, etc.) through direct removal, filling, hydrological interruption, or other means?

Based on the preliminary aquatic resources assessment, the Project would have no direct impact on federally protected wetlands; however, the drainage channel within the Study Area may be considered a Water of the U.S. and/or State. Project implementation may result in fill of this drainage within the development area.

The Project is adjacent to Burns Valley Creek, which may also be considered a Water of the U.S. and State. The Project does not propose impacts Burns Valley Creek.

Implementation of recommendations WATER1 through WATER5 described in Section 6.0 would avoid, minimize, and/or compensate for potential effects to Waters of the U.S. and State.

5.4 Wildlife Movement/Corridors

Would the Project interfere substantially with the movement of any native resident or migratory fish or wildlife species or with established native resident or migratory wildlife corridors, or impede the use of native wildlife nursery sites?

The Study Area provides limited migratory opportunities for terrestrial wildlife. Project construction is likely to temporarily disturb and displace most wildlife from the Study Area. Some wildlife such as birds or nocturnal species are likely to continue to use the habitats opportunistically for the duration of construction. Once construction is complete, wildlife movements are expected to resume but will likely be more limited through the developed areas of the Study Area. The Project is not expected to substantially interfere with wildlife movement.

There are no documented nursery sites and no nursery sites were observed within the Study Area during the site reconnaissance. Therefore, the Project is not expected to impact wildlife nursery sites.

5.5 Local Policies, Ordinances, and Other Plans

Does the Project conflict with any local policies or ordinances protecting biological resources, such as a tree preservation policy or ordinance?

The Project may impact trees protected under the City's Tree Ordinance. Implementation of recommendations BIO2 and TREE1 would prevent conflicts with the local tree ordinance.

Does the Project conflict with the provisions of an adopted Habitat Conservation Plan, Natural Community Conservation Plan, or other approved local, regional, or state habitat conservation plan?

The Study Area is not covered by any local, regional, or State conservation plan. Therefore, the Project would not conflict with a local, regional, or State conservation plan.

6.0 RECOMMENDATIONS

This section summarizes recommended measures to avoid, minimize, or compensate for potential impacts to biological resources from the proposed Project.

6.1 General Recommendations

The following general measures are recommended to avoid impacts to offsite and onsite biological resources:

- **BIO1:** The project should implement erosion control measures and BMPs to reduce the potential for sediment or pollutants at the Project site. Examples of appropriate measures are included below.
 - Avoided aquatic resources (including Burns Valley Creek) should be clearly demarcated prior to construction. Avoidance buffers should be consistent with the City of Clearlake requirements and/or requirements of regulatory permits. Erosion control measures should be placed between avoided aquatic resources and the outer edge of the impact limits prior to commencement of construction activities. Such identification and erosion control measures should be properly maintained until construction is completed and the soils have been stabilized.
 - Any fueling in the Study Area should use appropriate secondary containment techniques to prevent spills.
- **BIO2:** A qualified biologist should conduct a mandatory Worker Environmental Awareness Program for all contractors, work crews, and any onsite personnel to aid workers in recognizing special status species and sensitive biological resources that may occur on-site. The program shall include identification of the special status species and their habitats, a description of the regulatory status and general ecological characteristics of sensitive resources, and review of the limits of construction and Mitigation Measures required to reduce impacts to biological resources within the work area.

6.2 Special-Status Species

Recommendations to minimize impacts to special status species or habitats are summarized below by species or taxonomic group.

6.2.1 Plants

There is potential or low potential for 20 special-status plants to occur within the Study Area. The following measures are recommended to minimize potential impacts to special-status plants:

- **PLANT1:** Perform floristic plant surveys according to USFWS, CDFW, and CNPS protocols prior to construction. Surveys should be conducted by a qualified biologist and timed according to the appropriate phenological stage for identifying target species. Known reference populations should be visited and/or local herbaria records should be reviewed, if available, prior to surveys to confirm the phenological stage of the target species. If no special-status plants are found within the Project site, no further measures pertaining to special-status plants are necessary.
- **PLANT2:** If special-status plants are identified within 25-feet of the Project impact area, implement the following measures:
 - If avoidance of special-status plants is feasible, establish and clearly demarcate avoidance zones for special-status plant occurrences prior to construction. Avoidance zones should include the extent of the special-status plants plus a 25-foot buffer, unless otherwise determined by a qualified biologist, and should be maintained until the completion of construction. A qualified biologist/biological monitor should be present must occur within the avoidance buffer to ensure special-status plants are not impacted by the work.
 - If avoidance of special-status plants is not feasible, mitigate for significant impacts to special-status plants. Mitigation measures should be developed in consultation with CDFW. Mitigation measures may include permanent preservation of onsite or offsite habitat for special-status plants and/or translocation of plants or seeds from impacted areas to unaffected habitats.

6.2.2 *Northwestern Pond Turtle*

Northwestern pond turtles have low potential to incidentally occur within the Study Area. Implementation of recommendation BIO1, BIO2, and the following measure would avoid and/or minimize potential adverse effects to northwestern pond turtles:

- **NPT1:** Conduct a pre-construction northwestern pond turtle survey in Project impact and staging areas within 48 hours prior to construction activities. Any northwestern pond turtle individuals discovered in the Project work area immediately prior to or during Project activities shall be allowed to move out of the work area of their own volition. If this is not feasible, they shall be captured by a qualified biologist and relocated out of harm's way to the nearest suitable habitat at least 100 feet from the Project work area where they were found.

6.2.3 *Special-Status Birds and MBTA-Protected Birds (including nesting raptors)*

Three special-status birds and various other protected birds have the potential to nest within the Study Area. The following measures are recommended to minimize potential impacts to nesting birds:

- **BIRD1:** If construction is to occur during the nesting season (generally February 1 - August 31), conduct a pre-construction nesting bird survey of all suitable nesting habitat on the Project within 14 days of the commencement of construction. The survey shall be conducted within a 500-foot radius of Project work areas for raptors and within a 100-foot radius for other nesting birds. If any

active nests are observed, these nests shall be designated a sensitive area and protected by an avoidance buffer established in coordination with CDFW until the breeding season has ended or until a qualified biologist has determined that the young have fledged and are no longer reliant upon the nest or parental care for survival. Pre-construction nesting surveys are not required for construction activity outside the nesting season.

6.2.4 Special-Status Bats

There is potential for two special-status bats to occur within the Study Area, and the majority of the Study Area is planned for impact. The following measure is recommended to minimize potential impacts to special-status bats.

- **BAT1:** Within 14 days prior to Project activities that may impact bat roosting habitat (e.g., removal of manmade structures or trees), a qualified biologist will survey for all suitable roosting habitat within the Project impact limits. If suitable roosting habitat is not identified, no further measures are necessary. If suitable roosting habitat is identified, a qualified biologist will conduct an evening bat emergence survey that may include acoustic monitoring to determine whether or not bats are present. If roosting bats are determined to be present within the Project site, consultation with CDFW prior to initiation of construction activities and/or preparation of a Bat Management Plan outlining avoidance and minimization measures specific to the roost(s) potentially affected may be required.

6.3 Riparian and Sensitive Natural Communities

Valley oak woodland and riparian habitat is located within the Study Area. Measure TREE1 in Section 6.6 would avoid and/or minimize potential impacts to individual oak trees. The following measures are recommended to minimize potential impacts to riparian habitat:

- **RIP1:** Map the extent of riparian areas within the Study Area. Avoidance buffers for avoided riparian habitats (including riparian habitat for Burns Valley Creek) should be consistent with the City of Clearlake requirements and/or requirements of regulatory permits, should be clearly demarcated prior to construction, and should be maintained until the completion of construction. A qualified biologist/biological monitor should be present if work must occur within the avoidance buffer to ensure riparian habitat is not impacted by the work.
- **RIP2:** An SAA, pursuant to Section 1602 of the California Fish and Game Code, should be secured for any activity that will impact riparian habitats. Minimization measures will be developed during consultation with CDFW as part of the SAA agreement process to ensure protections for affected fish and wildlife resources.

6.4 Waters of the U.S./State

The Project site supports potential Waters of the U.S. and State. In addition to BIO1, the following measure is recommended if impacts are proposed to aquatic resources:

- **WATER1:** Prepare and submit an aquatic resources delineation for the Project to the USACE and obtain an Approved Jurisdictional Determination.
- **WATER2:** If necessary, file a request for authorization to fill wetlands and other Waters of the U.S. under the Section 404 of the federal CWA (Section 404 Permit) prior to discharging any dredged or fill materials into any Waters of the U.S. Mitigation measures will be developed as part of the Section 404 Permit process to ensure no net loss of wetland function and values. To facilitate such authorization, an application for a Section 404 Nationwide Permit for the Project should be prepared and submitted to USACE. Mitigation for impacts to Waters of the U.S. typically consists of a minimum of a 1:1 ratio for direct impacts; however final mitigation requirements will be developed in consultation with USACE.
- **WATER3:** If necessary, file a request for a Water Quality Certification or waiver pursuant to Section 401 of the CWA must be obtained from the RWQCB for Section 404 permit actions.
- **WATER4:** Pursuant to the Porter-Cologne Water Quality Act, a permit authorization from the RWQCB is required prior to the discharge of material in an area that could affect Waters of the State. Mitigation requirements for discharge to Waters of the State within the Project site will be developed in consultation with the RWQCB.
- **WATER5:** If necessary, prepare an LSA Notification to CDFW under California Fish and Game Code Section 1602 to request authorization to impact regulated aquatic features.

6.5 Wildlife Movement Corridors

No impacts to wildlife movement, corridors, or nursery sites are expected.

6.6 Trees

Oak trees are present within the Study Area and are protected under the City tree ordinance. The following measure is recommended to prevent conflicts with the local tree ordinance:

- **TREE1:** A native tree protection and removal permit, waiver, or similar approval should be secured prior to impacting trees protected under the City ordinance. Avoidance buffers for protected trees should be consistent with the City requirements, should be clearly demarcated prior to construction, and should be maintained until the completion of construction. A qualified biologist/biological monitor should be present if work must occur within the avoidance buffer to ensure avoided protected trees are not impacted by the work.

7.0 SUMMARY

No federal or State listed species have potential to occur within the Study Area. However, 21 non-listed special-status plants, one special-status turtle, three special-status birds, various birds protected under the MBTA and the California Fish and Game Code, and two special-status bats have potential or low potential to occur within the Study Area. One drainage channel located within the Study Area may be considered a Water of the U.S. and State. Individual oak trees within the Study Area are protected under the City

ordinance are located within the Study Area, and the oak woodlands onsite may be considered a sensitive natural community by CDFW.

With implementation of recommendations described in Section 6.0, the Project is not expected to have a significant effect on biological resources.

8.0 REFERENCES

- Baldwin, B.G., D.H. Goldman, D.J. Keil, R. Patterson, T.J. Rosatti, and D.H. Wilken, editors. 2012. *The Jepson Manual; Vascular Plants of California*, Second Edition. University of California Press, Berkeley, California.
- CDFW. 2021a. Rarefind 5. Online Version, commercial version dated February 28, 2021. California Natural Diversity Database. The Resources Agency, Sacramento.
- _____. 2021b. Biogeographic Information and Observation System (BIOS). Available <https://wildlife.ca.gov/data/BIOS>. Accessed February and March 2021.
- Cicero, C., P. Pyle, and M. A. Patten. 2020. Oak Titmouse (*Baeolophus inornatus*), version 1.0. In *Birds of the World* (P. G. Rodewald, Editor). Cornell Lab of Ornithology, Ithaca, NY, USA. <https://doi.org/10.2173/bow.oaktit.01>.
- City of Clearlake. 2020. City of Clearlake Municipal Code. Chapter XVIII (Zoning), Article 18-1 (Administration). Available <https://clearlake.municipal.codes/>. Accessed March 2021.
- _____. 2016a. *City of Clearlake 2040 General Plan Update*. Available https://clearlake.ca.us/DocumentCenter/View/608/A_Clearlake_2040_General_Planpdf. Accessed March 5, 2021.
- _____. 2016b. *City of Clearlake California 2040 General Plan Update Draft EIR*. November 2016. State Clearinghouse No. 2014012023. Available https://clearlake.ca.us/DocumentCenter/View/608/A_Clearlake_2040_General_Planpdf. Accessed March 5, 2021.
- CNPS. 2021. Inventory of Rare and Endangered Plants in California (online edition, v8-03 0.39). California Native Plant Society. Sacramento, CA. Available online: February and March 2021.
- Horton, John D., 2017. 0818, The State Geologic Map Compilation (SGMC) Geodatabase of the Conterminous United States: U.S. Geological Survey data release DOI: 10.5066/F7WH2N65, U.S. Geological Survey, Denver, CO. Available <https://doi.org/10.5066/F7WH2N65>
- Jennings, C.W., R.G. Strand, and T.H. Rogers. 1977. Geologic map of California: California Division of Mines and Geology, scale 1:750,000. Available <https://mrdata.usgs.gov/geology/state/sgmc-lith.php?code=5.14#California>. Accessed December 2020.
- Jennings, M. R. and M. P. Hayes. 1994. Amphibian and Reptile Species of Special Concern in California. Final report to California Department of Fish and Game, Inland Fisheries Branch. Rancho Cordova, CA.
- Lowther, P. E., P. Pyle, and M. A. Patten. 2020. Nuttall's Woodpecker (*Dryobates nuttallii*), version 1.0. In *Birds of the World* (P. G. Rodewald, Editor). Cornell Lab of Ornithology, Ithaca, NY, USA. <https://doi.org/10.2173/bow.nutwoo.01>.

- Moyle, P.B., R. M. Quiñones, J. V. Katz and J. Weaver. 2015. Fish Species of Special Concern in California. Sacramento: California Department of Fish and Wildlife. Available <https://wildlife.ca.gov/Conservation/SSC/Fishes>. Accessed March 2021.
- NOAA. 2021a. NOAA Fisheries West Coast Region California Species List Tools. Available online: https://archive.fisheries.noaa.gov/wcr/maps_data/california_species_list_tools.html. Accessed March 4, 2021.
- _____. 2021b. National Climatic Data Center 1981-2010 Climate Normals for Clearlake 4 SE, California. <https://www.ncdc.noaa.gov/cdo-web/datatools/normals>. Accessed March 2, 2021.
- NRCS. 2021a. Web Soil Survey. <http://websoilsurvey.nrcs.usda.gov/>. Accessed December 2020.
- _____. 2021b. State Soil Data Access Hydric Soils List. <https://www.nrcs.usda.gov/wps/portal/nrcs/main/soils/use/hydric/>. Accessed February 2, 2021.
- NRCS, USGS, and U.S. Environmental Protection Agency. 2016. Watershed Boundary Dataset for California. <http://datagateway.nrcs.usda.gov>.
- Safford, H. and Miller J.E.D. 2020. An updated database of serpentine endemism in the California flora. *Madroño* 67(2), 85-104, (October 16, 2020). <https://doi.org/10.3120/0024-9637-67.2.85>
- Sawyer, J., Keeler-Wolf T., Evens J. M. 2009. *A Manual of California Vegetation, Second Edition*. Sacramento, California: California Native Plant Society.
- SWRCB. State Wetland Definition and Procedures for Discharges of Dredged or Fill Material to Waters of the State. Adopted April 2, 2019. Available https://www.waterboards.ca.gov/water_issues/programs/cwa401/wrapp.html#officialdocuments. Accessed March 8, 2021.
- USACE. 2020. National Wetland Plant List. Document Number 2020-10630. Published May 18, 2020. Available <https://www.federalregister.gov/documents/2020/05/18/2020-10630/national-wetland-plant-list#citation-1-p29690>.
- USFWS. 2021a. USFWS Resource Report List. Information for Planning and Conservation. Available <https://ecos.fws.gov/ipac>. Accessed February 2021.
- _____. 2021b. Online Critical Habitat Mapper. Available <https://fws.maps.arcgis.com/home/webmap/viewer.html?webmap=9d8de5e265ad4fe09893cf75b8dbfb77>. Accessed February 2021.
- _____. 2008. Birds of Conservation Concern 2008. U.S. Fish and Wildlife Service, Division of Migratory Bird Management, Arlington, Virginia. Arlington, Virginia. <http://www.fws.gov/migratorybirds/>. Accessed March 2021.
- _____. 2005. Vernal Pool Recovery Plan: Species Account for Legenere. United States Department of the Interior, USFWS. Sacramento, California. Available Online:

<http://www.fws.gov/sacramento/ES/Recovery-Planning/Vernal-Pool/Documents/legenera.pdf>.
Accessed 2 October 2015.]

USGS. 1993. "Clearlake Highlands, California" 7.5-minute Quadrangle. U.S. Department of the Interior. Denver, Colorado.

Watt, D. J., P. Pyle, M. A. Patten, and J. N. Davis. 2020. Lawrence's Goldfinch (*Spinus lawrencei*), version 1.0. In *Birds of the World* (P. G. Rodewald, Editor). Cornell Lab of Ornithology, Ithaca, NY, USA. <https://doi.org/10.2173/bow.lawgol.01>.

WBWG. 2021. Western Bat Species Accounts. Available <http://wbwg.org/western-bat-species/>. Accessed March 2021.

LIST OF ATTACHMENTS

Attachment A – Results of Database Queries

Attachment B – Representative Site Photographs

ATTACHMENT A

Results of Database Searches

IPaC resource list

This report is an automatically generated list of species and other resources such as critical habitat (collectively referred to as *trust resources*) under the U.S. Fish and Wildlife Service's (USFWS) jurisdiction that are known or expected to be on or near the project area referenced below. The list may also include trust resources that occur outside of the project area, but that could potentially be directly or indirectly affected by activities in the project area. However, determining the likelihood and extent of effects a project may have on trust resources typically requires gathering additional site-specific (e.g., vegetation/species surveys) and project-specific (e.g., magnitude and timing of proposed activities) information.

Below is a summary of the project information you provided and contact information for the USFWS office(s) with jurisdiction in the defined project area. Please read the introduction to each section that follows (Endangered Species, Migratory Birds, USFWS Facilities, and NWI Wetlands) for additional information applicable to the trust resources addressed in that section.

Location

Lake County, California



Local offices

Red Bluff Fish And Wildlife Office

☎ (530) 527-3043

📠 (530) 529-0292

10950 Tyler Road
Red Bluff, CA 96080-7762

Sacramento Fish And Wildlife Office

☎ (916) 414-6600

 (916) 414-6713

Section 1, Item 5.

Federal Building
2800 Cottage Way, Room W-2605
Sacramento, CA 95825-1846

NOT FOR CONSULTATION

Endangered species

This resource list is for informational purposes only and does not constitute an analysis of project level impacts.

The primary information used to generate this list is the known or expected range of each species. Additional areas of influence (AOI) for species are also considered. An AOI includes areas outside of the species range if the species could be indirectly affected by activities in that area (e.g., placing a dam upstream of a fish population even if that fish does not occur at the dam site, may indirectly impact the species by reducing or eliminating water flow downstream). Because species can move, and site conditions can change, the species on this list are not guaranteed to be found on or near the project area. To fully determine any potential effects to species, additional site-specific and project-specific information is often required.

Section 7 of the Endangered Species Act **requires** Federal agencies to "request of the Secretary information whether any species which is listed or proposed to be listed may be present in the area of such proposed action" for any project that is conducted, permitted, funded, or licensed by any Federal agency. A letter from the local office and a species list which fulfills this requirement can **only** be obtained by requesting an official species list from either the Regulatory Review section in IPaC (see directions below) or from the local field office directly.

For project evaluations that require USFWS concurrence/review, please return to the IPaC website and request an official species list by doing the following:

1. Draw the project location and click CONTINUE.
2. Click DEFINE PROJECT.
3. Log in (if directed to do so).
4. Provide a name and description for your project.
5. Click REQUEST SPECIES LIST.

Listed species¹ and their critical habitats are managed by the [Ecological Services Program](#) of the U.S. Fish and Wildlife Service (USFWS) and the fisheries division of the National Oceanic and Atmospheric Administration (NOAA Fisheries²).

Species and critical habitats under the sole responsibility of NOAA Fisheries are **not** shown on this list. Please contact [NOAA Fisheries](#) for [species under their jurisdiction](#).

1. Species listed under the [Endangered Species Act](#) are threatened or endangered; IPaC also shows species that are candidates, or proposed, for listing. See the [listing status page](#) for more information. IPaC only shows species that are regulated by USFWS (see FAQ).
2. [NOAA Fisheries](#), also known as the National Marine Fisheries Service (NMFS), is an office of the National Oceanic and Atmospheric Administration within the Department of Commerce.

The Red Bluff Fish And Wildlife Office has not enabled species list delivery through IPaC. Please contact them directly to determine which endangered species need to be considered as part of your project.

Red Bluff Fish And Wildlife Office

☎ (530) 527-3043

📠 (530) 529-0292

10950 Tyler Road
Red Bluff, CA 96080-7762

The following species are potentially affected by activities in this location:

Birds

NAME	STATUS
<p>Northern Spotted Owl <i>Strix occidentalis caurina</i></p> <p>Wherever found</p> <p>There is final critical habitat for this species. The location of the critical habitat is not available.</p> <p>https://ecos.fws.gov/ecp/species/1123</p>	Threatened
<p>Yellow-billed Cuckoo <i>Coccyzus americanus</i></p> <p>There is proposed critical habitat for this species. The location of the critical habitat is not available.</p> <p>https://ecos.fws.gov/ecp/species/3911</p>	Threatened

Amphibians

NAME	STATUS
<p>California Red-legged Frog <i>Rana draytonii</i></p> <p>Wherever found</p> <p>There is final critical habitat for this species. The location of the critical habitat is not available.</p> <p>https://ecos.fws.gov/ecp/species/2891</p>	Threatened

Fishes

NAME	STATUS
<p>Delta Smelt <i>Hypomesus transpacificus</i></p> <p>Wherever found</p> <p>There is final critical habitat for this species. The location of the critical habitat is not available.</p> <p>https://ecos.fws.gov/ecp/species/321</p>	Threatened

Flowering Plants

NAME	STATUS
------	--------

Burke's Goldfields *Lasthenia burkei* Endangered

Wherever found

No critical habitat has been designated for this species.

<https://ecos.fws.gov/ecp/species/4338>

Few-flowered Navarretia *Navarretia leucocephala* ssp. *pauciflora* Endangered

(=*N. pauciflora*)

Wherever found

No critical habitat has been designated for this species.

<https://ecos.fws.gov/ecp/species/8242>

Lake County Stonecrop *Parvisedum leiocarpum* Endangered

Wherever found

No critical habitat has been designated for this species.

<https://ecos.fws.gov/ecp/species/2263>

Loch Lomond Coyote Thistle *Eryngium constancei* Endangered

Wherever found

No critical habitat has been designated for this species.

<https://ecos.fws.gov/ecp/species/5106>

Many-flowered Navarretia *Navarretia leucocephala* ssp. *plieantha* Endangered

plieantha

Wherever found

No critical habitat has been designated for this species.

<https://ecos.fws.gov/ecp/species/2491>

Slender Orcutt Grass *Orcuttia tenuis* Threatened

Wherever found

There is **final** critical habitat for this species. The location of the critical habitat is not available.

<https://ecos.fws.gov/ecp/species/1063>

Critical habitats

Potential effects to critical habitat(s) in this location must be analyzed along with the endangered species themselves.

THERE ARE NO CRITICAL HABITATS AT THIS LOCATION.

Migratory birds

Certain birds are protected under the Migratory Bird Treaty Act¹ and the Bald and Golden Eagle Protection Act².

Any person or organization who plans or conducts activities that may result in impacts to n birds, eagles, and their habitats should follow appropriate regulations and consider implementing appropriate conservation measures, as described [below](#).

1. The [Migratory Birds Treaty Act](#) of 1918.
2. The [Bald and Golden Eagle Protection Act](#) of 1940.

Additional information can be found using the following links:

- Birds of Conservation Concern <http://www.fws.gov/birds/management/managed-species/birds-of-conservation-concern.php>
- Measures for avoiding and minimizing impacts to birds <http://www.fws.gov/birds/management/project-assessment-tools-and-guidance/conservation-measures.php>
- Nationwide conservation measures for birds <http://www.fws.gov/migratorybirds/pdf/management/nationwidestandardconservationmeasures.pdf>

The birds listed below are birds of particular concern either because they occur on the [USFWS Birds of Conservation Concern](#) (BCC) list or warrant special attention in your project location. To learn more about the levels of concern for birds on your list and how this list is generated, see the FAQ [below](#). This is not a list of every bird you may find in this location, nor a guarantee that every bird on this list will be found in your project area. To see exact locations of where birders and the general public have sighted birds in and around your project area, visit the [E-bird data mapping tool](#) (Tip: enter your location, desired date range and a species on your list). For projects that occur off the Atlantic Coast, additional maps and models detailing the relative occurrence and abundance of bird species on your list are available. Links to additional information about Atlantic Coast birds, and other important information about your migratory bird list, including how to properly interpret and use your migratory bird report, can be found [below](#).

For guidance on when to schedule activities or implement avoidance and minimization measures to reduce impacts to migratory birds on your list, click on the PROBABILITY OF PRESENCE SUMMARY at the top of your list to see when these birds are most likely to be present and breeding in your project area.

NAME

BREEDING SEASON (IF A BREEDING SEASON IS INDICATED FOR A BIRD ON YOUR LIST, THE BIRD MAY BREED IN YOUR PROJECT AREA SOMETIME WITHIN THE TIMEFRAME SPECIFIED, WHICH IS A VERY LIBERAL ESTIMATE OF THE DATES INSIDE WHICH THE BIRD BREEDS ACROSS ITS ENTIRE RANGE. "BREEDS ELSEWHERE" INDICATES THAT THE BIRD DOES NOT LIKELY BREED IN YOUR PROJECT AREA.)

- Bald Eagle** *Haliaeetus leucocephalus* Breeds Jan 1 to Aug 31
 This is not a Bird of Conservation Concern (BCC) in this area, but warrants attention because of the Eagle Act or for potential susceptibilities in offshore areas from certain types of development or activities.
<https://ecos.fws.gov/ecp/species/1626>
- Clark's Grebe** *Aechmophorus clarkii* Breeds Jan 1 to Dec 31
 This is a Bird of Conservation Concern (BCC) throughout its range in the continental USA and Alaska.
- Common Yellowthroat** *Geothlypis trichas sinuosa* Breeds May 20 to Jul 31
 This is a Bird of Conservation Concern (BCC) only in particular Bird Conservation Regions (BCRs) in the continental USA
<https://ecos.fws.gov/ecp/species/2084>
- Golden Eagle** *Aquila chrysaetos* Breeds Jan 1 to Aug 31
 This is not a Bird of Conservation Concern (BCC) in this area, but warrants attention because of the Eagle Act or for potential susceptibilities in offshore areas from certain types of development or activities.
<https://ecos.fws.gov/ecp/species/1680>
- Lawrence's Goldfinch** *Carduelis lawrencei* Breeds Mar 20 to Sep 20
 This is a Bird of Conservation Concern (BCC) throughout its range in the continental USA and Alaska.
<https://ecos.fws.gov/ecp/species/9464>
- Nuttall's Woodpecker** *Picoides nuttallii* Breeds Apr 1 to Jul 20
 This is a Bird of Conservation Concern (BCC) only in particular Bird Conservation Regions (BCRs) in the continental USA
<https://ecos.fws.gov/ecp/species/9410>
- Oak Titmouse** *Baeolophus inornatus* Breeds Mar 15 to Jul 15
 This is a Bird of Conservation Concern (BCC) throughout its range in the continental USA and Alaska.
<https://ecos.fws.gov/ecp/species/9656>
- Song Sparrow** *Melospiza melodia* Breeds Feb 20 to Sep 5
 This is a Bird of Conservation Concern (BCC) only in particular Bird Conservation Regions (BCRs) in the continental USA
- Spotted Towhee** *Pipilo maculatus clementae* Breeds Apr 15 to Jul 20
 This is a Bird of Conservation Concern (BCC) only in particular Bird Conservation Regions (BCRs) in the continental USA
<https://ecos.fws.gov/ecp/species/4243>

Tricolored Blackbird *Agelaius tricolor*

Breeds Mar 15 to Aug

This is a Bird of Conservation Concern (BCC) throughout its range in the continental USA and Alaska.

<https://ecos.fws.gov/ecp/species/3910>

Wrentit *Chamaea fasciata*

Breeds Mar 15 to Aug 10

This is a Bird of Conservation Concern (BCC) throughout its range in the continental USA and Alaska.

Probability of Presence Summary

The graphs below provide our best understanding of when birds of concern are most likely to be present in your project area. This information can be used to tailor and schedule your project activities to avoid or minimize impacts to birds. Please make sure you read and understand the FAQ "Proper Interpretation and Use of Your Migratory Bird Report" before using or attempting to interpret this report.

Probability of Presence (■)

Each green bar represents the bird's relative probability of presence in the 10km grid cell(s) your project overlaps during a particular week of the year. (A year is represented as 12 4-week months.) A taller bar indicates a higher probability of species presence. The survey effort (see below) can be used to establish a level of confidence in the presence score. One can have higher confidence in the presence score if the corresponding survey effort is also high.

How is the probability of presence score calculated? The calculation is done in three steps:

1. The probability of presence for each week is calculated as the number of survey events in the week where the species was detected divided by the total number of survey events for that week. For example, if in week 12 there were 20 survey events and the Spotted Towhee was found in 5 of them, the probability of presence of the Spotted Towhee in week 12 is 0.25.
2. To properly present the pattern of presence across the year, the relative probability of presence is calculated. This is the probability of presence divided by the maximum probability of presence across all weeks. For example, imagine the probability of presence in week 20 for the Spotted Towhee is 0.05, and that the probability of presence at week 12 (0.25) is the maximum of any week of the year. The relative probability of presence on week 12 is $0.25/0.25 = 1$; at week 20 it is $0.05/0.25 = 0.2$.
3. The relative probability of presence calculated in the previous step undergoes a statistical conversion so that all possible values fall between 0 and 10, inclusive. This is the probability of presence score.

To see a bar's probability of presence score, simply hover your mouse cursor over the bar.

Breeding Season (■)

Yellow bars denote a very liberal estimate of the time-frame inside which the bird breeds across its entire range. If there are no yellow bars shown for a bird, it does not breed in your project area.

Survey Effort (I)

Vertical black lines superimposed on probability of presence bars indicate the number of surveys performed for that species in the 10km grid cell(s) your project area overlaps. The number of surveys is expressed as a range, for example, 33 to 64 surveys.

To see a bar's survey effort range, simply hover your mouse cursor over the bar.

No Data (–)

A week is marked as having no data if there were no survey events for that week.

Survey Timeframe

Surveys from only the last 10 years are used in order to ensure delivery of currently relevant information. The exception to this is areas off the Atlantic coast, where bird returns are based on all years of available data, since data in these areas is currently much more sparse.

Tell me more about conservation measures I can implement to avoid or minimize impacts to migratory birds.

[Nationwide Conservation Measures](#) describes measures that can help avoid and minimize impacts to all birds at any location year round. Implementation of these measures is particularly important when birds are most likely to occur in the project area. When birds may be breeding in the area, identifying the locations of any active nests and avoiding their destruction is a very helpful impact minimization measure. To see when birds are most likely to occur and be breeding in your project area, view the Probability of Presence Summary. [Additional measures](#) or [permits](#) may be advisable depending on the type of activity you are conducting and the type of infrastructure or bird species present on your project site.

What does IPaC use to generate the migratory birds potentially occurring in my specified location?

The Migratory Bird Resource List is comprised of USFWS [Birds of Conservation Concern \(BCC\)](#) and other species that may warrant special attention in your project location.

The migratory bird list generated for your project is derived from data provided by the [Avian Knowledge Network \(AKN\)](#). The AKN data is based on a growing collection of [survey, banding, and citizen science datasets](#) and is queried and filtered to return a list of those birds reported as occurring in the 10km grid cell(s) which your project intersects, and that have been identified as warranting special attention because they are a BCC species in that area, an eagle ([Eagle Act](#) requirements may apply), or a species that has a particular vulnerability to offshore activities or development.

Again, the Migratory Bird Resource list includes only a subset of birds that may occur in your project area. It is not representative of all birds that may occur in your project area. To get a list of all birds potentially present in your project area, please visit the [AKN Phenology Tool](#).

What does IPaC use to generate the probability of presence graphs for the migratory birds potentially occurring in my specified location?

The probability of presence graphs associated with your migratory bird list are based on data provided by the [Avian Knowledge Network \(AKN\)](#). This data is derived from a growing collection of [survey, banding, and citizen science datasets](#).

Probability of presence data is continuously being updated as new and better information becomes available. To learn more about how the probability of presence graphs are produced and how to interpret them, go the Probability of Presence Summary and then click on the "Tell me about these graphs" link.

How do I know if a bird is breeding, wintering, migrating or present year-round in my project area?

To see what part of a particular bird's range your project area falls within (i.e. breeding, wintering, migratory year-round), you may refer to the following resources: [The Cornell Lab of Ornithology All About Birds Bird Guide](#), or (if you are unsuccessful in locating the bird of interest there), the [Cornell Lab of Ornithology Neotropical Birds guide](#). If a bird on your migratory bird species list has a breeding season associated with it, if that bird does occur in your project area, there may be nests present at some point within the timeframe specified. If "Breeds elsewhere" is indicated, then the bird likely does not breed in your project area.

What are the levels of concern for migratory birds?

Migratory birds delivered through IPaC fall into the following distinct categories of concern:

1. "BCC Rangewide" birds are [Birds of Conservation Concern](#) (BCC) that are of concern throughout their range anywhere within the USA (including Hawaii, the Pacific Islands, Puerto Rico, and the Virgin Islands);
2. "BCC - BCR" birds are BCCs that are of concern only in particular Bird Conservation Regions (BCRs) in the continental USA; and
3. "Non-BCC - Vulnerable" birds are not BCC species in your project area, but appear on your list either because of the [Eagle Act](#) requirements (for eagles) or (for non-eagles) potential susceptibilities in offshore areas from certain types of development or activities (e.g. offshore energy development or longline fishing).

Although it is important to try to avoid and minimize impacts to all birds, efforts should be made, in particular, to avoid and minimize impacts to the birds on this list, especially eagles and BCC species of rangewide concern. For more information on conservation measures you can implement to help avoid and minimize migratory bird impacts and requirements for eagles, please see the FAQs for these topics.

Details about birds that are potentially affected by offshore projects

For additional details about the relative occurrence and abundance of both individual bird species and groups of bird species within your project area off the Atlantic Coast, please visit the [Northeast Ocean Data Portal](#). The Portal also offers data and information about other taxa besides birds that may be helpful to you in your project review. Alternately, you may download the bird model results files underlying the portal maps through the [NOAA NCCOS Integrative Statistical Modeling and Predictive Mapping of Marine Bird Distributions and Abundance on the Atlantic Outer Continental Shelf](#) project webpage.

Bird tracking data can also provide additional details about occurrence and habitat use throughout the year, including migration. Models relying on survey data may not include this information. For additional information on marine bird tracking data, see the [Diving Bird Study](#) and the [nanotag studies](#) or contact [Caleb Spiegel](#) or [Pam Loring](#).

What if I have eagles on my list?

If your project has the potential to disturb or kill eagles, you may need to [obtain a permit](#) to avoid violating the Eagle Act should such impacts occur.

Proper Interpretation and Use of Your Migratory Bird Report

The migratory bird list generated is not a list of all birds in your project area, only a subset of birds of priority concern. To learn more about how your list is generated, and see options for identifying what other birds may be in your project area, please see the FAQ "What does IPaC use to generate the migratory birds potentially occurring in my specified location". Please be aware this report provides the "probability of presence" of birds within the 10 km grid cell(s) that overlap your project; not your exact project footprint. On the graphs provided, please also look carefully at the survey effort (indicated by the black vertical bar) and for the existence of the "no data" indicator (a red horizontal bar). A high survey effort is the key component. If the survey effort is high, then the probability of presence score can be viewed as more dependable. In contrast, a low survey effort bar or no data bar means a lack of data and, therefore, a lack of certainty about presence of the species. This list is not perfect; it is simply a starting point for identifying what birds of concern have the potential to be in your project area, when they might be there, and if they might be breeding (which means nests might be present). The list helps you know what to look for to

confirm presence, and helps guide you in knowing when to implement conservation measures to avoid or minimize potential impacts from your project activities, should presence be confirmed. To learn more about conservation measures, visit the FAQ "Tell me about conservation measures I can implement to avoid or minimize impacts to migratory birds" at the bottom of your migratory bird trust resources page.

Facilities

Wildlife refuges and fish hatcheries

REFUGE AND FISH HATCHERY INFORMATION IS NOT AVAILABLE AT THIS TIME

Wetlands in the National Wetlands Inventory

Impacts to [NWI wetlands](#) and other aquatic habitats may be subject to regulation under Section 404 of the Clean Water Act, or other State/Federal statutes.

For more information please contact the Regulatory Program of the local [U.S. Army Corps of Engineers District](#).

Please note that the NWI data being shown may be out of date. We are currently working to update our NWI data set. We recommend you verify these results with a site visit to determine the actual extent of wetlands on site.

This location overlaps the following wetlands:

RIVERINE

[R4SBC](#)

A description for each wetland code can be found at the [National Wetlands Inventory website](#)

Data limitations

The Service's objective of mapping wetlands and deepwater habitats is to produce reconnaissance level information on the location, type and size of these resources. The maps are prepared from the analysis of high altitude imagery. Wetlands are identified based on vegetation, visible hydrology and geography. A margin of error is inherent in the use of imagery; thus, detailed on-the-ground inspection of any particular site may result in revision of the wetland boundaries or classification established through image analysis.

The accuracy of image interpretation depends on the quality of the imagery, the experience of the image analysts, the amount and quality of the collateral data and the amount of ground truth verification work conducted. Metadata should be consulted to determine the date of the source imagery used and any mapping problems.

Wetlands or other mapped features may have changed since the date of the imagery or field work. There may be occasional differences in polygon boundaries or classifications between the information depicted on the map and the actual conditions on site.

Data exclusions

Certain wetland habitats are excluded from the National mapping program because of the limitations of imagery as the primary data source used to detect wetlands. These habitats include seagrasses or submerged aquatic vegetation that are found in the intertidal and subtidal zones of estuaries and nearshore coastal waters. Some deepwater reef communities (coral or tubercid worm reefs) have also been excluded from the inventory. These habitats, because of their depth, go undetected by aerial imagery.

Section 1, Item 5.

Data precautions

Federal, state, and local regulatory agencies with jurisdiction over wetlands may define and describe wetlands in a different manner than that used in this inventory. There is no attempt, in either the design or products of this inventory, to define the limits of proprietary jurisdiction of any Federal, state, or local government or to establish the geographical scope of the regulatory programs of government agencies. Persons intending to engage in activities involving modifications within or adjacent to wetland areas should seek the advice of appropriate federal, state, or local agencies concerning specified agency regulatory programs and proprietary jurisdictions that may affect such activities.

NOT FOR CONSULTATION

*The database used to provide updates to the Online Inventory is under construction. [View updates and changes made since May 2019 here.](#)

Plant List

81 matches found. [Click on scientific name for details](#)

Search Criteria

Found in Quads 3912217, 3912216, 3912215, 3812287, 3812286, 3812285, 3812277 3812276 and 3812275;

[Modify Search Criteria](#) [Export to Excel](#) [Modify Columns](#) [Modify Sort](#) [Display Photos](#)

Scientific Name	Common Name	Family	Lifeform	Blooming Period	CA Rare Plant Rank	State Rank	Global Rank
Amsinckia lunaris	bent-flowered fiddleneck	Boraginaceae	annual herb	Mar-Jun	1B.2	S3	G3
Antirrhinum subcordatum	dimorphic snapdragon	Plantaginaceae	annual herb	Apr-Jul	4.3	S3	G3
Antirrhinum virga	twig-like snapdragon	Plantaginaceae	perennial herb	Jun-Jul	4.3	S3?	G3?
Arabis blepharophylla	coast rockcress	Brassicaceae	perennial herb	Feb-May	4.3	S4	G4
Arctostaphylos manzanita ssp. elegans	Konocti manzanita	Ericaceae	perennial evergreen shrub	(Jan)Mar-May(Jul)	1B.3	S3	G5T3
Arctostaphylos stanfordiana ssp. raichei	Raiche's manzanita	Ericaceae	perennial evergreen shrub	Feb-Apr	1B.1	S2	G3T2
Asclepias solanoana	serpentine milkweed	Apocynaceae	perennial herb	May-Jul(Aug)	4.2	S3	G3
Astragalus breweri	Brewer's milk-vetch	Fabaceae	annual herb	Apr-Jun	4.2	S3	G3
Astragalus clevelandii	Cleveland's milk-vetch	Fabaceae	perennial herb	Jun-Sep	4.3	S4	G4
Astragalus rattanii var. jepsonianus	Jepson's milk-vetch	Fabaceae	annual herb	Mar-Jun	1B.2	S3	G4T3
Azolla microphylla	Mexican mosquito fern	Azollaceae	annual / perennial herb	Aug	4.2	S4	G5
Brasenia schreberi	watershield	Cabombaceae	perennial rhizomatous herb (aquatic)	Jun-Sep	2B.3	S3	G5
Brodiaea rosea ssp. rosea	Indian Valley brodiaea	Themidaceae	perennial bulbiferous herb	May-Jun	3.1	S2	G2
Calamagrostis ophitidis	serpentine reed grass	Poaceae	perennial herb	Apr-Jul	4.3	S3	G3
Calochortus uniflorus	pink star-tulip	Liliaceae	perennial bulbiferous herb	Apr-Jun	4.2	S4	G4
Calyptridium quadripetalum	four-petaled pussypaws	Montiaceae	annual herb	Apr-Jun	4.3	S4	G4
	Mt. Saint Helena	Convolvulaceae	perennial	Apr-Jun	4.2	S3	G4

						Section I, Item 5.	
<u>Calystegia collina ssp. oxyphylla</u>	morning-glory		rhizomatous herb				
<u>Calystegia collina ssp. tridactylosa</u>	three-fingered morning-glory	Convolvulaceae	perennial rhizomatous herb	Apr-Jun	1B.2	S1	G4T1
<u>Carex praticola</u>	northern meadow sedge	Cyperaceae	perennial herb	May-Jul	2B.2	S2	G5
<u>Castilleja rubicundula var. rubicundula</u>	pink creamsacs	Orobanchaceae	annual herb (hemiparasitic)	Apr-Jun	1B.2	S2	G5T2
<u>Ceanothus confusus</u>	Rincon Ridge ceanothus	Rhamnaceae	perennial evergreen shrub	Feb-Jun	1B.1	S1	G1
<u>Ceanothus divergens</u>	Calistoga ceanothus	Rhamnaceae	perennial evergreen shrub	Feb-Apr	1B.2	S2	G2
<u>Chlorogalum pomeridianum var. minus</u>	dwarf soaproot	Agavaceae	perennial bulbiferous herb	May-Aug	1B.2	S3	G5T3
<u>Clarkia gracilis ssp. tracyi</u>	Tracy's clarkia	Onagraceae	annual herb	Apr-Jul	4.2	S3	G5T3
<u>Collomia diversifolia</u>	serpentine collomia	Polemoniaceae	annual herb	May-Jun	4.3	S4	G4
<u>Cordylanthus tenuis ssp. brunneus</u>	serpentine bird's-beak	Orobanchaceae	annual herb (hemiparasitic)	Jul-Aug	4.3	S3	G4G5T3
<u>Cryptantha dissita</u>	serpentine cryptantha	Boraginaceae	annual herb	Apr-Jun	1B.2	S2	G2
<u>Delphinium uliginosum</u>	swamp larkspur	Ranunculaceae	perennial herb	May-Jun	4.2	S3	G3
<u>Downingia willamettensis</u>	Cascade downingia	Campanulaceae	annual herb	Jun-Jul(Sep)	2B.2	S2	G4
<u>Eriastrum brandegeae</u>	Brandegee's eriastrum	Polemoniaceae	annual herb	Apr-Aug	1B.1	S1	G1Q
<u>Erigeron greenei</u>	Greene's narrow-leaved daisy	Asteraceae	perennial herb	May-Sep	1B.2	S3	G3
<u>Eriogonum nervulosum</u>	Snow Mountain buckwheat	Polygonaceae	perennial rhizomatous herb	Jun-Sep	1B.2	S2	G2
<u>Eryngium constancei</u>	Loch Lomond button-celery	Apiaceae	annual / perennial herb	Apr-Jun	1B.1	S1	G1
<u>Fritillaria pluriflora</u>	adobe-lily	Liliaceae	perennial bulbiferous herb	Feb-Apr	1B.2	S2S3	G2G3
<u>Gratiola heterosepala</u>	Boggs Lake hedge-hyssop	Plantaginaceae	annual herb	Apr-Aug	1B.2	S2	G2
<u>Grimmia torenii</u>	Toren's grimmia	Grimmiaceae	moss		1B.3	S2	G2
<u>Harmonia hallii</u>	Hall's harmonia	Asteraceae	annual herb	Apr-Jun	1B.2	S2?	G2?
<u>Hemizonia congesta ssp. congesta</u>	congested-headed hayfield tarplant	Asteraceae	annual herb	Apr-Nov	1B.2	S2	G5T2
<u>Hesperolinon adenophyllum</u>	glandular western flax	Linaceae	annual herb	May-Aug	1B.2	S2S3	G2G3
<u>Hesperolinon bicarpellatum</u>	two-carpellate western flax	Linaceae	annual herb	May-Jul	1B.2	S2	G2
<u>Hesperolinon didymocarpum</u>	Lake County western flax	Linaceae	annual herb	May-Jul	1B.2	S1	G1
<u>Hesperolinon sharsmithiae</u>	Sharsmith's western flax	Linaceae	annual herb	May-Jul	1B.2	S2	G2Q
<u>Horkelia bolanderi</u>	Bolander's horkelia	Rosaceae	perennial herb	(May)Jun-Aug	1B.2	S1	G1
<u>Imperata brevifolia</u>	California satintail	Poaceae	perennial	Sep-May	2B.1	S3	G4

							Section I, Item 5.	
			rhizomatous herb					
Lasthenia burkei	Burke's goldfields	Asteraceae	annual herb	Apr-Jun	1B.1		S1	G1
Layia septentrionalis	Colusa layia	Asteraceae	annual herb	Apr-May	1B.2		S2	G2
Legenere limosa	legenere	Campanulaceae	annual herb	Apr-Jun	1B.1		S2	G2
Leptosiphon acicularis	bristly leptosiphon	Polemoniaceae	annual herb	Apr-Jul	4.2		S4?	G4?
Leptosiphon jepsonii	Jepson's leptosiphon	Polemoniaceae	annual herb	Mar-May	1B.2		S2S3	G2G3
Limnanthes floccosa ssp. floccosa	woolly meadowfoam	Limnanthaceae	annual herb	Mar-May(Jun)	4.2		S3	G4T4
Lomatium repostum	Napa lomatium	Apiaceae	perennial herb	Mar-Jun	4.3		S3	G3
Lupinus sericatus	Cobb Mountain lupine	Fabaceae	perennial herb	Mar-Jun	1B.2		S2?	G2?
Malacothamnus helleri	Heller's bush-mallow	Malvaceae	perennial deciduous shrub	May-Jul	3.3		S3	G3Q
Micropus amphibolus	Mt. Diablo cottonweed	Asteraceae	annual herb	Mar-May	3.2		S3S4	G3G4
Mielichhoferia elongata	elongate copper moss	Mielichhoferiaceae	moss		4.3		S4	G5
Myosurus minimus ssp. apus	little mouse-tail	Ranunculaceae	annual herb	Mar-Jun	3.1		S2	G5T2Q
Navarretia cotulifolia	cotula navarretia	Polemoniaceae	annual herb	May-Jun	4.2		S4	G4
Navarretia jepsonii	Jepson's navarretia	Polemoniaceae	annual herb	Apr-Jun	4.3		S4	G4
Navarretia leucocephala ssp. bakeri	Baker's navarretia	Polemoniaceae	annual herb	Apr-Jul	1B.1		S2	G4T2
Navarretia leucocephala ssp. pauciflora	few-flowered navarretia	Polemoniaceae	annual herb	May-Jun	1B.1		S1	G4T1
Navarretia leucocephala ssp. plieantha	many-flowered navarretia	Polemoniaceae	annual herb	May-Jun	1B.2		S1	G4T1
Navarretia paradoxinota	Porter's navarretia	Polemoniaceae	annual herb	May-Jun(Jul)	1B.3		S2	G2
Orcuttia tenuis	slender Orcutt grass	Poaceae	annual herb	May-Sep(Oct)	1B.1		S2	G2
Panicum acuminatum var. thermale	Geysers panicum	Poaceae	annual / perennial herb	Jun-Aug	1B.2		S2	G5T2Q
Penstemon newberryi var. sonomensis	Sonoma beardtongue	Plantaginaceae	perennial herb	Apr-Aug	1B.3		S2	G4T2
Piperia michaelii	Michael's rein orchid	Orchidaceae	perennial herb	Apr-Aug	4.2		S3	G3
Potamogeton zosteriformis	eel-grass pondweed	Potamogetonaceae	annual herb (aquatic)	Jun-Jul	2B.2		S3	G5
Sedella leiocarpa	Lake County stonecrop	Crassulaceae	annual herb	Apr-May	1B.1		S1	G1
Senecio clevelandii var. clevelandii	Cleveland's ragwort	Asteraceae	perennial herb	Jun-Jul	4.3		S3	G4?T3Q
Sidalcea oregana ssp. hydrophila	marsh checkerbloom	Malvaceae	perennial herb	(Jun)Jul-Aug	1B.2		S2	G5T2
Streptanthus barbiger	bearded jewelflower	Brassicaceae	annual herb	May-Jul	4.2		S3	G3
Streptanthus brachiatus ssp. brachiatus	Socrates Mine jewelflower	Brassicaceae	perennial herb	May-Jun	1B.2		S1	G2T1
Streptanthus brachiatus ssp. hoffmanii	Freed's jewelflower	Brassicaceae	perennial herb	May-Jul	1B.2		S2	G2

Streptanthus glandulosus ssp. hoffmanii	Hoffman's bristly jewelflower	Brassicaceae	annual herb	Mar-Jul	1B.3	Section I, Item 5.	
Streptanthus hesperidis	green jewelflower	Brassicaceae	annual herb	May-Jul	1B.2	S2	G2
Streptanthus morrisonii ssp. elatus	Three Peaks jewelflower	Brassicaceae	perennial herb	Jun-Sep	1B.2	S1	G2T1
Streptanthus morrisonii ssp. kruckebergii	Kruckeberg's jewelflower	Brassicaceae	perennial herb	Apr-Jul	1B.2	S1	G2T1
Toxicoscordion fontanum	marsh zigadenus	Melanthiaceae	perennial bulbiferous herb	Apr-Jul	4.2	S3	G3
Trichostema ruygtii	Napa bluecurls	Lamiaceae	annual herb	Jun-Oct	1B.2	S1S2	G1G2
Trifolium hydrophilum	saline clover	Fabaceae	annual herb	Apr-Jun	1B.2	S2	G2
Viburnum ellipticum	oval-leaved viburnum	Adoxaceae	perennial deciduous shrub	May-Jun	2B.3	S3?	G4G5

Suggested Citation

California Native Plant Society, Rare Plant Program. 2021. Inventory of Rare and Endangered Plants of California (online edition, v8-03 0.39). Website <http://www.rareplants.cnps.org> [accessed 27 January 2021].

Search the Inventory

[Simple Search](#)

[Advanced Search](#)

[Glossary](#)

Information

[About the Inventory](#)

[About the Rare Plant Program](#)

[CNPS Home Page](#)

[About CNPS](#)

[Join CNPS](#)

Contributors

[The Calflora Database](#)

[The California Lichen Society](#)

[California Natural Diversity Database](#)

[The Jepson Flora Project](#)

[The Consortium of California Herbaria](#)

[CalPhotos](#)

Questions and Comments

rareplants@cnps.org

© Copyright 2010-2018 California Native Plant Society. All rights reserved.



Selected Elements by Element Code
California Department of Fish and Wildlife
California Natural Diversity Database

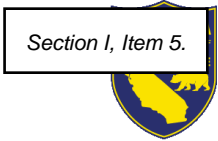

Query Criteria: Quad (Lucerne (3912217) OR Clearlake Highlands (3812286) OR Clearlake Oaks (3912216) OR Benmore Canyon (3912215) OR Kelseyville (3812287) OR Lower Lake (3812285) OR The Geysers (3812277) OR Whispering Pines (3812276) OR Middletown (3812275))

Element Code	Species	Federal Status	State Status	Global Rank	State Rank	Rare Plant Rank/CDFW SSC or FP
AAAAF02020	<i>Taricha rivularis</i> red-bellied newt	None	None	G4	S2	SSC
AAAAH01020	<i>Dicamptodon ensatus</i> California giant salamander	None	None	G3	S2S3	SSC
AAABH01022	<i>Rana draytonii</i> California red-legged frog	Threatened	None	G2G3	S2S3	SSC
AAABH01050	<i>Rana boylei</i> foothill yellow-legged frog	None	Endangered	G3	S3	SSC
ABNKC01010	<i>Pandion haliaetus</i> osprey	None	None	G5	S4	WL
ABNKC10010	<i>Haliaeetus leucocephalus</i> bald eagle	Delisted	Endangered	G5	S3	FP
ABNKC22010	<i>Aquila chrysaetos</i> golden eagle	None	None	G5	S3	FP
ABNRB02022	<i>Coccyzus americanus occidentalis</i> western yellow-billed cuckoo	Threatened	Endangered	G5T2T3	S1	
ABPAU01010	<i>Progne subis</i> purple martin	None	None	G5	S3	SSC
AFCHA0209G	<i>Oncorhynchus mykiss irideus pop. 8</i> steelhead - central California coast DPS	Threatened	None	G5T2T3Q	S2S3	
AFCJB19011	<i>Lavinia exilicauda chi</i> Clear Lake hitch	None	Threatened	G4T1	S1	
AFCQB07010	<i>Archoplites interruptus</i> Sacramento perch	None	None	G2G3	S1	SSC
AFCQK02013	<i>Hysterocarpus traskii lagunae</i> Clear Lake tule perch	None	None	G5T2T3	S2S3	SSC
AMACC01070	<i>Myotis evotis</i> long-eared myotis	None	None	G5	S3	
AMACC01090	<i>Myotis thysanodes</i> fringed myotis	None	None	G4	S3	
AMACC02010	<i>Lasionycteris noctivagans</i> silver-haired bat	None	None	G5	S3S4	
AMACC05030	<i>Lasiurus cinereus</i> hoary bat	None	None	G5	S4	
AMACC05060	<i>Lasiurus blossevillii</i> western red bat	None	None	G5	S3	SSC
AMACC08010	<i>Corynorhinus townsendii</i> Townsend's big-eared bat	None	None	G3G4	S2	SSC



Selected Elements by Element Code
California Department of Fish and Wildlife
California Natural Diversity Database

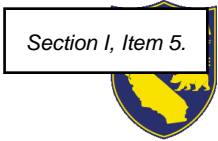

Element Code	Species	Federal Status	State Status	Global Rank	State Rank	Rare Plant Rank/CDFW SSC or FP
AMACC10010	<i>Antrozous pallidus</i> pallid bat	None	None	G5	S3	SSC
AMAFJ01010	<i>Erethizon dorsatum</i> North American porcupine	None	None	G5	S3	
ARAAD02030	<i>Emys marmorata</i> western pond turtle	None	None	G3G4	S3	SSC
CARA2422CA	Central Valley Drainage Rainbow Trout/Cyprinid Stream Central Valley Drainage Rainbow Trout/Cyprinid Stream	None	None	GNR	SNR	
CARA2520CA	Clear Lake Drainage Resident Trout Stream Clear Lake Drainage Resident Trout Stream	None	None	GNR	SNR	
CARA2530CA	Clear Lake Drainage Cyprinid/Catostomid Stream Clear Lake Drainage Cyprinid/Catostomid Stream	None	None	GNR	SNR	
CARA2550CA	Clear Lake Drainage Seasonal Lakefish Spawning Stream Clear Lake Drainage Seasonal Lakefish Spawning Stream	None	None	GNR	SNR	
CTT44131CA	Northern Basalt Flow Vernal Pool Northern Basalt Flow Vernal Pool	None	None	G3	S2.2	
CTT44133CA	Northern Volcanic Ash Vernal Pool Northern Volcanic Ash Vernal Pool	None	None	G1	S1.1	
CTT52410CA	Coastal and Valley Freshwater Marsh Coastal and Valley Freshwater Marsh	None	None	G3	S2.1	
CTT61420CA	Great Valley Mixed Riparian Forest Great Valley Mixed Riparian Forest	None	None	G2	S2.2	
ICBRA06010	<i>Lindleriella occidentalis</i> California linderiella	None	None	G2G3	S2S3	
ICMAL34010	<i>Calasellus californicus</i> An isopod	None	None	G2	S2	
IICOL5A010	<i>Dubiraphia brunnescens</i> brownish dubiraphian riffle beetle	None	None	G1	S1	
IICOL5V010	<i>Hydrochara rickseckeri</i> Ricksecker's water scavenger beetle	None	None	G2?	S2?	
IIHEM07010	<i>Saldula usingeri</i> Wilbur Springs shorebug	None	None	G1	S1	
IIHYM24250	<i>Bombus occidentalis</i> western bumble bee	None	Candidate Endangered	G2G3	S1	
IIHYM24380	<i>Bombus caliginosus</i> obscure bumble bee	None	None	G4?	S1S2	
IIHYM68020	<i>Hedychridium milleri</i> Borax Lake cuckoo wasp	None	None	G1	S1	
IMBIV19010	<i>Gonidea angulata</i> western ridged mussel	None	None	G3	S1S2	



Selected Elements by Element Code
California Department of Fish and Wildlife
California Natural Diversity Database

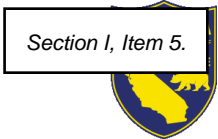

Element Code	Species	Federal Status	State Status	Global Rank	State Rank	Rare Plant Rank/CDFW SSC or FP
IMGASJ0F40	<i>Pyrgulopsis ventricosa</i> Clear Lake pyrg	None	None	G1	S1	
NBMUS32330	<i>Grimmia torenii</i> Toren's grimmia	None	None	G2	S2	1B.3
NBMUS4Q022	<i>Mielichhoferia elongata</i> elongate copper moss	None	None	G5	S3S4	4.3
PDAP10Z0W0	<i>Eryngium constancei</i> Loch Lomond button-celery	Endangered	Endangered	G1	S1	1B.1
PDAST3M5G0	<i>Erigeron greenii</i> Greene's narrow-leaved daisy	None	None	G3	S3	1B.2
PDAST4R065	<i>Hemizonia congesta ssp. congesta</i> congested-headed hayfield tarplant	None	None	G5T2	S2	1B.2
PDAST5L010	<i>Lasthenia burkei</i> Burke's goldfields	Endangered	Endangered	G1	S1	1B.1
PDAST5N0F0	<i>Layia septentrionalis</i> Colusa layia	None	None	G2	S2	1B.2
PDAST650A0	<i>Harmonia hallii</i> Hall's harmonia	None	None	G2?	S2?	1B.2
PDBOR01070	<i>Amsinckia lunaris</i> bent-flowered fiddleneck	None	None	G3	S3	1B.2
PDBRA2G071	<i>Streptanthus brachiatus ssp. hoffmanii</i> Freed's jewelflower	None	None	G2T2	S2	1B.2
PDBRA2G072	<i>Streptanthus brachiatus ssp. brachiatus</i> Socrates Mine jewelflower	None	None	G2T1	S1	1B.2
PDBRA2G0J4	<i>Streptanthus glandulosus ssp. hoffmanii</i> Hoffman's bristly jewelflower	None	None	G4T2	S2	1B.3
PDBRA2G510	<i>Streptanthus hesperidis</i> green jewelflower	None	None	G2G3	S2S3	1B.2
PDCAB01010	<i>Brasenia schreberi</i> watershield	None	None	G5	S3	2B.3
PDCAM060E0	<i>Downingia willamettensis</i> Cascade downingia	None	None	G4	S2	2B.2
PDCAM0C010	<i>Legenere limosa</i> legenere	None	None	G2	S2	1B.1
PDCON04032	<i>Calystegia collina ssp. oxyphylla</i> Mt. Saint Helena morning-glory	None	None	G4T3	S3	4.2
PDCON04036	<i>Calystegia collina ssp. tridactylosa</i> three-fingered morning-glory	None	None	G4T1	S1	1B.2
PDCPR07080	<i>Viburnum ellipticum</i> oval-leaved viburnum	None	None	G4G5	S3?	2B.3
PDCRA0F020	<i>Sedella leiocarpa</i> Lake County stonecrop	Endangered	Endangered	G1	S1	1B.1



Selected Elements by Element Code
California Department of Fish and Wildlife
California Natural Diversity Database

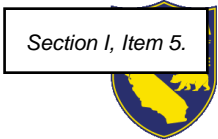

Element Code	Species	Federal Status	State Status	Global Rank	State Rank	Rare Plant Rank/CDFW SSC or FP
PDERI041G2	<i>Arctostaphylos stanfordiana ssp. raichei</i> Raiche's manzanita	None	None	G3T2	S2	1B.1
PDERI04271	<i>Arctostaphylos manzanita ssp. elegans</i> Konocti manzanita	None	None	G5T3	S3	1B.3
PDFAB0F7E1	<i>Astragalus rattanii var. jepsonianus</i> Jepson's milk-vetch	None	None	G4T3	S3	1B.2
PDFAB2B0C0	<i>Lupinus antoninus</i> Anthony Peak lupine	None	None	G2	S2	1B.2
PDFAB2B3J0	<i>Lupinus sericatus</i> Cobb Mountain lupine	None	None	G2?	S2?	1B.2
PDFAB400R5	<i>Trifolium hydrophilum</i> saline clover	None	None	G2	S2	1B.2
PDLAM220H0	<i>Trichostema ruygtii</i> Napa bluecurls	None	None	G1G2	S1S2	1B.2
PDLIM02043	<i>Limnanthes floccosa ssp. floccosa</i> woolly meadowfoam	None	None	G4T4	S3	4.2
PDLIN01010	<i>Hesperolinon adenophyllum</i> glandular western flax	None	None	G2G3	S2S3	1B.2
PDLIN01020	<i>Hesperolinon bicarpellatum</i> two-carpellate western flax	None	None	G2	S2	1B.2
PDLIN01070	<i>Hesperolinon didymocarpum</i> Lake County western flax	None	Endangered	G1	S1	1B.2
PDLIN010E0	<i>Hesperolinon sharsmithiae</i> Sharsmith's western flax	None	None	G2Q	S2	1B.2
PDMAL110K2	<i>Sidalcea oregana ssp. hydrophila</i> marsh checkerbloom	None	None	G5T2	S2	1B.2
PDPGN08440	<i>Eriogonum nervulosum</i> Snow Mountain buckwheat	None	None	G2	S2	1B.2
PDPLM03020	<i>Eriastrum brandegeae</i> Brandegee's eriastrum	None	None	G1Q	S1	1B.1
PDPLM09140	<i>Leptosiphon jepsonii</i> Jepson's leptosiphon	None	None	G2G3	S2S3	1B.2
PDPLM0C0E1	<i>Navarretia leucocephala ssp. bakeri</i> Baker's navarretia	None	None	G4T2	S2	1B.1
PDPLM0C0E4	<i>Navarretia leucocephala ssp. pauciflora</i> few-flowered navarretia	Endangered	Threatened	G4T1	S1	1B.1
PDPLM0C0E5	<i>Navarretia leucocephala ssp. pliantha</i> many-flowered navarretia	Endangered	Endangered	G4T1	S1	1B.2
PDPLM0C160	<i>Navarretia paradoxinota</i> Porter's navarretia	None	None	G2	S2	1B.3
PDRHA04220	<i>Ceanothus confusus</i> Rincon Ridge ceanothus	None	None	G1	S1	1B.1



Selected Elements by Element Code
California Department of Fish and Wildlife
California Natural Diversity Database

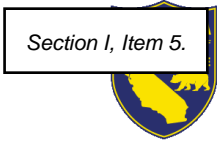

Element Code	Species	Federal Status	State Status	Global Rank	State Rank	Rare Plant Rank/CDFW SSC or FP
PDRHA04240	<i>Ceanothus divergens</i> Calistoga ceanothus	None	None	G2	S2	1B.2
PDROS0W011	<i>Horkelia bolanderi</i> Bolander's horkelia	None	None	G1	S1	1B.2
PDSCR0D482	<i>Castilleja rubicundula var. rubicundula</i> pink creamsacs	None	None	G5T2	S2	1B.2
PDSCR0R060	<i>Gratiola heterosepala</i> Boggs Lake hedge-hyssop	None	Endangered	G2	S2	1B.2
PDSCR1L483	<i>Penstemon newberryi var. sonomensis</i> Sonoma beardtongue	None	None	G4T3	S3	1B.3
PDSCR2S070	<i>Antirrhinum subcordatum</i> dimorphic snapdragon	None	None	G3	S3	4.3
PMCYP03B20	<i>Carex praticola</i> northern meadow sedge	None	None	G5	S2	2B.2
PMLIL0G042	<i>Chlorogalum pomeridianum var. minus</i> dwarf soaproot	None	None	G5T3	S3	1B.2
PMLIL0V0F0	<i>Fritillaria pluriflora</i> adobe-lily	None	None	G2G3	S2S3	1B.2
PMPOA24028	<i>Panicum acuminatum var. thermale</i> Geysers panicum	None	Endangered	G5T2Q	S2	1B.2
PMPOA3D020	<i>Imperata brevifolia</i> California satintail	None	None	G4	S3	2B.1
PMPOA4G050	<i>Orcuttia tenuis</i> slender Orcutt grass	Threatened	Endangered	G2	S2	1B.1
PMPOA03160	<i>Potamogeton zosteriformis</i> eel-grass pondweed	None	None	G5	S3	2B.2

Record Count: 94

Quad Name **Clearlake Highlands**

Quad Number **38122-H6**

ESA Anadromous Fish

- SONCC Coho ESU (T) - None
- CCC Coho ESU (E) - None
- CC Chinook Salmon ESU (T) - None
- CVSR Chinook Salmon ESU (T) - None
- SRWR Chinook Salmon ESU (E) - None
- NC Steelhead DPS (T) - None
- CCC Steelhead DPS (T) - None
- SCCC Steelhead DPS (T) - None
- SC Steelhead DPS (E) - None
- CCV Steelhead DPS (T) - None
- Eulachon (T) - None
- sDPS Green Sturgeon (T) - None

ESA Anadromous Fish Critical Habitat

- SONCC Coho Critical Habitat - None
- CCC Coho Critical Habitat - None
- CC Chinook Salmon Critical Habitat - None
- CVSR Chinook Salmon Critical Habitat - None
- SRWR Chinook Salmon Critical Habitat - None
- NC Steelhead Critical Habitat - None
- CCC Steelhead Critical Habitat - None
- SCCC Steelhead Critical Habitat - None
- SC Steelhead Critical Habitat - None
- CCV Steelhead Critical Habitat - None
- Eulachon Critical Habitat - None
- sDPS Green Sturgeon Critical Habitat - None

ESA Marine Invertebrates

- Range Black Abalone (E) - None
- Range White Abalone (E) - None

ESA Marine Invertebrates Critical Habitat

Black Abalone Critical Habitat - None

ESA Sea Turtles

East Pacific Green Sea Turtle (T) - None
Olive Ridley Sea Turtle (T/E) - None
Leatherback Sea Turtle (E) - None
North Pacific Loggerhead Sea Turtle (E) - None

ESA Whales

Blue Whale (E) - None
Fin Whale (E) - None
Humpback Whale (E) - None
Southern Resident Killer Whale (E) - None
North Pacific Right Whale (E) - None
Sei Whale (E) - None
Sperm Whale (E) - None

ESA Pinnipeds

Guadalupe Fur Seal (T) - None
Steller Sea Lion Critical Habitat - None

Essential Fish Habitat

Coho EFH - None
Chinook Salmon EFH - None
Groundfish EFH - None
Coastal Pelagics EFH - None
Highly Migratory Species EFH - None

MMPA Species (See list at left)

ESA and MMPA Cetaceans/Pinnipeds

**See list at left and consult the NMFS Long Beach office
562-980-4000**

MMPA Cetaceans - None
MMPA Pinnipeds - None

ATTACHMENT B

Representative Site Photographs



Photo 1. Representative photo of the walnut orchard that makes up the majority of the site. Photo taken January 29, 2021, facing north.



Photo 2. Culverted inlet for the onsite drainage located in the northeast corner of the Study Area. Photo taken January 29, 2021, facing west.



Photo 3. Representative photo of the vegetation along the drainage. Photo taken January 29, 2021, facing west.



Photo 4. Harding grass grassland and large oak trees in the southeast portion of the Study Area. Photo taken January 29, 2021, facing west-northwest



Photo 5. Representative photo of oak woodland riparian vegetation along Burns Valley Creek. Photo taken January 29, 2021, facing west.



Photo 6. Patch of Fremont cottonwood near the southern portion of the mapped drainage. Photo taken January 29, 2021, facing southwest.



Photo 7. A structure within the walnut orchard may provide roosting habitat for bats. Photo taken January 29, 2021, facing northeast.



Photo 8. Photo of foundations from old residential development and large oak trees. Photo taken January 29, 2021, facing west-northwest.

Attachment E
Geotechnical Report

Insert February 26, 2021 Geotechnical Report by NV5 here

Attachment E

Traffic Impact Study

Insert Traffic Impact Study for the Burns Valley Development by W-Trans here



Transportation Impact Study for the Burns Valley Development



Prepared for the City of Clearlake

Submitted by
W-Trans

June 20, 2022



This page intentionally left blank

Table of Contents

Executive Summary	1
Introduction.....	2
Transportation Setting.....	5
Project Data	8
Circulation System	12
Vehicle Miles Traveled (VMT).....	16
Safety Issues.....	19
Emergency Access.....	23
Capacity Analysis	24
Parking.....	39
Conclusions and Recommendations.....	40
Study Participants and References	42

Figures

1. Study Area and Existing Lane Configurations	4
2. Site Plan	9
3. Existing Traffic Volumes	27
4. Baseline Traffic Volumes	29
5. Future Traffic Volumes.....	31
6. Project Traffic Volumes and Trip Distribution	32
7. Existing plus Project Traffic Volumes	33
8. Baseline plus Project Traffic Volumes	35
9. Future plus Project Traffic Volumes.....	37

Tables

1. Collision Rates at the Study Intersections	7
2. Trip Generation Summary (Weekdays)	10
3. Trip Generation Summary (Saturday)	11
4. Trip Distribution Assumptions.....	11
5. Bicycle Facility Summary	14
6. Employee Vehicle Miles Traveled Analysis Summary	17
7. 95 th Percentile Queues (Weekday)	22
8. 95 th Percentile Queues (Weekend).....	22
9. Intersection Level of Service Criteria.....	25
10. Existing Peak Hour Intersection Levels of Service.....	26



- 11. Baseline Peak Hour Intersection Levels of Service..... 28
- 12. Future Peak Hour Intersection Levels of Service 30
- 13. Existing and Existing plus Project Peak Hour Intersection Levels of Service..... 34
- 14. Baseline plus Project Peak Hour Intersection Levels of Service..... 36
- 15. Future plus Project Peak Hour Intersection Levels of Service 38
- 16. Parking Analysis Summary 39

Plates

- 1. Vision Triangle Graphic..... 20

Appendices

- A. Collision Rate Calculations
- B. NCHRP Pedestrian Crossing Treatment Worksheet
- C. VMT Screening Tool Output
- D. Turn Lane Warrant Spreadsheets
- E. Maximum Left-Turn Queue Length Calculations
- F. Intersection Level of Service and Queuing Calculations



Executive Summary

The proposed Burns Valley Development would occupy approximately 29 acres of vacant land between Burns Valley Road and Olympic Drive in the City of Clearlake. The development includes a public works corporation yard, a drive-through coffee shop, six athletic fields, a 15,000 square-foot recreational center, and a separate affordable multi-family residential project. The development would be expected to generate an average of 1,332 new daily trips, with 77 new trips during the weekday a.m. peak hour, 182 new trips during the weekday p.m. peak hour, and 353 new trips during the Saturday p.m. peak hour.

A new crosswalk with high-visibility continental crosswalk markings would be provided on Olympic Drive at the North-South Project Street intersection, along with ADA-compliant curb ramps, pedestrian crossing signage, and advance yield line markings. Crosswalks would also be provided on the project street legs of the new street connections to Burns Valley Road and Olympic Drive. The long-term bicycle storage supply for the Oak Valley Villas should be increased from the proposed four spaces to seven spaces. A total supply of 19 bicycle parking spaces should be provided throughout the non-residential portions of the development site. With the construction of these facilities in addition to sidewalks, crosswalks, and bike lanes within the development site, access for pedestrians, bicyclists, and transit riders would be adequate.

Under guidance provided by the California Governor's Office of Planning and Research (OPR) as well as data contained in the *Senate Bill 743 Vehicle Miles Traveled Regional Baseline Study* for Lake County, all components of the proposed development would be expected to have a less-than-significant transportation impact on vehicle miles traveled (VMT), including the residential, coffee shop, corporation yard, and recreational uses.

The development site would be accessed via a new north-south street extending from Olympic Drive on the south to Burns Valley Road on the north, as well as a new east-west street to be constructed north of the Safeway commercial property and extending from the proposed City corporation yard on the west to Burns Valley Road on the east. The new project streets would provide full access to the parking lots and driveways throughout the development site. The Oak Valley Villas project would also be accessed via a new driveway on Burns Valley Road. Sight lines on Burns Valley Road and Olympic Drive are adequate to accommodate all turns into and out of the proposed intersections and driveways. To maintain clear sight lines, vision triangles at the access points should be kept free of obstructions. The planting of tall vegetation should be avoided at the northeast corner of the site near the intersection of Burns Valley Road/Bowers Avenue-Rumsey Road.

A left-turn lane would be warranted on Olympic Drive at the intersection with the project street. Therefore, it is recommended that the existing two-way left-turn lane (TWLTL) on Olympic Drive be extended to provide 75 feet west of stacking space at the proposed Olympic Drive/North-South Project Street Intersection; this improvement has been added to the site plan. The projected 95th percentile queues in turn pockets at the study intersections would remain within existing storage capacity at each location under all scenarios.

To assess the project's compliance with General Plan policies, operations were evaluated at intersections along Burns Valley Road and Olympic Drive, as well as at new intersections with project streets. For Future Conditions, operations with a roundabout at Olympic Drive/Lakeshore Drive were analyzed. Analysis indicates that all study intersections operate acceptably under Existing Conditions and would continue to do so under Baseline and Future Conditions, with and without project traffic added.

The proposed parking supply would be more than sufficient to meet City and State Density Bonus requirements.

Introduction

This report presents an analysis of the potential transportation impacts and operational effects that would be associated with the proposed Burns Valley Development to be located between Burns Valley Road and Olympic Drive in the City of Clearlake. The transportation study was completed in accordance with the criteria established by the City of Clearlake, reflects a scope of work approved by City staff, and is consistent with standard traffic engineering techniques.

Prelude

The purpose of a transportation impact study (TIS) is to provide City staff and policy makers with data that they can use to make an informed decision regarding the potential transportation impacts of a proposed project, and any associated improvements that would be required to mitigate these impacts to an acceptable level under CEQA, the City's General Plan, or other policies. This report provides an analysis of those items that are identified as areas of environmental concern under the California Environmental Quality Act (CEQA) and that, if significant, require an EIR. Impacts associated with access for pedestrians, bicyclists, and to transit; the vehicle miles traveled (VMT) generated by the project; potential safety concerns such as increased queuing in dedicated turn lanes, adequacy of sight distance, need for turn lanes, and need for additional right-of-way controls; and emergency access are addressed in the context of the CEQA criteria.

While no longer a part of the CEQA review process, vehicular traffic service levels at key intersections were evaluated for consistency with General Plan policies by determining the number of new trips that the proposed uses would be expected to generate, distributing these trips to the surrounding street system based on anticipated travel patterns specific to the proposed project, then analyzing the effect the new traffic would be expected to have on the study intersections and need for improvements to maintain acceptable operation. Adequacy of parking is also addressed as a policy issue. It is noted that while the transportation impacts and traffic effects of the proposed affordable housing project are being presented in this study, for the purposes of environmental clearance the Oak Valley Villas is being entitled separately from the rest of the Burns Valley Development.

Applied Standards and Criteria

The report is organized to provide background data that supports the various aspects of the analysis, followed by the assessment of CEQA issues and then evaluation of policy-related issues. The CEQA criteria evaluated are as follows.

Would the project:

- a. Conflict with a program, plan, ordinance, or policy addressing the circulation system, including transit, roadway, bicycle, and pedestrian facilities?
- b. Conflict or be inconsistent with CEQA Guidelines § 15064.3, subdivision (b)?
- c. Substantially increase hazards due to a geometric design feature (e.g., sharp curves or dangerous intersections) or incompatible uses (e.g., farm equipment)?
- d. Result in inadequate emergency access?

Project Profile

The project includes a public works corporation yard, a drive-through coffee shop, various recreational uses such as baseball, softball, and soccer fields as well as a 15,000 square-foot recreational center and a separate affordable multi-family residential project. As part of the development, a new north-south street would be constructed that

would extend from Olympic Drive to Burns Valley Road west of the Lake County Library. Additionally, an east-west street would be constructed north of the Safeway commercial property and would extend from the proposed City corporation yard on the west to Burns Valley Road on the east.

The project site is located on approximately 29 acres of vacant land between Burns Valley Road and Olympic Drive in the City of Clearlake, as shown in Figure 1.

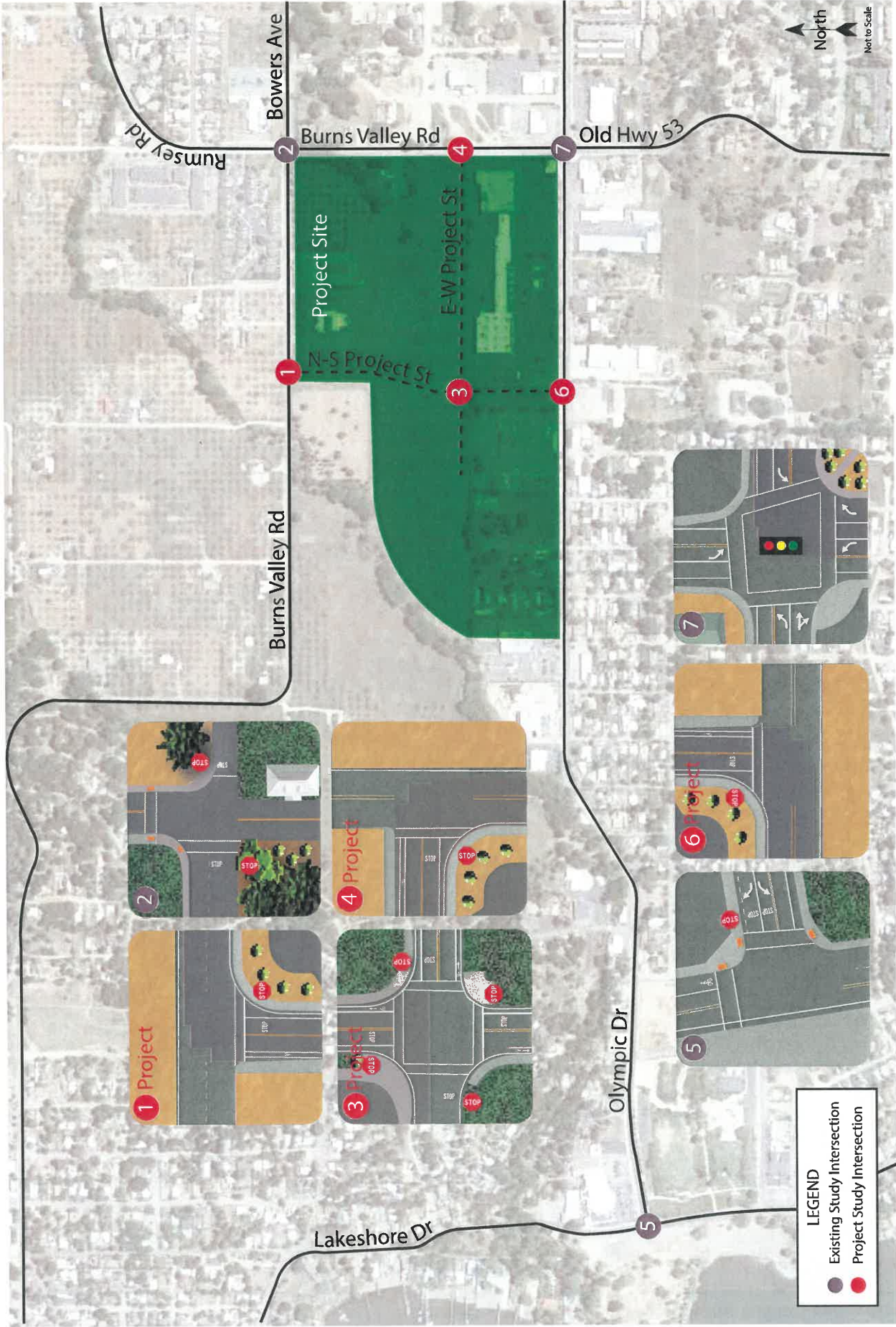

cle029.at 4/22



Transportation Impact Study for the Burns Valley Development
Figure 1 – Study Area, Existing and Proposed Lane Configurations

Transportation Setting

Study Area and Periods

The study area varies depending on the topic. For pedestrian trips it consists of all streets within a half-mile of the project site that would lie along primary routes of pedestrian travel, or those leading to nearby generators or attractors. For bicycle trips it consists of all streets within one mile of the project site that would lie along primary routes of bicycle travel. For the safety and operational analyses, the study area was selected with input from City staff and consists of the following intersections, three of which are existing and four that would be new intersections constructed by the proposed development:

1. Burns Valley Road/North-South Project Street (New)
2. Burns Valley Road/Bowers Avenue-Rumsey Road (Existing)
3. North-South Project Street/East-West Project Street (New)
4. Burns Valley Road/East-West Project Street (New)
5. Olympic Drive/Lakeshore Drive (Existing)
6. Olympic Drive/North-South Project Street (New)
7. Olympic Drive/Burns Valley Road-Old Highway 53 (Existing)

Operating conditions during the weekday a.m. and p.m. peak periods as well as the Saturday afternoon peak period were evaluated to capture the highest trip generation potential for the proposed uses as well as the highest volumes on the local transportation network. The weekday morning peak hour occurs between 7:00 and 9:00 a.m. and reflects conditions during the home to work or school commute, while the weekday p.m. peak hour occurs between 4:00 and 6:00 p.m. and typically reflects the highest level of congestion during the homeward bound commute. The Saturday afternoon peak hour generally occurs between 1:00 and 3:00 p.m. and reflects the highest level of activity associated with the recreational components of the development. New turning movement counts were obtained for the existing study intersections in January 2022.

Study Intersections

Burns Valley Road/North-South Project Street is a proposed tee intersection that would be created by the development and be located approximately 400 feet west of Sharp Lane. The intersection would be stop-controlled on the northbound terminating project street approach and a crosswalk would be provided on the south leg.

Burns Valley Road/Bowers Avenue-Rumsey Road is a four-legged existing intersection with stop controls on the eastbound and westbound Burns Valley Road and Bowers Avenue approaches, which are offset by approximately 20 feet. The south leg of the intersection is also Burns Valley Road, while the north leg is Rumsey Road. A marked crosswalk is provided on the north leg, about 30 feet north of the intersection.

North-South Project Street/East-West Project Street is a proposed four-legged intersection that would be stop-controlled on all approaches. Crosswalks would be provided on all legs.

Burns Valley Road/East-West Project Street is a tee intersection proposed to be located approximately 500 feet north of Olympic Drive. The intersection would be stop-controlled on the terminating eastbound project street approach.

Olympic Drive/Lakeshore Drive is an existing tee intersection with stop control and dedicated left- and right-turn lanes on the westbound terminating Olympic Drive approach. Crosswalks are marked on the north and east legs and the crossing on the north leg has a pedestrian-activated flashing beacon system.

Olympic Drive/North-South Project Street is a proposed tee intersection that would be located approximately 150 feet west of the westernmost driveway to the Safeway commercial center. The intersection would be stop-controlled on the southbound terminating project street approach. A crosswalk would be provided on the north leg.

Olympic Drive/Burns Valley Road-Old Highway 53 is an existing four-legged signalized intersection with left-turn lanes and protected left-turn phasing on all approaches. Crosswalks with pedestrian phasing are provided on all four legs.

The locations of the study intersections along with the existing and proposed lane configurations and controls are shown in Figure 1.

Study Roadways

Burns Valley Road has two travel lanes in each direction and bounds the development site on the eastern and northern boundaries as the roadway changes orientation from north-south to east-west at the intersection with Bowers Avenue-Rumsey Road. The north-south section of the roadway has a posted speed limit of 30 miles per hour (mph), while the east-west section has a posted speed limit of 35 mph. Based on count data collected in January 2022, the roadway has an average daily traffic (ADT) volume of approximately 2,100 vehicles to the west of Sharp Lane and 3,540 vehicles south of Turner Avenue.

Olympic Drive runs mostly east-west between Lakeshore Drive on the west and SR 53 on the east and has two travel lanes in each direction with a posted speed limit of 35 mph. A center two-way left-turn lane (TWLTL) is provided along the Safeway commercial center frontage, which extends to Emerson Street. Based on count data collected in January 2022, the roadway has an ADT volume of approximately 7,100 vehicles adjacent to the project site.

Vehicle Collision History

The collision history for the study area was reviewed to determine any trends or patterns that may indicate a safety issue for motorists in the project vicinity. Collision rates were calculated based on records available from the California Highway Patrol (CHP) as published in their Statewide Integrated Traffic Records System (SWITRS) reports. The most current five-year period available is August 1, 2016, through July 31, 2021.

As presented in Table 1, the calculated collision rates for the three existing study intersections were compared to average collision rates for similar facilities statewide, as indicated in *2018 Collision Data on California State Highways*, California Department of Transportation (Caltrans). These average rates statewide are for intersections in the same environment (urban, suburban, or rural), with the same number of approaches (three or four), and the same controls (all-way stop, two-way stop, or traffic signal). Calculated collision rates for the study intersections were all determined to be lower than the statewide average rates, indicating that the intersections are performing within normal safety parameters. The collision rate calculations are provided in Appendix A.

Table 1 – Collision Rates for the Study Intersections

Study Intersection	Number of Collisions (2016–2021)	Calculated Collision Rate (c/mve)	Statewide Average Collision Rate (c/mve)
2. Burns Valley Rd/Bowers Ave-Rumsey Rd	1	0.13	0.14
5. Olympic Dr/Lakeshore Dr	1	0.07	0.09
7. Olympic Dr/Burns Valley Rd-Old Hwy 53	4	0.21	0.24

Note: c/mve = collisions per million vehicles entering



Project Data

The proposed development consists of the following uses:

- A city corporation yard consisting of a 12,000 square-foot industrial building;
- Six sports fields consisting of full-size baseball, little league, and softball fields, two tee-ball fields, and one youth soccer field;
- A 15,000 square-foot community recreation center with sports features such as basketball and volleyball courts; and
- A 160 square-foot drive-through coffee shop; and
- A separate project with 80 multi-family apartment units dedicated as “affordable” housing known as the Oak Valley Villas.

Approximately 507 on-site parking spaces would be provided, with 144 of these spaces in a separate lot dedicated to the Oak Valley Villas.

The proposed project site plan is shown in Figure 2.

Trip Generation

The anticipated trip generation for the Burns Valley Development, including the Oak Valley Villas, was estimated using standard rates published by the Institute of Transportation Engineers (ITE) in *Trip Generation Manual*, 11th Edition, 2021. Rates for “Affordable Housing – Income Limits” (Land Use #223) were applied to the apartments, rates for “Soccer Complex” (Land Use #488) were applied to the sports field, rates for “Recreational Community Center” (Land Use #495) were applied to the recreation building, rates for “Coffee/Donut Shop with Drive-Through Window and No Indoor Seating” (Land Use #938) were applied to the coffee shop, and rates for “General Light Industrial” (Land Use #110) were applied to the City corporation yard. It is noted that rates for “Soccer Complex” were applied to all sports fields including the baseball, softball, and tee-ball fields as soccer fields and ball fields can be expected to generate similar numbers of trips. To estimate trips during the Saturday p.m. peak hour, standard ITE rates for the “Saturday Peak Hour of the Generator” were applied where available, though the Manual does not include Saturday data for industrial or coffee shop land uses so weekday p.m. peak hour rates were retained for these two uses for the Saturday peak. Further, it is noted that the trip generation calculations for the coffee shop were based on a floor area of 1,000 square feet upon reviewing the anticipated trip generation based on 160 square feet and determination that it would likely underestimate the number of trips that would be generated.

Internal Trips

Internal trips occur at mixed-use developments, and in this case, could consist of residents patronizing the coffee shop and recreational uses or guests visiting more than one establishment in a single round trip to the site, such as someone visiting the sports fields and the recreation center. If these facilities were located on separate sites these trips would occur on the streets between the facilities; however, since the entire development would be connected internally, these trips could occur without affecting operation of the adjacent street network and would therefore be considered internal. However, given the limited published standard internal trip data available for the proposed uses of the development and to result in a conservative analysis no trip deductions were taken for internal trips.



4/72
4/22
cfe029.al

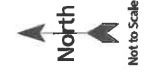

PROJECT NUMBER 31-710	SHEET 01 OF 01	CITY OF GILBERT PHASE 2 - PRELIMINARY GRADING	CALIFORNIA ENGINEERING COMPANY, INC. 11510 CHILDRIS BLDG. 11510 CHILDRIS BLVD. 4801 CHILDRIS BLVD. 4801 CHILDRIS BLVD. GILBERT, AZ 85004 PH: 480.345.1100 FAX: 480.345.1101
DATE 11/15/11	DESIGNED BY JL	CHECKED BY JL	DATE 11/15/11
SCALE AS SHOWN	PROJECT 31-710	DATE 11/15/11	PROJECT 31-710

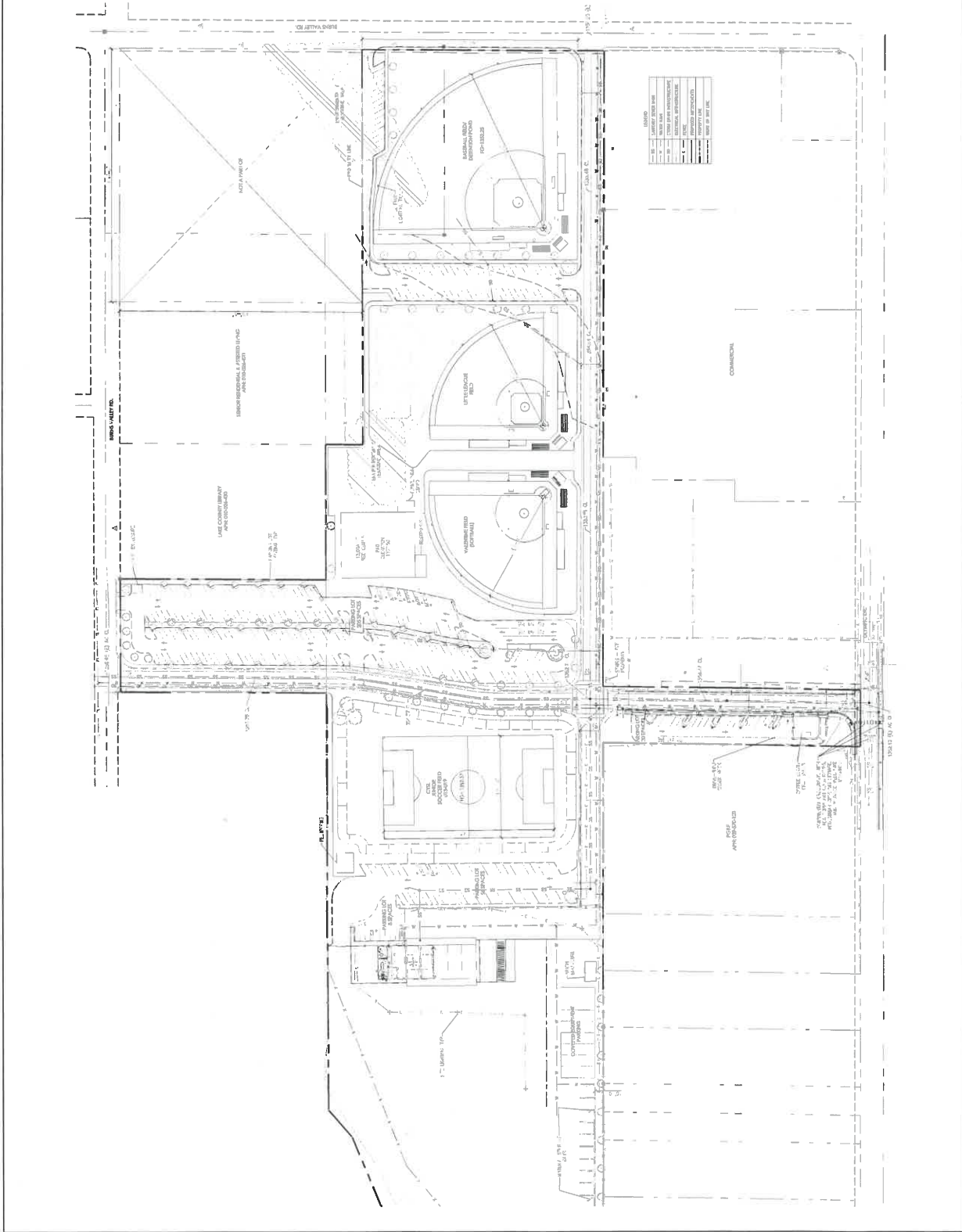

Source: California Engineering Company Inc. 4/72

Transportation Impact Study for the Burns Valley Development
Figure 2 – Site Plan

Pass-by Trips

As is typical of most retail uses, especially drive-through restaurant uses, a portion of the trips associated with the coffee shop would be drawn from existing traffic on nearby streets. These vehicle trips, known as pass-by trips, are not considered new trips since they consist of drivers who are already driving on the adjacent street and choose to make an interim stop. In the case of the proposed coffee shop which would not have indoor seating, most trips would be diverted from traffic already passing by the site on Olympic Drive. Data published in the *Trip Generation Manual* indicates pass-by percentages for a “Coffee/Donut Shop with Drive-Through Window and no Indoor Seating” (ITE LU 938) of 90 and 98 percent during the morning and evening peak hours, respectively, along with a pass-by rate of 84 percent during the weekday afternoon peak hour, which was applied to the Saturday p.m. peak hour. To estimate the number of daily trips that would be pass-by, the lower peak hour rate of 84 percent was applied for informational purposes.

Total Development Trip Generation

The expected trip generation potential for the proposed development is shown in Table 2 for weekdays and Table 3 for Saturdays, with deductions taken for pass-by trips. The development has the potential to result in an average of 1,332 new trips on local streets per day, with 77 new trips during the weekday a.m. peak hour, 182 new trips during the weekday p.m. peak hour, and 353 new trips during the Saturday p.m. peak hour.

Table 2 – Trip Generation Summary (Weekdays)											
Land Use	Units	Daily		Weekday AM Peak Hour				Weekday PM Peak Hour			
		Rate	Trips	Rate	Trips	In	Out	Rate	Trips	In	Out
Affordable Housing	80 du	4.81	385	0.36	29	8	21	0.46	37	22	15
Soccer Complex	6 fields	71.33	428	0.99	6	4	2	16.43	99	65	34
Recreation Center	15 ksf	28.82	432	1.91	29	19	10	2.50	38	18	20
General Light Ind'l	12 ksf	4.87	58	0.74	9	8	1	0.65	8	1	7
Coffee Shop	1 ksf*	179.00	179	39.81	40	20	20	15.08	15	8	7
<i>Pass-by Deduction</i>		-84%	-150	-90%	-36	-18	-18	-98%	-15	-8	-7
Total New Project Trips			1,332		77	41	36		182	106	76

Note: du = dwelling unit; ksf = 1,000 square feet; * = actual floor area is 160 sf

Table 3 – Trip Generation Summary (Saturday)

Land Use	Units	Saturday PM Peak Hour			
		Rate	Trips	In	Out
Affordable Housing	80 du	1.28	102	60	42
Soccer Complex	6 fields	37.48	225	108	117
Recreational Center	15 ksf	1.07	16	9	7
General Light Ind'l	12 ksf	0.65	8	1	7
Coffee Shop	1 ksf	15.08	15	8	7
<i>Pass-by Deduction</i>		-84%	-13	-7	-6
Total New Project Trips			353	179	174

Note: du = dwelling unit; ksf = 1,000 square feet

Trip Distribution

The pattern used to allocate new project trips to the surrounding street network was determined by reviewing existing turning movements at the study intersections, applying knowledge of the area and surrounding region, and considering anticipated travel patterns for patrons of the development. The applied trip distribution assumptions and resulting daily trips are shown in Table 4.

Table 4 – Trip Distribution Assumptions

Route	Percent	Daily Trips
To/from Rumsey Rd North of Bowers Ave	5%	67
To/from Burns Valley Rd West of Project Site	10%	133
To/from Lakeshore Dr North of Olympic Dr	10%	133
To/from Lakeshore Dr South of Olympic Dr	20%	266
To/from Old Hwy 53 South of Olympic Dr	25%	334
To/from Olympic Dr East of Old Hwy 53	20%	266
To/from Local Streets Accessed from Olympic Dr to the West of Project Site	10%	133
TOTAL	100%	1332

Circulation System

This section addresses the first bullet point on the CEQA checklist, which relates to the potential for a project to conflict with a program, plan, ordinance, or policy addressing the circulation system, including transit, roadway, bicycle, and pedestrian facilities.

Pedestrian Facilities

Existing and Planned Pedestrian Facilities

Pedestrian facilities include sidewalks, crosswalks, pedestrian signal phases, curb ramps, curb extensions, and various streetscape amenities such as lighting, benches, etc. In general, a network of sidewalks is provided on developed frontages surrounding the project site but is missing from undeveloped frontages.

- **Burns Valley Road** – Sidewalk coverage is provided on Burns Valley Road along developed property frontages but is missing from undeveloped parcels including the proposed project site. Existing sections of sidewalk are provided on the west side of Burns Valley Road between Olympic Drive and the northern boundary of the Safeway commercial center, the north side of Burns Valley Road between the project site and Rumsey Road, and on the south side of Burns Valley Road along the library and Orchard Park Senior Living Community frontages. Curb ramps and crosswalks are present at the intersection of Burns Valley Road/Rumsey Road/Bowers Avenue. Lighting is provided by overhead streetlights where sidewalks exist.
- **Olympic Drive** – Continuous sidewalks are provided on the northern side of Olympic Drive between Lakeshore Drive and Old Highway 53, while coverage on the southern side is sporadic. Lighting is provided by overhead streetlights. Crossing opportunities exist at the uncontrolled intersection at Madrone Street and at the signalized intersection with Old Highway 53-Burns Valley Road, which has pedestrian phasing.

Pedestrian Safety

The collision history for the study area was reviewed to determine any trends or patterns that may indicate a safety issue for pedestrians in the vicinity of the project site. For the same five-year study period used for the vehicle collision analysis of August 1, 2016 through July 31, 2021, there were no reported collisions involving pedestrians at the study intersections indicating that there are no readily apparent existing safety issues for pedestrians.

Project Impacts on Pedestrian Facilities

Given the proximity of residential and commercial uses surrounding the site, it is reasonable to assume that some project residents and patrons would want to walk, bicycle, and/or use transit to travel between the project site and surrounding areas. Upon construction of sidewalks along the project frontages with the north-south and east-west sections of Burns Valley Road, as shown on the project site plan, and upon construction of sidewalks along the new streets that would be constructed within the Burns Valley Development, the project site would be connected to the surrounding pedestrian network. A network of sidewalks and crosswalks would be provided throughout the Oak Valley Villas project site, resulting in connected on-site pedestrian circulation.

For the type of uses proposed, including athletic fields and a recreational center, the proposed development has the potential to generate high amounts of active transportation trips such as those made by walking and bicycling. Many of these trips would result in pedestrians needing to cross Olympic Drive when walking between the site and the residential neighborhoods on the south side of the street. The nearest existing pedestrian crossing opportunity on Olympic Drive to the west of the project site is at Madrone Street, approximately 1,400 feet away. Between Madrone Street and the development site, there are five residential streets (Buckeye Street, Maple Street,

Cypress Street, Sycamore Street, and Redwood Street) that intersect Olympic Drive and provide access to numerous homes; these residential streets also connect through to Austin Road, which provides access to even more homes further south. Pedestrians walking between residences located on these streets would not be expected to walk west in the opposite direction of the project site to use the existing crosswalk at Madrone Street to cross Olympic Drive; therefore, consideration was given to the need for a new crosswalk at the intersection that the North-South Project Street would form with Olympic Drive.

The National Cooperative Highway Research Program (NCHRP) Report 562 *Improving Pedestrian Safety at Unsignalized Intersections* Pedestrian Crossing Treatment Worksheet was completed to help determine if installation of a crosswalk or other pedestrian crossing measures would be appropriate at the new project street connection to Olympic Drive. The NCHRP worksheet recommends pedestrian treatment devices such as crosswalks, Rectangular Rapid Flashing Beacons (RRFBs), In-Roadway Warning Lights (IRWLs), High Visibility markings, and signage depending on pedestrian and vehicle volumes and geometrics of the crosswalk.

Based on vehicle counts collected in January 2022, approximately 20 pedestrian crossings would be needed within a single hour for a crosswalk to be warranted, while approximately 100 pedestrian crossings would be needed to warrant installation of a pedestrian-activated crossing device such as an RRFB. Between the demand for new crossings associated with the proposed development and existing demand associated with the Safeway commercial center, it would be reasonable to expect 20 peak hour pedestrian crossings at this location, though 100 pedestrian crossings are unlikely to be achieved; therefore, it is recommended that a crosswalk be striped on Olympic Drive at the North-South Project Street along with provision of ADA-compliant curb ramps and pedestrian crossing signage. A copy of the NCHRP Pedestrian Crossing Treatment Worksheet is contained in Appendix B.

Additionally, it is recommended that crosswalks be striped on the project street legs of the new street connections to Burns Valley Road and Olympic Drive.

Finding – Upon constructing sidewalks along the project frontages with Burns Valley Road and along the new project streets and with provision of a new crosswalk on Olympic Drive at the North-South Project Street intersection, the development would be connected to the existing pedestrian network and circulation for pedestrians would be adequate.

Recommendation – To ensure adequate connectivity for pedestrians traveling between the project site and the residential neighborhoods south of Olympic Drive, the new crosswalk with high visibility continental crosswalk markings proposed to be provided on Olympic Drive at the North-South Project Street intersection along with provision of ADA-compliant curb ramps, pedestrian crossing signage, and advanced yield line markings should be installed. Additionally, crosswalks on the project street legs of the new street connections to Burns Valley Road and Olympic Drive should be provided as proposed. These improvements are indicated on the site plan.

Bicycle Facilities

Existing and Planned Bicycle Facilities

The *Highway Design Manual*, Caltrans, 2017, classifies bikeways into four categories:

- **Class I Multi-Use Path** – a completely separated right-of-way for the exclusive use of bicycles and pedestrians with cross flows of motorized traffic minimized.
- **Class II Bike Lane** – a striped and signed lane for one-way bike travel on a street or highway.
- **Class III Bike Route** – signing only for shared use with motor vehicles within the same travel lane on a street or highway.

- **Class IV Bikeway** – also known as a separated bikeway, a Class IV Bikeway is for the exclusive use of bicycles and includes a separation between the bikeway and the motor vehicle traffic lane. The separation may include, but is not limited to, grade separation, flexible posts, inflexible physical barriers, or on-street parking.

In the project area, Class II bike lanes exist on Olympic Drive, Lakeshore Drive, Old Highway 53, and Burns Valley Road. Additional Class II bike lanes are planned on Burns Valley Road and Lakeshore Drive. Bicyclists ride in the roadway and/or on sidewalks along all other streets within the project study area. Table 5 summarizes the existing and planned bicycle facilities in the project vicinity, as contained in the *Active Transportation Plan for Lake County, 2016*.

Table 5 – Bicycle Facility Summary				
Status Facility	Class	Length (miles)	Begin Point	End Point
Existing				
Olympic Dr	II	1.7	Lakeshore Dr	SR 53
Lakeshore Dr	II	1.4	Olympic Dr	Old Hwy 53
Burns Valley Rd (SB only)	II	0.25	Bowers Ave	Olympic Dr
Old Hwy 53	II	0.25	Olympic Dr	Austin Rd
Planned				
Lakeshore Dr	II	0.57	Arrowhead Rd	Olympic Dr
Burns Valley Rd (NB only)	II	0.25	Bowers Ave	Olympic Dr

Source: *Active Transportation Plan for Lake County, Lake County/City Area Planning Council, 2016*

Bicyclist Safety

Collision records for the study area were reviewed to determine if any bicyclist-involved crashes were reported. During the five-year study period between August 1, 2016, and July 31, 2021, there were no reported collisions involving bicyclists at any of the study intersections indicating that there are no readily apparent safety issues for cyclists.

Project Impacts on Bicycle Facilities

As part of the project, Class II bike lanes would be provided on the proposed north-south and east-west project streets. These improvements together with the existing bicycle lanes on Olympic Drive, Burns Valley Road, Old Highway 53, and Lakeshore Drive and the planned facilities outlined in the County's *Active Transportation Plan* would provide adequate access for bicyclists.

Bicycle Storage

According to the Clearlake Municipal Code, bicycle parking shall be provided at a rate of five percent of the required vehicle parking spaces. For the Oak Valley Villas' proposed supply of 144 vehicle parking spaces, seven bicycle parking spaces would need to be supplied. According to the site plan, 40 short-term bicycle parking spaces would be provided in the form of bike racks throughout the residential project site along with four long-term bicycle lockers. To accommodate residents who own bicycles and since residents would not have private garages, it is recommended that the City Code requirements be applied to long-term bicycle lockers, meaning seven long-term bicycle parking spaces should be provided.

For the other development uses which would share 363 parking spaces, a supply of 19 bicycle parking spaces would need to be provided.

Finding – Bicycle facilities serving the project site would be adequate with the planned provision of Class II bike lanes on the new project streets.

Recommendation – The long-term bicycle storage supply for the Oak Valley Villas should be increased from four spaces to seven spaces. A total supply of 19 bicycle parking spaces should be provided throughout the non-residential portions of the development site.

Transit Facilities

Existing Transit Facilities

Lake Transit provides fixed route bus service in the City of Clearlake and throughout Lake County. Lake Transit Route 10 provides loop service in the northern part of the City and stops on Olympic Drive west of Old Highway 53. Route 10 operates Monday through Friday with approximately one-hour headways between 5:10 a.m. and 7:10 p.m. Route 11 provides loop service in the central portion of the City and stops on Burns Valley Road north of Olympic Drive and Rumsey Road north of Bowers Avenue. Route 11 operates Monday through Friday between 7:20 a.m. and 5:20 p.m.

Two bicycles can be carried on most Lake Transit buses. Bike rack space is on a first come, first served basis. Additional bicycles are allowed on Lake Transit buses at the discretion of the driver.

Dial-a-ride, also known as paratransit, or door-to-door service, is available for those who are unable to independently use the transit system due to a physical or mental disability. Lake Transit Dial-A-Ride and Flex Stops are designed to serve the needs of individuals with disabilities within Clearlake.

Impact on Transit Facilities

Existing stops are within an acceptable walking distance of the site and would be reachable upon completion of the proposed sidewalk improvements. Nothing proposed by the project would be expected to negatively impact Lake Transit operations; therefore, existing transit routes are adequate to accommodate project-generated transit trips.

Finding – Existing transit facilities serving the project site are adequate.

Vehicle Miles Traveled (VMT)

The potential for the project to conflict or be inconsistent with CEQA Guidelines § 15064.3, subdivision (b) was evaluated based the project’s anticipated Vehicle Miles Traveled (VMT).

Background and Guidance

Senate Bill (SB) 743 established VMT as the metric to be applied in determining transportation impacts associated with development projects. As of the date of this analysis, the City of Clearlake has not yet adopted a policy or thresholds of significance regarding VMT so the project-related VMT impacts were assessed based on guidance provided by the California Governor’s Office of Planning and Research (OPR) in the publication *Transportation Impacts (SB 743) CEQA Guidelines Update and Technical Advisory*, 2018 as well as information contained within the *Senate Bill 743 Vehicle Miles Traveled Regional Baseline Study (RBS)*, Fehr & Peers, 2020, prepared for the Lake Area Planning Council (LAPC). Many of the recommendations in the RBS are consistent with the OPR Technical Advisory. As allowed by CEQA, each component of the proposed development was assessed individually considering the residential, employee-based, retail, and recreational uses separately.

Residential VMT (Oak Valley Villas)

The OPR *Technical Advisory* notes that “a project consisting of a high percentage of affordable housing may be a basis for the lead agency to find a less-than-significant impact on VMT. Evidence supports a presumption of less-than-significant impact for a 100 percent affordable residential development (or the residential component of a mixed-use development) in infill locations.” Because the residential component of the proposed development is a 100 percent affordable housing project within a developed area of the City of Clearlake, the screening guidance provided by OPR would apply, and it is reasonable to conclude that the project would have a less-than-significant impact on VMT.

Finding – The Oak Valley Villas residential component of the proposed development would be expected to have a less-than-significant transportation impact on vehicle miles traveled.

Employee VMT

VMT impacts associated with employees of the proposed development, including those for the coffee shop, corporation yard, and recreational facilities, were assessed based on guidance contained in the both the *Technical Advisory* and the County’s RBS, which indicate that an employee-based project generating vehicle travel that is 15 or more percent below the existing average countywide VMT per worker may indicate a less-than-significant VMT impact. OPR encourages the use of screening maps to establish geographic areas that achieve the 15 percent below regional average thresholds, allowing jurisdictions to “screen” projects in those areas from quantitative VMT analysis since impacts can be presumed to be less than significant.

The RBS includes a link to a web-based VMT screening tool in the appendix of the document that can be used to screen employment-based projects that are located in low VMT-generating areas. The tool uses data from the Wine Country Travel Demand Model (WCTDM) to compare the home-based VMT per worker for the Traffic Analysis Zone (TAZ) in which a study parcel is located to the same measure for the County as a whole. The tool projects the Countywide average baseline VMT per worker to be 12.3 miles per day in 2022. A project generating a VMT that is 15 percent or more below this value, or 10.5 miles per employee or less per day, would have a less-than-significant VMT impact.

The development site is located within TAZ 1908, which is bounded by Burns Valley Road on the east and north, Olympic Drive on the south, and Lakeshore Drive on the west and has a baseline VMT per employee of 7.6 miles

per day. Because this per capita VMT ratio is below the significance threshold of 10.5 miles per day, the VMT generated by employees of the proposed development would be considered to have a less-than-significant VMT impact. A copy of the VMT screening tool output is provided in Appendix C and the VMT calculations are summarized in Table 6.

Table 6 – Employee Vehicle Miles Traveled Analysis Summary	
Proposed Development VMT for TAZ 1908	7.6
Countywide Average VMT	12.3
Significance Threshold VMT	10.5
Result	Less than Significant

Note: TAZ = Traffic Analysis Zone, VMT is measured in daily miles driven per employee

Finding – Employees of the proposed development including those for the coffee shop, City corporation yard, and the recreational facilities would be expected to have a less-than-significant transportation impact on vehicle miles traveled.

Retail VMT

The OPR *Technical Advisory* indicates that retail projects should generally be analyzed by examining total VMT, with an increase in total regional VMT being considered a significant impact. The *Technical Advisory* also indicates that local-serving retail uses may generally be presumed by lead agencies to have a less-than-significant VMT impact (see *Technical Advisory* pages 16-17). OPR based this presumption on substantial evidence and research demonstrating that adding local-serving retail uses typically improves destination accessibility to customers. The theory behind this criterion is that while a larger retail project may generate interregional trips that increase a region’s total VMT, small retail establishments do not necessarily add new trips to a region, but change where existing customers shop within the region, and often shorten trip lengths. OPR cites a size of 50,000 square feet or greater as being a potential indicator of regional-serving retail (versus local-serving) that would typically require a quantitative VMT analysis.

The retail component of the proposed development is a 160 square-foot coffee shop, which is well below the local-serving retail screening threshold of 50,000 square feet; therefore, it is reasonable to conclude that the coffee shop would have a less-than-significant transportation impact on VMT. This conclusion is further supported by the notion that approximately 84 percent of the total daily coffee shops are anticipated to be pulled from traffic already passing by the site on Olympic Drive.

Finding – The proposed coffee shop would be expected to have a less-than-significant transportation impact on vehicle miles traveled as a local-serving retail use.

Recreational Facilities VMT

The OPR *Technical Advisory* does not specifically address recreational uses such as the proposed sports fields and recreation center, indicating that lead agencies may develop their own thresholds for other land use types, and also allowing assessment on a case-by-case basis. For land uses not addressed in the *Technical Advisory*, it is common practice to consider whether the land use of interest has travel characteristics that are similar to the residential, employment-based, or retail land use types that are addressed. If so, similar VMT assessment methodologies can often be used. In some cases, recreation-based uses have similarities to retail, in that the total demand for services (shopping trips, or in this case recreation visits) tends to remain steady at a regional level and customers/visitors often choose to visit a store/facility based on convenience and its proximity to their home. The use of retail-based methods for assessing recreational uses is also consistent with opinions offered by OPR staff

during VMT “office hours” – informational sessions during the summer of 2020 – during which it was suggested that the analysis could be based on whether the recreational use would draw visitors from the wider region or whether it would be more local-serving.

In order to determine if the proposed recreation uses would have the potential to generate interregional trips, consideration was given to the project’s intended visitor base and whether or not it would include any notable components that would potentially draw new visitors to the region. The proposed recreation uses consist of various athletic fields and sports courts including a soccer field, softball field, little league field, two tee ball fields, and a baseball field; the recreation center building would include basketball and volleyball courts. These recreation facilities would be public facilities intended to serve the local residents of the City of Clearlake, as is the intent for most public recreation facilities to serve local residents. It is further noted that the proposed athletic fields and sports courts are common facilities that are typically provided in most cities so it is unlikely that they will draw new recreation visits to the City, but rather redistribute where existing residents choose to recreate. It is likely that the proposed recreation uses would redistribute trips within the City of Clearlake from other public parks such as Austin Park and Redbud Park, rather than generate new regional trips to the City. Therefore, it was determined that it would be appropriate to evaluate the recreation component of the development as a local-serving use.

Applying the aforementioned logic behind the screening of local-serving retail uses to the proposed recreation uses, adding new recreational facilities to the urban fabric of a City can be expected to shift automobile travel patterns within the City but would be unlikely to increase the region’s total VMT, and in fact may result in a reduction in total VMT by improving destination proximity. Since the public recreational uses are intending to be primarily local-serving, as opposed to a private athletic club which may have more of a tendency to draw recreation trips from a wider region, it is reasonable to conclude that the proposed uses would have a less-than-significant impact on VMT.

Finding – The proposed recreation uses would reasonably be classified as local-serving uses with a less-than-significant transportation impact on vehicle miles traveled.

Safety Issues

The potential for the project to impact safety was evaluated in terms of the adequacy of sight distance and need for turn lanes at the project accesses as well as the adequacy of stacking space in dedicated turn lanes at the study intersections to accommodate additional queuing due to adding project-generated trips and need for additional right-of-way controls. This section addresses the third bullet on the CEQA checklist which is whether or not the project would substantially increase hazards due to a geometric design feature (e.g., sharp curves or dangerous intersections) or incompatible uses (e.g., farm equipment).

Site Access

The development site would be accessed via a new north-south street that would extend from Olympic Drive on the south to Burns Valley Road on the north and a new east-west street would be constructed to the north of the Safeway commercial property and would extend from the proposed City corporation yard on the west to Burns Valley Road on the east. Both new streets would be public streets with one lane of vehicle travel in each direction along with Class II bike lanes. Within the development site, the project streets would provide full access to the various components of the development, including parking lots and associated driveways.

The Oak Valley Villas project would be accessed via a new driveway on Burns Valley Road approximately 125 feet west of the intersection with Rumsey Road and a connection to the proposed east-west project street. The driveway on the new east-west street would be positioned approximately 450 feet west of its intersection with Burns Valley Road.

Sight Distance

Sight distances along Burns Valley Road and Olympic Drive at the proposed intersections and driveways were evaluated based on sight distance criteria contained in the *Highway Design Manual* published by Caltrans. The recommended sight distance at intersections of public streets is based on corner sight distances, while recommended sight distances for minor street approaches that are either a private road or a driveway are based on stopping sight distance. Both use the approach travel speeds as the basis for determining the recommended sight distance. Additionally, the stopping sight distance needed for a following driver to stop if there is a vehicle waiting to turn into a side street or driveway is evaluated based on stopping sight distance criterion and the approach speed on the major street.

Field measurements were obtained at the locations of the proposed intersections and driveways.

Burns Valley Road/North-South Project Street Intersection

For the posted speed limit of 35 mph on the east-west segment of Burns Valley Road, the minimum corner sight distance needed at the proposed intersection is 385 feet. Sight lines were field measured to extend more than 400 feet in each direction, which is adequate to accommodate the anticipated travel speeds.

Oak Valley Villas Driveway

For the posted speed limit of 35 mph, the minimum stopping sight distance needed is 250 feet. Based on a review of field conditions, sight lines to and from the project driveway location were measured to extend more than 300 feet to the west, which would be more than adequate for the posted speed limit. While the project driveway would be located within about 125 feet of the intersection with Rumsey Road, clear sight lines of more than 300 feet are available from the driveway to the southbound and westbound approaches of the intersection and sight lines of approximately 150 feet would be available between a motorist on the driveway and a northbound motorist turning left onto the east-west section of Burns Valley Road. Those completing this turning movement

would likely be traveling in the 15 to 20 mph range for which only 100 to 125 feet of stopping sight distance would be needed and is available. Therefore, existing sight lines are adequate.

To preserve existing adequate sight lines, it is recommended that any new signage or other structures to be installed along the Oak Valley Villas project frontage be placed outside of the vision triangle of a driver waiting on the driveway. Additionally, it is recommended that planting of trees be avoided near the northeast corner of the project site near the intersection of Burns Valley Road/Rumsey Road.

Burns Valley Road/East-West Project Street Intersection

For the posted speed limit of 30 mph on the north-south segment of Burns Valley Road, the minimum corner sight distance needed is 330 feet. Sight lines were field measured to extend more than 400 feet in each direction, which is more than adequate for the posted speed limit.

Olympic Drive/North-South Project Street Intersection

For the posted speed limit of 35 mph on Olympic Drive, the minimum corner sight distance needed at the proposed intersection is 385 feet. Based on a review of field conditions, sight lines extend more than 400 feet in each direction, which is adequate for the posted speed limit.

Additionally, given the straight and flat alignments of Burns Valley Road and Olympic Drive adjacent to the proposed intersections and driveways, adequate stopping sight distances are available for following drivers to notice and react to a preceding motorist slowing to turn right or stopped waiting to turn left into any of the access points. While sight lines are currently clear, care should be taken to maintain unobstructed sight lines during the design and construction of the proposed development and placement of signage, monuments, or other structures should be avoided within the sight triangles at the access points, which are denoted graphically in Plate 1. The Intersection Sight Distance (ISD) lengths should be based on corner sight distance for the new intersections and stopping sight distance for the Oak Valley Villas driveway.

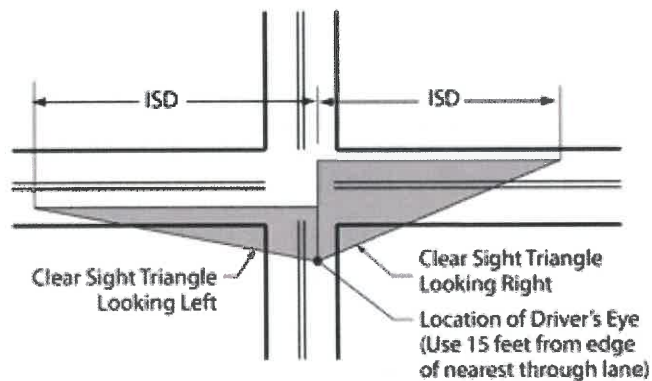

Plate 1 Vision Triangle Graphic

Finding – Sight lines on Burns Valley Road and Olympic Drive are adequate to accommodate all turns into and out of the proposed intersections and driveways.

Recommendation – To maintain adequate sight lines, any new signage, monuments, or other structures should be kept out of the vision triangles at the access points. Additionally, the planting of trees should be avoided near the northeast corner of the project site near the intersection of Burns Valley Road/Bowers Avenue-Rumsey Road.

Access Analysis

Left-Turn Lane Warrants

The need for left-turn lanes on Burns Valley Road and Olympic Drive at the proposed intersections and Oak Valley Villas driveway were evaluated based on criteria contained in the *Intersection Channelization Design Guide*, National Cooperative Highway Research Program (NCHRP) Report No. 279, Transportation Research Board, 1985, as well as an update of the methodology developed by the Washington State Department of Transportation and published in the *Method for Prioritizing Intersection Improvements*, January 1997. The NCHRP report references a methodology developed by M. D. Harmelink that includes equations that can be applied to expected or actual traffic volumes to determine the need for a left-turn pocket based on safety issues.

Using Future plus Project volumes, which represents worst-case conditions, it was determined that left-turn lanes would not be warranted on Burns Valley Road at any of the intersections with the project streets or the Oak Valley Villas driveway. However, a left-turn lane would be warranted under Baseline plus Project and Future plus Project volumes on Olympic Drive at the intersection with the project street. Copies of the turn lane warrant spreadsheets are provided in Appendix D.

There is an existing two-way left-turn lane (TWLTL) on Olympic Drive to the east of the proposed intersection along the commercial shopping center frontage so it is recommended that the TWLTL be extended to the west to facilitate left-turn movements into and out of the development site. In order to determine how far the existing TWLTL would need to be extended to the west, the projected maximum left-turn queue length was determined using a methodology contained in "Estimating Maximum Queue Length at Unsignalized Intersections," John T. Gard, *ITE Journal*, November 2001. Using Future plus Project volumes, the maximum eastbound left-turn queue on Olympic Drive would be no more than three vehicles. Therefore, it is recommended that the storage be based on three passenger cars, or 75 feet. Copies of the queue length calculations are contained in Appendix E.

Finding – Volumes would not be sufficient to warrant installation of a left-turn lane on Burns Valley Road at any of the access points to the development; however, volumes would be sufficient to meet the warrant at the Olympic Drive/North-South Project Street intersection.

Recommendation – The existing TWLTL on Olympic Drive which terminates east of the proposed intersection with the North-South Project Street should be extended to the west to provide a minimum of 75 feet of storage on the west leg of the proposed intersection, as is currently proposed and shown on the site plan.

Queuing

The City of Clearlake does not prescribe thresholds of significance regarding queue lengths. However, an increase in queue length due to project traffic was considered a potentially significant impact if the increase would cause the queue to extend out of a dedicated turn lane into a through traffic lane where moving traffic would be impeded, or the back of queue into a visually restricted area, such as a blind corner.

Unsignalized Intersections

The only existing unsignalized study intersection with a dedicated turn lane is Lakeshore Drive/Olympic Drive, which has a left-turn lane on the westbound approach. However, this approach terminates at the intersection so all traffic is slowing to be able to stop. Hence there is not a safety concern associated with the back of a queue potentially extending into the adjacent travel lane.

Signalized Intersection

Under each scenario, the projected 95th percentile queues in dedicated turn lanes at the signalized intersection of Olympic Drive/Burns Valley Road-Old Highway 53 were determined using the Vistro software. As summarized in

Table 7 and Table 8, the existing turn lanes are expected to have adequate storage capacity to accommodate queuing under all scenarios. It should be noted that while the southbound left-turn lane channelizing line is only 55 feet in length, the turn lane is preceded by a two-way left-turn lane (TWLTL) so the effective storage capacity would extend to the driveway to the commercial center before creating safety concerns; therefore, the storage length was considered to be 160 feet. Copies of the queuing projections are contained in Appendix F in the Vistro output.

Table 7 – 95th Percentile Queues (Weekday)

Study Intersection Turn Lane	Available Storage	95 th Percentile Queues											
		Weekday AM Peak Hour						Weekday PM Peak Hour					
		E	E+P	B	B+P	F	F+P	E	E+P	B	B+P	F	F+P
Olympic Dr/Burns Valley Rd- Old Hwy 53													
Northbound Left Turn	95	11	12	15	17	33	35	32	36	41	52	75	86
Northbound Right Turn	95	4	5	8	8	12	13	8	9	19	25	35	38
Eastbound Left Turn	50	7	7	8	8	12	13	8	8	11	12	23	26
Southbound Left Turn	160*	18	19	20	22	48	51	35	40	38	48	80	93
Westbound Left Turn	105	11	12	16	17	27	28	19	21	36	42	47	51

Notes: Maximum Queue based on Vistro output; all distances are measured in feet; E = Existing Conditions; E+P = Existing plus Project Conditions; B = Baseline Conditions; B+P = Baseline plus Project Conditions; F = Future Conditions; F+P = Future plus Project Conditions; * turn lane length includes adjacent TWLTL

Table 8 – 95th Percentile Queues (Weekend)

Study Intersection Turn Lane	Available Storage	95 th Percentile Queues					
		Weekend PM Peak Hour					
		E	E+P	B	B+P	F	F+P
Olympic Dr/Burns Valley Rd-Old Hwy 53							
Northbound Left Turn	96	19	26	41	46	46	55
Northbound Right Turn	96	5	5	22	19	14	16
Eastbound Left Turn	48	6	7	11	11	13	16
Southbound Left Turn	160*	23	5	36	44	51	65
Westbound Left Turn	106	9	10	37	39	20	23

Notes: Maximum Queue based on Vistro output; all distances are measured in feet; E = Existing Conditions; E+P = Existing plus Project Conditions; B = Baseline Conditions; B+P = Baseline plus Project Conditions; F = Future Conditions; F+P = Future plus Project Conditions; * turn lane length includes adjacent TWLTL

Finding – The project would not be expected to cause any queues to exceed available storage or extend into an adjacent intersection, so the impact is considered less than significant.

Emergency Access

The final bullet on the CEQA checklist requires an evaluation as to whether the project would result in inadequate emergency access or not.

Adequacy of Site Access

Access to the Oak Valley Villas project site for emergency response vehicles would be facilitated via the northern driveway on Burns Valley Road and southern driveway along the new east-west street, both of which would have a width of 26 feet; this would be adequate to satisfy the required minimum driveway width of 24 feet set forth in the City of Clearlake's *Design and Construction Standards*. On-site circulation includes a 26-foot drive aisle, which also exceeds the minimum width of 24 feet.

While the site plan for the rest of the Burns Valley Development is still preliminary, it is anticipated that all aspects of the site including street and driveway widths and parking lot circulation would be designed in accordance with applicable standards; therefore, access would be expected to function acceptably for emergency response vehicles. It should also be noted that the development site would have multiple access points so should one means of access be compromised during an emergency, responders would be able to use another access point to reach the various aspects of the development.

Off-Site Impacts

While the development would be expected to result in a minor increase in delay for traffic on Burns Valley Road and Olympic Drive, emergency response vehicles can claim the right-of-way by using their lights and sirens; therefore, the project would be expected to have a nominal effect on emergency response times.

Finding – Emergency access and circulation are anticipated to function acceptably with incorporation of applicable design standards into the site layout and traffic from the proposed development would be expected to have a less-than-significant impact on emergency response times.

Capacity Analysis

Though not relevant to the CEQA review process, in keeping with General Plan policies, the potential for the project to effect traffic operation was evaluated.

Intersection Level of Service Methodologies

Level of Service (LOS) is used to rank traffic operation on various types of facilities based on traffic volumes and roadway capacity using a series of letter designations ranging from A to F. Generally, Level of Service A represents free flow conditions and Level of Service F represents forced flow or breakdown conditions. A unit of measure that indicates a level of delay generally accompanies the LOS designation.

The study intersections were analyzed using methodologies published in the *Highway Capacity Manual (HCM)*, Transportation Research Board, 2018. This source contains methodologies for various types of intersection control, all of which are related to a measurement of delay in average number of seconds per vehicle.

The Levels of Service for the existing and proposed intersections with side street stop controls, or those which are unsignalized and have one or two approaches stop controlled, were analyzed using the “Two-Way Stop-Controlled” intersection capacity method from the HCM. This methodology determines a level of service for each minor turning movement by estimating the level of average delay in seconds per vehicle. Results are presented for individual movements together with the weighted overall average delay for the intersection.

The study intersection of the East-West and North-South Project Streets is proposed to have stop signs on all approaches so was analyzed using the “All-Way Stop-Controlled” Intersection methodology from the HCM. This methodology evaluates delay for each approach based on turning movements, opposing and conflicting traffic volumes, and the number of lanes. Average vehicle delay is computed for the intersection as a whole, and is then related to a Level of Service.

The study intersection of Olympic Drive/Burns Valley Road-Old Highway 53 is controlled by a traffic signal so was evaluated using the signalized methodology from the HCM. This methodology is based on factors including traffic volumes, green time for each movement, phasing, whether the signals are coordinated or not, truck traffic, and pedestrian activity. Average stopped delay per vehicle in seconds is used as the basis for evaluation in this LOS methodology. For purposes of this study, delays were calculated using optimized signal timing.

The study intersection of Lakeshore Drive/Olympic Drive is programmed to be controlled by a modern roundabout in the future according to the City’s Development Impact Fee Program so was evaluated using the Federal Highway Administration (FHWA) Roundabout Method, also contained within the Unsignalized Methodology of the HCM 6th Edition, Transportation Research Board, 2016. This methodology determines intersection operation using a gap acceptance method along with basic geometric and volume data to calculate entering and circulating flows. This information is then translated to average vehicle delays, with LOS break points at the same delays as used in the two-way stop-controlled methodology.

The ranges of delay associated with the various levels of service are indicated in Table 9.

Table 9 – Intersection Level of Service Criteria

LOS	Two-Way Stop-Controlled	All-Way Stop-Controlled	Signalized	Roundabout
A	Delay of 0 to 10 seconds. Gaps in traffic are readily available for drivers exiting the minor street.	Delay of 0 to 10 seconds. Upon stopping, drivers are immediately able to proceed.	Delay of 0 to 10 seconds. Most vehicles arrive during the green phase, so do not stop at all.	Delay of 0 to 10 seconds.
B	Delay of 10 to 15 seconds. Gaps in traffic are somewhat less readily available than with LOS A, but no queuing occurs on the minor street.	Delay of 10 to 15 seconds. Drivers may wait for one or two vehicles to clear the intersection before proceeding from a stop.	Delay of 10 to 20 seconds. More vehicles stop than with LOS A, but many drivers still do not have to stop.	Delay of 10 to 15 seconds.
C	Delay of 15 to 25 seconds. Acceptable gaps in traffic are less frequent, and drivers may approach while another vehicle is already waiting to exit the side street.	Delay of 15 to 25 seconds. Drivers will enter a queue of one or two vehicles on the same approach, and wait for vehicle to clear from one or more approaches prior to entering the intersection.	Delay of 20 to 35 seconds. The number of vehicles stopping is significant, although many still pass through without stopping.	Delay of 15 to 25 seconds.
D	Delay of 25 to 35 seconds. There are fewer acceptable gaps in traffic, and drivers may enter a queue of one or two vehicles on the side street.	Delay of 25 to 35 seconds. Queues of more than two vehicles are encountered on one or more approaches.	Delay of 35 to 55 seconds. The influence of congestion is noticeable, and most vehicles have to stop.	Delay of 25 to 35 seconds.
E	Delay of 35 to 50 seconds. Few acceptable gaps in traffic are available, and longer queues may form on the side street.	Delay of 35 to 50 seconds. Longer queues are encountered on more than one approach to the intersection.	Delay of 55 to 80 seconds. Most, if not all, vehicles must stop and drivers consider the delay excessive.	Delay of 35 to 50 seconds.
F	Delay of more than 50 seconds. Drivers may wait for long periods before there is an acceptable gap in traffic for exiting the side streets, creating long queues.	Delay of more than 50 seconds. Drivers enter long queues on all approaches.	Delay of more than 80 seconds. Vehicles may wait through more than one cycle to clear the intersection.	Delay of more than 50 seconds.

Reference: *Highway Capacity Manual*, Transportation Research Board, 2018

Traffic Operation Standards

City of Clearlake

The City of Clearlake established a standard of LOS D for all intersections and roadways in Policy CI 1.3.4 of *City of Clearlake 2040 General Plan Update*, City of Clearlake, 2017. Exceptions to this may be considered by the City Council when an unacceptable LOS (E or F) would result in clear public benefit. Such circumstances may include when improvements to achieve the LOS standard would result in impacts to unique historic resources or highly sensitive environmental areas; if right-of-way acquisition is infeasible; and/or if there are overriding economic or social circumstances.

Existing Conditions

The Existing Conditions scenario provides an evaluation of current operation based on existing traffic volumes during the weekday a.m., weekday p.m., and weekend p.m. peak periods. This condition does not include project-generated traffic volumes. Volume data was collected in January 2022 during typical traffic conditions and while local schools were in session. Peak hour factors (PHFs) were calculated based on the counts obtained and used in the analysis.

The three existing study intersections are currently operating acceptably at LOS A or B overall and on the minor street approaches. The existing traffic volumes are shown in Figure 3. A summary of the intersection Level of Service calculations is contained in Table 10, and copies of the calculations for all evaluated scenarios are provided in Appendix F.

Table 10 – Existing Peak Hour Intersection Levels of Service

Study Intersection Approach	Weekday AM Peak		Weekday PM Peak		Weekend PM Peak	
	Delay	LOS	Delay	LOS	Delay	LOS
2. Burns Valley Rd/Bowers Ave-Rumsey Rd	6.8	A	5.7	A	6.1	A
<i>Eastbound (Burns Valley Rd) Approach</i>	9.4	A	9.3	A	9.2	A
<i>Westbound (Bowers Ave) Approach</i>	13.4	B	12.6	B	11.5	B
5. Olympic Dr/Lakeshore Dr	2.8	A	4.8	A	4.3	A
<i>Westbound (Olympic Dr) Approach</i>	12.5	B	13.2	B	13.8	B
7. Olympic Dr/Burns Valley Rd-Old Hwy 53	11.2	B	13.3	B	11.7	B

Notes: Delay is measured in average seconds per vehicle; LOS = Level of Service; Results for minor approaches to two-way stop-controlled intersections are indicated in *italics*.

Baseline Conditions

Baseline (Existing plus Approved) operating conditions were determined with traffic from approved or pending projects in the study area that could be operational within the next five-year horizon added to the existing volumes. The following projects were identified for inclusion in the Baseline scenario through coordination with City staff.

- Konocti Gardens is a 102-unit multi-family affordable housing project that would be located at 3930 Old Highway 53. Based on standard rates published by the Institute of Transportation Engineers (ITE) in the *Trip Generation Manual*, 11th Edition, 2021, the project would be expected to generate an average of 491 daily trips on weekdays and 1,224 daily trips on weekend days, including 37 trips during the weekday a.m. peak hour, 47 trips during the weekday p.m. peak hour, and 131 trips during the weekend p.m. peak hour.
- A tribal health clinic of approximately 24,000 square feet is approved and will be located at 14440 and 14480 Olympic Drive. As evaluated in the *Traffic Impact Study for the Lake County Tribal Health Clinic*, W-Trans, 2019, the project is expected to generate 906 daily trips on average, including 88 trips during the weekday a.m. peak hour and 78 trips during the weekday p.m. peak hour. Trip rates for the weekday p.m. peak period were applied to the weekend p.m. peak hour. The same trip distribution assumptions as were applied in the project’s traffic study were also applied in this analysis.
- Four Corners is an approved cannabis project consisting of 8,000 square feet of dispensary retail space, 4,300 square feet of storage space, and 20,000 square feet of cultivation and processing space to be located on the southwest corner of the Olympic Drive/Old Highway 53-Burns Valley Road intersection. Over the last three

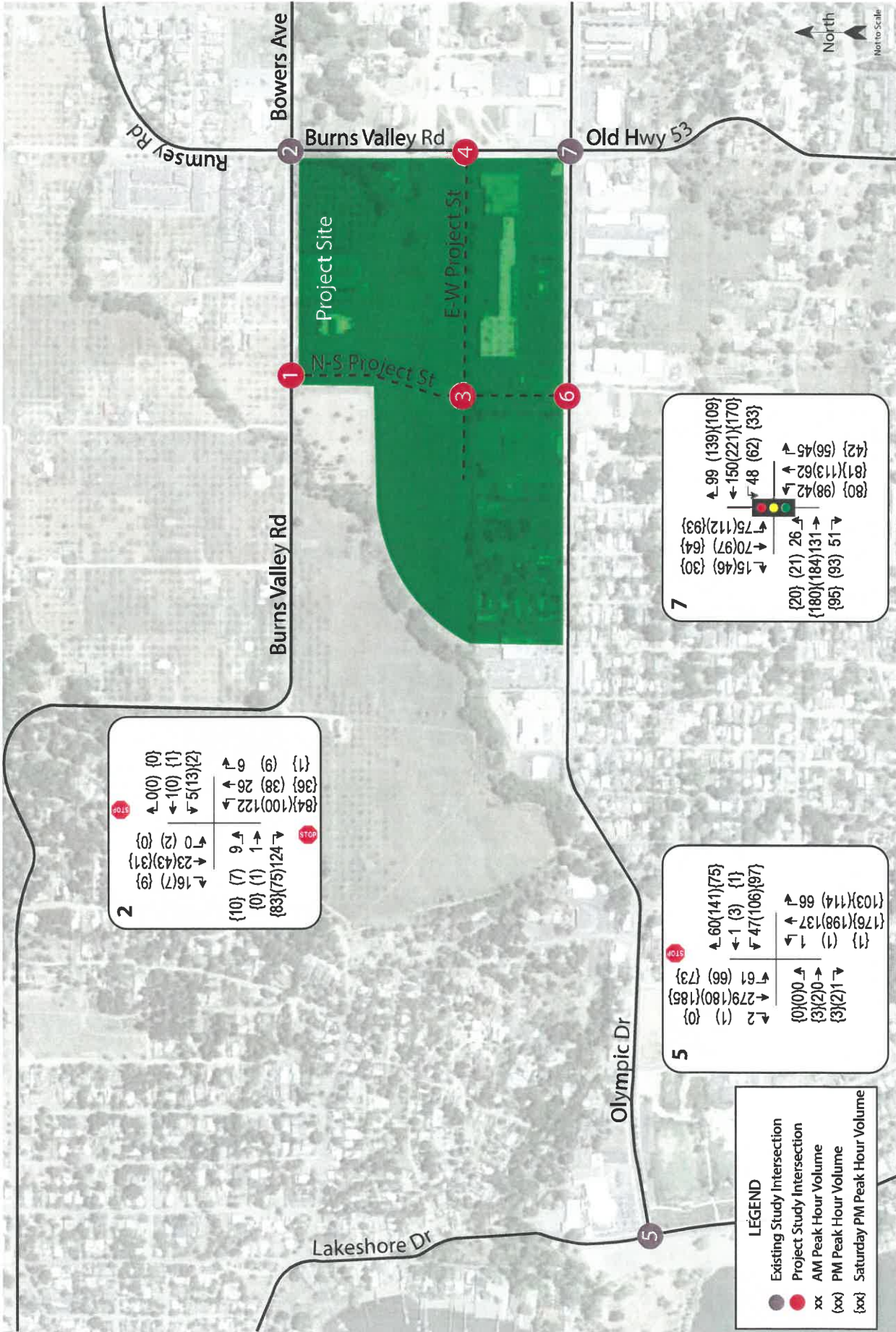

Transportation Impact Study for the Burns Valley Development
Figure 3 – Existing Traffic Volumes

years, W-Trans has collected data at several dispensaries in the North Bay Area, which was used to estimate the trip generation potential of the retail portion of the project. This data collection effort has identified that local dispensaries are expected to generate about 95 vehicle trips per day per 1,000 square feet of gross floor area, including two trips per 1,000 square feet during the weekday a.m. peak hour and 22 trips per 1,000 square feet during the weekday p.m. peak hour. Standard ITE rates for “Warehousing” and “Marijuana Cultivation and Processing Facility” were applied to the non-retail components of the project. Trip rates for the weekday p.m. peak period were applied to the weekend p.m. peak hour. Based on these rates, the project would be expected to generate an average of 32 trips during the weekday a.m. peak hour, 190 trips during the weekday p.m. peak hour, and 190 trips during the weekend p.m. peak hour.

- The addition of a drive-through window to an existing 1,600 square-foot Subway restaurant located at 15060 Lakeshore Drive has been approved. Based on standard ITE rates, the addition would be expected to generate an average of three new trips during the weekday a.m. peak hour, 10 new trips during the weekday p.m. peak hour, and one new trip during the weekend p.m. peak hour.
- The remodel and expansion of an existing Shell gasoline service station located at 15105 Lakeshore Drive has been approved. Based on standard ITE rates with pass-by trips deducted, the project would be expected to generate an average of 15 new trips during the weekday a.m. peak hour, 24 new trips during the weekday p.m. peak hour, and 26 new trips during the weekend p.m. peak hour.

Upon adding trips from approved or pending projects in the study area to existing volumes, all existing study intersections would continue to operate acceptably. These results are summarized in Table 11, and Baseline volumes are shown in Figure 4.

Table 11 – Baseline Peak Hour Intersection Levels of Service

Study Intersection <i>Approach</i>	Weekday AM Peak		Weekday PM Peak		Weekend PM Peak	
	Delay	LOS	Delay	LOS	Delay	LOS
2. Burns Valley Rd/Bowers Ave-Rumsey Rd	6.8	A	5.9	A	6.3	A
<i>Eastbound (Burns Valley Rd) Approach</i>	9.5	A	9.3	A	9.3	A
<i>Westbound (Bowers Ave) Approach</i>	13.7	B	13.2	B	12.1	B
5. Olympic Dr/Lakeshore Dr	3.1	A	5.5	A	5.7	A
<i>Westbound (Olympic Dr) Approach</i>	13.0	B	13.9	B	16.1	C
7. Olympic Dr/Burns Valley Rd-Old Hwy 53	11.8	B	14.3	B	14.2	B

Notes: Delay is measured in average seconds per vehicle; LOS = Level of Service; Results for minor approaches to two-way stop-controlled intersections are indicated in *italics*.

Future Conditions

Future volumes for the horizon year 2040, as developed for the traffic analysis that was prepared for the *City of Clearlake 2040 General Plan Update*, were used to project future operating conditions at the study intersections. For the study intersections that were not evaluated in the General Plan Update a growth factor was calculated based on the increase between existing and future volume projections for the nearest intersection that was analyzed in the General Plan analysis and then applied to the existing volumes at the study intersection in order to project likely future volumes. This same methodology was used to project future turning movement volumes for the Saturday afternoon peak hour since this period was not analyzed for the General Plan. The City’s Development Impact Fee program includes funding for installation of a single-lane modern roundabout at the intersection of Lakeshore Drive/Olympic Drive so this improvement was assumed to be in place for the evaluation of future operating conditions.

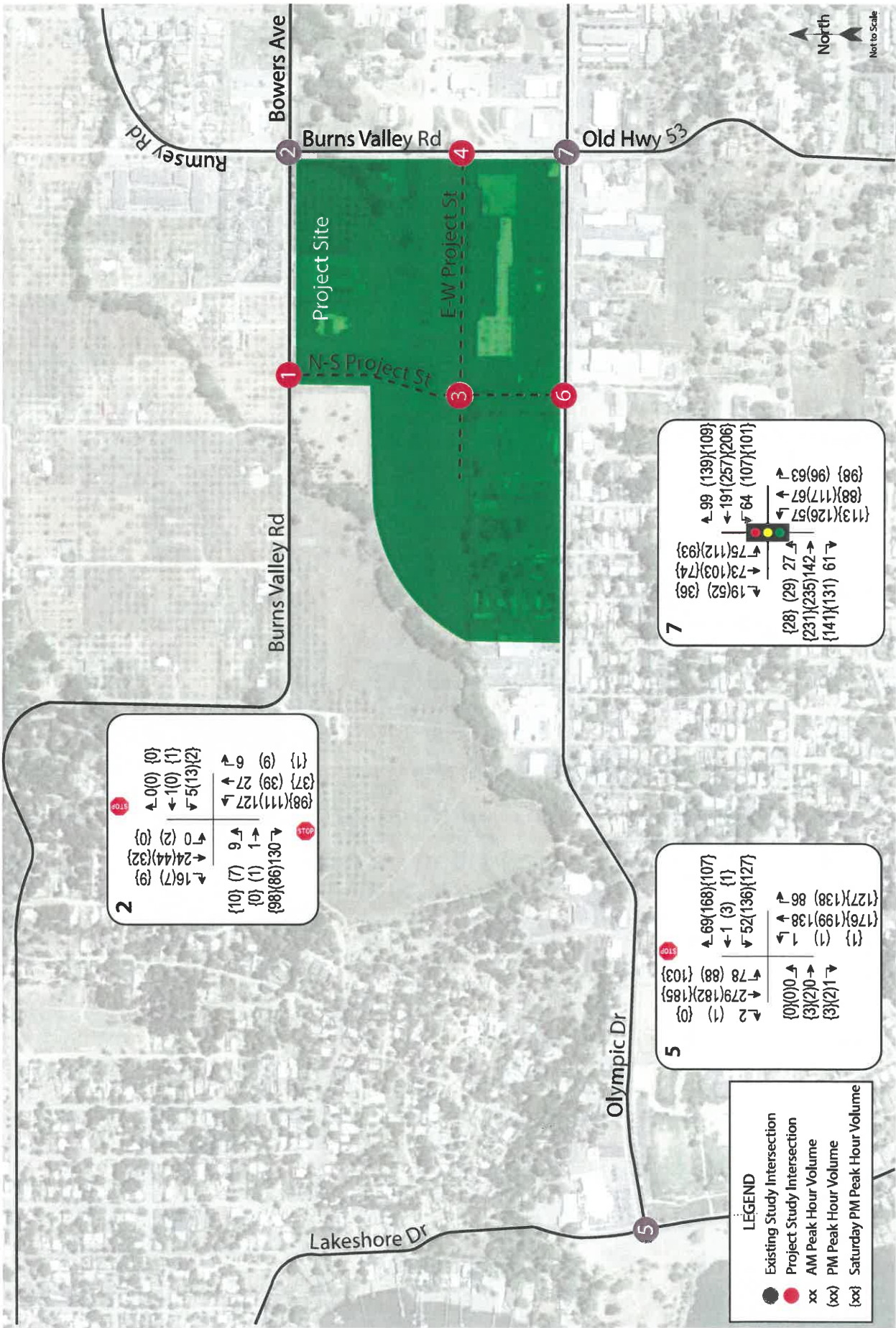

cle029.al 4/22



Transportation Impact Study for the Burns Valley Development
Figure 4 – Baseline Traffic Volumes

Under the anticipated future volumes that would be expected upon buildout of the City's General Plan, and with installation of a roundabout at the Lakeshore Drive/Olympic Drive intersection, the study intersections are expected to operate acceptably overall as well as on the minor street approaches.

Future volumes are shown in Figure 5 and operating conditions are summarized in Table 12.

Table 12 – Future Peak Hour Intersection Levels of Service						
Study Intersection <i>Approach</i>	Weekday AM Peak		Weekday PM Peak		Weekend PM Peak	
	Delay	LOS	Delay	LOS	Delay	LOS
2. Burns Valley Rd/Bowers Ave-Rumsey Rd	7.3	A	6.1	A	6.1	A
<i>Eastbound (Burns Valley Rd) Approach</i>	<i>10.4</i>	<i>A</i>	<i>9.8</i>	<i>A</i>	<i>9.7</i>	<i>A</i>
<i>Westbound (Bowers Ave) Approach</i>	<i>18.3</i>	<i>C</i>	<i>15.6</i>	<i>C</i>	<i>13.3</i>	<i>B</i>
5. Olympic Dr/Lakeshore Dr (Roundabout)	5.7	A	4.9	A	4.6	A
7. Olympic Dr/Burns Valley Rd-Old Hwy 53	14.4	B	19.4	B	14.8	B

Notes: Delay is measured in average seconds per vehicle; LOS = Level of Service; Results for minor approaches to two-way stop-controlled intersections are indicated in *italics*.

Project Conditions

Existing plus Project Conditions

The new North-South Project Street would be expected to redistribute some of the existing traffic in the area by allowing motorists to pass through the Burns Valley Development site, which would likely result in a faster route than traveling around the site using the north-south segment of Burns Valley Road for trips between the northwestern part of the City and the Safeway shopping center. Therefore, for Project Conditions, it was assumed that 10 percent of the existing traffic traveling along the north-south segment of Burns Valley Road would be redistributed to the North-South Project Street. To result in a conservative analysis, rerouted traffic was not deducted from the volumes at the north-south Burns Valley Road study intersections.

Upon the addition of trips associated with the entire Burns Valley Development, including the proposed Oak Valley Villas, the study intersections would be expected to continue operating acceptably during all three peak hours. These results are summarized in Table 13. Project-only traffic volumes are shown in Figure 6, and Existing plus Project volumes are shown in Figure 7.

cle029.ai 4/22

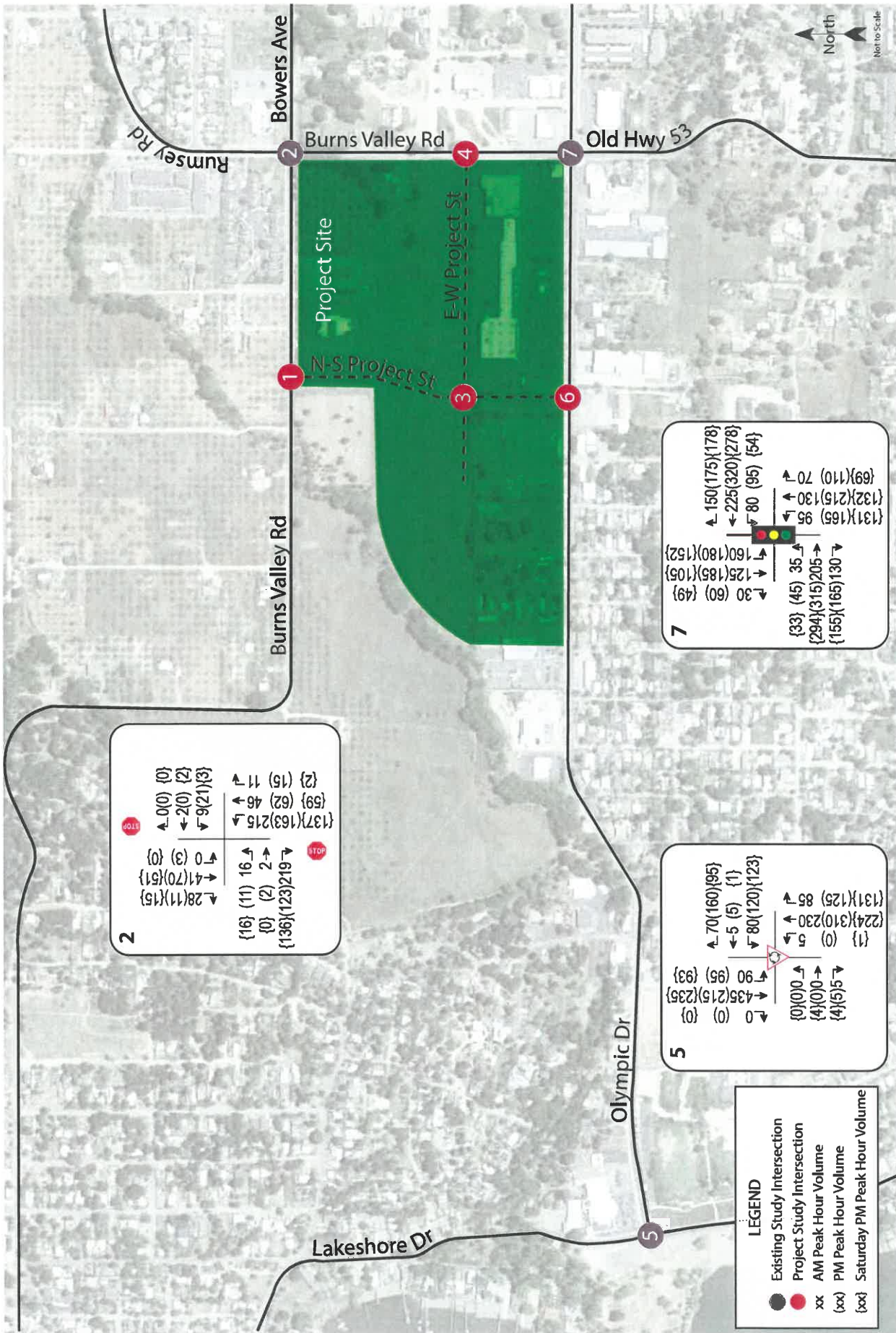

Transportation Impact Study for the Burns Valley Development
Figure 5 – Future Traffic Volumes

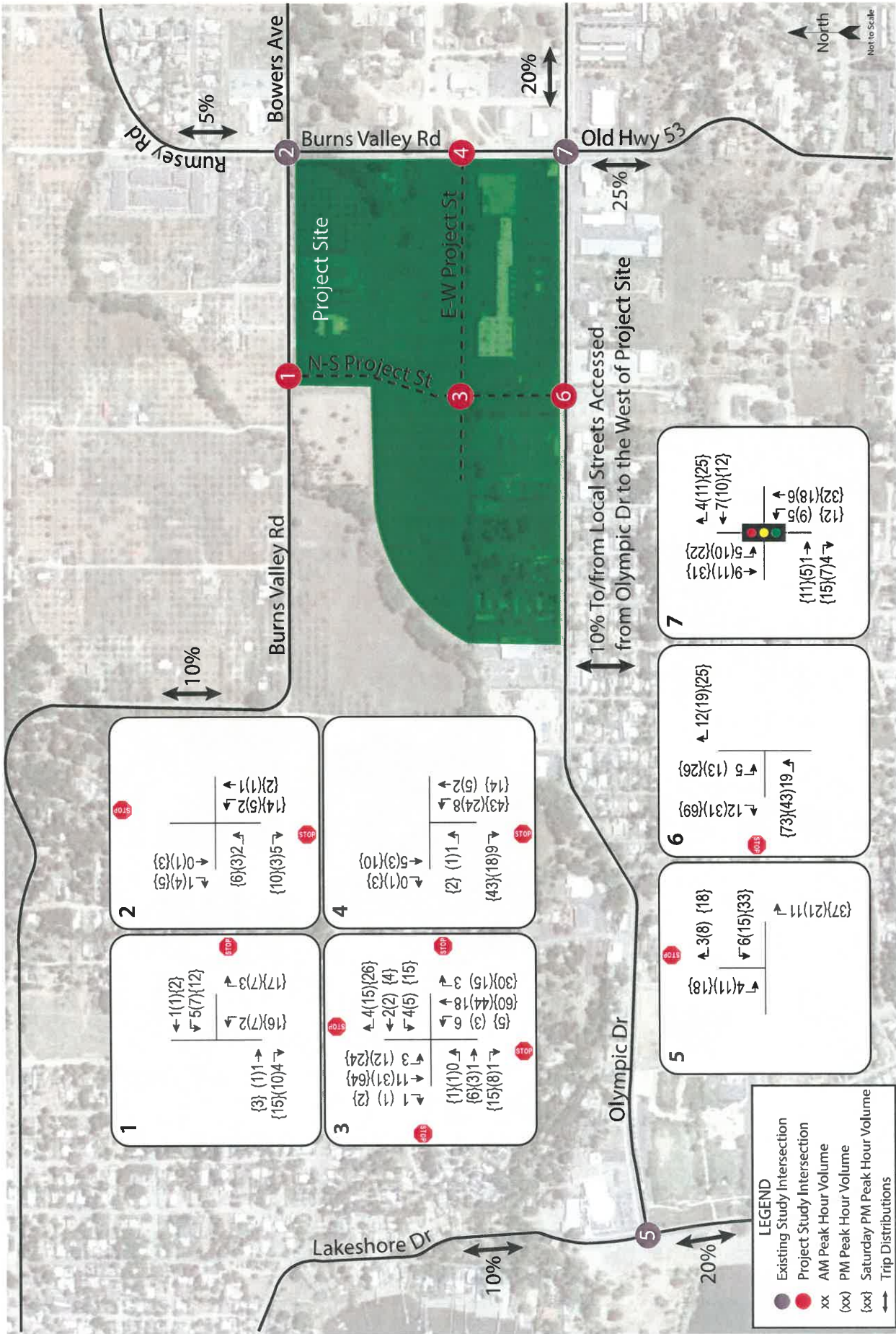

Transportation Impact Study for the Burns Valley Development
Figure 6 – Project Traffic Volumes and Trip Distributions

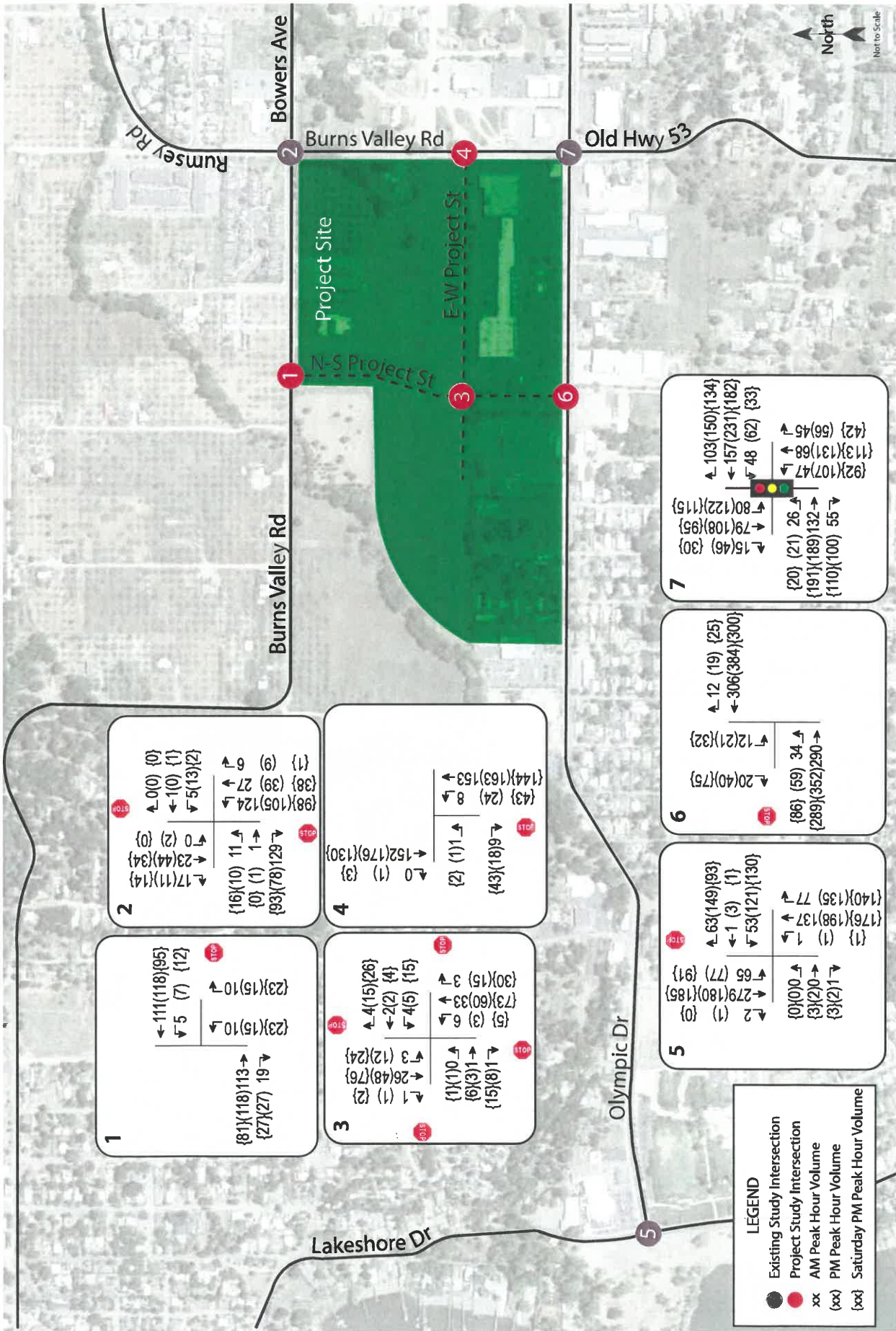

Transportation Impact Study for the Burns Valley Development
Figure 7 – Existing plus Project Traffic Volumes

Table 13 – Existing plus Project Peak Hour Intersection Levels of Service

Study Intersection <i>Approach</i>	Weekday AM		Weekday PM		Weekend PM	
	Delay	LOS	Delay	LOS	Delay	LOS
1. Burns Valley Rd/N-S Project St <i>NB (Project St) Approach</i>	0.9 <i>9.6</i>	A <i>A</i>	1.2 <i>9.8</i>	A <i>A</i>	2.0 <i>9.6</i>	A <i>A</i>
2. Burns Valley Rd/Bowers Ave-Rumsey Rd <i>EB (Burns Valley Rd) Approach</i> <i>WB (Bowers Ave) Approach</i>	6.9 <i>9.5</i> <i>13.6</i>	A <i>A</i> <i>B</i>	5.8 <i>9.5</i> <i>12.9</i>	A <i>A</i> <i>B</i>	6.3 <i>9.5</i> <i>12.1</i>	A <i>A</i> <i>B</i>
3. N-S Project St/E-W Project St	7.2	A	7.4	A	7.6	A
4. Burns Valley Rd/E-W Project St <i>EB (Project St) Approach</i>	0.5 <i>9.4</i>	A <i>A</i>	0.9 <i>9.5</i>	A <i>A</i>	2.0 <i>9.3</i>	A <i>A</i>
5. Olympic Dr/Lakeshore Dr <i>WB (Olympic Dr) Approach</i>	3.0 <i>12.9</i>	A <i>B</i>	5.2 <i>14.0</i>	A <i>B</i>	5.3 <i>15.9</i>	A <i>C</i>
6. Olympic Dr/N-S Project St <i>SB (Project St) Approach</i>	1.0 <i>12.8</i>	A <i>B</i>	1.7 <i>16.1</i>	A <i>C</i>	2.1 <i>15.5</i>	A <i>C</i>
7. Olympic Dr/Burns Valley Rd-Old Hwy 53	11.4	B	13.8	B	12.7	B

Notes: Delay is measured in average seconds per vehicle; LOS = Level of Service; Results for minor approaches to two-way stop-controlled intersections are indicated in italics.

Finding – The study intersections would continue to operate acceptably upon the addition of traffic associated with the Burns Valley Development (including the Oak Valley Villas) to existing volumes; therefore, the project would have an acceptable effect on operation of the surrounding roadway network.

Baseline plus Project Conditions

With project-related traffic added to the near-term Baseline volumes and including the redistribution of trips along the new North-South Project Street as detailed above, the study intersections are expected to operate acceptably. Baseline plus Project volumes are shown in Figure 8 and these results are summarized in Table 14.

cle029.al 4/22

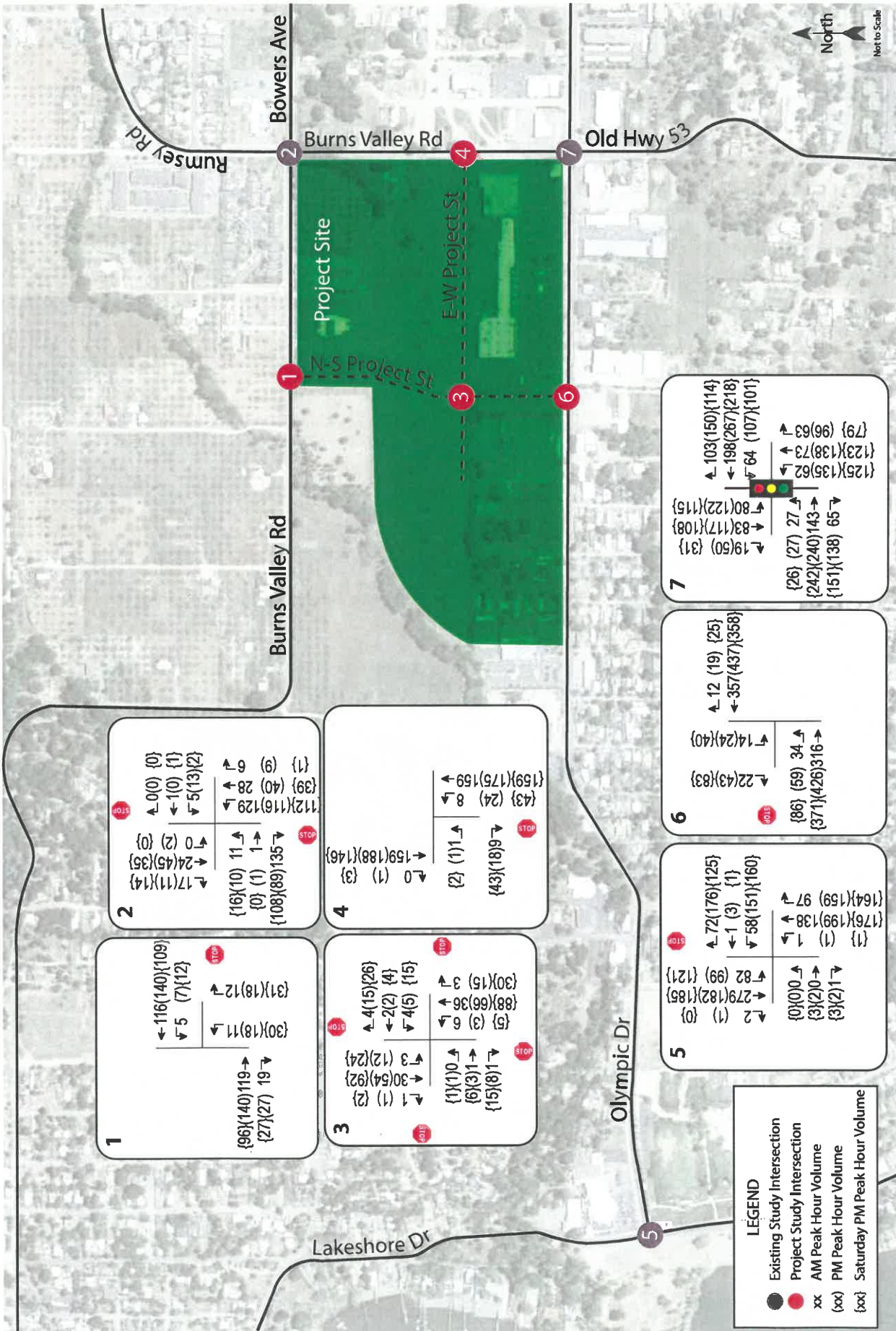

Transportation Impact Study for the Burns Valley Development
Figure 8 – Baseline plus Project Traffic Volumes

Table 14 – Baseline plus Project Peak Hour Intersection Levels of Service

Study Intersection Approach	Weekday AM		Weekday PM		Weekend PM	
	Delay	LOS	Delay	LOS	Delay	LOS
1. Burns Valley Rd/N-S Project St <i>NB (Project St) Approach</i>	0.9 <i>9.7</i>	A <i>A</i>	1.2 <i>10.1</i>	A <i>B</i>	2.3 <i>9.8</i>	A <i>A</i>
2. Burns Valley Rd/Bowers Ave-Rumsey Rd <i>EB (Burns Valley Rd) Approach</i> <i>WB (Bowers Ave) Approach</i>	6.9 <i>9.6</i> <i>13.9</i>	A <i>A</i> <i>B</i>	6.0 <i>9.5</i> <i>13.5</i>	A <i>A</i> <i>B</i>	6.5 <i>9.6</i> <i>12.7</i>	A <i>A</i> <i>B</i>
3. N-S Project St/E-W Project St	7.2	A	7.4	A	7.8	A
4. Burns Valley Rd/E-W Project St <i>EB (Project St) Approach</i>	0.5 <i>9.4</i>	A <i>A</i>	0.9 <i>9.6</i>	A <i>A</i>	1.9 <i>9.4</i>	A <i>A</i>
5. Olympic Dr/Lakeshore Dr <i>WB (Olympic Dr) Approach</i>	3.3 <i>13.4</i>	A <i>B</i>	6.4 <i>16.3</i>	A <i>C</i>	7.3 <i>19.9</i>	A <i>C</i>
6. Olympic Dr/N-S Project St <i>SB (Project St) Approach</i>	1.0 <i>13.9</i>	A <i>B</i>	1.8 <i>19.0</i>	A <i>C</i>	3.3 <i>19.9</i>	A <i>C</i>
7. Olympic Dr/Burns Valley Rd-Old Hwy 53	12.1	B	15.4	B	14.8	B

Notes: Delay is measured in average seconds per vehicle; LOS = Level of Service; Results for minor approaches to two-way stop-controlled intersections are indicated in italics.

Finding – The study intersections are expected to continue operating acceptably overall upon the addition of traffic from the Burns Valley Development (including the Oak Valley Villas) to near-term Baseline volumes; therefore, the project’s near-term effect on operation of the surrounding roadway network would be considered acceptable.

Future plus Project Conditions

Upon the addition of project-generated traffic to the anticipated future volumes, and with the planned roundabout at Olympic Drive/Lakeshore Drive, the study intersections are expected to operate acceptably. It should be noted that the land use assumptions developed for the General Plan Update analysis included some level of development on the proposed site so at least a portion of project trips would reasonably be expected to be included in the buildout volumes, though project trips were added to the projected future volumes to result in a conservative assessment of the project’s potential effect on operations. The Future plus Project volumes are shown in Figure 9 and operating conditions are summarized in Table 15.

cle029.ai 4/22

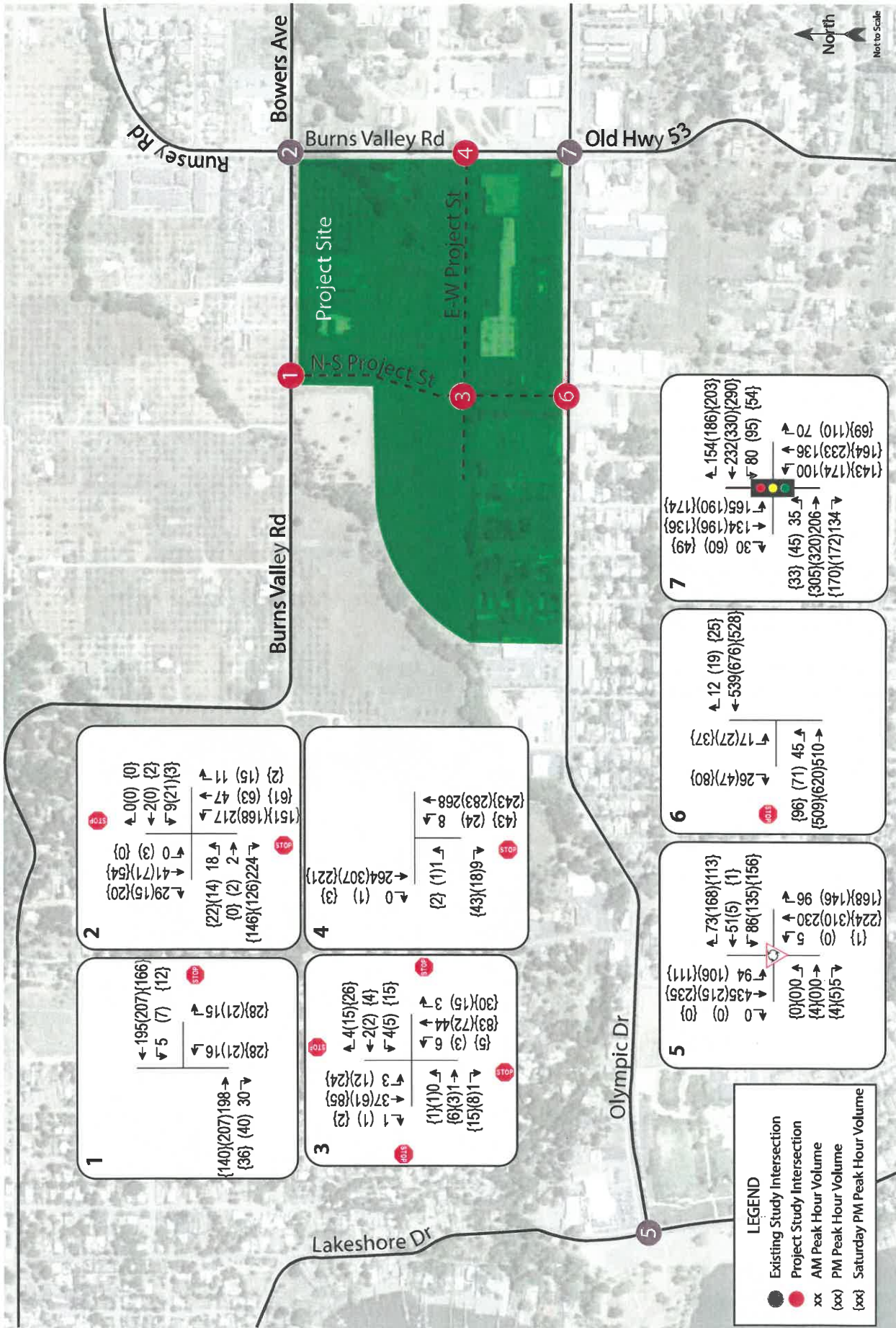

Transportation Impact Study for the Burnes Valley Development
Figure 9 – Future plus Project Traffic Volumes

Table 15 – Future plus Project Peak Hour Intersection Levels of Service

Study Intersection Approach	Weekday AM		Weekday PM		Weekend PM	
	Delay	LOS	Delay	LOS	Delay	LOS
1. Burns Valley Rd/N-S Project St <i>NB (Project St) Approach</i>	0.8 <i>10.5</i>	A <i>B</i>	1.0 <i>10.8</i>	A <i>B</i>	1.6 <i>10.2</i>	A <i>B</i>
2. Burns Valley Rd/Bowers Ave-Rumsey Rd <i>EB (Burns Valley Rd) Approach</i> <i>WB (Bowers Ave) Approach</i>	7.4 <i>10.5</i> <i>18.6</i>	A <i>B</i> <i>C</i>	6.2 <i>10.0</i> <i>16.0</i>	A <i>B</i> <i>C</i>	6.3 <i>10.0</i> <i>14.0</i>	A <i>B</i> <i>B</i>
3. N-S Project St/E-W Project St	7.2	A	7.4	A	7.7	A
4. Burns Valley Rd/E-W Project St <i>EB (Project St) Approach</i>	0.3 <i>10.0</i>	A <i>B</i>	0.6 <i>10.2</i>	A <i>B</i>	1.4 <i>9.8</i>	A <i>A</i>
5. Olympic Dr/Lakeshore Dr (Roundabout) <i>WB (Olympic Dr) Approach</i>	5.7 <i>1.6</i>	A <i>A</i>	5.0 <i>2.4</i>	A <i>A</i>	4.8 <i>3.8</i>	A <i>A</i>
6. Olympic Dr/N-S Project St <i>SB (Project St) Approach</i>	1.0 <i>17.6</i>	A <i>C</i>	1.8 <i>27.4</i>	A <i>D</i>	2.8 <i>22.8</i>	B <i>C</i>
7. Olympic Dr/Burns Valley Rd-Old Hwy 53	0.5	A	0.7	A	1.0	A

Notes: Delay is measured in average seconds per vehicle; LOS = Level of Service; Results for minor approaches to two-way stop-controlled intersections are indicated in italics.

Finding – The study intersections are expected to operate acceptably under Future plus Project conditions; therefore, the project’s cumulative effect on operation of the surrounding roadway network would be considered acceptable.

Parking

The proposed development was analyzed to determine whether the proposed parking supply would be sufficient to satisfy applicable requirements. The project site as proposed would provide a total of 507 parking spaces. Of these 507 spaces, 144 would be dedicated to the Oak Valley Villas.

Jurisdiction parking supply requirements are based on the City of Clearlake Municipal Code, Chapter 18-20.090; Parking Space Requirements. Vehicle parking for multifamily housing is required at a rate of one and one-half spaces for each one- or two-bedroom unit and two spaces for each unit with three or more bedrooms. The Oak Valley Villas project is also expected to qualify for a Density Bonus due to 100 percent of the units being affordable housing units, resulting in a reduction of required on-site parking for the residential project. Vehicle parking is required at a rate of one space per 750 square feet for light industrial uses, which was applied to the corporation yard, one space per 400 square feet for a community recreation center, 30 spaces per athletic field, and one space per 60 square feet for a drive-through restaurant.

The proposed parking supply and City and State requirements are shown in Table 16.

Table 16 – Parking Analysis Summary

Land Use	Units	Supply (spaces)	City Requirements		Density Bonus Requirements	
			Rate	Spaces Required	Rate	Spaces Required
Affordable Housing	20 1-bdr 36 2-bdr 18 3-bdr 6 4-bdr	144	1.5 for 1-2 bdr	84	1 for 1 bdr	20
			2.0 for 3+ bdr	48	1.5 for 2-3 bdr	81
<i>Oak Valley Villas Total</i>				132	2.5 for 4+ bdr	15
Corporation Yard	12,000 sf	363	1 per 750 sf	16	n/a	-
Recreation Center	15,000 sf		1 per 400 sf	38	n/a	-
Athletic Fields	6 fields		30 per field	180	n/a	-
Drive-Through Coffee Shop	160 sf		1 per 60 sf	3	n/a	-
<i>Non-Residential Total</i>					237	
Development Total		507		369		116

Notes: bdr = bedrooms; sf = square feet; n/a = not applicable.

For the Oak Valley Villas, the City requires one covered parking space per dwelling unit. The residential site plan indicates provision of 80 covered parking spaces, meeting the City requirements. The site plan also shows that out of the 144 spaces proposed, there are ten accessible stalls with two of those accessible stalls being van accessible. Based on requirements stipulated by the Federal Accessibility Guidelines, the required number of accessible stalls is five stalls, so the proposed supply is adequate. For the non-residential uses, eight accessible stalls are required, and a total of 12 accessible stalls would be provided, including five van accessible stalls.

Finding – The proposed parking supply would be more than sufficient to meet the applicable requirements.

Conclusions and Recommendations

Conclusions

CEQA Issues

- The proposed development (including the Oak Valley Villas) has the potential to result in an average of 1,332 new trips on local streets per day, with 77 new trips during the weekday a.m. peak hour, 182 new trips during the weekday p.m. peak hour, and 353 new trips during the Saturday p.m. peak hour.
- Calculated collision rates for the existing study intersections were all determined to be lower than the statewide average rates, indicating that there are no readily apparent safety issues for motorists in the vicinity of the development site. Nor were there any collisions reported involving a pedestrian or bicyclist.
- Upon constructing sidewalks along the project frontages with Burns Valley Road and along the new project streets, and the provision of a new crossing on Olympic Drive and the North-South Project Street, the development would be connected to the existing pedestrian network and circulation for pedestrians would be acceptable.
- Access for bicyclists would be adequate with the planned Class II bike lanes on the new project streets. Existing transit facilities are adequate.
- The entire Burns Valley Development, including the Oak Valley Villas, is anticipated to result in a less-than-significant transportation impact on VMT.
 - The Oak Valley Villas can be presumed to result in a less-than-significant impact as it would consist of 100 percent affordable housing.
 - Employees of the development, including those for the coffee shop, City corporation yard, and recreational facilities would be expected to have a less-than-significant impact on VMT based on data contained within the Lake County *Senate Bill 743 Vehicle Miles Traveled Regional Baseline Study* and the Wine Country Travel Demand Model.
 - The retail and recreational land uses would be expected to have less-than-significant impacts on VMT as local-serving uses.
- Sight lines on Burns Valley Road and Olympic Drive are adequate to accommodate all turns into and out of the proposed intersections and driveways.
- A left-turn lane would be warranted on Olympic Drive at the intersection with the North-South Project Street.
- The project would have a less-than-significant impact on queues in dedicated turn lanes at the existing study intersections.
- Emergency access and circulation are anticipated to function acceptably with incorporation of applicable design standards into the site layout and traffic from the proposed development would be expected to have a less-than-significant impact on emergency response times.

Policy Issues

- All existing and proposed study intersections are expected to operate at acceptable Levels of Service under Existing, near-term Baseline, and Future buildout volumes without and with the addition of trips from the proposed development. This evaluation was based on implementation of side-street stop controls at the intersections that the project streets would form with Olympic Drive and Burns Valley Road and all-way stop controls at the intersection of the north-south and east-west project streets, as shown on the preliminary site plan.
- The proposed parking supply satisfies City and State requirements.

Recommendations

CEQA Issues

- As proposed and indicated on the site plan, a crosswalk with high-visibility continental crosswalk markings, ADA-compliant curb ramps, pedestrian crossing signage, and advance yield line markings should be provided on Olympic Drive at the North-South Project Street intersection. Crosswalks should also be striped on the project street legs of the new street connections to Burns Valley Road and Olympic Drive.
- Long-term bicycle storage supply in the Oak Valley Villas should be increased from four spaces to seven spaces. A supply of 19 bicycle parking spaces should be provided throughout the non-residential portions of the project site.
- Sight lines at driveways and project street intersections should be clear of obstructions such as vegetation and signing within the vision triangles. The planting of tall vegetation should be avoided near the northeast corner of the project site near the intersection of Burns Valley Road/Bowers Avenue-Rumsey Road.
- Consistent with the site plan, the existing two-way left-turn lane which terminates east of the proposed Olympic Drive/North-South Project Street intersection should be extended to provide 75 feet of stacking at the proposed intersection.

Study Participants and References

Study Participants

Principal in Charge	Dalene J. Whitlock, PE, PTOE
Transportation Planner	Zack Matley, AICP
Associate Engineer	Cameron Nye, EIT
Assistant Engineer	Siddharth Gangrade
Graphics	Cameron Wong
Editing/Formatting	Hannah Yung-Boxdell
Quality Control	Dalene J. Whitlock, PE, PTOE

References

2018 Collision Data on California State Highways, California Department of Transportation, 2020

Active Transportation Plan for Lake County, Lake County/City Area Planning Council, 2016

City of Clearlake 2040 General Plan Update, City of Clearlake, 2017

Guide for the Preparation of Traffic Impact Studies, California Department of Transportation, 2002

Highway Capacity Manual, Transportation Research Board, 2018

Highway Design Manual, 6th Edition, California Department of Transportation, 2017

Intersection Channelization Design Guide, National Cooperative Highway Research Program (NCHRP) Report No. 279, Transportation Research Board, 1985

Lake Transit Authority, <http://www.laketransit.org>

Method for Prioritizing Intersection Improvements, Washington State Transportation Center, 1997

Municipal Code of the City of Clearlake, Coded Systems LLC, 2017

Senate Bill 743 Vehicle Miles Traveled Regional Baseline Study (RBS), Fehr & Peers, 2020

Statewide Integrated Traffic Records System (SWITRS), California Highway Patrol, 2016-2021

Technical Advisory on Evaluating Transportation Impacts in CEQA, Governor's Office of Planning and Research, 2018

Traffic Impact Study for the Lake County Tribal Health Clinic, W-Trans, 2019

Trip Generation Manual, 11th Edition, Institute of Transportation Engineers, 2021

CLE029



Appendix A

Collision Rate Calculations





This page intentionally left blank

Intersection Collision Rate Worksheet															
Burns Valley Development															
Intersection # 2: Burns Valley Rd & Bowers Ave-Rumsey Rd															
Date of Count: Thursday, January 20, 2022															
Number of Collisions: 1															
Number of Injuries: 1															
Number of Fatalities: 0															
Average Daily Traffic (ADT): 4200															
Start Date: August 1, 2016															
End Date: July 31, 2021															
Number of Years: 5															
Intersection Type: Four-Legged															
Control Type: Stop & Yield Controls															
Area: Urban															
Collision Rate = $\frac{\text{Number of Collisions} \times 1 \text{ Million}}{\text{ADT} \times \text{Days per Year} \times \text{Number of Years}}$															
Collision Rate = $\frac{1}{4,200} \times \frac{1,000,000}{365 \times 5}$															
<table border="1" style="width: 100%; border-collapse: collapse;"> <thead> <tr> <th style="width: 33%;">Study Intersection</th> <th style="width: 16.5%;">Collision Rate</th> <th style="width: 16.5%;">Fatality Rate</th> <th style="width: 16.5%;">Injury Rate</th> </tr> </thead> <tbody> <tr> <td></td> <td style="text-align: center;">0.13 c/mve</td> <td style="text-align: center;">0.0%</td> <td style="text-align: center;">100.0%</td> </tr> <tr> <td>Statewide Average*</td> <td style="text-align: center;">0.14 c/mve</td> <td style="text-align: center;">1.1%</td> <td style="text-align: center;">46.2%</td> </tr> </tbody> </table>				Study Intersection	Collision Rate	Fatality Rate	Injury Rate		0.13 c/mve	0.0%	100.0%	Statewide Average*	0.14 c/mve	1.1%	46.2%
Study Intersection	Collision Rate	Fatality Rate	Injury Rate												
	0.13 c/mve	0.0%	100.0%												
Statewide Average*	0.14 c/mve	1.1%	46.2%												
Notes															
ADT = average daily total vehicles entering intersection															
c/mve = collisions per million vehicles entering intersection															
* 2018 Collision Data on California State Highways, Caltrans															
Intersection # 5: Olympic Dr & Lakeshore Dr															
Date of Count: Thursday, January 20, 2022															
Number of Collisions: 1															
Number of Injuries: 0															
Number of Fatalities: 0															
Average Daily Traffic (ADT): 8200															
Start Date: August 1, 2016															
End Date: July 31, 2021															
Number of Years: 5															
Intersection Type: Tee															
Control Type: Stop & Yield Controls															
Area: Urban															
Collision Rate = $\frac{\text{Number of Collisions} \times 1 \text{ Million}}{\text{ADT} \times \text{Days per Year} \times \text{Number of Years}}$															
Collision Rate = $\frac{1}{8,200} \times \frac{1,000,000}{365 \times 5}$															
<table border="1" style="width: 100%; border-collapse: collapse;"> <thead> <tr> <th style="width: 33%;">Study Intersection</th> <th style="width: 16.5%;">Collision Rate</th> <th style="width: 16.5%;">Fatality Rate</th> <th style="width: 16.5%;">Injury Rate</th> </tr> </thead> <tbody> <tr> <td></td> <td style="text-align: center;">0.07 c/mve</td> <td style="text-align: center;">0.0%</td> <td style="text-align: center;">0.0%</td> </tr> <tr> <td>Statewide Average*</td> <td style="text-align: center;">0.09 c/mve</td> <td style="text-align: center;">1.2%</td> <td style="text-align: center;">46.9%</td> </tr> </tbody> </table>				Study Intersection	Collision Rate	Fatality Rate	Injury Rate		0.07 c/mve	0.0%	0.0%	Statewide Average*	0.09 c/mve	1.2%	46.9%
Study Intersection	Collision Rate	Fatality Rate	Injury Rate												
	0.07 c/mve	0.0%	0.0%												
Statewide Average*	0.09 c/mve	1.2%	46.9%												
Notes															
ADT = average daily total vehicles entering intersection															
c/mve = collisions per million vehicles entering intersection															
* 2018 Collision Data on California State Highways, Caltrans															

Intersection Collision Rate Worksheet			
Burns Valley Development			
Intersection # 7: Olympic Dr & Burns Valley Rd-Old Hwy 53			
Date of Count: Thursday, January 20, 2022			
Number of Collisions: 4			
Number of Injuries: 3			
Number of Fatalities: 0			
Average Daily Traffic (ADT): 10200			
Start Date: August 1, 2016			
End Date: July 31, 2021			
Number of Years: 5			
Intersection Type: Four-Legged			
Control Type: Signals			
Area: Urban			
Collision Rate = $\frac{\text{Number of Collisions} \times 1 \text{ Million}}{\text{ADT} \times \text{Days per Year} \times \text{Number of Years}}$			
Collision Rate = $\frac{4}{10,200} \times \frac{1,000,000}{365 \times 5}$			
	Collision Rate	Fatality Rate	Injury Rate
Study Intersection	0.21 c/mve	0.0%	75.0%
Statewide Average*	0.24 c/mve	0.5%	46.9%
Notes			
ADT = average daily total vehicles entering intersection			
c/mve = collisions per million vehicles entering intersection			
* 2018 Collision Data on California State Highways, Caltrans			

Appendix B

NCHRP Pedestrian Crossing Treatment Worksheet





This page intentionally left blank

GUIDELINES FOR PEDESTRIAN CROSSING TREATMENTS

This spreadsheet combines Worksheet 1 and Worksheet 2 (Appendix A, pages 69-70) of TCRP Report 112/NCHRP Report 562 (*Improving Pedestrian Safety at Unsignalized Intersections*) into an electronic format. This spreadsheet should be used in conjunction with, and not independent of, Appendix A documentation.

Key	
	Blue fields contain descriptive information.
	Green fields are required and must be completed.
	Tan fields are adjustments that are filled out only under certain conditions (follow instructions to the left of the cell).
	Gray fields are automatically calculated and should not be edited.

Analyst and Site Information			
Analyst	W-Trans	Major Street	Olympic Drive
Analysis Date	April 26, 2022	Minor Street or Location	North-South Project Street
Data Collection Date	January 20, 2022	Peak Hour	Weekday PM
Step 1: Select worksheet:			
Posted or statutory speed limit (or 85th percentile speed) on the major street (mph)	1a	30	
Is the population of the surrounding area <10,000? (enter YES or NO)	1b	NO	
Step 2: Does the crossing meet minimum pedestrian volumes to be considered for a traffic control device?			
Peak-hour pedestrian volume (ped/h), V_p	2a	20	
Result: Go to step 3.			
Step 3: Does the crossing meet the pedestrian warrant for a traffic signal?			
Major road volume, total of both approaches during peak hour (veh/h), V_{major}	3a	700	
[Calculated automatically] Preliminary (before min. threshold) peak hour pedestrian volume to meet warrant	3b	425	
[Calculated automatically] Minimum required peak hour pedestrian volume to meet traffic signal warrant	3c	425	
Is 15th percentile crossing speed of pedestrians less than 3.5 ft/s (1.1 m/s)? (enter YES or NO)	3d	NO	
If 15th percentile crossing speed of pedestrians is less than 3.5 ft/s (1.1 m/s), then reduce 3c by up to 50%.	3e	425	
	3f	425	
Result: The signal warrant is not met. Go to step 4.			
Step 4: Estimate pedestrian delay.			
Pedestrian crossing distance, curb to curb (ft), L	4a	36	
Pedestrian walking speed (ft/s), S_p (suggested speed = 3.5 ft/s)	4b	3.5	
Pedestrian start-up time and end clearance time (s), t_s (suggested start-up time = 3 sec)	4c	3	
[Calculated automatically] Critical gap required for crossing pedestrian (s), t_c	4d	13.2	
Major road volume, total both approaches OR approach being crossed if raised median island is present, during peak hour (veh/h), V_{major}	4e	700	
Major road flow rate (veh/s), v	4f	0.19	
Average pedestrian delay (s/person), d_p	4g	46	
Total pedestrian delay (h), D_p The value in 4h is the calculated estimated delay for all pedestrians crossing the major roadway without a crossing treatment (assumes 0% compliance). If the actual total pedestrian delay has been measured at the site, that value can be entered in 4i to replace the calculated value in 4h.	4h	0.3	
	4i		
Step 5: Select treatment based up on total pedestrian delay and expected motorist compliance.			
Expected motorist compliance at pedestrian crossings in region: enter HIGH for High Compliance or LOW for Low Compliance	5a	LOW	
Treatment Category:	CROSSWALK		

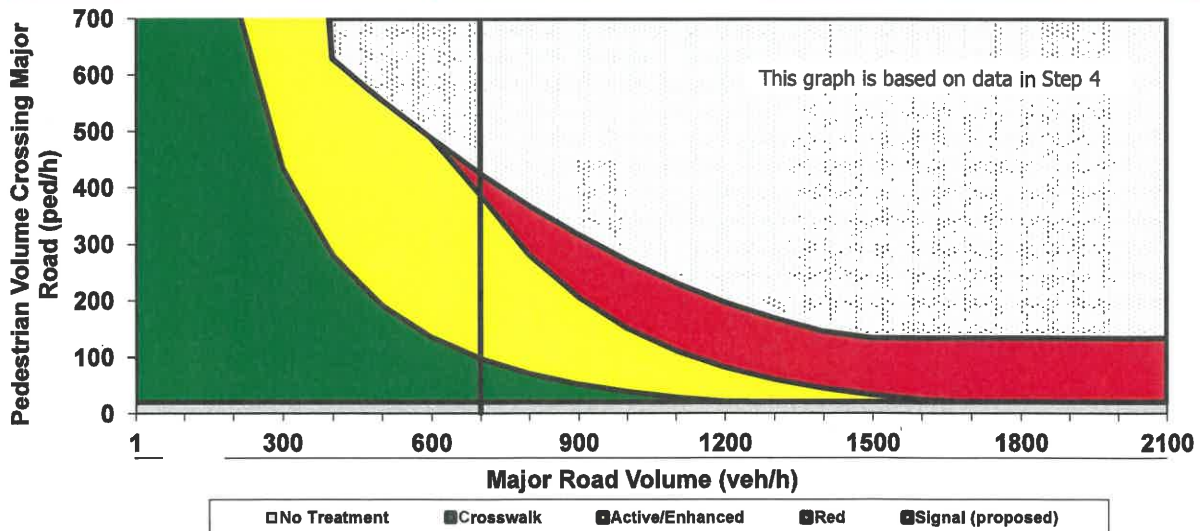

This worksheet provides general recommendations on pedestrian crossing treatments to consider at unsignalized intersections; in all cases, engineering judgment should be used in selecting a specific treatment for installation. This worksheet does not apply to school crossings. In addition to the results provided by this worksheet, users should consider whether a pedestrian treatment could present an increased safety risk to pedestrians, such as where there is poor sight distance, complex geometrics, or nearby traffic signals.



This page intentionally left blank

Appendix C

VMT Screening Tool Output







This page intentionally left blank

Screening Results

Screening Inputs

Criteria	Input
VMT Metric	Home-based Work VMT per Worker
Baseline Year	2022
Threshold (% reduction from Baseline Year)	Countywide Benchmark (-15%)
Legend	
Category	Color
Selected Project Area	
Traffic Analysis Zone ID	
Low VMT Generating TAZs	

Project Location



Project Proximity to Output Low VMT Generating TAZs

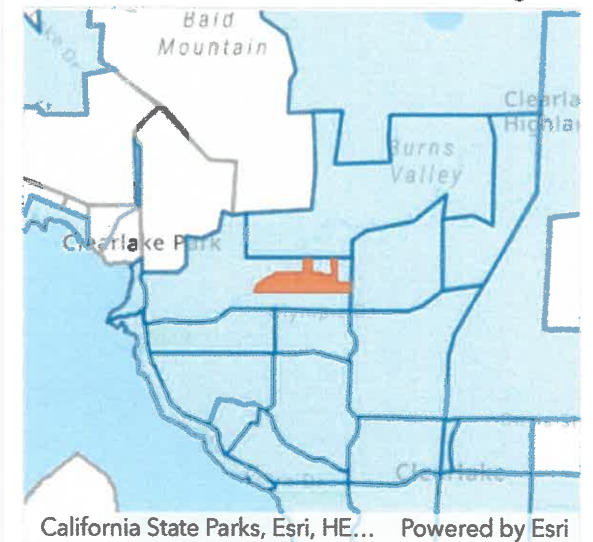

 **Passed**

Screening Questions	Results
Within a low VMT generating TAZ?	Yes (Pass) 

Screening results are based on location of parcel centroids. If results are desired considering the full parcel, please refer to the associated map layers to visually review parcel and TAZ boundary relationship.

Traffic Analysis Zone (TAZ) Details

TAZ Questions	TAZ ID: 1908
Jurisdiction	Clearlake
TAZ VMT	7.6
Countywide Average VMT	12.3
% Difference	-38.2%
VMT Metric	Home-based Work VMT per Worker
Threshold	10.5

Threshold Evaluation

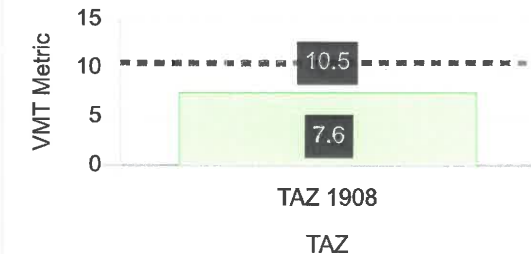



This page intentionally left blank

Appendix D

Turn Lane Warrant Spreadsheets





This page intentionally left blank

Turn Lane Warrant Analysis - Tee Intersections

Study Intersection: Olympic Dr/N-S Project St
 Study Scenario: E+P Weekday AM

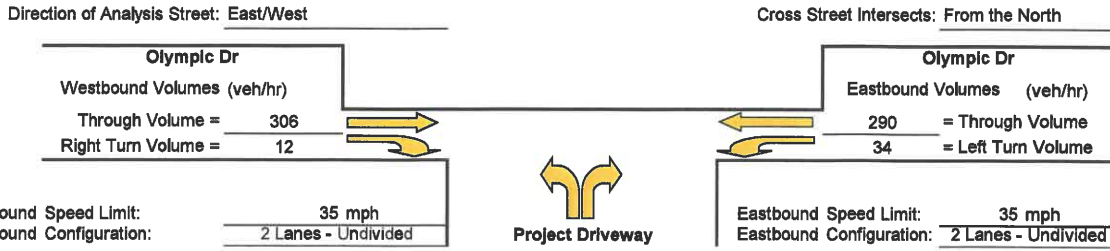

Westbound Right Turn Lane Warrants

1. Check for right turn volume criteria

Thresholds not met, continue to next step

2. Check advance volume threshold criteria for turn lane

Advancing Volume Threshold	AV =	960.1
Advancing Volume	Va =	318
If AV < Va then warrant is met		No

Right Turn Lane Warranted: NO

Westbound Right Turn Taper Warrants
(evaluate if right turn lane is unwarranted)

1. Check taper volume criteria

NOT WARRANTED - Less than 20 vehicles

2. Check advance volume threshold criteria for taper

Advancing Volume Threshold	AV =	-
Advancing Volume	Va =	318
If AV < Va then warrant is met		-

Right Turn Taper Warranted: NO

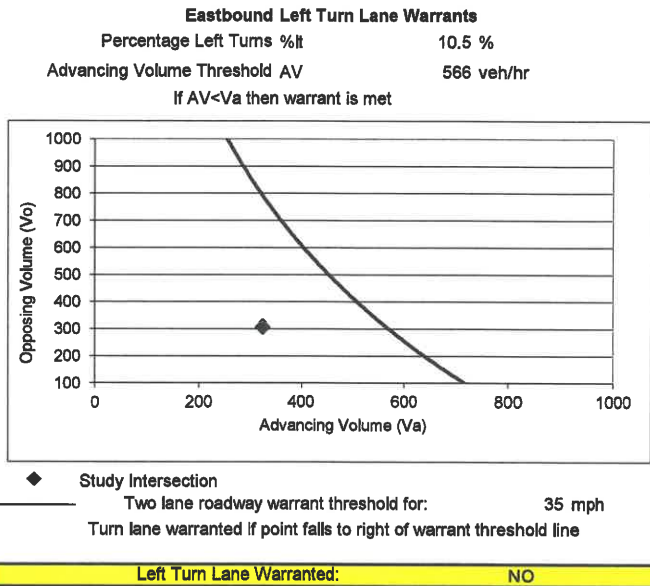

Methodology based on Washington State Transportation Center Research Report *Method For Prioritizing Intersection Improvements*, January 1997.
 The right turn lane and taper analysis is based on work conducted by Cottrell in 1981.
 The left turn lane analysis is based on work conducted by M.D. Harmelink in 1967, and modified by Kikuchi and Chakroborty in 1991.

Turn Lane Warrant Analysis - Tee Intersections

Study Intersection: Olympic Dr/N-S Project St
 Study Scenario: E+P Weekday PM

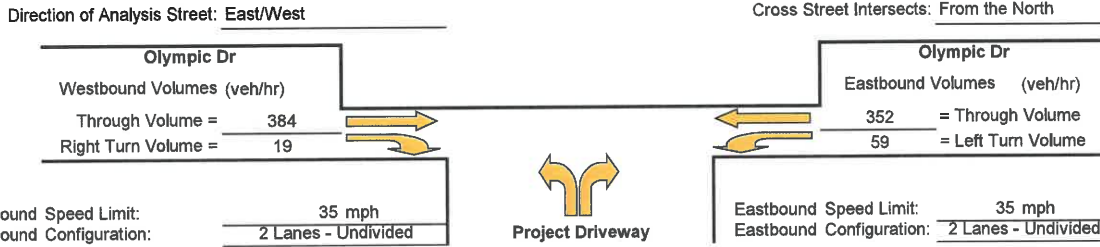

Westbound Right Turn Lane Warrants

1. Check for right turn volume criteria

Thresholds not met, continue to next step

2. Check advance volume threshold criteria for turn lane

Advancing Volume Threshold	AV =	907.6
Advancing Volume	Va =	403
If AV < Va then warrant is met		

Right Turn Lane Warranted: NO

Westbound Right Turn Taper Warrants
(evaluate if right turn lane is unwarranted)

1. Check taper volume criteria

NOT WARRANTED - Less than 20 vehicles

2. Check advance volume threshold criteria for taper

Advancing Volume Threshold	AV =	-
Advancing Volume	Va =	403
If AV < Va then warrant is met		

Right Turn Taper Warranted: NO

Eastbound Left Turn Lane Warrants

Percentage Left Turns %lt	14.4 %
Advancing Volume Threshold AV	443 veh/hr
If AV < Va then warrant is met	

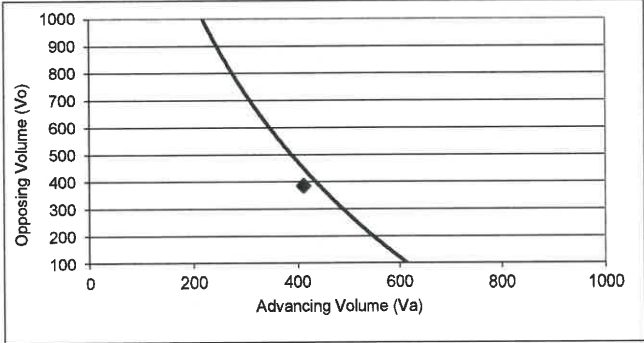

◆ Study Intersection

Two lane roadway warrant threshold for: 35 mph

Turn lane warranted if point falls to right of warrant threshold line

Left Turn Lane Warranted: NO

Methodology based on Washington State Transportation Center Research Report *Method For Prioritizing Intersection Improvements*, January 1997.
 The right turn lane and taper analysis is based on work conducted by Cottrell in 1981.
 The left turn lane analysis is based on work conducted by M.D. Harmelink in 1967, and modified by Kikuchi and Chakroborty in 1991.

Turn Lane Warrant Analysis - Tee Intersections

Study Intersection: Olympic Dr/N-S Project St
 Study Scenario: E+P Weekend PM

Direction of Analysis Street: East/West

Cross Street Intersects: From the North

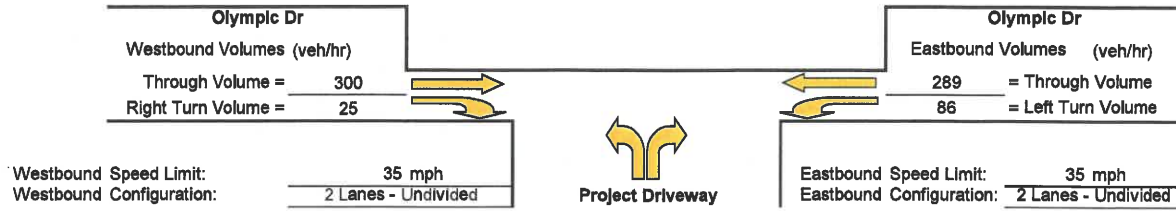

Westbound Right Turn Lane Warrants

1. Check for right turn volume criteria

Thresholds not met, continue to next step

2. Check advance volume threshold criteria for turn lane

Advancing Volume Threshold	AV =	862.6
Advancing Volume	Va =	325
If AV < Va then warrant is met		
		No

Right Turn Lane Warranted: NO

Westbound Right Turn Taper Warrants (evaluate if right turn lane is unwarranted)

1. Check taper volume criteria

Thresholds not met, continue to next step

2. Check advance volume threshold criteria for taper

Advancing Volume Threshold	AV =	650
Advancing Volume	Va =	325
If AV < Va then warrant is met		
		No

Right Turn Taper Warranted: NO

Eastbound Left Turn Lane Warrants

Percentage Left Turns %lt	22.9 %
Advancing Volume Threshold AV	411 veh/hr
If AV < Va then warrant is met	

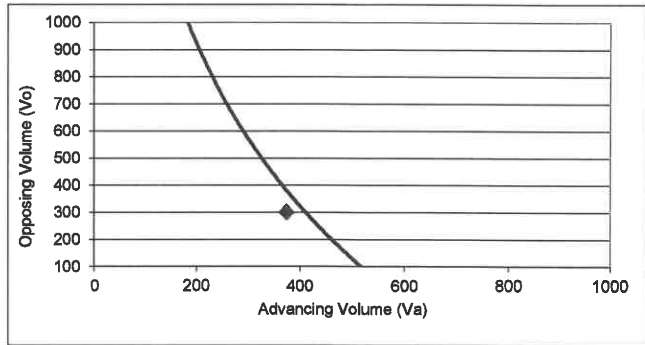

◆ Study Intersection
 Two lane roadway warrant threshold for: 35 mph
 Turn lane warranted if point falls to right of warrant threshold line

Left Turn Lane Warranted: NO

Methodology based on Washington State Transportation Center Research Report *Method For Prioritizing Intersection Improvements*, January 1997.
 The right turn lane and taper analysis is based on work conducted by Cottrell in 1981.
 The left turn lane analysis is based on work conducted by M.D. Harmelink in 1967, and modified by Kikuchi and Chakroborty in 1991.

Turn Lane Warrant Analysis - Tee Intersections

Study Intersection: Olympic Dr/N-S Project St
 Study Scenario: B+P Weekday AM

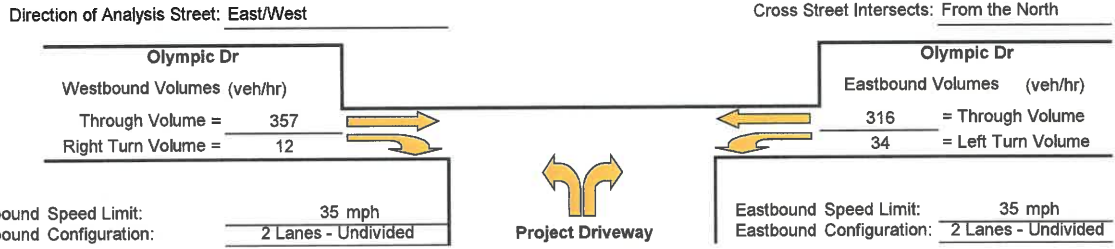

Westbound Right Turn Lane Warrants

1. Check for right turn volume criteria

Thresholds not met, continue to next step

2. Check advance volume threshold criteria for turn lane

Advancing Volume Threshold	AV = 960.1
Advancing Volume	Va = 369
If AV < Va then warrant is met	
	No

Right Turn Lane Warranted: NO

Westbound Right Turn Taper Warrants
(evaluate if right turn lane is unwarranted)

1. Check taper volume criteria

NOT WARRANTED - Less than 20 vehicles

2. Check advance volume threshold criteria for taper

Advancing Volume Threshold	AV = -
Advancing Volume	Va = 369
If AV < Va then warrant is met	
	-

Right Turn Taper Warranted: NO

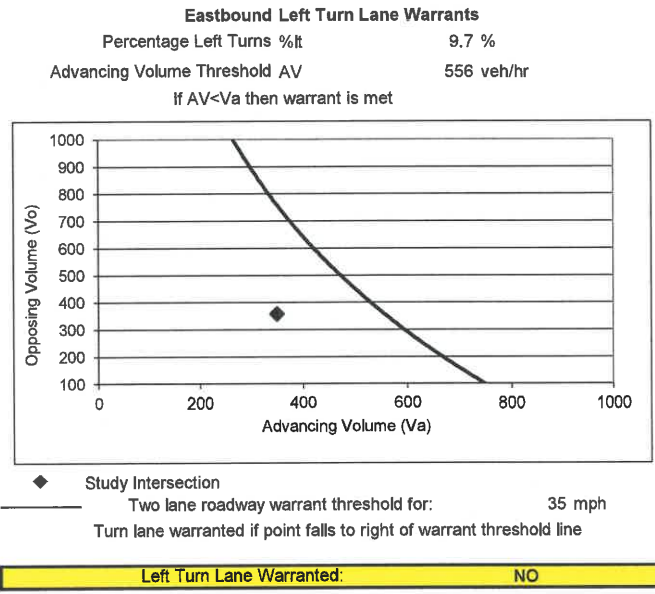

Methodology based on Washington State Transportation Center Research Report *Method For Prioritizing Intersection Improvements*, January 1997.
 The right turn lane and taper analysis is based on work conducted by Cottrell in 1981.
 The left turn lane analysis is based on work conducted by M.D. Harmelink in 1967, and modified by Kikuchi and Chakroborty in 1991.

Turn Lane Warrant Analysis - Tee Intersections

Study Intersection: Olympic Dr/N-S Project St
 Study Scenario: B+P Weekday PM

Direction of Analysis Street: East/West

Cross Street Intersects: From the North

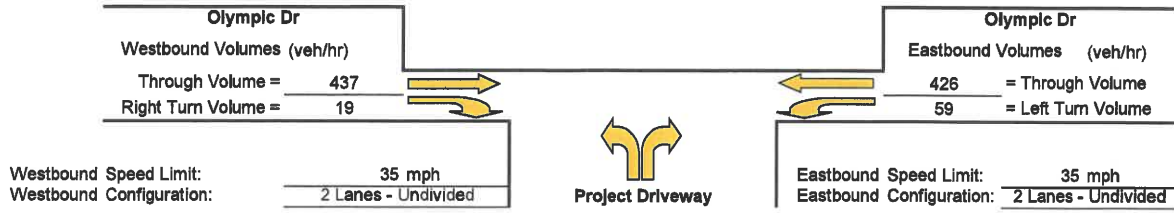

Westbound Right Turn Lane Warrants

1. Check for right turn volume criteria

Thresholds not met, continue to next step

2. Check advance volume threshold criteria for turn lane

Advancing Volume Threshold	AV =	907.6
Advancing Volume	Va =	456
If $AV < Va$ then warrant is met		
No		

Right Turn Lane Warranted: NO

Westbound Right Turn Taper Warrants (evaluate if right turn lane is unwarranted)

1. Check taper volume criteria

NOT WARRANTED - Less than 20 vehicles

2. Check advance volume threshold criteria for taper

Advancing Volume Threshold	AV =	-
Advancing Volume	Va =	456
If $AV < Va$ then warrant is met		
-		

Right Turn Taper Warranted: NO

Eastbound Left Turn Lane Warrants

Percentage Left Turns %lt	12.2 %
Advancing Volume Threshold AV	451 veh/hr
If $AV < Va$ then warrant is met	

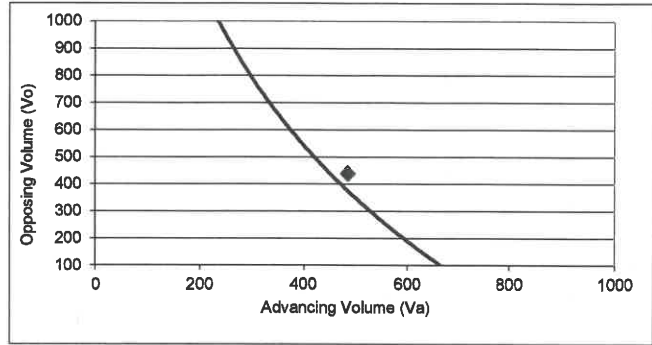

◆ Study Intersection
 Two lane roadway warrant threshold for: 35 mph
 Turn lane warranted if point falls to right of warrant threshold line

Left Turn Lane Warranted: YES

Methodology based on Washington State Transportation Center Research Report *Method For Prioritizing Intersection Improvements*, January 1997.
 The right turn lane and taper analysis is based on work conducted by Cottrell in 1981.
 The left turn lane analysis is based on work conducted by M.D. Harmelink in 1967, and modified by Kikuchi and Chakroborty in 1991.

Turn Lane Warrant Analysis - Tee Intersections

Study Intersection: Olympic Dr/N-S Project St
 Study Scenario: B+P Weekend PM

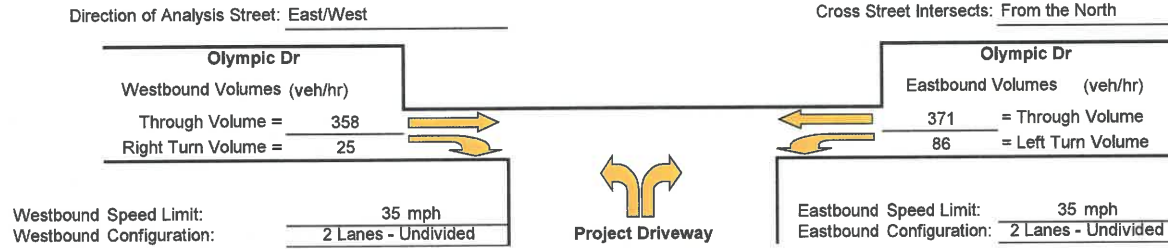

Westbound Right Turn Lane Warrants

1. Check for right turn volume criteria

Thresholds not met, continue to next step

2. Check advance volume threshold criteria for turn lane

Advancing Volume Threshold	AV =	862.6
Advancing Volume	Va =	383
If $AV < Va$ then warrant is met		No

Right Turn Lane Warranted: NO

Westbound Right Turn Taper Warrants
(evaluate if right turn lane is unwarranted)

1. Check taper volume criteria

Thresholds not met, continue to next step

2. Check advance volume threshold criteria for taper

Advancing Volume Threshold	AV =	650
Advancing Volume	Va =	383
If $AV < Va$ then warrant is met		No

Right Turn Taper Warranted: NO

Eastbound Left Turn Lane Warrants

Percentage Left Turns %lt	18.8 %
Advancing Volume Threshold AV	409 veh/hr
If $AV < Va$ then warrant is met	

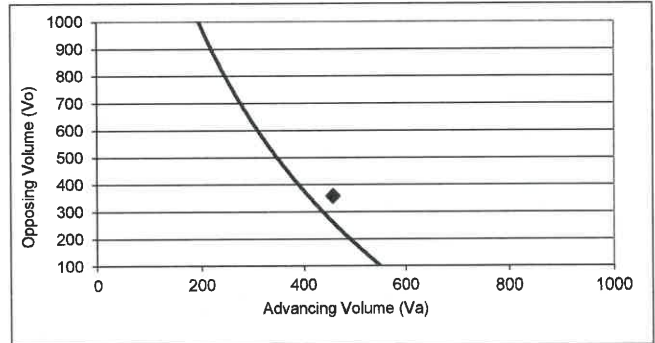

◆ Study Intersection
 — Two lane roadway warrant threshold for: 35 mph
 Turn lane warranted if point falls to right of warrant threshold line

Left Turn Lane Warranted: YES

Methodology based on Washington State Transportation Center Research Report *Method For Prioritizing Intersection Improvements*, January 1997.
 The right turn lane and taper analysis is based on work conducted by Cottrell in 1981.
 The left turn lane analysis is based on work conducted by M.D. Harmelink in 1967, and modified by Kikuchi and Chakrobrty in 1991.

Turn Lane Warrant Analysis - Tee Intersections

Study Intersection: Burns Valley Rd/N-S Project St
 Study Scenario: Weekday AM F+P

Direction of Analysis Street: East/West

Cross Street Intersects: From the South

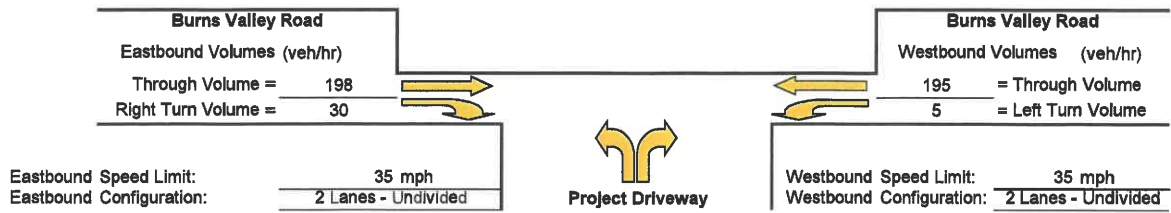

Eastbound Right Turn Lane Warrants

1. Check for right turn volume criteria

Thresholds not met, continue to next step

2. Check advance volume threshold criteria for turn lane

Advancing Volume Threshold	AV =	825.1
Advancing Volume	Va =	228
If $AV < Va$ then warrant is met		No

Right Turn Lane Warranted: NO

Eastbound Right Turn Taper Warrants (evaluate if right turn lane is unwarranted)

1. Check taper volume criteria

Thresholds not met, continue to next step

2. Check advance volume threshold criteria for taper

Advancing Volume Threshold	AV =	600
Advancing Volume	Va =	228
If $AV < Va$ then warrant is met		No

Right Turn Taper Warranted: NO

Westbound Left Turn Lane Warrants

Percentage Left Turns %lt 2.5 %
 Advancing Volume Threshold AV 1249 veh/hr
 If $AV < Va$ then warrant is met

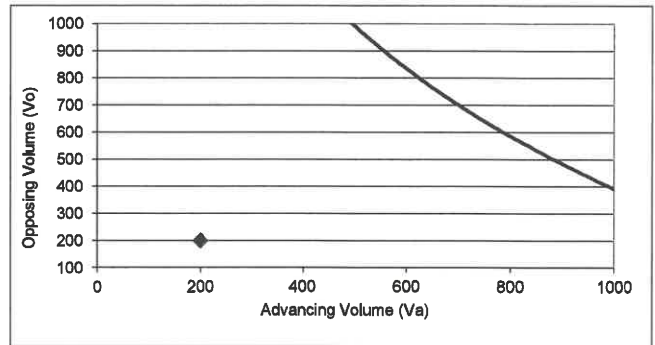

◆ Study Intersection
 Two lane roadway warrant threshold for: 35 mph
 Turn lane warranted if point falls to right of warrant threshold line

Left Turn Lane Warranted: NO

Methodology based on Washington State Transportation Center Research Report *Method For Prioritizing Intersection Improvements*, January 1997.
 The right turn lane and taper analysis is based on work conducted by Cottrell in 1981.
 The left turn lane analysis is based on work conducted by M.D. Harmelink in 1967, and modified by Kikuchi and Chakroborty in 1991.

Turn Lane Warrant Analysis - Tee Intersections

Study Intersection: Burns Valley Rd / Oak Valley Villas Northern Driveway
 Study Scenario: Weekday AM F+P

Direction of Analysis Street: East/West

Cross Street Intersects: From the South

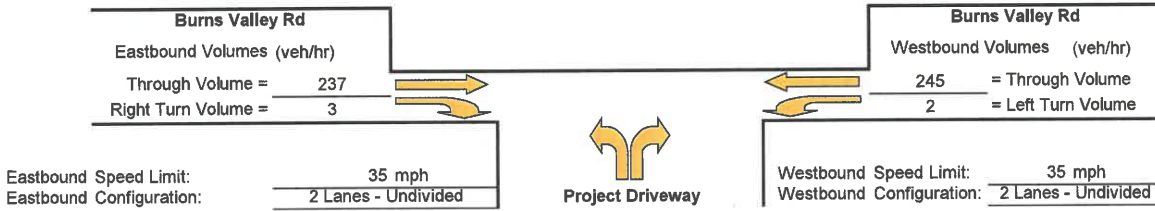

Eastbound Right Turn Lane Warrants

1. Check for right turn volume criteria

Thresholds not met, continue to next step

2. Check advance volume threshold criteria for turn lane

Advancing Volume Threshold	AV =	1027.6
Advancing Volume	Va =	240
If AV < Va then warrant is met		No

Right Turn Lane Warranted: NO

Eastbound Right Turn Taper Warrants (evaluate if right turn lane is unwarranted)

1. Check taper volume criteria

NOT WARRANTED - Less than 20 vehicles

2. Check advance volume threshold criteria for taper

Advancing Volume Threshold	AV =	-
Advancing Volume	Va =	240
If AV < Va then warrant is met		-

Right Turn Taper Warranted: NO

Westbound Left Turn Lane Warrants

Percentage Left Turns %lt	0.8 %
Advancing Volume Threshold AV	1520 veh/hr
If AV < Va then warrant is met	

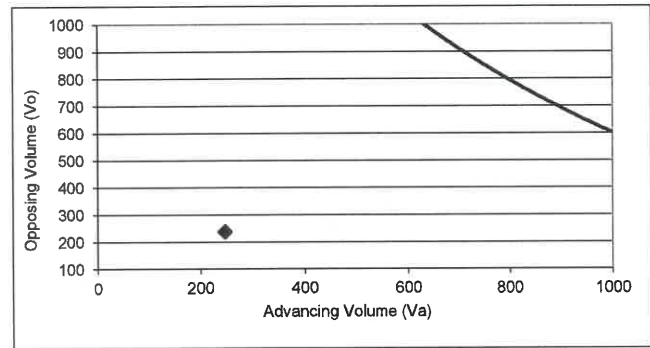

◆ Study Intersection
 — Two lane roadway warrant threshold for: 35 mph
 Turn lane warranted if point falls to right of warrant threshold line

Left Turn Lane Warranted: NO

Methodology based on Washington State Transportation Center Research Report *Method For Prioritizing Intersection Improvements*, January 1997.
 The right turn lane and taper analysis is based on work conducted by Cottrell in 1981.
 The left turn lane analysis is based on work conducted by M.D. Harmelink in 1967, and modified by Kikuchi and Chakroborty in 1991.

Turn Lane Warrant Analysis - Tee Intersections

Study Intersection: Burns Valley Rd/E-W Project St
 Study Scenario: F+P Weekday PM

Direction of Analysis Street: North/South

Cross Street Intersects: From the West

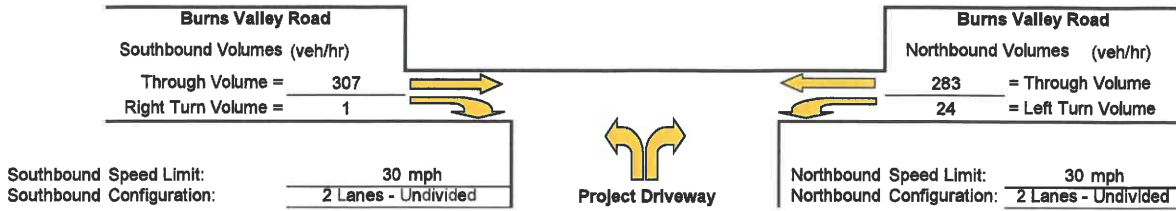

Southbound Right Turn Lane Warrants

1. Check for right turn volume criteria

Thresholds not met, continue to next step

2. Check advance volume threshold criteria for turn lane

Advancing Volume Threshold	AV =	1042.6
Advancing Volume	Va =	308
If $AV < Va$ then warrant is met		No

Right Turn Lane Warranted: NO

Southbound Right Turn Taper Warrants (evaluate if right turn lane is unwarranted)

1. Check taper volume criteria

NOT WARRANTED - Less than 20 vehicles

2. Check advance volume threshold criteria for taper

Advancing Volume Threshold	AV =	-
Advancing Volume	Va =	308
If $AV < Va$ then warrant is met		-

Right Turn Taper Warranted: NO

Northbound Left Turn Lane Warrants

Percentage Left Turns %lt	7.8 %
Advancing Volume Threshold AV	725 veh/hr
If $AV < Va$ then warrant is met	

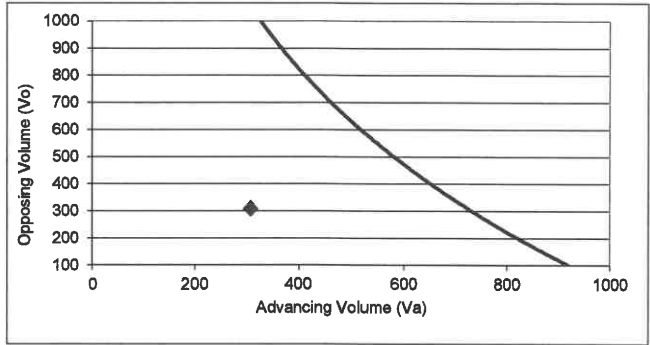

◆ Study Intersection
 Two lane roadway warrant threshold for: 30 mph
 Turn lane warranted if point falls to right of warrant threshold line

Left Turn Lane Warranted: NO

Methodology based on Washington State Transportation Center Research Report *Method For Prioritizing Intersection Improvements*, January 1997.
 The right turn lane and taper analysis is based on work conducted by Cottrell in 1981.
 The left turn lane analysis is based on work conducted by M.D. Harmelink in 1967, and modified by Kikuchi and Chakroborty in 1991.

Turn Lane Warrant Analysis - Tee Intersections

Study Intersection: Olympic Dr/N-S Project St
 Study Scenario: F+P Weekday AM

Direction of Analysis Street: East/West

Cross Street Intersects: From the North

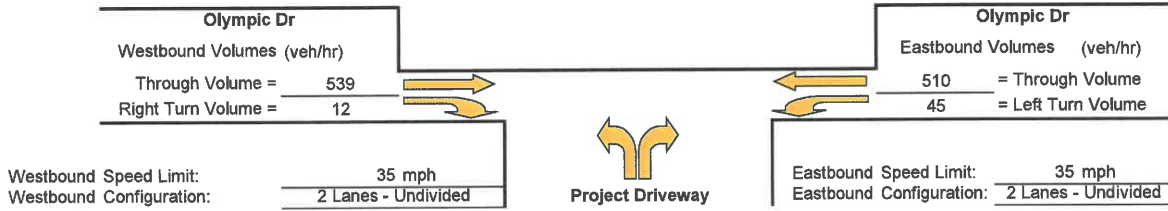

Westbound Right Turn Lane Warrants

1. Check for right turn volume criteria

Thresholds not met, continue to next step

2. Check advance volume threshold criteria for turn lane
 Advancing Volume Threshold AV = 960.1
 Advancing Volume Va = 551
 If $AV < Va$ then warrant is met No

Right Turn Lane Warranted: NO

Westbound Right Turn Taper Warrants (evaluate if right turn lane is unwarranted)

1. Check taper volume criteria

NOT WARRANTED - Less than 20 vehicles

2. Check advance volume threshold criteria for taper
 Advancing Volume Threshold AV = -
 Advancing Volume Va = 551
 If $AV < Va$ then warrant is met -

Right Turn Taper Warranted: NO

Eastbound Left Turn Lane Warrants

Percentage Left Turns %lt 8.1 %
 Advancing Volume Threshold AV 497 veh/hr
 If $AV < Va$ then warrant is met

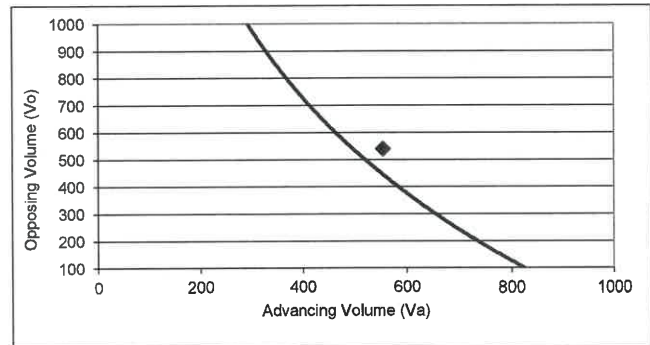

◆ Study Intersection
 — Two lane roadway warrant threshold for: 35 mph
 Turn lane warranted if point falls to right of warrant threshold line

Left Turn Lane Warranted: YES

Methodology based on Washington State Transportation Center Research Report *Method For Prioritizing Intersection Improvements*, January 1997.
 The right turn lane and taper analysis is based on work conducted by Cottrell in 1981.
 The left turn lane analysis is based on work conducted by M.D. Harmelink in 1967, and modified by Kikuchi and Chakroborty in 1991.

Turn Lane Warrant Analysis - Tee Intersections

Study Intersection: Burns Valley Rd/N-S Project St
 Study Scenario: Weekday PM F+P

Direction of Analysis Street: East/West

Cross Street Intersects: From the South



Eastbound Right Turn Lane Warrants

1. Check for right turn volume criteria

Thresholds not met, continue to next step

2. Check advance volume threshold criteria for turn lane

Advancing Volume Threshold	AV =	750
Advancing Volume	Va =	247
If $AV < Va$ then warrant is met		No

Right Turn Lane Warranted: NO

Eastbound Right Turn Taper Warrants (evaluate if right turn lane is unwarranted)

1. Check taper volume criteria

Thresholds not met, continue to next step

2. Check advance volume threshold criteria for taper

Advancing Volume Threshold	AV =	500
Advancing Volume	Va =	247
If $AV < Va$ then warrant is met		No

Right Turn Taper Warranted: NO

Westbound Left Turn Lane Warrants

Percentage Left Turns %t 3.3 %

Advancing Volume Threshold AV 1124 veh/hr

If $AV < Va$ then warrant is met

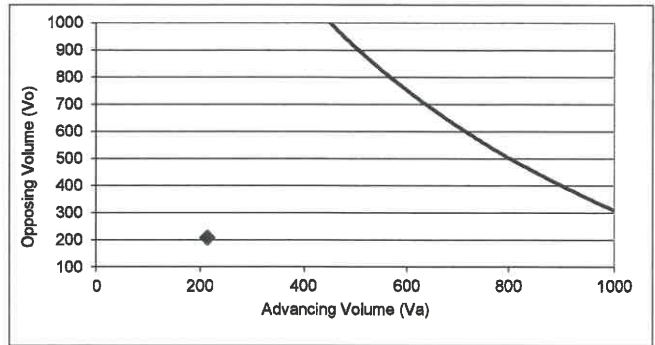

◆ Study Intersection
 Two lane roadway warrant threshold for: 35 mph
 Turn lane warranted if point falls to right of warrant threshold line

Left Turn Lane Warranted: NO

Methodology based on Washington State Transportation Center Research Report *Method For Prioritizing Intersection Improvements*, January 1997.
 The right turn lane and taper analysis is based on work conducted by Cottrell in 1981.
 The left turn lane analysis is based on work conducted by M.D. Harmelink in 1967, and modified by Kikuchi and Chakroborty in 1991.

Turn Lane Warrant Analysis - Tee Intersections

Study Intersection: Burns Valley Rd / Oak Valley Villas Northern Driveway
 Study Scenario: Weekday PM F+P

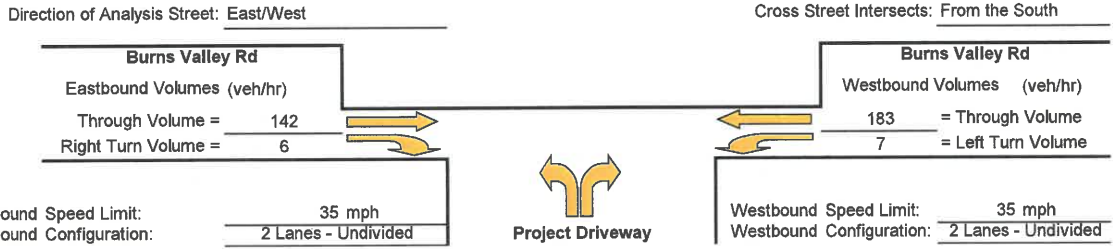

Eastbound Right Turn Lane Warrants

1. Check for right turn volume criteria

Thresholds not met, continue to next step

2. Check advance volume threshold criteria for turn lane

Advancing Volume Threshold	AV =	1005.1
Advancing Volume	Va =	148
If $AV < Va$ then warrant is met		
		No

Right Turn Lane Warranted: NO

Eastbound Right Turn Taper Warrants (evaluate if right turn lane is unwarranted)

1. Check taper volume criteria

NOT WARRANTED - Less than 20 vehicles

2. Check advance volume threshold criteria for taper

Advancing Volume Threshold	AV =	-
Advancing Volume	Va =	148
If $AV < Va$ then warrant is met		
		-

Right Turn Taper Warranted: NO

Westbound Left Turn Lane Warrants

Percentage Left Turns %lt	3.7 %
Advancing Volume Threshold AV	1155 veh/hr
If $AV < Va$ then warrant is met	

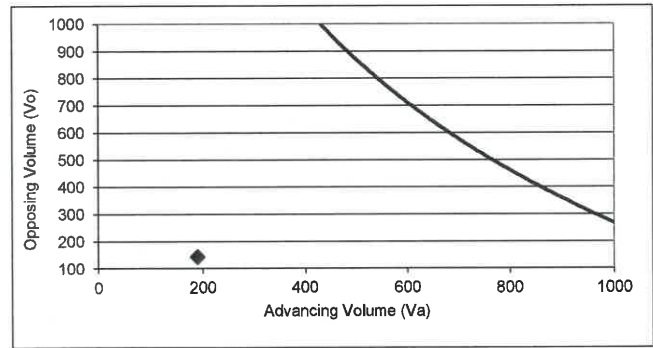

◆ Study Intersection
 — Two lane roadway warrant threshold for: 35 mph
 Turn lane warranted if point falls to right of warrant threshold line

Left Turn Lane Warranted: NO

Methodology based on Washington State Transportation Center Research Report *Method For Prioritizing Intersection Improvements*, January 1997.
 The right turn lane and taper analysis is based on work conducted by Cottrell in 1981.
 The left turn lane analysis is based on work conducted by M.D. Harmelink in 1967, and modified by Kikuchi and Chakroborty in 1991.

Turn Lane Warrant Analysis - Tee Intersections

Study Intersection: Burns Valley Rd/E-W Project St
 Study Scenario: F+P Weekday PM

Direction of Analysis Street: North/South

Cross Street Intersects: From the West

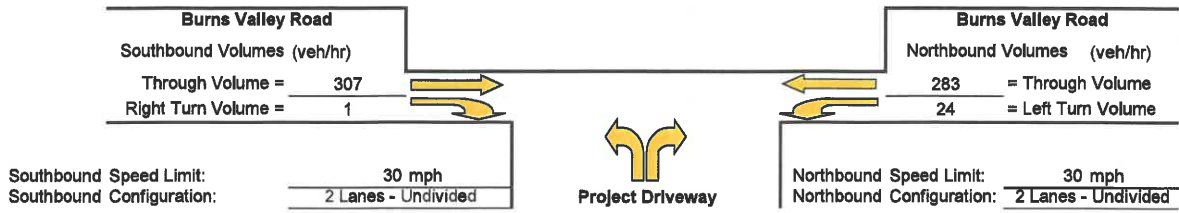

Southbound Right Turn Lane Warrants

1. Check for right turn volume criteria

Thresholds not met, continue to next step

2. Check advance volume threshold criteria for turn lane

Advancing Volume Threshold	AV =	1042.6
Advancing Volume	Va =	308
If AV < Va then warrant is met		No

Right Turn Lane Warranted: NO

Southbound Right Turn Taper Warrants
 (evaluate if right turn lane is unwarranted)

1. Check taper volume criteria

NOT WARRANTED - Less than 20 vehicles

2. Check advance volume threshold criteria for taper

Advancing Volume Threshold	AV =	-
Advancing Volume	Va =	308
If AV < Va then warrant is met		-

Right Turn Taper Warranted: NO

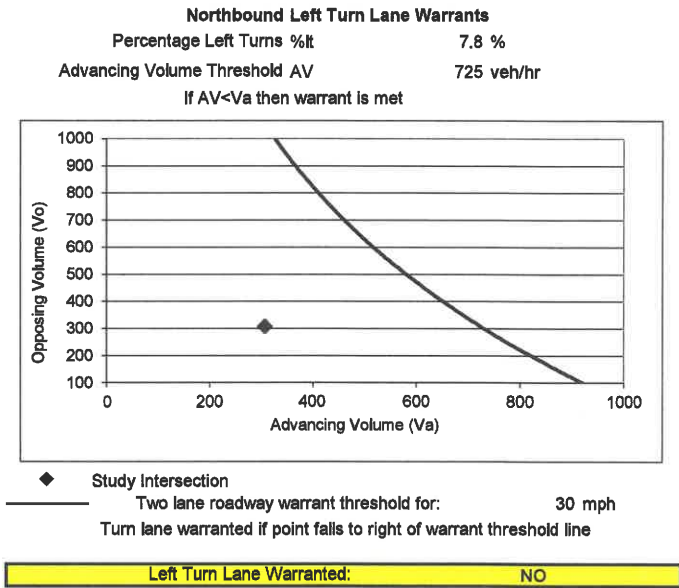

Methodology based on Washington State Transportation Center Research Report *Method For Prioritizing Intersection Improvements*, January 1997.
 The right turn lane and taper analysis is based on work conducted by Cottrell in 1981.
 The left turn lane analysis is based on work conducted by M.D. Harmelink in 1967, and modified by Kikuchi and Chakroborty in 1991.

Turn Lane Warrant Analysis - Tee Intersections

Study Intersection: Olympic Dr/N-S Project St
 Study Scenario: F+P Weekday PM

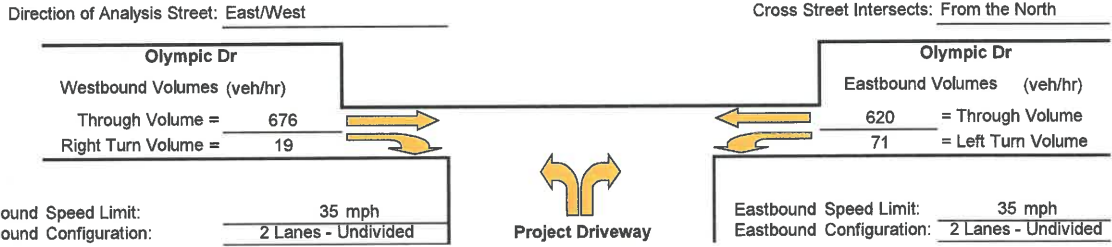

Westbound Right Turn Lane Warrants

1. Check for right turn volume criteria

Thresholds not met, continue to next step

2. Check advance volume threshold criteria for turn lane

Advancing Volume Threshold	AV =	907.6
Advancing Volume	Va =	695
If AV < Va then warrant is met		No

Right Turn Lane Warranted: NO

Westbound Right Turn Taper Warrants (evaluate if right turn lane is unwarranted)

1. Check taper volume criteria

NOT WARRANTED - Less than 20 vehicles

2. Check advance volume threshold criteria for taper

Advancing Volume Threshold	AV =	-
Advancing Volume	Va =	695
If AV < Va then warrant is met		-

Right Turn Taper Warranted: NO

Eastbound Left Turn Lane Warrants

Percentage Left Turns %lt	10.3 %
Advancing Volume Threshold AV	374 veh/hr
If AV < Va then warrant is met	

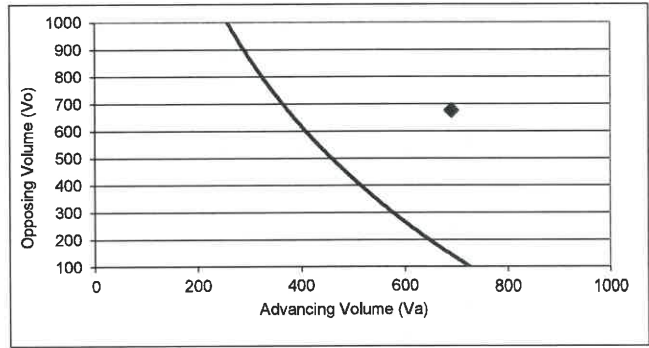

◆ Study Intersection
 — Two lane roadway warrant threshold for: 35 mph
 Turn lane warranted if point falls to right of warrant threshold line

Left Turn Lane Warranted: YES

Methodology based on Washington State Transportation Center Research Report *Method For Prioritizing Intersection Improvements*, January 1997.
 The right turn lane and taper analysis is based on work conducted by Cottrell in 1981.
 The left turn lane analysis is based on work conducted by M.D. Harmelink in 1967, and modified by Kikuchi and Chakroborty in 1991.

Turn Lane Warrant Analysis - Tee Intersections

Study Intersection: Burns Valley Rd/N-S Project St
 Study Scenario: Weekend PM F+P

Direction of Analysis Street: East/West

Cross Street Intersects: From the South

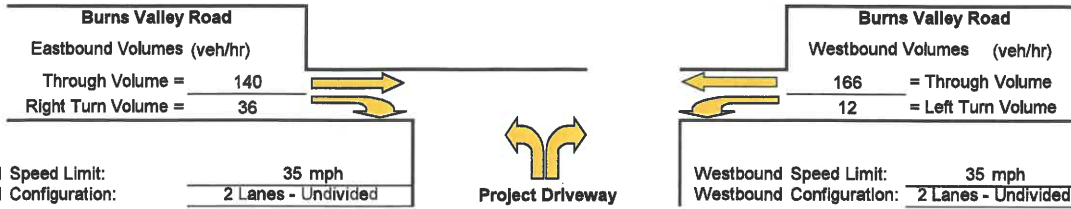

Eastbound Right Turn Lane Warrants

1. Check for right turn volume criteria

Thresholds not met, continue to next step

2. Check advance volume threshold criteria for turn lane

Advancing Volume Threshold	AV =	780
Advancing Volume	Va =	176
If AV < Va then warrant is met		No

Right Turn Lane Warranted: NO

Eastbound Right Turn Taper Warrants (evaluate if right turn lane is unwarranted)

1. Check taper volume criteria

Thresholds not met, continue to next step

2. Check advance volume threshold criteria for taper

Advancing Volume Threshold	AV =	540
Advancing Volume	Va =	176
If AV < Va then warrant is met		No

Right Turn Taper Warranted: NO

Westbound Left Turn Lane Warrants

Percentage Left Turns %lt	6.7 %
Advancing Volume Threshold AV	869 veh/hr
If AV < Va then warrant is met	

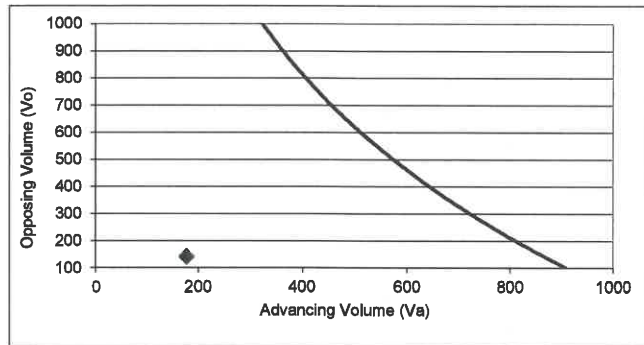

◆ Study Intersection
 Two lane roadway warrant threshold for: 35 mph
 Turn lane warranted if point falls to right of warrant threshold line

Left Turn Lane Warranted: NO

Methodology based on Washington State Transportation Center Research Report *Method For Prioritizing Intersection Improvements*, January 1997. The right turn lane and taper analysis is based on work conducted by Cottrell in 1981. The left turn lane analysis is based on work conducted by M.D. Harmelink in 1967, and modified by Kikuchi and Chakroborty in 1991.

Turn Lane Warrant Analysis - Tee Intersections

Study Intersection: Burns Valley Rd / Oak Valley Villas Northern Driveway
 Study Scenario: Weekend PM F+P

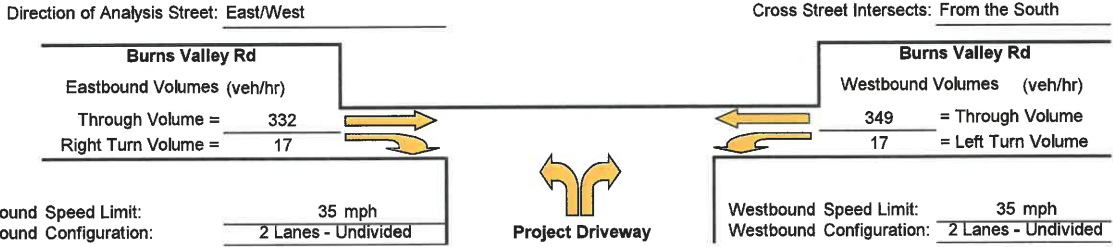

Eastbound Right Turn Lane Warrants

1. Check for right turn volume criteria

Thresholds not met, continue to next step

2. Check advance volume threshold criteria for turn lane

Advancing Volume Threshold	AV =	922.6
Advancing Volume	Va =	349
If AV < Va then warrant is met		No

Right Turn Lane Warranted: NO

Eastbound Right Turn Taper Warrants (evaluate if right turn lane is unwarranted)

1. Check taper volume criteria

NOT WARRANTED - Less than 20 vehicles

2. Check advance volume threshold criteria for taper

Advancing Volume Threshold	AV =	-
Advancing Volume	Va =	349
If AV < Va then warrant is met		-

Right Turn Taper Warranted: NO

Westbound Left Turn Lane Warrants

Percentage Left Turns %lt	4.6 %
Advancing Volume Threshold AV	839 veh/hr
If AV < Va then warrant is met	

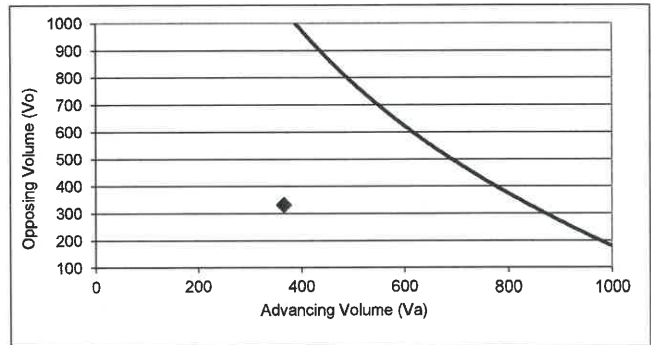

◆ Study Intersection
 Two lane roadway warrant threshold for: 35 mph
 Turn lane warranted if point falls to right of warrant threshold line

Left Turn Lane Warranted: NO

Methodology based on Washington State Transportation Center Research Report *Method For Prioritizing Intersection Improvements*, January 1997.
 The right turn lane and taper analysis is based on work conducted by Cottrell in 1981.
 The left turn lane analysis is based on work conducted by M.D. Harmelink in 1967, and modified by Kikuchi and Chakroborty in 1991.

Turn Lane Warrant Analysis - Tee Intersections

Study Intersection: Burns Valley Rd/E-W Project St
 Study Scenario: F+P Weekend PM

Direction of Analysis Street: North/South

Cross Street Intersects: From the West

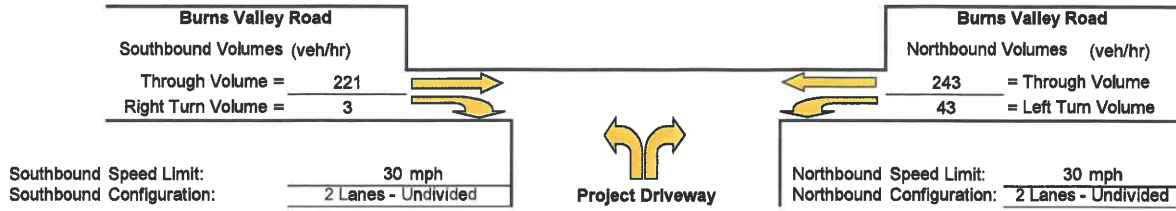

Southbound Right Turn Lane Warrants

1. Check for right turn volume criteria

Thresholds not met, continue to next step

2. Check advance volume threshold criteria for turn lane
- | | |
|----------------------------------|-------------|
| Advancing Volume Threshold | AV = 1027.6 |
| Advancing Volume | Va = 224 |
| If $AV < Va$ then warrant is met | No |

Right Turn Lane Warranted: NO

Southbound Right Turn Taper Warrants

(evaluate if right turn lane is unwarranted)

1. Check taper volume criteria

NOT WARRANTED - Less than 20 vehicles

2. Check advance volume threshold criteria for taper
- | | |
|----------------------------------|----------|
| Advancing Volume Threshold | AV = - |
| Advancing Volume | Va = 224 |
| If $AV < Va$ then warrant is met | - |

Right Turn Taper Warranted: NO

Northbound Left Turn Lane Warrants

Percentage Left Turns %t 15.0 %
 Advancing Volume Threshold AV 573 veh/hr
 If $AV < Va$ then warrant is met

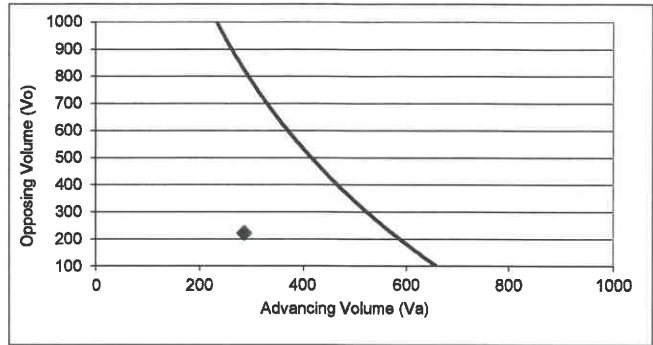

◆ Study Intersection
 Two lane roadway warrant threshold for: 30 mph
 Turn lane warranted if point falls to right of warrant threshold line

Left Turn Lane Warranted: NO

Methodology based on Washington State Transportation Center Research Report *Method For Prioritizing Intersection Improvements*, January 1997.
 The right turn lane and taper analysis is based on work conducted by Cottrell in 1981.
 The left turn lane analysis is based on work conducted by M.D. Harmelink in 1967, and modified by Kikuchi and Chakroborty in 1991.

Turn Lane Warrant Analysis - Tee Intersections

Study Intersection: Olympic Dr/N-S Project St
 Study Scenario: F+P Weekend PM

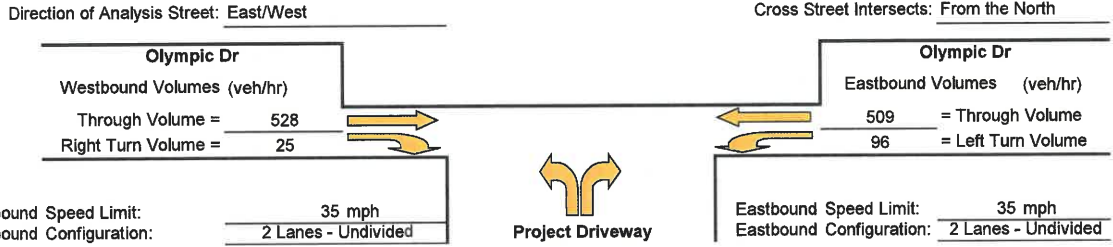

Westbound Right Turn Lane Warrants

1. Check for right turn volume criteria

Thresholds not met, continue to next step

2. Check advance volume threshold criteria for turn lane

Advancing Volume Threshold	AV =	862.6
Advancing Volume	Va =	553
If $AV < Va$ then warrant is met		No

Right Turn Lane Warranted: NO

Westbound Right Turn Taper Warrants
 (evaluate if right turn lane is unwarranted)

1. Check taper volume criteria

Thresholds not met, continue to next step

2. Check advance volume threshold criteria for taper

Advancing Volume Threshold	AV =	650
Advancing Volume	Va =	553
If $AV < Va$ then warrant is met		No

Right Turn Taper Warranted: NO

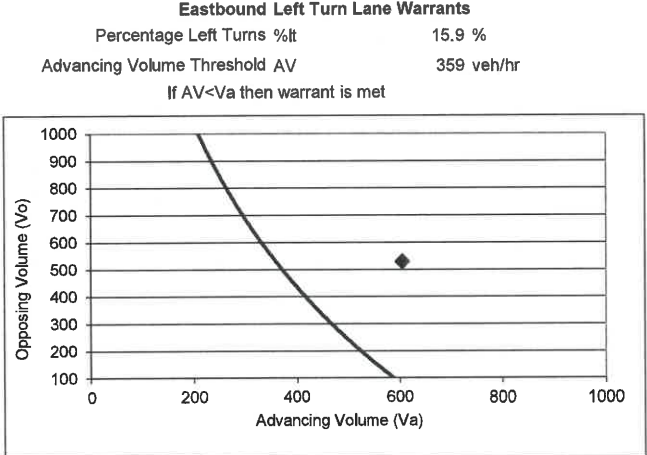

◆ Study Intersection

— Two lane roadway warrant threshold for: 35 mph

Turn lane warranted if point falls to right of warrant threshold line

Left Turn Lane Warranted: YES

Methodology based on Washington State Transportation Center Research Report *Method For Prioritizing Intersection Improvements*, January 1997.
 The right turn lane and taper analysis is based on work conducted by Cottrell in 1981.
 The left turn lane analysis is based on work conducted by M.D. Harmelink in 1967, and modified by Kikuchi and Chakroborty in 1991.

Appendix E

Maximum Left-Turn Queue Length Calculations



This page intentionally left blank

Maximum Queue Length Two-Way Stop-Controlled Intersections

Through Street: Olympic Dr Scenario: F+P Weekday AM
Side Street: North-South Project St Stop Controlled Legs: North/South

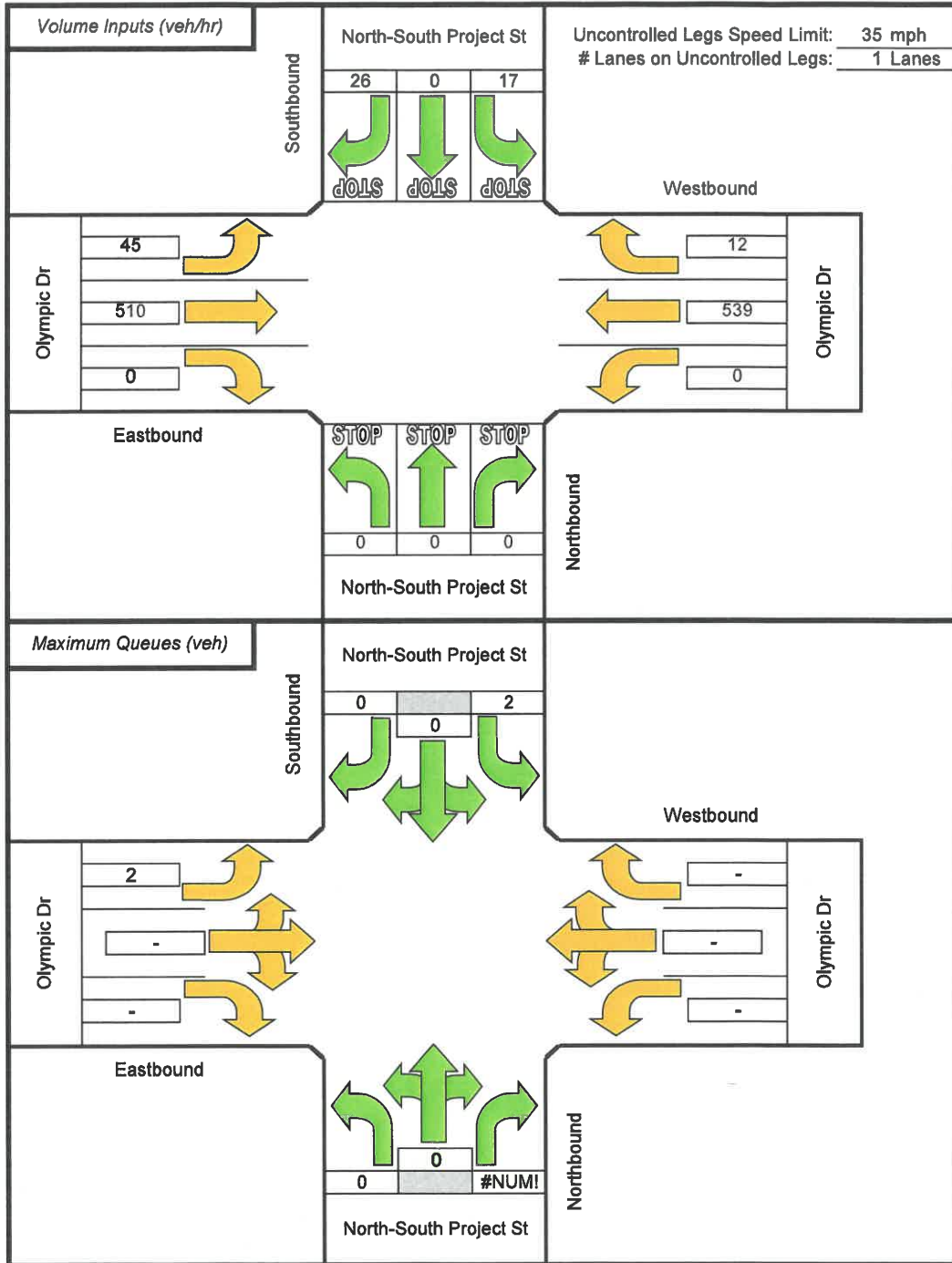

Source: John T. Gard, ITE Journal, November 2001, "Estimating Maximum Queue Length at Unsignalized Intersections"

Maximum Queue Length Two-Way Stop-Controlled Intersections

Through Street: Olympic Dr
Side Street: North-South Project St

Scenario: F+P Weekday PM
Stop Controlled Legs: North/South

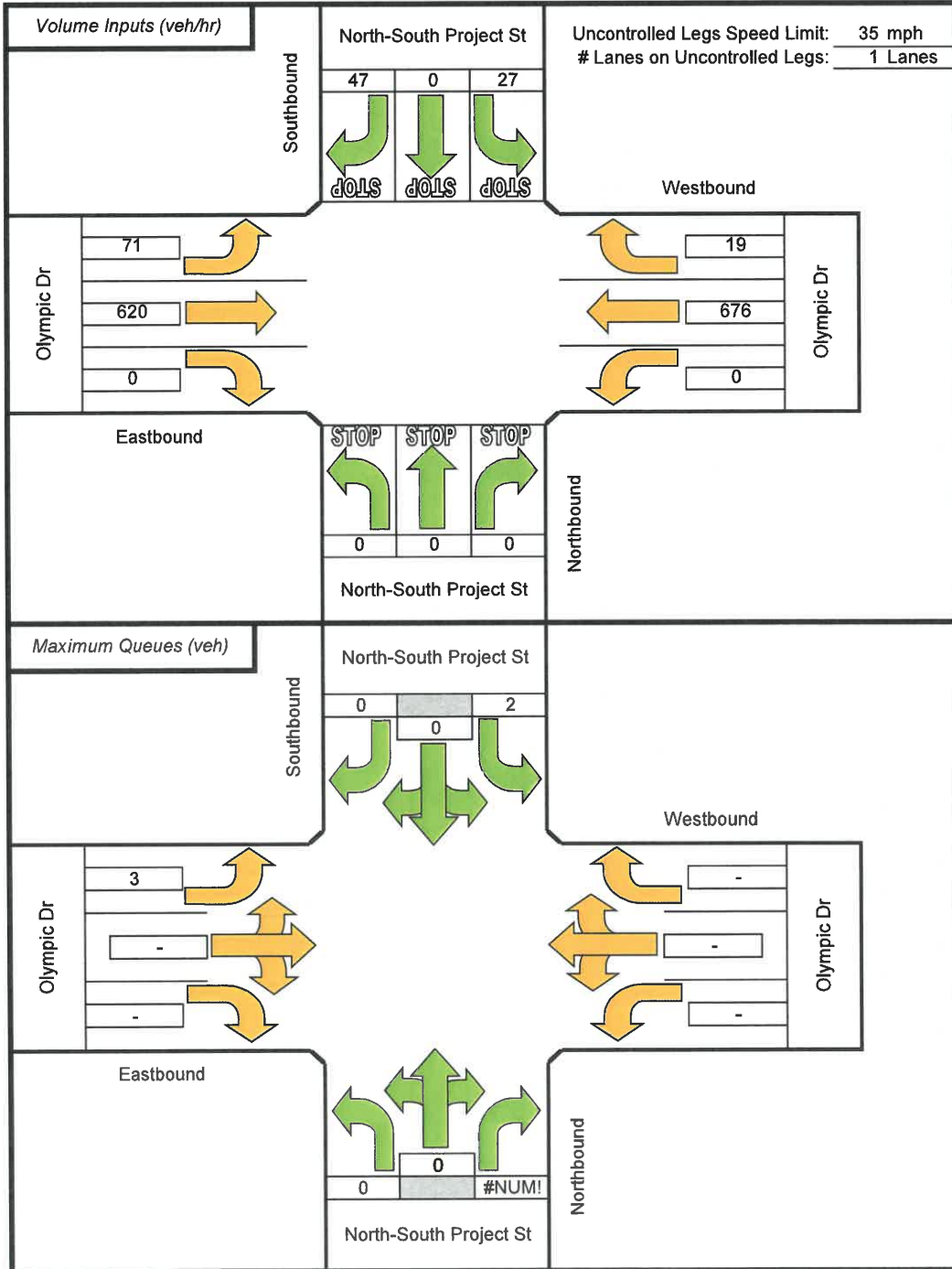

Source: John T. Gard, ITE Journal, November 2001, "Estimating Maximum Queue Length at Unsignalized Intersections"

Maximum Queue Length Two-Way Stop-Controlled Intersections

Through Street: Olympic Dr
Side Street: North-South Project St

Scenario: F+P Weekend PM
Stop Controlled Legs: North/South

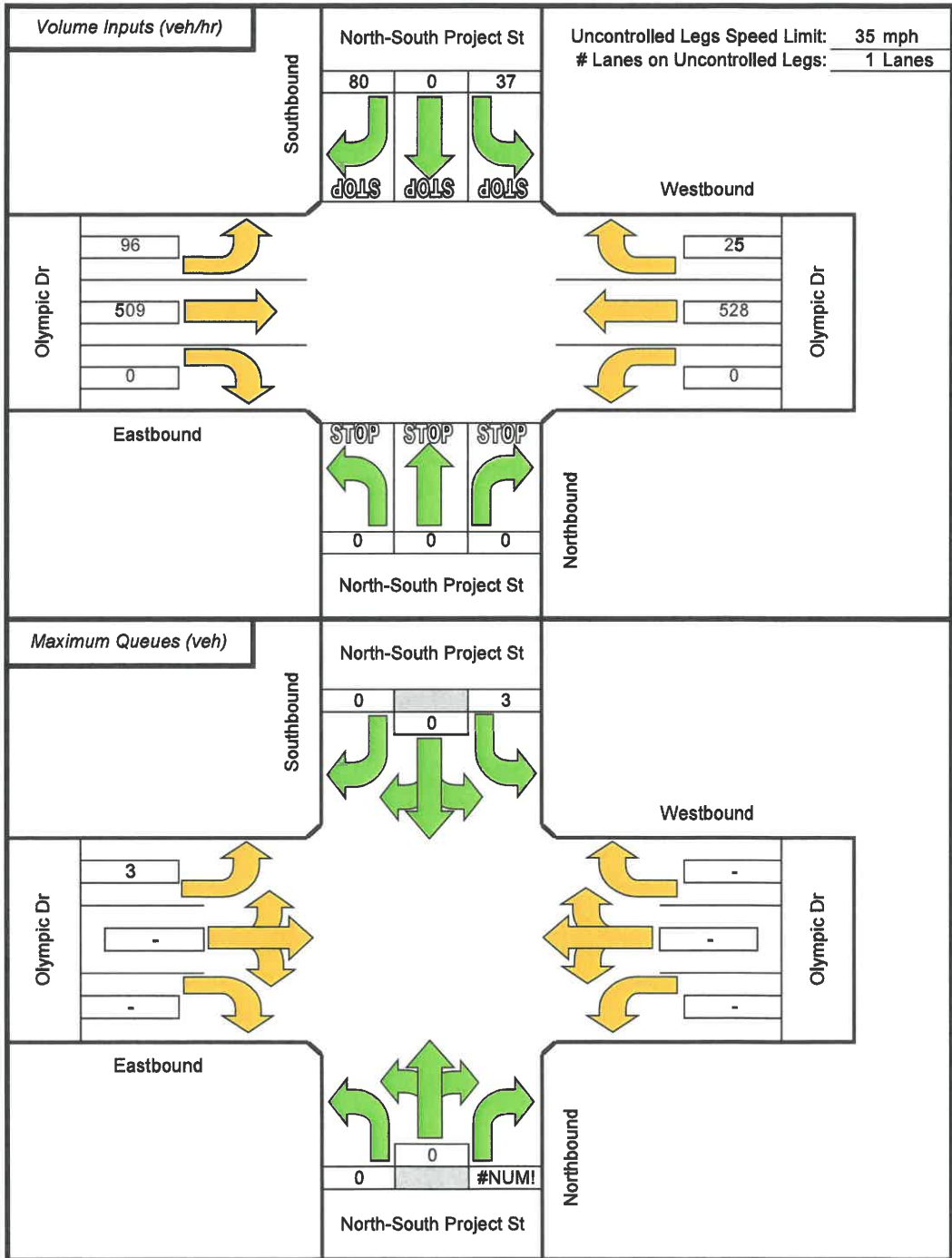

Source: John T. Gard, ITE Journal, November 2001, "Estimating Maximum Queue Length at Unsignalized Intersections"



This page intentionally left blank

Appendix F

Intersection Level of Service and Queuing Calculations



This page intentionally left blank

Intersection Level Of Service Report
Intersection 2: Burns Valley Rd/Bowers Ave-Runsey Rd

Control Type: Two-way stop Delay (sec / veh): 13.6
Analysis Method: HCM 6th Edition Level Of Service: B
Analysis Period: 15 minutes Volume to Capacity (v/c): 0.014

Intersection Setup

Name	Burns Valley Rd			Runsey Rd			Burns Valley Rd			Bowers Ave		
Approach	Northbound			Southbound			Eastbound			Westbound		
Lane Configuration	+			+			+			+		
Turning Movement	Left	Thru	Right	Left	Thru	Right	Left	Thru	Right	Left	Thru	Right
Lane Width [ft]	12.00	12.00	12.00	12.00	12.00	12.00	12.00	12.00	12.00	12.00	12.00	12.00
No. of Lanes in Entry Pocket	0	0	0	0	0	0	0	0	0	0	0	0
Entry Pocket Length [ft]	100.00	100.00	100.00	100.00	100.00	100.00	100.00	100.00	100.00	100.00	100.00	100.00
No. of Lanes in Exit Pocket	0	0	0	0	0	0	0	0	0	0	0	0
Exit Pocket Length [ft]	0.00	0.00	0.00	0.00	0.00	0.00	0.00	0.00	0.00	0.00	0.00	0.00
Speed [mph]	30.00			30.00			35.00			25.00		
Grade [%]	0.00			0.00			0.00			0.00		
Crosswalk	No			Yes			Yes			No		

Volumes

Name	Burns Valley Rd			Runsey Rd			Burns Valley Rd			Bowers Ave		
Base Volume Input [veh/h]	122	26	6	0	23	16	9	1	124	5	1	0
Base Volume Adjustment Factor	1.0000	1.0000	1.0000	1.0000	1.0000	1.0000	1.0000	1.0000	1.0000	1.0000	1.0000	1.0000
Heavy Vehicles Percentage [%]	2.00	2.00	2.00	2.00	2.00	2.00	2.00	2.00	2.00	2.00	2.00	2.00
Growth Factor	1.0000	1.0000	1.0000	1.0000	1.0000	1.0000	1.0000	1.0000	1.0000	1.0000	1.0000	1.0000
In-Process Volume [veh/h]	0	0	0	0	0	0	0	0	0	0	0	0
Site-Generated Trips [veh/h]	0	0	0	0	0	0	0	0	0	0	0	0
Diverted Trips [veh/h]	0	0	0	0	0	0	0	0	0	0	0	0
Pass-by Trips [veh/h]	0	0	0	0	0	0	0	0	0	0	0	0
Existing Site Adjustment Volume [veh/h]	0	0	0	0	0	0	0	0	0	0	0	0
Other Volume [veh/h]	0	0	0	0	0	0	0	0	0	0	0	0
Total Hourly Volume [veh/h]	122	26	6	0	23	16	9	1	124	5	1	0
Peak Hour Factor	0.8500	0.8500	0.8500	0.8500	0.8500	0.8500	0.8500	0.8500	0.8500	0.8500	0.8500	0.8500
Other Adjustment Factor	1.0000	1.0000	1.0000	1.0000	1.0000	1.0000	1.0000	1.0000	1.0000	1.0000	1.0000	1.0000
Total 15-Minute Volume [veh/h]	36	8	2	0	7	5	3	0	36	1	0	0
Total Analysis Volume [veh/h]	144	31	7	0	27	19	11	1	146	6	1	0
Pedestrian Volume [ped/h]	0	0	0	0	0	0	0	0	0	0	0	0



Intersection Settings

Priority Scheme	Free	Free	Stop	Stop
Flared Lane			No	No
Storage Area [veh]	0	0	0	0
Two-Stage Gap Acceptance			No	No
Number of Storage Spaces in Median	0	0	0	0

Movement, Approach, & Intersection Results

V/C, Movement V/C Ratio	0.09	0.30	0.00	0.00	0.00	0.00	0.02	0.00	0.14	0.01	0.00	0.00
d_M, Delay for Movement [s/veh]	7.54	0.30	0.00	7.29	0.00	0.00	12.24	12.75	9.20	13.62	12.22	0.00
Movement LOS	A	A	A	A	A	A	B	B	A	B	B	A
95th-Percentile Queue Length [veh/h]	0.30	0.30	0.30	0.00	0.00	0.00	0.58	0.58	0.58	0.05	0.05	0.05
95th-Percentile Queue Length [ft/h]	7.60	7.60	7.60	0.00	0.00	0.00	14.50	14.50	14.50	1.23	1.23	1.23
d_A, Approach Delay [s/veh]	5.96			0.00			9.43			13.42		
Approach LOS	A			A			A			B		
d_I, Intersection Delay [s/veh]	6.79											
Intersection LOS	B											



Intersection Level Of Service Report
Intersection 5: Olympic Dr/Lakeshore Dr

Control Type: Two-way stop
Analysis Method: HCM 6th Edition
Analysis Period: 15 minutes
Delay (sec / veh): 16.3
Level Of Service: C
Volume to Capacity (v/c): 0.147

Intersection Setup

Name	Lakeshore Dr			Lakeshore Dr			Eastbound			Olympic Dr		
Approach	Northbound			Southbound			Eastbound			Westbound		
Lane Configuration	[Diagram]			[Diagram]			[Diagram]			[Diagram]		
Turning Movement	Left	Thru	Right	Left	Thru	Right	Left	Thru	Right	Left	Thru	Right
Lane Width [ft]	12.00	12.00	12.00	12.00	12.00	12.00	12.00	12.00	12.00	12.00	12.00	12.00
No. of Lanes in Entry Pocket	0	0	1	0	0	0	0	0	0	0	0	1
Entry Pocket Length [ft]	100.00	100.00	120.00	100.00	100.00	100.00	100.00	100.00	100.00	100.00	100.00	250.00
No. of Lanes in Exit Pocket	0	0	0	0	0	0	0	0	0	0	0	0
Exit Pocket Length [ft]	0.00	0.00	0.00	0.00	0.00	0.00	0.00	0.00	0.00	0.00	0.00	0.00
Speed [mph]	25.00			25.00			30.00			30.00		
Grade [%]	0.00			0.00			0.00			0.00		
Crosswalk	No			Yes			No			Yes		

Volumes

Name	Lakeshore Dr			Lakeshore Dr			Eastbound			Olympic Dr		
Base Volume Input [veh/h]	1	137	66	81	279	2	0	0	1	47	1	60
Base Volume Adjustment Factor	1.0000	1.0000	1.0000	1.0000	1.0000	1.0000	1.0000	1.0000	1.0000	1.0000	1.0000	1.0000
Heavy Vehicles Percentage [%]	2.00	2.00	2.00	2.00	2.00	2.00	2.00	2.00	2.00	2.00	2.00	2.00
Growth Factor	1.0000	1.0000	1.0000	1.0000	1.0000	1.0000	1.0000	1.0000	1.0000	1.0000	1.0000	1.0000
In-Process Volume [veh/h]	0	0	0	0	0	0	0	0	0	0	0	0
Site-Generated Trips [veh/h]	0	0	0	0	0	0	0	0	0	0	0	0
Diverted Trips [veh/h]	0	0	0	0	0	0	0	0	0	0	0	0
Pass-by Trips [veh/h]	0	0	0	0	0	0	0	0	0	0	0	0
Existing Site Adjustment Volume [veh/h]	0	0	0	0	0	0	0	0	0	0	0	0
Other Volume [veh/h]	0	0	0	0	0	0	0	0	0	0	0	0
Total Hourly Volume [veh/h]	1	137	66	81	279	2	0	0	1	47	1	60
Peak Hour Factor	0.8600	0.8600	0.8600	0.8600	0.8600	0.8600	0.8600	0.8600	0.8600	0.8600	0.8600	0.8600
Other Adjustment Factor	1.0000	1.0000	1.0000	1.0000	1.0000	1.0000	1.0000	1.0000	1.0000	1.0000	1.0000	1.0000
Total 15-Minute Volume [veh/h]	0	40	19	18	81	1	0	0	0	14	0	17
Total Analysis Volume [veh/h]	1	159	77	71	324	2	0	0	1	55	1	70
Pedestrian Volume [ped/h]	0			0			0			1		



Intersection Settings

Priority Scheme	Free	Free	Stop	Stop
Flared Lane			No	No
Storage Area [veh]	0	0	0	0
Two-Stage Gap Acceptance			No	No
Number of Storage Spaces in Median	0	0	0	0

Movement, Approach, & Intersection Results

V/C, Movement V/C Ratio	0.00	0.00	0.00	0.05	0.00	0.00	0.00	0.00	0.00	0.15	0.00	0.08
d_M, Delay for Movement [s/veh]	7.92	0.79	0.00	7.86	0.03	0.00	10.70	15.71	10.03	16.29	15.05	9.44
Movement LOS	A	A	A	A	A	A	C	C	B	C	C	A
95th-Percentile Queue Length [veh/ln]	0.00	0.00	0.00	0.17	0.17	0.00	0.00	0.00	0.00	0.51	0.27	0.27
95th-Percentile Queue Length [ft/ln]	0.06	0.06	0.00	4.23	4.23	4.23	3.10	0.10	0.10	12.78	6.67	6.67
d_A, Approach Delay [s/veh]	0.03		1.41		10.03		12.47					
Approach LOS	A		A		B		B					
d_I, Intersection Delay [s/veh]	2.82											
Intersection LOS	C											



Intersection Level Of Service Report
Intersection 7: Olympic Dr/Burns Valley Rd-Old Hwy 53

Control Type: Signalized Delay (sec / veh): 11.2
 Analysis Method: HCM 6th Edition Level Of Service: B
 Analysis Period: 15 minutes Volume to Capacity (v/c): 0.655

Intersection Setup

Name	Old Hwy 53			Burns Valley Rd			Olympic Dr			Old Hwy 53		
	Northbound			Southbound			Eastbound			Westbound		
Approach	Northbound			Southbound			Eastbound			Westbound		
Lane Configuration	[Diagram]			[Diagram]			[Diagram]			[Diagram]		
Turning Movement	Left	Thru	Right	Left	Thru	Right	Left	Thru	Right	Left	Thru	Right
Lane Width [ft]	12.00	12.00	12.00	12.00	12.00	12.00	12.00	12.00	12.00	12.00	12.00	12.00
No. of Lanes in Entry Pocket	1	0	1	1	0	0	1	0	0	1	0	0
Entry Pocket Length [ft]	100.00	100.00	100.00	56.00	100.00	100.00	48.00	100.00	100.00	100.00	100.00	100.00
No. of Lanes in Exit Pocket	0	0	0	0	0	0	0	0	0	0	0	0
Exit Pocket Length [ft]	0.00	0.00	0.00	0.00	0.00	0.00	0.00	0.00	0.00	0.00	0.00	0.00
Speed [mph]	30.00			30.00			35.00			35.00		
Grade [%]	0.00			0.00			0.00			0.00		
Curb Present	No			No			No			No		
Crosswalk	Yes			Yes			Yes			Yes		

Volumes

Name	Old Hwy 53			Burns Valley Rd			Olympic Dr			Old Hwy 53		
Base Volume Input [veh/h]	42	62	45	75	70	15	26	131	51	48	150	99
Base Volume Adjustment Factor	1.0000	1.0000	1.0000	1.0000	1.0000	1.0000	1.0000	1.0000	1.0000	1.0000	1.0000	1.0000
Heavy Vehicles Percentage [%]	2.00	2.00	2.00	2.00	2.00	2.00	2.00	2.00	2.00	2.00	2.00	2.00
Growth Factor	1.0000	1.0000	1.0000	1.0000	1.0000	1.0000	1.0000	1.0000	1.0000	1.0000	1.0000	1.0000
In-Process Volume [veh/h]	0	0	0	0	0	0	0	0	0	0	0	0
Site-Generated Trips [veh/h]	0	0	0	0	0	0	0	0	0	0	0	0
Diverted Trips [veh/h]	0	0	0	0	0	0	0	0	0	0	0	0
Pass-by Trips [veh/h]	0	0	0	0	0	0	0	0	0	0	0	0
Existing Site Adjustment Volume [veh/h]	0	0	0	0	0	0	0	0	0	0	0	0
Other Volume [veh/h]	0	0	0	0	0	0	0	0	0	0	0	0
Right Turn on Red Volume [veh/h]	0	0	19	0	0	3	0	0	5	0	0	20
Total Hourly Volume [veh/h]	42	62	26	75	70	12	26	131	46	48	150	79
Peak Hour Factor	0.8900	0.8900	0.8900	0.8900	0.8900	0.8900	0.8900	0.8900	0.8900	0.8900	0.8900	0.8900
Other Adjustment Factor	1.0000	1.0000	1.0000	1.0000	1.0000	1.0000	1.0000	1.0000	1.0000	1.0000	1.0000	1.0000
Total 15-Minute Volume [veh/h]	12	17	7	21	20	3	7	37	13	13	42	22
Total Analysis Volume [veh/h]	47	70	29	84	79	13	29	147	52	54	169	89
Presence of On-Street Parking	No	No	No	No	No	No	No	No	No	No	No	No
On-Street Parking Maneuver Rate [h]	0	0	0	0	0	0	0	0	0	0	0	0
Local Bus Stopping Rate [h]	0	0	0	0	0	0	0	0	0	0	0	0
v_do, Outbound Pedestrian Volume crossing major street	1			0			1			1		
v_di, Inbound Pedestrian Volume crossing major street	1			1			0			1		
v_co, Outbound Pedestrian Volume crossing minor street	1			0			0			0		
v_ci, Inbound Pedestrian Volume crossing minor street	0			0			1			0		
v_ab, Corner Pedestrian Volume [ped/h]	0			0			0			0		
Bicycle Volume [bicycles/h]	0			0			0			1		



Intersection Settings

Located in CBD	Yes
Signal Coordination Group	-
Cycle Length [s]	109
Coordination Type	Time of Day Pattern Isolated
Actuation Type	Fully actuated
Offset [s]	0.0
Offset Reference	Lead Green - Beginning of First Green
Permissive Mode	SingleBand
Last time [s]	14.00

Phasing & Timing

Control Type	Protect	Permis	Permis	Protect	Permis	Permis	Protect	Permis	Permis	Protect	Permis	Permis
Signal Group	3	8	0	7	4	0	5	2	0	1	6	0
Auxiliary Signal Groups												
Lead / Lag	Lead	-	-	Lead	-	-	Lead	-	-	Lead	-	-
Minimum Green [s]	4	6	0	4	6	0	4	6	0	4	6	0
Maximum Green [s]	20	25	0	20	25	0	20	30	0	20	20	0
Amber [s]	3.0	3.3	0.0	3.0	3.3	0.0	3.0	3.6	0.0	3.0	3.6	0.0
All red [s]	0.0	0.3	0.0	0.0	0.3	0.0	0.0	0.3	0.0	0.0	0.3	0.0
Split [s]	23	29	0	23	29	0	23	34	0	23	34	0
Vehicle Extension [s]	0.0	0.0	0.0	0.0	0.0	0.0	0.0	0.0	0.0	0.0	0.0	0.0
Walk [s]	0	7	0	0	7	0	0	7	0	0	7	0
Pedestrian Clearance [s]	0	11	0	0	9	0	0	14	0	0	9	0
Delayed Vehicle Green [s]	0.0	0.0	0.0	0.0	0.0	0.0	0.0	0.0	0.0	0.0	0.0	0.0
Rest In Walk		No			No			No			No	
I1, Start-Up Lost Time [s]	2.0	2.0	0.0	2.0	2.0	0.0	2.0	2.0	0.0	2.0	2.0	0.0
I2, Clearance Lost Time [s]	1.0	1.6	0.0	1.0	1.6	0.0	1.0	1.9	0.0	1.0	1.9	0.0
Minimum Recall	No	No		No	No		No	No		No	No	
Maximum Recall	No	No		No	No		No	No		No	No	
Pedestrian Recall	No	No		No	No		No	No		No	No	
Detector Location [ft]	3.0	0.0	0.0	0.0	0.0	0.0	0.0	0.0	0.0	0.0	0.0	0.0
Detector Length [ft]	0.0	0.0	0.0	0.0	0.0	0.0	0.0	0.0	0.0	0.0	0.0	0.0
I, Upstream Filtering Factor	1.00	1.00	1.00	1.00	1.00	1.00	1.00	1.00	1.00	1.00	1.00	1.00

Exclusive Pedestrian Phase

Pedestrian Signal Group	0
Pedestrian Walk [s]	0
Pedestrian Clearance [s]	0

Lane Group Calculations

Lane Group	L	C	R	L	C	L	C	L	C
C, Cycle Length [s]	24	24	24	24	24	24	24	24	24
L, Total Lost Time per Cycle [s]	3.00	3.60	3.60	3.00	3.60	3.00	3.60	3.00	3.60
I1_p, Permitted Start-Up Lost Time [s]	0.00	0.30	0.00	0.00	0.00	0.00	0.00	0.00	0.00
I2, Clearance Lost Time [s]	1.00	1.60	1.60	1.00	1.60	1.00	1.60	1.00	1.60
g, Effective Green Time [s]	1	3	3	2	4	1	5	1	5
g / C, Green / Cycle	0.05	0.13	0.13	0.07	0.16	0.03	0.19	0.05	0.21
(v / s)_ Volume / Saturation Flow Rate	0.03	0.04	0.02	0.05	0.06	0.02	0.12	0.03	0.16
s, saturation flow rate [veh/h]	1603	1683	1419	1603	1641	1603	1608	1603	1573
c, Capacity [veh/h]	76	218	184	119	257	50	306	85	334
d1, Uniform Delay [s]	11.42	9.55	9.44	11.04	9.20	11.67	9.13	11.33	9.06
k, delay calibration	0.04	0.04	0.04	0.04	0.04	0.04	0.04	0.04	0.04
I, Upstream Filtering Factor	1.00	1.00	1.00	1.00	1.00	1.00	1.00	1.00	1.00
d2, Incremental Delay [s]	3.08	0.31	0.15	2.82	0.31	3.94	0.87	2.94	1.45
d3, Initial Queue Delay [s]	0.00	0.00	0.00	0.00	0.00	0.00	0.00	0.00	0.00
Rp, platoon ratio	1.00	1.00	1.00	1.00	1.00	1.00	1.00	1.00	1.00
PF, progression factor	1.00	1.00	1.00	1.00	1.00	1.00	1.00	1.00	1.00

Lane Group Results

X, volume / capacity	0.62	0.32	0.16	0.70	0.36	0.58	0.65	0.64	0.77
d, Delay for Lane Group [s/veh]	14.50	9.97	9.59	13.85	9.51	15.61	10.00	14.27	10.51
Lane Group LOS	B	A	A	B	A	B	A	B	B
Critical Lane Group	No	Yes	No	Yes	No	Yes	No	No	Yes
50th-Percentile Queue Length [veh/ln]	0.24	0.24	0.10	0.39	0.29	0.16	0.81	0.25	0.81
50th-Percentile Queue Length [ft/ln]	5.89	5.91	2.39	9.75	7.37	3.88	15.15	6.29	20.31
95th-Percentile Queue Length [veh/ln]	0.42	0.43	0.17	0.70	0.53	0.28	1.09	0.45	1.46
95th-Percentile Queue Length [ft/ln]	10.60	10.65	4.31	17.55	13.27	6.99	27.27	11.32	35.57



Movement, Approach, & Intersection Results

d_M, Delay for Movement [s/veh]	14.50	9.97	9.59	13.85	9.51	9.51	15.61	10.00	10.00	14.27	10.51	10.51
Movement LOS	B	A	A	B	A	A	B	A	A	B	B	B
d_A, Approach Delay [s/veh]	11.35		11.58		10.71		11.16					
Approach LOS	B		B		B		B					
d_I, Intersection Delay [s/veh]	11.16											
Intersection LOS	B											
Intersection V/C	0.655											

Other Modes

g_Walk,mi, Effective Walk Time [s]	11.0	11.0	11.0	11.0
M_corner, Corner Circulation Area [ft²/ped]	0.00	0.00	0.00	0.00
M_CW, Crosswalk Circulation Area [ft²/ped]	0.00	0.00	0.00	0.00
d_p, Pedestrian Delay [s]	3.60	3.60	3.60	3.60
I_p,int, Pedestrian LOS Score for Intersection	2.153	1.979	2.032	2.109
Crosswalk LOS	B	A	B	B
s_b, Saturation Flow Rate of the bicycle lane [bicycles/h]	2000	2000	2000	2000
c_b, Capacity of the bicycle lane [bicycles/h]	2098	2098	2487	2487
d_b, Bicycle Delay [s]	0.03	0.03	0.72	0.72
I_b,int, Bicycle LOS Score for Intersection	1.832	1.855	1.944	2.107
Bicycle LOS	A	A	A	B

Sequence

Ring 1	1	2	3	4	-	-	-	-	-	-	-	-	-	-
Ring 2	5	6	7	8	-	-	-	-	-	-	-	-	-	-
Ring 3	-	-	-	-	-	-	-	-	-	-	-	-	-	-
Ring 4	-	-	-	-	-	-	-	-	-	-	-	-	-	-

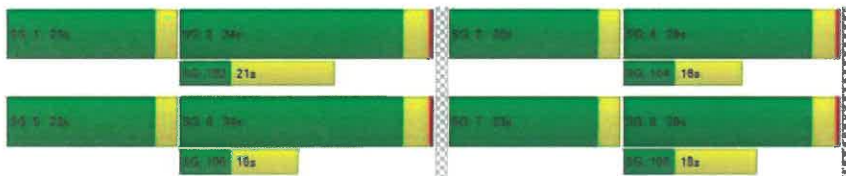

Intersection Level Of Service Report

Intersection 2: Burns Valley Rd/Bowers Ave-Runsey Rd

Control Type:	Two-way stop	Delay (sec / veh):	12.8
Analysis Method:	HCM 6th Edition	Level Of Service:	B
Analysis Period:	15 minutes	Volume to Capacity (v/c):	0.031

Intersection Setup

Name	Burns Valley Rd			Runsey Rd			Burns Valley Rd			Bowers Ave		
Approach	Northbound			Southbound			Eastbound			Westbound		
Lane Configuration	+			+			+			+		
Turning Movement	Left	Thru	Right	Left	Thru	Right	Left	Thru	Right	Left	Thru	Right
Lane Width [ft]	12.00	12.00	12.00	12.00	12.00	12.00	12.00	12.00	12.00	12.00	12.00	12.00
No. of Lanes in Entry Pocket	0	0	0	0	0	0	0	0	0	0	0	0
Entry Pocket Length [ft]	100.00	100.00	100.00	100.00	100.00	100.00	100.00	100.00	100.00	100.00	100.00	100.00
No. of Lanes in Exit Pocket	0	0	0	0	0	0	0	0	0	0	0	0
Exit Pocket Length [ft]	0.00	0.00	0.00	0.00	0.00	0.00	0.00	0.00	0.00	0.00	0.00	0.00
Speed [mph]	30.00			30.00			35.00			25.00		
Grade [%]	0.00			0.00			0.00			0.00		
Crosswalk	No			Yes			Yes			No		

Volumes

Name	Burns Valley Rd			Runsey Rd			Burns Valley Rd			Bowers Ave		
Base Volume Input [veh/h]	100	38	9	2	43	7	7	1	75	13	0	0
Base Volume Adjustment Factor	1.0000	1.0000	1.0000	1.0000	1.0000	1.0000	1.0000	1.0000	1.0000	1.0000	1.0000	1.0000
Heavy Vehicles Percentage [%]	2.00	2.00	2.00	2.00	2.00	2.00	2.00	2.00	2.00	2.00	2.00	2.00
Growth Factor	1.0000	1.0000	1.0000	1.0000	1.0000	1.0000	1.0000	1.0000	1.0000	1.0000	1.0000	1.0000
In-Process Volume [veh/h]	0	0	0	0	0	0	0	0	0	0	0	0
Site-Generated Trips [veh/h]	0	0	0	0	0	0	0	0	0	0	0	0
Diverted Trips [veh/h]	0	0	0	0	0	0	0	0	0	0	0	0
Pass-by Trips [veh/h]	0	0	0	0	0	0	0	0	0	0	0	0
Existing Site Adjustment Volume [veh/h]	0	0	0	0	0	0	0	0	0	0	0	0
Other Volume [veh/h]	0	0	0	0	0	0	0	0	0	0	0	0
Total Hourly Volume [veh/h]	100	38	9	2	43	7	7	1	75	13	0	0
Peak Hour Factor	0.8500	0.8500	0.8500	0.8500	0.8500	0.8500	0.8500	0.8500	0.8500	0.8500	0.8500	0.8500
Other Adjustment Factor	1.0000	1.0000	1.0000	1.0000	1.0000	1.0000	1.0000	1.0000	1.0000	1.0000	1.0000	1.0000
Total 15-Minute Volume [veh/h]	29	11	3	1	13	2	2	0	22	4	0	0
Total Analysis Volume [veh/h]	118	45	11	2	51	8	8	1	88	15	0	0
Pedestrian Volume [ped/h]	0			0			0			0		



Intersection Settings

Priority Scheme	Free	Free	Stop	Stop
Flared Lane			No	No
Storage Area [veh]	0	0	0	0
Two-Stage Gap Acceptance			No	No
Number of Storage Spaces in Median	0	0	0	0

Movement, Approach, & Intersection Results

V/C, Movement V/C Ratio	0.08	0.00	0.00	0.00	0.00	0.00	0.01	0.00	0.09	0.03	0.00	0.00
d_M, Delay for Movement [s/veh]	7.52	0.00	0.00	7.33	0.00	0.00	11.74	12.26	9.00	12.63	12.05	8.77
Movement LOS	A	A	A	A	A	A	B	B	A	B	B	A
95th-Percentile Queue Length [veh/h]	0.25	0.25	0.25	0.00	0.00	0.00	0.34	0.34	0.34	0.10	0.10	0.10
95th-Percentile Queue Length [ft/in]	6.19	6.19	6.19	0.10	0.10	0.10	8.57	8.57	8.57	2.38	2.38	2.38
d_A, Approach Delay [s/veh]	5.10			0.24			9.25			12.63		
Approach LOS	A			A			A			B		
d_I, Intersection Delay [s/veh]							5.73					
Intersection LOS	B											



Intersection Level Of Service Report
Intersection 5: Olympic Dr/Lakeshore Dr

Control Type:	Two-way stop	Delay (sec / veh):	16.8
Analysis Method:	HCM 6th Edition	Level Of Service:	C
Analysis Period:	15 minutes	Volume to Capacity (v/c):	0.273

Intersection Setup

Name	Lakeshore Dr			Lakeshore Dr			Olympic Dr					
Approach	Northbound			Southbound			Eastbound			Westbound		
Lane Configuration	←→			←→			←→			←→		
Turning Movement	Left	Thru	Right	Left	Thru	Right	Left	Thru	Right	Left	Thru	Right
Lane Width [ft]	12.00	12.00	12.00	12.00	12.00	12.00	12.00	12.00	12.00	12.00	12.00	12.00
No. of Lanes in Entry Pocket	0	0	1	0	0	0	0	0	0	0	0	1
Entry Pocket Length [ft]	100.00	100.00	120.00	100.00	100.00	100.00	100.00	100.00	100.00	100.00	100.00	250.00
No. of Lanes in Exit Pocket	0	0	0	0	0	0	0	0	0	0	0	0
Exit Pocket Length [ft]	0.00	0.00	0.00	0.00	0.00	0.00	0.00	0.00	0.00	0.00	0.00	0.00
Speed [mph]	25.00			25.00			30.00			30.00		
Grade [%]	0.00			0.00			0.00			0.00		
Crosswalk	No			Yes			No			Yes		

Volumes

Name	Lakeshore Dr			Lakeshore Dr			Olympic Dr					
Base Volume Input [veh/h]	1	198	114	66	180	1	0	2	2	106	3	141
Base Volume Adjustment Factor	1.0000	1.0000	1.0000	1.0000	1.0000	1.0000	1.0000	1.0000	1.0000	1.0000	1.0000	1.0000
Heavy Vehicles Percentage [%]	2.00	2.00	2.00	2.00	2.00	2.00	2.00	2.00	2.00	2.00	2.00	2.00
Growth Factor	1.0000	1.0000	1.0000	1.0000	1.0000	1.0000	1.0000	1.0000	1.0000	1.0000	1.0000	1.0000
In-Process Volume [veh/h]	0	0	0	0	0	0	0	0	0	0	0	0
Site-Generated Trips [veh/h]	0	0	0	0	0	0	0	0	0	0	0	0
Diverted Trips [veh/h]	0	0	0	0	0	0	0	0	0	0	0	0
Pass-by Trips [veh/h]	0	0	0	0	0	0	0	0	0	0	0	0
Existing Site Adjustment Volume [veh/h]	0	0	0	0	0	0	0	0	0	0	0	0
Other Volume [veh/h]	0	0	0	0	0	0	0	0	0	0	0	0
Total Hourly Volume [veh/h]	1	198	114	66	180	1	0	2	2	106	3	141
Peak Hour Factor	0.9300	0.9300	0.9300	0.9300	0.9300	0.9300	0.9300	0.9300	0.9300	0.9300	0.9300	0.9300
Other Adjustment Factor	1.0000	1.0000	1.0000	1.0000	1.0000	1.0000	1.0000	1.0000	1.0000	1.0000	1.0000	1.0000
Total 15-Minute Volume [veh/h]	0	53	31	18	48	0	0	1	1	28	1	38
Total Analysis Volume [veh/h]	1	213	123	71	194	1	0	2	2	114	3	152
Pedestrian Volume [ped/h]	0				0			0				1



Intersection Settings

Priority Scheme	Free	Free	Stop	Stop
Flared Lane			No	No
Storage Area [veh]	0	0	0	0
Two-Stage Gap Acceptance			No	No
Number of Storage Spaces in Median	0	0	0	0

Movement, Approach, & Intersection Results

V/C, Movement V/C Ratio	0.00	0.00	0.00	0.06	0.00	0.00	0.00	0.01	0.00	0.27	0.01	0.18
d_M, Delay for Movement [s/veh]	7.61	0.00	0.00	8.13	0.00	0.00	18.07	15.34	9.31	16.84	14.80	10.41
Movement LOS	A	A	A	A	A	C	C	A	C	B	B	B
95th-Percentile Queue Length [veh/ln]	0.00	0.00	0.00	0.18	0.18	0.18	0.02	0.02	1.10	0.70	0.70	0.70
95th-Percentile Queue Length [ft/ln]	0.05	0.05	0.00	4.62	4.62	4.62	0.81	0.81	27.41	17.61	17.61	17.61
d_A, Approach Delay [s/veh]	0.02			2.17			12.32			13.19		
Approach LOS	A			A			B			B		
d_I, Intersection Delay [s/veh]	4.77											
Intersection LOS	C											



Intersection Level Of Service Report

Intersection 7: Olympic Dr/Burns Valley Rd-Old Hwy 53

Control Type:	Signalized	Delay (sec / veh):	13.3
Analysis Method:	HCM 6th Edition	Level Of Service:	B
Analysis Period:	15 minutes	Volume to Capacity (v/c):	0.759

Intersection Setup

Name	Old Hwy 53			Burns Valley Rd			Olympic Dr			Old Hwy 53		
Approach	Northbound			Southbound			Eastbound			Westbound		
Lane Configuration	T T T			T T			T T			T T		
Turning Movement	Left	Thru	Right	Left	Thru	Right	Left	Thru	Right	Left	Thru	Right
Lane Width [ft]	12.00	12.00	12.00	12.00	12.00	12.00	12.00	12.00	12.00	12.00	12.00	12.00
No. of Lanes in Entry Pocket	1	0	1	1	0	0	1	0	0	1	0	0
Entry Pocket Length [ft]	100.00	100.00	100.00	58.00	100.00	100.00	48.00	100.00	100.00	100.00	100.00	100.00
No. of Lanes in Exit Pocket	0	0	0	0	0	0	0	0	0	0	0	0
Exit Pocket Length [ft]	0.00	0.00	0.00	0.00	0.00	0.00	0.00	0.00	0.00	0.00	0.00	0.00
Speed [mph]	30.00			30.00			35.00			35.00		
Grade [%]	0.00			0.00			0.00			0.00		
Curb Present	No			No			No			No		
Crosswalk	Yes			Yes			Yes			Yes		



Volumes

Name	Old Hwy 53			Burns Valley Rd			Olympic Dr			Old Hwy 53		
Base Volume Input [veh/h]	98	113	56	112	97	46	21	184	93	62	221	139
Base Volume Adjustment Factor	1.0000	1.0000	1.0000	1.0000	1.0000	1.0000	1.0000	1.0000	1.0000	1.0000	1.0000	1.0000
Heavy Vehicles Percentage [%]	2.00	2.00	2.00	2.00	2.00	2.00	2.00	2.00	2.00	2.00	2.00	2.00
Growth Factor	1.0000	1.0000	1.0000	1.0000	1.0000	1.0000	1.0000	1.0000	1.0000	1.0000	1.0000	1.0000
In-Process Volume [veh/h]	0	0	0	0	0	0	0	0	0	0	0	0
Site-Generated Trips [veh/h]	0	0	0	0	0	0	0	0	0	0	0	0
Diverted Trips [veh/h]	0	0	0	0	0	0	0	0	0	0	0	0
Pass-by Trips [veh/h]	0	0	0	0	0	0	0	0	0	0	0	0
Existing Site Adjustment Volume [veh/h]	0	0	0	0	0	0	0	0	0	0	0	0
Other Volume [veh/h]	0	0	0	0	0	0	0	0	0	0	0	0
Right Turn on Red Volume [veh/h]	0	0	18	0	0	11	0	0	14	0	0	25
Total Hourly Volume [veh/h]	98	113	38	112	97	35	21	184	79	62	221	114
Peak Hour Factor	0.9200	0.9200	0.9200	0.9200	0.9200	0.9200	0.9200	0.9200	0.9200	0.9200	0.9200	0.9200
Other Adjustment Factor	1.0000	1.0000	1.0000	1.0000	1.0000	1.0000	1.0000	1.0000	1.0000	1.0000	1.0000	1.0000
Total 15-Minute Volume [veh/h]	27	31	10	30	26	10	6	50	21	17	60	31
Total Analysis Volume [veh/h]	107	123	41	122	105	38	23	200	86	67	240	124
Presence of On-Street Parking	No	No	No	No	No	No	No	No	No	No	No	No
On-Street Parking Maneuver Rate [h]	0	0	0	0	0	0	0	0	0	0	0	0
Local Bus Stopping Rate [h]	0	0	0	0	0	0	0	0	0	0	0	0
v_do, Outbound Pedestrian Volume crossing major street	1			0			1			1		
v_di, Inbound Pedestrian Volume crossing major street	1			1			0			1		
v_co, Outbound Pedestrian Volume crossing minor street	1			0			0			0		
v_ci, Inbound Pedestrian Volume crossing minor street	0			0			1			0		
v_ab, Corner Pedestrian Volume [ped/h]	0			0			0			0		
Bicycle Volume [bicycles/h]	0			0			0			1		

Intersection Settings

Located in CBD	Yes
Signal Coordination Group	-
Cycle Length [s]	109
Coordination Type	Time of Day Pattern Isolated
Actuation Type	Fully actuated
Offset [s]	0.0
Offset Reference	Lead Green - Beginning of First Green
Permissive Mode	SingleBand
Lost time [s]	14.00

Phasing & Timing

Control Type	Protect	Permis	Permis	Protect	Permis	Permis	Protect	Permis	Permis	Protect	Permis	Permis
Signal Group	3	8	0	7	4	0	5	2	0	1	6	0
Auxiliary Signal Groups												
Lead / Lag	Lead	-	-	Lead	-	-	Lead	-	-	Lead	-	-
Minimum Green [s]	4	6	0	4	6	0	4	6	0	4	6	0
Maximum Green [s]	20	25	0	20	25	0	20	30	0	20	20	0
Amber [s]	3.0	3.3	0.0	3.0	3.3	0.0	3.0	3.6	0.0	3.0	3.6	0.0
All red [s]	0.0	0.3	0.0	0.0	0.3	0.0	0.0	0.3	0.0	0.0	0.3	0.0
Split [s]	23	29	0	23	29	0	23	34	0	23	34	0
Vehicle Extension [s]	0.0	0.0	0.0	0.0	0.0	0.0	0.0	0.0	0.0	0.0	0.0	0.0
Walk [s]	7	7	0	7	7	0	7	7	0	7	7	0
Pedestrian Clearance [s]	0	11	0	0	9	0	0	14	0	0	9	0
Delayed Vehicle Green [s]	0.0	0.0	0.0	0.0	0.0	0.0	0.0	0.0	0.0	0.0	0.0	0.0
Rest In Walk	No	No	No	No	No	No	No	No	No	No	No	No
I1, Start-Up Lost Time [s]	2.0	2.0	0.0	2.0	2.0	0.0	2.0	2.0	0.0	2.0	2.0	0.0
I2, Clearance Lost Time [s]	1.0	1.6	0.0	1.0	1.6	0.0	1.0	1.9	0.0	1.0	1.9	0.0
Minimum Recall	No	No	No	No	No	No	No	No	No	No	No	No
Maximum Recall	No	No	No	No	No	No	No	No	No	No	No	No
Pedestrian Recall	No	No	No	No	No	No	No	No	No	No	No	No
Detector Location [ft]	0.0	0.0	0.0	0.0	0.0	0.0	0.0	0.0	0.0	0.0	0.0	0.0
Detector Length [ft]	0.0	0.0	0.0	0.0	0.0	0.0	0.0	0.0	0.0	0.0	0.0	0.0
I, Upstream Filtering Factor	1.00	1.00	1.00	1.00	1.00	1.00	1.00	1.00	1.00	1.00	1.00	1.00

Exclusive Pedestrian Phase

Pedestrian Signal Group	0
Pedestrian Walk [s]	0
Pedestrian Clearance [s]	0



Lane Group Calculations

Lane Group	L	C	R	L	C	L	C	L	C
C, Cycle Length [s]	30	30	30	30	30	30	30	30	30
L, Total Lost Time per Cycle [s]	3.00	3.60	3.60	3.00	3.60	3.00	3.90	3.00	3.90
l1_p, Permitted Start-Up Lost Time [s]	0.00	0.00	0.00	0.00	0.00	0.00	0.00	0.00	0.00
l2, Clearance Lost Time [s]	1.00	1.60	1.60	1.00	1.60	1.00	1.90	1.00	1.90
g_l, Effective Green Time [s]	2	5	5	3	5	1	7	2	8
g / C, Green / Cycle	0.08	0.16	0.16	0.09	0.17	0.02	0.24	0.06	0.27
(v / s)_j Volume / Saturation Flow Rate	0.07	0.07	0.03	0.08	0.09	0.01	0.18	0.04	0.23
s, saturation flow rate [veh/h]	1603	1683	1421	1603	1606	1603	1597	1603	1575
c, Capacity [veh/h]	129	261	221	149	269	38	386	94	435
d1, Uniform Delay [s]	13.52	11.50	10.97	13.30	11.37	14.44	10.46	13.82	10.18
k, delay calibration	0.04	0.04	0.04	0.04	0.04	0.04	0.04	0.04	0.04
l, Upstream Filtering Factor	1.00	1.00	1.00	1.00	1.00	1.00	1.00	1.00	1.00
d2, Incremental Delay [s]	5.00	0.49	0.15	4.18	0.61	5.45	1.06	3.77	1.67
d3, Initial Queue Delay [s]	0.00	0.00	0.00	0.00	0.00	0.00	0.00	0.00	0.00
Rp, platoon ratio	1.00	1.00	1.00	1.00	1.00	1.00	1.00	1.00	1.00
PF, progression factor	1.00	1.00	1.00	1.00	1.00	1.00	1.00	1.00	1.00

Lane Group Results

X, volume / capacity	0.83	0.47	0.19	0.82	0.53	0.80	0.74	0.72	0.84
d, Delay for Lane Group [s/veh]	18.53	11.99	11.12	17.49	11.97	19.89	11.52	17.59	11.85
Lane Group LOS	B	B	B	B	B	B	B	B	B
Critical Lane Group	Yes	No	No	No	Yes	Yes	No	No	Yes
50th-Percentile Queue Length [veh/ln]	0.72	0.58	0.18	0.78	0.67	0.17	1.21	0.42	1.56
50th-Percentile Queue Length [ft/ln]	17.99	14.46	4.54	19.54	16.80	4.34	30.33	10.60	39.05
95th-Percentile Queue Length [veh/ln]	1.30	1.04	0.33	1.41	1.21	0.31	2.18	0.76	2.81
95th-Percentile Queue Length [ft/ln]	32.39	26.02	8.16	35.17	30.24	7.81	54.60	19.08	70.29



Movement, Approach, & Intersection Results

d_M, Delay for Movement [s/veh]	18.53	11.99	11.12	17.49	11.97	11.97	19.89	11.52	11.52	17.59	11.85	11.85
Movement LOS	B	B	B	B	B	B	B	B	B	B	B	B
d_A, Approach Delay [s/veh]	14.44			14.51			12.14			12.74		
Approach LOS	B			B			B			B		
d_I, Intersection Delay [s/veh]	13.33											
Intersection LOS	B											
Intersection V/C	0.759											

Other Modes

g_Walk,mi, Effective Walk Time [s]	11.0	11.0	11.0	11.0
M_corner, Corner Circulation Area [ft ² /ped]	0.00	0.00	0.00	0.00
M_CW, Crosswalk Circulation Area [ft ² /ped]	0.00	0.00	0.00	0.00
d_p, Pedestrian Delay [s]	5.89	5.89	5.89	5.89
L_p,int, Pedestrian LOS Score for Intersection	2.222	2.070	2.161	2.222
Crosswalk LOS	B	B	B	B
s_b, Saturation Flow Rate of the bicycle lane [bicycles/h]	2000	2000	2000	2000
c_b, Capacity of the bicycle lane [bicycles/h]	1710	1710	2026	2026
d_b, Bicycle Delay [s]	0.31	0.31	0.00	0.00
L_b,int, Bicycle LOS Score for Intersection	2.036	2.015	2.093	2.312
Bicycle LOS	B	B	B	B

Sequence

Ring 1	1	2	3	4	-	-	-	-	-	-	-	-	-	-	-	-
Ring 2	5	6	7	8	-	-	-	-	-	-	-	-	-	-	-	-
Ring 3	-	-	-	-	-	-	-	-	-	-	-	-	-	-	-	-
Ring 4	-	-	-	-	-	-	-	-	-	-	-	-	-	-	-	-

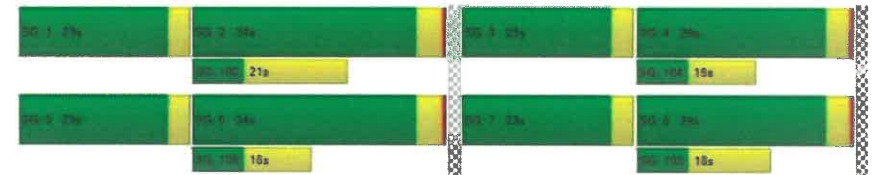

Intersection Level Of Service Report

Intersection 2: Burns Valley Rd/Bowers Ave-Rumsey Rd

Control Type: Two-way stop
Analysis Method: HCM 6th Edition
Analysis Period: 15 minutes
Delay (sec / veh): 11.7
Level Of Service: B
Volume to Capacity (v/c): 0.004

Intersection Setup

Name	Burns Valley Rd			Rumsey Rd			Burns Valley Rd			Bowers Ave		
Approach	Northbound			Southbound			Eastbound			Westbound		
Lane Configuration	+			+			+			+		
Turning Movement	Left	Thru	Right	Left	Thru	Right	Left	Thru	Right	Left	Thru	Right
Lane Width [ft]	12.00	12.00	12.00	12.00	12.00	12.00	12.00	12.00	12.00	12.00	12.00	12.00
No. of Lanes in Entry Pocket	0	0	0	0	0	0	0	0	0	0	0	0
Entry Pocket Length [ft]	100.00	100.00	100.00	100.00	100.00	100.00	100.00	100.00	100.00	100.00	100.00	100.00
No. of Lanes in Exit Pocket	0	0	0	0	0	0	0	0	0	0	0	0
Exit Pocket Length [ft]	0.00	0.00	0.00	0.00	0.00	0.00	0.00	0.00	0.00	0.00	0.00	0.00
Speed [mph]	30.00			30.00			35.00			25.00		
Grade [%]	0.00			0.00			0.00			0.00		
Crosswalk	No			Yes			Yes			No		

Volumes

Name	Burns Valley Rd			Rumsey Rd			Burns Valley Rd			Bowers Ave		
Base Volume Input [veh/h]	84	36	1	0	31	9	10	0	83	2	1	0
Base Volume Adjustment Factor	1.0000	1.0000	1.0000	1.0000	1.0000	1.0000	1.0000	1.0000	1.0000	1.0000	1.0000	1.0000
Heavy Vehicles Percentage [%]	2.00	2.00	2.00	2.00	2.00	2.00	2.00	2.00	2.00	2.00	2.00	2.00
Growth Factor	1.0000	1.0000	1.0000	1.0000	1.0000	1.0000	1.0000	1.0000	1.0000	1.0000	1.0000	1.0000
In-Process Volume [veh/h]	0	0	0	0	0	0	0	0	0	0	0	0
Site-Generated Trips [veh/h]	0	0	0	0	0	0	0	0	0	0	0	0
Diverted Trips [veh/h]	0	0	0	0	0	0	0	0	0	0	0	0
Pass-by Trips [veh/h]	0	0	0	0	0	0	0	0	0	0	0	0
Existing Site Adjustment Volume [veh/h]	0	0	0	0	0	0	0	0	0	0	0	0
Other Volume [veh/h]	0	0	0	0	0	0	0	0	0	0	0	0
Total Hourly Volume [veh/h]	84	36	1	0	31	9	10	0	83	2	1	0
Peak Hour Factor	0.8500	0.9600	0.9600	0.9600	0.9800	0.8500	0.8500	0.8500	0.8500	0.9600	0.8500	0.9600
Other Adjustment Factor	1.0000	1.0000	1.0000	1.0000	1.0000	1.0000	1.0000	1.0000	1.0000	1.0000	1.0000	1.0000
Total 15-Minute Volume [veh/h]	25	9	0	0	8	3	3	0	24	1	0	0
Total Analysis Volume [veh/h]	99	38	1	0	32	11	12	0	98	2	1	0
Pedestrian Volume [ped/h]	0			0			0			0		



Intersection Settings

Priority Scheme	Free	Free	Stop	Stop
Flared Lane			No	No
Storage Area [veh]	0	0	0	0
Two-Stage Gap Acceptance			No	No
Number of Storage Spaces in Median	0	0	0	0

Movement, Approach, & Intersection Results

V/C, Movement V/C Ratio	0.06	0.00	0.00	0.00	0.00	0.00	0.02	0.00	0.09	0.00	0.00	0.00
d_M, Delay for Movement [s/veh]	7.45	0.30	0.00	7.22	0.00	0.00	11.07	11.59	8.95	11.68	11.16	8.52
Movement LOS	A	A	A	A	A	A	B	B	A	B	B	A
95th-Percentile Queue Length [veh/ln]	0.20	0.20	0.20	0.60	0.00	0.00	0.38	0.38	0.38	0.02	0.02	0.02
95th-Percentile Queue Length [ft/ln]	5.06	5.06	5.06	0.92	0.00	0.00	9.56	9.56	9.56	0.41	0.41	0.41
d_A, Approach Delay [s/veh]	5.35			0.00			9.18			11.50		
Approach LOS	A			A			A			B		
d_I, Intersection Delay [s/veh]							6.06					
Intersection LOS							B					



Intersection Level Of Service Report
Intersection 5: Olympic Dr/Lakeshore Dr

Control Type: Two-way stop Delay (sec / veh): 16.9
 Analysis Method: HCM 8th Edition Level Of Service: C
 Analysis Period: 15 minutes Volume to Capacity (v/c): 0.282

Intersection Setup

Name	Lakeshore Dr			Lakeshore Dr			Olympic Dr		
	Northbound			Southbound			Westbound		
Lane Configuration	[Diagram]			[Diagram]			[Diagram]		
Turning Movement	Left	Thru	Right	Left	Thru	Right	Left	Thru	Right
Lane Width [ft]	12.00	12.00	12.00	12.00	12.00	12.00	12.00	12.00	12.00
No. of Lanes in Entry Pocket	0	0	1	0	0	0	0	0	1
Entry Pocket Length [ft]	100.00	100.00	120.00	100.00	100.00	100.00	100.00	100.00	250.00
No. of Lanes in Exit Pocket	0	0	0	0	0	0	0	0	0
Exit Pocket Length [ft]	0.00	0.00	0.00	0.00	0.00	0.00	0.00	0.00	0.00
Speed [mph]	25.00			25.00			30.00		
Grade [%]	0.00			0.00			0.00		
Crosswalk	No			Yes			Yes		

Volumes

Name	Lakeshore Dr			Lakeshore Dr			Olympic Dr		
	1	176	103	73	185	0	3	3	97
Base Volume Input [veh/h]	1	176	103	73	185	0	3	3	97
Base Volume Adjustment Factor	1.0000	1.0000	1.0000	1.0000	1.0000	1.0000	1.0000	1.0000	1.0000
Heavy Vehicles Percentage [%]	2.00	2.00	2.00	2.00	2.00	2.00	2.00	2.00	2.00
Growth Factor	1.0000	1.0000	1.0000	1.0000	1.0000	1.0000	1.0000	1.0000	1.0000
In-Process Volume [veh/h]	0	0	0	0	0	0	0	0	0
Site-Generated Trips [veh/h]	0	0	0	0	0	0	0	0	0
Diverted Trips [veh/h]	0	0	0	0	0	0	0	0	0
Pass-by Trips [veh/h]	0	0	0	0	0	0	0	0	0
Existing Site Adjustment Volume [veh/h]	0	0	0	0	0	0	0	0	0
Other Volume [veh/h]	0	0	0	0	0	0	0	0	0
Total Hourly Volume [veh/h]	1	176	103	73	185	0	3	3	97
Peak Hour Factor	0.9100	0.9100	0.9100	0.9100	0.9100	0.9100	0.9100	0.9100	0.9100
Other Adjustment Factor	1.0000	1.0000	1.0000	1.0000	1.0000	1.0000	1.0000	1.0000	1.0000
Total 15-Minute Volume [veh/h]	0	48	28	20	51	0	1	1	27
Total Analysis Volume [veh/h]	1	193	113	80	203	0	3	3	107
Pedestrian Volume [ped/h]	0	0	0	0	0	0	0	0	1



Intersection Settings

Priority Scheme	Free	Free	Stop	Stop
Flared Lane			No	No
Storage Area [veh]	0	0	0	0
Two-Stage Gap Acceptance			No	No
Number of Storage Spaces in Median	0	0	0	0

Movement, Approach, & Intersection Results

V/C, Movement V/C Ratio	0.00	0.00	0.00	0.06	0.00	0.00	0.00	0.01	0.00	0.26	0.00	0.10
d_M, Delay for Movement [s/veh]	7.63	0.00	0.00	8.07	0.00	0.00	15.29	15.40	9.39	16.90	14.36	9.73
Movement LOS	A	A	A	A	A	C	C	A	C	B	A	A
95th-Percentile Queue Length [veh/ln]	0.00	0.00	0.00	0.20	0.20	0.04	0.04	0.04	1.04	0.33	0.33	0.33
95th-Percentile Queue Length [ft/ln]	0.05	0.05	0.00	5.11	5.11	0.52	0.92	0.92	25.89	8.24	8.24	8.24
d_A, Approach Delay [s/veh]	0.02			2.28			12.39			13.79		
Approach LOS	A			A			B			B		
d_I, Intersection Delay [s/veh]	4.26											
Intersection LOS	C											



Intersection Level Of Service Report

Intersection 7: Olympic Dr/Burns Valley Rd-Old Hwy 53

Control Type: Signalized
 Analysis Method: HCM 6th Edition
 Analysis Period: 15 minutes
 Delay (sec / veh): 11.7
 Level Of Service: B
 Volume to Capacity (v/c): 0.682

Intersection Setup

Name	Old Hwy 53			Burns Valley Rd			Olympic Dr			Old Hwy 53		
	Northbound			Southbound			Eastbound			Westbound		
Lane Configuration	[Diagram]			[Diagram]			[Diagram]			[Diagram]		
Turning Movement	Left	Thru	Right	Left	Thru	Right	Left	Thru	Right	Left	Thru	Right
Lane Width [ft]	12.00	12.00	12.00	12.00	12.00	12.00	12.00	12.00	12.00	12.00	12.00	12.00
No. of Lanes in Entry Pocket	1	0	1	1	0	0	1	0	0	1	0	0
Entry Pocket Length [ft]	100.00	100.00	100.00	56.00	100.00	100.00	48.00	100.00	100.00	100.00	100.00	100.00
No. of Lanes in Exit Pocket	0	0	0	0	0	0	0	0	0	0	0	0
Exit Pocket Length [ft]	0.00	0.00	0.00	0.00	0.00	0.00	0.00	0.00	0.00	0.00	0.00	0.00
Speed [mph]	30.00			30.00			35.00			35.00		
Grade [%]	0.00			0.00			0.00			0.00		
Curb Present	No			No			No			No		
Crosswalk	Yes			Yes			Yes			Yes		

Volumes

Name	Old Hwy 53			Burns Valley Rd			Olympic Dr			Old Hwy 53		
Base Volume Input [veh/h]	80	81	42	93	64	30	20	180	95	33	170	109
Base Volume Adjustment Factor	1.0000	1.0000	1.0000	1.0000	1.0000	1.0000	1.0000	1.0000	1.0000	1.0000	1.0000	1.0000
Heavy Vehicles Percentage [%]	2.00	2.00	2.00	2.00	2.00	2.00	2.00	2.00	2.00	2.00	2.00	2.00
Growth Factor	1.0000	1.0000	1.0000	1.0000	1.0000	1.0000	1.0000	1.0000	1.0000	1.0000	1.0000	1.0000
In-Process Volume [veh/h]	0	0	0	0	0	0	0	0	0	0	0	0
Site-Generated Trips [veh/h]	0	0	0	0	0	0	0	0	0	0	0	0
Diverted Trips [veh/h]	0	0	0	0	0	0	0	0	0	0	0	0
Pass-by Trips [veh/h]	0	0	0	0	0	0	0	0	0	0	0	0
Existing Site Adjustment Volume [veh/h]	0	0	0	0	0	0	0	0	0	0	0	0
Other Volume [veh/h]	0	0	0	0	0	0	0	0	0	0	0	0
Right Turn on Red Volume [veh/h]	0	0	16	0	0	12	0	0	25	0	0	29
Total Hourly Volume [veh/h]	80	81	27	93	64	18	20	180	70	33	170	80
Peak Hour Factor	0.9300	0.9300	0.9300	0.9300	0.9300	0.9300	0.9300	0.9300	0.9300	0.9300	0.9300	0.9300
Other Adjustment Factor	1.0000	1.0000	1.0000	1.0000	1.0000	1.0000	1.0000	1.0000	1.0000	1.0000	1.0000	1.0000
Total 15-Minute Volume [veh/h]	22	22	7	25	17	5	5	48	19	9	46	22
Total Analysis Volume [veh/h]	86	87	29	100	69	19	22	194	75	35	183	86
Presence of On-Street Parking	No	No	No	No	No	No	No	No	No	No	No	No
On-Street Parking Maneuver Rate [h]	0	0	0	0	0	0	0	0	0	0	0	0
Local Bus Stopping Rate [h]	0	0	0	0	0	0	0	0	0	0	0	0
v_do, Outbound Pedestrian Volume crossing major street	1			0			1			1		
v_di, Inbound Pedestrian Volume crossing major street	1			1			0			1		
v_co, Outbound Pedestrian Volume crossing minor street	1			0			0			0		
v_ci, Inbound Pedestrian Volume crossing minor street	0			0			1			0		
v_ab, Corner Pedestrian Volume [ped/h]	0			0			0			0		
Bicycle Volume [bicycles/h]	0			0			0			1		



Intersection Settings	
Located In CBD	Yes
Signal Coordination Group	-
Cycle Length [s]	109
Coordination Type	Time of Day Pattern Isolated
Actuation Type	Fully actuated
Offset [s]	0.0
Offset Reference	Lead Green - Beginning of First Green
Permissive Mode	SingleBand
Last time [s]	14.00

Phasing & Timing													
Control Type	Protect	Permis	Permis	Protect	Permis	Permis	Protect	Permis	Permis	Protect	Permis	Permis	Protect
Signal Group	3	8	0	7	4	0	5	2	0	1	6	0	
Auxiliary Signal Groups													
Lead / Lag	Lead	-	-	Lead	-	-	Lead	-	-	Lead	-	-	
Minimum Green [s]	4	6	0	4	6	0	4	6	0	4	6	0	
Maximum Green [s]	20	25	0	20	25	0	20	30	0	20	20	0	
Amber [s]	3.0	3.3	0.0	3.0	3.3	0.0	3.0	3.6	0.0	3.0	3.6	0.0	
All red [s]	0.0	0.3	0.0	0.0	0.3	0.0	0.0	0.3	0.0	0.0	0.3	0.0	
Split [s]	23	29	0	23	29	0	23	34	0	23	34	0	
Vehicle Extension [s]	0.0	0.0	0.0	0.0	0.0	0.0	0.0	0.0	0.0	0.0	0.0	0.0	
Walk [s]	0	7	0	0	7	0	0	7	0	0	7	0	
Pedestrian Clearance [s]	0	11	0	0	9	0	0	14	0	0	9	0	
Delayed Vehicle Green [s]	0.0	0.0	0.0	0.0	0.0	0.0	0.0	0.0	0.0	0.0	0.0	0.0	
Rest in Walk		No			No			No			No		
M, Start-Up Lost Time [s]	2.0	2.0	0.0	2.0	2.0	0.0	2.0	2.0	0.0	2.0	2.0	0.0	
I2, Clearance Lost Time [s]	1.0	1.6	0.0	1.0	1.6	0.0	1.0	1.9	0.0	1.0	1.9	0.0	
Minimum Recall	No	No		No	No		No	No		No	No		
Maximum Recall	No	No		No	No		No	No		No	No		
Pedestrian Recall	No	No		No	No		No	No		No	No		
Detector Location [ft]	0.0	0.0	0.0	0.0	0.0	0.0	0.0	0.0	0.0	0.0	0.0	0.0	
Detector Length [ft]	0.0	0.0	0.0	0.0	0.0	0.0	0.0	0.0	0.0	0.0	0.0	0.0	
I, Upstream Filtering Factor	1.00	1.00	1.00	1.00	1.00	1.00	1.00	1.00	1.00	1.00	1.00	1.00	

Exclusive Pedestrian Phase	
Pedestrian Signal Group	0
Pedestrian Walk [s]	0
Pedestrian Clearance [s]	0



Lane Group Calculations									
Lane Group	L	C	R	L	C	L	C	L	C
C, Cycle Length [s]	25	25	25	25	25	25	25	25	25
L, Total Lost Time per Cycle [s]	3.00	3.60	3.60	3.00	3.60	3.00	3.60	3.00	3.90
M, Permitted Start-Up Lost Time [s]	0.00	0.00	0.00	0.00	0.00	0.00	0.00	0.00	0.00
I2, Clearance Lost Time [s]	1.00	1.60	1.60	1.00	1.60	1.00	1.60	1.00	1.90
g, Effective Green Time [s]	2	4	4	2	4	1	5	1	6
g / C, Green / Cycle	0.07	0.14	0.14	0.08	0.15	0.02	0.21	0.04	0.22
(v / s), Volume / Saturation Flow Rate	0.05	0.05	0.02	0.06	0.05	0.01	0.17	0.02	0.17
s, saturation flow rate [veh/h]	1603	1683	1420	1603	1620	1603	1603	1603	1581
c, Capacity [veh/h]	118	235	198	132	240	38	338	57	353
d1, Uniform Delay [s]	11.52	9.92	9.60	11.42	9.76	12.28	9.50	12.07	9.24
k, delay calibration	0.04	0.04	0.04	0.04	0.04	0.04	0.04	0.04	0.04
I, Upstream Filtering Factor	1.00	1.00	1.00	1.00	1.00	1.00	1.00	1.00	1.00
d2, Incremental Delay [s]	3.14	0.36	0.12	3.35	0.35	5.10	1.62	3.82	1.29
d3, Initial Queue Delay [s]	0.00	0.00	0.00	0.00	0.00	0.00	0.00	0.00	0.00
Rp, platoon ratio	1.00	1.00	1.00	1.00	1.00	1.00	1.00	1.00	1.00
PF, progression factor	1.00	1.00	1.00	1.00	1.00	1.00	1.00	1.00	1.00

Lane Group Results									
X, volume / capacity	0.73	0.37	0.15	0.76	0.37	0.58	0.79	0.61	0.76
d, Delay for Lane Group [s/veh]	14.86	10.26	9.72	14.77	10.10	17.38	11.12	15.90	10.53
Lane Group LOS	B	B	A	B	B	B	B	B	B
Critical Lane Group	No	Yes	No	Yes	No	No	Yes	Yes	No
50th-Percentile Queue Length [veh/m]	0.43	0.31	0.10	0.50	0.31	0.14	0.94	0.19	0.69
50th-Percentile Queue Length [ft/m]	10.79	7.82	2.50	12.54	7.78	3.43	23.46	4.79	22.19
95th-Percentile Queue Length [veh/m]	0.78	0.56	0.18	0.90	0.58	0.25	1.69	0.34	1.60
95th-Percentile Queue Length [ft/m]	19.42	14.07	4.51	22.57	14.00	6.17	42.24	8.62	39.94



Movement, Approach, & Intersection Results												
d_M, Delay for Movement [s/veh]	14.66	10.28	9.72	14.77	10.10	10.10	17.38	11.12	11.12	15.90	10.53	10.53
Movement LOS	B	B	A	B	B	B	B	B	B	B	B	B
d_A, Approach Delay [s/veh]	12.06		12.59		11.60		11.15					
Approach LOS	B		B		B		B					
d_I, Intersection Delay [s/veh]	11.74											
Intersection LOS	B											
Intersection V/C	0.682											

Other Modes				
g_Walk,mi, Effective Walk Time [s]	11.0	11.0	11.0	11.0
M_corner, Corner Circulation Area [ft²/ped]	0.00	0.00	0.00	0.00
M_CW, Crosswalk Circulation Area [ft²/ped]	0.00	0.00	0.00	0.00
d_p, Pedestrian Delay [s]	4.01	4.01	4.01	4.01
I_p,int, Pedestrian LOS Score for Intersection	2.168	2.008	2.122	2.149
Crosswalk LOS	B	B	B	B
s_b, Saturation Flow Rate of the bicycle lane [bicycles/h]	2000	2000	2000	2000
c_b, Capacity of the bicycle lane [bicycles/h]	2013	2013	2388	2388
d_b, Bicycle Delay [s]	0.00	0.00	0.47	0.47
I_b,int, Bicycle LOS Score for Intersection	1.918	1.890	2.081	2.109
Bicycle LOS	A	A	B	B

Sequence

Ring	1	2	3	4	-	-	-	-	-	-	-	-	-	-	-
Ring 1	1	2	3	4	-	-	-	-	-	-	-	-	-	-	-
Ring 2	5	6	7	8	-	-	-	-	-	-	-	-	-	-	-
Ring 3	-	-	-	-	-	-	-	-	-	-	-	-	-	-	-
Ring 4	-	-	-	-	-	-	-	-	-	-	-	-	-	-	-

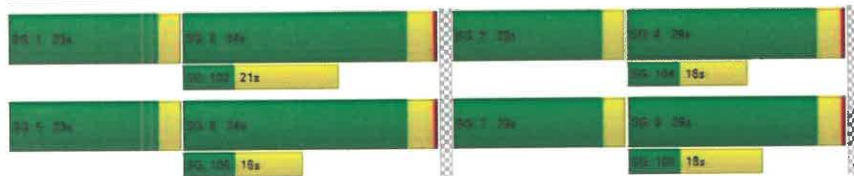

Intersection Level Of Service Report

Intersection 2: Burns Valley Rd/Bowers Ave-Rumsey Rd

Control Type:	Two-way stop	Delay (sec / veh):	13.9
Analysis Method:	HCM 6th Edition	Level Of Service:	B
Analysis Period:	15 minutes	Volume to Capacity (v/c):	0.015

Intersection Setup

Name	Burns Valley Rd			Rumsey Rd			Burns Valley Rd			Bowers Ave		
	Northbound			Southbound			Eastbound			Westbound		
Approach	+			+			+			+		
Lane Configuration	+			+			+			+		
Turning Movement	Left	Thru	Right	Left	Thru	Right	Left	Thru	Right	Left	Thru	Right
Lane Width [ft]	12.00	12.00	12.00	12.00	12.00	12.00	12.00	12.00	12.00	12.00	12.00	12.00
No. of Lanes in Entry Pocket	0	0	0	0	0	0	0	0	0	0	0	0
Entry Pocket Length [ft]	100.00	100.00	100.00	100.00	100.00	100.00	100.00	100.00	100.00	100.00	100.00	100.00
No. of Lanes in Exit Pocket	0	0	0	0	0	0	0	0	0	0	0	0
Exit Pocket Length [ft]	0.00	0.00	0.00	0.00	0.00	0.00	0.00	0.00	0.00	0.00	0.00	0.00
Speed [mph]	30.00			30.00			35.00			25.00		
Grade [%]	0.00			0.00			0.00			0.00		
Crosswalk	No			Yes			Yes			No		

Volumes

Name	Burns Valley Rd			Rumsey Rd			Burns Valley Rd			Bowers Ave		
Base Volume Input [veh/h]	122	26	6	0	23	16	9	1	124	5	1	0
Base Volume Adjustment Factor	1.0000	1.0000	1.0000	1.0000	1.0000	1.0000	1.0000	1.0000	1.0000	1.0000	1.0000	1.0000
Heavy Vehicles Percentage [%]	2.00	2.00	2.00	2.00	2.00	2.00	2.00	2.00	2.00	2.00	2.00	2.00
Growth Factor	1.0000	1.0000	1.0000	1.0000	1.0000	1.0000	1.0000	1.0000	1.0000	1.0000	1.0000	1.0000
In-Process Volume [veh/h]	0	0	0	0	0	0	0	0	0	0	0	0
Site-Generated Trips [veh/h]	5	1	0	0	1	0	0	0	6	0	0	0
Diverted Trips [veh/h]	0	0	0	0	0	0	0	0	0	0	0	0
Pass-by Trips [veh/h]	0	0	0	0	0	0	0	0	0	0	0	0
Existing Site Adjustment Volume [veh/h]	0	0	0	0	0	0	0	0	0	0	0	0
Other Volume [veh/h]	0	0	0	0	0	0	0	0	0	0	0	0
Total Hourly Volume [veh/h]	127	27	6	0	24	16	9	1	130	5	1	0
Peak Hour Factor	0.8500	0.8500	0.8500	0.8500	0.8500	0.8500	0.8500	0.8500	0.8500	0.8500	0.8500	0.8500
Other Adjustment Factor	1.0000	1.0000	1.0000	1.0000	1.0000	1.0000	1.0000	1.0000	1.0000	1.0000	1.0000	1.0000
Total 15-Minute Volume [veh/h]	37	8	2	0	7	5	3	0	38	1	0	0
Total Analysis Volume [veh/h]	149	32	7	0	28	19	11	1	153	6	1	0
Pedestrian Volume [ped/h]	0			0			0			0		



Intersection Settings				
Priority Scheme	Free	Free	Stop	Stop
Flared Lane			No	No
Storage Area [veh]	0	0	0	0
Two-Stage Gap Acceptance			No	No
Number of Storage Spaces in Median	0	0	0	0

Movement, Approach, & Intersection Results												
V/C, Movement V/C Ratio	0.10	0.00	0.00	0.00	0.00	0.00	0.02	0.00	0.15	0.01	0.00	0.00
d_M, Delay for Movement [s/veh]	7.55	0.00	0.00	0.00	0.00	0.00	12.42	12.93	9.24	13.92	12.37	6.52
Movement LOS	A	A	A	A	A	A	B	B	A	B	B	A
95th-Percentile Queue Length [veh/h]	0.32	0.32	0.32	0.00	0.00	0.00	0.61	0.61	0.61	0.05	0.05	0.05
95th-Percentile Queue Length [ft]	7.90	7.90	7.90	0.00	0.00	0.00	15.29	15.29	15.29	1.27	1.27	1.27
d_A, Approach Delay [s/veh]	5.88			0.00			9.47			13.70		
Approach LOS	A			A			A			B		
d_J, Intersection Delay [s/veh]	6.84											
Intersection LOS	B											

Intersection Level Of Service Report			
Intersection 5: Olympic Dr/Lakeshore Dr			
Control Type:	Two-way stop	Delay (sec / veh):	17.6
Analysis Method:	HCM 6th Edition	Level Of Service:	C
Analysis Period:	15 minutes	Volume to Capacity (v/c):	0.174

Intersection Setup												
Name	Lakeshore Dr			Lakeshore Dr			Eastbound			Olympic Dr		
Approach	Northbound			Southbound						Westbound		
Lane Configuration	T T			+			+			T T		
Turning Movement	Left	Thru	Right	Left	Thru	Right	Left	Thru	Right	Left	Thru	Right
Lane Width [ft]	12.00	12.00	12.00	12.00	12.00	12.00	12.00	12.00	12.00	12.00	12.00	12.00
No. of Lanes in Entry Pocket	0	0	1	0	0	0	0	0	0	0	0	1
Entry Pocket Length [ft]	105.00	100.00	120.00	105.00	100.00	100.00	100.00	100.00	100.00	100.00	100.00	250.00
No. of Lanes in Exit Pocket	0	0	0	0	0	0	0	0	0	0	0	0
Exit Pocket Length [ft]	0.00	0.00	0.00	0.00	0.00	0.00	0.00	0.00	0.00	0.00	0.00	0.00
Speed [mph]	25.00			25.00			30.00			30.00		
Grade [%]	0.00			0.00			0.00			0.00		
Crosswalk	No			Yes			No			Yes		

Volumes												
Name	Lakeshore Dr			Lakeshore Dr						Olympic Dr		
Base Volume Input [veh/h]	1	137	66	61	279	2	0	0	1	47	1	60
Base Volume Adjustment Factor	1.0000	1.0000	1.0000	1.0000	1.0000	1.0000	1.0000	1.0000	1.0000	1.0000	1.0000	1.0000
Heavy Vehicles Percentage [%]	2.00	2.00	2.00	2.00	2.00	2.00	2.00	2.00	2.00	2.00	2.00	2.00
Growth Factor	1.0000	1.0000	1.0000	1.0000	1.0000	1.0000	1.0000	1.0000	1.0000	1.0000	1.0000	1.0000
In-Process Volume [veh/h]	0	0	0	0	0	0	0	0	0	0	0	0
Site-Generated Trips [veh/h]	0	1	20	17	0	0	0	0	0	0	5	9
Diverted Trips [veh/h]	0	0	0	0	0	0	0	0	0	0	0	0
Pass-by Trips [veh/h]	0	0	0	0	0	0	0	0	0	0	0	0
Existing Site Adjustment Volume [veh/h]	0	0	0	0	0	0	0	0	0	0	0	0
Other Volume [veh/h]	0	0	0	0	0	0	0	0	0	0	0	0
Total Hourly Volume [veh/h]	1	138	66	78	279	2	0	0	1	52	1	69
Peak Hour Factor	0.8600	0.8600	0.8600	0.8600	0.8600	0.8600	0.8600	0.8600	0.8600	0.8600	0.8600	0.8600
Other Adjustment Factor	1.0000	1.0000	1.0000	1.0000	1.0000	1.0000	1.0000	1.0000	1.0000	1.0000	1.0000	1.0000
Total 15-Minute Volume [veh/h]	0	40	25	23	81	1	0	0	0	15	0	20
Total Analysis Volume [veh/h]	1	160	100	91	324	2	0	0	1	60	1	80
Pedestrian Volume [ped/h]	0			0			0			1		

Intersection Settings	Free	Free	Stop	Stop
Priority Scheme	Free	Free	Stop	Stop
Flared Lane			No	No
Storage Area [veh]	0	0	0	0
Two-Stage Gap Acceptance			No	No
Number of Storage Spaces in Median	0	0	0	0

Movement, Approach, & Intersection Results												
V/C, Movement V/C Ratio	0.00	0.00	0.00	0.07	0.00	0.00	0.00	0.00	0.17	0.00	0.09	
d_M, Delay for Movement [s/veh]	7.92	0.00	0.00	7.97	0.00	0.00	18.17	16.92	10.03	17.61	15.87	9.50
Movement LOS	A	A	A	A	A	A	C	B	C	C	C	A
95th-Percentile Queue Length [veh/ln]	0.00	0.00	0.00	0.23	0.23	0.23	3.00	0.00	0.00	0.62	0.31	0.31
95th-Percentile Queue Length [ft/ln]	0.06	0.06	0.00	5.63	5.63	5.63	0.10	0.10	0.10	15.51	7.71	7.71
d_A, Approach Delay [s/veh]	0.03			1.74			10.03			13.00		
Approach LOS	A			A			B			B		
d_I, Intersection Delay [s/veh]	3.14											
Intersection LOS	C											

Intersection Level Of Service Report
Intersection 7: Olympic Dr/Burns Valley Rd-Old Hwy 53
Control Type: Signalized Delay (sec / veh): 11.8
Analysis Method: HCM 6th Edition Level Of Service: B
Analysis Period: 15 minutes Volume to Capacity (v/c): 0.677

Intersection Setup												
Name	Old Hwy 53			Burns Valley Rd			Olympic Dr			Old Hwy 53		
Approach	Northbound			Southbound			Eastbound			Westbound		
Lane Configuration	T T T			T T			T T			T T		
Turning Movement	Left	Thru	Right	Left	Thru	Right	Left	Thru	Right	Left	Thru	Right
Lane Width [ft]	12.00	12.00	12.00	12.00	12.00	12.00	12.00	12.00	12.00	12.00	12.00	12.00
No. of Lanes in Entry Pocket	1	0	1	1	0	0	1	0	0	1	0	0
Entry Pocket Length [ft]	100.00	100.00	100.00	56.00	100.00	100.00	48.00	100.00	100.00	100.00	100.00	100.00
No. of Lanes in Exit Pocket	0	0	0	0	0	0	0	0	0	0	0	0
Exit Pocket Length [ft]	0.00	0.00	0.00	0.00	0.00	0.00	0.00	0.00	0.00	0.00	0.00	0.00
Speed [mph]	30.00			30.00			35.00			35.00		
Grade [%]	0.00			0.00			0.00			0.00		
Curb Present	No			No			No			No		
Crosswalk	Yes			Yes			Yes			Yes		



Volumes	Old Hwy 53			Burns Valley Rd			Olympic Dr			Old Hwy 53		
Base Volume Input [veh/h]	42	62	45	75	70	15	26	131	51	48	150	99
Base Volume Adjustment Factor	1.0000	1.0000	1.0000	1.0000	1.0000	1.0000	1.0000	1.0000	1.0000	1.0000	1.0000	1.0000
Heavy Vehicles Percentage [%]	2.00	2.00	2.00	2.00	2.00	2.00	2.00	2.00	2.00	2.00	2.00	2.00
Growth Factor	1.0000	1.0000	1.0000	1.0000	1.0000	1.0000	1.0000	1.0000	1.0000	1.0000	1.0000	1.0000
In-Process Volume [veh/h]	0	0	0	0	0	0	0	0	0	0	0	0
Site-Generated Trips [veh/h]	15	5	18	0	3	4	1	11	10	16	41	0
Diverted Trips [veh/h]	0	0	0	0	0	0	0	0	0	0	0	0
Pass-by Trips [veh/h]	0	0	0	0	0	0	0	0	0	0	0	0
Existing Site Adjustment Volume [veh/h]	0	0	0	0	0	0	0	0	0	0	0	0
Other Volume [veh/h]	0	0	0	0	0	0	0	0	0	0	0	0
Right Turn on Red Volume [veh/h]	0	0	19	0	0	3	0	0	5	0	0	20
Total Hourly Volume [veh/h]	57	67	44	75	73	16	27	142	56	64	191	79
Peak Hour Factor	0.8900	0.8900	0.8900	0.8900	0.8900	0.8900	0.8900	0.8900	0.8900	0.8900	0.8900	0.8900
Other Adjustment Factor	1.0000	1.0000	1.0000	1.0000	1.0000	1.0000	1.0000	1.0000	1.0000	1.0000	1.0000	1.0000
Total 15-Minute Volume [veh/h]	16	19	12	21	21	4	8	40	16	18	54	22
Total Analysis Volume [veh/h]	64	75	49	84	82	18	30	160	63	72	215	89
Presence of On-Street Parking	No	No	No	No	No	No	No	No	No	No	No	No
On-Street Parking Maneuver Rate [1/h]	0	0	0	0	0	0	0	0	0	0	0	0
Local Bus Stopping Rate [1/h]	0	0	0	0	0	0	0	0	0	0	0	0
v_do, Outbound Pedestrian Volume crossing major street	1			0			1			1		
v_di, Inbound Pedestrian Volume crossing major street	1			1			0			1		
v_co, Outbound Pedestrian Volume crossing minor street	1			0			0			0		
v_ci, Inbound Pedestrian Volume crossing minor street	0			0			1			0		
v_ab, Corner Pedestrian Volume [ped/h]	0			0			0			0		
Bicycle Volume [bicycles/h]	0			0			0			1		



Intersection Settings	
Located in CBD	Yes
Signal Coordination Group	-
Cycle Length [s]	109
Coordination Type	Time of Day Pattern Isolated
Actuation Type	Fully actuated
Offset [s]	0.0
Offset Reference	Lead Green - Beginning of First Green
Permissive Mode	SingleBand
Lost time [s]	14.00

Phasing & Timing		Protect	Permis	Permis	Protect	Permis	Permis	Protect	Permis	Permis	Protect	Permis	Permis
Control Type													
Signal Group		3	8	0	7	4	0	5	2	0	1	6	0
Auxiliary Signal Groups													
Lead / Lag		Lead	-	-	Lead	-	-	Lead	-	-	Lead	-	-
Minimum Green [s]		4	6	0	4	6	0	4	6	0	4	6	0
Maximum Green [s]		20	25	0	20	25	0	20	30	0	20	20	0
Amber [s]		3.0	3.3	0.0	3.0	3.3	0.0	3.0	3.6	0.0	3.0	3.6	0.0
All red [s]		0.0	0.3	0.0	0.0	0.3	0.0	0.0	0.3	0.0	0.0	0.3	0.0
Split [s]		23	29	0	23	29	0	23	34	0	23	34	0
Vehicle Extension [s]		0.0	0.0	0.0	0.0	0.0	0.0	0.0	0.0	0.0	0.0	0.0	0.0
Walk [s]		0	7	0	0	7	0	0	7	0	0	7	0
Pedestrian Clearance [s]		0	11	0	0	9	0	0	14	0	0	9	0
Delayed Vehicle Green [s]		0.0	0.0	0.0	0.0	0.0	0.0	0.0	0.0	0.0	0.0	0.0	0.0
Rest In Walk		No			No			No			No		
I1, Start-Up Lost Time [s]		2.0	2.0	0.0	2.0	2.0	0.0	2.0	2.0	0.0	2.0	2.0	0.0
I2, Clearance Lost Time [s]		1.0	1.6	0.0	1.0	1.6	0.0	1.0	1.9	0.0	1.0	1.9	0.0
Minimum Recall		No	No		No	No		No	No		No	No	
Maximum Recall		No	No		No	No		No	No		No	No	
Pedestrian Recall		No	No		No	No		No	No		No	No	
Detector Location [ft]		0.0	0.0	0.0	0.0	0.0	0.0	0.0	0.0	0.0	0.0	0.0	0.0
Detector Length [ft]		0.0	0.0	0.0	0.0	0.0	0.0	0.0	0.0	0.0	0.0	0.0	0.0
I, Upstream Filtering Factor		1.00	1.00	1.00	1.00	1.00	1.00	1.00	1.00	1.00	1.00	1.00	1.00

Exclusive Pedestrian Phase	
Pedestrian Signal Group	0
Pedestrian Walk [s]	0
Pedestrian Clearance [s]	0



Lane Group Calculations

Lane Group	L	C	R	L	C	L	C	L	C
C, Cycle Length [s]	26	26	26	26	26	26	26	26	26
L, Total Lost Time per Cycle [s]	3.00	3.60	3.60	3.00	3.60	3.00	3.90	3.00	3.90
H1_p, Permitted Start-Up Lost Time [s]	0.00	0.00	0.00	0.00	0.00	0.00	0.30	0.00	0.00
H2, Clearance Lost Time [s]	1.00	1.60	1.60	1.00	1.60	1.00	1.90	1.00	1.90
g_i, Effective Green Time [s]	2	4	4	2	4	1	5	2	6
g / C, Green / Cycle	0.06	0.14	0.14	0.07	0.16	0.03	0.20	0.06	0.23
(v / s)_i Volume / Saturation Flow Rate	0.04	0.04	0.03	0.05	0.06	0.02	0.14	0.04	0.19
s, saturation flow rate [veh/h]	1603	1683	1421	1603	1630	1603	1602	1603	1589
c, Capacity [veh/h]	94	242	204	115	256	50	324	103	374
d1, Uniform Delay [s]	12.04	10.01	9.90	11.86	9.88	12.48	9.64	11.96	9.42
k, delay calibration	0.04	0.04	0.04	0.04	0.04	0.04	0.04	0.04	0.04
I, Upstream Filtering Factor	1.00	1.00	1.00	1.00	1.00	1.00	1.00	1.00	1.00
d2, Incremental Delay [s]	3.18	0.27	0.22	3.25	0.36	4.24	0.97	3.17	1.63
d3, Initial Queue Delay [s]	0.00	0.00	0.00	0.00	0.00	0.00	0.00	0.00	0.00
Rp, platoon ratio	1.00	1.00	1.00	1.00	1.00	1.00	1.00	1.00	1.00
PF, progression factor	1.00	1.00	1.00	1.00	1.00	1.00	1.00	1.00	1.00

Lane Group Results

X, volume / capacity	0.68	0.31	0.24	0.73	0.39	0.60	0.89	0.70	0.81
d, Delay for Lane Group [s/veh]	15.21	10.28	10.13	15.11	10.24	16.72	10.61	15.13	11.05
Lane Group LOS	B	B	B	B	B	B	B	B	B
Critical Lane Group	Yes	No	No	No	Yes	Yes	No	No	Yes
50th-Percentile Queue Length [veh/ln]	0.34	0.28	0.18	0.44	0.37	0.18	0.77	0.36	1.07
50th-Percentile Queue Length [ft/ln]	8.57	6.80	4.48	11.03	9.14	4.43	19.29	9.11	28.83
95th-Percentile Queue Length [veh/ln]	0.62	0.50	0.32	0.79	0.66	0.32	1.39	0.66	1.93
95th-Percentile Queue Length [ft/ln]	15.43	12.41	8.07	19.85	16.45	7.97	34.73	16.39	48.30

Movement, Approach, & Intersection Results

d_M, Delay for Movement [s/veh]	15.21	10.28	10.13	15.11	10.24	10.24	16.72	10.61	10.61	15.13	11.05	11.05
Movement LOS	B	B	B	B	B	B	B	B	B	B	B	B
d_A, Approach Delay [s/veh]	11.92			12.46			11.33			11.83		
Approach LOS	B			B			B			B		
d_I, Intersection Delay [s/veh]	11.84											
Intersection LOS	B											
Intersection V/C	0.677											

Other Modes

g_Walk,mi, Effective Walk Time [s]	11.0	11.0	11.0	11.0
M_corner, Corner Circulation Area [ft²/pe/d]	0.00	0.00	0.00	0.00
M_CW, Crosswalk Circulation Area [ft²/pe/d]	0.00	0.00	0.00	0.00
d_p, Pedestrian Delay [s]	4.29	4.29	4.29	4.29
I_p,int, Pedestrian LOS Score for Intersection	2.178	1.991	2.075	2.153
Crosswalk LOS	B	A	B	B
s_b, Saturation Flow Rate of the bicycle lane [bicycles/h]	2000	2000	2000	2000
c_b, Capacity of the bicycle lane [bicycles/h]	1960	1960	2323	2323
d_b, Bicycle Delay [s]	0.01	0.01	0.34	0.34
I_b,int, Bicycle LOS Score for Intersection	1.901	1.868	1.985	2.213
Bicycle LOS	A	A	A	B

Sequence

Ring	1	2	3	4	-	-	-	-	-	-	-	-	-	-
Ring 1	1	2	3	4	-	-	-	-	-	-	-	-	-	-
Ring 2	5	6	7	8	-	-	-	-	-	-	-	-	-	-
Ring 3	-	-	-	-	-	-	-	-	-	-	-	-	-	-
Ring 4	-	-	-	-	-	-	-	-	-	-	-	-	-	-

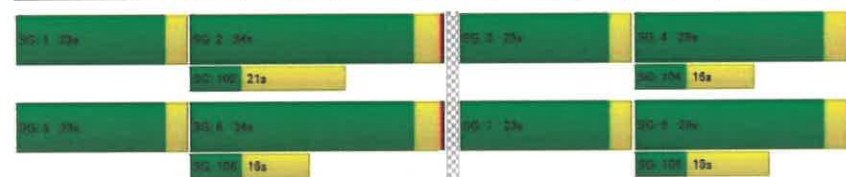

Intersection Level Of Service Report
Intersection 2: Burns Valley Rd/Bowers Ave-Rumsey Rd

Control Type: Two-way stop Delay (sec / veh): 13.2
Analysis Method: HCM 6th Edition Level Of Service: B
Analysis Period: 15 minutes Volume to Capacity (v/c): 0.033

Intersection Setup

Name	Burns Valley Rd			Rumsey Rd			Burns Valley Rd			Bowers Ave		
Approach	Northbound			Southbound			Eastbound			Westbound		
Lane Configuration	+			+			+			+		
Turning Movement	Left	Thru	Right	Left	Thru	Right	Left	Thru	Right	Left	Thru	Right
Lane Width [ft]	12.00	12.00	12.00	12.00	12.00	12.00	12.00	12.00	12.00	12.00	12.00	12.00
No. of Lanes in Entry Pocket	0	0	0	0	0	0	0	0	0	0	0	0
Entry Pocket Length [ft]	100.00	100.00	100.00	100.00	100.00	100.00	100.00	100.00	100.00	100.00	100.00	100.00
No. of Lanes in Exit Pocket	0	0	0	0	0	0	0	0	0	0	0	0
Exit Pocket Length [ft]	0.00	0.00	0.00	0.00	0.00	0.00	0.00	0.00	0.00	0.00	0.00	0.00
Speed [mph]	30.00			30.00			35.00			25.00		
Grade [%]	0.00			0.00			0.00			0.00		
Crosswalk	No			Yes			Yes			No		

Volumes

Name	Burns Valley Rd			Rumsey Rd			Burns Valley Rd			Bowers Ave		
Base Volume Input [veh/h]	100	38	9	2	43	7	7	1	75	13	0	0
Base Volume Adjustment Factor	1.0000	1.0000	1.0000	1.0000	1.0000	1.0000	1.0000	1.0000	1.0000	1.0000	1.0000	1.0000
Heavy Vehicles Percentage [%]	2.00	2.00	2.00	2.00	2.00	2.00	2.00	2.00	2.00	2.00	2.00	2.00
Growth Factor	1.0000	1.0000	1.0000	1.0000	1.0000	1.0000	1.0000	1.0000	1.0000	1.0000	1.0000	1.0000
In-Process Volume [veh/h]	0	0	0	0	0	0	0	0	0	0	0	0
Site-Generated Trips [veh/h]	11	1	0	0	1	0	0	0	11	0	0	0
Diverted Trips [veh/h]	0	0	0	0	0	0	0	0	0	0	0	0
Pass-by Trips [veh/h]	0	0	0	0	0	0	0	0	0	0	0	0
Existing Site Adjustment Volume [veh/h]	0	0	0	0	0	0	0	0	0	0	0	0
Other Volume [veh/h]	0	0	0	0	0	0	0	0	0	0	0	0
Total Hourly Volume [veh/h]	111	39	9	2	44	7	7	1	86	13	0	0
Peak Hour Factor	0.8500	0.8500	0.8500	0.8500	0.8500	0.8500	0.8500	0.8500	0.8500	0.8500	0.8500	0.8500
Other Adjustment Factor	1.0000	1.0000	1.0000	1.0000	1.0000	1.0000	1.0000	1.0000	1.0000	1.0000	1.0000	1.0000
Total 15-Minute Volume [veh/h]	33	11	3	1	13	2	2	2	25	4	0	0
Total Analysis Volume [veh/h]	131	46	11	2	52	8	8	1	101	15	0	0
Pedestrian Volume [ped/h]	0			0			0			0		



Intersection Settings

Priority Scheme	Free	Free	Stop	Stop
Flared Lane			No	No
Storage Area [veh]	0	0	C	C
Two-Stage Gap Acceptance			No	No
Number of Storage Spaces in Median	0	0	0	C

Movement, Approach, & Intersection Results

V/C, Movement V/C Ratio	0.08	0.00	0.00	0.00	0.00	0.00	0.01	0.00	0.10	0.03	0.00	0.00
d_M, Delay for Movement [s/veh]	7.55	0.00	0.00	7.33	0.00	0.00	12.12	12.65	9.07	13.23	12.49	8.81
Movement LOS	A	A	A	A	A	A	B	B	A	B	B	A
95th-Percentile Queue Length [veh/ln]	0.28	0.28	0.28	0.00	0.00	0.00	0.39	0.39	0.39	0.10	0.10	0.10
95th-Percentile Queue Length [ft/ln]	6.94	6.94	6.94	0.10	0.10	0.10	9.87	9.87	9.87	2.57	2.57	2.57
d_A, Approach Delay [s/veh]	5.28			0.24			9.32			13.23		
Approach LOS	A			A			A			B		
d_I, Intersection Delay [s/veh]							5.94					
Intersection LOS	B											



Intersection Level Of Service Report
Intersection 5: Olympic Dr/Lakeshore Dr

Control Type: Two-way stop
Analysis Method: HCM 6th Edition
Analysis Period: 15 minutes
Delay (sec / veh): 18.2
Level Of Service: C
Volume to Capacity (v/c): 0.334

Intersection Setup

Name	Lakeshore Dr			Lakeshore Dr			Eastbound			Olympic Dr		
	Northbound			Southbound			Eastbound			Westbound		
Approach	←←←			→→→			→→→			←←←		
Lane Configuration	←←←			→→→			→→→			←←←		
Turning Movement	Left	Thru	Right	Left	Thru	Right	Left	Thru	Right	Left	Thru	Right
Lane Width [ft]	12.00	12.00	12.00	12.00	12.00	12.00	12.00	12.00	12.00	12.00	12.00	12.00
No. of Lanes in Entry Pocket	0	0	1	0	0	0	0	0	0	0	0	1
Entry Pocket Length [ft]	100.00	100.00	120.00	100.00	100.00	100.00	100.00	100.00	100.00	100.00	100.00	250.00
No. of Lanes in Exit Pocket	0	0	0	0	0	0	0	0	0	0	0	0
Exit Pocket Length [ft]	0.00	0.00	0.00	0.00	0.00	0.00	0.00	0.00	0.00	0.00	0.00	0.00
Speed [mph]	25.00			25.00			30.00			30.00		
Grade [%]	0.00			0.00			0.00			0.00		
Crosswalk	No			Yes			No			Yes		

Volumes

Name	Lakeshore Dr			Lakeshore Dr			Eastbound			Olympic Dr		
	1	198	114	66	180	1	0	2	2	108	3	141
Base Volume Input [veh/h]	1	198	114	66	180	1	0	2	2	108	3	141
Base Volume Adjustment Factor	1.0000	1.0000	1.0000	1.0000	1.0000	1.0000	1.0000	1.0000	1.0000	1.0000	1.0000	1.0000
Heavy Vehicles Percentage [%]	2.00	2.00	2.00	2.00	2.00	2.00	2.00	2.00	2.00	2.00	2.00	2.00
Growth Factor	1.0000	1.0000	1.0000	1.0000	1.0000	1.0000	1.0000	1.0000	1.0000	1.0000	1.0000	1.0000
In-Process Volume [veh/h]	0	0	0	0	0	0	0	0	0	0	0	0
Site-Generated Trips [veh/h]	0	1	24	22	2	0	0	0	0	30	0	27
Diverted Trips [veh/h]	0	0	0	0	0	0	0	0	0	0	0	0
Pass-by Trips [veh/h]	0	0	0	0	0	0	0	0	0	0	0	0
Existing Site Adjustment Volume [veh/h]	0	0	0	0	0	0	0	0	0	0	0	0
Other Volume [veh/h]	0	0	0	0	0	0	0	0	0	0	0	0
Total Hourly Volume [veh/h]	1	199	138	88	182	1	0	2	2	136	3	168
Peak Hour Factor	1.0000	1.0000	1.0000	1.0000	1.0000	1.0000	1.0000	1.0000	1.0000	1.0000	1.0000	1.0000
Other Adjustment Factor	1.0000	1.0000	1.0000	1.0000	1.0000	1.0000	1.0000	1.0000	1.0000	1.0000	1.0000	1.0000
Total 15-Minute Volume [veh/h]	0	50	35	22	46	0	0	1	1	34	1	42
Total Analysis Volume [veh/h]	1	199	138	88	182	1	0	2	2	136	3	168
Pedestrian Volume [ped/h]		0		0			0			1		



Intersection Settings

Priority Scheme	Free	Free	Stop	Stop
Flared Lane			No	No
Storage Area [veh]	0	0	0	0
Two-Stage Gap Acceptance			No	No
Number of Storage Spaces in Median	0	0	0	0

Movement, Approach, & Intersection Results

V/C, Movement V/C Ratio	0.00	0.30	0.00	0.07	0.00	0.00	0.00	0.01	0.00	0.33	0.01	0.20
d_M, Delay for Movement [s/veh]	7.59	0.00	0.00	8.18	0.00	0.00	18.89	15.83	9.25	18.22	15.12	10.42
Movement LOS	A	A	A	A	A	C	C	A	C	C	B	B
95th-Percentile Queue Length [veh/ln]	0.00	0.00	0.00	0.23	0.23	0.23	0.03	0.03	0.03	1.44	0.78	0.78
95th-Percentile Queue Length [ft/ln]	0.05	0.05	0.00	5.82	5.82	5.82	3.53	0.63	0.63	36.10	19.45	19.45
d_A, Approach Delay [s/veh]	0.02		2.66			12.54		13.92				
Approach LOS	A		A			B		B				
d_I, Intersection Delay [s/veh]	5.49											
Intersection LOS	C											



Intersection Level Of Service Report
Intersection 7: Olympic Dr/Burns Valley Rd-Old Hwy 53

Control Type: Signalized
Analysis Method: HCM 6th Edition
Analysis Period: 15 minutes
Delay (sec / veh): 14.3
Level Of Service: B
Volume to Capacity (v/c): 0.815

Intersection Setup

Name	Old Hwy 53			Burns Valley Rd			Olympic Dr			Old Hwy 53		
Approach	Northbound			Southbound			Eastbound			Westbound		
Lane Configuration	[Diagram]			[Diagram]			[Diagram]			[Diagram]		
Turning Movement	Left	Thru	Right	Left	Thru	Right	Left	Thru	Right	Left	Thru	Right
Lane Width [ft]	12.00	12.00	12.00	12.00	12.00	12.00	12.00	12.00	12.00	12.00	12.00	12.00
No. of Lanes in Entry Pocket	1	0	1	1	0	0	1	0	0	1	0	0
Entry Pocket Length [ft]	100.00	100.00	100.00	56.00	100.00	100.00	48.00	100.00	100.00	100.00	100.00	100.00
No. of Lanes in Exit Pocket	0	0	0	0	0	0	0	0	0	0	0	0
Exit Pocket Length [ft]	0.00	0.00	0.00	0.00	0.00	0.00	0.00	0.00	0.00	0.00	0.00	0.00
Speed [mph]	30.00			30.00			35.00			35.00		
Grade [%]	0.00			0.00			0.00			0.00		
Curb Present	No			No			No			No		
Crosswalk	Yes			Yes			Yes			Yes		



Volumes

Name	Old Hwy 53			Burns Valley Rd			Olympic Dr			Old Hwy 53		
Base Volume Input [veh/h]	98	113	58	112	97	46	21	184	93	62	221	139
Base Volume Adjustment Factor	1.0000	1.0000	1.0000	1.0000	1.0000	1.0000	1.0000	1.0000	1.0000	1.0000	1.0000	1.0000
Heavy Vehicles Percentage [%]	2.00	2.00	2.00	2.00	2.00	2.00	2.00	2.00	2.00	2.00	2.00	2.00
Growth Factor	1.0000	1.0000	1.0000	1.0000	1.0000	1.0000	1.0000	1.0000	1.0000	1.0000	1.0000	1.0000
In-Process Volume [veh/h]	0	0	0	0	0	0	0	0	0	0	0	0
Site-Generated Trips [veh/h]	28	4	40	0	6	6	8	51	38	45	36	0
Diverted Trips [veh/h]	0	0	0	0	0	0	0	0	0	0	0	0
Pass-by Trips [veh/h]	0	0	0	0	0	0	0	0	0	0	0	0
Existing Site Adjustment Volume [veh/h]	0	0	0	0	0	0	0	0	0	0	0	0
Other Volume [veh/h]	0	0	0	0	0	0	0	0	0	0	0	0
Right Turn on Red Volume [veh/h]	0	0	19	0	0	3	0	0	5	0	0	20
Total Hourly Volume [veh/h]	126	117	77	112	103	49	29	235	126	107	257	119
Peak Hour Factor	1.0000	1.0000	1.0000	1.0000	1.0000	1.0000	1.0000	1.0000	1.0000	1.0000	1.0000	1.0000
Other Adjustment Factor	1.0000	1.0000	1.0000	1.0000	1.0000	1.0000	1.0000	1.0000	1.0000	1.0000	1.0000	1.0000
Total 15-Minute Volume [veh/h]	32	29	19	28	26	12	7	59	32	27	64	30
Total Analysis Volume [veh/h]	126	117	77	112	103	49	29	235	126	107	257	119
Presence of On-Street Parking	No	No	No	No	No	No	No	No	No	No	No	No
On-Street Parking Maneuver Rate [1/h]	0	0	0	0	0	0	0	0	0	0	0	0
Local Bus Stopping Rate [1/h]	0	0	0	0	0	0	0	0	0	0	0	0
v_do, Outbound Pedestrian Volume crossing major street	1						1					1
v_di, Inbound Pedestrian Volume crossing major street	1											1
v_oo, Outbound Pedestrian Volume crossing minor street	1											0
v_oi, Inbound Pedestrian Volume crossing minor street	0											0
v_ab, Corner Pedestrian Volume [ped/h]	0											0
Bicycle Volume [bicycles/h]	0											1



Intersection Settings

Located in CBD	Yes
Signal Coordination Group	-
Cycle Length [s]	109
Coordination Type	Time of Day Pattern Isolated
Actuation Type	Fully actuated
Offset [s]	0.0
Offset Reference	Lead Green - Beginning of First Green
Permissive Mode	SingleBand
Lost time [s]	14.00

Phasing & Timing

Control Type	Protect	Permis	Permis	Protect	Permis	Permis	Protect	Permis	Permis	Protect	Permis	Permis
Signal Group	3	8	0	7	4	0	5	2	0	1	6	0
Auxiliary Signal Groups												
Lead / Lag	Lead	-	-	Lead	-	-	Lead	-	-	Lead	-	-
Minimum Green [s]	4	6	0	4	6	0	4	6	0	4	6	0
Maximum Green [s]	20	25	0	20	25	0	20	30	0	20	20	0
Amber [s]	3.0	3.3	0.0	3.0	3.3	0.0	3.0	3.6	0.0	3.0	3.6	0.0
All red [s]	0.0	0.3	0.0	0.0	0.3	0.0	0.0	0.3	0.0	0.0	0.3	0.0
Split [s]	23	29	0	23	29	0	23	34	0	23	34	0
Vehicle Extension [s]	0.0	0.0	0.0	0.0	0.0	0.0	0.0	0.0	0.0	0.0	0.0	0.0
Walk [s]	0	7	0	0	7	0	0	7	0	0	7	0
Pedestrian Clearance [s]	0	11	0	0	9	0	0	14	0	0	9	0
Delayed Vehicle Green [s]	0.0	0.0	0.0	0.0	0.0	0.0	0.0	0.0	0.0	0.0	0.0	0.0
Rest In Walk		No			No			No			No	
I1, Start-Up Lost Time [s]	2.0	2.0	0.0	2.0	2.0	0.0	2.0	2.0	0.0	2.0	2.0	0.0
I2, Clearance Lost Time [s]	1.0	1.6	0.0	1.0	1.6	0.0	1.0	1.9	0.0	1.0	1.9	0.0
Minimum Recall	No	No		No	No		No	No		No	No	
Maximum Recall	No	No		No	No		No	No		No	No	
Pedestrian Recall	No	No		No	No		No	No		No	No	
Detector Location [ft]	0.0	0.0	0.0	0.0	0.0	0.0	0.0	0.0	0.0	0.0	0.0	0.0
Detector Length [ft]	0.0	0.0	0.0	0.0	0.0	0.0	0.0	0.0	0.0	0.0	0.0	0.0
I, Upstream Filtering Factor	1.00	1.00	1.00	1.00	1.00	1.00	1.00	1.00	1.00	1.00	1.00	1.00

Exclusive Pedestrian Phase

Pedestrian Signal Group	0
Pedestrian Walk [s]	0
Pedestrian Clearance [s]	0



Lane Group Calculations

Lane Group	L	C	R	L	C	L	C	L	C
C, Cycle Length [s]	33	33	33	33	33	33	33	33	33
L, Total Lost Time per Cycle [s]	3.00	3.60	3.60	3.00	3.60	3.00	3.90	3.00	3.90
I1_p, Permitted Start-Up Lost Time [s]	0.00	0.00	0.00	0.00	0.00	0.00	0.00	0.00	0.00
I2, Clearance Lost Time [s]	1.00	1.60	1.60	1.00	1.60	1.00	1.90	1.00	1.90
g1, Effective Green Time [s]	3	5	5	3	5	1	9	3	11
g / C, Green / Cycle	0.10	0.16	0.16	0.08	0.14	0.03	0.27	0.08	0.32
(v / s)_ Volume / Saturation Flow Rate	0.08	0.07	0.05	0.07	0.10	0.02	0.23	0.07	0.24
s, saturation flow rate [veh/h]	1603	1683	1421	1603	1590	1603	1584	1603	1582
c, Capacity [veh/h]	154	262	221	136	229	46	429	129	511
d1, Uniform Delay [s]	14.66	12.67	12.46	14.90	13.39	15.89	11.38	14.98	9.95
k, delay calibration	0.04	0.04	0.04	0.04	0.04	0.04	0.04	0.04	0.04
I, Upstream Filtering Factor	1.00	1.00	1.00	1.00	1.00	1.00	1.00	1.00	1.00
d2, Incremental Delay [s]	3.99	0.44	0.35	4.72	1.23	5.14	1.73	5.05	0.78
d3, Initial Queue Delay [s]	0.00	0.00	0.00	0.00	0.00	0.00	0.00	0.00	0.00
Rp, platoon ratio	1.00	1.00	1.00	1.00	1.00	1.00	1.00	1.00	1.00
PF, progression factor	1.00	1.00	1.00	1.00	1.00	1.00	1.00	1.00	1.00

Lane Group Results

X, volume / capacity	0.82	0.45	0.35	0.83	0.66	0.63	0.84	0.83	0.74
d, Delay for Lane Group [s/veh]	18.66	13.11	12.81	19.62	14.62	21.02	13.12	20.04	10.73
Lane Group LOS	B	B	B	B	B	C	B	C	B
Critical Lane Group	Yes	No	No	No	Yes	No	Yes	Yes	No
50th-Percentile Queue Length [veh/ln]	0.91	0.64	0.42	0.84	0.91	0.24	1.87	0.79	1.64
50th-Percentile Queue Length [ft/ln]	22.71	16.03	10.39	21.00	22.74	5.91	46.87	19.75	40.96
95th-Percentile Queue Length [veh/ln]	1.63	1.15	0.75	1.51	1.64	0.43	3.37	1.42	2.95
95th-Percentile Queue Length [ft/ln]	40.87	28.85	18.89	37.80	40.93	10.64	84.36	35.55	73.73



Movement, Approach, & Intersection Results

d_M, Delay for Movement [s/veh]	18.65	13.11	12.81	19.62	14.62	14.62	21.02	13.12	13.12	20.04	10.73	10.73
Movement LOS	B	B	B	B	B	B	C	B	B	C	B	B
d_A, Approach Delay [s/veh]	15.22			16.74			13.71			12.79		
Approach LOS	B			B			B			B		
d_I, Intersection Delay [s/veh]							14.29					
Intersection LOS							B					
Intersection V/C							0.815					

Other Modes

g_Walk, Effective Walk Time [s]	11.0	11.0	11.0	11.0
M_corner, Corner Circulation Area [ft²/ped]	0.00	0.00	0.00	0.00
M_CW, Crosswalk Circulation Area [ft²/ped]	0.00	0.00	0.00	0.00
d_p, Pedestrian Delay [s]	7.31	7.31	7.31	7.31
L_p,int, Pedestrian LOS Score for Intersection	2.261	2.061	2.199	2.264
Crosswalk LOS	B	B	B	B
s_b, Saturation Flow Rate of the bicycle lane [bicycles/s/ft]	2000	2000	2000	2000
c_b, Capacity of the bicycle lane [bicycles/h]	1542	1542	1827	1827
d_b, Bicycle Delay [s]	0.86	0.86	0.12	0.12
L_b,int, Bicycle LOS Score for Intersection	2.119	2.000	2.211	2.390
Bicycle LOS	B	B	B	B

Sequence

Ring 1	1	2	3	4	-	-	-	-	-	-	-	-	-	-
Ring 2	5	6	7	8	-	-	-	-	-	-	-	-	-	-
Ring 3	-	-	-	-	-	-	-	-	-	-	-	-	-	-
Ring 4	-	-	-	-	-	-	-	-	-	-	-	-	-	-

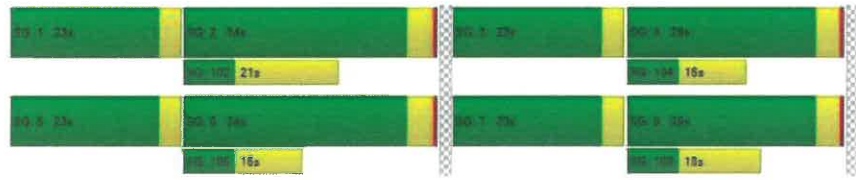

Intersection Level Of Service Report
Intersection 2: Burns Valley Rd/Bowers Ave-Rumsey Rd

Control Type:	Two-way stop	Delay (sec / veh):	12.3
Analysis Method:	HCM 6th Edition	Level Of Service:	B
Analysis Period:	15 minutes	Volume to Capacity (v/c):	0.004

Intersection Setup

Name	Burns Valley Rd			Rumsey Rd			Burns Valley Rd			Bowers Ave		
Approach	Northbound			Southbound			Eastbound			Westbound		
Lane Configuration	+			+			+			+		
Turning Movement	Left	Thru	Right	Left	Thru	Right	Left	Thru	Right	Left	Thru	Right
Lane Width [ft]	12.00	12.00	12.00	12.00	12.00	12.00	12.00	12.00	12.00	12.00	12.00	12.00
No. of Lanes in Entry Pocket	0	0	0	0	0	0	0	0	0	0	0	0
Entry Pocket Length [ft]	100.00	100.00	100.00	100.00	100.00	100.00	100.00	100.00	100.00	100.00	100.00	100.00
No. of Lanes in Exit Pocket	0	0	0	0	0	0	0	0	0	0	0	0
Exit Pocket Length [ft]	0.00	0.00	0.00	0.00	0.00	0.00	0.00	0.00	0.00	0.00	0.00	0.00
Speed [mph]	30.00			30.00			35.00			25.00		
Grade [%]	0.00			0.00			0.00			0.00		
Crosswalk	No			Yes			Yes			No		

Volumes

Name	Burns Valley Rd			Rumsey Rd			Burns Valley Rd			Bowers Ave		
Base Volume Input [veh/h]	84	36	1	0	31	9	10	0	83	2	1	0
Base Volume Adjustment Factor	1.0000	1.0000	1.0000	1.0000	1.0000	1.0000	1.0000	1.0000	1.0000	1.0000	1.0000	1.0000
Heavy Vehicles Percentage [%]	2.00	2.00	2.00	2.00	2.00	2.00	2.00	2.00	2.00	2.00	2.00	2.00
Growth Factor	1.0000	1.0000	1.0000	1.0000	1.0000	1.0000	1.0000	1.0000	1.0000	1.0000	1.0000	1.0000
In-Process Volume [veh/h]	0	0	0	0	0	0	0	0	0	0	0	0
Site-Generated Trips [veh/h]	14	1	0	0	1	0	0	0	15	0	0	0
Diverted Trips [veh/h]	0	0	0	0	0	0	0	0	0	0	0	0
Pass-by Trips [veh/h]	0	0	0	0	0	0	0	0	0	0	0	0
Existing Site Adjustment Volume [veh/h]	0	0	0	0	0	0	0	0	0	0	0	0
Other Volume [veh/h]	0	0	0	0	0	0	0	0	0	0	0	0
Total Hourly Volume [veh/h]	98	37	1	0	32	9	10	0	98	2	1	0
Peak Hour Factor	0.8500	0.9500	0.9600	0.9600	0.9600	0.8500	0.8500	0.8500	0.8500	0.9600	0.8500	0.9600
Other Adjustment Factor	1.0000	1.0000	1.0000	1.0000	1.0000	1.0000	1.0000	1.0000	1.0000	1.0000	1.0000	1.0000
Total 15-Minute Volume [veh/h]	29	10	0	0	8	3	3	0	29	1	0	0
Total Analysis Volume [veh/h]	115	39	1	0	33	11	12	0	115	2	1	0
Pedestrian Volume [ped/h]	0			0			0			0		



Intersection Settings

	Free	Free	Stop	Stop
Priority Scheme				
Flared Lane			No	No
Storage Area [veh]	0	0	0	0
Two-Stage Gap Acceptance			No	No
Number of Storage Spaces in Median	0	0	0	0

Movement, Approach, & Intersection Results

V/C, Movement V/C Ratio	0.07	0.06	0.00	0.00	0.00	0.02	0.00	0.11	0.00	0.00	0.00
d_M, Delay for Movement [s/veh]	7.48	0.00	0.00	7.29	0.00	0.00	11.50	11.99	9.04	12.32	11.51
Movement LOS	A	A	A	A	A	B	A	B	A	B	A
95th-Percentile Queue Length [veh/ln]	0.24	0.24	0.24	0.00	0.00	0.45	0.45	0.45	0.02	0.02	0.92
95th-Percentile Queue Length [ft/ln]	5.94	5.94	5.94	0.00	0.00	11.27	11.27	11.27	0.44	0.44	0.44
d_A, Approach Delay [s/veh]	5.55			0.00			9.28			12.05	
Approach LOS	A			A			A			B	
d_I, Intersection Delay [s/veh]	6.31										
Intersection LOS	B										



Intersection Level Of Service Report
Intersection 5: Olympic Dr/Lakeshore Dr

Control Type:	Two-way stop	Delay (sec / veh):	21.3
Analysis Method:	HCM 6th Edition	Level Of Service:	C
Analysis Period:	15 minutes	Volume to Capacity (v/c):	0.390

Intersection Setup

Name	Lakeshore Dr			Lakeshore Dr			Eastbound			Olympic Dr		
Approach	Northbound			Southbound			Eastbound			Westbound		
Lane Configuration	+			+			+			+		
Turning Movement	Left	Thru	Right	Left	Thru	Right	Left	Thru	Right	Left	Thru	Right
Lane Width [ft]	12.00	12.00	12.00	12.00	12.00	12.00	12.00	12.00	12.00	12.00	12.00	12.00
No. of Lanes in Entry Pocket	0	0	1	0	0	0	0	0	0	0	0	1
Entry Pocket Length [ft]	100.00	100.00	120.00	100.00	100.00	100.00	100.00	100.00	100.00	100.00	100.00	250.00
No. of Lanes in Exit Pocket	0	0	0	0	0	0	0	0	0	0	0	0
Exit Pocket Length [ft]	0.00	0.00	0.00	0.00	0.00	0.00	0.00	0.00	0.00	0.00	0.00	0.00
Speed [mph]	25.00			25.00			30.00			30.00		
Grade [%]	0.00			0.00			0.00			0.00		
Crosswalk	No			Yes			No			Yes		

Volumes

Name	Lakeshore Dr			Lakeshore Dr			Eastbound			Olympic Dr		
Base Volume Input [veh/h]	1	176	103	73	185	0	0	3	3	97	1	75
Base Volume Adjustment Factor	1.0000	1.0000	1.0000	1.0000	1.0000	1.0000	1.0000	1.0000	1.0000	1.0000	1.0000	1.0000
Heavy Vehicles Percentage [%]	2.00	2.00	2.00	2.00	2.00	2.00	2.00	2.00	2.00	2.00	2.00	2.00
Growth Factor	1.0000	1.0000	1.0000	1.0000	1.0000	1.0000	1.0000	1.0000	1.0000	1.0000	1.0000	1.0000
In-Process Volume [veh/h]	0	0	0	0	0	0	0	0	0	0	0	0
Site-Generated Trips [veh/h]	0	0	24	30	0	0	0	0	0	30	0	32
Diverted Trips [veh/h]	0	0	0	0	0	0	0	0	0	0	0	0
Pass-by Trips [veh/h]	0	0	0	0	0	0	0	0	0	0	0	0
Existing Site Adjustment Volume [veh/h]	0	0	0	0	0	0	0	0	0	0	0	0
Other Volume [veh/h]	0	0	0	0	0	0	0	0	0	0	0	0
Total Hourly Volume [veh/h]	1	176	127	103	185	0	0	3	3	127	1	107
Peak Hour Factor	0.9100	0.9100	0.9100	0.9100	0.9100	0.9100	0.9100	0.9100	0.9100	0.9100	0.9100	0.9100
Other Adjustment Factor	1.0000	1.0000	1.0000	1.0000	1.0000	1.0000	1.0000	1.0000	1.0000	1.0000	1.0000	1.0000
Total 15-Minute Volume [veh/h]	0	48	35	28	51	0	0	1	1	35	0	29
Total Analysis Volume [veh/h]	1	193	140	113	203	0	0	3	3	140	1	118
Pedestrian Volume [ped/h]	0	0	0	0	0	0	0	0	0	0	0	1



Intersection Settings

Priority Scheme	Free	Free	Stop	Stop
Flared Lane			No	No
Storage Area [veh]	0	0	0	0
Two-Stage Gap Acceptance			No	No
Number of Storage Spaces in Median	0	0	0	0

Movement, Approach, & Intersection Results

VIC, Movement V/C Ratio	0.00	0.07	0.06	0.09	0.03	0.06	0.00	0.01	0.00	0.39	0.00	0.14
d_M, Delay for Movement [s/veh]	7.63	0.00	0.06	8.24	0.03	0.00	16.10	17.19	9.41	21.27	15.74	9.96
Movement LOS	A	A	A	A	A	C	C	A	C	C	C	A
95th-Percentile Queue Length [veh/ln]	0.00	0.00	0.00	0.30	0.30	0.30	0.04	0.04	1.80	0.49	0.49	
95th-Percentile Queue Length [ft/ln]	0.05	0.05	0.00	7.61	7.61	7.61	1.04	1.04	44.63	12.36	12.36	
d_A, Approach Delay [s/veh]	0.02			2.95			13.30			16.10		
Approach LOS	A			A			B			C		
d_I, Intersection Delay [s/veh]	5.67											
Intersection LOS	C											

Intersection Level of Service Report

Intersection 7: Olympic Dr/Burns Valley Rd-Old Hwy 53

Control Type:	Signalized	Delay (sec / veh):	14.2
Analysis Method:	HCM 6th Edition	Level of Service:	B
Analysis Period:	15 minutes	Volume to Capacity (v/c):	0.799

Intersection Setup

Name	Old Hwy 53			Burns Valley Rd			Olympic Dr			Old Hwy 53		
Approach	Northbound			Southbound			Eastbound			Westbound		
Lane Configuration	T T T			T T			T T			T T		
Turning Movement	Left	Thru	Right	Left	Thru	Right	Left	Thru	Right	Left	Thru	Right
Lane Width [ft]	12.00	12.00	12.00	12.00	12.00	12.00	12.00	12.00	12.00	12.00	12.00	12.00
No. of Lanes in Entry Pocket	1	0	1	1	0	0	1	0	0	1	0	0
Entry Pocket Length [ft]	100.00	100.00	100.00	56.00	100.00	100.00	48.00	100.00	100.00	100.00	100.00	100.00
No. of Lanes in Exit Pocket	0	0	0	0	0	0	0	0	0	0	0	0
Exit Pocket Length [ft]	0.00	0.00	0.00	0.00	0.00	0.00	0.00	0.00	0.00	0.00	0.00	0.00
Speed [mph]	30.00			30.00			35.00			35.00		
Grade [%]	0.00			0.00			0.00			0.00		
Curb Present	No			No			No			No		
Crosswalk	Yes			Yes			Yes			Yes		



Volumes

Name	Old Hwy 53			Burns Valley Rd			Olympic Dr			Old Hwy 53		
Base Volume Input [veh/h]	80	81	42	93	64	30	20	180	95	33	170	109
Base Volume Adjustment Factor	1.0000	1.0000	1.0000	1.0000	1.0000	1.0000	1.0000	1.0000	1.0000	1.0000	1.0000	1.0000
Heavy Vehicles Percentage [%]	2.00	2.00	2.00	2.00	2.00	2.00	2.00	2.00	2.00	2.00	2.00	2.00
Growth Factor	1.0000	1.0000	1.0000	1.0000	1.0000	1.0000	1.0000	1.0000	1.0000	1.0000	1.0000	1.0000
In-Process Volume [veh/h]	0	0	0	0	0	0	0	0	0	0	0	0
Site-Generated Trips [veh/h]	33	7	56	0	10	6	8	51	46	68	36	0
Diverted Trips [veh/h]	0	0	0	0	0	0	0	0	0	0	0	0
Pass-by Trips [veh/h]	0	0	0	0	0	0	0	0	0	0	0	0
Existing Site Adjustment Volume [veh/h]	0	0	0	0	0	0	0	0	0	0	0	0
Other Volume [veh/h]	0	0	0	0	0	0	0	0	0	0	0	0
Right Turn on Red Volume [veh/h]	0	0	19	0	0	3	0	0	0	5	0	20
Total Hourly Volume [veh/h]	113	88	79	93	74	33	28	231	136	101	206	89
Peak Hour Factor	0.9300	0.9300	0.9300	0.9300	0.9300	0.9300	0.9300	0.9300	0.9300	0.9300	0.9300	0.9300
Other Adjustment Factor	1.0000	1.0000	1.0000	1.0000	1.0000	1.0000	1.0000	1.0000	1.0000	1.0000	1.0000	1.0000
Total 15-Minute Volume [veh/h]	30	24	21	25	20	9	8	62	37	27	55	24
Total Analysis Volume [veh/h]	122	95	85	100	80	35	30	248	146	109	222	96
Presence of On-Street Parking	No	No	No	No	No	No	No	No	No	No	No	No
On-Street Parking Maneuver Rate [1/h]	0	0	0	0	0	0	0	0	0	0	0	0
Local Bus Stopping Rate [1/h]	0	0	0	0	0	0	0	0	0	0	0	0
v_do, Outbound Pedestrian Volume crossing major street [ped/h]	1			0			1			1		
v_di, Inbound Pedestrian Volume crossing major street [ped/h]	1			1			0			0		
v_co, Outbound Pedestrian Volume crossing minor street [ped/h]	1			0			0			0		
v_ci, Inbound Pedestrian Volume crossing minor street [ped/h]	0			0			1			0		
v_ab, Corner Pedestrian Volume [ped/h]	0			0			0			0		
Bicycle Volume [bicycles/h]	0			0			0			1		



Intersection Settings

Located in CBD	Yes
Signal Coordination Group	-
Cycle Length [s]	109
Coordination Type	Time of Day Pattern Isolated
Actuation Type	Fully actuated
Offset [s]	0.0
Offset Reference	Lead Green - Beginning of First Green
Permissive Mode	SingleBand
Lost time [s]	14.00

Phasing & Timing

Control Type	Protect	Perms	Perms	Protect	Perms	Perms	Protect	Perms	Perms	Protect	Perms	Perms
Signal Group	3	8	0	7	4	0	5	2	0	1	6	0
Auxiliary Signal Groups												
Lead / Lag	Lead	-	-	Lead	-	-	Lead	-	-	Lead	-	-
Minimum Green [s]	4	6	0	4	6	0	4	6	0	4	6	0
Maximum Green [s]	20	25	0	20	25	0	20	30	0	20	20	0
Amber [s]	3.0	3.3	0.0	3.0	3.3	0.0	3.0	3.6	0.0	3.0	3.6	0.0
All red [s]	0.0	0.3	0.0	0.0	0.3	0.0	0.0	0.3	0.0	0.0	0.3	0.0
Split [s]	23	29	0	23	29	0	23	34	0	23	34	0
Vehicle Extension [s]	0.0	0.0	0.0	0.0	0.0	0.0	0.0	0.0	0.0	0.0	0.0	0.0
Walk [s]	0	7	0	0	7	0	0	7	0	0	7	0
Pedestrian Clearance [s]	0	11	0	0	9	0	0	14	0	0	9	0
Delayed Vehicle Green [s]	0.0	0.0	0.0	0.0	0.0	0.0	0.0	0.0	0.0	0.0	0.0	0.0
Rest In Walk	No			No			No			No		
I1, Start-Up Lost Time [s]	2.0	2.0	0.0	2.0	2.0	0.0	2.0	2.0	0.0	2.0	2.0	0.0
I2, Clearance Lost Time [s]	1.0	1.6	0.0	1.0	1.6	0.0	1.0	1.9	0.0	1.0	1.9	0.0
Minimum Recall	No	No		No	No		No	No		No	No	
Maximum Recall	No	No		No	No		No	No		No	No	
Pedestrian Recall	No	No		No	No		No	No		No	No	
Detector Location [ft]	0.0	0.0	0.0	0.0	0.0	0.0	0.0	0.0	0.0	0.0	0.0	0.0
Detector Length [ft]	0.0	0.0	0.0	0.0	0.0	0.0	0.0	0.0	0.0	0.0	0.0	0.0
I, Upstream Filtering Factor	1.00	1.00	1.00	1.00	1.00	1.00	1.00	1.00	1.00	1.00	1.00	1.00

Exclusive Pedestrian Phase

Pedestrian Signal Group	0
Pedestrian Walk [s]	0
Pedestrian Clearance [s]	0



Lane Group Calculations

Lane Group	L	C	R	L	C	L	C	L	C
C, Cycle Length [s]	34	34	34	34	34	34	34	34	34
L, Total Lost Time per Cycle [s]	3.00	3.00	3.00	3.00	3.00	3.00	3.00	3.00	3.00
M_p, Permitted Start-Up Lost Time [s]	0.00	0.00	0.00	0.00	0.00	0.00	0.00	0.00	0.00
I2, Clearance Lost Time [s]	1.00	1.60	1.60	1.00	1.60	1.00	1.60	1.00	1.60
g_i, Effective Green Time [s]	3	5	5	2	4	1	10	3	12
g / C, Green / Cycle	0.09	0.15	0.15	0.07	0.13	0.03	0.29	0.08	0.34
(v / s)_j Volume / Saturation Flow Rate	0.08	0.06	0.06	0.06	0.07	0.02	0.25	0.07	0.20
s, saturation flow rate [veh/h]	1603	1683	1421	1603	1595	1603	1579	1603	1586
c, Capacity [veh/h]	149	252	213	120	210	47	461	132	547
d1, Uniform Delay [s]	15.00	12.90	12.94	15.37	13.68	16.16	11.24	15.22	9.03
k, delay calibration	0.04	0.04	0.04	0.04	0.04	0.04	0.04	0.04	0.04
I, Upstream Filtering Factor	1.00	1.00	1.00	1.00	1.00	1.00	1.00	1.00	1.00
d2, Incremental Delay [s]	4.18	0.35	0.45	5.61	0.83	5.12	1.77	4.92	0.36
d3, Initial Queue Delay [s]	0.00	0.00	0.00	0.00	0.00	0.00	0.00	0.00	0.00
Rp, platoon ratio	1.00	1.00	1.00	1.00	1.00	1.00	1.00	1.00	1.00
PF, progression factor	1.00	1.00	1.00	1.00	1.00	1.00	1.00	1.00	1.00

Lane Group Results

X, volume / capacity	0.82	0.38	0.40	0.83	0.55	0.63	0.85	0.83	0.58
d, Delay for Lane Group [s/veh]	19.18	13.25	13.39	20.98	14.51	21.29	13.01	20.14	9.40
Lane Group LOS	B	B	B	C	B	C	B	C	A
Critical Lane Group	Yes	No	No	No	Yes	No	Yes	Yes	No
50th-Percentile Queue Length [veh/ln]	0.91	0.53	0.48	0.80	0.69	0.25	2.06	0.62	1.25
50th-Percentile Queue Length [ft/ln]	22.73	13.29	12.05	19.98	17.34	6.22	51.52	20.43	31.25
95th-Percentile Queue Length [veh/ln]	1.64	0.96	0.87	1.44	1.25	0.45	3.71	1.47	2.25
95th-Percentile Queue Length [ft/ln]	40.91	23.93	21.69	35.97	31.22	11.20	92.73	36.78	56.24

Movement, Approach, & Intersection Results

	19.18	13.25	13.39	20.98	14.51	14.51	21.29	13.01	13.01	20.14	9.40	9.40
d_M, Delay for Movement [s/veh]												
Movement LOS	B	B	B	C	B	B	C	B	B	C	A	A
d_A, Approach Delay [s/veh]	15.68			17.52			13.60			12.14		
Approach LOS	B			B			B			B		
d_I, Intersection Delay [s/veh]	14.22											
Intersection LOS	B											
Intersection V/C	0.799											

Other Modes

g_Walk,mi, Effective Walk Time [s]	11.0	11.0	11.0	11.0
M_corner, Corner Circulation Area [ft ² /ped]	0.00	0.00	0.00	0.00
M_CW, Crosswalk Circulation Area [ft ² /ped]	0.00	0.00	0.00	0.00
d_p, Pedestrian Delay [s]	7.58	7.58	7.58	7.58
L_p,int, Pedestrian LOS Score for Intersection	2.258	2.032	2.193	2.248
Crosswalk LOS	B	B	B	B
s_b, Saturation Flow Rate of the bicycle lane [bicycles/h]	2000	2000	2000	2000
c_b, Capacity of the bicycle lane [bicycles/h]	1514	1514	1794	1794
d_b, Bicycle Delay [s]	0.99	0.99	0.18	0.18
L_b,int, Bicycle LOS Score for Intersection	2.089	1.919	2.267	2.297
Bicycle LOS	B	A	B	B

Sequence

Ring	1	2	3	4	-	-	-	-	-	-	-	-	-	-	-
Ring 1	1	2	3	4	-	-	-	-	-	-	-	-	-	-	-
Ring 2	5	6	7	8	-	-	-	-	-	-	-	-	-	-	-
Ring 3	-	-	-	-	-	-	-	-	-	-	-	-	-	-	-
Ring 4	-	-	-	-	-	-	-	-	-	-	-	-	-	-	-

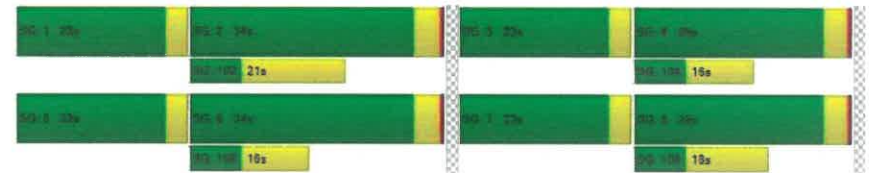

Intersection Level Of Service Report

Intersection 2: Burns Valley Rd/Bowers Ave-Rumsey Rd

Control Type: Two-way stop
 Analysis Method: HCM 6th Edition
 Analysis Period: 15 minutes
 Delay (sec / veh): 19.0
 Level Of Service: C
 Volume to Capacity (v/c): 0.034

Intersection Setup

Name	Burns Valley Rd			Rumsey Rd			Burns Valley Rd			Bowers Ave		
Approach	Northbound			Southbound			Eastbound			Westbound		
Lane Configuration	+			+			+			+		
Turning Movement	Left	Thru	Right	Left	Thru	Right	Left	Thru	Right	Left	Thru	Right
Lane Width [ft]	12.00	12.00	12.00	12.00	12.00	12.00	12.00	12.00	12.00	12.00	12.00	12.00
No. of Lanes in Entry Pocket	0	0	0	0	0	0	0	0	0	0	0	0
Entry Pocket Length [ft]	100.00	100.00	100.00	100.00	100.00	100.00	100.00	100.00	100.00	100.00	100.00	100.00
No. of Lanes in Exit Pocket	0	0	0	0	0	0	0	0	0	0	0	0
Exit Pocket Length [ft]	0.00	0.00	0.00	0.00	0.00	0.00	0.00	0.00	0.00	0.00	0.00	0.00
Speed [mph]	30.00			30.00			35.00			25.00		
Grade [%]	0.00			0.00			0.00			0.00		
Crosswalk	No			Yes			Yes			No		

Volumes

Name	Burns Valley Rd			Rumsey Rd			Burns Valley Rd			Bowers Ave		
Base Volume Input [veh/h]	215	46	11	0	41	28	16	2	219	9	2	0
Base Volume Adjustment Factor	1.0000	1.0000	1.0000	1.0000	1.0000	1.0000	1.0000	1.0000	1.0000	1.0000	1.0000	1.0000
Heavy Vehicles Percentage [%]	2.00	2.00	2.00	2.00	2.00	2.00	2.00	2.00	2.00	2.00	2.00	2.00
Growth Factor	1.0000	1.0000	1.0000	1.0000	1.0000	1.0000	1.0000	1.0000	1.0000	1.0000	1.0000	1.0000
In-Process Volume [veh/h]	0	0	0	0	0	0	0	0	0	0	0	0
Site-Generated Trips [veh/h]	0	0	0	0	0	0	0	0	0	0	0	0
Diverted Trips [veh/h]	0	0	0	0	0	0	0	0	0	0	0	0
Pass-by Trips [veh/h]	0	0	0	0	0	0	0	0	0	0	0	0
Existing Site Adjustment Volume [veh/h]	0	0	0	0	0	0	0	0	0	0	0	0
Other Volume [veh/h]	0	0	0	0	0	0	0	0	0	0	0	0
Total Hourly Volume [veh/h]	215	46	11	0	41	28	16	2	219	9	2	0
Peak Hour Factor	1.0000	1.0000	1.0000	1.0000	1.0000	1.0000	1.0000	1.0000	1.0000	1.0000	1.0000	1.0000
Other Adjustment Factor	1.0000	1.0000	1.0000	1.0000	1.0000	1.0000	1.0000	1.0000	1.0000	1.0000	1.0000	1.0000
Total 15-Minute Volume [veh/h]	54	12	3	0	10	7	4	1	55	2	1	0
Total Analysis Volume [veh/h]	215	46	11	0	41	28	16	2	219	9	2	0
Pedestrian Volume [ped/h]	0	0	0	0	0	0	0	0	0	0	0	0



Intersection Settings

Priority Scheme	Free	Free	Stop	Stop
Flared Lane			No	No
Storage Area [veh]	0	0	0	C
Two-Stage Gap Acceptance			No	No
Number of Storage Spaces in Median	0	0	0	0

Movement, Approach, & Intersection Results

V/C, Movement V/C Ratio	0.14	0.30	0.00	0.00	0.00	0.00	0.04	0.01	0.22	0.03	0.01	0.00
d_M, Delay for Movement [s/veh]	7.73	0.00	0.00	7.35	0.00	0.00	15.35	15.81	9.96	19.03	15.04	5.00
Movement LOS	A	A	A	A	A	A	C	C	A	C	C	A
95th-Percentile Queue Length [veh/ln]	0.49	0.49	0.49	0.00	0.00	0.00	1.05	1.05	1.05	0.12	0.12	0.12
95th-Percentile Queue Length [ft/ln]	12.21	12.21	12.21	0.00	0.00	0.00	26.22	26.22	26.22	3.04	3.04	3.04
d_A, Approach Delay [s/veh]	6.11		0.00		10.37		18.31					
Approach LOS	A		A		B		C					
d_I, Intersection Delay [s/veh]	7.34											
Intersection LOS	C											



Intersection Level Of Service Report
Intersection 5: Olympic Dr/Lakeshore Dr

Control Type: Roundabout Delay (sec / veh): 5.7
Analysis Method: HCM 6th Edition Level Of Service: A
Analysis Period: 15 minutes

Intersection Setup

Name	Lakeshore Dr			Lakeshore Dr			Olympic Dr					
	Northbound			Southbound			Eastbound			Westbound		
Approach	←→			←→			←→			←→		
Lane Configuration	←→			←→			←→			←→		
Turning Movement	Left	Thru	Right	Left	Thru	Right	Left	Thru	Right	Left	Thru	Right
Lane Width [ft]	12.00	12.00	12.00	12.00	12.00	12.00	12.00	12.00	12.00	12.00	12.00	12.00
No. of Lanes in Entry Pocket	0	0	1	0	0	0	0	0	0	0	0	1
Entry Pocket Length [ft]	100.00	100.00	120.00	100.00	100.00	100.00	100.00	100.00	100.00	100.00	100.00	250.00
No. of Lanes in Exit Pocket	0	0	0	0	0	0	0	0	0	0	0	0
Exit Pocket Length [ft]	0.00	0.00	0.00	0.00	0.00	0.00	0.00	0.00	0.00	0.00	0.00	0.00
Speed [mph]	25.00			25.00			30.00			30.00		
Grade [%]	0.00			0.00			0.00			0.00		
Crosswalk	No			Yes			No			Yes		

Volumes

Name	Lakeshore Dr			Lakeshore Dr			Olympic Dr					
	5	230	85	90	435	0	0	0	5	80	5	70
Base Volume Input [veh/h]	5	230	85	90	435	0	0	0	5	80	5	70
Base Volume Adjustment Factor	1.0000	1.0000	1.0000	1.0000	1.0000	1.0000	1.0000	1.0000	1.0000	1.0000	1.0000	1.0000
Heavy Vehicles Percentage [%]	2.00	2.00	2.00	2.00	2.00	2.00	2.00	2.00	2.00	2.00	2.00	2.00
Growth Factor	1.0000	1.0000	1.0000	1.0000	1.0000	1.0000	1.0000	1.0000	1.0000	1.0000	1.0000	1.0000
In-Process Volume [veh/h]	0	0	0	0	0	0	0	0	0	0	0	0
Site-Generated Trips [veh/h]	0	0	0	0	0	0	0	0	0	0	0	0
Diverted Trips [veh/h]	0	0	0	0	0	0	0	0	0	0	0	0
Pass-by Trips [veh/h]	0	0	0	0	0	0	0	0	0	0	0	0
Existing Site Adjustment Volume [veh/h]	0	0	0	0	0	0	0	0	0	0	0	0
Other Volume [veh/h]	0	0	0	0	0	0	0	0	0	0	0	0
Total Hourly Volume [veh/h]	5	230	85	90	435	0	0	0	5	80	5	70
Peak Hour Factor	1.0000	1.0000	1.0000	1.0000	1.0000	1.0000	1.0000	1.0000	1.0000	1.0000	1.0000	1.0000
Other Adjustment Factor	1.0000	1.0000	1.0000	1.0000	1.0000	1.0000	1.0000	1.0000	1.0000	1.0000	1.0000	1.0000
Total 15-Minute Volume [veh/h]	1	58	21	23	109	0	0	0	1	20	1	18
Total Analysis Volume [veh/h]	5	230	85	90	435	0	0	0	5	80	5	70
Pedestrian Volume [ped/h]	0			0			0			1		

Intersection Settings

Number of Conflicting Circulating Lanes	1			1			1			1		
Circulating Flow Rate [veh/h]	92			92			617			240		
Exiting Flow Rate [veh/h]	530			306			10			179		
Demand Flow Rate [veh/h]	5	230	85	90	435	0	0	0	5	80	5	70
Adjusted Demand Flow Rate [veh/h]	5	230	85	90	435	0	0	0	5	80	5	70

Lanes

Overwrite Calculated Critical Headway	No	No	No	No	No	No
User-Defined Critical Headway [s]	4.00	4.00	4.00	4.00	4.00	4.00
Overwrite Calculated Follow-Up Time	No	No	No	No	No	No
User-Defined Follow-Up Time [s]	3.00	3.00	3.00	3.00	3.00	3.00
A (intercept)	1420.00	1420.00	1380.00	1380.00	1420.00	1420.00
B (coefficient)	0.00091	0.00091	0.00102	0.00102	0.00091	0.00091
HV Adjustment Factor	0.98	0.98	0.98	0.98	0.98	0.98
Entry Flow Rate [veh/h]	240	87	536	6	82	77
Capacity of Entry and Bypass Lanes [veh/h]	1307	1307	1257	736	1142	1142
Pedestrian Impedance	1.00	1.00	1.00	1.00	1.00	1.00
Capacity per Entry Lane [veh/h]	1281	1281	1233	721	1119	1119
X, volume / capacity	0.18	0.07	0.43	0.01	0.07	0.07

Movement, Approach, & Intersection Results

Lane LOS	A	A	A	A	A	A
95th-Percentile Queue Length [veh]	0.67	0.21	2.17	0.02	0.23	0.22
95th-Percentile Queue Length [ft]	16.77	5.32	54.36	0.52	5.77	5.38
Approach Delay [s/veh]	4.09		7.20	5.06		3.81
Approach LOS	A		A	A		A
Intersection Delay [s/veh]	5.68					
Intersection LOS	A					



Intersection Level Of Service Report
Intersection 7: Olympic Dr/Burns Valley Rd-Old Hwy 53

Control Type: Signalized
Analysis Method: HCM 6th Edition
Analysis Period: 15 minutes
Delay (sec / veh): 14.4
Level Of Service: B
Volume to Capacity (v/c): 0.757

Intersection Setup

Name	Old Hwy 53			Burns Valley Rd			Olympic Dr			Old Hwy 53		
	Northbound			Southbound			Eastbound			Westbound		
Approach	[Diagram]			[Diagram]			[Diagram]			[Diagram]		
Lane Configuration	[Diagram]			[Diagram]			[Diagram]			[Diagram]		
Turning Movement	Left	Thru	Right	Left	Thru	Right	Left	Thru	Right	Left	Thru	Right
Lane Width [ft]	12.00	12.00	12.00	12.00	12.00	12.00	12.00	12.00	12.00	12.00	12.00	12.00
No. of Lanes in Entry Pocket	1	0	1	1	0	1	0	1	0	0	1	0
Entry Pocket Length [ft]	100.00	100.00	100.00	56.00	100.00	100.00	48.00	100.00	100.00	100.00	100.00	100.00
No. of Lanes in Exit Pocket	0	0	0	0	0	0	0	0	0	0	0	0
Exit Pocket Length [ft]	0.00	0.00	0.00	0.00	0.00	0.00	0.00	0.00	0.00	0.00	0.00	0.00
Speed [mph]	30.00			30.00			35.00			35.00		
Grade [%]	0.00			0.00			0.00			0.00		
Curb Present	No			No			No			No		
Crosswalk	Yes			Yes			Yes			Yes		



Volumes

Name	Old Hwy 53			Burns Valley Rd			Olympic Dr			Old Hwy 53		
Base Volume Input [veh/h]	95	130	70	160	125	30	35	205	130	80	225	150
Base Volume Adjustment Factor	1.0000	1.0000	1.0000	1.0000	1.0000	1.0000	1.0000	1.0000	1.0000	1.0000	1.0000	1.0000
Heavy Vehicles Percentage [%]	2.00	2.00	2.00	2.00	2.00	2.00	2.00	2.00	2.00	2.00	2.00	2.00
Growth Factor	1.0000	1.0000	1.0000	1.0000	1.0000	1.0000	1.0000	1.0000	1.0000	1.0000	1.0000	1.0000
In-Process Volume [veh/h]	0	0	0	0	0	0	0	0	0	0	0	0
Site-Generated Trips [veh/h]	0	0	0	0	0	0	0	0	0	0	0	0
Diverted Trips [veh/h]	0	0	0	0	0	0	0	0	0	0	0	0
Pass-by Trips [veh/h]	0	0	0	0	0	0	0	0	0	0	0	0
Existing Site Adjustment Volume [veh/h]	0	0	0	0	0	0	0	0	0	0	0	0
Other Volume [veh/h]	0	0	0	0	0	0	0	0	0	0	0	0
Right Turn on Red Volume [veh/h]	0	0	19	0	0	3	0	0	5	0	0	20
Total Hourly Volume [veh/h]	95	130	51	160	125	27	35	205	125	80	225	130
Peak Hour Factor	1.0000	1.0000	1.0000	1.0000	1.0000	1.0000	1.0000	1.0000	1.0000	1.0000	1.0000	1.0000
Other Adjustment Factor	1.0000	1.0000	1.0000	1.0000	1.0000	1.0000	1.0000	1.0000	1.0000	1.0000	1.0000	1.0000
Total 15-Minute Volume [veh/h]	24	33	13	40	31	7	9	51	31	20	56	33
Total Analysis Volume [veh/h]	95	130	51	160	125	27	35	205	125	80	225	130
Presence of On-Street Parking	No	No	No	No	No	No	No	No	No	No	No	No
On-Street Parking Maneuver Rate [h]	0	0	0	0	0	0	0	0	0	0	0	0
Local Bus Stopping Rate [h]	0	0	0	0	0	0	0	0	0	0	0	0
v_do, Outbound Pedestrian Volume crossing major street [ped/h]	1			0			1			1		
v_di, Inbound Pedestrian Volume crossing major street [ped/h]	1			1			0			1		
v_co, Outbound Pedestrian Volume crossing minor street [ped/h]	1			0			0			0		
v_ci, Inbound Pedestrian Volume crossing minor street [ped/h]	0			0			1			0		
v_ab, Corner Pedestrian Volume [ped/h]	0			0			0			0		
Bicycle Volume [bicycles/h]	0			0			0			1		



Intersection Settings	
Located in CBD	Yes
Signal Coordination Group	-
Cycle Length [s]	109
Coordination Type	Time of Day Pattern Isolated
Actuation Type	Fully actuated
Offset [s]	0.0
Offset Reference	Lead Green - Beginning of First Green
Permissive Mode	SingleBand
Lost time [s]	14.00

Phasing & Timing													
Control Type	Protect	Permis	Permis	Protect	Permis	Permis	Protect	Permis	Permis	Protect	Permis	Permis	Protect
Signal Group	3	8	0	7	4	0	5	2	0	1	6	0	
Auxiliary Signal Groups													
Lead / Lag	Lead	-	-	Lead	-	-	Lead	-	-	Lead	-	-	
Minimum Green [s]	4	6	0	4	6	0	4	6	0	4	6	0	
Maximum Green [s]	20	25	0	20	25	0	20	30	0	20	20	0	
Amber [s]	3.0	3.3	0.0	3.0	3.3	0.0	3.0	3.6	0.0	3.0	3.6	0.0	
All red [s]	0.0	0.3	0.0	0.0	0.3	0.0	0.0	0.3	0.0	0.0	0.3	0.0	
Split [s]	23	29	0	23	29	0	23	34	0	23	34	0	
Vehicle Extension [s]	0.0	0.0	0.0	0.0	0.0	0.0	0.0	0.0	0.0	0.0	0.0	0.0	
Walk [s]	0	7	0	0	7	0	0	7	0	0	7	0	
Pedestrian Clearance [s]	0	11	0	0	9	0	0	14	0	0	9	0	
Delayed Vehicle Green [s]	0.0	0.0	0.0	0.0	0.0	0.0	0.0	0.0	0.0	0.0	0.0	0.0	
Rest in Walk	No	No		No	No		No	No		No	No		
I1, Start-Up Lost Time [s]	2.0	2.0	0.0	2.0	2.0	0.0	2.0	2.0	0.0	2.0	2.0	0.0	
I2, Clearance Lost Time [s]	1.0	1.6	0.0	1.0	1.6	0.0	1.0	1.9	0.0	1.0	1.9	0.0	
Minimum Recall	No	No		No	No		No	No		No	No		
Maximum Recall	No	No		No	No		No	No		No	No		
Pedestrian Recall	No	No		No	No		No	No		No	No		
Detector Location [ft]	0.0	0.0	0.0	0.0	0.0	0.0	0.0	0.0	0.0	0.0	0.0	0.0	
Detector Length [ft]	0.0	0.0	0.0	0.0	0.0	0.0	0.0	0.0	0.0	0.0	0.0	0.0	
I Upstream Filtering Factor	1.00	1.00	1.00	1.00	1.00	1.00	1.00	1.00	1.00	1.00	1.00	1.00	

Exclusive Pedestrian Phase	
Pedestrian Signal Group	0
Pedestrian Walk [s]	0
Pedestrian Clearance [s]	0



Lane Group Calculations										
Lane Group	L	C	R	L	C	L	C	L	C	C
C, Cycle Length [s]	33	33	33	33	33	33	33	33	33	33
L, Total Lost Time per Cycle [s]	3.00	3.60	3.60	3.00	3.60	3.00	3.60	3.00	3.60	3.00
I1_p, Permitted Start-Up Lost Time [s]	0.00	0.30	0.30	0.00	0.30	0.00	0.30	0.00	0.30	0.00
I2, Clearance Lost Time [s]	1.00	1.60	1.60	1.00	1.60	1.00	1.60	1.00	1.60	1.00
g_i, Effective Green Time [s]	2	5	5	4	7	1	8	2	9	
g / C, Green / Cycle	0.07	0.15	0.15	0.12	0.20	0.03	0.25	0.06	0.28	
(v / s)_j Volume / Saturation Flow Rate	0.06	0.08	0.04	0.10	0.09	0.02	0.21	0.05	0.23	
s, saturation flow rate [veh/h]	1603	1683	1421	1603	1631	1603	1576	1603	1567	
c, Capacity [veh/h]	115	256	216	200	334	55	399	103	443	
d1, Uniform Delay [s]	15.21	12.95	12.39	14.14	11.59	15.85	11.73	15.32	11.05	
k, delay calibration	0.04	0.04	0.04	0.04	0.04	0.04	0.04	0.04	0.04	
I, Upstream Filtering Factor	1.00	1.00	1.00	1.00	1.00	1.00	1.00	1.00	1.00	
d2, Incremental Delay [s]	5.44	0.58	0.21	2.79	0.36	4.55	1.70	4.67	1.29	
d3, Initial Queue Delay [s]	0.00	0.00	0.00	0.00	0.00	0.00	0.00	0.00	0.00	
Rp, platoon ratio	1.00	1.00	1.00	1.00	1.00	1.00	1.00	1.00	1.00	
PF, progression factor	1.00	1.00	1.00	1.00	1.00	1.00	1.00	1.00	1.00	

Lane Group Results									
X, volume / capacity	0.82	0.51	0.24	0.80	0.46	0.64	0.83	0.78	0.80
d, Delay for Lane Group [s/veh]	20.65	13.53	12.60	16.94	11.95	20.40	13.43	19.99	12.33
Lane Group LOS	C	B	B	B	B	C	B	B	B
Critical Lane Group	No	Yes	No	Yes	No	No	Yes	Yes	No
50th-Percentile Queue Length [veh/m]	0.74	0.73	0.27	1.07	0.77	0.28	1.76	0.60	1.76
50th-Percentile Queue Length [ft/m]	18.59	18.28	6.79	26.80	19.35	6.88	43.91	14.88	43.91
95th-Percentile Queue Length [veh/m]	1.34	1.32	0.49	1.93	1.39	0.50	3.16	1.07	3.16
95th-Percentile Queue Length [ft/m]	33.46	32.91	12.21	48.24	34.84	12.38	79.04	26.78	79.04



Movement, Approach, & Intersection Results

d_M, Delay for Movement [s/veh]	20.65	13.53	12.60	16.94	11.95	11.95	20.40	13.43	13.43	19.99	12.33	12.33
Movement LOS	C	B	B	B	B	B	C	B	B	B	B	B
d_A, Approach Delay [s/veh]	15.81		14.51		14.10		13.74					
Approach LOS	B		B		B		B					
d_I, Intersection Delay [s/veh]	14.42											
Intersection LOS	B											
Intersection VIC	0.757											

Other Modes

g_Walk,mi, Effective Walk Time [s]	11.0	11.0	11.0	11.0
M_corner, Corner Circulation Area [ft²/ped]	0.00	0.00	0.00	0.00
M_CW, Crosswalk Circulation Area [ft²/ped]	0.00	0.00	0.00	0.00
d_p, Pedestrian Delay [s]	7.35	7.35	7.35	7.35
L_p,int, Pedestrian LOS Score for Intersection	2.249	2.087	2.158	2.243
Crosswalk LOS	B	B	B	B
s_b, Saturation Flow Rate of the bicycle lane [bicycles/h]	2000	2000	2000	2000
c_b, Capacity of the bicycle lane [bicycles/h]	1537	1537	1822	1822
d_b, Bicycle Delay [s]	0.88	0.88	0.13	0.13
I_b,int, Bicycle LOS Score for Intersection	2.048	2.079	2.170	2.310
Bicycle LOS	B	B	B	B

Sequence

Ring 1	1	2	3	4	-	-	-	-	-	-	-	-	-	-
Ring 2	5	6	7	8	-	-	-	-	-	-	-	-	-	-
Ring 3	-	-	-	-	-	-	-	-	-	-	-	-	-	-
Ring 4	-	-	-	-	-	-	-	-	-	-	-	-	-	-

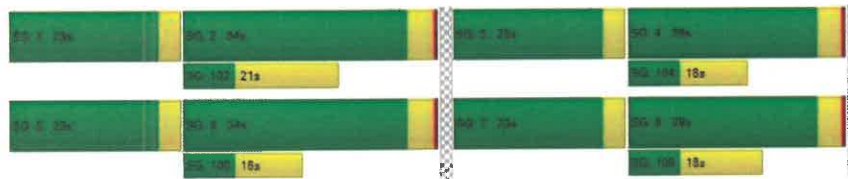

Intersection Level Of Service Report

Intersection 2: Burns Valley Rd/Bowers Ave-Rumsey Rd

Control Type:	Two-way stop	Delay (sec / veh):	15.6
Analysis Method:	HCM 6th Edition	Level Of Service:	C
Analysis Period:	15 minutes	Volume to Capacity (v/c):	0.058

Intersection Setup

Name	Burns Valley Rd			Rumsey Rd			Burns Valley Rd			Bowers Ave		
Approach	Northbound			Southbound			Eastbound			Westbound		
Lane Configuration	+			+			+			+		
Turning Movement	Left	Thru	Right	Left	Thru	Right	Left	Thru	Right	Left	Thru	Right
Lane Width [ft]	12.00	12.00	12.00	12.00	12.00	12.00	12.00	12.00	12.00	12.00	12.00	12.00
No. of Lanes in Entry Pocket	0	6	0	0	0	0	0	0	0	0	0	0
Entry Pocket Length [ft]	100.00	100.00	100.00	100.00	100.00	100.00	100.00	100.00	100.00	100.00	100.00	100.00
No. of Lanes in Exit Pocket	0	0	0	0	0	0	0	0	0	0	0	0
Exit Pocket Length [ft]	0.00	0.00	0.00	0.00	0.00	0.00	0.00	0.00	0.00	0.00	0.00	0.00
Speed [mph]	30.00			30.00			35.00			25.00		
Grade [%]	0.00			0.00			0.00			0.00		
Crosswalk	No			Yes			Yes			No		

Volumes

Name	Burns Valley Rd			Rumsey Rd			Burns Valley Rd			Bowers Ave		
Base Volume Input [veh/h]	163	62	15	3	70	11	11	2	123	21	0	0
Base Volume Adjustment Factor	1.0000	1.0000	1.0000	1.0000	1.0000	1.0000	1.0000	1.0000	1.0000	1.0000	1.0000	1.0000
Heavy Vehicles Percentage [%]	2.00	2.00	2.00	2.00	2.00	2.00	2.00	2.00	2.00	2.00	2.00	2.00
Growth Factor	1.0000	1.0000	1.0000	1.0000	1.0000	1.0000	1.0000	1.0000	1.0000	1.0000	1.0000	1.0000
In-Process Volume [veh/h]	0	0	0	0	0	0	0	0	0	0	0	0
Site-Generated Trips [veh/h]	0	0	0	0	0	0	0	0	0	0	0	0
Diverted Trips [veh/h]	0	0	0	0	0	0	0	0	0	0	0	0
Pass-by Trips [veh/h]	0	0	0	0	0	0	0	0	0	0	0	0
Existing Site Adjustment Volume [veh/h]	0	0	0	0	0	0	0	0	0	0	0	0
Other Volume [veh/h]	0	0	0	0	0	0	0	0	0	0	0	0
Total Hourly Volume [veh/h]	163	62	15	3	70	11	11	2	123	21	0	0
Peak Hour Factor	1.0000	1.0000	1.0000	1.0000	1.0000	1.0000	1.0000	1.0000	1.0000	1.0000	1.0000	1.0000
Other Adjustment Factor	1.0000	1.0000	1.0000	1.0000	1.0000	1.0000	1.0000	1.0000	1.0000	1.0000	1.0000	1.0000
Total 15-Minute Volume [veh/h]	41	16	4	1	18	3	3	1	31	5	0	0
Total Analysis Volume [veh/h]	163	62	15	3	70	11	11	2	123	21	0	0
Pedestrian Volume [ped/h]	0			0			0			0		



Intersection Settings

Priority Scheme	Free	Free	Stop	Stop
Flared Lane			No	No
Storage Area [veh]	0	0	0	0
Two-Stage Gap Acceptance			No	No
Number of Storage Spaces in Median	0	0	0	0

Movement, Approach, & Intersection Results

V/C, Movement V/C Ratio	0.11	0.00	0.00	0.00	0.00	0.00	0.02	0.00	0.12	0.06	0.00	0.00
d_M, Delay for Movement [s/veh]	7.66	0.00	0.00	7.37	0.00	0.00	13.65	14.16	9.39	15.60	14.02	9.24
Movement LOS	A	A	A	A	A	A	B	B	A	C	B	A
95th-Percentile Queue Length [veh/m]	0.36	0.36	0.36	0.01	0.01	0.01	0.54	0.54	0.54	0.18	0.14	0.18
95th-Percentile Queue Length [ft/m]	9.01	9.01	9.01	0.15	0.15	0.15	13.54	13.54	13.54	4.62	4.62	4.62
d_A, Approach Delay [s/veh]	5.20			0.26			9.80			15.60		
Approach LOS	A			A			A			C		
d_I, Intersection Delay [s/veh]	6.09											
Intersection LOS	C											



Intersection Level Of Service Report
Intersection 5: Olympic Dr/Lakeshore Dr

Control Type: Roundabout
Analysis Method: HCM 6th Edition
Analysis Period: 15 minutes
Delay (sec / veh): 4.9
Level Of Service: A

Intersection Setup

Name	Lakeshore Dr			Lakeshore Dr			Olympic Dr					
Approach	Northbound			Southbound			Eastbound			Westbound		
Lane Configuration	[Diagram]			[Diagram]			[Diagram]			[Diagram]		
Turning Movement	Left	Thru	Right	Left	Thru	Right	Left	Thru	Right	Left	Thru	Right
Lane Width [ft]	12.00	12.00	12.00	12.00	12.00	12.00	12.00	12.00	12.00	12.00	12.00	12.00
No. of Lanes in Entry Pocket	0	0	1	0	0	0	0	0	0	0	0	1
Entry Pocket Length [ft]	100.00	100.00	120.00	100.00	100.00	100.00	100.00	100.00	100.00	100.00	100.00	250.00
No. of Lanes in Exit Pocket	0	0	0	0	0	0	0	0	0	0	0	0
Exit Pocket Length [ft]	0.00	0.00	0.00	0.00	0.00	0.00	0.00	0.00	0.00	0.00	0.00	0.00
Speed [mph]	25.00			25.00			30.00			30.00		
Grade [%]	0.00			0.00			0.00			0.00		
Crosswalk	No			Yes			No			Yes		

Volumes

Name	Lakeshore Dr			Lakeshore Dr			Olympic Dr					
Base Volume Input [veh/h]	0	310	125	95	215	0	0	0	5	120	5	160
Base Volume Adjustment Factor	1.0000	1.0000	1.0000	1.0000	1.0000	1.0000	1.0000	1.0000	1.0000	1.0000	1.0000	1.0000
Heavy Vehicles Percentage [%]	2.00	2.00	2.00	2.00	2.00	2.00	2.00	2.00	2.00	2.00	2.00	2.00
Growth Factor	1.0000	1.0000	1.0000	1.0000	1.0000	1.0000	1.0000	1.0000	1.0000	1.0000	1.0000	1.0000
In-Process Volume [veh/h]	0	0	0	0	0	0	0	0	0	0	0	0
Site-Generated Trips [veh/h]	0	0	0	0	0	0	0	0	0	0	0	0
Diverted Trips [veh/h]	0	0	0	0	0	0	0	0	0	0	0	0
Pass-by Trips [veh/h]	0	0	0	0	0	0	0	0	0	0	0	0
Existing Site Adjustment Volume [veh/h]	0	0	0	0	0	0	0	0	0	0	0	0
Other Volume [veh/h]	0	0	0	0	0	0	0	0	0	0	0	0
Total Hourly Volume [veh/h]	0	310	125	95	215	0	0	0	5	120	5	160
Peak Hour Factor	1.0000	1.0000	1.0000	1.0000	1.0000	1.0000	1.0000	1.0000	1.0000	1.0000	1.0000	1.0000
Other Adjustment Factor	1.0000	1.0000	1.0000	1.0000	1.0000	1.0000	1.0000	1.0000	1.0000	1.0000	1.0000	1.0000
Total 15-Minute Volume [veh/h]	0	78	31	24	54	0	0	0	1	30	1	40
Total Analysis Volume [veh/h]	0	310	125	95	215	0	0	0	5	120	5	160
Pedestrian Volume [ped/h]	0			0			0			1		



Version 2021 (SP 0-6)

Intersection Settings

Number of Conflicting Circulating Lanes	1			1			1			1		
Circulating Flow Rate [veh/h]	97			128			439			316		
Exiting Flow Rate [veh/h]	347			479			5			224		
Demand Flow Rate [veh/h]	0	310	125	95	215	0	0	0	5	120	5	160
Adjusted Demand Flow Rate [veh/h]	0	310	125	95	215	0	0	0	5	120	5	160

Lanes

Overwrite Calculated Critical Headway	No	No	No	No	No	No
User-Defined Critical Headway [s]	4.00	4.00	4.00	4.00	4.00	4.00
Overwrite Calculated Follow-Up Time	No	No	No	No	No	No
User-Defined Follow-Up Time [s]	3.00	3.00	3.00	3.00	3.00	3.00
A (intercept)	1420.00	1420.00	1380.00	1380.00	1420.00	1420.00
B (coefficient)	0.00091	0.00091	0.00102	0.00102	0.00091	0.00091
HV Adjustment Factor	0.98	0.98	0.98	0.98	0.98	0.98
Entry Flow Rate [veh/h]	317	128	317	6	123	169
Capacity of Entry and Bypass Lanes [veh/h]	1301	1301	1212	883	1065	1065
Pedestrian Impedance	1.00	1.00	1.00	1.00	1.00	1.00
Capacity per Entry Lane [veh/h]	1275	1275	1188	885	1044	1044
X, volume / capacity	0.24	0.10	0.26	0.01	0.12	0.16

Movement, Approach, & Intersection Results

Lane LOS	A	A	A	A	A	A
95th-Percentile Queue Length [veh]	0.96	0.33	1.05	0.02	0.39	0.56
95th-Percentile Queue Length [ft]	23.91	8.14	26.23	0.44	9.72	14.02
Approach Delay [s/veh]	4.57		5.40	4.22	4.71	
Approach LOS	A		A	A	A	
Intersection Delay [s/veh]	4.86					
Intersection LOS	A					

Version 2021 (SP 0-6)

Intersection Level Of Service Report

Intersection 7: Olympic Dr/Burns Valley Rd-Old Hwy 53

Control Type:	Signalized	Delay (sec / veh):	19.4
Analysis Method:	HCM 6th Edition	Level Of Service:	B
Analysis Period:	15 minutes	Volume to Capacity (v/c):	0.866

Intersection Setup

Name	Old Hwy 53			Burns Valley Rd			Olympic Dr			Old Hwy 53		
Approach	Northbound			Southbound			Eastbound			Westbound		
Lane Configuration	T T T			T T			T T			T T		
Turning Movement	Left	Thru	Right	Left	Thru	Right	Left	Thru	Right	Left	Thru	Right
Lane Width [ft]	12.00	12.00	12.00	12.00	12.00	12.00	12.00	12.00	12.00	12.00	12.00	12.00
No. of Lanes in Entry Pocket	1	2	1	1	2	0	1	0	0	1	0	0
Entry Pocket Length [ft]	100.00	100.00	100.00	56.00	100.00	100.00	48.00	100.00	100.00	100.00	100.00	100.00
No. of Lanes in Exit Pocket	0	0	0	0	0	0	0	0	0	0	0	0
Exit Pocket Length [ft]	0.00	0.00	0.00	0.00	0.00	0.00	0.00	0.00	0.00	0.00	0.00	0.00
Speed [mph]	30.00			30.00			35.00			35.00		
Grade [%]	0.00			0.00			0.00			0.00		
Curb Present	No			No			No			No		
Crosswalk	Yes			Yes			Yes			Yes		



Volumes												
Name	Old Hwy 53			Burns Valley Rd			Olympic Dr			Old Hwy 53		
Base Volume Input [veh/h]	165	215	110	180	185	80	45	315	165	95	320	175
Base Volume Adjustment Factor	1.0000	1.0000	1.0000	1.0000	1.0000	1.0000	1.0000	1.0000	1.0000	1.0000	1.0000	1.0000
Heavy Vehicles Percentage [%]	2.00	2.00	2.00	2.00	2.00	2.00	2.00	2.00	2.00	2.00	2.00	2.00
Growth Factor	1.0000	1.0000	1.0000	1.0000	1.0000	1.0000	1.0000	1.0000	1.0000	1.0000	1.0000	1.0000
In-Process Volume [veh/h]	0	0	0	0	0	0	0	0	0	0	0	0
Site-Generated Trips [veh/h]	0	0	0	0	0	0	0	0	0	0	0	0
Diverted Trips [veh/h]	0	0	0	0	0	0	0	0	0	0	0	0
Pass-by Trips [veh/h]	0	0	0	0	0	0	0	0	0	0	0	0
Existing Site Adjustment Volume [veh/h]	0	0	0	0	0	0	0	0	0	0	0	0
Other Volume [veh/h]	0	0	0	0	0	0	0	0	0	0	0	0
Right Turn on Red Volume [veh/h]	0	0	18	0	0	11	0	0	14	0	0	25
Total Hourly Volume [veh/h]	165	215	92	180	185	49	45	315	151	95	320	150
Peak Hour Factor	1.0000	1.0000	1.0000	1.0000	1.0000	1.0000	1.0000	1.0000	1.0000	1.0000	1.0000	1.0000
Other Adjustment Factor	1.0000	1.0000	1.0000	1.0000	1.0000	1.0000	1.0000	1.0000	1.0000	1.0000	1.0000	1.0000
Total 15-Minute Volume [veh/h]	41	54	23	45	46	12	11	79	38	24	80	38
Total Analysis Volume [veh/h]	165	215	92	180	185	49	45	315	151	95	320	150
Presence of On-Street Parking	No	No	No	No	No	No	No	No	No	No	No	No
On-Street Parking Maneuver Rate [h]	0	0	0	0	0	0	0	0	0	0	0	0
Local Bus Stopping Rate [h]	0	0	0	0	0	0	0	0	0	0	0	0
v_do, Outbound Pedestrian Volume crossing major street	1			0			1			1		
v_di, Inbound Pedestrian Volume crossing major street	1			1			0			1		
v_co, Outbound Pedestrian Volume crossing minor street	1			0			0			0		
v_ci, Inbound Pedestrian Volume crossing minor street	0			0			1			0		
v_ab, Corner Pedestrian Volume [ped/h]	0			0			0			0		
Bicycle Volume [bicycles/h]	0			0			0			0		1



Intersection Settings												
Located in CBD	Yes											
Signal Coordination Group	-											
Cycle Length [s]	109											
Coordination Type	Time of Day Pattern Isolated											
Actuation Type	Fully actuated											
Offset [s]	0.0											
Offset Reference	Lead Green - Beginning of First Green											
Permissive Mode	SingleBand											
Lost time [s]	14.00											
Phasing & Timing												
Control Type	Protect	Permis	Permis	Protect	Permis	Permis	Protect	Permis	Permis	Protect	Permis	Permis
Signal Group	3	8	0	7	4	0	5	2	0	1	6	0
Auxiliary Signal Groups												
Lead / Lag	Lead	-	-	Lead	-	-	Lead	-	-	Lead	-	-
Minimum Green [s]	4	6	0	4	6	0	4	6	0	4	6	0
Maximum Green [s]	20	25	0	20	25	0	20	30	0	20	20	0
Amber [s]	3.0	3.3	0.0	3.0	3.3	0.0	3.0	3.6	0.0	3.0	3.6	0.0
All red [s]	0.0	0.3	0.0	0.0	0.3	0.0	0.0	0.3	0.0	0.0	0.3	0.0
Split [s]	23	29	0	23	29	0	23	34	0	23	34	0
Vehicle Extension [s]	0.0	0.0	0.0	0.0	0.0	0.0	0.0	0.0	0.0	0.0	0.0	0.0
Walk [s]	3	7	0	0	7	0	0	7	0	0	7	0
Pedestrian Clearance [s]	0	11	0	0	9	0	0	14	0	0	9	0
Delayed Vehicle Green [s]	0.0	0.0	0.0	0.0	0.0	0.0	0.0	0.0	0.0	0.0	0.0	0.0
Rest In Walk	No											
I1, Start-Up Lost Time [s]	2.0	2.0	0.0	2.0	2.0	0.0	2.0	2.0	0.0	2.0	2.0	0.0
I2, Clearance Lost Time [s]	1.0	1.6	0.0	1.0	1.6	0.0	1.0	1.9	0.0	1.0	1.9	0.0
Minimum Recall	No											
Maximum Recall	No											
Pedestrian Recall	No											
Detector Location [ft]	0.0	0.0	0.0	0.0	0.0	0.0	0.0	0.0	0.0	0.0	0.0	0.0
Detector Length [ft]	0.0	0.0	0.0	0.0	0.0	0.0	0.0	0.0	0.0	0.0	0.0	0.0
I, Upstream Filtering Factor	1.00	1.00	1.00	1.00	1.00	1.00	1.00	1.00	1.00	1.00	1.00	1.00
Exclusive Pedestrian Phase												
Pedestrian Signal Group	0											
Pedestrian Walk [s]	0											
Pedestrian Clearance [s]	0											



Lane Group Calculations

Lane Group	L	C	R	L	C	L	C	L	C
C, Cycle Length [s]	45	45	45	45	45	45	45	45	45
L, Total Lost Time per Cycle [s]	3.00	3.60	3.60	3.00	3.60	3.00	3.90	3.00	3.90
l1_p, Permitted Start-Up Lost Time [s]	0.00	0.00	0.00	0.00	0.00	0.00	0.00	0.00	0.00
l2, Clearance Lost Time [s]	1.00	1.60	1.60	1.00	1.60	1.00	1.90	1.00	1.90
g_u, Effective Green Time [s]	6	8	8	6	8	2	15	3	16
g / C, Green / Cycle	0.13	0.17	0.17	0.14	0.18	0.04	0.33	0.07	0.36
(v / s)_j Volume / Saturation Flow Rate	0.10	0.13	0.06	0.11	0.14	0.03	0.29	0.06	0.30
s, saturation flow rate [veh/h]	1603	1683	1422	1603	1622	1603	1591	1603	1581
c, Capacity [veh/h]	205	281	237	222	289	62	519	116	569
d1, Uniform Delay [s]	19.37	18.16	16.93	19.08	18.02	21.72	14.67	20.88	13.30
k, delay calibration	0.04	0.04	0.04	0.04	0.04	0.04	0.04	0.04	0.15
l, Upstream Filtering Factor	1.00	1.00	1.00	1.00	1.00	1.00	1.00	1.00	1.00
d2, Incremental Delay [s]	2.84	1.64	0.38	2.67	2.07	6.02	2.33	5.20	4.26
d3, Initial Queue Delay [s]	0.00	0.00	0.00	0.00	0.00	0.00	0.00	0.00	0.00
Rp, progression ratio	1.00	1.00	1.00	1.00	1.00	1.00	1.00	1.00	1.00
PF, progression factor	1.00	1.00	1.00	1.00	1.00	1.00	1.00	1.00	1.00

Lane Group Results

X, volume / capacity	0.81	0.76	0.39	0.81	0.81	0.73	0.90	0.82	0.83
d, Delay for Lane Group [s/veh]	22.21	19.80	17.31	21.74	20.10	27.74	17.00	26.07	17.56
Lane Group LOS	C	B	B	C	C	C	B	C	B
Critical Lane Group	Yes	No	No	No	Yes	No	Yes	Yes	No
50th-Percentile Queue Length [veh/ln]	1.66	2.01	0.78	1.79	2.22	0.52	3.90	1.04	4.01
50th-Percentile Queue Length [ft/m]	41.49	50.32	19.43	44.69	55.47	13.04	97.56	25.94	100.15
95th-Percentile Queue Length [veh/ln]	2.99	3.62	1.40	3.22	3.99	0.94	7.02	1.87	7.21
95th-Percentile Queue Length [ft/m]	74.68	90.58	34.97	80.44	99.85	23.48	175.61	46.70	180.26

Movement, Approach, & Intersection Results

d_M, Delay for Movement [s/veh]	22.21	19.80	17.31	21.74	20.10	20.10	27.74	17.00	17.00	26.07	17.56	17.56
Movement LOS	C	B	B	C	C	C	C	B	B	C	B	B
d_A, Approach Delay [s/veh]	20.16			20.81			17.94			18.99		
Approach LOS	C			C			B			B		
d_I, Intersection Delay [s/veh]							19.38					
Intersection LOS							B					
Intersection V/C							0.866					

Other Modes

g_Walk,mi, Effective Walk Time [s]	11.0	11.0	11.0	11.0
M_corner, Corner Circulation Area [ft²/ped]	0.00	0.00	0.00	0.00
M_CW, Crosswalk Circulation Area [ft²/ped]	0.00	0.00	0.00	0.00
d_p, Pedestrian Delay [s]	13.08	13.08	13.08	13.08
l_p.int, Pedestrian LOS Score for Intersection	2,345	2,196	2,326	2,389
Crosswalk LOS	B	B	B	B
s_b, Saturation Flow Rate of the bicycle lane [bicycles/h]	2000	2000	2000	2000
c_b, Capacity of the bicycle lane [bicycles/h]	1117	1117	1323	1323
d_b, Bicycle Delay [s]	4.44	4.44	2.61	2.61
l_b.int, Bicycle LOS Score for Intersection	2,368	2,261	2,426	2,533
Bicycle LOS	B	B	B	B

Sequence

Ring 1	1	2	3	4	-	-	-	-	-	-	-	-	-	-
Ring 2	5	6	7	8	-	-	-	-	-	-	-	-	-	-
Ring 3	-	-	-	-	-	-	-	-	-	-	-	-	-	-
Ring 4	-	-	-	-	-	-	-	-	-	-	-	-	-	-

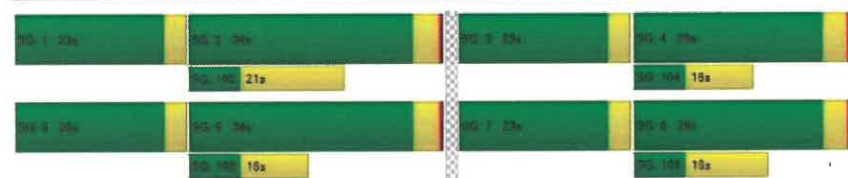

Intersection Level Of Service Report
Intersection 2: Burns Valley Rd/Bowers Ave-Rumsey Rd

Control Type: Two-way stop
Analysis Method: HCM 6th Edition
Analysis Period: 15 minutes

Delay (sec / veh): 13.9
Level Of Service: B
Volume to Capacity (v/c): 0.007

Intersection Setup

Name	Burns Valley Rd			Rumsey Rd			Burns Valley Rd			Bowers Ave		
Approach	Northbound			Southbound			Eastbound			Westbound		
Lane Configuration	+			+			+			+		
Turning Movement	Left	Thru	Right	Left	Thru	Right	Left	Thru	Right	Left	Thru	Right
Lane Width [ft]	12.00	12.00	12.00	12.00	12.00	12.00	12.00	12.00	12.00	12.00	12.00	12.00
No. of Lanes in Entry Pocket	0	0	0	0	0	0	0	0	0	0	0	0
Entry Pocket Length [ft]	100.00	100.00	100.00	100.00	100.00	100.00	100.00	100.00	100.00	100.00	100.00	100.00
No. of Lanes in Exit Pocket	0	0	0	0	0	0	0	0	0	0	0	0
Exit Pocket Length [ft]	0.00	0.00	0.00	0.00	0.00	0.00	0.00	0.00	0.00	0.00	0.00	0.00
Speed [mph]	30.00			30.00			35.00			25.00		
Grade [%]	0.00			0.00			0.00			0.00		
Crosswalk	No			Yes			Yes			No		

Volumes

Name	Burns Valley Rd			Rumsey Rd			Burns Valley Rd			Bowers Ave		
Base Volume Input [veh/h]	137	59	2	0	51	15	16	0	136	3	2	0
Base Volume Adjustment Factor	1.0000	1.0000	1.0000	1.0000	1.0000	1.0000	1.0000	1.0000	1.0000	1.0000	1.0000	1.0000
Heavy Vehicles Percentage [%]	2.00	2.00	2.00	2.00	2.00	2.00	2.00	2.00	2.00	2.00	2.00	2.00
Growth Factor	1.0000	1.0000	1.0000	1.0000	1.0000	1.0000	1.0000	1.0000	1.0000	1.0000	1.0000	1.0000
In-Process Volume [veh/h]	0	0	0	0	0	0	0	0	0	0	0	0
Site-Generated Trips [veh/h]	0	0	0	0	0	0	0	0	0	0	0	0
Diverted Trips [veh/h]	0	0	0	0	0	0	0	0	0	0	0	0
Pass-by Trips [veh/h]	0	0	0	0	0	0	0	0	0	0	0	0
Existing Site Adjustment Volume [veh/h]	0	0	0	0	0	0	0	0	0	0	0	0
Other Volume [veh/h]	0	0	0	0	0	0	0	0	0	0	0	0
Total Hourly Volume [veh/h]	137	59	2	0	51	15	16	0	136	3	2	0
Peak Hour Factor	1.0000	1.0000	1.0000	1.0000	1.0000	1.0000	1.0000	1.0000	1.0000	1.0000	1.0000	1.0000
Other Adjustment Factor	1.0000	1.0000	1.0000	1.0000	1.0000	1.0000	1.0000	1.0000	1.0000	1.0000	1.0000	1.0000
Total 15-Minute Volume [veh/h]	34	15	1	0	13	4	4	0	34	1	1	0
Total Analysis Volume [veh/h]	137	59	2	0	51	15	16	0	136	3	2	0
Pedestrian Volume [ped/h]	0			0			0			0		

Intersection Settings

Priority Scheme	Free	Free	Stop	Stop
Flared Lane			No	No
Storage Area [veh]	0	0	0	0
Two-Stage Gap Acceptance			No	No
Number of Storage Spaces in Median	0	0	0	0

Movement, Approach, & Intersection Results

V/C, Movement V/C Ratio	0.09	0.06	0.03	0.00	0.00	0.00	0.03	0.00	0.14	0.01	0.00	0.00
d_M, Delay for Movement [s/veh]	7.57	0.00	0.00	7.33	0.00	0.00	12.64	15.08	9.35	13.86	12.46	7.98
Movement LOS	A	A	A	A	A	A	B	B	A	B	B	A
95th-Percentile Queue Length [veh/m]	0.29	0.29	0.29	0.00	0.00	0.00	0.59	0.59	0.59	0.03	0.03	0.03
95th-Percentile Queue Length [ft/m]	7.33	7.33	7.33	0.00	0.00	0.00	14.78	14.78	14.78	0.86	0.86	0.86
d_A, Approach Delay [s/veh]	5.24			0.00			9.70			13.30		
Approach LOS	A			A			A			B		
d_I, Intersection Delay [s/veh]							6.12					
Intersection LOS	B											

Intersection Level Of Service Report
Intersection 5: Olympic Dr/Lakeshore Dr

Control Type: Roundabout
Analysis Method: HCM 6th Edition
Analysis Period: 15 minutes
Delay (sec / veh): 4.6
Level Of Service: A

Intersection Setup

Name	Lakeshore Dr			Lakeshore Dr			Olympic Dr					
Approach	Northbound			Southbound			Eastbound			Westbound		
Lane Configuration	[Diagram]			[Diagram]			[Diagram]			[Diagram]		
Turning Movement	Left	Thru	Right	Left	Thru	Right	Left	Thru	Right	Left	Thru	Right
Lane Width [ft]	12.00	12.00	12.00	12.00	12.00	12.00	12.00	12.00	12.00	12.00	12.00	12.00
No. of Lanes in Entry Pocket	0	0	1	0	0	0	0	0	0	0	0	1
Entry Pocket Length [ft]	100.00	100.00	120.00	100.00	100.00	100.00	100.00	100.00	100.00	100.00	100.00	250.00
No. of Lanes in Exit Pocket	0	0	0	0	0	0	0	0	0	0	0	0
Exit Pocket Length [ft]	0.00	0.00	0.00	0.00	0.00	0.00	0.00	0.00	0.00	0.00	0.00	0.00
Speed [mph]	25.00			25.00			30.00			30.00		
Grade [%]	0.00			0.00			0.00			0.00		
Crosswalk	No			Yes			No			Yes		

Volumes

Name	Lakeshore Dr			Lakeshore Dr			Olympic Dr					
Base Volume Input [veh/h]	1	224	131	93	235	0	0	4	4	123	1	95
Base Volume Adjustment Factor	1.0000	1.0000	1.0000	1.0000	1.0000	1.0000	1.0000	1.0000	1.0000	1.0000	1.0000	1.0000
Heavy Vehicles Percentage [%]	2.00	2.00	2.00	2.00	2.00	2.00	2.00	2.00	2.00	2.00	2.00	2.00
Growth Factor	1.0000	1.0000	1.0000	1.0000	1.0000	1.0000	1.0000	1.0000	1.0000	1.0000	1.0000	1.0000
In-Process Volume [veh/h]	0	0	0	0	0	0	0	0	0	0	0	0
Site-Generated Trips [veh/h]	0	0	0	0	0	0	0	0	0	0	0	0
Diverted Trips [veh/h]	0	0	0	0	0	0	0	0	0	0	0	0
Pass-by Trips [veh/h]	0	0	0	0	0	0	0	0	0	0	0	0
Existing Site Adjustment Volume [veh/h]	0	0	0	0	0	0	0	0	0	0	0	0
Other Volume [veh/h]	0	0	0	0	0	0	0	0	0	0	0	0
Total Hourly Volume [veh/h]	1	224	131	93	235	0	4	4	4	123	1	95
Peak Hour Factor	1.0000	1.0000	1.0000	1.0000	1.0000	1.0000	1.0000	1.0000	1.0000	1.0000	1.0000	1.0000
Other Adjustment Factor	1.0000	1.0000	1.0000	1.0000	1.0000	1.0000	1.0000	1.0000	1.0000	1.0000	1.0000	1.0000
Total 15-Minute Volume [veh/h]	0	56	33	23	59	0	1	1	1	31	0	24
Total Analysis Volume [veh/h]	1	224	131	93	235	0	4	4	4	123	1	95
Pedestrian Volume [ped/h]	0			0			0			1		



Intersection Settings

Number of Conflicting Circulating Lanes	1			1			1			1		
Circulating Flow Rate [veh/h]	99			128			460			230		
Exiting Flow Rate [veh/h]	369			325			2			233		
Demand Flow Rate [veh/h]	1	224	131	93	235	0	0	4	4	123	1	95
Adjusted Demand Flow Rate [veh/h]	1	224	131	93	235	0	0	4	4	123	1	95

Lanes

Override Calculated Critical Headway	No	No	No	No	No	No
User-Defined Critical Headway [s]	4.00	4.00	4.00	4.00	4.00	4.00
Override Calculated Follow-Up Time	No	No	No	No	No	No
User-Defined Follow-Up Time [s]	3.00	3.00	3.00	3.00	3.00	3.00
A (intercept)	1420.00	1420.00	1380.00	1380.00	1420.00	1420.00
B (coefficient)	0.00091	0.00091	0.00102	0.00102	0.00091	0.00091
HV Adjustment Factor	0.98	0.98	0.98	0.98	0.98	0.98
Entry Flow Rate [veh/h]	230	134	335	9	126	98
Capacity of Entry and Bypass Lanes [veh/h]	1298	1298	1212	864	1153	1153
Pedestrian Impedance	1.00	1.00	1.00	1.00	1.00	1.00
Capacity per Entry Lane [veh/h]	1273	1273	1188	847	1129	1129
X, volume / capacity	0.18	0.10	0.28	0.01	0.11	0.09

Movement, Approach, & Intersection Results

Lane LOS	A	A	A	A	A	A
95th-Percentile Queue Length [veh]	0.64	0.34	1.13	0.03	0.37	0.28
95th-Percentile Queue Length [ft]	16.03	8.59	28.31	0.72	9.15	6.96
Approach Delay [s/veh]	4.08		5.56	4.34	4.03	
Approach LOS	A		A	A	A	
Intersection Delay [s/veh]	4.60					
Intersection LOS	A					



Intersection Level Of Service Report
Intersection 7: Olympic Dr/Burns Valley Rd-Old Hwy 53

Control Type: Signalized
Analysis Method: HCM 6th Edition
Analysis Period: 15 minutes
Delay (sec / veh): 14.8
Level Of Service: B
Volume to Capacity (v/c): 0.783

Intersection Setup

Name	Old Hwy 53			Burns Valley Rd			Olympic Dr			Old Hwy 53		
	Northbound			Southbound			Eastbound			Westbound		
Approach												
Lane Configuration	T T T			T T			T T			T T		
Turning Movement	Left	Thru	Right	Left	Thru	Right	Left	Thru	Right	Left	Thru	Right
Lane Width [ft]	12.00	12.00	12.00	12.00	12.00	12.00	12.00	12.00	12.00	12.00	12.00	12.00
No. of Lanes in Entry Pocket	1	0	1	1	0	0	1	0	0	1	0	0
Entry Pocket Length [ft]	100.00	100.00	100.00	56.00	100.00	100.00	48.00	100.00	100.00	100.00	100.00	100.00
No. of Lanes in Exit Pocket	0	0	0	0	0	0	0	0	0	0	0	0
Exit Pocket Length [ft]	0.00	0.00	0.00	0.00	0.00	0.00	0.00	0.00	0.00	0.00	0.00	0.00
Speed [mph]	30.00			30.00			35.00			35.00		
Grade [%]	0.00			0.00			0.00			0.00		
Curb Present	No			No			No			No		
Crosswalk	Yes			Yes			Yes			Yes		

Volumes

Name	Old Hwy 53			Burns Valley Rd			Olympic Dr			Old Hwy 53		
Base Volume Input [veh/h]	131	132	69	152	105	49	33	294	155	54	278	178
Base Volume Adjustment Factor	1.0000	1.0000	1.0000	1.0000	1.0000	1.0000	1.0000	1.0000	1.0000	1.0000	1.0000	1.0000
Heavy Vehicles Percentage [%]	2.00	2.00	2.00	2.00	2.00	2.00	2.00	2.00	2.00	2.00	2.00	2.00
Growth Factor	1.0000	1.0000	1.0000	1.0000	1.0000	1.0000	1.0000	1.0000	1.0000	1.0000	1.0000	1.0000
In-Process Volume [veh/h]	0	0	0	0	0	0	0	0	0	0	0	0
Site-Generated Trips [veh/h]	0	0	0	0	0	0	0	0	0	0	0	0
Diverted Trips [veh/h]	0	0	0	0	0	0	0	0	0	0	0	0
Pass-by Trips [veh/h]	0	0	0	0	0	0	0	0	0	0	0	0
Existing Site Adjustment Volume [veh/h]	0	0	0	0	0	0	0	0	0	0	0	0
Other Volume [veh/h]	0	0	0	0	0	0	0	0	0	0	0	0
Right Turn on Red Volume [veh/h]	0	0	15	0	0	12	0	0	25	0	0	28
Total Hourly Volume [veh/h]	131	132	54	152	105	37	33	294	130	54	278	149
Peak Hour Factor	1.0000	1.0000	1.0000	1.0000	1.0000	1.0000	1.0000	1.0000	1.0000	1.0000	1.0000	1.0000
Other Adjustment Factor	1.0000	1.0000	1.0000	1.0000	1.0000	1.0000	1.0000	1.0000	1.0000	1.0000	1.0000	1.0000
Total 15-Minute Volume [veh/h]	33	33	14	38	26	9	8	74	33	14	70	37
Total Analysis Volume [veh/h]	131	132	54	152	105	37	33	294	130	54	278	149
Presence of On-Street Parking	No	No	No	No	No	No	No	No	No	No	No	No
On-Street Parking Maneuver Rate [h]	0	0	0	0	0	0	0	0	0	0	0	0
Local Bus Stopping Rate [h]	0	0	0	0	0	0	0	0	0	0	0	0
v_do, Outbound Pedestrian Volume crossing major street	1			0			1			1		
v_di, Inbound Pedestrian Volume crossing major street	1			1			0			1		
v_co, Outbound Pedestrian Volume crossing minor street	1						0			0		
v_ci, Inbound Pedestrian Volume crossing minor street	0			0			1			0		
v_ab, Corner Pedestrian Volume [ped/h]	0			0			0			0		
Bicycle Volume [bicycles/h]	0			0			0			0		1



Intersection Settings

Located in CBD	Yes
Signal Coordination Group	-
Cycle Length [s]	109
Coordination Type	Time of Day Pattern Isolated
Actuation Type	Fully actuated
Offset [s]	0.0
Offset Reference	Lead Green - Beginning of First Green
Permissive Mode	SingleBand
Lost time [s]	14.00

Phasing & Timing

Control Type	Protect	Permis	Permis	Protect	Permis	Permis	Protect	Permis	Permis	Protect	Permis	Permis
Signal Group	3	8	0	7	4	0	5	2	0	1	6	0
Auxiliary Signal Groups												
Lead / Lag	Lead	-	-	Lead	-	-	Lead	-	-	Lead	-	-
Minimum Green [s]	4	6	0	4	6	0	4	6	0	4	6	0
Maximum Green [s]	20	25	0	20	25	0	20	30	0	20	20	0
Amber [s]	3.0	3.3	0.0	3.0	3.3	0.0	3.0	3.6	0.0	3.0	3.6	0.0
All red [s]	0.0	0.3	0.0	0.0	0.3	0.0	0.0	0.3	0.0	0.0	0.3	0.0
Split [s]	23	29	0	23	29	0	23	34	0	23	34	0
Vehicle Extension [s]	0.0	0.0	0.0	0.0	0.0	0.0	0.0	0.0	0.0	0.0	0.0	0.0
Walk [s]	0	7	0	0	7	0	0	7	0	0	7	0
Pedestrian Clearance [s]	0	11	0	0	9	0	0	14	0	0	9	0
Delayed Vehicle Green [s]	0.0	0.0	0.0	0.0	0.0	0.0	0.0	0.0	0.0	0.0	0.0	0.0
Rest In Walk		No			No			No			No	
I1, Start-Up Lost Time [s]	2.0	2.0	0.0	2.0	2.0	0.0	2.0	2.0	0.0	2.0	2.0	0.0
I2, Clearance Lost Time [s]	1.0	1.5	0.0	1.0	1.6	0.0	1.0	1.9	0.0	1.0	1.9	0.0
Minimum Recall	No	No		No	No		No	No		No	No	
Maximum Recall	No	No		No	No		No	No		No	No	
Pedestrian Recall	No	No		No	No		No	No		No	No	
Detector Location [ft]	0.0	0.0	0.0	0.0	0.0	0.0	0.0	0.0	0.0	0.0	0.0	0.0
Detector Length [ft]	0.0	0.0	0.0	0.0	0.0	0.0	0.0	0.0	0.0	0.0	0.0	0.0
I, Upstream Filtering Factor	1.00	1.00	1.00	1.00	1.00	1.00	1.00	1.00	1.00	1.00	1.00	1.00

Exclusive Pedestrian Phase

Pedestrian Signal Group	0
Pedestrian Walk [s]	0
Pedestrian Clearance [s]	0



Lane Group Calculations

Lane Group	L	C	R	L	C	L	C	L	C
C, Cycle Length [s]	35	35	35	35	35	35	35	35	35
L, Total Lost Time per Cycle [s]	3.00	3.50	3.50	3.00	3.50	3.00	3.90	3.00	3.90
I1_p, Permitted Start-Up Lost Time [s]	0.00	0.00	0.00	0.00	0.00	0.00	0.00	0.00	0.00
I2, Clearance Lost Time [s]	1.00	1.60	1.60	1.00	1.60	1.00	1.90	1.00	1.90
g_i, Effective Green Time [s]	4	5	5	4	6	1	11	2	11
g / C, Green / Cycle	0.10	0.15	0.15	0.12	0.16	0.03	0.31	0.05	0.32
(v / s)_j, Volume / Saturation Flow Rate	0.08	0.08	0.04	0.09	0.09	0.02	0.27	0.03	0.27
s, saturation flow rate [veh/h]	1603	1683	1421	1603	1608	1503	1596	1603	1572
c, Capacity [veh/h]	162	247	209	189	263	51	491	76	508
d1, Uniform Delay [s]	15.62	14.01	13.42	15.25	13.61	16.97	11.58	16.66	11.16
k, delay calibration	0.04	0.04	0.04	0.04	0.04	0.04	0.04	0.04	0.04
I, Upstream Filtering Factor	1.00	1.00	1.00	1.00	1.00	1.00	1.00	1.00	1.00
d2, Incremental Delay [s]	3.65	0.67	0.24	3.05	0.64	4.99	1.80	4.56	1.47
d3, Initial Queue Delay [s]	0.00	0.00	0.00	0.00	0.00	0.00	0.00	0.00	0.00
Rp, platoon ratio	1.00	1.00	1.00	1.00	1.00	1.00	1.00	1.00	1.00
PF, progression factor	1.00	1.00	1.00	1.00	1.00	1.00	1.00	1.00	1.00

Lane Group Results

X, volume / capacity	0.81	0.53	0.26	0.81	0.54	0.65	0.86	0.71	0.84
d, Delay for Lane Group [s/veh]	19.26	14.68	13.66	18.30	14.25	21.97	13.38	21.22	12.62
Lane Group LOS	B	B	B	B	B	C	B	C	B
Critical Lane Group	No	Yes	No	Yes	No	No	Yes	Yes	No
50th-Percentile Queue Length [veh/m]	1.01	0.83	0.32	1.13	0.88	0.29	2.38	0.44	2.28
50th-Percentile Queue Length [ft/m]	25.30	20.80	8.05	28.27	21.90	7.16	59.45	11.12	57.06
95th-Percentile Queue Length [veh/m]	1.82	1.50	0.58	2.04	1.58	0.52	4.28	0.80	4.11
95th-Percentile Queue Length [ft/m]	45.55	37.44	14.49	50.89	39.42	12.88	107.00	20.01	102.72



Movement, Approach, & Intersection Results

d_M, Delay for Movement [s/veh]	19.25	14.68	13.66	18.30	14.25	14.25	21.97	13.38	13.38	21.22	12.62	12.62
Movement LOS	B	B	B	B	B	B	C	B	B	C	B	B
d_A, Approach Delay [s/veh]	16.40		16.35		14.00		13.59					
Approach LOS	B		B		B		B					
d_I, Intersection Delay [s/veh]	14.81											
Intersection LOS	B											
Intersection V/C	0.783											

Other Modes

g_Walk,mi, Effective Walk Time [s]	11.0	11.0	11.0	11.0
M_corner, Corner Circulation Area [ft ² /ped]	0.00	0.00	0.00	0.00
M_CW, Crosswalk Circulation Area [ft ² /ped]	0.00	0.00	0.00	0.00
d_p, Pedestrian Delay [s]	8.38	8.38	8.38	8.38
L_p,int, Pedestrian LOS Score for Intersection	2.252	2.111	2.275	2.313
Crosswalk LOS	B	B	B	B
s_b, Saturation Flow Rate of the bicycle lane [bicycles/s]	2000	2000	2000	2000
c_b, Capacity of the bicycle lane [bicycles/h]	1438	1438	1704	1704
d_b, Bicycle Delay [s]	1.40	1.40	0.39	0.39
L_b,int, Bicycle LOS Score for Intersection	2.107	2.065	2.355	2.401
Bicycle LOS	B	B	B	B

Sequence

Ring 1	1	2	3	4	-	-	-	-	-	-	-	-	-	-
Ring 2	5	6	7	8	-	-	-	-	-	-	-	-	-	-
Ring 3	-	-	-	-	-	-	-	-	-	-	-	-	-	-
Ring 4	-	-	-	-	-	-	-	-	-	-	-	-	-	-

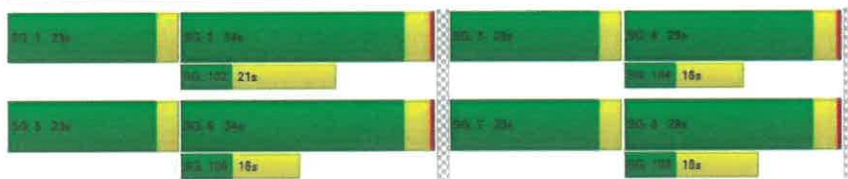

Intersection Level of Service Report

Intersection 1: Burns Valley Rd/N-S Project Street

Control Type:	Two-way stop	Delay (sec / veh):	10.2
Analysis Method:	HCM 6th Edition	Level of Service:	B
Analysis Period:	15 minutes	Volume to Capacity (v/c):	0.015

Intersection Setup

Name	N-S Project Street		Burns Valley Rd		Burns Valley Rd	
	Northbound		Eastbound		Westbound	
Approach	Northbound		Eastbound		Westbound	
Lane Configuration	T		T		T	
Turning Movement	Left	Right	Thru	Right	Left	Thru
Lane Width [ft]	12.00	12.00	12.00	12.00	12.00	12.00
No. of Lanes in Entry Pocket	0	0	0	0	0	0
Entry Pocket Length [ft]	100.00	100.00	100.00	100.00	100.00	100.00
No. of Lanes in Exit Pocket	0	0	0	0	0	0
Exit Pocket Length [ft]	0.00	0.00	0.00	0.00	0.00	0.00
Speed [mph]	25.00		35.00		35.00	
Grade [%]	0.00		0.00		0.00	
Crosswalk	No		No		No	

Volumes

Name	N-S Project Street		Burns Valley Rd		Burns Valley Rd	
Base Volume Input [veh/h]	8	7	112	15	0	110
Base Volume Adjustment Factor	1.0000	1.0000	1.0000	1.0000	1.0000	1.0000
Heavy Vehicles Percentage [%]	2.00	2.00	2.00	2.00	2.00	2.00
Growth Factor	1.0000	1.0000	1.0000	1.0000	1.0000	1.0000
In-Process Volume [veh/h]	0	0	0	0	0	0
Site-Generated Trips [veh/h]	2	3	1	4	5	1
Diverted Trips [veh/h]	0	0	0	0	0	0
Pass-by Trips [veh/h]	0	0	0	0	0	0
Existing Site Adjustment Volume [veh/h]	0	0	0	0	0	0
Other Volume [veh/h]	0	0	0	0	0	0
Total Hourly Volume [veh/h]	10	10	113	19	5	111
Peak Hour Factor	0.8890	0.8890	0.8890	0.8890	0.8890	0.8890
Other Adjustment Factor	1.0000	1.0000	1.0000	1.0000	1.0000	1.0000
Total 15-Minute Volume [veh/h]	3	3	32	5	1	31
Total Analysis Volume [veh/h]	11	11	127	21	6	125
Pedestrian Volume [ped/h]	0		0		0	



Generated with **PTV VISTRO**
Version 2021 (SP 0-6)

Burns Valley Development

5/2/2022

Intersection Settings

Priority Scheme	Stop	Free	Free
Flared Lane	No		
Storage Area [veh]	0	0	0
Two-Stage Gap Acceptance	No		
Number of Storage Spaces in Median	0	0	0

Movement, Approach, & Intersection Results

V/C, Movement V/C Ratio	0.02	0.01	0.00	0.00	0.00	0.00
d_M, Delay for Movement [s/veh]	10.18	9.08	0.00	0.00	7.52	0.00
Movement LOS	B	A	A	A	A	A
95th-Percentile Queue Length [veh/ln]	0.08	0.08	0.00	0.00	0.01	0.01
95th-Percentile Queue Length [ft/ln]	2.12	2.12	0.00	0.00	0.32	0.32
d_A, Approach Delay [s/veh]	9.63		0.00		0.34	
Approach LOS	A		A		A	
d_I, Intersection Delay [s/veh]			0.85			
Intersection LOS			B			

Weekday AM E+P



Generated with **PTV VISTRO**
Version 2021 (SP 0-6)

Burns Valley Development

5/2/2022

Intersection Level Of Service Report

Intersection 2: Burns Valley Rd/Bowers Ave-Rumsey Rd

Control Type: Two-way stop
Analysis Method: HCM 6th Edition
Analysis Period: 15 minutes
Delay (sec / veh): 13.8
Level Of Service: B
Volume to Capacity (v/c): 0.014

Intersection Setup

Name	Burns Valley Rd			Rumsey Rd			Burns Valley Rd			Bowers Ave		
Approach	Northbound			Southbound			Eastbound			Westbound		
Lane Configuration	+			+			+			+		
Turning Movement	Left	Thru	Right	Left	Thru	Right	Left	Thru	Right	Left	Thru	Right
Lane Width [ft]	12.00	12.00	12.00	12.00	12.00	12.00	12.00	12.00	12.00	12.00	12.00	12.00
No. of Lanes in Entry Pocket	0	0	0	0	0	0	0	0	0	0	0	0
Entry Pocket Length [ft]	100.00	100.00	100.00	100.00	100.00	100.00	100.00	100.00	100.00	100.00	100.00	100.00
No. of Lanes in Exit Pocket	0	0	0	0	0	0	0	0	0	0	0	0
Exit Pocket Length [ft]	3.00	0.00	0.00	0.00	0.00	0.00	0.00	0.00	0.00	0.00	0.00	0.00
Speed [mph]	30.00			30.00			35.00			25.00		
Grade [%]	0.00			0.00			0.00			0.00		
Crosswalk	No			Yes			Yes			No		

Volumes

Name	Burns Valley Rd			Rumsey Rd			Burns Valley Rd			Bowers Ave		
Base Volume Input [veh/h]	122	26	6	0	23	16	9	1	124	5	1	0
Base Volume Adjustment Factor	1.0000	1.0000	1.0000	1.0000	1.0000	1.0000	1.0000	1.0000	1.0000	1.0000	1.0000	1.0000
Heavy Vehicles Percentage [%]	2.00	2.00	2.00	2.00	2.00	2.00	2.00	2.00	2.00	2.00	2.00	2.00
Growth Factor	1.0000	1.0000	1.0000	1.0000	1.0000	1.0000	1.0000	1.0000	1.0000	1.0000	1.0000	1.0000
In-Process Volume [veh/h]	0	0	0	0	0	0	0	0	0	0	0	0
Site-Generated Trips [veh/h]	2	1	0	0	0	1	2	0	5	0	0	0
Diverted Trips [veh/h]	0	0	0	0	0	0	0	0	0	0	0	0
Pass-by Trips [veh/h]	0	0	0	0	0	0	0	0	0	0	0	0
Existing Site Adjustment Volume [veh/h]	0	0	0	0	0	0	0	0	0	0	0	0
Other Volume [veh/h]	0	0	0	0	0	0	0	0	0	0	0	0
Total Hourly Volume [veh/h]	124	27	6	0	23	17	11	1	129	5	1	0
Peak Hour Factor	0.8500	0.8500	0.8500	0.8500	0.8500	0.8500	0.8500	0.8500	0.8500	0.8500	0.8500	0.8500
Other Adjustment Factor	1.0000	1.0000	1.0000	1.0000	1.0000	1.0000	1.0000	1.0000	1.0000	1.0000	1.0000	1.0000
Total 15-Minute Volume [veh/h]	36	8	2	0	7	5	3	0	38	1	0	0
Total Analysis Volume [veh/h]	146	32	7	0	27	20	13	1	152	6	1	0
Pedestrian Volume [ped/h]	0			0			0			0		

Weekday AM E+P



Intersection Settings

Priority Scheme	Free	Free	Stop	Stop
Flared Lane			No	No
Storage Area [veh]	0	0	0	0
Two-Stage Gap Acceptance			No	No
Number of Storage Spaces in Median	0	0	0	0

Movement, Approach, & Intersection Results

V/C, Movement V/C Ratio	0.09	0.00	0.00	0.00	0.00	0.02	0.00	0.15	0.01	0.00	0.00	
d_M, Delay for Movement [s/veh]	7.54	0.00	0.00	7.29	0.00	0.00	12.36	12.87	0.26	13.80	12.30	8.61
Movement LOS	A	A	A	A	A	B	B	A	B	B	A	
95th-Percentile Queue Length [veh/ln]	0.31	0.31	0.31	0.00	0.00	0.62	0.62	0.62	0.05	0.05	0.05	0.05
95th-Percentile Queue Length [ft/ln]	7.73	7.73	7.73	0.00	0.00	15.54	15.54	15.54	1.25	1.25	1.25	1.25
d_A, Approach Delay [s/veh]	5.95			0.00			9.52			13.59		
Approach LOS	A			A			A			B		
d_I, Intersection Delay [s/veh]	6.86											
Intersection LOS	B											



Intersection Level Of Service Report

Intersection 3: N-S Project Street/E-W Project Street

Control Type:	All-way stop	Delay (sec / veh):	7.2
Analysis Method:	HCM 6th Edition	Level Of Service:	A
Analysis Period:	15 minutes	Volume to Capacity (v/c):	0.055

Intersection Setup

Name	N-S Project Street			N-S Project Street			E-W Project Street			E-W Project Street		
Approach	Northbound			Southbound			Eastbound			Westbound		
Lane Configuration	+			+			+			+		
Turning Movement	Left	Thru	Right	Left	Thru	Right	Left	Thru	Right	Left	Thru	Right
Lane Width [ft]	12.00	12.00	12.00	12.00	12.00	12.00	12.00	12.00	12.00	12.00	12.00	12.00
No. of Lanes in Entry Pocket	0	0	0	0	0	0	0	0	0	0	0	0
Entry Pocket Length [ft]	100.00	100.00	100.00	100.00	100.00	100.00	100.00	100.00	100.00	100.00	100.00	100.00
No. of Lanes in Exit Pocket	0	0	0	0	0	0	0	0	0	0	0	0
Exit Pocket Length [ft]	0.00	0.00	0.00	0.00	0.00	0.00	0.00	0.00	0.00	0.00	0.00	0.00
Speed [mph]	25.00			25.00			25.00			25.00		
Grade [%]	0.00			0.00			0.00			0.00		
Crosswalk	Yes			Yes			Yes			Yes		

Volumes

Name	N-S Project Street			N-S Project Street			E-W Project Street			E-W Project Street		
Base Volume Input [veh/h]	0	15	0	0	15	0	0	0	0	0	0	0
Base Volume Adjustment Factor	1.0000	1.0000	1.0000	1.0000	1.0000	1.0000	1.0000	1.0000	1.0000	1.0000	1.0000	1.0000
Heavy Vehicles Percentage [%]	2.00	2.00	2.00	2.00	2.00	2.00	2.00	2.00	2.00	2.00	2.00	2.00
Growth Factor	1.0000	1.0000	1.0000	1.0000	1.0000	1.0000	1.0000	1.0000	1.0000	1.0000	1.0000	1.0000
In-Process Volume [veh/h]	0	0	0	0	0	0	0	0	0	0	0	0
Site-Generated Trips [veh/h]	8	18	3	3	11	1	0	1	1	4	2	4
Diverted Trips [veh/h]	0	0	0	0	0	0	0	0	0	0	0	0
Pass-by Trips [veh/h]	0	0	0	0	0	0	0	0	0	0	0	0
Existing Site Adjustment Volume [veh/h]	0	0	0	0	0	0	0	0	0	0	0	0
Other Volume [veh/h]	0	0	0	0	0	0	0	0	0	0	0	0
Total Hourly Volume [veh/h]	6	33	3	3	26	1	0	1	1	4	2	4
Peak Hour Factor	0.8500	0.8500	0.8500	0.8500	0.8500	0.8500	0.8500	0.8500	0.8500	0.8500	0.8500	0.8500
Other Adjustment Factor	1.0000	1.0000	1.0000	1.0000	1.0000	1.0000	1.0000	1.0000	1.0000	1.0000	1.0000	1.0000
Total 15-Minute Volume [veh/h]	2	10	1	1	8	0	0	0	0	1	1	1
Total Analysis Volume [veh/h]	7	39	4	4	31	1	0	1	1	5	2	5
Pedestrian Volume [ped/h]	0			0			0			0		



Intersection Settings

Lanes				
Capacity per Entry Lane [veh/h]	906	896	941	911
Degree of Utilization, x	0.06	0.04	0.00	0.01

Movement, Approach, & Intersection Results

95th-Percentile Queue Length [veh]	0.18	0.13	0.01	0.04
95th-Percentile Queue Length [ft]	4.38	3.13	0.16	1.00
Approach Delay [s/veh]	7.21	7.18	6.84	7.00
Approach LOS	A	A	A	A
Intersection Delay [s/veh]	7.17			
Intersection LOS	A			



Intersection Level Of Service Report

Intersection 4: Burns Valley Rd/E-W Project Street

Control Type:	Two-way stop	Delay (sec / veh):	10.9
Analysis Method:	HCM 6th Edition	Level Of Service:	B
Analysis Period:	15 minutes	Volume to Capacity (v/c):	0.002

Intersection Setup

Name	Burns Valley Rd		Burns Valley Rd		E-W Project Street	
	Northbound		Southbound		Eastbound	
Approach	←		→		←	
Lane Configuration	←		→		←	
Turning Movement	Left	Thru	Thru	Right	Left	Right
Lane Width [ft]	12.00	12.00	12.00	12.00	12.00	12.00
No. of Lanes in Entry Pocket	0	0	0	0	0	0
Entry Pocket Length [ft]	100.00	100.00	100.00	100.00	100.00	100.00
No. of Lanes in Exit Pocket	0	0	0	0	0	0
Exit Pocket Length [ft]	0.00	0.00	0.00	0.00	0.00	0.00
Speed [mph]	30.00		30.00		25.00	
Grade [%]	0.00		0.00		0.00	
Crosswalk	No		No		Yes	

Volumes

Name	Burns Valley Rd		Burns Valley Rd		E-W Project Street	
	Northbound	Southbound	Northbound	Southbound	Eastbound	Westbound
Base Volume Input [veh/h]	0	151	147	0	0	0
Base Volume Adjustment Factor	1.0000	1.0000	1.0000	1.0000	1.0000	1.0000
Heavy Vehicles Percentage [%]	2.00	2.00	2.00	2.00	2.00	2.00
Growth Factor	1.0000	1.0000	1.0000	1.0000	1.0000	1.0000
In-Process Volume [veh/h]	0	0	0	0	0	0
Site-Generated Trips [veh/h]	8	2	5	0	1	9
Diverted Trips [veh/h]	0	0	0	0	0	0
Pass-by Trips [veh/h]	0	0	0	0	0	0
Existing Site Adjustment Volume [veh/h]	0	0	0	0	0	0
Other Volume [veh/h]	0	0	0	0	0	0
Total Hourly Volume [veh/h]	8	153	152	0	1	9
Peak Hour Factor	0.8500	0.8500	0.8500	0.8500	0.8500	0.8500
Other Adjustment Factor	1.0000	1.0000	1.0000	1.0000	1.0000	1.0000
Total 15-Minute Volume [veh/h]	2	45	45	0	0	3
Total Analysis Volume [veh/h]	9	180	179	0	1	11
Pedestrian Volume [ped/h]	0	0	0	0	0	0



Intersection Settings

Priority Scheme	Free	Free	Stop
Flared Lane			No
Storage Area [veh]	0	0	0
Two-Stage Gap Acceptance			No
Number of Storage Spaces in Median	0	0	0

Movement, Approach, & Intersection Results

V/C, Movement V/C Ratio	0.01	0.01	0.00	0.00	0.00	0.01
d_M, Delay for Movement [s/veh]	7.59	0.00	0.00	0.00	10.87	9.23
Movement LOS	A	A	A	A	B	A
95th-Percentile Queue Length [veh/ln]	0.02	0.02	0.00	0.00	0.04	0.04
95th-Percentile Queue Length [ft/ln]	0.49	0.49	0.00	0.00	1.09	1.09
d_A, Approach Delay [s/veh]	0.36		0.00		9.37	
Approach LOS	A		A		A	
d_I, Intersection Delay [s/veh]			0.46			
Intersection LOS			B			



Intersection Level Of Service Report
Intersection 5: Olympic Dr/Lakeshore Dr

Control Type: Two-way stop
Analysis Method: HCM 6th Edition
Analysis Period: 15 minutes
Delay (sec / veh): 16.8
Level Of Service: C
Volume to Capacity (v/c): 0.169

Intersection Setup

Name	Lakeshore Dr			Lakeshore Dr			Olympic Dr					
Approach	Northbound			Southbound			Eastbound			Westbound		
Lane Configuration	+			+			+			+		
Turning Movement	Left	Thru	Right	Left	Thru	Right	Left	Thru	Right	Left	Thru	Right
Lane Width [ft]	12.00	12.00	12.00	12.00	12.00	12.00	12.00	12.00	12.00	12.00	12.00	12.00
No. of Lanes in Entry Pocket	0	0	1	0	0	0	0	0	0	0	0	1
Entry Pocket Length [ft]	100.00	100.00	120.00	100.00	100.00	100.00	100.00	100.00	100.00	100.00	100.00	250.00
No. of Lanes in Exit Pocket	0	0	0	0	0	0	0	0	0	0	0	0
Exit Pocket Length [ft]	0.00	0.00	0.00	0.00	0.00	0.00	0.00	0.00	0.00	0.00	0.00	0.00
Speed [mph]	25.00			25.00			30.00			30.00		
Grade [%]	0.00			0.00			0.00			0.00		
Crosswalk	No			Yes			No			Yes		

Volumes

Name	Lakeshore Dr			Lakeshore Dr			Olympic Dr					
Base Volume Input [veh/h]	1	137	66	81	279	2	0	0	1	47	1	60
Base Volume Adjustment Factor	1.0000	1.0000	1.0000	1.0000	1.0000	1.0000	1.0000	1.0000	1.0000	1.0000	1.0000	1.0000
Heavy Vehicles Percentage [%]	2.00	2.00	2.00	2.00	2.00	2.00	2.00	2.00	2.00	2.00	2.00	2.00
Growth Factor	1.0000	1.0000	1.0000	1.0000	1.0000	1.0000	1.0000	1.0000	1.0000	1.0000	1.0000	1.0000
In-Process Volume [veh/h]	0	0	0	0	0	0	0	0	0	0	0	0
Site-Generated Trips [veh/h]	0	0	11	4	0	0	0	0	0	6	0	3
Diverted Trips [veh/h]	0	0	0	0	0	0	0	0	0	0	0	0
Pass-by Trips [veh/h]	0	0	0	0	0	0	0	0	0	0	0	0
Existing Site Adjustment Volume [veh/h]	0	0	0	0	0	0	0	0	0	0	0	0
Other Volume [veh/h]	0	0	0	0	0	0	0	0	0	0	0	0
Total Hourly Volume [veh/h]	1	137	77	85	279	2	0	0	1	53	1	63
Peak Hour Factor	0.8600	0.8600	0.8600	0.8600	0.8600	0.8600	0.8600	0.8600	0.8600	0.8600	0.8600	0.8600
Other Adjustment Factor	1.0000	1.0000	1.0000	1.0000	1.0000	1.0000	1.0000	1.0000	1.0000	1.0000	1.0000	1.0000
Total 15-Minute Volume [veh/h]	0	40	22	19	81	1	0	0	0	15	0	18
Total Analysis Volume [veh/h]	1	159	90	76	324	2	0	0	1	62	1	73
Pedestrian Volume [ped/h]		0		0			0			1		



Intersection Settings

	Free	Free	Stop	Stop
Priority Scheme				
Flared Lane			No	No
Storage Area [veh]	0	0	0	0
Two-Stage Gap Acceptance			No	No
Number of Storage Spaces in Median	0	0	0	0

Movement, Approach, & Intersection Results

V/C, Movement V/C Ratio	0.00	0.00	0.00	0.05	0.05	0.05	0.00	0.00	0.00	0.17	0.00	0.08
d_M, Delay for Movement [s/veh]	7.92	0.00	0.00	7.91	0.00	0.00	17.13	0.11	10.03	16.82	15.25	9.46
Movement LOS	A	A	A	A	A	A	C	C	B	C	C	A
95th-Percentile Queue Length [veh/ln]	0.00	0.00	0.00	0.18	0.18	0.18	0.00	0.00	0.60	0.28	0.28	0.28
95th-Percentile Queue Length [ft/ln]	0.05	0.05	0.00	4.60	4.60	4.60	0.10	0.10	15.04	6.97	6.97	6.97
d_A, Approach Delay [s/veh]		0.03			1.49			10.03			12.85	
Approach LOS		A			A			B			B	
d_I, Intersection Delay [s/veh]							3.00					
Intersection LOS							C					

Intersection Level Of Service Report

Intersection 6: Olympic Dr/N-S Project Street

Control Type:	Two-way stop	Delay (sec / veh):	16.0
Analysis Method:	HCM 6th Edition	Level Of Service:	C
Analysis Period:	15 minutes	Volume to Capacity (v/c):	0.041

Intersection Setup

Name	N-S Project Street		Olympic Dr		Olympic Dr	
Approach	Southbound		Eastbound		Westbound	
Lane Configuration	T		↑		↑	
Turning Movement	Left	Right	Left	Thru	Thru	Right
Lane Width [ft]	12.00	12.00	12.00	12.00	12.00	12.00
No. of Lanes in Entry Pocket	0	0	0	0	0	0
Entry Pocket Length [ft]	100.00	100.00	100.00	100.00	100.00	100.00
No. of Lanes in Exit Pocket	0	0	0	0	0	0
Exit Pocket Length [ft]	0.00	0.00	0.00	0.00	0.00	0.00
Speed [mph]	25.00		30.00		30.00	
Grade [%]	0.00		0.00		0.00	
Crosswalk	Yes		No		No	

Volumes

Name	N-S Project Street		Olympic Dr		Olympic Dr	
Base Volume Input [veh/h]	7	8	15	290	306	0
Base Volume Adjustment Factor	1.0000	1.0000	1.0000	1.0000	1.0000	1.0000
Heavy Vehicles Percentage [%]	2.00	2.00	2.00	2.00	2.00	2.00
Growth Factor	1.0000	1.0000	1.0000	1.0000	1.0000	1.0000
In-Process Volume [veh/h]	0	0	0	0	0	0
Site-Generated Trips [veh/h]	5	12	19	0	0	12
Diverted Trips [veh/h]	0	0	0	0	0	0
Pass-by Trips [veh/h]	0	0	0	0	0	0
Existing Site Adjustment Volume [veh/h]	0	0	0	0	0	0
Other Volume [veh/h]	0	0	0	0	0	0
Total Hourly Volume [veh/h]	12	20	34	290	306	12
Peak Hour Factor	0.8500	0.8500	0.8500	0.8500	0.8500	0.8500
Other Adjustment Factor	1.0000	1.0000	1.0000	1.0000	1.0000	1.0000
Total 15-Minute Volume [veh/h]	4	6	10	85	90	4
Total Analysis Volume [veh/h]	14	24	40	341	360	14
Pedestrian Volume [ped/h]	0		0		0	



Intersection Settings

Priority Scheme	Stop	Free	Free
Flared Lane	No		
Storage Area [veh]	0	0	0
Two-Stage Gap Acceptance	No		
Number of Storage Spaces in Median	0	0	0

Movement, Approach, & Intersection Results

V/C, Movement V/C Ratio	0.04	0.04	0.03	0.03	0.03	0.03
d_M, Delay for Movement [s/veh]	16.03	10.90	8.15	0.66	0.59	0.00
Movement LOS	C	B	A	A	A	A
95th-Percentile Queue Length [veh/ln]	0.25	0.25	0.10	0.10	0.00	0.00
95th-Percentile Queue Length [Min]	6.14	6.14	2.62	2.62	0.00	0.00
d_A, Approach Delay [s/veh]	12.79		0.86		0.00	
Approach LOS	B		A		A	
d_I, Intersection Delay [s/veh]			1.02			
Intersection LOS			C			



Intersection Level Of Service Report

Intersection 7: Olympic Dr/Burns Valley Rd-Old Hwy 53

Control Type:	Signalized	Delay (sec / veh):	11.4
Analysis Method:	HCM 6th Edition	Level Of Service:	B
Analysis Period:	15 minutes	Volume to Capacity (v/c):	0.668

Intersection Setup

Name	Old Hwy 53			Burns Valley Rd			Olympic Dr			Old Hwy 53		
Approach	Northbound			Southbound			Eastbound			Westbound		
Lane Configuration	T			T			T			T		
Turning Movement	Left	Thru	Right	Left	Thru	Right	Left	Thru	Right	Left	Thru	Right
Lane Width [ft]	12.00	12.00	12.00	12.00	12.00	12.00	12.00	12.00	12.00	12.00	12.00	12.00
No. of Lanes in Entry Pocket	1	0	1	1	0	0	1	0	0	1	0	0
Entry Pocket Length [ft]	100.00	100.00	100.00	56.00	100.00	100.00	48.00	100.00	100.00	100.00	100.00	100.00
No. of Lanes in Exit Pocket	0	0	0	0	0	0	0	0	0	0	0	0
Exit Pocket Length [ft]	0.00	0.00	0.00	0.00	0.00	0.00	0.00	0.00	0.00	0.00	0.00	0.00
Speed [mph]	30.00			30.00			35.00			35.00		
Grade [%]	0.00			0.00			0.00			0.00		
Curb Present	No			No			No			No		
Crosswalk	Yes			Yes			Yes			Yes		



Volumes

Name	Old Hwy 53			Burns Valley Rd			Olympic Dr			Old Hwy 53		
Base Volume Input [veh/h]	42	62	45	75	70	15	26	131	51	48	150	99
Base Volume Adjustment Factor	1.0000	1.0000	1.0000	1.0000	1.0000	1.0000	1.0000	1.0000	1.0000	1.0000	1.0000	1.0000
Heavy Vehicles Percentage [%]	2.00	2.00	2.00	2.00	2.00	2.00	2.00	2.00	2.00	2.00	2.00	2.00
Growth Factor	1.0000	1.0000	1.0000	1.0000	1.0000	1.0000	1.0000	1.0000	1.0000	1.0000	1.0000	1.0000
In-Process Volume [veh/h]	0	0	0	0	0	0	0	0	0	0	0	0
Site-Generated Trips [veh/h]	5	6	0	5	9	0	0	1	4	0	7	4
Diverted Trips [veh/h]	0	0	0	0	0	0	0	0	0	0	0	0
Pass-by Trips [veh/h]	0	0	0	0	0	0	0	0	0	0	0	0
Existing Site Adjustment Volume [veh/h]	0	0	0	0	0	0	0	0	0	0	0	0
Other Volume [veh/h]	0	0	0	0	0	0	0	0	0	0	0	0
Right Turn on Red Volume [veh/h]	0	0	18	0	0	11	0	0	14	0	0	25
Total Hourly Volume [veh/h]	47	68	27	80	79	4	26	132	41	48	157	78
Peak Hour Factor	0.8900	0.8900	0.8900	0.8900	0.8900	0.8900	0.8900	0.8900	0.8900	0.8900	0.8900	0.8900
Other Adjustment Factor	1.0000	1.0000	1.0000	1.0000	1.0000	1.0000	1.0000	1.0000	1.0000	1.0000	1.0000	1.0000
Total 15-Minute Volume [veh/h]	13	19	8	22	22	1	7	37	12	13	44	22
Total Analysis Volume [veh/h]	53	78	30	90	89	4	29	148	46	54	176	88
Presence of On-Street Parking	No	No	No	No	No	No	No	No	No	No	No	No
On-Street Parking Maneuver Rate [/h]	0	0	0	0	0	0	0	0	0	0	0	0
Local Bus Stopping Rate [/h]	0	0	0	0	0	0	0	0	0	0	0	0
v_do, Outbound Pedestrian Volume crossing major street	1			0			1			1		
v_di, Inbound Pedestrian Volume crossing major street	1			1			0			1		
v_co, Outbound Pedestrian Volume crossing minor street	1			0			0			0		
v_ci, Inbound Pedestrian Volume crossing minor street	0			0			1			0		
v_ab, Corner Pedestrian Volume [ped/h]	0			0			0			0		
Bicycle Volume [bicycles/h]	0			0			0			1		

Intersection Settings

Located in CBD	Yes
Signal Coordination Group	-
Cycle Length [s]	109
Coordination Type	Time of Day Pattern Isolated
Actuation Type	Fully actuated
Offset [s]	0.0
Offset Reference	Lead Green - Beginning of First Green
Permissive Mode	SingleBand
Lost time [s]	14.00

Phasing & Timing

Control Type	Protect	Permis	Permis	Protect	Permis	Permis	Protect	Permis	Permis	Protect	Permis	Permis
Signal Group	3	8	0	7	4	0	5	2	0	1	6	0
Auxiliary Signal Groups												
Lead / Lag	Lead	-	-	Lead	-	-	Lead	-	-	Lead	-	-
Minimum Green [s]	4	6	0	4	6	0	4	6	0	4	6	0
Maximum Green [s]	20	25	0	20	25	0	20	30	0	20	20	0
Amber [s]	3.0	3.3	0.0	3.0	3.3	0.0	3.0	3.6	0.0	3.0	3.6	0.0
All red [s]	0.0	0.3	0.0	0.0	0.3	0.0	0.0	0.3	0.0	0.0	0.3	0.0
Split [s]	23	29	0	23	29	0	23	34	0	23	34	0
Vehicle Extension [s]	0.0	0.0	0.0	0.0	0.0	0.0	0.0	0.0	0.0	0.0	0.0	0.0
Walk [s]	0	7	0	0	7	0	0	7	0	0	7	0
Pedestrian Clearance [s]	0	11	0	0	9	0	0	14	0	0	9	0
Delayed Vehicle Green [s]	0.0	0.0	0.0	0.0	0.0	0.0	0.0	0.0	0.0	0.0	0.0	0.0
Rest In Walk	No	No	No	No	No	No	No	No	No	No	No	No
I1, Start-Up Lost Time [s]	2.0	2.0	0.0	2.0	2.0	0.0	2.0	2.0	0.0	2.0	2.0	0.0
I2, Clearance Lost Time [s]	1.0	1.6	0.0	1.0	1.6	0.0	1.0	1.9	0.0	1.0	1.9	0.0
Minimum Recall	No	No	No	No	No	No	No	No	No	No	No	No
Maximum Recall	No	No	No	No	No	No	No	No	No	No	No	No
Pedestrian Recall	No	No	No	No	No	No	No	No	No	No	No	No
Detector Location [ft]	0.0	0.0	0.0	0.0	0.0	0.0	0.0	0.0	0.0	0.0	0.0	0.0
Detector Length [ft]	0.0	0.0	0.0	0.0	0.0	0.0	0.0	0.0	0.0	0.0	0.0	0.0
I, Upstream Filtering Factor	1.00	1.00	1.00	1.00	1.00	1.00	1.00	1.00	1.00	1.00	1.00	1.00

Exclusive Pedestrian Phase

Pedestrian Signal Group	0
Pedestrian Walk [s]	0
Pedestrian Clearance [s]	0



Lane Group Calculations

Lane Group	L	C	R	L	C	L	C	L	C
C, Cycle Length [s]	25	25	25	25	25	25	25	25	25
L, Total Lost Time per Cycle [s]	3.00	3.60	3.60	3.00	3.60	3.00	3.90	3.00	3.90
H_p, Permitted Start-Up Lost Time [s]	0.00	0.00	0.00	0.00	0.00	0.00	0.00	0.00	0.00
I2, Clearance Lost Time [s]	1.00	1.60	1.60	1.00	1.60	1.00	1.90	1.00	1.90
g_i, Effective Green Time [s]	1	3	3	2	4	1	5	1	5
g / C, Green / Cycle	0.05	0.13	0.13	0.08	0.16	0.03	0.19	0.05	0.21
(v / s)_j Volume / Saturation Flow Rate	0.03	0.05	0.02	0.06	0.06	0.02	0.12	0.03	0.17
s, saturation flow rate [veh/h]	1603	1683	1420	1603	1670	1603	1614	1603	1576
c, Capacity [veh/h]	83	227	191	125	269	50	305	85	332
d1, Uniform Delay [s]	11.51	9.71	9.47	11.15	9.23	11.84	9.25	11.50	9.26
k, delay calibration	0.04	0.04	0.04	0.04	0.04	0.04	0.04	0.04	0.04
I, Upstream Filtering Factor	1.00	1.00	1.00	1.00	1.00	1.00	1.00	1.00	1.00
d2, Incremental Delay [s]	2.95	0.32	0.14	2.88	0.28	3.92	0.82	2.94	1.64
d3, Initial Queue Delay [s]	0.00	0.00	0.00	0.00	0.00	0.00	0.00	0.00	0.00
Rp, platoon ratio	1.00	1.00	1.00	1.00	1.00	1.00	1.00	1.00	1.00
PF, progression factor	1.00	1.00	1.00	1.00	1.00	1.00	1.00	1.00	1.00

Lane Group Results

X, volume / capacity	0.64	0.33	0.16	0.72	0.35	0.58	0.64	0.64	0.79
d, Delay for Lane Group [s/veh]	14.46	10.03	9.61	14.03	9.52	15.76	10.07	14.43	10.90
Lane Group LOS	B	B	A	B	A	B	B	B	B
Critical Lane Group	No	Yes	No	Yes	No	Yes	No	No	Yes
50th-Percentile Queue Length [veh/ln]	0.26	0.26	0.10	0.43	0.30	0.16	0.60	0.26	0.86
50th-Percentile Queue Length [ft/ln]	6.62	6.52	2.50	10.63	7.53	3.94	15.12	6.41	21.88
95th-Percentile Queue Length [veh/ln]	0.48	0.47	0.18	0.77	0.54	0.26	1.09	0.46	1.58
95th-Percentile Queue Length [ft/ln]	11.92	11.73	4.50	19.13	13.56	7.10	27.22	11.53	39.38



Movement, Approach, & Intersection Results

d_M, Delay for Movement [s/veh]	14.46	10.03	9.61	14.03	9.52	9.52	15.76	10.07	10.07	14.43	10.90	10.90
Movement LOS	B	B	A	B	A	A	B	B	B	B	B	B
d_A, Approach Delay [s/veh]	11.43			11.74			10.81			11.50		
Approach LOS	B			B			B			B		
d_I, Intersection Delay [s/veh]	11.36											
Intersection LOS	B											
Intersection V/C	0.868											

Other Modes

g_Walk,mi, Effective Walk Time [s]	11.0	11.0	11.0	11.0
M_comer, Corner Circulation Area [ft ² /ped]	0.00	0.00	0.00	0.00
M_CW, Crosswalk Circulation Area [ft ² /ped]	0.00	0.00	0.00	0.00
d_p, Pedestrian Delay [s]	3.73	3.73	3.73	3.73
I_p,int, Pedestrian LOS Score for Intersection	2.159	2.000	2.053	2.124
Crosswalk LOS	B	A	B	B
s_b, Saturation Flow Rate of the bicycle lane [bicycles/h]	2000	2000	2000	2000
c_b, Capacity of the bicycle lane [bicycles/h]	2070	2070	2453	2453
d_b, Bicycle Delay [s]	0.02	0.02	0.63	0.63
I_b,int, Bicycle LOS Score for Intersection	1.852	1.880	1.951	2.126
Bicycle LOS	A	A	A	B

Sequence

Ring 1	1	2	3	4	-	-	-	-	-	-	-	-	-	-	-
Ring 2	5	6	7	8	-	-	-	-	-	-	-	-	-	-	-
Ring 3	-	-	-	-	-	-	-	-	-	-	-	-	-	-	-
Ring 4	-	-	-	-	-	-	-	-	-	-	-	-	-	-	-

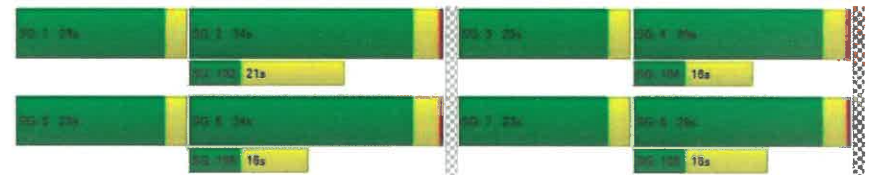

Intersection Level Of Service Report
Intersection 1: Burns Valley Rd/N-S Project Street

Control Type: Two-way stop
Analysis Method: HCM 6th Edition
Analysis Period: 15 minutes
Delay (sec / veh): 10.4
Level Of Service: B
Volume to Capacity (v/c): 0.025

Intersection Setup

Name	N-S Project Street		Burns Valley Rd		Burns Valley Rd	
	Northbound		Eastbound		Westbound	
Approach	←		→		←	
Lane Configuration	←		→		←	
Turning Movement	Left	Right	Thru	Right	Left	Thru
Lane Width [ft]	12.00	12.00	12.00	12.00	12.00	12.00
No. of Lanes in Entry Pocket	0	0	0	0	0	0
Entry Pocket Length [ft]	100.00	100.00	100.00	100.00	100.00	100.00
No. of Lanes in Exit Pocket	0	0	0	0	0	0
Exit Pocket Length [ft]	0.00	0.00	0.00	0.00	0.00	0.00
Speed [mph]	25.00		35.00		35.00	
Grade [%]	0.00		0.00		0.00	
Crosswalk	No		No		No	

Volumes

Name	N-S Project Street		Burns Valley Rd		Burns Valley Rd	
	Base Volume Input [veh/h]	8	8	117	17	0
Base Volume Adjustment Factor	1.0000	1.0000	1.0000	1.0000	1.0000	1.0000
Heavy Vehicles Percentage [%]	2.00	2.00	2.00	2.00	2.00	2.00
Growth Factor	1.0000	1.0000	1.0000	1.0000	1.0000	1.0000
In-Process Volume [veh/h]	0	0	0	0	0	0
Site-Generated Trips [veh/h]	7	7	1	10	7	1
Diverted Trips [veh/h]	0	0	0	0	0	0
Pass-by Trips [veh/h]	0	0	0	0	0	0
Existing Site Adjustment Volume [veh/h]	0	0	0	0	0	0
Other Volume [veh/h]	0	0	0	0	0	0
Total Hourly Volume [veh/h]	15	15	118	27	7	118
Peak Hour Factor	0.8930	0.8930	0.8930	0.8930	0.8930	0.8930
Other Adjustment Factor	1.0000	1.0000	1.0000	1.0000	1.0000	1.0000
Total 15-Minute Volume [veh/h]	4	4	33	8	2	33
Total Analysis Volume [veh/h]	17	17	132	30	8	132
Pedestrian Volume [ped/h]	0	0	0	0	0	0



Intersection Settings

Priority Scheme	Stop	Free	Free
Flared Lane	No		
Storage Area [veh]	0	0	0
Two-Stage Gap Acceptance	No		
Number of Storage Spaces in Median	0	0	0

Movement, Approach, & Intersection Results

V/C, Movement V/C Ratio	0.02	0.02	0.00	0.00	0.01	0.00
d_M, Delay for Movement [s/veh]	10.41	9.21	0.00	0.00	7.56	0.00
Movement LOS	B	A	A	A	A	A
95th-Percentile Queue Length [veh/ln]	0.14	0.14	0.00	0.00	0.02	0.02
95th-Percentile Queue Length [ft/ln]	3.40	3.40	0.00	0.00	0.43	0.43
d_A, Approach Delay [s/veh]	9.81		0.00		0.43	
Approach LOS	A		A		A	
d_I, Intersection Delay [s/veh]	1.17					
Intersection LOS	B					



Intersection Level Of Service Report

Intersection 2: Burns Valley Rd/Bowers Ave-Rumsey Rd

Control Type: Two-way stop
 Analysis Method: HCM 6th Edition
 Analysis Period: 15 minutes
 Delay (sec / veh): 12.9
 Level Of Service: B
 Volume to Capacity (v/c): 0.032

Intersection Setup

Name	Burns Valley Rd			Rumsey Rd			Burns Valley Rd			Bowers Ave		
Approach	Northbound			Southbound			Eastbound			Westbound		
Lane Configuration	+			+			+			+		
Turning Movement	Left	Thru	Right	Left	Thru	Right	Left	Thru	Right	Left	Thru	Right
Lane Width [ft]	12.00	12.00	12.00	12.00	12.00	12.00	12.00	12.00	12.00	12.00	12.00	12.00
No. of Lanes in Entry Pocket	0	0	0	0	0	0	0	0	0	0	0	0
Entry Pocket Length [ft]	100.00	100.00	100.00	100.00	100.00	100.00	100.00	100.00	100.00	100.00	100.00	100.00
No. of Lanes in Exit Pocket	0	0	0	0	0	0	0	0	0	0	0	0
Exit Pocket Length [ft]	0.00	0.00	0.00	0.00	0.00	0.00	0.00	0.00	0.00	0.00	0.00	0.00
Speed [mph]	30.00			30.00			35.00			25.00		
Grade [%]	0.00			0.00			0.00			0.00		
Crosswalk	No			Yes			Yes			No		

Volumes

Name	Burns Valley Rd			Rumsey Rd			Burns Valley Rd			Bowers Ave		
Base Volume Input [veh/h]	100	38	9	2	43	7	7	1	75	13	0	0
Base Volume Adjustment Factor	1.0000	1.0000	1.0000	1.0000	1.0000	1.0000	1.0000	1.0000	1.0000	1.0000	1.0000	1.0000
Heavy Vehicles Percentage [%]	2.00	2.00	2.00	2.00	2.00	2.00	2.00	2.00	2.00	2.00	2.00	2.00
Growth Factor	1.0000	1.0000	1.0000	1.0000	1.0000	1.0000	1.0000	1.0000	1.0000	1.0000	1.0000	1.0000
In-Process Volume [veh/h]	0	0	0	0	0	0	0	0	0	0	0	0
Site-Generated Trips [veh/h]	5	1	0	0	1	4	3	0	3	0	0	0
Diverted Trips [veh/h]	0	0	0	0	0	0	0	0	0	0	0	0
Pass-by Trips [veh/h]	0	0	0	0	0	0	0	0	0	0	0	0
Existing Site Adjustment Volume [veh/h]	0	0	0	0	0	0	0	0	0	0	0	0
Other Volume [veh/h]	0	0	0	0	0	0	0	0	0	0	0	0
Total Hourly Volume [veh/h]	105	39	9	2	44	11	10	1	78	13	0	0
Peak Hour Factor	0.8500	0.8500	0.8500	0.8500	0.8500	0.8500	0.8500	0.8500	0.8500	0.8500	0.8500	0.8500
Other Adjustment Factor	1.0000	1.0000	1.0000	1.0000	1.0000	1.0000	1.0000	1.0000	1.0000	1.0000	1.0000	1.0000
Total 15-Minute Volume [veh/h]	31	11	3	1	13	3	3	0	23	4	0	0
Total Analysis Volume [veh/h]	124	46	11	2	52	13	12	1	92	15	0	0
Pedestrian Volume [ped/h]	0			0			0			0		



Intersection Settings

Priority Scheme	Free	Free	Stop	Stop
Flared Lane			No	No
Storage Area [veh]	0	0	0	0
Two-Stage Gap Acceptance			No	No
Number of Storage Spaces in Median	0	0	0	0

Movement, Approach, & Intersection Results

V/C, Movement V/C Ratio	0.08	0.00	0.00	0.00	0.00	0.00	0.02	0.00	0.09	0.03	0.00	0.00
d_M, Delay for Movement [s/veh]	7.55	0.00	0.00	7.33	0.00	0.00	11.99	12.52	9.08	12.92	12.27	8.75
Movement LOS	A	A	A	A	A	A	B	B	A	B	B	A
95th-Percentile Queue Length [veh/m]	0.26	0.26	0.26	0.00	0.00	0.00	0.39	0.39	0.39	0.10	0.10	0.10
95th-Percentile Queue Length [ft/m]	6.57	6.57	6.57	0.10	0.10	0.10	9.70	9.70	9.70	2.47	2.47	2.47
d_A, Approach Delay [s/veh]	5.17			0.22			9.45			12.92		
Approach LOS	A			A			A			B		
d_I, Intersection Delay [s/veh]							5.81					
Intersection LOS	B											



Intersection Level Of Service Report

Intersection 3: N-S Project Street/E-W Project Street

Control Type: All-way stop
 Analysis Method: HCM 6th Edition
 Analysis Period: 15 minutes
 Delay (sec / veh): 7.4
 Level Of Service: A
 Volume to Capacity (v/c): 0.097

Intersection Setup

Name	N-S Project Street			N-S Project Street			E-W Project Street			E-W Project Street		
Approach	Northbound			Southbound			Eastbound			Westbound		
Lane Configuration	+			+			+			+		
Turning Movement	Left	Thru	Right	Left	Thru	Right	Left	Thru	Right	Left	Thru	Right
Lane Width [ft]	12.00	12.00	12.00	12.00	12.00	12.00	12.00	12.00	12.00	12.00	12.00	12.00
No. of Lanes in Entry Pocket	0	0	0	0	0	0	0	0	0	0	0	0
Entry Pocket Length [ft]	100.00	100.00	100.00	100.00	100.00	100.00	100.00	100.00	100.00	100.00	100.00	100.00
No. of Lanes in Exit Pocket	0	0	0	0	0	0	0	0	0	0	0	0
Exit Pocket Length [ft]	0.00	0.00	0.00	0.00	0.00	0.00	0.00	0.00	0.00	0.00	0.00	0.00
Speed [mph]	25.00			25.00			25.00			25.00		
Grade [%]	0.00			0.00			0.00			0.00		
Crosswalk	Yes			Yes			Yes			Yes		

Volumes

Name	N-S Project Street			N-S Project Street			E-W Project Street			E-W Project Street		
Base Volume Input [veh/h]	0	16	0	0	17	0	0	0	0	0	0	0
Base Volume Adjustment Factor	1.0000	1.0000	1.0000	1.0000	1.0000	1.0000	1.0000	1.0000	1.0000	1.0000	1.0000	1.0000
Heavy Vehicles Percentage [%]	2.00	2.00	2.00	2.00	2.00	2.00	2.00	2.00	2.00	2.00	2.00	2.00
Growth Factor	1.0000	1.0000	1.0000	1.0000	1.0000	1.0000	1.0000	1.0000	1.0000	1.0000	1.0000	1.0000
In-Process Volume [veh/h]	0	0	0	0	0	0	0	0	0	0	0	0
Site-Generated Trips [veh/h]	3	44	15	12	31	1	1	3	8	5	2	15
Diverted Trips [veh/h]	0	0	0	0	0	0	0	0	0	0	0	0
Pass-by Trips [veh/h]	0	0	0	0	0	0	0	0	0	0	0	0
Existing Site Adjustment Volume [veh/h]	0	0	0	0	0	0	0	0	0	0	0	0
Other Volume [veh/h]	0	0	0	0	0	0	0	0	0	0	0	0
Total Hourly Volume [veh/h]	3	60	15	12	48	1	1	3	8	5	2	15
Peak Hour Factor	0.8800	0.8800	0.8800	0.8800	0.8800	0.8800	0.8800	0.8800	0.8800	0.8800	0.8800	0.8800
Other Adjustment Factor	1.0000	1.0000	1.0000	1.0000	1.0000	1.0000	1.0000	1.0000	1.0000	1.0000	1.0000	1.0000
Total 15-Minute Volume [veh/h]	1	17	4	3	14	0	0	1	2	1	1	4
Total Analysis Volume [veh/h]	3	68	17	14	55	1	1	3	9	6	2	17
Pedestrian Volume [ped/h]	0			0			0			0		



Intersection Settings

Lanes	Capacity per Entry Lane [veh/h]	907	872	924	918
Degree of Utilization, x	0.10	0.08	0.01	0.03	

Movement, Approach, & Intersection Results

95th-Percentile Queue Length [veh]	0.32	0.26	0.04	0.08
95th-Percentile Queue Length [ft]	8.04	6.52	1.07	2.10
Approach Delay [s/veh]	7.40	7.48	6.95	7.03
Approach LOS	A	A	A	A
Intersection Delay [s/veh]	7.35			
Intersection LOS	A			



Intersection Level Of Service Report
Intersection 4: Burns Valley Rd/E-W Project Street

Control Type: Two-way stop Delay (sec / veh): 11.5
 Analysis Method: HCM 6th Edition Level Of Service: B
 Analysis Period: 15 minutes Volume to Capacity (v/c): 0.002

Intersection Setup

Name	Burns Valley Rd		Burns Valley Rd		E-W Project Street	
	Northbound		Southbound		Eastbound	
Approach	←		→		→	
Lane Configuration	←		→		→	
Turning Movement	Left	Thru	Thru	Right	Left	Right
Lane Width [ft]	12.00	12.00	12.00	12.00	12.00	12.00
No. of Lanes in Entry Pocket	0	0	0	0	0	0
Entry Pocket Length [ft]	100.00	100.00	100.00	100.00	100.00	100.00
No. of Lanes in Exit Pocket	0	0	0	0	0	0
Exit Pocket Length [ft]	0.00	0.00	0.00	0.00	0.00	0.00
Speed [mph]	30.00		30.00		25.00	
Grade [%]	0.00		0.00		0.00	
Crosswalk	No		No		Yes	

Volumes

Name	Burns Valley Rd		Burns Valley Rd		E-W Project Street	
	Northbound	Southbound	Northbound	Southbound	Eastbound	Westbound
Base Volume Input [veh/h]	0	158	173	0	0	0
Base Volume Adjustment Factor	1.0000	1.0000	1.0000	1.0000	1.0000	1.0000
Heavy Vehicles Percentage [%]	2.00	2.00	2.00	2.00	2.00	2.00
Growth Factor	1.0000	1.0000	1.0000	1.0000	1.0000	1.0000
In-Process Volume [veh/h]	0	0	0	0	0	0
Site-Generated Trips [veh/h]	24	5	3	1	1	18
Diverted Trips [veh/h]	0	0	0	0	0	0
Pass-by Trips [veh/h]	0	0	0	0	0	0
Existing Site Adjustment Volume [veh/h]	0	0	0	0	0	0
Other Volume [veh/h]	0	0	0	0	0	0
Total Hourly Volume [veh/h]	24	163	176	1	1	18
Peak Hour Factor	0.8800	0.8800	0.8800	0.8800	0.8800	0.8800
Other Adjustment Factor	1.0000	1.0000	1.0000	1.0000	1.0000	1.0000
Total 15-Minute Volume [veh/h]	7	46	50	0	0	5
Total Analysis Volume [veh/h]	27	185	200	1	1	20
Pedestrian Volume [ped/h]	0	0	0	0	0	0



Intersection Settings

Priority Scheme	Free	Free	Stop
Flared Lane			No
Storage Area [veh]	0	0	0
Two-Stage Gap Acceptance			No
Number of Storage Spaces in Median	0	0	0

Movement, Approach, & Intersection Results

V/C, Movement V/C Ratio	0.02	0.00	0.00	0.00	0.00	0.02
d_M, Delay for Movement [s/veh]	7.68	0.00	0.00	0.00	11.52	9.40
Movement LOS	A	A	A	A	B	A
95th-Percentile Queue Length [veh/ln]	0.06	0.06	0.00	0.00	0.08	0.08
95th-Percentile Queue Length [ft/ln]	1.51	1.51	0.00	0.00	1.97	1.97
d_A, Approach Delay [s/veh]	0.98		0.00		9.50	
Approach LOS	A		A		A	
d_I, Intersection Delay [s/veh]					0.94	
Intersection LOS	B					



Intersection Level Of Service Report
Intersection 5: Olympic Dr/Lakeshore Dr

Control Type: Two-way stop
 Analysis Method: HCM 6th Edition
 Analysis Period: 15 minutes
 Delay (sec / veh): 18.4
 Level Of Service: C
 Volume to Capacity (v/c): 0.327

Intersection Setup

Name	Lakeshore Dr			Lakeshore Dr			Olympic Dr					
Approach	Northbound			Southbound			Eastbound			Westbound		
Lane Configuration	[Diagram]			[Diagram]			[Diagram]			[Diagram]		
Turning Movement	Left	Thru	Right	Left	Thru	Right	Left	Thru	Right	Left	Thru	Right
Lane Width [ft]	12.00	12.00	12.00	12.00	12.00	12.00	12.00	12.00	12.00	12.00	12.00	12.00
No. of Lanes in Entry Pocket	0	0	1	0	0	0	0	0	0	0	0	1
Entry Pocket Length [ft]	100.00	100.00	120.00	100.00	100.00	100.00	100.00	100.00	100.00	100.00	100.00	250.00
No. of Lanes in Exit Pocket	0	0	0	0	0	0	0	0	0	0	0	0
Exit Pocket Length [ft]	0.00	0.00	0.00	0.00	0.00	0.00	0.00	0.00	0.00	0.00	0.00	0.00
Speed [mph]	25.00			25.00			30.00			30.00		
Grade [%]	0.00			0.00			0.00			0.00		
Crosswalk	No			Yes			No			Yes		

Volumes

Name	Lakeshore Dr			Lakeshore Dr			Olympic Dr					
Base Volume Input [veh/h]	1	198	114	66	180	1	0	2	2	106	3	141
Base Volume Adjustment Factor	1.0000	1.0000	1.0000	1.0000	1.0000	1.0000	1.0000	1.0000	1.0000	1.0000	1.0000	1.0000
Heavy Vehicles Percentage [%]	2.00	2.00	2.00	2.00	2.00	2.00	2.00	2.00	2.00	2.00	2.00	2.00
Growth Factor	1.0000	1.0000	1.0000	1.0000	1.0000	1.0000	1.0000	1.0000	1.0000	1.0000	1.0000	1.0000
In-Process Volume [veh/h]	0	0	0	0	0	0	0	0	0	0	0	0
Site-Generated Trips [veh/h]	0	0	21	11	0	0	0	0	0	15	0	8
Diverted Trips [veh/h]	0	0	0	0	0	0	0	0	0	0	0	0
Pass-by Trips [veh/h]	0	0	0	0	0	0	0	0	0	0	0	0
Existing Site Adjustment Volume [veh/h]	0	0	0	0	0	0	0	0	0	0	0	0
Other Volume [veh/h]	0	0	0	0	0	0	0	0	0	0	0	0
Total Hourly Volume [veh/h]	1	198	135	77	180	1	0	2	2	121	3	149
Peak Hour Factor	0.9300	0.9300	0.9300	0.9300	0.9300	0.9300	0.9300	0.9300	0.9300	0.9300	0.9300	0.9300
Other Adjustment Factor	1.0000	1.0000	1.0000	1.0000	1.0000	1.0000	1.0000	1.0000	1.0000	1.0000	1.0000	1.0000
Total 15-Minute Volume [veh/h]	0	53	36	21	48	0	0	1	1	33	1	40
Total Analysis Volume [veh/h]	1	213	145	83	194	1	0	2	2	130	3	160
Pedestrian Volume [ped/h]	0			0			0			1		



Intersection Settings

Priority Scheme	Free	Free	Stop	Stop
Flared Lane			No	No
Storage Area [veh]	0	0	0	0
Two-Stage Gap Acceptance			No	No
Number of Storage Spaces in Median	0	0	0	0

Movement, Approach, & Intersection Results



V/C, Movement V/C Ratio	0.00	0.30	0.00	0.07	0.00	0.00	0.00	0.01	0.00	0.33	0.01	0.19
d_M, Delay for Movement [s/veh]	7.61	0.30	0.00	8.23	0.00	0.00	16.20	16.14	9.32	18.38	15.27	10.48
Movement LOS	A	A	A	A	A	C	C	C	A	C	C	B
95th-Percentile Queue Length [veh/m]	0.00	0.00	0.00	0.22	0.22	0.22	0.00	0.03	0.03	1.40	0.75	0.75
95th-Percentile Queue Length [ft/m]	0.05	0.05	0.00	5.57	5.57	5.57	0.64	0.64	0.64	34.94	18.75	18.75
d_A, Approach Delay [s/veh]	0.02		2.46		12.73		14.03					
Approach LOS	A		A		B		B					
d_I, Intersection Delay [s/veh]	5.20											
Intersection LOS	C											



Intersection Level Of Service Report
Intersection 6: Olympic Dr/N-S Project Street

Control Type: Two-way stop Delay (sec / veh): 21.9
Analysis Method: HCM 6th Edition Level Of Service: C
Analysis Period: 15 minutes Volume to Capacity (v/c): 0.103

Intersection Setup

Name	N-S Project Street		Olympic Dr		Olympic Dr	
	Southbound		Eastbound		Westbound	
Approach						
Lane Configuration						
Turning Movement	Left	Right	Left	Thru	Thru	Right
Lane Width [ft]	12.00	12.00	12.00	12.00	12.00	12.00
No. of Lanes in Entry Pocket	0	0	0	0	0	0
Entry Pocket Length [ft]	100.00	100.00	100.00	100.00	100.00	100.00
No. of Lanes in Exit Pocket	0	0	0	0	0	0
Exit Pocket Length [ft]	0.00	0.00	0.00	0.00	0.00	0.00
Speed [mph]	25.00		30.00		30.00	
Grade [%]	0.00		0.00		0.00	
Crosswalk	Yes		No		No	

Volumes

Name	N-S Project Street		Olympic Dr		Olympic Dr	
	Base Volume Input [veh/h]	8	9	16	352	384
Base Volume Adjustment Factor	1.0000	1.0000	1.0000	1.0000	1.0000	1.0000
Heavy Vehicles Percentage [%]	2.00	2.00	2.00	2.00	2.00	2.00
Growth Factor	1.0000	1.0000	1.0000	1.0000	1.0000	1.0000
In-Process Volume [veh/h]	0	0	0	0	0	0
Site-Generated Trips [veh/h]	13	31	43	0	0	19
Diverted Trips [veh/h]	0	0	0	0	0	0
Pass-by Trips [veh/h]	0	0	0	0	0	0
Existing Site Adjustment Volume [veh/h]	0	0	0	0	0	0
Other Volume [veh/h]	0	0	0	0	0	0
Total Hourly Volume [veh/h]	21	40	59	352	384	19
Peak Hour Factor	0.8500	0.8500	0.8500	0.8500	0.8500	0.8500
Other Adjustment Factor	1.0000	1.0000	1.0000	1.0000	1.0000	1.0000
Total 15-Minute Volume [veh/h]	6	12	17	104	113	6
Total Analysis Volume [veh/h]	25	47	69	414	452	22
Pedestrian Volume [ped/h]	0		0		0	



Intersection Settings

Priority Scheme	Stop	Free	Free
Flared Lane	No		
Storage Area [veh]	0	0	0
Two-Stage Gap Acceptance	No		
Number of Storage Spaces in Median	0	0	0

Movement, Approach, & Intersection Results

V/C, Movement V/C Ratio	0.10	0.08	0.06	0.03	0.05	0.00
d_M, Delay for Movement [s/veh]	21.87	13.02	8.53	0.00	0.00	0.00
Movement LOS	C	B	A	A	A	A
95th-Percentile Queue Length [veh/ln]	0.66	0.66	0.20	0.20	0.00	0.00
95th-Percentile Queue Length [ft/ln]	16.38	16.38	5.07	5.07	0.00	0.00
d_A, Approach Delay [s/veh]	16.09		1.22		0.00	
Approach LOS	C		A		A	
d_I, Intersection Delay [s/veh]	1.70					
Intersection LOS	C					



Intersection Level Of Service Report

Intersection 7: Olympic Dr/Burns Valley Rd-Old Hwy 53

Control Type: Signalized
 Analysis Method: HCM 6th Edition
 Analysis Period: 15 minutes
 Delay (sec / veh): 13.8
 Level Of Service: B
 Volume to Capacity (v/c): 0.772

Intersection Setup

Name	Old Hwy 53			Burns Valley Rd			Olympic Dr			Old Hwy 53		
Approach	Northbound			Southbound			Eastbound			Westbound		
Lane Configuration	[Diagram]			[Diagram]			[Diagram]			[Diagram]		
Turning Movement	Left	Thru	Right	Left	Thru	Right	Left	Thru	Right	Left	Thru	Right
Lane Width [ft]	12.00	12.00	12.00	12.00	12.00	12.00	12.00	12.00	12.00	12.00	12.00	12.00
No. of Lanes in Entry Pocket	1	0	1	1	0	1	0	1	0	1	0	1
Entry Pocket Length [ft]	100.00	100.00	100.00	56.00	100.00	100.00	48.00	100.00	100.00	100.00	100.00	100.00
No. of Lanes in Exit Pocket	0	0	0	0	0	0	0	0	0	0	0	0
Exit Pocket Length [ft]	0.00	0.00	0.00	0.00	0.00	0.00	0.00	0.00	0.00	0.00	0.00	0.00
Speed [mph]	30.00			30.00			35.00			35.00		
Grade [%]	0.00			0.00			0.00			0.00		
Curb Present	No			No			No			No		
Crosswalk	Yes			Yes			Yes			Yes		

Volumes

Name	Old Hwy 53			Burns Valley Rd			Olympic Dr			Old Hwy 53		
Base Volume Input [veh/h]	98	113	56	112	97	46	21	184	93	62	221	139
Base Volume Adjustment Factor	1.0000	1.0000	1.0000	1.0000	1.0000	1.0000	1.0000	1.0000	1.0000	1.0000	1.0000	1.0000
Heavy Vehicles Percentage [%]	2.00	2.00	2.00	2.00	2.00	2.00	2.00	2.00	2.00	2.00	2.00	2.00
Growth Factor	1.0000	1.0000	1.0000	1.0000	1.0000	1.0000	1.0000	1.0000	1.0000	1.0000	1.0000	1.0000
In-Process Volume [veh/h]	0	0	0	0	0	0	0	0	0	0	0	0
Site-Generated Trips [veh/h]	9	18	0	10	11	0	0	5	7	0	10	11
Diverted Trips [veh/h]	0	0	0	0	0	0	0	0	0	0	0	0
Pass-by Trips [veh/h]	0	0	0	0	0	0	0	0	0	0	0	0
Existing Site Adjustment Volume [veh/h]	0	0	0	0	0	0	0	0	0	0	0	0
Other Volume [veh/h]	0	0	0	0	0	0	0	0	0	0	0	0
Right Turn on Red Volume [veh/h]	0	0	18	0	0	11	0	0	14	0	0	25
Total Hourly Volume [veh/h]	107	131	38	122	108	35	21	189	86	62	231	125
Peak Hour Factor	0.9200	0.9200	0.9200	0.9200	0.9200	0.9200	0.9200	0.9200	0.9200	0.9200	0.9200	0.9200
Other Adjustment Factor	1.0000	1.0000	1.0000	1.0000	1.0000	1.0000	1.0000	1.0000	1.0000	1.0000	1.0000	1.0000
Total 15-Minute Volume [veh/h]	29	36	10	33	29	10	6	51	23	17	63	34
Total Analysis Volume [veh/h]	116	142	41	133	117	38	23	205	93	67	251	136
Presence of On-Street Parking	No	No	No	No	No	No	No	No	No	No	No	No
On-Street Parking Maneuver Rate [h]	0	0	0	0	0	0	0	0	0	0	0	0
Local Bus Stopping Rate [h]	0	0	0	0	0	0	0	0	0	0	0	0
v_do, Outbound Pedestrian Volume crossing major street	1			0			1			1		
v_di, Inbound Pedestrian Volume crossing major street	1			1			0			1		
v_co, Outbound Pedestrian Volume crossing minor street	1			0			0			0		
v_ci, Inbound Pedestrian Volume crossing minor street	0			0			1			0		
v_ab, Corner Pedestrian Volume [ped/h]	0			0			0			0		
Bicycle Volume [bicycles/h]	0			0			0			1		



Intersection Settings

Located in CBD	Yes
Signal Coordination Group	-
Cycle Length [s]	109
Coordination Type	Time of Day Pattern Isolated
Actuation Type	Fully actuated
Offset [s]	0.0
Offset Reference	Lead Green - Beginning of First Green
Permissive Mode	SingleBand
Lost time [s]	14.00

Phasing & Timing

Control Type	Protect	Permis	Permis	Protect	Permis	Permis	Protect	Permis	Permis	Protect	Permis	Permis
Signal Group	3	8	0	7	4	0	5	2	0	1	6	0
Auxiliary Signal Groups												
Lead / Lag	Lead	-	-	Lead	-	-	Lead	-	-	Lead	-	-
Minimum Green [s]	4	6	0	4	6	0	4	6	0	4	6	0
Maximum Green [s]	20	25	0	20	25	0	20	30	0	20	20	0
Amber [s]	3.0	3.3	0.0	3.0	3.3	0.0	3.0	3.6	0.0	3.0	3.6	0.0
All red [s]	0.0	0.3	0.0	0.0	0.3	0.0	0.0	0.3	0.0	0.0	0.3	0.0
Split [s]	23	29	0	23	29	0	23	34	0	23	34	0
Vehicle Extension [s]	0.0	0.0	0.0	0.0	0.0	0.0	0.0	0.0	0.0	0.0	0.0	0.0
Walk [s]	0	7	0	0	7	0	0	7	0	0	7	0
Pedestrian Clearance [s]	0	11	0	0	9	0	0	14	0	0	9	0
Delayed Vehicle Green [s]	0.0	0.0	0.0	0.0	0.0	0.0	0.0	0.0	0.0	0.0	0.0	0.0
Rest In Walk	No			No			No			No		
M, Start-Up Lost Time [s]	2.0	2.0	0.0	2.0	2.0	0.0	2.0	2.0	0.0	2.0	2.0	0.0
I2, Clearance Lost Time [s]	1.0	1.6	0.0	1.0	1.6	0.0	1.0	1.9	0.0	1.0	1.9	0.0
Minimum Recall	No	No		No	No		No	No		No	No	
Maximum Recall	No	No		No	No		No	No		No	No	
Pedestrian Recall	No	No		No	No		No	No		No	No	
Detector Location [ft]	0.0	0.0	0.0	0.0	0.0	0.0	0.0	0.0	0.0	0.0	0.0	0.0
Detector Length [ft]	3.0	0.0	0.0	0.0	0.0	0.0	0.0	0.0	0.0	0.0	0.0	0.0
I, Upstream Filtering Factor	1.00	1.00	1.00	1.00	1.00	1.00	1.00	1.00	1.00	1.00	1.00	1.00

Exclusive Pedestrian Phase

Pedestrian Signal Group	0
Pedestrian Walk [s]	0
Pedestrian Clearance [s]	0



Lane Group Calculations

Lane Group	L	C	R	L	C	L	C	L	C
C, Cycle Length [s]	32	32	32	32	32	32	32	32	32
L, Total Lost Time per Cycle [s]	3.00	3.60	3.60	3.00	3.60	3.00	3.90	3.00	3.90
M_p, Permitted Start-Up Lost Time [s]	0.00	0.00	0.00	0.00	0.00	0.00	0.00	0.00	0.00
I2, Clearance Lost Time [s]	1.00	1.60	1.60	1.00	1.60	1.00	1.90	1.00	1.90
g_l, Effective Green Time [s]	3	5	5	3	5	1	8	2	9
g / C, Green / Cycle	0.09	0.16	0.16	0.10	0.17	0.02	0.26	0.06	0.29
(v / s)_j Volume / Saturation Flow Rate	0.07	0.08	0.03	0.08	0.10	0.01	0.19	0.04	0.25
s, saturation flow rate [veh/h]	1603	1683	1421	1603	1612	1603	1594	1603	1571
c, Capacity [veh/h]	142	264	223	164	276	38	410	92	457
d1, Uniform Delay [s]	14.19	12.29	11.59	13.92	12.04	15.31	10.76	14.68	10.58
k, delay calibration	0.04	0.04	0.04	0.04	0.04	0.04	0.04	0.04	0.04
I, Upstream Filtering Factor	1.00	1.00	1.00	1.00	1.00	1.00	1.00	1.00	1.00
d2, Incremental Delay [s]	4.35	0.63	0.15	3.60	0.67	5.57	0.93	4.04	1.71
d3, Initial Queue Delay [s]	0.00	0.00	0.00	0.00	0.00	0.00	0.00	0.00	0.00
Rp, platoon ratio	1.00	1.00	1.00	1.00	1.00	1.00	1.00	1.00	1.00
PF, progression factor	1.00	1.00	1.00	1.00	1.00	1.00	1.00	1.00	1.00

Lane Group Results

X, volume / capacity	0.82	0.54	0.18	0.81	0.56	0.60	0.73	0.73	0.85
d, Delay for Lane Group [s/veh]	18.54	12.92	11.73	17.51	12.71	20.88	11.89	18.73	12.29
Lane Group LOS	B	B	B	B	B	C	B	B	B
Critical Lane Group	Yes	No	No	No	Yes	Yes	No	No	Yes
50th-Percentile Queue Length [veh/m]	0.81	0.74	0.20	0.89	0.80	0.19	1.35	0.46	1.81
50th-Percentile Queue Length [ft/m]	20.23	18.58	4.97	22.15	20.02	4.84	33.83	11.57	45.33
95th-Percentile Queue Length [veh/m]	1.46	1.34	0.36	1.60	1.44	0.33	2.44	0.83	3.26
95th-Percentile Queue Length [ft/m]	36.42	33.44	8.94	39.88	36.04	8.36	60.89	20.63	81.59



Movement, Approach, & Intersection Results												
d_M, Delay for Movement [s/veh]	18.54	12.92	11.73	17.51	12.71	12.71	20.88	11.69	11.69	18.73	12.29	12.29
Movement LOS	B	B	B	B	B	B	C	B	B	B	B	B
d_A, Approach Delay [s/veh]	14.94		14.93		12.35		13.24					
Approach LOS	B		B		B		B					
d_I, Intersection Delay [s/veh]	13.76											
Intersection LOS	B											
Intersection V/C	0.772											

Other Modes				
g_Walk,mi, Effective Walk Time [s]	11.0	11.0	11.0	11.0
M_corner, Corner Circulation Area [ft²/ped]	0.00	0.00	0.00	0.00
M_CW, Crosswalk Circulation Area [ft²/ped]	0.00	0.00	0.00	0.00
d_p, Pedestrian Delay [s]	6.67	6.67	6.67	6.67
L_p,int, Pedestrian LOS Score for Intersection	2.238	2.092	2.178	2.241
Crosswalk LOS	B	B	B	B
s_b, Saturation Flow Rate of the bicycle lane [bicycles/h]	2000	2000	2000	2000
c_b, Capacity of the bicycle lane [bicycles/h]	1612	1612	1911	1911
d_b, Bicycle Delay [s]	0.59	0.59	0.03	0.03
L_b,int, Bicycle LOS Score for Intersection	2.083	2.053	2.112	2.350
Bicycle LOS	B	B	B	B

Sequence												
Ring 1	1	2	3	4	-	-	-	-	-	-	-	-
Ring 2	5	6	7	8	-	-	-	-	-	-	-	-
Ring 3	-	-	-	-	-	-	-	-	-	-	-	-
Ring 4	-	-	-	-	-	-	-	-	-	-	-	-

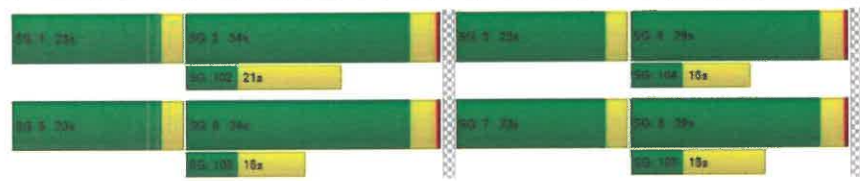

Intersection Level Of Service Report			
Intersection 1: Burns Valley Rd/N-S Project Street			
Control Type:	Two-way stop	Delay (sec / veh):	10.1
Analysis Method:	HCM 6th Edition	Level Of Service:	B
Analysis Period:	15 minutes	Volume to Capacity (v/c):	0.033

Intersection Setup						
Name	N-S Project Street		Burns Valley Rd		Burns Valley Rd	
	Northbound		Eastbound		Westbound	
Approach	Northbound		Eastbound		Westbound	
Lane Configuration	T		T		T	
Turning Movement	Left	Right	Thru	Right	Left	Thru
Lane Width [ft]	12.00	12.00	12.00	12.00	12.00	12.00
No. of Lanes in Entry Pocket	0	0	0	0	0	0
Entry Pocket Length [ft]	109.00	100.00	100.00	100.00	100.00	100.00
No. of Lanes in Exit Pocket	0	0	0	0	0	0
Exit Pocket Length [ft]	0.00	0.00	0.00	0.00	0.00	0.00
Speed [mph]	25.00		35.00		35.00	
Grade [%]	0.00		0.00		0.00	
Crosswalk	No		No		No	

Volumes						
Name	N-S Project Street		Burns Valley Rd		Burns Valley Rd	
	7	8	78	12	0	93
Base Volume Input [veh/h]	7	8	78	12	0	93
Base Volume Adjustment Factor	1.0000	1.0000	1.0000	1.0000	1.0000	1.0000
Heavy Vehicles Percentage [%]	2.00	2.00	2.00	2.00	2.00	2.00
Growth Factor	1.0000	1.0000	1.0000	1.0000	1.0000	1.0000
In-Process Volume [veh/h]	0	0	0	0	0	0
Site-Generated Trips [veh/h]	16	17	3	15	12	2
Diverted Trips [veh/h]	0	0	0	0	0	0
Pass-by Trips [veh/h]	0	0	0	0	0	0
Existing Site Adjustment Volume [veh/h]	0	0	0	0	0	0
Other Volume [veh/h]	0	0	0	0	0	0
Total Hourly Volume [veh/h]	23	23	81	27	12	95
Peak Hour Factor	0.9130	0.9130	0.9130	0.9130	0.9130	0.9130
Other Adjustment Factor	1.0000	1.0000	1.0000	1.0000	1.0000	1.0000
Total 15-Minute Volume [veh/h]	6	6	22	7	3	26
Total Analysis Volume [veh/h]	25	25	89	30	13	104
Pedestrian Volume [ped/h]	0	0	0	0	0	0

Intersection Settings			
Priority Scheme	Stop	Free	Free
Flared Lane	No		
Storage Area [veh]	0	0	0
Two-Stage Gap Acceptance	No		
Number of Storage Spaces in Median	0	0	0

Movement, Approach, & Intersection Results						
V/C, Movement V/C Ratio	0.03	0.03	0.03	0.03	0.01	0.03
d_M, Delay for Movement [s/veh]	10.09	9.06	0.03	0.03	7.47	0.03
Movement LOS	B	A	A	A	A	A
95th-Percentile Queue Length [veh/ln]	0.19	0.19	0.00	0.00	0.03	0.03
95th-Percentile Queue Length [ft/ln]	4.76	4.76	0.00	0.00	0.67	0.67
d_A, Approach Delay [s/veh]	9.58		0.00		0.83	
Approach LOS	A		A		A	
d_I, Intersection Delay [s/veh]	2.01					
Intersection LOS	B					



Intersection Level Of Service Report			
Intersection 2: Burns Valley Rd/Bowers Ave-Rumsey Rd			
Control Type:	Two-way stop	Delay (sec / veh):	12.3
Analysis Method:	HCM 6th Edition	Level Of Service:	B
Analysis Period:	15 minutes	Volume to Capacity (v/c):	0.004

Intersection Setup												
Name	Burns Valley Rd			Rumsey Rd			Burns Valley Rd			Bowers Ave		
Approach	Northbound			Southbound			Eastbound			Westbound		
Lane Configuration	+			+			+			+		
Turning Movement	Left	Thru	Right	Left	Thru	Right	Left	Thru	Right	Left	Thru	Right
Lane Width [ft]	12.00	12.00	12.00	12.00	12.00	12.00	12.00	12.00	12.00	12.00	12.00	12.00
No. of Lanes in Entry Pocket	0	0	0	0	0	0	0	0	0	0	0	0
Entry Pocket Length [ft]	100.00	100.00	100.00	100.00	100.00	100.00	100.00	100.00	100.00	100.00	100.00	100.00
No. of Lanes in Exit Pocket	0	0	0	0	0	0	0	0	0	0	0	0
Exit Pocket Length [ft]	0.00	0.00	0.00	0.00	0.00	0.00	0.00	0.00	0.00	0.00	0.00	0.00
Speed [mph]	30.00			30.00			35.00			25.00		
Grade [%]	0.00			0.00			0.00			0.00		
Crosswalk	No			Yes			Yes			No		

Volumes												
Name	Burns Valley Rd			Rumsey Rd			Burns Valley Rd			Bowers Ave		
Base Volume Input [veh/h]	84	36	1	0	31	9	10	0	83	2	1	0
Base Volume Adjustment Factor	1.0000	1.0000	1.0000	1.0000	1.0000	1.0000	1.0000	1.0000	1.0000	1.0000	1.0000	1.0000
Heavy Vehicles Percentage [%]	2.00	2.00	2.00	2.00	2.00	2.00	2.00	2.00	2.00	2.00	2.00	2.00
Growth Factor	1.0000	1.0000	1.0000	1.0000	1.0000	1.0000	1.0000	1.0000	1.0000	1.0000	1.0000	1.0000
In-Process Volume [veh/h]	0	0	0	0	0	0	0	0	0	0	0	0
Site-Generated Trips [veh/h]	14	2	0	0	3	5	6	0	10	0	0	0
Diverted Trips [veh/h]	0	0	0	0	0	0	0	0	0	0	0	0
Pass-by Trips [veh/h]	0	0	0	0	0	0	0	0	0	0	0	0
Existing Site Adjustment Volume [veh/h]	0	0	0	0	0	0	0	0	0	0	0	0
Other Volume [veh/h]	0	0	0	0	0	0	0	0	0	0	0	0
Total Hourly Volume [veh/h]	84	38	1	0	34	14	16	0	93	2	1	0
Peak Hour Factor	0.8500	0.9500	0.9600	0.9600	0.8500	0.8500	0.8500	0.8500	0.8500	0.9600	0.8500	0.9600
Other Adjustment Factor	1.0000	1.0000	1.0000	1.0000	1.0000	1.0000	1.0000	1.0000	1.0000	1.0000	1.0000	1.0000
Total 15-Minute Volume [veh/h]	29	10	0	0	9	4	5	0	27	1	0	0
Total Analysis Volume [veh/h]	115	40	1	0	35	16	19	0	109	2	1	0
Pedestrian Volume [ped/h]	0	0	0	0	0	0	0	0	0	0	0	0



Intersection Settings

	Free	Free	Stop	Stop
Priority Scheme			Stop	Stop
Flared Lane			No	No
Storage Area [veh]	0	0	0	0
Two-Stage Gap Acceptance			No	No
Number of Storage Spaces in Median	0	0	0	0

Movement, Approach, & Intersection Results

V/C, Movement V/C Ratio	0.07	0.00	0.00	0.00	0.00	0.00	0.03	0.00	0.11	0.00	0.00	0.00
d_M, Delay for Movement [s/veh]	7.50	0.00	0.00	7.20	0.00	0.00	11.61	12.00	9.12	12.31	11.58	8.55
Movement LOS	A	A	A	A	A	A	B	B	A	B	B	A
95th-Percentile Queue Length [veh/ln]	0.24	0.24	0.24	0.00	0.00	0.00	0.48	0.48	0.48	0.02	0.02	0.00
95th-Percentile Queue Length [ft/ln]	5.98	5.98	5.98	0.00	0.00	0.00	11.92	11.92	11.92	0.44	0.44	0.44
d_A, Approach Delay [s/veh]	5.53			0.00			9.49			12.06		
Approach LOS	A			A			A			B		
d_I, Intersection Delay [s/veh]	6.25											
Intersection LOS	B											



Intersection Level Of Service Report

Intersection 3: N-S Project Street/E-W Project Street

Control Type:	All-way stop	Delay (sec / veh):	7.6
Analysis Method:	HCM 6th Edition	Level Of Service:	A
Analysis Period:	15 minutes	Volume to Capacity (v/c):	0.124

Intersection Setup

Name	N-S Project Street			N-S Project Street			E-W Project Street			E-W Project Street		
Approach	Northbound			Southbound			Eastbound			Westbound		
Lane Configuration	+			+			+			+		
Turning Movement	Left	Thru	Right	Left	Thru	Right	Left	Thru	Right	Left	Thru	Right
Lane Width [ft]	12.00	12.00	12.00	12.00	12.00	12.00	12.00	12.00	12.00	12.00	12.00	12.00
No. of Lanes in Entry Pocket	0	0	0	0	0	0	0	0	0	0	0	0
Entry Pocket Length [ft]	100.00	100.00	100.00	100.00	100.00	100.00	100.00	100.00	100.00	100.00	100.00	100.00
No. of Lanes in Exit Pocket	0	0	0	0	0	0	0	0	0	0	0	0
Exit Pocket Length [ft]	0.00	0.00	0.00	0.00	0.00	0.00	0.00	0.00	0.00	0.00	0.00	0.00
Speed [mph]	25.00			25.00			25.00			25.00		
Grade [%]	0.00			0.00			0.00			0.00		
Crosswalk	Yes			Yes			Yes			Yes		

Volumes

Name	N-S Project Street			N-S Project Street			E-W Project Street			E-W Project Street		
Base Volume Input [veh/h]	0	13	0	0	12	0	0	0	0	0	0	0
Base Volume Adjustment Factor	1.0000	1.0000	1.0000	1.0000	1.0000	1.0000	1.0000	1.0000	1.0000	1.0000	1.0000	1.0000
Heavy Vehicles Percentage [%]	2.00	2.00	2.00	2.00	2.00	2.00	2.00	2.00	2.00	2.00	2.00	2.00
Growth Factor	1.0000	1.0000	1.0000	1.0000	1.0000	1.0000	1.0000	1.0000	1.0000	1.0000	1.0000	1.0000
In-Process Volume [veh/h]	0	0	0	0	0	0	0	0	0	0	0	0
Site-Generated Trips [veh/h]	5	60	30	24	64	2	1	6	15	15	4	26
Diverted Trips [veh/h]	0	0	0	0	0	0	0	0	0	0	0	0
Pass-by Trips [veh/h]	0	0	0	0	0	0	0	0	0	0	0	0
Existing Site Adjustment Volume [veh/h]	0	0	0	0	0	0	0	0	0	0	0	0
Other Volume [veh/h]	0	0	0	0	0	0	0	0	0	0	0	0
Total Hourly Volume [veh/h]	5	73	30	24	76	2	1	6	15	15	4	26
Peak Hour Factor	0.9720	0.9720	0.9720	0.9720	0.9720	0.9720	0.9720	0.9720	0.9720	0.9720	0.9720	0.9720
Other Adjustment Factor	1.0000	1.0000	1.0000	1.0000	1.0000	1.0000	1.0000	1.0000	1.0000	1.0000	1.0000	1.0000
Total 15-Minute Volume [veh/h]	1	19	8	6	20	1	0	2	4	4	1	7
Total Analysis Volume [veh/h]	5	75	31	25	78	2	1	6	15	15	4	27
Pedestrian Volume [ped/h]	0			0			0			0		



Intersection Settings

Lanes				
Capacity per Entry Lane [veh/h]	894	852	889	870
Degree of Utilization, x	0.12	0.12	0.02	0.05

Movement, Approach, & Intersection Results

95th-Percentile Queue Length [veh]	0.42	0.42	0.08	0.17
95th-Percentile Queue Length [ft]	10.60	10.50	1.90	4.18
Approach Delay [s/veh]	7.60	7.82	7.15	7.37
Approach LOS	A	A	A	A
Intersection Delay [s/veh]	7.61			
Intersection LOS	A			

Intersection Level of Service Report

Intersection 4: Burns Valley Rd/E-W Project Street

Control Type:	Two-way stop	Delay (sec / veh):	11.1
Analysis Method:	HCM 6th Edition	Level Of Service:	B
Analysis Period:	15 minutes	Volume to Capacity (v/c):	0.003

Intersection Setup

Name	Burns Valley Rd		Burns Valley Rd		E-W Project Street	
	Northbound		Southbound		Eastbound	
Lane Configuration	←		→		←→	
Turning Movement	Left	Thru	Thru	Right	Left	Right
Lane Width [ft]	12.00	12.00	12.00	12.00	12.00	12.00
No. of Lanes in Entry Pocket	0	0	0	0	0	0
Entry Pocket Length [ft]	100.00	100.00	100.00	100.00	100.00	100.00
No. of Lanes in Exit Pocket	0	0	0	0	0	0
Exit Pocket Length [ft]	0.00	0.00	0.00	0.00	0.00	0.00
Speed [mph]	30.00		30.00		25.00	
Grade [%]	0.00		0.00		0.00	
Crosswalk	No		No		Yes	

Volumes

Name	Burns Valley Rd		Burns Valley Rd		E-W Project Street	
Base Volume Input [veh/h]	0	130	120	0	0	0
Base Volume Adjustment Factor	1.0000	1.0000	1.0000	1.0000	1.0000	1.0000
Heavy Vehicles Percentage [%]	2.00	2.00	2.00	2.00	2.00	2.00
Growth Factor	1.0000	1.0000	1.0000	1.0000	1.0000	1.0000
In-Process Volume [veh/h]	0	0	0	0	0	0
Site-Generated Trips [veh/h]	43	14	10	3	2	43
Diverted Trips [veh/h]	0	0	0	0	0	0
Pass-by Trips [veh/h]	0	0	0	0	0	0
Existing Site Adjustment Volume [veh/h]	0	0	0	0	0	0
Other Volume [veh/h]	0	0	0	0	0	0
Total Hourly Volume [veh/h]	43	144	130	3	2	43
Peak Hour Factor	0.9720	0.9720	0.9720	0.9720	0.9720	0.9720
Other Adjustment Factor	1.0000	1.0000	1.0000	1.0000	1.0000	1.0000
Total 15-Minute Volume [veh/h]	11	37	33	1	1	11
Total Analysis Volume [veh/h]	44	148	134	3	2	44
Pedestrian Volume [ped/h]	0		0		0	



Intersection Settings

Priority Scheme	Free	Free	Stop
Flared Lane			No
Storage Area [veh]	3	0	0
Two-Stage Gap Acceptance			No
Number of Storage Spaces in Median	0	0	0

Movement, Approach, & Intersection Results

V/C, Movement V/C Ratio	0.03	0.00	0.00	0.00	0.00	0.05
d_M, Delay for Movement [s/veh]	7.57	0.00	0.00	0.00	11.14	9.16
Movement LOS	A	A	A	A	B	A
95th-Percentile Queue Length [veh/ln]	0.09	0.09	0.00	0.00	0.16	0.16
95th-Percentile Queue Length [ft/ln]	2.35	2.35	0.00	0.00	4.06	4.06
d_A, Approach Delay [s/veh]	1.73		0.00		9.25	
Approach LOS	A		A		A	
d_I, Intersection Delay [s/veh]			2.02			
Intersection LOS			B			



Intersection Level Of Service Report
Intersection 5: Olympic Dr/Lakeshore Dr

Control Type:	Two-way stop	Delay (sec / veh):	20.2
Analysis Method:	HCM 6th Edition	Level Of Service:	C
Analysis Period:	15 minutes	Volume to Capacity (v/c):	0.379

Intersection Setup

Name	Lakeshore Dr			Lakeshore Dr			Eastbound			Olympic Dr		
Approach	Northbound			Southbound			Eastbound			Westbound		
Lane Configuration	←→			←→			←→			←→		
Turning Movement	Left	Thru	Right	Left	Thru	Right	Left	Thru	Right	Left	Thru	Right
Lane Width [ft]	12.00	12.00	12.00	12.00	12.00	12.00	12.00	12.00	12.00	12.00	12.00	12.00
No. of Lanes in Entry Pocket	0	0	1	0	0	0	0	0	0	0	0	1
Entry Pocket Length [ft]	100.00	100.00	120.00	100.00	100.00	100.00	100.00	100.00	100.00	100.00	100.00	250.00
No. of Lanes in Exit Pocket	0	0	0	0	0	0	0	0	0	0	0	0
Exit Pocket Length [ft]	0.00	0.00	0.00	0.00	0.00	0.00	0.00	0.00	0.00	0.00	0.00	0.00
Speed [mph]	25.00			25.00			30.00			30.00		
Grade [%]	0.00			0.00			0.00			0.00		
Crosswalk	No			Yes			No			Yes		

Volumes

Name	Lakeshore Dr			Lakeshore Dr			Olympic Dr						
Base Volume Input [veh/h]	1	176	103	78	185	0	0	0	3	3	97	1	75
Base Volume Adjustment Factor	1.0000	1.0000	1.0000	1.0000	1.0000	1.0000	1.0000	1.0000	1.0000	1.0000	1.0000	1.0000	1.0000
Heavy Vehicles Percentage [%]	2.00	2.00	2.00	2.00	2.00	2.00	2.00	2.00	2.00	2.00	2.00	2.00	2.00
Growth Factor	1.0000	1.0000	1.0000	1.0000	1.0000	1.0000	1.0000	1.0000	1.0000	1.0000	1.0000	1.0000	1.0000
In-Process Volume [veh/h]	0	0	0	0	0	0	0	0	0	0	0	0	0
Site-Generated Trips [veh/h]	0	0	37	18	0	0	0	0	0	0	33	0	18
Diverted Trips [veh/h]	0	0	0	0	0	0	0	0	0	0	0	0	0
Pass-by Trips [veh/h]	0	0	0	0	0	0	0	0	0	0	0	0	0
Existing Site Adjustment Volume [veh/h]	0	0	0	0	0	0	0	0	0	0	0	0	0
Other Volume [veh/h]	0	0	0	0	0	0	0	0	0	0	0	0	0
Total Hourly Volume [veh/h]	1	176	140	91	185	0	0	0	3	3	130	1	93
Peak Hour Factor	0.9100	0.9100	0.9100	0.9100	0.9100	0.9100	0.9100	0.9100	0.9100	0.9100	0.9100	0.9100	0.9100
Other Adjustment Factor	1.0000	1.0000	1.0000	1.0000	1.0000	1.0000	1.0000	1.0000	1.0000	1.0000	1.0000	1.0000	1.0000
Total 15-Minute Volume [veh/h]	0	48	38	25	51	0	0	0	1	1	36	0	26
Total Analysis Volume [veh/h]	1	193	154	100	203	0	0	0	3	3	143	1	102
Pedestrian Volume [ped/h]		0			0			0				1	



Intersection Settings				
Priority Scheme	Free	Free	Stop	Stop
Flared Lane			No	No
Storage Area [veh]	0	0	0	0
Two-Stage Gap Acceptance			No	No
Number of Storage Spaces in Median	0	0	0	0

Movement, Approach, & Intersection Results												
V/C, Movement V/C Ratio	0.00	0.00	0.00	0.08	0.00	0.00	0.00	0.01	0.00	0.38	0.00	0.12
d_M, Delay for Movement [s/veh]	7.63	0.00	0.00	8.24	0.00	0.00	18.12	16.85	9.41	20.24	15.18	9.86
Movement LOS	A	A	A	A	A	A	C	C	A	C	C	A
95th-Percentile Queue Length [veh/ln]	0.00	0.00	0.00	0.27	0.27	0.27	0.04	0.04	1.73	0.42	0.42	0.42
95th-Percentile Queue Length [ft/ln]	0.05	0.05	0.00	6.75	6.75	6.75	1.02	1.02	43.20	10.48	10.48	10.48
d_A, Approach Delay [s/veh]	0.02			2.72			13.13			15.91		
Approach LOS	A			A			B			C		
d_I, Intersection Delay [s/veh]	5.34											
Intersection LOS	C											



Intersection Level Of Service Report			
Intersection 6: Olympic Dr/N-S Project Street			
Control Type:	Two-way stop	Delay (sec / veh):	21.0
Analysis Method:	HCM 6th Edition	Level Of Service:	C
Analysis Period:	15 minutes	Volume to Capacity (v/c):	0.139

Intersection Setup						
Name	N-S Project Street		Olympic Dr		Olympic Dr	
Approach	Southbound		Eastbound		Westbound	
Lane Configuration	T		T		T	
Turning Movement	Left	Right	Left	Thru	Thru	Right
Lane Width [ft]	12.00	12.00	12.00	12.00	12.00	12.00
No. of Lanes in Entry Pocket	0	0	0	0	0	0
Entry Pocket Length [ft]	100.00	100.00	100.00	100.00	100.00	100.00
No. of Lanes in Exit Pocket	0	0	0	0	0	0
Exit Pocket Length [ft]	0.00	0.00	0.00	0.00	0.00	0.00
Speed [mph]	25.00		30.00		30.00	
Grade [%]	0.00		0.00		0.00	
Crosswalk	Yes		No		No	

Volumes						
Name	N-S Project Street		Olympic Dr		Olympic Dr	
Base Volume Input [veh/h]	6	8	13	289	300	0
Base Volume Adjustment Factor	1.0000	1.0000	1.0000	1.0000	1.0000	1.0000
Heavy Vehicles Percentage [%]	2.00	2.00	2.00	2.00	2.00	2.00
Growth Factor	1.0000	1.0000	1.0000	1.0000	1.0000	1.0000
In-Process Volume [veh/h]	0	0	0	0	0	0
Site-Generated Trips [veh/h]	26	69	73	0	0	25
Diverted Trips [veh/h]	0	0	0	0	0	0
Pass-by Trips [veh/h]	0	0	0	0	0	0
Existing Site Adjustment Volume [veh/h]	0	0	0	0	0	0
Other Volume [veh/h]	0	0	0	0	0	0
Total Hourly Volume [veh/h]	32	75	86	289	300	25
Peak Hour Factor	0.8500	0.8500	0.8500	0.8500	0.8500	0.8500
Other Adjustment Factor	1.0000	1.0000	1.0000	1.0000	1.0000	1.0000
Total 15-Minute Volume [veh/h]	9	22	25	85	88	7
Total Analysis Volume [veh/h]	38	88	101	340	353	29
Pedestrian Volume [ped/h]	0		0		0	



Intersection Settings			
Priority Scheme	Stop	Free	Free
Flared Lane	No		
Storage Area [veh]	?	0	0
Two-Stage Gap Acceptance	No		
Number of Storage Spaces in Median	0	0	?

Movement, Approach, & Intersection Results						
V/C, Movement V/C Ratio	0.14	0.13	0.09	0.00	0.00	0.00
d_M, Delay for Movement [s/veh]	21.00	13.12	8.35	0.00	0.00	0.00
Movement LOS	C	B	A	A	A	A
95th-Percentile Queue Length [veh/ln]	1.08	1.08	0.28	0.28	0.00	0.00
95th-Percentile Queue Length [ft/ln]	26.94	26.94	7.03	7.03	0.00	0.00
d_A, Approach Delay [s/veh]	15.50		1.91		0.00	
Approach LOS	C		A		A	
d_I, Intersection Delay [s/veh]	2.95					
Intersection LOS	C					



Intersection Level Of Service Report			
Intersection 7: Olympic Dr/Burns Valley Rd-Old Hwy 53			
Control Type:	Signalized	Delay (sec / veh):	12.7
Analysis Method:	HCM 6th Edition	Level Of Service:	B
Analysis Period:	15 minutes	Volume to Capacity (v/c):	0.732

Intersection Setup												
Name	Old Hwy 53			Burns Valley Rd			Olympic Dr			Old Hwy 53		
Approach	Northbound			Southbound			Eastbound			Westbound		
Lane Configuration	T T T			T T			T T			T T		
Turning Movement	Left	Thru	Right	Left	Thru	Right	Left	Thru	Right	Left	Thru	Right
Lane Width [ft]	12.00	12.00	12.00	12.00	12.00	12.00	12.00	12.00	12.00	12.00	12.00	12.00
No. of Lanes in Entry Pocket	1	0	1	1	0	0	1	0	0	1	0	0
Entry Pocket Length [ft]	100.00	100.00	100.00	58.00	100.00	100.00	48.00	100.00	100.00	100.00	100.00	100.00
No. of Lanes in Exit Pocket	0	0	0	0	0	0	0	0	0	0	0	0
Exit Pocket Length [ft]	0.00	0.00	0.00	0.00	0.00	0.00	0.00	0.00	0.00	0.00	0.00	0.00
Speed [mph]	30.00			30.00			35.00			35.00		
Grade [%]	0.00			0.00			0.00			0.00		
Curb Present	No			No			No			No		
Crosswalk	Yes			Yes			Yes			Yes		



Volumes												
Name	Old Hwy 53			Burns Valley Rd			Olympic Dr			Old Hwy 53		
Base Volume Input [veh/h]	80	81	42	93	64	30	20	180	95	33	170	109
Base Volume Adjustment Factor	1.0000	1.0000	1.0000	1.0000	1.0000	1.0000	1.0000	1.0000	1.0000	1.0000	1.0000	1.0000
Heavy Vehicles Percentage [%]	2.00	2.00	2.00	2.00	2.00	2.00	2.00	2.00	2.00	2.00	2.00	2.00
Growth Factor	1.0000	1.0000	1.0000	1.0000	1.0000	1.0000	1.0000	1.0000	1.0000	1.0000	1.0000	1.0000
In-Process Volume [veh/h]	0	0	0	0	0	0	0	0	0	0	0	0
Site-Generated Trips [veh/h]	12	32	0	22	31	0	0	11	15	0	12	25
Diverted Trips [veh/h]	0	0	0	0	0	0	0	0	0	0	0	0
Pass-by Trips [veh/h]	0	0	0	0	0	0	0	0	0	0	0	0
Existing Site Adjustment Volume [veh/h]	0	0	0	0	0	0	0	0	0	0	0	0
Other Volume [veh/h]	0	0	0	0	0	0	0	0	0	0	0	0
Right Turn on Red Volume [veh/h]	0	0	15	0	0	12	0	0	25	0	0	29
Total Hourly Volume [veh/h]	92	113	27	115	95	18	20	191	95	33	182	105
Peak Hour Factor	0.9300	0.9300	0.9300	0.9300	0.9300	0.9300	0.9300	0.9300	0.9300	0.9300	0.9300	0.9300
Other Adjustment Factor	1.0000	1.0000	1.0000	1.0000	1.0000	1.0000	1.0000	1.0000	1.0000	1.0000	1.0000	1.0000
Total 15-Minute Volume [veh/h]	25	30	7	31	28	5	5	51	23	9	49	28
Total Analysis Volume [veh/h]	99	122	29	124	102	19	22	205	91	35	196	113
Presence of On-Street Parking	No		No	No		No	No		No	No		No
On-Street Parking Maneuver Rate [1/h]	0	0	0	0	0	0	0	0	0	0	0	0
Local Bus Stopping Rate [1/h]	0	0	0	0	0	0	0	0	0	0	0	0
v_do, Outbound Pedestrian Volume crossing major street	1			0			1			1		
v_di, Inbound Pedestrian Volume crossing major street	1			1			0			1		
v_co, Outbound Pedestrian Volume crossing minor street	1			0			0			0		
v_ci, Inbound Pedestrian Volume crossing minor street	0			0			1			0		
v_ab, Corner Pedestrian Volume [ped/h]	0			0			0			0		
Bicycle Volume [bicycles/h]	0			0			0			0		1



Intersection Settings	
Located in CBD	Yes
Signal Coordination Group	-
Cycle Length [s]	109
Coordination Type	Time of Day Pattern Isolated
Actuation Type	Fully actuated
Offset [s]	0.0
Offset Reference	Lead Green - Beginning of First Green
Permissive Mode	SingleBand
Lost time [s]	14.00

Phasing & Timing												
Control Type	Protect	Permis	Permis	Protect	Permis	Permis	Protect	Permis	Permis	Protect	Permis	Permis
Signal Group	3	8	0	7	4	0	5	2	0	1	6	0
Auxiliary Signal Groups												
Lead / Lag	Lead	-	-	Lead	-	-	Lead	-	-	Lead	-	-
Minimum Green [s]	4	6	0	4	6	0	4	6	0	4	6	0
Maximum Green [s]	20	25	0	20	25	0	20	30	0	20	20	0
Amber [s]	3.0	3.3	0.0	3.0	3.3	0.0	3.0	3.6	0.0	3.0	3.6	0.0
All red [s]	0.0	0.3	0.0	0.0	0.3	0.0	0.0	0.3	0.0	0.0	0.3	0.0
Split [s]	23	29	0	23	29	0	23	34	0	23	34	0
Vehicle Extension [s]	0.0	0.0	0.0	0.0	0.0	0.0	0.0	0.0	0.0	0.0	0.0	0.0
Walk [s]	0	7	0	0	7	0	0	7	0	0	7	0
Pedestrian Clearance [s]	0	11	0	0	9	0	0	14	0	0	9	0
Delayed Vehicle Green [s]	0.0	0.0	0.0	0.0	0.0	0.0	0.0	0.0	0.0	0.0	0.0	0.0
Rest In Walk	No			No			No			No		
I1, Start-Up Lost Time [s]	2.0	2.0	0.0	2.0	2.0	0.0	2.0	2.0	0.0	2.0	2.0	0.0
I2, Clearance Lost Time [s]	1.0	1.6	0.0	1.0	1.6	0.0	1.0	1.9	0.0	1.0	1.9	0.0
Minimum Recall	No	No		No	No		No	No		No	No	
Maximum Recall	No	No		No	No		No	No		No	No	
Pedestrian Recall	No	No		No	No		No	No		No	No	
Detector Location [ft]	0.0	0.0	0.0	0.0	0.0	0.0	0.0	0.0	0.0	0.0	0.0	0.0
Detector Length [ft]	0.0	0.0	0.0	0.0	0.0	0.0	0.0	0.0	0.0	0.0	0.0	0.0
I, Upstream Filtering Factor	1.00	1.00	1.00	1.00	1.00	1.00	1.00	1.00	1.00	1.00	1.00	1.00

Exclusive Pedestrian Phase	
Pedestrian Signal Group	0
Pedestrian Walk [s]	0
Pedestrian Clearance [s]	0



Lane Group Calculations

Lane Group	L	C	R	L	C	L	C	L	C
C, Cycle Length [s]	28	28	28	28	28	28	28	28	28
L, Total Lost Time per Cycle [s]	3.00	3.60	3.60	3.00	3.60	3.00	3.90	3.00	3.90
l1_p, Permitted Start-Up Lost Time [s]	0.00	0.00	0.00	0.00	0.00	0.00	0.00	0.00	0.00
l2, Clearance Lost Time [s]	1.00	1.60	1.60	1.00	1.60	1.00	1.90	1.00	1.90
g_i, Effective Green Time [s]	2	4	4	3	5	1	6	1	7
g / C, Green / Cycle	0.08	0.15	0.15	0.09	0.17	0.02	0.23	0.03	0.24
(v / s)_i Volume / Saturation Flow Rate	0.06	0.07	0.02	0.06	0.07	0.01	0.19	0.02	0.20
s, saturation flow rate [veh/h]	1603	1683	1421	1603	1637	1603	1595	1603	1567
c, Capacity [veh/h]	126	261	220	151	279	37	366	56	378
d1, Uniform Delay [s]	12.56	10.68	10.11	12.35	10.31	13.42	10.11	13.21	9.95
k, delay calibration	0.04	0.04	0.04	0.04	0.04	0.04	0.04	0.04	0.04
l, Upstream Filtering Factor	1.00	1.00	1.00	1.00	1.00	1.00	1.00	1.00	1.00
d2, Incremental Delay [s]	4.03	0.48	0.10	4.23	0.40	5.47	1.63	4.14	1.66
d3, Initial Queue Delay [s]	0.00	0.00	0.00	0.00	0.00	0.00	0.00	0.00	0.00
Rp, platoon ratio	1.00	1.00	1.00	1.00	1.00	1.00	1.00	1.00	1.00
PF, progression factor	1.00	1.00	1.00	1.00	1.00	1.00	1.00	1.00	1.00

Lane Group Results

X, volume / capacity	0.79	0.47	0.13	0.82	0.43	0.59	0.81	0.62	0.82
d, Delay for Lane Group [s/veh]	16.58	11.17	10.21	16.58	10.71	18.89	11.74	17.35	11.61
Lane Group LOS	B	B	B	B	B	B	B	B	B
Critical Lane Group	No	Yes	No	Yes	No	Yes	No	No	Yes
50th-Percentile Queue Length [veh/m]	0.58	0.51	0.11	0.72	0.49	0.15	1.18	0.22	1.22
50th-Percentile Queue Length [ft/m]	14.55	12.70	2.81	18.09	12.14	3.85	29.62	5.46	30.49
95th-Percentile Queue Length [veh/m]	1.05	0.91	0.20	1.30	0.87	0.28	2.13	0.39	2.20
95th-Percentile Queue Length [ft/m]	26.20	22.86	5.06	32.57	21.85	6.93	53.32	9.81	54.88



Movement, Approach, & Intersection Results

d_M, Delay for Movement [s/veh]	16.58	11.17	10.21	16.58	10.71	10.71	18.89	11.74	11.74	17.35	11.61	11.61
Movement LOS	B	B	B	B	B	B	B	B	B	B	B	B
d_A, Approach Delay [s/veh]	13.20			13.66			12.24			12.19		
Approach LOS	B			B			B			B		
d_I, Intersection Delay [s/veh]	12.74											
Intersection LOS	B											
Intersection V/C	0.732											

Other Modes

g_Walk,mi, Effective Walk Time [s]	11.0	11.0	11.0	11.0
M_corner, Corner Circulation Area [ft ² /ped]	0.00	0.00	0.00	0.00
M_CW, Crosswalk Circulation Area [ft ² /ped]	0.00	0.00	0.00	0.00
d_p, Pedestrian Delay [s]	4.99	4.99	4.99	4.99
l_p,int, Pedestrian LOS Score for Intersection	2.200	2.056	2.151	2.186
Crosswalk LOS	B	B	B	B
s_b, Saturation Flow Rate of the bicycle lane [bicycles/h]	2000	2000	2000	2000
c_b, Capacity of the bicycle lane [bicycles/h]	1841	1841	2182	2182
d_b, Bicycle Delay [s]	0.09	0.09	0.11	0.11
l_b,int, Bicycle LOS Score for Intersection	1.997	1.984	2.126	2.175
Bicycle LOS	A	A	B	B

Sequence

Ring 1	1	2	3	4	-	-	-	-	-	-	-	-	-	-
Ring 2	5	6	7	8	-	-	-	-	-	-	-	-	-	-
Ring 3	-	-	-	-	-	-	-	-	-	-	-	-	-	-
Ring 4	-	-	-	-	-	-	-	-	-	-	-	-	-	-

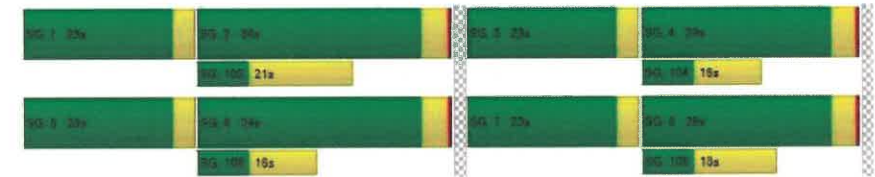

Intersection Level Of Service Report
Intersection 1: Burns Valley Rd/N-S Project Street

Control Type: Two-way stop Delay (sec / veh): 10.3
 Analysis Method: HCM 6th Edition Level Of Service: B
 Analysis Period: 15 minutes Volume to Capacity (v/c): 0.017

Intersection Setup

Name	N-S Project Street		Burns Valley Rd		Burns Valley Rd	
	Northbound		Eastbound		Westbound	
Approach	Northbound		Eastbound		Westbound	
Lane Configuration	T		T		T	
Turning Movement	Left	Right	Thru	Right	Left	Thru
Lane Width [ft]	12.00	12.00	12.00	12.00	12.00	12.00
No. of Lanes in Entry Pocket	0	0	0	0	0	0
Entry Pocket Length [ft]	100.00	100.00	100.00	100.00	100.00	100.00
No. of Lanes in Exit Pocket	0	0	0	0	0	0
Exit Pocket Length [ft]	0.00	0.00	0.00	0.00	0.00	0.00
Speed [mph]	25.00		35.00		35.00	
Grade [%]	0.00		0.00		0.00	
Crosswalk	No		No		No	

Volumes

Name	N-S Project Street		Burns Valley Rd		Burns Valley Rd	
	Base Volume Input [veh/h]	8	7	112	15	0
Base Volume Adjustment Factor	1.0000	1.0000	1.0000	1.0000	1.0000	1.0000
Heavy Vehicles Percentage [%]	2.00	2.00	2.00	2.00	2.00	2.00
Growth Factor	1.0000	1.0000	1.0000	1.0000	1.0000	1.0000
In-Process Volume [veh/h]	1	2	6	0	0	5
Site-Generated Trips [veh/h]	2	3	1	4	5	1
Diverted Trips [veh/h]	0	0	0	0	0	0
Pass-by Trips [veh/h]	0	0	0	0	0	0
Existing Site Adjustment Volume [veh/h]	0	0	0	0	0	0
Other Volume [veh/h]	0	0	0	0	0	0
Total Hourly Volume [veh/h]	11	12	119	19	5	116
Peak Hour Factor	0.8890	0.8890	0.8890	0.8890	0.8890	0.8890
Other Adjustment Factor	1.0000	1.0000	1.0000	1.0000	1.0000	1.0000
Total 15-Minute Volume [veh/h]	3	3	33	5	1	33
Total Analysis Volume [veh/h]	12	13	134	21	6	130
Pedestrian Volume [ped/h]	0	0	0	0	0	0



Intersection Settings

Priority Scheme	Stop	Free	Free
Flared Lane	No		
Storage Area [veh]	0	0	0
Two-Stage Gap Acceptance	No		
Number of Storage Spaces in Median	0	0	0

Movement, Approach, & Intersection Results

V/C, Movement V/C Ratio	0.02	0.01	0.00	0.00	0.00	0.00
d_M, Delay for Movement [s/veh]	10.29	9.14	0.00	0.00	7.54	0.00
Movement LOS	B	A	A	A	A	A
95th-Percentile Queue Length [veh/m]	0.10	0.10	0.00	0.00	0.01	0.01
95th-Percentile Queue Length [ft/m]	2.44	2.44	0.00	0.00	0.32	0.32
d_A, Approach Delay [s/veh]	9.69		0.00		0.33	
Approach LOS	A		A		- A	
d_I, Intersection Delay [s/veh]			0.91			
Intersection LOS			B			



Intersection Level Of Service Report

Intersection 2: Burns Valley Rd/Bowers Ave-Rumsey Rd

Control Type: Two-way stop
 Analysis Method: HCM 6th Edition
 Analysis Period: 15 minutes
 Delay (sec / veh): 14.1
 Level Of Service: B
 Volume to Capacity (v/c): 0.015

Intersection Setup

Name	Burns Valley Rd			Rumsey Rd			Burns Valley Rd			Bowers Ave		
Approach	Northbound			Southbound			Eastbound			Westbound		
Lane Configuration	+			+			+			+		
Turning Movement	Left	Thru	Right	Left	Thru	Right	Left	Thru	Right	Left	Thru	Right
Lane Width [ft]	12.00	12.00	12.00	12.00	12.00	12.00	12.00	12.00	12.00	12.00	12.00	12.00
No. of Lanes in Entry Pocket	0	0	0	0	0	0	0	0	0	0	0	0
Entry Pocket Length [ft]	100.00	100.00	100.00	100.00	100.00	100.00	100.00	100.00	100.00	100.00	100.00	100.00
No. of Lanes in Exit Pocket	0	0	0	0	0	0	0	0	0	0	0	0
Exit Pocket Length [ft]	0.00	0.00	0.00	0.00	0.00	0.00	0.00	0.00	0.00	0.00	0.00	0.00
Speed [mph]	30.00			30.00			35.00			25.00		
Grade [%]	0.00			0.00			0.00			0.00		
Crosswalk	No			Yes			Yes			No		

Volumes

Name	Burns Valley Rd			Rumsey Rd			Burns Valley Rd			Bowers Ave		
Base Volume Input [veh/h]	127	27	6	0	24	16	9	1	130	5	1	0
Base Volume Adjustment Factor	1.0000	1.0000	1.0000	1.0000	1.0000	1.0000	1.0000	1.0000	1.0000	1.0000	1.0000	1.0000
Heavy Vehicles Percentage [%]	2.00	2.00	2.00	2.00	2.00	2.00	2.00	2.00	2.00	2.00	2.00	2.00
Growth Factor	1.0000	1.0000	1.0000	1.0000	1.0000	1.0000	1.0000	1.0000	1.0000	1.0000	1.0000	1.0000
In-Process Volume [veh/h]	0	0	0	0	0	0	0	0	0	0	0	0
Site-Generated Trips [veh/h]	2	1	0	0	0	1	2	0	5	0	0	0
Diverted Trips [veh/h]	0	0	0	0	0	0	0	0	0	0	0	0
Pass-by Trips [veh/h]	0	0	0	0	0	0	0	0	0	0	0	0
Existing Site Adjustment Volume [veh/h]	0	0	0	0	0	0	0	0	0	0	0	0
Other Volume [veh/h]	0	0	0	0	0	0	0	0	0	0	0	0
Total Hourly Volume [veh/h]	129	28	6	0	24	17	11	1	135	5	1	0
Peak Hour Factor	0.8500	0.8500	0.8500	0.8500	0.8500	0.8500	0.8500	0.8500	0.8500	0.8500	0.8500	0.8500
Other Adjustment Factor	1.0000	1.0000	1.0000	1.0000	1.0000	1.0000	1.0000	1.0000	1.0000	1.0000	1.0000	1.0000
Total 15-Minute Volume [veh/h]	38	8	2	0	7	5	3	0	40	1	0	0
Total Analysis Volume [veh/h]	152	33	7	0	28	20	13	1	159	6	1	0
Pedestrian Volume [ped/h]	0	0	0	0	0	0	0	0	0	0	0	0



Intersection Settings

Priority Scheme	Free	Free	Stop	Stop
Flared Lane			No	No
Storage Area [veh]	0	0	0	0
Two-Stage Gap Acceptance			No	No
Number of Storage Spaces in Median	0	0	0	0

Movement, Approach, & Intersection Results

V/C, Movement V/C Ratio	0.10	0.30	0.50	0.00	0.50	3.00	0.02	0.00	0.15	0.01	0.00	0.00
d_M, Delay for Movement [s/veh]	7.56	0.00	0.00	7.20	0.00	0.00	12.57	13.08	9.30	14.15	12.47	8.53
Movement LOS	A	A	A	A	A	A	B	B	A	B	B	A
95th-Percentile Queue Length [veh/ln]	0.32	0.32	0.32	0.00	0.00	0.00	0.65	0.65	0.65	0.05	0.05	0.05
95th-Percentile Queue Length [ft/ln]	8.09	8.09	8.09	0.00	0.00	0.00	16.37	16.37	16.37	1.30	1.30	1.30
d_A, Approach Delay [s/veh]	5.98			0.00			9.57			13.91		
Approach LOS	A			A			A			B		
d_I, Intersection Delay [s/veh]	6.91											
Intersection LOS	B											



Intersection Level Of Service Report
Intersection 3: N-S Project Street/E-W Project Street

Control Type: All-way stop Delay (sec / veh): 7.2
 Analysis Method: HCM 6th Edition Level Of Service: A
 Analysis Period: 15 minutes Volume to Capacity (v/c): 0.059

Intersection Setup

Name	N-S Project Street			N-S Project Street			E-W Project Street			E-W Project Street		
Approach	Northbound			Southbound			Eastbound			Westbound		
Lane Configuration	+			+			+			+		
Turning Movement	Left	Thru	Right	Left	Thru	Right	Left	Thru	Right	Left	Thru	Right
Lane Width [ft]	12.00	12.00	12.00	12.00	12.00	12.00	12.00	12.00	12.00	12.00	12.00	12.00
No. of Lanes in Entry Pocket	0	0	0	0	0	0	0	0	0	0	0	0
Entry Pocket Length [ft]	100.00	100.00	100.00	100.00	100.00	100.00	100.00	100.00	100.00	100.00	100.00	100.00
No. of Lanes in Exit Pocket	0	0	0	0	0	0	0	0	0	0	0	0
Exit Pocket Length [ft]	0.00	0.00	0.00	0.00	0.00	0.00	0.00	0.00	0.00	0.00	0.00	0.00
Speed [mph]	25.00			25.00			25.00			25.00		
Grade [%]	0.00			0.00			0.00			0.00		
Crosswalk	Yes			Yes			Yes			Yes		

Volumes

Name	N-S Project Street			N-S Project Street			E-W Project Street			E-W Project Street		
Base Volume Input [veh/h]	0	18	0	0	19	0	0	0	0	0	0	0
Base Volume Adjustment Factor	1.0000	1.0000	1.0000	1.0000	1.0000	1.0000	1.0000	1.0000	1.0000	1.0000	1.0000	1.0000
Heavy Vehicles Percentage [%]	2.00	2.00	2.00	2.00	2.00	2.00	2.00	2.00	2.00	2.00	2.00	2.00
Growth Factor	1.0000	1.0000	1.0000	1.0000	1.0000	1.0000	1.0000	1.0000	1.0000	1.0000	1.0000	1.0000
In-Process Volume [veh/h]	0	0	0	0	0	0	0	0	0	0	0	0
Site-Generated Trips [veh/h]	6	18	3	3	11	1	0	1	1	4	2	4
Diverted Trips [veh/h]	0	0	0	0	0	0	0	0	0	0	0	0
Pass-by Trips [veh/h]	0	0	0	0	0	0	0	0	0	0	0	0
Existing Site Adjustment Volume [veh/h]	0	0	0	0	0	0	0	0	0	0	0	0
Other Volume [veh/h]	0	0	0	0	0	0	0	0	0	0	0	0
Total Hourly Volume [veh/h]	6	36	3	3	30	1	0	1	1	4	2	4
Peak Hour Factor	0.8500	0.8500	0.8500	0.8500	0.8500	0.8500	0.8500	0.8500	0.8500	0.8500	0.8500	0.8500
Other Adjustment Factor	1.0000	1.0000	1.0000	1.0000	1.0000	1.0000	1.0000	1.0000	1.0000	1.0000	1.0000	1.0000
Total 15-Minute Volume [veh/h]	2	11	1	1	9	0	0	0	0	1	1	1
Total Analysis Volume [veh/h]	7	42	4	4	35	1	0	1	1	5	2	5
Pedestrian Volume [ped/h]	0			0			0			0		



Intersection Settings

Lanes	1	2	3	4
Capacity per Entry Lane [veh/h]	905	897	937	908
Degree of Utilization, x	0.06	0.04	0.00	0.01

Movement, Approach, & Intersection Results

Movement	1	2	3	4
95th-Percentile Queue Length [veh]	0.19	0.14	0.01	0.04
95th-Percentile Queue Length [ft]	4.66	3.50	0.16	1.00
Approach Delay [s/veh]	7.23	7.20	6.85	7.02
Approach LOS	A	A	A	A
Intersection Delay [s/veh]	7.19			
Intersection LOS	A			



Intersection Level Of Service Report
Intersection 4: Burns Valley Rd/E-W Project Street

Control Type: Two-way stop Delay (sec / veh): 11.0
 Analysis Method: HCM 6th Edition Level Of Service: B
 Analysis Period: 15 minutes Volume to Capacity (v/c): 0.002

Intersection Setup

Name	Burns Valley Rd		Burns Valley Rd		E-W Project Street	
Approach	Northbound		Southbound		Eastbound	
Lane Configuration	←		→		→	
Turning Movement	Left	Thru	Thru	Right	Left	Right
Lane Width [ft]	12.00	12.00	12.00	12.00	12.00	12.00
No. of Lanes in Entry Pocket	0	0	0	0	0	0
Entry Pocket Length [ft]	100.00	100.00	100.00	100.00	100.00	100.00
No. of Lanes in Exit Pocket	0	0	0	0	0	0
Exit Pocket Length [ft]	0.00	0.00	0.00	0.00	0.00	0.00
Speed [mph]	30.00		30.00		25.00	
Grade [%]	0.00		0.00		0.00	
Crosswalk	No		No		Yes	

Volumes

Name	Burns Valley Rd		Burns Valley Rd		E-W Project Street	
Base Volume Input [veh/h]	0	157	154	0	0	0
Base Volume Adjustment Factor	1.0000	1.0000	1.0000	1.0000	1.0000	1.0000
Heavy Vehicles Percentage [%]	2.00	2.00	2.00	2.00	2.00	2.00
Growth Factor	1.0000	1.0000	1.0000	1.0000	1.0000	1.0000
In-Process Volume [veh/h]	0	0	0	0	0	0
Site-Generated Trips [veh/h]	8	2	5	0	1	9
Diverted Trips [veh/h]	0	0	0	0	0	0
Pass-by Trips [veh/h]	0	0	0	0	0	0
Existing Site Adjustment Volume [veh/h]	0	0	0	0	0	0
Other Volume [veh/h]	0	0	0	0	0	0
Total Hourly Volume [veh/h]	8	159	159	0	1	9
Peak Hour Factor	0.8500	0.8500	0.8500	0.8500	0.8500	0.8500
Other Adjustment Factor	1.0000	1.0000	1.0000	1.0000	1.0000	1.0000
Total 15-Minute Volume [veh/h]	2	47	47	0	0	3
Total Analysis Volume [veh/h]	9	187	187	0	1	11
Pedestrian Volume [ped/h]	0	0	0	0	0	0



Intersection Settings

Priority Scheme	Free	Free	Stop
Flared Lane			No
Storage Area [veh]	0	0	0
Two-Stage Gap Acceptance			No
Number of Storage Spaces in Median	0	0	0

Movement, Approach, & Intersection Results

V/C, Movement V/C Ratio	0.01	0.00	0.00	0.00	0.00	0.01
d_M, Delay for Movement [s/veh]	7.61	0.00	0.00	0.00	10.99	9.27
Movement LOS	A	A	A	A	B	A
95th-Percentile Queue Length [veh/ln]	0.02	0.02	0.00	0.00	0.04	0.04
95th-Percentile Queue Length [ft/ln]	0.49	0.49	0.00	0.00	1.10	1.10
d_A, Approach Delay [s/veh]	0.35		0.00		9.42	
Approach LOS	A		A		A	
d_I, Intersection Delay [s/veh]				0.46		
Intersection LOS	B					



Intersection Level Of Service Report
Intersection 5: Olympic Dr/Lakeshore Dr

Control Type: Two-way stop
Analysis Method: HCM 6th Edition
Analysis Period: 15 minutes
Delay (sec / veh): 18.2
Level Of Service: C
Volume to Capacity (v/c): 0.197

Intersection Setup

Name	Lakeshore Dr			Lakeshore Dr			Eastbound			Olympic Dr		
Approach	Northbound			Southbound			Eastbound			Westbound		
Lane Configuration	← →			← →			← →			← →		
Turning Movement	Left	Thru	Right	Left	Thru	Right	Left	Thru	Right	Left	Thru	Right
Lane Width [ft]	12.00	12.00	12.00	12.00	12.00	12.00	12.00	12.00	12.00	12.00	12.00	12.00
No. of Lanes in Entry Pocket	0	0	1	0	0	0	0	0	0	0	0	1
Entry Pocket Length [ft]	100.00	100.00	120.00	100.00	100.00	100.00	100.00	100.00	100.00	100.00	100.00	250.00
No. of Lanes in Exit Pocket	0	0	0	0	0	0	0	0	0	0	0	0
Exit Pocket Length [ft]	0.00	0.00	0.00	0.00	0.00	0.00	0.00	0.00	0.00	0.00	0.00	0.00
Speed [mph]	25.00			25.00			30.00			30.00		
Grade [%]	0.00			0.00			0.00			0.00		
Crosswalk	No			Yes			No			Yes		

Volumes

Name	Lakeshore Dr			Lakeshore Dr			Eastbound			Olympic Dr		
Base Volume Input [veh/h]	1	138	86	78	279	2	0	0	1	52	1	69
Base Volume Adjustment Factor	1.0000	1.0000	1.0000	1.0000	1.0000	1.0000	1.0000	1.0000	1.0000	1.0000	1.0000	1.0000
Heavy Vehicles Percentage [%]	2.00	2.00	2.00	2.00	2.00	2.00	2.00	2.00	2.00	2.00	2.00	2.00
Growth Factor	1.0000	1.0000	1.0000	1.0000	1.0000	1.0000	1.0000	1.0000	1.0000	1.0000	1.0000	1.0000
In-Process Volume [veh/h]	0	0	0	0	0	0	0	0	0	0	0	0
Site-Generated Trips [veh/h]	0	0	11	4	0	0	0	0	0	6	0	3
Diverted Trips [veh/h]	0	0	0	0	0	0	0	0	0	0	0	0
Pass-by Trips [veh/h]	0	0	0	0	0	0	0	0	0	0	0	0
Existing Site Adjustment Volume [veh/h]	0	0	0	0	0	0	0	0	0	0	0	0
Other Volume [veh/h]	0	0	0	0	0	0	0	0	0	0	0	0
Total Hourly Volume [veh/h]	1	138	97	82	279	2	0	0	1	58	1	72
Peak Hour Factor	0.8600	0.8600	0.8600	0.8600	0.8600	0.8600	0.8600	0.8600	0.8600	0.8600	0.8600	0.8600
Other Adjustment Factor	1.0000	1.0000	1.0000	1.0000	1.0000	1.0000	1.0000	1.0000	1.0000	1.0000	1.0000	1.0000
Total 15-Minute Volume [veh/h]	0	40	28	24	81	1	0	0	0	17	0	21
Total Analysis Volume [veh/h]	1	180	113	95	324	2	0	0	1	67	1	84
Pedestrian Volume [ped/h]	0			0			0			1		



Intersection Settings

Priority Scheme	Free	Free	Stop	Stop
Flared Lane			No	No
Storage Area [veh]	0	0	0	0
Two-Stage Gap Acceptance			No	No
Number of Storage Spaces in Median	0	0	0	0

Movement, Approach, & Intersection Results

V/C, Movement V/C Ratio	0.00	0.00	0.00	0.07	0.00	0.00	0.00	0.00	0.00	0.20	0.00	0.10
d_M, Delay for Movement [s/veh]	7.92	0.00	0.00	8.02	0.00	0.00	18.63	17.30	10.03	18.19	16.06	9.53
Movement LOS	A	A	A	A	A	A	C	C	B	C	C	A
95th-Percentile Queue Length [veh/m]	0.00	0.00	0.00	0.24	0.24	0.24	0.00	0.00	0.00	0.72	0.33	0.33
95th-Percentile Queue Length [ft/m]	0.06	0.06	0.00	5.96	5.96	5.96	0.00	0.00	0.10	18.05	8.13	8.13
d_A, Approach Delay [s/veh]	0.03			1.81			10.03			13.39		
Approach LOS	A			A			B			B		
d_I, Intersection Delay [s/veh]	3.32											
Intersection LOS	C											



Intersection Level Of Service Report
Intersection 6: Olympic Dr/N-S Project Street

Control Type: Two-way stop
Analysis Method: HCM 6th Edition
Analysis Period: 15 minutes
Delay (sec / veh): 17.7
Level Of Service: C
Volume to Capacity (v/c): 0.053

Intersection Setup

Name	N-S Project Street		Olympic Dr		Olympic Dr	
	Southbound		Eastbound		Westbound	
Approach	T		T		T	
Lane Configuration	T		T		T	
Turning Movement	Left	Right	Left	Thru	Thru	Right
Lane Width [ft]	12.00	12.00	12.00	12.00	12.00	12.00
No. of Lanes in Entry Pocket	0	0	0	0	0	0
Entry Pocket Length [ft]	100.00	100.00	100.00	100.00	100.00	100.00
No. of Lanes in Exit Pocket	0	0	0	0	0	0
Exit Pocket Length [ft]	0.00	0.00	0.00	0.00	0.00	0.00
Speed [mph]	25.00		30.00		30.00	
Grade [%]	0.00		0.00		0.00	
Crosswalk	Yes		No		No	

Volumes

Name	N-S Project Street		Olympic Dr		Olympic Dr	
	Base Volume Input [veh/h]	7	8	15	290	306
Base Volume Adjustment Factor	1.0000	1.0000	1.0000	1.0000	1.0000	1.0000
Heavy Vehicles Percentage [%]	2.00	2.00	2.00	2.00	2.00	2.00
Growth Factor	1.0000	1.0000	1.0000	1.0000	1.0000	1.0000
In-Process Volume [veh/h]	2	2	0	26	51	0
Site-Generated Trips [veh/h]	5	12	19	0	0	12
Diverted Trips [veh/h]	0	0	0	0	0	0
Pass-by Trips [veh/h]	0	0	0	0	0	0
Existing Site Adjustment Volume [veh/h]	0	0	0	0	0	0
Other Volume [veh/h]	0	0	0	0	0	0
Total Hourly Volume [veh/h]	14	22	34	316	357	12
Peak Hour Factor	0.8500	0.8500	0.8500	0.8500	0.8500	0.8500
Other Adjustment Factor	1.0000	1.0000	1.0000	1.0000	1.0000	1.0000
Total 15-Minute Volume [veh/h]	4	6	10	93	105	4
Total Analysis Volume [veh/h]	16	26	40	372	420	14
Pedestrian Volume [ped/h]	0		0		0	



Intersection Settings

Priority Scheme	Stop	Free	Free
Flared Lane	No		
Storage Area [veh]	0	0	0
Two-Stage Gap Acceptance	No		
Number of Storage Spaces in Median	C	0	0

Movement, Approach, & Intersection Results

V/C, Movement V/C Ratio	0.05	0.04	0.04	0.00	0.00	0.00
d_M, Delay for Movement [s/veh]	17.69	11.57	8.32	0.00	0.00	0.00
Movement LOS	C	B	A	A	A	A
95th-Percentile Queue Length [veh/m]	0.31	0.31	0.11	0.11	0.00	0.00
95th-Percentile Queue Length [ft/m]	7.74	7.74	2.76	2.78	0.00	0.00
d_A, Approach Delay [s/veh]	13.90		0.81		0.00	
Approach LOS	B		A		A	
d_I, Intersection Delay [s/veh]				1.03		
Intersection LOS	C					



Intersection Level Of Service Report

Intersection 7: Olympic Dr/Burns Valley Rd-Old Hwy 53

Control Type: Signalized
 Analysis Method: HCM 6th Edition
 Analysis Period: 15 minutes
 Delay (sec / veh): 12.0
 Level Of Service: B
 Volume to Capacity (v/c): 0.693

Intersection Setup

Name	Old Hwy 53			Burns Valley Rd			Olympic Dr			Old Hwy 53		
Approach	Northbound			Southbound			Eastbound			Westbound		
Lane Configuration	[Diagram]			[Diagram]			[Diagram]			[Diagram]		
Turning Movement	Left	Thru	Right	Left	Thru	Right	Left	Thru	Right	Left	Thru	Right
Lane Width [ft]	12.00	12.00	12.00	12.00	12.00	12.00	12.00	12.00	12.00	12.00	12.00	12.00
No. of Lanes in Entry Pocket	1	0	1	1	0	0	1	0	0	1	0	0
Entry Pocket Length [ft]	100.00	100.00	100.00	55.00	100.00	100.00	48.00	100.00	100.00	100.00	100.00	100.00
No. of Lanes in Exit Pocket	0	0	0	0	0	0	0	0	0	0	0	0
Exit Pocket Length [ft]	0.00	0.00	0.00	0.00	0.00	0.00	0.00	0.00	0.00	0.00	0.00	0.00
Speed [mph]	30.00			30.00			35.00			35.00		
Grade [%]	0.00			0.00			0.00			0.00		
Curb Present	No			No			No			No		
Crosswalk	Yes			Yes			Yes			Yes		



Volumes

Name	Old Hwy 53			Burns Valley Rd			Olympic Dr			Old Hwy 53		
Base Volume Input [veh/h]	57	67	63	75	74	19	27	142	61	84	191	99
Base Volume Adjustment Factor	1.0000	1.0000	1.0000	1.0000	1.0000	1.0000	1.0000	1.0000	1.0000	1.0000	1.0000	1.0000
Heavy Vehicles Percentage [%]	2.00	2.00	2.00	2.00	2.00	2.00	2.00	2.00	2.00	2.00	2.00	2.00
Growth Factor	1.0000	1.0000	1.0000	1.0000	1.0000	1.0000	1.0000	1.0000	1.0000	1.0000	1.0000	1.0000
In-Process Volume [veh/h]	0	0	0	0	0	0	0	0	0	0	0	0
Site-Generated Trips [veh/h]	5	6	0	5	9	0	0	1	4	0	7	4
Diverted Trips [veh/h]	0	0	0	0	0	0	0	0	0	0	0	0
Pass-by Trips [veh/h]	0	0	0	0	0	0	0	0	0	0	0	0
Existing Site Adjustment Volume [veh/h]	0	0	0	0	0	0	0	0	0	0	0	0
Other Volume [veh/h]	0	0	0	0	0	0	0	0	0	0	0	0
Right Turn on Red Volume [veh/h]	0	0	19	0	0	3	0	0	5	0	0	20
Total Hourly Volume [veh/h]	62	73	44	80	83	16	27	143	60	84	198	83
Peak Hour Factor	0.8900	0.8900	0.8900	0.8900	0.8900	0.8900	0.8900	0.8900	0.8900	0.8900	0.8900	0.8900
Other Adjustment Factor	1.0000	1.0000	1.0000	1.0000	1.0000	1.0000	1.0000	1.0000	1.0000	1.0000	1.0000	1.0000
Total 15-Minute Volume [veh/h]	17	21	12	22	23	4	8	40	17	18	56	23
Total Analysis Volume [veh/h]	70	82	49	90	93	18	30	161	67	72	222	93
Presence of On-Street Parking	No	No	No	No	No	No	No	No	No	No	No	No
On-Street Parking Maneuver Rate [h]	0	0	0	0	0	0	0	0	0	0	0	0
Local Bus Stopping Rate [h]	0	0	0	0	0	0	0	0	0	0	0	0
v_do, Outbound Pedestrian Volume crossing major street	1			0			1			1		
v_di, Inbound Pedestrian Volume crossing major street	1			1			0			1		
v_co, Outbound Pedestrian Volume crossing minor street	1			0			0			0		
v_ci, Inbound Pedestrian Volume crossing minor street	0			0			1			0		
v_ab, Corner Pedestrian Volume [ped/h]	0			0			0			0		
Bicycle Volume [bicycles/h]	0			0			0			0		1



Intersection Settings	
Located In CBD	Yes
Signal Coordination Group	-
Cycle Length [s]	109
Coordination Type	Time of Day Pattern Isolated
Actuation Type	Fully actuated
Offset [s]	0.0
Offset Reference	Lead Green - Beginning of First Green
Permissive Mode	SingleBand
Lost time [s]	14.00

Phasing & Timing													
Control Type	Protect	Permis	Permis	Protect	Permis	Permis	Protect	Permis	Permis	Protect	Permis	Permis	Protect
Signal Group	3	8	0	7	4	0	5	2	0	1	6	0	
Auxiliary Signal Groups													
Lead / Lag	Lead	-	-	Lead	-	-	Lead	-	-	Lead	-	-	
Minimum Green [s]	4	6	0	4	6	0	4	6	0	4	6	0	
Maximum Green [s]	20	25	0	20	25	0	20	30	0	20	20	0	
Amber [s]	3.0	3.3	0.0	3.0	3.3	0.0	3.0	3.6	0.0	3.0	3.6	0.0	
All red [s]	0.0	0.3	0.0	0.0	0.3	0.0	0.0	0.3	0.0	0.0	0.3	0.0	
Split [s]	23	29	0	23	29	0	23	34	0	23	34	0	
Vehicle Extension [s]	0.0	0.0	0.0	0.0	0.0	0.0	0.0	0.0	0.0	0.0	0.0	0.0	
Walk [s]	7	7	0	7	7	0	7	7	0	7	7	0	
Pedestrian Clearance [s]	9	11	0	9	9	0	14	0	0	9	9	0	
Delayed Vehicle Green [s]	0.0	0.0	0.0	0.0	0.0	0.0	0.0	0.0	0.0	0.0	0.0	0.0	
Rest in Walk		No		No	No		No			No			
I1, Start-Up Lost Time [s]	2.0	2.0	0.0	2.0	2.0	0.0	2.0	0.0	0.0	2.0	2.0	0.0	
I2, Clearance Lost Time [s]	1.0	1.6	0.0	1.0	1.6	0.0	1.0	1.9	0.0	1.0	1.9	0.0	
Minimum Recall	No	No		No	No		No	No		No	No		
Maximum Recall	No	No		No	No		No	No		No	No		
Pedestrian Recall	No	No		No	No		No	No		No	No		
Detector Location [ft]	0.0	0.0	0.0	0.0	0.0	0.0	0.0	0.0	0.0	0.0	0.0	0.0	
Detector Length [ft]	0.0	0.0	0.0	0.0	0.0	0.0	0.0	0.0	0.0	0.0	0.0	0.0	
I, Upstream Filtering Factor	1.00	1.00	1.00	1.00	1.00	1.00	1.00	1.00	1.00	1.00	1.00	1.00	

Exclusive Pedestrian Phase	
Pedestrian Signal Group	0
Pedestrian Walk [s]	0
Pedestrian Clearance [s]	0



Lane Group Calculations										
Lane Group	L	C	R	L	C	L	C	L	C	
C, Cycle Length [s]	27	27	27	27	27	27	27	27	27	
L, Total Lost Time per Cycle [s]	3.00	3.60	3.60	3.00	3.60	3.00	3.60	3.00	3.60	
I1_p, Permitted Start-Up Lost Time [s]	0.00	0.00	0.00	0.00	0.00	0.00	0.00	0.00	0.00	
I2, Clearance Lost Time [s]	1.00	1.60	1.60	1.00	1.60	1.00	1.60	1.00	1.60	
g_j, Effective Green Time [s]	2	4	4	2	4	1	6	2	6	
g / C, Green / Cycle	0.06	0.15	0.15	0.07	0.16	0.03	0.21	0.06	0.24	
(v / s)_J Volume / Saturation Flow Rate	0.04	0.05	0.03	0.06	0.07	0.02	0.14	0.04	0.20	
s, saturation flow rate [veh/h]	1603	1683	1421	1603	1635	1603	1599	1603	1588	
c, Capacity [veh/h]	100	247	208	120	260	50	337	102	387	
d1, Uniform Delay [s]	12.31	10.25	10.10	12.14	10.16	12.82	9.74	12.29	9.57	
k, delay calibration	0.04	0.04	0.04	0.04	0.04	0.04	0.04	0.04	0.04	
I, Upstream Filtering Factor	1.00	1.00	1.00	1.00	1.00	1.00	1.00	1.00	1.00	
d2, Incremental Delay [s]	3.26	0.29	0.21	3.46	0.41	4.29	0.89	3.26	1.61	
d3, Initial Queue Delay [s]	0.00	0.00	0.00	0.00	0.00	0.00	0.00	0.00	0.00	
Rp, platoon ratio	1.00	1.00	1.00	1.00	1.00	1.00	1.00	1.00	1.00	
PF, progression factor	1.00	1.00	1.00	1.00	1.00	1.00	1.00	1.00	1.00	

Lane Group Results										
X, volume / capacity	0.70	0.33	0.24	0.75	0.43	0.60	0.68	0.70	0.81	
d, Delay for Lane Group [s/veh]	15.57	10.64	10.31	16.61	10.57	17.11	10.63	15.55	11.18	
Lane Group LOS	B	B	B	B	B	B	B	B	B	
Critical Lane Group	Yes	No	No	No	Yes	Yes	No	No	Yes	
50th-Percentile Queue Length [veh/m]	0.39	0.32	0.19	0.49	0.43	0.18	0.81	0.38	1.15	
50th-Percentile Queue Length [ft/m]	9.68	7.89	4.66	12.33	10.66	4.58	20.28	9.51	28.84	
95th-Percentile Queue Length [veh/m]	0.70	0.57	0.34	0.89	0.77	0.33	1.46	0.68	2.08	
95th-Percentile Queue Length [ft/m]	17.42	14.20	8.38	22.19	19.22	8.25	36.51	17.11	51.91	



Movement, Approach, & Intersection Results

d_M, Delay for Movement [s/veh]	15.57	10.54	10.31	15.61	10.57	10.57	17.11	10.63	10.63	15.55	11.18	11.18
Movement LOS	B	B	B	B	B	B	B	B	B	B	B	B
d_A, Approach Delay [s/veh]	12.24				12.83		11.38				11.99	
Approach LOS	B				B		B				B	
d_I, Intersection Delay [s/veh]							12.05					
Intersection LOS							B					
Intersection V/C							0.693					

Other Modes

g_Walk,mi, Effective Walk Time [s]	11.0	11.0	11.0	11.0
M_corner, Corner Circulation Area [ft ² /ped]	0.00	0.00	0.00	0.00
M_CW, Crosswalk Circulation Area [ft ² /ped]	0.00	0.00	0.00	0.00
d_p, Pedestrian Delay [s]	4.58	4.58	4.58	4.58
L_p,int, Pedestrian LOS Score for Intersection	2.188	2.002	2.084	2.162
Crosswalk LOS	B	B	B	B
s_b, Saturation Flow Rate of the bicycle lane [bicycles/h]	2000	2000	2000	2000
c_b, Capacity of the bicycle lane [bicycles/h]	1909	1909	2262	2262
d_b, Bicycle Delay [s]	0.03	0.03	0.23	0.23
L_b,int, Bicycle LOS Score for Intersection	1.923	1.898	1.994	2.231
Bicycle LOS	A	A	A	B

Sequence

Ring 1	1	2	3	4	-	-	-	-	-	-	-	-	-	-
Ring 2	5	6	7	8	-	-	-	-	-	-	-	-	-	-
Ring 3	-	-	-	-	-	-	-	-	-	-	-	-	-	-
Ring 4	-	-	-	-	-	-	-	-	-	-	-	-	-	-

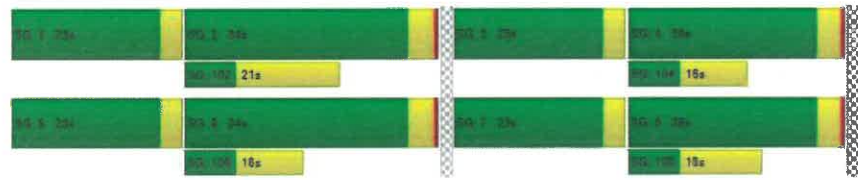

Intersection Level Of Service Report
Intersection 1: Burns Valley Rd/N-S Project Street

Control Type:	Two-way stop	Delay (sec / veh):	10.8
Analysis Method:	HCM 6th Edition	Level Of Service:	B
Analysis Period:	15 minutes	Volume to Capacity (v/c):	0.031

Intersection Setup

Name	N-S Project Street		Burns Valley Rd		Burns Valley Rd	
Approach	Northbound		Eastbound		Westbound	
Lane Configuration	T		T		T	
Turning Movement	Left	Right	Thru	Right	Left	Thru
Lane Width [ft]	12.00	12.00	12.00	12.00	12.00	12.00
No. of Lanes in Entry Pocket	0	0	0	0	0	0
Entry Pocket Length [ft]	100.00	100.00	100.00	100.00	100.00	100.00
No. of Lanes in Exit Pocket	0	0	0	0	0	0
Exit Pocket Length [ft]	0.00	0.00	0.00	0.00	0.00	0.00
Speed [mph]	25.00		35.00		35.00	
Grade [%]	0.00		0.00		0.00	
Crosswalk	No		No		No	

Volumes

Name	N-S Project Street		Burns Valley Rd		Burns Valley Rd	
Base Volume Input [veh/h]	8	8	117	17	0	117
Base Volume Adjustment Factor	1.0000	1.0000	1.0000	1.0000	1.0000	1.0000
Heavy Vehicles Percentage [%]	2.00	2.00	2.00	2.00	2.00	2.00
Growth Factor	1.0000	1.0000	1.0000	1.0000	1.0000	1.0000
In-Process Volume [veh/h]	3	3	11	0	0	11
Site-Generated Trips [veh/h]	7	7	1	10	7	1
Diverted Trips [veh/h]	0	0	0	0	0	0
Pass-by Trips [veh/h]	0	0	0	0	0	0
Existing Site Adjustment Volume [veh/h]	0	0	0	0	0	0
Other Volume [veh/h]	0	0	11	0	0	11
Total Hourly Volume [veh/h]	18	18	140	27	7	140
Peak Hour Factor	0.8930	0.8930	0.8930	0.8930	0.8930	0.8930
Other Adjustment Factor	1.0000	1.0000	1.0000	1.0000	1.0000	1.0000
Total 15-Minute Volume [veh/h]	5	5	39	8	2	39
Total Analysis Volume [veh/h]	20	20	157	30	8	157
Pedestrian Volume [ped/h]	0	0	0	0	0	0

Intersection Settings

Priority Scheme	Stop	Free	Free
Flared Lane	No		
Storage Area [veh]	0	0	0
Two-Stage Gap Acceptance	No		
Number of Storage Spaces in Median	0	0	0

Movement, Approach, & Intersection Results

V/C, Movement V/C Ratio	0.03	0.02	0.00	0.00	0.01	0.00
d_M, Delay for Movement [s/veh]	10.84	9.41	0.00	0.00	7.81	0.00
Movement LOS	B	A	A	A	A	A
95th-Percentile Queue Length [veh/ln]	0.17	0.17	0.00	0.00	0.02	0.02
95th-Percentile Queue Length [ft/ln]	4.26	4.26	0.00	0.00	0.43	0.43
d_A, Approach Delay [s/veh]	10.12		0.00		0.37	
Approach LOS	B		A		A	
d_I, Intersection Delay [s/veh]			1.19			
Intersection LOS			B			



Intersection Level Of Service Report

Intersection 2: Burns Valley Rd/Bowers Ave-Rumsey Rd

Control Type:	Two-way stop	Delay (sec / veh):	13.5
Analysis Method:	HCM 6th Edition	Level Of Service:	B
Analysis Period:	15 minutes	Volume to Capacity (v/c):	0.034

Intersection Setup

Name	Burns Valley Rd			Rumsey Rd			Burns Valley Rd			Bowers Ave		
Approach	Northbound			Southbound			Eastbound			Westbound		
Lane Configuration	+			+			+			+		
Turning Movement	Left	Thru	Right	Left	Thru	Right	Left	Thru	Right	Left	Thru	Right
Lane Width [ft]	12.00	12.00	12.00	12.00	12.00	12.00	12.00	12.00	12.00	12.00	12.00	12.00
No. of Lanes in Entry Pocket	0	0	0	0	0	0	0	0	0	0	0	0
Entry Pocket Length [ft]	100.00	100.00	100.00	100.00	100.00	100.00	100.00	100.00	100.00	100.00	100.00	100.00
No. of Lanes in Exit Pocket	0	0	0	0	0	0	0	0	0	0	0	0
Exit Pocket Length [ft]	0.00	0.00	0.00	0.00	0.00	0.00	0.00	0.00	0.00	0.00	0.00	0.00
Speed [mph]	30.00			30.00			35.00			25.00		
Grade [%]	0.00			0.00			0.00			0.00		
Crosswalk	No			Yes			Yes			No		

Volumes

Name	Burns Valley Rd			Rumsey Rd			Burns Valley Rd			Bowers Ave		
Base Volume Input [veh/h]	111	39	9	2	44	7	7	1	86	13	0	0
Base Volume Adjustment Factor	1.0000	1.0000	1.0000	1.0000	1.0000	1.0000	1.0000	1.0000	1.0000	1.0000	1.0000	1.0000
Heavy Vehicles Percentage [%]	2.00	2.00	2.00	2.00	2.00	2.00	2.00	2.00	2.00	2.00	2.00	2.00
Growth Factor	1.0000	1.0000	1.0000	1.0000	1.0000	1.0000	1.0000	1.0000	1.0000	1.0000	1.0000	1.0000
In-Process Volume [veh/h]	0	0	0	0	0	0	0	0	0	0	0	0
Site-Generated Trips [veh/h]	5	1	0	0	1	4	3	0	3	0	0	0
Diverted Trips [veh/h]	0	0	0	0	0	0	0	0	0	0	0	0
Pass-by Trips [veh/h]	0	0	0	0	0	0	0	0	0	0	0	0
Existing Site Adjustment Volume [veh/h]	0	0	0	0	0	0	0	0	0	0	0	0
Other Volume [veh/h]	0	0	0	0	0	0	0	0	0	0	0	0
Total Hourly Volume [veh/h]	116	40	9	2	45	11	10	1	89	13	0	0
Peak Hour Factor	0.8500	0.8500	0.8500	0.8500	0.8500	0.8500	0.8500	0.8500	0.8500	0.8500	0.8500	0.8500
Other Adjustment Factor	1.0000	1.0000	1.0000	1.0000	1.0000	1.0000	1.0000	1.0000	1.0000	1.0000	1.0000	1.0000
Total 15-Minute Volume [veh/h]	34	12	3	1	13	3	3	0	26	4	0	0
Total Analysis Volume [veh/h]	136	47	11	2	53	13	12	1	105	15	0	0
Pedestrian Volume [ped/h]	0			0			0			0		



Intersection Settings

Priority Scheme	Free	Free	Stop	Stop
Flared Lane			No	No
Storage Area [veh]	0	0	0	0
Two-Stage Gap Acceptance			No	No
Number of Storage Spaces in Median	0	0	0	0

Movement, Approach, & Intersection Results

V/C, Movement V/C Ratio	0.09	0.00	0.00	0.00	0.00	0.00	0.02	0.00	0.10	0.03	0.00	0.00
d_M, Delay for Movement [s/veh]	7.57	0.00	0.00	7.33	0.00	0.00	12.37	12.89	9.16	13.52	12.01	8.84
Movement LOS	A	A	A	A	A	A	B	B	A	B	B	A
95th-Percentile Queue Length [veh/ln]	0.29	0.29	0.29	0.00	0.00	0.00	0.44	0.44	0.44	0.11	0.11	0.11
95th-Percentile Queue Length [ft/ln]	7.27	7.27	7.27	0.10	0.10	0.10	11.06	11.06	11.06	2.86	2.86	2.86
d_A, Approach Delay [s/veh]	5.31			0.22			9.52			13.52		
Approach LOS	A			A			A			B		
d_I, Intersection Delay [s/veh]							6.00					
Intersection LOS							B					



Intersection Level of Service Report

Intersection 3: N-S Project Street/E-W Project Street

Control Type:	All-way stop	Delay (sec / veh):	7.4
Analysis Method:	HCM 6th Edition	Level Of Service:	A
Analysis Period:	15 minutes	Volume to Capacity (v/c):	0.105

Intersection Setup

Name	N-S Project Street			N-S Project Street			E-W Project Street			E-W Project Street		
Approach	Northbound			Southbound			Eastbound			Westbound		
Lane Configuration	+			+			+			+		
Turning Movement	Left	Thru	Right	Left	Thru	Right	Left	Thru	Right	Left	Thru	Right
Lane Width [ft]	12.00	12.00	12.00	12.00	12.00	12.00	12.00	12.00	12.00	12.00	12.00	12.00
No. of Lanes in Entry Pocket	0	0	0	0	0	0	0	0	0	0	0	0
Entry Pocket Length [ft]	100.00	100.00	100.00	100.00	100.00	100.00	100.00	100.00	100.00	100.00	100.00	100.00
No. of Lanes in Exit Pocket	0	0	0	0	0	0	0	0	0	0	0	0
Exit Pocket Length [ft]	0.00	0.00	0.00	0.00	0.00	0.00	0.00	0.00	0.00	0.00	0.00	0.00
Speed [mph]	25.00			25.00			25.00			25.00		
Grade [%]	0.00			0.00			0.00			0.00		
Crosswalk	Yes			Yes			Yes			Yes		

Volumes

Name	N-S Project Street			N-S Project Street			E-W Project Street			E-W Project Street		
Base Volume Input [veh/h]	0	22	0	0	23	0	0	0	0	0	0	
Base Volume Adjustment Factor	1.0000	1.0000	1.0000	1.0000	1.0000	1.0000	1.0000	1.0000	1.0000	1.0000	1.0000	
Heavy Vehicles Percentage [%]	2.00	2.00	2.00	2.00	2.00	2.00	2.00	2.00	2.00	2.00	2.00	
Growth Factor	1.0000	1.0000	1.0000	1.0000	1.0000	1.0000	1.0000	1.0000	1.0000	1.0000	1.0000	
In-Process Volume [veh/h]	0	0	0	0	0	0	0	0	0	0	0	
Site-Generated Trips [veh/h]	3	44	15	12	31	1	1	3	8	5	2	
Diverted Trips [veh/h]	0	0	0	0	0	0	0	0	0	0	0	
Pass-by Trips [veh/h]	0	0	0	0	0	0	0	0	0	0	0	
Existing Site Adjustment Volume [veh/h]	0	0	0	0	0	0	0	0	0	0	0	
Other Volume [veh/h]	0	0	0	0	0	0	0	0	0	0	0	
Total Hourly Volume [veh/h]	3	66	15	12	54	1	1	3	8	5	2	
Peak Hour Factor	0.8800	0.8800	0.8800	0.8800	0.8800	0.8800	0.8800	0.8800	0.8800	0.8800	0.8800	
Other Adjustment Factor	1.0000	1.0000	1.0000	1.0000	1.0000	1.0000	1.0000	1.0000	1.0000	1.0000	1.0000	
Total 15-Minute Volume [veh/h]	1	19	4	3	15	0	0	1	2	1	1	
Total Analysis Volume [veh/h]	3	75	17	14	61	1	1	3	9	6	2	
Pedestrian Volume [ped/h]	0			0			0			0		



Intersection Settings

Lanes				
Capacity per Entry Lane [veh/h]	903	872	918	911
Degree of Utilization, x	0.11	0.09	0.01	0.03

Movement, Approach, & Intersection Results

95th-Percentile Queue Length [veh]	0.35	0.29	0.04	0.08
95th-Percentile Queue Length [ft]	8.78	7.14	1.08	2.11
Approach Delay [s/veh]	7.46	7.52	6.98	7.06
Approach LOS	A	A	A	A
Intersection Delay [s/veh]	7.40			
Intersection LOS	A			



Intersection Level Of Service Report
Intersection 4: Burns Valley Rd/E-W Project Street

Control Type:	Two-way stop	Delay (sec / veh):	11.8
Analysis Method:	HCM 6th Edition	Level Of Service:	B
Analysis Period:	15 minutes	Volume to Capacity (v/c):	0.002

Intersection Setup

Name	Burns Valley Rd		Burns Valley Rd		E-W Project Street	
Approach	Northbound		Southbound		Eastbound	
Lane Configuration	←		→		←	
Turning Movement	Left	Thru	Thru	Right	Left	Right
Lane Width [ft]	12.00	12.00	12.00	12.00	12.00	12.00
No. of Lanes in Entry Pocket	0	0	0	0	0	0
Entry Pocket Length [ft]	100.00	100.00	100.00	100.00	100.00	100.00
No. of Lanes in Exit Pocket	0	0	0	0	0	0
Exit Pocket Length [ft]	0.00	0.00	0.00	0.00	0.00	0.00
Speed [mph]	30.00		30.00		25.00	
Grade [%]	0.00		0.00		0.00	
Crosswalk	No		No		Yes	

Volumes

Name	Burns Valley Rd		Burns Valley Rd		E-W Project Street	
Base Volume Input [veh/h]	0	170	185	0	0	0
Base Volume Adjustment Factor	1.0000	1.0000	1.0000	1.0000	1.0000	1.0000
Heavy Vehicles Percentage [%]	2.00	2.00	2.00	2.00	2.00	2.00
Growth Factor	1.0000	1.0000	1.0000	1.0000	1.0000	1.0000
In-Process Volume [veh/h]	0	0	0	0	0	0
Site-Generated Trips [veh/h]	24	5	3	1	1	18
Diverted Trips [veh/h]	0	0	0	0	0	0
Pass-by Trips [veh/h]	0	0	0	0	0	0
Existing Site Adjustment Volume [veh/h]	0	0	0	0	0	0
Other Volume [veh/h]	0	0	0	0	0	0
Total Hourly Volume [veh/h]	24	175	188	1	1	18
Peak Hour Factor	0.8800	0.8800	0.8800	0.8800	0.8800	0.8800
Other Adjustment Factor	1.0000	1.0000	1.0000	1.0000	1.0000	1.0000
Total 15-Minute Volume [veh/h]	7	50	53	0	0	5
Total Analysis Volume [veh/h]	27	199	214	1	1	20
Pedestrian Volume [ped/h]	0	0	0	0	0	0



Intersection Settings			
Priority Scheme	Free	Free	Stop
Flared Lane			No
Storage Area [veh]	0	0	0
Two-Stage Gap Acceptance			No
Number of Storage Spaces in Median	0	0	0

Movement, Approach, & Intersection Results						
V/C, Movement V/C Ratio	0.02	0.00	0.00	0.00	0.00	0.02
d_M, Delay for Movement [s/veh]	7.71	0.00	0.00	0.00	11.77	9.48
Movement LOS	A	A	A	A	B	A
95th-Percentile Queue Length [veh/ln]	0.05	0.05	0.00	0.00	0.08	0.08
95th-Percentile Queue Length [ft/ln]	1.52	1.52	0.00	0.00	2.01	2.01
d_A, Approach Delay [s/veh]	0.92		0.00		9.59	
Approach LOS	A		A		A	
d_I, Intersection Delay [s/veh]			0.89			
Intersection LOS			B			



Intersection Level Of Service Report			
Intersection 5: Olympic Dr/Lakeshore Dr			
Control Type:	Two-way stop	Delay (sec / veh):	22.8
Analysis Method:	HCM 6th Edition	Level Of Service:	C
Analysis Period:	15 minutes	Volume to Capacity (v/c):	0.448

Intersection Setup												
Name	Lakeshore Dr			Lakeshore Dr			Olympic Dr			Olympic Dr		
Approach	Northbound			Southbound			Eastbound			Westbound		
Lane Configuration	[Diagram]			[Diagram]			[Diagram]			[Diagram]		
Turning Movement	Left	Thru	Right	Left	Thru	Right	Left	Thru	Right	Left	Thru	Right
Lane Width [ft]	12.00	12.00	12.00	12.00	12.00	12.00	12.00	12.00	12.00	12.00	12.00	12.00
No. of Lanes in Entry Pocket	0	0	1	0	0	0	0	0	0	0	0	1
Entry Pocket Length [ft]	100.00	100.00	120.00	100.00	100.00	100.00	100.00	100.00	100.00	100.00	100.00	250.00
No. of Lanes in Exit Pocket	0	0	0	0	0	0	0	0	0	0	0	0
Exit Pocket Length [ft]	0.00	0.00	0.00	0.00	0.00	0.00	0.00	0.00	0.00	0.00	0.00	0.00
Speed [mph]	25.00			25.00			30.00			30.00		
Grade [%]	0.00			0.00			0.00			0.00		
Crosswalk	No			Yes			No			Yes		

Volumes												
Name	Lakeshore Dr			Lakeshore Dr			Olympic Dr			Olympic Dr		
Base Volume Input [veh/h]	1	199	138	88	182	1	0	2	2	136	3	168
Base Volume Adjustment Factor	1.0000	1.0000	1.0000	1.0000	1.0000	1.0000	1.0000	1.0000	1.0000	1.0000	1.0000	1.0000
Heavy Vehicles Percentage [%]	2.00	2.00	2.00	2.00	2.00	2.00	2.00	2.00	2.00	2.00	2.00	2.00
Growth Factor	1.0000	1.0000	1.0000	1.0000	1.0000	1.0000	1.0000	1.0000	1.0000	1.0000	1.0000	1.0000
In-Process Volume [veh/h]	0	0	0	0	0	0	0	0	0	0	0	0
Site-Generated Trips [veh/h]	0	0	21	11	0	0	0	0	0	15	0	8
Diverted Trips [veh/h]	0	0	0	0	0	0	0	0	0	0	0	0
Pass-by Trips [veh/h]	0	0	0	0	0	0	0	0	0	0	0	0
Existing Site Adjustment Volume [veh/h]	0	0	0	0	0	0	0	0	0	0	0	0
Other Volume [veh/h]	0	0	0	0	0	0	0	0	0	0	0	0
Total Hourly Volume [veh/h]	1	199	159	99	182	1	0	2	2	151	3	176
Peak Hour Factor	0.9300	0.9300	0.9300	0.9300	0.9300	0.9300	0.9300	0.9300	0.9300	0.9300	0.9300	0.9300
Other Adjustment Factor	1.0000	1.0000	1.0000	1.0000	1.0000	1.0000	1.0000	1.0000	1.0000	1.0000	1.0000	1.0000
Total 15-Minute Volume [veh/h]	0	53	43	27	49	0	0	1	1	41	1	47
Total Analysis Volume [veh/h]	1	214	171	106	186	1	0	2	2	162	3	189
Pedestrian Volume [ped/h]		0			0			0			1	



Intersection Settings

	Free	Free	Stop	Stop
Priority Scheme				
Flared Lane			No	No
Storage Area [veh]	0	0	0	0
Two-Stage Gap Acceptance			No	No
Number of Storage Spaces in Median	0	0	0	0

Movement, Approach, & Intersection Results

V/C, Movement V/C Ratio	0.00	0.00	0.00	0.09	0.00	0.00	0.00	0.01	0.00	0.45	0.01	0.23
d_M, Delay for Movement [s/veh]	7.62	0.00	0.00	8.38	0.00	0.00	22.09	17.64	9.34	22.79	16.40	10.75
Movement LOS	A	A	A	A	A	A	C	C	A	C	C	B
95th-Percentile Queue Length [veh/ln]	0.00	0.00	0.00	0.30	0.30	0.30	0.03	0.03	0.03	2.23	0.82	0.92
95th-Percentile Queue Length [ft/ln]	0.05	0.05	0.00	7.45	7.45	7.45	0.71	0.71	0.71	55.87	23.11	23.11
d_A, Approach Delay [s/veh]	0.02			2.93			13.49			16.31		
Approach LOS	A			A			B			C		
d_I, Intersection Delay [s/veh]	6.42											
Intersection LOS	C											



Intersection Level Of Service Report
Intersection 6: Olympic Dr/N-S Project Street

Control Type:	Two-way stop	Delay (sec / veh):	26.7
Analysis Method:	HCM 6th Edition	Level Of Service:	D
Analysis Period:	15 minutes	Volume to Capacity (v/c):	0.144

Intersection Setup

Name	N-S Project Street		Olympic Dr		Olympic Dr	
Approach	Southbound		Eastbound		Westbound	
Lane Configuration	T		T		T	
Turning Movement	Left	Right	Left	Thru	Thru	Right
Lane Width [ft]	12.00	12.00	12.00	12.00	12.00	12.00
No. of Lanes in Entry Pocket	0	0	0	0	0	0
Entry Pocket Length [ft]	100.00	100.00	100.00	100.00	100.00	100.00
No. of Lanes in Exit Pocket	0	0	0	0	0	0
Exit Pocket Length [ft]	0.00	0.00	0.00	0.00	0.00	0.00
Speed [mph]	25.00		30.00		30.00	
Grade [%]	0.00		0.00		0.00	
Crosswalk	Yes		No		No	

Volumes

Name	N-S Project Street		Olympic Dr		Olympic Dr	
Base Volume Input [veh/h]	8	9	16	352	384	0
Base Volume Adjustment Factor	1.0000	1.0000	1.0000	1.0000	1.0000	1.0000
Heavy Vehicles Percentage [%]	2.00	2.00	2.00	2.00	2.00	2.00
Growth Factor	1.0000	1.0000	1.0000	1.0000	1.0000	1.0000
In-Process Volume [veh/h]	3	3	0	74	53	0
Site-Generated Trips [veh/h]	13	31	43	0	0	19
Diverted Trips [veh/h]	0	0	0	0	0	0
Pass-by Trips [veh/h]	0	0	0	0	0	0
Existing Site Adjustment Volume [veh/h]	0	0	0	0	0	0
Other Volume [veh/h]	0	0	0	0	0	0
Total Hourly Volume [veh/h]	24	43	59	426	437	19
Peak Hour Factor	0.8500	0.8500	0.8500	0.8500	0.8500	0.8500
Other Adjustment Factor	1.0000	1.0000	1.0000	1.0000	1.0000	1.0000
Total 15-Minute Volume [veh/h]	7	13	17	125	129	6
Total Analysis Volume [veh/h]	28	51	69	501	514	22
Pedestrian Volume [ped/h]	0		0		0	



Intersection Settings			
Priority Scheme	Stop	Free	Free
Flared Lane	No		
Storage Area [veh]	∞	0	0
Two-Stage Gap Acceptance	No		
Number of Storage Spaces in Median	∞	0	0

Movement, Approach, & Intersection Results						
VIC, Movement VIC Ratio	0.14	0.09	0.07	0.01	0.01	3.00
d_M, Delay for Movement [s/veh]	26.74	14.80	8.74	0.00	0.00	0.00
Movement LOS	D	B	A	A	A	A
95th-Percentile Queue Length [veh/ln]	0.90	0.90	0.21	0.21	0.00	0.00
95th-Percentile Queue Length [ft/ln]	22.52	22.52	5.36	5.36	0.00	0.00
d_A, Approach Delay [s/veh]	19.04		1.06		0.00	
Approach LOS	C		A		A	
d_I, Intersection Delay [s/veh]	1.78					
Intersection LOS	D					



Intersection Level Of Service Report
Intersection 7: Olympic Dr/Burns Valley Rd-Old Hwy 53
 Control Type: Signalized
 Analysis Method: HCM 6th Edition
 Analysis Period: 15 minutes
 Delay (sec / veh): 15.4
 Level Of Service: B
 Volume to Capacity (v/c): 0.838

Intersection Setup												
Name	Old Hwy 53			Burns Valley Rd			Olympic Dr			Old Hwy 53		
Approach	Northbound			Southbound			Eastbound			Westbound		
Lane Configuration	T T T			T T			T T			T T		
Turning Movement	Left	Thru	Right	Left	Thru	Right	Left	Thru	Right	Left	Thru	Right
Lane Width [ft]	12.00	12.00	12.00	12.00	12.00	12.00	12.00	12.00	12.00	12.00	12.00	12.00
No. of Lanes in Entry Pocket	1	0	1	1	0	0	1	0	0	1	0	0
Entry Pocket Length [ft]	100.00	100.00	100.00	56.00	100.00	100.00	48.00	100.00	100.00	100.00	100.00	100.00
No. of Lanes in Exit Pocket	0	0	0	0	0	0	0	0	0	0	0	0
Exit Pocket Length [ft]	0.00	0.00	0.00	0.00	0.00	0.00	0.00	0.00	0.00	0.00	0.00	0.00
Speed [mph]	30.00			30.00			35.00			35.00		
Grade [%]	0.00			0.00			0.00			0.00		
Curb Present	No			No			No			No		
Crosswalk	Yes			Yes			Yes			Yes		



Volumes

Name	Old Hwy 53			Burns Valley Rd			Olympic Dr			Old Hwy 53		
Base Volume Input [veh/h]	126	120	96	112	106	50	27	235	131	107	257	139
Base Volume Adjustment Factor	1.0000	1.0000	1.0000	1.0000	1.0000	1.0000	1.0000	1.0000	1.0000	1.0000	1.0000	1.0000
Heavy Vehicles Percentage [%]	2.00	2.00	2.00	2.00	2.00	2.00	2.00	2.00	2.00	2.00	2.00	2.00
Growth Factor	1.0000	1.0000	1.0000	1.0000	1.0000	1.0000	1.0000	1.0000	1.0000	1.0000	1.0000	1.0000
In-Process Volume [veh/h]	0	0	0	0	0	0	0	0	0	0	0	0
Site-Generated Trips [veh/h]	9	18	0	10	11	0	0	5	7	0	10	11
Diverted Trips [veh/h]	0	0	0	0	0	0	0	0	0	0	0	0
Pass-by Trips [veh/h]	0	0	0	0	0	0	0	0	0	0	0	0
Existing Site Adjustment Volume [veh/h]	0	0	0	0	0	0	0	0	0	0	0	0
Other Volume [veh/h]	0	0	0	0	0	0	0	0	0	0	0	0
Right Turn on Red Volume [veh/h]	0	0	18	0	0	11	0	0	14	0	0	25
Total Hourly Volume [veh/h]	135	138	78	122	117	39	27	240	124	107	267	125
Peak Hour Factor	0.9200	0.9200	0.9200	0.9200	0.9200	0.9200	0.9200	0.9200	0.9200	0.9200	0.9200	0.9200
Other Adjustment Factor	1.0000	1.0000	1.0000	1.0000	1.0000	1.0000	1.0000	1.0000	1.0000	1.0000	1.0000	1.0000
Total 15-Minute Volume [veh/h]	37	38	21	33	32	11	7	65	34	29	73	34
Total Analysis Volume [veh/h]	147	150	85	133	127	42	29	261	135	116	290	136
Presence of On-Street Parking	No		No	No	No	No	No	No	No	No	No	No
On-Street Parking Maneuver Rate [/h]	0	0	0	0	0	0	0	0	0	0	0	0
Local Bus Stopping Rate [/h]	0	0	0	0	0	0	0	0	0	0	0	0
v_do, Outbound Pedestrian Volume crossing major street	1			0			1			1		
v_di, Inbound Pedestrian Volume crossing major street	1			1			0			1		
v_co, Outbound Pedestrian Volume crossing minor street	1			0			0			0		
v_ci, Inbound Pedestrian Volume crossing minor street	0			0			1			0		
v_ab, Corner Pedestrian Volume [ped/h]	0			0			0			0		
Bicycle Volume [bicycles/h]	0			0			0			1		

Intersection Settings

Located in CBD	Yes
Signal Coordination Group	-
Cycle Length [s]	109
Coordination Type	Time of Day Pattern Isolated
Actuation Type	Fully actuated
Offset [s]	0.0
Offset Reference	Lead Green - Beginning of First Green
Permissive Mode	SingleBand
Lost time [s]	14.00

Phasing & Timing

Control Type	Protect	Permis	Permis	Protect	Permis	Permis	Protect	Permis	Permis	Protect	Permis	Permis
Signal Group	3	8	0	7	4	0	5	2	0	1	6	0
Auxiliary Signal Groups												
Lead / Lag	Lead	-	-	Lead	-	-	Lead	-	-	Lead	-	-
Minimum Green [s]	4	6	0	4	6	0	4	6	0	4	6	0
Maximum Green [s]	20	25	0	20	25	0	20	30	0	20	20	0
Amber [s]	3.0	3.3	0.0	3.0	3.3	0.0	3.0	3.6	0.0	3.0	3.6	0.0
All red [s]	0.0	0.3	0.0	0.0	0.3	0.0	0.0	0.3	0.0	0.0	0.3	0.0
Split [s]	23	29	0	23	29	0	23	34	0	23	34	0
Vehicle Extension [s]	0.0	0.0	0.0	0.0	0.0	0.0	0.0	0.0	0.0	0.0	0.0	0.0
Walk [s]	0	7	0	0	7	0	0	7	0	0	7	0
Pedestrian Clearance [s]	0	11	0	0	9	0	0	14	0	0	9	0
Delayed Vehicle Green [s]	0.0	0.0	0.0	0.0	0.0	0.0	0.0	0.0	0.0	0.0	0.0	0.0
Rest In Walk		No			No			No			No	
I1, Start-Up Lost Time [s]	2.0	2.0	0.0	2.0	2.0	0.0	2.0	2.0	0.0	2.0	2.0	0.0
I2, Clearance Lost Time [s]	1.0	1.6	0.0	1.0	1.6	0.0	1.0	1.9	0.0	1.0	1.9	0.0
Minimum Recall	No	No		No	No		No	No		No	No	
Maximum Recall	No	No		No	No		No	No		No	No	
Pedestrian Recall	No	No		No	No		No	No		No	No	
Detector Location [ft]	0.0	0.0	0.0	0.0	0.0	0.0	0.0	0.0	0.0	0.0	0.0	0.0
Detector Length [ft]	0.0	0.0	0.0	0.0	0.0	0.0	0.0	0.0	0.0	0.0	0.0	0.0
I, Upstream Filtering Factor	1.00	1.00	1.00	1.00	1.00	1.00	1.00	1.00	1.00	1.00	1.00	1.00

Exclusive Pedestrian Phase

Pedestrian Signal Group	0
Pedestrian Walk [s]	0
Pedestrian Clearance [s]	0



Lane Group Calculations

Lane Group	L	C	R	L	C	L	C	L	C
C, Cycle Length [s]	37	37	37	37	37	37	37	37	37
L, Total Lost Time per Cycle [s]	3.00	3.60	3.60	3.00	3.60	3.00	3.90	3.00	3.90
l _{1,p} , Permitted Start-Up Lost Time [s]	0.00	0.00	0.00	0.00	0.00	0.00	0.00	0.00	0.00
l ₂ , Clearance Lost Time [s]	1.00	1.60	1.60	1.00	1.60	1.00	1.90	1.00	1.90
g _i , Effective Green Time [s]	4	6	6	4	5	1	11	3	13
g / C, Green / Cycle	0.11	0.15	0.15	0.10	0.14	0.03	0.29	0.09	0.35
(v / s) _i Volume / Saturation Flow Rate	0.09	0.09	0.08	0.08	0.10	0.02	0.25	0.07	0.27
s, saturation flow rate [veh/h]	1603	1683	1421	1603	1611	1603	1586	1603	1581
c, Capacity [veh/h]	182	256	217	164	227	45	460	142	554
d ₁ , Uniform Delay [s]	15.94	14.54	14.08	16.19	15.19	17.72	12.37	16.50	10.84
k, delay calibration	0.04	0.04	0.04	0.04	0.04	0.04	0.04	0.04	0.04
l, Upstream Filtering Factor	1.00	1.00	1.00	1.00	1.00	1.00	1.00	1.00	1.00
d ₂ , Incremental Delay [s]	3.18	0.79	0.43	3.58	1.80	5.45	1.87	4.28	0.86
d ₃ , Initial Queue Delay [s]	0.00	0.00	0.00	0.00	0.00	0.00	0.00	0.00	0.00
R _p , platoon ratio	1.00	1.00	1.00	1.00	1.00	1.00	1.00	1.00	1.00
PF, progression factor	1.00	1.00	1.00	1.00	1.00	1.00	1.00	1.00	1.00

Lane Group Results

X, volume / capacity	0.81	0.58	0.39	0.81	0.74	0.64	0.86	0.82	0.77
d, Delay for Lane Group [s/veh]	19.12	15.32	14.51	19.77	16.99	23.17	14.24	20.78	11.49
Lane Group LOS	B	B	B	B	B	C	B	C	B
Critical Lane Group	Yes	No	No	No	Yes	No	Yes	Yes	No
50th-Percentile Queue Length [veh/in]	1.16	1.00	0.55	1.07	1.22	0.27	2.42	0.94	2.19
50th-Percentile Queue Length [ft/in]	28.95	25.12	13.66	26.84	30.58	6.74	60.54	23.58	54.66
95th-Percentile Queue Length [veh/in]	2.09	1.81	0.98	1.93	2.20	0.49	4.36	1.70	3.94
95th-Percentile Queue Length [ft/in]	52.13	45.21	24.59	48.32	55.04	12.13	108.97	42.44	98.39



Movement, Approach, & Intersection Results

d _M , Delay for Movement [s/veh]	19,12	15,32	14,51	19,77	16,99	16,99	23,17	14,24	14,24	20,78	11,49	11,49
Movement LOS	B	B	B	B	B	B	C	B	B	C	B	B
d _A , Approach Delay [s/veh]	16.60			18.22			14.85			13.48		
Approach LOS	B			B			B			B		
d _I , Intersection Delay [s/veh]	15.42											
Intersection LOS	B											
Intersection V/C	0.838											

Other Modes

g _{Walk} , mi, Effective Walk Time [s]	11.0	11.0	11.0	11.0
M _{corner} , Corner Circulation Area [ft ² /ped]	0.00	0.00	0.00	0.00
M _{CW} , Crosswalk Circulation Area [ft ² /ped]	0.00	0.00	0.00	0.00
d _p , Pedestrian Delay [s]	9.01	9.01	9.01	9.01
l _{p,int} , Pedestrian LOS Score for Intersection	2.295	2.114	2.258	2.325
Crosswalk LOS	B	B	B	B
s _b , Saturation Flow Rate of the bicycle lane [bicycles/h]	2000	2000	2000	2000
c _b , Capacity of the bicycle lane [bicycles/h]	1383	1383	1639	1639
d _b , Bicycle Delay [s]	1.75	1.75	0.80	0.60
l _{b,int} , Bicycle LOS Score for Intersection	2.220	2.076	2.284	2.495
Bicycle LOS	B	B	B	B

Sequence

Ring 1	1	2	3	4	-	-	-	-	-	-	-	-
Ring 2	5	6	7	8	-	-	-	-	-	-	-	-
Ring 3	-	-	-	-	-	-	-	-	-	-	-	-
Ring 4	-	-	-	-	-	-	-	-	-	-	-	-

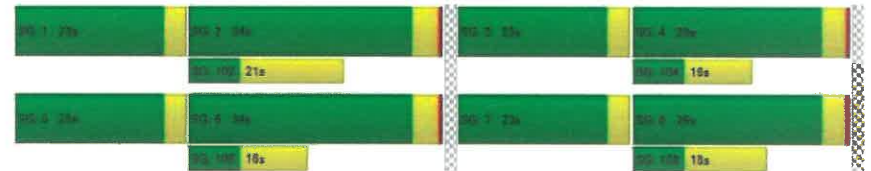

Intersection Level Of Service Report

Intersection 1: Burns Valley Rd/N-S Project Street

Control Type: Two-way stop
Analysis Method: HCM 6th Edition
Analysis Period: 15 minutes
Delay (sec / veh): 10.4
Level Of Service: B
Volume to Capacity (v/c): 0.046

Intersection Setup

Name	N-S Project Street		Burns Valley Rd		Burns Valley Rd	
Approach	Northbound		Eastbound		Westbound	
Lane Configuration	T		T		T	
Turning Movement	Left	Right	Thru	Right	Left	Thru
Lane Width [ft]	12.00	12.00	12.00	12.00	12.00	12.00
No. of Lanes in Entry Pocket	0	0	0	0	0	0
Entry Pocket Length [ft]	100.00	100.00	100.00	100.00	100.00	100.00
No. of Lanes in Exit Pocket	0	0	0	0	0	0
Exit Pocket Length [ft]	0.00	0.00	0.00	0.00	0.00	0.00
Speed [mph]	25.00		35.00		35.00	
Grade [%]	0.00		0.00		0.00	
Crosswalk	No		No		No	

Volumes

Name	N-S Project Street		Burns Valley Rd		Burns Valley Rd	
Base Volume Input [veh/h]	7	6	78	12	0	93
Base Volume Adjustment Factor	1.0000	1.0000	1.0000	1.0000	1.0000	1.0000
Heavy Vehicles Percentage [%]	2.00	2.00	2.00	2.00	2.00	2.00
Growth Factor	1.0000	1.0000	1.0000	1.0000	1.0000	1.0000
In-Process Volume [veh/h]	7	8	15	0	0	14
Site-Generated Trips [veh/h]	16	17	3	15	12	2
Diverted Trips [veh/h]	0	0	0	0	0	0
Pass-by Trips [veh/h]	0	0	0	0	0	0
Existing Site Adjustment Volume [veh/h]	0	0	0	0	0	0
Other Volume [veh/h]	0	0	0	0	0	0
Total Hourly Volume [veh/h]	30	31	96	27	12	109
Peak Hour Factor	0.9130	0.9130	0.9130	0.9130	0.9130	0.9130
Other Adjustment Factor	1.0000	1.0000	1.0000	1.0000	1.0000	1.0000
Total 15-Minute Volume [veh/h]	8	8	26	7	3	30
Total Analysis Volume [veh/h]	33	34	105	30	13	119
Pedestrian Volume [ped/h]	0	0	0	0	0	0



Intersection Settings

Priority Scheme	Stop	Free	Free
Flared Lane	No		
Storage Area [veh]	0	C	0
Two-Stage Gap Acceptance	No		
Number of Storage Spaces in Median	0	0	0

Movement, Approach, & Intersection Results

V/C, Movement V/C Ratio	0.05	0.04	0.00	0.00	0.01	0.00
d_M, Delay for Movement [s/veh]	10.42	9.26	0.00	0.00	7.51	0.00
Movement LOS	B	A	A	A	A	A
95th-Percentile Queue Length [veh/m]	0.27	0.27	0.00	0.00	0.03	0.03
95th-Percentile Queue Length [ft/m]	6.73	6.73	0.00	0.00	0.68	0.68
d_A, Approach Delay [s/veh]	9.83		0.00		0.74	
Approach LOS	A		A		A	
d_I, Intersection Delay [s/veh]				2.26		
Intersection LOS	B					



Intersection Level Of Service Report
Intersection 2: Burns Valley Rd/Bowers Ave-Rumsey Rd
 Control Type: Two-way stop Delay (sec / veh): 13.1
 Analysis Method: HCM 6th Edition Level Of Service: B
 Analysis Period: 15 minutes Volume to Capacity (v/c): 0.004

Intersection Setup

Name	Burns Valley Rd			Rumsey Rd			Burns Valley Rd			Bowers Ave		
Approach	Northbound			Southbound			Eastbound			Westbound		
Lane Configuration	+			+			+			+		
Turning Movement	Left	Thru	Right	Left	Thru	Right	Left	Thru	Right	Left	Thru	Right
Lane Width [ft]	12.00	12.00	12.00	12.00	12.00	12.00	12.00	12.00	12.00	12.00	12.00	12.00
No. of Lanes in Entry Pocket	0	0	0	0	0	0	0	0	0	0	0	0
Entry Pocket Length [ft]	100.00	100.00	100.00	100.00	100.00	100.00	100.00	100.00	100.00	100.00	100.00	100.00
No. of Lanes in Exit Pocket	0	0	0	0	0	0	0	0	0	0	0	0
Exit Pocket Length [ft]	0.00	0.00	0.00	0.00	0.00	0.00	0.00	0.00	0.00	0.00	0.00	0.00
Speed [mph]	30.00			30.00			35.00			25.00		
Grade [%]	0.00			0.00			0.00			0.00		
Crosswalk	No			Yes			Yes			No		

Volumes

Name	Burns Valley Rd			Rumsey Rd			Burns Valley Rd			Bowers Ave		
Base Volume Input [veh/h]	98	37	1	0	32	9	10	0	98	2	1	0
Base Volume Adjustment Factor	1.0000	1.0000	1.0000	1.0000	1.0000	1.0000	1.0000	1.0000	1.0000	1.0000	1.0000	1.0000
Heavy Vehicles Percentage [%]	2.00	2.00	2.00	2.00	2.00	2.00	2.00	2.00	2.00	2.00	2.00	2.00
Growth Factor	1.0000	1.0000	1.0000	1.0000	1.0000	1.0000	1.0000	1.0000	1.0000	1.0000	1.0000	1.0000
In-Process Volume [veh/h]	0	0	0	0	0	0	0	0	0	0	0	0
Site-Generated Trips [veh/h]	14	2	0	0	3	5	6	0	10	0	0	0
Diverted Trips [veh/h]	0	0	0	0	0	0	0	0	0	0	0	0
Pass-by Trips [veh/h]	0	0	0	0	0	0	0	0	0	0	0	0
Existing Site Adjustment Volume [veh/h]	0	0	0	0	0	0	0	0	0	0	0	0
Other Volume [veh/h]	0	0	0	0	0	0	0	0	0	0	0	0
Total Hourly Volume [veh/h]	112	39	1	0	35	14	16	0	108	2	1	0
Peak Hour Factor	0.8500	0.9600	0.9600	0.9600	0.9600	0.8500	0.8500	0.8500	0.9600	0.8500	0.9600	
Other Adjustment Factor	1.0000	1.0000	1.0000	1.0000	1.0000	1.0000	1.0000	1.0000	1.0000	1.0000	1.0000	
Total 15-Minute Volume [veh/h]	33	10	0	0	9	4	5	0	32	1	0	0
Total Analysis Volume [veh/h]	132	41	1	0	36	16	19	0	127	2	1	0
Pedestrian Volume [ped/h]	0			0			0			0		



Intersection Settings

Priority Scheme	Free	Free	Stop	Stop
Flared Lane			No	No
Storage Area [veh]	0	0	0	0
Two-Stage Gap Acceptance			No	No
Number of Storage Spaces in Median	0	0	0	0

Movement, Approach, & Intersection Results

VC, Movement V/C Ratio	0.08	0.00	0.00	0.00	0.00	0.00	0.03	0.00	0.12	0.00	0.00	0.00
d_M, Delay for Movement [s/veh]	7.53	0.30	0.00	7.35	0.50	0.00	12.11	12.69	9.23	13.06	11.98	8.55
Movement LOS	A	A	A	A	A	A	B	B	A	B	B	A
95th-Percentile Queue Length [veh/in]	0.28	0.28	0.28	0.00	0.00	0.00	0.56	0.56	0.56	0.02	0.02	0.02
95th-Percentile Queue Length [ft/in]	6.95	6.95	6.95	0.00	0.00	0.00	13.94	13.94	13.94	0.48	0.48	0.48
d_A, Approach Delay [s/veh]	5.71			0.00			9.61			12.70		
Approach LOS	A			A			A			B		
d_I, Intersection Delay [s/veh]	6.49											
Intersection LOS	B											



Intersection Level Of Service Report
Intersection 3: N-S Project Street/E-W Project Street

Control Type: All-way stop Delay (sec / veh): 7.7
 Analysis Method: HCM 6th Edition Level Of Service: A
 Analysis Period: 15 minutes Volume to Capacity (v/c): 0.144

Intersection Setup

Name	N-S Project Street			N-S Project Street			E-W Project Street			E-W Project Street		
Approach	Northbound			Southbound			Eastbound			Westbound		
Lane Configuration	+			+			+			+		
Turning Movement	Left	Thru	Right	Left	Thru	Right	Left	Thru	Right	Left	Thru	Right
Lane Width [ft]	12.00	12.00	12.00	12.00	12.00	12.00	12.00	12.00	12.00	12.00	12.00	12.00
No. of Lanes in Entry Pocket	0	0	0	0	0	0	0	0	0	0	0	0
Entry Pocket Length [ft]	100.00	100.00	100.00	100.00	100.00	100.00	100.00	100.00	100.00	100.00	100.00	100.00
No. of Lanes in Exit Pocket	0	0	0	0	0	0	0	0	0	0	0	0
Exit Pocket Length [ft]	0.00	0.00	0.00	0.00	0.00	0.00	0.00	0.00	0.00	0.00	0.00	0.00
Speed [mph]	25.00			25.00			25.00			25.00		
Grade [%]	0.00			0.00			0.00			0.00		
Crosswalk	Yes			Yes			Yes			Yes		

Volumes

Name	N-S Project Street			N-S Project Street			E-W Project Street			E-W Project Street		
Base Volume Input [veh/h]	0	28	0	0	28	0	0	0	0	0	0	0
Base Volume Adjustment Factor	1.0000	1.0000	1.0000	1.0000	1.0000	1.0000	1.0000	1.0000	1.0000	1.0000	1.0000	1.0000
Heavy Vehicles Percentage [%]	2.00	2.00	2.00	2.00	2.00	2.00	2.00	2.00	2.00	2.00	2.00	2.00
Growth Factor	1.0000	1.0000	1.0000	1.0000	1.0000	1.0000	1.0000	1.0000	1.0000	1.0000	1.0000	1.0000
In-Process Volume [veh/h]	0	0	0	0	0	0	0	0	0	0	0	0
Site-Generated Trips [veh/h]	5	60	30	24	64	2	1	6	15	15	4	26
Diverted Trips [veh/h]	0	0	0	0	0	0	0	0	0	0	0	0
Pass-by Trips [veh/h]	0	0	0	0	0	0	0	0	0	0	0	0
Existing Site Adjustment Volume [veh/h]	0	0	0	0	0	0	0	0	0	0	0	0
Other Volume [veh/h]	0	0	0	0	0	0	0	0	0	0	0	0
Total Hourly Volume [veh/h]	5	88	30	24	92	2	1	6	15	15	4	26
Peak Hour Factor	0.9720	0.9720	0.9720	0.9720	0.9720	0.9720	0.9720	0.9720	0.9720	0.9720	0.9720	0.9720
Other Adjustment Factor	1.0000	1.0000	1.0000	1.0000	1.0000	1.0000	1.0000	1.0000	1.0000	1.0000	1.0000	1.0000
Total 15-Minute Volume [veh/h]	1	23	8	6	24	1	0	2	4	4	1	7
Total Analysis Volume [veh/h]	5	91	31	25	95	2	1	6	15	15	4	27
Pedestrian Volume [ped/h]	0			0			0			0		



Intersection Settings

Lanes	Capacity per Entry Lane [veh/h]	885	848	873	855
Degree of Utilization, x	0.14	0.14	0.03	0.05	

Movement, Approach, & Intersection Results

95th-Percentile Queue Length [veh]	0.50	0.50	0.08	0.17
95th-Percentile Queue Length [ft]	12.51	12.52	1.94	4.26
Approach Delay [s/veh]	7.75	7.95	7.23	7.45
Approach LOS	A	A	A	A
Intersection Delay [s/veh]	7.75			
Intersection LOS	A			



Intersection Level Of Service Report
Intersection 4: Burns Valley Rd/E-W Project Street

Control Type: Two-way stop Delay (sec / veh): 11.4
Analysis Method: HCM 6th Edition Level Of Service: B
Analysis Period: 15 minutes Volume to Capacity (v/c): 0.003

Intersection Setup

Name	Burns Valley Rd		Burns Valley Rd		E-W Project Street	
	Northbound		Southbound		Eastbound	
Approach	←		→		→	
Lane Configuration	←		→		→	
Turning Movement	Left	Thru	Thru	Right	Left	Right
Lane Width [ft]	12.00	12.00	12.00	12.00	12.00	12.00
No. of Lanes in Entry Pocket	0	0	0	0	0	0
Entry Pocket Length [ft]	0.00	0.00	0.00	0.00	0.00	0.00
No. of Lanes in Exit Pocket	0	0	0	0	0	0
Exit Pocket Length [ft]	0.00	0.00	0.00	0.00	0.00	0.00
Speed [mph]	30.00		30.00		25.00	
Grade [%]	0.00		0.00		0.00	
Crosswalk	No		No		Yes	

Volumes

Name	Burns Valley Rd		Burns Valley Rd		E-W Project Street	
	Northbound		Southbound		Eastbound	
Base Volume Input [veh/h]	0	145	136	0	0	0
Base Volume Adjustment Factor	1.0000	1.0000	1.0000	1.0000	1.0000	1.0000
Heavy Vehicles Percentage [%]	2.00	2.00	2.00	2.00	2.00	2.00
Growth Factor	1.0000	1.0000	1.0000	1.0000	1.0000	1.0000
In-Process Volume [veh/h]	0	0	0	0	0	0
Site-Generated Trips [veh/h]	43	14	10	3	2	43
Diverted Trips [veh/h]	0	0	0	0	0	0
Pass-by Trips [veh/h]	0	0	0	0	0	0
Existing Site Adjustment Volume [veh/h]	0	0	0	0	0	0
Other Volume [veh/h]	0	0	0	0	0	0
Total Hourly Volume [veh/h]	43	159	146	3	2	43
Peak Hour Factor	0.9720	0.9720	0.9720	0.9720	0.9720	0.9720
Other Adjustment Factor	1.0000	1.0000	1.0000	1.0000	1.0000	1.0000
Total 15-Minute Volume [veh/h]	11	41	38	1	1	11
Total Analysis Volume [veh/h]	44	164	150	3	2	44
Pedestrian Volume [ped/h]	0		0		0	



Intersection Settings

Priority Scheme	Free	Free	Stop
Flared Lane			No
Storage Area [veh]	0	0	0
Two-Stage Gap Acceptance			No
Number of Storage Spaces in Median	0	0	0

Movement, Approach, & Intersection Results

V/C, Movement V/C Ratio	0.03	0.00	0.00	0.00	0.00	0.05
d_M, Delay for Movement [s/veh]	7.60	0.00	0.00	0.00	11.41	9.25
Movement LOS	A	A	A	A	B	A
95th-Percentile Queue Length [veh/ln]	0.10	0.10	0.00	0.00	0.17	0.17
95th-Percentile Queue Length [ft/ln]	2.38	2.38	0.00	0.00	4.16	4.16
d_A, Approach Delay [s/veh]	1.61		0.00		9.35	
Approach LOS	A		A		A	
d_I, Intersection Delay [s/veh]				1.88		
Intersection LOS	B					



Intersection Level Of Service Report
Intersection 5: Olympic Dr/Lakeshore Dr

Control Type: Two-way stop
Analysis Method: HCM 6th Edition
Analysis Period: 15 minutes
Delay (sec / veh): 27.6
Level Of Service: D
Volume to Capacity (v/c): 0.532

Intersection Setup

Name	Lakeshore Dr			Lakeshore Dr			Olympic Dr					
Approach	Northbound			Southbound			Eastbound			Westbound		
Lane Configuration	TT			+			+			TT		
Turning Movement	Left	Thru	Right	Left	Thru	Right	Left	Thru	Right	Left	Thru	Right
Lane Width [ft]	12.00	12.00	12.00	12.00	12.00	12.00	12.00	12.00	12.00	12.00	12.00	12.00
No. of Lanes in Entry Pocket	0	0	1	0	0	0	0	0	0	0	0	1
Entry Pocket Length [ft]	120.00	120.00	120.00	109.00	103.00	100.00	155.00	100.00	103.00	100.00	100.00	250.00
No. of Lanes in Exit Pocket	0	0	0	0	0	0	0	0	0	0	0	0
Exit Pocket Length [ft]	0.00	0.00	0.00	0.00	0.00	0.00	0.00	0.00	0.00	0.00	0.00	0.00
Speed [mph]	25.00			25.00			30.00			30.00		
Grade [%]	0.00			0.00			0.00			0.00		
Crosswalk	No			Yes			No			Yes		

Volumes

Name	Lakeshore Dr			Lakeshore Dr			Olympic Dr					
Base Volume Input [veh/h]	1	176	127	103	185	0	0	3	3	127	1	107
Base Volume Adjustment Factor	1.0000	1.0000	1.0000	1.0000	1.0000	1.0000	1.0000	1.0000	1.0000	1.0000	1.0000	1.0000
Heavy Vehicles Percentage [%]	2.00	2.00	2.00	2.00	2.00	2.00	2.00	2.00	2.00	2.00	2.00	2.00
Growth Factor	1.0000	1.0000	1.0000	1.0000	1.0000	1.0000	1.0000	1.0000	1.0000	1.0000	1.0000	1.0000
In-Process Volume [veh/h]	0	0	0	0	0	0	0	0	0	0	0	0
Site-Generated Trips [veh/h]	0	0	37	18	0	0	0	0	0	33	0	18
Diverted Trips [veh/h]	0	0	0	0	0	0	0	0	0	0	0	0
Pass-by Trips [veh/h]	0	0	0	0	0	0	0	0	0	0	0	0
Existing Site Adjustment Volume [veh/h]	0	0	0	0	0	0	0	0	0	0	0	0
Other Volume [veh/h]	0	0	0	0	0	0	0	0	0	0	0	0
Total Hourly Volume [veh/h]	1	176	164	121	185	0	0	3	3	160	1	125
Peak Hour Factor	0.9100	0.9100	0.9100	0.9100	0.9100	0.9100	0.9100	0.9100	0.9100	0.9100	0.9100	0.9100
Other Adjustment Factor	1.0000	1.0000	1.0000	1.0000	1.0000	1.0000	1.0000	1.0000	1.0000	1.0000	1.0000	1.0000
Total 15-Minute Volume [veh/h]	0	48	45	33	51	0	0	1	1	44	0	34
Total Analysis Volume [veh/h]	1	193	180	133	203	0	0	3	3	176	1	137
Pedestrian Volume [ped/h]	0			0			0			1		



Intersection Settings

Priority Scheme	Free	Free	Stop	Stop
Flared Lane			No	No
Storage Area [veh]	0	0	0	0
Two-Stage Gap Acceptance			No	No
Number of Storage Spaces in Median	0	0	0	0

Movement, Approach, & Intersection Results

V/C, Movement V/C Ratio	0.00	0.00	0.00	0.11	0.00	0.00	0.00	0.01	0.00	0.53	0.00	0.16
d_M, Delay for Movement [s/veh]	7.63	0.00	0.00	8.43	0.00	0.00	21.45	18.92	9.44	27.56	16.70	10.10
Movement LOS	A	A	A	A	A	A	C	C	A	D	C	B
95th-Percentile Queue Length [veh/ln]	0.00	0.00	0.00	0.38	0.38	0.38	0.05	0.05	0.05	2.95	0.59	0.59
95th-Percentile Queue Length [ft/ln]	0.05	0.05	0.00	9.47	9.47	9.47	1.15	1.15	1.15	73.85	14.70	14.70
d_A, Approach Delay [s/veh]	0.02			3.34			14.18			19.91		
Approach LOS	A			A			B			C		
d_I, Intersection Delay [s/veh]	7.25											
Intersection LOS	D											



Intersection Level Of Service Report
Intersection 6: Olympic Dr/N-S Project Street

Control Type: Two-way stop Delay (sec / veh): 27.4
 Analysis Method: HCM 6th Edition Level Of Service: D
 Analysis Period: 15 minutes Volume to Capacity (v/c): 0.219

Intersection Setup

Name	N-S Project Street		Olympic Dr		Olympic Dr	
	Southbound		Eastbound		Westbound	
Approach	Southbound		Eastbound		Westbound	
Lane Configuration	T		I		I	
Turning Movement	Left	Right	Left	Thru	Thru	Right
Lane Width [ft]	12.00	12.00	12.00	12.00	12.00	12.00
No. of Lanes in Entry Pocket	0	0	0	0	0	0
Entry Pocket Length [ft]	100.00	100.00	100.00	100.00	100.00	100.00
No. of Lanes in Exit Pocket	0	0	0	0	0	0
Exit Pocket Length [ft]	0.00	0.00	0.00	0.00	0.00	0.00
Speed [mph]	25.00		30.00		30.00	
Grade [%]	0.00		0.00		0.00	
Crosswalk	Yes		No		No	

Volumes

Name	N-S Project Street		Olympic Dr		Olympic Dr	
	Base Volume Input [veh/h]	6	6	13	288	300
Base Volume Adjustment Factor	1.0000	1.0000	1.0000	1.0000	1.0000	1.0000
Heavy Vehicles Percentage [%]	2.00	2.00	2.00	2.00	2.00	2.00
Growth Factor	1.0000	1.0000	1.0000	1.0000	1.0000	1.0000
In-Process Volume [veh/h]	8	8	0	82	58	0
Site-Generated Trips [veh/h]	26	89	73	0	0	25
Diverted Trips [veh/h]	0	0	0	0	0	0
Pass-by Trips [veh/h]	0	0	0	0	0	0
Existing Site Adjustment Volume [veh/h]	0	0	0	0	0	0
Other Volume [veh/h]	0	0	0	0	0	0
Total Hourly Volume [veh/h]	40	83	86	371	358	25
Peak Hour Factor	0.8500	0.8500	0.8500	0.8500	0.8500	0.8500
Other Adjustment Factor	1.0000	1.0000	1.0000	1.0000	1.0000	1.0000
Total 15-Minute Volume [veh/h]	12	24	25	109	105	7
Total Analysis Volume [veh/h]	47	98	101	436	421	29
Pedestrian Volume [ped/h]	0		0		0	



Intersection Settings

Priority Scheme	Stop	Free	Free
Flared Lane	No		
Storage Area [veh]	C	0	0
Two-Stage Gap Acceptance	No		
Number of Storage Spaces in Median	0	0	0

Movement, Approach, & Intersection Results

V/C, Movement V/C Ratio	0.22	0.16	0.09	0.00	0.00	0.00
d_M, Delay for Movement [s/veh]	27.35	16.36	8.57	0.00	0.00	0.00
Movement LOS	D	C	A	A	A	A
95th-Percentile Queue Length [veh/ln]	1.72	1.72	0.30	0.30	0.00	0.00
95th-Percentile Queue Length [ft/ln]	42.95	42.95	7.49	7.49	0.00	0.00
d_A, Approach Delay [s/veh]	19.92		1.61		0.00	
Approach LOS	C		A		A	
d_I, Intersection Delay [s/veh]			3.32			
Intersection LOS			D			



Intersection Level Of Service Report
Intersection 7: Olympic Dr/Burns Valley Rd-Old Hwy 53

Control Type: Signalized
Analysis Method: HCM 6th Edition
Analysis Period: 15 minutes
Delay (sec / veh): 14.8
Level Of Service: B
Volume to Capacity (v/c): 0.802

Intersection Setup

Name	Old Hwy 53			Burns Valley Rd			Olympic Dr			Old Hwy 53		
	Northbound			Southbound			Eastbound			Westbound		
Approach	[Diagram]			[Diagram]			[Diagram]			[Diagram]		
Lane Configuration	[Diagram]			[Diagram]			[Diagram]			[Diagram]		
Turning Movement	Left	Thru	Right	Left	Thru	Right	Left	Thru	Right	Left	Thru	Right
Lane Width [ft]	12.00	12.00	12.00	12.00	12.00	12.00	12.00	12.00	12.00	12.00	12.00	12.00
No. of Lanes in Entry Pocket	1	0	1	1	0	0	1	0	0	1	0	0
Entry Pocket Length [ft]	100.00	100.00	100.00	56.00	100.00	100.00	48.00	100.00	100.00	100.00	100.00	100.00
No. of Lanes in Exit Pocket	0	0	0	0	0	0	0	0	0	0	0	0
Exit Pocket Length [ft]	0.00	0.00	0.00	0.00	0.00	0.00	0.00	0.00	0.00	0.00	0.00	0.00
Speed [mph]	30.00			30.00			35.00			35.00		
Grade [%]	0.00			0.00			0.00			0.00		
Curb Present	No			No			No			No		
Crosswalk	Yes			Yes			Yes			Yes		



Volumes

Name	Old Hwy 53			Burns Valley Rd			Olympic Dr			Old Hwy 53		
Base Volume Input [veh/h]	113	91	79	93	77	31	26	231	136	101	206	89
Base Volume Adjustment Factor	1.0000	1.0000	1.0000	1.0000	1.0000	1.0000	1.0000	1.0000	1.0000	1.0000	1.0000	1.0000
Heavy Vehicles Percentage [%]	2.00	2.00	2.00	2.00	2.00	2.00	2.00	2.00	2.00	2.00	2.00	2.00
Growth Factor	1.0000	1.0000	1.0000	1.0000	1.0000	1.0000	1.0000	1.0000	1.0000	1.0000	1.0000	1.0000
In-Process Volume [veh/h]	0	0	0	0	0	0	0	0	0	0	0	0
Site-Generated Trips [veh/h]	12	32	0	22	31	0	0	11	15	0	12	25
Diverted Trips [veh/h]	0	0	0	0	0	0	0	0	0	0	0	0
Pass-by Trips [veh/h]	0	0	0	0	0	0	0	0	0	0	0	0
Existing Site Adjustment Volume [veh/h]	0	0	0	0	0	0	0	0	0	0	0	0
Other Volume [veh/h]	0	0	0	0	0	0	0	0	0	0	0	0
Right Turn on Red Volume [veh/h]	0	0	16	0	0	12	0	25	0	0	0	29
Total Hourly Volume [veh/h]	125	123	64	115	108	19	26	242	126	101	218	85
Peak Hour Factor	0.9300	0.9300	0.9300	0.9300	0.9300	0.9300	0.9300	0.9300	0.9300	0.9300	0.9300	0.9300
Other Adjustment Factor	1.0000	1.0000	1.0000	1.0000	1.0000	1.0000	1.0000	1.0000	1.0000	1.0000	1.0000	1.0000
Total 15-Minute Volume [veh/h]	34	33	17	31	29	5	7	65	34	27	59	23
Total Analysis Volume [veh/h]	134	132	69	124	116	20	28	260	135	109	234	91
Presence of On-Street Parking	No	No	No	No	No	No	No	No	No	No	No	No
On-Street Parking Maneuver Rate [h]	0	0	0	0	0	0	0	0	0	0	0	0
Local Bus Stopping Rate [h]	0	0	0	0	0	0	0	0	0	0	0	0
v_do, Outbound Pedestrian Volume crossing major street	1			0			1			1		
v_di, Inbound Pedestrian Volume crossing major street	1			1			0			1		
v_co, Outbound Pedestrian Volume crossing minor street	1			0			0			0		
v_ci, Inbound Pedestrian Volume crossing minor street	0			0			1			0		
v_ab, Corner Pedestrian Volume [ped/h]	0			0			0			0		
Bicycle Volume [bicycles/h]	0			0			0			1		



Intersection Settings	
Located in CBD	Yes
Signal Coordination Group	
Cycle Length [s]	109
Coordination Type	Time of Day Pattern Isolated
Actuation Type	Fully actuated
Offset [s]	0.0
Offset Reference	Left Green - Beginning of First Green
Permissive Mode	SingleBand
Last time [s]	14.00

Phasing & Timing													
Control Type	Protect	Permis	Permis	Protect	Permis	Permis	Protect	Permis	Permis	Protect	Permis	Permis	Protect
Signal Group	3	8	0	7	4	0	5	2	0	1	6	0	
Auxiliary Signal Groups													
Lead / Lag	Lead	-	-	Lead	-	-	Lead	-	-	Lead	-	-	
Minimum Green [s]	4	6	0	4	6	0	4	6	0	4	6	0	
Maximum Green [s]	20	25	0	20	25	0	20	30	0	20	20	0	
Amber [s]	3.0	3.3	0.0	3.0	3.3	0.0	3.0	3.6	0.0	3.0	3.6	0.0	
All red [s]	0.0	0.3	0.0	0.0	0.3	0.0	0.0	0.3	0.0	0.0	0.3	0.0	
Split [s]	23	29	0	23	29	0	23	34	0	23	34	0	
Vehicle Extension [s]	0.0	0.0	0.0	0.0	0.0	0.0	0.0	0.0	0.0	0.0	0.0	0.0	
Walk [s]	0	7	0	0	7	0	0	7	0	0	7	0	
Pedestrian Clearance [s]	0	11	0	0	9	0	0	14	0	0	9	0	
Delayed Vehicle Green [s]	0.0	0.0	0.0	0.0	0.0	0.0	0.0	0.0	0.0	0.0	0.0	0.0	
Rest in Walk		No			No			No			No		
I1, Start-Up Lost Time [s]	2.0	2.0	0.0	2.0	2.0	0.0	2.0	2.0	0.0	2.0	2.0	0.0	
I2, Clearance Lost Time [s]	1.0	1.6	0.0	1.0	1.6	0.0	1.0	1.9	0.0	1.0	1.9	0.0	
Minimum Recall	No	No		No	No		No	No		No	No		
Maximum Recall	No	No		No	No		No	No		No	No		
Pedestrian Recall	No	No		No	No		No	No		No	No		
Detector Location [ft]	0.0	0.0	0.0	0.0	0.0	0.0	0.0	0.0	0.0	0.0	0.0	0.0	
Detector Length [ft]	0.0	0.0	0.0	0.0	0.0	0.0	0.0	0.0	0.0	0.0	0.0	0.0	
I, Upstream Filtering Factor	1.00	1.00	1.00	1.00	1.00	1.00	1.00	1.00	1.00	1.00	1.00	1.00	

Exclusive Pedestrian Phase	
Pedestrian Signal Group	0
Pedestrian Walk [s]	0
Pedestrian Clearance [s]	0



Lane Group Calculations										
Lane Group	L	C	R	L	C	L	C	L	C	C
C, Cycle Length [s]	35	35	35	35	35	35	35	35	35	35
L, Total Lost Time per Cycle [s]	3.00	3.60	3.60	3.00	3.60	3.00	3.60	3.00	3.60	3.00
I1_p, Permitted Start-Up Lost Time [s]	0.00	0.00	0.00	0.00	0.00	0.00	0.00	0.00	0.00	0.00
I2, Clearance Lost Time [s]	1.00	1.60	1.60	1.00	1.60	1.00	1.60	1.00	1.60	1.00
g_L, Effective Green Time [s]	4	5	5	3	5	1	10	3	12	
g / C, Green / Cycle	0.10	0.15	0.15	0.09	0.14	0.03	0.29	0.08	0.34	
(v / s)_j Volume / Saturation Flow Rate	0.08	0.08	0.05	0.08	0.08	0.02	0.25	0.07	0.20	
s, saturation flow rate [veh/h]	1603	1683	1421	1603	1639	1603	1586	1603	1593	
c, Capacity [veh/h]	165	253	214	152	233	44	461	132	551	
d1, Uniform Delay [s]	15.54	13.86	13.42	15.71	14.20	17.03	11.86	15.98	9.52	
k, delay calibration	0.04	0.04	0.04	0.04	0.04	0.04	0.04	0.04	0.04	
I, Upstream Filtering Factor	1.00	1.00	1.00	1.00	1.00	1.00	1.00	1.00	1.00	
d2, Incremental Delay [s]	3.61	0.62	0.32	3.99	0.86	5.43	1.82	4.78	0.38	
d3, Initial Queue Delay [s]	0.00	0.00	0.00	0.00	0.00	0.00	0.00	0.00	0.00	
Rp, platoon ratio	1.00	1.00	1.00	1.00	1.00	1.00	1.00	1.00	1.00	
PF, progression factor	1.00	1.00	1.00	1.00	1.00	1.00	1.00	1.00	1.00	

Lane Group Results										
X, volume / capacity	0.81	0.52	0.32	0.82	0.58	0.63	0.86	0.82	0.59	
d, Delay for Lane Group [s/veh]	19.15	14.48	13.74	19.70	15.05	22.46	13.66	20.76	9.90	
Lane Group LOS	B	B	B	B	B	C	B	C	A	
Critical Lane Group	Yes	No	No	No	Yes	No	Yes	Yes	No	
50th-Percentile Queue Length [veh/m]	1.03	0.82	0.41	0.97	0.87	0.25	2.26	0.86	1.41	
50th-Percentile Queue Length [ft/m]	25.73	20.55	10.33	24.33	21.84	6.24	56.38	21.59	35.21	
95th-Percentile Queue Length [veh/m]	1.85	1.48	0.74	1.75	1.57	0.45	4.06	1.55	2.54	
95th-Percentile Queue Length [ft/m]	46.32	37.00	18.59	43.79	39.31	11.23	101.48	38.85	63.39	



Movement, Approach, & Intersection Results

d_M, Delay for Movement [s/veh]	19.15	14.48	13.74	19.70	15.05	15.05	22.46	13.68	13.68	20.76	9.90	9.90
Movement LOS	B	B	B	B	B	B	C	B	B	C	A	A
d_A, Approach Delay [s/veh]	16.19			17.27			14.26			12.62		
Approach LOS	B			B			B			B		
d_I, Intersection Delay [s/veh]	14.76											
Intersection LOS	B											
Intersection V/C	0.602											

Other Modes

g_Walk,mi, Effective Walk Time [s]	11.0	11.0	11.0	11.0
M_corner, Corner Circulation Area [ft²/ped]	0.00	0.00	0.00	0.00
M_CW, Crosswalk Circulation Area [ft²/ped]	0.00	0.00	0.00	0.00
d_p, Pedestrian Delay [s]	8.35	8.35	8.35	8.35
L_p,int, Pedestrian LOS Score for Intersection	2.274	2.079	2.240	2.277
Crosswalk LOS	B	B	B	B
s_b, Saturation Flow Rate of the bicycle lane [bicycles/h]	2000	2000	2000	2000
c_b, Capacity of the bicycle lane [bicycles/h]	1440	1440	1707	1707
d_b, Bicycle Delay [s]	1.38	1.38	0.38	0.38
L_b,int, Bicycle LOS Score for Intersection	2.137	2.008	2.299	2.324
Bicycle LOS	B	B	B	B

Sequence

Ring 1	1	2	3	4	-	-	-	-	-	-	-	-	-	-	-
Ring 2	5	6	7	8	-	-	-	-	-	-	-	-	-	-	-
Ring 3	-	-	-	-	-	-	-	-	-	-	-	-	-	-	-
Ring 4	-	-	-	-	-	-	-	-	-	-	-	-	-	-	-

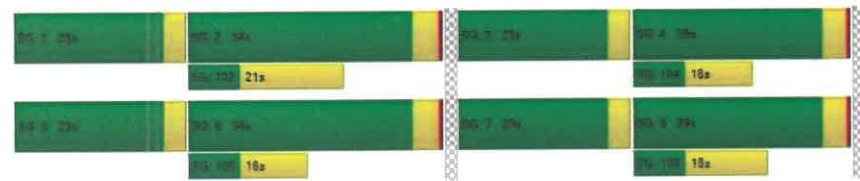

Intersection Level Of Service Report
Intersection 1: Burns Valley Rd/N-S Project Street

Control Type:	Two-way stop	Delay (sec / veh):	11.4
Analysis Method:	HCM 6th Edition	Level Of Service:	B
Analysis Period:	15 minutes	Volume to Capacity (v/c):	0.027

Intersection Setup

Name	N-S Project Street		Burns Valley Rd		Burns Valley Rd	
Approach	Northbound		Eastbound		Westbound	
Lane Configuration	T		T		T	
Turning Movement	Left	Right	Thru	Right	Left	Thru
Lane Width [ft]	12.00	12.00	12.00	12.00	12.00	12.00
No. of Lanes in Entry Pocket	0	0	0	0	0	0
Entry Pocket Length [ft]	100.00	100.00	100.00	100.00	100.00	100.00
No. of Lanes in Exit Pocket	0	0	0	0	0	0
Exit Pocket Length [ft]	0.00	0.00	0.00	0.00	0.00	0.00
Speed [mph]	25.00		35.00		35.00	
Grade [%]	0.00		0.00		0.00	
Crosswalk	No		No		No	

Volumes

Name	N-S Project Street		Burns Valley Rd		Burns Valley Rd	
Base Volume Input [veh/h]	8	7	112	15	0	110
Base Volume Adjustment Factor	1.0000	1.0000	1.0000	1.0000	1.0000	1.0000
Heavy Vehicles Percentage [%]	2.00	2.00	2.00	2.00	2.00	2.00
Growth Factor	1.7600	1.7600	1.7600	1.7600	1.7600	1.7600
In-Process Volume [veh/h]	0	0	0	0	0	0
Site-Generated Trips [veh/h]	2	3	1	4	5	1
Diverted Trips [veh/h]	0	0	0	0	0	0
Pass-by Trips [veh/h]	0	0	0	0	0	0
Existing Site Adjustment Volume [veh/h]	0	0	0	0	0	0
Other Volume [veh/h]	0	0	0	0	0	0
Total Hourly Volume [veh/h]	16	15	198	30	5	195
Peak Hour Factor	1.0000	1.0000	1.0000	1.0000	1.0000	1.0000
Other Adjustment Factor	1.0000	1.0000	1.0000	1.0000	1.0000	1.0000
Total 15-Minute Volume [veh/h]	4	4	50	8	1	49
Total Analysis Volume [veh/h]	16	15	198	30	5	195
Pedestrian Volume [ped/h]	0		0		0	



Intersection Settings

Priority Scheme	Stop	Free	Free
Flared Lane	No		
Storage Area [veh]	0	0	0
Two-Stage Gap Acceptance	No		
Number of Storage Spaces in Median	0	0	0

Movement, Approach, & Intersection Results

V/C, Movement V/C Ratio	0.03	0.02	0.00	0.00	0.00	0.00
d_M, Delay for Movement [s/Veh]	11.36	9.60	0.00	0.00	7.70	0.00
Movement LOS	B	A	A	A	A	A
95th-Percentile Queue Length [veh/ln]	0.14	0.14	0.00	0.00	0.01	0.01
95th-Percentile Queue Length [ft/ln]	3.55	3.55	0.00	0.00	0.28	0.28
d_A, Approach Delay [s/Veh]	10.51		0.00		0.19	
Approach LOS	B		A		A	
d_I, Intersection Delay [s/Veh]			0.79			
Intersection LOS			B			



Intersection Level Of Service Report

Intersection 2: Burns Valley Rd/Bowers Ave-Rumsey Rd

Control Type:	Two-way stop	Delay (sec / veh):	19.3
Analysis Method:	HCM 6th Edition	Level Of Service:	C
Analysis Period:	15 minutes	Volume to Capacity (v/c):	0.034

Intersection Setup

Name	Burns Valley Rd			Rumsey Rd			Burns Valley Rd			Bowers Ave		
Approach	Northbound			Southbound			Eastbound			Westbound		
Lane Configuration	+			+			+			+		
Turning Movement	Left	Thru	Right	Left	Thru	Right	Left	Thru	Right	Left	Thru	Right
Lane Width [ft]	12.00	12.00	12.00	12.00	12.00	12.00	12.00	12.00	12.00	12.00	12.00	12.00
No. of Lanes in Entry Pocket	0	0	0	0	0	0	0	0	0	0	0	0
Entry Pocket Length [ft]	100.00	100.00	100.00	100.00	100.00	100.00	100.00	100.00	100.00	100.00	100.00	100.00
No. of Lanes in Exit Pocket	0	0	0	0	0	0	0	0	0	0	0	0
Exit Pocket Length [ft]	0.00	0.00	0.00	0.00	0.00	0.00	0.00	0.00	0.00	0.00	0.00	0.00
Speed [mph]	30.00			30.00			35.00			25.00		
Grade [%]	0.00			0.00			0.00			0.00		
Crosswalk	No			Yes			Yes			No		

Volumes

Name	Burns Valley Rd			Rumsey Rd			Burns Valley Rd			Bowers Ave		
Base Volume Input [veh/h]	215	46	11	0	41	28	16	2	219	9	2	0
Base Volume Adjustment Factor	1.0000	1.0000	1.0000	1.0000	1.0000	1.0000	1.0000	1.0000	1.0000	1.0000	1.0000	1.0000
Heavy Vehicles Percentage [%]	2.00	2.00	2.00	2.00	2.00	2.00	2.00	2.00	2.00	2.00	2.00	2.00
Growth Factor	1.0000	1.0000	1.0000	1.0000	1.0000	1.0000	1.0000	1.0000	1.0000	1.0000	1.0000	1.0000
In-Process Volume [veh/h]	0	0	0	0	0	0	0	0	0	0	0	0
Site-Generated Trips [veh/h]	2	1	0	0	0	1	2	0	5	0	0	0
Diverted Trips [veh/h]	0	0	0	0	0	0	0	0	0	0	0	0
Pass-by Trips [veh/h]	0	0	0	0	0	0	0	0	0	0	0	0
Existing Site Adjustment Volume [veh/h]	0	0	0	0	0	0	0	0	0	0	0	0
Other Volume [veh/h]	0	0	0	0	0	0	0	0	0	0	0	0
Total Hourly Volume [veh/h]	217	47	11	0	41	29	18	2	224	9	2	0
Peak Hour Factor	1.0000	1.0000	1.0000	1.0000	1.0000	1.0000	1.0000	1.0000	1.0000	1.0000	1.0000	1.0000
Other Adjustment Factor	1.0000	1.0000	1.0000	1.0000	1.0000	1.0000	1.0000	1.0000	1.0000	1.0000	1.0000	1.0000
Total 15-Minute Volume [veh/h]	54	12	3	0	10	7	5	1	56	2	1	0
Total Analysis Volume [veh/h]	217	47	11	0	41	29	18	2	224	9	2	0
Pedestrian Volume [ped/h]	0			0			0			0		



Intersection Settings

Priority Scheme	Free	Free	Stop	Stop
Flared Lane			No	No
Storage Area [veh]	0	0	0	0
Two-Stage Gap Acceptance			No	No
Number of Storage Spaces in Median	0	0	0	0

Movement, Approach, & Intersection Results

V/C, Movement V/C Ratio	0.14	0.00	0.00	0.00	0.00	0.00	0.05	0.01	0.22	0.03	0.01	0.00
d_M, Delay for Movement [s/veh]	7.74	0.00	0.00	7.33	0.00	0.00	15.53	15.99	10.05	19.33	15.15	9.09
Movement LOS	A	A	A	A	A	A	C	C	B	C	C	A
95th-Percentile Queue Length [veh/ln]	0.49	0.49	0.49	0.00	0.00	0.00	1.11	1.11	1.11	0.12	0.12	0.12
95th-Percentile Queue Length [ft/ln]	12.35	12.35	12.35	0.00	0.00	0.00	27.65	27.65	27.65	3.10	3.10	3.10
d_A, Approach Delay [s/veh]	6.11			0.00			10.51			18.57		
Approach LOS	A			A			B			C		
d_I, Intersection Delay [s/veh]	7.41											
Intersection LOS	C											



Intersection Level Of Service Report

Intersection 3: N-S Project Street/E-W Project Street

Control Type:	All-way stop	Delay (sec / veh):	7.2
Analysis Method:	HCM 6th Edition	Level Of Service:	A
Analysis Period:	15 minutes	Volume to Capacity (v/c):	0.059

Intersection Setup

Name	N-S Project Street			N-S Project Street			E-W Project Street			E-W Project Street		
Approach	Northbound			Southbound			Eastbound			Westbound		
Lane Configuration	+			+			+			+		
Turning Movement	Left	Thru	Right	Left	Thru	Right	Left	Thru	Right	Left	Thru	Right
Lane Width [ft]	12.00	12.00	12.00	12.00	12.00	12.00	12.00	12.00	12.00	12.00	12.00	12.00
No. of Lanes in Entry Pocket	0	0	0	0	0	0	0	0	0	0	0	0
Entry Pocket Length [ft]	100.00	100.00	100.00	100.00	100.00	100.00	100.00	100.00	100.00	100.00	100.00	100.00
No. of Lanes in Exit Pocket	0	0	0	0	0	0	0	0	0	0	0	0
Exit Pocket Length [ft]	0.00	0.00	0.00	0.00	0.00	0.00	0.00	0.00	0.00	0.00	0.00	0.00
Speed [mph]	25.00			25.00			25.00			25.00		
Grade [%]	0.00			0.00			0.00			0.00		
Crosswalk	Yes			Yes			Yes			Yes		

Volumes

Name	N-S Project Street			N-S Project Street			E-W Project Street			E-W Project Street		
Base Volume Input [veh/h]	0	15	0	0	15	0	0	0	0	0	0	0
Base Volume Adjustment Factor	1.0000	1.0000	1.0000	1.0000	1.0000	1.0000	1.0000	1.0000	1.0000	1.0000	1.0000	1.0000
Heavy Vehicles Percentage [%]	2.00	2.00	2.00	2.00	2.00	2.00	2.00	2.00	2.00	2.00	2.00	2.00
Growth Factor	1.7600	1.7600	1.7600	1.7600	1.7600	1.7600	1.7600	1.7600	1.7600	1.7600	1.7600	1.7600
In-Process Volume [veh/h]	0	0	0	0	0	0	0	0	0	0	0	0
Site-Generated Trips [veh/h]	6	18	3	3	11	1	0	1	1	4	2	4
Diverted Trips [veh/h]	0	0	0	0	0	0	0	0	0	0	0	0
Pass-by Trips [veh/h]	0	0	0	0	0	0	0	0	0	0	0	0
Existing Site Adjustment Volume [veh/h]	0	0	0	0	0	0	0	0	0	0	0	0
Other Volume [veh/h]	0	0	0	0	0	0	0	0	0	0	0	0
Total Hourly Volume [veh/h]	6	44	3	3	37	1	0	1	1	4	2	4
Peak Hour Factor	1.0000	1.0000	1.0000	1.0000	1.0000	1.0000	1.0000	1.0000	1.0000	1.0000	1.0000	1.0000
Other Adjustment Factor	1.0000	1.0000	1.0000	1.0000	1.0000	1.0000	1.0000	1.0000	1.0000	1.0000	1.0000	1.0000
Total 15-Minute Volume [veh/h]	2	11	1	1	9	0	0	0	0	1	1	1
Total Analysis Volume [veh/h]	6	44	3	3	37	1	0	1	1	4	2	4
Pedestrian Volume [ped/h]	0			0			0			0		



Intersection Settings

Lanes				
Capacity per Entry Lane [veh/h]	903	899	937	906
Degree of Utilization, x	0.06	0.05	0.00	0.01

Movement, Approach, & Intersection Results

95th-Percentile Queue Length [veh]	0.19	0.14	0.01	0.03
95th-Percentile Queue Length [ft]	4.67	3.58	0.16	0.84
Approach Delay [s/veh]	7.23	7.20	6.85	7.02
Approach LOS	A	A	A	A
Intersection Delay [s/veh]	7.19			
Intersection LOS	A			



Intersection Level Of Service Report
Intersection 4: Burns Valley Rd/E-W Project Street

Control Type:	Two-way stop	Delay (sec / veh):	12.4
Analysis Method:	HCM 6th Edition	Level Of Service:	B
Analysis Period:	15 minutes	Volume to Capacity (v/c):	0.002

Intersection Setup

Name	Burns Valley Rd		Burns Valley Rd		E-W Project Street	
	Northbound		Southbound		Eastbound	
Approach	←		→		↑	
Lane Configuration	←		→		↑	
Turning Movement	Left	Thru	Thru	Right	Left	Right
Lane Width [ft]	12.00	12.00	12.00	12.00	12.00	12.00
No. of Lanes in Entry Pocket	0	0	0	0	0	0
Entry Pocket Length [ft]	100.00	100.00	100.00	100.00	100.00	100.00
No. of Lanes in Exit Pocket	0	0	0	0	0	0
Exit Pocket Length [ft]	0.00	0.00	0.00	0.00	0.00	0.00
Speed [mph]	30.00		30.00		25.00	
Grade [%]	0.00		0.00		0.00	
Crosswalk	No		No		Yes	

Volumes

Name	Burns Valley Rd		Burns Valley Rd		E-W Project Street	
	Northbound		Southbound		Eastbound	
Base Volume Input [veh/h]	0	151	147	0	0	0
Base Volume Adjustment Factor	1.0000	1.0000	1.0000	1.0000	1.0000	1.0000
Heavy Vehicles Percentage [%]	2.00	2.00	2.00	2.00	2.00	2.00
Growth Factor	1.7600	1.7600	1.7600	1.7600	1.7600	1.7600
In-Process Volume [veh/h]	0	0	0	0	0	0
Site-Generated Trips [veh/h]	8	2	5	0	1	9
Diverted Trips [veh/h]	0	0	0	0	0	0
Pass-by Trips [veh/h]	0	0	0	0	0	0
Existing Site Adjustment Volume [veh/h]	0	0	0	0	0	0
Other Volume [veh/h]	0	0	0	0	0	0
Total Hourly Volume [veh/h]	8	268	264	0	1	9
Peak Hour Factor	1.0000	1.0000	1.0000	1.0000	1.0000	1.0000
Other Adjustment Factor	1.0000	1.0000	1.0000	1.0000	1.0000	1.0000
Total 15-Minute Volume [veh/h]	2	67	66	0	0	2
Total Analysis Volume [veh/h]	8	288	264	0	1	9
Pedestrian Volume [ped/h]	0		0		0	



Intersection Settings

Priority Scheme	Free	Free	Stop
Flared Lane			No
Storage Area [veh]	0	0	0
Two-Stage Gap Acceptance			No
Number of Storage Spaces in Median	0	0	0

Movement, Approach, & Intersection Results

V/C, Movement V/C Ratio	0.01	0.01	0.03	0.00	0.00	0.01
d_M, Delay for Movement [s/veh]	7.79	0.00	0.03	0.00	12.36	9.72
Movement LOS	A	A	A	A	B	A
95th-Percentile Queue Length [veh/ln]	0.02	0.02	0.00	0.00	0.04	0.04
95th-Percentile Queue Length [ft/ln]	0.46	0.46	0.00	0.00	1.04	1.04
d_A, Approach Delay [s/veh]	0.23		0.00		9.98	
Approach LOS	A		A		A	
d_I, Intersection Delay [s/veh]			0.29			
Intersection LOS			B			



Intersection Level Of Service Report
Intersection 5: Olympic Dr/Lakeshore Dr

Control Type: Roundabout
Analysis Method: HCM 6th Edition
Analysis Period: 15 minutes
Delay (sec / veh): 5.7
Level Of Service: A

Intersection Setup

Name	Lakeshore Dr			Lakeshore Dr			Olympic Dr		
	Northbound			Southbound			Westbound		
Approach	Northbound			Southbound			Westbound		
Lane Configuration	T T			+			+		
Turning Movement	Left	Thru	Right	Left	Thru	Right	Left	Thru	Right
Lane Width [ft]	12.00	12.00	12.00	12.00	12.00	12.00	12.00	12.00	12.00
No. of Lanes in Entry Pocket	0	0	1	0	0	0	0	0	1
Entry Pocket Length [ft]	100.00	100.00	120.00	100.00	100.00	100.00	100.00	100.00	250.00
No. of Lanes in Exit Pocket	0	0	0	0	0	0	0	0	0
Exit Pocket Length [ft]	0.00	0.00	0.00	0.00	0.00	0.00	0.00	0.00	0.00
Speed [mph]	25.00			25.00			30.00		
Grade [%]	0.00			0.00			0.00		
Crosswalk	No			Yes			No		

Volumes

Name	Lakeshore Dr			Lakeshore Dr			Olympic Dr				
	5	230	85	90	435	0	0	5	80	5	70
Base Volume Input [veh/h]	5	230	85	90	435	0	0	5	80	5	70
Base Volume Adjustment Factor	1.0000	1.0000	1.0000	1.0000	1.0000	1.0000	1.0000	1.0000	1.0000	1.0000	1.0000
Heavy Vehicles Percentage [%]	2.00	2.00	2.00	2.00	2.00	2.00	2.00	2.00	2.00	2.00	2.00
Growth Factor	1.0000	1.0000	1.0000	1.0000	1.0000	1.0000	1.0000	1.0000	1.0000	1.0000	1.0000
In-Process Volume [veh/h]	0	0	0	0	0	0	0	0	0	0	0
Site-Generated Trips [veh/h]	0	0	11	4	0	0	0	0	6	0	3
Diverted Trips [veh/h]	0	0	0	0	0	0	0	0	0	0	0
Pass-by Trips [veh/h]	0	0	0	0	0	0	0	0	0	0	0
Existing Site Adjustment Volume [veh/h]	0	0	0	0	0	0	0	0	0	0	0
Other Volume [veh/h]	0	0	0	0	0	0	0	0	0	0	0
Total Hourly Volume [veh/h]	5	230	96	94	435	0	0	5	86	5	73
Peak Hour Factor	1.0000	1.0000	1.0000	1.0000	1.0000	1.0000	1.0000	1.0000	1.0000	1.0000	1.0000
Other Adjustment Factor	1.0000	1.0000	1.0000	1.0000	1.0000	1.0000	1.0000	1.0000	1.0000	1.0000	1.0000
Total 15-Minute Volume [veh/h]	1	58	24	24	109	0	0	1	22	1	18
Total Analysis Volume [veh/h]	5	230	96	94	435	0	0	5	86	5	73
Pedestrian Volume [ped/h]	0	0	0	0	0	0	0	0	0	0	1



Intersection Settings

Number of Conflicting Circulating Lanes	1		1		1		1					
Circulating Flow Rate [veh/h]	96		98		627		240					
Exiting Flow Rate [veh/h]	537		309		10		194					
Demand Flow Rate [veh/h]	5	230	96	94	435	0	0	0	5	86	5	73
Adjusted Demand Flow Rate [veh/h]	5	230	96	94	435	0	0	0	5	86	5	73

Lanes

Overwrite Calculated Critical Headway	No	No	No	No	No	No
User-Defined Critical Headway [s]	4.00	4.00	4.00	4.00	4.00	4.00
Overwrite Calculated Follow-Up Time	No	No	No	No	No	No
User-Defined Follow-Up Time [s]	3.00	3.00	3.00	3.00	3.00	3.00
A (intercept)	1420.00	1420.00	1380.00	1380.00	1420.00	1420.00
B (coefficient)	0.00091	0.00091	0.00102	0.00102	0.00091	0.00091
HV Adjustment Factor	0.98	0.98	0.98	0.98	0.98	0.98
Entry Flow Rate [veh/h]	240	98	540	6	88	80
Capacity of Entry and Bypass Lanes [veh/h]	1302	1302	1249	728	1142	1142
Pedestrian Impedance	1.00	1.00	1.00	1.00	1.00	1.00
Capacity per Entry Lane [veh/h]	1276	1276	1225	714	1119	1119
X, volume / capacity	0.18	0.08	0.43	0.01	0.08	0.07

Movement, Approach, & Intersection Results

Lane LOS	A	A	A	A	A	A
95th-Percentile Queue Length [veh]	0.67	0.24	2.23	0.02	0.25	0.22
95th-Percentile Queue Length [ft]	16.85	6.09	55.63	0.53	6.24	5.61
Approach Delay [s/veh]	4.10		7.32	5.12	3.84	
Approach LOS	A		A	A	A	
Intersection Delay [s/veh]	5.72					
Intersection LOS	A					



Intersection Level Of Service Report
Intersection 6: Olympic Dr/N-S Project Street

Control Type:	Two-way stop	Delay (sec / veh):	24.0
Analysis Method:	HCM 6th Edition	Level Of Service:	C
Analysis Period:	15 minutes	Volume to Capacity (v/c):	0.082

Intersection Setup

Name	N-S Project Street		Olympic Dr		Olympic Dr	
	Southbound		Eastbound		Westbound	
Lane Configuration	←		↑		↑	
Turning Movement	Left	Right	Left	Thru	Thru	Right
Lane Width [ft]	12.00	12.00	12.00	12.00	12.00	12.00
No. of Lanes in Entry Pocket	0	0	0	0	0	0
Entry Pocket Length [ft]	100.00	100.00	100.00	100.00	100.00	100.00
No. of Lanes in Exit Pocket	0	0	0	0	0	0
Exit Pocket Length [ft]	0.00	0.00	0.00	0.00	0.00	0.00
Speed [mph]	25.00		30.00		30.00	
Grade [%]	0.00		0.00		0.00	
Crosswalk	Yes		No		No	

Volumes

Name	N-S Project Street		Olympic Dr		Olympic Dr	
Base Volume Input [veh/h]	7	8	15	290	306	0
Base Volume Adjustment Factor	1.0000	1.0000	1.0000	1.0000	1.0000	1.0000
Heavy Vehicles Percentage [%]	2.00	2.00	2.00	2.00	2.00	2.00
Growth Factor	1.7600	1.7600	1.7600	1.7600	1.7600	1.7600
In-Process Volume [veh/h]	0	0	0	0	0	0
Site-Generated Trips [veh/h]	5	12	19	0	0	12
Diverted Trips [veh/h]	0	0	0	0	0	0
Pass-by Trips [veh/h]	0	0	0	0	0	0
Existing Site Adjustment Volume [veh/h]	0	0	0	0	0	0
Other Volume [veh/h]	0	0	0	0	0	0
Total Hourly Volume [veh/h]	17	28	45	510	539	12
Peak Hour Factor	1.0000	1.0000	1.0000	1.0000	1.0000	1.0000
Other Adjustment Factor	1.0000	1.0000	1.0000	1.0000	1.0000	1.0000
Total 15-Minute Volume [veh/h]	4	7	11	128	135	3
Total Analysis Volume [veh/h]	17	28	45	510	539	12
Pedestrian Volume [ped/h]	0		0		0	



Intersection Settings

Priority Scheme	Stop	Free	Free
Flared Lane	No		
Storage Area [veh]	0	0	0
Two-Stage Gap Acceptance	No		
Number of Storage Spaces in Median	0	0	1

Movement, Approach, & Intersection Results

V/C, Movement V/C Ratio	0.08	0.05	0.04	0.01	0.01	0.00
d_M, Delay for Movement [s/veh]	24.01	13.32	8.70	0.00	0.00	0.00
Movement LOS	C	B	A	A	A	A
95th-Percentile Queue Length [veh/ln]	0.44	0.44	0.14	0.14	0.00	0.00
95th-Percentile Queue Length [ft/ln]	11.11	11.11	3.46	3.46	0.00	0.00
d_A, Approach Delay [s/veh]	17.55		0.71		0.00	
Approach LOS	C		A		A	
d_I, Intersection Delay [s/veh]	1.00					
Intersection LOS	C					



Intersection Level Of Service Report

Intersection 7: Olympic Dr/Burns Valley Rd-Old Hwy 53

Control Type:	Signalized	Delay (sec / veh):	14.6
Analysis Method:	HCM 6th Edition	Level Of Service:	B
Analysis Period:	15 minutes	Volume to Capacity (v/c):	0.765

Intersection Setup

Name	Old Hwy 53			Burns Valley Rd			Olympic Dr			Old Hwy 53		
Approach	Northbound			Southbound			Eastbound			Westbound		
Lane Configuration	T T T			T T			T T			T T		
Turning Movement	Left	Thru	Right	Left	Thru	Right	Left	Thru	Right	Left	Thru	Right
Lane Width [ft]	12.00	12.00	12.00	12.00	12.00	12.00	12.00	12.00	12.00	12.00	12.00	12.00
No. of Lanes in Entry Pocket	1	0	1	1	0	0	1	0	0	1	0	0
Entry Pocket Length [ft]	100.00	100.00	100.00	56.00	100.00	100.00	48.00	100.00	100.00	100.00	100.00	100.00
No. of Lanes in Exit Pocket	0	0	0	0	0	0	0	0	0	0	0	0
Exit Pocket Length [ft]	0.00	0.00	0.00	0.00	0.00	0.00	0.00	0.00	0.00	0.00	0.00	0.00
Speed [mph]	30.00			30.00			35.00			35.00		
Grade [%]	0.00			0.00			0.00			0.00		
Curb Present	No			No			No			No		
Crosswalk	Yes			Yes			Yes			Yes		



Volumes	Old Hwy 53			Burns Valley Rd			Olympic Dr			Old Hwy 53		
Base Volume Input [veh/h]	95	130	70	160	125	30	35	205	130	80	225	150
Base Volume Adjustment Factor	1.0000	1.0000	1.0000	1.0000	1.0000	1.0000	1.0000	1.0000	1.0000	1.0000	1.0000	1.0000
Heavy Vehicles Percentage [%]	2.00	2.00	2.00	2.00	2.00	2.00	2.00	2.00	2.00	2.00	2.00	2.00
Growth Factor	1.0000	1.0000	1.0000	1.0000	1.0000	1.0000	1.0000	1.0000	1.0000	1.0000	1.0000	1.0000
In-Process Volume [veh/h]	0	0	0	0	0	0	0	0	0	0	0	0
Site-Generated Trips [veh/h]	5	6	0	5	9	0	0	1	4	0	7	4
Diverted Trips [veh/h]	0	0	0	0	0	0	0	0	0	0	0	0
Pass-by Trips [veh/h]	0	0	0	0	0	0	0	0	0	0	0	0
Existing Site Adjustment Volume [veh/h]	0	0	0	0	0	0	0	0	0	0	0	0
Other Volume [veh/h]	0	0	0	0	0	0	0	0	0	0	0	0
Right Turn on Red Volume [veh/h]	0	0	19	0	0	3	0	0	5	0	0	20
Total Hourly Volume [veh/h]	100	136	51	165	134	27	35	206	129	80	232	134
Peak Hour Factor	1.0000	1.0000	1.0000	1.0000	1.0000	1.0000	1.0000	1.0000	1.0000	1.0000	1.0000	1.0000
Other Adjustment Factor	1.0000	1.0000	1.0000	1.0000	1.0000	1.0000	1.0000	1.0000	1.0000	1.0000	1.0000	1.0000
Total 15-Minute Volume [veh/h]	25	34	13	41	34	7	9	52	32	20	58	34
Total Analysis Volume [veh/h]	100	136	51	165	134	27	35	206	129	80	232	134
Presence of On-Street Parking	No	No	No	No	No	No	No	No	No	No	No	No
On-Street Parking Maneuver Rate [1/h]	0	0	0	0	0	0	0	0	0	0	0	0
Local Bus Stopping Rate [1/h]	0	0	0	0	0	0	0	0	0	0	0	0
v_do, Outbound Pedestrian Volume crossing major street	1			0			1			1		
v_di, Inbound Pedestrian Volume crossing major street	1			1			0			1		
v_co, Outbound Pedestrian Volume crossing minor street	1			0			0			0		
v_ci, Inbound Pedestrian Volume crossing minor street	0			0			1			0		
v_ab, Corner Pedestrian Volume [ped/h]	0			0			0			0		
Bicycle Volume [bicycles/h]	0			0			0			0		1



Intersection Settings	Yes
Located in CBD	
Signal Coordination Group	-
Cycle Length [s]	109
Coordination Type	Time of Day Pattern Isolated
Actuation Type	Fully actuated
Offset [s]	0.0
Offset Reference	Lead Green - Beginning of First Green
Permissive Mode	SingleBand
Lost time [s]	14.00

Phasing & Timing	Protect	Permis	Permis	Protect	Permis	Permis	Protect	Permis	Permis	Protect	Permis	Permis
Control Type	Protect	Permis	Permis	Protect	Permis	Permis	Protect	Permis	Permis	Protect	Permis	Permis
Signal Group	3	8	0	7	4	0	5	2	0	1	6	0
Auxiliary Signal Groups												
Lead / Lag	Lead	-	-	Lead	-	-	Lead	-	-	Lead	-	-
Minimum Green [s]	4	6	0	4	6	0	4	6	0	4	6	0
Maximum Green [s]	20	25	0	20	25	0	20	30	0	20	20	0
Amber [s]	3.0	3.3	0.0	3.0	3.3	0.0	3.0	3.6	0.0	3.0	3.6	0.0
All red [s]	0.0	0.3	0.0	0.0	0.3	0.0	0.0	0.3	0.0	0.0	0.3	0.0
Split [s]	23	29	0	23	29	0	23	34	0	23	34	0
Vehicle Extension [s]	0.0	0.0	0.0	0.0	0.0	0.0	0.0	0.0	0.0	0.0	0.0	0.0
Walk [s]	0	7	0	0	7	0	0	7	0	0	7	0
Pedestrian Clearance [s]	0	11	0	0	9	0	0	14	0	0	9	0
Delayed Vehicle Green [s]	0.0	0.0	0.0	0.0	0.0	0.0	0.0	0.0	0.0	0.0	0.0	0.0
Rest In Walk	No	No	No	No	No	No	No	No	No	No	No	No
I1, Start-Up Lost Time [s]	2.0	2.0	0.0	2.0	2.0	0.0	2.0	2.0	0.0	2.0	2.0	0.0
I2, Clearance Lost Time [s]	1.0	1.6	0.0	1.0	1.6	0.0	1.0	1.9	0.0	1.0	1.9	0.0
Minimum Recall	No	No	No	No	No	No	No	No	No	No	No	No
Maximum Recall	No	No	No	No	No	No	No	No	No	No	No	No
Pedestrian Recall	No	No	No	No	No	No	No	No	No	No	No	No
Detector Location [ft]	0.0	0.0	0.0	0.0	0.0	0.0	0.0	0.0	0.0	0.0	0.0	0.0
Detector Length [ft]	0.0	0.0	0.0	0.0	0.0	0.0	0.0	0.0	0.0	0.0	0.0	0.0
I, Upstream Filtering Factor	1.00	1.00	1.00	1.00	1.00	1.00	1.00	1.00	1.00	1.00	1.00	1.00

Exclusive Pedestrian Phase	
Pedestrian Signal Group	0
Pedestrian Walk [s]	0
Pedestrian Clearance [s]	0



Lane Group Calculations

Lane Group	L	C	R	L	C	L	C	L	C
C, Cycle Length [s]	34	34	34	34	34	34	34	34	34
L, Total Lost Time per Cycle [s]	3.00	3.60	3.60	3.00	3.60	3.00	3.90	3.00	3.90
l1_p, Permitted Start-Up Lost Time [s]	0.00	0.00	0.00	0.00	0.00	0.00	0.00	0.00	0.00
l2, Clearance Lost Time [s]	1.00	1.60	1.60	1.00	1.60	1.00	1.90	1.00	1.90
g_l, Effective Green Time [s]	3	5	5	4	7	1	9	2	10
g / C, Green / Cycle	0.08	0.15	0.15	0.13	0.20	0.03	0.25	0.06	0.28
(v / s)_l Volume / Saturation Flow Rate	0.06	0.08	0.04	0.10	0.10	0.02	0.21	0.05	0.23
s, saturation flow rate [veh/h]	1603	1683	1421	1603	1634	1603	1575	1603	1567
c, Capacity [veh/h]	122	256	216	207	335	55	403	102	448
d1, Uniform Delay [s]	15.41	13.23	12.61	14.31	11.86	16.14	11.89	15.60	11.25
k, delay calibration	0.04	0.04	0.04	0.04	0.04	0.04	0.04	0.04	0.04
l, Upstream Filtering Factor	1.00	1.00	1.00	1.00	1.00	1.00	1.00	1.00	1.00
d2, Incremental Delay [s]	5.15	0.64	0.21	2.69	0.40	4.59	1.71	4.81	1.41
d3, Initial Queue Delay [s]	0.00	0.00	0.00	0.00	0.00	0.00	0.00	0.00	0.00
Rp, platoon ratio	1.00	1.00	1.00	1.00	1.00	1.00	1.00	1.00	1.00
PF, progression factor	1.00	1.00	1.00	1.00	1.00	1.00	1.00	1.00	1.00

Lane Group Results

X, volume / capacity	0.82	0.53	0.24	0.80	0.48	0.64	0.83	0.78	0.82
d, Delay for Lane Group [s/veh]	20.56	13.87	12.82	17.00	12.25	20.73	13.60	20.41	12.66
Lane Group LOS	C	B	B	B	B	C	B	C	B
Critical Lane Group	No	Yes	No	Yes	No	No	Yes	Yes	No
50th-Percentile Queue Length [veh/m]	0.79	0.79	0.28	1.12	0.85	0.28	1.83	0.61	1.88
50th-Percentile Queue Length [ft/m]	19.70	19.76	6.97	28.06	21.21	7.03	45.74	15.28	47.01
95th-Percentile Queue Length [veh/m]	1.42	1.42	0.50	2.02	1.53	0.51	3.29	1.10	3.39
95th-Percentile Queue Length [ft/m]	35.46	35.56	12.54	50.50	38.18	12.66	82.33	27.51	84.63



Movement, Approach, & Intersection Results

d_M, Delay for Movement [s/veh]	20.56	13.87	12.82	17.00	12.25	12.25	20.73	13.60	13.60	20.41	12.66	12.66
Movement LOS	C	B	B	B	B	B	C	B	B	C	B	B
d_A, Approach Delay [s/veh]	16.01			14.65			14.27			14.05		
Approach LOS	B			B			B			B		
d_I, Intersection Delay [s/veh]	14.64											
Intersection LOS	B											
Intersection V/C	0.765											

Other Modes

g_Walk,mi, Effective Walk Time [s]	11.0	11.0	11.0	11.0
M_corner, Corner Circulation Area [ft²/ped]	0.00	0.00	0.00	0.00
M_CW, Crosswalk Circulation Area [ft²/ped]	0.00	0.00	0.00	0.00
d_p, Pedestrian Delay [s]	7.61	7.61	7.61	7.61
l_p,int, Pedestrian LOS Score for Intersection	2.256	2.096	2.165	2.251
Crosswalk LOS	B	B	B	B
s_b, Saturation Flow Rate of the bicycle lane [bicycles/h]	2000	2000	2000	2000
c_b, Capacity of the bicycle lane [bicycles/h]	1511	1511	1790	1790
d_b, Bicycle Delay [s]	1.01	1.01	0.19	0.19
l_b,int, Bicycle LOS Score for Intersection	2.065	2.102	2.178	2.329
Bicycle LOS	B	B	B	B

Sequence

Ring 1	1	2	3	4	-	-	-	-	-	-	-	-	-	-	-
Ring 2	5	6	7	8	-	-	-	-	-	-	-	-	-	-	-
Ring 3	-	-	-	-	-	-	-	-	-	-	-	-	-	-	-
Ring 4	-	-	-	-	-	-	-	-	-	-	-	-	-	-	-

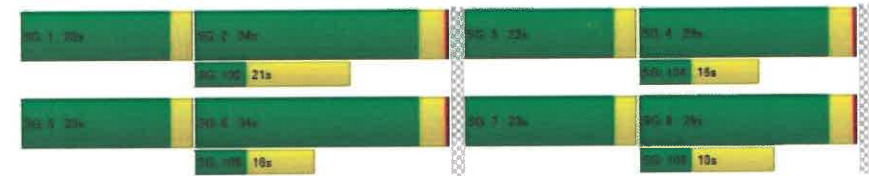

Generated with **PTV VISTRO**
Version 2021 (SP 0-6)

Burns Valley Development

5/2/2022

Intersection Level Of Service Report
Intersection 1: Burns Valley Rd/N-S Project Street

Control Type: Two-way stop
Analysis Method: HCM 6th Edition
Analysis Period: 15 minutes
Delay (sec / veh): 11.7
Level Of Service: B
Volume to Capacity (v/c): 0.037

Intersection Setup

Name	N-S Project Street		Burns Valley Rd		Burns Valley Rd	
	Northbound		Eastbound		Westbound	
Approach						
Lane Configuration	T		T		T	
Turning Movement	Left	Right	Thru	Right	Left	Thru
Lane Width [ft]	12.00	12.00	12.00	12.00	12.00	12.00
No. of Lanes in Entry Pocket	0	0	0	0	0	0
Entry Pocket Length [ft]	100.00	100.00	100.00	100.00	100.00	100.00
No. of Lanes in Exit Pocket	0	0	0	0	0	0
Exit Pocket Length [ft]	0.00	0.00	0.00	0.00	0.00	0.00
Speed [mph]	25.00		35.00		35.00	
Grade [%]	0.00		0.00		0.00	
Crosswalk	No		No		No	

Volumes

Name	N-S Project Street		Burns Valley Rd		Burns Valley Rd	
	Base Volume Input [veh/h]	8	8	117	17	0
Base Volume Adjustment Factor	1.0000	1.0000	1.0000	1.0000	1.0000	1.0000
Heavy Vehicles Percentage [%]	2.00	2.00	2.00	2.00	2.00	2.00
Growth Factor	1.7600	1.7600	1.7600	1.7600	1.7600	1.7600
In-Process Volume [veh/h]	0	0	0	0	0	0
Site-Generated Trips [veh/h]	7	7	1	10	7	1
Diverted Trips [veh/h]	0	0	0	0	0	0
Pass-by Trips [veh/h]	0	0	0	0	0	0
Existing Site Adjustment Volume [veh/h]	0	0	0	0	0	0
Other Volume [veh/h]	0	0	0	0	0	0
Total Hourly Volume [veh/h]	21	21	207	40	7	207
Peak Hour Factor	1.0000	1.0000	1.0000	1.0000	1.0000	1.0000
Other Adjustment Factor	1.0000	1.0000	1.0000	1.0000	1.0000	1.0000
Total 15-Minute Volume [veh/h]	5	5	52	10	2	52
Total Analysis Volume [veh/h]	21	21	207	40	7	207
Pedestrian Volume [ped/h]	0	0	0	0	0	0

Weekday PM F+P



Generated with **PTV VISTRO**
Version 2021 (SP 0-6)

Burns Valley Development

5/2/2022

Intersection Settings

Priority Scheme	Stop	Free	Free
Flared Lane	No		
Storage Area [veh]	0	0	0
Two-Stage Gap Acceptance	No		
Number of Storage Spaces in Median	0	0	0

Movement, Approach, & Intersection Results

V/C, Movement V/C Ratio	0.04	0.03	0.00	0.00	0.01	0.00
d_M, Delay for Movement [s/veh]	11.74	9.79	0.00	0.00	7.74	5.85
Movement LOS	B	A	A	A	A	A
95th-Percentile Queue Length [veh/ln]	0.20	0.20	0.00	0.00	0.02	0.02
95th-Percentile Queue Length [ft/ln]	5.03	5.03	0.00	0.00	0.40	0.40
d_A, Approach Delay [s/veh]	10.76		0.00		0.25	
Approach LOS	B		A		A	
d_I, Intersection Delay [s/veh]			1.01			
Intersection LOS			B			

Weekday PM F+P



Intersection Level Of Service Report

Intersection 2: Burns Valley Rd/Bowers Ave-Rumsey Rd

Control Type: Two-way stop
Analysis Method: HCM 6th Edition
Analysis Period: 15 minutes
Delay (sec / veh): 16.0
Level Of Service: C
Volume to Capacity (v/c): 0.060

Intersection Setup

Name	Burns Valley Rd			Rumsey Rd			Burns Valley Rd			Bowers Ave		
Approach	Northbound			Southbound			Eastbound			Westbound		
Lane Configuration	+			+			+			+		
Turning Movement	Left	Thru	Right	Left	Thru	Right	Left	Thru	Right	Left	Thru	Right
Lane Width [ft]	12.00	12.00	12.00	12.00	12.00	12.00	12.00	12.00	12.00	12.00	12.00	12.00
No. of Lanes in Entry Pocket	0	0	0	0	0	0	0	0	0	0	0	0
Entry Pocket Length [ft]	100.00	100.00	100.00	100.00	100.00	100.00	100.00	100.00	100.00	100.00	100.00	100.00
No. of Lanes in Exit Pocket	0	0	0	0	0	0	0	0	0	0	0	0
Exit Pocket Length [ft]	0.00	0.00	0.00	0.00	0.00	0.00	0.00	0.00	0.00	0.00	0.00	0.00
Speed [mph]	30.00			30.00			35.00			25.00		
Grade [%]	0.00			0.00			0.00			0.00		
Crosswalk	No			Yes			Yes			No		

Volumes

Name	Burns Valley Rd			Rumsey Rd			Burns Valley Rd			Bowers Ave		
Base Volume Input [veh/h]	163	62	15	3	70	11	11	2	123	21	0	0
Base Volume Adjustment Factor	1.0000	1.0000	1.0000	1.0000	1.0000	1.0000	1.0000	1.0000	1.0000	1.0000	1.0000	1.0000
Heavy Vehicles Percentage [%]	2.00	2.00	2.00	2.00	2.00	2.00	2.00	2.00	2.00	2.00	2.00	2.00
Growth Factor	1.0000	1.0000	1.0000	1.0000	1.0000	1.0000	1.0000	1.0000	1.0000	1.0000	1.0000	1.0000
In-Process Volume [veh/h]	0	0	0	0	0	0	0	0	0	0	0	0
Site-Generated Trips [veh/h]	5	1	0	0	1	4	3	0	3	0	0	0
Diverted Trips [veh/h]	0	0	0	0	0	0	0	0	0	0	0	0
Pass-by Trips [veh/h]	0	0	0	0	0	0	0	0	0	0	0	0
Existing Site Adjustment Volume [veh/h]	0	0	0	0	0	0	0	0	0	0	0	0
Other Volume [veh/h]	0	0	0	0	0	0	0	0	0	0	0	0
Total Hourly Volume [veh/h]	168	63	15	3	71	15	14	2	126	21	0	0
Peak Hour Factor	1.0000	1.0000	1.0000	1.0000	1.0000	1.0000	1.0000	1.0000	1.0000	1.0000	1.0000	1.0000
Other Adjustment Factor	1.0000	1.0000	1.0000	1.0000	1.0000	1.0000	1.0000	1.0000	1.0000	1.0000	1.0000	1.0000
Total 15-Minute Volume [veh/h]	42	16	4	1	18	4	4	1	32	5	0	0
Total Analysis Volume [veh/h]	168	63	15	3	71	15	14	2	126	21	0	0
Pedestrian Volume [ped/h]												



Intersection Settings

Priority Scheme	Free	Free	Stop	Stop
Flared Lane			No	No
Storage Area [veh]	0	0	0	0
Two-Stage Gap Acceptance			No	No
Number of Storage Spaces in Median	0	0	0	0

Movement, Approach, & Intersection Results

V/C, Movement V/C Ratio	0.11	0.30	0.00	0.00	0.00	0.00	0.03	0.00	0.13	0.06	0.00	0.00
d_M, Delay for Movement [s/veh]	7.68	0.00	0.00	7.37	0.00	0.00	13.94	14.44	9.49	15.96	14.28	3.29
Movement LOS	A	A	A	A	A	A	B	B	A	C	B	A
95th-Percentile Queue Length [veh/ln]	0.37	0.37	0.37	0.01	0.01	0.01	0.59	0.59	0.59	0.19	0.19	0.19
95th-Percentile Queue Length [ft/ln]	9.37	9.37	9.37	0.15	0.15	0.15	14.69	14.69	14.69	4.77	4.77	4.77
d_A, Approach Delay [s/veh]	5.25		0.25		10.00		15.96					
Approach LOS	A		A		A		C					
d_I, Intersection Delay [s/veh]							6.16					
Intersection LOS							C					



Intersection Level Of Service Report
Intersection 3: N-S Project Street/E-W Project Street

Control Type: All-way stop
Analysis Method: HCM 6th Edition
Analysis Period: 15 minutes
Delay (sec / veh): 7.4
Level Of Service: A
Volume to Capacity (v/c): 0.100

Intersection Setup

Name	N-S Project Street			N-S Project Street			E-W Project Street			E-W Project Street		
Approach	Northbound			Southbound			Eastbound			Westbound		
Lane Configuration	+			+			+			+		
Turning Movement	Left	Thru	Right	Left	Thru	Right	Left	Thru	Right	Left	Thru	Right
Lane Width [ft]	12.00	12.00	12.00	12.00	12.00	12.00	12.00	12.00	12.00	12.00	12.00	12.00
No. of Lanes in Entry Pocket	0	0	0	0	0	0	0	0	0	0	0	0
Entry Pocket Length [ft]	100.00	100.00	137.00	100.00	100.00	100.00	100.00	100.00	100.00	130.00	100.00	100.00
No. of Lanes in Exit Pocket	0	0	0	0	0	0	0	0	0	0	0	0
Exit Pocket Length [ft]	0.00	0.00	0.00	0.00	0.00	0.00	0.00	0.00	0.00	0.00	0.00	0.00
Speed [mph]	25.00			25.00			25.00			25.00		
Grade [%]	0.00			0.00			0.00			0.00		
Crosswalk	Yes			Yes			Yes			Yes		

Volumes

Name	N-S Project Street			N-S Project Street			E-W Project Street			E-W Project Street		
Base Volume Input [veh/h]	0	16	0	0	17	0	0	0	0	0	0	0
Base Volume Adjustment Factor	1.0000	1.0000	1.0000	1.0000	1.0000	1.0000	1.0000	1.0000	1.0000	1.0000	1.0000	1.0000
Heavy Vehicles Percentage [%]	2.00	2.00	2.00	2.00	2.00	2.00	2.00	2.00	2.00	2.00	2.00	2.00
Growth Factor	1.7600	1.7600	1.7600	1.7600	1.7600	1.7600	1.7600	1.7600	1.7600	1.7600	1.7600	1.7600
In-Process Volume [veh/h]	0	0	0	0	0	0	0	0	0	0	0	0
Site-Generated Trips [veh/h]	3	44	15	12	31	1	1	3	8	5	2	15
Diverted Trips [veh/h]	0	0	0	0	0	0	0	0	0	0	0	0
Pass-by Trips [veh/h]	0	0	0	0	0	0	0	0	0	0	0	0
Existing Site Adjustment Volume [veh/h]	0	0	0	0	0	0	0	0	0	0	0	0
Other Volume [veh/h]	0	0	0	0	0	0	0	0	0	0	0	0
Total Hourly Volume [veh/h]	3	72	15	12	61	1	1	3	8	5	2	15
Peak Hour Factor	1.0000	1.0000	1.0000	1.0000	1.0000	1.0000	1.0000	1.0000	1.0000	1.0000	1.0000	1.0000
Other Adjustment Factor	1.0000	1.0000	1.0000	1.0000	1.0000	1.0000	1.0000	1.0000	1.0000	1.0000	1.0000	1.0000
Total 15-Minute Volume [veh/h]	1	18	4	3	15	0	0	1	2	1	1	4
Total Analysis Volume [veh/h]	3	72	15	12	61	1	1	3	8	5	2	15
Pedestrian Volume [ped/h]	0			0			0			0		



Intersection Settings

Lanes				
Capacity per Entry Lane [veh/h]	905	876	919	916
Degree of Utilization, x	0.10	0.08	0.01	0.02

Movement, Approach, & Intersection Results

95th-Percentile Queue Length [veh]	0.33	0.28	0.04	0.07
95th-Percentile Queue Length [ft]	8.26	6.91	0.99	1.84
Approach Delay [s/veh]	7.42	7.49	6.97	7.03
Approach LOS	A	A	A	A
Intersection Delay [s/veh]	7.38			
Intersection LOS	A			



Intersection Level Of Service Report
Intersection 4: Burns Valley Rd/E-W Project Street

Control Type: Two-way stop
Analysis Method: HCM 6th Edition
Analysis Period: 15 minutes
Delay (sec / veh): 13.5
Level Of Service: B
Volume to Capacity (v/c): 0.002

Intersection Setup

Name	Burns Valley Rd		Burns Valley Rd		E-W Project Street	
	Northbound		Southbound		Eastbound	
Approach	←		→		←	
Lane Configuration	←		→		←	
Turning Movement	Left	Thru	Thru	Right	Left	Right
Lane Width [ft]	12.00	12.00	12.00	12.00	12.00	12.00
No. of Lanes in Entry Pocket	0	0	0	0	0	0
Entry Pocket Length [ft]	100.00	100.00	100.00	100.00	100.00	100.00
No. of Lanes in Exit Pocket	0	0	0	0	0	0
Exit Pocket Length [ft]	0.00	0.00	0.00	0.00	0.00	0.00
Speed [mph]	30.00		30.00		25.00	
Grade [%]	0.00		0.00		0.00	
Crosswalk	No		No		Yes	

Volumes

Name	Burns Valley Rd		Burns Valley Rd		E-W Project Street	
	Northbound		Southbound		Eastbound	
Base Volume Input [veh/h]	0	168	173	0	0	0
Base Volume Adjustment Factor	1.0000	1.0000	1.0000	1.0000	1.0000	1.0000
Heavy Vehicles Percentage [%]	2.00	2.00	2.00	2.00	2.00	2.00
Growth Factor	1.7600	1.7600	1.7600	1.7600	1.7600	1.7600
In-Process Volume [veh/h]	0	0	0	0	0	0
Site-Generated Trips [veh/h]	24	5	3	1	1	18
Diverted Trips [veh/h]	0	0	0	0	0	0
Pass-by Trips [veh/h]	0	0	0	0	0	0
Existing Site Adjustment Volume [veh/h]	0	0	0	0	0	0
Other Volume [veh/h]	0	0	0	0	0	0
Total Hourly Volume [veh/h]	24	283	307	1	1	18
Peak Hour Factor	1.0000	1.0000	1.0000	1.0000	1.0000	1.0000
Other Adjustment Factor	1.0000	1.0000	1.0000	1.0000	1.0000	1.0000
Total 15-Minute Volume [veh/h]	6	71	77	0	0	5
Total Analysis Volume [veh/h]	24	283	307	1	1	18
Pedestrian Volume [ped/h]	0	0	0	0	0	0



Intersection Settings

Priority Scheme	Free	Free	Stop
Flared Lane			No
Storage Area [veh]	0	0	0
Two-Stage Gap Acceptance			No
Number of Storage Spaces in Median	0	0	0

Movement, Approach, & Intersection Results

V/C, Movement V/C Ratio	0.02	0.00	0.00	0.00	0.00	0.02
d_M, Delay for Movement [s/veh]	7.93	0.00	0.00	0.00	13.50	10.06
Movement LOS	A	A	A	A	B	B
95th-Percentile Queue Length [veh/ln]	0.06	0.06	0.00	0.00	0.08	0.08
95th-Percentile Queue Length [ft/ln]	1.46	1.46	0.00	0.00	2.07	2.07
d_A, Approach Delay [s/veh]	0.62		0.00		10.24	
Approach LOS	A		A		B	
d_I, Intersection Delay [s/veh]					0.61	
Intersection LOS	B					



Intersection Level Of Service Report
Intersection 5: Olympic Dr/Lakeshore Dr

Control Type: Roundabout
Analysis Method: HCM 6th Edition
Analysis Period: 15 minutes
Delay (sec / veh): 5.0
Level Of Service: A

Intersection Setup

Name	Lakeshore Dr			Lakeshore Dr			Eastbound			Olympic Dr		
	Northbound			Southbound			Eastbound			Westbound		
Approach	[Diagram]			[Diagram]			[Diagram]			[Diagram]		
Lane Configuration	[Diagram]			[Diagram]			[Diagram]			[Diagram]		
Turning Movement	Left	Thru	Right	Left	Thru	Right	Left	Thru	Right	Left	Thru	Right
Lane Width [ft]	12.00	12.00	12.00	12.00	12.00	12.00	12.00	12.00	12.00	12.00	12.00	12.00
No. of Lanes in Entry Pocket	0	0	1	0	0	0	0	0	0	0	0	1
Entry Pocket Length [ft]	100.00	100.00	120.00	100.00	100.00	100.00	100.00	100.00	100.00	100.00	100.00	250.00
No. of Lanes in Exit Pocket	0	0	0	0	0	0	0	0	0	0	0	0
Exit Pocket Length [ft]	0.00	0.00	0.00	0.00	0.00	0.00	0.00	0.00	0.00	0.00	0.00	0.00
Speed [mph]	25.00			25.00			30.00			30.00		
Grade [%]	0.00			0.00			0.00			0.00		
Crosswalk	No			Yes			No			Yes		

Volumes

Name	Lakeshore Dr			Lakeshore Dr			Eastbound			Olympic Dr		
	0	310	125	95	215	0	0	0	5	120	5	160
Base Volume Input [veh/h]	0	310	125	95	215	0	0	0	5	120	5	160
Base Volume Adjustment Factor	1.0000	1.0000	1.0000	1.0000	1.0000	1.0000	1.0000	1.0000	1.0000	1.0000	1.0000	1.0000
Heavy Vehicles Percentage [%]	2.00	2.00	2.00	2.00	2.00	2.00	2.00	2.00	2.00	2.00	2.00	2.00
Growth Factor	1.0000	1.0000	1.0000	1.0000	1.0000	1.0000	1.0000	1.0000	1.0000	1.0000	1.0000	1.0000
In-Process Volume [veh/h]	0	0	0	0	0	0	0	0	0	0	0	0
Site-Generated Trips [veh/h]	0	0	21	11	0	0	0	0	0	15	0	8
Diverted Trips [veh/h]	0	0	0	0	0	0	0	0	0	0	0	0
Pass-by Trips [veh/h]	0	0	0	0	0	0	0	0	0	0	0	0
Existing Site Adjustment Volume [veh/h]	0	0	0	0	0	0	0	0	0	0	0	0
Other Volume [veh/h]	0	0	0	0	0	0	0	0	0	0	0	0
Total Hourly Volume [veh/h]	0	310	146	106	215	0	0	0	5	135	5	168
Peak Hour Factor	1.0000	1.0000	1.0000	1.0000	1.0000	1.0000	1.0000	1.0000	1.0000	1.0000	1.0000	1.0000
Other Adjustment Factor	1.0000	1.0000	1.0000	1.0000	1.0000	1.0000	1.0000	1.0000	1.0000	1.0000	1.0000	1.0000
Total 15-Minute Volume [veh/h]	0	78	37	27	54	0	0	0	1	34	1	42
Total Analysis Volume [veh/h]	0	310	146	106	215	0	0	0	5	135	5	168
Pedestrian Volume [ped/h]	0			0			0			1		



Intersection Settings

	1	1	1	1								
Number of Conflicting Circulating Lanes	1	1	1	1								
Circulating Flow Rate [veh/h]	108	143	465	316								
Exiting Flow Rate [veh/h]	362	488	5	257								
Demand Flow Rate [veh/h]	0	310	146	108	215	0	0	0	5	135	5	168
Adjusted Demand Flow Rate [veh/h]	0	310	146	108	215	0	0	0	5	135	5	168

Lanes

	No	No	No	No	No	No
Override Calculated Critical Headway	No	No	No	No	No	No
User-Defined Critical Headway [s]	4.00	4.00	4.00	4.00	4.00	4.00
Override Calculated Follow-Up Time	No	No	No	No	No	No
User-Defined Follow-Up Time [s]	3.00	3.00	3.00	3.00	3.00	3.00
A (intercept)	1420.00	1420.00	1380.00	1380.00	1420.00	1420.00
B (coefficient)	0.00091	0.00091	0.00102	0.00102	0.00091	0.00091
HV Adjustment Factor	0.98	0.98	0.98	0.98	0.98	0.98
Entry Flow Rate [veh/h]	317	149	328	6	138	177
Capacity of Entry and Bypass Lanes [veh/h]	1287	1287	1193	859	1065	1065
Pedestrian Impedance	1.00	1.00	1.00	1.00	1.00	1.00
Capacity per Entry Lane [veh/h]	1262	1262	1170	842	1044	1044
X, volume / capacity	0.25	0.12	0.27	0.01	0.13	0.17

Movement, Approach, & Intersection Results

	A	A	A	A	A	A
Lane LOS	A	A	A	A	A	A
95th-Percentile Queue Length [veh]	0.97	0.39	1.12	0.02	0.44	0.59
95th-Percentile Queue Length [ft]	24.23	9.79	28.07	0.45	11.11	14.83
Approach Delay [s/veh]	4.62		5.61	4.33		4.81
Approach LOS	A		A	A		A
Intersection Delay [s/veh]	4.97					
Intersection LOS	A					



Intersection Level Of Service Report
Intersection 6: Olympic Dr/N-S Project Street

Control Type: Two-way stop
Analysis Method: HCM 6th Edition
Analysis Period: 15 minutes
Delay (sec / veh): 40.3
Level Of Service: E
Volume to Capacity (v/c): 0.212

Intersection Setup

Name	N-S Project Street		Olympic Dr		Olympic Dr	
Approach	Southbound		Eastbound		Westbound	
Lane Configuration	T		T		T	
Turning Movement	Left	Right	Left	Thru	Thru	Right
Lane Width [ft]	12.00	12.00	12.00	12.00	12.00	12.00
No. of Lanes in Entry Pocket	0	0	0	0	0	0
Entry Pocket Length [ft]	100.00	100.00	100.00	100.00	100.00	100.00
No. of Lanes in Exit Pocket	0	0	0	0	0	0
Exit Pocket Length [ft]	0.00	0.00	0.00	0.00	0.00	0.00
Speed [mph]	25.00		30.00		30.00	
Grade [%]	0.00		0.00		0.00	
Crosswalk	Yes		No		No	

Volumes

Name	N-S Project Street		Olympic Dr		Olympic Dr	
Base Volume Input [veh/h]	8	9	16	352	384	0
Base Volume Adjustment Factor	1.0000	1.0000	1.0000	1.0000	1.0000	1.0000
Heavy Vehicles Percentage [%]	2.00	2.00	2.00	2.00	2.00	2.00
Growth Factor	1.7600	1.7600	1.7600	1.7600	1.7600	1.7600
In-Process Volume [veh/h]	0	0	0	0	0	0
Site-Generated Trips [veh/h]	13	31	43	0	0	19
Diverted Trips [veh/h]	0	0	0	0	0	0
Pass-by Trips [veh/h]	0	0	0	0	0	0
Existing Site Adjustment Volume [veh/h]	0	0	0	0	0	0
Other Volume [veh/h]	0	0	0	0	0	0
Total Hourly Volume [veh/h]	27	47	71	620	676	19
Peak Hour Factor	1.0000	1.0000	1.0000	1.0000	1.0000	1.0000
Other Adjustment Factor	1.0000	1.0000	1.0000	1.0000	1.0000	1.0000
Total 15-Minute Volume [veh/h]	7	12	18	155	169	5
Total Analysis Volume [veh/h]	27	47	71	620	676	19
Pedestrian Volume [ped/h]	0	0	0	0	0	0



Intersection Settings

Priority Scheme	Stop	Free	Free
Flared Lane	No		
Storage Area [veh]	0	0	0
Two-Stage Gap Acceptance	No		
Number of Storage Spaces in Median	0	0	0

Movement, Approach, & Intersection Results

V/C, Movement V/C Ratio	0.21	0.10	0.08	0.01	0.31	0.00
d_M, Delay for Movement [s/veh]	40.28	20.04	9.34	0.00	0.00	0.00
Movement LOS	E	C	A	A	A	A
95th-Percentile Queue Length [veh/ln]	1.31	1.31	0.26	0.26	0.00	0.00
95th-Percentile Queue Length [ft/ln]	32.68	32.68	6.40	6.40	0.00	0.00
d_A, Approach Delay [s/veh]	27.43		0.96		0.00	
Approach LOS	D		A		A	
d_I, Intersection Delay [s/veh]				1.84		
Intersection LOS	E					



Intersection Level Of Service Report
Intersection 7: Olympic Dr/Burns Valley Rd-Old Hwy 53

Control Type: Signalized
Analysis Method: HCM 6th Edition
Analysis Period: 15 minutes
Delay (sec / veh): 21.2
Level Of Service: C
Volume to Capacity (v/c): 0.867

Intersection Setup

Name	Old Hwy 53			Burns Valley Rd			Olympic Dr			Old Hwy 53		
Approach	Northbound			Southbound			Eastbound			Westbound		
Lane Configuration	T T T			T T T			T T			T T		
Turning Movement	Left	Thru	Right	Left	Thru	Right	Left	Thru	Right	Left	Thru	Right
Lane Width [ft]	12.00	12.00	12.00	12.00	12.00	12.00	12.00	12.00	12.00	12.00	12.00	12.00
No. of Lanes in Entry Pocket	1	0	1	1	0	0	1	0	0	1	0	0
Entry Pocket Length [ft]	100.00	100.00	100.00	56.00	100.00	100.00	48.00	100.00	100.00	100.00	100.00	100.00
No. of Lanes in Exit Pocket	0	0	0	0	0	0	0	0	0	0	0	0
Exit Pocket Length [ft]	0.00	0.00	0.00	0.00	0.00	0.00	0.00	0.00	0.00	0.00	0.00	0.00
Speed [mph]	30.00			30.00			35.00			35.00		
Grade [%]	0.00			0.00			0.00			0.00		
Curb Present	No			No			No			No		
Crosswalk	Yes			Yes			Yes			Yes		



Volumes

Name	Old Hwy 53			Burns Valley Rd			Olympic Dr			Old Hwy 53		
Base Volume Input [veh/h]	185	215	110	180	185	60	45	315	165	95	320	175
Base Volume Adjustment Factor	1.0000	1.0000	1.0000	1.0000	1.0000	1.0000	1.0000	1.0000	1.0000	1.0000	1.0000	1.0000
Heavy Vehicles Percentage [%]	2.00	2.00	2.00	2.00	2.00	2.00	2.00	2.00	2.00	2.00	2.00	2.00
Growth Factor	1.0000	1.0000	1.0000	1.0000	1.0000	1.0000	1.0000	1.0000	1.0000	1.0000	1.0000	1.0000
In-Process Volume [veh/h]	0	0	0	0	0	0	0	0	0	0	0	0
Site-Generated Trips [veh/h]	9	18	0	10	11	0	0	5	7	0	10	11
Diverted Trips [veh/h]	0	0	0	0	0	0	0	0	0	0	0	0
Pass-by Trips [veh/h]	0	0	0	0	0	0	0	0	0	0	0	0
Existing Site Adjustment Volume [veh/h]	0	0	0	0	0	0	0	0	0	0	0	0
Other Volume [veh/h]	0	0	0	0	0	0	0	0	0	0	0	0
Right Turn on Red Volume [veh/h]	0	0	18	0	0	11	0	14	0	0	0	25
Total Hourly Volume [veh/h]	174	233	92	190	196	49	45	320	158	95	330	161
Peak Hour Factor	1.0000	1.0000	1.0000	1.0000	1.0000	1.0000	1.0000	1.0000	1.0000	1.0000	1.0000	1.0000
Other Adjustment Factor	1.0000	1.0000	1.0000	1.0000	1.0000	1.0000	1.0000	1.0000	1.0000	1.0000	1.0000	1.0000
Total 15-Minute Volume [veh/h]	44	58	23	48	49	12	11	80	40	24	83	40
Total Analysis Volume [veh/h]	174	233	92	190	196	49	45	320	158	95	330	161
Presence of On-Street Parking	No	No	No	No	No	No	No	No	No	No	No	No
On-Street Parking Maneuver Rate [h]	0	0	0	0	0	0	0	0	0	0	0	0
Local Bus Stopping Rate [h]	0	0	0	0	0	0	0	0	0	0	0	0
v_do, Outbound Pedestrian Volume crossing major street	1			0			1			1		
v_di, Inbound Pedestrian Volume crossing major street	1			1			0			1		
v_co, Outbound Pedestrian Volume crossing minor street	1			0			0			0		
v_ci, Inbound Pedestrian Volume crossing minor street	0			0			1			0		
v_ab, Corner Pedestrian Volume [ped/h]	0			0			0			0		
Bicycle Volume [bicycles/h]	0			0			0			0		1



Intersection Settings

Located In CBD	Yes
Signal Coordination Group	-
Cycle Length [s]	109
Coordination Type	Time of Day Pattern Isolated
Actuation Type	Fully actuated
Offset [s]	0.0
Offset Reference	Lead Green - Segments of First Green
Permissive Mode	SingleBand
Lost time [s]	14.00

Phasing & Timing

Control Type	Protect	Permiss	Permiss	Protect	Permiss	Permiss	Protect	Permiss	Permiss	Protect	Permiss	Permiss
Signal Group	3	8	0	7	4	0	5	2	0	1	6	9
Auxiliary Signal Groups												
Lead / Lag	Lead	-	-	Lead	-	-	Lead	-	-	Lead	-	-
Minimum Green [s]	4	6	0	4	6	0	4	6	0	4	6	0
Maximum Green [s]	20	25	0	20	25	0	20	30	0	20	20	0
Amber [s]	3.0	3.3	0.0	3.0	3.3	0.0	3.0	3.6	0.0	3.0	3.6	0.0
All red [s]	0.0	0.3	0.0	0.0	0.3	0.0	0.0	0.3	0.0	0.0	0.3	0.0
Split [s]	23	29	0	23	29	0	23	34	0	23	34	0
Vehicle Extension [s]	0.0	0.0	0.0	0.0	0.0	0.0	0.0	0.0	0.0	0.0	0.0	0.0
Walk [s]	0	7	0	0	7	0	0	7	0	0	7	0
Pedestrian Clearance [s]	0	11	0	0	9	0	0	14	0	0	9	0
Delayed Vehicle Green [s]	0.0	0.0	0.0	0.0	0.0	0.0	0.0	0.0	0.0	0.0	0.0	0.0
Rest In Walk		No			No			No			No	
I1, Start-Up Lost Time [s]	2.0	2.0	0.0	2.0	2.0	0.0	2.0	2.0	0.0	2.0	2.0	0.0
I2, Clearance Lost Time [s]	1.0	1.6	0.0	1.0	1.6	0.0	1.0	1.9	0.0	1.0	1.9	0.0
Minimum Recall	No	No		No	No		No	No		No	No	
Maximum Recall	No	No		No	No		No	No		No	No	
Pedestrian Recall	No	No		No	No		No	No		No	No	
Detector Location [ft]	0.0	0.0	0.0	0.0	0.0	0.0	0.0	0.0	0.0	0.0	0.0	0.0
Detector Length [ft]	0.0	0.0	0.0	0.0	0.0	0.0	0.0	0.0	0.0	0.0	0.0	0.0
I, Upstream Filtering Factor	1.00	1.00	1.00	1.00	1.00	1.00	1.00	1.00	1.00	1.00	1.00	1.00

Exclusive Pedestrian Phase

Pedestrian Signal Group	0
Pedestrian Walk [s]	0
Pedestrian Clearance [s]	0



Lane Group Calculations

Lane Group	L	C	R	L	C	L	C	L	C
C, Cycle Length [s]	49	49	49	49	49	49	49	49	49
L, Total Lost Time per Cycle [s]	3.00	3.60	3.60	3.00	3.60	3.00	3.60	3.00	3.60
I1_p, Permitted Start-Up Lost Time [s]	0.00	0.00	0.00	0.00	0.00	0.00	0.00	0.00	0.00
I2, Clearance Lost Time [s]	1.00	1.60	1.60	1.00	1.60	1.00	1.60	1.00	1.60
g_l, Effective Green Time [s]	7	9	9	7	9	2	16	4	18
g / C, Green / Cycle	0.13	0.18	0.18	0.15	0.19	0.04	0.33	0.07	0.37
(v / s)_l Volume / Saturation Flow Rate	0.11	0.14	0.06	0.12	0.15	0.03	0.30	0.06	0.31
s, saturation flow rate [veh/h]	1603	1683	1422	1603	1625	1603	1589	1603	1579
c, Capacity [veh/h]	215	295	250	233	304	60	527	117	579
d1, Uniform Delay [s]	20.68	19.40	17.86	20.36	19.13	23.42	15.71	22.46	14.31
k, delay calibration	0.04	0.04	0.04	0.04	0.04	0.04	0.04	0.04	0.22
I, Upstream Filtering Factor	1.00	1.00	1.00	1.00	1.00	1.00	1.00	1.00	1.00
d2, Incremental Delay [s]	2.77	1.79	0.34	2.63	1.93	6.59	2.52	5.04	7.01
d3, Initial Queue Delay [s]	0.00	0.00	0.00	0.00	0.00	0.00	0.00	0.00	0.00
Rp, platoon ratio	1.00	1.00	1.00	1.00	1.00	1.00	1.00	1.00	1.00
PF, progression factor	1.00	1.00	1.00	1.00	1.00	1.00	1.00	1.00	1.00

Lane Group Results

X, volume / capacity	0.81	0.79	0.37	0.81	0.81	0.75	0.91	0.81	0.85
d, Delay for Lane Group [s/veh]	23.44	21.19	18.20	22.99	21.07	30.01	18.23	27.50	21.31
Lane Group LOS	C	C	B	C	C	C	B	C	C
Critical Lane Group	Yes	No	No	No	Yes	No	Yes	Yes	No
50th-Percentile Queue Length [veh/m]	1.90	2.40	0.84	2.06	2.52	0.57	4.46	1.12	5.06
50th-Percentile Queue Length [ft/m]	47.57	60.04	21.08	51.39	63.09	14.32	111.60	28.09	126.39
95th-Percentile Queue Length [veh/m]	3.42	4.32	1.52	3.70	4.54	1.03	7.93	2.02	8.74
95th-Percentile Queue Length [ft/m]	85.62	108.07	37.94	92.50	113.56	26.77	198.23	50.57	218.57



Movement, Approach, & Intersection Results

d_M, Delay for Movement [s/veh]	23.44	21.19	18.20	22.99	21.07	21.07	30.01	18.23	18.23	27.50	21.31	21.31
Movement LOS	C	C	B	C	C	C	C	B	B	C	C	C
d_A, Approach Delay [s/veh]	21.42		21.81		18.25		22.32					
Approach LOS	C		C		B		C					
d_I, Intersection Delay [s/veh]	21.22											
Intersection LOS	C											
Intersection VIC	0.867											

Other Modes

g_Walk,mi, Effective Walk Time [s]	11.0	11.0	11.0	11.0
M_corner, Corner Circulation Area [ft²/ped]	0.00	0.00	0.00	0.00
M_CW, Crosswalk Circulation Area [ft²/ped]	0.00	0.00	0.00	0.00
d_p, Pedestrian Delay [s]	14.73	14.73	14.73	14.73
I_p,int, Pedestrian LOS Score for Intersection	2.361	2.217	2.343	2.408
Crosswalk LOS	B	B	B	B
s_b, Saturation Flow Rate of the bicycle lane [bicycles/h]	2000	2000	2000	2000
c_b, Capacity of the bicycle lane [bicycles/h]	1037	1037	1229	1229
d_b, Bicycle Delay [s]	5.68	5.68	3.64	3.64
I_b,int, Bicycle LOS Score for Intersection	2.413	2.298	2.448	2.598
Bicycle LOS	B	B	B	B

Sequence

Ring 1	1	2	3	4	-	-	-	-	-	-	-	-	-	-
Ring 2	5	6	7	8	-	-	-	-	-	-	-	-	-	-
Ring 3	-	-	-	-	-	-	-	-	-	-	-	-	-	-
Ring 4	-	-	-	-	-	-	-	-	-	-	-	-	-	-

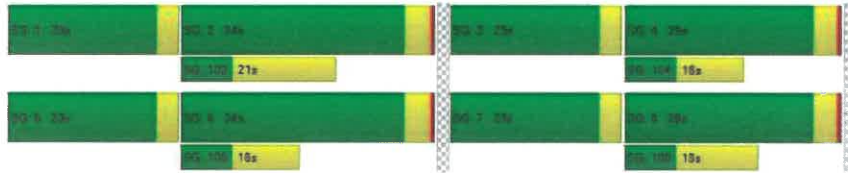

Intersection Level Of Service Report

Intersection 1: Burns Valley Rd/N-S Project Street

Control Type:	Two-way stop	Delay (sec / veh):	11.0
Analysis Method:	HCM 6th Edition	Level Of Service:	B
Analysis Period:	15 minutes	Volume to Capacity (v/c):	0.044

Intersection Setup

Name	N-S Project Street		Burns Valley Rd		Burns Valley Rd	
	Northbound		Eastbound		Westbound	
Approach	T		T		T	
Lane Configuration	T		T		T	
Turning Movement	Left	Right	Thru	Right	Left	Thru
Lane Width [ft]	12.00	12.00	12.00	12.00	12.00	12.00
No. of Lanes in Entry Pocket	0	0	0	0	0	0
Entry Pocket Length [ft]	100.00	100.00	100.00	100.00	100.00	100.00
No. of Lanes in Exit Pocket	0	0	0	0	0	0
Exit Pocket Length [ft]	0.00	0.00	0.00	0.00	0.00	0.00
Speed [mph]	25.00		35.00		35.00	
Grade [%]	0.00		0.00		0.00	
Crosswalk	No		No		No	

Volumes

Name	N-S Project Street		Burns Valley Rd		Burns Valley Rd	
	7	6	78	12	0	93
Base Volume Input [veh/h]	7	6	78	12	0	93
Base Volume Adjustment Factor	1.0000	1.0000	1.0000	1.0000	1.0000	1.0000
Heavy Vehicles Percentage [%]	2.00	2.00	2.00	2.00	2.00	2.00
Growth Factor	1.7600	1.7600	1.7600	1.7600	1.7600	1.7600
In-Process Volume [veh/h]	0	0	0	0	0	0
Site-Generated Trips [veh/h]	16	17	3	15	12	2
Diverted Trips [veh/h]	0	0	0	0	0	0
Pass-by Trips [veh/h]	0	0	0	0	0	0
Existing Site Adjustment Volume [veh/h]	0	0	0	0	0	0
Other Volume [veh/h]	0	0	0	0	0	0
Total Hourly Volume [veh/h]	28	28	140	36	12	166
Peak Hour Factor	1.0000	1.0000	1.0000	1.0000	1.0000	1.0000
Other Adjustment Factor	1.0000	1.0000	1.0000	1.0000	1.0000	1.0000
Total 15-Minute Volume [veh/h]	7	7	35	9	3	42
Total Analysis Volume [veh/h]	28	28	140	36	12	166
Pedestrian Volume [ped/h]	0		0		0	



Intersection Settings

Priority Scheme	Stop	Free	Free
Flared Lane	No		
Storage Area [veh]	0	0	0
Two-Stage Gap Acceptance	No		
Number of Storage Spaces in Median	0	0	0

Movement, Approach, & Intersection Results

V/C, Movement V/C Ratio	0.04	0.03	0.00	0.00	0.01	0.00
d_M, Delay for Movement [s/veh]	10.99	9.45	0.00	0.00	7.59	0.00
Movement LOS	B	A	A	A	A	A
95th-Percentile Queue Length [veh/ln]	0.24	0.24	0.00	0.00	0.03	0.03
95th-Percentile Queue Length [ft/ln]	6.07	6.07	0.00	0.00	0.65	0.65
d_A, Approach Delay [s/veh]	10.22		0.00		0.51	
Approach LOS	B		A		A	
d_I, Intersection Delay [s/veh]			1.62			
Intersection LOS			B			



Intersection Level Of Service Report

Intersection 2: Burns Valley Rd/Bowers Ave-Rumsey Rd

Control Type:	Two-way stop	Delay (sec / veh):	14.6
Analysis Method:	HCM 6th Edition	Level Of Service:	B
Analysis Period:	15 minutes	Volume to Capacity (v/c):	0.008

Intersection Setup

Name	Burns Valley Rd			Rumsey Rd			Burns Valley Rd			Bowers Ave		
Approach	Northbound			Southbound			Eastbound			Westbound		
Lane Configuration	+			+			+			+		
Turning Movement	Left	Thru	Right	Left	Thru	Right	Left	Thru	Right	Left	Thru	Right
Lane Width [ft]	12.00	12.00	12.00	12.00	12.00	12.00	12.00	12.00	12.00	12.00	12.00	12.00
No. of Lanes in Entry Pocket	0	0	0	0	0	0	0	0	0	0	0	0
Entry Pocket Length [ft]	100.00	100.00	100.00	100.00	100.00	100.00	100.00	100.00	100.00	100.00	100.00	100.00
No. of Lanes in Exit Pocket	0	0	0	0	0	0	0	0	0	0	0	0
Exit Pocket Length [ft]	0.00	0.00	0.00	0.00	0.00	0.00	0.00	0.00	0.00	0.00	0.00	0.00
Speed [mph]	30.00			30.00			35.00			25.00		
Grade [%]	0.00			0.00			0.00			0.00		
Crosswalk	No			Yes			Yes			No		

Volumes

Name	Burns Valley Rd			Rumsey Rd			Burns Valley Rd			Bowers Ave		
Base Volume Input [veh/h]	137	59	2	0	51	15	16	0	136	3	2	0
Base Volume Adjustment Factor	1.0000	1.0000	1.0000	1.0000	1.0000	1.0000	1.0000	1.0000	1.0000	1.0000	1.0000	1.0000
Heavy Vehicles Percentage [%]	2.00	2.00	2.00	2.00	2.00	2.00	2.00	2.00	2.00	2.00	2.00	2.00
Growth Factor	1.0000	1.0000	1.0000	1.0000	1.0000	1.0000	1.0000	1.0000	1.0000	1.0000	1.0000	1.0000
In-Process Volume [veh/h]	0	0	0	0	0	0	0	0	0	0	0	0
Site-Generated Trips [veh/h]	14	2	0	0	3	5	6	0	10	0	0	0
Diverted Trips [veh/h]	0	0	0	0	0	0	0	0	0	0	0	0
Pass-by Trips [veh/h]	0	0	0	0	0	0	0	0	0	0	0	0
Existing Site Adjustment Volume [veh/h]	0	0	0	0	0	0	0	0	0	0	0	0
Other Volume [veh/h]	0	0	0	0	0	0	0	0	0	0	0	0
Total Hourly Volume [veh/h]	151	61	2	0	54	20	22	0	146	3	2	0
Peak Hour Factor	1.0000	1.0000	1.0000	1.0000	1.0000	1.0000	1.0000	1.0000	1.0000	1.0000	1.0000	1.0000
Other Adjustment Factor	1.0000	1.0000	1.0000	1.0000	1.0000	1.0000	1.0000	1.0000	1.0000	1.0000	1.0000	1.0000
Total 15-Minute Volume [veh/h]	38	15	1	0	14	5	6	0	37	1	1	0
Total Analysis Volume [veh/h]	151	61	2	0	54	20	22	0	146	3	2	0
Pedestrian Volume [ped/h]	0			0			0			0		



Intersection Settings

Priority Scheme	Free	Free	Stop	Stop
Flared Lane			No	No
Storage Area [veh]	0	0	C	C
Two-Stage Gap Acceptance			No	No
Number of Storage Spaces in Median	0	0	0	0

Movement, Approach, & Intersection Results

V/C, Movement V/C Ratio	0.10	0.05	0.00	0.00	0.05	0.05	0.04	0.00	0.15	0.01	0.00	0.00
d_M, Delay for Movement [s/Veh]	7.62	0.00	0.00	7.33	0.00	0.00	13.27	13.70	9.56	14.63	12.94	8.70
Movement LOS	A	A	A	A	A	A	B	B	A	B	B	A
95th-Percentile Queue Length [veh/ln]	0.33	0.33	0.33	0.00	0.00	0.00	0.70	0.70	0.70	0.04	0.04	0.04
95th-Percentile Queue Length [ft/ln]	8.22	8.22	8.22	0.00	0.00	0.00	17.53	17.53	17.53	0.93	0.93	0.93
d_A, Approach Delay [s/veh]	5.38			0.00			10.04			13.95		
Approach LOS	A			A			B			B		
d_I, Intersection Delay [s/veh]	8.31											
Intersection LOS	B											



Intersection Level Of Service Report

Intersection 3: N-S Project Street/E-W Project Street

Control Type:	All-way stop	Delay (sec / veh):	7.7
Analysis Method:	HCM 6th Edition	Level Of Service:	A
Analysis Period:	15 minutes	Volume to Capacity (v/c):	0.133

Intersection Setup

Name	N-S Project Street			N-S Project Street			E-W Project Street			E-W Project Street		
Approach	Northbound			Southbound			Eastbound			Westbound		
Lane Configuration	+			+			+			+		
Turning Movement	Left	Thru	Right	Left	Thru	Right	Left	Thru	Right	Left	Thru	Right
Lane Width [ft]	12.00	12.00	12.00	12.00	12.00	12.00	12.00	12.00	12.00	12.00	12.00	12.00
No. of Lanes in Entry Pocket	0	0	0	0	0	0	0	0	0	0	0	0
Entry Pocket Length [ft]	100.00	100.00	100.00	100.00	100.00	100.00	100.00	100.00	100.00	100.00	100.00	100.00
No. of Lanes in Exit Pocket	0	0	0	0	0	0	0	0	0	0	0	0
Exit Pocket Length [ft]	0.00	0.00	0.00	0.00	0.00	0.00	0.00	0.00	0.00	0.00	0.00	0.00
Speed [mph]	25.00			25.00			25.00			25.00		
Grade [%]	0.00			0.00			0.00			0.00		
Crosswalk	Yes			Yes			Yes			Yes		

Volumes

Name	N-S Project Street			N-S Project Street			E-W Project Street			E-W Project Street		
Base Volume Input [veh/h]	0	13	0	0	12	0	0	0	0	0	0	0
Base Volume Adjustment Factor	1.0000	1.0000	1.0000	1.0000	1.0000	1.0000	1.0000	1.0000	1.0000	1.0000	1.0000	1.0000
Heavy Vehicles Percentage [%]	2.00	2.00	2.00	2.00	2.00	2.00	2.00	2.00	2.00	2.00	2.00	2.00
Growth Factor	1.7600	1.7600	1.7600	1.7600	1.7600	1.7600	1.7600	1.7600	1.7600	1.7600	1.7600	1.7600
In-Process Volume [veh/h]	0	0	0	0	0	0	0	0	0	0	0	0
Site-Generated Trips [veh/h]	5	60	30	24	64	2	1	6	15	15	4	26
Diverted Trips [veh/h]	0	0	0	0	0	0	0	0	0	0	0	0
Pass-by Trips [veh/h]	0	0	0	0	0	0	0	0	0	0	0	0
Existing Site Adjustment Volume [veh/h]	0	0	0	0	0	0	0	0	0	0	0	0
Other Volume [veh/h]	0	0	0	0	0	0	0	0	0	0	0	0
Total Hourly Volume [veh/h]	5	83	30	24	85	2	1	6	15	15	4	26
Peak Hour Factor	1.0000	1.0000	1.0000	1.0000	1.0000	1.0000	1.0000	1.0000	1.0000	1.0000	1.0000	1.0000
Other Adjustment Factor	1.0000	1.0000	1.0000	1.0000	1.0000	1.0000	1.0000	1.0000	1.0000	1.0000	1.0000	1.0000
Total 15-Minute Volume [veh/h]	1	21	8	6	21	1	0	2	4	4	1	7
Total Analysis Volume [veh/h]	5	83	30	24	85	2	1	6	15	15	4	26
Pedestrian Volume [ped/h]	0			0			0			0		



Intersection Settings

Lanes				
Capacity per Entry Lane [veh/h]	889	851	883	863
Degree of Utilization, x	0.13	0.13	0.02	0.05

Movement, Approach, & Intersection Results

95th-Percentile Queue Length [veh]	0.46	0.45	0.08	0.16
95th-Percentile Queue Length [ft]	11.43	11.19	1.92	4.12
Approach Delay [s/veh]	7.87	7.86	7.18	7.40
Approach LOS	A	A	A	A
Intersection Delay [s/veh]	7.86			
Intersection LOS	A			



Intersection Level Of Service Report

Intersection 4: Burns Valley Rd/E-W Project Street

Control Type:	Two-way stop	Delay (sec / veh):	12.8
Analysis Method:	HCM 6th Edition	Level Of Service:	B
Analysis Period:	15 minutes	Volume to Capacity (v/c):	0.004

Intersection Setup

Name	Burns Valley Rd		Burns Valley Rd		E-W Project Street	
	Northbound		Southbound		Eastbound	
Approach	←		→		←	
Lane Configuration	←		→		←	
Turning Movement	Left	Thru	Thru	Right	Left	Right
Lane Width [ft]	12.00	12.00	12.00	12.00	12.00	12.00
No. of Lanes in Entry Pocket	0	0	0	0	0	0
Entry Pocket Length [ft]	100.00	100.00	100.00	100.00	100.00	100.00
No. of Lanes in Exit Pocket	0	0	0	0	0	0
Exit Pocket Length [ft]	0.00	0.00	0.00	0.00	0.00	0.00
Speed [mph]	30.00		30.00		25.00	
Grade [%]	0.00		0.00		0.00	
Crosswalk	No		No		Yes	

Volumes

Name	Burns Valley Rd		Burns Valley Rd		E-W Project Street	
Base Volume Input [veh/h]	0	130	120	0	0	0
Base Volume Adjustment Factor	1.0000	1.0000	1.0000	1.0000	1.0000	1.0000
Heavy Vehicles Percentage [%]	2.00	2.00	2.00	2.00	2.00	2.00
Growth Factor	1.7600	1.7600	1.7600	1.7600	1.7600	1.7600
In-Process Volume [veh/h]	0	0	0	0	0	0
Site-Generated Trips [veh/h]	43	14	10	3	2	43
Diverted Trips [veh/h]	0	0	0	0	0	0
Pass-by Trips [veh/h]	0	0	0	0	0	0
Existing Site Adjustment Volume [veh/h]	0	0	0	0	0	0
Other Volume [veh/h]	0	0	0	0	0	0
Total Hourly Volume [veh/h]	43	243	221	3	2	43
Peak Hour Factor	1.0000	1.0000	1.0000	1.0000	1.0000	1.0000
Other Adjustment Factor	1.0000	1.0000	1.0000	1.0000	1.0000	1.0000
Total 15-Minute Volume [veh/h]	11	61	55	1	1	11
Total Analysis Volume [veh/h]	43	243	221	3	2	43
Pedestrian Volume [ped/h]	0		0		0	



Intersection Settings			
Priority Scheme	Free	Free	Stop
Flared Lane			No
Storage Area [veh]	0	0	0
Two-Stage Gap Acceptance			No
Number of Storage Spaces in Median	0	0	0

Movement, Approach, & Intersection Results						
V/C, Movement V/C Ratio	0.03	0.00	0.03	0.00	0.00	0.05
d_M, Delay for Movement [s/veh]	7.77	0.00	6.82	0.00	12.82	9.68
Movement LOS	A	A	A	A	B	A
95th-Percentile Queue Length [veh/ln]	0.10	0.10	0.00	0.00	0.18	0.18
95th-Percentile Queue Length [ft/ln]	2.48	2.48	0.00	0.00	4.51	4.51
d_A, Approach Delay [s/veh]	1.17		0.00		9.82	
Approach LOS	A		A		A	
d_I, Intersection Delay [s/veh]	1.40			B		
Intersection LOS	B			B		



Intersection Level Of Service Report Intersection 5: Olympic Dr/Lakeshore Dr			
Control Type:	Roundabout	Delay (sec / veh):	4.8
Analysis Method:	HCM 6th Edition	Level Of Service:	A
Analysis Period:	15 minutes		

Intersection Setup												
Name	Lakeshore Dr			Lakeshore Dr			Eastbound			Olympic Dr		
Approach	Northbound			Southbound			Eastbound			Westbound		
Lane Configuration	← →			← →			← →			← →		
Turning Movement	Left	Thru	Right	Left	Thru	Right	Left	Thru	Right	Left	Thru	Right
Lane Width [ft]	12.00	12.00	12.00	12.00	12.00	12.00	12.00	12.00	12.00	12.00	12.00	12.00
No. of Lanes in Entry Pocket	0	0	1	0	0	0	0	0	0	0	0	1
Entry Pocket Length [ft]	100.00	100.00	120.00	100.00	100.00	100.00	100.00	100.00	100.00	100.00	100.00	250.00
No. of Lanes in Exit Pocket	0	0	0	0	0	0	0	0	0	0	0	0
Exit Pocket Length [ft]	0.00	0.00	0.00	0.00	0.00	0.00	0.00	0.00	0.00	0.00	0.00	0.00
Speed [mph]	25.00			25.00			30.00			30.00		
Grade [%]	0.00			0.00			0.00			0.00		
Crosswalk	No			Yes			No			Yes		

Volumes												
Name	Lakeshore Dr			Lakeshore Dr			Eastbound			Olympic Dr		
Base Volume Input [veh/h]	1	224	131	93	235	0	0	4	4	123	1	96
Base Volume Adjustment Factor	1.0000	1.0000	1.0000	1.0000	1.0000	1.0000	1.0000	1.0000	1.0000	1.0000	1.0000	1.0000
Heavy Vehicles Percentage [%]	2.00	2.00	2.00	2.00	2.00	2.00	2.00	2.00	2.00	2.00	2.00	2.00
Growth Factor	1.0000	1.0000	1.0000	1.0000	1.0000	1.0000	1.0000	1.0000	1.0000	1.0000	1.0000	1.0000
In-Process Volume [veh/h]	0	0	0	0	0	0	0	0	0	0	0	0
Site-Generated Trips [veh/h]	0	0	37	18	0	0	0	0	0	33	0	18
Diverted Trips [veh/h]	0	0	0	0	0	0	0	0	0	0	0	0
Pass-by Trips [veh/h]	0	0	0	0	0	0	0	0	0	0	0	0
Existing Site Adjustment Volume [veh/h]	0	0	0	0	0	0	0	0	0	0	0	0
Other Volume [veh/h]	0	0	0	0	0	0	0	0	0	0	0	0
Total Hourly Volume [veh/h]	1	224	168	111	235	0	0	4	4	156	1	113
Peak Hour Factor	1.0000	1.0000	1.0000	1.0000	1.0000	1.0000	1.0000	1.0000	1.0000	1.0000	1.0000	1.0000
Other Adjustment Factor	1.0000	1.0000	1.0000	1.0000	1.0000	1.0000	1.0000	1.0000	1.0000	1.0000	1.0000	1.0000
Total 15-Minute Volume [veh/h]	0	55	42	28	59	0	0	1	1	39	0	28
Total Analysis Volume [veh/h]	1	224	168	111	235	0	0	4	4	156	1	113
Pedestrian Volume [ped/h]	0	0	0	0	0	0	0	0	0	0	0	1



Intersection Settings

Number of Conflicting Circulating Lanes	1		1		1		1					
Circulating Flow Rate [veh/h]	117		161		512		230					
Exiting Flow Rate [veh/h]	403		344		2		289					
Demand Flow Rate [veh/h]	1	224	168	111	235	0	0	4	4	156	1	113
Adjusted Demand Flow Rate [veh/h]	1	224	168	111	235	0	0	4	4	156	1	113

Lanes

Override Calculated Critical Headway	No	No	No	No	No	No
User-Defined Critical Headway [s]	4.00	4.00	4.00	4.00	4.00	4.00
Override Calculated Follow-Up Time	No	No	No	No	No	No
User-Defined Follow-Up Time [s]	3.00	3.00	3.00	3.00	3.00	3.00
A (intercept)	1420.00	1420.00	1380.00	1380.00	1420.00	1420.00
B (coefficient)	0.00091	0.00091	0.00102	0.00102	0.00091	0.00091
HV Adjustment Factor	0.98	0.98	0.98	0.98	0.98	0.98
Entry Flow Rate [veh/h]	230	172	353	9	160	117
Capacity of Entry and Bypass Lanes [veh/h]	1277	1277	1171	819	1153	1153
Pedestrian Impedance	1.00	1.00	1.00	1.00	1.00	1.00
Capacity per Entry Lane [veh/h]	1252	1252	1148	803	1129	1129
X, volume / capacity	0.18	0.13	0.30	0.01	0.14	0.10

Movement, Approach, & Intersection Results

Lane LOS	A	A	A	A	A	A
95th-Percentile Queue Length [veh]	0.65	0.46	1.28	0.03	0.48	0.34
95th-Percentile Queue Length [ft]	16.36	11.59	31.95	0.75	11.98	8.40
Approach Delay [s/veh]	4.23		5.99	4.58	4.25	
Approach LOS	A		A	A	A	
Intersection Delay [s/veh]	4.84					
Intersection LOS	A					



Intersection Level Of Service Report

Intersection 6: Olympic Dr/N-S Project Street

Control Type:	Two-way stop	Delay (sec / veh):	32.9
Analysis Method:	HCM 6th Edition	Level Of Service:	D
Analysis Period:	15 minutes	Volume to Capacity (v/c):	0.221

Intersection Setup

Name	N-S Project Street		Olympic Dr		Olympic Dr	
Approach	Southbound		Eastbound		Westbound	
Lane Configuration	T		↑		↑	
Turning Movement	Left	Right	Left	Thru	Thru	Right
Lane Width [ft]	12.00	12.00	12.00	12.00	12.00	12.00
No. of Lanes in Entry Pocket	0	0	0	0	0	0
Entry Pocket Length [ft]	100.00	100.00	100.00	100.00	100.00	100.00
No. of Lanes in Exit Pocket	0	0	0	0	0	0
Exit Pocket Length [ft]	0.00	0.00	0.00	0.00	0.00	0.00
Speed [mph]	25.00		30.00		30.00	
Grade [%]	0.00		0.00		0.00	
Crosswalk	Yes		No		No	

Volumes

Name	N-S Project Street		Olympic Dr		Olympic Dr	
Base Volume Input [veh/h]	6	6	13	288	300	0
Base Volume Adjustment Factor	1.0000	1.0000	1.0000	1.0000	1.0000	1.0000
Heavy Vehicles Percentage [%]	2.00	2.00	2.00	2.00	2.00	2.00
Growth Factor	1.7600	1.7600	1.7600	1.7600	1.7600	1.7600
In-Process Volume [veh/h]	0	0	0	0	0	0
Site-Generated Trips [veh/h]	26	69	73	0	0	25
Diverted Trips [veh/h]	0	0	0	0	0	0
Pass-by Trips [veh/h]	0	0	0	0	0	0
Existing Site Adjustment Volume [veh/h]	0	0	0	0	0	0
Other Volume [veh/h]	0	0	0	0	0	0
Total Hourly Volume [veh/h]	37	80	96	509	528	25
Peak Hour Factor	1.0000	1.0000	1.0000	1.0000	1.0000	1.0000
Other Adjustment Factor	1.0000	1.0000	1.0000	1.0000	1.0000	1.0000
Total 15-Minute Volume [veh/h]	9	20	24	127	132	6
Total Analysis Volume [veh/h]	37	80	96	509	528	25
Pedestrian Volume [ped/h]	0		0		0	



Intersection Settings

Priority Scheme	Stop	Free	Free
Flared Lane	No		
Storage Area [veh]	0	0	0
Two-Stage Gap Acceptance	No		
Number of Storage Spaces in Median	0	0	0

Movement, Approach, & Intersection Results

V/C, Movement V/C Ratio	0.22	0.15	0.09	0.01	0.01	0.00
d_M, Delay for Movement [s/veh]	32.95	18.12	8.91	0.00	0.00	0.00
Movement LOS	D	C	A	A	A	A
95th-Percentile Queue Length [veh/ln]	1.64	1.64	0.31	0.31	0.00	0.00
95th-Percentile Queue Length [ft/ln]	41.07	41.07	7.80	7.80	0.00	0.00
d_A, Approach Delay [s/veh]	22.81		1.41		0.00	
Approach LOS	C		A		A	
d_I, Intersection Delay [s/veh]	2.78					
Intersection LOS	D					



Intersection Level Of Service Report

Intersection 7: Olympic Dr/Burns Valley Rd-Old Hwy 53

Control Type:	Signalized	Delay (sec / veh):	16.6
Analysis Method:	HCM 6th Edition	Level Of Service:	B
Analysis Period:	15 minutes	Volume to Capacity (v/c):	0.834

Intersection Setup

Name	Old Hwy 53			Burns Valley Rd			Olympic Dr			Old Hwy 53		
Approach	Northbound			Southbound			Eastbound			Westbound		
Lane Configuration	T T T			T T			T T			T T		
Turning Movement	Left	Thru	Right	Left	Thru	Right	Left	Thru	Right	Left	Thru	Right
Lane Width [ft]	12.00	12.00	12.00	12.00	12.00	12.00	12.00	12.00	12.00	12.00	12.00	12.00
No. of Lanes in Entry Pocket	1	0	1	1	0	0	1	0	0	1	0	0
Entry Pocket Length [ft]	100.00	100.00	100.00	56.00	100.00	100.00	48.00	100.00	100.00	100.00	100.00	100.00
No. of Lanes in Exit Pocket	0	0	0	0	0	0	0	0	0	0	0	0
Exit Pocket Length [ft]	0.00	0.00	0.00	0.00	0.00	0.00	0.00	0.00	0.00	0.00	0.00	0.00
Speed [mph]	30.00			30.00			35.00			35.00		
Grade [%]	0.00			0.00			0.00			0.00		
Curb Present	No			No			No			No		
Crosswalk	Yes			Yes			Yes			Yes		



Volumes

Name	Old Hwy 53			Burns Valley Rd			Olympic Dr			Old Hwy 53		
Base Volume Input [veh/h]	131	132	69	152	106	49	33	294	165	54	278	178
Base Volume Adjustment Factor	1.0000	1.0000	1.0000	1.0000	1.0000	1.0000	1.0000	1.0000	1.0000	1.0000	1.0000	1.0000
Heavy Vehicles Percentage [%]	2.00	2.00	2.00	2.00	2.00	2.00	2.00	2.00	2.00	2.00	2.00	2.00
Growth Factor	1.0000	1.0000	1.0000	1.0000	1.0000	1.0000	1.0000	1.0000	1.0000	1.0000	1.0000	1.0000
In-Process Volume [veh/h]	0	0	0	0	0	0	0	0	0	0	0	0
Site-Generated Trips [veh/h]	12	32	0	22	31	0	0	11	15	0	12	25
Diverted Trips [veh/h]	0	0	0	0	0	0	0	0	0	0	0	0
Pass-by Trips [veh/h]	0	0	0	0	0	0	0	0	0	0	0	0
Existing Site Adjustment Volume [veh/h]	0	0	0	0	0	0	0	0	0	0	0	0
Other Volume [veh/h]	0	0	0	0	0	0	0	0	0	0	0	0
Right Turn on Red Volume [veh/h]	0	0	19	0	0	3	0	0	5	0	0	20
Total Hourly Volume [veh/h]	143	164	50	174	136	46	33	305	165	54	290	183
Peak Hour Factor	1.0000	1.0000	1.0000	1.0000	1.0000	1.0000	1.0000	1.0000	1.0000	1.0000	1.0000	1.0000
Other Adjustment Factor	1.0000	1.0000	1.0000	1.0000	1.0000	1.0000	1.0000	1.0000	1.0000	1.0000	1.0000	1.0000
Total 15-Minute Volume [veh/h]	36	41	13	44	34	12	8	76	41	14	73	46
Total Analysis Volume [veh/h]	143	164	50	174	136	46	33	305	165	54	290	183
Presence of On-Street Parking	No		No	No		No	No		No	No		No
On-Street Parking Maneuver Rate [1/h]	0	0	0	0	0	0	0	0	0	0	0	0
Local Bus Stopping Rate [1/h]	0	0	0	0	0	0	0	0	0	0	0	0
v_do, Outbound Pedestrian Volume crossing major street	1			0				1			1	
v_di, Inbound Pedestrian Volume crossing major street	1			1				0			1	
v_co, Outbound Pedestrian Volume crossing minor street	1			0				0			0	
v_ci, Inbound Pedestrian Volume crossing minor street	0			0				1			0	
v_ab, Corner Pedestrian Volume [ped/h]	0			0				0			0	
Bicycle Volume [bicycles/h]	0			0				0			1	



Intersection Settings

Located in CBD	Yes
Signal Coordination Group	-
Cycle Length [s]	109
Coordination Type	Time of Day Pattern Isolated
Actuation Type	Fully actuated
Offset [s]	0.0
Offset Reference	Lead Green - Beginning of First Green
Permissive Mode	SingleBand
Lost time [s]	14.00

Phasing & Timing

Control Type	Protect	Permis	Permis	Protect	Permis	Permis	Protect	Permis	Permis	Protect	Permis	Permis
Signal Group	3	8	0	7	4	0	5	2	0	1	6	0
Auxiliary Signal Groups												
Lead / Lag	Lead	-	-	Lead	-	-	Lead	-	-	Lead	-	-
Minimum Green [s]	4	6	0	4	6	0	4	6	0	4	6	0
Maximum Green [s]	20	25	0	20	25	0	20	30	0	20	20	0
Amber [s]	3.0	3.3	0.0	3.0	3.3	0.0	3.0	3.6	0.0	3.0	3.6	0.0
All red [s]	0.0	0.3	0.0	0.0	0.3	0.0	0.0	0.3	0.0	0.0	0.3	0.0
Split [s]	23	29	0	23	29	0	23	34	0	23	34	0
Vehicle Extension [s]	0.0	0.0	0.0	0.0	0.0	0.0	0.0	0.0	0.0	0.0	0.0	0.0
Walk [s]	0	7	0	0	7	0	0	7	0	0	7	0
Pedestrian Clearance [s]	0	11	0	0	9	0	0	14	0	0	9	0
Delayed Vehicle Green [s]	0.0	0.0	0.0	0.0	0.0	0.0	0.0	0.0	0.0	0.0	0.0	0.0
Rest In Walk	No			No			No			No		No
I1, Start-Up Lost Time [s]	2.0	2.0	0.0	2.0	2.0	0.0	2.0	2.0	0.0	2.0	2.0	0.0
I2, Clearance Lost Time [s]	1.0	1.6	0.0	1.0	1.6	0.0	1.0	1.9	0.0	1.0	1.9	0.0
Minimum Recall	No	No		No	No		No	No		No	No	
Maximum Recall	No	No		No	No		No	No		No	No	
Pedestrian Recall	No	No		No	No		No	No		No	No	
Detector Location [ft]	0.0	0.0	0.0	0.0	0.0	0.0	0.0	0.0	0.0	0.0	0.0	0.0
Detector Length [ft]	0.0	0.0	0.0	0.0	0.0	0.0	0.0	0.0	0.0	0.0	0.0	0.0
I, Upstream Filtering Factor	1.00	1.00	1.00	1.00	1.00	1.00	1.00	1.00	1.00	1.00	1.00	1.00

Exclusive Pedestrian Phase

Pedestrian Signal Group	0
Pedestrian Walk [s]	0
Pedestrian Clearance [s]	0



Lane Group Calculations

Lane Group	L	C	R	L	C	L	C	L	C
C, Cycle Length [s]	39	39	39	39	39	39	39	39	39
L, Total Lost Time per Cycle [s]	3.00	3.60	3.60	3.00	3.60	3.00	3.90	3.00	3.90
H1_p, Permitted Start-Up Lost Time [s]	1.00	1.60	1.60	1.00	1.60	1.00	1.90	1.00	1.90
H2, Clearance Lost Time [s]	1.00	1.60	1.60	1.00	1.60	1.00	1.90	1.00	1.90
g_i, Effective Green Time [s]	4	6	6	5	7	1	13	2	14
g / C, Green / Cycle	0.11	0.14	0.14	0.13	0.17	0.03	0.33	0.05	0.35
(v / s)_j, Volume / Saturation Flow Rate	0.09	0.10	0.04	0.11	0.11	0.02	0.30	0.03	0.30
s, saturation flow rate [veh/h]	1603	1683	1420	1603	1610	1603	1584	1603	1561
c, Capacity [veh/h]	178	239	202	216	267	50	530	74	545
d1, Uniform Delay [s]	17.10	16.08	15.04	16.54	15.46	18.89	12.41	18.57	11.97
k, delay calibration	0.04	0.04	0.04	0.04	0.04	0.04	0.04	0.04	0.08
I, Upstream Filtering Factor	1.00	1.00	1.00	1.00	1.00	1.00	1.00	1.00	1.00
d2, Incremental Delay [s]	3.21	1.31	0.24	2.65	1.14	5.37	2.05	5.17	3.34
d3, Initial Queue Delay [s]	0.00	0.00	0.00	0.00	0.00	0.00	0.00	0.00	0.00
Rp, platoon ratio	1.00	1.00	1.00	1.00	1.00	1.00	1.00	1.00	1.00
PF, progression factor	1.00	1.00	1.00	1.00	1.00	1.00	1.00	1.00	1.00

Lane Group Results

X, volume / capacity	0.80	0.89	0.25	0.80	0.68	0.66	0.89	0.73	0.87
d, Delay for Lane Group [s/veh]	20.31	17.39	15.27	19.19	16.60	24.25	14.45	23.74	15.32
Lane Group LOS	C	B	B	B	B	C	B	C	B
Critical Lane Group	No	Yes	No	Yes	No	No	Yes	Yes	No
50th-Percentile Queue Length [veh/m]	1.23	1.26	0.35	1.44	1.36	0.33	3.08	0.51	3.22
50th-Percentile Queue Length [ft/m]	30.73	31.58	8.72	36.98	33.98	8.15	76.95	12.84	80.44
95th-Percentile Queue Length [veh/m]	2.21	2.27	0.63	2.59	2.45	0.59	5.54	0.92	5.79
95th-Percentile Queue Length [ft/m]	55.32	56.84	15.69	64.76	61.17	14.67	138.51	23.11	144.79



Movement, Approach, & Intersection Results

d_M, Delay for Movement [s/veh]	20.31	17.39	15.27	19.19	16.60	16.60	24.25	14.45	14.45	23.74	15.32	15.32
Movement LOS	C	B	B	B	B	B	C	B	B	C	B	B
d_A, Approach Delay [s/veh]	18.26			17.86			15.09			16.18		
Approach LOS	B			B			B			B		
d_I, Intersection Delay [s/veh]	16.64											
Intersection LOS	B											
Intersection V/C	0.834											

Other Modes

g_Walk,mi, Effective Walk Time [s]	11.0	11.0	11.0	11.0
M_corner, Corner Circulation Area [ft ² /ped]	0.00	0.00	0.00	0.00
M_CW, Crosswalk Circulation Area [ft ² /ped]	0.00	0.00	0.00	0.00
d_p, Pedestrian Delay [s]	10.18	10.18	10.18	10.18
L_p,int, Pedestrian LOS Score for Intersection	2.288	2.141	2.273	2.334
Crosswalk LOS	B	B	B	B
s_b, Saturation Flow Rate of the bicycle lane [bicycles/h]	2000	2000	2000	2000
c_b, Capacity of the bicycle lane [bicycles/h]	1294	1294	1533	1533
d_b, Bicycle Delay [s]	2.45	2.45	1.07	1.07
L_b,int, Bicycle LOS Score for Intersection	2.160	2.152	2.398	2.462
Bicycle LOS	B	B	B	B

Sequence

Ring 1	1	2	3	4	-	-	-	-	-	-	-	-	-	-
Ring 2	5	6	7	8	-	-	-	-	-	-	-	-	-	-
Ring 3	-	-	-	-	-	-	-	-	-	-	-	-	-	-
Ring 4	-	-	-	-	-	-	-	-	-	-	-	-	-	-

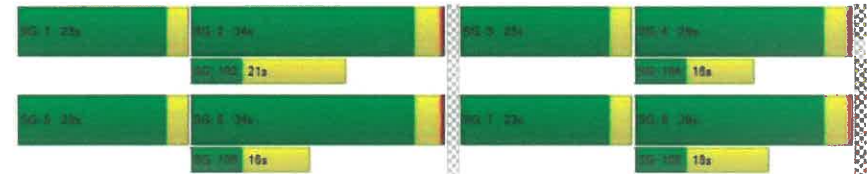

**Attachment F
Noise Study for Oak Valley Villas Apartments**



Oak Valley Villas Apartments Acoustic Mitigation Summary Report

By Douglas L. Gibson, A.I.A., California Architect C29792

2 March 2022

The Oak Valley Villas Apartment project is located in the northerly portion of the City of Clearlake, in what could best be described as a semi-rural, suburban area of impact. Nearby uses include multifamily residential to the north and west with farmland, orchards and vineyards to the north. To the south of the project is the more urban, developed center of town, for the city, along with commercial uses, and existing residential uses and zoning designations as well. As proposed, Oak Valley Villas Apartments, is to be located at the Southwest Corner of Burns Valley Road and Rumsey Road, a non-signalized intersection with traffic control by use of stop signs. Neither Burns Valley Road nor Rumsey Road are considered arterial or high-speed vehicular thoroughfares, both in width of roadway, posted allowable speeds and profiles of intersection. As these two roads are considered residential collector roads servicing a limited geographic area, the acoustical noise impact to the proposed development will be nominal, and within acceptable limitations per state statute and HUD standards at 24CFR Part 51B, averaging between 38 to 45 dBA (background) but no greater than an anticipated 65 dBA day night average. This assessment is based upon current traffic patterns, adjacent uses and the semi-rural nature of the primary frontage for the project, Burns Valley Road.

Secondary acoustical consideration for the development is specific to the future installation of a municipal sports field directly to the south of the apartment development by the City of Clearlake. The following summary report is based upon a Masterplan Format Document provided by the City of Clearlake to the Architect of Record, Douglas L. Gibson, on or about October 29, 2021. Physical dimensions of the proposed sports complex have been verified with the Owner provided ALTA document and reconciled with the approved site plan for the apartment complex, recorded by the City of Clearlake Planning Department. The architectural site plan used for this assessment was dated February 12, 2022, and noted as "Delta 2 Coordination Revisions" submitted to the city for permitting. All dimensions noted are approximate, but should be within less than 12" in accuracy. Final site plan dimensions for both the proposed apartment complex and the city owned sports facility will not be confirmed, in situ, until such time as a final ALTA is recorded for both properties.

For any sports complex of the proposed design, there are commonly noted or recorded three major sources of noise energy production (*Noise-Con 90, Jack B. Evans, P.E.*, "Community Annoyance with Sports Crowd Noise – A Case Study of the Facts in a Jury Decision"). These three major sources of noise are the following: 1.) Vehicular automobile, private truck and limited commercial truck engine noise; 2.) Amplified Public Announcement sounds, including both voice and music energy; and 3.) Spontaneous sound energy created by multiple voices, sound emissions and collective human generated sound energy of random sources, areas, zones and magnitude. Of the three recognized sound energy sources, the third is recognized as the most intrusive and acoustically difficult to address on account of various pitch, sound wave lengths and energy. Recent professional and collegiate football stadiums have had

430 E. State St., Ste. 100 • Eagle, ID 83616 • 208-908-4871 • 208-392-1269 Fax
Licensed Architect: Idaho • Utah • Nevada • Wyoming • Montana • Washington • Oregon • California • Hawaii • Alaska Arizona • Colorado • South Dakota • Louisiana • Nebraska • North Dakota • New Mexico



acoustical energy recordings in excess of 110 dB, for limited durations. Spectator noise is of serious concern for large and small sports venues, however, there is also a significant reduction in the production of sound energy from a group of 100 spectators, compared to 100,000 spectators. It is this smaller group of spectators that are to be addressed in this summary as the primary source of acoustical energy.

However, before addressing spectator noise, the first and second sources of anticipated sound energy will be reviewed, assessed and then noted for any anticipated mitigation measures. The first source of sound energy is proposed as vehicular sound created at the sports complex as participants, fans, officials and ancillary staff park cars, drive around the parking lot looking for a parking spot, or idle, waiting for a spot to clear. Anticipated sound production for the larger of the two parking lots in the sports complex are anticipated to be between 54 dBA and 59 dBA. The larger of the two parking lots, to the west of the proposed sports complex is approximately 500 linear feet from the western wall of Buildings 3 and 4 of Oak Valley Villas. In addition, this direct line of site sound source is buffered from the apartment project development by two existing single story structures, a municipal library that is approximately 25' tall and a single story senior living project which is contiguous to the western property line of Oak Valley Villas. Based upon distance from the two structures on site, physical obstacles that will prevent direct sound acquisition and which will deflect and refract sound energy, it is presumed that any sound energy reaching the interior of the units will be less than 40 to 45 dBA from these sources at the westerly parking lot.

A second parking lot for the sports field, proposed at the easterly portion of the facility is planned to be contiguous to the southern parcel line of the apartment complex. This fifty six (56) parking stall lot is directly adjacent to the primary baseball field at the easterly portion of the sports complex and is approximately 140' from the closest residential structure within the apartment development, Building 4 and approximately 290' from Building 5. Similar to the above calculation, it is anticipated that noise generation of this secondary lot will be in the 54 to 59 dBA range, with bursts associated with diesel engine rev up and bass sound production from vehicular stereo systems in excess of 65 decibels, for limited duration and magnitude. The closest structure to this source of noise, Building 4, has primary deck and patio openings parallel to the source of noise energy, and presents in the general direction of this noise source, a wall consisting of approximately 95% solid surface. There are six individual, fixed windows, facing south on this elevation. For these six windows, elevating the acoustical mitigation or STC rating from the standard STC 30 to STC 33 will result in sound level energy within the respective unit interiors of less than 45 dBA DNL (day night average) on standard days when the parking lot is utilized for sporting events or similar activities.

Similarly, Building 5, the second closest structure to this parking lot has approximately 60 to 65% of the facade designed as an opaque surface with three smaller, fixed windows and three larger bedroom egress windows at this south elevation. In addition, based upon the unit interior floor plans each unit in the three story structure at the south end of the building is provided with an approximately 80 square foot exterior private space, patio or balcony. Access to this patio and balcony is through a full light

430 E. State St., Ste. 100 • Eagle, ID 83616 • 208-908-4871 • 208-392-1269 Fax
 Licensed Architect: Idaho • Utah • Nevada • Wyoming • Montana • Washington • Oregon • California • Hawaii • Alaska Arizona • Colorado • South Dakota • Louisiana • Nebraska • North Dakota • New Mexico



French door (swinging) with a side light and window which provide natural daylighting into the interior of the unit. The windows on this portion of the structure will receive the majority of sound energy and will be provided with a higher acoustical rating of STC 33. Based upon the distance from the source of sound energy (parking lot and drive aisles) it is anticipated that maximum sound readings within this unit's living room and the bedrooms with direct exposure to the source of sound energy, would experience internal acoustic readings of approximately 45 to 50 dBA, for short durations as sporting activities occurred on an irregular basis. By providing for a more rigorous acoustical mitigation response in the project's construction document package, as permitted and approved for construction by local authorities having jurisdiction, it can be summarized that the interior of the residential units, upon completion, will have sound levels less than 45 dBA DNL. This analysis is based upon the design and construction of the exterior walls, that is, 2x6 wood construction with wood sheathing, sound absorptive stucco or EIFS siding, R-21 rated batt insulation, and acoustical dampening gypsum drywall within the unit interiors. From time to time resident use of their exterior patio may be compromised by the creation of sound energy at the parking lot, with sound levels in excess of 65 dBA. To fully address this sound source the only acceptable means of addressing mitigation at the exterior patios would be the introduction of solid half walls (currently shown as transparent railing to 4" AFF) and construction of such half walls to a minimum height of approximately 52". Based upon the limited events or occurrences of excessive sound levels generated by the sports complex the architect is of the professional opinion that retaining the current patio design is acceptable without additional mitigation being required.

The next source of noise energy to be addressed is that energy produced by both electrical amplification of voice and musical soundtracks over an energized audio system. At the time of the creation of this report and assessment the City of Clearlake had not sufficiently programmed the site nor provided the author of this report with any specific information on speaker location, mounting height, orientation, nor amplification metrics. Based upon the understanding that the baseball diamond anticipated to be built directly to the south of the proposed apartment complex, Oak Valley Villas, will be the largest of the five baseball diamonds, the other two being little league fields and T-ball fields, this diamond will be the only one to potentially contain an amplified sound system. Based upon the Master Plan Format document provided to the design team, the closest bleacher section to Building 4 is approximately 420' from the south face of that structure, and from Building 5 to this bleacher seating is approximately 440'. Based upon the prior cited source, Noise-Con 90 proceedings, Jack B. Evans, P.E., the anticipated noise energy production from these amplifications can range from 75 to 80 dBA, with high loads of over 85 dBA, when sound amplification energy is overlaid with organic noise production from spectators and players. This level of energy production (highest yield of 85 dBA) would occur approximately less than 15% of the time of total play or participant attendance of a baseball event. Anticipated noise levels of the combined amplified and crowd noise could be estimated to be between 60 to 65 dBA, for more than half of the time of attendance, but more generally within the 55 to 60 dBA for more than seventy percent of the time, when both physically active participants, spectators, and amplification are used.

As noted previously, the sound 'face' of the two closest buildings to this source of energy are Buildings 4 and 5, and by design, both structures present their smallest profile to the south, or that direction

430 E. State St., Ste. 100 • Eagle, ID 83616 • 208-908-4871 • 208-392-1269 Fax
 Licensed Architect: Idaho • Utah • Nevada • Wyoming • Montana • Washington • Oregon • California • Hawaii • Alaska Arizona • Colorado • South Dakota • Louisiana • Nebraska • North Dakota • New Mexico



specifically facing the proposed sports complex. By providing upgraded STC ratings for the fixed windows, Building 4 primarily, and the three fixed windows, six operable windows and three French patio doors, it will be possible to reduce the sound energy reception within these spaces to less than 52 dBA during peak energy events. Construction documents will note the installation of acoustical sealant or caulking at these two structures south elevations, upgraded STC ratings for vinyl windows from industry standard 30 to an upgraded STC 33 minimum, as all as the utilization of acoustic dampening gypsum wall board on these south facing unit interior walls. Combining the sound mitigation effects of these built components, and considering the distance from the source of sound energy, it is proposed that ambient sound energy within these residential units will remain less than 45 dBA, on average, and would be estimated in the 57 to 59 dBA range during most times when active sporting events are occurring. Based upon the anticipated duration of sporting events, e.g. summer weekends and evenings, and shoulder season (March through May) high school level sporting events, it can safely be stated that when averaged over a twenty four (24) hour period, the noise levels within these units would safely remain below HUD's required 45 dBA DNL standard.

430 E. State St., Ste. 100 • Eagle, ID 83616 • 208-908-4871 • 208-392-1269 Fax
 Licensed Architect: Idaho • Utah • Nevada • Wyoming • Montana • Washington • Oregon • California • Hawaii • Alaska Arizona •
 Colorado • South Dakota • Louisiana • Nebraska • North Dakota • New Mexico

Attachment G Flood Hazards Map

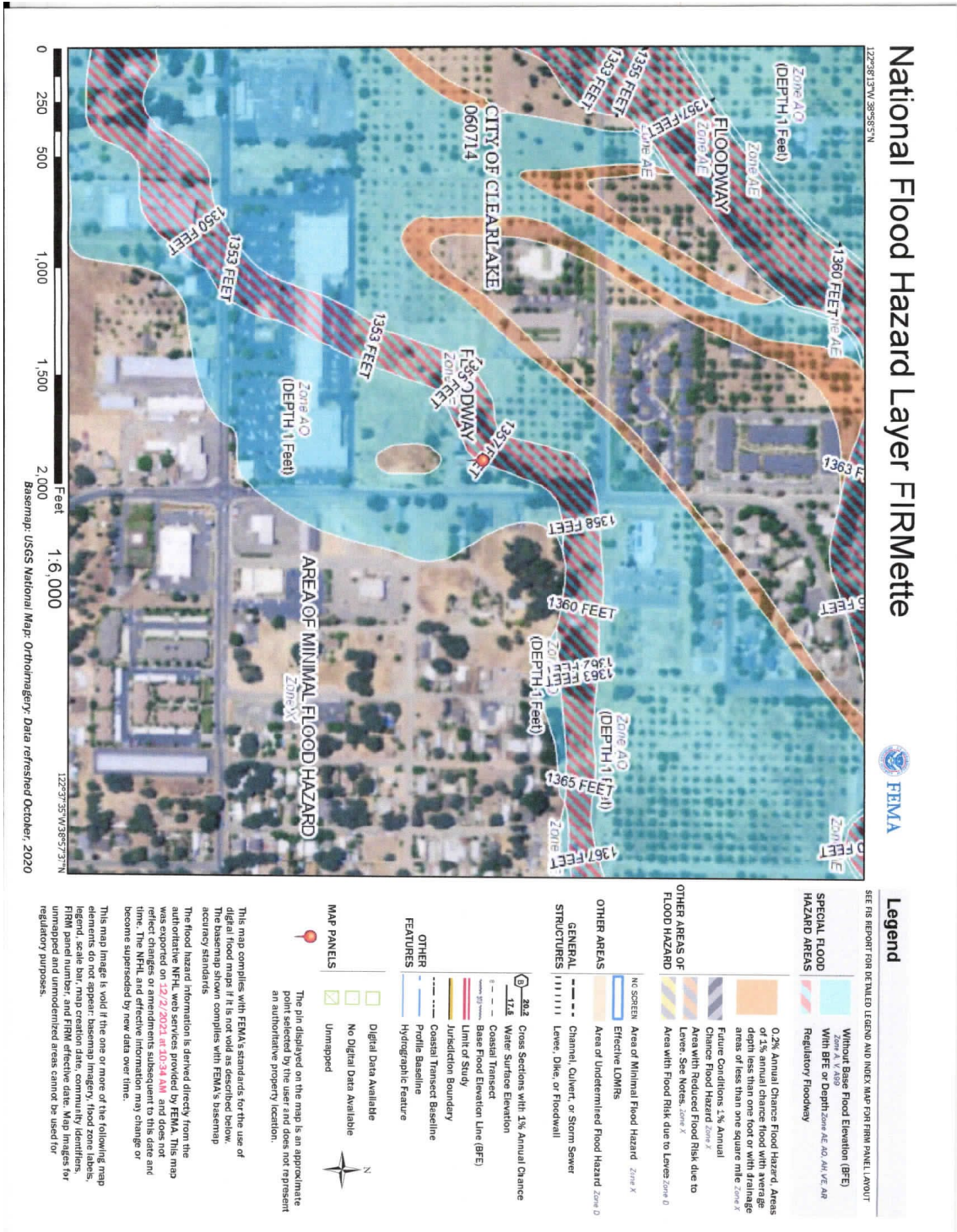

Legend

SEE FIS REPORT FOR DETAILED LEGEND AND INDEX MAP FOR FIRM PANEL LAYOUT

SPECIAL FLOOD HAZARD AREAS

- Without Base Flood Elevation (BFE) Zone A (V-A&P)
- With BFE or Depth Zone AE, AO, AH, VE, AP
- Regulatory Floodway

OTHER AREAS OF FLOOD HAZARD

- 0.2% Annual Chance Flood Hazard: Areas of 1% annual chance flood with average depth of less than one foot or with drainage areas of less than one square mile (Zone X)
- Future Conditions 1% Annual Chance Flood Hazard (Zone X)
- Areas with Reduced Flood Risk due to Levees, See Notes, Zone A
- Area with Flood Risk due to Levees, Zone D

OTHER AREAS

- Area of Minimal Flood Hazard Zone X
- Effective LOMRs
- Area of Underterraced Flood Hazard Zone D

GENERAL STRUCTURES

- Channel, Culvert, or Storm Sewer
- Levee, Dike, or Floodwall

OTHER FEATURES

- Cross Sections with 1% Annual Chance Water Surface Elevation
- 1:24
- 1:12
- Coastal Transect
- Base Flood Elevation Line (BFE)
- Limit of Study
- Jurisdiction Boundary
- Coastal Transect Baseline
- Profile Baseline
- Hydrographic Feature

MAP PANELS

- Digital Data Available
- No Digital Data Available
- Unmapped

The pin displayed on the map is an approximate point selected by the user and does not represent an authoritative property location.

This map complies with FEMA's standards for the use of digital flood maps. If it is not valid as described below. The basemap shown complies with FEMA's basemap accuracy standards.

The flood hazard information is derived directly from the authoritative NFHL web services provided by FEMA. This map was exported on 12/2/2021 at 10:34 AM and does not reflect changes or amendments subsequent to this date and time. The NFHL and effective information may change or become superseded by new data over time.

This map image is void if any one or more of the following map elements do not appear: basemap, imagery, flood zones, legend, scale bar, map creation date, community identifiers, FIRM panel number, and FIRM effective date. Map images for remapped and unmodernized areas cannot be used for regulatory purposes.

GEOTECHNICAL ENGINEERING INVESTIGATION REPORT
PROPOSED BURNS VALLEY DEVELOPMENT
BURNS VALLEY ROAD
CLEARLAKE, LAKE COUNTY, CALIFORNIA
February 26, 2021

Prepared For:

CITY OF CLEARLAKE
14050 Olympic Drive
Clearlake, California 95422

Ms. Adeline Brown, Engineering Tech/Construction Manager



N | V | 5

48 Bellarmine Court
Suite 40
Chico, CA 95928

125620-0071075.00.001



February 26, 2021
Project No. 71075.00.001

Ms. Adeline Brown,
Engineering Tech/Construction Manager
City of Clearlake
14050 Olympic Drive
Clearlake, California 95422

**Reference: Geotechnical Engineering Investigation Report
Proposed Burns Valley Development
Burns Valley Road, Clearlake, Lake County, California**

Dear Ms. Brown,

NV5 conducted a geotechnical engineering investigation for the proposed Burns Valley Development located at Burns Valley Road, Clearlake, California. NV5's geotechnical engineering investigation of the site was performed consistent with the scope of services presented in the November 6, 2020 proposal (PC20.230).

The findings, conclusions and recommendations presented in this report are based on the following relevant information collected and evaluated by NV5: literature review, surface observations, subsurface exploration, laboratory test results, and previous experience with similar projects, sites and conditions in the area. The approximately 25-acre parcel is proposed for mixed-use development including multi-story apartment buildings, a single-story commercial building, and a City of Clearlake Public Works (CCPW) Yard with an approximately 20,000-square-foot (sf) shop utilizing conventional design and construction practices. There were no seismic hazards identified on the site or in the immediate area that require design mitigation. Portions of the site support loose undocumented fills that are not considered suitable for support of the proposed improvements. Therefore, it is NV5's opinion that the site is suitable for the proposed construction provided the geotechnical engineering recommendations presented in this report are incorporated into the earthwork and structural improvements. This report should not be relied upon without review by NV5 if a period of 24 months elapses between the issuance report date shown above and the date when construction commences.

NV5 appreciates the opportunity to provide geotechnical engineering services for this important project. If you have questions or need additional information, please do not hesitate to contact the undersigned at 530-894-2487.

Sincerely,
NV5

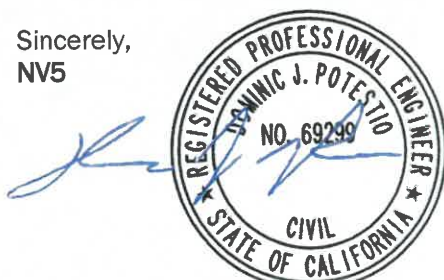

Dominic J. Potestio, PE 69299
Senior Engineer



Shane D. Cummings, CEG 2492
Senior Engineering Geologist

	Page
Title Sheet	i
Transmittal Letter with Engineer's/Geologist's Signature and Seal.....	ii
Table of Contents.....	iii
Acronyms	vi

TABLE OF CONTENTS

1.0 INTRODUCTION.....	1
1.1 SCOPE-OF-SERVICES.....	1
1.2 SITE LOCATION AND DESCRIPTION.....	1
1.3 PROPOSED IMPROVEMENTS.....	4
1.4 INVESTIGATION PURPOSE.....	4
2.0 SITE INVESTIGATION.....	6
2.1 LITERATURE REVIEW.....	6
2.1.1 Site Improvement Plans.....	6
2.1.2 Previous Site Investigation Reports.....	6
2.2 REGIONAL GEOLOGY.....	6
2.3 SITE GEOLOGY.....	7
2.4 REGIONAL FAULTING AND SEISMIC SOURCES.....	7
2.5 FIELD INVESTIGATION.....	7
2.5.1 Surface Conditions.....	8
2.5.2 Subsurface Conditions.....	8
3.0 LABORATORY TESTING.....	12
4.0 HISTORICAL SEISMICITY.....	14
5.0 LIQUEFACTION AND SEISMIC SETTLEMENT.....	15
5.1 LIQUEFACTION.....	15
5.2 SEISMIC SETTLEMENT AND LATERAL SPREADING.....	16
6.0 CONCLUSIONS.....	17
7.0 RECOMMENDATIONS.....	19
7.1 EARTHWORK GRADING.....	19
7.1.1 Demolition and Abandonment of Existing Site Improvements.....	19
7.1.2 Import Fill Soil.....	19
7.1.3 Temporary Excavations.....	20
7.1.4 Stripping and Grubbing.....	20
7.1.5 Native Soil Preparation for Engineered Fill Placement.....	20
7.1.6 Engineered Fill Construction with Testable Earth Materials.....	21
7.1.7 Cut and Fill Slope Grading.....	23
7.1.8 Erosion Controls.....	23
7.1.9 Underground Utility Trenches.....	24
7.1.10 Construction Dewatering.....	27
7.1.11 Soil Corrosion Potential.....	28

7.1.12	Subsurface Groundwater Drainage.....	28
7.1.13	Surface Water Drainage	28
7.1.14	Grading Plan Review and Construction Monitoring.....	29
7.2	STRUCTURAL IMPROVEMENTS	29
7.2.1	Seismic Design Parameters.....	29
7.2.2	Shallow Foundations.....	32
7.2.3	Retaining Walls Entirely Above the Groundwater Table	33
7.2.4	Retaining Wall Backfill.....	35
7.2.5	Concrete Slab-On-Grade Interior Floors, Sidewalk and Patio Construction.....	37
7.2.6	Rigid Concrete Pavement for Heavy Truck Traffic Areas and Fire Lanes	42
7.2.7	Flexible Pavement	43
8.0	REFERENCES	46
9.0	LIMITATIONS.....	47

LIST OF TABLES

Table 3.0-1, Laboratory Test Results	13
Table 5.1-1, Liquefaction Potential Calculated From Borings	16
Table 7.1.5-1, Minimum Testing Frequencies	21
Table 7.1.6.1-1, Minimum Testing Frequencies for Non-Expansive Soil	23
Table 7.1.9-1, Minimum Testing Frequencies for Utility Trench Backfill.....	27
Table 7.2.1-1 2019 CBC Seismic Design Parameters	31
Table 7.2.2-1, Foundation Bearing Pressures for Shallow Foundations	32
Table 7.2.3-1, Design Parameters for Retaining Walls.....	35
Table 7.2.7-1, Flexible Pavement Design.....	44

LIST OF FIGURES

Figure 1, Site Location Map.....	2
Figure 2, Site Plan and Exploratory Boring Location Map	5

APPENDICES

A	Important Information about This Geotechnical Engineering Report (Included with permission of GBA, Copyright 2019)
B	Exploratory Boring Logs
C	Soil Laboratory Test Results
D	Liquefaction Analysis Results
E	Seismic Design Parameters

ACRONYMS

°F	degrees Fahrenheit
AB	aggregate base
AC	asphalt concrete
ACI	American Concrete Institute
ASCE	American Society of Civil Engineers
ASTM	ASTM International
bgs	below ground surface
Cal/EPA	California Environmental Protection Agency
CAT	Caterpillar
CBC	California Building Code
CCPW	City of Clearlake Public Works
CEC	California Engineering Company
CGS	California Geological Survey
CQA	Construction Quality Assurance
DTSC	Department of Toxic Substances Control
DWR	Department of Water Resources
EERI	Earthquake Engineering Research Institute
EFP	equivalent fluid pressure
FS	factor of safety
ft/s	feet per second
GBA	Geoprofessional Business Association
H:V	horizontal to vertical slope ratio
IBC	International Building Code
km	kilometer
MCE	maximum considered earthquake
M _L	local magnitude earthquake
msl	mean sea level
M _w	modal magnitude
NEIC	National Earthquake Information Center
OSHA	Occupational Safety and Hazards Administration
oz/sy	ounce per square yard
P-wave	seismic compression wave
PCA	Portland Cement Association
pcf	pounds per cubic foot
PGA _m	peak ground acceleration
PG&E	Pacific Gas & Electric
PI	plasticity index
psf	pounds per square foot
psi	pounds per square inch
PVC	polyvinylchloride
Q _{al}	Quaternary Alluvium
S-wave	shear-wave
SEAOC	Structural Engineers Association of California
sf	square foot
SPT	standard penetration test
SRMS	Seismic Refraction Microtremor Survey

ACRONYMS (CONCLUDED)

SSD	saturated surface dry
TI	traffic index
USCS	Unified Soils Classification System
USGS	United States Geological Survey

1.0 INTRODUCTION

NV5 performed a geotechnical engineering investigation and prepared a geotechnical engineering investigation report for the proposed Burns Valley Development mixed-use project at Burns Valley Road in Clearlake, California, consistent with the scope of services presented in NV5's *Proposal for Geotechnical Engineering Services* (PC20.230), dated November 6, 2020. NV5's findings, conclusions and recommendations are presented herein.

For your review, Appendix A presents a document prepared by the Geoprofessional Business Association (GBA) entitled "*Important Information about This Geotechnical Engineering Report.*" This document summarizes project specific factors, limitations, content interpretation, responsibilities and other pertinent information.

1.1 SCOPE-OF-SERVICES

NV5 performed a specific scope-of-services to develop geotechnical engineering design recommendations for earthwork and structural improvements. Brief descriptions of each work scope task are presented below. A detailed description of each work scope task is presented in Section 2 (Site Investigation) of this report.

- **Task 1 Site Investigation:** NV5 performed a site investigation to characterize the existing surface and subsurface soil, rock and groundwater conditions encountered to the maximum depth excavated. NV5's field engineer/geologist made observations, took representative soil samples, and performed field tests at a limited number of subsurface exploratory locations. NV5 performed laboratory tests on selected soil samples to evaluate their engineering material properties.
- **Task 2 Data Analysis and Engineering Design:** NV5 evaluated the field and laboratory site data and the proposed site improvements and used this information to develop geotechnical engineering design recommendations for earthwork and structural improvements. NV5 used engineering judgment to extrapolate NV5's observations and conclusions regarding the field and laboratory data to other onsite areas located between and beyond the locations of NV5's subsurface exploratory excavations.
- **Task 3 Report Preparation:** NV5 prepared this report to present the findings, conclusions and recommendations for this geotechnical engineering investigation.

1.2 SITE LOCATION AND DESCRIPTION

The proposed Burns Valley Development are located at Burns Valley Road, in Clearlake, California, identified as Lake County Assessor's Parcel Numbers 010-026-40, 010-026-29 and 039-570-18. The proposed development is located at the southwest corner of Burns Valley Road and Rumsey Road. The site is centered at about latitude 38.9638 north and longitude -122.6349 west on the United States Geological Survey's (USGS), 7.5 minute Clearlake Highlands Quadrangle topographic map. The property elevation is approximately 1360 feet above mean sea level (msl), based on review of the USGS 7.5-minute Clearlake Highlands Quadrangle topographic map, and is generally flat with a gentle downgrade slope from east to west. Figure 1 shows the approximate site location and vicinity.



SITE LOCATION

T13N R7W

CLEARLAKE

Clearlake Highlands

SITE LOCATION MAP

CITY OF CLEARLAKE BURNS VALLEY DEVELOPMENT
BURNS VALLEY ROAD, CLEARLAKE, LAKE COUNTY, CALIFORNIA

DRAWN BY:	SC
CHECKED BY:	DJP
PROJECT:	71075.01.001
DATE:	FEBRUARY 2021

FIGURE

1

981





At the time the site investigation was performed on January 12 and 13, 2021, the following conditions were observed and are shown in the inset image:

The area of the proposed Burns Valley Development is comprised of Lake County Assessor's Parcel Numbers 010-026-40, 010-026-29 and 039-570-18. Each of the three parcels is described respectively.

- Parcel 010-026-40 is an irregular-shaped property generally comprised of an existing tree orchard and high concentrations of weeds and grasses. The terrain was relatively flat with a gentle downward slope from the east to the west. A drainage channel transected the east portion of the property in the southwest direction. To the east of the drainage channel the surface topography was relatively higher in elevation than the rest of the site. Large stockpiles consisting of soils, concrete and asphalt rubble, boulders, and other deleterious debris were present. Overhead power poles and power lines were present along the north and east boundaries of the property. The property was bounded to the east and north by Burns Valley Road; to the west by Burns Valley Creek; and, to the south by apartments, commercial buildings and a retail shopping center.
- Parcel 010-026-29 is a rectangular shaped property supporting a large number of mature oak trees, agricultural tress, and high concentrations of weeds and grasses. Concrete foundation remnants of a former structure and a large construction crane were present in the southern portion of the property. A drainage channel transected the center of the site and extended in the southwest direction. A California Department of Water Recourses (DWR) monitoring well was present in the northeast portion of the site. A water well pump house was present in the north half of the property. The site was bounded to the north and east by Burns Valley Road, to the south by fallow land and stockpiles; and, to the west by a senior living community.

- Parcel 039-570-18 is a rectangular shaped property comprised of fallow land supporting low to moderate concentrations of weeds and grasses. Sparse mature trees and fence posts were present throughout the site. Numerous utility markings were present indicating the presence of underground utilities. The property is bounded to the north by existing tree orchards; to the west by an existing Pacific Gas & Electric (PG&E) facility; to the south by Olympic Drive; and, to the east by a retail shopping center. Evidence of a former structure was observed in the northern portion of the parcel.

1.3 PROPOSED IMPROVEMENTS

Based on the preliminary project information provided by representatives of California Engineering Company (CEC), NV5 understands the approximately 30-acre parcel is proposed for mixed-use development including multi-story apartment buildings, a single-story commercial building, and a City of Clearlake Public Works (CCPW) Yard with an approximately 20,000-square-foot (sf) shop. The proposed residential and commercial structures are anticipated to be constructed with wood or light-metal framing and supported on shallow concrete foundations with interior concrete slab-on-grade floors. The proposed CCPW shop is anticipated to consist of a metal, prefabricated building, or constructed with light-metal framing, and supported on shallow concrete foundations with an interior concrete slab-on-grade floor.

Associated development is indicated to include construction of an asphalt concrete paved police department parking lot, recreational fields (baseball/softball, soccer, etc.), underground utilities, exterior slab-on-grade concrete flatwork, rigid concrete and asphalt concrete pavements, and landscaping. Earthwork grading may include general site preparation, and minor cuts and fills to balance the site to meet the proposed building grades. Figure 2 shows the proposed site location and approximate exploratory boring locations.

1.4 INVESTIGATION PURPOSE

The purpose of the geotechnical investigation was to obtain sufficient on-site information about the soil, rock and groundwater conditions to provide geotechnical engineering recommendations for the proposed earthwork and structural improvements. As part of this contract, NV5 did not evaluate the site for the presence of hazardous waste, mold, asbestos and radon gas. Therefore, the presence and removal of these materials are not discussed in this report.

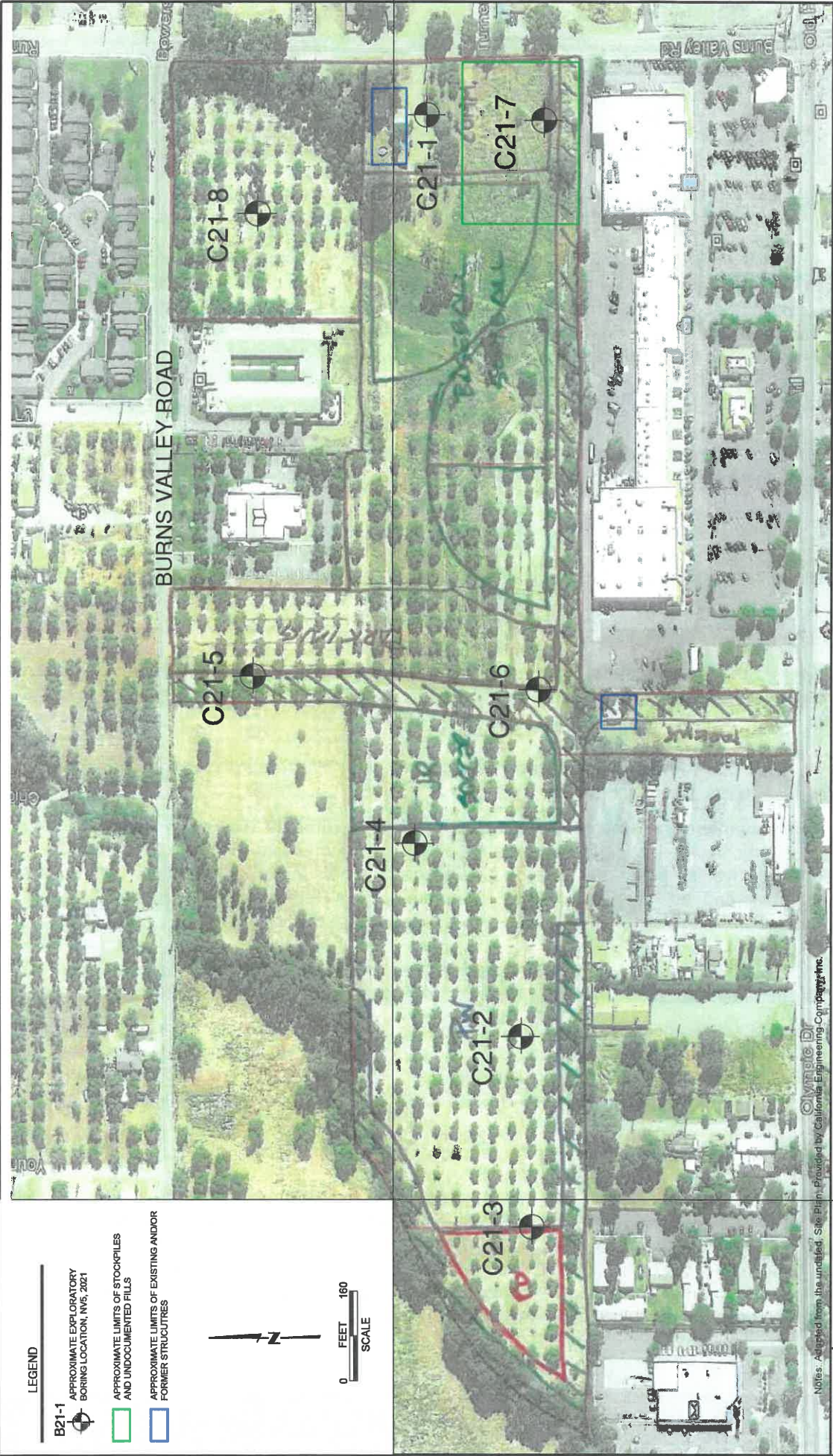

DRAWN BY:	SC
CHECKED BY:	DJP
PROJECT:	71075.01.001
DATE:	FEBRUARY 2021

SITE PLAN AND EXPLORATORY CORE LOCATION MAP
 CITY OF CLEARLAKE BURNS VALLEY DEVELOPMENT
 BURNS VALLEY ROAD, CLEARLAKE, LAKE COUNTY, CALIFORNIA

Notes: Adapted from the untitle... Site Plan. Provided by California Engineering Company, Inc.

NV5

FIGURE 2

2.0 SITE INVESTIGATION

NV5 performed a site investigation to characterize the existing surface and subsurface conditions beneath the proposed improvements. The site investigation included a literature review of published and unpublished geologic documents and maps, a surface reconnaissance investigation, and a subsurface exploratory investigation using a track-mounted drill rig to excavate exploratory borings. Each component of the site investigation is presented below.

2.1 LITERATURE REVIEW

NV5 performed a limited review of available literature that was pertinent to the project site. The following summarizes NV5's findings:

2.1.1 Site Improvement Plans

Improvement plans were not available for review at the time this report was prepared.

2.1.2 Previous Site Investigation Reports

NV5 reviewed the following reports associated with the project site area. The following identifies each report and summarizes the findings, conclusions and recommendations presented in each report:

- NV5, 2021, *Field Investigation Summary Report, Sulphur Fire Road Rehabilitation Project, Various Streets, Clearlake, California*, prepared by NV5, February XX.

The investigation consisted of evaluating various streets within the City of Clearlake. The evaluation consisted of logging the existing pavement conditions and thickness, collecting representative sample of the underlying subgrade materials for subgrade quality testing. Based on the field and laboratory information recommendations were provided for roadway rehabilitation with asphalt concrete overlay or full depth reconstruction.

- NV5, 2021, *Reconnaissance Geotechnical Engineering Report, City of Clearlake Sulphur Fire Cuts Rehabilitation Assessments, Clearlake, California*, prepared by NV5, January 11.

The investigation consisted of evaluating seven existing damaged road cuts for slope stability failure modes. The cuts only showed evidence of shallow erosion caused by surface water runoff, shallow sloughing and/or shallow soil creep. Recommendations for standard soil erosion prevention rehabilitation practices were provided to mitigate the erosion concerns.

2.2 REGIONAL GEOLOGY

The proposed Burns Valley Development is situated in the Coast Range Geomorphic Province of California. The Coast Range Geomorphic Province is characterized as northwest-trending mountain ranges and valleys that are subparallel to the San Andreas Fault. Strata of the Coast Range dip beneath alluvium of the Great Valley to the east and rise above the Pacific Ocean to the west. The Coast Range is comprised of thick Mesozoic and Cenozoic sedimentary rocks that were uplifted by the San Andreas Fault, terraced, and wave-cut. In the northern region, the Coast Range is dominated

by irregular and knobby topography of the Franciscan Complex. Locally, the Franciscan rocks are overlain by volcanic cones and flows of the Clearlake volcanic field.

In the Clearlake area, the geology is dominated by the late Pliocene to early Holocene Clearlake volcanic field. The volcanic field consists of lava domes, cinder cones, and maars comprised of basalt and rhyolite. Cobb Mountain and Mount Konocti are the two highest peaks in the volcanic field. The Geysers, which host the largest complex of geothermal plants in the world, are located within the volcanic field.

2.3 SITE GEOLOGY

Based on review of the *Geologic Map of the Santa Rosa Quadrangle*, published by the California Division of Mines and Geology (Wagner and Bortugno, 1982), the geology immediately underlying the subject site is comprised of Quaternary Alluvium. Quaternary Alluvium is comprised of Pleistocene to Holocene Age alluvial deposits of sand, gravel, silt, and clay.

2.4 REGIONAL FAULTING AND SEISMIC SOURCES

Regional faulting is associated with the Maacama Fault Zone and Konocti Bay Fault Zone to the west, the Bartlett Springs Fault Zone to the north and east and the Hunting Creek-Berryessa Fault Zone to the south. NV5 reviewed the Official Maps of Earthquake Fault Zones delineated by the California Geological Survey through December 2010, on the internet at <http://maps.conservation.ca.gov/cgs/informationwarehouse/index.html?map=regulatorymaps>. These maps are updates to Special Publication 42, Interim Revision 2007 edition *Fault Rupture Hazard Zones in California*, which describes active faults and fault zones (activity within 11,000 years), as part of the Alquist-Priolo Earthquake Fault Zoning Act. Special Publication 42 and the 2010 on-line update indicate that the site is not located within an Alquist-Priolo active fault zone. However, the Clearlake Highlands Alquist-Priolo active fault zone is located approximately 3 miles to the west of the site.

According to the Fault Activity Map of California (2010) by the California Geological Survey, Geologic Data Map No. 6 (<http://maps.conservation.ca.gov/cgs/fam/>), the closest known active fault which has surface displacement within Holocene time (about the last 11,000 years) is the Konocti Bay Fault Zone. The mapped fault zone is located approximately 3 miles west of the subject site. The Fault Activity Map of California (2010) also shows the Bartlett Springs Fault Zone located 6 miles (13 kilometer [km]) northeast of the site and the Hunting Creek-Berryessa Fault Zone located 10 miles (15 km) east of the site to be known active faults with surface displacement within Holocene time.

2.5 FIELD INVESTIGATION

NV5 performed a field investigation of the site on January 12 and 13, 2021. NV5's field engineer/geologist described the surface and subsurface soil, rock and groundwater conditions observed at the site using the procedures cited in the ASTM International, Inc. (ASTM), Volume 04.08, *Soil and Rock (I)* as general guidelines. The field engineer/geologist described the soil color using the general guideline procedures presented in the Munsell® Soil-Color Chart. Engineering judgment was used to extrapolate the observed surface and subsurface soil, rock and groundwater conditions to areas located between and beyond the subsurface exploratory locations.

The surface, subsurface and groundwater conditions observed during the field investigation are summarized below.

2.5.1 Surface Conditions

NV5 observed the following surface conditions during the field investigation of the property. Figure 2 shows the existing building footprint, surrounding improvements and the approximate exploratory boring locations. The area of the proposed Burns Valley Development is comprised of Lake County Assessor's Parcel Numbers 010-026-40, 010-026-29 and 039-570-18. Each of the three parcels is described respectively.

Parcel 010-026-40 is an irregular-shaped property generally comprised of an existing tree orchard and high concentrations of weeds and grasses. The terrain was relatively flat with a gentle downward slope from the east to the west. A drainage channel transected the east portion of the property in the southwest direction. To the east of the drainage channel the surface topography was relatively higher in elevation than the rest of the site. Large stockpiles consisting of soils, concrete and asphalt rubble, boulders, and other deleterious debris were present. Overhead power poles and power lines were present along the north and east boundaries of the property. The property was bounded to the east and north by Burns Valley Road; to the west by Burns Valley Creek; and, to the south by apartments, commercial buildings and a retail shopping center.

Parcel 010-026-29 is a rectangular shaped property supporting a large number of mature oak trees, agricultural tress, and high concentrations of weeds and grasses. Concrete foundation remnants of a former structure and a large construction crane were present in the southern portion of the property. A drainage channel transected the center of the site and extended in the southwest direction. A California DWR monitoring well was present in the northeast portion of the site. A water well pump house was present in the north half of the property. The site was bounded to the north and east by Burns Valley Road, to the south by fallow land and stockpiles; and, to the west by a senior living community.

Parcel 039-570-18 is a rectangular shaped property comprised of fallow land supporting low to moderate concentrations of weeds and grasses. Sparse mature trees and fence posts were present throughout the site. Numerous utility markings were present indicating the presence of underground utilities. The property is bounded to the north by existing tree orchards; to the west by an existing PG&E facility; to the south by Olympic Drive; and, to the east by a retail shopping center. Evidence of a former structure was observed in the northern portion of the parcel.

2.5.2 Subsurface Conditions

The subsurface soil, rock and groundwater conditions were investigated by drilling exploratory borings. The subsurface information obtained from this investigation method is described in the following subsections.

2.5.2.1 Exploratory Boring Information

NV5 provided engineering oversight for the excavation of 8 exploratory soil borings at the project site. The borings were advanced with a track-mounted CME-55 drill rig equipped with 8-inch outside diameter, continuous flight, hollow stem augers. Figure 2 shows the approximate locations of the

subsurface exploratory excavations. The borings were excavated to a maximum depth of 51.5 feet below ground surface (bgs). Engineering judgment was used to extrapolate the observed soil, rock and groundwater conditions to areas located between and beyond the subsurface exploratory excavations.

NV5's field engineer/geologist logged each exploratory boring using the ASTM D2487 USCS as guidelines for soil descriptions and the American Geophysical Union guidelines for rock descriptions. Relatively undisturbed soil samples were collected with an unlined standard penetration test (SPT) split-spoon sampler and 2.5-inch-inside-diameter, split-spoon sampler equipped with stainless steel liner sampler tubes. The samplers were driven into the soil using an overshot cathead hammer weighing 140 pounds with a 30-inch free-fall. The stainless-steel liner samples were sealed with labeled plastic caps. The samples collected with the SPT sampler were sealed in labeled plastic bags. Representative bulk samples of the near-surface soil materials generated from drilling the exploratory borings also were collected and placed in labeled sample bags. The soil samples collected in the exploratory borings were transported to NV5's Chico soil laboratory facility.

Detailed descriptions of the soil, rock and groundwater conditions that were encountered in each subsurface exploratory location are presented on the exploratory boring logs included in Appendix B. The soil and rock descriptions include: visual field estimates of the particle size percentages (by dry weight), color, relative density or consistency, moisture content and cementation that comprise each soil material encountered.

A generalized profile of the soil, rock and groundwater conditions encountered to the maximum depth excavated (51.5 feet) for the proposed building area is presented below. The soil and/or rock units encountered in the subsurface exploratory excavations were generally stratigraphically continuous across the site with some variations in gradations and thicknesses. The units encountered in general stratigraphic sequence during the subsurface investigation of the site are described below.

- **ML, Low Plasticity Silt Soil:** This soil is considered to be a native soil consisting of the following field estimated particle size percentages 70 percent low plasticity silt and clay fines and 30 percent fine sand. This soil is predominantly dark yellowish brown with a Munsell® Soil-Color Chart designation of (10YR, 4/4). This soil was stiff and damp at the time of the subsurface investigation.
- **SC, Clayey Sand Soil:** This soil is considered to be a native soil consisting of the following field estimated particle size percentages: 55 percent fine sand, 20 percent low plasticity silt and clay fines, and 25% Gravel. This soil is predominantly dark yellowish brown with a Munsell® Soil-Color Chart designation of (10YR, 4/6). This soil was medium dense and moist to damp at the time of the subsurface investigation
- **CL, Low Plasticity Clay Soil:** This soil is considered to be a native soil consisting of the following field estimated particle size percentages 85 percent low plasticity silt and clay fines and 15 percent fine sand. This soil is predominantly brown with a Munsell® Soil-Color Chart designation of (10YR, 4/3). This soil was stiff and moist at the time of the subsurface investigation.
- **GM, Silty Gravel Soil:** This soil is considered to be a native soil consisting of the following field estimated particle size percentages: 60 percent gravel, 30 percent fine sand and 10 percent low plasticity silt and clay fines. This soil is predominantly light gray with a Munsell® Soil-Color Chart

designation of (10YR, 7/1). This soil was medium dense and wet at the time of the subsurface investigation.

- **CH, High Plasticity Clay Soil:** This soil is considered to be a native soil consisting of the following field estimated particle size percentages 85 percent high plasticity silt and clay fines and 15 percent fine sand. This soil is predominantly dark greenish gray with a Munsell® Soil-Color Chart designation of (GLE Y 1, 4/1). This soil was firm and wet at the time of the subsurface investigation.
- **GP, Poorly Graded Gravel Soil:** This soil is considered to be a native soil consisting of the following field estimated particle size percentages: 80 percent gravel, 10 percent fine sand and 10 percent low plasticity silt and clay fines. This soil is predominantly gray with a Munsell® Soil-Color Chart designation of (10YR, 5/1). This soil was dense and very moist at the time of the subsurface investigation.
- **SM, Silty Sand Soil:** This soil is considered to be a native soil consisting of the following field estimated particle size percentages: 55 percent fine sand and 45 percent low plasticity silt and clay fines. This soil is predominantly dark grayish brown with a Munsell® Soil-Color Chart designation of (2.5YR, 4/2). This soil was medium dense and wet at the time of the subsurface investigation.

2.5.2.2 Seismic Refraction Microtremor Survey

A Seismic Refraction Microtremor Survey (SRMS) was performed at a nearby site, approximately ½-mile southeast of the subject property, using the SeisOpt® ReMi™ Vs30 method to determine the in-situ shear-wave (S-wave) velocity profile (Vs Model) of the uppermost 100 feet (30 meters) of soil beneath the site. The measured S-wave profile is used to determine the California Building Code (CBC) Site Class in accordance with Chapter 16, Section 1613.3.2 and Chapter 20 of ASCE 7-16.

The SRMS method is performed at the surface using a conventional seismograph equipped with geophones that record both seismic compression waves (P-waves) and S-waves. The P-wave and S-wave sources consist of ambient seismic microtremors which are constantly being generated by cultural activities and natural noise in the area. The data was collected in a series of twenty-one, 30-second-long, continuous recording periods. The inset image shows the Vs Model subsurface shear-wave

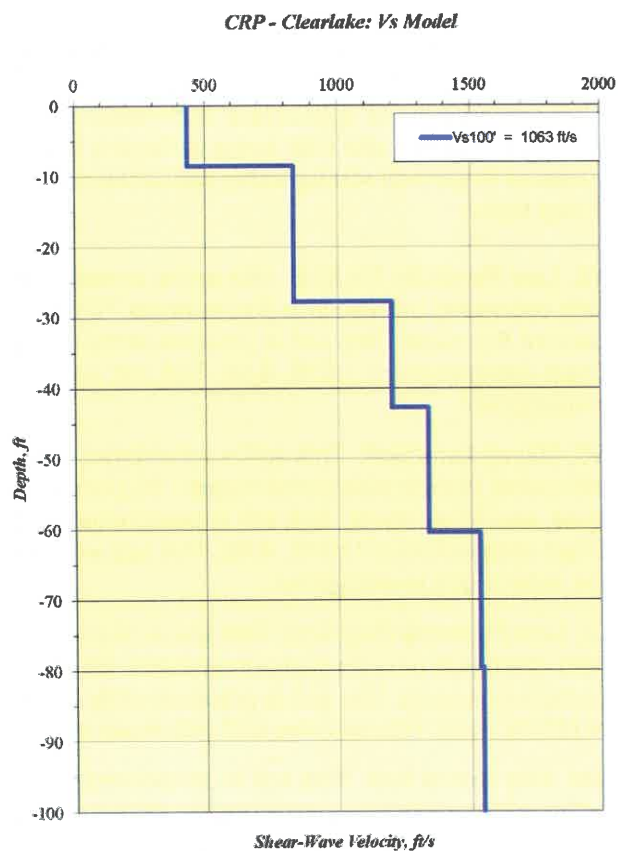

velocity profile for the site that was developed from the SeisOpt® ReMi™ data.

The Vs Model developed for the site indicates that the harmonic mean seismic shear wave velocity for the upper 100 feet of the subsurface is approximately 1063 feet per second (ft/s). This weighted shear wave velocity corresponds to the higher range of Site Class D, as described in Chapter 20, Table 20.3-1 Site Classification of ASCE 7-16.

2.5.2.3 Groundwater Conditions

The groundwater table was encountered at depths ranging between 19 to 30 feet below ground surface in exploratory borings B21-1, B21-2, B21-4, B21-6, and B21-8. The moisture content of each soil unit described on the exploratory boring logs is considered the natural moisture within the vadose soil zone (soil situated above the groundwater table).

NV5 used the Department of Water Resources Water Data Library database (wdl.water.ca.gov/waterdatalibrary) to review historical groundwater elevation data in the immediate area. Based on review of groundwater elevation data generated from a monitoring well located in the northeast portion of the project site, NV5 estimates that the historically high groundwater occurs at a depth of approximately 10 to 20 feet bgs in the late winter or spring during periods of above average and prolonged rainfall.

Fluctuations in groundwater elevation may also occur from agricultural irrigation in the area and the adjacent Burns Valley Creek

3.0 LABORATORY TESTING

NV5 performed laboratory tests on selected soil samples taken from the subsurface exploratory excavations to determine their geotechnical engineering material properties. These engineering material properties were used to develop geotechnical engineering design recommendations for earthwork and structural improvements. The following laboratory tests were performed using the cited ASTM guideline procedures:

- ASTM D422 Particle Size Gradation (Sieve Only)
- ASTM D2216 Soil Moisture Content
- ASTM D2487 Soil Classification by the USCS
- ASTM D2844 Resistance Value (R-Value)
- ASTM D2850 Unconsolidated-Undrained Triaxial Compression Test
- ASTM D2937 In Place Density of Soil
- ASTM D4318 Atterberg Limits (Dry Method)

Table 3.0-1 presents a summary of the geotechnical engineering laboratory test results. Appendix C presents the laboratory test data sheets.

Table 3.0-1, Laboratory Test Results

Boring No.	Sample		ASTM Test Results ⁽¹⁾								
	No.	Depth	D2487 D2488	D2216	D2937	D422		D4318		D2850	D2844
		(ft)	USCS (sym)	Moisture Content (%)	Dry Density (pcf)	Passing No. 4 Mesh Sieve (%)	Passing No. 200 Mesh Sieve (%)	Plasticity Index (%)	Liquid Limit (%)	UU Triaxial Compressive Strength (psf)	Resistance Value (R-Value) (dim)
B21-1	BK-1	0-3	SC	–	–	61.4	20.1	11	30	–	–
B21-1	B2-1-1	31.0	CH	–	–	–	–	31	54	–	–
B21-2	BK-2	1-3	CL	–	–	89.1	57.1	18	39	–	–
B21-2	L2-1-2	6.0	CL	16.1	100.8	–	–	–	–	–	–
B21-5	BK-4	0-4	ML	–	–	–	–	–	–	–	22
B21-8	L1-1-2	1.0	CL	18.5	101.6	–	–	–	–	1,538.51	–

Notes: (1) Laboratory test forms are presented in Appendix C
 % percent
 ASTM ASTM International
 dim dimensionless
 ft feet
 No. Number
 Pcf pounds per cubic foot
 psf pounds per square foot
 sym symbol
 UU Unconsolidated-Undrained
 USCS Unified Soils Classification System

4.0 HISTORICAL SEISMICITY

The regional geology and faulting are discussed in Section 2 of this report. NV5 used the USGS National Earthquake Information Center (NEIC) Earthquake Search Results on-line database (<http://earthquake.usgs.gov/earthquakes/search>) to identify historical seismic activity within a 100 km (62 miles) radial distance of the subject site. A search for earthquakes was limited to moderate to strong events with a minimum magnitude of 5.0 local magnitude [M_L]. The results produced three recent events that occurred within 100 km of the site since 2014. These earthquakes include the following events:

- August 24, 2014, 6.0 M_L South Napa earthquake main shock occurred at approximately 03:20 hours in the Napa Valley. The earthquake epicenter was approximately 87 km (54 miles) south of the subject site. The earthquake damaged many structures in the Napa County and Sonoma County surrounding areas. The mean intensity estimated at the distance of the subject property ranged from 2.9 to 3.4, which indicates weak to light shaking and no damage.
- December 14, 2016, 5.0 M_L earthquake occurred approximately 8 km northwest of The Geysers, approximately 26 km (16 miles) southwest of the subject site. The event recorded a mean intensity of 4.1 at the distance to the subject site, which indicates light shaking and no damage.
- August 10, 2016, 5.1 M_L earthquake occurred approximately 20 km northeast of Upper Lake, approximately 34 km (21 miles) north-northwest of the subject site. The event recorded a mean intensity of 3.4 at the distance to the subject site, which indicates light shaking and no damage.

Additionally, a number of moderate to strong earthquakes were recorded within the past 150 years, although many of them occurred more than 100 years ago.

- 1962 and 1869, a 5.2 M_L (1969) earthquake and a 5.0 M_L (1869) earthquake occurred approximately 40km (25 miles) northwest of the subject site, near Ukiah.
- 1969 and 1893, 5.1 M_L earthquakes occurred approximately 58 km (36 miles) south of the site, near Santa Rosa.
- 1898 and 1891, a 6.2 M_L (1898) earthquake and a 5.5 M_L (1891) earthquake occurred approximately 84 km (52 miles) south-southeast of the site, near Sonoma.
- 1968, a 5.0 M_L earthquake occurred approximately 80 km (50 miles) from the site, in Glenn County.
- April 1892, three earthquakes (5.5 M_L , 6.2 M_L , and 6.4 M_L) occurred approximately 89 km (55 miles) southeast of the site, near Vacaville.
- 1902, a 5.4 M_L earthquake occurred approximately 100 km (62 miles) southeast of the site, near Fairfield.

The Geysers area, located approximately 24 km (15 miles) from the site, also is very active and produces dozens of small earthquakes, below magnitude of 4.0 M_L , on a daily to weekly basis.

5.0 LIQUEFACTION AND SEISMIC SETTLEMENT

NV5 did not perform a detailed evaluation of the potential for seismically induced soil liquefaction at the site. However, NV5 believes that the site has a low potential for soil liquefaction. The following supports our assessment.

5.1 LIQUEFACTION

Soil liquefaction results when the shear strength of a saturated soil decreases to zero during cyclic loading that is generally caused by machine vibrations or earthquake shaking. Generally, saturated, clean, loose, uniformly graded sand and loose, silty sand soils of Holocene age are the most prone to undergo liquefaction. However, saturated, gravelly soil and some silt and clay-rich soil may be prone to liquefaction under certain conditions. The onsite soil is Pleistocene to Holocene age soil consisting of Quaternary Alluvium (Q_{al}) primarily composed of stiff, damp to wet, cohesive soil and dense to very dense, damp to moist, sandy and silty gravels. Groundwater was encountered in exploratory borings B20-1 through B20-3 at depths of approximately 19 to 30 feet bgs. Groundwater data collected from nearby groundwater monitoring wells indicate the historical high groundwater table in the area may be encountered as shallow as approximately 10 feet bgs. NV5 considers 10 feet bgs to be the historical high groundwater elevation and used this data in the liquefaction analysis.

NV5 evaluated the liquefaction potential of the site using the procedures presented in the 2008 Earthquake Engineering Research Institute (EERI) Monograph publication *Soil Liquefaction During Earthquakes* by I. M. Idriss and R. W. Boulanger (Idriss, I. M. & Boulanger, R. W., 2008). It should be noted that NV5 used the maximum considered earthquake (MCE) modal magnitude $9M_w$ from a Cascadian subduction zone event. The shear stress reduction coefficient currently established does not use historical data from model magnitude $9M_w$, however current evaluations using recent magnitude 9M events are being evaluated. The determination of a shear stress reduction coefficient for a $9M_w$ earthquake exceeds the current model computations, therefore, NV5 conservatively assumed no stress reductions which is represented by an r_d value of 1 for all depths. This is a very conservative approach for liquefaction analyses.

The California Geological Society (CGS) Special Publication 117A suggests a minimum factor of safety (FS) of 1.3 for liquefaction analyses when using their ground motion maps. NV5 used a computed FS of less than 1.3 to indicate the occurrence of liquefaction at the site. The computed liquefaction FS for the project site soils ranged from 0.13 to greater than 2.0 for the soil layer intervals evaluated. The calculation spreadsheet of this analysis is included in Appendix D. Table 5.1-1 summarizes the findings of each borehole analyses using a depth to groundwater of 10 ft bgs.

Table 5.1-1, Liquefaction Potential Calculated From Borings

Assumed Groundwater Level (ft bgs)	Earthquake Magnitude (Mm)	Deterministic PGA (g)	Boring ID (No.)	Liquefaction Interval FS<1.3 (ft bgs)	Seismically Induced Settlement (inches)	Expected Manifestation (Yes/No)
10.0	9.0	0.628	B21-1	25 to 30	0.75	No
			B21-2	N/A	0.0	No
Notes ft = feet bgs = below ground surface Mm = Moment Magnitude g = gravitational acceleration						

The liquefaction evaluation is a simplified procedure that has a number of limitations that cause it to produce conservative results. These limitations include the lack of a stress reduction coefficient (r_d) value for earthquake magnitudes over 8M, as well as the assumption that penetration resistance is a good indicator for liquefaction; however, other factors such as over consolidation and age of the deposit can influence the liquefaction potential. The procedure used does not take into account the age and over consolidation of the units.

Based on the subsurface exploratory boring 2.5-inch diameter California Modified split spoon sampler and standard penetration test (SPT) sampler blow counts, field data, expected seismic peak ground acceleration and literature review, NV5 believes the probability of liquefaction occurring during ground shaking caused by a maximum considered earthquake to be low at the site.

5.2 SEISMIC SETTLEMENT AND LATERAL SPREADING

The results of the liquefaction analysis performed for this investigation indicate a calculated seismic settlement of less than 1.0 inches. These settlement estimates represent ground settlement within the soil layers prone to liquefaction, not settlement at the ground surface.

Based on the relative flat terrain across the site and adjacent to the site and the existing development surrounding the site, NV5 considers there to be a low probability for the occurrence of lateral spreading that would be detrimental to the proposed site improvements.

6.0 CONCLUSIONS

The conclusions presented in this section are based on information developed from the field and laboratory investigations.

1. It is NV5's opinion that the site is suitable for the proposed improvements provided that the geotechnical engineering design recommendations presented in this report are incorporated into the earthwork and structural improvement project plans. Prior to construction, NV5 should be allowed to review the proposed final earthwork grading plan and structural improvement plans to determine if the geotechnical engineering recommendations were properly incorporated, are still applicable or need modifications.
2. Undocumented fills were observed in the southeastern portion of the site that extended to at least 36 inches feet bgs. These undocumented fills cannot be relied upon for support of the proposed improvements, due to their unknown quality, unknown method of placement, and potential for settlement. Recommendations for mitigating the undocumented fills are presented in Section 7.1 of this report.
3. Based on the site geology, the observations within the exploratory borings, the site soil profile can be modeled, according to the 2019 CBC, Chapter 16, and ASCE 7-16, Chapter 20, as a Site Class D (Stiff Soil Profile) designation for the purposes of establishing seismic design loads for the proposed improvements.
4. Based on the results of the liquefaction analyses, the subsurface exploratory boring blow counts, other field data, and literature review, NV5 believes that the probability of liquefaction occurring during a nearby earthquake to be low.
5. The site is comprised of Lake County Assessor's Parcel Numbers 010-026-40, 010-026-29 and 039-570-18. Each of the three parcels is described respectively.

Parcel 010-026-40 is an irregular-shaped property generally comprised of an existing tree orchard and high concentrations of weeds and grasses. The terrain was relatively flat with a gentle downward slope from the east to the west. A drainage channel transected the east portion of the property in the southwest direction. To the east of the drainage channel the surface topography was relatively higher in elevation than the rest of the site. Large stockpiles consisting of soils, concrete and asphalt rubble, boulders, and other deleterious debris were present. Overhead power poles and power lines were present along the north and east boundaries of the property. The property was bounded to the east and north by Burns Valley Road; to the west by Burns Valley Creek; and, to the south by apartments, commercial buildings and a retail shopping center.

Parcel 010-026-29 is a rectangular shaped property supporting a large number of mature oak trees, agricultural tress, and high concentrations of weeds and grasses. Concrete foundation remnants of a former structure and a large construction crane were present in the southern portion of the property. A drainage channel transected the center of the site and extended in the southwest direction. A California DWR monitoring well was present in the northeast portion of the site. A water well pump house was present in the northern half of the property. The site was bounded to the north and east by Burns Valley Road, to the south by fallow land and stockpiles; and, to the west by a senior living community.

Parcel 039-570-18 is a rectangular shaped property comprised of fallow land supporting low to moderate concentrations of weeds and grasses. Sparse mature trees and fence posts were present throughout the site. Numerous utility markings were present indicating the presence of underground utilities. The property is bounded to the north by existing tree orchards; to the west by an existing Pacific Gas & Electric (PG&E) facility; to the south by Olympic Drive; and, to the east by a retail shopping center. Evidence of a former structure was observed in the northern portion of the parcel.

6. The soil conditions observed to a maximum depth of 51.5 feet below the existing ground surface in our subsurface exploratory excavations (described relative to the existing ground surface) generally consisted of: dark yellowish brown, stiff, damp, sandy silt (ML); dark yellowish brown, medium dense, moist to damp, clayey sand (SC); brown, stiff to very stiff, moist, lean clay (CL); light gray, medium dense, wet, silty gravel (GM); dark greenish gray, firm, wet, fat clay (CH); gray, dense, very moist, poorly graded gravel (GP); and, dark grayish brown, medium dense, damp, silty sand.
7. NV5's field and laboratory test data indicates that the clayey sand (SC), lean clay (CL) and silt (ML) soil units encountered beneath the site has the following general geotechnical engineering properties: medium dense/stiff to very stiff, low plasticity and low to moderate bearing capacity that is suitable for supporting shallow foundations.
8. The groundwater table was encountered at depths ranging between 19 to 30 feet below ground surface in the exploratory borings B21-1, B21-2, B21-4, B21-6 and B21-8. Based on the above average rainfall, subsurface geologic conditions and review of monitoring well data near the site, NV5 assumes that for design and evaluation purposes, the historically high groundwater table will probably be encountered at a depth of approximately 10 to 20 feet bgs.

7.0 RECOMMENDATIONS

Undocumented fills were observed on the site and are not considered suitable for support of the proposed structural improvements. NV5 developed geotechnical engineering design recommendations for earthwork and structural improvements from the field and laboratory investigation data. Subsequent to earthwork and site preparation, it is anticipated that the proposed apartment building may be founded on conventional continuous and/or spread footings founded in undisturbed native soils or properly compacted fill. NV5's recommendations are presented below.

7.1 EARTHWORK GRADING

NV5's earthwork grading recommendations include: demolition and abandonment of existing site improvements, import fill soil, temporary excavations, stripping and grubbing, native soil preparation for engineered fill placement, engineered fill construction with testable earth materials, cut-fill transitions, cut and fill slope grading, erosion controls, underground utility trenches, construction dewatering, soil corrosion potential, subsurface groundwater drainage, surface water drainage, grading plan review and construction monitoring.

7.1.1 Demolition and Abandonment of Existing Site Improvements

NV5 anticipates that the existing site improvements within the proposed building areas will need to be demolished and removed from the site as described below.

1. The existing foundation remnants and exterior concrete slab-on-grade within the proposed building areas should be razed and disposed off-site. However, it may be possible to use some of this demolition material to construct engineered fills provided they meet the gradation requirements specified for "testable fill" materials presented in this report. The project geotechnical engineer should approve the use of both asphalt concrete (AC) and aggregate base (AB) rock demolition materials for use in constructing engineered fills.
2. All foundations, underground utilities and other existing site improvements that are encountered during construction within the proposed building area should be demolished and removed from the site. These demolition materials should be disposed off-site in compliance with applicable regulatory requirements.
3. Abandonment of any underground utilities within the construction area that will not interfere with the proposed site improvements should be plugged with cement grout to reduce migration of soil and/or water.

7.1.2 Import Fill Soil

Import fill soil should meet the geotechnical engineering material properties described in Section 7.1.6.1 (Engineered Fill Construction with Non-Expansive Soil) of this report. Prior to importation to the site, the source generator should document that the import fill meets the guidelines set forth by the California Environmental Protection Agency (CalEPA) Department of Toxic Substances Control (DTSC) in their 2001 "Information Advisory, Clean Imported Fill Material." This advisory represents the best practice for characterization of soil prior to import for use as engineered fill. The project engineer should approve all proposed import fill soil for use in constructing engineered fills at the site.

7.1.3 Temporary Excavations

All temporary excavations must comply with applicable local, state and federal safety regulations, including the current Occupational Safety and Hazards Administration (OSHA) excavation and trench safety standards. Construction site safety is the responsibility of the contractor, who is solely responsible for the means, methods and sequencing of construction operations. Under no circumstances should the findings, conclusions and recommendations presented herein be inferred to mean that NV5 is assuming any responsibility for temporary excavations, or for the design, installation, maintenance and performance of any temporary shoring, bracing, underpinning or other similar systems. NV5 could provide temporary cut slope gradients, if required.

7.1.4 Stripping and Grubbing

The site should be stripped and grubbed of vegetation and other deleterious materials, as described below.

1. Strip and remove the top 4 to 6 inches of organic-laden topsoil and other deleterious materials from the building area. Remove all existing trees within the proposed building pad areas. Grub the underlying 6 to 8 inches of soil to remove any large vegetation roots or other deleterious material while leaving the soil in place. The project geotechnical engineer or their representative should approve the use of any soil materials generated from the clearing and grubbing activities.
2. Completely remove all existing stockpiles, undocumented fill materials, concrete rubble, and other deleterious debris from the site. Excavate the remaining cavities or holes to a sufficient width so that an approved backfill soil can be placed and compacted in the cavities or holes. Enough backfill soil should be placed and compacted in order to match the surrounding elevations and grades. The project geotechnical engineer or their representative should observe and approve the preparation of the cavities and holes prior to placing and compacting engineered fill soil in the cavities and holes.
3. Excessively large amounts of vegetation, other deleterious materials and oversized rock materials should be removed from the site.

7.1.5 Native Soil Preparation for Engineered Fill Placement

After completing site stripping and grubbing activities, the exposed native soil should be prepared for placement and compaction of engineered fills, as described below.

1. The native soil should be scarified to a minimum depth of 8 inches below the existing land surface or stripped and grubbed surface and then uniformly moisture conditioned. If the soil is classified as a coarse-grained soil by the Unified Soils Classification System (USCS) (i.e., GP, GW, GC, GM, SP, SW, SC or SM) then it should be moisture conditioned to within ± 3 percentage points of the ASTM D1557 optimum moisture content. If the soil is classified as a low plasticity fine-grained soil by the USCS (i.e., CL, ML), then it should be moisture conditioned to between 2 and 4 percentage points greater than the ASTM D1557 optimum moisture content. If soil is classified as a high plasticity fine-grained soil by the USCS (i.e., CH, MH), the soil should be removed from the building pad area or contact NV5 for further recommendations.
2. The native soil should then be compacted to achieve a minimum relative compaction of 90 percent of the ASTM D1557 maximum dry unit weight (density). The moisture content, density

and relative percent compaction should be tested by the project engineer or his/her field representative to evaluate whether the compacted soil meets or exceeds the minimum percent compaction and moisture content requirements. The earthwork contractor shall assist the project engineer or his/her field representative by excavating test pads with the on-site earth moving equipment. Native soil preparation beneath concrete slab-on-grade structures (i.e., floors, sidewalks, patios, etc.) and AC pavement should be prepared as specified in Section 7.2 (Structural Improvements).

3. The prepared native soil surface should be proof-rolled with a fully loaded 4,000-gallon-capacity water truck with the rear of the truck supported on a double-axle, tandem-wheel undercarriage or approved equivalent. The proof-rolled surface should be visually observed by the project engineer or his/her field representative to be firm, competent and relatively unyielding. The project engineer or his/her field representative may also evaluate the surface material by hand probing with a ¼-inch-diameter steel probe; however, this evaluation method should not be performed in place of proof rolling as described above.
4. Construction Quality Assurance (CQA) tests should be performed using the minimum testing frequencies presented in Table 7.1.5-1 or as modified by the project engineer to better suit the site conditions.
5. The native soil surface should be graded to minimize ponding of water and to drain surface water away from the building foundations and associated structures. Where possible, surface water should be collected, conveyed and discharged into natural drainage courses, storm sewer inlet structures, permanent engineered storm water runoff percolation/evaporation basins or engineered infiltration subdrain systems.

Table 7.1.5-1, Minimum Testing Frequencies

ASTM No.	Test Description	Minimum Test Frequency ⁽¹⁾
D1557	Modified Proctor Compaction Curve	1 per 1,500 CY or Material Change ⁽²⁾
D6938	Nuclear Density and Nuclear Moisture Content	1 per 250 CY
Notes:		
(1)	These are minimum testing frequencies that may be increased or decreased at the project engineer's discretion based on the site conditions encountered during grading.	
(2)	Whichever criteria provide the greatest number of tests.	
ASTM	= ASTM International	
CY	= cubic yards	
No.	= number	

7.1.6 Engineered Fill Construction with Testable Earth Materials

Engineered fills are constructed to support structural improvements. Engineered fills should be constructed using non-expansive soil as described in Section 7.1.6.1. If possible, the use of expansive soil for constructing engineered fills should be avoided. If the use of expansive soil cannot be avoided, then engineered fills should be constructed as described in Section 7.1.6.2 or as modified by the project engineer. If soil is to be imported to the site for constructing engineered fills, then NV5 should be allowed to evaluate the suitability of the borrowed soil source by taking representative soil samples for laboratory testing. Testable earth materials are generally considered to be soils with gravel and larger particle sizes retained on the No. 4 mesh sieve that make up less

than 30 percent by dry weight of the total mass. The relative percent compaction of testable earth materials can readily be determined by the following ASTM test procedures: laboratory compaction curve (D1557), field moisture and density (D6938). Construction of engineered fills with non-expansive and expansive testable earth materials is described below.

7.1.6.1 Engineered Fill Construction with Non-Expansive Soil

Construction of engineered fills with non-expansive soil should be performed as described below.

1. Non-expansive soil used to construct engineered fills should consist predominantly of materials less than ½-inch in greatest dimension and should not contain rocks greater than 3 inches in greatest dimension (oversized material). Non-expansive soil should have a plasticity index (PI) of less than or equal to 15, as determined by ASTM D4318 Atterberg Indices testing. Oversized materials should be spread apart to prevent clustering so that void spaces are not created. The project engineer or his/her field representative should approve the use of oversized materials for constructing engineered fills.
2. Non-expansive soil used to construct engineered fills should be uniformly moisture conditioned. If the soil is classified by the USCS as coarse grained (i.e., GP, GW, GC, GM, SP, SW, SC or SM), then it should be moisture conditioned to within ± 3 percentage points of the ASTM D1557 optimum moisture content. If the soil is classified by the USCS as fine grained (i.e., CL, ML), then it should be moisture conditioned to between 2 and 4 percentage points greater than the ASTM D1557 optimum moisture content.
3. Engineered fills should be constructed by placing uniformly moisture conditioned soil in maximum 8-inch-thick loose lifts (layers) prior to compacting.
4. The soil should then be compacted to achieve a minimum relative compaction of 90 percent of the ASTM D1557 maximum dry density.
5. The earthwork contractor should compact each loose soil lift with a tamping foot compactor such as a Caterpillar (CAT) 815 Compactor or equivalent as approved by NV5's project engineer or his/her field representative. A smooth steel drum roller compactor should not be used to compact loose soil lifts for construction of engineered fills.
6. The field and laboratory CQA tests should be performed consistent with the testing frequencies presented in Table 7.1.6.1-1 or as modified by the project engineer to better suit the site conditions.

Table 7.1.6.1-1, Minimum Testing Frequencies for Non-Expansive Soil

ASTM No.	Test Description	Minimum Test Frequency ⁽¹⁾
D1557	Modified Proctor Compaction Curve	1 per 1,500 CY or Material Change ⁽²⁾
D6983	Nuclear Moisture and Density	1 per 250 CY
Notes:		
(1)	These are minimum testing frequencies that may be increased or decreased at the project engineer's discretion based on the site conditions encountered during grading.	
(2)	Whichever criteria provide the greatest number of tests.	
ASTM	= ASTM International	
CY	= cubic yards	
No.	= number	

7. The moisture content, density and relative percent compaction of all engineered fills should be tested by the project engineer's field representative during construction to evaluate whether the compacted soil meets or exceeds the minimum compaction and moisture content requirements. The earthwork contractor shall assist the project engineer's field representative by excavating test pads with the on-site earth-moving equipment.
8. The prepared finished grade or finished subgrade soil surface should be proof-rolled as mentioned above in Section 7.1.5, Paragraph 3.

7.1.6.2 Engineered Fill Construction with Expansive Soil

NV5 did not encounter highly expansive soil within the shallow soil or zone that would be influenced by the foundation loads at the site during the subsurface investigation. If expansive soils are encountered during grading of the site, and if the property owner desires to use expansive soil to construct engineered fills, then NV5 should be notified to prepare recommendation options for constructing fills with potentially expansive soil.

7.1.7 Cut and Fill Slope Grading

NV5 does not anticipate that grading of cut and fill slopes will have vertical heights greater than 3 feet at the site. In general, both cut and fill slopes should be graded at a maximum slope gradient of 2H:1V (horizontal to vertical slope ratio). Surface water should not be allowed to flow over the cut and fill slopes graded at the site. If steeper cut and/or fill slopes are designed, then NV5 should be allowed to review the proposed cuts and provide additional recommendations as appropriate.

7.1.8 Erosion Controls

Erosion controls should be installed as described below.

1. Erosion controls should be installed on all cut and fill slopes to minimize erosion caused by surface water runoff.
2. Install on all slopes either an appropriate hydroseed mixture compatible with the soil and climate conditions of the site, as determined by the local United States Soil Conservation District or apply an appropriate manufactured erosion control mat.

3. Install surface water drainage ditches at the top of cut and fill slopes (as necessary) to collect and convey both sheet flow and concentrated flow away from the slope face.
4. The intercepted surface water should be discharged into a natural drainage course or into other collection and disposal structures.

7.1.9 Underground Utility Trenches

Underground utility trenches should be excavated and backfilled as described below for each trench zone shown in the figure below.

1. **Trench Excavation Equipment:** NV5 anticipates that the contractor will be able to excavate all underground utility trenches with a Case 580 Backhoe or equivalent, however, deeper utility trenches (10-feet or greater) may require larger equipment.
2. **Trench Shoring:** All utility trenches that are excavated deeper than 5 feet bgs are required by California OSHA to be shored with bracing equipment or sloped back to an appropriate slope gradient prior to being entered by any individuals.
3. **Trench Dewatering:** NV5 does not anticipate that the proposed underground utility trenches will encounter shallow groundwater. However, if the utility trenches are excavated during the winter rainy season, then shallow or perched groundwater may be encountered. The earthwork contractor may need to employ dewatering methods as discussed in Section 7.1.10 in order to excavate, place and compact the trench backfill materials.
4. **Pipe Zone Backfill Type and Compaction Requirements:** The backfill material type and compaction requirements for the pipe zone, which includes the bedding zone, the shading zone and the cover zone, are described in Detail 7.1.9-1 below.

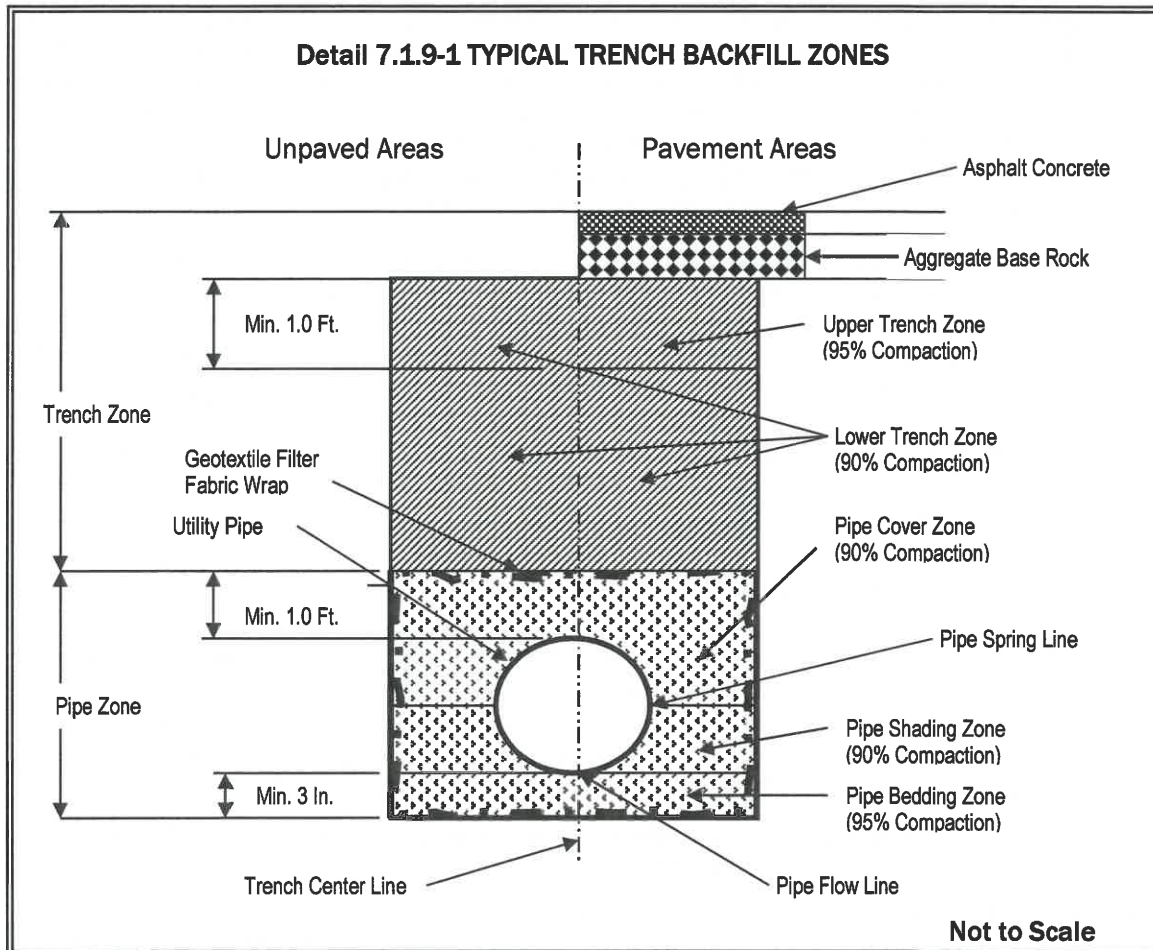

- Pipe Zone Backfill Material Type:** Trench backfill used within the pipe zone, which includes the bedding zone, the shading zone and the cover zone, should consist of $\frac{3}{4}$ -inch-minus, washed, crushed rock, imported sand, or Class 2 AB. The crushed rock particle size gradation should meet the following requirements (percentages are expressed as dry weights using ASTM D422 test method): 100 percent passing the $\frac{3}{4}$ -inch sieve, 80 to 100 percent passing the $\frac{1}{2}$ -inch sieve, 60 to 100 percent passing the $\frac{3}{8}$ -inch sieve, 0 to 30 percent passing the No. 4 sieve, 0 to 10 percent passing the No. 8 sieve, and 0 to 3 percent passing the No. 200 sieve. If groundwater is encountered within the trench during construction, or if groundwater is expected to rise during the rainy season to an elevation that will infiltrate the pipe zone within the trench, then the pipe zone material should be wrapped with a minimum 6 ounce per square yard, non-woven geotextile filter fabric such as TenCate® Mirafi N140 or an approved equivalent. The geotextile seam should be located along the trench centerline and have a minimum 1-foot overlap. If the utility pipes are coated with a corrosion protection material, then the pipes should be wrapped with a minimum 6 ounce per square yard, non-woven, geotextile cushion fabric such as TenCate® Mirafi N140 or an approved equivalent. The geotextile cushion fabric should have a minimum 6-inch seam overlap. The geotextile cushion fabric will protect the pipe from being scratched by the crushed rock backfill material.

- **Pipe Bedding Zone Compaction:** Crushed rock placed in the pipe bedding zone (beneath the utilities) should be consolidated using mechanical equipment to a firm unyielding condition. Imported sand or Class II AB placed in the pipe bedding zone (beneath the utilities) should be a minimum of 3 inches thick, moisture conditioned to within ± 3 percentage points of the ASTM D1557 optimum moisture content and compacted to achieve a minimum relative compaction of 95 percent of the ASTM D1557 maximum dry density. Crushed rock should be mechanically consolidated under the observation of NV5.
 - **Pipe Shading Zone Compaction:** Crushed rock placed within the pipe shading zone should be consolidated using mechanical equipment to a firm unyielding condition, shovel slicing material to support the pipe bells or haunches. Imported sand or Class II AB placed within the pipe shading zone (above the bedding zone and to a height of one pipe radius above the pipe spring line) should be moisture conditioned to within ± 3 percentage points of the ASTM D1557 optimum moisture content and compacted to achieve a minimum relative compaction of 90 percent of the ASTM D1557 maximum dry density. Crushed rock should be mechanically consolidated under the observation of NV5. The pipe shading zone backfill material should be shovel-sliced to remove voids, support the pipe bells or haunches and to promote compaction.
 - **Pipe Cover Zone Compaction:** Crushed rock placed within the pipe cover zone should be consolidated using mechanical equipment to a firm unyielding condition. Native soils, imported sand, and Class II AB placed within the pipe cover zone (above the pipe shading zone to 1 foot over the pipe top surface) should be moisture conditioned to within ± 3 percentage points of the ASTM D1557 optimum moisture content and compacted to achieve a minimum relative compaction of 90 percent of the ASTM D1557 maximum dry density. Crushed rock should be mechanically consolidated under the observation of NV5.
5. **Trench Zone Backfill and Compaction Requirements:** The trench zone backfill materials consist of both lower and upper zones, as discussed below.
- **Trench Zone Backfill Material Type:** Soil used as trench backfill within the lower and upper intermediate zones, as shown on the preceding figure, should consist of non-expansive soil with a PI of less than or equal to 15 (based on ASTM D4318) and should not contain rocks greater than 3 inches in greatest dimension.
 - **Lower Trench Zone Compaction:** Crushed rock placed within the lower trench zone should be consolidated using mechanical equipment to a firm unyielding condition. Soils, including imported sand and Class 2 AB, used to construct the lower trench zone backfills should be uniformly moisture conditioned to within 0 and 4 percentage points of the ASTM D1557 optimum moisture content, placed in maximum 12-inch-thick loose lifts prior to compacting and compacted to achieve a minimum relative compaction of 90 percent of the ASTM D1557 maximum dry density.
 - **Upper Trench Zone Compaction (Road and Parking Lot Areas):** Crushed rock placed within the upper trench zone should be consolidated using mechanical equipment to a firm unyielding condition. Soils, including imported sand and Class 2 AB, used to construct the upper trench zone backfills should be uniformly moisture conditioned to within 0 and 4 percentage points greater than the ASTM D1557 optimum moisture content, placed in maximum 8-inch-thick loose lifts (layers) prior to compacting and compacted to achieve a minimum relative compaction of 95 percent of the ASTM D1557 maximum dry density.

- **Upper Trench Zone Compaction (Non-Road and Non-Parking Lot Areas):** Crushed rock placed within the upper trench zone should be consolidated using mechanical equipment to a firm unyielding condition. Soils, including imported sand and Class 2 AB, used to construct the upper trench zone backfills should be uniformly moisture conditioned to within 0 and 2 percentage points greater than the ASTM D1557 optimum moisture content, placed in maximum 6-inch-thick loose lifts (layers) prior to compacting and compacted to achieve a minimum relative compaction of 90 percent of the ASTM D1557 maximum dry density.
6. **CQA Testing and Observation Engineering Services:** The moisture content, dry density and relative percent compaction of all engineered utility trench backfills should be tested by the project geotechnical engineer's field representative during construction to evaluate whether the compacted trench backfill materials meet or exceed the minimum compaction and moisture content requirements presented in this report. The earthwork contractor shall assist the project geotechnical engineer's field representative by excavating test pads with the on-site earth moving equipment.
- **Compaction Testing Frequencies:** The field and laboratory CQA tests should be performed consistent with the testing frequencies presented in Table 7.1.9-1 or as modified by the project engineer to better suit the site conditions.

Table 7.1.9-1, Minimum Testing Frequencies for Utility Trench Backfill

ASTM No.	Test Description	Minimum Test Frequency ⁽¹⁾
D1557	Modified Proctor Compaction Curve	1 per 500 CY ⁽²⁾ Or Material Change
D6983	Nuclear Moisture and Density	1 per 100 LF per 24-Inch-Thick Compacted Backfill Layer ⁽²⁾ The maximum loose lift thickness shall not exceed 12-inches prior to compacting.
Notes:		
(1)	These are minimum testing frequencies that may be increased or decreased at the project engineer's discretion based on the site conditions encountered during grading.	
(2)	Whichever criteria provide the greatest number of tests.	
ASTM	=	ASTM International
CY	=	cubic yards
No.	=	number

- **Final Proof Rolling:** The prepared finished grade AB rock surface and/or finished subgrade soil surface of utility trench backfills should be proof-rolled as mentioned above in Section 7.1.5, Paragraph 3.

7.1.10 Construction Dewatering

NV5 does not anticipate the need to perform dewatering of the site during earthwork grading however, the earthwork contractor should be prepared to dewater the utility trench excavations and any other excavations if perched water or the groundwater table is encountered during winter or spring grading. The following recommendations are preliminary and are not based on performing a groundwater flow analysis. A detailed dewatering analysis was not a part of the proposed work scope. It should be understood that it is the earthwork contractor's sole responsibility to select and employ a satisfactory dewatering method for each excavation.

1. NV5 anticipates that dewatering of utility trenches can be performed by constructing sumps to depths below the trench bottom and removing the water with sump pumps.
2. Additional sump excavations and pumps should be added as necessary to keep the excavation bottom free of standing water and relatively dry when placing and compacting the trench backfill materials.
3. If groundwater enters the trench faster than it can be removed by the dewatering system, thereby allowing the underlying compacted soil to become unstable while compacting successive soil lifts, then it may be necessary to remove the unstable soil and replace it with free-draining, granular drain rock. Native backfill soil can again be used after placing the granular rock to an elevation that is higher than the groundwater table.
4. If granular rock is used, it should be wrapped in a non-woven geotextile fabric, such as TenCate® Mirafi® N140 or an approved equivalent. The geotextile filter fabric should have minimum 1-foot overlapped seams. The granular rock should meet or exceed the following gradation specifications (all percentages are expressed as dry weights using ASTM D422 test method): 100 percent passing the 3/4-inch sieve, 80 to 100 percent passing the 1/2-inch sieve, 60 to 100 percent passing the 3/8-inch sieve, 0 to 30 percent passing the No. 4 sieve, 0 to 10 percent passing the No. 8 sieve, and 0 to 3 percent passing the No. 200 sieve.
5. NV5 recommends that the utility trench excavations be performed as late in the summer months as possible to allow the groundwater table to reach its lowest seasonal elevation.

7.1.11 Soil Corrosion Potential

The selected materials used for constructing underground utilities should be evaluated by a corrosion engineer for compatibility with the on-site soil and groundwater conditions. NV5 did not perform any testing to determine the corrosion potential of the shallow soils that are anticipated to be in contact with the underground pipes and concrete structures associated with the improvements. NV5's experience with soil encountered in the Clearlake area is that their corrosion potential is moderately corrosive. Buried iron, steel, cast iron, ductile iron, galvanized steel, and dielectric coated steel or iron should be properly protected against corrosion depending on the critical nature of the structure.

7.1.12 Subsurface Groundwater Drainage

NV5 does anticipate encountering perched groundwater or a shallow local groundwater table during the wet weather construction season. If groundwater is encountered during grading, then NV5 should be allowed to observe the conditions and provide site-specific dewatering recommendations.

7.1.13 Surface Water Drainage

NV5 recommends the following surface water drainage mitigation measures:

1. Grade all slopes to drain away from building areas with a minimum 4 percent slope for a distance of not less than 10 feet from the building foundations.
2. Grade all landscape areas near and adjacent to buildings to prevent ponding of water.

3. Direct all building downspouts to solid pipe collectors which discharge to natural drainage courses, storm sewers, catchment basins, infiltration subdrains or other drainage facilities.

7.1.14 Grading Plan Review and Construction Monitoring

CQA includes review of plans and specifications and performing construction monitoring, as described below.

1. NV5 should be allowed to review the final earthwork grading improvement plans prior to commencement of construction to determine whether the recommendations were implemented and, if necessary, to provide additional and/or modified recommendations.
2. NV5 should be allowed to perform CQA monitoring of all earthwork grading performed by the contractor to determine whether the recommendations have been implemented and, if necessary, to provide additional and/or modified recommendations.
3. NV5's experience, and that of the engineering profession, clearly indicates that during the construction phase of a project the risks of costly design, construction and maintenance problems can be significantly reduced by retaining a design geotechnical engineering firm to review the project plans and specifications and to provide geotechnical engineering observation and CQA testing services. Upon your request we will prepare a CQA geotechnical engineering services proposal that will present a work scope, a tentative schedule and a fee estimate for your consideration and authorization. If NV5 is not retained to provide geotechnical engineering CQA services during the construction phase of the project, then NV5 will not be responsible for geotechnical engineering CQA services provided by others nor any aspect of the project that fails to meet your or a third party's expectations in the future.

7.2 STRUCTURAL IMPROVEMENTS

NV5's structural improvement design criteria recommendations include seismic design parameters, shallow foundations, retaining walls entirely above the groundwater table, retaining wall backfill, concrete slab-on-grade interior floors, sidewalk and patio construction, rigid concrete pavement for heavy truck traffic areas and fire lanes, and flexible pavement. These recommendations are presented hereafter.

7.2.1 Seismic Design Parameters

NV5 developed the code-based seismic design parameters in accordance with Section 1613 of the 2019 CBC and the Structural Engineers Association of California (SEAOC), *Seismic Design Maps* web application. The internet based application (www.seismicmaps.org) is used for determining seismic design values from the 2016 ASCE-7 Standard (erratum released February 2019) and the 2018 International Building Code (IBC). The spectral acceleration, site class, site coefficients and adjusted maximum considered earthquake spectral response acceleration, and design spectral acceleration parameters are presented in Table 7.2.1-1. The Seismic Design Parameter detailed report from the SEAOC analysis is provided in Appendix E.

7.2.1.1 Long-Period Seismic Site Coefficient (F_v)

Using Table 1613.2.3(2) of the 2019 CBC, NV5 calculated the long-period site coefficient (F_v) using $S_1=0.541$ and linear interpolation of the values presented in the table. Linear interpolating the values resulted in the following equations for calculating F_v :

- $F_v = (-2 \times S_1) + 2.6$ (S_1 is less than 0.3)
- $F_v = (-1 \times S_1) + 2.3$ (S_1 is greater than 0.3)

$$F_v = (-1 \times S_1) + 2.3 = (-1 \times 0.541) + 2.3 = 1.759$$

7.2.1.2 Seismic Design Category

Based on the short period response acceleration ground motion parameters ($S_{DS} = 1.2$), the 1-S period response acceleration ground motion parameters ($S_{D1} = .634$), and the Risk Category of I through III, the Seismic Design Category is D.

7.2.1.3 Geometric Mean Peak Ground Acceleration

NV5 used the SEAOC *Seismic Design Maps* web application to determine the seismic design parameters for the site, including the geometric mean peak ground acceleration (PGA_M). The PGA_M is calculated by using the Site Coefficient (F_{PGA}) multiplied by the PGA mapped values found on Figure 22-9 from ASCE 7-16. The PGA_M was calculated using the following equation:

$$PGA_M = F_{PGA}PGA = 1.2 \times 0.523 = 0.628 \text{ g}$$

The Seismic Design Maps report from the SEAOC analysis is provided in Appendix E.

7.2.1.4 Site-Specific Ground Motion Hazard Analysis

Based on the preliminary information provided to NV5 on the proposed building sizes and types, NV5 understands a ground motion hazard analysis is not required for the site provided the seismic response coefficient (C_s) is determined in accordance with Exception 2 found in Section 11.4.8 of ASCE 7-16.

Table 7.2.1-1 2019 CBC Seismic Design Parameters

Description	Value	Reference
Latitude North (degrees)	39.9638	Google Earth
Longitude West (degrees)	-121.6349	Google Earth
Site Coefficient, F_A	1.2	2019 CBC, Table 1613.2.3(1), SEAOC Seismic Design Maps
Site Coefficient, F_V	1.759	2019 CBC, Table 1613.2.3(2), SEAOC Seismic Design Maps
Site Class	D = Stiff Soil	ASCE 7-16 Chapter 20, Table 20.3-1
Short (0.2 sec) Spectral Response, S_S (g)	1.5	ASCE 7-16, Section 11.4.2, SEAOC Seismic Design Maps
Long (1.0 sec) Spectral Response, S_L (g)	0.541	ASCE 7-16, Section 11.4.2, SEAOC Seismic Design Maps
Short (0.2 sec) MCE Spectral Response, S_{MS} (g)	1.8	ASCE 7-16, Section 11.4.4, SEAOC Seismic Design Maps
Long (1.0 sec) MCE Spectral Response, S_{M1} (g)	0.952	ASCE 7-16, Section 11.4.4, SEAOC Seismic Design Maps
Short (0.2 sec) Design Spectral Response, S_{DS} (g)	1.2	ASCE 7-16, Section 11.4.5, SEAOC Seismic Design Maps
Long (1.0 sec) Design Spectral Response, S_{D1} (g)	0.634	ASCE 7-16, Section 11.4.5, SEAOC Seismic Design Maps
Seismic Design Category (Risk Category I, II or III)	D	ASCE 7-16, Section 11.6, SEAOC Seismic Design Maps
Geometric Mean Peak Ground Acceleration (PGA_M) (g)	0.628	ASCE 7-16, Section 11.8.3, SEAOC Seismic Design Maps
CBC = California Building Code MCE = Maximum Considered Earthquake g = gravitational acceleration (9.81 meters per second ² = 32.2 feet per second ²) sec = second		

7.2.2 Shallow Foundations

Shallow continuous and isolated spread foundations that will support load bearing walls shall be designed as follows:

1. The base of all shallow foundations should bear on firm, competent non-expansive native soil, or non-expansive engineered fill compacted consistent with the earthwork recommendations of Section 7.1.
2. Continuous strip foundations should be constructed with the following dimensions:
 - a. Minimum Width = 12 Inches
 - b. Minimum Embedment Depth below the lowest adjacent exterior surface grade as shown in Table 7.2.2-1.
3. The bearing capacities to be used for structural design of shallow foundations embedded in either non-expansive native soil or non-expansive engineered fill are presented in Table 7.2.2-1.
 - The calculated factor of safety for allowable bearing pressures including live plus dead loads is 3.0 for all foundation embedment depths.
 - The allowable bearing pressure capacities were increased by a factor of 1.33 to include wind or seismic short-term loads.
 - The project structural engineer of record should review the FS and confirm that it is not less than the over-strength factor for this structure.

Table 7.2.2-1, Foundation Bearing Pressures for Shallow Foundations

Minimum Foundation Embedment Depth	Maximum Ultimate Bearing Pressures For Live + Dead Loads	Maximum Allowable Bearing Pressures For Live + Dead Loads	Maximum Allowable Bearing Pressures For Live + Dead + Wind or Seismic Loads	Allowable Safety Factor (Ultimate/Total)
(in)	(psf)	(psf)	(psf)	(dim.)
12	6,000	2,000	2,660	3.0
18	7,500	2,500	3,325	3.0
24	9,000	3,000	3,990	3.0

psf = pounds per square foot
in = inches
dim = dimensionless

4. Foundation lateral resistance may be computed from passive pressure along the side of the foundation and sliding friction/cohesion resistance along the foundation base; however, the larger of the two resistance forces should be reduced by 50 percent when combining these two forces. The passive pressure can be assumed to be equal to an equivalent fluid pressure (EFP) per foot of depth. The passive pressure force and sliding friction coefficient for computing lateral resistance are as follows:
 - a. Passive pressure = 225 (H), pounds per square foot (psf), where H = foundation embedment depth (feet) below lowest adjacent soil surface.
 - b. Foundation bottom sliding friction coefficient = 0.30 (dimensionless).

5. Minimum steel reinforcement for continuous strip foundations should consist of four No. 4 bars with two bar placed near the top and two bar placed near the bottom of each foundation or as designated by a California licensed structural engineer.
6. The concrete should have a minimum 3,000 pounds per square inch (psi) compressive break strength after 28 days of curing, have a water-to-cement ratio from 0.40 to 0.50, and should be placed with minimum and maximum slumps of 4 and 6 inches, respectively. Since water is often added to uncured concrete to increase workability, it is important that strict quality control measures be employed during placement of the foundation concrete to ensure that the water-to-cement ratio is not altered prior to or during placement.
7. Concrete coverage over steel reinforcements should be a minimum of 3 inches as recommended by the American Concrete Institute (ACI).
8. Prior to placing concrete in any foundation excavations, the contractor shall remove all loose soil, rock, wood debris or other deleterious materials from the foundation excavations.
9. Foundation excavations should be saturated prior to placing concrete to aid the concrete curing process; however, concrete should not be placed in standing water.
10. Total settlement of individual foundations will vary depending on the plan dimensions of the foundation and actual structural loading. Based on the anticipated foundation dimensions and loads, we estimate that the total post-construction settlement of foundations designed and constructed in accordance with the recommendations will be on the order of 1/2 inch. Differential settlement between similarly loaded, adjacent foundations is expected to be about 1/4 inch, provided the foundations are founded into similar materials (e.g., all on competent and firm engineered fill, native soil, or rock).
11. Prior to placing concrete in any foundation excavation, the project geotechnical engineer or his/her field representative should observe the excavations to document that the following requirements are achieved: minimum foundation dimensions, minimum reinforcement steel placement and dimensions, removal of all loose soil, rock, wood debris or other deleterious materials, and that firm and competent native or engineered fill soil is exposed along the entire foundation excavation bottom. Strict adherence to these requirements is paramount to the satisfactory behavior of a building foundation. Minor deviations from these requirements can cause the foundations to undergo minor to severe amounts of settlement which can result in cracks developing in the foundation and adjacent structural members, such as concrete slab-on-grade floors.

7.2.3 Retaining Walls Entirely Above the Groundwater Table

A California licensed professional engineer should design all retaining walls situated above the groundwater table with drained backfill using the following geotechnical engineering design criteria:

1. The retaining wall recommendations for static loading conditions are based on Rankine earth pressure theory published by W.J.M. Rankine (1857). The retaining wall recommendations for seismic loading conditions are based on the published work by Gerall and Sitar, *Seismic Earth Pressures on Retaining Structures in Cohesionless Soils*, (2013).
2. Retaining walls should be founded on firm native soils or engineered fill consistent with the requirements of Section 7.1.

3. The retaining wall should be designed using the geotechnical engineering design parameters presented in Table 7.2.3-1.
4. The retaining wall backfill soil should be free draining material that meets or exceeds the material requirements of and is placed and compacted consistent with the requirements of Section 7.2.4.
5. The static lateral earth pressures exerted on the retaining walls may be assumed to be equal to an equivalent fluid pressure per foot of depth below the top of the wall. The lateral pressures presented in the table below are ultimate values and, therefore, do not include a safety factor, and assumes a free draining backfill (no hydrostatic forces acting on the wall) and no surcharge loads applied within a distance of $0.50H$, where H equals the total vertical wall height.
6. The retaining wall backfill slope shall have a horizontal slope gradient for a minimum horizontal distance of $0.50H$, where H equals the total vertical wall height. If a steeper backfill slope ratio is desired, then NV5 should be notified and contracted to perform additional retaining wall designs.
7. The retaining wall foundation excavations should be saturated prior to placing concrete to aid the concrete curing process. However, concrete should not be placed in standing water.

Table 7.2.3-1, Design Parameters for Retaining Walls

Design Parameters for Retaining Walls		
Loading Conditions	Static Loads On Retaining Wall With Horizontal Backfill Slope	Seismic Load On Retaining Wall With Horizontal Backfill Slope
Wall Active Condition Pressures (psf)/ft ⁽¹⁾	50 (H) ⁽⁵⁾	9 (H ²)
Wall Passive Condition Pressures (psf)/ft ⁽²⁾	225 (H)	9 (H ²)
Wall At-Rest Condition Pressure (psf)/ft ⁽³⁾	70 (H)	21 (H ²)
P _{active} Force Located Above Foundation Base	0.33 (H)	Not Applicable
P _{passive} Force Located Above Foundation Base	0.33 (H)	Not Applicable
P _{at-rest} Force Located Above Foundation Base	0.33 (H)	Not Applicable
P _{earthquake} Force Located Above Foundation Base	Not Applicable	0.33(H)
Maximum Allowable Foundation Bearing Capacity (psf), (Live + Dead Loads)	2,000	2,000
Maximum Allowable Foundation Bearing Capacity (psf) (Live + Dead + Wind or Seismic Loads)	2,660	2,660
Minimum Foundation Embedment Depth (in)	12	12
Foundation Bottom Friction Coefficient (dim.) ⁽⁴⁾	0.30	0.30

Notes:

- (1) The active pressure condition applies to a retaining wall with an unrestrained top (deflection allowed).
- (2) The passive pressure condition applies to a retaining wall with soil resistance at the base. If passive pressures are used, then NV5 recommends that the top 1.0 feet of soil weight be ignored.
- (3) The At-Rest pressure condition applies to a retaining wall with the top restrained (no deflection allowed).
- (4) If the design horizontal resistance force acting on the wall foundation is computed by combining both the sliding friction force and passive soil pressure force, then the larger of the two forces should be reduced by 50 percent.
- (5) H = The distance to a point in the backfill soil where the pressure is desired. The H distance is measured from the top of the wall for active and at-rest conditions and from one foot below the soil height at the toe of the wall for the passive condition (See Note 2 for passive condition).

7.2.4 Retaining Wall Backfill

Place and compact all retaining wall backfill and drainage layer materials as described below. NV5 did not review the final improvement plans for the site. If sub-structure retaining walls for below grade rooms, basements, garages, etc., are designed for this project, then these structures should also incorporate a water proofing sealant as described below. The water proofing sealant products should be installed by a qualified waterproofing contractor according to the manufacturer's directions. A typical retaining wall and backfill material zones figure is shown below.

TYPICAL CANTILEVER RETAINING WALL AND BACKFILL MATERIALS

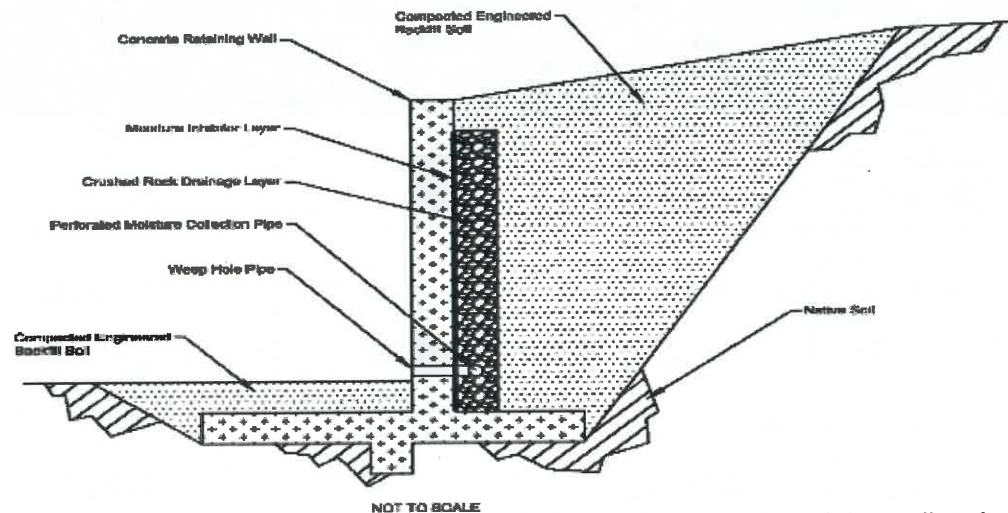

1. **Waterproofing:** Waterproofing materials should be installed behind retaining walls prior to backfilling if retaining walls will be constructed for below grade rooms, basements, garages, elevator shafts, etc. The waterproofing materials should be installed by a qualified waterproofing contractor according to the manufacturer's directions.
2. **Drainage Layer:** A drainage layer should be placed between the wall and backfill material to prevent buildup of hydrostatic pressures behind the wall. Additionally, care should be taken during placement of the drainage layer materials so as not to crush, tear, or damage the waterproofing materials. The drainage layer can be constructed from drain rock, geosynthetic drain nets or a combination of both as described below.
 - a. **Caltrans Class II Permeable Material Method:** Place a minimum 12-inch thick layer of Caltrans Class II Permeable Material directly against the wall or waterproofing system (as described below) without a geotextile wrapping to separate the backfill soil from the wall. The drainage material should extend from the wall bottom to within 12 inches of the wall top.
 - b. **Geotextile Wrapped Drain Rock Method:** Place a minimum 12-inch-thick layer of drain rock wrapped in a geotextile filter fabric directly against the wall or waterproofing system (as described below) to separate the backfill soil from the wall. The drain rock should extend from the wall bottom to within 12 inches of the wall top. A minimum 6-ounce per square yard (oz/sy) non-woven geotextile fabric, such as Mirafi 140N manufactured by Tencate Geosynthetics or equivalent should be used.
 - c. **Geosynthetic Composite Drainnet (Geonet) Method:** Place a geosynthetic composite drain-net (geonet) directly against the wall or waterproofing system (as described below) to separate the backfill soil from the wall. The composite geonet should extend from the wall bottom to within 12 inches of the wall top. A geosynthetic composite drainnet such as Hydroduct 200 or Hydroduct 220 distributed by Grace Construction Products or equivalent should be used.

3. **Drainage Layer Collection and Discharge Pipes:** A minimum 4-inch diameter schedule 40, polyvinylchloride (PVC) perforated drainpipe should be placed at the wall base inside the geotextile wrapped drain rock or wrapped by the composite geonet. ¼-inch diameter perforations should be drilled into the pipe. The perforations should be oriented in cross section view at 90 degrees to one another and along the pipe length on 6-inch centers. The pipe should be placed such that the perforations are oriented 45 degrees from the vertical. A minimum of 3 inches of drain rock should be placed below the perforated PVC pipe. The pipe should direct water away from the wall by gravity with a minimum 1 percent slope. The pipe should collect groundwater collected by the drainage layer discharged to the surface at the end of the wall or through weep-hole penetrations through the wall.
4. **Backfill Placement and Compaction Equipment:** Heavy conventional motorized compaction equipment should not be used directly adjacent to a retaining wall unless the wall is designed with sufficient steel reinforcements and/or bracing to resist the additional lateral pressures. Compaction of backfill materials within 5 feet of the retaining wall should be accomplished by lightweight, hand-operated, walk-behind, vibratory equipment. Additionally, care should be taken during placement of the general backfill materials so as not to crush, tear or damage the waterproofing and/or drainage layer materials.
5. **Backfill Materials and Compaction:** The backfill material should be free draining and classified by the USCS as a coarse-grained material (i.e., GP, GW, GC, GM, SP, SW, SC, and SM). Materials classified by the USCS as a fine-grained material (i.e., CL, CH, ML, or MH) should not be used as retaining wall backfill. The retaining wall backfill material placed between the drainage layer and temporary cut-slope should be moisture conditioned to between ± 3 percentage points of the ASTM D1557 optimum moisture content and then compacted to a minimum of 90 percent and a maximum of 95 percent of the ASTM D1557 maximum dry density.

7.2.5 Concrete Slab-On-Grade Interior Floors, Sidewalk and Patio Construction

In general, NV5 recommends that subgrade elevations on which the concrete slab-on-grade floors are constructed be a minimum of 6 inches above the elevation of the surrounding parking lots, driveways, and landscaped areas. Elevating the building will reduce the potential for subsurface water to enter beneath the concrete slab-on-grade floors and exterior surfaces and underground utility trenches.

The concrete slab-on-grade building floors, patios, and sidewalk areas should be evaluated by a California-licensed professional engineer for expected live and dead loads to determine if the minimum slab thickness and steel reinforcement recommendations presented in this report should be increased or redesigned.

NV5 recommends using the guideline procedures, methods and material properties that are presented in the following ASTM and ACI documents for construction of concrete slab-on-grade floors:

- ACI 302.1R-15, Guide for Concrete Floor and Slab Construction, reported by ACI Committee 302.
- ASTM E1643-18a, Standard Practice for Installation of Water Vapor Retarders Used in Contact with Earth or Granular Fill Under Concrete Slabs.

- ASTM E1745-17, Standard Specifications for Plastic Water Vapor Retarders Used in Contact with Soil or Granular Fill under Concrete Slabs.
- ASTM F710-19, Standard Practice for Preparing Concrete Floors to Receive Resilient Flooring.

The interior building concrete slab-on-grade floor and exterior slab-on-grade concrete components are described below from top to bottom. If static or intermittent live floor loads greater than 250 psf are anticipated, then a California-licensed professional engineer should design the necessary concrete slab-on-grade floor thickness and steel reinforcements.

7.2.5.1 Interior Office Floors

1. **Minimum 4-Inch-Thick Concrete Slab:** The concrete slab should be installed with a minimum 3,000 psi compressive strength after 28 days of curing. NV5 recommends that the concrete design use a water-to-cement ratio between 0.40 and 0.45 and should be placed with minimum and maximum slumps of 3 and 5 inches, respectively. The concrete mix design is the responsibility of the concrete supplier.
2. **Steel Reinforcement:** Reinforcement should be used to improve the load-carrying capacity, to reduce cracking caused by shrinkage during curing and from both differential and repeated loadings. It should be understood that it is nearly impossible to prevent all cracks from development in concrete slabs; in other words, it should be expected that some cracking will occur in all concrete slabs no matter how well they are reinforced. Concrete slabs that will be subjected to heavy loads should be designed with steel reinforcements by a California-licensed professional engineer.

Rebar: As a minimum, use No. 3 rebar (ASTM A615/A 615M-18e1 Grade 60), tied and placed with 18-inch centers in both directions (perpendicular) and supported on concrete “dobies” to position the rebar in the center of the slab during concrete pouring. NV5 does not recommend that the steel reinforcements of the concrete slab-on-grade floor be tied into the perimeter or interior continuous strip foundations or interior isolated column foundations. In other words, we recommend that the concrete slab-on-grade floors be constructed as independent structural members so that they can move (float) independently from the foundation structures.

3. **Underslab Vapor-Moisture Retarder Membrane:** The underslab retarder membrane should be placed in areas with moisture sensitive floor coverings as a floor component that will minimize transmission of both liquid water and water vapor transmission through the concrete slab-on-grade floor. NV5 recommends using at a minimum a Class A (ASTM E1745-17), minimum 10-mil-thick, plastic, vapor-moisture, retarder membrane material such as Stego Wrap® underslab vapor retarder membranes or equivalents. Additionally, the following materials are recommended: Stego® Tape and Stego® Mastic or equivalents to seal membrane joints and any utility penetrations.

Regardless of the type of moisture-vapor retarder membrane used moisture can wick up through a concrete slab-on-grade floor. Excessive moisture transmission through a concrete slab floor can cause adhesion loss, warping and peeling of resilient floor coverings, deterioration of adhesive, seam separation, formation of air pockets, mineral deposition beneath flooring, odor and both fungi and mold growth. Slabs can be tested for water transmissivity in areas that are moisture sensitive. Commercial sealants, polymer additives to the concrete at the batch plant, entrained air, flyash, and a reduced water-to-content ratio can be incorporated into the concrete

slab-on-grade floor mix design to reduce its permeability and water-vapor transmissivity properties. A waterproofing consultant should be contacted to provide detailed recommendations if moisture sensitive flooring materials will be installed on the concrete slab-on-grade floors.

4. **Minimum 4-Inch-Thick Crushed Rock or Class II Aggregate Base Rock Layer:** Interior floors should be underlain by clean crushed rock. Crushed rock should be mechanically consolidated under the observation of NV5. The crushed rock should be washed to produce a particle size distribution of 100 percent (by dry weight) passing the ¾ inch sieve and 5 percent passing the No. 4 sieve and 0 to 3 percent passing the No. 200 sieve. An alternative rock material for slab-on-grade concrete surfaces would include AB rock meeting the specification of Caltrans Class II AB. AB rock layers should be placed and compacted to a minimum of 95 percent of the ASTM D1557 dry density with a moisture content of ± 3 percentage points of the ASTM D1557 optimum moisture content. Just prior to pouring the concrete slab, the rock layer should be moistened to a saturated surface dry (SSD) condition. This measure will reduce the potential for water to be withdrawn from the bottom of the concrete slab while it is curing and will help minimize the development of shrinkage cracks.

If the current property owner elects to eliminate the crushed rock or AB rock layer beneath the interior concrete slabs-on-grade for economic reasons, then there will be an inherent greater risk assumed by the developer for the development of both shrinkage and bearing-related cracks in the associated slabs.

5. **Subgrade Soil Preparation:** All concrete slab-on-grade subgrade soil should be prepared and compacted consistent with the recommendations of Section 7.1. The top 12 inches of the non-expansive soil should be compacted to a minimum of 90 percent of the ASTM D1557 dry density with a moisture content within ± 3 percentage points of the ASTM D1557 optimum moisture content.
6. **Crack Control:** Crack control grooves should be installed during placement or saw cuts should be made in accordance with the ACI and Portland Cement Association (PCA) specifications. Generally, NV5 recommends that expansion joints be provided between the slab and perimeter footings, and that crack control grooves or saw cuts are installed on 10-foot-centers in both directions (perpendicular).
7. **Field Observations:** All concrete slab-on-grade surfaces and installed steel reinforcements should be observed and inspected by an NV5 construction monitor prior to pouring concrete.
8. **Field Curing of Concrete:** Prior to applying construction loads, all exposed concrete slab-on-grade floors should be moisture cured for a minimum of 7 days following placement of the concrete. If concrete is placed during the hot summer months when the ambient air temperatures may be as low as 50 to 60 degrees Fahrenheit (°F) in the early morning and in excess of 90 °F in the afternoon, then the contractor may need to implement special curing measures to reduce the development of shrinkage cracks. The concrete contractor is responsible for determining the appropriate curing process to be applied to the slab-on-grade floor.

7.2.5.2 Interior Floors with Vehicle Traffic

1. **Minimum 6-Inch-Thick Concrete Slab:** should be installed with a minimum 3,500 psi compressive strength after 28 days of curing. NV5 recommends that the concrete design uses a water to

cement ratio between 0.40 and 0.50 and should be placed with minimum and maximum slumps of 4 and 6 inches, respectively. The concrete mix design is the responsibility of the concrete supplier.

2. Concrete Slabs in Contact With Isolated Concrete Foundations: We do not recommend that concrete slab-on-grade floors be placed in direct contact with the top surface of isolated column concrete foundations. Our experience is that during curing period of the concrete slab-on-grade floors a significant thermal gradient may develop between the portions of the slab placed directly on the typically more massive isolated column concrete foundations and the portions of the slab placed over the vapor-moisture retarder membrane and crushed rock of the slab support layers. The development of adverse thermal gradients may cause the development of significant orthogonal and/or circular shrinkage cracks around the isolated column foundations.
3. Steel Reinforcement: should be used to improve the load carrying capacity and to reduce cracking caused by shrinkage during curing and from both differential and repeated loadings. It should be understood that it is nearly impossible to prevent all cracks from development in concrete slabs; in other words, it should be expected that some cracking will occur in all concrete slabs no matter how well they are reinforced. Concrete slabs that will be subjected to heavy loads should be designed with steel reinforcements by a California licensed professional engineer.

Steel Rebar: As a minimum, use No. 4 ribbed steel rebar (ASTM A615/A615M-18e1 Grade 60 deformed for reinforcement in concrete), tied and placed with 12-inch centers in both directions (perpendicular) and supported on concrete “dobies” to position the rebar in the center of the slab during concrete pouring.

4. Underslab Vapor-Moisture Retarder Membrane: should be placed as a floor component that will minimize transmission of both liquid water and water vapor transmission through the concrete slab-on-grade floor. NV5 recommends using at a minimum a Class A (ASTM E1745-17), minimum 10-mil-thick, plastic, vapor-moisture, retarder membrane material such as: Stego Wrap® underslab vapor retarder membranes or equivalents. Additionally, the following materials are recommended: Stego® Tape and Stego® Mastic or equivalents to seal membrane joints and any utility penetrations.

Regardless of the type of moisture-vapor retarder membrane used, moisture can wick up through a concrete slab-on-grade floor. Excessive moisture transmission through a concrete slab floor can cause adhesion loss, warping, and peeling of resilient floor coverings, deterioration of adhesive, seam separation, formation of air pockets, mineral deposition beneath flooring, odor and both fungi and mold growth. Slabs can be tested for water transmissivity in areas that are moisture sensitive. Commercial sealants, polymer additives to the concrete at the batch plant, entrained air, flyash, and reduced water to content ratio can be incorporated into the concrete slab-on-grade floor mix design to reduce its permeability and water-vapor transmissivity properties. A waterproofing consultant should be contacted to provide detailed recommendations if moisture sensitive flooring materials will be installed on the concrete slab-on-grade floors.

5. Minimum 6-Inch-Thick Crushed Rock Layer or Class II Aggregate Base Rock Layer: Interior floors should be underlain by clean crushed rock. Crushed rock should be mechanically consolidated under the observation of NV5. The crushed rock should be washed to produce a particle size distribution of 100 percent (by dry weight) passing the $\frac{3}{4}$ inch sieve and 5 percent passing the No. 4 sieve and 0 to 3 percent passing the No. 200 sieve. An alternative rock material for slab-

on-grade concrete surfaces would include AB rock meeting the specification of Caltrans Class II AB. AB rock layers should be placed and compacted to a minimum of 95 percent of the ASTM D1557 dry density with a moisture content of ± 3 percentage points of the ASTM D1557 optimum moisture content. Just prior to pouring the concrete slab, the rock layer should be moistened to a SSD condition. This measure will reduce the potential for water to be withdrawn from the bottom of the concrete slab while it is curing and will help minimize the development of shrinkage cracks.

If the current property owner elects to eliminate the crushed rock or AB rock layer beneath the interior concrete slabs-on-grade for economic reasons, then there will be an inherent greater risk assumed by the developer for the development of both shrinkage and bearing-related cracks in the associated slabs.

6. **Subgrade Soil Preparation:** All concrete slab-on-grade subgrade soil should be prepared and compacted consistent with the recommendations of Section 7.1. The top 12 inches of the non-expansive soil should be compacted to a minimum of 95 percent of the ASTM D1557 dry density with a moisture content within ± 3 percentage points of the ASTM D1557 optimum moisture content.
7. **Crack Control:** Crack control grooves should be installed during placement or saw cuts should be made in accordance with the ACI and PCA specifications. Generally, NV5 recommends that expansion joints be provided between the slab and perimeter footings, and that crack control grooves or saw cuts are installed on 10-foot-centers in both directions (perpendicular).
8. **Field Observations:** All concrete slab-on-grade surfaces and installed steel reinforcements should be observed and inspected by an NV5 construction monitor prior to pouring concrete.
9. **Field Curing of Concrete:** Prior to applying construction loads, all exposed concrete slab-on-grade floors should be moisture cured for a minimum of 7 days following placement of the concrete. If concrete is placed during the hot summer months when the ambient air temperatures may be as low as 50 to 60 °F in the early morning and in excess of 90 °F in the afternoon, then the contractor may need to implement special curing measures to reduce the development of shrinkage cracks. The concrete contractor is responsible for determining the appropriate curing process to be applied to the slab-on-grade floor.

7.2.5.3 Exterior Sidewalks and Patios

1. **Minimum 4-Inch-Thick Concrete Slab:** should be installed with a minimum 2,500 psi compressive strength after 28 days of curing. NV5 recommends that the concrete design uses a water to cement ratio between 0.40 and 0.45 and should be placed with minimum and maximum slumps of 4 and 6 inches, respectively. The concrete mix design is the responsibility of the concrete supplier.
2. **Concrete Slabs in Contact With Isolated Concrete Foundations:** NV5 does not recommend that concrete slab-on-grade floors be placed in direct contact with the top surface of isolated column concrete foundations. Our experience is that during curing period of the concrete slab-on-grade floor a significant thermal gradient may develop between the portions of the slab placed directly on the typically more massive isolated column concrete foundations and the portions of the slab placed over a vapor-moisture retarder membrane and crushed rock layers. The development of adverse thermal gradients may cause the development of significant orthogonal and/or circular shrinkage cracks around the isolated column foundations.

3. **Steel Reinforcement:** should be used to improve the load carrying capacity and to reduce cracking caused by shrinkage during curing and from both differential and repeated loadings. It should be understood that it is nearly impossible to prevent all cracks from development in concrete slabs; in other words, it should be expected that some cracking will occur in all concrete slabs no matter how well they are reinforced or cured. Concrete slabs that will be subjected to heavy loads should be designed with steel reinforcements by a California licensed professional engineer.

If the current property owner (developer) elects to eliminate the steel reinforcements from the exterior concrete slabs-on-grade for economic reasons, then there will be an inherent greater risk assumed by the developer for the development of both shrinkage and bearing related cracks in the associated slabs.

4. **Minimum 4-Inch-Thick Crushed Rock Layer:** Exterior concrete slabs-on-grade should be underlain by clean crushed rock. Crushed rock should be mechanically consolidated under the observation of NV5. The crushed rock should be washed to produce a particle size distribution of 100 percent (by dry weight) passing the $\frac{3}{4}$ inch sieve and 5 percent passing the No. 4 sieve and 0 to 3 percent passing the No. 200 sieve. An alternative rock material for slab-on-grade concrete surfaces would include AB rock meeting the specification of Caltrans Class II AB. AB rock layers should be placed and compacted to a minimum of 95 percent of the ASTM D1557 dry density with a moisture content of ± 3 percentage points of the ASTM D1557 optimum moisture content. Just prior to pouring the concrete slab, the rock layer should be moistened to a SSD condition. This measure will reduce the potential for water to be withdrawn from the bottom of the concrete slab while it is curing and will help minimize the development of shrinkage cracks.

If the current property owner elects to eliminate the crushed rock or AB rock layer beneath the interior concrete slabs-on-grade for economic reasons, then there will be an inherent greater risk assumed by the developer for the development of both shrinkage and bearing-related cracks in the associated slabs.

5. **Subgrade Soil Preparation:** All concrete slab-on-grade subgrade soil should be prepared and compacted consistent with the recommendations of Section 7.1. The top 12 inches of the non-expansive soil should be compacted to a minimum of 90 percent of the ASTM D1557 dry density with a moisture content within ± 3 percentage points of the ASTM D1557 optimum moisture content.
6. **Crack Control:** Crack control grooves should be installed during placement or saw cuts should be made in accordance with the ACI and PCA specifications. Generally, NV5 recommends that expansion joints be provided between the slab and perimeter footings, and that crack control grooves or saw cuts are installed on 10-foot-centers in both directions (perpendicular).
7. **Field Observations:** All concrete slab-on-grade surfaces and installed steel reinforcements should be observed and inspected by an NV5 construction monitor prior to pouring concrete.

7.2.6 Rigid Concrete Pavement for Heavy Truck Traffic Areas and Fire Lanes

The rigid concrete pavement components are described below from top to bottom. If static or intermittent live floor loads greater than 250 psf are anticipated, then a California-licensed professional engineer should design the necessary concrete slab-on-grade floor thickness and steel reinforcements.

1. The recommended modulus of subgrade value of 150 kips/cubic foot should be used if the site subgrade is prepared in accordance with the recommendations presented in Section 7.1 above.
2. **Minimum 6-Inch-Thick Concrete Slab:** The rigid concrete pavement should be installed with a minimum 3,500 pounds psi compressive strength after 28 days of curing. NV5 recommends that the concrete design uses a water-to-cement ratio between 0.40 and 0.45 and should be placed with minimum and maximum slumps of 4 and 6 inches, respectively. The concrete mix design is the responsibility of the concrete supplier.
3. **Steel Reinforcements:** The rigid concrete pavement sections should include steel reinforcement to improve the load carrying capacity and to minimize cracking caused by shrinkage during curing and from both differential and repeated loadings. It should be understood that it is nearly impossible to prevent all cracks from development in concrete slabs; in other words, it should be expected that some cracking will occur in all concrete slabs no matter how well they are reinforced. Rigid concrete pavement that will be subjected to heavy loads should be designed with steel reinforcements by a California-licensed professional engineer.

If the owner elects to eliminate the steel reinforcements from the exterior concrete slabs-on-grade for economic reasons, then there will be an inherent greater risk assumed by the developer for the development of both shrinkage and bearing related cracks in the associated slabs.

4. **Steel Rebar:** Use No. 4 steel rebar (ASTM A615/A615M-18e1 Grade 60 reinforcement), tied and placed with 18-inch centers in both directions (perpendicular) and supported on concrete “dobies” to position the rebar in the center of the slab during concrete pouring.
5. **Minimum 6-Inch Caltrans Class II AB Layer:** The rigid concrete pavement should be underlain by Class II AB placed and compacted to a minimum of 95 percent of the ASTM D1557 dry density with a moisture content of ± 3 percentage points of the ASTM D1557 optimum moisture content.
6. **Subgrade Soil Preparation:** The subgrade soil below the rigid concrete pavement sections designed for vehicle traffic should be prepared and compacted consistent with the recommendations of Section 7.1. The top 12 inches of the non-expansive soil should be compacted to a minimum of 95 percent of the ASTM D1557 dry density with a relatively uniform moisture content of 0 to 4 percentage points greater than the ASTM D1557 optimum moisture content.
7. **Crack Control Grooves:** The rigid concrete pavement should include crack control and expansion joint grooves installed during placement or saw cuts should be made in accordance with the ACI and PCA specifications. Generally, NV5 recommends that expansion joints be provided between the slab and perimeter footings, and that crack control grooves or saw cuts are installed on no greater than 10-foot-centers in both directions (perpendicular).
8. **Field Observations:** Field observations should be made by an NV5 construction monitor of all concrete slab-on-grade subgrade surfaces and installed steel reinforcements prior to placing concrete.

7.2.7 Flexible Pavement

NV5 used the Caltrans Highway Design Manual to develop several AC and AB rock pavement design alternatives to allow for different traffic loading conditions. NV5 used a Traffic Index (TI) of 4 to 8 which represents typical vehicle traffic for residential streets, collector streets, industrial/commercial

streets, minor arterial streets, major arterial streets, and truck route arterial streets. The actual TI for the project pavement areas should be determined in accordance with Chapter 600 of the Caltrans Highway Design Manual.

Laboratory test results performed on a representative sample of the anticipated pavement subgrade soils within the proposed pavement improvements indicate these materials generally possess an R-Value of 22. Based on the fair quality near-surface soils encountered an R-Value of 20 should be considered for design purposes. The actual subsurface soil conditions exposed at the finished subgrade surface of the proposed pavement areas may be different from this R-Value based on site grades, or the use of imported fill materials. The actual finished subgrade materials should be evaluated during construction to confirm the design recommendations below. Please note that the Caltrans design method requires that the maximum R-Value of the subgrade soil not exceed 50.

NV5 assumed that the pavement layers will be constructed with Class 2 Aggregate Base Rock (Minimum R-Value = 78) and Type A Asphalt Concrete in accordance with the requirements of Section 26 of the Caltrans Standard Specifications. Table 7.2.7-1 presents the AC pavement design sections for varying TI's. NV5 recommends that the AB rock layer be constructed with a minimum thickness of 6-inches for constructability issues and to achieve a higher level of confidence that the road will achieve the expected service life.

Table 7.2.7-1, Flexible Pavement Design

Parameters	Design Values				
Traffic Description (approximate)	Light Automobiles	Light to Medium Autos and Trucks	Medium to Heavy Trucks	Heavy Trucks	Very Heavy Trucks
Traffic Index (TI)	4	5	6	7	8
Design R-Values					
Class II AB Rock	78	78	78	78	78
Subgrade Soil	20	20	20	20	20
AC Thickness (inch) ⁽¹⁾	2.5	3.0	3.5	4.0	5.0
AB Rock Thickness (inch) ⁽²⁾ (95% Relative Compaction)	6.0	8.0	10.0	12.0	14.0
Subgrade Soil Thickness (inch) (95% Relative Compaction)	12.0	12.0	12.0	12.0	12.0
Notes:					
(1) The asphalt concrete thickness includes the Caltrans safety factor.					
(2) NV5 recommends that the minimum thickness of AB rock should be 6 inches regardless of what the Caltrans design method indicates. This minimum thickness is necessary for constructability issues and will increase the level of confidence that the roads will achieve the expected service life.					

The subgrade soil and AB rock should be placed and compacted as described below.

1. The subgrade soil to a depth of 12 inches from the finished grade surface should be compacted to a minimum relative compaction of 95 percent of the ASTM D1557 maximum dry density with a moisture content of 2 to 4 percentage points of the ASTM D1557 optimum moisture content. The compacted sub-grade soil shall be graded to achieve the design grades and tolerances.
2. The stability of the compacted subgrade soil should be evaluated by wheel rolling prior to placing the overlying AB rock layer. Wheel rolling should be performed with a fully loaded water truck with tire pressures between 60 and 95 psi. The subgrade soil surface should exhibit only minor deflections as the wheel load passes by. Any unstable areas should be reworked and then retested for percent relative compaction and percent moisture content and then proof rolled again. This process should be repeated until the area appears to be relatively stable.
3. The Caltrans Class II AB rock should be compacted to a minimum relative compaction of 95 percent of the ASTM D1557 maximum dry density with a moisture content of ± 3 percentage points of the ASTM D1557 optimum moisture content.
4. The stability of the compacted AB rock should be evaluated by wheel rolling prior to placing the overlying AC layer. Wheel rolling should be performed with a fully loaded water truck with tire pressures between 60 and 95 psi. The AB rock surface should exhibit only minor deflections as the wheel load passes by. Any unstable areas should be reworked and then retested for percent relative compaction and percent moisture content and then proof rolled again. This process should be repeated until the area appears to be relatively stable.
5. Concrete cut-off curbs should be constructed around all landscaped areas that are adjacent to AC paved driveways and parking areas. The curbs should extend to a minimum depth of 8 inches into the underlying subgrade soil. The extended curbs will reduce migration of irrigation and rain waters originating in the landscaped areas from entering the AB rock materials underlying the AC pavement material. This design is intended to minimize failures of the paved areas due to saturation of the underlying AB rock and subgrade soils.

8.0 REFERENCES

- American Society of Civil Engineers, 2016. *Minimum Design Loads for Buildings and Other Structures* (ASCE 7-16).
- ASTM International, Inc. (ASTM), 2019. *Soil and Rock (I)*. Volume 04.08.
- California Geological Survey (CGS), 1997. *Fault Rupture Hazard Zones in California, Alquist-Priolo Earthquake Fault Zoning Act with Index to Earthquake Fault Zones Maps*. Special Publication 42. Interim Revision.
- GBA 2019. *Important Information about Your Geotechnical Engineering Report*.
- Geraili and Sitar, *Seismic Earth Pressures on Retaining Structures in Cohesionless Soils*, (2013)
- Rankine, W.J.M., 1857, *On the Stability of Loose Earth*, Philosophical Transactions of the Royal Society, London, Vol. 147.
- United States Geological Survey, 2018. *Clearlake Highlands Quadrangle, California-Lake Co.* 7.5 Minute Series (Topographic).
- Wagner, D.L., and Bortugno, E.J., 1982. *Geologic Map of the Santa Rosa quadrangle Sheet, 1:250,000*. California Division of Mines and Geology, Regional Geologic Map 2A.

9.0 LIMITATIONS

The following limitations apply to the findings, conclusions and recommendations presented in this report:

1. This report should not be relied upon without review by NV5 if a period of 24 months elapses between the issuance report date shown above and the date when construction commences.
2. NV5's professional services were performed consistent with the generally accepted geotechnical engineering principles and practices employed in Northern California. No warranties are either expressed or implied.
3. NV5 provided engineering services for the site project consistent with the work scope and contract agreement presented in the proposal and agreed to by the client. The findings, conclusions and recommendations presented in this report apply to the conditions existing when NV5 performed the services and are intended only for the client, purposes, locations, timeframes and project parameters described herein. NV5 is not responsible for the impacts of any changes in environmental standards, practices or regulations subsequent to completing the services. NV5 does not warrant the accuracy of information supplied by others, or the use of segregated portions of this report. This report is solely for the use of the client unless noted otherwise. Any reliance on this report by a third party is at the party's sole risk.
4. If changes are made to the nature or design of the project as described in this report, then the conclusions and recommendations presented in this report should be considered invalid by all parties. The validity of the conclusions and recommendations presented in this report can only be made by NV5; therefore, NV5 should be allowed to review all project changes and prepare written responses with regards to their impacts on the conclusions and recommendations. However, additional fieldwork and laboratory testing may be required for NV5 to develop any modifications to the recommendations. The cost to review project changes and perform additional fieldwork and laboratory testing necessary to modify the recommendations is beyond the scope-of-services presented in this report. Any additional work will be performed only after receipt of an approved scope-of-work, budget and written authorization to proceed.
5. The analyses, conclusions and recommendations presented in this report are based on the site conditions as they existed at the time NV5 performed the surface and subsurface field investigations. NV5 has assumed that the subsurface soil and groundwater conditions encountered at the location of the exploratory borings are generally representative of the subsurface conditions throughout the entire project site; however, if the actual subsurface conditions encountered during construction are different than those described in this report, then NV5 should be notified immediately so that we can review these differences and, if necessary, modify the recommendations.
6. The elevation or depth to the groundwater table underlying the project site may differ with time and location; therefore, the depth to the groundwater table encountered in the exploratory borings is only representative of the specific time and location where it was observed.
7. The project site map shows approximate exploratory excavation locations as determined by pacing distances from identifiable site features; therefore, their locations should not be relied upon as being exact nor located with the accuracy of a California-licensed land surveyor.
8. NV5's geotechnical investigation scope-of-services did not include an evaluation of the project site for the presence of hazardous materials. Although NV5 did not observe the presence of

hazardous materials at the time of the field investigation, all project personnel should be careful and take the necessary precautions in the event hazardous materials are encountered during construction.

9. NV5's geotechnical investigation scope-of-services did not include an evaluation of the project site for the presence of mold nor for the future potential development of mold at the project site. If an evaluation of the presence of mold and/or for the future potential development of mold at the site is desired, then the property owner should contact a consulting firm specializing in these types of investigations. NV5 does not perform mold evaluation investigations.
10. NV5's experience and that of the civil engineering profession clearly indicates that during the construction phase of a project the risks of costly design, construction and maintenance problems can be significantly reduced by retaining a design geotechnical engineering firm to review the project plans and specifications and to provide geotechnical engineering CQA observation and testing services. Upon your request NV5 will prepare a CQA geotechnical engineering services proposal that will present a work scope, a tentative schedule and fee estimate for your consideration and authorization. If NV5 is not retained to provide geotechnical engineering CQA services during the construction phase of the project, then NV5 will not be responsible for geotechnical engineering CQA services provided by others nor any aspect of the project that fails to meet your or a third party's expectations in the future.

APPENDIX A:

Important Information about This Geotechnical Engineering Report (Included with permission of GBA, Copyright 2019)

Important Information about This Geotechnical-Engineering Report

Subsurface problems are a principal cause of construction delays, cost overruns, claims, and disputes.

While you cannot eliminate all such risks, you can manage them. The following information is provided to help.

The Geoprofessional Business Association (GBA) has prepared this advisory to help you – assumedly a client representative – interpret and apply this geotechnical-engineering report as effectively as possible. In that way, you can benefit from a lowered exposure to problems associated with subsurface conditions at project sites and development of them that, for decades, have been a principal cause of construction delays, cost overruns, claims, and disputes. If you have questions or want more information about any of the issues discussed herein, contact your GBA-member geotechnical engineer. Active engagement in GBA exposes geotechnical engineers to a wide array of risk-confrontation techniques that can be of genuine benefit for everyone involved with a construction project.

Understand the Geotechnical-Engineering Services Provided for this Report

Geotechnical-engineering services typically include the planning, collection, interpretation, and analysis of exploratory data from widely spaced borings and/or test pits. Field data are combined with results from laboratory tests of soil and rock samples obtained from field exploration (if applicable), observations made during site reconnaissance, and historical information to form one or more models of the expected subsurface conditions beneath the site. Local geology and alterations of the site surface and subsurface by previous and proposed construction are also important considerations. Geotechnical engineers apply their engineering training, experience, and judgment to adapt the requirements of the prospective project to the subsurface model(s). Estimates are made of the subsurface conditions that will likely be exposed during construction as well as the expected performance of foundations and other structures being planned and/or affected by construction activities.

The culmination of these geotechnical-engineering services is typically a geotechnical-engineering report providing the data obtained, a discussion of the subsurface model(s), the engineering and geologic engineering assessments and analyses made, and the recommendations developed to satisfy the given requirements of the project. These reports may be titled investigations, explorations, studies, assessments, or evaluations. Regardless of the title used, the geotechnical-engineering report is an engineering interpretation of the subsurface conditions within the context of the project and does not represent a close examination, systematic inquiry, or thorough investigation of all site and subsurface conditions.

Geotechnical-Engineering Services are Performed for Specific Purposes, Persons, and Projects, and At Specific Times

Geotechnical engineers structure their services to meet the specific needs, goals, and risk management preferences of their clients. A geotechnical-engineering study conducted for a given civil engineer

will not likely meet the needs of a civil-works constructor or even a different civil engineer. Because each geotechnical-engineering study is unique, each geotechnical-engineering report is unique, prepared *solely* for the client.

Likewise, geotechnical-engineering services are performed for a specific project and purpose. For example, it is unlikely that a geotechnical-engineering study for a refrigerated warehouse will be the same as one prepared for a parking garage; and a few borings drilled during a preliminary study to evaluate site feasibility will not be adequate to develop geotechnical design recommendations for the project.

Do not rely on this report if your geotechnical engineer prepared it:

- for a different client;
- for a different project or purpose;
- for a different site (that may or may not include all or a portion of the original site); or
- before important events occurred at the site or adjacent to it; e.g., man-made events like construction or environmental remediation, or natural events like floods, droughts, earthquakes, or groundwater fluctuations.

Note, too, the reliability of a geotechnical-engineering report can be affected by the passage of time, because of factors like changed subsurface conditions; new or modified codes, standards, or regulations; or new techniques or tools. *If you are the least bit uncertain about the continued reliability of this report, contact your geotechnical engineer before applying the recommendations in it. A minor amount of additional testing or analysis after the passage of time – if any is required at all – could prevent major problems.*

Read this Report in Full

Costly problems have occurred because those relying on a geotechnical-engineering report did not read the report in its entirety. Do not rely on an executive summary. Do not read selective elements only. *Read and refer to the report in full.*

You Need to Inform Your Geotechnical Engineer About Change

Your geotechnical engineer considered unique, project-specific factors when developing the scope of study behind this report and developing the confirmation-dependent recommendations the report conveys.

Typical changes that could erode the reliability of this report include those that affect:

- the site's size or shape;
- the elevation, configuration, location, orientation, function or weight of the proposed structure and the desired performance criteria;
- the composition of the design team; or
- project ownership.

As a general rule, *always* inform your geotechnical engineer of project or site changes – even minor ones – and request an assessment of their impact. *The geotechnical engineer who prepared this report cannot accept*

responsibility or liability for problems that arise because the geotechnical engineer was not informed about developments the engineer otherwise would have considered.

Most of the “Findings” Related in This Report Are Professional Opinions

Before construction begins, geotechnical engineers explore a site’s subsurface using various sampling and testing procedures. *Geotechnical engineers can observe actual subsurface conditions only at those specific locations where sampling and testing is performed.* The data derived from that sampling and testing were reviewed by your geotechnical engineer, who then applied professional judgement to form opinions about subsurface conditions throughout the site. Actual sitewide-subsurface conditions may differ – maybe significantly – from those indicated in this report. Confront that risk by retaining your geotechnical engineer to serve on the design team through project completion to obtain informed guidance quickly, whenever needed.

This Report’s Recommendations Are Confirmation-Dependent

The recommendations included in this report – including any options or alternatives – are confirmation-dependent. In other words, they are not final, because the geotechnical engineer who developed them relied heavily on judgement and opinion to do so. Your geotechnical engineer can finalize the recommendations *only after observing actual subsurface conditions* exposed during construction. If through observation your geotechnical engineer confirms that the conditions assumed to exist actually do exist, the recommendations can be relied upon, assuming no other changes have occurred. *The geotechnical engineer who prepared this report cannot assume responsibility or liability for confirmation-dependent recommendations if you fail to retain that engineer to perform construction observation.*

This Report Could Be Misinterpreted

Other design professionals’ misinterpretation of geotechnical-engineering reports has resulted in costly problems. Confront that risk by having your geotechnical engineer serve as a continuing member of the design team, to:

- confer with other design-team members;
- help develop specifications;
- review pertinent elements of other design professionals’ plans and specifications; and
- be available whenever geotechnical-engineering guidance is needed.

You should also confront the risk of constructors misinterpreting this report. Do so by retaining your geotechnical engineer to participate in prebid and preconstruction conferences and to perform construction-phase observations.

Give Constructors a Complete Report and Guidance

Some owners and design professionals mistakenly believe they can shift unanticipated-subsurface-conditions liability to constructors by limiting the information they provide for bid preparation. To help prevent the costly, contentious problems this practice has caused, include the complete geotechnical-engineering report, along with any attachments or appendices, with your contract documents, *but be certain to note*

conspicuously that you’ve included the material for information purposes only. To avoid misunderstanding, you may also want to note that “informational purposes” means constructors have no right to rely on the interpretations, opinions, conclusions, or recommendations in the report. Be certain that constructors know they may learn about specific project requirements, including options selected from the report, *only* from the design drawings and specifications. Remind constructors that they may perform their own studies if they want to, and *be sure to allow enough time* to permit them to do so. Only then might you be in a position to give constructors the information available to you, while requiring them to at least share some of the financial responsibilities stemming from unanticipated conditions. Conducting prebid and preconstruction conferences can also be valuable in this respect.

Read Responsibility Provisions Closely

Some client representatives, design professionals, and constructors do not realize that geotechnical engineering is far less exact than other engineering disciplines. This happens in part because soil and rock on project sites are typically heterogeneous and not manufactured materials with well-defined engineering properties like steel and concrete. That lack of understanding has nurtured unrealistic expectations that have resulted in disappointments, delays, cost overruns, claims, and disputes. To confront that risk, geotechnical engineers commonly include explanatory provisions in their reports. Sometimes labeled “limitations,” many of these provisions indicate where geotechnical engineers’ responsibilities begin and end, to help others recognize their own responsibilities and risks. *Read these provisions closely.* Ask questions. Your geotechnical engineer should respond fully and frankly.

Geoenvironmental Concerns Are Not Covered

The personnel, equipment, and techniques used to perform an environmental study – e.g., a “phase-one” or “phase-two” environmental site assessment – differ significantly from those used to perform a geotechnical-engineering study. For that reason, a geotechnical-engineering report does not usually provide environmental findings, conclusions, or recommendations; e.g., about the likelihood of encountering underground storage tanks or regulated contaminants. *Unanticipated subsurface environmental problems have led to project failures.* If you have not obtained your own environmental information about the project site, ask your geotechnical consultant for a recommendation on how to find environmental risk-management guidance.

Obtain Professional Assistance to Deal with Moisture Infiltration and Mold

While your geotechnical engineer may have addressed groundwater, water infiltration, or similar issues in this report, the engineer’s services were not designed, conducted, or intended to prevent migration of moisture – including water vapor – from the soil through building slabs and walls and into the building interior, where it can cause mold growth and material-performance deficiencies. Accordingly, *proper implementation of the geotechnical engineer’s recommendations will not of itself be sufficient to prevent moisture infiltration.* Confront the risk of moisture infiltration by including building-envelope or mold specialists on the design team. *Geotechnical engineers are not building-envelope or mold specialists.*



Telephone: 301/565-2733

e-mail: info@geoprofessional.org www.geoprofessional.org

Copyright 2019 by Geoprofessional Business Association (GBA). Duplication, reproduction, or copying of this document, in whole or in part, by any means whatsoever, is strictly prohibited, except with GBA’s specific written permission. Excerpting, quoting, or otherwise extracting wording from this document is permitted only with the express written permission of GBA, and only for purposes of scholarly research or book review. Only members of GBA may use this document or its wording as a complement to or as an element of a report of any kind. Any other firm, individual, or other entity that so uses this document without being a GBA member could be committing negligence.

APPENDIX B:

Exploratory Boring Logs

NV5

EXPLORATORY BORING LOG

48 BELLARMINE COURT, SUITE 40, CHICO, CA, 95928
 PHONE: 530-894-2487, FAX: 530-894-2437

Boring No.

B21-1

Sheet: 1 Of 3

Project Name: Proposed Burns Valley Development		Project No.: 71075.00.001	Task: 001	Start Date: 1-12-21
Location: Burns Valley Road, Clearlake, California		Estimated Ground Surface Elevation (Ft. AMSL): 1360.00		Finish Date: 1-12-21
Logged By: Santiago Carrillo	Drilling Cmpny: Taber Drilling		Drill Rig Type: CME-55	
Driller: Toby Baldazo	Drilling Method: Hollow Stem Auger (HSA)		Hammer Type: 140 Pound Auto Trip Hammer	
Boring Dia. (In.): 8.00	Total Depth (Ft.): 51.5	Backfill or Well Design: Neat Cement Grout		

24 Hour Clock Time (HH:MM)	Pocket Penetrometer (TSF)	Uncorrected Blow Counts (Blows / 6-inch)	Drilling Method and/or Sampler Type	Sample Recovery (Ft./Ft.)	Sample No.	Depth B.G.S. (Ft.)	Sample Interval And Symbol	Graphic Log	Ground Water Information			
									Date	1-12-21		
									Time (24 Hour)	11:10		
									Soil And/Or Rock Material Descriptions <small>SOIL: USCS Symbol; Name; Particle Size Gradation %; Munsell Color; Density/Consistency; Moisture; Odor; Organics; Cementation; Texture; Refuse; Etc. ROCK: Unit Name; Lithology; Munsell Color; Cementation; Weathering; Competency; Bedding/Foliation; Fracture/Joint Spacing & Roughness; RQD; Moisture.</small>			
8:55			HSA			0			(SC) CLAYEY SAND WITH GRAVEL, fld. Est.: 50% Fine to Medium Sand, 30% Gravel, and 20% Low Plastic Clay-Silt Fines; Dark Yellowish Brown (10YR, 4/4); Medium Dense; Damp.			
					BK-1	1						
8:56		6	2.5SS			2			Roots Encountered			
		6			L1-2-2	3						
	3.0	10	HSA	0.75/1.5	L1-1-2	3			Increased Drill Effort			
						4						
9:04		7	2.5SS			5			Yellowish Brown (10YR, 5/6); Stiff; Damp; Reddish Brown Mottling			
		14			L2-2-2	6						
	4.5	19	HSA	0.8/1.5	L2-1-2	6			Increased Drill Effort			
						7						
						8			(CL) SANDY CLAY, FLD. EST: 60% Low Plastic Clay-Silt Fines, 30% Fine Sand, and 10% Gravel; Light Olive Brown (2.5YR, 5/4); Hard; Damp.			
						9						
9:15		6	2.5SS			10			Increased Drill Effort			
		19			L3-2-2	11						
	4.5	29	HSA	0.9/1.5	L3-1-2	11			Increased Drill Effort			
						12						
						13			Increased Drill Effort			
						14						
9:24		9	2.5SS			15			Increased Drill Effort			
		8			L4-2-2	16						
	2.75	8	HSA	1.2/1.5	L4-1-2	16			Increased Drill Effort			
						17						
						18			Increased Drill Effort			
						19						
						20			Increased Drill Effort			
						21						

NOTES: SPT - Standard Penetration Test
 HSA - Hollow Stem Augers
 2.5SS - 2.5" Split Spoon Sampler

N|V|5

EXPLORATORY BORING LOG

Section 1, Item 5.

48 BELLARMINE COURT, SUITE 40, CHICO, CA., 95928
PHONE: 530-894-2487, FAX: 530-894-2437

Boring No.

B21-1

Project Name: Proposed Burns Valley Development

Project No.: 71075.00.001

Task: 001

Start Date: 1-12-21

Location: Burns Valley Road, Clearlake, California

Estimated Ground Surface Elevation (Ft. AMSL):

1360.00

Finish Date: 1-12-21

Sheet: 2 Of 3

Logged By: Santiago Carrillo

Drilling Cmpny: Taber Drilling

Drill Rig Type: CME-55

Driller: Toby Baldazo

Drilling Method: Hollow Stem Auger (HSA)

Hammer Type: 140 Pound Auto Trip Hammer

Boring Dia. (In.): 8.00

Total Depth (Ft.): 51.5

Backfill or Well Design: Neat Cement Grout

Ground Water Information

Date	1-12-21		
Time (24 Hour)	11:10		
Depth (Ft.)	23.0		

Soil And/Or Rock Material Descriptions

SOIL: USCS Symbol; Name; Particle Size Gradation %; Munsell Color; Density/Consistency; Moisture; Odor; Organics; Cementation; Texture; Refuse; Etc.
ROCK: Unit Name; Lithology; Munsell Color; Cementation; Weathering; Competency; Bedding/Foliation; Fracture/Joint Spacing & Roughness; RGD; Moisture.

24 Hour Clock Time (HH:MM)	Pocket Penetrometer (TSF)	Uncorrected Blow Counts (Blows / 6-inch)	Drilling Method and/or Sampler Type	Sample Recovery (Ft./Ft.)	Sample No.	Depth B.G.S. (Ft.)	Sample Interval And Symbol	Graphic Log	Soil And/Or Rock Material Descriptions
9:39		2	2.5SS			20			(CL) SANDY CLAY, FLD. EST: 60% Low Plastic Clay-Silt Fines, 30% Fine Sand, and 10% Gravel; Light Olive Brown (2.5Y, 5/4); Hard; Moist; Weakly Cemented.
		23			L5-2-2	21			
	1.5	43	HSA	1.5/1.5	L5-1-2	22			
						23		Hard Drilling	
						24			
9:58		15	SPT			25			(GM) SILTY GRAVEL WITH SAND, Fld. Est.: 60% Gravel; 20% Fine Sand; and 20% Low Plastic Clay-Silt Fines; Light Gray (10YR, 7/1); Medium Dense; Wet.
		10		0.3/1.5	B1-1-1	26			
		3	HSA			27			
						28			
						29			
10:11		2	SPT			30			(CH) FAT CLAY WITH SAND, FLD. EST: 85% High Plastic Clay-Silt Fines and 15% Fine Sand; Dark Greenish Gray (GLEYS 1, 4/1); Firm; Wet.
		2				31			
	1.5	3	HSA	1.5/1.5	B2-1-1	32			
						33			
						34			
10:21		7	SPT			35			Hard
		15				36			
	3.0	20	HSA	1.5/1.5	B3-1-1	37			
						38			
						39			
						40			

NOTES: SPT - Standard Penetration Test
HSA - Hollow Stem Augers
2.5SS - 2.5" Split Spoon Sampler



EXPLORATORY BORING LOG

Section 1, Item 5.

48 BELLARMINE COURT, SUITE 40, CHICO, CA., 95928
PHONE: 530-894-2487, FAX: 530-894-2437

Boring No.
B21-1

Project Name: Proposed Burns Valley Development

Project No.: 71075.00.001

Task: 001

Start Date: 1-12-21

Location: Burns Valley Road, Clearlake, California

Estimated Ground Surface

Elevation (Ft. AMSL): 1360.00

Finish Date: 1-12-21

Sheet: 3 Of 3

Logged By: Santiago Carrillo

Drilling Cmpny: Taber Drilling

Drill Rig Type: CME-55

Driller: Toby Baldazo

Drilling Method: Hollow Stem Auger (HSA)

Hammer Type: 140 Pound Auto Trip Hammer

Boring Dia. (In.): 8.00

Total Depth (Ft.): 51.5

Backfill or Well Design: Neat Cement Grout

24 Hour Clock Time (HH:MM)	Pocket Penetrometer (TSF)	Uncorrected Blow Counts (Blows / 6-inch)	Drilling Method and/or Sampler Type	Sample Recovery (Ft./Ft.)	Sample No.	Depth B.G.S. (Ft.)	Sample Interval And Symbol	Graphic Log	Ground Water Information			
									Date	1-12-21		
									Time (24 Hour)	11:10		
									Soil And/Or Rock Material Descriptions			
									SOIL: USCS Symbol; Name; Particle Size Gradation %; Munsel Color; Density/Consistency; Moisture; Odor; Organics; Cementation; Texture; Refuse; Etc. ROCK: Unit Name; Lithology; Munsel Color; Cementation; Weathering; Competency; Bedding/Foliation; Fracture/Joint Spacing & Roughness; RGD; Moisture.			
10:37		5	SPT			40			(CH) FAT CLAY WITH SAND, FLD. EST: 85% High Plastic Clay-Silt Fines and 15% Fine Sand; Dark Greenish Gray (GLEY 1, 4/1); Very Stiff; Wet.			
	1.5	9	HSA	1.5/1.5	B4-1-1	41						
						42						
						43						
						44						
10:52		4	SPT			45						
	1.0	10	HSA	1.5/1.5	B5-1-1	46			Stiff			
						47						
						48						
						49						
11:10		5	SPT			50						
		10				51						
11:10	2.0	12		1.0/1.5	B6-1-1	51			Increase in Sand Content; Very Stiff			
						52						
						53						
						54						
						55						
						56						
						57						
						58						
						59						
						60						

NOTES: SPT - Standard Penetration Test
HSA - Hollow Stem Augers
2.5SS - 2.5" Split Spoon Sampler

NV5

EXPLORATORY BORING LOG

48 BELLARMINE COURT, SUITE 40, CHICO, CA., 95928
 PHONE: 530-894-2487, FAX: 530-894-2437

Boring No.
B21-2

Project Name: Proposed Burns Valley Development		Project No.: 71075.00.001	Task: 001	Start Date: 1-12-21
Location: Burns Valley Road, Clearlake, California		Estimated Ground Surface Elevation (Ft. AMSL): 1352.00		Finish Date: 1-12-21
Logged By: Santiago Carrillo		Drilling Cmpny: Taber Drilling		Drill Rig Type: CME-55
Driller: Toby Baldazo		Drilling Method: Hollow Stem Auger (HSA)		Hammer Type: 140 Pound Auto Trip Hammer
Boring Dia. (In.): 8.00	Total Depth (Ft.): 51.5	Backfill or Well Design: Neat Cement Grout		

24 Hour Clock Time (HH:MM)	Pocket Penetrometer (TSF)	Uncorrected Blow Counts (Blows / 6-inch)	Drilling Method and/or Sampler Type	Sample Recovery (Ft./Ft.)	Sample No.	Depth B.G.S. (Ft.)	Sample Interval And Symbol	Graphic Log	Ground Water Information				
									Date	1-12-21			
									Time (24 Hour)	15:38			
									Depth (Ft.)	30.0			
										Soil And/Or Rock Material Descriptions			
<small>SOIL: USCS Symbol; Name; Particle Size Gradation %; Munsell Color; Density/Consistency; Moisture; Odor; Organics; Cementation; Texture; Refuse; Etc. ROCK: Unit Name; Lithology; Munsell Color; Cementation; Weathering; Competency; Bedding/Foliation; Fracture/Joint Spacing & Roughness; RQD; Moisture.</small>													
13:56			HSA			0			(CL) SANDY CLAY, fld. Est.: 60% Low Plastic Clay-Silt Fines, 30% Fine Sand, and 10% Gravel; Dark Yellowish Brown (10YR, 3/6); Very Stiff; Moist. Weakly Cemented Black Mottling				
					BK-2	1							
14:04		7	2.5SS			2							
		11			L1-2-2	3							
	4.5	12		0.8/1.5	L1-1-2	4							
			HSA			5							
14:10		6	2.5SS			6							
		12			L2-2-2	7							
	4.5	16		1.0/1.5	L2-1-2	8							
			HSA			9							
						10							
14:17		5	2.5SS			11							
		11			L3-2-2	12							
	4.5	18		1.0/1.5	L3-1-2	13							
			HSA			14							
						15							
14:23		3	2.5SS			16							
		7			L4-2-2	17							
	2.0	11		1.2/1.5	L4-1-2	18							
			HSA			19							
						20							

NOTES: SPT - Standard Penetration Test
 HSA - Hollow Stem Augers
 2.5SS - 2.5" Split Spoon Sampler



EXPLORATORY BORING LOG

48 BELLARMINE COURT, SUITE 40, CHICO, CA., 95928
 PHONE: 530-894-2487, FAX: 530-894-2437

Boring No.
B21-2

Project Name: Proposed Burns Valley Development

Project No.: 71075.00.001

Task: 001

Start Date: 1-12-21

Location: Burns Valley Road, Clearlake, California

Estimated Ground Surface Elevation (Ft. AMSL):

1352.00

Finish Date: 1-12-21

Sheet: 2 Of 3

Logged By: Santiago Carrillo

Drilling Cmpny: Taber Drilling

Drill Rig Type: CME-55

Driller: Toby Baldazo

Drilling Method: Hollow Stem Auger (HSA)

Hammer Type: 140 Pound Auto Trip Hammer

Boring Dia. (In.): 8.00

Total Depth (Ft.): 51.5

Backfill or Well Design: Neat Cement Grout

24 Hour Clock Time (HH:MM)	Pocket Penetrometer (TSF)	Uncorrected Blow Counts (Blows / 6-inch)	Drilling Method and/or Sampler Type	Sample Recovery (FL/FL)	Sample No.	Depth B.G.S. (Ft.)	Sample Interval And Symbol	Graphic Log	Ground Water Information			
									Date	1-12-21		
									Time (24 Hour)	15:38		
									Depth (Ft.)	30.0		
Soil And/Or Rock Material Descriptions												
<small>SOIL: USCS Symbol; Name; Particle Size Gradation %; Munsell Color; Density/Consistency; Moisture; Odor; Organics; Cementation; Texture; Refuse; Etc. ROCK: Unit Name; Lithology; Munsell Color; Cementation; Weathering; Competency; Bedding/Foliation; Fracture/Joint Spacing & Roughness; RQD; Moisture.</small>												
14:31		2	2.5SS			20			(CL) SANDY CLAY, Fld. Est.: 60% Low Plastic Clay-Silt Fines, 30% Fine Sand, and 10% Gravel; Dark Yellowish Brown (10YR, 3/6); Firm; Moist to Very Moist.			
		4			L5-2-2	21						
	0.5	6		1.4/1.5	L5-1-2	22						
			HSA			23						
						24						
						25						
14:46		7	SPT			26						
		9				27						
	2.0	9		1.5/1.5	B1-1-1	28						
			HSA			29						
						30						
14:49		2	SPT			30			(GP) POORLY GRADED GRAVELS, Fld. Est.: 80% Gravel; 10% Fine Sand; and 10% Low Plastic Clay-Silt Fines; Gray (10YR, 5/1); Dense; Very Moist.			
		2				31						
	.5	2		1.5/1.5	B2-1-1	32			(CL) LEAN CLAY WITH SAND, FLD. EST: 85% Low Plastic Clay-Silt Fines and 15% Fine Sand; Dark Greenish Gray (GLEY 1, 4/1); Soft; Wet.			
			HSA			33						
						34						
						35						
15:00		6	SPT			35			(SM) SILTY SAND, FLD. EST: 55% Fine Sand and 45% Low Plastic Clay-Silt Fines; Dark Grayish Brown (2.5YR, 4/2); Medium Dense; Wet.			
		9				36						
		10		1.5/1.5	B3-1-1	37						
			HSA			38						
						39						
						40			(CH) FAT CLAY, FLD. EST: 95% High Plastic Clay-Silt Fines and 5% Fine Sand; Dark Greenish Gray (GLEY 1, 4/1); Stiff; Wet.			
						41						

NOTES: SPT - Standard Penetration Test
 HSA - Hollow Stem Augers
 2.5SS - 2.5" Split Spoon Sampler



EXPLORATORY BORING LOG

48 BELLARMINE COURT, SUITE 40, CHICO, CA., 95928
PHONE: 530-894-2487, FAX: 530-894-2437

Boring No.
B21-2

Project Name: Proposed Burns Valley Development	Project No.: 71075.00.001	Task: 001	Start Date: 1-12-21
Location: Burns Valley Road, Clearlake, California	Estimated Ground Surface Elevation (Ft. AMSL): 1352.00	Finish Date: 1-12-21	Sheet: 3 Of 3
Logged By: Santiago Carrillo	Drilling Cmpny: Taber Drilling	Drill Rig Type: CME-55	
Driller: Toby Baldazo	Drilling Method: Hollow Stem Auger (HSA)	Hammer Type: 140 Pound Auto Trip Hammer	
Boring Dia. (In.): 8.00	Total Depth (Ft.): 51.5	Backfill or Well Design: Neat Cement Grout	

24 Hour Clock Time (HH:MM)	Pocket Penetrometer (TSF)	Uncorrected Blow Counts (Blows / 6-inch)	Drilling Method and/or Sampler Type	Sample Recovery (Ft./Ft.)	Sample No.	Depth B.G.S. (Ft.)	Sample Interval And Symbol	Graphic Log	Ground Water Information			
									Date	1-12-21		
									Time (24 Hour)	15:38		
									Soil And/OR Rock Material Descriptions			
									SOIL: USCS Symbol; Name; Particle Size Gradation %; Munsell Color; Density/Consistency; Moisture; Odor; Organics; Cementation; Texture; Refuse; Etc. ROCK: Unit Name; Lithology; Munsell Color; Cementation; Weathering; Competency; Bedding/Foliation; Fracture/Joint Spacing & Roughness; RQD; Moisture.			
15:13		3 6	SPT			40			(CH) FAT CLAY, FLD. EST: 95% High Plastic Clay-Silt Fines and 5% Fine Sand; Dark Greenish Gray (GLE 1, 4/1); Stiff; Wet.			
	1.75	8	HSA	1.5/1.5	B4-1-1	41						
						42						
						43						
						44						
						45						
15:25		3 5	SPT			45						
	1.0	7	HSA	1.5/1.5	B5-1-1	46						
						47						
						48						
						49						
15:37		6 6	SPT			50						
15:38	1.5	10		1.5/1.5	B6-1-1	51			Increase in Sand Content			
						52						
						53						
						54						
						55						
						56						
						57						
						58						
						59						
						60						

NOTES: SPT - Standard Penetration Test
HSA - Hollow Stem Augers
2.5SS - 2.5" Split Spoon Sampler

NV5

EXPLORATORY BORING LOG

48 BELLARMINE COURT, SUITE 40, CHICO, CA., 95928
PHONE: 530-894-2487, FAX: 530-894-2437

Boring No.

B21-3

Project Name: Proposed Burns Valley Development	Project No.: 71075.00.001	Task: 001	Start Date: 1-13-21
Location: Burns Valley Road, Clearlake, California	Estimated Ground Surface Elevation (Ft. AMSL): 1352.00	Finish Date: 1-13-21	Sheet: 1 Of 1
Logged By: Santiago Carrillo	Drilling Cmpny: Taber Drilling	Drill Rig Type: CME-55	
Driller: Toby Baldazo	Drilling Method: Hollow Stem Auger (HSA)	Hammer Type: 140 Pound Auto Trip Hammer	
Boring Dia. (In.): 8.00	Total Depth (Ft.): 15.0	Backfill or Well Design: Neat Cement Grout	

24 Hour Clock Time (HH:MM)	Pocket Penetrometer (TSF)	Uncorrected Blow Counts (Blows / 6-inch)	Drilling Method and/or Sampler Type	Sample Recovery (FL/FT)	Sample No.	Depth B.G.S. (Ft.)	Sample Interval And Symbol	Graphic Log	Ground Water Information				
									Date	1-13-21			
									Time (24 Hour)	9:00			
									Depth (Ft.)	None			
										Soil And/Or Rock Material Descriptions			
										<small>SOIL: USCS Symbol; Name; Particle Size Gradation %; Munsell Color; Density/Consistency; Moisture; Odor; Organics; Cementation; Texture; Refuse; Etc. ROCK: Unit Name; Lithology; Munsell Color; Cementation; Weathering; Competency; Bedding/Foliation; Fracture/Joint Spacing & Roughness; RQD; Moisture.</small>			
8:28			HSA			0			(SC) CLAYEY SAND WITH GRAVEL, fld. Est.: 55% Fine Sand, 20% Low Plastic Clay-Silt Fines, and 25% Gravel; Dark Yellowish Brown (10YR, 4/6); Medium Dense; Moist to Damp.				
8:31		5	2.5SS		BK-3	1							
		5			L1-2-2	2							
		8		0.9/1.5	L1-1-2	3							
			HSA			4							
8:40		5	2.5SS			5							
		7			L2-2-2	6							
		6		0.75/1.5	L2-1-2	7							
			HSA			8			(CL) LEAN CLAY WITH SAND, fld. Est.: 90% Low Plastic Clay-Silt Fines and 10% Fine Sand; Dark Brown (10YR, 5/3); Very Stiff; Moist.				
						9							
8:50		5	2.5SS			10							
		9			L3-2-2	11							
	4.25	11		1.25/1.5	L3-1-2	12							
			HSA			13							
						14							
9:00		3	2.5SS			15			Increase in Sand Content; Stiff; Very Moist.				
		7			L4-2-2	16							
9:00	2.25	9		1.5/1.5	L4-1-2	17							
						18							
						19							
						20							

NOTES: HSA - Hollow Stem Augers
2.5SS - 2.5" Split Spoon Sampler



EXPLORATORY BORING LOG

48 BELLARMINE COURT, SUITE 40, CHICO, CA., 95928
PHONE: 530-894-2487, FAX: 530-894-2437

Boring No.
B21-4

Project Name: Proposed Burns Valley Development		Project No.: 71075.00.001	Task: 001	Start Date: 1-13-21
Location: Burns Valley Road, Clearlake, California		Estimated Ground Surface Elevation (Ft. AMSL): 1355.00	Finish Date: 1-13-21	
Logged By: Santiago Carrillo		Drilling Cmpny: Taber Drilling		Drill Rig Type: CME-55
Driller: Toby Baldazo		Drilling Method: Hollow Stem Auger (HSA)		Hammer Type: 140 Pound Auto Trip Hammer
Boring Dia. (In.): 8.00	Total Depth (Ft.): 21.5	Backfill or Well Design: Neat Cement Grout		

24 Hour Clock Time (HH:MM)	Pocket Penetrometer (TSF)	Uncorrected Blow Counts (Blows / 6-inch)	Drilling Method and/or Sampler Type	Sample Recovery (Ft./Ft.)	Sample No.	Depth B.G.S. (Ft.)	Sample Interval And Symbol	Graphic Log	Ground Water Information			
									Date	1-13-21		
									Time (24 Hour)	10:06		
									Soil And/Or Rock Material Descriptions			
									SOIL: USCS Symbol; Name; Particle Size Gradation %; Munsell Color; Density/Consistency; Moisture; Odor; Organics; Cementation; Texture; Refuse; Etc. ROCK: Unit Name; Lithology; Munsell Color; Cementation; Weathering; Competency; Bedding/Foliation; Fracture/Joint Spacing & Roughness; RQD; Moisture.			
9:24			HSA			0			(CL) LEAN CLAY WITH SAND, fld. Est.: 85% Low Plastic Clay-Silt Fines and 15% Fine Sand; Brown (10YR, 4/3); Stiff; Moist.			
						1						
9:26		5	2.5SS		L1-2-2	2						
		9				3			Very Stiff			
	4.5	10		1.2/1.5	L1-1-2	3						
			HSA			4						
						5						
9:31		14	2.5SS		L2-2-2	5						
		27				6			Hard			
	4.5+	38		1.3/1.5	L2-1-2	6						
			HSA			7						
						8						
						9						
						10			(SC) CLAYEY SAND WITH GRAVEL, fld. Est.: 65% Fine Sand, 25% Low Plastic Clay-Silt Fines, and 10% Gravel; Strong Brown (7.5YR, 4/6); Medium Dense; Moist.			
9:41		10	2.5SS		L3-2-2	10						
		12				11						
	4.5+	17		.8/1.5	L3-1-2	11						
			HSA			12						
						13						
						14						
						15						
9:52		9	2.5SS		L4-2-2	15						
		5				16						
	1.5	7		1.1/1.5	L4-1-2	16			(CL) LEAN CLAY, fld. Est.: 90% Low Plastic Clay-Silt Fines and 10% Fine Sand; Dark Grayish Brown (10YR, 4/2); Firm; Moist; Orange Mottling.			
			HSA			17						
						18						
						19						
						20						
10:04		16	2.5SS		L5-2-2	20			(SM) SILTY SAND, fld. Est.: 80% Fine Sand and 15% Low Plastic Clay-Silt Fines, and, 5% Gravel; Brown (10YR, 4/3); Dense; Wet.			
		29				21						
10:06		16		.8/1.5	L5-1-2	21						

NOTES: HSA - Hollow Stem Augers
2.5SS - 2.5" Split Spoon Sampler

N/V5

EXPLORATORY BORING LOG

48 BELLARMINA COURT, SUITE 40, CHICO, CA., 95928
PHONE: 530-894-2487, FAX: 530-894-2437

Boring No.
B21-5
Sheet: 1 Of 1

Project Name: Proposed Burns Valley Development		Project No.: 71075.00.001	Task: 001	Start Date: 1-13-21
Location: Burns Valley Road, Clearlake, California		Estimated Ground Surface Elevation (Ft. AMSL): 1360.00		Finish Date: 1-13-21
Logged By: Santiago Carrillo		Drilling Cmpny: Taber Drilling		Drill Rig Type: CME-55
Driller: Toby Baldazo		Drilling Method: Hollow Stem Auger (HSA)		Hammer Type: 140 Pound Auto Trip Hammer
Boring Dia. (In.): 8.00	Total Depth (Ft.): 21.5	Backfill or Well Design: Neat Cement Grout		

24 Hour Clock Time (HH:MM)	Pocket Penetrometer (TSF)	Uncorrected Blow Counts (Blows / 6-inch)	Drilling Method and/or Sampler Type	Sample Recovery (F/U/L)	Sample No.	Depth B.G.S. (Ft.)	Sample Interval And Symbol	Graphic Log	Ground Water Information			
									Date	1-13-21		
									Time (24 Hour)	11:07		
									Soil And/Or Rock Material Descriptions			
									SOIL: USCS Symbol; Name; Particle Size Gradation %; Munsell Color; Density/Consistency; Moisture; Odor; Organics; Cementation; Texture; Refuse; Etc. ROCK: Unit Name; Lithology; Munsell Color; Cementation; Weathering; Competency; Bedding/Foliation; Fracture/Joint Spacing & Roughness; RQD; Moisture.			
10:30			HSA			0			(ML) SANDY SILT, FLD. EST: 70% Low Plastic Clay-Silt Fines and 30% Fine Sand; Dark Yellowish Brown; (10YR, 4/4); Stiff; Damp.			
					BK-4	1						
10:32		4	2.5SS			2						
		6			L1-2-2	3						
	4.25	8		.9/1.5	L1-1-2	4						
			HSA			5			(CL) LEAN CLAY WITH SAND, Fld. Est.: 80% Low Plastic Clay-Silt Fines and 20% Fine Sand; Brown (10YR, 4/4); Very Stiff; Damp to Moist.			
10:36		8	2.5SS			6						
		10		.9/1.5	L2-2-2	7						
	4.5+	17			L2-1-2	8						
			HSA			9						
						10						
10:45		10	2.5SS			11						
		16		.7/1.5	L3-2-2	12						
		19			L3-1-2	13						
			HSA			14						
						15						
10:56		3	2.5SS			16			Firm			
		6		1.4/1.5	L4-2-2	17						
	.75	6			L4-1-2	18						
			HSA			19						
						20						
11:07		4	2.5SS			21			Firm to Stiff			
		6			L5-2-2	22						
11:07	1.75	8		1.5/1.5	L5-1-2	23						

NOTES: HSA - Hollow Stem Augers
2.5SS - 2.5" Split Spoon Sampler



EXPLORATORY BORING LOG

48 BELLARMINE COURT, SUITE 40, CHICO, CA., 95928
 PHONE: 530-894-2487, FAX: 530-894-2437

Boring No.

B21-6

Sheet: 1 Of 2

Project Name: Proposed Burns Valley Development		Project No.: 71075.00.001	Task: 001	Start Date: 1-13-21
Location: Burns Valley Road, Clearlake, California		Estimated Ground Surface Elevation (Ft. AMSL): 1356.00		Finish Date: 1-13-21
Logged By: Santiago Carrillo		Drilling Cmpny: Taber Drilling		Drill Rig Type: CME-55
Driller: Toby Baldazo		Drilling Method: Hollow Stem Auger (HSA)		Hammer Type: 140 Pound Auto Trip Hammer
Boring Dia. (In.): 8.00		Total Depth (Ft.): 25.0	Backfill or Well Design: Neat Cement Grout	

24 Hour Clock Time (HH:MM)	Pocket Penetrometer (TSF)	Uncorrected Blow Counts (Blows / 6-inch)	Drilling Method and/or Sampler Type	Sample Recovery (Ft./Ft.)	Sample No.	Depth B.G.S. (Ft.)	Sample Interval And Symbol	Graphic Log	Ground Water Information				
									Date	1-13-21			
									Time (24 Hour)	12:10			
									Depth (Ft.)	18.0			
										Soil And/O Rock Material Descriptions			
										<small>SOIL: USCS Symbol, Name; Particle Size Gradation %, Munsell Color; Density/Consistency, Moisture, Odor; Organics; Cementation; Texture; Refuse; Etc. ROCK: Unit Name, Lithology, Munsell Color; Cementation; Weathering; Competency; Bedding/Foliation; Fracture/Joint Spacing & Roughness; RQD; Moisture.</small>			
11:30			HSA			0			(CL) LEAN CLAY WITH SAND, Fld. Est.: 90% Low Plastic Clay-Silt Fines and 10% Fine Sand; Dark Brown (10YR, 5/3); Very Stiff; Moist.				
11:32		6	2.5SS		L1-2-2	1							
		11		1.2/1.5	L1-1-2	2							
	4.5	12											
			HSA			3							
11:36		8	2.5SS		L2-2-2	4							
		13		1.5/1.5	L2-1-2	5							
	4.5	16											
			HSA			6							
						7							
						8							
11:45		5	2.5SS		L3-2-2	9							
		14		1.4/1.5	L3-1-2	10							
	4.5	16											
			HSA			11							
						12							
						13							
11:52		16	2.5SS		L4-2-2	14							
		16		1.0/1.5	L4-1-2	15							
	4.5+	12											
			HSA			16							
						17							
						18							
11:59		5	2.5SS		L5-2-2	19							
		26		1.0/1.5	L5-1-2	20							
		17											

(SC) CLAYEY SAND WITH GRAVEL, Fld. Est.: 45% Fine Sand, 35% Low Plastic Clay-Silt Fines, and 20% Gravel; Brown (10YR, 4/3); Medium Dense; Moist.

Dense; Wet

NOTES: HSA - Hollow Stem Augers
 2.5SS - 2.5" Split Spoon Sampler



EXPLORATORY BORING LOG

48 BELLARMINE COURT, SUITE 40, CHICO, CA., 95928
 PHONE: 530-894-2487, FAX: 530-894-2437

Boring No.
B21-6

Project Name: Proposed Burns Valley Development

Project No.: 71075.00.001

Task: 001

Start Date: 1-13-21

Location: Burns Valley Road, Clearlake, California

Estimated Ground Surface

Elevation (Ft. AMSL): 1357.00

Finish Date: 1-13-21

Sheet: 2 Of 2

Logged By: Santiago Carrillo

Drilling Cmpny: Taber Drilling

Drill Rig Type: CME-55

Driller: Toby Baldazo

Drilling Method: Hollow Stem Auger (HSA)

Hammer Type: 140 Pound Auto Trip Hammer

Boring Dia. (In.): 8.00

Total Depth (Ft.): 25.0

Backfill or Well Design: Neat Cement Grout

24 Hour Clock Time (HH:MM)	Pocket Penetrometer (TSF)	Uncorrected Blow Counts (Blows / 6-inch)	Drilling Method and/or Sampler Type	Sample Recovery (FL/Ft.)	Sample No.	Depth B.G.S. (Ft.)	Sample Interval And Symbol	Graphic Log	Ground Water Information			
									Date	1-13-21		
									Time (24 Hour)	12:10		
									Depth (Ft.)	18.0		
									Soil And/Or Rock Material Descriptions			
									<small>SOIL: USCS Symbol Name; Particle Size Gradation %; Munsell Color; Density/Consistency; Moisture; Odor; Organics; Cementation; Texture; Refuse; Etc. ROCK: Unit Name; Lithology; Munsell Color; Cementation; Weathering; Competency; Bedding/Foliation; Fracture/Joint Spacing & Roughness; RQD; Moisture.</small>			
			HSA			20			(SC) CLAYEY SAND WITH GRAVEL, fld. Est.: 45% Fine Sand, 35% Low Plastic Clay-Silt Fines, and 20% Gravel; Brown (10YR, 4/3); Dense; Moist.			
						21						
						22			(CH) FAT CLAY, FLD. EST: 90% High Plastic Clay-Silt Fines and 10% Fine Sand; Dark Greenish Gray (GLEYS 1, 4/1); Stiff; Wet.			
						23						
12:10		3	2.5SS			24			L6-2-2			
12:10	1.75	6		1.5/1.5	L6-1-2	25			L6-1-2			
						26						
						27						
						28						
						29						
						30						
						31						
						32						
						33						
						34						
						35						
						36						
						37						
						38						
						39						
						40						

NOTES: HSA - Hollow Stem Augers
 2.5SS - 2.5" Split Spoon Sampler



EXPLORATORY BORING LOG

48 BELLARMINE COURT, SUITE 40, CHICO, CA., 95928
PHONE: 530-894-2487, FAX: 530-894-2437

Boring No.
B21-7
Sheet: 1 Of 1

Project Name: Proposed Burns Valley Development
Project No.: 71075.00.001
Task: 001
Start Date: 1-13-21
Location: Burns Valley Road, Clearlake, California
Estimated Ground Surface Elevation (Ft. AMSL): 1365.00
Finish Date: 1-13-21

Logged By: Santiago Carrillo
Drilling Cmpny: Taber Drilling
Drill Rig Type: CME-55
Driller: Toby Baldazo
Drilling Method: Hollow Stem Auger (HSA)
Hammer Type: 140 Pound Auto Trip Hammer

Boring Dia. (In.): 8.00
Total Depth (Ft.): 21.5
Backfill or Well Design: Neat Cement Grout

24 Hour Clock Time (HH:MM)	Pocket Penetrometer (TSF)	Uncorrected Blow Counts (Blows / 6-inch)	Drilling Method and/or Sampler Type	Sample Recovery (Ft./Ft.)	Sample No.	Depth B.G.S. (Ft.)	Sample Interval And Symbol	Graphic Log	Ground Water Information			
									Date	1-13-21		
									Time (24 Hour)	13:33		
									Soil And/Or Rock Material Descriptions <small>SOIL: USCS Symbol, Name, Particle Size Gradation %, Munsel Color, Density/Consistency, Moisture, Odor, Organics, Cementation, Texture, Refuse, Etc. ROCK: Unit Name, Lithology, Munsel Color, Cementation, Weathering, Competency, Bedding/Foliation, Fracture/Joint Spacing & Roughness, RQD, Moisture.</small>			
12:56			HSA			0			(FILL) Undocumented Fill; Rocks; Garbage; Organics.			
						1						
						2						
						3						
						4						
13:01		9	2.5SS		L1-2-2	5						
		9			L1-1-2	6						
	4.5	8	HSA	.6/1.5		7						
						8						
						9						
						10						
13:09		8	2.5SS		L2-2-2	11			Very Stiff			
		12			L2-1-2	12						
	4.5	15	HSA	.8/1.5		13						
						14						
						15						
13:19		14	2.5SS		L3-2-2	16			Increase Gravels; Hard; Moist			
		25			L3-1-2	17						
		30	HSA	.9/1.5		18						
						19						
						20						
13:32		4	2.5SS		L4-2-2							
		7			L4-1-2							
13:33		10		1.5/1.5					Light Olive Brown (2.5Y, 5/6); Stiff			

NOTES: HSA - Hollow Stem Augers
2.5SS - 2.5" Split Spoon Sampler

NV5

EXPLORATORY BORING LOG

48 BELLARMINE COURT, SUITE 40, CHICO, CA., 95928
PHONE: 530-894-2487, FAX: 530-894-2437

Boring No.
B21-8

Project Name: Proposed Burns Valley Development

Project No.: 71075.00.001

Task: 001

Start Date: 1-13-21

Location: Burns Valley Road, Clearlake, California

Estimated Ground Surface Elevation (Ft. AMSL): 1363.00

Finish Date: 1-13-21

Sheet: 1 Of 1

Logged By: Santiago Carrillo

Drilling Cmpny: Taber Drilling

Drill Rig Type: CME-55

Driller: Toby Baldazo

Drilling Method: Hollow Stem Auger (HSA)

Hammer Type: 140 Pound Auto Trip Hammer

Boring Dia. (In.): 8.00

Total Depth (Ft.): 20.0

Backfill or Well Design: Neat Cement Grout

24 Hour Clock Time (HH:MM)	Pocket Penetrometer (TSF)	Uncorrected Blow Counts (Blows / 6-inch)	Drilling Method and/or Sampler Type	Sample Recovery (Ft./Ft.)	Sample No.	Depth B.G.S. (Ft.)	Sample Interval And Symbol	Graphic Log	Ground Water Information			
									Date	1-13-21		
									Time (24 Hour)	14:41		
Depth (Ft.)	19.0			Soil And/O Rock Material Descriptions								
<small>SOIL: USCS Symbol; Name; Particle Size Gradation %; Munsell Color; Density/Consistency; Moisture; Odor; Organics; Cementation; Texture; Refuse; Etc. ROCK: Unit Name; Lithology; Munsell Color; Cementation; Weathering; Competency; Bedding/Foliation; Fracture/Joint Spacing & Roughness; RGD; Moisture.</small>												
14:05			HSA			0			(CL) LEAN CLAY WITH SAND, fld. Est.:85% Low Plastic Clay-Silt Fines and 15% Fine Sand; Dark Yellowish Brown (10YR, 4/4); Stiff; Damp. Hard Dark Brown (10YR, 3/3); Very Stiff; White Mottling Stiff; Black Mottling Increase Sand Content; Brown (10YR, 4/4)			
14:08		4	2.5SS	BK-5	1							
		9		L1-2-2	2							
	4.5+	14		1.1/1.5	L1-1-2	3						
			HSA			4						
14:11		13	2.5SS			5						
		17		L2-2-2	6							
	4.5+	21		1.5/1.5	L2-1-2	7						
			HSA			8						
						9						
14:22		8	2.5SS			10						
		14		L3-2-2	11							
	4.25	18		1.5/1.5	L3-1-2	12						
			HSA			13						
						14						
14:32		4	2.5SS			15						
		7		L4-2-2	16							
	3.5+	8		1.5/1.5	L4-1-2	17						
			HSA			18						
						19						
14:41		3	2.5SS			20						
		6		L5-2-2								
14:41		11		1.2/1.5	L5-1-2							

NOTES:HSA - Hollow Stem Augers
2.5SS - 2.5" Split Spoon Sampler

APPENDIX C:

Soil Laboratory Test Results



ATTERBERG INDICES

ASTM D4318

DSA LEA No. 284

DSA File No. N/A
 DSA App No. N/A

Project No.	71075.00.001	Project Name	City of Clearlake Burns Valley Development	Date:	01/20/21	
Sample No.	BK-1	Boring/Trench	B21-1	Depth, (ft.):	0-3	
Description:	(SC) CLAYEY SAND WITH GRAVEL; Yellowish Brown (10YR, 4/4)				Tested By:	LGH
Sample Location:					Checked By:	DJP
					Lab. No.	C21-014

Estimated % of Sample Retained on No. 40 Sieve: _____ Sample Air Dried: _____
 Test Method A or B: A

Sample No.:	LIQUID LIMIT:					PLASTIC LIMIT:		
	1	2	3	4	5	1	2	3
Pan ID:	C	X	E			Z	W	
Wt. Pan (gr)	38.48	38.20	36.46			37.46	37.79	
Wt. Wet Soil + Pan	46.96	49.42	48.06			46.75	45.34	
Wt. Dry Soil + Pan	45.07	46.82	43.70			45.28	44.15	
Wt. Water (gr)	1.89	2.60	4.36			1.47	1.19	
Wt. Dry Soil (gr)	6.59	8.62	7.24			7.82	6.36	
Water Content (%)	28.7	30.2	60.2			18.8	18.7	
Number of Blows, N	35	25	15					

LIQUID LIMIT = 30 PLASTIC LIMIT = 19

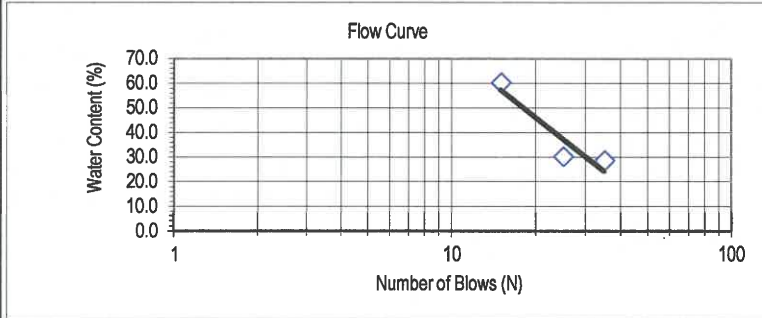

Plasticity Index = 11

Group Symbol = CL

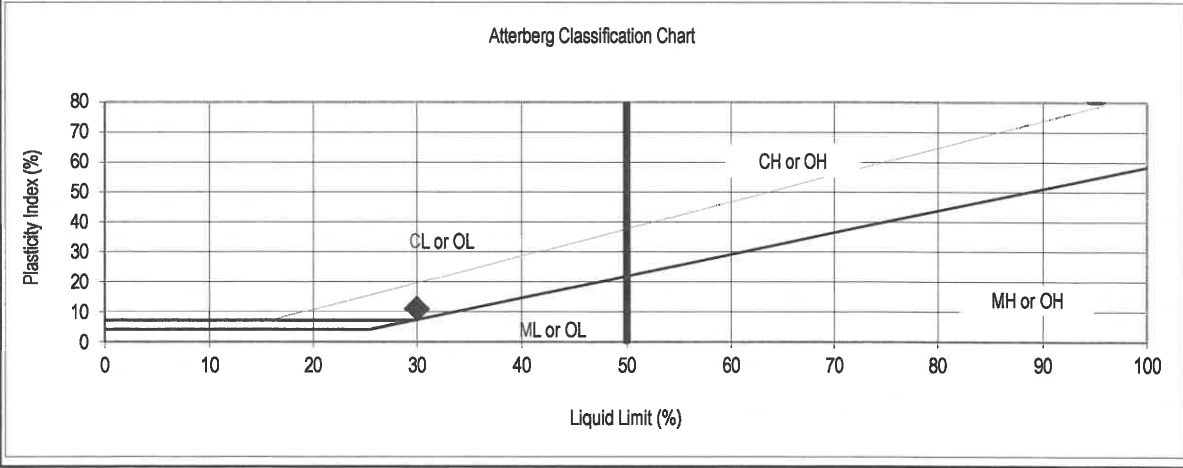



DSA LEA No. 284

PARTICLE SIZE DISTRIBUTION TEST WORK SHEET

ASTM D422, C136

DSA File No. N/A

DSA App No. N/A

Sieve Only Analysis Worksheet

Project No. 71075.00.001 Project Name: City of Clearlake Burns Valley Development Date: 01/20/21
 Sample No. BK-1 Boring/Trench: B21-1 Depth, (ft.): 0-3 Tested By: LGH
 Description: (SC) CLAYEY SAND WITH GRAVEL; Yellowish Brown (10YR, 4/4) Checked By: DJP
 Sample Location: Lab. No. C21-014

Moisture Content Data:		Total Material Sample Data:	
Pan ID		Pan ID	
Pan Weight	(gm)	Pan Weight	(gm)
Wet Soil + Pan	(gm)	Wet Soil + Pan Wt.	3,065.00 (gm)
Dry Soil + Pan	(gm)	Total Wet Weight	3,065.00 (gm)
Water Weight	0.00 (gm)	Total Dry Weight	3,065.00 (gm)
Dry Soil Weight	0.00 (gm)	Total Dry Wt. >#4 Sieve	1,183.20 (gm)
Moisture Content	0.0 (%)	Total Dry Wt. <#4 Sieve	1,881.80 (gm)
		Total Dry Wt. <#200 Sieve	614.73 (gm)
		Total Percent <#200 Sieve	20.06 (%)

GRAVEL PORTION SIEVE ANALYSIS (Portion Retained On > #4 Sieve)

Sieve Size	Particle Diameter		Wet Weight Retained On Sieve (gm)	Dry Weight			
	Inches (in.)	Millimeter (mm)		Retained On Sieve (gm)	Accum. On Sieve (gm)	Passing Sieve (gm)	Percent Passing (%)
6 Inch	6.0000	152.40		0.00	0.00	3,065.00	100.0
3 Inch	3.0000	76.20		0.00	0.00	3,065.00	100.0
2 Inch	2.0000	50.80		0.00	0.00	3,065.00	100.0
1.5 Inch	1.5000	38.10		0.00	0.00	3,065.00	100.0
1.0 Inch	1.0000	25.40	26.10	26.10	26.10	3,038.90	99.1
3/4 Inch	0.7500	19.05	66.10	66.10	92.20	2,972.80	97.0
1/2 Inch	0.5000	12.70	239.00	239.00	331.20	2,733.80	89.2
3/8 Inch	0.3750	9.53	235.60	235.60	566.80	2,498.20	81.5
#4	0.1870	4.75	616.40	616.40	1,183.20	1,881.80	61.4
PAN			1,881.80	1,881.80			

SAND PORTION SIEVE ANALYSIS (Portion Retained On < #4 Sieves)

Representative Sample Data:

Pan ID		#200 Wash Data:	
Pan Weight	(gm)	Portion >#200 Sieve:	222.40 (gm)
Wet Soil + Pan	330.30 (gm)	Portion <#200 Sieve:	107.90 (gm)
Wet Soil	330.30 (gm)	Percent <#200 Sieve	32.67 (%)
Dry Soil	330.30 (gm)	Total Wt. <#200 Sieve	614.73 (gm)

Sieve Size	Particle Diameter		Dry Weight Rep. Sample		Total Sample Weight Retained (gm)	Accum. Grand Total On Sieve (gm)	Total Percent Passing (%)
	Inches (in.)	Millimeter (mm)	Retained On Sieve (gm)	Percent Retained (%)			
#10	0.079	2.000	91.8	27.79	523.01	1,705.21	44.3
#20	0.033	0.850	48.50	14.68	276.32	1,982.52	35.3
#40	0.017	0.425	27.60	8.36	157.24	2,139.77	30.2
#60	0.010	0.250	16.50	5.00	94.00	2,233.77	27.1
#100	0.006	0.150	17.80	5.39	101.41	2,335.18	23.8
#200	0.003	0.075	20.20	6.12	115.08	2,450.27	20.1
PAN			Discard				



ATTERBERG INDICES

ASTM D4318

DSA LEA No. 284

DSA File No. N/A
 DSA App No. N/A

Project No.	71075.00.001	Project Name	City of Clearlake Burns Valley Development	Date:	01/20/21	
Sample No.	B2-1-1	Boring/Trench	B21-1	Depth, (ft.):	31.0	
Description:	(CH) FAT CLAY, Dark Greenish Gray (GLEYS 1, 4/1)				Tested By:	LGH
Sample Location:					Checked By:	DJP
					Lab. No.	C21-014

Estimated % of Sample Retained on No. 40 Sieve: _____ Sample Air Dried: _____
 Test Method A or B: A

Sample No.:	LIQUID LIMIT:					PLASTIC LIMIT:			
	1	2	3	4	5	1	2	3	
Pan ID:	E	C	X			D	Z		
Wt. Pan (gr)	36.45	38.47	38.20			38.29	37.46		
Wt. Wet Soil + Pan	44.43	48.24	47.42			44.50	43.55		
Wt. Dry Soil + Pan	41.69	44.81	44.07			43.31	42.43		
Wt. Water (gr)	2.74	3.43	3.35			1.19	1.12		
Wt. Dry Soil (gr)	5.24	6.34	5.87			5.02	4.97		
Water Content (%)	52.3	54.1	57.1			23.7	22.5		
Number of Blows, N	33	25	15						
LIQUID LIMIT =					54	PLASTIC LIMIT =			23

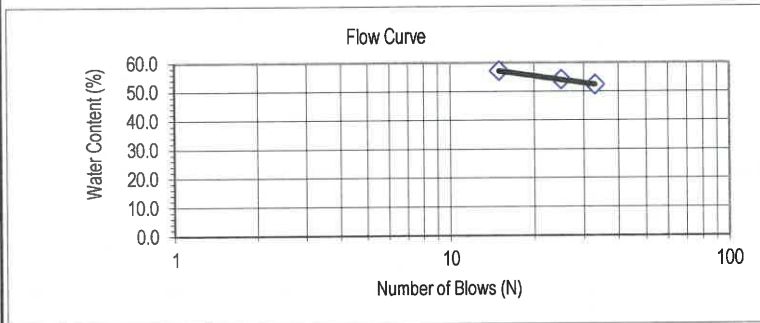

Plasticity Index = 31
 Group Symbol = CH

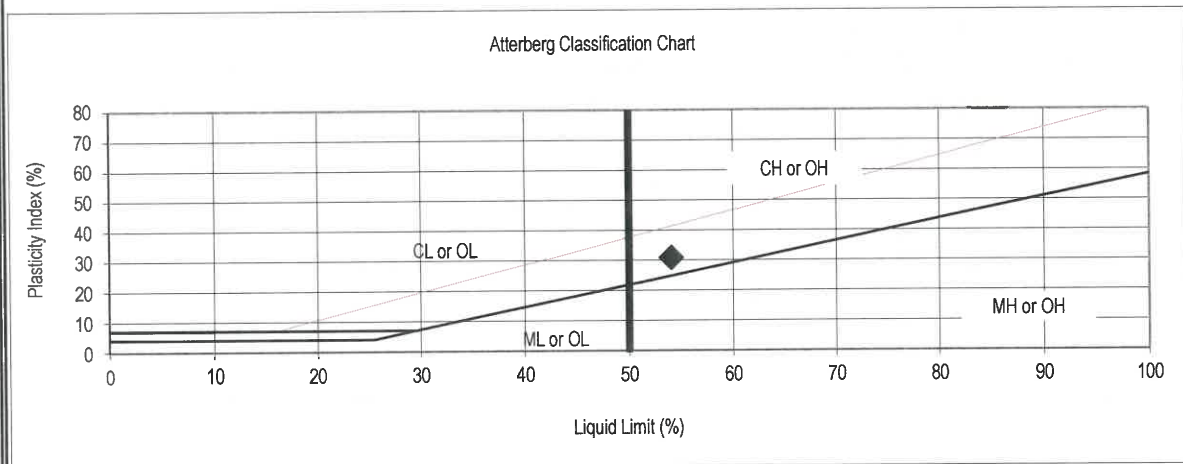



ATTERBERG INDICES

ASTM D4318

DSA LEA No. 284

DSA File No. N/A
 DSA App No. N/A

Project No.	71075.00.001	Project Name	City of Clearlake Burns Valley Development	Date:	01/20/21	
Sample No.	BK-2	Boring/Trench	B21-2	Depth, (ft.):	1-3	
Description:	(CL) SANDY CLAY; Dark Yellowish Brown (10YR, 3/6)				Tested By:	LGH
Sample Location:					Checked By:	0
					Lab. No.	C21-014

Estimated % of Sample Retained on No. 40 Sieve: _____ Sample Air Dried: _____
 Test Method A or B: A

	LIQUID LIMIT:					PLASTIC LIMIT:		
Sample No.:	1	2	3	4	5	1	2	3
Pan ID:	D	A	B			V	Y	
Wt. Pan (gr)	38.30	38.47	38.98			37.35	37.12	
Wt. Wet Soil + Pan	47.47	50.22	48.41			44.65	43.20	
Wt. Dry Soil + Pan	44.97	46.90	45.71			43.37	42.17	
Wt. Water (gr)	2.50	3.32	2.70			1.28	1.03	
Wt. Dry Soil (gr)	6.67	8.43	6.73			6.02	5.05	
Water Content (%)	37.5	39.4	40.1			21.3	20.4	
Number of Blows, N	35	22	15					

LIQUID LIMIT = 39

PLASTIC LIMIT = 21

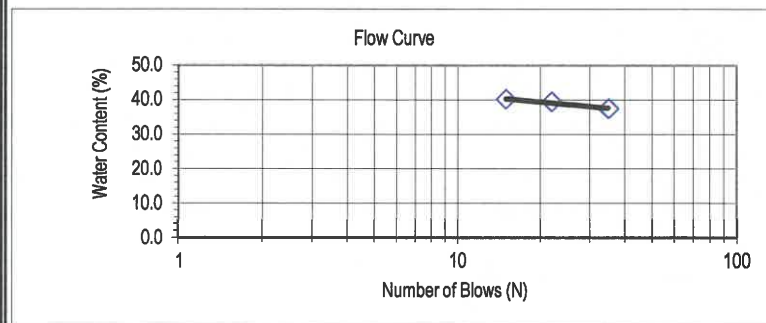

Plasticity Index = 18

Group Symbol = CL

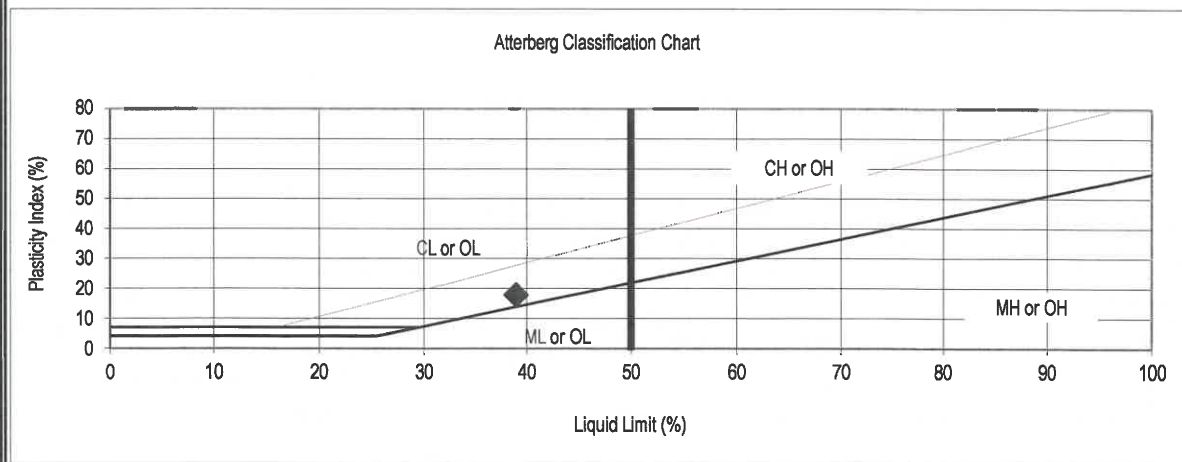



DSA LEA No. 284

PARTICLE SIZE DISTRIBUTION TEST WORK SHEET

ASTM D422, C136

DSA File No. N/A

DSA App No. N/A

Sieve Only Analysis Worksheet

Project No. 71075.00.001 Project Name: City of Clearlake Burns Valley Development Date: 01/20/21
 Sample No. BK-2 Boring/Trench: B21-2 Depth, (ft.): 1-3 Tested By: LGH
 Description: (CL) SANDY CLAY; Dark Yellowish Brown (10YR, 3/6) Checked By: 0
 Sample Location: Lab. No. C21-014

Moisture Content Data:		Total Material Sample Data:	
Pan ID		Pan ID	
Pan Weight	(gm)	Pan Weight	(gm)
Wet Soil + Pan	(gm)	Wet Soil + Pan Wt.	2,048.70 (gm)
Dry Soil + Pan	(gm)	Total Wet Weight	2,048.70 (gm)
Water Weight	0.00 (gm)	Total Dry Weight	2,048.70 (gm)
Dry Soil Weight	0.00 (gm)	Total Dry Wt. >#4 Sieve	224.20 (gm)
Moisture Content	0.0 (%)	Total Dry Wt. <#4 Sieve	1,824.50 (gm)
		Total Dry Wt. <#200 Sieve	1,169.67 (gm)
		Total Percent <#200 Sieve	57.09 (%)

GRAVEL PORTION SIEVE ANALYSIS (Portion Retained On > #4 Sieve)

Sieve Size	Particle Diameter		Wet Weight Retained On Sieve (gm)	Dry Weight			
	Inches (in.)	Millimeter (mm)		Retained On Sieve (gm)	Accum. On Sieve (gm)	Passing Sieve (gm)	Percent Passing (%)
6 Inch	6.0000	152.40		0.00	0.00	2,048.70	100.0
3 Inch	3.0000	76.20		0.00	0.00	2,048.70	100.0
2 Inch	2.0000	50.80		0.00	0.00	2,048.70	100.0
1.5 Inch	1.5000	38.10		0.00	0.00	2,048.70	100.0
1.0 Inch	1.0000	25.40		0.00	0.00	2,048.70	100.0
3/4 Inch	0.7500	19.05		0.00	0.00	2,048.70	100.0
1/2 Inch	0.5000	12.70		0.00	0.00	2,048.70	100.0
3/8 Inch	0.3750	9.53	28.20	28.20	28.20	2,020.50	98.6
#4	0.1870	4.75	196.00	196.00	224.20	1,824.50	89.1
PAN			1,824.50	1,824.50			

SAND PORTION SIEVE ANALYSIS (Portion Retained On < #4 Sieves)

Representative Sample Data:

Representative Sample Data:		#200 Wash Data:	
Pan ID		Portion >#200 Sieve:	117.40 (gm)
Pan Weight	(gm)	Portion <#200 Sieve:	209.70 (gm)
Wet Soil + Pan	327.10 (gm)	Percent <#200 Sieve	64.11 (%)
Wet Soil	327.10 (gm)	Total Wt. <#200 Sieve	1169.67 (gm)
Dry Soil	327.10 (gm)		

Sieve Size	Particle Diameter		Dry Weight Rep. Sample		Total Sample Weight Retained (gm)	Accum. Grand Total On Sieve (gm)	Total Percent Passing (%)
	Inches (in.)	Millimeter (mm)	Retained On Sieve (gm)	Percent Retained (%)			
#10	0.079	2.000	23.8	7.28	132.75	356.95	82.6
#20	0.033	0.850	17.10	5.23	95.38	452.33	77.9
#40	0.017	0.425	15.50	4.74	86.46	538.79	73.7
#60	0.010	0.250	13.70	4.19	76.42	615.20	70.0
#100	0.006	0.150	19.10	5.84	106.54	721.74	64.8
#200	0.003	0.075	28.20	8.62	157.29	879.03	57.1
PAN			Discard				



MOISTURE & DENSITY
ASTM D2216, D2937, C566

DSA File No. N/A
DSA App No. N/A

Project No. 71075.00.001 Project Name: City of Clearlake Burns Valley Development Date: 01/20/21
 Tested By: LGH
 Checked By: DJP
 Lab. No. C21-014

SAMPLE LOCATION DATA

Boring/Trench No.	Units	B21-2								
Sample No.		L2-1-2								
Depth Interval	(ft.)	6.0								
Sample Description		(CL) Sandy Clay; Dark Yellowish Brown (10YR,3/6)								
USCS Symbol		CL								

SAMPLE DIMENSION AND WEIGHT DATA

Sample Length	(in)	6.043								
Sample Diameter	(in)	2.367								
Sample Volume	(cf)	0.0154								
Wet Soil + Tube Wt.	(gr)	817.20								
Tube Wt.	(gr)	0.00								
Wet Soil Wt.	(gr)	817.20								

MOISTURE CONTENT DATA

Tare No.		ZZ-2								
Tare Wt.	(gr)	0.00								
Wet Soil + Tare Wt.	(gr)	817.20								
Dry Soil + Tare Wt.	(gr)	703.70								
Water Wt.	(gr)	113.50								
Dry Soil Wt.	(gr)	703.70								
Moisture Content	(%)	16.1								

TEST RESULTS

Wet Unit Wt.	(pcf)	117.1								
Moisture Content	(%)	16.1								
Dry Unit Wt.	(pcf)	100.8								

MOISTURE CORRECTION DATA

Gauge Moisture	(%)									
K Value Correction Factor										

COMPACTION CURVE DATA (ASTM D698, ASTM D1557, or CAL216)

Test Method										
Curve No.										
Max Wet Unit Wt.	(pcf)									
Max Dry Unit Wt.	(pcf)									
Optimum Moisture	(%)									
Wet Relative Comp.	(%)									
Dry Relative Comp.	(%)									



NV5
48 Bellarmine Court, Suite 40
Chico, CA 95928
530-894-2487

Unconsolidated Undrained Test

ASTM D2850

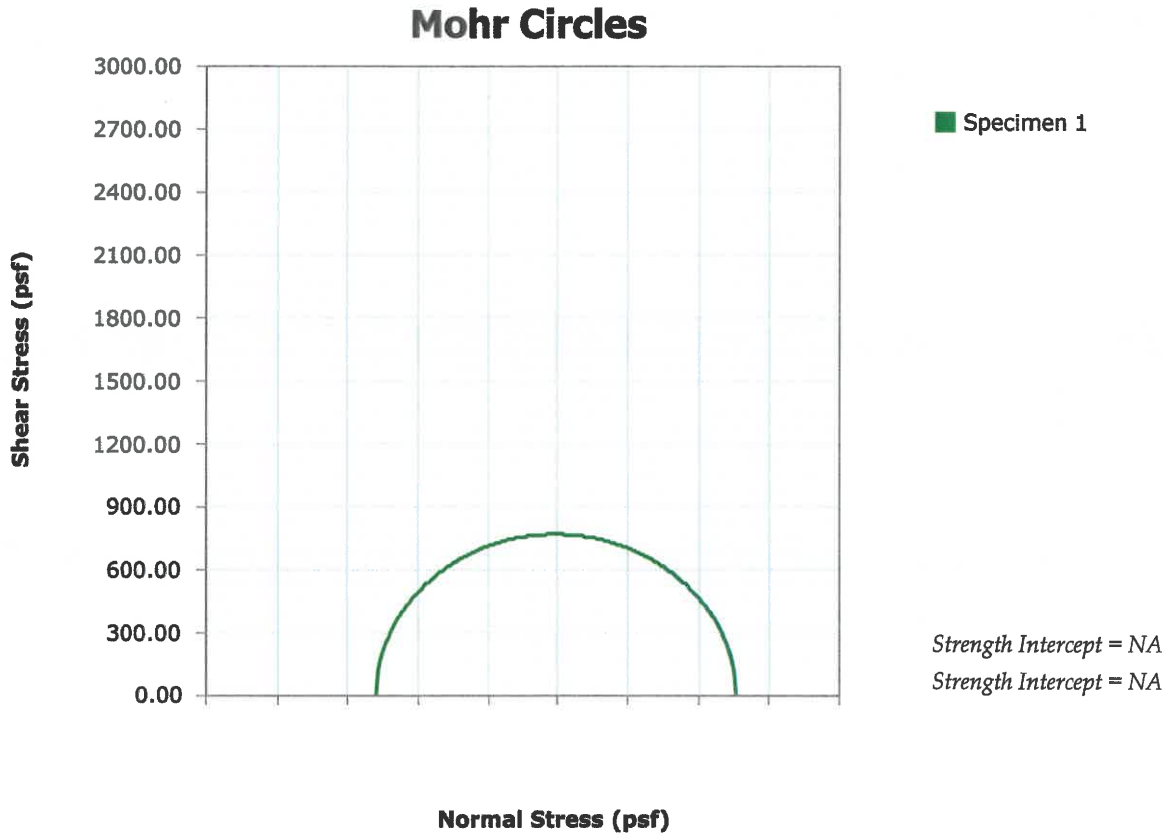

Project:	City of Clearlake Burns Valley Development
Project Number:	71075.00.001
Sampling Date:	
Sample Number:	L1-2-2
Sample Depth:	1.5 ft
Location:	B21-8
Client Name:	City of Clearlake
Remarks:	

Unconsolidated Undrained Test

ASTM D2850

Before Test	Specimen Number							
	1	2	3	4	5	6	7	8
Membrane Thickness (in)	0.001							
Initial Cell Pressure (psi)	5.0							
Height (in)	5.680							
Diameter (in)	2.375							
Water Content (%)	18.5							
Wet Density (Units)	120.4							
Dry Density (pcf)	101.6							
Degree of Saturation (%)	78.0							
Void Ratio	0.628							
Height To Diameter Ratio	2.392							
Test Data	1	2	3	4	5	6	7	8
Comp. Strength at Failure (psf)	1538.51							
σ_1 at Failure (psf)	2258.51							
σ_3 at Failure (psf)	720.00							
Rate of Strain (in/min)	0.085200							
Axial Strain at Failure (%)	20.44							
After Test	1	2	3	4	5	6	7	8
Final Water Content (%)	22.3							

Project:	City of Clearlake Burns Valley Development
Project Number:	71075.00.001
Sampling Date:	
Sample Number:	L1-2-2
Sample Depth:	1.5 ft
Location:	B21-8
Client Name:	City of Clearlake
Project Remarks:	

Specimen 1 Failure Sketch	Specimen 2 Failure Sketch	Specimen 3 Failure Sketch	Specimen 4 Failure Sketch	Specimen 5 Failure Sketch	Specimen 6 Failure Sketch	Specimen 7 Failure Sketch	Specimen 8 Failure Sketch
							



Unconsolidated Undrained Test

ASTM D2850

Specimen 1	
Test Description: D2850	
Other Associated Tests:	
Device Details:	
Test Specification:	
Test Time: 2/3/2021	
Technician: DJP	Sampling Method:
Specimen Code:	Specimen Lab #:
Specimen Description:	
Specific Gravity: 2.650	
Plastic Limit: 0	Liquid Limit: 0
Height (in): 5.680	Diameter (in): 2.375
Area (in ²): 4.430	Volume (in ³): 25.16
Large Particle:	
Moisture Material: Specimen	
Moist Weight (g): 795.4	
Test Remarks:	



NV5
48 Bellarmine Court, Suite 40
Chico, CA 95928
530-894-2487

Mohr Circles (Total Stress) Graph

ASTM D2850

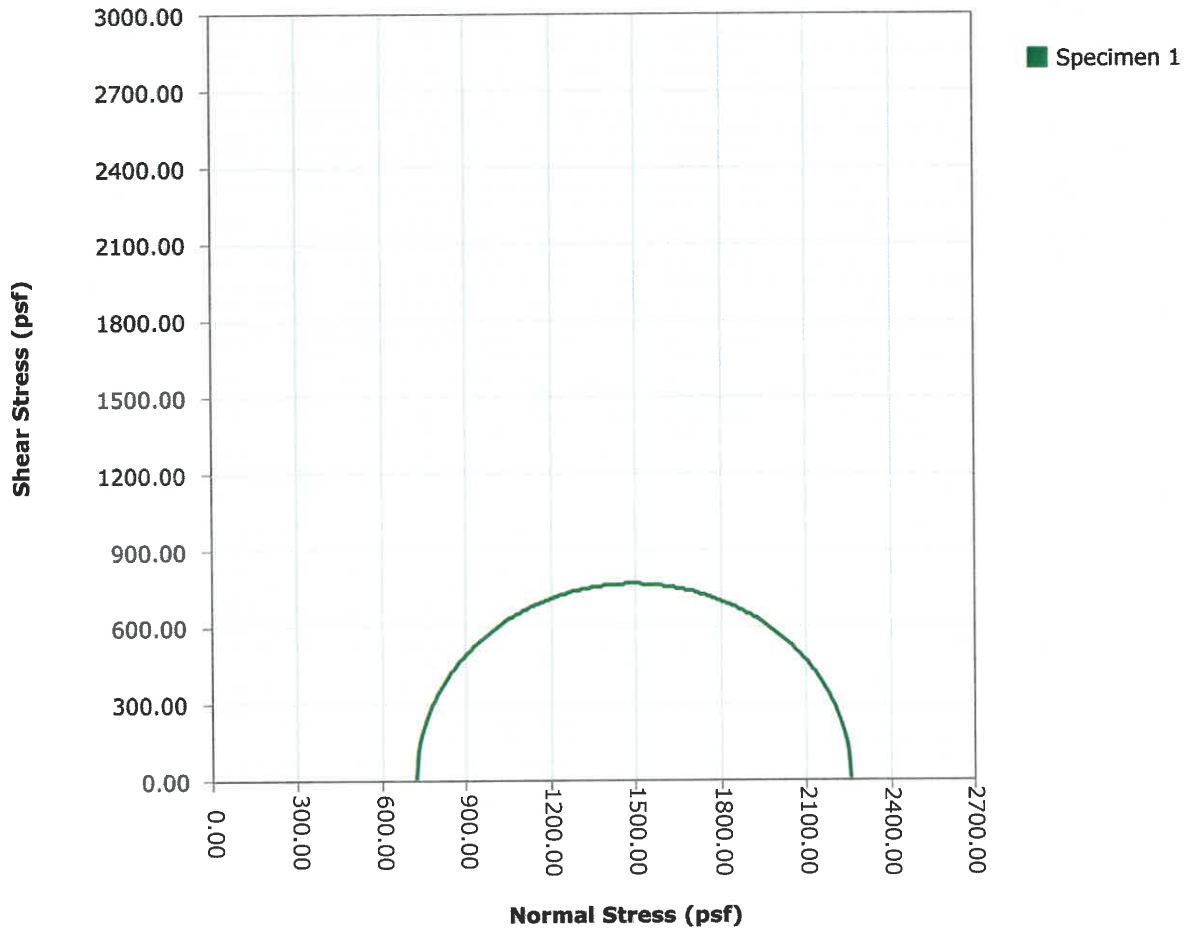

Tangent Results	
Strength Intercept (psi)	NA
Friction Angle (°)	NA



NV5
48 Bellarmine Court, Suite 40
Chico, CA 95928
530-894-2487

Stress-Strain Graph

ASTM D2850

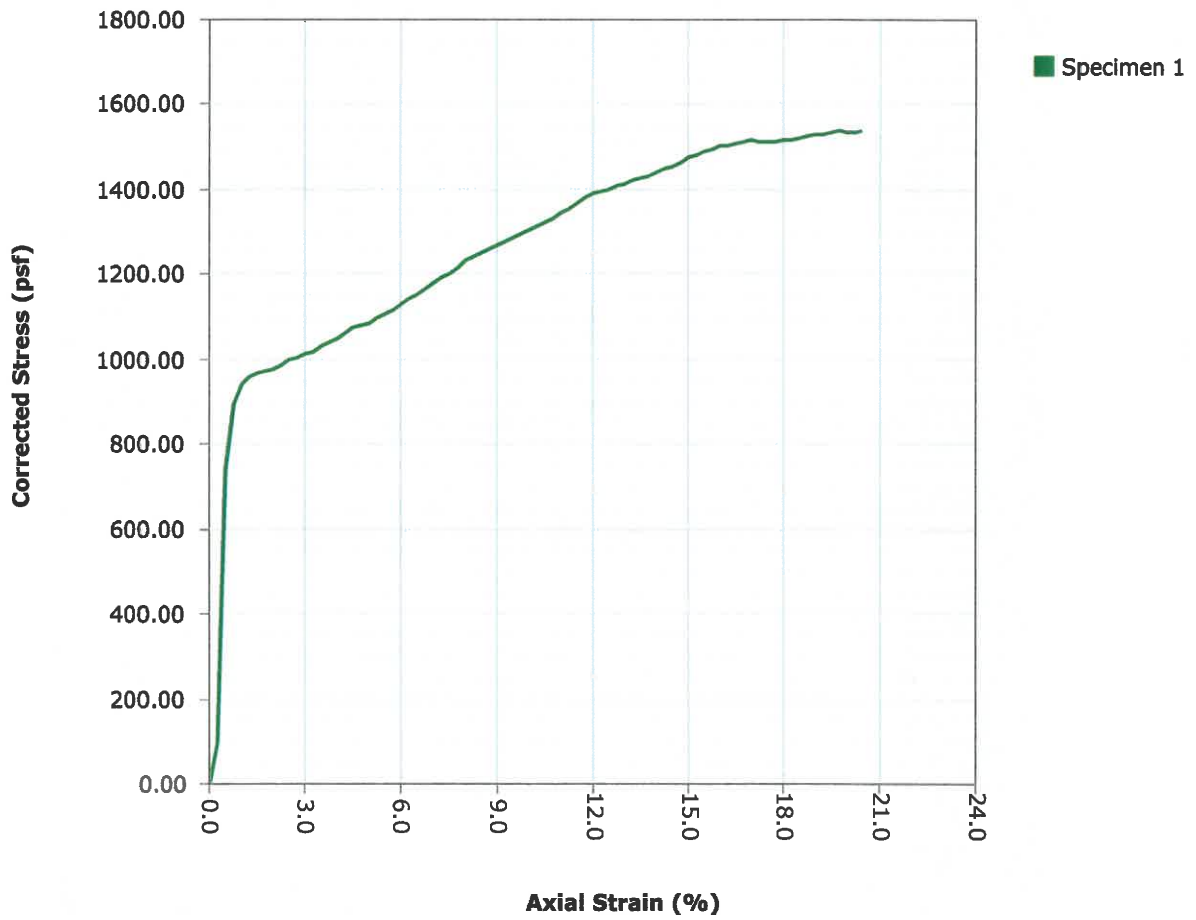

Unconsolidated Undrained Test - Tabulated Data - Specimen 1

ASTM D2850

Index	Elapsed Time (hh:mm:ss)	Load (Lbf)	Disp. (in)	Corrected			Axial Strain (%)	Stress (psf)	Corrected			σ ₁ - σ ₃ (psf)	P (psf)	q (psf)
				Load (Lbf)	Disp. (in)	Area (in ²)			Stress (psf)	Stress (psf)	σ ₁ (psf)			
0	00:00:00	2.1	0.0007	0.0	0.000	4.430	0.0	0.00	0.00	720.00	720.00	1.000	720.00	0.00
1	00:00:10	5.2	0.0151	3.0	0.014	4.441	0.3	97.84	97.47	817.47	720.00	1.135	768.74	48.74
2	00:00:20	24.9	0.0293	22.8	0.029	4.453	0.5	739.77	735.79	1,455.79	720.00	2.022	1,087.90	367.90
3	00:00:30	29.9	0.0439	27.7	0.043	4.464	0.8	901.70	894.48	1,614.48	720.00	2.242	1,167.24	447.24
4	00:00:40	31.4	0.0582	29.2	0.057	4.475	1.0	950.21	940.11	1,660.11	720.00	2.306	1,190.05	470.05
5	00:00:50	32.1	0.0723	29.9	0.072	4.487	1.3	972.86	960.59	1,680.59	720.00	2.334	1,200.30	480.30
6	00:01:00	32.4	0.0865	30.3	0.086	4.498	1.5	984.54	969.67	1,689.67	720.00	2.347	1,204.83	484.83
7	00:01:10	32.6	0.1006	30.4	0.100	4.509	1.8	988.69	971.30	1,691.30	720.00	2.349	1,205.65	485.65
8	00:01:20	32.8	0.1147	30.7	0.114	4.521	2.0	997.82	977.79	1,697.79	720.00	2.358	1,208.90	488.90
9	00:01:30	33.2	0.1288	31.1	0.128	4.532	2.3	1,009.64	986.88	1,706.88	720.00	2.371	1,213.44	493.44
10	00:01:40	33.6	0.1428	31.5	0.142	4.544	2.5	1,022.67	997.09	1,717.09	720.00	2.385	1,218.54	498.54
11	00:01:50	34.0	0.1569	31.8	0.156	4.555	2.8	1,034.12	1,005.68	1,725.68	720.00	2.397	1,222.84	502.84
12	00:02:00	34.2	0.1712	32.1	0.170	4.567	3.0	1,042.13	1,010.85	1,730.85	720.00	2.404	1,225.43	505.43
13	00:02:10	34.5	0.1854	32.4	0.185	4.579	3.3	1,052.95	1,018.71	1,738.71	720.00	2.415	1,229.35	509.35
14	00:02:20	35.0	0.1998	32.9	0.199	4.591	3.5	1,067.99	1,030.56	1,750.56	720.00	2.431	1,235.28	515.28
15	00:02:30	35.4	0.2141	33.2	0.213	4.603	3.8	1,079.56	1,039.01	1,759.01	720.00	2.443	1,239.50	519.50
16	00:02:40	35.7	0.2286	33.6	0.228	4.615	4.0	1,091.94	1,048.12	1,768.12	720.00	2.456	1,244.06	524.06
17	00:02:50	36.3	0.2431	34.1	0.242	4.628	4.3	1,109.38	1,062.04	1,782.04	720.00	2.475	1,251.02	531.02
18	00:03:00	36.7	0.2575	34.6	0.257	4.640	4.5	1,124.44	1,073.59	1,793.59	720.00	2.491	1,256.80	536.80
19	00:03:10	37.1	0.2716	34.9	0.271	4.652	4.8	1,135.74	1,081.57	1,801.57	720.00	2.502	1,260.78	540.78
20	00:03:20	37.3	0.2861	35.2	0.285	4.664	5.0	1,143.83	1,086.36	1,806.36	720.00	2.509	1,263.18	543.18
21	00:03:30	37.7	0.3001	35.6	0.299	4.677	5.3	1,156.95	1,095.97	1,815.97	720.00	2.522	1,267.98	547.98
22	00:03:40	38.1	0.3142	36.0	0.313	4.689	5.5	1,170.11	1,105.53	1,825.53	720.00	2.535	1,272.76	552.76
23	00:03:50	38.6	0.3283	36.5	0.328	4.701	5.8	1,186.37	1,117.94	1,837.94	720.00	2.553	1,278.97	558.97
24	00:04:00	39.2	0.3425	37.0	0.342	4.714	6.0	1,203.35	1,130.94	1,850.94	720.00	2.571	1,285.47	565.47
25	00:04:10	39.7	0.3567	37.5	0.356	4.726	6.3	1,219.44	1,143.02	1,863.02	720.00	2.588	1,291.51	571.51

Section I, Item 5.

Unconsolidated Undrained Test - Tabulated Data - Specimen 1

ASTM D2850

Index	Elapsed Time (hh:mm:ss)	Load (Lbf)	Disp. (in)	Corrected			Corrected			Corrected				
				Load (Lbf)	Disp. (in)	Area (in ²)	Area (in ²)	Disp. (in)	Axial Strain (%)	Stress (psf)	Stress (psf)	Stress (psf)	σ ₁ - σ ₃ (psf)	σ ₃ (psf)
26	00:04:20	40.1	0.3709	38.0	0.370	4.739	6.5	1,234.29	1,153.85	1,873.85	2.603	720.00	1,296.92	576.92
27	00:04:30	40.6	0.3850	38.5	0.384	4.752	6.8	1,249.92	1,165.35	1,885.35	2.619	720.00	1,302.67	582.67
28	00:04:40	41.1	0.3993	39.0	0.399	4.764	7.0	1,266.67	1,177.78	1,897.78	2.636	720.00	1,308.89	588.89
29	00:04:50	41.6	0.4137	39.5	0.413	4.778	7.3	1,283.95	1,190.58	1,910.58	2.654	720.00	1,315.29	595.29
30	00:05:00	42.2	0.4281	40.0	0.427	4.791	7.5	1,300.99	1,203.09	1,923.09	2.671	720.00	1,321.54	601.54
31	00:05:10	42.7	0.4424	40.6	0.442	4.804	7.8	1,319.49	1,216.87	1,936.87	2.690	720.00	1,328.43	608.43
32	00:05:20	43.4	0.4566	41.2	0.456	4.817	8.0	1,340.32	1,232.72	1,952.72	2.712	720.00	1,336.36	616.36
33	00:05:30	43.8	0.4707	41.6	0.470	4.830	8.3	1,353.01	1,241.05	1,961.05	2.724	720.00	1,340.53	620.53
34	00:05:40	44.2	0.4849	42.0	0.484	4.843	8.5	1,366.64	1,250.14	1,970.14	2.736	720.00	1,345.07	625.07
35	00:05:50	44.6	0.4989	42.5	0.498	4.856	8.8	1,380.45	1,259.36	1,979.36	2.749	720.00	1,349.68	629.68
36	00:06:00	45.0	0.5130	42.9	0.512	4.869	9.0	1,394.23	1,268.48	1,988.48	2.762	720.00	1,354.24	634.24
37	00:06:10	45.5	0.5270	43.3	0.526	4.883	9.3	1,408.09	1,277.61	1,997.61	2.774	720.00	1,358.80	638.80
38	00:06:20	45.9	0.5411	43.7	0.540	4.896	9.5	1,421.24	1,286.01	2,006.01	2.786	720.00	1,363.00	643.00
39	00:06:30	46.3	0.5552	44.1	0.554	4.909	9.8	1,434.51	1,294.48	2,014.48	2.798	720.00	1,367.24	647.24
40	00:06:40	46.7	0.5693	44.6	0.569	4.923	10.0	1,449.54	1,304.42	2,024.42	2.812	720.00	1,372.21	652.21
41	00:06:50	47.2	0.5835	45.1	0.583	4.937	10.3	1,465.35	1,315.00	2,035.00	2.826	720.00	1,377.50	657.50
42	00:07:00	47.6	0.5977	45.5	0.597	4.950	10.5	1,478.52	1,323.11	2,043.11	2.838	720.00	1,381.56	661.56
43	00:07:10	48.1	0.6122	45.9	0.611	4.965	10.8	1,493.14	1,332.40	2,052.40	2.851	720.00	1,386.20	666.20
44	00:07:20	48.6	0.6265	46.5	0.626	4.979	11.0	1,510.09	1,343.72	2,063.72	2.866	720.00	1,391.86	671.86
45	00:07:30	49.1	0.6410	47.0	0.640	4.993	11.3	1,527.66	1,355.46	2,075.46	2.883	720.00	1,397.73	677.73
46	00:07:40	49.8	0.6551	47.6	0.654	5.007	11.5	1,547.62	1,369.32	2,089.32	2.902	720.00	1,404.66	684.66
47	00:07:50	50.3	0.6693	48.1	0.669	5.021	11.8	1,564.00	1,379.91	2,099.91	2.917	720.00	1,409.95	689.95
48	00:08:00	50.7	0.6833	48.6	0.683	5.035	12.0	1,578.67	1,388.95	2,108.95	2.929	720.00	1,414.48	694.48
49	00:08:10	51.1	0.6974	48.9	0.697	5.050	12.3	1,589.90	1,394.88	2,114.88	2.937	720.00	1,417.44	697.44
50	00:08:20	51.4	0.7114	49.3	0.711	5.064	12.5	1,601.17	1,400.84	2,120.84	2.946	720.00	1,420.42	700.42
51	00:08:30	51.8	0.7256	49.6	0.725	5.078	12.8	1,613.14	1,407.27	2,127.27	2.955	720.00	1,423.64	703.64

Section I, Item 5.

Unconsolidated Undrained Test - Tabulated Data - Specimen 1

ASTM D2850

Index	Elapsed Time (hh:mm:ss)	Load (Lbf)	Disp. (in)	Corrected		Axial Strain (%)	Stress (psf)	Corrected		o1 - o3 (psf)	p (psf)	q (psf)		
				Load (Lbf)	Disp. (in)			Area (in ²)	Stress (psf)				o1 (psf)	o3 (psf)
52	00:08:40	52.1	0.7396	50.0	0.739	5.093	13.0	1,625.06	1,413.65	2,133.65	720.00	2.963	1,426.82	706.82
53	00:08:50	52.5	0.7536	50.4	0.753	5.107	13.3	1,637.06	1,420.06	2,140.06	720.00	2.972	1,430.03	710.03
54	00:09:00	52.8	0.7676	50.7	0.767	5.122	13.5	1,647.90	1,425.40	2,145.40	720.00	2.980	1,432.70	712.70
55	00:09:10	53.2	0.7817	51.1	0.781	5.136	13.8	1,660.51	1,432.18	2,152.18	720.00	2.989	1,436.09	716.09
56	00:09:20	53.7	0.7959	51.5	0.795	5.151	14.0	1,674.91	1,440.42	2,160.42	720.00	3.001	1,440.21	720.21
57	00:09:30	54.1	0.8103	51.9	0.810	5.167	14.3	1,687.55	1,447.00	2,167.00	720.00	3.010	1,443.50	723.50
58	00:09:40	54.5	0.8249	52.3	0.824	5.182	14.5	1,701.37	1,454.47	2,174.48	720.00	3.020	1,447.24	727.24
59	00:09:50	54.9	0.8393	52.8	0.839	5.197	14.8	1,715.53	1,462.25	2,182.25	720.00	3.031	1,451.13	731.13
60	00:10:00	55.5	0.8536	53.4	0.853	5.213	15.0	1,734.54	1,474.08	2,194.08	720.00	3.047	1,457.04	737.04
61	00:10:10	56.0	0.8677	53.8	0.867	5.228	15.3	1,749.72	1,482.63	2,202.63	720.00	3.059	1,461.31	741.31
62	00:10:20	56.3	0.8818	54.2	0.881	5.243	15.5	1,760.92	1,487.77	2,207.77	720.00	3.066	1,463.89	743.89
63	00:10:30	56.7	0.8956	54.6	0.895	5.259	15.8	1,773.36	1,493.95	2,213.95	720.00	3.075	1,466.98	746.98
64	00:10:40	57.1	0.9096	55.0	0.909	5.274	16.0	1,787.19	1,501.20	2,221.20	720.00	3.085	1,470.60	750.60
65	00:10:50	57.4	0.9236	55.3	0.923	5.290	16.2	1,797.26	1,505.23	2,225.23	720.00	3.091	1,472.61	752.61
66	00:11:00	57.7	0.9378	55.6	0.937	5.305	16.5	1,806.11	1,508.13	2,228.13	720.00	3.095	1,474.07	754.07
67	00:11:10	58.0	0.9518	55.8	0.951	5.321	16.7	1,813.88	1,510.15	2,230.15	720.00	3.097	1,475.08	755.08
68	00:11:20	58.3	0.9660	56.1	0.965	5.337	17.0	1,824.36	1,514.30	2,234.30	720.00	3.103	1,477.15	757.15
69	00:11:30	58.3	0.9802	56.1	0.979	5.353	17.2	1,824.55	1,509.92	2,229.92	720.00	3.097	1,474.96	754.96
70	00:11:40	58.5	0.9945	56.3	0.994	5.370	17.5	1,830.85	1,510.50	2,230.50	720.00	3.098	1,475.25	755.25
71	00:11:50	58.7	1.0088	56.6	1.008	5.386	17.7	1,839.20	1,512.77	2,232.77	720.00	3.101	1,476.39	756.39
72	00:12:00	59.0	1.0232	56.9	1.023	5.403	18.0	1,849.09	1,516.20	2,236.20	720.00	3.106	1,478.10	758.10
73	00:12:10	59.2	1.0376	57.1	1.037	5.419	18.3	1,855.67	1,516.91	2,236.91	720.00	3.107	1,478.46	758.46
74	00:12:20	59.5	1.0519	57.4	1.051	5.436	18.5	1,865.59	1,520.31	2,240.31	720.00	3.112	1,480.16	760.16
75	00:12:30	59.9	1.0663	57.8	1.066	5.453	18.8	1,877.79	1,525.51	2,245.51	720.00	3.119	1,482.76	762.76
76	00:12:40	60.3	1.0804	58.1	1.080	5.470	19.0	1,888.87	1,529.81	2,249.81	720.00	3.125	1,484.91	764.90
77	00:12:50	60.5	1.0943	58.4	1.094	5.487	19.3	1,897.28	1,531.97	2,251.97	720.00	3.128	1,485.99	765.99

Unconsolidated Undrained Test - Tabulated Data - Specimen 1

ASTM D2850

Index	Elapsed Time (hh:mm:ss)	Load (Lbf)	Disp. (in)	Corrected		Axial Strain (%)	Stress (psf)	Corrected Compressive		$\sigma_1 - \sigma_3$	p (psf)	q (psf)	
				Load (Lbf)	Disp. (in)			Area (in ²)	Stress (psf)				σ_1 (psf)
78	00:13:00	60.8	1.1081	58.6	1.107	5.503	1,906.28	1,534.61	2,254.61	720.00	3.131	1,487.31	767.31
79	00:13:10	61.1	1.1223	58.9	1.122	5.520	1,915.23	1,537.04	2,257.04	720.00	3.135	1,488.52	768.52
80	00:13:20	61.2	1.1364	59.1	1.136	5.537	1,920.64	1,536.60	2,256.60	720.00	3.134	1,488.30	768.30
81	00:13:30	61.4	1.1505	59.3	1.150	5.555	1,926.08	1,536.16	2,256.16	720.00	3.134	1,488.08	768.08
82	00:13:37	61.6	1.1615	59.5	1.161	5.568	1,933.71	1,538.51	2,258.51	720.00	3.137	1,489.25	769.25

APPENDIX D:

Liquefaction Analysis Results

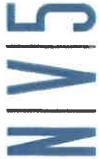

Appendix D: SPT-Based Liquefaction Triggering Analysis for a Single Boring

Project Name: Proposed Burns Valley Development

Project No.: 71075.00

Boring No.: BZ1-1

Input parameters:

Peak ground accel (g) = 0.628 PGA_w

Earthquake magnitude, M = 9

Water table depth (m) = 3.048

Average Y above water table (kN/m²) = 17.6

Average Y below water table (kN/m²) = 16.0

Borehole Diameter (mm) = 203.2

Requires correction for sampler liners (YES/NO) YES

Rod lengths assumed equal to the depth plus 1.5m (for the above ground extension).

*multiply unit weight in pcf by 0.16026 to obtain metric units

Liquefaction Potential and Triggering

SPT Sample Number	Depth (m)	Measured N	Soil Type (USCS)	Flag "Clay" "Unsaturated" "Unreliable"	Fines Content (%)	Energy Ratio, ER (%)	C _E	C _B	C _R	C _S	N ₆₀	α _{cs} ' (kPa)	α _{cs} ' (kPa)	C _N	(N) ₆₀	Δn for fines content (N) _{60cs}	Stress Reduct. Coefficient i _r	CSR	MSF for sand	K _s for sand	crit FOR m=7.5 & α _{cs} '=1aim	CRR	Factor of Safety
1	1.524	23	SC	unsaturated	20	75	1.25	1.15	0.8	1.3	34.4	27	27	1.42	48.7	4.5	1.00	0.410	0.87	1.10	2.000	n.a.	n.a.
2	3.048	34	CL	clay	60	75	1.25	1.15	0.85	1.3	54.0	54	54	1.18	63.8	5.6	1.00	0.410	0.87	1.10	2.000	n.a.	n.a.
3	4.572	11	CL	clay	60	75	1.25	1.15	0.95	1.3	19.5	78	63	1.13	n.a.	n.a.	1.01	0.507	0.67	1.10	n.a.	n.a.	n.a.
4	6.096	46	CL	clay	90	75	1.25	1.15	0.95	1.3	81.7	103	73	1.09	n.a.	n.a.	1.01	0.579	0.67	1.10	n.a.	n.a.	n.a.
5	7.620	13	GM	clay	20	75	1.25	1.15	0.95	1.2374	22.0	127	82	1.08	23.7	4.5	1.01	0.635	0.67	1.10	0.393	0.273	0.43
6	9.144	5	CH	clay	85	75	1.25	1.15	1	1.3	9.3	151	92	1.03	n.a.	n.a.	1.01	0.678	0.67	1.03	n.a.	n.a.	n.a.
7	10.668	35	CH	clay	85	75	1.25	1.15	1	1.3	65.4	176	101	1.00	n.a.	n.a.	1.00	0.713	0.67	1.00	n.a.	n.a.	n.a.
8	12.192	18	CH	clay	85	75	1.25	1.15	1	1.3	33.6	200	111	1.00	n.a.	n.a.	1.00	0.741	0.67	0.97	n.a.	n.a.	n.a.
9	13.716	16	CH	clay	85	75	1.25	1.15	1	1.3	29.9	225	120	0.96	n.a.	n.a.	1.00	0.764	0.67	0.95	n.a.	n.a.	n.a.
10	15.240	22	CH	clay	85	75	1.25	1.15	1	1.3	41.1	249	130	0.94	n.a.	n.a.	1.00	0.782	0.67	0.93	n.a.	n.a.	n.a.

Seismically Induced Settlement

SPT Sample Number	Depth (m)	Measured N	Soil Type (USCS)	Limiting shear strain γ _{lim}	Parameter F _{sr}	Maximum shear strain γ _{max}	ΔL _D	ΔLD _i	Vertical reconsol. Strain ε _v	ΔS _i	ΔS _i	ΔS _i
1	1.524	23	SC	0.000	-1.851	0.000	1.524	0.000	0.000	0.000	0.000	0.000
2	3.048	34	CL	0.000	-3.239	0.000	1.524	0.000	0.000	0.000	0.000	0.000
3	4.572	11	CL	0.000	0.000	0.000	1.524	0.000	0.000	0.000	0.000	0.000
4	6.096	46	CL	0.000	0.000	0.000	1.524	0.000	0.000	0.000	0.000	0.000
5	7.620	13	GM	0.059	0.029	0.059	1.524	0.090	0.012	0.019	0.749	0.749
6	9.144	5	CH	0.000	0.000	0.000	1.524	0.000	0.000	0.000	0.000	0.000
7	10.668	35	CH	0.000	0.000	0.000	1.524	0.000	0.000	0.000	0.000	0.000
8	12.192	18	CH	0.000	0.000	0.000	1.524	0.000	0.000	0.000	0.000	0.000
9	13.716	16	CH	0.000	0.000	0.000	1.524	0.000	0.000	0.000	0.000	0.000
10	15.240	22	CH	0.000	0.000	0.000	1.524	0.000	0.000	0.000	0.000	0.000
							LDI=	0.090	Total S=	0.019	0.749	

Field Data for Conversion

Sample Number	Sample Depth (ft)	Strata Δh (ft)	Depth to GW (ft)	Historic High Depth to GW (ft)	Ave. Unit Wt Above GW (pcf)	Ave. Unit Wt Below GW (pcf)	Borehole Dia. (in)
1	5	1.524	19	10	110	100	8
2	10	1.524					
3	15	1.524					
4	20	1.524					
5	25	1.524					
6	30	1.524					
7	35	1.524					
8	40	1.524					
9	45	1.524					
10	50	1.524					

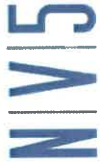

Appendix D: SPT-Based Liquefaction Triggering Analysis for a Single Boring

Project Name: Proposed Burns Valley Development
Project No.: 71075-00
Boring No.: B21-2

Input parameters:
 Peak ground accel (g) = 0.628 PG_A
 Earthquake magnitude, M = 9
 Water table depth (m) = 3.048
 Average γ above water table (kN/m³) = 17.6
 Average γ below water table (kN/m³) = 16.0

*multiply unit weight in pcf by 0.16026 to obtain metric units

Borehole Diameter (mm) = 203.2
 Requires correction for sampler liners (YES/NO) Yes
 Rod lengths assumed equal to the depth plus 1.5m (for the above ground extension).

Liquefaction Potential and Triggering

SPT Sample Number	Depth (m)	Measured N	Soil Type	Flag "Clay" "Unsaturated" "Unreliable"	Fines Content (%)	Energy Ratio, ER (%)	C _E	C _B	C _R	C _S	N ₆₀	q _{cs} ' (kPa)	q _{cs} (kPa)	C _N	(N ₁) ₆₀	Δn for fines content	(N ₁) ₆₀₋₃	Stress Reduct. Coefficient f _d	CSR	MSF for sand	K _{cs} for sand	crit FOR m=7.5 & α _{cs} =1atm	CRR	Factor of Safety
1	1.524	28	SC	unsaturated	60	75	1.25	1.15	0.8	1.3	41.9	27	27	1.42	59.3	5.6	64.91	1.00	0.410	0.67	1.10	2.000	n.a.	n.a.
2	3.048	29	CL	unsaturated	60	75	1.25	1.15	0.85	1.3	46.1	54	54	1.18	54.4	5.6	59.99	1.00	0.410	0.67	1.10	2.000	n.a.	n.a.
3	4.572	18	CL	clay	60	75	1.25	1.15	0.95	1.3	32.0	78	63	1.13	n.a.	n.a.	n.a.	1.01	0.507	0.67	1.10	n.a.	n.a.	n.a.
4	6.096	10	CL	clay	60	75	1.25	1.15	0.95	1.3	17.8	103	73	1.09	n.a.	n.a.	n.a.	1.01	0.579	0.67	1.10	n.a.	n.a.	n.a.
5	7.620	18	CL	clay	60	75	1.25	1.15	0.95	1.3	32.0	127	82	1.06	n.a.	n.a.	n.a.	1.01	0.635	0.67	1.06	n.a.	n.a.	n.a.
6	9.144	4	CL	clay	85	75	1.25	1.15	1	1.3	7.5	151	151	1.03	n.a.	n.a.	n.a.	1.01	0.678	0.67	1.03	n.a.	n.a.	n.a.
7	10.668	19	SM	clay	45	75	1.25	1.15	1	1.3	35.5	176	101	1.00	35.5	5.6	41.10	1.00	0.741	0.67	1.00	2.000	1.338	1.88
8	12.192	14	CH	clay	85	75	1.25	1.15	1	1.3	26.2	200	111	0.98	n.a.	n.a.	n.a.	1.00	0.764	0.67	0.97	n.a.	n.a.	n.a.
9	13.716	12	CH	clay	85	75	1.25	1.15	1	1.3	22.4	225	120	0.96	n.a.	n.a.	n.a.	1.00	0.782	0.67	0.95	n.a.	n.a.	n.a.
10	15.240	15	CH	clay	85	75	1.25	1.15	1	1.3	29.9	249	130	0.94	n.a.	n.a.	n.a.	1.00	0.782	0.67	0.93	n.a.	n.a.	n.a.

Seismically Induced Settlement

SPT Sample Number	Depth (m)	Measured N	Soil Type	Limiting shear strain γ _{lim}	Parameter F _r	Maximum shear strain γ _{max}	Δh _i (m)	ΔLD _i	Vertical reconsol. Strain ε _v	ΔS _i	ΔS _i (m)	ΔS _i (m)			
1	1.524	28	SC	0.000	-2.847	0.000	1.524	0.000	0.000	0.000	0.000	0.000			
2	3.048	29	CL	0.000	-2.422	0.000	1.524	0.000	0.000	0.000	0.000	0.000			
3	4.572	18	CL	0.000	0.000	0.000	1.524	0.000	0.000	0.000	0.000	0.000			
4	6.096	10	CL	0.000	0.000	0.000	1.524	0.000	0.000	0.000	0.000	0.000			
5	7.620	18	CL	0.000	0.000	0.000	1.524	0.000	0.000	0.000	0.000	0.000			
6	9.144	4	CL	0.000	0.000	0.000	1.524	0.000	0.000	0.000	0.000	0.000			
7	10.668	19	SM	0.007	-0.888	0.000	1.524	0.000	0.000	0.000	0.000	0.000			
8	12.192	14	CH	0.000	0.000	0.000	1.524	0.000	0.000	0.000	0.000	0.000			
9	13.716	12	CH	0.000	0.000	0.000	1.524	0.000	0.000	0.000	0.000	0.000			
10	15.240	16	CH	0.000	0.000	0.000	1.524	0.000	0.000	0.000	0.000	0.000			
											LDI=	0.000	Total S=	0.000	0.000

Field Data for Conversion

Sample Number	Sample Depth (ft)	Strata Δh	Depth to GW (ft)	Historic High Depth to GW (ft)	Ave. Unit Wt Above (pcf)	Unit Wt Below (pcf)	Ave. Unit Wt (pcf)	Borehole Dia. (m)
1	5	1.524	19	10	110	100	100	8
2	10	1.524						
3	15	1.524						
4	20	1.524						
5	25	1.524						
6	30	1.524						
7	35	1.524						
8	40	1.524						
9	45	1.524						
10	50	1.524						

APPENDIX E:

Seismic Design Parameters



City of Clearlake - Burns Valley Development

Latitude, Longitude: 38.9638, -122.6349

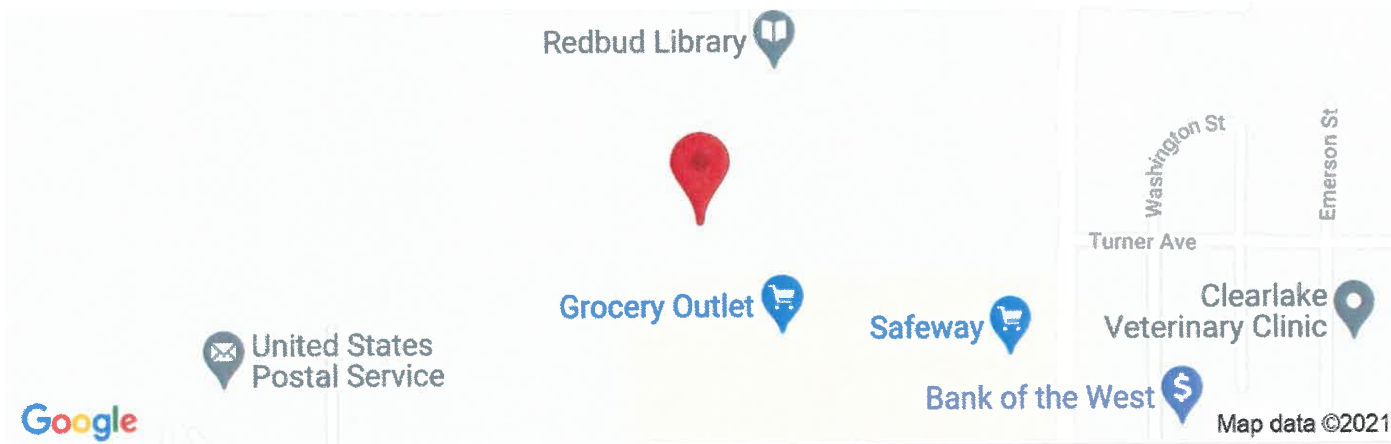

Date	2/19/2021, 12:14:23 PM
Design Code Reference Document	ASCE7-16
Risk Category	II
Site Class	D - Default (See Section 11.4.3)

Type	Value	Description
S_s	1.5	MCE_R ground motion. (for 0.2 second period)
S_1	0.541	MCE_R ground motion. (for 1.0s period)
S_{MS}	1.8	Site-modified spectral acceleration value
S_{M1}	null -See Section 11.4.8	Site-modified spectral acceleration value
S_{DS}	1.2	Numeric seismic design value at 0.2 second SA
S_{D1}	null -See Section 11.4.8	Numeric seismic design value at 1.0 second SA

Type	Value	Description
SDC	null -See Section 11.4.8	Seismic design category
F_a	1.2	Site amplification factor at 0.2 second
F_v	null -See Section 11.4.8	Site amplification factor at 1.0 second
PGA	0.523	MCE_G peak ground acceleration
F_{PGA}	1.2	Site amplification factor at PGA
PGA_M	0.628	Site modified peak ground acceleration
T_L	8	Long-period transition period in seconds
S_{sRT}	1.567	Probabilistic risk-targeted ground motion. (0.2 second)
S_{sUH}	1.672	Factored uniform-hazard (2% probability of exceedance in 50 years) spectral acceleration
S_{sD}	1.5	Factored deterministic acceleration value. (0.2 second)
S_{1RT}	0.541	Probabilistic risk-targeted ground motion. (1.0 second)
S_{1UH}	0.586	Factored uniform-hazard (2% probability of exceedance in 50 years) spectral acceleration.
S_{1D}	0.6	Factored deterministic acceleration value. (1.0 second)
PGA_d	0.523	Factored deterministic acceleration value. (Peak Ground Acceleration)
C_{RS}	0.937	Mapped value of the risk coefficient at short periods
C_{R1}	0.923	Mapped value of the risk coefficient at a period of 1 s

Agency Comments

From: [Alexandra Owens](#)
To: [Mark Roberts](#)
Subject: SCH Number 2022070344
Date: Tuesday, July 19, 2022 3:40:44 PM

CAUTION: This email originated from outside of the organization. Do not click links or open attachments unless you recognize the sender and know the content is safe.

Hello,

Your project is published and is available for review. Please note the State/Local review 'start' and 'end' period.

You can click "Navigation" and select "Published Document" to view your project and any attachments on CEQAnet.

Closing Letters: The State Clearinghouse (SCH) will not provide a close of review period acknowledgement on your CEQA environmental document, at this time. Comments submitted by a state agency at the close of review period (and after) are available on CEQAnet.

Please visit: <https://ceqanet.opr.ca.gov/Search/Advanced>

- Type in the SCH# of your project
 - If filtering by "Lead Agency"
 - Select the correct project
- Only State agency comments will be available in the "attachments" section **labeled "State Comment Letters"**; the SCH does not post comments received from non-State entities.

Thank you,

Alexandra Owens

SCH Student Assistant
Governor's Office of Planning and Research
alexandra.owens@opr.ca.gov

To view your submission, use the following link.

<https://ceqasubmit.opr.ca.gov/Document/Index/280258/1>

From: [Willie Sapeta](#)
To: [Mark Roberts](#)
Cc: [Miasha Rivas](#); [Tiffany Franklin](#); [Autumn Lancaster](#)
Subject: RE: Notice of Intent to Adopt a Mitigated Negative Declaration
Date: Wednesday, July 20, 2022 12:48:07 PM
Attachments: [image001.png](#)
[image003.png](#)

CAUTION: This email originated from outside of the organization. Do not click links or open attachments unless you recognize the sender and know the content is safe.

In my review I concur with the documents supplied, but I would like for our new Fire Marshal to take a quick review and respond with her comments if warranted.

Thank you

Chief Sapeta

From: Mark Roberts
Sent: Tuesday, July 19, 2022 3:49 PM
Subject: Notice of Intent to Adopt a Mitigated Negative Declaration
Importance: High

Good Afternoon,

City of Clearlake –Notice of Intent to Adopt a Mitigated Negative Declaration

Notice is hereby given that the City of Clearlake has tentatively determined that the project described below will not result in a significant adverse impact on the environment and that, in accordance with the California Environmental Quality Act, the City is prepared to issue a “mitigated negative declaration” in accordance with the California Environmental Quality Act (CEQA).

Project Title: BV Sports Complex

Project Location: 14885 Burns Valley Road; Clearlake, CA 95422. Assessor Parcel Number (APN): 010-026-40.

Summary: Development of a public park (sports complex), community center, public works yard with public works building facility and combined police department office and maintenance facilities, vehicle and equipment storage areas, public access and parking facilities on approximately 26 acres. The project is proposed to be located in the Burns Valley Area, north of Olympic Drive and South of Burns Valley Drive, behind the Safeway Shopping

Center, Clearlake, CA (Accessors Parcel No. 010-026-40). The park would include one full size baseball field, two smaller little league baseball fields, two small Tee-Ball Fields, a full-size soccer field. The project would include development of an approximately 15,000 to 20,000 square foot recreation center building for use for public events and activities. This building would contain sports features, such as basketball and volleyball courts. Being located next to the baseball area, a concession building/stand would be constructed next to or as part of this larger building. These combined facilities would be located on the east side of the project site. On the west side is proposed an approximate 12,000 square foot public works building, including a Police Department investigation facility. This building would include a vehicle wash station, and sections for equipment repair. This public works yard would be used to store and maintain city public vehicles, including public works and police department cars, trucks, and heavy equipment. Access to the project would be from a number of driveways/streets including access from Olympic Drive and Burns Valley Road. Approximately 365 parking spaces would be developed along access roads through the park (including 20 for the public works/police facility). Other related improvements would include sidewalks, fencing lighting features, baseball field protective netting and restroom facilities. All play fields will include lighting to allow for night operations. Project development is envisioned to be constructed in two development phasing depending on funding availability and City priority. The first phase is to develop the sports complex components, with the recreation center building and public works hop building to come later.

This tentative determination is based on an environmental study that assesses the project's potential environmental impacts and those potential impacts have been reduced to less than significant levels with the incorporated mitigation measures. Anyone can review this study at Clearlake City Hall, 14050 Olympic Drive, Clearlake, CA 95901, during normal business hours or by downloading from the State Clearinghouse Website at: I have also attached a Complete Initial Packet above for your convenience.

- <https://ceqanet.opr.ca.gov/>

Final environmental determinations are made by the decision-making body, which, in this case would be the City of Clearlake, Planning Commission. The public review period for this notice will remain open for a period of at least 30 days from the publication of this **Notice (07/19/2022), until (08/19/2022)**. For more information, please call (707) 994-8201 during normal business hours of City Hall (Monday through Thursday – 8am to 5pm).

During this period written comments on the project and the proposed mitigated negative declaration may be addressed. You may also submit comments via email at mroberts@clearlake.ca.us **(All comments must be received no later than August 19th, 2022, by 5pm).**

City of Clearlake
Planning Department
Attn: Mark Roberts
14050 Olympic Drive
Clearlake, CA 95422



COUNTY OF LAKE
Health Services Department
Environmental Health Division
922 Bevins Court
Lakeport, California 95453-9739
Telephone 707/263-1164
FAX 707/263-1681

Jonathan Portney
Health Services Director

Jennifer Baker
Deputy Health Services Director

Craig Wetherbee
Environmental Health Director

MEMORANDUM

DATE: July 22, 2022
TO: Mark Roberts, Senior Planner
FROM: Tina Dawn-Rubin, Environmental Health Aide
RE: BV Sports Complex
Notice of Intent
APN: 010-026-40 14885 Burns Valley Rd, Clearlake

If the applicant stores hazardous materials (defined as either virgin or waste materials) equal to or greater than 55 gallons of a liquid, 500 pounds of a solid or 200 cubic feet of compressed gas, the applicant will be required to submit a Hazardous Materials Business Plan to the Environmental Health Division via the California Electronic Reporting system (CERS) and it shall be renewed and updated annually or if quantities increase. If the amount of hazardous materials is less than the above quantities, the applicant will need to complete and submit a Hazardous Materials/Waste Declaration stating the name of the material and the quantity to be stored on site.

If the applicant increases hazardous material storage, they will need to update their Hazardous Materials Business Plan.

All wells shall be located an adequate horizontal distance from potential sources of contamination and pollution. The storage of hazardous materials shall be located a safe distance from any water well to prevent contamination. The applicant is required to implement measures to prevent contamination of the well(s).

Hazardous materials shall not be allowed to leak onto the ground or contaminate surface waters. Any release of a hazardous material must immediately be reported to Lake County Environmental Health (LCEH).

Collected hazardous or toxic materials shall be recycled or disposed of through a registered waste hauler to an approved site authorized to accept such materials.

Industrial Waste shall not be disposed of on-site without review or permit from the Environmental Health Division or the Regional Water Quality Control Board.

Promoting an Optimal State of Wellness in Lake County

Hazardous Waste must be handled according to all Hazardous Waste Control Laws. Any generation of a hazardous waste must be reported to Lake County Environmental Health (LCEH) within thirty (30) days.

If applicable, the applicant must comply with the California Health and Safety Code 25280 et seq. Underground Storage Tank Laws. The applicant will need to apply and pay for an Underground Storage Tank System installation permit and submit three (3) sets of full plans to the Environmental Health Division for review and approval.

The applicant shall comply with all Above Ground Petroleum Storage Tank Regulations if applicable.

The applicant must comply with the California Retail Food Code Regulations and applicant must have a potable water supply.

The applicant must apply and pay for plan check application: submit three sets of complete plans and supporting documents for review of any proposed retail food facility and must obtain approval from the Division of Environmental Health for construction before obtaining any building permits. Food facilities must be permitted and inspected prior to opening to the public.

If in the future the applicant proposes to install a public pool, spa or water feature such as a water slide, the applicant must comply with the California Health and Safety Code for the construction and operation of a public swimming pool and/or spa or water features. The applicant must submit complete sets of plans to this Division for approval, before obtaining any building permits. The pool/spa/water feature must be permitted and inspected by this Division.

From: [Lori Baca](#)
To: [Mark Roberts](#)
Subject: RE: Notice of Intent to Adopt a Mitigated Negative Declaration
Date: Tuesday, August 9, 2022 11:01:38 AM
Attachments: [image004.png](#)
[image001.png](#)

CAUTION: This email originated from outside of the organization. Do not click links or open attachments unless you recognize the sender and know the content is safe.

Mark,

I see they listed Clearlake Waste Solutions as waste management but I do not see Lake County Sanitation District listed for public sewer.

Lori A. Baca
Customer Service Supervisor
Lori.Baca@lakecountyca.gov
Office Number (707) 263-0119
Fax (707) 263-3836



From: Mark Roberts [mailto:mroberts@clearlake.ca.us]
Sent: Tuesday, July 19, 2022 3:49 PM
Subject: Notice of Intent to Adopt a Mitigated Negative Declaration
Importance: High

Good Afternoon,

City of Clearlake –Notice of Intent to Adopt a Mitigated Negative Declaration

Notice is hereby given that the City of Clearlake has tentatively determined that the project described below will not result in a significant adverse impact on the environment and that, in accordance with the California Environmental Quality Act, the City is prepared to issue a “mitigated negative declaration” in accordance with the California Environmental Quality Act (CEQA).

Project Title: BV Sports Complex

From: [Rightnar, Jacob@DOT](mailto:Rightnar.Jacob@DOT)
To: [Mark Roberts](mailto:Mark.Roberts)
Subject: RE: Notice of Intent to Adopt a Mitigated Negative Declaration
Date: Tuesday, August 2, 2022 3:27:52 PM
Attachments: [image001.png](#)
[image003.png](#)

CAUTION: This email originated from outside of the organization. Do not click links or open attachments unless you recognize the sender and know the content is safe.

Good Afternoon,

Thank you for providing Caltrans D1 the opportunity to review the BV Sports Complex project. We are still in the review process, however we could not seem to locate the traffic impact report in the project documents. Does the City of Clearlake have this document available or any other information regarding the traffic impact of this project? Your help is much appreciated.

Sincerely,
Jacob Rightnar
Caltrans District 1
Transportation Planning
Cell: (707)684-6895

From: Mark Roberts <mroberts@clearlake.ca.us>
Sent: Tuesday, July 19, 2022 3:49 PM
Subject: Notice of Intent to Adopt a Mitigated Negative Declaration
Importance: High

EXTERNAL EMAIL. Links/attachments may not be safe.

Good Afternoon,

City of Clearlake –Notice of Intent to Adopt a Mitigated Negative Declaration

Notice is hereby given that the City of Clearlake has tentatively determined that the project described below will not result in a significant adverse impact on the environment and that, in accordance with the California Environmental Quality Act, the City is prepared to issue a “mitigated negative declaration” in accordance with the California Environmental Quality Act (CEQA).

Project Title: BV Sports Complex

From: [Mark Roberts](#)
To: Rightnar, Jacob@DOT
Subject: FW: Notice of Intent to Adopt a Mitigated Negative Declaration
Date: Thursday, August 4, 2022 8:59:00 AM
Attachments: [Transportation Impact Study for the Burns Valley Development \(1\).pdf](#)
[image001.png](#)
[image003.png](#)
Importance: High

Hi Jacob,

Quick follow up, besides the Traffic Study attached above. Due to the size of the CEQA file, we were unable to attached it to the NOI email. If you click on the link below, you can review the entire CEQA packet from the State Clearing House Website.

Mark

From: Mark Roberts
Sent: Wednesday, August 3, 2022 10:48 AM
To: Rightnar, Jacob@DOT <Jacob.Rightnar@dot.ca.gov>
Subject: RE: Notice of Intent to Adopt a Mitigated Negative Declaration
Importance: High

Hi Jacob,

Please see the above attachment.

Mark

From: Rightnar, Jacob@DOT <Jacob.Rightnar@dot.ca.gov>
Sent: Tuesday, August 2, 2022 3:28 PM
To: Mark Roberts <mroberts@clearlake.ca.us>
Subject: RE: Notice of Intent to Adopt a Mitigated Negative Declaration

CAUTION: This email originated from outside of the organization. Do not click links or open attachments unless you recognize the sender and know the content is safe.

Good Afternoon,

Thank you for providing Caltrans D1 the opportunity to review the BV Sports Complex project. We are still in the review process, however we could not seem to locate the traffic impact report in the project documents. Does the City of Clearlake have this document available or any other information regarding the traffic impact of this project? Your help is much appreciated.

Sincerely,

Jacob Rightnar
Caltrans District 1
Transportation Planning
Cell: (707)684-6895

From: Mark Roberts <mroberts@clearlake.ca.us>
Sent: Tuesday, July 19, 2022 3:49 PM
Subject: Notice of Intent to Adopt a Mitigated Negative Declaration
Importance: High

EXTERNAL EMAIL. Links/attachments may not be safe.

Good Afternoon,

City of Clearlake –Notice of Intent to Adopt a Mitigated Negative Declaration

Notice is hereby given that the City of Clearlake has tentatively determined that the project described below will not result in a significant adverse impact on the environment and that, in accordance with the California Environmental Quality Act, the City is prepared to issue a “mitigated negative declaration” in accordance with the California Environmental Quality Act (CEQA).

Project Title: BV Sports Complex

Project Location: 14885 Burns Valley Road; Clearlake, CA 95422. Assessor Parcel Number (APN): 010-026-40.

Summary: Development of a public park (sports complex), community center, public works yard with public works building facility and combined police department office and maintenance facilities, vehicle and equipment storage areas, public access and parking facilities on approximately 26 acres. The project is proposed to be located in the Burns Valley Area, north of Olympic Drive and South of Burns Valley Drive, behind the Safeway Shopping Center, Clearlake, CA (Assessors Parcel No. 010-026-40). The park would include one full size baseball field, two smaller little league baseball fields, two small Tee-Ball Fields, a full-size soccer field. The project would include development of an approximately 15,000 to 20,000 square foot recreation center building for use for public events and activities. This building would contain sports features, such as basketball and volleyball courts. Being located next to the baseball area, a concession building/stand would be constructed next to or as part of this larger building. These combined facilities would be located on the east side of the project site. On the west side is proposed an approximate 12,000 square foot public works building, including a Police Department investigation facility. This building would include a vehicle wash station, and sections for equipment repair. This public works yard would be used to store and maintain city public vehicles, including public works and police department cars, trucks, and heavy equipment. Access to the project would be from a number of

driveways/streets including access from Olympic Drive and Burns Valley Road. Approximately 365 parking spaces would be developed along access roads through the park (including 20 for the public works/police facility). Other related improvements would include sidewalks, fencing lighting features, baseball field protective netting and restroom facilities. All play fields will include lighting to allow for night operations. Project development is envisioned to be constructed in two development phasing depending on funding availability and City priority. The first phase is to develop the sports complex components, with the recreation center building and public works hop building to come later.

This tentative determination is based on an environmental study that assesses the project's potential environmental impacts and those potential impacts have been reduced to less than significant levels with the incorporated mitigation measures. Anyone can review this study at Clearlake City Hall, 14050 Olympic Drive, Clearlake, CA 95901, during normal business hours or by downloading from the State Clearinghouse Website at: I have also attached a Complete Initial Packet above for your convenience.

- <https://ceqanet.opr.ca.gov/>

Final environmental determinations are made by the decision-making body, which, in this case would be the City of Clearlake, Planning Commission. The public review period for this notice will remain open for a period of at least 30 days from the publication of this **Notice (07/19/2022), until (08/19/2022)**. For more information, please call (707) 994-8201 during normal business hours of City Hall (Monday through Thursday – 8am to 5pm).

During this period written comments on the project and the proposed mitigated negative declaration may be addressed. You may also submit comments via email at mroberts@clearlake.ca.us (**All comments must be received no later than August 19th, 2022, by 5pm**).

City of Clearlake
Planning Department
Attn: Mark Roberts
14050 Olympic Drive
Clearlake, CA 95422

Published Date: **July 19, 2022**

Sincerely,

Mark Roberts
Senior Planner

Mark Roberts

From: Whitman, Terri <TWhitman@kmtg.com>
Sent: Friday, September 2, 2022 3:22 PM
To: Mark Roberts
Cc: Roberson, Holly; Kn@koination.com; rgeary@hpultribe-nsn.gov
Subject: Comments of Koi Nation of Northern California to BV Sports Complex Project Mitigated Negative Declaration
Attachments: 2022-09-02 FINAL Koi Nation Comment Letter.pdf

CAUTION: This email originated from outside of the organization. Do not click links or open attachments unless you recognize the sender and know the content is safe.

Good afternoon ~

Please find attached the Comments of Koi Nation of Northern California to BV Sports Complex Project Mitigated Negative Declaration. Thank you.

Terri Whitman

Assistant to Daniel J. O'Hanlon, Eric N. Robinson, Holly A. Roberson and Lauren Bernadett



Kronick Moskovitz Tiedemann & Girard
1331 Garden Hwy, 2nd Floor
Sacramento, CA 95833

916.321.4500 | T
916.321.4555 | F

kmtg.com | [vCard](#) | [map](#) | twhitman@kmtg.com



CONFIDENTIALITY: This communication may contain confidential information. If you are not the intended recipient, or believe that you have received this communication in error, please do not print, copy, retransmit, disseminate, or otherwise use the information. Also, please indicate to the sender that you have received this email in error, and delete the copy you received.

Mark Roberts

From: Whitman, Terri <TWhitman@kmtg.com>
Sent: Thursday, September 1, 2022 9:38 AM
To: Mark Roberts
Cc: Roberson, Holly
Subject: RE: Question regarding Comment Letter Re: BV Sports Complex Project

CAUTION: This email originated from outside of the organization. Do not click links or open attachments unless you recognize the sender and know the content is safe.

Thank you!

Terri Whitman

Assistant to Daniel J. O'Hanlon, Eric N. Robinson, Holly A. Roberson and Lauren Bernadett



Kronick Moskovitz Tiedemann & Girard
1331 Garden Hwy, 2nd Floor
Sacramento, CA 95833

916.321.4500 | T
916.321.4555 | F

kmtg.com | [vCard](#) | [map](#) | twhitman@kmtg.com



CONFIDENTIALITY: This communication may contain confidential information. If you are not the intended recipient, or believe that you have received this communication in error, please do not print, copy, retransmit, disseminate, or otherwise use the information. Also, please indicate to the sender that you have received this email in error, and delete the copy you received.

From: Mark Roberts <mroberts@clearlake.ca.us>
Sent: Thursday, September 1, 2022 9:33 AM
To: Whitman, Terri <TWhitman@kmtg.com>
Cc: Roberson, Holly <hroberson@kmtg.com>
Subject: RE: Question regarding Comment Letter Re: BV Sports Complex Project

Good Morning,

Thank you for your email and I hope you are well. Yes, either format is acceptable but we prefer to receive written comments via email. If you have any questions, please let me know.

Mark

From: Whitman, Terri <TWhitman@kmtg.com>
Sent: Wednesday, August 31, 2022 3:34 PM
To: Mark Roberts <mroberts@clearlake.ca.us>
Cc: Roberson, Holly <hroberson@kmtg.com>; Whitman, Terri <TWhitman@kmtg.com>
Subject: Question regarding Comment Letter Re: BV Sports Complex Project

CAUTION: This email originated from outside of the organization. Do not click links or open attachments unless you recognize the sender and know the content is safe.

Good afternoon ~

Can you tell me if Comment Letters regarding BV Sports Complex Project will be accepted by email and US Mail?

Thank you for your assistance in this regard.

Terri Whitman

Assistant to Daniel J. O'Hanlon, Eric N. Robinson, Holly A. Roberson and Lauren Bernadett



Kronick Moskowitz Tiedemann & Girard

1331 Garden Hwy, 2nd Floor
Sacramento, CA 95833

916.321.4500 | T

916.321.4555 | F

kmtg.com | [vCard](#) | [map](#) | twitman@kmtg.com



CONFIDENTIALITY: This communication may contain confidential information. If you are not the intended recipient, or believe that you have received this communication in error, please do not print, copy, retransmit, disseminate, or otherwise use the information. Also, please indicate to the sender that you have received this email in error, and delete the copy you received.



September 2, 2022

VIA E-MAIL AND U.S. MAIL

Mark Roberts
Senior Planner
City of Clearlake
14050 Olympic Drive
Clearlake, CA 95422
E-Mail: mroberts@clearlake.ca.us

Re: Comments of Koi Nation of Northern CA to BV Sports Complex Project Mitigated Negative Declaration

Dear Mr. Roberts:

Thank you for the opportunity to provide comments on the City of Clearlake's ("City") Notice of Intent ("NOI") to Adopt a Mitigated Negative Declaration ("MND") related to the proposed BV Sports Complex Project ("Project"). The Project is within the aboriginal territories of the Koi Nation of Northern California ("Koi Nation" or "Tribe"), and the Tribe has a cultural interest and authority in the proposed Project area. The Tribe offers these comments, consistent with the September 2, 2022, comment deadline, for the City's consideration, and we encourage the City to proceed with a more rigorous environmental review process than has been conducted to date.

As explained in this letter, the proposed MND is inadequate and does not adequately consider and remediate the adverse impacts of the Project on the environment. Substantial evidence provided in this letter demonstrates a fair argument exists that the Project will have substantial impacts on the environment. Therefore, the City should prepare an Environmental Impact Report ("EIR") including a meaningful consideration of project alternatives and adoption of feasible mitigation measures to reduce the impacts of the Project on the environment. (*See Protect Niles v. City of Fremont* (2016) 25 Cal.App.5th 1129, 1134 [holding that an EIR is required rather than a MND when substantial evidence supports a fair argument that there will be adverse environmental impacts from a project].)

APPLICABLE CEQA STANDARDS

Under the California Environmental Quality Act ("CEQA"), all lead agencies must prepare an EIR for projects "which may have a significant effect on the environment." (Pub. Res. Code §§ 21151(a) & 21060.5.) *In Laurel Heights Improvement Association v. Regents of the University of California* (1988) 47 Cal.3d 376, the California Supreme Court explained the role an EIR plays in the CEQA process, and instructed that: "The EIR is the primary means of achieving the Legislature's considered declaration that it is the policy of this state to 'take all action necessary to protect, rehabilitate, and enhance the environmental quality of the state.' [Citation.] The EIR is therefore the 'heart of CEQA.' [Citation]." (*Id.* at 392; *see also Friends of College of San Mateo Gardens v. San Mateo County Community College Dist.* (2016) 1 Cal.5th 937, 944 ["At the 'heart of CEQA' [citation] is the requirement that public agencies prepare an EIR for any 'project' that 'may have a significant effect on the environment.' [Citation]."]) "When the informational requirements of CEQA

Mark Roberts
 September 2, 2022
 Page 2

are not complied with, an agency has failed to proceed in a manner required by law and has therefore abused its discretion.” (*Save our Peninsula Committee v. Monterey County Board of Supervisors* (2001) 87 Cal.App.4th 99, 118.)

CEQA “creates a low threshold requirement for an initial preparation of an EIR and reflects a preference for resolving doubts in favor of environmental review when the question is whether any such review is warranted.” (*Sierra Club v. County of Sonoma* (1992) 6 Cal.App.4th 1307, 1316-1317). Accordingly, “if a lead agency is presented with a fair argument that a project may have a significant effect on the environment, the lead agency shall prepare an EIR even though it may also be presented with other substantial evidence that the project will not have a significant effect.” (*Berkeley Hillside Preservation v. City of Berkeley* (2015) 60 Cal.4th 1086, 1111.) When, as here, there is an argument that the lead agency, in this case the City, should have prepared an EIR rather than the proposed MND, a reviewing court reviews the administrative record to determine whether “it can be fairly argued on the basis of substantial evidence that the project may have significant environmental impacts.” (*Ibid.*) Substantial evidence is “enough relevant information and reasonable inferences from this information that a fair argument can be made to support a conclusion, even though other conclusions might also be reached.” (Cal. Code of Regs., tit.14, § 15384(a).) “The fair argument standard thus creates a low threshold for requiring an EIR, reflecting the legislative preference for resolving doubts in favor of environmental review. [Citations.]” (*Covina Residents for Responsible Development v. City of Covina* (2018) 21 Cal.App.5th 712, 723.) As explained in this comment letter, numerous aspects of the Project present a fair argument of significant environmental effects requiring the City to prepare an EIR rather than rely on a defective and inadequate MND for the Project.

CULTURAL RESOURCES AND TRIBAL CULTURAL RESOURCES

In the proposed MND, the City purports to address the category of Cultural Resources together with the distinct category of Tribal Cultural Resources by simply cross-referencing its prior cultural resources analysis. This has been illegal since July 1, 2015, when Assembly Bill 52 (“AB 52”) (2014 Stats, ch. 532.) went into effect. The City purports to rely on a Cultural Resource Investigation by Greg White, Ph.D., as attached to the MND at Attachment D. The proposed MND posted on the State’s CEQA website¹ indicates Attachment D is to be attached. However, the document listed on the website at Attachment D is a Geotechnical Report. It is difficult for any interested party to provide meaningful commentary on a document that is not posted.

Based on the proposed MND, it is apparent that the information developed by and relied upon by the City for purposes of cultural resources does not satisfy requirements applicable to an adequate tribal cultural resources analysis. Archaeological information may inform a tribal cultural resources assessment as a starting point, but it is no substitute for input from the California Native American Tribal government which is traditionally and culturally affiliated with the area. Such input can include both written and oral tradition information and must also recognize the need to maintain confidentiality of relevant data. (See AB 52, § 1 [“California Native American tribes may have expertise with regard to their tribal history and practices, which concern the tribal cultural resources with which they are traditionally and culturally affiliated.”]; *Confederated Tribes and Bands of Yakama Nation v. Klichitat County* (9th Cir. 2021) 1 F.4th 673, 682 fn. 9 [noting the importance of tribal oral history and traditions in interpreting information]; Gov. Code § 65352.4 [acknowledging the need to maintain confidentiality with respect to places that have traditional tribal cultural significance].) Although the City did initially reach out during the AB 52 process, and the City and Tribe met, this limited attempt at engagement does not satisfy the on-going and robust statutory requirements for consultation under AB 52 applicable to CEQA review for projects involving tribal lands.

¹ <https://ceqanet.opr.ca.gov/2022070344>

Mark Roberts
September 2, 2022
Page 3

The Koi Nation reached out and asked the City to continue to engage in tribal consultation on this Project, and the City Manager Alan Flora responded that the City was done consulting because the City met with the Tribe once, therefore consultation was done. Tribal consultation is not a box checking exercise. The Tribe's concerns were not given the full consideration that they deserve for this important tribal cultural resource site.

According to Public Resources Code section 21080.3.1, as enacted through AB 52,

(a) The Legislature finds and declares that California Native American tribes traditionally and culturally affiliated with a geographic area may have expertise concerning their tribal cultural resources.

(b) Prior to the release of a negative declaration, mitigated negative declaration, or environmental impact report for a project, the lead agency shall begin consultation with a California Native American tribe that is traditionally and culturally affiliated with the geographic area of the proposed project if: (1) the California Native American tribe requested to the lead agency, in writing, to be informed by the lead agency through formal notification of proposed projects in the geographic area that is traditionally and culturally affiliated with the tribe, and (2) the California Native American tribe responds, in writing, within 30 days of receipt of the formal notification, and requests the consultation.

Government Code section 65352.4 provides that:

"consultation" means the meaningful and timely process of seeking, discussing, and considering carefully the views of others, in a manner that is cognizant of all parties' cultural values and, where feasible, seeking agreement. Consultation between government agencies and Native American tribes shall be conducted in a way that is mutually respectful of each party's sovereignty. Consultation shall also recognize the tribes' potential needs for confidentiality with respect to places that have traditional tribal cultural significance.

Public Resources Code section 21080.3.2(b) provides that consultation is concluded if: "(1) The parties agree to measures to mitigate or avoid a significant effect, if a significant effect exists, on a tribal cultural resource" or "(2) A party, acting in good faith and after reasonable effort, concludes that mutual agreement cannot be reached."

According to Public Resources Code section 21082.3(d),

. . . the lead agency may certify an environmental impact report or adopt a mitigated negative declaration for a project with a significant impact on an identified tribal cultural resource only if one of the following occurs:

(1) The consultation process between the California Native American tribe and the lead agency has occurred as provided in Sections 21080.3.1 and 21080.3.2 and concluded pursuant to subdivision (b) of Section 21080.3.2.

(2) The California Native American tribe has requested consultation pursuant to Section 21080.3.1 and has failed to provide comments to the lead agency, or otherwise failed to engage, in the consultation process.

(3) The lead agency has complied with subdivision (d) of Section 21080.3.1 and the California Native American tribe has failed to request consultation within 30 days.

In the present case, the consultation has begun but is not complete according to the statutory criteria, and therefore adoption of a EIR or MND is premature under section 21082.3. There has certainly been no agreement on culturally appropriate mitigation measures to avoid, preserve, or mitigate impacts to tribal cultural resources for the Project. Full and complete consultation is required in order to fully understand the tribal cultural resources impacted by the Project and to develop meaningful and culturally appropriate mitigation measures. The Koi Nation wrote the City asking it to re-engage in tribal consultation on this project on August 30, 2022. The City's response was that the required AB 52 consultation occurred on March 9, 2022, no further consultation was required unless requested by the Tribe, and any obligation to consult terminated upon issuance of the draft MND. Once a MND issues, the City apparently believes that the Tribe is limited to submitting comments to the City and the time for any consultation has passed. False. The City also stated that the Tribe failed to produce substantial evidence of an impact, and it discounted and dismissed the Tribal Historic Preservation Officer Robert Geary's "verbal testimony." That is unacceptable. The City also appears focused solely on whether "intact cultural resources" were found on the site. Whether or not a resource is intact is not relevant from a tribal cultural resources perspective. That may matter for archaeology, but that is a different category of resource under CEQA. Here, the City can avoid the mistake that other public entities have made by taking these public comments and tribal consultation seriously, reaching out to the tribal government again for information, and properly analyzing the cultural and archaeological sites as tribal cultural resources prior to the adoption of an EIR or MND. (See Pub. Res. Code § 21074(a), 21082.3(b).)

Mr. Geary provided substantial evidence in consultation, including a detailed map of registered and significant tribal cultural resources in the project area. The City dismissed this evidence because the Tribe did not leave the map with the City, but the Tribe could not because of the California Historic Resource Information Center's (CHRIS) tribal access policies. The City's own archaeologist has access to the same information through the CHRIS center. Once presented with this evidence, the City's due diligence in the CEQA process should have included follow-up on these important sites. The City knew there was evidence of an environmental resource, and failed to analyze it. That is a clear CEQA violation.

Meaningful consultation will ultimately inform the local agency's CEQA determinations. According to Public Resources Code section 21082.3(b)

If a project may have a significant impact on a tribal cultural resource, the lead agency's environmental document shall discuss both of the following:

(1) Whether the proposed project has a significant impact on an identified tribal cultural resource.

(2) Whether feasible alternatives or mitigation measures, including those measures that may be agreed to pursuant to subdivision (a), avoid or substantially lessen the impact on the identified tribal cultural resource.

In an attempt to address these criteria, the City retained an archaeologist who conducted an investigation, and “[the investigation resulted in the discovery of two intact, buried, archeological sites . . . Both sites can be considered significant cultural resources.” (MND, at 28.) The archeologist also found moderate density artifact assemblages and noted the artifacts “suggests that the site also served as a temporary residential function.” (MND, at 28) The MND concludes that no further management measures are necessary “if potential impacts to these sites can be eliminated by means of avoidance or placement of fill.” (MND, at 28.)

The City may argue that the Archaeologist’s report indicates that the cultural resources are not significant because, from an archaeological perspective, they lack context and would not yield information that is important to California’s history. As demonstrated by the City’s August 30, 2022, email, the City appears focused, for example, on whether “intact cultural resources” were discovered, but the text of AB 52 clearly indicates its protections and procedures are broadly applicable to tribal cultural concerns and are not limited simply to instances in which an intact cultural resource is discovered on a site. The lack of an archaeological finding of significance does not mean that these tribal cultural resources are insignificant to the Tribe, or to the people of California. The relevant tribal government and tribal cultural practitioners can shed more light on these tribal cultural resources beyond simply an archeological analysis. Appropriate tribal consultation would elucidate the tribal cultural landscape and specific cultural context in which the known artifacts and other tribal cultural resources on the Project site exist.

Without a doubt, the Tribe has raised a fair argument that from a tribal cultural resources perspective there is valuable information available about the tribal cultural resources landscape and specific tribal cultural resources as informed by the presence of the tribal cultural resources on the site, and present on adjacent sites. To the extent that there is a conflict in the evidence, the City should not “weigh” the conflicting evidence to determine whether an EIR should be prepared. It should simply prepare an EIR. It is the function of an EIR, not a MND, to resolve conflicting claims based on substantial evidence, as to the environmental effects of a project. (See Pub. Res. Code § 21064.5)

Even if the City were to ignore its obligation to prepare an EIR, which it should not, the MND as drafted fails to satisfy the applicable standards of the law by improperly deferring to a later date the formulation of a plan, if further resources are found, rather than proactively developing culturally appropriate mitigation measures including alternatives, avoidance, and preservation in place, or potentially tribal monitoring, as required by AB 52. This impacts analysis in the MND is inaccurate, and the mitigation measures are inadequate. The City needs to continue the consultation process and include the Tribe’s reasonable and modest recommendations that will help protect these tribal cultural resources from damage during the construction process. During the consultation thus far, the Tribe has raised numerous such concerns that the City needs to address including:

- (1) Lack of appropriate inclusion and analysis of Archeological and Tribal Cultural Resources sites in and near the Project Area of Potential Effect;
- (2) Lack of incorporation of the Tribe’s Tribal Cultural Resources Treatment Protocols into project Mitigation Measures;
- (3) Lack of inclusion of a Tribal Monitor for all ground disturbance activities based upon a signed tribal monitoring agreement; and
- (4) Absence of necessary Cultural Sensitivity Training for all project personnel on the first day of construction prior to work starting.

This MND must be revised to be adequate by including the following avoidance, preservation in place, and mitigation measures for tribal cultural resources:

- (1) Avoidance: Change the Project design to avoid sensitive areas, to the extent feasible and if avoidance is not feasible, the environmental documentation must explain what options were considered and why they were rejected;
- (2) Preservation in Place: Use capping with culturally appropriate materials to cover and protect Tribal Cultural Resources and leave them in place;
- (3) Decisions about Tribal Cultural Resources must be made by the Koi Nation Tribal Historic Preservation Officer, in consultation with the Project Archaeologist;
- (4) A signed Tribal Cultural Resources Treatment Protocol must be in place before construction begins, which includes a Tribal Monitoring agreement;
- (5) A reburial location for Tribal Cultural Resources on site must be identified in advance of project construction, in a place not subject to further disturbance; and
- (6) All Tribal Cultural Resources must be recorded on the appropriate DPR forms and submitted to the CHRIS center within 90 days of project completion.

Thus, the City must analyze potential impacts of the proposed Project for their significance and assess whether there may be a culturally significant impact. If there is, then robust mitigation measures are required. Fully utilizing the consultation process with the Tribe which is traditionally and culturally affiliated with the area is key to avoiding impacts to these environmental resources to the extent feasible, as CEQA requires. This will allow the City to obtain more relevant information about the impacts of the Project on Tribal Cultural Resources and allow the City to set in place culturally appropriate mitigation measures for those impacts. It is impermissible under CEQA for the City to make an impact determination without first determining the extent of the resource, and whether avoidance of the resource is feasible. (*See Save the Agoura Cornell Knoll v. City of Agoura Hills* (2020) 46 Cal.App.5th 665 (“*Agoura Hills*”).)

In *Agoura Hills*, just like in this project, the City of Agoura Hills failed to identify and analyze a prehistoric archaeological site which was also a tribal cultural resource, as a tribal cultural resources, despite being notified by public comments that fairly apprised the City of Agoura Hills of the concern that it had failed to adequately address project alternatives or mitigation measures that could preserve tribal cultural resources. As a result, the City was sued, and it lost. After considerable expense and a lengthy delay of the project, the City was required by the Court of Appeal to prepare an EIR. The better course for this Project is to proceed immediately with the required EIR and avoid unnecessary expense and delay.

Additionally, if this Project moves forward at this location, and the Koi Nation or the Archaeologist indicates that Native American Human remains may be present on the Project site, then a reburial and repatriation plan should be developed with the Tribe since it is traditionally and culturally affiliated with the Project prior to any ground disturbance. The Koi Nation is also concerned that there may be inadvertent discoveries of Native American Human Remains during Project construction, which would

trigger the application of both the Native American Graves Protection and Repatriation Act (“NAGPRA”) and California NAGPRA. The MND for this project does address the potential for NAGPRA issues to arise on this project, but there is no viable plan in place to avoid impacts on Native American Human remains through appropriate tribal monitoring to avoid or preserve the Ancestors before they are disturbed, or worse, destroyed, during construction.

Aside from the impacts discussed above, the City is required to analyze environmental impacts which are cumulatively considerable. Impacts are cumulatively considerable if the effects of a project are significant when viewed in connection with the effect of past projects, other current projects and probable future projects. (Pub. Res. Code § 21083(b)(2).) An EIR is required if a Project will involve cumulatively significant impacts. (Pub. Res. Code § 21083(b).) The City is located within the aboriginal territory of the Tribe, and it contains numerous documented and undocumented sites used and inhabited by ancestral Tribal members. Some of these sites are the oldest in California. Lake County in general, and the City of Clearlake area in particular, are incredibly archaeologically, historically, culturally, and tribal culturally significant. Many of these sites have been, are currently, or will be subject to City projects including the present Project. These projects have resulted in, and will likely continue to result in, the discovery of human remains and a significant number of artifacts associated with the Tribe such as occurred at the recent Austin Park Splash Pad project. The City’s pattern and practice of engaging in development projects without meaningful good faith tribal consultation is creating a cumulative impact to tribal cultural resources which violates CEQA, and which is unethical and disrespectful to the Ancestors of people who are part of the Clearlake community.

In enacting AB 52, the Legislature acknowledged that “a substantial adverse change to a tribal cultural resource has a significant effect on the environment,” and consequently it sought to “[r]ecognize the unique history of California Native American tribes and uphold existing rights of all California Native American tribes to participate in, and contribute their knowledge to, the environmental review process pursuant to [CEQA].” The substantial change to tribal cultural resources and need for tribal participation in the environmental review process for projects involving artifacts, remains and ancestral lands is significant as to one project and this significance is amplified when numerous projects within the relatively small municipal boundaries of the City involve the same or similar cultural impacts. The City must fully examine such cumulatively considerable cultural impacts within the context of an EIR for this Project.

More broadly, the MND’s inadequate analysis and mitigation of tribal cultural concerns is part of a board pattern and practice of the City proceeding with projects without following applicable AB 52 CEQA procedures. This failure relating to tribal cultural concerns causes permanent and long-lasting impacts to the Tribe and their religious and cultural practices in a manner that the Legislature sought to avoid through its enactment of AB 52. Recent examples of this pattern and practice include the egregious situation in 2020 where, after soil containing Native American human remains was excavated, the City simply placed the soil containing the human remains in an unprotected location on the airport site. The City, to its credit, disclosed this situation to the Tribe and worked with the Tribe to come up with an appropriate plan. The Tribe appreciated that engagement. While the mutually agreed on plan was pending, the City had a duty to protect this cultural soil. It failed. The City’s negligence allowed a developer to take the soil, and the Native American human remains within it, and use it as fill for a housing development. The City did not engage in meaningful consultation as to the appropriate storage and reinternment of the remains, and the Native American human remains are now interned in the housing development without the Tribe being allowed to first conduct culturally appropriate reinternment or relocation practices.

Because of terrible and traumatic experiences like that, the Koi Nation now has to forcefully advocate for having tribal cultural resources treatment protocols and a tribal monitoring agreement in place for projects on sensitive sites such as this one, to avoid a repeat of that situation. For example, the treatment protocol would require that the City not remove cultural soils from the project site, which is a standard practice throughout the state which the City ignores.

Another example is that when over 1,500 tribal cultural resources and stone artifacts were revealed during one day of trenching on a nearby park project, the City again refused to engage in meaningful consultation with the Tribe as to the culturally appropriate way to handle such artifacts and tribal cultural resources. Instead, the City deemed it appropriate to simply re-use the soil containing the artifacts as fill for project trenches without sorting them out and reburying them in a respectful way.

Most recently, a set forth in an August 30, 2022, email from the City Manager to Tribal leaders, the City appears to take the position that AB 52 imposes a mere pro forma obligation to engage in one "consultation". The City is mistaken. AB 52 expressly establishes a consultation process rather a single meet and confer session. Also, this process does not end simply because the agency issues a draft MND. Public Resources Code section 21082.3(d) mandates that consultation must occur until: (1) The parties agree to measures to mitigate or avoid a significant effect, if a significant effect exists, on a tribal cultural resource; or (2) A party, acting in good faith and after reasonable effort, concludes that mutual agreement cannot be reached. Certainly no agreement has been reached as to the current Project, and the City fails to explain how no agreement is possible if the parties engaged in a reasonable and good faith effort, which the Tribe is willing to do. Each of these incidents demonstrates a pattern and practice by the City of ignoring the processes mandated by the Legislature through AB 52 as part of CEQA.

Thus, before proceeding, the relevant Koi Nation should be consulted about opportunities for avoidance, preservation in place, or mitigation of tribal cultural resources if avoidance and preservation in place is infeasible. Any development in tribal culturally sensitive areas, such as this site, must be done in a way that is respectful of tribal cultural resources and seeks to avoid, protect, preserve in place, or mitigate impacts to those resources as required by CEQA and AB 52. The Tribe is willing to consult and collaborate with the City to accomplish both goals. The tribal cultural heritage of Lake County is rich and diverse. Impacting and damaging these important tribal cultural resources impacts the Tribe's cultural practices and its religious practices, as well as the cultural, archaeological, and historic heritage of the Koi Nation and California. (*See, e.g., American Indian Religious Freedom Act.*) Such impacts are significant and the City must address them through the CEQA process including the processes of AB 52. In any event, a mitigated negative declaration is inappropriate given the significant tribal cultural impacts at stake. (*See Agoura Hills, supra, 46 Cal.App.5th at 690.*)

Finally, the City should keep in mind that the Koi Nation continues to support responsible development in the City. The Tribe merely asks that the City do so in a respectful manner that is cognizant of the original people of this land who have been here since time immemorial. Development to improve the community can continue, it just needs prudent mitigation measures in place so that new development does not destroy tribal cultural resources.

TURF IMPACTS

One significant aspect of the Project is the development of several sport fields which will utilize artificial turf rather than natural grass. The MND notes the use of such artificial turf in passing without analysis and simply states the Project will “reduce water use by the installation of artificial turf athletic fields.” (MND, at 30.) This use of artificial turf, and the associated impacts, is an important factor with significant impacts that the MND fails to consider.

Contrary to the MND’s representation, artificial turf does require irrigation as well as related drainage facilities. One commentator noted that in arid and semi-arid climate zones the surface temperature of the artificial turf fields can exceed 80°C during the summer, requiring irrigation and drainage systems to keep them cool enough for use. (Journal of Irrigation and Drainage Engineering (2020) Water Requirements for Cooling Artificial Turf.) As another commentator noted, “[s]urface temperatures of artificial grass are about 20-50°F higher than natural grass and typically reach the same temperature as asphalt pavement. . . . The Synthetic Turf Council has even published guidelines for minimizing risk of heat-related illness.” (Water Use It Wisely (2022) 10 Reasons Why Artificial Turf May Not Be What You’re Looking For.)² As the Sierra Club noted in a June 20, 2022, comment letter to a City of Burbank artificial turf project, “[s]ynthetic turf causes a heat island effect. Plastic Grass absorbs heat from the sun all day and stays hot at night for several hours after the sun sets. They radiate heat and increase the ambient temperature causing a giant heat island in the immediate area and the surrounding neighborhood.”³ Related to the heat island, the Sierra Club’s letter also noted that “[t]he entire surface area of heated plastic constantly off-gasses the greenhouse gasses methane and ethylene.”⁴

Water can temporarily reduce this heat impact, but one New Mexico State University study found that the amount of water required to maintain artificial turf at temperatures similar to irrigated natural turfgrass is comparable. (Journal of Irrigation and Drainage Engineering (2020) Water Requirements for Cooling Artificial Turf.) Aside from heat reduction, another commentator notes that irrigation is required “to flush contaminants such a dust, dirt, bodily fluids, etc., through the system.” (Parks and Rec Business (2016) Watering Synthetic Turf – Really?)⁵ The MND is completely silent as to the heat, greenhouse gas and water usage required by the artificial turf.

This necessary turf irrigation also requires drainage. The MND appears to recognize drainage is required since the Project will purportedly not increase impervious surface area impacting erosion or surface flows. (MND, at 34.) Whether not artificial turf is impervious depends upon how it is installed,

² <https://wateruseitwisely.com/saving-water-outdoors/grass-artificial-turf/10-reasons-why-artificial-turf-may-not-be-what-youre-looking-for/>

³ <https://drive.google.com/file/d/1bIDdJ365eyo5Nx7b6Pjo9hV62UYfXaKG/view?usp=sharing>

⁴ In support of its comments, the Sierra Club cited an extensive list of supporting materials at: [Docs.google.com/document/d/1ABYr6x7cGllhywuPmTtECm65CayA18N9fKK4k9vlxXLM/edit?usp=sharing](https://docs.google.com/document/d/1ABYr6x7cGllhywuPmTtECm65CayA18N9fKK4k9vlxXLM/edit?usp=sharing). These citations are incorporated by reference in support of the comments set forth in this letter.

⁵ <https://www.parksandrecbusiness.com/articles/2016/8/watering-synthetic-turfreally-part-1>

but the MND fails to delineate installation or drainage standards for the artificial turf. Assuming the Project will provide for drainage, such drainage from the artificial turf⁶ may contain potentially harmful chemicals such as: toxic metals including zinc, lead, arsenic, cadmium, and chromium which have many harmful effects on humans and the environment; Carcinogens including polycyclic aromatic hydrocarbons (PAHs); Latex and other rubbers which can cause allergic reactions; and Phthalates which have adverse effects on reproductive organs, lungs, kidneys and liver. (New Jersey Work Environment Council, Be Aware of Artificial Turf Hazards.)⁷ As a July 2010 Artificial Turf Study by the Connecticut Department of Environment Protection concludes: “The DEP concludes that there is a potential risk to surface waters and aquatic organisms associated with whole effluent and zinc toxicity of stormwater runoff from artificial turf fields. Zinc concentrations in the stormwater may cause exceedences of the acute aquatic toxicity criteria for receiving surface waters, especially smaller watercourses.”⁸ Another study noted the presence of PFAS in artificial turf of 190 to 300 parts per trillion, but the EPA advises that anything over 70 parts per trillion in drinking water can be hazardous to health, and can cause birth defects and hormonal problems. (WUSA9 (2022) DC Artificial turf fields tested as possible source of cancer-causing chemicals.)⁹

The MND fails to discuss the heat inducing impact, the water supply impacts, the drainage impacts and the toxicity impacts of the Project’s use of artificial turf. It also fails to discuss the impact of these substances on wildlife, such as special status turtle species, which will face potential exposure as the toxic chemicals drain from the sports complex into surface waterways and groundwater basins. Drainage into waterways and groundwater is especially important in Clearlake given the sensitivity of the Clearlake Hitch, a rare and culturally important fish which is presently being considered by the U.S. Environmental Protection Agency for listing under the Endangered Species Act.¹⁰ Thus, an EIR is required to fully analyze and address these significant health and safety issues with impacts on both humans and wildlife.

The Project description indicates it will include “[d]evelopment of a public park (sports complex), community center, public works yard with public works building facility and combined police department office and maintenance facilities, vehicle and equipment storage areas, public access and parking facilities . . .” (MND, at 3, emphasis added.) The traffic analysis section relies upon a Transportation Impact Study for the Burns Valley Development prepared by W Trans on June 22, 2022, and attached as Attachment E. The Study’s “Project Profile” indicates: “[t]he project includes a public works corporation yard, a drive-through coffee shop, various recreational uses such as baseball, softball, and soccer fields as well as a 15,000 square-foot recreational center and a separate affordable multi-family residential project.” Notably absent from the Study’s project profile description is any indication that the Project includes a “police department office and maintenance facilities.” Given this omission, it is unclear whether the Study includes traffic impacts arising from the

⁶ <https://www.installitdirect.com/learn/is-artificial-grass-permeable/>

⁷ <https://njwec.org/PDF/Factsheets/fact-artificialterf.pdf>

⁸ <https://portal.ct.gov/-/media/DEEP/artificialturf/DEPArtificialTurfReportpdf.pdf>

⁹ <https://www.wusa9.com/article/news/health/health-alert/hormone-changing-chemicals-found-in-artificial-turf/65-4783ea96-f407-4c88-b0de-0887b6a74bb8>

¹⁰ <https://biologicaldiversity.org/w/news/press-releases/californias-clear-lake-hitch-back-on-track-for-endangered-species-protections-2022-04-14/>

police station and maintenance facilities. Absent a full analysis, the accuracy of the MND's traffic impact conclusions is called into doubt especially its conclusion that access and circulation are anticipated to function acceptably which are based upon the incomplete traffic study. (MND, at 39.) Additionally, the traffic study necessarily did not consider the traffic and public service impacts of having a police facility adjacent to a sports complex which potentially impacts the ability of first responders to provide emergency services when they must first navigate in and around a potentially crowded sports complex. Thus, the MND is incomplete. It has safety and traffic issues that are unaddressed, and it does not satisfy the City's CEQA obligations.

LIGHTING

The MND acknowledges that "[o]ne building [of the Oak Valley Villas housing complex] would be impacted by lighting during nighttime use of the sport field." (MND, at 20.) AES-1 simply directs that the Project shall comply with all federal, state, and local agency requirements. (MND, at 20.) However, the MND acknowledges that the "City does not have a threshold of significance for lighting levels." (MND, at 20.) Thus, the MND acknowledges the lighting will cause an impact, and directs, in part, that the Project must mitigate such impact by following an unspecified and undefined local requirement. Such a vague and ambiguous requirement for addressing this impact is meaningless and cannot support a valid MND. Mitigation measures must be specific enough to be implemented, and not deferred.

AGRICULTURE

The introduction of the agriculture section of the MND directs that: "[i]n determining whether impacts to agricultural resources are significant environmental effects, lead agencies may refer to the California Agricultural Land Evaluation and Site Assessment Model (1997) prepared by the California Dept. of Conservation as an optional model to use in assessing impacts on agriculture and farmland." (MND, at 20.) However, the Lake County information on the Department's website was last updated in 2018. The Project property presently contains an orchard on at least part of site, so the Project will potentially impact farmland. In order to accurately address current impacts on agriculture, the MND should not rely on farmland classification information that is already four years old.

AIR QUALITY

The MND includes a finding that "unpaved roads were the largest source of particulate matter (PM) in the County" and "[m]ore than half of the area wide PM emissions come from travel on unpaved roads within the City." (MND, at 21.) AIR – 11 states that "[s]ignificant dust may be generated from increase vehicle traffic if driveways and parking areas are not adequately surfaced." (MND, at 24) AIR - 2 states "[d]riveways, access roads and parking areas shall be surfaced in a manner so as to minimize dust." (MND, at 23.) Based upon this mitigation, the MND concludes that "[o]nce fully operational, the proposed project would not generate volumes of criteria pollutants which may exceed thresholds of significance disclosed in the Bay Area Air Quality Management District Guidelines , , ,," (MND, at 23.) As an initial matter, the MND fails to explain why it is appropriate to rely upon BAAQMD Guidelines for Lake County, which is outside of the BAAQMD's jurisdiction and inapplicable to a rural area such as Clearlake. Instead, the environmental review for this project should focus on criteria considering the unique characteristics of the City. Additionally, while acknowledging the air quality impacts of unpaved roads, driveways and other surfaces, the MND also states that driveways and parking lots will not be paved until 2024. (MND, at 49.) To the extent this encompasses the operational rather

than the construction stage of the Project, the MND fails to address the impacts on air quality caused by these unpaved surfaces which will not be eliminated until at least 2024. The MND must address the air quality impacts of unpaved surfaces once the Project becomes operational.

WILDLIFE

The MND acknowledges that within the Project site “two special-status bats have potential or low potential to occur within the Study area” as well as “one special-status turtle.” (MND, at 25.) BIO-1 simply indicates the Project will use BMP to reduce the potential for sediment or pollutants at the Project site. BIO-5 generally references a “Bat Management Plan outlining avoidance and minimization measures specific to the roost(s) potentially affected.” Other mitigation measures deal with construction but not operational activities. Importantly, the Project will admittedly contains large light installations to illuminate the sports fields. As the abstract of one journal noted, “[b]eing nocturnal, bats are among the taxa most likely to be affected by light pollution” and “[l]ight pollution affects the ecological interactions across a range of taxa, and has adverse effects on behaviors such as foraging, reproduction and communication.” (80 Mammalian Biology (2015) Impacts of artificial lighting on bats: a review of challenges and solutions.) The MND is silent as to the impact of the lighting on the bat population. Additionally, as discussed above, the Project’s multiple playing fields with artificial turf will potentially generate toxic runoff, but the MND is silent on the impact of such toxic runoff on the special status turtle, let alone the Clearlake Hitch. The City must fully analyze these potentially catastrophic wildlife impacts within the scope of an EIR.

MIGRATION

According to the MND, “[t]he Study Area provides limited migratory opportunities for terrestrial wildlife. Project construction is likely to temporarily disturb and displace most wildlife from the Study Area. Some wildlife such as birds or nocturnal species are likely to continue to use the habitats opportunistically for the duration of construction. Once construction is complete, wildlife movements are expected to resume but will likely be more limited through the developed areas of the Study Area. The Project is not expected to substantially interfere with wildlife movement” (MND, at 27.) However, the MND also purports to show a “perimeter fencing concept” for the Project with high chain link fencing topped by barbed wire. (MND, at 14.) Surrounding the Project perimeter with high barbed wire topped fencing contradicts the statement that wildlife migration will face only minimal impacts once construction ends. The perimeter fence indicates a significant impact on terrestrial migration since wildlife will presumably no longer have access to a significant portion of the Project site. The City must fully explain and mitigate this impact through appropriate mitigation measures.

HAZARDS AND HAZAROUS MATERIALS

The MND focuses on materials used during construction but also admits that “[s]mall quantities of hazardous materials would likely be routinely used on the site, primarily fertilizers, herbicides and pesticides.” (MND, at 32.) However, the MND indicates the Project will include “[d]evelopments of a public park (sports complex), community center, public works yard with public works building facility and combined police department office and maintenance facilities, vehicle and equipment storage areas, public access and parking facilities” (Emphasis added.) A public works yard and maintenance facilities will certainly use chemicals and potentially hazardous materials other than “fertilizers, herbicides and pesticides,” and the City must analyze the use and disposal of these other potentially hazardous substances. These concerns coupled with hazardous substance concerns related to the artificial turf necessitate thorough analysis through an EIR.

NOISE

The MND attempts to limit noise impacts through NOI – 4 which restricts park operations to no later than 10 pm. (MND, at 37.) However, the noise study underlying the City’s findings explains that “[a]t the time of the creation of this report and assessment the City of Clearlake has not sufficiently programmed the site nor provided the author of this report with any specific information on speaker location, mounting height, orientation, nor amplification metrics.” (MND, at 81.) Lacking specific information, the Study relied upon assumptions and generalities to conclude that “[b]ased upon the anticipated duration of sporting events, e.g. summer weekends and evenings, and shoulder season (March through May) high school level sporting events, it can safely be stated that when averaged over a twenty-hour (24) hour period, the noise levels within these units would safely remain below HUD’s required 45 dBA DNL standard.” (MND, at 82, emphasis added.) Despite purporting to establish a mitigation measure, the City’s consultant lacked concrete information on actual sound systems for the Project including speaker location, mounting height, orientation and amplification metrics. Such information is necessary to establish a meaningful analysis rather than having to rely upon guesses, estimates and assumptions as to the sound system’s actual design. Additionally, listing noise based upon a 24-hour average is similarly meaningless since the noise level will be at or near zero at least during late night and early morning hours. Thus, a meaningful noise analysis requires information as to actual system design and must consider noise impacts throughout the day rather than rely on a 24-hour average.

WATER

The MND indicates summarily that the Project would be served by Highland Mutual Water Company, but it contains no indication the Water Company has the capacity to serve Project needs. (MND, at 40.) This contrasts with the MND’s statement as to sewage indicating the Project “would be served by Lake County Special Districts which has sufficient wastewater treatment capacity to service the project. (MND, at 40, emphasis added.) The lack of water availability analysis renders any conclusions about water service incomplete and requires further analysis. This is especially important since the MND purports to minimize the water requirements of the artificial turf, which as discussed above, is not accurate and requires analysis through an EIR.

WILDFIRE

The MND inconsistently reports the Project fire risk based upon both “Moderate to High Fire Hazard Severity Zone” (MND, at 41) and “Low to Moderate Fire Hazard Severity Zone” (MND, at 38.) The fire hazard zone is therefore unclear, and could impact appropriate wildfire mitigation. The City must clarify this important designation.

The issues raised in this letter show that the MND’s “Findings of Significance as to impact of fish and/or wildlife habitat or cultural tribal resources” are inaccurate. (MND, at 42.) One cannot reasonably conclude that the mitigation measures are sufficient due to the lack of complete analysis and tribal consultation. At a minimum, a fair argument exists that there are substantial environmental impacts which need further analysis, so the City must proceed to an EIR rather than adopt a defective MND.

Mark Roberts
September 2, 2022
Page 14

Please enter this letter into the administrative record for this Project. We also request that the City notify us via email to both kn@koination.com and hroberson@kmtg.com and mail of the public hearing for this Project, so that the Tribe and its Tribal Cultural Resources Counsel can submit further comments on the record.

Thank you for your anticipated consideration of these matters. Again, we remain willing to engage in further good faith, meaningful consultations with the City.

Very truly yours,

A handwritten signature in black ink, appearing to read "Darin F. Beltran". The signature is fluid and cursive, with a large initial "D" and "B".

Darin Beltran
Chairman
Koi Nation of Northern California



Central Valley Regional Water Quality Control Board

19 August 2022

Mark Roberts
 City of Clearlake
 14050 Olympic Drive
 Clearlake, CA 95422
 mroberts@clearlake.ca.us

COMMENTS TO REQUEST FOR REVIEW FOR THE MITIGATED NEGATIVE DECLARATION, BV SPORTS COMPLEX PROJECT, SCH#2022070344, LAKE COUNTY

Pursuant to the State Clearinghouse's 19 July 2022 request, the Central Valley Regional Water Quality Control Board (Central Valley Water Board) has reviewed the *Request for Review for the Mitigated Negative Declaration* for the BV Sports Complex Project, located in Lake County.

Our agency is delegated with the responsibility of protecting the quality of surface and groundwaters of the state; therefore, our comments will address concerns surrounding those issues.

I. Regulatory Setting

Basin Plan

The Central Valley Water Board is required to formulate and adopt Basin Plans for all areas within the Central Valley region under Section 13240 of the Porter-Cologne Water Quality Control Act. Each Basin Plan must contain water quality objectives to ensure the reasonable protection of beneficial uses, as well as a program of implementation for achieving water quality objectives with the Basin Plans. Federal regulations require each state to adopt water quality standards to protect the public health or welfare, enhance the quality of water and serve the purposes of the Clean Water Act. In California, the beneficial uses, water quality objectives, and the Antidegradation Policy are the State's water quality standards. Water quality standards are also contained in the National Toxics Rule, 40 CFR Section 131.36, and the California Toxics Rule, 40 CFR Section 131.38.

The Basin Plan is subject to modification as necessary, considering applicable laws, policies, technologies, water quality conditions and priorities. The original Basin Plans were adopted in 1975, and have been updated and revised periodically as required, using Basin Plan amendments. Once the Central Valley Water Board has adopted a Basin Plan amendment in noticed public hearings, it must be approved by the State Water Resources Control Board (State Water Board), Office of

MARK BRADFORD, CHAIR | PATRICK PULUPA, ESQ., EXECUTIVE OFFICER

Administrative Law (OAL) and in some cases, the United States Environmental Protection Agency (USEPA). Basin Plan amendments only become effective after they have been approved by the OAL and in some cases, the USEPA. Every three (3) years, a review of the Basin Plan is completed that assesses the appropriateness of existing standards and evaluates and prioritizes Basin Planning issues. For more information on the *Water Quality Control Plan for the Sacramento and San Joaquin River Basins*, please visit our website:

http://www.waterboards.ca.gov/centralvalley/water_issues/basin_plans/

Antidegradation Considerations

All wastewater discharges must comply with the Antidegradation Policy (State Water Board Resolution 68-16) and the Antidegradation Implementation Policy contained in the Basin Plan. The Antidegradation Implementation Policy is available on page 74 at:

https://www.waterboards.ca.gov/centralvalley/water_issues/basin_plans/sacsjr_2018_05.pdf

In part it states:

Any discharge of waste to high quality waters must apply best practicable treatment or control not only to prevent a condition of pollution or nuisance from occurring, but also to maintain the highest water quality possible consistent with the maximum benefit to the people of the State.

This information must be presented as an analysis of the impacts and potential impacts of the discharge on water quality, as measured by background concentrations and applicable water quality objectives.

The antidegradation analysis is a mandatory element in the National Pollutant Discharge Elimination System and land discharge Waste Discharge Requirements (WDRs) permitting processes. The environmental review document should evaluate potential impacts to both surface and groundwater quality.

II. Permitting Requirements

Construction Storm Water General Permit

Dischargers whose project disturb one or more acres of soil or where projects disturb less than one acre but are part of a larger common plan of development that in total disturbs one or more acres, are required to obtain coverage under the General Permit for Storm Water Discharges Associated with Construction and Land Disturbance Activities (Construction General Permit), Construction General Permit Order No. 2009-0009-DWQ. Construction activity subject to this permit includes clearing, grading, grubbing, disturbances to the ground, such as stockpiling, or excavation, but does not include regular maintenance activities performed to restore the original line, grade, or capacity of the facility. The Construction General Permit requires the development and implementation of a Storm Water Pollution Prevention Plan (SWPPP). For more information on the Construction General Permit, visit the State Water Resources Control Board website at:

http://www.waterboards.ca.gov/water_issues/programs/stormwater/constpermits.shtml

Phase I and II Municipal Separate Storm Sewer System (MS4) Permits¹

The Phase I and II MS4 permits require the Permittees reduce pollutants and runoff flows from new development and redevelopment using Best Management Practices (BMPs) to the maximum extent practicable (MEP). MS4 Permittees have their own development standards, also known as Low Impact Development (LID)/post-construction standards that include a hydromodification component. The MS4 permits also require specific design concepts for LID/post-construction BMPs in the early stages of a project during the entitlement and CEQA process and the development plan review process.

For more information on which Phase I MS4 Permit this project applies to, visit the Central Valley Water Board website at:

http://www.waterboards.ca.gov/centralvalley/water_issues/storm_water/municipal_permits/

For more information on the Phase II MS4 permit and who it applies to, visit the State Water Resources Control Board at:

http://www.waterboards.ca.gov/water_issues/programs/stormwater/phase_ii_municipal.shtml

Clean Water Act Section 404 Permit

If the project will involve the discharge of dredged or fill material in navigable waters or wetlands, a permit pursuant to Section 404 of the Clean Water Act may be needed from the United States Army Corps of Engineers (USACE). If a Section 404 permit is required by the USACE, the Central Valley Water Board will review the permit application to ensure that discharge will not violate water quality standards. If the project requires surface water drainage realignment, the applicant is advised to contact the Department of Fish and Game for information on Streambed Alteration Permit requirements. If you have any questions regarding the Clean Water Act Section 404 permits, please contact the Regulatory Division of the Sacramento District of USACE at (916) 557-5250.

Clean Water Act Section 401 Permit – Water Quality Certification

If an USACE permit (e.g., Non-Reporting Nationwide Permit, Nationwide Permit, Letter of Permission, Individual Permit, Regional General Permit, Programmatic General Permit), or any other federal permit (e.g., Section 10 of the Rivers and Harbors Act or Section 9 from the United States Coast Guard), is required for this project due to the disturbance of waters of the United States (such as streams and wetlands), then a Water Quality Certification must be obtained from the Central Valley Water Board prior to initiation of project activities. There are no waivers for 401 Water Quality Certifications. For more information on the Water Quality Certification, visit the Central Valley Water Board website at:

¹ Municipal Permits = The Phase I Municipal Separate Storm Water System (MS4) Permit covers medium sized Municipalities (serving between 100,000 and 250,000 people) and large sized municipalities (serving over 250,000 people). The Phase II MS4 provides coverage for small municipalities, including non-traditional Small MS4s, which include military bases, public campuses, prisons and hospitals.

https://www.waterboards.ca.gov/centralvalley/water_issues/water_quality_certification/

Waste Discharge Requirements – Discharges to Waters of the State

If USACE determines that only non-jurisdictional waters of the State (i.e., “non-federal” waters of the State) are present in the proposed project area, the proposed project may require a Waste Discharge Requirement (WDR) permit to be issued by Central Valley Water Board. Under the California Porter-Cologne Water Quality Control Act, discharges to all waters of the State, including all wetlands and other waters of the State including, but not limited to, isolated wetlands, are subject to State regulation. For more information on the Waste Discharges to Surface Water NPDES Program and WDR processes, visit the Central Valley Water Board website at: [https://www.waterboards.ca.gov/centralvalley/water_issues/waste to surface water/](https://www.waterboards.ca.gov/centralvalley/water_issues/waste_to_surface_water/)

Projects involving excavation or fill activities impacting less than 0.2 acre or 400 linear feet of non-jurisdictional waters of the state and projects involving dredging activities impacting less than 50 cubic yards of non-jurisdictional waters of the state may be eligible for coverage under the State Water Resources Control Board Water Quality Order No. 2004-0004-DWQ (General Order 2004-0004). For more information on the General Order 2004-0004, visit the State Water Resources Control Board website at:

https://www.waterboards.ca.gov/board_decisions/adopted_orders/water_quality/2004/wqo/wqo2004-0004.pdf

Dewatering Permit

If the proposed project includes construction or groundwater dewatering to be discharged to land, the proponent may apply for coverage under State Water Board General Water Quality Order (Low Threat General Order) 2003-0003 or the Central Valley Water Board’s Waiver of Report of Waste Discharge and Waste Discharge Requirements (Low Threat Waiver) R5-2018-0085. Small temporary construction dewatering projects are projects that discharge groundwater to land from excavation activities or dewatering of underground utility vaults. Dischargers seeking coverage under the General Order or Waiver must file a Notice of Intent with the Central Valley Water Board prior to beginning discharge.

For more information regarding the Low Threat General Order and the application process, visit the Central Valley Water Board website at:

http://www.waterboards.ca.gov/board_decisions/adopted_orders/water_quality/2003/wqo/wqo2003-0003.pdf

For more information regarding the Low Threat Waiver and the application process, visit the Central Valley Water Board website at:

https://www.waterboards.ca.gov/centralvalley/board_decisions/adopted_orders/waivers/r5-2018-0085.pdf

Limited Threat General NPDES Permit

If the proposed project includes construction dewatering and it is necessary to discharge the groundwater to waters of the United States, the proposed project will

BV Sports Complex Project
Lake County

- 5 -

xx August 2022

require coverage under a National Pollutant Discharge Elimination System (NPDES) permit. Dewatering discharges are typically considered a low or limited threat to water quality and may be covered under the General Order for *Limited Threat Discharges to Surface Water* (Limited Threat General Order). A complete Notice of Intent must be submitted to the Central Valley Water Board to obtain coverage under the Limited Threat General Order. For more information regarding the Limited Threat General Order and the application process, visit the Central Valley Water Board website at:

https://www.waterboards.ca.gov/centralvalley/board_decisions/adopted_orders/general_orders/r5-2016-0076-01.pdf

NPDES Permit

If the proposed project discharges waste that could affect the quality of surface waters of the State, other than into a community sewer system, the proposed project will require coverage under a National Pollutant Discharge Elimination System (NPDES) permit. A complete Report of Waste Discharge must be submitted with the Central Valley Water Board to obtain a NPDES Permit. For more information regarding the NPDES Permit and the application process, visit the Central Valley Water Board website at: <https://www.waterboards.ca.gov/centralvalley/help/permit/>

If you have questions regarding these comments, please contact me at (916) 464-4684 or Peter.Minkel2@waterboards.ca.gov.

Peter Minkel

Peter Minkel
Engineering Geologist

cc: State Clearinghouse unit, Governor's Office of Planning and Research,
Sacramento



KOI NATION OF NORTHERN CALIFORNIA

August 18, 2022

VIA E-MAIL AND U.S. MAIL

Mr. Dirk Slooten
 Mayor
 City of Clearlake
 14050 Olympic Drive
 Clear Lake, CA 95422
 E-Mail: dslooten@clearlake.ca.us

Re: Burns Valley Park and Public Works Yard Master Plan, Mitigated Negative Declaration

Dear Mayor Slooten:

I am the Chairman of the Koi Nation of Northern California ("Tribe"). I am writing to you with respect to the Tribe's interest in protecting tribal cultural resources that are impacted by various projects in Clearlake, including the Burns Valley Park and Public Works Yard Master Plan ("Project"). We have reviewed the Mitigated Negative Declaration ("MND") for the Project, which was circulated June 16, 2022. We have serious concerns that we would like to discuss with you before potentially filing a formal comment on the MND pursuant to the California Environmental Quality Act ("CEQA"). I understand that our Vice Chair Dino Beltran would like to meet you as soon as possible. To discuss this and other issues with the City's treatment of tribal cultural resources. I further understand that the City has extended the comment period for the MND by two weeks until Friday, September 2nd, thank you. Please include this letter in the administrative record for the Project.

First, we are appreciative of the City's efforts to reach out and consult with the Tribe pursuant to AB 52 (Gatto, 2014), hereafter "AB 52". The City met with the Tribe for government-to-government consultation on March 2, March 30, and April 11, 2022. At the March 2, 2022, consultation, seven representatives from the City met with Yolanda Tovar, leadership from the Koi Nation, and Robert Geary, our Tribal Historic Preservation Officer. (Burns Valley Development Project, Pre-Job Sign In Sheet [March 2, 2022]; see also Pre-Construction Meeting Agenda Minutes.) Unfortunately, the tribal cultural resources information shared through the consultation process is not reflected in the MND. The MND says simply that "[t]he Cultural Study documents all consultation conducted." (MND at p.4.) The Cultural Study, however, was not attached to the circulated MND. (MND at p. 76.) The MND does provide a placeholder for an Attachment D, Cultural Report, however, Attachment D uploaded to CEQANET.opr.gov is a Geotechnical Investigation Report, which contains no discussion of the consultation. (MND at p. 76; see also Attachment D, Geotechnical Engineering Investigation Report [Feb. 26, 2021].)

In any event, it is well known that the Project site includes several significant recorded archaeological and tribal cultural resources sites. The MND continues to confirm discovery of "intact, buried, archaeological sites . . . [that] can be considered significant cultural resources." (MND at pp. 27-29.)

Mr. Dirk Slooten
August 18, 2022
Page 2

Problematically, further description of these resources in the MND and the corresponding mitigation measures do not reflect any of the substantial evidence provided by the Tribe through the consultation process. (*Ibid.*) A confidential map of significant tribal cultural resources and archaeological sites on or near this area is attached.

We note further that pursuant to CEQA and AB 52, consultation shall only be considered concluded when either: (1) the parties agree to measures that mitigate or avoid significant effects on tribal cultural resources, or (2) a party, acting in good faith and after reasonable effort, concludes that mutual agreement cannot be reached. (Guidelines, § 21080.3.2(b).) Neither circumstance has occurred here, and the consultation is continuing. The City should include measures in the MND to avoid tribal cultural resources, preserve them in place, or mitigate them to the extent feasible. The current level of analysis of tribal cultural resources in the MND is inadequate because it focuses solely on archaeological resources and does not include the Tribe's perspective, which was shared in consultation. In addition, the cumulative impact analysis is sorely lacking, as there are a number of adjacent projects with impacts to significant tribal cultural resources. The Project is within a tribal cultural landscape, which is itself a tribal cultural resource.

Second, the City has requested, and the Tribe has provided, tribal monitoring at the Burns Valley I project site on at least two occasions- May 19 and June 29, 2022. Currently the Tribe's tribal monitors are working without a signed agreement, which is not appropriate, and which should be remedied immediately. A proposed agreement was provided to the City on March 1, 2022, and on August 5, 2022, the City Manager Alan Flora said that he would review it but he has not responded as of the date of this letter. (See Email from H. Roberson to R. Jones [Aug. 10, 2022], based on consultation debrief from R. Geary.) The Koi Nation's tribal monitors have already discovered intact arrowheads, stone tools, and lithics, all of which are tribal cultural resources. (See, e.g., Email from H. Roberson to R. Jones [Aug. 10, 2022] based on information received from R. Geary.) These finds confirm the fact that there are tribal cultural resources on the Burns Valley I project site and increase the likelihood of finding additional tribal cultural resources on the Burns Valley II project site. Again, this information is not reflected in the MND, and it should be included in the cumulative impacts analysis. It also appears that City has a pattern and practice of not promptly recording the discovery of tribal cultural resources and archaeological resources and thus sensitive sites so as to avoid future harm. All finds must be appropriately reported to the California Historical Resources Information Center within 90 days so that the City and other lead agencies have an opportunity to avoid tribal cultural resources in their project planning. The City is responsible for the compliance of its contractors, including archaeological consultants, with standard professional practices. It is clear that, without appropriate tribal cultural resources treatment protocol and mitigation measures, the Project will have significant impacts on tribal cultural resources. In fact, we are deeply concerned that such irreversible impacts may have already occurred on the Burns Valley I project site.

As you know, CEQA requires environmental review to be completed prior to approval of a project so that environmental damage can be considered and minimized. (Guidelines §§ 15004, 15061.) An EIR, rather than a negative declaration, must be prepared if it can be fairly argued on the basis of substantial evidence in light of the whole record that the project may have significant environmental effect, even though the agency has other substantial evidence that the project will not have a significant effect. (Pub. Res. Code, §§ 21080(d), 21082.2(d); Guidelines § 15064 (g)(1); *Protect Niles v. City of Fremont* (2018) 25 Cal.App.5th 1129, 1139.) "A project with an effect that may cause a substantial adverse change in the significance of a tribal cultural resource is a project that may have a significant effect on the environment." (Pub. Res. Code, § 21084.2.) Public agencies must mitigate such impacts. (Pub. Res. Code, § 21084.3.)

Mr. Dirk Slooten
August 18, 2022
Page 3

A mitigation measure brought to the attention of the lead agency should not be omitted unless infeasible on its face; and in that case, the infeasibility must be explained. (*Los Angeles Unified School Dist. v. City of Los Angeles* (1997) 58 Cal.App.4th 1019, 1029.)

As set forth in *Save the Agoura Cornell Knoll v. City of Agoura Hills*, where "the record contains substantial evidence supporting a fair argument that the MND's measures are inadequate to avoid or mitigate the impacts to [tribal cultural resources] 'to a point where clearly no significant effect on the environment would occur,' an EIR is required to consider the project's impacts on cultural resources." (*Save the Agoura Cornell Knoll v. City of Agoura Hills* (2020) 46 Cal.App.5th 665, 690.) In *Save the Agoura Cornell Knoll*, there was evidence that the City of Agoura Hills ("City") did not adequately consult with relevant tribes or properly identify and analyze tribal cultural resources in the project mitigated negative declaration. (*Id.* at 684.) The City responded that mitigation measures in the project MND ensured the resources would be avoided and undisturbed. (*Id.* at 686.) The court disagreed and found that there was substantial evidence the measures improperly deferred mitigation and were insufficient to avoid or reduce impacts to less than significant. (*Id.* at 686.) More specifically, the court found that measures providing for monitoring with allowances for work stoppage for "appropriate actions" were inadequate. (*Id.* at 687.) The project MND did not completely define the boundaries of the project site or the tribal cultural resources on the project site so as to determine the feasibility of avoidance. (*Id.* at 687.) Contrastingly, there was evidence in the record that avoidance of tribal cultural resources was not feasible given the project footprint. (*Id.* at 688.) Accordingly, there was substantial evidence supporting a fair argument that the project MND's measures were inadequate to avoid or mitigate the impacts to tribal cultural resources to less than significant, and hence, an EIR was required. (*Id.* at 690.) Likewise, the MND here fails to reflect evidence received during the ongoing tribal consultation or provide meaningful measures to mitigate potential impacts to tribal cultural resources to less than significant. Instead, the MND's mitigation measures provide for the same work stoppage found inadequate by the Court and include further investigation by the cultural resource consultant. (See MND, pp. 28-29, CUL-1 -CUL-2.)

Based on the ongoing consultation and the tribal monitoring performed to date, there is substantial evidence in the record to support a fair argument that the Project, even with the mitigation measures currently described in the MND, will have a significant effect on tribal cultural resources, and hence the environment. Therefore, if we cannot resolve this matter voluntarily during consultation, and if the City does not take proper steps to protect, avoid, and mitigate tribal cultural resources in the MND, then the Tribe is prepared to assert in its comment letter on the MND that an EIR should be prepared for this Project. Legally, the City cannot simply ignore the information received through the government-to-government tribal consultation process and proceed with the Project without adequate environmental analysis and appropriate mitigation. Through consultation, and our work with the City on other Projects, including the Austin Park Splash Pad, the Tribe has presented a tribal cultural resources agreement and treatment protocol, which would be the building blocks for appropriate avoidance and mitigation measures. We strongly urge you to consider that information and work with the Tribe to adequately address impacts to tribal cultural resources in a revised MND.

My Tribal Council was therefore shocked and disappointed that immediately after reaching an agreement for appropriate avoidance, preservation in place, and mitigation of tribal cultural resources on the Austin Park Splash Pad project site, the City issued such an inadequate MND for another culturally significant site without proper consideration of tribal cultural resources.

Mr. Dirk Slooten
August 18, 2022
Page 4

Despite disappointment in the inadequacy of the MND, the Tribe remains committed to consulting with the City and working to develop a tribal cultural resources agreement and treatment protocol as well as appropriate mitigation to lessen the impacts of the Project on tribal cultural resources to less than significant. If, however, the City fails to address these issues voluntarily through the consultation process, the Tribe will be required to submit its comment on the MND, alert the Attorney General's office and the Native American Heritage Commission to the City's pattern and practice of bad faith tribal consultation, and challenge any resulting project approval on the basis that the environmental analysis is insufficient.

Respectfully,



Darin Beltran
Chairman
Koi Nation of Northern California

Cc: Koi Nation Tribal Council
Robert Geary, Director of Cultural Resources/Tribal Historic Preservation Officer
Ryan Jones, City Attorney
Alan Flora, City Manager
Holly Roberson, Tribal Cultural Resources Counsel to the Koi Nation of Northern California

Enclosures:

(1) Confidential map of tribal cultural resources associated with the Project area. Note: This map contains sensitive tribal cultural resources information. It may only be shared with the Mayor, the City Manager, the City Attorney, and the Project Manager for the Project as part of the confidential AB 52 consultation process. This map is not for distribution in the public facing MND.

From: [Brian Hanson](#)
To: [Mark Roberts](#)
Subject: Sports complex
Date: Tuesday, September 27, 2022 6:41:14 PM

CAUTION: This email originated from outside of the organization. Do not click links or open attachments unless you recognize the sender and know the content is safe.

I love that the City of Clearlake is trying to be progressive in the development of resources for our community and youth through the advancement of sports in Lake County. This will bring people from inside and outside Lake County to the City of Clearlake.

As a former Lake County athlete/collegiate athlete, and now father and coach of local youth athletes, I am continually left shaking my head at our counties lack of clean, safe, and well maintained sports resources. Our children deserve better.

Sports brings people together. They instill life long skills such as discipline, teamwork, and a sense of community pride to name a few.

Thank you for bringing this project forward, it is absolutely supported by the community and surrounding communities.

Sincerely,
Brian Hanson

Sent from my iPhone



City of Clearlake

Draft Mitigation Monitoring Reporting Program (MMRP) Checklist

Project Name: Burns Valley Development Project

Location: 14885 Burns Valley Road, Clearlake, CA 95422; further described as Assessor parcel Number (APN) 010-026-40-000.

File Numbers:

- Environmental Analysis, CEQA IS 2022-05
- Conditional Use Permit, CUP 2022-16

Approval Date: Planning Commission April 25th, 2023. Neg. Dec.: Mitigated Negative Declaration

The mitigation measures outlined below were incorporated into the approval for this project in order to reduce potentially significant environmental impacts to a level of insignificance. A completed and signed checklist for each mitigation measure indicates that this mitigation measure has been complied with and implemented and fulfills the City's monitoring pursuant to Section 15097 of the CEQA Guidelines.

Additional mitigation measures have been added in order to reconfirm the protocols for avoidance and capping of the sensitive sites. These mitigation measures do not create new significant environmental effects and are not necessary to mitigate an avoidable significant effect. Thus, pursuant to CEQA Guidelines section 15073.5, recirculation of the MND is not required.

Mitigation Measure	Type	Monitoring Shown on Department Plans	Verified Implementation	Remarks
AES-1	Aesthetics	All outdoor lighting shall be directed downwards and shielded onto the project site and not onto adjacent properties. All lighting shall comply and adhere to all federal, state and local agency requirements, including all requirements in darksky.org. (Refer to the City's Design Standards).		

Mitigation Measure	Type	Monitoring Shown on Department Plans	Verified Implementation	Remarks
AES-2	Aesthetics	A final lighting design plan shall be submitted for review and approval by the Community Development Department. Lighting levels shall not exceed lighting levels beyond those referenced in Attachment A, Lighting Analysis for this project. Lighting shall be installed in accordance with the final approved lighting plan.		
AES-3	Aesthetics	All nighttime ball field lighting shall be operated no later than 10 pm.		
AIR-1	Air Quality	Construction activities shall be conducted with adequate dust suppression methods, including watering during grading and construction activities to limit the generation of fugitive dust or other methods approved by the Lake County Air Quality Management District. Prior to initiating soil removing activities for construction purposes, the applicant shall pre-wet affected areas with at least 0.5 gallons of water per square yard of ground area to control dust.		
AIR-2	Air Quality	Driveways, access roads and parking areas shall be surfaced in a manner so as to minimize dust. The applicant shall obtain all necessary encroachment permits for any work within the right-of-way. All improvement shall adhere to all applicable federal, State and local agency requirements.		
AIR-3.	Air Quality	Any disposal of vegetation removed as a result of lot clearing shall be lawfully disposed of, preferably by chipping and composting, or as authorized by the Lake County Air Quality Management District and the Lake County Fire Protection District..		
AIR 4.	Air Quality	During construction activities, the applicant shall remove daily accumulation of mud and dirt from any roads adjacent to the site.		

Mitigation Measure	Type	Monitoring Shown on Department Plans	Verified Implementation	Remarks
AIR 5.	Air Quality	Grading permits shall be secured for any applicable activity from the Community Development Department, Building Division. Applicable activities shall adhere to all grading permit conditions, including Best Management Practices. All areas disturbed by grading shall be either surfaced in manner to minimize dust, landscaped or hydro seeded. All BMPs shall be routinely inspected and maintained for lifer of the project.		
AIR-6.	Air Quality	All refuse generated by the facility shall be stored in approved disposal/storage containers, and appropriately covered. Removal of waste shall be on a weekly basis so as to avoid excess waste. All trash receptacles/containers shall remain covered at all times to prevent fugitive odors and rodent infestation. An odor control plan shall be submitted for review and approval by the City In accordance with the Zoning Code. Odor control shall be maintained to an acceptable level at all times.		
AIR-7.	Air Quality	Construction activities that involve pavement, masonry, sand, gravel, grading, and other activities that could produce airborne particulate should be conducted with adequate dust controls to minimize airborne emissions. A dust mitigation plan may be required should the applicant fail to maintain adequate dust controls.		
AIR-8.	Air Quality	If construction or site activities are conducted within Serpentine soils, a Serpentine Control Plan may be required. Any parcel with Serpentine soils must obtain proper approvals from LCAQMD prior to beginning any construction activities. Contact LCAQMD for more details.		

Mitigation Measure	Type	Monitoring Shown on Department Plans	Verified Implementation	Remarks
AIR-9.	Air Quality	All engines must notify LCAQMD prior to beginning construction activities and prior to engine Use. Mobile diesel equipment used for construction and/or maintenance must be in compliance with State registration requirements. All equipment units must meet Federal, State and local requirements. All equipment units must meet RICE NESHAP/ NSPS requirements including proper maintenance to minimize airborne emissions and proper record-keeping of all activities, all units must meet the State Air Toxic Control Measures for CI engines and must meet local regulations.		
AIR-10.	Air Quality	Site development, vegetation disposal, and site operation shall not create nuisance odors or dust. During the site preparation phase, the District recommends that any removed vegetation be chipped and spread for ground cover and erosion control. Burning of debris/construction material is not allowed on commercial property, materials generated from the commercial operation, and waste material from construction debris, must not be burned as a means of disposal.		
AIR-11.	Air Quality	Significant dust may be generated from increase vehicle traffic if driveways and parking areas are not adequately surfaced. Surfacing standards should be included as a requirement in the use permit to minimize dust impacts to the public, visitors, and road traffic. At a minimum, the district recommends chip seal as a temporary measure for primary access roads and parking. Paving with asphaltic concrete is preferred and should be required for long term occupancy. All areas subject to semi-truck / trailer traffic should require asphaltic concrete paving or equivalent to prevent fugitive dust generation. Gravel surfacing may be adequate for low use driveways and overflow parking areas; however, gravel surfaces require more maintenance to achieve dust control, and permit conditions should require regular palliative treatment if gravel is		

Mitigation Measure	Type	Monitoring Shown on Department Plans	Verified Implementation	Remarks
		utilized. White rock is not suitable for surfacing (and should be prohibited in the permit) because of its tendency to break down and create excessive dust. Grading and re-graveling roads should utilize water trucks, if necessary, reduce travel times through efficient time management and consolidating solid waste removal/supply deliveries, and speed limits		
BIO-1.	Biological Resources	The project should implement erosion control measures and BMPs to reduce the potential for sediment or pollutants at the Project site.		
BIO-2.	Biological Resources	A qualified biologist shall conduct a mandatory Worker Environmental Awareness Program for all contractors, work crews, and any onsite personnel to aid workers in recognizing special status species and sensitive biological resources that may occur on-site. The program shall include identification of the special status species and their habitats, a description of the regulatory status and general ecological characteristics of sensitive resources, and review of the limits of construction and Mitigation Measures required to reduce impacts to biological resources within the work area.		
BIO-3.	Biological Resources	Conduct a pre-construction northwestern pond turtle survey in Project impact and staging areas within 48 hours prior to construction activities. Any northwestern pond turtle individuals discovered in the Project work area immediately prior to or during Project activities shall be allowed to move out of the work area of their own volition. If this is not feasible, they shall be captured by a qualified biologist and relocated out of harm's way to the nearest suitable habitat at least 100 feet from the Project work area where they were found.		
BIO-4.	Biological Resources	If construction is to occur during the nesting season (generally February 1 - August 31), conduct a pre-construction nesting bird survey of all suitable nesting habitat on the Project within 14 days of the commencement of construction. The survey		

Mitigation Measure	Type	Monitoring Shown on Department Plans	Verified Implementation	Remarks
		<p>shall be conducted within a 500-foot radius of Project work areas for raptors and within a 100-foot radius for other nesting birds. If any active nests are observed, these nests shall be designated a sensitive area and protected by an avoidance buffer established in coordination with CDFW until the breeding season has ended or until a qualified biologist has determined that the young have fledged and are no longer reliant upon the nest or parental care for survival. Pre-construction nesting surveys are not required for construction activity outside the nesting season</p>		
BIO-5.	Biological Resources	<p>Within 14 days prior to Project activities that may impact bat roosting habitat (e.g., removal of manmade structures or trees), a qualified biologist will survey for all suitable roosting habitat within the Project impact limits. If suitable roosting habitat is not identified, no further measures are necessary. If suitable roosting habitat is identified, a qualified biologist will conduct an evening bat emergence survey that may include acoustic monitoring to determine whether or not bats are present. If roosting bats are determined to be present within the Project site, consultation with CDFW prior to initiation of construction activities and/or preparation of a Bat Management Plan outlining avoidance and minimization measures specific to the roost(s) potentially affected may be required</p>		
BIO-6	Biological Resources	<p>To minimize potential impacts to the ephemeral drainage on the project site during construction activity, a qualified biologist shall map the extent of the riparian habitat on the project site. Avoidance buffers for riparian habitat shall be applied in compliance with City of Clearlake requirements. The riparian habitat and avoidance buffer shall be demarcated prior to construction and shall be maintained until the completion of construction. A qualified biologist/biological monitor shall be present if work must occur within the</p>		

Mitigation Measure	Type	Monitoring Shown on Department Plans	Verified Implementation	Remarks
		avoidance buffer to ensure riparian habitat is not impacted by the construction activity.		
BIO-7	Biological Resources	A native tree protection and removal permit, waiver, or similar approval shall be secured prior to impacting trees protected under the City ordinance. Avoidance buffers for protected trees shall be consistent with the City requirements, shall be clearly demarcated prior to construction, and should be maintained until the completion of construction. A qualified biologist/biological monitor should be present if work must occur within the avoidance buffer to ensure avoided protected trees are not impacted by the work		
CUL-1.	Cultural Resources	During construction activities, if any subsurface archaeological remains are uncovered, all work shall be halted within 100 feet of the find and the owner shall utilize a qualified cultural resources consultant to identify and investigate any subsurface historic remains and define their physical extent and the nature of any built features or artifact-bearing deposits.		
CUL-2.	Cultural Resources	The cultural resource consultant's investigation shall proceed into formal evaluation to determine their eligibility for the California Register of Historical Resources. This shall include, at a minimum, additional exposure of the feature(s), photo-documentation and recordation, and analysis of the artifact assemblage(s). If the evaluation determines that the features and artifacts do not have sufficient data potential to be eligible for the California Register, additional work shall not be required. However, if data potential exists – e.g., there is an intact feature with a large and varied artifact assemblage – it will be necessary to mitigate any Project impacts. Mitigation of impacts might include avoidance of further disturbance to the resources through Project redesign. If avoidance is determined to be		

Mitigation Measure	Type	Monitoring Shown on Department Plans	Verified Implementation	Remarks
		<p>infeasible, pursuant to CEQA Guidelines Section 15126.4(b)(3)(C), a data recovery plan, which makes provisions for adequately recovering the scientifically consequential information from and about the historical resource, shall be prepared and adopted prior to any excavation being undertaken. Such studies shall be deposited with the California Historical Resources Regional Information Center. Archeological sites known to contain human remains shall be treated in accordance with the provisions of Section 7050.5 Health and Safety Code. If an artifact must be removed during Project excavation or testing, curation may be an appropriate mitigation. This language of this mitigation measure shall be included on any future grading plans and utility plans approved by the City for the Project.</p>		
CUL-3.	Cultural Resources	<p>If human remains are encountered, no further disturbance shall occur within 100 feet of the vicinity of the find(s) until the Lake County Coroner has made the necessary findings as to origin (California Health and Safety Code Section 7050.5). Further, pursuant to California Public Resources Code Section 5097.98(b) remains shall be left in place and free from disturbance until a final decision as to the treatment and disposition has been made. If the Lake County Coroner determines the remains to be Native American, the Native American Heritage Commission must be contacted within 24 hours. The Native American Heritage Commission must then identify the “most likely descendant(s)”. The landowner shall engage in consultations with the most likely descendant (MLD). The MLD will make recommendations concerning the treatment of the remains within 48 hours as provided in Public Resources Code 5097.98.</p>		
CUL-4.	Cultural Resources	<p>The sensitive site section noted on the project site plan shall not be disturbed during construction and/or maintenance of the park. This sensitive site is identified as investigation resulted in the discovery of two</p>		

Mitigation Measure	Type	Monitoring Shown on Department Plans	Verified Implementation	Remarks
		<p>intact, buried, archaeological sites, CCL-21-01 and CCL-21-02 (Figure 7, yellow polygons), both of the sites can be considered significant cultural resources. Both of the sites occupy relatively small areas and are buried at depths of 16–32 inches below grade. The project as currently designed, will not impact sites CCL-21-01 or CCL-21-02. If avoidance and/or preservation in place is not possible, the owner will consider re-design or other measures to avoid impacting resources consistent with CEQA. The owner will contract with tribal monitors for ground disturbance within 100 feet of sites CCL-21-01 and CCL-21-02. The owner and contract archeologist will consult with tribal representatives regarding ground disturbing work within these areas including the designation of a “reburial” location, if needed.</p>		
CUL-5	Cultural Resources	<p>On or prior to the first day of construction the owner shall organize cultural sensitivity training for contractors involved in ground disturbing activities.</p>		
CUL-6	Cultural Resources	<p>The southern two-thirds of site CCL-21-01 is contained within APN010-026-400-000 and the Burns Valley Development Project area. The area occupied by the site has been slated for a paved parking area serving planned playing fields nearby (Figure 2). This portion of the site is situated on the sloping bank of an extinct section of upper Miller Creek, an area marked by an overstory of mixed native oak and introduced conifer and hardwood trees. Because this part of the site is situated on a bank, the land surface is sloped and drops 10–15 feet in elevation. Current engineering plan calls for vegetation and tree removal as well as application of remote fill materials to bring it to a level grade, with installation of landscaping, drains, and underground utility lines in the area. Project revisions in design, location, and operations should be implemented in the area occupied by the footprint of site</p>		

Mitigation Measure	Type	Monitoring Shown on Department Plans	Verified Implementation	Remarks
		<p>CCL-21-01, inclusive to a 15-foot (4.5-meter) buffer around the site perimeter. Limitations to disturbance in this area shall be as follows:</p> <ol style="list-style-type: none"> 1. <i>Fill Cap.</i> Because CCL-21-01 is a buried archaeological deposit contained in a dense clay loam likely to resist compaction impacts, avoidance can be achieved by placing fill on the site surface; 2. <i>Flush Cut Vegetation.</i> Existing vegetation including shrubs and trees should be flush-cut, i.e., cut flush with the ground at a point not to exceed 10-inches below grade; 3. <i>Landscaping Fabric and Fill.</i> Once the flush cut is complete and surface cleared of debris, landscaping fabric should be laid over the area of the site to create a boundary between intact soils and remote fill. With respect to the fill, drainage, safety, and operational concerns may prevent adding a lot of elevation; however, an additional minimum 6–12-inches (15–30 centimeters) of fill should be added to the site area to provide a construction and compaction buffer to protect the deposit. This would result in an overburden of 21–27 inches (53–71 centimeters) of capping material; 4. <i>Avoid Installation of Subsurface Features.</i> Avoid placement of pier supports, subsurface landscaping features, subsurface drains, and utility lines in the site area. 5. <i>Avoid New Overstory Plantings.</i> Avoid placement of new overstory trees in the site area 		
CUL-7	Cultural Resources	<p>Site CCL-21-02 is contained within APN010-026-400-000 and the Burns Valley Development Project area. The area occupied by the site has been slated for open space. Project revisions in design, location, and operations should be</p>		

Mitigation Measure	Type	Monitoring Shown on Department Plans	Verified Implementation	Remarks
		<p>implemented in the area occupied by the footprint of site CCL-21-02, inclusive to a 15-foot (4.5-meter) buffer around the site perimeter. Limitations to disturbance in this area shall be as follows:</p> <ol style="list-style-type: none"> 1. <i>Fill Cap.</i> Because CCL-21-01 is a buried archaeological deposit contained in a dense clay loam likely to resist compaction impacts, avoidance can be achieved by placing fill on the site/buffer surface; 2. <i>Landscaping Fabric and Fill.</i> Prior to site prep and construction in the area, landscaping fabric should be laid over the area of the site to create a boundary between intact soils and remote fill. With respect to the fill, drainage, safety, and operational concerns may prevent adding a lot of elevation; however, an additional minimum 6–12-inches (15–30 centimeters) of fill should be added to the site area to provide a construction and compaction buffer to protect the deposit. This would result in an overburden of 21–27 inches (53–71 centimeters) of capping material; 3. <i>Avoid Installation of Subsurface Features.</i> Avoid placement of pier supports, subsurface landscaping features, subsurface drains, and utility lines in the site area. 4. <i>Avoid New Overstory Plantings.</i> Avoid placement of new overstory trees in the site area. 		

Mitigation Measure	Type	Monitoring Shown on Department Plans	Verified Implementation	Remarks
GEO-1	Geology and Soils	<p>GEO-1: Prior to any ground disturbance and/or operation, the applicant shall submit <u>Erosion Control and Sediment Plans</u> to the Community Development Department for review and approval.</p> <ul style="list-style-type: none"> <i>The project shall incorporate Best Management Practices (BMPs) consistent with the City Code and the State Storm Water Drainage Regulations to the maximum extent practicable to prevent and/or reduce discharge of all construction or post-construction pollutants into the local storm drainage system.</i> 		
GEO-2	Geology and Soils	Prior to any ground disturbance, (if applicable), the applicant shall submit and obtain a Grading Permit from the Community Development in accordance with the City of Clearlake Municipal code(s).		
GEO-3	Geology and Soils	The applicant shall monitor the site during the rainy season including post-installation, application of BMPs, erosion control maintenance, and other improvements as needed. Said measures shall be maintained for life of the project and replace/repared when necessary		
NOI-1.	Noise	All construction activities including engine warm-up shall be limited to weekdays and Saturday, between the hours of 7:00am and 7:00pm to minimize noise impacts on nearby residents.		
NOI-2.	Noise	Permanent potential noise sources such as, generators used for power shall be designed and located to minimize noise impacts to surrounding properties.		
NOI-3.	Noise	During construction noise levels shall not exceed 65 decibels within fifty (50) feet of any dwellings or transient accommodations between the hours of 7:00 AM and 6:00 PM. This threshold can be increased by the Building Inspector or City Engineer have approved an exception in accordance with Section 5-4.4(b)(1) of the City Code. An exception of up to 80 decibels may be approved within one hundred (100) feet from the source during daylight hours.		

Mitigation Measure	Type	Monitoring Shown on Department Plans	Verified Implementation	Remarks
		Project is expected to result in less than significant impacts with regard to noise and vibration.		
NOI-4	Noise	Park operations, including baseball at the northeasterly ball park shall be shall be restricted to not later than 10 pm.		
TCR-1	Tribal Cultural Resource	Requirement to develop a tribal cultural resources preservation plan that delineates the boundary of CCL-21-01 and CCL-21-02, describes the appropriate combination of materials and culturally sterile fill in capping, provides landscaping specifications that favor culturally important plants, and restricts certain types of post-project activities in or on the cap.		
TCR-2	Tribal Cultural Resource	Requirement to designate a project reburial area in advance of ground disturbing activities in the event that materials are discovered during construction.		
TCR-3	Tribal Cultural Resource	Requirement for contractors to receive meaningful training on cultural sensitivity and tribal cultural resources from a tribal representative.		
TCR-4	Tribal Cultural Resource	Requirement for tribal monitoring during ground disturbing activities in sensitive areas of the project area.		
TCR-5	Tribal Cultural Resource	Procedures for compliance with existing state law in the event of the discovery of human remains during construction.		
TCR-6	Tribal Cultural Resource	A prohibition on the removal of cultural soils from the project area.		

Explanation of Headings

Type = Project (mitigation for this specific project), ongoing, and/or cumulative.

Monitoring Department = Department or agency responsible for monitoring a particular mitigation measure.

Shown on Plans = When a mitigation measure is shown on the construction plans, this column must be initialed and dated.

Verified Implementation = When mitigation measure has been implemented, this column must be initialed and dated.

Remarks = Area for describing status of ongoing mitigation measure, or other information.

CITY OF CLEARLAKE

City Council



STAFF REPORT

SUBJECT: Adoption of the City of Clearlake's Budget for Fiscal Year 2023-24

MEETING DATE:
June 15, 2023

SUBMITTED BY: Kathy Wells, Finance Director
Alan D. Flora, City Manager

PURPOSE OF REPORT: Information only Discussion Action Item

WHAT IS BEING ASKED OF THE CITY COUNCIL/BOARD:

The June 15, 2023 City Council meeting will include a Budget Workshop at 5:00 p.m. and a public hearing during the regular meeting for the:

- FY 2023-24 Proposed Budget
- FY 2023-24 Gann/Appropriations Limit
- FY 2023-24 Fee Schedule

If the Council has no significant changes to the budget, all could be adopted on June 15th. Alternatively, the Council can provide other direction to staff, and the Public Hearing can be continued to a date before July 1st to reconsider adoption once the directed changes are made.

BACKGROUND/DISCUSSION:

Further detail on the financial and policy implications of the FY 2023-24 Budget are included within the Proposed Budget and will be explained at the Budget Workshop on June 15th at 5:00 p.m. The proposed Budget can be accessed through the City's website on the Finance Department webpage at <https://www.clearlake.ca.us/175/Finance> or directly through the City's OpenGov Budget portal at <https://stories.opengov.com/clearlake/published/tNI37Ia->

OPTIONS:

1. Move to adopt Resolution No. 2023-27
2. Other direction

FISCAL IMPACT:

None \$ Budgeted Item? Yes No

Budget Adjustment Needed? Yes No If yes, amount of appropriation increase:

Section I, Item 6.

Affected fund(s): General Fund Measure P Fund Measure V Fund Other: All Funds

Comments:

STRATEGIC PLAN IMPACT:

- Goal #1: Make Clearlake a Visibly Cleaner City
- Goal #2: Make Clearlake a Statistically Safer City
- Goal #3: Improve the Quality of Life in Clearlake with Improved Public Facilities
- Goal #4: Improve the Image of Clearlake
- Goal #5: Ensure Fiscal Sustainability of City
- Goal #6: Update Policies and Procedures to Current Government Standards
- Goal #7: Support Economic Development

SUGGESTED MOTIONS:

Move to adopt Resolution No. 2023-27, Adopting the City of Clearlake FY 2023-24 Budget

- Attachments:**
- 1) Resolution No. 2023-27
 - 2) Proposed FY 2023-24 Salary Schedule

CITY OF CLEARLAKE

RESOLUTION NO. 2023-27

**A RESOLUTION OF THE CITY COUNCIL OF THE CITY OF CLEARLAKE
ADOPTING THE CITY OF CLEARLAKE FY 2023-24 BUDGET**

WHEREAS, it is the practice of the city of Clearlake to adopt a budget for the following fiscal year by June 30 of every year; and

WHEREAS, the City Council of the City of Clearlake reviewed the FY 2023-24 Proposed Budget at a Noticed Public Hearing of the City Council meeting on June 15, 2023, received input from the public;

NOW, THEREFORE, BE IT RESOLVED, by the City Council of the City of Clearlake that the documents entitled “City of Clearlake FY 2023-24 Proposed Budget” are adopted,

PASSED AND ADOPTED this 15th day of June, 2023, by the following vote:

- AYES:
- NOES:
- ABSENT:
- ABSTAIN:

ATTEST:

City Clerk

Mayor, City of Clearlake

Proposed FY 2023-24 Salary Schedule

Position	UNIT	RANGE	FY 22-23	MONTHLY (Payroll Base)					F Step	ANNUAL					F Step	HOURLY (Payroll Input)					F Step
				A Step	B Step	C Step	D Step	E Step		A Step	B Step	C Step	D Step	E Step		A Step	B Step	C Step	D Step	E Step	
Maintenance Worker I	CMEA	11	2,312.04	2,381.41	2,500.48	2,625.50	2,756.78	2,894.61		28,576.87	30,005.72	31,506.00	33,081.30	34,735.37		13,738.9	14,425.8	15,147.1	15,904.5	16,697.7	
Office Worker	CMEA	11	2,312.04	2,381.41	2,500.48	2,625.50	2,756.78	2,894.61		28,576.87	30,005.72	31,506.00	33,081.30	34,735.37		13,738.9	14,425.8	15,147.1	15,904.5	16,697.7	
Office Assistant I	CMEA	13	2,427.65	2,500.48	2,625.50	2,756.78	2,894.62	3,039.35		30,005.72	31,506.06	33,081.36	34,735.43	36,472.20		14,425.8	15,147.1	15,904.5	16,697.7	17,534.7	
Kennel Technician	CMEA	15	2,549.04	2,625.51	2,756.79	2,894.63	3,039.36	3,191.33		31,506.13	33,081.44	34,735.51	36,472.29	38,295.90		15,147.2	15,904.6	16,698.8	17,534.8	18,411.5	
Office Assistant II	CMEA	18	2,743.40	2,825.70	2,966.99	3,115.34	3,271.11	3,434.66		33,081.44	35,603.88	37,384.07	39,253.28	41,215.94		16,302.1	17,117.3	17,973.1	18,871.8	19,815.4	
Maintenance Worker II	CMEA	21	2,950.83	3,039.36	3,191.32	3,350.89	3,518.44	3,694.36		36,472.28	38,295.90	40,210.69	42,221.23	44,332.29		17,534.8	18,411.5	19,332.1	20,298.7	21,313.6	
Facilities Maintenance Worker II	CMEA	21	2,950.83	3,039.36	3,191.32	3,350.89	3,518.44	3,694.36		36,472.28	38,295.90	40,210.69	42,221.23	44,332.29		17,534.8	18,411.5	19,332.1	20,298.7	21,313.6	
Office Assistant/Secretary	CMEA	24	3,175.83	3,271.10	3,434.66	3,606.39	3,786.71	3,976.04		39,253.21	41,215.87	43,276.65	45,440.50	47,712.53		18,871.7	19,815.3	20,806.1	21,846.4	22,938.7	
Account Clerk I	CMEA	26	3,334.62	3,434.65	3,606.39	3,786.71	3,976.04	4,174.84		41,215.85	43,276.65	45,440.48	47,712.50	50,098.13		19,815.3	20,806.1	21,846.4	22,938.7	24,085.6	
Code Enforcement Technician	CMEA	26	3,334.62	3,434.65	3,606.39	3,786.71	3,976.04	4,174.84		41,215.85	43,276.65	45,440.48	47,712.50	50,098.13		19,815.3	20,806.1	21,846.4	22,938.7	24,085.6	
Grants Technician	CMEA	26	3,334.62	3,434.65	3,606.39	3,786.71	3,976.04	4,174.84		41,215.85	43,276.65	45,440.48	47,712.50	50,098.13		19,815.3	20,806.1	21,846.4	22,938.7	24,085.6	
Planner, Technician	CMEA	26	3,334.62	3,434.65	3,606.39	3,786.71	3,976.04	4,174.84		41,215.85	43,276.65	45,440.48	47,712.50	50,098.13		19,815.3	20,806.1	21,846.4	22,938.7	24,085.6	
Secretary/Permit Technician	CMEA	26	3,334.62	3,434.65	3,606.39	3,786.71	3,976.04	4,174.84		41,215.85	43,276.65	45,440.48	47,712.50	50,098.13		19,815.3	20,806.1	21,846.4	22,938.7	24,085.6	
Dispatcher Aide	CMEA	26	3,334.62	3,434.65	3,606.39	3,786.71	3,976.04	4,174.84		41,215.85	43,276.65	45,440.48	47,712.50	50,098.13		19,815.3	20,806.1	21,846.4	22,938.7	24,085.6	
Maintenance Worker III	CMEA	29	3,586.75	3,694.35	3,879.07	4,073.02	4,276.67	4,490.51		44,332.20	46,548.81	48,876.25	51,320.07	53,886.07		21,313.6	22,379.2	23,498.2	24,673.1	25,908.8	
Support Services Technician I	CMEA	29	3,586.75	3,694.35	3,879.07	4,073.02	4,276.67	4,490.51		44,332.20	46,548.81	48,876.25	51,320.07	53,886.07		21,313.6	22,379.2	23,498.2	24,673.1	25,908.8	
Account Clerk II	CMEA	32	3,860.24	3,976.05	4,174.85	4,383.59	4,602.77	4,832.91		47,712.58	50,098.21	52,603.12	55,233.28	57,994.94		22,938.7	24,085.7	25,290.0	26,545.4	27,882.2	
Building Inspector I	CMEA	32	3,860.24	3,976.05	4,174.85	4,383.59	4,602.77	4,832.91		47,712.58	50,098.21	52,603.12	55,233.28	57,994.94		22,938.7	24,085.7	25,290.0	26,545.4	27,882.2	
Maintenance Worker, Senior	CMEA	32	3,860.24	3,976.05	4,174.85	4,383.59	4,602.77	4,832.91		47,712.58	50,098.21	52,603.12	55,233.28	57,994.94		22,938.7	24,085.7	25,290.0	26,545.4	27,882.2	
Dep City Clerk/ HR Tech	CMEA	34	4,053.25	4,174.85	4,383.59	4,602.77	4,832.91	5,074.56		50,098.20	52,603.11	55,233.27	57,994.93	60,894.68		24,085.7	25,290.0	26,545.4	27,882.2	29,276.3	
Maintenance Worker, Lead	CMEA	34	4,053.25	4,174.85	4,383.59	4,602.77	4,832.91	5,074.56		50,098.20	52,603.11	55,233.27	57,994.93	60,894.68		24,085.7	25,290.0	26,545.4	27,882.2	29,276.3	
Management Analyst I	CMEA	34	4,053.25	4,174.85	4,383.59	4,602.77	4,832.91	5,074.56		50,098.20	52,603.11	55,233.27	57,994.93	60,894.68		24,085.7	25,290.0	26,545.4	27,882.2	29,276.3	
Planner I, Assistant	CMEA	34	4,053.25	4,174.85	4,383.59	4,602.77	4,832.91	5,074.56		50,098.20	52,603.11	55,233.27	57,994.93	60,894.68		24,085.7	25,290.0	26,545.4	27,882.2	29,276.3	
Building Inspector II	CMEA	36	4,255.91	4,383.59	4,602.77	4,832.91	5,074.55	5,328.28		52,603.07	55,233.23	57,994.89	60,894.63	63,939.37		25,290.0	26,545.4	27,882.2	29,276.3	30,740.1	
Senior Account Clerk	CMEA	37	4,362.31	4,493.18	4,717.84	4,953.73	5,201.42	5,461.49		53,918.17	56,614.07	59,444.78	62,417.02	65,537.87		25,922.2	27,218.3	28,579.2	30,008.2	31,508.6	
Recreation/Event Coordinator	CMEA	37	4,362.31	4,493.18	4,717.84	4,953.73	5,201.42	5,461.49		53,918.17	56,614.07	59,444.78	62,417.02	65,537.87		25,922.2	27,218.3	28,579.2	30,008.2	31,508.6	
Associate Planner	CMEA	39	4,577.70	4,715.03	4,950.78	5,198.32	5,458.24	5,731.15		56,580.36	59,409.38	62,379.85	65,498.84	68,773.78		27,202.1	28,562.2	29,990.3	31,489.8	33,064.3	
Engineering Technician	CMEA	45	5,299.27	5,458.24	5,731.16	6,017.71	6,318.60	6,634.53		65,498.94	68,773.88	72,212.58	75,823.21	79,614.37		31,489.9	33,064.4	34,717.6	36,453.5	38,276.1	
Code Enforcement Officer I	CPA	28	3,669.69	3,779.78	3,968.77	4,167.21	4,375.57	4,594.35		45,357.37	47,625.24	50,006.50	52,506.82	55,132.16		21,806.4	22,896.7	24,041.6	25,243.7	26,505.8	
Animal Control Officer	CPA	30	3,853.17	3,968.77	4,167.21	4,375.57	4,594.35	4,824.06		47,625.24	50,006.50	52,506.82	55,132.16	57,888.77		22,896.7	24,041.6	25,243.7	26,505.8	27,831.1	
Support Services Tech	CPA	30	3,853.17	3,968.77	4,167.21	4,375.57	4,594.35	4,824.06		47,625.24	50,006.50	52,506.82	55,132.16	57,888.77		22,896.7	24,041.6	25,243.7	26,505.8	27,831.1	
Community Service Officer	CPA	30	3,853.17	3,968.77	4,167.21	4,375.57	4,594.35	4,824.06		47,625.24	50,006.50	52,506.82	55,132.16	57,888.77		22,896.7	24,041.6	25,243.7	26,505.8	27,831.1	
Police Trainee (P/T)	CPA	30	3,853.17	3,968.77	4,167.21	4,375.57	4,594.35	4,824.06		47,625.24	50,006.50	52,506.82	55,132.16	57,888.77		22,896.7	24,041.6	25,243.7	26,505.8	27,831.1	
Police Dispatcher	CPA	31	3,947.15	4,065.56	4,268.84	4,482.28	4,706.40	4,941.72		48,786.77	51,226.11	53,787.42	56,476.79	59,300.63		23,455.2	24,627.9	25,859.3	27,152.3	28,509.9	
Code Enforcement Officer, Senior	CPA	32	4,045.83	4,167.20	4,375.56	4,594.34	4,824.06	5,065.26		50,006.46	52,506.78	55,132.12	57,888.72	60,783.16		24,041.6	25,243.6	26,505.8	27,831.1	29,222.7	
Police Officer	CPA	42	5,292.71	5,451.49	5,724.07	6,010.27	6,310.78	6,626.32	6,957.64	65,417.90	68,688.79	72,123.23	75,729.39	79,515.86	83,491.65	31,450.9	33,023.5	34,674.7	36,408.4	38,228.8	40,140.3
Code Supervisor/Building Inspector	CPA	45	5,554.04	5,720.66	6,006.69	6,307.03	6,622.38	6,953.50		68,647.92	72,080.32	75,684.34	79,468.55	83,441.98		33,003.8	34,654.0	36,386.7	38,206.0	40,116.3	
Admin Assistant	MGT	50	5,567.71	5,734.74	6,021.48	6,322.55	6,638.68	6,970.62		68,816.91	72,257.76	75,870.65	79,664.18	83,647.39		33,085.1	34,739.3	36,476.3	38,300.1	40,215.1	
Construction/Project Manager	MGT	60	7,105.97	7,319.15	7,685.11	8,069.37	8,472.83	8,896.48		87,829.83	92,221.32	96,832.39	101,674.01	106,757.71		42,225.9	44,337.2	46,554.0	48,881.7	51,325.8	
Public Works Superintendent	MGT	60	7,105.97	7,319.15	7,685.11	8,069.37	8,472.83	8,896.48		87,829.83	92,221.32	96,832.39	101,674.01	106,757.71		42,225.9	44,337.2	46,554.0	48,881.7	51,325.8	
Senior Planner	MGT	60	7,105.97	7,319.15	7,685.11	8,069.37	8,472.83	8,896.48		87,829.83	92,221.32	96,832.39	101,674.01	106,757.71		42,225.9	44,337.2	46,554.0	48,881.7	51,325.8	
Admin. Services Dir./City Clerk	MGT	64	7,834.33	8,069.36	8,472.83	8,896.47	9,341.30	9,808.36		96,832.37	101,673.99	106,757.69	112,095.58	117,700.35		46,554.0	48,881.7	51,325.8	53,892.1	56,586.7	
Police Lieutenant	MGT	64	7,834.33	8,069.36	8,472.83	8,896.47	9,341.30	9,808.36		96,832.37	101,673.99	106,757.69	112,095.58	117,700.35		46,554.0	48,881.7	51,325.8	53,892.1	56,586.7	
City Engineer	MGT	65	8,025.42	8,266.19	8,679.50	9,113.47	9,569.14	10,047.60													

CITY OF CLEARLAKE

City Council



STAFF REPORT

SUBJECT: Adoption of Appropriations Limit (Gann Limit) for Fiscal Year 2023-24 and designating the formula to be used for calculation of same

MEETING DATE:
June 15, 2023

SUBMITTED BY: Kathy Wells, Finance Director
Alan D. Flora, City Manager

PURPOSE OF REPORT: Information only Discussion Action Item

WHAT IS BEING ASKED OF THE CITY COUNCIL/BOARD:

Annual adoption of appropriations limit as required by state law.

BACKGROUND/DISCUSSION:

It is necessary for the City Council to approve the attached Resolution Adopting an Appropriations Limit for each fiscal year, in compliance with Proposition 4 (Gann Limit). The City is well under the calculated appropriations limit and has the capacity to significantly increase the size of the budget, should that become necessary, or possible, at some future time.

The resolution, appropriations limit calculation (Schedule A), and reference material from the Department of Finance are attached here.

OPTIONS:

1. Move to adopt Resolution No. 2023-28
2. Other direction

FISCAL IMPACT:

None \$0 Budgeted Item? Yes No

Budget Adjustment Needed? Yes No If yes, amount of appropriation increase: \$

Affected fund(s): General Fund Measure P Fund Measure V Fund Other: All Funds

Comments:

STRATEGIC PLAN IMPACT:

Goal #1: Make Clearlake a Visibly Cleaner City

Goal #2: Make Clearlake a Statistically Safer City

- Goal #3: Improve the Quality of Life in Clearlake with Improved Public Facilities
- Goal #4: Improve the Image of Clearlake
- Goal #5: Ensure Fiscal Sustainability of City
- Goal #6: Update Policies and Procedures to Current Government Standards
- Goal #7: Support Economic Development

SUGGESTED MOTIONS:

Move to adopt Resolution No. 2023-28.

- Attachments:**
 - 1) Resolution No. 2023-28
 - 2) Gann Limit Schedule, with supporting reference material

**CITY OF CLEARLAKE
RESOLUTION NO. 2023-28**

**RESOLUTION OF THE CITY COUNCIL OF THE CITY OF CLEARLAKE
ADOPTING THE APPROPRIATIONS LIMIT FOR FY 2023-24 AND
DESIGNATING THE FORMULA TO BE USED FOR CALCULATION OF SAME**

WHEREAS, Article XIII B of the State Constitution requires that each Public Agency, including the City of Clearlake, adopt an appropriation limit for each fiscal year (FY); and

WHEREAS, pursuant to a 1990 amendment to the laws governing appropriation limits, authorizing and requiring public agencies to select a formula each fiscal year for the calculation of said limit; and

WHEREAS, allowable formulas for the calculation of said limit are:

- a. City population increase and the January 1, California per capita income index as provided by the California Department of Finance; or
- b. County population increase and the January 1, California per capita income index as provided by the California Department of Finance; or
- c. City population increase and increase in non-residential assessed valuation; or
- d. County population increase and increase in non-residential assessed valuation.

WHEREAS, the City of Clearlake has been unable to perform fiscal analysis of calculation formula c and d, as set forth herein, as the appropriate breakdown of assessed valuation figures are not available to the City at this time.

NOW, THEREFORE, BE IT RESOLVED by the City Council of the City of Clearlake that the formula will be selected as follows:

Section 1. Formula for Calculating: The FY 2023-2024 Appropriation Limit for the City of Clearlake shall be calculated using the percent change in population of the County of Lake from January 1, 2022 to January 1, 2023 (-0.96%) and the FY 2023-24 California per capita income price index as provided by the California Department of Finance in May, 2023 (4.44%).

Section 2. Appropriation Limit: The FY 2023-24 Appropriation Limit is hereby set at \$10,294,448, as calculated on attached Schedule A.

Section 3. Selection of Option for Calculation: The City Council of the City of Clearlake hereby reserves the right to amend its selection of the FY 2023-2024 calculation formula, subsequent to future availability of the necessary information and financial analysis of calculation formula “c” and “d” as set forth herein.

PASSED AND ADOPTED on this 15th day of June, 2023 by the following vote:

- AYES:
- NOES:
- ABSENT:
- ABSTAIN:

Mayor, City of Clearlake

ATTEST:

City Clerk, City of Clearlake

City of Clearlake

APPROPRIATIONS LIMIT CALCULATION

SCHEDULE A

CALCULATION OF FY 2023-24 APPROPRIATIONS LIMIT:

FY 2022-23 APPROPRIATIONS LIMIT	9,952,348
Change in County of Lake Population (1/1/22 TO 1/1/23)	-0.9600
Change in California Per Capita Personal Income	4.4400
Combined Population/Income Factor	1.0344

PROPOSED APPROPRIATIONS LIMIT FOR FY 2023-24:

(Prior Year Appropriations Limit multiplied by Combined Population/Income Factor) **10,294,448**

CALCULATION OF APPROPRIATIONS SUBJECT TO LIMIT:**PROPOSED FY 2023-24 PROCEEDS OF TAXES**

GENERAL FUND TAXES	5,217,802
MEASURE P TAXES	1,319,000
MEASURE V TAXES	2,637,000
TOTAL CITY OF CLEARLAKE APPROPRIATIONS SUBJECT TO LIMIT	9,173,802

COMPARISON OF FY APPROPRIATIONS LIMIT & APPROPRIATIONS SUBJECT TO LIMIT

PROPOSED APPROPRIATIONS LIMIT FOR FY 2023-24	10,294,448
LESS: FY 2023-24 APPROPRIATIONS SUBJECT TO LIMIT	9,173,802
REMAINING APPROPRIATIONS CAPACITY	1,120,646

Dear Fiscal Officer:

Subject: Price Factor and Population Information

Appropriations Limit

California Revenue and Taxation Code section 2227 requires the Department of Finance (Finance) to transmit an estimate of the percentage change in population to local governments. Each local jurisdiction must use their percentage change in population factor for January 1, 2023, in conjunction with a change in the cost of living, or price factor, to calculate their appropriations limit for fiscal year 2023-24. Attachment A provides the change in California's per capita personal income and an example for utilizing the price factor and population percentage change factor to calculate the 2023-24 appropriations limit. Attachment B provides the city and unincorporated county population percentage change. Attachment C provides the population percentage change for counties and their summed incorporated areas. The population percentage change data excludes federal and state institutionalized populations and military populations.

Population Percent Change for Special Districts

Some special districts must establish an annual appropriations limit. California Revenue and Taxation Code section 2228 provides additional information regarding the appropriations limit. Article XIII B, section 9(C) of the California Constitution exempts certain special districts from the appropriations limit calculation mandate. The code section and the California Constitution can be accessed at the following website: <http://leginfo.ca.gov/faces/codes.xhtml>.

Special districts required by law to calculate their appropriations limit must present the calculation as part of their annual audit. Any questions special districts have on this requirement should be directed to their county, district legal counsel, or the law itself. No state agency reviews the local appropriations limits.

Population Certification

The population certification program applies only to cities and counties. California Revenue and Taxation Code section 11005.6 mandates Finance to automatically certify any population estimate that exceeds the current certified population with the State Controller's Office. **Finance will certify the higher estimate to the State Controller by June 1, 2023.**

Please Note: The prior year's city population estimates may be revised. The per capita personal income change is based on historical data.

If you have any questions regarding this data, please contact the Demographic Research Unit at (916) 323-4086.

JOE SPEPHENSHAW
Director
By:

Erika Li
Chief Deputy Director

Attachment

A. **Price Factor:** Article XIII B specifies that local jurisdictions select their cost of living factor to compute their appropriation limit by a vote of their governing body. The cost of living factor provided here is per capita personal income. If the percentage change in per capita personal income is selected, the percentage change to be used in setting the fiscal year 2023-24 appropriation limit is:

Per Capita Personal Income

Fiscal Year (FY)	Percentage change over prior year
2023-24	4.44

B. Following is an example using sample population change and the change in California per capita personal income as growth factors in computing a 2023-24 appropriation limit.

2023-24:

Per Capita Cost of Living Change = 4.44 percent
Population Change = -0.35 percent

Per Capita Cost of Living converted to a ratio: $\frac{4.44 + 100}{100} = 1.0444$

Population converted to a ratio: $\frac{-0.35 + 100}{100} = 0.9965$

Calculation of factor for FY 2023-24: $1.0444 \times 0.9965 = 1.0407$

Fiscal Year 2023-24

Attachment B
Annual Percent Change in Population Minus Exclusions*
January 1, 2022 to January 1, 2023 and Total Population, January 1, 2023

County	<u>Percent Change</u>	<u>--- Population Minus Exclusions ---</u>		<u>Total</u>
City	2022-2023	1-1-22	1-1-23	1-1-2023
Lake				
Clearlake	-1.09	16,545	16,364	16,364
Lakeport	-0.82	5,008	4,967	4,967
Unincorporated	-0.93	45,826	45,400	45,469
County Total	-0.96	67,379	66,731	66,800

*Exclusions include residents on federal military installations and group quarters residents in state mental institutions, state and federal correctional institutions and veteran homes.

CITY OF CLEARLAKE

City Council



STAFF REPORT

SUBJECT: Adoption of the resolution approving the Fiscal Year 2023-24 Fee Schedule; Resolution No. 2023-29

MEETING DATE: June 15, 2023

SUBMITTED BY: Kathy Wells, Finance Director

PURPOSE OF REPORT: Information only Discussion Action Item

WHAT IS BEING ASKED OF THE CITY COUNCIL/BOARD:

The City Council is being asked to review and consider adopting by resolution the FY 2023-24 Fee Schedule by Public Hearing.

BACKGROUND/DISCUSSION:

The City reviews and asks Council to approve updates to the fee schedule annually. Minor changes are noted in red on the Proposed City of Clearlake Fee Schedule.

FISCAL IMPACT:

None Amount Budgeted Item? Yes No

Budget Adjustment Needed? Yes No

Affected fund(s): General Fund Measure P Fund Measure V Fund Other:

Comments:

STRATEGIC PLAN IMPACT:

Goal #1: Make Clearlake a Visibly Cleaner City

Goal #2: Make Clearlake a Statistically Safer City

Goal #3: Improve the Quality of Life in Clearlake with Improved Public Facilities

Goal #4: Improve the Image of Clearlake

Goal #5: Ensure Fiscal Sustainability of City

Goal #6: Update Policies and Procedures to Current Government Standards

Goal #7: Support Economic Development

SUGGESTED MOTIONS:

Move to adopt the resolution adopting the City of Clearlake Fee Schedule

- Attachments:**
- 1) Resolution No. 2023-29
 - 2) Fee schedule

RESOLUTION NO. 2023-29

ADOPTION OF THE FY 2023-24 FEE SCHEDULE

WHEREAS, the City Council reviews and updates the fee schedules as needed, on an annual basis,

WHEREAS, the City of Clearlake wishes to be an economically stable city while still maintaining a business friendly relationship with the community.

WHEREAS, the fee schedule has been thoroughly reviewed by staff and is requesting minor changes to the fee schedule.

WHEREAS, the City Council desires to approve the FY 2023-24 Fee Schedule to ensure fiscal stability for the City of Clearlake.

Therefore, the City of Clearlake moves to adopt the FY 2023-24 Fee Schedule.

PASSED AND ADOPTED by the City Council of the City of Clearlake, County of Lake, State of California, on this 15th day of July 2023, by the following vote:

AYES:

NOES:

ABSTAIN:

ABSENT:

ATTEST: _____
City Clerk

Mayor

**CITY OF CLEARLAKE
FEE SCHEDULE**

Proposed Fee Schedule - to be effective July 1, 2023



TABLE OF CONTENTS

	Page
Administrative Fees	2
Business License Fees	3
Building Fees	4
Engineering Fees	5
Planning Fees	6
Animal Control Fees	7
Code Enforcement Fees	9
Police Fees	10
Special Event Fees	11
Senior Community Center Fees	12
Youth Center Fees	13

Administrative & Miscellaneous Fees

Description	Fee
Technology Recovery Cost Applied to All Applications	2%
Publications & Maps	
Budget	\$ 20.00
Design & Construction Standards	\$ 12.00
Drainage Master Plan Study	\$ 18.00
General Plan Policies	\$ 30.00
General Plan Technical Background	\$ 12.00
General Plan Housing Element	\$ 24.00
General Plan Land Use Map	\$ 18.00
Lakeshore Drive Design Guidelines	\$ 12.00
Parks Master Plan	\$ 12.00
Redevelopment Plan	\$ 18.00
Redevelopment Five Year Implementation Plan	\$ 12.00
Sphere of Influence Study	\$ 12.00
Zoning Chapter XVIII	\$ 36.00
Zoning Map	\$ 1.20
Site Development Assessment & Business Attraction Strategy	\$ 14.40
Subdivision Ordinance	\$ 12.00
Copy Fees (per page)	
Public Record General 8 1/2 x 11 Copy	\$ 0.20
8 1/2 x 14 Copy (Legal Size)	\$ 0.20
11 x 17 Copy	\$ 0.25
Parcel Maps	\$ 4.00
Topographical Maps	\$ 7.00
Copies of City Council/Planning Commission Meetings	
Meeting Recordings	Per CD \$ 5.00
Planning Commission Agenda Cover Sheet Mailing	Per year \$ 50.00
Planning Commission Agenda Packets (in advance of meeting)	Per Meeting \$ 25.00
Electronic Records	CPO - 50%
<i>Deposit to be determined by the City Manager on a case-by-case basis</i>	
Other Fees	
Return Check Fee	\$ 35.00
Credit Card Chargeback Fee	\$ 30.00
Credit/Debit Card Fee	3%
Credit/Debit Card Fee (Collected through Citation Processing Center)	3.5%
Civil Subpoenas	\$275 deposit at time of service
<i>The service of civil subpoenas, depositions, and attendance in civil court proceedings of employees will be governed pursuant to Government Code Section 68096.1, 68097, 68097.1, 68097.2, 68907.5, 68907.6, 68907.7, 68907.9, and 68907.10, all inclusive</i>	<i>Per Government Code</i>

Business License Fees

Licensing Period: October 1st through September 30th

General Business License Annual Fees

	Fee
Business License Annual Fee	\$ 90.00
	<i>+\$10 for each additional employee</i>
	<i>10% fee per total business license cost will be added per each month delinquent</i>
	<i>\$4 State Fee will be added to each application</i>

Secondary Business License

	\$ 45.00
	<i>+ \$10 per employee</i>
<i>Secondary Business license shall be one half of the general business license fee if you have more than one business in the City limits (i.e., general license \$90.00 plus \$45.00 for second business, plus \$10 per employee)</i>	

Special Category Business License Annual Fees

a) Beauty Shops	\$ 90.00
	<i>+ \$10 for each booth</i>

b) Real Estate Broker	\$ 90
	<i>+ \$10.00 for each agent and/or employee who was paid a commission for salary during the previous licensing year</i>

c) Flea Market/Farmers Market	\$ 90.00
	<i>+ \$5.00 for each permanent space</i>

Special Event Business License **\$79 per day**

Quarterly Business License **\$25 per quarter**
(applicants requiring more than one quarter must submit for Annual Business License)

Vacation Rental Application **\$70 per year**
 Vacation Rental Owners must register for TOTs at: [Welcome \(hdlgov.com\)](http://Welcome(hdlgov.com))

Business Listing Fee **\$ 10.00**
(one time fee for new listings)

Business Licenses go to: [Applying for a Business License | Clearlake, CA - Official Website](#)

Taxicabs & For-Hire Vehicles	
Operator's Permit	\$ 125.00
Driver Permit	\$ 75.00
Vehicle Permit	\$ 25.00

Building Permit Applications

	Fee	
Failure to obtain any required permits before work begins	5 x Permit fee	2 x Permit Fee
 <i>Building Permits - City staff will calculate cost using the most recent issue of the 'Building Valuation Data' (BVD) fee table published by the International Code Council (ICC).</i>		
Other Permits - CBC	100%	Per BVD Fee Table, as noted
Building Plan Check	100%	Per BVD Fee Table, as noted
Building Plan Check Amendments	100%	Per BVD Fee Table, as noted
Residential Electrical/Mechanical Service Upgrade/Repair	\$	150.00
Residential Plumbing	\$	150.00
Residential Plumbing with Trenching	\$	150.00
Commercial Electrical Service Upgrade	\$	175.00
Electrical Vehicle Charging Port	\$	125.00
Generator	\$	200.00
Residential Demo	\$	150.00
Comercial Demo	\$	200.00
Residential Roof Mounted Solar	\$	400.00
Comercial Roof Mounted Solar	\$	500.00
Retrofit Foundation	\$	150.00
Reissuance of Certificate of Occupancy	\$	45.00
Plan Revision Review		\$ 100.00
Reinspection Fee		\$ 100.00

California Building Standards Commission

State Mandated Fee added to Applications - Building Standards Administration Special Revolving Fund Based on Permit Valuation.

Permit Valuation:		
\$1 - 25,000	\$	1.00
\$25,001 - 50,000	\$	2.00
\$50,001 - 75,000	\$	3.00
\$75,001 - 100,000	\$	4.00
Every \$25,000 or fraction thereof above \$100,000		Add \$1.00

Seismic Fees

- i. Group R occupancies, as defined in the current Uniform Building Code, one to three stories in height, except hotels and motels, shall be assessed at the rate of ten dollars (\$10.00) per one hundred thousand dollars (\$100,000.00), with appropriate fractions thereof.*
Per Calculation
- ii. All other buildings shall be assessed at the rate of twenty - one dollars (\$21.00) per one hundred thousand dollars (\$100,000.00) with appropriate fractions thereof.*
Per Calculation
- iii. The fee shall be the amount assessed under paragraph 1. or 2., depending on building type, or fifty cents (\$0.50), whichever is the higher.*
Per Calculation

Mobile Home Park Fees

	Fee
Mobile Home Park Annual Inspection Fee	\$ 40.00
per site including the 1st unit, plus	\$ 15.00
Non-compliance re-inspection	\$ 30.00
per site including the 1st unit, plus	\$ 10.00
	<i>for each additional unit on site</i>
Mobile Home Park Annual Permit to Operate Fees	\$ 1.00

All fees for 'Mobile Home Parks Annual Permit to Operate' and related fees shall be as set forth in the current Mobile Home Parks Act, Title 25, Section 1008, et seq. The CA Department of Housing and Community Development (HCD) calculates annual fees. The City of Clearlake collects payment on behalf of HCD.

Engineering Fees

Grading Permits - 2019 California Building Code Fee Schedule

As Calculated by City Staff

Grading Permits - City staff will calculate cost based on the grading plan, and review if required, as noted on the Grading Application.

Encroachment Permits

Driveway Adjacent to Paved Street	\$ 170.00
Driveway Adjacent to Unpaved Street	\$ 125.00
Trenching - Paved Streets	\$250 + \$1.00/LF
Trenching - Unpaved Streets	\$200 + \$0.50/LF
Other Plan Check and Inspections	<i>4.5% of engineer's Estimate (\$200 minimum)</i>
Minimum Fee	\$ 200.00
Engineer's Estimate	As Calculated by City Staff

Calculation based on type of work requested in encroachment permit

Heavy Load Permits for Overweight, Over-Width, Over-Length and Over-Height	\$ 75.00
Re-Inspection	\$ 55.00
Failure to obtain any required permits before work begins	5 x Permit fee 2 x Permit Fee

Development Fees

Plan Check Fee	4.5 % of Engineer Estimate up to \$200k	
	3.5% of Engineer Estimate between above \$200k and \$500K	
	2.5% of Engineer Estimate between above \$500 and \$1 Million	
	2% of Engineer Estimate above \$1 Million	
Development Inspection	2 % of Engineer Estimate up to \$200k	
	1.5% of Engineer Estimate between above \$200k and \$500K	
	1% of Engineer Estimate between above \$500 and \$1 Million	
	.5% of Engineer Estimate above \$1 Million	

Planning Fees

	Fee	Deposit
Marijuana Dispensary Annual Renewals		
LiveScan	\$10 + DOJ Fee	
Renewal Processing	\$ 250.00	
 Zoning Clearance		
Sign Permit	\$ 102.00	
Sign Face Copy Change	\$ 54.00	
Single Family Residence	\$ 125.00	
Second Residential Unit	\$ 125.00	
Multifamily Residence <4 units	\$ 250.00	
5 to 14 units	\$ 816.00	
Multifamily Residence >15 units	CPO - 50%	\$ 4,000.00
Commercial <5,000 SF	\$ 555.00	
5001 to 9999 SF	\$ 840.00	
>10,000 SF	CPO - 50%	\$ 4,000.00
Temporary Use Permit	\$ 125.00	
Outdoor Annual Display Permit	\$ 800.00	
Lot Line Adjustment	\$ 500.00	
Lot Merger	\$ 800.00	
PM/Sub. Map Checking	\$ 150/per lot	

	Fee	Deposit	
Conditional Use Permits	\$ 2,200.00		
Administrative Use Permits	\$ 2,200.00		
Temporary Use Permit	\$ 500.00		\$ 125.00
Categorical Exemption (CE) from CEQA	\$ 150.00		
Environmental Impact Report	<i>(deposit required, applicant will be responsible for actual cost)</i>	\$ 5,000.00	
Initial Study Fee	\$ 1,500.00		
Street name change fee	\$ 400.00		
Tree Replacement Fee	\$ 600.00	<i>per tree</i>	
Variance	\$ 500.00		
Minor Subdivision (Four or Fewer Lots)			
Initial Study	\$ 1,500.00		
Tentative Map Processing	\$ 2,450.00		
Total Fee:	\$ 3,950.00		
Improvement Plan Processing and Inspections	CPO-50%	\$ 4,000.00	
Parcel Map Processing	CPO-50%	\$ 1,000.00	
Subdivision Construction Agreement	\$ 570.00		
Acceptance of Easements and Improvements	\$ 450.00		
Appeals			
Appeal of Staff Decision	\$ 880.00		
Appeal of Planning Commission Decision	\$ 880.00		
Extension of Approval	\$ 345.00		
Abandonment of Easement	\$ 715.00		
Major Subdivision	CPO-50%	\$ 6,000.00	
Zone Amendment	CPO-50%	\$ 2,400.00	
General Plan Amendment	CPO-50%	\$ 6,000.00	
Certificate of Compliance	CPO-50%	\$ 1,200.00	
Annexation	CPO-50%	\$ 6,000.00	
Development Agreement	CPO-50%	\$ 6,000.00	
Special Requests or Studies	CPO-50%	\$ 6,000.00	
Technology fee - 2% of total fees charged		2%	
Legal Services	CPO-50%		
General Plan Maintenance Fee		\$ 25.00	

Animal Control Fees

Adoption Fees

	Fee
Dog Adoption	\$ 90.00
Cat Adoption	\$ 70.00
Barn Cat Adoption	No Fee
Rabbit Adoption	\$ 10.00
Small Animal Adoption	\$ 10.00
Large Bird Adoption	\$ 25.00
Small Bird Adoption	\$ 36.00
Cat Carrier	\$ 5.00

Dog License Fees

License Issued with Proof of Current Rabies Vaccination

With Proof of Spay & Neuter*	\$ 20.00
Specialized Animals - AKC, UKC, or Others as listed in Clearlake Municipal Code 7-10.3*	\$ 25.00
Service Animals (Excludes therapy animals)	No Fee
Late Fee (Unaltered)	\$ 25.00
Late Fee (Altered)	\$ 21.00
Tag Replacement	\$ 6.00
Engravable Collar	\$ 20.00

Deceased Animal Disposal

Disposal Cat	\$ 42.00
Disposal Small Animal	\$ 26.00
Disposal Dog < 50 pounds	\$ 42.00
Group Cremation Dog	\$ 54.00
Group Cremation Cat	\$ 48.00
Group Cremation 75-99 pounds	\$ 54.00
Group Cremation 100+ pounds	\$ 75.00
Private Cremation 0-2 pounds	\$ 140.00
Private Cremation 3-49 pounds	\$ 140.00
Private Cremation 50-99 pounds	\$ 175.00
Private Cremation 100+ pounds	\$ 260.00
Private Cremation Paw Print	\$ 84.00

Euthanasia Fees (at vets)

Cats	Actual Cost
Dogs	Actual Cost

Field Services

ACO Transport Animal to Vet	\$ 75.00
ACO Transport to Vet After Hours	\$ 175.00
ACO Field Euthanasia	\$ 106.00
ACO Service Fee	\$ 75.00

Kennel Permits (Annual Fee)

Prior to issuance of Kennel Permit - Use Permits, Zoning Verification and Neighbor Acknowledgements may be required.

	Fee
5 - 7 Dogs	\$ 90.00
8 - 16 Dogs	\$ 150.00
16 + Dogs	\$ 225.00

Impound/Redemption Fees

Altered Animal	Doesn't include boarding	\$ 45.00
Unaltered Animal	Doesn't include boarding	\$ 45.00
Repeat Impound Unaltered Additional Fee		\$ 30.00
- 2nd Offense		\$ 50.00
- 3rd Offense		\$ 100.00
Board (Per Day)		\$ 20.00
Quarantine Board (per day)		\$ 32.00
Veterinarian		Actual Cost
Livestock		Actual Cost

Surrender Fees

Owner Surrender Dog Altered	\$ 46.00
Owner Surrender Dog Unaltered	\$ 69.00
Owner Surrender Cat Altered	\$ 46.00
Owner Surrender Cat Unaltered	\$ 69.00
Owner Surrender Small Animal Altered	\$ 46.00
Owner Surrender Small Animal Unaltered	\$ 69.00
Owner Surrender for Litter (per animal)	\$ 19.00

Vicious Dog Hearing fee

\$ 150.00

Medical

Microchip Dog	\$ 20.00
Microchip Cat	\$ 10.00
Other Medical @ Vet Clinic	Actual Cost

Code Enforcement Fees

Abandoned Vehicle Abatement

	Fee
Voluntary Compliance (Gone Upon Arrival)	\$ 75.00
Voluntary Compliance (Removed By City)	\$ 125.00
Property Owner Requested Vehicle Abatement - Passenger Vehicle	\$ 250.00
Property Owner Requested Vehicle Abatement - Other (RV, Boat,Trailer, etc...)	Actual Cost

Code Enforcement Hearing Fee \$ 200.00

Cultivation Permit Application Fee \$ 250.00

Following Admin Cite for No Permit w/Code Enf Approval \$ 500.00

Boarding Permit (Non-refundable upon application)

Commercial Building Boarding Permit \$ 150.00

Commercial Building Boarding Permit Renewal/Extension \$ 150.00

Re-Inspection Fee \$ 50.00

Red Tagged Building Entry Permit \$ 25.00

Vacant Commercial Buildings

Registration \$100 + 12.50 per month until July 1st

Annual Renewal \$250 Renewal + \$200 per month Monitoring Fee

Response Fee (per day) \$ 50.00

Police Fees

	Fee
DUI Cost Recovery	\$ 425.00
Police Reports	\$ 10.00
Criminal Offender Registration	
Initial Registration	\$ 50.00
Change of Address	\$ 30.00
Photographs	
CD/Audio-Video	\$ 10.00
4 x 5 8.5x11 color copy	\$ 10.00
5 x 7	\$ 15.00
8 x 10	\$ 20.00
Citation Sign-Off	\$ 15.00
CPD Parking/Mech/Reg Cites	No Charge
Deer Tag Sign-Off	\$ 15.00
Release of Vehicle	\$ 100.00
22651(h) & (p), DUI and 23109 VC	\$ 150.00
Citizen Clearance Letter	\$ 10.00
Repossession Fee	\$ 15.00
Booking Fee	(Arrestee) Actual Cost
V.I.N. Verification	
At Police Department	\$ 10.00
Other	\$ 20.00
False Alarm	
1st - 2nd	\$ -
3rd - 4th	\$ 100.00
5th - 6th	\$ 200.00
7th - 8th	\$ 400.00
9th - 10th	\$ 800.00
11th +	\$ 1,000.00
Fingerprinting (Rolled)	\$ 10.00
LiveScan	\$10 + DOJ Fee
Secondhand Dealer Permit (New + Renewal)	\$50 + DOJ Fee
Plus LiveScan fee	\$10 + DOJ Fee
Sidewalk Wendor/Itinerant Vendor	\$ 45.00
Plus Livescan fee	\$10 + DOJ Fee

Parking Citation Fines

	Fee
21113(A) VC Parking, School Grounds	\$ 50.00
21210 VC Bicycle Parking, Sidewalk	\$ 50.00
21211(A)-(B) VC Obstructing Bikeway, Path or Trail	\$ 50.00
22500(A) VC Parked in Intersection	\$ 50.00
22500(B) VC Parked in Crosswalk	\$ 50.00
22500(C) VC Parked in Safety Zone	\$ 50.00
22500(E) VC Parked Blocking Driveway	\$ 50.00
22500(F) VC Parked on Sidewalk	\$ 50.00
22500(H) VC Double Parked	\$ 50.00
22500(I) VC Parked in Bus Zone	\$ 250.00
22500(K) VC Parked on Bridge	\$ 50.00
22500(L) VC Parked in Wheelchair Access	\$ 250.00
22500.1 VC Fire Lane	\$ 70.00
22502(A) VC Right Wheel to Curb	\$ 50.00
22504(A) VC Parking Unincorporated Area	\$ 50.00
22505(B) VC Posted No Parking, State Highway	\$ 70.00
22507.8(A)-(C) VC Parking in Handicap Space	\$ 275.00
22514 VC Parked by Fire Hydrant	\$ 50.00
22515 VC Unattended Vehicle	\$ 40.00
22516 VC Parked w Person Locked in Vehicle	\$ 145.00
22517 VC Open Door on Traffic Side When Unsafe	\$ 145.00
22522 VC Parked by Sidewalk Ramp	\$ 275.00
22523(A) VC Abandoned Vehicle, Highway	\$ 350.00
22523(B) VC Abandoned Vehicle, Public-Private Property	\$ 350.00
22526 VC Anti-Gridlock	\$ 70.00
4461(A)-(D) VC Misuse Disabled Person Placard/Plate	\$ 275.00
4000(A)(1) VC Unregistered Vehicle/Expired Registration	\$ 85.00
5204(A) VC Expired/Improper Tabs Displayed	\$ 85.00
9850 VC Numbering of Undocumented Vessels	\$ 85.00
8-6.3 CMC Parked Over 72 hours	\$ 145.00
10-6.13 CMC Abandonment Prohibited	\$ 350.00
10-6.14 CMC Failure to Abate	\$ 350.00
All Other Parking Codes Not Listed (VC and CMC)	\$ 50.00
All Mechanical Violations	\$ 50.00
Mechanical Violations w Proof of Correction	\$ 10.00
40203.5 VC 15 Days After Mailing of Notification of Violation	50% of Violation Not to Exceed \$150
40203.5 VC DMV Hold	\$ 10.00
40220 VC Low Income Payment Plan Fee	\$ 5.00
40220 VC Standard Payment Plan Fee	\$ 25.00

Other Fees

Returned Check Fee	\$ 35.00
Credit Card Chargeback	\$ 30.00

Special Events

**RESERVATION DEPOSIT : Non-refundable deposit for reservations made up to twelve (12) months in advance is \$25.00.
Reservation deposit will be applied toward facility rental fee.**

Austin Park

	Daily	Deposit
Non-profit	\$ 35.00	\$ 100.00
All Others Under 50 Attendees	\$ 75.00	\$ 500.00
All Others Over 50 Attendees	\$ 125.00	\$ 1,000.00
Covered Bench Area at Playground (3 tables for 4 hours)	\$ 50.00	\$ 100.00
Bandshell	\$ 500.00	\$ 500.00
Dog Park - 4 hours	\$ 100.00	\$ 150.00

** These fees are adjustable by the City Manager based on past performance.

Large Events

	Deposit
200-300 People or 2-3 day event	\$ 500.00
300-500 People or 3-5 day event	\$ 1,000.00

Electrical/Trash

Electricity		\$ 25.00
Additional Trash Cans (per can)		\$ 25.00

Senior/Community Center

		Standard Rate	Non-Profit Rate
Building w/o Kitchen (4042 sq ft)	4 hours	\$ 235.00	\$ 131.00
Each Additional Hour		\$ 59.00	\$ 32.00
Cleaning Deposit		\$ 300.00	\$ 300.00
Multi-purpose Room (2964 sq ft)	4 hours	\$ 179.00	\$ 95.00
Each Additional Hour		\$ 44.00	\$ 23.00
Auxiliary Room (1078 sq ft)	4 hours	\$ 68.00	\$ 39.00
Each Additional Hour		\$ 16.00	\$ 9.00
Cleaning Deposit		\$ 100.00	\$ 100.00
Kitchen Only (1078 sq ft)	4 hours	\$ 55.00	\$ 30.00
Each Additional Hour		\$ 20.00	\$ 10.00
Cleaning Deposit		\$ 300.00	\$ 300.00
Classroom (320 sq ft)	4 hours	\$ 25.00	\$ 15.00
Each Additional Hour		\$ 5.00	\$ 3.00
Cleaning Deposit		\$ 100.00	\$ 100.00

Sq ft are approximations

Alcohol Use Additional Deposit	\$	200.00	\$ 200.00
Returned Check Fee	\$	35.00	\$ 35.00

Youth Center

Building with Kitchen (3500 sq ft)	4 hours	\$	270.00	\$	151.00
Each Additional Hour		\$	59.00	\$	35.00
Cleaning Deposit		\$	300.00	\$	300.00
Large Room (1200 sq ft)	4 hours	\$	179.00	\$	95.00
Each Additional Hour		\$	44.00	\$	23.00
Cleaning Deposit		\$	250.00	\$	250.00
Smaller Room (1078 sq ft)	4 hours	\$	150.00	\$	90.00
Each Additional Hour		\$	26.00	\$	19.00
Cleaning Deposit		\$	200.00	\$	200.00
Returned Check Fee		\$	35.00	\$	35.00

CITY OF CLEARLAKE

City Council



STAFF REPORT	
SUBJECT: Consideration of a Memorandum of Understanding between the City of Clearlake and Clearlake Middle Management Association	MEETING DATE: June 15, 2023
SUBMITTED BY: Alan D. Flora, City Manager	
PURPOSE OF REPORT: <input type="checkbox"/> Information only <input checked="" type="checkbox"/> Discussion <input checked="" type="checkbox"/> Action Item	

WHAT IS BEING ASKED OF THE CITY COUNCIL/BOARD:

The City Council is being asked to approve the MOU and authorize the City Manager to sign.

BACKGROUND/DISCUSSION:

The City’s MOU with the Clearlake Middle Management Association expires on June 30, 2023. Over the past several months the City have been in negotiations over a new agreement.

The proposed MOU includes the following key points:

1. Term of one year
2. COLA of 3% for all members
3. Market adjustment of 2.8% for the sergeant classification
4. Addition of the Code Enforcement Supervisor into the MMA
5. Increase in sick leave accrual for employees after 10 years of service
6. Longevity pay for each year of service beyond retirement age for sergeants

OPTIONS:

1. Approve the MOU and authorize the City Manager to sign.
2. Other direction

FISCAL IMPACT:

None \$120,000 Budgeted Item? Yes No
 Budget Adjustment Needed? Yes No If yes, amount of appropriation increase: \$
 Affected fund(s): General Fund Measure P Fund Measure V Fund Other:

Comments:

STRATEGIC PLAN IMPACT:

Goal #1: Make Clearlake a Visibly Cleaner City

- Goal #2: Make Clearlake a Statistically Safer City
- Goal #3: Improve the Quality of Life in Clearlake with Improved Public Facilities
- Goal #4: Improve the Image of Clearlake
- Goal #5: Ensure Fiscal Sustainability of City
- Goal #6: Update Policies and Procedures to Current Government Standards
- Goal #7: Support Economic Development

Attachments: 1) Proposed 2023-2024 MMA MOU - redline

MEMORANDUM OF UNDERSTANDING
BETWEEN

CITY OF CLEARLAKE
AND
MIDDLE MANAGEMENT ASSOCIATION

COVERING THE PERIOD OF

JULY 1, 2023

THROUGH

JUNE 30, 2024

TABLE OF CONTENTS

ARTICLE I GENERAL PROVISIONS 1

Section 1.0 Preamble 1

Section 2.0 Purpose 1

Section 3.0 Recognition 1

Section 4.0 Employee Rights and Responsibilities 1

Section 5.0 Management Rights and Responsibilities 2

ARTICLE II WAGES AND BENEFITS 3

Section 1.0 Pension Benefits 3

1.1 Retirement Contribution – Miscellaneous Members: 3

1.2 Retirement Contribution - Safety Officers: 4

1.3 Unused Sick Leave Conversion: 4

Section 2.0 Salary Adjustment and Longevity Pay 4

2.1 Salary Adjustment 4

2.2 Longevity Pay 5

Section 3.0 Medical/Dental and Life Insurance 6

3.1 Health Insurance Plan 6

3.2 Waiver of participation 6

3.3 Alternative Health Insurance Plan 6

3.4 Life Insurance 6

Section 4.0 Attendance Leave and other Benefits 7

4.1 Sick Leave 7

4.2 Illness while on vacation leave 7

4.3 Holidays while on sick leave 7

4.4 Sick Leave Incentive 7

4.5 Mental Health Leave 8

Section 5.0 Bereavement Leave 8

Section 6.0 Vacation Leave 8

6.1 Vacation Accrual 8

6.2 Maximum Vacation Leave Accrual: 9

6.3 Separation: 10

6.4 Pay for Vacation Time: 10

Section 7.0 Holidays 10

7.1 Holidays 10

7.2	Holiday Pay:	11
Section	8.0 Uniform Regulations	11
Section	9.0 Tuition and Books	12
Section	10.0 Deferred Compensation	14
Section	11.0 Overtime/Compensatory Time	14
11.1	Overtime:	14
11.2	Compensatory Time:	14
11.3	Call Back:	15
Section	12.0 Shift Differential Pay	15
Section	13.0 Disability	15
13.1	State Disability Insurance:	15
13.2	Temporary Disability-Integrated Pay:	15
Section	14.0 Incentives - Certificate Incentive	15
14.1	Intermediate Certificate Incentive	16
14.2	Advanced Certificate Incentive	16
Section	15.0 Special Duty Pay	16
Section	16.0 Stand By Pay	16
Section	17.0 Wellness Program	16
Section	18.0 Day	17
ARTICLE III	GRIEVANCE AND DISCIPLINE	17
Section	1.0 Grievance Procedure	17
Section	2.0 Discipline	19
ARTICLE	IV TERM	21
Section	1.0 Term of Agreement	21
Section	2.0 Agreement Renewal	21
2.1	Renewal:	21
2.2	Non-Economic Negotiations	21
ARTICLE V	IMPLEMENTATION	22
Section	1.0 Severability	22

Section	2.0 Ratification and Implementation	22
EXHIBIT A		23
EXHIBIT B - Pay Scales		21

ARTICLE I GENERAL PROVISIONS

Section 1.0 Preamble

This Memorandum of Understanding (hereinafter referred to as MOU or Agreement, interchangeably) has been prepared pursuant to California Government Code Sections 3500 et seq, the City of Clearlake Personnel System Rules and Regulations Resolution (No. 81-40), and the City of Clearlake Employer-Employee Organization Relations Resolution (No. 83-40), which are hereby incorporated by reference. This Agreement has been made and executed by the Clearlake Middle Management Association (hereinafter referred to as "Association") and the Employee Relations Officer of the City of Clearlake (hereinafter referred to as "City") and satisfies the City's duty to meet and confer with the Association.

The parties have met and conferred in good faith regarding the terms and conditions of employment for members of the Association, and having reached agreement as herein set forth, agree to submit this MOU to the City Council with the joint recommendation that the City Council adopt its terms and conditions and take such action as may be necessary to implement its provisions.

Section 2.0 Purpose

It is the purpose of this MOU to promote and provide for continuity of operation and employment through harmonious relations, cooperation and understanding between the management of the City and the Employees covered by the provisions of this agreement, and to set forth the understanding reached between the parties as a result of good faith negotiations on the matters set forth herein.

Section 3.0 Recognition

The City acknowledges the Association as the Exclusively Recognized Employee Organization representing the permanent employees occupying job classifications set forth in Exhibit A.

Section 4.0 Employee Rights and Responsibilities

Association members shall be free to participate in Association activities without interference, intimidation or discrimination in accord with State

and City rules and regulations. Association rights and responsibilities include:

- 4.1 The right to represent its members before the City Council with regard to wages, hours and working conditions.
- 4.2 The right of reasonable notice of any proposed ordinance, resolution, regulation or rule relating to wages, hours and working conditions.
- 4.3 The right to reasonable time off without loss of compensation or benefits when meeting and conferring with management representatives on matters relating to wages, hours and working conditions.
- 4.4 The right of reasonable use of City facilities for Association activities, provided that appropriate advance arrangements are made and applicable costs to the public are borne by the Association.
- 4.5 The right of reasonable access to employees and applicable documents for the purpose of processing grievances and appeals. Such access shall not interfere with the normal operations of the City or with safety and security requirements of the Police Department.
- 4.6 The right to maintain a bulletin board in an area readily accessible to Association members.
- 4.7 The right to have payroll deductions made for payment of Association dues, subject to written request of each individual Association member.
- 4.8 The right to recommend changes to the Personnel System and Personnel Rules and meet and confer on changes thereof.

Section

5.0 Management Rights and Responsibilities

The City shall reserve and retain the sole and exclusive right, whether exercised or not, to administer, manage and operate its municipal services and the work force employed to perform those services. Management rights and responsibilities include:

- 5.1 The right to determine the organization of the City government and the purpose and mission of its constituent parts.

- 5.2 The right to set standards of service and levels of staffing for both routine services and emergency operations.
- 5.3 The right to determine the type and kind of goods and services to be made, purchased and contracted for.
- 5.4 The right to determine the methods of financing municipal services.
- 5.5 The right to administer the Personnel System in accord with Ordinance No. 10, the Personnel Rules and Regulations, the Employer-Employee Organization Relations Resolution and this MOU.
- 5.6 The right to assign work and direct employees.
- 5.7 The right to establish and implement rules, regulations, policies and procedures related to efficiency, productivity, performance, personal appearance, codes of conduct and safety and to require compliance therewith.

ARTICLE II WAGES AND BENEFITS

Section 1.0 Pension Benefits

1.1 Retirement Contribution – Miscellaneous Members:

“Classic” (Employed by the City or other eligible public agency prior to January 1, 2013 as defined by CalPERS¹) non-sworn unit employees shall be provided the benefit of the Miscellaneous Member 2%@55 retirement formula.

“Classic” non-sworn employees represented under this MOU shall pay 100% of the employee’s share of the Public Employees Retirement System (PERS) contribution, which is currently 7%.

“PEPRA” non-sworn employees (employed by the City or other eligible public agency on or after January 1, 2013 as defined by CalPERS) shall be provided the benefit of the Miscellaneous Member 2%@62 retirement formula.

¹ Defined by CalPERS as of finalization of this MOU as an employee who “Joined CalPERS prior to January 1, 2013, but are hired by a different CalPERS employer following a break in service of less than six months on or after January 1, 2013. However, if this definition is lawfully changed, any such change would control. (Rev. 2021)

“PEPRA” non-sworn employees represented under this MOU shall pay 100% of employee’s share of the PERS contribution, which is currently 6.25%.

1.2 Retirement Contribution - Safety Officers:

“Classic” (Employed by the City or other eligible public agency prior to January 1, 2013 as defined by CalPERS) sworn unit employees shall be provided the benefit of the local Safety Members 3%@50 retirement formula.

“Classic” sworn employees represented under this MOU shall pay 100% of the employee’s share of the Public Employees Retirement System (PERS) contribution for Safety Members, which is currently 9%.

“PEPRA” (Employed by the City or other eligible public agency on or after January 1, 2013, as defined by CalPERS) sworn unit employees shall be provided the benefit of the local Safety Members 2.7%@57 retirement formula.

“PEPRA” sworn employees represented under this MOU shall pay 100% of the employee’s share of the Public Employees Retirement System(PERS) contribution for Safety Members, which is currently 12%.

1.3 Unused Sick Leave Conversion:

The City’s contract with the California Public Employees Retirement System (CalPERS) will allow unit employees to convert unused sick leave to service credit upon retirement.

Section 2.0 Salary Adjustment and Longevity Pay

2.1 Salary Adjustment

Effective the first full pay period after July 1, 2023, all unit members will receive a three percent (3%) cost of living adjustment (COLA) increase.

Effective the first full pay period after July 1, 2023, and retroactive to the first full pay period after January 1, 2023, all Sergeants shall receive an additional 2.8% market adjustment. The retroactive payment shall be processed as soon as feasible for the Finance Department after July 1st.

Further, the City recognizes the intent and purpose of maintaining a minimum of 5% salary separation between the rank of police officer and sergeant classification.

2.2 Working Group:

City and the bargaining unit shall cooperate in the establishment and operation of a working group comprised of City representatives as well as one or more representatives from each City bargaining unit.

a) This working group will meet at least monthly, commencing upon an agreed-upon date in the first week of September 2021 and continuing thereafter at least once per month.

b) This working group will discuss and, if possible, agree upon a plan for the conversion of existing specialty pays to a sum to be applied to base pay for all classifications and ranks, or such other concepts which may be identified by the working group and which if adopted would go to the objective of eliminating specialty pays and increasing the across-the-board base rate for City employees by the realignment of existing pay.

2.2 Longevity Pay

City will provide a longevity payment to all sworn and non-sworn unit employees based on the following schedule (applies only to continuous service at the City of Clearlake):

Completion of Years of Service	% of Salary Longevity Payment
5	1.0%
6	2.0%
7	3.0%
8	4.0%
9	5.0%
10	6.0%
11	7.0%
12	8.0%
13	9.0%
14	10.0%
15	11.0%

Sworn employees that continue City service beyond their eligible retirement age, shall receive an additional 2% longevity pay for each year of service completed after eligible retirement age, effective annually on the first full payroll date after the sworn employee’s anniversary date.

Section 3.0 Medical/Dental and Life Insurance

3.1 Health Insurance Plan

The City shall provide a Medical/Dental/Vision Plan for unit employees and their dependents. The medical plan shall be offered by Operating Engineers Local No. 3 with individuals paying the associate membership fee.

The City shall be responsible for 80% of the monthly premium and the employee will be responsible for the remaining 20%.

3.2 Waiver of participation

In addition to the above provisions of this section, employees who elect to waive participation in the City's health insurance program due to participation in a spouse's insurance program or private health insurance plan shall, upon written request to waive said participation and proof of alternative health insurance coverage, shall receive from the City the equivalent of 50% of the City's contribution toward the employee's health insurance plan.

3.3 Alternative Health Insurance Plan

Further, the parties agree to work mutually toward seeking health and benefit plans which are acceptable to both parties, including counseling services provided by an independent contractor.

If an alternative Health Insurance Plan is identified by either party during the term of this agreement, the City and Association agree to re-open negotiations for the sole purpose of re-negotiating the City and employee levels of contribution and implementation of the plan.

Both parties agree to the importance of finding an alternative Health Insurance Plan that will save both the employee and the City money.

3.4 Life Insurance²

The City shall provide a \$50,000 Life Insurance Policy for each non-sworn and sworn employee, and an additional \$100,000 policy as a line of duty benefit for sworn employees, with the option for each unit employee to purchase additional coverage.

² Rev. 2021

Section 4.0 Attendance Leave and other Benefits

4.1 Sick Leave

Every full-time regular employee and probationary employee shall earn sick leave accrual at the rate of eight (8) hours per month, or major fraction thereof. Permanent part-time employees shall earn sick leave at a ratio of their hours to full time positions.

After 10 years of service to the City of Clearlake, and if the full-time employee maintains a balance of at least 500 hours of sick leave, the monthly accrual shall increase to a rate of sixteen (16) hours per month, or major fraction thereof. This accrual shall not be eligible for the sick leave incentive program as outlined in Section 2-7.19 of the City of Clearlake Employee Handbook.

4.2 Illness while on vacation leave

An employee who becomes ill while on vacation may have such period of illness charged to his/her accumulated sick leave instead of to vacation, provided that:

- a. Immediately upon return to duty, the employee submits to the appointing authority a written statement signed by the employee's physician citing the nature and dates of the illness.
- b. The appointing authority recommends, and the personnel officer approves the granting of such sick leave.

4.3 Holidays while on sick leave

Observed holidays occurring during sick leave shall not be counted as a day of sick leave, except for employees receiving holiday pay.

Section 5.0 Bereavement Leave

An employee shall receive forty (40) hours bereavement leave due to the death of his or her parent, stepparent, mother-in-law, father-in-law, spouse, child, step child, adopted child, grandchild, grandparent, sister, brother, sister-in-law, brother-in-law, or the death of any person residing in the immediate household of the employee at the time of death.

Section 6.0 Vacation Leave

6.1 Vacation Accrual

Every full time regular and probationary employee shall earn vacation leave with pay as follows:

After Years of Service	Vacation Hours per Year
0	88
1	92
2	96
3	100
4	104
5	108

6	112
7	116
8	120
9	124
10	128
11	132
12	136
13	140
14	144
15	148
16	152
17	156
18	160
19	164

6.2 Maximum Vacation Leave Accrual:

An employee may accumulate unused vacation leave up to a maximum of twice the number of days due annually. Under extraordinary circumstances and when the best interest of the City so requires, the City may permit a temporary accumulation of vacation leave in excess of the maximum accrued. Except for the above exception, annual vacation leave shall not accrue nor accumulate in excess of the following amounts:

After Years of Service	Vacation Hours per Year	Maximum Accrued Hours
0	88	176
1	92	184
2	96	192
3	100	200
4	104	208
5	108	216
6	112	224
7	116	232
8	120	240
9	124	248
10	128	256

11	132	264
12	136	272
13	140	280
14	144	288
15	148	296
16	152	304
17	156	312
18	160	320
19	164	328

6.3 Separation:

An employee who is eligible for vacation time shall be paid for such accumulated vacation time on the effective date of termination. It shall not be necessary to carry such employee on the payroll for the vacation period and the vacancy thus created may be filled at any time after the effective date of termination. When separation is caused by death of the employee, payment shall be made to the employee's designated beneficiary.

In addition, an employee who is eligible for executive leave shall be paid for the unused annual executive leave account balance on the effective date of termination.

6.4 Pay for Vacation Time:

Unit employees shall be considered as management employees for the purposes of determining the amount of vacation time a unit employee may request for pay off.

Section 7.0 Holidays

7.1 Holidays

The following holidays shall be observed except for the shift employees in the Police Department.

- New Year's Day - January 1
- Martin Luther King's Birthday - January 15
- Washington's Birthday - 3rd Monday in February
- Memorial Day - Last Monday in May
- Independence Day - July 4
- Labor Day - 1st Monday in September
- Veteran's Day - November 11

Thanksgiving Day - 4th Thursday in November
Day after Thanksgiving Day
One-half day Christmas Eve
Christmas Day - December 25th
One-half day New Year's Eve
One Floating Holiday per calendar year

Section 8.0 Uniform & Safety Equipment

8.1

For a new employee to City service hired into the Sergeant classification, the City will initially provide the following uniforms and equipment, which will then be maintained and replaced by the employee

:

- Two uniform shirts
- Two uniform pants
- Neck tie
- Tie bar
- Name Tag
- Uniform belt
- Duty belt

If a new employee does not pass their initial probationary period and does not remain in City service, they shall return to the city any and all uniform items that were provided by the City upon hire.

The City will provide and maintain the following items:

- Firearm
- Ballistic vest
- Flashlight
- Handcuffs
- Baton

- Pepper spray

8.2

8.3

Section 9.0 Education

9.1 Tuition and Books

The City will reimburse those classifications represented by the Association up to \$600 per year for the cost of educational classes and books to encourage higher education subject to the approval of the Department Head. Employees are not eligible for both tuition and books reimbursement and the Safety Education Loan Forgiveness Program below.

9.2 Safety Education Loan Forgiveness (SELF) Program

MMA and the City agree with the interest of enhancing the training and retaining of MMA employees. Safety Education Loan Forgiveness (SELF) Program would be established to provide a forgivable loan amount of up to a maximum \$10,000 per employee for a program leading to a bachelor’s degree or other advanced degree (master’s or doctorate). TheCity would pay an amount up to \$5,000 per fiscal year on behalf of the employee to the educational institution for tuition and related direct expenses as provided below:

A. In order to be eligible for the program, an employee must have been an employee of the City or a minimum of one year and completed field training. The course of study must be approved in advance, be relevant to the City, and be from a regionally accredited, degree-granting institution. The City Manager may approve a course of study from a

nationally-accredited, degree-granting institution. The City will develop a list of preapproved courses of study in consultation with the MMA.

B. Employees would have up to a maximum of four years to successfully complete the program by obtaining their degree. The maximum loan amount is limited to \$5,000 per year, with a total of \$10,000 per employee within the four-year period.

C. If an employee (1) does not complete the program within the four years, (2) quits the program, or (3) leaves City service prior to completion of the program, repayment of all funds disbursed under the program would be due back to the City. The repayment would be required to be paid via a payroll deduction (presumably from paid leave cash-out). In the event of insufficient paid leave balances, employees would be permitted to spread the amount due back to the City in equal payments for up to one year, provided they are in City service during this time. If they leave City service during this repayment period, any balance remaining on the final date of employment would become immediately due.

D. Upon successful completion of the program, provided an employee remains in City service, the loan would be forgiven after the fifth year after the two-year program period. If an employee successfully completes the program, but leaves City service prior to this time, the loan would be required to be paid via a payroll deduction (presumably from paid leave cash-out) based on the following schedule:

- 100% repayment for an employee who leaves City service during the first two years after the initial two-year program period.
- 75% repayment for an employee who leaves City service during the third year after the initial two-year program period.
- 50% repayment for an employee who leaves City service during the fourth year after the initial two-year program period.
- 25% repayment for an employee who leaves City service during the fifth year after the initial two-year program period.
- 0% repayment for an employee who leaves City service after the fifth year after the initial two-year program period (loan forgiven).

9.3 Sergeant Job Description

MMA agrees to support the City's efforts to modify the job description for Sergeants to require a minimum level of 60 college credits to qualify for promotion into the Sergeant classification.

Section 10.0 Deferred Compensation

10.1 The City agrees to deposit the equivalent of five percent (5%) of the Record and Communication Supervisor's base salary into a deferred compensation plan of the City's choice and investment option. Ownership of the plan will be vested with the employee.

Section 11.0 Overtime/Compensatory Time

11.1 Overtime:

Overtime shall be paid at the rate of one and one-half (1-1/2) times the base rate of pay for hours worked over and above the regularly scheduled work period. All overtime shall be subject to approval of the department head. For the purpose of overtime, sick leave, holiday leave and vacation shall be included in the hours worked during the workperiod.

11.2 Compensatory Time:

An employee shall be compensated for overtime at the rate of one and one-half (1-1/2) times the base rate of pay. Compensatory time up to one-hundred and eighty (180) hours at any one time, in lieu of overtime, shall be accumulated with the approval of the department head and the City Manager . Employees who have accumulated compensatory time shall provide the department head with two weeks notice prior to reducing compensatory time. Exceptions may be considered by the department head on a case-by-case basis.

During the month of June of each year, unit employees may, upon recommendation of the Department Head and approval of the City Manager , request pay-off of up to 50 hours of their accumulated compensatory leave balance. Requests shall be submitted in writing to the Department Head no earlier than June 1st and no later than June 26th of each year. Approved pay off shall be issued no later than June 30th of each year.

11.3 Call Back:
Unit employees who are called back to work shall receive a minimum four (4) hours at an overtime rate, if not in conjunction with regularly scheduled work hours.

Section 12.0 Shift Differential Pay

12.1 Member shall receive a differential of five (5%) percent of their base pay for actual hours worked during the night shift period as defined below.

12.2 Night shift shall be 6:00 p.m. (1800 hrs) to 6:00 a.m. (0600 hrs). The start and end time for this period are based on the current 3/12 alternative work schedule for patrol.

12.3 An employee shall be compensated only for the actual hours worked within the period for which shift differential is applicable.

12.4 Shift differential pay is applicable only to the classifications of Sergeant and Records & Communications Supervisor.

12.5 The City agrees to meet and confer regarding shift differential if the City changes from the current 3/12 alternative work schedule for patrol to another schedule (eg. 4/10, 5/8).

Section 13.0 Disability

13.1 State Disability Insurance:

City agrees to pay 100% of the employee contribution for State Disability Insurance.

13.2 Temporary Disability-Integrated Pay:

An employee who is entitled to temporary disability indemnity under State Labor Code may elect to take that number of hours or portions of hours of his/her full salary. When accumulated sick leave, or vacation, or both are exhausted, the employee is still entitled to receive disability indemnity.

Section 14.0 Incentives - Certificate Incentive

The City agrees to provide a Certificate Incentive equivalent to the members of the Police Officer Association in the following manner:

14.1 Advanced Certificate Incentive

Two and one-half (2.5%) percent incentive pay shall be paid on base salary for possession of a POST Advanced Certificate.

Section 15.0 Special Duty Pay

15.1 K-9 Care & Maintenance

Sergeants who are assigned a K-9 shall be provided one half (1/2) hour per day of overtime pay at the base rate of \$19.30 per hour for the care and maintenance of the K-9.

15.2 Investigations Assignment

Sergeants who are assigned to the Investigations Bureau shall receive a five (5%) percent incentive pay above their base salary during the course of the assignment. Any sergeant so assigned is expected to remain on-call, except when on approved leave, and the Stand By Pay provided in Section 16.0 is not applicable.

Section 16.0 Standby Pay

Sergeants to receive \$25.00 for each twenty-four (24) hour shift when assigned by the Chief of Police or his designee, in writing, for on-call/standby duty.

Public Works Supervisor to be compensated at straight time for two hours pay for each Saturday, Sunday and holiday and three hours for the period of Monday through Friday when assigned by the Public Works Superintendent for on-call/standby duty.

Section 17.0 Wellness Program

17.1 The City will reimburse unit employees fifty percent (50%) of the covered charges up to a maximum of \$80 charge, therefore, paying up to a maximum of \$40 per visit, with an overall maximum of twelve (12) visits

per fiscal year for outpatient psychiatric care which is eligible and covered under the health insurance plan provided to unit employees.

Section 18.0 Day

For purposes of administering benefits such as vacation accrual, holiday leave, mental health leave, etc. a “day” shall mean an eight (8) hour period.

Section 19.0 Vehicles

The responsible Department Head may recommend that the City provide employees a take home vehicle if it has been determined a vehicle is available, and based on the approval of the City Manager.

Section 20.0 Bi-Lingual Pay

Bi-Lingual Pay up to 5% (2.5% for speaking and/or 2.5% for writing). Bilingual pay granted based upon successful passing of testing through Language Testing International and the American Council on the Teaching of Foreign Languages and proficiency of an Intermediate Mid or higher test result. Employee validations are valid for two years from the date of testing.

ARTICLE III GRIEVANCE AND DISCIPLINE

Section 1.0 Grievance Procedure

A grievance shall be a claim, filed by an employee on his/her own behalf, or the Association (for alleged violations of Association rights) contending that the City has violated or misapplied an obligation expressed, referenced and/or written in the Agreement.

Every effort shall be made to resolve a grievance through discussion between the grievant and the immediate supervisor. The grievant must bring the grievance to the attention of his/her immediate supervisor within 14 days of the grievable event. Failure to do so will constitute a waiver of the grievance³.

If, after such discussion, the grievant does not feel that the grievance has

³ Rev 2021

been satisfactorily resolved, the grievant shall have the right to discuss the matter with the supervisor's superior, if any, within the departmental organization. Otherwise, the grievant shall have the right to discuss the matter with the department head.

If the grievant is not in agreement with the decision rendered in the informal grievance procedure, the grievant shall have the right to present a formal grievance, in writing, to the department head. If such a formal grievance has not been submitted within twelve (12) calendar days from the date of receiving the informal decision, the informal decision shall be considered as final.

When discussing the formal grievance with the department head, the grievant shall have the right to appear with a representative who may also participate in the discussion. The department head receiving the grievance shall review it, render a decision and comments in writing and return them to the grievant within twelve (12) calendar days after receiving the formal grievance. If the grievant does not agree with the decision reached, the grievant may present an appeal in writing to the City Manager within twelve (12) calendar days. Failure of the grievant to take further action within twelve (12) calendar days after receipt of the decision of the department head will constitute withdrawal of the grievance.

Upon receipt of an appeal, the City Manager or designated representative shall discuss the grievance with the grievant, the representative, if any, and other appropriate persons. The City Manager may designate a fact-finding committee, an individual not in the normal line of the grievant's supervision, or the City Attorney to render advice concerning the appeal. Within twelve (12) calendar days, the City Manager shall render a formal decision in writing to the grievant. If the grievant does not agree with the decision reached, the grievant may present an appeal in writing to the City Council within twelve (12) calendar days.

Upon receipt of an appeal, the City Council shall discuss the grievance with the grievant, the representative, if any, and other appropriate persons. The City Council shall designate a fact-finding committee, an individual not in the normal line of the grievant's supervision, or the City Attorney to render written advice concerning the appeal. Within twelve (12) calendar days, the City Council shall render a formal decision in writing to the grievant.

The time limitations mentioned above with reference to filing and response may be extended by mutual agreement between the employee and the City Manager and/or department head.

Section 2.0 Discipline

Disciplinary action may only be taken for just cause and should reflect consideration of the severity of the offense or performance problem, previous performance problems or offenses of the same nature and of the time between occurrences, overall work record and treatment of other employees in similar circumstances. Prior to any disciplinary action as defined in Government Code Section 3303 against any regular employee pursuant to provisions of the Personnel Ordinance and Rules, the following procedure shall be complied with:

Written notice of the proposed disciplinary action shall be given to the employee. Such notice shall include a statement of the reason(s) for the proposed disciplinary action, the charge(s) being considered, the time periods in which the employee may respond, and shall be signed by the appointing authority.

The employee shall be given an opportunity to review the documents or materials upon which the proposed disciplinary action is based, and, if practical, he/she shall be supplied with a copy of the documents or materials.

Within seven (7) calendar days after the employee has had the review opportunity provided above, he/she shall have the right to respond, orally or in writing, or both, at the employee's option, to the appointing authority concerning the proposed action. Upon the request of the employee or the appointing authority, the Personnel Officer may, at his/her discretion, grant an extension of such time period to facilitate fair administration of the disciplinary process. The failure of the employee to respond shall constitute the employee's waiver of the opportunity to respond. Notwithstanding the above, a reasonable request for additional time within which to respond shall not be denied.

If the employee does not agree with the decision reached by the Appointing Authority, the employee may request a hearing before the Personnel Officer within seven (7) calendar days.

Within ten (10) calendar days of receipt of a written request for hearing, the Personnel Officer will schedule a date to hear the appeal of the appointing authority's decision. The failure of the employee to appeal shall constitute the employee's waiver of the opportunity to appeal and the appointing authority decision will become final

If the employee does not agree with the decision reached by the Personnel Officer, the employee may request a hearing before the Personnel Board within seven (7) calendar days.

Appeals shall be in writing and filed with the Personnel Officer, who shall, within seven (7) days after receipt of the appeal, inform each member of the Personnel Board and other such persons named or affected by the appeal of the filing of the appeal. The appeal shall be a written statement, addressed to the Personnel Board, explaining the matter appealed from and setting forth therein a statement of the action desired by the appellant, with his/her reason thereof. The formality of a legal pleading is not required.

Upon the filing of an appeal, the Personnel Officer shall set a date for a hearing on the appeal not less than ten (10) days, nor more than thirty (30) days, from the date of filing. The Personnel Officer shall notify all named or affected parties of the date, time, and place of hearing at such places as the Personnel Board shall prescribe.

The appellant shall appear personally unless physically unable to do so, before the Personnel Board at the time and place of the hearings. He/she may select and may at the hearing produce on his/her behalf relevant oral or documentary evidence. Cross-examination of witnesses shall be permitted. The conduct and decorum of the hearing shall be under the control of the Personnel Board by its Chairperson, unless a Hearing Officer has been appointed by the Board, with due regard to the rights and privileges of the parties appearing before it. Hearings need not be conducted according to technical rules relating to evidence and witnesses. Hearings shall be closed unless the appellant, in writing, requests an open hearing.

The Personnel Board shall, within ten (10) days after the conclusion of the hearing, certify its findings and recommendations in writing to the appellant, to the person from whose action the appeal was taken and to the Personnel Officer. The Personnel Officer shall review the findings and

recommendations of the Personnel Board with the person from whose action the appeal was made with a view toward implementing the recommendations of the Personnel Board. The actions taken by the Personnel Board shall be considered final. Any member of the Personnel Board may submit a minority or supplemental finding and recommendations. In case of suspension, discharge or demotion, the appointing authority shall reinstate any employee to his/her former status if finding is made by the Personnel Board that the action taken was unwarranted and/or in error.

Notwithstanding the provisions of this section, upon the recommendation of appointing authority, the Personnel Officer may approve the temporary assignment of an employee to a status of leave with pay pending an investigation(s) or hearing(s) as may be required to determine if disciplinary action is to be taken.

Throughout the above procedure, the employee may be represented.

ARTICLE IV TERM

Section 1.0 Term of Agreement

The term of this agreement shall be for the period July 1, 2023 through June 30, 2024.

Section 2.0 Agreement Renewal

2.1 Renewal:

In January of 2024 the City and Association agree to open negotiations covering the contents of the agreement to become effective July 1, 2024.

In the absence of an executed agreement for the period commencing July 1, 2024, the provisions of this agreement shall remain in effect.

2.2 Non-Economic Negotiations

The Association shall notify, in writing, no later than sixty (60) days prior to March 30th of each year if it wishes to change any provision in the collective bargaining agreement excluding salary, fringe benefits, or cost of living increases.

ARTICLE V IMPLEMENTATION

Section 1.0 Severability

If any article or section of this Memorandum of Understanding should be found invalid, unlawful, or unenforceable by reason of any existing or subsequent enacted legislation or judicial authority, all other articles and section of the Memorandum of Understanding shall remain in full force for the duration of this Memorandum. In the event of invalidation of any article or section, the City and Association agree to meet within thirty (30) days for the purpose of renegotiating said article or section.

Section 2.0 Ratification and Implementation

2.1 The City and Association acknowledge that this Memorandum of Understanding shall not be in full force and effect until ratified by a simple majority vote of those employees voting who are in classifications represented by the Association set forth in this agreement and adopted in the form of a resolution by the City council.

2.2 This agreement constitutes a mutual recommendation by the parties hereto, to the City Council, that one or more ordinances and/or Resolutions be adopted accepting its provisions and effecting the changes enumerated herein relating to wages, hours, fringe benefits and other terms and conditions of employment for unit employees represented by the Association.

2.3 Subject to the foregoing, this Memorandum of Understanding is hereby agreed to be recommended for approval by the authorized representative of the City and Association and entered into.

Dated: _____

Elvis Cook, President
Middle Management
Association

Alan D. Flora
City Manager

EXHIBIT A

MIDDLE MANAGEMENT ASSOCIATION

MEMORANDUM OF UNDERSTANDING

SERGEANTS

RECORDS AND COMMUNICATIONS SUPERVISOR

PUBLIC WORKS SUPERVISOR

CODE ENFORCEMENT SUPERVISOR



CITY OF CLEARLAKE

City Council

STAFF REPORT

SUBJECT: Award of contract to Case Excavating in the amount of \$113,800.00 for demolition of structure(s) and abatement of properties located at 3191 6th Street, 3662 Cottonwood Street, 16272 32nd Avenue, 14870 Clement Drive, 3556 Madrone Street, 14081 Woodland Drive, 3628 Johnson Avenue, 16052 19 th Avenue, 3287 3 rd Street and 15582 Sharpe Lane Clearlake, CA 95422.	MEETING DATE: 06/15/2023
---	---------------------------------

SUBMITTED BY:	Lee Lambert- Code Enforcement Supervisor
----------------------	--

PURPOSE OF REPORT	<input type="checkbox"/> Information Only <input type="checkbox"/> Discussion <input checked="" type="checkbox"/> Action Item
--------------------------	---

WHAT IS BEING ASKED OF THE CITY COUNCIL/BOARD:

1. The City Council is being asked to authorize the City Manager to execute a contract with Case Excavating and in the amount of \$113,800.00, for the demolition and abatement of properties located at 3191 6th Street, 3662 Cottonwood Street, 16272 32nd Avenue, 14870 Clement Drive, 3556 Madrone Street, 14081 Woodland Drive, 3628 Johnson Avenue, 16052 19th Avenue, 3287 3rd Street and 15582 Sharpe Lane Clearlake, CA 95422.

BACKGROUND/DISCUSSION: The purpose of this hearing is to authorize the City Manager to execute a contract with Case Excavating for the demolition and abatement of real properties, as referenced below.

All properties were deemed to be health and safety hazards, as well as public nuisances by a Code Enforcement Officer. A Notice of Violation was issued to each property owner.

Ample and sufficient time was given to each property owner to voluntarily abate the hazards and nuisances.

The property owners failed to abate the hazards and nuisances. An Order to Abate was then issued to the property owner of each property.

The property owners failed to comply with the Order to Abate and a Notice of Intention to Abate was issued.

The properties currently remain in a condition that presents health and safety hazards to their surrounding community, as well as being public nuisances.

The City has advertised for bids for the demolition of structure(s) and abatement of the properties. On June 8, 2023 the city opened 3 bids for the demolition of the building(s) and abatement of the properties.

The following is a summary identifying subject property, property owner(s) and violations:

1. Location: 3191 6th Street Clearlake, CA 95422 A.P.N.# 038-181-650

Owner: Estate of Wayne Normile

Violation(s): CMC violations are as follows: 10-1.6(b), 10-1.6(j), 10-1.6(w)

HSC violations are as follows: 17920.3(a)14

2. Location: 3662 Cottonwood Street Clearlake, CA 95422 A.P.N.# 039-192-290

Owner: Nakooka, Sheila A & Rudy

Violation(s): CMC violations are as follows: 10-1.6(b), 10-1.6(j), 10-1.6(w)

3. Location: 16272 32nd Avenue Clearlake, CA 95422 A.P.N.# 042-242-340

Owner: Jones, Verna Louise Trustee

Violation(s): CMC violations are as follows: 10-1.6(b) 10-1.6(j), 100-1.6(n), 10-1.6(q)

HSC violations are as follows: 17920.3(a)14

4. Location: 14870 Clement Drive Clearlake, CA 95422 A.P.N.# 040-303-090

Owner: Freiling, Randon S

Violation(s): CMC violations are as follows: 10-1.6(b), 10-1.6(c), 10-1.6(d), 10-1.6(e), 10-1.6(j), 10-1.6(q)

5. Location: 3556 Madrone Street Clearlake, CA 95422 A.P.N.# 039-164-090

Owner: Wong, Peter

Violation(s): CMC violations are as follows: 10-1.6(f), 10-1.6(j), 10-1.6(k), 10-1.6(n), 10-1.6(w)

HSC violations are as follows: 17920.3(a)14

6. Location: 14081 Woodland Drive Clearlake, CA 95422 A.P.N.# 039-065-370

Owner: Syvertson, Samuel

Violation(s): CMC violations are as follows: 10-1.6(j), 10-1.6(q), 10-1.6(z), 18-19.010(c)4, 18-20.030,

18-20.070(b)

7. Location: 3628 Johnson Avenue Clearlake, CA 95422 A.P.N.# 039-453-490

Owner: Fox, Su N

Violation(s): CMC violations are as follows: 10-1.6(b), 10-1.6(e), 10-1.6(j), 10-1.6(q), 18-5.801

HSC violations are as follows: 17920.3(a)10, 17920.3(a)14, 17920.3(b)2, 17920.3(b)6, 17920.3(b)8, 17920.3(d), 17920.3(g), 17920.3(n)

CBC violations are as follows: 314.3, 315.5

8. Location: 16052 19th Avenue Clearlake, CA 95422 A.P.N.# 042-202-360

Owner: Koll, Shelley

Violation(s): CMC violations are as follows: 10-1.6(j), 118-19.360(b), 18-20.030

9. Location: 3287 3rd Street Clearlake, CA 95422 A.P.N.# 038-294-270

Owner: Pendarvis, Leon T & Mildred Y

Violation(s): CMC violations are as follows: 10-1.6(j), 10-1.6(q), 10-1.6(t), 10-6.13

10. Location: 15582 Sharpe Drive Clearlake, CA 95422 A.P.N.# 042-101-410

Owner: Gibson, Jerdean Trustee

Violation(s): CMC violations are as follows: 10-1.6(g), 10-1.6(j), 10-1.6(q)

OPTIONS:

Move to authorize the City Manager to execute a contract for the demolition and abatement of real properties as described above or deny the authorization for the City manager to execute the contract.

FISCAL IMPACT:

\$113,800.00 Budgeted Item? Yes No

Budget Adjustment Needed? Yes No If yes, amount of appropriation increase: \$.

Affected fund(s): General Fund Measure P Fund Measure V Fund Other:

Comments: Funding will be allocated from the Code Enforcement Property Abatement Account in FY22/23 and FY23/24.

STRATEGIC PLAN IMPACT

Goal #1: Make Clearlake a Visibly Cleaner City

Goal #2: Make Clearlake a Statistically Safer City

Goal #3: Improve the Quality of Life in Clearlake with Improved Public Facilities

Goal #4 Improve the Image of Clearlake

Goal #5 Ensure Fiscal Sustainability of City

Goal #6: Update Policies and Procedures to Current Government Standards

Goal #7: Support Economic Development

SUGGESTED MOTIONS:

- 1 Authorize the City Manager to execute a contract with Case Excavating in the amount of \$113,800.00, for the demolition and abatement of real properties located at 3191 6th Street, 3662 Cottonwood Street, 16272 32nd Avenue, 14870 Clement Drive, 3556 Madrone Street, 14081 Woodland Drive, 3628 Johnson Avenue, 16052 19th Avenue, 3287 3rd Street and 15582 Sharpe Lane Clearlake, CA 95422.

X **Attachments:** 1) Contract

CITY OF CLEARLAKE
NOTICE INVITING BIDS AND CONTRACT

NOTICE INVITING BIDS

Date Issued: May 17, 2023

Bids covering the work described in this Notice Inviting Bids, Insurance Requirements, Special Provisions, and Plans entitled:

Demolition of Building(s) and property abatement(s) at the following location(s): 3191 6th Street, 3662 Cottonwood Street, 16272 32nd Avenue, 14870 Clement Drive, 3556 Madrone Street, 14081 Woodland Drive, 3628 Johnson Avenue, 16052 19th Avenue, 3287 3rd Street and 15582 Sharpe Lane in the City of Clearlake,

will be accepted until 5:00PM local time on June 8, 2023. To register, visit the City's electronic bidding website, OpenGov Procurement, and proceed to "Subscribe" as a vendor with the City to receive new project notifications and full solicitation requirements. Interested proposers may "Follow" the RFP to view and/or download the RFP details, receive addenda alerts and notices, and draft and submit a response.

Engineer's Estimate: N/A Minimum License Requirement: See "Special Provisions" section

BID OR PROPOSAL (this section to be completed by bidder) Date submitted: 6-7-23

The undersigned agrees, if this bid is accepted within 30 days after the date of opening, to complete the work specified in strict accordance with the above identified documents and the general provisions on the reverse side within () calendar days after the date of the Notice to Proceed, for the following amount:

Bid \$ 113,800

Amount in words: one Hundred Thirteen Thousand Eight Hundred dollars and 0 cents.

REQUIRED: List bid amount for each specific property location, as described below:

- | | |
|---|--|
| 3191 6 th Street: \$ <u>15,000</u> | 3662 Cottonwood Street: \$ <u>6,000</u> |
| 16272 32 nd Avenue: \$ <u>34,400</u> | 14870 Clement Drive: \$ <u>21,000</u> |
| 3556 Madrone Street: \$ <u>6,500</u> | 14081 Woodland Drive: \$ <u>7,000</u> |
| 3628 Johnson Avenue: \$ <u>6,000</u> | 16052 19 th Avenue: \$ <u>5,900</u> |
| 3287 3 rd Street: \$ <u>6,200</u> | 15582 Sharpe Lane: \$ <u>5,800</u> |

This includes all applicable taxes. The undersigned further agrees, for any contract award resulting from this bid, to furnish evidence of insurance acceptable to the City, as listed in Exhibit A and B.

Bidder's comments and exceptions:

Name and address of bidder:
2735 Robin LN Clear Lake
95422

Phone No.: (707) 994-6815

Brian Case
Signature of person authorized to sign
Brian CASE owner Brian Case
Signer's name and title (type or print)
895670 Brian CASE owner
License No. 895670
Federal ID Number or Social Security Number
20-8421843

PROPERTY LOCATION	Description	Quantity	Unit of Measure	Unit Cost	Total
3191 6th Street	Fire damaged single family mobile home	1	Parcel	\$15,000.00	\$15,000.00
3662 Cottonwood Street	Fire damaged single family mobile home	1	Parcel	\$6,000.00	\$6,000.00
16272 32nd Avenue	Fire damaged single family mobile home	1	Parcel	\$34,400.00	\$34,400.00
14870 Clement Drive	Fire damaged single family mobile home	1	Parcel	\$21,000.00	\$21,000.00
3556 Madrone Street	Single family mobile home to remain; property cleanup, interior and exterior	1	Parcel	\$6,500.00	\$6,500.00
14081 Woodland Drive	Occupied RV and property abatement	1	Parcel	\$7,000.00	\$7,000.00
3628 Johnson Avenue	Property abatement / structures / RVs / vehicles	1	Parcel	\$6,000.00	\$6,000.00
16052 19th Avenue	Property abatement / structures / RVs / vehicles	1	Parcel	\$5,900.00	\$5,900.00
3287 3rd Street	Property abatement / trash / vehicles	1	Parcel	\$6,200.00	\$6,200.00
15582 Sharpe Lane	Property abatement / structures / RVs / vehicles	1	Parcel	\$5,800.00	\$5,800.00
Total					\$113,800.00