



**City of Chipley  
City Council Meeting**

April 14, 2026 at 5:00 PM

City Hall - 1442 Jackson Avenue, Chipley, FL 32428

**AGENDA**

---

**A. CALL TO ORDER**

**B. PRAYER AND PLEDGE**

**C. APPROVAL OF AGENDA**

**D. CITIZENS REQUEST**

The City of Chipley welcomes you to this meeting. This is time set aside for the Citizens of Chipley to address the City Council. This is not a question and answer period, it is not a political forum, nor is it a time for personal accusations and derogatory remarks to/or about city personnel. If you would like to address the City Council please raise your hand to speak, state your name and address for the record and limit your comments to no more than three (3) minutes per Florida Statute 286.0114. To ask a question via phone; dial \*9 and wait to be recognized/unmuted. If you are attending via webinar, there will be an onscreen option to ask a question during the public comment portion of the meeting. Your participation is welcomed and appreciated.

**E. APPROVAL OF MINUTES**

- [1.](#) Regular Meeting Minutes - March 10, 2026

**F. DEPARTMENT REPORTS**

- [1.](#) Attorney Report
- [2.](#) CRA Report
- [3.](#) Fire Department Report
- [4.](#) Code Enforcement Report
- [5.](#) Planning & Zoning Report
- [6.](#) Police Department Report
- [7.](#) Public Works Department Report
- [8.](#) Recreation Department Report
- [9.](#) Water Utilities Department Report

10. Finance Department Report

11. City Administrator Report

## **G. PRESENTATIONS**

1. Proclamation for Lupus Awareness Month

## **H. CONSENT AGENDA**

1. **Resolution No. 26-28** – Florida Department of Commerce Rural Infrastructure Fund (RIF) Grant Agreement No. D0299 – Brickyard Road Wastewater Project – Amendment No. 1

2. **Resolution No. 26-29** – Updated Parades

3. **Resolution No. 26-30** – Florida Department of Environmental Protection Grant Agreement No. 26PLN63 – Gilbert Acres Drainage Improvements Project

4. **Resolution No. 26-31** – Community Planning Technical Assistance (CPTA) Grant Program Application Submission

5. **Resolution No. 26-33** – FY 23-24 State Assistance for Fentanyl Eradication (S.A.F.E.) - Chipley Police Department – Amendment Two

6. **Agreement for Professional Services** – Amendment No. 1 – Mott MacDonald Florida, LLC

7. **FY 24-25 Updated Minutes**

8. **Special Event Application** – The Annual Friends & Family Luau

9. **Special Event Application** – Panhandle Watermelon Festival Parade

10. **Special Event Application** – Community Outreach – Washington County Christian School

11. **Request for a Variance** – Chipola Area Habitat for Humanity – Corner of Pecan Street and 4th Avenue

12. **Bid No. 25-01** – Florida Commerce CDBG-NR Peach Street Lift Station Project – GCUC, LLC - Changer Order No. 3

## **I. AGENDA ITEMS**

1. **CDBG First Public Hearing Notice**

2. **Ordinance No. 998 (First Reading)** – Florida Power & Light Franchise Agreement

3. **Revolution Road Interpretive Panels & Wayfinding Locations & Driving Tour Directions** – Heather Lopez

4. **Resolution No. 26-32** – State of Florida Department of Transportation Surplus Property – State Road 77 and Highway 90

**J. OTHER BUSINESS**

**K. ADJOURN**

**L. ZOOM**

1. ZOOM Information

Any subject on the agenda, regardless of how stated, may be acted upon by the Council. The Council reserves the right to add other items to the agenda. Anyone desiring a verbatim transcript of the meeting must make personal arrangements as the City takes only summary minutes. Persons with disabilities needing special accommodations to participate in this proceeding should contact City Hall at (850) 638-6350, at least 48 prior to the proceedings.

**City of Chipley  
Council Meeting  
Minutes  
March 10, 2026 at 5:00 p.m.**

**Attendees:**

Ms. Tracy Andrews, Mayor  
Mrs. Linda Cain, Council Member  
Mr. Leonard Blount, Council Member

Mr. Kevin Russell, Mayor Pro-Tem  
Ms. Cheryl McCall, Council Member

**Others Present Were:**

Mrs. Patrice Tanner, City Administrator  
Mr. Guy Lane, Asst. City Admin./Public Works Dir.

Ms. Sherry Snell, City Clerk  
Mr. Michael Richter, Police Chief

Mrs. Michelle Jordan, City Attorney (via Zoom)

The data reflected in these proceedings constitute an extrapolation of information elicited from notes, observations, recording tapes, photographs, and/or videotapes. Comments reflected herein are sometimes paraphrased, condensed, and/or have been edited to reflect essential subject matter addressed during the meeting. Parties interested in receiving a verbatim account of the proceedings are responsible for coordinating with the City Administrator and providing their own representative and equipment pursuant to Chapters 119 and 283, Florida Statutes.

**A. CALL TO ORDER**

The meeting was called to order by Mayor Andrews at 5:00 p.m.

**B. PRAYER AND PLEDGE**

Prayer was given by Council Member Russell and Mayor Andrews led the pledge to the American Flag.

**C. APPROVAL OF AGENDA**

Mayor Andrews added Consent Agenda Item #13 – Special Event Application – Thursday Night Lights; Removed Agenda Item #6 Animal Control Ordinance and added Agenda Item #6 Request for Executive Session – Attorney Michelle Jordan.

**A motion was made by Council Member Russell and seconded by Council Member McCall to approve the agenda with the changes. The motion passed unanimously.**

**D. CITIZENS REQUEST**

The City of Chipley welcomes you to this meeting. This is time set aside for the Citizens of Chipley to address the City Council. This is not a question and answer period, it is not a political forum, nor is it a time for personal accusations and derogatory remarks to/or about city personnel. If you would like to address the City Council please raise your hand to speak, state your name and address for the record and limit your comments to no more than three (3) minutes per Florida Statute 286.0114. To ask a question via phone; dial \*9 and wait to be recognized/unmuted. If you are attending via webinar, there

will be an onscreen option to ask a question during the public comment portion of the meeting. Your participation is welcome and appreciated.

No further discussion.

**E. APPROVAL OF MINUTES**

1. Regular Council Meeting – February 10, 2026

**A motion was made by Council Member Russell and seconded by Council Member Blount to approve the minutes as presented. The motion passed unanimously.**

**F. PRESENTATIONS**

Proclamation for Red Cross Month. The City Council recognized March as Red Cross Month, celebrating our local heroes and resolving to continue lifting each other up, so no one faces an emergency alone.

**G. CONSENT AGENDA ITEMS**

1. **Resolution No. 26-23** – Capital City Bank – 2026 Ford Police Interceptor – Police Department. This resolution will approve a loan with Capital City Bank for the purchase of (1) New 2026 Ford Police Interceptor for the Police Department in the amount of \$46,317.00 with an interest rate of 4.15% with five (5) annual payments.
2. **Resolution No. 26-24** – Capital City Bank – Aries Mobile Voyage System (Main Line Sewer Camera) – Water Utilities Department. This resolution will approve a loan with Capital City Bank for the purchase of (1) Aries Mobile Voyage System (Main Line Sewer Camera) for the Water Utilities Department in the amount of \$119,199.00 with an interest rate of 4.15% with seven (7) annual payments.
3. **Bid No. 2025-04** – Citywide Flooding Resiliency Improvements – Change Order #1. This will add an additional 240 days to the project due to delays in utility relocations and in the overlapping project for the removal and replacement of the Peach Street Lift Station. The project is 75% complete as of March 1, 2026 and the remaining work, minus the utility relocation and Peach Street lift station, is anticipated to be completed within the next 2 weeks. There is no change in the contract cost.
4. **Continuing Engineering Services Contract Extension** – David H. Melvin, Inc. This will approve an extension of the Contract for Continuing Professional Engineering Services with David H. Melvin, Inc. for a period of one (1) year with an expiration date of March 8, 2027.
5. **Continuing Grants Administration Services Contract Extension** – David H. Melvin, Inc. This will approve an extension of the Contract for Continuing Professional Grants Administration Services with David H. Melvin, Inc. for a period of one (1) year with an expiration date of June 14, 2027.
6. **Chipley Redevelopment Agency** – Administration Contract. This will approve the Contract with the Chipley Redevelopment Agency (CRA) and the Washington County Chamber of Commerce. This will be retroactive to October 1, 2025 with an expiration date of September 30, 2026.
7. **Chipley Redevelopment Agency** – Grant Funding Breakdown Updated. This will update the Grant Funding Breakdown for interior, exterior, start-up fees and permitting, and the max amount allowed for CRA grant funds in the amount of \$50,000.

- 8. **Special Event Application** – Color Run – Chipley Band Boosters. Chipley Band Boosters are requesting to hold a color run on Saturday, April 11, 2026 starting at 7:30 a.m. The run will start at Philip Rountree Stadium and head West on North Railroad Avenue to Griffin Road, then North to Old Bonifay Road, then East to 2<sup>nd</sup> Street and South back to North Railroad Avenue. The money raised will go to the Chipley Tiger Band. Insurance is not required for this event.
  
- 9. **Special Event Application** – Community Outreach – Washington County Christian School. The Washington County Christian School would like to have a community outreach event on Saturday, April 18, 2026 from 4:00 p.m. to 6:00 p.m. at Shivers Park. There will be foodtrucks, a train and they will be playing Christian music.
  
- 10. **Special Event Application** – Law Enforcement Torch Run for Special Olympics Florida – Northwest Florida Reception Center. This event will be held on Tuesday, March 17, 2026 from 9:00-11:00 a.m. They will be walking a pre-determined route to bring awareness to the Special Olympics of Florida. The route will depart at the Washington County Courthouse and head east for .2 miles then turn South onto SR 77 and continue for 2 miles to end at PeoplesSouth Bank. The East Bound lane of Jackson Avenue/South Bound lane of Main Street will be closed by transport vehicles during the event. Insurance is not required for this event.
  
- 11. **Special Event Application** – T.J. Roulhac School Reunion & Parade. Carla Rhynes-Campbell would like to have a parade on Saturday, June 20, 2026 from 9:00 a.m. to 10:00 a.m. The route would start at the old Chipley High School and go down Church Avenue to Pecan Street at the T.J. Roulhac Enrichment Center.  
  
They would also like to use the field facilities located behind the T.J. Roulhac Enrichment Center for a cook-out, parking and a gathering. The field would be utilized on Friday, June 19, 2026 from 8:00 a.m. – 10:00 p.m. which would include time to clean up. Also on Saturday, June 20, 2026 from 8:00 a.m. – Midnight. Insurance is not required for this event.
  
- 12. **Farmer's Market & Gazebo Rental Application** – Robert David. Mr. Robert David is requesting to rent the Farmer's Market & Gazebo for a food give away to the community on Sunday, April 26, 2026 from 1:00 p.m. to 6:00 p.m. With Council approval, the rental fee of \$150.00 will be waived due to it being a community event. Insurance is required and will be submitted prior to the event.
  
- 13. **Special Event Application** – Thursday Night Lights – Kristin Martin. This event will be held on the third Thursday from 6:00 p.m. – 8:00 p.m. Dates include April 16, 2026, May 21, 2026, June 18, 2026, July 16, 2026, August 20, 2026, and September 17, 2026.

**A motion was made by Council Member Cain and seconded by Council Member Russell to approve the consent agenda items. The motion passed unanimously.**

**H. AGENDA ITEMS**

- 1. **Ordinance No. 997** – Waste Management Contract Amendment and Renewal. Mayor Andrews closed the regular meeting and opened the public hearing at 5:07 p.m. Mrs. Tanner read Ordinance No. 997 by title:

**AN AMENDMENT TO ORDINANCE NO. 834 RENEWING AND EXTENDING THE NON-EXCLUSIVE FRANCHISE TO WASTE MANAGEMENT INC. OF FLORIDA FOR THE COLLECTION AND DISPOSAL OF RESIDENTIAL AND COMMERCIAL SOLID WASTE COLLECTION; AMENDING SECTION 9, B, 6; PROVIDING FOR RATE ADJUSTMENTS; AND PROVIDING AN EFFECTIVE DATE.**

Mrs. Tanner explained this Ordinance will approve the final reading of Ordinance No. 997 – amending, renewing, and extending the non-exclusive franchise for the collection and disposal of residential and commercial solid waste collection to Waste Management, Inc. of Florida for a period of five (5) years. Section 2 – CPI Adjustment will be amended. Official notice to advise the public of the proposed adoption of Ordinance No. 997 was published in the Washington County News on February 25, 2026. The ad complied with the legal requirements of the City Code and Florida Statutes.

Mayor Andrews closed the public hearing and opened the regular meeting at 5:10 p.m. No further discussion.

**A motion was made by Council Member Cain and seconded by Council Member Russell to approve the final reading of Ordinance No. 997. The motion passed unanimously.**

- 2. **Firm Gas Supply Authorization Under All Requirements Gas Services Agreements – Extending Terms at Re-pricing Periods – Florida Gas Utility – Katie Hall.** Mrs. Hall gave an overview of the discounts that were available with this directive agreement. No further discussion.

**A motion was made by Council Member Russell and seconded by Council Member Cain to approve the Firm Gas Supply Authorization Under All Requirements Gas Services Agreements. The motion passed unanimously.**

- 3. **Resolution No. 26-25 – FDEP State Revolving Loan Fund Program Application.** Mr. Amir Zafar, Ardurra, stated this resolution will approve a loan application through the FDEP Sewer Overflow and Stormwater Reuse Municipal Grant (OGS) Program for a Sanitary Sewer Overflows (SSO) Mitigation Project. The total project amount is \$500,000.00, which qualifies for 100% principal forgiveness. No revenue pledge is required for this funding. No further discussion.

**A motion was made by Council Member Russell and seconded by Council Member Cain to approve Resolution No. 26-25 FDEP State Revolving Loan Fund Program Application. The motion passed unanimously.**

- 4. **Resolution No. 26-26 – Hometown Heroes Banner Policy.** Mrs. Tanner stated this resolution will adopt the official policy establishing the program and outlining eligibility requirements, application procedures, and display guidelines for the creation of a Hometown Heroes Banner Program to honor veterans and active-duty military members. The banners will be displayed annually from Memorial Day through Veterans Day. There will be a limited number of banners that can be displayed and it will be a first-come, first-serve basis for a period of two years. The cost to sponsor a banner will be \$100.00. Discussion ensued.

**A motion was made by Council Member Russell and seconded by Council Member McCall to approve Resolution No. 26-26 – Hometown Heroes Banner Policy. The motion passed unanimously.**

- 5. **Resolution No. 26-27 – Sale of Surplus Property – Washington County.** Mrs. Tanner stated this resolution will approve the sale of surplus property containing 98.47 acres to Washington County for the amount of \$140,457.61. This was the industrial park sprayfield. No further discussion.

**A motion was made by Council Member McCall and seconded by Council Member Cain to approve Resolution No. 26-27 – Sale of Surplus Property – Washington County. The motion passed unanimously.**

- 6. **Executive Session Request – Attorney Jordan.** Mrs. Jordan requested the Executive Session be rescheduled for March 31, 2026 at 5:00 p.m. for the Chipley Course.

**A motion was made by Council Member Russell and seconded by Council Member Blount to approve the Executive Session to be held March 31, 2026 at 5:00 p.m.**

**I. OTHER BUSINESS**

Ms. McCall asked about the utility kiosk on Mrs. Tanner's monthly report. Mrs. Tanner stated that the City is waiting on the Peach Street Lift Station project to be completed to ensure there are no additional expenditures.

**J. ADJOURN**

The meeting was adjourned by Mayor Andrews at 5:28 p.m.

City of Chipley

Attest:

\_\_\_\_\_  
Tracy L. Andrews, Mayor

\_\_\_\_\_  
Sherry Snell,  
City Clerk

Attorney	Court Judge Docket No.	Parties	Case Status	Case Name	Description	Outside Counsel	Opposing Counsel	Defendant Name	Street Address	Street Address	Street Address
Goldhagen, Matt	<b>Court:</b> Washington Co. <b>Case No.</b> <b>Judge:</b> <b>Magistrate Judge:</b>	<b>Plaintiff(s):</b> City of Chipley <b>Defendant(s):</b> Richard Barrentine and Diana Barrentine <b>Third Parties:</b> N/A	2/19/25 - Property sent to foreclosure auction & sold.	COC v. Richard Barrentine	Foreclosure of Code Enforcement Lien / 1219 Johnson Avenue	Matt Goldhagen Blankenship Jordan P.A. 1512 Highway 90 Chipley, FL 32428 matt@blankenshipjordanpa.com (850) 638-9701		Barrentine, Richard	1219 Johnson Ave.		
Goldhagen, Matt	<b>Court:</b> Washington Co. - Circuit Civil <b>Case No.</b> 2023-CA-123 <b>Judge:</b> Timothy Register <b>Magistrate Judge:</b> N/A	<b>Plaintiff(s):</b> Chipley Course, LLC <b>Defendant(s):</b> City of Chipley <b>Third Parties:</b> N/A	1/16/26 - NJ Trial scheduled for 5/202/26 and PT Conf scheduled for 4/29/26. 3/30/26 - Scheduling depo of CC's expert.	Chipley Course, LLC v. COC	Breach of Contract - Dec. Judgment	Matt Goldhagen Blankenship Jordan P.A. 1512 Highway 90 Chipley, FL 32428 matt@blankenshipjordanpa.com (850) 638-9689	Mitch Dever, Esq. FL Bar No. 0939730 PO Box 9811 Panama City Beach, FL 32417 (850) 234-7677 mitchdever@comcast.net	Chipley Course			
Goldhagen, Matt	<b>Court:</b> Washington Co. - County Civil <b>Case No.</b> 2024-CA-61 <b>Judge:</b> Frederick Peel <b>Magistrate Judge:</b> N/A	<b>Plaintiff(s):</b> City of Chipley <b>Defendant(s):</b> Terry Davis, Washington Co. Clerk of Court and Washington County Tax Collector <b>Third Parties:</b> N/A	11/3/25 - Order Granting Stay entered. Proceedings stayed until February 2, 2026.	COC v. Terry Davis	Foreclosure of Code Enforcement Lien / 504 MLK Drive	Matt Goldhagen Blankenship Jordan P.A. 1512 Highway 90 Chipley, FL 32428 matt@blankenshipjordanpa.com (850) 638-9689		Davis, Terry	504 MLK Dr.		

Attorney	Court Judge Docket No.	Parties	Case Status	Case Name	Description	Outside Counsel	Opposing Counsel	Defendant Name	Street Address	Street Address
Goldhagen, Matt	<b>Court:</b> Washington Co. - Circuit Civil <b>Case No.</b> 2023-CA-47 <b>Judge:</b> Christopher Patterson <b>Magistrate Judge:</b> N/A	<b>Plaintiff(s):</b> City of Chipley <b>Defendant(s):</b> Estate of Dennie Gilmore a/k/a Dennie Gilmore, Deceased; All Heirs, Beneficiaries, Devisees, Legatees, Spouses & Creditors of Dennie Gilmore a/k/a Dennie	3/2/26 - Damages & foreclosure granted. waiting on signed order from Judge.	COC v. Estate of Dennie Gilmore a/k/a Dennie Gilmore, Deceased et al	Foreclosure of Code Enforcement Lien / 1209 Campbellton Ave	Matt Goldhagen Blankenship Jordan P.A. 1512 Highway 90 Chipley, FL 32428 matt@blankenshipjordanpa.com (850) 638-9699		Gilmore, Estate of Dennie	1209 Campbellton Ave	
Goldhagen, Matt	<b>Court:</b> Washington Co. - County Civil <b>Case No.</b> 2024-CC-094 <b>Judge:</b> Colby Peel <b>Magistrate Judge:</b>	<b>Plaintiff(s):</b> City of Chipley <b>Defendant(s):</b> Impulsive Expressions, LLC <b>Third Parties:</b> N/A	2/18/26 - CMC held.	COC v. Impulsive Expressions, LLC	Foreclosure of Code Enforcement Lien / 746 West Blvd.	Matt Goldhagen Blankenship Jordan P.A. 1512 Highway 90 Chipley, FL 32428 matt@blankenshipjordanpa.com (850) 638-9703	R. Wes Adkison, Esq. Kerry Adkison, P.A. P. O. Box 669 Chipley, FL 32428 Phone: (850) 638-2643 office@adkisonfirm.com kavla@adki	Impulsive Expressions	746 West Blvd	
Goldhagen, Matt	<b>Court:</b> Washington Co. - Circuit Civil	<b>Plaintiff(s):</b> City of Chipley <b>Defendant(s):</b>	1/21/26 - Foreclosure sale scheduled for March 4. 3/4/26 - Foreclosure sale.	COC v. Estate of Joseph R. Ledlow et al	Foreclosure of Code Enforcement Lien / 1278	Matt Goldhagen Blankenship Jordan		Ledlow, Estate of Joseph	1278 Holley Ave	492 2nd Street
Goldhagen, Matt	<b>Court:</b> Washington Co. <b>Case No.</b> 2025-CA-30 <b>Judge:</b> Timothy Register <b>Magistrate Judge:</b>	<b>Plaintiff(s):</b> Chipley Police Dept. <b>Defendant(s):</b> Jayson McCoy, Walter McCoy and Heather Flemming <b>Third Parties:</b> N/A	2/10/26 - MSJ filed. 2/20/26 - MSJ hrg scheduled for 5/13/26.	CPD v. Jayson McCoy	Forfeiture / 616 Main Street	Matt Goldhagen Blankenship Jordan P.A. 1512 Highway 90 Chipley, FL 32428 matt@blankenshipjordanpa.com (850) 638-9700		McCoy, Jayson	616 Main St.	

Attorney	Court Judge Docket No.	Parties	Case Status	Case Name	Description	Outside Counsel	Opposing Counsel	Defendant Name	Street Address	Street Address
Goldhagen, Matt	<b>Court:</b> Washington Co. <b>Case No.</b> <b>Judge:</b> <b>Magistrate Judge:</b>	<b>Plaintiff(s):</b> City of Chipley <b>Defendant(s):</b> Latonia McKinnie <b>Third Parties:</b> N/A	11/10/25 - Council voted waive fines & have owner's pay attorney fees.	COC v. Latonia McKinnie	Foreclosure of Code Enforcement Lien / 1167 6th Street	Matt Goldhagen Blankenship Jordan P.A. 1512 Highway 90 Chipley, FL 32428 matt@blankenshipjordanpa.com (850) 638-9708		McKinnie, Latonia	1167 6th Street	
Goldhagen, Matt	<b>Court:</b> Washington Co. - County Civil <b>Case No.</b> 2023-CC-39 <b>Judge:</b> Frederick Peel <b>Magistrate Judge:</b> N/A	<b>Plaintiff(s):</b> City of Chipley <b>Defendant(s):</b> Estate of Mary C. Mydosh a/k/a Mary Mydosh a/k/a Marh Carmella Davis; Charles Smejkal, Jr.; All Heirs, Beneficiaries, Devisees, Legatees, Spouses & Creditors of Mary C. Mydosh a/k/a	12/3/25 - Foreclosure sale.	COC v. Estate of Mary C. Mydosh et al.	Foreclosure of Code Enforcement Lien / 589 Main Street & 592 Main Street	Matt Goldhagen Blankenship Jordan P.A. 1512 Highway 90 Chipley, FL 32428 matt@blankenshipjordanpa.com (850) 638-9697	N/A	MyDosh, Estate of Mary C.	589 Main St.	592 Main St.
Goldhagen, Matt	<b>Court:</b> Washington Co. - County Civil	<b>Plaintiff(s):</b> City of Chipley <b>Defendant(s):</b>	1/26/26 - dismissal set aside, default judgment granted. 2/10/26 - Settlement between City Council & Hartzog. Hrg on damages scheduled for 5/11/26 in the	COC v Jeremie & Carlie Peters et al	Foreclosure of Code Enforcement Lien / 1471	Matt Goldhagen Blankenship Jordan		Peters, Jeremie	1471 S. Railroad Ave	
Goldhagen, Matt	<b>Court:</b> Washington Co. <b>Case No.</b> 2025-CA-34 <b>Judge:</b> Timothy Register <b>Magistrate Judge:</b>	<b>Plaintiff(s):</b> Chipley Police Dept. <b>Defendant(s):</b> Estate of Martha D. Deal Pippin, and Felecia Nickels <b>Third Parties:</b> N/A	1/23/26 - Serve heirs w/initial pleadings. 1/21/26 - CM Conf scheduled for 2/23. 2/11/26 - property sold at tax deed sale. Need to amend complaint to include new owners.	CPD v. Estate of Martha Pippin	Forfeiture / 499 Martin Luther King Drive	Matt Goldhagen Blankenship Jordan P.A. 1512 Highway 90 Chipley, FL 32428 matt@blankenshipjordanpa.com (850) 638-9700		Pippin, Estate of Martha	499 MLK Dr.	

Attorney	Court Judge Docket No.	Parties	Case Status	Case Name	Description	Outside Counsel	Opposing Counsel	Defendant Name	Street Address	Street Address
Goldhagen, Matt	<b>Court:</b> Washington Co. <b>Case No.</b> 2025-CA-09 <b>Judge:</b> Timothy Register <b>Magistrate Judge:</b>	<b>Plaintiff(s):</b> City of Chipley <b>Defendant(s):</b> Estate of Martha D. Deal Pippin, Felecia Nickels, and Carl Hogue <b>Third Parties:</b> N/A	2/23/26 - CMC held.	COC v. Estate of Martha Pippin	Nuisance Abatement of Code Enforcement Lien / 499 Martin Luther King Drive	Matt Goldhagen Blankenship Jordan P.A. 1512 Highway 90 Chipley, FL 32428 matt@blankenshipjordanpa.com (850) 638-9700		Pippin, Estate of Martha	499 MLK Dr.	
Goldhagen, Matt	<b>Court:</b> Washington Co. - County Civil <b>Case No.</b> 2024-CA-120 <b>Judge:</b> Federick Peel <b>Magistrate Judge:</b> N/A	<b>Plaintiff(s):</b> City of Chipley <b>Defendant(s):</b> Gwaun Reed & Ken Naker, Washington Co. Tax Collector <b>Third Parties:</b> N/A	2/23/26 - Need to send discovery once approved by MG.	COC v. Gwuan Reed	Foreclosure of Code Enforcement Lien / 618 Bennett Dr. & 618 9th St	Matt Goldhagen Blankenship Jordan P.A. 1512 Highway 90 Chipley, FL 32428 matt@blankenshipjordanpa.com (850) 638-9688		Reed, Gwuan	618 Bennett Dr.	618 9th St.

Tracking Number	Timestamp	Email Address	Legal Service Requested	Summary of Request	Date Submitted	Response Deadline	Contact Name	Supporting Documentation for Request	MBJ Reviewed	Notes	Status
26-001	1/13/2026 10:42:23	tdonjuan@cityofchipley.com	Document/Contract Review	<b>Can you provide me with a total for the lien and attorney fees for Case No. 808, Redd Whyte, LLC, 550 Bennett Drive?</b>	1/13/2026	1/20/2026	Tamara Donjuan	<a href="https://drive.google.com/open?id=1cOHBUEjLwtYTVUitPGYBRwkAZ4BsKRVm">https://drive.google.com/open?id=1cOHBUEjLwtYTVUitPGYBRwkAZ4BsKRVm</a>	1/19/2026	Sent total to TD	Complete
26-002	2/12/2026 12:28:48	ptanner@cityofchipley.com	Draft Document	<b>City Council asked that you prepare a policy for the cemetery per the discussion at the January meeting. I have attached the minutes and I am emailing the audio of the meeting so you can hear what they are looking for. Thank you.</b>	2/12/2026	3/2/2026	Patti Tanner	<a href="https://drive.google.com/open?id=18_QdgmegBGsV6K6mNUAtJc4wUHf4Rrw0">https://drive.google.com/open?id=18_QdgmegBGsV6K6mNUAtJc4wUHf4Rrw0</a>	3/5/2026	Sent memo to PT, pending April meeting	PENDING
26-003	2/17/2026 13:53:15	tdonjuan@cityofchipley.com	Document/Contract Review	<b>Michelle these are two code enforcement cases that have tax deed surplus. Will you complete them for the city. 550 Bennett Dr and 499 Martin Luther King Dr</b>	2/17/2026	3/3/2026	Tamara Donjuan	<a href="https://drive.google.com/open?id=1wrdRiuU75-N7alzOg0b4OrceMNRZqFNF">https://drive.google.com/open?id=1wrdRiuU75-N7alzOg0b4OrceMNRZqFNF</a> , <a href="https://drive.google.com/open?id=1JMEJHcp_hxzd8sE4tmsmg-C-9kH06YZW">https://drive.google.com/open?id=1JMEJHcp_hxzd8sE4tmsmg-C-9kH06YZW</a>	2/27/2026	Sent surplus claim forms to TD	Complete
26-004	2/20/2026 14:06:04	ptanner@cityofchipley.com	Draft Document	<b>We need legal authority letters for the attached resolution please.</b>	2/20/2026	2/24/2026	Patti Tanner	<a href="https://drive.google.com/open?id=1dIL0D2P9w5x5UPQIQ1hEHd14RSddKzk">https://drive.google.com/open?id=1dIL0D2P9w5x5UPQIQ1hEHd14RSddKzk</a> , <a href="https://drive.google.com/open?id=1wIJoXcWk7nwbNX7W27M4jpDQpljLMZm3">https://drive.google.com/open?id=1wIJoXcWk7nwbNX7W27M4jpDQpljLMZm3</a> , <a href="https://drive.google.com/open?id=1lIO8b3H6F1VeUCJYbqrquYr6Yf4p0Y-o">https://drive.google.com/open?id=1lIO8b3H6F1VeUCJYbqrquYr6Yf4p0Y-o</a> ,	3/2/2026	Sent letters to PT	Complete



Chipley Redevelopment Agency  
P.O. Box 457 – 672 5<sup>th</sup> St. Chipley, FL 32428  
850.638.4157 – [director@washcomall.com](mailto:director@washcomall.com)

April 4, 2026

Dear Mayor and Council Members,

We are pleased to provide this month's update on the continued progress of the Community Redevelopment Agency (CRA). The new fiscal year continues to build momentum, with increased activity in the grant program and steady engagement from property owners and business operators throughout the district.

**Project Activity**

No projects reached completion during the last quarter; however, several projects are currently in the pipeline. The CRA staff is working closely with grant applicants to support efficient project startups and ensure compliance with program guidelines as work progresses.

**Looking Ahead:**

1. The funding breakdown was updated with the City Council and approved.
2. Workshop to update guidelines has been scheduled by Susan Williams, CRA Administrator, within the next week.

The CRA remains committed to fostering revitalization, economic growth, and reinvestment across the district. There has been an influx of requests for applications for various business in the downtown Chipley area. We look forward to another productive year of strengthening our community through strategic redevelopment efforts.

**Updates:**

- a) Hometown Vet Grant (11/14/2023) 1380 Clayton Rd. Exterior Grant: provided receipts from CRA staff to City Adm and check has been requested .
- b) Website update: The CRA staff is currently looking to updating its website we will be contacting tec support for training.
- c) Board Vacancy – We request City of Chipley post on their social media about CRA Board Vacancy.

Thank you for your ongoing support and partnership as we continue advancing the CRA's mission.

Sincerely,

Shirley Parrado, MA, CRA Director



# City of Chipley

1442 Jackson Avenue  
Post Office Box 1007  
Chipley, Florida 32428  
Phone: (850) 638-6350

April 2, 2026

Chipley Redevelopment Agency  
Post Office Box 457  
Chipley, Florida 32428

Dear Mrs. Parrado:

The Chipley Redevelopment Agency bank accounts have the following balances as of March 31, 2026:

<u>Account Name</u>	<u>SBA Account</u>	<u>Checking Account</u>	<u>Total Amount</u>
CRA Trust Escrow	\$ 13,932.51	\$ 9,991.45	\$ 23,923.96
CRA Trust Fund	201,494.14	47,333.96	248,828.10
CRA Revolving Loan	<u>25,190.05</u>	<u>22,903.65</u>	<u>48,093.70</u>
Total	\$ 240,616.70 =====	\$ 80,229.06 =====	\$ 320,845.76 =====

If you have any questions or if you should need additional information, please contact me at the number listed above or by email at [jrichter@cityofchipley.com](mailto:jrichter@cityofchipley.com).

Sincerely,

Jamie Richter  
Finance Director

**City of Chipley**  
**Community Redevelopment Agency**  
**Revolving Loan Acitivity**  
**Fiscal Year 2025 - 2026**

Section F, Item2.

Name	Loan Balance As of 10/01/25	New Loans (10/01/25 - 09/30/26)	Principal Paid (10/01/25 to 09/30/26)	Balance As of 03/31/26
Sister's Southern Charm (11/20/18)	4,831.22	0.00	4,418.63	0.00
Leanne and John Pedraja (07/18/19)	2,997.25	0.00	2,014.10	983.15
Cynthia H. Brown (02/10/22)	9,872.24	0.00	1,439.35	8,432.89
Tiffany Hitchcock (04/12/22)	10,586.37	0.00	1,432.31	9,153.85
Rachel & James Jenkins (05/27/22)	5,412.48	0.00	715.07	4,697.36
Mickey Knapp (02/17/25)	18,213.30	0.00	1,355.73	16,857.57
<b>Totals</b>	<b>\$ 51,912.86</b>	<b>\$ -</b>	<b>\$ 11,375.19</b>	<b>\$ 40,124.82</b>

	Due Date	Monthly Payment Due	Last Payment
Sister's Southern Charm - 827 Main St.	20th	262.02	12/02/25
Leanne and John Pedraja - 1261 Church St.	18th	255.35	03/24/26
Cynthia H. Brown - 689 3rd St.	10th	255.35	03/02/26
Tiffany Hitchcock - 795 Main St.	13th	255.37	03/18/26
Rachel & James Jenkins - 1323 Watts Ave.	27th	127.67	03/03/26
Mickey Knapp - 1342 North Railroad Ave.	17th	255.37	03/17/26

ALL LOANS ARE CURRENT

# Chipley Fire Department

Chipley, FL

Section F, Item 3.



## Total Incidents per Personnel (5274)

Start Date: 3/1/2026 0:00:00 | End Date: 3/31/2026 23:59:00

**Record Status**

**District**

**Station**

**Shift**

**Unit**

Select an option

Select an option

Select an option

Select an option

Select an option

**Average Personnel Responding**

7

**Total Runs**

48

### Personnel On/Off Apparatus

Personnel	On Appatatus	Off Apparatus	Total # of Incidents	% of All Incidents
201 Aycock, Hunter	43	3	46	95.83%
202 Adams, James	16	15	31	64.58%
204 Ostrowski, Steven	26	13	39	81.25%
205 Finch, Donald	28	10	38	79.17%
206 Adams, Bradly	9	5	14	29.17%
207 Cook, Mathew	4	10	14	29.17%
208 Hobby, Brad	23	8	31	64.58%
209 Webb, Corey	8	4	12	25.00%
210 Gavaller, Jason	18	11	29	60.42%
211 Wilson, Sawyer	5	2	7	14.58%
212 Bass, Adam	4	4	8	16.67%
213 Pickens, Tyler	5	5	10	20.83%
214 Cook, James	7	9	16	33.33%
215 Wilcox, Jerad	4	0	4	8.33%
216 Lane, Noah	30	8	38	79.17%
217 Odum, Matt	9	16	25	52.08%
218 Burnham, Christopher	5	2	7	14.58%
221 Aycock, Floyd	8	11	19	39.58%
224 Hall Jr., Gary	4	8	12	25.00%

Section F, Item 3.

Total Incidents per Personnel for Date Range



emergencynetworking.com  
#5274

# Chipley Fire Department

Chipley, FL

Section F, Item 3.



## Breakdown by Major Incident Types (5530)

Start Date: 3/1/2026 0:00:00 | End Date: 3/31/2026 23:59:59

**City Calls - 31**  
**County Calls - 16**  
**Total Calls - 334**

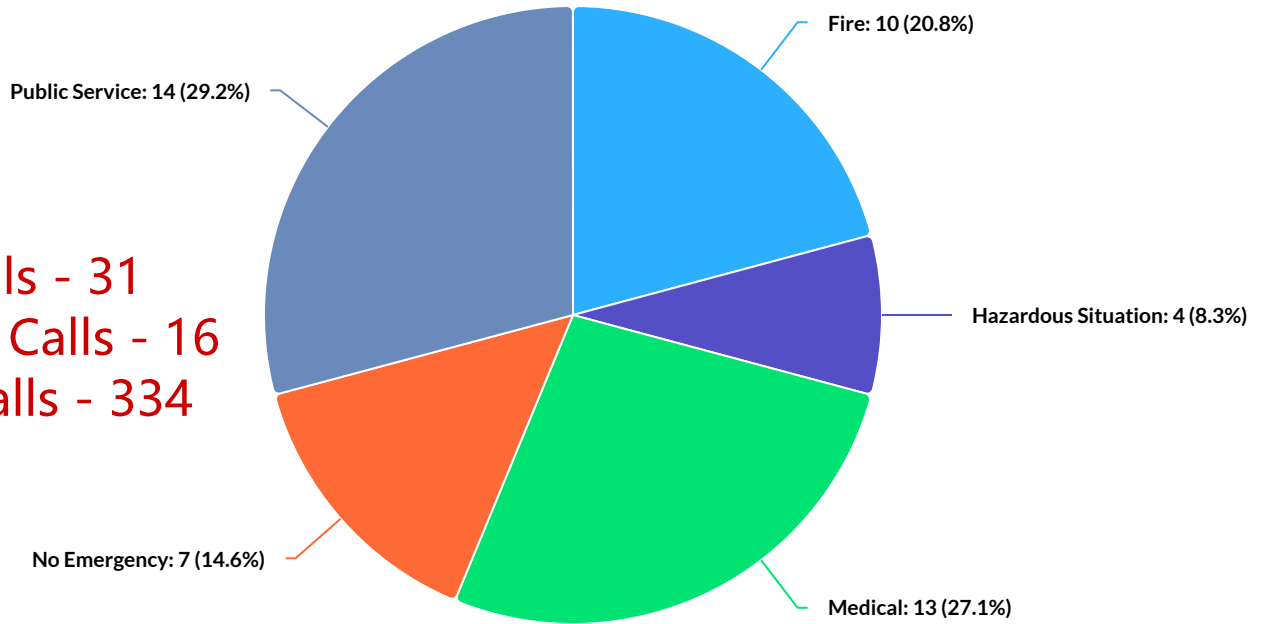

Fire	Hazardous Situation	Medical	No Emergency	Public Service
10	4	13	7	14

Primary Incident Type	Count	Percentage
Cancelled	4	8.33%
Confined Cooking / Appliance Fire	1	2.08%
Controlled Burning (Authorized)	3	6.25%
Electrical Power Line Down / Arching / Malfunction	1	2.08%
Elevator / Escalator Rescue	1	2.08%
Fire Alarm	7	14.58%
Lift Assist	1	2.08%
Motor Vehicle Collision	13	27.08%
Smoke Investigation	3	6.25%
Standby	5	10.42%

Section F, Item3.

Structural Involvement	1	2.08%
Vegetation / Grass Fire	4	8.33%
Vehicle Fire - Commercial	1	2.08%
Vehicle Fire - Passenger	3	6.25%
<b>Grand Total</b>	<b>49</b>	<b>100.00%</b>

This report runs off of the Dispatch Time. If you do not have a Dispatch Time in a report it will not show here.



emergencynetworking.com  
#5530



# City of Chipley

**CODE ENFORCEMENT**  
 1442 Jackson Avenue  
 P.O. Box 1007  
 Chipley, Florida 32428  
 (850) 638-6350 Fax: (850) 638-6318



## MARCH 2026

### 1. Total Active Cases: 3

These cases include multiple violations. Public Nuisance: **15** Violations

### 2. New cases opened this month: 1

### 3. Properties Posted this month: 4

### 4. Cases brought before this month's Special Magistrate: 0

### 5. Cases Closed this Month: 0

These cases include multiple violations. Public Nuisance: **0** Violations

- **0** of these violations are from previous months.

### 6. Courtesy Letters Mailed Out: 15

### 7. Code Enforcement Verification: 0

### 8. Signage Removal: 20

### 9. Properties with Active Liens: 15

1. 1209 Campbellton Avenue 08/05/2020 Sent to attorney. **Hearing on 03/02/26.**
2. 1278 Holley Avenue (Two Liens) 08/05/2020 & 08/26/2022 Sent to attorney. **Foreclosed 03/04/26**
3. 592 Main Street 09/19/2022 Sent to attorney. **Foreclosed 12/03/25**
4. 746 West Boulevard 4/12/2023 Sent to attorney
5. 1167 6th Avenue 8/10/2023 Sent to attorney. **Attorney fees due 11/10/25**
6. 492 2nd Street 8/10/2023 Sent to attorney. **Foreclosed 03/04/2025**
7. 504 Martin Luther King Drive 11/21/23 Sent to attorney. **Stay until 02/02/26.**
8. 869 Chesnut Hill Street 12/4/23 Sent to attorney.
9. 737 Pecan Street 1/11/24 Sent to attorney.
10. 566 Martin Luther King Drive 6/26/24 Sent to attorney.
11. 618 Bennett Drive 6/26/24 Sent to attorney.
12. 618 9th Street 6/26/24 Sent to attorney.
13. 550 Bennett Drive 12/26/2024 (**TD auction 02/10/26 a surplus has been applied for.**)
14. 1257 Plum Ave 03/04/2025 Liens.
15. 499 Martin Luther King Drive 01/09/2023 (**TD auction 01/27/26 a surplus has been applied for.**)



**CITY OF CHIPLEY  
PLANNING & ZONING REPORT  
FOR THE MONTH OF MARCH 2026**



**TO:** City Council  
**FROM:** Tamara Donjuan – Planning Officer  
**DATE:** April 1, 2026

---

- (1) Land Use Compliance Certificates: 24**
- (2) Tree Removal Permits: 2**
- (3) Demolition Permits: 1**
- (4) Zoning Changes: 0**
- (5) Planning and Zoning Hearing: 0**
- (6) Signage Permit: 4**
- (7) Variances: 0**
- (8) Development Orders: 0**
- (9) Request to Site Manufactured Home Unit: 0**
- (10) Request for Certificate of Appropriateness: 0**
- (11) Construction Permits: 0**
- (12) Zoning Verifications: 0**
- (13) Solicitor Permit: 0**
- (14) Alcoholic Beverages and Tobacco: 0**

## 03/01/2026 - 03/31/2026

Permit Type	Applicant Name	Description	Land Use Designation	Owner Name	Parcel Address
Demolition	Altreas Ward	Demo of residence	Low Density Residential	WARD ALTREAS R	651 PEARSON ST
Land Use Compliance	Brittney Leigh Sanders	HVAC Replacement	Low Density Residential	BRITTNEY LEIGH SANDERS	828 5TH ST
Land Use Compliance	Tamara Donjuan	Fence Installation	Low Density Residential	Edgar & Tamara Donjuan	770 Glenwood Ave
Land Use Compliance	Anthony Pate	Fence Installation	Low Density Residential	ANTHONY JOEL & ANNA ALYSSA PATE	632 MAIN ST
Land Use Compliance	Matthew Sawyer	Fence Installation	Low Density Residential	SAWYER MATTHEW L & CHELSEA	641 5TH ST
Land Use Compliance	Washington County EMS	Electrical	Public/Semi-Public/Educational	Washington County Government Annex	818 3rd Street
Land Use Compliance	City of Chipley	Lift Station Rehab	Low Density Residential	SHARPE ANGELA	710 PEACH ST
Land Use Compliance	Destiny Davis	Renovations/Electrical	Low Density Residential	DESTINY L DAVIS	996 HAYWOOD DR
Land Use Compliance	Eduardo Gonzalez	Fence Installation / New Siding	Low Density Residential	Itzel Garcia & Eduardo Gonzelez	1237 COURT AVE
Land Use Compliance	Melissa Martin	New Construction	Low Density Residential	Jason & Melissa Martin	1300 Church Ave
Land Use Compliance	Robert D Towne	Portable carport for boat	Low Density Residential	ROBERT DAVID TOWNE	645 GROVE ST
Land Use Compliance	Christopher Chambers	Portable shed	Low Density Residential	C CHAMBERS & A L CARTHON	584 RHYNES LN
Land Use Compliance	Latonia McKinnie	Reroof Installation	Low Density Residential	LATONIA MC KINNIE	1167 6TH AVE
Land Use Compliance	Theodis Lee	Fence Installation	Low Density Residential	Theodis Lee	1246 CHURCH AVE
Land Use Compliance	Susanna Curlett	Solar Installation	Commercial	SUSANNA CURLETT	781 MAIN ST

Land Use Compliance	Chipola Area Habitat for Humanity	Renovations / Fencing	Historic Commercial	HABITAT FOR HUMANITY WASH CO	1368 NORTH RAILROAD AVE
Land Use Compliance	Cheryl Dentavious & Bryant	Roof Replacement	Low Density Residential	DENTAVIOUS & CHERYL BRYANT	753 ORANGE ST
Land Use Compliance	Microproperties Corner LLC Arby's DBA	Water Heater Change Out	Commercial	MICROPROPERTIES CORNER LLC	1600 MAIN ST
Land Use Compliance	Ronnie's Carwash	Plumbing Installation	Neighborhood Commercial	HARDING R DOUGLAS / BILLY R SMITH JR	941 MAIN ST
Land Use Compliance	Damarius Jones	Garage Installation	Low Density Residential	DAMARIUS J JONES	796 ORANGE ST
Land Use Compliance	Tracy Andrews	Fence Installation	Low Density Residential	ANDREWS TRACY L	802 ORANGE ST
Land Use Compliance / Signage	McDonalds USA LLC	Land Use / Signage	Commercial	MCDONALD'S USA LLC% STEVEN KILLEBREW	1291 MAIN ST
Land Use Compliance	Theodis Lee	Roof Replacement	Low Density Residential	Theodis Lee	1246 CHURCH AVE
Land Use Compliance	Juanita Finney	Screen Enclosure	Low Density Residential	FINNEY ALFRED & JUANITA	562 BENNETT DR
Sign	Teresa Shannon	Signage	Commercial	LINDA BARTON	719 7TH ST
Sign	Werner KIA and Hyundai	2 Temporary Signage (Banners)	Commercial	KENT CHARLES & JAMEY WESTBROOK	1332 MAIN ST
Tree Removal	Theresa Malloy	Tree Removal (2)	Low Density Residential	DST / THERESA MALLOY	737 SINCLAIR ST
Tree Removal / Signage	Joe Bailey	Tree Removal / Temporary Signage	Low Density Residential	BAILEY JOE	728 1ST ST

4/1/2026



# Michael Richter, Chief of Police

*Chipley Police Department City of Chipley, Florida*  
 1430 JACKSON AVENUE, • P.O. BOX 1007 • CHIPLEY, FLORIDA 32428  
 PHONE (850) 638-6310 • FAX (850) 638-6327

## MONTHLY ACTIVITY REPORT

March 1- March 31, 2026:

<u>OFFENSE:</u>	<u>NUMBER:</u>
WARRANT SERVICE	7
INFORMATION	3
TRANSPORT	1
WELFARE CHECK	1
AGENCY ASSIST	2
CIVIL ISSUE	1
DISTURBANCE	0
DISTURBANCE: VERBAL	2
ABUSE COMPLTAIN: ADULT	1
DECEASED PERSON	0
MISSING PERSON	0
SEX OFFENSE	0
BATTERY	0
ASSAULT	0
HARASSMENT/THREATS	0
SHOTS FIRED	0
THEFT	2
BURGLARY: VEHICLE	0
FRAUD	1
CRIMINAL MISCHIEF	0
STOLEN VEHICLE	0
LOST/STOLEN FIREARM	1
TRESPASSING	2
FOUND/ABANDONDED PROPERTY	2
LOST/STOLEN PROPERTY	1
STOLEN TAG	2
SUSPICIOUS PERSON	4
DRUG CASE	5
DWLSR	3
TRAFFIC STOP	9
<b>TOTAL</b>	<b>50</b>



# Michael Richter, Chief of Police

*Chipley Police Department City of Chipley, Florida*  
1430 JACKSON AVENUE, • P.O. BOX 1007 • CHIPLEY, FLORIDA 32428  
PHONE (850) 638-6310 • FAX (850) 638-6327

## TRAFFIC TOTALS

	FEB (LAST MONTH)	MAR (THIS MONTH)
TRAFFIC CITATIONS	32	96
TRAFFIC WARNINGS	438	676
TRAFFIC CRASHES	10	17

## Traffic Crash Summary March 1- March 31, 2026:

<u>DATE:</u>	<u>Time:</u>	<u>Road:</u>	<u>Closest Crossroad:</u>	<u>Intersection:</u>	<u>Form:</u>
3/3	5:50pm	Main St.	Parking Lot- Walmart	Not Intersection Related	Short
3/4	1:20pm	Main St.	North RR Ave.	Not Intersection Related	Short
3/4	3:00pm	Main St.	Nadia Ave.	Not Intersection Related	Short
3/4	7:09pm	Glenwood Ave.	Bennett Dr.	Intersection Related	Long
3/4	7:34pm	Main St.	Nadia Ave.	Intersection Related	Long
3/7	6:00pm	Main St.	Parking Lot- KFC	Not Intersection Related	Short
3/9	9:46am	Main St.	S RR Ave.	Not Intersection Related	Short
3/10	12:09pm	Jackson Ave.	S 7 <sup>th</sup> St.	Intersection Related	Long
3/10	4:00pm	Jackson Ave.	Hoyt St.	Intersection Related	Long
3/13	6:40pm	Main St.	Parking Lot- Arby's	Not Intersection Related	Short
3/16	12:00pm	Church Ave.	Parking Lot- Piggly Wiggly	Not Intersection Related	Short
3/17	9:25am	Church Ave.	5 <sup>th</sup> St.	Intersection Related	Short
3/18	12:00pm	Main St.	Parking Lot- Tractor Supply	Not Intersection Related	Short
3/21	11:15am	Main St.	Parking Lot- Walmart	Not Intersection Related	Short
3/26	4:40pm	Brickyard Rd.	Parking Lot- Brickyard Market	Not Intersection Related	Short
3/27	12:30pm	South Blvd.	Parking Lot- Tax Collector	Not Intersection Related	Short
3/28	4:01pm	Main St.	E I-10/SR 8 Ramp	Not Intersection Related	Long



# City of Chipley



PUBLIC WORKS DEPARTMENT  
671 Rustin Drive  
P.O. Box 1007  
Chipley, Florida 32428  
(850) 638-6346 - Fax: (850) 638-6314

Monthly Departmental Report to City Council

**Date: March/2026**

Prepared by: Guy Lane

## Building Maintenance

1. **Daily-** (Shivers, Gilmore, Northside, Farmers Market) Pick up trash, clean and stock restrooms, and check for vandalism.
2. **Weekly-** (Glenwood Cemetery, Public Works, City Hall, Big Flag) Flag poles, ropes, flags, and lights are checked.
3. **Weekly-** (Glenwood Cemetery, Main Street, North & South Railroad Avenue, Farmers market) Empty the trash cans at these locations.
4. **Monthly-** (Public Works, City Hall, Fire Department, Police Department) Every month the lights, fire extinguishers, HVAC filters, smoke detectors, and timers are checked.
5. **Monthly-** (All traffic signals and crosswalks) The cabinets, filters, buttons and lights are checked at these locations.
6. **Monthly-** (Shivers, Northside, Gilmore) The playground equipment is checked monthly.
7. **Monthly-** Escort Cross Country to Jim Trawick Park and Bill Lee station for monthly service.
8. **Monthly-** Change door codes on bathrooms at Farmer's Market.

## March Work Orders

1. Replaced State of Florida flag at Glenwood Cemetery.
2. Straighten flags and banners at the Farmer's Market.
3. Replaced timer on downtown antique streetlamp and reset timers due to time change.
4. Assembled a bookcase for City Hall.
5. Met with customers at Glenwood Cemetery to purchase plot.
6. Got quotes from auto body shops for City Administrator's truck repair.
7. Replaced a flag at the Historical Society.
8. Worked on electrical at Mongoven Building for antique streetlamps.
9. Took big USA flag down due to inclement weather and put back up.
10. Replaced bulb, photocell and contact switch on the lights at the big flag at Wendy's.

## Water Department

1. **Monthly**- We have 243 fire hydrants in the system. We flush approximately 20 per month. We do this to ensure the hydrant is operating properly. We also weed eat around the hydrants, so they are easy to see and access.
2. **Monthly**- We have 177 water valves in the system. We turn 20 per month. We do this to ensure the valves are not seizing up.
3. **Monthly**- We have 25 dead end lines in the system. We try to flush at least 5 per month. We do this to keep the water from becoming stagnant in these lines.

DEP requires we turn every hydrant, valve, and dead-end line at least once per year. We record the dates and times for our DEP inspections.

Locates	35
Service Leaks	12
After Hours Service Leaks	2
Water Availability Request	0
Water Taps	1
Water Main Breaks	4

### March Work Orders

1. Re-reads for City Hall.
2. Assisted Street Department with tree removal on 1<sup>st</sup> Street.
3. Assisted Building Maintenance Department with lighting.
4. Spotted water lines on Bennett Drive for contractors.
5. Put lime rock on drive at Old Roulhac.
6. Cut limbs back from around fire hydrants at the Industrial spray field.
7. Counted streetlights on Hwy 90 & Hwy 77.
8. Pulled meter at 651 Pearson Street for house demo.
9. Added cold mix to patch on 8<sup>th</sup> Street.
10. Cut dirt down around drain and added under sidewalk on South Blvd.
11. Cleaned leaves at Jim Trawick Park for baseball opening.
12. Lifted PBWN on McDougald Drive.
13. Put cold mix in old patch on Sinclair Street.

### **Water Meter Technician**

Water Connects	21
Water Disconnects	29
Re-Reads	1,115
Door Knockers	45
Replaced Meter Boxes	2
Replaced Meter Lids	1
Hydrant Meter Set	2
Set meters	0

## Street Department

### March Work Orders

1. Sign maintenance.
2. Equipment maintenance.
3. Maintained streets, sidewalks and driveways.
4. Special pickups.
5. Limb pickups 4 days.
6. Leaf pickup 2 days.
7. Mowed ditch between Hwy. 77 & MLK Dr. approximately 600 feet.
8. Mowed ditch on Watts Avenue to ditch between MLK Dr. & Hwy. 77 approximately 350 feet.
9. Took out concrete driveway on 3<sup>rd</sup> Street due to slope and repoured.
10. Patched potholes in all Wards.
11. Assisted Sewer Department with sewer stoppage.
12. Checked outfall ditches and drains in all Wards.
13. Edged and cleaned sidewalks swept parking lots and cleaned up around the shop at Jim Trawick Park for opening baseball season.
14. Put mill material down on Warren Avenue between 2<sup>nd</sup> Street and 6<sup>th</sup> Street.
15. Hauled mill material that was purchased from Anderson-Columbia in Marianna.
16. Hauled off spoiled dirt to Washington County pit.
17. Assisted Water Department with water lines on Bennett Drive.

### Inmate Crew performed the following:

**Ward 1**-Cut and cleaned from old Fire Department and North Railroad Avenue. Assisted with cleaning up Jim Trawick Park for opening baseball season. Cut all of Ward 1 once then went back and cut roads that needed to be done.

**Ward 2**-Cut and cleaned Communication Tower. Cut and cleaned Plum Avenue. Cleaned and cut 7<sup>th</sup> Street and Campbellton Avenue. Cut all of 2<sup>nd</sup> Ward. Cut TJ Roulhac field.

**Ward 3**-Cut all of 3<sup>rd</sup> Ward. Cleaned ditch on 7<sup>th</sup> Street between houses then back on 7<sup>th</sup> Street and East Blvd.

**Ward 4**-Cut Iona Street and 5<sup>th</sup> Street. Cut and cleaned North and South 5<sup>th</sup> Street. Cut 1<sup>st</sup> Street, 2<sup>nd</sup> Street, 3<sup>rd</sup> Street and Coleman Avenue, Sinclair Street and Forrest Avenue, Dalton Street, West Blvd., Westbourne Avenue, Cypress Avenue, Cherry Avenue, Estelle Avenue and Wells Avenue.

Vehicle/Equipment Maintenance

## Gas Department

1. **Weekly**- Change Gas Charts.
2. **Weekly**-Check regulator station and odorant station.
3. **Monthly**- Check the voltage at the Rectifier Station.
4. **Monthly**- Conduct field odorant test.
5. **Monthly**- Check odorant station to ensure adequate odorant is injected into the system.
6. **Monthly** -Check cathodic protection in all wards.

Locates	39
Gas Calls	4
New Service – Upgraded	1
Pressure Test	1
Replaced Meters	1
Pulled Inactive Meters	0
Replaced Gas Warning Signs	36
Gas Availability Request	1
Abandonments	0
Gas Connects	0
Gas Disconnects	0

March Work Orders

1. Raised valve box at 6<sup>th</sup> Street and Hwy. 77.
2. Assisted Water Department with water leaks on Bennett Drive, moving a water line on Campbellton Avenue & Bennett Drive and replacing a water line at Pecan St. & Church Ave.
3. Spotted and located gas lines for contractors on Bennett Drive for paving project.
4. Assisted with re-reads for City Hall.
5. Ran new gas service to 1388 Forrest Avenue.
6. Assisted Building Maintenance with pressure washing City Hall and Jim Trawick Park.
7. Assisted Building Maintenance with installing new toilet paper dispensers in bathrooms at City Hall.

**Animal Control**

Animal Complaints	15
Cats Impounded	7
Dogs Impounded	1
Dog Bite Cases	0
Dead Animal Pick up	1

# *City of Chipley*

**RECREATION DEPT.**

1442 Jackson Avenue

P.O. Box 1007

Chipley, Florida 32428

(850) 638-6348 Fax: (850) 638-6318



## **Recreation Department**

### Report for March 2026

1. Started Baseball Practice.
2. Prepared Park for Opening Night, April 10<sup>th</sup>.
3. Updated Entrance sign.
4. Gym Maintenance
5. Equipment Maintenance.
6. Field Maintenance.
7. Splashpad Maintenance.
8. Grounds and Janitorial Maintenance.



# City of Chipley

**Water Utilities Department  
P. O. Box 1007  
Chipley, Florida 32428  
(850) 638-6347 - Fax: (850) 638-6052**

**April 1, 2026**

## **Water Utilities Department Report for March 2026**

To: City Council and Administrator

**Wastewater Treatment Facility:** The analytical results of the Wastewater Reclamation Facility for the month of February 2026 showed no violations. We have not received all the results from March 2026, but what have received show no violations. All clean outs have been plotted in diamond maps. Continue smoke testing. Both SBRs back online.

**Lift Stations:** Routine inspections. Cut grass at all lift stations.

**Water Wells:** The bacteriological samples for the month of March 2026 passed. Check generators weekly. Cut Grass

**Spray Field:** Routine inspections of spray field. Repaired leak at Pike Pond spray field. Cut grass at spray field.

**Main Jetted: 1**

**Locates: 38**

**Work orders: 7**

**Sewer Stoppages: 5**

**Abonnement Sewer Lateral: 1**

**Replace Clean Out Caps: 3**

**Sewer Taps: 0**

**Replace/Repair Sewer Lateral: 1**

**Development Order: 1**

**Install Clean Out Boxes: 16**

**Replace Clean Outs: 1**

**Demolition Order: 1**

**Rain Guards installed: 1**

**Raised manholes: 0**

**Recorded Rainfall for the month: 1.50 inches**

Jimmy Cook  
Water Utilities Director





# Finance Office Report - March 2026

## City of Chipley, Florida

1442 Jackson Avenue • Post Office Box 1007  
 Chipley, Florida 32428  
 Phone: (850) 638-6350 • Fax: (850) 638-6318

To:	Mayor and Council
From:	Jamie A. Richter - Finance Director
Date:	April 7, 2026
Subject:	Finance Office Report - March 2026

### Monthly Activity Summary

Activity	Previous Month	Current Month
Utility bills (normal billing cycle)	2,048	2,050
New accounts opened	15	24
Accounts closed	17	14
Accounts transferred	0	03
Work orders issued	74	122
Availability of service forms issued	3	1
Business licenses issued	6	9
Credit card payments (counter/phone)	286	315
Online payments (credit card/e-check)	419	426
Notary Service	01	02
Purchase Orders issued	109 - \$120,003.75	112 - \$108,138.18
Accounts payable - checks issued	51 - \$776,078.08	162 - \$870,776.86

### Delinquent Accounts & Service Disconnections

Category	Previous Month	Current Month
Delinquent accounts (early cycle)	414 (02/19/26)	345 (03/20/26)
Customer contacts (door notices & calls)	67	61
Delinquent accounts (late cycle)	200 (02/26/26)	173 (03/30/26)
Service disconnections	48	69

**Notes:**

Disconnects began on **March 30, 2026** and were still in progress as of **April 1, 2026**.

Please contact me if you have any questions or need additional information.

**City of Chipley  
Schedule of Projects**

Section F, Item 11.

Federal or State Agency	Agreement Number	Type of Work	Number	Funding Amount	Agreement Effective Date	Agreement End Date
<p><b>Chipley Water Meter Upgrade Project</b> Northwest Florida Water Management District</p>	<p>Consultant: Liberty Partners of Tallahassee</p>			<p>\$1,037,119.00</p>		
<p>Project: This funding will upgrade and replace all water meters in the city automatic meter read system. This project was not approved for funding.</p>						
<p><b>2025 PHMSA Technical Assistance Grant</b> U.S. Department of Transportation, Pipeline and Hazardous Materials Safety Administration, Technical Assistance Grants</p>	<p>Consultant: Florida Gas Utility</p>	<p>Equipment Purchase</p>	<p>20.710</p>	<p>\$ 60,863</p>		
<p>Project: The 2025 PHMSA Technical Assistance Grant which will purchase GIS Mapping software and contracting and combustible gas detection equipment. This project was not approved for funding.</p>						
<p><b>Bennett Drive Resurfacing Project</b> Florida Department of Transportation, Small County Outreach Program (SCOP)</p>	<p>Consultant: David H. Melvin, Inc.</p>	<p>Design Construction CEI</p>	<p>55.009</p>	<p>\$ 794,759.57</p>	<p>09/10/24</p>	<p>12/31/25</p>
<p>Project: This funding will be used for drainage and resurfacing improvements to Bennett Drive from East Church Ave. to Glenwood Avenue (approx. 0.52 miles). The engineering agreement was approved by the City Council in January 2025 and the design is 100% complete. The construction and CEI contracts were approved in October 2025. The preconstruction meeting was held and the NTP was issued with a start date of January 12, 2026. The construction is progressing and is 19% complete.</p>						
<p><b>FDEP I &amp; I Planning Project</b> Florida Department of Environmental Protection, Cleanwater Program</p>		<p>Planning Design</p>		<p>\$ 500,000.00</p>		
<p>Project: This project will fund planning and design of the collection system and pump stations to develop targeted strategies for preventing future sanitary sewer overflows (SSO's) by working toward inflow and infiltration issues within our sanitary sewer system. The resolution to submit the application was approved by council last month and was submitted for funding.</p>						

Federal or State Agency	Agreement Number	Type of Work	Number	Funding Amount	Agreement Effective Date	Section F, Item 11.
<b>Chipley Lead Service Line Replacement</b> Florida Department of Environmental Protection, Drinking Water State Revolving Fund	Consultant: Mott MacDonald	Planning Engineering Construction Technical Services		\$ 275,000 \$540,000 \$8,800,000 \$640,000 \$ 10,255,000.00		
Project: This grant/loan funding will allow us to replace any lead service lines that are found during the inventory that is currently being completed. The inventory has been completed and we have not received further direction from FDEP at this time.						
<b>Shivers Park Project</b> Florida Department of Environmental Protection, Florida Recreation Development Assistance Program (FRDAP)	Consultant: Fred Fox Enterprises	Development	37.017	\$ 200,000	12/02/24	06/30/27
Project: The City Council approved the agreement in November 2024. This funding will be used to construct pickleball courts, an ADA playground and sidewalks to the new courts and playground, along with renovations to the existing parking lot, playground area, picnic pavilion and restrooms. The construction of the pickleball courts has been advertised for bids and the bids will close on March 12, 2026.						
<b>Gilmore Park Project</b> Florida Department of Environmental Protection, Florida Recreation Development Assistance Program (FRDAP)	Consultant: Fred Fox Enterprises	Development	37.017	\$ 50,000	12/02/24	06/30/27
Project: The City Council approved the agreement in November 2024. This funding will be used to construct a new playground, picnic pavilion and security lighting, along with renovations to the existing playground, restrooms and parking lot. The required commencement documents have been submitted and approved by the State. We are currently working on elements of the project.						
<b>Law Enforcement Equipment</b> Florida Department of Law Enforcement Edward Byrne Memorial Justice Assistance Grant Program		Purchase Equipment	16.738	\$ 59,360	10/01/25	06/30/26
Project: This grant will purchase (6) in-car radios, (5) portable radios, (14) raincoats, (14) traffic vests, (10) duty belts, (14) tourniquets, (16) glock pistols with sights, (16) glock holsters, (50) boxes of 9mm ammunition, (100) boxes CCI target ammo, and (16) rifles. The majority of these items have been ordered and received.						

Federal or State Agency	Agreement Number	Type of Work	Number	Funding Amount	Agreement Effective Date	Section F, Item 11.
<b>2023 Bulletproof Vest Program</b> United States Department of Justice, Bureau of Justice Assistance, Bulletproof Vest Partnership	2023 BVP	Bulletproof Vests	16.607	\$ 1,275 Match \$ 1,275	04/01/23	06/30/26
Project: This funding will be used to purchase three (3) bulletproof vests. Bulletproof Vests have a life of five (5) years and then they are required to be replaced. This grant covers up to 50% of the cost of the vests. We are working on closeout of this grant.						
<b>Chipley Lift Station Generators Project</b> Federal Emergency Management Association, Florida Division of Emergency Management and Florida Department of Commerce, Comm. Development Block Grant	H0767  M0143 Consultant: Wheeler EMC	Generators	97.039  14.228	\$ 117,520 Match \$ 38,561	02/07/22  07/25/22	10/31/25  09/30/26
Project: This funding will be used to purchase one (1) generator for John Teal Lift Station and one (1) generator for Vo-Tech Lift Station. These generators will help during power outages related to hurricanes and prevent sewage spills. The generators have been installed, the electrical is complete, the additional fencing has been installed around the generators, and we are working on the closeout.						
<b>NW Stormwater System Restoration</b> U.S. Department of Housing & Urban Development, Florida Department of Commerce, Community Development Block Grant	M0014  Consultant: David H. Melvin, Inc.	Administration Engineering Construction CEI	14.228	\$ 2,916,119	04/25/22	09/30/26
Project: This funding will be used to clean, reshape and stabilize ditches, construct new lateral outfall ditches, and expand existing crossdrains in the Northeast section of the City. This will include new culverts and a major box culvert at Griffin Road. Project locations will be on or near the following: west of Griffin Road, Griffin Road, North and South Railroad Avenue, Old Bonifay Road, the corner of North Railroad Avenue and Rustin Drive, 1st Street, Watts Avenue, 2nd Street and Glenwood Avenue. The construction agreement was approved in October 2025 and the preconstruction meeting was held on 10/28/2025. The NTP was issued with a project begin date of January 26, 2026. The constructions has started and the work is progressing and is 45% complete.						
<b>Washington County Industrial Park Project</b>				\$ 7,714,100.00		
Project: This is a joint effort between the County and the City to develop water, sewer and gas infrastructure, along with a roadway in the Washington County Industrial Park.						

Federal or State Agency	Agreement Number	Type of Work	Number	Funding Amount	Agreement Effective Date	Section F, Item 11.
<b>City Hall and Public Works Generator Project</b> Federal Emergency Management Association, Florida Division of Emergency Management	Consultant: Liberty Partners	Purchase Two Generators		\$ 277,200.00		
Project: We are currently working on applying for a generator for the City Hall and Public Works buildings for storm related backup power through Legislative Appropriations. Awaiting funding approval.						
<b>Comprehensive Plan Update</b> Florida Commerce, Community Planning & Technical Assistance Grant				\$ 75,000.00		
Project: This funding will allow us to update our entire comprehensive plan. We have a resolution on the agenda this month for approval to resubmit for this funding cycle.						
<b>Chipley Mongoven Building</b> U.S. Department of Housing & Urban Development, Florida Department of Economic Opportunity, Community Development Block Grant	M0041  Consultant: David H. Melvin, Inc.	Engineering Construction CEI	14.228	\$ 1,027,102.81	04/14/22	09/30/26
Project: This funding will be used to purchase the Mongoven Building property, demolish the building, and build a nice park area. The property has been purchased and the demolition bids have been received. The change order for Phase III was approved at last months meeting and the work is 85% complete. The project is complete on the contractors side and we are working on a few additional items.						
<b>Chipley Peach Street Lift Station Improvements</b> U.S. Department of Housing and Urban Development, Community Development Block Grant	H2567  Consultant: Fred Fox Enterprises	Administration Engineering Construction CEI	14.228	\$ 700,000 CDBG-MIT Funds \$ 626,787 City Funds \$ 50,000.00	01/01/23	07/31/26
Project: This funding will be used to replace the Peach Street Lift Station and if the funds are available also complete septic to sewer on 1st Avenue. The Notice to Proceed for construction was issued in July 2025. The construction started on this project on 10/13/2025 and it is currently at 60% complete, with an estimated project completion date of May 2026.						

Federal or State Agency	Agreement Number	Type of Work	Number	Funding Amount	Agreement Effective Date	Section F, Item 11.
<b>Downtown Beautification Grant</b> Florida Department of Transportation, Beautification Grant Program				\$ 153,460.00		
Project: This project funding will assist us in replacing existing landscape trees and bushes to create a more attractive and ADA-accessible corridor. We will include new landscape trees, tree wells, and lower ground cover as part of the improvements. Currently waiting for funding approval.						
<b>Citywide Flooding Resiliency Improvements</b> U.S. Department of Housing and Urban Development, Community Development Block Grants (CDBG-MIT) General Infrastructure Program	MT148	Administration Engineering Construction CEI	14.228	\$ 2,936,950	01/19/23	01/19/27
Consultant: David H. Melvin, Inc. Project: This funding will be used to clean, reshape and stabilize existing ditches, construct new lateral outfall ditches; restore and expand existing cross drains to ensure proper conveyance to the stormwater management facility. This project has been advertised for construction bids and awarded. The construction is approximately 80% complete with an estimated completion date of July 2026.						
<b>Brickyard Road Wastewater Design Project</b> Florida Department of Commerce, Rural Infrastructure Fund		Planning	40.042	\$ 295,000	12/06/24	12/06/26
Consultant: Liberty Partners of Tallahassee and Mott MacDonald Project: This funding will be used for the design, engineering, and survey work needed to extend public sanitary sewer service approximately 5,500 linear feet along Brickyard Road. This is a critical east/west corridor, and the extent of the project includes SR-77 to Hoyt Street. The agreement between the City and Mott MacDonald has been approved and the survey data is 100% complete and design is 30% complete. We have a resolution to approve an amendment to the grant agreement on the agenda for approval this month.						
<b>Chipley Fire Tanker Truck</b> U.S. Department of Homeland Security Assistance to Firefighters Grant		Fire Tanker		\$ 650,000.00		
Consultant: Liberty Partners of Tallahassee Project: This funding will be used to purchase a new Fire Tanker Truck. We are awaiting funding approval.						

Federal or State Agency	Agreement Number	Type of Work	Number	Funding Amount	Agreement Effective Date	Section F, Item 11.
<b>2024 Bulletproof Vest Program</b> United States Department of Justice, Bureau of Justice Assistance, Bulletproof Vest Partnership	2024 BVP	Bulletproof Vests	16.607	\$ 1,045 Match \$ 1,045		08/31/26
Project: This funding will be used to purchase two (2) bulletproof vests. Bulletproof Vests have a life of five (5) years and then they are required to be replaced. This grant covers up to 50% of the cost of the vests. We are working on closeout of this grant.						
<b>Firearm Training</b> Florida Department of Law Enforcement Edward Byrne Memorial Justice Assistance Grant Program, Florida JAG Direct		Purchase Ammunition	16.738	\$ 1,360	10/01/25	06/30/26
Project: This grant will purchase non-lethal training rounds of Simunition FX ammunition. This grant has been approved and the ammunition has been ordered.						
<b>Gilbert Acres Stormwater Improvements</b> Florida Department of Environmental Protection, Resilient Florida Program		Planning Design		\$ 336,000		
Consultant: David H. Melvin, Inc.						
Project: If approved, this funding will be used to improve the outfalls from Gilbert Acres to the west (toward Alligator Creek) and back to the east toward US 90, where the City also has the Peach Street project and lift station project. This project was approved for funding and we have a resolution on the agenda for approval this month to approve the agreement.						
<b>Utility Kiosk</b>						
Project: We have reached out to companies about kiosks and we are currently working with our software provider to determine the best route for us to go in order to be able to make the most efficient use of the equipment we purchase. Some kiosks are compatible and some are not so we are working through that and will know more soon. Now that we have worked through the finalization of the ARPA funding we should be able to now move forward with this project utilizing city funds. I am waiting until we know for sure what we will need for the Peach Street project.						
<b>Chipley Downtown Parking Project</b> Florida Department of Commerce, Rural Infrastructure Fund		Design Construction		\$911,980		
Consultant: David H. Melvin, Inc.						
Project: This funding will be used to construct and rehabilitate a city-owned propert (the old Fire Station) to alleviate the parking insufficiency in the downtown area. We have reapplied for this project this grant cycle. This project was not approved for funding.						

Federal or State Agency	Agreement Number	Type of Work	Number	Funding Amount	Agreement Effective Date	Section F, Item 11.
<b>Old Chipley City Hall - Construction</b> Florida Department of State, Division of Historical Resources		Construction  Design/Construction		\$ 338,000 City Match \$75,000		
Project: This funding will be used for a new roof system/blocking/hurricane ties/repair roof framing. The city will be required to match \$75,000 for design and construction. We are awaiting approval of this funding.						
<b>COPS Hiring Grant Program</b> U.S. Department of Justice, COPS Hiring Grant Program				\$ 250,000.00 Match \$ 315,000.00		
Project: This funding will allow us to hire two (2) additional police officers. This grant and the matching funds are over a three year period. We have been awarded this funding and we have hired two Police Officers that will be partially funded by this grant.						
<b>Chipley Wastewater Energy Efficiency Project</b> Florida Department of Agriculture & Consumer Services, Florida's Fiscally Constrained Energy Efficiency Program	Consultant: David H. Melvin, Inc.			\$ 661,500	07/07/25	07/31/26
Project: This funding will be used to optimize energy consumption, reduce operational costs, and ensure compliance with regulatory standards. The goal is to replace pumps/motors/scada system to enhance the performance and sustainability of our wastewater treatment processes. The grant administration and engineering agreements have been approved and the design is complete. We are working on the bid approval at this time.						
<b>Jim Trawick Park - Phase X</b> Florida Department of Environmental Protection, Florida Recreation Development Assistance Program (FRDAP)	Consultant: Fred Fox Enterprises	Development	37.017	\$ 200,000		
Project: This funding will be used for Soccer Field Renovation, Playground Renovation to include ADA Equipment; Baseball Field No. 7 Renovation, Softball/T-Ball Field No. 8 Renovation, Add Exercise Station to Walking Trail, Picnic Facility Renovation, New Batting Cages, New Bleachers, Sidewalk to Batting Cages and Sidewalk to Playground Renovation. We have reapplied for this funds and are awaiting approval.						

Federal or State Agency	Agreement Number	Type of Work	Number	Funding Amount	Agreement Effective Date	Section F, Item 11.
<b>State of Florida Legislative Appropriations Request - Police Vehicles &amp; Equipment</b>  Consultant: Liberty Partners of Tallahassee  Project: This funding will purchase new police vehicles along with some much needed police equipment that the city has been unable to purchase during the budget cycle. This project was not funded during the last legislative session but we have resubmitted and are awaiting approval.		Purchase Vehicles and Equipment		\$ 500,000.00		
<b>State of Florida Legislative Appropriations Request - Pecan Street Resurfacing</b>  Consultant: Liberty Partners of Tallahassee  Project: This funding will allow us to work on the drainage and resurfacing of Pecan Street. This project was funded during the legislarive session and we utilized our continuing engineering services agreement and David H. Melvin, Inc. has started the design on this project.		Design Construction		\$ 750,000.00		10/31/26
<b>State of Florida Legislative Appropriations Request - Construction for Bickyard Road Sewer</b>  Consultant: Liberty Partners of Tallahassee  Project: This funding will allow us to construct the 5,500 linear feet of gravity sewer main on Brickyard Road that we are currently advertising for engineering services. This project was not funded during the legislative session but we have resubmitted and are awaiting approval.		Construction		\$ 1,000,000.00		
<b>Wastewater Facilities Plan</b> Florida Department of Environmental Protection - State Revolving Fund  Consultant: Mott MacDonald  Project: This funding will allow us to have a Wastewater Facilities Plan prepared in order to allow for us to apply for future State Revolving Fund funding. This project is currently in progress.		Planning		\$ 90,000.00		08/15/26
<b>Drinking Water Facilities Plan</b> Florida Department of Environmental Protection - State Revolving Fund  Consultant: Mott MacDonald  Project: This funding will allow us to have a Wastewater Facilities Plan prepared in order to allow for us to apply for future State Revolving Fund funding. This project is currently in progress.	DW670140	Planning	66.468	\$ 90,000.00		10/15/26

Federal or State Agency	Agreement Number	Type of Work	Number	Funding Amount	Agreement Effective Date	Section F, Item 11.
<b>FDEP Septic to Sewer Project</b> Florida Department of Environmental Protection , Nonpoint Source Grant Program		Design Construction		\$ 1,325,500.00		
Project: This funding will allow us to improve water quality, protect public health, and enhance wastewater infrastructure by moving 32 septic systems onto our city sewer system. This project was not approved for funding.						
<b>Pecan Street Improvements Project</b> Florida Department of Transportation, Municipal SCOP		Design CEI Construction		\$ 1,844,457.98 (\$750,000.00 Legislative Appropriations Approved)		
Project: This funding will allow us to make improvements to Pecan Street from South Boulevard to Church Avenue, which is approximately .738 miles. This project has been approved for funding and we will receive an agreement from FDOT in mid 2026.						
<b>FDEP I &amp; I Planning Project</b> Florida Department of Environmental Protection, Cleanwater Program		Planning Design		\$ 500,000.00		
Project: This project will fund planning and design of the collection system and pump stations to develop targeted strategies for preventing future sanitary sewer overflows (SSO's) by working toward inflow and infiltration issues within our sanitary sewer system. The resolution to submit the application was approved by council last month and was submitted for funding.						

**Proclamation**

**Lupus Awareness Month  
May 2026**

**WHEREAS**, lupus is a chronic autoimmune disease that can cause inflammation, pain, and damage to any part of the body, affecting millions of people worldwide; and

**WHEREAS**, lupus disproportionately impacts women of color, particularly Black women, who are three times more likely to develop the disease and experience more severe symptoms; and

**WHEREAS**, the month of May is recognized nationally as Lupus Awareness Month to educate, support, and encourage those living with lupus and to promote earlier diagnosis, treatment, and research; and

**WHEREAS**, community awareness and advocacy are vital in improving access to care and resources for individuals and families affected by lupus; and

**WHEREAS**, Mesha McLean, the founder of the Fight of the Butterfly movement, has worked to raise awareness, advocate for and empower lupus warriors, and promote understanding of chronic illness throughout the Southeastern United States; and

**WHEREAS**, the City of Chipley acknowledges the courage, strength, and perseverance of lupus warriors, caregivers, and advocates who continue to fight for visibility, understanding, and better healthcare outcomes;

**NOW, THEREFORE, BE IT PROCLAIMED** by the Mayor and City Council of the City of Chipley that, May 2026 is Lupus Awareness Month. I encourage all citizens to learn more about lupus, support those impacted, and join the Fight of the Butterfly movement in efforts to increase awareness and find a cure.

---

Tracy L. Andrews, Mayor

# CITY OF CHIPLEY

## STAFF REPORT

**SUBJECT:** Resolution No. 26-28 – Florida Department of Commerce Rural Infrastructure Fund (RIF) Grant Agreement No. D0299 – Brickyard Road Wastewater Project – Amendment No. 1

### MEETING DATE

Tuesday, April 14, 2026

### PREPARED BY

Patrice Tanner, City Administrator

### SUMMARY

This resolution will approve Amendment No. 1 for the Florida Department of Commerce Rural Infrastructure Fund (RIF) Grant Agreement No. D0299 – Brickyard Road Wastewater Project. It will add the following: DD. Contracting with Entities of Foreign Counties of Concern Prohibited; EE. Foreign Influence; FF. Human Trafficking; and replace the following: Section 1 – Project Description; Section 2 – Grantee's Responsibilities; Section 4 – Deliverables of Attachment 1, Scope of Work to be amended as follows: The City of Chipley (“Grantee”) will use funding for survey, design, and engineering work that is needed to extend the public sanitary sewer service approximately 3,100 linear feet along Brickyard Road and approximately 3,100 linear feet along Kirkland and Usery Road. The project will include final design and engineering plans to extend the wastewater main, including design elements to accommodate the conversion of existing businesses from individual lift stations or septic to central sewer.; Attachment 2, Audit Requirements; Attachment 3, Audit Compliance Certification.

### RECOMMENDATION

City Staff recommends approval of Resolution No. 26-28 – Florida Department of Commerce Rural Infrastructure Fund (RIF) Grant Agreement No. D0299 – Brickyard Road Wastewater Project

### ATTACHMENTS

1. Resolution No. 26-28
2. Agreement No. D0299 - Amendment No. 1

**RESOLUTION NO. 26-28**

**A RESOLUTION APPROVING AN AGREEMENT AMENDMENT IDENTIFIED AS AMENDMENT ONE TO THE FEDERALLY FUNDED RURAL INFRASTRUCTURE FUND (RIF) GRANT SUBRECIPIENT AGREEMENT NO. D0299, BETWEEN THE STATE OF FLORIDA, DEPARTMENT OF COMMERCE AND THE CITY OF CHIPLEY, FLORIDA.**

**WHEREAS**, the State of Florida, Department of Commerce “Commerce”, and the City of Chipley, Florida “Grantee” entered into agreement D0299 “Agreement”; and

**WHEREAS**, Commerce and the Grantee may individually be referred to herein as a “Party” or collectively as the “Parties”; and

**WHEREAS**, the Parties wish to amend the Sanitary Wastewater Improvements Project Agreement adding the following: DD. Contracting with Entities of Foreign Counties of Concern Prohibited; EE. Foreign Influence; FF. Human Trafficking; and replacing the following: Section 1 – Project Description; Section 2 – Grantee's Responsibilities; Section 4 – Deliverables of Attachment 1, Scope of Work; Attachment 2, Audit Requirements; Attachment 3, Audit Compliance Certification.

**NOW, THEREFORE, BE IT RESOLVED BY THE CITY COUNCIL OF THE CITY OF CHIPLEY, FLORIDA, THAT:**

1. The City of Chipley hereby approves the State of Florida, Department of Commerce Agreement No. D0299, Amendment One.
2. The City for and in consideration of the covenants and obligations set forth herein and for other good and valuable consideration, the receipt and sufficiency of which are hereby acknowledged, intending to be legally bound hereby agree to perform the duties of this agreement as amended.
3. The Mayor or Mayor Pro-Tem of the City of Chipley be hereby authorized and directed to execute the agreement.
4. A certified copy of this Resolution be forwarded to the FDEO along with the executed Agreement.

**PASSED AND ADOPTED THIS 14TH DAY OF APRIL, 2026.**

ATTEST:

\_\_\_\_\_  
Tracy L. Andrews, Mayor

\_\_\_\_\_  
Sherry Snell,  
City Clerk

DRAFT

**AMENDMENT ONE  
TO THE GRANT AGREEMENT BETWEEN  
THE FLORIDA DEPARTMENT OF COMMERCE  
AND  
THE CITY OF CHIPLEY, FLORIDA**

On February 19, 2025, the State of Florida, Department of Commerce (“Commerce”), and the City of Chipley, Florida, a unit of general local government (“Grantee”) (collectively the “Parties”), entered into Rural Infrastructure Fund (“RIF”) grant agreement D0299 (“Agreement”), pursuant to paragraph 288.0655(2)(c), Florida Statutes.

**WHEREAS**, Paragraph D, Modification, of the Agreement provides that any amendment to the Agreement shall be in writing executed by the Parties thereto; and

**WHEREAS**, the Parties wish to amend the Agreement as set forth herein;

**NOW THEREFORE**, in consideration of the mutual covenants and obligations set forth herein, the receipt and sufficiency of which are hereby acknowledged, the Parties agree to the following:

1. This Agreement is hereby amended to add the following:

**DD.CONTRACTING WITH ENTITIES OF FOREIGN COUNTRIES OF CONCERN  
PROHIBITED**

If applicable, and in accordance with section 287.138, F.S., a contract between a governmental entity and an entity which would give access to an individual’s personal identifying information which is executed, extended, or renewed on or after the dates provided in section 287.138(4), F.S., must include an attestation by the entity on Form PUR 1355, “Foreign Country of Concern Attestation Form,” which is incorporated herein by reference.

If applicable, Grantee must provide Commerce with a signed Foreign Country of Concern Attestation Form pursuant to section 287.138(4), F.S., and rule 60A-1.020, F.A.C.

**EE. FOREIGN INFLUENCE**

In accordance with section 286.101, F.S., if this Agreement has a value of \$100,000 or more, Grantee shall disclose to Commerce any current or prior interest of, any contract with, or any grant or gift received from a foreign country of concern if such interest, contract, or grant or gift has a value of \$50,000 or more and such interest existed at any time or such contract or grant or gift was received or in force at any time during the previous five (5) years. The disclosure requirements are more fully defined within the statute. Grantee represents that it is, and for the duration of this Agreement will remain, in compliance with section 286.101, F.S.

**FF. HUMAN TRAFFICKING**

If applicable, and in accordance with section 787.06, F.S., when a contract is executed, renewed, or extended between a nongovernmental entity and a governmental entity, the nongovernmental entity must provide the governmental entity with an affidavit signed by an officer or a representative of the nongovernmental entity under penalty of perjury attesting that the nongovernmental entity does not use coercion for labor or services as defined in that statute.

If applicable, Grantee must provide Commerce with an affidavit signed by an officer or a representative of Grantee under penalty of perjury attesting that Grantee does not use coercion for labor or services as defined in section 787.06, F.S.

- 2. Section 1, Project Description of Attachment 1, Scope of Work** is hereby deleted in its entirety and is replaced by the following:

**1. Project Description:**

Section 288.0655, Florida Statutes (“F.S.”), created the Rural Infrastructure Fund (“RIF”) to facilitate the planning, preparing, and financing of infrastructure projects in rural communities which will encourage job creation, capital investment, and strengthening and diversification of rural economies by promoting tourism, trade, and economic development.

Section 288.0655(2)(c), F.S., provides that Commerce may award grants for up to \$300,000 for infrastructure feasibility studies, design and engineering activities, or other infrastructure planning and preparation activities in order to facilitate timely response and induce the location or expansion of specific job creating opportunities in rural communities.

The City of Chipley (“Grantee”) will use funding for survey, design, and engineering work that is needed to extend the public sanitary sewer service approximately 3,100 linear feet along Brickyard Road and approximately 3,100 linear feet along Kirkland and Usery Road. The project will include final design and engineering plans to extend the wastewater main, including design elements to accommodate the conversion of existing businesses from individual lift stations or septic to central sewer.

- 3. Section 2, Grantee’s Responsibilities of Attachment 1, Scope of Work** is hereby deleted in its entirety and is replaced by the following:

**2. Grantee’s Responsibilities:** Grantee shall, in addition to all other requirements set forth in the Agreement and this Scope of Work, complete the following tasks:

- A. Survey- Brickyard Road
  - a. Complete survey of approximately 3,100 linear feet along Brickyard Road.
  
- B. Design – Brickyard Road
  - a. Complete design and engineering of approximately 5,500 linear feet of PVC gravity main, utility relocation, 1,600 linear feet of asphalt pavement repair/resurfacing, removal of abandoned lift stations, and design of the new force main.
  
- C. Survey- Kirkland Road, Usery Road, and Vo Tech Pump Station
  - a. Complete survey of Vo Tech Pump Station and surrounding area.
  - b. Complete survey of approximately 2,700 linear feet along Kirkland Road.
  - c. Complete survey of approximately 400 linear feet along Usery Road.
  
- D. Design- Kirkland and Usery Road
  - a. Evaluate and design rehabilitation of Vo Tech Pump Station to include changes in pump design, electrical design, piping design, site design, and any other items needed to design a fully operational pumping station.
  - b. Evaluate and design new utilities to include design of water and wastewater facilities, utility relocation and adjustment, and roadway repair/resurfacing.

4. **Section 4, Deliverables of Attachment 1, Scope of Work** is hereby deleted in its entirety and is replaced by the following:

4. **DELIVERABLES:** Grantee agrees to provide the following services as specified:

<b>Deliverable No. 1 – Survey- Brickyard Road</b>		
<b>Tasks</b>	<b>Minimum Level of Service</b>	<b>Financial Consequences</b>
Grantee shall complete Survey-Brickyard Road activities in accordance with Section 2.A. of this Scope of Work.	Grantee may be allowed reimbursements upon 20% increments up to 80%, and 100% completion of identified tasks in accordance with Section 2.A of this Scope of Work, evidenced by submission to Commerce’s Agreement Manager of the following:  1)Invoice package as defined by Section 6 of this Scope of Work.  2)Copy of survey.	Failure to complete the Minimum Level of Service as specified shall result in non-payment.  Commerce shall withhold 20% of the total deliverable amount until Grantee provides proof to Commerce, and Commerce accepts, that the deliverable is 100% complete.
<b>Deliverable No. 1 Not to Exceed: \$37,500.00</b>		
<b>Deliverable No. 2 – Design- Brickyard Road</b>		
<b>Tasks</b>	<b>Minimum Level of Service</b>	<b>Financial Consequences</b>
Grantee shall complete Design-Brickyard Road activities in accordance with Section 2.B. of this Scope of Work.	Grantee may be allowed reimbursements upon 10% increments up to 90% and 100% completion of identified tasks in accordance with Section 2.B of this Scope of Work, evidenced by submission to Commerce’s Agreement Manager of the following:  1)Invoice package as defined by Section 6 of this Scope of Work.  2)Copy of final designs, site plans, plans and specifications.  3)Copy of all required permits.  4)Copy of City Commission Meeting minutes reflecting approval of construction contractor.	Failure to complete the Minimum Level of Service as specified shall result in non-payment.  Commerce shall withhold 10% of the total deliverable amount until Grantee provides proof to Commerce, and Commerce accepts, that the deliverable is 100% complete.
<b>Deliverable No. 2 Not to Exceed: \$124,696.00</b>		
<b>Deliverable No. 3 – Survey- Kirkland Road, Usery Road and Vo Tech Pump Station</b>		
<b>Tasks</b>	<b>Minimum Level of Service</b>	<b>Financial Consequences</b>
Grantee shall complete Survey-Kirkland Road, Usery Road and Vo Tech Pump Station activities in accordance with Section 2.C. of this Scope of Work.	Grantee may be allowed reimbursement upon 50% and 100% completion of identified tasks in accordance with Section 2.C of this Scope of Work, evidenced by submission to Commerce’s Agreement	Failure to complete the Minimum Level of Service as specified shall result in non-payment.

	Manager of the following:  1) Invoice package as defined by section 6 of this scope of work.  2) Copy of surveys.	Commerce shall withhold 50% of the total deliverable amount until Grantee provides proof to Commerce, and Commerce accepts, that the deliverable is 100% complete.
<b>Deliverable No. 3 Not to Exceed: \$23,000.00</b>		
<b>Deliverable No.4- Design- Kirkland Road and Usery Road</b>		
<b>Tasks</b>	<b>Minimum Level of Service</b>	<b>Financial Consequences</b>
Grantee shall complete Design-Kirkland Road and Usery Road activities in accordance with Section 2.D. of this Scope of Work.	Grantee may be allowed reimbursements upon 10% increments up to 90% and 100% completion of identified tasks in accordance with Section 2.D of this Scope of Work, evidenced by submission to Commerce’s Agreement Manager of the following:  1) Invoice package as defined by Section 6 of this Scope of Work.  2) Copy of final designs, site plans, plans and specifications.  3) Copy of all required permits.  4) Copy of City Commission Meeting minutes reflecting approval of construction contractor.	Failure to complete the Minimum Level of Service as specified shall result in non-payment.  Commerce shall withhold 10% of the total deliverable amount until Grantee provides proof to Commerce, and Commerce accepts, that the deliverable is 100% complete.
<b>Deliverable No.4 Not to Exceed: \$109,804.00</b>		
<b>TOTAL AWARD NOT TO EXCEED: \$295,000.00</b>		

**COST SHIFTING:** The deliverable amounts specified within the Deliverables section 4 table above are established based on the Parties’ estimation of sufficient delivery of services fulfilling grant purposes under the Agreement in order to designate payment points during the Agreement Period; however, this is not intended to restrict Commerce’s ability to approve and reimburse allowable costs Grantee incurred providing the deliverables herein. Prior written approval from Commerce’s Agreement Manager is required for changes to the above Deliverable amounts that do not exceed **10%** of each deliverable total funding amount. Changes that exceed **10%** of each deliverable total funding amount will require a formal written amendment request from Grantee, as described in **MODIFICATION** section of the Agreement. Regardless, in no event shall Commerce reimburse costs of more than the total amount of this Agreement.

5. **Attachment 2, Audit Requirements**, is hereby deleted in its entirety and replaced with the attached Attachment 2, Audit Requirements.
6. **Attachment 3, Audit Compliance Certification**, is hereby deleted in its entirety and replaced with the attached Attachment 3, Audit Compliance Certification.
7. All other terms and conditions of the Agreement not in conflict with this Amendment remain in full force and effect and are to be performed as specified in the Agreement.

Commerce Agreement Number: Section H, Item 1.

**IN WITNESS HEREOF**, by signature below, the Parties agree to abide by the terms, conditions, and provisions of Agreement D0299, as amended. The terms of this Amendment will become effective upon execution by Florida Department of Commerce.

**FLORIDA DEPARTMENT OF  
COMMERCE**

**CITY OF CHIPLEY, FLORIDA**

By \_\_\_\_\_  
Signature  
**J. Alex Kelly**

By \_\_\_\_\_  
Signature  
**Tracy L. Andrews**

Title **Secretary**

Title **Mayor**

Date \_\_\_\_\_

Date \_\_\_\_\_

Approved as to form and legal sufficiency, subject only to full and proper execution by the Parties.

**OFFICE OF GENERAL COUNSEL  
FLORIDA DEPARTMENT OF COMMERCE**

By: \_\_\_\_\_

Approved Date: \_\_\_\_\_

## Attachment 2 AUDIT REQUIREMENTS

The administration of resources awarded by Commerce to the recipient (herein otherwise referred to as “Grantee”) may be subject to audits and/or monitoring by Commerce as described in this Attachment 2.

**MONITORING.** In addition to reviews of audits conducted in accordance with 2 CFR 200, Subpart F - Audit Requirements, and section 215.97, Florida Statutes (F.S.), as revised (see AUDITS below), monitoring procedures may include, but not be limited to, on-site visits by Commerce staff, limited scope audits as defined by 2 CFR §200.425, or other procedures. By entering into this agreement, the recipient agrees to comply and cooperate with any monitoring procedures or processes deemed appropriate by Commerce. In the event the Commerce determines that a limited scope audit of the recipient is appropriate, the recipient agrees to comply with any additional instructions provided by Commerce staff to the recipient regarding such audit. The recipient further agrees to comply and cooperate with any inspections, reviews, investigations, or audits deemed necessary by the Chief Financial Officer (CFO) or Auditor General.

### **AUDITS.**

**PART I: FEDERALLY FUNDED.** This part is applicable if the recipient is a state or local government or a nonprofit organization as defined in 2 CFR §200.90, §200.64, and §200.70.

1. A recipient that expends \$1,000,000 or more in federal awards in its fiscal year must have a single or program-specific audit conducted in accordance with the provisions of 2 CFR 200, Subpart F - Audit Requirements. EXHIBIT 1 to this form lists the federal resources awarded through Commerce by this agreement. In determining the federal awards expended in its fiscal year, the recipient shall consider all sources of federal awards, including federal resources received from Commerce. The determination of amounts of federal awards expended should be in accordance with the guidelines established in 2 CFR §§200.502-503. An audit of the recipient conducted by the Auditor General in accordance with the provisions of 2 CFR §200.514 will meet the requirements of this Part.
2. For the audit requirements addressed in Part I, paragraph 1, the recipient shall fulfill the requirements relative to auditee responsibilities as provided in 2 CFR §§200.508-512.
3. A recipient that expends less than \$1,000,000 in federal awards in its fiscal year is not required to have an audit conducted in accordance with the provisions of 2 CFR 200, Subpart F - Audit Requirements. If the recipient expends less than \$1,000,000 in federal awards in its fiscal year and elects to have an audit conducted in accordance with the provisions of 2 CFR 200, Subpart F - Audit Requirements, the cost of the audit must be paid from non-federal resources (i.e., the cost of such an audit must be paid from recipient resources obtained from other than federal entities).

**PART II: STATE FUNDED.** This part is applicable if the recipient is a nonstate entity as defined by Section 215.97(2), Florida Statutes.

1. In the event that the recipient expends a total amount of state financial assistance equal to or in excess of \$750,000 in any fiscal year of such recipient (for fiscal years ending June 30, 2017, and thereafter), the recipient must have a state single or project-specific audit for such fiscal year in accordance with section 215.97, F.S.; Rule Chapter 69I-5, F.A.C., State Financial Assistance; and Chapters 10.550 (local governmental entities) and 10.650 (nonprofit and for-profit organizations), Rules of the Auditor General. EXHIBIT 1 to this form lists the state financial assistance awarded through Commerce by this agreement. In determining the state financial assistance expended in its fiscal year,

the recipient shall consider all sources of state financial assistance, including state financial assistance received from Commerce, other state agencies, and other nonstate entities. State financial assistance does not include federal direct or pass-through awards and resources received by a nonstate entity for federal program matching requirements.

2. For the audit requirements addressed in Part II, paragraph 1, the recipient shall ensure that the audit complies with the requirements of section 215.97(8), F.S. This includes submission of a financial reporting package as defined by section 215.97(2), F.S., and Chapters 10.550 (local governmental entities) and 10.650 (nonprofit and for-profit organizations), Rules of the Auditor General.
3. If the recipient expends less than \$750,000 in state financial assistance in its fiscal year (for fiscal years ending June 30, 2017, and thereafter), an audit conducted in accordance with the provisions of section 215.97, F.S., is not required. If the recipient expends less than \$750,000 in state financial assistance in its fiscal year and elects to have an audit conducted in accordance with the provisions of section 215.97, F.S., the cost of the audit must be paid from the nonstate entity’s resources (i.e., the cost of such an audit must be paid from the recipient’s resources obtained from other than state entities).

**PART III: OTHER AUDIT REQUIREMENTS.**

*(NOTE: This part would be used to specify any additional audit requirements imposed by the State awarding entity that are solely a matter of that State awarding entity’s policy (i.e., the audit is not required by Federal or State laws and is not in conflict with other Federal or State audit requirements). Pursuant to Section 215.97(8), Florida Statutes, State agencies may conduct or arrange for audits of state financial assistance that are in addition to audits conducted in accordance with Section 215.97, Florida Statutes. In such an event, the State awarding agency must arrange for funding the full cost of such additional audits.)*

N/A

**PART IV: REPORT SUBMISSION.**

1. Copies of reporting packages for audits conducted in accordance with 2 CFR 200, Subpart F - Audit Requirements, and required by Part I of this form shall be submitted, when required by 2 CFR §200.512, by or on behalf of the recipient directly to the Federal Audit Clearinghouse (FAC) as provided in 2 CFR §200.36 and §200.512.

The FAC’s website provides a data entry system and required forms for submitting the single audit reporting package. Updates to the location of the FAC and data entry system may be found at the OMB website.

2. Copies of financial reporting packages required by Part II of this form shall be submitted by or on behalf of the recipient directly to each of the following:
  - a. Commerce at each of the following addresses:

Electronic copies (preferred): <a href="mailto:Audit@commerce.fl.gov">Audit@commerce.fl.gov</a>	or	Paper (hard copy): Florida Department of Commerce MSC # 75, Caldwell Building 107 East Madison Street Tallahassee, FL 32399-4126
--	----	--

b. The Auditor General’s Office at the following address:

Auditor General  
 Local Government Audits/342  
 Claude Pepper Building, Room  
 401 111 West Madison Street  
 Tallahassee, Florida 32399-1450

The Auditor General’s website (<https://flauditor.gov/>) provides instructions for filing an electronic copy of a financial reporting package.

3. Copies of reports or the management letter required by Part III of this form shall be submitted by or on behalf of the recipient directly to:

Electronic copies (preferred): <a href="mailto:Audit@commerce.fl.gov">Audit@commerce.fl.gov</a>	or	Paper (hard copy): Florida Department of Commerce MSC # 75, Caldwell Building 107 East Madison Street Tallahassee, FL. 32399-4126
--	----	---

4. Any reports, management letters, or other information required to be submitted Commerce pursuant to this agreement shall be submitted timely in accordance with 2 CFR §200.512, section 215.97, F.S., and Chapters 10.550 (local governmental entities) and 10.650 (nonprofit and for-profit organizations), Rules of the Auditor General, as applicable.

5. Recipients, when submitting financial reporting packages to Commerce for audits done in accordance with 2 CFR 200, Subpart F - Audit Requirements, or Chapters 10.550 (local governmental entities) and 10.650 (nonprofit and for-profit organizations), Rules of the Auditor General, should indicate the date that the reporting package was delivered to the recipient in correspondence accompanying the reporting package.

**PART V: RECORD RETENTION.** The recipient shall retain sufficient records demonstrating its compliance with the terms of this Agreement for a period of five (5) years from the date the audit report is issued, or five (5) state fiscal years after all reporting requirements are satisfied and final payments have been received, whichever period is longer, and shall allow Commerce, or its designee, CFO, or Auditor General access to such records upon request. The recipient shall ensure that audit working papers are made available to Commerce, or its designee, CFO, or Auditor General upon request for a period of five (5) years from the date the audit report is issued, unless extended in writing by Commerce. In addition, if any litigation, claim, negotiation, audit, or other action involving the records has been started prior to the expiration of the controlling period as identified above, the records shall be retained until completion of the action and resolution of all issues which arise from it, or until the end of the controlling period as identified above, whichever is longer.

*- Remainder of Page Intentionally Left Blank -*

**Attachment 3**

**AUDIT COMPLIANCE CERTIFICATION**

Grantee Name: \_\_\_\_\_

FEIN: \_\_\_\_\_

Grantee's Fiscal Year: \_\_\_\_\_

Contact Person Name and Phone Number: \_\_\_\_\_

Contact Person Email Address: \_\_\_\_\_

1. Did Grantee expend state financial assistance, during its fiscal year, that it received under any agreement (e.g., agreement, grant, memorandum of agreement, memorandum of understanding, economic incentive award agreement, etc.) between Grantee and the Florida Department of Commerce (Commerce)?  Yes  No

If the above answer is yes, also answer the following before proceeding to item 2:

Did Grantee expend \$750,000 or more of state financial assistance (from Commerce and all other sources of state financial assistance combined) during its fiscal year?  Yes  No

**If yes, Grantee certifies that it will timely comply with all applicable state single or project-specific audit requirements of s. 215.97, Florida Statutes, and the applicable rules of the Department of Financial Services and the Auditor General.**

2. Did Grantee expend federal awards, during its fiscal year that it received under any agreement (e.g., agreement, grant, memorandum of agreement, memorandum of understanding, economic incentive award agreement, etc.) between Grantee and Commerce?  Yes  No

If the above answer is yes, also answer the following before proceeding to execution of this certification:

Did Grantee expend \$1,000,000 or more in federal awards (from Commerce and all other sources of federal awards combined) during its fiscal year?  Yes  No

**If yes, Grantee certifies that it will timely comply with all applicable single or program-specific audit requirements of 2 CFR Part 200, Subpart F, as revised.**

**By signing below, I certify, on behalf of Grantee, that the above representations for items 1 and 2 are true and correct.**

\_\_\_\_\_  
Signature of Authorized Representative

\_\_\_\_\_  
Date

\_\_\_\_\_  
Printed Name of Authorized Representative

\_\_\_\_\_  
Title of Authorized Representative

# CITY OF CHIPLEY

## STAFF REPORT

**SUBJECT:** Resolution No. 26-29 – Updated Parades

**MEETING DATE**  
Tuesday, April 14, 2026

**PREPARED BY**  
Patrice Tanner, City Administrator

**SUMMARY**  
This resolution will approve the addition of the T.J. Roulhac School Reunion Parade to be held on June 20, 2026.

**RECOMMENDATION**  
City Staff recommends approval of Resolution No. 26-29 – Updated Parades

**ATTACHMENTS**

1. Resolution No. 26-29

**RESOLUTION NO. 26-29**

**A RESOLUTION OF THE CITY OF CHIPLEY, FLORIDA, DETERMINING THAT THE TEMPORARY CLOSURE OF STATE ROADS IS NECESSARY FOR SPECIAL EVENTS AND AUTHORIZING THE APPROPRIATE ADMINISTRATIVE OFFICIALS TO APPLY TO THE DEPARTMENT OF TRANSPORTATION FOR APPROVAL FOR TEMPORARY ROAD CLOSURES.**

**WHEREAS**, the City Council is the governing body of the City of Chipley, Florida, and has the responsibility for traffic control and other operational duties on the state highway system within the City of Chipley; and

**WHEREAS**, there are a number of recurring and non-recurring public events scheduled throughout the year within the City of Chipley which require the temporary closure of state roads; and

**WHEREAS**, the administrative officials of the City of Chipley will attempt to minimize the time that the roads are closed for these events.

**NOW, THEREFORE, BE IT RESOLVED BY THE CITY COUNCIL OF THE CITY OF CHIPLEY AS FOLLOWS:**

1. The City has determined that the closure of certain state roads is necessary for the recurring special events listed on the attached Exhibit "A" and for other non-recurring events approved by the City Administrator.
2. The Chief of Police is authorized to obtain prior written approval for the temporary road closures from the Department of Transportation and the City Administrator is authorized to vary the time and date of road closures.
3. Exhibit "A", attached hereto, included the recurring events requiring road closures, with the addition of one new parade.

**PASSED AND ADOPTED THIS 14TH DAY OF APRIL, 2026.**

CITY OF CHIPLEY

ATTEST:

\_\_\_\_\_  
Tracy L. Andrews, Mayor

\_\_\_\_\_  
Sherry Snell,  
City Clerk

**EXHIBIT “A”**

**MARTIN LUTHER KING PARADE – JANUARY**

**WATERMELON FESTIVAL PARADE – JUNE**

**T.J. ROULHAC SCHOOL REUNION PARADE – JUNE 20, 2026**

**CHIPLEY HIGH SCHOOL HOMECOMING PARADE – OCTOBER/NOVEMBER**

**CHRISTMAS FESTIVAL & PARADE – DECEMBER**

DRAFT

# CITY OF CHIPLEY

## STAFF REPORT

**SUBJECT:** Resolution No. 26-30 – Florida Department of Environmental Protection Grant Agreement No. 26PLN63 – Gilbert Acres Drainage Improvements Project

**MEETING DATE**  
Tuesday, April 14, 2026

**PREPARED BY**  
Patrice Tanner, City Administrator

### SUMMARY

This resolution will approve the Florida Department of Environmental Protection Grant Agreement No. 26PLN63, for a grant in the amount of \$336,000.00 for the Gilbert Acres Drainage Improvements Project. This project will include the engineering, design, and permitting of a drainage improvement project within the existing drainage in the area south of US 90, north of South Boulevard, east of Sinclair Street, and west of Peach Street. The Project will address the impacts of flooding along roadways and critical transportation routes, such as State Road 77.

### RECOMMENDATION

City Staff recommends approval of Resolution No. 26-30 - Florida Department of Environmental Protection Grant Agreement No. 26PLN63 – Gilbert Acres Drainage Improvements Project.

### ATTACHMENTS

1. Resolution No. 26-30
2. Agreement No. 26PLN63

**RESOLUTION NO. 26-30**

**A RESOLUTION OF THE CITY OF CHIPLEY, FLORIDA, APPROVING AN AGREEMENT IDENTIFIED AS THE STATE OF FLORIDA, DEPARTMENT OF ENVIRONMENTAL PROTECTION FOR DRAINAGE IMPROVEMENTS IN GILBERT ACRES BETWEEN THE STATE OF FLORIDA DEPARTMENT OF ENVIRONMENTAL PROTECTION AND THE CITY OF CHIPLEY, FLORIDA.**

**WHEREAS**, the State of Florida, Department of Environmental Protection, has approved Grant Agreement No. 26PLN63 "Agreement" for the City of Chipley "Grantee"; and

**WHEREAS**, the City of Chipley will use the funding for the Gilbert Acres Drainage Improvements project. This project will include the engineering, design, and permitting of a drainage improvement project within the existing drainage in the area south of US 90, north of South Boulevard, east of Sinclair Street, and west of Peach Street. The Project will address the impacts of flooding along roadways and critical transportation routes, such as State Road 77.; and

**WHEREAS**, the City of Chipley hereby represents and warrants that Grantee's signatory to this Agreement has authority to bind Grantee to this Agreement as of the Effective Date and that Grantee, through its undersigned duly-authorized representative in his or her official capacity, has the authority to request, accept, and expend the Award Funds for Grantee's purposes in accordance with the terms and conditions of this Agreement.

**NOW, THEREFORE, BE IT RESOLVED BY THE CITY COUNCIL OF THE CITY OF CHIPLEY AS FOLLOWS:**

1. The City of Chipley hereby approves the State of Florida, Department of Environmental Protection Agreement No. 26PLN63 in the amount of \$336,000.00.
2. The City for and in consideration of the covenants and obligations set forth herein and for other good and valuable consideration, the receipt and sufficiency of which are hereby acknowledged, intending to be legally bound hereby agree to perform the duties described herein in the attached Exhibit "A".
3. The Mayor or Mayor Pro-Tem of the City of Chipley be hereby authorized and directed to execute the agreement.
4. A certified copy of this Resolution be forwarded to the FDEP along with the executed Agreement.

**PASSED AND ADOPTED THIS 14TH DAY OF APRIL, 2026.**

CITY OF CHIPLEY

ATTEST:

\_\_\_\_\_  
Tracy L. Andrews, Mayor

\_\_\_\_\_  
Sherry Snell,  
City Clerk

DRAFT

**STATE OF FLORIDA**  
**DEPARTMENT OF ENVIRONMENTAL PROTECTION**  
**Standard Grant Agreement**

Section H, Item 3.

This Agreement is entered into between the Parties named below, pursuant to section 215.971, Florida Statutes:

1. Project Title (Project): City of Chipley Gilbert Acres Drainage Improvements Agreement Number: 26PLN63

2. Parties **State of Florida Department of Environmental Protection,  
 3900 Commonwealth Boulevard  
 Tallahassee, Florida 32399-3000** (Department)

Grantee Name: City of Chipley Entity Type: Local Government

Grantee Address: Post Office Box 1007  
 Chipley, Florida  
 32428-0000 FEID: 59-6000299 (Grantee)

3. Agreement Begin Date: 7/1/2025 Date of Expiration: 6/30/2028

4. Project Number: \_\_\_\_\_ Project Location(s): Washington County, Florida  
 (If different from Agreement Number)

Project Description: The City of Chipley will complete the City of Chipley Gilbert Acres Drainage Improvements Project to include the engineering, design, and permitting of a drainage improvement project within the existing drainage in the area south of US 90, north of South Boulevard, east of Sinclair Street, and west of Peach Street.

5. Total Amount of Funding:	Funding Source?	Award #s or Line-Item Appropriations:	Amount per Source(s):
\$336,000.00	<input checked="" type="checkbox"/> State <input type="checkbox"/> Federal	FY 25-26 GAA Line Item #1659	\$ 336,000.00
	<input type="checkbox"/> State <input type="checkbox"/> Federal		\$
	<input type="checkbox"/> State <input type="checkbox"/> Federal		\$
	<input type="checkbox"/> Grantee Match		\$
Total Amount of Funding + Grantee Match, if any:			\$ 336,000.00

6. Department's Grant Manager Name: <u>Anthony Sabol</u> _____ or successor Address: <u>Resilient Florida Program</u> <u>3900 Commonwealth Boulevard, MS230</u> <u>Tallahassee, Florida 32399</u> Phone: <u>850-245-3013</u> Email: <u>Anthony.Sabol@FloridaDEP.gov</u>	Grantee's Grant Manager Name: <u>Patrice Tanner</u> _____ or successor Address: <u>Post Office Box 1007</u> <u>Chipley, Florida 32428</u> Phone: <u>850-638-6350</u> Email: <u>ptanner@cityofchipley.com</u>
---	---

7. The Parties agree to comply with the terms and conditions of the following attachments and exhibits which are hereby incorporated by reference:

<input checked="" type="checkbox"/> Attachment 1: Standard Terms and Conditions Applicable to All Grants Agreements
<input checked="" type="checkbox"/> Attachment 2: Special Terms and Conditions
<input checked="" type="checkbox"/> Attachment 3: Grant Work Plan
<input checked="" type="checkbox"/> Attachment 4: Public Records Requirements
<input checked="" type="checkbox"/> Attachment 5: Special Audit Requirements
<input checked="" type="checkbox"/> Attachment 6: Program-Specific Requirements
<input type="checkbox"/> Attachment 7: Grant Award Terms (Federal) *Copy available at <a href="https://facts.fldfs.com">https://facts.fldfs.com</a> , in accordance with section 215.985, F.S.
<input type="checkbox"/> Attachment 8: Federal Regulations and Terms (Federal)
<input type="checkbox"/> Additional Attachments (if necessary):
<input checked="" type="checkbox"/> Exhibit A: Progress Report Form
<input type="checkbox"/> Exhibit B: Property Reporting Form
<input checked="" type="checkbox"/> Exhibit C: Payment Request Summary Form
<input type="checkbox"/> Exhibit D: Quality Assurance Requirements
<input checked="" type="checkbox"/> Exhibit E: Advance Payment Terms and Interest Earned Memo
<input checked="" type="checkbox"/> Exhibit J: Common Carrier or Contracted Carrier Attestation Form PUR1808

<input checked="" type="checkbox"/> Additional Exhibits (if necessary): Exhibit F: Final Project Report, Exhibit G: Photographer Release Form, Exhibit H: Contractual Se	
8. The following information applies to Federal Grants only and is identified in accordance with 2 CFR 200.331 (a) (1):	
Federal Award Identification Number(s) (FAIN):	
Unique Entity Identifier (UEI):	
Federal Award Date to Department:	
Federal Award Project Description:	
Total Federal Funds Obligated by this Agreement:	
Federal Awarding Agency:	
Award R&D?	<input type="checkbox"/> Yes <input checked="" type="checkbox"/> N/A

**IN WITNESS WHEREOF, this Agreement shall be effective on the date indicated by the Agreement Begin Date unless another date is specified in the grant documents.**

City of Chipley **GRANTEE**

Grantee Name

By  Date Signed

*(Authorized Signature)*

Tracy L. Andrews, Mayor

---

Print Name and Title of Person Signing

State of Florida Department of Environmental Protection **DEPARTMENT**

By  Date Signed

Secretary or Designee

Alex Reed, Director of the Office of Resilience and Coastal Protection

---

Print Name and Title of Person Signing

Additional signatures attached on separate page.

---

---

ORCP Additional Signatures

---

---

  
\_\_\_\_\_  
DEP Grant Manager,

  
\_\_\_\_\_  
DEP QC Reviewer,

---

---

Grantee may add additional signatures below, if needed.

---

---

STATE OF FLORIDA  
DEPARTMENT OF ENVIRONMENTAL PROTECTION  
STANDARD TERMS AND CONDITIONS  
APPLICABLE TO GRANT AGREEMENTS

ATTACHMENT 1

**1. Entire Agreement.**

This Grant Agreement, including any Attachments and Exhibits referred to herein and/or attached hereto (Agreement), constitutes the entire agreement between the parties with respect to the subject matter hereof and supersedes all prior agreements, whether written or oral, with respect to such subject matter. Any terms and conditions included on Grantee’s forms or invoices shall be null and void.

**2. Grant Administration.**

- a. Order of Precedence. If there are conflicting provisions among the documents that make up the Agreement, the order of precedence for interpretation of the Agreement is as follows:
  - i. Standard Grant Agreement
  - ii. Attachments other than Attachment 1, in numerical order as designated in the Standard Grant Agreement
  - iii. Attachment 1, Standard Terms and Conditions
  - iv. The Exhibits in the order designated in the Standard Grant Agreement
- b. All approvals, written or verbal, and other written communication among the parties, including all notices, shall be obtained by or sent to the parties’ Grant Managers. All written communication shall be by electronic mail, U.S. Mail, a courier delivery service, or delivered in person. Notices shall be considered delivered when reflected by an electronic mail read receipt, a courier service delivery receipt, other mail service delivery receipt, or when receipt is acknowledged by recipient. If the notice is delivered in multiple ways, the notice will be considered delivered at the earliest delivery time.
- c. If a different Grant Manager is designated by either party after execution of this Agreement, notice of the name and contact information of the new Grant Manager will be submitted in writing to the other party and maintained in the respective parties’ records. A change of Grant Manager does not require a formal amendment or change order to the Agreement.
- d. This Agreement may be amended, through a formal amendment or a change order, only by a written agreement between both parties. A formal amendment to this Agreement is required for changes which cause any of the following:
  - (1) an increase or decrease in the Agreement funding amount;
  - (2) a change in Grantee’s match requirements;
  - (3) a change in the expiration date of the Agreement;
  - (4) changes to the cumulative amount of funding transfers between approved budget categories, as defined in Attachment 3, Grant Work Plan, that exceeds or is expected to exceed twenty percent (20%) of the total budget as last approved by Department; and/or
  - (5) any changes to the terms and conditions of the Agreement other than the specific instances enumerated below when a change order may be used.
 A change order to this Agreement may be used when:
  - (1) task timelines within the current authorized Agreement period change;
  - (2) the cumulative transfer of funds between approved budget categories, as defined in Attachment 3, Grant Work Plan, are less than twenty percent (20%) of the total budget as last approved by Department;
  - (3) changing the current funding source as stated in the Standard Grant Agreement; and/or
  - (4) fund transfers between budget categories for the purposes of meeting match requirements.
 This Agreement may be amended to provide for additional services if additional funding is made available by the Legislature.
- e. All days in this Agreement are calendar days unless otherwise specified.

**3. Agreement Duration.**

The term of the Agreement shall begin and end on the dates indicated in the Standard Grant Agreement, unless extended or terminated earlier in accordance with the applicable terms and conditions. The Grantee shall be eligible for reimbursement for work performed on or after the date of execution through the expiration date of this Agreement, unless otherwise specified in Attachment 2, Special Terms and Conditions. However, work performed prior to the

Attachment 1

execution of this Agreement may be reimbursable or used for match purposes if permitted by the Special Terms and Conditions.

**4. Deliverables.**

The Grantee agrees to render the services or other units of deliverables as set forth in Attachment 3, Grant Work Plan. The services or other units of deliverables shall be delivered in accordance with the schedule and at the pricing outlined in the Grant Work Plan. Deliverables may be comprised of activities that must be completed prior to Department making payment on that deliverable. The Grantee agrees to perform in accordance with the terms and conditions set forth in this Agreement and all attachments and exhibits incorporated by the Standard Grant Agreement.

**5. Performance Measures.**

The Grantee warrants that: (1) the services will be performed by qualified personnel; (2) the services will be of the kind and quality described in the Grant Work Plan; (3) the services will be performed in a professional and workmanlike manner in accordance with industry standards and practices; (4) the services shall not and do not knowingly infringe upon the intellectual property rights, or any other proprietary rights, of any third party; and (5) its employees, subcontractors, and/or subrecipients shall comply with any security and safety requirements and processes, if provided by Department, for work done at the Project Location(s). The Department reserves the right to investigate or inspect at any time to determine whether the services or qualifications offered by Grantee meet the Agreement requirements. Notwithstanding any provisions herein to the contrary, written acceptance of a particular deliverable does not foreclose Department's remedies in the event deficiencies in the deliverable cannot be readily measured at the time of delivery.

**6. Acceptance of Deliverables.**

- a. Acceptance Process. All deliverables must be received and accepted in writing by Department's Grant Manager before payment. The Grantee shall work diligently to correct all deficiencies in the deliverable that remain outstanding, within a reasonable time at Grantee's expense. If Department's Grant Manager does not accept the deliverables within 30 days of receipt, they will be deemed rejected.
- b. Rejection of Deliverables. The Department reserves the right to reject deliverables, as outlined in the Grant Work Plan, as incomplete, inadequate, or unacceptable due, in whole or in part, to Grantee's lack of satisfactory performance under the terms of this Agreement. The Grantee's efforts to correct the rejected deliverables will be at Grantee's sole expense. Failure to fulfill the applicable technical requirements or complete all tasks or activities in accordance with the Grant Work Plan will result in rejection of the deliverable and the associated invoice. Payment for the rejected deliverable will not be issued unless the rejected deliverable is made acceptable to Department in accordance with the Agreement requirements. The Department, at its option, may allow additional time within which Grantee may remedy the objections noted by Department. The Grantee's failure to make adequate or acceptable deliverables after a reasonable opportunity to do so shall constitute an event of default.

**7. Financial Consequences for Nonperformance.**

- a. Withholding Payment. In addition to the specific consequences explained in the Grant Work Plan and/or Special Terms and Conditions, the State of Florida (State) reserves the right to withhold payment when the Grantee has failed to perform/comply with provisions of this Agreement. None of the financial consequences for nonperformance in this Agreement as more fully described in the Grant Work Plan shall be considered penalties.
- b. Invoice reduction  
If Grantee does not meet a deadline for any deliverable, the Department will reduce the invoice by 1% for each day the deadline is missed, unless an extension is approved in writing by the Department.
- c. Corrective Action Plan. If Grantee fails to correct all the deficiencies in a rejected deliverable within the specified timeframe, Department may, in its sole discretion, request that a proposed Corrective Action Plan (CAP) be submitted by Grantee to Department. The Department requests that Grantee specify the outstanding deficiencies in the CAP. All CAPs must be able to be implemented and performed in no more than sixty (60) calendar days.
  - i. The Grantee shall submit a CAP within ten (10) days of the date of the written request from Department. The CAP shall be sent to the Department's Grant Manager for review and approval. Within ten (10) days of receipt of a CAP, Department shall notify Grantee in writing whether the CAP proposed has been accepted. If the CAP is not accepted, Grantee shall have ten (10) days from receipt of Department letter rejecting the proposal to submit a revised proposed CAP. Failure to obtain Department approval of a CAP as specified above may result in Department's termination of this Agreement for cause as authorized in this Agreement.

- ii. Upon Department’s notice of acceptance of a proposed CAP, Grantee shall have ten (10) days to commence implementation of the accepted plan. Acceptance of the proposed CAP by Department does not relieve Grantee of any of its obligations under the Agreement. In the event the CAP fails to correct or eliminate performance deficiencies by Grantee, Department shall retain the right to require additional or further remedial steps, or to terminate this Agreement for failure to perform. No actions approved by Department or steps taken by Grantee shall preclude Department from subsequently asserting any deficiencies in performance. The Grantee shall continue to implement the CAP until all deficiencies are corrected. Reports on the progress of the CAP will be made to Department as requested by Department’s Grant Manager.
- iii. Failure to respond to a Department request for a CAP or failure to correct a deficiency in the performance of the Agreement as specified by Department may result in termination of the Agreement.

**8. Payment.**

- a. Payment Process. Subject to the terms and conditions established by the Agreement, the pricing per deliverable established by the Grant Work Plan, and the billing procedures established by Department, Department agrees to pay Grantee for services rendered in accordance with section 215.422, Florida Statutes (F.S.).
- b. Taxes. The Department is exempted from payment of State sales, use taxes and Federal excise taxes. The Grantee, however, shall not be exempted from paying any taxes that it is subject to, including State sales and use taxes, or for payment by Grantee to suppliers for taxes on materials used to fulfill its contractual obligations with Department. The Grantee shall not use Department's exemption number in securing such materials. The Grantee shall be responsible and liable for the payment of all its FICA/Social Security and other taxes resulting from this Agreement.
- c. Maximum Amount of Agreement. The maximum amount of compensation under this Agreement, without an amendment, is described in the Standard Grant Agreement. Any additional funds necessary for the completion of this Project are the responsibility of Grantee.
- d. Reimbursement for Costs. The Grantee shall be paid on a cost reimbursement basis for all eligible Project costs upon the completion, submittal, and approval of each deliverable identified in the Grant Work Plan. Reimbursement shall be requested on Exhibit C, Payment Request Summary Form. To be eligible for reimbursement, costs must be in compliance with laws, rules, and regulations applicable to expenditures of State funds, including, but not limited to, the Reference Guide for State Expenditures, which can be accessed at the following web address: <https://www.myfloridacfo.com/docs-sf/accounting-and-auditing-libraries/state-agencies/reference-guide-for-state-expenditures.pdf>
- e. Rural Communities and Rural Areas of Opportunity. If Grantee is a county or municipality that qualifies as a "rural community" or "rural area of opportunity" (RAO) as defined in subsection 288.0656(2), F.S., such Grantee may request from the Department that all invoice payments under this Agreement be directed to the relevant county or municipality or to the RAO itself. The Department will agree to Grantee's request if:
  - i. Grantee demonstrates that it is a county or municipality that qualifies as a "rural community" or "rural area of opportunity" under subsection 288.0656(2), F.S.;
  - ii. Grantee demonstrates current financial hardship using one (1) or more of the "economic distress" factors defined in subsection 288.0656(2)(c), F.S.;
  - iii. Grantee's performance has been verified by the Department, which has determined that Grantee is eligible for invoice payments and that Grantee's performance has been completed in accordance with this Agreement's terms and conditions; and
  - iv. Applicable federal and state law(s), rule(s) and regulation(s) allow for such payments.
 This subsection may not be construed to alter or limit any other applicable provisions of federal or state law, rule, or regulation. A current list of Florida's designated RAOs can be accessed at the following web address: <https://floridajobs.org/community-planning-and-development/rural-community-programs/rural-areas-of-opportunity>.
- f. Invoice Detail. All charges for services rendered or for reimbursement of expenses authorized by Department pursuant to the Grant Work Plan shall be submitted to Department in sufficient detail for a proper pre-audit and post-audit to be performed. The Grantee shall only invoice Department for deliverables that are completed in accordance with the Grant Work Plan.
- g. State Funds Documentation. Pursuant to section 216.1366, F.S., if Grantee meets the definition of a non-profit organization under section 215.97(2)(m), F.S., Grantee must provide the Department with documentation that indicates the amount of state funds:

**Attachment 1**

- i. Allocated to be used during the full term of the contract or agreement for remuneration to any member of the board of directors or an officer.
- ii. Allocated under each payment by the public agency to be used for remuneration of any member of the board of directors or an officer.

The documentation must indicate the amounts and recipients of the remuneration. Such information must be posted on the State's the contract tracking system and maintained pursuant to section 215.985, F.S., and must be posted on the Grantee's website, if Grantee maintains a website.

- h. Interim Payments. Interim payments may be made by Department, at its discretion, if the completion of deliverables to date have first been accepted in writing by Department's Grant Manager.
- i. Final Payment Request. A final payment request should be submitted to Department no later than sixty (60) days following the expiration date of the Agreement to ensure the availability of funds for payment. However, all work performed pursuant to the Grant Work Plan must be performed on or before the expiration date of the Agreement.
- j. Annual Appropriation Contingency. The State's performance and obligation to pay under this Agreement is contingent upon an annual appropriation by the Legislature. This Agreement is not a commitment of future appropriations. Authorization for continuation and completion of work and any associated payments may be rescinded, with proper notice, at the discretion of Department if the Legislature reduces or eliminates appropriations.
- k. Interest Rates. All interest rates charged under the Agreement shall be calculated on the prevailing rate used by the State Board of Administration. To obtain the applicable interest rate, please refer to: <https://www.myfloridacfo.com/division/aa/local-governments/judgement-interest-rates>.
- l. Refund of Payments to the Department. Any balance of unobligated funds that have been advanced or paid must be refunded to Department. Any funds paid in excess of the amount to which Grantee or subgrantee is entitled under the terms of the Agreement must be refunded to Department. If this Agreement is funded with federal funds and the Department is required to refund the federal government, the Grantee shall refund the Department its share of those funds.

**9. Documentation Required for Cost Reimbursement Grant Agreements and Match.**

If Cost Reimbursement or Match is authorized in Attachment 2, Special Terms and Conditions, the following conditions apply. Supporting documentation must be provided to substantiate cost reimbursement or match requirements for the following budget categories:

- a. Salary/Wages. Grantee shall list personnel involved, position classification, direct salary rates, and hours spent on the Project in accordance with Attachment 3, Grant Work Plan in their documentation for reimbursement or match requirements.
- b. Overhead/Indirect/General and Administrative Costs. If Grantee is being reimbursed for or claiming match for multipliers, all multipliers used (i.e., fringe benefits, overhead, indirect, and/or general and administrative rates) shall be supported by audit. If Department determines that multipliers charged by Grantee exceeded the rates supported by audit, Grantee shall be required to reimburse such funds to Department within thirty (30) days of written notification. Interest shall be charged on the excessive rate.
- c. Contractual/Subaward Costs (Subcontractors/Subrecipients). Match or reimbursement requests for payments to subcontractors/subrecipients must be substantiated by copies of invoices with backup documentation identical to that required from Grantee. Subcontracts/subawards which involve payments for direct salaries shall clearly identify the personnel involved, salary rate per hour, and hours spent on the Project. All eligible multipliers used (i.e., fringe benefits, overhead, indirect, and/or general and administrative rates) shall be supported by audit. If Department determines that multipliers charged by any subcontractor/subrecipient exceeded the rates supported by audit, Grantee shall be required to reimburse such funds to Department within thirty (30) days of written notification. Interest shall be charged on the excessive rate. Nonconsumable and/or nonexpendable personal property or equipment costing \$5,000 or more purchased for the Project under a subcontract/subaward is subject to the requirements set forth in chapters 273 and/or 274, F.S., and Chapter 69I-72, Florida Administrative Code (F.A.C.) and/or Chapter 69I-73, F.A.C., as applicable. For grants funded with federal funds, nonconsumable and/or nonexpendable personal property or equipment costing \$10,000 or more purchased for the Project under a subcontract/subaward is subject to the requirements set forth in 2 CFR 200. The Grantee shall be responsible for maintaining appropriate property records for any subcontracts/subawards that include the purchase of equipment as part of the delivery of services. The Grantee shall comply with this requirement and ensure its subcontracts/subaward issued under this Agreement, if any, impose this requirement, in writing, on its subcontractors/subrecipients.

**Attachment 1**

- i. For fixed-price (vendor) subcontracts/subawards, the following provisions shall apply: The Grantee may award, on a competitive basis, fixed-price subcontracts/subawards to consultants/contractors in performing the work described in Attachment 3, Grant Work Plan. Invoices submitted to Department for fixed-price subcontracted/subawarded activities shall be supported with a copy of the subcontractor/subrecipient's invoice and a copy of the tabulation form for the competitive procurement process (e.g., Invitation to Bid, Request for Proposals, or other similar competitive procurement document) resulting in the fixed-price subcontract/subaward. The Grantee may request approval from Department to award a fixed-price subcontract/subaward resulting from procurement methods other than those identified above. In this instance, Grantee shall request the advance written approval from Department's Grant Manager of the fixed price negotiated by Grantee. The letter of request shall be supported by a detailed budget and Scope of Services to be performed by the subcontractor/subrecipient. Upon receipt of Department Grant Manager's approval of the fixed-price amount, Grantee may proceed in finalizing the fixed-price subcontract/subaward.
  - ii. If the procurement is subject to the Consultant's Competitive Negotiation Act under section 287.055, F.S., or the Brooks Act, Grantee must provide documentation clearly evidencing it has complied with the statutory or federal requirements.
- d. Travel. All requests for match or reimbursement of travel expenses shall be in accordance with section 112.061, F.S.
- e. Direct Purchase Equipment. For grants funded fully or in part with state funds, equipment is defined as capital outlay costing \$5,000 or more. For grants funded fully with federal funds, equipment is defined as capital outlay costing \$10,000 or more. Match or reimbursement for Grantee's direct purchase of equipment is subject to specific approval of Department and does not include any equipment purchased under the delivery of services to be completed by a subcontractor/subrecipient. Include copies of invoices or receipts to document purchases, and a properly completed Exhibit B, Property Reporting Form.
- f. Rental/Lease of Equipment. Match or reimbursement requests for rental/lease of equipment must include copies of invoices or receipts to document charges.
- g. Miscellaneous/Other Expenses. If miscellaneous or other expenses, such as materials, supplies, non-excluded phone expenses, reproduction, or mailing, are reimbursable or available for match or reimbursement under the terms of this Agreement, the documentation supporting these expenses must be itemized and include copies of receipts or invoices. Additionally, independent of Grantee's contract obligations to its subcontractor/subrecipient, Department shall not reimburse any of the following types of charges: cell phone usage; attorney's fees or court costs; civil or administrative penalties; or handling fees, such as set percent overages associated with purchasing supplies or equipment.
- h. Land Acquisition. Reimbursement for the costs associated with acquiring interest and/or rights to real property (including access rights through ingress/egress easements, leases, license agreements, or other site access agreements; and/or obtaining record title ownership of real property through purchase) must be supported by the following, as applicable: Copies of Property Appraisals, Environmental Site Assessments, Surveys and Legal Descriptions, Boundary Maps, Acreage Certification, Title Search Reports, Title Insurance, Closing Statements/Documents, Deeds, Leases, Easements, License Agreements, or other legal instrument documenting acquired property interest and/or rights. If land acquisition costs are used to meet match requirements, Grantee agrees that those funds shall not be used as match for any other Agreement supported by State or Federal funds.

**10. Status Reports.**

The Grantee shall submit status reports quarterly, unless otherwise specified in the Attachments, on Exhibit A, Progress Report Form, to Department's Grant Manager describing the work performed during the reporting period, problems encountered, problem resolutions, scheduled updates, and proposed work for the next reporting period. Quarterly status reports are due no later than twenty (20) days following the completion of the quarterly reporting period. For the purposes of this reporting requirement, the quarterly reporting periods end on March 31, June 30, September 30 and December 31. The Department will review the required reports submitted by Grantee within thirty (30) days.

**11. Retainage.**

The following provisions apply if Department withholds retainage under this Agreement:

- a. The Department reserves the right to establish the amount and application of retainage on the work performed under this Agreement up to the maximum percentage described in Attachment 2, Special Terms and Conditions. Retainage may be withheld from each payment to Grantee pending satisfactory completion of work and approval of all deliverables.

**Attachment 1**

- b. If Grantee fails to perform the requested work or fails to perform the work in a satisfactory manner, Grantee shall forfeit its right to payment of the retainage associated with the work. Failure to perform includes, but is not limited to, failure to submit the required deliverables or failure to provide adequate documentation that the work was actually performed. The Department shall provide written notification to Grantee of the failure to perform that shall result in retainage forfeiture. If the Grantee does not correct the failure to perform within the timeframe stated in Department's notice, the retainage will be forfeited to Department.
- c. No retainage shall be released or paid for incomplete work while this Agreement is suspended.
- d. Except as otherwise provided above, Grantee shall be paid the retainage associated with the work, provided Grantee has completed the work and submits an invoice for retainage held in accordance with the invoicing procedures under this Agreement.

**12. Insurance.**

- a. Insurance Requirements for Subrecipients and/or Subcontractors. The Grantee shall require its subrecipients and/or subcontractors, if any, to maintain insurance coverage of such types and with such terms and limits as described in this Agreement. The Grantee shall require all its subrecipients and/or subcontractors, if any, to make compliance with the insurance requirements of this Agreement a condition of all contracts that are related to this Agreement. Subrecipients and/or subcontractors must provide proof of insurance upon request.
- b. Deductibles. The Department shall be exempt from, and in no way liable for, any sums of money representing a deductible in any insurance policy. The payment of such deductible shall be the sole responsibility of the Grantee providing such insurance.
- c. Proof of Insurance. Upon execution of this Agreement, Grantee shall provide Department documentation demonstrating the existence and amount for each type of applicable insurance coverage *prior to* performance of any work under this Agreement. Upon receipt of written request from Department, Grantee shall furnish Department with proof of applicable insurance coverage by standard form certificates of insurance, a self-insured authorization, or other certification of self-insurance.
- d. Duty to Maintain Coverage. In the event that any applicable coverage is cancelled by the insurer for any reason, or if Grantee cannot get adequate coverage, Grantee shall immediately notify Department of such cancellation and shall obtain adequate replacement coverage conforming to the requirements herein and provide proof of such replacement coverage within ten (10) days after the cancellation of coverage.
- e. Insurance Trust. If the Grantee's insurance is provided through an insurance trust, the Grantee shall instead add the Department of Environmental Protection, its employees, and officers as an additional covered party everywhere the Agreement requires them to be added as an additional insured.

**13. Termination.**

- a. Termination for Convenience. When it is in the State's best interest, Department may, at its sole discretion, terminate the Agreement in whole or in part by giving 30 days' written notice to Grantee. The Department shall notify Grantee of the termination for convenience with instructions as to the effective date of termination or the specific stage of work at which the Agreement is to be terminated. The Grantee must submit all invoices for work to be paid under this Agreement within thirty (30) days of the effective date of termination. The Department shall not pay any invoices received after thirty (30) days of the effective date of termination.
- b. Termination for Cause. The Department may terminate this Agreement if any of the events of default described in the Events of Default provisions below occur or in the event that Grantee fails to fulfill any of its other obligations under this Agreement. If, after termination, it is determined that Grantee was not in default, or that the default was excusable, the rights and obligations of the parties shall be the same as if the termination had been issued for the convenience of Department. The rights and remedies of Department in this clause are in addition to any other rights and remedies provided by law or under this Agreement.
- c. Grantee Obligations upon Notice of Termination. After receipt of a notice of termination or partial termination unless as otherwise directed by Department, Grantee shall not furnish any service or deliverable on the date, and to the extent specified, in the notice. However, Grantee shall continue work on any portion of the Agreement not terminated. If the Agreement is terminated before performance is completed, Grantee shall be paid only for that work satisfactorily performed for which costs can be substantiated. The Grantee shall not be entitled to recover any cancellation charges or lost profits.
- d. Continuation of Prepaid Services. If Department has paid for any services prior to the expiration, cancellation, or termination of the Agreement, Grantee shall continue to provide Department with those services for which it has already been paid or, at Department's discretion, Grantee shall provide a refund for services that have been paid for but not rendered.

- e. Transition of Services Upon Termination, Expiration, or Cancellation of the Agreement. If services provided under the Agreement are being transitioned to another provider(s), Grantee shall assist in the smooth transition of Agreement services to the subsequent provider(s). This requirement is at a minimum an affirmative obligation to cooperate with the new provider(s), however additional requirements may be outlined in the Grant Work Plan. The Grantee shall not perform any services after Agreement expiration or termination, except as necessary to complete the transition or continued portion of the Agreement, if any.

**14. Notice of Default.**

If Grantee defaults in the performance of any covenant or obligation contained in the Agreement, including, any of the events of default, Department shall provide notice to Grantee and an opportunity to cure that is reasonable under the circumstances. This notice shall state the nature of the failure to perform and provide a time certain for correcting the failure. The notice will also provide that, should the Grantee fail to perform within the time provided, Grantee will be found in default, and Department may terminate the Agreement effective as of the date of receipt of the default notice.

**15. Events of Default.**

Provided such failure is not the fault of Department or outside the reasonable control of Grantee, the following non-exclusive list of events, acts, or omissions, shall constitute events of default:

- a. The commitment of any material breach of this Agreement by Grantee, including failure to timely deliver a material deliverable, failure to perform the minimal level of services required for a deliverable, discontinuance of the performance of the work, failure to resume work that has been discontinued within a reasonable time after notice to do so, or abandonment of the Agreement;
- b. The commitment of any material misrepresentation or omission in any materials, or discovery by the Department of such, made by the Grantee in this Agreement or in its application for funding;
- c. Failure to submit any of the reports required by this Agreement or having submitted any report with incorrect, incomplete, or insufficient information;
- d. Failure to honor any term of the Agreement;
- e. Failure to abide by any statutory, regulatory, or licensing requirement, including an entry of an order revoking the certificate of authority granted to the Grantee by a state or other licensing authority;
- f. Failure to pay any and all entities, individuals, and furnishing labor or materials, or failure to make payment to any other entities as required by this Agreement;
- g. Employment of an unauthorized alien in the performance of the work, in violation of Section 274 (A) of the Immigration and Nationality Act;
- h. Failure to maintain the insurance required by this Agreement;
- i. One or more of the following circumstances, uncorrected for more than thirty (30) days unless, within the specified 30-day period, Grantee (including its receiver or trustee in bankruptcy) provides to Department adequate assurances, reasonably acceptable to Department, of its continuing ability and willingness to fulfill its obligations under the Agreement:
  - i. Entry of an order for relief under Title 11 of the United States Code;
  - ii. The making by Grantee of a general assignment for the benefit of creditors;
  - iii. The appointment of a general receiver or trustee in bankruptcy of Grantee’s business or property; and/or
  - iv. An action by Grantee under any state insolvency or similar law for the purpose of its bankruptcy, reorganization, or liquidation.

**16. Suspension of Work.**

The Department may, in its sole discretion, suspend any or all activities under the Agreement, at any time, when it is in the best interest of the State to do so. The Department shall provide Grantee written notice outlining the particulars of suspension. Examples of reasons for suspension include, but are not limited to, budgetary constraints, declaration of emergency, or other such circumstances. After receiving a suspension notice, Grantee shall comply with the notice. Within 90 days, or any longer period agreed to by the parties, Department shall either: (1) issue a notice authorizing resumption of work, at which time activity shall resume; or (2) terminate the Agreement. If the Agreement is terminated after 30 days of suspension, the notice of suspension shall be deemed to satisfy the thirty (30) days’ notice required for a notice of termination for convenience. Suspension of work shall not entitle Grantee to any additional compensation.

**17. Force Majeure.**

The Grantee shall not be responsible for delay resulting from its failure to perform if neither the fault nor the negligence of Grantee or its employees or agents contributed to the delay and the delay is due directly to acts of God, wars, acts

of public enemies, strikes, fires, floods, or other similar cause wholly beyond Grantee’s control, or for any of the foregoing that affect subcontractors/subrecipients or suppliers if no alternate source of supply is available to Grantee. In case of any delay Grantee believes is excusable, Grantee shall notify Department in writing of the delay or potential delay and describe the cause of the delay either (1) within ten days after the cause that creates or will create the delay first arose, if Grantee could reasonably foresee that a delay could occur as a result; or (2) if delay is not reasonably foreseeable, within five days after the date Grantee first had reason to believe that a delay could result. **THE FOREGOING SHALL CONSTITUTE THE GRANTEE’S SOLE REMEDY OR EXCUSE WITH RESPECT TO DELAY.** Providing notice in strict accordance with this paragraph is a condition precedent to such remedy. No claim for damages, other than for an extension of time, shall be asserted against Department. The Grantee shall not be entitled to an increase in the Agreement price or payment of any kind from Department for direct, indirect, consequential, impact or other costs, expenses or damages, including but not limited to costs of acceleration or inefficiency, arising because of delay, disruption, interference, or hindrance from any cause whatsoever. If performance is suspended or delayed, in whole or in part, due to any of the causes described in this paragraph, after the causes have ceased to exist Grantee shall perform at no increased cost, unless Department determines, in its sole discretion, that the delay will significantly impair the value of the Agreement to Department, in which case Department may: (1) accept allocated performance or deliveries from Grantee, provided that Grantee grants preferential treatment to Department with respect to products subjected to allocation; (2) contract with other sources (without recourse to and by Grantee for the related costs and expenses) to replace all or part of the products or services that are the subject of the delay, which purchase may be deducted from the Agreement quantity; or (3) terminate Agreement in whole or in part.

**18. Indemnification.**

- a. The Grantee shall be fully liable for the actions of its agents, employees, partners, and subcontractors/subrecipients and shall fully indemnify, defend, and hold harmless Department and its officers, agents, and employees, from suits, actions, damages, and costs of every name and description arising from or relating to:
  - i. personal injury and damage to real or personal tangible property alleged to be caused in whole or in part by Grantee, its agents, employees, partners, and subcontractors/subrecipients; provided, however, that Grantee shall not indemnify for that portion of any loss or damages proximately caused by the negligent act or omission of Department;
  - ii. the Grantee’s breach of this Agreement or the negligent acts or omissions of Grantee.
- b. The Grantee’s obligations under the preceding paragraph with respect to any legal action are contingent upon Department giving Grantee: (1) written notice of any action or threatened action; (2) the opportunity to take over and settle or defend any such action at Grantee’s sole expense; and (3) assistance in defending the action at Grantee’s sole expense. The Grantee shall not be liable for any cost, expense, or compromise incurred or made by Department in any legal action without Grantee’s prior written consent, which shall not be unreasonably withheld.
- c. Notwithstanding sections a. and b. above, the following is the sole indemnification provision that applies to Grantees that are governmental entities: Each party hereto agrees that it shall be solely responsible for the negligent or wrongful acts of its employees and agents. However, nothing contained herein shall constitute a waiver by either party of its sovereign immunity or the provisions of section 768.28, F.S. Further, nothing herein shall be construed as consent by a state agency or subdivision of the State to be sued by third parties in any matter arising out of any contract or this Agreement.
- d. No provision in this Agreement shall require Department to hold harmless or indemnify Grantee, insure or assume liability for Grantee’s negligence, waive Department’s sovereign immunity under the laws of Florida, or otherwise impose liability on Department for which it would not otherwise be responsible. Any provision, implication or suggestion to the contrary is null and void.

**19. Limitation of Liability.**

The Department’s liability for any claim arising from this Agreement is limited to compensatory damages in an amount no greater than the sum of the unpaid balance of compensation due for goods or services rendered pursuant to and in compliance with the terms of the Agreement. Such liability is further limited to a cap of \$100,000.

**20. Remedies.**

Nothing in this Agreement shall be construed to make Grantee liable for force majeure events. Nothing in this Agreement, including financial consequences for nonperformance, shall limit Department’s right to pursue its remedies for other types of damages under the Agreement, at law or in equity. The Department may, in addition to

other remedies available to it, at law or in equity and upon notice to Grantee, retain such monies from amounts due Grantee as may be necessary to satisfy any claim for damages, penalties, costs and the like asserted by or against it.

**21. Waiver.**

The delay or failure by Department to exercise or enforce any of its rights under this Agreement shall not constitute or be deemed a waiver of Department’s right thereafter to enforce those rights, nor shall any single or partial exercise of any such right preclude any other or further exercise thereof or the exercise of any other right.

**22. Statutory Notices Relating to Unauthorized Employment and Subcontracts/Subawards.**

a. The Department shall consider the employment by any Grantee of unauthorized aliens a violation of Section 274A(e) of the Immigration and Nationality Act. If Grantee/subcontractor/subrecipient knowingly employs unauthorized aliens, such violation shall be cause for unilateral cancellation of this Agreement. The Grantee shall be responsible for including this provision in all subcontracts/subawards with private organizations issued as a result of this Agreement.

b. Pursuant to sections 287.133, 287.134, and 287.137 F.S., the following restrictions apply to persons placed on the convicted vendor list, discriminatory vendor list, or the antitrust violator vendor list:

i. Public Entity Crime. A person or affiliate who has been placed on the convicted vendor list following a conviction for a public entity crime may not submit a bid, proposal, or reply on a contract to provide any goods or services to a public entity; may not submit a bid, proposal, or reply on a contract with a public entity for the construction or repair of a public building or public work; may not submit bids, proposals, or replies on leases of real property to a public entity; may not be awarded or perform work as a Grantee, supplier, subcontractor, or consultant under a contract with any public entity; and may not transact business with any public entity in excess of the threshold amount provided in section 287.017, F.S., for CATEGORY TWO for a period of 36 months following the date of being placed on the convicted vendor list.

ii. Discriminatory Vendors. An entity or affiliate who has been placed on the discriminatory vendor list may not submit a bid, proposal, or reply on a contract to provide any goods or services to a public entity; may not submit a bid, proposal, or reply on a contract with a public entity for the construction or repair of a public building or public work; may not submit bids, proposals, or replies on leases of real property to a public entity; may not be awarded or perform work as a contractor, supplier, subcontractor, or consultant under a contract with any public entity; and may not transact business with any public entity.

iii. Antitrust Violator Vendors. A person or an affiliate who has been placed on the antitrust violator vendor list following a conviction or being held civilly liable for an antitrust violation may not submit a bid, proposal, or reply on any contract to provide any good or services to a public entity; may not submit a bid, proposal, or reply on any contract with a public entity for the construction or repair of a public building or public work; may not submit a bid, proposal, or reply on leases of real property to a public entity; may not be awarded or perform work as a Grantee, supplier, subcontractor, or consultant under a contract with a public entity; and may not transact new business with a public entity.

iv. Notification. The Grantee shall notify Department if it or any of its suppliers, subcontractors, or consultants have been placed on the convicted vendor list, the discriminatory vendor list, or antitrust violator vendor list during the life of the Agreement. The Florida Department of Management Services is responsible for maintaining the discriminatory vendor list and the antitrust violator vendor list and posts the list on its website. Questions regarding the discriminatory vendor list or antitrust violator vendor list may be directed to the Florida Department of Management Services, Office of Supplier Development, at (850) 487-0915.

**23. Compliance with Federal, State and Local Laws.**

a. The Grantee and all its agents shall comply with all federal, state and local regulations, including, but not limited to, nondiscrimination, wages, social security, workers’ compensation, licenses, and registration requirements. The Grantee shall include this provision in all subcontracts/subawards issued as a result of this Agreement.

b. The Grantee, its subrecipients, subcontractors and agents must also comply with the following civil rights laws and regulations:

i. Title VI of the Civil Rights Act of 1964 as amended (prohibiting discrimination in federally assisted programs on the basis of race, color, or national origin in the delivery of services or benefits);

- ii. Section 13 of the 1972 Amendment to the Federal Water Pollution Control Act (prohibiting discrimination on the basis of sex in the delivery of services or benefits under the Federal Water Pollution Control Act as amended);
  - iii. Section 504 of the Rehabilitation Act of 1973 (prohibiting discrimination in federally assisted programs on the basis of disability, both in employment and in the delivery of services and benefits);
  - iv. Age Discrimination Act of 1975 (prohibiting discrimination in federally assisted programs on the basis of age in the delivery of services or benefits);
  - v. 40 C.F.R. Part 7, (implementing Title VI of the Civil Rights Act of 1964, Section 13 of the 1972 Amendments to the Federal Water Pollution Control Act, and Section 504 of the Rehabilitation Act of 1973);
  - vi. Florida Civil Rights Act of 1992 (Title XLIV Chapter 760, Sections 760.01, 760.11 and 509.092, F.S.), including Part I, chapter 760, F.S. (prohibiting discrimination on the basis of race, color, religion, sex, pregnancy, national origin, age, handicap, or marital status).
- c. This Agreement shall be governed by and construed in accordance with the laws of the State of Florida.
- d. Any dispute concerning performance of the Agreement shall be processed as described herein. Jurisdiction for any damages arising under the terms of the Agreement will be in the courts of the State, and venue will be in the Second Judicial Circuit, in and for Leon County. Except as otherwise provided by law, the parties agree to be responsible for their own attorney fees incurred in connection with disputes arising under the terms of this Agreement.

**24. Build America, Buy America Act (BABA) - Infrastructure Projects with Federal Funding.**  
**This provision does not apply to Agreements that are wholly funded by Coronavirus State and Local Fiscal Recovery Funds under the American Rescue Plan Act. Also, this provision does not apply where there is a valid waiver in place. However, the provision may apply to funds expended before the waiver or after expiration of the waiver.**

If applicable, Recipients or Subrecipients of an award of Federal financial assistance from a program for infrastructure are required to comply with the Build America, Buy America Act (BABA), including the following provisions:

- a. All iron and steel used in the project are produced in the United States--this means all manufacturing processes, from the initial melting stage through the application of coatings, occurred in the United States;
- b. All manufactured products used in the project are produced in the United States--this means the manufactured product was manufactured in the United States; and the cost of the components of the manufactured product that are mined, produced, or manufactured in the United States is greater than 55 percent of the total cost of all components of the manufactured product, unless another standard for determining the minimum amount of domestic content of the manufactured product has been established under applicable law or regulation; and
- c. All construction materials are manufactured in the United States--this means that all manufacturing processes for the construction material occurred in the United States.

The Buy America preference only applies to articles, materials, and supplies that are consumed in, incorporated into, or affixed to an infrastructure project. As such, it does not apply to tools, equipment, and supplies, such as temporary scaffolding, brought to the construction site and removed at or before the completion of the infrastructure project. Nor does a Buy America preference apply to equipment and furnishings, such as movable chairs, desks, and portable computer equipment, that are used at or within the finished infrastructure project but are not an integral part of the structure or permanently affixed to the infrastructure project.

**25. Investing in America**  
 Grantees of an award for construction projects in whole or in part by the Bipartisan Infrastructure Law or the Inflation Reduction Act, including the following provision:

- a. Signage Requirements
  - a. Investing in America Emblem: The recipient will ensure that a sign is placed at construction sites supported in whole or in part by this award displaying the official Investing in America emblem and must identify the project as a “project funded by President Biden’s Bipartisan Infrastructure Law” or “project funded by President Biden’s Inflation Reduction Act” as applicable. The sign must be placed at construction sites in an easily visible location that can be directly linked to the work taking place and must be maintained in good condition throughout the construction period.

The recipient will ensure compliance with the guidelines and design specifications provided by EPA for using the official Investing in America emblem available at: <https://www.epa.gov/invest/investing-america-signage>.

b. Procuring Signs: Consistent with section 6002 of RCRA, 42 U.S.C. 6962, and 2 CFR 200.323, recipients are encouraged to use recycled or recovered materials when procuring signs. Signage costs are considered an allowable cost under this assistance agreement provided that the costs associated with signage are reasonable. Additionally, to increase public awareness of projects serving communities where English is not the predominant language, recipients are encouraged to translate the language on signs (excluding the official Investing in America emblem or EPA logo or seal) into the appropriate non-English language(s). The costs of such translation are allowable, provided the costs are reasonable.

**26. Scrutinized Companies.**

- a. Grantee certifies that it is not on the Scrutinized Companies that Boycott Israel List or engaged in a boycott of Israel. Pursuant to section 287.135, F.S., the Department may immediately terminate this Agreement at its sole option if the Grantee is found to have submitted a false certification; or if the Grantee is placed on the Scrutinized Companies that Boycott Israel List or is engaged in the boycott of Israel during the term of the Agreement.
- b. If this Agreement is for more than one million dollars, the Grantee certifies that it is also not on the Scrutinized Companies with Activities in Sudan, Scrutinized Companies with Activities in the Iran Petroleum Energy Sector List, or engaged with business operations in Cuba or Syria as identified in section 287.135, F.S. Pursuant to section 287.135, F.S., the Department may immediately terminate this Agreement at its sole option if the Grantee is found to have submitted a false certification; or if the Grantee is placed on the Scrutinized Companies with Activities in Sudan List, or Scrutinized Companies with Activities in the Iran Petroleum Energy Sector List, or engaged with business operations in Cuba or Syria during the term of the Agreement.
- c. As provided in subsection 287.135(8), F.S., if federal law ceases to authorize these contracting prohibitions, then they shall become inoperative.

**27. Lobbying and Integrity.**

The Grantee agrees that no funds received by it under this Agreement will be expended for the purpose of lobbying the Legislature or a State agency pursuant to section 216.347, F.S., except that pursuant to the requirements of section 287.058(6), F.S., during the term of any executed agreement between Grantee and the State, Grantee may lobby the executive or legislative branch concerning the scope of services, performance, term, or compensation regarding that agreement. The Grantee shall comply with sections 11.062 and 216.347, F.S.

**28. Record Keeping.**

The Grantee shall maintain books, records and documents directly pertinent to performance under this Agreement in accordance with United States generally accepted accounting principles (US GAAP) consistently applied. The Department, the State, or their authorized representatives shall have access to such records for audit purposes during the term of this Agreement and for five (5) years following the completion date or termination of the Agreement. In the event that any work is subcontracted or subawarded, Grantee shall similarly require each subcontractor/subrecipient to maintain and allow access to such records for audit purposes. Upon request of Department's Inspector General, or other authorized State official, Grantee shall provide any type of information the Inspector General deems relevant to Grantee's integrity or responsibility. Such information may include, but shall not be limited to, Grantee's business or financial records, documents, or files of any type or form that refer to or relate to Agreement. The Grantee shall retain such records for the longer of: (1) three years after the expiration of the Agreement; or (2) the period required by the General Records Schedules maintained by the Florida Department of State (available at: <http://dos.myflorida.com/library-archives/records-management/general-records-schedules/>).

**29. Audits.**

- a. Inspector General. The Grantee understands its duty, pursuant to section 20.055(5), F.S., to cooperate with the inspector general in any investigation, audit, inspection, review, or hearing. The Grantee will comply with this duty and ensure that its subrecipients and/or subcontractors issued under this Agreement, if any, impose this requirement, in writing, on its subrecipients and/or subcontractors, respectively.
- b. Physical Access and Inspection. Department personnel shall be given access to and may observe and inspect work being performed under this Agreement, with reasonable notice and during normal business hours, including by any of the following methods:

- i. Grantee shall provide access to any location or facility on which Grantee is performing work, or storing or staging equipment, materials or documents;
  - ii. Grantee shall permit inspection of any facility, equipment, practices, or operations required in performance of any work pursuant to this Agreement; and,
  - iii. Grantee shall allow and facilitate sampling and monitoring of any substances, soils, materials or parameters at any location reasonable or necessary to assure compliance with any work or legal requirements pursuant to this Agreement.
- c. Special Audit Requirements. The Grantee shall comply with the applicable provisions contained in Attachment 5, Special Audit Requirements. Each amendment that authorizes a funding increase or decrease shall include an updated copy of Exhibit 1, to Attachment 5. If Department fails to provide an updated copy of Exhibit 1 to include in each amendment that authorizes a funding increase or decrease, Grantee shall request one from the Department’s Grants Manager. The Grantee shall consider the type of financial assistance (federal and/or state) identified in Attachment 5, Exhibit 1 and determine whether the terms of Federal and/or Florida Single Audit Act Requirements may further apply to lower tier transactions that may be a result of this Agreement. For federal financial assistance, Grantee shall utilize the guidance provided under 2 CFR §200.331 for determining whether the relationship represents that of a subrecipient or vendor. For State financial assistance, Grantee shall utilize the form entitled “Checklist for Nonstate Organizations Recipient/Subrecipient vs Vendor Determination” (form number DFS-A2-NS) that can be found under the “Links/Forms” section appearing at the following website: <https://apps.fldfs.com/fsaa>.
- d. Proof of Transactions. In addition to documentation provided to support cost reimbursement as described herein, Department may periodically request additional proof of a transaction to evaluate the appropriateness of costs to the Agreement pursuant to State guidelines (including cost allocation guidelines) and federal, if applicable. Allowable costs and uniform administrative requirements for federal programs can be found under 2 CFR 200. The Department may also request a cost allocation plan in support of its multipliers (overhead, indirect, general administrative costs, and fringe benefits). The Grantee must provide the additional proof within thirty (30) days of such request.
- e. No Commingling of Funds. The accounting systems for all Grantees must ensure that these funds are not commingled with funds from other agencies. Funds from each agency must be accounted for separately. Grantees are prohibited from commingling funds on either a program-by-program or a project-by-project basis. Funds specifically budgeted and/or received for one project may not be used to support another project. Where a Grantee's, or subrecipient's, accounting system cannot comply with this requirement, Grantee, or subrecipient, shall establish a system to provide adequate fund accountability for each project it has been awarded.
  - i. If Department finds that these funds have been commingled, Department shall have the right to demand a refund, either in whole or in part, of the funds provided to Grantee under this Agreement for non-compliance with the material terms of this Agreement. The Grantee, upon such written notification from Department shall refund, and shall forthwith pay to Department, the amount of money demanded by Department. Interest on any refund shall be calculated based on the prevailing rate used by the State Board of Administration. Interest shall be calculated from the date(s) the original payment(s) are received from Department by Grantee to the date repayment is made by Grantee to Department.
  - ii. In the event that the Grantee recovers costs, incurred under this Agreement and reimbursed by Department, from another source(s), Grantee shall reimburse Department for all recovered funds originally provided under this Agreement and interest shall be charged for those recovered costs as calculated on from the date(s) the payment(s) are recovered by Grantee to the date repayment is made to Department.
  - iii. Notwithstanding the requirements of this section, the above restrictions on commingling funds do not apply to agreements where payments are made purely on a cost reimbursement basis.

**30. Conflict of Interest.**

The Grantee covenants that it presently has no interest and shall not acquire any interest which would conflict in any manner or degree with the performance of services required.

**31. Independent Contractor.**

The Grantee is an independent contractor and is not an employee or agent of Department.

**32. Subcontracting/Subawards.**

- a. Unless otherwise specified in the Special Terms and Conditions, all services contracted for are to be performed solely by Grantee.

**Attachment 1**

- b. The Department may, for cause, require the replacement of any Grantee employee, subcontractor/subrecipient, or agent. For cause, includes, but is not limited to, technical or training qualifications, quality of work, change in security status, or non-compliance with an applicable Department policy or other requirement.
- c. The Department may, for cause, deny access to Department's secure information or any facility by any Grantee employee, subcontractor/subrecipient, or agent.
- d. The Department's actions under paragraphs b. or c. shall not relieve Grantee of its obligation to perform all work in compliance with the Agreement. The Grantee shall be responsible for the payment of all monies due under any subcontract/subaward. The Department shall not be liable to any subcontractor/subrecipient for any expenses or liabilities incurred under any subcontract/subaward, and Grantee shall be solely liable to the subcontractor for all expenses and liabilities incurred under any subcontract/subaward.
- e. The Department will not deny Grantee's employees, subcontractors/subrecipients, or agents access to meetings within the Department's facilities, unless the basis of Department's denial is safety or security considerations.
- f. A list of minority-owned firms that could be offered subcontracting opportunities may be obtained by contacting the Office of Supplier Development at (850) 487-0915.
- g. The Grantee shall not be liable for any excess costs for a failure to perform, if the failure to perform is caused by the default of a subcontractor/subrecipient at any tier, and if the cause of the default is completely beyond the control of both Grantee and the subcontractor(s)/subrecipient(s), and without the fault or negligence of either, unless the subcontracted/subawarded products or services were obtainable from other sources in sufficient time for Grantee to meet the required delivery schedule.

**33. Guarantee of Parent Company.**

If Grantee is a subsidiary of another corporation or other business entity, Grantee asserts that its parent company will guarantee all of the obligations of Grantee for purposes of fulfilling the obligations of Agreement. In the event Grantee is sold during the period the Agreement is in effect, Grantee agrees that it will be a requirement of sale that the new parent company guarantee all of the obligations of Grantee.

**34. Survival.**

The respective obligations of the parties, which by their nature would continue beyond the termination or expiration of this Agreement, including without limitation, the obligations regarding confidentiality, proprietary interests, and public records, shall survive termination, cancellation, or expiration of this Agreement.

**35. Third Parties.**

The Department shall not be deemed to assume any liability for the acts, failures to act or negligence of Grantee, its agents, servants, and employees, nor shall Grantee disclaim its own negligence to Department or any third party. This Agreement does not and is not intended to confer any rights or remedies upon any person other than the parties. If Department consents to a subcontract/subaward, Grantee will specifically disclose that this Agreement does not create any third-party rights. Further, no third parties shall rely upon any of the rights and obligations created under this Agreement.

**36. Severability.**

If a court of competent jurisdiction deems any term or condition herein void or unenforceable, the other provisions are severable to that void provision, and shall remain in full force and effect.

**37. Grantee's Employees, Subcontractors/Subrecipients and Agents.**

All Grantee employees, subcontractors/subrecipients, or agents performing work under the Agreement shall be properly trained technicians who meet or exceed any specified training qualifications. Upon request, Grantee shall furnish a copy of technical certification or other proof of qualification. All employees, subcontractors/subrecipients, or agents performing work under Agreement must comply with all security and administrative requirements of Department and shall comply with all controlling laws and regulations relevant to the services they are providing under the Agreement.

**38. Assignment.**

The Grantee shall not sell, assign, or transfer any of its rights, duties, or obligations under the Agreement, or under any purchase order issued pursuant to the Agreement, without the prior written consent of Department. In the event of any assignment, Grantee remains secondarily liable for performance of the Agreement, unless Department expressly waives such secondary liability. The Department may assign the Agreement with prior written notice to Grantee of its intent to do so.

**39. Compensation Report.**

If this Agreement is a sole-source, public-private agreement or if the Grantee, through this agreement with the State, annually receive 50% or more of their budget from the State or from a combination of State and Federal funds, the Grantee shall provide an annual report, including the most recent IRS Form 990, detailing the total compensation for

the entities' executive leadership teams. Total compensation shall include salary, bonuses, cashed-in leave, cash equivalents, severance pay, retirement benefits, deferred compensation, real-property gifts, and any other payout. The Grantee must also inform the Department of any changes in total executive compensation between the annual reports. All compensation reports must indicate what percent of compensation comes directly from the State or Federal allocations to the Grantee.

**40. Disclosure of Gifts from Foreign Sources.**

If the value of the grant under this Agreement is \$100,000 or more, Grantee shall disclose to Department any current or prior interest of, any contract with, or any grant or gift received from a foreign country of concern, as defined in section 286.101, F.S., if such interest, contract, or grant or gift has a value of \$50,000 or more and such interest existed at any time or such contract or grant or gift was received or in force at any time during the previous 5 years. Such disclosure shall include the name and mailing address of the disclosing entity, the amount of the contract or grant or gift or the value of the interest disclosed, the applicable foreign country of concern and, if applicable, the date of termination of the contract or interest, the date of receipt of the grant or gift, and the name of the agent or controlled entity that is the source or interest holder. If the disclosure requirement is applicable as described above, then within 1 year before applying for any grant, Grantee must also provide a copy of such disclosure to the Department of Financial Services.

**41. Food Commodities.**

To the extent authorized by federal law, the Department, its grantees, contractors and subcontractors/subrecipients shall give preference to food commodities grown or produced in this state when purchasing food commodities, including farm products as defined in section 823.14, F.S., of any class, variety, or use thereof in their natural state or as processed by a farm operation or processor for the purpose of marketing such product.

**42. Anti-human Trafficking.**

If the Grantee is a nongovernmental entity, the Grantee must provide the Department with an affidavit signed by an officer or a representative of the Grantee under penalty of perjury attesting that the Grantee does not use coercion for labor or services as defined in section 787.06, F.S.

**43. Iron and Steel for Public Works Projects.**

If this Agreement funds a “public works project” as defined in section 255.0993, F.S., or the purchase of materials to be used in a public works project, any iron or steel permanently incorporated in the Project must be “produced in the United States,” as defined in section 255.0993, F.S. This requirement does not apply if the Department determines that any of the following circumstances apply to the Project:

- (1) iron or steel products produced in the United States are not produced in sufficient quantities, reasonably available, or of satisfactory quality;
- (2) the use of iron or steel products produced in the United States will increase the total cost of the project by more than twenty percent (20%); or
- (3) complying with this requirement is inconsistent with the public interest.

Further, this requirement does not prevent the Contractor’s minimal use of foreign steel and iron materials if:

- (1) such materials are incidental or ancillary to the primary product and are not separately identified in the project specifications; and
- (2) the “cost” of such materials, as defined in section 255.0993, F.S., does not exceed one-tenth of one percent (1%) of the total Project Cost under this Agreement or \$2,500, whichever is greater.

Electrical components, equipment, systems, and appurtenances, including supports, covers, shielding, and other appurtenances related to an electrical system that are necessary for operation or concealment (excepting transmission and distribution poles) are not considered to be iron or steel products and are, therefore, exempt from the requirements of this paragraph.

This provision shall be applied in a manner consistent with and may not be construed to impair the state’s obligations under any international agreement.

**44. Complete and Accurate information.**

Grantee represents and warrants that all statements and information provided to DEP are current, complete, and accurate. This includes all statements and information in this Grant, as well as its Attachments and Exhibits.

**45. Execution in Counterparts and Authority to Sign.**

This Agreement, any amendments, and/or change orders related to the Agreement, may be executed in counterparts, each of which shall be an original and all of which shall constitute the same instrument. In accordance with the Electronic Signature Act of 1996, electronic signatures, including facsimile transmissions, may be used and shall have the same force and effect as a written signature. Each person signing this Agreement warrants that he or she is duly authorized to do so and to bind the respective party to the Agreement.

STATE OF FLORIDA  
DEPARTMENT OF ENVIRONMENTAL PROTECTION  
Special Terms and Conditions  
AGREEMENT NO. 26PLN63

ATTACHMENT 2

These Special Terms and Conditions shall be read together with general terms outlined in the Standard Terms and Conditions, Attachment 1. Where in conflict, these more specific terms shall apply.

**1. Scope of Work.**

The Project funded under this Agreement is City of Chipley Gilbert Acres Drainage Improvements. The Project is defined in more detail in Attachment 3, Grant Work Plan.

**2. Duration.**

- a. Reimbursement Period. The reimbursement period for this Agreement is the same as the term of the Agreement.
- b. Extensions. There are extensions available for this Project.
- c. Service Periods. Additional service periods may be added in accordance with 2.a above and are contingent upon proper and satisfactory technical and administrative performance by the Grantee and the availability of funding.

**3. Payment Provisions.**

- a. Compensation. This is a cost reimbursement Agreement. The Grantee shall be compensated under this Agreement as described in Attachment 3.
- b. Invoicing. Invoicing will occur as indicated in Attachment 3.
- c. Advance Pay. Advance Pay is authorized under this Agreement.

**4. Cost Eligible for Reimbursement or Matching Requirements.**

Reimbursement for costs or availability for costs to meet matching requirements shall be limited to the following budget categories, as defined in the Reference Guide for State Expenditures, as indicated:

<u>Reimbursement</u>	<u>Match</u>	<u>Category</u>
<input type="checkbox"/>	<input type="checkbox"/>	Salaries/Wages
		Overhead/Indirect/General and Administrative Costs:
<input type="checkbox"/>	<input type="checkbox"/>	a. Fringe Benefits, N/A.
<input type="checkbox"/>	<input type="checkbox"/>	b. Indirect Costs, N/A.
<input checked="" type="checkbox"/>	<input type="checkbox"/>	Contractual/Subaward (Subcontractors/Subrecipients)
<input type="checkbox"/>	<input type="checkbox"/>	Travel, in accordance with Section 112, F.S.
<input type="checkbox"/>	<input type="checkbox"/>	Equipment
<input type="checkbox"/>	<input type="checkbox"/>	Rental/Lease of Equipment
<input type="checkbox"/>	<input type="checkbox"/>	Miscellaneous/Other Expenses
<input type="checkbox"/>	<input type="checkbox"/>	Land Acquisition

**5. Equipment Purchase.**

No Equipment purchases shall be funded under this Agreement.

**6. Land Acquisition.**

There will be no Land Acquisitions funded under this Agreement.

**7. Match Requirements**

There is no match required on the part of the Grantee under this Agreement.

**8. Insurance Requirements**

**Required Coverage.** At all times during the Agreement the Grantee, at its sole expense, shall maintain insurance coverage of such types and with such terms and limits described below. The limits of coverage under each policy maintained by the Grantee shall not be interpreted as limiting the Grantee’s liability and obligations under the Agreement. All insurance policies shall be through insurers licensed and authorized to issue policies in Florida, or alternatively, Grantee may provide coverage through a self-insurance program established and operating under the laws of Florida. Additional insurance requirements for this Agreement may be required elsewhere in this Agreement, however the minimum insurance requirements applicable to this Agreement are:

- a. Commercial General Liability Insurance.  
The Grantee shall provide adequate commercial general liability insurance coverage and hold such liability insurance at all times during the Agreement. The Department, its employees, and officers shall be named as an additional insured on any general liability policies. The minimum limits shall be \$250,000 for each occurrence and \$500,000 policy aggregate.
- b. Commercial Automobile Insurance.  
If the Grantee’s duties include the use of a commercial vehicle, the Grantee shall maintain automobile liability, bodily injury, and property damage coverage. Insuring clauses for both bodily injury and property damage shall provide coverage on an occurrence basis. The Department, its employees, and officers shall be named as an additional insured on any automobile insurance policy. The minimum limits shall be as follows:  

\$200,000/300,000	Automobile Liability for Company-Owned Vehicles, if applicable
\$200,000/300,000	Hired and Non-owned Automobile Liability Coverage
- c. Workers’ Compensation and Employer’s Liability Coverage.  
The Grantee shall provide workers’ compensation, in accordance with Chapter 440, F.S. and employer liability coverage with minimum limits of \$100,000 per accident, \$100,000 per person, and \$500,000 policy aggregate. Such policies shall cover all employees engaged in any work under the Grant.
- d. Other Insurance. None.

**9. Quality Assurance Requirements.**

There are no special Quality Assurance requirements under this Agreement.

**10. Retainage.**

No retainage is required under this Agreement.

**11. Subcontracting/Subawards.**

The Grantee may subcontract/subaward work under this Agreement without the prior written consent of the Department’s Grant Manager except for certain fixed-price subcontracts/subawards pursuant to this Agreement, which require prior approval. The Grantee shall submit a copy of the executed subcontracts/subaward to the Department prior to submitting any invoices for subcontracted/subawarded work. Regardless of any subcontract/subaward, the Grantee is ultimately responsible for all work to be performed under this Agreement.

**12. State-owned Land.**

The work will not be performed on State-owned land.

**13. Office of Policy and Budget Reporting.**

There are no special Office of Policy and Budget reporting requirements for this Agreement.

**14. Common Carrier.**

- a. Applicable to contracts/subawards with a common carrier – firm/person/corporation that as a regular business transports people or commodities from place to place. If applicable, Contractor/Subrecipient must also fill out and return PUR 1808 before contract/subaward execution. If Contractor/Subrecipient is a common carrier pursuant to section 908.111(1)(a), Florida Statutes, the Department will terminate this Agreement immediately if Contractor/Subrecipient is found to be in violation of the law or the attestation in PUR 1808.
- b. Applicable to solicitations for a common carrier – Before contract execution, the winning Contractor(s) must fill out and return PUR 1808, and attest that it is not willfully providing any service in furtherance of transporting a person into this state knowing that the person unlawfully present in the United States

according to the terms of the federal Immigration and Nationality Act, 8 U.S.C. ss. 1101 et seq. The Department will terminate a contract immediately if Contractor is found to be in violation of the law or the attestation in PUR 1808.

**15. Financial Assistance and Payment of Invoices to Rural Communities or Rural Areas of Opportunity**

In the event that this Agreement facilitates the provision of federal or state financial assistance to a county or municipality classified as a rural community or rural area of opportunity, as defined in Section 288.0656(2), Department is authorized, in accordance with section 215.971, F.S., to process the payment of invoices to such county or municipality.

Such payments shall be made for verified and eligible performance that has been completed in accordance with the terms and conditions stipulated in this Agreement. The Grantee must provide subcontractor proof of payment to the Department with its next payment request or within sixty (60) days if the payment was a final payment.

**16. Additional Terms.**

None.

STATE OF FLORIDA  
DEPARTMENT OF ENVIRONMENTAL PROTECTION  
GRANT WORK PLAN  
AGREEMENT NO. 26PLN63

ATTACHMENT 3

**PROJECT TITLE:** City of Chipley Gilbert Acres Drainage Improvements.

**PROJECT LOCATION:** The Project is located in the City of Chipley within Washington County, Florida.

**PROJECT DESCRIPTION:**

The City of Chipley (Grantee) will complete the City of Chipley Gilbert Acres Drainage Improvements Project (Project) to include the engineering, design, and permitting of a drainage improvement project within the existing drainage in the area south of US 90, north of South Boulevard, east of Sinclair Street, and west of Peach Street. The Project will address the impacts of flooding along roadways and critical transportation routes, such as State Road 77.

**TASKS AND DELIVERABLES:**

**Task 1: Design and Permitting**

**Description:** The Grantee will acquire professional services for the engineering and design of the Gilbert Acres Project and obtain all necessary permits for construction of the Project. Design and permitting activities may include coastal or civil engineering analyses, preparation of plans and specifications, physical and environmental surveys, cultural resource surveys, design-level geotechnical services, environmental analyses, orthophotography, plan formulations, identification of necessary easements, and other necessary studies for obtaining environmental permits, and other Project-related authorizations. The Grantee will submit all work products to the appropriate local, state, and federal regulatory agencies.

**Deliverables:** The Grantee will provide the following:

- **1.1:** Project Stakeholder Meeting, including coordination with city staff, regulatory agencies (as applicable), and key stakeholders to confirm project objectives, constraints, data needs, and design criteria, with meeting summary documentation provided;
- **1.2:** A copy of all data collected and surveys conducted, such as field review; survey; utility locate/SUE; geotechnical investigation; hydrologic and hydraulic data; environmental review; GIS and mapping; and supporting technical field measurements, to support the engineering and design of the Project;
- **1.3:** A Preliminary Engineering Report, prepared under the responsible charge of a Florida-registered Professional Engineer, identifying existing hazards and deficiencies within the Project area and providing proposed conceptual mitigation solutions to be approved by the City Council;
- **1.4:** 30% Plans, including preliminary layout, typical sections, drainage concepts, and supporting engineering analyses sufficient for review of the proposed design approach;
- **1.5:** 90% Plans, including items such as substantially complete construction drawings, updated engineering calculations, and an opinion of probable construction cost for final review;
- **1.6:** Final Plans, signed and sealed by a Florida-registered Professional Engineer or other applicable Florida Licensed Professional in responsible charge of the design, suitable for bidding and construction.

**PERFORMANCE MEASURES:** The Grantee will submit all deliverables for each task to [ResilientFloridaGrants@FloridaDEP.gov](mailto:ResilientFloridaGrants@FloridaDEP.gov) on or before the Task Due Date listed in the Project Timeline. The Department’s Grant Manager will review the deliverable(s) to verify that they meet the specifications in the Grant Work Plan and the task description, to include any work being performed by any subcontractor(s), and will provide written acceptance or non-acceptance of the deliverable(s) to the Grantee within thirty (30) calendar days. Deliverables that the Department determines are not acceptable must be corrected and resubmitted within thirty (30) calendar days prior to the Agreement’s Date of Expiration, and in coordination with the Department’s Grant Manager. Tasks may include multiple deliverables to be completed. The Department will accept partial and full deliverables. Incomplete deliverables will not be accepted. A “partial deliverable” is defined as a deliverable consisting of one (1) or more (but not all) subcomponents listed in the deliverable list for a single task, where such subcomponent(s) are delivered to the Department at one hundred percent (100%) completion. A “full deliverable” is defined as a deliverable comprising all subcomponents listed in the deliverable list for a single task, all delivered to the Department at one hundred percent (100%) completion. An “incomplete deliverable” is defined as a deliverable for which one hundred percent (100%) completion has not been achieved for any of the subcomponents listed in the deliverable list for a single task. A task is considered one hundred percent (100%) complete upon the Department’s receipt and approval of all deliverable(s) listed within the task and the Department’s approval provided by the Deliverable Acceptance Letter. All deliverables must be received by the Task Due Date and accepted by the Department on or before the Agreement’s Date of Expiration, or the Consequences for Non-Performance set forth herein shall apply.

**CONSEQUENCES FOR NON-PERFORMANCE:** For each task deliverable not received and accepted by the Department at one hundred percent (100%) completion on or before the Agreement’s Date of Expiration, the Department will reduce the relevant Task Funding Amount(s) paid to Grantee in proportion to the percentage of the deliverable(s) not fully completed. For each task deliverable not received by the Department by the specified Task Due Date listed in the Agreement’s most recent Project Timeline, the Department will reduce the relevant Task Funding Amount(s) by 5% per calendar day, which will be imposed until the Department has received the task deliverable. The Consequence for Non-Performance will be applied to and included in the relevant task deliverable's payment request.

**PAYMENT REQUEST SCHEDULE:** Following the Grantee’s full or partial completion of a task’s deliverable(s) and acceptance by the Department’s Grant Manager, the Grantee may submit a payment request for cost reimbursement using the Exhibit C, Payment Request Summary Form. All payment requests must be accompanied by the Deliverable Acceptance Letter; the Exhibit A, Progress Report Form, detailing all progress made in the invoice period; and supporting fiscal documentation including match, if applicable. If the payment request includes the Contractual Services budget category, the Exhibit H, Contractual Services Certification, and all supporting documentation required therein, must be submitted for each of the Grantee’s contractors included in the payment request. Interim payments will not be accepted. Payment requests will not be accepted until all required Exhibit A, Progress Report Forms, have been submitted to the Department’s Grant Manager for all reporting periods dating back to the Agreement Execution Date. For the reporting period beginning on the Agreement Begin Date and ending on the Agreement Execution Date, submittal of a single Exhibit A, Progress Report Form, covering only this reporting period will be acceptable. Upon the Department’s receipt of the aforementioned documents and supporting fiscal documentation, the Department’s Grant Manager will have ten (10) working days to review and approve or deny the payment request.

**ADVANCE PAYMENT:** For grant agreements for which full advance payment has been authorized and approved, the Grantee shall submit an invoice (i.e., payment request) to its Department Grant Manager for the expected cash needs for the initial three (3) month term of the agreement. Once the initial advance amount has been fully expended, the Grantee may request additional advance payments as needed, but no more frequently than quarterly. The Grantee shall submit all invoice documentation for each previously

expended advance with each new payment request. All previous advance payment funds must be fully expended prior to initiating another request. Upon receipt of the advanced funds, the Exhibit E, Advanced Funds Expended and Interest Earned Memo, must be submitted to the Department on a quarterly basis in conjunction with the Exhibit A, Progress Report Form.

**PROJECT TIMELINE AND BUDGET DETAIL:** The tasks must be completed by, and all deliverables received by, the corresponding task due date listed in the table below and must be an allowable expenditure category pursuant to Attachment 2, Special Terms and Conditions. Cost-reimbursable grant funding must not exceed the budget amounts indicated below. Requests for any change(s) to the task due date(s) must be submitted on or before the current task due date listed in the Project Timeline. Requests are to be sent via email to the Department’s Grant Manager, with the details of the request and the reason for the request made clear.

Task No.	Task Title	Budget Category	DEP Amount	Match Amount	Total Amount	Task Start Date	Task Due Date
1	Design and Permitting	Contractual Services	\$336,000	\$0	\$336,000	7/1/2025	3/31/2028
<b>Total:</b>			<b>\$336,000</b>	<b>\$0</b>	<b>\$336,000</b>		

STATE OF FLORIDA  
DEPARTMENT OF ENVIRONMENTAL PROTECTION  
Public Records Requirements

Attachment 4

1. **Public Records.**

- a. If the Agreement exceeds \$35,000.00, and if Grantee is acting on behalf of Department in its performance of services under the Agreement, Grantee must allow public access to all documents, papers, letters, or other material, regardless of the physical form, characteristics, or means of transmission, made or received by Grantee in conjunction with the Agreement (Public Records), unless the Public Records are exempt from section 24(a) of Article I of the Florida Constitution and section 119.07(1), F.S.
- b. The Department may unilaterally terminate the Agreement if Grantee refuses to allow public access to Public Records as required by law.

2. **Additional Public Records Duties of Section 119.0701, F.S., If Applicable.**

For the purposes of this paragraph, the term “contract” means the “Agreement.” If Grantee is a “contractor” as defined in section 119.0701(1)(a), F.S., the following provisions apply and the contractor shall:

- a. Keep and maintain Public Records required by Department to perform the service.
- b. Upon request, provide Department with a copy of requested Public Records or allow the Public Records to be inspected or copied within a reasonable time at a cost that does not exceed the cost provided in Chapter 119, F.S., or as otherwise provided by law.
- c. A contractor who fails to provide the Public Records to Department within a reasonable time may be subject to penalties under section 119.10, F.S.
- d. Ensure that Public Records that are exempt or confidential and exempt from Public Records disclosure requirements are not disclosed except as authorized by law for the duration of the contract term and following completion of the contract if the contractor does not transfer the Public Records to Department.
- e. Upon completion of the contract, transfer, at no cost, to Department all Public Records in possession of the contractor or keep and maintain Public Records required by Department to perform the service. If the contractor transfers all Public Records to Department upon completion of the contract, the contractor shall destroy any duplicate Public Records that are exempt or confidential and exempt from Public Records disclosure requirements. If the contractor keeps and maintains Public Records upon completion of the contract, the contractor shall meet all applicable requirements for retaining Public Records. All Public Records stored electronically must be provided to Department, upon request from Department’s custodian of Public Records, in a format specified by Department as compatible with the information technology systems of Department. These formatting requirements are satisfied by using the data formats as authorized in the contract or Microsoft Word, Outlook, Adobe, or Excel, and any software formats the contractor is authorized to access.

f. **IF THE CONTRACTOR HAS QUESTIONS REGARDING THE APPLICATION OF CHAPTER 119, F.S., TO THE CONTRACTOR’S DUTY TO PROVIDE PUBLIC RECORDS RELATING TO THE CONTRACT, CONTACT THE DEPARTMENT’S CUSTODIAN OF PUBLIC RECORDS AT:**

**Telephone:** (850) 245-2118  
**Email:** [public.services@floridadep.gov](mailto:public.services@floridadep.gov)  
**Mailing Address:** Department of Environmental Protection  
**ATTN: Office of Ombudsman and Public Services**  
**Public Records Request**  
**3900 Commonwealth Boulevard, MS 49**  
**Tallahassee, Florida 32399**

**STATE OF FLORIDA  
DEPARTMENT OF ENVIRONMENTAL PROTECTION  
Special Audit Requirements  
(State and Federal Financial Assistance)**

**Attachment 5**

The administration of resources awarded by the Department of Environmental Protection (*which may be referred to as the "Department", "DEP", "FDEP" or "Grantor", or other name in the agreement*) to the recipient (*which may be referred to as the "Recipient", "Grantee" or other name in the agreement*) may be subject to audits and/or monitoring by the Department of Environmental Protection, as described in this attachment.

**MONITORING**

In addition to reviews of audits conducted in accordance with 2 CFR Part 200, Subpart F-Audit Requirements, and Section 215.97, F.S., as revised (see "AUDITS" below), monitoring procedures may include, but not be limited to, on-site visits by DEP Department staff, limited scope audits as defined by 2 CFR 200.425, or other procedures. By entering into this Agreement, the recipient agrees to comply and cooperate with any monitoring procedures/processes deemed appropriate by the Department of Environmental Protection. In the event the Department of Environmental Protection determines that a limited scope audit of the recipient is appropriate, the recipient agrees to comply with any additional instructions provided by the Department to the recipient regarding such audit. The recipient further agrees to comply and cooperate with any inspections, reviews, investigations, or audits deemed necessary by the Chief Financial Officer (CFO) or Auditor General.

**AUDITS**

**PART I: FEDERALLY FUNDED**

This part is applicable if the recipient is a State or local government or a non-profit organization as defined in 2 CFR §200.330

1. A recipient that expends \$1,000,000 or more in Federal awards in its fiscal year, must have a single or program-specific audit conducted in accordance with the provisions of 2 CFR Part 200, Subpart F. EXHIBIT 1 to this Attachment indicates Federal funds awarded through the Department of Environmental Protection by this Agreement. In determining the federal awards expended in its fiscal year, the recipient shall consider all sources of federal awards, including federal resources received from the Department of Environmental Protection. The determination of amounts of federal awards expended should be in accordance with the guidelines established in 2 CFR 200.502-503. An audit of the recipient conducted by the Auditor General in accordance with the provisions of 2 CFR Part 200.514 will meet the requirements of this part.
2. For the audit requirements addressed in Part I, paragraph 1, the recipient shall fulfill the requirements relative to auditee responsibilities as provided in 2 CFR 200.508-512.
3. A recipient that expends less than \$1,000,000 in federal awards in its fiscal year is not required to have an audit conducted in accordance with the provisions of 2 CFR Part 200, Subpart F-Audit Requirements. If the recipient expends less than \$1,000,000 in federal awards in its fiscal year and elects to have an audit conducted in accordance with the provisions of 2 CFR 200, Subpart F-Audit Requirements, the cost of the audit must be paid from non-federal resources (i.e., the cost of such an audit must be paid from recipient resources obtained from non-federal entities).
4. The recipient may access information regarding the Catalog of Federal Domestic Assistance (CFDA) via the internet at <https://sam.gov/content/assistance-listings>.

**PART II: STATE FUNDED**

This part is applicable if the recipient is a nonstate entity as defined by Section 215.97(1)(n), Florida Statutes.

1. In the event that the recipient expends a total amount of state financial assistance equal to or in excess of \$750,000 in any fiscal year of such recipient (for fiscal years ending June 30, 2017, and thereafter), the recipient must have a State single or project-specific audit for such fiscal year in accordance with Section 215.97, F.S.; Rule Chapter 69I-5, F.A.C., State Financial Assistance; and the current Rules of the Auditor General. EXHIBIT 1 to this form lists the state financial assistance awarded through the Department of Environmental Protection by this agreement. In determining the state financial assistance expended in its fiscal year, the recipient shall consider all sources of state financial assistance, including state financial assistance received from the Department of Environmental Protection, other state agencies, and other nonstate entities. State financial assistance does not include federal direct or pass-through awards and resources received by a nonstate entity for Federal program matching requirements.
2. In connection with the audit requirements addressed in Part II, paragraph 1; the recipient shall ensure that the audit complies with the requirements of Section 215.97(8), Florida Statutes. This includes submission of a financial reporting package as defined by Section 215.97(2), Florida Statutes, and the current Rules of the Auditor General.
3. If the recipient expends less than \$750,000 in state financial assistance in its fiscal year (for fiscal year ending June 30, 2017, and thereafter), an audit conducted in accordance with the provisions of Section 215.97, Florida Statutes, is not required. In the event that the recipient expends less than \$750,000 in state financial assistance in its fiscal year, and elects to have an audit conducted in accordance with the provisions of Section 215.97, Florida Statutes, the cost of the audit must be paid from the non-state entity’s resources (i.e., the cost of such an audit must be paid from the recipient’s resources obtained from other than State entities).
4. For information regarding the Florida Catalog of State Financial Assistance (CSFA), a recipient should access the Florida Single Audit Act website located at <https://apps.fldfs.com/fsaa> for assistance. In addition to the above websites, the following websites may be accessed for information: Legislature's Website at <http://www.leg.state.fl.us/Welcome/index.cfm>, State of Florida’s website at <http://www.myflorida.com/>, Department of Financial Services’ Website at <https://www.myfloridacfo.com/> and the Auditor General's Website at <http://www.myflorida.com/audgen/>.

**PART III: OTHER AUDIT REQUIREMENTS**

*(NOTE: This part would be used to specify any additional audit requirements imposed by the State awarding entity that are solely a matter of that State awarding entity’s policy (i.e., the audit is not required by Federal or State laws and is not in conflict with other Federal or State audit requirements). Pursuant to Section 215.97(8), Florida Statutes, State agencies may conduct or arrange for audits of State financial assistance that are in addition to audits conducted in accordance with Section 215.97, Florida Statutes. In such an event, the State awarding agency must arrange for funding the full cost of such additional audits.)*

**PART IV: REPORT SUBMISSION**

1. Copies of reporting packages for audits conducted in accordance with 2 CFR Part 200, Subpart F-Audit Requirements, and required by PART I of this form shall be submitted, when required by 2 CFR 200.512, by or on behalf of the recipient directly to the Federal Audit Clearinghouse (FAC) as provided in 2 CFR 200.36 and 200.512
  - A. The Federal Audit Clearinghouse designated in 2 CFR §200.501(a) (the number of copies required by 2 CFR §200.501(a) should be submitted to the Federal Audit Clearinghouse), at the following address:

By Mail:

Federal Audit Clearinghouse  
Bureau of the Census  
1201 East 10th Street  
Jeffersonville, IN 47132

Submissions of the Single Audit reporting package for fiscal periods ending on or after January 1, 2008, must be submitted using the Federal Clearinghouse’s Internet Data Entry System which can be found at <http://harvester.census.gov/facweb/>

2. Copies of financial reporting packages required by PART II of this Attachment shall be submitted by or on behalf of the recipient directly to each of the following:

A. The Department of Environmental Protection at one of the following addresses:

By Mail:

**Audit Director**  
Florida Department of Environmental Protection  
Office of Inspector General, MS 40  
3900 Commonwealth Boulevard  
Tallahassee, Florida 32399-3000

Electronically:

[FDEPSingleAudit@dep.state.fl.us](mailto:FDEPSingleAudit@dep.state.fl.us)

B. The Auditor General’s Office at the following address:

Auditor General  
Local Government Audits/342  
Claude Pepper Building, Room 401  
111 West Madison Street  
Tallahassee, Florida 32399-1450

The Auditor General’s website (<http://flauditor.gov/>) provides instructions for filing an electronic copy of a financial reporting package.

3. Copies of reports or management letters required by PART III of this Attachment shall be submitted by or on behalf of the recipient directly to the Department of Environmental Protection at one of the following addresses:

By Mail:

**Audit Director**  
Florida Department of Environmental Protection  
Office of Inspector General, MS 40  
3900 Commonwealth Boulevard  
Tallahassee, Florida 32399-3000

Electronically:

[FDEPSingleAudit@dep.state.fl.us](mailto:FDEPSingleAudit@dep.state.fl.us)

4. Any reports, management letters, or other information required to be submitted to the Department of Environmental Protection pursuant to this Agreement shall be submitted timely in accordance with 2 CFR 200.512, section 215.97, F.S., and the current Rules of the Auditor General, as applicable.

5. Recipients, when submitting financial reporting packages to the Department of Environmental Protection for audits done in accordance with 2 CFR 200, Subpart F-Audit Requirements, or the current Rules of the Auditor

**Attachment 5**

General, should indicate the date and time the reporting package was delivered to the recipient and any correspondence accompanying the reporting package.

**PART V: RECORD RETENTION**

The recipient shall retain sufficient records demonstrating its compliance with the terms of the award and this Agreement for a period of **five (5)** years from the date the audit report is issued, and shall allow the Department of Environmental Protection, or its designee, Chief Financial Officer, or Auditor General access to such records upon request. The recipient shall ensure that audit working papers are made available to the Department of Environmental Protection, or its designee, Chief Financial Officer, or Auditor General upon request for a period of **three (3)** years from the date the audit report is issued, unless extended in writing by the Department of Environmental Protection.

**EXHIBIT – 1**

FUNDS AWARDED TO THE RECIPIENT PURSUANT TO THIS AGREEMENT CONSIST OF THE FOLLOWING:

*Note: If the resources awarded to the recipient represent more than one federal program, provide the same information shown below for each federal program and show total federal resources awarded*

<b>Federal Resources Awarded to the Recipient Pursuant to this Agreement Consist of the Following:</b>					
<b>Federal Program A</b>	Federal Agency	CFDA Number	CFDA Title	Funding Amount	State Appropriation Category
				\$	
<b>Federal Program B</b>	Federal Agency	CFDA Number	CFDA Title	Funding Amount	State Appropriation Category
				\$	

*Note: Of the resources awarded to the recipient represent more than one federal program, list applicable compliance requirements for each federal program in the same manner as shown below:*

<b>Federal Program A</b>	First Compliance requirement: i.e.: (what services of purposes resources must be used for)	
	Second Compliance requirement: i.e.: (eligibility requirement for recipients of the resources)	
	Etc.	
	Etc.	
<b>Federal Program B</b>	First Compliance requirement: i.e.: (what services of purposes resources must be used for)	
	Second Compliance requirement: i.e.: (eligibility requirement for recipients of the resources)	
	Etc.	
	Etc.	

Note: If the resources awarded to the recipient for matching represent more than one federal program, provide the same information shown below for each federal program and show total state resources awarded for matching.

State Resources Awarded to the Recipient Pursuant to this Agreement Consist of the Following Matching Resources for Federal Programs:					
Federal Program A	Federal Agency	CFDA	CFDA Title	Funding Amount	State Appropriation Category
Federal Program B	Federal Agency	CFDA	CFDA Title	Funding Amount	State Appropriation Category

Note: If the resources awarded to the recipient represent more than one state project, provide the same information shown below for each state project and show total state financial assistance awarded that is subject to section 215.97, F.S.

State Resources Awarded to the Recipient Pursuant to this Agreement Consist of the Following Resources Subject to Section 215.97, F.S.:						
State Program A	State Awarding Agency	State Fiscal Year <sup>1</sup>	CSFA Number	CSFA Title or Funding Source Description	Funding Amount	State Appropriation Category
<b>Original Agreement</b>	Florida Department of Environmental Protection	FY 25.26	37.098	Resilient Florida Programs	\$336,000.00	140078
State Program B	State Awarding Agency	State Fiscal Year <sup>2</sup>	CSFA Number	CSFA Title or Funding Source Description	Funding Amount	State Appropriation Category

Total Award	\$336,000.00	
-------------	--------------	--

Note: List applicable compliance requirement in the same manner as illustrated above for federal resources. For matching resources provided by the Department for DEP for federal programs, the requirements might be similar to the requirements for the applicable federal programs. Also, to the extent that different requirements pertain to different amount for the non-federal resources, there may be more than one grouping (i.e. 1, 2, 3, etc.) listed under this category.

For each program identified above, the recipient shall comply with the program requirements described in the Catalog of Federal Domestic Assistance (CFDA) [<https://sam.gov/content/assistance-listings>] and/or the Florida Catalog of State Financial Assistance (CSFA) [<https://apps.fldfs.com/fsaa/searchCatalog.aspx>], and State Projects Compliance Supplement (Part Four: State Projects Compliance Supplement [<https://apps.fldfs.com/fsaa/compliance.aspx>]). The services/purposes for which the funds are to be used are included in the Agreement’s Grant Work Plan. Any match required by the Recipient is clearly indicated in the Agreement.

<sup>1</sup> Subject to change by Change Order.

<sup>2</sup> Subject to change by Change Order.

**STATE OF FLORIDA  
DEPARTMENT OF ENVIRONMENTAL PROTECTION  
PROGRAM-SPECIFIC REQUIREMENTS  
RESILIENT FLORIDA PROGRAM**

**ATTACHMENT 6**

**General**

1. Deliverable and Payment Request Submissions. All grant deliverables and payment requests (Exhibit C) must be submitted to [ResilientFloridaGrants@FloridaDEP.gov](mailto:ResilientFloridaGrants@FloridaDEP.gov).
2. Progress Reports. The Exhibit A, Progress Report Form, must be submitted on a quarterly basis to [ResilientFloridaGrants@FloridaDEP.gov](mailto:ResilientFloridaGrants@FloridaDEP.gov) starting in the quarter of the Agreement Execution Date through the quarter in which the final task deliverable is accepted and the Grantee is provided a Deliverable Acceptance Letter.
3. Contractual Services. For all grant agreements that include Contractual Services as a budget category, the Grantee must submit Exhibit H, Contractual Services Certification, and all supporting documentation required therein, for each of the Grantee’s contractors prior to submitting a payment request for contractual services.
4. Grantee Match Form. If the grant agreement includes match requirements in Attachment 2, the Grantee must submit the Grantee Match Form upon execution of the grant agreement and at any time there are changes to the match funding amount and/or funding source throughout the grant agreement period.
5. Project Photos. The Grantee must submit Exhibit G, Photo Release Form, with the first submission of deliverables and reports (Exhibit A and F) that include photos.
6. DEP Logo and Funding Source Disclaimer. The final Vulnerability Assessment Report, Adaptation Plan report or document, and any permanent signage created for an implementation project included on the Statewide Flooding and Sea Level Rise Resilience Plan must include the Department’s logo (which can be found on the Department’s website at: <https://floridadep.gov> or by contacting the Grant Manager for a copy) as well as the following language:

“This work was funded in part through a grant agreement from the Florida Department of Environmental Protection’s Office of Resilience and Coastal Protection Resilient Florida Program. The views, statements, findings, conclusions, and recommendations expressed herein are those of the author(s) and do not necessarily reflect the views of the State of Florida or any of its subagencies.”

7. Final Project Report. The Grantee must submit Exhibit F, Final Project Report Form, prior to requesting final payment. For grants funded with American Rescue Plan Act (ARPA) Funds that are not completed by the Agreement’s Date of Expiration, Exhibit F must also be submitted to [ResilientFloridaGrants@FloridaDEP.gov](mailto:ResilientFloridaGrants@FloridaDEP.gov) upon completion of the project, which may be after the Agreement’s Date of Expiration.
8. Copyright, Patent and Trademark. The Department reserves a royalty-free, nonexclusive, and irrevocable license to reproduce, publish or otherwise use, and to authorize others to use, for state government purposes:
  - a. The copyright in any work developed under this Agreement; and
  - b. Any rights or copyright to which the Grantee or subcontractor purchases ownership with grant support.If any funds awarded by this Agreement are used to purchase ownership of or license to any copyrighted,

patented, and/or trademarked software and/or programming used to complete this Project, such software and/or programming must comply with Chapter 119, F.S. The Department will not approve payment for Grantee's purchase or use of any copyrighted, patented, and/or trademarked software and/or programming that does not fully comply with the requirements of Chapter 119, F.S.

9. Geographic Information System (GIS) files and associated metadata. All GIS files and associated metadata must adhere to the Resilient Florida Program's GIS Data Standards, found on the Resilient Florida Program website: <https://floridadep.gov/rcp/resilient-florida-program/documents/resilient-florida-program-gis-data-standards>, and raw data sources shall be defined within the associated metadata.
10. Program Deliverable Acceptance and Disclaimer. The Department's acceptance of any specific project's task deliverables required by that project's Resilient Florida Program grant agreement, does not guarantee the Department's acceptance of the same or similar task deliverables, as required by a different Resilient Florida Program grant agreement, notwithstanding the Grantee(s) and/or project(s) at issue being the same or similar. The Department will review and accept all deliverables individually, pursuant to the terms and conditions of each grant agreement for which they are submitted, including Attachment 3, Grant Work Plan. The Department's acceptance of a specific deliverable does not constitute the Department's confirmation that the conclusions or statements made within said deliverable are truthful or accurate, including, but not limited to, claims of scientific validity and the certification of engineering practices. If a dispute arises between the Department and Grantee regarding the veracity of a specific deliverable's content, the Department may request that the Grantee provide additional documentation (e.g., a certification statement signed and sealed by a licensed Professional Engineer), verifying that the conclusions or statements at issue are true and correct to the best of the Grantee's knowledge, prior to the Department's acceptance of said deliverable.
11. Sunshine Law Compliance. As per Paragraph 23 to Attachment 1, Standard Terms and Conditions, the Grantee is solely responsible for ensuring that its actions (and those of its agents) under the Agreement are made in compliance with Section 286.011, Florida Statutes—Florida's Government in the Sunshine Law—where applicable.

### Implementation Grants

12. Sea Level Impact Projection Study Requirement. If a state-funded construction project is located within an area where a Sea Level Impact Protection (SLIP) study is required pursuant to Section 380.0937, Florida Statutes, the Grantee is responsible for conducting such a SLIP study and submitting the resulting report to the Department. The SLIP study report must be received by the Department, approved by the Department, and published on the Department's website for at least thirty (30) days before construction can commence. Upon submission to the Department, SLIP study reports must meet all relevant statutory requirements, as well as the standards and criteria indicated in Chapter 62S-7, Florida Administrative Code.
13. Permits. The Grantee acknowledges that receipt of this grant does not imply nor guarantee that a federal, state, or local permit will be issued for a particular activity. The Grantee agrees to ensure that all necessary permits are obtained prior to implementation of any grant-funded activity that may fall under applicable federal, state, or local laws. Further, the Grantee shall abide by all terms and conditions of each applicable permit for any grant-funded activity. Upon request, the Grantee must provide a copy of all required, acquired, and approved permits for the project.
14. Grant funds may not be used to support ongoing efforts to comply with certain legal requirements or actions that were unanticipated, non-existent, or unknown to the Department at the time of this Agreement's execution, including regulatory and permit compliance requirements, non-compliance and citation fees, fees resulting from unanticipated permit conditions, settlement agreements, and compliance with formal or informal enforcement actions to resolve violations of applicable rules and statutes (including consent orders, Closed Without Official Enforcement agreements, and similar enforcement actions). Grant funds may be utilized to support ongoing efforts to comply with permit-required conditions, as approved by the Resilient

Florida Program (e.g., pre-, during-, and post-construction monitoring and mitigation efforts).

**Grants Funded with American Rescue Plan Act (ARPA) Funds**

- 15. Match Expenditure Monitoring. For any match-funded deliverable(s) identified in Attachment 3, Grant Work Plan, not accepted by the Department by the Date of Expiration listed in Section 3 to the Standard Grant Agreement (as modified by any properly executed amendment(s), as applicable), the Grantee must submit Exhibit M, Match Expenditure Monitoring Form, to the Department prior to ARPA-funded grant closeout to identify all remaining deliverable(s) which are to be completed solely using Grantee match funding. Failure to submit Exhibit M and all remaining Project deliverables to the Department, as well as meet the Match Requirements identified in Section 7 to Attachment 2, may hinder the Grantee’s chances of receiving future grant awards from the Resilient Florida Program.

**STATE OF FLORIDA  
DEPARTMENT OF ENVIRONMENTAL PROTECTION  
RESILIENT FLORIDA GRANT PROGRAM  
EXHIBIT A  
PROGRESS REPORT FORM**

The current **Exhibit A, Progress Report Form** for the Resilient Florida Program grant agreements can be found on the Department’s website at the link below. Each progress report must be submitted on the current form. The Department will notify grantees of any substantial changes to Exhibit A that occur during the grant agreement period.

<https://floridadep.gov/Resilient-Florida-Program/Grants>

**STATE OF FLORIDA  
DEPARTMENT OF ENVIRONMENTAL PROTECTION  
RESILIENT FLORIDA GRANT PROGRAM  
EXHIBIT C  
PAYMENT REQUEST SUMMARY FORM**

The current **Exhibit C, Payment Request Summary Form** for the Resilient Florida Program grant agreements can be found on the Department’s website at the link below. Each payment request must be submitted on the current form. The Department will notify grantees of any substantial changes to Exhibit C that occur during the grant agreement period.

<https://floridadep.gov/Resilient-Florida-Program/Grants>

## Advance Payment Terms

## Exhibit E

**1. Advance Payments.**

- a. The Grantee shall submit a written request on letterhead to the Department explaining the need for the advance payment and why the advance payment is in the best interest of the State. If the advance payment requested is beyond the expected cash needs of the entity for the initial three months of the Agreement, the Grantee must also request a waiver of this requirement by submitting a written request with justification on letterhead to the Department. Advance payment is subject to written approval from the State's Chief Financial Officer (CFO) and the Department.
- b. The CFO may identify additional requirements that must be met in order for advance payment to be authorized. If additional requirements are imposed by the CFO, the Grantee shall be notified, in writing, by the Department's Grant Manager regarding the additional requirements. Prior to releasing any advanced funds, the Grantee shall be required to provide a written acknowledgement to the Department's Grant Manager of the Grantee's acceptance of the additional requirements imposed by the CFO for release of the funds.
- c. If advance payment is authorized, the Grantee shall report, on a quarterly basis in conjunction with the Progress Report as required under in this Agreement, the amount of funds expended during the reporting period, the Agreement expenditures to date, and interest earned during the quarter, and clearly indicate the method for repayment of the interest to the Department. Expenditures shall be documented in accordance with the requirements for reimbursement identified below. Interest earned and method of repayment shall be reported on the **Advance Payment – Interest Earned Memorandum, Exhibit E1** below.
- d. The Grantee must temporarily invest the advanced funds, and return any interest income to the Department, within thirty (30) days of each calendar quarter or apply said interest income against the Department's obligation to pay, if applicable, under this Agreement. Interest earned must be returned to the Department within the timeframe identified above or invoices must be received within the same timeframe that shows the offset of the interest earned.
- e. Unused funds, and interest accrued on any unused portion of advanced funds that has not been remitted to the Department, shall be returned to the Department within sixty (60) days of Agreement completion.
- f. If an advance payment is not approved by the CFO, the Grantee shall make its reimbursement requests in accordance with the reimbursement process described in Attachment 1, Standard Terms and Conditions.

Memorandum

EXHIBIT E1
Advanced Funds Expended and Interest Earned Memo

WHEN REPORTING OR REMITTING, PLEASE RETURN A COPY OF THIS REQUEST

TO: Contract Manager Name
FROM: Lydia L. Griffin, Bureau Chief
Bureau of Finance and Accounting
DATE: MM/DD/YYYY
SUBJECT: Advanced Funds for:
Agreement No.
Begin Date:

In accordance with Section 216.181(14)(b), Florida Statutes, the Department requires that advanced funds be deposited into an interest bearing account until all funds have been depleted. In order to update the status on the unused portion of the advanced funds and/or interest due, the following information is needed no later than MM/DD/YYYY.

Interest Due to DEP: Yes [ ] No [ ]
(If No, Advanced Funds Recipient is required to report only the amount of Advanced Funds Expended or Returned to DEP.)

Project % of Completion as of MM/DD/YY: \_\_\_\_\_ Final Report: [ ] Yes or [ ] No
Project % of Completion as of MM/DD/YY: \_\_\_\_\_ Estimated Project Completion Date: \_\_\_\_\_
Initial advanced funds disbursed MM/DD/YY Cumulative amount of advanced funds \$ \_\_\_\_\_
1 Advanced funds principal expended by contractor covering period of MM/DD/YY to MM/DD/YY \$ \_\_\_\_\_
2 Advanced funds principal returned by contractor covering period of MM/DD/YY to MM/DD/YY \$ \_\_\_\_\_
3 Advanced funds principal balance available on hand \$ \_\_\_\_\_
4 Interest earned on advanced funds covering period of MM/DD/YY to MM/DD/YY \$ \_\_\_\_\_
5 Amount of interest paid to DEP as of MM/DD/YY \$ \_\_\_\_\_
6 Interest balance due to DEP as of MM/DD/YY \$ \_\_\_\_\_

Project Management Certification:

By evidence of my signature below, the above information is true and correct. I have knowledge of the work performed and the advanced funds principal on hand is needed to complete the project(s) by the Estimated Project Completion Date.

DEP Grant Manager Printed Name

Advanced Funds Recipient Printed Name

DEP Grant Manager Signature Date

Advanced Funds Recipient Signature Date

DEP USE ONLY

Project Management Verification (please explain): \_\_\_\_\_

Thank you for your cooperation in providing the above information. If you have any questions, please contact the Contract Disbursements Section at (850) 245-2465, in the Bureau of Finance & Accounting.

**Memorandum**

**INSTRUCTIONS TO COMPLETE THE ADVANCED FUNDS EXPENDED & INTEREST EARNED MEMO:**

*This form should be completed by the Advanced Funds Recipient in its entirety, signed and dated by the appropriate personnel and submitted each reporting period. Please ensure each field on the form is completed according to the guidance provided.*

Percentage of Project Completion must be completed, indicating the percentage of progress for the current reporting period.

Estimated Project Completion Date must be completed, indicating the anticipated project completion date in the MM/DD/YYYY format.

The Final Report indicator (Yes or No) must be completed.

If the contract states that no interest is due, quarterly reporting of the expended advanced funds is still required. Lines 1, 2, and 3 must be completed.

In all cases the lines 1, 2, and 3 reported amounts are on a cash basis for the advanced funds principal. Do not include receivables, payables, or interest previously paid to DEP.

If the grant/contract requires quarterly accrued interest payments to DEP, the advanced funds recipient must complete lines 1 through 6 for each quarterly report. Payments of interest due to DEP shall be paid within the specifications of the grant/contract. Project Management Certification: This section is to be completed by the DEP Grant Manager and the Advanced Funds Recipient to certify that the information provided on this form is true and accurately reflects the status of the advanced funds received from the Department.

Project Management Verification: This section is to be completed by the DEP Grant Manager in providing the method used to verify that the information received from the Advanced Funds Recipient is true and accurately reflects the status of the advanced funds received from the Department.

**EXHIBIT F**  
**DEP AGREEMENT NO. 26PLN63**

**CITY OF CHIPLEY GILBERT ACRES DRAINAGE IMPROVEMENTS**

**City of Chipley**

**Final Project Report**



Insert Month & Year

This report is funded in part through a grant agreement from the Florida Department of Environmental Protection. The views, statements, findings, conclusions, and recommendations expressed herein are those of the author(s) and do not necessarily reflect the views of the State of Florida or any of its subagencies.

**Part I. Executive Summary**

**Part II. Methodology**

**Part III. Outcome**

*Include the following: 1) evaluation of project’s ability to meet goals and expected performance measures and provide explanation for why goals were not met, if applicable; 2) identify successful outcomes, areas for improvement, and quantifiable metrics (including the assigned metric in Exhibit A, if applicable) as a result of the project; and 3) final project photos, if an implementation construction project.*

**Part IV. Further Recommendations**

**Instructions for completing Exhibit F Final Project Report Form:**

DEP AGREEMENT NO.: This is the number on your grant agreement.

GRANTEE NAME: Enter the name of the grantee’s agency.

PROJECT TITLE: Enter the title shown on the first page of the grant agreement.

MONTH & YEAR: Enter month and year of publication

The final Project Report must contain the following sections: Executive Summary, Methodology, Outcome, and Further Recommendations. The Final Project Report must comply with the publication requirements in the grant agreement. Please limit the final project report to no more than five (5) pages. One electronic copy shall be submitted to the Department’s Grant Manager for approval. Final payment will be held until receipt and approval of the Final Project Report.

Questions regarding completion of the Final Project Report should be directed to the Department’s Grant Manager, identified in paragraph 18 of this agreement.



EXHIBIT G

PHOTOGRAPHER RELEASE FORM
FOR PHOTOGRAPHS, VIDEOS, AUDIO RECORDINGS AND ARTWORKS

DEP AGREEMENT NO: 26PLN63

RELEASE FORM FOR PHOTOGRAPHS, VIDEOS, AUDIO RECORDINGS AND ARTWORKS

Owner/Submitter's Name: \_\_\_\_\_

Address: \_\_\_\_\_

City: \_\_\_\_\_ State: \_\_\_\_\_ Zip: \_\_\_\_\_

Phone Number: ( ) \_\_\_\_\_ Email: \_\_\_\_\_

License and Indemnification

I certify that I am the owner of the photograph(s), video(s), audio recording(s) and/or artwork(s) being submitted and am eighteen (18) years of age or older.

I hereby grant to the Florida Department of Environmental Protection the royalty-free and non-exclusive right to distribute, publish and use the photograph(s), video(s), audio recording(s) and art work(s) submitted herewith (the "Work") to promote the Florida Department of Environmental Protection. Uses may include, but are not limited to:

- 1. Promotion of FDEP (including, but limited to publications, websites, social media venues, advertisements, etc.); and
2. Distribution to the media; and
3. Use in commercial products.

The Florida Department of Environmental Protection reserves the right to use/not use any Work as deemed appropriate by the Florida Department of Environmental Protection. No Work will be returned once submitted.

I hereby acknowledge that the Florida Department of Environmental Protection shall bear no responsibility whatsoever for protecting the Work against third-party infringement of my copyright interest or other intellectual property rights or other rights I may hold in such Work, and in no way shall be responsible for any losses I may suffer as a result of any such infringement; and I hereby represent and warrant that the Work does not infringe the rights of any other individual or entity.

I hereby unconditionally release, hold harmless and indemnify the Florida Department of Environmental Protection, its employees, volunteers, and representatives of and from all claims, liabilities and losses arising out of or in connection with the Florida Department of Environmental Protection's use of the Work. This release and indemnification shall be binding upon me, and my heirs, executors, administrators and assigns.

I have read and understand the terms of this release.

Owner signature: \_\_\_\_\_ Date: \_\_\_\_\_

Photo/video/audio/artwork/recording file name(s): \_\_\_\_\_

Location of photo/video/audio recording/artwork: \_\_\_\_\_

Name of person accepting Work submission \_\_\_\_\_

STATE OF FLORIDA  
DEPARTMENT OF ENVIRONMENTAL PROTECTION  
RESILIENT FLORIDA GRANT PROGRAM  
CONTRACTUAL SERVICES CERTIFICATION

Exhibit H

Required for all grant agreements that include Contractual Services as an expenditure category.

DEP Agreement Number: 26PLN63

Project Title: City of Chipley Gilbert Acres Drainage Improvements

Grantee: City of Chipley

Subcontractor:

Note: A separate Exhibit H is required for each of the Grantee's contractor(s).

Prior to making a request for payment of contractual services, the Grantee must provide the following to the Department Grant Manager:

1. Documentation of the Grantee's procurement process, as consistent with Attachment 1, Paragraph 9(c) and Attachment 2, Paragraph 11;
2. For competitively procured fixed-price (vendor) subcontracts: A copy of the tabulation form (i.e., list of all quotes or bid amounts, as applicable) for the competitive procurement process (e.g., Invitation to Bid, Request for Proposals, or other similar competitive procurement documents), as required by Attachment 1, Paragraph 9(c)(i);
3. A copy of the Grantee's executed subcontract agreement, as required by Attachment 2, Paragraph 11. This submittal should include any relevant executed task/work/purchase order(s) and all subsequent amendments and/or change orders, as applicable, and as required for the work conducted under the above-mentioned DEP Agreement Number; and
4. This Exhibit H, signed and dated by the Grantee Grant Manager.

By signing below, I certify that, on behalf of the Grantee, I have provided all the information required by items 1. through 3. of this Exhibit, as stated above, to the Department Grant Manager. I also certify that the procurement process the Grantee utilized follows all of said Grantee's non-Departmental policies and procedures for subcontractors.

[Signature Line]

Grantee's Grant Manager Signature

[Print Name Line]

Print Name

[Date Line]

Date

**COMMON CARRIER OR CONTRACTED CARRIER ATTESTATION  
FORM  
(PUR 1808)**

**Exhibit J**

This form must be completed by a Common Carrier or contracted carrier and submitted to the Governmental Entity with which a Contract being is executed, amended, or renewed. Capitalized terms used herein have the definitions ascribed in section 908.111, F.S.

The City of Chipley \_\_\_\_\_ is not willfully providing and will not willfully provide any service during the Contract term in furtherance of transporting a person into this state knowing that the person is an Unauthorized Alien, except to facilitate the detention, removal, or departure of the person from this state or the United States.

Under penalties of perjury, I declare that I have read the foregoing statement and that the facts stated in it are true.

Printed Name: Tracy L. Andrews

Title: Mayor

Signature: *Tracy L. Andrews*

Date: 01/09/2026

# CITY OF CHIPLEY

## STAFF REPORT

**SUBJECT:** Resolution No. 26-31 – Community Planning Technical Assistance (CPTA) Grant Program Application Submission

**MEETING DATE**  
Tuesday, April 14, 2026

**PREPARED BY**  
Patrice Tanner, City Administrator

**SUMMARY**  
This resolution will approve the submission of an application to the Florida Department of Commerce for the Community Planning Technical Assistance Grant Program to address updates to the City’s Planning Documents to address land use, rural character preservation and economic development issues in the City.

**RECOMMENDATION**  
City Staff recommends approval of Resolution No. 26-31 – Community Planning Technical Assistance (CPTA) Grant Program Application Submission.

**ATTACHMENTS**

1. Resolution No. 26-31

**RESOLUTION NO. 26-31**

**A RESOLUTION OF THE CITY COUNCIL OF THE CITY OF CHIPLEY, FLORIDA, AUTHORIZING THE SUBMISSION OF AN APPLICATION TO THE FLORIDA DEPARTMENT OF COMMERCE FOR THE COMMUNITY PLANNING TECHNICAL ASSISTANCE GRANT PROGRAM FOR STATE FISCAL YEAR 2026-2027.**

**WHEREAS**, the Florida Department of Commerce administers the Community Planning Technical Assistance (CPTA) Grant Program to assist local governments in addressing critical planning issues, promoting innovative planning solutions, and meeting statutory requirements under the Community Planning Act; and

**WHEREAS**, the City of Chipley seeks to enhance its planning capacity and address local challenges related to land use and economic development; and

**WHEREAS**, the CPTA Grant Program provides funding on a cost-reimbursement basis for eligible projects that support comprehensive planning, land development regulation updates, and other strategic planning initiatives; and

**WHEREAS**, the City of Chipley is committed to providing the necessary staff support, resources, and oversight to successfully implement the proposed project and fulfill all grant requirements; and

**NOW, THEREFORE, BE IT RESOLVED** by the City Council of the City of Chipley that:

CPTA application for the candidate project listed below is hereby approved for submission and endorsed as a high priority planning project which the City will utilize once developed.

1. The City of Chipley hereby endorses, as a high priority planning project, updates to the City’s Planning Documents to address land use, rural character preservation and economic development issues in the City.
2. The City of Chipley hereby authorizes the submission of an application to the Florida Department of Commerce Community Planning Technical Assistance Grant Program for State Fiscal Year 2026-2027.
3. The Mayor, Mayor Pro-Tem, or City Administrator are hereby authorized to execute all documents required in connection with the preparation and submission of said applications.

**PASSED AND ADOPTED** by the City Council of the City of Chipley, Florida on this 14<sup>th</sup> day of April, 2026.

City of Chipley

\_\_\_\_\_  
Tracy L. Andrews, Mayor

ATTEST:

\_\_\_\_\_  
Sherry Snell,  
City Clerk

# CITY OF CHIPLEY

## STAFF REPORT

**SUBJECT:** Resolution No. 26-33 – FY 23-24 State Assistance for Fentanyl Eradication (S.A.F.E.)  
- Chipley Police Department – Amendment Two

**MEETING DATE**

Tuesday, April 14, 2026

**PREPARED BY**

Patrice Tanner, City Administrator

**SUMMARY**

This will approve an amendment to the Florida Department of Law Enforcement Agreement Number 2023-SAFE-SF-052 Adjustment Two, extending the Project End Date and the Overview and Funding Project End Date to 06/30/2026, the Deliverables, Performance and Reports amendment, and the Administration section updated. The requested amount is \$100,000.

**RECOMMENDATION**

City Staff recommend approval of Resolution No. 26-33.

**ATTACHMENTS**

- 1. Resolution No 26-33

**RESOLUTION NO. 26-33**

**A RESOLUTION APPROVING AN AGREEMENT AMENDMENT IDENTIFIED AS ADJUSTMENT NUMBER TWO FOR FENTANYL ERADICATION (S.A.F.E.) IN FLORIDA PROGRAM (CSFA 71.122), BETWEEN THE FLORIDA DEPARTMENT OF LAW ENFORCEMENT “DEPARTMENT”, AND THE CITY OF CHIPLEY “RECIPIENT”.**

**WHEREAS**, the Florida Department of Law Enforcement (Department) and the Chipley Police Department entered into an agreement to be a recipient of a FY 23-24 State Assistance for Fentanyl Eradication (SAFE) in Florida Program, Agreement Number 2023-SAFE-SF-052 dated March 15, 2024; and

**WHEREAS**, the Parties to the aforementioned Grant agree that all provisions of that Grant and all Adjustments should remain in full force and effect except those amended hereby; and

**WHEREAS**, The State of Florida Governor signed the General Appropriations Act of 2024, which provides funding for the S.A.F.E. in Florida Program’s continued operation into State Fiscal Year 2024-2025, and

**WHEREAS**, the Parties wish to amend the Agreement as set forth in Attachment “A”, regarding Project Extension, extending the Project End Date and the Overview and Funding Project End Date to 06/30/2026, the Deliverables, Performance and Reports amendment, and the Administration section updated.

**NOW, THEREFORE, BE IT RESOLVED BY THE CITY COUNCIL OF CHIPLEY, FLORIDA, THAT:**

1. The City of Chipley hereby approves the Florida Department of Law Enforcement, Agreement Number 2023-SAFE-SF-052, Adjustment Two for the amount of \$100,000.00. The adjustments herein proposed will promote the efficient and effective performance of the contractual requirements.
2. The City for and in consideration of the covenants and obligations set forth herein and for other good and valuable consideration, the receipt and sufficiency of which are hereby acknowledged, intending to be legally bound hereby agree to perform the duties described herein in the attached Attachment “A”.
3. The Mayor or Mayor Pro-Tem of the City of Chipley be hereby authorized and directed to execute the agreement adjustment.
4. A certified copy of this Resolution be forwarded to the FDLE along with the executed Amendment.

**PASSED AND ADOPTED THIS 14TH DAY OF APRIL, 2026.**

ATTEST:

\_\_\_\_\_  
Tracy L. Andrews, Mayor

\_\_\_\_\_  
Sherry Snell,  
City Clerk

DRAFT

# CITY OF CHIPLEY

## STAFF REPORT

**SUBJECT:** Agreement for Professional Services – Amendment No. 1 – Mott MacDonald Florida, LLC

**MEETING DATE**  
Tuesday, April 14, 2026

**PREPARED BY**  
Patrice Tanner, City Administrator

### SUMMARY

This will approve Amendment No. 1 for the Professional Services Agreement with Mott MacDonald, Florida LLC for the Kirkland and Usey Road Project to include final design and engineering plans to extend the wastewater main, including design elements to accommodate the conversion of existing businesses from individual lift stations or septic to central sewer. This will be a fixed price of \$129,500.00. The original agreement amount for this project was \$162,199.00 and the state has agreed to allow the city to utilize the additional funds we were awarded in the grant to do the additional work.

### RECOMMENDATION

City Staff recommends approval of Agreement for Professional Services – Amendment No. 1 – Mott MacDonald Florida, LLC

### ATTACHMENTS

1. Amendment No. 1

AMENDMENT 01  
TO  
AGREEMENT FOR PROFESSIONAL SERVICES

This Amendment 01 (“Amendment”) to an Agreement by and between City of Chipley a Municipality of the State of Florida with offices located at 1442 Jackson Avenue, Chipley, FL 32428 (“CLIENT”), and Mott MacDonald Florida, LLC a Florida limited liability corporation, with an office located at 1022 West 23<sup>rd</sup> Street, Panama City, FL 32405 (“ENGINEER”) effective the 20<sup>th</sup> day of March, 2026. CLIENT and ENGINEER are collectively referred to as the “Parties” or individually as a “Party.”

**WHEREAS**, CLIENT and ENGINEER entered into an Agreement dated July 8, 2025 (“Agreement”); and

**WHEREAS**, the Parties desire to make certain changes to the Agreement.

**NOW, THEREFORE**, in consideration of the mutual promises, covenants, conditions, and terms contained in the Agreement and this Amendment, and as hereinafter set forth, the Agreement is amended as follows:

- 1. See Exhibit A – Scope of Services.
- 2. ENGINEER’s compensation for the Services as described in Exhibit A shall be a fixed price (lump sum) of \$129,500.00.

Original Agreement Amount:	\$162,196.00
Amendment 01 Amount:	\$129,500.00
New Agreement Total:	\$291,696.00

- 3. All other terms and conditions of the Agreement shall remain in full force and effect unless changed by this Amendment.

*(Signatures appear on following page)*

IN WITNESS WHEREOF, this Amendment is executed effective as of the day and year first above written.

**MOTT MACDONALD FLORIDA, LLC**

**CITY OF CHIPLEY**

By: \_\_\_\_\_

By: \_\_\_\_\_

Name: \_\_\_\_\_

Name: \_\_\_\_\_

Title: \_\_\_\_\_

Title: \_\_\_\_\_

Date: \_\_\_\_\_

Date: \_\_\_\_\_

EXHIBIT A – SCOPE OF SERVICES

The City of Chipley (“CLIENT”) will use funding for survey, design, and engineering work that is needed to extend the public sanitary sewer service approximately 3,100 linear feet along Kirkland and Usery Road. The project will include final design and engineering plans to extend the wastewater main, including design elements to accommodate the conversion of existing businesses from individual lift stations or septic to central sewer.

- A. Survey- Kirland Road, Usery Road and Vo Tech Pump Station (Not to Exceed \$23,000)
  - a. Complete survey of Vo Tech Pump Station and surrounding area.
  - b. Complete survey of approximately 2,700 linear feet along Kirkland Road.
  - c. Complete survey of approximately 400 linear feet along Usery Road.
  
- B. Design- Kirland and Usery Road (Not to Exceed \$106,500)
  - a. Evaluate and design rehabilitation of Vo-Tech Pump Station to include changes in pump design, electrical design, piping design, site design, and any other items needed to design a fully operational pumping station.
  - b. Evaluate and design new utilities to include design of water and wastewater facilities, utility relocation and adjustment, and roadway repair/resurfacing.

# CITY OF CHIPLEY

## STAFF REPORT

**SUBJECT:** FY 24-25 Updated Minutes

**MEETING DATE**  
Tuesday, April 14, 2026

**PREPARED BY**  
Patrice Tanner, City Administrator

**SUMMARY**  
The FY 24-25 Minutes have been updated by adding explanations to the consent agenda items.

**RECOMMENDATION**  
City Staff recommend approval of the FY 24-25 Updated Minutes

**ATTACHMENTS**

1. FY 24-25 Updated Minutes

**City of Chipley  
Council Meeting  
Minutes  
October 8, 2024 at 5:00 p.m.**

**Attendees:**

Ms. Tracy Andrews, Mayor  
Mrs. Linda Cain, Council Member  
Mr. Leonard Blount, Council Member

Mr. Kevin Russell, Mayor Pro-Tem  
Ms. Cheryl McCall, Council Member

**Others Present Were:**

Mrs. Patrice Tanner, City Administrator  
Mr. Curtis Porter, Police Captain  
Mr. Hunter Aycock, Fire Chief  
Mr. Ambers Carter, Asst. Public Works Director  
Mrs. Michelle Jordan, City Attorney

Ms. Sherry Snell, City Clerk  
Mr. Guy Lane, Asst. City Admin./Public Works Director  
Mr. Jimmy Cook, Water Utilities Director  
Mrs. Tamara Donjuan, Planning/Code Enf. Officer

The data reflected in these proceedings constitute an extrapolation of information elicited from notes, observations, recording tapes, photographs, and/or videotapes. Comments reflected herein are sometimes paraphrased, condensed, and/or have been edited to reflect essential subject matter addressed during the meeting. Parties interested in receiving a verbatim account of the proceedings are responsible for coordinating with the City Administrator and providing their own representative and equipment pursuant to Chapters 119 and 283, Florida Statutes.

**A. CALL TO ORDER**

The meeting was called to order by Mayor Andrews at 5:00 p.m.

**B. PRAYER AND PLEDGE**

Prayer was given by Council Member Blount and Mayor Andrews led the pledge to the American Flag.

**C. SWEARING IN OF LEONARD BLOUNT, LINDA CAIN AND KEVIN RUSSELL.**

Honorable Timothy Register did the swearing in of Mr. Leonard Blount, Mrs. Linda Cain and Mr. Kevin Russell.

**D. APPOINTMENT OF MAYOR**

**A motion was made by Council Member Russell and seconded by Council Member Cain to approve Ms. Tracy Andrews as Mayor. The motion passed unanimously.**

**E. APPOINTMENT OF MAYOR PRO-TEM**

**A motion was made by Mayor Andrews and seconded by Council Member Cain to approve Mr. Kevin Russell as Mayor Pro-Tem. The motion passed unanimously.**

**F. APPOINTMENT OF COUNCIL LIASIONS**

**Mayor Andrews identified the liaisons as follows:**

Tracy Andrews: Administration, External Affairs, Tourist Development Council (TDC).  
Cheryl McCall: Historic Merchants of Chipley, Planning & Zoning, Police.  
Linda Cain: Fire Department, Code Enforcement.  
Vacant: Industrial Park, Water Utilities Department.  
Kevin Russell: CRA, Public Works/Cemetery, Recreation Department.

There was discussion on the list. Mayor Andrews stated she would come back to the list later in the meeting.

**G. APPROVAL OF AGENDA**

**A motion was made by Council Member Cain and seconded by Council Member Blount to approve the agenda as presented. The motion passed unanimously.**

**H. CITIZENS REQUEST**

The City of Chipley welcomes you to this meeting. This is time set aside for the Citizens of Chipley to address the City Council. This is not a question and answer period, it is not a political forum, nor is it a time for personal accusations and derogatory remarks to/or about city personnel. If you would like to address the City Council please raise your hand to speak, state your name and address for the record and limit your comments to no more than three (3) minutes per Florida Statute 286.0114. To ask a question via phone; dial \*9 and wait to be recognized/unmuted. If you are attending via webinar, there will be an onscreen option to ask a question during the public comment portion of the meeting. Your participation is welcomed and appreciated.

No citizen requests. No further discussion.

**I. APPROVAL OF MINUTES**

1. Regular Council Meeting – September 10, 2024
2. Special Council Meeting – Tentative Millage & Budget Hearing – September 12, 2024
3. Budget Workshop – September 16, 2024
4. Budget Workshop – September 17, 2024
5. Special Council Meeting – September 23, 2024
6. Special Council Meeting – Final Millage & Budget Hearing – September 30, 2024
7. Special Council Meeting – September 30, 2024

**A motion was made by Council Member Russell and seconded by Council Member McCall to approve the minutes as presented. The motion passed unanimously.**

**J. DEPARTMENT REPORTS**

1. Attorney Report – Michelle Jordan. There were no questions. No further discussion.
2. CRA Report – Leah Pettis. There were no questions. No further discussion.
3. Fire Department Report – Hunter Aycock. There were no questions. No further discussion.
4. Code Enforcement Report – Tamara Donjuan There were no questions. No further discussion.
5. Planning & Zoning Report – Tamara Donjuan. Mr. Russell asked about an informational item on Facebook regarding the fence code. Mrs. Tanner stated that was an existing policy and we would be posting something separately to clarify. Discussion ensued.

6. Police Department Report – Curtis Porter. Ms. McCall stated there have been two more accidents at Main Street and Brickyard Road. Mrs. Tanner stated she was looking into the issue with No further discussion.
7. Public Works Department Report – Guy Lane. Mr. Russell asked about the Christmas decorations and lights. Mr. Carter stated they would start decorating in a few weeks. Discussion ensued.
8. Recreation Department Report – Brock Tate. There were no questions. No further discussion.
9. Water Utilities Department Report – Jimmy Cook. Ms. McCall asked about the manholes on 7<sup>th</sup> Street and SR 90. Mr. Lane stated they won't raise the manholes until the final layer of asphalt is put down. Mrs. Tanner stated we have submitted for reimbursement of the costs. Discussion ensued.
10. Finance Department Report – Patrice Tanner. There were no questions. No further discussion.
11. City Administrator Report – Patrice Tanner. Mrs. Tanner explained there were four grants that we have applied for in the last thirty days. Mayor Andrews stated we were awarded the grant for Project Gantry at the Industrial Park which is a county project and the grant will cover the city's costs for utility infrastructure.

**K. CONSENT AGENDA ITEMS**

1. **Resolution No. 25-01** – Natural Gas Rate Schedule. This resolution will approve the new Natural Gas Rate Schedule, which includes a CPI increase of 3.2%. This resolution will approve the new Natural Gas Rate Schedule, which includes a CPI increase of 3.2%. Attached is a copy of the prior year rates.
2. **Resolution No. 25-02** – Water and Sewer Rate Schedule. This resolution will approve the new Water and Sewer Rate Schedule, which includes a CPI increase of 3.2%. Attached is a copy of the prior year rates.
3. **Resolution No. 25-03** – Water & Sewer Tap and Impact Fee Schedule. This resolution will approve the new Water & Sewer Tap and Impact Fee Schedule, which includes a CPI increase of 3.2%. Attached is a copy of the prior year rates.
4. **Resolution No. 25-04** – Florida City Government Week. This resolution will recognize October 21-27, 2024 as Florida City Government Week where the City of Chipley encourages all citizens, city government officials and employees to participate in events that recognize and celebrate Florida City Government Week.
5. **Resolution No. 25-05** – State of Florida, Department of Financial Assistance Grant Program – Firefighter Assistance Grant Program. This resolution will authorize the submission of an application to the State of Florida, Department of Financial Services for the Firefighter Assistance Grant Program for State Fiscal Year 2024-2025. These grant funds will be utilized to purchase powered spreader & cutter extrication equipment in the amount of \$23,720.00.
6. **Request for Development Order and Certificate of Appropriateness** – 1176 E. Jackson Avenue – Summit Locations, LLC. This will approve a Development Order and Certificate of Appropriateness for property located at 1176 E Jackson Avenue, Parcel ID:00000000-00-1035-0001, .777 acreage for new construction of a billboard.
7. **Resolution No. 26-06** – FDOT Utility Work by Highway Contractor Agreement. This resolution will approve the Utility Work by Highway Contractor Agreement FPID No. 220762-2-52-02. This work is identified as SR 77 from south of SR 273 to Jackson County Line, State Road No. 77.

**A motion was made by Council Member Russell and seconded by Council Member M to approve the consent agenda items. The motion passed unanimously.**

**L. AGENDA ITEMS**

- 1. Ordinance No. 986 (Public Hearing)** – Property Rights Element. Mayor Andrews closed the regular meeting and opened the public hearing at 5:27 p.m. Mrs. Tanner read Ordinance No. 986 by title:

**AN ORDINANCE OF THE CITY OF CHIPLEY, FLORIDA, AMENDING THE COMPREHENSIVE PLAN BY ADDING A NEW PROPERTY RIGHTS ELEMENT; PROVIDING FOR SEVERABILITY; PROVIDING FOR REPEALER; AND PROVIDING FOR AN EFFECTIVE DATE.**

Mrs. Tanner explained this Ordinance, if approved, will add a Property Rights Element to the Comprehensive Plan. Official notice to advise the public of the proposed adoption of Ordinance No. 986 was published in the Washington County News on September 25, 2024. The ad complied with the legal requirements of the City Code and Florida Statutes.

Mayor Andrews closed the public hearing and opened the regular meeting at 5:29 p.m. No further discussion.

**A motion was made by Council Member Cain and seconded by Council Member McCall to approve the final reading of Ordinance No. 986. The motion passed unanimously.**

- 2. Ordinance No. 987 (Public Hearing)** – Land Use Amendment. Mayor Andrews closed the regular meeting and opened the public hearing at 5:29 p.m. Mrs. Tanner read Ordinance No. 987 by title:

**AN ORDINANCE OF THE CITY OF CHIPLEY, FLORIDA, AMENDING ITS ADOPTED COMPREHENSIVE PLAN; PROVIDING FOR AUTHORITY; PROVIDING FOR FINDINGS OF FACT; PROVIDING FOR FUTURE LAND USE CHANGE OF A PARCEL OF PROPERTY WITH PARCEL NO. 00000000-00-1941-0001 LOCATED ON 5<sup>TH</sup> STREET, FROM PUBLIC/SEMI-PUBLIC/EDUCATIONAL TO LOW DENSITY RESIDENTIAL; PROVIDING FOR AMENDMENT TO THE FUTURE LAND USE MAP; PROVIDING FOR A SMALL SCALE AMENDMENT TO THE ADOPTED COMPREHENSIVE PLAN; PROVIDING FOR THE FILING WITH THE CLERK OF CIRCUIT COURT AND THE FLORIDA DEPARTMENT OF ECONOMIC OPPORTUNITY; AND DECLARING AN EFFECTIVE DATE.**

Mrs. Tanner explained this Ordinance, if approved, will amend the Future Land Use Map changing the land use designation of Parcel No. 00-1941-0001 from Public/Semi Public/Educational to Low Density Residential. Official notice to advise the public of the proposed adoption of Ordinance No. 987 was published in the Washington County News on September 25, 2024. The ad complied with the legal requirements of the City Code and Florida Statutes.

Mrs. Teresa McCoy, 737 Sinclair Street, asked what this parcel was used for. Mrs. Cain stated it was previously owned by First Baptist Church and a house would be built there now. Discussion ensued.

Mayor Andrews closed the public hearing and opened the regular meeting at 5:32 p.m. No further discussion.

**A motion was made by Council Member Russell and seconded by Council Member N to approve the final reading of Ordinance No. 987. The motion passed unanimously.**

Section H, Item 7.

3. **Ordinance No. 988 (Public Hearing)** – Property Rights Element. Mayor Andrews closed the regular meeting and opened the public hearing at 5:33 p.m. Mrs. Tanner read Ordinance No. 988 by title:

**AN ORDINANCE OF THE CITY OF CHIPLEY, FLORIDA, PROVIDING FOR ANNEXATION OF CONTIGUOUS LANDS AS DESCRIBED HEREIN TO THE CITY; PROVIDING FOR AUTHORITY; PROVIDING FOR BOUNDARY; PROVIDING FOR LAND USE DESIGNATION OF AFFECTED LANDS AS MEDIUM DENSITY RESIDENTIAL; PROVIDING FOR AMENDMENT TO THE FUTURE LAND USE MAP; PROVIDING FOR A SMALL SCALE AMENDMENT TO THE ADOPTED COMPREHENSIVE PLAN; PROVIDING FOR FILING WITH THE CLERK OF CIRCUIT COURT AND THE FLORIDA DEPARTMENT OF STATE; AND DECLARING AN EFFECTIVE DATE.**

Mrs. Tanner explained this Ordinance, if approved, will amend the future land use map annexing Parcels # 00-2245-0000 located at 1240 Panhandle Lane & # 00-2245-0003 located at 1237 Panhandle Lane, a total of approximately 8.96 acres, to the Medium Density Land Use Category. Official notice to advise the public of the proposed adoption of Ordinance No. 988 was published in the Washington County News on September 25, 2024. The ad complied with the legal requirements of the City Code and Florida Statutes.

Mayor Andrews closed the public hearing and opened the regular meeting at 5:35 p.m. No further discussion.

**A motion was made by Council Member Cain and seconded by Council Member Russell to approve the final reading of Ordinance No. 988. The motion passed unanimously.**

4. **Ordinance No. 989 (Public Hearing)** – Property Rights Element. Mayor Andrews closed the regular meeting and opened the public hearing at 5:35 p.m. Mrs. Tanner read Ordinance No. 989 by title:

**AN ORDINANCE OF THE CITY OF CHIPLEY, FLORIDA, PROVIDING FOR ANNEXATION OF CONTIGUOUS LANDS AS DESCRIBED HEREIN TO THE CITY; PROVIDING FOR AUTHORITY; PROVIDING FOR BOUNDARY; PROVIDING FOR LAND USE DESIGNATION OF AFFECTED LANDS AS COMMERCIAL; PROVIDING FOR AMENDMENT TO THE FUTURE LAND USE MAP; PROVIDING FOR A SMALL SCALE AMENDMENT TO THE ADOPTED COMPREHENSIVE PLAN; PROVIDING FOR FILING WITH THE CLERK OF CIRCUIT COURT AND THE FLORIDA DEPARTMENT OF STATE; AND DECLARING AN EFFECTIVE DATE.**

Mrs. Tanner explained this Ordinance, if approved, will amend the Future Land Use Map annexing Parcel# 00-2222-0001 located at 1447 Main Street, a total of approximately 3.52 acres, to the Commercial Land Use Category. Official notice to advise the public of the proposed adoption of Ordinance No. 989 was published in the Washington County News on September 25, 2024. The ad complied with the legal requirements of the City Code and Florida Statutes.

Mayor Andrews closed the public hearing and opened the regular meeting at 5:37 p.m. No further discussion.

**A motion was made by Council Member Cain and seconded by Council Member Russell to approve the final reading of Ordinance No. 989. The motion passed unanimously.**

- 5. **Ordinance No. 990 (Public Hearing)** – Property Rights Element. Mayor Andrews closed regular meeting and opened the public hearing at 5:38 p.m. Mrs. Tanner read Ordinance No. 990 by title:

**AN ORDINANCE OF THE CITY OF CHIPLEY, FLORIDA, AMENDING ITS ADOPTED COMPREHENSIVE PLAN; PROVIDING FOR AUTHORITY; PROVIDING FOR FINDINGS OF FACT; PROVIDING FOR FUTURE LAND USE CHANGE OF A PARCEL OF PROPERTY WITH PARCEL NO. 00000000-00-2698-0001 LOCATED AT 1218 CAMPBELLTON AVENUE, FROM LOW DENSITY RESIDENTIAL TO HIGH DENSITY RESIDENTIAL; PROVIDING FOR AMENDMENT TO THE FUTURE LAND USE MAP; PROVIDING FOR A SMALL SCALE AMENDMENT TO THE ADOPTED COMPREHENSIVE PLAN; PROVIDING FOR THE FILING WITH THE CLERK OF CIRCUIT COURT AND THE FLORIDA DEPARTMENT OF COMMERCE; AND DECLARING AN EFFECTIVE DATE.**

Mrs. Tanner explained this Ordinance, if approved, will amend the Future Land Use Map changing the land use designation of Parcel # 00-2698-0001 located at 1218 Campbellton Avenue, a total of approximately .417 acres, from Low Density Residential to the High-Density Residential Land Use Category. Official notice to advise the public of the proposed adoption of Ordinance No. 990 was published in the Washington County News on September 25, 2024. The ad complied with the legal requirements of the City Code and Florida Statutes.

Mayor Andrews closed the public hearing and opened the regular meeting at 5:40 p.m. No further discussion.

**A motion was made by Council Member McCall and seconded by Council Member Russell to approve the final reading of Ordinance No. 990. The motion passed unanimously.**

- 6. **National Wreaths Across America Day – Discussion.** Lieutenant Colonel Shayne Moore, Chipley High School JROTC Instructor, stated this is a program to place wreaths on the headstone of an American hero to honor all veterans laid to rest. Wreaths are purchased with donations from the community. They would like to place the wreaths at Glenwood Cemetery and hopefully in the future place them at other cemeteries in the area. Discussion ensued.

**A motion was made by Council Member Russell and seconded by Council Member Cain to approve the Wreaths Across America to be placed at the Glenwood Cemetery. The motion passed unanimously.**

**Mayor Andrews stated Mr. Blount would be added to the Liaison list as follows:**

- Tracy Andrews: Administration, External Affairs, Tourist Development Council (TDC).
- Cheryl McCall: Historic Merchants of Chipley, Planning & Zoning, Police.
- Linda Cain: Fire Department, Code Enforcement.
- Leonard Blount: Industrial Park, Water Utilities Department.
- Kevin Russell: CRA, Public Works/Cemetery, Recreation Department.

**M. OTHER BUSINESS**

Mr. Russell asked about the status of the Mongoven building. Mrs. Tanner stated the design is 58% complete and she would follow up with David H. Melvin, Inc. on the timeline.

**N. ADJOURN**

The meeting was adjourned by Mayor Andrews at 5:54 p.m.

City of Chipley

Attest:

Tracy L. Andrews, Mayor

Sherry Snell,  
City Clerk

**City of Chipley  
Council Meeting  
Minutes  
November 12, 2024 at 5:00 p.m.**

**Attendees:**

Ms. Tracy Andrews, Mayor  
Mrs. Linda Cain, Council Member  
Mr. Leonard Blount, Council Member

Mr. Kevin Russell, Mayor Pro-Tem  
Ms. Cheryl McCall, Council Member

**Others Present Were:**

Mrs. Patrice Tanner, City Administrator  
Mr. Guy Lane, Asst. City Admin./Public Works Director  
Mr. Hunter Aycock, Fire Chief

Ms. Sherry Snell, City Clerk  
Mr. Michael Richter, Police Chief  
Mrs. Michelle Jordan, City Attorney

The data reflected in these proceedings constitute an extrapolation of information elicited from notes, observations, recording tapes, photographs, and/or videotapes. Comments reflected herein are sometimes paraphrased, condensed, and/or have been edited to reflect essential subject matter addressed during the meeting. Parties interested in receiving a verbatim account of the proceedings are responsible for coordinating with the City Administrator and providing their own representative and equipment pursuant to Chapters 119 and 283, Florida Statutes.

**A. CALL TO ORDER**

The meeting was called to order by Mayor Andrews at 5:00 p.m.

**B. PRAYER AND PLEDGE**

Prayer was given by Council Member Blount and Mayor Andrews led the pledge to the American Flag.

**C. APPROVAL OF AGENDA**

Mayor Andrews added the Fire Department Truck Purchase as agenda item #4 and moved the remainder of the agenda items down.

**A motion was made by Council Member Russell and seconded by Council Member McCall to approve the agenda with the addition. The motion passed unanimously.**

**D. CITIZENS REQUEST**

The City of Chipley welcomes you to this meeting. This is time set aside for the Citizens of Chipley to address the City Council. This is not a question and answer period, it is not a political forum, nor is it a time for personal accusations and derogatory remarks to/or about city personnel. If you would like to address the City Council please raise your hand to speak, state your name and address for the record and limit your comments to no more than three (3) minutes per Florida Statute 286.0114. To ask a question via phone; dial \*9 and wait to be recognized/unmuted. If you are attending via webinar, there will be an onscreen option to ask a question during the public comment portion of the meeting. Your participation is welcomed and appreciated.

No citizen requests. No further discussion.

## E. APPROVAL OF MINUTES

1. Regular Council Meeting – October 8, 2024

**A motion was made by Council Member Russell and seconded by Council Member Cain to approve the minutes as presented. The motion passed unanimously.**

## F. PRESENTATIONS

**Recognition of Mr. Thomas Lancaster** – Planning & Zoning Commission. The Council recognized Mr. Thomas Lancaster for 10 years of dedicated service on the Planning & Zoning Commission by presenting him with a plaque.

**International City/County Management Association (ICMA) 25<sup>th</sup> Anniversary Recognition.** Mr. Mark Ryan, Senior Advisor, presented the City Council and City Administrator, Patrice Tanner, with a certificate from the International City/County Management Association (ICMA) recognizing 25 years of the Council-Manager form of government.

## K. CONSENT AGENDA ITEMS

1. **Resolution No. 25-07** – Florida Department of Environmental Protection Grant Agreement – FRDAP – Shivers Park. This resolution will approve the Florida Department of Environmental Protection – FRDAP Grant Agreement for Shivers Park in the amount of \$200,000.00. This funding will allow improvements to Shivers Park including Soccer field Renovation, Playground Renovation to include ADA Equipment; Baseball Field No. 7 Renovation, Softball/T-Ball Field No. 8 Renovation, Add Exercise Station to the Walking Trail, Picnic Facility Renovation, New Batting Cages, Restroom Renovation, Batting Cages Renovation, New Bleachers, Sidewalk to Batting Cages and Sidewalk to Playground Renovation.
2. **Resolution No. 25-08** – Florida Department of Environmental Protection Grant Agreement FRDAP – Gilmore Park. This resolution will approve the Florida Department of Environmental Protection – FRDAP Grant Agreement for Gilmore Park in the amount of \$50,000.00. This funding will allow improvements to Gilmore Park including adding a new Playground, Parking Lot renovations, Playground renovations Picnic Facility renovations, Restroom renovations, new Security Lighting and a new Picnic Pavilion.
3. **Resolution No. 25-09** – Florida Department of Commerce, CDBG-DR Agreement No. M0014 – Amendment No. 3. This resolution will approve the Florida Department of Commerce, CDBG-DR Agreement No. M0014 – Amendment No. 3 for the Northwest Stormwater Restoration Project. It will extend the project end date to September 30, 2025, amend Attachment A – Project Description and Deliverables, Section 7, and amend Attachment G – Reports, Section 6 to include updated information.
4. **State Governmental Consulting Services Contract Renewal** – Liberty Partners of Tallahassee, LLC. This will renew the State Governmental Consulting Services Contract for Lobbyist Services with Liberty Partners of Tallahassee, LLC in the amount of \$3,000 per month for one (1) year, with the option of one additional one-year term.
5. **Special Event Application** – MLK Parade. The MLK Parade will be held on Monday, January 20, 2025 starting at 10:00 a.m. using the new parade route.

**A motion was made by Council Member Cain and seconded by Council Member McCall to approve the consent agenda items. The motion passed unanimously.**

## L. AGENDA ITEMS

1. **Florida Commerce Rural Infrastructure Fund Grant No. D0190** – Citywide Drainage Study

– Preliminary Engineering Report. Mr. Brent Melvin, Melvin Engineering, explained that he received a grant from Florida Commerce to do a citywide drainage study and the report is complete and ready to submit. He gave an overview of the report stating they identified twenty-seven specific problem areas around the city.

**A motion was made by Council Member McCall and seconded by Council Member Russell to approve the submission of the Citywide Drainage Study – Preliminary Engineering Report to Florida Commerce. The motion passed unanimously.**

- 2. Connections Worship Center – Blessing Box Discussion.** Mr. Derick Balkcom, Youth Pastor, explained they are working with the youth group to go outside the church and be more involved in the community. Haley Forehand, Youth Group Member, stated they have been discussing getting into the community more as a group and the blessing box would be an outreach program and an ongoing mission for them. Mr. Guy Lane stated there is a grass area behind the church where it could be placed. Discussion ensued.

**A motion was made by Council Member Cain and seconded by Council Member McCall to approve the placement of the Blessing Box behind Connections Worship Center. The motion passed unanimously.**

- 3. Opioid Use Disorder Recovery Management Program – Pancare – Valorie Hall.** Mrs. Hall explained Pancare offers many programs that they would like to share. Alexis Balbuena, Community Health Educator, gave an overview of a program called Startingpoint which is an opioid use disorder recovery management program; Community and provider trainings; and drug take back kiosks where anyone can safely drop off unused prescription medication, over the counter medications, and illicit substances. Mayor Andrews thanked Chief Michael Richter for having a drug take back kiosk at the Police Department. Discussion ensued.
- 4. Fire Department Truck Purchase – Chief Hunter Aycock** explained they are having some mechanical issues with the rescue truck which is 28 years old. He is proposing to take his truck and turn it into a brush truck and also turn the current brush truck into the rescue truck. Mrs. Tanner stated there is a current loan for the Chief’s truck that will be paid off this fiscal year. The purchase of a new truck can be funded with a loan that has a first payment in the next fiscal year, which would not require any additional payments this year. Mrs. Tanner stated the cost of the truck is \$66,473.00. No further discussion.

**A motion was made by Council Member Cain and seconded by Council Member McCall to approve the purchase of a new F-250 truck for the Fire Department in the amount of \$66,473.00. The motion passed unanimously.**

- 5. Pride Committee – Discussion.** Mrs. Tanner explained the Pride Committee has not been active for some time and that Ms. McCall wanted to discuss possibly reactivating the committee. Ms. McCall stated she has people that want to help decorate in town. Mayor Andrews stated Pride encompasses the entire city for clean up or decorating. Mrs. Tanner stated there is money budgeted each year for this purpose. Mayor Andrews stated there should be a process and nominations for the committee from each Ward and one from the downtown merchants as a collaborative effort. Mrs. Tanner stated she could put something together for guidelines.
- 6. Cheerleading for Basketball – Discussion.** Mrs. Tanner explained that she, Mr. Tate, Mayor Andrews and Jalisa Brown met and discussed the possibility of cheerleading during the basketball season. Mr. Tate conducted a poll on Facebook receiving 60 responses, with 59 in favor and only one against. Ms. Jalisa Brown stated there are parents interested in having their children ages 5-12 cheer at the basketball games. She feels it is important to show team spirit and to build skills for school cheerleading. Mrs. Tanner stated Mr. Tate proposes that we offer cheerleading for the upcoming basketball season on a trial basis to make sure there is adequate room for the cheerleaders and to see what type of participation there is. The charges would be the same as the other charges for sports and there would also be sponsors for individual teams to be able to

purchase uniforms. If it goes well, then the program could be continued. Mr. Russell asked age groups and size of each. Ms. Brown stated there are four (4) age groups: Pee Wee, Boomers with eight (8) members on each team and Juniors and Seniors with 12 members on each team. Discussion ensued.

Section H, Item 7.

**A motion was made by Council Member Cain and seconded by Council Member McCall to approve the cheerleading for basketball on a trial basis for the upcoming basketball season. The motion passed unanimously.**

7. **Blue Star Memorial Veterans Marker** - Discussion. Mike & Stacy Hansen, Chipley Garden Club and the Blue Star Memorial Highway Marker Committee, explained there is a Blue Star Memorial Highway Marker located on State Road 90 by the Florida Department of Transportation office, that pays tribute to the US Armed Forces. It was placed there by the Garden Club on April 26, 1961. The current location makes visibility low due to a utility pole and overgrown landscaping around it. FDOT has notified them that the sign is in violation of state guidelines due to the post it is on and it needs to be relocated. We are asking for a new location for the sign that is fading so it can be updated. We are requesting to place it in front of City Hall near the time capsule monument. The Garden Club would provide the funds for a new post and to refurbish the sign. Mr. Guy Lane will coordinate with the Garden Club on the placement of the sign. Discussion ensued.

**A motion was made by Council Member McCall and seconded by Council Member Blount to approve the placement of the Blue Star Memorial Highway Marker in front of City Hall. The motion passed unanimously.**

#### **I. OTHER BUSINESS**

Mr. Russell asked about readdressing the garbage can ordinance. Mrs. Tanner stated she will address it on Facebook and advertise in the newspaper to explain further.

Mr. Tim Parsons, Liberty Partners of Tallahassee, LLC, gave an update on annexation after meeting with Representative Shane Abbott. Representative Abbott understands the City is committed and they will be discussing it further with the House Local Administrative Committee staff.

Mr. Parsons stated the City will be preparing their appropriation requests for the 2025 legislative session. Mayor Andrews stated we may need a workshop in December to discuss and understand our priorities and know which projects would have a higher approval rate.

#### **J. ADJOURN**

The meeting was adjourned by Mayor Andrews at 6:17 p.m.

City of Chipley

Attest:

Tracy L. Andrews, Mayor

Sherry Snell,  
City Clerk

*Section H, Item 7.*

**City of Chipley  
Council Meeting  
Minutes  
January 14, 2025 at 5:00 p.m.**

**Attendees:**

Ms. Tracy Andrews, Mayor  
Mrs. Linda Cain, Council Member  
Mr. Leonard Blount, Council Member

Mr. Kevin Russell, Mayor Pro-Tem  
Ms. Cheryl McCall, Council Member

**Present Via ZOOM:**

Mrs. Michelle Jordan, City Attorney

**Others Present Were:**

Mrs. Patrice Tanner, City Administrator  
Mr. Guy Lane, Asst. City Admin. /Public Works Dir.  
Mr. Hunter Aycock, Fire Chief  
Mrs. Tamara Donjuan, Planning/Code Enf. Officer

Ms. Sherry Snell, City Clerk  
Mr. Michael Richter, Police Chief  
Mr. Jimmy Cook, Water Utilities Director  
Mr. Brock Tate, Recreation Director

The data reflected in these proceedings constitute an extrapolation of information elicited from notes, observations, recording tapes, photographs, and/or videotapes. Comments reflected herein are sometimes paraphrased, condensed, and/or have been edited to reflect essential subject matter addressed during the meeting. Parties interested in receiving a verbatim account of the proceedings are responsible for coordinating with the City Administrator and providing their own representative and equipment pursuant to Chapters 119 and 283, Florida Statutes.

**A. CALL TO ORDER**

The meeting was called to order by Mayor Andrews at 5:00 p.m.

**B. PRAYER AND PLEDGE**

Prayer was given by Council Member Russell and Mayor Andrews led the pledge to the American Flag.

**C. APPROVAL OF AGENDA**

Mayor Andrews added #5 – Blackburn Building – Jennifer Corbitt; added #6 – Traffic Study.

**A motion was made by Council Member Russell and seconded by Council Member Cain to approve the agenda with the additions. The motion passed unanimously.**

**D. CITIZENS REQUEST**

The City of Chipley welcomes you to this meeting. This is time set aside for the Citizens of Chipley to address the City Council. This is not a question and answer period, it is not a political forum, nor is it a time for personal accusations and derogatory remarks to/or about city personnel. If you would like to address the City Council please raise your hand to speak, state your name and address for the record and limit your comments to no more than three (3) minutes per Florida Statute 286.0114. To ask a question via phone; dial \*9 and wait to be recognized/unmuted. If you are attending via webinar, there will be an onscreen option to ask a question during the public comment portion of the meeting. Your participation is welcomed and appreciated.

Bishop John McMillion - 3639 Blaine Drive, Marianna, FL stated he has recently established Truth and Prayer Church at 1247 East Church Avenue in Chipley, FL. He has talked with the Planning & Zoning office and has been made aware of possible parking issues. He is seeking a waiver of the paving ordinance. Mayor Andrews stated city staff would look into the matter and respond back to him.

#### **E. APPROVAL OF MINUTES**

1. Regular Council Meeting – November 12, 2024
2. Special Council Meeting – November 26, 2024
3. Special Council Workshop – December 16, 2024
4. Special Council Meeting – December 16, 2024
5. Special Council Meeting – December 30, 2024

**A motion was made by Council Member McCall and seconded by Council Member Russell to approve the minutes as presented. The motion passed unanimously.**

#### **F. DEPARTMENT REPORTS**

1. Attorney Report – Michelle Jordan. There were no questions. No further discussion.
2. CRA Report – Leah Pettis. There were no questions. No further discussion.
3. Fire Department Report – Chief Hunter Aycock. Chief Aycock stated they were very busy in December. Tanker 2 is back in service and they are working on Brush 1. The monument for the fire department will not have names or years, but will honor all firemen. We didn't want to miss anyone and felt this would be the best way to honor everyone. Discussion ensued.
4. Code Enforcement Report – Tamara Donjuan. Mr. Russell asked about the property located at 1278 Holley Avenue. Attorney Jordan stated they are in the process of doing constructive service on the heirs which will take several months. Discussion ensued.
5. Planning & Zoning Report – Tamara Donjuan. There were no questions. No further discussion.
6. Police Department Report – Chief Michael Richter. Mr. Russell asked how many officers the department was short. Chief Richter stated two, but he is in the process of hiring for those positions. December was busy with the parade, festival, and movie night in addition to security details. We received the body cameras and have them going, and we are installing the new radar units now. Mayor Andrews stated we submitted all the information to the Legislative delegation process for equipment needed. Mrs. Tanner stated the total we submitted for the Police Department equipment was \$468,000. Discussion ensued.
7. Public Works Department Report – Guy Lane. There were no questions. No further discussion.
8. Recreation Department Report – Brock Tate. Mr. Tate stated cheerleading has started. No further discussion.
9. Water Utilities Department Report – Jimmy Cook. There were no questions. No further discussion.
10. Finance Department Report – Patrice Tanner. Mrs. Tanner stated all was going well. I will be doing interviews for the Finance Director this week and next. No further discussion.
11. City Administrator Report – Patrice Tanner. Mrs. Tanner stated there was one grant not included, the Assistance to Firefighters Grant for the tanker truck in the amount of \$650,000. We are looking at a few other grants as well. Mayor Andrews asked about the drive thru window being down. Mrs. Tanner stated we have a quote for repairs in the amount of a little over \$11,000. We were planning on replacing the drive thru with the utility kiosk this year. I am waiting on a glass company to come by and see if we can install an opening in the glass to be able to make payments, but also have a locking device to keep the building secure. This might be a cheaper temporary

## G. PRESENTATIONS

1. **ChIPLEY Christmas Fest Parade Contest Winners** – Heather Lopez. Mrs. Lopez presented trophies to the winners of the parade floats as follows:

Mayors Holiday Showstopper – Poplar Springs Queens  
3<sup>rd</sup> Place – First Baptist Church  
2<sup>nd</sup> Place – Washington County Livestock Club  
1<sup>st</sup> Place – Wausau Assembly of God

2. **Presentation of the ChIPLEY Christmas House Decoration Awards. Mayor Andrews and the City Council presented plaques to the Christmas House Decoration Award Winners as follows:**

Paul Riley #AllForPaul – 863 Earl Street  
Thomas & Amanda Hall – 764 3<sup>rd</sup> Street  
Edgar & Tamara Donjuan – 769 3<sup>rd</sup> Street

Mayor Andrews read the plaque as follows: Your “ChIPLEY Pride” shows by the appearance of your Christmas decorations. The care you devoted to your grounds not only makes your neighborhood look good, but it inspires others to follow. We commend you for showing your Christmas spirit in helping make ChIPLEY a nicer more attractive place in which to live.

The Mayor and Council thanked each of the award winners. No further discussion.

## K. CONSENT AGENDA ITEMS

1. **Resolution No. 25-17** – Capital City Bank Loan – Police Department. This resolution will approve a loan with Capital City Bank for the purchase of (1) New 2024 Ford Police Interceptor Utility AWD Vehicle for the Police Department in the amount of \$69,152.20 with an interest rate of 4.95% with seven (7) annual payments.
2. **Resolution No. 25-18** – Capital City Bank Loan – Police Department. This resolution will approve a loan with Capital City Bank for the purchase of (1) New 2025 Ford Explorer Police Vehicle for the Police Department in the amount of \$45,543.00 with an interest rate of 4.85% with five (5) annual payments.
3. **Award of RFQ No. 2025-01** - Bennett Drive Resurfacing Project. This will approve the award of RFQ No. 2025-01 and the Professional Engineering Services for the Bennett Drive Resurfacing Project to David H. Melvin in the amount of \$68,000.00. The project will include milling and resurfacing of Bennett Drive from SR 273 to Church Avenue including drainage improvements within the Old Bonifay/Bennett Drive intersection. The total project length is approximately .53 mile.
4. **Award of RFQ No. 2025-02** - Old ChIPLEY City Hall Phase II. This will award the Professional Engineering Services for the Old ChIPLEY City Hall Project – Phase II to Baker Design Build, subject to negotiation per CCNA for fair and reasonable compensation. The City advertised for Professional Engineering Services and received one (1) submittal. The project will include services related to a Division of Historical Resources grant through the State of Florida for inspection and creation of a plan for repairs, restoration, and storm hardening of the Old ChIPLEY City Hall, a historic structure, owned by the City.
5. **Request for Development Order and Certificate of Appropriateness** - 1012 Main Street - First Federal Bank of ChIPLEY. First Federal Bank of ChIPLEY request approval of a Development Order and Certificate of Appropriateness for the property located at 1012 Main Street, Parcel ID: 00-

- 6. Request for a Variance for a Development Order and Certificate of Appropriateness** - 1238 Main Street - Summit Locations, LLC. Summit Locations, LLC request approval of a development order and variance for the property located at 1238 Main Street, Parcel ID: 00-2159-0002 for a permanent outdoor advertising sign (billboard).

**A motion was made by Council Member McCall and seconded by Council Member Blount to approve the consent agenda items. The motion passed unanimously.**

**L. AGENDA ITEMS**

- 1. Ordinance No. 991 (First Reading)** - Amendment to Chapter 30 – Signs. Mrs. Tanner explained this Ordinance, if approved, will approve an Amendment to Chapter 30 – Signs to change the spacing of permanent outdoor advertising signs from no closer than 1,000 feet to no closer than 750 feet from any other permanent outdoor advertising sign on either side of the thoroughfare to which the permanent advertising sign is directed. Mrs. Tanner read the Ordinance by title:

**ORDINANCE NO. 991**

**AN ORDINANCE OF THE CITY OF CHIPLEY, FLORIDA, AMENDING CHAPTER 30 – SIGNS OF THE CODE OF ORDINANCES; PROVIDING FOR SEVERABILITY; PROVIDING FOR CONFLICTS; AND PROVIDING FOR AN EFFECTIVE DATE.**

Ms. McCall asked about regulating the brightness of the signs. Mrs. Tanner stated she understood some businesses could make the adjustments themselves. Mr. Thomas Lancaster, Planning & Zoning Commission Chairman, stated that was discussed in the last Planning & Zoning meeting. A company representative had stated at the last meeting that most signs have the ability to be dimmed or brightened. Discussion ensued.

**A motion was made by Council Member Cain and seconded by Council Member McCall to approve the first reading of Ordinance No. 991. The motion passed unanimously.**

- 2. Code Enforcement Case** – 499 Martin Luther King Drive. Attorney Jordan stated the property located at 499 Martin Luther King Drive has been accruing fines of \$75 per day since January 3, 2023. The total fines as of January 14, 2024 are \$28,200.00. The property is still not in compliance, has title issues and there is a potential homestead claim. There are different options with nuisance abatement being one where the city could go in and clean up. Mrs. Tanner stated we could get quotes on the clean-up to bring into compliance. Discussion ensued.

**A motion was made by Council Member McCall and seconded by Council Member Cain to proceed with the Nuisance Abatement process. The motion passed unanimously.**

- 3. Farmer’s Market & Gazebo Rental** – Cornerstone New Life Fellowship. Mrs. Tanner stated cornerstone New Life Fellowship would like to hold a community outreach event on Saturday, March 1, 2025 at the Farmer’s Market from 2:00 p.m. – 6:00 p.m. The church will give out free popcorn, there will be food trucks and vendors selling items and gospel music. Insurance is pending council approval. Discussion ensued.

**A motion was made by Council Member Russell and seconded by Council Member Cain to approve the Farmer’s Market & Gazebo Rental for Cornerstone New Life Fellowship. The motion passed unanimously.**

- 4. Pomeroy Foundation Historical Marker** – Old City Hall Building. Heather Lopez explained the marker would preserve history, educate the public, encourage pride of place and promote historic tourism. A marker grant from the William G. Pomeroy foundation would pay for the

entire cost of the marker, the pole and shipping. Discussion ensued.

**A motion was made by Council Member McCall and seconded by Council Member Blount to approve the historical marker. The motion passed unanimously.**

- 5. **Blackburn Building** – Jennifer Corbitt. Mrs. Corbitt explained a mural would reflect both aesthetic values and the city’s heritage. The CRA grant has been approved for painting and the cost is the same for paint or a mural. The concept would be created and the design could be brought back for council approval. Discussion ensued.

**A motion was made by Council Member McCall and seconded by Council Member Cain to approve the concept of a mural for the Blackburn building and for the actual design to be brought back for approval. The motion passed unanimously.**

- 6. **Traffic Study** – Discussion. Mrs. Tanner explained she has received some complaints on the city moving forward with a traffic study on just one street. Other streets suggested are Church Avenue from 2<sup>nd</sup> Street to Pecan Street, 5<sup>th</sup> Street from SR 90 to South Boulevard. These streets are in the area where children play in city parks. Brent Melvin discussed options for radar studies using an off duty officer. Mayor Andrews stated 5<sup>th</sup> Street from Church Avenue to Old Bonifay Road has already been approved for the study.

**Council Member Cain made a motion to not do a study at all. The motion died for lack of a second.**

Attorney Jordan explained you could use a petition process which requires a certain number or percentage of people that live on the street. Mrs. Tanner stated this process is in our current Speed Hump Policy and requires five signatures from the owners of five separate properties in the neighborhood. Attorney Jordan stated other cities charge a petition fee to help reduce costs. Discussion ensued.

**Council Member Cain made a motion to rescind the motion made at the Special Council Meeting on December 30, 2024 to do a study on 5<sup>th</sup> Street from Old Bonifay Road to Church Avenue. The motion passed with four (4) ayes and one (1) naye, with Council Member McCall opposed.**

**Council Member Russell made a motion to amend the current Speed Hump Policy to a requirement of 51% of citizens, one person per property, on the street and for the citizens to pay 20% of the study. The motion passed unanimously.**

**I. OTHER BUSINESS**

There was no other business.

**J. ADJOURN**

The meeting was adjourned by Mayor Andrews at 7:05 p.m.

City of Chipley

Attest:

Tracy L. Andrews, Mayor

Sherry Snell,  
City Clerk

Section H, Item 7.

**City of Chipley  
Council Meeting  
Minutes  
February 11, 2025 at 5:00 p.m.**

**Attendees:**

Ms. Tracy Andrews, Mayor  
Mrs. Linda Cain, Council Member  
Mr. Leonard Blount, Council Member

Mr. Kevin Russell, Mayor Pro-Tem  
Ms. Cheryl McCall, Council Member

**Others Present Were:**

Mrs. Patrice Tanner, City Administrator  
Mr. Guy Lane, Asst. City Admin. /Public Works Dir.  
Mrs. Jamie Richter, Finance Director

Ms. Sherry Snell, City Clerk  
Mr. Curtis Porter, Captain  
Mrs. Michelle Jordan, City Attorney

The data reflected in these proceedings constitute an extrapolation of information elicited from notes, observations, recording tapes, photographs, and/or videotapes. Comments reflected herein are sometimes paraphrased, condensed, and/or have been edited to reflect essential subject matter addressed during the meeting. Parties interested in receiving a verbatim account of the proceedings are responsible for coordinating with the City Administrator and providing their own representative and equipment pursuant to Chapters 119 and 283, Florida Statutes.

**A. CALL TO ORDER**

The meeting was called to order by Mayor Andrews at 5:00 p.m.

**B. PRAYER AND PLEDGE**

Prayer was given by Council Member Blount and Mayor Andrews led the pledge to the American Flag.

**C. APPROVAL OF AGENDA**

**A motion was made by Council Member Russell and seconded by Council Member McCall to approve the agenda as presented. The motion passed unanimously.**

**D. CITIZENS REQUEST**

The City of Chipley welcomes you to this meeting. This is time set aside for the Citizens of Chipley to address the City Council. This is not a question and answer period, it is not a political forum, nor is it a time for personal accusations and derogatory remarks to/or about city personnel. If you would like to address the City Council please raise your hand to speak, state your name and address for the record and limit your comments to no more than three (3) minutes per Florida Statute 286.0114. To ask a question via phone; dial \*9 and wait to be recognized/unmuted. If you are attending via webinar, there will be an onscreen option to ask a question during the public comment portion of the meeting. Your participation is welcomed and appreciated.

No citizen requests. No further discussion.

**E. APPROVAL OF MINUTES**

1. Regular Council Meeting – January 14, 2025

**A motion was made by Council Member Russell and seconded by Council Member Cain to approve the minutes as presented. The motion passed unanimously.**

**F. CONSENT AGENDA ITEMS**

- 1. Resolution No. 25-19** – Public Records Exemption. This resolution will approve a public records exemption for Municipal Clerks and employees who perform municipal elections work.
- 2. Resolution No. No. 25-20** - Amendment to the City of Chipley Speed Hump Policy. This resolution will amend the City of Chipley Speed Hump Policy.
- 3. Resolution No. 25-21** – Florida Department of Commerce Rural Infrastructure Fund (RIF) Grant Agreement – Brickyard Road Wastewater Project. This resolution will approve the grant agreement with the Florida Department of Commerce for a Rural Infrastructure Fund (RIF) Grant in the amount of \$295,000.00 for the Brickyard Wastewater Project to spur economic development and tourism.
- 4. Disposition of Surplus Property** - Fire Department. This will approve the disposition of a 1997 Ford Super Duty Truck that is out of service due to mechanical and reliability issues. The truck will be disposed of at auction.
- 5. Disposition of Surplus Property** - Fire Department. This will approve the disposition of a 2004 Ford F-250 Truck that has a blown motor. The truck will be disposed of at auction.
- 6. Special Event Application** - Color Run 5K - Project Grad Class of 2025. CHS Project Grad Class of 2025 is requesting to hold a 5K color run on Saturday, March 29, 2025 starting at 8:00 a.m. The run will start at Philip Rountree Stadium and head W on North Railroad Avenue to Griffin Road, then N to Old Bonifay Road, then E to 2<sup>nd</sup> Street and S back to N Railroad Avenue. The money raised will go toward Project Graduation for the Class of 2025.

Mr. Russell asked if the Amendment to the Speed Hump Policy was one vote for each person or one vote for each owner. Attorney Jordan stated she could change the language to one tenant or one owner.

**A motion was made by Council Member Cain and seconded by Council Member Blount to approve the consent agenda items. The motion passed unanimously.**

**G. AGENDA ITEMS**

- 1. Ordinance No. 991 (Public Hearing)** – Amendment to Chapter 30. Mayor Andrews closed the regular meeting and opened the public hearing at 5:05 p.m. Mrs. Tanner read Ordinance No. 991 by title:

**AN ORDINANCE OF THE CITY OF CHIPLEY, FLORIDA, AMENDING CHAPTER 30 – SIGNS OF THE CODE OF ORDINANCES; PROVIDING FOR SEVERABILITY; PROVIDING FOR CONFLICTS; AND PROVIDING FOR AN EFFECTIVE DATE.**

Mrs. Tanner explained this Ordinance, if approved, will amend to Chapter 30 – Signs to change the spacing of permanent outdoor advertising signs from no closer than 1,000 feet to no closer than 750 feet from any other permanent outdoor advertising sign on either side of the thoroughfare to which the permanent advertising sign is directed. Official notice to advise the public of the proposed adoption of Ordinance No. 991 was published in the Washington County News on January 29, 2025. The ad complied with the legal requirements of the City Code and Florida Statutes.

**A motion was made by Council Member Russell and seconded by Council Member Cain to approve the final reading of Ordinance No. 991. The motion passed unanimously.**

- 2. Resolution No. 25-22** – Chipola Area Habitat for Humanity – Kevin Yoder, Executive Director. Mr. Yoder introduced himself as the new Executive Director for Chipola Area Habitat for Humanity. Mayor Andrews welcomed him and congratulated him on his new position. This resolution will approve support for Habitat for Humanity’s project located at 1182 East 4<sup>th</sup> Avenue, Chipley, FL. The Florida Statutes require that the nonprofits submit with their applications to DEO a resolution adopted by the Council, certifying that their projects are consistent with local plans and regulations. Mayor Andrews stated there are nine Habitat for Humanity homes coming to Chipley. Mr. Yoder stated three are complete with the others to follow. Discussion ensued.

**A motion was made by Council Member McCall and seconded by Council Member Russell to approve Resolution No. 25-22. The motion passed unanimously.**

- 3. Resolution No. 25-23** – Chipola Area Habitat for Humanity – Kevin Yoder, Executive Director. This will approve support for Habitat for Humanity’s project located at 1184 East 4<sup>th</sup> Avenue, Chipley, FL. No further discussion.

**A motion was made by Council Member Russell and seconded by Council Member McCall to approve Resolution No. 25-23. The motion passed unanimously.**

- 4. Award of Bid No. 2025-02** – City Hall Front Entrance and Restroom Renovations. Mrs. Tanner explained the City advertised Bid No. 2025-02 for the City Hall Front Entrance and Restroom Renovations. This will include the renovation of the men’s and women’s restrooms as well as the removal and installation of the front door with double glass doors with ADA access. This job will require minor demolition, removal and replacing of fixtures such as sinks, toilets, mirrors and lights. New floor tile for both restrooms. Install a wall mounted, quartz, white counter-top, app. 8ftx2ft, at least one basin must meet dimensional requirements and have proper reach, knee, and toe clearance per ADA standards. Replacement of lights, paper-towel and soap dispensers. Applying orange peel texture to the walls and painting the bathroom, walls and ceilings. Three bids were received with the low bid from Finch Fire-N-Water in the amount of \$43,535.00. Discussion ensued.

**A motion was made by Council Member Cain and seconded by Council Member Blount to approve Award of Bid No. 2025-02 to Finch Fire-N-Water in the amount of \$43,535.00. The motion passed unanimously.**

- 5. Award of Bid No. 2025-03 – Chipley Mongoven Building – Phase 2.** Mr. David Melvin, David H. Melvin, Inc., explained the City advertised for the Mongoven Building Phase 2 to provide structural stabilization to the brick walls including the installation of concrete bond beams, concrete columns, helical piles and masonry work. Two bids were received with the low bid from Arris General Contractors, Inc. in the amount of \$191,685.00 We have reviewed the bids and recommend award of bid to Arris General Contractors, Inc. Discussion ensued.

**A motion was made by Council Member McCall and seconded by Council Member Russell to approve Award of Bid No. 2025-03 to Arris General Contractors, Inc. in the amount of \$191,685.00. The motion passed unanimously.**

- 6. Award of Bid No. 2025-04** – Citywide Flooding Resiliency Improvements. Mr. David Melvin, David H. Melvin, Inc., explained the City advertised Bid No. 2025-04 for paving and drainage improvements on Peach Street. Seven bids were received with the low bid from Extreme Land Restoration, LLC in the amount of \$1,457,236.15. The bids were reviewed and we recommend

award of bid to Extreme Land Restoration LLC. There is \$400,000 left in the grant which are in the process of trying to transfer to another Florida Commerce CDBG-HRP Grant for lift station on Peach Street to cover the total funding needed there to complete the project. Mr. Blount spoke regarding other streets that need work and grant funding that is needed. Mrs. Tanner explained she and Mr. Lane will continue to look for other grants, but it is a process that takes time. Discussion ensued.

**A motion was made by Council Member Cain and seconded by Council Member McCall to approve Award of Bid No. 2025-04 to Extreme Land Restoration, LLC. in the amount of \$1,457,236.15. The motion passed unanimously.**

7. **Award of RFQ 2025-02** – Professional Engineering Services Contract – Old Chipley City Hall – Phase II. Mrs. Heather Lopez explained this will approve the contract with Baker Design Build for the Professional Engineering Services for the Old Chipley City Hall Project – Phase II in the amount of \$49,600.00. The project will include services for inspection and creation of a plan for repairs, restoration, and storm hardening of the Old Chipley City Hall. Discussion ensued.

**A motion was made by Council Member Russell and seconded by Council Member McCall to approve Award of RFQ 2025-02 to Baker Design Build in the amount of \$49,600.00. The motion passed unanimously.**

8. **Affirmation of Finance Director.** Mrs. Tanner explained City Code Section 2-64 states the City Administrator shall nominate a Finance Director for confirmation by the city council and she is requesting the affirmation of Jamie Richter for the position. Ms. McCall asked if this would be a department head under the City Administrator. Mrs. Tanner stated yes it will be. No further discussion.

**A motion was made by Council Member Russell and seconded by Council Member McCall to approve the Affirmation of the Finance Director Position as Jamie Richter. The motion passed unanimously.**

Mrs. Jamie Richter was recognized by Council as the new Finance Director.

Ms. McCall asked if Planning & Zoning and Code Enforcement was a department head. Mrs. Tanner stated no. Mrs. Cain asked why. Mrs. Tanner stated the position has never been a department head and is not over any employees, so there is not a need for there to be a department head. Mrs. Cain asked how do you categorize Code and Planning & Zoning. Mrs. Tanner stated it is part of the Administration Department that I supervise. Mrs. Cain stated if she isn't a department head then she shouldn't have to be at the meetings for department reports. Mrs. Tanner stated that she agreed and she could answer any questions on those reports since she is the supervisor over those. Ms. McCall stated she always thought that position was a department head until Mrs. Tanner stated it wasn't. Discussion ensued.

9. **Tower Lease Agreement** – Cellco Partnership d/b/a Verizon Wireless. Mrs. Tanner explained this will approve a tower lease agreement with Cellco Partnership d/b/a/ Verizon Wireless to lease a space on the tower located along Brickyard Road for a period of five (5) years with an automatic extension for four (4) additional five (5) year terms. Rental payments will be in the amount \$24,000.00 annually to be paid in equal monthly installments of \$2,000.00 each month. Discussion ensued.

**A motion was made by Council Member Russell and seconded by Council Member Blount to approve the Tower Lease Agreement with Cellco Partnership d/b/a/ Verizon Wireless. The motion passed unanimously.**

10. **Professional Engineering Continuing Services Agreement Task Order** – Chipley Clean Water SRF Facilities Plan Study – Mott MacDonald Florida, LLC. Mr. Heath Roberts, Mott MacDonald Florida, LLC, explained the two task orders on the agenda are for planning activities for water

and wastewater activities throughout the City of Chipley. That includes the treatment plants, stations, piping in the ground, wells, tanks, and any type of capital improvements that may not be needed. Included in this type of report is an evaluation of all the facilities through various measures in coordination with Mr. Cook and Mr. Lane to identify areas that they know are in great need from the wastewater perspective. This will create a planned document of funding to go after state revolving funds for the next ten years for the projects that we select during this evaluation process. Mrs. Tanner stated resolutions were approved by Council last year for these projects. No further discussion.

**A motion was made by Council Member Russell and seconded by Council Member Cain to approve the Professional Engineering Continuing Services Agreement Task Order for the Chipley Clean Water SRF Facilities Plan Study in the amount of \$90,000. The motion passed unanimously.**

- 11. Professional Engineering Continuing Services Agreement Task Order** – Chipley Drinking Water SRF Facilities Plan Study – Mott MacDonald Florida, LLC. No further discussion.

**A motion was made by Council Member Russell and seconded by Council Member McCall to approve Professional Engineering Continuing Services Agreement Task Order for the Chipley Drinking Water SRF Facilities Plan Study in the amount of \$90,000. The motion passed unanimously.**

**H. OTHER BUSINESS**

There was no other business.

**I. ADJOURN**

The meeting was adjourned by Mayor Andrews at 5:53 p.m.

City of Chipley

Attest:

Tracy L. Andrews, Mayor

Sherry Snell,  
City Clerk

**City of Chipley  
Council Meeting  
Minutes  
March 11, 2025 at 5:00 p.m.**

**Attendees:**

Ms. Tracy Andrews, Mayor  
Mrs. Linda Cain, Council Member  
Mr. Leonard Blount, Council Member

Mr. Kevin Russell, Mayor Pro-Tem  
Ms. Cheryl McCall, Council Member

**Others Present Were:**

Mrs. Patrice Tanner, City Administrator  
Mr. Guy Lane, Asst. City Admin./Public Works Director  
Mrs. Michelle Jordan, City Attorney

Ms. Sherry Snell, City Clerk  
Mr. Michael Richter, Police Chief

The data reflected in these proceedings constitute an extrapolation of information elicited from notes, observations, recording tapes, photographs, and/or videotapes. Comments reflected herein are sometimes paraphrased, condensed, and/or have been edited to reflect essential subject matter addressed during the meeting. Parties interested in receiving a verbatim account of the proceedings are responsible for coordinating with the City Administrator and providing their own representative and equipment pursuant to Chapters 119 and 283, Florida Statutes.

**A. CALL TO ORDER**

The meeting was called to order by Mayor Andrews at 5:00 p.m.

**B. PRAYER AND PLEDGE**

Prayer was given by Council Member Russell and Mayor Andrews led the pledge to the American Flag.

**C. APPROVAL OF AGENDA**

Mayor Andrews added regular agenda item #6 Washington County Phenoms – Carlton Smith, Jr.; added #7 Tree Maintenance.

**A motion was made by Council Member Russell and seconded by Council Member McCall to approve the agenda with the additions. The motion passed unanimously.**

**D. CITIZENS REQUEST**

The City of Chipley welcomes you to this meeting. This is time set aside for the Citizens of Chipley to address the City Council. This is not a question and answer period, it is not a political forum, nor is it a time for personal accusations and derogatory remarks to/or about city personnel. If you would like to address the City Council please raise your hand to speak, state your name and address for the record and limit your comments to no more than three (3) minutes per Florida Statute 286.0114. To ask a question via phone; dial \*9 and wait to be recognized/unmuted. If you are attending via webinar, there will be an onscreen option to ask a question during the public comment portion of the meeting. Your participation is welcomed and appreciated.

No citizen requests. No further discussion.

**E. APPROVAL OF MINUTES**

- 1. Regular Council Meeting – February 11, 2025

Ms. McCall stated she would like the wording changed on agenda item #8. Mrs. Tanner stated the change would be made. Discussion ensued.

**A motion was made by Council Member Russell and seconded by Council Member Cain to approve the minutes with the change. The motion passed unanimously.**

**F. PRESENTATIONS**

- 1. **Proclamation** – National Red Cross Month. The City Council honored Mr. Wayland Patterson, Red Cross Volunteer, with a Proclamation for National Red Cross Month.
- 2. **Proclamation** – Music in Our Schools. The City Council honored Sevdelina Twining, Kate Smith Elementary School; Sam Toole, Roulhac Middle School; and Shad Steptoe, Chipley High School

- 3. **Proclamation** – Theatre in Our Schools. The City Council honored Justin Conley, Chipley High School with a Proclamation for Theatre in Our Schools Month.

**G. CONSENT AGENDA ITEMS**

- 1. **Special Event Application** – Community Easter Egg Hunt. The Community Easter Egg Hunt will be held on Wednesday, April 16, 2026 from 5:30 p.m. to 6:30 p.m. at Shiver's Park.
- 2. **Special Event Application** – Law Enforcement Torch Run for Special Olympics Florida. This event will be held on Monday, March 17, 2025 from 9-11:00 a.m. They will be walking a pre-determined route to bring awareness to the Special Olympics of Florida. The route will depart at the Washington County Courthouse and head east for .2 miles then turn South onto SR 77 and continue for 2 miles to end at PeoplesSouth Bank. The East Bound lane of Jackson Ave/South Bound lane of Main Street will be closed by transport vehicles during event.
- 3. **Appointment of CRA Board Member** – Kevin Yoder. This will appoint Mr. Kevin Yoder, Chipola Area Habitat for Humanity Executive Director, to the CRA Board for a four-year term ending on March 11, 2029.
- 4. **Award of Bid No. 2025-03 – Chipley Mongoven Building** – Phase 2 - Arris General Contractors, Inc. This will approve the contract with Arris General Contractors, Inc. for the Mongoven Building Phase 2 in the amount of \$191,685.00. The project will include structural stabilization of the brick walls including the installation of concrete bond beams, concrete columns, helical piles and masonry work.

Mr. Russell asked about #4 and pictures of the plans of what will be done. Mr. Brent Melvin, David H. Melvin, Inc. stated Phase 2 is the stabilization only. Phase 3 will be the concept drawings for the actual site improvements which will come to Council for approval hopefully next month. Discussion ensued.

**A motion was made by Council Member Blount and seconded by Council Member Cain to approve the consent agenda items. The motion passed unanimously.**

**H. AGENDA ITEMS**

- 1. **Ordinance No. 992 (First Reading)** – Amendment to Chapter 16 – Fire Prevention and Protection. Mrs. Tanner read Ordinance No. 992 by title:

**AN ORDINANCE OF THE CITY OF CHIPLEY, FLORIDA, PROVIDING FOR AN AMENDMENT TO CHAPTER 16 – OF THE CITY CODE RELATING TO OPEN BURNING, REGULATIONS; PROVIDING FOR SEVERABILITY, CONFLICTS, AND FOR AN EFFECTIVE DATE.**

Chief Aycock stated his concern was the liability of giving burn permits. This will get away from that and go back to state laws where it clearly states what you can and can't do. No further discussion.

**A motion was made by Council Member Russell and seconded by Council Member McCall to approve the first reading of Ordinance No. 992. The motion passed unanimously.**

- 2. **Resolution No. 25-24** – FDOT MSCOP Application Submission. Mrs. Tanner explained this resolution will allow the submission of an application for funding for the Municipal Small County Outreach Program for Pecan Street. This will include improvements to Pecan Street from CR 273 (South Blvd) to Church Avenue (approximately 0.738 miles). We have increased the distance from South Blvd instead of just to SR 90 on to Church Avenue due to expected growth in the near future at the industrial park. FDOT gave us a suggestion to apply for the entire project through MSCOP and we have also separately applied for legislative appropriations in the amount of \$750,000. If we are able to get both approved then the legislative appropriations will offset the total cost. Discussion ensued.

**A motion was made by Council Member Russell and seconded by Council Member McCall to approve Resolution No. 25-24. The motion passed unanimously.**

- 3. **Purchase of Rope Rescue Equipment** – Fire Department. Mrs. Tanner explained the rope rescue equipment was cut from the Fire Department budget this year. Chief Aycock stated he has looked for alternative ways to fund this. We have several pieces of equipment at auction right now and we would like to use those funds for the purchase. No further discussion.

**A motion was made by Council Member Cain and seconded by Council Member McCall to approve the purchase of the rope rescue equipment with the funds from the auction. The motion passed unanimously.**

4. **Florida Commerce M0014 Stormwater Grant** – FGT Gas Line Relocation Agreement. Tanner explained there have been some changes to this just today. This was referenced in reimbursement not to exceed \$25,000 just for FGT to prepare the design of the relocation of the natural gas pipeline located on Griffin Road. Then the relocation would be included as part of the grant funding. They have agreed not to charge us the 50% for the design of the relocation. We will just have the construction dollars coming from the grant funds. Mr. Brent Melvin, David H. Melvin, Inc., stated the box culvert under Griffin Road is the major constriction point for the drainage along Railroad Avenue and behind City Hall. We have 90% plans completed for an expanded box culvert, as part of that, the pipeline currently impedes stormwater mitigation work that the City is currently undertaking. These funds will be reimbursed by the Florida Commerce CDBG-Disaster Recovery Grant No. M0014. Discussion ensued.

**A motion was made by Council Member Russell and seconded by Council Member McCall to approve the FGT Gas Line Relocation Agreement in the amount of \$25,000.00. The motion passed unanimously.**

5. **Football League for Adults** – Brad Holt. Mr. Holt stated he is proposing to bring an Adult Flag Football League to Chipley this summer. He has organized teams and competed in flag football leagues and tournaments over the last 20 years and brings the experience and contacts necessary to make it a successful venture. He would like to use the large field at Jim Trawick Park which would be marked and maintained by the city. They would sign the rental agreement provided by the city to rent the field and lights. The dates would be Sunday afternoons and evenings in June, July and August. Each player would sign a liability waiver to participate. Once the league is established he will contact food trucks, bounce house companies and vendors to attempt to create an event for children near the end of the season. Discussion ensued.

**A motion was made by Council Member Russell and seconded by Council Member Cain to approve the Football League for Adults. The motion passed unanimously.**

6. **Washington County Phenoms** – Carlton Smith Jr. Mr. Smith, founder of the Washington County Phenoms; Jessica Simmons, Program Director; and NaQuitta O'Neal, Financial Advisor & Treasurer, addressed the council regarding the use of the field located by the T.J. Roulhac Enrichment Center. Mr. Smith stated the field could be a resource for the community to bring our kids closer together and build a family environment through the sport of football. They would use 7 on 7 which is the structural foundation of football without pads in which you run routes and different coverages and learn how to throw and catch a football. The basic necessity that a kid needs in order to be successful in the game of football. We have an insurance package, sponsors and donations in order. Mayor Andrews stated to clarify this, the T.J. Roulhac Enrichment Center is the facility up front and the City of Chipley owns the field. Mr. Blount stated there is discrepancy with the management of the field. Mayor Andrews stated the field belongs to the City of Chipley. She added that they could put port-o-lets on the field or ask for permission from T.J. Roulhac Enrichment Center for the use of their restroom facilities since there are none on the field. Mr. Blount mentioned that originally the county owned both and gave the property to the T.J. Roulhac Enrichment Center and the City of Chipley. Mayor Andrews stated we could research the history of the property ownership. Mrs. Tanner stated the City of Chipley owns the field. Mr. Blount stated there is discrepancy in who manages the property. Mrs. Tanner stated that she could do research to see what exactly took place. Mrs. O'Neal stated they would like to get their guys to mow and weed eat to teach them how to do maintenance on the field and make it part of their job in order to play. Mrs. Valerie Sheffield, T.J. Roulhac Board Member, stated her concern was parking. Mayor Andrews stated they could pull into the field area by the tennis courts and would not have to park in the lot in front of the T.J. Roulhac Enrichment Center which is located inside the locked fence. Mrs. Tanner stated that no one has been utilizing the property and that public works has mowed and checked for holes and would make sure it is safe for them to play on. Once their guys start doing the mowing, public works will still check periodically to oversee. Mr. Russell stated his concern was parking. Mrs. Tanner stated they would need to park on city property and if they could direct them to the appropriate area that would help. Discussion ensued.

**A motion was made by Council Member Cain and seconded by Council Member Russell to approve the Washington County Phenoms to use the field located at 1196 Church Avenue. The motion passed unanimously.**

7. **Tree Maintenance** – Discussion. Mrs. Tanner stated there have been issues over the years with the trimming of the crepe myrtles in the cemetery and downtown as well as the Bradford pears and Dogwood trees. We stopped a few years ago from trimming the trees downtown, but now they are touching some of the buildings and that is an issue. We need to consider doing something with them and in the past they were not trimmed correctly. We could hire an arborist to come in and trim but at a cost. Ms. McCall stated there are master gardeners next door at the Ag Center that could help advise on how to trim the trees. Mrs. Tanner stated we are working on reaching out to FDOT to get them to come up with a plan for us and then we could apply for beautification funds, but in the mean time they are getting large. Mr. Russell stated the trees at the cemetery don't look good after being cut back. Mrs. Tanner stated she needs council to decide what to do because some like them cut back and some don't. Mr. Lane stated there are 66 trees in the cemetery. Mrs. Cain stated to take care of the trees downtown first and leave the trees at the

cemetery alone until next year. Discussion ensued.

Attorney Jordan asked about the issue with headstones at the cemetery and the discoloring. Mr. Lane stated he had discussed it with Mr. Rustin at Rustin Vault and it was mildew. Mrs. Jordan stated the maintenance crew has hit the headstones and damaged them. Mrs. Tanner stated she has had complaints that some have been driven over and cracked and we are going to have to work with the contractor. Mr. Lane asked if people don't want the headstones sprayed or weedeated, what do we want to do so he knows what to discuss with the contractor. Mrs. Tanner stated some people think the spray is discoloring the headstones but it's mildew. Mayor Andrews stated we need to let the contractor know we are still getting complaints about the weedeating and there has to be an improved difference out there. Mrs. Tanner stated they would talk to the contractor about the issues.

**I. OTHER BUSINESS**

There was no other business.

**J. ADJOURN**

The meeting was adjourned by Mayor Andrews at 6:07 p.m.

City of Chipley

Attest:

Tracy L. Andrews, Mayor

Sherry Snell,  
City Clerk

**City of Chipley  
Council Meeting  
Minutes  
April 8, 2025 at 5:00 p.m.**

**Attendees:**

Ms. Tracy Andrews, Mayor  
Mrs. Linda Cain, Council Member  
Mr. Leonard Blount, Council Member

Mr. Kevin Russell, Mayor Pro-Tem  
Ms. Cheryl McCall, Council Member

**Others Present Were:**

Mrs. Patrice Tanner, City Administrator  
Mr. Guy Lane, Asst. City Admin. /Public Works Dir.  
Mr. Hunter Aycock, Fire Chief  
Mrs. Tamara Donjuan, Planning/Code Enf. Officer  
Mrs. Michelle Jordan, City Attorney

Ms. Sherry Snell, City Clerk  
Mr. Michael Richter, Police Chief  
Mr. Rodney Pittman, Collection System Foreman  
Mr. Brock Tate, Recreation Director

The data reflected in these proceedings constitute an extrapolation of information elicited from notes, observations, recording tapes, photographs, and/or videotapes. Comments reflected herein are sometimes paraphrased, condensed, and/or have been edited to reflect essential subject matter addressed during the meeting. Parties interested in receiving a verbatim account of the proceedings are responsible for coordinating with the City Administrator and providing their own representative and equipment pursuant to Chapters 119 and 283, Florida Statutes.

**A. CALL TO ORDER**

The meeting was called to order by Mayor Andrews at 5:00 p.m.

**B. PRAYER AND PLEDGE**

Prayer was given by Council Member Blount and Mayor Andrews led the pledge to the American Flag.

**C. APPROVAL OF AGENDA**

Mayor Andrews added regular agenda item #9 - Resolution No. 25-26.

**A motion was made by Council Member Russell and seconded by Council Member Cain to approve the agenda with the addition. The motion passed unanimously.**

**D. CITIZENS REQUEST**

The City of Chipley welcomes you to this meeting. This is time set aside for the Citizens of Chipley to address the City Council. This is not a question and answer period, it is not a political forum, nor is it a time for personal accusations and derogatory remarks to/or about city personnel. If you would like to address the City Council please raise your hand to speak, state your name and address for the record and limit your comments to no more than three (3) minutes per Florida Statute 286.0114. To ask a question via phone; dial \*9 and wait to be recognized/unmuted. If you are attending via webinar, there will be an onscreen option to ask a question during the public comment portion of the meeting. Your participation is welcomed and appreciated.

No citizen requests. No further discussion.

## E. APPROVAL OF MINUTES

1. Regular Council Meeting – March 11, 2025

**A motion was made by Council Member Russell and seconded by Council Member McCall to approve the minutes as presented. The motion passed unanimously.**

## F. DEPARTMENT REPORTS

1. Recreation Department Report – Brock Tate stated opening day was April 4<sup>th</sup> and everything went well. Mayor Andrews stated she appreciates the Recreation Department doing a good job. No further discussion.
2. Attorney Report - Michelle Jordan. Attorney Jordan stated she needed direction on a code case at 1471 South Railroad Avenue. Mayor Andrews stated this item could be revisited at the end of the meeting. Discussion ensued.
3. CRA Report - Leah Pettis. Mrs. Pettis stated there is a House and Senate Bill that is proposing the dissolution of all Community Redevelopment Agencies across the state and urged everyone to reach out to our state legislators. Discussion ensued.
4. Fire Department Report - Chief Hunter Aycock. Chief Aycock stated it was a busy month with a lot of fires. He stated seven volunteers participated in a ropes course training last week and it shows their dedication by taking the time away from their jobs and family to do this. Some of the other volunteers stayed local to handle calls during this time. Mayor Andrews thanked them for all of their hard work at a recent hotel structure fire. Discussion ensued.
5. Code Enforcement Report - Tamara Donjuan. Mrs. Donjuan stated it has been a busy month. There were no questions. No further discussion.
6. Planning & Zoning Report - Tamara Donjuan. Mrs. Donjuan stated it has been a busy month. There were no questions. No further discussion.
7. Police Department Report - Chief Michael Richter. Mr. Russell asked about late night foot traffic on streets. Chief Richter stated there is a curfew for juveniles. We have a new hire, Logan Foster, who is a certified K-9 handler and we are in the works to get a second K-9. The Police Department received 10 LifeVac systems last month and Officer White was able to utilize one yesterday on a choking child and may have saved the child's life. Mayor Andrews thanked Officer White for his service. Discussion ensued.
8. Public Works Department Report - Guy Lane. Mr. Lane stated they started the arthropod program last month. The Spring Clean Up will be held in May and is being advertised. Discussion ensued.
9. Water Utilities Department Report – Rodney Pittman. Mr. Pittman stated the generators at John Teal and Vo-Tech were installed. Discussion ensued.
10. Finance Department Report – Jamie Richter. Mrs. Richter stated everything is going great and has been busy. Discussion ensued.
11. City Administrator Report - Patrice Tanner. Mrs. Tanner stated the design on Bennett Drive Improvements is 30% complete; Chipley Lift Station Generators Project – once that project is 100% complete, and the permit has been closed out with the county, then we will work toward the close out of the FEMA grant and the Florida Department of Commerce grant; Chipley Peach Street Lift Station Improvements – the Council approved the award of contract at a special meeting contingent upon the bid documents and contract being approved by Florida Commerce; Chipley Wastewater Energy Efficient Project – this project which will be used to optimize energy consumption, reduce operational costs, and ensure compliance with regulatory standards. The

goal is to replace pumps/motors/scada system to enhance the performance and sustainability of our wastewater treatment processes. We have been approved for a site visit in the next couple of weeks at which time we will know if we have been approved for funding; FDEP Septic to Sewer Project – this funding will allow us to improve water quality, protect public health, and enhance wastewater infrastructure by moving 32 septic systems onto our city sewer system. We are currently awaiting funding approval to see if we will be awarded in the amount of \$1,325,500.00; Mongoven Building – the construction contract was approved last month and the contractor has started work. We do have some concepts for your review for the next phase. A decision does not have to be made tonight. Mr. Brent Melvin stated they have worked on the concepts and wanted to note they are still evaluating the restroom option. Another item is the shading with trees. Our landscape architect has suggested two options: Eagleston Holly tree which would have less maintenance but would produce berries or Crepe myrtles. Discussion ensued.

## G. PRESENTATIONS

1. **Professional Municipal Clerks Week Proclamation** – The City Council honored the City Clerk with a proclamation for Professional Municipal Clerks Week, May 4-10, 2025, to recognize the time honored and vital part of local government of the Municipal City Clerk.
2. **National Police Week Proclamation** – The City Council honored the Chipley Police Department with a proclamation for National Police Week, May 11-17, 2025, to recognize and honor the selfless and heroic service provided by the men and women of the Chipley Police Department.
3. **International Firefighters Day Proclamation** – The City Council honored the Chipley Fire Department with a proclamation for International Firefighters Day, May 4, 2025, to recognize and honor the dedication of their lives to the protection of life and property provided by the men of the Chipley Fire Department.

## H. CONSENT AGENDA ITEMS

1. **Recreational Facility Use Agreement** - The Washington County Phenoms. This will approve the Recreational Facility Use Agreement for the Washington County Phenoms to use the parking and playing field facilities located behind the T.J. Roulhac Enrichment Center at 1196 Church Avenue, Chipley, Florida. This will be for the purpose of allowing them to conduct recreational sports activities. This will be retroactive to March 25, 2025 since the City Council approved the use of the facilities at the March 11, 2025 Council Meeting.
2. **Special Event Application** – Watermelon Festival Parade. This event will be held on Saturday, June 21, 2025 starting at 10:00 a.m. using the new standard parade route.
3. **Request for Development Order and Certificate of Appropriateness** - Waffle House, Inc. Waffle House Inc request approval of a Development Order and Certificate of Appropriateness. The property is located at 1680 Main Street, Parcel ID:00-2341-0007 for renovations for the exterior and interior.
4. **Special Event Application** - Thursday Night Lights. This event will be held on the third Thursday from 6:00 p.m. – 8:00 p.m. Dates include: April 17, 2025, May 15, 2025, June 19, 2025, July 17 2025, August 15, 2025, September 18, 2025, and November 21, 2025.

**A motion was made by Council Member Cain and seconded by Council Member Russell to approve the consent agenda items. The motion passed unanimously.**

## H. AGENDA ITEMS

1. **CDBG First Public Hearing** – The regular meeting was closed and the public hearing was

opened at 5:38 p.m. Mr. Brent Melvin, David H. Melvin, Inc., stated this was the First Hearing for the City to apply to the Florida Commerce for a FFY 2023-2024 Small Community Development Block Grant (CDBG) He discussed the four (4) funding categories which must meet one of the following National Objectives: Benefit to low and moderate income (LMI) persons; Prevent or eliminate slum or blight conditions; or Meet a need of recent origin having a particular urgency. The types of activities for which the CDBG funds can be used include constructing stormwater ponds, paving roads and sidewalks, installing sewer and water lines, building a community center or park, making improvements to a sewage treatment plant, and rehabilitating low-income homes. Discussion ensued. The public hearing was closed and the regular meeting was opened at 5:44 p.m.

2. **Ordinance No. 992 (Public Hearing)** – Amendment to Chapter 16 – Fire Prevention and Protection. Mayor Andrews closed the regular meeting and opened the public hearing at 5:44 p.m. Mrs. Tanner read Ordinance No. 992 by title:

**AN ORDINANCE OF THE CITY OF CHIPLEY, FLORIDA, PROVIDING FOR AN AMENDMENT TO CHAPTER 16 OF THE CITY CODE, RELATING TO OPEN BURNING, REGULATIONS; PROVIDING FOR SEVERABILITY, CONFLICTS, AND FOR AN EFFECTIVE DATE.**

Mrs. Tanner explained this Ordinance, if approved, will amend Chapter 16 – Fire Prevention and Protection to update Section 16-6 Open Burning. This will allow burning of natural products such as yard debris in the city limits without a permit. Burning of unnatural material such as plastics, oil, tar, rubbers, garbage, etc. will be prohibited. Official notice to advise the public of the proposed adoption of Ordinance No. 992 was published in the Washington County News on March 26, 2025. The ad complied with the legal requirements of the City Code and Florida Statutes.

Mayor Andrews closed the regular meeting and opened the public hearing at 5:46 p.m. Discussion ensued.

**A motion was made by Council Member Russell and seconded by Council Member McCall to approve the final reading of Ordinance No. 992. The motion passed unanimously.**

3. **Request for Land Use Map Amendment** – 735 Main Street – Lota Kay Braxton. Mrs. Tanner explained applicant Lota Kay Braxton’s request for a Small-Scale Amendment. Per City Ordinance Chapter 44, Zoning, Article XII- Amendment approval through Planning and Zoning and City Council is a requirement. The location for the small-scale amendment is at 735 Main Street. The applicant would like to rezone the property to allow business to be permitted for land use.

The property is located at 735 Main Street, parcel 00000000-00-1238-0000, 1.465 acreage is currently low density residential. Approval of the Small-Scale Future Land Use Map Amendment would change the property to neighborhood commercial which would provide a transitional use zone in which residential uses, institutional uses, professional uses and certain types of neighborhood convenience/shopping/retail sales and service uses can be intermixed. The proposed amendment is consistent to the area with no substantial changes to the district. Approval of the small-scale amendment would allow the ability to redevelop property for business use, which could generate income, create jobs and stimulate economic growth to the community.

Signage posted to the property on February 25, 2025, provided public notice of the hearing satisfactory to the 30 days required. Public notices were sent certified to fifty-nine (59) property owners within five hundred (500) feet of said property. Forty-four (44) letters claimed, seven (7) returned unclaimed.

A motion was made by Council Member Cain and seconded by Council Member Blount to

approve the Land Use Map Amendment for 735 Main Street. No vote taken.

Mayor Andrews called for any discussion.

Jennifer Jones, 720 Main Street, spoke in opposition to the amendment.

Cindy Birge, Elite Realty, spoke in support of the amendment.

Kristin Martin 766 4<sup>th</sup> Street, spoke in support of the amendment.

Patricia Dedge, 730 Main Street, spoke in support of the amendment.

Kevin Crystal, 761 Main Street, spoke in support of the amendment.

Mr. Russell stated he was concerned about Coggin Avenue and the increase in traffic, the parking area, and what might happen ten years down the road.

Ms. McCall stated Coggin Avenue was just a milled asphalt road that does not meet standards and is only fifteen feet wide.

Mr. Crystal stated he is working on a solution for Coggin Avenue due to the affordable housing that is coming to the lot that he owns located at 761 Main Street. As a developer I may have to take on some additional responsibilities for it as a developer.

Mrs. Birge stated that she understands that Mr. Russell's grandmother lives across the road and that Ms. McCall is located within 500' which I don't think ethically either of you should vote due to the Florida Statutes, but I don't have a problem with you voting.

Mr. Russell asked Attorney Jordan if he would have any personal gain if he doesn't own the property where his grandmother lives at. Attorney Jordan stated she would need to research it further. Ms. McCall stated she was told years ago to think logically not emotionally. Emotionally I understand what they are going to do, but logically I have to look at the other people that have come to me. I haven't had one person come to me and say they are for this. Mr. Russell stated he would not vote until he knew it was legal. Ms. McCall agreed with Mr. Russell. Mayor Andrews stated Attorney Jordan should find out within 10-15 minutes so it can be handled. Attorney Jordan stated there are two different situations with each Council Member. Attorney Jordan stated she would need more time. Mrs. Tanner asked about in the past if a council member has asked in a meeting if they needed to abstain, I believe your response was, if you feel like you have gain from this or could be in jeopardy of voting you should not be voting on then you should abstain. But you have always left it up to the council member. Is this different? Attorney Jordan stated this is two different issues that have been raised and I don't have an answer right now.

The item was tabled until the end of the meeting.

Mayor Andrews moved agenda item #8 up to the next item for discussion.

4. **Code Enforcement Case** – Thelma Woods – 771 Pecan Street. Mrs. Tanner stated this is the parcel located at 771 Pecan Street – Thelma Woods, that had some code violations and fees that have accrued to the point that foreclosure documents have been served. Attorney Jordan would have additional information. Mrs. Wood has requested to speak to the council regarding this parcel. Thelma Wood – 2767 Owens Community Road, Vernon, FL stated she was supposed to be in violation of some code issues but was totally unaware of some of it. I need help to understand and see if it can be rectified. Someone served us papers about two weeks ago. I have been in and out of rehab for the past 2 years. The property has been in my family for well over 50 years and was built by my dad. I would like to be allowed time to get this done. Mr. Russell asked what the

issues were that needed correcting. Mrs. Tanner stated originally there was the roof and the facing 6<sup>th</sup> Avenue and the missing 911 address. Additional areas of the siding and a couple places on the roof now need fixing. The biggest things are some items that need to be brought into compliance and Mrs. Wood has agreed to do that. There is a lien against the property and Attorney Jordan can give you more information. Attorney Jordan stated the order was entered on October 30, 2023 and was she was given 30 days with a \$50 fine. Attorney Hubert Brown, Brown & Lane in Tallahassee, FL, stated he would like to point out a few things. Dr. Wood is 96 years old and has health issues. I have what was served and the issue is the mail was just regular mail and not certified, which is part of the reason that she was not aware of this issue. Also the fine is \$23,750 and someone mentioned they have pictures and that is close to the value of the home. I am working with her now to make sure all the requirements are done, but this was based on no 911 address and some shingles in the beginning. I am here to help make sure she gets it in compliance. It would be a financial hardship on her living on a fixed income at her age which would be very detrimental to her. Mr. Blount stated Mrs. Wood is a highly respected person in our community and he is familiar with her home. He asked for any leniency for this case based upon Mrs. Wood's character. Attorney Jordan stated the amount of fines is \$24,750 through today. The attorney fees are \$609, but that is not all of the cost. Mayor Andrews stated the biggest thing is to keep it out of foreclosure and allow her time to make the repairs and to look at all the fines. Mr. Russell stated his red flag was the papers were not sent certified mail. Mrs. Donjuan stated the notice of the meeting was sent certified but the order that the Special Magistrate issued was not mailed certified. Mrs. Tanner stated the last communication was from Tamara in March 2024 so there would not have been any more communication after that. Mayor Andrews stated noting was communicated from March of 2024 until it was filed this year. I remember discussing something at the January 2024 council meeting about taking care of this. Mrs. Tanner stated it was mentioned but the recording wasn't clear to state any action to be taken. In March of 2024 Mrs. Donjuan sent it to the city attorney so there would not have been any more communication until when Attorney Jordan filed for foreclosure in March 2025 and Mrs. Wood was served with the papers. Attorney Jordan stated in the past I've only seen council waive fees twice and this is a different situation. There are no guidelines established. Mayor Andrews stated the bigger thing for us is how do we justify a lapse of no communication for a year, no last-minute attempt to make contact. We don't want these properties and we may need to enhance our process to mail certified letters. Mrs. Tanner commented we do not want the property; our long-term goal is to get properties cleaned up and not go through the foreclosure process and have to pay the attorney fees. Our goal is to rectify the problem and terminate the issue and be done with the property. This did not happen in this case but Dr. Wood is agreeing to make that happen. So is that under the circumstances of her going through the illness and having problems over the last 2 years during the entire process she has been going through rehab for 2 years. Is that something that needs to be considered when making a decision like this? In any foreclosure case or code case in general the end goal is to have the property cleaned up because we don't want to have to take the property over or to spend our taxpayer dollars to demo the buildings. Is this something we need to look at if a determination is made today that we need to look at in the future and come up with guidelines that would better enable the city council to make those decisions or be allowed to make those decisions. Mr. Russell asked about the total of the fines being taken from the city or just what is in place that we collect on some and we don't on others. Attorney Jordan stated the fines were the amount the Special Magistrate put in place. Mr. Russell stated this has not cost us anything for fines and asked the amount that it had cost the city. Attorney Brown pointed out Dr. Wood has already engaged someone to make the repairs. Other jurisdictions have waived fines and for Dr. Wood it's not a pandora's box because it is unique to have someone her age with her health conditions. She is not one to ignore things that need to be done. Mr. Russell asked if the city was out approximately \$1,500 that they have actually had to pay out versus the \$24,750 for fines. Attorney Jordan stated that was pretty close. Mrs. Tanner stated she was not asking council to go against what Attorney Jordan was saying but asked Attorney Jordan if the council makes the decision to stop the foreclosure and waive the fees, is there a policy that you would be able to draw up that would from this point forward give the council specific guidelines to follow when making these types of decisions. Attorney Jordan stated she would want direction from council on what kind of conditions and could make suggestions like the property must be in compliance before you will even consider the request. This would be an objective requirement that I can

defend. Mr. Russell stated the fines of \$24,750 has not cost the city or Dr. Wood anything are the fees there. No one has lost anything, it's just a document. Mr. Russell made a motion to cease the fines as of today, give Dr. Wood 90 days to get the property into compliance at which time the \$24,750 will be waived and not to waive any fees that have been accrued. Mr. Russell asked if the foreclosure would continue if we don't stop it. Attorney Jordan stated she would file a motion to abate the court proceedings but the property needed to be in compliance before then. Mr. Russell asked if the foreclosure would carry on while Dr. Wood is trying to get it in compliance. Attorney Jordan stated they do not move that fast. Mrs. Tanner asked if there is anything that would happen over the next three months with it being in foreclosure that the council would have to be concerned with. Attorney Jordan stated no. Mayor Andrews asked for a list of the things that need to be corrected for Dr. Wood and to make sure Attorney Brown gets a copy. Discussion ensued.

**A motion was made by Council Member Russell and seconded by Council Member Blount to give Dr. Wood ninety days to get the property into compliance then readdress the fines after that, and to abate/pause the foreclosure proceedings for ninety days. The motion passed unanimously.**

5. **National Wreaths Across America Day** – Mrs. Tanner stated this is an effort to honor our nation's interred heroes while bringing attention to a yearlong mission to Remember the fallen, Honor those who served, and Teach the next generation the value of freedom. Lieutenant Colonel Shayne Moore and Sergeant Jerome Finn will be the volunteer location coordinators planning the wreath-laying ceremony to be held at Glenwood Cemetery on December 13, 2025. Colonel Shayne Moore thanked the city for allowing them to host at Glenwood Cemetery. There were 132 sponsored wreaths in 2024 with 150 being the goal this year. Discussion ensued.

**A motion was made by Council Member Russell and seconded by Council Member McCall to approve December 13, 2025 for the wreath-laying ceremony at Glenwood Cemetery. The motion passed unanimously.**

6. **Reach America Christian Outreach** – Richard McMahon. Mr. McMahon stated Reach America would like to share the gospel in Chipley at the intersection of SR 77 and SR 90 which is a feeder to the beach with high traffic volume. A person on their team, Scott Daniel, would do outreach handing out leaflets when people stop. We just walk down with a little speaker so people with their windows down can hear. He would give out little cards with information. He would also have a sign that would include please donate. Ms. McCall asked Chief Richter if that would require a permit from FDOT. Chief Richter stated he would have to check with FDOT but according to city code, what they want to do is not allowed. Mr. McMahon stated they normally don't do fundraising but they have some significant expenses for internet, computers, cell phones and advertising. Scott Daniel works for them and is in public housing and in order for him to do this he has to have help with his finances. As he goes down the road he hands out the cards and has a jar that says thank you. People want to see this and are voting to see this continue by putting a few dollars in the jar. Mr. Daniel was able to go from full time work to part time work because of the tip jar. We would like to get approval for him to do this two (2) days a week in Chipley. Mr. Russell stated we need more information. Mayor Andrews stated we would need to do some research and communicate with you once that is finalized. Discussion ensued.
7. **Resolution No. 25-26** – FDEP State Revolving Fund Loan Program – Drinking Water Facilities Plan. Mrs. Tanner stated this resolution will approve the submission of a FDEP State Revolving Fund Loan Program Application for a Drinking Water Facilities Plan. The State Revolving Fund loan priority list designates Project No. DW670140 as eligible for available funding. The total cost for the Facilities Plan to be prepared is \$90,000. This project is funded 50%/50% loan and principal forgiveness. This Facilities Plan will include a listing of projects that need to be done in the city and will be required to apply for funding through the FDEP SRF Program. Discussion ensued.

**A motion was made by Council Member Cain and seconded by Council Member McCall to**

**approve Resolution No. 25-26. The motion passed unanimously.**

Section H, Item 7.

8. Mayor Andrews asked to go back to the item discussed earlier in the meeting for the code case at 1471 South Railroad Avenue. Attorney Jordan stated the fine as of today was \$74,500. The attorney fees and costs are \$5,000 and asked for direction in the foreclosure. Mayor Andrews stated we need to cover fees and costs. Attorney Jordan stated typically I will bid up to our judgement amount which is the amount of fines plus attorney fees and costs. She asked council if they wanted to cap the total amount at \$50,000 and stay in the county court or move into the circuit court.

**A motion was made by Council Member Russell and seconded by Council Member Cain to not exceed \$50,000 on the bid. The motion passed unanimously.**

Mayor Andrews asked to go back to agenda item #3.

9. **Request for Land Use Map Amendment** – 735 Main Street – Lota Kay Braxton. Attorney Jordan stated she could not find current opinions on the ethics issue and would like to call the Commission on Ethics to get an answer. She asked Council to table this item until she can get an answer. Council set a Special Meeting for April 10, 2025 at 11:00 a.m. to discuss further. Mrs. Tanner stated there will be 2 items on the agenda which will be the approval of the land use amendment and approval of Ordinance No. 993 (First Reading). Discussion ensued.

This item and Ordinance No. 993 (First Reading) were tabled until a Special Meeting on April 10, 2025.

10. **Resolution No. 25-25** – Background Screening Policy. Mayor Andrews brought this item back up and it was decided to move this item to the May Council Meeting agenda.

#### **I. OTHER BUSINESS**

Mrs. Tanner stated she has had some complaints and discussions about downtown buildings that are not maintained up to the standards that other buildings owners maintain their buildings at. The City has never enforced peeling paint on a building that I know of. The code is very vague and states diminution of property. So, what constitutes the diminishing value of property. Deferred maintenance can, but it does not specify in our code. I wanted to bring this to Council to let you decide how we move forward with this or if we want the attorney to look at it and come up with more specifics that can be put in the code to help us address these issues. It was decided we will hold a workshop to discuss this further. Discussion ensued.

#### **J. ADJOURN**

The meeting was adjourned by Mayor Andrews at 7:55 p.m.

City of Chipley

Attest:

Tracy L. Andrews, Mayor

Sherry Snell,



**City of Chipley  
Council Meeting  
Minutes  
May 13, 2025 at 5:00 p.m.**

**Attendees:**

Ms. Tracy Andrews, Mayor  
Mrs. Linda Cain, Council Member  
Mr. Leonard Blount, Council Member

Mr. Kevin Russell, Mayor Pro-Tem  
Ms. Cheryl McCall, Council Member

**Others Present Were:**

Mrs. Patrice Tanner, City Administrator  
Mr. Guy Lane, Asst. City Admin. /Public Works Dir.  
Mrs. Michelle Jordan, City Attorney

Ms. Sherry Snell, City Clerk  
Mr. Michael Richter, Police Chief

The data reflected in these proceedings constitute an extrapolation of information elicited from notes, observations, recording tapes, photographs, and/or videotapes. Comments reflected herein are sometimes paraphrased, condensed, and/or have been edited to reflect essential subject matter addressed during the meeting. Parties interested in receiving a verbatim account of the proceedings are responsible for coordinating with the City Administrator and providing their own representative and equipment pursuant to Chapters 119 and 283, Florida Statutes.

**A. CALL TO ORDER**

The meeting was called to order by Mayor Andrews at 5:00 p.m.

**B. PRAYER AND PLEDGE**

Prayer was given by Council Member Russell and Mayor Andrews led the pledge to the American Flag.

**C. APPROVAL OF AGENDA**

**A motion was made by Council Member Russell and seconded by Council Member Cain to approve the agenda as presented. The motion passed unanimously.**

**D. CITIZENS REQUEST**

The City of Chipley welcomes you to this meeting. This is time set aside for the Citizens of Chipley to address the City Council. This is not a question and answer period, it is not a political forum, nor is it a time for personal accusations and derogatory remarks to/or about city personnel. If you would like to address the City Council please raise your hand to speak, state your name and address for the record and limit your comments to no more than three (3) minutes per Florida Statute 286.0114. To ask a question via phone; dial \*9 and wait to be recognized/unmuted. If you are attending via webinar, there will be an onscreen option to ask a question during the public comment portion of the meeting. Your participation is welcomed and appreciated.

Beth Watford, 916 Main Street, stated she would like the Council to consider changing the policy for Flea Across Florida and letting people use the city parking lot located by Regions Bank. No further discussion.

**E. APPROVAL OF MINUTES**

1. Special Council Meeting - April 3, 2025
2. Regular Council Meeting - April 8, 2025
3. Special Council Meeting - April 10, 2025
4. Special Council Meeting - April 24, 2025

Ms. McCall stated she would like the minutes from April 8, 2025 and April 10, 2025 updated to include her comments against the land use amendment.

**A motion was made by Council Member Russell and seconded by Council Member Blount to approve the minutes for April 3, 2025 and April 24, 2025 and update the April 8, 2025 and April 10, 2025 minutes and bring back for approval. The motion passed unanimously.**

#### F. PRESENTATIONS

1. **Certificate of Appreciation** – Mike & Stacy Hansen – The City Council honored Mike & Stacy Hansen with a Certificate of Appreciation for their commitment in moving and refurbishing the Blue Star Memorial Marker.
2. **National Garden Week Proclamation** – The City Council honored the Chipley Garden Club with a proclamation for National Garden Week, June 1-7, 2025, to recognize and honor the importance of gardening and the contribution of gardeners in our community by the men and women of the Chipley Garden Club.
3. **National Public Works Week Proclamation** – The City Council honored the Public Works Department with a proclamation for National Public Works Week, May 18-24, 2025, to recognize the services provided in our community by the men and women of the Chipley Public Works Department.
4. **Micosukee Tribe of Indians of Florida** – Councilman William J. (Popeye) Osceola and Edward Ornstein, Esq. Mr. Osceola gave an overview of the Micosukee Tribe of Indians of Florida.

#### G. CONSENT AGENDA ITEMS

1. **Resolution No. 25-27** – State of Florida - Division of Historical Resources Grant Agreement Amendment – Old Chipley City Hall. This resolution will approve an amendment to the agreement with the State of Florida – Division of Historical Resources for architectural/engineering services to plan for the restoration of the Old Chipley City Hall extending the agreement end date to 07/31/2025. This will allow more time for review turnaround and incorporation of comments into the final report.
2. **Resolution No. 25-28** - Support for Re-designation of Rural Area of Opportunity in Northwest Florida. This resolution will show support for the re-designation of Rural Area of Opportunity (RAO) to continue to apply to the Northwest Florida region and the continuation of all staffing grant funding for the Northwest Florida Business Development Council, Inc. D/B/A Opportunity Florida through funds appropriated by the Florida Legislature and administered through Florida Commerce.
3. **Resolution No. 25-29** - Florida Division of Emergency Management Hazard Mitigation Grant Program – Lift Station Generator Project - Agreement Modification #2. This resolution will approve an agreement modification to the Florida Division of Emergency Management Hazard Mitigation Grant Program – Lift Station Generator Project to extend the expiration date to October 31, 2025.
4. **Resolution No. 25-31** – Fiscal Year 2024-2025 Budget Amendment. This resolution will approve an increase the Fiscal Year 2024-2025 Budget by \$903,520.00.

5. **Award of RFQ No. 2025-03** – Professional Real Estate Services. The City advertised Professional Real Estate Services and two (2) RFQ’s were received on April 25, 2025 and by a Selection Committee.
6. **Award of RFQ No. 2025-04** – Professional Engineering Services – Rural Infrastructure Fund Grant – Brickyard Road. The City advertised for Professional Engineering Services – Rural Infrastructure Fund Grant – Brickyard Road and six (6) RFQ’s were received on April 11, 2025 and scored by a Selection Committee.
7. **Special Event Application** – Annual Friends & Family Luau – Nikeh Daniels. This event will be held on Saturday, June 28, 2025 from 5:30 p.m. – 11:00 p.m. at the city field located behind the T.J. Roulhac Enrichment Center at 1196 Church Avenue, Chipley, Florida. They would like an additional hour to clean up after the event and leave by 12:00 a.m. Approximately 250 people will attend this event which will have a DJ for music.
8. **Resolution No. 25-32** – Chipley Redevelopment Agency – Budget Amendment. This resolution will approve a budget amendment for the Chipley Redevelopment Agency for the Fiscal Year 2024-2025. The amendment will transfer \$8,000 from Special Projects to the Commercial Improvement Grant Program and \$40,000 from the CRA Revolving Loan Program to the Commercial Improvement Grant Program.

Ms. McCall asked about the Special Event Application and the curfew time for kids. Mrs. Tanner stated the event ends at 11:00 p.m. and the additional hour would be for clean-up. Chief Richter stated the curfew was at 11:00 p.m.

**A motion was made by Council Member Cain and seconded by Council Member Blount to approve the consent agenda items. The motion passed unanimously.**

## H. AGENDA ITEMS

1. **Firm Gas Supply Authorization Under All Requirements Gas Services Agreement** – MGAG Pending Transaction 2025B – Florida Gas Utility – Katie Hall. Ms. Hall, General Manager and CEO, Florida Gas Utility, gave a presentation on Discounted Natural Gas Supply. No further discussion.

**A motion was made by Council Member McCall and seconded by Council Member Cain to approve the Firm Gas Supply Authorization Under All Requirements Gas Services Agreement – MGAG Pending Transaction 2025B. The motion passed unanimously.**

2. **Firm Gas Supply Authorization Under All Requirements Gas Services Agreement** – Extending Terms at Re-pricing Periods – Florida Gas Utility – Katie Hall. Mrs. Hall gave a presentation on a Directive to Extend Discounted Gas Transactions. No further discussion.

**A motion was made by Council Member Russell and seconded by Council Member Cain to approve the Firm Gas Supply Authorization Under All Requirements Gas Services Agreement – Extending Terms at Re-pricing Periods. The motion passed unanimously.**

Mrs. Hall gave an update on Natural Gas Financial Hedging. No further discussion.

3. **Resolution No. 25-25 – Sale of Industrial Park Property and As Is Purchase and Sale Agreement.** Mrs. Tanner stated this resolution will approve the Purchase and Sale Agreement for municipal real property located at Fowler Road in the Chipley Industrial Park to MBN Properties, LLC. There are 2.2409 acres at \$5,000.00 per acre for a total of \$11,204.50. The city attorney has worked with the title company and will close on it. Ms. McCall asked who did the appraisal. Mrs. Tanner stated appraisals are not done on the industrial park parcels. The city attorney will work with the title company and handle the closing. No further discussion.

**A motion was made by Council Member McCall and seconded by Council Member to approve Resolution No. 25-25. The motion passed unanimously.**

Section H, Item 7.

- 4. CDBG Second Public Hearing Notice** - The Mayor closed the regular meeting and opened the public hearing at 5:33 p.m. Mr. Brent Melvin, David H. Melvin, Inc., stated this was the Second Public Hearing for the city to apply to the Florida Commerce for a FFY 2024-2025 Small Cities Community Development Block Grant (CDBG) The initial public hearing was to request input from both the community as well as council members for potential projects that the city would like to apply for. The purpose of the second public hearing is to come forward with a proposed project the city would like to apply to Florida Commerce for. This project would consist of drainage and roadway improvements on Orange Street as well as South 6<sup>th</sup> Avenue from Orange Street over to Peach Street. The total grant amount that would be applied for on this project is \$1,784,192.02. This project is anticipated to benefit at least 24 low to moderate households that live along those roadways. Mrs. Tanner stated the only reason we are able to do this project is because Mr. Guy Lane went out and did all of the surveys for us. Mr. Melvin stated the surveys were one of the requirements for the grant and took a lot of time and effort and thanked Mr. Lane for his work. No further discussion. The public hearing was closed and the regular meeting was opened at 5:37 p.m.

There were no public comments.

- 5. Resolution No. 25-30** – Community Development Block Grant Neighborhood Revitalization (CDBG-NR) Application – Orange Street and 6<sup>th</sup> Avenue. Mrs. Tanner stated this resolution would approve the application that was just discussed in the CDBG public hearing. No further discussion.

**A motion was made by Council Member Russell and seconded by Council Member McCall to approve Resolution No. 25-30. The motion passed unanimously.**

- 6. Mongoven Park Concepts** – Discussion. Mr. Brent Melvin presented some concepts for the Phase 3 Improvements at the First National Bank (aka Mongoven Building) Project. He asked the Council for input on things they liked or things they didn't for the general layout. Ms. McCall stated she liked Concept D with Eagleston Holly trees that have low maintenance. Mr. Melvin stated they will formalize the concept into a 30% plan set and bring back for final approval. Mrs. Cain asked about the faux turf. Mr. Melvin stated they have had good success with it in other projects and it is easy to repair. Mayor Andrews asked about Concept B. Mr. Melvin stated that would leave the existing mosaic tile up front that would be seal coated and the rest would be concrete. Mrs. Cain asked about putting the shade sails over the picnic tables in the back on Concept D. Mr. Melvin said additional shade could be put in the back as well. Mrs. Tanner stated with the concepts showing faux turf, that someone had recently asked about putting it in as part of their landscaping and our code does not allow it. We will have to look at to see if we need to bring our code more up to date. Mr. Melvin asked for direction with the concept that they would like to proceed with. Ms. McCall stated Concept D with an additional shade sail over the back. Discussion ensued.
- 7. Chipley Station** – Discussion. Mr. Jeffery Dexter, Chipley Station, stated they were out of compliance with the parking spaces and didn't realize it. We went by the plans and thought we did everything right. Mrs. Tanner stated the information from the beginning of this project all stated six (6) parking spaces and a boundary survey was done for the lease agreement. They were able to get a little extra space where they cut the curbing to be more ADA compliant. When they did this they got a few extra feet that was not included in the lease agreement. With the plans the City Planning and Zoning Commission and City Council only approved the building plans. When the complete plans came out I saw them at the Chipley Station for the first time. This showed the entire plans which went to the county for approval and not the city. Mr. Dexter stated there was confusion between the plans and the lease and we were not trying to take advantage of anything. He asked what they need to do to get in compliance. We would like to ask for an additional 8 feet to the end of their fence line. Mr. Russell asked if the plans and the lease do not match. Mrs.

Tanner stated the lease agreement was based off Council approval for six (6) parking spaces. Russell stated the parking spaces in that parking lot are different sizes. We discussed re-striping that parking lot and we never did it. Ms. McCall asked how fair it was to the other businesses for them to take additional parking spaces. Mrs. Tanner stated she met with Mr. Lane regarding the dumpster that is currently sitting in a parking space and having it moved to a different location as well as coming up with a location for Chipley Station's dumpster. We feel confident that this will open one (1) more space up in that area. Ms. McCall stated there would be more spaces if the Chipley Station employees didn't park in them. Mr. Dexter stated it would not be a problem to ask his employees to park in a different location. Mayor Andrews stated there was parking in other areas and it was just a suggestion for them. Ms. McCall stated people are using the business dumpsters located downtown. Mrs. Tanner stated we could identify them so the public would know not to use them. Mr. Russell asked about revamping the parking lot as discussed at a prior meeting. Mrs. Tanner stated we can get an engineer to look at it. Mr. Russell stated we need to see how it can benefit everyone and we need to look at the parking lot to see how it can work better. Mayor Andrews stated we need to look at a way to resolve the issue of six (6) spaces versus nine (9). Mr. Blount asked how many handicapped spaces are needed. Mrs. Tanner stated one (1) per twenty spaces and there are three (3) located in this parking lot and at least two (2) at the Farmer's Market. Mrs. Cain asked if they put the fence up and took up more parking spots without realizing what they were doing. Mr. Dexter stated in his mind it was six (6) food carts instead of spaces. Ms. McCall stated the biggest point of contention is the six (6) spaces and you saying you don't understand it. This is the big issue between all the other businesses. I've had more people complain about the parking than people saying good things about it. I was asked why is the city letting them do that. Mr. Dexter stated there was no intention of doing something they were not supposed to do. Mayor Andrews stated our job tonight is to come up with a resolution for the situation and one of two things can happen. One is to move the fence for just six (6) parking spaces or the city can decide to give some kind of variance in allowing them the extra space. Mrs. Tanner stated when this came up we discussed with the owners and they wanted to do what they could to resolve this. I don't think there was any ill will. I'm putting information out there that if it's an option, are all 3 handicap parking spaces necessary. Would doing away with one handicap space and making it a regular space work along with moving the dumpster to make another parking space? If council decided to allow them to keep the spaces they currently utilize then we would have a new boundary survey done to include the additional space from the curb being cut down. The Chipley Station is willing to pay for the boundary survey so the city would not have that expense. They have also agreed to enclose their dumpster area and pour a pad if necessary and add a fence to hide it. Just so you are aware of what they have offered to try to resolve the issue.

Jerry Lenz, 829 Main Street, stated he knows there is some animosity but he is not against a new business coming into town. We get more foot traffic when that happens. The parking lot has issues at times. I agree with employees not parking in the lot any more and mine will move to another location. I love the idea of the dumpsters being marked. Revamping the parking lot, I would love to see that happen with some green area for customers to sit and eat at. The handicap spot closest to us does not have a ramp on it, so if that one might be able to be eliminated. If we could look at revamping the street lights in the area for better visibility that would help. Ms. McCall stated we had looked at it and the cost was the issue. Mrs. Tanner stated we could look at it again. Mr. Lenz stated he would like for everyone to work together. Mrs. Tanner stated we are also looking at putting in a pedestrian crosswalk from the Farmers Market across 7<sup>th</sup> Street. Mrs. Cain said they are taking up three (3) extra parking spaces and we have come up with possibly adding two (2) more. Re-striping the lot might come up with a third space. Mrs. Tanner stated we know two (2) will be added with the handicap and dumpster. I will reach out to the engineer tomorrow on looking at the parking lot for a better solution.

Kathie Storlie, Chipley Station, stated she can guarantee we did not take extra parking spaces intentionally and there is no ill will or manipulation.

Discussion ensued.

A motion was made by Council Member Russell and seconded by Council Member Cain to allow

the current state of parking spaces taken by the Chipley Station to stay as it, revise the agreement, and the City of Chipley to do their due diligence on revamping the parking additional parking spaces. Discussion ensued.

Attorney Jordan stated she thinks Wolfpack Alliance, LLC should be responsible for all costs related to these alternative parking plans. Mrs. Tanner stated it will not take engineers to do the two (2) parking spaces. Based on council discussion from two years ago, the city was already looking at hiring an engineer to try and find a way to revamp the parking lot if we were able to. Attorney Jordan stated there needs to be some additional consideration for the council making this concession. Mr. Russell stated we are looking at fixing the parking lot for the benefit of all businesses, but we are going to make only one responsible for the cost. I can't agree with that. Mrs. Cain stated she did agree with them paying for the boundary survey. Ms. McCall asked if the motion had been amended because she doesn't like to go against what the attorney advises.

A motion was made by Council Member Russell and seconded by Council Member Cain to leave the current state of the property stay as it is, with the stipulation that the lease agreement would be updated and Wolfpack Alliance be responsible for the cost of the boundary survey, and the city be responsible for looking at redeveloping the parking lot that would benefit all businesses. Discussion ensued.

Attorney Jordan stated she still feels like they should be responsible for paying for the resolve of the problems that were caused by their actions. Mrs. Tanner stated maybe they could pay the cost to redo the handicap parking spaces. We are going to move a dumpster to open one (1) space. The handicap spot will be repainted to make it a regular space which is just paint and public works labor so it will be a minimal cost. The 3rd parking spot, we can look at the handicap space across the road and count the total spaces and make a determination on how many are needed. As far as the engineering, it wouldn't be hard to find the third parking spot, it would be for what to do with the entire parking lot and whether we want to close off South Railroad Avenue. Attorney Jordan stated this is all caused by a problem that a private entity created. You don't know what all your costs will be. Mr. Russell asked how many additional parking spaces have been taken in the fence put up by the Chipley Station. Mrs. Tanner stated three (3). Mr. Russell stated moving the dumpster will give one back and making the handicap space a regular parking space that makes two (2). Are we trying for three or are we ok with two? Mrs. Tanner stated all the handicap spaces can be looked at to make sure we have the required number of spots or if there are others that can be changed to a regular spot. Mrs. Tanner stated we can come up with the cost to repaint the handicap spots to make them a regular spot and can discuss that with Wolfpack Alliance. It should be minimal in cost and if they are in agreeance we can do that. As far as the engineering goes the city wanted to look at it and will not benefit just them, but all the businesses.

Mr. Dexter stated they will pay for the cost to repaint the handicap parking spaces and for the new boundary survey.

**A motion was made by Council Member Russell and seconded by Council Member Cain to let the current state of the property stay as it is, let Mrs. Tanner negotiate with Wolfpack Alliance, LLC on the cost of repainting the handicap parking spaces, update the lease agreement for the spaces currently being used by Wolfpack Alliance, and to make Wolfpack Alliance responsible for the cost of the updated boundary survey. The motion passed unanimously.**

8. **Ordinance No. 994** – Sidewalk Solicitation. Attorney Jordan stated there were questions raised at the last council meeting about our existing solicitation ordinance. I have researched it and I agree that there are some constitutional concerns with it due to it being out of date. It restricts speech in ways that are not appropriate as far as time, place and manner. There are some public safety concerns that do need to be addressed. We do have existing regulations that we have already updated for our special event application which is appropriate for the time, place and manner restrictions and protection of the public and city. I suggest we follow that process. When

you solicitate to raise funds and enter the flow of traffic, this will be regulated by the change I've made to the solicitation ordinance. If you block the sidewalks you will have to go through the special event application process. Mrs. Tanner read Ordinance No. 994 by title:

**AN ORDINANCE OF THE CITY COUNCIL OF THE CITY OF CHIPLEY, FLORIDA, REPEALING SECTIONS 34-5 AND 34-6 OF THE CITY OF CHIPLEY CODE OF ORDINANCES IN THEIR ENTIRETIES; ESTABLISHING REGULATIONS FOR THE SOLICITATION OF DONATIONS AND SALE OF GOODS AND SERVICES ON PUBLIC ROADWAYS AND DESIGNATED AREAS; PROVIDING FOR PERMIT REQUIREMENTS AND APPROVAL CRITERIA; AND PROVIDING FOR TEMPORARY EXCEPTIONS FOR SPECIAL EVENTS; WITH THE PURPOSE OF PROMOTING PUBLIC SAFETY AND ENSURING THE ORDERLY USE OF PUBLIC SPACES; PROVIDING FOR SEVERABILITY; AND PROVIDING FOR AN EFFECTIVE DATE.**

No further discussion.

**A motion was made by Council Member McCall and seconded by Council Member Blount to approve the first reading of Ordinance No. 994. The motion passed unanimously.**

9. **Special Event Application** – Reach America Christian Outreach. Mrs. Tanner stated this event will be held three (3) days per week, Monday thru Saturday, for a period of one (1) year on the sidewalks located at the intersection of SR 77 and SR 90. They will have signs, walk along the sidewalk, carry a small belt speaker and speak phrases about Jesus. They will offer gospel cards and accept donations if offered only when people stop for the light. I reached out to Chief Whitaker with the City of Bonifay who said they have had some complaints but they are minimal. The concern was them getting into traffic, but once the window rolls down they have the right to access the roadway. There have been no repercussions from them doing their ministry. Mr. Russell stated this would be for an entire year. Mrs. Tanner stated that is what they are asking for, but you can always change that. Mr. Russell stated 3 days a week for a year seems pretty excessive. Attorney Jordan stated there is no liability insurance included with the application. Ms. McCall asked if anyone had talked with FDOT about needing a permit for this. Attorney Jordan stated we don't have the authority to regulate that and it would be between Mr. McMahan and FDOT. Mrs. Tanner asked the attorney since it is a public sidewalk they are requesting to use, are they required to have special event insurance. Attorney Jordan stated everyone that gets a special event application approved should have insurance. If the application requests a street closure then we are minimizing the risk to people. This event increases the risk to the people participating. The intersection they want to use has heavy traffic constantly and they need to be adequately insured with at least two million in aggregate. Mr. McMahan stated three days would be the maximum amount of days each week and donations are just an implied solicitation. Ms. McCall stated that Mr. McMahan told council at the last meeting that the man doing the ministry was making his living doing this, so the donations are not implied. Mr. McMahan stated the man has to get donations or get another part time job to make a living. Mayor Andrews stated our biggest concern is this will go on three days a week for a year at our busiest intersection with no insurance. This type of event is going to require insurance in case something happens. The three days is the bigger piece. Mr. Blount asked what would happen if someone else wanted to do it too. If we had 3 more people doing that, then we need a time limit. We wouldn't say no, but set a time limit. Mr. Russell stated three days a week with a donation jar is a job. Mrs. Tanner asked Mr. McMahan if they have insurance. Mr. McMahan stated they do not and if required we will have to decide whether to do it or not. Ms. McCall stated the biggest concerns were the request to use the busiest intersection, the period of one year, and no insurance. Attorney Jordan asked if they would consider a different intersection like Church Avenue and SR 77. Mr. Russell stated it still comes back to not having insurance. Mayor Andrews stated that Mr. McMahan needs to get with his organization to see if they are willing

to get insurance. Discussion ensued.

**A motion was made by Council Member Russell and seconded by Council Member McCall to table this item until we find out about insurance. The motion passed unanimously.**

Mrs. Cain said they need to move it down to Church Avenue and SR 77 and get insurance. Mrs. Tanner stated if you are not interested in doing it all year you can look at a shorter period of time, pending insurance.

**I. OTHER BUSINESS**

**J. ADJOURN**

The meeting was adjourned by Mayor Andrews at 6:57 p.m.

City of Chipley

Attest:

Tracy L. Andrews, Mayor

Sherry Snell,  
City Clerk

**City of Chipley  
Council Meeting  
Minutes  
June 10, 2025 at 5:00 p.m.**

**Attendees:**

Ms. Tracy Andrews, Mayor  
Mrs. Linda Cain, Council Member  
Mr. Leonard Blount, Council Member

Mr. Kevin Russell, Mayor Pro-Tem  
Ms. Cheryl McCall, Council Member

**Others Present Were:**

Mrs. Patrice Tanner, City Administrator  
Mr. Guy Lane, Asst. City Admin. /Public Works Dir.  
Mrs. Michelle Jordan, City Attorney

Ms. Sherry Snell, City Clerk  
Mr. Michael Richter, Police Chief

The data reflected in these proceedings constitute an extrapolation of information elicited from notes, observations, recording tapes, photographs, and/or videotapes. Comments reflected herein are sometimes paraphrased, condensed, and/or have been edited to reflect essential subject matter addressed during the meeting. Parties interested in receiving a verbatim account of the proceedings are responsible for coordinating with the City Administrator and providing their own representative and equipment pursuant to Chapters 119 and 283, Florida Statutes.

**A. CALL TO ORDER**

The meeting was called to order by Mayor Andrews at 5:00 p.m.

**B. PRAYER AND PLEDGE**

Prayer was given by Council Member Russell and Mayor Andrews led the pledge to the American Flag.

**C. APPROVAL OF AGENDA**

Mayor Andrews added #4) Code Case – 777 West Blvd; #5) Little STEM Library and added Tim Parsons – Liberty Partners of Tallahassee, LLC following the proclamation.

**A motion was made by Council Member Russell and seconded by Council Member Blount to approve the agenda with the additions. The motion passed unanimously.**

**D. CITIZENS REQUEST**

The City of Chipley welcomes you to this meeting. This is time set aside for the Citizens of Chipley to address the City Council. This is not a question and answer period, it is not a political forum, nor is it a time for personal accusations and derogatory remarks to/or about city personnel. If you would like to address the City Council please raise your hand to speak, state your name and address for the record and limit your comments to no more than three (3) minutes per Florida Statute 286.0114. To ask a question via phone; dial \*9 and wait to be recognized/unmuted. If you are attending via webinar, there will be an onscreen option to ask a question during the public comment portion of the meeting. Your participation is welcomed and appreciated.

No citizen requests. No further discussion.

## E. APPROVAL OF MINUTES

1. Regular Council Meeting - April 8, 2025
2. Special Council Meeting - April 10, 2025
3. Special Council Meeting – May 6, 2025
4. Regular Council Meeting – May 13, 2025
5. Special Council Meeting – May 29, 2025

**A motion was made by Council Member Russell and seconded by Council Member McCall to approve the minutes as presented. The motion passed unanimously.**

## F. PRESENTATIONS

### 1. Proclamation – Small Cities Month

Mayor Andrews read the proclamation recognizing June 2025 as Small Cities Month encouraging everyone to recognize this event and to work together this month and throughout the year to invest in small cities and towns to better the lives of all citizens.

**Tim Parsons, Liberty Partners of Tallahassee, LLC.** Mr. Parsons stated the legislature still has not passed the budget and it's been a difficult session. The city submitted three projects for legislative appropriation funding and yesterday there was some confirmation that two of those requests will be approved. We have not received official notice but I wanted to share with you that it looks like the Pecan Street Resurfacing Project will be funded at \$750,000 and the Police Equipment request will be funded at \$400,000. Once it is official, I will send the end of session summary to you. Discussion ensued.

## G. CONSENT AGENDA ITEMS

1. **Resolution No. 25-36** – Florida Department of Agriculture and Consumer Services Agreement – Wastewater Treatment Facility (WWTF). This resolution will approve the Federal Financial Assistance Subrecipient Agreement between the Florida Department of Agriculture and Consumer Services, Office of Energy, and the City of Chipley in the amount of \$661,500.00. This will be used for significant infrastructure upgrades at the Wastewater Treatment Facility (WWTF) located at 692 Rustin Drive to improve energy efficiency, reliability and sustainability.
2. **Resolution No. 25-37** - State of Florida – Department of Management Services Local Government Cybersecurity Grant Program Agreement No. DMS-24/25-340 (CSFA No. 72.016). This resolution will approve the State of Florida, Department of Management Services Local Government Cybersecurity Grant Program Agreement No. DMS-24/25-340 (CSFA No. 72.016) between the State of Florida, Department of Management Services and the City of Chipley. This will be used for the development and enhancement of cybersecurity risk management programs.
3. **Resolution No. 25-38** - Peoples South Bank Loan – Police Department. This resolution will approve a loan with Peoples South Bank in the amount of \$73,651.20 with an interest rate of 5.05% with five (5) annual payments to be used to purchase (1) New 2025 Ford Interceptor, SUV Police Vehicle from Duval Ford, Government Sales in the amount of \$65,118.00 and the installation of a camera system from Motorola in the amount of \$8,533.20. The purchase will be made using the Florida Sheriffs Association contract pricing.
4. **Reappointment of Planning & Zoning Commission Member** – Wanda Owens. Board Member Wanda Owens' term expires on 07/11/2025. She has expressed interest in remaining on the Board for an additional three (3) year term.

Mr. Russell asked if Planning & Zoning Commission members were required to live in or own a business inside the city limits. Mrs. Tanner stated the city code allows any interested person to be appointed. Discussion ensued.

**A motion was made by Council Member Cain and seconded by Council Member McCall to approve the consent agenda items. The motion passed unanimously.**

**H. AGENDA ITEMS**

- 1. Ordinance No. 994 (Public Hearing)** – Sidewalk Solicitation. Mayor Andrews closed the regular meeting and opened the public hearing at 5:14 p.m. Mrs. Tanner read Ordinance No. 994 by title:

**AN ORDINANCE OF THE CITY COUNCIL OF THE CITY OF CHIPLEY, FLORIDA, REPEALING SECTIONS 34-5 AND 34-6 OF THE CITY OF CHIPLEY CODE OF ORDINANCES IN THEIR ENTIRETIES; ESTABLISHING REGULATIONS FOR THE SOLICITATION OF DONATIONS AND SALE OF GOODS AND SERVICES ON PUBLIC ROADWAYS AND DESIGNATED AREAS; PROVIDING FOR PERMIT REQUIREMENTS AND APPROVAL CRITERIA; AND PROVIDING FOR TEMPORARY EXCEPTIONS FOR SPECIAL EVENTS; WITH THE PURPOSE OF PROMOTING PUBLIC SAFETY AND ENSURING THE ORDERLY USE OF PUBLIC SPACES; PROVIDING FOR SEVERABILITY; AND PROVIDING FOR AN EFFECTIVE DATE.**

Mrs. Tanner explained this Ordinance, if approved, will repeal Sections 34-5 and 34-6 of the City of Chipley Code of Ordinances establishing regulations for the solicitation of donations and sale of goods and services on public roadways and designated areas. Provide for permit requirements and approval criteria. And provide for temporary exceptions for special events. Official notice to advise the public of the proposed adoption of Ordinance No. 994 was published in the Washington County News on May 28, 2025. The ad complied with the legal requirements of the City Code and Florida Statutes.

Mayor Andrews closed the public hearing and opened the regular meeting at 5:16 p.m. No further discussion.

**A motion was made by Council Member Russell and seconded by Council Member McCall to approve the final reading of Ordinance No. 994. The motion passed unanimously.**

- 2. Ordinance No. 995 (First Reading)** – Amendment to Chapter 6 – Animal Control. Mrs. Tanner explained this Ordinance, if approved, will amend Chapter 6 – Animal Control of the City Code of Chipley, Florida, addressing animal control by removing breed-specific regulations and introducing provisions for dangerous animals. It establishes clear definitions and measurements for noise nuisances, implements tiered penalties for violations, and outlines owner responsibilities and enforcement mechanisms. The ordinance also mandates community education on responsible pet ownership, ensures alignment with Florida Statutes. Attorney Jordan stated she focused on the mandated changes and added some guidelines for dogs on chains. Mayor Andrews asked about cats roaming on your property or fences for dogs. Attorney Jordan stated she did not make any changes for cats but Section 6-38 does address them being a nuisance. She stated other cities implement a catch/neuter/release program. Mr. Russell asked about the cost to do that. Attorney Jordan stated you would have to discuss a program with local veterinarians. Mrs. Cain stated we have a leash law. Mr. Lane stated they have to be on a leash or under verbal control if you are not on your property. Mr. Russell asked about a stronger punishment. Mr. Lane stated if we carry an animal to the animal control facility, the owner has to pay a fee of \$45 at City Hall and pays the facility for a rabies shot if they can't provide proof from a veterinarian. With the changes in this Ordinance it states a fee of \$100 for the second violation and \$250 with the third violation. Mrs. Tanner asked how would we enforce the mandatory attendance at a city-approved responsible pet ownership class. Attorney Jordan stated you would have to put a system in place. Mrs. Tanner asked if community education is required by the Florida Statutes. Attorney Jordan stated it was not and was just a suggestion. Mrs. Tanner stated it could possibly be offered once a year and

they could be required to talk to Mr. Lane before getting their animal back. Mrs. Tanner we could also post some information on the website. Mayor Andrews stated that Attorney would go back over the ordinance to make changes and bring back to council for review. Discussion ensued.

3. **Washington County School District Summer Lunch Program** – Jiranda White, Director of Federal Programs and Food Service. Mrs. White stated the Washington County School District offers a Summer Lunch Program with eight different sites they can go to get meals. The program runs June 9 – July 31, Monday through Thursday from 9 a.m. to 12:00 p.m. and they are trying to let everyone know to help increase participation. Mr. Russell asked if the information could be placed in the July bills and posted on the city Facebook page. Mrs. Tanner said she would make sure that is done. Discussion ensued.
4. **Code Case #189 – 777 West Boulevard, Parcel #00-1990-0000.** Mrs. Tanner explained Code Case # 189 - Michael & Amanda Taylor, 777 West Boulevard, Parcel # 00-1990-0000, is an active case and was heard before the Special Magistrate, on October 27, 2022. An order was issued stating the owner had 60 days to bring property into compliance or the property would be assessed with daily fines of \$50 until the property is brought into compliance. This property is still in non-compliance with the City of Chipley, Code of Ordinances. This property is homestead property and has not gone through the foreclosure process with the City of Chipley. The fines total as of 06/10/2025 are \$47,450 and legal fees \$1,090, for a total of \$48,540.00. Mr. Adrian Rodriguez is in attendance via zoom to discuss the fines and the lien on this property.

Mr. Rodriguez stated he is under contract to purchase the home, renovate and clean up the property. The title work and lien search found code violations. My intention is to bring it into compliance by cleaning up the outside. I wanted to find out if you offer a stipulated agreement if I buy it to be given 45-60 days to mitigate for a reduced payoff. Mayor Andrews stated we currently do not have a program in place, but would love to see the property brought into compliance in hopes of beautifying our community. Mrs. Tanner stated he is asking to waive or reduce the fees. Ms. McCall stated the employee costs should be included in the total as well. Mr. Rodriguez stated the closing date was June 20<sup>th</sup> but he could try and request more time. Mr. Russell asked if he could meet with the City Administrator to make a plan. Mr. Rodriguez stated he is in south Florida but could do a conference call. Attorney Jordan asked if he is given 60 days and does not meet the timeline what would be the penalty. Mr. Rodriguez stated if he does not meet the timeline, then he is on the hook for the full amount for fines and legal fees. Attorney Jordan stated she could work with that. Mrs. Tanner stated after going over the order written by the Special Magistrate, she found something that was not included. The order stated a permit was not pulled, but the fence is also in violation with the height and materials used which are not allowed. Mayor Andrews stated if we give Mrs. Tanner the authority to negotiate and work with the attorney then she can let council know the final outcome. Mr. Rodriguez stated his due diligence period is over on the 14<sup>th</sup> but he can try to extend. Mrs. Tanner asked Attorney Jordan if she gets the numbers to her by the 17<sup>th</sup>, how long would it take her to prepare an agreement. Attorney Jordan stated she would be able to get it done by then. Discussion ensued.

**A motion was made by Council Member Russell and seconded by Council Member Cain to let the City Administrator negotiate the cost with Mr. Rodriguez, finalize the agreement and then notify council of the outcome. The motion passed unanimously.**

5. **Little STEM Library – Nikole Arrant.** Nikole Arrant, HNTB Corporation, stated she is part of the 2025 Florida Engineering Leadership Institute (FELI) Class. Each year, the FELI Class develops a Vision and Mission specific to the class and ours is Science, Technology, Engineering and Mathematics (STEM) outreach. We would like to expand the STEM exposure through the patronage of Little STEM Libraries and implementation of FDOT STEM boxes to inspire curiosity and hands-on learning. Our class project would be the installation of Little STEM Libraries in public places with a high traffic area of kids. Each library will be stocked with STEM-related books and activities to spread awareness and educate kids in the local community about STEM. We would like to place one in a city park. Council agreed they would like to see one at

Shivers and Gilmore Parks. Mrs. Arrant stated she would check and see if they could put  
Discussion ensued.

Section H, Item 7.

**A motion was made by Council Member McCall and seconded by Council Member Cain to approve the placement of a Little STEM Library at both Shivers and Gilmore Parks. The motion passed unanimously.**

**I. OTHER BUSINESS**

Attorney Jordan stated there have been 3-4 code cases lately asking for forgiveness of fines and when we see it being repeated we need a policy in place. She asked council if they would like her to establish a standard for owners with written agreements and come up with a percentage to use. She stated she would reach out to other cities and see what they use. Council agreed for Attorney Jordan to come up with a policy and bring back to them for review.

Mayor Andrews stated her niece, Victoria McQueen, was visiting from Penn State where she is seeking a political science degree. She is shadowing her for two weeks learning about the weak government system and how it works.

**J. ADJOURN**

The meeting was adjourned by Mayor Andrews at 6:29 p.m.

City of Chipley

Attest:

Tracy L. Andrews, Mayor

Sherry Snell,  
City Clerk

**City of Chipley  
Council Meeting  
Minutes  
July 8, 2025 at 5:00 p.m.**

**Attendees:**

Ms. Tracy Andrews, Mayor  
Mrs. Linda Cain, Council Member  
Mr. Leonard Blount, Council Member

Mr. Kevin Russell, Mayor Pro-Tem  
Ms. Cheryl McCall, Council Member

**Others Present Were:**

Mrs. Patrice Tanner, City Administrator  
Mr. Guy Lane, Asst. City Admin. /Public Works Dir.  
Mr. Hunter Aycock, Fire Chief  
Mrs. Jamie Richter, Finance Director  
Mrs. Michelle Jordan, City Attorney

Ms. Sherry Snell, City Clerk  
Mr. Michael Richter, Police Chief  
Mr. Brock Tate, Recreation Director  
Mrs. Tamara Donjuan, Planning/Code Enf. Officer

The data reflected in these proceedings constitute an extrapolation of information elicited from notes, observations, recording tapes, photographs, and/or videotapes. Comments reflected herein are sometimes paraphrased, condensed, and/or have been edited to reflect essential subject matter addressed during the meeting. Parties interested in receiving a verbatim account of the proceedings are responsible for coordinating with the City Administrator and providing their own representative and equipment pursuant to Chapters 119 and 283, Florida Statutes.

**A. CALL TO ORDER**

The meeting was called to order by Mayor Andrews at 5:00 p.m.

**B. PRAYER AND PLEDGE**

Prayer was given by Pastor Phillip Horvath and Mayor Andrews led the pledge to the American Flag.

**C. APPROVAL OF AGENDA**

Mayor Andrews added #6 - Proposed Annexation, Water and Sewer Services – South Boulevard and Kirkland Road

**A motion was made by Council Member Russell and seconded by Council Member McCall to approve the agenda with the addition. The motion passed unanimously.**

**D. CITIZENS REQUEST**

The City of Chipley welcomes you to this meeting. This is time set aside for the Citizens of Chipley to address the City Council. This is not a question and answer period, it is not a political forum, nor is it a time for personal accusations and derogatory remarks to/or about city personnel. If you would like to address the City Council please raise your hand to speak, state your name and address for the record and limit your comments to no more than three (3) minutes per Florida Statute 286.0114. To ask a question via phone; dial \*9 and wait to be recognized/unmuted. If you are attending via webinar, there will be an onscreen option to ask a question during the public comment portion of the meeting. Your participation is welcomed and appreciated.

## E. APPROVAL OF MINUTES

1. Regular Council Meeting – June 10, 2025
2. Special Council Meeting – June 26, 2025

**A motion was made by Council Member Russell and seconded by Council Member Cain to approve the minutes as presented. The motion passed unanimously.**

## F. DEPARTMENT REPORTS

1. Attorney Report – Michelle Jordan. Attorney Jordan stated there will be a summary judgement hearing on Friday for the golf course via ZOOM. Mayor Andrews stated she had a letter that was submitted regarding attorney fees. Attorney Jordan stated it could be included in the budget review since it would not take effect until October. No further discussion.
2. Fire Department Report – Chief Hunter Aycock. Chief Aycock stated calls had slowed down due to the rainy weather. We have been busy doing training. Tanker 1 should have a final inspection in September. Mayor Andrews thanked them for cooking at the Watermelon Festival. Discussion ensued.
3. Code Enforcement Report – Tamara Donjuan. Mr. Russell asked about the property located at 1278 Holley Avenue. Attorney Jordan stated they filed a motion for summary judgement so we are three months out. The case had complicated title issues. Mayor Andrews stated there were a lot of excessive grass cases on the report. There has been so much rain that causes the grass to grow quicker and also it prevents normal grass cutting. People that have to pay for their yards to be cut might not be able to afford cutting it more often. I would be grateful for more leniency on this issue. Mrs. Tanner stated we are making a change to the way we handle this. A courtesy letter will be sent before a case is actually started to try and get it in compliance. I am working with Mrs. Donjuan to put this in place this next week. Discussion ensued.
4. Planning & Zoning Report – Tamara Donjuan. There were no questions. No further discussion.
5. Police Department Report – Chief Michael Richter. Chief Richter stated it had been a busy month. The Watermelon Festival went really well. Traffic crashes are lower than in the past few years. We are monitoring that to see if the increase in traffic enforcement is helping to reduce crashes. We are down 2 positions, but are in the process of hiring for those. The 4<sup>th</sup> of July went well with only a total of 4 calls. Discussion ensued.
6. Public Works Department Report – Guy Lane. Mr. Lane stated everything was going good except the rain has put them behind on cutting grass. Ms. McCall stated the cemetery looks good at the top, but further down they are slacking on the grass and not spraying. Mr. Lane stated he would follow up on that. Mr. Larry Zezula, 835 Maple Street, stated the ditches needed to be cleaned out on South Boulevard. Ms. McCall stated that is a county road and he would need to talk to them. Mr. Zezula stated they directed him to the city. Mayor Andrews asked Mr. Zezula to talk to Mr. Lane after the meeting. Discussion ensued.
7. Recreation Department Report – Brock Tate. Mr. Tate stated baseball and softball had just wrapped up. We kicked off an adult flag football league and soccer registration will start the end of August. No further discussion.
8. Water Utilities Department Report – There were no questions. No further discussion.
9. Finance Department Report – Jamie Richter. Mrs. Richter stated all was going well. Mrs. Cain thanked Mrs. Richter for doing such a good job. No further discussion.

Mr. David Melvin gave an update on the status of several grants. The Griffin Road box culvert is

out for bid. The Mongoven Building has a substantial completion inspection later this week. We have some energy grants for the wastewater treatment plant. Mrs. Tanner stated that we received the agreement for that. Mr. Melvin stated that project will be moving along as well as the Pecan Street drainage project. The legislative session has completed this cycle and fortunately you received some funding from that. They will roll out the new grants very quickly, and we've given you a list of those grants for you to look at and think about. Discussion ensued.

Section H, Item 7.

10. City Administrator Report – Patrice Tanner. Mrs. Tanner stated we were waiting for the 2025 PHMSA Technical Assistance Grant to open back up. We will submit for the purchase of GIS mapping software and combustible gas detection equipment; Bennett Drive is getting ready to bid construction next week; Old Chipley City Hall – Phase II – the final report is on the agenda for approval tonight; City Hall Generator – the FEMA grant did not get approved for funding. At the time that grant was written, it was for the utilization of the building for emergency operations and there was not enough money that we utilize for that purpose, so the benefit was not enough for them to fund the project. Next time there may be other generators that we can apply for through that same program; State of Florida Legislative Appropriations Request – Police Vehicles & Equipment – the vehicles did not get approved, so Chief Richter and I are going to try and find some alternatives and will get back with the council hopefully by budget time; State of Florida Legislative Appropriations Request – Pecan Street Resurfacing did get approved and we should receive the grant agreement within the next few months; Old Chipley City Hall – Construction – We have submitted for this and are awaiting approval; COPS Hiring Grant Program – We have submitted for this grant for two additional police officers and are awaiting approval. Discussion ensued.

## G. CONSENT AGENDA ITEMS

1. **Request for Development Order and Certificate of Appropriateness** – 1414 Main Street – Rivertown Community Church, Inc. Rivertown Community Church Inc. request for Development Order and Certificate of Appropriateness for redevelopment and a variance for the proposed new construction of an overflow parking lot. The property is located at 1414 Main Street, Parcel ID:00-2218-0000.
2. **Resolution No. 25-39** – Firefighters Assistance Grant. This resolution will approve the submittal of a Firefighter Assistance Grant with the Florida Department of Financial Services, Division of the State Fire Marshall in the amount of \$32,509.10 to replace approximately seven sets of outdated bunker gear. Receiving this grant would allow them to not only resolve the issues of outdated PPE but would ensure our firefighters can continue to safely protect and serve our community without the concern of obsolete equipment.
3. **Resolution No. 25-40** – FDEP SRF Clean Water Loan Reserve Repayment Account. This resolution will approve the FDEP Capitalization Grant for Clean Water Loan Reserve Repayment Account. This funding will be used to pay 50% of the total cost to prepare a Clean Water Facilities Plan which is \$90,000. The other 50% will be grant funds.

Item #1 – Discussion. Ms. McCall stated the plans call for milled asphalt in the parking area which has previously been permitted as a stormwater treatment area and there is no lighting in the back. They are also going to plant trees in the front area, but there are light poles there, so they will have the same problem that we had downtown where the trees cover the lights. Those issues are a concern to me. Mr. David Melvin stated the parking lot would eventually be paved and lighting will be included. Mr. Russell asked what the deadline was for eventually. Mr. Melvin stated the goal was to be operational by Easter of next year and I would think within six months after that it would probably be done. The lighting will go in when it opens because that is a safety issue. He added that the staff will utilize that parking area to leave the parking in front for others.

**A motion was made by Council Member Cain and seconded by Council Member Blount to approve the consent agenda items. The motion passed unanimously.**

## H. AGENDA ITEMS

Section H, Item 7.

1. **RFQ No. 2025-03** – Real Estate Master Agreement and Task Order No. 1 – Elite Realty. Mrs. Tanner explained that council approved the award of the real estate consultant last month. This will approve the agreement with Elite Realty for Real Estate Services for the City. The agreement shall be for a period of one year, with possible one-year extensions if needed to assist the City in the purchase/lease/sale of specified properties within the City. Elite Realty will do a vacant land contract for any properties that we are going to sell that have the cost associated with them, and we will bring it to the council for approval. Task Order No. 1 will be for the sale of the Oswald Road property. Ms. McCall asked who does the appraisals. Mrs. Tanner stated that the appraisal for the property that we are trying to sell has already been done. Attorney Jordan stated that each property will operate under standard conditions. If you want an appraisal, it can be negotiated. Mrs. Cindy Birge, Elite Realty, stated the appraisal was generous, and the market has since declined. Most appraisals are good for 1 year. The buyer can also get an appraisal if they want. Mrs. Tanner stated that the city doesn't have a lot of land to sell, just this one parcel for now. Discussion ensued.

**A motion was made by Council Member Russell and seconded by Council Member McCall to approve RFQ No. 2025-03 Real Estate Master Agreement and Task Order No. 1 with Elite Realty. The motion passed unanimously.**

2. **RFQ No. 2025-04** – Agreement for Professional Services – Rural Infrastructure Fund Grant – Mott MacDonald Florida, LLC. Mrs. Tanner explained this will approve the agreement with Mott MacDonald Florida, LLC for the Professional Engineering Services for Brickyard Road Gravity Design in the amount of \$162,196.00. The total grant is \$295,000.00, so it falls well within the amount of funding that we've been appropriated. No further discussion.

**A motion was made by Council Member Russell and seconded by Council Member Cain to approve RFQ No. 2025-04 Agreement for Professional Services – Rural Infrastructure Fund Grant with Mott MacDonald Florida, LLC.**

3. **Code Enforcement Fines** – 566 Martin Luther King Drive. Mrs. Tanner explained that the property located at 566 Martin Luther King Drive, property owner – David Roulhac, has been accruing fines of \$50 per day since 05/03/2024. The total legal fees are \$1,921.20, and the total fines are \$40,450.00 as of May 31, 2025, for a total of \$42,371.20. Mr. David Roulhac is present to discuss his property. Mrs. Doris Robinson, 608 Bennett Drive, stated she was here to discuss Mr. Roulhac's property. A summary of how I became involved is that he was talking with a friend, and my daughter heard them discussing a water and sewer bill that was due, and he was told that he had to pay it. On June 5, 2025, we took the bill to city hall, and it was removed and closed out. On the same day, we talked to the code enforcement officer to see if any other issues would prevent Mr. Roulhac from putting a manufactured home on his property. We were told that David had purchased a shed and put it on his lot without a permit. My daughter and I talked to him and told him he needed to get a permit. The next day David went to city hall and purchased a permit for the shed and brought it to us. We then decided to talk to the code officer on the same day to see if there were any other issues. She told us that David was being fined \$50 per day. She gave us a copy of the order from the meeting with the special magistrate on April 25, 2025. The highlights of that meeting were that on February 23, 2024, the property was inspected and found abandoned material, inoperable vehicles, and trash throughout. Pictures were taken that day. The property owner was given 7 days to bring the property into compliance. On March 11, 2024, the property was inspected and was still not in compliance. On April 24, 2024, the property was inspected and was still not in compliance, and pictures were taken. The penalties from the meeting with the magistrate on April 25, 2024, the owner had 30 days from the order date to remove the abandoned material, junk, and trash to bring the property into compliance with the code or be fined \$50 per day until the property is compliant. I don't know who explained this to David, but I'm sure he did not understand. On June 6, 2025, after we got the paper from the code officer, we took the paper to David, and he was not aware of the fines. David said that the code office called him that day for the first time and told him about the fines. My daughter and I went back to city hall to speak

to the city manager. We were told by Sherry that she was in a meeting and she would get with us. Sherry took my phone number and said she would have her call me. On June 9 Sherry called and said the city manager could see us on June 10, 2025, at 3:00 p.m. The council meeting was at 5:00 p.m. that day, so we could not bring it to the council that day because David was already at work. We told her we would have David bring the property up to code as soon as possible. On June 11, 2025, we talked to David and we explained to him that the trash, abandoned vehicles, and rubbish had to be removed from the property. On July 2, 2025, pictures were taken and he had cleaned up the property in less than a month and this is why I know that David did not understand that he was being fined \$50 per day. That is why I am here with pictures for you to see. Mrs. Cain asked what day he cleaned up the property. Mrs. Robinson stated he started on June 11<sup>th</sup> and had it cleaned up by July 2<sup>nd</sup>. If David understood, I know he would not have let it go on that long. Mr. Russell asked if any certified letters were sent. Attorney Jordan stated he was present at the hearing with the special magistrate. Mayor Andrews asked when he cleaned it up in March and said come and inspect. Were there specific things that were pointed out to him to let him know exactly what he needed to do? Mr. Roulhac stated no. Mayor Andrews asked what the things were that were corrected. Mrs. Donjuan stated he had multiple vehicles on his property with no tags. There are 2 different violations. When he came to the hearing, he was given 7 days to get the vehicle registrations and there's a \$50 fine for the abandoned materials. Mrs. Cain asked if he could cover the vehicles like everyone else does. Yes, he could have, but the magistrate is the one that made the order to say that he needed to produce the registration. Mrs. Tanner stated it was her understanding that there was possibly some confusion as to how well it was understood. Mr. Russell asked if we tell someone that they are out of compliance, do we give them a checklist that says these are the things that are out of compliance so they can check those off. Mrs. Donjuan stated it's real broad. Mrs. Tanner stated what we run into with that is it is the proper way of handling it I believe, but there's no way unless they continuously call us and we continuously go out there and check what they are doing to know if they have satisfied everything that we feel is out of compliance because it does not specify it. Mrs. Donjuan stated communication is the big thing and a lot of it is that nobody contacts me. So if they don't contact me I can't talk to them. Mrs. Tanner stated the question Mr. Russell is asking is do we communicate it with them if they do call you. Mrs. Donjuan stated yes. Mrs. Tanner asked if it was specifics or do you still just give them the broad. Mrs. Donjuan stated this issue was just the vehicles so it was simple. Mayor Andrews asked if it was just the vehicles. Mrs. Donjuan stated he also had abandoned materials, scrap metal or something. The property is cleared up today. Mr. Russell stated that's where his confusion is, when he realized he had to do then it was cleaned up immediately. I'm not sure where the communication gap was. Mrs. Tanner stated there was a disconnect in the communication. Mrs. Robinson stated when she asked David about the permit, he got it the very next day. So I know he didn't understand what he had to do. Mrs. Donjuan stated he had someone helping him at the time, I just don't know what they did. I assumed she was helping him. Mrs. Robinson stated she didn't explain it to him because he got this cleaned up in less than a month once he knew. Mrs. Tanner stated that's a little confusing to me as well because whenever you and I discussed this Tamara, my understanding was that we were going to meet Jalissa out there one day with Mr. Roulhac and she didn't show up. So I don't know if we could have assumed that she was helping him because we never ended up meeting her. Mrs. Donjuan stated she did bring in registration for a couple of the vehicles, but not all of them. Mr. Russell asked if we have them sign anything, just in general, that says I understand what I'm being asked to do. If the property owner signs it then we have proof. Sometimes you have individuals that can look at a packet of paper and not understand anything on it, but they're just not comfortable saying I don't understand this. I'm dealing with that in a classroom setting. I do that with students all the time. Mrs. Tanner stated she did not know the legality of that and it would come from Attorney Jordan. I do know that we're looking at things closer now to see if there's anything that we can do to prevent issues like this moving forward because this isn't the first one. Ms. McCall stated if I was the property owner and she met with me and I have no proof of it, just like going to the doctor, if you pay the copay but you don't have proof of it then they tell you that you owe it. Mrs. Tanner stated we are working to try and come up with procedures that will help us to alleviate some of these issues moving forward. Attorney Jordan stated from a legal standpoint, if you attend the hearing and participate in the hearing, there's a presumption that you understand what was going through. You have to think of the magistrate basically as a judge. It's on the magistrate to determine if the person has the capacity

to understand what's happening at the hearing. She did not raise any concerns about code enforcement issues. If someone participates in the code enforcement hearing we presume that they are going to do what they are asked to do. We don't have them sign off on the order. Mr. Russell stated he didn't like to presume or assume. Those are two words that are cloudy to me and I'm concerned about it. Are there proper ways of having an individual sign a document? I can't go to a car lot and buy a car and you just assume I have the money to pay for it, I have to sign a document saying I'm going to pay the bill. Attorney Jordan asked what you would do with the people that don't show up for a hearing. Mr. Russell stated that's a signature in itself or another communication issue. Are they getting the letter, because we already have that issue before with not sending certified letters so how do we know they even know there was a meeting? We have had that in just the last 2 months. Mrs. Robinson stated this is a vacant lot with a mailbox on it and a shed in the back. I don't know how the mail was done. Mrs. Donjuan stated she sends a certified letter for the notice of violation and posts the property as well. I use the address from the property appraiser's website for mail. The orders are certified, but they may get returned as well. Mr. Russell asked from a legal standpoint, how do you proceed with something if you don't know the individual is aware that we are proceeding? Attorney Jordan stated as a practicing attorney we are expected to be able to evaluate the competency of the person that we are interacting with. The magistrate has an obligation to evaluate the participant's competency and there were no concerns raised at that time that he did not understand what the hearing was about. Mayor Andrews asked if at any point during the hearing, just out of curiosity, I know he has a representative for him tonight, but he has also verbally spoke out a couple of times and said things to us. She asked Mr. Roulhac if he was asked to say anything? Did you understand what was going on? Mr. Roulhac stated the man, the judge, asked what I was doing here and I told him I didn't know because I did everything they told me. They told me to clean up the junk and I did. That man said nothing about a car. When I got this about the car, then they tried to make me pay a \$171 water bill. Then that's when this came up. Why didn't he come to me when I came into the hearing the first time? Ms. McCall asked who he was. Attorney Jordan stated Pittman Law Firm in Tallahassee sends different lawyers, every once in a while there might be a man, but usually it's a woman. I wasn't at this particular hearing, but he was able to participate, so I don't know that there were any red flags raised at that time. Mayor Andrews stated she has red flags now. Mr. Blount stated if he didn't know anything about a car then we need to improve the system and be more specific. Attorney Jordan stated the magistrate has to put forth her case just like a prosecutor and has to provide photographic evidence and the noncompliance of the specific ordinance they are in violation of. We have a very good process that works. Mrs. Cain stated she has been to those meetings and they are very formal, nothing informal about it. So he could not have understood what was going on. Mrs. Tanner asked if he spoke at the hearing or if Jalissa spoke for him. Mrs. Josephine Robinson Floyd stated she was with him at the hearing and she knew he did not understand what it was all about. I never saw anything written down that he was supposed to do and he said he never got it. You can't just tell people what they are supposed to do, sometimes and not give them something they can hold in their hands. A lot of people have to have that before they can understand what's going on. I don't know where the confusion started. I taught students that were special and we have to give them special treatment and I am asking you all to give this man special treatment because he needs it. Ms. McCall asked if we could use this as a learning process and to fix whatever we might have that's a problem with communication. Attorney Jordan stated the order was pretty detailed and Jalissa Brown were present at the hearing and sworn in to testify. They both spoke about the case but did not present any evidence or bring any photos to prove the violations were corrected. Mr. Russell asked if they were told to do that. Attorney Jordan stated we cannot advise property owners on what they need. Mr. Russell asked if we aren't allowed to tell them these are some of the things they might ask for without telling them exactly what to bring. Attorney Jordan stated the property owners could get their own counsel. Mayor Andrews stated what we have learned is that we can have different levels of communication and we need to make sure we have exhausted all alternatives of communication. Mrs. Cain stated we want people to be treated fair.

Mrs. Robinson-Floyd discussed the need for changes in code enforcement. The east side of SR 77 needs cleaning. Martin Luther King Drive needs help and would like someone to write grants. You need to look at the east side and see what needs to be done. The streets need to be improved. Mrs. Tanner stated for streets we have Bennett Drive resurfacing that is getting ready to go out to

bid and construction should start within a few months. Peach Street drainage and resurfacing being done as well as the lift station. We also have applied for a grant with FDOT for Pecan from South Boulevard north to Church Avenue. We are just waiting for approval for different projects and hoping that we get them. We have applied for MLK thru FDOT at the same time we applied for Pecan but MLK did not get approved. We have applied for it again this year and are waiting on approval, it just takes time. I think what we have discussed in the past is trying to get properties cleaned up, not necessarily foreclose on them and take them from people. I believe from what the picture shows is that they have cleaned up the property and maybe that's what the discussion is about.

Mayor Andrews stated the attorney fees show \$1921.20 through May 31, 2025 but the total is about \$42,000 so the question is that his property has been cleared up and legal fees have to be paid. Attorney Jordan stated there shouldn't be much more in legal fees, but we had difficulty getting Mr. Roulhac served and wasn't sure he was even still living because we had so much difficulty serving him. I was tasked with creating some kind of standard policy or procedure for requests for a waiver of fines and after hearing discussion tonight I'm going to make a recommendation to you that will cost you more because it will require an additional proceeding with the magistrate, but I think they need to go back before the magistrate before they come to you all. You need to have the magistrate to recommend to make an official finding. Mayor Andrews stated we could come up with a policy that will help us. We found these last two cases and we just want to make sure we have some things in place to prevent us from always having to hear these cases. Mayor Andrews asked Attorney Jordan if she had drawn the policy up for us. Attorney Jordan stated just a skeleton policy based on some other communities that I have looked at that do bring cases back before the magistrate. The magistrate could make recommendations to the council to waive fines if the property was brought into compliance. Mrs. Cain stated Attorney Jordan was our lawyer and should be able to come up with something so we didn't have to go back through the magistrate. Attorney Jordan stated that was the most logical solution to go back through them. Mr. Russell stated if we made Mr. Roulhac go back through the magistrate then the attorney fees would continue to climb and for the daily fines to continue to climb so then he would be back in front of us with even more money owed with the possibility that the magistrate might say the exact same thing. Mayor Andrews stated she would like to see the policy developed for future issues that we may have. Mr. Blount stated this is the same conversation that was had with Dr. Wood, and he thinks Attorney Jordan knows the council's feelings about a policy. You know the legal side, and you've heard the heart of the council saying we don't want to take property. We want the legal fees to be paid, and then we want a document for someone to sign saying you saw this. Tamara has to go through the same cycle over and over saying she did it, but we get here and there is still cloudy stuff. There's no cloud when there's a signature. Ms. McCall stated there is a way to take the cloud away by going back through the magistrate. Mr. Blount stated Attorney Jordan has heard us enough to be able to anticipate a time for a framework to be produced. Attorney Jordan stated the council is not all on the same page. Ms. McCall stated we have not seen what the magistrate has seen, and Attorney Jordan is trying to keep us in line by doing the right thing and going back to the magistrate. The magistrate could do the right thing, but we are not attorneys. Mrs. Cain stated the bottom line is that we need to make sure the people who own the property understand what they have to do to clean it up and the timeline they have to get it done. Some people may understand that but all people don't and that's the problem. Ms. McCall stated the magistrate is the one that heard it, we didn't. Mayor Andrews stated the magistrate works for us. Attorney Jordan stated in this case there were two people put under oath, the property owner and a representative who was allowed to speak on behalf of the property owner. Mrs. Cain stated that didn't mean he understood it because it's so formal that if I didn't have the paperwork in front of me, I wouldn't understand it. Mayor Andrews stated we have a sensitive case before us again and we need to get something in place or we will continue to keep having these issues. Mrs. Tanner stated I can tell you that there were definitely cases that have been sent to the magistrate that I would not have approved to go. I would have made sure there was more information before that happened. Tamara and I have gone over a lot of stuff in the past year and we continue to go over stuff. I think being able to take care of stuff before it gets to the point of the special magistrate and sending it to them when you know there is no other alternative is what we have looked at doing moving forward. That is what we are working on, once we look

into those things, we have to run it by Attorney Jordan to make sure that we are not against code or going against legal proceedings. There have been cases that have gone to the magistrate that I feel could have been resolved prior to that point, but they went, and some of them before I was put in the position I'm in, and that's why we're where we are now with some of the cases. I think some of that can be resolved moving forward, but that doesn't take care of tonight though. Gerald Lenz, Mug on Main, thanked the council for putting up with everything they have. If you see something that needs to be taken care of, then take a picture of it and on that page put everything that needs to be done along with the deadline. Mayor Andrews stated the bigger question is, after the magistrate, maybe Mr. Roulhac didn't understand it was \$50 per day from the date of the meeting, totaling up to over \$40,000. The question tonight is the fines and if the council will have leniency with him on his lack of understanding of it. We don't negotiate our attorney fees, but we have considered some of the fines. Mr. Russell stated we have made it public that our process is flawed. Not by any one person's doing, it's just a process that needs to be looked at. Mrs. Tanner stated not the legal process but the steps prior to it that we are working on. Mrs. Robinson asked if there was anything the council could do about Mr. Roulhac's fines today. Mr. Russell stated he was in favor of eliminating the fines because it hasn't cost the city anything. We have done it before, where the attorney fees had to be paid because it is a process we had to go through, and the city had to pay it. Mrs. Robinson asked Attorney Jordan if there was anything she could do to help eliminate some of the legal fees. Attorney Jordan stated no, she had already paid her staff. Mrs. Robinson asked for the total of the legal fees. Attorney Jordan stated it was a little over \$2,000.00. Mrs. Cain asked if he could make payments. Mr. Russell asked Mrs. Tanner if she could help make a payment plan with Mr. Roulhac. Mrs. Tanner stated if the council would like her to then she could. She asked Attorney Jordan if Mr. Roulhac was being served at the vacant property. Attorney Jordan stated she had to do multiple searches on Lexus, and we had to make requests about vital statistics because we attempted service at the property address multiple times and at addresses that we were able to pull off Lexus. We were getting to the point where we were going to have to do constructive service. He was not able to be located by law enforcement, and I don't know how else to put that. That's where a lot of the cost came in. Mayor Andrews asked Mrs. Tanner to work with them on the payment plan and get the final balance from Attorney Jordan. Discussion ensued.

**A motion was made by Council Member Russell and seconded by Council Member Cain to eliminate the \$40,450.00 with the understanding that the attorney's fees must be paid. The motion passed unanimously.**

4. **FDOS Old City Hall Grant Final Report.** Mrs. Heather Lopez. Mrs. Lopez stated that this will complete the grant for the remainder of the existing conditions assessment and rehabilitation plan for the old city hall. These are the components that we had to pull out of the grant in the first phase due to a rise in cost on the contractor's side. This includes the mechanical, electrical, mold inspection, and ADA compliance. Mrs. Tanner stated we are working on an invitation to bid for the mold remediation. No further discussion.
5. **Parking Space Lease** – Jeanette Rathburn – Discussion. Jeanette Rathburn, owner of Purradise City, located at 1333 S Railroad Avenue would like to discuss the option of allowing business owners in the building where she is located and the attached building to lease parking spaces. The businesses would include Purradise City, The Mug on Main, Bella Salon, and the new owners of the Sister's Sweets building. The lease would include two (2) spaces in front of each business for a total of eight (8) spaces. The business owners would purchase the signs that would be placed to designate the spaces are reserved for each business. Mrs. Rathburn stated she is requesting to lease eight (8) parking spaces on behalf of not only herself but the Mug on Main, the business that will replace Sister's Sweets, the salon that is coming along with any other business that comes in that building and the adjacent one. This would be for our visitors because at this time a lot of the parking is being taken up by food truck vendors and Chipley Station employees. I am open the same hours that the Chipley Station is open, so the parking area that is convenient for my guests is reduced. I have submitted some photos that show the repeated vehicles in the same spots, which are typically food truck vendors. My guests, which include adults and children, are having to walk from farther away from the park or behind our building

at the bank which has dim lights. We cater to a lot of autistic children, and having them those large distances with low lights makes a lot of parents nervous. We are seeing a reduction in repeat business compared to before the Chipley Station opened. Also, the cars that park at the front of the Chipley Station stick out into the street which makes it hard to see. A pedestrian crosswalk and lighting have already been discussed at a previous council meeting. Ms. McCall stated when council talked to the Chipley Station at a previous council meeting, they were specifically asked for their employees to park somewhere else. Mrs. Tanner stated we can address that because they said in a meeting that they would. Mr. Lenz stated the Mug on Main has been parking further away. Mr. Russell stated to make it clear, when they agreed and we agreed that their employees would park across the street, then are the food truck people their employees. There may be a gap in communication there that they didn't tell them they need to park further away too. Mrs. Tanner stated she would reach out to them. Mr. Russell asked where we were in redeveloping the entire parking lot. Mrs. Tanner stated we have had an engineer review the parking lot and have come up with a couple of different options and plans for us. It does not include closing part of South Railroad Avenue because council did not seem to be in favor of moving forward with the complete overhaul of the parking lot. This was something that was just to correct the issue and come up with a few more parking spaces. We are going to continue working on that. As far as lighting goes, we are working with FPL to put up at least one additional light and a tree was removed that was covering a light. That doesn't address the issue at hand, but I wanted to make sure the council was aware of that. Mr. Russell asked if we lease these spaces, who is going to be responsible for monitoring them to make sure they are being utilized correctly. Mrs. Rathburn stated the business owners would purchase the signs to put up in the designated spaces. Mrs. Tanner asked Mrs. Rathburn if we are able to work with the Chipley Station to get their food truck vendors' employees to park across the road or on the other side of the green space, do you think that would help with the parking issue? Ms. McCall stated she asked Steve that when she was in the Chipley Station and he said Ledbetter's is a veteran but is not willing to park anywhere else. Mrs. Rathburn stated each food truck has multiple employees that all have vehicles that park there. Mayor Andrews stated we need to have a good conversation with the Chipley Station about their employees and the food truck vendors to clarify what is happening based on the pictures submitted by Mrs. Rathburn. If it doesn't get better then maybe we have to do something to help with relief for them. Mr. Russell asked about the design effort of the parking lot of how we're going to do that because of this request and the number of spaces could change with a redesign. Mrs. Tanner stated we are looking at doing that very soon. Mr. Russell stated we need to have the conversations, finish the parking lot redesign, and continue to monitor this to make sure this is corrected. I want all businesses to have parking. He asked Attorney Jordan if it came to leasing the parking spots, would we have to do a lease with the building owner or tenant. Attorney Jordan stated it wouldn't matter. We would need to adopt an ordinance for the signs. Ms. McCall stated she was watching the parking area and a lot of it is the employees and that's what upsets me because when you give me your word that should be it. Mr. Russell asked about the old Amtrak parking on the grass inside the fence that Mrs. Harrell owns, which would be inside a fence and safe parking for employees. Mr. Lenz stated the parking issue in front of the Chipley Station on 7<sup>th</sup> Street is scary because sometimes there will be the end of an extended truck sticking out into the roadway. Maybe ask for it to be made compact car parking only. Mayor Andrews stated maybe compact cars and motorcycles. Mr. Lenz stated he wanted to stress again that all of you do a fantastic job and we appreciate your time and effort. Anytime anyone has an issue, there are people that are willing to talk and help and I want to thank you all for that. Discussion ensued.

6. **Proposed Annexation, Water and Sewer Services** – South Boulevard and Kirkland Road. A business came to me and has purchased a piece of property near South Boulevard and Kirkland Road. Mr. Lane, Mr. Cook, and myself have discussed the possibility of annexing it in. The school board property would make it contiguous if they would allow us to annex them in. The rest of the school is already in the city, just that one parcel isn't. The owner is looking to build a couple of houses off of South Boulevard and a couple of houses off of Kirkland Road. We do not have services there. What we would like to do is get council approval to move forward with advertising for bids to do a new eight-inch water main from South Boulevard across to Kirkland Road. Our water stops at Kate Smith Elementary School, so it would be going across South

Boulevard, down Kirkland Road to Brickyard Road. An estimate right now is the city putting \$65,000-\$70,000 and the developer putting in close to \$30,000, not counting their tap and installation fees. This would be just for the portion of the waterline that we would be putting in that would allow them to build and have water and sewer services. We do not have sewer services there either which is a bigger issue, but there is a sewer line there owned by a business and we would like to be able to reach out to them and see if they would allow the city to take that sewer line over. We would be able to utilize that sewer line moving forward to add on those four homes to sewer. From there, we would have to look at doing something with sewer south on Kirkland Road. This would not be an immediate thing. There are a lot of things that we have to work through, but we would like permission to move forward if the council would like us to do that. Discussion ensued.

**A motion was made by Council Member McCall and seconded by Council Member Russell to approve the project on South Boulevard and Kirkland Road. The motion passed unanimously.**

**I. OTHER BUSINESS**

Attorney Jordan stated the individual that discussed the West Boulevard property with Council last month did not proceed with the purchase. She stated she met with Mrs. Tanner and Mr. Lane about the animal ordinance and there will be an extensive review. She also stated she feels like she is getting mixed feelings on the waiver of code fines and would like to discuss again in August. Discussion ensued.

Stephanie Lee, 653 Bennett Drive, stated the fireworks that Mr. Hooks set off were right behind her house and it was very loud. Mrs. Tanner stated for the past three years the fireworks had been set off in the middle of the roadway. Before that, they used the east side of the field, but they were too close to the trees. Chief Richter asked for the road to remain open due to safety concerns so they were unable to do the fireworks in the roadway. Mr. Blount stated he understands why the tennis court was picked because it is closed in. Ms. Lee stated her children were screaming due to the loud noise. Mr. Russell stated the concept of it coming to council just 5 days prior to the event was concerning because it's a large event. He stated it needs to be here by January for us to go over. Mrs. Cain stated we need to know where it's going to be. Mayor Andrews stated that it may need to go to Jim Trawick Park because it is the safest place to hold it. Mrs. Cain agreed. Mrs. Tanner stated we checked the application which does say 45 days and we made a post on Facebook that special events need to be turned in 45 days prior to the event for approval. Mr. Russell stated he was concerned that fireworks were being shot over homes and the whole event needs to be discussed before it is approved again. Mayor Andrews stated we probably need to have them pay a guy to be in the middle of the field with everyone parked far away. Ms. McCall stated the lack of preparation on their part does not constitute an emergency on ours. Discussion ensued.

**J. ADJOURN**

The meeting was adjourned by Mayor Andrews at 7:01 p.m.

City of Chipley

Attest:

Tracy L. Andrews, Mayor

Sherry Snell,  
City Clerk

**City of Chipley  
Council Meeting  
Minutes  
August 12, 2025 at 5:00 p.m.**

**Attendees:**

Ms. Tracy Andrews, Mayor  
Ms. Cheryl McCall, Council Member

Mr. Kevin Russell, Mayor Pro-Tem  
Mr. Leonard Blount, Council Member

**Absent:**

Mrs. Linda Cain, Council Member

**Others Present Were:**

Mrs. Patrice Tanner, City Administrator  
Mr. Guy Lane, Asst. City Admin./Public Works Dir.  
Mrs. Michelle Jordan, City Attorney

Ms. Sherry Snell, City Clerk  
Mr. Michael Richter, Police Chief  
Mrs. Tamara Donjuan, Planning/Code Enf. Officer

The data reflected in these proceedings constitute an extrapolation of information elicited from notes, observations, recording tapes, photographs, and/or videotapes. Comments reflected herein are sometimes paraphrased, condensed, and/or have been edited to reflect essential subject matter addressed during the meeting. Parties interested in receiving a verbatim account of the proceedings are responsible for coordinating with the City Administrator and providing their own representative and equipment pursuant to Chapters 119 and 283, Florida Statutes.

**A. CALL TO ORDER**

The meeting was called to order by Mayor Andrews at 5:00 p.m.

**B. PRAYER AND PLEDGE**

Prayer was given by Council Member Blount and Mayor Andrews led the pledge to the American Flag.

**C. APPROVAL OF AGENDA**

**A motion was made by Council Member Russell and seconded by Council Member Blount to approve the agenda as presented. The motion passed unanimously.**

**D. CITIZENS REQUEST**

The City of Chipley welcomes you to this meeting. This is time set aside for the Citizens of Chipley to address the City Council. This is not a question and answer period, it is not a political forum, nor is it a time for personal accusations and derogatory remarks to/or about city personnel. If you would like to address the City Council please raise your hand to speak, state your name and address for the record and limit your comments to no more than three (3) minutes per Florida Statute 286.0114. To ask a question via phone; dial \*9 and wait to be recognized/unmuted. If you are attending via webinar, there will be an onscreen option to ask a question during the public comment portion of the meeting. Your participation is welcomed and appreciated.

No citizen requests. No further discussion.

**E. APPROVAL OF MINUTES**

1. Regular Council Meeting - July 8, 2025
2. Special Council Meeting – July 29, 2025

**A motion was made by Council Member Russell and seconded by Council Member Blount to approve the minutes as presented. The motion passed unanimously.**

**F. PRESENTATIONS**

1. Recognition Award – Florida Engineering Leadership Institute (FELI) Class 2025
2. Recognition Award – Southern Splash & Dash LLC – Miken Hooks
3. Recognition Award – Project Downtown Chipley LLC – Kristin Martin

The City Council recognized the outstanding contributions and selfless dedication to the betterment of our community by the Florida Engineering Leadership Institute (FELI) Class 2025, Southern Splash & Dash LLC – Miken Hooks, and Project Downtown Chipley LLC – Kristin Martin. The Council presented them with awards for their significant impact on the City of Chipley.

**G. CONSENT AGENDA ITEMS**

1. **Resolution No. 25-44** – Florida Department of Commerce, CDBG-DR Agreement No. M0014 – Amendment No. 4. This resolution will approve the Florida Department of Commerce, CDBG-DR Agreement No. M0014 – Amendment No. 4 for the Northwest Stormwater Restoration Project. It will extend the project end date to September 30, 2026.
2. **Resolution No. 25-45** – FEDP SRF Clean Water State Revolving Fund. This resolution will approve the FDEP Capitalization Grant Agreement for Clean Water State Revolving Fund Planning Loan Agreement No. WW670150, in the amount of \$90,000.00.
3. **Fiscal Year 2025-2026 Budget and TRIM Schedule.** This will approve the Budget and TRIM schedule with the required dates and times for the tentative and final public hearings as well as all other steps required for the annual millage and budget process. The Tentative Millage and Budget Hearing will be held on September 16, 2025 at 5:05 p.m. and the Final Millage and Budget Hearing will be held on September 29, 2025 at 5:05 p.m.
4. **Reappointment of Chipley Housing Authority Commissioner** – Linda Justice. This will reappoint Linda Justice to the Chipley Housing Authority for a four-year term ending on September 30, 2029.
5. **Appointment of Recreation Advisory Committee Member** – Rasheida Patrick. This will appoint Rasheida Patrick to the Recreation Advisory Committee for a period of two years, effective 08/12/2025.
6. **Special Event Application** – Annual Trunk or Treat. The Annual Trunk or Treat will be held on Saturday, October 25, 2025, from 4:00 p.m. – 6:00 p.m. at the Jim Trawick Park Soccer Field.
7. **Special Event Application** – Arts and Craft Show – Washington County Historical Society. The Arts and Craft Show will be held on Saturday, September 13, 2025, from 12:00 p.m. – 7:00 p.m. at the Farmers Market Pavillion. This event will be in celebration of Washington County's Bicentennial with approximately 200 people attending.

**A motion was made by Council Member McCall and seconded by Council Member Blount to approve the consent agenda items. The motion passed unanimously.**

**H. AGENDA ITEMS**

1. **Request Waiver of Fines** – Dr. Thelma Wood Property – 771 Pecan Street. Mrs. Tanner

explained on April 8, 2025, Council voted to give Dr. Wood ninety days to get her proper compliance, then readdress the fines after that, and to abate/pause the foreclosure proceedings ninety days. The property has been brought into compliance. The fines total \$24,750 and attorney fees through June 30, 2025 are \$1,298.35. No further discussion.

**A motion was made by Council Member Russell and seconded by Council Member McCall to waive the fines but not the attorney fees. The motion passed unanimously.**

- 2. Request for Development Order and Certificate of Appropriateness – 941 Main Street – Ronny's Carwash of Chipley.** Mrs. Donjuan explained Ronny's Carwash of Chipley is requesting a Development Order and Certificate of Appropriateness for a new development to construct a 2,240 square foot automated carwash with 25 vacuum stalls with two access driveways, one from Main Street and the other from 7<sup>th</sup> Street. The Planning and Zoning Commission approved this at their meeting held on July 17, 2025. Mr. Russell questioned the neighborhood commercial allowances. Mrs. Donjuan stated the city's planning firm, Kimley-Horn determined it was an allowable use due to it being a service. Mr. Russell questioned the high traffic in the area. Mrs. Donjuan stated a traffic study analysis was reviewed by Kimley-Horn and FDOT who approved it. Ms. McCall asked about the flow rates not being calculated correctly by the engineer. It was determined that the Fire Chief usually does the calculations, not the engineer. She also expressed concerns about the poor drainage on the property. Gregory Campbell, engineer for Ronny's Carwash, was present via ZOOM/phone and answered questions regarding the drainage issues. Ms. McCall stated we can't handle the water that is already coming off 7<sup>th</sup> Street and Gilbert Acres. Mr. Campbell stated you will have less water with this development than you do now going into that system. Mr. Russell asked how high the property would have to be built up before construction begins, because he is concerned about the property owners on each side catching the overflow water. Mrs. McCall asked how much higher from the current elevation will this be built. Mr. Campbell stated it will be built up two to three feet higher. Mr. Russell and Ms. McCall expressed concern for the drainage on the neighbor's property due to the elevation. Mr. Campbell stated there is a swell that collects water from a portion of their property and the adjacent south property owners. It goes into an inlet that basically goes into a pipe in the roadway. I had to account for the offsite drainage into the swell. On our property, we will have curbing and inlets and no drainage will go south. It will hit the curbs and then go into the inlets and to the pond. The swell will still be there for the drainage. Mr. Russell questioned the location of the retention ponds. Ms. McCall stated she didn't think that was the right place to put a car wash. Jackson Penton, Ronny's Carwash, asked if nothing can go there due to the drainage concerns. Mr. Russell stated what you are trying to put in is going to limit the water flow with so much concrete. Mr. Smith, Ronny's Carwash, stated over half of the property will still be grass on the back side.

Paula Cunningham, 856 Chesnut Hill Street, stated she has a family home next to the location where the carwash wants to be built. The property does flood and the home flooded with Hurricane Sally. The retention pond is going to be placed 25' from the home that my daughter and sister live in. She was concerned about the noise that will be generated by the carwash and how it will affect them. There are also boundary issues from a deed dated in 1990.

Jennifer Corbitt stated she owned 740 7<sup>th</sup> Street and sold it earlier this year due to drainage issues. She expressed concerns about the drainage issues that exist now. Also, it is zoned neighborhood commercial, which is a gradual change. The existing businesses are located in older homes which does not change the aesthetic. The proper path would be rezoning, which I would not support. I respectfully request that this development is denied as it is presented.

Mr. Michael Tiller, 887 Main Street, stated that Hurricane Michael and Sally both flooded his backyard. He expressed concern about drainage and flooding in the area. He didn't say he was for or against the development except for the aesthetics.

Ms. McCall stated the data was not correct and you have to vote the way the people want it and the people don't want it right there. I don't want it right there in the middle of the historical part

of town.

Mr. Tate Bruner, 720 7<sup>th</sup> Street, stated he purchased his home in 2021 and he has experienced a complete flood in his front yard with just a regular rain. He expressed concerns with drainage issues if the development is built. The carwash would be a great addition to our town in a different location. He stated it would not be visually appealing to the area. He stated he is against the development at this location.

Discussion ensued.

**The item died for lack of a motion.**

- 3. Amendment to Non-Residential Net Ground Lease – Wolpack Alliance LLC.** Mrs. Tanner explained this will approve the amendment for Wolpack Alliance at the Chipley Station to include a new legal description and survey. No further discussion.

**A motion was made by Council Member Russell and seconded by Council Member Blount to approve the Amendment to Non-Residential Net Ground Lease – Wolpack Alliance LLC. The motion passed unanimously.**

- 4. Bid No. 2025-03 – Chipley Mongoven Building – Phase 2 – Arris General Contractors, Inc. – Change Order #2.** Mr. Brent Melvin, DHM Melvin Engineering, explained this will approve Change Order #2 for the Mongoven Building Phase II Project in the amount of \$170,182.94 to complete and close out the final scope of work. This will include concrete and curb improvements, tree well installation, vault door restoration, column reinstallation, and contingency tasks necessary to finalize the project. This will use the balance of the funds available in this grant. The city will have to fund the balance of the work for the project to include tables, striping of the parking area and shade structures. Mrs. Tanner stated the remaining items are minimal and the city has additional funds that could be used. This does not include restrooms and we will continue to look at options for that. Discussion ensued.

**A motion was made by Council Member McCall and seconded by Council Member Russell to approve Bid No. 2025-03 – Chipley Mongoven Building – Phase 2 – Arris General Contractors, Inc. – Change Order #2. The motion passed unanimously.**

- 5. Chipley Library Expansion Project Update – Renae Rountree, Library Director.** Mrs. Rountree explained the expansion looks to add three new sections to the library. On the west side, a large meeting room with a kitchen that can be used for library programs and classes as well as community needs. The east side will eliminate the drive-thru window that seldom sees use and instead will transform into a much needed children's area to promote early literacy. Finally, the north side will see additional staff offices and storage space to facilitate our continued growth. Ms. McCall asked about drainage. Mr. Brent Melvin stated the original library is permitted under the existing pond and the Griffin Road project will help with that issue. Flood panels will also be purchased to go with the flood panels already purchased by the city for the library. Discussion ensued.
- 6. Code Enforcement Fines – 1214 Johnson Avenue.** Mrs. Tanner explained the property at 1214 Johnson Avenue is owned by Truist Bank through foreclosure. They are requesting for the code fines on the property to be paused while they evict the tenant. It was conveyed to VA and they just reconveyed it back to Truist recently, and now LOGS Legal Group has been retained to work on the eviction. They can't work on the code issue while it's occupied, which is the issue in having it resolved. Summer Hodges, Attorney for Truist Bank, stated they would like to ask you to pause for six months so we can finish the eviction which requires a 90 day notice. Discussion ensued.

**A motion was made by Council Member Russell and seconded by Council Member Blount to pause the code fines for 90 days and follow-up after that. The motion passed unanimously.**

7. **Request Waiver of Fines – 777 West Boulevard.** Mrs. Tanner explained the property is contract with over \$40,000 in liens and \$1,600 in attorney fees/costs. The buyer is requiring lien satisfaction at closing but the sellers cannot financially make that happen. Buyer would like to request a waiver of the fines prior to closing, but if the Council does not approve, then Attorney Jordan would propose a waiver if they can get the property cleaned up within 30 days of the closing date. Attorney Jordan spoke with both agents and if the Council will not consider waiving the fines prior to closing, she is comfortable offering a lien release in escrow where the title company would hold back the lien amount from the closing proceeds and would hold an executed release until Code Enforcement certifies to the title company that the property is in compliance. At that point, the lien release would be recorded by the title agent and the remaining proceeds released to the seller. Attorney Jordan also explained that the Council does not waive attorney fees and costs so those will be paid at closing under this arrangement. Mr. Carl Schmidt, potential buyer, stated he wasn't sure about the trash on the property. Attorney Jordan stated the property being sold has a final judgement due to a divorce and our lien will prohibit them from satisfying the debt. The buyer has to request the waiver. Mr. Schmidt asked for 90 days to clean up the property. Attorney Jordan stated it would be 90 days from the closing date. Discussion ensued.

**A motion was made by Council Member Russell and seconded by Council Member Blount to waive the \$40,000 lien fees to be dissolved at closing, but keep the \$1,600 attorney fees. The motion passed unanimously.**

**I. OTHER BUSINESS**

**J. ADJOURN**

The meeting was adjourned by Mayor Andrews at 6:34 p.m.

City of Chipley

Attest:

Tracy L. Andrews, Mayor

Sherry Snell,  
City Clerk

**City of Chipley  
Council Meeting  
Minutes  
September 9, 2025 at 5:00 p.m.**

**Attendees:**

Ms. Tracy Andrews, Mayor  
Ms. Cheryl McCall, Council Member  
Mrs. Linda Cain, Council Member

Mr. Kevin Russell, Mayor Pro-Tem  
Mr. Leonard Blount, Council Member

**Others Present Were:**

Mrs. Patrice Tanner, City Administrator  
Mr. Guy Lane, Asst. City Admin./Public Works Dir.  
Mrs. Michelle Jordan, City Attorney

Ms. Sherry Snell, City Clerk  
Mr. Michael Richter, Police Chief  
Mrs. Tamara Donjuan, Planning/Code Enf. Officer

The data reflected in these proceedings constitute an extrapolation of information elicited from notes, observations, recording tapes, photographs, and/or videotapes. Comments reflected herein are sometimes paraphrased, condensed, and/or have been edited to reflect essential subject matter addressed during the meeting. Parties interested in receiving a verbatim account of the proceedings are responsible for coordinating with the City Administrator and providing their own representative and equipment pursuant to Chapters 119 and 283, Florida Statutes.

**A. CALL TO ORDER**

The meeting was called to order by Mayor Andrews at 5:00 p.m.

**B. PRAYER AND PLEDGE**

Prayer was given by Pastor J. Samuel Johnson and Mayor Andrews led the pledge to the American Flag.

**C. APPROVAL OF AGENDA**

**A motion was made by Council Member Russell and seconded by Council Member McCall to approve the agenda as presented. The motion passed unanimously.**

**D. CITIZENS REQUEST**

The City of Chipley welcomes you to this meeting. This is time set aside for the Citizens of Chipley to address the City Council. This is not a question and answer period, it is not a political forum, nor is it a time for personal accusations and derogatory remarks to/or about city personnel. If you would like to address the City Council please raise your hand to speak, state your name and address for the record and limit your comments to no more than three (3) minutes per Florida Statute 286.0114. To ask a question via phone; dial \*9 and wait to be recognized/unmuted. If you are attending via webinar, there will be an onscreen option to ask a question during the public comment portion of the meeting. Your participation is welcomed and appreciated.

No citizen requests. No further discussion.

**E. APPROVAL OF MINUTES**

**A motion was made by Council Member Russell and seconded by Council Member McCall to approve the minutes as presented. The motion passed unanimously.**

**F. PRESENTATIONS**

1. Constitution Week Proclamation. The City Council recognized the week of September 17-23, 2025 as Constitution Week to recognize the 238<sup>th</sup> Anniversary of the framing of the Constitution of the United States of America by the Constitutional Convention. Mrs. Doris Spears, Regent for the Chipola Chapter Daughters of the American Revolution, was present to accept the proclamation.
2. AVID Day Proclamation. The City Council recognized September 12, 2025 as Advancement Via Individual Determination (AVID) Professional Learning Recognition Day. Cindy Johnson Brown, Susan Saunders, Bernadette Hardman Strong, Leanne Pedraja and Kevin Russell were present to accept the proclamation.

**G. CONSENT AGENDA ITEMS**

1. **Resolution No. 25-46** – State of Florida, Department of Commerce – CDBG Modification Number 1 to Subgrant Agreement. This resolution will approve the State of Florida Department of Commerce, CDBG Modification Number 1 to Subgrant Agreement to extend the deadline to July 31, 2026. It will also amend the original agreement with the new name of Florida Department of Commerce and update invoice payment information.
2. **Resolution No. 25-47** – State of Florida Department of Transportation, State-Funded Grant Agreement – Pecan Street Roadway Resurfacing Improvements. This resolution will approve the State of Florida Department of Transportation, State-Funded Grant Agreement for the resurfacing of Pecan Street. This includes the design, construction, and CEI services. The project will consist of resurfacing the roadway from South Boulevard to Church Avenue.
3. **Award of RFP No. 2025-01** – FDACS Wastewater Energy Efficiency Grant Administration Services – David H. Melvin, Inc. The City advertised Grant Administration Services for the FDACS Wastewater Energy Efficiency Project. Three (3) RFP's were received on August 13, 2025, and scored by a Selection Committee.
4. **Agreement for Grant Administration Services** – RFP No. 2025-01 - FDACS Wastewater Energy Efficiency Project – David H. Melvin, Inc. This will approve the Agreement for Grant Administration Services for the FDACS Wastewater Energy Efficiency Project with David H. Melvin, Inc. in the amount of \$29,500.00.
5. **Award of RFQ No. 2025-05** – FDOT M-SCOP Bennett Drive Resurfacing Project CEI Services – Alday- Howell. The City advertised CEI Services for the FDOT M-SCOP Bennett Drive Resurfacing Project. Seven (7) RFQ's were received on August 12, 2025, and scored by the Selection Committee.
6. **Award of RFQ No. 2025-06** – FDACS Wastewater Energy Efficiency Engineering & Inspection Services – David H. Melvin, Inc. The City advertised Engineering & Inspection Services for the FDACS Wastewater Energy Efficiency Project. Three (3) RFQ's were received on August 14, 2025, and scored by the Selection Committee.
7. **Agreement for Engineering Design/CEI Services** – RFQ No. 2025-06 - FDACS Wastewater Energy Efficiency Project – David H. Melvin, Inc. This will approve the Agreement for Engineering Design/CEI Services for the FDACS Wastewater Energy Efficiency Project with David H. Melvin, Inc. The engineering design services will be \$39,500.00 and the CEI services will be \$32,500.00 for a total fee of \$72,000.00.

- 8. **Professional Engineering Services Continuing Contract Extension** – David H. Melvin. City Council approved the Professional Engineering Services Continuing Contract with David H. Melvin, Inc. on March 8, 2022. The contract provided for an initial term of three (3) years with option to renew for two additional one-year terms. This extension will extend the contract until March 8, 2026.
- 9. **Professional Grant Administration Services Continuing Contract Extension** – David H. Melvin, Inc. City Council approved the Professional Grant Administration Services Continuing Contract with David H. Melvin, Inc. on June 14, 2022. The contract provided for an initial term of three (3) years with the option to renew for two additional one-year terms. This extension will extend the contract until June 14, 2026.
- 10. **Special Event Application** – Homecoming Parade – Chipley High School. The Homecoming Parade will be held on Friday, October 17, 2025, starting at 12:30 p.m. using the new parade route.
- 11. **Special Event Application** – Fall Block Party – Project Downtown Chipley, LLC. Project Downtown Chipley, LLC is requesting to hold a Fall Block Party on Thursday, October 23, 2025 from 6:00 p.m. – 9:00 p.m. in the downtown area. This includes road closures on North Railroad (2<sup>nd</sup> Street to MLK), South Railroad (2<sup>nd</sup> Street to 7<sup>th</sup> Street), 5<sup>th</sup> Street (Hwy 90 to Church Avenue) and 7<sup>th</sup> Street (Hwy 90 to Church Avenue). Various other alleyways and additional closings per City Police Department as needed for safety and traffic flow.
- 12. **Resolution No. 25-48** – Florida Commerce Agreement No. M0041 – Amendment No. 3 – Mongoven Building Project. This resolution will approve the Florida Department of Commerce Agreement No. M0041 – Amendment No. 3 in order to amend the Mongoven Building Project Agreement Section 3, Period of Agreement extending the Project End Date to September 30, 2026, unless otherwise terminated as provided in this Agreement.
- 13. **Resolution No. 25-49** – FDEP FRDAP Grant Application Submission - Jim Trawick Park Phase X. This resolution will approve the submittal of an application for a FRDAP grant for Jim Trawick Park Phase X in the amount of \$200,000. These improvements will include: Soccer Field Renovation, Playground Renovation to include ADA Equipment; Baseball Field No. 7 Renovation, Softball/T-Ball Field No. 8 Renovation, Add Exercise Station to Walking Trail, Picnic Facility Renovation, New Batting Cages, Restroom Renovation, Batting Cages Renovation, New Bleachers, Sidewalk to Batting Cages and Sidewalk to Playground Renovation.
- 14. **Special Event Application** –Blues & Brews Music Festival – Washington County Chamber of Commerce. The Blues & Brews Outdoor Music Festival will be held on Saturday, November 15, 2025 from 3:00 p.m. to 8:00 p.m. A road closure is requested for MLK Drive and 7<sup>th</sup> Street from the alley behind the Farmer's Market to N Railroad Avenue during the event. Insurance will be submitted prior to the event.

Mr. Russell asked about insurance for the special events. Mrs. Tanner stated they will send it prior to the event.

**A motion was made by Council Member McCall and seconded by Council Member Cain to approve the consent agenda items. The motion passed unanimously.**

**H. AGENDA ITEMS**

- 1. **Request for Land Use Map Amendment** - 1237 Church Avenue - Thomas James Simmons III. Mrs. Donjuan explained that Mr. Simmons is requesting a Small-Scale Amendment at 1237 Church Avenue to change from low density to commercial to allow a business to be permitted.

Ms. McCall stated six people spoke against the change at the Planning & Zoning Commission

meeting. Mr. Russell stated there were several red flags for him including not having funding for the development, future use if this business does not continue, a retention pool the lot size. Mr. Blount stated Mr. Simmons was going to mentor kids which will benefit the community. Let everyone get together in the community to come up with a plan.

Mrs. Tanner stated they still have to follow the city guidelines for engineered plans, parking, and stormwater for whatever goes there. It still has to get approved by the city.

Mr. Simmons stated he would like to purchase the lot next to it to increase the lot size. I have researched the chemicals that will be used. I will be funding this and do not need a grant.

Ms. McCall stated we have to listen to the people.

Mr. Tommy Andrews, citizen, asked if this could be delayed for later.

Mrs. Juanita Finney, citizen, stated this is just a request for the land use amendment to re-zone, not to approve any specific business. Speculation about the future is premature.

Mr. Mark Odom, citizen, stated he stands for individual rights and with neighborhood commercial, it must benefit the neighborhood not allowing a free for all. Just because it's approved does not mean it's a green light for anything.

**A motion was made by Council Member Blount and seconded by Council Member Cain to approve the Request for Land Use Map Amendment. The motion passed with three (3) ayes and two (2) nays, with Council Member Russell and Council Member McCall being opposed.**

- 2. **Award of Bid No. 2025-05** – FDOT M-SCOP Bennett Drive Resurfacing Project. Discussion ensued. Mrs. Tanner explained the City advertised the construction of the FDOT M-SCOP Bennett Drive Resurfacing Project. The project will consist of milling and resurfacing Bennett Drive from Church Avenue to SR 273 (Approximately 0.5 miles). The existing roadway will be widened 1.5' on each side from Old Bonifay Road to SR 273. Also included in this project is isolated roadway reconstruction, excavation, new road base, grassing and drainage improvements consisting of ditch grading, culvert replacements and concrete drainage structures. Painted pavement markings are also included along with thermoplastic markings to be placed on final pavement surface. Eight (8) bids were received with the low bid from Anderson Columbia in the amount of \$569,170.26. David H. Melvin Engineering has reviewed the bids and recommends award of bid to Anderson Columbia. No further discussion.

**A motion was made by Council Member McCall and seconded by Council Member Russell to approve the Award of Bid No. 2025-05 to Anderson Columbia in the amount of \$569,170.26. The motion passed unanimously.**

- 3. **Award of Bid No. 2025-04** – FC Northwest Stormwater System Restoration Griffin Road Drainage Improvements Project – Gulf Coast Utility Contractors of Panama City. Mrs. Tanner explained the City advertised for the FC Northwest Stormwater System Restoration Griffin Road Drainage Improvements Project. This project primarily consists of drainage improvements on Griffin Road within the Chipley consisting of the construction of a new double 10'x7' concrete box culvert along with approximately 550 linear feet of new lateral ditch excavation to relieve flooding in the area. Roadway excavation and reconstruction will be required in the vicinity of the new box culvert along with guardrail placement, riprap rubble, sodding and thermoplastic pavement markings. Utility relocation is also included consisting of approximately 100 feet of 8" water main installed by directional bore. Nine (9) bids were received with the low bid from Gulf Coast Utility Contractors of Panama City in the amount of \$778,359.50. David H. Melvin, Inc. has reviewed the bids and recommends award of bid to Gulf Coast Utility Contractors of Panama City. No further discussion

**A motion was made by Council Member Cain and seconded by Council Member Russell to approve the Award of Bid No. 2025-04 to Gulf Coast Utility Contractors of Panama in the amount of \$778,359.50. The motion passed unanimously.**

Section H, Item 7.

- 4. Legislative Priorities** – Liberty Partners of Tallahassee, LLC. Mrs. Jennifer Green, Liberty Partners of Tallahassee, LLC discussed the legislative priorities for the 2026 Legislative Session. Last year the Brickyard Road Sanitary Sewer Improvements and the Police Department Equipment Modernization were not approved. We suggest you submit those again this year. Brickyard Road in the amount of \$1.5 million and the Police Department Equipment Modernization for \$500,000 will be submitted. The third item could be something like a Public Safety Preparedness project, possibly for generators at City Hall. She stated they could work with Mayor Andrews and Mrs. Tanner on the submittal for the projects. Mr. Russell asked if the other departments have generators. Mrs. Tanner stated that Police and Fire do have them, but Public Works does not. Mr. Russell asked if we could get some for that location as well. Mrs. Green stated it could be submitted as a government complex to include more than one department. Discussion ensued.

**I. OTHER BUSINESS**

**J. ADJOURN**

The meeting was adjourned by Mayor Andrews at 6:10 p.m.

City of Chipley

Attest:

Tracy L. Andrews, Mayor

Sherry Snell,  
City Clerk

# CITY OF CHIPLEY

## STAFF REPORT

**SUBJECT:** Special Event Application – The Annual Friends & Family Luau

**MEETING DATE**

Tuesday, April 14, 2026

**PREPARED BY**

Patrice Tanner, City Administrator

**SUMMARY**

Nikeh Daniels is requesting approval to hold The Annual Friends & Family Luau on Saturday, June 27, 2026 from 5:00 p.m. to 11:00 p.m. at the field located behind the T.J. Roulhac Enrichment Center. Proof of insurance has been provided.

**RECOMMENDATION**

City Staff recommends approval of the Special Event Application for The Annual Friends & Family Luau.

**ATTACHMENTS**

- 1. Special Event Application
- 2. Insurance



# City of Chipley

CITY HALL

1442 Jackson Avenue

P.O. Box 1007

Chipley, Florida 32428

(850) 638-6350 Fax: (850) 638-6353



## Special Event Application

Name/Organization: The Annual Friends & Family Luau

Address: 803 Ingle Rd, DeFuniak Springs, FL 32428

Contact person: Nikesh Daniels Phone: 850 703 9734 Fax: \_\_\_\_\_

E-mail: annualfriendsfamilyluau@gmail.com

Type of Event: Annual ~~Luau~~ Luau

Purpose of Event: family & friends event

Field @ T.J. Routhac

Location of Event: 1189 E Church Avenue Indoors/Outdoors

Date(s) & Time(s) of Event: June 27th, 2026 5pm - 11pm

Amount of Liability Insurance: 1,000,000 (attach copy of policy)

Concert Yes/No  No If yes, What type of music? \_\_\_\_\_

Will food and nonalcoholic beverages be sold? No

Will fireworks be displayed? Yes/No  No If yes, provide name, license number and pyrotechnic plan to be approved by Fire Chief.

Will amusement rides be available? No

Number of participants anticipated per day: 50 - 100

Are security and/or medical services provided? Security yes

Applicant Signature: Nikesh Daniels Date: 3-9-26

RECEIVED  
MAR 09 2026  
By S. Srell

Approved { } Denied { }  
Mayor's Signature: \_\_\_\_\_ Date: \_\_\_\_\_

**RELEASE AND HOLD HARMLESS AGREEMENT**

**FOR THE SOLE CONSIDERATION OF the City of Chipley** granting permission for the undersigned to conduct a Family & Friends League upon street(s) as provided for in it's letter of request, the undersigned agrees to indemnify and hold harmless the City of Chipley, it's successors, agents and assigns and all other persons, firms or corporations, from any and all claims, demands, damages, actions, causes of actions or suits of any kind or nature whatsoever, and particularly on account of all injuries, both to person and property, which may result from the use of the street(s) as described above, and releases forever discharges the City of Chipley, for any such Claims.

Undersigned hereby declares that the terms of this agreement and lease have been completely read and are fully understood and voluntarily accepted.

**IN WITNESS WHEREOF**, the undersigned has executed this release, this June day of 27th, 2026.

**FIRM OR ORGANIZATION:**

Nitah Daniels  
Signature

Nitah Daniels  
Print Name

Sherry Snell  
Witness

\_\_\_\_\_  
Witness

Sherry Snell  
Print Name

\_\_\_\_\_  
Print Name

**STATE OF FLORIDA  
COUNTY OF WASHINGTON**

The foregoing instrument was acknowledged before me by \_\_\_\_\_, who is personally known to me or who produced FL Drivers License as identification, and who executed the foregoing instrument and acknowledge before me that he/she executed the same freely and voluntarily and for purposes expressed therein.

Witness my hand and seal in the County and State last aforesaid this 9th day of March, 2026.

Sherry Snell  
Notary Public



# CERTIFICATE OF LIABILITY INSURANCE

Section H, Item 8.

THIS CERTIFICATE IS ISSUED AS A MATTER OF INFORMATION ONLY AND CONFERS NO RIGHTS UPON THE CERTIFICATE HOLDER. THIS CERTIFICATE DOES NOT AFFIRMATIVELY OR NEGATIVELY AMEND, EXTEND OR ALTER THE COVERAGE AFFORDED BY THE POLICIES BELOW. THIS CERTIFICATE OF INSURANCE DOES NOT CONSTITUTE A CONTRACT BETWEEN THE ISSUING INSURER(S), AUTHORIZED REPRESENTATIVE OR PRODUCER, AND THE CERTIFICATE HOLDER.

**IMPORTANT:** If the certificate holder is an ADDITIONAL INSURED, the policy(ies) must be endorsed. If SUBROGATION IS WAIVED, subject to the terms and conditions of the policy, certain policies may require an endorsement. A statement on this certificate does not confer rights to the certificate holder in lieu of such endorsement(s).

<b>PRODUCER</b> Foresite Sports LLC DBA: Eventsured 3553 West Chester Pike #418 Newtown Square, PA 19073	<b>CONTACT NAME:</b> Eventsured Customer Service <b>PHONE (A/C, No, Ext):</b> 888-882-5902 <b>E-MAIL ADDRESS:</b> info@eventsured.com	<b>FAX (A/C, No):</b>
	<b>INSURER(S) AFFORDING COVERAGE</b>	
<b>INSURED</b>  Nikeh Daniels 803 Ingle Rd DeFuniak Springs, FL 32428	<b>INSURER A:</b> Houston Casualty Company	<b>NAIC #</b> 42374
	<b>INSURER B:</b>	
	<b>INSURER C:</b>	
	<b>INSURER D:</b>	
	<b>INSURER E:</b>	
	<b>INSURER F:</b>	

**COVERAGES**                      **CERTIFICATE NUMBER:** TM507999                      **REVISION NUMBER:**

THIS IS TO CERTIFY THAT THE POLICIES OF INSURANCE LISTED BELOW HAVE BEEN ISSUED TO THE INSURED NAMED ABOVE FOR THE POLICY PERIOD INDICATED. NOTWITHSTANDING ANY REQUIREMENT, TERM OR CONDITION OF ANY CONTRACT OR OTHER DOCUMENT WITH RESPECT TO WHICH THIS CERTIFICATE MAY BE ISSUED OR MAY PERTAIN, THE INSURANCE AFFORDED BY THE POLICIES DESCRIBED HEREIN IS SUBJECT TO ALL THE TERMS, EXCLUSIONS AND CONDITIONS OF SUCH POLICIES. LIMITS SHOWN MAY HAVE BEEN REDUCED BY PAID CLAIMS.

INSR LTR	TYPE OF INSURANCE	ADDL SUBR INSR   WVD	POLICY NUMBER	POLICY EFF (MM/DD/YYYY)	POLICY EXP (MM/DD/YYYY)	LIMITS	
A	<b>GENERAL LIABILITY</b> <input checked="" type="checkbox"/> COMMERCIAL GENERAL LIABILITY <input type="checkbox"/> CLAIMS-MADE <input checked="" type="checkbox"/> OCCUR <input checked="" type="checkbox"/> Host Liquor Liability		H25SE00172/TM507999	06/27/2026 12:01AM	06/29/2026 2:01AM	EACH OCCURRENCE \$ 1,000,000	
	GENL AGGREGATE LIMIT APPLIES PER:					DAMAGE TO RENTED PREMISES (Ea occurrence) \$ 100,000	
	<input checked="" type="checkbox"/> POLICY	<input type="checkbox"/> PROJECT				<input type="checkbox"/> LOC	MED EXP (Any one person) \$ 1,000
						PERSONAL & ADV INJURY \$ 1,000,000	
	<b>AUTOMOBILE LIABILITY</b> <input type="checkbox"/> ANY AUTO <input type="checkbox"/> ALL OWNED AUTOS <input type="checkbox"/> HIRED AUTOS <input type="checkbox"/> SCHEDULED AUTOS <input type="checkbox"/> NON-OWNED AUTOS					COMBINED SINGLE LIMIT (Ea accident) \$ BODILY INJURY (Per person) \$ BODILY INJURY (Per accident) \$ PROPERTY DAMAGE (Per accident) \$ \$	
	<b>UMBRELLA LIAB</b> <input type="checkbox"/> EXCESS LIAB <input type="checkbox"/> OCCUR <input type="checkbox"/> CLAIMS-MADE DED      RETENTION \$					EACH OCCURRENCE \$ AGGREGATE \$ \$	
	<b>WORKERS COMPENSATION AND EMPLOYERS' LIABILITY</b> ANY PROPRIETOR/PARTNER/EXECUTIVE OFFICER/MEMBER EXCLUDED? (Mandatory in NH) If yes, describe under DESCRIPTION OF OPERATIONS below	Y/N <input type="checkbox"/> N/A				WC STATUTORY LIMITS      OTH-ER E.L. EACH ACCIDENT \$ E.L. DISEASE - EA EMPLOYEE \$ E.L. DISEASE - POLICY LIMIT \$	

**DESCRIPTION OF OPERATIONS / LOCATIONS / VEHICLES (Attach ACORD 101, Additional Remarks Schedule, if more space is required)**  
Additional Insureds must be venue managers or municipalities and are added with respect to our insureds operations only. Waiver of Subrogation (WOS) and Primary & Non-Contributory (PNC) wording applies only when coverage is purchased by the insured, required by written contract and as indicated below. This coverage is with respect to the Family Reunion to be held on 06/27/2026 - 06/28/2026 with 500 attendees at City of Chipley 1189 E Church Avenue chipley, FL 32428.

<b>CERTIFICATE HOLDER</b>  City of Chipley 1189 E Church Avenue chipley FL. 32428	<b>CANCELLATION</b>  SHOULD ANY OF THE ABOVE DESCRIBED POLICIES BE CANCELLED BEFORE THE EXPIRATION DATE THEREOF, NOTICE WILL BE DELIVERED IN ACCORDANCE WITH THE POLICY PROVISIONS.  AUTHORIZED REPRESENTATIVE 
---	---

The ACORD name and logo are registered marks of ACORD

# CITY OF CHIPLEY

## STAFF REPORT

**SUBJECT:** Special Event Application – Panhandle Watermelon Festival Parade

**MEETING DATE**

Tuesday, April 14, 2026

**PREPARED BY**

Patrice Tanner, City Administrator

**SUMMARY**

This event will be held on Saturday, June 27, 2026 starting at 10:00 a.m. using the standard parade route. Insurance is not required for this event.

**RECOMMENDATION**

City Staff recommends approval of the Special Event Application for the Panhandle Watermelon Festival Parade.

**ATTACHMENTS**

1. Special Event Application



# City of Chipley



**CITY HALL**  
1442 Jackson Avenue  
P.O. Box 1007  
Chipley, Florida 32428  
(850) 638-6350

## Special Event Application

Name/Organization: Panhandle Watermelon Festival

Address: P.O. Box 550 Chipley FL 32428

Contact person: Lora Fisher Phone: 850-527-8256 Fax: \_\_\_\_\_

E-mail: lorafisher15@yahoo.com

Type of Event: Festival Parade 10:00am June 27, 2026

Purpose of Event: To provide the community with a free concert, parade, car show and other free activities June 26 & 27.

Location of Event: Jim Trawick Park/Ag Center Indoors/Outdoors

Date(s) & Time(s) of Event: June 26 & 27, 2026

Amount of Liability Insurance: Yes \$1,000,000 (attach copy of policy)

Concert Yes/No If yes, What type of music? Yes Country

Will food and nonalcoholic beverages be sold? Yes

Will fireworks be displayed? Yes  No  If yes, provide name, license number and pyrotechnic plan to be approved by Fire Chief.

Will amusement rides be available? No

Number of participants anticipated per day: 1800

Are security and/or medical services provided? Yes

Applicant Signature: Lora Fisher Date: 3/13/2026

Approved { } Denied { }  
Mayor's Signature: \_\_\_\_\_ Date: \_\_\_\_\_

**RELEASE AND HOLD HARMLESS AGREEMENT**

**FOR THE SOLE CONSIDERATION OF** the City of Chipley granting permission for the undersigned to conduct a Parade June 27, 2026 upon street(s) as provided for in it's letter of request, the undersigned agrees to indemnify and hold harmless the City of Chipley, it's successors, agents and assigns and all other persons, firms or corporations, from any and all claims, demands, damages, actions, causes of actions or suits of any kind or nature whatsoever, and particularly on account of all injuries, both to person and property, which may result from the use of the street(s) as described above, and releases forever discharges the City of Chipley, for any such Claims.

Undersigned hereby declares that the terms of this agreement and lease have been completely read and are fully understood and voluntarily accepted.

**IN WITNESS WHEREOF**, the undersigned has executed this release, this 13<sup>th</sup> day of March, 2026.

**FIRM OR ORGANIZATION:** Panhandle Watermelon Festival

*Lora Fisher*  
Signature

Lora Fisher  
Print Name

*Christina Gentes*  
Witness

Christina Gentes  
Witness

Ashley Corbin  
Print Name

Ashley Corbin  
Print Name

**STATE OF FLORIDA  
COUNTY OF WASHINGTON**

The foregoing instrument was acknowledged before me by Lora Fisher, who is personally known to me or who produced FLDL as identification, and who executed the foregoing instrument and acknowledge before me that he/she executed the same freely and voluntarily and for purposes expressed therein.

Witness my hand and seal in the County and State last aforesaid this 13<sup>th</sup> day of March, 2026.

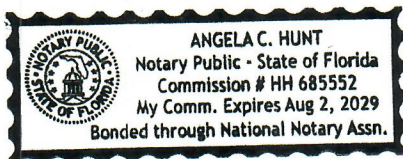

*Angela C. Hunt*  
Notary Public

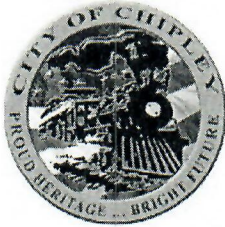

# City of Chipley

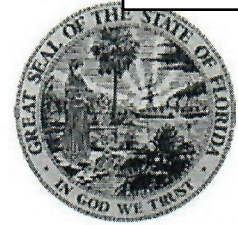

**CITY HALL**  
 1442 Jackson Avenue  
 P.O. Box 1007  
 Chipley, Florida 32428  
 (850) 638-6350

## Request for Temporary Closure of City Road/Sidewalk/Alleyway

Name of Organization: <i>Panhandle Watermelon Festival</i>		Person in Charge: <i>Colby Peel</i>		Date: <i>3/15/26</i>
Address of Organization: <i>PO Box 550 Chipley FL 32428</i>			Telephone Number: <i>850-258-6290</i>	
Title of Event: <i>Panhandle Watermelon Festival Parade</i>				
Date of Event: <i>4/27/2026</i>	Starting Time of Event: <i>10:00 AM</i>	Duration of Event: <i>1 hour</i>	Actual Closing Time (Set up of barriers, Etc.) <i>9:30-11:00</i>	
Proposed Parade Route or Road/Sidewalk/Alleyway Closure (Include Exact Road Names and Map of Route):  				
This section is to be completed when closure is for special event filming.				
Liability Insurance Carrier:		Policy E#	Date:	
Coverage Amount:		(\$1,000)	Minimum	
Length of Coverage:		Days		
Licenses Pyrotechnics Operator: _____				
License Number: _____				
Approval of Local Fire Department: _____				
Federal Aviation Administration Approval for Low Flying Filming: _____				
Additional Liability Insurance Amount: _____				
<b>PLEASE DO NOT WRITE BELOW THIS LINE</b>				
Detour Route (Include Exact Road Names and Map of Detour Route):  				
Name of Department Responsible for Traffic Control (City Police Department, Sheriff's Department, Highway Patrol): <b>Chipley City Police Department</b>				
Special Conditions: <b>Use this route only!</b>				
Name of Police Chief: <b>Michael Richter</b>		Signature of Police Chief:		Date Signed:
Name and Title of City Official: <b>Patrice Tanner, City Administrator</b>		Signature of City Official:		Date Signed:

# CITY OF CHIPLEY

## STAFF REPORT

**SUBJECT:** Special Event Application – Community Outreach – Washington County Christian School

**MEETING DATE**

Tuesday, April 14, 2026

**PREPARED BY**

Patrice Tanner, City Administrator

**SUMMARY**

Correction of date: This event will be held on Friday, April 17, 2026.

The Washington County Christian School would like to have a community outreach event on Friday, April 17, 2026 from 4:00 p.m. to 6:00 p.m. at Shivers Park. There will be food trucks and a train and will be playing Christian music.

**RECOMMENDATION**

City Staff recommends approval of the Special Event Application for the Community Outreach by the Washington County Christian School.

**ATTACHMENTS**

- 1. Special Event Application
- 2. Insurance



# City of Chipley



CITY HALL  
1442 Jackson Avenue  
P.O. Box 1007  
Chipley, Florida 32428  
(850) 638-6350

## Special Event Application

Name/Organization: Washington County Christian School

Address: 1405 Brickyard Rd. Chipley, Fl. 32428

Contact person: Francesca Kirkman Phone: 850-638-9227 Fax: \_\_\_\_\_

E-mail: wccslions@gmail.com

Type of Event: Spring Fling

Purpose of Event: Community Outreach

Location of Event: Shivers Park Indoors  Outdoors

Date(s) & Time(s) of Event: April 17, 2026 4:00 pm - 6:00 pm

Amount of Liability Insurance: Attached (attach copy of policy)

Concert Yes  No  If yes, What type of music? Will be playing Christian music

Will food and nonalcoholic beverages be sold? Yes, Foodtrucks.

Will fireworks be displayed? Yes  No  If yes, provide name, license number and pyrotechnic plan to be approved by Fire Chief.

Will amusement rides be available? No, would like to have a train.

Number of participants anticipated per day: 350

Are security and/or medical services provided? If required.

Applicant Signature: Francesca Kirkman Date: 2/17/26

Approved { } Denied { }

Mayor's Signature: \_\_\_\_\_ Date: \_\_\_\_\_

RELEASE AND HOLD HARMLESS AGREEMENT

FOR THE SOLE CONSIDERATION OF the City of Chipley granting permission for the undersigned to conduct a Spring Fling upon street(s) as provided for in it's letter of request, the undersigned agrees to indemnify and hold harmless the City of Chipley, it's successors, agents and assigns and all other persons, firms or corporations, from any and all claims, demands, damages, actions, causes of actions or suits of any kind or nature whatsoever, and particularly on account of all injuries, both to person and property, which may result from the use of the street(s) as described above, and releases forever discharges the City of Chipley, for any such Claims.

Undersigned hereby declares that the terms of this agreement and lease have been completely read and are fully understood and voluntarily accepted.

IN WITNESS WHEREOF, the undersigned has executed this release, this 17th day of February, 2026.

FIRM OR ORGANIZATION: Washington County Christian School

Handwritten signature of Francesca Kirkman over a line, with the word 'Signature' printed below.

Printed name 'Francesca Kirkman' over a line, with the words 'Print Name' printed below.

Horizontal line with the word 'Witness' printed below it.

Horizontal line with the word 'Witness' printed below it.

Horizontal line with the words 'Print Name' printed below it.

Horizontal line with the words 'Print Name' printed below it.

STATE OF FLORIDA
COUNTY OF WASHINGTON

The foregoing instrument was acknowledged before me by Francesca Kirkman, who is personally known to me or who produced Personally Known as identification, and who executed the foregoing instrument and acknowledge before me that he/she executed the same freely and voluntarily and for purposes expressed therein.

Witness my hand and seal in the County and State last aforesaid this 17th day of February, 2026.

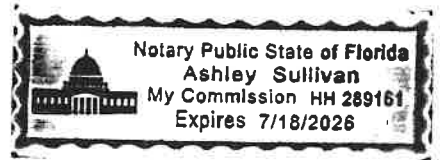

Handwritten signature of the Notary Public over a line, with the words 'Notary Public' printed below.



# CERTIFICATE OF LIABILITY INSURANCE

Section H, Item 10.

THIS CERTIFICATE IS ISSUED AS A MATTER OF INFORMATION ONLY AND CONFERS NO RIGHTS UPON THE CERTIFICATE HOLDER. THIS CERTIFICATE DOES NOT AFFIRMATIVELY OR NEGATIVELY AMEND, EXTEND OR ALTER THE COVERAGE AFFORDED BY THE POLICIES BELOW. THIS CERTIFICATE OF INSURANCE DOES NOT CONSTITUTE A CONTRACT BETWEEN THE ISSUING INSURER(S), AUTHORIZED REPRESENTATIVE OR PRODUCER, AND THE CERTIFICATE HOLDER.

**IMPORTANT:** If the certificate holder is an **ADDITIONAL INSURED**, the policy(ies) must have **ADDITIONAL INSURED** provisions or be endorsed. If **SUBROGATION IS WAIVED**, subject to the terms and conditions of the policy, certain policies may require an endorsement. A statement on this certificate does not confer rights to the certificate holder in lieu of such endorsement(s).

<b>PRODUCER</b> Rogers Insurance Agency 1396 JACKSON AVENUE P.O. BOX 430 CHIPLEY FL 32428	<b>CONTACT NAME:</b> Robert Lane <b>PHONE (A/C, No, Ext):</b> (850) 638-1805 <b>E-MAIL ADDRESS:</b> robert@riachipley.com	<b>FAX (A/C, No):</b> (850) 638-7255
	<b>INSURER(S) AFFORDING COVERAGE</b> <b>INSURER A:</b> Guide One Mutual Insurance Company <b>INSURER B:</b> <b>INSURER C:</b> <b>INSURER D:</b> <b>INSURER E:</b> <b>INSURER F:</b>	
<b>INSURED</b> Washington County Christian School, Inc. 1405 Brickyard Road Chipley FL 32428		

**COVERAGES**                      **CERTIFICATE NUMBER:** CL2621004247                      **REVISION NUMBER:**

THIS IS TO CERTIFY THAT THE POLICIES OF INSURANCE LISTED BELOW HAVE BEEN ISSUED TO THE INSURED NAMED ABOVE FOR THE POLICY PERIOD INDICATED. NOTWITHSTANDING ANY REQUIREMENT, TERM OR CONDITION OF ANY CONTRACT OR OTHER DOCUMENT WITH RESPECT TO WHICH THIS CERTIFICATE MAY BE ISSUED OR MAY PERTAIN, THE INSURANCE AFFORDED BY THE POLICIES DESCRIBED HEREIN IS SUBJECT TO ALL THE TERMS, EXCLUSIONS AND CONDITIONS OF SUCH POLICIES. LIMITS SHOWN MAY HAVE BEEN REDUCED BY PAID CLAIMS.

INSR LTR	TYPE OF INSURANCE	ADDL INSD	SUBR WVD	POLICY NUMBER	POLICY EFF (MM/DD/YYYY)	POLICY EXP (MM/DD/YYYY)	LIMITS
A	<input checked="" type="checkbox"/> <b>COMMERCIAL GENERAL LIABILITY</b> <input type="checkbox"/> CLAIMS-MADE <input checked="" type="checkbox"/> OCCUR  GEN'L AGGREGATE LIMIT APPLIES PER: <input type="checkbox"/> POLICY <input type="checkbox"/> PRO-JECT <input type="checkbox"/> LOC OTHER:			1261-822	04/02/2025	04/02/2026	EACH OCCURRENCE \$ 1,000,000 DAMAGE TO RENTED PREMISES (Ea occurrence) \$ MED EXP (Any one person) \$ 5,000 PERSONAL & ADV INJURY \$ 1,000,000 GENERAL AGGREGATE \$ 3,000,000 PRODUCTS - COMP/OP AGG \$ 3,000,000 Damage to Premises \$ 1,000,000
	<b>AUTOMOBILE LIABILITY</b> <input type="checkbox"/> ANY AUTO <input type="checkbox"/> OWNED AUTOS ONLY <input type="checkbox"/> SCHEDULED AUTOS <input type="checkbox"/> HIRED AUTOS ONLY <input type="checkbox"/> NON-OWNED AUTOS ONLY						COMBINED SINGLE LIMIT (Ea accident) \$ BODILY INJURY (Per person) \$ BODILY INJURY (Per accident) \$ PROPERTY DAMAGE (Per accident) \$
	<input type="checkbox"/> <b>UMBRELLA LIAB</b> <input type="checkbox"/> OCCUR <input type="checkbox"/> <b>EXCESS LIAB</b> <input type="checkbox"/> CLAIMS-MADE DED    RETENTION \$						EACH OCCURRENCE \$ AGGREGATE \$
	<b>WORKERS COMPENSATION AND EMPLOYERS' LIABILITY</b> ANY PROPRIETOR/PARTNER/EXECUTIVE OFFICER/MEMBER EXCLUDED? (Mandatory in NH) If yes, describe under DESCRIPTION OF OPERATIONS below			N/A			PER STATUTE    OTH-ER E.L. EACH ACCIDENT \$ E.L. DISEASE - EA EMPLOYEE \$ E.L. DISEASE - POLICY LIMIT \$

DESCRIPTION OF OPERATIONS / LOCATIONS / VEHICLES (ACORD 101, Additional Remarks Schedule, may be attached if more space is required)

<b>CERTIFICATE HOLDER</b>  City of Chipley 1442 Jackson Avenue P O Box 1007 Chipley FL 32428	<b>CANCELLATION</b>  SHOULD ANY OF THE ABOVE DESCRIBED POLICIES BE CANCELLED BEFORE THE EXPIRATION DATE THEREOF, NOTICE WILL BE DELIVERED IN ACCORDANCE WITH THE POLICY PROVISIONS.  <b>AUTHORIZED REPRESENTATIVE</b> 
---	--

# ADDITIONAL COVERAGES

Section H, Item 10.

<b>Ref #</b>	<b>Description</b> Sexual Misconduct Liability Medical Expense	<b>Coverage Code</b>	<b>Form No.</b>	<b>Edition Date</b>
<b>Limit 1</b> 10,000	<b>Limit 2</b>	<b>Limit 3</b>	<b>Deductible Amount</b>	<b>Deductible Type</b>
				<b>Premium</b>
<b>Ref #</b>	<b>Description</b> Employee Benefits Liab Aggregate Limit	<b>Coverage Code</b>	<b>Form No.</b>	<b>Edition Date</b>
<b>Limit 1</b> 3,000,000	<b>Limit 2</b>	<b>Limit 3</b>	<b>Deductible Amount</b> 1,000	<b>Deductible Type</b> Flat
				<b>Premium</b>
<b>Ref #</b>	<b>Description</b> D&O Educators Legal Each Policy period Non Mo	<b>Coverage Code</b>	<b>Form No.</b>	<b>Edition Date</b>
<b>Limit 1</b> 10,000	<b>Limit 2</b>	<b>Limit 3</b>	<b>Deductible Amount</b> 1,000	<b>Deductible Type</b> Flat
				<b>Premium</b>
<b>Ref #</b>	<b>Description</b> D&O Educators Legal Aggregate Limit	<b>Coverage Code</b>	<b>Form No.</b>	<b>Edition Date</b>
<b>Limit 1</b> 1,000,000	<b>Limit 2</b>	<b>Limit 3</b>	<b>Deductible Amount</b> 1,000	<b>Deductible Type</b> Flat
				<b>Premium</b>
<b>Ref #</b>	<b>Description</b> Crisis Management Organizational Limit Aggreg	<b>Coverage Code</b>	<b>Form No.</b>	<b>Edition Date</b>
<b>Limit 1</b> 100,000	<b>Limit 2</b>	<b>Limit 3</b>	<b>Deductible Amount</b>	<b>Deductible Type</b>
				<b>Premium</b>
<b>Ref #</b>	<b>Description</b> D&O Educators Legal Each Claim Limit	<b>Coverage Code</b>	<b>Form No.</b>	<b>Edition Date</b>
<b>Limit 1</b> 1,000,000	<b>Limit 2</b>	<b>Limit 3</b>	<b>Deductible Amount</b> 1,000	<b>Deductible Type</b> Flat
				<b>Premium</b>
<b>Ref #</b>	<b>Description</b> EMPLOYMENT PRACTICES LIABILITY	<b>Coverage Code</b>	<b>Form No.</b>	<b>Edition Date</b>
<b>Limit 1</b> 1,000,000	<b>Limit 2</b>	<b>Limit 3</b>	<b>Deductible Amount</b> 5,000	<b>Deductible Type</b> Flat
				<b>Premium</b>
<b>Ref #</b>	<b>Description</b> Employee Benefits Liab Each Employee	<b>Coverage Code</b>	<b>Form No.</b>	<b>Edition Date</b>
<b>Limit 1</b> 1,000,000	<b>Limit 2</b>	<b>Limit 3</b>	<b>Deductible Amount</b> 1,000	<b>Deductible Type</b> Flat
				<b>Premium</b>
<b>Ref #</b>	<b>Description</b> Crisis Management Individual Exp Aggregate	<b>Coverage Code</b>	<b>Form No.</b>	<b>Edition Date</b>
<b>Limit 1</b> 200,000	<b>Limit 2</b>	<b>Limit 3</b>	<b>Deductible Amount</b>	<b>Deductible Type</b>
				<b>Premium</b>
<b>Ref #</b>	<b>Description</b> Sexual Misconduct Liability Aggregate Limit	<b>Coverage Code</b>	<b>Form No.</b>	<b>Edition Date</b>
<b>Limit 1</b> 300,000	<b>Limit 2</b>	<b>Limit 3</b>	<b>Deductible Amount</b>	<b>Deductible Type</b>
				<b>Premium</b>
<b>Ref #</b>	<b>Description</b> Crisis Management Medical Exp/Person Limit	<b>Coverage Code</b>	<b>Form No.</b>	<b>Edition Date</b>
<b>Limit 1</b> 50,000	<b>Limit 2</b>	<b>Limit 3</b>	<b>Deductible Amount</b>	<b>Deductible Type</b>
				<b>Premium</b>

# ADDITIONAL COVERAGES

Section H, Item 10.

<b>Ref #</b>	<b>Description</b> Sexual Misconduct Liability Each Claim	<b>Coverage Code</b>	<b>Form No.</b>	<b>Edition Date</b>
<b>Limit 1</b> 100,000	<b>Limit 2</b> 300,000	<b>Limit 3</b>	<b>Deductible Amount</b>	<b>Deductible Type</b>
<b>Premium</b>				
<b>Ref #</b>	<b>Description</b> Crisis Management Event Aggregate Limit	<b>Coverage Code</b>	<b>Form No.</b>	<b>Edition Date</b>
<b>Limit 1</b> 300,000	<b>Limit 2</b>	<b>Limit 3</b>	<b>Deductible Amount</b>	<b>Deductible Type</b>
<b>Premium</b>				
<b>Ref #</b>	<b>Description</b> Crisis Event Individual Counseling Exp/Person	<b>Coverage Code</b>	<b>Form No.</b>	<b>Edition Date</b>
<b>Limit 1</b> 2,500	<b>Limit 2</b>	<b>Limit 3</b>	<b>Deductible Amount</b>	<b>Deductible Type</b>
<b>Premium</b>				
<b>Ref #</b>	<b>Description</b>	<b>Coverage Code</b>	<b>Form No.</b>	<b>Edition Date</b>
<b>Limit 1</b>	<b>Limit 2</b>	<b>Limit 3</b>	<b>Deductible Amount</b>	<b>Deductible Type</b>
<b>Premium</b>				
<b>Ref #</b>	<b>Description</b>	<b>Coverage Code</b>	<b>Form No.</b>	<b>Edition Date</b>
<b>Limit 1</b>	<b>Limit 2</b>	<b>Limit 3</b>	<b>Deductible Amount</b>	<b>Deductible Type</b>
<b>Premium</b>				
<b>Ref #</b>	<b>Description</b>	<b>Coverage Code</b>	<b>Form No.</b>	<b>Edition Date</b>
<b>Limit 1</b>	<b>Limit 2</b>	<b>Limit 3</b>	<b>Deductible Amount</b>	<b>Deductible Type</b>
<b>Premium</b>				
<b>Ref #</b>	<b>Description</b>	<b>Coverage Code</b>	<b>Form No.</b>	<b>Edition Date</b>
<b>Limit 1</b>	<b>Limit 2</b>	<b>Limit 3</b>	<b>Deductible Amount</b>	<b>Deductible Type</b>
<b>Premium</b>				
<b>Ref #</b>	<b>Description</b>	<b>Coverage Code</b>	<b>Form No.</b>	<b>Edition Date</b>
<b>Limit 1</b>	<b>Limit 2</b>	<b>Limit 3</b>	<b>Deductible Amount</b>	<b>Deductible Type</b>
<b>Premium</b>				
<b>Ref #</b>	<b>Description</b>	<b>Coverage Code</b>	<b>Form No.</b>	<b>Edition Date</b>
<b>Limit 1</b>	<b>Limit 2</b>	<b>Limit 3</b>	<b>Deductible Amount</b>	<b>Deductible Type</b>
<b>Premium</b>				
<b>Ref #</b>	<b>Description</b>	<b>Coverage Code</b>	<b>Form No.</b>	<b>Edition Date</b>
<b>Limit 1</b>	<b>Limit 2</b>	<b>Limit 3</b>	<b>Deductible Amount</b>	<b>Deductible Type</b>
<b>Premium</b>				
<b>Ref #</b>	<b>Description</b>	<b>Coverage Code</b>	<b>Form No.</b>	<b>Edition Date</b>
<b>Limit 1</b>	<b>Limit 2</b>	<b>Limit 3</b>	<b>Deductible Amount</b>	<b>Deductible Type</b>
<b>Premium</b>				

# CITY OF CHIPLEY

## STAFF REPORT

**SUBJECT:** Request for a Variance - Chipola Area Habitat for Humanity - Corner of Pecan Street & 4th Avenue

**MEETING DATE** Tuesday, April 14, 2026 **PREPARED BY** Tamara Donjuan, Planning & Zoning Officer

### SUMMARY

Chipola Area Habitat for Humanity requests a variance for the signage for property located at the corner of Pecan Street and 4<sup>th</sup> Avenue. The proposed variance will allow signage to be placed in the right of way. The right of way is seventy (70) feet on Pecan Street and fifty (50) feet on 4<sup>th</sup> Avenue. The applicant is requesting placement of signage approximately twenty-two (22) feet encroached into the right of way, diagonally between 4<sup>th</sup> Avenue and Pecan Street. The signage placement would be between the property line and a fire hydrant. Installing proper signage for the Chipley Heights subdivision offers essential benefits, including improved navigation for emergency services, easier location for visitors/deliveries and creates community identity. Strategically placing the signage will ensure clear identification without causing traffic obstructions, enhancing safety and visibility.

City of Chipley’s Code of Ordinances reviewed are listed below.

### ARTICLE VI. - DISTRICT REGULATIONS

#### Sec. 44-150. - Residential land use districts.

Yard setback:

- (i) Front: 30 feet.
- (ii) Side: Ten feet.
- (iii) Rear: 20 feet, principal building.

### ARTICLE XI. - VARIANCES

#### Sec. 44-293. - Hearing on petition.

- (b) In considering variances to the land development code, the city council shall, before making a decision in a specific case, first determine:
  - (1) That the proposed variation does not constitute a change in the districts shown on the zoning map;
  - (2) That the proposed variation will not significantly increase congestion in the public streets nor impair the public safety;
  - (3) That the proposed variation will not impair the established values of property in the surrounding area;
  - (4) That special conditions and circumstances exist which are peculiar to the land, structure or building involved and which are not applicable to other lands, structures or buildings in the same zoning district;
  - (5) That the special conditions and circumstances do not result from the actions of the applicant;
  - (6) That granting the variance requested will not confer on the applicant any special privilege that is denied by the Code to other lands, buildings or structures in the same zoning district;

- (7) That literal interpretation of the provisions of the Code would deprive the applicant of rights commonly enjoyed by others in the same zoning district under the terms of the Code and would work unnecessary and undue hardship on the applicant:
- (8) That the variance granted is the minimum variance that will make possible the reasonable use of the land, building or structure:
- (9) That the grant of the variance will be in harmony with the general intent and purpose of the Code and that such variance will not be injurious to the area involved or otherwise detrimental to the public welfare:

The notice of hearing was sent via certified mail on March 12, 2026, to thirty-six (36) property owners located within 300 feet of the property requesting the variance, at the corner of Pecan Street and 4th Avenue. To date, eighteen (18) recipients have signed for the certified mail, and one notice has been returned.

According to FEMA National Flood Hazard Layer data maps approximately 100% of the property is in Flood Zone "X", which is an area of minimal flood hazard.

The Planning and Zoning Commission met on April 7, 2026, at 3:00 p.m. and approved the recommendation by a vote of four (4) to zero (0).

**RECOMMENDATION**

City Staff recommend approval of the proposed variance for signage placement, due to limited frontage for code-compliant signage.

**ATTACHMENTS**

Variance packet with supporting documents.



# City of Chipley

1442 Jackson Avenue  
Post Office Box 1007  
Chipley, Florida 32428  
Phone: (850) 638-6350



## Variance Application Review – Corner of Pecan Street and 4<sup>th</sup> Avenue

We performed a review of the request for variance for an exception to signage requirements. The property is located at the corner of Pecan Street and 4<sup>th</sup> Avenue, Chipley, Florida. The purpose of the review is to identify whether the proposed placement of the signage is consistent with Article XI – Variances of the City of Chipley Code of Ordinances.

### *Variance Application Requirements*

#### Article XI – Variances

Pursuant to Sec. 44-289 the applicant submitted a variance application on January 28, 2026. This was reviewed against the requirements listed in Sec. 44-290.

Pursuant to Sec. 44-290, the petition for a variance to the land development code shall be evaluated based on the below determinations:

(1) That the proposed variation does not constitute a change in the districts shown on the zoning map:

*No zoning district will be changed with this variance.*

(2) That the proposed variation will not significantly increase congestion in the public streets nor impair the public safety:

*There will be no increased congestion or public safety concerns with this variance.*

(3) That the proposed variation will not impair the established values of property in the surrounding area:

*Property values will not be impaired by this variance.*

(4) That special conditions and circumstances exist which are peculiar to the land, structure or building involved and which are not applicable to other lands, structures, or buildings in the same zoning district:

*The special condition of the signage is that the signage will be encroached into the right of way approximately (22) twenty-two feet. Signage will be placed (10) ten feet behind fire hydrant. Placement of the signage would be between the property line and fire hydrant. Signage would be approximately (42) forty-two square feet in size. Materials for*

*the sign will be stucco over foam with thin metal signboard on one side with vinyl lettering. The City of Chipley Land Development Code does not provide requirements for or exceptions to the code as it relates to signage placement.*

- (5) That the special conditions and circumstances do not result from the actions of the applicant:

*The applicant is aware that the signage placement is prohibited according to City of Chipley’s Code of Ordinance, Chapter 30, Sec. 30-3 Prohibited signs. It shall be unlawful to erect, cause to be erected, maintain, or cause to be maintained any sign not expressly authorized by or exempted from this chapter. The following signs are expressly prohibited: (17) Signs erected on public property, or on private property (such as private utility poles) located on public property, other than signs erected by a public authority for public purposes and signs authorized in writing pursuant to F.S. § [337.407](#) and is requesting a variance due to the unique physical hardship to the limited frontage for placement of signage for Chipley Height’s Subdivision.*

- (6) That granting the variance requested will not confer on the applicant any special privilege that is denied by the Code to other lands, buildings, or structures in the same zoning district:

*No special privileges will be granted to this applicant. The request is necessitated by unique, pre-existing physical characteristics of the land—such as limited frontage that make it impossible to place code-compliant signage. Placement of the signage would be between the property line and fire hydrant. Signage would be approximately (42) forty-two square feet in size.*

- (7) That literal interpretation of the provisions of the Code would deprive the applicant of rights commonly enjoyed by others in the same zoning district under the terms of the Code and would work unnecessary and undue hardship on the applicant:

*The unique physical hardship is due to limited frontage that makes it impossible to place code-compliant signage.*

- (8) That the variance granted is the minimum variance that will make possible the reasonable use of the land, building, or structure:

*Due to the limited frontage the request is for the minimum area required for safe identification and does not represent a special privilege.*

- (9) That the grant of the variance will be in harmony with the general intent and purpose of the Code and that such variance will not be injurious to the area involved or otherwise detrimental to the public welfare:

*Granting the variance will not be injurious to the area involved or otherwise detrimental to the public welfare. The placement of the signage will not be a sight-distance hazard for*

*drivers.*

Prepared By: Tamara Donjuan  
Final Review: 03/31/2026



---

Proudly Serving Jackson and Washington Counties

January 30, 2026

Tamara Donjuan  
City of Chipley Planning and Zoning Board,

On behalf of Chipola Area Habitat for Humanity, I respectfully submit this request for a variance to allow the installation of an identification sign at the corner of Pecan Street and 4th Avenue.

The purpose of this sign is to clearly identify the Chipley Heights subdivision for residents, visitors, emergency services, and delivery providers. This marker will enhance visibility, safety, and community identity without creating distraction or obstruction.

The proposed sign will have the following specifications:

- Base dimensions: 8 feet wide by 2 feet deep
- Overall height: 7 feet
- Construction: foam-based core material finished with a stucco exterior.
- Installation: mounted on two concealed poles for stability and a clean appearance

The design is intended to be attractive, durable, and consistent with the character of the surrounding neighborhood. The concealed supports and stucco finish will give the sign a permanent, attractive appearance rather than that of a typical freestanding sign. Due to the design materials, it will not create a hazard in the unfortunate case of a vehicle collision.

We believe this sign will contribute positively to the appearance of the area and serve a practical function for wayfinding and identification, while maintaining the aesthetic standards of the City of Chipley.

We respectfully request your consideration and approval of this variance and thank you for your ongoing partnership. Should you have questions or need additional information regarding our support of this project, please feel free to send an email to, [kevin@chipolahabitat.org](mailto:kevin@chipolahabitat.org), or call, (850) 482-2187.

In Community Partnership,

A handwritten signature in blue ink that reads "Kevin L. Yoder".

Kevin L. Yoder  
Executive Director

ZONING CHANGE OR VARIANCE REQUEST OR SPECIAL EXCEPTION

FEE: 8150. PD 1/28/26

Any applicant requesting a particular service specified herein shall make formal application to the City and shall pay the appropriate fee. No portion of the appropriate fee shall be refunded whether the request is withdrawn by the applicant or denied or granted by the City of Chipley.

Date 01/22/2026 Applicant's Name Kevin Yoder  
CHIPOLA AREA HABITAT

Phone 8504822187 Address PO BOX 6114, MARIANNA, FL 32447

[Signature] Signature of Applicant 1/22/2026 Date

\*\*\*\*\*

ADDRESS OR DESCRIPTION OF PROPERTY TO BE CONSIDERED: \_\_\_\_\_  
730 PECAN ST, CHIPLEY, FL

TYPE OF REQUEST: Zoning Change (O) Variance (⊙)

REASON FOR REQUEST: Request to place sign for Chipley Heights at the corner of Pecan St and 4th Ave within the right-of-way.

SUPPORTING DOCUMENT(S): site plan

\*\*\*\*\*

**ZONING BOARD USE ONLY**

DECISION OF ZONING BOARD: \_\_\_\_\_

\_\_\_\_\_  
Signature of Board Chairman Date

PERSON TO BE NOTIFIED OF BOARD DECISION: \_\_\_\_\_

Address: \_\_\_\_\_ Phone # \_\_\_\_\_

# City of Chipley — Site Plan Form

Applicant Name: CHIPOLA AREA HABITAT Address: corner of Pecan St

Section H, Item 11.

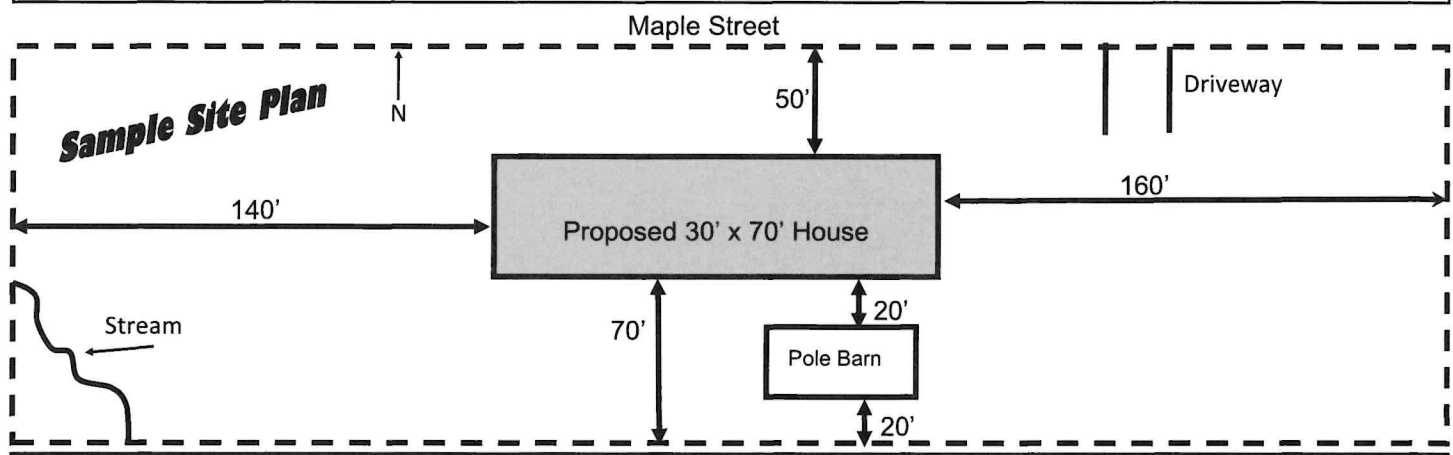

- Use the space below to provide a site plan. Your drawing must include the following:**
- Show which way is North on the property
  - Distance to proposed structure from property line and other structures
  - Nearest Public Road(s) including driveway connections or easements
  - All proposed and existing structures on the property
  - Proposed & existing septic tanks and well locations
  - Locations of lakes, ponds, rivers and streams and/or wetlands
  - Any other helpful information.



### Add/Change/Void Cash Receipt CD1280129

Money Received

	Amount	Type	Payment Info
<input checked="" type="checkbox"/>	150.00	CK	5208

Distributions

	Type	Amount	Apply To	Description	For	Discount Pen Forgive
<input checked="" type="checkbox"/>	FMSD	150.00	DIST CD: 2550	PLANNING & ZONING FEES-730 PECAN ST		0.00

Operator Code:

Receipt Code:

Receipt Date:

Voided

Distributions:

Money:

Change Due:

From:

Email Address:

Destination Phone:



# City of Chipley

1442 Jackson Avenue  
P.O. Box 1007  
Chipley, Florida 32428  
(850) 638-6350



## NOTICE OF PUBLIC HEARING

March 12, 2026

Dear Citizen:

The City of Chipley Planning & Zoning Commission will conduct a public hearing on April 7, 2026, at 3:00 p.m., City Hall Council Chambers. The purpose of this hearing is to review and consider the following request:

**Chipola Area Habitat for Humanity is requesting approval of a variance for signage setbacks that do not meet current code requirements.**

Property Location: Corner of Pecan Street and 4<sup>th</sup> Avenue

City Code Chapter 44 — Zoning  
Section 44-150 — Residential Land Use Districts

- a. Yard setback:
  - (i). Front; 30 feet.
  - (ii) Side; 10 feet.
  - (iii)Rear; 20 feet, principal building

In accordance with City Code of Ordinances Chapter 44, Article XI, property owners located within 300 feet of said location are to be notified.

The City Council will review the development order and variance at their meeting to be held on April 14, 2026, at 5:00 p.m., City Hall Council Chambers.

If you have any questions or need additional information regarding this request, please contact City Hall prior to the public hearing at (850) 638-6350.

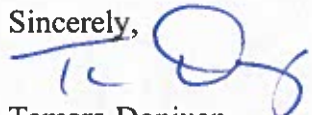
Sincerely,  

Tamara Donjuan  
Code Enforcement / Planning Officer

# CITY OF CHIPLEY AFFIDAVIT OF MAILING

March 12, 2026

Re: Notice of Public Hearing for the Planning and Zoning Commission, on April 7, 2026, at 3:00 pm., and Notice of Public Hearing for City Council on April 14, 2026, at 5:00 pm both located at 1442 Jackson Avenue, Chipley, FL 32428, in the city's chambers,

I, Tamara Donjuan, designated and employed by the City of Chipley, Florida, did mail the notice of a public hearings to the following:

See Exhibit A, on March 12, 2026.

	<u>3/12/26</u>
_____ Employee Signature	_____ Date

Sworn to and subscribed before me this 12<sup>th</sup> day of March, 2026 by Tamara Donjuan, who is personally known by me.

  
\_\_\_\_\_  
Signature of Notary Public

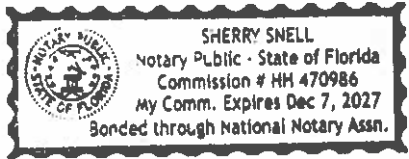

# Exhibit A

Section H, Item 11.

BELCHER BRENDA E, BELCHER DRESI  
PO BOX 513  
CHIPLEY, FL 32428

BELCHER BRENDA, BLECHER ANDRE  
PO BOX 513  
CHIPLEY, FL 32428

BOONE TIMOTHY JR, BOONE LINDSAY  
2959 HWY 277  
VERNON, FL 32462

BOSTON SABRINA & ETAL, TANNER LAS  
PO BOX 72  
CHIPLEY, FL 32428

BOYETTE SHANNON CATHERINE  
739 EAST BLVD  
CHIPLEY, FL 32428

CARTHON ARRIE  
637 BENNETT DR  
CHIPLEY, FL 32428

CHIPOLA AREA HAB FOR HUMANITY  
PO BOX 6114  
MARIANNA, FL 32447

DAVENPORT FRANKLIN E, PATTON JAN  
542 2ND ST  
APT G3  
CHIPLEY, FL 32428

DAVIS CLARKE  
747 EAST BLVD  
CHIPLEY, FL 32428

DAY PAUL PETE, DAY DEIDRA  
726 ALFORD RD  
CHIPLEY, FL 32428

ENGUM SHEILA  
PO BOX 237  
VERNON, FL 32462

HANCOCK LOUISE AKA & ETAL, HANCO  
30375 SHAMROCK ST N  
TALLAHASSEE, FL 32309

HOGAN EDITH JAUNITA  
C/O JOHNNY SMITH  
5089 WELLS DR  
EVANS, GA 30809

HUTCHINS ROBERT EARL  
% CHARLES HUTCHINS  
1535 HICKORY ST  
NICEVILLE, FL 32578

KENNEDY MABEL WILSON  
1174 4TH AVE  
CHIPLEY, FL 32428

KENNEDY TIFFANY K  
1182 4TH AVE  
CHIPLEY, FL 32428

MC DONALD JAMES R, MC DONALD JE/  
729 PECAN ST  
CHIPLEY, FL 32428

MORRIS PERCY  
PO BOX 302  
CHIPLEY, FL 32428

MUNYON PAUL J, MUNYON GAY L  
3037 SHAMROCK ST N  
TALLAHASSEE, FL 32309

PATRICK SHIRLEY, PATRICK MARK  
737 EAST BLVD  
CHIPLEY, FL 32428

PETERSON SHEILA L  
2979 SYLVANIA RD  
VERNON, FL 32462

POTTER JOSEPHINE C  
1184 4TH AVE  
CHIPLEY, FL 32428

REED GWUAN & ETAL, EDWARDS CHRI  
750 ORANGE ST  
CHIPLEY, FL 32428

RHYNE LESTER AKA, RHYNES LESTER  
637 BENNETT DR  
CHIPLEY, FL 32428

RITTMAN CHARITY, KENNEDY LEDELL  
747 PECAN ST  
CHIPLEY, FL 32428

ROUSE EDITH  
1181 4TH AVE  
CHIPLEY, FL 32428

SAPP MELISSA MYRL  
745 EAST BLVD  
CHIPLEY, FL 32428

SHACKELFORD FREDERICK & ETAL, SH  
2220 MINGO LN  
COTTONDALE, FL 32431

SHARPE ALVIN JR & ETAL, DOUGLAS M  
1179 4TH AVE  
CHIPLEY, FL 32428

SIMMONS BEVERLY  
757 EAST BLVD  
CHIPLEY, FL 32428

SIMMONS ELMER, SIMMONS BEVERLY  
757 EAST BLVD  
CHIPLEY, FL 32428

VANN BILLY, VANN CHRISTINE  
PO BOX 312  
CHIPLEY, FL 32428

VANN MAMIE & ETAL, VANN BRIDGET  
741 PECAN ST  
CHIPLEY, FL 32428

WHITTINGTON STEVEN C, WHITTINGTON  
1143 WHITTINGTON RD  
CHIPLEY, FL 32428

WILLIAMS MORDECAI  
756 ORANGE ST  
CHIPLEY, FL 32428

WILSON KATHY GAIL  
1119 BATON ROUGE CT  
TALLAHASSEE, FL 32305

# National Flood Hazard Layer FIRMette



85°32'13"W 30°46'47"N

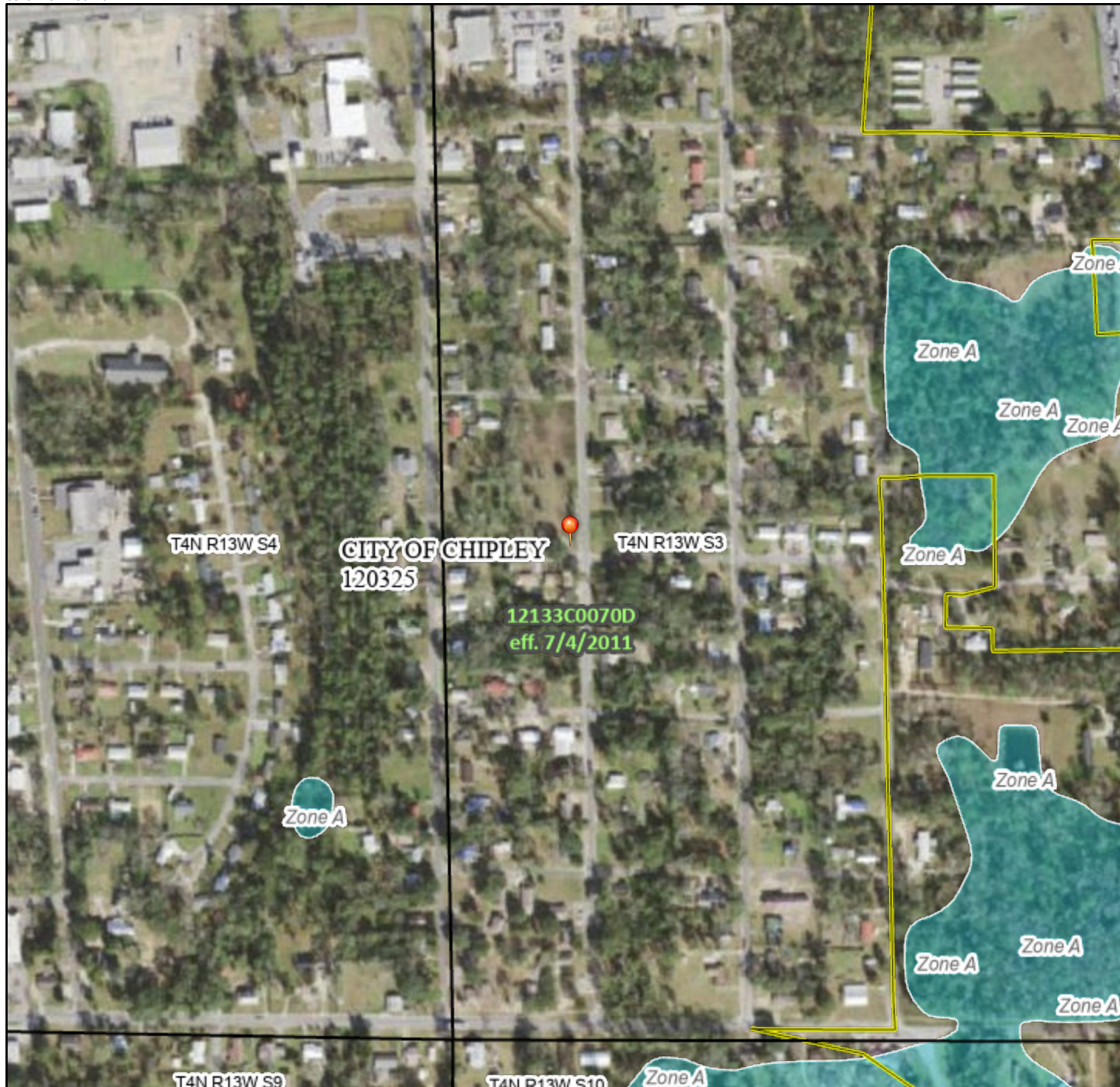

0 250 500 1,000 1,500 2,000 Feet 1:6,000

Basemap Imagery Source: USGS National Map 2023

## Legend

Section H, Item 11.

SEE FIS REPORT FOR DETAILED LEGEND AND INFORMATION

- SPECIAL FLOOD HAZARD AREAS**
  - Without Base Flood Elevation (BFE) Zone A, V, A99
  - With BFE or Depth Zone AE, AO, AH, VE, AR
  - Regulatory Floodway
  
- OTHER AREAS OF FLOOD HAZARD**
  - 0.2% Annual Chance Flood Hazard, Areas of 1% annual chance flood with average depth less than one foot or with drainage areas of less than one square mile Zone X
  - Future Conditions 1% Annual Chance Flood Hazard Zone X
  - Area with Reduced Flood Risk due to Levee. See Notes. Zone X
  - Area with Flood Risk due to Levee Zone D
  
- OTHER AREAS**
  - NO SCREEN Area of Minimal Flood Hazard Zone X
  - Effective LOMRs
  - Area of Undetermined Flood Hazard Zone D
  
- GENERAL STRUCTURES**
  - Channel, Culvert, or Storm Sewer
  - Levee, Dike, or Floodwall
  
- OTHER FEATURES**
  - B 20.2 Cross Sections with 1% Annual Chance Water Surface Elevation
  - 17.5 Coastal Transect
  - Base Flood Elevation Line (BFE)
  - Limit of Study
  - Jurisdiction Boundary
  - Coastal Transect Baseline
  - Profile Baseline
  - Hydrographic Feature
  
- MAP PANELS**
  - Digital Data Available
  - No Digital Data Available
  - Unmapped



The pin displayed on the map is an approximate point selected by the user and does not represent an authoritative property location.

This map complies with FEMA's standards for the use of digital flood maps if it is not void as described below. The basemap shown complies with FEMA's basemap accuracy standards

The flood hazard information is derived directly from the authoritative NFHL web services provided by FEMA. This map was exported on 1/30/2026 at 3:58 PM and does not reflect changes or amendments subsequent to this date and time. The NFHL and effective information may change or become superseded by new data over time.

This map image is void if the one or more of the following map elements do not appear: basemap imagery, flood zone labels, legend, scale bar, map creation date, community id, FIRM panel number, and FIRM effective date. Map is unmapped and unmodernized areas cannot be used for regulatory purposes.

# CITY OF CHIPLEY

## STAFF REPORT

**SUBJECT:** Bid No. 25-01 – Florida Commerce CDBG-NR Peach Street Lift Station Project – GCUC, LLC - Changer Order No. 3

### MEETING DATE

Tuesday, April 14, 2026

### PREPARED BY

Patrice Tanner, City Administrator

### SUMMARY

This change order is for time extension only. Due to delays in the procurement of the control panel and electrical components, an additional 75 days are needed. This will make the final completion date June 24, 2026.

### RECOMMENDATION

City Staff recommend approval of Bid No. 25-01 – Florida Commerce CDBG-NR Peach Street Lift Station Project – GCUC, LLC - Changer Order No. 3

### ATTACHMENTS

1. Change Order No. 3



Change Order No. 3

Date of Issuance:	4/9/2026	Effective Date:	
Owner:	City of Chipley	Owner's Contract No:	25-01
Contractor:	GCUC, LLC	Contractor's Project No:	25-10
Engineer:	Mott MacDonald	Engineer's Project No:	502101554
Project:	CDBG Peach Street PS Replacement	Contract Name:	CDBG Peach Street PS Replacement

The Contract is modified as follows upon execution of this Change Order:

This Change Order is for time extension only. Due to delays on obtaining control panel and electrical components, and additional 75 days is needed.

<b>Total</b>	\$	-
--------------	----	---

**Total Change: NO CONTRACT CHANGE**

<p><b>CHANGE IN CONTRACT PRICE</b></p> <p>Original Contract Price:</p> <p>\$ 1,510,925.00</p>	<p><b>CHANGE IN CONTRACT TIMES</b> [note changes in Milestones if applicable]</p> <p>Original Contract Times:</p> <p>Substantial Completion: 240 Ready for Final Payment: 270 days or dates</p>	
<p>[Decrease] from previously approved Change Orders No. 0 to No. 2</p> <p>\$ (271,042.57)</p>	<p><b>No change</b> from previously approved Change Orders No. 0 to No. 2</p> <p>Substantial Completion: 0 Ready for Final Payment: 0 days</p>	
<p>Contract Price prior to this Change Order:</p> <p>\$ 1,239,882.43</p>	<p>Contract Times prior to this Change Order:</p> <p>Substantial Completion: 240 Ready for Final Payment: 270 days or dates</p>	
<p><b>No change</b> of this Change Order:</p> <p>\$ -</p>	<p>[Increase] of this Change Order:</p> <p>Substantial Completion: 75 Ready for Final Payment: 75 days or dates</p>	
<p>Contract Price incorporating this Change Order:</p> <p>\$ 1,239,882.43</p>	<p>Contract Times with all approved Change Orders:</p> <p>Substantial Completion: 315 Ready for Final Payment: 345 days or dates</p>	
<p>RECOMMENDED:</p> <p>By: <i>C. Heath Roberts</i></p> <p>Engineer (if required)</p> <p>Title: <b>Project Engineer</b></p> <p>Title: <b>04/09/2026</b></p>	<p>ACCEPTED:</p> <p>By: _____</p> <p>Owner (Authorized Signature)</p>	<p>ACCEPTED:</p> <p>By: <i>Chris Corbin</i></p> <p>Contractor (Authorized Signature)</p> <p>Title: _____ VP _____</p> <p>Date: _____ 04/09/2026 _____</p>
<p>Date: _____ Date: _____</p> <p>APPROVED by Funding Agency (if applicable)</p> <p>By: _____ Date: _____</p> <p>Title: _____</p>		

# CITY OF CHIPLEY

## STAFF REPORT

**SUBJECT:** CDBG First Public Hearing Notice

### MEETING DATE

Tuesday, April 14, 2026

### PREPARED BY

Patrice Tanner, City Administrator

### SUMMARY

This public hearing is to obtain citizen comment concerning the city's economic and community development needs for an application to the Florida Department of Commerce for a FFY 2025-2026 Small Cities Community Development Block Grant (CDBG).

### RECOMMENDATION

Public Hearing - Discussion.

### ATTACHMENTS

1. CDBG First Public Hearing Notice

## **CDBG First Public Hearing Notice**

### **City of Chipley, Florida First Public Hearing Notice**

The City of Chipley is considering applying to the Florida Department of Economic Opportunity for a FFY 2025 Small Cities Community Development Block Grant (CDBG). The City is eligible to apply for funding in the neighborhood revitalization, commercial revitalization and housing rehabilitation categories and the economic development category. Construction activities funded through the CDBG Program must meet one of the following National Objectives:

1. Provide benefit to low- and moderate-income persons;
2. Prevent or eliminate slum or blight conditions; or
3. Meet a need of recent origin having a particular urgency.

The types of activities that CDBG funds may be used for include constructing stormwater ponds, paving roads and sidewalks, installing sewer and water lines, building a community center or park, making improvements to a sewage treatment plant, and rehabilitating low-income homes. Additional information regarding the range of activities that could be funded will be provided at the public hearing.

In developing a CDBG application, the City of Chipley must plan to minimize displacement of persons as a result of the activities. In addition, the City of Chipley is required to develop a plan to assist displaced persons.

A public hearing to obtain citizen comment concerning the city's economic and community development needs will be held at City of Chipley Administrative Office at 1442 Jackson Avenue, Chipley, on Tuesday, April 14, 2026 at 5:00 p.m. or shortly thereafter. For information concerning the public hearing, contact Patrice Tanner, City Administrator, at (850) 638-6350 or by e-mail at [ptanner@cityofchipley.com](mailto:ptanner@cityofchipley.com).

The public hearing is being conducted in a handicapped accessible location. Pursuant to the provisions of the Americans with Disabilities Act, any person requiring special accommodations to participate in the hearing is asked to advise the City at least five days before the hearing by contacting Patrice Tanner at (850) 638-6350. If you are hearing or speech impaired, please contact the city using the Florida Relay Service, 1(800) 955-8771 (TDD) or 1(800) 955-8770 (Voice).

Any non-English speaking person wishing to attend the public hearing should contact Patrice Tanner at (850) 638-6350 at least five days prior to the hearing and an interpreter will be provided.

# CITY OF CHIPLEY

## STAFF REPORT

**SUBJECT:** Ordinance No. 998 (First Reading) – Florida Power & Light Franchise Agreement

### MEETING DATE

Tuesday, April 14, 2026

### PREPARED BY

Patrice Tanner, City Administrator

### SUMMARY

This will approve the first reading of Ordinance No. 998 – granting to Florida Power & Light Company an electric franchise for a period of 30 years.

### RECOMMENDATION

City Staff recommend approval of the first reading of Ordinance No. 998.

### ATTACHMENTS

1. Ordinance No. 998

**ORDINANCE NO. 998**

**AN ORDINANCE GRANTING TO FLORIDA POWER & LIGHT COMPANY, ITS SUCCESSORS AND ASSIGNS, AN ELECTRIC FRANCHISE, IMPOSING PROVISIONS AND CONDITIONS RELATING THERETO, PROVIDING FOR MONTHLY PAYMENTS TO THE CITY OF CHIPLEY, FLORIDA, AND PROVIDING FOR AN EFFECTIVE DATE.**

**WHEREAS**, the Council of the City of Chipley recognizes that the City of Chipley and its citizens need and desire the benefits of electric service; and

**WHEREAS**, the provision of such service requires substantial investments of capital and other resources in order to construct, maintain and operate facilities essential to the provision of such service in addition to costly administrative functions, and the City of Chipley does not desire to undertake to provide such services; and

**WHEREAS**, Florida Power & Light Company (FPL) is a public utility which has the demonstrated ability to supply such services; and

**WHEREAS**, FPL and the City of Chipley desire to enter into a franchise agreement providing for the payment of fees to the City of Chipley in exchange for the nonexclusive right and privilege of supplying electricity and other services within the City of Chipley free of competition from the City of Chipley, pursuant to certain terms and conditions;

**NOW, THEREFORE, BE IT ORDAINED BY THE COUNCIL OF THE CITY OF CHIPLEY, FLORIDA:**

Section 1. There is hereby granted to Florida Power & Light Company, its successors and assigns (hereinafter called the "Grantee"), for the period of 30 years from the effective date hereof, the nonexclusive right, privilege and franchise (hereinafter called "franchise") to construct, operate and maintain in, under, upon, along, over and across the present and future roads, streets, alleys, bridges, easements, rights-of-way and other public places (hereinafter called "public rights-of-way") throughout all of the incorporated areas, as such incorporated areas may be constituted from time to time, of the City of Chipley, Florida, and its successors (hereinafter called the "Grantor"), in accordance with the Grantee's customary practice with respect to construction and maintenance, electric light and power facilities, including, without limitation, conduits, poles, wires, transmission and distribution lines, and all other facilities installed in conjunction with or ancillary to all of the Grantee's operations (herein called "facilities"), for the purpose of supplying electricity and other services to the Grantor and its successors, the inhabitants thereof, and persons beyond the limits thereof.

Section 2. The facilities of the Grantee shall be installed, located or relocated so as to not unreasonably interfere with traffic over the public rights-of-way or with reasonable egress from and ingress to abutting property. To avoid conflicts with traffic, the location or relocation of all facilities shall be made as representatives of the Grantor may prescribe in accordance with the Grantor's reasonable rules and regulations with reference to the placing and maintaining in, under, upon, along, over and across said public rights-of-way; provided, however, that such rules or regulations (a) shall not prohibit the exercise of the Grantee's right to use said public rights-of-way for reasons other than

unreasonable interference with motor vehicular traffic, (b) shall not unreasonably interfere with the Grantee's ability to furnish reasonably sufficient, adequate and efficient electric service to all of its customers, and (c) shall not require the relocation of any of the Grantee's facilities installed before or after the effective date hereof in public rights-of-way unless or until widening or otherwise changing the configuration of the paved portion of any public right-of-way used by motor vehicles causes such installed facilities to unreasonably interfere with motor vehicular traffic. Such rules and regulations shall recognize that above-grade facilities of the Grantee installed after the effective date hereof should be installed near the outer boundaries of the public rights-of-way to the extent possible. When any portion of a public right-of-way is excavated by the Grantee in the location or relocation of any of its facilities, the portion of the public right-of-way so excavated shall within a reasonable time be replaced by the Grantee at its expense and in as good condition as it was at the time of such excavation. The Grantor shall not be liable to the Grantee for any cost or expense in connection with any relocation of the Grantee's facilities required under subsection (c) of this Section, except, however, the Grantee shall be entitled to reimbursement of its costs from others and as may be provided by law.

Section 3. The Grantor shall in no way be liable or responsible for any accident or damage that may occur in the construction, operation or maintenance by the Grantee of its facilities hereunder, and the acceptance of this ordinance shall be deemed an agreement on the part of the Grantee to indemnify the Grantor and hold it harmless against any and all liability, loss, cost, damage or expense which may accrue to the Grantor by reason of the negligence, default or misconduct of the Grantee in the construction, operation or maintenance of its facilities hereunder.

Section 4. All rates and rules and regulations established by the Grantee from time to time shall be subject to such regulation as may be provided by law.

Section 5. As a consideration for this franchise, the Grantee shall pay to the Grantor, commencing 90 days after the effective date hereof, and each month thereafter for the remainder of the term of this franchise, an amount which added to the amount of all licenses, excises, fees, charges and other impositions of any kind whatsoever (except ad valorem property taxes and non-ad valorem tax assessments on property) levied or imposed by the Grantor against the Grantee's property, business or operations and those of its subsidiaries during the Grantee's monthly billing period ending 60 days prior to each such payment will equal six percent (6%) of the Grantee's billed revenues, less actual write-offs, from the sale of electrical energy to residential, commercial and industrial customers (as such customers are defined by FPL's tariff) within the incorporated areas of the Grantor for the monthly billing period ending 60 days prior to each such payment, and in no event shall payment for the rights and privileges granted herein exceed six percent (6%) of such revenues for any monthly billing period of the Grantee.

The Grantor understands and agrees that such revenues as described in the preceding paragraph are limited, as in the existing franchise, Ordinance No. 774, to the precise revenues described therein, and that such revenues do not include, by way of example and not limitation: (a) revenues from the sale of electrical energy for Public Street and Highway Lighting (service for lighting public ways and areas); (b) revenues from Other Sales to Public Authorities (service with eligibility restricted to governmental entities); (c) revenues from Sales to Railroads and Railways (service supplied for propulsion of electric transit vehicles); (d) revenues from Sales for Resale (service to other utilities for resale purposes); (e) franchise fees; (f) Late Payment Charges; (g) Field Collection Charges; (h) other service charges.

Section 6. As a further consideration, during the term of this franchise or any extension thereof, the Grantor agrees: (a) not to engage in the distribution and/or sale, in competition with the

Grantee, of electric capacity and/or electric energy to any ultimate consumer of electric utility service (herein called a "retail customer") or to any electrical distribution system established solely to serve any retail customer formerly served by the Grantee, (b) not to participate in any proceeding or contractual arrangement, the purpose or terms of which would be to obligate the Grantee to transmit and/or distribute, electric capacity and/or electric energy from any third party(ies) to any other retail customer's facility(ies), and (c) not to seek to have the Grantee transmit and/or distribute electric capacity and/or electric energy generated by or on behalf of the Grantor at one location to the Grantor's facility(ies) at any other location(s). Nothing specified herein shall prohibit the Grantor from engaging with other utilities or persons in wholesale transactions which are subject to the provisions of the Federal Power Act.

Nothing herein shall prohibit the Grantor, if permitted by law, (i) from purchasing electric capacity and/or electric energy from any other person, or (ii) from seeking to have the Grantee transmit and/or distribute to any facility(ies) of the Grantor electric capacity and/or electric energy purchased by the Grantor from any other person; provided, however, that before the Grantor elects to purchase electric capacity and/or electric energy from any other person, the Grantor shall notify the Grantee. Such notice shall include a summary of the specific rates, terms and conditions which have been offered by the other person and identify the Grantor's facilities to be served under the offer. The Grantee shall thereafter have 90 days to evaluate the offer and, if the Grantee offers rates, terms and conditions which are equal to or better than those offered by the other person, the Grantor shall be obligated to continue to purchase from the Grantee electric capacity and/or electric energy to serve the previously-identified facilities of the Grantor for a term no shorter than that offered by the other person. If the Grantee does not agree to rates, terms and conditions which equal or better the other person's offer, all of the terms and conditions of this franchise shall remain in effect.

Section 7. If the Grantor grants a right, privilege or franchise to any other person or otherwise enables any other such person to construct, operate or maintain electric light and power facilities within any part of the incorporated areas of the Grantor in which the Grantee may lawfully serve or compete on terms and conditions which the Grantee determines are more favorable than the terms and conditions contained herein, the Grantee may at any time thereafter terminate this franchise if such terms and conditions are not remedied within the time period provided hereafter. The Grantee shall give the Grantor at least 60 days advance written notice of its intent to terminate. Such notice shall, without prejudice to any of the rights reserved for the Grantee herein, advise the Grantor of such terms and conditions that it considers more favorable. The Grantor shall then have 60 days in which to correct or otherwise remedy the terms and conditions complained of by the Grantee. If the Grantee determines that such terms or conditions are not remedied by the Grantor within said time period, the Grantee may terminate this franchise agreement by delivering written notice to the Grantor's Clerk and termination shall be effective on the date of delivery of such notice.

Section 8. If as a direct or indirect consequence of any legislative, regulatory or other action by the United States of America or the State of Florida (or any department, agency, authority, instrumentality or political subdivision of either of them) any person is permitted to provide electric service within the incorporated areas of the Grantor to a customer then being served by the Grantee, or to any new applicant for electric service within any part of the incorporated areas of the Grantor in which the Grantee may lawfully serve, and the Grantee determines that its obligations hereunder, or otherwise resulting from this franchise in respect to rates and service, place it at a competitive disadvantage with respect to such other person, the Grantee may, at any time after the taking of such action, terminate this franchise if such competitive disadvantage is not remedied within the time period provided hereafter. The Grantee shall give the Grantor at least 90 days advance written notice

of its intent to terminate. Such notice shall, without prejudice to any of the rights reserved for the Grantee herein, advise the Grantor of the consequences of such action which resulted in the competitive disadvantage. The Grantor shall then have 90 days in which to correct or otherwise remedy the competitive disadvantage. If such competitive disadvantage is not remedied by the Grantor within said time period, the Grantee may terminate this franchise agreement by delivering written notice to the Grantor's Clerk and termination shall take effect on the date of delivery of such notice.

Section 9. Failure on the part of the Grantee to comply in any substantial respect with any of the provisions of this franchise shall be grounds for forfeiture, but no such forfeiture shall take effect if the reasonableness or propriety thereof is protested by the Grantee until there is final determination (after the expiration or exhaustion of all rights of appeal) by a court of competent jurisdiction that the Grantee has failed to comply in a substantial respect with any of the provisions of this franchise, and the Grantee shall have six months after such final determination to make good the default before a forfeiture shall result with the right of the Grantor at its discretion to grant such additional time to the Grantee for compliance as necessities in the case require.

Section 10. Failure on the part of the Grantor to comply in substantial respect with any of the provisions of this ordinance, including, but not limited to: (a) denying the Grantee use of public rights-of-way for reasons other than unreasonable interference with motor vehicular traffic; (b) imposing conditions for use of public rights-of-way contrary to Florida law or the terms and conditions of this franchise; (c) unreasonable delay in issuing the Grantee a use permit, if any, to construct its facilities in public rights-of-way, shall constitute breach of this franchise and entitle the Grantee to withhold all or part of the payments provided for in Section 5 hereof until such time as a use permit is issued or a court of competent jurisdiction has reached a final determination in the matter. The Grantor recognizes and agrees that nothing in this franchise agreement constitutes or shall be deemed to constitute a waiver of the Grantee's delegated sovereign right of condemnation and that the Grantee, in its sole discretion, may exercise such right.

Section 11. The Grantor may, upon reasonable notice and within 90 days after each anniversary date of this franchise, at the Grantor's expense, examine the records of the Grantee relating to the calculation of the franchise payment for the year preceding such anniversary date. Such examination shall be during normal business hours at the Grantee's office where such records are maintained. Records not prepared by the Grantee in the ordinary course of business may be provided at the Grantor's expense and as the Grantor and the Grantee may agree in writing. Information identifying the Grantee's customers by name or their electric consumption shall not be taken from the Grantee's premises. Such audit shall be impartial and all audit findings, whether they decrease or increase payment to the Grantor, shall be reported to the Grantee. The Grantor's right to examine the records of the Grantee in accordance with this Section shall not be conducted by any third party employed by the Grantor whose fee, in whole or part, for conducting such audit is contingent on findings of the audit.

Section 12. The provisions of this ordinance are interdependent upon one another, and if any of the provisions of this ordinance are found or adjudged to be invalid, illegal, void or of no effect, the entire ordinance shall be null and void and of no force or effect.

Section 13. As used herein "person" means an individual, a partnership, a corporation, a business trust, a joint stock company, a trust, an incorporated association, a joint venture, a governmental authority or any other entity of whatever nature.

Section 14. Ordinance No. 774, passed and adopted April 8, 1997 and all other ordinances and parts of ordinances and all resolutions and parts of resolutions in conflict herewith, are hereby repealed.

Section 15. As a condition precedent to the taking effect of this ordinance, the Grantee shall file its acceptance hereof with the Grantor's Clerk within 30 days of adoption of this ordinance. The effective date of this ordinance shall be the date upon which the Grantee files such acceptance.

PASSED on first reading this 14th day of April, 2026.

PASSED AND ADOPTED on second reading this 12th day of May, 2026.

CITY OF CHIPLEY

---

Tracy L. Andrews, Mayor

ATTEST:

---

Sherry Snell  
City Clerk

APPROVED AS TO FORM:

---

Michelle Blankenship Jordan  
City Attorney

# CITY OF CHIPLEY

## STAFF REPORT

**SUBJECT:** Revolution Road Interpretive Panels & Wayfinding Locations & Driving Tour  
Directions – Heather Lopez

### MEETING DATE

Tuesday, April 14, 2026

### PREPARED BY

Patrice Tanner, City Administrator

### SUMMARY

The TDC is launching their America 250 driving tour that will include interpretive panels like those we did as part of the Old Spanish Trail project. This time, we will have the painted black metal frames. We are proposing one 24x42 sign that will include the full map of our trail overlaid on the 1776 British Purcell Map used during the Revolutionary War and two 24x24 signs (one on each side of the map) that will describe the Revolutionary War and the Declaration of Independence. We would like to have them placed on the left-hand side of the front door of the building, if you are looking straight at the building. This was the same location we had the Old Spanish Trail sign before it was removed. A 511 was already done for that sign so unless something has been added since 2023, we shouldn't need to do another one, unless this is something the city or state requires.

The trail will be permanent, and the Washington County Chamber of Commerce/Washington County TDC Visitor Center building, located at 672 5<sup>th</sup> Street, will be the starting point. We are planning to have the frames in hand around May 13<sup>th</sup> with the panels soon to follow. Washington County Public Works is storing and helping to install the frames for us. We will hold a launch event on July 2<sup>nd</sup> for the trail. A ribbon cutting will happen at the building around 10am and then we will travel on to Orange Hill Park for the rest of the event.

### RECOMMENDATION

City Staff recommend approval of the Revolution Road Interpretive Panels & Wayfinding Locations & Driving Tour Directions.

### ATTACHMENTS

1. Frame Designs
2. Tour Directions

**Revolution Road Interpretive Panels & Wayfinding Locations & Driving Tour Directions**

- 1) WC TDC Visitor Center (in the front of the building on the south side of the front entrance)**
  - a. Welcome to the Tour with Map/Declaration of Independence
  - b. Wayfinding - down Church Ave, right onto Hwy 77, left onto State Park Rd, left onto Joiner Rd, right onto Orange Hill Rd
- 2) Orange Hill Park (behind the OH Fire Dept - beside the current interpretive panels in the park)**
  - a. British Military Camp
  - b. Wayfinding - left onto Ryan Ln, left into park parking lot
- 3) Orange Hill (in front of OH Missionary Baptist Church - pine tree)**
  - a. British at Orange Hill
  - b. Wayfinding - Right out of park parking lot onto Ryan Ln, left onto Orange Hill Rd, left onto Sunday Rd, left into church parking lot
- 4) Hard Labor Creek (Ted's property across from the church)**
  - a. Hard Labor Crossing
  - b. Wayfinding - Right onto Sunday Rd, right onto Orange Hill Rd, left onto Clayton Rd, cross over Hwy 77, left onto Hard Labor Rd, left onto Owens Pond Rd
- 5) Wausau (green space in front of fire department)**
  - a. Revolutionary Road
  - b. Wayfinding - Back on Owens Pond Rd, right onto Cane Mill Rd, right onto Hwy 77, left onto 2nd Ave
- 6) Porter Lake (at White Oak Landing primitive campground & boat launch - under giant oak tree)**
  - a. Porter Lake
  - b. Wayfinding - Back onto 2nd Ave, left onto Hwy 77, left onto Sunny Hills Blvd, right onto Country Club Blvd, left on Gap Blvd, right on Deltona Blvd/Porter Pond Rd, left into parking lot at White Oak Landing
- 7) Walsingham Bridge (at the primitive campground & canoe launch area)**
  - a. Econfinia Creek

- b. Wayfinding - left out of White Oak Landing onto Porter Pond Rd, left onto Hampshire Blvd, left onto Walsingham Bridge Rd
- 8) Williford Spring (either to the south side of the parking area or right out front of the gated entrance)**
- a. Path to the Forks - Natural Bridge
  - b. Wayfinding - Take Walsingham Bridge Rd, right onto Hampshire Blvd, left onto Porter Pond Rd, right onto Strickland Rd/Porter Pond Rd, left into Williford Spring Recreation Area
- 9) Pine Log State Forest (in the day use area right before the RV/primitive camping area)**
- a. Path to Little Ockchoyce
  - b. Wayfinding - Right out of Williford Spring Recreation Area onto Strickland Rd/Porter Pond Rd, left onto Hwy 20, cross over Hwy 77, left on Hwy 79 in Ebro, left onto Environmental Rd, turn into Sand Pond Campground
- 10) Vernon (at Vernon Wayside Park or right over the property line on Holmes Creek Canoe Livery's property)**
- a. Florida's First Weekie Wachee
  - b. Wayfinding - Turn out of Sand Pond Campground left onto Environmental Rd, turn left onto Hwy 79, turn right onto road leading to Vernon Wayside Park (CE Miller Landing)
- 11) Burnt Sock Landing (right over the fencing on the path going towards the canoe launch)**
- a. Little Ockchoyce - Indian Village
  - b. Wayfinding - Come back out of Vernon Wayside Park, turn left onto Hwy 79, turn left onto Hwy 277, left onto Clayton Rd, right onto Johnson Rd, right onto Burnt Sock Landing Rd

4 3

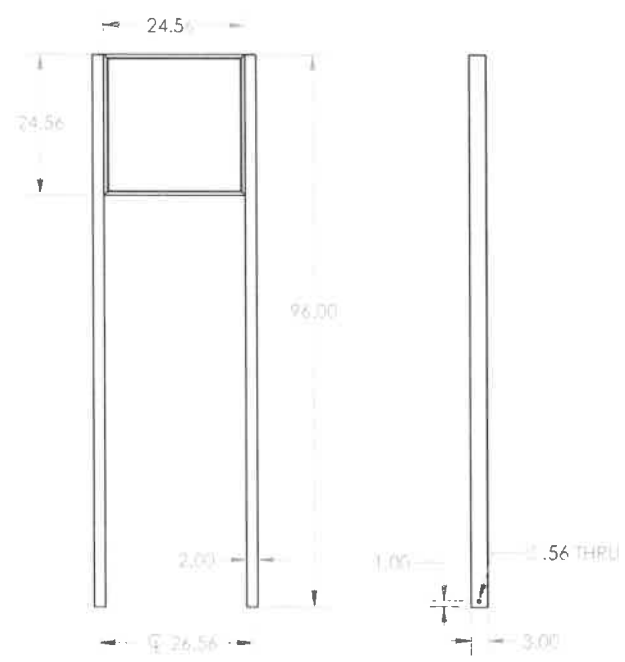
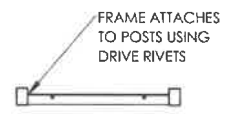

2 1

ITEM NO.	PART NUMBER	DESCRIPTION	QTY.
1	UP-P2396-24	UPRIGHT POST ASM	2
2	FA-2424R	24X24 PANEL FRAME	1

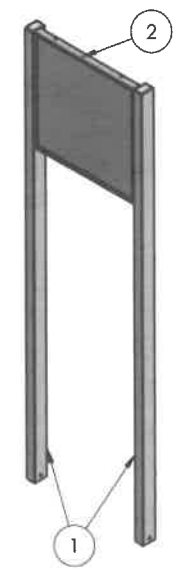

APPROVED AS IS *Heather Joffe*  
 MAKE CHANGES AND PROCEED  
 MAKE CHANGES AND RESUBMIT

B

B

A

A

PROJECT ID BD29901-1 P4462  
 SUBMITTED TO JP  
 SUBMITTED BY MM  
 SUBMITTAL DATE 3-16-26  
 MATERIAL ALUMINUM  
 COLOR BLACK TEX PC  
 QTY 18

CUSTOMER'S SIGNATURE DATE  
 DESCRIPTION UPRIGHT EXHIBIT  
 DIMENSIONS ARE IN INCHES  
 FRACTIONAL ± 1/32  
 MACHINED ANGLE ± 0.5 DEG  
 BEND ANGLE ± 1.0 DEG  
 TWO PLACE DECIMAL ±0.030  
 THREE PLACE DECIMAL ±0.010  
 PROPRIETARY AND CONFIDENTIAL  
 THE INFORMATION CONTAINED IN THIS DRAWING IS THE SOLE PROPERTY OF BDD. ANY REPRODUCTION IN PART OR AS A WHOLE WITHOUT THE WRITTEN PERMISSION OF BDD IS PROHIBITED.  
 SIZE FILE NAME B EB-U2424  
 SCALE: 1:20 WEIGHT: 1538.00 SHEET 1 OF 1

4 3

2 1

4

3

2

1

ITEM NO.	PART NUMBER	DESCRIPTION	QTY.
1	FA-2424R-1	"F" EXTRUSION	1
2	FA-2424R-2	"F" EXTRUSION	2
3	FA-2424R-3	"L" EXTRUSION	1
4	FA-2424R-4	BACK SHEET	1
5	FA-24-ANGLE	FRAME ANGLE	1

DO NOT WELD ANGLES TO "L" EXTRUSION

TOP "L" EXTRUSION ATTACHES TO FRAME USING 1/4-20 FHSCS & NYLOCK NUTS

B

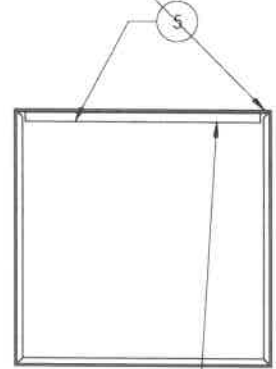

SKIP ANGLE TO SHEET TYP

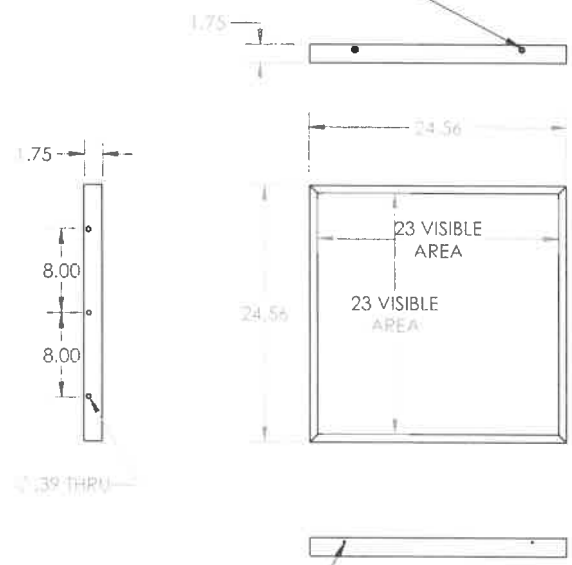

2X DRAIN HOLES

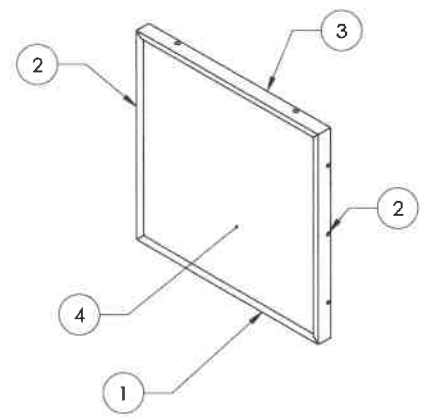

APPROVED AS IS  
MAKE CHANGES AND PROCEED  
MAKE CHANGES AND RESUBMIT

A

B

A

PROJECT ID  
SUBMITTED TO  
SUBMITTED BY  
SUBMITTAL DATE  
MATERIAL ALUMINUM  
COLOR  
QTY

DIMENSIONS ARE IN INCHES  
FRACTIONAL ± 1/32  
MACHINED ANGLE ± 0.5 DEG  
BEND ANGLE ± 1.0 DEG  
TWO PLACE DECIMAL ±0.030  
THREE PLACE DECIMAL ±0.010

PROPRIETARY AND CONFIDENTIAL  
THE INFORMATION CONTAINED IN THIS DRAWING IS THE SOLE PROPERTY OF BOND. ANY REPRODUCTION IN PART OR AS A WHOLE WITHOUT THE WRITTEN PERMISSION OF BOND IS PROHIBITED.

CUSTOMER'S SIGNATURE DATE

DESCRIPTION  
**24X24 PANEL FRAME**

SIZE FILE NAME  
**B FA-2424R**

SCALE: 1:11 WEIGHT: 15.7506 SHEET 1 OF 2

REV

4

3

2

1

4 3 2 1

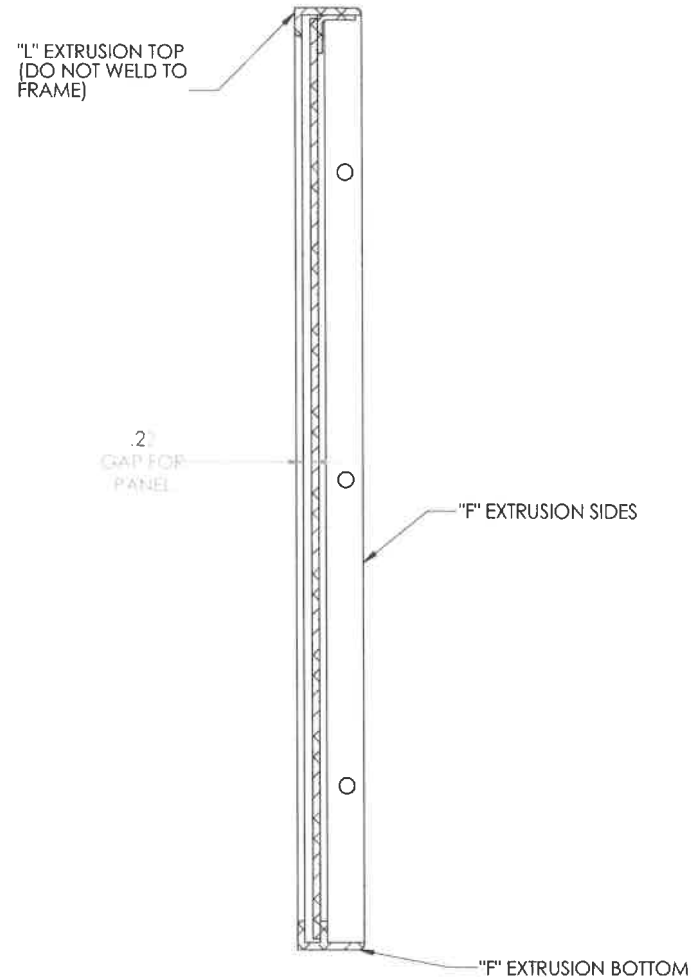

SECTION D-D  
SCALE 1 : 3

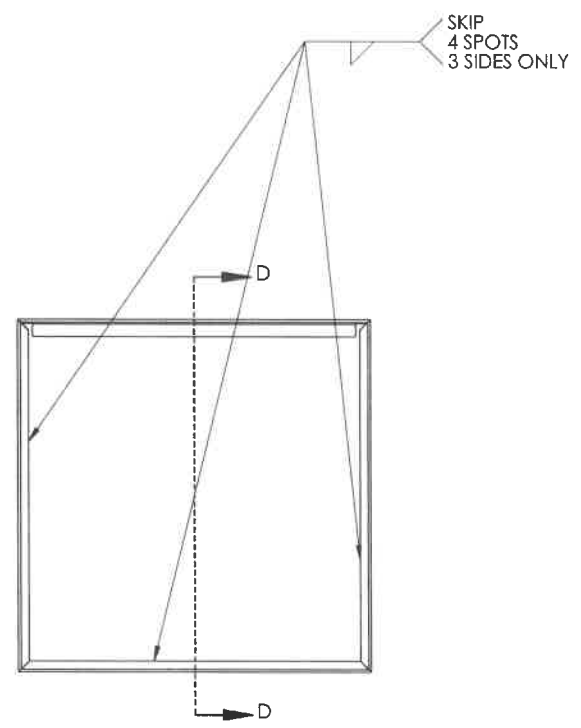

DESIGNED BY

MATERIAL  
ALUMINUM

DIMENSIONS ARE IN INCHES  
FRACTIONAL ± 1/32  
MACHINED ANGLE ± 0.5 DEG  
BEND ANGLE ± 1.0 DEG  
TWO PLACE DECIMAL ±0.030  
THREE PLACE DECIMAL ±0.010

**PROPRIETARY AND CONFIDENTIAL**  
THE INFORMATION CONTAINED IN THIS  
DRAWING IS THE SOLE PROPERTY OF  
BARKING DOG INTERPRETIVE DESIGN, INC.  
ANY REPRODUCTION IN PART OR AS A  
WHOLE WITHOUT THE WRITTEN PERMISSION  
OF BARKING DOG INTERPRETIVE DESIGN,  
INC. IS PROHIBITED

DESCRIPTION  
24X24 PANEL FRAME

SIZE FILE NAME  
B FA-2424R

SCALE: 1:10 WEIGHT: 15.7506 SHEET 2 OF 2

REV	REVISION DESCRIPTION	REV BY	DATE

4 3 2 1

4 3

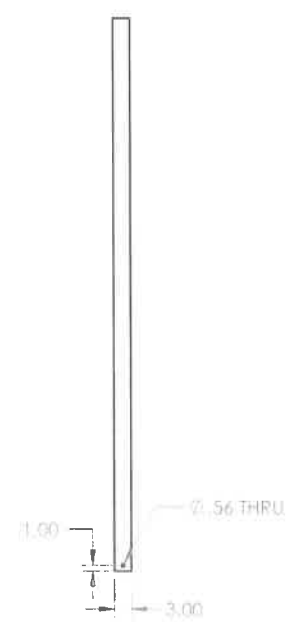
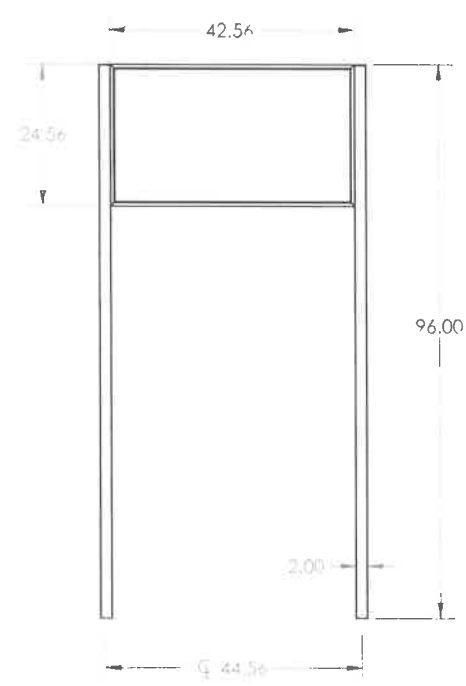

2 1

ITEM NO.	PART NUMBER	DESCRIPTION	QTY.
1	UP-P2396-24	UPRIGHT POST ASM	2
2	FA-2442R	24X42 PANEL FRAME	1

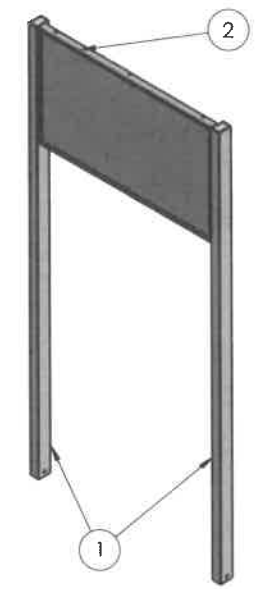

APPROVED AS IS  
 MAKE CHANGES AND PROCEED  
 MAKE CHANGES AND RESUBMIT

*Heather Jeff*

A

PROJECT ID BD29901-1 P4462  
 SUBMITTED TO JP  
 SUBMITTED BY MM  
 SUBMITTAL DATE 3-16-26  
 MATERIAL ALUMINUM  
 COLOR BLACK TEX PC  
 QTY 8

DIMENSIONS ARE IN INCHES  
 FRACTIONAL ± 1/32  
 MACHINED ANGLE ± 0.5 DEG  
 BEND ANGLE ± 1.0 DEG  
 TWO PLACE DECIMAL ±0.030  
 THREE PLACE DECIMAL ±0.010

CUSTOMER'S SIGNATURE DATE  
 DESCRIPTION UPRIGHT EXHIBIT  
 SIZE FILE NAME B EB-U2442  
 SCALE:1:20 WEIGHT: 1b47.97 SHEET 1 OF 1

4 3 2 1

8  
BARKING DOG

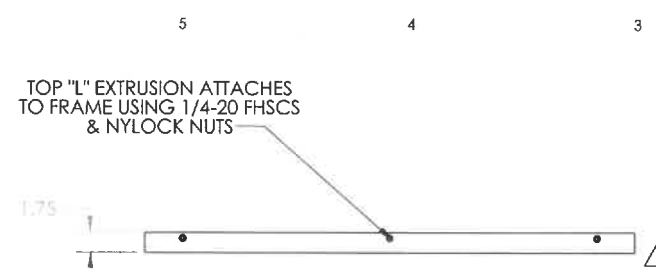

ITEM	PART NUMBER	DESCRIPTION	MATERIAL	QTY
1	FA-2442R-1	PRE-CUT "E" EXTRUSION	6061 (AL)	1
2	FA-2442R-2	PRE-CUT "F" EXTRUSION	6061 (AL)	2
3	FA-2442R-3	PRE-CUT "L" EXTRUSION	6061 (AL)	1
4	FA-2442R-4	BACK SHEET FOR 24 X 42" PANEL	5052 (AL)	1
5	FA-42-ANGLE	ALUMINUM ANGLE	5052 (AL)	1

D

C

B

A

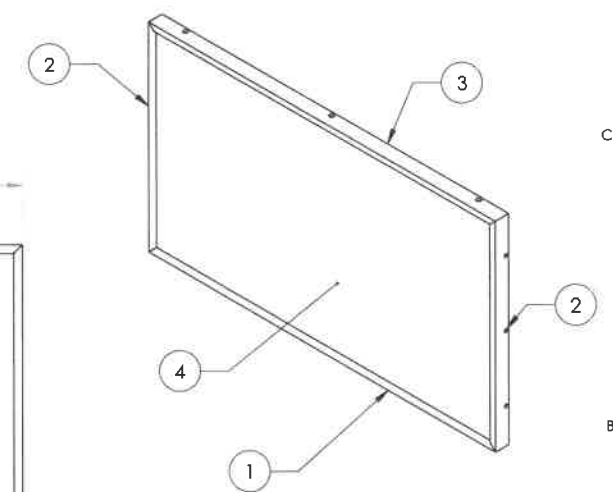
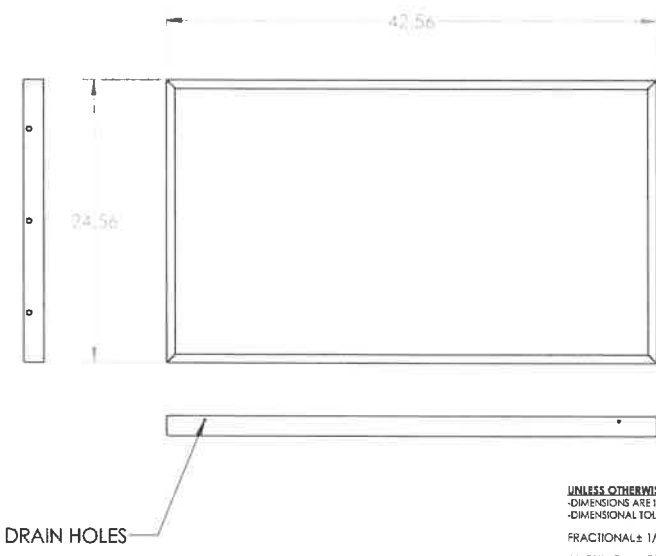
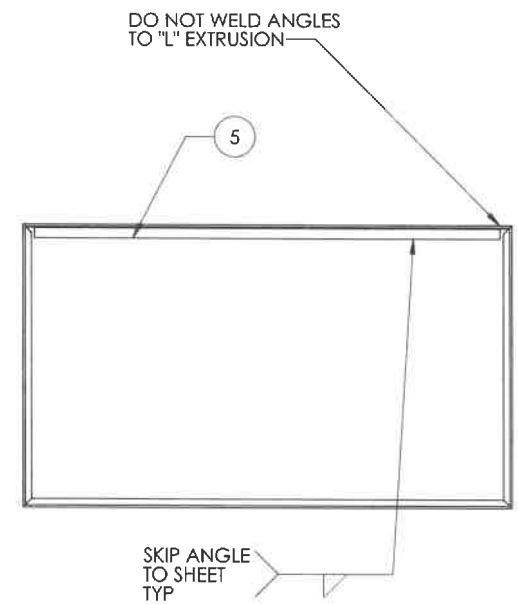

**UNLESS OTHERWISE SPECIFIED**  
 -DIMENSIONS ARE IN INCHES  
 -DIMENSIONAL TOLERANCES  
 FRACTIONAL: ± 1/32  
 ANGULAR: MACH ± .5°/BEND ± 1°  
 TWO PLACE DECIMAL ± .030  
 THREE PLACE DECIMAL ± .010

NAME DATE  
 DRAWN DDH 6/19/2013  
 LAST SAVE Barking Dog 6/20/2024

**MATERIAL:** ALUMINUM  
**TITLE:** 24 X 42 PANEL FRAME

PROJECTION: DWG. NO.

**FA-2442R**

REV SIZE  
**A B**  
 SHEET 1 OF 2

SCALE: 1:10 WEIGHT:

REV.	DESCRIPTION	DATE
A	FA-42-ANGLE WAS FA-2442R-5	11/28/2022

**PROPRIETARY AND CONFIDENTIAL**  
 THE INFORMATION CONTAINED IN THIS DRAWING IS THE SOLE PROPERTY OF BARKING DOG EXHIBITS. ANY REPRODUCTION IN PART OR AS A WHOLE WITHOUT THE WRITTEN PERMISSION OF BARKING DOG EXHIBITS IS PROHIBITED.

DO NOT SCALE DRAWING

8  
BARKING DOG

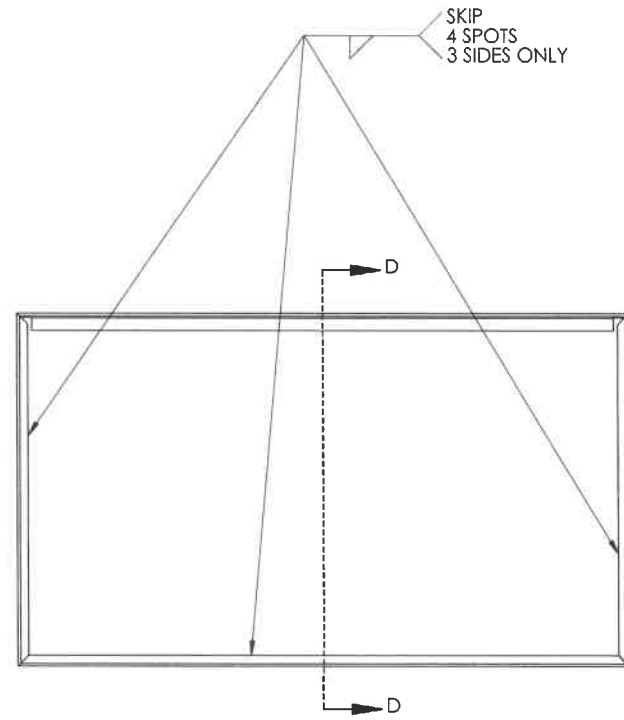
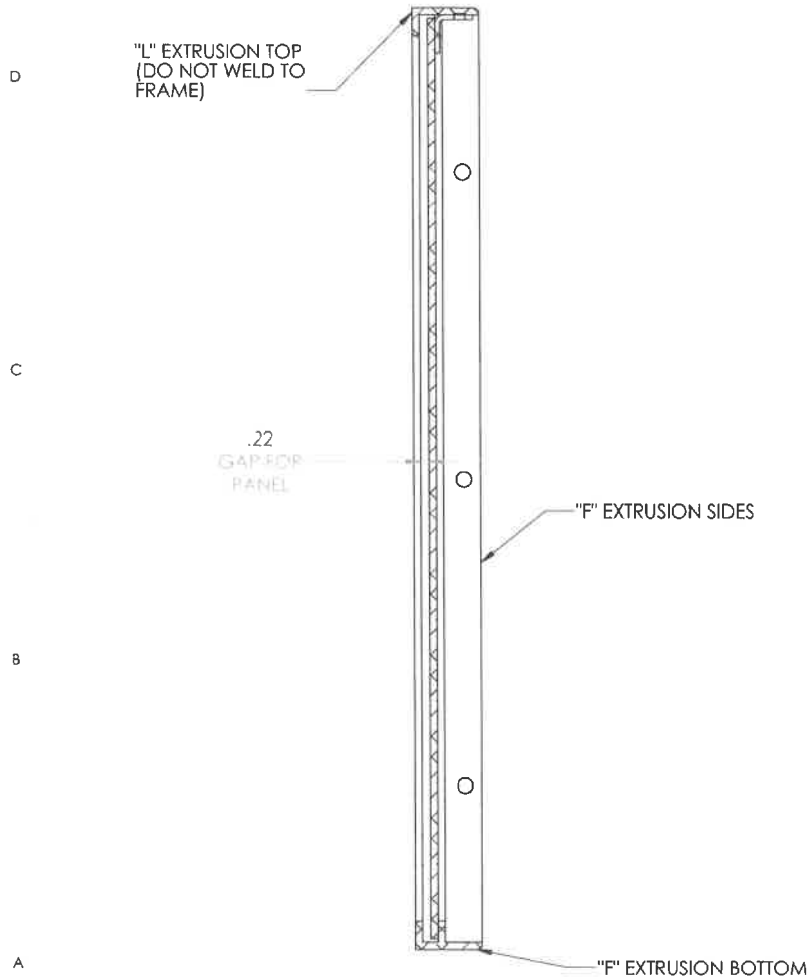

**UNLESS OTHERWISE SPECIFIED**  
-DIMENSIONS ARE IN INCHES  
-DIMENSIONAL TOLERANCES  
FRACTIONAL  $\pm 1/32$   
ANGULAR: MACH  $\pm .5^\circ$  / BEND  $\pm 1^\circ$   
TWO PLACE DECIMAL  $\pm .030$   
THREE PLACE DECIMAL  $\pm .010$

NAME DATE  
DRAWN DDH 6/19/2013  
LAST SAVE Barking Dog 3/19/2024

**MATERIAL:**  
ALUMINUM

**TITLE:**  
24 X 42 PANEL FRAME

PROJECTION: DWG. NO.

FA-2442R

REV SIZE  
A B  
SHEET 2 OF 2

**PROPRIETARY AND CONFIDENTIAL**  
THE INFORMATION CONTAINED IN THIS DRAWING IS THE SOLE PROPERTY OF  
BARKING DOG EXHIBITS. ANY REPRODUCTION IN PART OR AS A WHOLE  
WITHOUT THE WRITTEN PERMISSION OF BARKING DOG EXHIBITS IS PROHIBITED.

DO NOT SCALE DRAWING

SCALE: 1:10

WEIGHT:

# CITY OF CHIPLEY

## STAFF REPORT

**SUBJECT:** Resolution No. 26-32 – State of Florida Department of Transportation Surplus Property – State Road 77 and Highway 90

### MEETING DATE

Tuesday, April 14, 2026

### PREPARED BY

Patrice Tanner, City Administrator

### SUMMARY

This will approve the transfer of ownership of the property located at the corner of State Road 77 and Highway 90 containing 3,252 square feet, more or less from the Florida Department of Transportation to the City of Chipley. The city is asking for the surplus property to be used as a landscaped green space to become a beautiful entryway to our downtown area, to include some type of signage.

### RECOMMENDATION

City Staff recommend approval of Resolution No. 26-32.

### ATTACHMENTS

1. Resolution No 26-32
2. Deed
3. Diagram

**RESOLUTION NO. 26-32****A RESOLUTION OF THE CITY OF CHIPLEY, FLORIDA, DECLARING THE ACCEPTANCE OF CERTAIN PROPERTY FROM THE STATE OF FLORIDA DEPARTMENT OF TRANSPORTATION TO THE CITY OF CHIPLEY, FLORIDA.**

**WHEREAS**, the State of Florida Department of Transportation has legal title to the property located at SR 77 and Hwy 90, Chipley, Florida, and being more particularly described as:

That portion of Lots 226 and 227, per Map of Chipley by L.W. Mordt, as recorded in Plat Book 1, Page 13 of the Public Records of Washington County, Florida and being in the South  $\frac{1}{2}$  of the Northeast  $\frac{1}{4}$  of Section 4, Township 4 North, Range 13 West, Washington County, Florida described as follows: Commence at the southwest corner of said Lot 226; thence North  $05^{\circ}31'13''$  West 140.00 feet along the west line of said Lot 226, as shown on Florida Department of Transportation (F.D.O.T.) Right of Way Map F.P. No. 4508021 (said map being on file at F.D.O.T. District 3 Office, Chipley, Florida) to the north line of that certain property as described in Official Records Book 1216, Page 794 of the Public Records of Washington County, Florida; thence North  $84^{\circ}40'42''$  East 55.00 feet along said north property line; thence continue North  $84^{\circ}40'42''$  East 25.00 feet to POINT OF BEGINNING; thence continue North  $84^{\circ}40'42''$  East 20.00 feet to the east line of Lot 227; thence South  $05^{\circ}31'13''$  East 119.00 feet along said east lot line; thence departing said east lot line, run South  $84^{\circ}40'42''$  West 56.06 feet; thence North  $42^{\circ}23'05''$  West 25.06 feet; thence North  $84^{\circ}40'42''$  East 51.09 feet; thence North  $05^{\circ}31'13''$  West 99.00 feet to POINT OF BEGINNING;

Containing 3,252 square feet, more or less.

Referred to as "Property" herein; and

**WHEREAS**, the City of Chipley desires to use the property as a landscaped green space to become a beautiful entryway to our downtown area, to include some type of signage.

**NOW, THEREFORE, BE IT RESOLVED BY THE CITY COUNCIL OF THE CITY OF CHIPLEY, FLORIDA, THAT:**

1. The Mayor is hereby authorized to execute any and all documents in connection with the conveyance of said Surplus Property including the execution of a special warranty deed from the City to the County.

**PASSED AND ADOPTED** by the City Council of the City of Chipley, Florida on this 14<sup>th</sup> day of April, 2026.

CITY OF CHIPLEY

ATTEST:

\_\_\_\_\_  
Sherry Snell, City Clerk

\_\_\_\_\_  
Tracy L. Andrews, Mayor

DRAFT

Prepared under the direction of:  
Office of the General Counsel  
Cary Hawkins, Assistant General Counsel *CH*  
Florida Department of Transportation  
P. O. Box 607  
Chipley, Florida 32428

COUNTY: Washington  
PROJECT: 4508021  
STATE ROAD: 77  
PARCEL NO.: 100 part

**PUBLIC PURPOSE QUITCLAIM DEED**

THIS INDENTURE, made this \_\_\_\_ day of \_\_\_\_\_, 2022, by and between the **STATE OF FLORIDA**, by and through the **STATE OF FLORIDA DEPARTMENT OF TRANSPORTATION**, whose address is 1074 Highway 90, Chipley, Florida 32428, as the Party of the First Part and **THE CITY OF CHIPLEY, FLORIDA**, a municipal corporation organized and existing under the laws of the State of Florida, whose address is 1442 Jackson Avenue, Chipley, Florida 32428, as the Party of the Second part.

**WITNESSETH**

WHEREAS, the hereinafter described property held by the Department of Transportation is no longer used or needed and the Secretary of the Department on January 28, 2026, has approved conveyance to the Grantee without consideration, to be used solely for public purposes, pursuant to the provisions of Section 337.25 (3), Florida Statutes.

NOW, THEREFORE, THIS INDENTURE WITNESSETH: That the party of the First Part does hereby remise, release and quitclaim unto the Party (Parties) of the Second part, and assigns, forever, all the right, title and interest of the State of Florida and/or the State of Florida Department of Transportation to the property described below:

**DESCRIPTION OF PROPERTY TO BE QUITCLAIMED BY THE STATE OF FLORIDA DEPARTMENT OF TRANSPORTATION (Being a part of Parcel 100, Financial Project 4508021)**

That portion of Lots 226 and 227, per Map of Chipley by L.W. Mordt, as recorded in Plat Book 1, Page 13 of the Public Records of Washington County, Florida and being in the South ½ of the Northeast ¼ of Section 4, Township 4 North, Range 13 West, Washington County, Florida described as follows: Commence at the southwest corner of said Lot 226; thence North 05°31'13" West 140.00 feet along the west line of said Lot 226, as shown on Florida Department of Transportation (F.D.O.T.) Right of Way Map F.P. No. 4508021 (said map being on file at F.D.O.T. District 3 Office, Chipley, Florida) to the north line of that certain property as described in Official Records Book 1216, Page 794 of the Public Records of Washington County, Florida; thence North 84°40'42" East 55.00 feet along said north property line; thence continue North 84°40'42" East 25.00 feet to POINT OF BEGINNING; thence continue North 84°40'42" East 20.00 feet to the east line of Lot 227; thence South 05°31'13" East 119.00 feet along said east lot line; thence departing said east lot line, run South 84°40'42" West 56.06 feet; thence North 42°23'05" West 25.06 feet; thence North 84°40'42" East 51.09 feet; thence North 05°31'13" West 99.00 feet to POINT OF BEGINNING;

Containing 3,252 square feet, more or less.

SUBJECT TO ALL UTILITIES REMAINING IN PLACE AND IN USE.

COUNTY: Washington  
PROJECT: 4508021  
STATE ROAD: 77  
PARCEL NO.: 100 part

TO HAVE AND TO HOLD the said premises and the appurtenances thereof unto the Party (parties) of the Second Part.

REVERTER: The property herein described is to be used for public purpose only. If property ceases to be used for this purpose, all property rights shall revert back to the said party of the first part.

Reserving unto the Grantor and its successors an undivided three-fourths interest in, and title in and to, and undivided three-fourths interest in all the phosphate, minerals and metals that are or may be in, on or under the said land and undivided one-half interest in all petroleum that is or may be in, on, or under said land with the privilege to enter in and develop the same on all lands wherein the Grantor holds the requisite interest.

THIS CONVEYANCE IS made subject to any unpaid taxes, assessments, liens, or encumbrances of any nature whatsoever which the Party (Parties) of the Second Part hereunder and herein assumes.

IN WITNESS WHEREOF, the State of Florida Department of Transportation has caused these presents to be signed in the name of the State of Florida and in the name of the State of Florida Department of Transportation by its District Secretary, District 3 and its seal to be hereunto affixed, attested by its Executive Secretary, on the date first above written.

Signed and sealed  
in our presence:

STATE OF FLORIDA DEPARTMENT OF  
TRANSPORTATION

Witness: Lyndsey Crosby  
1074 Hwy 90 East  
Chipley, Florida 32428

BY: \_\_\_\_\_  
Tim Smith, P.E.  
District Three Secretary

Witness: Heather Banas  
1074 Hwy 90 East  
Chipley, Florida 32428

ATTEST: \_\_\_\_\_  
Krissy Cook  
Executive Secretary

STATE OF FLORIDA  
COUNTY OF WASHINGTON

The foregoing instrument was acknowledged before me by means of  physical presence or  online notarization this \_\_\_\_ day of \_\_\_\_\_, 20\_\_, by Tim Smith, as Secretary for District 3, who is personally known to me or who has produced \_\_\_\_\_ as identification.

(NOTARIAL SEAL)

\_\_\_\_\_  
Bryan O. Yongue  
Notary Public in and for the  
County and State last aforesaid  
My commission expires 01/17/2028.  
Commission #HH477472

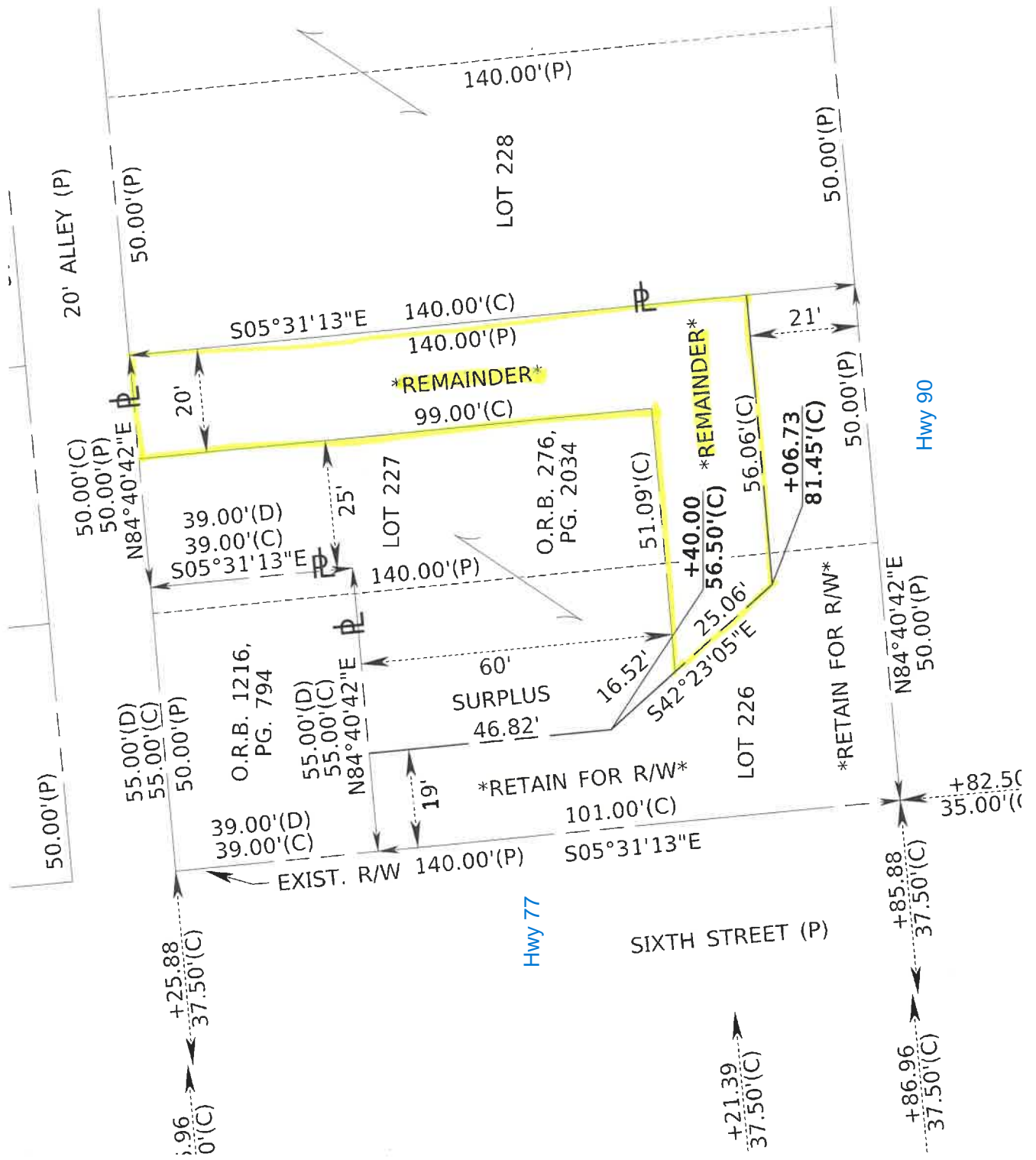

**DESCRIPTION OF PROPERTY TO BE QUITCLAIMED BY THE STATE OF FLORIDA DEPARTMENT OF TRANSPORTATION (Being a part of Parcel 100, Financial Project 4508021)**

That portion of Lots 226 and 227, per Map of Chipley by L.W. Mordt, as recorded in Plat Book 1, Page 13 of the Public Records of Washington County, Florida and being in the South ½ of the Northeast ¼ of Section 4, Township 4 North, Range 13 West, Washington County, Florida described as follows: Commence at the southwest corner of said Lot 226; thence North 05°31'13" West 140.00 feet along the west line of said Lot 226, as shown on Florida Department of Transportation (F.D.O.T.) Right of Way Map F.P. No. 4508021 (said map being on file at F.D.O.T. District 3 Office, Chipley, Florida) to the north line of that certain property as described in Official Records Book 1216, Page 794 of the Public Records of Washington County, Florida; thence North 84°40'42" East 55.00 feet along said north property line; thence continue North 84°40'42" East 25.00 feet to POINT OF BEGINNING; thence continue North 84°40'42" East 20.00 feet to the east line of Lot 227; thence South 05°31'13" East 119.00 feet along said east lot line; thence departing said east lot line, run South 84°40'42" West 56.06 feet; thence North 42°23'05" West 25.06 feet; thence North 84°40'42" East 51.09 feet; thence North 05°31'13" West 99.00 feet to POINT OF BEGINNING;

Containing 3,252 square feet, more or less.

SUBJECT TO ALL UTILITIES REMAINING IN PLACE AND IN USE.

You are invited to a Zoom webinar!

When: April 14, 2026 at 05:00 PM Central Time (US and Canada)

Topic: Regular Council Meeting

Join from PC, Mac, iPad, or Android:

<https://us02web.zoom.us/j/83119078026>

Phone one-tap:

+13017158592,,83119078026# US (Washington DC)

+13052241968,,83119078026# US

Join via audio:

+1 301 715 8592 US (Washington DC)

+1 305 224 1968 US

+1 309 205 3325 US

+1 312 626 6799 US (Chicago)

+1 646 558 8656 US (New York)

+1 646 931 3860 US

+1 507 473 4847 US

+1 564 217 2000 US

+1 669 444 9171 US

+1 669 900 9128 US (San Jose)

+1 689 278 1000 US

+1 719 359 4580 US

+1 253 205 0468 US

+1 253 215 8782 US (Tacoma)

+1 346 248 7799 US (Houston)

+1 360 209 5623 US

+1 386 347 5053 US

Webinar ID: 831 1907 8026