



Town of Century, Florida
Council Meeting Agenda
September 02, 2025 at 6:15 PM
7995 N. Century Blvd. Century, Florida 32535
(850)256-3208 | www.TownOfCenturyFlorida.com

Call Meeting to Order

1. **Roll Call**
2. **Open Meeting with Prayer and Pledge of Allegiance**
3. **Consent Agenda**
 - A.** Approval of Minutes of 08/19/2025
 - B.** Approval of Bill List
4. **Public Forum #1**
5. **Action Items**
 - A.** Resolution 2025-011-Town Seal
 - B.** Adopt Resolution No. 2025-010 Employment Agreement with Mr. David Murzin to serve as Town Administrator.
 - C.** Award of Exclusive Municipal Solid Waste and Recycling Franchise Agreement (RFP No. 2025-01) to Waste Pro of Florida, Inc.; Authorization for Mayor to Negotiate and Execute Franchise Agreement and Ordinance Repealing Conflicting Provisions
 - D.** Change Order 2 for Century Misc Wastewater Improvements
6. **Mayor's Report**
7. **Council Comments**
8. **Staff Comments/ Report**
9. **Public Forum #2**
10. **Adjourn**

§ In accordance with the Americans with Disabilities Act and Section 286.26, Florida Statutes, persons with disabilities needing special accommodation to participate in this proceeding should contact the Town Clerk no later than noon the day of the meeting to request assistance. § If HEARING impaired, please contact TDD (TDD-Telecommunications Device for the Deaf) at 1-800-955-8771. § If VOICE impaired, please contact the Florida Relay Service at 1-800-955-8770, for assistance. § If a person decides to appeal any decision with respect to any matter considered at such meeting or hearing, he will need a record of the proceedings, and for that purpose, he may need to ensure that a "verbatim record of the proceedings is made, which record includes the testimony and evidence upon which the

appeal to be based." Minutes of the Town Council meetings can be obtained from the Town Clerk's office. The cost of duplication and/or court reporter will be at the expense of the requesting party. Minutes are recorded but are not transcribed verbatim.

Town of Century Council Meeting Minutes August 19, 2025, at 6:15 PM

The data reflected in these proceedings constitute an extrapolation of information elicited from notes, observations, recording tapes, photographs, and/or videotapes. Comments reflected herein are sometimes paraphrased, condensed, and/or have been edited to reflect essential subject matter addressed during the meeting. Parties interested in receiving a verbatim account of the proceedings are responsible for coordinating with the Town Clerk and providing their own representative and equipment pursuant to Chapters 119 and 283, Florida Statutes.

Call Meeting to Order

1. Roll Call

PRESENT

Mayor Ben Boutwell

President Dynette Lewis

Henry Cunningham

John Bass

Sparkie Harrison

ABSENT

Shelisa Abraham

2. Open Meeting with Prayer and Pledge of Allegiance

Council President Lewis lead the meeting in prayer.

3. Consent Agenda

A. Approval of Minutes 08/05/2025

Motion made by Bass, Seconded by Cunningham.

Voting Yea: President Lewis, Cunningham, Bass, Harrison

B. Approval of Bill List

Motion made by Cunningham, Seconded by Bass.

Voting Yea: President Lewis, Cunningham, Bass, Harrison

Public Forum #1

NA

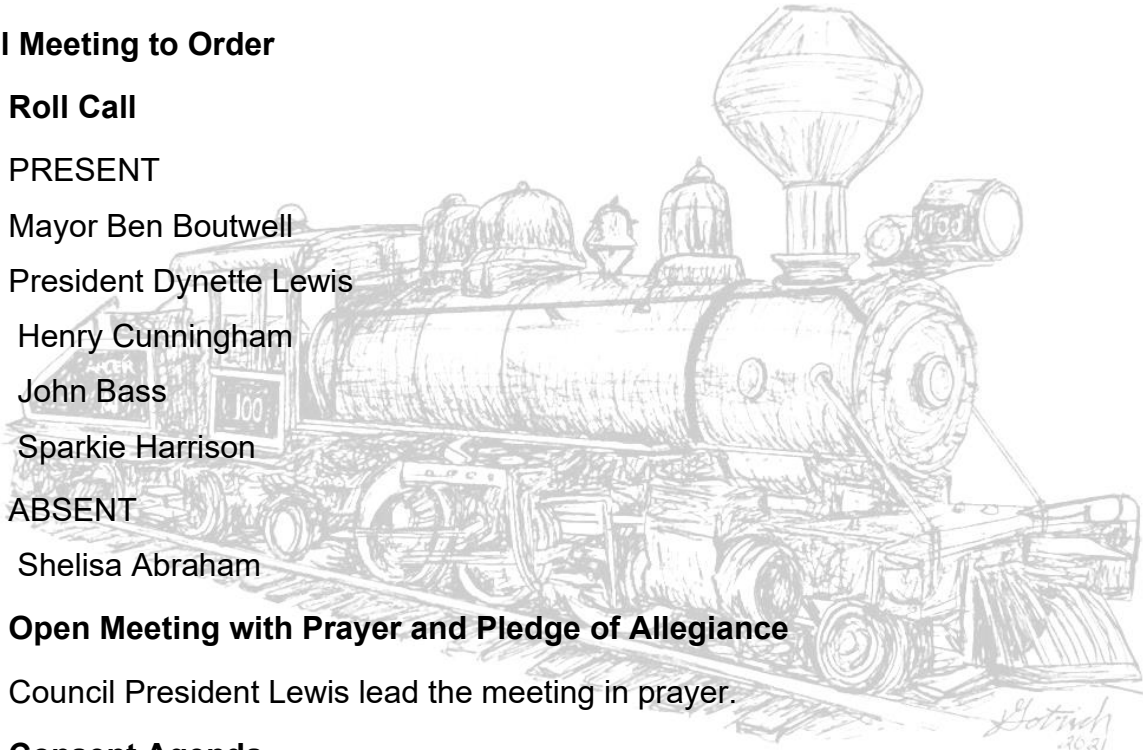

4. Action Items

- A. Selection of Town Administrator and Resolution 2025-009 Authorization for Mayor to Negotiate Employment Agreement

Mayor Boutwell asked for a Motion to allow him to negotiate the contact with David Murzin.

Motion made by Bass, Seconded by Harrison.

Voting Yea: Cunningham, Bass, Harrison

Voting Nay: President Lewis

- B. ECRC Agreement for Professional Staff Services

Motion made by Bass, Seconded by Cunningham.

Voting Yea: President Lewis, Cunningham, Bass, Harrison

- C. Promotion of Gary Small to Gas Superintendent

Motion made by Cunningham, Seconded by Bass.

Voting Yea: President Lewis, Cunningham, Bass, Harrison

- D. Ordinance 08-2025 Second Reading and Adoption of Cross Connection Control Program

Motion made by Harrison, Seconded by Cunningham.

Voting Yea: President Lewis, Cunningham, Bass, Harrison

5. Mayor's Report

Senator Gatez will be here on the 25th and will be here around 3:30pm.

6. Council Comments

President Lewis attended the conference in Orlando. Very informative conference, eye openers, AI in all kinds of locations, Building effective City Manager relations was one of the workshops, good listening skills was something to look for in a Town Manager. President Lewis had a great experience with the conference. A large item that was spoken on was DOGE at the conference, making sure we are prepared.

7. Staff Comments/ Report

Clerk Moore stated that the AC units are being replaced and that someone is coming to Town Hall daily to check on everything.

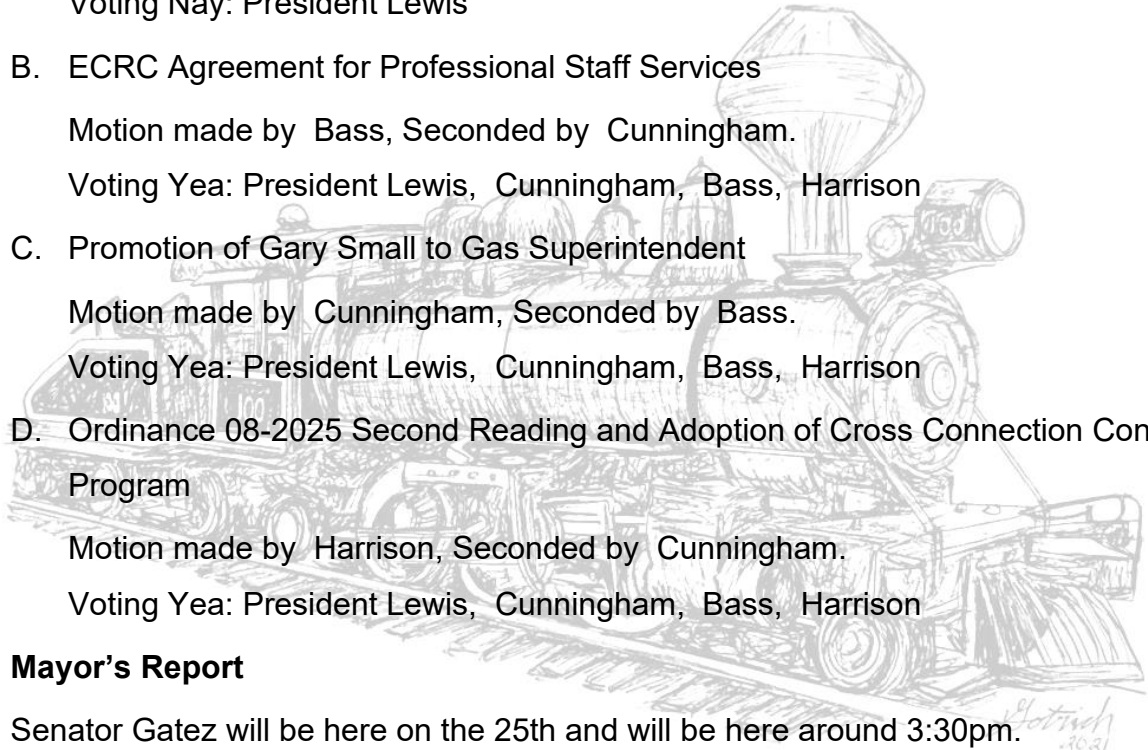

Mr. Brown said that training is very important especially for all new members of the council.

8. Public Forum #2

It was asked how often the night drop was pulled and when the payment would be posted.

Adams Sanitation stated that they missed the cut off for submitting their bid. Stated that they currently work locally and would like an opportunity the next bid time.

9. Adjourn

at 6:53PM

Motion made by Bass, Seconded by Harrison.

Voting Yea: President Lewis, Cunningham, Bass, Harrison

- 10. *§ In accordance with the Americans with Disabilities Act and Section 286.26, Florida Statutes, persons with disabilities needing special accommodation to participate in this proceeding should contact the Town Clerk no later than noon the day of the meeting to request assistance. § If HEARING impaired, please contact TDD (TDD-Telecommunications Device for the Deaf) at 1-800-955-8771. § If VOICE impaired, please contact the Florida Relay Service at 1-800-955-8770, for assistance. § If a person decides to appeal any decision with respect to any matter considered at such meeting or hearing, he will need a record of the proceedings, and for that purpose, he may need to ensure that a "verbatim record of the proceedings is made, which record includes the testimony and evidence upon which the appeal to be based." Minutes of the Town Council meetings can be obtained from the Town Clerk's office. The cost of duplication and/or court reporter will be at the expense of the requesting party. Minutes are recorded but are not transcribed verbatim.*

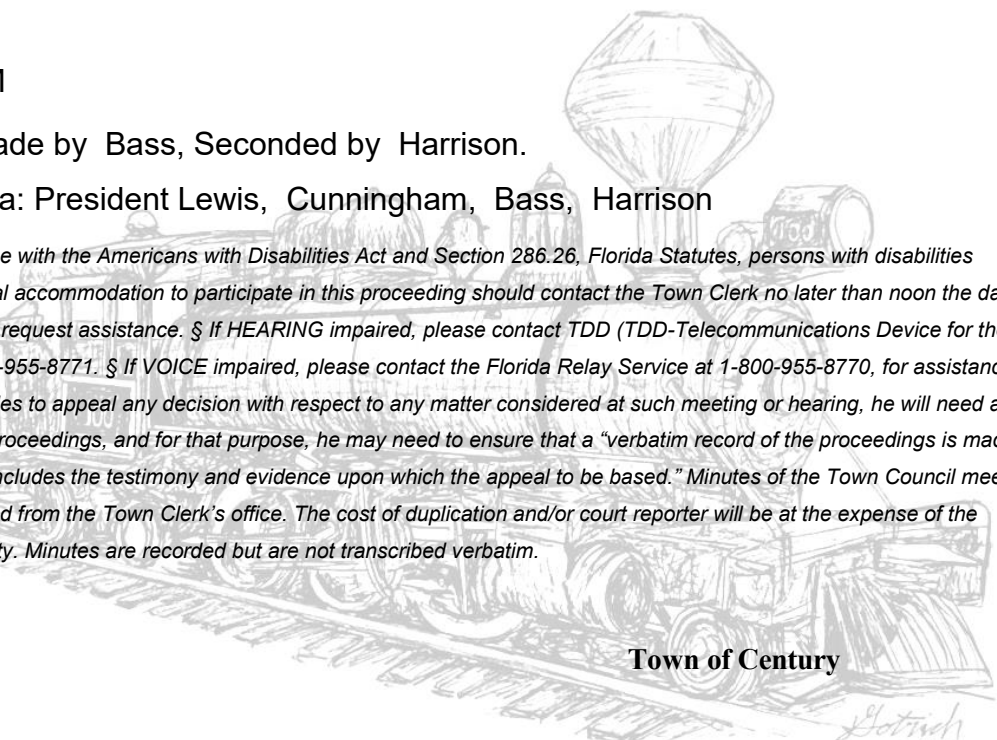

Town of Century

Attest:

Benjamin Boutwell, Mayor

Carrie Moore, Town Clerk

Town of Century
September 02, 2025
Bill List

Section 3, Item B.

Account Number	Account Name	Fund	Payee	Amount	Inv #	Month	Date Paid	YTD Spent	Annual Budget
			Gas Fund						
401-32-5-27000	Operating Supplies Gas	Gas Fund	Bondurant Lumber & Hardware (barb wire)	\$89.99	470703	August		\$11,859.49	\$12,000.00
401-32-5-27000	Operating Supplies Gas	Gas Fund	Bondurant Lumber & Hardware (blade chop saw)	\$12.99	470772	August		\$11,859.49	\$12,000.00
401-32-5-27000	Operating Supplies Gas	Gas Fund	Bondurant Lumber & Hardware (pipe, white cap slip)	\$105.76	470708	August		\$11,859.49	\$12,000.00
401-32-5-27000	Operating Supplies Gas	Gas Fund	Bondurant Lumber & Hardware (Velcro strip, glue sticks, glue gun)	\$20.47	470756	August		\$11,859.49	\$12,000.00
401-32-5-27001	Natural Gas Purchases	Gas Fund	BP Energy Company (monthly invoice-varies)	\$6,400.22	21482066	July		\$121,280.17	\$90,000.00
Grant Expense	Grant Expense	Gas Fund	Weston & Sampson Engineers, Inc. (will be reimbursed by grant -PHMSA--gate station)	\$11,637.50	1250634	January			
Grant Expense	Grant Expense	Gas Fund	Weston & Sampson Engineers, Inc. (will be reimbursed by grant -PHMSA--gate station)	\$612.50	4250489	April			
			Total	\$18,879.43					
			General Fund						
100-41-4-67003	Equipment Maintenance Small	General Fund	A 1 Small Engines (scag blade)	\$203.40	8/14/2025	August		\$7,484.51	\$8,000.00
100-41-4-65000	Vehicle Expense Street	General Fund	Buck Shot's Off Road & Tire (four tires- Howard Kressly work truck)	\$1,153.72	1917	August		\$6,367.99	\$5,000.00
100-12-4-61000	Office Equipment Maintenance	General Fund	CIT (canon copier)	\$188.82	47572917	August		\$36,188.30	\$22,000.00
100-12-8-10002	Consulting Services	General Fund	Emerald Coast Regional Council (monthly invoice-varies)	\$382.00	8643	July		\$26,989.50	\$50,000.00
100-12-4-61000	Office Equipment Maintenance	General Fund	Harris Business Machines (canon copier-copies)	\$336.91	439370	August		\$36,188.30	\$22,000.00
100-41-4-65000	Vehicle Expense Street	General Fund	JHB Auto Parts (med duty torch kit)	\$259.00	122812	August		\$6,367.99	\$5,000.00
100-41-4-65000	Vehicle Expense Street	General Fund	JHB Auto Parts (welding helmet)	\$56.99	122637	August		\$6,367.99	\$5,000.00
100-41-4-67004	Equipment Maintenance Large	General Fund	Parish Tractor (mower belt, blades)	\$352.22	9480	August		\$11,720.04	\$10,000.00
100-12-4-61000	Office Equipment Maintenance	General Fund	Southern Computer Services (assist with park NVR)	\$276.99	21631	August		\$36,188.30	\$22,000.00
100-12-4-61000	Office Equipment Maintenance	General Fund	Southern Computer Services (assisted with billing software issue)	\$178.00	21642	August		\$36,188.30	\$22,000.00
100-12-4-61000	Office Equipment Maintenance	General Fund	Southern Computer Services (check equipment connections, set up Wi-Fi for equipment)	\$89.00	21630	August		\$36,188.30	\$22,000.00
100-12-5-01001	Flowers	General Fund	Southern Treasures (Mr. Sonny Jeter Fresh Spray)	\$160.00	787662	August		\$485.00	\$1,000.00
100-41-4-67003	Equipment Maintenance Small	General Fund	Thomas Radiator & Welding (six echo speed feed head)	\$215.94	18952	August		\$7,484.51	\$8,000.00
100-12-6-20001	Capital Outlay Admin	General Fund	Trane US, Inc. (Council Room -A/C Unit-paid from LOST Funds)	\$15,825.00	990252721	August		\$22,601.26	
100-12-6-20001	Capital Outlay Admin	General Fund	Trane US, Inc. (Back Office-A/C Unit-paid from LOST Funds)	\$6,048.68	990252907	August		\$22,601.26	
100-12-6-20001	Capital Outlay Admin	General Fund	Trane US, Inc. (3-Touchscreen Programmable-paid from LOST Funds)	\$727.58	990252339	August		\$22,601.26	
			Total	\$26,454.25					
			Grand Total	\$45,333.68					

Town of Century
September 02, 2025
Bill List

Section 3, Item B.

Account Number	Account Name	Amount
	Gas Fund	
401-32-5-27000	Operating Supplies Gas	\$229.21
Grant Expense	Grant Expense	\$12,250.00
401-32-5-27001	Natural Gas Purchases	\$6,400.22
	Total	\$18,879.43
	General Fund	
100-41-4-67003	Equipment Maintenance Small	\$419.34
100-41-4-65000	Vehicle Expense Street	\$1,469.71
100-12-4-61000	Office Equipment Maintenance	\$1,069.72
100-12-8-10002	Consulting Services	\$382.00
100-41-4-67004	Equipment Maintenance Large	\$352.22
100-12-5-01001	Flowers	\$160.00
100-12-6-20001	Capital Outlay Admin	\$22,601.26
	Total	\$26,454.25
	Grand Total	\$45,333.68

Town of Century
September 02, 2025
Bill List

Section 3, Item B.

Payee	Amount
A 1 Small Engines	\$203.40
Bondurant Lumber & Hardware	\$229.21
BP Energy Company	\$6,400.22
Buck Shot's Off Road & Tire	\$1,153.72
CIT	\$188.82
Emerald Coast Regional Council	\$382.00
Harris Business Machines	\$336.91
JHB Auto Parts	\$315.99
Parish Tractor	\$352.22
Southern Computer Services	\$543.99
Southern Treasures	\$160.00
Thomas Radiator & Welding	\$215.94
Trane US. Inc.	\$22,601.26
Weston & Samspon Engineers, Inc.	\$12,250.00
Grand Total	\$45,333.68

Town of Century, Florida

Town Council Regular Meeting – September 02, 2025

Agenda Item

Title:

Approval of Transfer from LOST for \$70,771.50 to L & K Contracting Co., Inc. for Pay Request 1

Background:

Water Meter Replacement Project

Purpose:

Pay Request 1 – Will pay State Board of Administration back once money is reimbursed by the County.

Summary of Ordinance Provisions:

Water Meter Replacement Project

Recommended Action:

Motion to approve the transfer of \$70,771.50 to pay invoice



EXCELLENCE IN ENGINEERING SERVICE

July 18, 2025
150004-023

VIA EMAIL: bboutwell@centuryflorida.us

Honorable Ben Boutwell
Mayor
Town of Century
7995 N Century Blvd
Century, FL 32535

RE: Town of Century Water Meter Replacement Project –
Pay Request No. 1 (L&K Contracting Co.,Inc.)

Dear Mayor Boutwell:

Please find attached a copy of Pay Request No. 1, executed by L&K Contracting Co., Inc. and Municipal Engineering Services, Inc., along with the Contractor’s Release of Lien, in the amount of \$70,771.50.

We have reviewed each of these items and find them to be in order. Please review them for yourself and if you take no exception, please sign and return. We will then submit to the state for payment.

Should you have any questions or concerns, please do not hesitate to call.

Sincerely,

MUNICIPAL ENGINEERING SERVICES, INC.

Tommy Standefer, Jr.

/TJSJ

Attachments

Item	Description	Contract				This Period		Total to Date		% Completed
		Unit	Quantity	Unit Price	Amount	Quantity	Amount	Quantity	Amount	
BASE BID - WATER METER REPLACEMENT PROJECT										
1	Mobilization (Max 4% of Bid Amount)	LS	1	\$53,400.00	\$53,400.00	1	\$53,400.00	1.00	\$53,400.00	100%
2	Stormwater Pollution Prevention, Project Clean-Up and Restoration Complete (Includes Installation and Maintenance)	LS	1	\$9,550.00	\$9,550.00	0	\$0.00	0.00	\$0.00	0%
3	Relocate Existing Water Meter Box and Contents from Private Property to the Right of Way (Complete)	EA	29	\$1,935.00	\$56,115.00	0	\$0.00	0.00	\$0.00	0%
4	3/4" Curb Stop (Furnish and Install)	EA	916	\$163.00	\$149,308.00	1	\$163.00	1.00	\$163.00	0%
5	1" Curb Stop (Furnish and Install)	EA	31	\$298.00	\$9,238.00	0	\$0.00	0.00	\$0.00	0%
6	1.5" Curb Stop (Furnish and Install)	EA	3	\$723.00	\$2,169.00	0	\$0.00	0.00	\$0.00	0%
7	2" Curb Stop (Furnish and Install)	EA	15	\$1,185.00	\$17,775.00	0	\$0.00	0.00	\$0.00	0%
8	5/8" x 3/4" AMR Water Meter Replacement Complete (Furnish and Install)	EA	916	\$493.00	\$451,588.00	33	\$16,269.00	33.00	\$16,269.00	4%
9	1" AMR Water Meter Replacement Complete (Furnish and Install)	EA	31	\$720.00	\$22,320.00	0	\$0.00	0.00	\$0.00	0%
10	1.5" AMR Water Meter Replacement Complete (Furnish and Install)	EA	3	\$1,800.00	\$5,400.00	0	\$0.00	0.00	\$0.00	0%
11	2" AMR Water Meter Replacement Complete (Furnish and Install)	EA	15	\$2,360.00	\$35,400.00	0	\$0.00	0.00	\$0.00	0%
12	Furnish and Install Meter Box (Dig Up and Replace Existing)	EA	725	\$97.00	\$70,325.00	19	\$1,843.00	19.00	\$1,843.00	3%
13	Meter Box Lid (Furnish and Install)	EA	245	\$39.00	\$9,555.00	16	\$624.00	16.00	\$624.00	7%
14	3/4" Dual Check (Furnish and Install)	EA	805	\$192.00	\$154,560.00	33	\$6,336.00	33.00	\$6,336.00	4%
15	1" Dual Check (Furnish and Install)	EA	1	\$305.00	\$305.00	0	\$0.00	0.00	\$0.00	0%
16	3/4" RPZ Commercial BFP Above Ground with Insulated Enclosure (Furnish and Install)	EA	114	\$1,407.00	\$160,398.00	0	\$0.00	0.00	\$0.00	0%
17	1" RPZ Commercial BFP Above Ground with Insulated Enclosure (Furnish and Install)	EA	31	\$1,635.00	\$50,685.00	0	\$0.00	0.00	\$0.00	0%
18	1.5" RPZ Commercial BFP Above Ground with Insulated Enclosure (Furnish and Install)	EA	3	\$2,720.00	\$8,160.00	0	\$0.00	0.00	\$0.00	0%
19	2" RPZ Commercial BFP Above Ground with Insulated Enclosure (Furnish and Install)	EA	15	\$3,020.00	\$45,300.00	0	\$0.00	0.00	\$0.00	0%
20	Cut and Patch Concrete Sidewalk	SY	100	\$119.00	\$11,900.00	0	\$0.00	0.00	\$0.00	0%
21	Cut and Patch Concrete Driveway	SY	100	\$119.00	\$11,900.00	0	\$0.00	0.00	\$0.00	0%
22	Cut and Patch Asphalt Driveway	SY	100	\$77.00	\$7,700.00	0	\$0.00	0.00	\$0.00	0%
23	Mobile AMR Read Equipment, Hardware, Vehicle Mounting Hardware, Software, Training and 1 Year Support	LS	1	\$24,400.00	\$24,400.00	0	\$0.00	0.00	\$0.00	0%
24	Billing Company Conversion Fee (Allowance)	LS	1	\$2,000.00	\$2,000.00	0	\$0.00	0.00	\$0.00	0%
25	Miscellaneous Fittings as Required for Reconections and Tie-Ins (Allowance)	LS	1	\$5,000.00	\$5,000.00	0	\$0.00	0.00	\$0.00	0%
TOTALS					\$1,374,451.00		\$78,635.00		\$78,635.00	6%

SECTION 01710 - RELEASE OF LIEN

COUNTY OF Houston

STATE OF Alabama

Before me, the undersigned authority, personally appeared Cameron Kelley, who after being duly sworn deposes and says:

- (1) In accordance with the Bid Documents for the construction of the Water Meter Replacement Project and in consideration of \$ 70,771.50 paid, (Contractor) releases and waives for itself and its subcontractors, materialmen, successors and assigns, all claims demands, costs and expenses, whether in contract or in tort, against Town of Century (Owner) relating in any way to the performance of the Agreement between Contractor and Owner dated 4/9/25 for the period from 5/27/25 to 6/27/25.
- (2) Contractor certifies for itself and its subcontractors, materialmen, successors and assigns, that all charges for labor, materials, supplies, lands, licenses and other expenses for which Owner might be sued or for which a lien or a demand against any payment bond might be filed, have been fully satisfied and paid.
- (3) Contractor agrees to indemnify, defend, and save harmless the Owner from all demands or suits, actions, claims of liens or other charges filed or asserted against the Owner arising out of the performance by Contractor of the Work by this Release of Lien.
- (4) Contractor acknowledges that the Performance Bond for the Contract is valid for the full length of the Contract including the warranty period as specified herein.

01710-1

(5) This Release of Lien is given in connection with Contractor's final application for Payment
No. _____

[Corporate Seal]

CONTRACTOR: L&K Contracting Co, Inc.

By: Cameron Kelley

Its: vice president

Date: 7/1/25

The foregoing instrument was acknowledged before me this 1 day of July, 2025, by, Cameron Kelley, as vice president of L&K Contracting Co, Inc., a corporation, on behalf of the corporation. He/she is personally known to me OR has produced a driver's license as identification and did (did not) take an oath.

[Signature]
(Signature)

Name: Ronald Plunk
(Legibly Printed)

Notary Public, State of: Alabama

My Commission Expires: 8/19/2028

(AFFIX OFFICIAL SEAL)

END OF SECTION 01710

Town of Century, Florida

Town Council Regular Meeting – September 02, 2025

Agenda Item

Title:

Approval of Transfer from LOST for \$57,416.40 to L & K Contracting Co., Inc. for Pay Request 2

Background:

Water Meter Replacement Project

Purpose:

Pay Request 2 – Will pay State Board of Administration back once money is reimbursed by County.

Summary of Ordinance Provisions:

Water Meter Replacement Project

Recommended Action:

Motion to approve the transfer of \$57,416.40 to pay invoice



EXCELLENCE IN ENGINEERING SERVICE

August 20, 2025
150004-023

VIA EMAIL: bboutwell@centuryflorida.us

Honorable Ben Boutwell
Mayor
Town of Century
7995 N Century Blvd
Century, FL 32535

RE: Town of Century Water Meter Replacement Project –
Pay Request No. 2 (L&K Contracting Co.,Inc.)

Dear Mayor Boutwell:

Please find attached a copy of Pay Request No. 2, executed by L&K Contracting Co., Inc. and Municipal Engineering Services, Inc., along with the Contractor's Release of Lien, in the amount of \$57,416.40.

We have reviewed each of these items and find them to be in order. Please review them for yourself and if you take no exception, please execute, and provide one fully executed copy to our office, and one fully executed copy along with payment to the Contractor.

Should you have any questions or concerns, please do not hesitate to call.

Sincerely,

MUNICIPAL ENGINEERING SERVICES, INC.

Tommy Standefer, Jr.

/TJSJ

Attachments

Town of Century Water Meter Replacement Project			CONTRACT NO: 150004-023		
			PAYMENT # <u>2</u>		
OWNER: <u>Town of Century</u> 7995 N. Century Blvd. Century, RI 02835			CONTRACTOR: <u>I.&K Contracting Co., Inc.</u> 4506 Hartford Hwy. Taylor, AL 36305		
			PAGE <u>1</u> of <u>3</u>		
			PERIOD OF ESTIMATE FROM <u>6/28/2025</u> TO <u>8/1/2025</u>		
CONTRACT CHANGE ORDER SUMMARY				ESTIMATE	
NO.	AGENCY APPROVAL DATE	AMOUNT			
		ADDITIONS	DEDUCTIONS		
				1. Original Contract.....	\$ 1,374,451.00
				2. Change Orders.....	\$0.00
				3. Revised Contract.....	\$ 1,374,451.00
				4. Work Completed.....	\$ 142,431.00
				5. Stored Materials.....	\$ -
				6. Subtotal (4+5).....	\$ 142,431.00
				7. Retainage.....	\$ 14,243.10
				8. Previous Payments.....	\$ 70,771.50
				9. Amount Due.....	\$ 57,416.40
TOTALS		\$ -	\$ -		
NET CHANGE		\$0.00			
CONTRACT TIME					
Original (days):	<u>300</u>	On Schedule <input checked="" type="checkbox"/> Yes <input type="checkbox"/> No	Starting Date:	<u>May 27, 2025</u>	
Revised:	<u>0</u>		Projected Completion:	<u>March 23, 2026</u>	
Remaining:	<u>234</u>				
CONTRACTOR'S CERTIFICATION: The undersigned Contractor certifies that to the best of their knowledge, information and belief the work covered by this payment estimate has been completed in accordance with the contract documents, that all amounts have been paid by the contractor for work for which previous payment estimates was issued and payments received from the owner, and that current payment shown herein is now due.			ENGINEER'S CERTIFICATION: The undersigned certifies that the work has been carefully inspected and to the best of their knowledge and belief, the quantities shown in this estimate are correct and the work has been performed in accordance with the contract documents.		
Contractor:	<u>I.&K Contracting Co., Inc.</u>		Engineer:	<u>Municipal Engineering Services Inc.</u>	
By:	<u>[Signature]</u>		By:	<u>[Signature]</u>	
Date:	<u>8/4/25</u>		Date:	<u>8/20/2025</u>	
Owner:	<u>Town of Century</u>				
By:					
Date:					

Item	Description	Contract				This Period		Total to Date		% Completed
		Unit	Quantity	Unit Price	Amount	Quantity	Amount	Quantity	Amount	
		BASE BID - WATER METER REPLACEMENT PROJECT								
1	Mobilization (Max 4% of Bid Amount)	LS	1	\$53,400.00	\$53,400.00	0	\$0.00	1.00	\$53,400.00	100%
2	Stormwater Pollution Prevention, Project Clean-Up and Restoration Complete (Includes Installation and Maintenance)	LS	1	\$9,550.00	\$9,550.00	0	\$0.00	0.00	\$0.00	0%
3	Relocate Existing Water Meter Box and Contents from Private Property to the Right of Way (Complete)	EA	29	\$1,935.00	\$56,115.00	0	\$0.00	0.00	\$0.00	0%
4	3/4" Curb Stop (Furnish and Install)	EA	916	\$163.00	\$149,308.00	13	\$2,119.00	14.00	\$2,282.00	2%
5	1" Curb Stop (Furnish and Install)	EA	31	\$298.00	\$9,238.00	0	\$0.00	0.00	\$0.00	0%
6	1.5" Curb Stop (Furnish and Install)	EA	3	\$723.00	\$2,169.00	0	\$0.00	0.00	\$0.00	0%
7	2" Curb Stop (Furnish and Install)	EA	15	\$1,185.00	\$17,775.00	0	\$0.00	0.00	\$0.00	0%
8	5/8" x 3/4" AMR Water Meter Replacement Complete (Furnish and Install)	EA	916	\$493.00	\$451,588.00	78	\$38,454.00	111.00	\$54,723.00	12%
9	1" AMR Water Meter Replacement Complete (Furnish and Install)	EA	31	\$720.00	\$22,320.00	0	\$0.00	0.00	\$0.00	0%
10	1.5" AMR Water Meter Replacement Complete (Furnish and Install)	EA	3	\$1,800.00	\$5,400.00	0	\$0.00	0.00	\$0.00	0%
11	2" AMR Water Meter Replacement Complete (Furnish and Install)	EA	15	\$2,360.00	\$35,400.00	0	\$0.00	0.00	\$0.00	0%
12	Furnish and Install Meter Box (Dig Up and Replace Existing)	EA	725	\$97.00	\$70,325.00	54	\$5,238.00	73.00	\$7,081.00	10%
13	Meter Box Lid (Furnish and Install)	EA	245	\$39.00	\$9,555.00	87	\$3,393.00	103.00	\$4,017.00	42%
14	3/4" Dual Check (Furnish and Install)	EA	805	\$192.00	\$154,560.00	76	\$14,592.00	109.00	\$20,928.00	14%
15	1" Dual Check (Furnish and Install)	EA	1	\$305.00	\$305.00	0	\$0.00	0.00	\$0.00	0%
16	3/4" RPZ Commercial BFP Above Ground with Insulated Enclosure (Furnish and Install)	EA	114	\$1,407.00	\$160,398.00	0	\$0.00	0.00	\$0.00	0%
17	1" RPZ Commercial BFP Above Ground with Insulated Enclosure (Furnish and Install)	EA	31	\$1,635.00	\$50,685.00	0	\$0.00	0.00	\$0.00	0%
18	1.5" RPZ Commercial BFP Above Ground with Insulated Enclosure (Furnish and Install)	EA	3	\$2,720.00	\$8,160.00	0	\$0.00	0.00	\$0.00	0%
19	2" RPZ Commercial BFP Above Ground with Insulated Enclosure (Furnish and Install)	EA	15	\$3,020.00	\$45,300.00	0	\$0.00	0.00	\$0.00	0%
20	Cut and Patch Concrete Sidewalk	SY	100	\$119.00	\$11,900.00	0	\$0.00	0.00	\$0.00	0%
21	Cut and Patch Concrete Driveway	SY	100	\$119.00	\$11,900.00	0	\$0.00	0.00	\$0.00	0%
22	Cut and Patch Asphalt Driveway	SY	100	\$77.00	\$7,700.00	0	\$0.00	0.00	\$0.00	0%
23	Mobile AMR Read Equipment, Hardware, Vehicle Mounting Hardware, Software, Training and 1 Year Support	LS	1	\$24,400.00	\$24,400.00	0	\$0.00	0.00	\$0.00	0%
24	Billing Company Conversion File (Allowance)	LS	1	\$2,000.00	\$2,000.00	0	\$0.00	0.00	\$0.00	0%
25	Miscellaneous Fittings as Required for Reconections and Tie-Ins (Allowance)	LS	1	\$5,000.00	\$5,000.00	0	\$0.00	0.00	\$0.00	0%
TOTALS					\$1,374,451.00	\$63,796.00	\$142,431.00	10%		

SECTION 01710 - RELEASE OF LIEN

COUNTY OF Houston

STATE OF Alabama

Before me, the undersigned authority, personally appeared Cameron Kelley who after being duly sworn deposes and says:

- (1) In accordance with the Bid Documents for the construction of the Water Meter Replacement Project and in consideration of \$ 57,416.40 paid, (Contractor) releases and waives for itself and its subcontractors, materialmen, successors and assigns, all claims demands, costs and expenses, whether in contract or in tort, against Town of Century (Owner) relating in any way to the performance of the Agreement between Contractor and Owner dated 4/9/25 for the period from 6/28/25 to 8/1/25.
- (2) Contractor certifies for itself and its subcontractors, materialmen, successors and assigns, that all charges for labor, materials, supplies, lands, licenses and other expenses for which Owner might be sued or for which a lien or a demand against any payment bond might be filed, have been fully satisfied and paid.
- (3) Contractor agrees to indemnify, defend, and save harmless the Owner from all demands or suits, actions, claims of liens or other charges filed or asserted against the Owner arising out of the performance by Contractor of the Work by this Release of Lien.
- (4) Contractor acknowledges that the Performance Bond for the Contract is valid for the full length of the Contract including the warranty period as specified herein.

01710-1

(5) This Release of Lien is given in connection with Contractor's final application for Payment
No. _____.

[Corporate Seal]

CONTRACTOR: L&K Contracting Co., Inc.
By: Cameron Kelley
Its: Vice President
Date: 8/4/25

The foregoing instrument was acknowledged before me this 8 day of August, 2025, by, Cameron Kelley, as vice president of L&K Contracting Co., Inc., a corporation, on behalf of the corporation. He/she is personally known to me OR has produced a driver's license as identification and did (did not) take an oath.

[Signature]
(Signature)

Name: Ronald D. King
(Legibly Printed)

(AFFIX OFFICIAL SEAL)

Notary Public, State of: Alabama

My Commission Expires: 8/19/2028

END OF SECTION 01710

TOWN OF CENTURY, FLORIDA
TOWN COUNCIL AGENDA ITEM

MEETING DATE: September 02, 2025

AGENDA ITEM: Resolution No. 2025-011 – Adoption of Official Town Seal/Logo

SUBJECT:

Consideration and approval of Resolution No. 2025-011 adopting an official Town Seal/Logo for the Town of Century.

BACKGROUND:

The Town Council has expressed the desire to establish an official Town Seal/Logo to provide a consistent, professional, and recognizable symbol of the Town’s government. An official seal/logo will:

- Ensure uniformity on Town ordinances, resolutions, proclamations, and official correspondence.
- Provide a clear and professional image for signage, websites, and public documents.
- Strengthen civic identity and community pride.

A proposed design has been developed and is attached as Exhibit A to Resolution No. 2025-011.

RECOMMENDATION:

Staff recommends approval of Resolution No. 2025-011, formally adopting the attached design as the official Town Seal of the Town of Century.

FISCAL IMPACT:

Minimal. Costs are limited to updating stationery, signage, and digital materials over time.

ATTACHMENTS:

1. Resolution No. 2025-011
2. Exhibit A – Proposed Town Seal/Logo

REQUESTED ACTION:

Motion to approve Resolution No. 2025-011, adopting the attached design as the official Town Seal of the Town of Century, Florida.

SEAL DESIGN BREAKDOWN

Sawblade Motif

The Alger-Sullivan Lumber Company, located in Century, was built at the turn of the twentieth century (hence the town's name) by northern speculators General R.A. Alger of Detroit and Martin Sullivan, residing in Pensacola, but originally from New York State.

Sunshine Element

With its subtropical climate and abundant sunshine, Florida is widely known by the nickname "The Sunshine State". Century has often been referred to as "The Northern Gate to the Sunshine State".

Railroad Track

The Alger-Sullivan Lumber Company railroad, a vital part of Century's early logging industry, stretched 90 miles into Alabama and carried virgin longleaf pine to the company's massive sawmill

This railroad played a central role in Century's growth and timber-based economy..

Orange Blossom

The Orange Blossom from the sweet orange tree, *Citrus x sinensis*, was made Florida's state flower in 1909.

Founding Year

Century, Florida, was founded in 1901 as a sawmill company town and was named because 1901 was the first year of the 20th century.

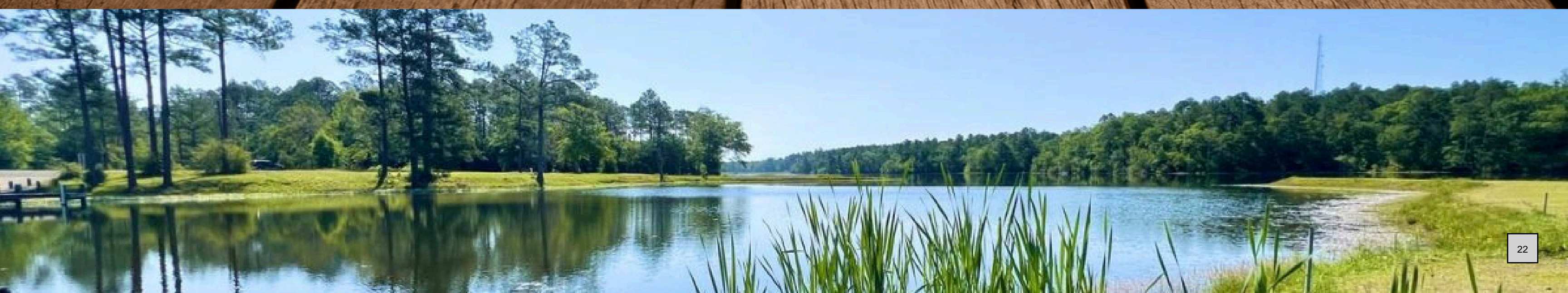



WELCOME TO CENTURY



Century, Florida, was founded in 1901 as a sawmill company town and was named because 1901 was the first year of the 20th century.

It was officially incorporated as the Town of Century in 1945. The community was originally an unincorporated part of Escambia County, neighboring the Town of South Flomaton, which later changed its name to Town of Century in 1979.



RESOLUTION NO. 2025-011

A RESOLUTION OF THE TOWN COUNCIL OF THE TOWN OF CENTURY, FLORIDA, ADOPTING AN OFFICIAL TOWN SEAL; PROVIDING FOR ITS USE IN OFFICIAL CAPACITY; AND PROVIDING FOR AN EFFECTIVE DATE.

WHEREAS, the Town Council of the Town of Century recognizes the importance of establishing an official town seal to provide a consistent and professional representation of the Town; and

WHEREAS, the Town Council finds it appropriate to formally adopt said seal for use on Town documents, signage, and other official materials; and

WHEREAS, the adoption of an official seal will strengthen the Town’s identity and ensure consistent branding in its official capacity;

NOW, THEREFORE, BE IT RESOLVED BY THE TOWN COUNCIL OF THE TOWN OF CENTURY, FLORIDA:

SECTION 1. ADOPTION OF SEAL.

The design attached hereto as Exhibit A is hereby adopted as the official Town Seal of the Town of Century, Florida.

SECTION 2. USE OF SEAL.

The official Town Seal shall be used exclusively for official purposes of the Town of Century, including but not limited to correspondence, ordinances, resolutions, proclamations, signage, and other authorized municipal uses.

SECTION 3. EFFECTIVE DATE.

This Resolution shall take effect immediately upon adoption.

PASSED AND ADOPTED this ___ day of _____, 2025, by the Town Council of the Town of Century, Florida.

Benjamin Boutwell, Mayor

ATTEST:

Carrie Moore, Town Clerk

EXHIBIT A

OFFICIAL TOWN SEAL



TOWN OF CENTURY, FLORIDA

TOWN COUNCIL MEETING

September 2, 2025

Agenda Item: Approval of Employment Agreement with Mr. David Murzin, Town Administrator

Requested Action:

Adopt Resolution No. 2025-XX approving and authorizing execution of an Employment Agreement between the Town of Century, Florida, and Mr. David Murzin to serve as Town Administrator.

Background:

The Town Council has identified the need to formally appoint and contract with a qualified individual to serve as Town Administrator. Following review of candidates, the Council has selected Mr. David Murzin and negotiated the terms of an Employment Agreement.

The agreement provides:

- Position: Town Administrator
- Term: Two (2) years, commencing September 1, 2025, with automatic two-year renewals unless ninety (90) days' notice of nonrenewal is given by either party
- Compensation: \$112,000 annually, payable consistent with Town payroll practices
- Benefits: Standard benefits provided to full-time employees, including retirement, health, and leave accruals
- Training & Development: The Town shall provide reasonable travel and training opportunities, subject to budget availability, including programs of the Florida League of Cities and the Florida City and County Management Association
- Termination: Employee may resign with ninety (90) days' notice; the Town may terminate with or without cause upon written notice

Resolution No. 2025-XX authorizes Mayor Benjamin D. Boutwell to execute the Employment Agreement on behalf of the Town, with the Town Clerk attesting.

Fiscal Impact:

The agreement establishes a base annual salary of \$112,000, funded through the Town's adopted budget for FY 2025-2026, plus standard employee benefits.

Recommendation:

Staff recommends that the Town Council adopt Resolution No. 2025-XX and approve the Employment Agreement with Mr. David Murzin to serve as Town Administrator.

Attachments:

- 1. Resolution No. 2025-XX
- 2. Employment Agreement – Mr. David Murzin
- 3. Exhibit A – Town Administrator Job Description

RESOLUTION NO. 2025-10

A RESOLUTION OF THE TOWN COUNCIL OF THE TOWN OF CENTURY, FLORIDA, APPROVING CHANGE ORDER NO. 2 FOR THE CENTURY MISCELLANEOUS WASTEWATER IMPROVEMENTS (PHASE II) PROJECT; PROVIDING FOR PAYMENT OF ADDITIONAL COSTS FROM TOWN FUNDS; AND PROVIDING FOR AN EFFECTIVE DATE.

WHEREAS, the Town of Century is currently undertaking the Century Miscellaneous Wastewater Improvements (Phase II) Project; and

WHEREAS, the Contractor, Talcon Group, LLC, has submitted Change Order No. 2 in the amount of \$62,700.00 with a contract time extension of sixty (60) days for the demolition and reconstruction of the existing sludge press building; and

WHEREAS, significant structural deterioration of the sludge press building framing, columns, purlins, and girts has been documented, making replacement more cost-effective and structurally sound than repair; and

WHEREAS, Municipal Engineering Services, Inc., after inspection and review, has recommended approval of the Change Order as being in order and reasonable under the circumstances; and

WHEREAS, this Change Order will exceed the project's existing grant funding, requiring the additional cost to be paid from Town funds (LOST or another designated account);

NOW, THEREFORE, BE IT RESOLVED BY THE TOWN COUNCIL OF THE TOWN OF CENTURY, FLORIDA:

1. Approval of Change Order No. 2. The Town Council hereby approves Change Order No. 2 with Talcon Group, LLC, in the amount of \$62,700.00 and sixty (60) additional calendar days, for the demolition and reconstruction of the sludge press building.

2. Funding Source. The additional cost of \$62,700.00 shall be paid from Town funds, specifically LOST funds or such other account as may be designated by the Town Council.

3. Execution. The Mayor is authorized to execute Change Order No. 2 and any necessary documents on behalf of the Town of Century.

4. Effective Date. This Resolution shall take effect immediately upon adoption.

ADOPTED this ___ day of _____, 2025, by the Town Council of the Town of Century, Florida.

TOWN COUNCIL OF THE TOWN OF CENTURY, FLORIDA

Benjamin Boutwell, Mayor

ATTEST:

Carrie Moore, Town Clerk

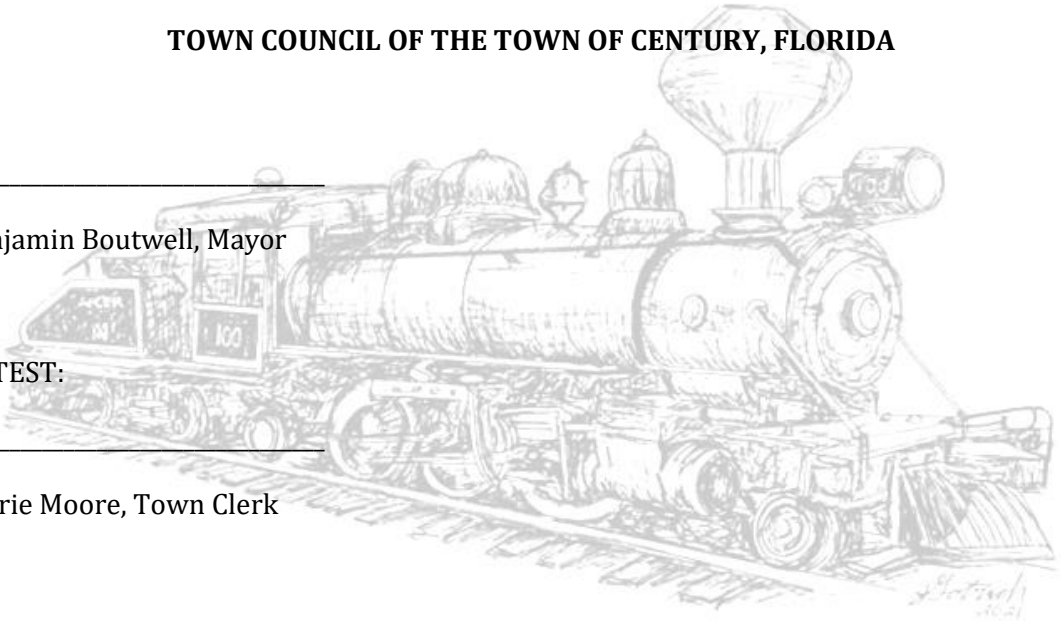

EXHIBIT A – JOB DESCRIPTION

TOWN ADMINISTRATOR

Location: Town of Century, FL

Reports To: Mayor

Approval: Town Council

Position Type: Full-Time

Job Summary

The Town of Century is actively seeking a qualified individual to fill the role of Town Administrator. The chosen candidate will serve under the leadership of the Mayor and will be responsible for the effective administration of all town departments. The Town Administrator will work collaboratively to implement policies and strategic initiatives as directed by the Mayor, with the backing of the Town Council. Preferred candidates will have a strong background in municipal management and experience in a leadership capacity within a City Manager's office.

Qualifications

Education: Bachelor’s degree in Public Administration, Business Administration, or related field; a Master’s degree is preferred.

Experience: A minimum of five years in a managerial role in municipal government is required, with preference for experience as a department head or within a City Manager’s office.

Skills: Outstanding leadership, strategic planning, budgeting, and fiscal management abilities, along with a commitment to public service.

Licensing: A valid Florida Driver’s License is required.

Responsibilities

- Administer the day-to-day operations of the town, ensuring efficient coordination and management of all departments.
- Support the Mayor in formulating and executing town policies and goals.
- Oversee the development and management of the town’s budget, upholding fiscal integrity and accountability.
- Drive sustainable economic growth and cultivate strong community relations.
- Engage with the Town Council to gain support for and authorization of various policy initiatives and municipal projects.
- Respond to and resolve community concerns, enhancing the town’s public engagement

and transparency.

- Promote and support the professional growth of town staff.
- Provide informed and strategic advice to the Mayor and Council.

Skills and Abilities

- Understanding of municipal governance principles, strategic planning, and public policy.
- Capacity to work within a political environment, upholding impartiality and professionalism.
- Proficient in public speaking and community engagement.
- Strong analytical and problem-solving abilities.

Working Conditions

Predominantly office-based, with the necessity to attend meetings beyond standard office hours. Availability to manage and respond to town emergencies as needed.

The Town of Century is an Equal Opportunity Employer, dedicated to creating a diverse and inclusive workplace.

EMPLOYMENT AGREEMENT BETWEEN THE TOWN OF CENTURY,
FLORIDA AND MR. DAVID MURZIN

This Employment Agreement (“Agreement”) is made and entered into this ___ day of September, 2025, by and between the Town of Century, Florida, a municipal corporation (hereinafter the “Employer” or the “Town”), and Mr. David Murzin (hereinafter the “Employee”).

ARTICLE I. TERM AND DUTIES

1.01 Term. This Agreement shall commence on September __, 2025, and shall remain in full force and effect for two (2) years, unless otherwise terminated as provided herein. Thereafter, it shall automatically renew for successive two (2)-year terms unless either party provides written notice of nonrenewal at least ninety (90) days prior to expiration of the then-current term.

1.02 Duties and Authority. Employer agrees to employ Employee as Town Administrator to perform the functions and duties described in the position description approved by the Town Council and as may be assigned by the Mayor and Town Council.

ARTICLE II. COMPENSATION AND BENEFITS

2.01 Compensation. Employer agrees to pay Employee an annual base salary of One Hundred Twelve Thousand Dollars (\$112,000.00), payable in installments at the same intervals as other management employees of the Town.

2.02 Benefits. Employee shall receive all benefits provided to full-time employees of the Town, including but not limited to retirement plan participation, health, dental, and life insurance, leave accruals, and other standard benefits, consistent with Town policy.

2.03 Professional Development. The Town shall budget and pay for reasonable travel and training for Employee for as long as the Town’s budget can accommodate. This shall include dues and expenses for participation in the Florida League of Cities (FLC) and the Florida City and County Management Association (FCCMA), or other similar professional organizations as approved.

2.04 General Business Expenses. Employer shall reimburse Employee for all reasonable and necessary expenses incurred in the performance of his duties in accordance with Town policy.

ARTICLE III. GENERAL WORK CONDITIONS

3.01 Performance Evaluation. The Employer may conduct an annual performance evaluation of Employee in a form and manner determined by the Employer. A copy of the written evaluation, if conducted, shall be provided to Employee and discussed with him.

3.02 Hours of Work. It is recognized that Employee must devote time outside normal office hours to the business of the Town. Employee shall be allowed to establish a work schedule that is consistent with the needs of the Town.

3.03 Outside Activities. Employee shall not engage in any outside employment or activity that is inconsistent or in conflict with his official duties or that could impair his independence of judgment or performance of duties.

ARTICLE IV. EMPLOYMENT SEPARATION

4.01 Resignation. Employee may resign at any time with ninety (90) days' written notice to Employer.

4.02 Termination by Employer. Employer may terminate Employee at any time with or without cause by providing written notice.

ARTICLE V. GENERAL COVENANTS

5.01 Indemnification. To the fullest extent permitted by law, Employer shall indemnify and defend Employee against claims or demands arising out of his performance of duties, subject to the limitations of Section 768.28, Florida Statutes.

5.02 Bonding. Employer shall bear the full cost of any fidelity or other bonds required of Employee by law or policy.

5.03 Other Terms and Conditions. Employer shall fix any additional conditions of employment as are consistent with state law and Town policy.

ARTICLE VI. GENERAL PROVISIONS

6.01 Governing Law. This Agreement shall be governed by and construed under the laws of the State of Florida.

6.02 Severability. If any provision of this Agreement is held invalid, the remainder shall not be affected and shall remain in full force and effect.

6.03 Entire Agreement. This Agreement represents the entire agreement between the parties and supersedes all prior negotiations or understandings. It may only be amended in writing signed by both parties.

6.04 Notices. Notices under this Agreement shall be in writing and delivered to the parties at their addresses on file with the Town Clerk.

EXECUTION

IN WITNESS WHEREOF, the parties have executed this Employment Agreement as of the date first written above.

TOWN OF CENTURY, FLORIDA

By: _____

Benjamin D. Boutwell, Mayor

EMPLOYEE

By: _____

Mr. David Murzin

Attest: _____

Carrie Moore, Town Clerk

Town of Century – Agenda Item

Meeting Date: Tuesday, September 2, 2025

Subject: Evaluation Results and Direction on RFP No. 2025-01 – Exclusive Solid Waste Collection & Recycling Services

Requested Action: Accept the Evaluation Committee’s rankings and authorize the Mayor to negotiate and finalize a franchise agreement with the top-ranked proposer, and bring the contract back for Council approval.

Background

The Town issued RFP No. 2025-01 for an exclusive solid waste and recycling franchise. Two proposals were received:

1. Waste Pro of Florida, Inc.
2. BFI Waste Services, LLC dba Republic Services of Escambia County.

The evaluation meeting was held Friday, August 22, 2025, at 8:00 AM CST. The Evaluation Committee consisted of:

- Mayor Benjamin D. Boutwell
- Howard W. Brown, Jr., Interim Town Manager
- Bobbie Williams, Procurement Consultant

Evaluation Results

Scoring Summary

Proposer	Mayor Boutwell	Howard Brown	Bobbie Williams	Average
Waste Pro of Florida, Inc.	95.5	91	94	93.5
Republic Services (BFI Waste Services, LLC)	62.8	72	82	72.3

Waste Pro of Florida, Inc. consistently scored the highest across all evaluators, with strengths in cost proposal, service plan, equipment, and community engagement.

Republic Services was evaluated as adequate but with key weaknesses: missing commercial pricing, incomplete forms, and a weaker overall service plan.

Committee Consensus

The Committee unanimously ranked:

- 1. Waste Pro of Florida, Inc. – Top Ranked (Avg. Score: 93.5)
- 2. Republic Services (BFI Waste Services, LLC) – Second (Avg. Score: 72.3)

Fiscal Impact

Final fiscal impact will be determined through negotiations. Proposals contain detailed rate structures; final terms will be brought back for Council approval.

Alternatives

- 1. Accept the rankings and authorize negotiations with the top-ranked proposer (recommended).
- 2. Direct staff to seek clarifications or best-and-final offers.
- 3. Reject all proposals and re-issue the RFP.

Proposed Motion

I move to accept the Evaluation Committee’s rankings for RFP No. 2025-01, designating Waste Pro of Florida, Inc. as the top-ranked proposer and BFI Waste Services, LLC dba Republic Services of Escambia County as second; and to authorize the Mayor to negotiate and bring back a final franchise agreement with the top-ranked proposer for Town Council approval.

Firm's Qualifications Rating Worksheet

RFP#: 2025-002 RFP Name: Solid Waste Franchise Proposal

Firm: BFI Waste Services, LLC DBA Republic Services

Score: 82

EVALUATION CRITERIA		Maximum Points	Score	Comments
1	Cost Proposal	40	30	Proposal does not include price proposal for commercial bulk pick up nor commercial yard waste (vegetative). Recycling was listed as optional in RFP, therefore no points were decreased due to its omission. Residential rate of \$18.30 per unit, is this no change in the current rate structure or increase?
2	Experience & Past Performance	20	20	Appears to be a great company that has served the Town of Century well. Are there any performance reviews documenting any noncompliance or lag in responses to customers?
3	Service Plan & Equipment	20	15	Service plan appears to be excellent with the on-time tracking system. Plan does not support the bulk pick up for commercial accounts.
4	Customer Service & Local Presence	10	10	Use of call center is excellent; included an analysis of the call volume. For local presence, does the company provide a financial donation to the Town of Century? It was mention vaguely that the company provides support. Is it possible to include a community contribution or other partnerships in the contract?
5	Completeness of Proposal	10	7	Submitter Andrew J. Rodgers does not appear to be authorized to submit proposals on behalf of the vendor. It is recommended that an authorization form be completed by the company. Many of the forms were not properly executed and notarized where required.
Total Score		100	82	

Rater: *Bobbi J. Williams*

Firm's Qualifications Rating Worksheet

RFP#: 2025-002 RFP Name: Solid Waste Franchise Proposal

Firm: BFI Waste Services, LLC DBA Republic Services

Score: 72

EVALUATION CRITERIA		Maximum Points	Score	Comments
1	Cost Proposal	40	28	Rate competitive, but incomplete. Omissions reduce clarity for Town budgeting.
2	Experience & Past Performance	20	17	Longstanding provider, but proposal lacks detail on performance metrics or past audits.
3	Service Plan & Equipment	20	15	Excellent technology. Did not demonstrate use of technology ion capabilities in bulk or recycling.
4	Customer Service & Local Presence	10	7	Customer service strong; local presence/community partnership weak. While not required, as long as the vendor has been with the Town, the current Town Council has not been provided with an direct update on operations, etc
5	Completeness of Proposal	10	5	Documentation deficiencies create compliance risks.
Total Score		100		

Rater:

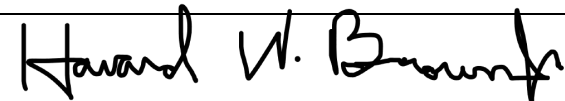

Howard W. Brown, Jr., ICMA-CM
Interim Town Manager

Firm's Qualifications Rating Worksheet

RFP#: 2025-002 RFP Name: Solid Waste Franchise Proposal

Firm: BFI Waste Services, LLC DBA Republic Services

Score: 62.8

EVALUATION CRITERIA		Maximum Points	Score	Comments
1	Cost Proposal	40	16	
2	Experience & Past Performance	20	13.3	
3	Service Plan & Equipment	20	16	
4	Customer Service & Local Presence	10	10	
5	Completeness of Proposal	10	7.5	
Total Score		100	62.8	

Rater: *Benjamin D Boutwell, Mayor*

Firm's Qualifications Rating Worksheet

RFP#: 2025-002 RFP Name: Solid Waste Franchise Proposal

Firm: Waste Pro

Score: 91

EVALUATION CRITERIA		Maximum Points	Score	Comments
1	Cost Proposal	40	36	Complete and competitive proposal with cost structure.
2	Experience & Past Performance	20	18	Strong Florida presence in the Florida Panhandle
3	Service Plan & Equipment	20	18	Excellent technology; responsive RFP.
4	Customer Service & Local Presence	10	9	Local/community presence
5	Completeness of Proposal	10	10	Complete Response to all elements of RFP;
Total Score		100		

Rater:



Howard W. Brown, Jr., ICMA-CM
Interim Town Manager

Firm's Qualifications Rating Worksheet

RFP#: 2025-002 RFP Name: Solid Waste Franchise Proposal

Firm: Waste Pro of Florida, Inc.

Score: 94

EVALUATION CRITERIA		Maximum Points	Score	Comments
1	Cost Proposal	40	35	Cost proposal at \$19 per unit for residential but increases to \$40.75 for the services required by the Town of Century. Does the hauler set its own rate for commercial pick up?
2	Experience & Past Performance	20	20	Waste Pro of Florida appears to be an excellent service provider. The company has over 20 years of experience and has municipal and franchise experience. The day in the life if a waste pro driver section of the proposal was a great addition, as it details of the level of care and safety carried out by the company. It gives the feeling of family and trust.
3	Service Plan & Equipment	20	20	Proposal provides a detailed plan of how services will be rendered to include the types of equipment that will be used. Uses routing software to manage routes.
4	Customer Service & Local Presence	10	9	Customer service plan is well thought out and provides the alternatives for inclement weather. Waste Pro plans to hire additional staffing to support the Town of Century. Consideration....educate, educate, educate on clean recycling before contaminated recycling is refused. Waste Pro partners with numerous organizations and provides monetary contributions. Will the contract include a Town of Century contribution or opportunities to partner?
5	Completeness of Proposal	10	10	Well written proposal. Ralph Mills is authorized per President/CEO of organization to submit on behalf.
Total Score		100	94	

Rater: *Bobbi J. Williams*

Firm's Qualifications Rating Worksheet

RFP#: 2025-002 RFP Name: Solid Waste Franchise Proposal

Firm: Waste Pro of Florida, Inc.

Score: 95.5

EVALUATION CRITERIA		Maximum Points	Score	Comments
1	Cost Proposal	40	40	
2	Experience & Past Performance	20	20	
3	Service Plan & Equipment	20	20	
4	Customer Service & Local Presence	10	8	
5	Completeness of Proposal	10	7.5	
Total Score		100	95.5	

Rater: *Benjamin D Boutwell, Mayor*

POWER OF ATTORNEY

This Power of Attorney made this 31st day of July 2025, I, Sean M. Jennings, President and CEO of Waste Pro of Florida, Inc., hereby appoint, Ralph Mills, Senior Vice President, to do, bind, and execute the following on behalf of Waste Pro of Florida, Inc.

1. Execute, bid, and deliver any documents related to the – Town of Century – Exclusive Franchise for Solid Waste Collections and Recycling Services, including any addendums.
2. This Power of Attorney is intended to grant broad powers to Ralph Mills to execute documents in this matter.

This Power of Attorney is to remain in full force and effect until written revocation by an officer of Waste Pro of Florida, Inc.

Sean Jennings

 SIGNATURE of Sean M. Jennings
 President and CEO of Waste Pro of Florida, Inc.

STATE OF FLORIDA

COUNTY OF SEMINOLE

The foregoing instrument was acknowledged before me by means of X physical presence or ___ online notarization, this 31st day of July 2025, by Sean M. Jennings, CEO and President of Waste Pro of Florida, Inc.

Malenie Velez

 (Signatory of Notary Public – State of Florida)

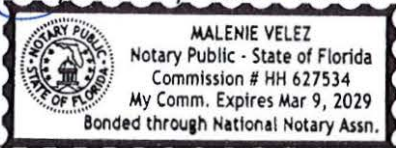

(Name of Notary Public)

Personally Known X or produced Identification _____ Type of Identification Produced _____



TABLE OF CONTENTS

- TAB 1: TRANSMITTAL LETTER**
- TAB 2: COMPANY OVERVIEW**
- TAB 3: EXPERIENCE AND REFERENCES**
- TAB 4: SERVICE PLAN**
- TAB 5: COST PROPOSAL**
- TAB 6: CUSTOMER SERVICE PLAN**
- TAB 7: INSURANCE AND BONDING**
- TAB 8: DISPOSAL FACILITY PLAN**
- TAB 9: FORMS AND EXHIBITS**



Waste Pro USA Inc. CEO John J. Jennings said he believes in maintaining the company's core values even as his Longwood, Fla.-based solid waste management company continues to rapidly expand.

By Jim Johnson

Waste Pro USA Inc. is far from the single-plant operation that started a decade ago, now generating \$400 million annually. The company now has operations in seven southern states, running more than 1,400 trucks, employing 2,400 people and servicing 100,000 customers.

locations to maintain and promote company beliefs.

"As we grow, we want to make sure that we're able to maintain and keep that schwa-culture going that really has been a part of our success," Jennings said.

"I started the company really with the idea of keeping it simple. And what do we really mean by 'simple'?" Jennings asked. "It's not about the size of the company, but about the culture."

been working with Jennings for about a quarter of a century in the trash business, even before the creation of Waste Pro.

Traveling from his home base of Athens, Ga., Wood will hit the road a week or two at a time to talk to employees about company culture.

©2011 Waste Pro USA Inc. All rights reserved.

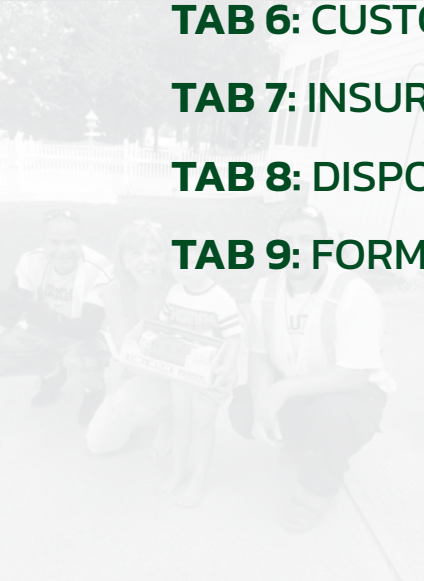

EXCLUSIVE FRANCHISE FOR SOLID WASTE COLLECTION AND RECYCLING SERVICES
TOWN OF CENTURY, FL | RFP NO. 2025-02

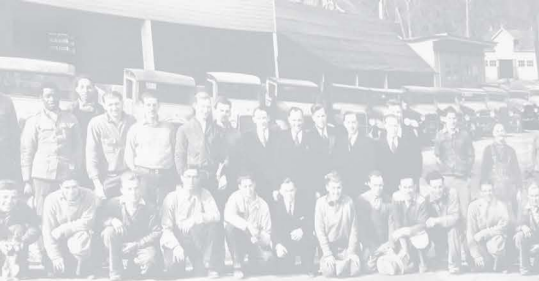

WASTE & RECYCLING NEWS

MAY 2, 2011

Crain's News Source for Environmental Management

Waste Pro keeps it simple



Waste Pro USA Inc. CEO John J. Jennings said he believes in maintaining the company's core values even as his Longwood, Fla.-based solid waste management company continues to rapidly expand.

By Jim Johnson

Waste Pro USA Inc. is far from the single-truck operation that started a decade ago. With sales topping \$400 million annually, the company now has operations in seven southern states, running more than 1,400 trucks, employing 2,400 people and servicing 7.7 million customers.

locations to maintain and promote company beliefs. "As we grow, we want to make sure that we're able to maintain and keep that active culture going that really has been a part of our success," Jennings said. "I started the company really with the idea of keeping it simple. And what do we really mean by simple? We come from a small business

been working with Jennings for about a quarter of a century in the trash business, even before the creation of Waste Pro. Traveling from his home base of Athens, Ga., Wood will hit the road a week or two at a time to talk to employees about company culture. "We do believe that our employees are





August 11, 2025

Carrie Moore, Town Clerk
Town of Century
7995 N Century Blvd, Century, FL 32535



Dear Committee Members,

Solid waste and recycling collection services are vital to the happiness, well-being, and environmental health of the Town of Century. Waste Pro of Florida, Inc. (hereafter referred to as Waste Pro) is committed to providing these services—with a “Distinguishable Difference.”

Waste Pro is excited to submit our proposal for RFP No. 2025-02 to provide exclusive municipal residential and commercial and recycling collection throughout the Town. We have examined the Request for Proposals (RFP), understand the scope of services required, and are pleased to offer our experienced services to the Town. Our enclosed materials are formatted as requested.

Waste Pro’s “Distinguishable Difference” is our local commitment to world-class service—service that begins with state-of-the-art equipment; professional, locally-based personnel; and collections that happen on schedule, without fail.

Our “Distinguishable Difference” boils down to a simple truth: As a Florida-based company embedded in our local communities, our municipal partners are our neighbors, and we believe in always doing our best by our neighbors. This focus on local relationships drives our commitment to creating more sustainable, cost-effective waste and recycling solutions. “Caring for Our Communities” is both our motto and the hallmark of Waste Pro founder John Jennings’s business philosophy.

With revenue projected to exceed \$1.4 billion in 2025, we have the resources to provide the Town of Century with the world-class service residents and businesses deserve. We are proud to be one of the largest providers of exclusive residential solid waste services in Florida, with operations in 61 of 67 counties. Waste Pro has contracts in 11 Southeastern states, serving two million residential and 100,000 commercial customers across more than 260 exclusive municipal franchises. Throughout our footprint, Waste Pro believes that making our service “world-class” begins and ends with our local commitments to our municipal partners. We remain a privately-owned, family-operated company with a decentralized management structure. This means that decisions about operations for the Town of Century will be made quickly and efficiently by local leadership with boots on the ground.

Waste Pro has the resources to serve the Town of Century with the exceptional reliability its residents deserve. Our Escambia County operations, served by our nearby Pensacola Division facility in Milton, houses 46 collection vehicles, 40 drivers, and a full team of eight technicians, along with seasoned dispatchers and administrative support staff locally. With a fleet of more than 4,200 trucks, Waste Pro can allocate resources to meet the needs of Century’s residential and commercial customers—and scale support as needed over the five-year contract term and optional renewal.

We’ve maintained successful relationships throughout Escambia County since 2008 and are proud to serve neighboring communities such as Santa Rosa County where we currently serve over 47,000 subscription-based customers, making Waste Pro the overall choice by the people and the leader in the industry amongst other competitors. We also service a total of nine municipalities in nearby Alabama



cities including Century’s sister towns Atmore and Flomaton in Escambia County, Alabama as well as Spanish Fort in Baldwin County, Saraland, Creola, Mount Vernon, and the City of Mobile in Mobile County. We also continue to support open-market commercial accounts in Escambia County, Alabama; Escambia County, Florida; Santa Rosa County, Florida; Baldwin County, Alabama; and Mobile County, Alabama.

As demonstrated in our proposal, Waste Pro’s services for the Town of Century will feature value-added benefits that create a “Distinguishable Difference”:

- ✓ **State-of-the-Art Equipment** Our trucks are kept clean and have a striking, environmentally themed color scheme. Trucks will be equipped with 360° monitoring cameras for safety and service verification purposes.
- ✓ **Locally Trained, Safety-Minded Drivers** We train our drivers locally, with a focus on local roads, disposal facilities, and service needs. Our drivers are encouraged to “go the extra mile” when servicing customers, and we reward them for this effort—we are the only solid waste company in the United States to offer a \$10,000 Safety Award to encourage safe driving and exemplary customer service. As a result, we have one of the lowest employee turnover rates in the industry and a safety rating that exceeds industry standards.
- ✓ **Career Advancement for Employees** Waste Pro is one of only two solid waste companies in Florida to offer DOT-approved CDL classes. We invest in our people, supporting qualified helpers as they advance their careers and are promoted to drivers.
- ✓ **Local, Responsive Customer Service** All calls to Waste Pro are answered by a real person who lives and works alongside our customers. Customer service is one of our top priorities, and we are committed to responding quickly to any customer concerns. Our customer service center will be located at our Pensacola-Milton hauling facility and staffed by local residents.
- ✓ **Engaged Community Partnership** In addition to facilitating education, public awareness, and increased recycling participation, we look forward to participating in community initiatives beyond bid requirements. Across our footprint, Waste Pro donates over \$1 million annually to local charities and engages in hands-on service at local community events. “Caring for Our Communities” means being a great service provider *and* a good neighbor.

We feel confident that Waste Pro is uniquely qualified to handle the Town of Century’s collection service requirements. Municipal contracts and **partnering with local communities are our areas of expertise.** We have enclosed references and encourage you to contact these municipalities—your Florida neighbors—and ask their opinion of Waste Pro. We have conducted all necessary due diligence to confirm the material facts upon which our submittal is based. I will sign the agreement, and I have total control of contract authority over services and state that the contents of our response to this RFP are true and accurate.

We appreciate your time and consideration, and we look forward to becoming your next partner in providing the Town of Century with the “Distinguishable Difference” in the solid waste industry.

Best Regards,

Ralph Mills | Senior Vice President | Waste Pro of Florida, Inc.



WASTE & RECYCLING NEWS

crain Crain's News Source for Environmental Management



Waste Pro keeps it simple



Waste Pro USA Inc. CEO John J. Jennings said he believes in maintaining the company's core values even as his Longwood, Fla.-based solid waste management company continues to rapidly expand.

By Jim Johnson
Waste Pro USA Inc. is far from the single-truck operation that started a decade ago. With sales topping \$400 million annually, the company now has operations in seven southern states, running more than 1,400 trucks, employing 2,400 people and servicing 7.4 million customers.

locations to maintain and promote company beliefs. "As we grow, we want to make sure that we're able to maintain and keep that active culture going that really has been a part of our success," Jennings said. "I started the company really with the idea of keeping it simple. And what do we really mean by that? We mean, keep it simple and

been working with Jennings for about a quarter of a century in the trash business, even before the creation of Waste Pro. Traveling from his home base of Athens, Ga., Wood will hit the road a week or two at a time to talk to employees about company culture. "We do believe that our employees are



TAB 1 TRANSMITTAL LETTER



TAB 2 COMPANY OVERVIEW

Waste Pro keeps it simple



Waste Pro USA Inc. CEO John J. Jennings said he believes in maintaining the company's core values even as his Longwood, Fla.-based solid waste management company continues to rapidly expand.

By Jim Johnson

Waste Pro USA Inc. is far from the single-truck operation that started a decade ago. With sales topping \$400 million annually, the company now has operations in seven southern states, running more than 1,400 trucks, employing 2,400 people and servicing 7.7 million customers.

As the company grows, Jennings has had to find ways to maintain and promote company beliefs. "As we grow, we want to make sure that we're able to maintain and keep that culture going that really has been a part of our success," Jennings said. "I started the company really with the idea of keeping it simple. And what do we really mean by that? We mean, don't overcomplicate things."

Jennings has been working with Jennings for about a quarter of a century in the trash business, even before the creation of Waste Pro. "Traveling from his home base of Athens, Ga., Wood will hit the road a week or two at a time to talk to employees about company culture."

"It's the belief that one employee can



EXCLUSIVE FRANCHISE FOR SOLID WASTE COLLECTION AND RECYCLING SERVICES
TOWN OF CENTURY, FL | RFP NO. 2025-02

Company Overview

3. Proposal Contents: Company Overview

For more than 20 years, Waste Pro has been partnering with communities across the Southeast to provide values-driven solid waste services. Founded in 2001 by industry legend John J. Jennings, Waste Pro is known as a “people” company because our employees and customers work hand-in-hand to create a “Distinguishable Difference” in the waste industry. Our focus on long-term local relationships drives our commitment to creating sustainable, cost-effective waste and recycling solutions for cities and counties like the Town of Century.

Waste Pro is headquartered in Longwood, Florida and is managed by the most experienced team of professionals in the Southeastern United States. **Under two generations of Jennings leadership, Waste Pro has grown to become one of the country’s largest privately-owned waste collection, recycling, and disposal companies.** Today, as a result of two decades of organic and strategic growth, annual revenues are projected to exceed \$1.4 billion in 2025.

Waste Pro has been serving municipal customers in Florida since 2001. We enjoy partnerships with many of your neighboring cities, and we are proud to be an engaged community partner, both on and off the road. Our local team participates in community activities such as Career on Wheels and Touch-A-Truck events, and we are active sponsors of organizations such as the League of Cities, Keep Santa Rosa Beautiful, and other city and county events throughout the local community. We are proud of our partnerships across the state, including our role as the exclusive hauler for the University of Central Florida.

WASTE PRO BY THE NUMBERS

 <p>OPERATING LOCATIONS 90+ operating facilities 32 landfills 20 transfer stations 4 materials recovery facilities (MRFs)</p>	 <p>CUSTOMERS 2 million+ residential 100,000+ commercial</p>	
 <p>FLEET 4,200+ state-of-the-art trucks with 3rd Eye 360 degree onboard cameras</p>	 <p>MRFS (recycling processing) Ft. Myers, FL; Ocala, FL; Sarasota, FL; Columbus, MS (commercial corrugated only)</p>	 <p>EMPLOYEES 5,000+</p>
 <p>MUNICIPAL CONTRACTS 260+ exclusive municipal franchises</p>	 <p>REVENUE Projected to exceed \$1.4 billion in 2025</p>	

Waste Pro's Family Legacy

John Jennings, the son of a garbageman on Long Island, started his first waste collection company in 1973. He had no notion of how large the company might become, but his mission was simple: **to distinguish himself from the competition by providing the best possible service for his customers.** Fifty years later, the Jennings family continues to live and lead by this philosophy.

1973	John Jennings moves to Florida and breaks into the business by acquiring Pete's Garbage Service, starting with one truck. For the next two decades, he grows his presence in the Central Florida market, builds his reputation, and becomes a recognized leader in the industry.
1992	Jennings starts his first name-sake company: Jennings Environmental Services.
1996	As the result of a long-standing professional friendship between John Jennings and John Drury, Chairman and CEO of USA Waste Services, Inc., Jennings Environmental becomes first-tier subsidiary of USA in Florida and the Caribbean. Commanding a management team composed of many of Waste Pro's current leaders, Jennings oversees more than 160 municipal contracts.
1998	Jennings Environmental and USA experience rapid growth, leading to USA's acquisition of Waste Management, Inc. Because Waste Management dwarfs USA in size, the board of directors elects to change the USA name to Waste Management.
2000	Because they prefer to deal with local vendors and to facilitate personal connections with employees and their families, the Jennings Team operates differently from the bureaucratic makeup of a big national company. The entire Jennings Team decides to leave Waste Management to preserve their people-centric philosophy.
2001	Waste Pro begins operations. In the 20+ years since, Waste Pro has grown from a single operating location to a footprint across 12 states by sticking true to John Jennings's vision: <i>To create a more sustainable future through a mix of innovative, premium waste management solutions and back-to-basics investment in local relationships with our community partners.</i>
2018	The family legacy continues as Sean Jennings is named Waste Pro President.
2020	Sean Jennings is named Waste Pro CEO. Industry veteran and long-time Waste Pro VP Keith Banasiak is named COO.

Today, John's son Sean carries on the family legacy as a third-generation garbage man. With a lifetime of industry knowledge and over a decade of experience in operations and management, Sean Jennings has been Waste Pro President since 2018 and was named CEO in 2020. Waste Pro veteran Keith Banasiak was also named Chief Operating Officer in 2020, bringing nearly 40 years of management experience in the industry to the role. Much of our current leadership has been with Waste Pro for the

long haul, invested in building the company from its earliest days. John Jennings maintains his dedication to Waste Pro’s mission and future direction as Executive Board Chairman.

Waste Pro Partners with Communities in Florida and Across the Southeast

Waste Pro maintains exclusive contracts with more than 260 cities and counties in Alabama, Arkansas, Florida, Georgia, Louisiana, Mississippi, Missouri, North Carolina, South Carolina, Tennessee, Kentucky, and recently, Texas. Waste Pro operates out of 90 locations, including more than 50 in Florida.

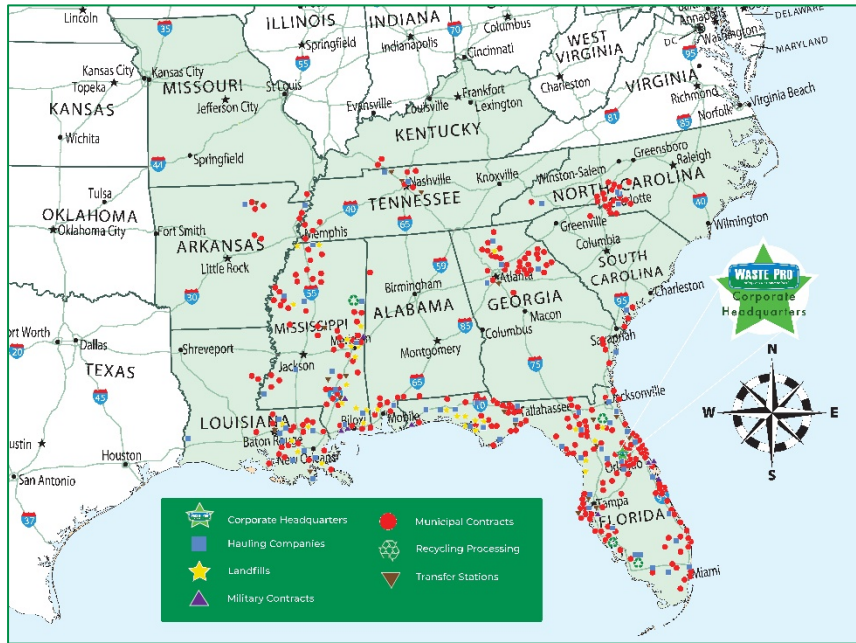

Across our footprint, we serve **more than two million residential customers** and **more than 100,000 businesses**. Waste Pro owns and operates **Material Recovery Facilities** in Ocala, FL; Ft. Myers, FL; Sarasota-Bradenton, FL; and Columbus, MS (commercial corrugated only). We also operate more than two dozen **construction and debris landfills** that have been of critical help to communities rebuilding after major storms.

The more than **4,200 heavy trucks in our fleet** (including many powered by CNG, compressed natural gas) are built for longevity. While we know that our drivers are our greatest safety and service asset, Waste Pro has invested in state-of-the-art truck-based and routing technologies to assist our teams in providing safe, efficient, and environmentally-friendly service.

We are proud to be based in Central Florida, where we have the distinction of being the region’s second largest privately-owned company. Waste Pro is also one of the state’s largest providers of exclusive residential solid waste services. **In Florida, Waste Pro currently services municipalities as small as LaCrosse, with 58 homes, and municipalities as large as Lee County, where we provide service to approximately 140,000 homes.**

Waste Pro of Florida at a Glance

- 120** exclusive municipal contracts
- 33** hauling companies
- 1.6M+** residential customers serviced
- 61** of Florida’s **67** counties

As our references will show, we currently provide franchised residential collection services to several Florida and Alabama municipalities, including nearby Flomaton, Atmore, Gulf Breeze, and Laural Hill. We also currently service over 47,000 subscription base customers in Santa Rosa County, making us the people’s choice and the leader amongst other competitors throughout our local footprint.



This local knowledge and experience will drive our partnership with the Town of Century as we focus on the unique needs of your residents and businesses.

Our local team fully understands the scope of work that is specified for the Town of Century’s collection services. Across our 12-state footprint, Waste Pro provides a range of single-family residential, multi-family residential, and commercial services to our municipal partners, including:

- ✓ Garbage Service
- ✓ Yard Waste Service
- ✓ Recycling Service (Single and Dual Stream)
- ✓ Bulk Waste Service
- ✓ Construction Debris Removal
- ✓ Fully or Semi-Automated Service
- ✓ Waste Transfer and Disposal
- ✓ Recyclables Processing and Marketing
- ✓ Special Event Service

Our Local Commitment to World-Class Service

Waste Pro’s key to providing premium, people-focused service is empowered local leadership. Our surprisingly lean corporate management team is focused on one function: supporting the regions in operations, administration, and marketing. Waste Pro’s local operations are managed by a highly experienced team of Regional Vice Presidents, Divisional Vice Presidents, Division Managers, and support staff. These regional teams are mandated to make decisions about local service plans. **Waste Pro’s decentralized management structure is designed to benefit our municipal partners: our local teams have the operational agility to respond to local needs without going through layers of corporate approvals.**

For Waste Pro, “local teams” are truly local. Our Florida and Alabama Waste Pros are your neighbors in the City of Atmore and Flomaton as well as in Escambia and Santa Rosa Counties. When a resident picks up the phone to call us, the person on the other end is right down the road. They know the ins and outs of your services, streets, and daily operations.

When it comes to serving our municipal partners, Waste Pro also understands that **our drivers and helpers are the heart—and the local face—of our operations.** They are encouraged to “go the extra mile” for our customers, and we reward these efforts:

Waste Pro incentivizes safety and customer service by offering our drivers an industry-high \$10,000 Safety Award and our helpers a \$5,000 Safety Award. Since 2004, more than 1050 drivers and helpers combined have earned over \$10 million in Safety Awards—30+ of them repeat winners.

We invest in career advancement. Our **Co-Heart Program** has allowed 500+ employees to earn their CDL through our DOT-certified in-house training. These newly-licensed employees—already experienced industry veterans—further build our team of talented drivers from within.

From our corporate management to our local leadership and staff, Waste Pro employees are taught the **Waste Pro Way: From the end of the driveway to the environment, Waste Pro has a commitment to caring.** Our mission is simple—we care for our people, who care for the people we serve. We are



committed to helping our Waste Pros build fulfilling, balanced, lifelong careers, and this commitment is then reflected in the service our Waste Pros provide to our customers.

Innovating Today, Caring for Tomorrow

Since our founding in 2001, protecting the environment by providing innovative waste management solutions has been one of Waste Pro’s core commitments. This commitment is reflected in everything we do, from our daily operations and our investments in new technology to the colors we paint our trucks and cans. Waste Pro’s colors are both an aspiration and our environmental promise: **Blue Sky, Green Earth.**

But for Waste Pro, sustainability is more than working to reduce our company’s impact on the environment. It is also about building long-lasting relationships with our customers, recognizing and taking care of our highly committed employees by helping them build long-term careers with work-life balance, and investing in the communities in which we operate.

As a family-run business, our commitment to environmental stewardship and sustainable, long-term partnerships is not just a business commitment. It’s our promise to our children—and yours.



WASTE & RECYCLING NEWS

MAY 2, 2011

Crain's News Source for Environmental Management

Waste Pro keeps it simple



Waste Pro USA Inc. CEO John J. Jennings said he believes in maintaining the company's core values even as his Longwood, Fla.-based solid waste management company continues to rapidly expand.

By Jim Johnson

Waste Pro USA Inc. is far from the single-truck operation that started a decade ago. With sales topping \$400 million annually, the company now has operations in seven southern states, running more than 1,400 trucks, employing 2,400 people and servicing 7.4 million customers.

locations to maintain and promote company beliefs. "As we grow, we want to make sure that we're able to maintain and keep that active culture going that really has been a part of our success," Jennings said. "I started the company really with the idea of keeping it simple. And what do we really mean by 'simple'?" He says, "Keep it simple and

been working with Jennings for about a quarter of a century in the trash business, even before the creation of Waste Pro. Traveling from his home base of Athens, Ga., Wood will hit the road a week or two at a time to talk to employees about company culture. "We do believe that our employees are



TAB 2 COMPANY OVERVIEW





TAB 3

EXPERIENCE AND REFERENCES

Waste Pro keeps it simple



Waste Pro USA Inc. CEO John J. Jennings said he believes in maintaining the company's core values even as his Longwood, Fla.-based solid waste management company continues to rapidly expand.

By Jim Johnson

Waste Pro USA Inc. is far from the single-truck operation that started a decade ago. With sales topping \$400 million annually, the company now has operations in seven southern states, running more than 1,400 trucks, employing 2,400 people and servicing 7.7 million customers.

As the company grows, Jennings has had to find ways to maintain and promote company beliefs.

"As we grow, we want to make sure that we're able to maintain and keep that culture going that really has been a part of our success," Jennings said. "I started the company really with the idea of keeping it simple. And what do we really mean by 'simple'?"

Jennings has been working with Jennings for about a quarter of a century in the trash business, even before the creation of Waste Pro.

Traveling from his home base of Athens, Ga., Wood will hit the road a week or two at a time to talk to employees about company culture.

"It's the belief that our employees are











EXCLUSIVE FRANCHISE FOR SOLID WASTE COLLECTION AND RECYCLING SERVICES
TOWN OF CENTURY, FL | RFP NO. 2025-02

TAB 3
EXPERIENCE AND REFERENCES

Experience

3. Proposal Contents: Experience

Waste Pro is uniquely situated to service the Town of Century, given our current Alabama Panhandle Florida footprint. Waste Pro has been servicing local municipalities in both Florida and Alabama counties for nearly 20 years, including:

-  **Flomaton, AL**
-  **Gulf Breeze, FL**
-  **Laura Hill, FL**
-  **Mount Vernon, AL**
-  **Saraland, AL**
-  **Creola, AL**
-  **Floral, AL**
-  **Citronelle, AL**

Waste Pro will run our Town of Century operations out of our Pensacola hauling facility, located in Milton. Additional support resources from our fully staffed and equipped Spanish Fort/Mobile facilities—located less than an hour away— will be available to the Town of Century if needed.

Local Leadership

Glenn Schweiger, Division Manager, Pensacola

gschweiger@wasteprousa.com



Glenn has more than 30 years of experience in the waste industry and has been a vital member of the Waste Pro family for over six years. As Division Manager, Glenn oversees 72 employees who operate 45 collection vehicles and provide services to over 51,000 residential and commercial customers. Glenn began his career at Waste Pro as lead driver in Spanish Fort; his work ethic and willingness to advance his career have taken him from the driver's seat to Supervisor, Operations Manager, and now Division Manager in Milton. He works with Division Vice President Rick Chancey and Senior Vice President Ralph Mills, managing day-to-day operations for the Pensacola division, overseeing its team members, and ensuring the satisfaction of our local customers and community. Glenn is known to be passionate about his team and bringing more diversity to the workforce. He currently has nine female residential drivers on staff, serving the communities in and around Milton: that's 20%, a high percentage for the industry. For the Town of Century, Glenn will be actively involved in operations and routing during contract startup and operational and financial oversight for the duration of the contract.

Scott Lewin, Operations Manager, Pensacola

slewin@wasteprousa.com



Scott Lewin is an organized and talented solid waste and recycling professional with over 25 years of experience and a solid background in human resources, training, transportation, and management. He has excellent analytical, organizational, and problem-solving skills, is able to meet challenging deadlines while maintaining the highest ethical standards, and is adept at adapting his leadership style to meet the situation's needs. Scott is currently the Operations Manager for Waste Pro's Pensacola Division. His duties include managing all aspects of residential service, dispatch, commercial front load, and roll-off operations. For the Town of Century, his responsibilities will entail managing the drivers and supervisors directly servicing the routes for the contract, ensuring accurate and excellent service.

Jennifer Fletcher, Office Manager, Pensacola, FL

jfletcher@wasteprousa.com



Jennifer Fletcher has been with Waste Pro since 2022 and is an integral part of the operations staff at the Pensacola Division. She works alongside Division Manager Glenn Schweiger to maintain organization and day-to-day operations. As office manager, she coordinates with multiple departments, including customer service, dispatch, accounting, and maintenance. Jennifer works to create and maintain a pleasant work environment, ensuring high levels of organizational effectiveness and communication with all customers, vendors, and employees. Her daily responsibilities include overseeing the office's general administrative functions and activities. She is the first to communicate with many of the municipalities for which the division provides solid waste and recycling services. Jennifer will ensure that customer service representatives are educated in the contract so that all calls are appropriately handled.

Kathy Davis, Lead Dispatcher, Santa Rosa County, FL

kdavis@wasteprousa.com



Kathy Davis is the lead dispatcher for Santa Rosa County, Florida. Her solid waste and recycling career started with Waste Management in 2001. Joining Waste Pro in 2020, she began in the customer service department and soon transitioned to sales. As an inside sales rep, she maintained a designated book of business exceeding her sales goals, piloted a new sales model for the Ft. Walton Beach office, and was recognized as a top sales rep within the company. She recently moved to operations as a lead dispatcher, seeking a more hands-on service role. Kathy is responsible for managing daily route services, managing requests for service issues or inquiries, assisting with as-needed projects, and providing excellent customer service to anyone with whom the company interacts. She is a key asset in the division's organization, assisting with day-to-day client operational needs. As lead dispatcher, Kathy will oversee day-to-day communication with the drivers servicing Century residents.

Ralph Mills, Senior Vice President, FL Coastal Region

rmills@wasteprousa.com



Florida native Ralph Mills was named Waste Pro Senior Vice President in 2021. In this role, he is responsible for negotiating all waste disposal agreements across the company's 11-state footprint and assists in managing acquisitions. He also oversees Waste Pro's Coastal and Northeast Florida Regions, managing 12 hauling facilities, three satellite offices, four transfer stations, eight landfills, a recycling facility, and two CNG stations across north Florida and southern Alabama. In his regional leadership role, he supervises the work of 762 employees who operate 485 trucks each day, servicing more than 455,000 residential and nearly 11,000 commercial customers.

Ralph has more than 40 years of experience in the waste industry, which includes managing collection, disposal, landfill, and recycling operations. He joined Waste Pro in 2006 as Regional Vice President in northwest Florida, growing Waste Pro's operations from a single contract with the City of Tallahassee to five hauling divisions and three satellite offices across the Florida Panhandle and Alabama Gulf Coast. Throughout his tenure with Waste Pro, Ralph has provided leadership to additional regions across the company's footprint, previously managing Waste Pro operations in Georgia, Mississippi, Louisiana, and Tennessee.

Ralph is a graduate of Florida State University with a B.S. in Accounting and a B.S. in Finance.

Rick Chancey, Divisional Vice President, FL Coastal Region

rchancey@wasteprousa.com



Rick has more than 30 years of experience in the solid waste industry. His career began in 1990 when he was fortunate to learn the business as a waste collection driver. Rick has been a longtime Waste Pro employee serving in Division Manager roles in Mississippi, Alabama, and Florida. He first joined Waste Pro in 2011, working in our Pensacola Division. Rick then moved to Gautier, MS in 2012 to help with a municipal start-up in Harrison County. He remained in Gautier as the Division Manager until 2015, when a Division Manager position became available in Florida at Waste Pro's Lake County Division. In 2018, Rick relocated and accepted a position as the Division Manager in Pensacola, overseeing service to over 48,000 customers. Now, as the Divisional Vice President of the Coastal Region, Rick oversees operations in the Milton, Tallahassee, and Crestview Divisions and the Panhandle transfer stations. The regional area provides collection services to over 220,000 residential and commercial customers. Rick will be actively involved in the Town of Century operations and routing during contract startup and operational and financial oversight for the duration of the contract.

Mi-Lim Chun, Regional Controller

mchun@wasteprousa.com



Mi-Lim began her Waste Pro career in 2014 and has more than 20 years of experience within the solid waste industry. Before joining the waste industry, she worked at KPMG as an associate. During this time, she had numerous roles as an internal auditor, pricing manager, operations improvement manager, and business process improvement manager. Currently, Mi-Lim is the Regional Controller for Waste Pro's Florida- Alabama Coastal Region, where she is responsible for all aspects of accounting, customer service, and collections. Mi-Lim is a graduate of North Florida University, where she earned a Master of Accountancy, a Master of Business

Administration with a concentration in logistics, and a bachelor's degree with majors in economics, banking, and finance.

Christina Schweiger, Director of Govt. Affairs, FL Coastal Region

cschweiger@wasteprousa.com



Christina began her Waste Pro career as a Territory Sales Manager for Santa Rosa and Escambia County, Florida, and Escambia County, Alabama. For five years, she handled all commercial and roll off contracts and sales in the City of Pensacola. In 2021 she was the recipient of one of Waste Pro's prestigious Eagle Awards celebrating the company's top commercial sales managers. She has recently been named Director of Government Affairs for the Florida Coastal region, allowing her to work closely with Waste Pro's municipal partners in the Panhandle. With over 30 years of experience in sales and marketing, Christina is known for her resourcefulness, professionalism, and attention to detail.

She is also active in the local community, President for Keep Santa Rosa Beautiful and as a Waste Pro outreach representative at local Touch-A-Truck events and community festivals. Christina will be the Town of Century contact for any non-operations matters related to the residential contract, and she will be Waste Pro's local leader in community involvement and education efforts.

Sean Jennings, President & Chief Executive Officer

sjennings@wasteprousa.com



Sean Jennings, son of Waste Pro Founder John Jennings, has been exposed to every facet of the waste and recycling business throughout his life, and more formally since joining the industry officially in 2012. Following graduation from the University of Alabama, where he majored in finance and minored in economics, Sean spent a year working in collection and landfill disposal in Costa Rica. When he returned to the U.S., he worked in operations and landfill construction in Georgia and Mississippi before joining Waste Pro in 2014 as Division Manager in Tampa-Clearwater. He then assumed the management role at the company's Sarasota/Bradenton Division in 2016. Sean led

the charge of building a compressed natural gas (CNG) station and recycling facility in Sarasota. Sean was named Waste Pro President in 2018 and CEO in 2020. In addition to his role as President & CEO, Sean serves on numerous community boards. In 2018, he was honored with Waste360's 40 Under 40 Award and named Orlando Business Journal's 40 Under 40 business leaders.

John Jennings, Executive Board Chairman, founder

jjennings@wasteprousa.com



John J. Jennings is the founder and visionary behind Waste Pro USA. His father, Michael Jennings, was an Irish immigrant who worked as a garbage man on Long Island and taught his son the importance of a diligent work ethic. The lessons he learned from his father translated into what is now Waste Pro's mission: to create more sustainable, cost-effective waste and recycling solutions. After moving to Florida, he started in the industry at the bottom and worked his way up, eventually starting his own company, Jennings Environmental Services, which became the largest privately owned waste disposal company in Central Florida. Waste Pro, as we know it today, was created in 2001. In 2020, John Jennings passed the torch to his son, Sean, to become President & CEO. He remains Executive Board Chairman and an active part of the company's leadership team. Jennings has been recognized as one of Florida Trend's 500 most influential business leaders in 2018, 2019, 2020, and 2021. Recognized continuously for his contributions to the solid waste and recycling industry and as a pioneer in entrepreneurship, in 2011 he was unanimously elected to the National Waste and Recycling Association Hall of Fame.

Keith Banasiak, Executive Vice President & Chief Operating officer

kbanasiak@wasteprousa.com



Keith Banasiak has more than 35 years of management experience in the waste industry. In 1987, he started in the non-ferrous scrap processing and reclamation industry. Primarily responsible for processing operations, he managed fleet operations, disposal of special residual waste, and the facility environmental requirements of state and local governments. Keith joined Waste Pro shortly after relocating to Ft. Myers in 2001. In 2019, he was named Senior Vice President, and in 2020, he was promoted to Chief Operating Officer. Keith manages Waste Pro's Regional and Division Vice Presidents and the exclusive municipal franchise contracts in 10 states throughout the Southeast. He is also involved in many local and regional community organizations, including serving as Chairman Emeritus of Keep Lee County Beautiful and Keep Manatee Beautiful. He also serves as Chairman of the Community Cooperative and board member for The Foundation for Lee County Public Schools.

Building a Culture of Highly Committed Employees

For Waste Pro, "local teams" are truly local as our featured drivers show. Waste Pro is proud to be part of the fabric of the local community. For more information on our staffing plan and our hiring and training process, please see Tab 4.

Waste Pro Employee Spotlight and Growth



Employee Spotlight: Emily Kubiak — Living the Waste Pro Culture

Since joining Waste Pro Pensacola in 2021, Residential Driver Emily Kubiak has exemplified the values that define our culture—commitment, safety, service, and community. Transitioning from a long career in school transportation, she earned her CDL and stepped into her role with confidence and pride.

Emily balances professional excellence with personal resilience, raising two special needs children with the support of a team that understands the importance of flexibility and family. Her mentors, including Scott Lewin and Division Manager Glenn Schweiger, have fostered her growth through encouragement and leadership.

Her positive energy, reliability, and customer-first mindset earned her the \$10,000 Driver Safety Award in 2025, a testament to her dedication. Emily's journey reflects Waste Pro's promise: when we invest in our people, we build not only careers—but lasting loyalty.



Employee Growth in Action: Employee Spotlight: Trevor Brown — Earning His Captain's Hat

Trevor Brown's six-year journey with Waste Pro Pensacola reflects the company's commitment to recognizing and uplifting dedicated employees. Initially hired as a helper, Trevor's exceptional performance earned him a \$5,000 bonus in 2022, but his aspirations didn't stop there.

In 2024, Trevor pursued his CDL permit and enrolled in the Waste Pro Co-Heart Program. He passed his skills test on April 13, followed by a perfect score on his final exam at the Atlanta Driver Training Center. After weeks of mentorship, Trevor officially became a driver and finally a captain of his own ship on June 10, 2024.

To honor this achievement, Trevor was presented with a "Captain's Hat" during the team's safety meeting—a symbolic gesture celebrating his transition from crew member to leader. His story not only highlights individual growth, but also Waste Pro's investment in its workforce. This emerging tradition in Pensacola reinforces the culture of empowerment for every Co-Heart graduate.

Throughout the course of our contract, **we are committed to continuing to hire employees who live in the community alongside the residents and businesses we service.** For any staffing needs that may arise during our partnership with the Town of Century, Waste Pro has a multi-pronged approach to recruitment and training to help us fill positions with talented employees who are looking for long-term careers.



Division Manager, Glenn Schweiger speaks to the drivers in the morning safety huddle.



Waste Pro fun Day Pensacola-Milton team celebrating accomplishments with steak cook-out

References

3. Proposal Contents: References

Waste Pro is pleased to provide reference information for contracts that call for similar services to those requested in the Town of Century. Below, please find information for Flomaton, Alabama and the City of Gulf Breeze, Florida.

Following our reference information, we provide several recommendation letters from other local community partners. Additional references for contracts in Alabama and across our footprint are available upon request.

Town of Flomaton, AL			
Description of Services Provided	1 x week garbage		
Number of Homes Served	637		
Contract & Transition Dates	<table border="1" style="width: 100%;"> <tr> <td style="width: 50%;">Start: 2019</td> <td style="width: 50%;">End: 2028</td> </tr> </table>	Start: 2019	End: 2028
Start: 2019	End: 2028		
Current Contact	Shaun Moye		
Contact Address	2125 Ringold Street Flomaton, Alabama 36441		
Contact Phone	251-236-1182		
Contact Email	smoye@flomatonal.org		

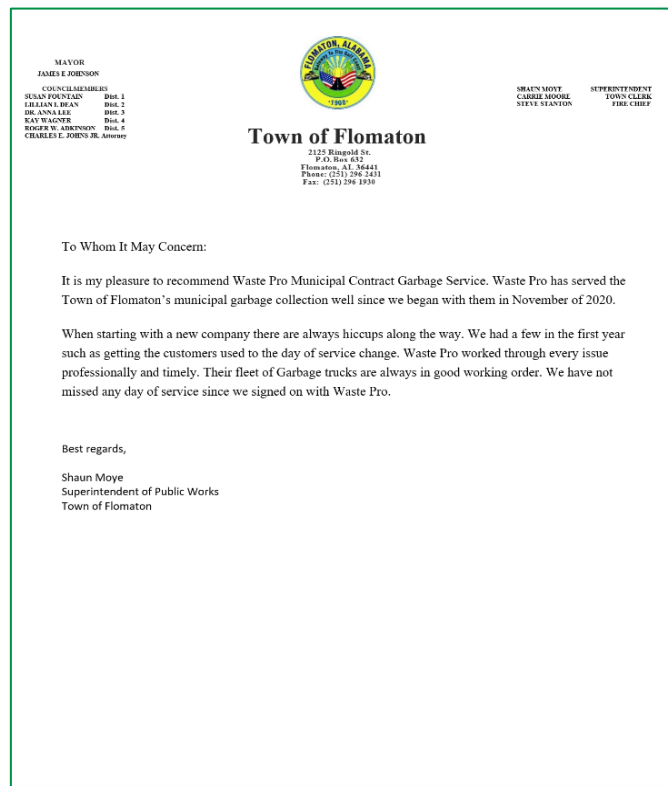



City of Atmore, Alabama	
Description of Services Provided	1 x week garbage
Number of Homes Served	2,340
Contract & Transition Dates	Start: 2024 End: 2029
Current Contact	Chris Walker
Contact Address	201 East Louisville Avenue Atmore, AL 36502
Contact Phone	251-368-2253
Contact Email	cwalker@cityofatmore.com

CITY OF ATMORE



August 5, 2025

ADMINISTRATION

Becca Smith, City Clerk
 Chuck Brooks, Police Chief
 Ronald Peebles, Fire Chief
 Calvin Grace, Street Superintendent
 Chris Walker, Economic Planner

CITY COUNCIL

Shawn Lassiter, Mayor
 Webb Nall, District 1
 Jerome Webster, District 2
 Eunice Johnson, District 3
 David Dobson, District 4
 Chris Harrison, District 5

To Whom It May Concern,

I am pleased to write this letter of recommendation on behalf of Waste Pro, a company that has consistently demonstrated professionalism, reliability, and a strong commitment to quality service. Throughout our time with Waste Pro, we have been thoroughly impressed with their efficiency and dedication to customer satisfaction.

Waste Pro's staff members are courteous, punctual, and knowledgeable, and they consistently go above and beyond to ensure that our waste management needs are met with minimal disruption. In addition, their communication and billing practices are clear and transparent, making them a trusted and easy partner to work with.

In an industry where reliability and environmental responsibility are essential, Waste Pro stands out as a leader. I have no hesitation in recommending their services to any business, municipality, or individual seeking a dependable waste management solution.

Sincerely,



Shawn Lassiter
Mayor

P.O. Drawer 1297
 Atmore, Alabama 36504
 (251) 368-2253 • Fax: (251) 368-1841



WASTE & RECYCLING NEWS

MAY 2, 2011
Crain's News Source for Environmental Management

Waste Pro keeps it simple



Waste Pro USA Inc. CEO John J. Jennings said he believes in maintaining the company's core values even as his Longwood, Fla.-based solid waste management company continues to rapidly expand.

By Jim Johnson

Waste Pro USA Inc. is far from the single-truck operation that started a decade ago. With sales topping \$400 million annually, the company now has operations in seven southern states, running more than 1,400 trucks, employing 2,400 people and servicing 7.4 million customers.

locations to maintain and promote company beliefs. "As we grow, we want to make sure that we're able to maintain and keep that active culture going that really has been a part of our success," Jennings said. "I started the company really with the idea of keeping it simple. And what do we really mean by 'simple'?" He says, "I mean, I mean, I mean."

been working with Jennings for about a quarter of a century in the trash business, even before the creation of Waste Pro. "Traveling from his home base of Athens, Ga., Wood will hit the road a week or two at a time to talk to employees about company culture. "We do believe that our employees are"



TAB 3 EXPERIENCE AND REFERENCES





TAB 4

SERVICE PLAN



Waste Pro keeps it simple



Waste Pro USA Inc. CEO John J. Jennings said he believes in maintaining the company's core values even as his Longwood, Fla.-based solid waste management company continues to rapidly expand.

By Jim Johnson

Waste Pro USA Inc. is far from the single-truck operation that started a decade ago. With sales topping \$400 million annually, the company now has operations in seven southern states, running more than 1,400 trucks, employing 2,400 people and servicing 7.7 million customers.

As the company grows, Jennings has had to find ways to maintain and promote company beliefs. "As we grow, we want to make sure that we're able to maintain and keep that culture going that really has been a part of our success," Jennings said. "I started the company really with the idea of keeping it simple. And what do we really mean by 'it simple'?"

Jennings has been working with Jennings for about a quarter of a century in the trash business, even before the creation of Waste Pro. "Traveling from his home base of Athens, Ga., Wood will hit the road a week or two at a time to talk to employees about company culture."



EXCLUSIVE FRANCHISE FOR SOLID WASTE COLLECTION AND RECYCLING SERVICES
TOWN OF CENTURY, FL | RFP NO. 2025-02

TAB 4
SERVICE PLAN

grapple truck. Waste Pro will service 2 cubic yards per home per quarter. We have allocated one

Bulk Waste: All residential bulk waste will receive quarterly curbside collection by



- Yard waste materials will be taken to Santa Rosa County Landfill for disposal.

maintenance.
 one reserve truck and one reserve solid waste driver in case of unexpected absences or vehicle
 content of cart only for yard waste service. Routes will run one day per week. We have allocated
 curbside collection by Automated Side Loader (ASL) truck. Waste Pro will service cart and

Yard Waste: All residential yard waste will receive one 96-gal cart for one time per week



- Solid waste materials will be taken to Santa Rosa County Landfill for disposal.

case of unexpected absences or vehicle maintenance.
 run one day per week. We have allocated one reserve truck and one reserve solid waste driver in
 content of cart only for solid waste services. Waste Pro will run one solid waste ASL. Routes will
 emptied and placed back in an upright position with lids closed. Waste Pro will service cart and
 collection by automated side load (ASL) trucks. Each resident's 96-gal cart will be completely

Solid Waste: All residential solid waste will receive one time per week curbside



As indicated by the RFP, Waste Pro will provide solid waste, yard waste, bulk waste, recycling services,
 and side door services to Century residents. Details for each service that Waste Pro will provide for
 residents of Century are as follows:

Residential Collections

Approach to Collection Services

- ✓ Approach to Collection Services
- ✓ Equipment
- ✓ Service Startup
- ✓ Staffing, Hiring, and Employee Retention
- ✓ Recycling Education
- ✓ Technology
- ✓ Continuity of Operations and Contingency Planning

In what follows, we provide detailed information about Waste Pro's plan for the Town of Century collection services. This section is divided into the following subsections:

2. Scope of Services: Residential: Weekly garbage, yard waste, bi-weekly recycling, quarterly bulk waste, side door service for eligible residents. Commercial: Containerized garbage collection (2, 4, 6, 8-yard), optional recycling, roll-off and compactor services (roll-off non-exclusive). Municipal: Collection at Town buildings only. Carts and Containers: Provided and maintained at no cost with Town branding. Operating Schedule: Monday to Saturday, 7 AM to 6 PM.

Waste Pro's "Distinguishable Difference" in Collection Services



Exclusive Franchise for Solid Waste Collection and Recycling Services

Town of Century, Florida
RFP Number: 2025-25

reserve truck and one reserve bulk waste driver in case of unexpected absences or vehicle maintenance.

- Bulk waste materials will be taken to Santa Rosa County Landfill for disposal.



Recycling Services: All residential recycling waste will receive bi-weekly curbside collection by ASL trucks. Each resident's 96-gal cart will be completely emptied and placed back in an upright position with lids closed. Waste Pro will service cart and content of cart only for recycling services. Waste Pro will run one recycle waste ASL truck. Routes will run one day bi-weekly. We have allocated one reserve truck, and one reserve recycle waste driver in case of unexpected absences or vehicle maintenance.

- Recycle waste materials will be taken to Santa Rosa County Landfill for disposal.

Commercial Collections



Commercial Services: As indicated by the RFP, Waste Pro will provide commercial services for 2-, 4-, 6-, and 8-yard dumpsters to approximately 50 businesses in the Town. Waste Pro will run one front load truck. Routes will run one day per week. We have allocated one reserve truck, and one reserve front load driver in case of unexpected absences or vehicle maintenance.

- All waste materials will be taken to Santa Rosa County Landfill for disposal.

Municipal Collections



Municipal Services: Our team will provide solid waste -*services for municipal buildings. Waste Pro will provide waste collection for Town-owned facilities, including:

- Town Hall
- Public Works Facility
- Other municipal administrative or utility structure
- Branded carts with Town logo and maintenance protocols.

Routing

Waste Pro is prepared to utilize its state-of-the-art routing software, **RouteSmart**, for route optimization. Our **route optimization** software allows us to plan safe, efficient routes that take into account a number of parameters, including number of homes, subscriber density, driving distances, collection hours.

Collection Hours

With the exception of specified holidays, all collections will happen between 7:00 am and 6:00 pm, Monday through Friday. Holiday collections will be coordinated with the Town of Century, and any changes to the regular collection schedule will be communicated to residents through multiple channels, including on our dedicated Town of Century Waste Pro website and via our Call-Em-All and Text-Em-All system.

Premium and Disability Side Door Service

Waste Pro understands that there are some Town residents for whom it is difficult or impossible to move carts to the road for curbside collection. We are happy to provide disability service for eligible residents at no additional charge. We train our drivers to service these homes carefully, making sure to remove even small items from the can.

Contaminated Recycling Carts and Non-Conforming Waste

Visibly contaminated recycling or non-conforming waste will be tagged with a Non-Collection Notice to explain why the material was not picked up and provide education about Town recycling and waste collection guidelines, ensuring the customer can be serviced moving forward.

A Day in the Life of a Waste Pro Driver

Each day, our drivers and helpers work hard to provide the residents we serve with the “Distinguishable Difference” in solid waste and recycling services. In our Pensacola division, here’s what a typical day looks like.

For residential drivers, the day begins with pre-trip protocols and daily morning safety meetings. Drivers pick up an updated route sheet for the day, noting any changes to their typical routes. They attend the division safety meeting, which addresses such topics as route conditions for the day, weather issues, possible changes in morning school traffic, disposal facility challenges, and personal protective equipment. Before leaving for their routes, all drivers participate in a pre-trip maintenance inspection called the Safety Lane, which is described in detail below.

For our drivers and route supervisors, safety is a continued focus throughout the day. Supervisors run route observations, and all trucks are equipped with in-cab and external SmarTruck HD to monitor driving and provide safety coaching, if necessary. Routes are designed so that drivers work approximately 10 hours per day. Throughout the day, residential drivers are in communication with their supervisor—particularly if there are issues or delays. Drivers are prepared to handle unforeseen events, such as leaks or spills. Supervisors are also ready to assist with any contingencies, such as deploying a reserve vehicle if there are emergent maintenance issues that prevent a truck from completing a route. When a route is closed, or completed, for the day, the driver completes a post-trip Safety Lane inspection.



Commercial drivers are also **well-versed in Waste Pro’s safety protocol**, participating in daily pre-trip and post-trip Safety Lane inspections and receiving feedback from supervisors from observations and 3rd Eye camera monitoring. These drivers are **cross trained to ensure route coverage** in case of driver illness, vacation, or absence. Because commercial customers must ensure that containers are being filled properly, without overflow, **commercial route supervisors are engaged in communication with drivers and customers when necessary**.

All Waste Pro drivers are experts in their routes long before their first collection day. During dry runs in company pickup trucks, drivers and supervisors pay careful attention to potential service interruptions such as low-hanging wires and trees and tight turnarounds.

A Culture of Safety

Waste Pro is committed to fostering a culture of safety, and this culture directly benefits our municipal partners as safe operations translate to efficient, reliable service.

Weekly Safety Meetings facilitate interactions between supervisors and drivers. They are a place for reminders about safety, customer service, OSHA compliance, and efficiency. In addition to these local division-level meetings, regional and corporate safety calls take a proactive approach to safety issues, reviewing weather safety, holidays or events that may impact service, laws and regulations, and internal policies.

Supervisor Ride-Alongs give drivers the opportunity to hear and express real-time feedback as supervisors observe driver behaviors and route particulars.

We understand that for even the most conscientious drivers, mishaps do sometimes occur. Our **Complete the Routine** education course strives to help drivers recover from these incidents and return to their routes with the knowledge and confidence to maintain a safe driving record.

Waste Pro’s **Daily Safety Lane** empowers drivers to recognize potential issues and communicate directly with mechanics and, by extension, local leadership. Our decentralized management structure means that these local leaders can take immediate action to maintain safe, efficient service—without waiting for the levels of bureaucratic approval required in most large national or international companies. All drivers pass through the routine Safety Lane with their equipment in the morning when trucks leave the yard and again in the afternoon or evening when they return to the facility. In the Safety Lane, a mechanic is waiting to visually inspect each truck and speak with each driver.



Each numbered yellow box represents an inspection point. Our focus on safety means fewer maintenance issues, lower environmental impact, and fewer service delays for Pensacola.

Equipment

Waste Pro’s fully-equipped Pensacola-Milton hauling facility will service this contract for the Town of Century.

Below is a list of equipment available at our local hauling facility. Our Town of Century collections will be run using 1 automated side loader each for solid waste, yard waste and recycling, 1 grapple truck for bulk waste, and 1 front loader for commercial dumpers. These vehicles are part of our existing fleet and are ready to go on day one..

Rear Load	8
Automated Side Load	24
Front load, Roll Off, and Grapple	11

Maintaining a Clean and Safe Fleet

The first step in maintaining a safe, efficient, and environmentally-friendly fleet is to purchase the safest and best equipment available, and our fleet in Pensacola is no exception. **To maintain this top-of-the-line fleet, we adhere to a rigorous preventive maintenance schedule based on vehicle utilization by hours and/or days.**

Waste Pro uses **Dossier Fleet Maintenance Software** to manage our preventive maintenance schedule efficiently, which results in benefits that directly impact our operations and costs, **including reduced downtime, lower spare parts inventories, extended equipment life, and increased mechanic productivity.**

Beyond their safe and efficient operation, **we want residents to welcome our trucks to their streets.** This means that we take pride in our appearance and in controlling the unpleasant odors that accompany solid waste collection.





Below we include a chart with an excerpt of our **preventive maintenance schedule.**

Maintenance Item	Inspection Interval
Annual DOT Inspection	No later than 365 days
Coolant System	2,000 hours CNG; diesel as needed
Engine Valve Inspection	At 2,400 hours
Engine Oil	900 hours CNG; 600 hours diesel
Hydraulic System	300 hours
Power Steering Filters	2,400 hours
Transmission Oil	
⇒ Manual	⇒ No later than 365 days
⇒ Non-Synthetic	⇒ 2,400 hours
⇒ Synthetic	⇒ 9,600 hours
Rear Carriers	2,400 hours
Grease Fittings	50 hours
Air Filters	
⇒ Check, Blow Out	⇒ 600 hours
⇒ Replace	⇒ When needed based on restriction gauge

contract.

In the charts below, Waste Pro outlines our staffing commitments for our new Town of Century

Staffing, Hiring, and Employee Retention

- 
 • Routing
 Following the Town efforts, we will utilize our Routesmart route optimization software to build our route maps, which we will submit to the Town.
- 
 • Personnel
 Waste Pro currently has staff ready to service this contract from our Milton hauling facility.
- 
 • Equipment
 Waste Pro currently has collection equipment ready to deploy for this contract at our Pensacola-Milton hauling facility.
- 
 • Drivers will also participate in route “dry runs,” providing feedback to local Waste Pro leadership.

Solid Waste Collection and Recycling Services Startup

What follows is a task list that illustrates our contract planning and implementation process. We look forward to collaborating with the Town on a more detailed startup timeline.

mapping out safe, reliable, and efficient services that meet unique local needs and challenges. our new community partners—no matter how big or small the City or County—to ensure that we are **dependability that customers expect from a local, family-run business.** We take the time to work with **To do things the Waste Pro Way is to do them right, with a commitment to caring and the**

encourage you to reach out to them to hear for yourself how smoothly this transition was conducted. are currently contracted by the **nearby municipalities of Flomaton, Atmore, and Gulf Breeze,** and we plan the implementation of the Town’s new exclusive solid waste collection and recycling program. Waste Pro will work diligently with the Town to

From the careful work of coordinating with our municipal partners to execute a seamless startup to maintaining a high level of customer service and satisfaction for years down the line, Waste Pro’s “Distinguishable Difference” is our highly local commitment to world-class service.

Waste Pro not only understands the importance of seamless service startups—we are the industry Pros. **We have started 300 municipal contracts and executed more than 100 successful transitions over the past 20 years,** and we have this process down to a science.

Service Startup



Waste Pro's Town of Century Personnel Team	
Position	Number of Staff
Division Manager	1
Operations Manager	1
Route Manager	1
Drivers	2
Helpers	1
Office Manager	1
Customer Service Supervisor	1
Customer Service Representatives	8
Dispatch	2
Maintenance Manager	1
Maintenance Technicians	6

Throughout the course of our contract, we are committed to giving back to the Century community—in part by hiring local. For any staffing needs that may arise during our partnership with the Town, Waste Pro has a multi-pronged approach to recruitment and training to help us fill positions with talented employees who are looking for long-term careers with opportunities for professional advancement.

Recruitment

Waste Pro will use several avenues to recruit new employees. We are an Equal Opportunity employer, comply with all Florida E-Verify requirements, and are a drug-free workplace.

Pictured to the right is the safety lane morning crew out that starts at 6am



Local Recruitment

Waste Pro recruits drivers locally at the Truck Driver Institute in Santa Rosa County. We will also recruit incumbent drivers from the previous hauler to reduce local job loss and maintain service continuity.

Online Job Postings

Vacancies are posted on our website and several external sites, including Career Builder, Indeed, LinkedIn, Facebook, and Twitter. America's Job Exchange posts Waste Pro vacancies with their partner organizations and one-stop career centers throughout the United States.

Waste Pro's Certified In-House CDL School

We build our talented team of local drivers from within by offering helpers and other Waste Pro employees the opportunity to train and test for their CDL in our DOT-certified in-house CDL school. This allows us to combat driver shortages while facilitating career advancement for our dedicated employees.

Drawing on Waste Pro's Extensive Florida Footprint

If the need arises, Waste Pro has the ability to temporarily pull in drivers from across our Florida/Alabama footprint to ensure that there is no lapse in service for Century customers while hiring occurs.

When a prospective employee applies for a job with Waste Pro, their application enters a tracking system that allows us to begin reviewing potential candidates within hours of a position being posted. Once a new employee is hired, they are welcomed to the Waste Pro family and begin their service- and safety-focused training with experienced local staff. In addition to their local training, new drivers also participate in an intensive safety refresher at our state-of-the-art, Florida/Georgia-based **Driver Training Center**. Throughout our partnership, our training ensures that all new Waste Pros in Century will be fully educated in the Town's contract as well as the **Waste Pro Way—our commitment to caring for our community partners and providing Century residents with world-class, people-focused service.**

Waste Pro's commitment to caring for our communities has an important corollary: **In order to care for our communities, we must first care for our people.** Waste Pro employees experience this care throughout their tenure with the company—from our carefully planned onboarding process to our commitment to work-life balance, our excellent benefits, and our industry-high driver and helper safety awards.

Waste Pro's **New Employee Onboarding Program** features comprehensive safety training, a focus on customer service, and a commitment to mentorship. Our **Onboarding Program Timeline**, which features 90 days of ongoing check ins, training reinforcements, and intentional efforts to help new employees find success in their roles at Waste Pro, is available upon request.

The goal of our extensive training process is to make sure new Waste Pro employees are confident and well-prepared to service our customers. **We know that when our staff feel well-prepared and confident, our municipal partners benefit from their care and attention to detail.**

Employee Retention

At Waste Pro, we pride ourselves on being a "people company." We understand that our drivers and other frontline employees are the heart—and the public face—of our operations, and it is our goal to ensure that working for Waste Pro is not just a job but a fulfilling career. There is nothing more important to us than the health and welfare of our employees. **The table below summarizes some of the ways we recognize our employees for their commitment to our customers.**

Benefits

Waste Pro offers one of the most comprehensive benefits packages in the industry. Health and wellness benefits include medical, dental, vision, preventive care, 24-hour physician access, Flexible Spending Accounts to cover out-of-pocket healthcare costs, free wellness exams to encourage healthy habits, employee assistance programs, short- and long-term disability, eligible dependent benefits, and retirement savings plans. Waste Pro also offers employees access to free benefits programs such as non-emergency surgical treatments, imaging, physical therapy, and diabetes and kidney disease case management through our Pathway to Free Healthcare.

Work/Life Balance

We are committed to helping our employees build both fulfilling careers and maintain fulfilling personal lives. Routes have been built so that our drivers work a 10-hour day and have time to enjoy with their families.

Employee Bonuses

Employees are eligible for retention bonuses and a year-end gift up to \$2500. Technicians are eligible for tool reimbursement and pay increases based on completion of training programs.

Employee Recognition Awards

We offer performance incentives ranging from our \$100 Franklin Awards for exemplary service to our safety-focused Driver, Helper, and Supervisor Awards. The Route Supervisor Bonus Program, through which supervisors can earn up to \$14,000 per year, recognizes and rewards supervisors for their commitment to safety and their role in keeping our employees and community safe. We are also proud to offer our industry-high \$10,000 Safety Awards for drivers and \$5,000 Safety Awards for helpers. These drivers and helpers embody the Waste Pro Way and maintain a perfect safety record for three years. To date, Waste Pro has paid over \$10 million in \$10k and \$5k awards to more than 1050 employees--including 30+ repeat winners!

Co-Heart Program

At Waste Pro, we believe in investing in upward mobility. Given recent labor shortages, we are proud that we have the infrastructure to build our army of drivers from within and foster career advancement for our helpers. Our DOT-certified in-house CDL school—one of only two run by solid waste companies in Florida--has trained and certified more than 500 drivers. Graduates of the

program who commit to a year of service with Waste Pro can receive their CDL for as little as \$50, saving new drivers thousands of dollars.

Employee Transfer Program

We know that sometimes, circumstances arise that require employees to relocate. We retain these employees through our Employee Transfer Program, allowing them to continue their careers in their new community. For drivers displaced by contract changes, we offer a moving and transfer package.

Recycling Education

The **Reduce, Reuse, Recycle** mantra is fundamental to our operation. Our mission is to create sustainable recycling solutions for our municipal partners. We encourage and help build local recycling programs that do the following:

- ✓ Increase waste diversion from local landfills
- ✓ Reduce recycling contamination
- ✓ Contribute to local economies

Across our 12-state footprint, Waste Pro has ample experience partnering with local municipalities to help them meet their recycling goals. Our services are **highly local and tailored to each community partner we serve**. These highly local, tailored recycling programs are part of our “Distinguishable Difference.”

We operate from the understanding that **the biggest recycling gains are made when residents understand how to recycle correctly**. This means that only non-bagged program recyclables are going into recycling carts. The benefits that come from increasing recycling volumes are negated if that recycled material is so contaminated that the processing facility cannot accept it.

As described under our “Approach to Collection Services,” Waste Pro will monitor recycling and leave an **educational non-collection notice** should a resident’s cart contain non-recyclable materials. The goal of these notices is to enhance the success of the recycling program—when people know better, they recycle better! **We will work with the Town to produce a tag specific to your recycling program.**

Once residents and commercial customers understand which materials belong in their local recycling stream, **our next goal is to make**

What is recycling contamination?

Recycling contamination occurs when materials that do not fit a local processing facility’s list of accepted program recyclables are mixed in with recyclable materials. High contamination rates make recycling less economically viable—and sometimes logistically impossible. We find that high contamination rates are often caused by people not understanding which materials can and cannot be recycled in their city or county. Our education and outreach programs are designed to combat recycling contamination.

sorting materials for recycling the natural choice. To do this, we partner with local municipalities to **raise awareness about the importance of recycling** through various strategies.

Finally, **when it comes to raising recycling awareness and promoting “clean” recycling, Waste Pro has always taken a boots-on-the-ground approach.** We attend local community events, like rotary club meetings and community festivals, to talk about recycling, and we present to students in local schools using age-appropriate educational materials—such as coloring books for younger students and a tailored curriculum program for middle-grade students. You’ll also find us at Community Clean Ups and Touch-A-Truck events.



Waste Pro’s Technology Solutions Enhance Operational Efficiency

While we know that our people, their deep industry knowledge, and our boots-on-the-ground local operations are our greatest assets, Waste Pro is also committed to investing in **technological solutions to enhance the safety and efficiency of our operations and further elevate the quality of our service in Century.**

Safety

- ✓ Every Waste Pro vehicle is equipped with **3rd Eye internal and external cameras.** This camera system is a critical safety tool for the Waste Pro team. 3rd Eye cameras enhance safety through three primary features:
 1. Real-time views from rear cameras provide an additional check for drivers during backing
 2. Live camera streaming allows supervisors to monitor and assess driver activity outside of official, in-person ride alongs.
 3. AI-enhanced technology recognizes an increasing array of inconsistent driving behavior, allowing us to provide drivers with additional safety coaching if necessary.

Efficiency

- ✓ **Routeware,** our tablet-based turn-by-turn navigation software, will provide drivers with clear routing instructions—and allow reserve (spare) drivers to easily and effectively cover routes.
- ✓ **Tower,** Waste Pro’s operational software, stores routing, collection, and billing information for our community partners. Tower is a key tool for data management and reporting.

- ✓ Waste Pro's routing software, **RouteSmart**, will enable route optimization in Century. This software allows us to maximize efficiency by taking into account a number of parameters, including number of homes, home density, driving distances, collection hours, and landfill location.
- ✓ **Dossier**, our fleet maintenance software, helps us streamline maintenance workflows, including scheduling and managing preventive maintenance.

Customer Service

- ✓ Waste Pro's Voice over Internet Protocol (VoIP) phone system, **8x8**, features call back capabilities, customized front-end messaging, and press options. It also offers data analytics and tracking for reporting and quality assurance purposes. Customer Service Representatives can answer calls from anywhere, including from home should inclement weather cause office closures.
- ✓ All calls received by Waste Pro Customer Service Representatives from Century residents [and businesses] will be logged into our web-based **Trac-EZ** customer service system. This system facilitates seamless internal communication between Waste Pro's customer service staff, dispatch, and our supervisors and drivers out on Century streets.
- ✓ In addition to enhancing driver safety, **3rd Eye** will provide real-time service verification for our Century collection program.

Continuity of Operations and Contingency Planning

As a Florida-based company, preparing for storm events is an area where Waste Pro has seasoned experience. With over 22 years of storm and hurricane cleanup in service areas from Miami to the Panhandle, we have a time-tested method for storm preparation and post-storm continuity of operations. **As one of the largest service providers in the state, we have demonstrated experience with severe storms.** We are happy to provide the Town of Century with more detailed information upon request.



WASTE & RECYCLING NEWS

MAY 2, 2011

Crain's News Source for Environmental Management

Waste Pro keeps it simple



Waste Pro USA Inc. CEO John J. Jennings said he believes in maintaining the company's core values even as his Longwood, Fla.-based solid waste management company continues to rapidly expand.

By Jim Johnson

Waste Pro USA Inc. is far from the single-truck operation that started a decade ago. With sales topping \$400 million annually, the company now has operations in seven southern states, running more than 1,400 trucks, employing 2,400 people and servicing 7.4 million customers.

locations to maintain and promote company beliefs. "As we grow, we want to make sure that we're able to maintain and keep that active culture going that really has been a part of our success," Jennings said. "I started the company really with the idea of keeping it simple. And what do we really mean by that? We come down to words and

been working with Jennings for about a quarter of a century in the trash business, even before the creation of Waste Pro. Traveling from his home base of Athens, Ga., Wood will hit the road a week or two at a time to talk to employees about company culture. "We do believe that our employees are



TAB 4 SERVICE PLAN





TAB 5

COST PROPOSAL



Waste Pro keeps it simple



Waste Pro USA Inc. CEO John J. Jennings said he believes in maintaining the company's core values even as his Longwood, Fla.-based solid waste management company continues to rapidly expand.

By Jim Johnson

Waste Pro USA Inc. is far from the single-truck operation that started a decade ago. With sales topping \$400 million annually, the company now has operations in seven southern states, running more than 1,400 trucks, employing 2,400 people and servicing 7.7 million customers.

As the company grows, Jennings has had to find ways to maintain and promote company beliefs. "As we grow, we want to make sure that we're able to maintain and keep that culture going that really has been a part of our success," Jennings said. "I started the company really with the idea of keeping it simple. And what do we really mean by that? We mean, don't overcomplicate things."

Jennings has been working with Jennings for about a quarter of a century in the trash business, even before the creation of Waste Pro. "Traveling from his home base of Athens, Ga., Wood will hit the road a week or two at a time to talk to employees about company culture."



EXCLUSIVE FRANCHISE FOR SOLID WASTE COLLECTION AND RECYCLING SERVICES
TOWN OF CENTURY, FL | RFP NO. 2025-02

Cost Proposal

3. Proposal Contents: *cost proposal*

Town of Century, Florida

RFP Number: 2025-02

Price Sheet by Waste Pro of Florida, Inc.

\$ _____ 19.00 1x Week Household Waste Pickup (curbside cart content only)

\$ _____ 40.75 Includes all of the following:

- 1x Week Household Waste Pickup (curbside cart content only);
- 1x Week Household Yard Waste Pickup (curbside cart content only);
- Bi-weekly Household Recycle Pickup (curbside cart content only); and
- Quarterly Bulk



WASTE & RECYCLING NEWS

MAY 2, 2011

Crain's News Source for Environmental Management

Waste Pro keeps it simple



Waste Pro USA Inc. CEO John J. Jennings said he believes in maintaining the company's core values even as his Longwood, Fla.-based solid waste management company continues to rapidly expand.

By Jim Johnson

Waste Pro USA Inc. is far from the single-truck operation that started a decade ago. With sales topping \$400 million annually, the company now has operations in seven southern states, running more than 1,400 trucks, employing 2,400 people and servicing 7.4 million customers.

locations to maintain and promote company beliefs. "As we grow, we want to make sure that we're able to maintain and keep that active culture going that really has been a part of our success," Jennings said. "I started the company really with the idea of keeping it simple. And what do we really mean by that? We mean, keep it simple and

been working with Jennings for about a quarter of a century in the trash business, even before the creation of Waste Pro. Traveling from his home base of Athens, Ga., Wood will hit the road a week or two at a time to talk to employees about company culture. "We do believe that our employees are



TAB 5
COST PROPOSAL





TAB 6

CUSTOMER SERVICE PLAN



Waste Pro keeps it simple



Waste Pro USA Inc. CEO John J. Jennings said he believes in maintaining the company's core values even as his Longwood, Fla.-based solid waste management company continues to rapidly expand.

By Jim Johnson

Waste Pro USA Inc. is far from the single-truck operation that started a decade ago. With sales topping \$400 million annually, the company now has operations in seven southern states, running more than 1,400 trucks, employing 2,400 people and servicing 7.7 million customers.

As the company grows, Jennings said, he wants to maintain and promote company beliefs. "As we grow, we want to make sure that we're able to maintain and keep that culture going that really has been a part of our success," Jennings said. "I started the company really with the idea of keeping it simple. And what do we really mean by that? We mean, don't overcomplicate things."

Jennings has been working with Jennings for about a quarter of a century in the trash business, even before the creation of Waste Pro. "Traveling from his home base of Athens, Ga., Wood will hit the road a week or two at a time to talk to employees about company culture. "It's the belief that our employees are



EXCLUSIVE FRANCHISE FOR SOLID WASTE COLLECTION AND RECYCLING SERVICES
TOWN OF CENTURY, FL | RFP NO. 2025-02



Customer Service

3. Proposal Contents: Customer service plan

At Waste Pro, we believe that people make the difference, and caring never goes to waste. The Town of Century will see this “**Distinguishable Difference**” in our approach to customer service. Whether we are answering a call from a resident or participating in local community events, we are committed to providing the Town of Century with world-class service—locally.

We believe that when a Town customer picks up the phone, they should reach a customer service team operating locally. Our local office will have 1 office manager, 1 lead CSR and 8 dedicated customer service office staffed with local employees. As experts in Waste Pro’s day-to-day operations for the Town of Century, customer service representatives will answer questions and quickly forward comments or complaints to the relevant parties for immediate resolution. Our live, locally-based customer service teams provide a direct line of communication between our municipal partners and our hauling operations. We look forward to coordinating with the Town of Century to finalize our customer service protocol. Below, we describe what Waste Pro’s commitment to customer service looks like in practice.

Effective Operations and Training

The first step to effective customer service is operations. We check and double-check our work to eliminate complaints before they happen. The operations piece of our customer service protocol includes training, route planning, and boots-on-the-ground supervision:

Employees are educated on the specific needs, rules, and regulations of the Town of Century's contract.	All employees undergo comprehensive training focused on company policies and procedures.	Employees are taught the <i>Waste Pro Way</i> , which includes professional conduct and customer service.
New drivers and helpers run supervised routes for two weeks before they begin to work independently.	Routes are set up so that teams can assist one another if unexpected service delays occur.	Route Supervisors communicate with drivers and spot check routes to ensure service is running on time and up to Waste Pro's high standards.

This is the start of our customer service philosophy: **If you perform the service correctly, there are no complaints.** However, we know that even with the best laid plans and most dedicated team members, sometimes issues or customer questions do arise. This drives the second part of our customer service philosophy: **All customer issues are resolved in a timely and prompt manner. As our detailed customer service protocols below illustrate, Waste Pro has technology and processes in place to ensure that any questions that cannot be answered during a customer’s initial phone call are immediately forwarded to the appropriate parties for resolution.**

Our Dedicated Century Customer Service Office and Local Staff

Waste Pro will provide world-class customer service to the residents of the Town of Century **We believe that when a Century customer picks up the phone, they should reach a local customer service team.** As experts in Waste Pro's day-to-day operations, our Milton-based customer service representatives can answer questions and quickly forward comments or complaints to the relevant parties for immediate resolution. We employ software and reporting tools for workforce management to assess staffing capacities and requirements, ensuring that we maintain an adequate number of employees to deliver high-quality customer service. As we describe above, our Customer Service Representatives will be hired locally, to the benefit of our customers in Century. When customers call their local division, they will reach staff who are well-versed in the specifics of their municipal contract—and who have firsthand knowledge of local roads and neighborhoods and the kinds of local events or conditions that may impact collections.

Town of Century Customer Service Representatives Provide a High Level of Service

- ✓ **No automated attendants**—Real people answer the phone!
- ✓ Using our Trac-EZ system (described in our Service Plan), Century's dedicated Office Manager, Jennifer Fletcher, will ensure all issues are closed out or scheduled by the end of the day.
- ✓ In addition to their training in company policies and Waste Pro's best practices in customer service, all CSRs hired to support our Century contract will receive two weeks of real-world, hands-on training as they answer calls under the supervision of the Office Manager.
- ✓ Contingency planning: Pensacola/Milton CSRs are also trained in the Century contract and can assist customers if needed, such as during severe weather events.
- ✓ To maintain quality assurance, we implement a quality monitoring form for both live and recorded calls, with feedback provided on the interactions. Additionally, we employ a Monitor, Barge, Whisper program, enabling supervisors to listen to calls, offer feedback, or intervene when required.

The customer service office for Century will provide a local, toll-free phone number—850-365-1900 available from 8:00 am to 5:00 pm, Monday through Friday. Individuals calling after hours are invited to leave a message, which will be addressed promptly on the next business day.

Incoming Calls

8x8 Phone System

Waste Pro employs a Voice over Internet Protocol (VoIP) phone system known as 8 x 8. This cloud-based service allows calls to be answered from any location, including home, which is particularly beneficial during inclement weather that may prevent staff from reaching the office or cause power and internet disruptions. In such cases, 8 x 8 enables us to operate our phone systems remotely before transitioning our phone lines back to the local office once services are restored.

The 8x8 system is engineered for user convenience and can be tailored to meet the specific requirements of the Town of Century and its residents. Features include:

- ✓ **Call Back:** Our system will inform customers of their queue position and allow them to choose between waiting or receiving a return call. The callback feature also enables us to reconnect in the unlikely event of a dropped call or an unintentional disconnection.
- ✓ **Customized Front-End Messages in Multiple Languages:** In the case of modifications to services, the system can inform residents of these changes, particularly during adverse weather conditions and holidays.
- ✓ **Customized Phone Numbers:** When Century customers need to reach Waste Pro, they will call a dedicated local phone number.
- ✓ **Press Options:** Our system can be configured with various press off options should the Town choose to utilize this feature.

Beyond customer interaction, 8x8 also offers data analytics and tracking capabilities, enabling the monitoring of call times, wait durations, and overall call quality. This functionality allows Waste Pro to generate reports and statistics from call logs, ensuring transparency regarding customer service levels and compliance with reporting obligations.

Trac-EZ Enhances Customer Service for Century Residents

Waste Pro plans to implement a web-based customer service platform for the Town of Century called Trac-EZ. Trac-EZ is a web-based system designed to help Waste Pro and its community partners, like the Town of Century, manage customer service workflows. When a customer calls our local customer service line, a CSR will log the customer request into the Trac-EZ system, where it will be attached to the customer’s account. Trac-EZ provides Town staff as well as Waste Pro staff, both in the office and out in the field, with **real-time access to customer service requests**. Every call that Waste Pro receives will be logged, and resolution times will be easily available to the Town for review.

We will provide the Town of Century with access to this tracking system at **no cost** and in the spirit of **full transparency**—every call that Waste Pro receives will be logged, and resolution times will be easily available to the Town for review.

When a call is received at our local facility or an online Trac-EZ ticket is generated by a customer or Town staff, the following **customer service workflow** will be activated:

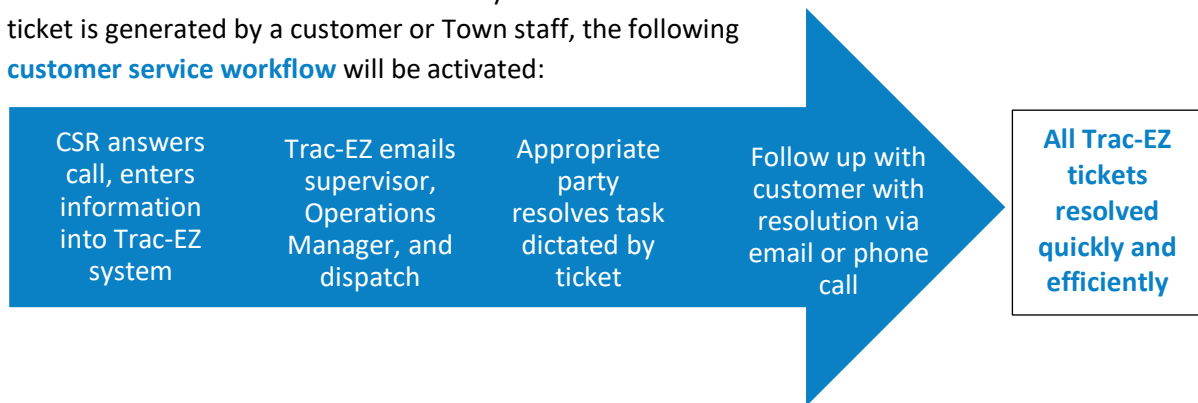

The screenshots below, from our CSRs at Waste Pro’s Pensacola/Milton Division, illustrate what the Town of Century can expect from our Trac-EZ software. Customer requests, complaints, questions, and

the second screenshot, below, shows the **logging and resolution of a single customer call**. At 1:47 pm on July 30, a customer called and informed the local Waste Pro team that we missed his garbage collection. By the following afternoon, the log was closed, with a note indicating that the driver confirmed this customer had been serviced.

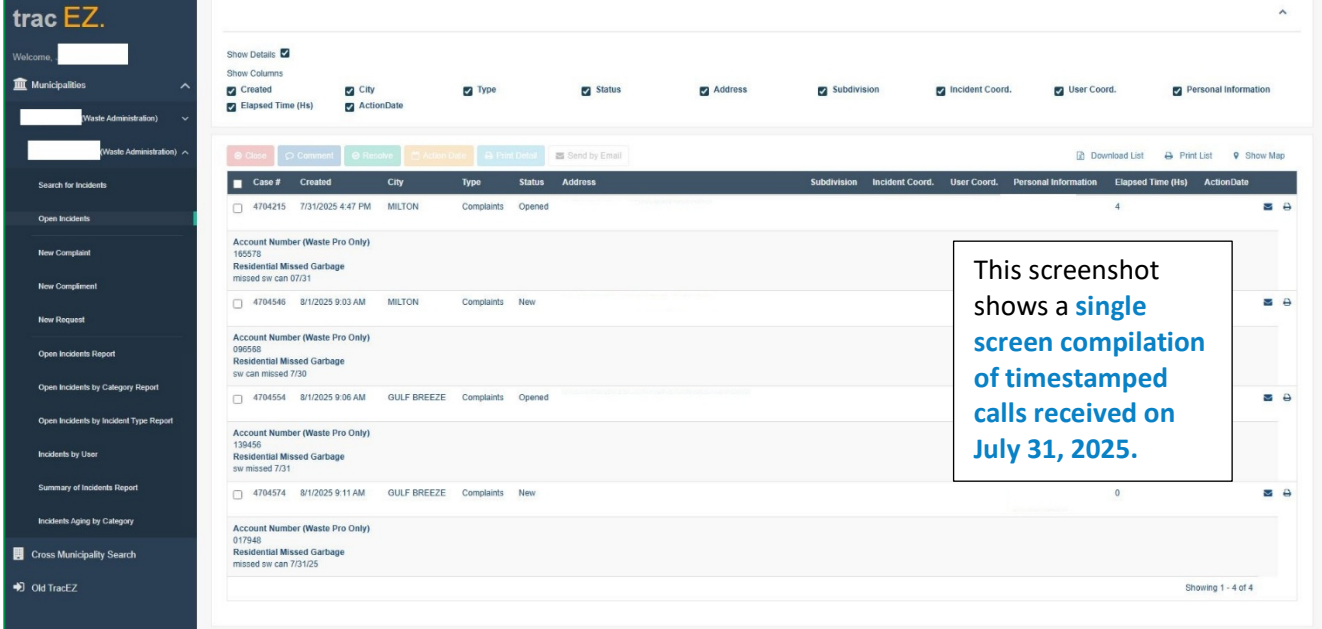

The screenshot shows the tracEZ software interface. On the left is a navigation sidebar with options like 'Municipalities', 'Search for Incidents', and 'Open Incidents'. The main area displays a table of incidents with columns for Case #, Created, City, Type, Status, Address, Subdivision, Incident Coord., User Coord., Personal Information, Elapsed Time (Hrs), and ActionDate. A callout box on the right side of the table contains the text: 'This screenshot shows a single screen compilation of timestamped calls received on July 31, 2025.'

Note: Identifying information has been redacted from both screenshots for customer privacy.

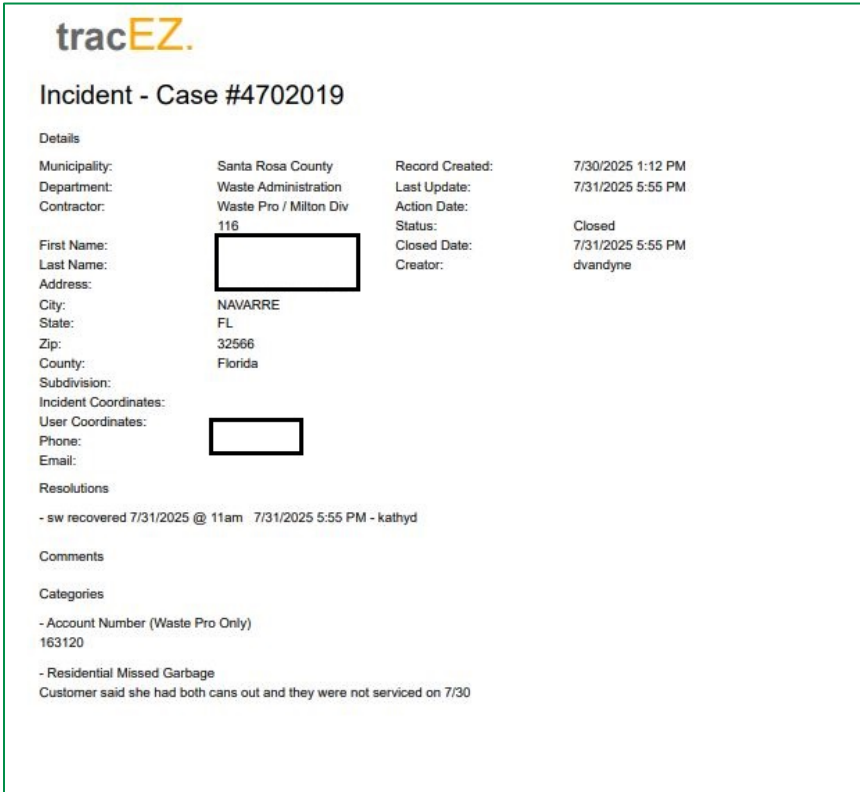

The screenshot shows the details for Incident - Case #4702019. The details are as follows:

Details

Municipality: Santa Rosa County
 Department: Waste Administration
 Contractor: Waste Pro / Milton Div 116

Record Created: 7/30/2025 1:12 PM
 Last Update: 7/31/2025 5:55 PM
 Action Date:
 Status: Closed
 Closed Date: 7/31/2025 5:55 PM
 Creator: dvandyne

First Name: [Redacted]
 Last Name: [Redacted]
 Address: [Redacted]
 City: NAVARRE
 State: FL
 Zip: 32566
 County: Florida
 Subdivision:
 Incident Coordinates:
 User Coordinates: [Redacted]
 Phone:
 Email:

Resolutions

- sw recovered 7/31/2025 @ 11am 7/31/2025 5:55 PM - kathyd

Comments

Categories

- Account Number (Waste Pro Only)
 163120

- Residential Missed Garbage
 Customer said she had both cans out and they were not serviced on 7/30

Waste Pro’s Commitment to Effective Customer Communication

Waste Pro is always happy to hear from our customers via phone. When our customers need to hear from us, for updates including holiday schedules and potential service changes during adverse weather, Waste Pro utilizes several fast and effective communication channels.

Call-Em-All and Text-Em-All

Our Call-Em-All and Text-Em-All automated notification program allows us to quickly reach out to residents via phone call and/or text message to inform them of temporary service changes, including adverse weather collection schedules.

We work with our municipal partners to gather the necessary customer data to implement this program.

Online Communication

Waste Pro’s corporate communications team will work with our local staff to design a custom Town of Century Waste Pro service webpage. This site will include local contact information and service information and will be updated to include holiday schedules.

As an example, we have included the landing page for our Winter Park, Florida customers. The links at left provide residents and businesses with additional information specific to the City’s collection program, including pickup schedules, recycling specifications, and commercial service details.

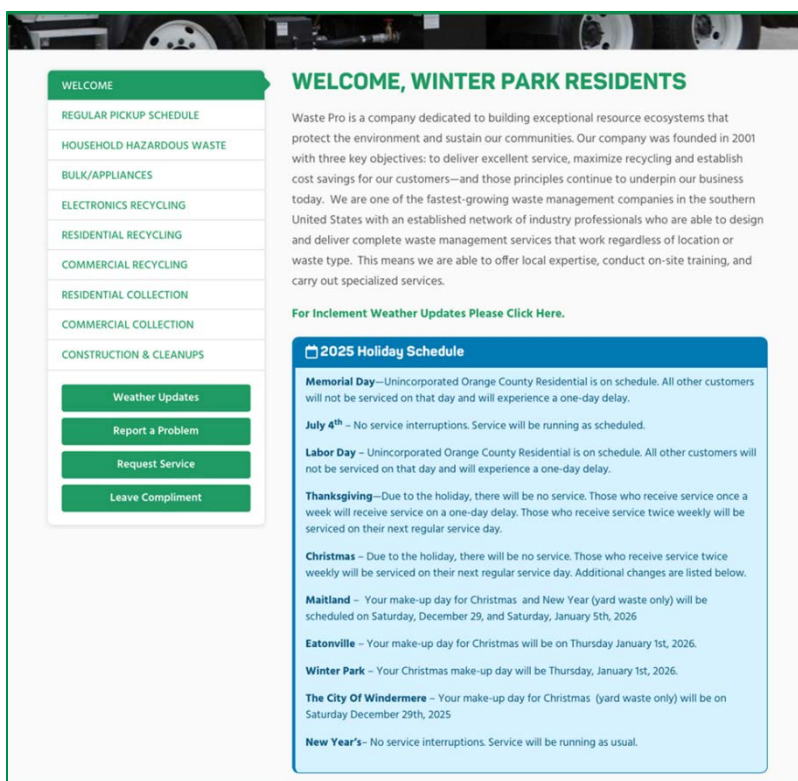

A Customer Service Approach That Speaks for Itself

Each facet of our customer service approach adds value to the customer service experience. Our training and operations approach, refined through years of experience in and around Florida, helps to prevent service issues before they even happen. When issues do arise, our local, contract-specific CSRs and dedicated Office Manager provide personable support to our customers. Our technology capabilities through our 8x8 phone system and Trac-EZ platform provide convenient and transparent methods of communication between Waste Pro, the customer, and the Town of Century. Combining each element results in a high level of customer service and leaves no question unresolved.

We take pride in our dedication to providing exemplary services and customer service. For Waste Pro, hearing from satisfied customers confirms that our approach works. Our Google Ratings and Reviews from our Waste Pro – Pensacola/Milton location, sampled below, paint a picture of our high level of service and satisfaction.

Division	Google Rating	Number of Reviews
Waste Pro – Pensacola/Milton	4.7	3,673

Division 2 (Delete if not applicable)	Google Rating	Number of Reviews
Waste Pro – Spanish Fort	4.5	433

Google Reviews

Hanna: The Waste Pro Wonder Woman of Customer Service! If there were an Olympic event for setting up waste accounts and handling customer issues with grace, speed, and a touch of sass—Hanna would be walking away with gold and probably waving from a garbage truck-themed float. Need a new account? Hanna’s on it. Missed pickup? She’ll fix it faster than you can say “Why is there still a raccoon in my recycling bin?” Confused about your bill? Hanna will explain it so clearly, even your trash can will understand. She’s got the patience of a saint and the knowledge of someone who’s basically earned a PhD in Trash-onomics. Every call she takes is a customer rescued from the clutches of waste-related confusion. She’s not just answering phones—she’s restoring faith in humanity, one garbage complaint at a time. And let’s not forget her sense of humor. When asked if trash ever takes a break, she replied, “Nope—it’s got a rubbish work ethic.” Hanna, you’re a 5-star legend. Waste Pro hit the jackpot with you. And frankly, if customer service had capes—you’d be wearing one made out of recycled invoices and unmatched socks.
 Jason Caudle July 2025 ★★★★★

I recently cancelled another trash service in our area due to multiple reasons. I called Waste Pro today to start up service. Alissa is the lovely lady that answered my call without having to be on hold for someone to answer. She was extremely knowledgeable, patient and kind. She answered every question I had before I even had the chance to ask them. I look forward to working with Alissa & Waste Pro from here on out.
 Chelseigh Vann – July, 2025 ★★★★★

I appreciate that a person always answers when I call Waste Pro. I have spoken to Shay a couple times, and she is great! Always pleasant and helpful.
 Mary Q., – July, 2025 ★★★★★

Jamya was helpful and very professional. I was able to setup my service fast and with ease, which makes a difference compared to other companies who are impossible to get a hold of. I am glad Waste Pro is in our area! Lacie Hall – July, 2025 ★★★★★

Kelsie was such a great help to me today and sweet as can be. I had to switch from Adam sanitation to waste pro, she was so helpful and made the process not stressful!
 Kristie Conaughtty- June, 2025 ★★★★★



I signed up for trash service with Adam's Sanitation because I wanted to give a small business a shot!! From the moment I signed up with them (Adams), I had nothing but issues!! So, after contemplating for a year, I finally decided to start new service with Waste Pro!! I am so glad I did!! The customer service rep I had (SHAY) was on point... She was knowledgeable, went over everything with me, and she was very patient with all my questions!! She truly made it very easy for me to make the switch! Not to mention, the services are cheaper than Adams, and from what I've seen the driver doesn't have issues backing down the road!!

Rachael S. – June, 2023 ★★★★★

Great customer service experience and I love the fact that someone answers the phone instead of going through automated prompts! Chase Lee – July, 2025 ★★★★★

Trish is an Amazing Driver!! She is an Asset to your Team!! Deborah Kosmas – July, 2025 ★★★★★



Hanna



Taylor

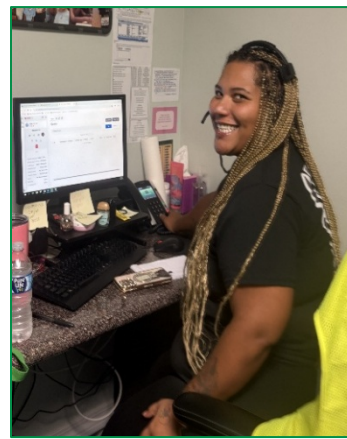

Shay



Jamya

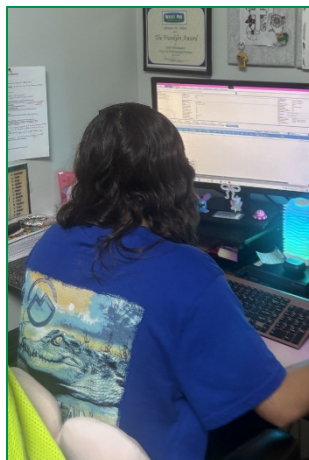

Kelsie

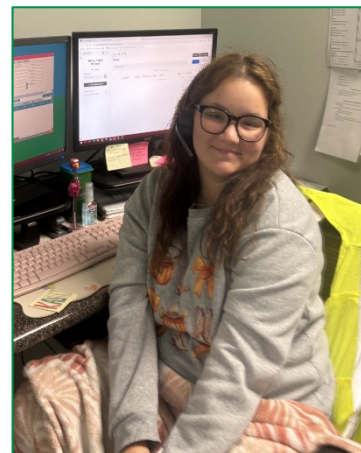

Kailey

Caring for the Town of Century: Community Engagement

As your service partner, it is our goal to be a **good neighbor** and an **engaged member of the Century community**. This people-first philosophy drives our engagement across our coastal region as well as and throughout our 12-state footprint. What's important to us in our community partnerships is what's important to you—the events and organizations that give the Town of Century its sense of place.

Waste Pro spends over **\$1 million annually** to help facilitate the success of community organizations and events across our footprint. In addition to monetary contributions, we are proud to partner with community organizations such as the **American Cancer Society, local Rotary Clubs, local Boys and Girls Clubs, the Leukemia and Lymphoma Society, Backpacks for Kids, the NAACP's Freedom Fund, League of Cities, and Neighborhood Watch**.

Here in the Coastal Region of Alabama and the Florida Panhandle, we are proud to sponsor a number of local organizations, including:

-  Keep Santa Rosa Beautiful
-  Great American Clean Up
-  Opening Doors of Northwest Florida
-  REAP- Re-Entry Alliance Pensacola
-  Toys For Tots
-  Manna Food Bank
-  Pensacola 5K Run
-  Smokin' On The Square Charity Events
-  Emerald Coast Wildlife Refuge
-  Panhandle Butterfly House
-  Monarch Madness
-  Pollination Celebration
-  Santa Rosa Creek Band Creek Fest
-  Flomaton Summer Bazaar
-  LakeFest DeFuniak Springs
-  Defender of Freedom FL Inc
-  Saraland Career On Wheels
-  Santa Rosa County Chamber of Commerce
-  Pensacola Chamber of Commerce

The Pensacola-Milton Division is richly involved in our community and extends beyond these important sponsorships. **We are part of the fabric of day-to-day life throughout our local footprint as we also support many other events and local youth educational programs.** The photographs below show Waste Pro out and about in the communities we serve. Sometimes, we even get requests to bring trucks to children's birthday parties!



Saraland Career on Wheels



Holley by the Sea Great American Clean Up



Flomaton Summer Bazaar



LakeFest Defuniak Springs



Panhandle Butterfly House

Little Azai's Birthday Wish



Little Azai's Birthday Wish that Waste Pro fulfilled Saturday March 30, 2024.

Ms. Johnson called into the office asking if it was possible that we stop by for a few minutes to give little Azai a special tour for his third birthday. **Jennifer Rivera** – residential driver pictured below has been helping the team with Touch-A-Truck events for several years and was the obvious choice to fulfill Azai's wish. She and Nick Rivera spent about 20 minutes with the small group of children.

Ms. Johnson was overjoyed with gratefulness and was very touched by how much Waste Pro cares about our communities- after all it is our motto- and how we took the time to make them feel so special on this very important milestone in their lives. To the left you will see a thank you letter, and pictures provided by Ms. Johnson and Family.

Good morning, Waste Pro

Thank you so much for your help in wishing my little one, Azai a special 3rd birthday by stopping by on March 30, 2024.

Backstory on Azai loving garbage trucks: My mom is a bus driver so whenever he rides on the bus with her, he sees them a lot riding around Milton collecting trash. When he first started to walk, he would wobble to the front door and peek out for the trashcan to come and would be so happy to see the green truck come up the road and stop. For Christmas, we got him two trashcans because he tells everyone he likes garbage truck, so it was no surprise when I asked him last month about his themed birthday party and he shouted out "garbage trucks." Other kids would want cartoons, nope Azai would rather have garbage truck party favors for everyone!

HUGE THANK YOU to Mrs. Jenny and Mr. Nick!!! The crew even brought a bag of candy and balloon for him which was very special. They were on time and explained so many things about the truck and even let the children blow both horns. We enjoyed the demonstration of the arm grabbing a trashcan and dumping the trash into the back of the truck, the kids loved the noise and were excited about an empty trash can. It was an amazing experience for the little ones, and we truly appreciate the time and effort for someone to come out on a Saturday.

This will be something he remembers and will be adding to the scrapbook on how amazing this opportunity was for us. He talked about the garbage truck after they left and wanted to even drive the truck.

Thank you thank you!!!! I'll be dropping off a photo this week.

Best regards,
Justice Johnson
850-394-7776





WASTE & RECYCLING NEWS

MAY 2, 2011

Crain's News Source for Environmental Management

Waste Pro keeps it simple



Waste Pro USA Inc. CEO John J. Jennings said he believes in maintaining the company's core values even as his Longwood, Fla.-based solid waste management company continues to rapidly expand.

By Jim Johnson
Waste Pro USA Inc. is far from the single-truck operation that started a decade ago. With sales topping \$400 million annually, the company now has operations in seven southern states, running more than 1,400 trucks, employing 2,400 people and servicing 7.4 million customers.

locations to maintain and promote company beliefs. "As we grow, we want to make sure that we're able to maintain and keep that active culture going that really has been a part of our success," Jennings said. "I started the company really with the idea of keeping it simple. And what do we really mean by that? We want to keep it simple and

been working with Jennings for about a quarter of a century in the trash business, even before the creation of Waste Pro. Traveling from his home base of Athens, Ga., Wood will hit the road a week or two at a time to talk to employees about company culture. "We do believe that our employees are





TAB 7

INSURANCE AND BONDING

Waste Pro keeps it simple



Waste Pro USA Inc. CEO John J. Jennings said he believes in maintaining the company's core values even as his Longwood, Fla.-based solid waste management company continues to rapidly expand.

By Jim Johnson

Waste Pro USA Inc. is far from the single-truck operation that started a decade ago. With sales topping \$400 million annually, the company now has operations in seven southern states, running more than 1,400 trucks, employing 2,400 people and servicing 7.7 million customers.

As the company grows, Jennings has had to learn how to maintain and promote company beliefs.

"As we grow, we want to make sure that we're able to maintain and keep that culture going that really has been a part of our success," Jennings said.

"I started the company really with the idea of keeping it simple. And what do we really mean by 'keep it simple'?" Jennings said.

Jennings has been working with Jennings for about a quarter of a century in the trash business, even before the creation of Waste Pro.

Traveling from his home base of Athens, Ga., Wood will hit the road a week or two at a time to talk to employees about company culture.

"It's the belief that our employees are



EXCLUSIVE FRANCHISE FOR SOLID WASTE COLLECTION AND RECYCLING SERVICES
TOWN OF CENTURY, FL | RFP NO. 2025-02

TAB 7
INSURANCE AND BONDING



August 8, 2025

**Re: Waste Pro of Florida, Inc.
5859 Commerce Road
Milton, Florida 32583**

To Whom It May Concern:

Waste Pro of Florida, Inc. is a client of Sompo International and its subsidiary companies.

Reserving our rights to practice normal underwriting functions, we are prepared to consider single bonds up to \$10,000,000.00 with aggregate bonding capacity of \$75,000,000.00 for Waste Pro of Florida, Inc. At this time, Waste Pro of Florida, Inc. has \$36,000,000.00 of aggregate bonding capacity available for use.

Any consideration by the surety is subject to the following conditions:

- 1) All terms and conditions of the contracts including any amendments or supplemental conditions meet the surety's satisfactory review and approval
- 2) Bond form(s) meet the surety's satisfactory review and approval
- 3) Financing of the contract meets the surety's satisfactory review and approval
- 4) All other normal underwriting conditions as determined by the surety have been met by PRINCIPAL at the time of contract award and final bond request

Reserving the surety's right to practice normal underwriting functions, we are prepared to have them issue bonds covering parameters referenced above and in accordance with the Request for Proposals for Exclusive Franchise for Solid Waste Collection and Recycling Services for the Town of Century, Florida, and furnish a Performance Bond as security for the faithful performance of the contract if awarded.

Sompo International's subsidiary companies include Endurance American Insurance Company, Endurance Assurance Corporation and Lexon Insurance Company, all of which are members of the United States Department of the Treasury Circular 570 list of approved sureties and maintain A+ (Superior) A.M. Best & Co. ratings with combined XV (\$2 billion or greater) financial size category.

Sompo International and its subsidiaries assume no liability if for any reason we do not execute any requested bonds. If you have any questions regarding this account, please do not hesitate to contact us.

Sincerely,

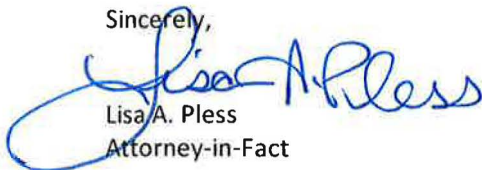

Lisa A. Pless
Attorney-in-Fact



**Sompo International
12890 Lebanon Rd
Mt. Juliet, TN 37122
(615) 553-9587**

KNOW ALL BY THESE PRESENTS, that **Endurance Assurance Corporation**, a Delaware corporation ("EAC"), **Endurance American Insurance Company**, a Delaware corporation ("EAIC"), **Lexon Insurance Company**, a Texas corporation ("LIC"), and/or **Bond Safeguard Insurance Company**, a South Dakota corporation ("BSIC"), each, a "Company" and collectively, "**Sompo International**," do hereby constitute and appoint: **Lisa A. Pless, Chaun M Wilson** as true and lawful Attorney(s)-In-Fact to make, execute, seal, and deliver for, and on its behalf as surety or co-surety; bonds and undertakings given for any and all purposes, also to execute and deliver on its behalf as aforesaid renewals, extensions, agreements, waivers, consents or stipulations relating to such bonds or undertakings provided, however, that no single bond or undertaking so made, executed and delivered shall obligate the Company for any portion of the penal sum thereof in excess of the sum of **One Hundred Million Dollars (\$100,000,000.00)**.

Such bonds and undertakings for said purposes, when duly executed by said attorney(s)-in-fact, shall be binding upon the Company as fully and to the same extent as if signed by the President of the Company under its corporate seal attested by its Corporate Secretary.

This appointment is made under and by authority of certain resolutions adopted by the board of directors of each Company by unanimous written consent effective the 30th day of March, 2023 for BSIC and LIC and the 17th day of May, 2023 for EAC and EAIC, a copy of which appears below under the heading entitled "Certificate".

This Power of Attorney is signed and sealed by facsimile under and by authority of the following resolution adopted by the board of directors of each Company by unanimous written consent effective the 30th day of March, 2023 for BSIC and LIC and the 17th day of May, 2023 for EAC and EAIC and said resolution has not since been revoked, amended or repealed:

RESOLVED, that the signature of an individual named above and the seal of the Company may be affixed to any such power of attorney or any certificate relating thereto by facsimile, and any such power of attorney or certificate bearing such facsimile signature or seal shall be valid and binding upon the Company in the future with respect to any bond or undertaking to which it is attached.

IN WITNESS WHEREOF, each Company has caused this instrument to be signed by the following officers, and its corporate seal to be affixed this 25th day of May, 2023.

<p>Endurance Assurance Corporation</p> <p>By: <i>Richard M Appel</i> Richard Appel; SVP & Senior Counsel</p> 	<p>Endurance American Insurance Company</p> <p>By: <i>Richard M Appel</i> Richard Appel; SVP & Senior Counsel</p> 	<p>Lexon Insurance Company</p> <p>By: <i>Richard M Appel</i> Richard Appel; SVP & Senior Counsel</p> 	<p>Bond Safeguard Insurance Company</p> <p>By: <i>Richard M Appel</i> Richard Appel; SVP & Senior Counsel</p> 
---	--	--	--

ACKNOWLEDGEMENT

On this 25th day of May, 2023, before me, personally came the above signatories known to me, who being duly sworn, did depose and say that he/she is an officer of each of the Companies; and that he executed said instrument on behalf of each Company by authority of his office under the by-laws of each Company.

By: *Amy Taylor*
Amy Taylor, Notary Public - My Commission Expires 3/9/27



CERTIFICATE

I, the undersigned Officer of each Company, DO HEREBY CERTIFY that:

1. That the original power of attorney of which the foregoing is a copy was duly executed on behalf of each Company and has not since been revoked, amended or modified; that the undersigned has compared the foregoing copy thereof with the original power of attorney, and that the same is a true and correct copy of the original power of attorney and of the whole thereof;
2. The following are resolutions which were adopted by the board of directors of each Company by unanimous written consent effective 30th day of March, 2023 for BSIC and LIC and the 17th day of May, 2023 for EAC and EAIC and said resolutions have not since been revoked, amended or modified:

"RESOLVED, that each of the individuals named below is authorized to make, execute, seal and deliver for and on behalf of the Company any and all bonds, undertakings or obligations in surety or co-surety with others: RICHARD M. APPEL, MATTHEW E. CURRAN, MARGARET HYLAND, SHARON L. SIMS, CHRISTOPHER L. SPARRO,

and be it further

RESOLVED, that each of the individuals named above is authorized to appoint attorneys-in-fact for the purpose of making, executing, sealing and delivering bonds, undertakings or obligations in surety or co-surety for and on behalf of the Company."

3. The undersigned further certifies that the above resolutions are true and correct copies of the resolutions as so recorded and of the whole thereof.

IN WITNESS WHEREOF, I have hereunto set my hand and affixed the corporate seal this 8th day of August 2025.

By: *Daniel S. Lurie*
Daniel S. Lurie, Secretary

NOTICE: U. S. TREASURY DEPARTMENT'S OFFICE OF FOREIGN ASSETS CONTROL (OFAC)

No coverage is provided by this Notice nor can it be construed to replace any provisions of any surety bond or other surety coverage provided. This Notice provides information concerning possible impact on your surety coverage due to directives issued by OFAC. **Please read this Notice carefully.**

The Office of Foreign Assets Control (OFAC) administers and enforces sanctions policy, based on Presidential declarations of "national emergency". OFAC has identified and listed numerous foreign agents, front organizations, terrorists, terrorist organizations, and narcotics traffickers as "Specially Designated Nationals and Blocked Persons". This list can be located on the United States Treasury's website - <https://www.treasury.gov/resource-center/sanctions/SDN-List>.

In accordance with OFAC regulations, if it is determined that you or any other person or entity claiming the benefits of any coverage has violated U.S. sanctions law or is a Specially Designated National and Blocked Person, as identified by OFAC, any coverage will be considered a blocked or frozen contract and all provisions of any coverage provided are immediately subject to OFAC. When a surety bond or other form of surety coverage is considered to be such a blocked or frozen contract, no payments nor premium refunds may be made without authorization from OFAC. Other limitations on the premiums and payments may also apply.

Any reproductions are void.

Surety Claims Submission: LexonClaimAdministration@sompo-intl.com

Telephone: 615-553-9500 Mailing Address: Sompo International; 12890 Lebanon Road; Mount Juliet, TN 37122-2870



TAB 7 INSURANCE AND BONDING



WASTE & RECYCLING NEWS

MAY 2, 2011

Crain's News Source for Environmental Management

Waste Pro keeps it simple



Waste Pro USA Inc. CEO John J. Jennings said he believes in maintaining the company's core values even as his Longwood, Fla.-based solid waste management company continues to rapidly expand.

By Jim Johnson
Waste Pro USA Inc. is far from the single-truck operation that started a decade ago. With sales topping \$400 million annually, the company now has operations in seven southern states, running more than 1,400 trucks, employing 2,400 people and servicing 7.4 million customers.

locations to maintain and promote company beliefs. "As we grow, we want to make sure that we're able to maintain and keep that active culture going that really has been a part of our success," Jennings said. "I started the company really with the idea of keeping it simple. And what do we really mean by that? We mean, keep it simple and

been working with Jennings for about a quarter of a century in the trash business, even before the creation of Waste Pro. Traveling from his home base of Athens, Ga., Wood will hit the road a week or two at a time to talk to employees about company culture. "We do believe that our employees are





WASTE & RECYCLING NEWS

MAY 2, 2011
Crain's News Source for Environmental Management

Waste Pro keeps it simple



Waste Pro USA Inc. CEO John J. Jennings said he believes in maintaining the company's core values even as his Longwood, Fla.-based solid waste management company continues to rapidly expand.

By Jim Johnson
Waste Pro USA Inc. is far from the single-truck operation that started a decade ago. With sales topping \$400 million annually, the company now has operations in seven southern states, running more than 1,400 trucks, employing 2,400 people and servicing 7.7 million customers.
As the company grows, Jennings has had to learn how to maintain and promote company beliefs. "As we grow, we want to make sure that we're able to maintain and keep that culture going that really has been a part of our success," Jennings said. "I started the company really with the idea of keeping it simple. And what do we really mean by 'simple'?"
Jennings has been working with Jennings for about a quarter of a century in the trash business, even before the creation of Waste Pro. "Traveling from his home base of Athens, Ga., Wood will hit the road a week or two at a time to talk to employees about company culture."
"It's the belief that one employee can

TAB 8

DISPOSAL FACILITY PLAN



EXCLUSIVE FRANCHISE FOR SOLID WASTE COLLECTION AND RECYCLING SERVICES
TOWN OF CENTURY, FL | RFP NO. 2025-02

TAB 8
DISPOSAL FACILITY PLAN

Disposal Facility Plan

3. Proposal Contents: Disposal facility plan

Primary Disposal Site: Santa Rosa County Central Landfill 5693 Arthur Lane Milton, Florida 32583



Facility Overview

Waste Pro of Florida, Inc. proposes to utilize the Santa Rosa County Central Landfill as the designated disposal facility for solid waste collected under this franchise. Located approximately 15 miles from the Town of Century, the landfill offers convenient access and sufficient capacity to accommodate residential, commercial, and municipal waste volumes generated under this agreement.

This Class I facility is operated by the Santa Rosa County Environmental Department and is fully licensed and compliant with the Florida Department of Environmental Protection (FDEP) regulations. It accepts municipal solid waste, construction and demolition debris, and other non-hazardous materials.

Capacity & Compliance

The Santa Rosa Landfill maintains robust infrastructure for waste processing, including:



Solid waste tipping operations



Designated areas for yard waste and bulk debris



Environmental monitoring and leachate management



Regulatory compliance in accordance with F.A.C. Chapter 62-701

Waste Pro maintains an active disposal agreement with Santa Rosa County and ensures all transferred waste will be managed within applicable laws and permit conditions. Disposal records are tracked via daily tickets and monthly tonnage logs submitted to the County and available for Town review upon request.

Transportation & Logistics

Waste Pro will haul collected waste directly from Century routes to Santa Rosa Landfill using GPS-tracked vehicles. All transport activities follow U.S. DOT hauling standards and Escambia County Solid Waste Ordinance Chapter 82 requirements. Safety protocols and alternate routing plans are in place to minimize disruptions during inclement weather or high-volume periods.

Licensing & Documentation

As required by the RFP, Waste Pro affirms:



A valid **Certificate of Need** will be maintained through Escambia County



An active **Solid Waste Management Permit** will be kept on file



All disposal agreements and tipping fee records can be provided upon request



The designated landfill site complies fully with the disposal provisions outlined in Section 3 of the RFP Scope of Services



WASTE & RECYCLING NEWS

MAY 2, 2011

Crain's News Source for Environmental Management

Waste Pro keeps it simple



Waste Pro USA Inc. CEO John J. Jennings said he believes in maintaining the company's core values even as his Longwood, Fla.-based solid waste management company continues to rapidly expand.

By Jim Johnson

Waste Pro USA Inc. is far from the single-truck operation that started a decade ago. With sales topping \$400 million annually, the company now has operations in seven southern states, running more than 1,400 trucks, employing 2,400 people and servicing 7.4 million customers.

locations to maintain and promote company beliefs. "As we grow, we want to make sure that we're able to maintain and keep that active culture going that really has been a part of our success," Jennings said. "I started the company really with the idea of keeping it simple. And what do we really mean by simple? We mean, keep it simple and

been working with Jennings for about a quarter of a century in the trash business, even before the creation of Waste Pro. Traveling from his home base of Athens, Ga., Wood will hit the road a week or two at a time to talk to employees about company culture. "We do believe that our employees are



TAB 8
DISPOSAL FACILITY PLAN





TAB 9

FORMS AND EXHIBITS

Waste Pro keeps it simple



Waste Pro USA Inc. CEO John J. Jennings said he believes in maintaining the company's core values even as his Longwood, Fla.-based solid waste management company continues to rapidly expand.

By Jim Johnson

Waste Pro USA Inc. is far from the single-truck operation that started a decade ago. With sales topping \$400 million annually, the company now has operations in seven southern states, running more than 1,400 trucks, employing 2,400 people and servicing 7.7 million customers.

locations to maintain and promote company beliefs.

"As we grow, we want to make sure that we're able to maintain and keep that culture going that really has been a part of our success," Jennings said.

"I started the company really with the idea of keeping it simple. And what do we really mean by 'it'?" He says. "It's simple and

been working with Jennings for about a quarter of a century in the trash business, even before the creation of Waste Pro.

Traveling from his home base of Athens, Ga., Wood will hit the road a week or two at a time to talk to employees about company culture.

"It's the belief that our employees are



EXCLUSIVE FRANCHISE FOR SOLID WASTE COLLECTION AND RECYCLING SERVICES
TOWN OF CENTURY, FL | RFP NO. 2025-02

TAB 9
FORMS AND EXHIBITS

State of Florida

Department of State

I certify from the records of this office that WASTE PRO OF FLORIDA, INC. is a corporation organized under the laws of the State of Florida, filed on January 5, 2001.

The document number of this corporation is P01000003611.

I further certify that said corporation has paid all fees due this office through December 31, 2025, that its most recent annual report/uniform business report was filed on January 10, 2025, and that its status is active.

I further certify that said corporation has not filed Articles of Dissolution.

*Given under my hand and the
Great Seal of the State of Florida
at Tallahassee, the Capital, this
the Sixteenth day of July, 2025*



Secretary of State

Tracking Number: 8855703264CU

To authenticate this certificate, visit the following site, enter this number, and then follow the instructions displayed.

<https://services.sunbiz.org/Filings/CertificateOfStatus/CertificateAuthentication>

ESCAMBIA COUNTY BUSINESS TAX RECEIPT



Scott Lunsford
Escambia County Tax Collector
SANITATION SERVICE

WASTE PRO OF FLORIDA INC
5983 COMMERCE RD
MILTON, FL 32583

2024 / 2025

EXPIRES: SEPTEMBER 30, 2025

BUSINESS: WASTE PRO OF FLORIDA INC

ACCOUNT NO: 654411

OWNER NAME: WASTE PRO OF FLORIDA INC

LOCATION: ESCAMBIA COUNTY **GROUP TYPE:** 47170 **TOTAL:** 26.25

Paid 08/21/2024 **26.25**

This business tax receipt is in addition to and not in lieu of any other license required by law or local ordinance and is subject to regulations of zoning, health, contractor licensing, and other lawful authority.

THE ISSUANCE OF THIS RECEIPT DOES NOT ENSURE COMPETENCY

Scott Lunsford · Escambia County Tax Collector

EscambiaTaxCollector.com facebook.com/ECTaxCollector twitter.com/escambiatc

To renew, verify, or make address changes to your Business Tax Receipt, visit our payment center at EscambiaTaxCollector.com.

Contact our office by email at etc@EscambiaTaxCollector.com if any of the following changes occur with your business:

- Ownership
- Location
- Name

The law requires this business tax receipt to be displayed conspicuously at the place of business in such a manner that it can be open to the view of the public and subject to inspection by all duly authorized officers of the County.

All business tax receipts expire September 30 of each year.

Note: If your business is closing, an application for a Going Out of Business Permit may be required, along with the surrender of your original business tax receipt and payment of any outstanding tangible tax liability for the business. This provision also applies to fire sales.

BUSINESS OWNER: You may be eligible to use the installment plan to help manage your cash flow and pay your tangible personal property taxes. More information is available at EscambiaTaxCollector.com.

A business tax receipt is in addition to and not in lieu of any other license required by law or local ordinance and is subject to regulations of zoning, health, contractor licensing, and any other lawful authority.



PERMIT NUMBER 129

**ESCAMBIA COUNTY
BOARD OF COUNTY COMMISSIONERS
WASTE SERVICES
PENSACOLA, FLORIDA**

This certifies that Waste Pro of Florida
at 5859 Commerce Rd. Milton FL 32583
owned or operated by Waste Pro of Florida

has submitted the information as required under County Ordinance 85-7, and the Department of Solid Waste management has found such documents to conform with the provisions in this Ordinance. It is hereby declared that the person named above is granted a permit to operate a solid waste management activity in Escambia County, Florida consistent with the provisions of Escambia County Code of Ordinances Chapter 82.

Granted this 24th day of July 2025,

Andy Liess, Department Director

Permit Expires: August 1, 2026



Company ID Number: 32855

Client Company ID Number: 788343

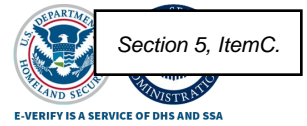

THE E-VERIFY MEMORANDUM OF UNDERSTANDING FOR EMPLOYERS USING A WEB SERVICES E-VERIFY EMPLOYER AGENT

ARTICLE I PURPOSE AND AUTHORITY

The parties to this agreement are the Department of Homeland Security (DHS), the (Employer), and the Web Services E-Verify Employer Agent. The purpose of this agreement is to set forth terms and conditions which the Employer and the Web Services E-Verify Employer Agent will follow while participating in E-Verify.

E-Verify is a program that electronically confirms an employee’s eligibility to work in the United States after completion of Form I-9, Employment Eligibility Verification (Form I-9). This Memorandum of Understanding (MOU) explains certain features of the E-Verify program and describes specific responsibilities of the Employer, the E-Verify Employer Agent, the Social Security Administration (SSA), and DHS.

References in this MOU to the Employer include the Web Services E-Verify Employer Agent when acting on behalf of the Employer.

For purposes of this MOU, the E-Verify browser refers to the website that provides direct access to the E-Verify system: <https://E-Verify.uscis.gov/emp/>. You may access E-Verify directly free of charge via the E-Verify browser.

Authority for the E-Verify program is found in Title IV, Subtitle A, of the Illegal Immigration Reform and Immigrant Responsibility Act of 1996 (IIRIRA), Pub. L. 104-208, 110 Stat. 3009, as amended (8 U.S.C. § 1324a note). The Federal Acquisition Regulation (FAR) Subpart 22.18, “Employment Eligibility Verification” and Executive Order 12989, as amended, provide authority for Federal contractors and subcontractors (Federal contractor) to use E-Verify to verify the employment eligibility of certain employees working on Federal contracts.

ARTICLE II RESPONSIBILITIES

A. RESPONSIBILITIES OF THE EMPLOYER

For purposes of this MOU, references to the Employer include the Web Services E-Verify Employer Agent when acting on behalf of the Employer.

1. By enrolling in E-Verify and signing the applicable MOU, the Employer asserts that it is a legitimate company which intends to use E-Verify for legitimate purposes only and in accordance with the laws, regulations and DHS policies and procedures relating to the use of E-Verify.

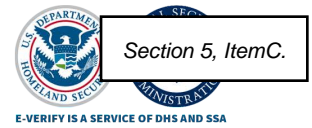

Company ID Number: 32855

Client Company ID Number: 788343

2. The Employer agrees to display the following notices supplied by DHS (though the Web Services E-Verify Employer Agent) in a prominent place that is clearly visible to prospective employees and all employees who are to be verified through the system:

- a. Notice of E-Verify Participation
- b. Notice of Right to Work

3. The Employer agrees to provide to the SSA and DHS the names, titles, addresses, and telephone numbers of the Employer representatives to be contacted about E-Verify. The Employer also agrees to keep such information current by providing updated information to SSA and DHS whenever the representatives' contact information changes.

4. The Employer agrees to become familiar with and comply with the most recent version of the

E-Verify User Manual. The Employer will obtain the E-Verify User Manual from the Web Services E-Verify Employer Agent, and will be notified by the Web Services E-Verify Employer Agent when a new version of the E-Verify User Manual becomes available.

5. The Employer agrees to comply with current Form I-9 procedures, with two exceptions:

- a. If an employee presents a "List B" identity document, the Employer agrees to only accept "List B" documents that contain a photo. (List B documents identified in 8 C.F.R. 274a.2(b)(1)(B)) can be presented during the Form I-9 process to establish identity.) If an employee objects to the photo requirement for religious reasons, the Employer should contact E-Verify at 888-464-4218.
- b. If an employee presents a DHS Form I-551 (Permanent Resident Card), Form I-766 (Employment Authorization Document), or U.S. Passport or Passport Card to complete Form I-9, the Employer agrees to make a photocopy of the document and to retain the photocopy with the employee's Form I-9. The Employer will use the photocopy to verify the photo and to assist DHS with its review of photo mismatches that employees contest. DHS may in the future designate other documents that activate the photo screening tool.

Note: Subject only to the exceptions noted previously in this paragraph, employees still retain the right to present any List A, or List B and List C, document(s) to complete the Form I-9.

6. The Employer agrees to record the case verification number on the employee's Form I-9 or to print the screen containing the case verification number and attach it to the employee's Form I-9.

7. The Employer agrees that, although it participates in E-Verify, the Employer has a responsibility to complete, retain, and make available for inspection Forms I-9 that relate to its employees, or from other requirements of applicable regulations or laws, including the obligation to comply with the antidiscrimination requirements of section 274B of the INA with respect to Form I-9 procedures.

- a. The following modified requirements are the only exceptions to an Employer's obligation to not employ unauthorized workers and comply with the anti-discrimination provision of the INA: (1) List B identity documents must have photos, as described in paragraph 6 above; (2) When an Employer confirms the identity and employment eligibility of newly hired employee using E-Verify procedures, the Employer establishes a rebuttable presumption that it has not violated section 274A(a)(1)(A) of

Company ID Number: 32855

Client Company ID Number: 788343

the Immigration and Nationality Act (INA) with respect to the hiring of that employee; (3) If the Employer receives a final nonconfirmation for an employee, but continues to employ that person, the Employer must notify DHS and the Employer is subject to a civil money penalty between \$550 and \$1,100 for each failure to notify DHS of continued employment following a final nonconfirmation; (4) If the Employer continues to employ an employee after receiving a final nonconfirmation, then the Employer is subject to a rebuttable presumption that it has knowingly employed an unauthorized alien in violation of section 274A(a)(1)(A); and (5) no E-Verify participant is civilly or criminally liable under any law for any action taken in good faith based on information provided through the E-Verify.

b. DHS reserves the right to conduct Form I-9 compliance inspections, as well as any other enforcement or compliance activity authorized by law, including site visits, to ensure proper use of E-Verify.

8. The Employer is strictly prohibited from creating an E-Verify case before the employee has been hired, meaning that a firm offer of employment was extended and accepted and Form I-9 was completed. The Employer agrees to create an E-Verify case for new employees within three Employer business days after each employee has been hired (after both Sections 1 and 2 of Form I-9 have been completed), and to complete as many steps of the E-Verify process as are necessary according to the E-Verify User Manual. If E-Verify is temporarily unavailable, the three-day time period will be extended until it is again operational in order to accommodate the Employer's attempting, in good faith, to make inquiries during the period of unavailability.

9. The Employer agrees not to use E-Verify for pre-employment screening of job applicants, in support of any unlawful employment practice, or for any other use that this MOU or the E-Verify User Manual does not authorize.

10. The Employer must use E-Verify (through its Web Services E-Verify Employer Agent) for all new employees. The Employer will not verify selectively and will not verify employees hired before the effective date of this MOU. Employers who are Federal contractors may qualify for exceptions to this requirement as described in Article II.B of this MOU.

11. The Employer agrees to follow appropriate procedures (see Article III below) regarding tentative nonconfirmations. The Employer must promptly notify employees in private of the finding and provide them with the notice and letter containing information specific to the employee's E-Verify case. The Employer agrees to provide both the English and the translated notice and letter for employees with limited English proficiency to employees. The Employer agrees to provide written referral instructions to employees and instruct affected employees to bring the English copy of the letter to the SSA. The Employer must allow employees to contest the finding, and not take adverse action against employees if they choose to contest the finding, while their case is still pending. Further, when employees contest a tentative nonconfirmation based upon a photo mismatch, the Employer must take additional steps (see Article III.B below) to contact DHS with information necessary to resolve the challenge.

12. The Employer agrees not to take any adverse action against an employee based upon the employee's perceived employment eligibility status while SSA or DHS is processing the verification request unless the Employer obtains knowledge (as defined in 8 C.F.R. § 274a.1(l)) that the employee is not work authorized. The Employer understands that an initial inability of the SSA or DHS automated

Company ID Number: 32855

Client Company ID Number: 788343

verification system to verify work authorization, a tentative nonconfirmation, a case in continuance (indicating the need for additional time for the government to resolve a case), or the finding of a photo mismatch, does not establish, and should not be interpreted as, evidence that the employee is not work authorized. In any of such cases, the employee must be provided a full and fair opportunity to contest the finding, and if he or she does so, the employee may not be terminated or suffer any adverse employment consequences based upon the employee's perceived employment eligibility status (including denying, reducing, or extending work hours, delaying or preventing training, requiring an employee to work in poorer conditions, withholding pay, refusing to assign the employee to a Federal contract or other assignment, or otherwise assuming that he or she is unauthorized to work) until and unless secondary verification by SSA or DHS has been completed and a final nonconfirmation has been issued. If the employee does not choose to contest a tentative nonconfirmation or a photo mismatch or if a secondary verification is completed and a final nonconfirmation is issued, then the Employer can find the employee is not work authorized and terminate the employee's employment. Employers or employees with questions about a final nonconfirmation may call E-Verify at 1-888-464-4218 (customer service) or 1-888-897-7781 (worker hotline).

13. The Employer agrees to comply with Title VII of the Civil Rights Act of 1964 and section 274B of the INA as applicable by not discriminating unlawfully against any individual in hiring, firing, employment eligibility verification, or recruitment or referral practices because of his or her national origin or citizenship status, or by committing discriminatory documentary practices. The Employer understands that such illegal practices can include selective verification or use of E-Verify except as provided in part D below, or discharging or refusing to hire employees because they appear or sound "foreign" or have received tentative nonconfirmations. The Employer further understands that any violation of the immigration-related unfair employment practices provisions in section 274B of the INA could subject the Employer to civil penalties, back pay awards, and other sanctions, and violations of Title VII could subject the Employer to back pay awards, compensatory and punitive damages. Violations of either section 274B of the INA or Title VII may also lead to the termination of its participation in E-Verify. If the Employer has any questions relating to the anti-discrimination provision, it should contact OSC at 1-800-255-8155 or 1-800-237-2515 (TDD).

14. The Employer agrees that it will use the information it receives from E-Verify (through its Web Services E-Verify Employer Agent) only to confirm the employment eligibility of employees as authorized by this MOU. The Employer agrees that it will safeguard this information, and means of access to it (such as Personal Identification Numbers and passwords), to ensure that it is not used for any other purpose and as necessary to protect its confidentiality, including ensuring that it is not disseminated to any person other than employees of the Employer who are authorized to perform the Employer's responsibilities under this MOU, except for such dissemination as may be authorized in advance by SSA or DHS for legitimate purposes.

15. The Employer agrees to notify DHS immediately in the event of a breach of personal information. Breaches are defined as loss of control or unauthorized access to E-Verify personal data. All suspected or confirmed breaches should be reported by calling 1-888-464-4218 or via email at E-Verify@uscis.dhs.gov. Please use "Privacy Incident – Password" in the subject line of your email when sending a breach report to E-Verify.

16. The Employer acknowledges that the information it receives from SSA through its Web Services

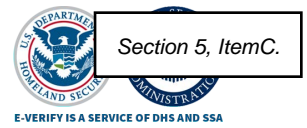

Company ID Number: 32855

Client Company ID Number: 788343

E-Verify Employer Agent is governed by the Privacy Act (5 U.S.C. § 552a(i)(1) and (3)) and the Social Security Act (42 U.S.C. 1306(a)). Any person who obtains this information under false pretenses or uses it for any purpose other than as provided for in this MOU may be subject to criminal penalties.

17. The Employer agrees to cooperate with DHS and SSA in their compliance monitoring and evaluation of E-Verify, which includes permitting DHS, SSA, their contractors and other agents, upon reasonable notice, to review Forms I-9 and other employment records and to interview it and its employees regarding the Employer’s use of E-Verify, and to respond in a prompt and accurate manner to DHS requests for information relating to their participation in E-Verify.

18. The Employer shall not make any false or unauthorized claims or references about its participation in E-Verify on its website, in advertising materials, or other media. The Employer shall not describe its services as federally-approved, federally-certified, or federally-recognized, or use language with a similar intent on its website or other materials provided to the public. Entering into this MOU does not mean that E-Verify endorses or authorizes your E-Verify services and any claim to that effect is false.

19. The Employer shall not state in its website or other public documents that any language used therein has been provided or approved by DHS, USCIS or the Verification Division, without first obtaining the prior written consent of DHS.

20. The Employer agrees that [E-Verify trademarks](#) and logos may be used only under license by DHS/ USCIS (see [M-795 \(Web\)](#)) and, other than pursuant to the specific terms of such license, may not be used in any manner that might imply that the Employer’s services, products, websites, or publications are sponsored by, endorsed by, licensed by, or affiliated with DHS, USCIS, or E-Verify.

21. The Employer understands that if it uses E-Verify procedures for any purpose other than as authorized by this MOU, the Employer may be subject to appropriate legal action and termination of its participation in E-Verify according to this MOU.

B. RESPONSIBILITIES OF THE WEB SERVICES E-VERIFY EMPLOYER AGENT

1. The Web Services E-Verify Employer Agent agrees to complete its Web Services interface no later than six months after the date the Web Services User signs this MOU. E-Verify considers your interface to be complete once it has been built pursuant to the Interface Control Agreement (ICA), submitted to E-Verify for testing, and approved for system access.

2. The Web Services E-Verify Employer Agent agrees to perform sufficient maintenance on the Web Services interface in accordance with the requirements listed in the ICA. These requirements include, but are not limited to, updating the Web Services interface to ensure that any updates or enhancements are incorporated no later than six months after the issuance of an ICA. Web Services E-Verify Employer Agents should be aware that this will require the investment of time and resources. Compliance with the requirements of the ICA must be carried out to the satisfaction of DHS and or its assignees.

3. The Web Services E-Verify Employer Agent agrees to provide to SSA and/or DHS the names, titles, addresses, e-mail addresses, and telephone numbers of the Web Services E-Verify Employer Agent representative who will access information, as well as ensure cooperation, communication, and coordination with E-Verify.

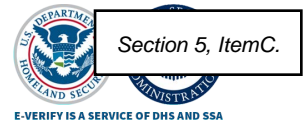

Company ID Number: 32855

Client Company ID Number: 788343

In addition, Web Services E-Verify Employer Agents must provide to SSA and/or DHS the names, titles, addresses, and telephone numbers of its clients and their staff who will access information through E-Verify. Web Services E-Verify Employer Agents must ensure the contact information is updated with SSA and DHS whenever the points of contact change.

4. The Web Services E-Verify Employer Agent agrees to become familiar with and comply with the E-Verify User Manual and provide a copy of the most current version of the manual to the Employer so that the Employer can become familiar with and comply with E-Verify policy and procedures. The Web Services E-Verify Employer Agent agrees to obtain a revised E-Verify User Manual as it becomes available and to provide a copy of the revised version to the Employer no later than 30 days after the manual becomes available.
5. The Web Services E-Verify Employer Agent agrees that any person accessing E-Verify on its behalf is trained on the most recent E-Verify policy and procedures.
6. The Web Services E-Verify Employer Agent agrees that any of its representatives who will perform employment verification cases will complete the E-Verify Tutorial before that individual initiates any cases.
 - a. The Web Services E-Verify Employer Agent agrees that all of its representatives will take the refresher tutorials initiated by E-Verify as a condition of continued use of E-Verify, including any tutorials for Federal contractors, if any of the Employers represented by the Web Services E-Verify Employer Agent is a Federal contractor.
 - b. Failure to complete a refresher tutorial will prevent the Web Services E-Verify Employer Agent and Employer from continued use of E-Verify.
7. The Web Services E-Verify Employer Agent agrees to grant E-Verify access only to current employees who need E-Verify access. The Web Services E-Verify Employer Agent must promptly terminate an employee’s E-Verify access if the employee is separated from the company or no longer needs access to E-Verify.
8. The Web Services E-Verify Employer Agent agrees to obtain the necessary equipment to use E-Verify as required by the E-Verify rules and regulations as modified from time to time.
9. The Web Services E-Verify Employer Agent agrees to, consistent with applicable laws, regulations, and policies, commit sufficient personnel and resources to meet the requirements of this MOU.
10. The Web Services E-Verify Employer Agent agrees to provide its clients with training on E-Verify processes, policies, and procedures. The E-Verify Employer Agent also agrees to provide its clients with ongoing E-Verify training as needed. E-Verify is not responsible for providing training to clients of E-Verify Employer Agents.
11. The Web Services E-Verify Employer Agent agrees to provide the Employer with the notices described in Article II.B.2 below.
12. The Web Services E-Verify Employer Agent agrees to create E-Verify cases for the Employer it represents in accordance with the E-Verify Manual, the E-Verify Web-Based Tutorial and all other published E-Verify

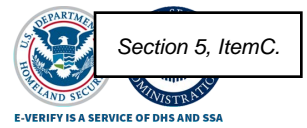

Company ID Number: 32855

Client Company ID Number: 788343

rules and procedures. The Web Services E-Verify Employer Agent will create E-Verify cases using information provided by the Employer and will immediately communicate the response back to the Employer. If E-Verify is temporarily unavailable, the three-day time period will be extended until it is again operational in order to accommodate the Web Services E-Verify Employer Agent’s attempting, in good faith, to make inquiries on behalf of the Employer during the period of unavailability. If, however, the Web Services interface is unavailable due to no fault of E-Verify, then the three-day time period is not extended. In such a case, the Web Services E-Verify Employer Agent must use the E-Verify browser during the outage.

13. The Web Services E-Verify Employer Agent agrees to ensure that all notices, referral letters and any other materials otherwise including instructions regarding tentative nonconfirmations, will be consistent with the most current E-Verify tentative nonconfirmation notices and referral letters, which are available on E-Verify’s website.

14. The Web Services E-Verify Employer Agent agrees that any system or interface it develops will follow the steps for creating E-Verify cases and processing tentative nonconfirmations, as laid out in the ICA, this MOU and the User Manual, including but not limited to allowing an employer to close an invalid case where appropriate, allowing an employer to refer a tentative nonconfirmation only when an employee chooses to contest a tentative nonconfirmation (no automatic referrals), and referring a tentative nonconfirmation to the appropriate agency at the time the employer prints the referral letter and provides the letter to the employee. The Web Services E-Verify Employer Agent understands that any failure to make its system or interface consistent with proper E-Verify procedures can result in DHS terminating the Web Services E-Verify Employer Agent’s agreement and access with or without notice.

15. When the Web Services E-Verify Employer Agent receives notice from a client company that it has received a contract with the FAR clause, then the Web Services E-Verify Employer Agent must update the company’s E-Verify profile within 30 days of the contract award date.

16. If data is transmitted between the Web Services E-Verify Employer Agent and its client, then the Web Services E-Verify Employer Agent agrees to protect personally identifiable information during transmission to and from the Web Services E-Verify Employer Agent.

17. The Web Services E-Verify Employer Agent agrees to notify DHS immediately in the event of a breach of personal information. Breaches are defined as loss of control or unauthorized access to E-Verify personal data. All suspected or confirmed breaches should be reported by calling 1-888-464-4218 or via email at E-Verify@uscis.dhs.gov. Please use “Privacy Incident – Password” in the subject line of your email when sending a breach report to E-Verify.

18. The Web Services E-Verify Employer Agent agrees to fully cooperate with DHS and SSA in their compliance monitoring and evaluation of E-Verify, including permitting DHS, SSA, their contractors and other agents, upon reasonable notice, to review Forms I-9, employment records, and all records pertaining to the Web Services E-Verify Employer Agent’s use of E-Verify, and to interview it and its employees regarding the use of E-Verify, and to respond in a timely and accurate manner to DHS requests for information relating to their participation in E-Verify.

a. The Web Services E-Verify Employer Agent agrees to cooperate with DHS if DHS requests

Company ID Number: 32855

Client Company ID Number: 788343

information about the Web Services E-Verify Employer Agent's interface, including requests by DHS to view the actual interface operated by the Web Services E-Verify Employer Agent as well as related business documents. The Web Services E-Verify Employer Agent agrees to demonstrate for DHS the functionality of its interface to E-Verify upon request.

b. The Web Services E-Verify Employer Agent agrees to demonstrate, if requested by DHS, that it has provided training to its clients that meets E-Verify standards. Training programs must provide a focused study of the topics covered in the E-Verify User Manual and pertinent Supplemental Guides. Furthermore, training programs and materials must be updated as E-Verify changes occur. The Web Services E-Verify Employer Agent is encouraged to incorporate information from existing E-Verify materials, including the Enrollment Quick Reference Guide, the E-Verify Employer Agent Client Handbook (formerly known as the Designated Agent Client Handbook), and existing tutorials and manuals into their training program. E-Verify also encourages the Web Services E-Verify Employer Agent to supervise first-time use of the E-Verify browser or Web Services interface by its staff and Employer clients as part of any training program. The Web Services E-Verify Employer Agent agrees to submit its training program materials to DHS for review upon request.

Failure to provide adequate training could, in some instances, lead to penalties as described in Article V.F.1. of this MOU.

19. The Web Services E-Verify Employer Agent shall not make any false or unauthorized claims or references about its participation in E-Verify on its website, in advertising materials, or other media. The Web Services E-Verify Employer Agent shall not describe its services as federally-approved, federally-certified, or federally-recognized, or use language with a similar intent on its website or other materials provided to the public. Entering into this MOU does not mean that E-Verify endorses or authorizes your Web Services E-Verify Employer Agent services and any claim to that effect is false.

20. The Web Services E-Verify Employer Agent shall not state in its website or other public documents that any language used therein has been provided or approved by DHS, USCIS or the Verification Division, without first obtaining the prior written consent of DHS.

21. The Web Services E-Verify Employer Agent agrees that [E-Verify trademarks](#) and logos may be used only under license by DHS/USCIS (see [M-795 \(Web\)](#)) and, other than pursuant to the specific terms of such license, may not be used in any manner that might imply that the Web Services E-Verify Employer Agent's services, products, websites, or publications are sponsored by, endorsed by, licensed by, or affiliated with DHS, USCIS, or E-Verify.

22. The Web Services E-Verify Employer Agent understands that if it uses E-Verify procedures for any purpose other than as authorized by this MOU, the Web Services E-Verify Employer Agent may be subject to appropriate legal action and termination of its participation in E-Verify according to this MOU.

C. RESPONSIBILITIES OF FEDERAL CONTRACTORS

The Web Services E-Verify Employer Agent shall ensure that the Web Services E-Verify Employer Agent and the Employers it represents carry out the following responsibilities if the Employer is a Federal contractor or becomes a federal contractor. The Web Services E-Verify Employer Agent should instruct the client to keep the Web Services E-Verify Employer Agent informed about any changes or updates related to federal contracts. It is the Web Services E-Verify Employer Agent's responsibility to ensure that its clients are in compliance



Company ID Number: 32855

Client Company ID Number: 788343

with all E-Verify policies and procedures.

1. If the Employer is a Federal contractor with the FAR E-Verify clause subject to the employment verification terms in Subpart 22.18 of the FAR, it will become familiar with and comply with the most current version of the E-Verify User Manual for Federal Contractors as well as the E-Verify Supplemental Guide for Federal Contractors.
2. In addition to the responsibilities of every employer outlined in this MOU, the Employer understands that if it is a Federal contractor subject to the employment verification terms in Subpart 22.18 of the FAR it must verify the employment eligibility of any “employee assigned to the contract” (as defined in FAR 22.1801). Once an employee has been verified through E-Verify by the Employer, the Employer may not reverify the employee through E-Verify.
 - a. An Employer that is not enrolled in E-Verify as a Federal contractor at the time of a contract award must enroll as a Federal contractor in the E-Verify program within 30 calendar days of contract award and, within 90 days of enrollment, begin to verify employment eligibility of new hires using E-Verify. The Employer must verify those employees who are working in the United States, whether or not they are assigned to the contract. Once the Employer begins verifying new hires, such verification of new hires must be initiated within three business days after the hire date. Once enrolled in E-Verify as a Federal contractor, the Employer must begin verification of employees assigned to the contract within 90 calendar days after the date of enrollment or within 30 days of an employee’s assignment to the contract, whichever date is later.
 - b. Employers enrolled in E-Verify as a Federal contractor for 90 days or more at the time of a contract award must use E-Verify to begin verification of employment eligibility for new hires of the Employer who are working in the United States, whether or not assigned to the contract, within three business days after the date of hire. If the Employer is enrolled in E-Verify as a Federal contractor for 90 calendar days or less at the time of contract award, the Employer must, within 90 days of enrollment, begin to use E-Verify to initiate verification of new hires of the contractor who are working in the United States, whether or not assigned to the contract. Such verification of new hires must be initiated within three business days after the date of hire. An Employer enrolled as a Federal contractor in E-Verify must begin verification of each employee assigned to the contract within 90 calendar days after date of contract award or within 30 days after assignment to the contract, whichever is later.
 - c. Federal contractors that are institutions of higher education (as defined at 20 U.S.C. 1001(a)), state or local governments, governments of Federally recognized Indian tribes, or sureties performing under a takeover agreement entered into with a Federal agency under a performance bond may choose to only verify new and existing employees assigned to the Federal contract. Such Federal contractors may, however, elect to verify all new hires, and/or all existing employees hired after November 6, 1986. Employers in this category must begin verification of employees assigned to the contract within 90 calendar days after the date of enrollment or within 30 days of an employee’s assignment to the contract, whichever date is later.
 - d. Upon enrollment, Employers who are Federal contractors may elect to verify employment eligibility of all existing employees working in the United States who were hired after November 6, 1986, instead of verifying only those employees assigned to a covered Federal contract. After enrollment, Employers must elect to verify existing staff following DHS procedures and begin E-Verify verification of all

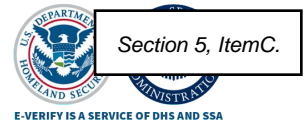

Company ID Number: 32855

Client Company ID Number: 788343

existing employees within 180 days after the election.

e. The Employer may use a previously completed Form I-9 as the basis for creating an E-Verify case for an employee assigned to a contract as long as:

- i. That Form I-9 is complete (including the SSN) and complies with Article II.A.6,
- ii. The employee's work authorization has not expired, and
- iii. The Employer has reviewed the information reflected in the Form I-9 either in person or in communications with the employee to ensure that the employee's Section 1, Form I-9 attestation has not changed (including, but not limited to, a lawful permanent resident alien having become a naturalized U.S. citizen).

f. The Employer shall complete a new Form I-9 consistent with Article II.A.6 or update the previous Form I-9 to provide the necessary information if:

- i. The Employer cannot determine that Form I-9 complies with Article II.A.6,
- ii. The employee's basis for work authorization as attested in Section 1 has expired or changed, or
- iii. The Form I-9 contains no SSN or is otherwise incomplete.

Note: If Section 1 of Form I-9 is otherwise valid and up-to-date and the form otherwise complies with Article II.C.5, but reflects documentation (such as a U.S. passport or Form I-551) that expired after completing Form I-9, the Employer shall not require the production of additional documentation, or use the photo screening tool described in Article II.A.5, subject to any additional or superseding instructions that may be provided on this subject in the E-Verify User Manual.

g. The Employer agrees not to require a second verification using E-Verify of any assigned employee who has previously been verified as a newly hired employee under this MOU or to authorize verification of any existing employee by any Employer that is not a Federal contractor based on this Article.

3. The Employer understands that if it is a Federal contractor, its compliance with this MOU is a performance requirement under the terms of the Federal contract or subcontract, and the Employer consents to the release of information relating to compliance with its verification responsibilities under this MOU to contracting officers or other officials authorized to review the Employer's compliance with Federal contracting requirements.

D. RESPONSIBILITIES OF SSA

1. SSA agrees to allow DHS to compare data provided by the Employer (through the E-Verify Employer Agent) against SSA's database. SSA sends DHS confirmation that the data sent either matches or does not match the information in SSA's database.
2. SSA agrees to safeguard the information the Employer provides (through the E-Verify Employer Agent) through E-Verify procedures. SSA also agrees to limit access to such information, as is appropriate by law, to individuals responsible for the verification of Social Security numbers or responsible for evaluation of E-Verify or such other persons or entities who may be authorized by SSA as governed by the Privacy Act (5 U.S.C. § 552a), the Social Security Act (42 U.S.C. 1306(a)), and SSA regulations (20 CFR Part 401).

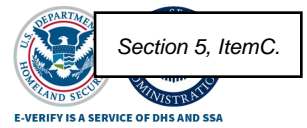

Company ID Number: 32855

Client Company ID Number: 788343

3. SSA agrees to provide case results from its database within three Federal Government work days of the initial inquiry. E-Verify provides the information to the E-Verify Employer Agent.
4. SSA agrees to update SSA records as necessary if the employee who contests the SSA tentative nonconfirmation visits an SSA field office and provides the required evidence. If the employee visits an SSA field office within the eight Federal Government work days from the date of referral to SSA, SSA agrees to update SSA records, if appropriate, within the eight-day period unless SSA determines that more than eight days may be necessary. In such cases, SSA will provide additional instructions to the employee. If the employee does not visit SSA in the time allowed, E-Verify may provide a final nonconfirmation to the E-Verify Employer Agent.

Note: If an Employer experiences technical problems, or has a policy question, the employer should contact E-Verify at 1-888-464-4218.

E. RESPONSIBILITIES OF DHS

1. DHS agrees to provide the Employer with selected data from DHS databases to enable the Employer (through the E-Verify Employer Agent) to conduct, to the extent authorized by this MOU:
 - a. Automated verification checks on alien employees by electronic means, and
 - b. Photo verification checks (when available) on employees.
2. DHS agrees to assist the E-Verify Employer Agent with operational problems associated with its participation in E-Verify. DHS agrees to provide the E-Verify Employer Agent names, titles, addresses, and telephone numbers of DHS representatives to be contacted during the E-Verify process.
3. DHS agrees to provide to the E-Verify Employer Agent with access to E-Verify training materials as well as an E-Verify User Manual that contain instructions on E-Verify policies, procedures, and requirements for both SSA and DHS, including restrictions on the use of E-Verify.
4. DHS agrees to train E-Verify Employer Agents on all important changes made to E-Verify through the use of mandatory refresher tutorials and updates to the E-Verify User Manual. Even without changes to E-Verify, DHS reserves the right to require E-Verify Employer Agents to take mandatory refresher tutorials.
5. DHS agrees to provide to the Employer (through the E-Verify Employer Agent) a notice, which indicates the Employer's participation in E-Verify. DHS also agrees to provide to the Employer anti-discrimination notices issued by the Office of Special Counsel for Immigration-Related Unfair Employment Practices (OSC), Civil Rights Division, U.S. Department of Justice.
6. DHS agrees to issue each of the E-Verify Employer Agent's E-Verify users a unique user identification number and password that permits them to log in to E-Verify.
7. DHS agrees to safeguard the information the Employer provides (through the E-Verify Employer Agent), and to limit access to such information to individuals responsible for the verification process, for evaluation of E-Verify, or to such other persons or entities as may be authorized by applicable law. Information will be used only to verify the accuracy of Social Security numbers and employment eligibility, to enforce the INA and Federal criminal laws, and to administer Federal contracting requirements.

Company ID Number: 32855

Client Company ID Number: 788343

8. DHS agrees to provide a means of automated verification that provides (in conjunction with SSA verification procedures) confirmation or tentative nonconfirmation of employees' employment eligibility within three Federal Government work days of the initial inquiry.
9. DHS agrees to provide a means of secondary verification (including updating DHS records) for employees who contest DHS tentative nonconfirmations and photo mismatch tentative nonconfirmations. This provides final confirmation or nonconfirmation of the employees' employment eligibility within 10 Federal Government work days of the date of referral to DHS, unless DHS determines that more than 10 days may be necessary. In such cases, DHS will provide additional verification instructions.

ARTICLE III REFERRAL OF INDIVIDUALS TO SSA AND DHS

A. REFERRAL TO SSA

1. If the Employer receives a tentative nonconfirmation issued by SSA, the Employer must print the notice as directed by E-Verify. The Employer must promptly notify employees in private of the finding and provide them with the notice and letter containing information specific to the employee's E-Verify case. The Employer also agrees to provide both the English and the translated notice and letter for employees with limited English proficiency to employees. The Employer agrees to provide written referral instructions to employees and instruct affected employees to bring the English copy of the letter to the SSA. The Employer must allow employees to contest the finding, and not take adverse action against employees if they choose to contest the finding, while their case is still pending.
2. The Employer agrees to obtain the employee's response about whether he or she will contest the tentative nonconfirmation as soon as possible after the Employer receives the tentative nonconfirmation. Only the employee may determine whether he or she will contest the tentative nonconfirmation.
3. After a tentative nonconfirmation, the Employer will refer employees to SSA field offices only as directed by E-Verify. The Employer must record the case verification number, review the employee information submitted to E-Verify to identify any errors, and find out whether the employee contests the tentative nonconfirmation. The Employer will transmit the Social Security number, or any other corrected employee information that SSA requests, to SSA for verification again if this review indicates a need to do so.
4. The Employer will instruct the employee to visit an SSA office within eight Federal Government work days. SSA will electronically transmit the result of the referral to the Employer within 10 Federal Government work days of the referral unless it determines that more than 10 days is necessary.
5. While waiting for case results, the Employer agrees to check the E-Verify system regularly for case updates.
6. The Employer agrees not to ask the employee to obtain a printout from the Social Security Administration number database (the Numident) or other written verification of the SSN from the SSA.

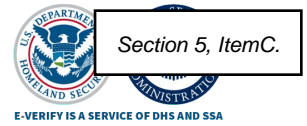

Company ID Number: 32855

Client Company ID Number: 788343

B. REFERRAL TO DHS

1. If the Employer receives a tentative nonconfirmation issued by DHS, the Employer must promptly notify employees in private of the finding and provide them with the notice and letter containing information specific to the employee's E-Verify case. The Employer also agrees to provide both the English and the translated notice and letter for employees with limited English proficiency to employees. The Employer must allow employees to contest the finding, and not take adverse action against employees if they choose to contest the finding, while their case is still pending.
2. The Employer agrees to obtain the employee's response about whether he or she will contest the tentative nonconfirmation as soon as possible after the Employer receives the tentative nonconfirmation. Only the employee may determine whether he or she will contest the tentative nonconfirmation.
3. The Employer agrees to refer individuals to DHS only when the employee chooses to contest a tentative nonconfirmation.
4. If the employee contests a tentative nonconfirmation issued by DHS, the Employer will instruct the employee to contact DHS through its toll-free hotline (as found on the referral letter) within eight Federal Government work days.
5. If the Employer finds a photo mismatch, the Employer must provide the photo mismatch tentative nonconfirmation notice and follow the instructions outlined in paragraph 1 of this section for tentative nonconfirmations, generally.
6. The Employer agrees that if an employee contests a tentative nonconfirmation based upon a photo mismatch, the Employer will send a copy of the employee's Form I-551, Form I-766, U.S. Passport, or passport card to DHS for review by:
 - a. Scanning and uploading the document, or
 - b. Sending a photocopy of the document by express mail (furnished and paid for by the employer).
7. The Employer understands that if it cannot determine whether there is a photo match/mismatch, the Employer must forward the employee's documentation to DHS as described in the preceding paragraph. The Employer agrees to resolve the case as specified by the DHS representative who will determine the photo match or mismatch.
8. DHS will electronically transmit the result of the referral to the Employer within 10 Federal Government work days of the referral unless it determines that more than 10 days is necessary.
9. While waiting for case results, the Employer agrees to check the E-Verify system regularly for case updates.



Company ID Number: 32855

Client Company ID Number: 788343

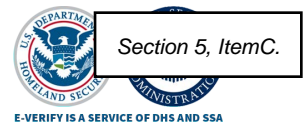

ARTICLE IV SERVICE PROVISIONS

A. NO SERVICE FEES

1. SSA and DHS will not charge the Employer or the Web Services E-Verify Employer Agent for verification services performed under this MOU. The Employer is responsible for providing equipment needed to make inquiries. To access E-Verify, an Employer will need a personal computer with Internet access.

ARTICLE V SYSTEM SECURITY AND MAINTENANCE

A. DEVELOPMENT REQUIREMENTS

1. Software developed by Web Services E-Verify Employer Agents must comply with federally-mandated information security policies and industry security standards to include but not limited to:

- a. Public Law 107-347, “E-Government Act of 2002, Title III, Federal Information Security Management Act (FISMA),” December 2002.
- b. Office of Management and Budget (OMB) Memorandum (M-10-15), “FY 2010 Reporting Instructions for the Federal Information Security Management Act and Agency Privacy Management,” April 2010.
- c. National Institute of Standards and Technology (NIST) Special Publication (SP) and Federal Information Processing Standards Publication (FIPS).
- d. International Organization for Standardization/International Electrotechnical Commission (ISO/IEC) 27002, Information Technology — Security Techniques — Code of Practice for Information Security Management.

2. The Web Services E-Verify Employer Agent agrees to update its Web Services interface to reflect system enhancements within six months from the date DHS notifies the Web Services User of the system update. The Web Services User will receive notice from DHS in the form of an Interface Control Agreement (ICA). The Web Services E-Verify Employer Agent agrees to institute changes to its interface as identified in the ICA, including all functionality identified and all data elements detailed therein.

3. The Web Services E-Verify Employer Agent agrees to demonstrate progress of its efforts to update its Web Services interface if and when DHS requests such progress reports.

4. The Web Services E-Verify Employer Agent acknowledges that if its system enhancements are not completed to the satisfaction of DHS or its assignees within six months from the date DHS notifies the Web Services User of the system update, then the Web Services User’s E-Verify account may be suspended, and support for previous releases of E-Verify may no longer be available to the Web Services User. The Web Services E-Verify Employer Agent also acknowledges that DHS may suspend the Web Services User’s account after the six-month period has elapsed.

5. The Web Services E-Verify Employer Agent agrees to incorporate error handling logic into its development or software to accommodate and act in a timely fashion should an error code be returned.

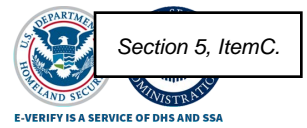

Company ID Number: 32855

Client Company ID Number: 788343

- 6. The Web Services E-Verify Employer Agent agrees to complete the technical requirements testing which is confirmed upon receiving approval of test data and connectivity between the Web Services E-Verify Employer Agent and DHS.
- 7. DHS will not reimburse any Web Services E-Verify Employer Agent or software developer who has expended resources in the development or maintenance of a Web Services interface if that party is unable, or becomes unable, to meet any of the requirements set forth in this MOU.
- 8. Housing, development, infrastructure, maintenance, and testing of the Web Services applications may take place outside the United States and its territories, but testing must be conducted to ensure that the code is correct and secure.
- 9. If the Web Services E-Verify Employer Agent includes an electronic Form I-9 as part of its interface, then it must comply with the standards for electronic retention of Form I-9 found in 8 CFR 274a.2(e).

B. INFORMATION SECURITY REQUIREMENTS

Web Services E-Verify Employer Agents performing verification services under this MOU must ensure that information that is shared between the Web Services E-Verify Employer Agent and DHS is appropriately protected comparable to the protection provided when the information is within the DHS environment [OMB Circular A-130 Appendix III].

To achieve this level of information security, the Web Services E-Verify Employer Agent agrees to institute the following procedures:

- 1. Conduct periodic assessments of risk, including the magnitude of harm that could result from the unauthorized access, use, disclosure, disruption, modification, or destruction of information and information systems that support the operations and assets of the DHS, SSA, and the Web Services E-Verify Employer Agent and its clients;
- 2. Develop policies and procedures that are based on risk assessments, cost-effectively reduce information security risks to an acceptable level, and ensure that information security is addressed throughout the life cycle of each organizational information system;
- 3. Implement subordinate plans for providing adequate information security for networks, facilities, information systems, or groups of information systems, as appropriate;
- 4. Conduct security awareness training to inform the Web Services E-Verify Employer Agent’s personnel (including contractors and other users of information systems that support the operations and assets of the organization) of the information security risks associated with their activities and their responsibilities in complying with organizational policies and procedures designed to reduce these risks;
- 5. Develop periodic testing and evaluation of the effectiveness of information security policies, procedures, practices, and security controls to be performed with a frequency depending on risk, but no less than once per year;

Company ID Number: 32855

Client Company ID Number: 788343

6. Develop a process for planning, implementing, evaluating, and documenting remedial actions to address any deficiencies in the information security policies, procedures, and practices of the organization;
7. Implement procedures for detecting, reporting, and responding to security incidents;
8. Create plans and procedures to ensure continuity of operations for information systems that support the operations and assets of the organization;
9. In information-sharing environments, the information owner is responsible for establishing the rules for appropriate use and protection of the subject information and retains that responsibility even when the information is shared with or provided to other organizations [NIST SP 800-37].
10. DHS reserves the right to restrict Web Services calls from certain IP addresses.
11. DHS reserves the right to audit the Web Services E-Verify Employer Agent's application.
12. Web Services E-Verify Employer Agents and Software Developers agree to cooperate willingly with the DHS assessment of information security and privacy practices used by the company to develop and maintain the software.

C. DATA PROTECTION AND PRIVACY REQUIREMENTS

1. Web Services E-Verify Employer Agents must practice proper Internet security; this means using HTTP over SSL/TLS (also known as HTTPS) when accessing DHS information resources such as E-Verify [NIST SP 800-95]. Internet security practices like this are necessary because Simple Object Access Protocol (SOAP), which provides a basic messaging framework on which Web Services can be built, allows messages to be viewed or modified by attackers as messages traverse the Internet and is not independently designed with all the necessary security protocols for E-Verify use.
2. In accordance with DHS standards, the Web Services E-Verify Employer Agent agrees to maintain physical, electronic, and procedural safeguards to appropriately protect the information shared under this MOU against loss, theft, misuse, unauthorized access, and improper disclosure, copying use, modification or deletion.
3. Any data transmission requiring encryption shall comply with the following standards:
 - Products using FIPS 197 Advanced Encryption Standard (AES) algorithms with at least 256-bit encryption that has been validated under FIPS 140-2.
 - NSA Type 2 or Type 1 encryption.
4. User ID Management (Set Standard): All information exchanged between the parties under this MOU will be done only through authorized Web Services E-Verify Employer Agent representatives identified above.
5. The Web Services E-Verify Employer Agent agrees to use the E-Verify browser instead of its own interface if it has not yet upgraded its interface to comply with the Federal Acquisition Regulation (FAR) system changes. In addition, Web Services E-Verify Employer Agents whose interfaces do not support the Form I-9 from 2/2/2009 or 8/7/2009 should also use the E-Verify browser until the system upgrade is completed.

Company ID Number: 32855

Client Company ID Number: 788343

6. The Web Services E-Verify Employer Agent agrees to use the E-Verify browser instead of its own interface if it has not completed updates to its system within six months from the date DHS notifies the Web Services E-Verify Employer Agent of the system update. The Web Services E-Verify Employer Agent can resume use of its interface once it is up-to-date, unless the Web Services E-Verify Employer Agent has been suspended or terminated from continued use of the system.

D. COMMUNICATIONS

1. Web Services E-Verify Employer Agents and Software Developers agree to develop an electronic system that is not subject to any agreement that would restrict access to and use of by an agency of the United States.
2. The Web Services E-Verify Employer Agent agrees to develop effective controls to ensure the integrity, accuracy and reliability of its electronic system.
3. The Web Services E-Verify Employer Agent agrees to develop an inspection and quality assurance program that regularly, at least once per year, evaluates the electronic system, and includes periodic checks of electronically stored information. The Web Services E-Verify Employer Agent agrees to share the results of its regular inspection and quality assurance program with DHS upon request.
4. The Web Services E-Verify Employer Agent agrees to develop an electronic system with the ability to produce legible copies of applicable notices, letters, etc.
5. All information exchanged between the parties under this MOU will be in accordance with applicable laws, regulations, and policies, including but not limited to, information security guidelines of the sending party with respect to any information that is deemed Personally Identifiable Information (PII), including but not limited to the employee or applicant's Social Security number, alien number, date of birth, or other information that may be used to identify the individual.
6. Suspected and confirmed information security breaches must be reported to DHS according to Article II.A.17. Reporting such breaches does not relieve the Web Services E-Verify Employer Agent from further requirements as directed by state and local law. The Web Services E-Verify Employer Agent is subject to applicable state laws regarding data protection and incident reporting in addition to the requirements herein.

E. SOFTWARE DEVELOPER RESTRICTIONS

1. The Web Services E-Verify Employer Agent agrees that if it develops a Web Services interface and sells such interface, then it can be held liable for any misuse by the company that purchases the interface. It is the responsibility of the Web Services E-Verify Employer Agent to ensure that its interface is used in accordance with E-Verify policies and procedures.
2. The Web Services E-Verify Employer Agent agrees to provide software updates to each client who purchases its software. Because of the frequency Web Services updates, an ongoing relationship between the software developer and the client is necessary.

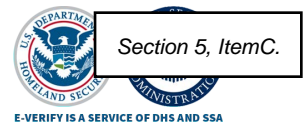

Company ID Number: 32855

Client Company ID Number: 788343

- 3. DHS reserves the right to terminate the access of any software developer with or without notice who creates or uses an interface that does not comply with E-Verify procedures.
- 4. Web Services Software Developers pursuing software development independent of serving clients as a Web Services E-Verify Employer Agent are not eligible to receive an ICA. At this time, E-Verify does not permit Web Services software development without also being a Web Services E-Verify Employer Agent or Web Services Employer.

F. PENALTIES

- 1. The Web Services E-Verify Employer Agent agrees that any failure on its part to comply with the terms of the MOU may result in account suspension, termination, or other adverse action.
- 2. DHS is not liable for any financial losses to Web Services E-Verify Employer Agent, its clients, or any other party as a result of your account suspension or termination.

**ARTICLE VI
MODIFICATION AND TERMINATION**

A. MODIFICATION

- 1. This MOU is effective upon the signature of all parties and shall continue in effect for as long as the SSA and DHS operates the E-Verify program unless modified in writing by the mutual consent of all parties.
- 2. Any and all E-Verify system enhancements by DHS or SSA, including but not limited to E-Verify checking against additional data sources and instituting new verification policies or procedures, will be covered under this MOU and will not cause the need for a supplemental MOU that outlines these changes.

B. TERMINATION

- 1. The Web Services E-Verify Employer Agent may terminate this MOU and its participation in E-Verify at any time upon 30 days prior written notice to the other parties. In addition, any Employer represented by the Web Services E-Verify Employer Agent may voluntarily terminate its MOU upon giving DHS 30 days' written notice. The Web Services E-Verify Employer Agent may not refuse to terminate the Employer based upon an outstanding bill for verification services.
- 2. Notwithstanding Article V, part A of this MOU, DHS may terminate this MOU, and thereby the Web Services E-Verify Employer Agent's participation in E-Verify, with or without notice at any time if deemed necessary because of the requirements of law or policy, or upon a determination by SSA or DHS that there has been a breach of system integrity or security by the Web Services E-Verify Employer Agent or Employer, or a failure on the part of either party to comply with established E-Verify procedures and/or legal requirements. The Employer understands that if it is a Federal contractor, termination of this MOU by any party for any reason may negatively affect the performance of its contractual responsibilities. Similarly, the Employer understands that if it is in a state where E-Verify is mandatory, termination of this by any party MOU may negatively affect the Employer's business.

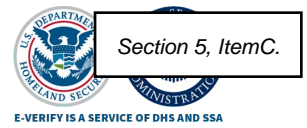

Company ID Number: 32855

Client Company ID Number: 788343

3. A Web Services E-Verify Employer Agent for an Employer that is a Federal contractor may terminate this MOU when the Federal contract that requires its participation in E-Verify is terminated or completed. In such cases, the Web Services E-Verify Employer Agent must provide written notice to DHS. If the Web Services E-Verify Employer Agent fails to provide such notice, then that Employer will remain an E-Verify participant, will remain bound by the terms of this MOU that apply to non-Federal contractor participants, and will be required to use the E-Verify procedures to verify the employment eligibility of all newly hired employees.

4. The Web Services E-Verify Employer Agent agrees that E-Verify is not liable for any losses, financial or otherwise, if the Web Services E-Verify Employer Agent or the Employer is terminated from E-Verify.

ARTICLE VII PARTIES

A. Some or all SSA and DHS responsibilities under this MOU may be performed by contractor(s), and SSA and DHS may adjust verification responsibilities between each other as necessary. By separate agreement with DHS, SSA has agreed to perform its responsibilities as described in this MOU.

B. Nothing in this MOU is intended, or should be construed, to create any right or benefit, substantive or procedural, enforceable at law by any third party against the United States, its agencies, officers, or employees, or against the Web Services E-Verify Employer Agent, its agents, officers, or employees.

C. The Web Services E-Verify Employer Agent may not assign, directly or indirectly, whether by operation of law, change of control or merger, all or any part of its rights or obligations under this MOU without the prior written consent of DHS, which consent shall not be unreasonably withheld or delayed. Any attempt to sublicense, assign, or transfer any of the rights, duties, or obligations herein is void.

D. Each party shall be solely responsible for defending any claim or action against it arising out of or related to E-Verify or this MOU, whether civil or criminal, and for any liability wherefrom, including (but not limited to) any dispute between the Web Services E-Verify Employer Agent or the Employer and any other person or entity regarding the applicability of Section 403(d) of IIRIRA to any action taken or allegedly taken by the Web Services E-Verify Employer Agent or the Employer.

E. The Web Services E-Verify Employer Agent understands that its participation in E-Verify is not confidential information and may be disclosed as authorized or required by law and DHS or SSA policy, including but not limited to, Congressional oversight, E-Verify publicity and media inquiries, determinations of compliance with Federal contractual requirements, and responses to inquiries under the Freedom of Information Act (FOIA).

F. The individuals whose signatures appear below represent that they are authorized to enter into this MOU on behalf of the Employer, the Web Services E-Verify Employer Agent and DHS respectively. The Web Services E-Verify Employer Agent understands that any inaccurate statement, representation, data or other information provided to DHS may subject the Web Services E-Verify Employer Agent, as the case may be, its subcontractors, its employees, or its representatives to: (1) prosecution for false statements pursuant to 18 U.S.C. 1001 and/or; (2) immediate termination of its MOU and/or; (3) possible debarment or suspension.

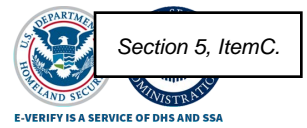

Company ID Number: 32855

Client Company ID Number: 788343

G. The foregoing constitutes the full agreement on this subject between DHS, the Employer, and the E-Verify Employer Agent.
(Employer) hereby designates and appoint
(E-Verify Employer Agent) including its officers and employees,
as the E-Verify Employer Agent for the purpose of carrying out (Employer) responsibilities under the MOU
between the Employer, the E-Verify Employer Agent, and DHS.
If you have any questions, contact E-Verify at 1-888-464-4218.

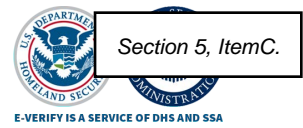

Company ID Number: 32855

Client Company ID Number: 788343

Approved by:

Employer Waste Pro USA, Inc.	
Name (Please Type or Print) Joyce Embley	Title
Signature Electronically Signed	Date 06/06/2014
E-Verify Employer Agent ADP, Inc.	
Name (Please Type or Print) Joyce Embley	Title
Signature Electronically Signed	Date 06/06/2014
Department of Homeland Security – Verification Division	
Name (Please Type or Print) USCIS Verification Division	Title
Signature Electronically Signed	Date 06/17/2014

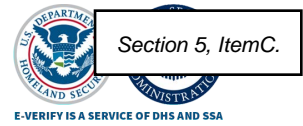

Company ID Number: 32855

Client Company ID Number: 788343

Information Required for the E-Verify Program	
Information relating to your Company:	
Company Name	Waste Pro USA, Inc.
Company Facility Address	2101 W SR 434 Suite 315 Longwood, FL 32779
Company Alternate Address	
County or Parish	SEMINOLE
Employer Identification Number	592733978
North American Industry Classification Systems Code	562
Parent Company	
Number of Employees	2,500 to 4,999
Number of Sites Verified for	98 site(s)

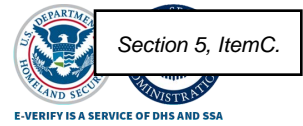

Company ID Number: 32855

Client Company ID Number: 788343

Are you verifying for more than 1 site? If yes, please provide the number of sites verified for in each State:

AL	2
AR	2
FL	51
GA	6
LA	7
MS	23
NC	4
SC	1
TN	2

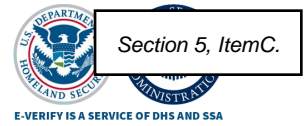

Company ID Number: 32855

Client Company ID Number: 788343

Information relating to the Program Administrator(s) for your Company on policy questions or operational problems:

Name Shannon Early
Phone Number 4079372666
Fax
Email searly@wasteprousa.com

Name Judi Craigo
Phone Number 4079372635
Fax
Email jcraigo@wasteprousa.com



Company ID Number: 32855

Client Company ID Number: 788343

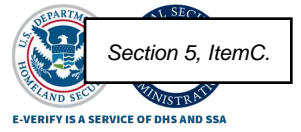

This list represents the first 20 Program Administrators listed for this company.



ORIGINAL

Exhibit A – Contact Sheet / Proposal Form

Company Name: Waste Pro of Florida, Inc.

Address: 5859 Commerce Road

City, State, ZIP: Milton, FL, 32583

Phone: 850-365-1900

Email: rmills@wasteprousa.com

Authorized Representative Name: Ralph Mills

Signature: E. Ralph Mills

Date: 8/10/25

Exhibit B - Public Entity Crimes Statement

SWORN STATEMENT UNDER SECTION 287.133(3)(a), FLORIDA STATUTES, ON PUBLIC ENTITY CRIMES

This form must be signed and sworn to in the presence of a notary public or other officer authorized to administer oaths.

1. This sworn statement is submitted to Town of Century
(Print name of the public entity)

by Ralph Mills/ Senior Vice president
(Print individual's name and title)

for Waste Pro of Florida Inc.
(Print name of entity submitting sworn statement)

whose business address is 5859 Commerce Rd, Milton, FL 32583

(If applicable) its Federal Employer Identification Number (FEIN) is 59-3701785

(If the entity has no FEIN, include the Social Security Number of the individual signing this sworn statement: On the attached sheet.) Required as per IRS Form W-9.

2. I understand that a "public entity crime" as defined in Paragraph 287.133(1)(g), Florida Statutes, means a violation of any state or federal law by a person with respect to and directly related to the transaction of business with any public entity or with an agency or political subdivision of any other state or with the United States, including but not limited to, and bid or contract for goods or services to be provided to any public entity or agency or political subdivision or any other state or of the United States, and involving antitrust, fraud, theft, bribery, collusion, racketeering, conspiracy, or material misrepresentation.

3. I understand that "convicted" or "conviction" as defined in Paragraph 287.133(1)(b), Florida Statutes, means a finding of guilt or a conviction of a public entity crime, with or without an adjudication of guilt, in any federal or state trial court of record relating to charges brought by indictment or information after July 1, 1989, as a result of a jury verdict, nonjury trial, or entry of a plea of guilty or nolo contendere.

4. I understand that "affiliate" as defined in Paragraph 287.133(1)(a), Florida Statutes, means:

1. A predecessor or successor of a person convicted of a public entity crime:
or:
2. An entity under the control of any natural person who is active in the management of the entity and who has been convicted of a public entity crime. The term "affiliate" includes those officers, directors, executives, partners, shareholders, employees, members and agents who are active in the management of the affiliate. The ownership by one person of shares constituting a controlling interest in another person, or a pooling of equipment or income among persons when not fair market value under an arm's length agreement, shall be a facie case that one person controls another person. A person who knowingly enters into a joint venture with a person who has been convicted of a public entity crime in Florida during the preceding 36 months shall be considered an affiliate.

5. I understand that a "person" as defined in Paragraph 287.133(1)(c), Florida Statutes, means any natural person or entity organized under the laws of any state or of the United States with the legal power to enter a binding contract and which bids or applies to bid on contracts for the provision of goods or services let by a public entity, or which otherwise transacts or applies to transact business with a public entity. The term "person" includes those officers, directors, executives, partners, shareholders, employees, members, and agents who are active in management of the entity.

 ORIGINAL

6. Based on information and belief, the statement, which I have marked below, is true in relation to the entity submitting those sworn statements. (Please indicate which statement applies.)

X Neither the entity submitted this sworn statement, nor any officers, directors, executives, partners, shareholders, employees, members, and agents who are active in management of an entity nor affiliate of the entity have been charged with and convicted of a public entity crime subsequent to July 1, 1989.

___ The entity submitting this sworn statement, or one or more of the officers, directors, executives, partners, shareholders, employees, member, or agents who are active in management of the entity, or an affiliate of the entity have been charged with and convicted of a public entity crime subsequent to July 1, 1989.

___ The entity submitting this sworn statement, or one or more of its officers, directors, executives, partners, shareholders, employees, member, or agents who are active in management of the entity, or an affiliate of the entity has been charged with and convicted of a public entity crime subsequent to July 1, 1989. However, there has been subsequent proceeding before a Hearing Officer of the State of Florida, Division of Administrative Hearing and the Final Order entered by the Hearing Officer determined that it was not in the public interest to place the entity submitting this sworn statement on the convicted vendor list. (Attach a copy of the final order)

I UNDERSTAND THAT THE SUBMISSION OF THIS FORM TO THE CONTRACTING OFFICER FOR THE PUBLIC ENTITY IDENTIFIED IN PARAGRAPH 1 (ONE) ABOVE IS FOR THAT PUBLIC ENTITY ONLY AND, THAT TIDS FORM IS VALID THROUGH DECEMBER 31 OF THE CALENDAR YEAR IN WHICH IS FILED. I ALSO UNDERSTAND THAT I AM REQUIRED TO INFORM THE PUBLIC ENTITY PRIOR TO ENTERING INTO A CONTRACT IN EXCESS OF THE THRESHOLD AMOUNT PROVIDED IN SECTION 287.017, FLORIDA STATUTES, FOR CATEGORY TWO OR ANY CHANGE IN THE INFORMATION CONTAINED IN THIS FORM.

E. Ralph Mills
(Signature)
8/10/25
(Date)

STATE OF Florida
COUNTY OF Leon

Sworn to (or affirmed) and subscribed before me by mean of physical presence or online notarization, this 10th day of, Aug by E. Ralph Mills

[Signature]
(Signature of Notary Public, State of Florida)

(Print, Type, or Stamp Commissioned Name of Notary Public)

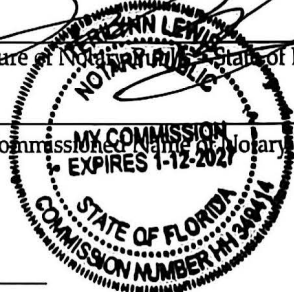

K personally known or ___ Produced Identification
Type of Identification Produced _____

Exhibit C- Drug-Free Workplace Certification

Town of Century
DRUG-FREE WORKPLACE CERTIFICATION

In order to be given preference in the award process for having implemented a drug-free workplace program prior to the Bid/Proposal submission date, the Bidder/Proposer is requested to certify that as part of their drug-free workplace program, they have:

1. Published a statement notifying employees that the unlawful manufacture, distribution, dispensing, possession, or use of a controlled substance is prohibited in the workplace and specified the actions that will be taken against employees for violations of such prohibition.
2. Informed employees about the dangers of drug abuse in the workplace, the business policy of maintaining a drug-free workplace, any available drug counseling, rehabilitation, and employee assistance programs, and the penalties that may be imposed upon employees for drug abuse violations.
3. Given each employee engaged in providing the commodities or contractual services that are under bid a copy of the statement specified in Subsection 1.
4. In the statement specified in Subsection 1, notified the employees that, as a condition of working on the commodities or contractual services that are under bid, the employee will abide by the terms of the statement and will notify the employer of any conviction of, or plea of guilty or nolo contendere to, any violation of Chapter 893 or of any controlled substance law of the United States or any state, for a violation occurring in the workplace no later than five (5) days after such conviction.
5. Imposed a sanction on, or required the satisfactory participation in a drug abuse assistance or rehabilitation program if such is available in the employee's community by any employee who is so convicted.
6. Made a good faith effort to continue to maintain a drug-free workplace through implementation of this section.

PROGRAM IMPLEMENTED

I certify that I/we have established a drug-free workplace program meeting the foregoing minimum requirements.

E. RALPH MILLS
[Printed, typed name]

E. Ralph Mills
[Signature]

8/10/25
[Date]

Town of Century, Florida
RFP Number: 2025-02
Exclusive Franchise for Solid Waste Collection and Recycling Services



Exhibit D - E-Verify Statement

Statement confirming compliance with E-Verify requirements.

Company Name: Waste Pro of Florida, Inc.

Address: 5859 Commerce Road

City, State, Zip: Milton, Florida, 32571

Phone: 850-365-1900

Email: rmills@wasteopro.com

Authorized Representative Name:

Printed Name E. RALPH MILLS

Signature E Ralph Mills

Date 8/10/25

EXHIBIT E – PROPOSER ACKNOWLEDGEMENTS AND AGREEMENTS

By signing below, the Proposer acknowledges and agrees to the following:

1. The Proposer has read and fully understands all terms, conditions, and requirements set forth in the Town of Century RFP No. 2025-02.
2. The Proposer agrees to comply with all provisions of the RFP, including but not limited to the scope of services, submission requirements, evaluation criteria, and contract terms.
3. The Proposer affirms that all information provided in its proposal is true, accurate, and complete to the best of its knowledge.
4. The Proposer understands that failure to comply with the RFP requirements may result in disqualification or termination of any resulting agreement.
5. The Proposer agrees to enter into good faith negotiations with the Town of Century should its proposal be selected for award.

Authorized Signature:

Company Name: WASTE PRO OF FLORIDA, INC

Authorized Representative Name (Printed): E. RALPH MILLS

Title: SENIOR VICE PRESIDENT

Signature: E. Ralph Mills

Date: 8/10/25

Exhibit F- Conflict of Interest Disclosure Form

Town of Century – Bid/RFP Submission

The award of a bid or acceptance of proposal is subject to Chapter 112, Florida Statutes*. All Bidders/Proposers must disclose with their Bid/Proposal the name of any officer, director, or agent who is a Town official or employee, or a member of an official's or employee's immediate family. Further, Bidders/Proposers must disclose the name of any Town official or employee, or a member of an official's or employee's immediate family, who owns directly or indirectly an interest of ten percent (10%) or more in the bidder's/proposer's firm or related business.

Certification

I declare that I do not have any matters which might give rise to a real or perceived conflict of interest. I hereby disclose that the following named person(s) is an Officer, Director, or Agent who is also a Town Official, Employee, or member of a Town Official or Employee's immediate family and could pose a possible conflict of interest:

- Name: E. Ralph Mills
- Affiliation: SR. Vice President

By signing below, I affirm that I have read and understood the principles of conflict-of-interest disclosure and I have made full disclosure of all matters that may put me in a conflict of interest situation in performing my role.

I acknowledge that non-disclosure could result in action being taken to terminate my work with the Town of Century and potentially bar me from submissions of Bids/RFPs in the future.

Signature: E. Ralph Mills

Printed Name: E. RALPH MILLS

Company: WASTE PRO OF FLORIDA, INC.

Project/Bid/RFP Number: RFP NO. 2025-02

Date: 8/10/25

Notary Acknowledgment

State of Florida County of Lee

Subscribed and sworn to (or affirmed) before me on this 10th day of August, 2025, by E. Ralph Mills, who is personally known to me has produced identification Type of identification produced: _____

Notary Public Signature: _____ Printed Name of Notary: _____

My Commission Expires: _____

Notary Seal: (Place seal here)

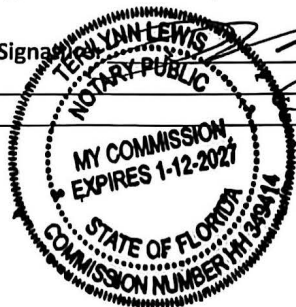

Exhibit G - Anti-Collusion Affidavit

Company Name: Waste Pro of Florida Inc
Address: 5859 Commerce Road Milton, FL 32583
Contact Person: E. Ralph Mills
Phone: 850-365-1900 Email: Rmills@WasteProUSA.com

Affidavit Statement I hereby affirm that this proposal is made independently and without collusion, consultation, communication, or agreement with any other proposer or competitor. No attempt has been made or will be made to induce any other person or firm to submit or not submit a proposal for the purpose of restricting competition.

I further certify that the information contained in this proposal is true and accurate and that I am authorized to submit this proposal on behalf of the company listed above.

Authorized Representative Name (Printed): E. RALPH MILLS
Title: SENIOR VICE PRESIDENT
Signature: E. Ralph Mills Date: 8/10/25

Notary Acknowledgment

State of Florida County of Leon
Subscribed and sworn to (or affirmed) before me on this 10th day of August, 2025 by E. Ralph Mills, who is personally known to me or has produced _____ as identification.

Notary Public Signature: _____
Printed Name of Notary: _____
My Commission Expires: _____
Notary Seal:

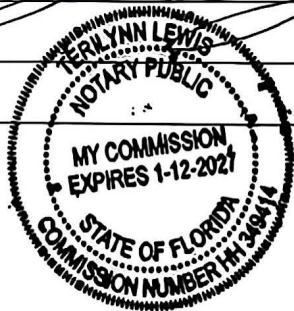

Exhibit H – Disputes Disclosure

Disclosure of any pending or past disputes related to municipal service contracts.

In the last five years, no city, county, or other governmental entity has terminated a solid waste contract with Waste Pro. There have been no criminal actions against us pertaining to non-performance of solid waste services, we have been party to no civil actions, and we have not had any proposal or performance bond claims made against us.

Five-Year Litigation History

City of Port St. Lucie v. Waste Pro of Florida, Inc., pending in the Circuit Court of Nineteenth Judicial Circuit in and for St. Lucie County, Florida

Summary: In 2021, Port St. Lucie filed a declaratory relief action against Waste Pro seeking a declaration that Waste Pro’s declaration of an event of force majeure did not fall within the terms of the contract. Waste Pro had declared an event of force majeure after the Delta variant caused an increase in Covid-19 cases creating workforce issues for Waste Pro. Port St. Lucie later amended to bring anticipatory breach and breach of contract claims. Due to claimed performance issues, Waste Pro had nearly \$2 million in liquidated damages withheld by Port St. Lucie. Port St. Lucie also made a claim against Waste Pro’s performance bond, although no amounts were paid out by the surety. Waste Pro believes that the withheld amounts were punitive and not reasonably related to any costs expended by Port St. Lucie. After attempting to resolve the issues at mediation, Waste Pro terminated the contract and counter-sued to recover the amounts it believes were improperly withheld. The action is currently pending.

Waste Pro of Florida v. City of Cape Coral

Summary: Litigation was initiated to determine if certain contract assessments were proper under the contract. The parties had negotiated for many months before resorting to the court system. The parties amicably resolved the issue through mediation, and subsequent negotiations between the parties. The litigation had no impact on the working relationship between Waste Pro and the City, or the current service level to the residents.



Authorized Signature:

Date: 8/10/25



WASTE & RECYCLING NEWS

MAY 2, 2011

Crain's News Source for Environmental Management

Waste Pro keeps it simple



Waste Pro USA Inc. CEO John J. Jennings said he believes in maintaining the company's core values even as his Longwood, Fla.-based solid waste management company continues to rapidly expand.

By Jim Johnson
Waste Pro USA Inc. is far from the single-truck operation that started a decade ago. With sales topping \$400 million annually, the company now has operations in seven southern states, running more than 1,400 trucks, employing 2,400 people and servicing 7.4 million customers.

locations to maintain and promote company beliefs. "As we grow, we want to make sure that we're able to maintain and keep that active culture going that really has been a part of our success," Jennings said. "I started the company really with the idea of keeping it simple. And what do we really mean by that? We mean, keep it simple and

been working with Jennings for about a quarter of a century in the trash business, even before the creation of Waste Pro. Traveling from his home base of Athens, Ga., Wood will hit the road a week or two at a time to talk to employees about company culture. "We do believe that our employees are



TAB 9 FORMS AND EXHIBITS





EXCELLENCE IN ENGINEERING SERVICE

August 26, 2025
150004-014

Honorable Benjamin Boutwell, Mayor
Town of Century
7995 North Century Boulevard
Century, FL 32535

RE: Century Miscellaneous Wastewater Improvements (Phase II) – Change Order No. 2

Dear Mayor Boutwell:

Please find attached Change Order Request No. 2 from Talcon Group, LLC. This Change Order includes an additional cost to the project of \$62,700.00 (as well as 60 additional days) to compensate the Contractor for demolition and reconstruction of the existing sludge press building. As noted in the attached letter from the Contractor, they have discovered some significant damage to the building framing (columns, purlins, and girts). As noted in their letter and email dated August 19, 2025, they are proposing to demolish the existing building to the foundation and construct a new identical building in the same location and of the same size.

We have reviewed the Contractor’s request and find it to be in order. While we are not structural engineers and have not completed a detailed structural evaluation, we have inspected the deterioration noted in the contractor’s letter and concur with their assessment. Given the cost of replacement proposed, we believe that this change order will yield a new building at a reasonable cost and recommend approval by the Council to allow you to execute the Change Order. You will recall that this project budget already exceeds the total grant funds, and therefore the cost of this Change Order will need to be paid out of Town funds (LOST or another account).

Please review the Change Order for yourself and should you have any questions or concerns, please do not hesitate to contact me. Additionally, I can be available at the next Council meeting to present this Change Order to Council and address any questions that they may have if required.

Sincerely,

MUNICIPAL ENGINEERING SERVICES, INC.

Dale E. Long, P.E., LEED AP
Senior Project Engineer

/DEL

Attachments

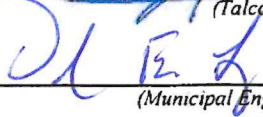
CONTRACT CHANGE ORDER							ORDER NO. 2
							DATE August 21, 2025
							STATE Florida
							COUNTY Escambia
CONTRACT FOR: Miscellaneous Wastewater System Improvements - Phase II - WWTP Improvements)							
PROJECT NO.: 150004-011							
OWNER: Town of Century							
TO CONTRACTOR: Talcon Group, LLC							
156 Dupont Road							
Havana, FL 32333							
You are hereby requested to comply with the following changes from the contract plans and specifications.							
Bid Item No.	Add/Deduct	No	Unit	Description of Changes (Supplemental Plans And Specifications Attached)	Unit Price	DECREASE In Contract Price	INCREASE In Contract Price
BASE BID D - Sludge Press Replacement							
9	Add	1	LS	Demolish Electrical Panels (salvage) and Disconnect Power	\$4,000.00	\$0.00	\$4,000.00
10	Add	1	LS	Demolish Sludge Press Building and Haul Off	\$10,000.00	\$0.00	\$10,000.00
11	Add	1	LS	Erect New Building (materials, sealed plans, and permits included)	\$45,000.00	\$0.00	\$45,000.00
12	Deduct	1	LS	Delete Painting Existing Columns and Purlins	\$6,000.00	\$6,000.00	\$0.00
13	Add	1	LS	Reinstall Electrical Panels (salvage) and Reconnect Power	\$4,000.00	\$0.00	\$4,000.00
14	Add	1	LS	Overhead and Profit	\$5,700.00	\$0.00	\$5,700.00
TOTALS						\$6,000.00	\$68,700.00
NET CHANGE IN CONTRACT PRICE						\$62,700.00	
JUSTIFICATION:							
The existingsludge press building structure (columns, purlins, girts, etc.) are rusted and corroded such that the building integrity has been compromised. To this end, the Contractor recommends demolition of the existing building and replacement with a new building.							
<p>The amount of the Contract will be INCREASED By The Sum Of:</p> <p style="text-align: right;">Sixty-Two Thousand, seven Hundred Dollars, and No Cents \$62,700.00</p> <p>The Contract Total Including this and Previous Change Orders Will Be:</p> <p style="text-align: right;">Five Million, Four Hundred Twenty-Two Thousand, One Hundred Forty-Six Dollars, and No Cents \$5,422,146.00</p> <p>The Contract Period Completion of Project Will Be UNCHANGED <u>21</u> DAYS</p> <p>The Contract Completion Date Shall Therefore Be <u>5/28/2026</u></p> <p style="text-align: center;"><i>This document will become a supplement to the contract and all provisions will apply hereto.</i></p> <p>Requested _____  _____ <u>8/22/2025</u> (Talcon Group, LLC) (Date)</p> <p>Recommended _____  _____ <u>8/25/2025</u> (Municipal Engineering Services, Inc.) (Date)</p> <p>Accepted _____ (Town of Century) (Date)</p>							

From: Cameron Helms <chelms@talcongroup.com>
Sent: Tuesday, August 19, 2025 2:28 PM
To: Dale Long
Subject: Re: Sludge Press Building Change Order 2

Follow Up Flag: Follow up
Flag Status: Completed

Talcon’s proposal includes the demolition of the existing sludge press building down to the existing concrete slab. The newly designed building layout, as shown in the attached photos, will match the existing building footprint exactly.

Included in Talcon’s scope of work:

- Demolition of the existing structure down to the concrete slab
- Erection of a new building matching the original footprint with new anchor bolts
- Installation of a new single personnel door
- Installation of one exhaust fan and one metal louver
- New roofing installation
- Installation of the siding and overhead door (as per the original contract)
- Electrical work to include:
 - Demolition and removal of existing electrical components
 - Reinstallation of the existing panel and control switches

Please review the attached layout images for further details. Let us know if any modifications or clarifications are required.

TC080725A
TALCON
BRYANT MC CALL

CODE: FBC 23
EXP C
CAT II
COLL LOAD 2#
WIND 140 MPH

CENTRY TREATMENT PLANT
CENTRY, FL.

BACK SW
TAPERED COL.
BY PASS WALL GIRTS

NOTE:
1) ALL WALL PANELS BY OTHERS

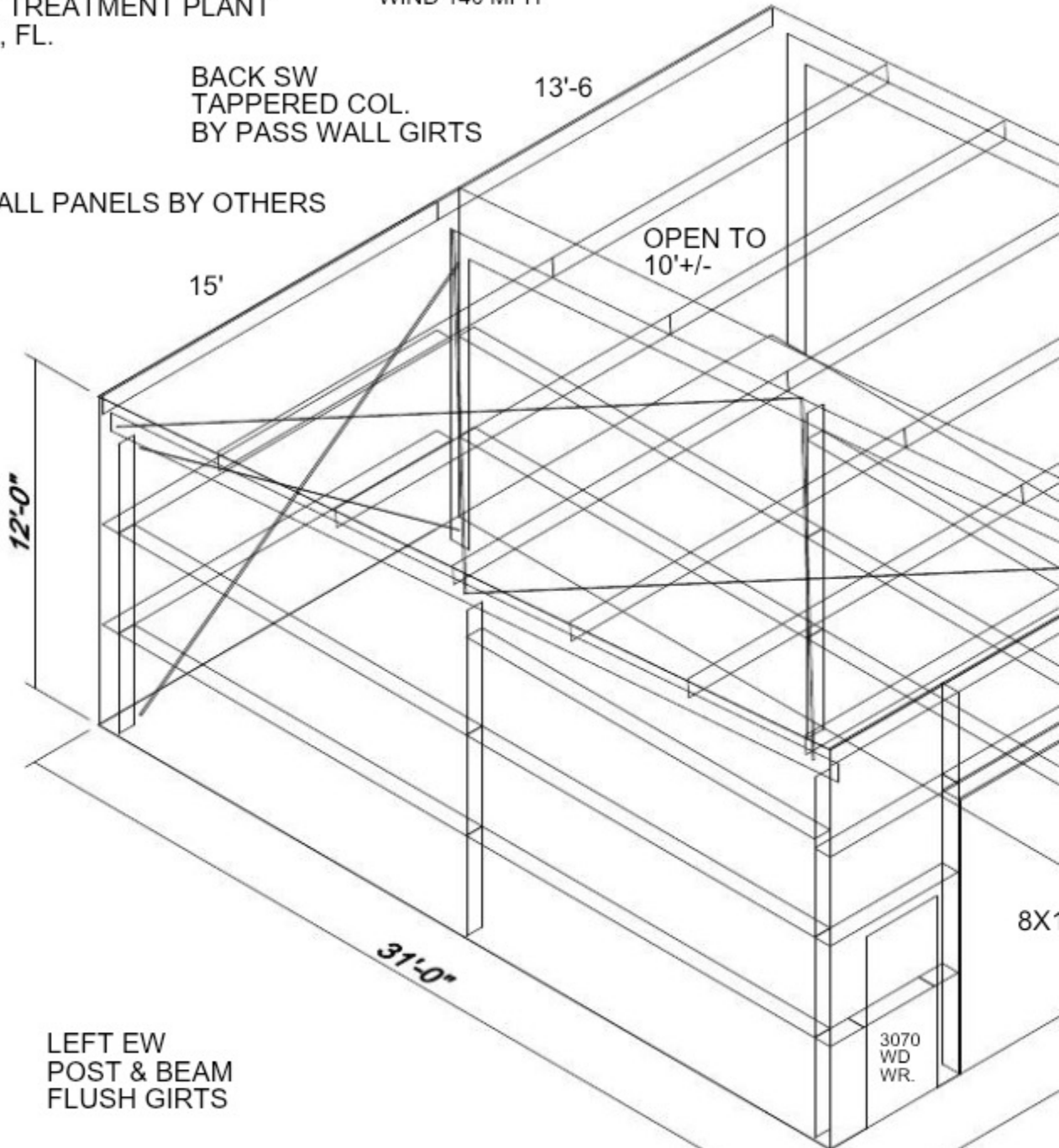

SKETCH IS FOR REFERENCE ONLY



Cameron Helms
Cameron Helms - Project Manager
chelms@talcongroup.com
850-637-0049

West Division	East Division
P: 850-500-8820	P: 850-574-4400
F: 850-574-0686	F: 850-574-0686
8820 Grow Dr.	156 Dupont Rd
Pensacola, FL 32514	Havana, FL 32333

From: Dale Long <dlong@mesi-fl.com>
Date: Tuesday, August 19, 2025 at 12:10 PM
To: Cameron Helms <chelms@talcongroup.com>
Subject: RE: Sludge Press Building Change Order 2

Cameron,

Please also confirm that this includes the roofing, louvers/exhaust fan, and what you plan to do with the lean to portion where the dumpster is located. I want to be certain that when I speak with the Council on this subject, I have a complete understanding of what all is included for the \$62,000. Thanks!

Dale

From: Cameron Helms <chelms@talcongroup.com>
Sent: Tuesday, August 19, 2025 8:08 AM
To: Dale Long <dlong@mesi-fl.com>
Subject: Sludge Press Building Change Order 2

Dale,

Attached is the change order for the renovation/demo and reinstall new sludge press building.

Please let me know what you think and if we can move forward with this so I can get materials ordered. 2-3 months on lead times for some of it.

West Division
8820 Grow Dr.
Pensacola, FL 32514
Phone 850-500-8820



www.TalconGroup.com

East Division
156 Dupont Road
Havana, FL 32333
Phone 850-574-4400 • Fax 850-574-0686

Structural Integrity Concerns During Demolition of Existing Sludge Press Building

During the demolition of the siding on the existing sludge press building, we have uncovered significant structural deterioration in multiple areas throughout the structure. This includes severe rust and corrosion compromising the integrity of critical load-bearing elements such as the girts, columns, and Z-purlins, which are essential components of the building's structural framework.

In order for Talcon to repair these deteriorated areas, an extensive amount of manpower and resources would be required to reinforce and patch structurally unsound components. These repairs would amount to a temporary fix — essentially placing a "band-aid" on a compromised structure — rather than a long-term solution.

Given the extent of the damage and the level of effort required to remediate it, we believe that replacing the metal building in its entirety with new, structurally sound materials could be achieved at a comparable cost, while offering greater safety, durability, and long-term value.

Cameron Helms
Project Manager
Talcon Group LLC











