



## Town of Century, Florida

### Council Meeting Agenda

May 06, 2025 at 6:15 PM

7995 N. Century Blvd. Century, Florida 32535

(850)256-3208 | [www.TownOfCenturyFlorida.com](http://www.TownOfCenturyFlorida.com)

---

#### Call Meeting to Order

**1. Roll Call**

**2. Open Meeting with Prayer and Pledge of Allegiance**

**3. Consent Agenda**

**A. Approval of Bill List**

**4. Public Forum #1**

**5. Action Items**

**A. Town of Century Project Update-Daniel Magro, PE with Aclus Engineering,LLC**

**B. Resolution No. 2025-004 Authorizing the Mayor to Submit FloridaCommerce CDBG Grant Applications and Execute Related Documents**

**C. Direction to Mayor Regarding Land Request to Escambia County for PHMSA-Funded Gas Project**

**D. Approval of Resolution No. 2025-003 - Amendments to the 1993 Employee Personnel Manual**

**E. Approval of Resolution No. 2025-005 Adopting a Formal Employee Pay Plan and Authorizing the Mayor to Implement the Plan**

**F. Discussion and Direction Regarding Utility Services (Water, Sewer, and Gas)**

**6. Mayor's Report**

**7. Council Comments**

**8. Staff Comments/ Report**

**9. Public Forum #2**

**10. Adjourn**

*§ In accordance with the Americans with Disabilities Act and Section 286.26, Florida Statutes, persons with disabilities needing special accommodation to participate in this proceeding should contact the Town Clerk no later than noon the day of the meeting to request assistance.*

*§ If HEARING impaired, please contact TDD (TDD-Telecommunications Device for the Deaf) at 1-800-955-8771.*

*§ If VOICE impaired, please contact the Florida Relay Service at 1-800-955-8770, for assistance.*

*§ If a person decides to appeal any decision with respect to any matter considered at such meeting or hearing, he will need a record of the proceedings, and for that purpose, he may need to ensure that a "verbatim record of the proceedings is made, which record includes the testimony and evidence upon which the appeal to be based." Minutes of the Town Council meetings can be obtained from the Town Clerk's office. The cost of duplication and/or court reporter will be at the expense of the requesting party. Minutes are recorded but are not transcribed verbatim.*

Account Name	Payee	Amount	Inv #	Month	YTD Spent	Annual Budget
	<b>Gas Fund</b>					
Equipment Maintenance	Accurate Control Equipment (preventative maintenance-bill stuffer)	\$112.97	223480	April	\$2,152.97	\$3,000.00
Operating Supplies Gas	Bondurant Lumber & Hardware	\$31.99	466240	April	\$9,995.85	\$12,000.00
Operating Supplies Gas	Bondurant Lumber & Hardware	\$51.98	466661	April	\$9,995.85	\$12,000.00
Vehicle Expense Gas	JHB Auto Parts	\$166.43	112743	April	\$9,090.59	\$3,000.00
Vehicle Expense Gas	JHB Auto Parts (brakes)	\$39.99	112695	April	\$9,090.59	\$3,000.00
	<b>Total</b>	<b>\$403.36</b>				
	<b>General Fund</b>					
Office Equipment Maintenance	CIT (canon copier)	\$98.53	46858946	April	\$22,733.78	\$22,000.00
Street Lights	Escambia River Electric Cooperative (Street Lights-Boat Ramp)	\$393.76	1119001	March	\$18,202.24	\$25,000.00
Flowers	Southern Treasure (James McMurray Service)	\$110.00	576936	April	\$215.00	\$1,000.00
	<b>Total</b>	<b>\$602.29</b>				
	<b>Water Fund</b>					
Equipment Maintenance	Accurate Control Equipment (preventative maintenance-bill stuffer)	\$338.93	223480	April	\$9,051.90	\$5,000.00
Lift Stations/Pump Maint	Bondurant Lumber & Hardware (nipple, coupling)	\$10.16	466321	April	\$25,620.81	\$125,000.00
Field Supplies Water	Bondurant Lumber & Hardware (pvc pipe, elbow, coupling)	\$15.04	466004	April	\$36,971.26	\$40,000.00
Field Supplies Water	Bondurant Lumber & Hardware (tape Barcade caution, lumber, concrete)	\$124.36	466499	April	\$36,971.26	\$40,000.00
Utilities Sewer Lifts	Escambia River Electric Cooperative (170 W State Line Road)	\$183.30	1119010	March	\$19,703.68	\$20,000.00
Utilities Sewer Lifts	Escambia River Electric Cooperative (Hadley Lane)	\$51.73	1119006	March	\$19,703.68	\$20,000.00
Utilities Sewer Lifts	Escambia River Electric Cooperative (Hwy 4 West)	\$70.53	1119004	March	\$19,703.68	\$20,000.00
Utilities Sewer Lifts	Escambia River Electric Cooperative (Hwy 4-Freedom Road)	\$93.62	1119003	March	\$19,703.68	\$20,000.00
Utilities Sewer Lifts	Escambia River Electric Cooperative (Jefferson Circle)	\$127.22	1119007	March	\$19,703.68	\$20,000.00
Utilities Sewer Lifts	Escambia River Electric Cooperative (Jefferson Street-Hwy 4)	\$81.48	1119008	March	\$19,703.68	\$20,000.00
Utilities Sewer Lifts	Escambia River Electric Cooperative (Williams Street)	\$55.12	1119005	March	\$19,703.68	\$20,000.00
Testing Sewer	Eurofins Environmental Testing (testing samples)	\$255.00	4000158420	April	\$9,130.00	\$15,000.00
Testing Water	Eurofins Environmental Testing (testing samples)	\$240.00	4000158740	April	\$3,550.00	\$15,000.00
Testing Sewer	Eurofins Environmental Testing (testing samples)	\$320.00	4000158998	April	\$9,130.00	\$15,000.00
Testing Sewer	Eurofins Environmental Testing (testing samples)	\$255.00	4000159058	April	\$9,130.00	\$15,000.00
Field Supplies Water	Ferguson	\$599.00	1586201	April	\$36,971.26	\$40,000.00
Field Supplies Water	Ferguson (12-grip coupling)	\$388.80	1566906-1	April	\$36,971.26	\$40,000.00
Chemicals WWTP	Hawkins Inc. (chlorine, sulfur dioxide)	\$3,952.50	7048858	April	\$17,760.30	\$22,000.00
Vehicle Expense Water/Sewer	JHB Auto Parts (oil, oil filter)	\$90.97	112779	April	\$4,923.89	\$3,000.00
Engineering/Surveying	Municipal Engineering Services	\$450.00	250043	April	\$22,918.31	\$20,000.00
Engineering/Surveying	Municipal Engineering Services	\$3,255.00	250045	April	\$22,918.31	\$20,000.00

Account Name	Payee	Amount	Inv #	Month	YTD Spent	Annual Budget
Grant Expenses	Municipal Engineering Services	\$13,011.20	250049	April		
Equipment Maintenance	Southern Custom Solutions (removed/installed fire hydrant)	\$5,500.00	2511	April	\$9,051.90	\$5,000.00
	<b>Total</b>	<b>\$29,468.96</b>				
	<b>Grand Total</b>	<b>\$30,474.61</b>				

<b>Payee</b>	<b>Amount</b>
Accurate Control Equipment	\$451.90
Bondurant Lumber & Hardware	\$233.53
CIT	\$98.53
Escambia River Electric Cooperative	\$1,056.76
Eurofins Environmental Testing	\$1,070.00
Ferguson	\$987.80
Hawkins Inc.	\$3,952.50
JHB Auto Parts	\$297.39
Municipal Engineering Services	\$16,716.20
Southern Custom Solutions	\$5,500.00
Southern Treasure	\$110.00
<b>Grand Total</b>	<b>\$30,474.61</b>



# ACCURATE CONTROL EQUIPMENT

YOUR MAILING & SHIPPING TECHNOLOGY EXPERTS

30652 Sgt E I Boots Thomas Dr Spanish Fort, AL 36527  
P: 251-928-4976 F: 251-928-4935

**SERVICE I** Section 3, Item A.

**Invoice Number:** 223480  
**Invoice Date:** 4/14/2025  
**Account Number:** 60885811  
**Balance Due:** \$451.90

**Bill To:** TOWN OF CENTURY  
7995 N CENTURY BLVD  
CENTURY, FL 32535

Work Order Date	Work Order No.
4/11/2025	WO38549

Payment Terms	Payment Due
Net 30	5/14/2025
Description	

Call Number	Equipment Number	Serial Number	Make/Model	Labor Charges	Travel Charges	Materials Charges	Other Charges	Total Charges
-------------	------------------	---------------	------------	---------------	----------------	-------------------	---------------	---------------

SC40582	F542	ZB2418501975	Quadient USA - IX5B Mailing Machine	\$ 0.00	\$ 0.00	\$ 451.90	\$ 0.00	\$ 451.90
---------	------	--------------	-------------------------------------	---------	---------	-----------	---------	-----------

**Service Date:** 4/11/2025      **Contract Number:** MA-N24081920-01      **Description:** PREVENTATIVE MAINTENANCE

**Location:** TOWN OF CENTURY  
7995 N CENTURY BLVD  
CENTURY, FL 32535

**PO #:**  
**Contact:** ANGELA SUGGS  
**Phone:** 850-256-3208  
**Fax:**  
**Caller:** SHANTEA --  
850-256-3208 --

**Remarks:** CLEANED ROLLERS  
CHECKED SEPARATOR TIPS & BRUSH/SPONGE.  
CLEANED UPPER AND LOWER TRANSPORT PLATE  
CHECKED SCALE  
RAN & TESTED.

A0106980- 2 - TOTAL: 451.90

Material Charges								\$451.90
Item	Description	Quantity	UM	Price	Discount	Amount		
IXINK357	IX-3/5/7 Series Ink Cartridge - A0106980	2	EA	\$ 225.95	0.00	\$ 451.90		

*338.93 water  
112.97 gas*

<b>Totals:</b>	\$ 0.00	\$ 0.00	\$ 451.90	\$ 0.00	\$ 451.90
----------------	---------	---------	-----------	---------	-----------

www.accuratecontrolequipment.com  
office@accuratecontrolequipment.com  
EIN: 63-1073026

Make checks payable and remit to:  
Accurate Control Equipment, Inc.  
30652 Sgt. E I Boots Thomas Drive  
Spanish Fort, AL 36527-7649

Invoice Subtotal:	\$451.90
Tax:	\$0.00
Invoice Total:	\$451.90
<b>Balance Due:</b>	<b>\$451.90</b>

**BONDURANT LUMBER AND HARDWARE, INC.**

**P O BOX 1944**

**FLOMATON, AL 36441**

**email dgunn1@bellsouth.net**

**PHONE: (850) 256-9000**

THANKS FOR SHOPPING WITH US!!

(850) 256-9000

Section 3, Item A.

CUST NO: 31    JOB NO: 000    PURCHASE ORDER: GARY    REFERENCE: PO # GARY    TERMS: NET 10TH    CLERK: TRB    DATE / TIME: 4/2/25 12:20

TERMINAL: 560

SOLD TO:  
CENTURY, TOWN OF  
  
P O DRAWER 790  
CENTURY FL 32535  
  
850-256-3208

SHIP TO:

TAX: 010 FLORIDA-CENTURY

**INVOICE: 466240**

LINE	SHIPPED	ORDERED	UM	SKU	DESCRIPTION	SUGG	UNITS	PRICE/ PER	EXTENSION
1	1	1	EA	7114366	MATTCK CUTR 2.5# FG HNDL		1	31.99 /EA	31.99 N
					<p><i>GAS PER Pick 527-000</i></p>				

TAXABLE 0.00  
NON-TAXABLE 31.99  
SUBTOTAL 31.99

(KRISTINA)  
\*\* AMOUNT CHARGED TO STORE ACCOUNT \*\* 31.99

TAX AMOUNT 0.00  
**TOTAL 31.99**

TOT WT: 4.50

X   
Received By

**BONDURANT LUMBER AND HARDWARE, INC.**

**P O BOX 1944**

**FLOMATON, AL 36441**

**email dgunn1@bellsouth.net**

**PHONE: (850) 256-9000**

THANKS FOR SHOPPING WITH US!!

(850) 256-9000

PAGE NO 1

Section 3, ItemA.

CUST NO: 31	JOB NO: 000	PURCHASE ORDER: DARRIN	REFERENCE: PO # DARRIN	TERMS: NET 10TH	CLERK: RH	DATE / TIME: 4/15/25 9:30
----------------	----------------	---------------------------	---------------------------	--------------------	--------------	------------------------------

TERMINAL: 560

SOLD TO:  
CENTURY, TOWN OF  
  
P O DRAWER 790  
CENTURY FL 32535  
  
850-256-3208

SHIP TO:

TAX: 010 FLORIDA-CENTURY

**INVOICE: 466661**

LINE	SHIPPED	ORDERED	UM	SKU	DESCRIPTION	SUGG	UNITS	PRICE/ PER	EXTENSION
1	1	1	EA	2116564	RULE TAPE 1X25'LEVERLOCK		1	13.99 /EA	13.99 N
2	1	1	EA	1001092	MARKING WAND PRO		1	37.99 /EA	37.99 N

*Gas Dept.  
~~STP~~  
468-001*

TAXABLE 0.00  
NON-TAXABLE 51.98  
SUBTOTAL 51.98

(KRISTINA)  
\*\* AMOUNT CHARGED TO STORE ACCOUNT \*\* 51.98

TAX AMOUNT 0.00  
**TOTAL 51.98**

TOT WT: 1.60

*[Signature]*  
Received By



700002464  
 JHB AUTO PARTS LLC.  
 P O BOX 702  
 Milton, FL 32572  
 (251) 296-3445

Invoice Number 112743 Page: 1/1

Invoice Date: 04/17/2025

Section 3, Item A.



eInvoice# JAX00464112743

850  
 Town Of Century  
 P O Drawer 790  
 Century, FL 32535-0000

Employee: 25 , Zac  
 Sales Rep: 0 , Salesman  
 Accounting Day: 15  
 Tax Exemption:

Attention:  
 PO#:  
 Delivery:  
 Terms: NET 30

Part Number	Line	Description	Quantity	Price	Net	Total	
		2013 Chevrolet Silverado 2500HD 3/4 Ton - Pickup					
2727XA	ADC	NAPA Adaptive One Front Right	1.00	146.50	100.4300	100.43	T
2727XA	ADC	Core Deposit	1.00	66.00	66.0000	66.00	TD

*Gas Dept.  
 465-000*

ON ACCOUNT

ALL GOODS RETURNED MUST BE ACCOMPANIED BY THIS INVOICE

Customer Signature

INSIST ON THE BEST  
 NAPA..WHERE THE STANDARD  
 IS QUALITY!!!

Tender Type: Amount:  
 Charge Sale 166.43

Subtotal 166.43  
 TAXTABLE 4 0.0000% 0.00

**Total 166.43**



700002464  
 JHB AUTO PARTS LLC.  
 P O BOX 702  
 Milton, FL 32572  
 (251) 296-3445

Invoice Number 112695 Page: 1/1  
 Invoice Date: 04/16/2025  
  
 eInvoice# JAX00464112695

Section 3, Item A.

850 Town Of Century P O Drawer 790 Century, FL 32535-0000	Employee: 88 , Max Sales Rep: 0 , Salesman Accounting Day: 14 Tax Exemption:	Attention: PO#: 13 GMC BRAK PADS Delivery: Terms: NET 30
--	---	---

Part Number	Line	Description	Quantity	Price	Net	Total
SG8523X	PSG	2013 GMC Sierra 2500HD 3/4 Ton - Pickup NAPA SilentGUARD Front Disc Brake	6.0	366.00	39.9900	39.99 T

~~STREET~~  
~~465-000~~

Gas Dept.  
 465-000

ON ACCOUNT

ALL GOODS RETURNED MUST BE ACCOMPANIED BY THIS INVOICE

DARRIN  
 Customer Signature

INSIST ON THE BEST  
 NAPA...BECAUSE THERE ARE  
 NO UNIMPORTANT PARTS!!!!

Tender Type:	Amount:	Subtotal	39.99
Charge Sale	39.99	TAXTABLE 4 0.0000%	0.00
		<b>Total</b>	<b>39.99</b>



Section 3, Item A.

Invoice Total	
Due Date	04/30/2025



Customer No.	2000294439
Invoice No.	46858946
Invoice Date	04/10/2025

Customer Service inquiries, call 888-204-0799

Invoice Detail				
Contract Number Asset Description	Itemized Charge(s)	Amount Due	Sales Tax	Total Due
900-0351973-000 CANON COPIER S/N WXF11013 C5535I 7995 N. CENTURY BLVD, CENTURY FL 32535	<b>CREDIT BALANCE APPLIED</b> TOTAL CREDITS	(83.99)	(6.30)	(90.29)
	<b>CURRENT CHARGES</b> PAYMENT DUE 04/30/2025	175.65	13.17	188.82
	<b>SUBTOTAL</b>	91.66	6.87	98.53
<b>INVOICE TOTAL</b>		<b>91.66</b>	<b>6.87</b>	<b>98.53</b>

Please return this portion with your payment



Do not send PAYMENTS to this address  
 RETURN ADDRESS ONLY  
 P.O. Box 550599  
 Jacksonville, FL 32255-0599

Invoice Total	98.53
Due Date	04/30/2025

Customer No.	2000294439
Invoice No.	46858946
Invoice Date	04/10/2025

0000766 01 MB 0.62 \*\*AUTO T3 0 1252 32535-162195 -C01-P00766-11



CENTURY, TOWN OF  
 ACCOUNTS PAYABLE  
 7995 N. CENTURY BLVD.  
 CENTURY FL 32535-1621



SEND PAYMENTS TO:

  
 FIRST-CITIZENS BANK & TRUST CO  
 21146 NETWORK PLACE  
 CHICAGO IL 60673-1211

02000294 01004600 85894600 00000098533



**Escambia River Electric Coop., Inc**

P O Box 428 • Jay, FL 32565-0428

(850) 675-4521 or 1-800-235-3848

Office Hours: 7:30 A.M. - 4:00 P.M. Monday- Friday

www.erec.com

Section 3, Item A.

ACCOUNT NUMBER	NAME		RATE	CLASS	METER NUMBER	LOCATION NUMBER	SERVICE ADDRESS	
1119001	TOWN OF CENTURY		9	1	0	9000000000003	STREET LIGHTS & BOAT RAMP	
SERVICE PERIOD		NO. DAYS	RDG CODE	METER READING		METER MULTIPLIER	KWH/GAL USAGE	CHARGES
FROM	TO			PREVIOUS	PRESENT			
03/01/25	04/01/25	31						0.00
35 SECURITY LIGHT STANDARD								350.00
3 REGULAR WOODEN YL POLE								3.00
CITY/COUNTY FRANCHISE TAX								21.18
STATE GROSS RECEIPTS TAX								9.58
TOTAL CURRENT ELECTRIC BILL DUE 05/01/25								383.76
PREVIOUS AMOUNT DUE								393.76
THANK YOU FOR YOUR PAYMENT 04/08/25								-383.76
PREVIOUS UNPAID BALANCE								10.00
TOTAL AMOUNT DUE								393.76
(CURRENT BILL DUE DATE DOES NOT APPLY TO THE PREVIOUS UNPAID BALANCE)								
BILLING DATE	PAST DUE AFTER		ADD THIS AMOUNT AFTER PAST DUE		TOTAL DUE NOW		\$	
04/15/25	05/01/25		10.00		AFTER DUE DATE PAY		\$	403.76

COMPARISONS

	DAYS SERVICE	TOTAL KWH	AVG. KWH/DAY	COST PER DAY
CURRENT BILLING PERIOD	31	0	0	0.00
PREVIOUS BILLING PERIOD	28	0	0	0.00
SAME PERIOD LAST YEAR	31	0	0	0.00

MESSAGE

**WE HOPE TO SEE YOU AT OUR ANNUAL MEETING ON APRIL 26. FESTIVITIES BEGIN AT 8 AM; BUSINESS MEETING BEGINS AT 10 AM. YOU CAN VOTE BY ABSENTEE, MAIL IN OR IN PERSON.**

IMPORTANT INFORMATION

- \* **PAST DUE BILLS.** An unpaid bill becomes delinquent 15 days after the bill date and is subject to a penalty. Payments will be credited to your account as of the date received.
- \* **TELEPHONE NUMBER.** Please furnish telephone number on return portion of your bill if not shown.
- \* **QUESTION OR COMMENT.** Please write your question or comment on the back of the return portion of your bill.

RETAIN THIS COPY FOR YOUR RECORDS

PLEASE DETACH AND RETURN THIS PORTION WITH PAYMENT

FL08220F



**ESCAMBIA RIVER ELECTRIC CO-OP.**  
P.O. Box 428  
Jay, FL 32565

ACCOUNT NUMBER	DUE DATE		AMOUNT DUE
1119001	05/01/25		393.76
PHONE NUMBER	BC	CYCLE	AFTER DUE DATE PAY
(850) 256-3208	0	16	403.76

PLEASE INDICATE CHANGE OF ADDRESS OR PHONE NUMBER HERE

\*\*\*\*\*AUTO\*\*5-DIGIT 32577



TOWN OF CENTURY 2  
PO BOX 790 281  
CENTURY FL 32535-0790

ESCAMBIA RIVER ELECTRIC COOP INC  
PO BOX 428  
JAY FL 32565-0428



0000000000 00001119001 00000039376 00000040376 0

576936

Payable upon

Statement

DATE 4-15-25

TERMS Receipt

TO Town of Century

per Kristina W.

IN ACCOUNT WITH

Southern Treasures Florist  
PO Box 565  
Center HI 32535

James McMurray

plant

Del. 100.00  
10.00

WDS

Town of Century  
Manager, Council  
and Town Staff

110.00

+x 0

CURRENT

OVER 30 DAYS

OVER 60 DAYS

TOTAL AMOUNT

110.00

01-11

**BONDURANT LUMBER AND HARDWARE, INC.**

**P O BOX 1944**  
**FLOMATON, AL 36441**  
**email dgunn1@bellsouth.net**  
**PHONE: (850) 256-9000**  
 THANKS FOR SHOPPING WITH US!!  
 (850) 256-9000

CUST NO: 31    JOB NO: 000    PURCHASE ORDER: GARY    REFERENCE: PO # GARY    TERMS: NET 10TH    CLERK: JN    DATE / TIME: 4/4/25 9:48

TERMINAL: 559

SOLD TO:  
 CENTURY, TOWN OF  
 P O DRAWER 790  
 CENTURY FL 32535  
 850-256-3208

SHIP TO:

TAX: 010 FLORIDA-CENTURY

**INVOICE: 466321**

LINE	SHIPPED	ORDERED	UM	SKU	DESCRIPTION	SUGG	UNITS	PRICE/ PER	EXTENSION
1	1	1	EA	15915119	1/4 X 1 1/2 NIPPLE		1	1.89 /EA	1.89 N
2	2	2	EA	15911407	1/4" GALV.COUPLING		2	2.99 /EA	5.98 N
3	1	1	EA	15915143	1/4 X 3 NIPPLE		1	2.29 /EA	2.29 N

*Lift Station*

*water DEPT.  
459-000*

~~\_\_\_\_\_~~  
~~\_\_\_\_\_~~

TAXABLE 0.00  
 NON-TAXABLE 10.16  
 SUBTOTAL 10.16

(KRISTINA)  
 \*\* AMOUNT CHARGED TO STORE ACCOUNT \*\* 10.16

TAX AMOUNT 0.00  
**TOTAL 10.16**

TOT WT: 0.00

X \_\_\_\_\_  
 Received By

**BONDURANT LUMBER AND HARDWARE, INC.**

**P O BOX 1944**

**FLOMATON, AL 36441**

**email dgunn1@bellsouth.net**

**PHONE: (850) 256-9000**

THANKS FOR SHOPPING WITH US!!

(850) 256-9000

Section 3, Item A.

CUST NO: 31	JOB NO: 000	PURCHASE ORDER: 0177	REFERENCE: PO # 0177	TERMS: NET 10TH	CLERK: JN	DATE / TIME: 3/27/25 8:42
----------------	----------------	-------------------------	-------------------------	--------------------	--------------	------------------------------

TERMINAL: 561

SOLD TO:  
CENTURY, TOWN OF  
  
P O DRAWER 790  
CENTURY FL 32535  
  
850-256-3208

SHIP TO:

TAX: 010 FLORIDA-CENTURY

**INVOICE: 466004**

LINE	SHIPPED	ORDERED	UM	SKU	DESCRIPTION	SUGG	UNITS	PRICE/ PER	EXTENSION
1	10	10	EA	34PVC40	3/4 SCH 40 PVC PIPE		10	0.79 /EA	7.90 N
2	1	1	EA	43123	3/4" PVC 90 ELBOW		1	0.99 /EA	.99 N
3	1	1	EA	43129	3/4 WHT 45 DEG ELL SXS		1	1.79 /EA	1.79 N
4	1	1	EA	43105	3/4 WHT COUPLING SXS		1	0.79 /EA	.79 N
5	1	1	EA	43123	3/4" PVC 90 ELBOW		1	0.99 /EA	.99 N
6	1	1	EA	43105	3/4 WHT COUPLING SXS		1	0.79 /EA	.79 N
7	1	1	EA	43129	3/4 WHT 45 DEG ELL SXS		1	1.79 /EA	1.79 N

*Water Dept.  
468-001*

TAXABLE	0.00
NON-TAXABLE	15.04
<b>SUBTOTAL</b>	<b>15.04</b>

(KRISTINA)  
\*\* AMOUNT CHARGED TO STORE ACCOUNT \*\* 15.04

TAX AMOUNT	0.00
<b>TOTAL</b>	<b>15.04</b>

TOT WT: 0.00

*X. J. [Signature]*

Received By

**BON IRANT LUMBER AND HARDWARE, INC.**

**P O BOX 1944**

**FLOMATON, AL 36441**

**email dgunn1@bellsouth.net**

**PHONE: (850) 256-9000**

**THANKS FOR SHOPPING WITH US!!**

**(850) 256-9000**

Section 3, Item A.

CUST NO: 31    JOB NO: 000    PURCHASE ORDER: WATER LEAK    REFERENCE: PO # WATER LEAK    TERMS: NET 10TH    CLERK: BH    DATE / TIME: 4/10/25 9:42

TERMINAL: 559

SOLD TO:  
CENTURY, TOWN OF

P O DRAWER 790  
CENTURY FL 32535

850-256-3208

SHIP TO:  
MICKY CALLED BUBBA 9 PM  
4-9 -25  
EMERGENCY

SALESPERSON: BH BUBBA HAMMAC  
TAX: 010 FLORIDA-CENTURY

**INVOICE: 466499**

LINE	SHIPPED	ORDERED	UM	SKU	DESCRIPTION	SUGG	UNITS	PRICE/ PER	EXTENSION
1	1	1	EA	28139	TAPE BARCADE CAUTION1000		1	13.99 /EA	13.99 N
2	11	11	EA	CONMIX	QUIKRETE CONCRETE MIX 80LB.		11	7.49 /EA	82.39 N
3	2	2	EA	448PT	4X4X8 PT		2	13.99 /EA	27.98 N

WATER  
468-001

Mackay

TAXABLE 0.00  
NON-TAXABLE 124.36  
SUBTOTAL 124.36

(KRISTINA)  
\*\* AMOUNT CHARGED TO STORE ACCOUNT \*\* 124.36

TAX AMOUNT 0.00  
**TOTAL 124.36**

TOT WT: 0.00

*xBubba*  
Received By



**Escambia River Electric Coop., Inc.**  
 P O Box 428 • Jay, FL 32565-0428  
 (850) 675-4521 or 1-800-235-3848  
 Office Hours: 7:30 A.M. - 4:00 P.M. Monday- Friday  
 www.erec.com

ACCOUNT NUMBER	NAME		RATE	CLASS	METER NUMBER	LOCATION NUMBER	SERVICE ADDRESS	
1119010	TOWN OF CENTURY		3	1	16010104	50000200	170 W STATE LINE RD	
SERVICE PERIOD		NO. DAYS	RDG CODE	METER READING		METER MULTIPLIER	KWH/GAL USAGE	CHARGES
FROM	TO			PREVIOUS	PRESENT			
03/01/25	04/01/25	31	0	116752	117451	1	699	122.81
DEMAND:		READING		ACTUAL		BILLED		
		3.452		3.452		3.452		29.34
0.020000 PURCHASED POWER COST ADJ								13.98
CITY/COUNTY FRANCHISE TAX								8.31
STATE GROSS RECEIPTS TAX								4.46
TOTAL CURRENT ELECTRIC BILL DUE 05/01/25								178.90
PREVIOUS AMOUNT DUE								99.23
THANK YOU FOR YOUR PAYMENT 04/08/25								-94.83
PREVIOUS UNPAID BALANCE								4.40
TOTAL AMOUNT DUE								183.30
(CURRENT BILL DUE DATE DOES NOT APPLY TO THE PREVIOUS UNPAID BALANCE)								
BILLING DATE	PAST DUE AFTER	ADD THIS AMOUNT AFTER PAST DUE		TOTAL DUE NOW		\$ 183.30		
04/15/25	05/01/25	8.30		AFTER DUE DATE PAY		\$ 191.60		

COMPARISONS				
	DAYS SERVICE	TOTAL KWH	AVG. KWH/DAY	COST PER DAY
CURRENT BILLING PERIOD	31	699	23	5.36
PREVIOUS BILLING PERIOD	28	202	7	3.15
SAME PERIOD LAST YEAR	31	658	21	4.50

**MESSAGE**  
 WE HOPE TO SEE YOU AT OUR ANNUAL MEETING ON APRIL 26. FESTIVITIES BEGIN AT 8 AM; BUSINESS MEETING BEGINS AT 10 AM. YOU CAN VOTE BY ABSENTEE, MAIL IN OR IN PERSON.

Your Electricity Use Over The Last 13 Months

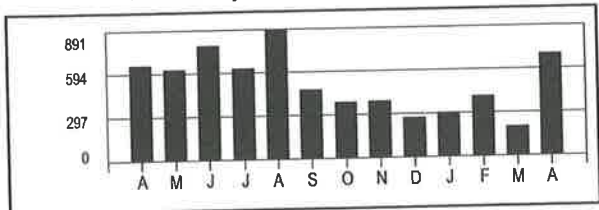

**IMPORTANT INFORMATION**

- PAST DUE BILLS.** An unpaid bill becomes delinquent 15 days after the bill date and is subject to a penalty. Payments will be credited to your account as of the date received.
- TELEPHONE NUMBER.** Please furnish telephone number on return portion of your bill if not shown.
- QUESTION OR COMMENT.** Please write your question or comment on the back of the return portion of your bill.



**Escambia River Electric Coop., Inc.**  
 P O Box 428 • Jay, FL 32565-0428  
 (850) 675-4521 or 1-800-235-3848  
 Office Hours: 7:30 A.M. - 4:00 P.M. Monday- Friday  
 www.erec.com

ACCOUNT NUMBER	NAME		RATE	CLASS	METER NUMBER	LOCATION NUMBER	SERVICE ADDRESS	
1119006	TOWN OF CENTURY		2	1	20940443	16013605	HADLEY LANE	
SERVICE PERIOD		NO. DAYS	RDG CODE	METER READING		METER MULTIPLIER	KWH/GAL USAGE	CHARGES
FROM	TO			PREVIOUS	PRESENT			
03/01/25	04/01/25	31	0	1223	1230	1	7	45.77
0.020000 PURCHASED POWER COST ADJ								0.14
CITY/COUNTY FRANCHISE TAX								2.30
STATE GROSS RECEIPTS TAX								1.23
TOTAL CURRENT ELECTRIC BILL DUE 05/01/25								49.44
PREVIOUS AMOUNT DUE								51.73
THANK YOU FOR YOUR PAYMENT 04/08/25								-49.44
PREVIOUS UNPAID BALANCE								2.29
TOTAL AMOUNT DUE								51.73
(CURRENT BILL DUE DATE DOES NOT APPLY TO THE PREVIOUS UNPAID BALANCE)								
BILLING DATE	PAST DUE AFTER	ADD THIS AMOUNT AFTER PAST DUE		TOTAL DUE NOW		\$ 51.73		
04/15/25	05/01/25	2.29		AFTER DUE DATE PAY		\$ 54.02		

COMPARISONS

	DAYS SERVICE	TOTAL KWH	AVG. KWH/DAY	COST PER DAY
CURRENT BILLING PERIOD	31	7	0	1.48
PREVIOUS BILLING PERIOD	28	7	0	1.64
SAME PERIOD LAST YEAR	31	4	0	1.37

MESSAGE

WE HOPE TO SEE YOU AT OUR ANNUAL MEETING ON APRIL 26. FESTIVITIES BEGIN AT 8 AM; BUSINESS MEETING BEGINS AT 10 AM. YOU CAN VOTE BY ABSENTEE, MAIL IN OR IN PERSON.

Your Electricity Use Over The Last 13 Months

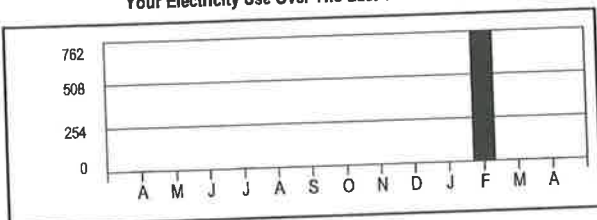

IMPORTANT INFORMATION

- \* **PAST DUE BILLS.** An unpaid bill becomes delinquent 15 days after the bill date and is subject to a penalty. Payments will be credited to your account as of the date received.
- \* **TELEPHONE NUMBER.** Please furnish telephone number on return portion of your bill if not shown.
- \* **QUESTION OR COMMENT.** Please write your question or comment on the back of the return portion of your bill.



**Escambia River Electric Coop., Inc.**  
 P O Box 428 • Jay, FL 32565-0428  
 (850) 675-4521 or 1-800-235-3848  
 Office Hours: 7:30 A.M. - 4:00 P.M. Monday- Friday  
 www.erec.com

ACCOUNT NUMBER	NAME				RATE	CLASS	METER NUMBER	LOCATION NUMBER	SERVICE ADDRESS
1119004	TOWN OF CENTURY				3	1	16010142	50000111	HWY 4 W
SERVICE PERIOD		NO. DAYS	RDG CODE	METER READING		METER MULTIPLIER	KWH/GAL USAGE	CHARGES	
FROM	TO			PREVIOUS	PRESENT				
03/01/25	04/01/25	31	0	55007	55007	1	0	62.00	
DEMAND:		READING		ACTUAL		BILLED			
		0.003		0.003		0.003		0.03	
CITY/COUNTY FRANCHISE TAX								3.72	
STATE GROSS RECEIPTS TAX								1.68	
TOTAL CURRENT ELECTRIC BILL DUE 05/01/25								67.43	
PREVIOUS AMOUNT DUE								70.53	
THANK YOU FOR YOUR PAYMENT 04/08/25								-67.43	
PREVIOUS UNPAID BALANCE								3.10	
TOTAL AMOUNT DUE								70.53	
(CURRENT BILL DUE DATE DOES NOT APPLY TO THE PREVIOUS UNPAID BALANCE)									
BILLING DATE	PAST DUE AFTER			ADD THIS AMOUNT AFTER PAST DUE		TOTAL DUE NOW		\$	
04/15/25	05/01/25			3.10		AFTER DUE DATE PAY		\$ 73.63	

COMPARISONS

	DAYS SERVICE	TOTAL KWH	AVG. KWH/DAY	COST PER DAY
CURRENT BILLING PERIOD	31	0	0	2.00
PREVIOUS BILLING PERIOD	28	0	0	2.22
SAME PERIOD LAST YEAR	31	129	4	3.28

MESSAGE

**WE HOPE TO SEE YOU AT OUR ANNUAL MEETING ON APRIL 26. FESTIVITIES BEGIN AT 8 AM; BUSINESS MEETING BEGINS AT 10 AM. YOU CAN VOTE BY ABSENTEE, MAIL IN OR IN PERSON.**

Your Electricity Use Over The Last 13 Months

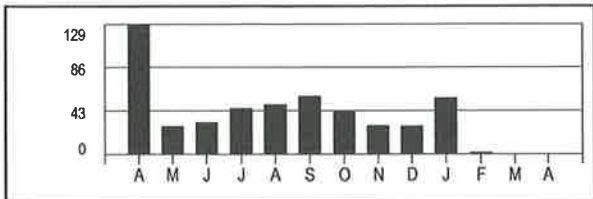

IMPORTANT INFORMATION

- PAST DUE BILLS.** An unpaid bill becomes delinquent 15 days after the bill date and is subject to a penalty. Payments will be credited to your account as of the date received.
- TELEPHONE NUMBER.** Please furnish telephone number on return portion of your bill if not shown.
- QUESTION OR COMMENT.** Please write your question or comment on the back of the return portion of your bill.



**Escambia River Electric Coop., Inc.**  
 P O Box 428 • Jay, FL 32565-0428  
 (850) 675-4521 or 1-800-235-3848  
 Office Hours: 7:30 A.M. - 4:00 P.M. Monday- Friday  
 www.erec.com

ACCOUNT NUMBER	NAME		RATE	CLASS	METER NUMBER	LOCATION NUMBER	SERVICE ADDRESS	
1119003	TOWN OF CENTURY		3	1	16010037	50005261	HWY 4/FREEDOM RD	
SERVICE PERIOD		NO. DAYS	RDG CODE	METER READING		METER MULTIPLIER	KWH/GAL USAGE	CHARGES
FROM	TO			PREVIOUS	PRESENT			
03/01/25	04/01/25	31	0	51594	51675	1	81	69.05
DEMAND:		READING		ACTUAL		BILLED		
		1.418		1.418		1.418		12.05
0.020000 PURCHASED POWER COST ADJ							81	1.62
CITY/COUNTY FRANCHISE TAX								4.96
STATE GROSS RECEIPTS TAX								2.24
TOTAL CURRENT ELECTRIC BILL DUE 05/01/25								89.92
PREVIOUS AMOUNT DUE								84.14
THANK YOU FOR YOUR PAYMENT 04/08/25								-80.44
PREVIOUS UNPAID BALANCE								3.70
TOTAL AMOUNT DUE								93.62
(CURRENT BILL DUE DATE DOES NOT APPLY TO THE PREVIOUS UNPAID BALANCE)								
BILLING DATE	PAST DUE AFTER		ADD THIS AMOUNT AFTER PAST DUE		TOTAL DUE NOW		\$	93.62
04/15/25	05/01/25		4.13		AFTER DUE DATE PAY		\$	97.75

RECEIVED  
 APR 22 2025

COMPARISONS	DAYS SERVICE	TOTAL KWH	AVG. KWH/DAY	COST PER DAY
CURRENT BILLING PERIOD	31	81	3	2.67
PREVIOUS BILLING PERIOD	28	67	2	2.64
SAME PERIOD LAST YEAR	31	55	2	2.01

**MESSAGE**  
 WE HOPE TO SEE YOU AT OUR ANNUAL MEETING ON APRIL 26. FESTIVITIES BEGIN AT 8 AM; BUSINESS MEETING BEGINS AT 10 AM. YOU CAN VOTE BY ABSENTEE, MAIL IN OR IN PERSON.

Your Electricity Use Over The Last 13 Months

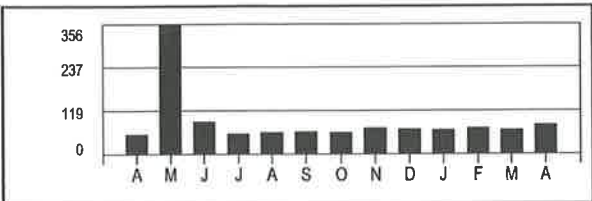

**IMPORTANT INFORMATION**

- \* **PAST DUE BILLS.** An unpaid bill becomes delinquent 15 days after the bill date and is subject to a penalty. Payments will be credited to your account as of the date received.
- \* **TELEPHONE NUMBER.** Please furnish telephone number on return portion of your bill if not shown.
- \* **QUESTION OR COMMENT.** Please write your question or comment on the back of the return portion of your bill.



**Escambia River Electric Coop., Inc.**  
 P O Box 428 • Jay, FL 32565-0428  
 (850) 675-4521 or 1-800-235-3848  
 Office Hours: 7:30 A.M. - 4:00 P.M. Monday- Friday  
 www.erec.com

ACCOUNT NUMBER	NAME		RATE	CLASS	METER NUMBER	LOCATION NUMBER	SERVICE ADDRESS	
1119007	TOWN OF CENTURY		3	1	16010016	50005211	JEFFERSON CIRCLE	
SERVICE PERIOD		NO. DAYS	RDG CODE	METER READING		METER MULTIPLIER	KWH/GAL USAGE	CHARGES
FROM	TO			PREVIOUS	PRESENT			
03/01/25	04/01/25	31	0	22141	22424	1	283	86.62
DEMAND:		READING		ACTUAL		BILLED		
		2.282		2.282		2.282		19.40
0.020000 PURCHASED POWER COST ADJ						283		5.66
CITY/COUNTY FRANCHISE TAX								6.70
STATE GROSS RECEIPTS TAX								3.03
TOTAL CURRENT ELECTRIC BILL DUE 05/01/25								121.41
PREVIOUS AMOUNT DUE								132.27
THANK YOU FOR YOUR PAYMENT 04/08/25								-126.46
PREVIOUS UNPAID BALANCE								5.81
TOTAL AMOUNT DUE								127.22
(CURRENT BILL DUE DATE DOES NOT APPLY TO THE PREVIOUS UNPAID BALANCE)								
BILLING DATE	PAST DUE AFTER		ADD THIS AMOUNT AFTER PAST DUE		TOTAL DUE NOW		\$	
04/15/25	05/01/25		5.58		AFTER DUE DATE PAY		\$	132.80

**COMPARISONS**

	DAYS SERVICE	TOTAL KWH	AVG. KWH/DAY	COST PER DAY
CURRENT BILLING PERIOD	31	283	9	3.60
PREVIOUS BILLING PERIOD	28	279	10	4.15
SAME PERIOD LAST YEAR	31	382	12	4.25

**MESSAGE**

**WE HOPE TO SEE YOU AT OUR ANNUAL MEETING ON APRIL 26. FESTIVITIES BEGIN AT 8 AM; BUSINESS MEETING BEGINS AT 10 AM. YOU CAN VOTE BY ABSENTEE, MAIL IN OR IN PERSON.**

Your Electricity Use Over The Last 13 Months

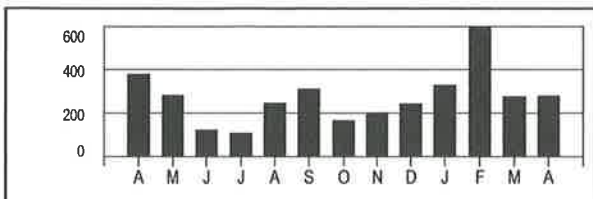

**IMPORTANT INFORMATION**

- \* **PAST DUE BILLS.** An unpaid bill becomes delinquent 15 days after the bill date and is subject to a penalty. Payments will be credited to your account as of the date received.
- \* **TELEPHONE NUMBER.** Please furnish telephone number on return portion of your bill if not shown.
- \* **QUESTION OR COMMENT.** Please write your question or comment on the back of the return portion of your bill.



**Escambia River Electric Coop., Inc.**  
 P O Box 428 • Jay, FL 32565-0428  
 (850) 675-4521 or 1-800-235-3848  
 Office Hours: 7:30 A.M. - 4:00 P.M. Monday- Friday  
 www.erec.com

ACCOUNT NUMBER	NAME		RATE	CLASS	METER NUMBER	LOCATION NUMBER	SERVICE ADDRESS	
1119008	TOWN OF CENTURY		3	1	16010018	50005111	JEFFERSON ST/HWY 4	
SERVICE PERIOD		NO. DAYS	RDG CODE	METER READING		METER MULTIPLIER	KWH/GAL USAGE	CHARGES
FROM	TO			PREVIOUS	PRESENT			
03/01/25	04/01/25	31	0	5831	5864	1	33	64.87
DEMAND:		READING		ACTUAL		BILLED		
		0.691		0.691		0.691		5.87
0.020000 PURCHASED POWER COST ADJ						33		0.66
CITY/COUNTY FRANCHISE TAX								4.28
STATE GROSS RECEIPTS TAX								1.93
TOTAL CURRENT ELECTRIC BILL DUE 05/01/25								77.61
PREVIOUS AMOUNT DUE								88.08
THANK YOU FOR YOUR PAYMENT 04/08/25								-84.21
PREVIOUS UNPAID BALANCE								3.87
TOTAL AMOUNT DUE								81.48
(CURRENT BILL DUE DATE DOES NOT APPLY TO THE PREVIOUS UNPAID BALANCE)								
BILLING DATE	PAST DUE AFTER		ADD THIS AMOUNT AFTER PAST DUE		TOTAL DUE NOW		\$	
04/15/25	05/01/25		3.57		AFTER DUE DATE PAY		\$	85.05

**COMPARISONS**

	DAYS SERVICE	TOTAL KWH	AVG. KWH/DAY	COST PER DAY
CURRENT BILLING PERIOD	31	33	1	2.30
PREVIOUS BILLING PERIOD	28	55	2	2.77
SAME PERIOD LAST YEAR	31	48	2	1.95

**MESSAGE**

**WE HOPE TO SEE YOU AT OUR ANNUAL MEETING ON APRIL 26. FESTIVITIES BEGIN AT 8 AM; BUSINESS MEETING BEGINS AT 10 AM. YOU CAN VOTE BY ABSENTEE, MAIL IN OR IN PERSON.**

Your Electricity Use Over The Last 13 Months

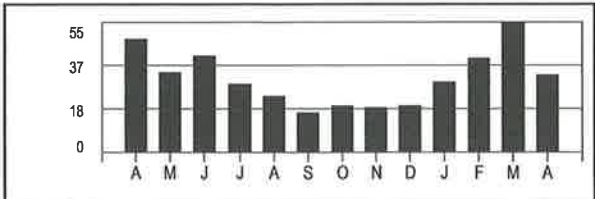

**IMPORTANT INFORMATION**

- \* **PAST DUE BILLS.** An unpaid bill becomes delinquent 15 days after the bill date and is subject to a penalty. Payments will be credited to your account as of the date received.
- \* **TELEPHONE NUMBER.** Please furnish telephone number on return portion of your bill if not shown.
- \* **QUESTION OR COMMENT.** Please write your question or comment on the back of the return portion of your bill.



**Escambia River Electric Coop., Inc.**  
 P O Box 428 • Jay, FL 32565-0428  
 (850) 675-4521 or 1-800-235-3848  
 Office Hours: 7:30 A.M. - 4:00 P.M. Monday- Friday  
 www.erec.com

ACCOUNT NUMBER	NAME		RATE	CLASS	METER NUMBER	LOCATION NUMBER	SERVICE ADDRESS	
1119005	TOWN OF CENTURY		2	1	20940471	16014055	WILLIAMS ST	
SERVICE PERIOD		NO. DAYS	RDG CODE	METER READING		METER MULTIPLIER	KWH/GAL USAGE	CHARGES
FROM	TO			PREVIOUS	PRESENT			
03/01/25	04/01/25	31	0	3687	3714	1	27	47.97
0.020000 PURCHASED POWER COST ADJ							27	0.54
CITY/COUNTY FRANCHISE TAX								2.91
STATE GROSS RECEIPTS TAX								1.31
TOTAL CURRENT ELECTRIC BILL DUE 05/01/25								52.73
PREVIOUS AMOUNT DUE								54.41
THANK YOU FOR YOUR PAYMENT 04/08/25								-52.02
PREVIOUS UNPAID BALANCE								2.39
TOTAL AMOUNT DUE								55.12
(CURRENT BILL DUE DATE DOES NOT APPLY TO THE PREVIOUS UNPAID BALANCE)								
BILLING DATE	PAST DUE AFTER		ADD THIS AMOUNT AFTER PAST DUE		TOTAL DUE NOW		\$	
04/15/25	05/01/25		2.42		AFTER DUE DATE PAY		\$ 57.54	

**COMPARISONS**

	DAYS SERVICE	TOTAL KWH	AVG. KWH/DAY	COST PER DAY
CURRENT BILLING PERIOD	31	27	1	1.56
PREVIOUS BILLING PERIOD	28	22	1	1.71
SAME PERIOD LAST YEAR	31	27	1	1.47

**MESSAGE**

**WE HOPE TO SEE YOU AT OUR ANNUAL MEETING ON APRIL 26. FESTIVITIES BEGIN AT 8 AM; BUSINESS MEETING BEGINS AT 10 AM. YOU CAN VOTE BY ABSENTEE, MAIL IN OR IN PERSON.**

Your Electricity Use Over The Last 13 Months

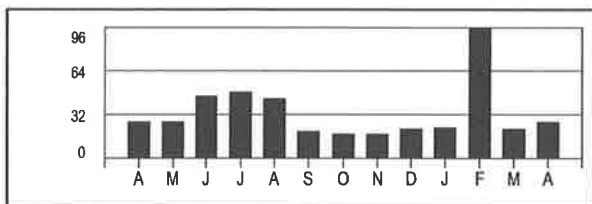

**IMPORTANT INFORMATION**

- \* **PAST DUE BILLS.** An unpaid bill becomes delinquent 15 days after the bill date and is subject to a penalty. Payments will be credited to your account as of the date received.
- \* **TELEPHONE NUMBER.** Please furnish telephone number on return portion of your bill if not shown.
- \* **QUESTION OR COMMENT.** Please write your question or comment on the back of the return portion of your bill.

**RETAIN THIS COPY FOR YOUR RECORDS**



Environment Testing

<b>Invoice No.</b>	4000158420	<b>Invoice Date</b>	April 16, 2025
<b>Terms</b>	Net 30 days	<b>Federal Tax ID</b>	87-2895395
<b>Remit to</b>	Eurofins Environment Testing Southeast, LLC, PO BOX 3213, Carol Stream, IL 60132-3213		
<b>Wire</b>	Citibank ABA: 031100209 Acct# 54064616 SWIFT Code: CITIUS33		
<b>ACH</b>	Citibank ABA: 031100209 Acct# 54064616 SWIFT Code: CITIUS33		

<b>Bill to:</b>
Town of Century Attn: Accounts Payable 7995 N Century Blvd Century, FL 32535

<b>Ship to:</b>
Town of Century 7995 N Century Blvd Century, FL 32535

<b>P.O. Number</b>	<b>W.O. Number</b>	<b>Contract Number</b>	<b>Work Ordered by</b>
Purchase Order not required			Bob Johnson
<b>Job Description</b>	<b>Site Name</b>	<b>SDG Number</b>	<b>Invoice Contact</b>
See below			Alicia Johnson

Job No.	Job Description	Receipt Date	Quantity	Unit Price	Amount
Method/Test Description					
<b>J273662-1</b>	<b>Monthly Testing</b>	<b>04/04/2025</b>			
	SM 2540D - Solids, Total Suspended (TSS)		2.00	15.00	30.00
	350.1 - Nitrogen, Ammonia		1.00	20.00	20.00
	351.2 - Nitrogen, Total Kjeldahl		1.00	30.00	30.00
	353.2 - Nitrogen, Nitrate-Nitrite		1.00	20.00	20.00
	365.4 - Phosphorus, Total		1.00	20.00	20.00
	SM 9222D - Coliforms, Fecal (Membrane Filter)		1.00	25.00	25.00
	SM 9223 - Coliforms, Total, and E.Coli (Colilert - Quanti Tray)		1.00	35.00	35.00
	Total Nitrogen - Nitrogen, Total		1.00	10.00	10.00
	SM5210B CBOD - Carbonaceous BOD, 5 Day		2.00	25.00	50.00
	Safe and Environmentally Responsible Waste Management (per sample)		3.00	5.00	15.00

<b>Project Number</b>	<b>Client Number</b>	<b>Project Manager</b>	<b>Subtotal (USD)</b>	<b>\$255.00</b>
40010692	4100570	Cheyenne Whitmire		
<b>Latest Sample Receipt Date</b>	<b>Latest Report Date</b>	<b>Phone Number</b>	<b>Total (USD)</b>	<b>\$255.00</b>
04/04/2025	04/16/2025	(850) 471-6222		

For proper credit, please include invoice number on all remittance.

Eurofins Pensacola - 3355 McLemore Drive, Pensacola, FL 32514

This invoice falls under Eurofins Environment Testing Southeast, LLC Standard T&C's of Net 30 Days unless superseded by another valid contract vehicle in place at the time these services were rendered.





Environment Testing

<b>Invoice No.</b>	4000158740	<b>Invoice Date</b>	April 18, 2025
<b>Terms</b>	Net 30 days	<b>Federal Tax ID</b>	87-2895395
<b>Remit to</b>	Eurofins Environment Testing Southeast, LLC, PO BOX 3213, Carol Stream, IL 60132-3213		
<b>Wire</b>	Citibank ABA: 031100209 Acct# 54064616 SWIFT Code: CITIUS33		
<b>ACH</b>	Citibank ABA: 031100209 Acct# 54064616 SWIFT Code: CITIUS33		

Bill to:
Town of Century Attn: Accounts Payable 7995 N Century Blvd Century, FL 32535

Ship to:
Town of Century 7995 N Century Blvd Century, FL 32535

<b>P.O. Number</b>	<b>W.O. Number</b>	<b>Contract Number</b>	<b>Work Ordered by</b>
Purchase Order not required			Bob Johnson
<b>Job Description</b>	<b>Site Name</b>	<b>SDG Number</b>	<b>Invoice Contact</b>
See below			Alicia Johnson

Job No.	Job Description	Receipt Date	Quantity	Unit Price	Amount
	Method/Test Description				
J274443-1	Bacti	04/17/2025	6.00	35.00	210.00
	SM 9223B - Coliforms, Total, and E.Coli (Colilert - Presence/Absence)		6.00	5.00	30.00
	Safe and Environmentally Responsible Waste Management (per sample)				

<b>Project Number</b>	<b>Client Number</b>	<b>Project Manager</b>	<b>Subtotal (USD)</b>	<b>\$240.00</b>
40010692	4100570	Cheyenne Whitmire		
<b>Latest Sample Receipt Date</b>	<b>Latest Report Date</b>	<b>Phone Number</b>	<b>Total (USD)</b>	<b>\$240.00</b>
04/17/2025	04/18/2025	(850) 471-6222		

For proper credit, please include invoice number on all remittance.

Eurofins Pensacola - 3355 McLemore Drive, Pensacola, FL 32514

This invoice falls under Eurofins Environment Testing Southeast, LLC Standard T&C's of Net 30 Days unless superseded by another valid contract vehicle in place at the time these services were rendered.

# Chain of Custody Record

Section 3, Item A.

<b>Client Information</b>		Lab PM: Whitmire, Cheyenne R		Center Tracking No(s): 400-137776-43050.1		
Client Contact: Bob Johnson		E-Mail: Cheyenne.Whitmire@et.eurofinsus.com		Page: Page 1 of 1		
Company: Town of Century		PWSID:		Job #:		
Address: 7995 N Century Blvd		Due Date Requested:		Preservation Codes: R - NaThioSO4		
City: Century		TAT Requested (days):		Other:		
State, Zip: FL, 32535		Compliance Project: <input type="checkbox"/> Yes <input type="checkbox"/> No		Special Instructions/Note:		
Phone: 448-207-9989(Tel)		PO #: Purchase Order not required		<div style="text-align: center;">             400-274443 Chain of Custody         </div>		
Email: Bbj4671@gmail.com		WO #:				
Project Name: Bacti		Project #: 400-10692				
Site:		SSOW#:				
Sample Identification		Sample Date	Sample Time	Sample Type (C=Comp, G=grab)	Matrix (Water, Sewage, Stormwater, Other)	BT#(TASUS, AVAL)
Well #1		4-17-25	11:00	G	Water	
Well #2		4-17-25	11:10	G	Water	
10 Taddy Road		4-17-25	11:25	G	Water	
930 Campbell Road		4-17-25	11:40	G	Water	
917 Fannie Road		4-17-25	11:55	G	Water	
2900 N. Century Blvd		4-17-25	10:50	G	Water	
<b>Possible Hazard Identification</b> <input type="checkbox"/> Non-Hazard <input type="checkbox"/> Flammable <input type="checkbox"/> Skin Irritant <input type="checkbox"/> Poison B <input type="checkbox"/> Unknown <input type="checkbox"/> Radiological <b>Deliverable Requested:</b> I, II, III, IV, Other (specify)						
<b>Empty Kit Relinquished by:</b> Date: Time: Method of Shipment:						
Relinquished by: Bob Johnson		Date: 4-17-25		Time: 3:15		Company: TOC
Relinquished by:		Date/Time:		Date/Time:		Company:
Relinquished by:		Date/Time:		Date/Time:		Company:
Custody Seals Intact: <input type="checkbox"/> Yes <input type="checkbox"/> No		Custody Seal No.:		Date/Time: 4/17/25		Company: 136
				Cooler Temperature(s) °C and Other Remarks: 0.0C #8		Company:



Environment Testing

<b>Invoice No.</b>	4000158998	<b>Invoice Date</b>	April 25, 2025
<b>Terms</b>	Net 30 days	<b>Federal Tax ID</b>	87-2895395
<b>Remit to</b>	Eurofins Environment Testing Southeast, LLC, PO BOX 3213, Carol Stream, IL 60132-3213		
<b>Wire</b>	Citibank ABA: 031100209 Acct# 54064616 SWIFT Code: CITIUS33		
<b>ACH</b>	Citibank ABA: 031100209 Acct# 54064616 SWIFT Code: CITIUS33		

Bill to:
Town of Century Attn: Accounts Payable 7995 N Century Blvd Century, FL 32535

Ship to:
Town of Century 7995 N Century Blvd Century, FL 32535

<b>P.O. Number</b>	<b>W.O. Number</b>	<b>Contract Number</b>	<b>Work Ordered by</b>
Purchase Order not required			Bob Johnson
<b>Job Description</b>	<b>Site Name</b>	<b>SDG Number</b>	<b>Invoice Contact</b>
See below			Alicia Johnson

Job No.	Job Description	Receipt Date	Quantity	Unit Price	Amount
	Method/Test Description				
J274105-1	<b>Monthly Testing + Metals</b>	<b>04/11/2025</b>			
	SM 2540D - Solids, Total Suspended (TSS)		2.00	15.00	30.00
	350.1 - Nitrogen, Ammonia		1.00	20.00	20.00
	351.2 - Nitrogen, Total Kjeldahl		1.00	30.00	30.00
	353.2 - Nitrogen, Nitrate-Nitrite		1.00	20.00	20.00
	365.4 - Phosphorus, Total		1.00	20.00	20.00
	SM 9222D - Coliforms, Fecal (Membrane Filter)		1.00	25.00	25.00
	SM 9223 - Coliforms, Total, and E.Coli (Colilert - Quanti Tray)		1.00	35.00	35.00
	Total Nitrogen - Nitrogen, Total		1.00	10.00	10.00
	SM5210B CBOD - Carbonaceous BOD, 5 Day		2.00	25.00	50.00
	200.7 Rev 4.4 - Total Recoverable Cu		1.00	40.00	40.00
	2340C-2011 - Hardness, Total (mg/l as CaCO3)		1.00	25.00	25.00
	Safe and Environmentally Responsible Waste Management (per sample)		3.00	5.00	15.00

<b>Project Number</b>	<b>Client Number</b>	<b>Project Manager</b>	<b>Subtotal (USD)</b>	<b>\$320.00</b>
40010692	4100570	Cheyenne Whitmire		
<b>Latest Sample Receipt Date</b>	<b>Latest Report Date</b>	<b>Phone Number</b>	<b>Total (USD)</b>	<b>\$320.00</b>
04/11/2025	04/23/2025	(850) 471-6222		

For proper credit, please include invoice number on all remittance.

Eurofins Pensacola - 3355 McLemore Drive, Pensacola, FL 32514

This invoice falls under Eurofins Environment Testing Southeast, LLC Standard T&C's of Net 30 Days unless superseded by another valid contract vehicle in place at the time these services were rendered.

<b>Client Information</b>		Sampler: <b>Bob Johnson</b>		Lab Pk: <b>Whitmore, Cheyenne R</b>		Carrier Tracking No(s):		COG No: <b>400-137766-43049.1</b>	
Client Contact: <b>Bob Johnson</b>		Phone: <b>448-207-9989</b>		E-Mail: <b>Cheyenne.Whitmore@et.eurofins.com</b>		State of Origin:		Page: <b>1 of 1</b>	
Company: <b>Town of Century</b>		RVSID:		Analysis Requested		Job #:		Preservation Codes: N - None S - H2SO4 D - HNO3 R - NaThioSO4	
Address: <b>7995 N Century Blvd</b>		Due Date Requested:		2540D - TSS		351.2, 353.2, Pres, Nitrogen, Total		350.1, 356.4	
City: <b>Century</b>		TAT Requested (days):		9M510B, CBOD, SD - CBOD		2340C - Hardness		200.7, CWA - Copper	
State, Zip: <b>FL, 32535</b>		Compliance Project: <input type="checkbox"/> Yes <input checked="" type="checkbox"/> No		Sample Date		9222D - Fecal		9223, Coliforms - QT	
Phone: <b>448-207-9989(Tel)</b>		Purchase Order not required		Sample Time		200.7, CWA - Copper		Special Instructions/Note:	
Email: <b>Bb4671@gmail.com</b>		PO #:		Sample Type (C=Comp, G=grab)		2340C - Hardness		400-274105 Chain of Custody	
Project Name: <b>Monthly Testing + Metals</b>		Project #: <b>40010692</b>		Matrix (Water, Swab, Composite, Other)		350.1, 356.4			
Site: <b></b>		SOW#:		Sample Date		351.2, 353.2, Pres, Nitrogen, Total			
<b>Sample Identification</b>		<b>Sample Identification</b>		<b>Sample Identification</b>		<b>Sample Identification</b>		<b>Sample Identification</b>	
INF COMP	4-11-25	11:00	C	Water	KK				
EFF COMP	4-11-25	11:10	C	Water	KA	KA	KA	KA	PH C. 38
EFF GRAB	4-11-25	11:20	G	Water	KK	KK	KK	KK	
Possible Hazard Identification <input type="checkbox"/> Non-Hazard <input type="checkbox"/> Flammable <input type="checkbox"/> Skin Irritant <input type="checkbox"/> Poison B <input type="checkbox"/> Unknown <input type="checkbox"/> Radiological Deliverable Requested: I, II, III, IV, Other (specify)									
Sample Disposal (A fee may be assessed if samples are retained longer than 1 month) <input type="checkbox"/> Return To Client <input type="checkbox"/> Disposal By Lab <input type="checkbox"/> Archive For _____ Months									
Special Instructions/QC Requirements:									
Empty Kit Relinquished by:		Date:		Time:		Method of Shipment:		Company:	
Relinquished by: <b>Bob Johnson</b>		4-11-25 2:35p		10C		Company		Company	
Relinquished by:		Date/Time:		Date/Time:		Date/Time:		Date/Time:	
Relinquished by:		Date/Time:		Date/Time:		Date/Time:		Date/Time:	
Custody Seals Intact: <input type="checkbox"/> Yes <input checked="" type="checkbox"/> No		Custody Seal No.:		Cooler Temperature(s) °C and Other Remarks:		4/11/25 1435		B.P.	
						0.0		10/10/2024	



<b>Invoice No.</b>	4000159058	<b>Invoice Date</b>	April 25, 2025
<b>Terms</b>	Net 30 days	<b>Federal Tax ID</b>	87-2895395
<b>Remit to</b>	Eurofins Environment Testing Southeast, LLC, PO BOX 3213, Carol Stream, IL 60132-3213		
<b>Wire</b>	Citibank ABA: 031100209 Acct# 54064616 SWIFT Code: CITIUS33		
<b>ACH</b>	Citibank ABA: 031100209 Acct# 54064616 SWIFT Code: CITIUS33		

<b>Bill to:</b>
Town of Century Attn: Accounts Payable 7995 N Century Blvd Century, FL 32535

<b>Ship to:</b>
Town of Century 7995 N Century Blvd Century, FL 32535

<b>P.O. Number</b>	<b>W.O. Number</b>	<b>Contract Number</b>	<b>Work Ordered by</b>
Purchase Order not required			Bob Johnson
<b>Job Description</b>	<b>Site Name</b>	<b>SDG Number</b>	<b>Invoice Contact</b>
See below			Alicia Johnson

Job No.	Job Description	Receipt Date	Quantity	Unit Price	Amount
	Method/Test Description				
J274442-1	<b>Monthly Testing</b>	<b>04/17/2025</b>			
	SM 2540D - Solids, Total Suspended (TSS)		2.00	15.00	30.00
	350.1 - Nitrogen, Ammonia		1.00	20.00	20.00
	351.2 - Nitrogen, Total Kjeldahl		1.00	30.00	30.00
	353.2 - Nitrogen, Nitrate-Nitrite		1.00	20.00	20.00
	365.4 - Phosphorus, Total		1.00	20.00	20.00
	SM 9222D - Coliforms, Fecal (Membrane Filter)		1.00	25.00	25.00
	SM 9223 - Coliforms, Total, and E.Coli (Colilert - Quanti Tray)		1.00	35.00	35.00
	Total Nitrogen - Nitrogen, Total		1.00	10.00	10.00
	SM5210B CBOD - Carbonaceous BOD, 5 Day		2.00	25.00	50.00
	Safe and Environmentally Responsible Waste Management (per sample)		3.00	5.00	15.00

<b>Project Number</b>	<b>Client Number</b>	<b>Project Manager</b>	<b>Subtotal (USD)</b>	<b>\$255.00</b>
40010692	4100570	Cheyenne Whitmire		
<b>Latest Sample Receipt Date</b>	<b>Latest Report Date</b>	<b>Phone Number</b>	<b>Total (USD)</b>	<b>\$255.00</b>
04/17/2025	04/25/2025	(850) 471-6222		

For proper credit, please include invoice number on all remittance.

This invoice falls under Eurofins Environment Testing Southeast, LLC Standard T&C's of Net 30 Days unless superseded by another valid contract vehicle in place at the time these services were rendered.



# FERGUSON® WATERWORKS

133 SHANNON LANE  
SANTA ROSA BEACH, FL 32459

Please contact with Questions: 850-622-9166

8835 1 MB 0.622 E0065X I0108 D14246207558 S2 P10781110 0001:0001



TOWN OF CENTURY  
7995 N CENTURY BLVD  
CENTURY FL 32535-1621

INVOICE NUMBER	TOTAL DUE	CUSTOMER NUMBER	Section 3, Item A.
1586201	\$599.00	51861	1 of 1

**PLEASE REFER TO INVOICE NUMBER WHEN  
MAKING PAYMENT AND REMIT TO:**

FERGUSON WATERWORKS #1204  
PO BOX 100286  
ATLANTA, GA 30384-0286

**MASTER ACCOUNT NUMBER: 797285**

**SHIP TO:**

COUNTER PICK UP  
8769 ELY RD  
PENSACOLA, FL 32514

SHIP WHSE.	SELL WHSE.	TAX CODE	CUSTOMER ORDER NUMBER	SALESMAN	JOB NAME	INVOICE DATE	BATCH
335	335	FLE	KEVIN	CJN	MIXED MATERIAL	04/21/25	JO 104106

ORDERED	SHIPPED	ITEM NUMBER	DESCRIPTION	UNIT PRICE	UM	AMOUNT
2		K86054008816	3 HYMAX 2 FLIP REP COUP 3.46-4.33	232.300	EA	464.60
2		SSLCEP3	3 PVC WDG REST GLND PK *ONELOK	67.200	EA	134.40
<b>INVOICE SUB-TOTAL</b>						<b>599.00</b>

LEAD LAW WARNING: IT IS ILLEGAL TO INSTALL PRODUCTS THAT ARE NOT "LEAD FREE" IN ACCORDANCE WITH US FEDERAL OR OTHER APPLICABLE LAW IN POTABLE WATER SYSTEMS ANTICIPATED FOR HUMAN CONSUMPTION. PRODUCTS WITH \*NP IN THE DESCRIPTION ARE NOT LEAD FREE AND CAN ONLY BE INSTALLED IN NON-POTABLE APPLICATIONS. BUYER IS SOLELY RESPONSIBLE FOR PRODUCT SELECTION.

Looking for a more convenient way to pay your bill?

Log in to **Ferguson.com** and request access to Online Bill Pay.



TERMS: NET 10TH PROX	ORIGINAL INVOICE	TOTAL DUE	\$599.00
----------------------	------------------	-----------	----------

All past due amounts are subject to a service charge of 1.5% per month, or the maximum allowed by law, if lower. If Buyer fails to pay within terms, then in addition to other remedies, Buyer agrees to pay Seller all costs of collection, including reasonable attorney fees. Complete terms and conditions are available upon request or at <https://www.ferguson.com/content/website-info/terms-of-sale>, incorporated by reference. Seller may convert checks to ACH.

# FERGUSON® WATERWORKS

133 SHANNON LANE  
SANTA ROSA BEACH, FL 32459

Please contact with Questions: 850-622-9166

2925 1 MB 0.622 E0143X I0246 D14240618964 S2 P10779128 0001:0001



TOWN OF CENTURY  
7995 N CENTURY BLVD  
CENTURY FL 32535-1621

INVOICE NUMBER	TOTAL DUE	CU	Section 3, ItemA.
1566906-1	\$388.80	51861	1 of 1

**PLEASE REFER TO INVOICE NUMBER WHEN  
MAKING PAYMENT AND REMIT TO:**

FERGUSON WATERWORKS #1204  
PO BOX 100286  
ATLANTA, GA 30384-0286

**MASTER ACCOUNT NUMBER: 797285**

**SHIP TO:**

TOWN OF CENTURY  
7860 ALGER RD  
CENTURY, FL 32535

SHIP WHSE.	SELL WHSE.	TAX CODE	CUSTOMER ORDER NUMBER	SALESMAN	JOB NAME	INVOICE DATE	BATCH
335	335	FLE	KEVIN	CJN	STOCK MATERIAL	04/18/25	IO 104094

ORDERED	SHIPPED	ITEM NUMBER	DESCRIPTION	UNIT PRICE	UM	AMOUNT
12	12	FC0433GNL	LF 3/4 FCTH X CTS GRIP COUP	32.400	EA	388.80
<b>INVOICE SUB-TOTAL</b>						<b>388.80</b>

\*\*\*\*\*  
LEAD LAW WARNING: IT IS ILLEGAL TO INSTALL PRODUCTS THAT ARE NOT "LEAD FREE" IN ACCORDANCE WITH US FEDERAL OR OTHER APPLICABLE LAW IN POTABLE WATER SYSTEMS ANTICIPATED FOR HUMAN CONSUMPTION. PRODUCTS WITH \*NP IN THE DESCRIPTION ARE NOT LEAD FREE AND CAN ONLY BE INSTALLED IN NON-POTABLE APPLICATIONS. BUYER IS SOLELY RESPONSIBLE FOR PRODUCT SELECTION.

Looking for a more convenient way to pay your bill?

Log in to **Ferguson.com** and request access to Online Bill Pay.



TERMS: NET 10TH PROX	ORIGINAL INVOICE	TOTAL DUE	\$388.80
----------------------	------------------	-----------	----------

All past due amounts are subject to a service charge of 1.5% per month, or the maximum allowed by law, if lower. If Buyer fails to pay within terms, then in addition to other remedies, Buyer agrees to pay Seller all costs of collection, including reasonable attorney fees. Complete terms and conditions are available upon request or at <https://www.ferguson.com/content/website-info/terms-of-sale>, incorporated by reference. Seller may convert checks to ACH.

Original



Hawkins, Inc.  
2381 Rosegate  
Roseville, MN 55113  
Phone: (612) 331-6910

# INVOICE

Total Invoice **\$3,952.50**  
 Invoice Number **7048858**  
 Invoice Date **4/25/25**  
 Sales Order Number/Type **4795065 SL**  
 Branch Plant **87**  
 Shipment Number **5736229**

**Sold To:** 417033  
 Accounts Payable  
 TOWN OF CENTURY  
 PO BOX 790  
 ACCOUNTS PAYABLE  
 Century FL 32535-0790

**Ship To:** 417033  
 TOWN OF CENTURY  
 PO BOX 790  
 ACCOUNTS PAYABLE  
 Century FL 32535-0790

Net Due Date	Terms	FOB Description	Ship Via	Customer P.O.#	P.O. Release	Sales Agent #
6/9/25	Net 45	PPD Origin	HWTG			372

Line #	Item Number	Item Name/ Description	Tax	Qty Shipped	Trans UOM	Unit Price	Price UOM	Weight Net/Gross	Extended Price
1.000	4800	Chlorine - EPA Reg. No. 7870-2	N	7.0000	CY	\$253.5000	CY	1,050.0 LB	\$1,774.50
		150 LB CYL		7.0000	CY			1,833.3 GW	
		Customer Item #: L1128565							

*Demurrage charges may be invoiced if not returned timely.*

Container Barcodes: 096183, 096565, 096690, 115286, 115349, 115556, 126187

1.001	699913	150 LB Chlorine Cylinder	N	7.0000	CY	\$0.0000	RT	.0 LB	\$0.00
		CYL 3AA480		7.0000	RT			700.0 GW	

Related Order #: 4795065

1.010	Fuel Surcharge	Freight	N	1.0000	EA	\$50.0000			\$50.00
-------	----------------	---------	---	--------	----	-----------	--	--	---------

2.000	18350	Sulfur Dioxide	N	7.0000	CY	\$304.0000	CY	1,050.0 LB	\$2,128.00
		150 LB CYL		7.0000	CY			1,750.0 GW	

*Demurrage charges may be invoiced if not returned timely.*

Container Barcodes: 089080, 089140, 099826, 110281, 110774, 120576, 127333

2.001	699938	150 LB Sulfur Dioxide Cylinder	N	7.0000	CY	\$0.0000	RT	.0 LB	\$0.00
		Cylinder Only (150 LB)		7.0000	RT			700.0 GW	

Tax Rate  
0 %

Sales Tax  
\$0.00

Invoice Total

Continued on next page

**No Discounts on Freight**  
**IMPORTANT:** All products are sold without warranty of any kind and purchasers will, by their own tests, determine suitability of such products for their own use. Seller warrants that all goods covered by this invoice were produced in compliance with the requirements of the Fair Labor Standards Act of 1938, as amended. Seller specifically disclaims and excludes any warranty of merchantability and any warranty of fitness for a particular purpose.  
**NO CLAIMS FOR LOSS, DAMAGE OR LEAKAGE ALLOWED AFTER DELIVERY IS MADE IN GOOD CONDITION.**

**CHECK REMITTANCE:**  
 Hawkins, Inc.  
 P.O. Box 860263  
 Minneapolis, MN 55486-0263

**WIRING CONTACT INFORMATION:**  
 Email: Credit.Dept@Hawkinsinc.com  
 Phone Number: (612) 331-6910  
 Fax Number: (612) 225-6702

**FINANCIAL INSTITUTION:**  
 US Bank  
 800 Nicollet Mall  
 Minneapolis, MN 55402

Account Name: Hawkins, Inc.  
 Account #: 180120759469  
 ABA/Routing #: 091000022  
 Swift Code#: USBKUS441MT  
 Type of Account: Corporate Checking

**ACH PAYMENTS:**  
 CTX (Corporate Trade Exchange) is our preferred method. Please remember to include in the addendum the document numbers pertaining to the payment.  
 For other than CTX, the remit to information may be emailed to Credit.Dept@Hawkinsinc.com

**CASH IN ADVANCE/EFT PAYMENTS:**  
 Please list the Hawkins, Inc. sales order number or your purchase order number if the invoice has not been processed yet.

Original

# INVOICE



Hawkins, Inc.  
2381 Rosegate  
Roseville, MN 55113  
Phone: (612) 331-6910

Total Invoice **\$3,952.50**  
Invoice Number **7048858**  
Invoice Date **4/25/25**  
Sales Order Number/Type **4795065 SL**  
Branch Plant **87**  
Shipment Number **5736229**

Line #	Item Number	Item Name/ Description	Tax	Qty Shipped	Trans UOM	Unit Price	Price UOM	Weight Net/Gross	Extended Price
--------	-------------	---------------------------	-----	----------------	--------------	---------------	--------------	---------------------	-------------------

Continued from previous page

Related Order #: 4795065

\*\*\*\*\* Receive Your Invoice Via Email \*\*\*\*\*

Please contact our Accounts Receivable Department via email at [Credit.Dept@HawkinsInc.com](mailto:Credit.Dept@HawkinsInc.com) or call 612-331-6910 to get it setup on your account.

Tax Rate **0 %**  
Sales Tax **\$0.00**

**Invoice Total \$3,952.50**

**No Discounts on Freight**  
**IMPORTANT:** All products are sold without warranty of any kind and purchasers will, by their own tests, determine suitability of such products for their own use. Seller warrants that all goods covered by this invoice were produced in compliance with the requirements of the Fair Labor Standards Act of 1938, as amended. Seller specifically disclaims and excludes any warranty of merchantability and any warranty of fitness for a particular purpose.  
**NO CLAIMS FOR LOSS, DAMAGE OR LEAKAGE ALLOWED AFTER DELIVERY IS MADE IN GOOD CONDITION.**

**CHECK REMITTANCE:**  
Hawkins, Inc.  
P.O. Box 860263  
Minneapolis, MN 55486-0263  
  
**WIRING CONTACT INFORMATION:**  
Email: [Credit.Dept@Hawkinsinc.com](mailto:Credit.Dept@Hawkinsinc.com)  
  
Phone Number: (612) 331-6910  
Fax Number: (612) 225-6702

**FINANCIAL INSTITUTION:**  
US Bank  
800 Nicollet Mall  
Minneapolis, MN 55402  
  
Account Name: Hawkins, Inc.  
Account #: 180120759469  
ABA/Routing #: 091000022  
Swift Code#: USBKUS44IMT  
Type of Account: Corporate Checking

**ACH PAYMENTS:**  
CTX (Corporate Trade Exchange) is our preferred method. Please remember to include in the addendum the document numbers pertaining to the payment.  
For other than CTX, the remit to information may be emailed to [Credit.Dept@Hawkinsinc.com](mailto:Credit.Dept@Hawkinsinc.com)  
  
**CASH IN ADVANCE/EFT PAYMENTS:**  
Please list the Hawkins, Inc. sales order number or your purchase order number if the invoice has not been processed yet.



700002464  
 JHB AUTO PARTS LLC.  
 P O BOX 702  
 Milton, FL 32572  
 (251) 296-3445

Invoice Number 112779 Page: 1/1

Invoice Date: 04/17/2025

Section 3, ItemA.



eInvoice# JAX00464112779

850  
 Town Of Century  
 P O Drawer 790  
 Century, FL 32535-0000

Employee: 25 , Zac  
 Sales Rep: 0 , Salesman  
 Accounting Day: 15  
 Tax Exemption:

Attention:  
 PO#:  
 Delivery:  
 Terms: NET 30

Part Number	Line	Description	Quantity	Price	Net	Total	
400110	FIL	OIL FILTER	1.00	130.34	39.1000	39.10	TR
550045126	SHE	ROT T4 15W40 1GL	3.00	38.04	17.2900	51.87	T
		Above Item on Sale					

Water Dept.  
 465-000

ON ACCOUNT

ALL GOODS RETURNED MUST BE ACCOMPANIED BY THIS INVOICE

Customer Signature

INSIST ON THE BEST  
 NAPA..WHERE THE STANDARD  
 IS QUALITY!!!

Tender Type: Amount:  
 Charge Sale 90.97

Subtotal 90.97  
 TAXTABLE 4 0.0000% 0.00

Total 90.97

**MUNICIPAL ENGINEERING SERVICES, Inc.**

Excellence in Engineering Service

**INVOICE**

Date: **7-Apr-2025**  
Invoice No. **250043**

**Ms. Carrie Moore**  
**Town Clerk**  
**Town of Century**  
**PO Box 790**  
**Century, FL 32535**

Project: **150004-003 Miscellaneous Engineering Services**  
Professional Services: *March 5, 2025 through April 1, 2025*  
Task Order No. **MES-1**

Description: **Correspond with client and FPL regarding prison generator replacement. Prepare grant summary for Auditors. Correspond with ECRC and resident at 9600 Shady Lane regarding placing a new driveway.**

	Hours	Hourly Rate	Amount Earned
Sr. Project Manager		\$165.00	\$0.00
Sr. Professional Engineer	3.00	\$150.00	\$450.00
Professional Engineer		\$125.00	\$0.00
Design Engineer		\$78.00	\$0.00
CAD Technician		\$85.00	\$0.00
Clerical		\$55.00	\$0.00

**Total This Work Task \$450.00**

Direct Expenses

Mileage Rate =	\$0.625	per mile
Miles Driven =	0.0	miles
Total Mileage Expenses =	\$0.00	
<b>Total Direct Expenses =</b>	<b>\$0.00</b>	

**AMOUNT DUE THIS INVOICE: \$450.00**

*a*

**Municipal Engineering Services Appreciates your Patronage.**  
Prompt Payment is Appreciated. Payment should be submitted to the address below.  
Should you have any questions or concerns, please contact us.

INVOICE

Date: 7-Apr-2025
Invoice No. 250045

Ms. Carrie Moore
Town Clerk
Town of Century
PO Box 790
Century, FL 32535

Project: 150004-020 Consent Order (OGC File 22-1893)
Professional Services: February 5, 2025 through April 1, 2025
Task Order No. MES-19

Description: Correspond with client and client's attorney and prepare response to FDEP 2/25/2025 comments.

Table with 4 columns: Job Title, Hours, Hourly Rate, Amount Earned. Rows include Sr. Project Manager, Sr. Professional Engineer, Professional Engineer, Design Engineer, CAD Technician, and Clerical.

Total This Work Task \$3,255.00

Direct Expenses
Mileage Rate = \$0.625 per mile
Miles Driven = 0.0 miles
Total Direct Expenses = \$0.00

AMOUNT DUE THIS INVOICE: \$3,255.00

Municipal Engineering Services Appreciates your Patronage.
Prompt Payment is Appreciated. Payment should be submitted to the address below.
Should you have any questions or concerns, please contact us.

# MUNICIPAL ENGINEERING SERVICES, Inc.

Excellence in Engineering Service

## INVOICE

Date: **7-Apr-2025**  
Invoice No. **250049**

Ms. Carrie Moore  
Town Clerk  
Town of Century  
PO Box 790  
Century, FL 32535

Project: **150004-014 WW System Misc. Impr. Phase II - LS Rehab, Prison Bar Screen/Gen., and WWTP Rehab (Construction Phase)**

Professional Services: *February 5, 2025 through April 1, 2025*

### LUMP SUM WORK

Phase / Task	Fee	Percent Complete	Amount Earned	Previously Billed	Current Amount
Cultural Resources Assessment Survey (CRAS)	\$7,125.00	100.00%	\$7,125.00	\$7,125.00	\$0.00
Concrete Tankage Structural Evaluation (Structural Engineer)	\$62,150.00	100.00%	\$62,150.00	\$62,150.00	\$0.00
Final Design Plan Revisions	\$25,000.00	100.00%	\$25,000.00	\$25,000.00	\$0.00
Bidding	\$8,000.00	100.00%	\$8,000.00	\$8,000.00	\$0.00
Bidding (Structural Engineer)	\$2,310.00	100.00%	\$2,310.00	\$2,310.00	\$0.00
Construction Administration/Monitoring (Structural Engineer)	\$23,540.00	8.00%	\$1,883.20	\$0.00	\$1,883.20
Construction Administration/Monitoring (CA/CM)	\$222,560.00	10.00%	\$22,256.00	\$11,128.00	\$11,128.00
Grant/Loan Admin	\$20,000.00	30.00%	\$6,000.00	\$6,000.00	\$0.00
<b>MES Totals</b>	<b>\$370,685.00</b>	<b>36.34%</b>	<b>\$134,724.20</b>	<b>\$121,713.00</b>	<b>\$13,011.20</b>

**AMOUNT DUE THIS INVOICE: \$13,011.20**

*DL*

**Municipal Engineering Services Appreciates your Patronage.**  
Prompt Payment is Appreciated. Payment should be submitted to the address below.  
Should you have any questions or concerns, please contact us.



**JOE DEREUIL ASSOCIATES, LLC**  
**STRUCTURAL ENGINEERS**

150004-014  
Billed on Invoice No.  
250049

April 7, 2025  
22138

Municipal Engineering Services  
8574 Turkey Bluff Rd.  
Navarre, FL 32566

RE: **Town of Century WWTP Tankage Leak Assessment and Repair**  
JDA Project #: 22138

**INVOICE #22138-06**

Structural Engineering Services:  
(Fee As Agreed: \$80,000)

Task 4	Submittal Review/RFI/Pre-Con	50%	\$1,850.00
--------	------------------------------	-----	------------

<b>Total Due This Invoice:</b>	<b>\$1,850.00</b>	Ok to Pay When Paid DEL
--------------------------------	-------------------	-------------------------------

**Please remit payment by check to:**  
**Joe DeReuil Associates**  
**301 West Cervantes Street**  
**Pensacola, FL 32501**

# MUNICIPAL ENGINEERING SERVICES, Inc.

Excellence in Engineering Service

## INVOICE

Date: **7-Apr-2025**  
 Invoice No. **250050**

Ms. Carrie Moore  
 Town Clerk  
 Town of Century  
 PO Box 790  
 Century, FL 32535

Project: **150004-027 Miscellaneous Water System Improvements**  
 Professional Services: *February 27, 2025 through April 1, 2025*  
 Task Order No. **MES-31**

### LUMP SUM WORK

Phase / Task	Fee	Percent Complete	Amount Earned	Previously Billed	Current Amount
<b>PLANNING DOCUMENT</b>	<b>\$40,000.00</b>	<b>0.00%</b>	<b>\$0.00</b>	<b>\$0.00</b>	<b>\$0.00</b>
Facilities Plan Development	\$40,000.00	0.00%	\$0.00	\$0.00	\$0.00
<b>TEDDER ROAD BOOSTER PUMP STATION</b>	<b>\$58,400.00</b>	<b>4.94%</b>	<b>\$2,885.00</b>	<b>\$0.00</b>	<b>\$2,885.00</b>
Booster Pump Station	\$30,015.00	0.00%	\$0.00	\$0.00	\$0.00
Booster Pump Station (Electrical)	\$18,000.00	0.00%	\$0.00	\$0.00	\$0.00
Boundary/Topographic Survey:	\$2,885.00	100.00%	\$2,885.00	\$0.00	\$2,885.00
Title Search/Easement Work	\$7,500.00	0.00%	\$0.00	\$0.00	\$0.00
<b>WELL NO. 3 REPLACEMENT/REHABILITATION</b>	<b>\$20,600.00</b>	<b>0.00%</b>	<b>\$0.00</b>	<b>\$0.00</b>	<b>\$0.00</b>
Repackaging the Well No. 3 Plans (Civil)	\$10,000.00	0.00%	\$0.00	\$0.00	\$0.00
Repackaging the Well No. 3 Plans (Electrical)	\$10,600.00	0.00%	\$0.00	\$0.00	\$0.00
<b>WELL NO. 2 REHABILITATION</b>	<b>\$8,200.00</b>	<b>0.00%</b>	<b>\$0.00</b>	<b>\$0.00</b>	<b>\$0.00</b>
Well 2 Treatment/SCADA Design & Plan Updates	\$3,500.00	0.00%	\$0.00	\$0.00	\$0.00
Well 2 Treatment/SCADA Design & Plan Updates (Electrical)	\$4,700.00	0.00%	\$0.00	\$0.00	\$0.00
<b>WELL NO. 1 REHABILITATION</b>	<b>\$9,700.00</b>	<b>0.00%</b>	<b>\$0.00</b>	<b>\$0.00</b>	<b>\$0.00</b>
Repackaging the Well No. 1 Plans	\$5,000.00	0.00%	\$0.00	\$0.00	\$0.00
Repackaging the Well No. 3 Plans (Electrical)	\$4,700.00	0.00%	\$0.00	\$0.00	\$0.00
<b>GRANT ADMINISTRATION</b>	<b>\$2,500.00</b>	<b>0.00%</b>	<b>\$0.00</b>	<b>\$0.00</b>	<b>\$0.00</b>
<b>MES Totals</b>	<b>\$139,400.00</b>	<b>2.07%</b>	<b>\$2,885.00</b>	<b>\$0.00</b>	<b>\$2,885.00</b>

**AMOUNT DUE THIS INVOICE: \$2,885.00**

**Municipal Engineering Services Appreciates your Patronage.**  
 Prompt Payment is Appreciated. Payment should be submitted to the address below.  
 Should you have any questions or concerns, please contact us.





# Town of Century Projects Update

May 6<sup>th</sup>, 2025

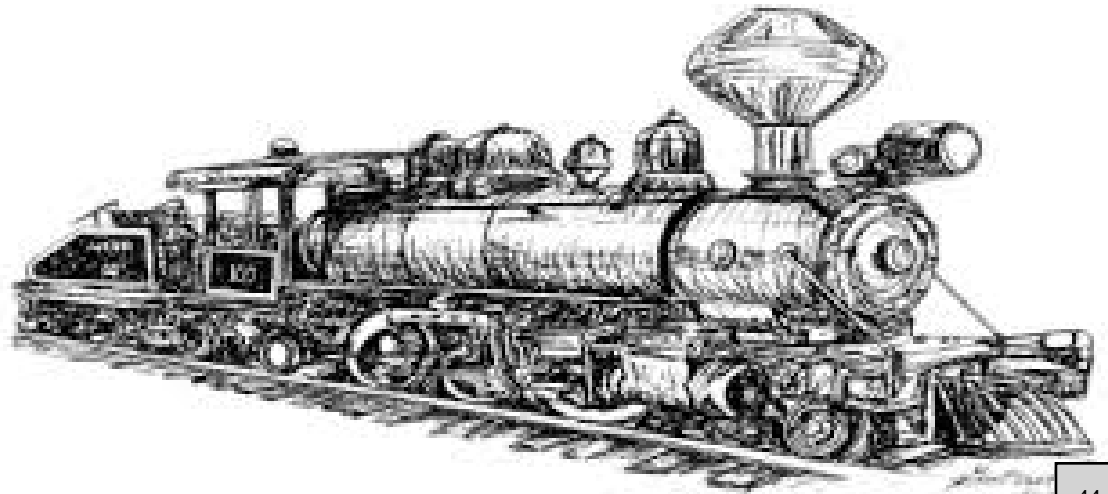

# Purpose of Today's Presentation

- Status update of current projects.
  - Scope
  - Funding
  - Project Schedule
  - Current Status
- Status update of existing grants and new applications.
- Feedback and questions from Council.

# Summary of Grants & Loans (1)

- FDEP Wastewater State Revolving Fund Loan (WW170301)
  - \$8,865,336 (90% PF & 10% Loan)
  - Miscellaneous Wastewater Improvements – Phase II
  - Lift Station Rehabs & WWTF Improvements
- State Legislative Appropriation Grant (LPA0150)
  - \$468,453 (100% grant)
  - Wells No. 1, 2, and 3 Rehabilitation
- State Legislative Appropriation Grant (LPA0284)
  - \$1,301,892 (100% grant)
  - Water Meter and Service Replacements.
  - Grant Managed by Escambia County.

# Summary of Grants & Loans (2)

- State Legislative Appropriation Grant (G2P32)
  - \$1,297,000 (100% grant)
  - Freedom Road Bridge
- State Legislative Appropriation Grant (LPA0484)
  - \$628,500 (100% grant)
  - Well #3 Replacement
- FDEP Water State Revolving Fund Planning & Design Loan (DW17034)
  - \$150,000 (50% PF & 50% Loan)
  - Booster Pump Station Replacement
  - Well No. 1, 2, and 3 Improvements
  - Service Renewals.
  - Utility Billing Software.
- FDEP Pilot Grants
  - \$40,000 Well No. 2 Lime Feed System
  - \$1,360,500 Well No. 3 Replacement and Well Building Rehab

**Overall: \$14 million in funding!**

# Well #3 Replacement

Section 5, Item A.



- **Scope:** Construction of new well at the prison water plant.
- **Funding:**
  - FDEP Grant LPA0484
  - SRF Loan DW17034
  - FDEP Pilot Grant
- **Status:** Bids received in November were higher than expected (\$1.2 million).
- **Next Step:** Final funding step in August 2025.
- **Completion:** 2026 (contingent on funding).



*Next Meeting: Council update in June.*

# Freedom Road Bridge

- **Scope:** Bridge Replacement
- **Budget:** \$1,297,000
- **Funding:** FDOT Grant G2P32
- **Status:** Design & Permitting. Project On-Budget and On-Schedule.
- **Next Steps:**
  - 1) Receive US Army Core Permit (Under Review)
  - 2) Design & Permitting is 99% Complete
  - 3) Bidding (August 2025)
  - 4) Begin Construction (December 2025)
- **Completion:** October 2026



# Lift Stations Rehabilitation

- **Scope:** Rehab Lift Stations

Prison LS #1

Century Woods LS #5

Highway 4 West LS #8

Jefferson Ave. LS #16

Pond and Jefferson LS #20

- **Budget:** \$3,365,175
- **Funding:** SRF Loan WW170301
- **Contractor:** Talcon Group.
- **Status:** Under construction. Delivery of equipment May/June.
- **Completion:** December 27<sup>th</sup>, 2025



*Next Meeting:  
Construction Progress Meeting  
End of June 2025*

# Wastewater Treatment Plant Improvements

Section 5, Item A.

- **Scope:** Miscellaneous Improvements

Sludge Screw Press.

Filter repair.

Automatic Transfer Switch.

Air line replacement.

EQ pump replacements.

Tank repairs.

Coatings

Etc.

- **Budget:** \$5,129,476

- **Funding:** SRF Loan WW170301

- **Status:** Project awarded (\$5,359,446). Initial tank repair activities have started.

- **Next Steps:** Continue construction.

- **Completion:** May 7<sup>th</sup>, 2026.



*Next Meeting:  
Pre-Construction Progress Meeting  
End of June 2025*

# Wells No. 1, 2 and 3 Rehabilitations

**Overall Budget:** \$468,453

**Funding:** FDEP Grant LPA0150

- **Scope:** Well #2 - Electrical
  - **Status:** Awarded to Dunaway Electrical Services, Inc.
  - **Cost:** \$264,877
  - **Next Step:** Start construction in February 2025. Waiting on delivery of materials.
  - **Completion:**  
~~December 2025~~    March 2026
- **Scope:** Well #2 - Building & Site
  - **Status:** Awarded to Evans Contracting, Inc.
  - **Cost:** \$334,707
  - **Next Step:** Start construction in February 2025.
  - **Completion:**  
~~December 2025~~    March 2026

*Next Meeting:  
Construction Progress Meeting  
June 2025*

*Next Meeting:  
Construction Progress Meeting  
June 2025*

***Well No. 1 & 3 improvements are currently unfunded.***

# Water Meter & Service Replacement

Section 5, Item A.

- **Scope:** Replacement of water service lines and meters throughout the distribution system.
- **Budget:** \$1.3 million
- **Funding:** FDEP Grant LPA0284
- **Status:** Awarded.
- **Next Steps:** Begin construction.
- **Completion:** December 2025

*Next Meeting:*

*Pre-construction Meeting May 8<sup>th</sup>, 2025 at Town Hall*

# Future Projects

## Known Needs

- Additional Well #1, #2, and #3 Improvements.
  - SRF is pending, and Pilot grant has been awarded.
- Tedder Rd. water booster pump station rehab ~\$500,000.
  - SRF is pending.

## Future Needs

- Water service replacements → Applied for WMD Grant & Legislative appropriation, but unlikely to be funded. Apply through SRF program.
- SCADA system → Applied for Legislative appropriation (\$2 million).
- Motor Control Center replacement at WWTF (not funded).
- Remaining lift station rehabs (not funded).
- Develop a formal CIP & Master Plan (not funded).

# Next Steps

- Continue advancing current projects.  
***Significant construction activities in 2025 & 2026 !***
- Continue grant application efforts.
- Schedule an update to the Council (July 2025)?

## Questions?

Daniel Magro, P.E.

Aclus Engineering, LLC

daniel.magro@acluseng.com

# TOWN OF CENTURY, FLORIDA

---

DATE: May 6, 2025

TITLE: Authorization for the Mayor to Submit Grant Applications to FloridaCommerce

## **BACKGROUND:**

The Town of Century intends to apply for grant funding through FloridaCommerce to support critical community development and infrastructure projects. As part of the application process, formal authorization is required from the governing body for the Mayor to submit applications and related documentation on behalf of the Town.

To ensure transparency and public engagement, the Town held two public hearings regarding these applications on April 29, 2025 and May 6, 2025, in accordance with Florida Administrative Code requirements and federal guidelines for public participation.

Based on staff recommendations and community input, the following projects have been prioritized for submission:

1. **Carver Community Center – Construction Funding** - To secure financial assistance for the construction of the Carver Community Center, a key facility for public programming, events, and youth services.
2. **Minor Home Repair Program** - To address substandard housing conditions by funding critical home repairs for low-to-moderate income residents.
3. **Design Funds for Cottage Street and Cedar Street Improvements** - To support engineering and design work necessary for future infrastructure and streetscape enhancements along Cottage and Cedar Streets.

## **RECOMMENDED ACTION:**

Authorize the Mayor to submit the identified project applications to FloridaCommerce, and to execute all related documents, certifications, and agreements necessary for the completion of the application process.

## **PROPOSED MOTION:**

I move to authorize the Mayor of the Town of Century to submit applications to FloridaCommerce for (1) construction funding for the Carver Community Center, (2) minor home repair program funding, and (3) design funds for Cottage Street and Cedar Street infrastructure improvements. The Mayor is further authorized to execute all related documents and take necessary actions on behalf of the Town in connection with these applications.

**FISCAL IMPACT:**

None at this time. Projects submitted will only proceed if awarded funding. Any grant funds received will be subject to Council acceptance prior to implementation.

**PREPARED BY:**

Howard W. Brown, Jr., ICMA-CM  
Interim Town Manager

**RESOLUTION NO. 2025-04**

**A RESOLUTION OF THE TOWN COUNCIL OF THE TOWN OF CENTURY, FLORIDA, AUTHORIZING THE MAYOR TO SUBMIT GRANT APPLICATIONS TO FLORIDACOMMERCE FOR CONSTRUCTION FUNDING FOR THE CARVER COMMUNITY CENTER, MINOR HOME REPAIR PROGRAM FUNDING, AND DESIGN FUNDS FOR COTTAGE AND CEDAR STREET INFRASTRUCTURE IMPROVEMENTS; PROVIDING FOR AN EFFECTIVE DATE.**

**WHEREAS**, the Town of Century is committed to improving public facilities, housing conditions, and infrastructure for its residents; and

**WHEREAS**, the Town has identified three priority projects for funding through FloridaCommerce’s Community Development Block Grant (CDBG) Program, namely the construction of the Carver Community Center, a Minor Home Repair Program, and the design of improvements for Cottage and Cedar Streets; and

**WHEREAS**, the Town has conducted public hearings on April 29, 2025 and May 6, 2025, in compliance with Florida Administrative Code and federal public participation requirements; and

**WHEREAS**, the Town Council finds that submitting these applications is in the best interest of the community and furthers the Town’s goals for community development and revitalization.

**NOW, THEREFORE, BE IT RESOLVED BY THE TOWN COUNCIL OF THE TOWN OF CENTURY, FLORIDA, THAT:**

1. The Mayor is hereby authorized to submit grant applications to FloridaCommerce for the following projects:
  - a. Construction funding in the amount of \$5.4 million for the Carver Community Center;
  - b. Minor Home Repair Program funding in the amount of \$750,000;
  - c. Design funds in the approximate amount of \$750,000 for infrastructure improvements to Cottage and Cedar Streets.
2. The Mayor is further authorized to execute all documents, certifications, and agreements necessary to complete the application process and secure funding.
3. There is no local match required other than in-kind contributions, including the CDBG consultant fee and administrative support.

4. This Resolution shall become effective immediately upon its adoption.

**PASSED AND ADOPTED by the Town Council of the Town of Century, Florida, this 6th day of May, 2025.**

\_\_\_\_\_  
Interim Mayor

ATTEST:

\_\_\_\_\_  
Town Clerk

**TOWN COUNCIL AGENDA ITEM**

**MEETING DATE:** May 6, 2025

**AGENDA TITLE:** Authorization for the Mayor to Request Use of County-Owned Parcel for Natural Gas Gate Station Project

**RECOMMENDED ACTION:**

Authorize the Mayor to submit a formal request to Escambia County for either an easement or the acquisition of Parcel ID 085N302305000000, currently owned by Escambia County, to support the construction of a new gate station as part of the Town’s federally funded Natural Gas Infrastructure Modernization Project. The Town’s request is intended to be presented to the Escambia County Board of Commissioners by County staff at their May 15, 2025 meeting.

**BACKGROUND:**

The Town of Century has received federal grant funding from the Pipeline and Hazardous Materials Safety Administration (PHMSA) under the Natural Gas Distribution Infrastructure Safety Modernization Program. This grant supports the development of a new gate station that will replace the Town’s outdated infrastructure, which currently receives gas from the Gulf South Pipeline via BP.

The project will connect the Town’s gas distribution system to the Peninsula Pipeline, enabling access to Florida Gas Utility’s (FGU) aggregated supply network. This connection is expected to result in cost savings, improved operational efficiency, and enhanced safety.

Florida Gas Utility (FGU)—a joint-action municipal agency that has partnered with the Town of Century for several years—is representing the Town in this effort. FGU is assisting with grant administration, project management, and the facilitation of real estate acquisition necessary to execute the project.

The preferred site for the new gate station is a vacant County-owned parcel (Parcel ID 085N302305000000) on N. Century Blvd., which was formerly the site of a residence. The Town’s formal request will enable Escambia County staff to place the item on the County Commission agenda for consideration on May 15, 2025.

**FISCAL IMPACT:**

There is no immediate fiscal impact. Any required funding for acquisition or easement agreements will be presented to the Town Council for approval at a future date.

**ATTACHMENTS:**

1. Summary Email from Florida Gas Utility
2. Parcel Location Map
3. Preliminary Engineering Drawings for Gate Station

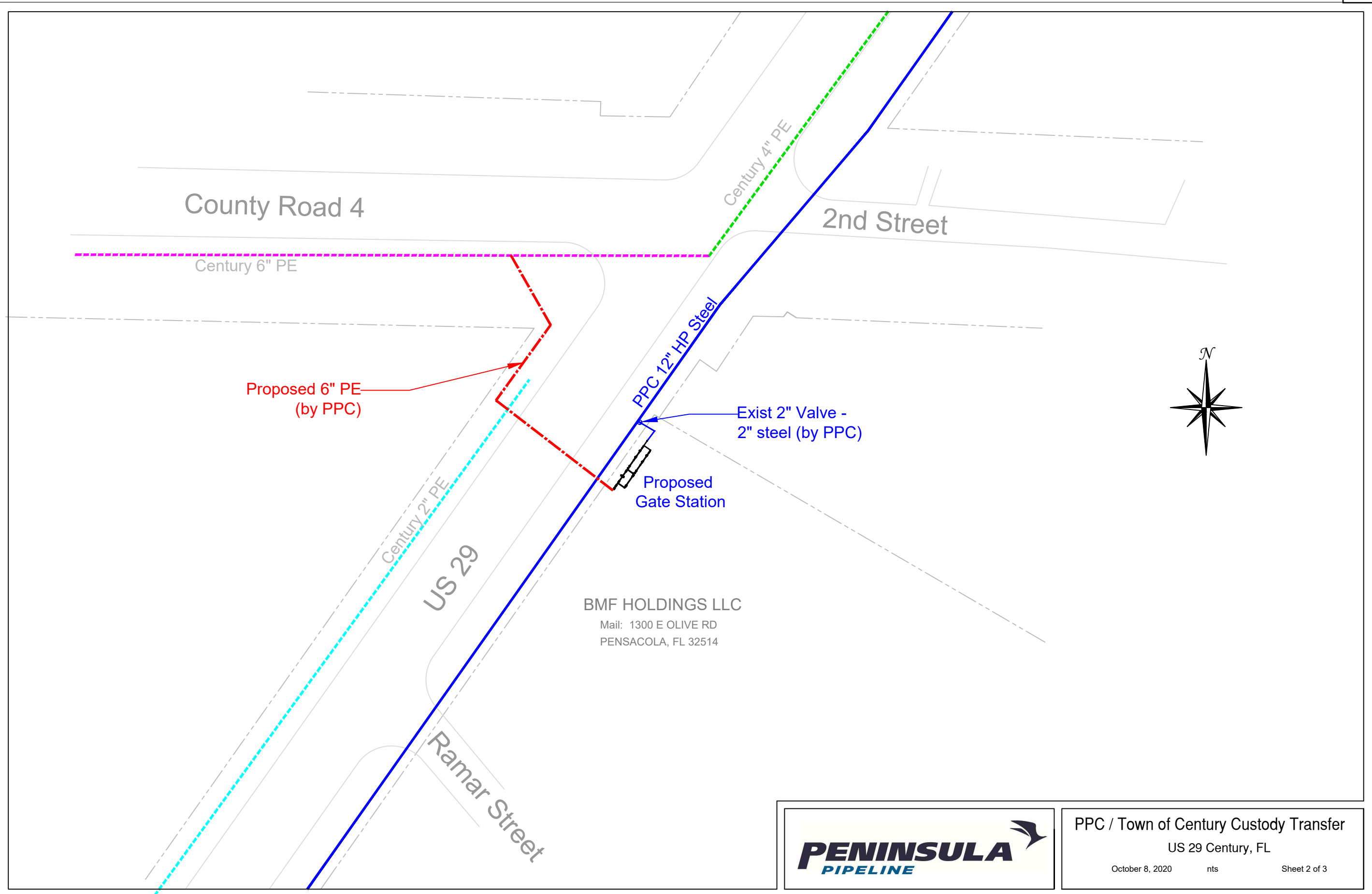

BMF HOLDINGS LLC  
 Mail: 1300 E OLIVE RD  
 PENSACOLA, FL 32514



PPC / Town of Century Custody Transfer  
 US 29 Century, FL  
 October 8, 2020    nts    Sheet 2 of 3

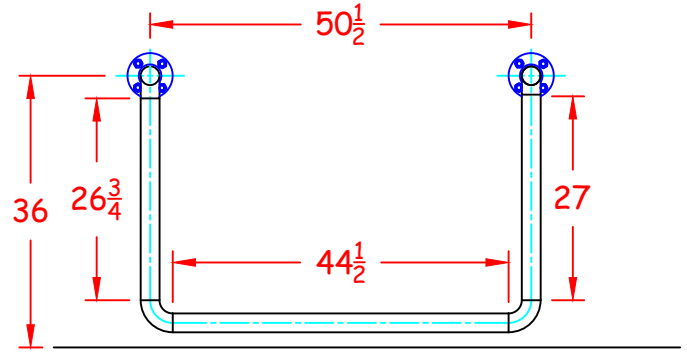
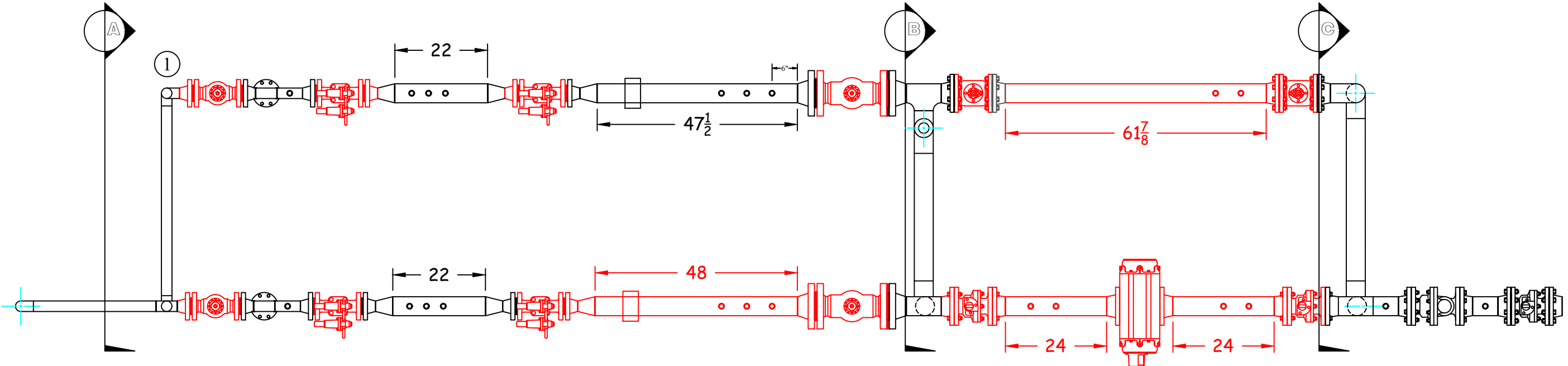

**Section "A-A"**  
Inlet Riser

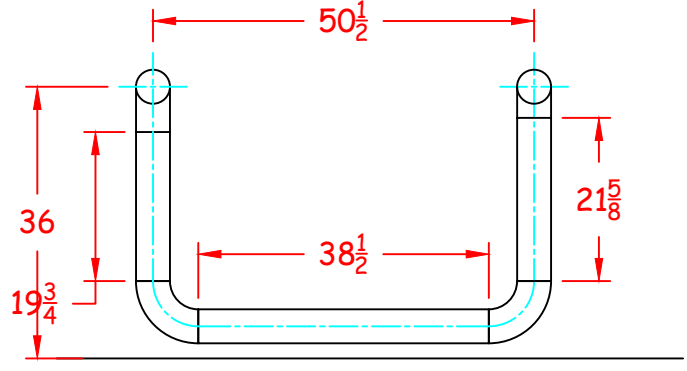

**Section "C-C"**  
Outlet Riser

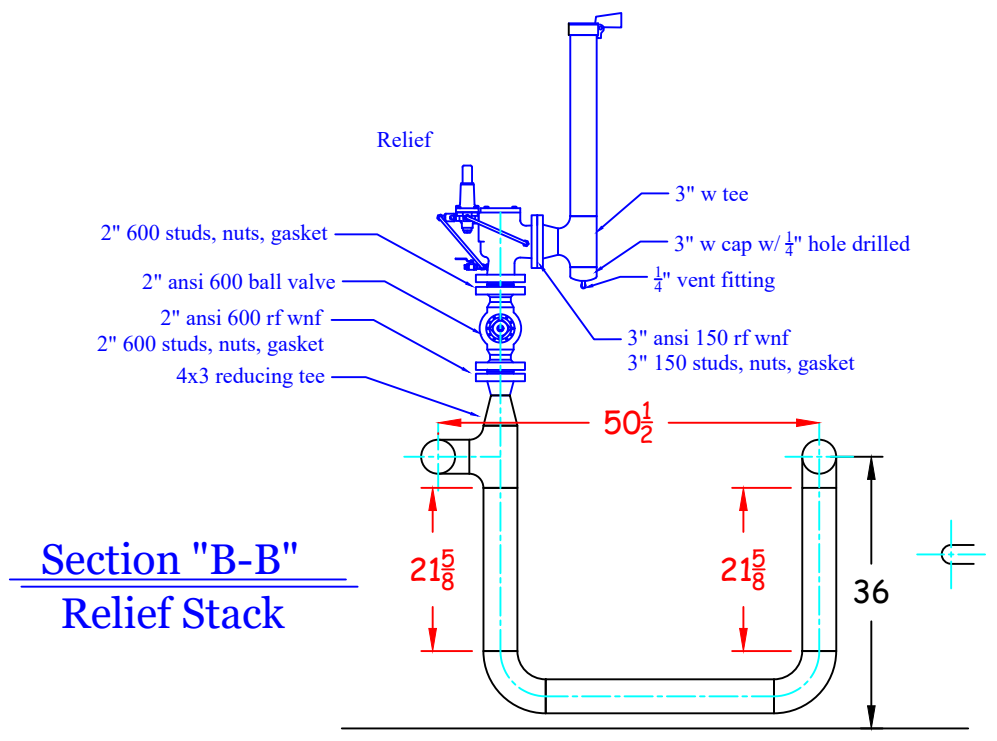

**Section "B-B"**  
Relief Stack

Relief: 2x3 FlowSafe F7000  
 Set at 40 psig  
 Q = 187.98  
 Set at 30 psig  
 Q = 152.76 mcfh

Information for Regulators modified for Town of Century Gate

REGS 1 and 2: 2" x 1" MOONEY FG 53-35 ANSI 600 RFFE, 35% Throttle Set @ 750 psig (w) / 28 psig (m) @ 900 psig inlet, Q <sub>w</sub> = 129.4 mcfh @ 900 psig inlet, Q <sub>m</sub> = 128.4 mcfh @ 800 psig inlet, Q <sub>w</sub> = 77.4 mcfh @ 800 psig inlet, Q <sub>m</sub> = 114.9 mcfh Q <sub>w/o</sub> = 141.02 mcfh	REGS 3 and 4: 2" x 1" MOONEY FG 53-35 ANSI 600 RFFE, 35% Throttle Set @ 25 psig, 750 psig inlet Q = 107.8 mcfh Q <sub>w/o</sub> = 130.05
---	--



PPC / Town of Century Custody Transfer  
 US 29 Century, FL  
 October 8, 2020 nts  
 Sheet 3 of 3 63

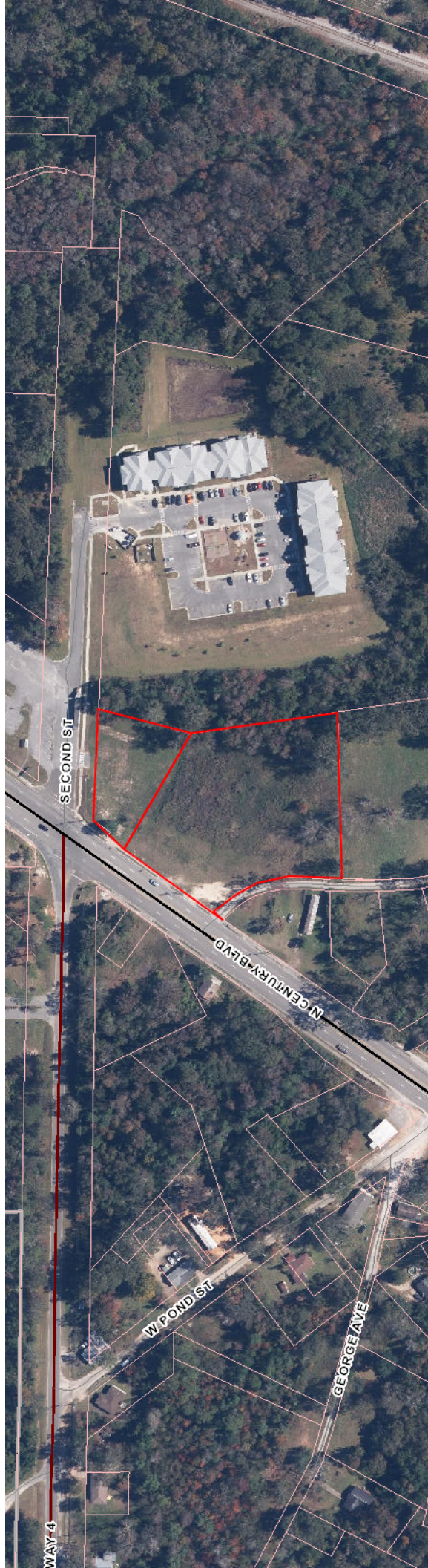

08-5N-30-2305-000-000	085N302305000000	ESCAMBIA COUNTY BOARD OF COUNTY COMMISSIONERS	221 PALAFOX PL STE 420	PENSACOLA FL	32502	111846000	7470 N CENTURY BLVD	CENTURY	32535
07-5N-30-1101-000-001	075N301101000001	BMF HOLDINGS LLC	1300 E OLIVE RD	PENSACOLA FL	32514	111594100	7450 N CENTURY BLVD BLK	CENTURY	32535

**Agenda Item for Town Council Meeting**

Date: May 6, 2025

Subject: Adoption of the Updated Town of Century Personnel Administration Policy Manual

**Background:**

On March 18, 2025, during a regularly scheduled Town Council meeting, Council Member Dynette Lewis requested that staff develop a policy to address temporary employment. Staff was directed to prepare recommendations for Council review. Subsequently, on April 15, 2025, Council Member Shelisa McCall presented draft language intended to improve and modernize the Town's 1993 Employee Personnel Manual. Based on Council direction, staff combined, updated, and expanded the two documents to create a comprehensive and improved Personnel Administration Policy Manual.

**Discussion:**

The updated Personnel Administration Policy Manual (“Manual”) presented for adoption:

- Integrates and improves upon both the 1993 Employee Handbook and the April 2025 McCall draft.
- Clearly outlines 'at-will' employment status under Florida law.
- Establishes a structured recruitment, probation, promotion, and evaluation process.
- Clarifies standards of conduct, confidentiality, and outside employment expectations.
- Updates leave, benefits, holidays, and retirement provisions.
- Introduces an Anti-Drug Workplace policy compliant with federal and state regulations.
- Establishes a defined disciplinary procedure with a right of appeal to the Town Council.

All new or revised provisions are clearly underlined in the draft Manual.

**Recommendation:**

Adopt Resolution No. 2025-\_\_, formally approving and adopting the updated Town of Century Personnel Administration Policy Manual, superseding all prior personnel policies and handbooks.

**Proposed Motion:**

Motion to adopt Resolution No. 2025-\_\_, approving the Town of Century Personnel Administration Policy Manual dated May 6, 2025, and authorizing the Mayor and Town Clerk to execute and implement the same.

**Attachment:**

- Proposed Resolution No. 2025-\_\_
- Updated Personnel Administration Policy Manual

**Resolution No. 2025-003**

A RESOLUTION OF THE TOWN COUNCIL OF THE TOWN OF CENTURY, FLORIDA, APPROVING AND ADOPTING THE UPDATED TOWN OF CENTURY PERSONNEL ADMINISTRATION POLICY MANUAL; SUPERSEDING PRIOR PERSONNEL POLICIES; PROVIDING FOR IMPLEMENTATION; PROVIDING FOR CONFLICTS; PROVIDING FOR SEVERABILITY; AND PROVIDING FOR AN EFFECTIVE DATE.

**WHEREAS:**

The Town Council of the Town of Century, Florida, finds it necessary and in the public interest to adopt an updated Personnel Administration Policy Manual to ensure compliance with applicable federal and state laws, promote operational efficiency, and establish clear and consistent personnel management policies.

**NOW, THEREFORE, BE IT RESOLVED BY THE TOWN COUNCIL OF THE TOWN OF CENTURY, FLORIDA:**

Section 1. Adoption. The Town Council hereby approves and adopts the Town of Century Personnel Administration Policy Manual dated May 6, 2025, attached hereto and incorporated herein by this reference.

Section 2. Supersession. All prior personnel policies, handbooks, or manuals are hereby repealed to the extent of any conflict with the newly adopted Personnel Administration Policy Manual.

Section 3. Implementation. The Mayor and Town Clerk are hereby authorized and directed to implement the provisions of the Personnel Administration Policy Manual and take all necessary actions to ensure its effectuation.

Section 4. Conflict. All resolutions or parts of resolutions in conflict herewith are hereby repealed to the extent of such conflict.

Section 5. Severability. If any section, sentence, clause, or phrase of this resolution is held to be invalid or unconstitutional, such invalidity shall not affect the remaining portions.

Section 6. Effective Date. This Resolution shall become effective immediately upon its adoption.

PASSED AND ADOPTED by the Town Council of the Town of Century, Florida, this

6th day of May, 2025.

\_\_\_\_\_  
Mayor

ATTEST:

\_\_\_\_\_  
Town Clerk

## **Section I - GENERAL PROVISIONS**

All employees of the Town are "at will" employees under Florida state law, and as such their terms and conditions of employment may be altered or amended at the will of the employer. Employment is subject to the provisions of applicable collective bargaining agreements, individual contracts, or the benefits and procedures provided by Florida state law and this policy.

### **1.01 AUTHORITY:**

Appointing Authority – The Town Council or their designee.

The Town Council of the Town of Century, Florida, as a board of elected public officials, derive authority and responsibility from the Constitution of the State of Florida and the charter of the Town of Century. The elected Town Council is ultimately responsible for all that transpires under the town's authority.

### **1.02 PURPOSE AND SCOPE:**

- a. The purpose of this statement of rules is to promote effective execution of the duties of the town, increase efficiency and economy, reward merit, increase employee satisfaction, respond to, decrease and, if appropriate resolve sources of employee dissatisfaction, and establish equitable standards for the administration and compensation of all employees of the town.
- b. This manual contains the major personnel policies, rules, regulations, and procedures by which the Personnel System of the town shall be conducted. This manual is intended to serve as a statement of policy for existing and new employees. The content includes the general standards by which all employees will conduct themselves, the rules covering pay and leave, the procedures for recruitment and employment of new employees, and the guidelines for the various personnel actions which may affect the status and progress of all employees.

### **1.03 APPLICABILITY:**

Unless specifically noted to the contrary, these rules apply to all town employees: permanent and temporary; regular and probationary; full and part time.

## **Section II - STANDARDS OF CONDUCT**

### **2.01 WORK PERIODS:**

- a. The standard work week will be 40 hours and not less than 35 hours for all full-time employees. The work week shall be the same for all persons occupying full-time positions.
- b. Absences and tardiness affect the overall performance of the town. Serious absences will become subject of personnel actions.

All employees should notify the Town Clerk as far in advance of all anticipated absences and should notify the Town Clerk by 9:00 a.m. on the day of an unexpected absence. Doctor's

excuses may be required for absences of more than three working days which are necessitated by illness or injuries due to accident.

**2.02 PUBLIC APPEARANCE AND CONDUCT:**

As representatives of the town, all employees are expected to know what is appropriate and acceptable attire, grooming and behavior for their work site and for the individual department or function. If any doubt exists as to what may be appropriate, the employee is encouraged to consult his or her supervisor. Employees are requested to avoid extremes, particularly exotic or bizarre costumes and grooming which are not suited to a business or public service situation.

**2.03 PUBLIC RELATIONS:**

Each employee of the town should treat people and handle their matters in such a way as to instill respect for the reputation already earned for courteous and efficient service. Friendliness, cheerfulness, helpfulness, courtesy, informality and sincerity are expected from all employees, especially in service to the public.

**2.04 CONFIDENTIALITY:**

Employees are expected to remain mindful of the confidential nature of many aspects of the work of some departments of the town. Good judgment should be exercised regarding the release or discussion of official matters or other information which may affect the personal or business affairs of others. Supervisory permission is required for release of sensitive or privileged information.

**2.05 GENERAL QUALITY OF WORK:**

Each employee is expected to achieve maximum efficiency and accuracy on assigned duties. Errors affect the performance of the employee, the work load of fellow workers and supervisors, the reputation of the department and the town and, most importantly, the lives of members of the public. Error free work is our goal.

**2.06 PERSONAL COMMUNICATIONS**

- a. Personal telephone calls, incoming or outgoing, should be restricted to those of an emergency nature as much as possible. If a telephone call during office hours becomes necessary, it should be brief in order that the telephone lines may be available for town business calls.
- b. Similarly, employee should not receive personal mail or other deliveries at their place of work at the town. Such deliveries may be refused or opened in the course of the town's business. Personal visits by friends, relatives or other contacts should not be received during work hours, and not within the working areas of the town.

**2.07 EQUAL EMPLOYMENT OPPORTUNITY:**

The Town of Century is an Equal Opportunity Employer. People who are selected for employment in the town are hired on the basis of qualifications. No discrimination will be made concerning employment, compensation, promotion, and other conditions of employment for reasons of age, sex, race, color, creed, or national origin. See Resolution 9-96

## **2.08 OUTSIDE EMPLOYMENT**

Full-time employment by the town shall be considered primary employment for full-time permanent employees, if an employee must engage in outside employment during off-duty hours, such outside employment should not interfere with the general work quality or demeanor of the employee while on town duty. (The fact of outside employment, shall not constitute a justification or excuse for an employee's failure to comply with personnel policies, standards of conduct or guidelines for disciplinary action.)

## **2.09 CONFLICT OF INTEREST**

Employment of relatives is prohibited when it creates or is perceived to create favoritism. No appointing authority can appoint, employ, promote, or transfer any relative to a position where the appointing authority exercises jurisdiction or control. The appointment, employment, promotion, advancement, or transfer of a relative into any division, activity, or section is prohibited if the action creates a prohibited relationship where a relative would supervise (directly or indirectly), make or influence personnel decisions concerning a relative, or creates a conflict of interest or the appearance of a conflict of interest. Prior to relatives being employed, promoted, or transferred into any division, activity, or section, a department director/administrator/manager must certify to the Mayor that no prohibited relationship would occur now or in the future.

To avoid misunderstanding and conflict of interests which could arise, the following policy will be adhered to by all employees of the town. (This policy is in accordance with Section 112.311 et. Seq., Florida Statutes, entitled "Code of Ethics for Public Officers and Employees."):

- (1) Employees shall not accept any gifts, including Christmas gifts, favors or services that may reasonably tend to improperly influence them in the discharge of their official duties.
- (2) Employees shall not use or attempt to use their position to secure special privileges or exemptions for themselves or others, except as may be provided by policy and/or law.
- (3) Employees shall not accept employment or engage in any business or professional activity which they may reasonably expect would require or induce them to disclose confidential information acquired by them by reason of their official position.
- (4) Employees shall not disclose confidential information gained by reason of their official position, nor shall they otherwise use such information for their personal gain or benefit.
- (5) If an employee of the Town is an officer, director, agent or member of, or owns controlling interest in, any corporation, firm, partnership or other business entity which is subject to current proceedings of the town, he or she shall file a sworn statement to this effect with the Mayor.

- (6) Employees shall not transact any business in their official town capacity with any business entity of which he or she is an officer, director, agent, or member, or in which he or she owns a controlling interest, excluding civic, charitable or religious organizations.
- (7) Employees shall not have personal investments in any enterprise which will create a substantial conflict between their private interests and the public interest.

**2.10 ELECTIONS AND POLITICAL ACTIVITIES:**

- a. No employee shall use his or her official authority or influence for the purpose of interfering with an election or a nomination of office or coercing or influencing another person's vote or affecting the result thereof.
- b. No employee shall directly or indirectly coerce or attempt to coerce, command or advise any other officer or employee to pay, lend or contribute any part of his or her salary, kick back any sum of money, or anything else of value to any party, committee, or organization, agency or person for political purposes.
- c. No employee shall participate in political activities of any kind during office hours, nor engage in unauthorized use of any town equipment or supplies for political purposes.
- d. No employee shall engage in activities which bring discredit upon the town.
- e. Notwithstanding the above, all employees shall retain the right to vote as they choose and to express their opinion on all political subjects and candidates. They shall also have the right to participate in any political campaign during off-duty hours so long as such activities are not in conflict with any provision of Florida law.
- f. As responsible public employees, town employees are encouraged to be well-informed, registered voters (if eligible) in all elections.

**2.11 DRIVER'S LICENSE:**

Those employees whose job description requires a valid driver's license or chauffeur's license are expected to keep that license current and free from jeopardy. Any change in the status of a required license must be reported to the employee's supervisor, and may affect the employee's employment.

**Section III - PAY AND BENEFITS ADMINISTRATION**

**3.01 ELIGIBILITY FOR EMPLOYEE BENEFITS:**

Full employee benefits shall be extended to full-time, regular and permanent employees, according to the rules set forth below.

**3.02 WAGES AND SALARY:**

At least annually, the Council will select two of its members who, together with the Mayor, shall review the wage rate of each employee. They shall consider, but shall not be restricted to, inflation, wage rate for a similar position in the local area, merit, time in grade, and the report of the employee's supervisor. They will report their findings and recommendations to the full Council within thirty (30) days. The Council will determine what wage rate adjustments will be made.

### **3.03 PAY PERIODS:**

Wage/salary payments are based on a regular weekly pay period of 40 working hours. The pay period shall begin on Friday and end at the close of the work day on Thursday of the following week. Time and attendance reports shall be submitted to the Town Clerk no later than Friday morning of the pay week.

### **3.04 HOLIDAYS:**

The following will be observed as official holidays by the Town of Century, Florida and all offices, except for essential services, will be closed:

New Year's Day  
 Martin Luther King's Birthday  
President's Day  
 Good Friday  
 Memorial Day  
Juneteenth  
 The Fourth of July  
 Labor Day  
Veteran's Day  
 Thanksgiving  
 Friday following Thanksgiving  
 Christmas Eve  
 Christmas Day

When a holiday falls on Saturday or Sunday, the preceding Friday or following Monday will be observed as a holiday. When Christmas Day falls on Sunday or Monday, then the town offices will be closed on the following Monday or Tuesday.

### **3.05 PAYROLL CHECKS AND DEDUCTIONS:**

- a. Payroll checks are issued on the Friday following the close of the preceding pay period.
- b. Deductions (e.g., for Social Security and Withholding Tax) are made from the employee's paycheck. A list of the amounts for each of these deductions is shown on the paycheck stub. Employees are advised to promptly report any changes which may affect payroll deductions to the Town Clerk. Errors in an employee's check should be reported immediately.

### **3.06 OVERTIME:**

- a. It shall be the general policy of the town for each employee to be assigned regular work duties and responsibilities which can normally be accomplished within the established work day and work week. However, the appropriate supervisor may request an employee to work overtime when necessary in order to meet emergency situations or operating needs. The acceptance of overtime work by the employee shall be voluntary.
- b. The Town Clerk shall maintain records of all overtime worked by all employees. No overtime pay or compensatory time will be granted except on the basis of such records.
  - (1) With respect to all employees or FSLA exempt employees, all overtime will be compensated by compensatory time off, or overtime pay, at a rate of one and half hours of time off for each hours of over-time worked.
  - (2) With respect to all employees earning compensatory time off, compensatory time may be accumulated to a maximum of 240 hours per year. Any compensatory time hours in excess of 240 hours will be forfeited at the end of the calendar year.
  - (3) Only permanent full-time employees are eligible to work overtime.

**3.07 VACATION LEAVE:**

- a. All permanent full-time employees are entitled to vacation leave.
- b. Accrual of vacation leave.
  - (1) All full-time employees who have been employed for six months and completed the probationary period are granted 40 hours of vacation leave.
  - (2) Upon completion of the probationary period and 12 months of continuous employment, all full-time employees are granted an additional 40 hours of vacation leave. No more than 3 weeks of vacation leave may be taken within any 18 month period of employment.
  - (3) All permanent full-time employees who have worked continuously for one to ten years are granted 80 hours vacation leave per year. Thereafter vacation will be granted as follows:
 

1 Year to 10 Years	– 2 Weeks
10 Years to 15 Years	– 3 Weeks
15 Years to 20 Years	– 4 Weeks
20 Years and over	– 5 Weeks
- c. Use of vacation leave.
  - (1) Any vacation time not used at the end of the calendar year is forfeited.

**3.08 SICK LEAVE:**

- I. General. Sick leave may be used by all full-time employees for employee illness, disability or health care appointments or treatments that cannot be scheduled outside normal working hours. Abuse of sick leave may result in employee discipline or discharge.
- II. Persons Entitled. All full-time permanent employees earn sick leave as of the date of commencement of employment. Sick leave cannot be used by an employee until the completion of the six month probationary period.
- III. Amount of Sick Leave. Full-time employees who complete the six month probationary period will be granted 40 hours of sick leave. Thereafter, sick leave may be earned according to the following schedule:

<u>Year of Service Completed</u>	<u>Hours/Year</u>
6 Months to 1 Year	40
1 Year to 5 Years	80
5 Years to 10 Years	120
10 Years and Over	160

Beginning January 1 of each year, each employee will be granted the amount of sick leave that corresponds to his/her years of service. All unused sick leave will be accumulated up to a total of six months.

- IV. Reporting Sick Leave. An employee who is absent from work due to illness must notify his or her department head within one hour of regular reporting time, and daily thereafter. In the case of employees engaged in 24 hour service, the employee should report to the department head two (2) hours prior to his or her regular reporting time, then daily. Failure to report on a timely basis may result in leave without pay being charged.
- V. Records of Sick Leave. The Town Clerk shall keep records of all sick leave used by all employees, including the reason such leave was required and the number of hours used.
- VI. Exhaustion of Earned Sick Leave. Upon the approval of the Mayor and Town Council, an employee may use vacation leave if sick leave has been exhausted.
- VII. Justification for Sick Leave. Upon the request of the Mayor or Town Council, employees may be required to supply a doctor's certificate for any absences due to illness in excess of two days.
- VIII. Forfeiture of Sick Leave. Employees who separate from town service in good standing may be paid for unused sick leave at a rate of two (2) hours for each (8) hours unused at termination. In the event of death of an employee, unused sick leave will be paid in full to their beneficiary. Employees who are dismissed

or leave the service of the town without proper notice shall forfeit all unused sick leave.

**3.09 MILITARY LEAVE:**

When employees are required to be absent from their positions due to military commitments, military leave will be compensated for in conformity with 115.07, Florida Statutes (1992).

**3.10 CIVIL LEAVE - JURY DUTY:**

Any employee shall be given necessary leave without loss of pay when performing jury duty or other duties required by law as long as he or she is not required to do so under the performance of his or her duties. Those employees who become parties to litigation are not eligible for leave with pay, unless they become such parties in the course of their employment with the town. Employees on civil leave will be compensated by the town only for the difference (if any) in the employee's regular salary for the time on civil leave and the amount received for participation in legal proceedings.

**3.11 FUNERAL LEAVE:**

All full-time permanent employees will be granted three (3) days paid funeral leave for a death in the employee's or the employee's spouse's immediate family. "Immediate family" includes spouse, child, parent, sister, brother, grandmother, or grandfather. In certain cases involving distances, unusual circumstances, etc., the Mayor may grant additional leave with pay.

**3.12 MATERNITY LEAVE:**

Leave for maternity shall be treated as sick leave. If sick leave is exhausted, the employee may opt to use either or a combination of vacation leave and/or leave without pay.

**3.13 UNEMPLOYMENT COMPENSATION:**

The town of Century is registered with the State of Florida Bureau of Unemployment Compensation. Employees who are involuntarily separated from employment and who file a claim and meet certain qualifications may be eligible to receive unemployment compensation benefits.

**3.14 SOCIAL SECURITY:**

Social Security deductions are made from all eligible employees' pay and an equal amount is added to it by the town for all employees as set forth in the State Municipal Agreement for coverage of local government employees under the Federal Old Age.

**Section IV - PERSONNEL RELATIONS**

**4.01 POLICY:**

These policies are intended to provide regular employees a fair and equitable review of any grievance without fear of discrimination, coercion, restraint or reprisal. Further, they shall insure that every reasonable effort will be made to resolve the matter as efficiently and

effectively as possible. It shall be the policy of the town insofar as possible to prevent the occurrence of grievances and to deal promptly with those which occur. It is the intent and desire of the town to adjust complaints or grievances informally, and both administrative staff and employees are expected to make every effort to resolve problems as they arise. However, it is recognized that there will be grievances which will be resolved only after review. This grievance procedure is established to provide full opportunity to employees to bring to the attention of administrative staff, or the Mayor or the Town Council complaints, grievances, or situations that the employee feels need either adjustment or resolution.

#### **4.02 GRIEVANCE PROCEDURE:**

Level 1: An employee may bring any complaint, grievance, or inquiry to his or her supervisor who may consult with the Mayor concerning the matter. The supervisor will respond to the employee within three working days after receiving the complaint, grievance or inquiry.

Level 2: If the matter is not resolved by the supervisor to the employee's satisfaction, the employee may submit a written grievance to the Mayor within seven working days of receipt of the supervisor's response. The Mayor will make the appropriate investigation and respond in writing to the employee within fifteen working days of the filing by the employee of the written grievance.

Level 3: If the matter is not resolved by the Mayor to the employee's satisfaction, he or she may bring the matter before the Town Council by submitting, within seven days of the Mayor's response, a written statement of the complaint, grievance, or inquiry and request that the issue be placed on the agenda for the next meeting of the Town Council. The employee may appear at such meeting and present his complaint, grievance or inquiry, to which the employee's supervisor or the Mayor may respond. The Town Council will make a decision concerning such matter, which decision will be final.

### **Section V - PERSONNEL POLICIES, ACTIONS & PROCEDURES**

#### **5.01 EMPLOYEE SELECTION:**

The Town of Century will advertise all job openings in a newspaper of local circulation for at least two weeks prior to the actual interview and selection process. Such advertisements will identify the town as an Equal Opportunity Employer.

Any person seeking employment with the town will be required to execute an application for employment form as prescribed by the town.

All vacancies occurring within the town shall be filled whenever possible with a qualified employee of the town. Promotion within the town staff shall be based upon the qualifications of the person being appointed. The first consideration in the filling of vacancies will be given to the most qualified applicant within the department. Next consideration will be given to the most qualified applicant from outside the department. If no acceptable applicant is found within the town staff, the vacancy may be filled from outside the town staff. The criteria used in selection of the most qualified applicant shall be based upon examination, promotional potential rating, oral interview, and/or demonstrated performance.

The department supervisor will review applications for employment and conduct a personal interview with each applicant and, with the approval of the Mayor, will select the applicant(s) to be employed. The Council must approve the selection of any individual to be by the town. At the discretion of the Council, any prospective employee may be required to appear before the Council for an interview.

## 5.015 **TEMPORARY EMPLOYMENT PROVISIONS**

### **1. Definition of Temporary Employment**

A temporary employee is one appointed to a position for a limited duration to meet a specific short-term need, such as a vacancy, leave of absence, seasonal work, or special project.

### **2. Duration of Appointment**

Temporary appointments shall not exceed six (6) months without Town Council approval. Extensions beyond six months may be considered by a majority vote of the Council upon recommendation by the Mayor.

### **3. Town Council Approval**

Any temporary appointment recommended by the Mayor must be submitted to the Town Council for approval at the next scheduled meeting. No temporary employee shall begin work prior to Council approval unless authorized on an emergency basis by resolution.

### **4. Posting of Vacancy**

Vacancies intended to be filled on a temporary basis must be posted publicly, both internally and externally, for a minimum of five (5) business days unless waived due to urgent need with written justification.

### **5. Pre-Employment Requirements**

All temporary employees are subject to:

- a. A criminal background check;
- b. A pre-employment drug screening;
- c. A pre-employment physical if the position requires physical labor or operation of equipment.

### **6. Compensation**

Temporary employees shall be paid hourly wages based on the approved classification and experience. They are not eligible for step increases or salary ranges.

### **7. Benefits Eligibility**

Temporary employees do not receive benefits, including:

- a. Health, dental, or vision insurance;
- b. Paid time off (sick leave, vacation);
- c. Retirement contributions;
- d. Bereavement or jury duty leave.

**8. Holidays**

Temporary employees are not compensated for holidays unless they are scheduled to work and do work on the holiday, in which case they receive regular pay.

**9. Eligibility for Temporary Appointment**

A temporary employee may only be appointed to a position that is both:

- A. Vacant, and
- B. Included in the adopted budget and authorized by the Town Council.

No temporary employment shall be approved for unbudgeted or newly created positions unless:

- C. The Town Council takes formal action to create and fund such position;
- D. And/Or the position is included in the Town's Personnel Authorization List.

**5.02 PROBATIONARY PERIOD:**

Under the direction of the Mayor or designee, the Town Clerk administers a program for rating the work performance of Town of Century employees. The Performance Evaluation Program is designed to provide procedures and guidelines for supervisors to evaluate the performance of Town employees in the accomplishment of their assigned duties and responsibilities. Through the uniform application of these procedures and guidelines, supervisors can use the Performance Evaluation Program as an effective management tool to recognize accomplishments, guide and reward performance, and improve productivity and morale. Approved forms must be developed by the Town Clerk and approved by the Mayor. Notwithstanding the existing probationary period requirements, all regular employees shall receive an annual performance evaluation. Probationary employees remain subject to the existing policy which requires a six-month performance evaluation prior to permanent appointment by the Town Council.

- a. Intent: The probationary period, or working test, shall be regarded as an integral part of the selection process and shall be used for closely observing the employee's work; for securing the most effective adjustment of a new employee to his or her position; and for rejecting any employee whose performance is not satisfactory.
- b. Conditions of Probationary Period: All employees appointed or promoted to permanent positions shall serve a probationary period of six months.
  - (1) The probationary employee may accumulate sick leave, but cannot use sick leave during the probationary period except upon special approval granted by the Town Council.

- (2) Probationary employees will not work overtime.
- (3) Probationary employees are granted 40 hours vacation time at the completion of the probationary period.
- (4) The probationary employees may be dismissed for any lawful reason and such employee has no right to appeal the dismissal.
- (5) The probationary employee's supervisor shall submit a written evaluation of the employee's performance to the Mayor and Town Council twenty days before the expiration of the probationary period. The Mayor and Town Council, at the next meeting of the Town Council and according to the provisions of the Town Charter, will decide whether to grant the employee permanent status.

### **5.03 DISCIPLINE**

#### **A. DISCIPLINARY ACTIONS.**

The Mayor shall have the authority to discipline employees of the Town in accordance with the provisions of this section 5.03. The types of discipline which the Mayor is authorized to administer include but are not limited to dismissal, suspensions, demotions, and formal warnings (either written or oral). An employee shall have the right to appeal to the Town Council in accordance with the provisions of this Section 5.03 any disciplinary action administered by the Mayor which results in a loss or reduction of the employee's compensation.

#### **B. SUSPENSIONS:**

The Mayor may, on his/her own initiative or upon the recommendation of the employee's supervisor, suspend an employee without pay for disciplinary purposes for such length of time as the Mayor considers appropriate but not to exceed sixty (60) days in any twelve (12) month period.

#### **C. DEMOTIONS:**

The Mayor may, upon his/her determination or upon the recommendation of the employee's supervisor that an employee is unable to satisfactorily perform the duties of the position in which s/he is employed and/or that demotion is an appropriate disciplinary action under the circumstances, demote an employee to a position having duties which the employee can successfully perform and which may have lower compensation, or the Mayor may reduce the salary or hourly wage of the employee.

An employee may be demoted at his/her own written request to a vacant position in a lower class, subject to the approval of his/her supervisor and the Mayor. The Mayor will determine whether the employee is qualified to perform the duties and responsibilities of the lower job class.

D. DISMISSALS:

The Mayor may, on his/her own initiative or upon the recommendation of the employee's supervisor, dismiss an employee for cause.

E. CAUSES FOR SUSPENSION, DEMOTION OR DISMISSAL:

An employee may be suspended, demoted or dismissed for just cause. For purposes of this Section 5.03 "just cause" shall mean cause based upon reasonable grounds governed by good faith. Although suspension, demotion or dismissal may be based on other causes, any one or more of the following shall be sufficient. If the employee:

1. has been convicted of a felony, or of a misdemeanor involving turpitude;
2. is a member of a subversive organization, or knowingly or willfully violates the laws of the United States, the State of Florida, and/or the ordinances, rules, and regulations of the Town;
3. willfully, wantonly, unreasonably, unnecessarily, or through culpable negligence has been guilty of brutality or cruelty to a person provided the act committed was not necessarily or lawfully done in self-defense, or to protect the lives of others, or to defend or to protect the lives of others;
4. violates any of the provisions of this manual;
5. is offensive in his/her conduct or language in public, or toward the public, Town officials, or fellow employees, either on or off duty;
6. violates any lawful official regulation or order, or fails to obey any proper direction made and given by a superior;
7. uses intoxicants and/or illegal drugs while on duty;
8. becomes afflicted with any disease or has any physical ailment or defect which, in the opinion of the Mayor after confirmation by a physician, renders the employee unfit for employment, and reasonable accommodations, as defined by the Americans with Disabilities Act, cannot be made;
9. is incompetent, inefficient, or ineffective in the performance of the duties of his/her position;
10. is careless or negligent with the monies or other property of the Town;
11. takes any property of the Town for his/her own personal use or for sale or gift to, or use by, others;

12. has used or threatened to use, or attempted to use personal or political influence in securing promotion, leave of absence, transfer, change of pay rate, or in any manner related to his/her work;
13. induces, or has attempted to induce, an officer or employee in the service of the Town to commit an unlawful act or to act in violation of any lawful or official regulation or order;
14. takes for his/her personal use from any person, any fee, gift, or other valuable thing in the course of his/her work or in connection with it, when such a gift or other valuable thing is given in the hope or expectation of receiving a favor or better treatment than that accorded other persons, or accepts any bribe, gift, token, monies, or other things of value intended as an inducement to perform or refrain from performing any official act, or engages in any action of extortion or other means of obtaining money or other things of value, through his/her position;
15. speaks disrespectfully of, publicly criticizes, or maliciously ridicules any official or employee of the Town;
16. hinders the regular operation of the Town because of excessive absenteeism;
17. does not have the capacity for the proper performance of duties because of a permanent or chronic physical or mental defect, and reasonable accommodations as defined by the Americans with Disabilities Act cannot be made;
18. is absent without leave or failing to report after leave of absence has expired;
19. fails to notify the employee's supervisor within one working day of suspension or revocation of valid operator's or chauffeur's license (applies only to employees whose job requires valid operator or chauffeur license).
20. has unauthorized absence from work;
21. makes a false statement of a material fact or practicing or attempting to practice any fraud or deception in an attempt to secure any job related benefits;
22. commits such acts, or fails to undertake acts, which impede or hinder the Town from fulfilling its service to the community, or which are contrary to or which jeopardize the health, safety, and welfare of other employees or officials or the citizens of the Town.

F. DISCIPLINARY PROCEDURE:

1. Dismissal, Suspension or Demotion of Regular Town Employees:

- a. When the dismissal, suspension or demotion of any regular full-time Town employee is contemplated, the Mayor and/or the employee's supervisor may hold such informational meetings as they deem necessary. The Mayor and/or supervisor shall have the right to question any employee of the Town who might be able to shed light on the circumstances involving the subject employee.

It is not required that a meeting with the employee be held; rather, it is expected that the Mayor and/or supervisor will meet with the employee only when there is sufficient doubt as to whether or not the employee committed the acts for which discipline is contemplated.

- b. In considering the appropriate disciplinary action (if any), the Mayor or supervisor may take into account all prior disciplinary action of the subject employee and the employee's employment record. If such prior disciplinary actions or record contributes to the disciplinary action, the same shall be reflected in the summary contemplated in the following paragraph.
- c. The Mayor or the supervisor will prepare a written summary of the facts, evidence, and documents relating to the disciplinary action. Said summary will further set forth the Mayor's final disciplinary decision.
- d. The Mayor will furnish to subject employee written notice of the disciplinary action, which notice shall include a brief summary or explanation of the grounds for the disciplinary action. Such notice will either be hand-delivered or sent by certified mail. The notice shall also state that the employee shall have five (5) working days from the date of such notice within which to file with the Mayor, a written response requesting an appeal hearing before the Town Council.
- e. If no written response is received from the employee within the said five (5) day period, then the employee shall be deemed to have accepted the disciplinary action. It will be the responsibility of the employee to make a timely written request of the Mayor for the appeal, and if the employee does not request (or timely request) the same, s/he will be deemed to have waived the right to appeal the disciplinary action to the Town Council.

2. Employee Appeal Process:

- a. If the employee disagrees with the Mayor's disciplinary action, the employee may request a review of the Mayor's decision by the Town Council. The employee's written request for an appeal hearing must state all of the employee's reasons and grounds for appealing the

disciplinary action. If the employee's written request fails to set forth any reasons or grounds for the appeal, the appeal may be summarily denied without need to proceed with an appeal hearing before the Town Council.

- b. The decision of the Mayor may be overturned by the Town Council only upon clear and convincing evidence that the Mayor did not have just cause (as defined in Section 5.03.E, above) for his/her decision. The burden of proving that there was not just cause, which must be demonstrated by clear and convincing evidence, shall be upon the employee. The employee may assert at the appeal hearing only those reasons or grounds set forth in the employee's written request for an appeal hearing, and the Town Council shall not consider any reasons or grounds that are not set forth in the employee's written request.
- c. The appeal hearing before the Town Council shall be informal and guided only by minimum due process requirements. The Town Council shall not have the authority to modify or alter the extent of discipline or action reflected in the Mayor's decision. Rather, the sole function of the Town Council during the appeal hearing shall be to determine whether, on the basis of the evidence presented during the hearing, it has been clearly and convincingly demonstrated that there was not just cause for the Mayor's decision. In other words, it must be demonstrated that the Mayor's decision was unreasonable and/or made in bad faith. If it is demonstrated by clear and convincing evidence that the Mayor did not have just cause, his/her decision shall be overturned. Otherwise, the Mayor's decisions must be upheld. The standard and burden of proof for reversal of the Mayor's decision is intentionally established at a high level and is intended to provide the mere assurance that the Mayor's decisions will not be arbitrary and capricious. The determination of the Town Council shall be final and there shall be no basis for further appeal or redress of the disciplinary action.

#### **5.04 TYPES OF SEPARATION FROM EMPLOYMENT**

##### **A. DISMISSAL:**

The termination of an employee shall be termed a dismissal when, in the opinion of the Mayor, the employee fails to render satisfactory services for any reason contemplated in Section 5.03.E. An employee who has been dismissed from employment with the Town shall not be eligible for re-employment for a period of five years from the date of dismissal.

##### **B. RESIGNATION:**

An employee may voluntarily terminate his/her employment by resignation stating reasons therefore, in writing, to the Mayor. If the Mayor finds that reported resignation was not voluntary, s/he will treat the separation as a dismissal. An employee who has submitted his/her resignation may, with the

approval of the Mayor, be continued in his/her position as though the resignation had not been filed, on his/her written request for authorization to withdraw the resignation, filed before the effective date thereof or within thirty (30) days thereafter. An employee who resigns from his/her employment with the Town with the Mayor's approval shall be immediately eligible for further employment with the Town.

C. LAYOFF:

A layoff shall mean the involuntary separation from employment through no fault of the employee, but for reasons deemed appropriate by the Mayor (e.g., lack of funds, changes in organizational structure, lack of need for position or type of work performed, etc.), and without adverse effect on the employee's immediate eligibility for further employment with the Town. The order of layoff is hereby declared to be as follows:

1. The order of the layoff will be inverse to the relative value of the employees to the Town as determined by the Mayor.
2. No permanent employee will be laid off from any position while any temporary employee is continued in a position of the same class.
3. Each employee laid off shall be given a written notice. Whenever practicable, this notice should be given at least three (3) days prior to the effective date, and should include the reasons for the layoff, the effective date, and any other information deemed necessary by the Mayor.
4. In the event of a lay-off, the Town will adhere to the statutory requirements of Chapter 295.07, Florida Statutes, which provide preference in retention for eligible veterans. Employees discharged by reason of a lay-off will have their names entered on an eligible register for each title or class for which positions were eliminated. The register will remain effective for one year, unless extended by request of the appointing authority. If positions become available while the register is effective, the appointing authority will consider these individuals for reemployment.

## Section VI - ANTI-DRUG POLICY

### 6.01 SOURCE AND POLICY:

- a. The Anti-Drug policy is based on the provisions of the Pipeline Safety Regulations, Code of Federal Regulations, Code of Federal Regulations, Title 49, 40 C.F.R. Part 199.
- b. In recognition of the adverse effects illegal drugs have on an individual's health, attitude, performance, and safety, it is the policy of the town to require its employees to undergo drug testing.

**6.02 APPLICATION:**

This policy applies to all employees.

**6.03 PRIMARY REQUIREMENTS:**

- a. All employees who work directly or indirectly with the town's natural gas system must be tested.
- b. The laboratory selected for analysis must establish its certification.
- c. The laboratory must forward testing results only to the medical review officer.
- d. The medical review officer must:
  1. receive and interpret drug test results.
  2. inform the employee of drug test results.
  3. give employee opportunity to discuss test results.
  4. order a reanalysis of the original specimen if employee contests validity.
  5. maintain confidentiality.
  6. inform employee of results of second test.
  7. give opportunity to discuss results of second test.
  8. only after all of the above, inform Mayor and Town Council of test results.

**6.04 LABORATORY AND MEDICAL REVIEW OFFICER:**

- a. Laboratory: Flomaton Medical Center laboratory will analyze all specimens collected for drug testing. Flomaton Medical Center will submit to the Town Council, before conducting any analyses, evidence that they possess the required certification to perform such analysis.
- b. Medical Review Officer: Dr. John Vanlandingham is selected as the town's medical review officer.

**6.05 TYPES OF DRUG TESTING:**

- a. Pre-Employment Testing: Employees may be required to undergo pre-employment testing. Any individual who refuses to undergo or fails such drug test will be ineligible for employment. Such applicants have no right to retesting of their samples.
- b. Random Testing: All employees are subject to unannounced testing based on random selection.
- c. Post-Accident Testing:
  1. Any employee whose performance contributed to an accident or cannot be completely discounted as a contributory factor to the accident will be tested.

2. Such employee will be tested as soon as possible but no later than 32 hours after the accident.

d. Reasonable Cause Testing:

1. Where there is reasonable cause to believe that an employee covered by this policy is using a prohibited drug, the employee will be required to take a drug test.
2. Only a supervisor who has been trained in drug use symptoms can determine that reasonable cause for a drug test exists. Such determination must be based on objective factors, such as performance errors.

**6.06 TESTING PROCEDURES:**

- a. Test Methods. All drug testing will utilize urine samples.
- b. Target Drugs. Tests for marijuana, cocaine, opiates, amphetamines, and phencyclidine will be performed.
- c. Upon notification that a drug test is required, an employee will report as soon as possible but no later than 24 hours (32 hours for post-accident) after notification to the drug collection site and provide a specimen of his/her urine.
- d. The laboratory will forward the drug testing results to the medical review officer.

**6.07 REVIEW OF DRUG TESTING RESULTS:**

- a. Duties of medical review officer:
  1. Review of drug test results before they are reported to any town representative, including the mayor.
  2. Determine whether there is an alternative medical explanation for positive test result.
    - i. Conduct medical interview of affected employee.
    - ii. Review employee's medical history and medical records, with specific reference to prescribed medication.
    - iii. If necessary, order reanalysis of original specimen to determine accuracy.
    - iv. Verify laboratory report and assessment are correct.
  3. Determine if employee who refused to take test or who did not pass test may be safely returned to duty.
- b. Determination Rules

1. If the medical review officer determines, after appropriate review, that there is a legitimate medical explanation for the positive test result, no further action is required and affected employee will not be disciplined in any way.
2. If the medical review officer cannot identify a legitimate medical explanation for the positive test result, he will forward the employee's name and test results to the Mayor for disciplinary proceedings in accordance with the provisions of this Personnel Policy.

**6.08 EMPLOYEE ASSISTANCE PROGRAM:**

- a. Drug Use Education – All employees will be provided a copy of these personnel rules and, on a periodic basis, drug-use information.
- b. Due to economic constraints, no rehabilitation programs will be afforded to employees.
- c. Community Service Hotline Number: 1-800-888-9383

**6.09 RECORDKEEPING:**

The Town Clerk will maintain the following records:

- a. Results of drug tests which were positive for drug use:
  - i. Must be kept 5 years.
  - ii. Must identify employee's job duties, age.
  - iii. Must specify drugs detected.
  - iv. Must identify employee status – suspension, termination, etc.
- b. Results which were negative for drugs must be kept 1 year.
- c. Records showing numbers of employees tested must be kept 5 years.

**6.10 CONFIDENTIALITY:**

- a. All records of testing and test results must be maintained private and confidential.
- b. Test results may be released only to the following without prior authorization of the affected employee:
  - i. Laboratory
  - ii. Medical Review Officer
  - iii. Town Clerk
  - iv. Mayor
  - v. State and local officials as necessary to their investigation of an accident.
- c. Test results can be released to the Town Clerk and Mayor without authorization of the affected employee only after the medical review officer has completed all specified duties and employee contests results of initial and repeat drug testing.

- d. All written records must be stored in a locked container or in a secure location accessible only to the above listed individuals.
- e. Drug test results will not be released to subsequent employers without prior authorization of the affected employee.

**TOWN OF CENTURY DEFERRED COMPENSATION PLAN**

**ORDINANCE NO. 5-89**

The Town of Century hereby establishes an Employee Deferred Compensation Plan (hereinafter referred to as the "Century Plan"). The Century Plan consists of the provisions set forth in this ordinance and is applicable to each employee who elects to participate in the Century Plan. The Plan is effective as to each such employee upon the date the employee becomes a "Participant" by signing and filing a Participant Agreement with the Town of Century.

The purpose of the Century Plan is to permit employees and independent contractors to participate in a deferred compensation plan by entering into an agreement with the Town of Century wherein a portion of their salary not yet earned will be deferred.

**SECTION 1.           DEFINITIONS**

- 1.01 "State" – The term "State" means a state, a political subdivision of a state, and an agency or instrumentality of a state or political subdivision of a state.
- 1.02 "Performance of Service" – The "performance of service" includes performance of service as an independent contractor.
- 1.03 "Participant" – The term "participant" means an individual who is eligible to defer compensation under the plan.
- 1.04 "Beneficiary" – The term "beneficiary" means a beneficiary of the participant, his estate, or any other person whose interest in the plan is derived from the participant.
- 1.05 "Includible compensation" – The term "includible compensation" means compensation for service performed for the Town of Century, which (taking into account the provisions of this section and Section 403(b)) is currently includible in gross income.
- 1.06 "Compensation, taken into account at present value" – Compensation shall be taken into account at its present value.
- 1.07 "Community Property Laws" – The amount of includible compensation shall be determined without regard to any...

**Page 27 Missing in pdf file**

- e. For plan years beginning on or after January 1, 1988, amounts deferred pursuant to Code Section 402(a)(b) and 402(h)(1)(B) under a 401(k) plan shall be treated as amounts deferred for purposes of (a), (b), (c) and (d) above.
- 1.12 "Employee" means (a) any officer, full-time employee or elected official of the Town of Century who performs personal service for the Town of Century, including service as an independent contractor.
- 1.13 "Employer" means the Town of Century.
- 1.14 "Normal Retirement Age" means not earlier than age 65.
- 1.15 "Participation Agreement" means the contract or agreement between the employee and the employer pursuant to which a portion of the employee's compensation will be deferred in accordance with the provisions of this plan.
- 1.16 "Plan" means the Deferred Compensation Plan of the Town of Century, which is intended to meet the applicable requirements of Section 457 of the Code.
- 1.17 "Plan Administrator" means the Town of Century or its duly authorized designee for that purpose who shall exercise the discretion or other functions given to the Town of Century under the terms of the plan.
- 1.18 "Plan Year" means the calendar year in which the plan becomes effective, and each succeeding calendar year during the existence of the plan.

**SECTION 2.            OPERATIONS OF THE CENTURY PLAN**

- 2.01 "Participation" Upon signing the Participation Agreement, the participant elects to participate in the Century Plan and consents for the Town of Century to deduct the amount of Deferred Compensation specified in the Participation Agreement from the participant's compensation for each pay period.
- 2.02 "Deferred Compensation" The Town of Century and the participant mutually acknowledge that the compensation of each employee is as by written or oral contract and that said compensation includes the dollar amount of funds the participant elects to defer under the terms of this plan or set aside under any other code Section 457 deferred compensation plan or any code Section 403(b) tax deferred annuity. Employee compensation shall be paid as provided except that during each employment year in which the employee is a participant in the Century Plan, that portion of his compensation which is specified by such employee in the Participation Agreement shall be deferred, invested and distributed in accordance with the provisions of the Century Plan.
- 2.03 "Investment of the Deferred Amount". The amount deferred will be invested by the Town of Century in interest bearing accounts or other income producing vehicles.

- 2.04 "Ownership of Deferred Amounts". The Town of Century shall own and maintain the amounts deferred in accordance with Section 2.02 to provide a convenient method of setting aside the amount of its assets required to meet its future obligations under the plan. The Town of Century shall at all times be the legal and beneficial owner of all such deferred amounts, including the income thereof and any increments thereon and the cash surrender value and any death benefits payable under a life insurance policy purchased on the life of a participant, and the existence of neither the plan nor any investment fund attributable to amounts deferred under the plan or the maintenance of any certificate or contract intended to measure participants interests in the investment fund shall be deemed to create a trust or limit use by the Town of Century of the funds therein for general employer purposes. The obligation of the employer to make payments pursuant to this plan is contractual only and no participant or beneficiary shall have a preferred claim or lien on or to the assets of any investment fund or certificate or contract therein, but shall have only the right to receive the benefits payable under the plan from the employer. Interest of a participant in the investment fund who changes employment may, under certain prescribed conditions, be transferred to an eligible plan of a new employer.
- 2.05 "Transfer of Funds to Another Plan". Notwithstanding any other provisions of this plan amounts deferred by a former participant may be transferred to another eligible deferred compensation plan in which such former participant has become a participant if:
1. the receiving plan provides for acceptance of such amounts, and,
  2. the participant requests, in writing, that the transfer be made.
- 2.06 "Transfer of Funds to this Plan". Amounts deferred by a participant from a deferred compensation plan in which he formerly participated may be transferred to this plan if:
1. The first plan provides that the participant be separated from service and,
  2. The participant requests, in writing, that the transfer be made.

### **SECTION 3. ADMINISTRATION AND ACCOUNTING**

- 3.01 "Administration by Employer". This plan shall be administered by the Town of Century, who shall prescribe such forms and adopt such rules and regulations as are necessary to carry out the purposes of the plan.
- 3.02 "Election to Participate". An employee election to participate in this plan shall be made by filing a duly executed Participation Agreement with the Town of Century and not otherwise.
- 3.03 "Enrollment Periods". Any person who is an employee shall have the option to elect to participate in the plan and such election shall be effective as of the first day of the next calendar month.
- 3.04 "Contents of Participation Agreement". The Participation Agreement shall be filed with the Town of Century and shall contain, among other provisions, the following:

- a. A provision whereby the participant specifies the portion of his compensation which is to be deferred, and
  - b. A provision whereby the participant shall designate a beneficiary or beneficiaries, including one or more contingent beneficiaries, to receive any benefits which may be payable under this plan on death of the participant, and
  - c. A provision whereby the participant shall indicate his investment election, if any.
- 3.05 "Termination of Participation". A participant may revoke his election to participate in the plan by signing and filing with the Town of Century a written revocation of participation. The revocation shall be effective as of the first day of the next payroll period.
- 3.06 "Amendment of Participation Agreement". A participant may change the amount of compensation to be deferred under the plan (or may amend his statement of investment preference, if applicable), by filing with the employer a signed amendment of a form approved by the employer. Such amendment will apply only to future amounts deferred under the plan. If a participant requests that amounts then held in a participant's account also be invested in accordance with an amended investment preference, the employer may approve such change, if it deems it in the best interest of the participant to do so.
- 3.07 "Participant Certificate and Contracts". A separate certificate or contract shall be maintained for each participant. For convenience and to facilitate the orderly administration of the plan, individual certificates or contracts for all participants will be maintained by the employer showing the participant's name. The participant's certificate or contract with the employer shall be credited each pay period with the amount deferred from the preceding pay period on the day received by the Town of Century. A written report of the status of the participant's certificate or contract shall be furnished to the participant at least annually by the Town of Century. All interests shall be credited or debited to the certificate or contract as they occur.

#### **SECTION 4.           BENEFITS**

The participant is entitled to have paid to him the benefits created by his participation in the plan in accordance with provisions of this section

- 4.01 Notwithstanding the provisions under subsections (a), (b), and (c) below, the payment of amounts deferred will commence not later than the latter of:
- 1. 60 days after the close of the plan year in which the participant attains (or would have attained) normal retirement age; or
  - 2. for plans beginning on or after January 1, 1989, no later than April 1 of the calendar year following the calendar year in which the participant attains the age of 70-1/2.

Benefits paid to a participant shall be reported to the participant as wages subject to withholding for federal income taxes and reportable on form W-2.

- a. "Normal Retirement". Upon the participants attaining normal retirement age, he may retire and receive the benefits provided under this plan. Such benefits shall commence no later than the date described above and shall be paid in accordance with options described below.
- b. "Termination of Employment". If the participant terminates his employment with the Town of Century, benefits may be taken in a lump sum at any time or deferred until normal retirement age.
- c. "Death". If the participant dies while employed with the Town of Century or terminates his employment and dies before the commencement of benefits under the plan, the entire amount deferred, including any death benefit payable under a life insurance policy purchased on the life of the participant, must be paid to his beneficiary over a period not in excess of:
  - 1. the life of the beneficiary, if the beneficiary is the participant's surviving spouse; or
  - 2. 15 years, if the beneficiary is not the participant's surviving spouse.

If the participant dies while benefits are being paid to him under this plan and before such benefits have been exhausted, then benefit payments will continue only in accordance with any survivorship option selected by the participant in accordance with subsection (d) below.

"Designation of Beneficiary". The participant has the right to name and file with the Town of Century a written beneficiary or change of beneficiary form, designating the person or persons who shall receive the benefits payable under this plan in the event of the participant's death. The form for this purpose shall be provided by the Town of Century. It is not binding on the Town of Century until it is signed, filed with the Town of Century by the participant and accepted by the Town of Century. If the participant dies without having a beneficiary form on file, or if a participant's designated beneficiary predeceased him, any death benefits shall be paid to the participant's surviving children, in equal shares or, should none survive, then to the participant's executors or administrators. The participant accepts and acknowledges that he has the burden for executing and filing with the Town of Century a proper beneficiary designation form.

- d. "Benefits Options". The following options are available for selection by the participant. If at normal retirement age the participant fails to select a payment option, he shall be deemed to have elected to have his benefits payable,
  - 1. If the participant has designated his spouse as beneficiary, under the Joint and Life Annuity form, with the participant's spouse as the contingent annuitant (100% continuation) or
  - 2. If the participant has not designated his spouse as beneficiary, under the Life Annuity form, the participant may elect one of the following benefit options:

**Joint and Survivor Life Annuity.** The term "Joint and Survivor Life Annuity" means an annuity providing monthly payments while either of the two persons upon whose lives such payments depend is living. The monthly amount to be continued when only one of the persons is living will be equal to a percentage of the monthly amount that was paid while both were living. This percentage may be 50% or any higher percentage up to and including 100% as elected by the participant. The payments commence as of the date determined under Subsection a, b, or c above and terminate with the last payment due before the death of the survivor.

**Joint and Survivor Ten Years Certain Annuity.** The term "Joint and Survivor Ten Years Certain Annuity" means an annuity providing monthly payments while either of two persons upon whose lives such payments depend is living, with a guarantee that installments will be paid for at least ten years. The monthly amount to be continued when only one of the persons is living will be equal to a percentage of the monthly amount that was paid while both were living. This percentage may be 50% or any higher percentage up to and including 100%, as elected by the participant.

Joint annuitants do not live for the ten year certain period, the remaining payments will be made to their beneficiaries. The payments commence as of the date determined under Subsection (a), (b), or (c) above and terminate with the last payment due before the death of the survivor.

**Life Annuity.** The term "Life Annuity" means an annuity providing monthly payments only during the lifetime of the person upon whose life such payments depend. The payments commence as of the date determined under Subsection (a), (b), or (c) above and terminate with the last payment due before the death of such person.

If the participant elects a benefit option which allows amounts to be paid to a beneficiary, then the amounts payable to the participant must exceed one-half of the maximum amount that could have been payable to the participant if no provisions were made for payment to a beneficiary.

For plan years beginning on or after January 1, 1989, if distributions have begun prior to the date of the participant's death, the form of payment elected will provide that at least two-thirds (66%) of the amount payable will be paid to the participant over his life expectancy, determined as of the date payments are to commence, and any amount not distributed as of his date of death will be paid at least as rapidly as the method of distribution in effect on the date of his death.

For plans beginning on or after January 1, 1989, all benefits payable under the plan shall satisfy the provisions of Code Section 401(a)(9).

- 4.02 "Financial Hardship". Notwithstanding any other provisions herein, for "financial hardship" a participant may apply to the Town of Century to withdraw, in whole, or in part, benefits from the plan prior to retirement or any other termination of his employment with the Town of Century. Benefits to be paid upon any withdrawal shall be limited strictly to that amount necessary to meet the emergency situation constituting

financial hardship. Any remaining benefits shall be paid upon retirement, termination of employment, or death in accordance with Section 4.01 above. Withdrawal for "financial hardship" shall be limited to real emergencies beyond the control of the participant which would cause him great hardship if early withdrawal were not permitted. Financial hardship shall include the following: impending personal bankruptcy; unexpected and unreimbursed major expenses resulting from illness or accident of the participant or any dependent thereof; major property loss or any other type of unexpected and unreimbursed personal expense. Expenditures of a major nature that would be normally budgetable, such as a down payment for a home, the purchase of an automobile, college or other schooling expense, etc. will not constitute a financial hardship. The decision of the employer concerning financial hardship shall be final as to all participants. Notwithstanding the foregoing, financial hardship shall be limited to such circumstances as may be prescribed by the Secretary of the Treasury by regulation pursuant to the authority contained in Section 457 of the Code.

**SECTION 5.            MISCELLANEOUS**

- 5.01 "Retirement System Integration". Benefits payable by, and deductions for employee contributions to, any retirement system of the employer shall be computed without reference to amounts deferred pursuant to this plan and shall instead be based upon gross compensation the participant would receive if such participant had not elected to participate in this plan and to defer compensation.
- 5.02 "Amendment and Termination". This plan may be amended or terminated by the Town of Century at any time. No amendment or termination of the plan shall reduce or impair the rights of any participant or his beneficiary which have already accrued. Upon the termination of the plan, the Town of Century shall distribute all amounts credited to each participant's account in accordance with the participant's payment option selected. All participants shall be treated in the same manner.
- 5.03 "Creditors". Except to the extent otherwise required by law, a participant may not assign, transfer, sell, hypothecate, or otherwise dispose of any or all of his interest or right which he may have under the Plan, and any attempt to do so shall be void and of no effect.
- 5.04 "Employment". Participation in the plan shall not be construed as giving any participant any right to continue his employment with the Town of Century.
- 5.05 "Successors and Assigns". The plan shall be binding upon and shall insure to the benefit of the Town of Century, its successors and assigns, all participants and beneficiaries and their heirs and legal representatives.
- 5.06 "Written Notice". Any notice or other communication required or permitted under the plan shall be in writing, and if directed to the Town of Century shall be sent to the designated office of the Town of Century and if directed to a participant or to a beneficiary at his last known address as it appears on the Town of Century records.
- 5.07 "Total Agreement". This plan and the participation agreement and any subsequently adopted amendment thereof, shall constitute the total agreement or contract between

the employer and the participant regarding the plan. No oral statement regarding the plan may be relied upon by the participant.

**SECTION 6. TOWN OF CENTURY DEFINED CONTRIBUTION PLAN**

The Town of Century hereby establishes a defined contribution plan for its employees. The plan is effective to each such employee upon the date the employee becomes a participant by signing and filing a participant agreement with the Town of Century.

**OPERATIONS OF THE PLAN**

The Town of Century, Florida will match up to 5% of the base wage paid to a participant of the plan, or will match that amount that the participant agrees to set aside for the deferred compensation plan.

**BENEFITS TO BE PAID BY THE PLAN**

As this is a defined contribution plan the benefit will be the annual contribution, plus the allocated trust investment earnings on the accumulated contributions at the time of retirement.

**VESTING**

A participant has a nonforfeitable right to a percentage of the employee's accrued benefit derived from the Town of Century contributions as determined by the following table:

Years of Service	Nonforfeitable Percentage
3	20
4	40
5	60
6	80
7 or more	100

**SERVICE INCLUDED IN DETERMINATION OF NONFORFEITABLE PERCENTAGE**

In computing the period of service under the plan for purpose of determining the nonforfeitable percentage, all of an employee's years of service with the employer or employees maintaining the plan shall be taken into account, except that the following may be disregarded:

- a. Years of service before age 18
- b. Years of service during a period for which the employee declined to contribute to a plan requiring employee contributions.

The term "year of service" means a calendar year, plan year.

NORMAL RETIREMENT AGE

The term "normal retirement age" means the earlier of:

- a. the time a plan participant attains normal retirement age under the plan, or
- b. the latter of the time a participant attains age 65.

BENEFITS PAYABLE

Benefits are payable as in accordance with Section 4 of the Century Deferred Compensation Plan.

INVESTMENTS

Employer contributions will be invested by the Town of Century in interest bearing accounts, funds, or other income producing vehicles that are allowed by the State of Florida.

ADOPTED THIS 7TH DAY OF AUGUST, 1989.

The Town of Century Personnel Policy Manual was adopted the 15<sup>th</sup> day of March 1993

Attest:

\_\_\_\_\_  
Mayor

\_\_\_\_\_

\_\_\_\_\_

\_\_\_\_\_

\_\_\_\_\_

SAMPLE LETTER

Dear \_\_\_\_\_

This letter will advise you that charges have been made against you which are cause for disciplinary measures as provided for in the Town of Century Personnel Policy Manual. The specific charges made against you are:

- 1.
- 2.
- 3.

The individual who has made these charges against you is \_\_\_\_\_.

The Town Council wishes to provide you a full opportunity to hear the evidence offered in support of the charges brought against you. Therefore, the Town Council intends to hold a special meeting concerning these charges which you are invited to attend. The meeting will be held on \_\_\_\_\_ (date) at \_\_\_\_\_ (time) at the Town Hall. You are invited to be represented by yourself, an attorney, or any other individual you choose. You are invited to tell your own story and to present to the Town Council any witnesses who have information as to the falsity of these charges. You should be aware that the Mayor and/or your supervisor will present those witnesses whom they consider to have evidence showing that such charges are true. Following a presentation of all evidence by both sides, the Town Council will vote as to whether the charges merit suspension without pay or termination.

This letter is the only notice you will receive concerning such hearing. Should you be unable to attend the meeting at the date and time stated above, please advise me immediately so that an alternative date and time may be selected. Should you fail to contact me and fail to appear at the meeting at the above date and time, the Town Council will proceed to vote on your case without consideration of any arguments or evidence in support of your innocence and such vote will be binding on you.

This will advise you that the meeting will be open to the public as is required by Florida law. The town will maintain the confidentiality of the charges made against you only until the meeting.

**Section VII - DEFINITIONS (Comprehensive)**

Appointing Authority – The Town Council or their designee.

Appointment – Initial employment of a person in a position within the service of the Town of Century.

Class – A group of positions similar in duties, qualifications, and compensation range.

Demotion – A change from one class to another with lower pay and responsibility.

Eligible List – Names of top candidates (internal: top 5; external: top 25) used for appointment and promotion.

Employee – A person appointed to a position with compensation, part-time or full-time.

Employment – The initial appointment to a position within the Town's service.

Internal Recruitment – Position open to Town employees only.

External Recruitment – Position open to candidates outside the organization.

Lay-off – Authorized reduction in force due to funding, reorganization, or efficiency.

Minimum Qualifications – The required education, skills, and certifications needed for a position.

Probation – A 180-day introductory period for new or promoted employees to prove suitability.

Promotion – Advancement to a higher position with more responsibility and pay.

Transfer – Lateral movement within the same class or compensation level.

Relatives – A detailed list of familial relationships for use in nepotism policies.

Seniority – Service duration used to determine order in layoffs or promotions.

## **Section I - GENERAL PROVISIONS**

All employees of the Town are "at will" employees under Florida state law, and as such their terms and conditions of employment may be altered or amended at the will of the employer. Employment is subject to the provisions of applicable collective bargaining agreements, individual contracts, or the benefits and procedures provided by Florida state law and this policy.

### **1.01 AUTHORITY:**

Appointing Authority – The Town Council or their designee.

The Town Council of the Town of Century, Florida, as a board of elected public officials, derive authority and responsibility from the Constitution of the State of Florida and the charter of the Town of Century. The elected Town Council is ultimately responsible for all that transpires under the town's authority.

### **1.02 PURPOSE AND SCOPE:**

- a. The purpose of this statement of rules is to promote effective execution of the duties of the town, increase efficiency and economy, reward merit, increase employee satisfaction, respond to, decrease and, if appropriate resolve sources of employee dissatisfaction, and establish equitable standards for the administration and compensation of all employees of the town.
- b. This manual contains the major personnel policies, rules, regulations, and procedures by which the Personnel System of the town shall be conducted. This manual is intended to serve as a statement of policy for existing and new employees. The content includes the general standards by which all employees will conduct themselves, the rules covering pay and leave, the procedures for recruitment and employment of new employees, and the guidelines for the various personnel actions which may affect the status and progress of all employees.

### **1.03 APPLICABILITY:**

Unless specifically noted to the contrary, these rules apply to all town employees: permanent and temporary; regular and probationary; full and part time.

## **Section II - STANDARDS OF CONDUCT**

### **2.01 WORK PERIODS:**

- a. The standard work week will be 40 hours and not less than 35 hours for all full-time employees. The work week shall be the same for all persons occupying full-time positions.
- b. Absences and tardiness affect the overall performance of the town. Serious absences will become subject of personnel actions.

All employees should notify the Town Clerk as far in advance of all anticipated absences and should notify the Town Clerk by 9:00 a.m. on the day of an unexpected absence. Doctor's

excuses may be required for absences of more than three working days which are necessitated by illness or injuries due to accident.

## **2.02 PUBLIC APPEARANCE AND CONDUCT:**

As representatives of the town, all employees are expected to know what is appropriate and acceptable attire, grooming and behavior for their work site and for the individual department or function. If any doubt exists as to what may be appropriate, the employee is encouraged to consult his or her supervisor. Employees are requested to avoid extremes, particularly exotic or bizarre costumes and grooming which are not suited to a business or public service situation.

## **2.03 PUBLIC RELATIONS:**

Each employee of the town should treat people and handle their matters in such a way as to instill respect for the reputation already earned for courteous and efficient service. Friendliness, cheerfulness, helpfulness, courtesy, informality and sincerity are expected from all employees, especially in service to the public.

## **2.04 CONFIDENTIALITY:**

Employees are expected to remain mindful of the confidential nature of many aspects of the work of some departments of the town. Good judgment should be exercised regarding the release or discussion of official matters or other information which may affect the personal or business affairs of others. Supervisory permission is required for release of sensitive or privileged information.

## **2.05 GENERAL QUALITY OF WORK:**

Each employee is expected to achieve maximum efficiency and accuracy on assigned duties. Errors affect the performance of the employee, the work load of fellow workers and supervisors, the reputation of the department and the town and, most importantly, the lives of members of the public. Error free work is our goal.

## **2.06 PERSONAL COMMUNICATIONS**

- a. Personal telephone calls, incoming or outgoing, should be restricted to those of an emergency nature as much as possible. If a telephone call during office hours becomes necessary, it should be brief in order that the telephone lines may be available for town business calls.
- b. Similarly, employee should not receive personal mail or other deliveries at their place of work at the town. Such deliveries may be refused or opened in the course of the town's business. Personal visits by friends, relatives or other contacts should not be received during work hours, and not within the working areas of the town.

## **2.07 EQUAL EMPLOYMENT OPPORTUNITY:**

The Town of Century is an Equal Opportunity Employer. People who are selected for employment in the town are hired on the basis of qualifications. No discrimination will be made concerning employment, compensation, promotion, and other conditions of employment for reasons of age, sex, race, color, creed, or national origin. See Resolution 9-96

## **2.08 OUTSIDE EMPLOYMENT**

Full-time employment by the town shall be considered primary employment for full-time permanent employees, if an employee must engage in outside employment during off-duty hours, such outside employment should not interfere with the general work quality or demeanor of the employee while on town duty. (The fact of outside employment, shall not constitute a justification or excuse for an employee's failure to comply with personnel policies, standards of conduct or guidelines for disciplinary action.)

## **2.09 CONFLICT OF INTEREST**

Employment of relatives is prohibited when it creates or is perceived to create favoritism. No appointing authority can appoint, employ, promote, or transfer any relative to a position where the appointing authority exercises jurisdiction or control. The appointment, employment, promotion, advancement, or transfer of a relative into any division, activity, or section is prohibited if the action creates a prohibited relationship where a relative would supervise (directly or indirectly), make or influence personnel decisions concerning a relative, or creates a conflict of interest or the appearance of a conflict of interest. Prior to relatives being employed, promoted, or transferred into any division, activity, or section, a department director/administrator/manager must certify to the Mayor that no prohibited relationship would occur now or in the future.

To avoid misunderstanding and conflict of interests which could arise, the following policy will be adhered to by all employees of the town. (This policy is in accordance with Section 112.311 et. Seq., Florida Statutes, entitled "Code of Ethics for Public Officers and Employees."):

- (1) Employees shall not accept any gifts, including Christmas gifts, favors or services that may reasonably tend to improperly influence them in the discharge of their official duties.
- (2) Employees shall not use or attempt to use their position to secure special privileges or exemptions for themselves or others, except as may be provided by policy and/or law.
- (3) Employees shall not accept employment or engage in any business or professional activity which they may reasonably expect would require or induce them to disclose confidential information acquired by them by reason of their official position.
- (4) Employees shall not disclose confidential information gained by reason of their official position, nor shall they otherwise use such information for their personal gain or benefit.
- (5) If an employee of the Town is an officer, director, agent or member of, or owns controlling interest in, any corporation, firm, partnership or other business entity which is subject to current proceedings of the town, he or she shall file a sworn statement to this effect with the Mayor.

- (6) Employees shall not transact any business in their official town capacity with any business entity of which he or she is an officer, director, agent, or member, or in which he or she owns a controlling interest, excluding civic, charitable or religious organizations.
- (7) Employees shall not have personal investments in any enterprise which will create a substantial conflict between their private interests and the public interest.

**2.10 ELECTIONS AND POLITICAL ACTIVITIES:**

- a. No employee shall use his or her official authority or influence for the purpose of interfering with an election or a nomination of office or coercing or influencing another person's vote or affecting the result thereof.
- b. No employee shall directly or indirectly coerce or attempt to coerce, command or advise any other officer or employee to pay, lend or contribute any part of his or her salary, kick back any sum of money, or anything else of value to any party, committee, or organization, agency or person for political purposes.
- c. No employee shall participate in political activities of any kind during office hours, nor engage in unauthorized use of any town equipment or supplies for political purposes.
- d. No employee shall engage in activities which bring discredit upon the town.
- e. Notwithstanding the above, all employees shall retain the right to vote as they choose and to express their opinion on all political subjects and candidates. They shall also have the right to participate in any political campaign during off-duty hours so long as such activities are not in conflict with any provision of Florida law.
- f. As responsible public employees, town employees are encouraged to be well-informed, registered voters (if eligible) in all elections.

**2.11 DRIVER'S LICENSE:**

Those employees whose job description requires a valid driver's license or chauffeur's license are expected to keep that license current and free from jeopardy. Any change in the status of a required license must be reported to the employee's supervisor, and may affect the employee's employment.

**Section III - PAY AND BENEFITS ADMINISTRATION**

**3.01 ELIGIBILITY FOR EMPLOYEE BENEFITS:**

Full employee benefits shall be extended to full-time, regular and permanent employees, according to the rules set forth below.

**3.02 WAGES AND SALARY:**

At least annually, the Council will select two of its members who, together with the Mayor, shall review the wage rate of each employee. They shall consider, but shall not be restricted to, inflation, wage rate for a similar position in the local area, merit, time in grade, and the report of the employee's supervisor. They will report their findings and recommendations to the full Council within thirty (30) days. The Council will determine what wage rate adjustments will be made.

### **3.03 PAY PERIODS:**

Wage/salary payments are based on a regular weekly pay period of 40 working hours. The pay period shall begin on Friday and end at the close of the work day on Thursday of the following week. Time and attendance reports shall be submitted to the Town Clerk no later than Friday morning of the pay week.

### **3.04 HOLIDAYS:**

The following will be observed as official holidays by the Town of Century, Florida and all offices, except for essential services, will be closed:

New Year's Day  
 Martin Luther King's Birthday  
President's Day  
 Good Friday  
 Memorial Day  
Juneteenth  
 The Fourth of July  
 Labor Day  
Veteran's Day  
 Thanksgiving  
 Friday following Thanksgiving  
 Christmas Eve  
 Christmas Day

When a holiday falls on Saturday or Sunday, the preceding Friday or following Monday will be observed as a holiday. When Christmas Day falls on Sunday or Monday, then the town offices will be closed on the following Monday or Tuesday.

### **3.05 PAYROLL CHECKS AND DEDUCTIONS:**

- a. Payroll checks are issued on the Friday following the close of the preceding pay period.
- b. Deductions (e.g., for Social Security and Withholding Tax) are made from the employee's paycheck. A list of the amounts for each of these deductions is shown on the paycheck stub. Employees are advised to promptly report any changes which may affect payroll deductions to the Town Clerk. Errors in an employee's check should be reported immediately.

### **3.06 OVERTIME:**

- a. It shall be the general policy of the town for each employee to be assigned regular work duties and responsibilities which can normally be accomplished within the established work day and work week. However, the appropriate supervisor may request an employee to work overtime when necessary in order to meet emergency situations or operating needs. The acceptance of overtime work by the employee shall be voluntary.
- b. The Town Clerk shall maintain records of all overtime worked by all employees. No overtime pay or compensatory time will be granted except on the basis of such records.
  - (1) With respect to all employees or FSLA exempt employees, all overtime will be compensated by compensatory time off, or overtime pay, at a rate of one and half hours of time off for each hours of over-time worked.
  - (2) With respect to all employees earning compensatory time off, compensatory time may be accumulated to a maximum of 240 hours per year. Any compensatory time hours in excess of 240 hours will be forfeited at the end of the calendar year.
  - (3) Only permanent full-time employees are eligible to work overtime.

**3.07 VACATION LEAVE:**

- a. All permanent full-time employees are entitled to vacation leave.
- b. Accrual of vacation leave.
  - (1) All full-time employees who have been employed for six months and completed the probationary period are granted 40 hours of vacation leave.
  - (2) Upon completion of the probationary period and 12 months of continuous employment, all full-time employees are granted an additional 40 hours of vacation leave. No more than 3 weeks of vacation leave may be taken within any 18 month period of employment.
  - (3) All permanent full-time employees who have worked continuously for one to ten years are granted 80 hours vacation leave per year. Thereafter vacation will be granted as follows:

1 Year to 10 Years	– 2 Weeks
10 Years to 15 Years	– 3 Weeks
15 Years to 20 Years	– 4 Weeks
20 Years and over	– 5 Weeks
- c. Use of vacation leave.
  - (1) Any vacation time not used at the end of the calendar year is forfeited.

**3.08 SICK LEAVE:**

- I. General. Sick leave may be used by all full-time employees for employee illness, disability or health care appointments or treatments that cannot be scheduled outside normal working hours. Abuse of sick leave may result in employee discipline or discharge.
- II. Persons Entitled. All full-time permanent employees earn sick leave as of the date of commencement of employment. Sick leave cannot be used by an employee until the completion of the six month probationary period.
- III. Amount of Sick Leave. Full-time employees who complete the six month probationary period will be granted 40 hours of sick leave. Thereafter, sick leave may be earned according to the following schedule:

<u>Year of Service Completed</u>	<u>Hours/Year</u>
6 Months to 1 Year	40
1 Year to 5 Years	80
5 Years to 10 Years	120
10 Years and Over	160

Beginning January 1 of each year, each employee will be granted the amount of sick leave that corresponds to his/her years of service. All unused sick leave will be accumulated up to a total of six months.

- IV. Reporting Sick Leave. An employee who is absent from work due to illness must notify his or her department head within one hour of regular reporting time, and daily thereafter. In the case of employees engaged in 24 hour service, the employee should report to the department head two (2) hours prior to his or her regular reporting time, then daily. Failure to report on a timely basis may result in leave without pay being charged.
- V. Records of Sick Leave. The Town Clerk shall keep records of all sick leave used by all employees, including the reason such leave was required and the number of hours used.
- VI. Exhaustion of Earned Sick Leave. Upon the approval of the Mayor and Town Council, an employee may use vacation leave if sick leave has been exhausted.
- VII. Justification for Sick Leave. Upon the request of the Mayor or Town Council, employees may be required to supply a doctor's certificate for any absences due to illness in excess of two days.
- VIII. Forfeiture of Sick Leave. Employees who separate from town service in good standing may be paid for unused sick leave at a rate of two (2) hours for each (8) hours unused at termination. In the event of death of an employee, unused sick leave will be paid in full to their beneficiary. Employees who are dismissed

or leave the service of the town without proper notice shall forfeit all unused sick leave.

**3.09 MILITARY LEAVE:**

When employees are required to be absent from their positions due to military commitments, military leave will be compensated for in conformity with 115.07, Florida Statutes (1992).

**3.10 CIVIL LEAVE - JURY DUTY:**

Any employee shall be given necessary leave without loss of pay when performing jury duty or other duties required by law as long as he or she is not required to do so under the performance of his or her duties. Those employees who become parties to litigation are not eligible for leave with pay, unless they become such parties in the course of their employment with the town. Employees on civil leave will be compensated by the town only for the difference (if any) in the employee's regular salary for the time on civil leave and the amount received for participation in legal proceedings.

**3.11 FUNERAL LEAVE:**

All full-time permanent employees will be granted three (3) days paid funeral leave for a death in the employee's or the employee's spouse's immediate family. "Immediate family" includes spouse, child, parent, sister, brother, grandmother, or grandfather. In certain cases involving distances, unusual circumstances, etc., the Mayor may grant additional leave with pay.

**3.12 MATERNITY LEAVE:**

Leave for maternity shall be treated as sick leave. If sick leave is exhausted, the employee may opt to use either or a combination of vacation leave and/or leave without pay.

**3.13 UNEMPLOYMENT COMPENSATION:**

The town of Century is registered with the State of Florida Bureau of Unemployment Compensation. Employees who are involuntarily separated from employment and who file a claim and meet certain qualifications may be eligible to receive unemployment compensation benefits.

**3.14 SOCIAL SECURITY:**

Social Security deductions are made from all eligible employees' pay and an equal amount is added to it by the town for all employees as set forth in the State Municipal Agreement for coverage of local government employees under the Federal Old Age.

**Section IV - PERSONNEL RELATIONS**

**4.01 POLICY:**

These policies are intended to provide regular employees a fair and equitable review of any grievance without fear of discrimination, coercion, restraint or reprisal. Further, they shall insure that every reasonable effort will be made to resolve the matter as efficiently and

effectively as possible. It shall be the policy of the town insofar as possible to prevent the occurrence of grievances and to deal promptly with those which occur. It is the intent and desire of the town to adjust complaints or grievances informally, and both administrative staff and employees are expected to make every effort to resolve problems as they arise. However, it is recognized that there will be grievances which will be resolved only after review. This grievance procedure is established to provide full opportunity to employees to bring to the attention of administrative staff, or the Mayor or the Town Council complaints, grievances, or situations that the employee feels need either adjustment or resolution.

#### **4.02 GRIEVANCE PROCEDURE:**

Level 1: An employee may bring any complaint, grievance, or inquiry to his or her supervisor who may consult with the Mayor concerning the matter. The supervisor will respond to the employee within three working days after receiving the complaint, grievance or inquiry.

Level 2: If the matter is not resolved by the supervisor to the employee's satisfaction, the employee may submit a written grievance to the Mayor within seven working days of receipt of the supervisor's response. The Mayor will make the appropriate investigation and respond in writing to the employee within fifteen working days of the filing by the employee of the written grievance.

Level 3: If the matter is not resolved by the Mayor to the employee's satisfaction, he or she may bring the matter before the Town Council by submitting, within seven days of the Mayor's response, a written statement of the complaint, grievance, or inquiry and request that the issue be placed on the agenda for the next meeting of the Town Council. The employee may appear at such meeting and present his complaint, grievance or inquiry, to which the employee's supervisor or the Mayor may respond. The Town Council will make a decision concerning such matter, which decision will be final.

### **Section V - PERSONNEL POLICIES, ACTIONS & PROCEDURES**

#### **5.01 EMPLOYEE SELECTION:**

The Town of Century will advertise all job openings in a newspaper of local circulation for at least two weeks prior to the actual interview and selection process. Such advertisements will identify the town as an Equal Opportunity Employer.

Any person seeking employment with the town will be required to execute an application for employment form as prescribed by the town.

All vacancies occurring within the town shall be filled whenever possible with a qualified employee of the town. Promotion within the town staff shall be based upon the qualifications of the person being appointed. The first consideration in the filling of vacancies will be given to the most qualified applicant within the department. Next consideration will be given to the most qualified applicant from outside the department. If no acceptable applicant is found within the town staff, the vacancy may be filled from outside the town staff. The criteria used in selection of the most qualified applicant shall be based upon examination, promotional potential rating, oral interview, and/or demonstrated performance.

The department supervisor will review applications for employment and conduct a personal interview with each applicant and, with the approval of the Mayor, will select the applicant(s) to be employed. The Council must approve the selection of any individual to be by the town. At the discretion of the Council, any prospective employee may be required to appear before the Council for an interview.

## 5.015 **TEMPORARY EMPLOYMENT PROVISIONS**

### **1. Definition of Temporary Employment**

A temporary employee is one appointed to a position for a limited duration to meet a specific short-term need, such as a vacancy, leave of absence, seasonal work, or special project.

### **2. Duration of Appointment**

Temporary appointments shall not exceed six (6) months without Town Council approval. Extensions beyond six months may be considered by a majority vote of the Council upon recommendation by the Mayor.

### **3. Town Council Approval**

Any temporary appointment recommended by the Mayor must be submitted to the Town Council for approval at the next scheduled meeting. No temporary employee shall begin work prior to Council approval unless authorized on an emergency basis by resolution.

### **4. Posting of Vacancy**

Vacancies intended to be filled on a temporary basis must be posted publicly, both internally and externally, for a minimum of five (5) business days unless waived due to urgent need with written justification.

### **5. Pre-Employment Requirements**

All temporary employees are subject to:

- a. A criminal background check;
- b. A pre-employment drug screening;
- c. A pre-employment physical if the position requires physical labor or operation of equipment.

### **6. Compensation**

Temporary employees shall be paid hourly wages based on the approved classification and experience. They are not eligible for step increases or salary ranges.

### **7. Benefits Eligibility**

Temporary employees do not receive benefits, including:

- a. Health, dental, or vision insurance;
- b. Paid time off (sick leave, vacation);
- c. Retirement contributions;
- d. Bereavement or jury duty leave.

## **8. Holidays**

Temporary employees are not compensated for holidays unless they are scheduled to work and do work on the holiday, in which case they receive regular pay.

## **9. Eligibility for Temporary Appointment**

A temporary employee may only be appointed to a position that is both:

- A. Vacant, and
- B. Included in the adopted budget and authorized by the Town Council.

No temporary employment shall be approved for unbudgeted or newly created positions unless:

- C. The Town Council takes formal action to create and fund such position;
- D. And/Or the position is included in the Town's Personnel Authorization List.

### **5.02 PROBATIONARY PERIOD:**

Under the direction of the Mayor or designee, the Town Clerk administers a program for rating the work performance of Town of Century employees. The Performance Evaluation Program is designed to provide procedures and guidelines for supervisors to evaluate the performance of Town employees in the accomplishment of their assigned duties and responsibilities. Through the uniform application of these procedures and guidelines, supervisors can use the Performance Evaluation Program as an effective management tool to recognize accomplishments, guide and reward performance, and improve productivity and morale. Approved forms must be developed by the Town Clerk and approved by the Mayor. Notwithstanding the existing probationary period requirements, all regular employees shall receive an annual performance evaluation. Probationary employees remain subject to the existing policy which requires a six-month performance evaluation prior to permanent appointment by the Town Council.

- a. Intent: The probationary period, or working test, shall be regarded as an integral part of the selection process and shall be used for closely observing the employee's work; for securing the most effective adjustment of a new employee to his or her position; and for rejecting any employee whose performance is not satisfactory.
- b. Conditions of Probationary Period: All employees appointed or promoted to permanent positions shall serve a probationary period of six months.
  - (1) The probationary employee may accumulate sick leave, but cannot use sick leave during the probationary period except upon special approval granted by the Town Council.

- (2) Probationary employees will not work overtime.
- (3) Probationary employees are granted 40 hours vacation time at the completion of the probationary period.
- (4) The probationary employees may be dismissed for any lawful reason and such employee has no right to appeal the dismissal.
- (5) The probationary employee's supervisor shall submit a written evaluation of the employee's performance to the Mayor and Town Council twenty days before the expiration of the probationary period. The Mayor and Town Council, at the next meeting of the Town Council and according to the provisions of the Town Charter, will decide whether to grant the employee permanent status.

### **5.03 DISCIPLINE**

#### **A. DISCIPLINARY ACTIONS.**

The Mayor shall have the authority to discipline employees of the Town in accordance with the provisions of this section 5.03. The types of discipline which the Mayor is authorized to administer include but are not limited to dismissal, suspensions, demotions, and formal warnings (either written or oral). An employee shall have the right to appeal to the Town Council in accordance with the provisions of this Section 5.03 any disciplinary action administered by the Mayor which results in a loss or reduction of the employee's compensation.

#### **B. SUSPENSIONS:**

The Mayor may, on his/her own initiative or upon the recommendation of the employee's supervisor, suspend an employee without pay for disciplinary purposes for such length of time as the Mayor considers appropriate but not to exceed sixty (60) days in any twelve (12) month period.

#### **C. DEMOTIONS:**

The Mayor may, upon his/her determination or upon the recommendation of the employee's supervisor that an employee is unable to satisfactorily perform the duties of the position in which s/he is employed and/or that demotion is an appropriate disciplinary action under the circumstances, demote an employee to a position having duties which the employee can successfully perform and which may have lower compensation, or the Mayor may reduce the salary or hourly wage of the employee.

An employee may be demoted at his/her own written request to a vacant position in a lower class, subject to the approval of his/her supervisor and the Mayor. The Mayor will determine whether the employee is qualified to perform the duties and responsibilities of the lower job class.

D. DISMISSALS:

The Mayor may, on his/her own initiative or upon the recommendation of the employee's supervisor, dismiss an employee for cause.

E. CAUSES FOR SUSPENSION, DEMOTION OR DISMISSAL:

An employee may be suspended, demoted or dismissed for just cause. For purposes of this Section 5.03 "just cause" shall mean cause based upon reasonable grounds governed by good faith. Although suspension, demotion or dismissal may be based on other causes, any one or more of the following shall be sufficient. If the employee:

1. has been convicted of a felony, or of a misdemeanor involving turpitude;
2. is a member of a subversive organization, or knowingly or willfully violates the laws of the United States, the State of Florida, and/or the ordinances, rules, and regulations of the Town;
3. willfully, wantonly, unreasonably, unnecessarily, or through culpable negligence has been guilty of brutality or cruelty to a person provided the act committed was not necessarily or lawfully done in self-defense, or to protect the lives of others, or to defend or to protect the lives of others;
4. violates any of the provisions of this manual;
5. is offensive in his/her conduct or language in public, or toward the public, Town officials, or fellow employees, either on or off duty;
6. violates any lawful official regulation or order, or fails to obey any proper direction made and given by a superior;
7. uses intoxicants and/or illegal drugs while on duty;
8. becomes afflicted with any disease or has any physical ailment or defect which, in the opinion of the Mayor after confirmation by a physician, renders the employee unfit for employment, and reasonable accommodations, as defined by the Americans with Disabilities Act, cannot be made;
9. is incompetent, inefficient, or ineffective in the performance of the duties of his/her position;
10. is careless or negligent with the monies or other property of the Town;
11. takes any property of the Town for his/her own personal use or for sale or gift to, or use by, others;

12. has used or threatened to use, or attempted to use personal or political influence in securing promotion, leave of absence, transfer, change of pay rate, or in any manner related to his/her work;
13. induces, or has attempted to induce, an officer or employee in the service of the Town to commit an unlawful act or to act in violation of any lawful or official regulation or order;
14. takes for his/her personal use from any person, any fee, gift, or other valuable thing in the course of his/her work or in connection with it, when such a gift or other valuable thing is given in the hope or expectation of receiving a favor or better treatment than that accorded other persons, or accepts any bribe, gift, token, monies, or other things of value intended as an inducement to perform or refrain from performing any official act, or engages in any action of extortion or other means of obtaining money or other things of value, through his/her position;
15. speaks disrespectfully of, publicly criticizes, or maliciously ridicules any official or employee of the Town;
16. hinders the regular operation of the Town because of excessive absenteeism;
17. does not have the capacity for the proper performance of duties because of a permanent or chronic physical or mental defect, and reasonable accommodations as defined by the Americans with Disabilities Act cannot be made;
18. is absent without leave or failing to report after leave of absence has expired;
19. fails to notify the employee's supervisor within one working day of suspension or revocation of valid operator's or chauffeur's license (applies only to employees whose job requires valid operator or chauffeur license).
20. has unauthorized absence from work;
21. makes a false statement of a material fact or practicing or attempting to practice any fraud or deception in an attempt to secure any job related benefits;
22. commits such acts, or fails to undertake acts, which impede or hinder the Town from fulfilling its service to the community, or which are contrary to or which jeopardize the health, safety, and welfare of other employees or officials or the citizens of the Town.

F. DISCIPLINARY PROCEDURE:

1. Dismissal, Suspension or Demotion of Regular Town Employees:

- a. When the dismissal, suspension or demotion of any regular full-time Town employee is contemplated, the Mayor and/or the employee's supervisor may hold such informational meetings as they deem necessary. The Mayor and/or supervisor shall have the right to question any employee of the Town who might be able to shed light on the circumstances involving the subject employee.

It is not required that a meeting with the employee be held; rather, it is expected that the Mayor and/or supervisor will meet with the employee only when there is sufficient doubt as to whether or not the employee committed the acts for which discipline is contemplated.

- b. In considering the appropriate disciplinary action (if any), the Mayor or supervisor may take into account all prior disciplinary action of the subject employee and the employee's employment record. If such prior disciplinary actions or record contributes to the disciplinary action, the same shall be reflected in the summary contemplated in the following paragraph.
- c. The Mayor or the supervisor will prepare a written summary of the facts, evidence, and documents relating to the disciplinary action. Said summary will further set forth the Mayor's final disciplinary decision.
- d. The Mayor will furnish to subject employee written notice of the disciplinary action, which notice shall include a brief summary or explanation of the grounds for the disciplinary action. Such notice will either be hand-delivered or sent by certified mail. The notice shall also state that the employee shall have five (5) working days from the date of such notice within which to file with the Mayor, a written response requesting an appeal hearing before the Town Council.
- e. If no written response is received from the employee within the said five (5) day period, then the employee shall be deemed to have accepted the disciplinary action. It will be the responsibility of the employee to make a timely written request of the Mayor for the appeal, and if the employee does not request (or timely request) the same, s/he will be deemed to have waived the right to appeal the disciplinary action to the Town Council.

2. Employee Appeal Process:

- a. If the employee disagrees with the Mayor's disciplinary action, the employee may request a review of the Mayor's decision by the Town Council. The employee's written request for an appeal hearing must state all of the employee's reasons and grounds for appealing the

disciplinary action. If the employee's written request fails to set forth any reasons or grounds for the appeal, the appeal may be summarily denied without need to proceed with an appeal hearing before the Town Council.

- b. The decision of the Mayor may be overturned by the Town Council only upon clear and convincing evidence that the Mayor did not have just cause (as defined in Section 5.03.E, above) for his/her decision. The burden of proving that there was not just cause, which must be demonstrated by clear and convincing evidence, shall be upon the employee. The employee may assert at the appeal hearing only those reasons or grounds set forth in the employee's written request for an appeal hearing, and the Town Council shall not consider any reasons or grounds that are not set forth in the employee's written request.
- c. The appeal hearing before the Town Council shall be informal and guided only by minimum due process requirements. The Town Council shall not have the authority to modify or alter the extent of discipline or action reflected in the Mayor's decision. Rather, the sole function of the Town Council during the appeal hearing shall be to determine whether, on the basis of the evidence presented during the hearing, it has been clearly and convincingly demonstrated that there was not just cause for the Mayor's decision. In other words, it must be demonstrated that the Mayor's decision was unreasonable and/or made in bad faith. If it is demonstrated by clear and convincing evidence that the Mayor did not have just cause, his/her decision shall be overturned. Otherwise, the Mayor's decisions must be upheld. The standard and burden of proof for reversal of the Mayor's decision is intentionally established at a high level and is intended to provide the mere assurance that the Mayor's decisions will not be arbitrary and capricious. The determination of the Town Council shall be final and there shall be no basis for further appeal or redress of the disciplinary action.

#### **5.04 TYPES OF SEPARATION FROM EMPLOYMENT**

##### **A. DISMISSAL:**

The termination of an employee shall be termed a dismissal when, in the opinion of the Mayor, the employee fails to render satisfactory services for any reason contemplated in Section 5.03.E. An employee who has been dismissed from employment with the Town shall not be eligible for re-employment for a period of five years from the date of dismissal.

##### **B. RESIGNATION:**

An employee may voluntarily terminate his/her employment by resignation stating reasons therefore, in writing, to the Mayor. If the Mayor finds that reported resignation was not voluntary, s/he will treat the separation as a dismissal. An employee who has submitted his/her resignation may, with the

approval of the Mayor, be continued in his/her position as though the resignation had not been filed, on his/her written request for authorization to withdraw the resignation, filed before the effective date thereof or within thirty (30) days thereafter. An employee who resigns from his/her employment with the Town with the Mayor's approval shall be immediately eligible for further employment with the Town.

C. LAYOFF:

A layoff shall mean the involuntary separation from employment through no fault of the employee, but for reasons deemed appropriate by the Mayor (e.g., lack of funds, changes in organizational structure, lack of need for position or type of work performed, etc.), and without adverse effect on the employee's immediate eligibility for further employment with the Town. The order of layoff is hereby declared to be as follows:

1. The order of the layoff will be inverse to the relative value of the employees to the Town as determined by the Mayor.
2. No permanent employee will be laid off from any position while any temporary employee is continued in a position of the same class.
3. Each employee laid off shall be given a written notice. Whenever practicable, this notice should be given at least three (3) days prior to the effective date, and should include the reasons for the layoff, the effective date, and any other information deemed necessary by the Mayor.
4. In the event of a lay-off, the Town will adhere to the statutory requirements of Chapter 295.07, Florida Statutes, which provide preference in retention for eligible veterans. Employees discharged by reason of a lay-off will have their names entered on an eligible register for each title or class for which positions were eliminated. The register will remain effective for one year, unless extended by request of the appointing authority. If positions become available while the register is effective, the appointing authority will consider these individuals for reemployment.

## **Section VI - ANTI-DRUG POLICY**

### **6.01 SOURCE AND POLICY:**

- a. The Anti-Drug policy is based on the provisions of the Pipeline Safety Regulations, Code of Federal Regulations, Code of Federal Regulations, Title 49, 40 C.F.R. Part 199.
- b. In recognition of the adverse effects illegal drugs have on an individual's health, attitude, performance, and safety, it is the policy of the town to require its employees to undergo drug testing.

**6.02 APPLICATION:**

This policy applies to all employees.

**6.03 PRIMARY REQUIREMENTS:**

- a. All employees who work directly or indirectly with the town's natural gas system must be tested.
- b. The laboratory selected for analysis must establish its certification.
- c. The laboratory must forward testing results only to the medical review officer.
- d. The medical review officer must:
  1. receive and interpret drug test results.
  2. inform the employee of drug test results.
  3. give employee opportunity to discuss test results.
  4. order a reanalysis of the original specimen if employee contests validity.
  5. maintain confidentiality.
  6. inform employee of results of second test.
  7. give opportunity to discuss results of second test.
  8. only after all of the above, inform Mayor and Town Council of test results.

**6.04 LABORATORY AND MEDICAL REVIEW OFFICER:**

- a. Laboratory: Flomaton Medical Center laboratory will analyze all specimens collected for drug testing. Flomaton Medical Center will submit to the Town Council, before conducting any analyses, evidence that they possess the required certification to perform such analysis.
- b. Medical Review Officer: Dr. John Vanlandingham is selected as the town's medical review officer.

**6.05 TYPES OF DRUG TESTING:**

- a. Pre-Employment Testing: Employees may be required to undergo pre-employment testing. Any individual who refuses to undergo or fails such drug test will be ineligible for employment. Such applicants have no right to retesting of their samples.
- b. Random Testing: All employees are subject to unannounced testing based on random selection.
- c. Post-Accident Testing:
  1. Any employee whose performance contributed to an accident or cannot be completely discounted as a contributory factor to the accident will be tested.

2. Such employee will be tested as soon as possible but no later than 32 hours after the accident.
- d. Reasonable Cause Testing:
1. Where there is reasonable cause to believe that an employee covered by this policy is using a prohibited drug, the employee will be required to take a drug test.
  2. Only a supervisor who has been trained in drug use symptoms can determine that reasonable cause for a drug test exists. Such determination must be based on objective factors, such as performance errors.

**6.06 TESTING PROCEDURES:**

- a. Test Methods. All drug testing will utilize urine samples.
- b. Target Drugs. Tests for marijuana, cocaine, opiates, amphetamines, and phencyclidine will be performed.
- c. Upon notification that a drug test is required, an employee will report as soon as possible but no later than 24 hours (32 hours for post-accident) after notification to the drug collection site and provide a specimen of his/her urine.
- d. The laboratory will forward the drug testing results to the medical review officer.

**6.07 REVIEW OF DRUG TESTING RESULTS:**

- a. Duties of medical review officer:
  1. Review of drug test results before they are reported to any town representative, including the mayor.
  2. Determine whether there is an alternative medical explanation for positive test result.
    - i. Conduct medical interview of affected employee.
    - ii. Review employee's medical history and medical records, with specific reference to prescribed medication.
    - iii. If necessary, order reanalysis of original specimen to determine accuracy.
    - iv. Verify laboratory report and assessment are correct.
  3. Determine if employee who refused to take test or who did not pass test may be safely returned to duty.
- b. Determination Rules

1. If the medical review officer determines, after appropriate review, that there is a legitimate medical explanation for the positive test result, no further action is required and affected employee will not be disciplined in any way.
2. If the medical review officer cannot identify a legitimate medical explanation for the positive test result, he will forward the employee's name and test results to the Mayor for disciplinary proceedings in accordance with the provisions of this Personnel Policy.

**6.08 EMPLOYEE ASSISTANCE PROGRAM:**

- a. Drug Use Education – All employees will be provided a copy of these personnel rules and, on a periodic basis, drug-use information.
- b. Due to economic constraints, no rehabilitation programs will be afforded to employees.
- c. Community Service Hotline Number: 1-800-888-9383

**6.09 RECORDKEEPING:**

The Town Clerk will maintain the following records:

- a. Results of drug tests which were positive for drug use:
  - i. Must be kept 5 years.
  - ii. Must identify employee's job duties, age.
  - iii. Must specify drugs detected.
  - iv. Must identify employee status – suspension, termination, etc.
- b. Results which were negative for drugs must be kept 1 year.
- c. Records showing numbers of employees tested must be kept 5 years.

**6.10 CONFIDENTIALITY:**

- a. All records of testing and test results must be maintained private and confidential.
- b. Test results may be released only to the following without prior authorization of the affected employee:
  - i. Laboratory
  - ii. Medical Review Officer
  - iii. Town Clerk
  - iv. Mayor
  - v. State and local officials as necessary to their investigation of an accident.
- c. Test results can be released to the Town Clerk and Mayor without authorization of the affected employee only after the medical review officer has completed all specified duties and employee contests results of initial and repeat drug testing.

- d. All written records must be stored in a locked container or in a secure location accessible only to the above listed individuals.
- e. Drug test results will not be released to subsequent employers without prior authorization of the affected employee.

**TOWN OF CENTURY DEFERRED COMPENSATION PLAN**

**ORDINANCE NO. 5-89**

The Town of Century hereby establishes an Employee Deferred Compensation Plan (hereinafter referred to as the "Century Plan"). The Century Plan consists of the provisions set forth in this ordinance and is applicable to each employee who elects to participate in the Century Plan. The Plan is effective as to each such employee upon the date the employee becomes a "Participant" by signing and filing a Participant Agreement with the Town of Century.

The purpose of the Century Plan is to permit employees and independent contractors to participate in a deferred compensation plan by entering into an agreement with the Town of Century wherein a portion of their salary not yet earned will be deferred.

**SECTION 1.           DEFINITIONS**

- 1.01 "State" – The term "State" means a state, a political subdivision of a state, and an agency or instrumentality of a state or political subdivision of a state.
- 1.02 "Performance of Service" – The "performance of service" includes performance of service as an independent contractor.
- 1.03 "Participant" – The term "participant" means an individual who is eligible to defer compensation under the plan.
- 1.04 "Beneficiary" – The term "beneficiary" means a beneficiary of the participant, his estate, or any other person whose interest in the plan is derived from the participant.
- 1.05 "Includible compensation" – The term "includible compensation" means compensation for service performed for the Town of Century, which (taking into account the provisions of this section and Section 403(b)) is currently includible in gross income.
- 1.06 "Compensation, taken into account at present value" – Compensation shall be taken into account at its present value.
- 1.07 "Community Property Laws" – The amount of includible compensation shall be determined without regard to any...

**Page 27 Missing in pdf file**

- e. For plan years beginning on or after January 1, 1988, amounts deferred pursuant to Code Section 402(a)(b) and 402(h)(1)(B) under a 401(k) plan shall be treated as amounts deferred for purposes of (a), (b), (c) and (d) above.
- 1.12 "Employee" means (a) any officer, full-time employee or elected official of the Town of Century who performs personal service for the Town of Century, including service as an independent contractor.
- 1.13 "Employer" means the Town of Century.
- 1.14 "Normal Retirement Age" means not earlier than age 65.
- 1.15 "Participation Agreement" means the contract or agreement between the employee and the employer pursuant to which a portion of the employee's compensation will be deferred in accordance with the provisions of this plan.
- 1.16 "Plan" means the Deferred Compensation Plan of the Town of Century, which is intended to meet the applicable requirements of Section 457 of the Code.
- 1.17 "Plan Administrator" means the Town of Century or its duly authorized designee for that purpose who shall exercise the discretion or other functions given to the Town of Century under the terms of the plan.
- 1.18 "Plan Year" means the calendar year in which the plan becomes effective, and each succeeding calendar year during the existence of the plan.

**SECTION 2.           OPERATIONS OF THE CENTURY PLAN**

- 2.01 "Participation" Upon signing the Participation Agreement, the participant elects to participate in the Century Plan and consents for the Town of Century to deduct the amount of Deferred Compensation specified in the Participation Agreement from the participant's compensation for each pay period.
- 2.02 "Deferred Compensation" The Town of Century and the participant mutually acknowledge that the compensation of each employee is as by written or oral contract and that said compensation includes the dollar amount of funds the participant elects to defer under the terms of this plan or set aside under any other code Section 457 deferred compensation plan or any code Section 403(b) tax deferred annuity. Employee compensation shall be paid as provided except that during each employment year in which the employee is a participant in the Century Plan, that portion of his compensation which is specified by such employee in the Participation Agreement shall be deferred, invested and distributed in accordance with the provisions of the Century Plan.
- 2.03 "Investment of the Deferred Amount". The amount deferred will be invested by the Town of Century in interest bearing accounts or other income producing vehicles.

- 2.04 "Ownership of Deferred Amounts". The Town of Century shall own and maintain the amounts deferred in accordance with Section 2.02 to provide a convenient method of setting aside the amount of its assets required to meet its future obligations under the plan. The Town of Century shall at all times be the legal and beneficial owner of all such deferred amounts, including the income thereof and any increments thereon and the cash surrender value and any death benefits payable under a life insurance policy purchased on the life of a participant, and the existence of neither the plan nor any investment fund attributable to amounts deferred under the plan or the maintenance of any certificate or contract intended to measure participants interests in the investment fund shall be deemed to create a trust or limit use by the Town of Century of the funds therein for general employer purposes. The obligation of the employer to make payments pursuant to this plan is contractual only and no participant or beneficiary shall have a preferred claim or lien on or to the assets of any investment fund or certificate or contract therein, but shall have only the right to receive the benefits payable under the plan from the employer. Interest of a participant in the investment fund who changes employment may, under certain prescribed conditions, be transferred to an eligible plan of a new employer.
- 2.05 "Transfer of Funds to Another Plan". Notwithstanding any other provisions of this plan amounts deferred by a former participant may be transferred to another eligible deferred compensation plan in which such former participant has become a participant if:
1. the receiving plan provides for acceptance of such amounts, and,
  2. the participant requests, in writing, that the transfer be made.
- 2.06 "Transfer of Funds to this Plan". Amounts deferred by a participant from a deferred compensation plan in which he formerly participated may be transferred to this plan if:
1. The first plan provides that the participant be separated from service and,
  2. The participant requests, in writing, that the transfer be made.

### **SECTION 3.            ADMINISTRATION AND ACCOUNTING**

- 3.01 "Administration by Employer". This plan shall be administered by the Town of Century, who shall prescribe such forms and adopt such rules and regulations as are necessary to carry out the purposes of the plan.
- 3.02 "Election to Participate". An employee election to participate in this plan shall be made by filing a duly executed Participation Agreement with the Town of Century and not otherwise.
- 3.03 "Enrollment Periods". Any person who is an employee shall have the option to elect to participate in the plan and such election shall be effective as of the first day of the next calendar month.
- 3.04 "Contents of Participation Agreement". The Participation Agreement shall be filed with the Town of Century and shall contain, among other provisions, the following:

- a. A provision whereby the participant specifies the portion of his compensation which is to be deferred, and
  - b. A provision whereby the participant shall designate a beneficiary or beneficiaries, including one or more contingent beneficiaries, to receive any benefits which may be payable under this plan on death of the participant, and
  - c. A provision whereby the participant shall indicate his investment election, if any.
- 3.05 "Termination of Participation". A participant may revoke his election to participate in the plan by signing and filing with the Town of Century a written revocation of participation. The revocation shall be effective as of the first day of the next payroll period.
- 3.06 "Amendment of Participation Agreement". A participant may change the amount of compensation to be deferred under the plan (or may amend his statement of investment preference, if applicable), by filing with the employer a signed amendment of a form approved by the employer. Such amendment will apply only to future amounts deferred under the plan. If a participant requests that amounts then held in a participant's account also be invested in accordance with an amended investment preference, the employer may approve such change, if it deems it in the best interest of the participant to do so.
- 3.07 "Participant Certificate and Contracts". A separate certificate or contract shall be maintained for each participant. For convenience and to facilitate the orderly administration of the plan, individual certificates or contracts for all participants will be maintained by the employer showing the participant's name. The participant's certificate or contract with the employer shall be credited each pay period with the amount deferred from the preceding pay period on the day received by the Town of Century. A written report of the status of the participant's certificate or contract shall be furnished to the participant at least annually by the Town of Century. All interests shall be credited or debited to the certificate or contract as they occur.

#### **SECTION 4.           BENEFITS**

The participant is entitled to have paid to him the benefits created by his participation in the plan in accordance with provisions of this section

- 4.01 Notwithstanding the provisions under subsections (a), (b), and (c) below, the payment of amounts deferred will commence not later than the latter of:
- 1. 60 days after the close of the plan year in which the participant attains (or would have attained) normal retirement age; or
  - 2. for plans beginning on or after January 1, 1989, no later than April 1 of the calendar year following the calendar year in which the participant attains the age of 70-1/2.

Benefits paid to a participant shall be reported to the participant as wages subject to withholding for federal income taxes and reportable on form W-2.

- a. "Normal Retirement". Upon the participants attaining normal retirement age, he may retire and receive the benefits provided under this plan. Such benefits shall commence no later than the date described above and shall be paid in accordance with options described below.
- b. "Termination of Employment". If the participant terminates his employment with the Town of Century, benefits may be taken in a lump sum at any time or deferred until normal retirement age.
- c. "Death". If the participant dies while employed with the Town of Century or terminates his employment and dies before the commencement of benefits under the plan, the entire amount deferred, including any death benefit payable under a life insurance policy purchased on the life of the participant, must be paid to his beneficiary over a period not in excess of:
  - 1. the life of the beneficiary, if the beneficiary is the participant's surviving spouse; or
  - 2. 15 years, if the beneficiary is not the participant's surviving spouse.

If the participant dies while benefits are being paid to him under this plan and before such benefits have been exhausted, then benefit payments will continue only in accordance with any survivorship option selected by the participant in accordance with subsection (d) below.

"Designation of Beneficiary". The participant has the right to name and file with the Town of Century a written beneficiary or change of beneficiary form, designating the person or persons who shall receive the benefits payable under this plan in the event of the participant's death. The form for this purpose shall be provided by the Town of Century. It is not binding on the Town of Century until it is signed, filed with the Town of Century by the participant and accepted by the Town of Century. If the participant dies without having a beneficiary form on file, or if a participant's designated beneficiary predeceased him, any death benefits shall be paid to the participant's surviving children, in equal shares or, should none survive, then to the participant's executors or administrators. The participant accepts and acknowledges that he has the burden for executing and filing with the Town of Century a proper beneficiary designation form.

- d. "Benefits Options". The following options are available for selection by the participant. If at normal retirement age the participant fails to select a payment option, he shall be deemed to have elected to have his benefits payable,
  - 1. If the participant has designated his spouse as beneficiary, under the Joint and Life Annuity form, with the participant's spouse as the contingent annuitant (100% continuation) or
  - 2. If the participant has not designated his spouse as beneficiary, under the Life Annuity form, the participant may elect one of the following benefit options:

**Joint and Survivor Life Annuity.** The term "Joint and Survivor Life Annuity" means an annuity providing monthly payments while either of the two persons upon whose lives such payments depend is living. The monthly amount to be continued when only one of the persons is living will be equal to a percentage of the monthly amount that was paid while both were living. This percentage may be 50% or any higher percentage up to and including 100% as elected by the participant. The payments commence as of the date determined under Subsection a, b, or c above and terminate with the last payment due before the death of the survivor.

**Joint and Survivor Ten Years Certain Annuity.** The term "Joint and Survivor Ten Years Certain Annuity" means an annuity providing monthly payments while either of two persons upon whose lives such payments depend is living, with a guarantee that installments will be paid for at least ten years. The monthly amount to be continued when only one of the persons is living will be equal to a percentage of the monthly amount that was paid while both were living. This percentage may be 50% or any higher percentage up to and including 100%, as elected by the participant.

Joint annuitants do not live for the ten year certain period, the remaining payments will be made to their beneficiaries. The payments commence as of the date determined under Subsection (a), (b), or (c) above and terminate with the last payment due before the death of the survivor.

**Life Annuity.** The term "Life Annuity" means an annuity providing monthly payments only during the lifetime of the person upon whose life such payments depend. The payments commence as of the date determined under Subsection (a), (b), or (c) above and terminate with the last payment due before the death of such person.

If the participant elects a benefit option which allows amounts to be paid to a beneficiary, then the amounts payable to the participant must exceed one-half of the maximum amount that could have been payable to the participant if no provisions were made for payment to a beneficiary.

For plan years beginning on or after January 1, 1989, if distributions have begun prior to the date of the participant's death, the form of payment elected will provide that at least two-thirds (66%) of the amount payable will be paid to the participant over his life expectancy, determined as of the date payments are to commence, and any amount not distributed as of his date of death will be paid at least as rapidly as the method of distribution in effect on the date of his death.

For plans beginning on or after January 1, 1989, all benefits payable under the plan shall satisfy the provisions of Code Section 401(a)(9).

- 4.02 "Financial Hardship". Notwithstanding any other provisions herein, for "financial hardship" a participant may apply to the Town of Century to withdraw, in whole, or in part, benefits from the plan prior to retirement or any other termination of his employment with the Town of Century. Benefits to be paid upon any withdrawal shall be limited strictly to that amount necessary to meet the emergency situation constituting

financial hardship. Any remaining benefits shall be paid upon retirement, termination of employment, or death in accordance with Section 4.01 above. Withdrawal for "financial hardship" shall be limited to real emergencies beyond the control of the participant which would cause him great hardship if early withdrawal were not permitted. Financial hardship shall include the following: impending personal bankruptcy; unexpected and unreimbursed major expenses resulting from illness or accident of the participant or any dependent thereof; major property loss or any other type of unexpected and unreimbursed personal expense. Expenditures of a major nature that would be normally budgetable, such as a down payment for a home, the purchase of an automobile, college or other schooling expense, etc. will not constitute a financial hardship. The decision of the employer concerning financial hardship shall be final as to all participants. Notwithstanding the foregoing, financial hardship shall be limited to such circumstances as may be prescribed by the Secretary of the Treasury by regulation pursuant to the authority contained in Section 457 of the Code.

**SECTION 5.            MISCELLANEOUS**

- 5.01 "Retirement System Integration". Benefits payable by, and deductions for employee contributions to, any retirement system of the employer shall be computed without reference to amounts deferred pursuant to this plan and shall instead be based upon gross compensation the participant would receive if such participant had not elected to participate in this plan and to defer compensation.
- 5.02 "Amendment and Termination". This plan may be amended or terminated by the Town of Century at any time. No amendment or termination of the plan shall reduce or impair the rights of any participant or his beneficiary which have already accrued. Upon the termination of the plan, the Town of Century shall distribute all amounts credited to each participant's account in accordance with the participant's payment option selected. All participants shall be treated in the same manner.
- 5.03 "Creditors". Except to the extent otherwise required by law, a participant may not assign, transfer, sell, hypothecate, or otherwise dispose of any or all of his interest or right which he may have under the Plan, and any attempt to do so shall be void and of no effect.
- 5.04 "Employment". Participation in the plan shall not be construed as giving any participant any right to continue his employment with the Town of Century.
- 5.05 "Successors and Assigns". The plan shall be binding upon and shall insure to the benefit of the Town of Century, its successors and assigns, all participants and beneficiaries and their heirs and legal representatives.
- 5.06 "Written Notice". Any notice or other communication required or permitted under the plan shall be in writing, and if directed to the Town of Century shall be sent to the designated office of the Town of Century and if directed to a participant or to a beneficiary at his last known address as it appears on the Town of Century records.
- 5.07 "Total Agreement". This plan and the participation agreement and any subsequently adopted amendment thereof, shall constitute the total agreement or contract between

the employer and the participant regarding the plan. No oral statement regarding the plan may be relied upon by the participant.

**SECTION 6. TOWN OF CENTURY DEFINED CONTRIBUTION PLAN**

The Town of Century hereby establishes a defined contribution plan for its employees. The plan is effective to each such employee upon the date the employee becomes a participant by signing and filing a participant agreement with the Town of Century.

**OPERATIONS OF THE PLAN**

The Town of Century, Florida will match up to 5% of the base wage paid to a participant of the plan, or will match that amount that the participant agrees to set aside for the deferred compensation plan.

**BENEFITS TO BE PAID BY THE PLAN**

As this is a defined contribution plan the benefit will be the annual contribution, plus the allocated trust investment earnings on the accumulated contributions at the time of retirement.

**VESTING**

A participant has a nonforfeitable right to a percentage of the employee’s accrued benefit derived from the Town of Century contributions as determined by the following table:

Years of Service	Nonforfeitable Percentage
3	20
4	40
5	60
6	80
7 or more	100

**SERVICE INCLUDED IN DETERMINATION OF NONFORFEITABLE PERCENTAGE**

In computing the period of service under the plan for purpose of determining the nonforfeitable percentage, all of an employee’s years of service with the employer or employees maintaining the plan shall be taken into account, except that the following may be disregarded:

- a. Years of service before age 18
- b. Years of service during a period for which the employee declined to contribute to a plan requiring employee contributions.

The term "year of service" means a calendar year, plan year.

NORMAL RETIREMENT AGE

The term "normal retirement age" means the earlier of:

- a. the time a plan participant attains normal retirement age under the plan, or
- b. the latter of the time a participant attains age 65.

BENEFITS PAYABLE

Benefits are payable as in accordance with Section 4 of the Century Deferred Compensation Plan.

INVESTMENTS

Employer contributions will be invested by the Town of Century in interest bearing accounts, funds, or other income producing vehicles that are allowed by the State of Florida.

ADOPTED THIS 7TH DAY OF AUGUST, 1989.

The Town of Century Personnel Policy Manual was adopted the 15<sup>th</sup> day of March 1993

Attest:

\_\_\_\_\_  
Mayor

\_\_\_\_\_

\_\_\_\_\_  
\_\_\_\_\_  
\_\_\_\_\_

SAMPLE LETTER

Dear \_\_\_\_\_

This letter will advise you that charges have been made against you which are cause for disciplinary measures as provided for in the Town of Century Personnel Policy Manual. The specific charges made against you are:

- 1.
- 2.
- 3.

The individual who has made these charges against you is \_\_\_\_\_.

The Town Council wishes to provide you a full opportunity to hear the evidence offered in support of the charges brought against you. Therefore, the Town Council intends to hold a special meeting concerning these charges which you are invited to attend. The meeting will be held on \_\_\_\_\_ (date) at \_\_\_\_\_ (time) at the Town Hall. You are invited to be represented by yourself, an attorney, or any other individual you choose. You are invited to tell your own story and to present to the Town Council any witnesses who have information as to the falsity of these charges. You should be aware that the Mayor and/or your supervisor will present those witnesses whom they consider to have evidence showing that such charges are true. Following a presentation of all evidence by both sides, the Town Council will vote as to whether the charges merit suspension without pay or termination.

This letter is the only notice you will receive concerning such hearing. Should you be unable to attend the meeting at the date and time stated above, please advise me immediately so that an alternative date and time may be selected. Should you fail to contact me and fail to appear at the meeting at the above date and time, the Town Council will proceed to vote on your case without consideration of any arguments or evidence in support of your innocence and such vote will be binding on you.

This will advise you that the meeting will be open to the public as is required by Florida law. The town will maintain the confidentiality of the charges made against you only until the meeting.

**Section VII - DEFINITIONS (Comprehensive)**

Appointing Authority – The Town Council or their designee.

Appointment – Initial employment of a person in a position within the service of the Town of Century.

Class – A group of positions similar in duties, qualifications, and compensation range.

Demotion – A change from one class to another with lower pay and responsibility.

Eligible List – Names of top candidates (internal: top 5; external: top 25) used for appointment and promotion.

Employee – A person appointed to a position with compensation, part-time or full-time.

Employment – The initial appointment to a position within the Town's service.

Internal Recruitment – Position open to Town employees only.

External Recruitment – Position open to candidates outside the organization.

Lay-off – Authorized reduction in force due to funding, reorganization, or efficiency.

Minimum Qualifications – The required education, skills, and certifications needed for a position.

Probation – A 180-day introductory period for new or promoted employees to prove suitability.

Promotion – Advancement to a higher position with more responsibility and pay.

Transfer – Lateral movement within the same class or compensation level.

Relatives – A detailed list of familial relationships for use in nepotism policies.

Seniority – Service duration used to determine order in layoffs or promotions.

## TOWN COUNCIL MEETING

Date: May 6, 2025

### Agenda Item Title: Adoption of Formal Employee Pay Plan

**Recommendation:**

Staff recommends that the Town Council adopt the attached formal Employee Pay Plan, and authorize the Mayor to take all necessary administrative actions to implement the Pay Plan.

**Background:**

The Town of Century has historically operated without a formally adopted Employee Pay Plan. During the Town Council meeting on March 18, 2025, the Council directed staff to prepare a comprehensive Pay Plan that would establish clear salary ranges, structured step increases, and defined pay grades for all full-time Town employees.

The attached Employee Pay Plan provides a systematic framework for employee compensation, promoting fairness, transparency, and competitiveness in the Town's workforce.

**Key Features:**

- Establishes pay grades with minimum, midpoint, and maximum hourly wages
- Provides a structured seven-step system within each pay grade
- Defines FLSA (Fair Labor Standards Act) exempt and non-exempt positions
- Applies to all current and future full-time employees

**Fiscal Impact:**

Implementation of the Employee Pay Plan will impact the Town's operating budget for FY 2025-2026. Budget adjustments will be incorporated accordingly to fund salary adjustments.

**Attachment:**

- Resolution No. 2025-005
- Employee Pay Plan

**Action Requested:**

Adopt Resolution No. 2025-005 formally adopting the Employee Pay Plan and further authorize the Mayor to implement the plan effective October 1, 2025.

**RESOLUTION NO. 2025-005**

**A RESOLUTION OF THE TOWN COUNCIL OF THE TOWN OF CENTURY, FLORIDA, ADOPTING A FORMAL EMPLOYEE PAY PLAN FOR THE TOWN; AUTHORIZING THE MAYOR TO TAKE ALL NECESSARY ADMINISTRATIVE ACTIONS TO IMPLEMENT THE PAY PLAN; PROVIDING FOR CONFLICTS; PROVIDING FOR SEVERABILITY; AND PROVIDING FOR AN EFFECTIVE DATE.**

WHEREAS, the Town Council of the Town of Century, Florida ("Town"), recognizes the importance of establishing a formal and structured Employee Pay Plan to promote fairness, transparency, and competitiveness in employee compensation; and

WHEREAS, until now, the Town has not had an officially adopted Employee Pay Plan in place, and compensation practices have varied without a consistent formal structure; and

WHEREAS, on March 18, 2025, the Town Council directed staff to prepare a comprehensive Pay Plan providing clearly defined salary ranges, step increases, and pay grades to guide employee compensation practices; and

WHEREAS, the Employee Pay Plan has been presented to the Town Council, and the Council finds that adoption of the Pay Plan serves the best interests of the Town and its employees.

**NOW, THEREFORE, BE IT RESOLVED BY THE TOWN COUNCIL OF THE TOWN OF CENTURY, FLORIDA, AS FOLLOWS:**

**SECTION 1. Adoption of Employee Pay Plan.**

The Town Council hereby formally adopts the Employee Pay Plan attached hereto and incorporated by reference, effective October 1, 2025.

**SECTION 2. Authorization to Implement.**

The Mayor is hereby authorized to take all necessary administrative actions to implement the adopted Employee Pay Plan, including setting salaries within the established pay grades, administering step advancements, and applying the plan to all current and future full-time Town employees.

**SECTION 3. Conflicts.**

All resolutions or policies in conflict herewith are hereby repealed to the extent of such conflict.

SECTION 4. Severability.

If any section, subsection, sentence, clause, phrase, or portion of this Resolution is for any reason held invalid or unconstitutional by any court of competent jurisdiction, such portion shall be deemed a separate, distinct, and independent provision and such holding shall not affect the validity of the remaining portions.

SECTION 5. Effective Date.

This Resolution shall become effective immediately upon its passage and adoption.

PASSED AND ADOPTED by the Town Council of the Town of Century, Florida, this 6th day of May, 2025.

TOWN OF CENTURY, FLORIDA

By: \_\_\_\_\_  
Mayor

ATTEST:

\_\_\_\_\_  
Town Clerk

# of Employees	Employee Name	Date of Hire	Position Title	Hourly Rate	Pay Grade	Position Category	Min	Mid	Max	Step 1	Step 2	Step 3	Step 4	Step 5	Step 6
1	Vacant		Customer Service Rep I/II		101	Administrative Support	\$16.00	\$18.00	\$20.00	\$16.00	\$16.67	\$17.33	\$18.00	\$18.67	\$19.33
3	Shantia Brown	6/22/2022	Customer Service Rep I/II	16.00	101	Administrative Support	\$16.00	\$18.00	\$20.00	\$16.00	\$16.67	\$17.33	\$18.00	\$18.67	\$19.33
4	Vacant		Deputy Town Clerk	16.00	101	Administrative Support	\$16.00	\$18.00	\$20.00	\$16.00	\$16.67	\$17.33	\$18.00	\$18.67	\$19.33
2	Felicia Grice	2/9/2023	Utility Billing Specialist	16.00	101	Administrative Support	\$16.00	\$18.00	\$20.00	\$16.00	\$16.67	\$17.33	\$18.00	\$18.67	\$19.33
9	Vacant		Gas Superintendent	26.00	104	Department Supervisors	\$27.50	\$33.00	\$38.50	\$27.50	\$29.33	\$31.17	\$33.00	\$34.83	\$36.67
6	Kevin Merchant	8/9/2013	Streets Superintendent	28.13	104	Department Supervisors	\$27.50	\$33.00	\$38.50	\$27.50	\$29.33	\$31.17	\$33.00	\$34.83	\$36.67
5	Carrie Moore	1/7/2025	Town Clerk	36.54	105	Department Supervisors	\$37.80	\$42.00	\$46.20	\$37.80	\$39.20	\$40.60	\$42.00	\$43.40	\$44.80
7	Larry Hammonds	7/14/2014	Utility Worker I - Parks	17.61	102	Department Supervisors	\$18.00	\$21.00	\$24.00	\$18.00	\$19.00	\$20.00	\$21.00	\$22.00	\$23.00
8	Vacant		Water/ Waste Water Superintendent	26.30	104	Department Supervisors	\$27.50	\$33.00	\$38.50	\$27.50	\$29.33	\$31.17	\$33.00	\$34.83	\$36.67
10	Vacant		Town Administrator	47.00	106	Executive Level	\$46.00	\$52.00	\$59.00	\$46.00	\$48.17	\$50.33	\$52.50	\$54.67	\$56.83
16	Vacant		Gas Utility Worker II	21.84	103	Field Technicians	\$22.00	\$24.00	\$27.00	\$22.00	\$22.83	\$23.67	\$24.50	\$25.33	\$26.17
18	Gary Small	8/24/2018	Gas Utility Worker I	20.60	102	Field Technicians	\$18.00	\$21.00	\$24.00	\$18.00	\$19.00	\$20.00	\$21.00	\$22.00	\$23.00
24	Vacant		Uitlity Worker II - Water & Sewer		103	Field Technicians	\$22.00	\$24.00	\$27.00	\$22.00	\$22.83	\$23.67	\$24.50	\$25.33	\$26.17
17	Darrin Merchant	2/18/2025	Utility Worker I - Streets	18.00	102	Field Technicians	\$18.00	\$21.00	\$24.00	\$18.00	\$19.00	\$20.00	\$21.00	\$22.00	\$23.00
19	Howard Kressly	8/9/2024	Utility Worker I - Streets	21.00	102	Field Technicians	\$18.00	\$21.00	\$24.00	\$18.00	\$19.00	\$20.00	\$21.00	\$22.00	\$23.00
20	Michael Peterson	8/21/2018	Utility Worker I - Streets	18.52	102	Field Technicians	\$22.00	\$26.00	\$30.00	\$22.00	\$23.33	\$24.67	\$26.00	\$27.33	\$28.67
21	Robert Tims	8/1/1988	Utility Worker I - Water & Sewer	22.75	102	Field Technicians	\$18.00	\$21.00	\$24.00	\$18.00	\$19.00	\$20.00	\$21.00	\$22.00	\$23.00
27	Sedrick Lowery	3/8/2002	Utility Worker I - Water & Sewer	20.92	102	Field Technicians	\$18.00	\$21.00	\$24.00	\$18.00	\$19.00	\$20.00	\$21.00	\$22.00	\$23.00
23	Vacant		Utility Worker II - Water & Sewer		103	Field Technicians	\$22.00	\$24.00	\$27.00	\$22.00	\$22.83	\$23.67	\$24.50	\$25.33	\$26.17
22	Vacant		Water and Waste Water Operator		103	Field Technicians	\$22.00	\$24.00	\$27.00	\$22.00	\$22.83	\$23.67	\$24.50	\$25.33	\$26.17
26	Kristina Wood	8/10/2001	Accounting Technician	24.19	102	Senior Staff / Leads	\$18.00	\$21.00	\$24.00	\$18.00	\$19.00	\$20.00	\$21.00	\$22.00	\$23.00
25	August Whorff	11/1/2024	Meter Reader	14.00	101	Senior Staff / Leads	\$16.00	\$18.00	\$20.00	\$16.00	\$16.67	\$17.33	\$18.00	\$18.67	\$19.33
11	Henry Cunningham		Council Member		106	Elected Official									
12	Alicia Johnson		Interim Mayor		106	Executive Level									
13	Dynette Lewis		Council Member		106	Elected Official									
14	Sandra McMurray Jackson		Council Member		106	Elected Official									
15	Shelisa McCall Abraham		Council Member		106	Elected official									
27	Vacant - Seat 4		Council Member		106	Elected Official									

Step 7	Job Desc.	FLSA Status	Empt Type
\$20.00	TBD	Non-Exempt	Full-Time
\$20.00	TBD	Non-Exempt	Full-Time
\$20.00	TBD	Non-Exempt	Full-Time
\$20.00	TBD	Non-Exempt	Full-Time
\$38.50	Yes	Exempt	Full-Time
\$38.50	TBD	Exempt	Full-Time
\$46.20	Yes	Exempt	Full-Time
\$24.00	TBD	Non-Exempt	Full-Time
\$38.50	Yes	Exempt	Full-Time
\$59.00	Yes	Exempt	Full-Time
\$27.00	TBD	Non-Exempt	Full-Time
\$24.00	TBD	Non-Exempt	Full-Time
\$27.00	TBD	Non-Exempt	Full-Time
\$24.00	TBD	Non-Exempt	Full-Time
\$24.00	TBD	Non-Exempt	Full-Time
\$30.00	TBD	Non-Exempt	Full-Time
\$24.00	TBD	Non-Exempt	Full-Time
\$24.00	TBD	Non-Exempt	Full-Time
\$27.00	TBD	Non-Exempt	Full-Time
\$27.00	Yes	Non-Exempt	Full-Time
\$24.00	TBD	Non-Exempt	Full-Time
\$20.00	TBD	Non-Exempt	Full-Time

Exempt  
Exempt  
Exempt  
Exempt  
Exempt  
Exempt

# TOWN OF CENTURY, FLORIDA

---

## REGULAR TOWN COUNCIL MEETING

### AGENDA ITEM

Date: May 6, 2025

Prepared by: Howard W. Brown, Jr., ICMA-CM, Interim Town Manager

#### **Agenda Title:**

Discussion and Direction Regarding Utility Services (Water, Sewer, and Gas)

#### **Recommended Action:**

That the Town Council discuss current and future considerations related to water, sewer, and gas services within the Town of Century, and authorize the Mayor and Interim Town Manager to initiate negotiations and, if deemed appropriate and in the best interest of the Town, return to the Council with a formal proposal for consideration and possible action.

#### **Background:**

The Town is exploring options to ensure long-term sustainability, reliability, and affordability of essential utility services, including water, sewer, and gas. This discussion is intended to provide the Council an opportunity to offer direction on potential improvements, partnerships, or service delivery adjustments that may better serve residents and businesses.

#### **Fiscal Impact:**

To be determined based on the outcome of negotiations and any future proposals.