AGENDA

THE DESIGN REVIEW COMMITTEE OF THE CITY OF BUCHANAN, in compliance with Michigan’s Open Meetings Act, as amended, B2103192 of 2021, hereby gives notice of a regular meeting of the Design Review Committee to be held electronically in order to protect the health and safety of our community due to the novel coronavirus (COVID-19).

Join Meeting via Computer: <https://zoom.us/j/2435931819>

Join Meeting via Mobile Phone: +16465588656,,2435931819#

Join Meeting via Land Line Telephone: +1 646 558 8656

Meeting ID: 243 593 1819

Toggle #6 to mute/unmute. #9 to raise your hand.

** All members of the public will be muted by the moderator with the exception the public comment portions of the agenda. In order to minimize background noise and/or feedback, we ask that participants manually mute their phone or computer microphone during this portion of the agenda if not speaking.*

** Comments may also be submitted in writing at least 4 hours in advance to the Community Development Director/Zoning Administrator at rmurphy@cityofbuchanan.com.*

I. Call to Order**II. Pledge of Allegiance****III. Roll Call****IV. Public Comments - Agenda Items Only (3-minute limit)****V. Approve Agenda****VI. Approve Minutes**

A. Approve February 4, 2021 Regular Meeting Minutes.

VII. Public Comment - Non-Agenda Items Only (3-minute limit)**VIII. Reports by Committees****IX. Unfinished Business****X. New Business**

A. Redbud Hardware, 266 E. Front St. - review of proposed sign

B. Consider Board Applications from Michael Rowland, Joe Paolucci and Dan Carlson.

XI. Business from the Floor**XII. Public Comment - Non-Agenda Items Only (3-minute limit)****XIII. Staff/Committee Comments****XIV. Adjournment**



Design Review Committee Meeting Minutes February 4, 2021

The scheduled meeting of Design Review Committee was held via electronic meeting on February 4, 2021 and was called to order at 10:00 a.m. by Community Development Director Rich Murphy.

Committee members Kevin Barker, Chris Brayak, and Rich Murphy were in attendance.

There were two items to discuss under New Business:

- Brief orientation on Design Review Committee
- Sign permit application for Zen, 259 E. Front Street

Committee members discussed the mission and scope of the Design Review Committee. Committee member Chris Brayak offered to recirculate the original committee guidelines to the committee for their review.

Committee members discussed the sign permit application for Zen, 259 E. Front St. Committee members discussed that signage affixed to a historic facade must be able to be removed without negatively impacting the facade.

Community development Director Murphy stated the sign was reviewed by him from zoning standpoint and by Building Commissioner Guy from an installation standpoint that both departments recommend approval.

Committee member Barker made a motion to recommend the approval of the sign to the plan commission. There was a second by Committee member Barker. The vote was unanimous to recommend approval.

With no other business before the committee, Committee member Kevin Barker made a motion to adjourn followed by a second by Committee member Chris Brayak. Meeting was adjourned at 10:49 a.m.

Buchanan City Building Safety Department
302 N. Redbud Trail
Buchanan, MI 49107
Phone: 269-695-0011 Fax: 269-695-0009
Email: glewis@cityofbuchanan.com

Planning & Zoning Department
302 N. Redbud Trail
Buchanan, MI 49107
T: 269 695 3844x19 F:269 695 4330
dpatzer@cityofbuchanan.com

SIGN PERMIT APPLICATION

PROPERTY ID# _____ ZONING _____

VALUE OF SIGN \$3,145 PERMIT FEE _____

JOB ADDRESS 266 E. Front St.

SIGN OWNER'S NAME Tracy Dippo

ADDRESS 266 E. Front St. Buchanan, MI

PHONE # 269-362-4364 EMAIL dippo@gtm.net

SIGN CONTRACTOR'S NAME North American Signs

ADDRESS 3601 W. Cathrop South Bend, IN 46608

PHONE# 574-234-5252 EMAIL sfd@northamericansigns.com

TYPE OF SIGN

BANNER ___ GROUND ___ WALL X OTHER(specify) _____

GROUND SIGN

SIZE OF SIGN FACE ___ X ___ = ___ SQ. FT.

HEIGHT OF SIGN FROM GRADE TO TOP OF SIGN _____

ATTACH DRAWING OF PLOT PLAN SHOWING LOCATION OF SIGN ON THE PROPERTY.

WILL SIGN BE ON THE PROPERTY RENDERING THE ADVERTISED GOODS OR SERVICES? _____

NUMBER OF GROUND SIGNS NOW ON THE PROPERTY _____

WALL SIGN

SIZE OF SIGN 36" X 28'6" = 85.5 SQ. FT.

NUMBER OF WALL SIGNS NOW ON THE BUILDING 0

LOCATION OF NEW WALL SIGN ON THE BUILDING over entrance

LENGTH OF BUILDING/STRUCTURE ON WHICH THE SIGN WILL
BE ATTACHED 125'

IS THERE A SIGN ON THIS PROPERTY CURRENTLY? No

IF SO, DESCRIBE _____

METHOD OF ATTACHING NEW SIGN mechanically fastened to masonry
behind siding.

INTEGRAL ROOF SIGN ONLY

ATTACH DRAWING SHOWING SIZE, LOCATION & ATTACHMENT METHOD
(NON INTEGRAL ROOF SIGNS ARE PROHIBITED)

OTHER SIGN

ATTACH DRAWING SHOWING SIZE, LOCATION & ATTACHMENT METHOD

**PLEASE ATTACH A SKETCH, PHOTO OR ARTISTIC RENDERING OF THE
PROPOSED SIGN SHOWING THE OVERALL HEIGHT & LENGTH OF THE
SIGN & THE NATURE OF THE ADVERTISING COPY TO BE ON THE SIGN.**

**ALL ELECTRICAL WORK/INSTALLATIONS MUST BE DONE BY A COMPANY
WITH A VALID MICHIGAN SIGN SPECIALIST CONTRACTOR'S LICENSE OR
A MICHIGAN MASTER ELECTRICAL LICENSE. ALL WORK MUST BE DONE
IN CONFORMANCE WITH LOCAL ZONING ORDINANCES AND THE
MICHIGAN BUILDING AND ELECTRICAL CODES. ELECTRICAL WORK
REQUIRES A SEPARATE ELECTRICAL PERMIT AND INSPECTIONS.**

APPLICANT'S SIGNATURE:  DATE 4-9-21

BLG: APPROVED BY: _____ DATE _____

P&Z: APPROVED BY: _____ DATE _____



A PROPOSED STOREFRONT
NTS

* CENTER SIGN TO STOREFRONT DOOR AND VERTICALLY IN AREA ABOVE AWNING

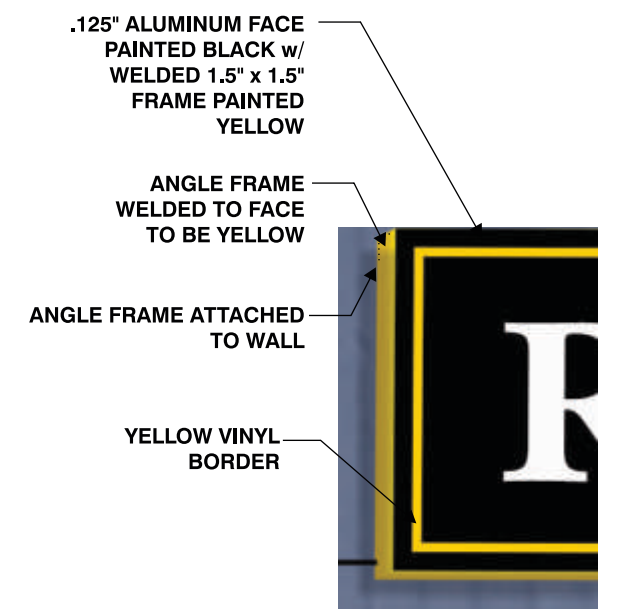

SIDE VIEW:
NTS



A NON-ILLUMINATED S/F WALL SIGN w/ 1 1/2" ANGLE FRAME & VINYL GRAPHICS

SCALE: 3/8" = 1'-0"
SQ FT: 85.5

QTY: 1 S/F SIGN

FACE

.125" ALUMINUM FACE PAINTED BLACK w/ VINYL GRAPHICS APPLIED 1st SURFACE. VINYL COLORS TO MATCH PMS 2350C RED, PMS 122C YELLOW, WHITE & BLACK. 1 1/2" ANGLE FRAME WELDED TO FACE AND PAINTED TO MATCH PMS 122C YELLOW.

MOUNTING

1 1/2" ANGLE ATTACHED TO WALL w/ NON-CORROSIVE HARDWARE APPROPRIATE FOR WALL MATERIAL. FACE MOUNTED FLUSH TO STOREFRONT w/ COUNTERSUNK SCREWS THROUGH WELDED ANGLE ON FACE.

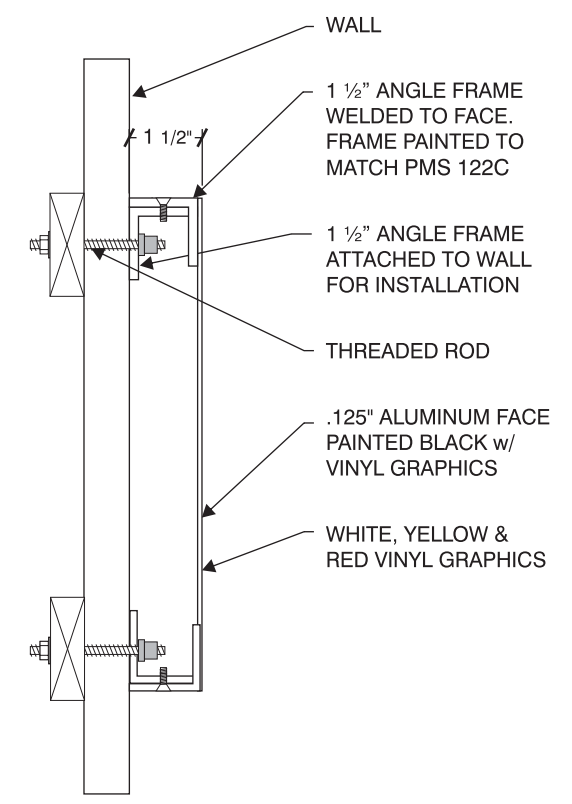

SECTION VIEW
NTS



SALES:	SEAN DENISON
PM:	
ART:	CAD 3.16.21

DWG #	2101068-02
REVISION	

LOCATION: REDBUD HARDWARE
266 E FRONT ST.
BUCHANAN, MI 49107

COPYRIGHT NORTH AMERICAN SIGNS INC. - NOTE: ANY FIELD MEASUREMENTS THAT ARE DIFFERENT PLEASE NOTIFY NORTH AMERICAN SIGNS (800) 348-9999



B PROPOSED REDBUD TRAIL ELEVATION SIGNAGE
NTS

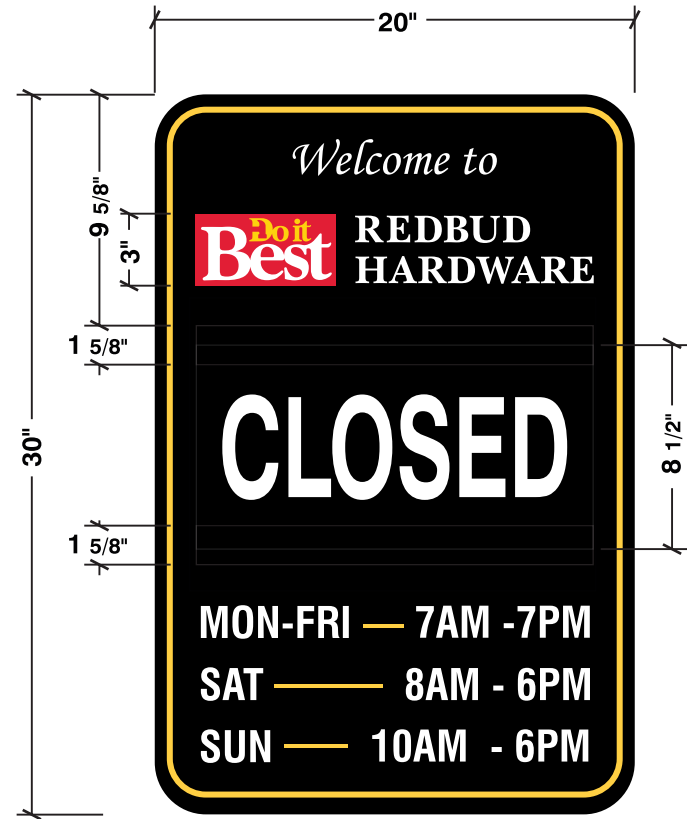

B ONE (1) S/F ALUMINUM WALL SIGN
SCALE: 1 1/2" = 1'- 0"
SQ FT: 4.17

QTY: 1 S/F SIGN

FACES
ALUMINUM FACE PAINTED BLACK WITH FIRST SURFACE OPAQUE VINYL GRAPHICS. (COLORS TO MATCH PMS 2350C RED & PMS 122C YELLOW & WHITE.)
WAGNER MUTUAL ZIP TRACK GLUED TO FACES w/ TWO (2) .060 LEXAN 'SLIDE IN' CHANGEABLE PIECES .060 LEXAN CHANGEABLE PIECE TO BE COVERED WITH BLACK VINYL, FRONT AND BACK SIDE. WHITE VINYL TEXT, 'OPEN' FOR SIDE ONE(1) AND 'CLOSED' FOR SIDE TWO (2) APPLIED FIRST SURFACE,

MOUNTING
FACE MOUNTED FLUSH TO STOREFRONT FACADE THRU FACE w/ HARDWARE APPROPRIATE FOR WALL MATERIAL.