



# **TOWN OF BRISTOL, RHODE ISLAND**

## **HISTORIC DISTRICT COMMISSION MEETING**

**Historic District Commission Meeting Agenda  
Thursday, February 13, 2025 at 2:00 PM  
366 Hope Street, Bristol, RI 02809**

Written comments may be submitted to the Historic District Commission via regular mail addressed to: Historic District Commission, Bristol Town Hall, 10 Court Street, Bristol RI 02809 or via email to [ntoth@bristolri.gov](mailto:ntoth@bristolri.gov)

Application packets can be found online at: <https://bristol-ri.municodemeetings.com/>

**1. Application Reviews**

**1.** Discuss and Act on replacement of 11 Windows.

**2. Adjourn**



# Bristol Historic District Commission

Item 1.

## Application for Review of Proposed Work - Printable Application

HDC-24-161	Contributing	October 24, 2024
------------	--------------	------------------

**THIS DOCUMENT IS NOT A SUBSTITUTE FOR A BUILDING, ELECTRICAL, SIGN, MECHANICAL, DEMOLITION, SOLAR OR FENCE PERMIT APPLICATION. THESE PERMITS MUST BE APPLIED FOR AND APPROVED BY THE BRISTOL BUILDING DEPARTMENT BEFORE WORK CAN BEGIN.**

Project Address	Assessor's Plat	Assessor's Lot
366 Hope Street	14	70

Applicant	Applicant Phone	Applicant Email
Thomas M. Bergenholtz	774-696-5300	brgnhltz@gmail.com

Property Owner (If Different from Applicant)	Owner Mailing Address

Architect/Engineer	A/E Phone Number	A/E Email

Contractor	Contractor Phone Number	Contractor Email
Humphrey Building Supply		

Work Category:	Replacing in Kind
----------------	-------------------

Description of proposed work:

install 11 new windows on 3rd floor at 366 Hope Street. Facing West; North and South.  
Existing windows are not original.

Property History

Building Survey Data	
RIHPHC ID #:	BRIS00659
HISTORIC NAME:	
ARCH. STYLE:	Federal/Queen Anne
ORIGINAL CONSTRUCTION DATE (est.):	1800 ca

ALTERATIONS TO MAJOR ARCH. SINCE 1978 (Height, Massing, Wall Covering, Trim, Windows, Porches)  
[none observed]

Thomas M. Bergenholtz  
Applicant's Name – Printed

**Thomas Michael Bergenholtz**  
Applicant's Digital Signature

Date: October 24, 2024



# CAI Property Card

Town of Bristol, RI

GENERAL PROPERTY INFORMATION	BUILDING EXTERIOR
<b>LOCATION:</b> 366 HOPE ST <b>ACRES:</b> 0.2654 <b>PARCEL ID:</b> 014-0070-000 <b>LAND USE CODE:</b> 03 <b>CONDO COMPLEX:</b> <b>OWNER:</b> LEONARD PLACE LLC <b>CO - OWNER:</b> <b>MAILING ADDRESS:</b> 385 HIGH ST  <b>ZONING:</b> D <b>PATRIOT ACCOUNT #:</b> 866	<b>BUILDING STYLE:</b> Apt <b>UNITS:</b> 6 <b>YEAR BUILT:</b> 1900 <b>FRAME:</b> Wood Frame <b>EXTERIOR WALL COVER:</b> Clapboard <b>ROOF STYLE:</b> Hip <b>ROOF COVER:</b> Asphalt Shin
	BUILDING INTERIOR
<b>SALE INFORMATION</b> <b>SALE DATE:</b> 5/29/2014 <b>BOOK &amp; PAGE:</b> 1757-114 <b>SALE PRICE:</b> 1 <b>SALE DESCRIPTION:</b> Business Par <b>SELLER:</b> CHAPMAN, KAREN & HARPER, KAREN	<b>INTERIOR WALL:</b> Plaster <b>FLOOR COVER:</b> <b>HEAT TYPE:</b> Hydro Forced <b>FUEL TYPE:</b> Oil <b>PERCENT A/C:</b> True <b># OF ROOMS:</b> 22 <b># OF BEDROOMS:</b> 10 <b># OF FULL BATHS:</b> 6 <b># OF HALF BATHS:</b> 0 <b># OF ADDITIONAL FIXTURES:</b> 0 <b># OF KITCHENS:</b> 6 <b># OF FIREPLACES:</b> 4 <b># OF METAL FIREPLACES:</b> 0 <b># OF BASEMENT GARAGES:</b> 0
PRINCIPAL BUILDING AREAS	
<b>GROSS BUILDING AREA:</b> 11412 <b>FINISHED BUILDING AREA:</b> 8079 <b>BASEMENT AREA:</b> 1760 <b># OF PRINCIPAL BUILDINGS:</b> 2	
ASSESSED VALUES	
<b>LAND:</b> \$256,200 <b>YARD:</b> \$0 <b>BUILDING:</b> \$739,700 <b>TOTAL:</b> \$995,900	
SKETCH	PHOTO



www.cai-tech.com

This information is believed to be correct but is subject to change and is not warranted.

1/27/2025

Property Information - Bristol, RI



# 200 feet Abutters List Report

Bristol, RI  
January 27, 2025

### Subject Property:

Parcel Number: 14-70  
CAMA Number: 14-70  
Property Address: 366 HOPE ST

Mailing Address: LEONARD PLACE LLC  
385 HIGH ST  
BRISTOL, RI 02809

### Abutters:

Parcel Number: 10-28  
CAMA Number: 10-28  
Property Address: 377 HOPE ST

Mailing Address: ST MICHAELS CHURCH P.O. BOX 414  
399 HOPE ST  
BRISTOL, RI 02809

Parcel Number: 10-29  
CAMA Number: 10-29  
Property Address: 15 CHURCH ST

Mailing Address: VAN ALLEN APPELYARD, DEBORAH  
15 CHURCH ST  
BRISTOL, RI 02809

Parcel Number: 10-34  
CAMA Number: 10-34  
Property Address: 365 HOPE ST

Mailing Address: ST ALBANS ASSOCIATION, LLC. C/O  
RORY HANMER  
125 SUNRISE DR  
BRISTOL, RI 02809

Parcel Number: 10-35  
CAMA Number: 10-35  
Property Address: 353 HOPE ST

Mailing Address: REMIERES, MARY LIFE ESTATE  
DONOVAN, SUSAN A. & DEGALLEY,  
353 HOPE ST  
BRISTOL, RI 02809

Parcel Number: 10-36  
CAMA Number: 10-36  
Property Address: 18 CHURCH ST

Mailing Address: ENGELL, BETH A. TOREY JT  
18 CHURCH ST  
BRISTOL, RI 02809

Parcel Number: 10-40  
CAMA Number: 10-40  
Property Address: 341 HOPE ST

Mailing Address: HOLMSTROM, GARRY CATHARINE C.  
TRST & GARY & CA  
341 HOPE ST  
BRISTOL, RI 02809

Parcel Number: 10-43  
CAMA Number: 10-43  
Property Address: 317 HOPE ST

Mailing Address: BRISTOL LOFTS LLC  
649 ALDEN ST, SUITE 1  
FALL RIVER, MA 02723

Parcel Number: 10-71  
CAMA Number: 10-71  
Property Address: 325 HOPE ST

Mailing Address: BRISTOL LOFTS LLC  
649 ALDEN ST, SUITE 1  
FALL RIVER, MA 02723

Parcel Number: 10-75  
CAMA Number: 10-75  
Property Address: 315 HOPE ST

Mailing Address: BOOTH, PATRICIA J  
316 HOPE ST  
BRISTOL, RI 02809

Parcel Number: 10-76  
CAMA Number: 10-76  
Property Address: HOPE ST

Mailing Address: BRISTOL LOFTS LLC  
649 ALDEN ST, SUITE 1  
FALL RIVER, MA 02723



www.cai-tech.com

Data shown on this report is provided for planning and informational purposes only. The municipality and CAI Technologies are not responsible for any use for other purposes or misuse or misrepresentation of this report.



# 200 feet Abutters List Report

Bristol, RI  
January 27, 2025

Parcel Number: 14-107 CAMA Number: 14-107 Property Address: 38 CHURCH ST	Mailing Address: CAMPAGNA FAMILY, LP 15 LOW LANE BRISTOL, RI 02809
Parcel Number: 14-112 CAMA Number: 14-112 Property Address: 4 MILK ST	Mailing Address: CHRISTINA, DANIEL & JULIE TE 4 MILK ST BRISTOL, RI 02809
Parcel Number: 14-118 CAMA Number: 14-118 Property Address: 12 BYFIELD ST	Mailing Address: GARDNER, MATTHEW R (1/3); GARDNER, STEVEN D & ANN TRUSTEES-GARDNER TRUST (2/3) 12 BYFIELD ST BRISTOL, RI 02809
Parcel Number: 14-41 CAMA Number: 14-41 Property Address: 49 CHURCH ST	Mailing Address: FORTY-NINE CHURCH STREET, LLC 26 PATRICIA ANN DR BRISTOL, RI 02809
Parcel Number: 14-43 CAMA Number: 14-43 Property Address: 43 CHURCH ST	Mailing Address: BONNER, KERRY S & MERRILL, DEBRA A TC 43 CHURCH ST BRISTOL, RI 02809
Parcel Number: 14-44 CAMA Number: 14-44 Property Address: 41 CHURCH ST	Mailing Address: BERGENHOLTZ, THOMAS A. MARIANNE 366 HOPE ST UNIT 1 BRISTOL, RI 02809
Parcel Number: 14-46 CAMA Number: 14-46 Property Address: 39 CHURCH ST	Mailing Address: SCOTT, DONALD & MARCIA TE 39 CHURCH ST BRISTOL, RI 02809
Parcel Number: 14-47 CAMA Number: 14-47 Property Address: 400 HOPE ST	Mailing Address: TOWN OF BRISTOL 10 COURT ST BRISTOL, RI 02809
Parcel Number: 14-48 CAMA Number: 14-48 Property Address: 35 CHURCH ST	Mailing Address: JACOBUS, ROBERT J & CAROLINE W TE 35 CHURCH ST BRISTOL, RI 02809
Parcel Number: 14-49 CAMA Number: 14-49 Property Address: 378 HOPE ST	Mailing Address: ST MICHAELS CHURCH P.O. BOX 414 399 HOPE ST BRISTOL, RI 02809
Parcel Number: 14-50 CAMA Number: 14-50 Property Address: 378 HOPE ST	Mailing Address: ST MICHAELS CHURCH P.O. BOX 414 399 HOPE ST BRISTOL, RI 02809
Parcel Number: 14-63 CAMA Number: 14-63 Property Address: 48 CHURCH ST	Mailing Address: CHITTICK, WILLIAM F 48 CHURCH STREET BRISTOL, RI 02809



www.cai-tech.com

Data shown on this report is provided for planning and informational purposes only. The municipality and CAI Technologies are not responsible for any use for other purposes or misuse or misrepresentation of this report.



# 200 feet Abutters List Report

Bristol, RI  
January 27, 2025

Parcel Number: 14-64 CAMA Number: 14-64 Property Address: 25 BYFIELD ST	Mailing Address: PELLEGRINO, MARY B. LIFE EST PELLEGRINO, MARY ANN 25 BYFIELD ST BRISTOL, RI 02809
Parcel Number: 14-65 CAMA Number: 14-65 Property Address: 44 CHURCH ST	Mailing Address: ANDERSON, ZANE & ANDERSON, CAROLE TRUSTEES 44 CHURCH STREET BRISTOL, RI 02809
Parcel Number: 14-66 CAMA Number: 14-66 Property Address: 40 CHURCH ST	Mailing Address: JGR, LLC 443 HOPE ST BRISTOL, RI 02809
Parcel Number: 14-67 CAMA Number: 14-67 Property Address: 19 BYFIELD ST	Mailing Address: BAO, ELENA M - TRUSTEE ELENA M BAO REVOCABLE TRUST 19 BYFIELD ST BRISTOL, RI 02809
Parcel Number: 14-69 CAMA Number: 14-69 Property Address: 11 BYFIELD ST	Mailing Address: MONAHAN-BELL LIVING TRUST 11 BYFIELD ST BRISTOL, RI 02809
Parcel Number: 14-71 CAMA Number: 14-71 Property Address: 344 HOPE ST	Mailing Address: JOHNSON, JOAN D TRUSTEE 344 HOPE STREET BRISTOL, RI 02809
Parcel Number: 14-84 CAMA Number: 14-84 Property Address: 22 BYFIELD ST	Mailing Address: FEINSTEIN, JONATHAN L. CAROL M. TE 22 BYFIELD ST BRISTOL, RI 02809
Parcel Number: 14-85 CAMA Number: 14-85 Property Address: 18 BYFIELD ST	Mailing Address: MOREIRA, ELIZABETH H LIFE EST MOREIRA, MARK S. ETAL TC 47 COTTAGE ST BRISTOL, RI 02809
Parcel Number: 14-86 CAMA Number: 14-86 Property Address: 328 HOPE ST	Mailing Address: REYNOLDS, MARTIN BURTON & REYNOLDS, LINDA MARIE CO- TRUSTEES 328 HOPE ST BRISTOL, RI 02809
Parcel Number: 14-87 CAMA Number: 14-87 Property Address: 314 HOPE ST	Mailing Address: SAFE WAY REALTY, LLC C/O STEPHEN COELHO PO BOX 210 BRISTOL, RI 02809



www.cai-tech.com

Data shown on this report is provided for planning and informational purposes only. The municipality and CAI Technologies are not responsible for any use for other purposes or misuse or misrepresentation of this report.

# HARBORSIDE HOLDINGS

## 360 HOPE ST.

Quote #: UYQZELB

A Proposal for Window and Door Products prepared for:

**Shipping Address:**

HUMPHREYS MARVIN BUILDING CTR  
590 MAIN RD  
TIVERTON, RI 02878-1300



MARK SHUMAN  
HUMPHREYS MARVIN BUILDING CTR  
590 MAIN RD  
TIVERTON, RI 02878-1300  
Phone: (401) 841-8800

Email: marks@hbsri.com

This report was generated on 10/31/2024 2:01:28 PM using the Marvin Order Management System, version 0004.12.00 (Current). Price in USD. Unit availability and price are subject to change. Dealer terms and conditions may apply.

**Project Description:**

*REVIEW ALL SIZES, COUNTS, SPECIFICATIONS, TEMPERING AND EGRESS PRIOR TO ORDERING. THIS QUOTE EXCLUDES ANYTHING NOT STATED. \*\*\*UNIT AVAILABILITY AND PRICES SUBJECT TO CHANGE\*\*\**

*ULTIMATE CLAD INSERT PRODUCT*

*EBONY EXTERIOR - PREFINISHED DESIGNER BLACK INTERIOR*

*LOW E II WITH ARGON GLAZING - 4 STATIONARY UNITS LOW E ONLY DUE TO SIZE*

*5/8" SDL GRILLES WITH SPACER BAR*

*MATTE BLACK HARDWARE & FULL SCREENS ON WINDOWS*

*3 1/4" BASE JAMB*

**Featuring products from:**





## UNIT SUMMARY

The following is a schedule of the windows and doors for this project. For additional unit details, please see Line Item Quotes.

Additional charges, tax or Terms and Conditions may apply. Detail pricing is per unit.

NUMBER OF LINES: 6		TOTAL UNIT QTY: 17		EXT NET PRICE: USD 23,689.44		
LINE	MARK UNIT	PRODUCT LINE	ITEM	NET PRICE	QTY	EXTENDED NET PRICE
1		Ultimate	Double Hung Insert G2 IO 28" X 52 1/2" Entered as Inside Opening 28" X 52 1/2"	1,418.40	10	14,184.00
2		Ultimate	Double Hung Insert G2 IO 25 1/2" X 44 1/2" Entered as Inside Opening 25 1/2" X 44 1/2"	1,296.72	1	1,296.72
3		Ultimate	Double Hung Insert G2 IO 36" X 47 1/2" Entered as Inside Opening 36" X 47 1/2"	1,460.16	3	4,380.48
4		Ultimate	Double Hung Insert G2 IO 26" X 47 1/2" Entered as Inside Opening 26" X 47 1/2"	1,355.76	1	1,355.76
5		Ultimate	Double Hung Insert G2 IO 32 1/2" X 60 1/2" Entered as Inside Opening 32 1/2" X 60 1/2"	1,588.32	1	1,588.32
6		Ultimate	Casement Narrow Frame IO 12 1/2" X 52 1/2" Entered as Inside Opening 12 1/2" X 52 1/2"	884.16	1	884.16

## LINE ITEM QUOTES

The following is a schedule of the windows and doors for this project. For additional unit details, please see Line Item Quotes. Additional charges, tax or Terms and Conditions may apply. Detail pricing is per unit.

Line #1	Mark Unit:	Net Price:		1,418.40
Qty: 10		Ext. Net Price:	USD	14,184.00

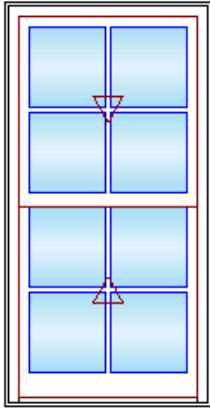

As Viewed From The Exterior

**Entered As:** IO  
**FS** 27 5/8" X 52 49/64"  
**IO** 28" X 52 1/2"  
**Egress Information**  
 Width: 23 15/16" Height: 21 21/64"  
 Net Clear Opening: 3.55 SqFt  
**Performance Information**  
 U-Factor: 0.31  
 Solar Heat Gain Coefficient: 0.27  
 Visible Light Transmittance: 0.46  
 Condensation Resistance: 55  
 CPD Number: MAR-N-441-01613-00001  
**Performance Grade**  
 Licensee #1149  
 AAMA/WDMA/CSA/101/I.S.2/A440-11  
 LC-PG50 1153X2215 mm (45.38X87.19 in)  
 LC-PG50 DP +50/-50  
 FL28134

Ebony Clad Exterior  
 Painted Interior Finish - Designer Black - Pine Interior  
 Ultimate Double Hung Insert G2  
 Inside Opening 28" X 52 1/2"  
 8° Degree Frame Bevel  
 Top Sash  
 Ebony Clad Sash Exterior  
 Painted Interior Finish - Designer Black - Pine Sash Interior  
 IG  
 Low E2 w/Argon  
 Black Perimeter and Spacer Bar  
 5/8" SDL - With Spacer Bar - Black  
 Rectangular - Special Cut 2W2H  
 Ebony Clad Ext - Painted Interior Finish - Designer Black - Pine Int  
 Ogee Interior Glazing Profile  
 Bottom Sash  
 Ebony Clad Sash Exterior  
 Painted Interior Finish - Designer Black - Pine Sash Interior  
 IG  
 Low E2 w/Argon  
 Black Perimeter and Spacer Bar  
 5/8" SDL - With Spacer Bar - Black  
 Rectangular - Special Cut 2W2H  
 Ebony Clad Ext - Painted Interior Finish - Designer Black - Pine Int  
 Ogee Interior Glazing Profile  
 Black Interior Weather Strip Package  
 Black Exterior Weather Strip Package  
 Matte Black Sash Lock  
 Matte Black Top Sash Strike Plate Assembly Color  
 Aluminum Screen  
 Ebony Surround  
 Bright View Mesh  
 \*\*\*Screen/Combo Ship Loose  
 3 1/4" Jamb

\*\*\*Note: Unit Availability and Price is Subject to Change

Line #2	Mark Unit:	Net Price:		1,296.72
Qty: 1		Ext. Net Price:	USD	1,296.72



Ebony Clad Exterior  
 Painted Interior Finish - Designer Black - Pine Interior  
 Ultimate Double Hung Insert G2  
 Inside Opening 25 1/2" X 44 1/2"  
 8° Degree Frame Bevel  
 Top Sash  
 Ebony Clad Sash Exterior  
 Painted Interior Finish - Designer Black - Pine Sash Interior  
 IG  
 Low E2 w/Argon  
 Black Perimeter and Spacer Bar  
 5/8" SDL - With Spacer Bar - Black  
 Rectangular - Special Cut 2W2H  
 Ebony Clad Ext - Painted Interior Finish - Designer Black - Pine Int  
 Ogee Interior Glazing Profile

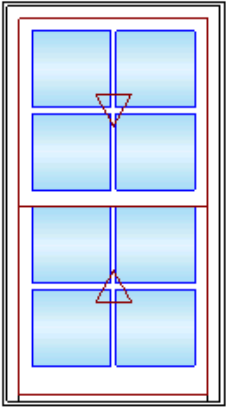

As Viewed From The Exterior

**Entered As:** IO

**FS** 25 1/8" X 44 49/64"

**IO** 25 1/2" X 44 1/2"

**Egress Information**

Width: 21 7/16" Height: 17 21/64"

Net Clear Opening: 2.58 SqFt

**Performance Information**

U-Factor: 0.31

Solar Heat Gain Coefficient: 0.27

Visible Light Transmittance: 0.46

Condensation Resistance: 55

CPD Number: MAR-N-441-01613-00001

**Performance Grade**

Licensee #1149

AAMA/WDMA/CSA/101/I.S.2/A440-11

LC-PG50 1153X2215 mm (45.38X87.19 in)

LC-PG50 DP +50/-50

FL28134

- Bottom Sash
- Ebony Clad Sash Exterior
- Painted Interior Finish - Designer Black - Pine Sash Interior
- IG
- Low E2 w/Argon
- Black Perimeter and Spacer Bar
- 5/8" SDL - With Spacer Bar - Black
- Rectangular - Special Cut 2W2H
- Ebony Clad Ext - Painted Interior Finish - Designer Black - Pine Int
- Ogee Interior Glazing Profile
- Black Interior Weather Strip Package
- Black Exterior Weather Strip Package
- Matte Black Sash Lock
- Matte Black Top Sash Strike Plate Assembly Color
- Aluminum Screen
- Ebony Surround
- Bright View Mesh
- \*\*\*Screen/Combo Ship Loose

3 1/4" Jambs

**\*\*\*Note: Unit Availability and Price is Subject to Change**

Line #3	Mark Unit:	Net Price:		1,460.16
Qty: 3		Ext. Net Price:	USD	4,380.48

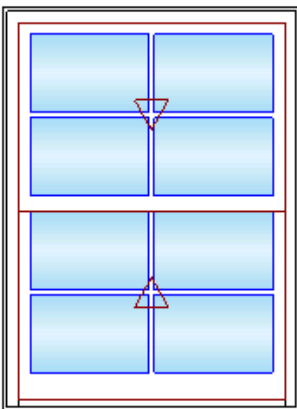

As Viewed From The Exterior

**Entered As:** IO

**FS** 35 5/8" X 47 1/4"

**IO** 36" X 47 1/2"

**Egress Information**

Width: 31 15/16" Height: 18 9/16"

Net Clear Opening: 4.12 SqFt

**Performance Information**

U-Factor: 0.31

Solar Heat Gain Coefficient: 0.27

- Ebony Clad Exterior
- Painted Interior Finish - Designer Black - Pine Interior
- Ultimate Double Hung Insert G2
- Inside Opening 36" X 47 1/2"
- 0° Degree Frame Bevel
- Top Sash
- Ebony Clad Sash Exterior
- Painted Interior Finish - Designer Black - Pine Sash Interior
- IG
- Low E2 w/Argon
- Black Perimeter and Spacer Bar
- 5/8" SDL - With Spacer Bar - Black
- Rectangular - Special Cut 2W2H
- Ebony Clad Ext - Painted Interior Finish - Designer Black - Pine Int
- Ogee Interior Glazing Profile
- Bottom Sash
- Ebony Clad Sash Exterior
- Painted Interior Finish - Designer Black - Pine Sash Interior
- IG
- Low E2 w/Argon
- Black Perimeter and Spacer Bar
- 5/8" SDL - With Spacer Bar - Black
- Rectangular - Special Cut 2W2H
- Ebony Clad Ext - Painted Interior Finish - Designer Black - Pine Int
- Ogee Interior Glazing Profile
- Black Interior Weather Strip Package
- Black Exterior Weather Strip Package
- Matte Black Sash Lock
- Matte Black Top Sash Strike Plate Assembly Color

Visible Light Transmittance: 0.46  
 Condensation Resistance: 55  
 CPD Number: MAR-N-441-01613-00001  
**Performance Grade**  
 Licensee #1149  
 AAMA/WDMA/CSA/101/I.S.2/A440-11  
 LC-PG50 1153X2215 mm (45.38X87.19 in)  
 LC-PG50 DP +50/-50  
 FL28134

Aluminum Screen  
 Ebony Surround  
 Bright View Mesh  
 \*\*\*Screen/Combo Ship Loose  
 3 1/4" Jambs  
**\*\*\*Note: Unit Availability and Price is Subject to Change**

Line #4	Mark Unit:	Net Price:		1,355.76
Qty: 1		Ext. Net Price:	USD	1,355.76

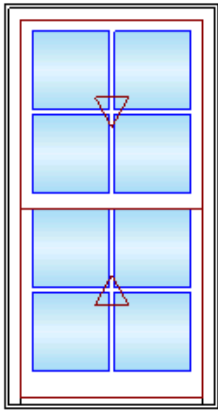

As Viewed From The Exterior

**Entered As:** IO  
**FS** 25 5/8" X 47 1/4"  
**IO** 26" X 47 1/2"  
**Egress Information**  
 Width: 21 15/16" Height: 18 9/16"  
 Net Clear Opening: 2.83 SqFt  
**Performance Information**  
 U-Factor: 0.31  
 Solar Heat Gain Coefficient: 0.27  
 Visible Light Transmittance: 0.46  
 Condensation Resistance: 55  
 CPD Number: MAR-N-441-01613-00001  
**Performance Grade**  
 Licensee #1149  
 AAMA/WDMA/CSA/101/I.S.2/A440-11  
 LC-PG50 1153X2215 mm (45.38X87.19 in)  
 LC-PG50 DP +50/-50  
 FL28134

Ebony Clad Exterior  
 Painted Interior Finish - Designer Black - Pine Interior  
 Ultimate Double Hung Insert G2  
 Inside Opening 26" X 47 1/2"  
 0° Degree Frame Bevel  
 Top Sash  
 Ebony Clad Sash Exterior  
 Painted Interior Finish - Designer Black - Pine Sash Interior  
 IG  
 Low E2 w/Argon  
 Black Perimeter and Spacer Bar  
 5/8" SDL - With Spacer Bar - Black  
 Rectangular - Special Cut 2W2H  
 Ebony Clad Ext - Painted Interior Finish - Designer Black - Pine Int  
 Ogee Interior Glazing Profile  
 Bottom Sash  
 Ebony Clad Sash Exterior  
 Painted Interior Finish - Designer Black - Pine Sash Interior  
 IG  
 Low E2 w/Argon  
 Black Perimeter and Spacer Bar  
 5/8" SDL - With Spacer Bar - Black  
 Rectangular - Special Cut 2W2H  
 Ebony Clad Ext - Painted Interior Finish - Designer Black - Pine Int  
 Ogee Interior Glazing Profile  
 Black Interior Weather Strip Package  
 Black Exterior Weather Strip Package  
 Matte Black Sash Lock  
 Matte Black Top Sash Strike Plate Assembly Color  
 Aluminum Screen  
 Ebony Surround  
 Bright View Mesh  
 \*\*\*Screen/Combo Ship Loose  
 3 1/4" Jambs  
**\*\*\*Note: Unit Availability and Price is Subject to Change**

Line #5	Mark Unit:	Net Price:		1,588.32
Qty: 1		Ext. Net Price:	USD	1,588.32



Ebony Clad Exterior  
 Painted Interior Finish - Designer Black - Pine Interior  
 Ultimate Double Hung Insert G2  
 Inside Opening 32 1/2" X 60 1/2"  
 0° Degree Frame Bevel  
 Top Sash  
 Ebony Clad Sash Exterior  
 Painted Interior Finish - Designer Black - Pine Sash Interior  
 IG  
 Low E2 w/Argon  
 Black Perimeter and Spacer Bar  
 5/8" SDL - With Spacer Bar - Black

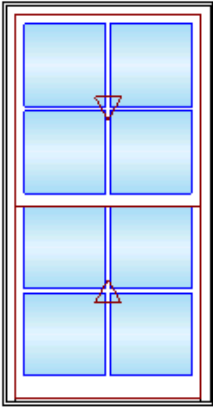

As Viewed From The Exterior

**Entered As:** IO  
**FS** 32 1/8" X 60 1/4"  
**IO** 32 1/2" X 60 1/2"  
**Egress Information**  
 Width: 28 7/16" Height: 25 1/16"  
 Net Clear Opening: 4.95 SqFt  
**Performance Information**  
 U-Factor: 0.31  
 Solar Heat Gain Coefficient: 0.27  
 Visible Light Transmittance: 0.46  
 Condensation Resistance: 55  
 CPD Number: MAR-N-441-01613-00001  
**Performance Grade**  
 Licensee #1149  
 AAMA/WDMA/CSA/101/I.S.2/A440-11  
 LC-PG50 1153X2215 mm (45.38X87.19 in)  
 LC-PG50 DP +50/-50  
 FL28134

Rectangular - Special Cut 2W2H  
 Ebony Clad Ext - Painted Interior Finish - Designer Black - Pine Int  
 Ogee Interior Glazing Profile  
 Bottom Sash  
 Ebony Clad Sash Exterior  
 Painted Interior Finish - Designer Black - Pine Sash Interior  
 IG  
 Low E2 w/Argon  
 Black Perimeter and Spacer Bar  
 5/8" SDL - With Spacer Bar - Black  
 Rectangular - Special Cut 2W2H  
 Ebony Clad Ext - Painted Interior Finish - Designer Black - Pine Int  
 Ogee Interior Glazing Profile  
 Black Interior Weather Strip Package  
 Black Exterior Weather Strip Package  
 Matte Black Sash Lock  
 Matte Black Top Sash Strike Plate Assembly Color  
 Extruded Aluminum Screen  
 Ebony Surround  
 Bright View Mesh  
 \*\*\*Screen/Combo Ship Loose  
 3 1/4" Jamb  
**\*\*\*Note: Unit Availability and Price is Subject to Change**

Line #6	Mark Unit:	Net Price:	884.16
Qty: 1		Ext. Net Price:	884.16
		USD	

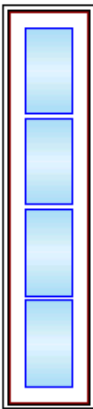

As Viewed From The Exterior

**Entered As:** IO  
**FS** 12 1/8" X 52 1/4"  
**IO** 12 1/2" X 52 1/2"  
**Egress Information**  
 No Egress Information available.  
**Performance Information**  
 Product Performance Information is currently  
 unavailable in the OMS for this product and  
 glazing option. To request product performance

Ebony Clad Exterior  
 Painted Interior Finish - Designer Black - Pine Interior  
 Ultimate Casement Narrow Frame - Stationary  
 Inside Opening 12 1/2" X 52 1/2"  
 0 Degree Frame Bevel  
 Ebony Clad Sash Exterior  
 Painted Interior Finish - Designer Black - Pine Sash Interior  
 IG  
 Low E2  
 Black Perimeter and Spacer Bar  
 5/8" SDL - With Spacer Bar - Black  
 Rectangular - Special Cut 1W4H  
 Ebony Clad Ext - Painted Interior Finish - Designer Black - Pine Int  
 Putty Exterior Glazing Profile  
 Ogee Interior Glazing Profile  
 Standard Bottom Rail  
 Black Weather Strip  
 Solid Wood Covers  
 2 3/16" Jamb  
 No Installation Method  
 \*\*\*Note: The overall frame depth will be 1 1/16" larger than the jamb size  
 shown above. For example, a 3 1/4" overall frame depth will have a 2 3/16"  
 jamb.  
**\*\*\*Note: Unit Availability and Price is Subject to Change**

information not in the OMS, contact your Marvin representative or submit an Assistance Request.

**Performance Grade**

Licensee #918  
AAMA/WDMA/CSA/101/I.S.2/A440-11  
CW-PG50 914X2442 mm (36X96.13 in)  
CW-PG50 DP +50/-50  
FL10321

Project Subtotal Net Price: USD	23,689.44
7.000% Sales Tax: USD	1,658.26
Project Total Net Price: USD	25,347.70

## PRODUCT AND PERFORMANCE INFORMATION

### NFRC Ratings:

NFRC energy ratings may vary depending on the exact configuration of glass thickness used on the unit. NFRC energy values and ratings may change over time due to ongoing product changes, updated test results or requirements. NFRC values and ratings are finalized on the date of manufacture.

The National Fenestration Rating Council (NFRC) has developed and operates a uniform rating system for the energy performance of fenestration products, including windows, doors and skylights. For additional information regarding this rating system, see [www.nfrc.org](http://www.nfrc.org).

### Code (residential, building or energy) Compliance:

Determining the suitability and compliance with state, provincial, local, or other applicable building codes or standards, including energy codes, is the responsibility of the buyer, user, architect, contractor, installer, and/or other construction professional.



ORDERING PRODUCTS WITH REFERENCE TO SHOP DRAWINGS: Before ordering the Marvin Window and Door products illustrated within these shop drawings, a copy of these drawings accompanied by an approved signature of the purchaser must be returned to the Architectural Department at Marvin Windows & Doors, Inc., Box 100, Grand Rapids, Michigan 49501. The purchaser must also return the drawings to the Architect to the approved shop drawings. Marvin Windows and Doors assumes no responsibility in guaranteeing product coordination with the drawings.

REVISION:

CREATED: 11/13/2024

PK VERSION: 0004.12.00

PROJ/JOB: HARBORSIDE HOLDINGS / 360 HOPE ST.  
DIST/DEALER: HUMPHREYS WINDOW & DOOR DESIGN GLRY-GO  
DRAWN: MARK SHUMAN  
QUOTE#: UYQZELB

SHEET  
1  
OF 3

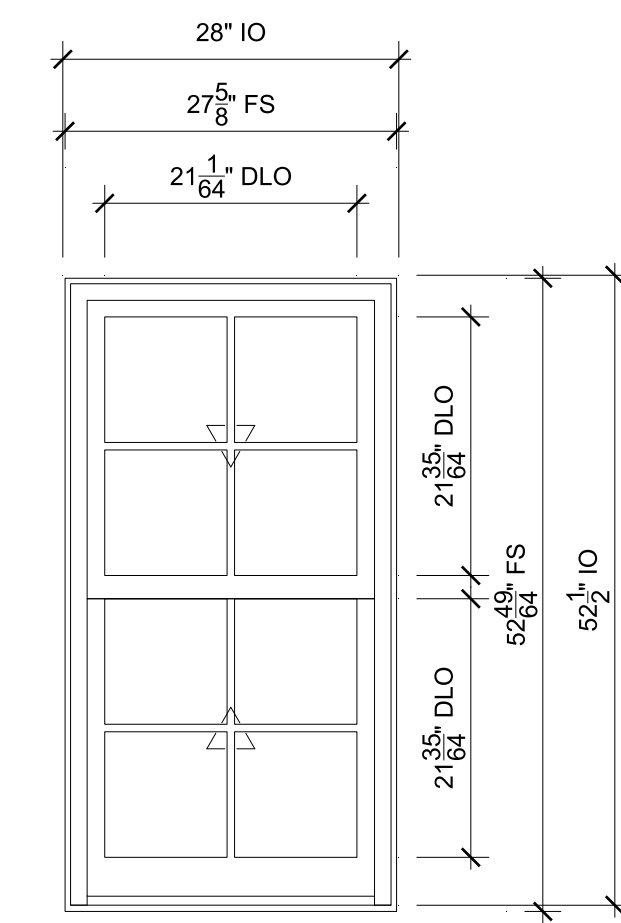

- 01**  
SCALE: 3/4" = 1'-0"
- ⊕ Head
  - ⊕ Jamb
  - ⊕ Sill
  - ⊕ Divided Lite
  - ⊕ Checkrail

**SPECIFICATIONS**

Line #: 1  
Qty: 10  
Mark Unit: None  
Product Line: Ultimate  
Unit Description: Double Hung Insert G2  
Rough Opening: 28" X 52 1/2"  
Frame Size: 27 5/8" X 52 49/64"  
Unit Type: Double Hung Insert G2  
Call Number: None  
Jamb Depth: 3 1/4

**FOR DESIGN INTENT ONLY, NOT FOR MANUFACTURE.**

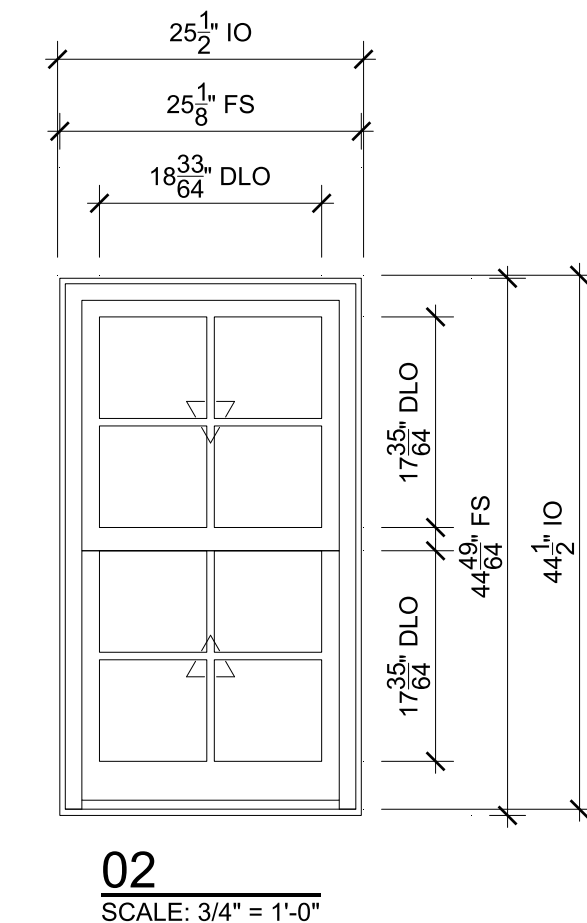

- 02**  
SCALE: 3/4" = 1'-0"
- ⊕ Head
  - ⊕ Jamb
  - ⊕ Sill
  - ⊕ Divided Lite
  - ⊕ Checkrail

**SPECIFICATIONS**

Line #: 2  
Qty: 1  
Mark Unit: None  
Product Line: Ultimate  
Unit Description: Double Hung Insert G2  
Rough Opening: 25 1/2" X 44 1/2"  
Frame Size: 25 1/8" X 44 49/64"  
Unit Type: Double Hung Insert G2  
Call Number: None  
Jamb Depth: 3 1/4

**FOR DESIGN INTENT ONLY, NOT FOR MANUFACTURE.**

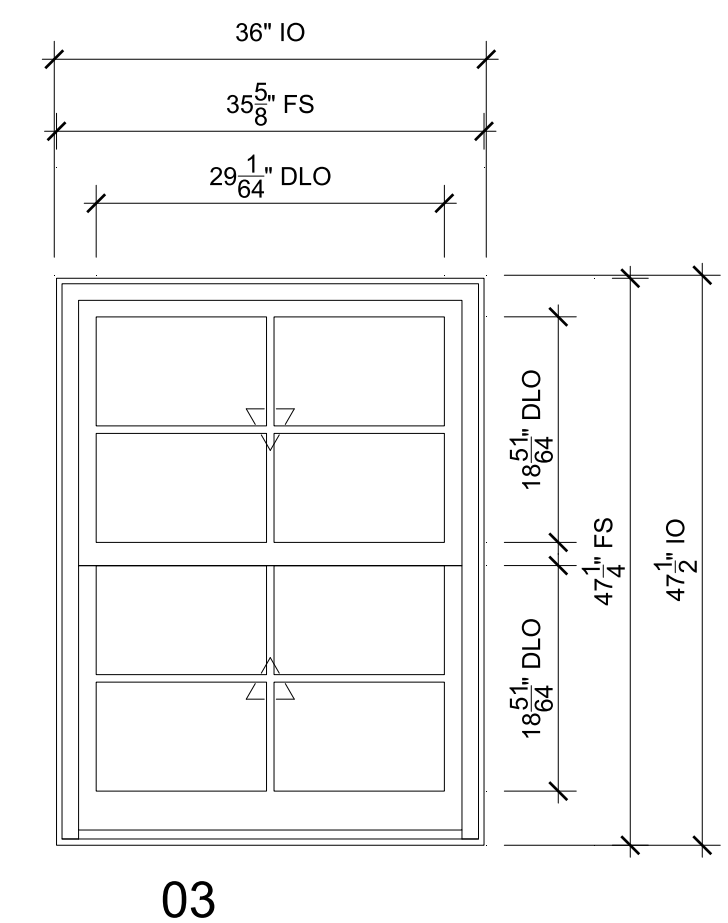

- 03**  
SCALE: 3/4" = 1'-0"
- ⊕ Head
  - ⊕ Jamb
  - ⊕ Sill
  - ⊕ Divided Lite
  - ⊕ Checkrail

**SPECIFICATIONS**

Line #: 3  
Qty: 3  
Mark Unit: None  
Product Line: Ultimate  
Unit Description: Double Hung Insert G2  
Rough Opening: 36" X 47 1/2"  
Frame Size: 35 5/8" X 47 1/4"  
Unit Type: Double Hung Insert G2  
Call Number: None  
Jamb Depth: 3 1/4

**FOR DESIGN INTENT ONLY, NOT FOR MANUFACTURE.**

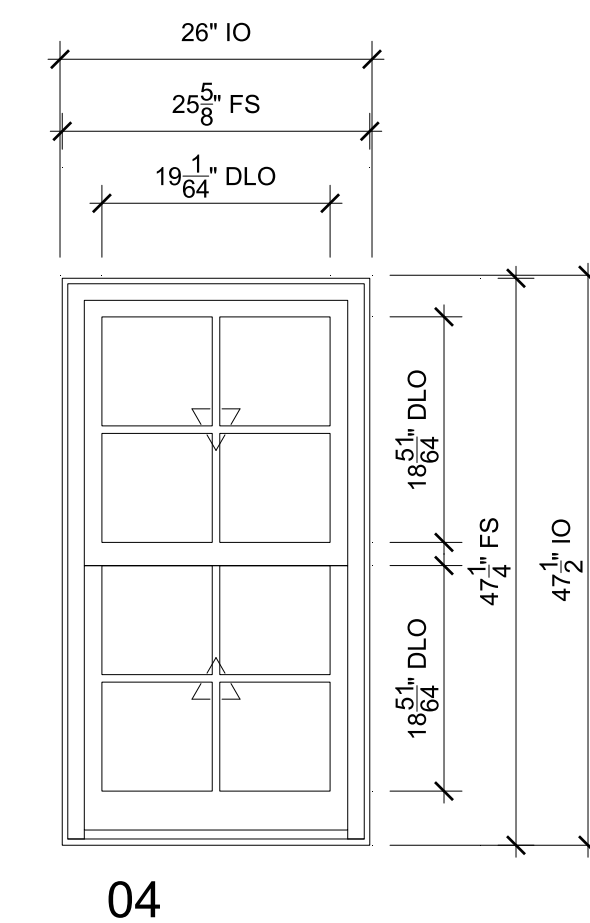

- 04**  
SCALE: 3/4" = 1'-0"
- ⊕ Head
  - ⊕ Jamb
  - ⊕ Sill
  - ⊕ Divided Lite
  - ⊕ Checkrail

**SPECIFICATIONS**

Line #: 4  
Qty: 1  
Mark Unit: None  
Product Line: Ultimate  
Unit Description: Double Hung Insert G2  
Rough Opening: 26" X 47 1/2"  
Frame Size: 25 5/8" X 47 1/4"  
Unit Type: Double Hung Insert G2  
Call Number: None  
Jamb Depth: 3 1/4

**FOR DESIGN INTENT ONLY, NOT FOR MANUFACTURE.**

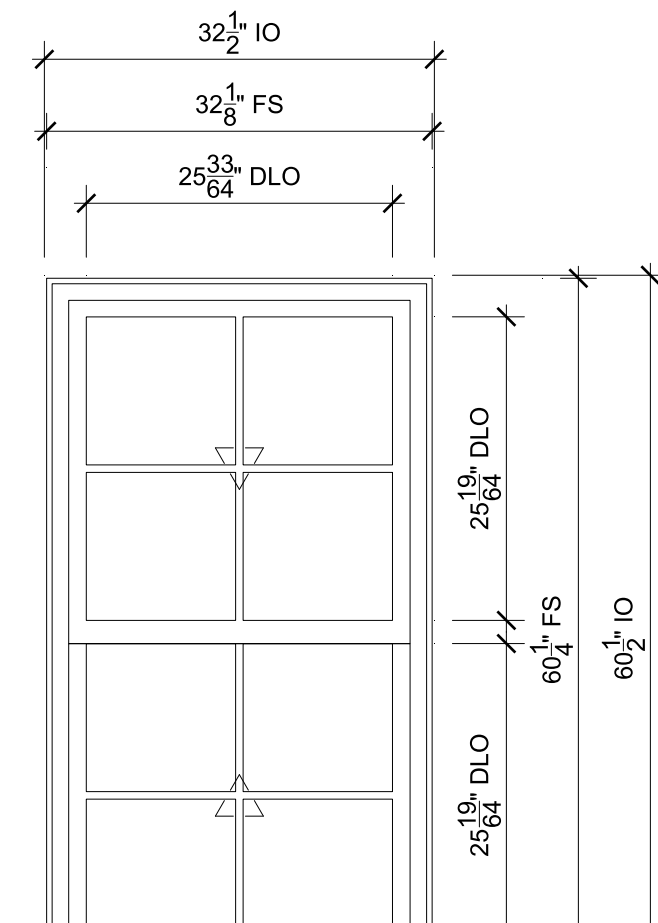

- 05**  
SCALE: 3/4" = 1'-0"
- ⊕ Head
  - ⊕ Jamb
  - ⊕ Sill
  - ⊕ Divided Lite
  - ⊕ Checkrail

**SPECIFICATIONS**

Line #: 5  
Qty: 1  
Mark Unit: None  
Product Line: Ultimate  
Unit Description: Double Hung Insert G2  
Rough Opening: 32 1/2" X 60 1/2"  
Frame Size: 32 1/8" X 60 1/4"  
Unit Type: Double Hung Insert G2  
Call Number: None  
Jamb Depth: 3 1/4

**FOR DESIGN INTENT ONLY, NOT FOR MANUFACTURE.**

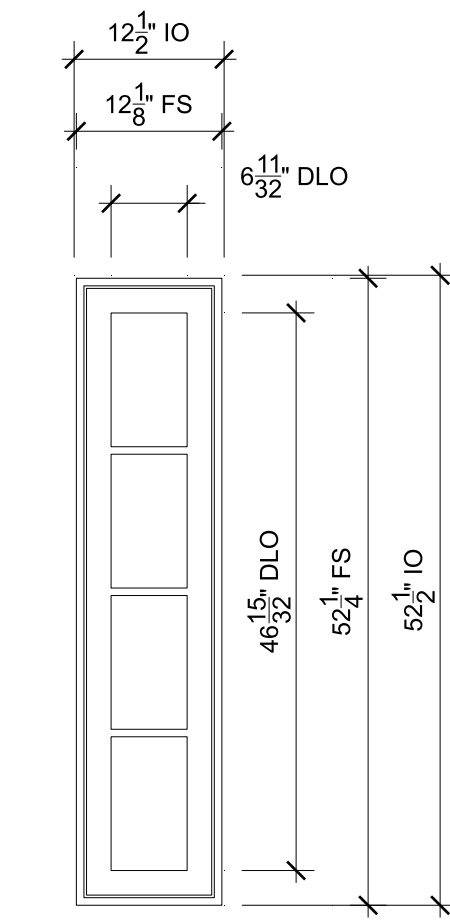

- 06**  
SCALE: 3/4" = 1'-0"
- ⊕ Head
  - ⊕ Jamb
  - ⊕ Sill
  - ⊕ Divided Lite

**SPECIFICATIONS**

Line #: 6  
Qty: 1  
Mark Unit: None  
Product Line: Ultimate  
Unit Description: Casement Narrow Frame  
Rough Opening: 12 1/2" X 52 1/2"  
Frame Size: 12 1/8" X 52 1/4"  
Unit Type: Casement Narrow Frame, Stationary  
Call Number: None  
Jamb Depth: 2 3/16"

**FOR DESIGN INTENT ONLY, NOT FOR MANUFACTURE.**





ORDERING PRODUCTS WITH REFERENCE TO SHOP DRAWINGS: Before ordering the Marvin Window and Door products illustrated within these shop drawings, a copy of these drawings accompanied by an approved signature of the purchaser must be returned to the Architectural Department at Marvin Windows & Doors, P.O. Box 100, Grand Rapids, Michigan 49503. The purchaser must also return a copy of these drawings to the approved shop drawings. Marvin Windows and Doors assumes no responsibility in guaranteeing product coordination with the drawings.

PROJ/JOB: HARBORSIDE HOLDINGS / 360 HOPE ST.  
DIST/DEALER: HUMPHREYS WINDOW & DOOR DESIGN GLRY-GO  
DRAWN: MARK SHUMAN  
QUOTE#: UYQZELB  
PK VERSION: 0004.12.00  
CREATED: 11/13/2024  
REVISION:

PROJ/JOB: HARBORSIDE HOLDINGS / 360 HOPE ST.  
DIST/DEALER: HUMPHREYS WINDOW & DOOR DESIGN GLRY-GO  
DRAWN: MARK SHUMAN  
QUOTE#: UYQZELB  
PK VERSION: 0004.12.00  
CREATED: 11/13/2024  
REVISION:

SHEET  
2  
OF 3

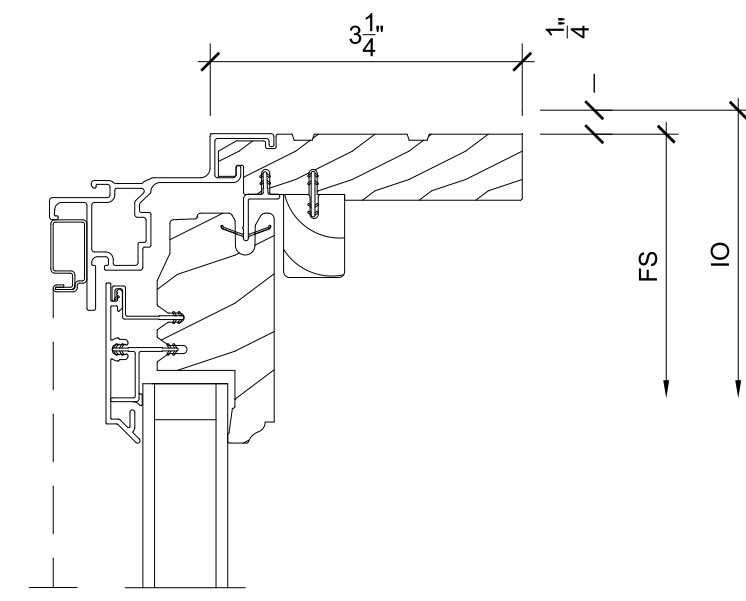

1/2 Head SCALE: 6" = 1'-0"

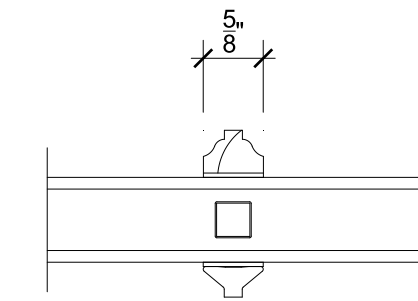

4/2 Divided Lite SCALE: 6" = 1'-0"

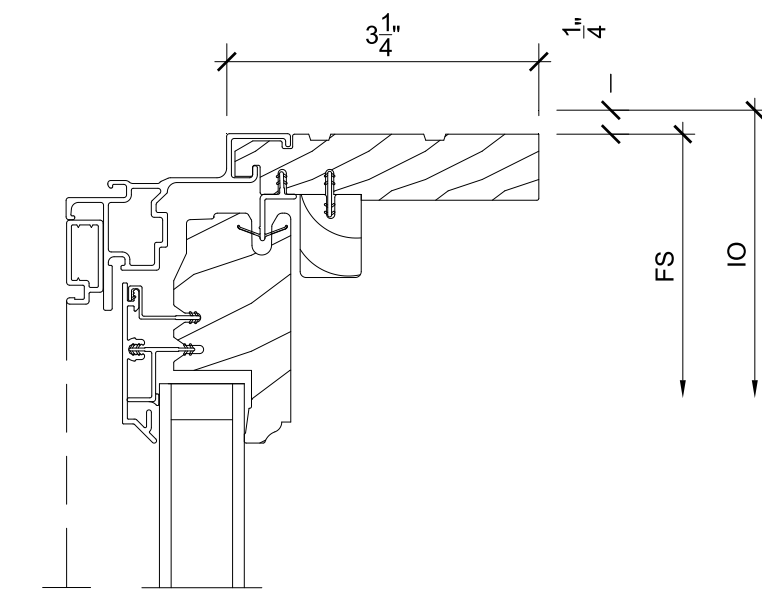

7/2 Head SCALE: 6" = 1'-0"

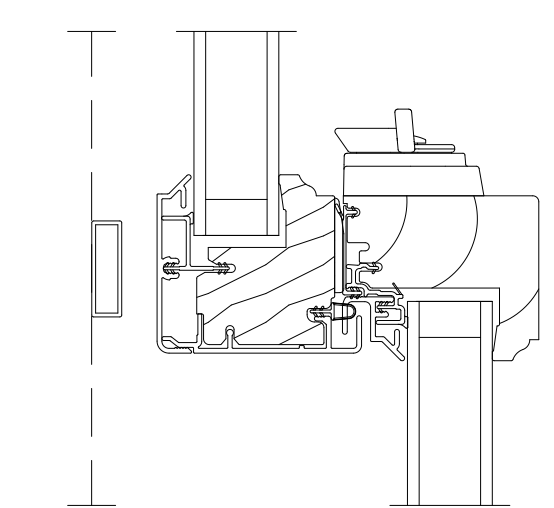

10/2 Checkrail SCALE: 6" = 1'-0"

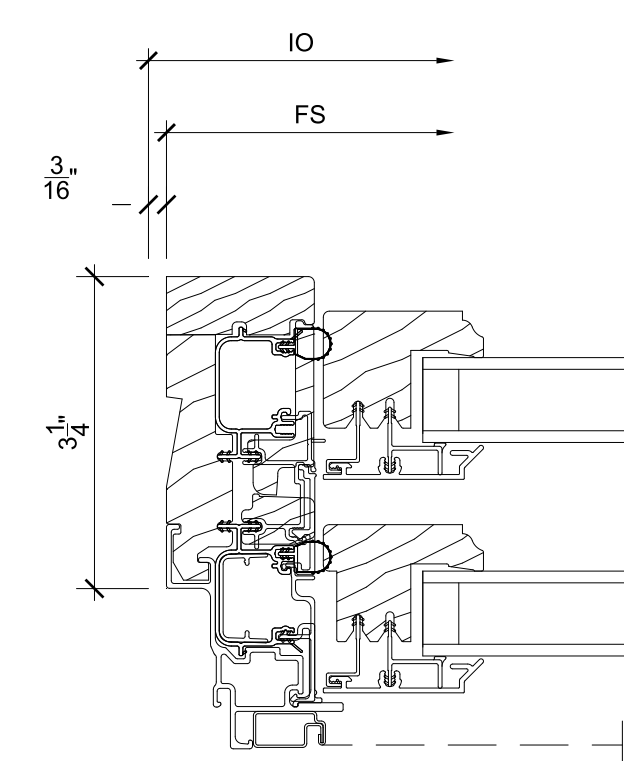

2/2 Jamb SCALE: 6" = 1'-0"

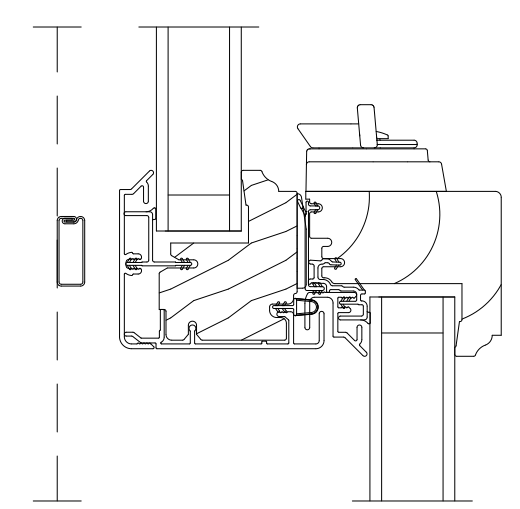

5/2 Checkrail SCALE: 6" = 1'-0"

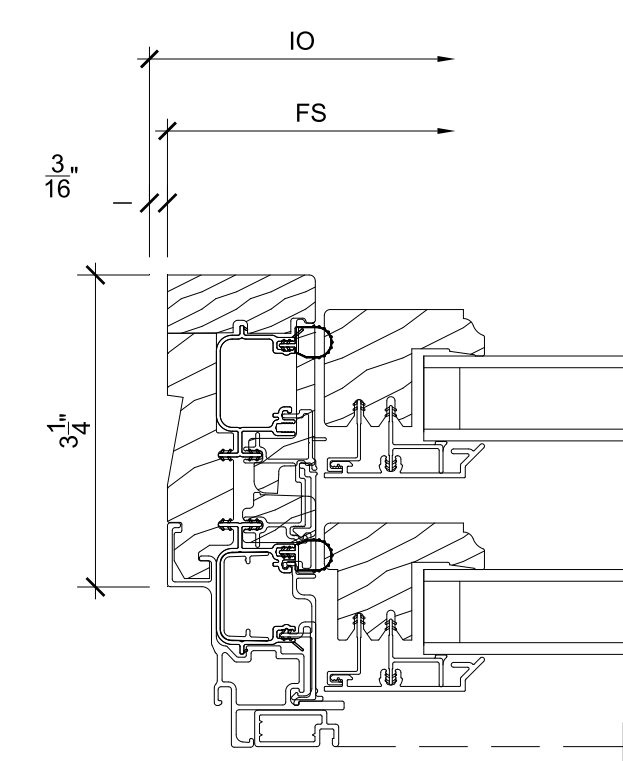

8/2 Jamb SCALE: 6" = 1'-0"

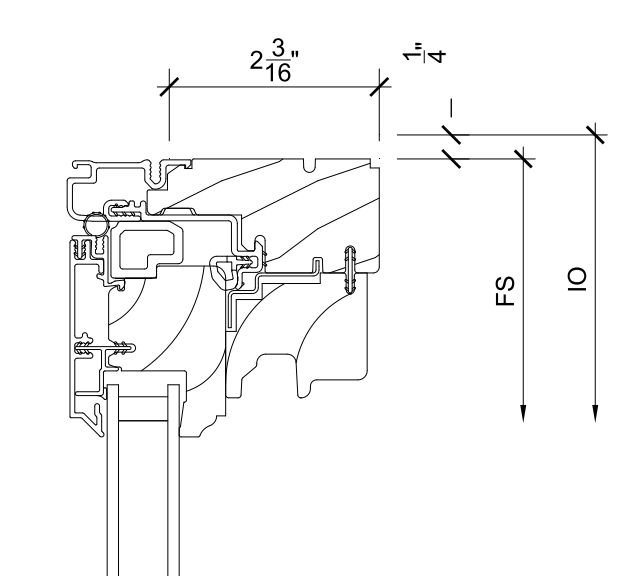

11/2 Head SCALE: 6" = 1'-0"

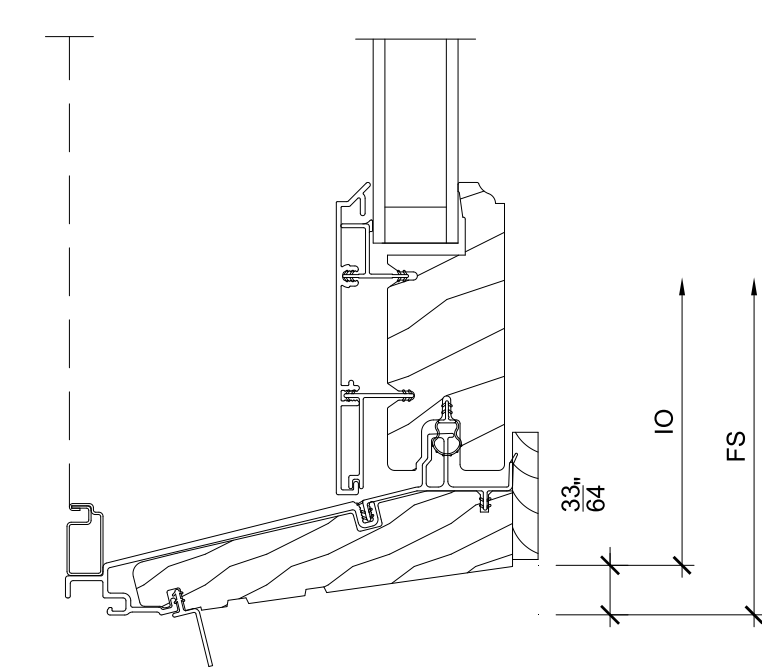

3/2 Sill SCALE: 6" = 1'-0"

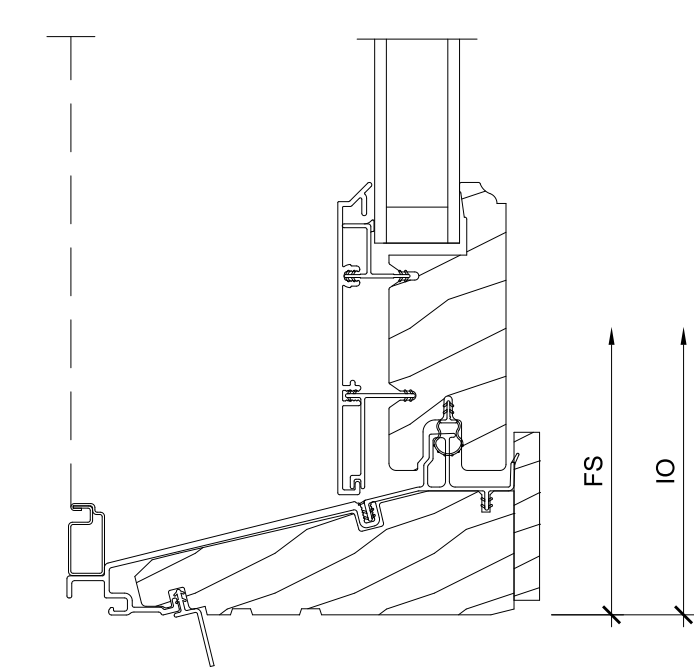

6/2 Sill SCALE: 6" = 1'-0"

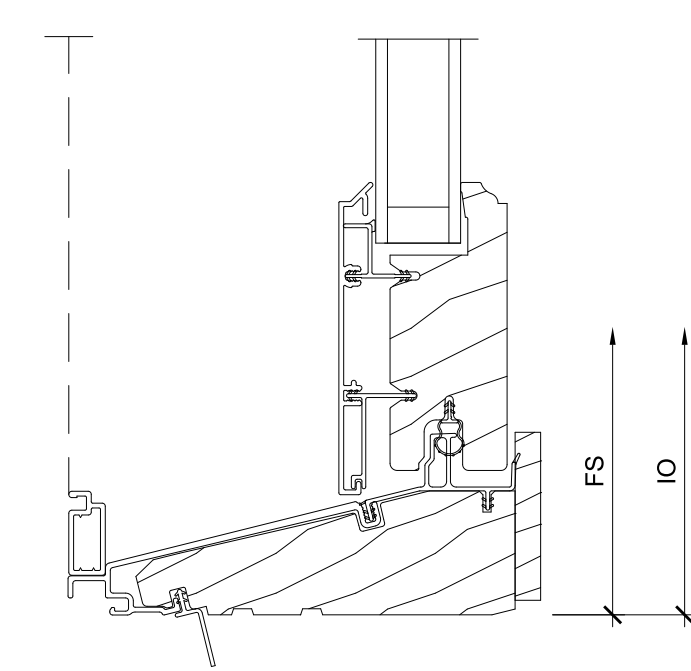

9/2 Sill SCALE: 6" = 1'-0"

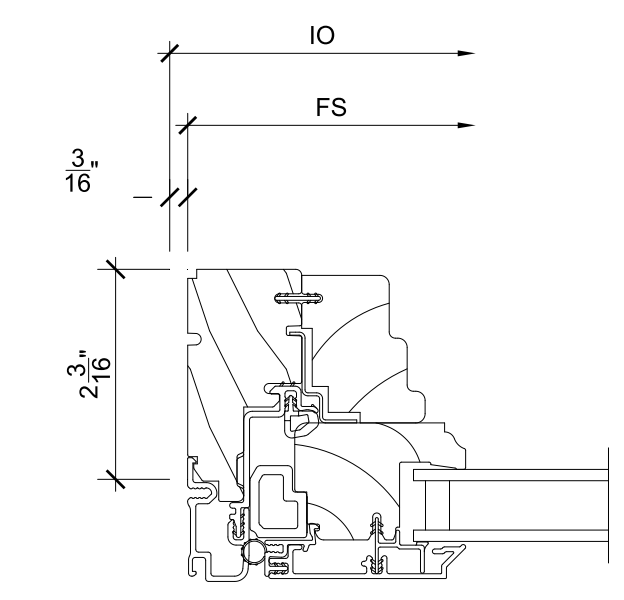

12/2 Jamb SCALE: 6" = 1'-0"



**ORDERING PRODUCTS WITH REFERENCE TO SHOP DRAWINGS:**  
Before ordering the Marvin Window and Door products illustrated within these shop drawings, a copy of these drawings accompanied by an approved signature of the purchaser must be returned to the Architectural Department, Marvin Windows & Doors, P.O. Box 100, Grand Rapids, Michigan 49503. The purchaser must also be sure to refer to the instructions to the approved shop drawings. Marvin Windows and Doors assumes no responsibility in guaranteeing product coordination with the drawings.

PROJ/JOB: HARBORSIDE HOLDINGS / 360 HOPE ST.  
DIST/DEALER: HUMPHREYS WINDOW & DOOR DESIGN GLRY-GO  
DRAWN: MARK SHUMAN  
QUOTE#: UYQZELB  
PK VERSION: 0004.12.00  
CREATED: 11/13/2024  
REVISION:

SHEET  
**3**  
OF 3

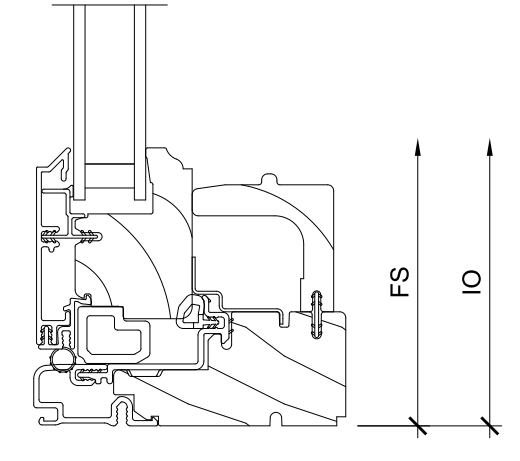

1  
3 Sill SCALE: 6" = 1'-0"

4  
3 NOT USED SCALE: 6" = 1'-0"

7  
3 NOT USED SCALE: 6" = 1'-0"

10  
3 NOT USED SCALE: 6" = 1'-0"

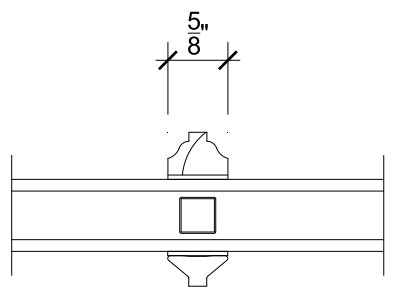

2  
3 Divided Lite SCALE: 6" = 1'-0"

5  
3 NOT USED SCALE: 6" = 1'-0"

8  
3 NOT USED SCALE: 6" = 1'-0"

11  
3 NOT USED SCALE: 6" = 1'-0"

3  
3 NOT USED SCALE: 6" = 1'-0"

6  
3 NOT USED SCALE: 6" = 1'-0"

9  
3 NOT USED SCALE: 6" = 1'-0"

12  
3 NOT USED SCALE: 6" = 1'-0"









