



# Regular Meeting of the Breckenridge City Commission

Tuesday, March 02, 2021 at 5:30 PM

Breckenridge City Offices Commission Chambers  
105 North Rose Avenue  
Breckenridge, Texas 76424

---

## AGENDA

### CALL TO ORDER

### INVOCATION

Invocation led by Brother Otho Noggle

### PLEDGE OF ALLEGIANCE

### APPROVAL OF MINUTES

1. Request to approve Minutes of the February 2, 2021 City Commission Meeting

### PUBLIC TESTIMONY

2. Texas History Month

### CONSENT AGENDA

*All items listed below are considered to be routine by the City Commission and will be enacted with one motion. There will be no separate discussion of items unless a Commission Member or Citizen so request, in which event, the item will be removed from the General Order of Business and considered in its normal sequence.*

3. Request to approve Departmental Reports
4. Request to approve the 2019-2020 Breckenridge Economic Development Corporation Audit
5. Request to approve Resolution 21-03 to appoint members to Planning and Zoning Commission

### INDIVIDUAL CONSIDERATION

6. Request to approve Resolution 21-05 to Apply for Criminal Justice Division Grant for new in car video/audio systems
7. Request to approve Resolution 21-06 requesting financial assistance from the Texas Water Development Board for wastewater system improvements, and approving all other matters pertaining thereto

8. Request to approve the Certification of Unopposed Candidates for the May 1, 2021 Election

#### DEPARTMENTAL REPORTS

9. Aquatic Center Operations
10. Brush Chipping
11. Annual Clean-Up
12. Lift Stations

#### CITY MANAGER REPORT

13. Weather Watch Class
14. Request to approve Chamber of Commerce - Frontier Days
15. City Manager Position / SGR

#### ITEMS NOT REQUIRING FORMAL ACTION

#### ADJOURN

**The City Commission of the City of Breckenridge reserves the right to adjourn into executive (closed) session at any time during the course of this meeting to discuss any of the matters listed above, as authorized by Texas Government Code Sections 551.071 (Consultation with Attorney); 551.072 (Deliberations regarding Real Property); 551.073 (Deliberations regarding Gifts and Donations); 551.074 (Personnel Matters); 551.076 (Deliberations regarding Security Devices); and 551.087 (Economic Development Negotiations).**

I certify that this notice was posted at the City Offices, 105 North Rose Avenue, Breckenridge, Texas at 4:00 P.M., Friday, xxxxx, 2021.

---

Heather Robertson-Caraway, CCCII, TRMC  
Interim City Manager / City Secretary

This facility is wheelchair accessible, and accessible parking spaces are available. Request for accommodations or interpretive services must be made 48 hours prior to this meeting. Please contact the City Secretary's Office at (254)559-8287 or FAX (254)559-7322 for further information.

Removed from the City Offices bulletin board at \_\_\_\_\_ on \_\_\_\_\_ by \_\_\_\_\_.



## Regular Meeting of the Breckenridge City Commission

Tuesday, February 02, 2021 at 5:30 PM

Breckenridge City Offices Commission Chambers  
105 North Rose Avenue  
Breckenridge, Texas 76424

### MINUTES

#### CALL TO ORDER

Mayor Sims opened meeting at 5:33 PM

#### INVOCATION

Invocation led by Don Sackett

#### PLEDGE OF ALLEGIANCE

Pledge of Allegiance led by Don Sackett

#### APPROVAL OF MINUTES

1. Request to approve Minutes of the January 5, 2021 City Commission Meeting

Motion made by Commissioner Wimberley, Seconded by Commissioner Cyprian.  
Voting Yea: Mayor Sims, Commissioner Blue, Commissioner Cyprian, Commissioner Wimberley

#### PUBLIC TESTIMONY

None

#### CONSENT AGENDA

*All items listed below are considered to be routine by the City Commission and will be enacted with one motion. There will be no separate discussion of items unless a Commission Member or Citizen so request, in which event, the item will be removed from the General Order of Business and considered in its normal sequence.*

2. Request to approve City Funds Quarterly Investment Report – 1st Quarter 2020-21
3. Request to approve the 4th Quarter 2020 Financial Statement for Hotel/Motel Funds
4. Request to approve the 2021 Hotel/Motel Budget
5. Request to approve the 2019-20 Worker's Compensation Payroll Audit
6. Request to approve the Racial Profiling Statistical Report

Motion made by Commissioner Blue, Seconded by Commissioner Cyprian.  
 Voting Yea: Mayor Sims, Commissioner Blue, Commissioner Cyprian, Commissioner Wimberley

## INDIVIDUAL CONSIDERATION

7. Request to Approve second reading of Ordinance 21-01 the Electric Franchise Agreement with Oncor

Motion made by Commissioner Wimberley, Seconded by Commissioner Cyprian.  
 Voting Yea: Mayor Sims, Commissioner Blue, Commissioner Cyprian, Commissioner Wimberley

8. Request to approve Ordinance 21-02 Revising Chapter 15, Parks and Recreation, clarifying nuisance animal abatement by designated city employees and providing a penalty clause

Asst. City Manager of Operations Houston Satterwhite stated we have had people ask about eradicating wild animals. We have a TCEQ mandate stating to eradicate them, neighboring landowners have not agreed with this. The Ordinance will simply give us the right to take care of this nuisance at the City Managers discretion. A clause was added to allow swimming at Lake Daniels and also a clause about alcohol use.

Motion made by Commissioner Wimberley, Seconded by Commissioner Cyprian.  
 Voting Yea: Mayor Sims, Commissioner Blue, Commissioner Cyprian, Commissioner Wimberley

9. Request to approve Ordinance 21-03 of Order & Notice to set the General Election for May 1, 2021, as well as appoint Election Judge

Interim City Manager / City Secretary Heather Robertson-Caraway stated this Ordinance is to set the City's General Election for Place 3 and 4 currently held by Tom Cyprian and David Wimberley. Candidates can pick up packets at City Offices or print one off our website. We have had one individual pick-up a packet, but no one has filed for a place on the ballot. The Ordinance also sets Anita Lockhart as our Election Judge, she has worked several elections for the City.

Motion made by Commissioner Blue, Seconded by Commissioner Cyprian.  
 Voting Yea: Mayor Sims, Commissioner Blue, Commissioner Cyprian, Commissioner Wimberley

10. Request to approve the City's Audit for Fiscal Year 2020-21  
 (Audit will be provided by GMS at the meeting)

Daniel Hungerford with George, Morgan & Sneed explained the revenues are up this year, values were down, sales taxes are up. Expenses were down and General fund balances are up. Overall, it was a fairly good year for the City this year. Heather Robertson-Caraway stated she would like to thank the department heads and staff for cutting back on expenditures and making changes to help with the money situation. million red. The

Department Heads were great help spending the TDEM money and we are waiting for reimbursement.

Motion made by Commissioner Wimberley, Seconded by Commissioner Cyprian.  
Voting Yea: Mayor Sims, Commissioner Blue, Commissioner Cyprian, Commissioner Wimberley

11. Discuss and possibly take action with regard to Strategic Government Resources services to fill the City Manager position

Larry Gilley with Strategic Government Resources stated he is working with Heather and Houston on gathering information to produce a brochure to help target the right person for the City. Mayor Bob Sims stated Heather and Houston have done a phenomenal job even with all the stress it has put on them. Sims stated we need another Scott Dixon. Wimberley stated Scott had a lot of knowledge and was a great asset while he was here. We really need someone that is strong in financial. Heather Robertson-Caraway stated Dixon had some ideas that we are looking into and waiting on the rate study to be completed and Scott had planned for another rate increase on both Water and Wastewater rates. In order for the Water and Wastewater Funds to be self-supporting rates will have to increase. Gilley asked what does the Commission want in their ideal City Manager? Wimberley and Sims both stated Heather and Houston could tell him more of what we the City needs.

Heather and Houston stated that what the City needs in a City Manager is someone who understands the financial aspects of a municipality, but mostly, someone who has a strong background within Public Works. Heather mentions that the infrastructure is very old. Some is marked 1920's - 100 years old. Heather also discussed the need for employee raises. It has been 4 years or longer since the employees were given even a COLA increase. We cannot keep employees; we train them, and other entities or businesses hire them away for more money. We have a good benefits package, but the younger people just care about the paycheck.

No Motion Required

## **CITY MANAGER REPORT**

12. Personnel

Houston Satterwhite spoke about the problem with keeping employees. He stated the need for pay raises, we have lost a lot of employees due to pay. Heather Robertson-Caraway stated she will start work on the budget this week and will be looking into pay raises. If the Government does the minimum wage increase some of the services will have to be cut.

Power point was reviewed on the City's Lift stations. Satterwhite stated we will be able to rehab 4 out of 5 Lift Stations instead of replacing and that will save the City money. We have available grants and loans to help pay for the rehab.

Harrison stated the cracks in bottom of the Pool have been repaired and new bond coating is down. Pool rehab should be completed soon pending on weather.

**ITEMS NOT REQUIRING FORMAL ACTION**

None

**ADJOURN**

Adjourn 6:28 pm

Motion made by Commissioner Cyprian, Seconded by Commissioner Blue.

Voting Yea: Mayor Sims, Commissioner Blue, Commissioner Cyprian, Commissioner Wimberley

Meeting closed at 6:28 PM

\_\_\_\_\_  
Bob Sims, Mayor

ATTEST

\_\_\_\_\_  
Heather Robertson-Caraway, CCCII, TRMC  
Interim City Manager / City Secretary

SEAL

# Texas History Month Proclamation

**WHEREAS,** on March 2, 1836, the Texas Declaration of Independence was signed by members of the Republic of Texas, stating in part, “that the people of Texas do now constitute a free, sovereign, and independent republic, and are fully invested with all the rights and attributes which properly belong to independent nations”; and

**WHEREAS,** on March 6, 1836, Texans under Col. William B. Travis were overwhelmed by the Mexican army after a two-week siege at the Battle of the Alamo in San Antonio; and

**WHEREAS,** The Picketville Chapter of The Daughters of the Republic of Texas desire to perpetuate the memory and spirit of the men and women who achieved and maintained the Independence of Texas; and

**NOW, THEREFORE, I, Bob Sims,** by virtue of the authority vested in me as Mayor of the City of Breckenridge, in the State of Texas, do hereby proclaim

## **MARCH**

**AS**

## **TEXAS HISTORY MONTH**

and ask our citizens to reaffirm the ideals that the authors and defenders of Texas Independence had in 1836 by vigilantly protecting the freedoms guaranteed to us, remembering that lost rights may never be regained.

**IN TESTIMONY, WHEREOF,** I have hereunto set my hand and caused the Official Seal of the City to be affixed this 25<sup>th</sup> day of February, in the year of our Lord two thousand twenty-one.

\_\_\_\_\_  
Bob Sims, Mayor

\_\_\_\_\_  
Heather Robertson-Caraway, CCCII, TRMC  
Interim City Manager / City Secretary

SEAL

CITY OF BRECKENRIDGE  
105 NORTH ROSE AVE.  
BRECKENRIDGE, TX 76424

CHARGE OFFS

FOR THE MONTH OF July 2020

TO BE CHARGED OFF IN February 2021

WATER 488.13

SEWER 369.23

TRASH 174.67

ADMIN FEE \_\_\_\_\_

TAX <sup>\$</sup> 11.58

OTHER \_\_\_\_\_

TOTAL <sup>\$</sup> 1043.61

APPROVED BY THE CITY COMMISSION \_\_\_\_\_

CITY SECRETARY \_\_\_\_\_

chargeoffs(dl)



W R I T E O F F A U D I T R E G I S T E R

02-19-2021 11:11 AM

G/L POSTING DATE: 2/19/2021

PACKET: 6917

POSTING TYPE: BOTH

COMMENT CODE: BAD -BAD DEBT ACCOUNT

FLAG ACCOUNT: NO

\*\* TRANSFER TO BAD DEBT \*\*

ACCOUNT NO	NAME	BALANCE	LAST BILL						
04-000113-02-0	GUZMAN, ERNESTO	202.88	7/08/2020	100-WATER	65.82	116-RDSUR	20.72	200-SEW	74.20
	** LAST PAYMENT MADE:	3/16/2020	7/08/2020	300-PCTCLR	30.80	320-ASF	8.79	390-GT	2.55
04-000129-01-0	CAULEY, AUSTIN	45.85	7/23/2020	100-WATER	18.27	116-RDSUR	6.02	200-SEW	21.56
	** LAST PAYMENT MADE:	4/22/2020	7/23/2020						
06-000455-01-0	SNOWDEN, C E	394.36	7/23/2020	100-WATER	124.04	116-RDSUR	36.37	200-SEW	130.06
	** LAST PAYMENT MADE:	2/12/2020	7/23/2020	300-PCTCLR	81.65	320-ASF	15.53	390-GT	6.71
08-000022-00-0	LOVE, JAMES	310.18	7/23/2020	100-WATER	96.90	116-RDSUR	31.94	200-SEW	114.36
	** LAST PAYMENT MADE:	2/21/2020	7/23/2020	300-PCTCLR	48.96	320-ASF	13.97	390-GT	4.05
11-000190-02-0	OLIVER, EDALIA	8.13	7/08/2020	100-WATER	40.02	116-RDSUR	7.19	200-SEW	2.06
	** LAST PAYMENT MADE:	7/27/2020	7/08/2020	300-PCTCLR	21.03	320-ASF	4.00	390-GT	1.73
11-000417-00-0	HOLT, BILLY	76.76	7/08/2020	100-WATER	48.75	116-RDSUR	3.58	200-SEW	24.43
	** LAST PAYMENT MADE:	6/25/2020	7/08/2020						
13-000209-04-0	ROBERTSON, LARRY	5.45	7/08/2020	100-WATER	2.18	116-RDSUR	0.71	200-SEW	2.56
	** LAST PAYMENT MADE:	5/26/2020	7/08/2020						
**TOTALS** NUMBER OF ACCOUNTS: 7									
		1,043.61		100-WATER	395.98	116-RDSUR	92.15	200-SEW	369.23
				300-PCTCLR	140.38	320-ASF	34.29	390-GT	11.58

ACCOUNT	SOURCE NAME	AMOUNT
101-1229	ACCOUNTS RECEIVABLE SALES TAX	11.58CR
101-1290	ALLOWANCE FOR DOUBTFUL ACCOUNT	11.58
102-1221	Accounts Receivable Water	395.98CR
102-1231	Accts Rec Waterline Surcharge	92.15CR
102-1290	Allowance for Doubtful Account	488.13
103-1223	Accounts Receivable Sewer	369.23CR
103-1290	Allowance for Doubtful Account	369.23
104-1225	Accounts Receivable Trash	140.38CR
104-1226	Accts. Receivable Admin Sanita	34.29CR
104-1290	Allowance for Doubtful Account	174.67

WARNINGS: 0

ERRORS: 0

\*\* END OF REPORT \*\*

### Cemetery Activity Report City of Breckenridge

Month: January 2021

By: [Signature]

Date	Time	Mortuary	Location	Deceased	Comment
1/6	10:00 Ch	Meltons	C-132-3	Bobby Anderson	2801
1/6	1:00 Ch	All Faith Funerals Home <sup>Austrian</sup>	F-7-4	William Nikson	2802
1/9	1:00 HS	Meltons	K-1-6	Diviska Booth	2803
1/11	2:00 <del>HS</del>	Baumgardner	D-51-4	Loris Walters	2804
1/16	2:00 <del>HS</del>	Morehart	K-50-2	Evelyn Perry	2805
1/21	2:00 Ch	Morehart	B-85-3	Margarita Diaz	2806

# Dispatch Stats

January 2021

Breckenridge PD Dispatch  
Karen Roberson 911 Telecommunications Supervisor  
210 E Dyer  
Breckenridge Tx 76424  
254-559-2211  
[kroberson@breckenridgetx.gov](mailto:kroberson@breckenridgetx.gov)

<b>CALLS FOR SERVICE</b>	<b>783</b>
<b>CITATIONS</b>	<b>127</b>
<b>WARRANTS ENTERED</b>	<b>17</b>
<b>WARRANTS CLEARED</b>	<b>15</b>
<b>INCIDENT REPORTS</b>	<b>41</b>
<b>BPD PHONE CALLS</b>	<b>3873</b>
<b>SCSO PHONE CALLS</b>	<b>2575</b>
<b>TELETYPES PD</b>	<b>1342</b>
<b>TELETYPES SC</b>	<b>600</b>

**Phone calls for the Stephens Count Sheriff's Dept are an estimate they are not on our recorder.**

**All citations and warrant entries and cleared entries are double checked, so they are handled twice to ensure accuracy, the numbers above only reflect entries.**



# Arrests by Date (Adult Report)

Item 3.

## Arrested Between 01/01/2021 And 01/31/2021

### BRECKENRIDGE POLICE DEPARTMENT

Date	Number	Name	DOB	Age	Race	Sex	#Days	Arresting Officer
	Offense		Arrest Type	Disposition				Incident#
1/2/2021	7728G	JOHNSON, MATTHEW WADE		31	W	M	31	6078 - BUFKIN, BRYCE
	TAMPER FABRICATE PHYSICAL EVIDENCE W/INTENT TO IMPAIR		O					20210002
	Charge Note: Subject was arrested on the charge of Tampering with evidence and transported to Stephens County Jail without incident.							
1/2/2021	7728F	JOHNSON, MATTHEW WADE		31	W	M	31	6078 - BUFKIN, BRYCE
	POSSESSION OF DRUG PARAPHERNALIA		O					20210003
	Charge Note: Subject was arrested on sight for possession of drug paraphernalia and was transported to Stephens County Jail without incident.							
1/2/2021	7728H	JOHNSON, MATTHEW WADE		31	W	M	31	6078 - BUFKIN, BRYCE
	EVADING ARREST DETENTION W/VEHICLE		O					20210001
	Charge Note: Subject was arrested on sight for evading arrest/detention and transported to Stephens County Jail without incident.							
1/3/2021	5297I	RILEY, MICHAEL SHANE		42	W	M	30	1008 - BOGGS, DREW
	WARRANT (LOCAL)		T					20200460
	Charge Note: Subject was arrest for warrant 36424 Terroristic Threat cause fear of imminent SBI Case#20200460 without incident.							
1/5/2021	5604A	GILL, ERIC SHANE		39	W	M	28	0143 - BERKLEY, BRANDON
	WARRANT (OTHER AGENCY)		T					
	Charge Note: Subject was arrested on Young County Warrant on the original charge of UNL Carrying weapon and transported to Stephens County Jail without incident.							
1/5/2021	5604B	GILL, ERIC SHANE		39	W	M	28	0143 - BERKLEY, BRANDON
	POSSESS CONTROLLED SUBSTANCE PG 1 >=4G <200G		O					20210005
	Charge Note: Subject was arrested for Possesion of a controlled substance and transported to Stephens County Jail without incident.							
1/5/2021	5604C	GILL, ERIC SHANE		39	W	M	28	0143 - BERKLEY, BRANDON
	VIOLATION OF BOND/PROTECTIVE ORDER		O					20210006
	Charge Note: Subject was arrested on the charge of Violation of a Protective order #CV32740. Subject was observed by Officer less than 500 yards from the protected location at 1022 West Walker Street Breckenridge Texas, and transported to Stephens County Jail without incident.							

## BRECKENRIDGE POLICE DEPARTMENT

Item 3.

Date	Number	Name	DOB	Age	Race	Sex	#Days	Arresting Officer	Offense	Arrest Type	Disposition	Incident#
1/7/2021	113V	TAYLOR, RICKY LYNNE		64	W	M	26	1624 - RAMIREZ, CHEYENNE				
									POSSESS CONTROLLED SUBSTANCE PG 1 <1G	O		20210010
									Charge Note: Arrested on site for Possession of Controlled Substance PG1 <1G			
1/7/2021	113W	TAYLOR, RICKY LYNNE		64	W	M	26	1624 - RAMIREZ, CHEYENNE				
									POSSESSION OF DRUG PARAPHERNALIA	O		20210011
									Charge Note: Arrested on site for Possession of Drug Paraphernalia (methamphetamines smokikng pipe)			
1/10/2021	7888	THRIFT, JACQUELINE LEIGHANN		27	W	F	23	6078 - BUFKIN, BRYCE				
									DROVE WITHOUT LIGHTS-WHEN REQUIRED	O		20210013
									Charge Note: subject was arrested for driving without lights when required.			
1/11/2021	6161S	VILLA, ABBY KAY		30	W	F	22	1624 - RAMIREZ, CHEYENNE				
									CRIMINAL MISCHIEF < \$100	O		20210015
									Charge Note: Abby Villa was arrested at 609 N Oakwood on the charge of Criminal Mischief and transported to Stephens County Jail without incident.			
1/12/2021	7879A	MAYO, EASTON TANNER		26	W	M	21	1624 - RAMIREZ, CHEYENNE				
									WARRANT (OTHER AGENCY)	O		
									Charge Note: Easton Mayo was arrested at 2444 West Elliot on Warrant #2025 out of Taylor County on a Larceny charge. Mayo was transported to the Stephens County Jail without incident			
1/15/2021	7565C	RODGERS, WILLIAM MICHAEL		45	W	M	18	1624 - RAMIREZ, CHEYENNE				
									WARRANT (LOCAL)	T		20200550
									Charge Note: William Michael Rodgers was arrested at 1031 S Smith on an outstanding warrant, Warrant# F9691. Transported to the Stephens County Jail without incident.			
1/17/2021	7879B	MAYO, EASTON TANNER		26	W	M	16	1624 - RAMIREZ, CHEYENNE				
									WARRANT (LOCAL)	T		20200574
									Charge Note: Easton Tanner Mayo turned himself in for Warrant F9696, Debit Credit Card Abuse. Walked back to the Stepehens County Jail without incident.			
1/17/2021	6208AS	HIGHT, PATRICK SHERMAN		35	W	M	16	6078 - BUFKIN, BRYCE				
									WARRANT (LOCAL)	T		20200432
									Charge Note: PATRICK HIGHTS WAS ARRESTED ON 500 N LIVEOAK FOR A WARRANT FOR THEFT OUT OF STEPHENS COUNTY			
1/17/2021	6208AT	HIGHT, PATRICK SHERMAN		35	W	M	16	6078 - BUFKIN, BRYCE				
									POSSESSION OF DRUG PARAPHERNALIA	O		20210017
									Charge Note:			

BRECKENRIDGE POLICE DEPARTMENT

Item 3.

Date	Number	Name	DOB	Age	Race	Sex	#Days	Arresting Officer	Incident#
	Offense		Arrest Type	Disposition					
1/17/2021	6208AU	HIGHT, PATRICK SHERMAN		35	W	M	16	4689 - SHOCKLEY, JUSTIN	
	POSSESSION OF MARIHUANA <=2 OZ DRUG FREE ZONE		O						20210018
	Charge Note: Subject was arrested for possession of Marijuana under 2oz in a drug free zone.								
1/18/2021	7440K	NEELY, MACKENZIE		23	W	M	15	1008 - BOGGS, DREW	
	WARRANT (OTHER AGENCY)		T						
	Charge Note: Subject turned himself in on Erath county warrant# 48611R Revocation of probation-Theft of prop O/\$100 u/\$750.								
1/19/2021	5245AL	FOSTER, LARRY WAYNE JR		40	W	M	14	4541 - GRAY, NOAH	
	CRIMINAL MISCHIEF >=\$100 <\$750		O						20210022
	Charge Note:								
1/21/2021	7890	WHEELER, ELIZABETH		22	W	F	12	1624 - RAMIREZ, CHEYENNE	
	CREDIT CARD OR DEBIT CARD ABUSE AGAINST ELDERLY		T						20210007
	Charge Note: Subject came to the Stephens County LEC and turned herself in reference Stephens County Warrant #F9701 without incident.								
1/22/2021	7080R	HOBBS, KODY ALAN		23	W	M	11	0147 - MCBRIDE, BRIAN	
	WARRANT (LOCAL)		T						
	Charge Note: Subject was arrested on Stephens County warrant #36443, Assault Causing Bodily Injury, Class A Misd with bond to be set. Subject was transported to the Stephens County jail for booking without incident.								
1/24/2021	6329U	MARTIN, JODY KENT		33	W	M	9	1624 - RAMIREZ, CHEYENNE	
	VIOLATION OF BOND/PROTECTIVE ORDER WITH 2+ PREVIOUS CONVICTIONS		O						20210031
	Charge Note: Jody Kent Martin was arrested at walmart in violation of a protective order with Rosalia Acosta. Jody Martin was transported to the stephens county jail without incident.								
1/24/2021	6329V	MARTIN, JODY KENT		33	W	M	9	1624 - RAMIREZ, CHEYENNE	
	TERRORISTIC THREAT		O						20210030
	Charge Note: Jody Kent Martin was arrested at walmart in violation of a protective order with Rosalia Acosta. Jody Martin was transported to the stephens county jail without incident.								
	TERRORISTIC THREAT		O						20210030
	Charge Note:								
1/25/2021	7847B	BOYETT, SILAS WADE		46	W	M	8	4689 - SHOCKLEY, JUSTIN	
	WARRANT (OTHER AGENCY)		T						
	Charge Note: Officer Shockley arrested subject on warrant #36460 during a traffic stop.								

BRECKENRIDGE POLICE DEPARTMENT

Item 3.

Date	Number	Name	DOB	Age	Race	Sex	#Days	Arresting Officer	Incident#
	Offense		Arrest Type	Disposition					
1/25/2021	7256B	DYE, STEVEN GARRETT		41	W	M	8	1008 - BOGGS, DREW	
	WARRANT (LOCAL)		T						
	Charge Note: Subject was arrested on Stephens county Warrant# F35607 MTA and transported to the Stephens county Jail without incident.								
1/26/2021	6873F	TINKLE, NATHAN MARTIN		34	W	M	7	1008 - BOGGS, DREW	
	WARRANT (LOCAL)		T						
	Charge Note: Subject was arrest at the LEC on local Warrant f-9684 IBO, and taken to the jail without incident.								
1/28/2021	5791A	GONZALES, JAVIER CAMPOS		45	W	M	5	4541 - GRAY, NOAH	
	WARRANT (LOCAL)		T						20210004
	Charge Note: Above subject was arrested on Stephens County Warrant warrant number 36437								
1/28/2021	5791B	GONZALES, JAVIER CAMPOS		45	W	M	5	4541 - GRAY, NOAH	
	WARRANT (LOCAL)		T						20200549
	Charge Note: Above subject was arrested on Stephens County Warrant number 36438								
1/31/2021	106V	WILLIAMS, DAVID FARRELL		64	W	M	2	0147 - MCBRIDE, BRIAN	
	WARRANT (LOCAL)		T						20200432
	Charge Note: Subject was contacted and found to have an active Stephens County warrant (#36433) for Theft of Property over \$100 but under \$750, a Class B Misd. Subject was taken to the Stephens County jail for booking. Mr. Williams was on a bicycle. That bicycle was taken to the Breckenridge Police Station and help for safe keeping until he could come get it.								

Male Inmates:	26
Female Inmates:	3
Other:	0
<b>Total Arrests Printed:</b>	<b>29</b>



## Property List Report

Report Date from 01/01/2021 to 01/31/2021

### BRECKENRIDGE POLICE DEPARTMENT

Incident#	Property#	Report Date	Loss Type	Property Type					
Vin/Serial#			Tag/Impound#	Stored		Value			
Lic#	Lic State	Lic Year	Year	Color	Brand		Model		
20210003	20210003		6		DRUG/NARCOTIC EQUIPMENT				
					EVIDENCE ROOM	\$0.00			
					EVIDENCE				
20210003	20210003		6		DRUG/NARCOTIC EQUIPMENT				
						\$0.00			
20210002	20210002		6		DRUG/NARCOTIC EQUIPMENT				
					EVIDENCE ROOM	\$0.00			
					EVIDENCE N2				
20210005	20210005		6		DRUGS/NARCOTICS				
					LAB SHELF	\$0.00			
20210007	20210007		7		NEGOTIABLE INSTRUMENTS				
						\$0.00			
20210010	20210010		6		DRUGS/NARCOTICS				
					LAB SHELF	\$0.00			
					METHAMPHETAMINE		RED STRAW AND METH		
20210011	20210011		6		DRUG/NARCOTIC EQUIPMENT				
					EVIDENCE ROOM	\$0.00			
					EVIDENCE				
					CLEAR BAG METH PIPE				
					TORCH				
20210009	20210009		7		OTHER				
						\$0.00			
					HOUSE KEYS				
20210009	20210009		E		OTHER				
						\$500.00			
					1ZVBP8AN7A5106427				
					CWJ2256				
					TX				
					2020				
					2010				
					BLU				
					FORD				
									300



## BRECKENRIDGE POLICE DEPARTMENT

Incident#	Property#	Report Date	Loss Type	Property Type		
Vin/Serial#		Tag/Impound#	Stored		Value	
Lic#	Lic State	Lic Year	Year	Color	Brand	Model
20210009	20210009		7		PORTABLE ELECTRONIC COMMUNICAT	
P2032EAL						\$100.00
					LENOVO300E	
20210015	20210015		1		HOUSEHOLD GOODS	\$0.00
					HEATER	TEST
20210014	20210014		6		DRUG/NARCOTIC EQUIPMENT	
					EVIDENCE ROOM EVIDENCE	\$0.00
	202100356		1		FIREARMS	
XD182632					EVIDENCE ROOM LOCKER 026	\$0.00
					SPRINGFIELD	SA-XD
20210018	20210018		6		DRUGS/NARCOTICS	
					EVIDENCE ROOM EVIDENCE N2	\$0.00
20210018	20210018		6		DRUG/NARCOTIC EQUIPMENT	
					EVIDENCE ROOM EVIDENCE N2	\$0.00
20210018	20210018		E		CREDIT/DEBIT CARDS	
					EVIDENCE ROOM EVIDENCE N2	\$0.00
20210018	20210018		6		DRUG/NARCOTIC EQUIPMENT	
					EVIDENCE ROOM EVIDENCE N2	\$0.00
					GRN	
20210017	20210017		6		DRUG/NARCOTIC EQUIPMENT	
					EVIDENCE ROOM EVIDENCE	\$0.00
20210021	20210021		7		HOUSEHOLD GOODS	\$10.98
					SECRET SE OOH LA	

## BRECKENRIDGE POLICE DEPARTMENT

Incident#	Property#	Report Date	Loss Type	Property Type		
Vin/Serial#		Tag/Impound#	Stored		Value	
Lic#	Lic State	Lic Year	Year	Color	Brand	Model
20210021	20210021		7		HOUSEHOLD GOODS	
					\$10.99	
					PHONE CHARGER	
20210019	20210019		E		FIREARMS	
363249					EVIDENCE ROOM	\$0.00
					EVIDENCE PISTOL	
					RACK	
				SIL	JENNINGS FIREARMS	JENNINGS J-22
20210020	20210020		6		DRUG/NARCOTIC EQUIPMENT	
					EVIDENCE ROOM	\$0.00
					EVIDENCE	
20210022	20210022		4		HOUSEHOLD GOODS	
					\$150.00	
20210022	20210022		4		HOUSEHOLD GOODS	
					\$75.00	
20210022	20210022		4		HOUSEHOLD GOODS	
					\$300.00	
20210025	20210025		1		HOUSEHOLD GOODS	
					\$0.00	
					ENTERTAINMENT	
					CENTER	
20210026	20210026		7		MONEY	
					\$200.00	
					US CURRENCY	
20210026	20210026		7		COMPUTER HARDWARE/SOFTWARE	
					\$200.00	
				APPLE		AIRPODS
20210026	20210026		7		COMPUTER HARDWARE/SOFTWARE	
					\$29.00	
					APPLE WATCH	
					CHARGER	

## BRECKENRIDGE POLICE DEPARTMENT

Incident#	Property#	Report Date	Loss Type	Property Type	Value	
Vin/Serial#	Tag/Impound#	Stored				
Lic#	Lic State	Lic Year	Year	Color	Brand	Model
20210032	20210032		7		HOUSEHOLD GOODS	
						\$95.00
20210030	20210030		E		WEAPONS - OTHER	
						\$10.00
				BLK	BENCHMADE SPRING ASSIST	DOUBLE EDGE BLADE
20210033	20210033		7		MONEY	
						\$28.75
					FNB A/B	
20210034	20210034		7		BICYCLES	
						\$190.00
20210036	20210036		6		DRUGS/NARCOTICS	
					EVIDENCE ROOM LOCKER 020	\$0.00
20210037	20210037		4		STRUCTURES-OTHER COMMERCIAL/BU	
						\$1,500.00
					DOUBLE PANED WINDOWS	
	202100739		E		STRUCTURES-PUBLIC/COMMUNITY	
						\$0.00
20210041	20210041		6		DRUGS/NARCOTICS	
						\$0.00
<b>Total: \$3,399.72</b>						



# Citation by Violation

01/01/2021 - 01/31/2021

## BRECKENRIDGE POLICE DEPARTMENT

All Violations

Citation#	Date	Name	Location
<b>Violation: 3173 DEFECTIVE EQUIPMENT</b>			
W6253A	1/3/2021	RILEY, MICHAEL SHANE	3100 WALKER W
W6256	1/7/2021	GILL, JAMES FRANKLIN II	ELLIOTT ST
W6380	1/12/2021	HOBBS, DAKOTA OMA KEY LEE	100 WALKER ST W
W6048	1/17/2021	BLEVINS, JASON EDWARD	1300 JEANETTE ST W
W6222	1/23/2021	BOYER, AUBREE	200 DOUGLAS ST N
			<b>Total number of citations for this violation: 5</b>
<b>Violation: 3162 DEFECTIVE HEADLAMP/ MOTORCYCLE</b>			
W6510	1/28/2021	BARRETT, BRYSON	LIVEOAK ST
W6220	1/21/2021	BRUTON, JOEY DON	1800 WALKER ST W
W025853	1/16/2021	RUSSELL, PAYTON TRAIce	200 LINDSEY ST W
W6252	1/2/2021	STRALEY, JON M	WALKER
			<b>Total number of citations for this violation: 4</b>
<b>Violation: 3170 DEFECTIVE STOP LAMPS</b>			
W6509	1/20/2021	VALENZUELA, EDDIE ALEJANDRO	100 OLD CADDO RD
W6703A	1/27/2021	SCARBROUGH, JACOB ALLEN	1600 WALKER ST W
			<b>Total number of citations for this violation: 2</b>
<b>Violation: 3167 DEFECTIVE TAIL LAMPS</b>			
W25876A	1/8/2021	HARRIS, CHRISTOPHER LEE	600 PARKS N
W6605	1/17/2021	SMITH, ZEKE LLOYD	100 PARKS ST N
			<b>Total number of citations for this violation: 2</b>
<b>Violation: 3658 DISPLAY UNCLEAN LICENSE PLATES</b>			
W6267	1/26/2021	ABLES, FRANK ELDEAN	900 WALKER ST W
			<b>Total number of citations for this violation: 1</b>
<b>Violation: 545.060(B) DRIVE IN CENTER LANE</b>			
W6610	1/26/2021	DURAN, MARIAELENA R	900 WALKER ST W
W5096	1/6/2021	CARNLEY, RANDY JOHN	600 WALKER ST W
			<b>Total number of citations for this violation: 2</b>
<b>Violation: 3939 DRIVING WHILE LICENSE INVALID</b>			
025911	1/29/2021	PEREZ, JORGE EDUARDO RAMIREZ JR	3800 WALKER ST W
			<b>Total number of citations for this violation: 1</b>
<b>Violation: 3910 DRIVING WITHOUT LICENSE DRIVER</b>			
025853	1/16/2021	RUSSELL, PAYTON TRAIce	200 LINDSEY ST W

## BRECKENRIDGE POLICE DEPARTMENT

## All Violations

Citation#	Date	Name	Location
			<b>Total number of citations for this violation: 1</b>
<b>Violation: 3198</b>	<b>DROVE W/O LIGHTS WHEN REQUIRED</b>		
W6701	1/25/2021	CROCKETT, JUDY WIMBERLEY	1200 WALKER ST W
W6618	1/30/2021	HINSON, JOHN WESLEY	100 WALKER ST W
W6504	1/16/2021	KINYON, CRYSTAL LYNN	LINDSEY ST E
			<b>Total number of citations for this violation: 3</b>
<b>Violation: 3259</b>	<b>EXPIRED OPERATOR LICENSE</b>		
025549A	1/11/2021	DUPUY, FREEDOM MICHELLE	2000 WALKER ST W
025546A	1/2/2021	THRIFT, JACQUELINE LEIGHANN	900 WALKER ST E
			<b>Total number of citations for this violation: 2</b>
<b>Violation: 3155</b>	<b>FAIL DIM HEADLIGHTS-MEETING</b>		
W6225	1/30/2021	PENDLETON, RANDALL CORY	200 MERRILL ST N
W6050	1/22/2021	THRIFT, JACQUELINE LEIGHANN	1000 WALKER ST W
			<b>Total number of citations for this violation: 2</b>
<b>Violation: 3263</b>	<b>FAIL DISPLAY DL</b>		
025912A	1/30/2021	PEREZ, ROBERT ARMANDO	1500 WALKER ST W
W6256A	1/7/2021	GILL, JAMES FRANKLIN II	ELLIOTT ST
			<b>Total number of citations for this violation: 2</b>
<b>Violation: 3070</b>	<b>FAIL DRIVE IN SINGLE LANE</b>		
W5799	1/9/2021	STATLER, TIVIS	2500 WALKER ST W
			<b>Total number of citations for this violation: 1</b>
<b>Violation: 3025</b>	<b>FAIL MAINT FINANCIAL RESPONSIBILTY</b>		
025876	1/8/2021	HARRIS, CHRISTOPHER LEE	600 PARKS N
025549	1/11/2021	DUPUY, FREEDOM MICHELLE	2000 WALKER ST W
025878A	1/13/2021	TREVINO, MANUEL RODRIQUEZ	1100 PARKS AVE N
W6253	1/3/2021	RILEY, MICHAEL SHANE	3100 WALKER ST W
025548A	1/9/2021	CROWSON, ROBYN	1200 WALKER ST W
025546B	1/2/2021	THRIFT, JACQUELINE LEIGHANN	900 WALKER ST E
025841A	1/4/2021	CRUZ, RAMIRO JR	700 WALKER ST W
025911A	1/29/2021	PEREZ, JORGE EDUARDO RAMIREZ JR	3800 WALKER ST W
W025855	1/21/2021	NEELY, BLAYTON PHILLIP	300 WALKER ST W
W6608A	1/25/2021	ALEXANDER, RHEAGAN MARIE	1400 ELLIOTT ST W
			<b>Total number of citations for this violation: 10</b>
<b>Violation: 3096</b>	<b>FAIL SIGNAL WITH TURN SIGNAL</b>		
W6254	1/5/2021	THORNHILL, DAWN NICOLE	INDUSTRIAL LP
025547A	1/3/2021	ABBOTT, CASEY DALE	100 ELLIOTT ST W
W5795	1/4/2021	TREVATHAN, LARRY GLENN	300 WALKER ST W

## BRECKENRIDGE POLICE DEPARTMENT

All Violations

Citation#	Date	Name	Location	
W6047	1/15/2021	HOPE, JAYME LYNN	700 WALKER ST W	
			<b>Total number of citations for this violation:</b>	<b>4</b>
<b>Violation: 3060</b>	<b>FAIL STOP-AT STOP SIGN</b>			
W6605A	1/17/2021	SMITH, ZEKE LLOYD	100 PARKS ST N	
			<b>Total number of citations for this violation:</b>	<b>1</b>
<b>Violation: 3005</b>	<b>FAIL YIELD RIGHT OF WAY</b>			
W5798	1/6/2021	CURTIS, KORRISSA HOPE	509 THIRD ST W	
W6508	1/19/2021	BILLS, SHADEN P	100 ROSE ST S	
W6219	1/20/2021	REYES, JOSE LUIS	1000 WALKER ST W	
			<b>Total number of citations for this violation:</b>	<b>3</b>
<b>Violation: 545.104</b>	<b>FAILED TO SIGNAL REQUIRED DISTANCE BEFORE TUR</b>			
W6265	1/25/2021	SMITH, BRADLEY NEAL	400 HARVEY ST N	
W6702	1/25/2021	BOYETT, SILAS WADE	WALKER ST W	
			<b>Total number of citations for this violation:</b>	<b>2</b>
<b>Violation: 544.010</b>	<b>FAILED TO STOP AT DESIGNATED POINT (STOP SIGN</b>			
W6608	1/25/2021	ALEXANDER, RHEAGAN MARIE	1400 ELLIOTT ST W	
			<b>Total number of citations for this violation:</b>	<b>1</b>
<b>Violation: 36050001</b>	<b>INDECENT EXPOSURE</b>			
W025661	1/11/2021	LOPEZ, AARON CLAY	1000 ELLIOTT ST W	
			<b>Total number of citations for this violation:</b>	<b>1</b>
<b>Violation: 3227</b>	<b>MUFFLER VIOLATION</b>			
W6263	1/19/2021	NELSON, RICKY WAYNE	100 BRECKENRIDGE AVE N	
			<b>Total number of citations for this violation:</b>	<b>1</b>
<b>Violation: 3103</b>	<b>NO DRIVER LICENSE</b>			
025662	1/19/2021	SNOWDEN, ZACKARY BRIAN	400 MCAMIS ST N	
W6265A	1/25/2021	SMITH, BRADLEY NEAL	400 HARVEY ST N	
025878	1/13/2021	TREVINO, MANUEL RODRIQUEZ	1100 PARKS AVE N	
W6503A	1/13/2021	BALADEZ, MARIAH GUADALUPE	1000 WALKER ST W	
W025877	1/9/2021	GARCIA, MIRIAM VANESSA	1100 WALKER ST W	
025801	1/8/2021	NAVARRO, TROY	1400 WALKER ST E	
025841	1/4/2021	CRUZ, RAMIRO JR	700 WALKER ST W	
025547	1/3/2021	ABBOTT, CASEY DALE	100 ELLIOTT ST W	
			<b>Total number of citations for this violation:</b>	<b>8</b>
<b>Violation: 3161</b>	<b>NO HEADLAMP ON MOTORCYCLE</b>			
W6503	1/13/2021	BALADEZ, MARIAH GUADALUPE	1000 WALKER ST W	
W5098	1/24/2021	ROBERTSON, HAILEY BREANN	700 WALKER ST W	

## BRECKENRIDGE POLICE DEPARTMENT

All Violations

Citation#	Date	Name	Location
			<b>Total number of citations for this violation: 2</b>
<b>Violation: 3166</b>	<b>NO TAIL LAMP-NO EQUIPPED</b>		
W025662	1/19/2021	SNOWDEN, ZACKARY BRIAN	400 MCAMIS ST N
			<b>Total number of citations for this violation: 1</b>
<b>Violation: 3026</b>	<b>PARKING ON ROADWAY</b>		
W6217	1/15/2021	HOPE, LYNETTE MARIE	1300 ELLIOTT ST W
W6218	1/15/2021	POHORENEC, MICHAEL JOSEPH	1300 ELLIOTT ST W
			<b>Total number of citations for this violation: 2</b>
<b>Violation: 3909</b>	<b>POSS DRUG PARAPHENILA</b>		
025661	1/11/2021	LOPEZ, AARON CLAY	1000 ELLIOTT ST W
025851	1/2/2021	JOHNSON, MATTHEW WADE	100 BUTTE ST N
025662A	1/19/2021	SNOWDEN, ZACKARY BRIAN	400 MCAMIS ST N
			<b>Total number of citations for this violation: 3</b>
<b>Violation: 3006</b>	<b>RAN STOP SIGN</b>		
W6221	1/23/2021	ENSEY, JANELL RENEE	3700 WALKER ST W
W6613	1/28/2021	BRANNAN, JANET LANDRETH	200 ROSE ST S
WV6653	1/8/2021	KIM, BONG HO	3800 WALKER ST W
			<b>Total number of citations for this violation: 3</b>
<b>Violation: 3001</b>	<b>SPEEDING</b>		
W5097	1/6/2021	OVERMAN, RILEY WAYNE	1100 WALKER ST E
WV6258	1/8/2021	MADISON, AMY MARIE	900 WALKER ST E
W6261	1/9/2021	MONTOYA, ANGHELO	500 WALKER ST E
W6260	1/9/2021	CLAY, HAROLD DENNIS	500 WALKER ST E
025877	1/9/2021	GARCIA, MIRIAM VANESSA	1100 WALKER ST W
W6502	1/2/2021	WORTHY, WALTON JAMES	900 BRECKENRIDGE AVE N
W6501	1/2/2021	BARRETT, THOMAS ALAN	500 WALKER ST E
025546	1/2/2021	THRIFT, JACQUELINE LEIGHANN	900 WALKER ST E
025903	1/6/2021	MARTINEZ, MARIA ISABEL	900 WALKER ST W
025902	1/6/2021	RAMOS, MOISES	1300 WALKER ST E
025901	1/6/2021	SPARTI, COLTON BANKS	900 WALKER ST W
W6601	1/6/2021	OWEN, ASHLEY NICOLE	900 WALKER ST W
W6602	1/6/2021	TRIMBLE, ANTHONY WILLIAM	1000 WALKER ST E
W5797	1/6/2021	SHEPHERD, DEVAN	1000 WALKER ST E
W025549	1/11/2021	DUPUY, FREEDOM MICHELLE	2000 WALKER ST W
025548	1/9/2021	CROWSON, ROBYN	1200 WALKER ST W
W6046	1/14/2021	WALLACE, DEBRA KAY	500 WALKER ST E
W6262	1/14/2021	MADRID, PHILLIP	500 WALKER ST W

## BRECKENRIDGE POLICE DEPARTMENT

## All Violations

Citation#	Date	Name	Location
W5800	1/12/2021	NEELY, BLAYTON PHILLIP	800 WALKER ST W
W6603	1/12/2021	ARRIOLA, ANDREA FERNANDEZ	900 WALKER ST W
W6216	1/15/2021	SHIPES, BRANDON ROSS	1100 WALKER ST E
025904	1/15/2021	MANUEL, MACKENZIE RACHEL	1000 WALKER ST W
025905	1/16/2021	SOTO, ROBERT JR	2500 WALKER ST W
W6049	1/17/2021	DIAZ, ADELFA	300 ELLIOTT ST E
W6604	1/17/2021	KILBURN, BRANDY SHAYLEA	100 BAYLOR ST S
025906	1/17/2021	MOONEY, GRANT CASPER	800 INDUSTRIAL BLVD
W66505	1/17/2021	REID, ZENOBIA KEMPER	3800 WALKER ST W
W6507	1/17/2021	FLORES, ALEXANDER	100 WALKER ST E
W6506	1/17/2021	THORNHILL, BRITTONI CYMONE	700 GRAHAM ST N
025909	1/28/2021	PARK, SEOL KI	500 WALKER ST E
025856	1/28/2021	HOKE, BLAKE AUSTIN	1200 WLAKER ST E
025880	1/29/2021	MCGRADY, ZACHARY ANDREW	700 GRAHAM ST N
025926	1/29/2021	HILTON, ZACHERY RYAN	1000 WALKER TS W
W5099	1/27/2021	MORGAN, CARL WAYNE	3000 WALKER
W6703	1/27/2021	SCARBROUGH, JACOB ALLEN	1600 WALKER ST W
W6511	1/24/2021	FLATT, CHERYL LYNN	3700 WALKER ST W
025663	1/26/2021	NEELY, BLAYTON PHILLIP	600 IND LOOP
W6264	1/22/2021	FLORES, ALEXIS REYES	3200 WALKER ST W
WV6381	1/23/2021	MCNABB, MICHELLE WALKER	3200 WALKER ST W
W6150	1/23/2021	PRATT, MERILU ANN	1400 WALKER ST E
W6611	1/21/2021	FLOURNOY, ETHAN TAYLOR	1300 WALKER ST W
W6607	1/21/2021	SARGENT, TUCKER BRANNDON	900 WALKER ST W
W6606	1/21/2021	DAWKINS, DEMARIO CORTEZ	1300 WALKER ST E
025907	1/21/2021	SALAS, ISAIAH NICHOLAS	900 WALKER ST W
025855	1/21/2021	NEELY, BLAYTON PHILLIP	300 WALKER ST W
W6616	1/29/2021	MEJIAS, STEPHANIE	700 WALKER ST
W6614	1/29/2021	BROOKS, GLENN DELL JR	400 WALKER ST W
W6619	1/30/2021	FRAZEE, HOPE ANNEMARIE	3000 WALKER ST W
W6620	1/30/2021	NGUYEN, UYEN	800 WALKER ST W
W6615	1/30/2021	JAMISON, AMANDA ELLEN	700 INDUSTRIAL LOOP
W6617	1/30/2021	BROOKS, DEBORAH KAY	2100 WALKER ST W
W6224	1/30/2021	SPECK, MATTHEW AARON	3800 WALKER ST W
W6223	1/30/2021	GARCIA, NOE	1800 WALKER ST W
W6654	1/31/2021	BAILEY, KYRAH JESSE	1800 WALKER ST W
W6622	1/31/2021	GUTIERREZ, CARLOS PEREZ	700 INDUSTRIAL LOOP
W6621	1/31/2021	MYERS, KENNETH BRIAN	900 WALKER ST W



Item 3.

BRECKENRIDGE POLICE DEPARTMENT

All Violations

Citation#	Date	Name	Location
025912	1/30/2021	PEREZ, ROBERT ARMANDO	1500 WALKER ST W
			Total number of citations for this violation: 57
			Total number of matching citations: 127

02/01/2021 07:35

210 EAST DYER BRECKENRIDGE, TX 76424

Page 6 of

25

# Fire Department Summary Report

## JANUARY 2021

	This Month	YTD
<b>1. NUMBER of ALARMS ANSWERED:</b>		
Inside City	22	22
Outside City	22	22
<b>2. CALLS:</b>		
Smoke Scares	4	4
Gas Leaks/Hazardous Responses	9	9
Structures	1	1
Trash	0	0
Vehicles or Equipment	0	0
Grass	6	6
Service Calls	4	4
Departmental Assistance	2	2
False Alarms/Good intent calls	7	7
Emergency or Rescue	1	1
Other	3	3
<b>3. NUMBER OF ACRES BURNED:</b>	36	36
<b>4. MUTUAL AID GIVEN (STRUCTURE):</b>	0	0
<b>5. MUTUAL AID RECEIVED (STRUCTURE):</b>	1	1
<b>6. VEHICLE ACCIDENTS (WITH OR WITHOUT EXTRICATION):</b>	7	7
<b>7. FIREFIGHTER INJURIES OR DEATHS:</b>	0	0
<b>8. CIVILIAN INJURIES OR DEATHS:</b>	0	0
<b>9. EXTINGUISHING AGENT OR CONTROL:</b>		
Out Before Arrival	1	1
Hose	15	15
<b>10. WATER USAGE:</b>	14,060	14,060
<b>11. MILES TRAVELED</b>		
Inside City	48	48
Outside City	280	280
Combined	328	328

## Daily Inspections JANUARY 2021

Type	Date	Owner & Address	Contractor	A	DA
Electric	1/4/21	King Donut/201 E. Walker	J&J Electric	X	
Shower pan	1/4/21	Caddo Creek Investments/ 1305 W. Lindsey	Stowe Independent Services	X	
Plumbing final	1/4/21	EZ Stop/800 W. Walker	Fernandez Plumbing	X	
Temp pole	1/6/21	Donnie Sechrest/1608 W. Walker	Keen Electric	X	
Electric	1/15/21	Refugio Gallegos/1208 E. Walker	Keen Electric	X	
Plumbing rough in	1/25/21	Breckenridge Smile Center/ 1905 W. Walker	West Texas Plumbing Solutions	X	
Water line	1/18/21	Jay Moreno/1010 W. Wall	Rickey Chaney Plumbing	X	
Partial frame	1/18/21	Donnie Schrest/1608 W. Walker	Sechrest Construction	X	
Plumbing rough in	1/21/21	Caddo Creek Investments/ 316 E. Dyer	Stowe Independent Services	X	
Meter loop	1/27/21	Caddo Creek Investments/ 313 W. 4 <sup>th</sup>	Stowe Independent Services	X	
Shower pan	1/25/21	Gary Trammel/703 W. Hullum	Shower pan	X	
Electric	1/28/21	Larry Robertson/1502 E. Elliott	Eller Electric	X	
Plumbing rough in	1/29/21	Angela Jennings/709 E. Wheeler	Stowe Independent Services	X	
Water line	1/29/21	Angela Jennings/709 E. Wheeler	Stowe Independent Services	X	

### JANUARY 2021 Code Violation Report

Complaint Date	Violation	Case Number	Address	Inspection Date	Disposition
12/6/16	Dangerous building	16-309	218 E. Walker		Pending
12/6/16	Dangerous building	16-310	216 E. Walker		Pending
11/4/19	Rubbish, junk vehicles	19-507	704 S. Roberts		Pending
3/2/20	Rubbish	20-59	2217 Sha Lane	3/30/20	Progress being monitored
4/21/20	Expired building permit	20-119	213 Pembroke	11/30/20	Construction is progressing
5/4/20	Rubbish	20-153	302 N. Parks		Slowly making progress
8/28/20	Alley encroachment	20-255	1107 E. Elm		Pending
9/24/20	Garage debris	20-266	708 W. 3 <sup>rd</sup>		Pending
12/1/20	Rubbish	20-288	504 S. Miller	12/15/20	Agreement made with City to pay for clean up
12/15/20	Minimum standards violation	20-293	305 S. Miller		Pending
12/15/20	No construction permit	20-295	222 Ridge Rd.		Pending
1/5/21	Minimum standards violation	21-01	209 S. Jackson	2/1/21	House boarded up
1/11/21	Rubbish	21-02	1102 W. Elliott	1/25/21	Cleaned up
1/26/21	Mobile home needs underpinned	21-03	1302 W. 1 <sup>st</sup>		Due for inspection 2/6/21
1/26/21	Rubbish	21-04	911 W. Lindsey		Due for inspection 2/6/21
1/26/21	Rubbish	21-05	1005 W. Lindsey		Due for inspection 2/6/21
1/21/21	No water utility	21-06	109 W. Hullum		Due for inspection 2/1/21

City manager

OFFICE OF COURT ADMINISTRATION  
TEXAS JUDICIAL COUNCIL

Official Municipal Court Monthly Report

Month January Year 2021

Municipal Court for the City of BRECKENRIDGE

Presiding Judge KIM BAGGETT

If new, date assumed office \_\_\_\_\_

Court Mailing Address 120 W ELM

City BRECKENRIDGE, TX Zip 76424

Phone Number 254-559-2160

Fax Number 254-559-7375

Court's Public Email kbaggett@breckenridgetx.gov

Court's Website http://

THE ATTACHED IS A TRUE AND ACCURATE REFLECTION OF THE RECORDS OF THIS COURT.

Prepared by \_\_\_\_\_

Date \_\_\_\_\_ Phone: (254) 559-2160

PLEASE RETURN THIS FORM NO LATER THAN 20 DAYS FOLLOWING THE END OF THE MONTH REPORTED TO:

OFFICE OF COURT ADMINISTRATION  
P.O. BOX 12066  
AUSTIN, TX  
78711-2066

PHONE: (512) 463-1625  
Fax: (512) 936-2423

2/09/2021 10:51 AM

OFFICIAL MUNICIPAL COURT MONTHLY REPORT

CRIMINAL SECTION

COURT CITY OF BRECKENRIDGE MONTH January YEAR 2021	NON-PARKING	TRAFFIC PARKING	CITY ORD	PENAL CODE	NON-TRAFFIC STATE LAW
1. Total Cases Pending First of Month:	2,109	3	0	119	225
a. Active Cases	1,823	3	0	97	204
b. Inactive Cases	286	0	0	22	21
2. New Cases Filed	27	1	0	1	7
3. Cases Reactivated	0	0	0	0	1
4. All Other Cases Added	0	0	0	0	0
5. Total Cases on Docket	1,850	4	0	98	212
6. Dispositions Prior to Court Appearance or Trial:	XXXXXXXXXX	XXXXXXXXXX	XXXXXXXXXX	XXXXXXXXXX	XXXXXXXXXX
a. Uncontested Dispositions	12	0	0	1	3
b. Dismissed by Prosecution	0	0	0	0	1
7. Dispositions at Trial:	XXXXXXXXXX	XXXXXXXXXX	XXXXXXXXXX	XXXXXXXXXX	XXXXXXXXXX
a. Convictions:	XXXXXXXXXX	XXXXXXXXXX	XXXXXXXXXX	XXXXXXXXXX	XXXXXXXXXX
1) Guilty Plea or Nolo Contendere	0	0	0	1	0
2) By the Court	0	0	0	0	0
3) By the Jury	0	0	0	0	0
b. Acquittals:	XXXXXXXXXX	XXXXXXXXXX	XXXXXXXXXX	XXXXXXXXXX	XXXXXXXXXX
1) By the Court	0	0	0	0	0
2) By the Jury	0	0	0	0	0
c. Dismissed by Prosecution	0	0	0	0	0

2/09/2021 10:51 AM

OFFICIAL MUNICIPAL COURT MONTHLY REPORT

CRIMINAL SECTION

COURT CITY OF BRECKENRIDGE	NON-PARKING	TRAFFIC PARKING	CITY ORD	PENAL CODE	NON-TRAFFIC STATE LAW
MONTH January YEAR 2021					
8. Compliance Dismissals:	XXXXXXXXXX	XXXXXXXXXX	XXXXXXXXXX	XXXXXXXXXX	XXXXXXXXXX X
a. After Driver Safety Course	0	XXXXXXXXXX	XXXXXXXXXX	XXXXXXXXXX	XXXXXXXXXX X
b. After Deferred Disposition	0	0	0	0	0
c. After Teen Court	0	0	0	0	0
d. After Tobacco Awareness Course	XXXXXXXXXX	XXXXXXXXXX	XXXXXXXXXX	XXXXXXXXXX	0 X
e. After Treatment for Chemical Dependency	XXXXXXXXXX	XXXXXXXXXX	XXXXXXXXXX	0	0 X
f. After Proof of Financial Responsibility	0	XXXXXXXXXX	XXXXXXXXXX	XXXXXXXXXX	XXXXXXXXXX X
g. All Other Transportation Code Dismissals	0	0	0	0	1
9. All Other Dispositions	0	0	0	0	0
10. Total Cases Disposed	12	0	0	2	5
11. Cases Placed on Inactive Status	0	0	0	0	0
12. Total Cases Pending End of Month:	2,124	4	0	118	227
a. Active Cases	1,838	4	0	96	207
b. Inactive Cases	286	0	0	22	20
13. Show Cause Hearings Held	0	0	0	0	0
14. Cases Appealed:	XXXXXXXXXX	XXXXXXXXXX	XXXXXXXXXX	XXXXXXXXXX	XXXXXXXXXX X
a. After Trial	0	0	0	0	0
b. Without Trial	0	0	0	0	0

2/09/2021 10:51 AM

OFFICIAL MUNICIPAL COURT MONTHLY REPORT

CIVIL SECTION

COURT CITY OF BRECKENRIDGE	TOTAL CASES
MONTH January YEAR 2021	
1. Total Cases Pending First of Month:	0
a. Active Cases	0
b. Inactive Cases	0
2. New Cases Filed	0
3. Cases Reactivated	0
4. All Other Cases Added	0
5. Total Cases on Docket	0
6. Uncontested Civil Fines or Penalties	0
7. Default Judgments	0
8. Agreed Judgments	0
9. Trial/Hearing by Judge/Hearing Officer	0
10. Trial by Jury	0
11. Dismissed for Want of Prosecution	0
12. All Other Dispositions	0
13. Total Cases Disposed	0
14. Cases Placed on Inactive Status	0
15. Total Cases Pending End of Month:	0
a. Active Cases	0
b. Inactive Cases	0
16. Cases Appealed:	XXXXXXXXXXXXXXXXXXXX
a. After Trial	0
b. Without Trial	0



2/09/2021 10:51 AM

OFFICIAL MUNICIPAL COURT MONTHLY REPORT

JUVENILE/MINOR ACTIVITY

COURT CITY OF BRECKENRIDGE MONTH January YEAR 2021	TOTAL
1. Transportation Code Cases Filed	2
2. Non-driving Alcoholic Beverage Code Cases Filed	0
3. Driving Under the Influence of Alcohol Cases Filed	0
4. Drug Paraphernalia Cases Filed	0
5. Tobacco Cases Filed	0
6. Truancy Cases Filed	0
7. Education Code (Except Failure to Attend) Cases Filed	0
8. Violation of Local Daytime Curfew Ordinance Cases Filed	0
9. All Other Non-traffic Fine-only Cases Filed	0
10. Transfer to Juvenile Court:	XXXXXXXXXXXXXXXXXX
a. Mandatory Transfer	0
b. Discretionary Transfer	0
11. Accused of Contempt and Referred to Juvenile Court (Delinquent Conduct)	0
12. Held in Contempt by Criminal Court (Fined and/or Denied Driving Privileges)	0
13. Juvenile Statement Magistrate Warning:	XXXXXXXXXXXXXXXXXX
a. Warnings Administered	0
b. Statements Certified	0
14. Detention Hearings Held	0
15. Orders for Non-secure Custody Issued	0
16. Parent Contributing to Nonattendance Cases Filed	0





2/09/2021 10:51 AM

OFFICIAL MUNICIPAL COURT MONTHLY REPORT

---

Run By: kim  
Report Type: Summary  
Date Range: 1/01/2021 - 1/31/2021  
Finalize Report: Yes  
Correction: No

\*\*\* END OF REPORT \*\*\*

City manager

2/09/2021 9:51 AM

Citation Date: 1/01/2021 - 1/31/2021

COFFRPT Page: 1  
Summary

-----

Beginning Citation Date.....: 01/01/2021  
 Ending Citation Date.....: 01/31/2021  
 Type of Citation.....: Regular  
 Type of Offense.....: Include: All  
 Agency.....: Include: All  
 Specific Offenses.....: Include: All  
 Entered By.....: Include: All  
 Summary or Detail.....: Summary  
 Sort By.....: Offense Code  
 Print Def. Name.....: Yes  
 Inc Park w/o Name.....: No  
 Total by Race/Sex.....: No

Checked for status and conviction date

2/09/2021 9:51 AM

Citation Date: 1/01/2021 - 1/31/2021

COFFRPT Page: 2  
Summary

1000 CRIMINAL MISCHIEF/CLASS C  
Statute: PENAL CODE 28.03(1)(A)

VILLA, ABBY KAY ✓ W/F 9/18/1990 TX 24474955

Totals for Offense

Number of Citations for Offense.....:	1
Number of Violations for Offense.....:	1
Amount of Fines/Fines Assessed.....:	\$384.00
Number of Citations to Juveniles.....:	0
Number of Citations to Minors.....:	0

2100 POSSESSION OF DRUG PARAPHERNALIA  
Statute: 481.125 H&S Code

LOPEZ, AARON CLAY ✓	W/M	2/15/1998	TX ID #38875781
SNOWDEN, ZACKARY BRIAN ✓	W/M	1/22/2002	TX NONE
JOHNSON, MATTHEW WADE ✓	W/M	6/21/1989	TX NONE
TAYLOR, RICKY LYNN ✓	W/M	4/04/1956	TX 11030721
HIGHT, PATRICK SHERMAN ✓	W/M	8/20/1985	TX 19649280

Totals for Offense

Number of Citations for Offense.....:	5
Number of Violations for Offense.....:	5
Amount of Fines/Fines Assessed.....:	\$2,920.00
Number of Citations to Juveniles.....:	0
Number of Citations to Minors.....:	1

3039 SPEEDING OVER 15MPH  
Statute: 522.003

THRIFT, JAQUELIN LEIGHANN ✓	W/F	12/01/1993	NC 000034576540
GARCIA, MIRIAM VANESSA ✓	W/F	3/14/1984	TX NONE
SOTO, ROBERT ✓	W/M	4/08/1980	TX 44194426
PEREZ, ROBERT ARMANDO ✓	W/M	7/10/1989	TX 22039610

Totals for Offense

Number of Citations for Offense.....:	4
Number of Violations for Offense.....:	4
Amount of Fines/Fines Assessed.....:	\$1,066.60
Number of Citations to Juveniles.....:	0
Number of Citations to Minors.....:	0

3049 FAIL TO MAINTAIN FINANCIAL RESPONSIBILITY  
Statute: 601.191

THRIFT, JAQUELIN LEIGHANN ✓	W/F	12/01/1993	NC 000034576540
CROWSON, ROBYN JOLYNN ✓	W/F	11/08/1999	TX 40872750
CRUZ, RAMIRO ✓	W/M	7/28/1955	TX 01385309

2/09/2021 9:51 AM

Citation Date: 1/01/2021 - 1/31/2021

COFFRPT Page: 3  
Summary

HARRIS, CHRISTOPHER LEE ✓	W/M	3/07/1977	TX 15943243
TREVINO, MANUEL RODRIGUEZ ✓	W/M	3/02/1973	TX 00042568
ELKINS, CLARENCE ZACHARY ✓	W/M	1/28/1982	TX 35106489
PEREZ, JORGE EDUARDO JR ✓	W/M	5/16/1997	TX NONE

Totals for Offense

Number of Citations for Offense.....	7
Number of Violations for Offense.....	7
Amount of Fines/Fines Assessed.....	\$2,325.00
Number of Citations to Juveniles.....	0

Number of Citations to Minors.....	0
------------------------------------	---

3096 FAILED TO SIGNAL TURN / LANE CHANGE  
Statute: 545.104

ABBOTT, CASEY DALE ✓	W/M	3/21/1991	TX 27392539
----------------------	-----	-----------	-------------

Totals for Offense

Number of Citations for Offense.....	1
Number of Violations for Offense.....	1
Amount of Fines/Fines Assessed.....	\$197.90
Number of Citations to Juveniles.....	0

Number of Citations to Minors.....	0
------------------------------------	---

3103 NO DRIVER'S LICENSE  
Statute: 521.021

ABBOTT, CASEY DALE ✓	W/M	3/21/1991	TX 27392539
SNOWDEN, ZACKARY BRIAN ✓	W/M	1/22/2002	TX NONE
NAVARO, TROY MATHANIEL ✓	H/M	4/18/1992	TX N/A
CRUZ, RAMIRO ✓	W/M	7/28/1955	TX 01385309
RUSSELL, PAYTON TRAICE ✓	W/M	2/03/2004	TX NONE
TREVINO, MANUEL RODRIGUEZ ✓	W/M	3/02/1973	TX 00042568
PEREZ, JORGE EDUARDO JR ✓	W/M	5/16/1997	TX NONE

Totals for Offense

Number of Citations for Offense.....	7
Number of Violations for Offense.....	7
Amount of Fines/Fines Assessed.....	\$1,348.30
Number of Citations to Juveniles.....	1

Number of Citations to Minors.....	1
------------------------------------	---

3112 NO MOTOR CYCLE ENDORSEMENT  
Statute: 521.221

ELKINS, CLARENCE ZACHARY ✓	W/M	1/28/1982	TX 35106489
----------------------------	-----	-----------	-------------

Totals for Offense

2/09/2021 9:51 AM

Citation Date: 1/01/2021 - 1/31/2021

COFFRPT Page: 4  
Summary

-----

Number of Citations for Offense.....:	1
Number of Violations for Offense.....:	1
Amount of Fines/Fines Assessed.....:	\$219.90
Number of Citations to Juveniles.....:	0
Number of Citations to Minors.....:	0

-----

3198 DROVE WITHOUT LIGHTS (WHEN REQUIRED)  
Statute: 547.302

THRIFT, JAQUELIN LEIGHANN ✓ W/F 12/01/1993 NC 000034576540

Totals for Offense

Number of Citations for Offense.....:	1
Number of Violations for Offense.....:	1
Amount of Fines/Fines Assessed.....:	\$217.90
Number of Citations to Juveniles.....:	0
Number of Citations to Minors.....:	0

-----

3259 EXPIRED OPERATOR'S LICENSE  
Statute: 522.001

THRIFT, JAQUELIN LEIGHANN ✓ W/F 12/01/1993 NC 000034576540  
DUPUY, FREEDOM MICHELLE ✓ W/F 4/02/1973 TX 13238585

Totals for Offense

Number of Citations for Offense.....:	2
Number of Violations for Offense.....:	2
Amount of Fines/Fines Assessed.....:	\$324.00
Number of Citations to Juveniles.....:	0
Number of Citations to Minors.....:	0

-----

3263 FAIL TO DISPLAY DRIVER'S LICENSE  
Statute: 521.025

PEREZ, ROBERT ARMANDO ✓ W/M 7/10/1989 TX 22039610

Totals for Offense

Number of Citations for Offense.....:	1
Number of Violations for Offense.....:	1
Amount of Fines/Fines Assessed.....:	\$162.00
Number of Citations to Juveniles.....:	0
Number of Citations to Minors.....:	0

-----

3586 SPEEDING 10% OR OVER  
Statute: 708.52

CROWSON, ROBYN JOLYNN ✓ W/F 11/08/1999 TX 40872750



2/09/2021 9:51 AM

Citation Date: 1/01/2021 - 1/31/2021

COFFRPT Page: 5  
Summary

NEELY, BLAYTON PHILLIP ✓	W/M	6/24/2002	TX	44657243
NEELY, BLAYTON PHILLIP ✓	W/M	6/24/2002	TX	44657243
MCGRADY, ZACHARY ANDREW ✓	W/M	7/16/2002	TX	43824602
MOONEY, GRANT CASPER ✓	W/M	6/28/2004	TX	44826349
PARK, SEOL KI ✓	W/F	10/04/1990	TX	25159264

Totals for Offense

Number of Citations for Offense.....:	6
Number of Violations for Offense.....:	6
Amount of Fines/Fines Assessed.....:	\$1,397.40
Number of Citations to Juveniles.....:	1

Number of Citations to Minors.....:	3
-------------------------------------	---

3596 SPEEDING SCHOOL ZONE 10% OR OVER  
Statute: 541.302

HÖKE, BLAKE AUSTIN ✓	W/M	6/11/1993	TX	43098005
SPARTI, COLTEN BANKS ✓	W/M	8/06/1989	NC	000046301574
RAMOS, MOISES A PEREZ ✓	W/M	2/07/1992	TX	39504219
MARTINEZ, MARIA ISABEL ✓	W/F	3/05/1979	TX	21275747
MANUEL, MACKENZIE RACHEL ✓	W/F	12/29/2001	OK	Y084118994
SALAS, ISAIAH NICHOLAS ✓	W/M	3/06/2001	TX	41330170
HILTON, ZACHERY RYAN ✓	W/M	5/25/1996	TX	42181898

Totals for Offense

Number of Citations for Offense.....:	7
Number of Violations for Offense.....:	7
Amount of Fines/Fines Assessed.....:	\$1,835.20
Number of Citations to Juveniles.....:	0

Number of Citations to Minors.....:	2
-------------------------------------	---

6001 PARENT CONTRIBUTING TO NON-ATTENDANCE  
Statute: SEC.25.093 EDUCATION CODE

CANALES, MICHAEL ✓	/	0/00/0000		
CANALES, MICHAEL ✓	/	0/00/0000		
ENSEY, TERRY ✓	/	0/00/0000		
NELSON, APRIL ✓	/	0/00/0000		
PRESLEY, MATTHEW SCOTT ✓	W/M	12/18/1979	TX	00259468
SMITH, CHASTITY ✓	/	0/00/0000		

Totals for Offense

Number of Citations for Offense.....:	6
Number of Violations for Offense.....:	6
Amount of Fines/Fines Assessed.....:	\$1,242.00
Number of Citations to Juveniles.....:	0

Number of Citations to Minors.....:	0
-------------------------------------	---

2/09/2021 9:51 AM

Citation Date: 1/01/2021 - 1/31/2021

COFFRPT Page: 6  
Summary

---

Totals for Offense Level

Total Citations for Offense Level....:	49
Total Violations for Offense Level..:	49
Amount of Fines/Fines Assessed.....:	\$13,640.20
Total Citations to Juveniles.....:	2
Total Citations to Minors.....:	7

---

Grand Totals

Total Number of Citations.....:	49
Total Number of Violations.....:	49
Total Amount of Fines/Fines Assessed:	\$13,640.20
Total Number of Citations Juveniles.:	2
Total Number of Citations Minors....:	7

Total Number of Offenses

DEPARTMENT	FUND	VENDOR NAME	DESCRIPTION	AMOUNT
NON-DEPARTMENTAL	GENERAL FUND	AFLAC	JAN AFLAC INS	813.76
		COB GENERAL FUND	AIRMED 101	669.18
			AIRMED 101	669.18
			BOOTS 101	142.49
			BOOTS 101	328.99
		COB WATER FUND	WATER BILL	50.00
			WATER BILL	100.00
		INTERNAL REVENUE SERVICE	FEDERAL W/H	6,417.16
			FEDERAL W/H	4,838.45
			FICA W/H	4,730.34
			FICA W/H	3,779.92
			MEDICARE W/H	1,106.26
			MEDICARE W/H	884.01
		OMNIBASE SERVICES OF TEXAS, LP	FTA 4TH QTR FEES 2020	6.00
		PERDUE BRANDON FIELDER COLLINS & MOIT	DEC 2020 COLL AGENCY FEES	263.10
		TEXAS ATTORNEY GENERAL	CHILD SUPPORT	403.15
			CHILD SUPPORT	403.15
		TEXAS MUNICIPAL RETIREMENT SYSTEM	TMRS	3,756.03
			TMRS	2,979.44
		STATE COMPTROLLER	4TH QTR FEES	1,958.37
		TXU ENERGY	ELECTRICITY-JAN 2021	9.94
		BEDC	DEC SALES & TRASH TAX	36,037.42
			TOTAL:	70,346.34
CITY MANAGER	GENERAL FUND	BANK OF AMERICA-HR	MARKERS/INK/PAPER-QUILL	20.98
		INTERNAL REVENUE SERVICE	FICA W/H	66.84
			FICA W/H	66.84
			MEDICARE W/H	15.63
			MEDICARE W/H	15.63
		TEXAS MUNICIPAL RETIREMENT SYSTEM	TMRS	97.02
			TMRS	97.02
		LLOYD GOSSELINK ROCHELLE & TOWNSEND, P.	MEMBERSHIP	1,470.00
			MEMBERSHIP	350.00
			TOTAL:	2,199.96
CITY SECRETARY	GENERAL FUND	AMERICAN SOCIETY OF COMPOSERS, AUTHORS	RENEWAL FEE	367.00
		BANK OF AMERICA-HR	SEMINAR-DIANE,HRC	150.00
		BRECKENRIDGE AMERICAN	SUBSCRIPTION-CITY	42.00
			SUBSCRIPTION	42.00
			SUBSCRIPTION	42.00
		HEATHER ROBERTSON-CARAWAY	CK1607 PER DIEM ELECTION S	117.00
		INTERNAL REVENUE SERVICE	FICA W/H	144.34
			FICA W/H	144.34
			MEDICARE W/H	33.76
			MEDICARE W/H	33.76
		PALO PINTO COMMUNICATIONS, LP	LE0098/RE0359	92.29
		STEPHENS CO APPRAISAL DISTRICT	JAN TAX CONTRACT	4,743.82
		TEXAS MUNICIPAL RETIREMENT SYSTEM	TMRS	209.52
			TMRS	209.52
		TMCA BLUEBONNET CHAPTER	HEATHER ROBERTSON-CARAWAY	25.00
		THE GRAHAM Y FUELS, INC.	GAS/OIL	111.28
		CHRISTI TIDROW	JAN MONTHLY REIMBURSE	25.00
			TOTAL:	6,532.63
PUBLIC WORKS DIRECTOR	GENERAL FUND	ENVIRONMENT CONSULTANTS, INC.	H2S TRAINING	40.00
		HIBBS & TODD, INC.	GIS SERVICES	3,120.00

DEPARTMENT	FUND	VENDOR NAME	DESCRIPTION	AMOUNT
		INTERNAL REVENUE SERVICE	FICA W/H	139.88
			FICA W/H	139.88
			MEDICARE W/H	32.71
			MEDICARE W/H	32.71
		PF&E OIL CO.	GAS/OIL JAN 2021	106.27
		TEXAS MUNICIPAL RETIREMENT SYSTEM	TMRS	208.26
			TMRS	208.26
			TOTAL:	4,027.97
ACCOUNTING	GENERAL FUND	ABC PRINTING SERVICE	1099 NEC	27.50
		BANK OF AMERICA-HR	SEMINAR-DIANE,HRC	150.00
		DIANE LATHAM	CK1608 PER DIEM ELECTION S	117.00
		INTERNAL REVENUE SERVICE	FICA W/H	139.62
			FICA W/H	139.74
			MEDICARE W/H	32.66
			MEDICARE W/H	32.69
		TEXAS MUNICIPAL RETIREMENT SYSTEM	TMRS	204.26
			TMRS	204.44
		TMCA BLUEBONNET CHAPTER	DIANE LATHAM DUES	25.00
			TOTAL:	1,072.91
CITY OFFICES	GENERAL FUND	ABC PRINTING SERVICE	DEPOSIT STAMP	48.00
		AT&T	INTERNET-CITY	74.56
		AT&T	TELEPHONE/INTERNET	371.88
		BANK OF AMERICA-HR	PAPER/POCKETS/LEGAL PAD/FI	93.24
			TISSUES/PENS/INK-QUILL	78.76
			KEYBOARD/PADS/MARKERS/RUBB	119.64
			MARKERS/INK/PAPER-QUILL	119.90
		CINTAS CORPORATION LOC.439	UNIFORMS	11.73
			UNIFORMS	11.73
			UNIFORMS	11.73
			UNIFORMS	11.73
		DEPARTMENT OF INFORMATION RESOURCES	12-1-20/12-31-20	9.76
		DIALSTONE SERVICES L.P.	SATELLITE PHONE	16.17
		LADYBUG PEST CONTROL	PEST CONTROL	30.00
		PURCHASE POWER	STAMPS	1,005.00
		TX GAS SERVICE COMPANY	NATURAL GAS	638.91
		TXU ENERGY	ELECTRICITY-JAN 2021	237.69
		VERIZON WIRELESS	WIRELESS	120.83
		WILLIS SUPPLY CO.	PINE QUAT-CITY	75.80
		RICOH USA, INC	PRINTER RENTALS	456.86
		BAR W ELECTRIC & WELDING	NEW BREAKER BOX	693.20
		LOWE'S	KITCHEN RENOVATIONS	1,742.79
			TOTAL:	5,979.91
CITY HALL	GENERAL FUND	CINTAS CORPORATION LOC.439	UNIFORMS	9.04
			UNIFORMS	9.04
			UNIFORMS	9.04
			UNIFORMS	9.04
		LADYBUG PEST CONTROL	PEST CONTROL	25.00
		TX GAS SERVICE COMPANY	NATURAL GAS	544.12
		TXU ENERGY	ELECTRICITY-JAN 2021	880.36
			TOTAL:	1,485.64
POLICE	GENERAL FUND	AT&T	TELEPHONE/INTERNET	321.32
		BANK OF AMERICA-HR	PAPER/POCKETS/LEGAL PAD/FI	53.96

DEPARTMENT	FUND	VENDOR NAME	DESCRIPTION	AMOUNT
		CINTAS CORPORATION LOC.439	SERIES BELT CLIP	42.75
			TISSUES/PENS/INK-QUILL	47.98
			KEYBOARD/PADS/MARKERS/RUBB	46.78
			FILE POCKETS	35.77
			MARKERS/INK/PAPER-QUILL	55.98
			UNIFORMS	11.29
			UNIFORMS	11.29
			UNIFORMS	11.29
			UNIFORMS	11.29
			UNIFORMS	11.29
		CLAYS WELDING & TIRE SERVICE	2064 CHANGED OLD STEM	10.00
		DEPARTMENT OF INFORMATION RESOURCES	12-1-20/12-31-20	9.50
		INTERNAL REVENUE SERVICE	FICA W/H	1,847.01
			FICA W/H	1,300.36
			MEDICARE W/H	431.95
			MEDICARE W/H	304.13
		O'REILLY AUTO PARTS	MOTOR OIL	3.99
		PF&E OIL CO.	GAS/OIL JAN 2021	157.98
		TEXAS MUNICIPAL RETIREMENT SYSTEM	TMRS	2,733.63
			TMRS	1,907.74
		TXU ENERGY	ELECTRICITY-JAN 2021	19.23
		VERIZON WIRELESS	WIRELESS	527.21
		WALMART COMMUNITY	CLIPS/CABINET/CORD	104.54
			COFFEE AND OFFICE SUPPLIES	32.34
			COFFEE AND OFFICE SUPPLIES	57.74
		WILLIS SUPPLY CO.	2065 H11 SS	21.52
		RICOH USA, INC	PAPER/TOLIET PAPER	92.90
		THE GRAHAM Y FUELS, INC.	PRINTER RENTALS	285.32
		PAULA GRISSOM	GAS/OIL	1,517.99
			SEWED 9 PATCHES	10.00
			TOTAL:	12,024.78
ANIMAL WELFARE	GENERAL FUND	AT&T	TELEPHONE/INTERNET	65.54
		INTERNAL REVENUE SERVICE	FICA W/H	138.88
			FICA W/H	97.66
			MEDICARE W/H	32.48
			MEDICARE W/H	22.84
		LADYBUG PEST CONTROL	PEST CONTROL	35.00
		PATE'S HARDWARE	DEADBOLT/KEY BULK	47.90
		TXU ENERGY	ELECTRICITY-JAN 2021	501.31
		VERIZON WIRELESS	WIRELESS	77.59
		PAULA GRISSOM	SEWED 9 PATCHES	35.00
			TOTAL:	1,054.20
MUNICIPAL COURT	GENERAL FUND	AT&T	TELEPHONE/INTERNET	219.60
		BANK OF AMERICA-HR	VACCUM BAGS	91.95
		DEPARTMENT OF INFORMATION RESOURCES	12-1-20/12-31-20	1.05
		INTERNAL REVENUE SERVICE	FICA W/H	113.26
			FICA W/H	113.42
			MEDICARE W/H	26.49
			MEDICARE W/H	26.52
		TEXAS MUNICIPAL RETIREMENT SYSTEM	TMRS	166.05
			TMRS	166.28
		U. S. POST OFFICE	STAMPS	55.00
		WILLIS SUPPLY CO.	CUPS/BAGS/TOWELS/AEROSAL-M	102.90
		RICOH USA, INC	PRINTER RENTALS	228.42
			TOTAL:	1,310.94

DEPARTMENT	FUND	VENDOR NAME	DESCRIPTION	AMOUNT
FIRE	GENERAL FUND	ABC PRINTING SERVICE	PAPER FOR STATION	20.29
		AT&T	INTERNET-FIRE	100.94
		AT&T	TELEPHONE	71.70
			TELEPHONE/INTERNET	119.43
			MARKERS/INK/PAPER-QUILL	55.38
			2598 OIL CHANGE	113.76
			DIESEL EXHAUST FLUID	29.94
			CYLINDER RENTAL	18.75
			CYLINDER	15.00
			COOLANT UNIT 2592	75.76
			DUES FOR NOV/DEC 2020	77.00
			REIMBURSE FOR ANTENNA #259	32.40
			12-1-20/12-31-20	0.11
			2590 STRAINER/HOSE/CLAMP	215.54
			H2S TRAINING	240.00
			SPRAYER/HOSE	60.18
			BRUSHES/HOSES	47.96
			FICA W/H	1,415.47
			FICA W/H	1,030.55
			MEDICARE W/H	331.03
			MEDICARE W/H	241.01
			BATTERIES	149.99
			PLUMBING INSP REN FOR C CH	85.00
			TMRS	2,064.82
			TMRS	1,460.29
	WIRELESS	31.98		
	STATION SUPPLIES	30.04		
	BOUNTY/FBRZ/BOWLS/GV BATH	59.69		
	DAY ROOM SUPPLIES	34.63		
	GAS/OIL	951.59		
	REPAIR BRAKES/PADS UNIT 25	342.00		
	LEASE & MONTHLY SERVICE CO	147.65		
	REIMBURSE FOR PRESSURE WAS	368.03		
	TARP FOR HOSE BED UNIT #25	75.00		
	TOTAL:		10,112.91	
AGING SERVICE PROGRAM	GENERAL FUND	LADYBUG PEST CONTROL	PEST CONTROL	20.00
		TXU ENERGY	ELECTRICITY-JAN 2021	78.82
		TOTAL:		98.82
CEMETERY	GENERAL FUND	AT&T	TELEPHONE/INTERNET	63.10
		CINTAS CORPORATION LOC.439	UNIFORMS	5.15
			UNIFORMS	32.25
			UNIFORMS	5.15
			UNIFORMS	5.15
			FLAT REPAIR UNIT 3232	15.00
			12-1-20/12-31-20	0.09
			FICA W/H	58.68
			FICA W/H	58.92
			MEDICARE W/H	13.72
			MEDICARE W/H	13.78
			JAN CEMETERY PYMT	412.50
			TMRS	85.18
			TMRS	85.54
			NATURAL GAS	154.54
	ELECTRICITY-JAN 2021	62.51		

DEPARTMENT	FUND	VENDOR NAME	DESCRIPTION	AMOUNT	
PARKS & RECREATION	GENERAL FUND	THE GRAHAM Y FUELS, INC.	GAS/OIL	19.70	
		TOTAL:			1,090.96
		AT&T	INTERNET-PARK	74.19	
		AT&T	TELEPHONE/INTERNET	99.28	
		BRECKENRIDGE AUTO & ENGINE SUPPLY	BATTERY DEPT 33	155.93	
		CINTAS CORPORATION LOC.439	BATTERY CORE DEPT 33	19.00-	
			UNIFORMS	25.67	
			UNIFORMS	25.67	
			UNIFORMS	25.67	
			UNIFORMS	25.67	
			FICA W/H	214.00	
			FICA W/H	209.44	
			MEDICARE W/H	50.04	
			MEDICARE W/H	48.97	
			REPAIR TO PAVILLION DOOR	7.95	
	RUSTOLEUM WHITE	5.19			
	TMRS	310.65			
	TMRS	304.02			
	NATURAL GAS	613.97			
	ELECTRICITY-JAN 2021	804.17			
	ELECTRICITY-JAN 2021	69.26			
	ELECTRICITY-JAN 2021	1,360.10			
	WIRELESS	31.98			
	CLEANING SUPPLIES	31.43			
	GAS/OIL	179.12			
TOTAL:			4,653.37		
STREET DEPT	GENERAL FUND	BANK OF AMERICA-HR	SCHOOLING-FELICIA	113.75	
			TWUA-FELICIA	375.00	
		BRECKENRIDGE AUTO & ENGINE SUPPLY	BATTERY TERM UNIT 4333	6.82	
			4351 NEW BATTERIES	314.98	
			4391 FILTERS	86.78	
			UNIFORMS	29.21	
			UNIFORMS	29.11	
			UNIFORMS	29.21	
			UNIFORMS	29.21	
			H2S TRAINING	200.00	
			BOOTS-STANLEY	139.99	
			PVC BOOT/REG BOOT-MARVIN	153.98	
			MUCK BOOTS	119.99	
			FD MUCK BOOTS	139.99	
			FLIP BOOTS - EXCHANGED	1.00	
	BAR/CHAIN OIL	8.99			
	FICA W/H	452.36			
	FICA W/H	478.77			
	MEDICARE W/H	105.79			
	MEDICARE W/H	111.97			
	MINI EXCAVATOR	215.00			
	CHAIN DEPT 43	26.99			
	GLOVES	19.29			
	GLOVES	14.59			
	GAS/OIL JAN 2021	11.40			
	GAS/OIL JAN 2021	233.98			
	4351 LOADER TIRES	2,161.90			
	TMRS	681.42			
		INTERNAL REVENUE SERVICE			
		PATE'S HARDWARE			
		TEXAS MUNICIPAL RETIREMENT SYSTEM			
		TX GAS SERVICE COMPANY			
		TXU ENERGY			
		VERIZON WIRELESS			
		WALMART COMMUNITY			
		THE GRAHAM Y FUELS, INC.			
		BANK OF AMERICA-HR			
		BRECKENRIDGE AUTO & ENGINE SUPPLY			
		CINTAS CORPORATION LOC.439			
		ENVIRONMENT CONSULTANTS, INC.			
		CEBO'S			
		INTERNAL REVENUE SERVICE			
		BRECKENRIDGE RENTAL & SALES			
PATE'S HARDWARE					
PF&E OIL CO.					
ROBERTS TIRE & AUTO					
TEXAS MUNICIPAL RETIREMENT SYSTEM					

DEPARTMENT	FUND	VENDOR NAME	DESCRIPTION	AMOUNT
		TXU ENERGY	TMRS	719.77
			ELECTRICITY-JAN 2021	5,999.52
			ELECTRICITY-JAN 2021	66.58
			ELECTRICITY-JAN 2021	11.89
		THE GRAHAM Y FUELS, INC.	GAS/OIL	708.81
			GAS/OIL	35.25
		VERMEER TEXAS-LOUISIANA	MOUNT-ENGINE	147.48
			THROWOUT BEARING DEPT 43	1,326.34
		EQUIPATRON	RPIC MOTOR ON WACKER RD88	1,650.21
			TOTAL:	16,957.32
GARAGE & WAREHOUSE	GENERAL FUND	AT&T	TELEPHONE/INTERNET	126.56
		BRECK WELDING SUPPLY	CYLINDER RENTAL	18.75
		HERRINGTON HEATING & COOLING	NEW HEATER AT SHOP	534.29
		LADYBUG PEST CONTROL	PEST CONTROL	35.00
		PATE'S HARDWARE	CAULK GUN RATCHET	9.39
			FILTER	6.59
		TX GAS SERVICE COMPANY	NATURAL GAS	775.41
		TXU ENERGY	ELECTRICITY-JAN 2021	984.81
		VERIZON WIRELESS	WIRELESS	67.26
			TOTAL:	2,558.06
NON-DEPARTMENTAL	GENERAL FUND	TML INTERGOVERNMENTAL RISK POOL	CK1511QRTLY INSPYMT AUTO,B	20,498.00
			CK1511QRTLY INSPYMT AUTO,B	983.00
			CK1511QRTLY INSPYMT AUTO,B	10,003.00
			CK1511QRTLY INSPYMT AUTO,B	3,643.00
			CK1511QRTLY INSPYMT AUTO,B	6,354.00
			CK1511QRTLY INSPYMT AUTO,B	11,574.00-
		BRECKENRIDGE FINE ARTS CENTER	JUN USE PYMT	1,341.67
		BRECKENRIDGE LIBRARY	JAN USE PYMT	1,158.33
		CNA SURETY	15K CITY MANAGER 10K BASIC	490.00
		MESSER, FORT & MCDONALD, PLLC	LAWYER FEE	1,165.35
			LAWYER FEE	2,757.10
		TALK CORPORATION	UNEMPLOYMENT CASE FEE	1,247.36
		TXU ENERGY	ELECTRICITY-JAN 2021	774.22
		AIRMEDCARE	AIRMEDCARE	1,585.00
		TOLLAR SYSTEMS INC,	YEAR END BACKUP/ONSITE	341.74
		KELLI A WINDSOR	JAN HEALTH OFFICER	25.00
			TOTAL:	40,792.77
NON-DEPARTMENTAL	WATER FUND	AFLAC	JAN AFLAC INS	197.76
		COB WATER FUND	AIRMED 102	241.26
			AIRMED 102	241.26
			BOOTS 102	52.33
			FEDERAL W/H	1,080.84
			FEDERAL W/H	884.72
			FICA W/H	820.34
			FICA W/H	709.99
			MEDICARE W/H	191.85
			MEDICARE W/H	166.05
		TEXAS ATTORNEY GENERAL	CHILD SUPPORT	130.73
			CHILD SUPPORT	130.73
		TEXAS MUNICIPAL RETIREMENT SYSTEM	TMRS	674.35
			TMRS	585.35
			TOTAL:	6,107.56



DEPARTMENT	FUND	VENDOR NAME	DESCRIPTION	AMOUNT
WATER & SEWER COMM	WATER FUND	INTERNAL REVENUE SERVICE	FICA W/H	49.81
			FICA W/H	49.81
			MEDICARE W/H	11.65
			MEDICARE W/H	11.65
			TMRS	74.16
			TMRS	74.16
			TOTAL:	271.24
WATER METERS	WATER FUND	BENMARK SUPPLY CO. INC.	METER BOXES	6,096.80
		CINTAS CORPORATION LOC.439	UNIFORMS	12.25
			UNIFORMS	12.10
			UNIFORMS	12.10
			UNIFORMS	34.21
		EDI/QUINN ALS, LLC	2IN BRASS VALVE	52.09
		INTERNAL REVENUE SERVICE	FICA W/H	112.50
			FICA W/H	117.58
			MEDICARE W/H	26.31
			MEDICARE W/H	27.50
		O'REILLY AUTO PARTS	MICRO CABLE	7.99
		PATE'S HARDWARE	WIRE PINS	9.96
			ADAPTER/VALVE	5.08
		ROBERTS TIRE & AUTO	7160 INSPECTION	7.00
		TEXAS MUNICIPAL RETIREMENT SYSTEM	7159 FLAT REPAIR	15.00
			TMRS	166.23
			TMRS	173.60
		THE GRAHAM Y FUELS, INC.	GAS/OIL	274.32
		SECUREVISION OF AMERICA INC.	3/4 IN METERS -3 BOXES	6,087.84
			TOTAL:	13,250.46
LAKE DANIEL	WATER FUND	JAMES D WIMBERLEY SR DBA BUBBA'S PORTA	PORTABLE TOILET/CLEANING	140.00
		TXU ENERGY	ELECTRICITY-JAN 2021	26.33
			TOTAL:	166.33
WATER TREATMENT	WATER FUND	ABILENE, CITY OF	WATER TESTING	375.00
		ANA-LAB CORP.	LABS	193.00
		AT&T	TELEPHONE/INTERNET	190.54
		CINTAS CORPORATION LOC.439	UNIFORMS	22.10
			UNIFORMS	22.10
			UNIFORMS	22.10
			UNIFORMS	22.10
		DPC INDUSTRIES, INC.	CHEMICAL	2,211.00
		ENVIRONMENT CONSULTANTS, INC.	OTRLY SITE VISIT AND INSPE	1,500.00
		HACH COMPANY	LAB REAG AND SUPPLIES	543.03
		INTERNAL REVENUE SERVICE	FICA W/H	436.97
			FICA W/H	362.13
			MEDICARE W/H	102.19
			MEDICARE W/H	84.69
		LADYBUG PEST CONTROL	PEST CONTROL	25.00
		LOWER COLORADO RIVER AUTHORITY	LABS	213.92
		TEXAS MUNICIPAL RETIREMENT SYSTEM	TMRS	649.34
			TMRS	540.70
		TXU ENERGY	ELECTRICITY-JAN 2021	3,682.63
		VERIZON WIRELESS	WIRELESS	62.27
		WALMART COMMUNITY	CLEANING/DISINFECTING SUPP	72.56
		WILLIS SUPPLY CO.	TOILET PAPER-WTP	59.95
		EAGLE LABS, INC	CHEMICAL DISPOSAL	725.00

DEPARTMENT	FUND	VENDOR NAME	DESCRIPTION	AMOUNT
		RICOH USA, INC	PRINTER RENTALS	45.50
		THE GRAHAM Y FUELS, INC.	GAS/OIL	42.35
		NEWGEN STRATEGIES AND SOLUTIONS, LLC	W/WW UTILITY RATE STUDY	2,655.00
			TOTAL:	14,861.17
		APSCO ABILENE	RETURN GLOVES	366.10-
			DOUBLE BAND FULL CIRCLE	429.25
			CLAMP FOR W ELLIOTT	429.25
		BENMARK SUPPLY CO. INC.	INVENTORY	2,012.21
			INVENTORY	515.35
			VALVE/COUPLING/PVC	175.43
			2IN HYMAX	725.79
		BRECKENRIDGE AUTO & ENGINE SUPPLY	KEY DEPT 74	10.50
			RECOIL ROPE DEPT 74	4.18
		CINTAS CORPORATION LOC.439	UNIFORMS	8.77
			UNIFORMS	30.73
			UNIFORMS	8.62
			UNIFORMS	8.77
		EDI/QUINN ALS, LLC	BALON CHECK VALVE	326.90
			BLACK PVC DEPT 74	22.04
			POLY PIPE	44.08
		ENVIRONMENT CONSULTANTS, INC.	H2S TRAINING	120.00
		GEBO'S	WATER BOOTS	19.99
		HIGGINBOTHAM-BARTLETT CO. #56	ROPE NYLON BRAID	19.50
		INTERNAL REVENUE SERVICE	FICA W/H	221.06
			FICA W/H	180.47
			MEDICARE W/H	51.70
			MEDICARE W/H	42.21
		BRECKENRIDGE RENTAL & SALES	MINI EXCAVATOR	555.00
		MOSS DIESEL SERVICE	7476 CASE BACKHOE REPAIR	1,331.58
		O'REILLY AUTO PARTS	GLOVES/SPRAY GREASE	12.48
		PATE'S HARDWARE	VALVE GATE	37.99
			BLADE DIAMOND SEG DEPT 74	66.29
			ADAPT/PRIMER/PVC/TIE DOWN	55.52
		TEXAS MUNICIPAL RETIREMENT SYSTEM	ELBOW/PVC DEPT 74	8.29
			SEWER ROD FLAT	168.79
			TWRS	324.07
			TWRS	265.14
		TXU ENERGY	ELECTRICITY-JAN 2021	328.42
			ELECTRICITY-JAN 2021	164.59
			ELECTRICITY-JAN 2021	10.74
		HOUSTON SATTERWHITE	REIMBURSE FOR HEATERS	199.98
		THE GRAHAM Y FUELS, INC.	GAS/OIL	235.14
			GAS/OIL	43.19
		TEXAS GAS SERVICE	DAMAGE ON 2116 W WALKER	665.46
			TOTAL:	9,513.37
NON-DEPARTMENTAL	WATER FUND	AIRMEDCARE	AIRMEDCARE	1,345.00
			TOTAL:	1,345.00
NON-DEPARTMENTAL	WASTE WATER FUND	AFLAC	JAN AFLAC INS	239.90
		COB WASTEWATER FUND	AIRMED 103	71.88
			AIRMED 103	71.88
			BOOTS 103	55.66
		INTERNAL REVENUE SERVICE	FEDERAL W/H	528.82
			FEDERAL W/H	355.95

DEPARTMENT	FUND	VENDOR NAME	DESCRIPTION	AMOUNT
			FICA W/H	355.02
			FICA W/H	261.00
			MEDICARE W/H	83.03
			MEDICARE W/H	61.04
			CHILD SUPPORT	149.98
			CHILD SUPPORT	149.98
			TMRS	290.99
			TMRS	215.16
			TOTAL:	2,890.29
SEWER COLLECTION	WASTE WATER FUND	BRECKENRIDGE AUTO & ENGINE SUPPLY	7678 PARTS FOR MAINSTREET	334.90
			7678 FLUID	21.86
			PRECLEANER/12V BATTERY	131.50
			FUEL/CLAMP/SAFETY STRIPE	7.56
			FUEL CUT OFF DEPT 76	8.82
			STARTER HANDLE DEPT 76	4.11
			AIR IMPACT/TEFLON TAPE/PLU	328.82
		CHEMICAL UNIVERSE, INC	CHEMICALS	2,299.25
			CALCIUM HYPOCHLORITE GRANU	243.50
		CINTAS CORPORATION LOC.439	UNIFORMS	11.03
			UNIFORMS	11.03
			UNIFORMS	11.03
		ENVIRONMENT CONSULTANTS, INC.	H2S TRAINING	80.00
		GEBO'S	BOOTS-CAMPBELL	139.99
			WATER BOOTS	16.99
			AIR COMPRESSOR	1,114.99
			HEATER DEPT 76	27.99
		HIGGINBOTHAM-BARTLETT CO. #56	HOSE BARB COUP	2.69
			SHOVEL DEPT 76	34.99
		INTERNAL REVENUE SERVICE	FICA W/H	199.12
			FICA W/H	111.27
			MEDICARE W/H	46.57
			MEDICARE W/H	26.02
		BRECKENRIDGE RENTAL & SALES	AUGER RENTAL	255.00
		KEEN ELECTRIC SERVICE	LIFT STATION ELECTRICAL CO	601.50
			LSS BREAKER	380.00
		O'REILLY AUTO PARTS	VENT WRAP	7.98
		PATE'S HARDWARE	CONCRETE MIX	9.18
			FENCE TOOL/BOLT CUTTER DEP	43.08
			VALVE DEPT 76	37.99
			SAW DEPT 76	15.76
			PATE'S HARDWARE	1.39
		TEXAS MUNICIPAL RETIREMENT SYSTEM	TMRS	294.03
			TMRS	166.50
		TXU ENERGY	ELECTRICITY-JAN 2021	707.05
			ELECTRICITY-JAN 2021	493.78
		WALMART COMMUNITY	PRIMER BULB	18.96
		HOUSTON SATTERWHITE	REIMBURSE FOR HEATERS	99.99
		UNDERGROUND UTILITY SUPPLY	HYD MOTOR FOR TRL/MOUNT JE	582.43
		THE GRAHAM Y FUELS, INC.	GAS/OIL	106.69
			GAS/OIL	166.90
		YVES CUSTOMS	WORK ON UNIT 7678	1,711.52
		FAMBERO CONSTRUCTION, LLC	CK1503INSTALL6"GRAVITYWLLI	3,000.00
		MAINSTREET AUTO	7678 INGNITION, STARTER, F	416.00
		BASS & HAYES FOUNDRY, INC	CAST IRON GRATE/SEWERING &	1,725.40

DEPARTMENT	FUND	VENDOR NAME	DESCRIPTION	AMOUNT
SEWER TREATMENT	WASTE WATER FUND	ABC PRINTING SERVICE ANA-LAB CORP.	INK COLOR/BLACK	91.32
			LABS	220.00
			LABS	820.00
		AT&T	TELEPHONE/INTERNET	196.66
		BRECKENRIDGE AUTO & ENGINE SUPPLY	KEY	3.00
			7778 COOLANT	29.91
		CHEMICAL UNIVERSE, INC	CHEMICALS	2,299.25
		CINTAS CORPORATION LOC.439	CALCIUM HYPOCHLORITE GRANU	243.50
			UNIFORMS	14.01
			UNIFORMS	106.76
			UNIFORMS	38.06
			UNIFORMS	14.01
		DEPARTMENT OF INFORMATION RESOURCES	12-1-20/12-31-20	0.19
		DPC INDUSTRIES, INC.	CHEMICALS	904.92
			CHLORINE#150	678.69
		ENVIRONMENT CONSULTANTS, INC.	H2S TRAINING	80.00
		GEBO'S	FITTING	2.98
		INTERNAL REVENUE SERVICE	FICA W/H	155.90
			FICA W/H	149.73
			MEDICARE W/H	36.46
			MEDICARE W/H	35.02
		BRECKENRIDGE RENTAL & SALES	MINI EXCAVATOR	218.74
		KEEN ELECTRIC SERVICE	NEW RAZ PUMPS	1,076.50
		LADYBUG PEST CONTROL	PEST CONTROL	20.00
		O'REILLY AUTO PARTS	ANTI FREEZE DEPT 77	21.98
			ANTI FREEZE DEPT 77	21.98
		PATE'S HARDWARE	ANTIFREEZE/FLUID/VENT STIC	33.96
		PF&E OIL CO.	BIT MASONRY SET/KEY	38.05
		REPUBLIC SERVICES, INC	GAS/OIL JAN 2021	48.33
		TEXAS MUNICIPAL RETIREMENT SYSTEM	HAUL SLUDGE	1,625.94
			TWRS	229.75
		TXU ENERGY	TWRS	220.79
		USA BLUEBOOK	ELECTRICITY-JAN 2021	4,860.22
		VERIZON WIRELESS	LAB SUPPLIES	103.82
			WIRELESS	47.13
			TOTAL:	14,687.56
NON-DEPARTMENTAL	WASTE WATER FUND	AIRMEDCARE	AIRMEDCARE	575.00
			TOTAL:	575.00
NON-DEPARTMENTAL	SANITATION FUND	INTERNAL REVENUE SERVICE	FEDERAL W/H	43.33
			FEDERAL W/H	43.33
			FICA W/H	35.76
			FICA W/H	35.76
			MEDICARE W/H	8.36
			MEDICARE W/H	8.36
			TOTAL:	174.90
SOLID WASTE STATION	SANITATION FUND	AT&T	TELEPHONE/INTERNET	65.54
		BRECKENRIDGE AUTO & ENGINE SUPPLY	O-RING/LEVER/BRAKE SHOE #4	128.24
			PWR STRG DEPT 42	27.24
		DEPARTMENT OF INFORMATION RESOURCES	12-1-20/12-31-20	1.35
		INTERNAL REVENUE SERVICE	FICA W/H	35.76
			FICA W/H	35.76

DEPARTMENT	FUND	VENDOR NAME	DESCRIPTION	AMOUNT
		REPUBLIC SERVICES, INC	MEDICARE W/H	8.36
			MEDICARE W/H	8.36
			TDCJ	5,940.89
			DUMPSTER	38,926.08
			POLY CART	25,270.00
			ROLL OFF	4,136.64
			CONV STATION	179.95
			ELECTRICITY-JAN 2021	38.98
			TOTAL:	74,803.15
POLICE		EQUIPMENT REPLACEM DELAGE LANDEN PUBLIC FINANCE LLC	FINAL PYMT 2 TAHOE LEASES	29,373.02
			TOTAL:	29,373.02
STREET MAINT SALES TAX		FAMERO CONSTRUCTION, LLC	ASPHALTREPAIR BRWN RD&IND	2,550.00
		BASS & HAYES FOUNDRY, INC	CAST IRON GRATE/SEWERING &	434.21
			TOTAL:	2,984.21

```

===== FUND TOTALS =====
101 GENERAL FUND 182,299.49
102 WATER FUND 45,515.13
103 WASTE WATER FUND 34,219.04
104 SANITATION FUND 74,978.05
111 EQUIPMENT REPLACEMENT FUN 29,373.02
113 STREET MAINT SALES TAX FD 2,984.21
-----
GRAND TOTAL: 369,368.94
-----

```

SELECTION CRITERIA

-----  
SELECTION OPTIONS

VENDOR SET: 01-CITY OF BRECKENRIDGE  
VENDOR: All  
CLASSIFICATION: All  
BANK CODE: All  
ITEM DATE: 1/01/2021 THRU 1/31/2021  
ITEM AMOUNT: 99,999,999.00CR THRU 99,999,999.00  
GL POST DATE: 0/00/0000 THRU 99/99/9999  
CHECK DATE: 0/00/0000 THRU 99/99/9999  
-----

PAYROLL SELECTION

PAYROLL EXPENSES: NO  
EXPENSE TYPE: N/A  
CHECK DATE: 0/00/0000 THRU 99/99/9999  
-----

PRINT OPTIONS

PRINT DATE: None  
SEQUENCE: By Department  
DESCRIPTION: Distribution  
GL ACCTS: NO  
REPORT TITLE: C O U N C I L R E P O R T  
SIGNATURE LINES: 0  
-----

PACKET OPTIONS

INCLUDE REFUNDS: YES  
INCLUDE OPEN ITEM:NO  
-----

## January 2021 Street Department

1. Friday – Holiday
2. Saturday
3. Sunday
4. Monday – Felicia, Felipe, Mikey, Marvin Nathan off  
Chipper truck 4222 and chipper 4239, on-call truck 3384 – picked up brush from snowstorm, dumped once, Felipe worked with water crew.
5. Tuesday – Felipe, Mikey, Marvin, Nathan Felicia (over half day)  
Chipper truck 4222 and chipper 4239, on-call truck 3384 – picked up brush from snowstorm, dumped once. Felipe worked with water crew.
6. Wednesday – Felicia, Felipe, Marvin, Nathan Mikey off  
Chipper truck 4222 and chipper 4239, on-call truck 3384 – picked up brush from snowstorm, dumped once. Felipe worked with water crew.
7. Thursday – Felicia, Felipe, Marvin, Nathan Mikey off  
Trash route, welded the gate at the water plant. Chipper truck 4222 and chipper 4239, on-call truck 3384 – picked up brush from snowstorm, dumped once. Felipe worked with water crew half day. Felipe and Felicia picked up small brush piles in 4333 – 1 ton – dumped 3 loads.
8. Friday – Felicia, Felipe, Mikey, Marvin, Nathan  
Dropped loader 4351 off at Goodyear for tires, rented Case from Breck rentals and filled up roll-off at 504 S Miller, cashed out ticket at scrap yard, used chainsaw and hauled off tree that fell in alley behind 1213 E Hullum, Felipe and Nathan worked with water crew.
9. Saturday
10. Sunday
11. Monday – Felicia, Felipe, Mikey, Marvin, Nathan  
Got window installed on Skid steer 4391, got loader 4351 back to shop, replaced the oil filter housing and changed oil on loader, crew with chainsaw and pole saw picking up large limbs in 4333, 4342 picking up brush piles, dumped 4 times and made list for chipper truck.
12. Tuesday – Felipe, Marvin, Nathan Felicia out am, Mikey out pm  
Mikey worked on chipper truck 4222, called on prices for all three chippers, cleaned off wash pad. 5 loads of brush hauled off in 4333 and 1 in 4342. Pushed brush pile up. Dumped 6 loads of brush in 4333 and 3384. Felipe worked with the water crew for an hour.
13. Wednesday – Felicia, Marvin, Mikey, Nathan Felipe out last 3 hours of day  
Picked up brush in 4333 and 3384 – dumped 11 times. Worked on chippers – ordered parts and temporarily fixed 4239 chipper.
14. Thursday – Felicia, Marvin, Mikey, Nathan Felipe out  
Trash route, smashed down roll-offs at convenience station. Chipper truck 4222, chipper 4239 and 3384 picking up brush – dumped one load. Received motor for steel roller 4393 and motor mounts for 4239.
15. Friday – Felicia, Marvin, Mikey, Nathan Felipe off  
Lake Daniels trash route, Chipper truck 4222, chipper 4239 and 3384 picking up brush, smashed roll-offs at convenience station.
16. Saturday
17. Sunday

18. Monday – Felicia, Marvin  
Felipe, Mikey, Nathan out  
Seth worked with Marvin – Chipper truck 4222, chipper 4239 picking up brush, wrote down brush pile address for N side of town.
19. Tuesday – Felicia, Marvin, Mikey, Nathan  
Felipe out  
Mikey worked on 6" pump and roll-up bay door at bottom shop. 4222 and 4239 picking up brush AM. Marvin, Nathan and Felicia called in and worked a water leak at W Elm and N Harvey – ¾" pipe, fixed with clamp.
20. Wednesday – Felicia, Marvin, Mikey  
Felipe out and Nathan half day  
Felicia worked in office. Worked on 4239 and the skid steer sweeper front wheel.
21. Thursday – Felicia, Marvin, Mikey, Nathan  
Felipe out  
Felicia worked in office. Smashed down dumpsters at convenience station. Put base down on water cuts and huge potholes.
22. Friday – Felicia, Marvin, Mikey, Nathan  
Felipe out  
Felicia worked in office. Marvin filled up roll-off at 504 S Miller. Worked at bottom shop.
23. Saturday
24. Sunday
25. Monday – Felicia, Marvin, Mikey, Nathan  
Felipe out  
Felicia worked in office. Picked up 5 loads of brush am, 90 potholes on East to West Elliott. Worked on 4222.
26. Tuesday – Felicia, Marvin, Nathan  
Felipe out, Mikey out half day  
Mikey worked on 4222, picked up brush in 4333 and dumped 3 times in the AM and done 50 potholes in PM on Dubois, N Harvey, N Oakwood, W 4<sup>th</sup> and N Smith. Felicia did Water Utilities Safety class.
27. Wednesday – Felicia, Mikey, Nathan  
Marvin and Felipe out  
Picked up 4 loads of brush AM and started patching on Scenic Drive. Felicia did Water Utilities Safety class.
28. Thursday – Marvin, Mikey, Nathan  
Felipe out and Felicia half day  
Trash route, picked up trash out of road at 1100 blk of N Harvey and picked up brush. Mikey worked on left blinker light on Jetter and worked on 4222. Felicia finished Water Utilities Safety class.
29. Friday – Felicia, Marvin, Mikey, Nathan  
Felipe out  
Picked up brush AM. Charged Black and White dump truck and Loader batteries. Got coke machine out of City Office and into Top Shop. Felicia finished 1099 MISC and NEC in office.
30. Saturday
31. Sunday



**BRECKENRIDGE ECONOMIC  
DEVELOPMENT CORPORATION**  
**(A Component Unit of the City of Breckenridge, Texas)**

**ANNUAL FINANCIAL REPORT**  
**FOR THE YEAR ENDED SEPTEMBER 30, 2020**



**GMS** CERTIFIED PUBLIC  
ACCOUNTANTS  
GEORGE | MORGAN | SNEED



**BRECKENRIDGE ECONOMIC DEVELOPMENT CORPORATION**  
**Annual Financial Report**  
**For the Year Ended September 30, 2020**

**TABLE OF CONTENTS**

	<u>Page</u>
Officers and Board of Directors	1
Independent Auditor’s Report	2 -3
Management’s Discussion and Analysis	4 - 10
Basic Financial Statements:	
Government-wide Financial Statements:	
Statement of Net Position	11
Statement of Activities	12
Governmental Fund Financial Statements:	
Balance Sheet – Governmental Fund	13
Reconciliation of the Balance Sheet of Governmental Fund to the Statement of Net Position	14
Statement of Revenues, Expenditures and Changes in Fund Balance – Governmental Fund	15
Reconciliation of the Statement of Revenues, Expenditures, and Changes in Fund Balance of Governmental Fund to the Statement of Activities	16
Notes to the Financial Statements	17 - 24
Required Supplementary Information	
Schedule of Revenues, Expenses and Changes in Fund Balance – Budget and Actual – General Fund	25
Notes to the Required Supplementary Information	26
Overall Compliance and Internal Control Section	
Independent Auditor’s Report on Internal Control over Financial Reporting and on Compliance and Other Matters based on an audit of Financial Statements Performed in Accordance with Government Auditing Standards	27 - 28

This page intentionally left blank.

**BRECKENRIDGE ECONOMIC DEVELOPMENT CORPORATION  
BRECKENRIDGE, TEXAS**

**OFFICERS AND BOARD OF DIRECTORS**

**MIKE PARRACK – PRESIDENT**

**NIC McCLYMOND – VICE PRESIDENT**

**MIKE GRIFFITH – SECRETARY**

**DAVID DUGGAN – TREASURER**

**RONNIE ANDERSON – DIRECTOR**

**KEVIN SIMMONS – DIRECTOR**

**KY KENNEDY – DIRECTOR**

**VIRGIL MOORE, III – EXECUTIVE DIRECTOR**

This page intentionally left blank.



## INDEPENDENT AUDITOR'S REPORT

To the Board of Directors  
Breckenridge Economic Development Corporation  
Breckenridge, Texas

### Report on the Financial Statements

We have audited the accompanying financial statements of the governmental activities and general fund of Breckenridge Economic Development Corporation ("BEDC, a component of the City of Breckenridge, Texas), as of and for the year ended September 30, 2020, and the related notes to the financial statements, which collectively comprise the BEDC' basic financial statements as listed in the table of contents.

### Management's Responsibility for the Financial Statements

Management is responsible for the preparation and fair presentation of these financial statements in accordance with accounting principles generally accepted in the United States of America; this includes the design, implementation, and maintenance of internal control relevant to the preparation and fair presentation of financial statements that are free from material misstatement, whether due to fraud or error.

### Auditor's Responsibility

Our responsibility is to express opinions on these financial statements based on our audit. We conducted our audit in accordance with auditing standards generally accepted in the United States of America and the standards applicable to financial audits contained in *Government Auditing Standards*, issued by the Comptroller General of the United States. Those standards require that we plan and perform the audit to obtain reasonable assurance about whether the financial statements are free of material misstatement.

An audit involves performing procedures to obtain audit evidence about the amounts and disclosures in the financial statements. The procedures selected depend on the auditor's judgment, including the assessment of the risks of material misstatement of the financial statements, whether due to fraud or error. In making those risk assessments, the auditor considers internal control relevant to the entity's preparation and fair presentation of the financial statements in order to design audit procedures that are appropriate in the circumstances, but not for the purpose of expressing an opinion on the effectiveness of the entity's internal control. Accordingly, we express no such opinion. An audit also includes evaluating the appropriateness of accounting policies used and the reasonableness of significant accounting estimates made by management, as well as evaluating the overall presentation of the financial statements.

We believe that the audit evidence we have obtained is sufficient and appropriate to provide a basis for our audit opinions.

## Opinions

In our opinion, the financial statements referred to above present fairly, in all material respects, the respective financial position of the governmental activities and general fund of the Breckenridge Economic Development Corporation, as of September 30, 2020, and the respective changes in financial position for the year then ended in accordance with accounting principles generally accepted in the United States of America.

## Other Matters

### Required Supplementary Information

Accounting principles generally accepted in the United States of America require that the management's discussion and analysis on pages 4 through 10 and budgetary comparison information on pages 25 through 26 be presented to supplement the basic financial statements. Such information, although not a part of the basic financial statements, is required by the Governmental Accounting Standards Board, who considers it to be an essential part of financial reporting for placing the basic financial statements in an appropriate operational, economic, or historical context. We have applied certain limited procedures to the required supplementary information in accordance with auditing standards generally accepted in the United States of America, which consisted of inquiries with management about the methods of preparing the information and comparing the information for consistency with management's responses to our inquiries, the basic financial statement, and other knowledge we obtained during our audit of the basic financial statements. We do not express an opinion or provide any assurance on the information because the limited procedures do not provide us with sufficient evidence to express an opinion or provide any assurance.

### Other Reporting Required by Government Auditing Standards

In accordance with *Government Auditing Standards*, we have also issued our report dated February 2, 2021, on our consideration of the BEDC' internal control over financial reporting and our tests of its compliance with certain provisions of laws, regulations, contracts and grant agreements and other matters. The purpose of that report is to describe the scope of our testing of internal control over financial reporting and compliance and the results of that testing, and not to provide any opinion on the internal control over financial reporting or on compliance. That report is an integral part of an audit performed in accordance with Government Auditing Standards in considering BEDC' internal control over financial reporting and compliance.

*George Morgan Frazier, P.C.*

Weatherford, Texas  
February 2, 2021



## MANAGEMENT'S DISCUSSION AND ANALYSIS

As management of the Breckenridge Economic Development Corporation, we offer readers of BEDC's financial statements this narrative overview and analysis of the financial activities for the fiscal year ended September 30, 2020. We encourage readers to consider the information presented here.

### FINANCIAL HIGHLIGHTS

- The assets of the Breckenridge Economic Development Corporation exceeded its liabilities by \$3,853,042 (net position) for the current year reported. Of this amount, \$3,165,168 (unrestricted net position) may be used to meet BEDC's ongoing obligations and operations. In the prior year, the assets exceeded its liabilities by \$3,691,472.
- The BEDC's total net position increased by \$161,570 compared to a \$220,265 increase in the prior year.
- As of the close of the current year, the BEDC's governmental fund reported ending fund balance of \$3,767,175, of which, \$1,708,878 is unassigned fund balance. In the prior year, the governmental fund reported ending fund balance of \$3,630,873.

### OVERVIEW OF THE FINANCIAL STATEMENTS

This discussion and analysis are intended to serve as an introduction to the Breckenridge Economic Development Corporation's basic financial statements. The BEDC's basic financial statements comprise three components: 1) government-wide financial statements, 2) fund financial statements, and 3) notes to the financial statements. This report also contains other supplementary information in addition to the basic financial statements themselves.

**Government-wide financial statements.** The government-wide financial statements are designed to provide readers with a broad overview of the BEDC's finances, in a manner similar to a private-sector business.

The *statement of net position* presents information on all of the BEDC's assets and liabilities, with the difference between the two reported as *net position*. Over time, increases or decreases in net position may serve as a useful indicator of whether the financial position of the BEDC is improving or deteriorating.

The *statement of activities* presents information showing how the government's net position changed during the most recent fiscal year. All changes in net position are reported as soon as the underlying event giving rise to the change occurs, regardless of the timing of related cash flows. Thus, revenues and expenses are reported in this statement for some items that will only result in cash flows in future periods.

Both of the government-wide financial statements distinguish functions of the BEDC that are principally supported by sales taxes.

The government-wide financial statements can be found on pages 11 and 12 of this report.

**Fund financial statements.** A fund is a grouping of related accounts that is used to maintain control over resources that have been segregated for specific activities or objective. The BEDC uses fund accounting to ensure and demonstrate compliance with finance-related legal requirements.

**Governmental funds.** Governmental funds are used to account for essentially the same functions reported as governmental activities in the government-wide financial statements. However, unlike the government-wide financial statements, governmental fund financial statements focus on near-term inflows and outflows of spendable resources, as well as on balances of spendable resources available at the end of the fiscal year. Such information may be useful in evaluating a government's near-term financing requirements.

Because the focus of governmental funds is narrower than that of the government-wide financial statements, it is useful to compare the information presented for governmental funds with similar information presented for governmental activities in the government-wide financial statements. By doing so, readers may better understand the long-term impact of the government's near-term financing decisions. Both the governmental fund balance sheet and the governmental fund statement of revenues, expenditures, and changes in fund balance provide a reconciliation to facilitate this comparison between governmental funds and governmental activities.

The BEDC only has one governmental fund – the general fund.

The BEDC adopts an annual appropriated budget for its general fund. A budgetary comparison statement has been provided for these funds to demonstrate compliance with this budget.

The basic governmental fund financial statements can be found on pages 13 - 16 of this report.

**Notes to the financial statements.** The notes provide additional information that is essential to a full understanding of the data provided in the government-wide and fund financial statements. The notes to the financial statements can be found on pages 17 - 24 of this report.

**Other information.** In addition to the basic financial and accompanying notes, this report also presents certain required supplementary information that further explains and supports the information in the financial statements. Required supplementary information can be found on pages 25 - 26 of this report.

## **Government-wide Financial Analysis**

### **Governmental Activities**

As noted earlier, net position may serve over time as a useful indicator of a government's financial position. In the case of the BEDC, assets exceeded liabilities by \$3,853,042 as of September 30, 2020.

A portion of the BEDC's net position (\$222,428) reflects its investment in capital assets (e.g. land, building and improvements, furniture and equipment); less any related debt used to acquire those assets that is still outstanding. The BEDC uses these capital assets to provide services to citizens; consequently, these assets are not available for future spending.

An additional portion of the BEDC's net position (\$465,446) represent resources that are subject to external restrictions on how they may be used. The remaining balance of unrestricted net position (\$3,165,168) may be used to meet the government's ongoing obligations to citizens and creditors.

Governmental activities increased the BEDC's net position by \$161,570 compared with a \$220,265 increase in the prior year. BEDC's total revenues were \$526,556. Total revenues increased \$14,080 (3%) from the prior year. Sales tax revenue increased \$33,512 (8%), however, rental income decreased \$20,000.

The total cost of all programs and services was \$364,986. Of this amount, 61% was for economic and community development services, 37% for general administration, and 2% for interest payment. Total expenses increased \$72,775 (25%) primarily due to economic incentives provided to businesses.

Below are summaries of the BEDC's Statement of Net Position and Statement of Activities.

#### Condensed Statement of Net Position

	Governmental Activities	
	2020	2019
Current and other assets	\$ 2,176,607	\$ 1,802,987
Capital assets	222,428	229,292
Properties held for economic development	1,592,851	1,830,131
<b>Total Assets</b>	<b>3,991,886</b>	<b>3,862,410</b>
Current liabilities	2,283	2,245
Long-term liabilities	136,561	168,693
<b>Total Liabilities</b>	<b>138,844</b>	<b>170,938</b>
Net position		
Net investment in capital assets	222,428	229,292
Restricted	465,446	456,399
Unrestricted	3,165,168	3,005,781
<b>Total Net Position</b>	<b>\$ 3,853,042</b>	<b>\$ 3,691,472</b>

## Changes in Net Position

	Governmental Activities	
	2020	2019
Revenues		
General revenues		
Sales tax	\$ 462,874	\$ 429,362
Rental income	40,000	60,000
Miscellaneous	-	100
Investment earnings	23,682	23,014
Total revenues	<u>526,556</u>	<u>512,476</u>
Expenses		
General administration	135,403	138,078
Economic development	199,279	69,998
Community development	24,352	73,782
Interest on long-term debt	5,952	10,353
Total expenses	<u>364,986</u>	<u>292,211</u>
Change in net position	161,570	220,265
Net position - beginning	3,691,472	3,471,207
	<u>\$ 3,853,042</u>	<u>\$ 3,691,472</u>

**Financial Analysis of the Government's Funds**

As noted earlier, Breckenridge Economic Development Corporation uses fund accounting to ensure and demonstrate compliance with finance-related legal requirements.

**Governmental funds.** The focus of BEDC's governmental fund is to provide information on near-term inflows, outflows, and balances of spendable resources. Such information is useful in assessing the BEDC's financing requirements. In particular, unreserved fund balance may serve as a useful measure of a government's net resources available for spending at the end of the current year.

At year end, BEDC's governmental fund reported ending fund balance of \$3,767,175. \$1,708,878 (45%) constitutes unassigned fund balance, which is available for spending at the government's discretion.

The general fund is the chief operating fund of the BEDC. At the end of the current year, unassigned fund balance of the general fund was \$1,708,878. As a measure of the general fund's liquidity, it may be useful to compare unassigned fund balance to total general fund expenditures. Unassigned fund balance represents 438% percent of the total general fund expenditures. During the current year, the fund balance of the BEDC's general fund increased by \$136,302. Below is a comparison of the general fund's net change in fund balance for 2020 and 2019:

	2020	2019	Increase (Decrease)
<b>Revenues</b>			
<b>General revenues</b>			
Sales tax	\$ 462,874	\$ 429,362	\$ 33,512
Rental income	40,000	60,000	(20,000)
Miscellaneous	-	100	(100)
Investment earnings	23,682	23,014	668
<b>Total revenues</b>	<u>526,556</u>	<u>512,476</u>	<u>14,080</u>
<b>Expenditures</b>			
General administration	128,539	131,809	(3,270)
Economic development	199,279	69,998	129,281
Community development	24,352	73,782	(49,430)
Capital outlay	-	9,995	(9,995)
Debt service::			
Principal	32,132	28,679	3,453
Interest on long-term debt	5,952	10,353	(4,401)
<b>Total expenditures</b>	<u>390,254</u>	<u>324,616</u>	<u>65,638</u>
<b>Excess (deficiency) of revenues over expenditures</b>	<u>\$ 136,302</u>	<u>\$ 187,860</u>	<u>\$ (51,558)</u>

### General Fund Budgetary Highlights

The original and the final budget can be briefly summarized by the following:

	Budgeted Amounts		Increase (Decrease)
	Original	Final	in Budget
<b>Expenditures:</b>			
General administration	\$ 134,309	\$ 134,309	\$ -
Economic development	273,462	273,462	-
Community development	64,000	64,000	-
Debt service	39,143	39,143	-
	<u>\$ 510,914</u>	<u>\$ 510,914</u>	<u>\$ -</u>

Total actual expenditures was under budget by \$120,660.

## Capital Assets

At September 30, 2020, BEDC had invested \$222,428 (net of accumulated depreciation) in capital assets, including land, building and improvements and furniture and equipment.

### BEDC's Capital Assets (Net of Depreciation)

	Governmental Activities	
	2020	2019
Land	\$ 56,546	\$ 56,546
Building and improvements	165,882	172,746
	<u>\$ 222,428</u>	<u>\$ 229,292</u>

More detailed information about the capital assets is presented in Note 1H and Note 4 to the Financial Statements.

## Long-Term Debt

At year-end, Breckenridge Economic Development Corporation has outstanding notes in the amount of \$136,561 secured by sales tax revenues.

Additional information on the BEDC's debt is presented in Note 6 to the Financial Statements.

## Economic Factors and the Next Year's Budgets and Rates

Breckenridge has seen a decrease in the economy during the 2019-2020 fiscal year. Because of low oil and gas prices throughout most of the year, the oil industry, the primary economic driver for economic activity in Breckenridge and Stephens County was much less active, resulting in fewer jobs, fewer hours per employee, and less spending.

Also, COVID-19 had a substantial negative effect on employment sectors. One of our primary employers, New Vision Manufacturing, went out of business in the first half of 2020. Overall unemployment figures were twice the normal numbers for most of 2020.

An interesting positive from the COVID-19 pandemic for Breckenridge was that people stayed in town more, thus they went out of town to shop and eat less often. This resulted in an overall 8% increase in sales tax collections for fiscal year 2020.

Management expects performance for next year's sales tax collections to continue to increase if COVID-19 is controlled. At the time of this report, oil prices are on the rise again and resulting increased activity is visible. Additionally, two new primary employers had already open in November of 2020. RGN Manufacturing already employs about 75 full-time employees.

However, until a longer positive trend is evident, and until COVID is less impactful, the BEDC board chose to project flat sales tax collections for the coming year, and set their 2020-21 budget revenue projections approximately the same last year's actual collections.

**Request for Information**

The financial report is designed to provide a general overview of the BEDC's finances for all those with an interest in the government's finances. Questions concerning any of the information provided in this report or requests for additional financial information should be addressed to the Executive Director, 100 E. Elm St. PO Box 1466, Breckenridge, Texas 76424.

BRECKENRIDGE ECONOMIC DEVELOPMENT CORPORATION  
Statement of Net Position  
September 30, 2020

	Governmental Activities
<b>ASSETS</b>	
Cash and cash equivalents	\$ 1,750,438
Sales tax receivable	78,533
Notes receivable, net of allowance	347,636
Capital assets (net of accumulated depreciation):	
Land	56,546
Buildings and improvements	165,882
Properties held for economic development, at cost	1,592,851
Total Assets	3,991,886
<b>LIABILITIES</b>	
Payroll liabilities	2,283
Noncurrent liabilities	
Due within one year	33,234
Due in more than one year	103,327
Total liabilities	138,844
<b>NET POSITION</b>	
Net investment in capital assets	222,428
Restricted for USDA loan program	465,446
Unrestricted	3,165,168
Total net position	\$ 3,853,042

The notes to the financial statements are an integral part of this statement.



**BRECKENRIDGE ECONOMIC DEVELOPMENT CORPORATION**  
**Statement of Activities**  
**For the Year Ended September 30, 2020**

Functions/Programs	Expenses	Program Revenues		Net (Expense) Revenue and Changes in Net Position
		Charges for Services	Capital Grants and Contributions	Governmental Activities
<b>Primary Government</b>				
Governmental activities:				
General administration	\$ 135,403	\$ -	\$ -	\$ 135,403
Economic development	199,279	-	-	199,279
Community development	24,352	-	-	24,352
Interest on long-term debt	5,952	-	-	5,952
<b>Total primary government</b>	<b>364,986</b>	<b>-</b>	<b>-</b>	<b>364,986</b>
General revenues:				
Sales tax				462,874
Rental income				40,000
Investment earnings				23,682
<b>Total general revenues</b>				<b>526,556</b>
Change in net position				161,570
Net position - beginning				3,691,472
Net position - ending				<b>\$ 3,853,042</b>

The notes to the financial statements are an integral part of this statement.

BRECKENRIDGE ECONOMIC DEVELOPMENT CORPORATION  
 Balance Sheet  
 Governmental Fund  
 September 30, 2020

Assets	<u>General Fund</u>
Cash	\$ 1,750,438
Sales tax receivable	78,533
Notes receivable, net of allowance	347,636
Properties held for economic development, at cost	1,592,851
Total assets	<u>\$ 3,769,458</u>
Liabilities and Fund Balance	
Liabilities:	
Payroll liabilities	\$ 2,283
Fund balance	
Nonspendable	
Properties held for economic development	1,592,851
Restricted fund balance	
USDA loan program	465,446
Unassigned fund balance	1,708,878
Total fund balance	<u>3,767,175</u>
Total liabilities and fund balance	<u>\$ 3,769,458</u>

The notes to the financial statements are an integral part of this statement.

BRECKENRIDGE ECONOMIC DEVELOPMENT CORPORATION  
 Reconciliation of the Governmental Fund Balance Sheet  
 To the Statement of Net Position  
 September 30, 2020

Total Fund Balance - Governmental Fund	\$ 3,767,175
Capital assets used in governmental activities are not financial resources and therefore are not reported in the governmental fund. The cost of these assets was \$295,294 and accumulated depreciation was \$72,866. The net effect of including the ending balances for capital assets (net of depreciation) in the governmental activities is to increase net position.	222,428
Long-term liabilities are not due and payable in the current period and therefore are not reported in the fund financial statements. The net effect of including \$136,561 note payable is to decrease net position.	(136,561)
Net Position of Governmental Activities	<u>\$ 3,853,042</u>

The notes to the financial statements are an integral part of this statement.

BRECKENRIDGE ECONOMIC DEVELOPMENT CORPORATION  
 Schedule of Revenues, Expenditures and Changes in Fund Balance - Budget and Actual  
 General Fund  
 For the Year Ended September 30, 2020

	Budgeted		ACTUAL	VARIANCE WITH BUDGET POSITIVE (NEGATIVE)
	Original	Final		
<b>REVENUES:</b>				
Sales tax	\$ 426,000	\$ 426,000	\$ 462,874	\$ 36,874
Rental income	60,000	60,000	40,000	(20,000)
Investment income	24,914	24,914	23,682	(1,232)
Total revenues	<u>510,914</u>	<u>510,914</u>	<u>526,556</u>	<u>15,642</u>
<b>EXPENDITURES:</b>				
General administration	134,309	134,309	128,539	5,770
Economic development	273,462	273,462	199,279	74,183
Community development	64,000	64,000	24,352	39,648
Debt service				
Principal	32,381	32,381	32,132	249
Interest	6,762	6,762	5,952	810
Total expenditures	<u>510,914</u>	<u>510,914</u>	<u>390,254</u>	<u>120,660</u>
Excess (deficiency) of revenues over (under) expenditures	-	-	136,302	136,302
Fund balance - beginning	<u>3,630,873</u>	<u>3,630,873</u>	<u>3,630,873</u>	-
Fund balance - ending	<u>\$ 3,630,873</u>	<u>\$ 3,630,873</u>	<u>\$ 3,767,175</u>	<u>\$ 136,302</u>

**BRECKENRIDGE ECONOMIC DEVELOPMENT CORPORATION**  
**Notes to the Required Supplementary Information**  
**For the Year Ended September 30, 2020**

**1. Budget Information**

The Board of Directors follow these procedures in establishing budgetary data reflected in the financial statements.

- a. Unencumbered appropriations for annually budgeted funds lapse at year end.
- b. Prior to the beginning of the fiscal year, proposed operating budget is submitted to the City Commission for the fiscal year commencing the following October 1. The operating budget includes proposed expenditures and the means of financing them for the general fund.
- c. The budget may be amended with the approval of the Board of Directors and the City Commission.
- d. Budgetary control is maintained at the line item level, subject to adjustments permitted as described above.





**INDEPENDENT AUDITOR'S REPORT ON INTERNAL CONTROL OVER FINANCIAL REPORTING AND ON COMPLIANCE AND OTHER MATTERS BASED ON AN AUDIT OF FINANCIAL STATEMENTS PERFORMED IN ACCORDANCE WITH *GOVERNMENT AUDITING STANDARDS***

To the Board of Directors  
Breckenridge Economic Development Corporation

We have audited, in accordance with auditing standards general accepted in the United States of America and the standards applicable to financial audits contained in Government Auditing Standards issued by the Comptroller General of the United States, the financial statements of the governmental activities and general fund of Breckenridge Economic Development Corporation as of and for the year ended September 30, 2020, and the related notes to the financial statements, which collectively comprise BEDC's basic financial statements and have issued our report thereon dated February 2, 2021.

Internal Control over Financial Reporting

In planning and performing our audit of the financial statements, we considered the BEDC's internal control over financial reporting (internal control) to determine the audit procedures that are appropriate in the circumstances for the purpose of expressing our opinions on the financial statements but not for the purpose of expressing an opinion on the effectiveness of BEDC's internal control. Accordingly, we do not express an opinion on the effectiveness of BEDC's internal control.

A deficiency in internal control exists when the design or operation of a control does not allow management or employees, in the normal course of performing their assigned functions, to prevent, or detect and correct misstatements on a timely basis. A material weakness is a deficiency, or combination of deficiencies, in internal control, such that there is a reasonable possibility that a material misstatement of the entity's financial statements will not be prevented, or detected and corrected on a timely basis. A significant deficiency is a deficiency, or a combination of deficiencies, in internal control that is less severe than a material weakness, yet important enough to merit attention by those charged with governance.

Our consideration of internal control was for the limited purpose described in the first paragraph of this section and was not designed to identify all deficiencies in internal control that might be material weaknesses or, significant deficiencies. Given these limitations, during our audit we did not identify any deficiencies in internal control that we consider to be material weaknesses. However, material weaknesses may exist that have not been identified.

Compliance and Other Matters

As part of obtaining reasonable assurance about whether BEDC's financial statements are free from material misstatement, we performed tests of its compliance with certain provisions of laws, regulations, contracts and grant agreements, noncompliance with which could have a direct and material effect on the financial statements. However, providing an opinion on compliance with those provisions was not an objective of our audit, and accordingly, we do not express such an opinion. The results of our tests disclosed no instances of noncompliance or other matters that are required to be reported under *Government Auditing Standards*.

Purpose of this Report

The purpose of this report is solely to describe the scope of our testing of internal control and compliance and the results of that testing, and not to provide an opinion on the effectiveness of the entity's internal control or on compliance. This report is an integral part of an audit performed in accordance with Government Auditing Standards in considering the entity's internal control and compliance. Accordingly, this communication is not suitable for any other purpose.

*George Morgan Sneed, P.C.*

Weatherford, Texas  
February 2, 2021



1. The first part of the document discusses the importance of maintaining accurate records of all transactions and activities. It emphasizes that this is crucial for ensuring transparency and accountability in the organization's operations. The text highlights that proper record-keeping is essential for identifying trends, detecting anomalies, and providing a clear audit trail.

2. The second part of the document focuses on the role of technology in streamlining record-keeping processes. It mentions that modern software solutions can significantly reduce the time and effort required to manage large volumes of data. The text suggests that investing in reliable technology is a key strategy for improving operational efficiency and reducing the risk of human error.

3. The third part of the document addresses the challenges associated with data security and privacy. It notes that as organizations collect and store more data, they also increase their vulnerability to cyber threats. The text stresses the need for robust security measures, such as encryption and access controls, to protect sensitive information from unauthorized access and data breaches.

4. The fourth part of the document discusses the importance of regular data backups and disaster recovery planning. It explains that having up-to-date backups is critical for ensuring business continuity in the event of a system failure or data loss. The text recommends that organizations should test their recovery procedures regularly to ensure they are effective and can be executed quickly.

5. The fifth part of the document concludes by summarizing the key points discussed and reiterating the overall goal of maintaining accurate and secure records. It encourages organizations to adopt a proactive approach to record management, continuously evaluating and improving their processes to meet the evolving needs of the business and regulatory requirements.



**RESOLUTION NO. 21-03**

**A RESOLUTION BY THE CITY COMMISSION OF THE CITY OF BRECKENRIDGE, TEXAS, TO REAPPOINT OR APPOINT A MEMBER TO THE PLANNING AND ZONING COMMISSION AND TO SET TERM OF OFFICE FOR APPOINTEE.**

**WHEREAS**, Section 2-40 of the Code of Ordinances of the City of Breckenridge creates the Planning and Zoning Commission for the City of Breckenridge and provides appointment procedures, and Section 2-40.5 provides for setting terms of office; and

**WHEREAS**, the terms of Randy Hash and William Hardy will expire February 28, 2021.

**NOW, THEREFORE, BE IT RESOLVED BY THE CITY COMMISSION OF THE CITY OF BRECKENRIDGE, TEXAS:** That Raul Duran Jr. and Blaine Reatherford shall be appointed to the Planning and Zoning Commission for a three year term to expire February 28, 2024.

**PASSED AND APPROVED** this 2<sup>nd</sup> day of March 2021 by the City Commission.

\_\_\_\_\_  
**Bob Sims, Mayor**

**ATTEST:**

\_\_\_\_\_  
**Heather Robertson-Caraway, CCCII, TRMC**  
**Interim City Manager/City Secretary**

SEAL

**RESOLUTION 21-05**

**A RESOLUTION BY THE CITY COMMISSION OF THE CITY OF BRECKENRIDGE, TEXAS, AUTHORIZING THE CITY MANAGER TO APPLY FOR A CRIMINAL JUSTICE DIVISION GRANT THROUGH THE GOVERNOR’S OFFICE FOR IN CAR VIDEO/AUDIO SYSTEMS PROJECT.**

**WHEREAS**, The Breckenridge City Commission finds it in the best interest of the citizens of Breckenridge Texas, that the In-Car Video/Audio Systems project be operated for the 2021 year; and

**WHEREAS**, The Breckenridge City Commission agrees to provide applicable matching funds for the said project as required by the Criminal Justice Division of the state of Texas, and the Justice Assistance Grant application; and

**WHEREAS**, The Breckenridge City Commission agrees that in the event of loss or misuse of the Criminal justice Division funds, the Breckenridge City Commission assures that the funds will be returned to the Criminal Justice Division in full.

**WHEREAS**, The Breckenridge City Commission designates Heather Robertson-Caraway Breckenridge City manager, as the grantee’s authorized official. The authorized official is given the power to apply for, accept, reject, alter or terminate the grant on behalf of the applicant agency.

**NOW THEREFORE, BE IT RESOLVED** that the Breckenridge City Commission approves submission of the grant application for the In-Car Video/Audio Systems project to the office of the Governor, Criminal Justice Division.

**PASSED AND APPROVED** this 2<sup>nd</sup> day of March 2021 by the following recorded vote:

**COMMISSIONERS VOTING “AYE”:**

**COMMISSIONERS VOTING “NAY”:**

**COMMISSIONERS ABSTAINING:**

**COMMISSIONERS ABSENT:**

\_\_\_\_\_  
**Bob Sims,**  
**Mayor**

**ATTEST:**

\_\_\_\_\_  
**Heather Robertson-Caraway, CCCII, TRMC**  
**Interim City Manager / City Secretary**

RESOLUTION 21-06

RESOLUTION AUTHORIZING APPLICATION FOR FINANCIAL ASSISTANCE FROM THE TEXAS WATER DEVELOPMENT BOARD FOR WASTEWATER SYSTEM IMPROVEMENTS; EXPRESSING INTENT TO REIMBURSE COSTS OF THE WASTEWATER SYSTEM PROJECT SUBJECT TO THE APPLICATION, AND MAKING CERTAIN FINDINGS IN CONNECTION THEREWITH

THE STATE OF TEXAS §
COUNTY OF STEPHENS §
CITY OF BRECKENRIDGE §

WHEREAS, the City of Breckenridge, Texas (the "City") hereby finds and determines that there is an urgent need for the construction of improvements to the City's wastewater system; and

WHEREAS, such capital improvements cannot be reasonably financed unless financial assistance is obtained from the Texas Water Development Board (the "TWDB"); and

WHEREAS, it is hereby officially found and determined: that public notice of the time, place, and purpose of said meeting was given, all as required by Texas Government Code, Chapter 551; and

WHEREAS, the City expects to pay, or have paid on its behalf, expenditures in connection with the project described in Section 1, below (the "Project"), prior to the issuance of tax-exempt obligations or other obligations for which a prior expression of intent to finance or refinance is required by Federal or state law (collectively and individually, the "Obligations") to finance the Project; and

WHEREAS, the City finds, considers and declares that the reimbursement for the payment of such expenditures will be appropriate and consistent with the lawful objectives of the City and, as such, chooses to declare its intention to reimburse itself for such payments at such time as it issues Obligations to finance the Project;

BE IT RESOLVED BY THE CITY COMMISSION OF THE CITY OF BRECKENRIDGE, TEXAS:

1. That an application is hereby approved and authorized to be filed with the TWDB seeking financial assistance in an amount not to exceed \$6,000,000 for purposes of the planning, acquisition, design and construction of improvements to the City's wastewater system, including upgrades/replacement of multiple lift station, replacement of various manholes and collection lines, construction of an equalization basin and pump station at the Wastewater Treatment Plant (WWTP), along with equipment replacement/upgrades and other necessary system improvements.

2. That the Mayor and City Secretary of said City are each hereby designated as authorized representatives of the City for the purpose of furnishing such information and executing such documents as may be required in connection with the preparing and filing of such application for financial assistance and with complying with the rules of the TWDB.

3. That the following firms and individuals are hereby authorized and directed to aid and assist in the preparation and submission of such application and appear on behalf of and represent the City before any hearing held by the TWDB on such application, to-wit:

**Financial Advisor**

Eric Macha  
Hilltop Securities, Inc.  
1201 Elm Street, Suite 3500  
Dallas, Texas 75270  
Phone: (214) 953-4033  
erick.macha@hilltopsecurities.com

**Bond Counsel**

Dan Culver  
McCall, Parkhurst & Horton L.L.P.  
717 N. Harwood, 9th Floor  
Dallas, Texas 75201-6587  
Phone: (214) 754-9275  
Fax: (214) 754-9250  
dculver@mphlegal.com

**Engineer**

Sage Diller, P.E.  
Enprotec / Hibbs &  
Todd, Inc.  
402 Cedar St  
Abilene, Texas 79601  
Phone: (325) 698-5560  
sage.diller@e-ht.com

and the Mayor of the City is hereby authorized and directed to execute contracts for services with such firms and individuals on behalf of the City.

4. That the City reasonably expects to incur debt, as one or more series of Obligations, with an aggregate principal amount not to exceed \$6,000,000 for the purpose of paying the costs of the Project.

5. That all costs to be reimbursed pursuant hereto will be capital expenditures. No tax-exempt Obligations will be issued by the City in furtherance of this Statement after a date which is later than 18 months after the later of (1) the date the expenditures are paid or (2) the date on which the property, with respect to which such expenditures were made, is placed in service.

6. That the foregoing notwithstanding, no tax-exempt Obligation will be issued pursuant to this Statement more than three years after the date any expenditure which is to be reimbursed is paid.

7. That this Resolution shall become effective immediately upon adoption.

**PASSED AND APPROVED** this, the 2<sup>nd</sup> day of March, 2021.

**ATTEST:**

\_\_\_\_\_  
**Bob Sims,**  
Mayor

\_\_\_\_\_  
**Heather Robertson-Caraway, CCCII, TRMC**  
City Secretary

**Exhibit A**

MAP REQUIRED BY SECTION 208 OF THE FEDERAL WATER POLLUTION CONTROL ACT





3. That the Mayor or Mayor Pro-Tem of said City has approved and hereby approves the aforesaid Resolution; that the Mayor or Mayor Pro-Tem and the City Secretary of said City have duly signed said Resolution; and that the Mayor or Mayor Pro-Tem and the City Secretary of said City hereby declare that their signing of this Certificate shall constitute the signing of the attached and following copy of said Resolution for all purposes.

SIGNED this, the 2nd day of March  
, 2021.

\_\_\_\_\_  
Mayor

\_\_\_\_\_  
City Secretary

RESOLUTION AUTHORIZING APPLICATION FOR FINANCIAL ASSISTANCE FROM THE TEXAS  
WATER DEVELOPMENT BOARD

APPLICATION AFFIDAVIT

THE STATE OF TEXAS

§

COUNTY OF STEPHENS

§

§

BEFORE ME, the undersigned, a Notary Public in and for the State of Texas, on this day personally appeared Bob Sims, Mayor of the City of Breckenridge, Texas, as the Authorized Representative of said City, who being by me duly sworn, upon oath says that:

1. The decision by the City Commission of the City of Breckenridge, Texas ("City") to request financial assistance from the Texas Water Development Board ("Board") was made in a public meeting held in accordance with the Open Meetings Act (Government Code, §551.001, et seq.) and after providing all such notice as required by such Act as is applicable to the City.

2. The information submitted in each application is true and correct according to my best knowledge and belief.

3. The City has no pending, threatened, or outstanding judgments, orders, fines, penalties, taxes, assessment or other enforcement or compliance issue of any kind or nature by the Environmental Protection Agency ("EPA"), Texas Commission on Environmental Quality ("TCEQ"), Texas Comptroller, Texas Secretary of State, or any other federal, state or local government, except as disclosed in the City's application for financial assistance.

4. The City warrants compliance with the representations made in each application in the event that the Board provides the financial assistance.

5. The City will comply with all applicable federal laws, rules, and regulations as well as the laws of the State of Texas and the rules and regulations of the Board.

\_\_\_\_\_  
Bob Sims, Mayor  
City of Breckenridge, Texas

SWORN TO AND SUBSCRIBED BEFORE ME by Bob Sims, Mayor of the City of Breckenridge, Texas, this 2<sup>nd</sup> day of March, 2021.

\_\_\_\_\_  
Notary Public, State of Texas

(NOTARY SEAL)

# Response to RFP

## Statement of Qualifications for Bond Counsel Services to the City of Breckenridge, Texas

600 Congress Ave.  
Suite 1800  
Austin, Texas 78701  
T 512.478.3805  
F 512.472.0871

717 North Harwood  
Suite 900  
Dallas, Texas 75201  
T 214.754.9200  
F 214.754.9250

Two Allen Center  
1200 Smith Street, Suite 1550  
Houston, Texas 77002  
T 713.980.0500  
F 713.980.0510

700 N. St. Mary's Street  
Suite 1525  
San Antonio, Texas 78205  
T 210.225.2800  
F 210.225.2984

## COVER LETTER

November 10, 2020

City of Breckenridge, Texas  
Attn: Mr. R. Scott Dixon  
Interim City Manager  
105 North Rose Ave.  
Breckenridge, Texas 76424

Mr. Dixon:

On behalf of McCall, Parkhurst & Horton L.L.P. (“McCall,” the “firm,” or “us”), I submit this statement of qualifications for bond counsel services to the City of Breckenridge, Texas (“you” or the “City”).

McCall serves as bond counsel to more issuers of tax-exempt debt than any other law firm in the State of Texas or in the Southwestern United States. Accordingly, we serve as bond counsel to more Texas political subdivisions than any other lawyer or law firm. We are consistently ranked by Thompson Reuters among the top ten bond counsel firms in the United States, as well as the #1 bond counsel firm here in Texas. McCall frequently serves as bond counsel on more bond transactions than any other law firm in the country.

For over 100 years, we have been committed to providing Texas political subdivisions with quality bond counsel services, and we hereby reaffirm our commitment to provide the City with such services to the best of our collective abilities. Investment banks, local and state government agencies, financial advisors and other professionals rely on us daily to guide them through the most basic, and the most complicated, financings in the State of Texas and in the United States. We are confident that our level of service to you will be unmatched.

Respectfully,

McCall, Parkhurst & Horton L.L.P.

By:

Dan S. Culver

Enclosures

**1. TABLE OF CONTENTS**

Cover Letter ..... i

1. Table of Contents ..... ii

2. Scope; General information about the firm..... 1

    Name, address, and telephone number of the firm ..... 1

    History of the firm ..... 1

    National Rankings and Texas Dominance ..... Error! Bookmark not defined.

    Scope of Work ..... 2

3. Staff Qualifications and Organization Experience ..... 4

    Dan S. Culver .....5

    Stefano J. Taverna .....5

4. References ..... 177

5. Proposed Contract Terms ..... 199

6. Additional Data or Services Offerings ..... 25

    Financial Condition and Professional Liability Insurance ..... 25

    No Litigation ..... 25

    Information Pertaining to the Firm’s Compliance with Licensing and Other Requirements ..... 25

## 2. SCOPE; GENERAL INFORMATION ABOUT THE FIRM

### NAME, ADDRESS, AND TELEPHONE NUMBER OF THE FIRM

McCall, Parkhurst & Horton L.L.P.  
717 N. Harwood, Suite 900  
Dallas, TX 75201  
(214) 754-9268

### HISTORY OF THE FIRM

McCall, Parkhurst & Horton L.L.P. (“McCall” or the “firm”) is a law firm that practices exclusively in the area of public finance law. The law firm was founded in Dallas in 1919, and was the first law firm west of the Mississippi River to render a nationally-accepted bond counsel opinion. Our firm’s founder, John D. McCall, pioneered some of the earliest water legislation and water financing systems in Texas, including serving as bond counsel to the first river authority (Brazos), created in 1929. Beginning in 1946, McCall worked with Gene Spence, Simon Freese, and J.B. Thomas to create the Colorado River Municipal Water District, and McCall served as bond counsel on the financings for O.H. Ivie, E.V. Spence, and J.B. Thomas reservoirs. In 1949, at the request of Governor Allan Shivers, McCall served as Secretary of the newly created Water Code Committee, which was organized to study the water laws of the state and propose new laws to address the state’s growing water shortage. With John’s guidance, the Legislature began to authorize the creation of dozens of regional water districts, including Eastland County Water Supply District, North Texas Municipal Water District, Northeast Texas Municipal Water District, Upper Leon River Municipal Water District, and many others. With McCall’s assistance, the Texas Water Development Board was created by legislative act and constitutional amendment in 1957. McCall served as bond counsel on the first statewide bond election to authorize the issuance of \$200 million in State of Texas General Obligation Water Development Bonds, the proceeds of which would be used to make loans to political subdivisions throughout the state.

Today, McCall stands strong as one of the nation’s leading public finance firms, representing thousands of clients around Texas, as well as in New Mexico and Oklahoma. The firm represents clients as diverse as the Cities of Austin, Dallas, Fort Worth and San Antonio, the Texas Water Development Board, Oklahoma Water Resources Board, The University of Texas System, Dallas Fort Worth International Airport, the Texas Department of Transportation and the Texas Higher Education Coordinating Board. McCall has served large utility clients, including the Texas Municipal Power Authority, the Lower Colorado River Authority, the Trinity River Authority, and the utility systems of Austin, Dallas, Fort Worth and Denton.

Since 2008, Thomson Reuters, the publisher of The Bond Buyer, has annually ranked McCall first in volume and in number of bond issues delivered in Texas by issuers of public securities, as well as in the top ten nationally. McCall dominates the Texas public finance market by a significant margin. The second-ranked bond counsel firms from 2008 to 2017 trailed McCall by a combined 1,178 bond issues and \$42.1 billion in principal amount.

Beginning in 2012, McCall was instrumental in the creation and implementation of the State Water Implementation Fund for Texas (SWIFT), which was approved by voters in a statewide election in 2013. In addition to representing the TWDB itself, our firm has represented many Texas cities, counties,

water districts, water supply corporations and other entities in issues sold to the Texas Water Development Board as shown below. McCall has garnered eight Southwest Region “Deal of the Year” awards since The Bond Buyer created the distinction in 2002.

## NATIONAL RANKINGS AND TEXAS DOMINANCE

The following table summarizes the number of transactions and dollar value of public finance issues for which McCall served as bond counsel from 2015 to the third quarter of 2020, as provided by Refinitiv, a Thomson Reuters subsidiary:

McCall, Parkhurst & Horton L.L.P. Bond Counsel Rankings						
National Ranking				Texas State Ranking		
Year	Rank	Amount	No. of Issues	Rank	Amount	No. of Issues
2020*	2	\$19,198,900,000	351	1	\$19,185,800,000	346
2019	5	\$12,789,600,000	334	1	\$12,586,900,000	327
2018	5	\$10,368,800,000	251	1	\$10,271,500,000	243
2017	5	\$13,210,200,000	385	1	\$13,150,100,000	377
2016	5	\$15,364,200,000	485	1	\$15,212,700,000	470
2015	3	\$14,859,600,000	436	1	\$14,722,400,000	424
* Nine Months 2020						
The information shown is compiled from reports of Refinitiv, a Thomson Reuters subsidiary.						

## SCOPE OF WORK

If engaged by the City, we expect to perform the following duties as bond counsel with respect to the issuance of any debt obligations (Obligations) by the City:

(a) Prepare all resolutions, ordinances, orders and other instruments pursuant to which the Obligations will be authorized, issued, delivered and secured, in cooperation and upon consultation with the City Council, its financial advisors and other consultants of the City.

(b) Attend meetings of the City Council with reference to the authorization and issuance of the Obligations to the extent required or requested.

(c) Cooperate with the City Council and all other interested parties in the sale of the Obligations to the TWDB.

(d) Supervise the execution of the Obligations, their approval by the Attorney General of Texas and registration by the Comptroller of Public Accounts of Texas, and the delivery thereof to the purchaser, the TWDB.

(e) When so delivered, give our objective approving opinion (our “Legal Opinion”) covering the validity of the Obligations and, if applicable, the exemption of interest thereon from federal income taxes, it being understood that the approving opinion will be fully acceptable nationally in regular commercial investment banking bond marketing channels.

Our Legal Opinion will be delivered by us on the date the Obligations are exchanged for their purchase price (the "Closing"). The City will be entitled to rely on our Legal Opinion.

The Legal Opinion will be based on facts and law existing as of its date. In rendering our Legal Opinion, we will rely upon the certified proceedings and other certifications of public officials and other persons furnished to us without undertaking to verify the same by independent investigation, and we will assume continuing compliance by the City with applicable laws relating to the Obligations. During the course of this engagement, we will rely on you to provide us with complete and timely information on all developments pertaining to any aspect of the Obligations and their security. We understand that you will direct members of your staff and other employees of the City to cooperate with us in this regard.

In this engagement, if the project financing involves the receipt of Principal Forgiveness by the City from the TWDB, we expect to perform the following duties:

(a) Prepare all resolutions, ordinances and other instruments pursuant to which Principal Forgiveness will be authorized, executed and delivered, in cooperation and upon consultation with the City Council, its financial advisors and other consultants of the City.

(b) Review the grant or Principal Forgiveness agreement and provide comments as necessary or appropriate.

(c) Prepare an escrow agreement and other documentation regarding the escrow of Principal Forgiveness funds and assist the City in engaging a qualified escrow agent.

(d) Coordinate the execution and delivery of various Principal Forgiveness documents and the delivery thereof to the TWDB.



### 3. STAFF QUALIFICATIONS AND ORGANIZATION EXPERIENCE

The professional staff of McCall, Parkhurst & Horton L.L.P. is composed of the following 33 active attorneys. Each and every attorney practices exclusively in the area of public finance.

<u>Name</u>	<u>Position</u>	<u>Location</u>	<u>Years Experience</u>
Jeffrey A. Leuschel	Partner	Dallas	39
L.E. (Ted) Brizzolara III	Partner	Dallas	39
Thomas K. Spurgeon	Partner	San Antonio	38
Dan S. Culver	Partner	Dallas	34
Carol D. Polumbo*	Partner	Austin	34
Gregory B. Salinas	Partner	Austin	30
Mark A. Malveaux	Partner	Dallas	27
Clayton S. Binford	Partner	San Antonio	18
Gregory C. Schaecher	Partner	Dallas	23
Richard S. Donoghue, Jr.	Partner	Austin	20
Noel Valdez	Partner	San Antonio	19
J. Bart Fowler*	Partner	Austin	21
Stefano Taverna	Partner	Dallas	17
Jeff Gulbas	Partner	Dallas	13
Christopher A. Settle	Partner	Dallas	16
Rodolfo Segura Jr	Partner	Dallas	10
Sam M. Gill	Partner	Dallas	12
Clayton Chandler	Associate	Austin	11
Hasan Mack	Associate	Austin	9
Lauren S. Ferrero	Associate	San Antonio	6
Orlando Juarez, Jr.	Associate	San Antonio	9
Molly E. Carson	Associate	Dallas	9
Abe Benavides	Associate	Dallas	5
M. Clark Kimball	Associate	Dallas	3
Jacqueline Hensley	Associate	Austin	1
Alan H. Raynor	Of Counsel	Dallas	46
G. Charles Kobdich*	Of Counsel	Dallas	45
Harold T. Flanagan	Of Counsel	Dallas	41
Leroy Grawunder, Jr.*	Of Counsel	Dallas	41
Michael R. Harris	Of Counsel	Houston	22
Jana Cogburn	Of Counsel	Houston	40
Ronald J. Freeman	Of Counsel	Austin	47
Rose Kanusky	Of Counsel	San Antonio	25

\*Served as Assistant Attorney General of Texas in the Public Finance Division.

Although the entire firm and its facilities will be available to the City, below are the names, titles, office locations and years of experience in the area of public finance for each of the persons to be primarily responsible for the City's account, followed by brief résumés for each:

<u>Name</u>	<u>Title</u>	<u>Office Location</u>	<u>Experience</u>
Dan S. Culver	Partner	Dallas	34 years
Stefano J. Taverna	Partner	Dallas	17 Years

## DAN S. CULVER

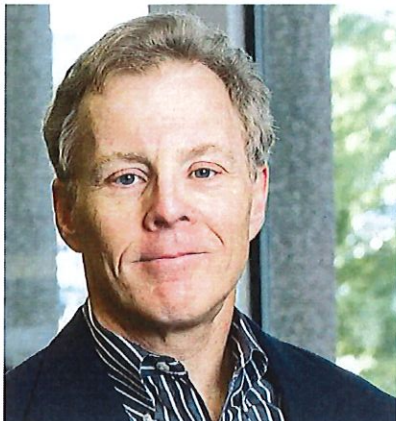

Dan Culver is a partner in the Dallas office who has spent the entirety of his 35+ year legal career at McCall. Dan represents a diverse group of general governmental issuers, including cities, counties, school districts, junior college districts, hospital districts and special utility districts. He also represents a variety of regional issuers, including joint powers agencies and river authorities, for whom he has provided bond counsel services for both governmental bonds, as well as for private activity “conduit” issues. His practice in the area of conduit financing has included a large volume of sewage and solid waste, dock and wharf and small issue manufacturing projects, as well as transactions involving 501(c)(3) organizations that use tax-exempt financing for university, primary and secondary educational facilities.

Since 2012, Dan Culver has served as lead attorney for the firm in a variety of TWDB issuances for firm clients, including issues for the Cities of Brownwood, Breckenridge, Colorado City, Marlin, Paris and Stephenville, Paris and the Johnson County Special Utility District.

Among other representations, Dan has served as disclosure counsel for the Texas Permanent School Fund since the initiation of SEC Rule 15c-12 in 1996. Dan provides leadership to the firm with respect to its representation of governmental issuers as disclosure counsel, and he frequently represents regional and national investment banking firms as underwriters’ counsel on negotiated governmental and 501(c)(3) transactions.

Dan is a graduate of the University of Alabama and the Southern Methodist University School of Law.

## STEFANO J. TAVERNA



Stefano Taverna, a partner of the firm, practices exclusively in the area of federal income taxation of tax-exempt and tax-credit bonds. Stefano provides tax advice to issuers and underwriters regarding tax-exempt bond financings involving new money projects, current and advance refundings, capital and working capital financings, commercial paper issues, and pooled bonds. He guides clients with respect to the structuring of tax-exempt bonds, private activity bonds, qualified school construction bonds, recovery zone bonds, qualified zone academy bonds, and other types of tax-credit bonds. Stefano also represents numerous clients before the IRS in connection with audits of tax-exempt and tax-credit bonds, Voluntary Compliance Agreements, and other administrative proceedings.

Prior to joining the firm, Stefano was a tax attorney at two law firms with an established Wall Street presence. Stefano has served as bond counsel, underwriters’ counsel and special tax counsel for numerous financing transactions throughout the country. Additionally, Stefano has advised clients on the federal and state tax aspects of domestic and international hedge fund formations and operations,

mergers, acquisitions and reorganizations, public and private debt and equity offerings, and general corporate, partnership and investment issues. Stefano has represented numerous clients on swap transactions and has advised tax-exempt entities with regard to the federal and state tax implications related to their formation and operations. Prior to joining private practice, Stefano clerked for the Honorable O’C. Wefing, Appellate Division, Superior Court of the State of New Jersey.

Stefano is a graduate of Rutgers, the State University of New Jersey (B.A., summa cum laude), Brooklyn Law School (J.D.) and New York University School of Law (LL.M.). He is admitted in New York and New Jersey and is a member of the American Bar Association, the New York State Bar Association, and the National Association of Bond Lawyers. Stefano has been a speaker and panelist at various events, including panels on public finance and federal tax matters. In addition, Stefano is a past Editor-in-Chief of the National Association of Bond Lawyers treatise *“Federal Taxation of Municipal Bonds”*, and is the Vice Chair of the Tax-Exempt Finance Committee of the American Bar Association.

McCall has served as bond counsel on a large number of transactions involving the Texas Water Development Board (“TWDB”), totaling **228 issuances over the past eight years** having an aggregate par amount of \$3,941,423,260. The following table is a list of certain transactions with the TWDB during the last 8 years in which McCall, Parkhurst & Horton served as bond counsel:

<b>McCall as Bond Counsel: Issues sold to Texas Water Development Board 2013-2020 (through September)</b>		
<b>Issuer</b>	<b>Issue</b>	<b>Principal</b>
<b>2020</b>		
Alto, Texas (City of)	Combination Tax and Surplus Revenue Certificates of Obligation, Series 2020	\$1,795,000
Austin, Texas (City of)	Water and Wastewater System Revenue Bonds, Series 2020A	\$11,200,000
Austin, Texas (City of)	Water and Wastewater System Revenue Bonds, Series 2020B	\$3,800,000
Blanco, Texas (City of)	Combination Tax and Surplus Revenue Certificates of Obligation, Series 2020	\$3,400,000
Brownsville, Texas (City of)	Combination Tax and Revenue Certificates of Obligation, Series 2020	\$6,975,000
Childress, Texas (City of)	Combination Tax and Surplus Revenue Certificates of Obligation, Series 2020	\$895,000
Dallas, Texas (City of)	Waterworks and Sewer System Revenue Bonds, Series 2020A	\$22,000,000
Dallas, Texas (City of)	Waterworks and Sewer System Revenue Bonds, Series 2020B	\$44,000,000
Edgewood, Texas (City of)	Combination Tax and Surplus Revenue Certificates of Obligation, Series 2020	\$1,540,000
Fort Worth, Texas (City of)	Water and Sewer System Revenue Bonds, Series 2020	\$62,725,000
Grand Saline, Texas (City of)	Combination Tax and Surplus Revenue Certificates of Obligation, Series 2020	\$405,000

Laredo, Texas (City of)	Waterworks and Sewer System Revenue Bonds, New Series 2020	\$52,000,000
Lefors, Texas (City of)	Combination Tax and Surplus Revenue Certificates of Obligation, Series 2020	\$395,000
North Texas Municipal Water District	Regional Wastewater System Revenue Bonds, Series 2020	\$458,920,000
Paducah, Texas (City of)	Combination Tax and Surplus Revenue Certificates of Obligation, Series 2020	\$1,715,000
Palo Pinto County, Texas	Combination Tax and Surplus Revenue Certificates of Obligation, Series 2020	\$500,000
Quitaque, Texas (City of)	Combination Tax and Surplus Revenue Certificates of Obligation, Series 2020	\$545,000
Rotan, Texas (City of)	Combination Tax and Surplus Revenue Certificates of Obligation, Taxable Series 2020A	\$235,000
Rotan, Texas (City of)	Combination Tax and Surplus Revenue Certificates of Obligation, Taxable Series 2020B	\$2,040,000
<b>2019</b>		
Alice, Texas (City of)	Combination Tax and Surplus Revenue Certificates of Obligation, Series 2019A	\$2,995,000
Alice, Texas (City of)	Combination Tax and Surplus Revenue Certificates of Obligation, Series 2019B	\$1,025,000
Alliance Regional Water Authority	Contract Revenue Bonds (Regional Water Supply Contract Project - Canyon Regional Water Authority), Series 2019A	\$26,530,000
Alliance Regional Water Authority	Contract Revenue Bonds (Regional Water Supply Contract Project - City of Buda, Texas), Series 2019D	\$4,370,000
Alliance Regional Water Authority	Contract Revenue Bonds (Regional Water Supply Contract Project - City of Kyle, Texas), Series 2019B	\$24,200,000
Alliance Regional Water Authority	Contract Revenue Bonds (Regional Water Supply Contract Project - City of San Marcos, Texas), Series 2019C	\$30,800,000
Austin, Texas (City of)	Water and Wastewater Systems Revenue Bonds, Series 2019	\$6,200,000
Blanco, Texas (City of)	Combination Tax and Surplus Revenue Certificates of Obligation, Series 2019	\$2,550,000
Bonham, Texas (City of)	Combination Tax and Surplus Revenue Certificates of Obligation, Series 2019A	\$4,810,000
Bonham, Texas (City of)	Combination Tax and Surplus Revenue Certificates of Obligation, Series 2019B	\$9,830,000
Borden County, Texas	Combination Tax and Surplus Revenue Certificates of Obligation, Series 2019	\$1,285,000
Cameron County Irrigation District No. 6	System Revenue Notes, Series 2019	\$865,000

Colorado City, Texas (City of)	Combination Tax and Surplus Revenue Certificates of Obligation, Series 2019	\$2,650,000
Dallas, Texas (City of)	Waterworks and Sewer System Revenue Bonds, Series 2019A	\$22,000,000
Dallas, Texas (City of)	Waterworks and Sewer System Revenue Bonds, Series 2019B	\$44,000,000
Del Rio, Texas (City of)	Combination Tax and Revenue Certificates of Obligation, Series 2019A	\$500,000
Del Rio, Texas (City of)	Combination Tax and Revenue Certificates of Obligation, Series 2019B	\$3,000,000
Del Rio, Texas (City of)	Combination Tax and Revenue Certificates of Obligation, Series 2019C	\$5,500,000
Dripping Springs, Texas (City of)	Combination Tax and Surplus Revenue Certificates of Obligation, Series 2019	\$23,500,000
Eastland County Water Supply District	Water Supply Revenue Bonds, Series 2019	\$805,000
Ector County Utility District	Water System Revenue Bonds, Series 2019	\$45,275,000
Goliad, Texas (City of)	Combination Tax and Surplus Revenue Certificates of Obligation, Series 2019	\$1,000,000
Guadalupe-Blanco River Authority	Contract Revenue Bonds, Series 2019 (Low-Interest Financing) (Carrizo Groundwater Supply Project) & Master Agreement between Texas Water Development Board and the Issuer regarding Board Participation - Carrizo Groundwater Supply Project	\$40,000,000
Kerr County, Texas	Combination Tax and Surplus Revenue Certificates of Obligation, Series 2019 (Center Point/East Kerr County Wastewater System Project)	\$2,105,000
Laguna Madre Water District	Waterworks and Sewer System Revenue Bonds, Series 2019	\$5,425,000
Marlin, Texas (City of)	Combination Tax and Surplus Revenue Certificates of Obligations, Series 2019A	\$3,055,000
Marlin, Texas (City of)	Combination Tax and Surplus Revenue Certificates of Obligations, Series 2019B	\$2,330,000
Nacogdoches County Municipal Utility District No. 1	Waterworks and Sewer System Revenue Bonds, Series 2019	\$1,010,000
North Texas Municipal Water District	Water System Revenue Bonds, Series 2019	\$101,345,000
Palo Pinto Water Supply Corporation	Promissory Note, Taxable Series 2019	\$615,000
Parker County Special Utility District	Utility System Revenue Bonds, Series 2019	\$15,080,000
Ropesville, Texas (City of)	Combination Tax and Surplus Revenue Certificates of Obligation, Series 2019	\$500,000

Roscoe, Texas (City of)	Combination Tax and Surplus Revenue Certificates of Obligation, Series 2019	\$1,965,000
Sabine River Authority of Texas	Gulf Coast Division Water Supply System Revenue Bonds, Taxable Series 2019	\$22,865,000
San Angelo, Texas (City of)	Waterworks and Sewer System Improvement Revenue Bonds, Series 2019	\$56,075,000
Stephens Regional Special Utility District	Revenue Bonds, Series 2019	\$900,000
Wills Point, Texas (City of)	Combination Tax and Surplus Revenue Certificates of Obligation, Series 2019	\$4,500,000
Wolfe City, Texas (City of)	Combination Tax and Surplus Revenue Certificates of Obligation, Series 2019A	\$2,325,000
Wolfe City, Texas (City of)	Combination Tax and Surplus Revenue Certificates of Obligation, Series 2019B	\$2,035,000
Wolfe City, Texas (City of)	Combination Tax and Surplus Revenue Certificates of Obligation, Series 2019C	\$870,000
Wolfe City, Texas (City of)	Combination Tax and Surplus Revenue Certificates of Obligation, Series 2019D	\$3,065,000
<b>2018</b>		
Abilene, Texas (City of)	Combination Tax and Surplus Revenue Certificates of Obligation, Series 2018	\$18,370,000
Alba, Texas (City of)	Combination Tax and Surplus Revenue Certificates of Obligation, Series 2018	\$990,000
Austin, Texas (City of)	Water and Wastewater System Revenue Bonds, Series 2018	\$3,000,000
Bandera, Texas (City of)	Combination Tax and Surplus Revenue Certificates of Obligation, Series 2018	\$3,000,000
Brushy Creek Regional Utility Authority, Inc.	City of Cedar Park, Texas Contract Revenue Bonds, (Brushy Creek Regional Water Treatment and Distribution Project), Series 2018	\$6,970,000
Chandler, Texas (City of)	Combination Tax and Revenue Certificates of Obligation, Series 2018	\$750,000
Cisco, Texas (City of)	Combination Tax and Surplus Revenue Certificates of Obligation, Series 2018A	\$4,565,000
Cisco, Texas (City of)	Combination Tax and Surplus Revenue Certificates of Obligation, Series 2018B	\$1,550,000
Dallas, Texas (City of)	Waterworks and Sewer System Revenue Bonds, Series 2018A	\$22,000,000
Dallas, Texas (City of)	Waterworks and Sewer System Revenue Bonds, Series 2018B	\$44,000,000
Dickens, Texas	Combination Tax and Surplus Revenue Certificates of Obligation, Series 2018	\$460,000
Eastland, Texas (City of)	Combination Tax and Surplus Revenue Certificates of Obligation, Series 2018	\$695,000

Eldorado, Texas (City of)	Combination Tax and Surplus Revenue Certificates of Obligation, Series 2018	\$1,200,000
Ennis, Texas (City of)	Combination Tax and Revenue Certificates of Obligation, Series 2018A	\$4,500,000
Farwell, Texas (City of)	Combination Tax and Waterworks and Sewer System Surplus Revenue Certificates of Obligation, Series 2018	\$1,500,000
Gorman, Texas (City of)	Combination Tax and Waterworks and Sewer System Surplus Revenue Certificates of Obligation, Series 2018	\$1,000,000
Guadalupe-Blanco River Authority	Contract Revenue Bonds, Series 2018A (Deferred Financing) (Carrizo Groundwater Supply Project)	\$12,030,000
Guadalupe-Blanco River Authority	Contract Revenue Bonds, Series 2018B (Low-Interest Financing) (Carrizo Groundwater Supply Project)	\$11,895,000
Guadalupe-Blanco River Authority	Master Agreement between Texas Water Development Board and Guadalupe-Blanco River Authority (Regarding Board Participation Carrizo Groundwater Supply Project No. 51055)	\$34,285,000
Johnson County Special Utility District	Revenue Bonds, Series 2018	\$22,000,000
Kerr County, Texas	Combination Tax and Surplus Revenue Certificates of Obligation, Series 2018	\$4,330,000
Kerrville, Texas (City of)	Combination Tax and Surplus Revenue Certificates of Obligation, Series 2018A	\$8,000,000
Kerrville, Texas (City of)	Combination Tax and Surplus Revenue Certificates of Obligation, Series 2018B	\$5,000,000
Lawn, Texas (City of)	Combination Tax and Waterworks and Sewer System Surplus Revenue Certificates of Obligation, Series 2018	\$885,000
Llano, Texas (City of)	Combination Tax and Surplus Revenue Certificates of Obligation, Series 2018A	\$3,390,000
Llano, Texas (City of)	Combination Tax and Surplus Revenue Certificates of Obligation, Series 2018B	\$890,000
Llano, Texas (City of)	Combination Tax and Surplus Revenue Certificates of Obligation, Series 2018C	\$630,000
Lone Star Regional Water Authority	(East Williamson County Regional Water Transmission System Project) Contract Revenue Bonds, Series 2018	\$1,285,000
Lone Star Regional Water Authority	(East Williamson County Regional Water Transmission System Project) Contract Revenue Bonds, Taxable Series 2018	\$215,000
Mason, Texas (City of)	Combination Tax and Surplus Revenue Certificates of Obligation, Series 2018	\$990,000
McAllen, Texas (City of)	Waterworks and Sewer System Revenue Bonds, Series 2018-A	\$7,000,000

McAllen, Texas (City of)	Waterworks and Sewer System Revenue Bonds, Series 2018-B	\$12,000,000
McAllen, Texas (City of)	Waterworks and Sewer System Revenue Bonds, Series 2018-C	\$6,900,000
North Texas Municipal Water District	Water System Revenue Bonds, Series 2018	\$800,000,000
North Texas Municipal Water District	Water System Revenue Bonds, Series 2018A	\$530,985,000
Ranger, Texas (City of)	Combination Tax and Surplus Revenue Certificates of Obligation, Series 2018A	\$570,000
Ranger, Texas (City of)	Combination Tax and Surplus Revenue Certificates of Obligation, Taxable Series 2018B	\$420,000
Sabine River Authority	Gulf Coast Division Water Supply System Revenue Bonds, Taxable Series 2018	\$33,310,000
San Marcos, Texas (City of)	Combination Tax and Surplus Revenue Certificates of Obligation, Series 2018	\$1,935,000
Stephenville, Texas (City of)	Combination Tax and Surplus Revenue Certificates of Obligation, Series 2018	\$17,030,000
West Wise Special Utility District	Revenue Bonds, Series 2018	\$13,430,000
Westlake, Texas (Town of)	Combination Tax and Surplus Revenue Certificates of Obligation, Taxable Series 2018	\$2,100,000
<b>2017</b>		
Alliance Regional Water Authority	Contract Revenue Bonds (Regional Water Supply Contract Project-Canyon Regional Water Authority), Series 2017A	\$9,865,000
Alliance Regional Water Authority	Contract Revenue Bonds (Regional Water Supply Contract Project-City of Buda, Texas), Series 2017D	\$1,625,000
Alliance Regional Water Authority	Contract Revenue Bonds (Regional Water Supply Contract Project-City of Kyle, Texas), Series 2017B	\$8,995,000
Alliance Regional Water Authority	Contract Revenue Bonds (Regional Water Supply Contract Project-City of San Marcos, Texas), Series 2017C	\$11,450,000
Angelina and Neches River Authority	Contract Revenue Bonds (Angelina County Fresh Water Supply District No. 1 Wastewater Project), Series 2017	\$1,400,000
Austin, Texas (City of)	Water and Wastewater System Revenue Bonds, Series 2017A	\$45,175,000
Blanco, Texas (City of)	Combination Tax and Surplus Revenue Certificates of Obligation, Series 2017A	\$3,150,000
Blanco, Texas (City of)	Combination Tax and Surplus Revenue Certificates of Obligation, Series 2017B	\$3,150,000
Booker, Texas (City of)	Combination Tax and Surplus Revenue Certificates of Obligation, Series 2017	\$455,000



Brushy Creek Regional Utility Authority, Inc.	City of Cedar Park, Texas Contract Revenue Bonds, Series 2017 (Brushy Creek Regional Water Treatment and Distribution Project), Series 2017	\$4,430,000
Brushy Creek Regional Utility Authority, Inc.	City of Round Rock, Texas Contract Revenue Bonds (Brushy Creek Regional Water Treatment and Distribution Project), Series 2017	\$4,435,000
Crystal Clear Special Utility District	Combination Water and Sewer System Revenue Bonds, Series 2017	\$15,000,000
Eastland, Texas (City of)	Combination Tax and Surplus Revenue Certificates of Obligation, Series 2017	\$6,765,000
Fort Worth, Texas (City of)	Water and Sewer System Revenue Bonds, Series 2017	\$16,045,000
Gladewater, Texas (City of)	Combination Tax and Surplus Revenue Certificates of Obligation, Series 2017A	\$1,600,000
Gladewater, Texas (City of)	Combination Tax and Surplus Revenue Certificates of Obligation, Series 2017B	\$3,900,000
Gordon, Texas (City of)	Combination Tax and Surplus Revenue Certificates of Obligation, Taxable Series 2017	\$460,000
Jarrell, Texas (City of)	Combination Tax and Revenue Certificates of Obligation, Series 2017	\$12,000,000
Melvin, Texas (City of)	Water System Revenue Bonds, Series 2017	\$180,000
Mustang Special Utility District	Revenue Bonds, Series 2017B	\$3,555,000
New Deal, Texas (City of)	Combination Tax and Surplus Revenue Certificates of Obligation, Series 2017	\$935,000
North Texas Municipal Water District	Water System Revenue Bonds, Series 2017	\$44,650,000
Quinlan, Texas (City of)	Combination Tax and Surplus Revenue Certificates of Obligation, Series 2017	\$1,675,000
River Oaks, Texas (City of)	Combination Tax and Surplus Revenue Certificates of Obligation, Series 2017A	\$7,000,000
River Oaks, Texas (City of)	Combination Tax and Surplus Revenue Certificates of Obligation, Series 2017B	\$8,000,000
San Antonio River Authority	Wastewater System Revenue Bonds, Series 2017	\$9,500,000
San Marcos, Texas (City of)	Waterworks and Waste Water System Revenue Bonds, Series 2017A	\$4,760,000
San Marcos, Texas (City of)	Waterworks and Waste Water System Revenue Bonds, Series 2017B	\$1,000,000
Seymour, Texas (City of)	Combination Tax and Surplus Revenue Certificates of Obligation, Series 2017	\$2,115,000
Troy, Texas (City of)	Combination Tax and Revenue Certificates of Obligation, Series 2017	\$2,100,000
West Tawakoni, Texas (City of)	Tax and Waterworks and Sewer System Surplus Revenue Certificates of Obligation, Series 2017	\$1,125,000

2016		
Angelina and Neches River Authority	Revenue Bonds (Angelina Country Fresh Water Supply District No. 1 WW Project), Series 2016	\$1,820,000
Anthony, Texas (Town of)	Combination Tax and Surplus Revenue Certificates of Obligation, Series 2016	\$980,000
Austin, Texas (City of)	Water and Wastewater Sys Rev Bonds, Series 2016A	\$20,430,000
Beeville, Texas (City of)	Combination Tax and Surplus Revenue Certificates of Obligation, Series 2016	\$3,300,000
Beeville, Texas (City of)	General Obligation Bonds, Series 2016	\$4,500,000
Bonham, Texas (City of)	Combination Tax and Surplus Revenue Certificates of Obligation, Series 2016	\$3,800,000
Cameron, Texas (City of)	Combination Tax and Surplus Revenue Certificates of Obligation, Series 2016A	\$9,305,000
Cameron, Texas (City of)	Combination Tax and Surplus Revenue Certificates of Obligation, Series 2016B	\$12,000,000
Coryell City Water Supply District	Utility System Net Revenue Bonds, Series 2016	\$2,000,000
City of Dodd City, Texas	Combination Tax and Surplus Revenue Certificates of Obligation, Series 2016	\$1,255,000
Edinburg, Texas (City of)	Utility System Junior Lien Revenue Bonds, Series 2016	\$5,405,000
Eldorado, Texas (City of)	Combination Tax and Surplus Revenue Certificates of Obligation, Series 2016	\$575,000
Jefferson, Texas (City of)	Combination Tax and Revenue Certificates of Obligation, Series 2016A	\$2,600,000
Jefferson, Texas (City of)	Combination Tax and Revenue Certificates of Obligation, Series 2016B	\$1,630,000
Jefferson, Texas (City of)	Combination Tax and Revenue Certificates of Obligation, Series 2016C	\$1,030,000
Kerr County, Texas	Combination Tax and Surplus Revenue Certificates of Obligation, Series 2016	\$5,295,000
Keller, Texas (City of)	Combination Tax and Surplus Revenue Certificates of Obligation Bonds, Series 2016	\$4,060,000
Laguna Madre Water District	Waterworks and Sewer System Revenue Bonds, Series 2016	\$5,815,000
Liberty, Texas (City of)	Utility System Revenue Bonds, Series 2016A	\$900,000
Liberty, Texas (City of)	Utility System Revenue Bonds, Series 2016B	\$915,000
McAllen, Texas (City of)	Waterworks and Sewer System Revenue Bonds, Series 2016	\$7,110,000
Stamford, Texas (City of)	Combination Tax and Revenue Certificates of Obligation, Series 2016	\$9,530,000
Sulphur Springs, Texas (City of)	Combination Tax and Surplus Revenue Certificates of Obligation, Series 2016	\$18,200,000

Sweetwater, Texas (City of)	Combination Tax and Surplus Revenue Certificates of Obligation, Series 2016	\$5,000,000
Tioga, Texas (City of)	Combination Tax and Revenue Certificates of Obligation, Series 2016	\$1,050,000
United Irrigation District	System Revenue Notes, Series 2016A	\$6,455,000
United Irrigation District	System Revenue Notes, Taxable Series 2016B	\$1,645,000
<b>2015</b>		
Alba, Texas (City of)	Combination Tax and Surplus Revenue Certificates of Obligation, Series 2015	\$840,000
Anton, Texas (City of)	Combination Tax and Surplus Revenue Certificates of Obligation, Series 2015	\$3,000,000
Early, Texas (City of)	Combination Tax and Surplus Revenue Certificates of Obligation, Series 2015	\$8,365,000
Fort Worth, Texas (City of)	Water and Sewer System Revenue Bonds, Series 2015	\$39,000,000
Gorman, Texas (City of)	Combination Tax and Waterworks and Sewer System Surplus Revenue Certificates of Obligation, Series 2015	\$140,000
Guadalupe-Blanco River Authority	General Improvement Revenue Bonds, Series 2015	\$2,000,000
Hays Caldwell Public Utility Agency	Contract Revenue Bonds (Regional Water Supply Contract Project - Canyon Regional Water Authority), Series 2015A	\$3,960,000
Hays Caldwell Public Utility Agency	Contract Revenue Bonds (Regional Water Supply Contract Project - City of Kyle, Texas), Series 201B	\$3,530,000
Hidalgo County Irrigation District No. One	Hidalgo County Irrigation District No. One System Revenue Notes, Series 2015	\$7,100,000
Johnson City, Texas (City of)	Tax and Surplus Revenue Certificates of Obligation, Series 2015	\$895,000
Laredo, Texas (City of)	Subordinate Waterworks and Sewer System Revenue Bonds, Series 2015	\$5,500,000
Laredo, Texas (City of)	Subordinate Waterworks and Sewer System Revenue Bonds, Series 2015A	\$4,600,000
Laredo, Texas (City of)	Subordinate Waterworks and Sewer System Revenue Bonds, Series 2015B	\$22,075,000
Lone Star Regional Water Authority	Contract Revenue Bonds, Taxable Series 2015 (East Williamson County Regional Water Transmission System Project)	\$940,000
Lone Star Regional Water Authority	Lone Star Regional Water Authority Contract Revenue Bonds, Series 2015 (East Williamson County Regional Water Transmission System Project)	\$4,590,000
Marfa, Texas (City of)	Combination Tax and Surplus Revenue Certificates of Obligation, Series 2015	\$705,000
McAllen, Texas (City of)	Waterworks and Sewer System Revenue Bonds,	\$40,000,000

	Series 2015	
Olney, Texas (City of)	Combination Tax and Revenue Certificates of Obligation, Series 2015	\$2,440,000
Palo Pinto County Municipal Water District No. 1	Revenue Bonds, Series 2015A	\$9,915,000
Palo Pinto County Municipal Water District No. 1	Revenue Bonds, Taxable Series 2015B	\$7,185,000
San Marcos, Texas (City of)	Waterworks and Waste Water System Revenue Bonds, Series 2015	\$410,000
Seagraves, Texas (City of)	Combination Tax and Surplus Revenue Certificates of Obligation, Series 2015	\$3,375,000
Tarrant Regional Water District, a Water Control and Improvement District	Transmission Facilities Contract Revenue Bonds (City of Dallas Project), Series 2015	\$140,000,000
Tarrant Regional Water District, a Water Control and Improvement District	Water Revenue Bonds, Series 2015A	\$300,000,000
Upper Leon River Municipal Water District	Tax-Exempt Water System Revenue Bonds, Series 2015A	\$7,452,000
Upper Leon River Municipal Water District	Taxable Water System Revenue Bonds, Series 2015B	\$1,863,000
Wichita Falls, Texas (City of)	Combination Tax and Revenue Certificates of Obligation, Series 2015	\$33,545,000
<b>2014</b>		
Angelina Neches River Authority	Contract Revenue Bonds (Angelina County Fresh Water Supply District No. 1 Wastewater Project), Series 2014	\$205,000
Anthony, Texas (Town of)	Combination Tax and Surplus Revenue Certificates of Obligation, Series 2014	\$735,000
Bandera County Fresh Water Supply District #1	Water Supply System Revenue Note, Series 2014	\$585,000
Breckenridge, Texas (City of)	Combination Tax and Surplus Revenue Certificates of Obligation, Series 2014	\$2,380,000
Carbon, Texas (City of)	Combination Tax and Surplus Revenue Certificates of Obligation, Series 2014 (Taxable)	\$95,000
Cisco, Texas (City of)	Combination Tax and Surplus Revenue Certificates of Obligation, Series 2014	\$475,000
Dell City, Texas (City of)	Combination Tax and Surplus Revenue Certificates of Obligation, Series 2014	\$75,000
Dell City, Texas (City of)	Loan Forgiveness Agreement 2014	\$116,223
Edinburg, Texas (City of)	Utility System Junior Lien Revenue Bonds, Series 2014	\$10,425,000
Ingram, Texas (City of)	Combination Tax and Surplus Revenue Certificates of Obligation, Series 2014	\$1,185,000

Lake Palo Pinto Area Water Supply Corporation	Loan Forgiveness Agreement 2014 (Taxable)	\$130,000
Olney, Texas (City of)	Combination Tax and Revenue Certificates of Obligation, Series 2014	\$285,000
Ralls, Texas (City of)	Utility System Revenue Bonds, Series 2014	\$130,000
Robstown, Texas (city of)	Sewer System Revenue Bonds, Series 2014	\$490,000
Sweetwater, Texas (City of)	Combination Tax and Surplus Revenue Certificates of Obligation, Series 2014	\$1,935,000
Valley Water Supply Corp	Loan Forgiveness Agreement 2014 (Taxable)	\$981,000
<b>2013</b>		
Bell County Water Control and Improvement District No. 2	Utility System Revenue Bonds, Series 2013	\$1,500,000
Bistone Municipal Water Supply District	Water Supply Revenue Bonds, Series 2013	\$6,130,000
Breckenridge, Texas (City of)	Combination Tax and Surplus Revenue Certificates of Obligation, Series 2013	\$840,000
Buda, Texas (City of)	Combination Tax and Surplus Revenue Certificates of Obligation, Series 2013	\$125,000
Eldorado, Texas (City of)	Combination Tax and Surplus Revenue Certificates of Obligation, Series 2013A	\$1,200,000
Eldorado, Texas (City of)	Combination Tax and Surplus Revenue Certificates of Obligation, Series 2013B	\$560,000
Goldthwaite, Texas (City of)	Combination Tax and Surplus Revenue Certificates of Obligation, Series 2013	\$1,480,000
Hico, Texas (City of)	Combination Tax and Surplus Revenue Certificates of Obligation, Series 2013	\$1,520,000
Ingram, Texas (City of)	Combination Tax and Surplus Revenue Certificates of Obligation, Series 2013	\$175,000
McAllen, Texas (City of)	Waterworks and Sewer System Revenue Bonds, Series 2013, Series 2013A and Series 2013B	\$9,867,000
McAllen, Texas (City of)	Loan Forgiveness Agreement 2013	\$1,620,904
Menard, Texas (City of)	Combination Tax and Revenue Certificates of Obligation, Series 2013	\$550,000
Moran, Texas (City of)	Combination Tax and Surplus Revenue Certificates of Obligation, Series 2013	\$180,000
Paris, Texas (City of)	Combination Tax and Surplus Revenue Certificates of Obligation, Series 2013	\$2,900,000
Roscoe, Texas (City of)	Combination Tax and Surplus Revenue Certificates of Obligation, Series 2013	\$1,040,000
San Antonio River Authority	Wastewater System Revenue Improvement Bonds, Series 2013A	\$4,300,000
San Juan, Texas (City of)	Waterworks and Sewer System Revenue Bonds, Series 2013-A	\$6,170,000

San Juan, Texas (City of)	Loan Forgiveness Agreement 2013	\$2,586,308
Smyer, Texas (City of)	Combination Tax and Surplus Revenue Certificates of Obligation, Series 2013	\$135,000
Upper Leon River Municipal Water District	Taxable Water System Revenue Bonds, Series 2013	\$775,000
Valley Water Supply Corp	Loan Forgiveness Agreement 2013 (Taxable)	\$121,825

#### 4. REFERENCES

Below is contact information for clients with borrowing needs that are similar to those of the City who can speak to the firm's abilities and to the qualifications and experience of the members of the proposed project team.

	<u>Name, Address, Contact, Title, Phone Number</u>
1.	City of Paris, Texas Gene Anderson, Director of Finance 135 SE 1st St. Paris, Texas 75460-5803 903-784-9241
2.	City of Longview Angela Coen, Director of Finance 300 West Cotton Street Longview, Texas 75601 (903) 239-5521
3.	City of Colorado City David Hoover, City Manager City of Colorado City 180 W. 3rd St. Colorado City, Texas 79512 (325) 728-3464
4.	City of Coleman, Texas Diana Lopez, City Manager P.O. Box 592 Coleman, Texas 76834 (325) 625-5114
5.	Town of Prosper, Texas Harlan Jefferson, Town Manager 200 S Main Street Prosper, Texas 75078 (972) 569-1011
6.	City of Stephenville, Texas Allen Barnes, City Administrator 298 West Washington Stephenville, Texas 76401 (254) 918-1225
7.	City of Henrietta, Texas Kelley Bloodworth, City Administrator 101 North Main

Henrietta, Texas 76365

(940) 538-4316

8.

City of Brownwood, Texas

Walter Middleton, Director of Finance

501 Center Avenue

Brownwood, Texas 76804

(325) 643-4477

## 5. PROPOSED CONTRACT TERMS

Below are our typical contract terms for debt obligations to be sold to (and grant funding to be received from) the Texas Water Development Board:

*“Mayor and Members of the City Council  
City of Breckenridge  
105 North Rose Ave.  
Breckenridge, Texas 76424*

*Re: Request for Financial Assistance from the Texas Water Development Board for the purpose of financing utility system improvements*

*Ladies and Gentlemen:*

*This letter is submitted to state our fees and describe the legal services of the undersigned law firm to be performed for the City of Breckenridge, Texas (the “City”) with reference to the City’s request for financial assistance from the Texas Water Development Board (“TWDB”), which financial assistance may include the sale of debt obligations (the “Obligations”) to the TWDB and/or the receipt of grant or principal forgiveness funding (“Principal Forgiveness”) by the City from the TWDB. We understand that the City is requesting such financial assistance from the TWDB for the purpose of planning, acquiring, designing and constructing improvements to the City’s waterworks and sewer system (the “Project”).*

### **SCOPE OF ENGAGEMENT**

*(1) In this engagement, if the Project financing involves the issuance of Obligations, we expect to perform the following duties as bond counsel with respect to the Obligations:*

*(a) Prepare all resolutions, ordinances, orders and other instruments pursuant to which the Obligations will be authorized, issued, delivered and secured, in cooperation and upon consultation with the City Council, its financial advisors and other consultants of the City.*

*(b) Attend meetings of the City Council with reference to the authorization and issuance of the Obligations to the extent required or requested.*

*(c) Cooperate with the City Council and all other interested parties in the sale of the Obligations to the TWDB.*

*(d) Supervise the execution of the Obligations, their approval by the Attorney General of Texas and registration by the Comptroller of Public Accounts of Texas, and the delivery thereof to the purchaser, the TWDB.*



(e) When so delivered, give our objective approving opinion (our "Legal Opinion") covering the validity of the Obligations and, if applicable, the exemption of interest thereon from federal income taxes, it being understood that the approving opinion will be fully acceptable nationally in regular commercial investment banking bond marketing channels.

Our Legal Opinion will be delivered by us on the date the Obligations are exchanged for their purchase price (the "Closing"). The City will be entitled to rely on our Legal Opinion.

The Legal Opinion will be based on facts and law existing as of its date. In rendering our Legal Opinion, we will rely upon the certified proceedings and other certifications of public officials and other persons furnished to us without undertaking to verify the same by independent investigation, and we will assume continuing compliance by the City with applicable laws relating to the Obligations. During the course of this engagement, we will rely on you to provide us with complete and timely information on all developments pertaining to any aspect of the Obligations and their security. We understand that you will direct members of your staff and other employees of the City to cooperate with us in this regard.

(2) In this engagement, if the Project financing involves the receipt of Principal Forgiveness by the City from the TWDB, we expect to perform the following duties:

(a) Prepare all resolutions, ordinances and other instruments pursuant to which Principal Forgiveness will be authorized, executed and delivered, in cooperation and upon consultation with the City Council, its financial advisors and other consultants of the City.

(b) Review the grant or Principal Forgiveness agreement and provide comments as necessary or appropriate.

(c) Prepare an escrow agreement and other documentation regarding the escrow of Principal Forgiveness funds and assist the City in engaging a qualified escrow agent.

(d) Coordinate the execution and delivery of various Principal Forgiveness documents and the delivery thereof to the TWDB.

(3) Our duties in this engagement are limited to those expressly set forth above. Unless we are separately engaged in writing to perform other services, our duties do not include any other services, including the following:

(a) Preparing requests for tax rulings from the Internal Revenue Service, or no action letters from the Securities and Exchange Commission.

(b) *Drafting state constitutional or legislative amendments.*

(c) *Pursuing test cases or other litigation.*

(d) *Making an investigation or expressing any view as to the creditworthiness of the City or the Obligations.*

(e) *Representing the City in Internal Revenue Service examinations or inquiries, or Securities and Exchange Commission investigations.*

(f) *Except as described in subsection (1)(a) above, assisting in the preparation of, or opining on, a continuing disclosure undertaking pertaining to the Obligations or, after Closing, providing advice concerning any actions necessary to assure compliance with any continuing disclosure undertaking.*

(g) *After Closing, monitoring the City's compliance with federal tax requirements to assure that interest paid on the Obligations will continue to be excludable from gross income for federal income tax purposes (e.g., our engagement does not include rebate calculations for the Obligations).*

(h) *Addressing any other matter not specifically set forth above that is not required to render our Legal Opinion.*

(i) *Issuing any legal opinion or assurance letter with respect to Principal Forgiveness funding.*

#### **ATTORNEY-CLIENT RELATIONSHIP**

*Upon execution of this engagement letter, the City will be our client and an attorney-client relationship will exist between us. We further assume that all other parties in this transaction understand that we represent only the City in this transaction, we are not counsel to any other party, and we are not acting as an intermediary among the parties. Our services as bond counsel are limited to those contracted for in this letter; the City's execution of this engagement letter will constitute an acknowledgment of those limitations. Our representation of the City will not affect, however, our responsibility to render an objective Legal Opinion.*

*Our representation of the City and the attorney-client relationship created by this engagement letter will be concluded upon issuance of the Obligations. Nevertheless, subsequent to Closing, we will mail the appropriate Internal Revenue Service Form 8038, prepare and distribute to the participants in the transaction a transcript of the proceedings pertaining to the Obligations.*

## NO BOYCOTT OF ISRAEL

*The firm hereby represents that during the term of this agreement we do not, nor will we, boycott Israel, in compliance with and within the meaning of 50 U.S.C. Section 4607 and Section 2271.002, of the Texas Government Code.*

## CONFLICTS

*As you are aware, our firm represents many political subdivisions and investment banking firms, among others, who do business with political subdivisions. Our firm also represents the TWDB in the capacity as bond counsel. It is possible that during the time that we are representing the City, one or more of our present or future clients will have transactions with the City. It is also possible that we may be asked to represent, in an unrelated matter, one or more of the entities involved in the issuance of the Obligations. We do not believe such representation, if it occurs, will adversely affect our ability to represent you as provided in this letter, either because such matters will be sufficiently different from the issuance of the Obligations and/or Principal Forgiveness so as to make such representations not adverse to our representation of you, or because the potential for such adversity is remote or minor and outweighed by the consideration that it is unlikely that advice given to the other client will be relevant to any aspect of the issuance of the Obligations and/or Principal Forgiveness. Execution of this letter will signify the City's consent to our representation of others consistent with the circumstances described in this paragraph.*

## FIRM NOT A MUNICIPAL ADVISOR

*As a consequence of the adoption of Rule 15Ba1-1 pursuant to the Securities Exchange Act of 1934 (the "Municipal Advisor Rule"), which has been promulgated by the Securities and Exchange Commission as a result of the enactment of the Dodd-Frank Wall Street Reform and Consumer Protection Act (the "Dodd-Frank Act"), we hereby inform the City that we are not a "Municipal Advisor" within the meaning of the Municipal Advisor Rule or the Dodd-Frank Act (collectively, the "MA Rule"). In the course of performing our services as Bond Counsel in this transaction, we may engage in analysis, discussion, negotiation, and advice to the City regarding the legal ramifications of the structure, timing, terms, and other provisions of the financial transaction that culminates with the planned issuance of the Obligations, and such services and advice may be essential to the development of the plan of finance for the issuance of the Obligations. In turn, these services become, among other things, the basis for the transaction's basic legal documents, the preparation and delivery of the official statement or any other disclosure document that describes the material terms and provisions of the transaction, if an offering document is used in the offering of the Obligations, the preparation of the various*

*closing certificates that embody the terms and provisions of this transaction and the preparation and delivery of our Legal Opinion. Moreover, legal advice and services of a traditional legal nature in the area of municipal finance inherently involve a financial advice component; but we hereby advise the City that while we have expertise with respect to the legal aspects relating to the issuance of municipal securities, we are not “financial advisors” or “financial experts” in a manner that would subject us to the provisions of the MA Rule. As Bond Counsel, we provide only legal advice, not purely financial advice that is not inherent in our legal advice to the City. The City should seek the advice of its financial advisor with respect to the financial aspects of the issuance of the Obligations. By signing this engagement letter, the City acknowledges receipt of this information, and evidences its understanding of the limitations of our role to the City as Bond Counsel with respect to the MA Rule, as discussed in this paragraph.*

### **FEES**

*Based upon: (i) our current understanding of the terms, structure, size and schedule of the financing represented by the Obligations; (ii) the duties we will undertake pursuant to this engagement letter with respect to the Obligations; (iii) the time we anticipate devoting to the financing represented by the Obligations; and (iv) the responsibilities we will assume in connection therewith, our fee for serving in the capacity of bond counsel with respect to each series of Obligations sold to the TWDB will be \$XXXXX for the first \$1,000,000 in principal amount of Obligations issued, plus \$X per \$1,000 for the next \$XXXXX in principal amount of obligations issued, plus \$X per \$1,000 for principal amounts of Obligations issued in excess of \$5,000,000; provided that there shall be a minimum fee of \$XXXXX for each series of Obligations issued.*

*In addition to the foregoing, we will be reimbursed for our out-of-pocket expenses reasonably and necessarily incurred in connection with the issuance of Obligations (e.g., electronic research, photocopying, shipping, telecommunication, travel, and other similar expenses), and said fee and expenses will be payable at the time of the delivery of and payment for the Obligations. Fees for litigation and any other special services not normally included in the legal services performed by bond counsel will be negotiated between the City and the undersigned. Our fee will be billed after the Closing.*

*In the event that the resolution of the TWDB granting the City’s request for financial assistance provides for 100% Principal Forgiveness funding for the Project, we will charge a separate, hourly fee (calculated in ¼-hour increments) for any legal work done in connection with any Principal Forgiveness received by the City from the TWDB. The City shall pay our firm for each hour of work performed with respect to Principal Forgiveness according to the following schedule:*

Partners: \$XXX per hour

Associates: \$XXX per hour

*In addition to such hourly fees, we will be reimbursed for our out-of-pocket expenses reasonably and necessarily incurred in connection with any Principal Forgiveness (e.g., electronic research, photocopying, shipping, telecommunication, travel, and other similar expenses), and said fees and expenses will be payable at the time of the initial delivery of such Principal Forgiveness funds to the City.*

### **RECORDS**

*After the transactions have closed, you will receive from us a transcript of proceedings that contain the primary financing and closing documents related to the transaction. At your request, papers and property furnished by you, and work product belonging to you and to which you are entitled, will be returned promptly. We may have copies of any and all documents made for our files at our sole cost and expense, to be retained by us. For various reasons, including the minimization of unnecessary storage expenses, we reserve the right to dispose of any documents or other materials retained by us after the closing of each transaction.*

### **ELECTRONIC COMMUNICATION AND STORAGE**

*In the interest of facilitating our services to you, we may send documents, information or data electronically or via the Internet or store electronic documents or data via computer software applications hosted remotely or utilize cloud-based storage. Your confidential electronic documents or data may be transmitted or stored using these methods. We may use third party service providers to store or transmit these documents or data. In using these electronic communication and storage methods, we employ reasonable efforts to keep such communications, documents and data secure in accordance with our obligations under applicable laws, regulations, and professional standards; however, you recognize and accept that we have no control over the unauthorized interception or breach of any communications, documents or data once it has been transmitted or if it has been subject to unauthorized access while stored, notwithstanding all reasonable security measures employed by us or by our third party vendors. By your acceptance of this letter, you consent to our use of these electronic devices and applications and submission of confidential client information to or through third party service providers during this engagement.*

## ACCEPTANCE OF TERMS OF ENGAGEMENT

*If the foregoing terms are acceptable to you, please so indicate by returning the enclosed copy of this engagement letter dated and signed by an authorized officer, retaining the original for your files. We look forward to working with you.*

*Very truly yours,*

*McCall, Parkhurst & Horton L.L.P.*

## 6. ADDITIONAL DATA OR SERVICES OFFERINGS

### FINANCIAL CONDITION AND PROFESSIONAL LIABILITY INSURANCE

During each of last three calendar years, McCall has generated gross revenues of over \$22,500,000 per year

Our firm maintains legal professional liability insurance with coverage of \$5,000,000. We have never filed a claim on our professional liability insurance.

### NO LITIGATION

There are no litigation proceedings against our firm, whether pending, final or of record, nor has our firm been involved in any such proceedings in the previous five years.

### INFORMATION PERTAINING TO THE FIRM'S COMPLIANCE WITH LICENSING AND OTHER REQUIREMENTS

There are no legal or administrative proceedings in which our firm, or any of its attorneys, have been involved as defendants relative to investigations into or violations of any regulatory agency rules including, but not limited to, the Securities and Exchange Commission, the New York Stock Exchange, the Financial Industry Regulatory Authority (formerly the National Association of Security Dealers), the Municipal Securities Regulatory Board, and the Texas Bond Review Board.

Neither the firm nor any individuals assigned to the City's account are suspended, or otherwise prohibited from professional practice by any federal, state, or local agency. All attorneys in the firm are members of the State Bar of Texas and are fully licensed to practice law in Texas. Some attorneys are licensed to practice law in other jurisdictions as well. The firm maintains a strong commitment to the continuing education of its attorneys and other professional staff in order to provide the highest level of service to our clients, and to ensure compliance with all licensing requirements imposed on our attorneys.

March 2, 2021

Mayor and Members of the City Council  
City of Breckenridge  
105 North Rose Ave.  
Breckenridge, TX 76424

Re: Request for Financial Assistance from the Texas Water Development Board for the purpose of financing utility system improvements

Ladies and Gentlemen:

This letter is submitted to state our fees and describe the legal services of the undersigned law firm to be performed for the City of Breckenridge, Texas (the “City”) with reference to the City’s request for financial assistance from the Texas Water Development Board (“TWDB”), which financial assistance may include the sale of debt obligations (the “Obligations”) to the TWDB and/or the receipt of grant or principal forgiveness funding (“Principal Forgiveness”) by the City from TWDB. We understand that the City is requesting such financial assistance from the TWDB for the purpose of planning, acquiring, designing and constructing improvements to the City’s waterworks and sewer system (the “Project”).

### SCOPE OF ENGAGEMENT

(1) In this engagement, if the Project financing involves the issuance of Obligations, we expect to perform the following duties as bond counsel with respect to the Obligations:

(a) Prepare all resolutions, ordinances, orders and other instruments pursuant to which the Obligations will be authorized, issued, delivered and secured, in cooperation and upon consultation with the City Council, its financial advisors and other consultants of the City.

(b) Attend meetings of the City Council with reference to the authorization and issuance of the Obligations to the extent required or requested.

(c) Cooperate with the City Council and all other interested parties in the sale of the Obligations to the TWDB.

(d) Supervise the execution of the Obligations, their approval by the Attorney General of Texas and registration by the Comptroller of Public Accounts of Texas, and the delivery thereof to the purchaser, the TWDB.

(e) When so delivered, give our objective approving opinion (our “Legal Opinion”) covering the validity of the Obligations and, if applicable, the exemption of interest thereon from federal income taxes, it being understood that the approving opinion will be fully acceptable nationally in regular commercial investment banking bond marketing channels.



Our Legal Opinion will be delivered by us on the date the Obligations are exchanged for their purchase price (the “Closing”). The City will be entitled to rely on our Legal Opinion.

The Legal Opinion will be based on facts and law existing as of its date. In rendering our Legal Opinion, we will rely upon the certified proceedings and other certifications of public officials and other persons furnished to us without undertaking to verify the same by independent investigation, and we will assume continuing compliance by the City with applicable laws relating to the Obligations. During the course of this engagement, we will rely on you to provide us with complete and timely information on all developments pertaining to any aspect of the Obligations and their security. We understand that you will direct members of your staff and other employees of the City to cooperate with us in this regard.

(2) In this engagement, if the Project financing involves the receipt of Principal Forgiveness by the City from the TWDB, we expect to perform the following duties:

(a) Prepare all resolutions, ordinances and other instruments pursuant to which Principal Forgiveness will be authorized, executed and delivered, in cooperation and upon consultation with the City Council, its financial advisors and other consultants of the City.

(b) Review the grant or Principal Forgiveness agreement and provide comments as necessary or appropriate.

(c) Prepare an escrow agreement and other documentation regarding the escrow of Principal Forgiveness funds and assist the City in engaging a qualified escrow agent.

(d) Coordinate the execution and delivery of various Principal Forgiveness documents and the delivery thereof to the TWDB.

(3) Our duties in this engagement are limited to those expressly set forth above. Unless we are separately engaged in writing to perform other services, our duties do not include any other services, including the following:

(a) Preparing requests for tax rulings from the Internal Revenue Service, or no action letters from the Securities and Exchange Commission.

(b) Drafting state constitutional or legislative amendments.

(c) Pursuing test cases or other litigation.

(d) Making an investigation or expressing any view as to the creditworthiness of the City or the Obligations.

(e) Representing the City in Internal Revenue Service examinations or inquiries, or Securities and Exchange Commission investigations.





(f) Except as described in subsection (1)(a) above, assisting in the preparation of, or opining on, a continuing disclosure undertaking pertaining to the Obligations or, after Closing, providing advice concerning any actions necessary to assure compliance with any continuing disclosure undertaking.

(g) After Closing, providing continuing advice to the City or any other party concerning any actions necessary to assure that interest paid on the Obligations will continue to be excludable from gross income for federal income tax purposes (e.g., our engagement does not include rebate calculations for the Obligations).

(h) Addressing any other matter not specifically set forth above that is not required to render our Legal Opinion.

(i) Issuing any legal opinion or assurance letter with respect to Principal Forgiveness funding.

#### **ATTORNEY-CLIENT RELATIONSHIP**

Upon execution of this engagement letter, the City will be our client and an attorney-client relationship will exist between us. We further assume that all other parties in this transaction understand that we represent only the City in this transaction, we are not counsel to any other party, and we are not acting as an intermediary among the parties. Our services as bond counsel are limited to those contracted for in this letter; the City's execution of this engagement letter will constitute an acknowledgment of those limitations. Our representation of the City will not affect, however, our responsibility to render an objective Legal Opinion.

Our representation of the City and the attorney-client relationship created by this engagement letter will be concluded upon issuance of the Obligations. Nevertheless, subsequent to Closing, we will mail the appropriate Internal Revenue Service Form 8038, prepare and distribute to the participants in the transaction a transcript of the proceedings pertaining to the Obligations.

#### **NO BOYCOTT OF ISRAEL**

The firm hereby represents that during the term of this agreement we do not, nor will we, boycott Israel, in compliance with and within the meaning of 50 U.S.C. Section 4607 and Section 2271.002, of the Texas Government Code.

#### **CONFLICTS**

As you are aware, our firm represents many political subdivisions and investment banking firms, among others, who do business with political subdivisions. Our firm also represents the TWDB in the capacity as bond counsel. It is possible that during the time that we are representing the City, one or more of our present or future clients will have transactions with



the City. It is also possible that we may be asked to represent, in an unrelated matter, one or more of the entities involved in the issuance of the Obligations. We do not believe such representation, if it occurs, will adversely affect our ability to represent you as provided in this letter, either because such matters will be sufficiently different from the issuance of the Obligations and/or Principal Forgiveness so as to make such representations not adverse to our representation of you, or because the potential for such adversity is remote or minor and outweighed by the consideration that it is unlikely that advice given to the other client will be relevant to any aspect of the issuance of the Obligations and/or Principal Forgiveness. Execution of this letter will signify the City's consent to our representation of others consistent with the circumstances described in this paragraph.

### **FIRM NOT A MUNICIPAL ADVISOR**

As a consequence of the adoption of Rule 15Ba1-1 pursuant to the Securities Exchange Act of 1934 (the "Municipal Advisor Rule"), which has been promulgated by the Securities and Exchange Commission as a result of the enactment of the Dodd-Frank Wall Street Reform and Consumer Protection Act (the "Dodd-Frank Act"), we hereby inform the City that we are not a "Municipal Advisor" within the meaning of the Municipal Advisor Rule or the Dodd-Frank Act (collectively, the "MA Rule"). In the course of performing our services as Bond Counsel in this transaction, we may engage in analysis, discussion, negotiation, and advice to the City regarding the legal ramifications of the structure, timing, terms, and other provisions of the financial transaction that culminates with the planned issuance of the Obligations, and such services and advice may be essential to the development of the plan of finance for the issuance of the Obligations. In turn, these services become, among other things, the basis for the transaction's basic legal documents, the preparation and delivery of the official statement or any other disclosure document that describes the material terms and provisions of the transaction, if an offering document is used in the offering of the Obligations, the preparation of the various closing certificates that embody the terms and provisions of this transaction and the preparation and delivery of our Legal Opinion. Moreover, legal advice and services of a traditional legal nature in the area of municipal finance inherently involve a financial advice component; but we hereby advise the City that while we have expertise with respect to the legal aspects relating to the issuance of municipal securities, we are not "financial advisors" or "financial experts" in a manner that would subject us to the provisions of the MA Rule. As Bond Counsel, we provide only legal advice, not purely financial advice that is not inherent in our legal advice to the City. The City should seek the advice of its financial advisor with respect to the financial aspects of the issuance of the Obligations. By signing this engagement letter, the City acknowledges receipt of this information, and evidences its understanding of the limitations of our role to the City as Bond Counsel with respect to the MA Rule, as discussed in this paragraph.

### **ELECTRONIC COMMUNICATION AND STORAGE**

In the interest of facilitating our services to you, we may send documents, information or data electronically or via the Internet or store electronic documents or data via computer software applications hosted remotely or utilize cloud-based storage. Your confidential electronic documents or data may be transmitted or stored using these methods. We may use third party



service providers to store or transmit these documents or data. In using these electronic communication and storage methods, we employ reasonable efforts to keep such communications, documents and data secure in accordance with our obligations under applicable laws, regulations, and professional standards; however, you recognize and accept that we have no control over the unauthorized interception or breach of any communications, documents or data once it has been transmitted or if it has been subject to unauthorized access while stored, notwithstanding all reasonable security measures employed by us or by our third party vendors. By your acceptance of this letter, you consent to our use of these electronic devices and applications and submission of confidential client information to or through third party service providers during this engagement.

### FEES

Based upon: (i) our current understanding of the terms, structure, size and schedule of the financing represented by the Obligations; (ii) the duties we will undertake pursuant to this engagement letter with respect to the Obligations; (iii) the time we anticipate devoting to the financing represented by the Obligations; and (iv) the responsibilities we will assume in connection therewith, our fee for serving in the capacity of bond counsel with respect to each series of Obligations sold to the TWDB will be \$12,500 for the first \$1,000,000 in principal amount of Obligations issued, plus \$5 per \$1,000 for the next \$4,000,000 in principal amount of obligations issued, plus \$2 per \$1,000 for principal amounts of Obligations issued in excess of \$5,000,000; provided that there shall be a minimum fee of \$20,000 for each series of Obligations issued.

In addition to the foregoing, we will be reimbursed for our out-of-pocket expenses reasonably and necessarily incurred in connection with the issuance of Obligations (e.g., electronic research, photocopying, shipping, telecommunication, travel, and other similar expenses), and said fee and expenses will be payable at the time of the delivery of and payment for the Obligations. Fees for litigation and any other special services not normally included in the legal services performed by bond counsel will be negotiated between the City and the undersigned. Our fee will be billed after the Closing.

In the event that the resolution of the TWDB granting the City's request for financial assistance provides for 100% Principal Forgiveness funding for the Project, we will charge a separate, hourly fee (calculated in ¼-hour increments) for any legal work done in connection with any Principal Forgiveness received by the City from the TWDB. The City shall pay our firm for each hour of work performed with respect to Principal Forgiveness according to the following schedule:

Partners:	\$450 per hour
Associates:	\$350 per hour

In addition to such hourly fees, we will be reimbursed for our out-of-pocket expenses reasonably and necessarily incurred in connection with any Principal Forgiveness (e.g., electronic research, photocopying, shipping, telecommunication, travel, and other similar expenses), and said fees



and expenses will be payable at the time of the initial delivery of such Principal Forgiveness funds to the City; provided, however, that so long as Obligations are actually delivered and our fees and expenses with respect to our services performed as bond counsel are paid, we will not invoice the City for our fees or expenses incurred in connection with Principal Forgiveness funding.

### RECORDS

After the transaction has closed, you will receive from us a transcript of proceedings that contain the primary financing and closing documents related to the transaction. At your request, papers and property furnished by you, and work product belonging to you and to which you are entitled, will be returned promptly. We may have copies of any and all documents made for our files at our sole cost and expense, to be retained by us. For various reasons, including the minimization of unnecessary storage expenses, we reserve the right to dispose of any documents or other materials retained by us after the closing of the transaction.

### ACCEPTANCE OF TERMS OF ENGAGEMENT

If the foregoing terms are acceptable to you, please so indicate by returning the enclosed copy of this engagement letter dated and signed by an authorized officer, retaining the original for your files. We look forward to working with you. With best wishes, I am

Very truly yours,

McCall, Parkhurst & Horton L.L.P.

By: \_\_\_\_\_

  
Dan S. Culver

Accepted this March 2, 2021

**City of Breckenridge, Texas**

By: \_\_\_\_\_

Bob Sims, Mayor

## Heather Robertson-Caraway

---

**From:** Erick Macha (HTS) <erick.macha@hilltopsecurities.com>  
**Sent:** Tuesday, February 23, 2021 10:00 AM  
**To:** Heather Robertson-Caraway  
**Cc:** George Williford (HTS); Jonathan McClellan (HTS)  
**Subject:** Breckenridge TWDB CW application proforma  
**Attachments:** Breckenridge TX - TWDB Proforma - 2.23.2021.pdf

Good morning Heather,

In preparing information for the TWDB application for the sewer project, we wanted to send a few proforma variations for planning purposes. Included are worksheets designed to calculate the revenues (column B) that would be needed to support operating expenses, transfers (if applicable), existing debt service and proposed debt service while providing for 1.1x coverage. This is the coverage level TWDB requires on their loans that are supported by combined utility and tax revenues. Included are the following schedules, each illustrating funding for a overall project size of \$4,160,000:

Assumes net transfers out of \$475,000 to remain constant

- Schedule 1: 30% grant + 0% interest rate on \$1,000,000 + subsidized interest rate on remaining \$1,915,000
- Schedule 2: 30% grant + subsidized interest rate on \$2,915,000
- Schedule 3: 100% loan at subsidized interest rate (no grant or 0% interest rate)

Schedules 1A-3A are the same as above but do not include the \$475,000 transfer out.

Based on the recent council presentation prepared by eHT, we would plan to include Schedule 1 in the application to TWDB. This schedule assumes the 30% grant and 0% interest rate on \$1,000,000. We did want to provide the other variations to the City, in the event the grant or 0% interest is not available once TWDB finalizes their review and determines funding levels for all their applicants.

After review, please do not hesitate to contact us with questions, thoughts or to discuss any of the assumptions.

Thanks,  
 Erick

---

**Erick Macha**

**Director**

**Hilltop Securities Inc.**

1201 Elm Street, Suite 3500, Dallas, TX 75270

Direct: 214.953.4033 | Mobile: 214.796.8969 | Text: 214.225.4773

[erick.macha@hilltopsecurities.com](mailto:erick.macha@hilltopsecurities.com)

---

**From:** Keith Kindle <Keith.Kindle@e-ht.com>  
**Sent:** Monday, February 1, 2021 12:00 PM  
**To:** Heather Robinson (hrobertson@breckenridgetx.gov) <hrobertson@breckenridgetx.gov>  
**Cc:** Sage Diller <sage.diller@e-ht.com>; Erick Macha (HTS) <erick.macha@hilltopsecurities.com>; Colden Rich <colden.rich@e-ht.com>  
**Subject:** Council Update

**EXTERNAL SENDER**

Heather –

Please see the attached Council update for the Council meeting. As we discussed, we recommend the City proceed with submitting the financial application (there is no cost to prepare it if the City decides not to pursue the funding). The application is due March 31, 2021. We know the rate study will not be complete then but the City does not have to make a decision to move forward with the loan until late July or August 2021. We have asked the City's FA to prepare an analysis on the affordability of the loan and grant (\$1.2M+) this month so the City can see where they stand when the rate study is complete.

Please note that the City has only been invited to apply for the CWSRF. The City's DWSRF was not in the top 20 and was not invited for this first round. The City will have a chance to apply for the DWSRF after March 31, 2021 if it wishes to do so.

Let me know if you have any questions!

Best Wishes,

Keith Kindle, PE  
 Chief Operating Officer  
**Enprotec / Hibbs & Todd, Inc. (eHT)**  
 T (682) 498-6000 | F (682) 498-6293 | M (210) 683-6542 | E [keith.kindle@e-ht.com](mailto:keith.kindle@e-ht.com)



**Enprotec / Hibbs & Todd**

PE Firm Registration No. 1151 | PG Firm Registration No. 50103

RPLS Firm Registration No. 10011900

[Facebook](#) | [Twitter](#) | [LinkedIn](#)

---

CONFIDENTIALITY NOTICE: The information contained in this email communication (including any attachment(s)) is strictly confidential and intended solely for the person or entity named above. If you are not the intended recipient of this email, you are hereby notified that any disclosure, distribution, reproduction, or other use of this communication is strictly prohibited. If you have received this communication in error, please immediately notify the sender by return email and permanently delete this communication (including any attachment(s)) from your system.

E-mail cannot be guaranteed to be secure or without error. Hilltop Securities Inc. and its affiliates employ e-mail monitoring software for the review of incoming and outgoing messages. The sender of this e-mail does not accept or assume any liability for any error or omissions arising as a result of transmission. Nothing in the content of this e-mail should be considered a specific investment recommendation or tax or legal advice. All prices and yields are subject to change and availability.

Schedule 1 - 2.23.2021

**Breckenridge, Texas**

**\$4,160,000 Clean Water Project - 30% Grant & \$1,000,000 at 0% Interest**

**Existing Debt Utility Supported - With Transfers**

**Level Debt Service - 30 Repayment Schedules**

**Preliminary, Structure and Terms Subject to TWDB Approval**

A	B	C	D	E	F	G	H	I	J	K	L	M	N	O	P					
																FYE	Gross Revenues	Growth	Operating Expenses	Net Transfers
2021	\$ 2,867,315	0.0%	\$ 1,755,501	\$ 475,000	\$ 636,814	\$ 466,592	\$ -	\$ -	\$ -	\$ -	\$ -	\$ -	\$ -	\$ -	\$ -	\$ 466,592	1.26x	2021		
2022	2,867,315	0.0%	1,755,501	475,000	636,814	464,139	-	-	-	-	39,789	39,789	-	-	503,928	1.26x	2022			
2023	2,868,732	0.0%	1,755,501	475,000	638,231	462,360	35,000	35,000	35,000	45,000	37,850	82,850	35,000	35,000	580,210	1.10x	2023			
2024	2,875,639	0.2%	1,755,501	475,000	645,138	464,589	35,000	35,000	35,000	50,000	36,900	86,900	35,000	35,000	586,489	1.10x	2024			
2025	2,875,639	0.0%	1,755,501	475,000	645,138	460,816	35,000	35,000	35,000	50,000	35,900	85,900	35,000	35,000	581,716	1.11x	2025			
2026	2,875,639	0.0%	1,755,501	475,000	645,138	458,191	35,000	35,000	35,000	50,000	34,900	84,900	35,000	35,000	578,091	1.12x	2026			
2027	2,875,639	0.0%	1,755,501	475,000	645,138	459,274	35,000	35,000	35,000	50,000	33,900	83,900	35,000	35,000	578,174	1.12x	2027			
2028	2,875,639	0.0%	1,755,501	475,000	645,138	461,355	35,000	35,000	35,000	50,000	32,900	82,900	35,000	35,000	579,255	1.11x	2028			
2029	2,875,639	0.0%	1,755,501	475,000	645,138	461,452	35,000	35,000	35,000	55,000	31,850	86,850	35,000	35,000	583,302	1.11x	2029			
2030	2,875,639	0.0%	1,755,501	475,000	645,138	458,599	35,000	35,000	35,000	55,000	30,750	85,750	35,000	35,000	579,349	1.11x	2030			
2031	2,875,639	0.0%	1,755,501	475,000	645,138	458,482	35,000	35,000	35,000	55,000	29,650	84,650	35,000	35,000	578,132	1.12x	2031			
2032	2,875,639	0.0%	1,755,501	475,000	645,138	459,373	35,000	35,000	35,000	55,000	28,550	83,550	35,000	35,000	577,923	1.12x	2032			
2033	2,875,885	0.0%	1,755,501	475,000	645,384	464,313	35,000	35,000	35,000	60,000	27,400	87,400	35,000	35,000	586,713	1.10x	2033			
2034	2,875,885	0.0%	1,755,501	475,000	645,384	464,135	35,000	35,000	35,000	60,000	26,200	86,200	35,000	35,000	585,335	1.10x	2034			
2035	2,875,885	0.0%	1,755,501	475,000	645,384	458,692	35,000	35,000	35,000	60,000	25,000	85,000	35,000	35,000	578,692	1.12x	2035			
2036	2,875,885	0.0%	1,755,501	475,000	645,384	459,233	35,000	35,000	35,000	60,000	23,800	83,800	35,000	35,000	578,033	1.12x	2036			
2037	2,875,885	0.0%	1,755,501	475,000	645,384	461,821	35,000	35,000	35,000	60,000	22,600	82,600	35,000	35,000	579,421	1.11x	2037			
2038	2,875,885	0.0%	1,755,501	475,000	645,384	461,267	35,000	35,000	35,000	65,000	21,350	86,350	35,000	35,000	582,617	1.11x	2038			
2039	2,875,885	0.0%	1,755,501	475,000	645,384	459,352	35,000	35,000	35,000	65,000	20,050	85,050	35,000	35,000	579,402	1.11x	2039			
2040	2,875,885	0.0%	1,755,501	475,000	645,384	463,256	35,000	35,000	35,000	65,000	18,750	83,750	35,000	35,000	582,006	1.11x	2040			
2041	2,875,885	0.0%	1,755,501	475,000	645,384	465,246	35,000	35,000	35,000	65,000	17,450	82,450	35,000	35,000	582,696	1.11x	2041			
2042	2,875,885	0.0%	1,755,501	475,000	645,384	458,175	30,000	30,000	30,000	70,000	16,100	86,100	30,000	30,000	574,275	1.12x	2042			
2043	2,875,885	0.0%	1,755,501	475,000	645,384	456,855	30,000	30,000	30,000	70,000	14,700	84,700	30,000	30,000	571,555	1.13x	2043			
2044	2,875,885	0.0%	1,755,501	475,000	645,384	463,225	30,000	30,000	30,000	70,000	13,300	83,300	30,000	30,000	576,525	1.12x	2044			
2045	2,875,885	0.0%	1,755,501	475,000	645,384	350,994	30,000	30,000	30,000	75,000	11,850	86,850	30,000	30,000	467,844	1.38x	2045			
2046	2,875,885	0.0%	1,755,501	475,000	645,384	213,870	30,000	30,000	30,000	75,000	10,350	85,350	30,000	30,000	329,220	1.96x	2046			
2047	2,875,885	0.0%	1,755,501	475,000	645,384	213,524	30,000	30,000	30,000	75,000	8,850	83,850	30,000	30,000	327,374	1.97x	2047			
2048	2,875,885	0.0%	1,755,501	475,000	645,384	213,210	30,000	30,000	30,000	80,000	7,300	87,300	30,000	30,000	330,510	1.95x	2048			
2049	2,875,885	0.0%	1,755,501	475,000	645,384	213,490	30,000	30,000	30,000	80,000	5,700	85,700	30,000	30,000	329,190	1.96x	2049			
2050	2,875,885	0.0%	1,755,501	475,000	645,384	213,773	30,000	30,000	30,000	80,000	4,100	84,100	30,000	30,000	327,873	1.97x	2050			
2051	2,875,885	0.0%	1,755,501	475,000	645,384	213,919	30,000	30,000	30,000	80,000	2,500	82,500	30,000	30,000	326,419	1.98x	2051			
2052	2,875,885	0.0%	1,755,501	475,000	645,384	213,030	35,000	35,000	35,000	85,000	850	85,850	35,000	35,000	333,880	1.93x	2052			
2053	2,875,885	0.0%	1,755,501	475,000	645,384	213,825	-	-	-	-	-	-	-	-	213,825	3.02x	2053			
2054	2,875,885	0.0%	1,755,501	475,000	645,384	213,558	-	-	-	-	-	-	-	-	213,558	3.02x	2054			
2055	2,875,885	0.0%	1,755,501	475,000	645,384	213,154	-	-	-	-	-	-	-	-	213,154	3.03x	2055			
2056	2,875,885	0.0%	1,755,501	475,000	645,384	213,629	-	-	-	-	-	-	-	-	213,629	3.02x	2056			
2057	2,875,885	0.0%	1,755,501	475,000	645,384	213,877	-	-	-	-	-	-	-	-	213,877	3.02x	2057			
													\$ 13,984,642		\$ 1,000,000	\$ 1,515,000	\$ 671,139	\$ 2,586,139		\$ 17,570,781

(1) Assumes FYE 2021 budgeted revenues and expenses. Assumes revenue growth to meet 1.10x coverage.

(2) The City currently supports all debt service from ad valorem tax. It is the City's intent to adjust utility rates sufficient to support all debt service from utility revenues.

Schedule 2 - 2.23.2021

**Breckenridge, Texas**

**\$4,160,000 Clean Water Project - 30% Grant  
Existing Debt Utility Supported - With Transfers  
Level Debt Service - 30 Repayment Schedules**

**Preliminary, Structure and Terms Subject to TWDB Approval**

A	B	C	D	E	F	G	H	I	J	K	L	M
FYE	Gross Revenues	Growth	Operating Expenses	Net Transfers	Net Available Revenues (1)	Utility Supported Debt Service	Principal	Interest	Debt Service	Aggregate Utility Supported Debt Service	Annual Coverage	FYE
2021	\$ 2,867,315	0.0%	\$ 1,755,501	\$ 475,000	\$ 636,814	\$ 466,592	\$ -	\$ -	\$ -	\$ 466,592	2021	2021
2022	2,867,315	0.0%	1,755,501	475,000	636,814	464,139	-	60,567	60,567	524,706	1.21x	2022
2023	2,879,457	0.4%	1,755,501	475,000	648,956	462,360	70,000	57,600	127,600	589,960	1.10x	2023
2024	2,885,814	0.2%	1,755,501	475,000	655,313	464,589	75,000	56,150	131,150	595,739	1.10x	2024
2025	2,885,814	0.0%	1,755,501	475,000	655,313	460,816	75,000	54,650	129,650	590,466	1.11x	2025
2026	2,885,814	0.0%	1,755,501	475,000	655,313	458,191	75,000	53,150	128,150	586,341	1.12x	2026
2027	2,885,814	0.0%	1,755,501	475,000	655,313	459,274	80,000	51,600	131,600	590,874	1.11x	2027
2028	2,885,814	0.0%	1,755,501	475,000	655,313	461,355	80,000	50,000	130,000	591,355	1.11x	2028
2029	2,885,814	0.0%	1,755,501	475,000	655,313	461,452	80,000	48,400	128,400	589,852	1.11x	2029
2030	2,885,814	0.0%	1,755,501	475,000	655,313	458,599	80,000	46,800	126,800	585,399	1.12x	2030
2031	2,885,814	0.0%	1,755,501	475,000	655,313	458,482	85,000	45,150	130,150	588,632	1.11x	2031
2032	2,885,814	0.0%	1,755,501	475,000	655,313	459,373	85,000	43,450	128,450	587,823	1.11x	2032
2033	2,885,814	0.0%	1,755,501	475,000	655,313	464,313	85,000	41,750	126,750	591,063	1.11x	2033
2034	2,885,814	0.0%	1,755,501	475,000	655,313	464,135	90,000	40,000	130,000	594,135	1.10x	2034
2035	2,885,814	0.0%	1,755,501	475,000	655,313	458,692	90,000	38,200	128,200	586,892	1.12x	2035
2036	2,885,814	0.0%	1,755,501	475,000	655,313	459,233	95,000	36,350	131,350	590,583	1.11x	2036
2037	2,885,814	0.0%	1,755,501	475,000	655,313	461,821	95,000	34,450	129,450	591,271	1.11x	2037
2038	2,885,814	0.0%	1,755,501	475,000	655,313	461,267	95,000	32,550	127,550	588,817	1.11x	2038
2039	2,885,814	0.0%	1,755,501	475,000	655,313	459,352	100,000	30,600	130,600	589,952	1.11x	2039
2040	2,885,814	0.0%	1,755,501	475,000	655,313	463,256	100,000	28,600	128,600	591,856	1.11x	2040
2041	2,885,814	0.0%	1,755,501	475,000	655,313	465,246	100,000	26,600	126,600	591,846	1.11x	2041
2042	2,885,814	0.0%	1,755,501	475,000	655,313	458,175	105,000	24,550	129,550	587,725	1.11x	2042
2043	2,885,814	0.0%	1,755,501	475,000	655,313	456,855	105,000	22,450	127,450	584,305	1.12x	2043
2044	2,885,814	0.0%	1,755,501	475,000	655,313	463,225	110,000	20,300	130,300	593,525	1.10x	2044
2045	2,885,814	0.0%	1,755,501	475,000	655,313	350,994	110,000	18,100	128,100	479,094	1.37x	2045
2046	2,885,814	0.0%	1,755,501	475,000	655,313	213,870	115,000	15,850	130,850	344,720	1.90x	2046
2047	2,885,814	0.0%	1,755,501	475,000	655,313	213,524	115,000	13,550	128,550	342,074	1.92x	2047
2048	2,885,814	0.0%	1,755,501	475,000	655,313	213,210	120,000	11,200	131,200	344,410	1.90x	2048
2049	2,885,814	0.0%	1,755,501	475,000	655,313	213,490	120,000	8,800	128,800	342,290	1.91x	2049
2050	2,885,814	0.0%	1,755,501	475,000	655,313	213,773	125,000	6,350	131,350	345,123	1.90x	2050
2051	2,885,814	0.0%	1,755,501	475,000	655,313	213,919	125,000	3,850	128,850	342,769	1.91x	2051
2052	2,885,814	0.0%	1,755,501	475,000	655,313	213,030	130,000	1,300	131,300	344,330	1.90x	2052
2053	2,885,814	0.0%	1,755,501	475,000	655,313	213,825	-	-	-	213,825	3.06x	2053
2054	2,885,814	0.0%	1,755,501	475,000	655,313	213,558	-	-	-	213,558	3.07x	2054
2055	2,885,814	0.0%	1,755,501	475,000	655,313	213,154	-	-	-	213,154	3.07x	2055
2056	2,885,814	0.0%	1,755,501	475,000	655,313	213,629	-	-	-	213,629	3.07x	2056
2057	2,885,814	0.0%	1,755,501	475,000	655,313	213,877	-	-	-	213,877	3.06x	2057
						\$ 13,984,642	\$ 2,915,000	\$ 1,022,917	\$ 3,937,917	\$ 17,922,559		

(1) Assumes FYE 2021 budgeted revenues and expenses. Assumes revenue growth to meet 1.10x coverage.  
 (2) The City currently supports all debt service from ad valorem tax. It is the City's intent to adjust utility rates sufficient to support all debt service from utility revenues.



Schedule 3 - 2.23.2021

**Breckenridge, Texas**

**\$4,160,000 Clean Water Project - 100% Loan**

**Existing Debt Utility Supported - With Transfers**

**Level Debt Service - 30 Repayment Schedules**

**Preliminary, Structure and Terms Subject to TWDB Approval**

A	B	C	D	E	F	G	H	I	J	K	L	M
FYE	Gross Revenues	Growth	Operating Expenses	Net Transfers	Net Available Revenues (1)	Utility Supported Debt Service	Planned (2)	Principal	Interest	Debt Service	Aggregate Utility Supported Debt Service	Annual Coverage
2021	\$ 2,867,315	0.0%	\$ 1,755,501	\$ 475,000	\$ 636,814	\$ 466,592	\$ -	\$ -	\$ -	\$ -	\$ 466,592	2021
2022	2,867,315	0.0%	1,755,501	475,000	636,814	464,139	86,436	86,436	86,436	86,436	550,574	2022
2023	2,939,517	2.5%	1,755,501	475,000	709,016	462,360	82,200	82,200	82,200	182,200	644,560	2023
2024	2,945,214	0.2%	1,755,501	475,000	714,713	464,589	80,150	80,150	80,150	185,150	649,739	2024
2025	2,945,214	0.0%	1,755,501	475,000	714,713	460,816	78,050	78,050	78,050	183,050	643,866	2025
2026	2,945,214	0.0%	1,755,501	475,000	714,713	458,191	75,900	75,900	75,900	185,900	644,091	2026
2027	2,945,214	0.0%	1,755,501	475,000	714,713	459,274	73,700	73,700	73,700	183,700	642,974	2027
2028	2,945,214	0.0%	1,755,501	475,000	714,713	461,355	71,450	71,450	71,450	186,450	647,805	2028
2029	2,945,214	0.0%	1,755,501	475,000	714,713	461,452	69,150	69,150	69,150	184,150	645,602	2029
2030	2,945,214	0.0%	1,755,501	475,000	714,713	458,599	66,800	66,800	66,800	186,800	645,399	2030
2031	2,945,214	0.0%	1,755,501	475,000	714,713	458,482	64,400	64,400	64,400	184,400	642,882	2031
2032	2,945,214	0.0%	1,755,501	475,000	714,713	459,373	62,000	62,000	62,000	182,000	641,373	2032
2033	2,945,214	0.0%	1,755,501	475,000	714,713	464,313	59,550	59,550	59,550	184,550	648,863	2033
2034	2,945,214	0.0%	1,755,501	475,000	714,713	464,135	57,050	57,050	57,050	182,050	646,185	2034
2035	2,945,214	0.0%	1,755,501	475,000	714,713	458,692	54,500	54,500	54,500	184,500	643,192	2035
2036	2,945,214	0.0%	1,755,501	475,000	714,713	459,233	51,850	51,850	51,850	186,850	646,083	2036
2037	2,945,214	0.0%	1,755,501	475,000	714,713	461,821	49,150	49,150	49,150	184,150	645,971	2037
2038	2,945,214	0.0%	1,755,501	475,000	714,713	461,267	46,400	46,400	46,400	186,400	647,667	2038
2039	2,945,214	0.0%	1,755,501	475,000	714,713	459,952	43,600	43,600	43,600	183,600	642,952	2039
2040	2,945,214	0.0%	1,755,501	475,000	714,713	463,256	40,750	40,750	40,750	185,750	649,006	2040
2041	2,945,214	0.0%	1,755,501	475,000	714,713	465,246	37,850	37,850	37,850	182,850	648,096	2041
2042	2,945,214	0.0%	1,755,501	475,000	714,713	458,175	34,900	34,900	34,900	184,900	643,075	2042
2043	2,945,214	0.0%	1,755,501	475,000	714,713	456,855	31,900	31,900	31,900	181,900	638,755	2043
2044	2,945,214	0.0%	1,755,501	475,000	714,713	463,225	28,850	28,850	28,850	183,850	647,075	2044
2045	2,945,214	0.0%	1,755,501	475,000	714,713	350,994	25,700	25,700	25,700	185,700	596,694	2045
2046	2,945,214	0.0%	1,755,501	475,000	714,713	213,870	22,500	22,500	22,500	182,500	396,370	2046
2047	2,945,214	0.0%	1,755,501	475,000	714,713	213,524	19,250	19,250	19,250	184,250	397,774	2047
2048	2,945,214	0.0%	1,755,501	475,000	714,713	213,210	15,900	15,900	15,900	185,900	399,110	2048
2049	2,945,214	0.0%	1,755,501	475,000	714,713	213,490	12,500	12,500	12,500	182,500	395,990	2049
2050	2,945,214	0.0%	1,755,501	475,000	714,713	213,773	9,050	9,050	9,050	184,050	397,823	2050
2051	2,945,214	0.0%	1,755,501	475,000	714,713	213,919	5,500	5,500	5,500	185,500	399,419	2051
2052	2,945,214	0.0%	1,755,501	475,000	714,713	213,030	1,850	1,850	1,850	186,850	399,880	2052
2053	2,945,214	0.0%	1,755,501	475,000	714,713	213,825	-	-	-	-	213,825	3.34x
2054	2,945,214	0.0%	1,755,501	475,000	714,713	213,558	-	-	-	-	213,558	3.35x
2055	2,945,214	0.0%	1,755,501	475,000	714,713	213,154	-	-	-	-	213,154	3.35x
2056	2,945,214	0.0%	1,755,501	475,000	714,713	213,629	-	-	-	-	213,629	3.35x
2057	2,945,214	0.0%	1,755,501	475,000	714,713	213,877	-	-	-	-	213,877	3.34x
						\$ 13,984,642	\$ 4,160,000	\$ 1,458,836	\$ 5,618,836	\$ 19,603,477		

(1) Assumes FYE 2021 budgeted revenues and expenses. Assumes revenue growth to meet 1.10x coverage.  
 (2) The City currently supports all debt service from ad valorem tax. It is the City's intent to adjust utility rates sufficient to support all debt service from utility revenues.



Schedule 2A - 2.23.2021

**Breckenridge, Texas**

**\$4,160,000 Clean Water Project - 30% Grant**  
**Existing Debt Utility Supported - Without Transfers**  
**Level Debt Service - 30 Repayment Schedules**  
**Preliminary, Structure and Terms Subject to TWDB Approval**

A	B	C	D	E	F	G	H	I	J	K	L	M
FYE	Gross Revenues	Growth	Operating Expenses	Net Transfers	Net Available Revenues (1)	Utility Supported Debt Service	Planned (2)	Interest	Debt Service	Aggregate Utility Supported Debt Service	Annual Coverage	FYE
								9/1/2021 - 2.00%				
2021	\$ 2,867,315		\$ 1,755,501	\$ -	\$ 1,111,814	\$ 466,592	\$ -	\$ -	\$ -	\$ 466,592	2021	2021
2022	2,867,315	0.0%	1,755,501	-	1,111,814	464,139	60,567	60,567	60,567	524,706	2.12x	2022
2023	2,867,315	0.0%	1,755,501	-	1,111,814	462,360	57,600	127,600	127,600	589,960	1.88x	2023
2024	2,867,315	0.0%	1,755,501	-	1,111,814	464,589	56,150	131,150	131,150	595,739	1.87x	2024
2025	2,867,315	0.0%	1,755,501	-	1,111,814	460,816	54,650	129,650	129,650	590,466	1.88x	2025
2026	2,867,315	0.0%	1,755,501	-	1,111,814	458,191	53,150	128,150	128,150	586,341	1.90x	2026
2027	2,867,315	0.0%	1,755,501	-	1,111,814	459,274	51,600	131,600	131,600	590,874	1.88x	2027
2028	2,867,315	0.0%	1,755,501	-	1,111,814	461,355	50,000	130,000	130,000	591,355	1.88x	2028
2029	2,867,315	0.0%	1,755,501	-	1,111,814	461,452	48,400	128,400	128,400	589,852	1.88x	2029
2030	2,867,315	0.0%	1,755,501	-	1,111,814	458,599	46,800	126,800	126,800	585,399	1.90x	2030
2031	2,867,315	0.0%	1,755,501	-	1,111,814	458,482	45,150	130,150	130,150	588,632	1.89x	2031
2032	2,867,315	0.0%	1,755,501	-	1,111,814	459,373	43,450	128,450	128,450	587,823	1.89x	2032
2033	2,867,315	0.0%	1,755,501	-	1,111,814	464,313	41,750	126,750	126,750	591,063	1.88x	2033
2034	2,867,315	0.0%	1,755,501	-	1,111,814	464,135	40,000	130,000	130,000	594,135	1.87x	2034
2035	2,867,315	0.0%	1,755,501	-	1,111,814	458,692	38,200	128,200	128,200	586,892	1.88x	2035
2036	2,867,315	0.0%	1,755,501	-	1,111,814	459,233	36,350	131,350	131,350	590,583	1.88x	2036
2037	2,867,315	0.0%	1,755,501	-	1,111,814	461,821	34,450	129,450	129,450	591,271	1.88x	2037
2038	2,867,315	0.0%	1,755,501	-	1,111,814	461,267	32,550	127,550	127,550	588,817	1.89x	2038
2039	2,867,315	0.0%	1,755,501	-	1,111,814	459,352	30,600	130,600	130,600	589,952	1.88x	2039
2040	2,867,315	0.0%	1,755,501	-	1,111,814	463,256	28,600	128,600	128,600	591,856	1.88x	2040
2041	2,867,315	0.0%	1,755,501	-	1,111,814	465,246	26,600	126,600	126,600	591,846	1.88x	2041
2042	2,867,315	0.0%	1,755,501	-	1,111,814	458,175	24,550	129,550	129,550	587,725	1.89x	2042
2043	2,867,315	0.0%	1,755,501	-	1,111,814	456,855	22,450	127,450	127,450	584,305	1.90x	2043
2044	2,867,315	0.0%	1,755,501	-	1,111,814	463,225	20,300	130,300	130,300	593,525	1.87x	2044
2045	2,867,315	0.0%	1,755,501	-	1,111,814	350,994	18,100	128,100	128,100	479,094	2.32x	2045
2046	2,867,315	0.0%	1,755,501	-	1,111,814	213,870	15,850	130,850	130,850	344,720	3.23x	2046
2047	2,867,315	0.0%	1,755,501	-	1,111,814	213,524	13,550	128,550	128,550	342,074	3.25x	2047
2048	2,867,315	0.0%	1,755,501	-	1,111,814	213,210	11,200	131,200	131,200	344,410	3.23x	2048
2049	2,867,315	0.0%	1,755,501	-	1,111,814	213,490	8,800	128,800	128,800	342,290	3.25x	2049
2050	2,867,315	0.0%	1,755,501	-	1,111,814	213,773	6,350	131,350	131,350	345,123	3.22x	2050
2051	2,867,315	0.0%	1,755,501	-	1,111,814	213,919	3,850	128,850	128,850	342,769	3.24x	2051
2052	2,867,315	0.0%	1,755,501	-	1,111,814	213,030	1,300	131,300	131,300	344,330	3.23x	2052
2053	2,867,315	0.0%	1,755,501	-	1,111,814	213,825	-	-	-	213,825	5.20x	2053
2054	2,867,315	0.0%	1,755,501	-	1,111,814	213,558	-	-	-	213,558	5.21x	2054
2055	2,867,315	0.0%	1,755,501	-	1,111,814	213,154	-	-	-	213,154	5.22x	2055
2056	2,867,315	0.0%	1,755,501	-	1,111,814	213,629	-	-	-	213,629	5.20x	2056
2057	2,867,315	0.0%	1,755,501	-	1,111,814	213,877	-	-	-	213,877	5.20x	2057
						\$ 13,984,642	\$ 2,915,000	\$ 1,022,917	\$ 3,937,917	\$ 17,922,559		

(1) Assumes FYE 2021 budgeted revenues and expenses. Assumes revenue growth to meet 1.10x coverage.  
 (2) The City currently supports all debt service from ad valorem tax. It is the City's intent to adjust utility rates sufficient to support all debt service from utility revenues.

Schedule 3A - 2.23.2021  
**Breckenridge, Texas**

**\$4,160,000 Clean Water Project - 100% Loan**  
**Existing Debt Utility Supported - Without Transfers**  
**Level Debt Service - 30 Repayment Schedules**

**Preliminary, Structure and Terms Subject to TWDB Approval**

A	B	C	D	E	F	G	H	I	J	K	L	M
FYE	Projected Revenues Available for Debt Service			Net Transfers	Net Available Revenues (1)	Planned (2)		\$4,160,000 CWSRF		Aggregate Utility Supported Debt Service	Annual Coverage	FYE
	Gross Revenues	Growth	Operating Expenses			Utility Supported Debt Service	Interest	Debt Service	Principal			
2021	\$ 2,867,315	0.0%	\$ 1,755,501	\$ -	\$ 1,111,814	\$ 466,592	\$ -	\$ -	\$ -	\$ 466,592	2.02x	2021
2022	2,867,315	0.0%	1,755,501	-	1,111,814	464,139	86,436	86,436	86,436	550,574	2.02x	2022
2023	2,867,315	0.0%	1,755,501	-	1,111,814	462,360	82,200	82,200	182,200	644,560	1.72x	2023
2024	2,867,315	0.0%	1,755,501	-	1,111,814	464,589	80,150	80,150	185,150	649,739	1.71x	2024
2025	2,867,315	0.0%	1,755,501	-	1,111,814	460,816	78,050	78,050	183,050	643,866	1.73x	2025
2026	2,867,315	0.0%	1,755,501	-	1,111,814	458,191	75,900	75,900	185,900	644,091	1.73x	2026
2027	2,867,315	0.0%	1,755,501	-	1,111,814	459,274	73,700	73,700	183,700	642,974	1.73x	2027
2028	2,867,315	0.0%	1,755,501	-	1,111,814	461,355	71,450	71,450	186,450	647,805	1.72x	2028
2029	2,867,315	0.0%	1,755,501	-	1,111,814	461,452	69,150	69,150	184,150	645,602	1.72x	2029
2030	2,867,315	0.0%	1,755,501	-	1,111,814	458,599	66,800	66,800	186,800	645,399	1.72x	2030
2031	2,867,315	0.0%	1,755,501	-	1,111,814	458,482	64,400	64,400	184,400	642,882	1.73x	2031
2032	2,867,315	0.0%	1,755,501	-	1,111,814	459,373	62,000	62,000	182,000	641,373	1.73x	2032
2033	2,867,315	0.0%	1,755,501	-	1,111,814	464,313	59,550	59,550	184,550	648,863	1.71x	2033
2034	2,867,315	0.0%	1,755,501	-	1,111,814	464,135	57,050	57,050	182,050	646,185	1.72x	2034
2035	2,867,315	0.0%	1,755,501	-	1,111,814	458,692	54,500	54,500	184,500	643,192	1.73x	2035
2036	2,867,315	0.0%	1,755,501	-	1,111,814	459,239	51,850	51,850	186,850	646,083	1.72x	2036
2037	2,867,315	0.0%	1,755,501	-	1,111,814	461,821	49,150	49,150	184,150	645,971	1.72x	2037
2038	2,867,315	0.0%	1,755,501	-	1,111,814	461,267	46,400	46,400	186,400	647,667	1.72x	2038
2039	2,867,315	0.0%	1,755,501	-	1,111,814	459,352	43,600	43,600	183,600	642,952	1.73x	2039
2040	2,867,315	0.0%	1,755,501	-	1,111,814	463,256	40,750	40,750	185,750	649,006	1.71x	2040
2041	2,867,315	0.0%	1,755,501	-	1,111,814	465,246	37,850	37,850	182,850	648,096	1.72x	2041
2042	2,867,315	0.0%	1,755,501	-	1,111,814	458,175	34,900	34,900	184,900	643,075	1.73x	2042
2043	2,867,315	0.0%	1,755,501	-	1,111,814	456,855	31,900	31,900	181,900	638,755	1.74x	2043
2044	2,867,315	0.0%	1,755,501	-	1,111,814	463,225	28,850	28,850	183,850	647,075	1.72x	2044
2045	2,867,315	0.0%	1,755,501	-	1,111,814	350,994	25,700	25,700	185,700	536,694	2.07x	2045
2046	2,867,315	0.0%	1,755,501	-	1,111,814	213,870	22,500	22,500	182,500	396,370	2.80x	2046
2047	2,867,315	0.0%	1,755,501	-	1,111,814	213,524	19,250	19,250	184,250	397,774	2.80x	2047
2048	2,867,315	0.0%	1,755,501	-	1,111,814	213,210	15,900	15,900	185,900	399,110	2.79x	2048
2049	2,867,315	0.0%	1,755,501	-	1,111,814	213,490	12,500	12,500	182,500	395,990	2.81x	2049
2050	2,867,315	0.0%	1,755,501	-	1,111,814	213,773	9,050	9,050	184,050	397,823	2.79x	2050
2051	2,867,315	0.0%	1,755,501	-	1,111,814	213,919	5,500	5,500	185,500	399,419	2.78x	2051
2052	2,867,315	0.0%	1,755,501	-	1,111,814	213,030	1,850	1,850	186,850	399,880	2.78x	2052
2053	2,867,315	0.0%	1,755,501	-	1,111,814	213,825	-	-	-	213,825	5.20x	2053
2054	2,867,315	0.0%	1,755,501	-	1,111,814	213,558	-	-	-	213,558	5.21x	2054
2055	2,867,315	0.0%	1,755,501	-	1,111,814	213,154	-	-	-	213,154	5.22x	2055
2056	2,867,315	0.0%	1,755,501	-	1,111,814	213,629	-	-	-	213,629	5.20x	2056
2057	2,867,315	0.0%	1,755,501	-	1,111,814	213,877	-	-	-	213,877	5.20x	2057
						\$ 13,984,642	\$ 4,160,000	\$ 1,458,836	\$ 5,618,836	\$ 19,603,477		

(1) Assumes FYE 2021 budgeted revenues and expenses. Assumes revenue growth to meet 1.10x coverage.  
 (2) The City currently supports all debt service from ad valorem tax. It is the City's intent to adjust utility rates sufficient to support all debt service from utility revenues.

AW12-1  
 Prescribed by Secretary of State  
 Section 2.051 – 2.053, Texas Election Code  
 2/14

**CERTIFICATION OF UNOPPOSED CANDIDATES FOR  
 OTHER POLITICAL SUBDIVISIONS (NOT COUNTY)  
 CERTIFICACIÓN DE CANDIDATOS ÚNICOS  
 PARA OTRAS SUBDIVISIONES POLITICAS (NO EL CONDADO)**

**To: Presiding Officer of Governing Body**  
*Al: Presidente de la entidad gobernante*

As the authority responsible for having the official ballot prepared, I hereby certify that the following candidates are unopposed for election to office for the election scheduled to be held on May 1, 2021.

*Como autoridad a cargo de la preparación de la boleta de votación oficial, por la presente certifico que los siguientes candidatos son candidatos únicos para elección para un cargo en la elección que se llevará a cabo el 1 de mayo de 2021.*

**List offices and names of candidates:**  
*Lista de cargos y nombres de los candidatos:*

<b>Office(s) Cargo(s)</b>	<b>Candidate(s) Candidato(s)</b>
<i>City Commission, Place 3 Comisión de la ciudad, lugar 3</i>	<i>Vince Moore</i>
<i>City Commission, Place 4 Comisión de la ciudad, lugar 4</i>	<i>Gary Mercer</i>

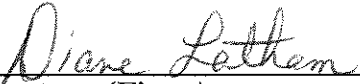
  
 \_\_\_\_\_  
**Signature (Firma)**

*Diane Latham*  
 \_\_\_\_\_  
**Printed name (Nombre en letra de molde)**

*Asst. City Secretary / Asst. Secretaria de la ciudad*  
 \_\_\_\_\_  
**Title (Puesto)**

*February 20, 2021 / 20 de Febrero de 2021*  
 \_\_\_\_\_

**Date of signing (Fecha de firma)**

**(Seal) (sello)**

See reverse side for instructions  
*(Instrucciones en el reverso)*

### Instructions for certification of unopposed candidates:

The authority responsible for preparing the ballot must certify the unopposed status to the authority responsible for ordering the election. This document is filed with the presiding officer of the political subdivision. The governing body must meet, accept this certification, and issue an order or ordinance declaring the election cancelled and the unopposed candidates elected. To complete the cancellation process, a copy of the order or ordinance canceling the election must be posted on Election Day at each polling place that would have been used in the election. See sample Order of Cancellation and outlines for additional instructions.

#### An election\* may be cancelled if:

- 1) The election is one in which a declaration of write-in candidacy is required; and
- 2) No opposed at-large race is on the ballot\* within that election;\*and
- 3) Each candidate whose name is to appear on the ballot\* is unopposed, with some exceptions;

This means:

- In an all at-large election\* (with no single-member districts), if there is one or more opposed at-large races, then all the races go on the ballot within that election.\*
- In an election\* in which any members of the governing body are elected from single-member districts, an election in a particular district may be cancelled if the candidate is unopposed and the election otherwise meets the above requirements (i.e., there is no at-large opposed race on the ballot).

**Note:** A general election (for full terms) or a special election (to fill a vacancy in an unexpired term) is considered a *separate election* with a *separate ballot* for purposes of these tests, even if held on the same election date. See our online Cancellation guide for details.

### Instrucciones para la certificación de una elección con candidatos únicos:

*La autoridad a cargo de preparar la boleta de votación debe certificar los candidatos únicos sin oposición a la autoridad encargada de ordenar la elección. Este documento se debe presentar al presidente de la subdivisión política. La entidad gobernante debe reunirse, aceptar esta certificación y emitir una orden o una ordenanza en la que declara la cancelación de la elección y la elección de los candidatos únicos sin oposición. Para completar el proceso de cancelación, se debe exhibir el Día de la Elección una copia de la orden u ordenanza de cancelación de la elección en todos los sitios de votación que se hubieran utilizado en la elección. Vea el ejemplo Orden de Cancelación y el resumen para más instrucciones.*

#### Una elección\* puede ser cancelada si:

- 1) *la elección es una en la que se requiere una declaración de candidatos por escrito en la boleta de votación; y,*
- 2) *no hay oposición para la carrera por acumulación en la boleta\* de votación dentro de esa elección\**  
*y*
- 3) *Todos los candidatos cuyos nombres deben aparecer en la boleta\* de votación no tienen oposición, con unas excepciones;*

*Esto significa:*

- *En una elección\* por acumulación (sin ningún distrito con miembro único), si se encuentra una o más de una carrera por acumulación con oposición, entonces todas las carreras estarán en la boleta dentro de esa elección\*.*
- *En una elección\* en la que cualquiera de los miembros de la entidad gobernante se eligen de distritos con un solo miembro, se puede cancelar una elección en un distrito específico si hay oposición para el candidato y la elección cumple con los requisitos que anteceden (ej. no hay oposición para la carrera por acumulación en la boleta).*

*Nota: Una elección general (con términos completos) o una elección especial (para llenar una vacante de un término no vencido) es considerada como una elección distinta con una boleta distinta con los propósitos de estas pruebas, aunque se lleven a cabo en la misma fecha electoral. Vea nuestra guía de cancelación en línea para más detalles.*

## NEWS RELEASE

The City of Breckenridge and Stephens County have announced that, as a cooperative effort, they will be picking up brush with a woodchipper inside the corporate limits of Breckenridge March 15, 2021 to March 19, 2021. It will be necessary for the citizens to have brush that they would like chipped and hauled off at curbside by Friday, March 12, 2021.

No brush larger than 4" in diameter will be picked up. Brush **MUST** be cut in lengths no longer than 6 feet long, and the butt ends **MUST** be placed toward the street or curb. Uprooted trees with roots attached cannot be run through the chipper. No dirt can be encrusted on the brush.

It will not be necessary to contact either the City of Breckenridge or Stephens County to receive this service, as the trucks will run the entire city during this week. This will be a service provided by the City of Breckenridge and Stephens County at no charge to the residents. This is, once again, a cooperative effort between the City of Breckenridge and Stephens County providing a service to the residents of Breckenridge for the disposal of their tree trimmings. This service has been provided to the residents inside the corporate limits of the City on a semi-annual basis for several years now. The trucks will be running in separate sections of the City during this period of time. Any brush put at the curbside after March 12, 2021 will not be removed.

### **REMINDER:**

Throughout the year tree limbs can be brought into the Convenience Station at no charge to customers. Convenience station hours are Tuesday thru Thursday, 1PM to 5PM and Friday & Saturday, 9AM to 5PM.

Should you have any questions about the disposal, please call the City Offices at (254)559-8287.

newsreleasechipping(dl)

## CITY OF BRECKENRIDGE

## CLEAN UP

A clean up week will be held, Monday, March 15, 2021 thru Saturday, March 20, 2021 from 9:00AM till 5:00PM at the City of Breckenridge Convenience Station to all City Water Customers (must bring water bill). City water customers may bring a truck or bumper pull trailer loaded with trash. Items accepted are stoves, refrigerators (CFS's must be removed and tagged), water tanks, washing machines, furniture, any other waste materials. Items not excepted are construction debris, dead animals, hazardous waste, stable matter, chemicals, paints, thinners, tires, batteries, oil or oil filters, antifreeze, drums, asbestos, untreated medical wastes, contaminated soils, sludge, liquids, and automobile/truck engine parts.





City of Breckenridge

February 22, 2021

Attn: Houston Satterwhite

Ref: Apartment Lift Station

1- Lift Station Equipment Package to include:

- 2- Ebara Model 100DLMKFU65.5 4" 7.5 HP, 1800RPM, 3phs submersible pump
- 2- 4" Cast iron base elbow with guide rail adapter and stainless steel upper guide rail bracket
- 2- Stainless steel lifting chain
- 1- Aluminum hatch cover, 72X36, double door
- 1- Duplex control panel, NEMA 4X stainless steel enclosure, with alternator, HOA switches, seal fail relays, high temp relays, elapsed time meters and high water alarm
- 2- Stainless steel cable hanger
- 1- Item stainless steel guide rails ( for pit depth up to 20' )
- 4- Float switch with 30' power cord

1- Item freight to jobsite

1- Field start-up supervision

LOT NET TOTAL WITH FREIGHT ALLOWED TO JOBSITE.....\$ 19,815.00

Shipment: 3-4 weeks after order

Note: Anchor bolts, discharge piping beyond base elbows, valves, panel mounting stand, wiring conduit, concrete, unloading and installation all by others.

Prepared by,

Randy Key

DXP Enterprises, Inc.  
1510 W. Shady Grove, Grand Prairie, TX, 75050 (972) 441-5500 fax (866) 916-1905



*Celebrating a Century of Pioneering Solutions in Industrial Distribution*





Customer :  
Reference :

**Pump Performance Datasheet**  
Ebara Quotation System 20.1.1

Item number : 001  
Service :  
Quantity : 1  
Quote number : 928475

Product Description : 100DLMKFU65.5  
Stages : 1  
Based on curve number : DLMK-C608-9203  
Date last saved : 15 Apr 2020 4:59 PM

**Operating Conditions**

Flow, rated : 250.0 USgpm  
Differential head / pressure, rated (requested) : 50.00 ft  
Differential head / pressure, rated (actual) : 49.71 ft  
Suction pressure, rated / max : 0.00 / 0.00 psi.g  
NPSH available, rated : Ample  
Frequency : 60 Hz

**Performance**

Speed, rated : 1745 rpm  
Impeller diameter, rated : 8.15 / 8.15 in  
Impeller diameter, maximum : 8.15 / 8.15 in  
Impeller diameter, minimum : 7.32 / 7.32 in  
Efficiency : 51.95 %  
NPSH required / margin required : - / 0.00 ft  
Ns (imp. eye flow) / Nss (imp. eye flow) : 2,180 / - US Units  
MCSF : 75.00 USgpm  
Head, maximum, rated diameter : 66.78 ft  
Head rise to shutoff : 34.32 %  
Flow, best eff. point : 388.0 USgpm  
Flow ratio, rated / BEP : 64.43 %  
Diameter ratio (rated / max) : 100.00 %  
Head ratio (rated dia / max dia) : 100.00 %  
Cq/Ch/Ce/Cn [ANSI/HI 9.6.7-2010] : 1.00 / 1.00 / 1.00 / 1.00  
Selection status : Near miss

**Liquid**

Liquid type : Water  
Additional liquid description :  
Solids diameter, max : 0.00 in  
Solids concentration, by volume : 0.00 %  
Temperature, max : 68.00 deg F  
Fluid density, rated / max : 1.000 / 1.000 SG  
Viscosity, rated : 1.00 cP  
Vapor pressure, rated : 0.00 psi.a

**Material**

Material selected : Standard

**Pressure Data**

Maximum working pressure : 28.91 psi.g  
Maximum allowable working pressure : N/A  
Maximum allowable suction pressure : N/A  
Hydrostatic test pressure : N/A

**Driver & Power Data (@Max density)**

Driver sizing specification : Rated power  
Margin over specification : 0.00 %  
Service factor : 1.00  
Power, hydraulic : 3.14 hp  
Power, rated : 6.04 hp  
Power, maximum, rated diameter : 6.84 hp  
Minimum recommended motor rating : 7.50 hp / 5.59 kW (Fixed)

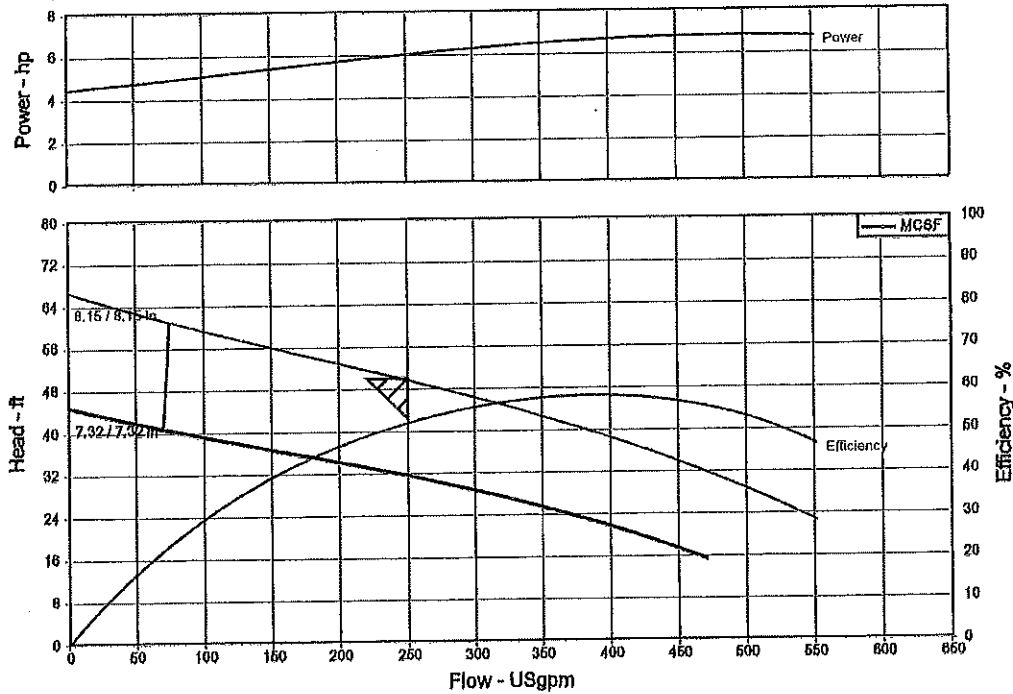

DXP Enterprises (Ebara)

Tel: Fax: dxpe.com

# SERIES S2S ACCESS DOOR



www.HallidayProducts.com  
 Phone 800-298-1027  
 Fax 407-298-4534  
 Sales@HallidayProducts.com

## STANDARD FEATURES:

- AUTO-LOCK T-316 STAINLESS STEEL HOLD OPEN ARM WITH RELEASE HANDLE
- T-316 STAINLESS STEEL HINGES AND ATTACHING HARDWARE
- T-316 STAINLESS STEEL SLAM LOCK WITH REMOVABLE KEY
- STAINLESS STEEL COMPRESSION SPRING ASSIST
- BUILT-IN NEOPRENE CUSHION/GASKET
- NON-OZONE DEPLETING BITUMINOUS COATING
- DOUBLE LEAF CONSTRUCTION
- 300 LBS. PER SQ. FT. LOAD RATING (1464 KG. PER SQ. METER LOAD RATING)
- EXTRUDED ALUMINUM FRAME
- RECESSED LIFTING HANDLE
- LIFETIME GUARANTEE

## STANDARD SIZES

QTY.	MODEL NO.	A DIM. INCHES (MM)	C DIM. INCHES (MM)	UNIT WT. LBS. (KG.)
	S2S4242	42 (1067)	42 (1067)	93 (42)
	S2S4842	48 (1219)	42 (1067)	99 (45)
	S2S4848	48 (1219)	48 (1219)	110 (50)
	S2S5442	54 (1372)	42 (1067)	108 (49)
	S2S5448	54 (1372)	48 (1219)	119 (54)
	S2S5454	54 (1372)	54 (1372)	127 (58)
	S2S6030	60 (1524)	30 (762)	87 (39)
	S2S6036	60 (1524)	36 (914)	100 (45)
	S2S6042	60 (1524)	42 (1067)	115 (52)
	S2S6048	60 (1524)	48 (1219)	130 (59)
	S2S6054	60 (1524)	54 (1372)	143 (65)
	S2S6060	60 (1524)	60 (1524)	158 (72)
	S2S6636	66 (1676)	36 (914)	109 (49)
	S2S6648	66 (1676)	48 (1219)	141 (64)
	S2S7238	72 (1829)	36 (914)	116 (53)
	S2S7242	72 (1829)	42 (1067)	135 (61)
	S2S7248	72 (1829)	48 (1219)	151 (68)
	S2S7254	72 (1829)	54 (1372)	168 (76)
	S2S7260	72 (1829)	60 (1524)	178 (81)

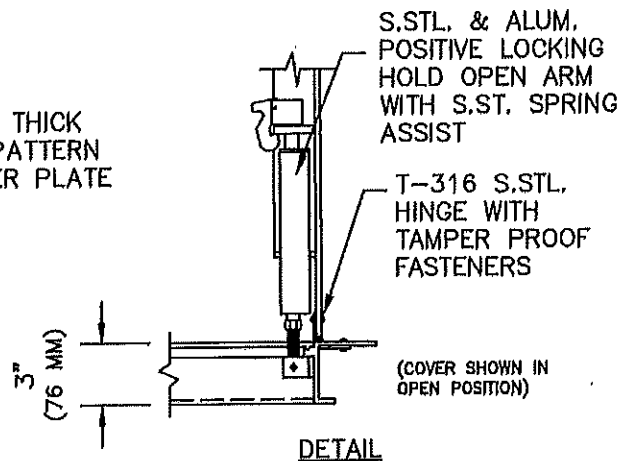
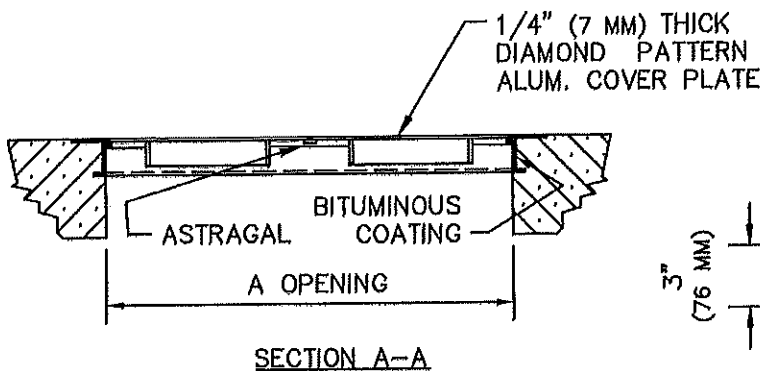
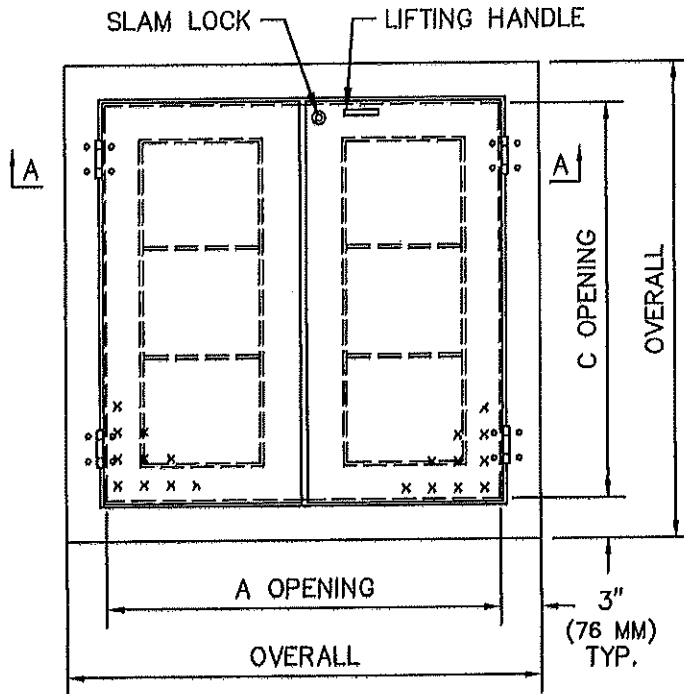

## General Arrangement

**EBARA Pumps  
Dimensions**

**Model: 100DLMKFU65.54 460V - Weight 309.0 lb**

**QDC Model: Standard LL100 4" Base - Weight 109.0 lb**

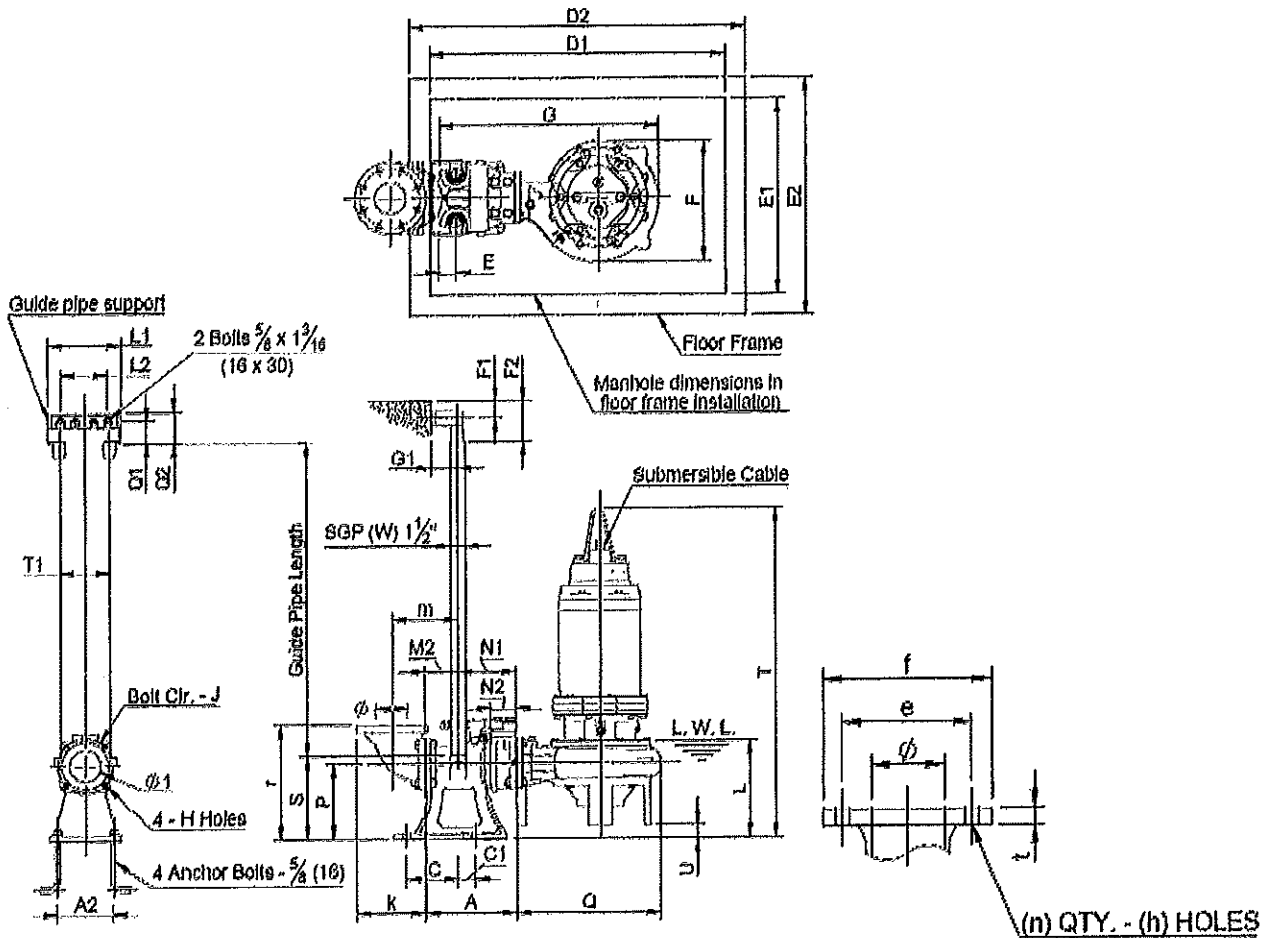

PUMP & MOTOR					
F	G	L	Q	T	U
13.19	26.36	15.65	15.91	46.13	4.63

Discharge Flange (ANSI 125 PSI FF)								
ø (mm/In)	a	f	l	n	h	r	m	k
100 / 4	7.52	9.02	0.94	0.31	0.75	14.37	8.27	8.66

QDC															
A	A1	A2	B1	B2	C	C1	H	J	M2	N	N1	N2	P	S	ø1
11.42	-	7.09	-	-	6.60	2.17	0.75	6.89	4.13	-	7.28	3.15	9.45	10.43	3.94

UGB								
E	F1	F2	G1	L1	L2	Q1	Q2	T1
2.17	1.57	3.64	3.35	9.69	5.91	2.76	3.94	6.30

ACCESS HOLE			
D1	D2	E1	E2
31.50	36.61	27.56	32.68

**NOTES:**

1. Dimensions are in inches

**EBARA Quick Discharge Connector**

**Dimensions**

Project: \_\_\_\_\_ Model: \_\_\_\_\_ Chk'd: \_\_\_\_\_ Date: \_\_\_\_\_

**Model LL100**

Weight: 101 Lb (46 kg)

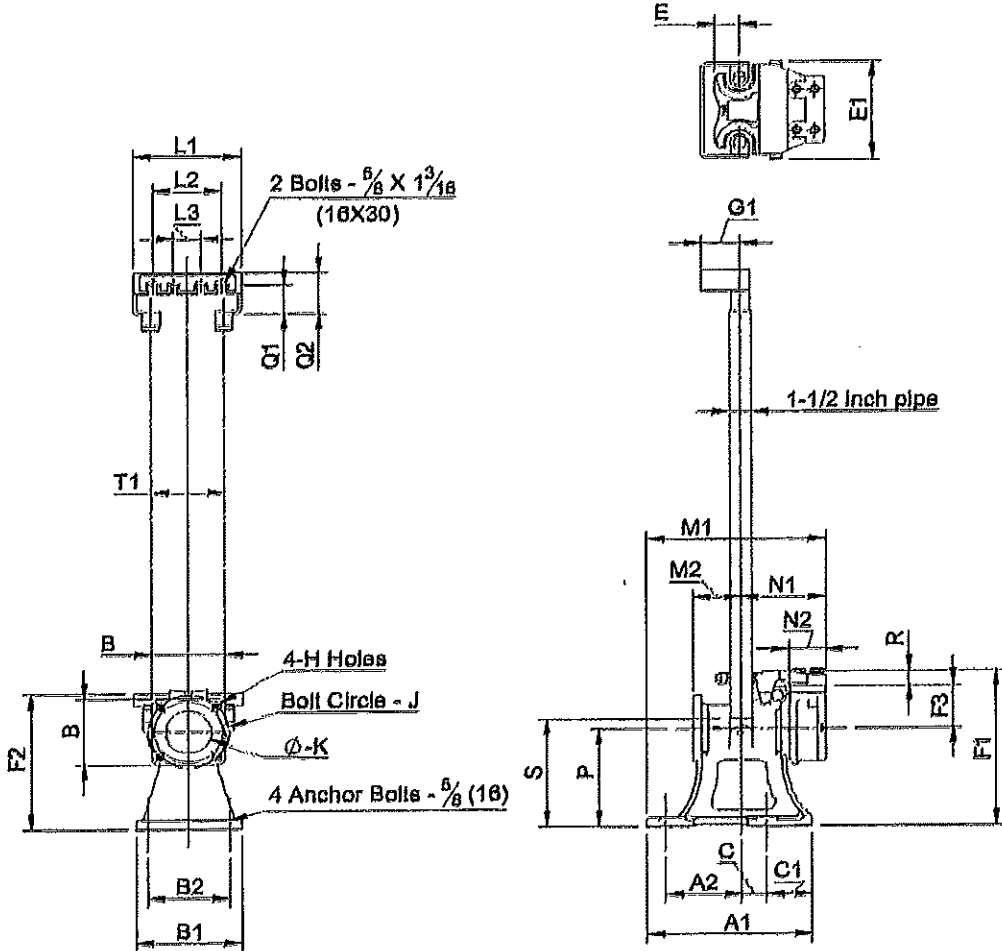

**Dimensions: Inch**

A1	A2	B	B1	B2	C	C1	E	E1	F1	F2
14.19	6.50	6.31	9.06	7.06	2.19	3.94	2.19	9.44	14.94	12.63
F3	G1	H	J	K	L1	L2	L3	M1	M2	N1
4.13	3.38	0.76	6.88	4	9.69	5.88	2.38	15.38	4.13	7.31
N2	P	Q1	Q2	R	S	T1				
3.13	9.44	2.75	3.94	1.38	10.44	6.31				

**Dimensions: mm**

A1	A2	B	B1	B2	C	C1	E	E1	F1	F2
360	165	160	230	180	55	100	55	240	380	320
F3	G1	H	J	K	L1	L2	L3	M1	M2	N1
105	85	19	175	100	246	150	60	390	105	185
N2	P	Q1	Q2	R	S	T1				
80	240	70	100	35	265	160				





**City Manager – City of Breckenridge, Texas**

**National Association recommendations:**

- SGR Job Board - \$0
- League of Women in Government - \$0
- National Forum for Black Public Administrators (NFBPA) - \$350
- Local Government Hispanic Network (LGHN) - \$75
- International City Manager's Association (ICMA) - \$450

**State/Municipal Association recommendations:**

- Texas Municipal League - \$0
- Oklahoma Municipal League - \$10
- City Management Association of Oklahoma (CMAO) - \$0
- Florida City and County Management Association (FCCMA) - \$0

**Additional, Pass-Through Position-Specific/Targeted recommendations:**

- Urban Management Assistants of North Texas (UMANT) - \$0
- GovernmentJobs.com - \$199
- Careers in Government - \$275

# CITY MANAGER

## *Breckenridge, Texas*



EXECUTIVE SEARCH PROVIDED BY





## THE COMMUNITY

Breckenridge, Texas is the county seat of Stephens County and is home to approximately 5,500 friendly people. The gateway to West Texas, with a vast range of recreational opportunities, the community is located at the intersection of U.S. Hwy 183 and U.S. Hwy 180, 100 miles west of Fort Worth. Breckenridge offers residents a great quality of life as well as exceptional education and business opportunities. Known as the Mural Capital of Texas, 12 murals are located through the town, many of them by artist Billy Ines.

An outdoor lover's destination, Breckenridge is surrounded by three area lakes, Hubbard Creek Lake, Lake Daniel, and Possum Kingdom, all of which are popular for their bass, catfish, and crappie fishing. Some of the best hunting in the state for white-tailed deer, quail, dove, and wild turkey can be found in Breckenridge.

Breckenridge is home to the historic National Theatre, offering entertaining productions and venue space for community events. Other attractions and events include the Breckenridge Fine Arts Center, Swenson Museum, Stephens County Air Museum, Frontier Days, an Antique Car Show, and the Breckenridge Air Show. There is something for everyone in this lovely Texas town!

Breckenridge is an official Texas Main Street City. It still has its original red brick streets downtown and buildings constructed mainly during the 1920s feature red brick along with native sandstone. The Stephens County Courthouse is listed on the National Register of Historic Places. The City has a rich oil history dating back to the 1920's oil boom which changed the Breckenridge population from 1,500 to 30,000 in 12

months with hundreds of oil derricks sprouting within the city limits.

Presently, the economy is based on ranching, oil and gas, small manufacturing, service business, and a greatly expanded recreation sector.

Public education in Breckenridge is provided by the Breckenridge Independent School District (BISD), which is comprised of two elementary schools, one junior high, and one high school serving approximately 1,700 students. BISD includes a gifted and talented program, early childhood program, and pre-school.

The Breckenridge campus of Texas State Technical College (TSTC) offers certificates and Associate of Applied Science degrees for a variety of technical careers including Air Conditioning Technology, Associate Degree Nursing, Chemical Dependency Counseling, Computer-Aided Drafting & Design Technology, Computer Networking Systems and Administration, Computer Science Database & Web Programming, Construction Management Technology, Digital Signage Technology, Energy Management, Environmental Science Technology, Health Information Technology,



# THE COMMUNITY *continued*

Software & Business Accounting, Software & Business Publishing, Vocational Nursing, and Welding Technology.

Stephens Memorial Hospital, Breckenridge Medical Center, and Resource Care Health Center provide quality medical care to the community

Plenty of desirable housing is available and – thanks to local law enforcement agencies – Breckenridge enjoys a low crime rate. The Breckenridge Fire Department, a paid full-time entity, provides superior service and fire protection to the community.

Breckenridge has a median household income of \$42,952 and an average home value of \$64,000.

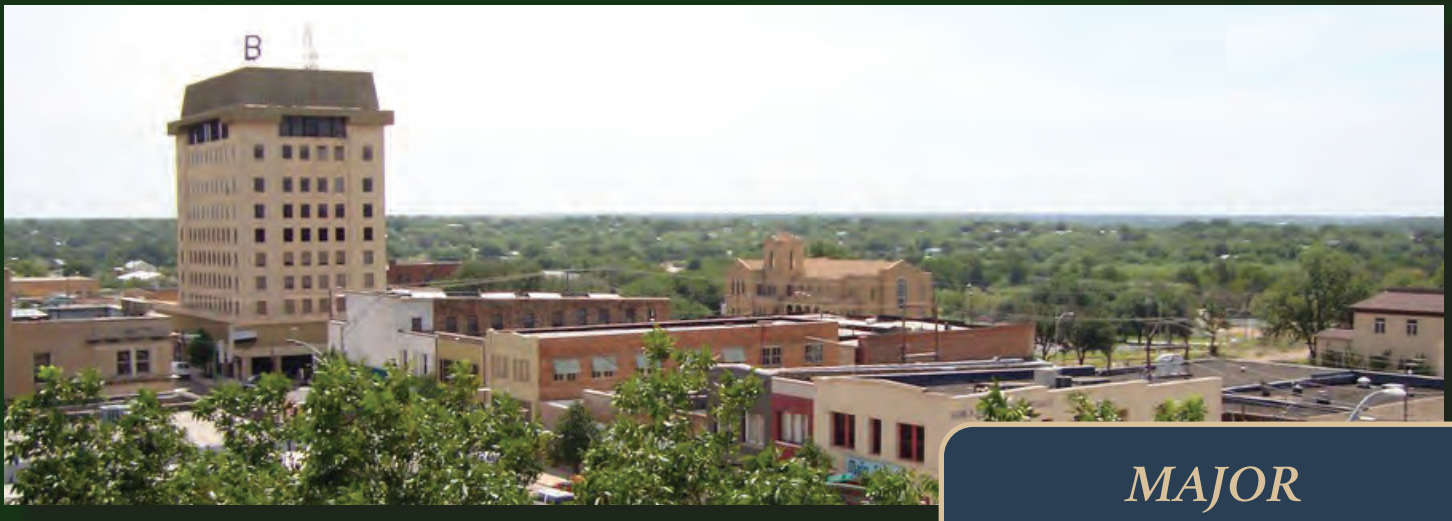

## GOVERNANCE AND ORGANIZATION

The City of Breckenridge is a Home Rule city that operates under the commissioner-manager form of government. The governing and lawmaking body of the City of Breckenridge consists of four commissioners and a mayor, all elected at-large. The Commissioners appoint a professional City Manager who serves as the chief administrative officer, implements commission policies, provides organizational leadership for department directors and employees, and oversees the day-to-day business of government operations.

The City has a fiscal year budget of just over \$3 million and 69 employees. The ad valorem tax rate is \$1.12 per \$100 of valuation.

### MAJOR EMPLOYERS

- Jonell Filtration Systems
- RGN Manufactured Housing
- Bridgeport Manufacturing
- Breckenridge ISD
- Stephens Memorial Hospital
- Ezell Aviation
- BASA Resources
- J & J Oilfield Electric
- R.E. Dye Mfg.
- Badger Oilfield Service

# CHALLENGES AND OPPORTUNITIES

Like many cities, aging infrastructure creates challenges in keeping up with community growth and the delivery of essential services. A high priority for the new City Manager will be to assess and prioritize the town's infrastructure needs and develop innovative ways to address improvements.

Restructuring the City's debt service will be an important responsibility for the incoming City Manager to maximize the use of revenue to support the overall needs of the community. Additionally, a utility rate study needs to be conducted to assure that adequate funding is available to maintain and enhance services to residents.



# THE IDEAL CANDIDATE

The City of Breckenridge seeks a servant leader with strong organizational skills coupled with expertise in local government finance and a strong knowledge of public works operations including capital project funding mechanisms. The ideal candidate will be a dedicated and experienced leader who understands and appreciates a small-town environment and who embraces the community and its people. The ability to identify and respond to sensitive community and organizational needs, concerns, and challenges is essential.

Excellent communication and listening skills are key. The new City Manager will be able to have meaningful dialogue with elected officials, staff, residents, and stakeholders at all levels and establish and maintain effective working relationships.

Working collaboratively with the Mayor and City Commissioners, the successful candidate will manage the development and implementation of organizational and departmental goals, objectives, and priorities, and recommending operational and financial policy improvements.



## EDUCATION AND EXPERIENCE

The selected individual must hold a Bachelor’s degree in Public Administration, Government, Business, or a related field and have at least five years of experience and progressive management responsibilities in municipal government, or related field. A Master’s Degree or credentialing as a Certified Public Manager is preferred.

The successful candidate will have comprehensive knowledge in the areas of human resources, public safety, and community development.

# COMPENSATION AND BENEFITS

The salary for this position is commensurate with experience and education. A full slate of excellent benefits, including a car allowance, is provided. The City participates in the Texas Municipal Retirement System (TMRS) at an employee contribution rate of 5% with a matching municipal ratio of 1.5:1.



# APPLICATION PROCESS

Please apply online at <http://bit.ly/SGROpenRecruitments>

For more information on this position contact:  
**Larry Gilley, Sr. Vice President, Recruitment**  
[LarryGilley@GovernmentResource.com](mailto:LarryGilley@GovernmentResource.com)  
325-660-4208



The City of Breckenridge is an Equal Opportunity Employer and values diversity in its workforce. Applicants selected as finalists for this position will be subject to a comprehensive background check.

# RESOURCES

**City of Breckenridge**  
[breckenridgetx.gov](http://breckenridgetx.gov)

**Breckenridge Economic Development Corporation**  
[breckenridgetexas.com/edc](http://breckenridgetexas.com/edc)

**Breckenridge Chamber of Commerce**  
[breckenridgetexas.com](http://breckenridgetexas.com)

