



# BLUE RIVER PLANNING & ZONING COMMISSION MEETING JUNE 2024

June 04, 2024 at 6:00 PM  
0110 Whispering Pines Circle, Blue River, CO

---

## AGENDA

---

The public is welcome to attend the meeting either in person or via Zoom.

The Zoom link is available on the Town website:

<https://townofblueriver.colorado.gov/planning-zoning>

Please note that seating at Town Hall is limited.

**I. CALL TO ORDER, ROLL CALL**

**II. APPROVAL OF MINUTES**

[A.](#) Minutes from May 7, 2024

**III. PUBLIC HEARING**

[B.](#) 0132 Mountain View Home Addition Variance Request

**IV. PROJECT APPROVAL**

[C.](#) 0034 Rustic-Addition

**V. OTHER BUSINESS**

[D.](#) Land Use Building Size Review

**VI. ADJOURN**

**NEXT MEETING -**



## PLANNING & ZONING COMMISSION MAY 2024

May 07, 2024 at 6:00 PM  
0110 Whispering Pines Circle, Blue River, CO

---

### MINUTES

---

The public is welcome to attend the meeting either in person or via Zoom.

The Zoom link is available on the Town website:

<https://townofblueriver.colorado.gov/planning-zoning>

Please note that seating at Town Hall is limited.

#### I. CALL TO ORDER, ROLL CALL

PRESENT

Travis Beck

Mike Costello

Tim Johnson

Gordon Manin

Doug O'Brien

Ben Stuckey

Troy Watts had connectivity issues.

Also present Town Manager Eddy; Board Liaison Trustee Noah Hopkins

#### II. APPROVAL OF MINUTES

A. Minutes from April 9, 2024

Motion made by Manin, Seconded by Costello to approve the minutes of April 9, 2024. Voting Yea: Costello, Johnson, Manin, O'Brien

#### III. PROJECT APPROVAL

B. 0345 Coronet New Construction

Manager Eddy provided an overview of the project. Noting the roof pitches mirror the neighbor. A concern with the siding was noted. The architect provided clarification on the siding material as well as the design and what will be exposed as well as the project in general. It was noted that it fits a mountain modern design complimenting the neighboring property.

Motion made by Costello, Seconded by Beck to approve the new construction at 0345 Coronet. Voting Yea: Beck, Costello, Johnson, Manin, O'Brien, Stuckey. Motion passed unanimously.

**IV. OTHER BUSINESS**

C. Land Use Discussion-Buildable Area

The Town Attorney's office provided a memo of options if the Planning & Zoning Commission should wish to make a recommendation to add to the Land Use Code.

Town Manager Eddy provided an overview of the memo and options. Discussion of reasoning for limiting size of homes and area allowed to be built within the buildable area. Discussion to potentially limit by total lot and not buildable area. Discussion to read through the memo and come back with suggestions in June.

**V. ADJOURN**

Motion made by Beck, Seconded by O'Brien to adjourn the meeting at 6:52 p.m. Voting Yea: Beck, Costello, Johnson, Manin, O'Brien, Stuckey Motion passed unanimously.

**NEXT MEETING -**

June 4, 2024



### VARIANCE APPLICATION

Legal Description: Lot LOT 137 Subdivision Mountain View Sub  
Street Address: 132 Mountain View Dr

Homeowner Name: Jason and Meredith Himmelman Phone: 970-470-1816  
Mailing Address: PO Box 6658- Breckenridge CO 80424 Email: jake@breckenridgeassociates.com

**Variance Being Requested:**

We are requesting a variance to the street side of our home. We have another baby on the way and need more space. The other side of the home is the river and wetlands

Zoning Ordinance to which the variance is requested, and specify the nature of the variance requested:

Sec. 16-5-50. Site and structure requirements

a. Front yard. The front yard requirement shall be twenty-five (25) feet

We are requesting that the front setback as measured from road easement be reduced as shown on attached site plan.

State if the variance requested meets each of the following six (6) conditions. Please explain for each one:

1. That the granting of the variance will not authorize a use not permitted by the zoning regulations of the Town:  
There is no proposed change to the existing use of this lot with the approval of this variance.
2. That the granting of the variance will not constitute a grant of special privilege inconsistent with the limitation on other properties having the same classification in the same zone district:  
We believe that any other property with similar existing hardships could apply for similar setback variances. We also feel that numerous homes within our subdivision are already within the easement due to the challenges that the river/wetlands present
3. That the granting of the variance will not be detrimental to the public health, safety or welfare, materially injurious to properties or improvements in the vicinity, or prevent the proper access of light and air to adjacent properties:  
The requested variance presents no detrimental effects to the health, safety, and welfare of the public.
4. That the strict, literal interpretation and enforcement of the specified regulation would result in unnecessary hardship inconsistent with the objectives of the Title:

Driveway and garage access are already in place, additions to the north end would exclude access to your existing garage. West Side- pedestrian access easement and wetland setbacks. Existing on site wastewater treatment system in place prohibits additions to the south. Also need privacy from house above

- 5. That the circumstances found to create a hardship were not created by the owner, and are not due to, or the result of, general conditions in the zone district and cannot reasonably be corrected:

The hardships were created outside of the control of the existing homeowner. The river/wetlands run the length of the house. Septic cant be moved.

House above us is extremely close

- 6. That the variance would not be out of harmony with the intent and purpose of the zoning code:

The variance would be in harmony with the purpose of the code. The variance would be small but would allow us comfortable living without disturbing the natural environment. Would also be in line with other homes in the sub that previously faced these challenges

**NO VARIANCE AUTHORIZING A CHANGE IN THE PERMITTED USE OF THE PROPERTY SHALL BE GRANTED.**

The following documents are submitted herewith for the Commission’s information and review:

- 1. Completed Application Form / Application Fee
- 2. Site plan diagram with proposed addition and setbacks / Proposed plans and elevations.
- 3. Adjacent neighbor mailing list.
- 4. \_\_\_\_\_

I/We the applicant named herein understand the following:

- 1. That the main function of the Planning and Zoning Commission is to provide for reasonable interpretations of codes and ordinances with relation to their intent, so that the spirit of the ordinance(s) shall be observed, public safety and welfare secured and justice adhered to.
- 2. Notice of hearings to be given at the expense of the applicant by publication in a newspaper of general circulation within the Town by posting on the premises and by mailing to all property owners within three hundred (300) feet of the property in question. Notices shall be posted, published and mailed at least ten (10) days before the hearing date and shall contain the time and date of the hearing, the name of the applicant, a general description of the property indicating its location (which may be shown by map), what relief is being sought and the grounds on which the relief is being sought. The owners within three hundred (300) feet of the affected property were notified of the variance request. This letter shall contain all the names and addresses of those notified, and shall be submitted to the Building Department at least ten (10) days prior to the scheduled hearing. The application must be submitted to the Building Department at least twenty (20) days prior to the date of the hearing.
- 3. I/We (the applicant) shall be notified of the Commission’s decision within thirty (30) days after the date of the hearing.
- 4. That any decision made by the Planning and Zoning Commission is not binding as to covenants, which apply to the property in question. Applicant is responsible for obtaining any necessary approvals from the Homeowner’s Associations or Committees, which administer the covenants within the subdivision where the property is located.
- 5. Within seven (7) days following action by the Planning and Zoning Commission, written findings and decision, in the form of a resolution, shall be transmitted to the applicant and to the Board of Trustees. Such decision of the Planning and Zoning Commission, with respect

to variances, is final and is subject to appeal only through a court competent jurisdiction pursuant to §31-23-307, C. R. S.

Signature: \_\_\_\_\_ Date: \_\_\_\_\_

Findings of the Planning & Zoning Commission:

---

---

---

## GENERAL INFORMATION AND GUIDELINES

The Town of Blue River has established specified distances from the front, back and sides of all lots as “setbacks” wherein no structures may be erected. These setbacks are maintained to create more open space between homes and structures upon and adjacent to other lots and to maintain open areas along roads and lot lines to prevent encroachment problems along these lines. It is expected that all property owners will respect the concepts and guidelines established by the Town with respect to these setback distances. It is incumbent upon the property owner to consider these setback distances prior to purchasing a new lot, or prior to attempting to enlarge any building or structure upon an existing lot that may not allow such improvements within the allowable building envelope, considering all setback distances.

Only after a property owner has fully demonstrated a true hardship, which was not caused and/or could have been reasonably averted by the applicant, will the Planning and Zoning Commission consider granting a variance to those established setback distances.

The Commission’s main criterion for granting a variance is that of a demonstrated “hardship” upon the applicant. Many times an applicant wishes to build a larger structure that is not conducive to the available area (building envelope) upon a lot, taking into account all front, side, and rear setbacks, and they request a variance. You must demonstrate a true hardship, not created by the applicant, to the Commission, which explains why the structure(s) cannot be placed elsewhere without a variance, or downsized to permit the structure to be placed on your lot without a variance, or modified to request the smallest possible sized variance for your situation. The Commission will request you to fully discuss all these other possible alternatives and why they will not work prior to considering a variance for your situation.

The Planning and Zoning Commission (P&Z) consists of seven (7) voting members appointed by the Town of Blue River Board of Trustees for two and four year terms. Assistance with application questions can be obtained from the Town of Blue River Building Official, who is not a member of the Commission and can answer questions and provide guidance without compromising the voting procedure.

After receipt, the Chairman of the P&Z, and/or the Town Building Official, will verify that the application is complete; all questions answered clearly and concisely, with appropriate attachments (maps) that are legible, drawn to scale (not reduced), marked with property locations (subdivisions and lot numbers), dates of survey and by whom, and that the drawings display the variance request clearly (i.e.- locations of all lot lines, structures and sizes, wells, septic system tanks and fields, roads, easements, setbacks, etc.). It is strongly suggested that a registered land surveyor prepare an Improvement Location Certificate (ILC) or a detailed survey for the property and submit it with the application. Applicants must be aware that this is not an extra step; if the variance is approved, the TOBR Building Official must receive an ILC prior to any excavation or construction commencing on the property. Applicants should be aware that surveys in the middle of winter, with heavy snow cover present, are more difficult, costly and time consuming. Such ILC surveys can easily take several weeks to perform, dependent on weather conditions and surveyor workloads. Also, specific dimensions must be stated in the variance request. For example, if a garage or home is requested to be built within a lot setback, the exact distances and exact location from the lot lines to all

home/garage corners and sides (to drip lines) within that variance request must be accurately labeled on the ILC survey, stated on the map, in the application and staked with labeled lath or stakes on the lot for P&Z and public inspection. If a variance is approved, the written approval will state these same exact dimensions in the approval and/or attachments.

The applicant shall also provide an accurate drawing to scale (not reduced) copy of the map they used to determine all property owners located within 300 feet of the subject property seeking the variance. Such a map may be obtained from the Summit County Clerk and Recorder's Office. The Summit County Assessor's Office can provide ownership addresses of the property owners to be notified. Both offices are located at the Summit County Courthouse, 208 E. Lincoln in Breckenridge. The map submitted to the TOBR Clerk should be marked with a line encompassing the 300-foot mark, measured from all points along the property lines. A pencil, compass and straight edge are necessary to perform this task properly.

Accompanying that map shall be a list of all the Subdivision name(s), lot number, and names and addresses of the owners of record that fall within the 300-foot mark. The P&Z Chairman or Building Official may verify with the Assessor's Office regarding the accuracy of the data submitted on the list. Applicant's failure to notify owners of record within 300 feet of the subject property can cause unnecessary delays. If the applicant fails to properly notify a landowner, the applications may be rejected. Applicants should also be aware that the County Assessor's Office maps are not survey accurate, and can be slightly misleading as to exact distances. However, they do show all adjoining subdivisions in relation to each other. Therefore, re-checking exact distances on the official recorded plat in the Clerk and Recorder's Office may be necessary. If there is any question as to a "close distance" of a property to the 300-foot requirement, it is strongly suggested to add extra neighbor notifications rather than risk missing a property owner.

A property owner located within the 300-foot distance that must be notified also includes all Municipal, County, State or Federal landowners (i.e.-county, state or federal roads, national or state forest or lands, county lands, etc.).

If the P&Z Chairman and/or the Building Inspector now deem, the application complete, the TOBR Clerk will send copies of the application and supporting documents to all P&Z members for their information.

The applicant must then pick up a poster from the TOBR Clerk to be displayed upon the lot, which will inform all interested parties of the date, time, and location of the scheduled public hearing regarding the variance request for that property ten days before the hearing. The applicant must also publish notice of the public hearing in the Summit County Journal ten days before the scheduled hearing. Call the TOBR Clerk (970) 547-0545 for assistance with timetables in publishing the notice. The property shall also be marked with stakes identifying the lot lines, setback, and exact location of corners requested in the variance so that interested parties and the P&Z members can relate to the variance request on the ground and identify the specifics of the variance request. It is preferred for these markings to be completed by a registered land surveyor, as part of the ILC survey. After this is completed, the applicant must mail notice to all the property owners on the list provided located within 300-feet of the property. Notice shall include the complete application, including all supporting document and maps along with a brief letter explaining the nature of the variance request.



As an overview, considering all the above steps, it can easily take a considerable amount of time to properly schedule a public meeting, providing all steps are correctly followed, and depending upon time of year, availability of surveyors, publication notices, review of applications, etc.

#### APPLICANT CHECKLIST

1. \$400.00 refundable deposit, payable to the Town of Blue River
2. Completed "Request for hearing and variance" application including—
  - A. Name and address of the owner and, if the applicant is not the owner, written authorization of the owner to the applicant to make application and act as agent for the owner.
  - B. Evidence of ownership (such as an informational title commitment) and a legal description for all property to be considered for rezoning.
  - C. A written description of the precise nature of the proposed variance and its operating characteristics, and measures proposed to make the variance compatible with other properties in the vicinity
  - D. A site plan, (ILC or survey) preferably by a registered land surveyor, showing proposed development of the site, including topography, building or structure locations, parking, traffic circulation, landscaped area, utilities, drainage features, setbacks and all easements (if any).
  - E. Preliminary building plans and elevations sufficient to indicate the dimensions, general appearance, scale and interior plan of all buildings
3. Notice of hearings to be given at the expense of the applicant by publication in a newspaper of general circulation within the Town by posting on the premises and by mailing to all property owners within three hundred (300) feet of the property in question. Notices shall be posted, published and mailed at least ten (10) days before the hearing date and shall contain the time and date of the hearing, the name of the applicant, a general description of the property indicating its locations (which may be shown by map), what relief is being sought and the grounds on which the relief is being sought.
4. The applicant shall submit a letter certifying to the Commission all property owners within three hundred (300) feet of the affected property that were notified of the variance request. This letter shall contain all the names and addresses of those notified, and shall be submitted to the Building Department at least ten (10) days prior to the scheduled hearing date. In addition, the applicant shall also provide a copy, to scale (not reduced) of the map they used to determine all property owners within 300 feet of the subject property, which shows the 300 foot distances from all property lines and the affected lots (property owners) to be notified within these distances.
5. The application must be submitted to the Building Department at least twenty (20) days prior to the date of the hearing.

## ARTICLE XI Variances

### **Sec. 16-11-10. Application; public hearing.**

An application for a variance shall be heard by the Planning and Zoning Commission in accordance with Section 16-2-60(b) of this Chapter. The application shall include the following information, unless determined by the Building Official to be unnecessary for its consideration:

- (1) Name and address of the owner and, if the applicant is not the owner, written authorization of the owner to the applicant to make application and act as agent for the owner;
- (2) Evidence of ownership (such as an informational title commitment) and a legal description for all property to be considered for rezoning;
- (3) A list of the owners of all properties within the boundaries of the area to be rezoned or changed, and of all properties within three hundred (300) feet of the property proposed to be rezoned or changed. The owners list shall include the name of all owners, their addresses and a general description of the property owned by each.
- (4) A description of the precise nature of the proposed variance and its operating characteristics, and measures proposed to make the variance compatible with other properties in the vicinity;
- (5) A site plan, showing proposed development of the site, including topography, building or structure locations, parking, traffic circulation, usable open space, landscaped area and utilities and drainage features;
- (6) Preliminary building plans and elevations sufficient to indicate the dimensions, general appearance, scale and interior plan of all buildings;
- (7) Such additional materials as the Planning and Zoning Commission may prescribe or the applicant may submit pertinent to the application and to the findings prerequisite to the granting of a variance. (Ord. 05-02 §6, 2005)

### **Sec. 16-11-20. Approval criteria.**

The following criteria shall be considered in reviewing applications for a variance:

- (1) The relationship of the requested variance to other existing or potential uses and structures in the vicinity;
- (2) The degree to which relief from the strict or literal interpretation and enforcement of a specified regulation is necessary to achieve compatibility and uniformity of treatment objectives of this Chapter without grant of special privilege;
- (3) The effect of the requested variance on light and air, traffic movement, public facilities and utilities and public safety;
- (4) Such other factors and criteria as the Planning and Zoning Commission deems applicable to the proposed variance. (Ord. 05-02 §6, 2005; Ord. 06-01 §1, 2006)

### **Sec. 16-11-30. Findings required.**

The Planning and Zoning Commission shall make all the following written findings before granting a variance:

- (1) That the granting of the variance will not authorize a use not permitted by the zoning regulations of the Town;
- (2) That the granting of the variance will not constitute a grant of special privilege inconsistent with the limitations on other properties having the same classification in the same district;
- (3) That the granting of the variance will not be detrimental to the public health, safety or welfare, materially injurious to properties or improvements in the vicinity or prevent the proper access of light and air to adjacent properties;
- (4) That the strict, literal interpretation and enforcement of the specified regulation would result in unnecessary physical hardship inconsistent with the objectives of this Chapter;

(5) That the circumstances found to create a hardship were not created by the owner, are not due to or the result of general conditions in the zone district and cannot reasonably be corrected; and

(6) That the variance would not be out of harmony with the intent and purpose of this Chapter. (Ord. 05-02 §6, 2005)

**Sec. 16-11-40. Decision final.**

Any decision of the Planning and Zoning Commission shall be final unless an appeal is taken to a court of competent jurisdiction pursuant to Section 31-23-307, C.R.S. (Ord. 05-02 §6, 2005)

**Sec. 16-2-30. Deposit and fees for land use development applications.**

Any person applying for a land use development application, including but not limited to an annexation, subdivision, planned residential development, conditional use permit, easement vacation, replat, rezoning, variance, lot line adjustment, or any other land use development application, shall pay all direct costs accrued by the Town as a result of the application and development process, including but not limited to publication of notices, public hearing and professional costs, including engineering, attorney, consultant and recordation fees. In order to ensure that these fees are paid and development pays its own way, as well as the prompt payment of such costs to the Town, all land use applicants shall deposit the following sums with the Town at the time of initial land use development application:

<i>Land Use Application</i>	<i>Deposit Fees</i>
Annexations, subdivisions, replats or planned residential developments	\$2,000.00
Lot line vacation applications	250.00
Lot line adjustments or rezoning requests	500.00
Conditional use permit	300.00
Easement vacation or relocations	1,500.00
Variances	400.00
Any other land use applications	500.00

Any balance remaining after the payment of all costs to the Town shall be returned to the applicant. If the balance on deposit with the Town falls below twenty-five percent (25%) of the initial amount deposited, the applicant shall deposit such additional sums as the Town deems necessary in order to raise the balance to the initial amount deposited. Any dispute regarding the reasonableness or appropriateness of fees charged shall be presented to and resolved by the Board of Trustees. (Prior code 1-6-3)



**ROOTED**  
ARCHITECTURE

SEAL:

NOT FOR CONSTRUCTION

DRAWINGS AND SPECIFICATIONS AS INSTRUMENTS OF SERVICE ARE THE PROPERTY OF THE ARCHITECT. THEY SHALL NOT BE USED, TRANSFERRED, OR SOLD FOR USE EXCEPT BY AN AGREEMENT IN WRITING FROM THE ARCHITECT.

**HIMMELMAN ADDITION**

0132 MOUNTAIN VIEW DRIVE  
BLUE RIVER, CO

No. Date Revisions

Project No: 2024-04  
Stage: VARIANCE REQUEST  
Date: 05/13/2024  
Scale: As indicated

DRAWING TITLE:

**SITE PLAN**

DRAWING NO:

**A0.2**

**NOTES: SITE PLAN**

1. VERIFY ALL UTILITY LOCATIONS PRIOR TO ANY WORK. COORDINATE UTILITY ROUTING WITH APPLICABLE UTILITY COMPANY. ALL UTILITIES TO BE UNDERGROUND.
2. SURFACE DRAINAGE SHALL BE DIVERTED TO A STORM SEWER CONVEYANCE OR OTHER APPROVED POINT OF COLLECTION THAT DOES NOT CREATE A HAZARD. LOTS SHALL BE GRADED TO DRAIN SURFACE WATER AWAY FROM FOUNDATION WALLS. THE GRADE SHALL FALL NOT FEWER THAN 6 INCHES WITHIN THE FIRST 10 FEET.
3. REFER TO FOUNDATION PLAN FOR FOUNDATION DRAIN LOCATION AND SLOPE.
4. FLAG ALL TREES FOR OWNER PRIOR TO THINNING OR REMOVAL.
5. PROTECT REMAINING TREES WITH APPROVED BARRIER DURING CONSTRUCTION.
6. GENERAL CONTRACTOR SHALL REVIEW AND COMPLY WITH ALL ZONING AND SUBDIVISION CONDITIONS.
7. FINISHED GRADING SHALL BE A MINIMUM OF 6" BELOW FOUNDATION REFERENCE ADOPTED IRC.
8. CONTRACTOR TO TRIM OR REMOVE ANY TREES ADJACENT TO BUILDING FOUNDATION AS REQUIRED, VERIFY WITH OWNER PRIOR TO REMOVAL.

**NOTES: SITE CONTOUR LEGEND**

- EXISTING MAJOR CONTOUR: 10.000'
- EXISTING MINOR CONTOUR: 10.002'
- PROPOSED CONTOUR:

**NOTES: SITE DRAINAGE**

1. CONTRACTOR SHALL PROVIDE PROPER SITE GRADING THAT DIRECTS SURFACE WATER AWAY FROM BUILDING FOUNDATIONS, WALLS AND NEIGHBORING PROPERTIES.
2. GRADING AND LANDSCAPING SHOULD BE PLANNED WITH A SURFACE GRADE
3. OF AT LEAST 4% AROUND AND AWAY FROM THE ENTIRE STRUCTURE. REFER TO DALLAS DEVELOPMENT CODE FOR SITE DRAINAGE REQUIREMENT.
4. PROPOSED SITE DRAINAGE INDICATED ON SITE PLAN WITH FLOW ARROWS:

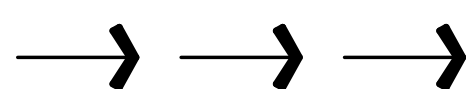

**NOTES: FOUNDATION DRAIN**

- INSTALL DRAIN TILE (PERFORATED PLASTIC DRAINAGE PIPE) ALONG THE EXTERIOR OF THE FOOTINGS OF BASEMENT OR CRAWLSPACE WALLS TO PROVIDE DRAINAGE AROUND FOUNDATION PERIMETER.
1. INSTALL DRAIN PIPE TO SIT OUTSIDE OF, NOT ON TOP OF, THE FOOTINGS AND BELOW THE BOTTOM OF THE CONCRETE SLAB OR CRAWLSPACE FLOOR.
  2. LAY THE PIPE WITH ENOUGH SLOPE TO DRAIN TO A NON-PERFORATED PIPE THAT CARRIES THE COLLECTED WATER TO DAYLIGHT, TO A DRYWELL, TO A STORM SEWER IF APPROVED BY THE LOCAL MUNICIPALITY, OR TO A SUMP PUMP THAT WILL TRANSPORT IT TO DAYLIGHT, A STORM SEWER, OR A DRYWELL.
  3. LAY THE DRAIN PIPE, PERFORATIONS DOWN, IN A GRAVEL TRENCH WITH AT LEAST 6 INCHES OF 1/2-INCH TO 3/4-INCH WASHED GRAVEL OR STONE ABOVE THE PIPE AND AT LEAST 2 INCHES BELOW (IRC).
  4. INSTALL LANDSCAPE FABRIC UNDER, AROUND, AND OVER THE WASHED GRAVEL (IRC) ALTERNATELY, USE DRAIN PIPE ENCASED IN A FILTER-FABRIC SOCK AND SURROUND THE CLOTH-COVERED PIPE WITH GRAVEL. OR, INSTALL A CODE-APPROVED COMPOSITE FOUNDATION DRAINAGE SYSTEM (CFDS) (IRC).

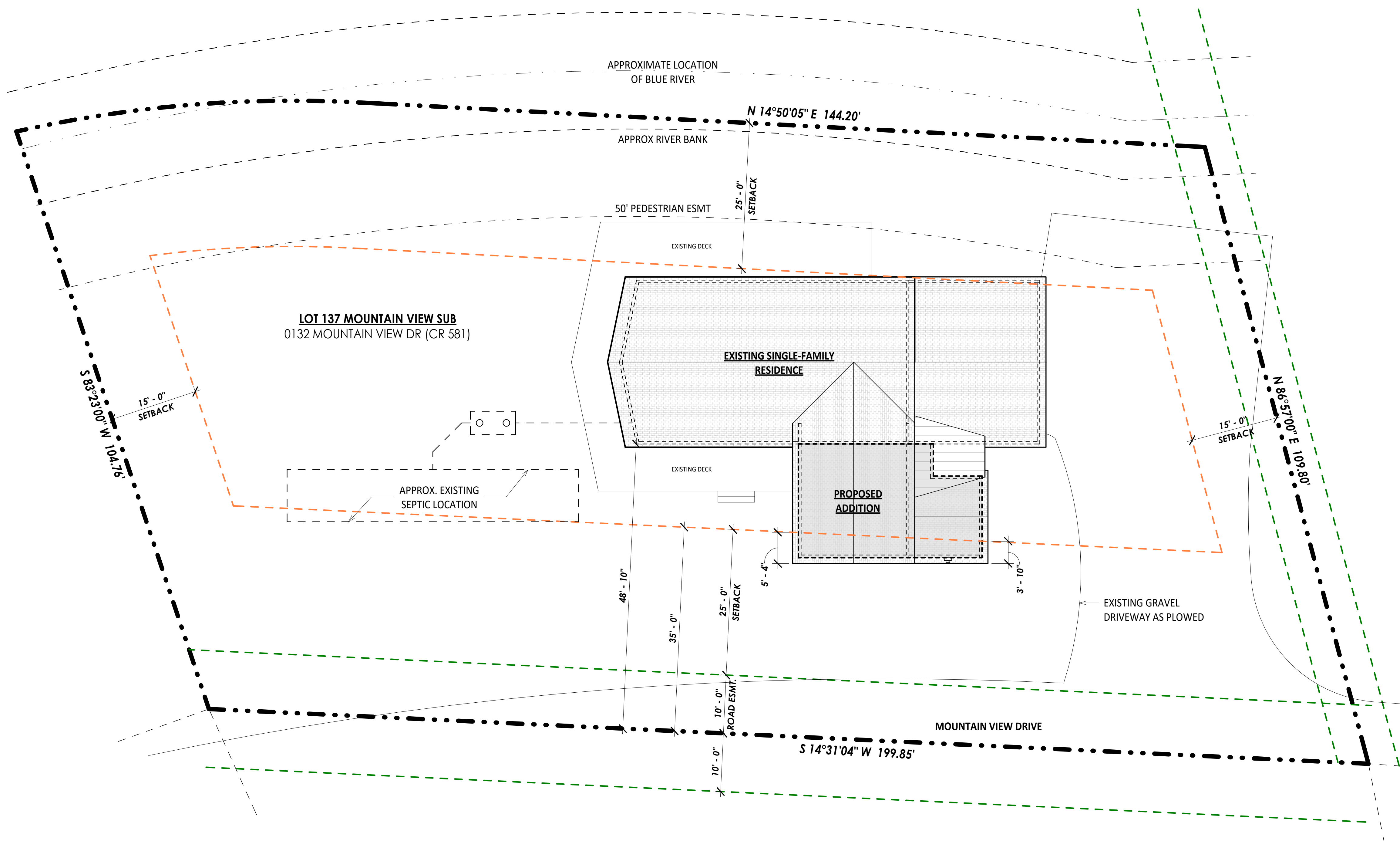

**1** PROPOSED SITE PLAN  
1" = 10'-0"





**ROOTED**  
ARCHITECTURE

SEAL:

NOT FOR CONSTRUCTION

DRAWINGS AND SPECIFICATIONS AS INSTRUMENTS OF SERVICE ARE THE PROPERTY OF THE ARCHITECT. THEY SHALL NOT BE USED, TRANSFERRED, OR SOLD FOR USE EXCEPT BY AN AGREEMENT IN WRITING FROM THE ARCHITECT.

**HIMMELMAN ADDITION**

0132 MOUNTAIN VIEW DRIVE  
BLUE RIVER, CO

No. Date Revisions

Project No: 2024-04  
Stage: VARIANCE REQUEST  
Date: 05/13/2024  
Scale: As indicated

DRAWING TITLE:

**FLOOR PLAN - LOWER**

DRAWING NO:

**A1.1**

**WALL LEGEND**

- NEW 2X4 / 2X6 WOOD STUD WALL
- EXISTING 2X4 / 2X6 WOOD STUD WALL
- EXISTING WALL TO BE REMOVED

**NOTES: FLOOR PLAN**

1. ALL INFORMATION MUST BE CONFIRMED PRIOR TO COMMENCEMENT OF CONSTRUCTION. ANY ERRORS OR DISCREPANCIES MUST BE BROUGHT TO THE ATTENTION OF THE ARCHITECT PRIOR TO PROCEEDING WITH WORK.
2. IT SHALL BE THE RESPONSIBILITY OF THE CONTRACTOR AND/OR INDIVIDUAL CONTRACTORS TO SEE THAT ALL ITEMS MEET OR EXCEED CODE REQUIREMENTS.
3. BUILDING SHALL VERIFY ALL DIMENSIONS, INTERIOR & EXTERIOR FINISHES, CONSTRUCTION & FRAMING METHODS PRIOR TO CONSTRUCTION.
4. ALL MATERIALS & WORKMANSHIP INVOLVED IN THE CONSTRUCTION OF THIS PROJECT ARE TO CONFORM WITH ALL LOCAL, STATE, NATIONAL, & INTERNATIONAL BUILDING CODES AS DESCRIBED IN THE INTERNATIONAL ONE & TWO FAMILY DWELLING CODE.
5. DRAWINGS ARE NOT TO BE SCALED. ALL DIMENSIONS ARE FROM FACE OF STUD TO FACE OF STUD, U.N.O. ALL DIMENSIONS LABELED "CLEAR" ARE TO FACE OF FINISH MATERIAL.
6. ALL INTERIOR GYPSUM BOARD TO BE 1/2" MINIMUM. USE WATER RESISTANT GYPSUM BOARD AT ALL WET WALL LOCATIONS. USE 5/8" TYPE "X" DRYWALL SEPARATIONS BETWEEN LIVING SPACES AND GARAGES AS REQUIRED BY CODE.
7. ALL TUB & SHOWER UNITS TO HAVE ANTI-SCALDING DEVICES INSTALLED.
8. GARAGE DOORS TO BE CERTIFIED BY MANUFACTURER FOR LOCAL WIND REQUIREMENTS
9. CONTRACTOR TO COORDINATE ELECTRICAL, PLUMBING AND HEATING WORK WITH SUBCONTRACTORS PRIOR TO STARTING WORK. PROVIDE ARCHITECT AND OWNER WITH SUBMITTALS WHERE APPLICABLE.
10. ALL ANGLED WALLS TO BE 45° UNLESS NOTED OTHERWISE.
11. MILLWORK SUBCONTRACTOR TO PROVIDE MILLWORK SHOP DRAWINGS TO THE ARCHITECTS, OWNER, AND CONTRACTOR FOR APPROVAL PRIOR TO COMMENCING FABRICATION.

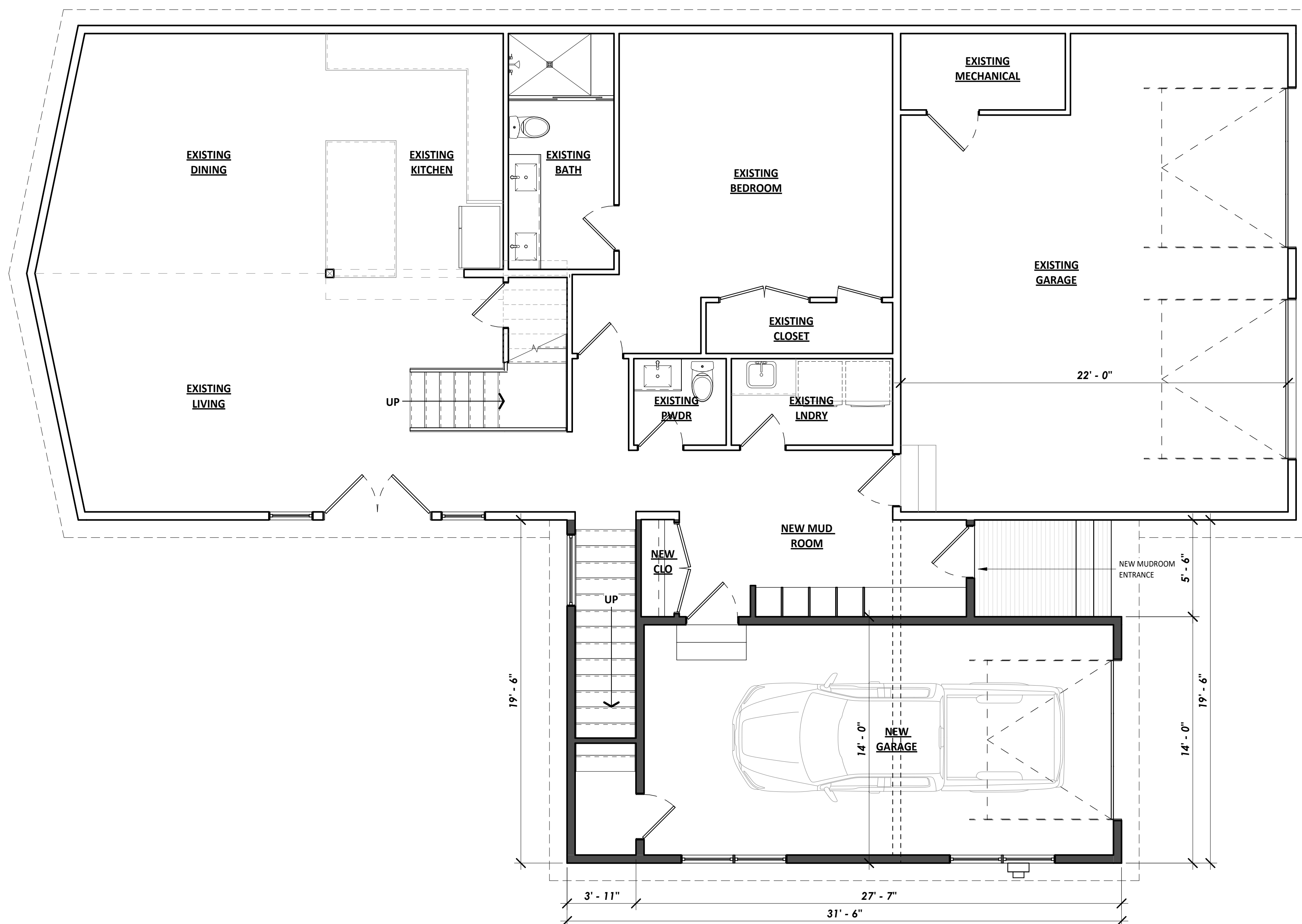

**1 LOWER LEVEL FLOOR PLAN**  
1/4" = 1'-0"

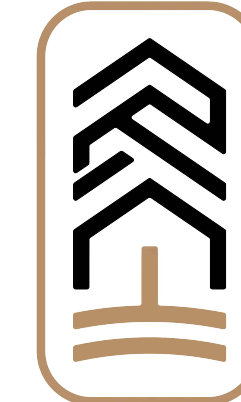

**ROOTED**  
ARCHITECTURE

SEAL:

NOT FOR CONSTRUCTION

DRAWINGS AND SPECIFICATIONS AS INSTRUMENTS OF SERVICE ARE THE PROPERTY OF THE ARCHITECT. THEY SHALL NOT BE USED, TRANSFERRED, OR SOLD FOR USE EXCEPT BY AN AGREEMENT IN WRITING FROM THE ARCHITECT.

**HIMMELMAN ADDITION**

0132 MOUNTAIN VIEW DRIVE  
BLUE RIVER, CO

No. Date Revisions

Project No: 2024-04  
Stage: VARIANCE REQUEST  
Date: 05/13/2024  
Scale: As indicated

DRAWING TITLE:

**FLOOR PLAN - UPPER**

DRAWING NO:

**A1.2**

**WALL LEGEND**

NEW 2X4 / 2X6 WOOD STUD WALL

EXISTING 2X4 / 2X6 WOOD STUD WALL

EXISTING WALL TO BE REMOVED

**NOTES: FLOOR PLAN**

1. ALL INFORMATION MUST BE CONFIRMED PRIOR TO COMMENCEMENT OF CONSTRUCTION. ANY ERRORS OR DISCREPANCIES MUST BE BROUGHT TO THE ATTENTION OF THE ARCHITECT PRIOR TO PROCEEDING WITH WORK.
2. IT SHALL BE THE RESPONSIBILITY OF THE CONTRACTOR AND/OR INDIVIDUAL CONTRACTORS TO SEE THAT ALL ITEMS MEET OR EXCEED CODE REQUIREMENTS.
3. BUILDING SHALL VERIFY ALL DIMENSIONS, INTERIOR & EXTERIOR FINISHES, CONSTRUCTION & FRAMING METHODS PRIOR TO CONSTRUCTION.
4. ALL MATERIALS & WORKMANSHIP INVOLVED IN THE CONSTRUCTION OF THIS PROJECT ARE TO CONFORM WITH ALL LOCAL, STATE, NATIONAL, & INTERNATIONAL BUILDING CODES AS DESCRIBED IN THE INTERNATIONAL ONE & TWO FAMILY DWELLING CODE.
5. DRAWINGS ARE NOT TO BE SCALED. ALL DIMENSIONS ARE FROM FACE OF STUD TO FACE OF STUD, U.N.O. ALL DIMENSIONS LABELED "CLEAR" ARE TO FACE OF FINISH MATERIAL.
6. ALL INTERIOR GYPSUM BOARD TO BE 1/2" MINIMUM. USE WATER-RESISTANT GYPSUM BOARD AT ALL WET WALL LOCATIONS. USE 5/8" TYPE "X" DRYWALL SEPARATIONS BETWEEN LIVING SPACES AND GARAGES AS REQUIRED BY CODE.
7. ALL TUB & SHOWER UNITS TO HAVE ANTI-SCALDING DEVICES INSTALLED.
8. GARAGE DOORS TO BE CERTIFIED BY MANUFACTURER FOR LOCAL WIND REQUIREMENTS
9. CONTRACTOR TO COORDINATE ELECTRICAL, PLUMBING AND HEATING WORK WITH SUBCONTRACTORS PRIOR TO STARTING WORK. PROVIDE ARCHITECT AND OWNER WITH SUBMITTALS WHERE APPLICABLE.
10. ALL ANGLED WALLS TO BE 45° UNLESS NOTED OTHERWISE.
11. MILLWORK SUBCONTRACTOR TO PROVIDE MILLWORK SHOP DRAWINGS TO THE ARCHITECTS, OWNER, AND CONTRACTOR FOR APPROVAL PRIOR TO COMMENCING FABRICATION.

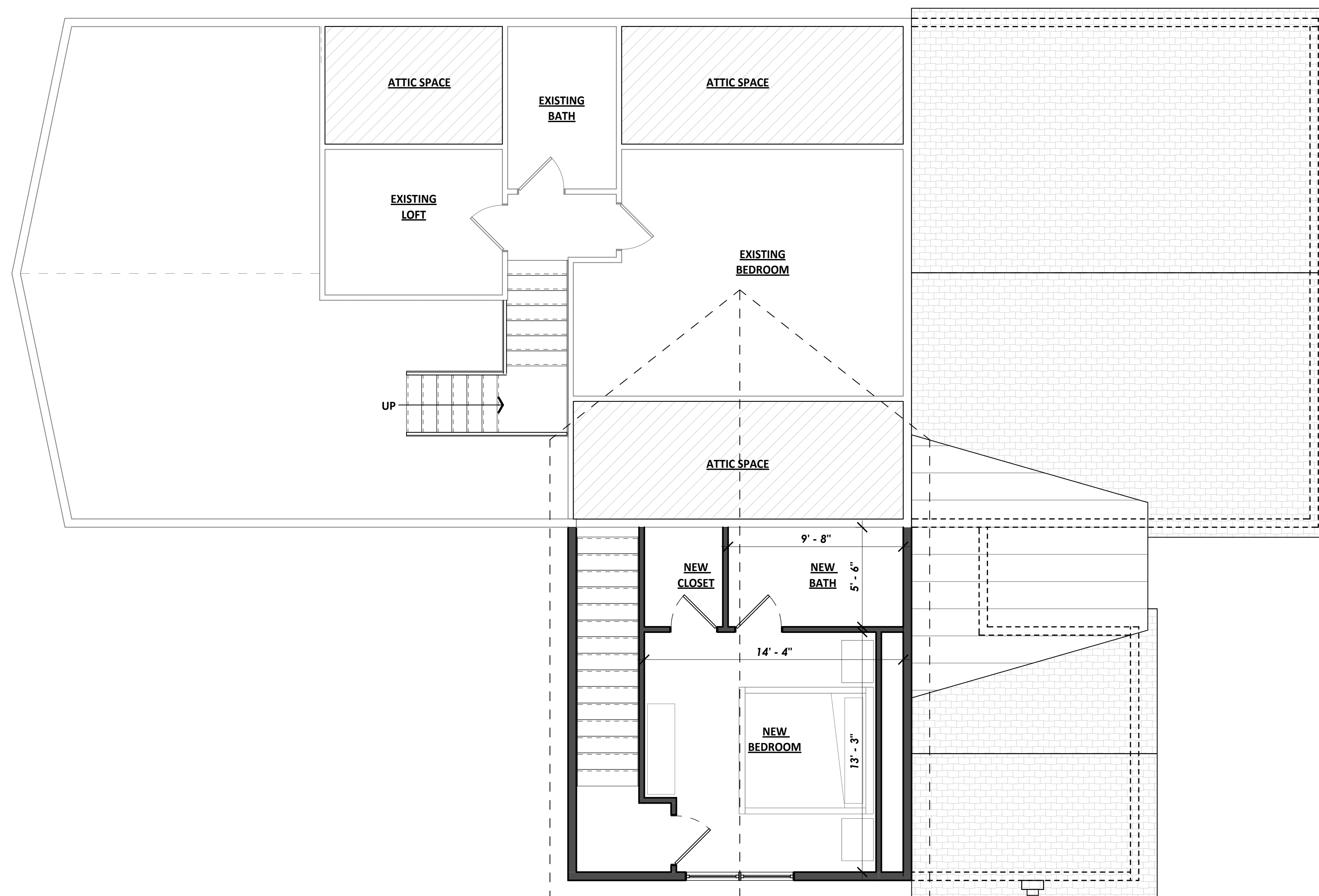

**1 LOWER LEVEL FLOOR PLAN**  
1/4" = 1'-0"



**ROOTED**  
ARCHITECTURE

SEAL:

NOT FOR CONSTRUCTION

DRAWINGS AND SPECIFICATIONS AS INSTRUMENTS OF SERVICE ARE THE PROPERTY OF THE ARCHITECT. THEY SHALL NOT BE USED, TRANSFERRED, OR SOLD FOR USE EXCEPT BY AN AGREEMENT IN WRITING FROM THE ARCHITECT.

**HIMMELMAN ADDITION**

0132 MOUNTAIN VIEW DRIVE  
BLUE RIVER, CO

**NOTES: ROOF PLAN**

1. COORDINATE INSTALLATION OF NEW ROOFING WITH OTHER TRADES. REPORT ANY CONFLICTS WITH ITEMS INSTALLED BY OTHER TRADES TO DESIGNER.
2. REFER TO SPECIFICATIONS. PROVIDE ROOF PRIMER, ROOF MEMBRANE AND ALL ROOFING PER SPECIFICATION REQUIREMENTS. PROVIDE "W.R. GRACE" MANUFACTURER CERTIFICATION LETTER STATING THAT ALL MEMBRANES HAVE BEEN INSTALLED IN COMPLETE COMPLIANCE WITH ALL MANUFACTURER'S REQUIREMENTS.
3. ALL PLUMBING VENTS SHALL EXTEND ABOVE THE FINISHED SURFACE OF THE ROOF SYSTEM AS REQUIRED TO PROVIDE FOR A MINIMUM OF 8" BASE FLASHING.
4. ALL EXPOSED METAL FLASHING/ TRIM PIECES TO BE PRE-FINISHED 24 GA. STL. U.N.O.. PROVIDE PRE-FINISHED OR FIELD PAINT FLASHING ONLY AS NOTED.
5. GUTTERS - ALL GUTTERS TO BE PRE-FINISHED. PROVIDE PRE-FINISHED SUPPORTS AND SPACERS @ 36" O.C. MAX. MATCH EXISTING GUTTER PROFILE AND FINISH.
6. ALL DOWNSPOUTS TO BE PRE-FINISHED, REFERENCE ELEVATIONS FOR LOCATIONS.
7. PROVIDE HEAT TAPE AT GUTTERS AND DOWNSPOUTS. REFER TO ROOF PLAN FOR ADDITIONAL FUTURE HEAT TAPE OUTLETS. SEE ROOF PLAN FOR WATERPROOF OUTLETS AT SIDEWALL AREAS. ALL GUTTERS AND DOWNSPOUTS TO BE HEATED. REFER TO PLAN FOR ALL SOLAR AND HEAT TAPE.
8. PAINT ALL EXPOSED PIPING EXTENDING THROUGH ROOF TO MATCH ROOF
9. PROVIDE VALLEY FLASHING AT ALL VALLEYS AS INDICATED ON PLANS.
10. OVERHANG DIMENSIONS ARE TO END OF RAFTER OR TRUSS AS INDICATED ON PLANS.
11. PROVIDE KICK-OUT FLASHING AT ALL EAVE/WALL JUNCTURES.
12. PROVIDE ILC AS REQUIRED.
13. CONTRACTOR TO COORDINATE HEATED GUTTER AND DOWNSPOUT LOCATIONS WITH ARCHITECT.
14. DOWNSPOUTS SHALL NOT DISCHARGE ONTO FLATWORK OR DECKS BELOW. CONTRACTOR TO ROUTE DISCHARGE BELOW SURFACE OR PROVIDE CHANNEL DRAIN IN FLATWORK WITH HEAT TAPE.
15. REFER TO SPECIFICATIONS. PROVIDE ROOF PRIMER, ROOF MEMBRANE AND ALL ROOFING PER SPECIFICATION REQUIREMENTS. PROVIDE "W.R. GRACE" MANUFACTURER CERTIFICATION LETTER STATING THAT ALL MEMBRANES HAVE BEEN INSTALLED IN COMPLETE COMPLIANCE WITH ALL MANUFACTURER'S REQUIREMENTS.
16. UNVENTED ROOFS SHALL HAVE A MINIMUM 60% AIR IMPERMEABLE CLOSED CELL INSULATION AT UNDERSIDE OF DECK.

**NOTES: ROOF MAINTENANCE**

THE OWNER HAS BEEN ADVISED THAT ALL ROOF AND DECK SURFACES MUST BE MAINTAINED RELATIVELY FREE OF SNOW & ICE.

**RIDGE HEIGHT CALCULATIONS**

RIDGE	RIDGE HEIGHT (USGS)	PROP. GRADE (USGS)	EXIST. GRADE (USGS)	ROOF HEIGHT
A	XXX	XXX	XXX	XXX
B	---	---	---	---
C	---	---	---	---
D	---	---	---	---

NOTE:

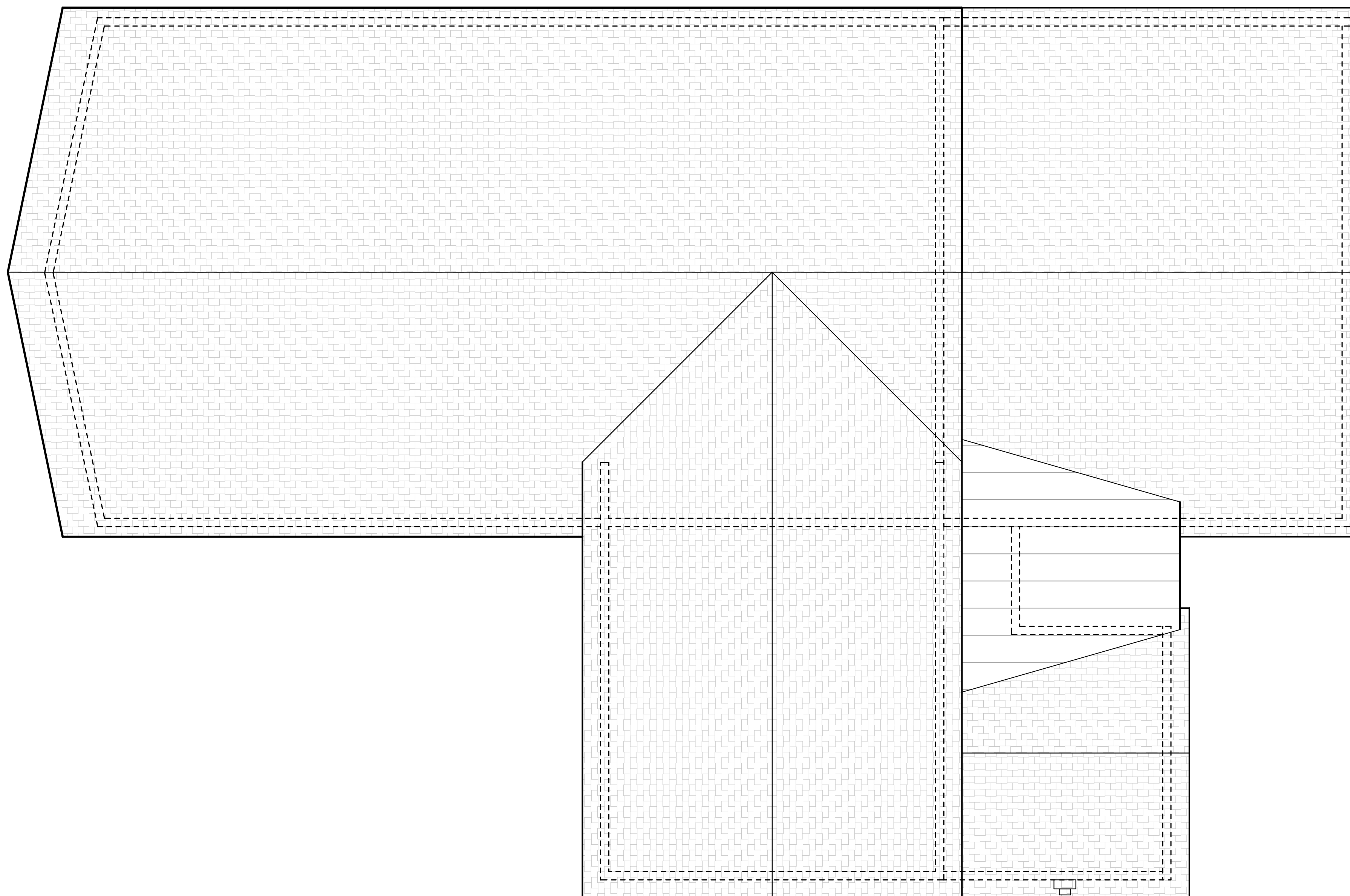

**1 LOWER LEVEL FLOOR PLAN**  
1/4" = 1'-0"

No. Date Revisions

Project No: 2024-04  
Stage: VARIANCE REQUEST  
Date: 05/13/2024  
Scale: As indicated

DRAWING TITLE:

**ROOF PLAN**

DRAWING NO:

**A3.1**

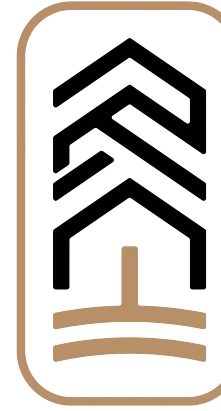

**ROOTED**  
ARCHITECTURE

SEAL:

NOT FOR CONSTRUCTION

DRAWINGS AND SPECIFICATIONS AS INSTRUMENTS OF SERVICE ARE THE PROPERTY OF THE ARCHITECT. THEY SHALL NOT BE USED, TRANSFERRED, OR SOLD FOR USE EXCEPT BY AN AGREEMENT IN WRITING FROM THE ARCHITECT.

**NOTES: AIR BARRIER / VAPOR BARRIER**

IN COMPLIANCE WITH ENERGY CODE REQUIREMENTS, PROVIDE CONTINUOUS, SOLID AIR BARRIERS OVER ALL INSULATION SURFACES. PROVIDE AIR BARRIERS BEHIND ALL CONCEALED AREAS, SUCH AS TUBS, DROPPED CEILING AREAS, SOFFITS DECORATIVE BEAMS AND STRUCTURAL BEAMS ADJACENT TO THERMAL ENVELOPE WALLS. THESE BARRIERS SHOULD BE COORDINATED AND INSTALLED AT THE TIME OF FRAMING AND MUST BE CONTINUOUS AND UNBROKEN. PROVIDE AIR BARRIERS AND INSULATION AT THE THERMAL ENVELOPE LINE OF ALL CHIMNEYS. AIR BARRIERS CAN BE 6 MIL POLYFILM PLASTIC, DRYWALL OR SOLID SHEATHING. COORDINATE ALL AIR BARRIERS WITH VAPOR BARRIERS AND INSULATION REQUIREMENTS AS OUTLINED IN DIVISION VII. PROVIDE AND SCHEDULE A PRE-MEETING WITH THE ARCHITECT AND FRAMER TO REVIEW THESE REQUIREMENTS PRIOR TO ANY FRAMING WORK.

**NOTES: WEATHER RESISTIVE BARRIER**

1. INSTALL WEATHER RESISTIVE BARRIER IN STRICT COMPLIANCE WITH MANUFACTURERS RECOMMENDATIONS AND DETAILS. USE ONLY APPROVED PRODUCTS AND FASTENING METHODS.
2. REFERENCE LOCAL AND NATIONAL BUILDING CODES AND REGULATIONS PRIOR TO INSTALLATION. INSTALL PER GOVERNING CODE REQUIREMENTS. NOTIFY ARCHITECT IF ANY CONFLICT ARISES.

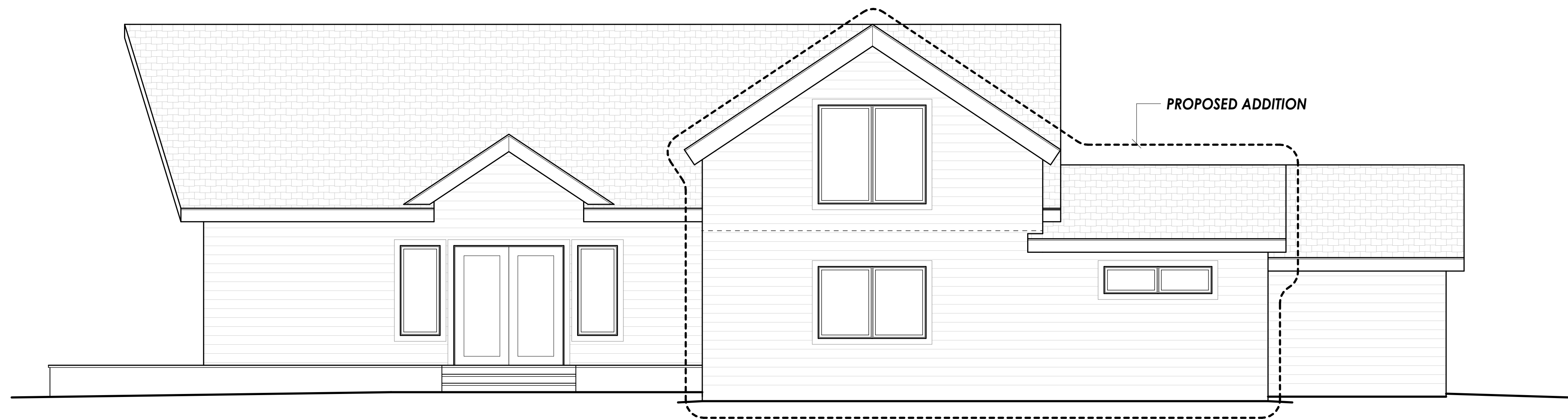

**1** PROPOSED EAST ELEVATION  
1/4" = 1'-0"

**HIMMELMAN ADDITION**

0132 MOUNTAIN VIEW DRIVE  
BLUE RIVER, CO

No.	Date	Revisions

Project No: 2024-04  
Stage: VARIANCE REQUEST  
Date: 05/13/2024  
Scale: As indicated

DRAWING TITLE:

**EXTERIOR ELEVATIONS**

DRAWING NO:

**A4.1**



**Improvement Survey Plat**  
**Lot 137**  
**Blue River Estates**  
**Mountain View**  
**Town of Blue River**  
**Summit County, Colorado**  
**Section 19, T7S, R77W, 6th P.M.**  
**(0132 Mountain View Drive)**



- Legend**
- (F) Field Measurement
  - (P) Plat, Rec. No. 92845
  - (C) Calculated from Plat
  - ◆ Found rebar with aluminum cap LS19588
  - Ⓟ Power
  - Ⓠ Gas
  - Ⓡ Communications

- Notes:**
- 1) Bearings are based on the north line of Lot 137, N86°57'E per record plat. Both ends said line are rebar with aluminum cap LS19588.
  - 2) Lineal Units: US Survey foot.
  - 3) Lot Area: 0.488 Acres, 2125.3 Square feet
  - 4) Only visible utilities located. Underground locate not done.
  - 5) Approximately 6 inches of snow on the ground at the time of the survey. Improvements, utilities and encroachments at or near ground level would not have been seen or shown on this survey.
  - 6) River shown based on best available evidence at the time of the survey (survey records, aerial and edge locations in a few spots). River was snow and ice covered at the time of the survey. Platted 50 foot Pedestrian easement centered on river per record plat.
  - 8) The boundary shown is based on found monumentation and is consistent with the survey by Flatirons survey dated December 19, 2007. Per record plat, the westerly lot boundary line is intended to roughly follow the centerline of the Blue River, 197 +/- of frontage.

This survey does not constitute a title or ownership search by Blue River Land Surveying. All ownership, easement and public record information was based on the Owner's Title Commitment Order No. 01330-91148, issued by Stewart Title.

Property is subject to exceptions as described in the title policy as referenced.

I, Renee B. Parent, being a Registered Land Surveyor in the State of Colorado, do hereby certify that this plat was prepared by me and under my supervision from a survey made by me and under my supervision and that both the plat and the survey are true and correct to the best of my knowledge and belief.

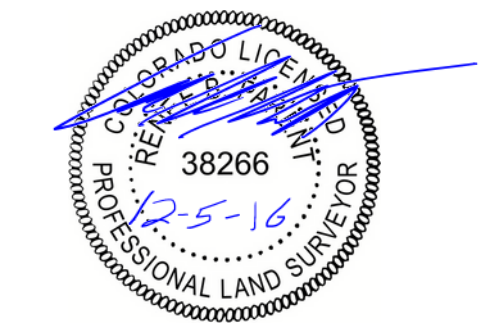

Notice: According to Colorado law you must commence any legal action based upon any defect in this survey within three years after you first discover such defect. In no event may any action based upon any defect in this survey be commenced more than ten years from the date of the certification shown hereon.

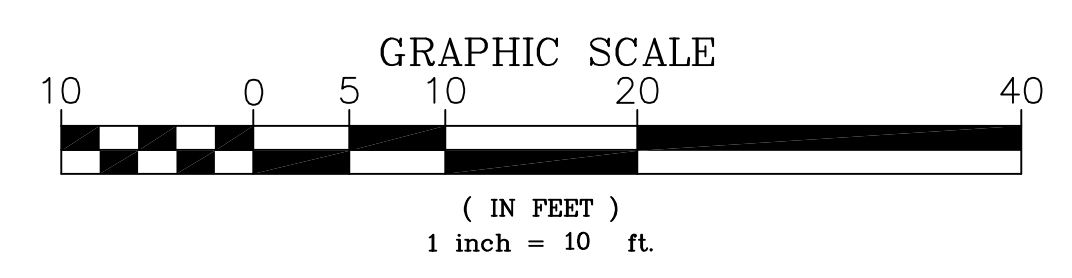

**Blue River**  
**Land Surveying**  
**(970) 668-3730**  
 PO Box 2820 Breckenridge, CO 80424  
 www.blueriverlandsurveying.com

*Improvement Survey Plat*  
 Lot 137  
 Blue River Estates  
 Mountain View  
 Town of Blue River  
 Summit County, Colorado  
 Section 19, T7S, R77W, 6th P.M.  
 (0132 Mountain View Drive)



## Building Permit Application

Email to: [info@townofblueriver.org](mailto:info@townofblueriver.org)

Questions? Call (970) 547-0545 ext. 1

**Lot Number:** #8 \_\_\_\_\_ **Subdivision:** Blue Rock Springs Sub \_\_\_\_\_  
**Blue River Physical Address:** 34 Rustic Terrace \_\_\_\_\_

**Homeowner Information:**

Name: \_\_\_\_\_  
 Mailing Address: 34 Rustic Terrace \_\_\_\_\_  
 Phone: \_\_\_\_\_  
 Email: \_\_\_\_\_

**Contractor Information**

Company Name: The Ashlan Group LLC \_\_\_\_\_  
 Contact Name: Matt Krigman \_\_\_\_\_  
 Mailing Address: 400 North Park Ave - Suite 12-B \_\_\_\_\_  
 Phone: 970-333-8624 \_\_\_\_\_  
 Email: MattKrigman@Gmail.com \_\_\_\_\_  
 Contractor Registration #: \_\_\_\_\_

*\*\*Please note a Town of Blue River Business License is required for all businesses to conduct business in the Town of Blue River including contractors, sub-contractors and architects. \*\**

**Description of Project:**

Adding on to existing home - 1500 sq. ft. 2 bedroom/ 1 bathroom \_\_\_\_\_

Distance to Property Line	Type of Heat:	Construction Type: wood
North:	Roof:	Building Height: 33' - 10 1/4"
South:	Exterior Walls:	No. Stories: 3
East:	Interior Walls:	Total # Bedrooms: 4
West:	Basement Fin. Sq.Ft.:	Total # Bathrooms: 3
New Addition/Res. Sq.Ft.:	Main Level Sq.Ft.: 1499	Septic or Sewer:
Garage Sq.Ft.:	2 <sup>nd</sup> Level Sq.Ft.:	1783
Total Square footage:	3 <sup>rd</sup> Level Sq.Ft.:	803

SEPARATE PERMITS ARE REQUIRED FOR ELECTRICAL, PLUMBING, HEATING, VENTILATION WORK, & FIREPLACES. THIS PERMIT BECOMES NULL AND VOID IF CONSTRUCTION AUTHORIZED IS NOT COMMENCED WITHIN \_\_\_\_ OR IF CONSTRUCTION IS SUSPENDED OR ABANDONED FOR A PERIOD OF \_\_\_\_ AT ANY TIME AFTER WORK IS COMMENCED.

I HEREBY CERTIFY THAT I HAVE READ AND EXAMINED THIS APPLICATION AND KNOW THE SAME TO BE TRUE AND CORRECT. I AGREE TO COMPLY WITH ALL TOWN ORDINANCES AND STATE LAWS REGARDING BUILDING CONSTRUCTION AND TO BUILD ACCORDING TO THE APPROVED PLANS. THE GRANT OF A PERMIT DOES NOT PRESUMED TO GIVE AUTHORITY TO VIOLATE OR CANCEL THE PROVISIONS OF ANY OTHER STATE OR LOCAL LAW REGULATING CONSTRUCTION OR THE PERFORMANCE OF CONSTRUCTION.

Signature of Owner or Contractor: Matt Krigman Date: 5/16/2024

# Submittal Requirements

**\*\*ALL Submittals Must be Electronic\*\***  
**Emailed to: info@townofblueriver.org**

## Planning & Zoning Review Submittal Requirements

**\*\*Please indicate via check box item included as well as page number in submitted packet.**

Completed <input checked="" type="checkbox"/>	Item	Description	Page #
	<b>Site Plan</b>	Scale: 1" = 10'; May appear on a single sight plan. IF on a separate page, please indicate the page.	AO.1 AO.2
		Property Boundaries	AO.2
		Building Envelope with setbacks	AO.2
		Proposed Buildings	AO.2
		Structures (existing & proposed)	AO.2
		Driveway & Grades	AO.2
		A wetlands delineation & Stream crossing structures where applicable.	<b>AO.2</b>
		Topographic survey, prepared and stamped by a licensed surveyor, indicating site contours at 2' intervals, easements, and significant natural features such as rock outcroppings, drainages and mature tree stands.	AO.2
		Transformer & vault location (if installed by owner or existing)	<b>AO.2</b>
		Well location; septic if applicable	AO.2
		Snow storage areas and calculations	AO.2
		Major site improvements	AO.2
		Existing & proposed grading & drainage	<b>N/A</b>
	<b>Landscaping Plan</b>	<b>*May be included in the site plan**</b>	N/A
		Landscaping must indicate tree removal for defensible space requirement; any trees 6" or more primarily noting the removal of any ponderosa pines or large trees. Clear cutting of a site is not allowed.	N/A
		Indicate the percentage of trees removed and revegetation to be conducted.	N/A
		Upon completion of the construction project, all land must be raked and	

		reseeded with native seed prior to issuance of CO. in cases of completion during snow coverage and/or winter, CO may be issued with conditions for completions within 60 days of the last snow and a deposit.	yes
		Any major structures (retaining walls; fences; landscaping rocks) must be indicated in detail on plans in conformance with the design regulations.	AO.2
		Indicating building walls, floors and roof relative to the site, including existing and proposed grades, retaining wall and proposed site improvements.	A1.1 -A7.1
	<b>Floor Plans</b>	<i>Scale 1/8" = 1'</i>	
		Indicate the general layout of all rooms, approximate size, and total square footage of enclosed space for each floor level.	AO.1
	<b>Exterior Elevations</b>	<i>Scale same as floor plans</i>	
		Detail to indicate the architectural character of the residence, fenestration and existing and proposed grades. Elevations must include a description of exterior materials and colors.	A4.1 A5.1
	<b>Roof Plan</b>	<i>Scale same as floor plans</i>	
		Indicate the proposed roof pitch, overhang lengths, flue locations, roofing materials and elevations of major ridge lines and all eave lines.	A5.1
	<b>Materials Sheet</b>	Display materials to be used. Color renderings are suggested as well. In cases of additions, if matching the existing structure, photos of current home.	TBD

After Approval and BEFORE Permit is Issued:

**ELECTRONIC COPY Stamped set.**

- All of the above mentioned plus items below in one plan set.

Completed <input checked="" type="checkbox"/>	Item	Page #
	Soils report if applicable	at time of excavation
	Electrical, plumbing and mechanical plans.	A2.1
	Construction Management Plan. Please refer to the Town Code and Architectural Guidelines for all requirements.	AO.1
	Stamped structural plan	S1.1-S2.2
	Current Summit County Septic System Permit (including system plot plan), or evidence of full payment of tap fees to Upper Blue Sanitary District.	
	Current Colorado Well Permit or evidence of full payment of tap fees to Timber Creek Water District	
	Colorado Department of Transportation Hwy Access Permit	
	Designation of General Contractor, except for bona fide homeowner contractor	
	For Manufactured Homes the following additional information is required	
	<ul style="list-style-type: none"> <li>• State of Colorado Division of Housing Approved Plans</li> </ul>	
	<ul style="list-style-type: none"> <li>• State of Colorado Division of Housing Registered Installer Certificate</li> </ul>	

# Blue River Plan Submittal Requirements for Residential Plan Review

- ❖ When designing the structure, refer to the Blue River Municipal Town Code, Chapter 16 for zoning information and allowable uses/construction. The Building Code information is available under Chapter 18. <https://townofblueriver.colorado.gov>.
- ❖ Building Codes Adopted:
  - International Residential Code 2018
  - The Electrical Code is the current code adopted by the State of Colorado: 2020

**Note: Applicable codes are required to be notated on plans.**

- ❖ Snow loads:
  - Roofs shall be designed in accordance with accepted engineering practice based upon a ground snow load of 100 psf.
  - Balconies/decks-125 psf.
  - No reductions for duration.
- ❖ Frost line depth:
  - Foundation footing minimum depth below grade-40 inches.
  - Uncovered deck piers may be set at 24 inches.
- ❖ Roof underlayment 100% Ice & Water shield.
- ❖ Roof may be metal; 30-year minimum architectural grade, composition fiberglass (dark brown, dark gray, dark green, weathered wood or black only); or class-A #1 cedar shakes.
- ❖ Wind speed: 90 mph, exposure “B”. Seismic design category: “B”.
- ❖ Propane gas alarm/shutoff system required.
- ❖ Wood burning stoves: Required to meet Colorado Dept. of Health, Regulation No. 4.
- ❖ The building height limit in the Town is 35 feet. Refer to the Architectural Guidelines for additional information.
- ❖ Locally re-settable GFCI breakers are required in bathrooms.
- ❖ Compliance with the International Energy Conservation Code is required.
- ❖ Any application that would create an accessory apartment must meet zoning regulations and will not be processed without prior approval of the Town Board of Trustees.
- ❖ Note that Hwy 9 access permits may require 3-4 months and well permits 5-6 weeks.
- ❖ Planning & Zoning Commission approvals become void if the building permit is not issued within eighteen (18) months.
- ❖ Building permits become void if construction is discontinued for more than 180 days.

In order for your permit application to be reviewed and processed properly, the following construction information must be provided. **Note:** "Preliminary" and/or plans shown as "Not for Construction" or similar are unacceptable. ***Hardcopy submittals will not be accepted.***

***Note: Items below are not all inclusive of the requirements. Please review the Building Application Packet, design guidelines, building and land use codes for complete information.***

**Soils Report**

Must be sealed and signed by a licensed Colorado Engineer.

- Provide an engineer's soil investigation report indicating type of soil and recommended foundation design. include any required shoring.

**Improvement Survey Plat**

- Provide an Improvement Survey Plat (ISP) following Colorado Revised Statutes for new principal structures, substantial expansions (25% or more) to principal structures and new accessory dwelling units (ADU's).
- Provide a permanent reference to spot elevation (benchmark) that will not be disturbed during construction.
- Provide existing spot elevations at property corners and at midpoints of the side property lines.
- Must be stamped and signed by a Professional Land Surveyor (PLS) licensed by the state of Colorado.

**Site Plan**

- Provide site plan that shows dimensions reflecting the distances to property lines
- Indicate all public or private easements
- Show location of all proposed and existing structures with dimensions
- Prove type of construction for all structures on site
- Provide landscaping plan.
- Show permanent reference spot elevation (benchmark), existing spot elevations at property corners and at midpoints of the side property lines.
- Indicate roof drainage on site plan with arrows showing the direction of the gutter downspouts. Roof drainage shall flow towards the road and away from all structures.

**Structural Plans**

Plans must be sealed and signed by a Colorado Structural Engineer or Architect

- Indicate size, location and method of reinforcement for all proposed footings, column pads, piers, caissons, grad beams, foundation walls, decks, guardrails, guardrail posts. Specify location of reinforcing steel and anchor bolts.

- Provide complete and clearly dimensioned floor framing plan for each level and roof framing plan which indicates the materials, types, sizes and location of all structural elements.
- Provide complete structural design criteria including but not limited to required design loads, material specifications and structural construction requirements.
- Provide complete structural calculations for each structure.

### **Architectural Plans**

- Provide complete and dimensioned floor layout at each level which identifies the use of each room.
- Provide Complete and dimensioned roof plan and indicate all roof slopes.
- Provide complete and dimensioned reflected ceiling plan.
- Provide exterior elevations for each side of the building which contains an overall building height and floor-to-floor heights and indicate location, size and types of all doors and glazed openings including hazardous glazing and fall protection locations.
- Provide a bulk plane diagram on front and rear exterior elevations relative to the base plane elevation. The base plan for the bulk plane is establishing by taking the average of the existing grades of the midpoints of the two side property lines.
- Provide building and wall sections which clearly identify the required type and location of all materials for construction of beams, columns, floors, walls, ceilings, roofs.
- Provide stair geometry. Include rise and run, handrail and guardrail heights.
- Provide one major section through the exterior wall from footings to the highest part of the roof (min. scale 1/4"=1')
- Provide square foot area breakdown per floor level.

### **Electrical Plans**

Provide electrical plans showing the location and capacity of the service equipment and electrical panels, the location of all smoke detectors, carbons monoxide detectors, electrical receptacles, switches, and lighting fixtures.

### **Mechanical Plans**

- Provide mechanical plans and indicate the location of all heating, ventilating and air conditioning equipment. Show the location of the condensing unit. Detail the equipment access and working clearances.
- Show dryer exhaust termination location and clearances, environmental exhaust termination locations and clearances.
- Provide Manual J and Manual D calculations. Must be legible. No exceptions.
- Provide all fireplace specifications, rated separation details, direct vent termination details when applicable, hearth extensions when required, chimney clearances, shutoff and control access.



### **Plumbing Plans**

- Provide plumbing plans and indicate the location of all plumbing fixtures and appliances (Isometric may be required per the discretion of the plans examiner.)
- Provide the supply line size and main discharge size. Note the water supply inlet location.
- Indicate whether appliances are gas-operated, electric, or otherwise. List types of material to be used for all water supply, drainage and vent piping. Provide fixture max flow rates and insulation values.
- Gas load calculations and piping diagram is required.

### **Energy Conservation Plans**

Provide verification that the project meets the requirements of the IECC, or provide a simulated energy performance analysis such as RES-check. Provide all required information per 2012 IECC R103.2.

### **Resubmittal Requirements**

- Provide a written response addressing each correction.
- Provide revision clouds for each correction made.
- Provide updated information in the revision section of the title block.
- Provide complete plan packs per discipline requiring corrections. Example: If you are resubmitting for Civil corrections, provide a complete revised plan pack.

**2022 WETLAND DELINEATION REPORT – FITZGERALD**

Best Ecological Design Group (BEDG) has been contracted by Tom & Alex Fitzgerald to conduct a delineation of wetlands located on the subject property.

The description of the subject property is as follows.  
Lot 8, Blue Rock Springs Sub, Blue River, Colorado 80424  
Address: 0034 Rustic Terrace/CR 603, Blue River, Colorado  
Latitude: 39.4357° North  
Longitude: -106.0423° West  
Elevation: ~9,990'  
Lot Acreage: Approx. 1.22-Acres  
Nearest Town: Blue River, Colorado  
Nearest TNW/Water Body: Blue River/Dillon Reservoir  
Nearest Stream: N/A  
NRCS Soils Map Type: Histic cryaquolls  
Date(s) of Fieldwork: May 2023  
Date of Corps Site visit: None required  
Date of Submittal to Client: 17 June 2023

Location of Wetlands on Subject Property - See Map 1.

Habitat of the surrounding area includes subalpine pine-spruce forest with extensive stands of Aspen, and broad wetlands associated with the valley floor and riparian corridor of the Blue River; the valley is dominated by Riparian and Palustrine scrub-shrub wetlands with inclusions of Palustrine forested habitat.

Located at approximately 9,990' elevation and positioned within the upper Blue River valley & drainage area, the wetlands of the property are typical for the ecological position. Hydrology is provided by groundwater seeps and sheet flows, for deep rooted species. In addition to groundwater, snowpack and summer precipitation supply the subject wetland, contributing hydrology to the shallow root zone.

The subject wetlands are Palustrine scrub-shrub with hydrophytic herbaceous, shrub, and tree strata dominants. The wetland boundary delineation is identified by a single flag series, W-1 through W-8. The subject wetlands are a portion of a greater wetland complex, contiguous, and within the historic river floodplain. Multiple probe samples were utilized to identify hydric soil variations and the wetland boundary. See map 1 for the location of the subject wetlands.

Natural Resources Conservation Service mapped for the area of the Subject Property as Histic cryaquolls; gravelly sandy soils were verified along the wetland boundary.

The delineation was conducted during the 2023 season, during multiple visits. Delineation methodology was conducted in accordance with the 1987 "U.S. Army Corps of Engineers Wetlands Delineation Manual" with updates according to the Western Mountains, Valleys & Coast Regional Supplement. Schmidt Land Surveying conducted surveying of the wetland boundaries. Indicators examined to determine the presence of wetlands include vegetation, hydrology, and soils.

DESCRIPTION OF WETLANDS

Palustrine shrub wetlands of the property are associated with the riparian corridor of the valley floor, Palustrine scrub-shrub wetlands dominate the site; the subject wetland complex is contiguous within the greater wetland complex. No surface flows were observed along the identified boundary.

Palustrine Scrub-Shrub

Palustrine wetlands (PSS1B) of the subject property exhibit varied qualities, Hydrophytic shrubs dominate in the richest portions, some dead or stressed shrubs mark the diminished portions along the boundary. The diminished portion also demonstrates encroachment by non-wetland plant species.

Multiple *Salix* species and *Alnus* dominate the shrub layer. Ground cover vegetation of varied density is dominated by *Calamagrostis canadensis*, *Mertensia ciliata*, and *Carex* species.

Soil indicators for wetland presence are variable but verified in probe samples.

The flag boundaries were set according to the density and quality of hydrophytic plant species, hydric soil indicators, and presence of hydrology.

PLANT LISTDominant plant species

<u>Wetland Species</u>	<u>Indicator Status</u>
<i>Calamagrostis canadensis</i>	Obl
<i>Mertensia ciliata</i>	FacW
<i>Salix drummondiana</i>	FacW
<i>Salix planifolia</i>	Obl

Upland Species

*Chamerion danielsii*  
*Fragaria virginiana*

Resources

U.S. Army Corps of Engineers, Wetland Delineation Manual (1987) & Western Mountains, Valleys, and Coast Region Supplement (2010)  
Lichvar, R.W., D.L. Banks, W.N. Kirchner, and N.C. Melvin. 2016.  
*The National Wetland Plant List: 2016 wetland ratings.*  
Phytoneuron 2016-30: 1-17. Published 28 April 2016. ISSN 2153 733X  
U.S. Natural Resources Conservation Service, WSS Web Soil Survey of Summit County Area (2016)  
Weber, W. A. and, R. C. Wittmann, Colorado Flora – Western Slope, (2001)

CONTACT INFORMATIONClient/Applicant

TOM FITZGERALD  
POST OFFICE BOX 2710  
BRECKENRIDGE, COLORADO 80424  
TMFITZGERALD@GMAIL.COM

Wetland Consulting

VIRGIL O. BEST II  
BEST ECOLOGICAL DESIGN GROUP  
POST OFFICE BOX 2301-152  
SILVERTHORNE, COLORADO 80498  
970.389.7670 MOBILE

Surveying

SCHMIDT LAND SURVEYING  
970.409.9963

Map 1 – Location of Subject Wetlands on Subject Property

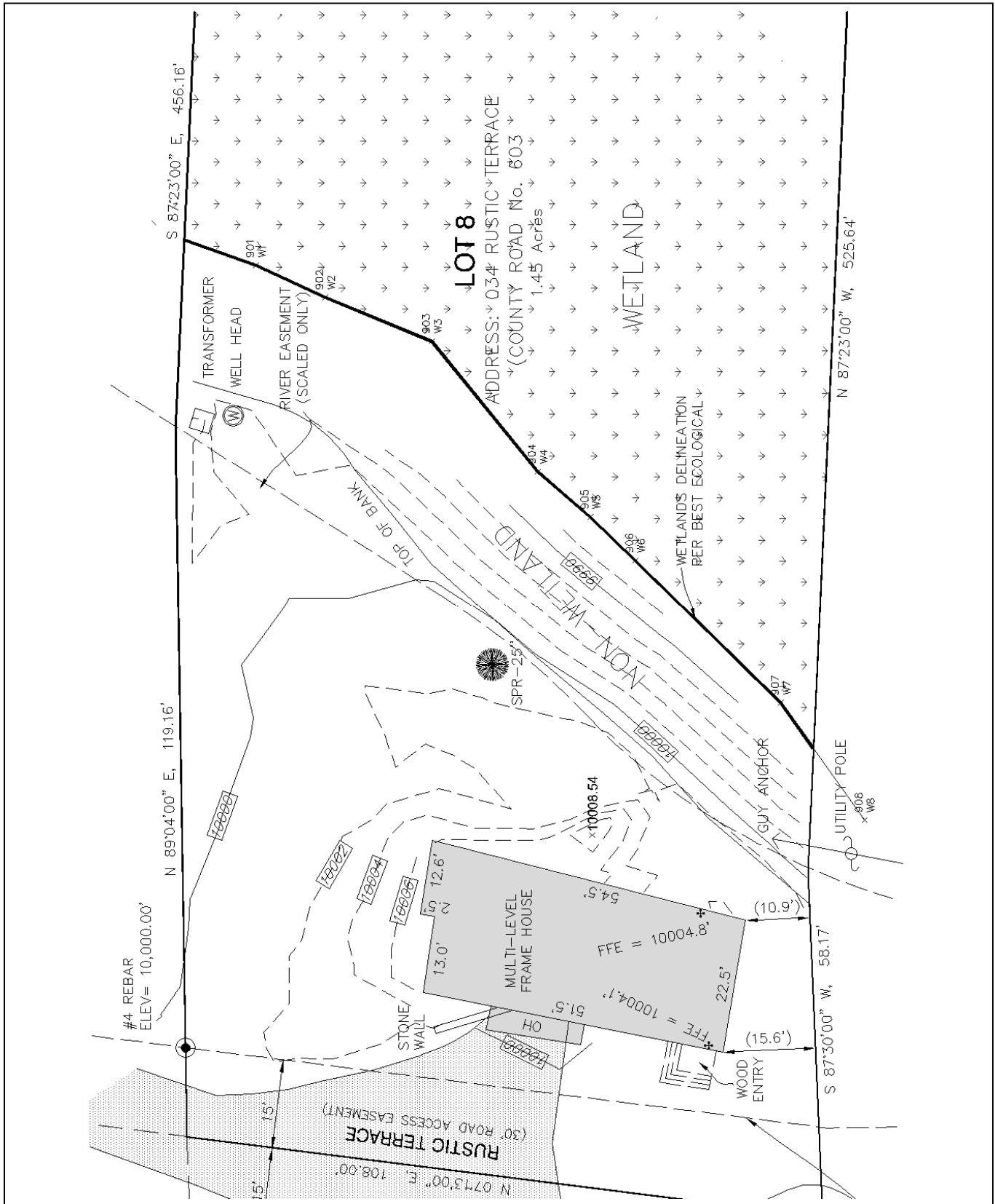





ROOTED ARCHITECTURE

SEAL:

NOT FOR CONSTRUCTION

DRAWINGS AND SPECIFICATIONS AS INSTRUMENTS OF SERVICE ARE THE PROPERTY OF THE ARCHITECT. THEY SHALL NOT BE USED, TRANSFERRED, OR SOLD FOR USE EXCEPT BY AN AGREEMENT IN WRITING FROM THE ARCHITECT.

FITZGERALD ADDITION

34 RUSTIC TERRACE BLUE RIVER, CO

No. Date Revisions

Project No: 2023-16  
Stage: FINAL REVIEW SET  
Date: 05/02/2024  
Scale: As indicated

DRAWING TITLE:

ENLARGED SITE PLAN

DRAWING NO:

A0.2

NOTES: SITE PLAN

- 1. VERIFY ALL UTILITY LOCATIONS PRIOR TO ANY WORK. COORDINATE UTILITY ROUTING WITH APPLICABLE UTILITY COMPANY. ALL UTILITIES TO BE UNDERGROUND.
2. SURFACE DRAINAGE SHALL BE DIVERTED TO A STORM SEWER CONVEYANCE OR OTHER APPROVED POINT OF COLLECTION THAT DOES NOT CREATE A HAZARD. LOTS SHALL BE GRADED TO DRAIN SURFACE WATER AWAY FROM FOUNDATION WALLS. THE GRADE SHALL FALL NOT FEWER THAN 6 INCHES WITHIN THE FIRST 10 FEET.
3. REFER TO FOUNDATION PLAN FOR FOUNDATION DRAIN LOCATION AND SLOPE.
4. FLAG ALL TREES FOR OWNER PRIOR TO THINNING OR REMOVAL.
5. PROTECT REMAINING TREES WITH APPROVED BARRIER DURING CONSTRUCTION.
6. GENERAL CONTRACTOR SHALL REVIEW AND COMPLY WITH ALL ZONING AND SUBDIVISION CONDITIONS.
7. FINISHED GRADING SHALL BE A MINIMUM OF 6" BELOW FOUNDATION REFERENCE ADOPTED IRC.
8. CONTRACTOR TO TRIM OR REMOVE ANY TREES ADJACENT TO BUILDING FOUNDATION AS REQUIRED, VERIFY WITH OWNER PRIOR TO REMOVAL.

NOTES: SITE CONTOUR LEGEND

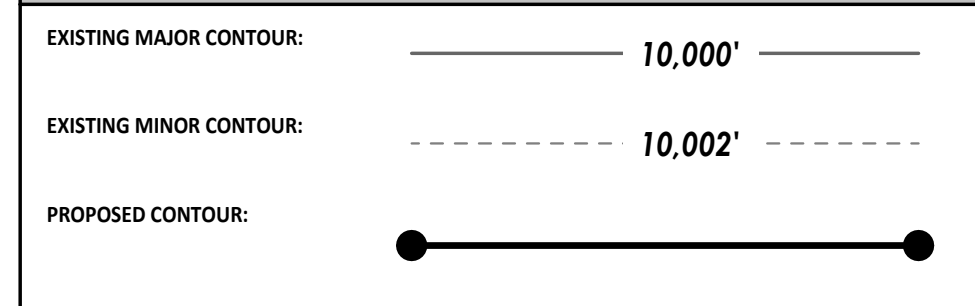

NOTES: SITE DRAINAGE

- 1. CONTRACTOR SHALL PROVIDE PROPER SITE GRADING THAT DIRECTS SURFACE WATER AWAY FROM BUILDING FOUNDATIONS, WALLS AND NEIGHBORING PROPERTIES.
2. GRADING AND LANDSCAPING SHOULD BE PLANNED WITH A SURFACE GRADE OF AT LEAST 1/4% AROUND AND AWAY FROM THE ENTIRE STRUCTURE. REFER TO LAKE COUNTY DEVELOPMENT CODE FOR SITE DRAINAGE REQUIREMENTS.
3. PROPOSED SITE DRAINAGE INDICATED ON SITE PLAN WITH FLOW ARROWS.

NOTES: FOUNDATION DRAIN

- INSTALL DRAIN TILE (PERFORATED PLASTIC DRAINAGE PIPE) ALONG THE EXTERIOR OF THE FOOTINGS OF BASEMENT OR CRAWLSPACE WALLS TO PROVIDE DRAINAGE AROUND FOUNDATION PERIMETER.
1. INSTALL DRAIN PIPE TO SIT OUTSIDE OF, NOT ON TOP OF, THE FOOTINGS AND BELOW THE BOTTOM OF THE CONCRETE SLAB OR CRAWLSPACE FLOOR.
2. LAY THE PIPE WITH ENOUGH SLOPE TO DRAIN TO A NON-PERFORATED PIPE THAT CARRIES THE COLLECTED WATER TO DAYLIGHT, TO A DRYWELL, TO A STORM SEWER IF APPROVED BY THE LOCAL MUNICIPALITY, OR TO A SUMP PUMP THAT WILL TRANSPORT IT TO DAYLIGHT, A STORM SEWER, OR A DRYWELL.
3. LAY THE DRAIN PIPE, PERFORATIONS DOWN, IN A GRAVEL TRENCH WITH AT LEAST 6 INCHES OF 3/4-INCH TO 1-INCH WASHED GRAVEL OR STONE ABOVE THE PIPE AND AT LEAST 2 INCHES BELOW (IRC).
4. INSTALL LANDSCAPE FABRIC UNDER, AROUND, AND OVER THE WASHED GRAVEL (IRC) ALTERNATELY, USE DRAIN PIPE ENCASED IN A FILTER-FABRIC SOCK AND SURROUND THE CLOTH-COVERED PIPE WITH GRAVEL. OR, INSTALL A CODE-APPROVED COMPOSITE FOUNDATION DRAINAGE SYSTEM (CFDS) (IRC).

SNOWSTACK CALCULATIONS

Table with 3 columns: Item, Square Footage, Percentage. Rows include Existing Driveway (998 SF), New Driveway (317 SF), Decks and Hardscape (NA), Total Coverage (1,315 SF, 100%), Snowstack Required (329 SF, 25%), Snowstack Provided (605 SF, 46%), and Total Lot Area (1.45 ACRES).

NOTES: LANDSCAPE

- 1. VERIFY ALL UTILITY LOCATIONS PRIOR TO ANY WORK. COORDINATE UTILITY ROUTING WITH APPLICABLE UTILITY COMPANY. ALL UTILITIES TO BE UNDERGROUND. PROVIDE 2"-3" (MIN.) CLAY FREE TOPSOIL AND SEED ALL DISTURBED AREAS WITH SUMMIT CO. SHORT SEED MIX (AS APPROVED BY STRIP AND STOCKPILE EXISTING TOPSOIL IN CONSTRUCTION AREA. SCREEN TOPSOIL PRIOR TO INSTALLATION.
2. KEEP EXISTING TREES WHERE POSSIBLE, TAKING INTO CONSIDERATION DRIP LINES AND ROOT STRUCTURE. PROTECT EXISTING TREES WITH FENCING LOCATED AT OR OUTSIDE DRIP LINE OF TREE. STOCKPILE AND REUSE EXISTING TREES WHERE POSSIBLE.
3. GENERAL CONTRACTOR SHALL PROVIDE POSITIVE DRAINAGE AWAY FROM ALL BUILDING FOUNDATIONS PER SPECIFICATIONS AND CODE REQUIREMENTS.
4. PRIOR TO ANY LANDSCAPE WORK, REMOVE ALL DEBRIS, PAINT, CONCRETE, STUMPS, SLASH, ETC. FROM LANDSCAPE AREA.
5. LOCATE ALL PLANTINGS TO AVOID SNOW STACKING & SNOW SLIDE AREAS FROM ABOVE.
6. SHRUBS ARE TO BE FIELD LOCATED AS APPROVED BY OWNER AND ARCHITECT.
7. ALL NEW LANDSCAPING TO BE IRRIGATED WITH DRIP IRRIGATION SYSTEM. PROVIDE SUBMITTAL.
8. ALL NEW PLANTINGS SHOULD BE HIGH ALTITUDE GROWN AND OR COLLECTED TO ENSURE BETTER SURVIVAL.
9. NATURALIZE GROUPING OF TREES BY VARYING HEIGHT & LOCATION WHEREVER POSSIBLE.
10. SCREEN ALL UTILITY PEDESTALS WITH LANDSCAPE MATERIAL.
11. PROVIDE 3" TO 4" DIAMETER STONE RIPRAP OVER WEED BARRIER FABRIC AT BUILDING DRIP LINES. UNDULATE EDGES AND PROVIDE LANDSCAPE EDGING AT RIPRAP TO TOPSOIL JUNCTURE.
12. INSTALL & BACKFILL ALL PLANTINGS WITH SOIL MIX INCLUDING ORGANIC SOIL AMENDMENTS PER SPECIES REQUIREMENTS AND LANDSCAPE DETAILS.
13. ROOT FEED ALL NEWLY PLANTED TREES DURING INSTALLATION. PROVIDE LIQUID GROWTH TREE STIMULATOR AND SOLUBLE FERTILIZER AT RECOMMENDED RATE FOR EACH TREE SPECIES.
14. PROVIDE 3" OF SHREDDED BARK MULCH AT ALL SHRUB AND TREE WELLS.
15. LANDSCAPE BOULDERS OF 2' OR LARGER SHALL BE RETAINED ON SITE FOR USE IN LANDSCAPE WORK. BURY DECORATIVE BOULDERS ONE-HALF OF DIAMETER.
16. ADDITIONAL CONSULTATION WITH A QUALIFIED LANDSCAPE PROFESSIONAL AT OWNER OPTION IS RECOMMENDED.
17. REVEGETATE ALL DISTURBED SITE AREAS WITH APPROVED SEED MIX.

NOTE: ALL LANDSCAPING SHALL BE INSTALLED IN STRICT ACCORDANCE WITH TOWN OF BLUE RIVER GUIDELINES.

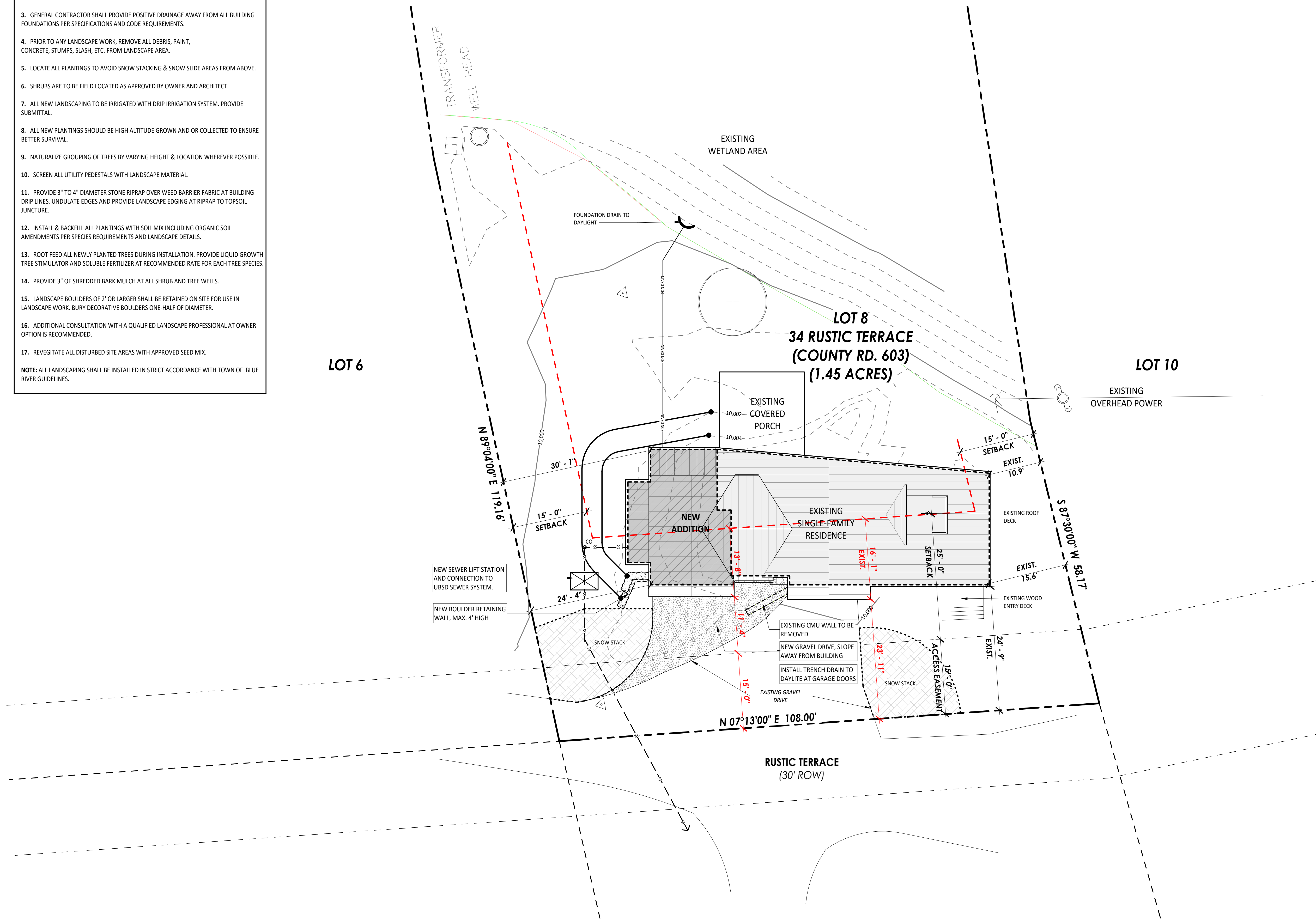

1 SITE PLAN - ENLARGED 1" = 10'-0"





ROOTED ARCHITECTURE

SEAL:

NOT FOR CONSTRUCTION

DRAWINGS AND SPECIFICATIONS AS INSTRUMENTS OF SERVICE ARE THE PROPERTY OF THE ARCHITECT. THEY SHALL NOT BE USED, TRANSFERRED, OR SOLD FOR USE EXCEPT BY AN AGREEMENT IN WRITING FROM THE ARCHITECT.

FITZGERALD ADDITION  
34 RUSTIC TERRACE  
BLUE RIVER, CO

No. Date Revisions

Project No: 2023-16  
Stage: FINAL REVIEW SET  
Date: 05/02/2024  
Scale: As indicated

DRAWING TITLE:

FLOOR PLAN - LOWER

DRAWING NO:

A1.1

NOTES: FLOOR PLAN

- 1. ALL INFORMATION MUST BE CONFIRMED PRIOR TO COMMENCEMENT OF CONSTRUCTION. ANY ERRORS OR DISCREPANCIES MUST BE BROUGHT TO THE ATTENTION OF THE ARCHITECT PRIOR TO PROCEEDING WITH WORK.
2. IT SHALL BE THE RESPONSIBILITY OF THE CONTRACTOR AND/OR INDIVIDUAL CONTRACTORS TO SEE THAT ALL ITEMS MEET OR EXCEED CODE REQUIREMENTS.
3. BUILDING SHALL VERIFY ALL DIMENSIONS, INTERIOR & EXTERIOR FINISHES, CONSTRUCTION & FRAMING METHODS PRIOR TO CONSTRUCTION.
4. ALL MATERIALS & WORKMANSHIP INVOLVED IN THE CONSTRUCTION OF THIS PROJECT ARE TO CONFORM WITH ALL LOCAL, STATE, NATIONAL, & INTERNATIONAL BUILDING CODES AS DESCRIBED IN THE INTERNATIONAL ONE & TWO FAMILY DWELLING CODE.
5. DRAWINGS ARE NOT TO BE SCALED. ALL DIMENSIONS ARE FROM FACE OF STUD TO FACE OF STUD, U.N.O. ALL DIMENSIONS LABELED "CLEAR" ARE TO FACE OF FINISH MATERIAL.
6. ALL INTERIOR GYPSUM BOARD TO BE 1/2" MINIMUM. USE WATER-RESISTANT GYPSUM BOARD AT ALL WET WALL LOCATIONS. USE 5/8" TYPE "X" DRYWALL SEPARATIONS BETWEEN LIVING SPACES AND GARAGES AS REQUIRED BY CODE.
7. ALL TUB & SHOWER UNITS TO HAVE ANTI-SCALDING DEVICES INSTALLED.
8. GARAGE DOORS TO BE CERTIFIED BY MANUFACTURER FOR LOCAL WIND REQUIREMENTS
9. CONTRACTOR TO COORDINATE ELECTRICAL, PLUMBING AND HEATING WORK WITH SUBCONTRACTORS PRIOR TO STARTING WORK. PROVIDE ARCHITECT AND OWNER WITH SUBMITTALS WHERE APPLICABLE.
10. ALL ANGLED WALLS TO BE 45° UNLESS NOTED OTHERWISE.
11. MILLWORK SUBCONTRACTOR TO PROVIDE MILLWORK SHOP DRAWINGS TO THE ARCHITECTS, OWNER, AND CONTRACTOR FOR APPROVAL PRIOR TO COMMENCING FABRICATION.
12. CONTRACTOR TO COORDINATE BASEBOARD RADIANT HEAT LOCATIONS WITH OWNER AND MECHANICAL DESIGNER PRIOR TO INSTALLATION.

NOTES: DOOR AND WINDOW

- 1. ALL WINDOWS ARE DIMENSIONED TO THE CENTERLINE OF WINDOW; CONTRACTOR TO COORDINATE ACTUAL REQUIRED ROUGH OPENING WITH WINDOW MANUFACTURER. PRIOR TO ANY FRAMING WORK, VERIFY ROUGH OPENING DIMENSIONS WITH WINDOW MANUFACTURER. NOTIFY ARCHITECT OF ANY DISCREPANCIES.
2. SEE PLANS / DOOR AND WINDOW SCHEDULES FOR WINDOW / DOOR OPERATION, SIZES AND TYPES. VERIFY JAMB WIDTHS WITH WALL THICKNESS PRIOR TO INSTALLATION
3. PROVIDE WEATHER STRIPPING AND ALUMINUM THRESHOLD SET IN SEALANT AT ALL EXTERIOR DOORS.
4. PROVIDE SAFETY GLASS TO COMPLY WITH CODE REQUIREMENTS (SEE CURRENT I.R.C.). WINDOWS LOCATED MORE THAN 72" ABOVE FINISHED GRADE AND LESS THAN 24" ABOVE THE FINISHED FLOOR OF THE ROOM IN WHICH THE WINDOW IS LOCATED SHALL HAVE OPENING CONTROL DEVICES IN ACCORDANCE WITH IRC R310.2.2. WINDOWS / DOORS LOCATED IN SLEEPING ROOMS SHALL ACT AS EMERGENCY ESCAPE AND RESCUE OPENINGS PER IRC R310.1
5. ALL GLAZING SYSTEMS SHALL BE RATED FOR USE AT HIGH ALTITUDES PER MANUFACTURER'S REQUIREMENTS. GLAZED FENESTRATION SHALL COMPLY WITH THE MINIMUM REQUIREMENTS OF IRC AND SUMMIT COUNTY SUSTAINABILITY CODE.
6. WRAP ALL EXTERIOR OPENINGS WITH WEATHER RESISTIVE BARRIER PER MANUFACTURERS SPECIFICATIONS. PROVIDE 1-1/2" X 1-1/2" HEAD FLASHING AT ALL EXTERIOR OPENINGS (PRIME AND PAINT OR COLOR CLAD). INSULATE ALL EXTERIOR SHIM SPACES AT WINDOWS AND DOORS.
7. PROVIDE SHOP DRAWINGS FOR ALL SPECIAL/CUSTOM DOORS AND WINDOWS PRIOR TO FABRICATION. FIELD MEASURE TO VERIFY ALL CUSTOM UNIT SIZES.
8. WINDOWS AND PATIO DOORS REFER TO 'JELD-WEN' BRAND OR COMPARABLE
9. INTERIOR DOORS TO BE CENTERED ON SPACES OR INSTALLED W/ 4 1/2" OFFSET TO NEAREST WALL (U.N.O.). ALL WINDOW OPENINGS TO HAVE PAINTED GYPSUM BOARD RETURNS ON INTERIOR SIDE UNLESS NOTED OTHERWISE, REF. INTERIORS.
10. ALL WINDOW OPENINGS TO HAVE PAINTED GYPSUM BOARD RETURNS ON INTERIOR SIDE UNLESS NOTED OTHERWISE, REF. INTERIORS.
11. WINDOWS LOCATED IN SLEEPING ROOMS SHALL ACT AS EMERGENCY ESCAPE AND RESCUE OPENINGS PER IRC R310.1
12. COORDINATE WINDOW SILL HEIGHT WITH GYPCRETE AND FLOOR FINISH THICKNESS WHERE REQUIRED. VERIFY AT LOCATIONS WHERE WINDOW SILLS TERMINATE AT FLOOR LEVEL OR AT TOP OF MILLWORK.
13. VERIFY WINDOW STYLE, OPERATION, FINISH AND HARDWARE WITH OWNER PRIOR TO PLACING ORDER.
14. WINDOW SUPPLIER TO PROVIDE TEMPERED GLAZING WHERE REQUIRED BY CODE.

WALL LEGEND

- NEW 2X4 / 2X6 WOOD STUD WALL
EXISTING 2X4 / 2X6 WOOD STUD WALL
EXISTING WALL TO BE REMOVED

NOTES: REMODEL

- 1. PROTECTION OF EXISTING TO REMAIN: THE CONTRACTOR SHALL PROVIDE PROTECTIVE COVERING FOR CARPET, FURNISHINGS, AND FINISHES IN EXISTING AREAS NOT DESIGNATED FOR DEMOLITION OR NEW CONSTRUCTION. THE CONTRACTOR SHALL BE RESPONSIBLE FOR THE REPAIR OF ANY DAMAGE CAUSED BY HIS WORK OR ANY SUBCONTRACTOR. IN PARTICULAR, THE CONTRACTOR SHALL MAINTAIN A DUST-FREE ENVIRONMENT WITHIN THE MAGNET VAULT.
2. SCHEDULING: THE CONTRACTOR SHALL MEET WITH THE OWNER IN ADVANCE OF CONSTRUCTION COMMENCEMENT TO:
A. SCHEDULE, SEQUENCE AND COORDINATE ALL WORK
B. MAINTAIN EXITS AND EGRESS WIDTHS REQUIRED BY CODES DURING ALL PHASES OF CONSTRUCTION
3. CLEARANCES: THE CONTRACTOR SHALL VERIFY THAT NEW CEILINGS CAN BE INSTALLED IN EXISTING SPACES TO CLEAR DUCTWORK AND OTHER CONSTRUCTED ITEMS AND MAINTAIN FLOOR TO CEILING HEIGHTS INDICATED ON DRAWINGS. IF DISCREPANCIES OCCUR DUE TO EXISTING CONDITIONS, CONSULT WITH THE ARCHITECT BEFORE PROCEEDING.
4. MATERIAL ALIGNMENT: THE FINISH FACE OF MATERIAL OF NEW PARTITIONS SHALL ALIGN ON BOTH SIDES OF THE PARTITION WITH THE FACE OF THE MATERIALS ON EXISTING COLUMNS, WALLS, OR PARTITIONS, UNLESS NOTED OTHERWISE.
5. AS BUILT VERIFICATION: THE CONTRACTOR SHALL VERIFY DIMENSIONS OF AS-BUILT CONDITIONS, AND NOTIFY THE ARCHITECT IN WRITING OF ANY DISCREPANCIES. ALL INFORMATION SHOWN ON THE CONSTRUCTION DOCUMENTS IS BASED ON FIELD OBSERVATIONS AND/OR THE ORIGINAL CONSTRUCTION DOCUMENTS OF THE FACILITY.
6. REMOVAL SURVEY: THE CONTRACTOR SHALL SURVEY AND DETERMINE THE REMOVAL OF EXISTING CONSTRUCTION, EITHER WHOLE OR IN PART, AS REQUIRED FOR THE INSTALLATION OF THE NEW MECHANICAL, PLUMBING AND ELECTRICAL WORK.
7. CONSTRUCTION DEFECTS: THE CONTRACTOR SHALL NOTIFY THE ARCHITECT IN WRITING OF ANY CONSTRUCTION DEFECTS FOUND IN UNCOVERING WORK IN THE EXISTING CONSTRUCTION.
8. CORRECTING DEFECTIVE WORK: THE CONTRACTOR SHALL BE RESPONSIBLE FOR CORRECTING DEFECTIVE WORK IN EXISTING CONSTRUCTION WITHIN THE LIMITS OF THE CONSTRUCTION AREA. THIS INCLUDES, BUT IS NOT LIMITED TO, UNEVEN SURFACES AND FINISHES AT PLASTER OR GYPSUM BOARD. THE CONTRACTOR SHALL PATCH AND REPAIR SURFACES TO MATCH NEW ADJACENT SURFACES.
9. PIPING: ALL PIPING ABOVE GRADE AND INSIDE THE BUILDING REQUIRED BY THE CONSTRUCTION DOCUMENTS SHALL BE INSTALLED IN AREAS WHERE IT WILL BE CONCEALED. THE CONTRACTOR SHALL CONSULT WITH THE ARCHITECT AND COORDINATE WITH OTHER TRADES TO PROVIDE FURRING FOR PIPING INSTALLED IN FINISH AREAS.
10. FIXTURE REMOVAL: REMOVE MECHANICAL AND ELECTRICAL FIXTURES AND CAP OR REMOVE EXISTING BRANCH LINES AS INDICATED IN THE MECHANICAL AND ELECTRICAL DOCUMENTS.
11. COORDINATION: COORDINATE PLANS FOR NEW CONSTRUCTION WITH DEMOLITION PLANS FOR EXTENT OF REMOVAL. REMOVE ONLY THOSE PORTIONS OF WALLS, FLOORS, CEILINGS, ETC. NECESSARY TO ACCOMMODATE NEW CONSTRUCTION.

1 FLOOR PLAN - LOWER LEVEL
1/4" = 1'-0"

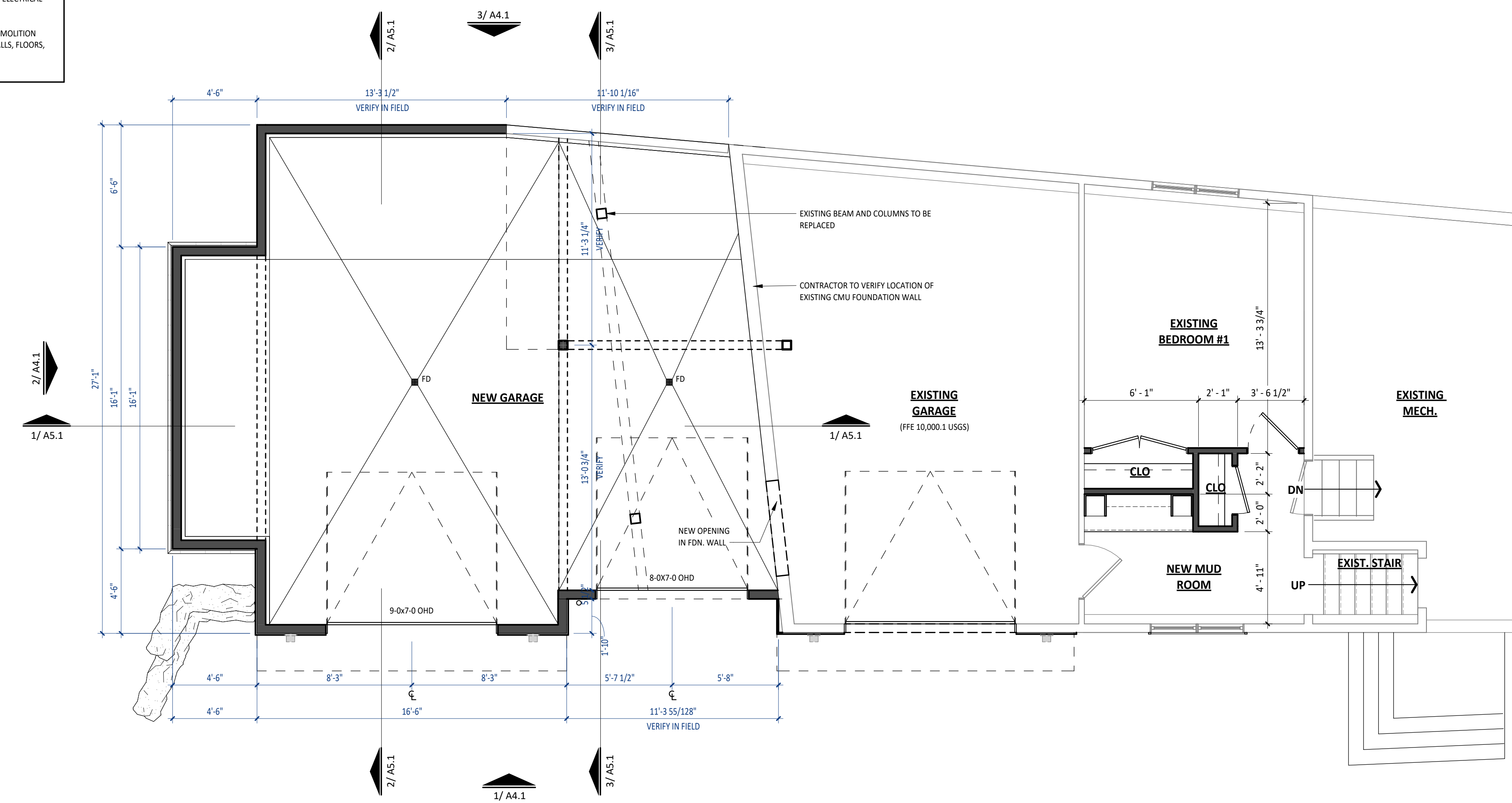



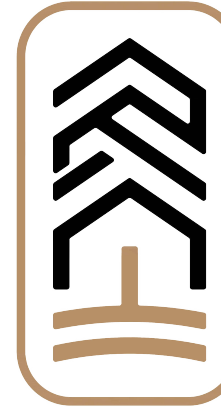

ROOTED ARCHITECTURE

SEAL:

NOT FOR CONSTRUCTION

DRAWINGS AND SPECIFICATIONS AS INSTRUMENTS OF SERVICE ARE THE PROPERTY OF THE ARCHITECT. THEY SHALL NOT BE USED, TRANSFERRED, OR SOLD FOR USE EXCEPT BY AN AGREEMENT IN WRITING FROM THE ARCHITECT.

FITZGERALD ADDITION

34 RUSTIC TERRACE  
BLUE RIVER, CO

No. Date Revisions

Project No: 2023-16  
Stage: FINAL REVIEW SET  
Date: 05/02/2024  
Scale: As indicated

DRAWING TITLE:

FLOOR PLAN - MAIN

DRAWING NO:

A1.2

NOTES: FLOOR PLAN

- 1. ALL INFORMATION MUST BE CONFIRMED PRIOR TO COMMENCEMENT OF CONSTRUCTION. ANY ERRORS OR DISCREPANCIES MUST BE BROUGHT TO THE ATTENTION OF THE ARCHITECT PRIOR TO PROCEEDING WITH WORK.
2. IT SHALL BE THE RESPONSIBILITY OF THE CONTRACTOR AND/OR INDIVIDUAL CONTRACTORS TO SEE THAT ALL ITEMS MEET OR EXCEED CODE REQUIREMENTS.
3. BUILDING SHALL VERIFY ALL DIMENSIONS, INTERIOR & EXTERIOR FINISHES, CONSTRUCTION & FRAMING METHODS PRIOR TO CONSTRUCTION.
4. ALL MATERIALS & WORKMANSHIP INVOLVED IN THE CONSTRUCTION OF THIS PROJECT ARE TO CONFORM WITH ALL LOCAL, STATE, NATIONAL, & INTERNATIONAL BUILDING CODES AS DESCRIBED IN THE INTERNATIONAL ONE & TWO FAMILY DWELLING CODE.
5. DRAWINGS ARE NOT TO BE SCALED. ALL DIMENSIONS ARE FROM FACE OF STUD TO FACE OF STUD, U.N.O. ALL DIMENSIONS LABELED "CLEAR" ARE TO FACE OF FINISH MATERIAL.
6. ALL INTERIOR GYPSUM BOARD TO BE 1/2" MINIMUM. USE WATER-RESISTANT GYPSUM BOARD AT ALL WET WALL LOCATIONS. USE 5/8" TYPE "X" DRYWALL SEPARATIONS BETWEEN LIVING SPACES AND GARAGES AS REQUIRED BY CODE.
7. ALL TUB & SHOWER UNITS TO HAVE ANTI-SCALDING DEVICES INSTALLED.
8. GARAGE DOORS TO BE CERTIFIED BY MANUFACTURER FOR LOCAL WIND REQUIREMENTS
9. CONTRACTOR TO COORDINATE ELECTRICAL, PLUMBING AND HEATING WORK WITH SUBCONTRACTORS PRIOR TO STARTING WORK. PROVIDE ARCHITECT AND OWNER WITH SUBMITTALS WHERE APPLICABLE.
10. ALL ANGLED WALLS TO BE 45° UNLESS NOTED OTHERWISE.
11. MILLWORK SUBCONTRACTOR TO PROVIDE MILLWORK SHOP DRAWINGS TO THE ARCHITECTS, OWNER, AND CONTRACTOR FOR APPROVAL PRIOR TO COMMENCING FABRICATION.
12. CONTRACTOR TO COORDINATE BASEBOARD RADIANT HEAT LOCATIONS WITH OWNER AND MECHANICAL DESIGNER PRIOR TO INSTALLATION.

NOTES: DOOR AND WINDOW

- 1. ALL WINDOWS ARE DIMENSIONED TO THE CENTERLINE OF WINDOW; CONTRACTOR TO COORDINATE ACTUAL REQUIRED ROUGH OPENING WITH WINDOW MANUFACTURER. PRIOR TO ANY FRAMING WORK, VERIFY ROUGH OPENING DIMENSIONS WITH WINDOW MANUFACTURER. NOTIFY ARCHITECT OF ANY DISCREPANCIES.
2. SEE PLANS / DOOR AND WINDOW SCHEDULES FOR WINDOW / DOOR OPERATION, SIZES AND TYPES. VERIFY JAMB WIDTHS WITH WALL THICKNESS PRIOR TO INSTALLATION
3. PROVIDE WEATHER STRIPPING AND ALUMINUM THRESHOLD SET IN SEALANT AT ALL EXTERIOR DOORS.
4. PROVIDE SAFETY GLASS TO COMPLY WITH CODE REQUIREMENTS (SEE CURRENT I.R.C.). WINDOWS LOCATED MORE THAN 72" ABOVE FINISHED GRADE AND LESS THAN 24" ABOVE THE FINISHED FLOOR OF THE ROOM IN WHICH THE WINDOW IS LOCATED SHALL HAVE OPENING CONTROL DEVICES IN ACCORDANCE WITH IRC R310.2.2. WINDOWS / DOORS LOCATED IN SLEEPING ROOMS SHALL ACT AS EMERGENCY ESCAPE AND RESCUE OPENINGS PER IRC R310.1
5. ALL GLAZING SYSTEMS SHALL BE RATED FOR USE AT HIGH ALTITUDES PER MANUFACTURER'S REQUIREMENTS. GLAZED FENESTRATION SHALL COMPLY WITH THE MINIMUM REQUIREMENTS OF IRC AND SUMMIT COUNTY SUSTAINABILITY CODE.
6. WRAP ALL EXTERIOR OPENINGS WITH WEATHER RESISTIVE BARRIER PER MANUFACTURERS SPECIFICATIONS. PROVIDE 1-1/2" X 1-1/2" HEAD FLASHING AT ALL EXTERIOR OPENINGS (PRIME AND PAINT OR COLOR CLAD). INSULATE ALL EXTERIOR SHIM SPACES AT WINDOWS AND DOORS.
7. PROVIDE SHOP DRAWINGS FOR ALL SPECIAL/CUSTOM DOORS AND WINDOWS PRIOR TO FABRICATION. FIELD MEASURE TO VERIFY ALL CUSTOM UNIT SIZES.
8. WINDOWS AND PATIO DOORS REFER TO 'JELD-WEN' BRAND OR COMPARABLE
9. INTERIOR DOORS TO BE CENTERED ON SPACES OR INSTALLED W/ 4 1/2" OFFSET TO NEAREST WALL (U.N.O.). ALL WINDOW OPENINGS TO HAVE PAINTED GYPSUM BOARD RETURNS ON INTERIOR SIDE UNLESS NOTED OTHERWISE, REF. INTERIORS.
10. ALL WINDOW OPENINGS TO HAVE PAINTED GYPSUM BOARD RETURNS ON INTERIOR SIDE UNLESS NOTED OTHERWISE, REF. INTERIORS.
11. WINDOWS LOCATED IN SLEEPING ROOMS SHALL ACT AS EMERGENCY ESCAPE AND RESCUE OPENINGS PER IRC R310.1
12. COORDINATE WINDOW SILL HEIGHT WITH GYPCRETE AND FLOOR FINISH THICKNESS WHERE REQUIRED. VERIFY AT LOCATIONS WHERE WINDOW SILLS TERMINATE AT FLOOR LEVEL OR AT TOP OF MILLWORK.
13. VERIFY WINDOW STYLE, OPERATION, FINISH AND HARDWARE WITH OWNER PRIOR TO PLACING ORDER.
14. WINDOW SUPPLIER TO PROVIDE TEMPERED GLAZING WHERE REQUIRED BY CODE.

WALL LEGEND

- NEW 2X4 / 2X6 WOOD STUD WALL
EXISTING 2X4 / 2X6 WOOD STUD WALL
EXISTING WALL TO BE REMOVED

NOTES: REMODEL

- 1. PROTECTION OF EXISTING TO REMAIN: THE CONTRACTOR SHALL PROVIDE PROTECTIVE COVERING FOR CARPET, FURNISHINGS, AND FINISHES IN EXISTING AREAS NOT DESIGNATED FOR DEMOLITION OR NEW CONSTRUCTION. THE CONTRACTOR SHALL BE RESPONSIBLE FOR THE REPAIR OF ANY DAMAGE CAUSED BY HIS WORK OR ANY SUBCONTRACTOR. IN PARTICULAR, THE CONTRACTOR SHALL MAINTAIN A DUST-FREE ENVIRONMENT WITHIN THE MAGNET VAULT.
2. SCHEDULING: THE CONTRACTOR SHALL MEET WITH THE OWNER IN ADVANCE OF CONSTRUCTION COMMENCEMENT TO:
A. SCHEDULE, SEQUENCE AND COORDINATE ALL WORK
B. MAINTAIN EXITS AND EGRESS WIDTHS REQUIRED BY CODES DURING ALL PHASES OF CONSTRUCTION
3. CLEARANCES: THE CONTRACTOR SHALL VERIFY THAT NEW CEILINGS CAN BE INSTALLED IN EXISTING SPACES TO CLEAR DUCTWORK AND OTHER CONSTRUCTED ITEMS AND MAINTAIN FLOOR TO CEILING HEIGHTS INDICATED ON DRAWINGS. IF DISCREPANCIES OCCUR DUE TO EXISTING CONDITIONS, CONSULT WITH THE ARCHITECT BEFORE PROCEEDING.
4. MATERIAL ALIGNMENT: THE FINISH FACE OF MATERIAL OF NEW PARTITIONS SHALL ALIGN ON BOTH SIDES OF THE PARTITION WITH THE FACE OF THE MATERIALS ON EXISTING COLUMNS, WALLS, OR PARTITIONS, UNLESS NOTED OTHERWISE.
5. AS BUILT VERIFICATION: THE CONTRACTOR SHALL VERIFY DIMENSIONS OF AS-BUILT CONDITIONS, AND NOTIFY THE ARCHITECT IN WRITING OF ANY DISCREPANCIES. ALL INFORMATION SHOWN ON THE CONSTRUCTION DOCUMENTS IS BASED ON FIELD OBSERVATIONS AND/OR THE ORIGINAL CONSTRUCTION DOCUMENTS OF THE FACILITY.
6. REMOVAL SURVEY: THE CONTRACTOR SHALL SURVEY AND DETERMINE THE REMOVAL OF EXISTING CONSTRUCTION, EITHER WHOLE OR IN PART, AS REQUIRED FOR THE INSTALLATION OF THE NEW MECHANICAL, PLUMBING AND ELECTRICAL WORK.
7. CONSTRUCTION DEFECTS: THE CONTRACTOR SHALL NOTIFY THE ARCHITECT IN WRITING OF ANY CONSTRUCTION DEFECTS FOUND IN UNCOVERING WORK IN THE EXISTING CONSTRUCTION.
8. CORRECTING DEFECTIVE WORK: THE CONTRACTOR SHALL BE RESPONSIBLE FOR CORRECTING DEFECTIVE WORK IN EXISTING CONSTRUCTION WITHIN THE LIMITS OF THE CONSTRUCTION AREA. THIS INCLUDES, BUT IS NOT LIMITED TO, UNEVEN SURFACES AND FINISHES AT PLASTER OR GYPSUM BOARD. THE CONTRACTOR SHALL PATCH AND REPAIR SURFACES TO MATCH NEW ADJACENT SURFACES.
9. PIPING: ALL PIPING ABOVE GRADE AND INSIDE THE BUILDING REQUIRED BY THE CONSTRUCTION DOCUMENTS SHALL BE INSTALLED IN AREAS WHERE IT WILL BE CONCEALED. THE CONTRACTOR SHALL CONSULT WITH THE ARCHITECT AND COORDINATE WITH OTHER TRADES TO PROVIDE FURRING FOR PIPING INSTALLED IN FINISH AREAS.
10. FIXTURE REMOVAL: REMOVE MECHANICAL AND ELECTRICAL FIXTURES AND CAP OR REMOVE EXISTING BRANCH LINES AS INDICATED IN THE MECHANICAL AND ELECTRICAL DOCUMENTS.
11. COORDINATION: COORDINATE PLANS FOR NEW CONSTRUCTION WITH DEMOLITION PLANS FOR EXTENT OF REMOVAL. REMOVE ONLY THOSE PORTIONS OF WALLS, FLOORS, CEILING, ETC. NECESSARY TO ACCOMMODATE NEW CONSTRUCTION.

1 FLOOR PLAN - MAIN LEVEL
1/4" = 1'-0"

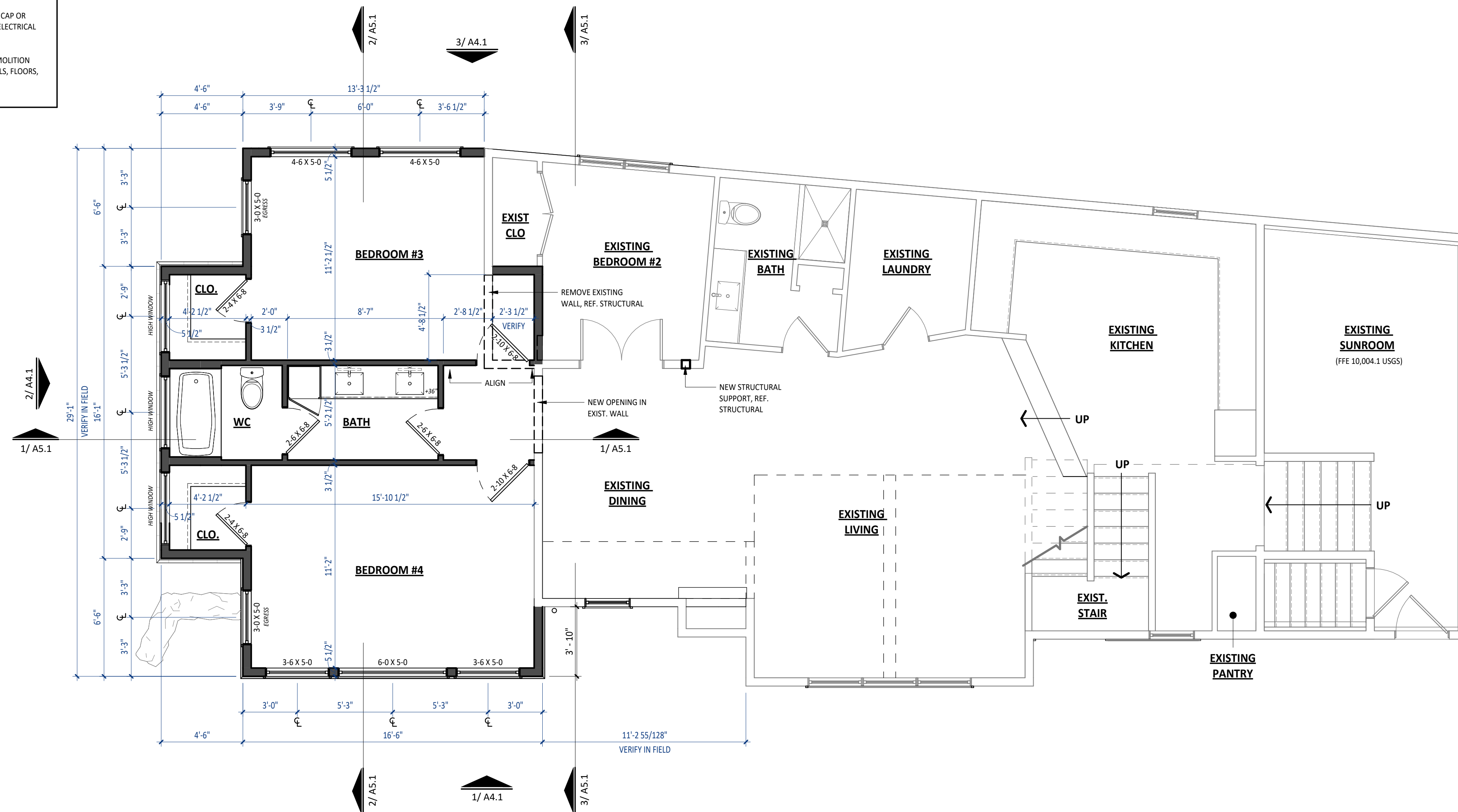



ROOTED ARCHITECTURE

SEAL:

NOT FOR CONSTRUCTION

DRAWINGS AND SPECIFICATIONS AS INSTRUMENTS OF SERVICE ARE THE PROPERTY OF THE ARCHITECT. THEY SHALL NOT BE USED, TRANSFERRED, OR SOLD FOR USE EXCEPT BY AN AGREEMENT IN WRITING FROM THE ARCHITECT.

FITZGERALD ADDITION  
34 RUSTIC TERRACE  
BLUE RIVER, CO

No. Date Revisions

Project No: 2023-16  
Stage: FINAL REVIEW SET  
Date: 05/02/2024  
Scale: As indicated

DRAWING TITLE:

FLOOR PLAN - UPPER

DRAWING NO:

A1.3

NOTES: FLOOR PLAN

- 1. ALL INFORMATION MUST BE CONFIRMED PRIOR TO COMMENCEMENT OF CONSTRUCTION. ANY ERRORS OR DISCREPANCIES MUST BE BROUGHT TO THE ATTENTION OF THE ARCHITECT PRIOR TO PROCEEDING WITH WORK.
2. IT SHALL BE THE RESPONSIBILITY OF THE CONTRACTOR AND/OR INDIVIDUAL CONTRACTORS TO SEE THAT ALL ITEMS MEET OR EXCEED CODE REQUIREMENTS.
3. BUILDING SHALL VERIFY ALL DIMENSIONS, INTERIOR & EXTERIOR FINISHES, CONSTRUCTION & FRAMING METHODS PRIOR TO CONSTRUCTION.
4. ALL MATERIALS & WORKMANSHIP INVOLVED IN THE CONSTRUCTION OF THIS PROJECT ARE TO CONFORM WITH ALL LOCAL, STATE, NATIONAL, & INTERNATIONAL BUILDING CODES AS DESCRIBED IN THE INTERNATIONAL ONE & TWO FAMILY DWELLING CODE.
5. DRAWINGS ARE NOT TO BE SCALED. ALL DIMENSIONS ARE FROM FACE OF STUD TO FACE OF STUD, U.N.O. ALL DIMENSIONS LABELED "CLEAR" ARE TO FACE OF FINISH MATERIAL.
6. ALL INTERIOR GYPSUM BOARD TO BE 1/2" MINIMUM. USE WATER-RESISTANT GYPSUM BOARD AT ALL WET WALL LOCATIONS. USE 5/8" TYPE "X" DRYWALL SEPARATIONS BETWEEN LIVING SPACES AND GARAGES AS REQUIRED BY CODE.
7. ALL TUB & SHOWER UNITS TO HAVE ANTI-SCALDING DEVICES INSTALLED.
8. GARAGE DOORS TO BE CERTIFIED BY MANUFACTURER FOR LOCAL WIND REQUIREMENTS
9. CONTRACTOR TO COORDINATE ELECTRICAL, PLUMBING AND HEATING WORK WITH SUBCONTRACTORS PRIOR TO STARTING WORK. PROVIDE ARCHITECT AND OWNER WITH SUBMITTALS WHERE APPLICABLE.
10. ALL ANGLED WALLS TO BE 45° UNLESS NOTED OTHERWISE.
11. MILLWORK SUBCONTRACTOR TO PROVIDE MILLWORK SHOP DRAWINGS TO THE ARCHITECTS, OWNER, AND CONTRACTOR FOR APPROVAL PRIOR TO COMMENCING FABRICATION.
12. CONTRACTOR TO COORDINATE BASEBOARD RADIANT HEAT LOCATIONS WITH OWNER AND MECHANICAL DESIGNER PRIOR TO INSTALLATION.

NOTES: DOOR AND WINDOW

- 1. ALL WINDOWS ARE DIMENSIONED TO THE CENTERLINE OF WINDOW; CONTRACTOR TO COORDINATE ACTUAL REQUIRED ROUGH OPENING WITH WINDOW MANUFACTURER. PRIOR TO ANY FRAMING WORK, VERIFY ROUGH OPENING DIMENSIONS WITH WINDOW MANUFACTURER. NOTIFY ARCHITECT OF ANY DISCREPANCIES.
2. SEE PLANS / DOOR AND WINDOW SCHEDULES FOR WINDOW / DOOR OPERATION, SIZES AND TYPES. VERIFY JAMB WIDTHS WITH WALL THICKNESS PRIOR TO INSTALLATION
3. PROVIDE WEATHER STRIPPING AND ALUMINUM THRESHOLD SET IN SEALANT AT ALL EXTERIOR DOORS.
4. PROVIDE SAFETY GLASS TO COMPLY WITH CODE REQUIREMENTS (SEE CURRENT I.R.C.). WINDOWS LOCATED MORE THAN 72" ABOVE FINISHED GRADE AND LESS THAN 24" ABOVE THE FINISHED FLOOR OF THE ROOM IN WHICH THE WINDOW IS LOCATED SHALL HAVE OPENING CONTROL DEVICES IN ACCORDANCE WITH IRC R310.2.2. WINDOWS / DOORS LOCATED IN SLEEPING ROOMS SHALL ACT AS EMERGENCY ESCAPE AND RESCUE OPENINGS PER IRC R310.1
5. ALL GLAZING SYSTEMS SHALL BE RATED FOR USE AT HIGH ALTITUDES PER MANUFACTURER'S REQUIREMENTS. GLAZED FENESTRATION SHALL COMPLY WITH THE MINIMUM REQUIREMENTS OF IRC AND SUMMIT COUNTY SUSTAINABILITY CODE.
6. WRAP ALL EXTERIOR OPENINGS WITH WEATHER RESISTIVE BARRIER PER MANUFACTURERS SPECIFICATIONS. PROVIDE 1-1/2" X 1-1/2" HEAD FLASHING AT ALL EXTERIOR OPENINGS (PRIME AND PAINT OR COLOR CLAD). INSULATE ALL EXTERIOR SHIM SPACES AT WINDOWS AND DOORS.
7. PROVIDE SHOP DRAWINGS FOR ALL SPECIAL/CUSTOM DOORS AND WINDOWS PRIOR TO FABRICATION. FIELD MEASURE TO VERIFY ALL CUSTOM UNIT SIZES.
8. WINDOWS AND PATIO DOORS REFER TO 'JELD-WEN' BRAND OR COMPARABLE
9. INTERIOR DOORS TO BE CENTERED ON SPACES OR INSTALLED W/ 4 1/2" OFFSET TO NEAREST WALL (U.N.O.). ALL WINDOW OPENINGS TO HAVE PAINTED GYPSUM BOARD RETURNS ON INTERIOR SIDE UNLESS NOTED OTHERWISE, REF. INTERIORS.
10. ALL WINDOW OPENINGS TO HAVE PAINTED GYPSUM BOARD RETURNS ON INTERIOR SIDE UNLESS NOTED OTHERWISE, REF. INTERIORS.
11. WINDOWS LOCATED IN SLEEPING ROOMS SHALL ACT AS EMERGENCY ESCAPE AND RESCUE OPENINGS PER IRC R310.1
12. COORDINATE WINDOW SILL HEIGHT WITH GYPCRETE AND FLOOR FINISH THICKNESS WHERE REQUIRED. VERIFY AT LOCATIONS WHERE WINDOW SILLS TERMINATE AT FLOOR LEVEL OR AT TOP OF MILLWORK.
13. VERIFY WINDOW STYLE, OPERATION, FINISH AND HARDWARE WITH OWNER PRIOR TO PLACING ORDER.
14. WINDOW SUPPLIER TO PROVIDE TEMPERED GLAZING WHERE REQUIRED BY CODE.

WALL LEGEND

- NEW 2X4 / 2X6 WOOD STUD WALL
EXISTING 2X4 / 2X6 WOOD STUD WALL
EXISTING WALL TO BE REMOVED

NOTES: REMODEL

- 1. PROTECTION OF EXISTING TO REMAIN: THE CONTRACTOR SHALL PROVIDE PROTECTIVE COVERING FOR CARPET, FURNISHINGS, AND FINISHES IN EXISTING AREAS NOT DESIGNATED FOR DEMOLITION OR NEW CONSTRUCTION. THE CONTRACTOR SHALL BE RESPONSIBLE FOR THE REPAIR OF ANY DAMAGE CAUSED BY HIS WORK OR ANY SUBCONTRACTOR. IN PARTICULAR, THE CONTRACTOR SHALL MAINTAIN A DUST-FREE ENVIRONMENT WITHIN THE MAGNET VAULT.
2. SCHEDULING: THE CONTRACTOR SHALL MEET WITH THE OWNER IN ADVANCE OF CONSTRUCTION COMMENCEMENT TO:
A. SCHEDULE, SEQUENCE AND COORDINATE ALL WORK
B. MAINTAIN EXITS AND EGRESS WIDTHS REQUIRED BY CODES DURING ALL PHASES OF CONSTRUCTION
3. CLEARANCES: THE CONTRACTOR SHALL VERIFY THAT NEW CEILINGS CAN BE INSTALLED IN EXISTING SPACES TO CLEAR DUCTWORK AND OTHER CONSTRUCTED ITEMS AND MAINTAIN FLOOR TO CEILING HEIGHTS INDICATED ON DRAWINGS. IF DISCREPANCIES OCCUR DUE TO EXISTING CONDITIONS, CONSULT WITH THE ARCHITECT BEFORE PROCEEDING.
4. MATERIAL ALIGNMENT: THE FINISH FACE OF MATERIAL OF NEW PARTITIONS SHALL ALIGN ON BOTH SIDES OF THE PARTITION WITH THE FACE OF THE MATERIALS ON EXISTING COLUMNS, WALLS, OR PARTITIONS, UNLESS NOTED OTHERWISE.
5. AS BUILT VERIFICATION: THE CONTRACTOR SHALL VERIFY DIMENSIONS OF AS-BUILT CONDITIONS, AND NOTIFY THE ARCHITECT IN WRITING OF ANY DISCREPANCIES. ALL INFORMATION SHOWN ON THE CONSTRUCTION DOCUMENTS IS BASED ON FIELD OBSERVATIONS AND/OR THE ORIGINAL CONSTRUCTION DOCUMENTS OF THE FACILITY.
6. REMOVAL SURVEY: THE CONTRACTOR SHALL SURVEY AND DETERMINE THE REMOVAL OF EXISTING CONSTRUCTION, EITHER WHOLE OR IN PART, AS REQUIRED FOR THE INSTALLATION OF THE NEW MECHANICAL, PLUMBING AND ELECTRICAL WORK.
7. CONSTRUCTION DEFECTS: THE CONTRACTOR SHALL NOTIFY THE ARCHITECT IN WRITING OF ANY CONSTRUCTION DEFECTS FOUND IN UNCOVERING WORK IN THE EXISTING CONSTRUCTION.
8. CORRECTING DEFECTIVE WORK: THE CONTRACTOR SHALL BE RESPONSIBLE FOR CORRECTING DEFECTIVE WORK IN EXISTING CONSTRUCTION WITHIN THE LIMITS OF THE CONSTRUCTION AREA. THIS INCLUDES, BUT IS NOT LIMITED TO, UNEVEN SURFACES AND FINISHES AT PLASTER OR GYPSUM BOARD. THE CONTRACTOR SHALL PATCH AND REPAIR SURFACES TO MATCH NEW ADJACENT SURFACES.
9. PIPING: ALL PIPING ABOVE GRADE AND INSIDE THE BUILDING REQUIRED BY THE CONSTRUCTION DOCUMENTS SHALL BE INSTALLED IN AREAS WHERE IT WILL BE CONCEALED. THE CONTRACTOR SHALL CONSULT WITH THE ARCHITECT AND COORDINATE WITH OTHER TRADES TO PROVIDE FURRING FOR PIPING INSTALLED IN FINISH AREAS.
10. FIXTURE REMOVAL: REMOVE MECHANICAL AND ELECTRICAL FIXTURES AND CAP OR REMOVE EXISTING BRANCH LINES AS INDICATED IN THE MECHANICAL AND ELECTRICAL DOCUMENTS.
11. COORDINATION: COORDINATE PLANS FOR NEW CONSTRUCTION WITH DEMOLITION PLANS FOR EXTENT OF REMOVAL. REMOVE ONLY THOSE PORTIONS OF WALLS, FLOORS, CEILINGS, ETC. NECESSARY TO ACCOMMODATE NEW CONSTRUCTION.

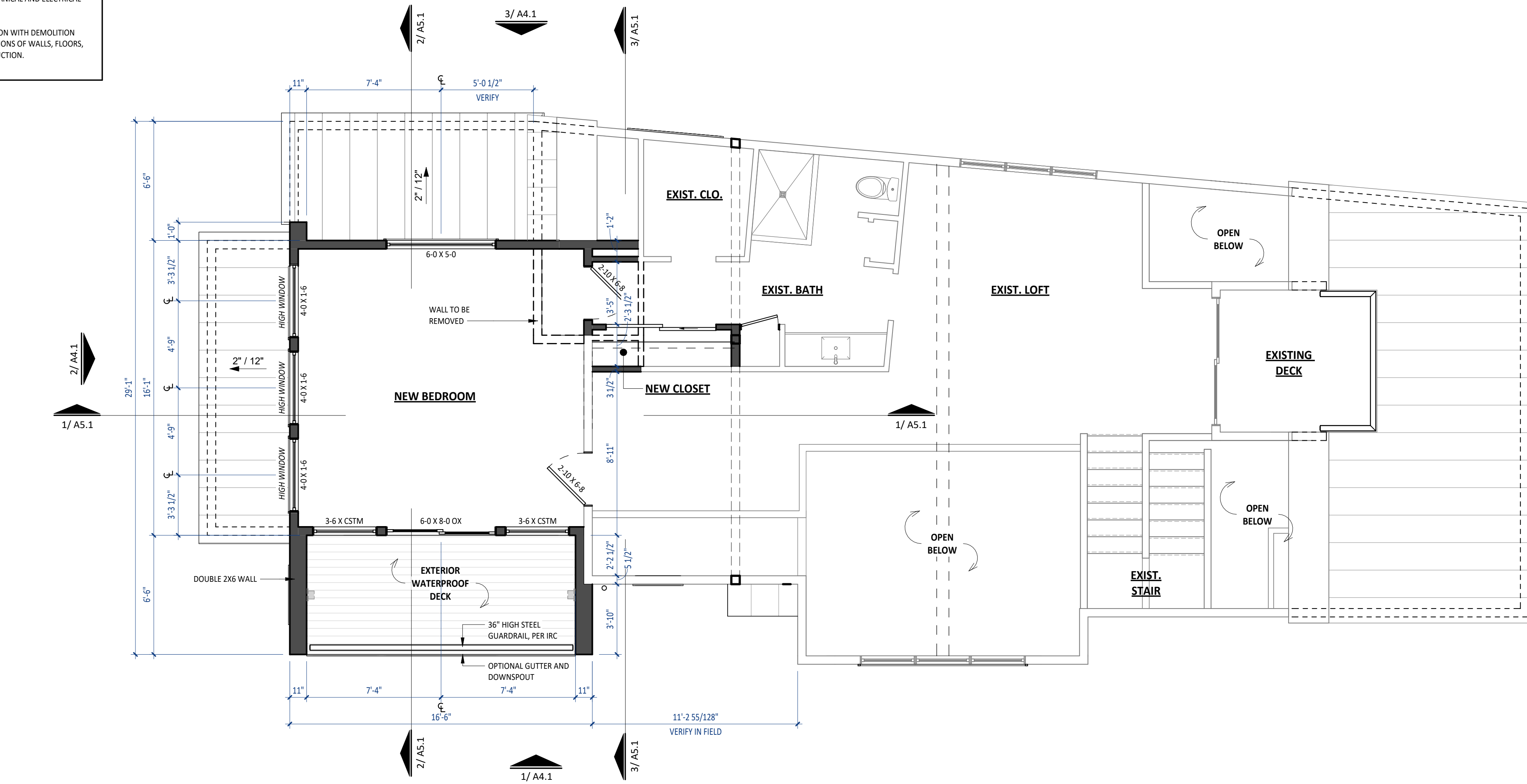

1 FLOOR PLAN - UPPER LEVEL  
1/4" = 1'-0"



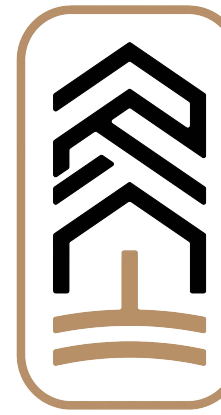

**ROOTED**  
ARCHITECTURE

SEAL:

NOT FOR CONSTRUCTION

DRAWINGS AND SPECIFICATIONS AS INSTRUMENTS OF SERVICE ARE THE PROPERTY OF THE ARCHITECT. THEY SHALL NOT BE USED, TRANSFERRED, OR SOLD FOR USE EXCEPT BY AN AGREEMENT IN WRITING FROM THE ARCHITECT.

**NOTES: ROOF PLAN**

- COORDINATE INSTALLATION OF NEW ROOFING WITH OTHER TRADES. REPORT ANY CONFLICTS WITH ITEMS INSTALLED BY OTHER TRADES TO DESIGNER.
- REFER TO SPECIFICATIONS. PROVIDE ROOF PRIMER, ROOF MEMBRANE AND ALL ROOFING PER SPECIFICATION REQUIREMENTS. PROVIDE "W.R. GRACE" MANUFACTURER CERTIFICATION LETTER STATING THAT ALL MEMBRANES HAVE BEEN INSTALLED IN COMPLETE COMPLIANCE WITH ALL MANUFACTURER'S REQUIREMENTS.
- ALL PLUMBING VENTS SHALL EXTEND ABOVE THE FINISHED SURFACE OF THE ROOF SYSTEM AS REQUIRED TO PROVIDE FOR A MINIMUM OF 8" BASE FLASHING.
- ALL EXPOSED METAL FLASHING/ TRIM PIECES TO BE PRE-FINISHED 24 GA. STL. U.N.O.. PROVIDE PRE-FINISHED OR FIELD PAINT FLASHING ONLY AS NOTED.
- GUTTERS - ALL GUTTERS TO BE PRE-FINISHED. PROVIDE PRE-FINISHED SUPPORTS AND SPACERS @ 36" O.C. MAX. MATCH EXISTING GUTTER PROFILE AND FINISH.
- ALL DOWNSPOUTS TO BE PRE-FINISHED, REFERENCE ELEVATIONS FOR LOCATIONS.
- PROVIDE HEAT TAPE AT GUTTERS AND DOWNSPOUTS. REFER TO ROOF PLAN FOR ADDITIONAL FUTURE HEAT TAPE OUTLETS. SEE ROOF PLAN FOR WATERPROOF OUTLETS AT SIDEWALL AREAS. ALL GUTTERS AND DOWNSPOUTS TO BE HEATED. REFER TO PLAN FOR ALL SOLAR AND HEAT TAPE.
- PAINT ALL EXPOSED PIPING EXTENDING THROUGH ROOF TO MATCH ROOF
- PROVIDE VALLEY FLASHING AT ALL VALLEYS AS INDICATED ON PLANS.
- OVERHANG DIMENSIONS ARE TO END OF RAFTER OR TRUSS AS INDICATED ON PLANS.
- PROVIDE KICK-OUT FLASHING AT ALL EAVE/WALL JUNCTURES.
- PROVIDE ILC AS REQUIRED.
- CONTRACTOR TO COORDINATE HEATED GUTTER AND DOWNSPOUT LOCATIONS WITH ARCHITECT.
- DOWNSPOUTS SHALL NOT DISCHARGE ONTO FLATWORK OR DECKS BELOW. CONTRACTOR TO ROUTE DISCHARGE BELOW SURFACE OR PROVIDE CHANNEL DRAIN IN FLATWORK WITH HEAT TAPE.
- REFER TO SPECIFICATIONS. PROVIDE ROOF PRIMER, ROOF MEMBRANE AND ALL ROOFING PER SPECIFICATION REQUIREMENTS. PROVIDE "W.R. GRACE" MANUFACTURER CERTIFICATION LETTER STATING THAT ALL MEMBRANES HAVE BEEN INSTALLED IN COMPLETE COMPLIANCE WITH ALL MANUFACTURER'S REQUIREMENTS.
- UNVENTED ROOFS SHALL HAVE A MINIMUM 60% AIR IMPERMEABLE CLOSED CELL INSULATION AT UNDERSIDE OF DECK.

**NOTES: ROOF MAINTENANCE**

THE OWNER HAS BEEN ADVISED THAT ALL ROOF AND DECK SURFACES MUST BE MAINTAINED RELATIVELY FREE OF SNOW & ICE.

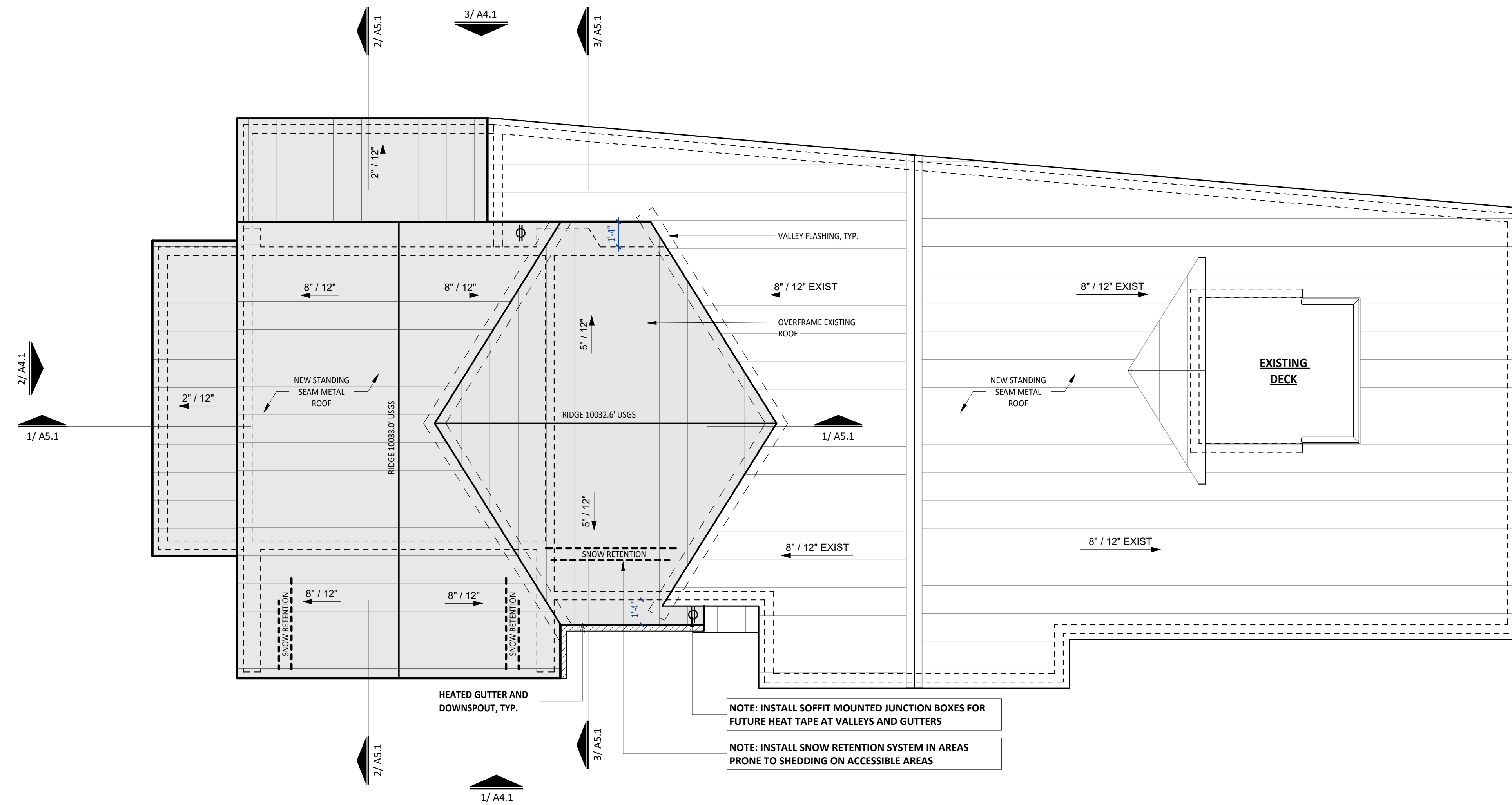

**1 ROOF PLAN**  
1/4" = 1'-0"

**FITZGERALD ADDITION**

34 RUSTIC TERRACE  
BLUE RIVER, CO

No.	Date	Revisions

Project No: 2023-16  
 Stage: FINAL REVIEW SET  
 Date: 05/02/2024  
 Scale: As indicated

DRAWING TITLE:

**ROOF PLAN**

DRAWING NO:

**A1.4**

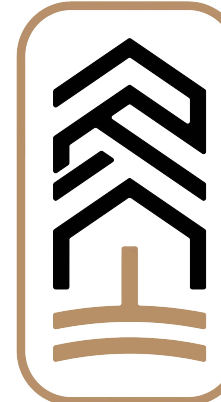

ROOTED ARCHITECTURE

SEAL:

NOT FOR CONSTRUCTION

DRAWINGS AND SPECIFICATIONS AS INSTRUMENTS OF SERVICE ARE THE PROPERTY OF THE ARCHITECT. THEY SHALL NOT BE USED, TRANSFERRED, OR SOLD FOR USE EXCEPT BY AN AGREEMENT IN WRITING FROM THE ARCHITECT.

FITZGERALD ADDITION

34 RUSTIC TERRACE  
BLUE RIVER, CO

No. Date Revisions

Project No: 2023-16  
Stage: FINAL REVIEW SET  
Date: 05/02/2024  
Scale: As indicated

DRAWING TITLE:

CEILING PLANS

DRAWING NO:

A2.1

FIXTURE / DEVICE LEGEND	
	A 6" RECESSED CAN LIGHT FIXTURE TO BE SELECTED - FLUORESCENT OR LED LIGHT SOURCE
	A1 6" RECESSED CAN LIGHT (MOISTURE RESISTANT) FIXTURE TO BE SELECTED - FLUORESCENT OR LED LIGHT SOURCE
	B 4" RECESSED CAN LIGHT FIXTURE TO BE SELECTED - FLUORESCENT OR LED LIGHT SOURCE
	B1 4" RECESSED CAN LIGHT (MOISTURE RESISTANT) FIXTURE TO BE SELECTED - FLUORESCENT OR LED LIGHT SOURCE
	B2 4" RECESSED CAN LIGHT (WALL WASHER) FIXTURE TO BE SELECTED - FLUORESCENT OR LED LIGHT SOURCE
	C DECORATIVE PENDANT FIXTURE FIXTURE TO BE SELECTED
	D 4" SURFACE MOUNT FLUORESCENT FIXTURE FIXTURE TO BE SELECTED
	E LINEAR LED UNDERCABINET TASK LIGHTING FIXTURE TO BE SELECTED
	F SURFACE MOUNT FIXTURE FIXTURE TO BE SELECTED
	WS WALL MOUNTED SCONCE FIXTURE FIXTURE TO BE SELECTED
	EX WALL MOUNTED EXTERIOR FIXTURE FIXTURE TO BE SELECTED
	FL WALL MOUNTED EXTERIOR FLOOD LIGHT FIXTURE FIXTURE TO BE SELECTED
	SD CEILING MOUNTED COMBINATION SMOKE AND CARBON MONOXIDE DETECTOR
	FAN CEILING MOUNTED CEILING FAN (WITH OPTIONAL LIGHT KIT) FIXTURE TO BE SELECTED

DEVICE CONTROL LEGEND	
	S SINGLE POLE SWITCH LEGRAND "RADIANT" OR SIMILAR - WHITE
	S <sup>D</sup> SINGLE POLE DIMMER SWITCH LEGRAND "RADIANT" OR SIMILAR - WHITE
	S <sup>3</sup> SINGLE POLE 3 WAY SWITCH LEGRAND "RADIANT" OR SIMILAR - WHITE
	S <sup>3/D</sup> SINGLE POLE 3 WAY DIMMER SWITCH LEGRAND "RADIANT" OR SIMILAR - WHITE
	S <sup>4/D</sup> SINGLE POLE 4 WAY DIMMER SWITCH LEGRAND "RADIANT" OR SIMILAR - WHITE
	S <sup>5</sup> SINGLE POLE DOOR JAMB SWITCH LEVITON 1865 OR SIMILAR

NOTES: REFLECTED CEILING PLAN

- ALL RCP DIMENSIONS ARE TO FACE OF FINISH OR FIXTURE CENTERLINE U.N.O.
- ALL CEILINGS ARE PAINTED GYPSUM BOARD U.N.O.
- REFERENCE FIXTURE LEGEND FOR FIXTURE TYPES AND DESIGNATIONS.
- LOCATE PAINTED METAL CEILING ACCESS PANELS BENEATH:
  - MECHANICAL EQUIPMENT PER MANUFACTURER'S RECOMMENDATIONS.
  - VALVES, BALANCING DEVICES, ELECTRICAL JUNCTIONS, F/S DAMPERS AND ALL OTHER ITEMS REQUIRING MAINTENANCE.
- COORDINATE LOCATION OF ALL MECHANICAL EQUIPMENT AND DUCTWORK WITH STRUCTURAL, AS WELL AS, WITH CEILING HEIGHTS SHOWN. NOTIFY ARCHITECT IMMEDIATELY OF CONFLICTS BEFORE PROCEEDING.
- IF ANY LIGHTING ITEMS OR CEILING FIXTURES CANNOT BE INSTALLED AT LOCATIONS SHOWN DUE TO FIELD CONDITIONS, NOTIFY ARCHITECT IMMEDIATELY FOR ALTERNATE LOCATIONS BEFORE PROCEEDING.

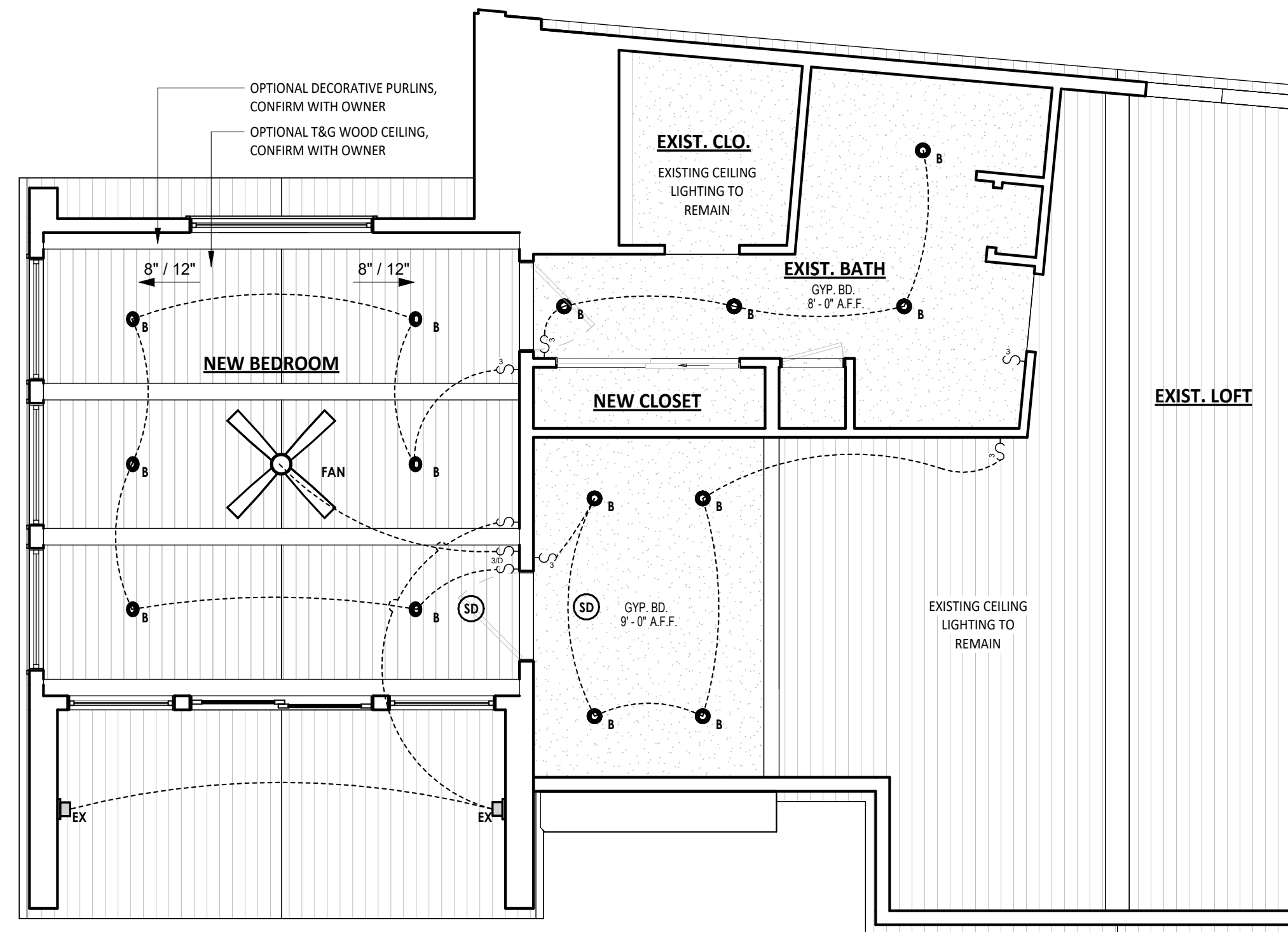

3 CEILING PLAN - LOFT LEVEL  
1/4" = 1'-0"

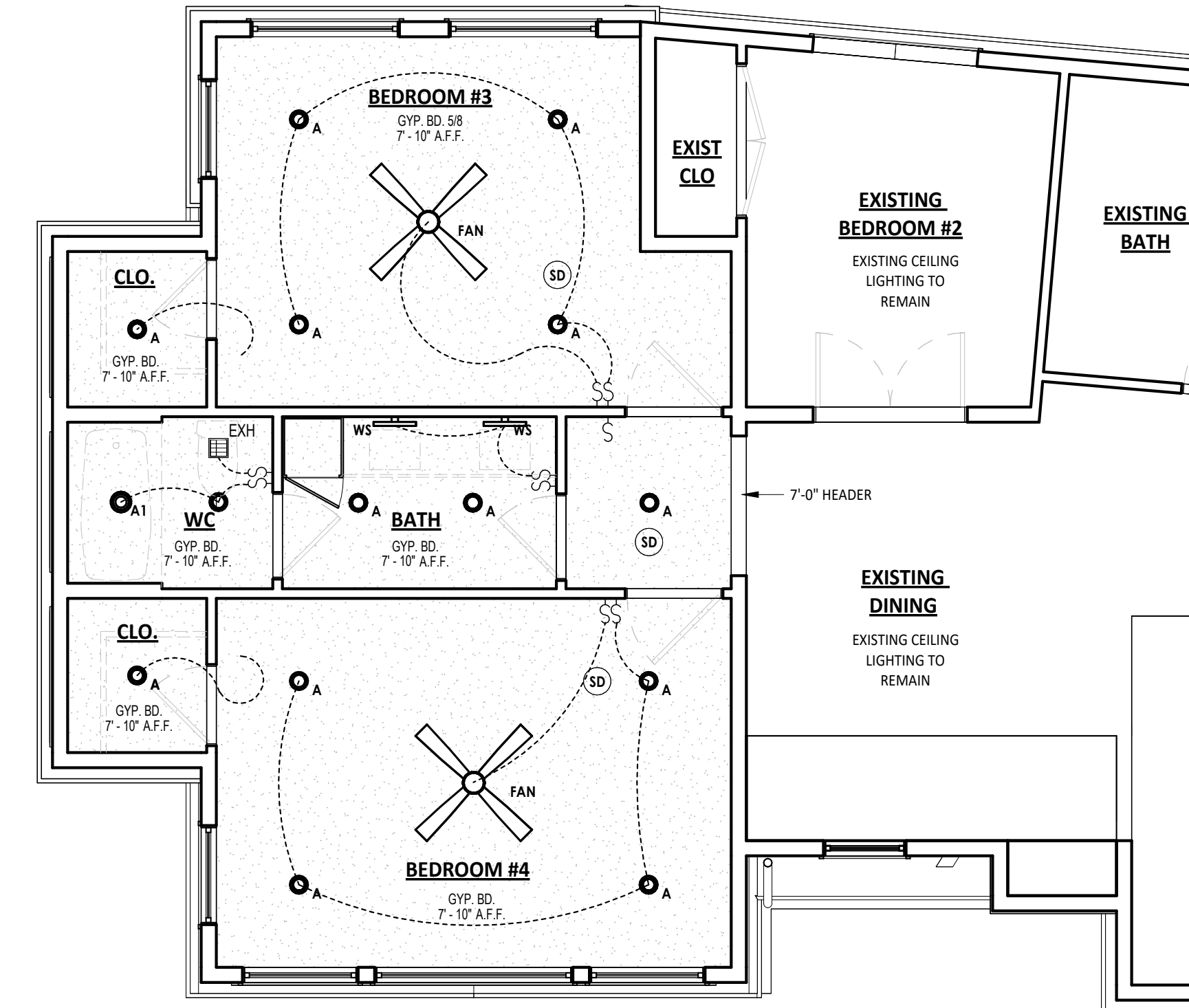

2 CEILING PLAN - MAIN LEVEL  
1/4" = 1'-0"

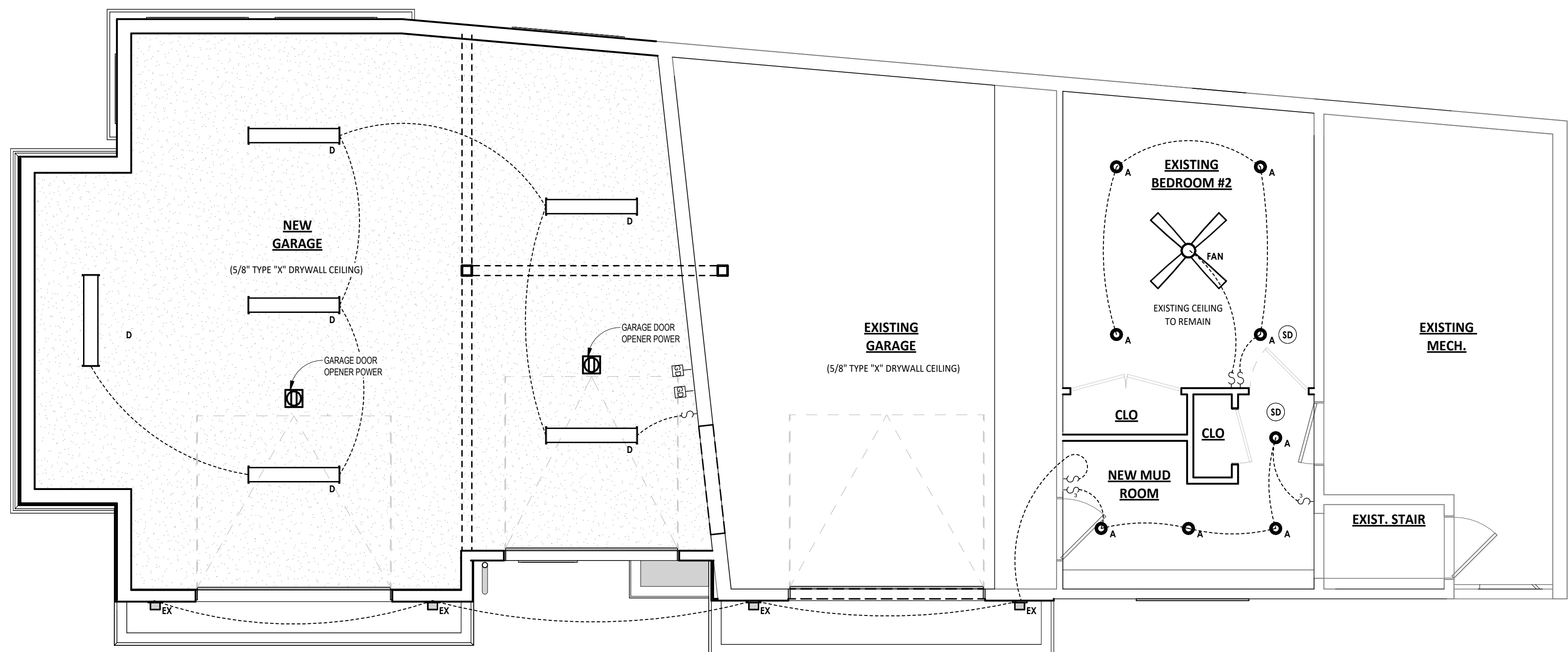

1 CEILING PLAN - LOWER LEVEL  
1/4" = 1'-0"



**ROOTED**  
ARCHITECTURE

SEAL:

NOT FOR CONSTRUCTION

DRAWINGS AND SPECIFICATIONS AS INSTRUMENTS OF SERVICE ARE THE PROPERTY OF THE ARCHITECT. THEY SHALL NOT BE USED, TRANSFERRED, OR SOLD FOR USE EXCEPT BY AN AGREEMENT IN WRITING FROM THE ARCHITECT.

**FITZGERALD ADDITION**

34 RUSTIC TERRACE  
BLUE RIVER, CO

No. Date Revisions

Project No: 2023-16  
Stage: FINAL REVIEW SET  
Date: 05/02/2024  
Scale: As indicated

DRAWING TITLE:

**EXTERIOR ELEVATIONS**

DRAWING NO:

**A4.1**

NOTES: AIR BARRIER / VAPOR BARRIER		
IN COMPLIANCE WITH ENERGY CODE REQUIREMENTS, PROVIDE CONTINUOUS, SOLID AIR BARRIERS OVER ALL INSULATION SURFACES. PROVIDE AIR BARRIERS BEHIND ALL CONCEALED AREAS, SUCH AS TUBS, DROPPED CEILING AREAS, SOFFITS DECORATIVE BEAMS AND STRUCTURAL BEAMS ADJACENT TO THERMAL ENVELOPE WALLS. THESE BARRIERS SHOULD BE COORDINATED AND INSTALLED AT THE TIME OF FRAMING AND MUST BE CONTINUOUS AND UNBROKEN. PROVIDE AIR BARRIERS AND INSULATION AT THE THERMAL ENVELOPE LINE OF ALL CHIMNEYS. AIR BARRIERS CAN BE 6 MIL POLYFILM PLASTIC, DRYWALL OR SOLID SHEATHING. COORDINATE ALL AIR BARRIERS WITH VAPOR BARRIERS AND INSULATION REQUIREMENTS AS OUTLINED IN DIVISION VII. PROVIDE AND SCHEDULE A PRE-MEETING WITH THE ARCHITECT AND FRAMER TO REVIEW THESE REQUIREMENTS PRIOR TO ANY FRAMING WORK.		
NOTES: WEATHER RESISTIVE BARRIER		
1. INSTALL WEATHER RESISTIVE BARRIER IN STRICT COMPLIANCE WITH MANUFACTURERS RECOMMENDATIONS AND DETAILS. USE ONLY APPROVED PRODUCTS AND FASTENING METHODS.		
2. REFERENCE LOCAL AND NATIONAL BUILDING CODES AND REGULATIONS PRIOR TO INSTALLATION. INSTALL PER GOVERNING CODE REQUIREMENTS. NOTIFY ARCHITECT IF ANY CONFLICT ARISES.		
EXTERIOR FINISH LEGEND		
MATERIAL SYMBOL	TYPE	NOTES:
(WD1)	T&G WOOD VENEER	HORIZONTAL T&G THERMALLY MODIFIED PRE-FINISHED WOOD SIDING (OWNER TO VERIFY COLOR)
(WD2)	WOOD TRIM	1X OR 2X THERMALLY MODIFIED PRE-FINISHED WOOD TRIM (MATCH SIDING) (OWNER TO VERIFY COLOR)
(MP1)	PREFINISHED METAL PANEL VENEER	METAL BOARD AND BATTEN SIDING FLATIRON STEEL "BOARD AND BATTEN" COLOR: BLACK OR MIDNIGHT BRONZE (CONFIRM WITH OWNER)
(M1)	PREFINISHED METAL FASCIA	PREFINISHED METAL TO MATCH SIDING
(ST1)	STONE VENEER	TELLURIDE STONE OPTIONAL STONE VENEER (CONFIRM WITH OWNER) COLOR: SILVERLEAF
(R1)	METAL ROOFING	STANDING SEAM METAL ROOFING COLOR: BLACK (CONFIRM WITH OWNER)
NOTE: CONTRACTOR TO PROVIDE PHYSICAL MATERIAL SAMPLE BOARD FOR OWNER / ARCHITECT APPROVAL		
NOTE: ALL EXTERIOR MATERIALS TO BE NON-REFLECTIVE		



**1 WEST ELEVATION**  
1/4" = 1'-0"

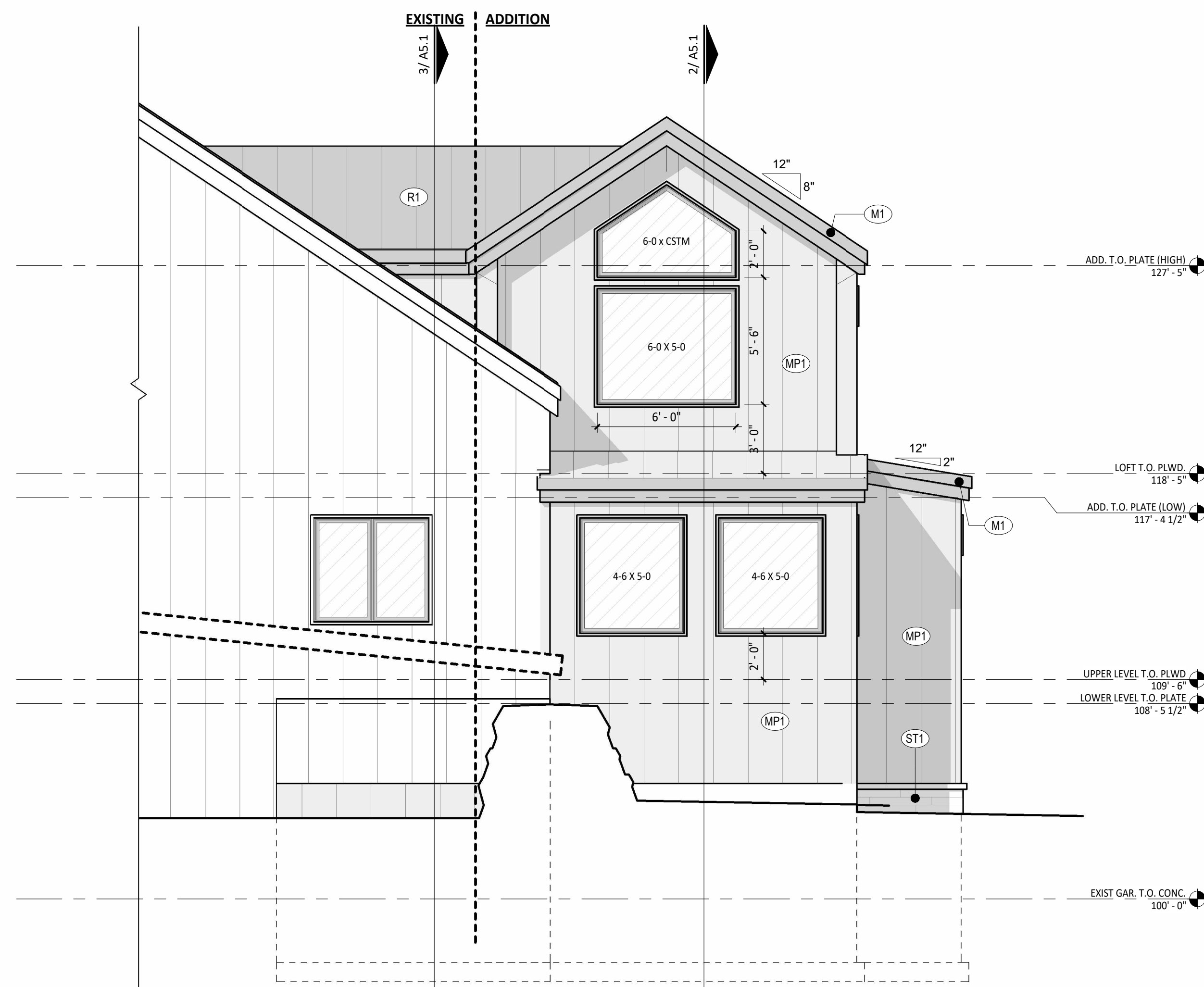

**3 EAST ELEVATION**  
1/4" = 1'-0"

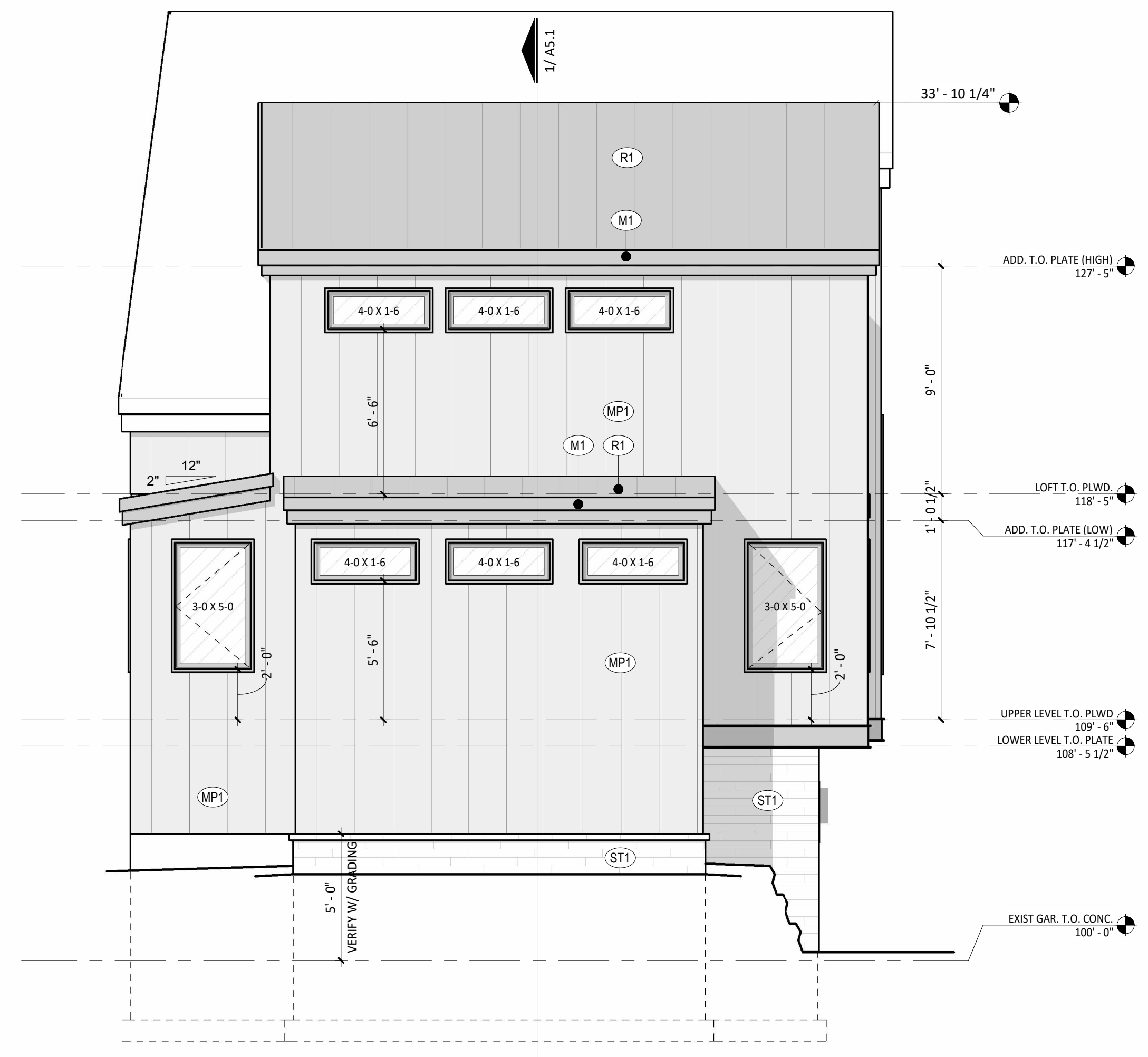

**2 NORTH ELEVATION**  
1/4" = 1'-0"

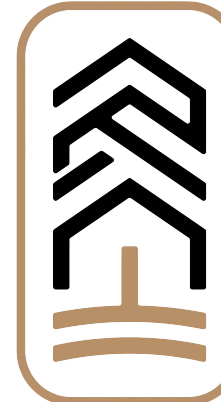

**ROOTED**  
ARCHITECTURE

SEAL:

NOT FOR CONSTRUCTION

DRAWINGS AND SPECIFICATIONS AS INSTRUMENTS OF SERVICE ARE THE PROPERTY OF THE ARCHITECT. THEY SHALL NOT BE USED, TRANSFERRED, OR SOLD FOR USE EXCEPT BY AN AGREEMENT IN WRITING FROM THE ARCHITECT.

**FITZGERALD ADDITION**

34 RUSTIC TERRACE  
BLUE RIVER, CO

No. Date Revisions

Project No: 2023-16  
Stage: FINAL REVIEW SET  
Date: 05/02/2024  
Scale: As indicated

DRAWING TITLE:

**BUILDING SECTIONS**

DRAWING NO:

**A5.1**

**NOTES: FRAMING**

1. ALL FRAMING SHOWN IS DIAGRAMMATIC AND SHALL BE STRUCTURALLY ENGINEERED WHERE APPLICABLE. CONTRACTOR TO CONFIRM COMPLIANCE WITH LOCAL CODES AND AUTHORITIES HAVING JURISDICTION.
2. ALL ROOF AND FLOOR TRUSSES SHALL BE PRE-ENGINEERED IN COMPLIANCE WITH LOCAL CODES AND AUTHORITIES HAVING JURISDICTION.
3. CONTRACTOR SHALL USE PRESSURE TREATED LUMBER WHERE REQUIRED IN COMPLIANCE WITH LOCAL CODES AND AUTHORITIES HAVING JURISDICTION.

**NOTES: WEATHER RESISTIVE BARRIER**

1. INSTALL WEATHER RESISTIVE BARRIER IN STRICT COMPLIANCE WITH MANUFACTURERS RECOMMENDATIONS AND DETAILS. USE ONLY APPROVED PRODUCTS AND FASTENING METHODS.
2. REFERENCE LOCAL AND NATIONAL BUILDING CODES AND REGULATIONS PRIOR TO INSTALLATION. INSTALL PER GOVERNING CODE REQUIREMENTS. NOTIFY ARCHITECT IF ANY CONFLICT ARISES.

**NOTES: AIR BARRIER / VAPOR BARRIER**

IN COMPLIANCE WITH ENERGY CODE REQUIREMENTS, PROVIDE CONTINUOUS, SOLID AIR BARRIERS OVER ALL INSULATION SURFACES. PROVIDE AIR BARRIERS BEHIND ALL CONCEALED AREAS, SUCH AS TUBS, DROPPED CEILING AREAS, SOFFITS DECORATIVE BEAMS AND STRUCTURAL BEAMS ADJACENT TO THERMAL ENVELOPE WALLS. THESE BARRIERS SHOULD BE COORDINATED AND INSTALLED AT THE TIME OF FRAMING AND MUST BE CONTINUOUS AND UNBROKEN. PROVIDE AIR BARRIERS AND INSULATION AT THE THERMAL ENVELOPE LINE OF ALL CHIMNEYS. AIR BARRIERS CAN BE 6 MIL POLYFILM PLASTIC, DRYWALL OR SOLID SHEATHING. COORDINATE ALL AIR BARRIERS WITH VAPOR BARRIERS AND INSULATION REQUIREMENTS AS OUTLINED IN DIVISION VII. PROVIDE AND SCHEDULE A PRE-MEETING WITH THE ARCHITECT AND FRAMER TO REVIEW THESE REQUIREMENTS PRIOR TO ANY FRAMING WORK.

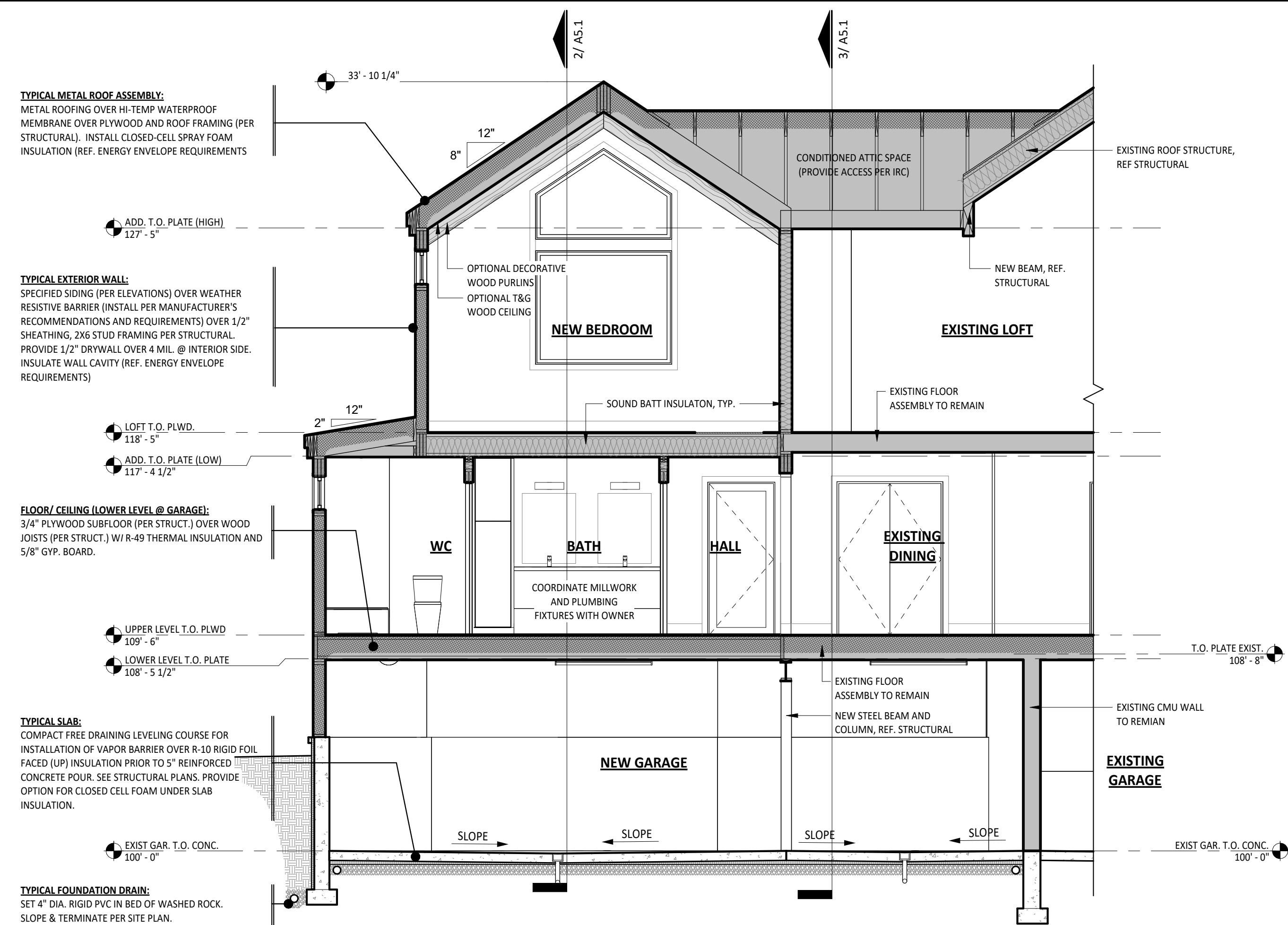

**1 SECTION A**  
1/4" = 1'-0"

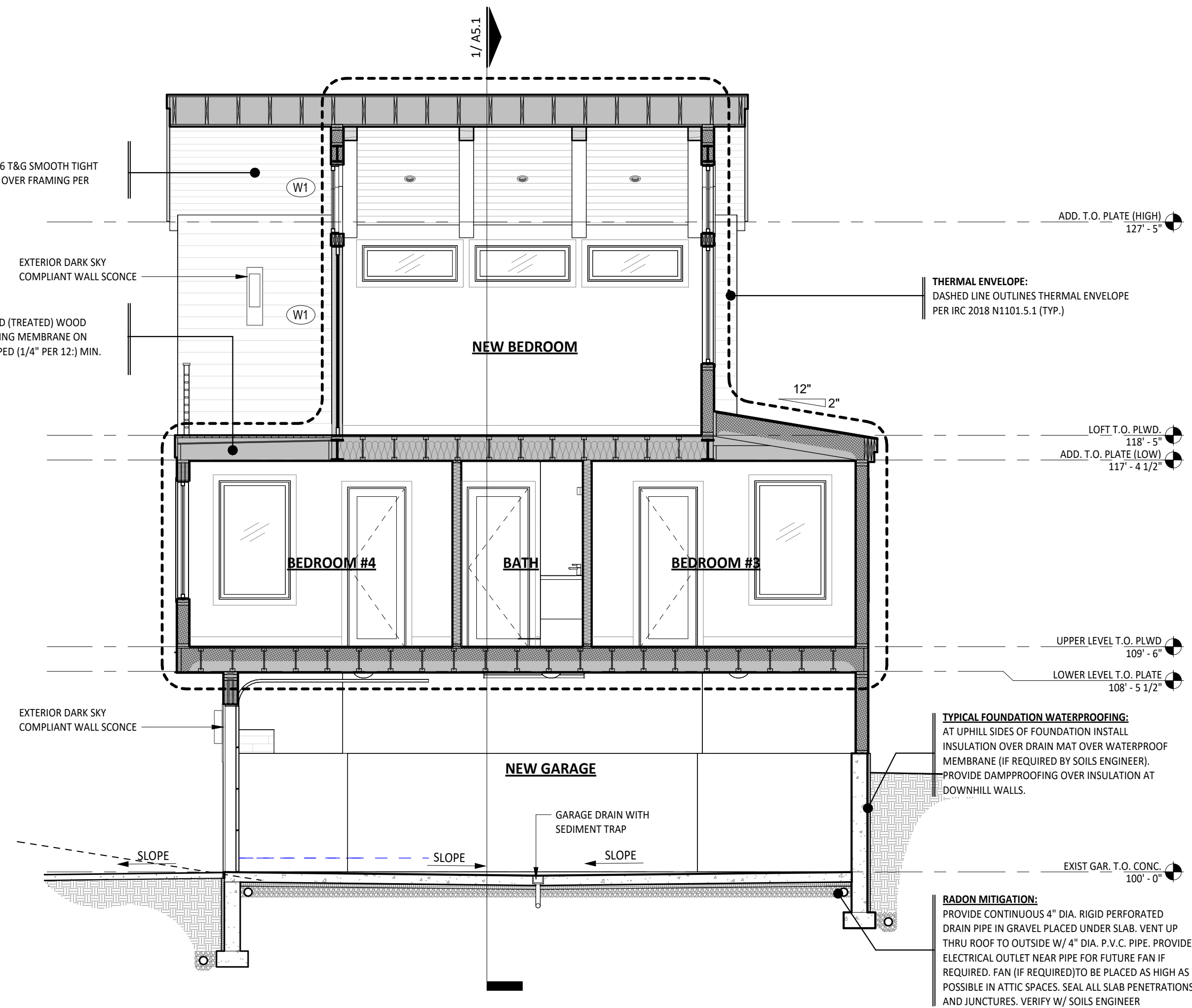

**2 SECTION B**  
1/4" = 1'-0"

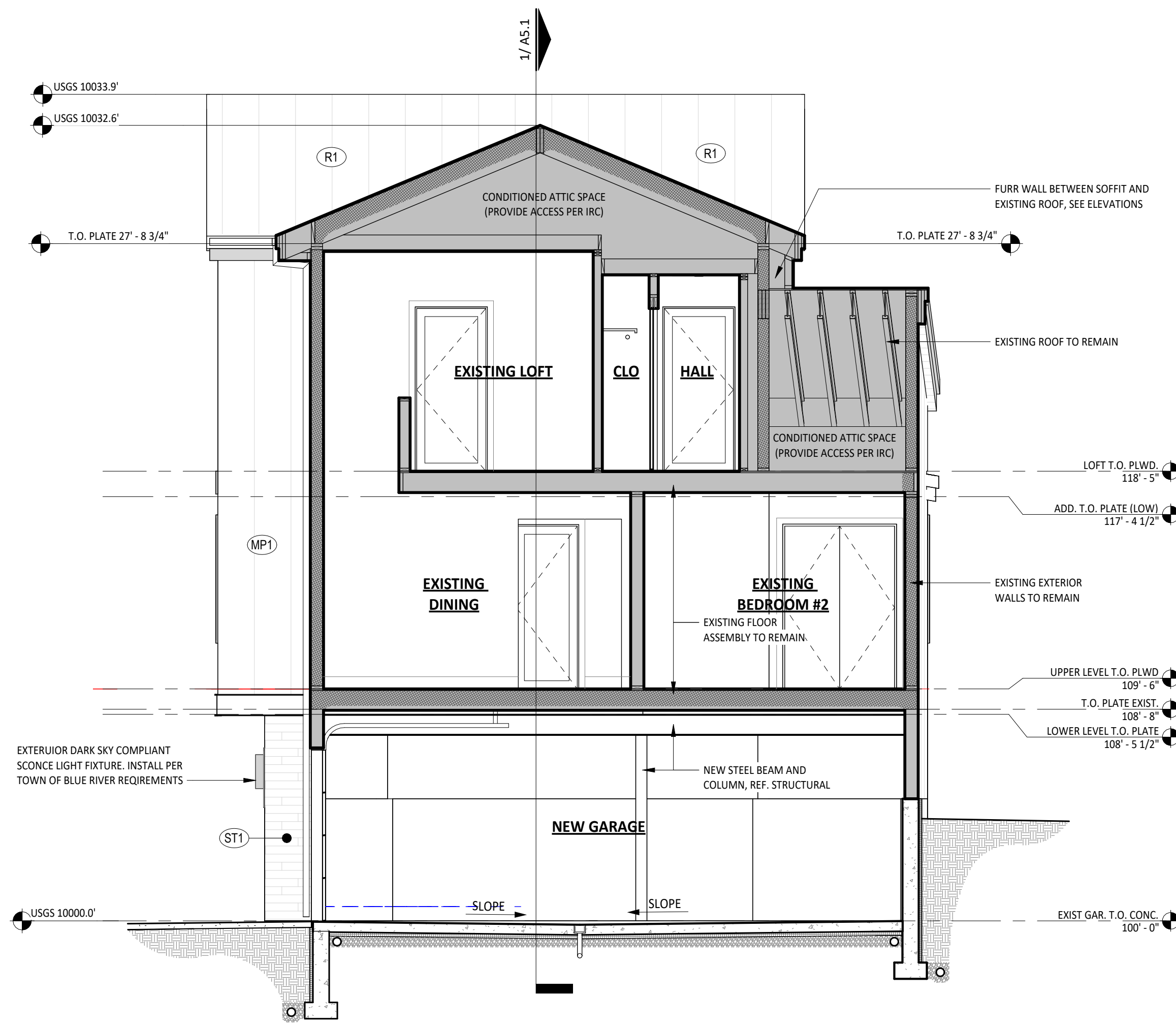

**3 SECTION C**  
1/4" = 1'-0"



**ROOTED**  
ARCHITECTURE

SEAL:

NOT FOR CONSTRUCTION

DRAWINGS AND SPECIFICATIONS AS INSTRUMENTS OF SERVICE ARE THE PROPERTY OF THE ARCHITECT. THEY SHALL NOT BE USED, TRANSFERRED, OR SOLD FOR USE EXCEPT BY AN AGREEMENT IN WRITING FROM THE ARCHITECT.

**FITZGERALD ADDITION**  
34 RUSTIC TERRACE  
BLUE RIVER, CO

No.	Date	Revisions

Project No: 2023-16  
Stage: FINAL REVIEW SET  
Date: 05/02/2024  
Scale: As indicated

DRAWING TITLE:  
**POWER PLANS**

DRAWING NO:

**A6.1**

ELECTRICAL DEVICE LEGEND	
	DOUBLE RECEPTACLE OUTLET LEGRAND "RADIANT" OR SIMILAR - WHITE
	220V RECEPTACLE OUTLET WHITE
	DOUBLE RECEPTACLE OUTLET W/ GROUND FAULT INTERRUPTER LEGRAND "RADIANT" OR SIMILAR - WHITE
	DOUBLE RECEPTACLE OUTLET W/ GROUND FAULT INTERRUPTER INSTALL WATERPROOF COVER FOR EXTERIOR USE
	FOURPLEX RECEPTACLE OUTLET LEGRAND "RADIANT" OR SIMILAR - WHITE
	DOUBLE RECEPTACLE FLOOR OUTLET INSTALL RECESSED FLOOR OUTLET COVER
	TEL / DATA FLOOR OUTLET
	RECESSED JUNCTION BOX COORDINATE LOCATION WITH EQUIPMENT MANUFACTURER
	TEL / DATA OUTLET CAT 6 OUTLET 14" AFF U.N.O.
	DATA OUTLET CAT 6 OUTLET 14" AFF U.N.O.
	TELEVISION OUTLET PROVIDE RECESSED POWER AND OUTLET FOR WALL MOUNTING WHERE REQUIRED BY OWNER

- NOTES: LOW VOLTAGE**
- ROUGH-IN PHONE, INTERNET, AND CATV FROM SITE UTILITY LOCATION TO MECHANICAL / AV ROOM.
  - PROVIDE PHONE, SECURITY, AND DATA BOARDS IN MECHANICAL / AV ROOM.
  - PROVIDE CONDUIT OR STRUCTURED CABLE TO SOUTH ROOF FOR SATELLITE DISH WIRING OPTION.
  - COORDINATE PHONE LINE WITH SECURITY SYSTEM REQUIREMENTS.
  - COORDINATE CATV / DATA / LIGHTING / HOME COMPUTER CONTROL REQUIREMENTS WITH OWNER.
  - COORDINATE HOME AUTOMATION / MECHANICAL CONTROLS INTERFACE AS REQUIRED BY OWNER.
  - COORDINATE SOUND SYSTEM, HOME AUTOMATION AND ALL OTHER LOW VOLTAGE SYSTEMS PER OWNER REQUIREMENTS.

- NOTES: WINDOW SHADES**
- PROVIDE OPTION FOR MOTORIZED WINDOW SHADE SYSTEMS WHERE INDICATED ON ELECTRICAL PLANS. CONFIRM SHADE LOCATIONS WITH OWNER PRIOR TO ELECTRICAL ROUGH-IN. COORDINATE WITH ELECTRICAL AND HOME AUTOMATION WORK. ALL SHADES TO BE INSTALLED IN RECESSED WINDOW POCKETS WHERE REQUIRED.
- NOTES: HOME AUTOMATION**
- PRIOR TO ANY ELECTRICAL WORK CONFIRM SCOPE OF SMART HOME CONTROL AND AUTOMATION REQUIREMENTS WITH OWNER. WORK TO INCLUDE PROCESSOR USER INTERFACE, SCOPE OF DEVICES AND/OR SYSTEMS TO BE CONTROLLED. SCOPE OF CABLE OR WIRELESS LINKS AND POSSIBLE EMERGENCES BACKUP POWER.
- SYSTEMS TO INCLUDE SECURITY, ENTERTAINMENT, BUILDING SERVICES, AND ENVIRONMENTAL COMPONENTS.

- NOTES: MECHANICAL / ELECTRICAL**
- ALL MECHANICAL AND ELECTRICAL WORK SHALL CONFORM TO CURRENT UNIFORM MECHANICAL AND NATIONAL ELECTRIC CODES AND RELATED NFPA REQUIREMENTS.
  - MECHANICAL AND ELECTRICAL INFORMATION SHOWN IS FOR DESIGN INFORMATION PURPOSES ONLY AND IT SHALL BE THE RESPONSIBILITY OF THE MECHANICAL/ELECTRICAL CONTRACTOR(S) TO PROVIDE NECESSARY INFORMATION TO LOCAL BUILDING DEPARTMENT FOR ISSUANCE OF PERMITS FOR CONSTRUCTION.
  - SUBMIT SHOP DRAWINGS AND PRODUCT DATA FOR TO ARCHITECT / OWNER FOR REVIEW.
  - CONTRACTOR SHALL VERIFY AND CONFORM TO PRODUCT INSTALLATION REQUIREMENTS AND SHALL PROVIDE ANY ADDITIONAL BLOCKING/PREP WORK NECESSARY FOR INSTALLATION PER MANUFACTURERS SPECIFICATIONS.
  - ALL RECESSED FIXTURES WITHIN INSULATED FLOOR AND OR CEILING SPACES MUST BE U.L. APPROVED FOR USE IN THESE LOCATIONS.
  - UNLESS OTHERWISE SHOWN, FIXTURES ARE TO BE PLACED CENTERED IN GIVEN SPACE. VERIFY ALL FIXTURE AND OUTLET LOCATIONS WITH DRAWINGS.
  - VERIFY ELECTRICITY, GAS, WATER, AND DRAINAGE REQUIREMENTS OF EQUIPMENT AND PROVIDE ANDY MECHANICAL SERVICE OR VENTING REQUIRED PRIOR TO OPERATION. PLUMB PRESSURE RELIEF OR OVERFLOW VALVES TO A DRAIN. COORDINATE WITH CARPENTRY CONTRACTOR TO PROVIDE PROPER ACCESS PANELS FOR ALL EQUIPMENT.
  - PROVIDE DUCTING TO EXTERIOR FOR ALL REQUIRED MECHANICAL EQUIPMENT. COORDINATE ALL EXTERIOR VENTS AND EXHAUST OUTLETS TO MINIMIZE VISIBILITY.
  - ALL PLUMBING FIXTURES SHALL HAVE WATER SAVING DEVICES AND/OR AERATORS TO COMPLY WITH LOCAL REQUIREMENTS.
  - ALL PENETRATIONS IN CEILINGS AND WALLS MUST BE DAFT STOPPED WITH APPROVED MATERIALS.
  - CHECK DOOR SWINGS BEFORE INSTALLATION OF WALL SWITCHES AND RELOCATE AS REQUIRED. LOCATE LIGHTING FIXTURES IN MECHANICAL ROOMS OR ATTIC SPACES TO CORRELATE WITH EQUIPMENT LOCATIONS AND PROVIDE ADEQUATE ILLUMINATION FOR SERVICING.
  - COORDINATE ELECTRICAL BRANCH CIRCUITS WITH FINAL MECHANICAL EQUIPMENT LOAD. ADVISE ARCHITECT/OWNER OF CHANGES FROM ANY DRAWING REQUIREMENTS PRIOR TO INSTALLATION OF ANY ELECTRICAL OR MECHANICAL WORK.
  - INSTALLATION OF ALL EQUIPMENT SHALL BE IN STRICT ACCORDANCE WITH MANUFACTURER'S INSTALLATION SPECIFICATIONS AND RECOMMENDATIONS. CONTRACTOR SHALL INCLUDE ALL NECESSARY ACCESSORIES AND PIPING FOR A COMPLETE AND OPERATIONAL SYSTEM.

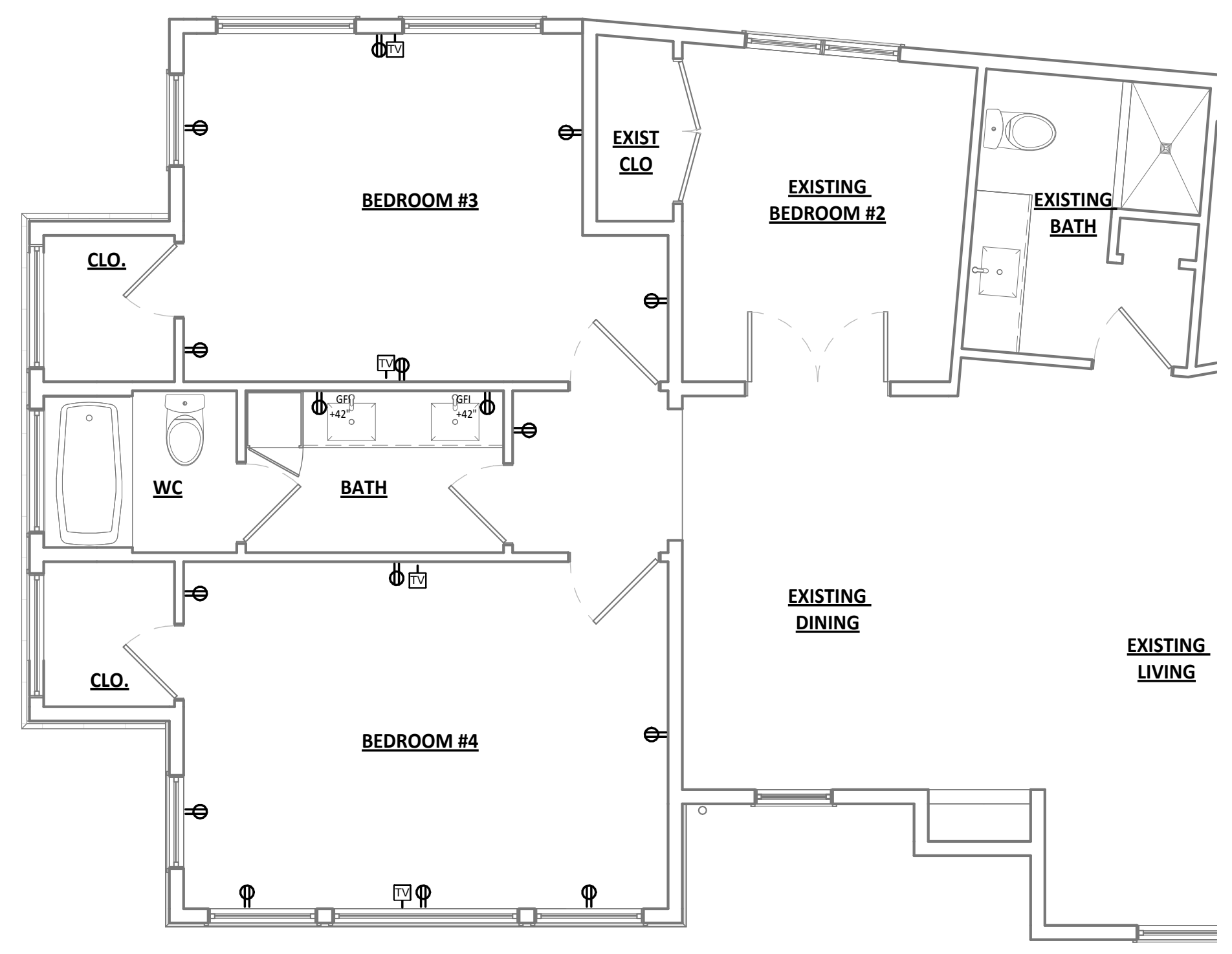

**2 POWER PLAN - MAIN LEVEL**  
1/4" = 1'-0"

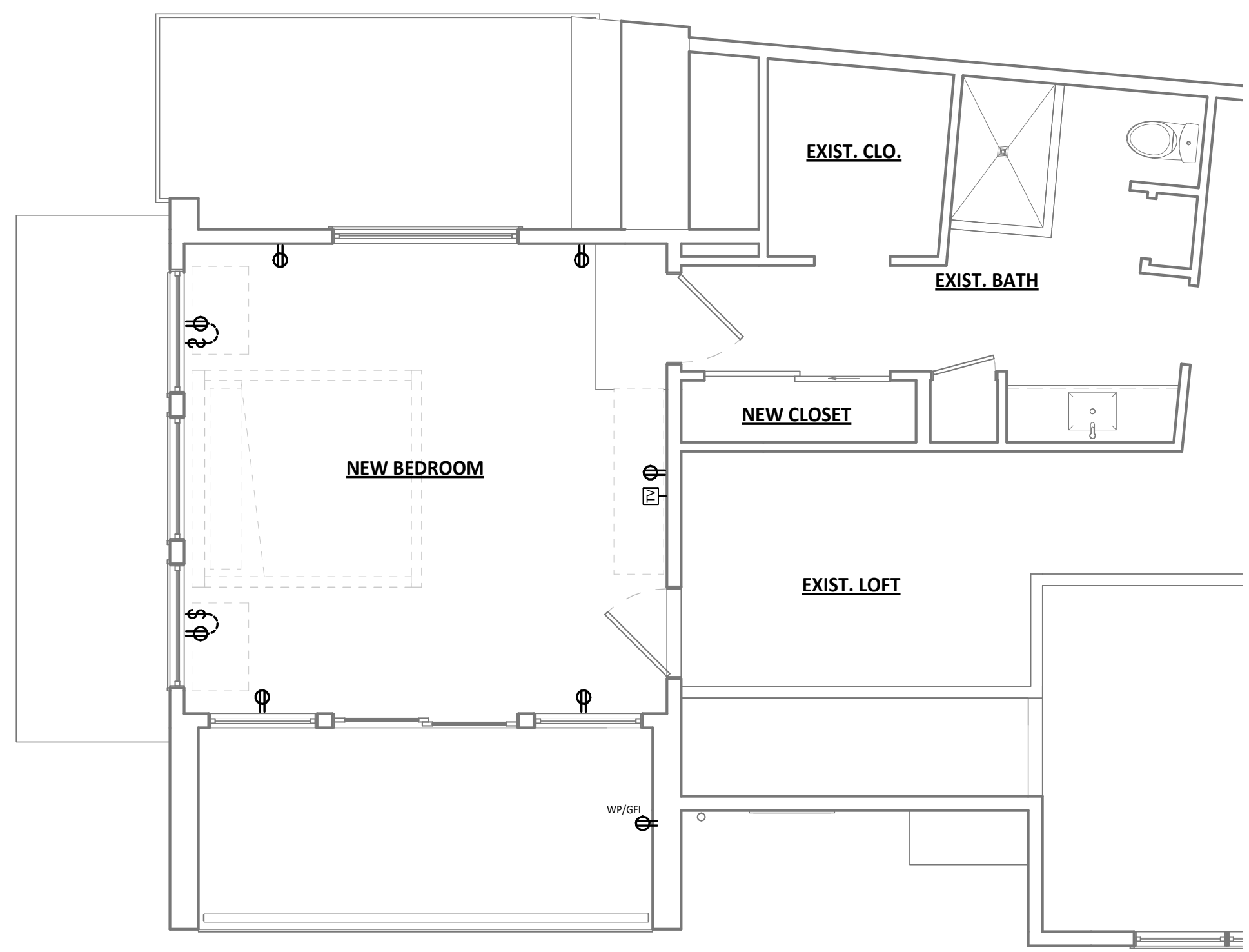

**3 POWER PLAN - LOFT LEVEL**  
1/4" = 1'-0"

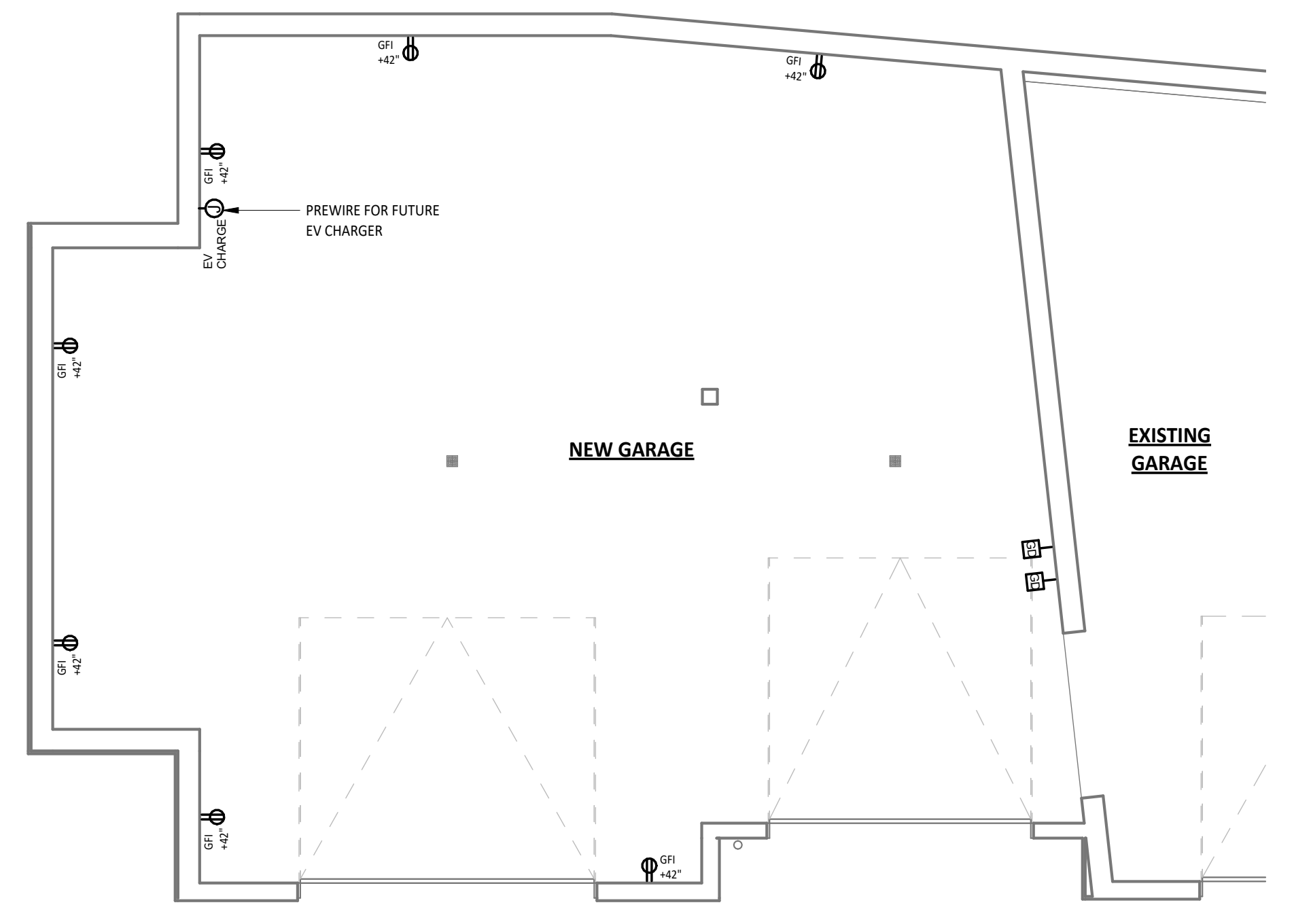

**1 POWER PLAN - LOWER LEVEL**  
1/4" = 1'-0"



ROOTED ARCHITECTURE

SEAL:

NOT FOR CONSTRUCTION

DRAWINGS AND SPECIFICATIONS AS INSTRUMENTS OF SERVICE ARE THE PROPERTY OF THE ARCHITECT. THEY SHALL NOT BE USED, TRANSFERRED, OR SOLD FOR USE EXCEPT BY AN AGREEMENT IN WRITING FROM THE ARCHITECT.

FITZGERALD ADDITION  
34 RUSTIC TERRACE  
BLUE RIVER, CO

NOTE: INSTALL WEATHER RESISTIVE BARRIER, FLASHING, AND WINDOWS IN ACCORDANCE WITH MANUFACTURERS SPECIFICATIONS

1. CUT MODIFIED "H" INTO WEATHER RESISTIVE BARRIER

MAKE ANGLE CUTS AT CORNERS AND FOLD UP FLAP

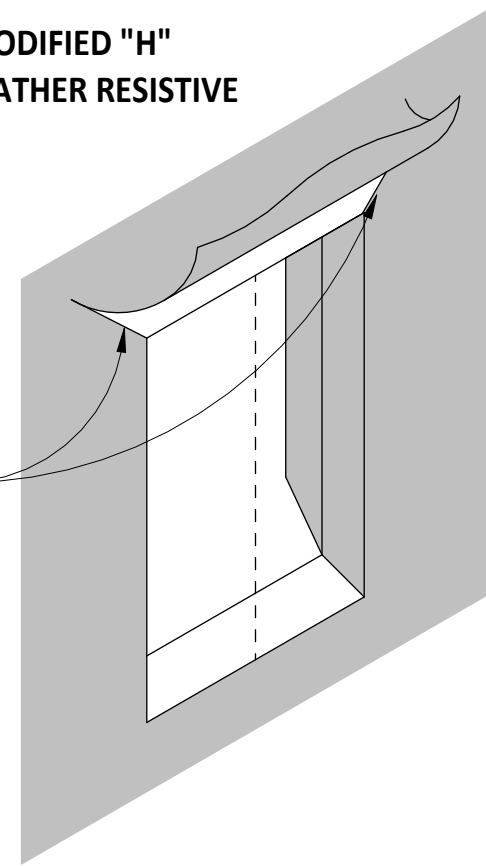

2. INSTALL PAN FLASHING AND SEALANT

SEALANT ALONG HEAD AND SIDES ONLY

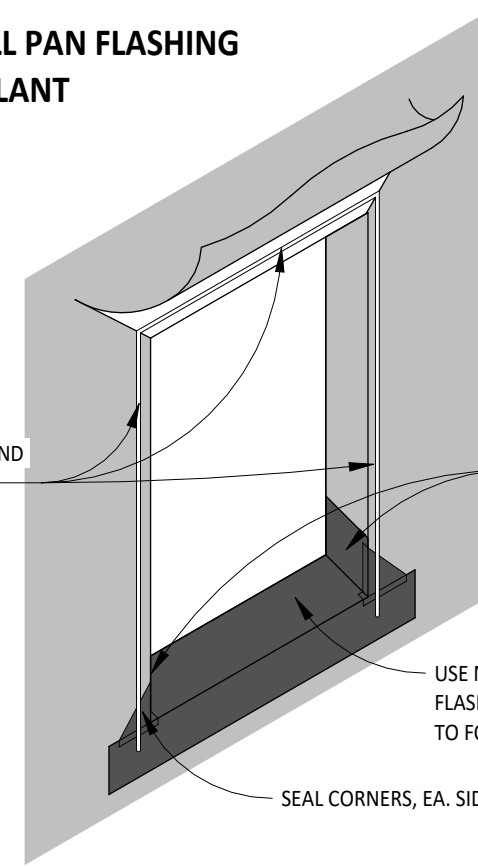

TURN SILL PAN FLASHING UP EA. SIDE 6" MIN.  
USE MOLDABLE SILL PAN FLASHING, OR CUT AND FOLD TO FORM SILL PAN  
SEAL CORNERS, EA. SIDE

3. INSTALL WINDOW AND SIDE FLASHINGS

EXTEND UP 6"

PEEL AND STICK FLASHING TAPE OVER NAIL FLANGE, EA. SIDE

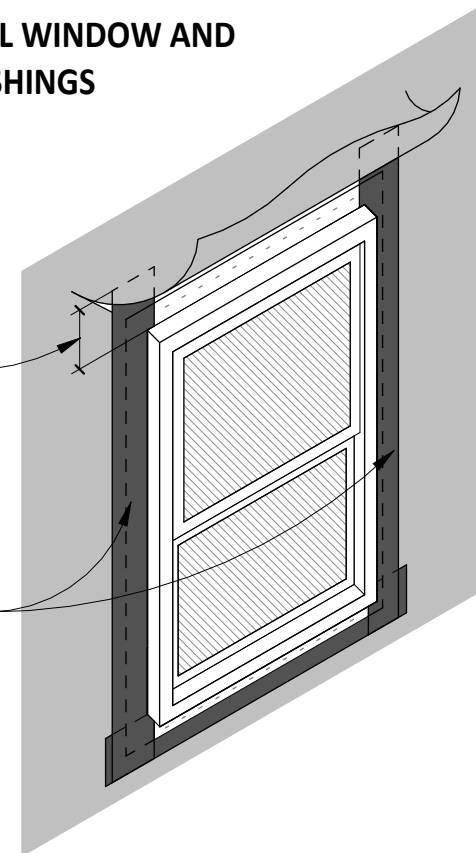

4. APPLY HEAD FLASHING

APPLY HEAD FLASHING TAPE OVER NAIL FLANGE, ADHERE TO SHEATHING ABOVE WINDOW

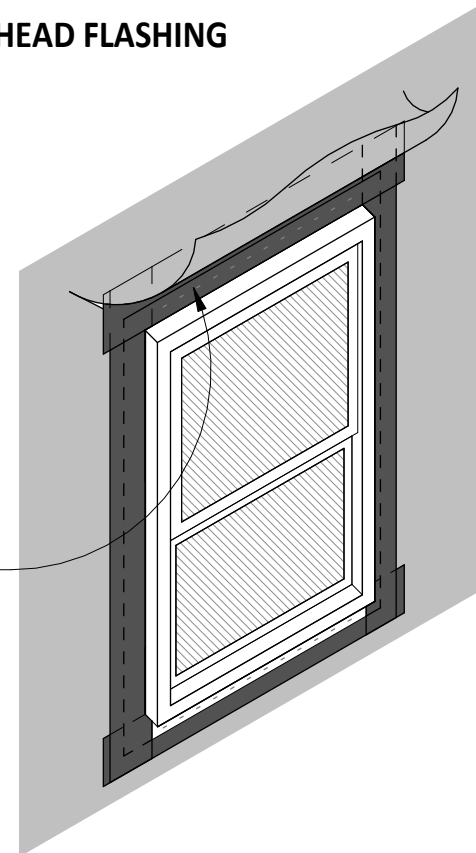

5. TAPE CUTS OVER HEAD FLASHING

FOLD DOWN WEATHER RESISTIVE BARRIER OVER FLASHING TAPE AND TAPE CORNER SEAMS

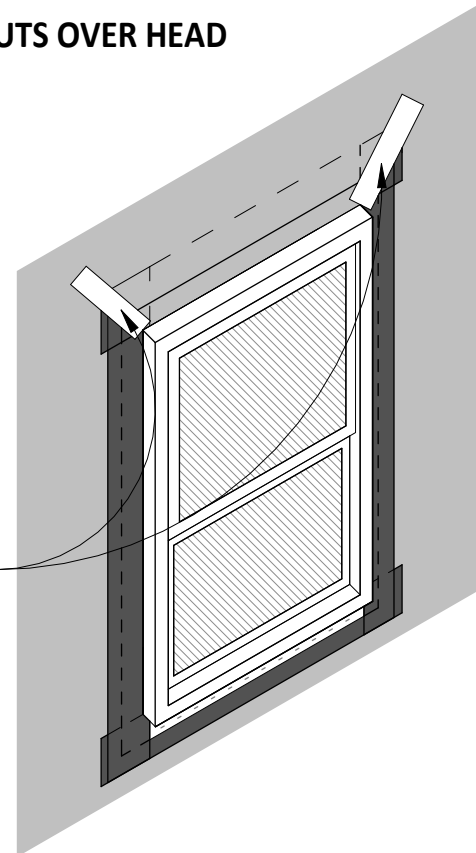

13 TYP. WINDOW FLASHING DETAIL  
NOT TO SCALE

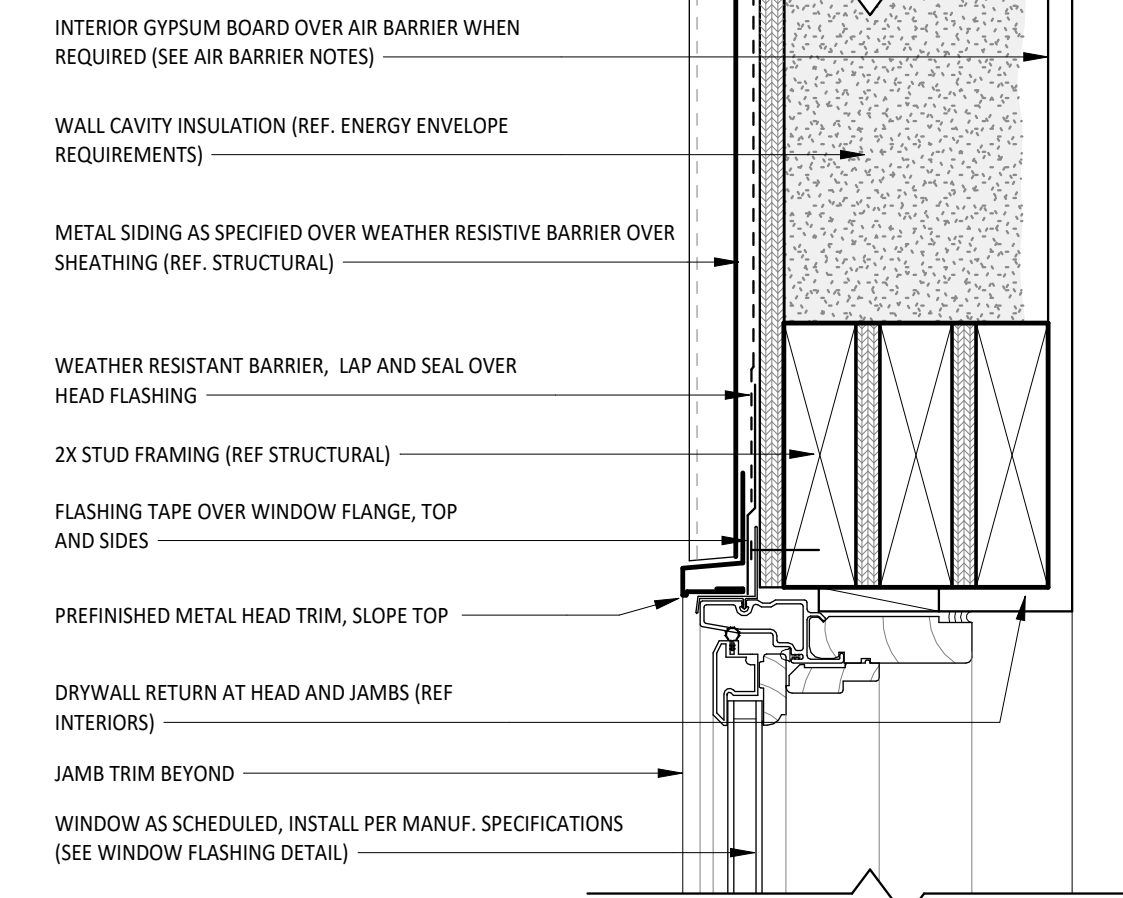

12 TYP. WINDOW HEAD @ METAL  
3" = 1'-0"

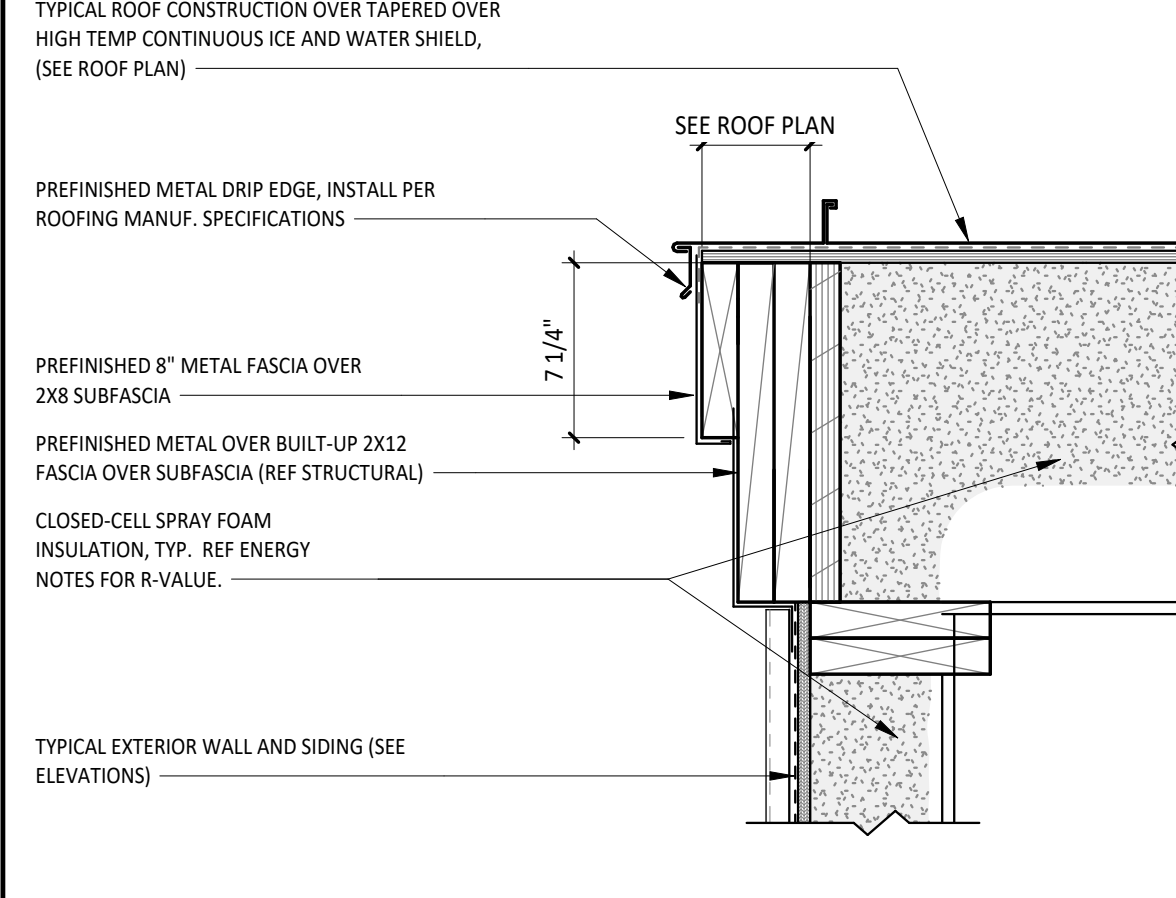

8 ROOF RAKE @ METAL ROOFING  
1 1/2" = 1'-0"

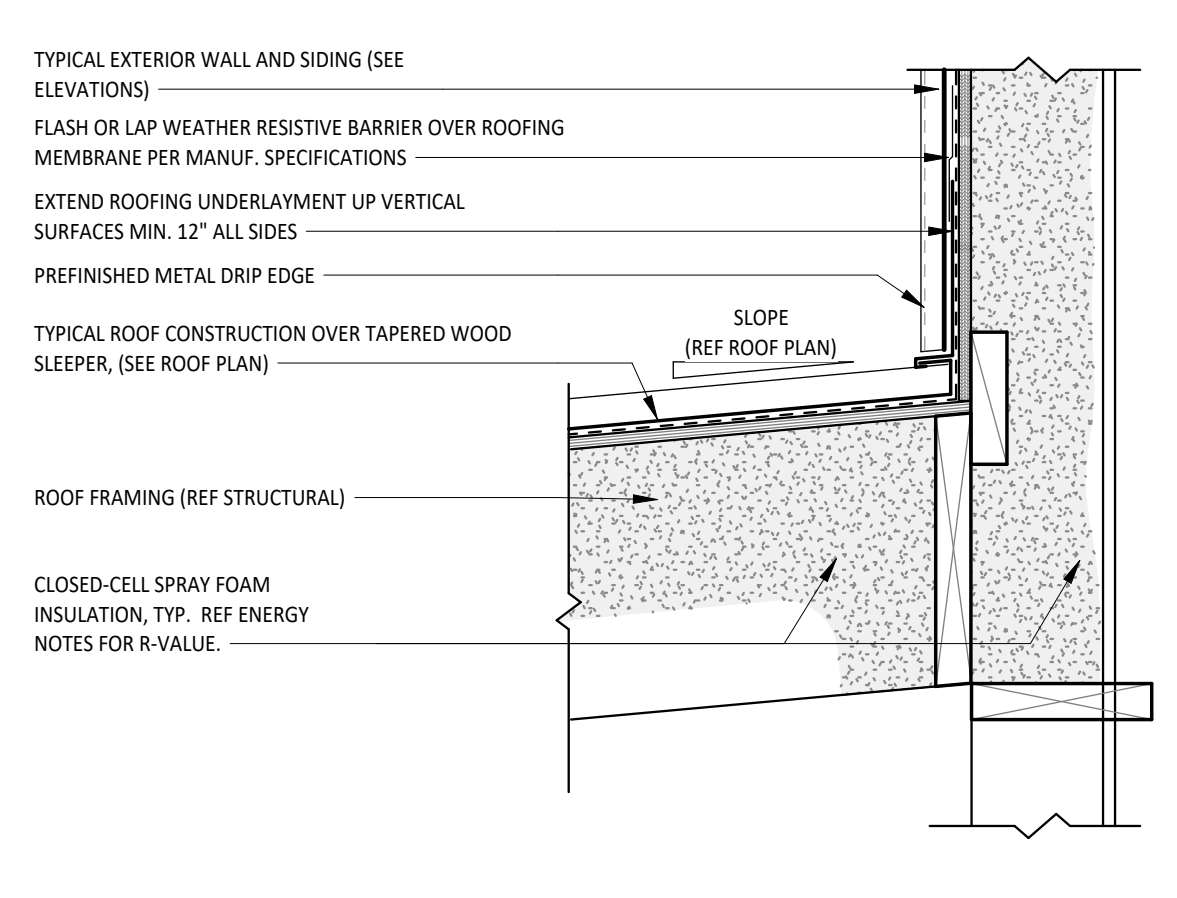

4 PITCHED ROOF WALL JUNCTURE  
1 1/2" = 1'-0"

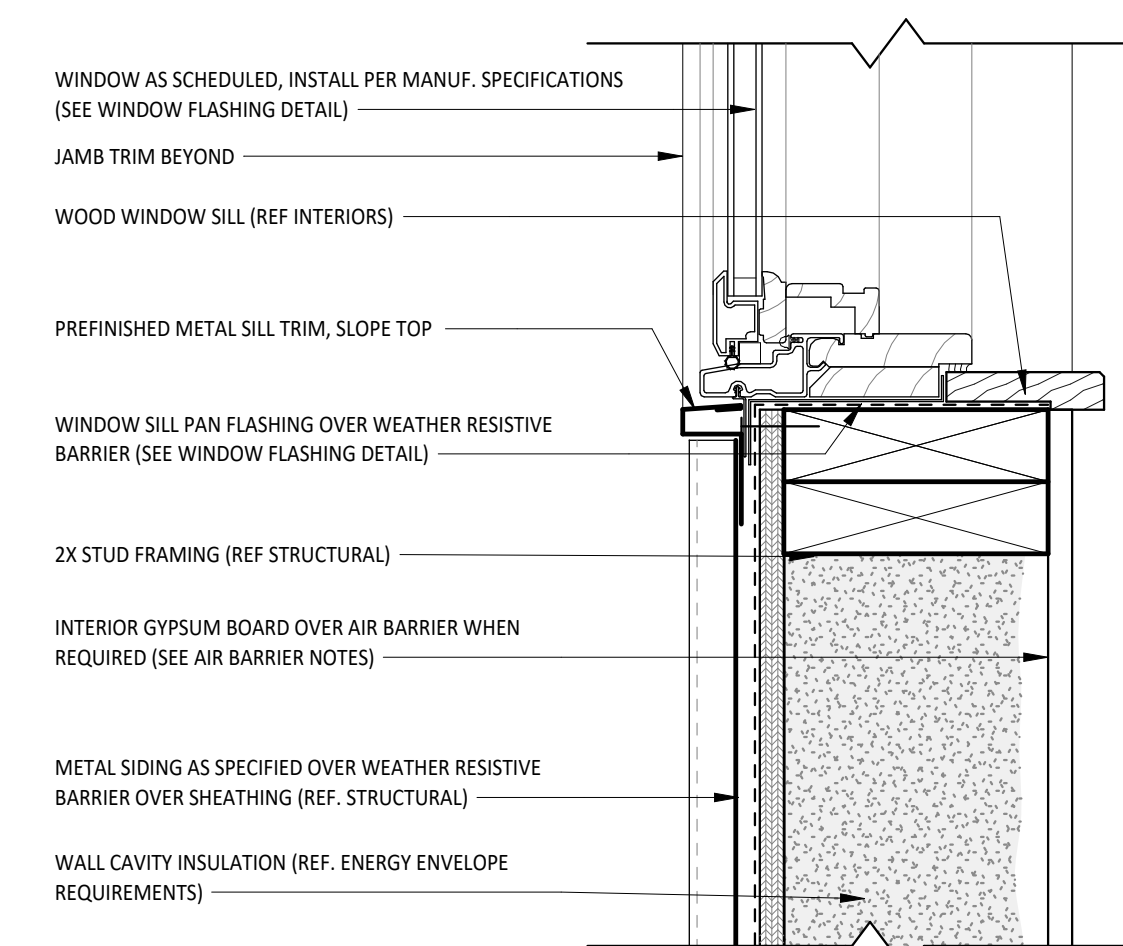

11 TYP. WINDOW SILL @ METAL  
3" = 1'-0"

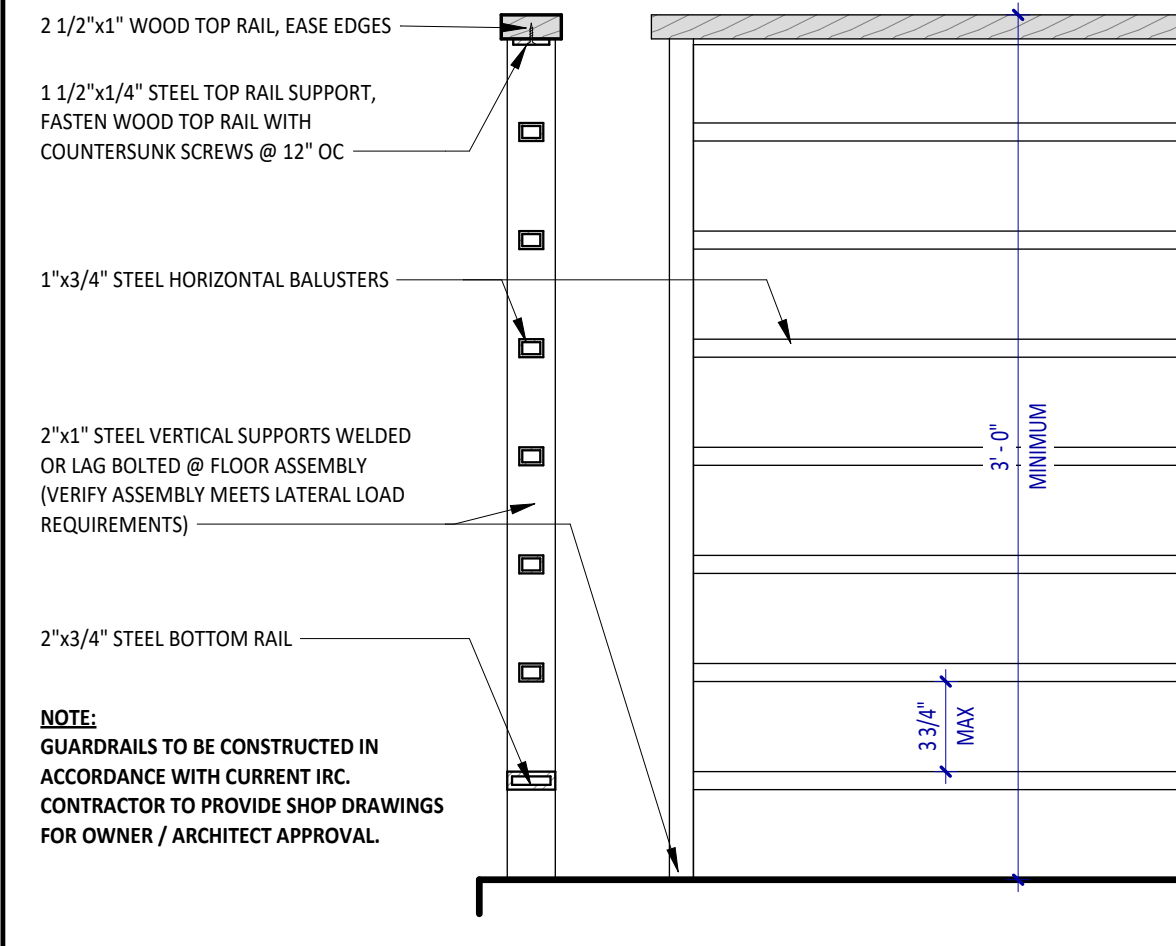

7 EXT. RAILING DETAIL  
1 1/2" = 1'-0"

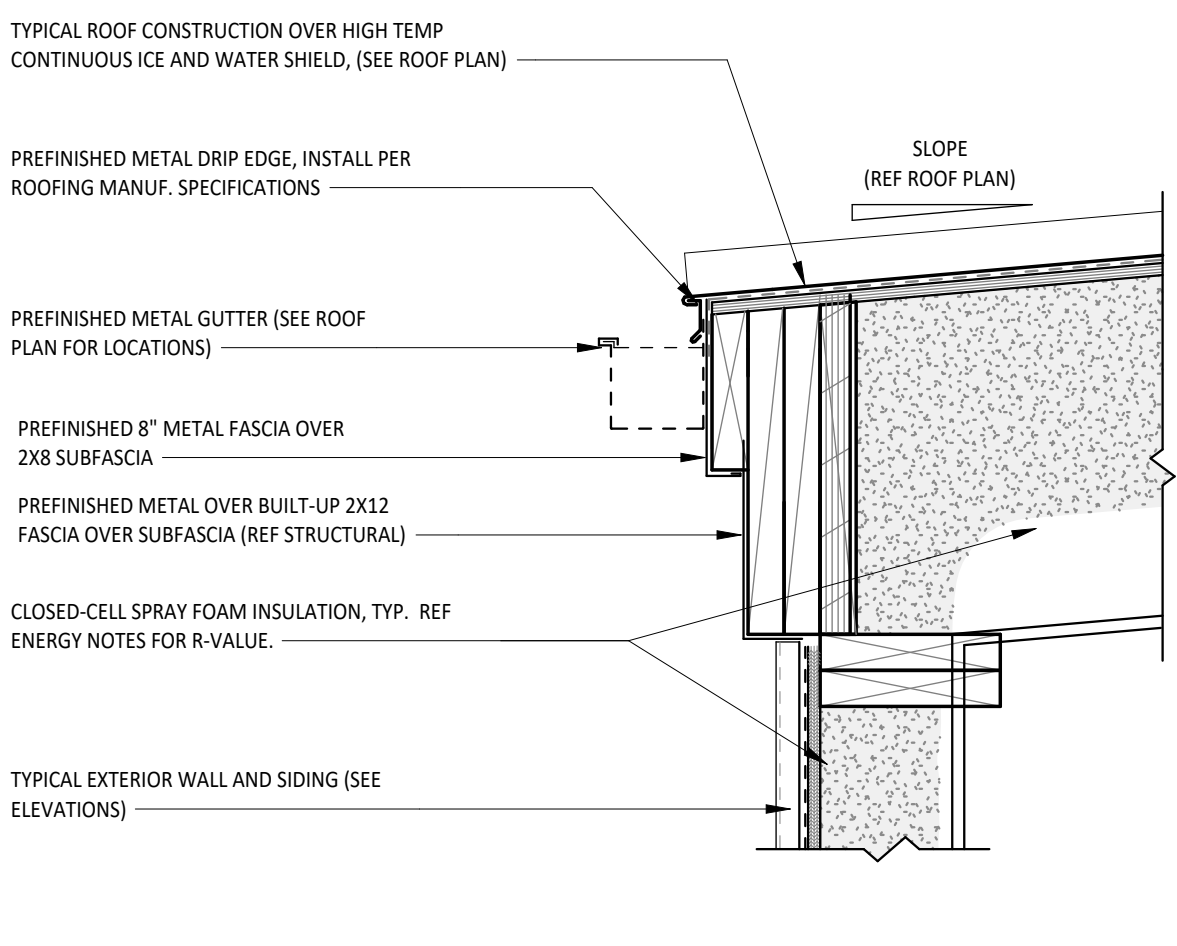

3 ROOF EAVE @ MEAL ROOFING  
1 1/2" = 1'-0"

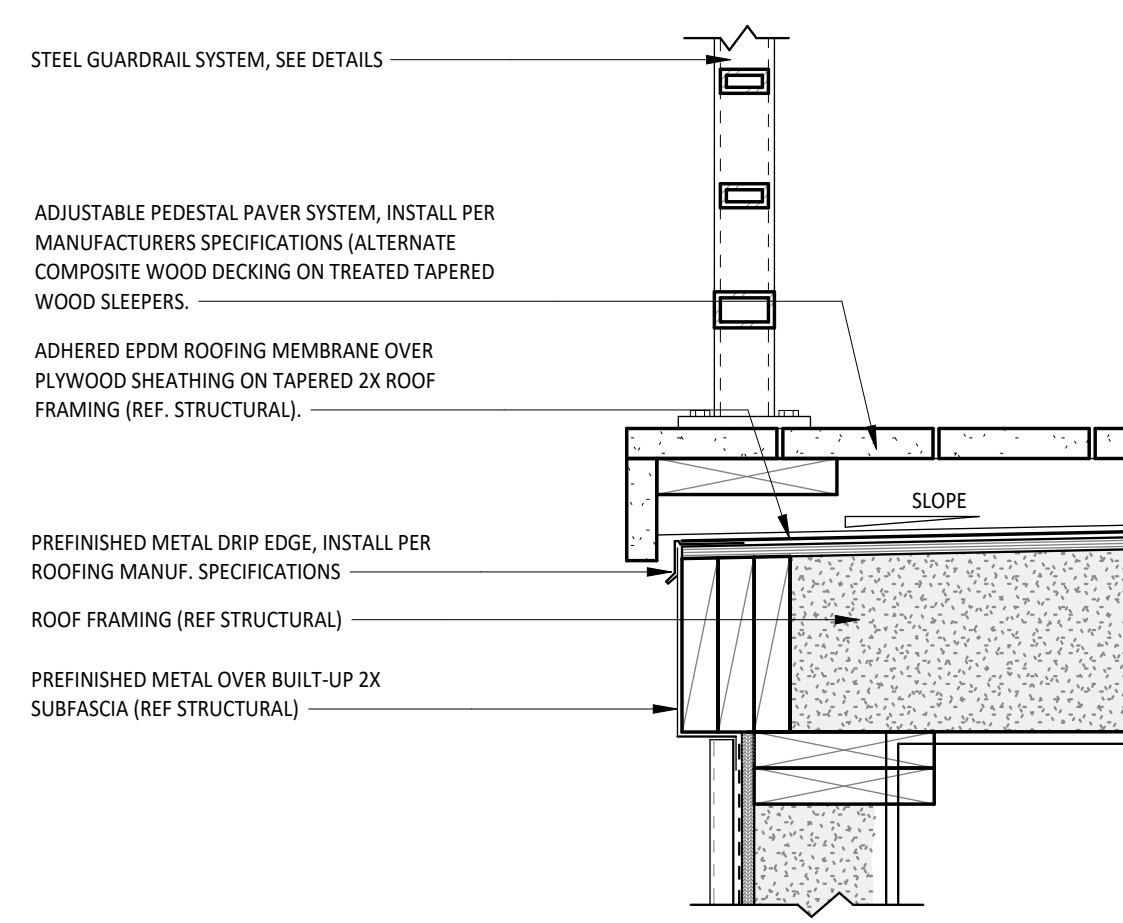

10 ROOF DECK FASCIA  
1 1/2" = 1'-0"

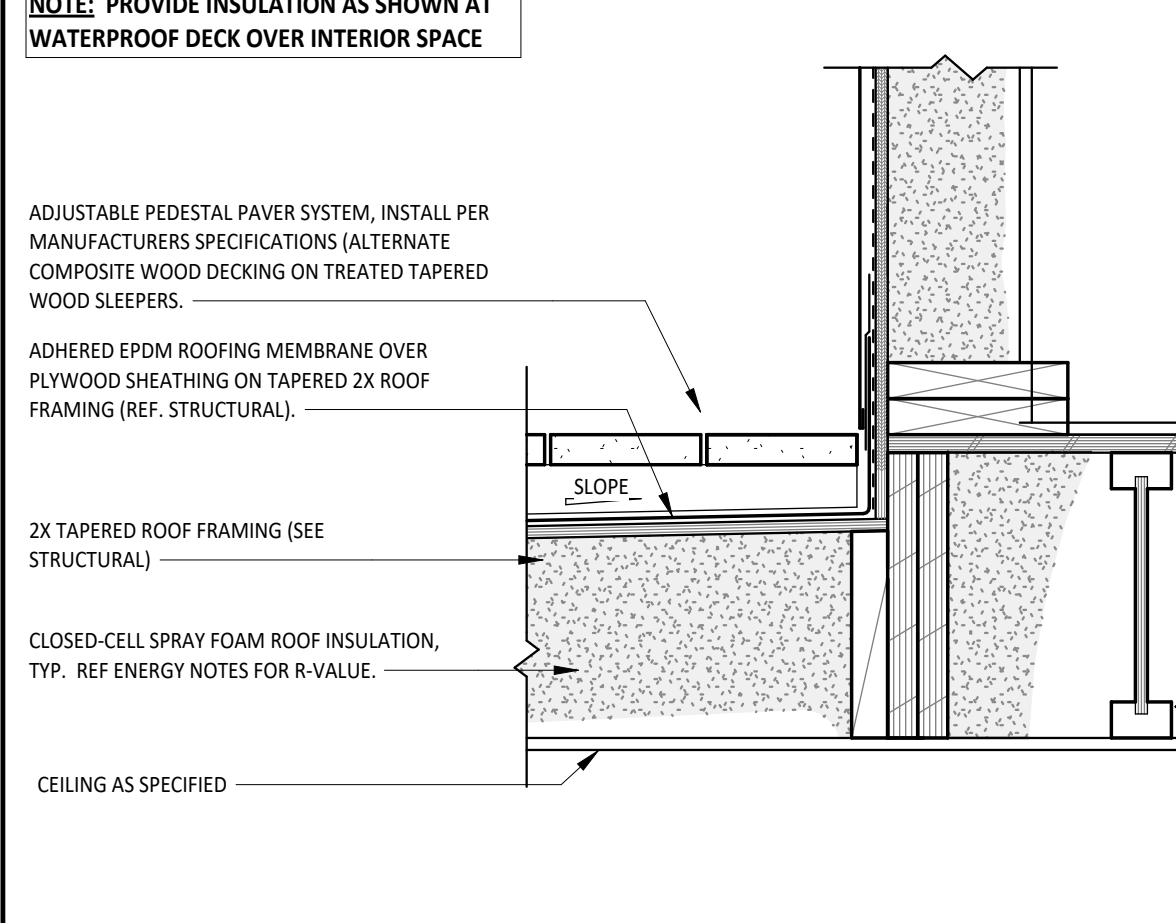

6 ROOF DECK @ WALL (INT)  
1 1/2" = 1'-0"

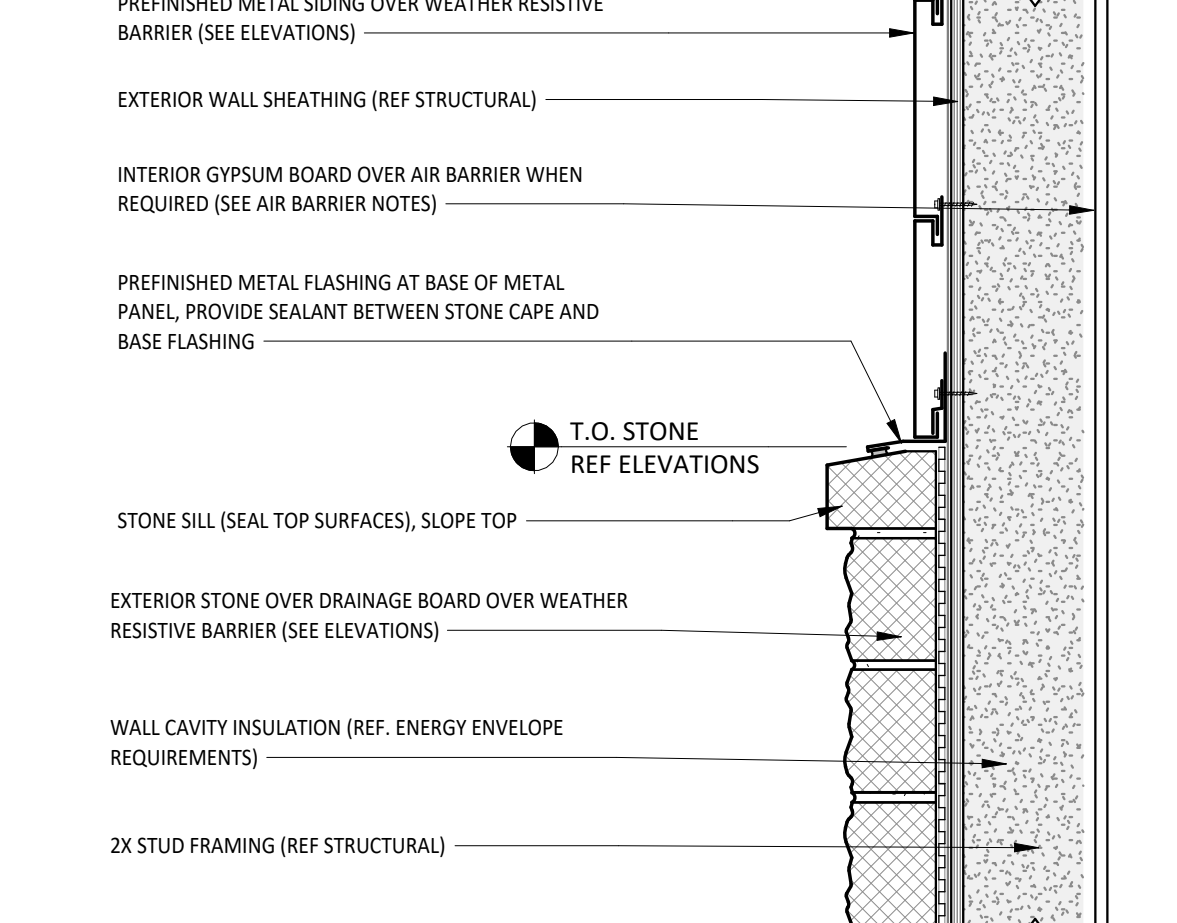

2 CAP AT STONE VENEER  
1 1/2" = 1'-0"

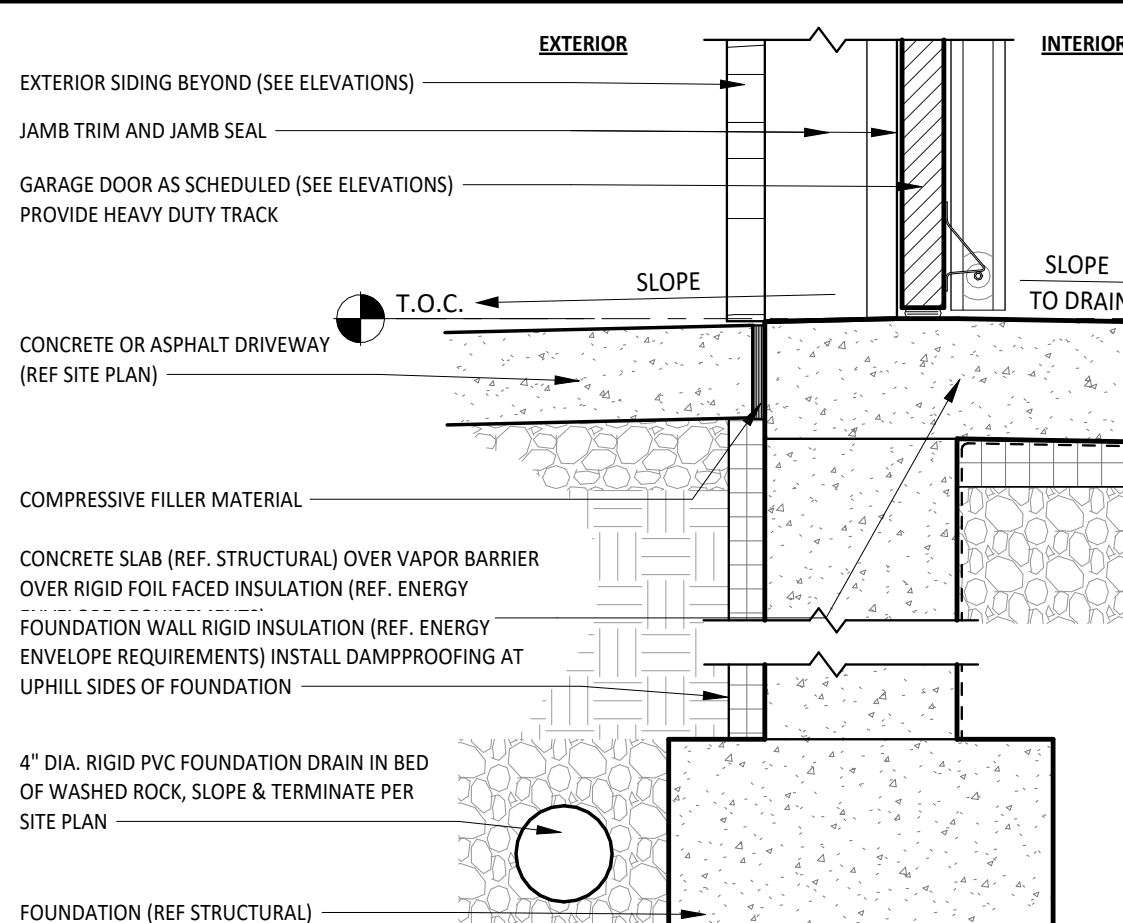

9 GARAGE DOOR THRESHOLD  
1 1/2" = 1'-0"

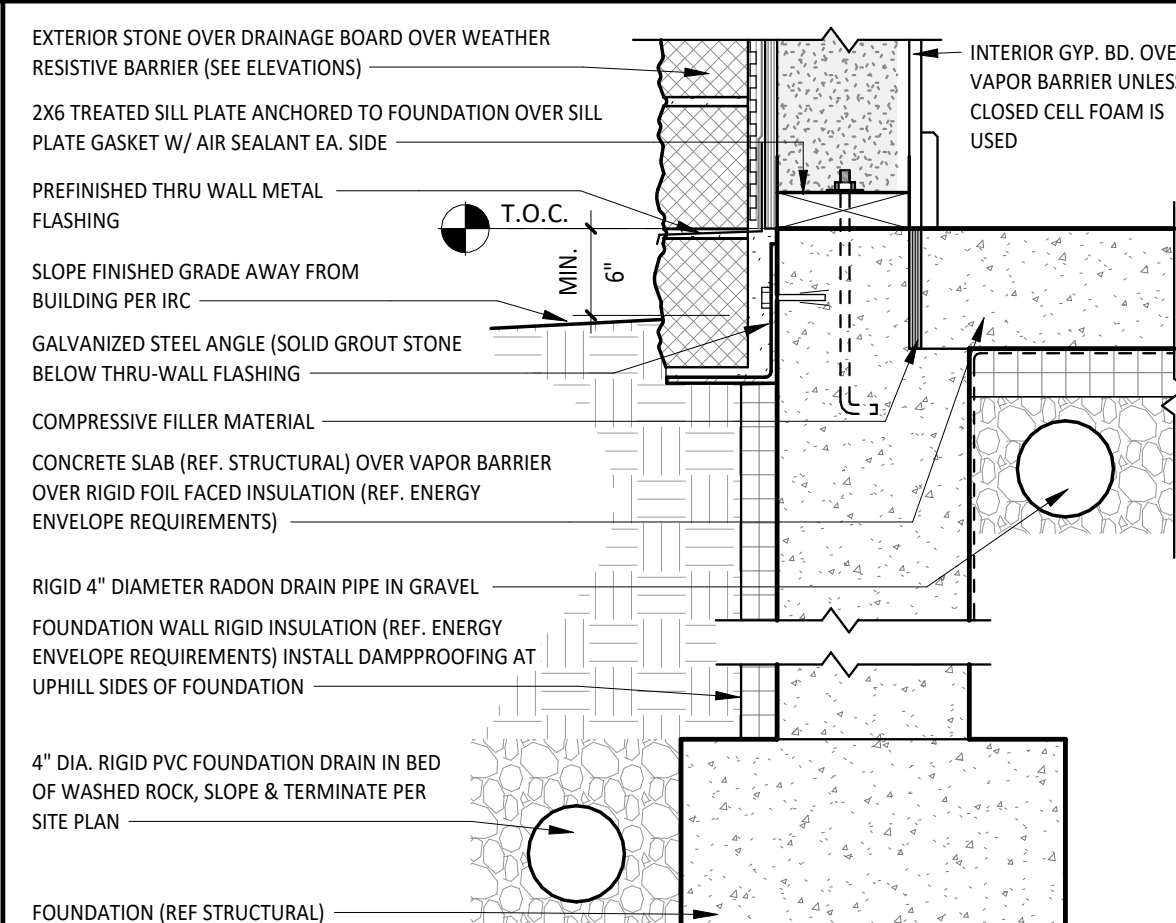

5 TYP. FOUNDATION DETAIL @ STONE  
1 1/2" = 1'-0"

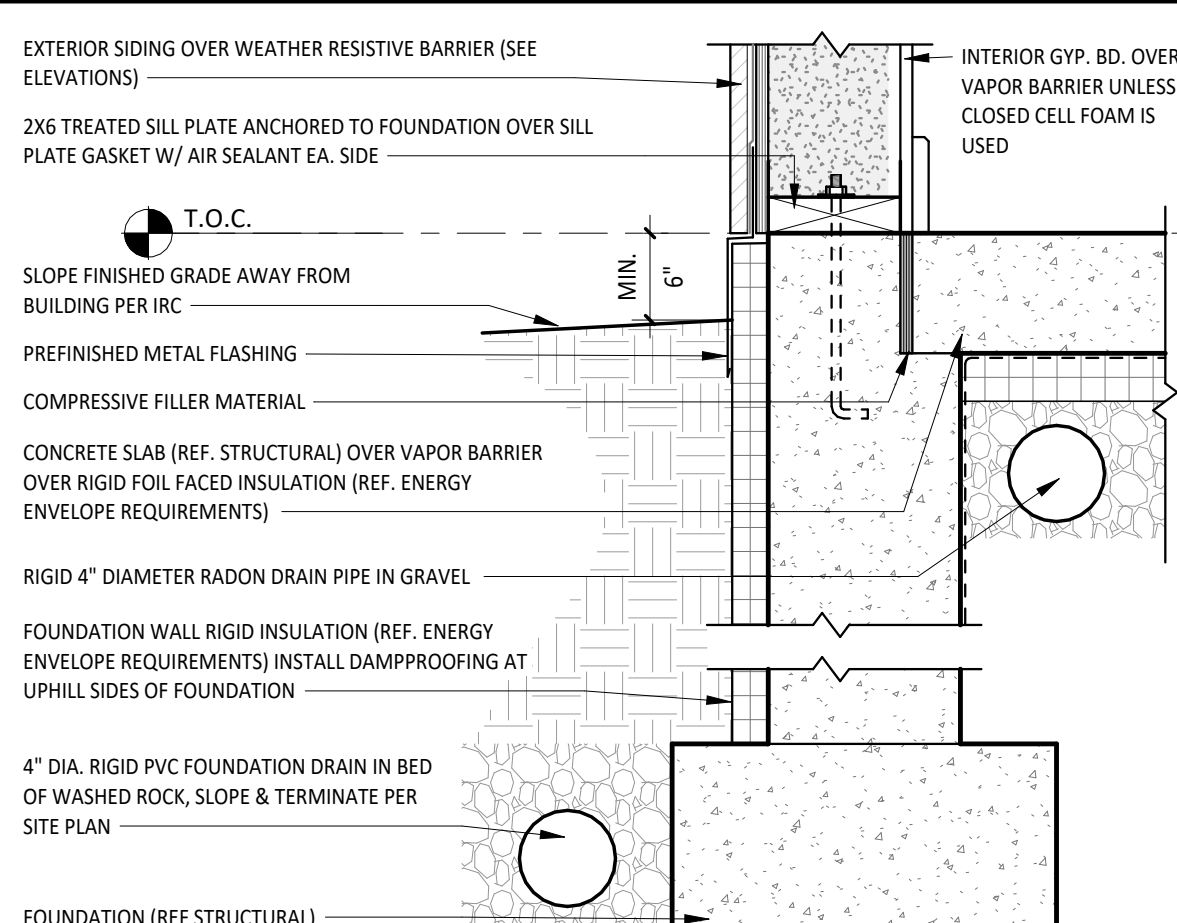

1 TYP. FOUNDATION DETAIL @ WOOD  
1 1/2" = 1'-0"

No.	Date	Revisions

Project No: 2023-16  
Stage: FINAL REVIEW SET  
Date: 05/02/2024  
Scale: As indicated

DRAWING TITLE:

DETAILS

DRAWING NO:

A7.1



**FITZGERALD ADDITION**  
 34 RUSTIC TERRACE  
 BLUE RIVER, COLORADO

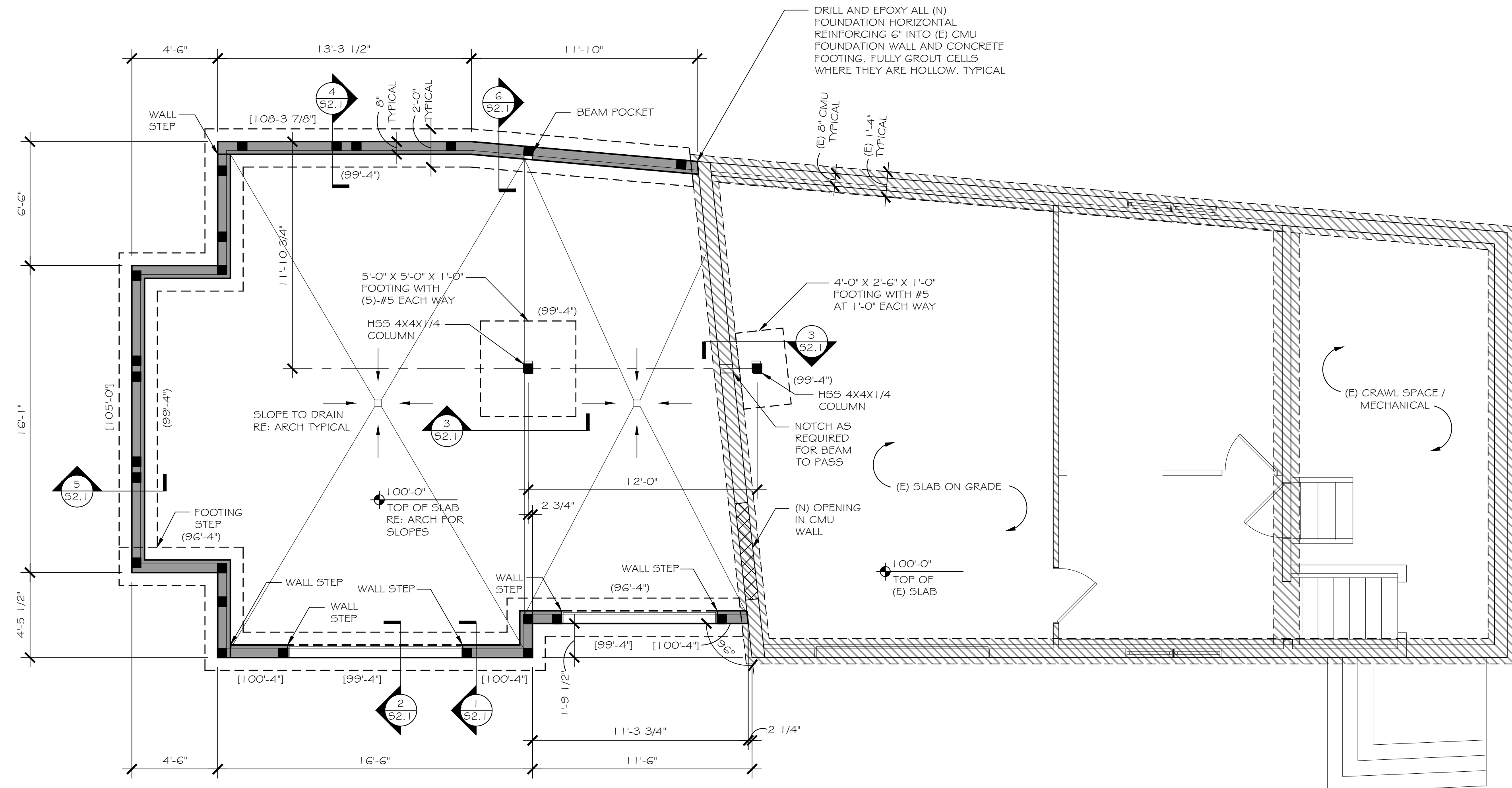

**FOUNDATION PLAN**  
 SCALE: 1/4" = 1'-0"

- FOUNDATION NOTES:**
- DATUM ELEVATION 100'-0" EQUALS LOWER LEVEL TOP OF SLAB ELEVATION. RE: ARCH FOR USGS.
  - [(xx'-xx")] INDICATES TOP OF FOUNDATION WALL ELEVATION.
  - [(xx'-xx")] INDICATES TOP OF FOOTING ELEVATION.
  - FLOOR ELEVATIONS SHOWN ARE AT TOP OF SLAB OR AT TOP OF PLYWOOD FLOOR SHEATHING.
  - FOOTING ELEVATIONS SHOWN ARE MAXIMUMS AND MAY NEED TO BE LOWERED DUE TO SOIL CONDITIONS. VERIFY CHANGES WITH STRUCTURAL ENGINEER.
  - ALL SLABS ON GRADE ARE 4" THICK WITH GXG W2.1XW2.1 WELDED WIRE FABRIC UNLESS NOTED OTHERWISE.
  - SITE WALLS NOT SHOWN ON THIS PLAN SHALL BE BUILT PER ARCHITECTURAL LANDSCAPE PLANS, DETAILS AND ELEVATIONS. SITE WALLS SHALL NOT BE CONNECTED TO BUILDING UNLESS NOTED OTHERWISE.
  - REFERENCE GENERAL NOTES FOR ADDITIONAL REQUIREMENTS.

PROJECT #2337  
 DRAWN: CM/KF  
 DATE: 04/23/2024  
 FOR PERMIT

**S1.1**  
 FOUNDATION PLAN

**FITZGERALD ADDITION**  
 34 RUSTIC TERRACE  
 BLUE RIVER, COLORADO

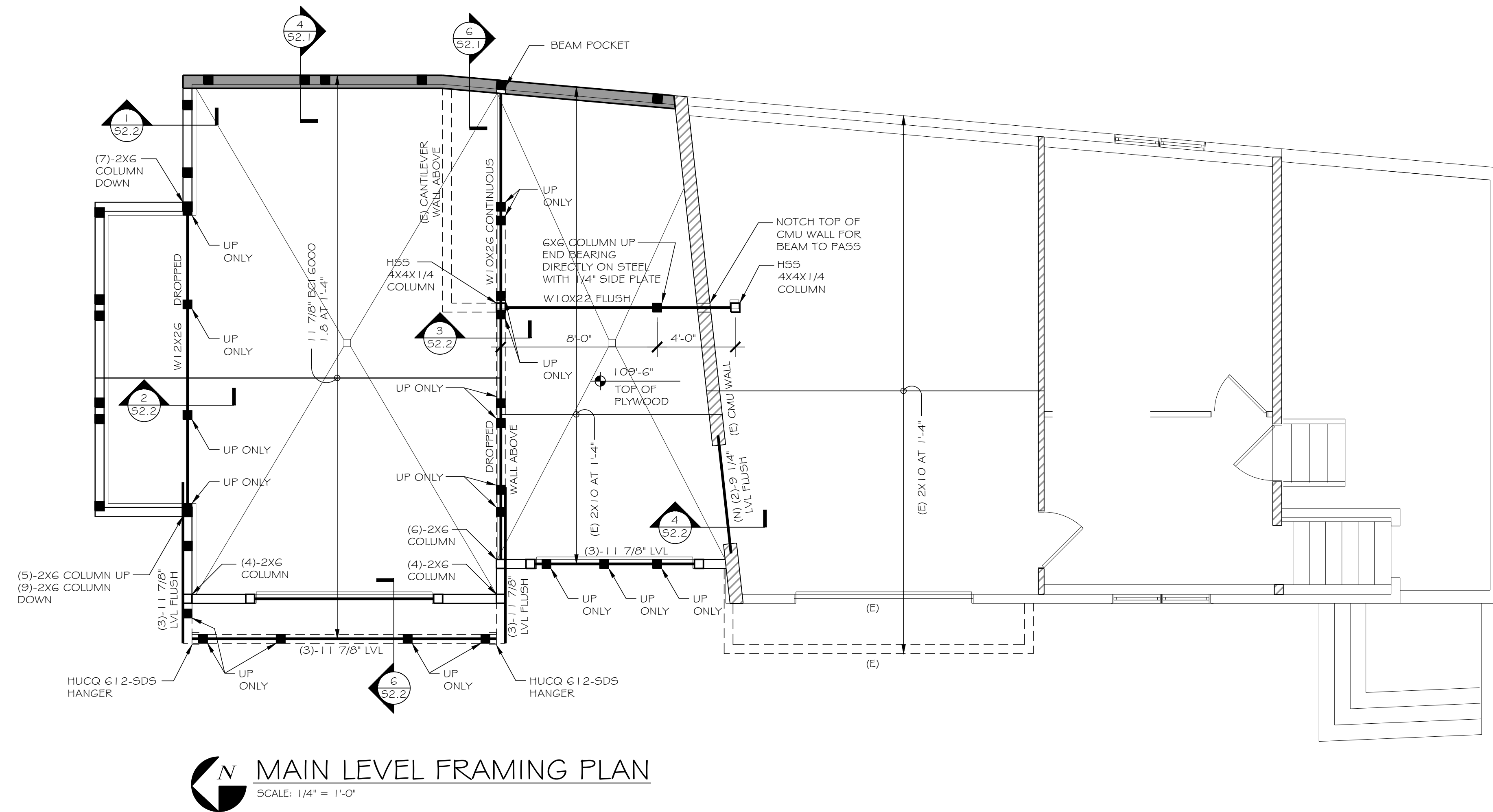

**FRAMING NOTES:**

1. □ INDICATES COLUMN DOWN ONLY.
2. ■ INDICATES COLUMN UP AND DOWN UNLESS IT BEARS ON CONCRETE BELOW, OR IT IS LABELED UP ONLY OR SUB COLUMN.
3. ▨▨▨▨ INDICATES INTERIOR BEARING WALLS, JOISTS BEARING LOCATIONS SHALL LINE UP WITH STUDS BELOW.
4. ALL COLUMNS SHALL BE (3)-2X6 MINIMUM UNLESS NOTED OTHERWISE. COLUMNS AND STUDS SHALL BE CONTINUOUS FLOOR TO FLOOR OR FLOOR TO ROOF.
5. <XX-XX> INDICATES TOP OF BEAM ELEVATION OR PLATE HEIGHT ELEVATION.
6. HEADERS SHALL BE (2)-9 1/4" LVL UNLESS NOTED OTHERWISE. ALL HEADERS SHALL BE BUILT OUT TO 5 1/2" WIDTH BY ADDING RIGID INSULATION RE: ARCH.
7. ALL HEADERS 6'-0" AND LONGER SHALL REQUIRE TWO TRIM STUDS AND TWO KING STUDS EACH SIDE. HEADERS SHORTER THAN 6'-0" REQUIRE ONE TRIM STUD AND ONE KING STUD EACH SIDE UNLESS NOTED OTHERWISE.
8. ROOF JOIST HANGERS SHALL BE SIMPSON LSSR OR LRUZ TYPE UNLESS NOTED OTHERWISE. FLOOR JOIST HANGERS SHALL BE SIMPSON IUS TYPE UNLESS NOTED OTHERWISE.
9. ALL EXTERIOR WALLS SHALL BE CONSTRUCTED USING 2X6 STUDS. REFER TO EXTERIOR WALL DETAILS FOR MORE INFORMATION. STUDS CAN BE SPACED AT 2'-0" FOR WALLS SHORTER THAN 10'-0" UNLESS NOTED OTHERWISE. STUDS SHALL BE SPACED 1'-0" FOR WALLS SHORTER THAN 14'-0" AND TALLER THAN 10'-0" UNLESS NOTED OTHERWISE.
10. REFERENCE ARCHITECTURAL DRAWINGS FOR LOCATION AND SIZE OF ROUGH OPENINGS IN WOOD STUD WALLS.
11. REFERENCE GENERAL NOTES FOR ADDITIONAL REQUIREMENTS.
12. BCI 6000 1.8 JOISTS MAY BE REPLACED WITH TJI 210 JOISTS EQUAL DEPTH AND SPACING RE: GENERAL NOTES.
13. FLOOR FRAMING IS NOT SIZED FOR GYPCRETE TOPPING.

PROJECT #2337  
 DRAWN: CM/KF  
 DATE: 04/23/2024  
 FOR PERMIT

**S1.2**  
 MAIN LEVEL FRAMING PLAN

**FITZGERALD ADDITION**  
34 RUSTIC TERRACE  
BLUE RIVER, COLORADO

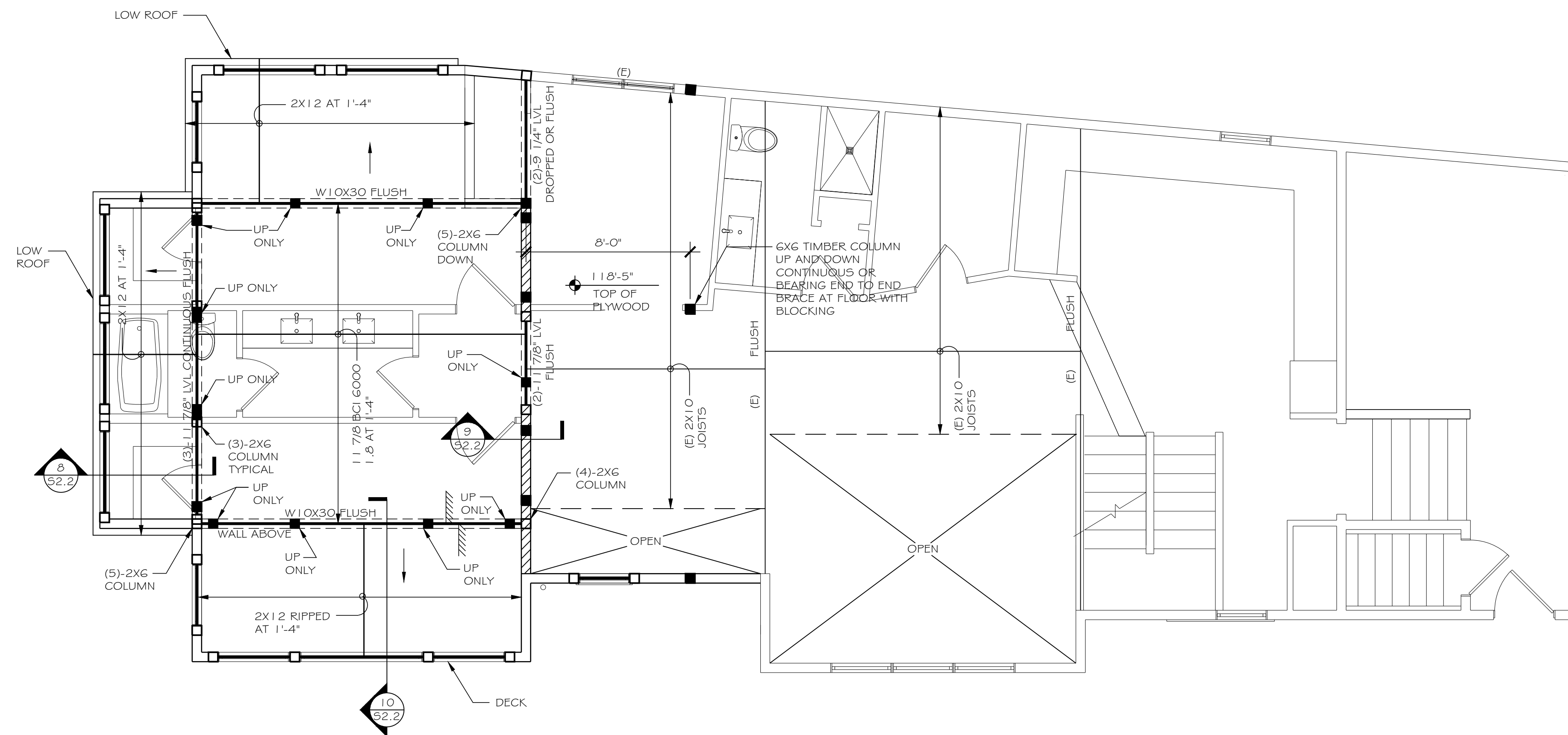

**UPPER LEVEL FRAMING PLAN**  
SCALE: 1/4" = 1'-0"

**FRAMING NOTES:**

1. □ INDICATES COLUMN DOWN ONLY.
2. ■ INDICATES COLUMN UP AND DOWN UNLESS IT BEARS ON CONCRETE BELOW, OR IT IS LABELED UP ONLY OR SUB COLUMN.
3. ▨▨▨▨ INDICATES INTERIOR BEARING WALLS, JOISTS BEARING LOCATIONS SHALL LINE UP WITH STUDS BELOW.
4. ALL COLUMNS SHALL BE (3)-2X6 MINIMUM UNLESS NOTED OTHERWISE. COLUMNS AND STUDS SHALL BE CONTINUOUS FLOOR TO FLOOR OR FLOOR TO ROOF.
5. <XX-XX> INDICATES TOP OF BEAM ELEVATION OR PLATE HEIGHT ELEVATION.
6. HEADERS SHALL BE (2)-9 1/4" LVL UNLESS NOTED OTHERWISE. ALL HEADERS SHALL BE BUILT OUT TO 5 1/2" WIDTH BY ADDING RIGID INSULATION RE: ARCH.
7. ALL HEADERS 6'-0" AND LONGER SHALL REQUIRE TWO TRIM STUDS AND TWO KING STUDS EACH SIDE. HEADERS SHORTER THAN 6'-0" REQUIRE ONE TRIM STUD AND ONE KING STUD EACH SIDE UNLESS NOTED OTHERWISE.
8. ROOF JOIST HANGERS SHALL BE SIMPSON LSSR OR LRUZ TYPE UNLESS NOTED OTHERWISE. FLOOR JOIST HANGERS SHALL BE SIMPSON IUS TYPE UNLESS NOTED OTHERWISE.
9. ALL EXTERIOR WALLS SHALL BE CONSTRUCTED USING 2X6 STUDS. REFER TO EXTERIOR WALL DETAILS FOR MORE INFORMATION. STUDS CAN BE SPACED AT 2'-0" FOR WALLS SHORTER THAN 10'-0" UNLESS NOTED OTHERWISE. STUDS SHALL BE SPACED 1'-0" FOR WALLS SHORTER THAN 14'-0" AND TALLER THAN 10'-0" UNLESS NOTED OTHERWISE.
10. REFERENCE ARCHITECTURAL DRAWINGS FOR LOCATION AND SIZE OF ROUGH OPENINGS IN WOOD STUD WALLS.
11. REFERENCE GENERAL NOTES FOR ADDITIONAL REQUIREMENTS.
12. BCI 6000 1.8 JOISTS MAY BE REPLACED WITH TJI 210 JOISTS EQUAL DEPTH AND SPACING RE: GENERAL NOTES.
13. FLOOR FRAMING IS NOT SIZED FOR GYPCRETE TOPPING.

PROJECT #2337  
DRAWN: CM/KF  
DATE: 04/23/2024  
FOR PERMIT

**S1.3**  
UPPER LEVEL FRAMING  
PLAN

**FOX STRUCTURAL ENGINEERING, LLC**  
 216 SNOWBERRY WAY  
 DILLON, COLORADO 80435  
 (970) 376-2005

**FITZGERALD ADDITION**  
 34 RUSTIC TERRACE  
 BLUE RIVER, COLORADO

PROJECT #2337  
 DRAWN: CM/KF  
 DATE: 04/23/2024  
 FOR PERMIT

**S1.4**  
 ROOF FRAMING PLAN

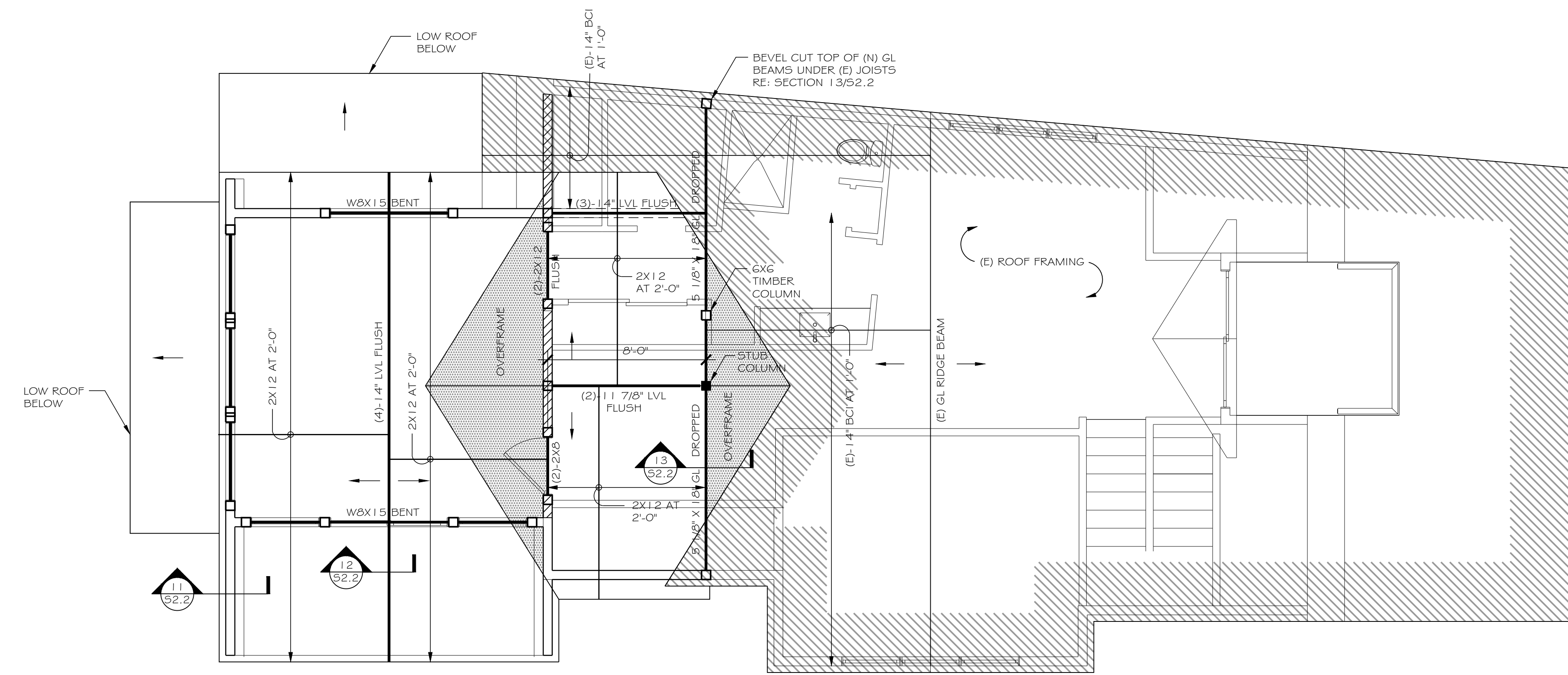

**ROOF FRAMING PLAN**  
 SCALE: 1/4" = 1'-0"

**FRAMING NOTES:**

1. □ INDICATES COLUMN DOWN ONLY.
2. ■ INDICATES COLUMN UP AND DOWN UNLESS IT BEARS ON CONCRETE BELOW, OR IT IS LABELED UP ONLY OR STUB COLUMN.
3. ▨▨▨▨ INDICATES INTERIOR BEARING WALLS, JOISTS BEARING LOCATIONS SHALL LINE UP WITH STUDS BELOW.
4. ALL COLUMNS SHALL BE (3)-2X6 MINIMUM UNLESS NOTED OTHERWISE. COLUMNS AND STUDS SHALL BE CONTINUOUS FLOOR TO FLOOR OR FLOOR TO ROOF.
5. <XX-XX> INDICATES TOP OF BEAM ELEVATION OR PLATE HEIGHT ELEVATION.
6. HEADERS SHALL BE (2)-9 1/4" LVL UNLESS NOTED OTHERWISE. ALL HEADERS SHALL BE BUILT OUT TO 5 1/2" WIDTH BY ADDING RIGID INSULATION RE: ARCH.
7. ALL HEADERS 6'-0" AND LONGER SHALL REQUIRE TWO TRIM STUDS AND TWO KING STUDS EACH SIDE. HEADERS SHORTER THAN 6'-0" REQUIRE ONE TRIM STUD AND ONE KING STUD EACH SIDE UNLESS NOTED OTHERWISE.
8. ROOF JOIST HANGERS SHALL BE SIMPSON LSSR OR LRJZ TYPE UNLESS NOTED OTHERWISE. FLOOR JOIST HANGERS SHALL BE SIMPSON IUS TYPE UNLESS NOTED OTHERWISE.
9. ALL EXTERIOR WALLS SHALL BE CONSTRUCTED USING 2X6 STUDS. REFER TO EXTERIOR WALL DETAILS FOR MORE INFORMATION. STUDS CAN BE SPACED AT 2'-0" FOR WALLS SHORTER THAN 10'-0" UNLESS NOTED OTHERWISE. STUDS SHALL BE SPACED 1'-0" FOR WALLS SHORTER THAN 14'-0" AND TALLER THAN 10'-0" UNLESS NOTED OTHERWISE.
10. REFERENCE ARCHITECTURAL DRAWINGS FOR LOCATION AND SIZE OF ROUGH OPENINGS IN WOOD STUD WALLS.
11. REFERENCE GENERAL NOTES FOR ADDITIONAL REQUIREMENTS.

**GENERAL NOTES:**

1. LIVE LOADS USED IN DESIGN

- A. ROOF SNOW 1 00 PSF
- B. DECK LIVE LOAD 1 25 PSF
- C. INTERIOR FLOOR 40 PSF
- D. ULTIMATE DESIGN WIND 1 15 MPH EXPOSURE B
- E. SEISMIC SITE CLASS D, DESIGN CATEGORY B

2. TESTING, INSPECTIONS AND OBSERVATIONS

- A. THE STRUCTURAL ENGINEER DOES NOT PROVIDE INSPECTIONS OF CONSTRUCTION. STRUCTURAL ENGINEER MAY MAKE PERIODIC OBSERVATIONS OF THE CONSTRUCTION. SUCH OBSERVATIONS SHALL NOT REPLACE REQUIRED INSPECTIONS BY THE GOVERNING AUTHORITIES OR SERVE AS "SPECIAL INSPECTIONS" AS MAY BE REQUIRED BY CHAPTER 17 OF THE INTERNATIONAL BUILDING CODE.

3. FOUNDATIONS

- A. ALLOWABLE SOIL BEARING PRESSURE ASSUMED IN DESIGN IS 2000 PSF.
- B. CONTRACTOR SHALL RETAIN A LICENSED SOILS ENGINEER TO INSPECT THE FOUNDATION EXCAVATION. SOILS ENGINEER SHALL VERIFY IN WRITING THE ACTUAL SOILS CAPACITY IS EQUAL TO OR GREATER THAN ASSUMED.
- C. THE PREPARATION OF THE SUBGRADE SHALL BE IN STRICT ACCORDANCE WITH THE SOILS ENGINEER. QUESTIONS REGARDING THE SUBGRADE PREPARATION SHALL BE DIRECTED TO THE GEOTECHNICAL ENGINEER.
- D. NOTIFY SOILS ENGINEER WHEN EXCAVATION IS COMPLETE SO THAT CONDITIONS MAY BE INSPECTED PRIOR TO PLACEMENT OF ANY FILL OR CONCRETE.
- E. CONTRACTOR TO PROVIDE, AT HIS EXPENSE, FIELD DENSITY TESTS ON COMPACTED FILL UNDER FOOTINGS AND INTERIOR SLABS ON GRADE.
- F. ALL FOOTING BEARING ELEVATIONS SHOWN ARE ASSUMED. EXACT BEARING ELEVATIONS SHALL BE VERIFIED IN THE FIELD WITH ACTUAL CONDITIONS BY CONTRACTOR WITH APPROVAL OF SOILS ENGINEER. ALL BOTTOMS OF FOOTINGS SHALL BE A MINIMUM OF 40" BELOW EXTERIOR GRADE.
- G. ALL FOOTINGS SHALL BE PLACED ON FIRM, UNDISTURBED NATIVE SOIL OR PROPERLY COMPACTED STRUCTURAL BACKFILL, APPROVED BY THE SOILS ENGINEER.
- H. CONTRACTOR SHALL BACKFILL EQUALLY ON EACH SIDE OF FOUNDATION WALLS IN 1 2 INCH MAXIMUM VERTICAL LIFTS OR AS RECOMMENDED BY THE SOILS ENGINEER. REFER TO SOILS ENGINEER FOR BACKFILL MATERIAL.
- I. CENTER ALL FOOTINGS UNDER WALLS OR COLUMNS UNLESS DIMENSIONED OTHERWISE.
- J. REFERENCE THE SOILS ENGINEER AND GRADING DRAWINGS FOR SOIL DRAINAGE REQUIREMENTS.

4. CONCRETE AND REINFORCEMENT

- A. CAST-IN-PLACE CONCRETE SHALL BE MADE WITH TYPE I/II PORTLAND CEMENT AND SHALL SATISFY 3000 PSI MINIMUM. GARAGE FLOOR SLAB SHALL SATISFY 4000 PSI MINIMUM. CONCRETE WITH EXPOSURE TO WEATHER, INCLUDING GARAGE FLOOR SLABS, SHALL BE AIR ENTRAINED AND MEET ALL REQUIREMENTS IN TABLE R402.2 FOR SEVERE WEATHERING POTENTIAL.
- B. ALL CONCRETE AND REINFORCEMENT WORK SHALL BE IN ACCORDANCE WITH ACI BUILDING CODE 318 LATEST EDITION.
- C. CONTRACTOR SHALL SAWCUT OR TROWELCUT JOINTS IN SLABS ON GRADE. JOINTS SHALL BE SPACED 12 FEET MAXIMUM AND CUT 1/4 OF SLAB DEPTH X 3/16" WIDE WITHIN 12 HOURS AFTER POURING. AREA BETWEEN JOINTS SHALL NOT EXCEED 100 SQUARE FEET. CARRY ALL SLAB REINFORCEMENT THROUGH JOINT.
- D. ALL REINFORCING SHALL BE HIGH-STRENGTH DEFORMED BARS CONFORMING TO ASTM A615, GRADE 60, EXCEPT TIES, STIRRUPS AND PLATE ANCHORS WHICH SHALL BE DEFORMED BARS, ASTM DESIGNATION A615, GRADE 40 OR A706 GRADE 60.
- E. WELDED WIRE FABRIC SHALL CONFORM TO ASTM A185 GRADE 65 AND SHALL BE LAPPED ONE FULL MESH AT SIDE AND END SPLICES AND WIRED TOGETHER.
- F. NO SPLICES OF REINFORCEMENT SHALL BE MADE EXCEPT AS DETAILED OR AUTHORIZED BY THE STRUCTURAL ENGINEER. LAP SPLICES, WHERE PERMITTED, SHALL BE A MINIMUM OF 48 BAR DIAMETERS. MAKE ALL BARS CONTINUOUS AROUND CORNERS. USE STANDARD HOOKS FOR DOWELS UNLESS NOTED OTHERWISE.

5. STRUCTURAL STEEL

- A. STRUCTURAL STEEL WIDE FLANGE BEAMS SHALL CONFORM TO ASTM 992, 50 KSI; TUBES SHALL CONFORM TO ASTM A500, GRADE B; PIPES SHALL CONFORM TO ASTM A53, GRADE B. MISCELLANEOUS ITEMS SHALL BE A36 STEEL.
- B. ALL STRUCTURAL BOLTS SHALL BE A325N INSTALLED TO A MINIMUM SHUG TIGHT CONDITION. ALL ANCHOR BOLTS SHALL CONFORM TO ASTM A307.
- C. STRUCTURAL STEEL SHALL BE DETAILED AND FABRICATED IN ACCORDANCE WITH THE LATEST PROVISIONS OF AISC "MANUAL OF STEEL CONSTRUCTION".
- D. ALL WELDERS SHALL HAVE EVIDENCE OF PASSING THE AMERICAN WELDING SOCIETY STANDARD QUALIFICATIONS TESTS AS OUTLINED IN AWS-D1.1.
- E. MINIMUM WELDS TO BE PER AISC TABLE J2.4 BUT NOT LESS THAN 3/16" CONTINUOUS FILLET UNLESS NOTED OTHERWISE.
- F. SUBMIT SHOP AND ERECTION DRAWINGS TO ENGINEER FOR REVIEW OF ALL STRUCTURAL STEEL MEMBERS. THE MANUFACTURING OR FABRICATION OF ANY ITEMS PRIOR TO WRITTEN REVIEW OF SHOP DRAWINGS WILL BE ENTIRELY AT RISK OF THE CONTRACTOR.

6. WOOD

- A. ALL FRAMING LUMBER SHALL BE DRY HEM-FIR, GRADED BY WESTERN WOOD PRODUCTS ASSOCIATION AND CONFORMING TO NO. 2 GRADE (F<sub>b</sub> = 850 PSI). WALL STUDS ONLY MAY CONFORM TO STUD GRADE (F<sub>b</sub> = 675 PSI).
- B. ALL FRAMING TIMBERS (5"X5" AND LARGER) SHALL BE DRY DOUGLAS FIR LARCH, GRADED BY WESTERN WOOD PRODUCTS ASSOCIATION AND CONFORMING TO NO. 1 GRADE (F<sub>b</sub> = 1350 PSI).
- C. PREFABRICATED WOOD MEMBERS SHALL BE "BCI" JOIST AS MANUFACTURED BY BOISE CASCADE OR "TJI" JOIST AS MANUFACTURED BY TRUS JOIST WEYERHAEUSER, TYPES AS NOTED ON THE DRAWINGS. THE BCI JOISTS SPECIFIED HAVE SLIGHTLY HIGHER CAPACITIES THAN THE TJI JOISTS SPECIFIED. ALTERNATES SHALL BE REVIEWED BY THE ENGINEER. TO BE CONSIDERED, ALTERNATES SHALL HAVE A LOAD CAPACITY IN BENDING, SHEAR AND DEFLECTION EQUAL TO OR GREATER THAN THE SIZES SHOWN ON THE DRAWINGS. WEB BLOCKING AND BRIDGING TO BE AS REQUIRED BY THE JOIST MANUFACTURER.
- D. "LVL" INDICATES 1 3/4" WIDE LAMINATED VENEER LUMBER MEMBERS, WHICH SHALL HAVE THE FOLLOWING MINIMUM STRESS CAPACITIES: F<sub>b</sub> = 2600 PSI, F<sub>v</sub> = 285 PSI, E = 2,000,000 PSI. BUILT UP MEMBERS SHALL BE CONNECTED IN ACCORDANCE WITH MANUFACTURER'S RECOMMENDATIONS.
- E. "GL" INDICATES GLULAM MEMBERS, WHICH SHALL BE FABRICATED OF DOUGLAS FIR LARCH AT 12 PERCENT MOISTURE CONTENT IN ACCORDANCE WITH WCLUB. PROVIDE MEMBERS CONFORMING WITH AITC 117, 24F-V4 DF/DF UNLESS NOTED OTHERWISE.
- F. PROVIDE SOLID BLOCKING BETWEEN ALL JOISTS AT ALL SUPPORTS AND ENDS OF CANTILEVERS.
- G. WHEN PRESERVATIVE TREATED LUMBER IS USED ALL CONNECTIONS AND NAILING SHALL BE ADEQUATELY GALVANIZED.
- H. ALL BEAM/BEAM AND BEAM/COLUMN CONNECTIONS SHALL BE MADE WITH SIMPSON STEEL PLATE CONNECTORS UNLESS NOTED OTHERWISE.
- I. FASTEN ALL WOOD MEMBERS WITH COMMON NAILS ACCORDING TO THE IRC TABLE R602.3(1) UNLESS NOTED OTHERWISE.
- J. ALL EXTERIOR WALLS SHALL HAVE CONTINUOUS STUDS FROM FLOOR TO FLOOR OR FLOOR TO ROOF (INCLUDING RAKE WALLS).
- K. OVERFRAMING SHALL BE 2X6 MINIMUM POSTED DOWN TO MAIN JOISTS ON A GRID NOT TO EXCEED 2'-0" X 2'-0".
- L. PLYWOOD DECK AND/OR ORIENTED STRAND BOARD
  - 1. APPLICATION SHALL BE IN ACCORDANCE WITH RECOMMENDATIONS OF THE AMERICAN PLYWOOD ASSOCIATION.
  - 2. EACH PANEL SHALL BE IDENTIFIED WITH THE GRADE-TRADEMARK OF THE AMERICAN PLYWOOD ASSOCIATION AND SHALL MEET THE REQUIREMENTS OF U.S. PRODUCTS STANDARD PSI, LATEST EDITION FOR PLYWOOD.
  - 3. FOR FLOORING USE 3/4" T&G STURD-I-FLOOR SHEATHING GLUED AND NAILED WITH 1 0D NAILS AT 6" ON CENTER ALONG PANEL EDGES AND AT 12" ALONG INTERMEDIATE SUPPORTS.
  - 4. FOR ROOF USE 5/8" (40/20 SPAN RATING) EXPOSURE 1 SHEATHING NAILED WITH 1 0D NAILS AT 6" ON CENTER ALONG PANEL EDGES AND AT 12" ALONG INTERMEDIATE SUPPORTS.
  - 5. EXTERIOR WALLS SHALL HAVE ONE LAYER 7/16" EXPOSURE 1 SHEATHING NAILED WITH 8D NAILS AT 6" ON CENTER ALONG PANEL EDGES AND AT 12" ALONG INTERMEDIATE SUPPORTS UNLESS NOTED OTHERWISE. ALL PANEL EDGES SHALL BE BLOCKED.
  - 6. FLOOR AND ROOF SHEATHING SHALL BE INSTALLED WITH THE FACE GRAIN PERPENDICULAR TO SUPPORTS WITH END JOINTS STAGGERED.
  - 7. INSTALL SUITABLE EDGE SUPPORT BY USE OF PLYCLIPS, TONGUE AND GROOVE PANELS OR SOLID WOOD BLOCKING SUPPORTS.

7. GENERAL

- A. ENGINEER'S ACCEPTANCE MUST BE SECURED FOR ALL STRUCTURAL SUBSTITUTIONS.
- B. ALL DIMENSIONS AND DETAILS ON STRUCTURAL DRAWINGS SHALL BE FIELD VERIFIED AND CHECKED AGAINST ARCHITECTURAL DRAWINGS.
- C. WATERPROOFING, VAPOR BARRIERS, WATERSTOP, ETC., SHALL BE AS SHOWN IN ARCHITECTURAL DRAWINGS AND DETAILS.
- D. ELEMENTS SUCH AS NON-BEARING PARTITIONS ATTACHED TO AND/OR SUPPORTED BY THE STRUCTURE SHALL TAKE INTO ACCOUNT DEFLECTIONS AND OTHER STRUCTURAL MOVEMENTS.
- E. VERIFY ALL OPENINGS THROUGH FLOORS, ROOF AND WALLS WITH MECHANICAL AND ELECTRICAL CONTRACTORS. VERIFICATION OF LOCATIONS, SIZES AND REQUIRED CONNECTIONS ARE CONTRACTOR'S RESPONSIBILITY. ENGINEER'S APPROVAL OF CONNECTIONS AND SUPPORTS SHALL BE OBTAINED PRIOR TO INSTALLATION OF MECHANICAL AND ELECTRICAL EQUIPMENT OR OTHER ITEMS TO BE ATTACHED TO THE STRUCTURE.
- F. REFER TO ARCHITECTURAL DRAWINGS FOR STAIR FRAMING DETAILS AND LANDING SLAB ELEVATIONS.
- G. ALL STONE VENEERS SHALL BE THIN ADHERED TYPE AND SHALL BE ATTACHED TO INTERIOR AND EXTERIOR WALLS AS SPECIFIED IN SECTION R703.8 OF THE INTERNATIONAL RESIDENTIAL CODE.
- H. (E) INDICATES EXISTING, (N) INDICATES NEW.

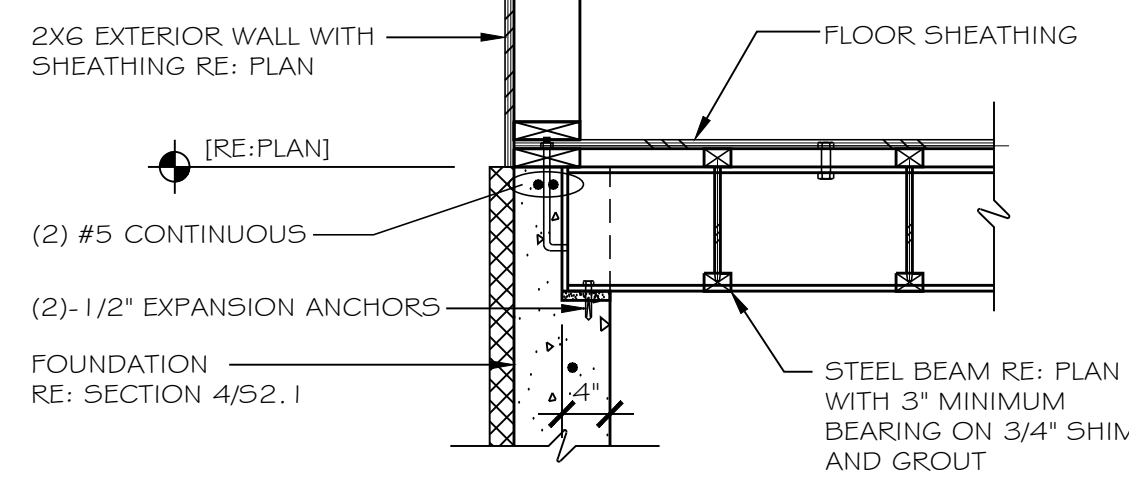

**BEAM POCKET**  
SCALE: 3/4" = 1'-0"

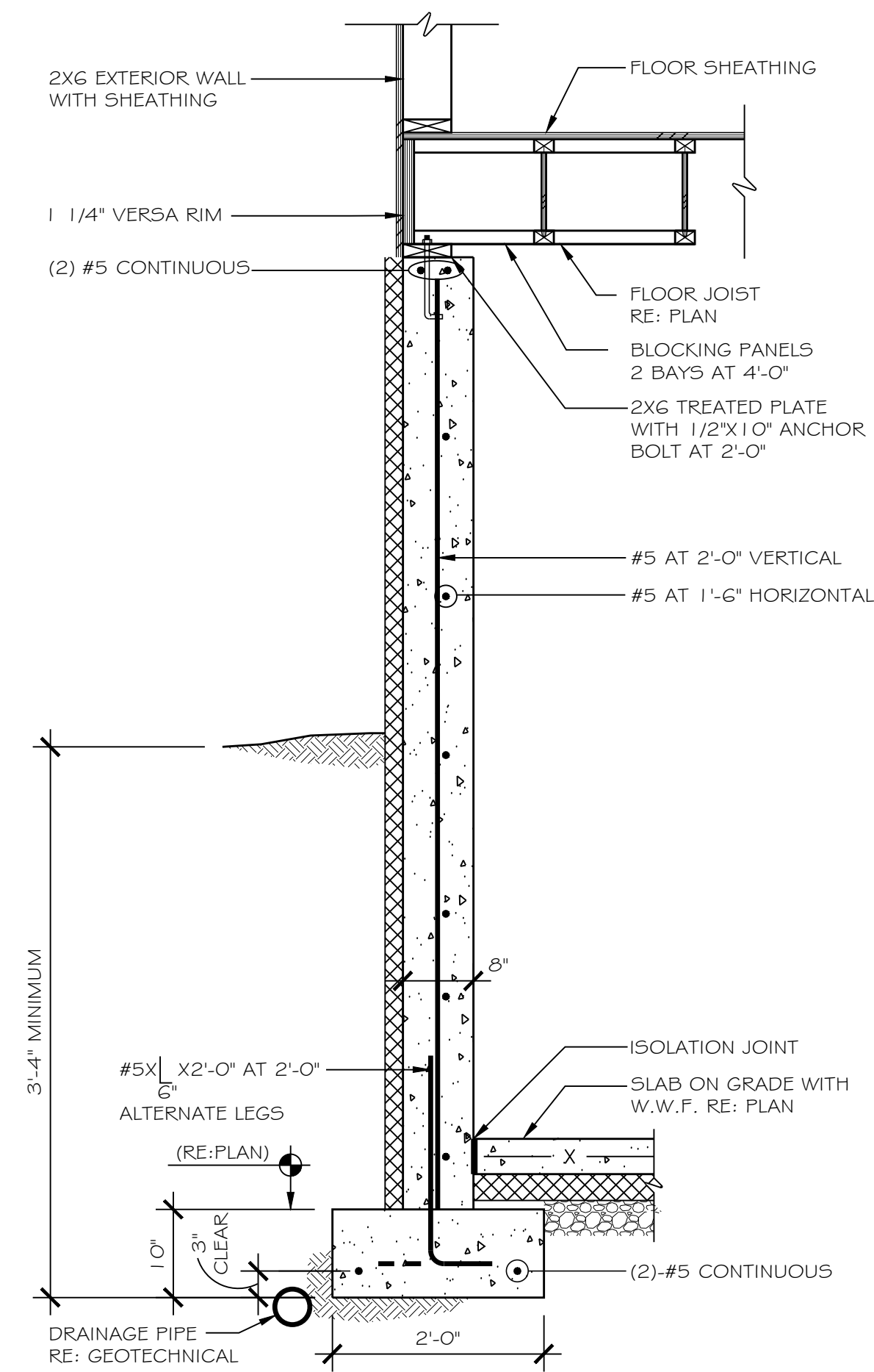

**GARAGE BACK WALL**  
SCALE: 3/4" = 1'-0"

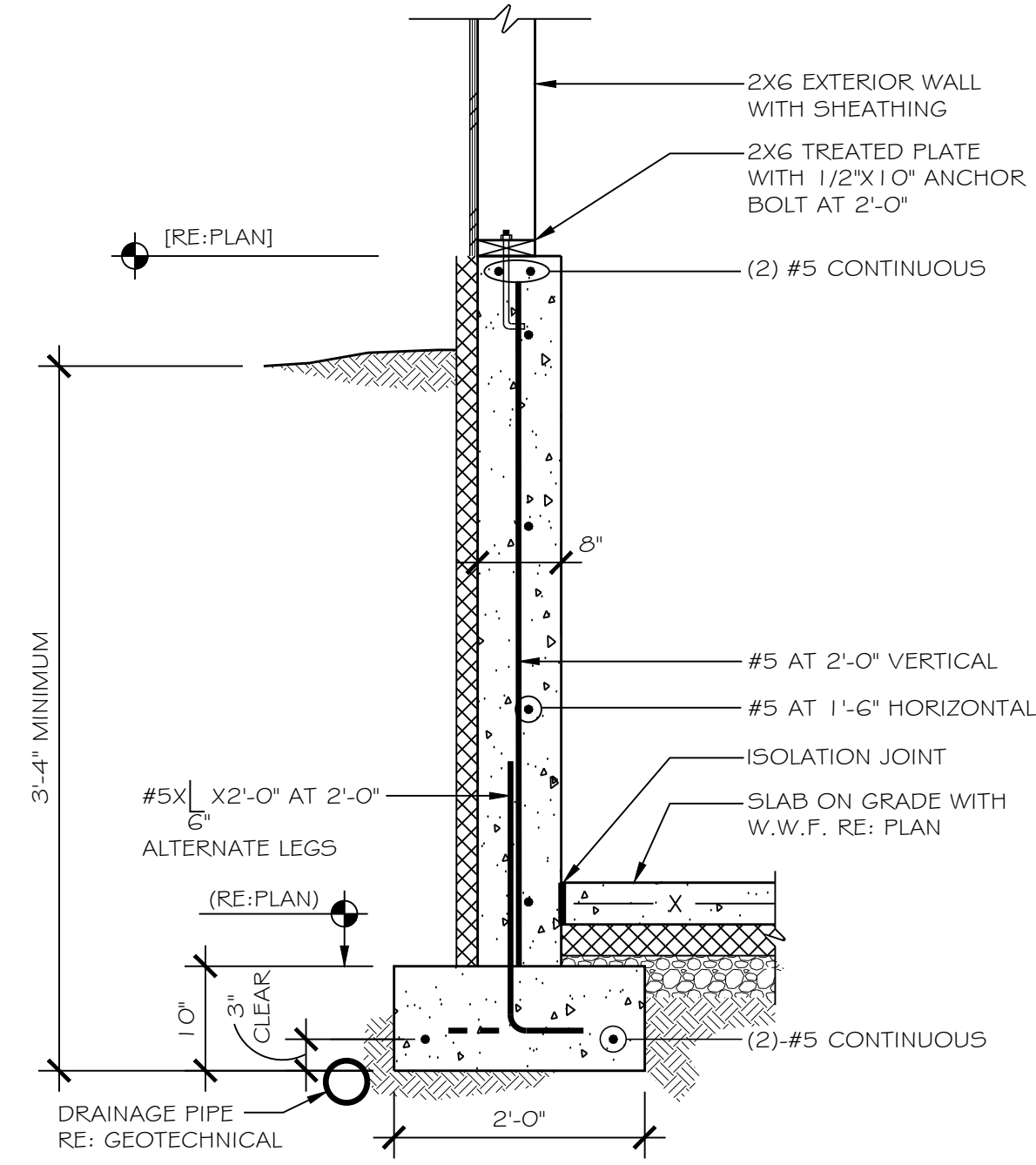

**GARAGE SIDE WALL**  
SCALE: 3/4" = 1'-0"

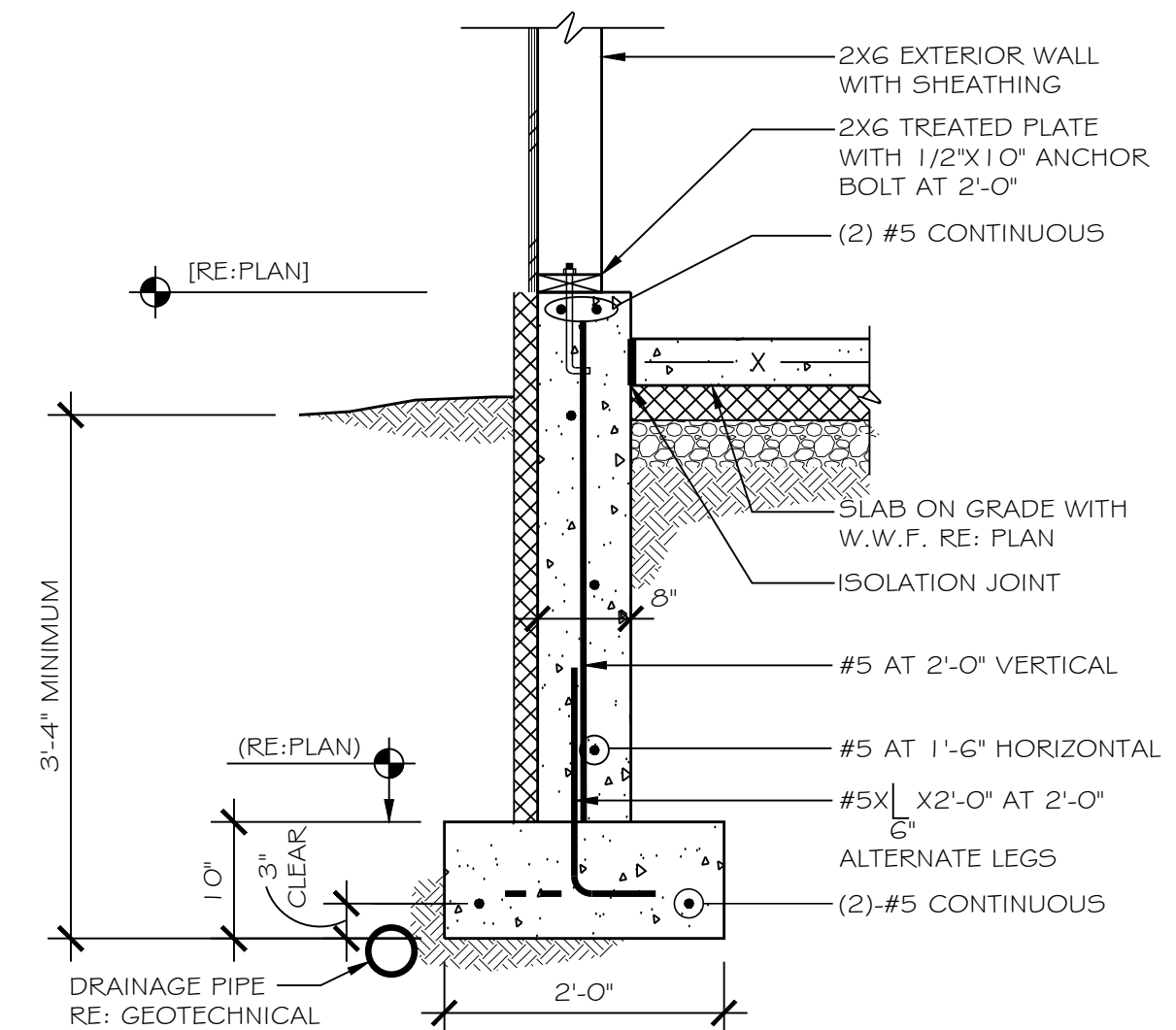

**LOWER FOUNDATION**  
SCALE: 3/4" = 1'-0"

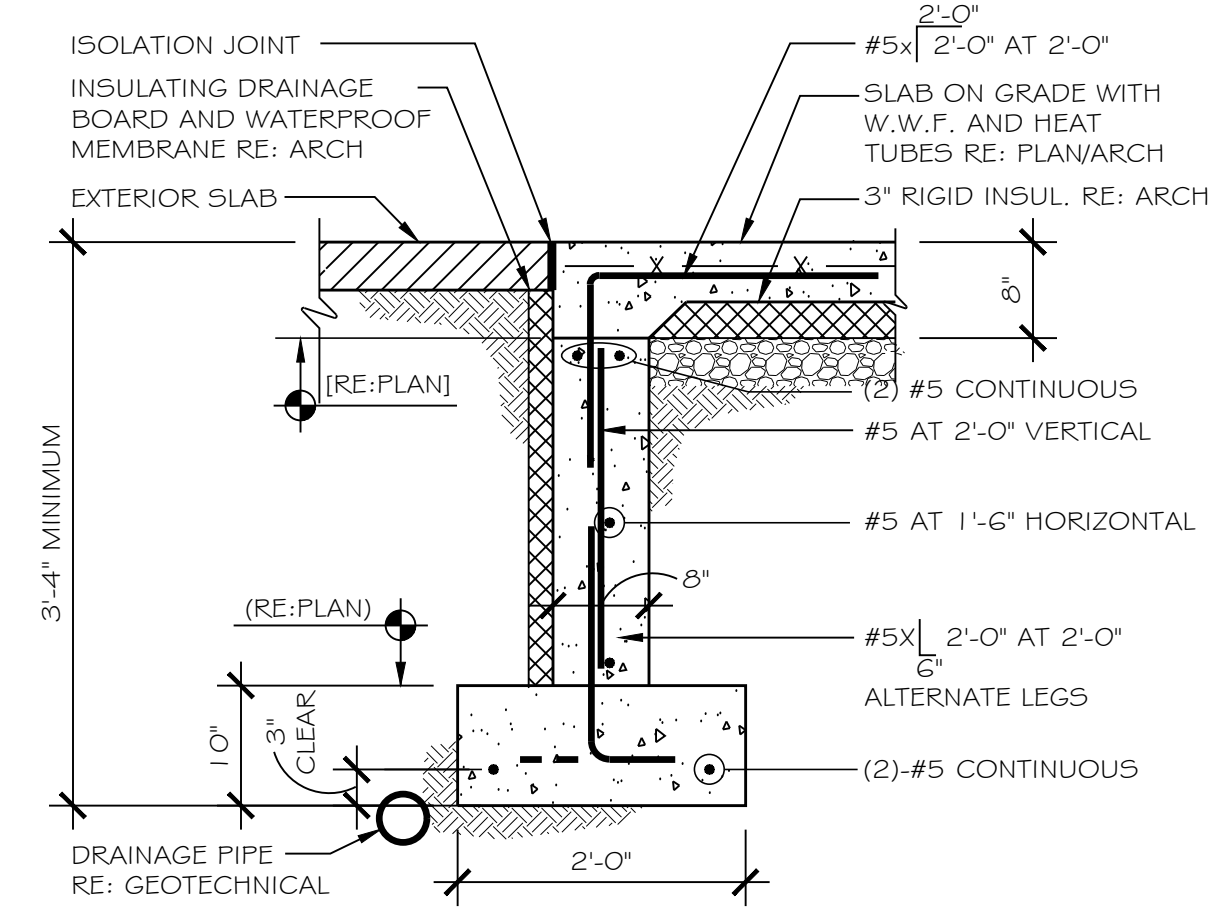

**FOUNDATION AT DOOR**  
SCALE: 3/4" = 1'-0"

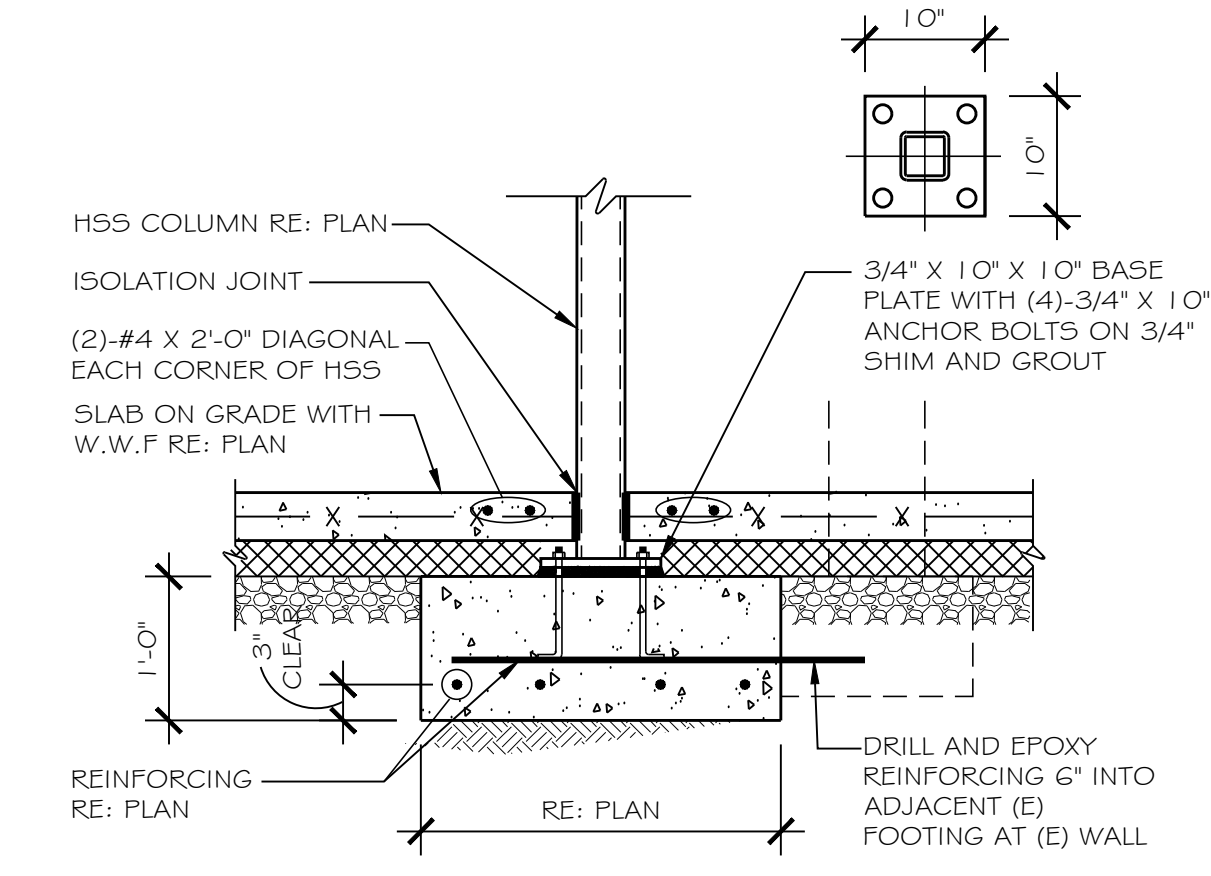

**HSS COLUMN FOOTING**  
SCALE: 3/4" = 1'-0"

**FOX STRUCTURAL ENGINEERING, LLC**  
216 SNOWBERRY WAY  
DILLON, COLORADO 80435  
(970) 376-2005

**FITZGERALD ADDITION**  
34 RUSTIC TERRACE  
BLUE RIVER, COLORADO

PROJECT #2337  
DRAWN: CM/KF  
DATE: 04/23/2024  
FOR PERMIT

**S2.1**  
NOTES & DETAILS

**FITZGERALD ADDITION**  
34 RUSTIC TERRACE  
BLUE RIVER, COLORADO

PROJECT #2337  
DRAWN: CM/KF  
DATE: 04/23/2024  
FOR PERMIT

**S2.2**  
FRAMING DETAILS

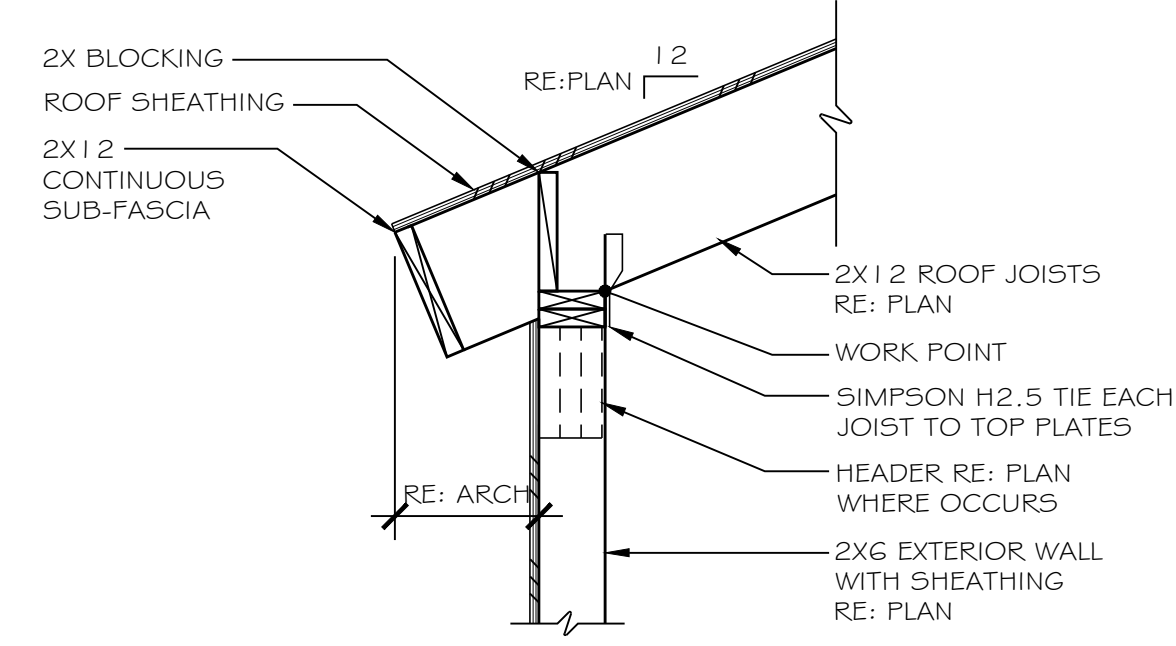

**11 EAVE SECTION**  
SCALE: 3/4" = 1'-0"

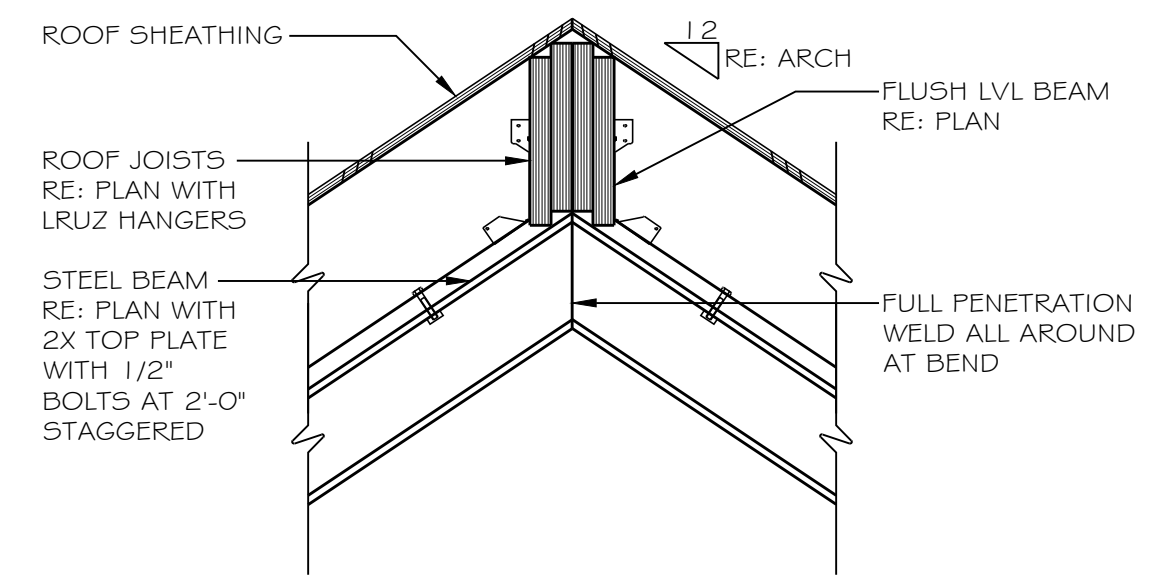

**12 FLUSH LVL RIDGE**  
SCALE: 3/4" = 1'-0"

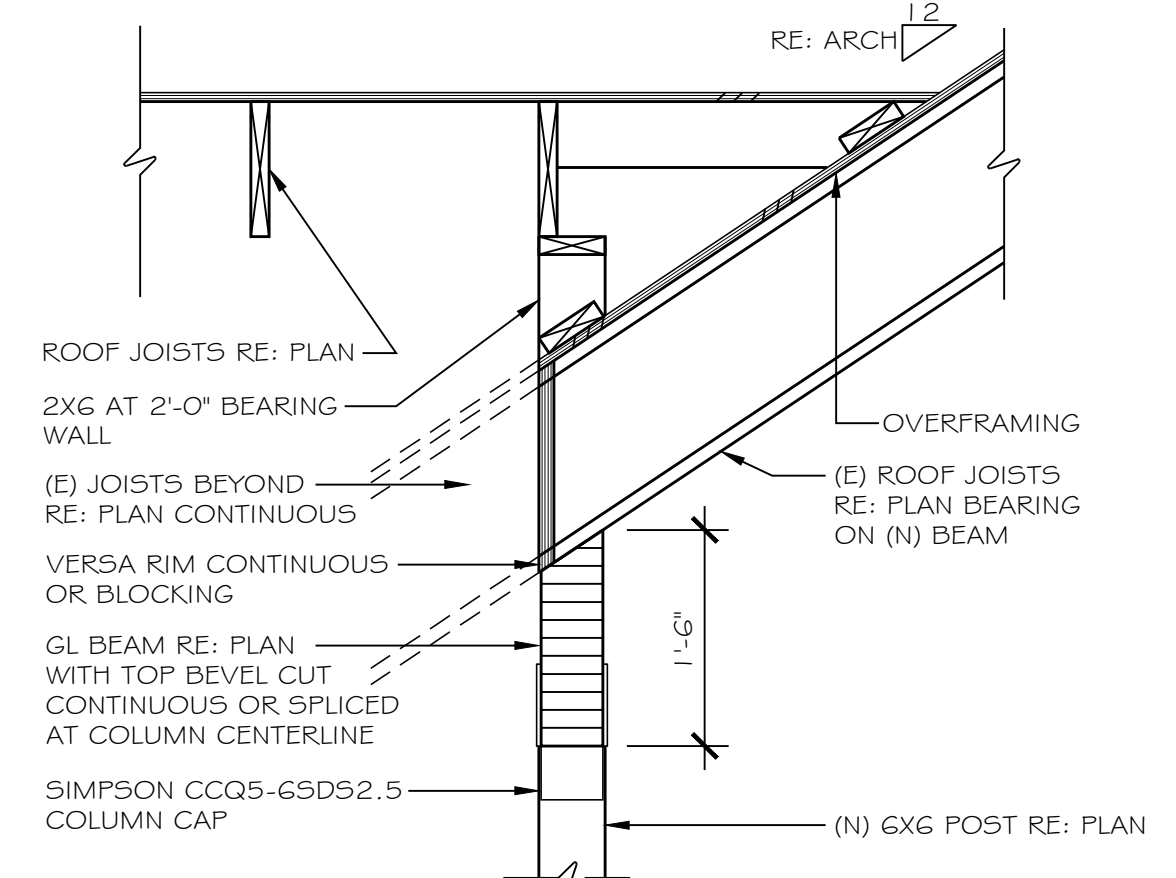

**13 (N) ROOF BEAM AT (E)**  
SCALE: 3/4" = 1'-0"

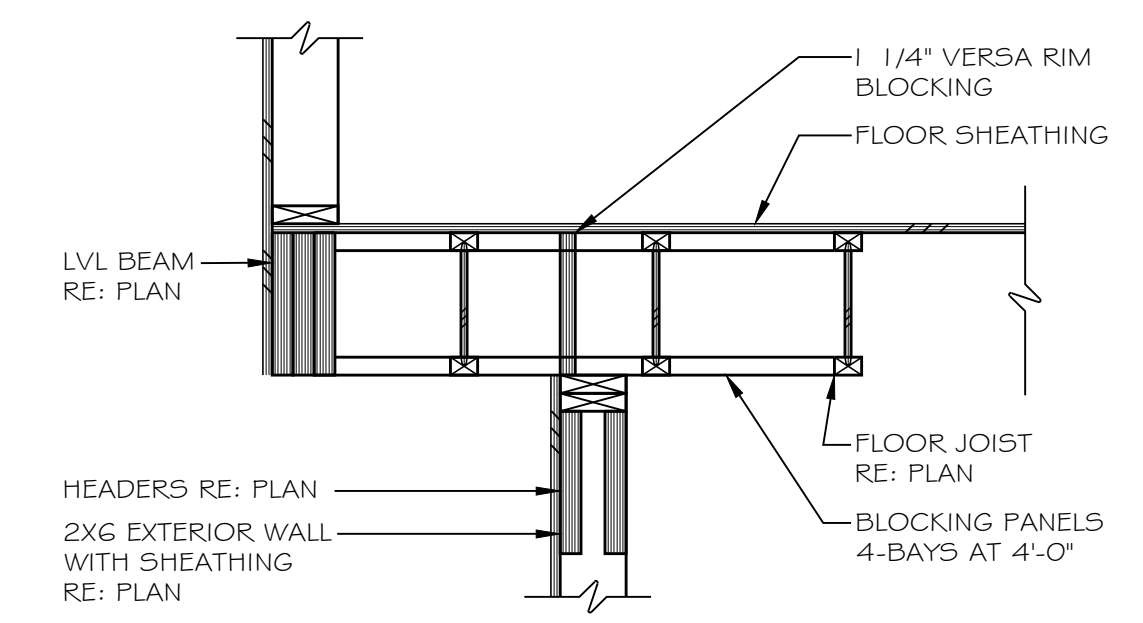

**6 FLOOR SECTION**  
SCALE: 3/4" = 1'-0"

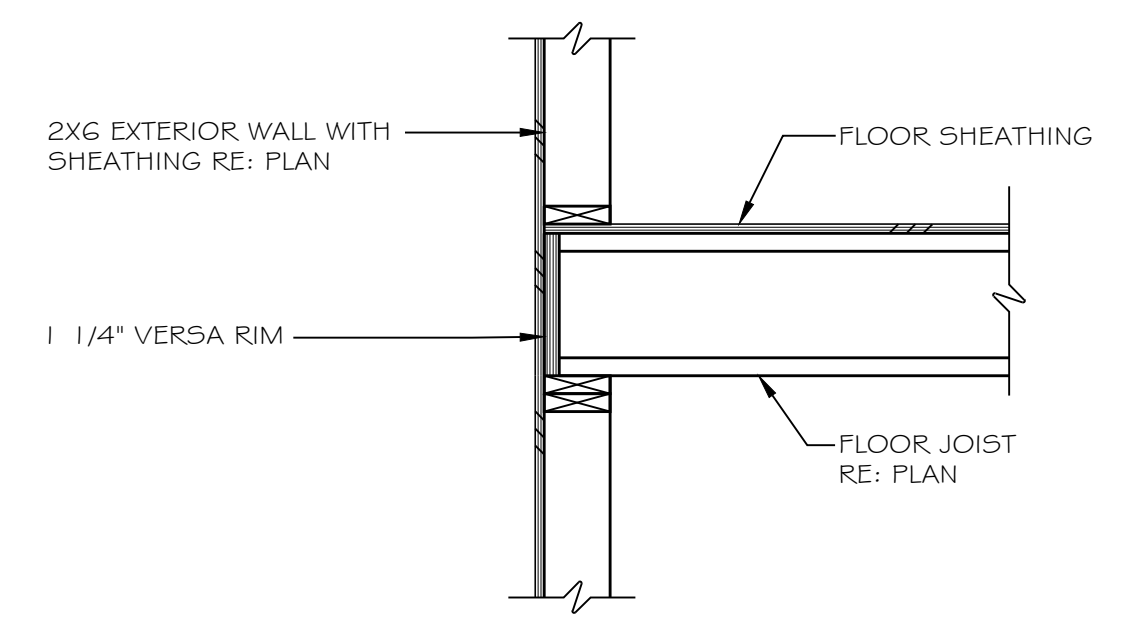

**1 FLOOR SECTION**  
SCALE: 3/4" = 1'-0"

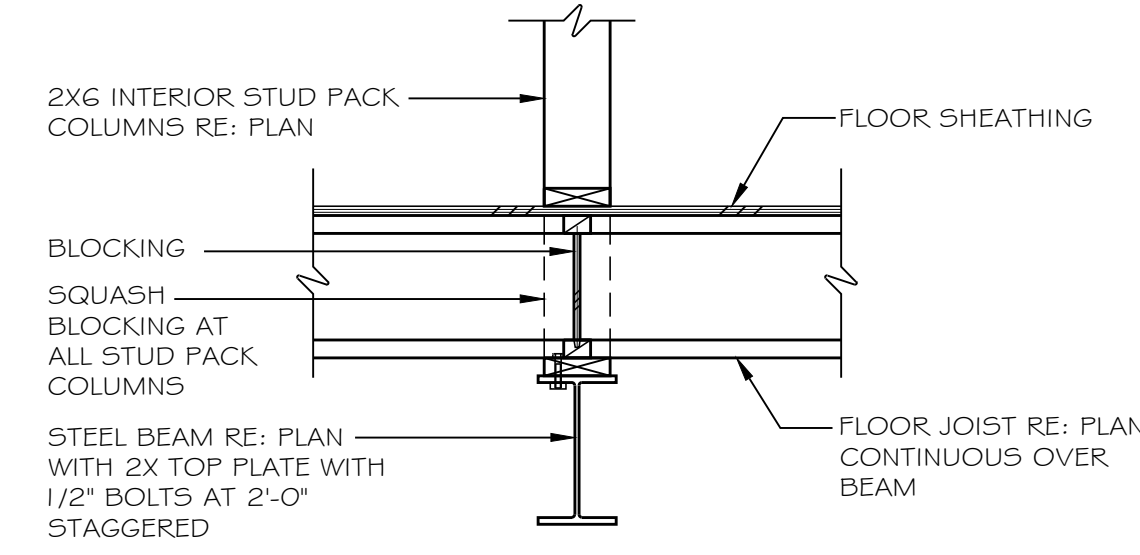

**2 DROPPED STEEL BEAM**  
SCALE: 3/4" = 1'-0"

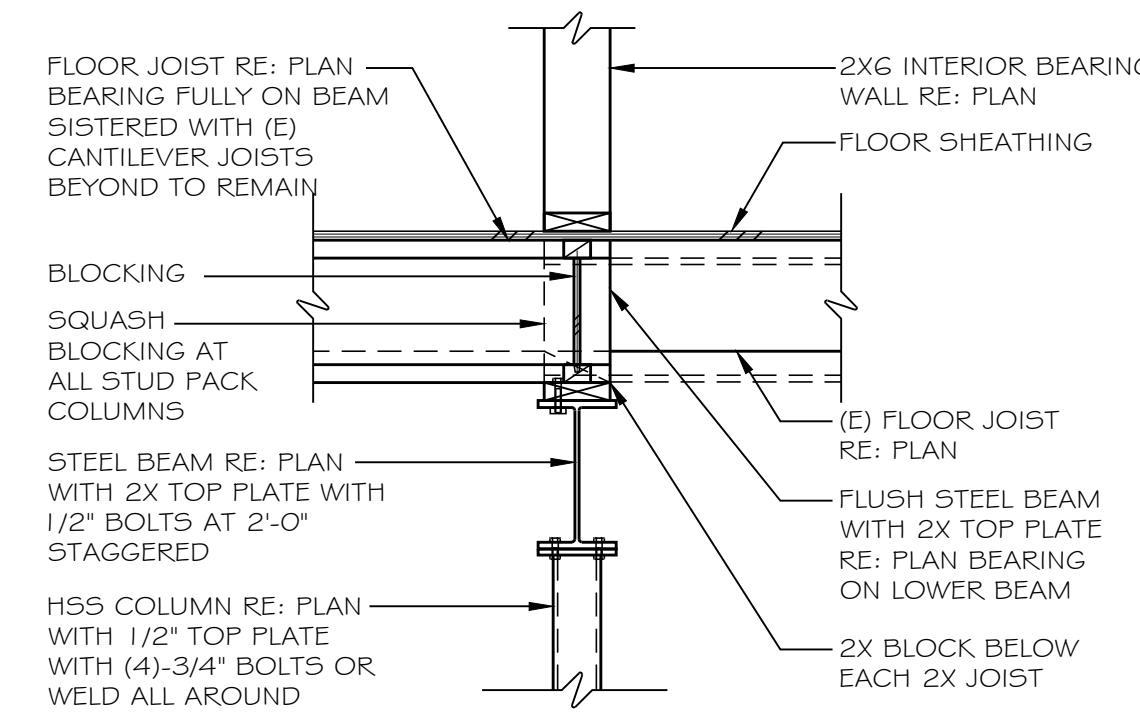

**3 DROPPED STEEL BEAM**  
SCALE: 3/4" = 1'-0"

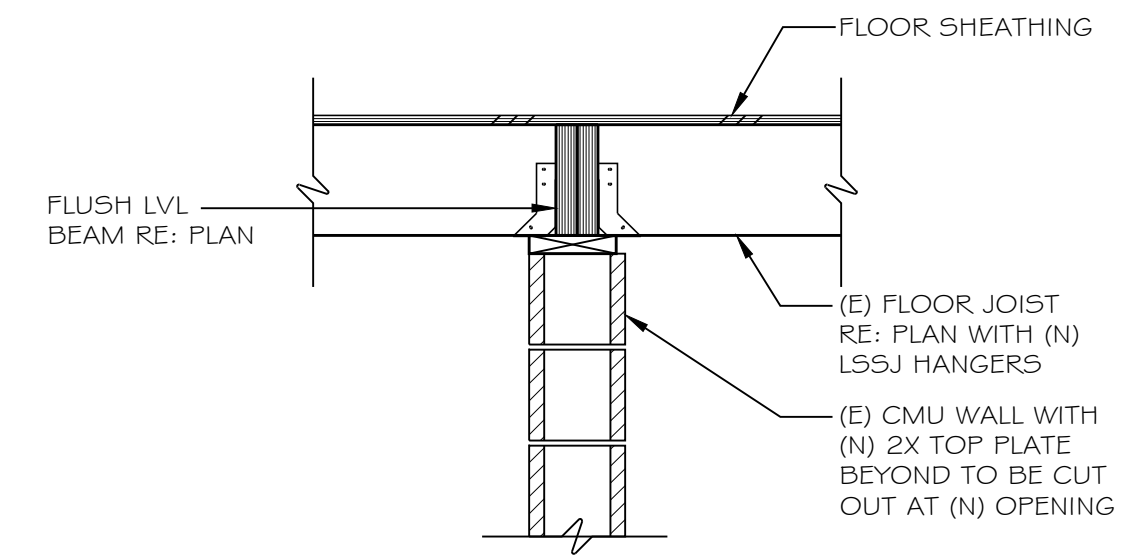

**4 FLUSH BEAM AT CMU**  
SCALE: 3/4" = 1'-0"

**7 NOT USED**  
SCALE: 3/4" = 1'-0"

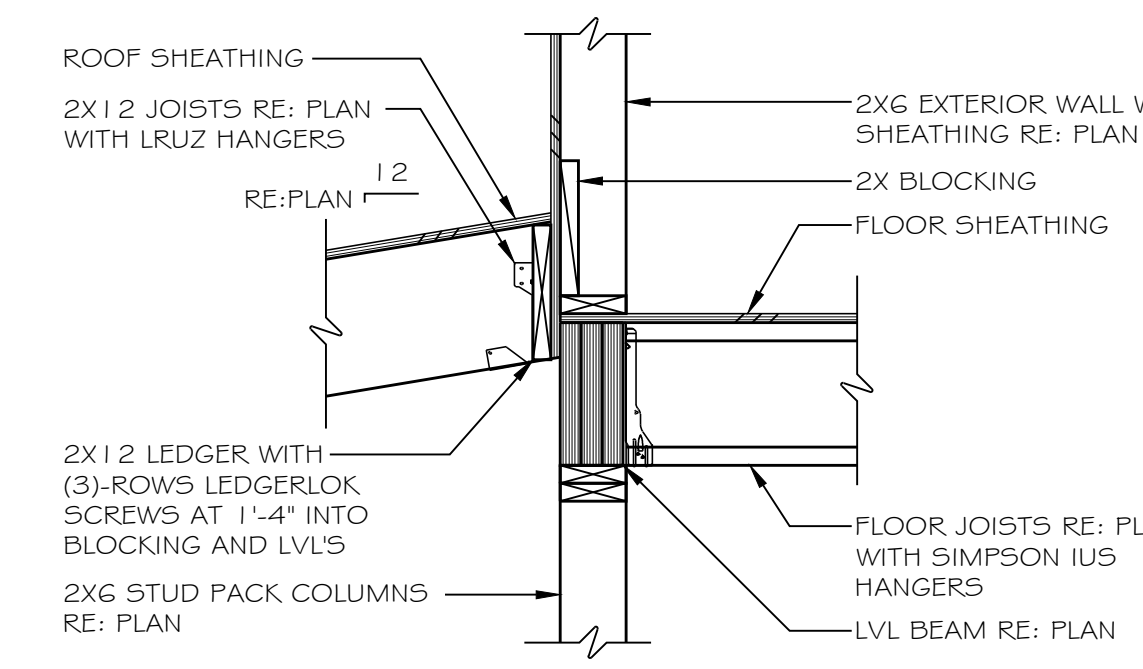

**8 FLUSH LVL BEAM / LOW ROOF**  
SCALE: 3/4" = 1'-0"

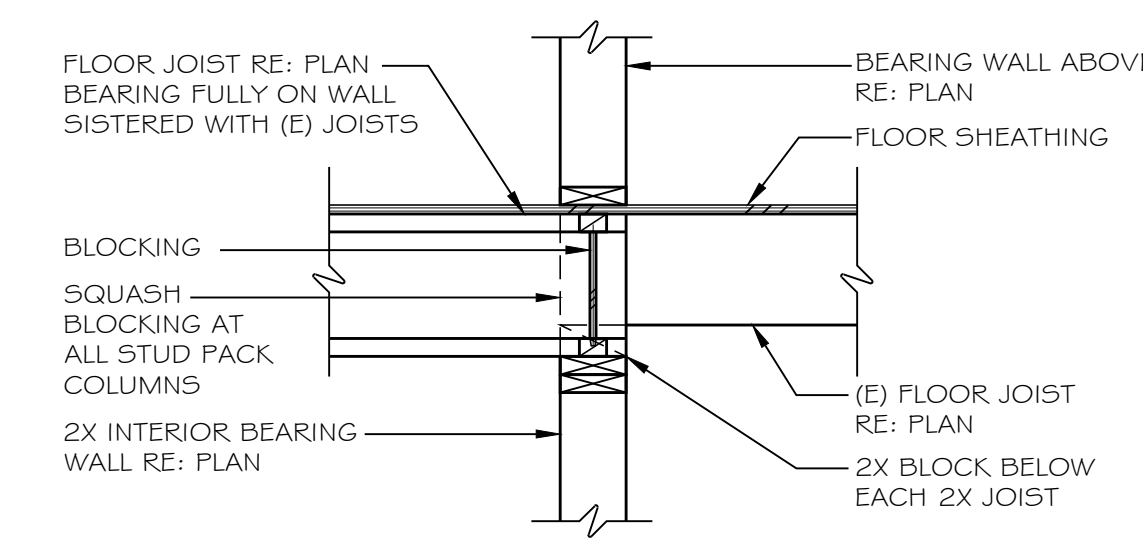

**9 BEARING WALL SECTION**  
SCALE: 3/4" = 1'-0"

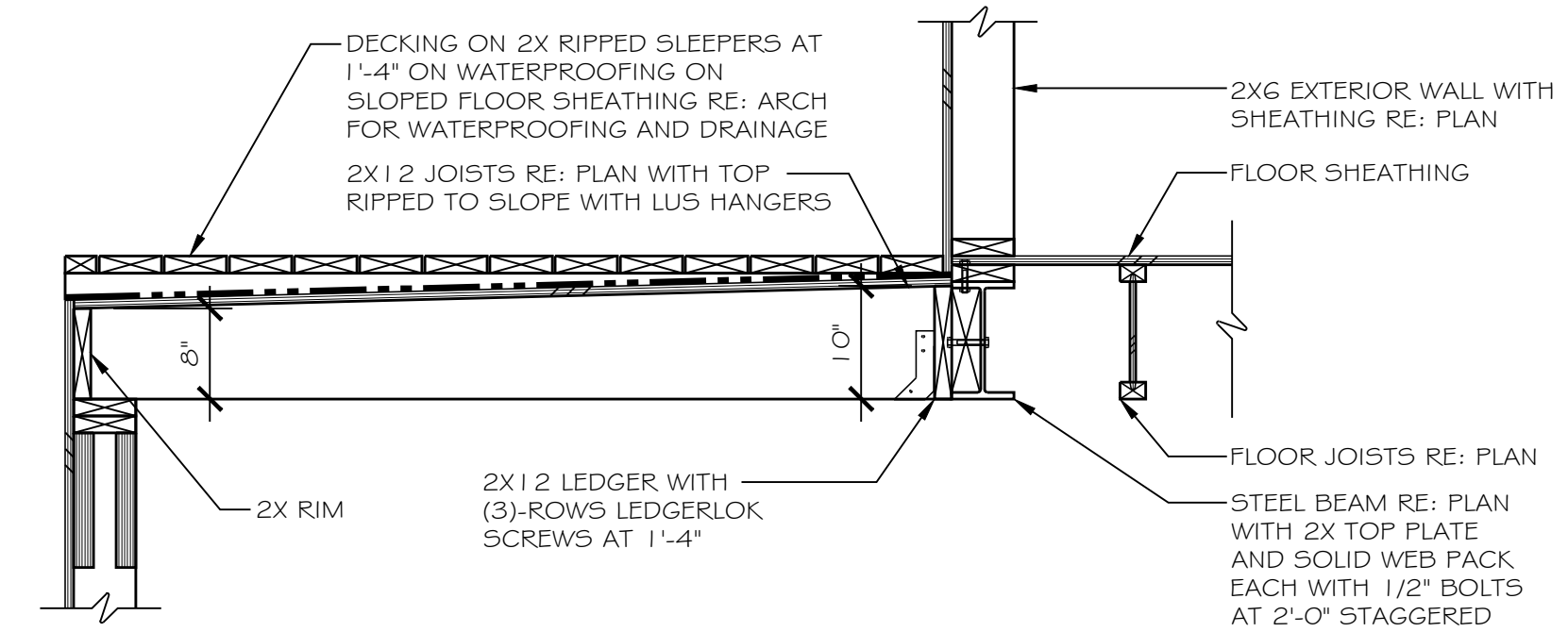

**10 UPPER LEVEL DECK**  
SCALE: 3/4" = 1'-0"

**5 NOT USED**  
SCALE: 3/4" = 1'-0"

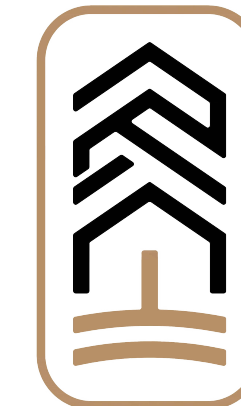

ROOTED ARCHITECTURE

SEAL:

NOT FOR CONSTRUCTION

DRAWINGS AND SPECIFICATIONS AS INSTRUMENTS OF SERVICE ARE THE PROPERTY OF THE ARCHITECT. THEY SHALL NOT BE USED, TRANSFERRED, OR SOLD FOR USE EXCEPT BY AN AGREEMENT IN WRITING FROM THE ARCHITECT.

FITZGERALD ADDITION

34 RUSTIC TERRACE  
BLUE RIVER, CO

# Fitzgerald Addition

## 0034 RUSTIC TERRACE - BLUE RIVER, COLORADO

### GENERAL NOTES PROJECT DATA SHEET INDEX

**1) COPYRIGHT:**  
ALL PLANS, DESIGNS, AND CONCEPTS SHOWN IN THESE DRAWINGS ARE THE EXCLUSIVE PROPERTY OF ROOTED ARCHITECTURE, LLC. AND SHALL NOT BE USED, DISCLOSED, OR REPRODUCED FOR OR ANY PURPOSE WHATSOEVER WITHOUT THE ARCHITECT'S WRITTEN PERMISSION.

**2) CODES:**  
THIS PROJECT IS GOVERNED BY THE INTERNATIONAL RESIDENTIAL CODE, 2018 EDITION AS ADOPTED BY BLUE RIVER, COLORADO. CODE COMPLIANCE IS MANDATORY. THE DRAWINGS AND SPECIFICATIONS SHALL NOT PERMIT WORK THAT DOES NOT CONFORM TO THESE CODES. THE GENERAL CONTRACTOR AND SUBCONTRACTORS SHALL BE RESPONSIBLE FOR SATISFYING ALL APPLICABLE CODES AND OBTAINING ALL PERMITS AND REQUIRED APPROVALS. BUILDING AREAS ARE SHOWN FOR CODE PURPOSES ONLY AND SHALL BE RECALCULATED FOR ANY OTHER PURPOSES.

**3) FIELD VERIFICATION:**  
VERIFY ALL DIMENSIONS, CONDITIONS, AND UTILITY LOCATIONS ON THE JOB SITE PRIOR TO BEGINNING ANY WORK OR ORDERING ANY MATERIALS. NOTIFY ARCHITECT OF ANY CONFLICTS OR DISCREPANCIES IN THE DRAWINGS IMMEDIATELY.

**4) DIMENSIONS:**  
WRITTEN DIMENSIONS ALWAYS TAKE PRECEDENCE OVER SCALED DIMENSIONS. DO NOT SCALE DRAWINGS. VERIFY ALL DIMENSIONS SHOWN PRIOR TO BEGINNING ANY WORK AND NOTIFY ARCHITECT OF ANY CONFLICTS OR DISCREPANCIES FOR INTERPRETATION OR CLARIFICATION. PLAN DIMENSIONS ARE TO THE FACE OF FRAMING MEMBERS, FACE OF WOOD FURRING OR FACE OF CONCRETE WALLS UNLESS OTHERWISE NOTED. SECTION OR ELEVATION DIMENSIONS ARE TO TOP OF CONCRETE, TOP OF PLYWOOD, OR OP OF WALL PLATES OR BEAMS UNLESS OTHERWISE NOTED.

**5) DISCREPANCIES:**  
THE OWNER HAS REQUESTED THE ARCHITECT TO PROVIDE LIMITED ARCHITECTURAL AND ENGINEERING SERVICES. IN THE EVENT ADDITIONAL DETAILS OR GUIDANCE IS NEEDED BY THE CONTRACTOR FOR CONSTRUCTION OF ANY ASPECT OF THIS PROJECT, HE SHALL IMMEDIATELY NOTIFY THE ARCHITECT. FAILURE TO GIVE SIMPLE NOTICE SHALL RELIEVE THE ARCHITECT OF RESPONSIBILITY. DO NOT PROCEED IN AREAS OF DISCREPANCY UNTIL ALL SUCH DISCREPANCIES HAVE BEEN FULLY RESOLVED WITH WRITTEN DIRECTION FROM THE ARCHITECT.

**6) DUTY OF COOPERATION:**  
RELEASE OF THESE PLANS CONTEMPLATES FURTHER COOPERATION AMONG THE OWNER, CONTRACTOR, AND THE ARCHITECT. DESIGN AND CONSTRUCTION ARE COMPLEX. ALTHOUGH THE ARCHITECT AND HIS CONSULTANTS HAVE PERFORMED THEIR SERVICES WITH DUE CARE AND DILIGENCE, THEY CANNOT GUARANTEE PERFECTION. COMMUNICATION IS IMPERFECT, AND EVERY CONTINGENCY CANNOT BE ANTICIPATED. ANY AMBIGUITY OR DISCREPANCY DISCOVERED BY THE USE OF THESE PLANS SHALL BE REPORTED IMMEDIATELY TO THE ARCHITECT. FAILURE TO NOTIFY THE ARCHITECT COMPOUNDS MISUNDERSTANDING AND INCREASES CONSTRUCTION COSTS. A FAILURE TO COOPERATE BY A SIMPLE NOTICE TO THE ARCHITECT SHALL RELIEVE THE ARCHITECT FROM RESPONSIBILITY FOR ALL CONSEQUENCES.

**7) CHANGES TO THE WORK:**  
ANY ITEMS DESCRIBED HEREIN THAT IMPACT PROJECT BUDGET OR TIME SHALL BE REQUESTED FROM THE CONTRACTOR VIA A WRITTEN CHANGE ORDER REQUEST PRIOR TO SUCH WORK. PERFORMANCE OF SUCH WORK WITHOUT APPROVAL BY CHANGE ORDER INDICATES GENERAL CONTRACTOR'S ACKNOWLEDGMENT OF NO INCREASE IN CONTRACT SUM OR TIME. CHANGES FROM THE PLANS OR SPECIFICATIONS MADE WITHOUT CONSENT OF THE ARCHITECT ARE UNAUTHORIZED AND SHALL RELIEVE THE ARCHITECT OF RESPONSIBILITY FOR ANY AND ALL CONSEQUENCES RESULTING FROM SUCH CHANGES.

**8) WORKMANSHIP:**  
IT IS THE INTENT AND MEANING OF THESE DRAWINGS THAT THE CONTRACTOR AND EACH SUBCONTRACTOR PROVIDE ALL LABOR, MATERIALS, TRANSPORTATION, SUPPLIES, EQUIPMENT, ETC., TO OBTAIN A COMPLETE JOB WITHIN THE RECOGNIZED STANDARDS OF THE INDUSTRY.

**9) SUBSTITUTIONS:**  
SUBSTITUTION OF "EQUAL" PRODUCTS WILL BE ACCEPTABLE WITH ARCHITECT'S WRITTEN APPROVAL.

**10) CONSTRUCTION SAFETY:**  
THESE DRAWINGS DO NOT INCLUDE THE NECESSARY COMPONENTS FOR CONSTRUCTION SAFETY. THE GENERAL CONTRACTOR SHALL PROVIDE FOR THE SAFETY, CARE OF UTILITIES AND ADJACENT PROPERTIES DURING CONSTRUCTION, AND SHALL COMPLY WITH STATE AND FEDERAL SAFETY REGULATIONS.

**11) EXCAVATION PROCEDURES:**  
UPON COMPLETION OF ANY EXCAVATION, THE OWNER SHALL RETAIN A SOILS ENGINEER TO INSPECT THE SUBSURFACE CONDITIONS IN ORDER TO DETERMINE THE ADEQUACY OF FOUNDATION DESIGN. CONTRACTOR SHALL NOT POUR ANY CONCRETE UNTIL APPROVAL IS OBTAINED FROM SOILS ENGINEER.

**12) FIELD CUTTING OF STRUCTURAL MEMBERS:**  
THE GENERAL CONTRACTOR AND SUBCONTRACTORS SHALL FIELD COORDINATE AND OBTAIN APPROVAL FROM ENGINEER BEFORE ANY CUTTING, NOTCHING OR DRILLING OF ANY CAST-IN-PLACE CONCRETE, STEEL FRAMING, OR ANY OTHER STRUCTURAL ELEMENTS WHICH MAY AFFECT THE STRUCTURAL INTEGRITY OF THE BUILDING. REFER TO CURRENT INTERNATIONAL BUILDING CODE, MANUFACTURER'S OR SUPPLIER'S INSTRUCTIONS, AND STRUCTURAL DRAWINGS FOR ADDITIONAL REQUIREMENTS.

**13) EXTERIOR MATERIAL MOCK UP:**  
THE GENERAL CONTRACTOR SHALL PROVIDE A MOCK UP OF ALL EXTERIOR MATERIALS FOR REVIEW BY THE OWNER, ARCHITECT AND INTERIOR DESIGNER. THIS MOCK UP SHALL BE PROVIDED AND SIGNED OFF IN WRITING PRIOR TO ANY EXTERIOR FINISH WORK. THE SAMPLE SHALL INCLUDE FASCIA, TRIM WINDOW CLADDING, AND ALL OTHER EXTERIOR FINISHES INCLUDING 3'X3' SAMPLE OF EXTERIOR STONE WORK. THIS SHALL BE RETAINED ON SITE UNTIL THE FINAL PUNCH LIST IS COMPLETE.

**14) WEATHER CONDITIONS:**  
THE OWNER HAS BEEN ADVISED THAT DUE TO HARSH WINTER CONDITIONS, ROOF AND DECK SURFACES MUST BE MAINTAINED REASONABLY FREE OF ICE AND SNOW TO ENSURE MINIMAL PROBLEMS WITH THESE SURFACES. ALL ROOFING, ROOFING MEMBRANES, AND WATERPROOFING SHALL BE APPROVED IN WRITING BY PRODUCT MANUFACTURER (W.R. GRACE FOR BITUTHENE, ETC.) PRIOR TO PROCEEDING WITH ANY WORK. FAILURE TO PROVIDE THESE WRITTEN APPROVALS REMOVES ALL RESPONSIBILITY FOR THE WORK FROM THE ARCHITECT.

**15) BUILDING AREA**  
BUILDING AREAS ARE SHOWN FOR CODE PURPOSES ONLY AND SHALL BE RECALCULATED FOR ANY OTHER USE.

**16) PROJECT STAKING**  
THE GENERAL CONTRACTOR SHALL VERIFY ALL EXISTING GRADES AND STAKE ALL BUILDING CORNERS AND DRIVEWAY LOCATION FOR OWNER/ARCHITECT AND DESIGN REVIEW BOARD APPROVAL PRIOR TO BEGINNING ANY SITE CLEARING.

**17) SITE DISTURBANCE**  
IT IS THE RESPONSIBILITY OF THE CONTRACTOR TO PROTECT THE EXISTING TREES TO REMAIN AND ADJACENT PROPERTIES FROM DAMAGE DURING CONSTRUCTION. PROVIDE PROTECTIVE FENCING THROUGHOUT CONSTRUCTION.

**18) PROJECT GRADES**  
THE GENERAL CONTRACTOR SHALL CHECK AND VERIFY ALL GRADES INCLUDING PAVED AREA SLOPES PRIOR TO POURING ANY FOUNDATIONS. SURVEY WORK SHOULD BE VERIFIED IN DETAIL.

**19) EXISTING CONDITIONS**  
THE PLANNED MODIFICATIONS AND ADDITIONS INCLUDED IN THESE DOCUMENTS DO NOT REQUIRE CHANGES OR MODIFICATIONS TO THE EXISTING STRUCTURAL COMPONENTS OF THIS BUILDING. THE GENERAL CONTRACTOR IS TO FIELD VERIFY ALL STRUCTURAL CONDITIONS ARE UNCHANGED DURING DEMOLITION AND CONSTRUCTION. ANY AND ALL STRUCTURAL COMPONENTS DISCOVERED TO REQUIRE MODIFICATION SHALL BE REPORTED TO THE ARCHITECT AND IF REQUIRED, REFERRED TO A STRUCTURAL ENGINEER FOR EVALUATION AND RECOMMENDATION BEFORE WORK PROCEEDS IN AFFECTED AREA.

**20) 3D MODELING**  
THIS PROJECT HAS BEEN DIGITALLY MODELED IN 3D SOFTWARE. THE DIGITAL MODEL IS PROVIDED FOR REFERENCE PURPOSES ONLY. TRANSMISSION OF DIGITAL MODEL FILES CONSTITUTES A WARRANTY BY THE PARTY TRANSMITTING FILES TO THE PARTY RECEIVING FILES THAT THE TRANSMITTING PARTY IS THE COPYRIGHT OWNER OF THE DIGITAL DATA, UNLESS OTHERWISE AGREED IN WRITING. ANY USE OF, TRANSMISSION OF, OR RELIANCE ON THE MODEL IS AT THE RECEIVING PARTY'S RISK. THE CONTRACTOR SHALL NOTIFY THE ARCHITECT OF QUESTIONS OR COORDINATION ISSUES BETWEEN THE CONTRACT DOCUMENTS AND DIGITAL MODEL.

**LEGAL DESCRIPTION:**  
0034 RUSTIC TER (CR 603) BLUE RIVER, COLORADO 80461  
LOT 8 BLUE ROCK SPRINGS SUBDIVISION

**USGS DATUMS**

EXISTING GARAGE: 100'-0" = 10,000.1' USGS  
 MAIN LEVEL: 109'-6" = 10,009.6' USGS  
 LOFT LEVEL: 118'-5" = 10,018.4' USGS

**NOTE: CONTRACTOR TO VERIFY ALL EXISTING DATUMS PRIOR TO CONSTRUCTION**

**AREAS CALCULATIONS**

	FINISHED (EXIST)	UNFINISHED (EXIST)	FINISHED (NEW)	UNFINISHED (NEW)	TOTAL
LOWER LEVEL	298 SF	434 SF	0 SF	767 SF	1,499 SF
MAIN LEVEL	1,277 SF	0 SF	506 SF	0 SF	1,783 SF
LOFT LEVEL	532 SF	0 SF	271 SF	0 SF	803 SF
<b>TOTAL:</b>	<b>2,107 SF</b>	<b>434 SF</b>	<b>777 SF</b>	<b>767 SF</b>	<b>4,085 SF</b>

NOTE: SQUARE FOOTAGE CALCULATIONS ARE FOR CODE PURPOSES ONLY AND SHOULD BE RECALCULATED FOR ANY OTHER PURPOSES

**CODE INFORMATION**

**ADOPTED CODES:**

- 2018 International Residential Code with Blue River Amendments
- 2018 International Energy Conservation Code with Blue River Amendments
- Blue River Development Code

### ENERGY REQUIREMENTS

- ENERGY EFFICIENT DESIGN FEATURES:**
- RADIANT HEATING SYSTEM, MINIMUM 95% AFUE.
  - HIGH-EFFICACY LED LIGHTING
  - ENERGY EFFICIENT WATER HEATER. ELECTRIC MINIMUM 0.95 ENERGY FACTOR /GAS, MINIMUM 0.76 ENERGY FACTOR.
  - PROVIDE AN ELECTRICAL CAR CHARGING ROUGH IN, INCLUDING A BLANKED ELECTRICAL BOX, AND A RACEWAY TERMINATING IN THE ELECTRICAL PANEL.
  - PROVIDE PV READY CONSTRUCTION INCLUDING A METAL RACEWAY FROM THE ELECTRICAL PANEL TO THE ROOF LOCATION WHERE THE PANELS WILL BE INSTALLED, INCLUDING A ROOF JACK, A #8 COPPER GROUND, A 2 PULL BLANK IN THE ELECTRICAL PANEL AND AN ELECTRICAL CONDUIT FROM THE ELECTRICAL PANEL OUT TO THE ELECTRIC METER.
  - WATERSENSE FIXTURES THROUGHOUT.
  - (OPTIONAL) HRV/ ERV, 65% SENSIBLE HEAT RECOVERY EFFICIENCY, MEETING MINIMUM AIRFLOW RATES PER IRC INSTALLED.
  - PROGRAMMABLE THERMOSTATS.

**THERMAL ENVELOPE REQUIREMENTS (2018 IRC CH. 11 - SUMMIT COUNTY ZONE 7):**

**ROOF/ CEILING:** R49 CLOSED-CELL SPRAY FOAM  
**ABOVE GRADE WALLS:** R23 CAVITY CLOSED-CELL SPRAY FOAM PER AMENDMENT TO TABLE N1102.1.2 (IECC R402.1.2)  
 R10 /4'  
 MAX U 0.30 / SHGC N/A

**SLABS, INCLUDING SLAB EDGE:** R38  
**FENESTRATIONS:** R15 CI OR R19 CAVITY  
**FLOOR R-VALUE:** R15 CI OR R19 CAVITY  
**BASEMENT WALL:** R15 CI OR R19 CAVITY  
**BLOWER DOOR:** ACH 2.7 AT A PRESSURE 0.2 INCHES W.G. (50 PASCALS)

THESE SPECIFICATIONS ARE BASED OFF OF THE 2018 IECC RESIDENTIAL THERMAL ENVELOPE REQUIREMENTS AS DESCRIBED IN TABLE R402.1.3, WHICH SHOULD BE REFERRED TO FOR INTERPRETATION REASONS. SEE PLANS AND DETAILS RELATED TO SPECIFIC INSULATION REQUIREMENTS FOR EXTERIOR BUILDING ENVELOPE.

THERMAL AND VAPOR CONTROL DESIGN BASED ON CLOSED-CELL FOAM INSULATION AND AIR SEALING THROUGHOUT.

**SHEET INDEX**

SHEET NUMBER	SHEET NAME	SHEET ISSUE DATE
A0.1	COVER SHEET	05.01.2023
A0.2	ENLARGED SITE PLAN	05.01.2023
A1.1	FLOOR PLAN - LOWER	05.01.2023
A1.2	FLOOR PLAN - MAIN	05.01.2023
A1.3	FLOOR PLAN - UPPER	05.01.2023
A1.4	ROOF PLAN	05.01.2023
A2.1	CEILING PLANS	05.01.2023
A4.1	EXTERIOR ELEVATIONS	05.01.2023
A5.1	BUILDING SECTIONS	05.01.2023
A6.1	POWER PLANS	05.01.2023
A7.1	DETAILS	05.01.2023
S1.1	FOUNDATION PLAN	05.01.2023
S1.2	MAIN LEVEL FRAMING PLAN	05.01.2023
S1.3	UPPER LEVEL FRAMING PLAN	05.01.2023
S1.4	ROOF FRAMING PLAN	05.01.2023
S2.1	NOTES AND DETAILS	05.01.2023
S2.2	FRAMING DETAILS	05.01.2023

### LOCATION MAP

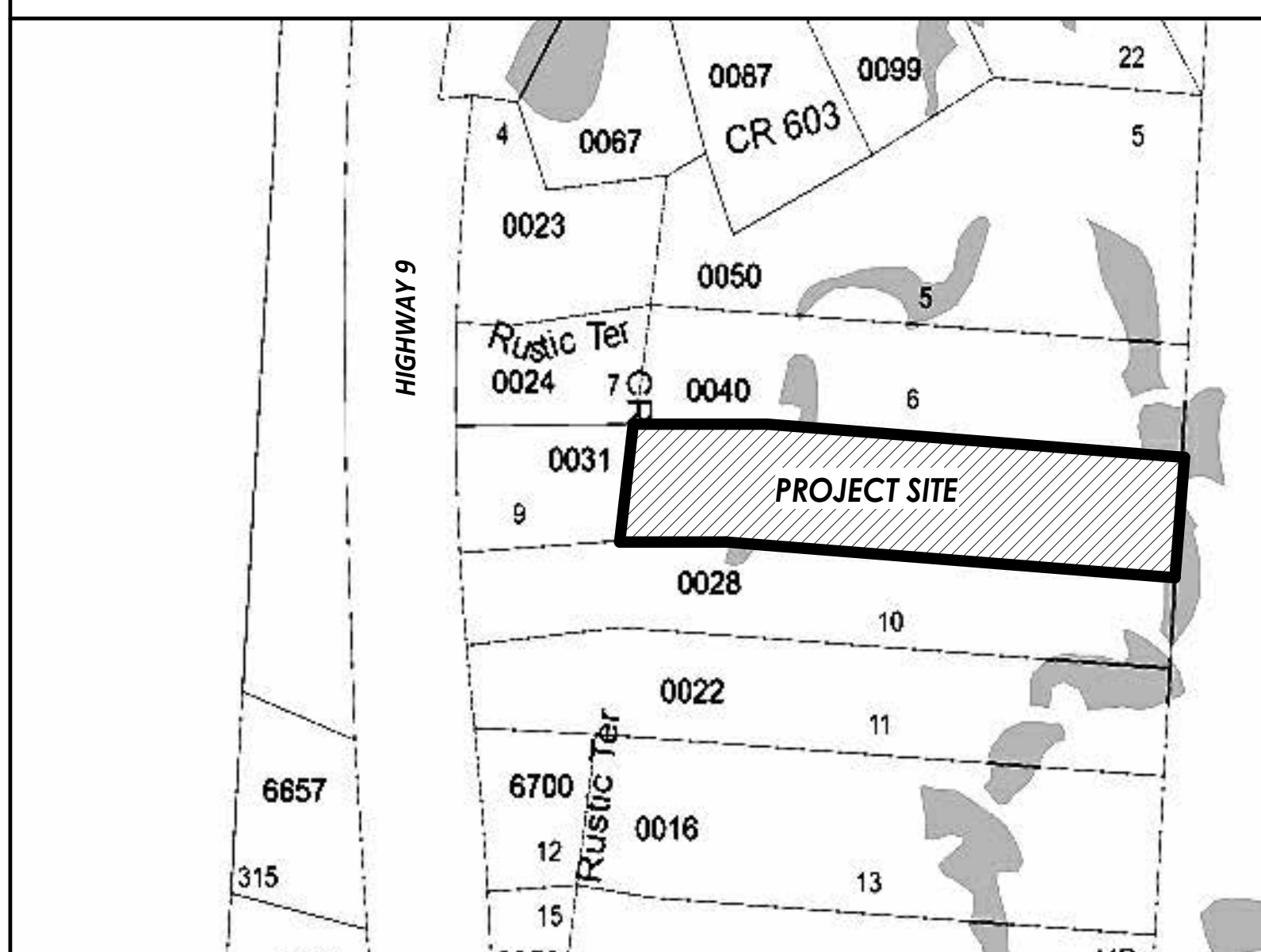

### SURVEYOR INTERIOR DESIGN STRUCTURAL ENG. CONTRACTOR ARCHITECT OWNER

**SURVEYOR:** SCHMIDT LAND SURVEYING, INC. LIZ SCHMIDT 970 409-9963

**INTERIOR DESIGN:**

**STRUCTURAL ENG.:** FOX STRUCTURAL ENGINEERING, LLC KRISTEN E. FOX, P.E. (970)376-2005

**CONTRACTOR:** THE ASHLAN GROUP MATT KRIGMAN 970-333-8624

**ARCHITECT:** ROOTED ARCHITECTURE, LLC BRANDON SMITH BRANDON@ROOTEDARCH.COM 469.363.2821

**OWNER:** TOM AND ALEX FITZGERALD ATAYLORFITZ@GMAIL.COM TMFITZGERALD@GMAIL.COM

No.	Date	Revisions

**Project No:** 2023-16  
**Stage:** FINAL REVIEW SET  
**Date:** 05/02/2024  
**Scale:** 12" = 1'-0"

**DRAWING TITLE:**  
**COVER SHEET**

**DRAWING NO:**

**A0.1**



ROOTED ARCHITECTURE

SEAL:

NOT FOR CONSTRUCTION

DRAWINGS AND SPECIFICATIONS AS INSTRUMENTS OF SERVICE ARE THE PROPERTY OF THE ARCHITECT. THEY SHALL NOT BE USED, TRANSFERRED, OR SOLD FOR USE EXCEPT BY AN AGREEMENT IN WRITING FROM THE ARCHITECT.

FITZGERALD ADDITION

34 RUSTIC TERRACE BLUE RIVER, CO

No.	Date	Revisions

Project No: 2023-16  
 Stage: FINAL REVIEW SET  
 Date: 05/02/2024  
 Scale: As indicated

DRAWING TITLE:  
**ENLARGED SITE PLAN**  
 DRAWING NO:

A0.2

- NOTES: SITE PLAN**
1. VERIFY ALL UTILITY LOCATIONS PRIOR TO ANY WORK. COORDINATE UTILITY ROUTING WITH APPLICABLE UTILITY COMPANY. ALL UTILITIES TO BE UNDERGROUND.
  2. SURFACE DRAINAGE SHALL BE DIVERTED TO A STORM SEWER CONVEYANCE OR OTHER APPROVED POINT OF COLLECTION THAT DOES NOT CREATE A HAZARD. LOTS SHALL BE GRADED TO DRAIN SURFACE WATER AWAY FROM FOUNDATION WALLS. THE GRADE SHALL FALL NOT FEWER THAN 6 INCHES WITHIN THE FIRST 10 FEET.
  3. REFER TO FOUNDATION PLAN FOR FOUNDATION DRAIN LOCATION AND SLOPE.
  4. FLAG ALL TREES FOR OWNER PRIOR TO THINNING OR REMOVAL.
  5. PROTECT REMAINING TREES WITH APPROVED BARRIER DURING CONSTRUCTION.
  6. GENERAL CONTRACTOR SHALL REVIEW AND COMPLY WITH ALL ZONING AND SUBDIVISION CONDITIONS.
  7. FINISHED GRADING SHALL BE A MINIMUM OF 6" BELOW FOUNDATION REFERENCE ADOPTED IRC.
  8. CONTRACTOR TO TRIM OR REMOVE ANY TREES ADJACENT TO BUILDING FOUNDATION AS REQUIRED, VERIFY WITH OWNER PRIOR TO REMOVAL.

- NOTES: SITE CONTOUR LEGEND**
- EXISTING MAJOR CONTOUR: 10.000'
- EXISTING MINOR CONTOUR: 10.002'
- PROPOSED CONTOUR: 10.002'

- NOTES: SITE DRAINAGE**
1. CONTRACTOR SHALL PROVIDE PROPER SITE GRADING THAT DIRECTS SURFACE WATER AWAY FROM BUILDING FOUNDATIONS, WALLS AND NEIGHBORING PROPERTIES.
  2. GRADING AND LANDSCAPING SHOULD BE PLANNED WITH A SURFACE GRADE OF AT LEAST 1/4" AROUND AND AWAY FROM THE ENTIRE STRUCTURE. REFER TO LAKE COUNTY DEVELOPMENT CODE FOR SITE DRAINAGE REQUIREMENTS.
  3. PROPOSED SITE DRAINAGE INDICATED ON SITE PLAN WITH FLOW ARROWS:
- 

- NOTES: FOUNDATION DRAIN**
- INSTALL DRAIN TILE (PERFORATED PLASTIC DRAINAGE PIPE) ALONG THE EXTERIOR OF THE FOOTINGS OF BASEMENT OR CRAWLSPACE WALLS TO PROVIDE DRAINAGE AROUND FOUNDATION PERIMETER.
1. INSTALL DRAIN PIPE TO SIT OUTSIDE OF, NOT ON TOP OF, THE FOOTINGS AND BELOW THE BOTTOM OF THE CONCRETE SLAB OR CRAWLSPACE FLOOR.
  2. LAY THE PIPE WITH ENOUGH SLOPE TO DRAIN TO A NON-PERFORATED PIPE THAT CARRIES THE COLLECTED WATER TO DAYLIGHT, TO A DRYWELL, TO A STORM SEWER IF APPROVED BY THE LOCAL MUNICIPALITY, OR TO A SUMP PUMP THAT WILL TRANSPORT IT TO DAYLIGHT, A STORM SEWER, OR A DRYWELL.
  3. LAY THE DRAIN PIPE, PERFORATIONS DOWN, IN A GRAVEL TRENCH WITH AT LEAST 6 INCHES OF 3/4-INCH TO 1-INCH WASHED GRAVEL OR STONE ABOVE THE PIPE AND AT LEAST 2 INCHES BELOW (IRC).
  4. INSTALL LANDSCAPE FABRIC UNDER, AROUND, AND OVER THE WASHED GRAVEL (IRC) ALTERNATELY, USE DRAIN PIPE ENCASED IN A FILTER-FABRIC SOCK AND SURROUND THE CLOTH-COVERED PIPE WITH GRAVEL. OR, INSTALL A CODE-APPROVED COMPOSITE FOUNDATION DRAINAGE SYSTEM (CFDS) (IRC).

**SNOWSTACK CALCULATIONS**

	SQUARE FOOTAGE	PERCENTAGE
EXISTING DRIVEWAY	998 SF	
NEW DRIVEWAY	317 SF	
DECKS AND HARDSCAPE	NA	
TOTAL COVERAGE	1,315 SF	100%
SNOWSTACK REQUIRED	329 SF	25%
SNOWSTACK PROVIDED	605 SF	46%

TOTAL LOT AREA: 1.45 ACRES

- NOTES: LANDSCAPE**
1. VERIFY ALL UTILITY LOCATIONS PRIOR TO ANY WORK. COORDINATE UTILITY ROUTING WITH APPLICABLE UTILITY COMPANY. ALL UTILITIES TO BE UNDERGROUND. PROVIDE 2"-3" (MIN.) CLAY FREE TOPSOIL AND SEED ALL DISTURBED AREAS WITH SUMMIT CO. SHORT SEED MIX (AS APPROVED BY STRIP AND STOCKPILE EXISTING TOPSOIL IN CONSTRUCTION AREA. SCREEN TOPSOIL PRIOR TO INSTALLATION.
  2. KEEP EXISTING TREES WHERE POSSIBLE, TAKING INTO CONSIDERATION DRIP LINES AND ROOT STRUCTURE. PROTECT EXISTING TREES WITH FENCING LOCATED AT OR OUTSIDE DRIP LINE OF TREE. STOCKPILE AND REUSE EXISTING TREES WHERE POSSIBLE.
  3. GENERAL CONTRACTOR SHALL PROVIDE POSITIVE DRAINAGE AWAY FROM ALL BUILDING FOUNDATIONS PER SPECIFICATIONS AND CODE REQUIREMENTS.
  4. PRIOR TO ANY LANDSCAPE WORK, REMOVE ALL DEBRIS, PAINT, CONCRETE, STUMPS, SLASH, ETC. FROM LANDSCAPE AREA.
  5. LOCATE ALL PLANTINGS TO AVOID SNOW STACKING & SNOW SLIDE AREAS FROM ABOVE.
  6. SHRUBS ARE TO BE FIELD LOCATED AS APPROVED BY OWNER AND ARCHITECT.
  7. ALL NEW LANDSCAPING TO BE IRRIGATED WITH DRIP IRRIGATION SYSTEM. PROVIDE SUBMITTAL.
  8. ALL NEW PLANTINGS SHOULD BE HIGH ALTITUDE GROWN AND OR COLLECTED TO ENSURE BETTER SURVIVAL.
  9. NATURALIZE GROUPING OF TREES BY VARYING HEIGHT & LOCATION WHEREVER POSSIBLE.
  10. SCREEN ALL UTILITY PEDESTALS WITH LANDSCAPE MATERIAL.
  11. PROVIDE 3" TO 4" DIAMETER STONE RIPRAP OVER WEED BARRIER FABRIC AT BUILDING DRIP LINES. UNDULATE EDGES AND PROVIDE LANDSCAPE EDGING AT RIPRAP TO TOPSOIL JUNCTURE.
  12. INSTALL & BACKFILL ALL PLANTINGS WITH SOIL MIX INCLUDING ORGANIC SOIL AMENDMENTS PER SPECIES REQUIREMENTS AND LANDSCAPE DETAILS.
  13. ROOT FEED ALL NEWLY PLANTED TREES DURING INSTALLATION. PROVIDE LIQUID GROWTH TREE STIMULATOR AND SOLUBLE FERTILIZER AT RECOMMENDED RATE FOR EACH TREE SPECIES.
  14. PROVIDE 3" OF SHREDDED BARK MULCH AT ALL SHRUB AND TREE WELLS.
  15. LANDSCAPE BOULDERS OF 2' OR LARGER SHALL BE RETAINED ON SITE FOR USE IN LANDSCAPE WORK. BURY DECORATIVE BOULDERS ONE-HALF OF DIAMETER.
  16. ADDITIONAL CONSULTATION WITH A QUALIFIED LANDSCAPE PROFESSIONAL AT OWNER OPTION IS RECOMMENDED.
  17. REVEGETATE ALL DISTURBED SITE AREAS WITH APPROVED SEED MIX.
- NOTE:** ALL LANDSCAPING SHALL BE INSTALLED IN STRICT ACCORDANCE WITH TOWN OF BLUE RIVER GUIDELINES.

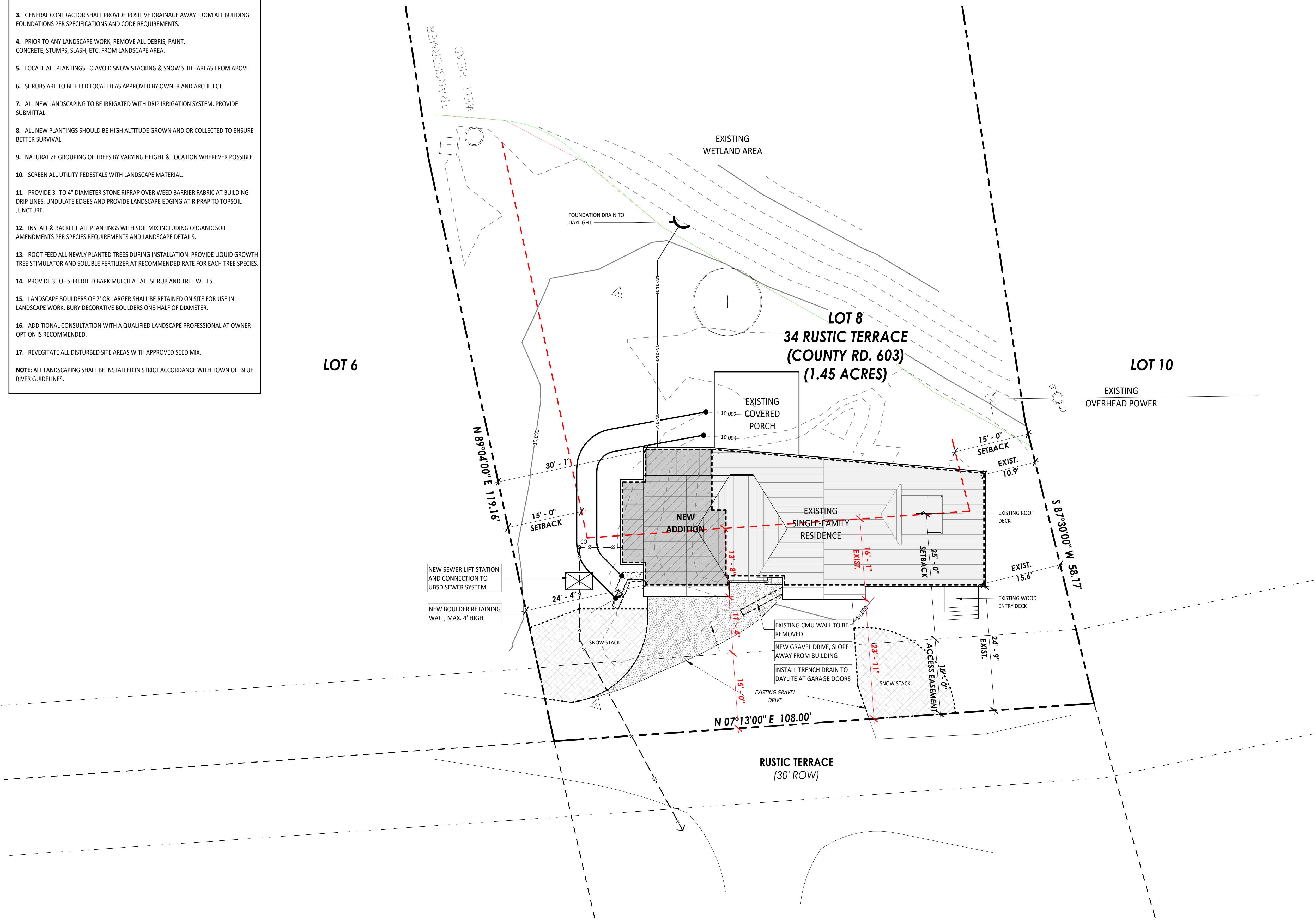

1 SITE PLAN - ENLARGED  
1" = 10'-0"







ROOTED ARCHITECTURE

SEAL:

NOT FOR CONSTRUCTION

DRAWINGS AND SPECIFICATIONS AS INSTRUMENTS OF SERVICE ARE THE PROPERTY OF THE ARCHITECT. THEY SHALL NOT BE USED, TRANSFERRED, OR SOLD FOR USE EXCEPT BY AN AGREEMENT IN WRITING FROM THE ARCHITECT.

FITZGERALD ADDITION  
34 RUSTIC TERRACE  
BLUE RIVER, CO

No.	Date	Revisions

Project No: 2023-16  
 Stage: FINAL REVIEW SET  
 Date: 05/02/2024  
 Scale: As indicated

DRAWING TITLE:  
**FLOOR PLAN - LOWER**  
 DRAWING NO:

A1.1

- NOTES: FLOOR PLAN**
1. ALL INFORMATION MUST BE CONFIRMED PRIOR TO COMMENCEMENT OF CONSTRUCTION. ANY ERRORS OR DISCREPANCIES MUST BE BROUGHT TO THE ATTENTION OF THE ARCHITECT PRIOR TO PROCEEDING WITH WORK.
  2. IT SHALL BE THE RESPONSIBILITY OF THE CONTRACTOR AND/OR INDIVIDUAL CONTRACTORS TO SEE THAT ALL ITEMS MEET OR EXCEED CODE REQUIREMENTS.
  3. BUILDING SHALL VERIFY ALL DIMENSIONS, INTERIOR & EXTERIOR FINISHES, CONSTRUCTION & FRAMING METHODS PRIOR TO CONSTRUCTION.
  4. ALL MATERIALS & WORKMANSHIP INVOLVED IN THE CONSTRUCTION OF THIS PROJECT ARE TO CONFORM WITH ALL LOCAL, STATE, NATIONAL, & INTERNATIONAL BUILDING CODES AS DESCRIBED IN THE INTERNATIONAL ONE & TWO FAMILY DWELLING CODE.
  5. DRAWINGS ARE NOT TO BE SCALED. ALL DIMENSIONS ARE FROM FACE OF STUD TO FACE OF STUD, U.N.O. ALL DIMENSIONS LABELED "CLEAR" ARE TO FACE OF FINISH MATERIAL.
  6. ALL INTERIOR GYPSUM BOARD TO BE 1/2" MINIMUM. USE WATER-RESISTANT GYPSUM BOARD AT ALL WET WALL LOCATIONS. USE 5/8" TYPE "X" DRYWALL SEPARATIONS BETWEEN LIVING SPACES AND GARAGES AS REQUIRED BY CODE.
  7. ALL TUB & SHOWER UNITS TO HAVE ANTI-SCALDING DEVICES INSTALLED.
  8. GARAGE DOORS TO BE CERTIFIED BY MANUFACTURER FOR LOCAL WIND REQUIREMENTS
  9. CONTRACTOR TO COORDINATE ELECTRICAL, PLUMBING AND HEATING WORK WITH SUBCONTRACTORS PRIOR TO STARTING WORK. PROVIDE ARCHITECT AND OWNER WITH SUBMITTALS WHERE APPLICABLE.
  10. ALL ANGLED WALLS TO BE 45° UNLESS NOTED OTHERWISE.
  11. MILLWORK SUBCONTRACTOR TO PROVIDE MILLWORK SHOP DRAWINGS TO THE ARCHITECTS, OWNER, AND CONTRACTOR FOR APPROVAL PRIOR TO COMMENCING FABRICATION.
  12. CONTRACTOR TO COORDINATE BASEBOARD RADIANT HEAT LOCATIONS WITH OWNER AND MECHANICAL DESIGNER PRIOR TO INSTALLATION.

- NOTES: DOOR AND WINDOW**
1. ALL WINDOWS ARE DIMENSIONED TO THE CENTERLINE OF WINDOW; CONTRACTOR TO COORDINATE ACTUAL REQUIRED ROUGH OPENING WITH WINDOW MANUFACTURER. PRIOR TO ANY FRAMING WORK, VERIFY ROUGH OPENING DIMENSIONS WITH WINDOW MANUFACTURER. NOTIFY ARCHITECT OF ANY DISCREPANCIES.
  2. SEE PLANS / DOOR AND WINDOW SCHEDULES FOR WINDOW / DOOR OPERATION, SIZES AND TYPES. VERIFY JAMB WIDTHS WITH WALL THICKNESS PRIOR TO INSTALLATION
  3. PROVIDE WEATHER STRIPPING AND ALUMINUM THRESHOLD SET IN SEALANT AT ALL EXTERIOR DOORS.
  4. PROVIDE SAFETY GLASS TO COMPLY WITH CODE REQUIREMENTS (SEE CURRENT I.R.C.). WINDOWS LOCATED MORE THAN 72" ABOVE FINISHED GRADE AND LESS THAN 24" ABOVE THE FINISHED FLOOR OF THE ROOM IN WHICH THE WINDOW IS LOCATED SHALL HAVE OPENING CONTROL DEVICES IN ACCORDANCE WITH IRC R310.2.2. WINDOWS / DOORS LOCATED IN SLEEPING ROOMS SHALL ACT AS EMERGENCY ESCAPE AND RESCUE OPENINGS PER IRC R310.1
  5. ALL GLAZING SYSTEMS SHALL BE RATED FOR USE AT HIGH ALTITUDES PER MANUFACTURER'S REQUIREMENTS. GLAZED FENESTRATION SHALL COMPLY WITH THE MINIMUM REQUIREMENTS OF IRC AND SUMMIT COUNTY SUSTAINABILITY CODE.
  6. WRAP ALL EXTERIOR OPENINGS WITH WEATHER RESISTIVE BARRIER PER MANUFACTURERS SPECIFICATIONS. PROVIDE 1-1/2" X 1-1/2" HEAD FLASHING AT ALL EXTERIOR OPENINGS (PRIME AND PAINT OR COLOR CLAD). INSULATE ALL EXTERIOR SHIM SPACES AT WINDOWS AND DOORS.
  7. PROVIDE SHOP DRAWINGS FOR ALL SPECIAL/CUSTOM DOORS AND WINDOWS PRIOR TO FABRICATION. FIELD MEASURE TO VERIFY ALL CUSTOM UNIT SIZES.
  8. WINDOWS AND PATIO DOORS REFER TO 'JELD-WEN' BRAND OR COMPARABLE
  9. INTERIOR DOORS TO BE CENTERED ON SPACES OR INSTALLED W/ 4 1/2" OFFSET TO NEAREST WALL (U.N.O.). ALL WINDOW OPENINGS TO HAVE PAINTED GYPSUM BOARD RETURNS ON INTERIOR SIDE UNLESS NOTED OTHERWISE, REF. INTERIORS.
  10. ALL WINDOW OPENINGS TO HAVE PAINTED GYPSUM BOARD RETURNS ON INTERIOR SIDE UNLESS NOTED OTHERWISE, REF. INTERIORS.
  11. WINDOWS LOCATED IN SLEEPING ROOMS SHALL ACT AS EMERGENCY ESCAPE AND RESCUE OPENINGS PER IRC R310.1
  12. COORDINATE WINDOW SILL HEIGHT WITH GYPCRETE AND FLOOR FINISH THICKNESS WHERE REQUIRED. VERIFY AT LOCATIONS WHERE WINDOW SILLS TERMINATE AT FLOOR LEVEL OR AT TOP OF MILLWORK.
  13. VERIFY WINDOW STYLE, OPERATION, FINISH AND HARDWARE WITH OWNER PRIOR TO PLACING ORDER.
  14. WINDOW SUPPLIER TO PROVIDE TEMPERED GLAZING WHERE REQUIRED BY CODE.

- WALL LEGEND**
- NEW 2X4 / 2X6 WOOD STUD WALL
  - EXISTING 2X4 / 2X6 WOOD STUD WALL
  - EXISTING WALL TO BE REMOVED

- NOTES: REMODEL**
1. **PROTECTION OF EXISTING TO REMAIN:** THE CONTRACTOR SHALL PROVIDE PROTECTIVE COVERING FOR CARPET, FURNISHINGS, AND FINISHES IN EXISTING AREAS NOT DESIGNATED FOR DEMOLITION OR NEW CONSTRUCTION. THE CONTRACTOR SHALL BE RESPONSIBLE FOR THE REPAIR OF ANY DAMAGE CAUSED BY HIS WORK OR ANY SUBCONTRACTOR. IN PARTICULAR, THE CONTRACTOR SHALL MAINTAIN A DUST-FREE ENVIRONMENT WITHIN THE MAGNET VAULT.
  2. **SCHEDULING:** THE CONTRACTOR SHALL MEET WITH THE OWNER IN ADVANCE OF CONSTRUCTION COMMENCEMENT TO:
    - A. SCHEDULE, SEQUENCE AND COORDINATE ALL WORK
    - B. MAINTAIN EXITS AND EGRESS WIDTHS REQUIRED BY CODES DURING ALL PHASES OF CONSTRUCTION
  3. **CLEARANCES:** THE CONTRACTOR SHALL VERIFY THAT NEW CEILINGS CAN BE INSTALLED IN EXISTING SPACES TO CLEAR DUCTWORK AND OTHER CONSTRUCTED ITEMS AND MAINTAIN FLOOR TO CEILING HEIGHTS INDICATED ON DRAWINGS. IF DISCREPANCIES OCCUR DUE TO EXISTING CONDITIONS, CONSULT WITH THE ARCHITECT BEFORE PROCEEDING.
  4. **MATERIAL ALIGNMENT:** THE FINISH FACE OF MATERIAL OF NEW PARTITIONS SHALL ALIGN ON BOTH SIDES OF THE PARTITION WITH THE FACE OF THE MATERIALS ON EXISTING COLUMNS, WALLS, OR PARTITIONS, UNLESS NOTED OTHERWISE.
  5. **AS BUILT VERIFICATION:** THE CONTRACTOR SHALL VERIFY DIMENSIONS OF AS-BUILT CONDITIONS, AND NOTIFY THE ARCHITECT IN WRITING OF ANY DISCREPANCIES. ALL INFORMATION SHOWN ON THE CONSTRUCTION DOCUMENTS IS BASED ON FIELD OBSERVATIONS AND/OR THE ORIGINAL CONSTRUCTION DOCUMENTS OF THE FACILITY.
  6. **REMOVAL SURVEY:** THE CONTRACTOR SHALL SURVEY AND DETERMINE THE REMOVAL OF EXISTING CONSTRUCTION, EITHER WHOLE OR IN PART, AS REQUIRED FOR THE INSTALLATION OF THE NEW MECHANICAL, PLUMBING AND ELECTRICAL WORK.
  7. **CONSTRUCTION DEFECTS:** THE CONTRACTOR SHALL NOTIFY THE ARCHITECT IN WRITING OF ANY CONSTRUCTION DEFECTS FOUND IN UNCOVERING WORK IN THE EXISTING CONSTRUCTION.
  8. **CORRECTING DEFECTIVE WORK:** THE CONTRACTOR SHALL BE RESPONSIBLE FOR CORRECTING DEFECTIVE WORK IN EXISTING CONSTRUCTION WITHIN THE LIMITS OF THE CONSTRUCTION AREA. THIS INCLUDES, BUT IS NOT LIMITED TO, UNEVEN SURFACES AND FINISHES AT PLASTER OR GYPSUM BOARD. THE CONTRACTOR SHALL PATCH AND REPAIR SURFACES TO MATCH NEW ADJACENT SURFACES.
  9. **PIPING:** ALL PIPING ABOVE GRADE AND INSIDE THE BUILDING REQUIRED BY THE CONSTRUCTION DOCUMENTS SHALL BE INSTALLED IN AREAS WHERE IT WILL BE CONCEALED. THE CONTRACTOR SHALL CONSULT WITH THE ARCHITECT AND COORDINATE WITH OTHER TRADES TO PROVIDE FURRING FOR PIPING INSTALLED IN FINISH AREAS.
  10. **FIXTURE REMOVAL:** REMOVE MECHANICAL AND ELECTRICAL FIXTURES AND CAP OR REMOVE EXISTING BRANCH LINES AS INDICATED IN THE MECHANICAL AND ELECTRICAL DOCUMENTS.
  11. **COORDINATION:** COORDINATE PLANS FOR NEW CONSTRUCTION WITH DEMOLITION PLANS FOR EXTENT OF REMOVAL. REMOVE ONLY THOSE PORTIONS OF WALLS, FLOORS, CEILINGS, ETC. NECESSARY TO ACCOMMODATE NEW CONSTRUCTION.

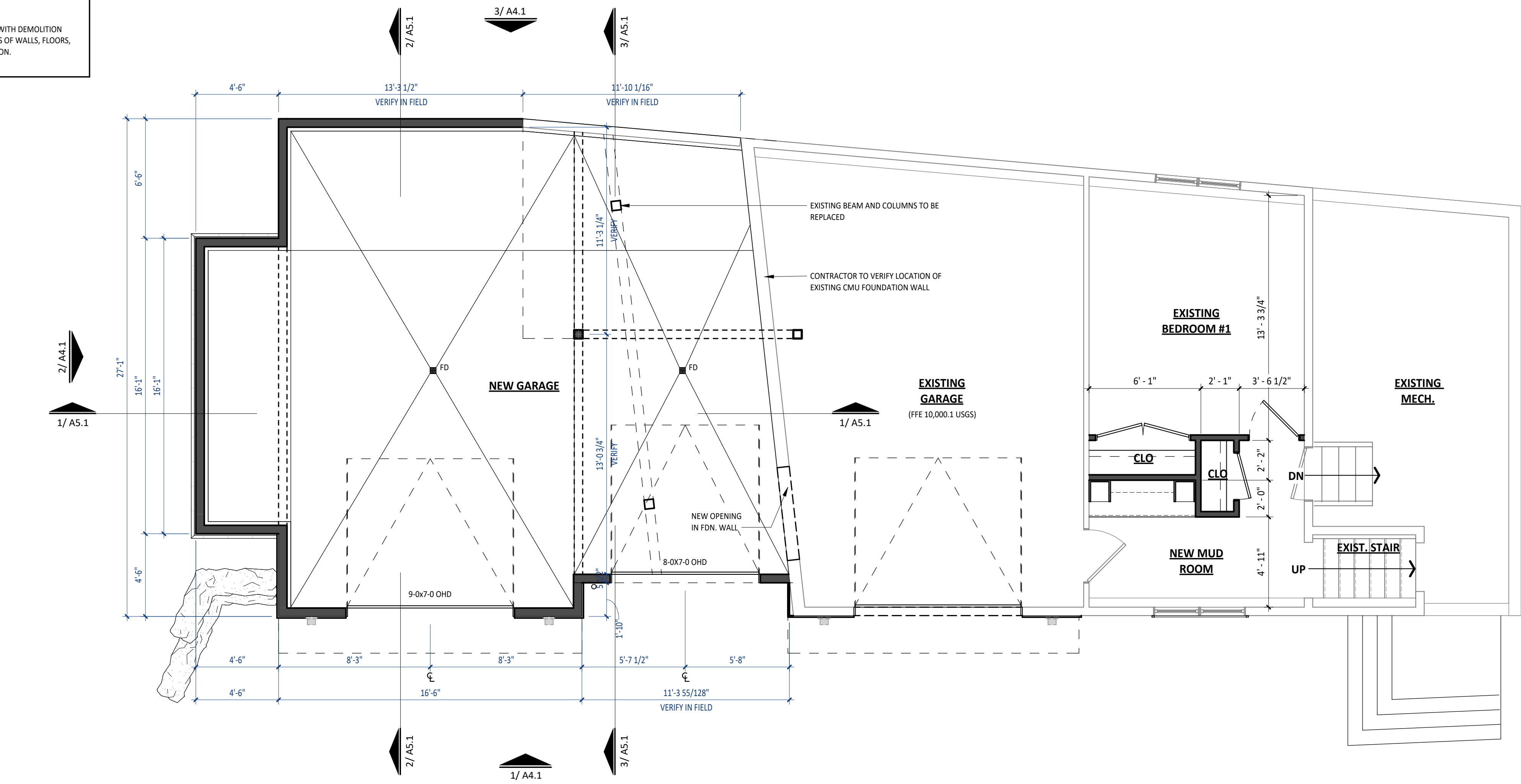

1 FLOOR PLAN - LOWER LEVEL  
1/4" = 1'-0"

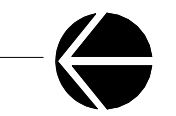

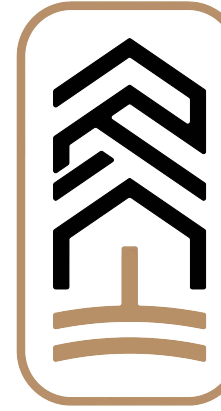

ROOTED ARCHITECTURE

SEAL:

NOT FOR CONSTRUCTION

DRAWINGS AND SPECIFICATIONS AS INSTRUMENTS OF SERVICE ARE THE PROPERTY OF THE ARCHITECT. THEY SHALL NOT BE USED, TRANSFERRED, OR SOLD FOR USE EXCEPT BY AN AGREEMENT IN WRITING FROM THE ARCHITECT.

FITZGERALD ADDITION

34 RUSTIC TERRACE  
BLUE RIVER, CO

No. Date Revisions

Project No: 2023-16  
Stage: FINAL REVIEW SET  
Date: 05/02/2024  
Scale: As indicated

DRAWING TITLE:

FLOOR PLAN - MAIN

DRAWING NO:

A1.2

NOTES: FLOOR PLAN

- 1. ALL INFORMATION MUST BE CONFIRMED PRIOR TO COMMENCEMENT OF CONSTRUCTION. ANY ERRORS OR DISCREPANCIES MUST BE BROUGHT TO THE ATTENTION OF THE ARCHITECT PRIOR TO PROCEEDING WITH WORK.
2. IT SHALL BE THE RESPONSIBILITY OF THE CONTRACTOR AND/OR INDIVIDUAL CONTRACTORS TO SEE THAT ALL ITEMS MEET OR EXCEED CODE REQUIREMENTS.
3. BUILDING SHALL VERIFY ALL DIMENSIONS, INTERIOR & EXTERIOR FINISHES, CONSTRUCTION & FRAMING METHODS PRIOR TO CONSTRUCTION.
4. ALL MATERIALS & WORKMANSHIP INVOLVED IN THE CONSTRUCTION OF THIS PROJECT ARE TO CONFORM WITH ALL LOCAL, STATE, NATIONAL, & INTERNATIONAL BUILDING CODES AS DESCRIBED IN THE INTERNATIONAL ONE & TWO FAMILY DWELLING CODE.
5. DRAWINGS ARE NOT TO BE SCALED. ALL DIMENSIONS ARE FROM FACE OF STUD TO FACE OF STUD, U.N.O. ALL DIMENSIONS LABELED "CLEAR" ARE TO FACE OF FINISH MATERIAL.
6. ALL INTERIOR GYPSUM BOARD TO BE 1/2" MINIMUM. USE WATER-RESISTANT GYPSUM BOARD AT ALL WET WALL LOCATIONS. USE 5/8" TYPE "X" DRYWALL SEPARATIONS BETWEEN LIVING SPACES AND GARAGES AS REQUIRED BY CODE.
7. ALL TUB & SHOWER UNITS TO HAVE ANTI-SCALDING DEVICES INSTALLED.
8. GARAGE DOORS TO BE CERTIFIED BY MANUFACTURER FOR LOCAL WIND REQUIREMENTS
9. CONTRACTOR TO COORDINATE ELECTRICAL, PLUMBING AND HEATING WORK WITH SUBCONTRACTORS PRIOR TO STARTING WORK. PROVIDE ARCHITECT AND OWNER WITH SUBMITTALS WHERE APPLICABLE.
10. ALL ANGLED WALLS TO BE 45° UNLESS NOTED OTHERWISE.
11. MILLWORK SUBCONTRACTOR TO PROVIDE MILLWORK SHOP DRAWINGS TO THE ARCHITECTS, OWNER, AND CONTRACTOR FOR APPROVAL PRIOR TO COMMENCING FABRICATION.
12. CONTRACTOR TO COORDINATE BASEBOARD RADIANT HEAT LOCATIONS WITH OWNER AND MECHANICAL DESIGNER PRIOR TO INSTALLATION.

NOTES: DOOR AND WINDOW

- 1. ALL WINDOWS ARE DIMENSIONED TO THE CENTERLINE OF WINDOW; CONTRACTOR TO COORDINATE ACTUAL REQUIRED ROUGH OPENING WITH WINDOW MANUFACTURER. PRIOR TO ANY FRAMING WORK, VERIFY ROUGH OPENING DIMENSIONS WITH WINDOW MANUFACTURER. NOTIFY ARCHITECT OF ANY DISCREPANCIES.
2. SEE PLANS / DOOR AND WINDOW SCHEDULES FOR WINDOW / DOOR OPERATION, SIZES AND TYPES. VERIFY JAMB WIDTHS WITH WALL THICKNESS PRIOR TO INSTALLATION
3. PROVIDE WEATHER STRIPPING AND ALUMINUM THRESHOLD SET IN SEALANT AT ALL EXTERIOR DOORS.
4. PROVIDE SAFETY GLASS TO COMPLY WITH CODE REQUIREMENTS (SEE CURRENT I.R.C.). WINDOWS LOCATED MORE THAN 72" ABOVE FINISHED GRADE AND LESS THAN 24" ABOVE THE FINISHED FLOOR OF THE ROOM IN WHICH THE WINDOW IS LOCATED SHALL HAVE OPENING CONTROL DEVICES IN ACCORDANCE WITH IRC R310.2.2. WINDOWS / DOORS LOCATED IN SLEEPING ROOMS SHALL ACT AS EMERGENCY ESCAPE AND RESCUE OPENINGS PER IRC R310.1
5. ALL GLAZING SYSTEMS SHALL BE RATED FOR USE AT HIGH ALTITUDES PER MANUFACTURER'S REQUIREMENTS. GLAZED FENESTRATION SHALL COMPLY WITH THE MINIMUM REQUIREMENTS OF IRC AND SUMMIT COUNTY SUSTAINABILITY CODE.
6. WRAP ALL EXTERIOR OPENINGS WITH WEATHER RESISTIVE BARRIER PER MANUFACTURERS SPECIFICATIONS. PROVIDE 1-1/2" X 1-1/2" HEAD FLASHING AT ALL EXTERIOR OPENINGS (PRIME AND PAINT OR COLOR CLAD). INSULATE ALL EXTERIOR SHIM SPACES AT WINDOWS AND DOORS.
7. PROVIDE SHOP DRAWINGS FOR ALL SPECIAL/CUSTOM DOORS AND WINDOWS PRIOR TO FABRICATION. FIELD MEASURE TO VERIFY ALL CUSTOM UNIT SIZES.
8. WINDOWS AND PATIO DOORS REFER TO 'JELD-WEN' BRAND OR COMPARABLE
9. INTERIOR DOORS TO BE CENTERED ON SPACES OR INSTALLED W/ 4 1/2" OFFSET TO NEAREST WALL (U.N.O.). ALL WINDOW OPENINGS TO HAVE PAINTED GYPSUM BOARD RETURNS ON INTERIOR SIDE UNLESS NOTED OTHERWISE, REF. INTERIORS.
10. ALL WINDOW OPENINGS TO HAVE PAINTED GYPSUM BOARD RETURNS ON INTERIOR SIDE UNLESS NOTED OTHERWISE, REF. INTERIORS.
11. WINDOWS LOCATED IN SLEEPING ROOMS SHALL ACT AS EMERGENCY ESCAPE AND RESCUE OPENINGS PER IRC R310.1
12. COORDINATE WINDOW SILL HEIGHT WITH GYPCRETE AND FLOOR FINISH THICKNESS WHERE REQUIRED. VERIFY AT LOCATIONS WHERE WINDOW SILLS TERMINATE AT FLOOR LEVEL OR AT TOP OF MILLWORK.
13. VERIFY WINDOW STYLE, OPERATION, FINISH AND HARDWARE WITH OWNER PRIOR TO PLACING ORDER.
14. WINDOW SUPPLIER TO PROVIDE TEMPERED GLAZING WHERE REQUIRED BY CODE.

WALL LEGEND

- NEW 2X4 / 2X6 WOOD STUD WALL
EXISTING 2X4 / 2X6 WOOD STUD WALL
EXISTING WALL TO BE REMOVED

NOTES: REMODEL

- 1. PROTECTION OF EXISTING TO REMAIN: THE CONTRACTOR SHALL PROVIDE PROTECTIVE COVERING FOR CARPET, FURNISHINGS, AND FINISHES IN EXISTING AREAS NOT DESIGNATED FOR DEMOLITION OR NEW CONSTRUCTION. THE CONTRACTOR SHALL BE RESPONSIBLE FOR THE REPAIR OF ANY DAMAGE CAUSED BY HIS WORK OR ANY SUBCONTRACTOR. IN PARTICULAR, THE CONTRACTOR SHALL MAINTAIN A DUST-FREE ENVIRONMENT WITHIN THE MAGNET VAULT.
2. SCHEDULING: THE CONTRACTOR SHALL MEET WITH THE OWNER IN ADVANCE OF CONSTRUCTION COMMENCEMENT TO:
A. SCHEDULE, SEQUENCE AND COORDINATE ALL WORK
B. MAINTAIN EXITS AND EGRESS WIDTHS REQUIRED BY CODES DURING ALL PHASES OF CONSTRUCTION
3. CLEARANCES: THE CONTRACTOR SHALL VERIFY THAT NEW CEILINGS CAN BE INSTALLED IN EXISTING SPACES TO CLEAR DUCTWORK AND OTHER CONSTRUCTED ITEMS AND MAINTAIN FLOOR TO CEILING HEIGHTS INDICATED ON DRAWINGS. IF DISCREPANCIES OCCUR DUE TO EXISTING CONDITIONS, CONSULT WITH THE ARCHITECT BEFORE PROCEEDING.
4. MATERIAL ALIGNMENT: THE FINISH FACE OF MATERIAL OF NEW PARTITIONS SHALL ALIGN ON BOTH SIDES OF THE PARTITION WITH THE FACE OF THE MATERIALS ON EXISTING COLUMNS, WALLS, OR PARTITIONS, UNLESS NOTED OTHERWISE.
5. AS BUILT VERIFICATION: THE CONTRACTOR SHALL VERIFY DIMENSIONS OF AS-BUILT CONDITIONS, AND NOTIFY THE ARCHITECT IN WRITING OF ANY DISCREPANCIES. ALL INFORMATION SHOWN ON THE CONSTRUCTION DOCUMENTS IS BASED ON FIELD OBSERVATIONS AND/OR THE ORIGINAL CONSTRUCTION DOCUMENTS OF THE FACILITY.
6. REMOVAL SURVEY: THE CONTRACTOR SHALL SURVEY AND DETERMINE THE REMOVAL OF EXISTING CONSTRUCTION, EITHER WHOLE OR IN PART, AS REQUIRED FOR THE INSTALLATION OF THE NEW MECHANICAL, PLUMBING AND ELECTRICAL WORK.
7. CONSTRUCTION DEFECTS: THE CONTRACTOR SHALL NOTIFY THE ARCHITECT IN WRITING OF ANY CONSTRUCTION DEFECTS FOUND IN UNCOVERING WORK IN THE EXISTING CONSTRUCTION.
8. CORRECTING DEFECTIVE WORK: THE CONTRACTOR SHALL BE RESPONSIBLE FOR CORRECTING DEFECTIVE WORK IN EXISTING CONSTRUCTION WITHIN THE LIMITS OF THE CONSTRUCTION AREA. THIS INCLUDES, BUT IS NOT LIMITED TO, UNEVEN SURFACES AND FINISHES AT PLASTER OR GYPSUM BOARD. THE CONTRACTOR SHALL PATCH AND REPAIR SURFACES TO MATCH NEW ADJACENT SURFACES.
9. PIPING: ALL PIPING ABOVE GRADE AND INSIDE THE BUILDING REQUIRED BY THE CONSTRUCTION DOCUMENTS SHALL BE INSTALLED IN AREAS WHERE IT WILL BE CONCEALED. THE CONTRACTOR SHALL CONSULT WITH THE ARCHITECT AND COORDINATE WITH OTHER TRADES TO PROVIDE FURRING FOR PIPING INSTALLED IN FINISH AREAS.
10. FIXTURE REMOVAL: REMOVE MECHANICAL AND ELECTRICAL FIXTURES AND CAP OR REMOVE EXISTING BRANCH LINES AS INDICATED IN THE MECHANICAL AND ELECTRICAL DOCUMENTS.
11. COORDINATION: COORDINATE PLANS FOR NEW CONSTRUCTION WITH DEMOLITION PLANS FOR EXTENT OF REMOVAL. REMOVE ONLY THOSE PORTIONS OF WALLS, FLOORS, CEILINGS, ETC. NECESSARY TO ACCOMMODATE NEW CONSTRUCTION.

1 FLOOR PLAN - MAIN LEVEL
1/4" = 1'-0"

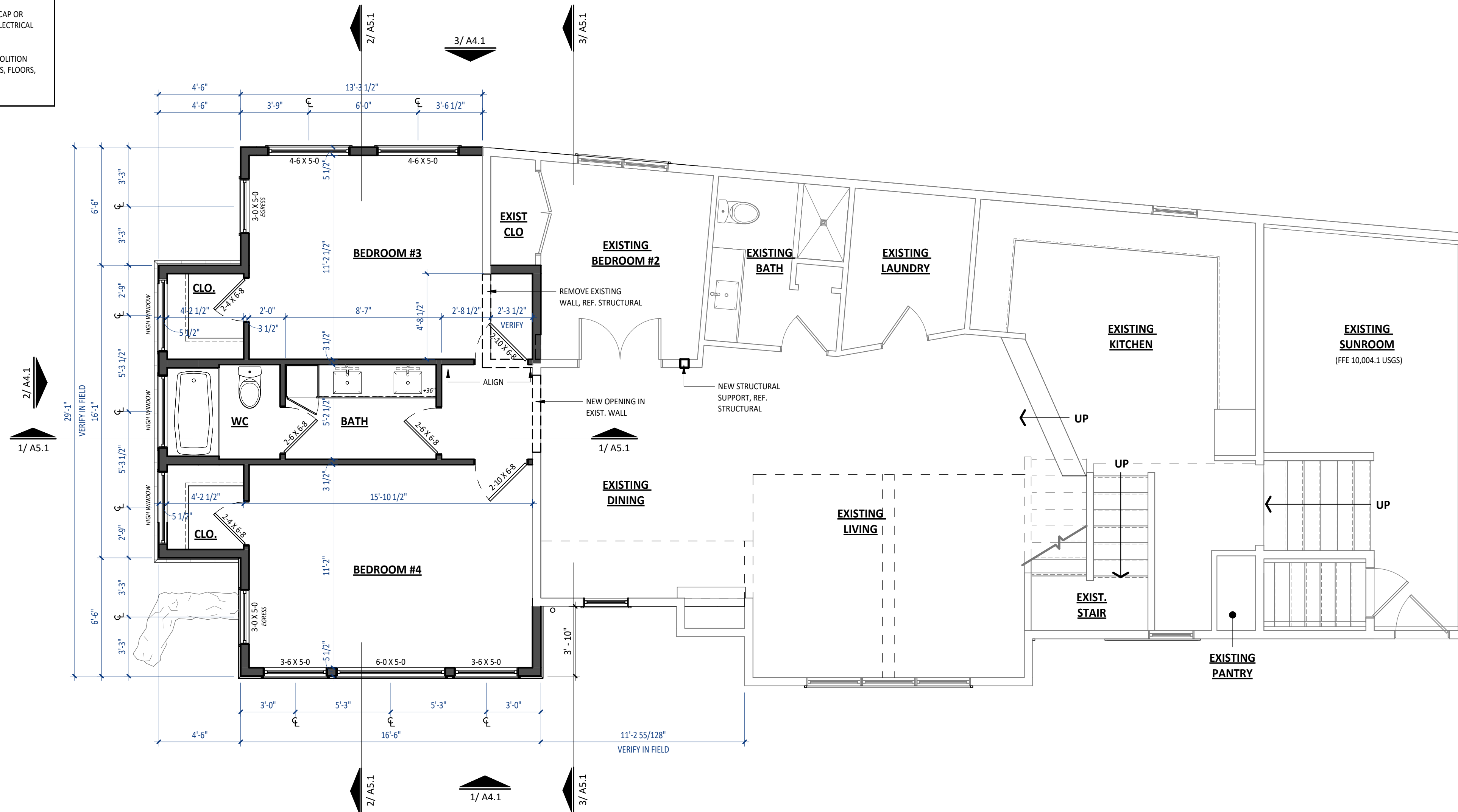

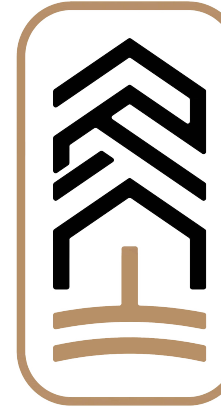

ROOTED ARCHITECTURE

SEAL:

NOT FOR CONSTRUCTION

DRAWINGS AND SPECIFICATIONS AS INSTRUMENTS OF SERVICE ARE THE PROPERTY OF THE ARCHITECT. THEY SHALL NOT BE USED, TRANSFERRED, OR SOLD FOR USE EXCEPT BY AN AGREEMENT IN WRITING FROM THE ARCHITECT.

FITZGERALD ADDITION

34 RUSTIC TERRACE  
BLUE RIVER, CO

No. Date Revisions

Project No: 2023-16  
Stage: FINAL REVIEW SET  
Date: 05/02/2024  
Scale: As indicated

DRAWING TITLE:

FLOOR PLAN - UPPER

DRAWING NO:

A1.3

NOTES: FLOOR PLAN

- 1. ALL INFORMATION MUST BE CONFIRMED PRIOR TO COMMENCEMENT OF CONSTRUCTION. ANY ERRORS OR DISCREPANCIES MUST BE BROUGHT TO THE ATTENTION OF THE ARCHITECT PRIOR TO PROCEEDING WITH WORK.
2. IT SHALL BE THE RESPONSIBILITY OF THE CONTRACTOR AND/OR INDIVIDUAL CONTRACTORS TO SEE THAT ALL ITEMS MEET OR EXCEED CODE REQUIREMENTS.
3. BUILDING SHALL VERIFY ALL DIMENSIONS, INTERIOR & EXTERIOR FINISHES, CONSTRUCTION & FRAMING METHODS PRIOR TO CONSTRUCTION.
4. ALL MATERIALS & WORKMANSHIP INVOLVED IN THE CONSTRUCTION OF THIS PROJECT ARE TO CONFORM WITH ALL LOCAL, STATE, NATIONAL, & INTERNATIONAL BUILDING CODES AS DESCRIBED IN THE INTERNATIONAL ONE & TWO FAMILY DWELLING CODE.
5. DRAWINGS ARE NOT TO BE SCALED. ALL DIMENSIONS ARE FROM FACE OF STUD TO FACE OF STUD, U.N.O. ALL DIMENSIONS LABELED "CLEAR" ARE TO FACE OF FINISH MATERIAL.
6. ALL INTERIOR GYPSUM BOARD TO BE 1/2" MINIMUM. USE WATER-RESISTANT GYPSUM BOARD AT ALL WET WALL LOCATIONS. USE 5/8" TYPE "X" DRYWALL SEPARATIONS BETWEEN LIVING SPACES AND GARAGES AS REQUIRED BY CODE.
7. ALL TUB & SHOWER UNITS TO HAVE ANTI-SCALDING DEVICES INSTALLED.
8. GARAGE DOORS TO BE CERTIFIED BY MANUFACTURER FOR LOCAL WIND REQUIREMENTS
9. CONTRACTOR TO COORDINATE ELECTRICAL, PLUMBING AND HEATING WORK WITH SUBCONTRACTORS PRIOR TO STARTING WORK. PROVIDE ARCHITECT AND OWNER WITH SUBMITTALS WHERE APPLICABLE.
10. ALL ANGLED WALLS TO BE 45° UNLESS NOTED OTHERWISE.
11. MILLWORK SUBCONTRACTOR TO PROVIDE MILLWORK SHOP DRAWINGS TO THE ARCHITECTS, OWNER, AND CONTRACTOR FOR APPROVAL PRIOR TO COMMENCING FABRICATION.
12. CONTRACTOR TO COORDINATE BASEBOARD RADIANT HEAT LOCATIONS WITH OWNER AND MECHANICAL DESIGNER PRIOR TO INSTALLATION.

NOTES: DOOR AND WINDOW

- 1. ALL WINDOWS ARE DIMENSIONED TO THE CENTERLINE OF WINDOW; CONTRACTOR TO COORDINATE ACTUAL REQUIRED ROUGH OPENING WITH WINDOW MANUFACTURER. PRIOR TO ANY FRAMING WORK, VERIFY ROUGH OPENING DIMENSIONS WITH WINDOW MANUFACTURER. NOTIFY ARCHITECT OF ANY DISCREPANCIES.
2. SEE PLANS / DOOR AND WINDOW SCHEDULES FOR WINDOW / DOOR OPERATION, SIZES AND TYPES. VERIFY JAMB WIDTHS WITH WALL THICKNESS PRIOR TO INSTALLATION
3. PROVIDE WEATHER STRIPPING AND ALUMINUM THRESHOLD SET IN SEALANT AT ALL EXTERIOR DOORS.
4. PROVIDE SAFETY GLASS TO COMPLY WITH CODE REQUIREMENTS (SEE CURRENT I.R.C.). WINDOWS LOCATED MORE THAN 72" ABOVE FINISHED GRADE AND LESS THAN 24" ABOVE THE FINISHED FLOOR OF THE ROOM IN WHICH THE WINDOW IS LOCATED SHALL HAVE OPENING CONTROL DEVICES IN ACCORDANCE WITH IRC R310.2.2. WINDOWS / DOORS LOCATED IN SLEEPING ROOMS SHALL ACT AS EMERGENCY ESCAPE AND RESCUE OPENINGS PER IRC R310.1
5. ALL GLAZING SYSTEMS SHALL BE RATED FOR USE AT HIGH ALTITUDES PER MANUFACTURER'S REQUIREMENTS. GLAZED FENESTRATION SHALL COMPLY WITH THE MINIMUM REQUIREMENTS OF IRC AND SUMMIT COUNTY SUSTAINABILITY CODE.
6. WRAP ALL EXTERIOR OPENINGS WITH WEATHER RESISTIVE BARRIER PER MANUFACTURERS SPECIFICATIONS. PROVIDE 1-1/2" X 1-1/2" HEAD FLASHING AT ALL EXTERIOR OPENINGS (PRIME AND PAINT OR COLOR CLAD). INSULATE ALL EXTERIOR SHIM SPACES AT WINDOWS AND DOORS.
7. PROVIDE SHOP DRAWINGS FOR ALL SPECIAL/CUSTOM DOORS AND WINDOWS PRIOR TO FABRICATION. FIELD MEASURE TO VERIFY ALL CUSTOM UNIT SIZES.
8. WINDOWS AND PATIO DOORS REFER TO 'JELD-WEN' BRAND OR COMPARABLE
9. INTERIOR DOORS TO BE CENTERED ON SPACES OR INSTALLED W/ 4 1/2" OFFSET TO NEAREST WALL (U.N.O.). ALL WINDOW OPENINGS TO HAVE PAINTED GYPSUM BOARD RETURNS ON INTERIOR SIDE UNLESS NOTED OTHERWISE, REF. INTERIORS.
10. ALL WINDOW OPENINGS TO HAVE PAINTED GYPSUM BOARD RETURNS ON INTERIOR SIDE UNLESS NOTED OTHERWISE, REF. INTERIORS.
11. WINDOWS LOCATED IN SLEEPING ROOMS SHALL ACT AS EMERGENCY ESCAPE AND RESCUE OPENINGS PER IRC R310.1
12. COORDINATE WINDOW SILL HEIGHT WITH GYPCRETE AND FLOOR FINISH THICKNESS WHERE REQUIRED. VERIFY AT LOCATIONS WHERE WINDOW SILLS TERMINATE AT FLOOR LEVEL OR AT TOP OF MILLWORK.
13. VERIFY WINDOW STYLE, OPERATION, FINISH AND HARDWARE WITH OWNER PRIOR TO PLACING ORDER.
14. WINDOW SUPPLIER TO PROVIDE TEMPERED GLAZING WHERE REQUIRED BY CODE.

WALL LEGEND

- NEW 2X4 / 2X6 WOOD STUD WALL
EXISTING 2X4 / 2X6 WOOD STUD WALL
EXISTING WALL TO BE REMOVED

NOTES: REMODEL

- 1. PROTECTION OF EXISTING TO REMAIN: THE CONTRACTOR SHALL PROVIDE PROTECTIVE COVERING FOR CARPET, FURNISHINGS, AND FINISHES IN EXISTING AREAS NOT DESIGNATED FOR DEMOLITION OR NEW CONSTRUCTION. THE CONTRACTOR SHALL BE RESPONSIBLE FOR THE REPAIR OF ANY DAMAGE CAUSED BY HIS WORK OR ANY SUBCONTRACTOR. IN PARTICULAR, THE CONTRACTOR SHALL MAINTAIN A DUST-FREE ENVIRONMENT WITHIN THE MAGNET VAULT.
2. SCHEDULING: THE CONTRACTOR SHALL MEET WITH THE OWNER IN ADVANCE OF CONSTRUCTION COMMENCEMENT TO:
A. SCHEDULE, SEQUENCE AND COORDINATE ALL WORK
B. MAINTAIN EXITS AND EGRESS WIDTHS REQUIRED BY CODES DURING ALL PHASES OF CONSTRUCTION
3. CLEARANCES: THE CONTRACTOR SHALL VERIFY THAT NEW CEILINGS CAN BE INSTALLED IN EXISTING SPACES TO CLEAR DUCTWORK AND OTHER CONSTRUCTED ITEMS AND MAINTAIN FLOOR TO CEILING HEIGHTS INDICATED ON DRAWINGS. IF DISCREPANCIES OCCUR DUE TO EXISTING CONDITIONS, CONSULT WITH THE ARCHITECT BEFORE PROCEEDING.
4. MATERIAL ALIGNMENT: THE FINISH FACE OF MATERIAL OF NEW PARTITIONS SHALL ALIGN ON BOTH SIDES OF THE PARTITION WITH THE FACE OF THE MATERIALS ON EXISTING COLUMNS, WALLS, OR PARTITIONS, UNLESS NOTED OTHERWISE.
5. AS BUILT VERIFICATION: THE CONTRACTOR SHALL VERIFY DIMENSIONS OF AS-BUILT CONDITIONS, AND NOTIFY THE ARCHITECT IN WRITING OF ANY DISCREPANCIES. ALL INFORMATION SHOWN ON THE CONSTRUCTION DOCUMENTS IS BASED ON FIELD OBSERVATIONS AND/OR THE ORIGINAL CONSTRUCTION DOCUMENTS OF THE FACILITY.
6. REMOVAL SURVEY: THE CONTRACTOR SHALL SURVEY AND DETERMINE THE REMOVAL OF EXISTING CONSTRUCTION, EITHER WHOLE OR IN PART, AS REQUIRED FOR THE INSTALLATION OF THE NEW MECHANICAL, PLUMBING AND ELECTRICAL WORK.
7. CONSTRUCTION DEFECTS: THE CONTRACTOR SHALL NOTIFY THE ARCHITECT IN WRITING OF ANY CONSTRUCTION DEFECTS FOUND IN UNCOVERING WORK IN THE EXISTING CONSTRUCTION.
8. CORRECTING DEFECTIVE WORK: THE CONTRACTOR SHALL BE RESPONSIBLE FOR CORRECTING DEFECTIVE WORK IN EXISTING CONSTRUCTION WITHIN THE LIMITS OF THE CONSTRUCTION AREA. THIS INCLUDES, BUT IS NOT LIMITED TO, UNEVEN SURFACES AND FINISHES AT PLASTER OR GYPSUM BOARD. THE CONTRACTOR SHALL PATCH AND REPAIR SURFACES TO MATCH NEW ADJACENT SURFACES.
9. PIPING: ALL PIPING ABOVE GRADE AND INSIDE THE BUILDING REQUIRED BY THE CONSTRUCTION DOCUMENTS SHALL BE INSTALLED IN AREAS WHERE IT WILL BE CONCEALED. THE CONTRACTOR SHALL CONSULT WITH THE ARCHITECT AND COORDINATE WITH OTHER TRADES TO PROVIDE FURRING FOR PIPING INSTALLED IN FINISH AREAS.
10. FIXTURE REMOVAL: REMOVE MECHANICAL AND ELECTRICAL FIXTURES AND CAP OR REMOVE EXISTING BRANCH LINES AS INDICATED IN THE MECHANICAL AND ELECTRICAL DOCUMENTS.
11. COORDINATION: COORDINATE PLANS FOR NEW CONSTRUCTION WITH DEMOLITION PLANS FOR EXTENT OF REMOVAL. REMOVE ONLY THOSE PORTIONS OF WALLS, FLOORS, CEILINGS, ETC. NECESSARY TO ACCOMMODATE NEW CONSTRUCTION.

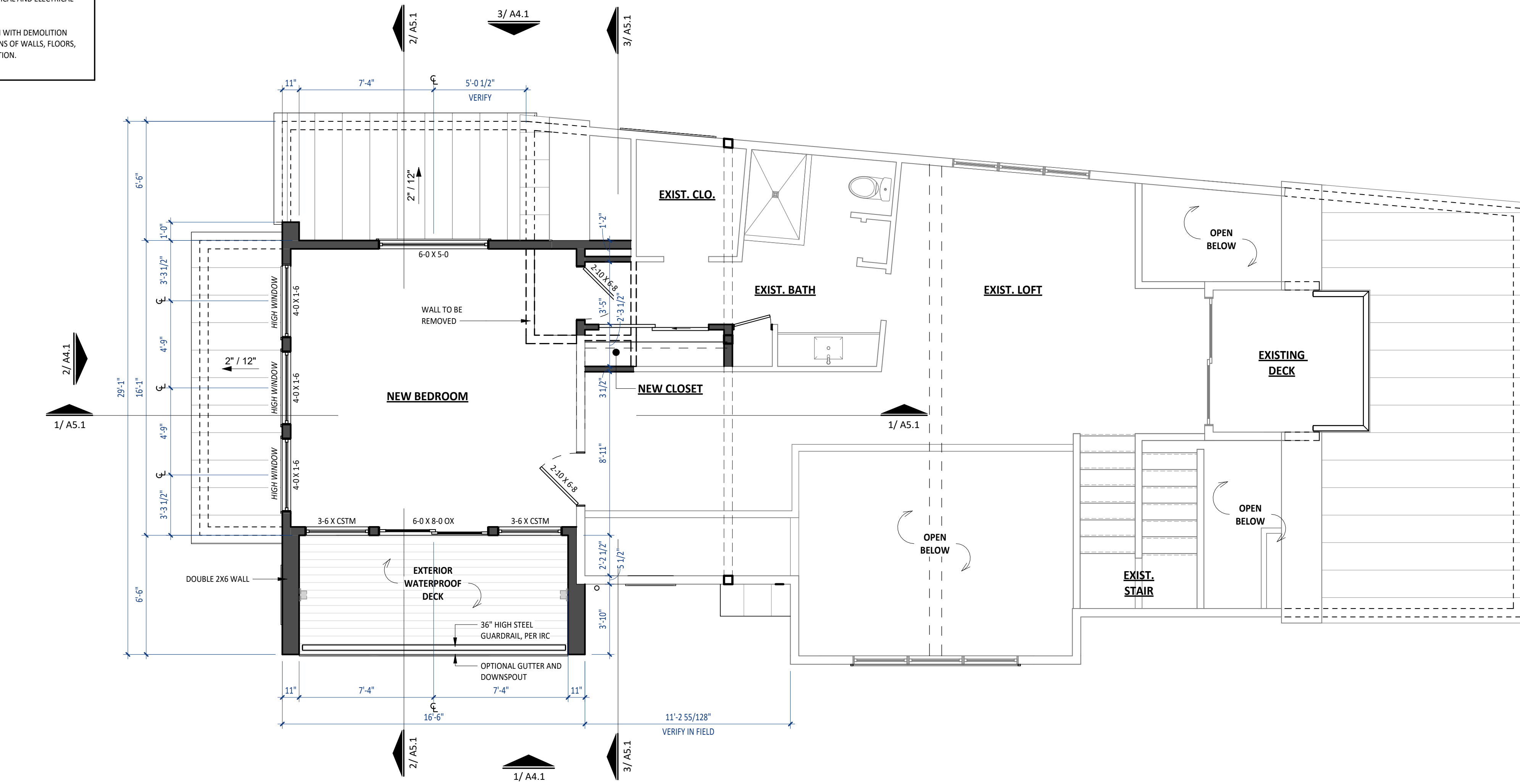

1 FLOOR PLAN - UPPER LEVEL  
1/4" = 1'-0"



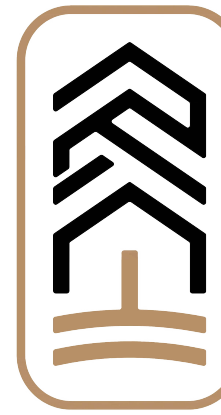

**ROOTED**  
ARCHITECTURE

SEAL:

NOT FOR CONSTRUCTION

DRAWINGS AND SPECIFICATIONS AS INSTRUMENTS OF SERVICE ARE THE PROPERTY OF THE ARCHITECT. THEY SHALL NOT BE USED, TRANSFERRED, OR SOLD FOR USE EXCEPT BY AN AGREEMENT IN WRITING FROM THE ARCHITECT.

**NOTES: ROOF PLAN**

1. COORDINATE INSTALLATION OF NEW ROOFING WITH OTHER TRADES. REPORT ANY CONFLICTS WITH ITEMS INSTALLED BY OTHER TRADES TO DESIGNER.
2. REFER TO SPECIFICATIONS. PROVIDE ROOF PRIMER, ROOF MEMBRANE AND ALL ROOFING PER SPECIFICATION REQUIREMENTS. PROVIDE "W.R. GRACE" MANUFACTURER CERTIFICATION LETTER STATING THAT ALL MEMBRANES HAVE BEEN INSTALLED IN COMPLETE COMPLIANCE WITH ALL MANUFACTURER'S REQUIREMENTS.
3. ALL PLUMBING VENTS SHALL EXTEND ABOVE THE FINISHED SURFACE OF THE ROOF SYSTEM AS REQUIRED TO PROVIDE FOR A MINIMUM OF 8" BASE FLASHING.
4. ALL EXPOSED METAL FLASHING/ TRIM PIECES TO BE PRE-FINISHED 24 GA. STL. U.N.O.. PROVIDE PRE-FINISHED OR FIELD PAINT FLASHING ONLY AS NOTED.
5. GUTTERS - ALL GUTTERS TO BE PRE-FINISHED. PROVIDE PRE-FINISHED SUPPORTS AND SPACERS @ 36" O.C. MAX. MATCH EXISTING GUTTER PROFILE AND FINISH.
6. ALL DOWNSPOUTS TO BE PRE-FINISHED, REFERENCE ELEVATIONS FOR LOCATIONS.
7. PROVIDE HEAT TAPE AT GUTTERS AND DOWNSPOUTS. REFER TO ROOF PLAN FOR ADDITIONAL FUTURE HEAT TAPE OUTLETS. SEE ROOF PLAN FOR WATERPROOF OUTLETS AT SIDEWALL AREAS. ALL GUTTERS AND DOWNSPOUTS TO BE HEATED. REFER TO PLAN FOR ALL SOLAR AND HEAT TAPE.
8. PAINT ALL EXPOSED PIPING EXTENDING THROUGH ROOF TO MATCH ROOF
9. PROVIDE VALLEY FLASHING AT ALL VALLEYS AS INDICATED ON PLANS.
10. OVERHANG DIMENSIONS ARE TO END OF RAFTER OR TRUSS AS INDICATED ON PLANS.
11. PROVIDE KICK-OUT FLASHING AT ALL EAVE/WALL JUNCTURES.
12. PROVIDE ILC AS REQUIRED.
13. CONTRACTOR TO COORDINATE HEATED GUTTER AND DOWNSPOUT LOCATIONS WITH ARCHITECT.
14. DOWNSPOUTS SHALL NOT DISCHARGE ONTO FLATWORK OR DECKS BELOW. CONTRACTOR TO ROUTE DISCHARGE BELOW SURFACE OR PROVIDE CHANNEL DRAIN IN FLATWORK WITH HEAT TAPE.
15. REFER TO SPECIFICATIONS. PROVIDE ROOF PRIMER, ROOF MEMBRANE AND ALL ROOFING PER SPECIFICATION REQUIREMENTS. PROVIDE "W.R. GRACE" MANUFACTURER CERTIFICATION LETTER STATING THAT ALL MEMBRANES HAVE BEEN INSTALLED IN COMPLETE COMPLIANCE WITH ALL MANUFACTURER'S REQUIREMENTS.
16. UNVENTED ROOFS SHALL HAVE A MINIMUM 60% AIR IMPERMEABLE CLOSED CELL INSULATION AT UNDERSIDE OF DECK.

**NOTES: ROOF MAINTENANCE**

THE OWNER HAS BEEN ADVISED THAT ALL ROOF AND DECK SURFACES MUST BE MAINTAINED RELATIVELY FREE OF SNOW & ICE.

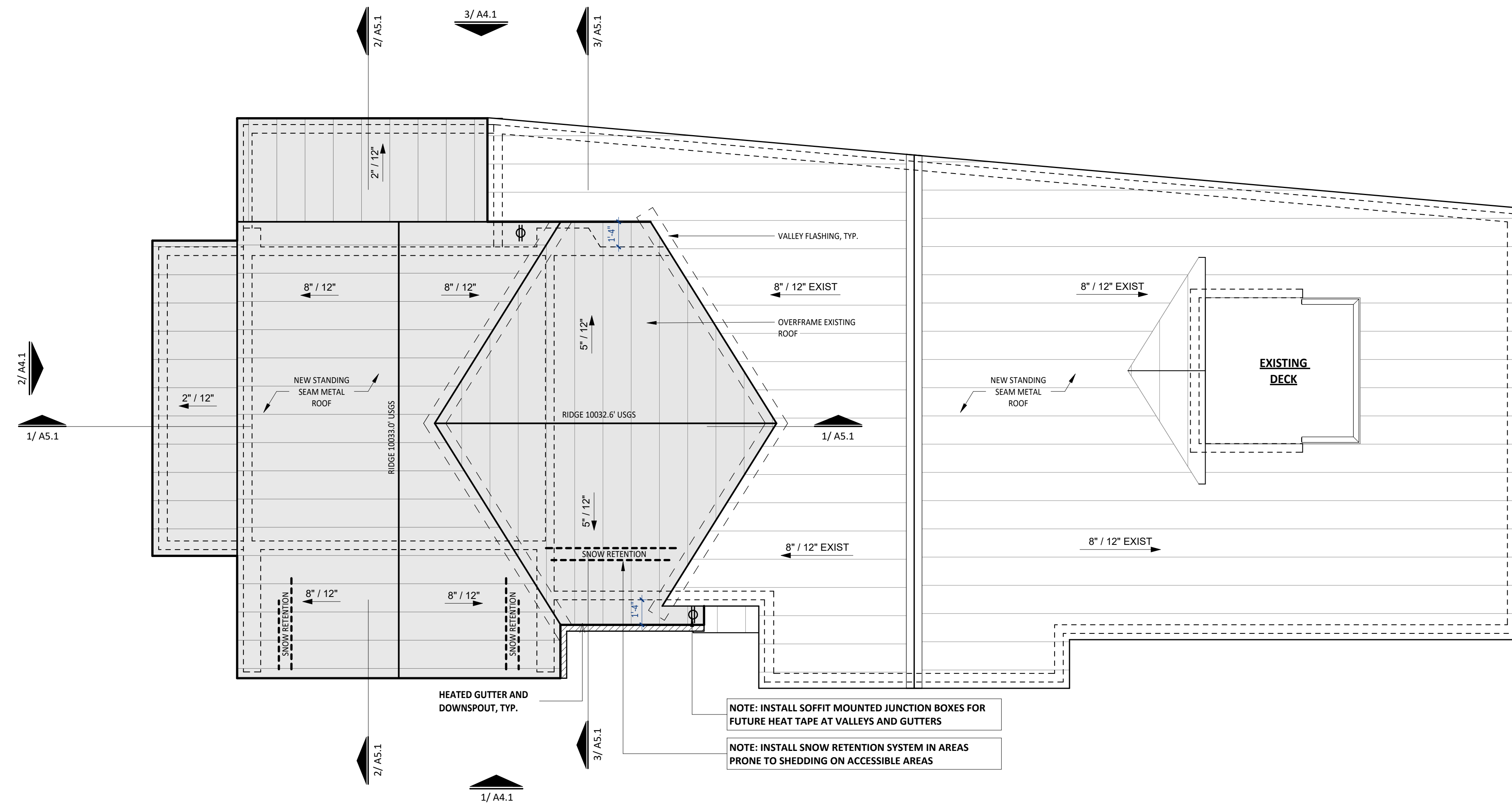

**1 ROOF PLAN**  
1/4" = 1'-0"

**FITZGERALD ADDITION**

34 RUSTIC TERRACE  
BLUE RIVER, CO

No.	Date	Revisions

Project No: 2023-16  
 Stage: FINAL REVIEW SET  
 Date: 05/02/2024  
 Scale: As indicated

DRAWING TITLE:

**ROOF PLAN**

DRAWING NO:

**A1.4**

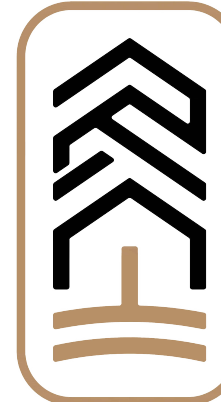

**ROOTED**  
ARCHITECTURE

SEAL:

NOT FOR CONSTRUCTION

DRAWINGS AND SPECIFICATIONS AS INSTRUMENTS OF SERVICE ARE THE PROPERTY OF THE ARCHITECT. THEY SHALL NOT BE USED, TRANSFERRED, OR SOLD FOR USE EXCEPT BY AN AGREEMENT IN WRITING FROM THE ARCHITECT.

**FITZGERALD ADDITION**  
34 RUSTIC TERRACE  
BLUE RIVER, CO

FIXTURE / DEVICE LEGEND	
	A 6" RECESSED CAN LIGHT FIXTURE TO BE SELECTED - FLUORESCENT OR LED LIGHT SOURCE
	A1 6" RECESSED CAN LIGHT (MOISTURE RESISTANT) FIXTURE TO BE SELECTED - FLUORESCENT OR LED LIGHT SOURCE
	B 4" RECESSED CAN LIGHT FIXTURE TO BE SELECTED - FLUORESCENT OR LED LIGHT SOURCE
	B1 4" RECESSED CAN LIGHT (MOISTURE RESISTANT) FIXTURE TO BE SELECTED - FLUORESCENT OR LED LIGHT SOURCE
	B2 4" RECESSED CAN LIGHT (WALL WASHER) FIXTURE TO BE SELECTED - FLUORESCENT OR LED LIGHT SOURCE
	C DECORATIVE PENDANT FIXTURE FIXTURE TO BE SELECTED
	D 4" SURFACE MOUNT FLUORESCENT FIXTURE FIXTURE TO BE SELECTED
	E LINEAR LED UNDERCABINET TASK LIGHTING FIXTURE TO BE SELECTED
	F SURFACE MOUNT FIXTURE FIXTURE TO BE SELECTED
	WS WALL MOUNTED SCONCE FIXTURE FIXTURE TO BE SELECTED
	EX WALL MOUNTED EXTERIOR FIXTURE FIXTURE TO BE SELECTED
	FL WALL MOUNTED EXTERIOR FLOOD LIGHT FIXTURE FIXTURE TO BE SELECTED
	SD CEILING MOUNTED COMBINATION SMOKE AND CARBON MONOXIDE DETECTOR
	FAN CEILING MOUNTED CEILING FAN (WITH OPTIONAL LIGHT KIT) FIXTURE TO BE SELECTED

DEVICE CONTROL LEGEND	
	S SINGLE POLE SWITCH LEGRAND "RADIANT" OR SIMILAR - WHITE
	S <sup>D</sup> SINGLE POLE DIMMER SWITCH LEGRAND "RADIANT" OR SIMILAR - WHITE
	S <sup>3</sup> SINGLE POLE 3 WAY SWITCH LEGRAND "RADIANT" OR SIMILAR - WHITE
	S <sup>3/D</sup> SINGLE POLE 3 WAY DIMMER SWITCH LEGRAND "RADIANT" OR SIMILAR - WHITE
	S <sup>4/D</sup> SINGLE POLE 4 WAY DIMMER SWITCH LEGRAND "RADIANT" OR SIMILAR - WHITE
	S <sup>5</sup> SINGLE POLE DOOR JAMB SWITCH LEVITON 1865 OR SIMILAR

**NOTES: REFLECTED CEILING PLAN**

- ALL RCP DIMENSIONS ARE TO FACE OF FINISH OR FIXTURE CENTERLINE U.N.O.
- ALL CEILINGS ARE PAINTED GYPSUM BOARD U.N.O.
- REFERENCE FIXTURE LEGEND FOR FIXTURE TYPES AND DESIGNATIONS.
- LOCATE PAINTED METAL CEILING ACCESS PANELS BENEATH:
  - MECHANICAL EQUIPMENT PER MANUFACTURER'S RECOMMENDATIONS.
  - VALVES, BALANCING DEVICES, ELECTRICAL JUNCTIONS, F/S DAMPERS AND ALL OTHER ITEMS REQUIRING MAINTENANCE.
- COORDINATE LOCATION OF ALL MECHANICAL EQUIPMENT AND DUCTWORK WITH STRUCTURAL, AS WELL AS, WITH CEILING HEIGHTS SHOWN. NOTIFY ARCHITECT IMMEDIATELY OF CONFLICTS BEFORE PROCEEDING.
- IF ANY LIGHTING ITEMS OR CEILING FIXTURES CANNOT BE INSTALLED AT LOCATIONS SHOWN DUE TO FIELD CONDITIONS, NOTIFY ARCHITECT IMMEDIATELY FOR ALTERNATE LOCATIONS BEFORE PROCEEDING.

**3 CEILING PLAN - LOFT LEVEL**  
1/4" = 1'-0"

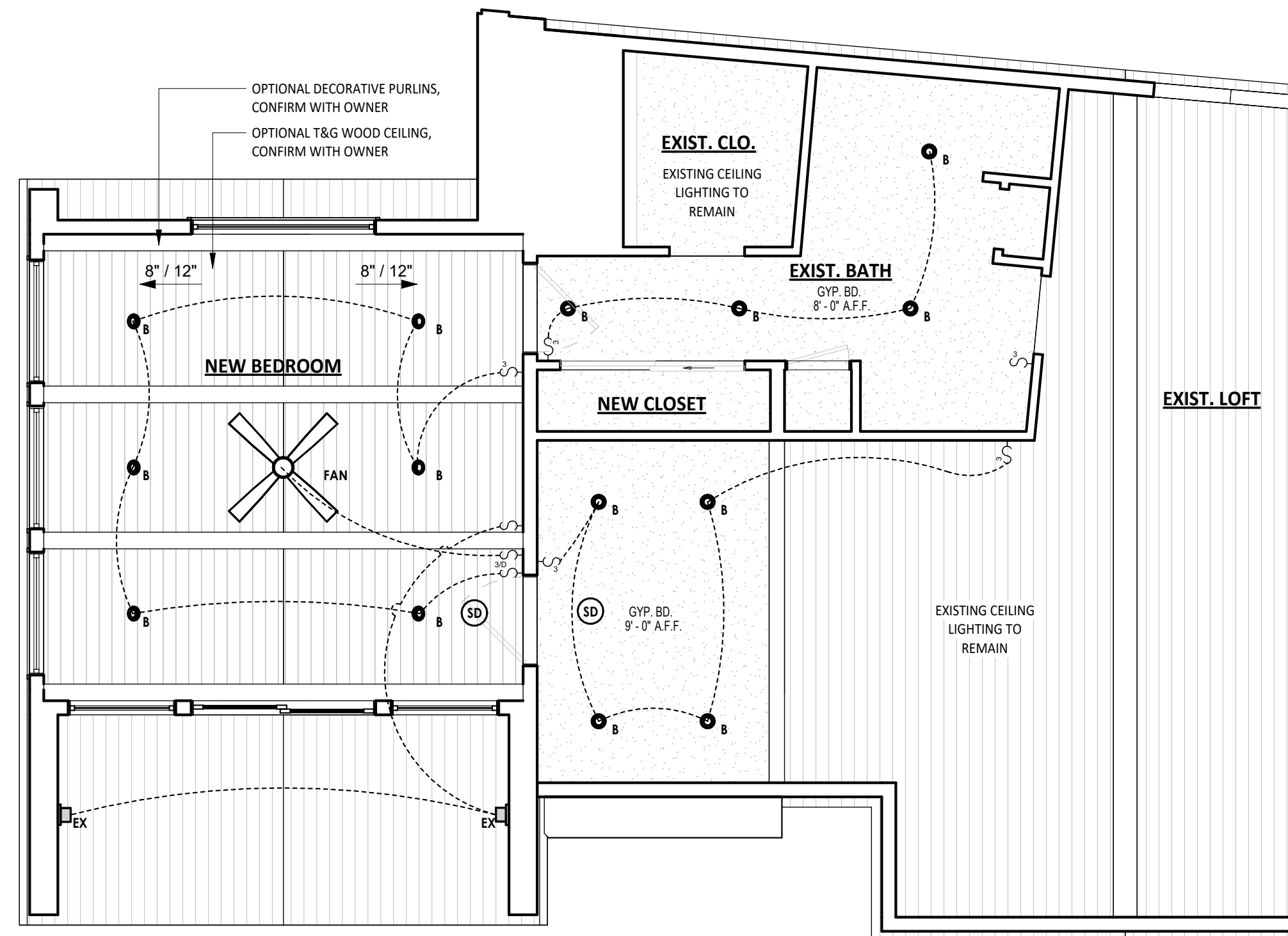

**2 CEILING PLAN - MAIN LEVEL**  
1/4" = 1'-0"

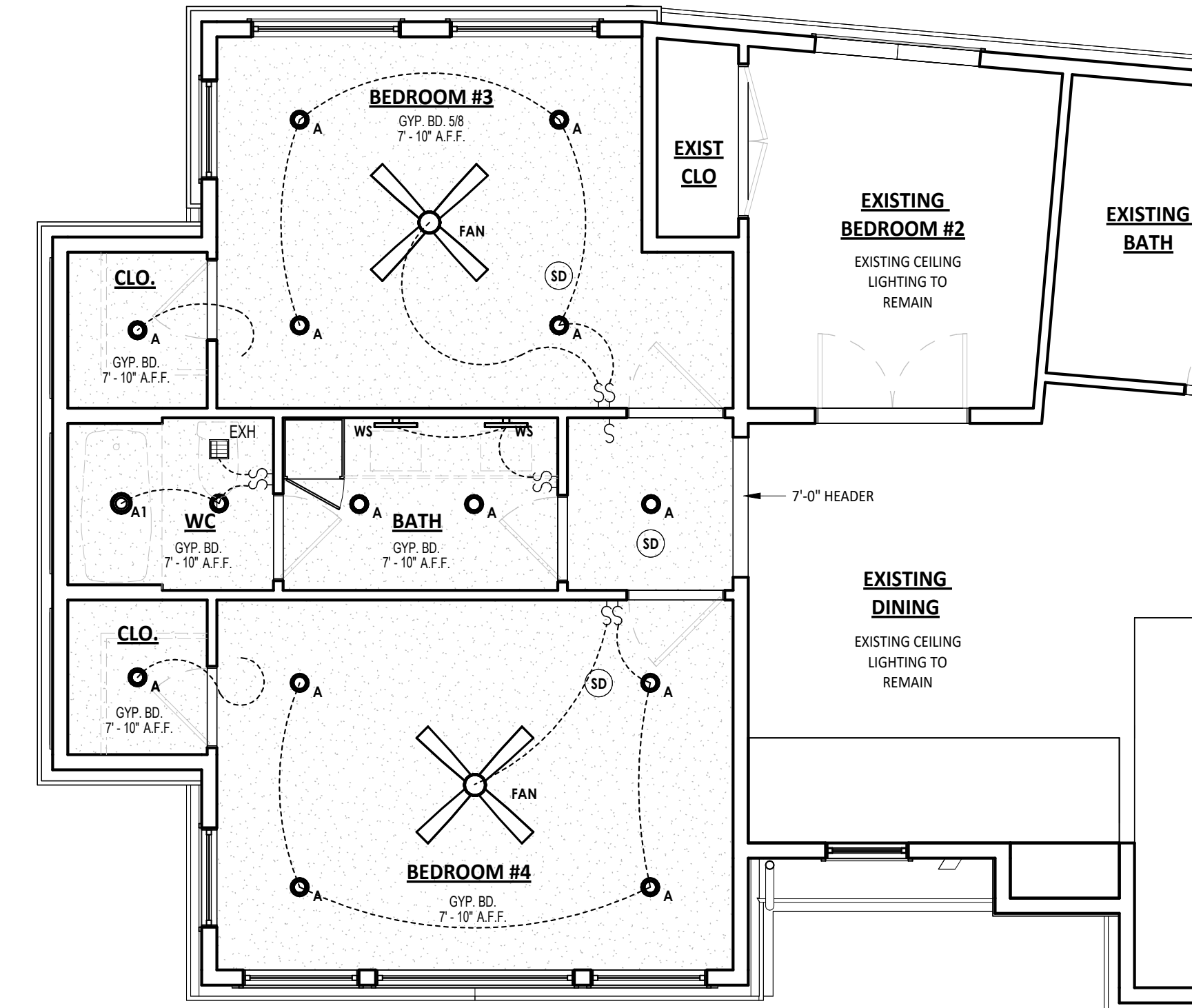

**1 CEILING PLAN - LOWER LEVEL**  
1/4" = 1'-0"

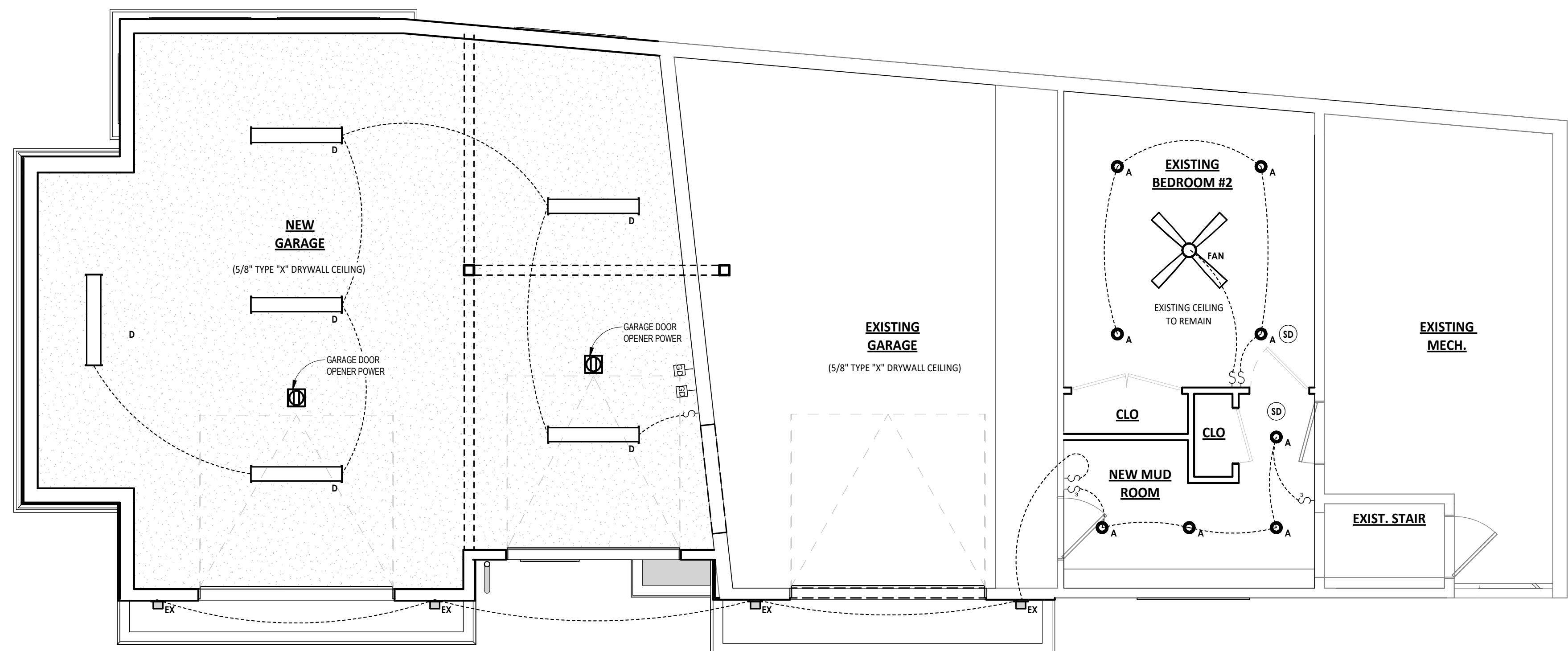

No. Date Revisions

Project No: 2023-16  
Stage: FINAL REVIEW SET  
Date: 05/02/2024  
Scale: As indicated

DRAWING TITLE:

**CEILING PLANS**

DRAWING NO:

**A2.1**

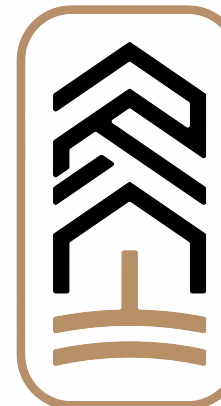

**ROOTED**  
ARCHITECTURE

SEAL:

NOT FOR CONSTRUCTION

DRAWINGS AND SPECIFICATIONS AS INSTRUMENTS OF SERVICE ARE THE PROPERTY OF THE ARCHITECT. THEY SHALL NOT BE USED, TRANSFERRED, OR SOLD FOR USE EXCEPT BY AN AGREEMENT IN WRITING FROM THE ARCHITECT.

**FITZGERALD ADDITION**

34 RUSTIC TERRACE  
BLUE RIVER, CO

No. Date Revisions

Project No: 2023-16  
Stage: FINAL REVIEW SET  
Date: 05/02/2024  
Scale: As indicated

DRAWING TITLE:

**EXTERIOR ELEVATIONS**

DRAWING NO:

**A4.1**

NOTES: AIR BARRIER / VAPOR BARRIER		
IN COMPLIANCE WITH ENERGY CODE REQUIREMENTS, PROVIDE CONTINUOUS, SOLID AIR BARRIERS OVER ALL INSULATION SURFACES. PROVIDE AIR BARRIERS BEHIND ALL CONCEALED AREAS, SUCH AS TUBS, DROPPED CEILING AREAS, SOFFITS DECORATIVE BEAMS AND STRUCTURAL BEAMS ADJACENT TO THERMAL ENVELOPE WALLS. THESE BARRIERS SHOULD BE COORDINATED AND INSTALLED AT THE TIME OF FRAMING AND MUST BE CONTINUOUS AND UNBROKEN. PROVIDE AIR BARRIERS AND INSULATION AT THE THERMAL ENVELOPE LINE OF ALL CHIMNEYS. AIR BARRIERS CAN BE 6 MIL POLYFILM PLASTIC, DRYWALL OR SOLID SHEATHING. COORDINATE ALL AIR BARRIERS WITH VAPOR BARRIERS AND INSULATION REQUIREMENTS AS OUTLINED IN DIVISION VII. PROVIDE AND SCHEDULE A PRE-MEETING WITH THE ARCHITECT AND FRAMER TO REVIEW THESE REQUIREMENTS PRIOR TO ANY FRAMING WORK.		
NOTES: WEATHER RESISTIVE BARRIER		
1. INSTALL WEATHER RESISTIVE BARRIER IN STRICT COMPLIANCE WITH MANUFACTURERS RECOMMENDATIONS AND DETAILS. USE ONLY APPROVED PRODUCTS AND FASTENING METHODS.		
2. REFERENCE LOCAL AND NATIONAL BUILDING CODES AND REGULATIONS PRIOR TO INSTALLATION. INSTALL PER GOVERNING CODE REQUIREMENTS. NOTIFY ARCHITECT IF ANY CONFLICT ARISES.		
EXTERIOR FINISH LEGEND		
MATERIAL SYMBOL	TYPE	NOTES:
(WD1)	T&G WOOD VENEER	HORIZONTAL T&G THERMALLY MODIFIED PRE-FINISHED WOOD SIDING (OWNER TO VERIFY COLOR)
(WD2)	WOOD TRIM	1X OR 2X THERMALLY MODIFIED PRE-FINISHED WOOD TRIM (MATCH SIDING) (OWNER TO VERIFY COLOR)
(MP1)	PREFINISHED METAL PANEL VENEER	METAL BOARD AND BATTEN SIDING FLATIRON STEEL "BOARD AND BATTEN" COLOR: BLACK OR MIDNIGHT BRONZE (CONFIRM WITH OWNER)
(M1)	PREFINISHED METAL FASCIA	PREFINISHED METAL TO MATCH SIDING
(ST1)	STONE VENEER	TELLURIDE STONE OPTIONAL STONE VENEER (CONFIRM WITH OWNER) COLOR: SILVERLEAF
(R1)	METAL ROOFING	STANDING SEAM METAL ROOFING COLOR: BLACK (CONFIRM WITH OWNER)
NOTE: CONTRACTOR TO PROVIDE PHYSICAL MATERIAL SAMPLE BOARD FOR OWNER / ARCHITECT APPROVAL		
NOTE: ALL EXTERIOR MATERIALS TO BE NON-REFLECTIVE		



**1 WEST ELEVATION**  
1/4" = 1'-0"

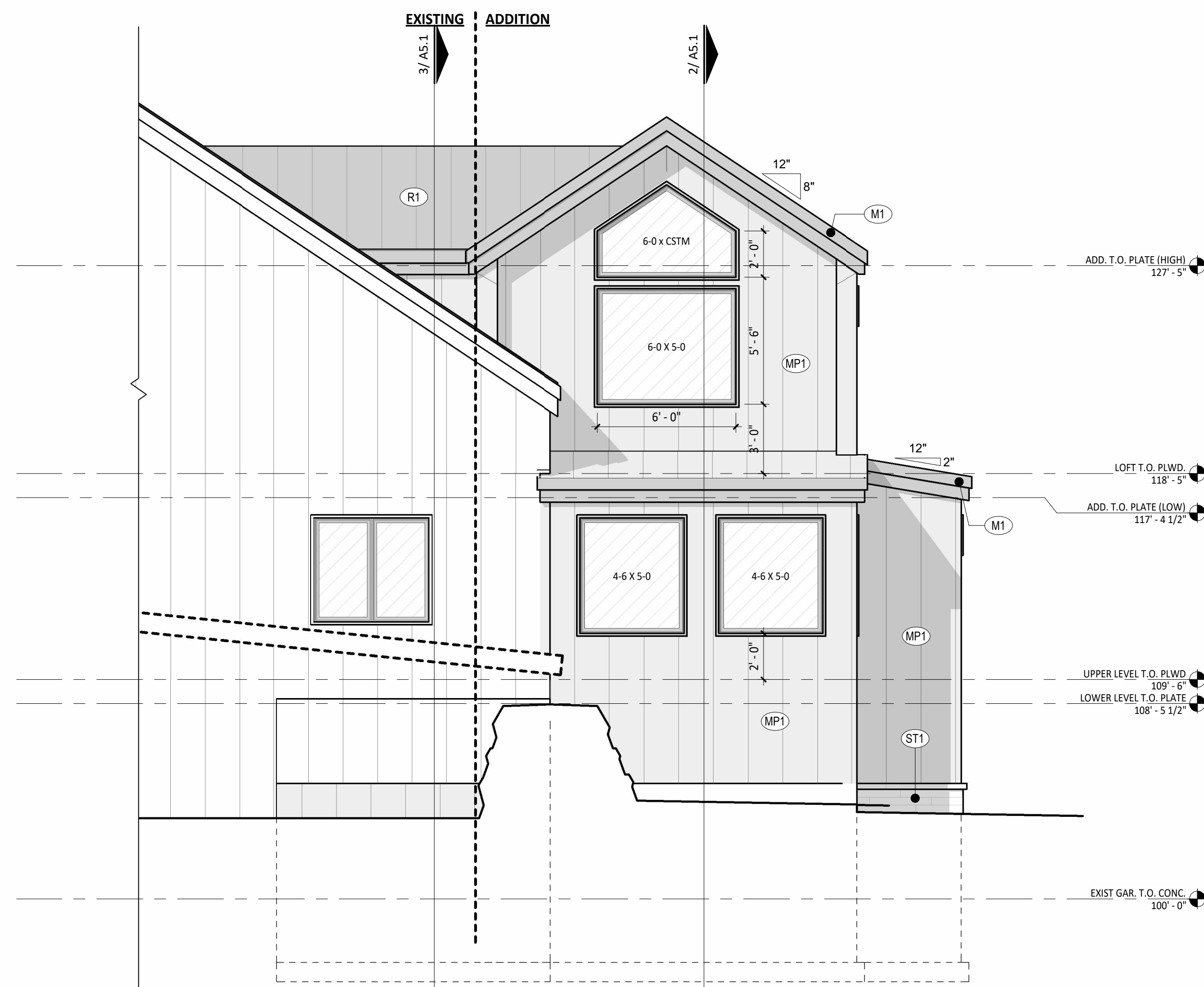

**3 EAST ELEVATION**  
1/4" = 1'-0"

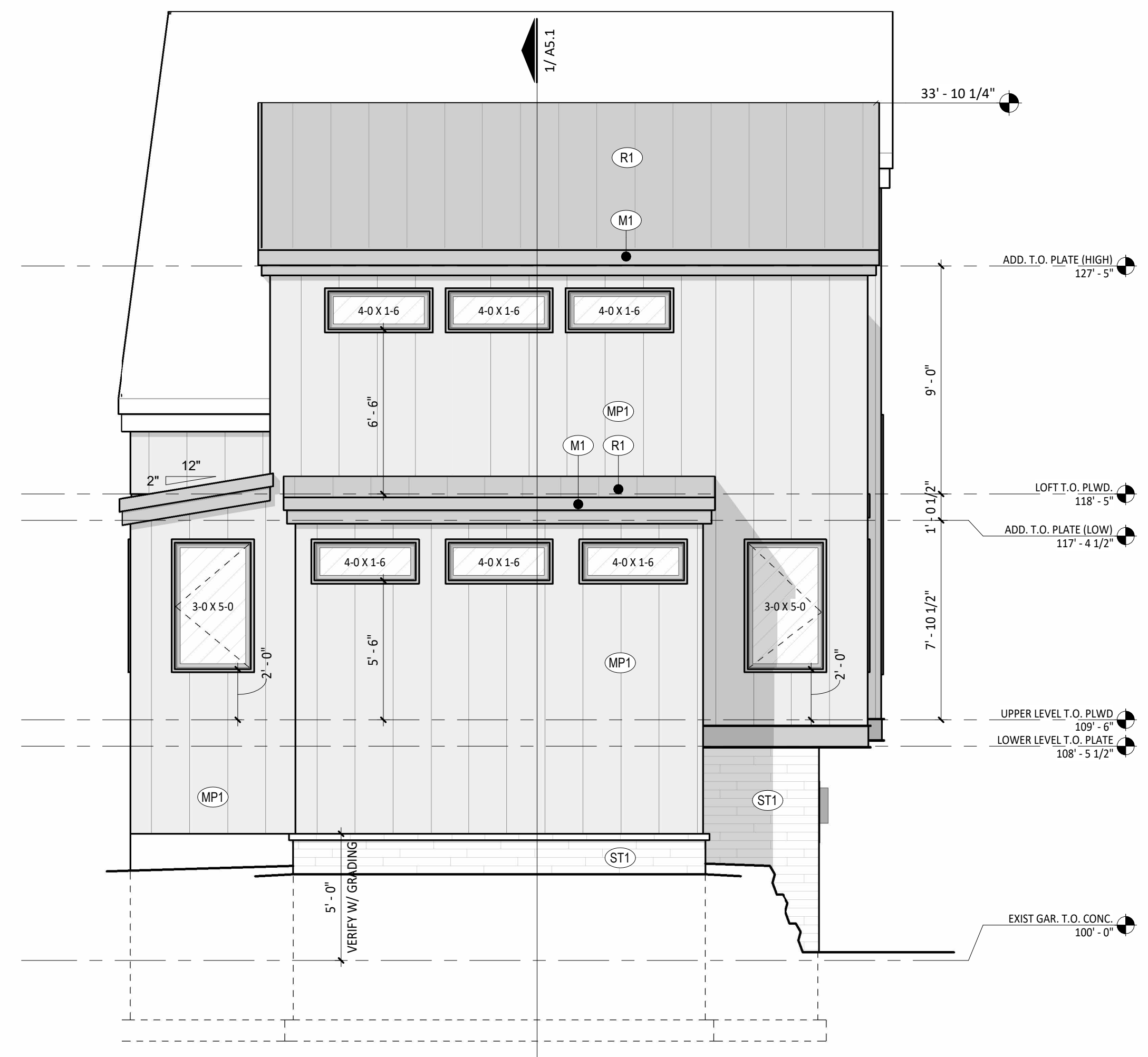

**2 NORTH ELEVATION**  
1/4" = 1'-0"



**ROOTED**  
ARCHITECTURE

SEAL:

NOT FOR CONSTRUCTION

DRAWINGS AND SPECIFICATIONS AS INSTRUMENTS OF SERVICE ARE THE PROPERTY OF THE ARCHITECT. THEY SHALL NOT BE USED, TRANSFERRED, OR SOLD FOR USE EXCEPT BY AN AGREEMENT IN WRITING FROM THE ARCHITECT.

**FITZGERALD ADDITION**

34 RUSTIC TERRACE  
BLUE RIVER, CO

No. Date Revisions

Project No: 2023-16  
Stage: FINAL REVIEW SET  
Date: 05/02/2024  
Scale: As indicated

DRAWING TITLE:

**BUILDING SECTIONS**

DRAWING NO:

**A5.1**

**NOTES: FRAMING**

1. ALL FRAMING SHOWN IS DIAGRAMMATIC AND SHALL BE STRUCTURALLY ENGINEERED WHERE APPLICABLE. CONTRACTOR TO CONFIRM COMPLIANCE WITH LOCAL CODES AND AUTHORITIES HAVING JURISDICTION.
2. ALL ROOF AND FLOOR TRUSSES SHALL BE PRE-ENGINEERED IN COMPLIANCE WITH LOCAL CODES AND AUTHORITIES HAVING JURISDICTION.
3. CONTRACTOR SHALL USE PRESSURE TREATED LUMBER WHERE REQUIRED IN COMPLIANCE WITH LOCAL CODES AND AUTHORITIES HAVING JURISDICTION.

**NOTES: WEATHER RESISTIVE BARRIER**

1. INSTALL WEATHER RESISTIVE BARRIER IN STRICT COMPLIANCE WITH MANUFACTURERS RECOMMENDATIONS AND DETAILS. USE ONLY APPROVED PRODUCTS AND FASTENING METHODS.
2. REFERENCE LOCAL AND NATIONAL BUILDING CODES AND REGULATIONS PRIOR TO INSTALLATION. INSTALL PER GOVERNING CODE REQUIREMENTS. NOTIFY ARCHITECT IF ANY CONFLICT ARISES.

**NOTES: AIR BARRIER / VAPOR BARRIER**

IN COMPLIANCE WITH ENERGY CODE REQUIREMENTS, PROVIDE CONTINUOUS, SOLID AIR BARRIERS OVER ALL INSULATION SURFACES. PROVIDE AIR BARRIERS BEHIND ALL CONCEALED AREAS, SUCH AS TUBS, DROPPED CEILING AREAS, SOFFITS DECORATIVE BEAMS AND STRUCTURAL BEAMS ADJACENT TO THERMAL ENVELOPE WALLS. THESE BARRIERS SHOULD BE COORDINATED AND INSTALLED AT THE TIME OF FRAMING AND MUST BE CONTINUOUS AND UNBROKEN. PROVIDE AIR BARRIERS AND INSULATION AT THE THERMAL ENVELOPE LINE OF ALL CHIMNEYS. AIR BARRIERS CAN BE 6 MIL POLYFILM PLASTIC, DRYWALL OR SOLID SHEATHING. COORDINATE ALL AIR BARRIERS WITH VAPOR BARRIERS AND INSULATION REQUIREMENTS AS OUTLINED IN DIVISION VII. PROVIDE AND SCHEDULE A PRE-MEETING WITH THE ARCHITECT AND FRAMER TO REVIEW THESE REQUIREMENTS PRIOR TO ANY FRAMING WORK.

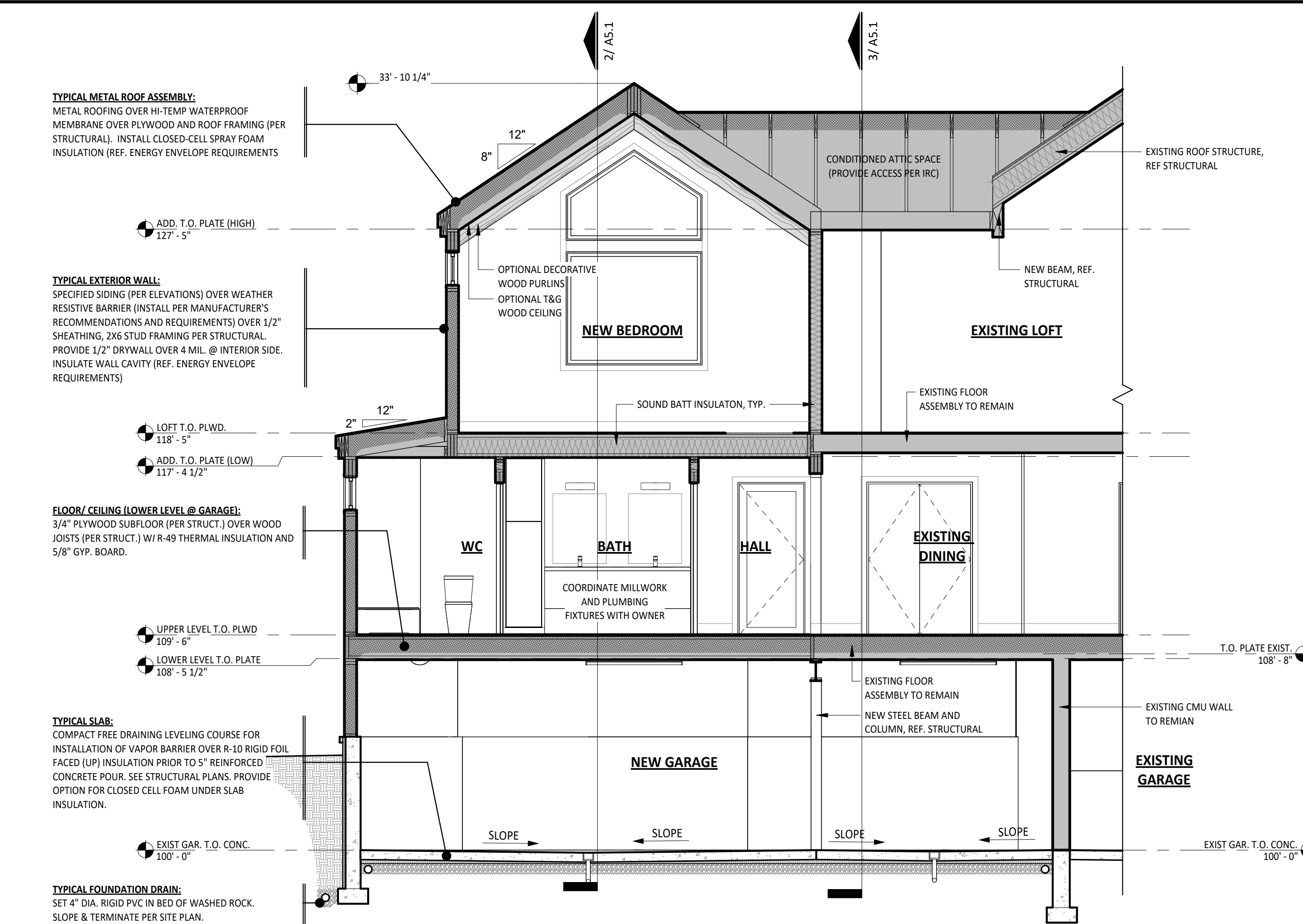

**1 SECTION A**  
1/4" = 1'-0"

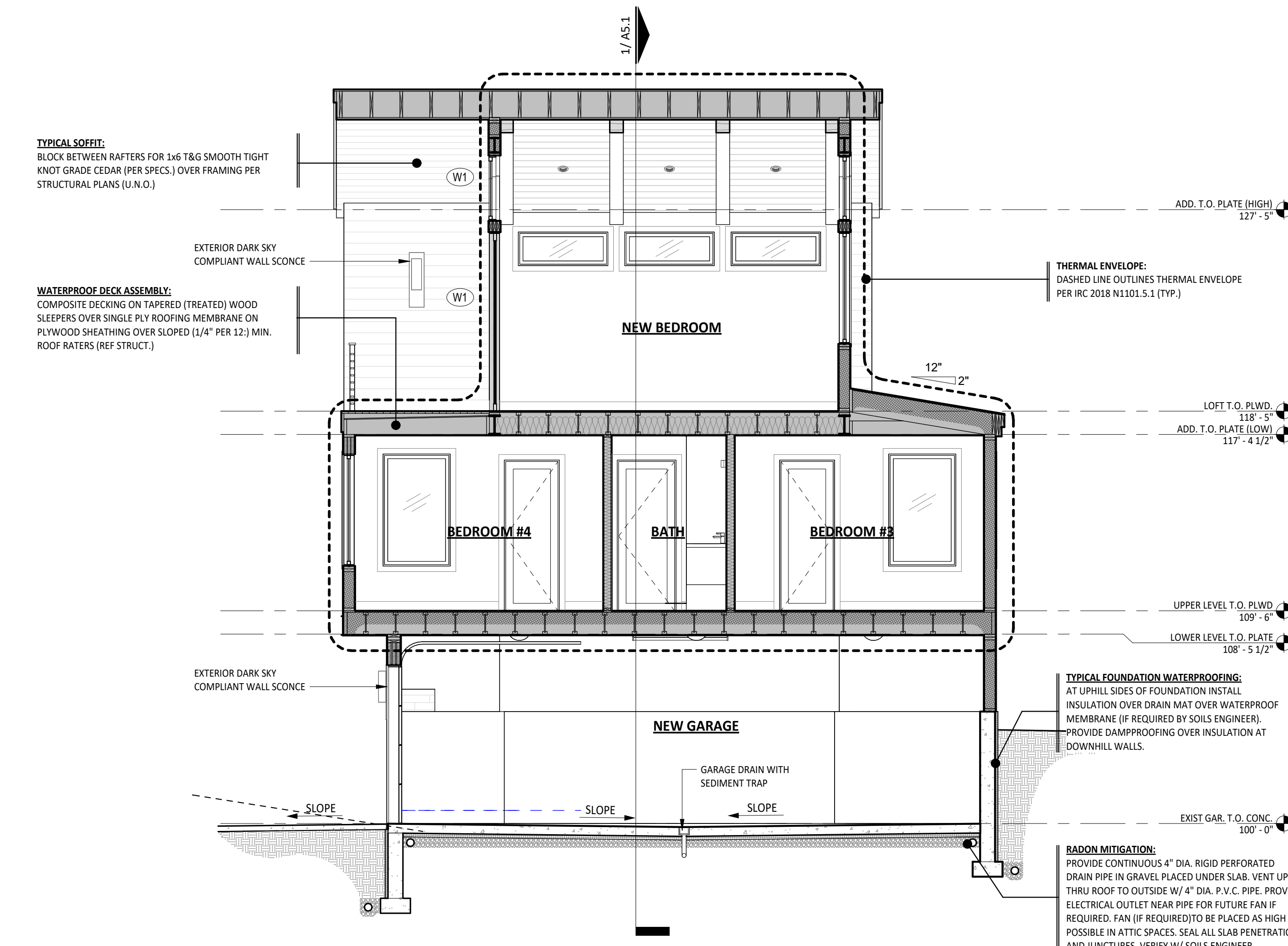

**2 SECTION B**  
1/4" = 1'-0"

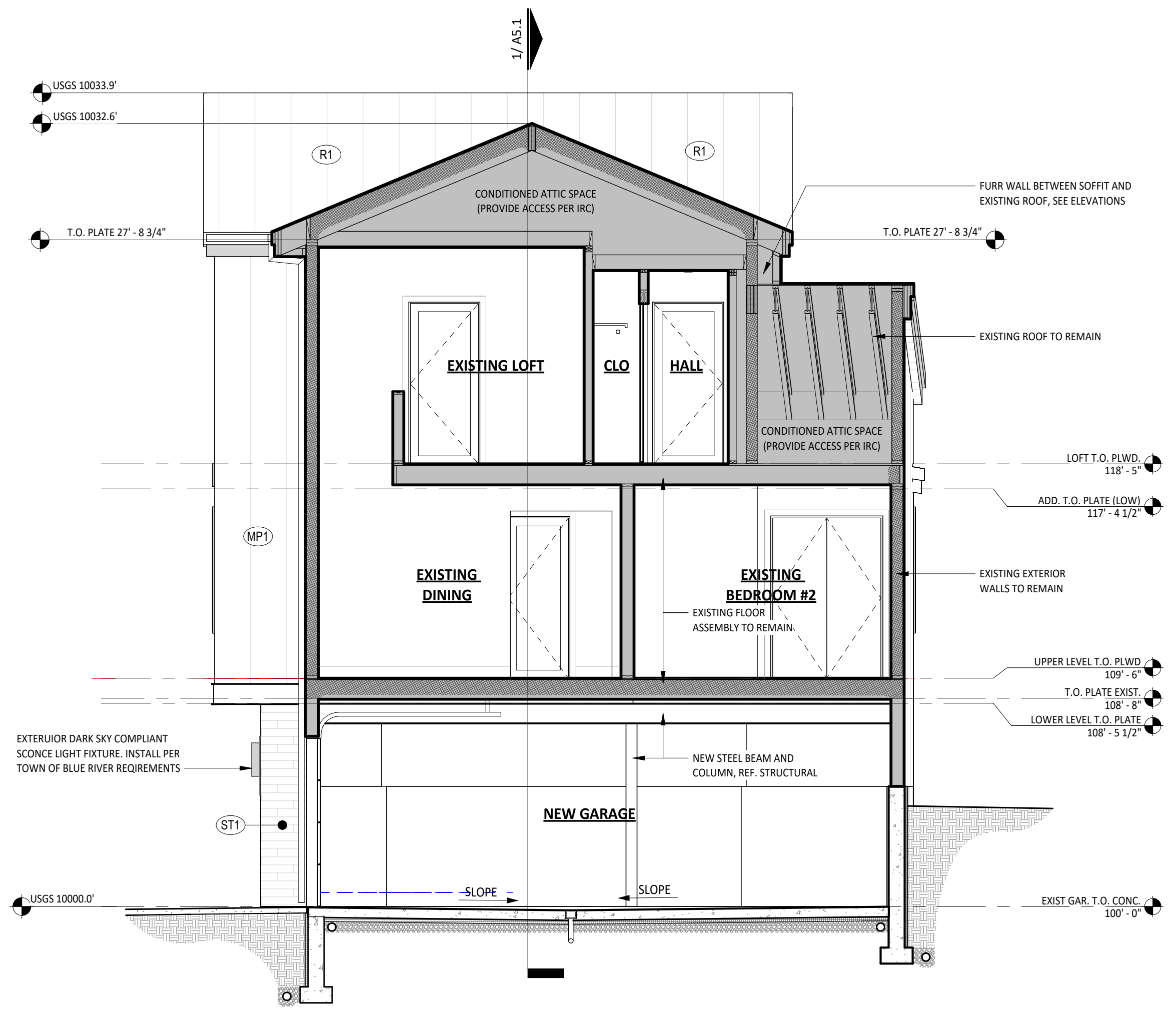

**3 SECTION C**  
1/4" = 1'-0"



**ROOTED**  
ARCHITECTURE

SEAL:

NOT FOR CONSTRUCTION

DRAWINGS AND SPECIFICATIONS AS INSTRUMENTS OF SERVICE ARE THE PROPERTY OF THE ARCHITECT. THEY SHALL NOT BE USED, TRANSFERRED, OR SOLD FOR USE EXCEPT BY AN AGREEMENT IN WRITING FROM THE ARCHITECT.

**FITZGERALD ADDITION**

34 RUSTIC TERRACE  
BLUE RIVER, CO

No. Date Revisions

Project No: 2023-16  
Stage: FINAL REVIEW SET  
Date: 05/02/2024  
Scale: As indicated

DRAWING TITLE:

**POWER PLANS**

DRAWING NO:

**A6.1**

- NOTES: LOW VOLTAGE**
- ROUGH-IN PHONE, INTERNET, AND CATV FROM SITE UTILITY LOCATION TO MECHANICAL / AV ROOM.
  - PROVIDE PHONE, SECURITY, AND DATA BOARDS IN MECHANICAL / AV ROOM.
  - PROVIDE CONDUIT OR STRUCTURED CABLE TO SOUTH ROOF FOR SATELLITE DISH WIRING OPTION.
  - COORDINATE PHONE LINE WITH SECURITY SYSTEM REQUIREMENTS.
  - COORDINATE CATV / DATA / LIGHTING / HOME COMPUTER CONTROL REQUIREMENTS WITH OWNER.
  - COORDINATE HOME AUTOMATION / MECHANICAL CONTROLS INTERFACE AS REQUIRED BY OWNER.
  - COORDINATE SOUND SYSTEM, HOME AUTOMATION AND ALL OTHER LOW VOLTAGE SYSTEMS PER OWNER REQUIREMENTS.

- NOTES: WINDOW SHADES**
- PROVIDE OPTION FOR MOTORIZED WINDOW SHADE SYSTEMS WHERE INDICATED ON ELECTRICAL PLANS. CONFIRM SHADE LOCATIONS WITH OWNER PRIOR TO ELECTRICAL ROUGH-IN. COORDINATE WITH ELECTRICAL AND HOME AUTOMATION WORK. ALL SHADES TO BE INSTALLED IN RECESSED WINDOW POCKETS WHERE REQUIRED.

- NOTES: HOME AUTOMATION**
- PRIOR TO ANY ELECTRICAL WORK CONFIRM SCOPE OF SMART HOME CONTROL AND AUTOMATION REQUIREMENTS WITH OWNER. WORK TO INCLUDE PROCESSOR USER INTERFACE, SCOPE OF DEVICES AND/OR SYSTEMS TO BE CONTROLLED. SCOPE OF CABLE OR WIRELESS LINKS AND POSSIBLE EMERGENCIES BACKUP POWER.
- SYSTEMS TO INCLUDE SECURITY, ENTERTAINMENT, BUILDING SERVICES, AND ENVIRONMENTAL COMPONENTS.

**ELECTRICAL DEVICE LEGEND**

	DOUBLE RECEPTACLE OUTLET LEGRAND "RADIANT" OR SIMILAR - WHITE
	220V RECEPTACLE OUTLET WHITE
	DOUBLE RECEPTACLE OUTLET W/ GROUND FAULT INTERRUPTER LEGRAND "RADIANT" OR SIMILAR - WHITE
	DOUBLE RECEPTACLE OUTLET W/ GROUND FAULT INTERRUPTER INSTALL WATERPROOF COVER FOR EXTERIOR USE
	FOURPLEX RECEPTACLE OUTLET LEGRAND "RADIANT" OR SIMILAR - WHITE
	DOUBLE RECEPTACLE FLOOR OUTLET INSTALL RECESSED FLOOR OUTLET COVER
	TEL / DATA FLOOR OUTLET
	RECESSED JUNCTION BOX COORDINATE LOCATION WITH EQUIPMENT MANUFACTURER
	TEL / DATA OUTLET CAT 6 OUTLET 14" AFF U.N.O.
	DATA OUTLET CAT 6 OUTLET 14" AFF U.N.O.
	TELEVISION OUTLET PROVIDE RECESSED POWER AND OUTLET FOR WALL MOUNTING WHERE REQUIRED BY OWNER

- NOTES: MECHANICAL / ELECTRICAL**
- ALL MECHANICAL AND ELECTRICAL WORK SHALL CONFORM TO CURRENT UNIFORM MECHANICAL AND NATIONAL ELECTRIC CODES AND RELATED NFPA REQUIREMENTS.
  - MECHANICAL AND ELECTRICAL INFORMATION SHOWN IS FOR DESIGN INFORMATION PURPOSES ONLY AND IT SHALL BE THE RESPONSIBILITY OF THE MECHANICAL/ELECTRICAL CONTRACTOR(S) TO PROVIDE NECESSARY INFORMATION TO LOCAL BUILDING DEPARTMENT FOR ISSUANCE OF PERMITS FOR CONSTRUCTION.
  - SUBMIT SHOP DRAWINGS AND PRODUCT DATA FOR TO ARCHITECT / OWNER FOR REVIEW.
  - CONTRACTOR SHALL VERIFY AND CONFORM TO PRODUCT INSTALLATION REQUIREMENTS AND SHALL PROVIDE ANY ADDITIONAL BLOCKING/PREP WORK NECESSARY FOR INSTALLATION PER MANUFACTURERS SPECIFICATIONS.
  - ALL RECESSED FIXTURES WITHIN INSULATED FLOOR AND OR CEILING SPACES MUST BE U.L. APPROVED FOR USE IN THESE LOCATIONS.
  - UNLESS OTHERWISE SHOWN, FIXTURES ARE TO BE PLACED CENTERED IN GIVEN SPACE. VERIFY ALL FIXTURE AND OUTLET LOCATIONS WITH DRAWINGS.
  - VERIFY ELECTRICITY, GAS, WATER, AND DRAINAGE REQUIREMENTS OF EQUIPMENT AND PROVIDE ANDY MECHANICAL SERVICE OR VENTING REQUIRED PRIOR TO OPERATION. PLUMB PRESSURE RELIEF OR OVERFLOW VALVES TO A DRAIN. COORDINATE WITH CARPENTRY CONTRACTOR TO PROVIDE PROPER ACCESS PANELS FOR ALL EQUIPMENT.
  - PROVIDE DUCTING TO EXTERIOR FOR ALL REQUIRED MECHANICAL EQUIPMENT. COORDINATE ALL EXTERIOR VENTS AND EXHAUST OUTLETS TO MINIMIZE VISIBILITY.
  - ALL PLUMBING FIXTURES SHALL HAVE WATER SAVING DEVICES AND/OR AERATORS TO COMPLY WITH LOCAL REQUIREMENTS.
  - ALL PENETRATIONS IN CEILINGS AND WALLS MUST BE DAFT STOPPED WITH APPROVED MATERIALS.
  - CHECK DOOR SWINGS BEFORE INSTALLATION OF WALL SWITCHES AND RELOCATE AS REQUIRED. LOCATE LIGHTING FIXTURES IN MECHANICAL ROOMS OR ATTIC SPACES TO CORRELATE WITH EQUIPMENT LOCATIONS AND PROVIDE ADEQUATE ILLUMINATION FOR SERVICING.
  - COORDINATE ELECTRICAL BRANCH CIRCUITS WITH FINAL MECHANICAL EQUIPMENT LOAD. ADVISE ARCHITECT/OWNER OF CHANGES FROM ANY DRAWING REQUIREMENTS PRIOR TO INSTALLATION OF ANY ELECTRICAL OR MECHANICAL WORK.
  - INSTALLATION OF ALL EQUIPMENT SHALL BE IN STRICT ACCORDANCE WITH MANUFACTURER'S INSTALLATION SPECIFICATIONS AND RECOMMENDATIONS. CONTRACTOR SHALL INCLUDE ALL NECESSARY ACCESSORIES AND PIPING FOR A COMPLETE AND OPERATIONAL SYSTEM.

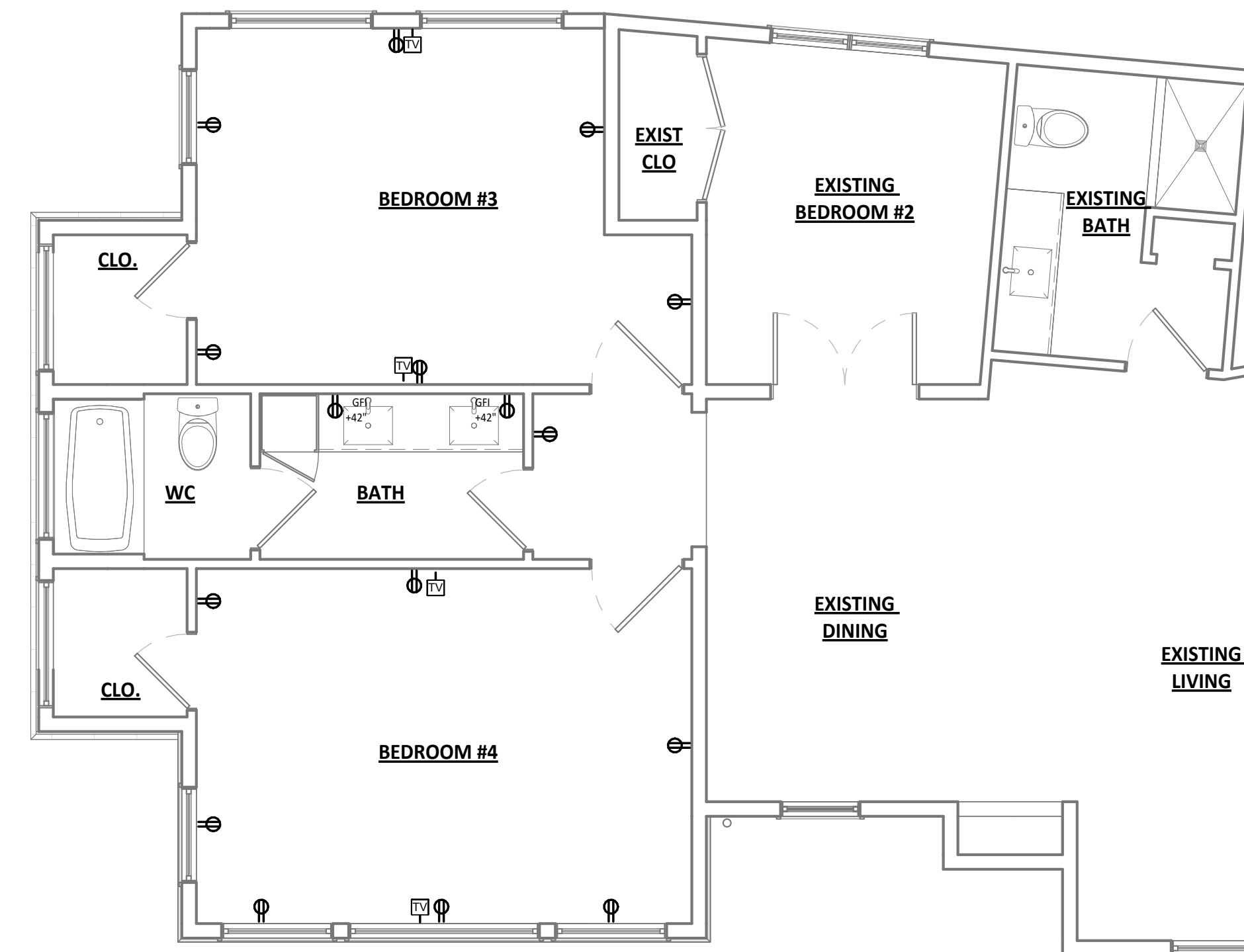

**2 POWER PLAN - MAIN LEVEL**  
1/4" = 1'-0"

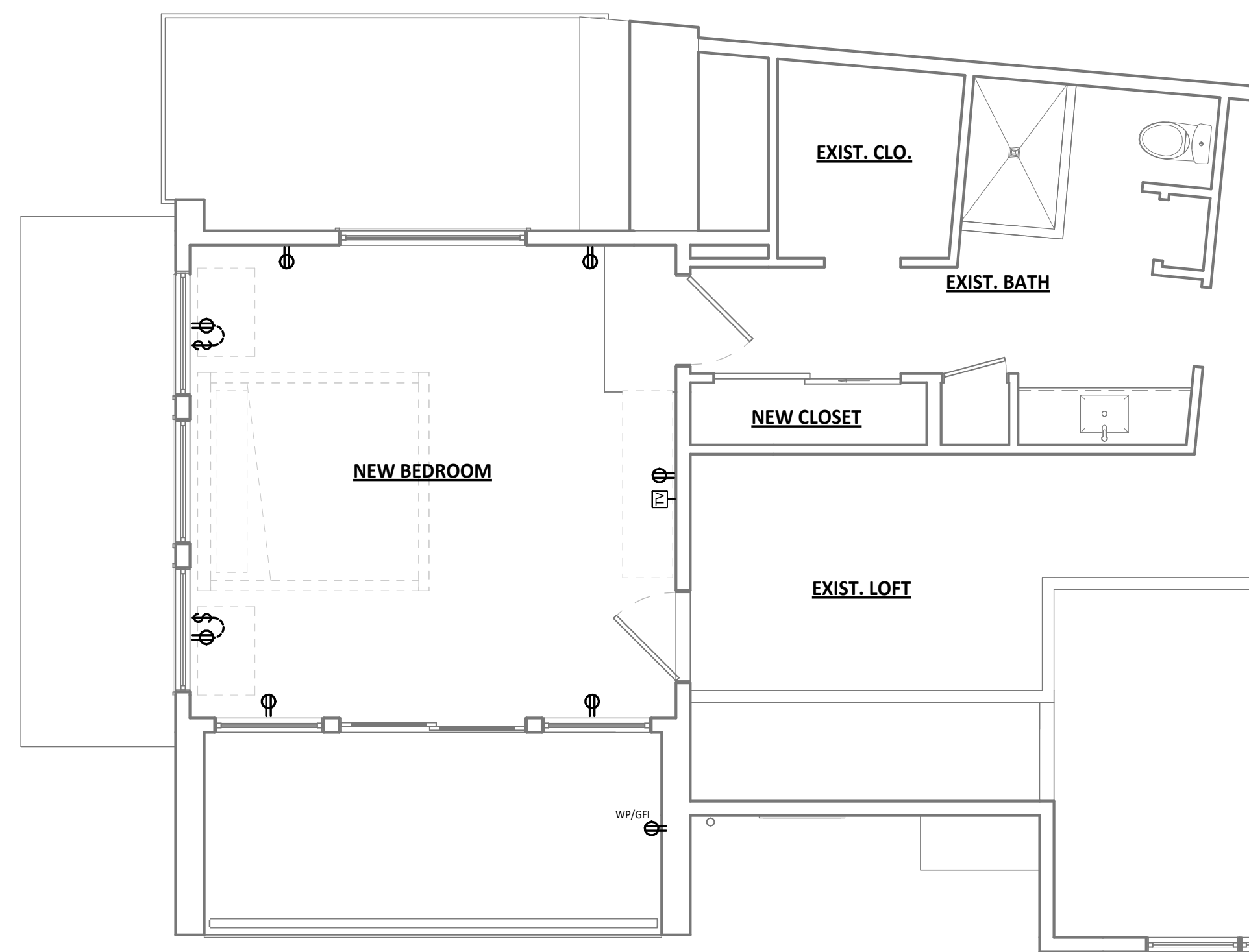

**3 POWER PLAN - LOFT LEVEL**  
1/4" = 1'-0"

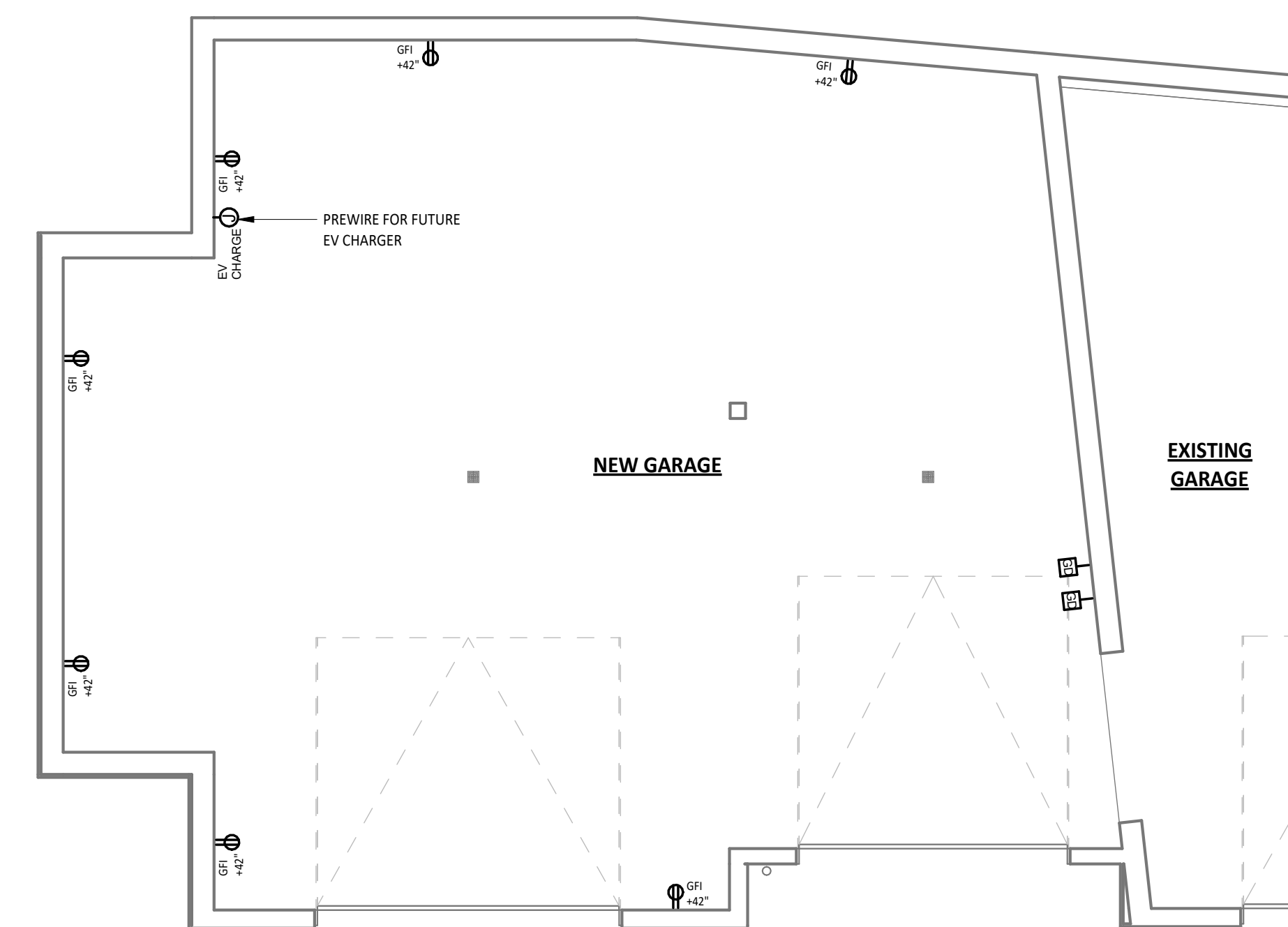

**1 POWER PLAN - LOWER LEVEL**  
1/4" = 1'-0"





ROOTED ARCHITECTURE

SEAL:

NOT FOR CONSTRUCTION

DRAWINGS AND SPECIFICATIONS AS INSTRUMENTS OF SERVICE ARE THE PROPERTY OF THE ARCHITECT. THEY SHALL NOT BE USED, TRANSFERRED, OR SOLD FOR USE EXCEPT BY AN AGREEMENT IN WRITING FROM THE ARCHITECT.

FITZGERALD ADDITION  
34 RUSTIC TERRACE  
BLUE RIVER, CO

NOTE: INSTALL WEATHER RESISTIVE BARRIER, FLASHING, AND WINDOWS IN ACCORDANCE WITH MANUFACTURERS SPECIFICATIONS

1. CUT MODIFIED "H" INTO WEATHER RESISTIVE BARRIER

MAKE ANGLE CUTS AT CORNERS AND FOLD UP FLAP

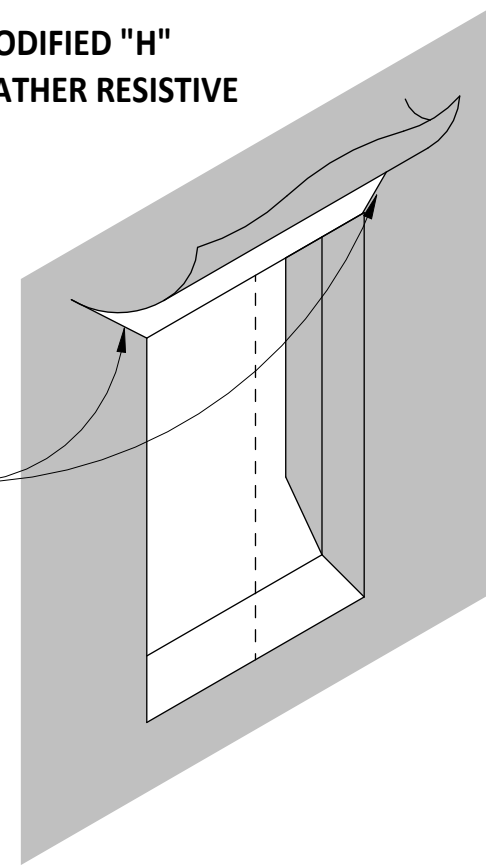

2. INSTALL PAN FLASHING AND SEALANT

SEALANT ALONG HEAD AND SIDES ONLY

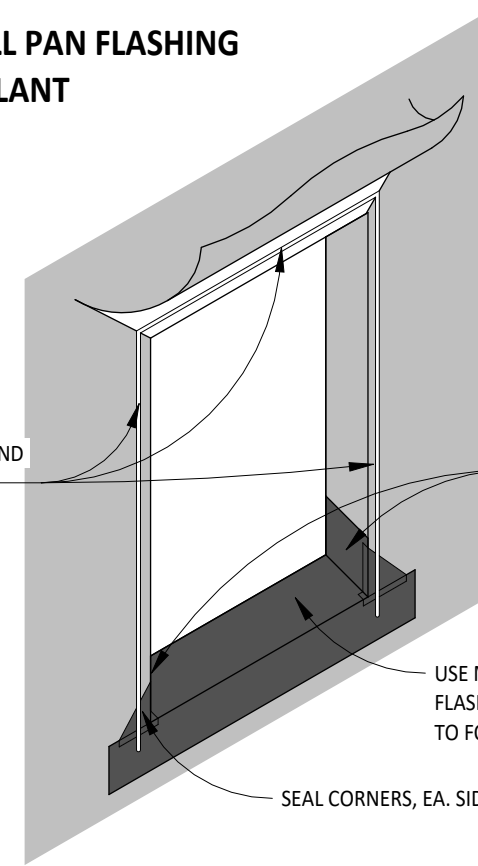

TURN SILL PAN FLASHING UP EA. SIDE 6" MIN.  
USE MOLDABLE SILL PAN FLASHING, OR CUT AND FOLD TO FORM SILL PAN

SEAL CORNERS, EA. SIDE

3. INSTALL WINDOW AND SIDE FLASHINGS

EXTEND UP 6"

PEEL AND STICK FLASHING TAPE OVER NAIL FLANGE, EA. SIDE

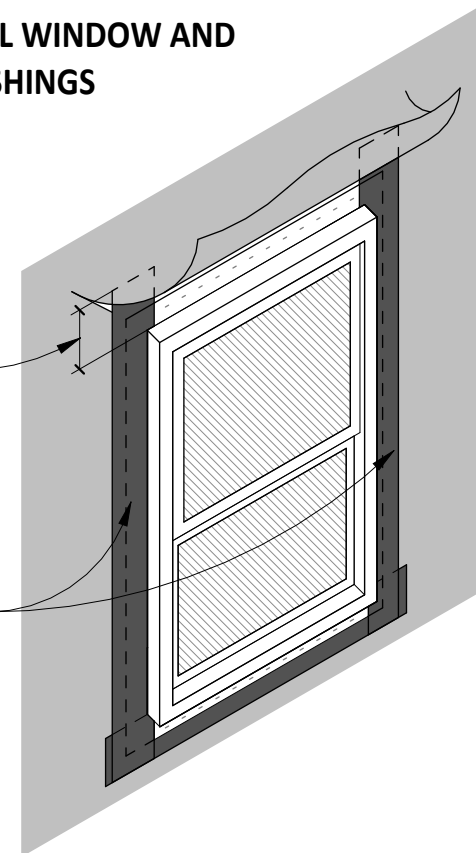

4. APPLY HEAD FLASHING

APPLY HEAD FLASHING TAPE OVER NAIL FLANGE, ADHERE TO SHEATHING ABOVE WINDOW

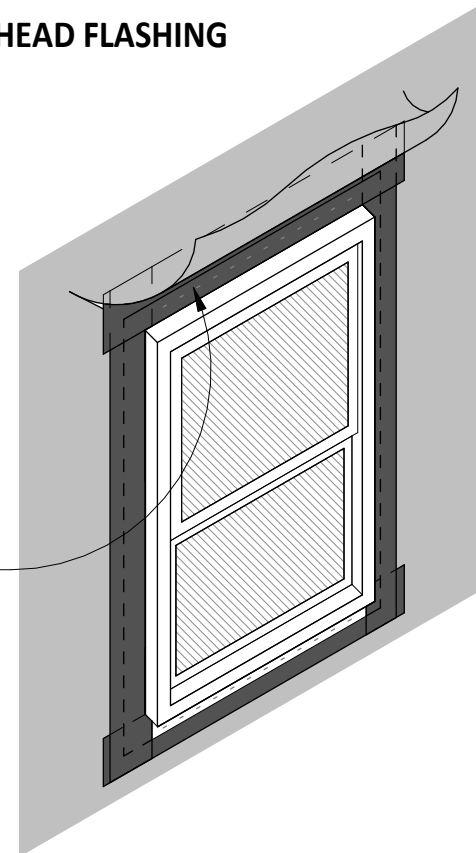

5. TAPE CUTS OVER HEAD FLASHING

FOLD DOWN WEATHER RESISTIVE BARRIER OVER FLASHING TAPE AND TAPE CORNER SEAMS

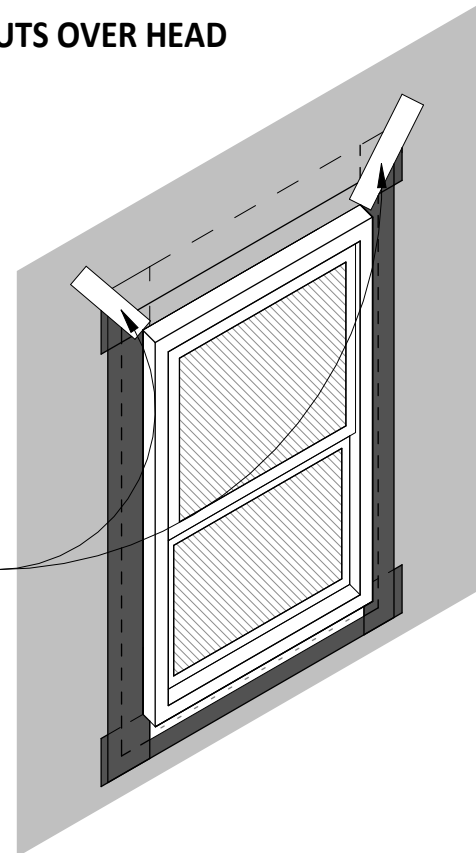

13 TYP. WINDOW FLASHING DETAIL  
NOT TO SCALE

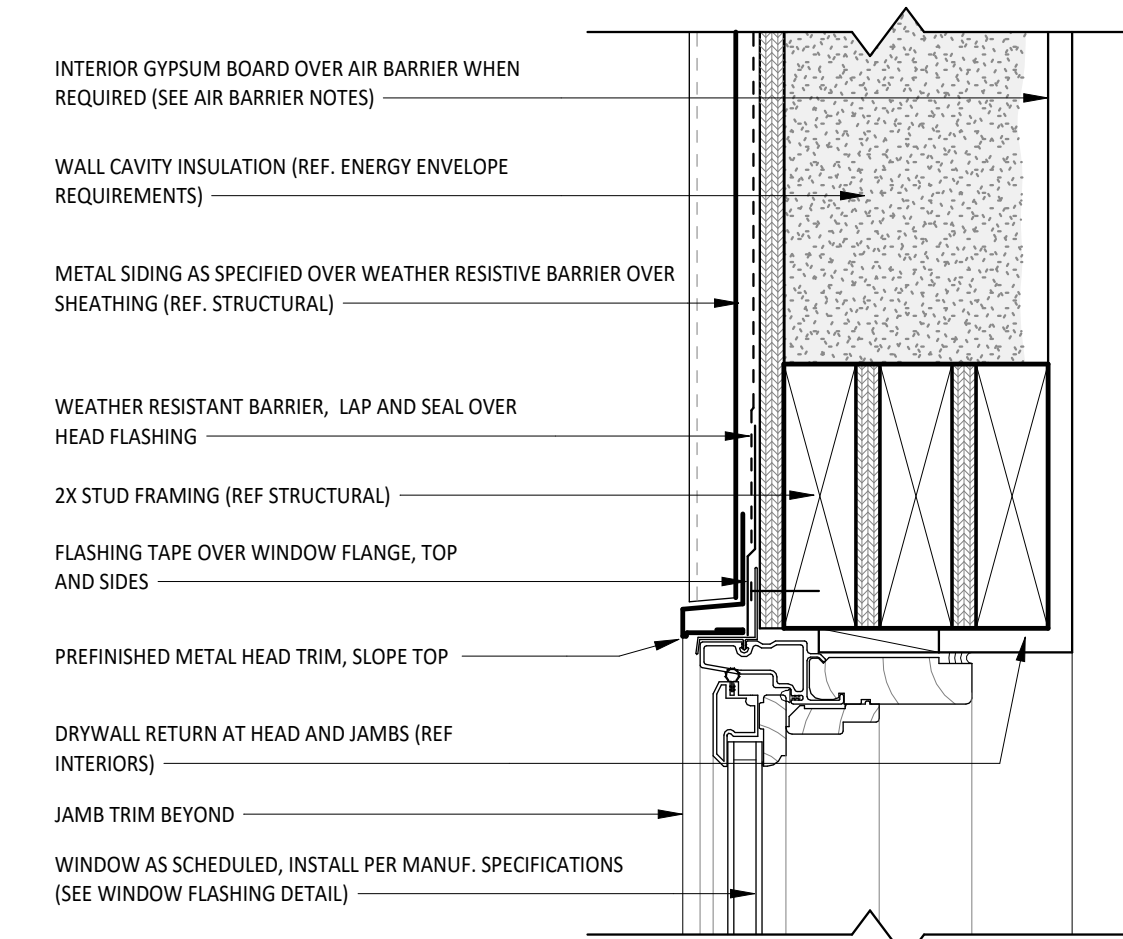

12 TYP. WINDOW HEAD @ METAL  
3" = 1'-0"

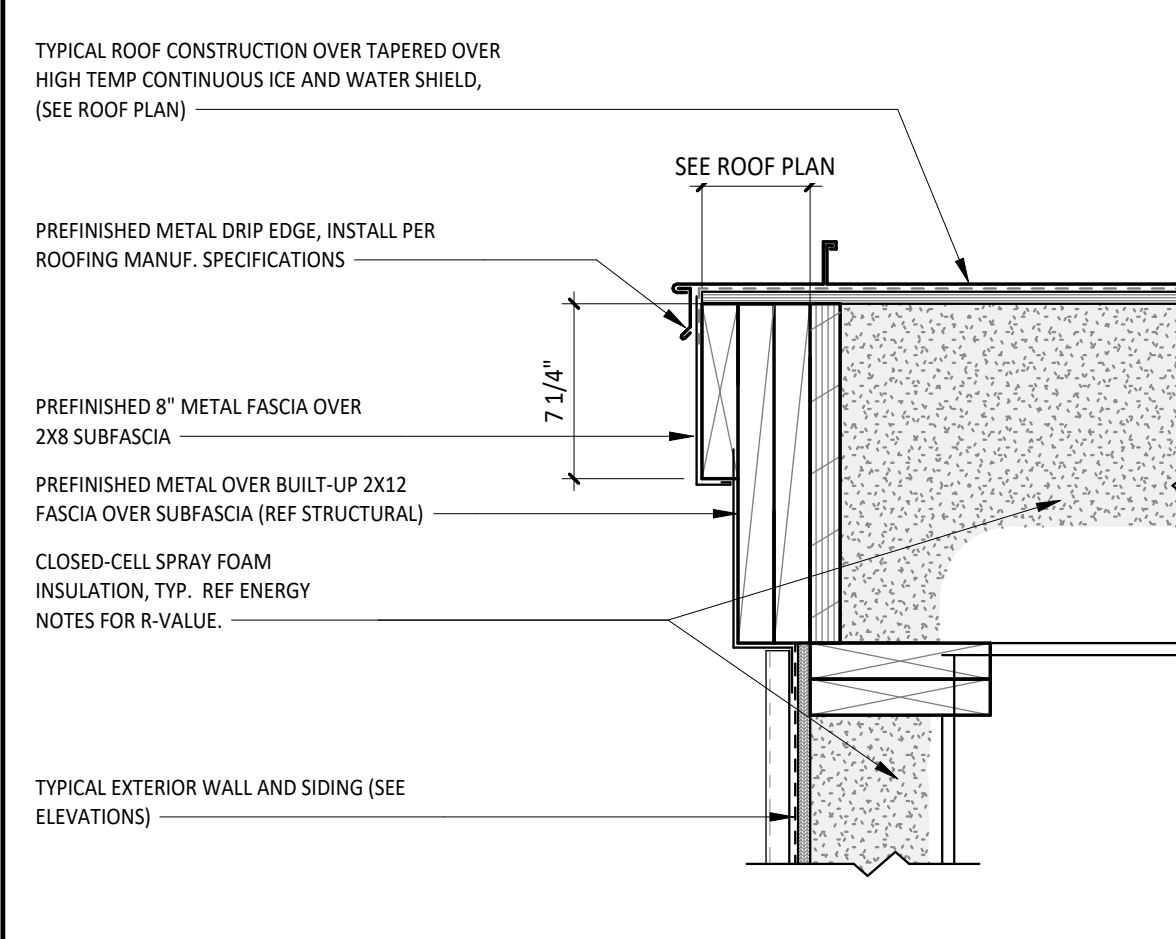

8 ROOF RAKE @ METAL ROOFING  
1 1/2" = 1'-0"

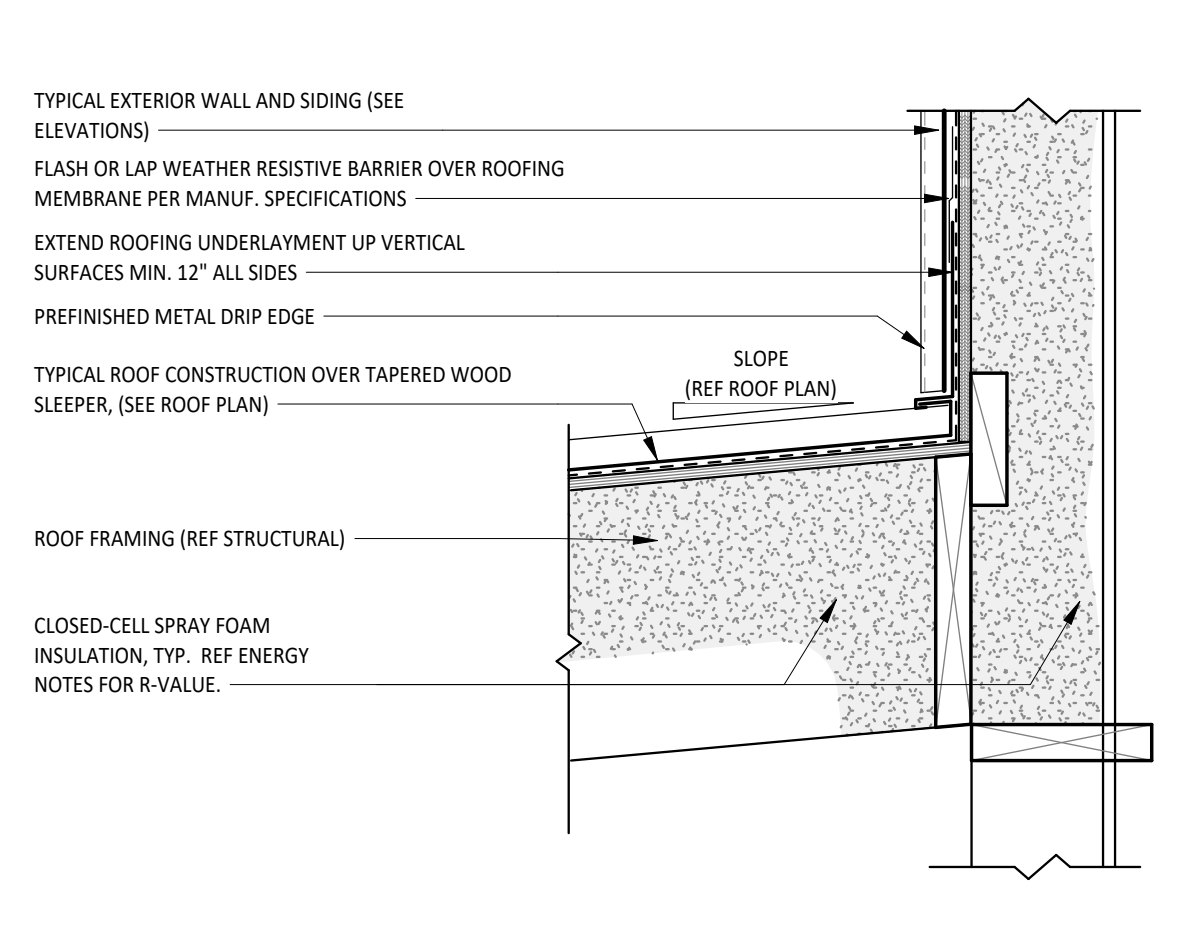

4 PITCHED ROOF WALL JUNCTURE  
1 1/2" = 1'-0"

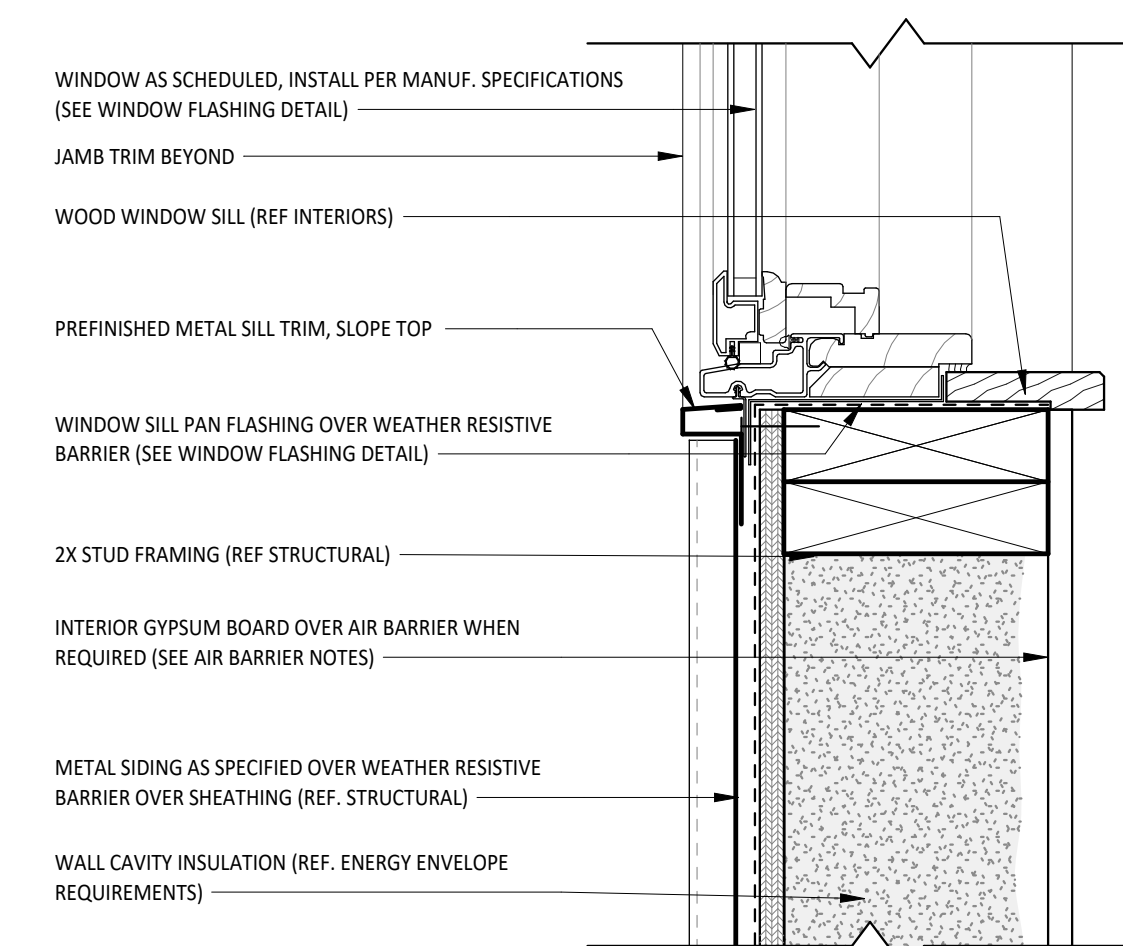

11 TYP. WINDOW SILL @ METAL  
3" = 1'-0"

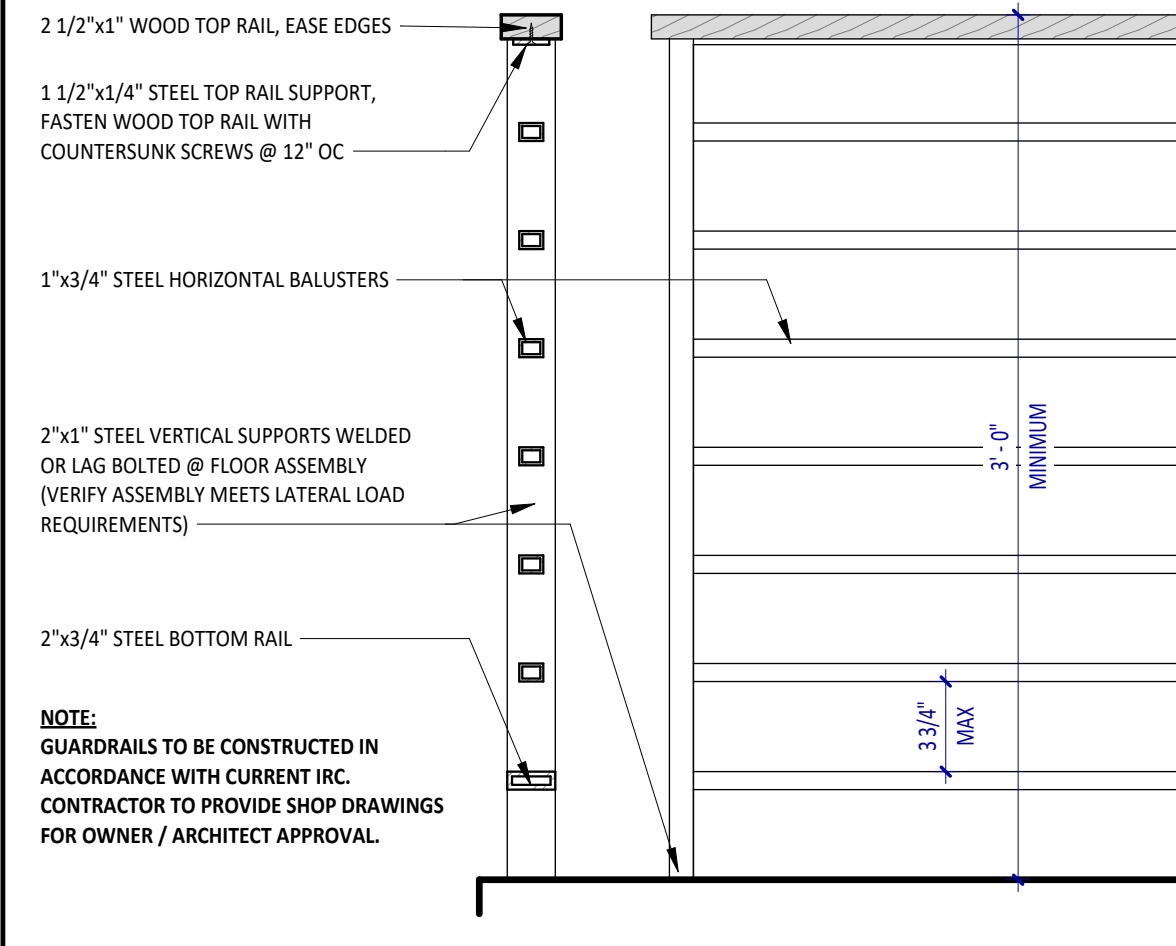

7 EXT. RAILING DETAIL  
1 1/2" = 1'-0"

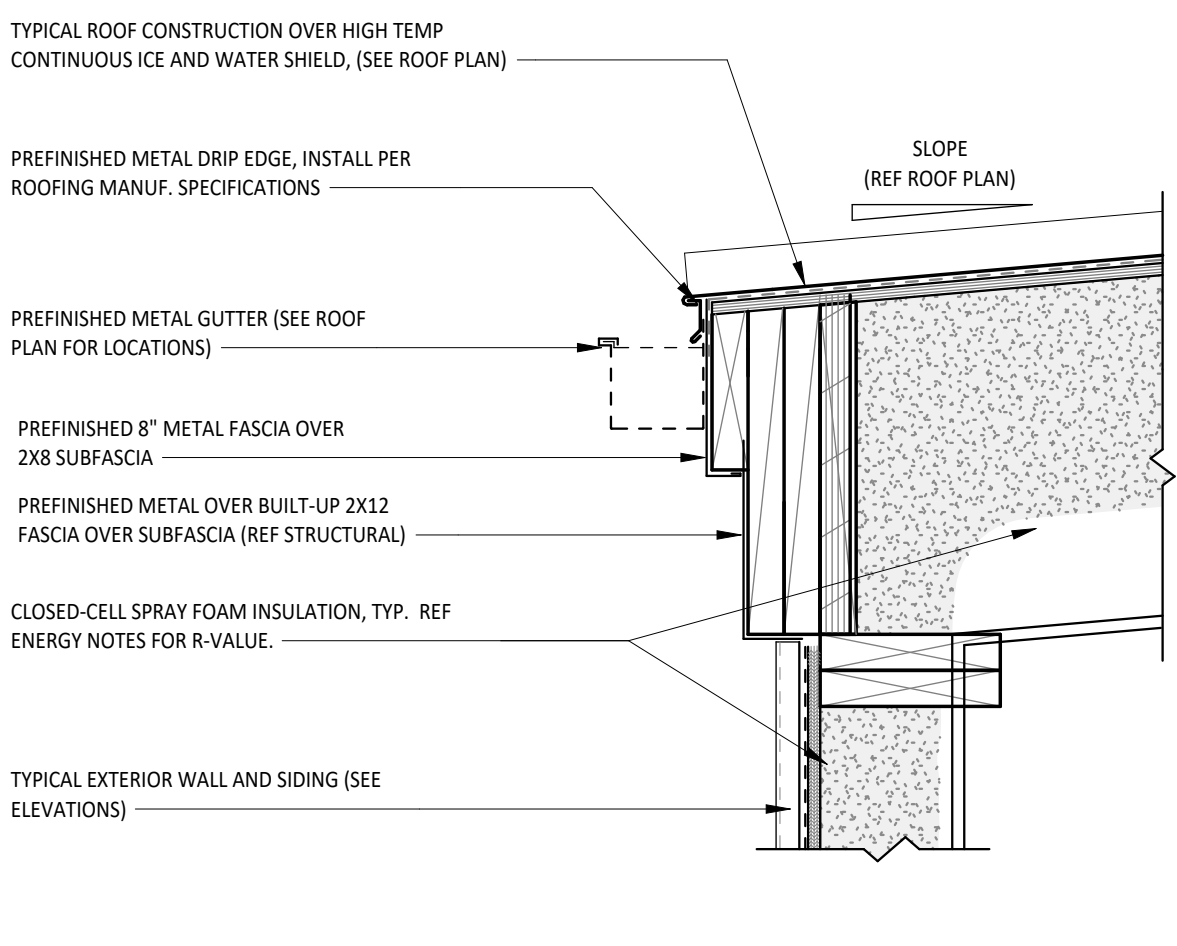

3 ROOF EAVE @ MEAL ROOFING  
1 1/2" = 1'-0"

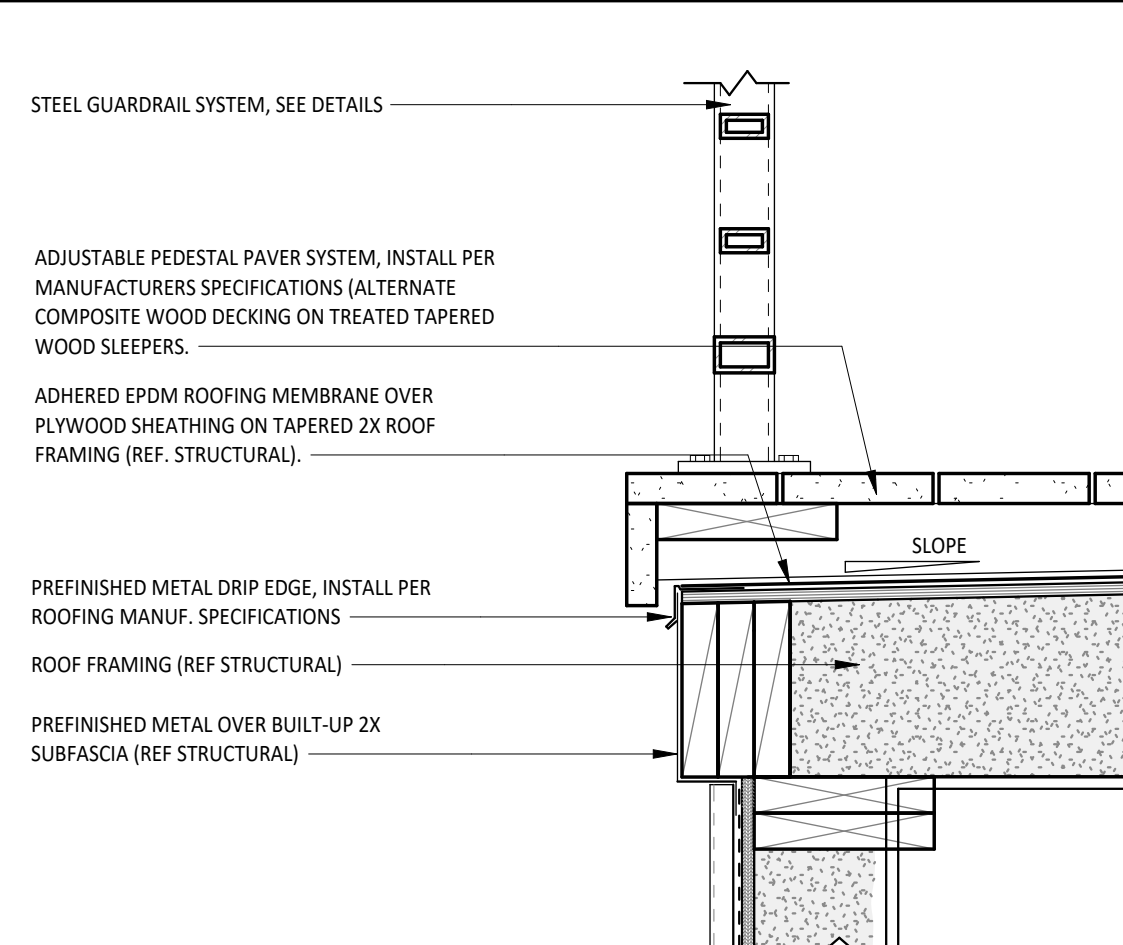

10 ROOF DECK FASCIA  
1 1/2" = 1'-0"

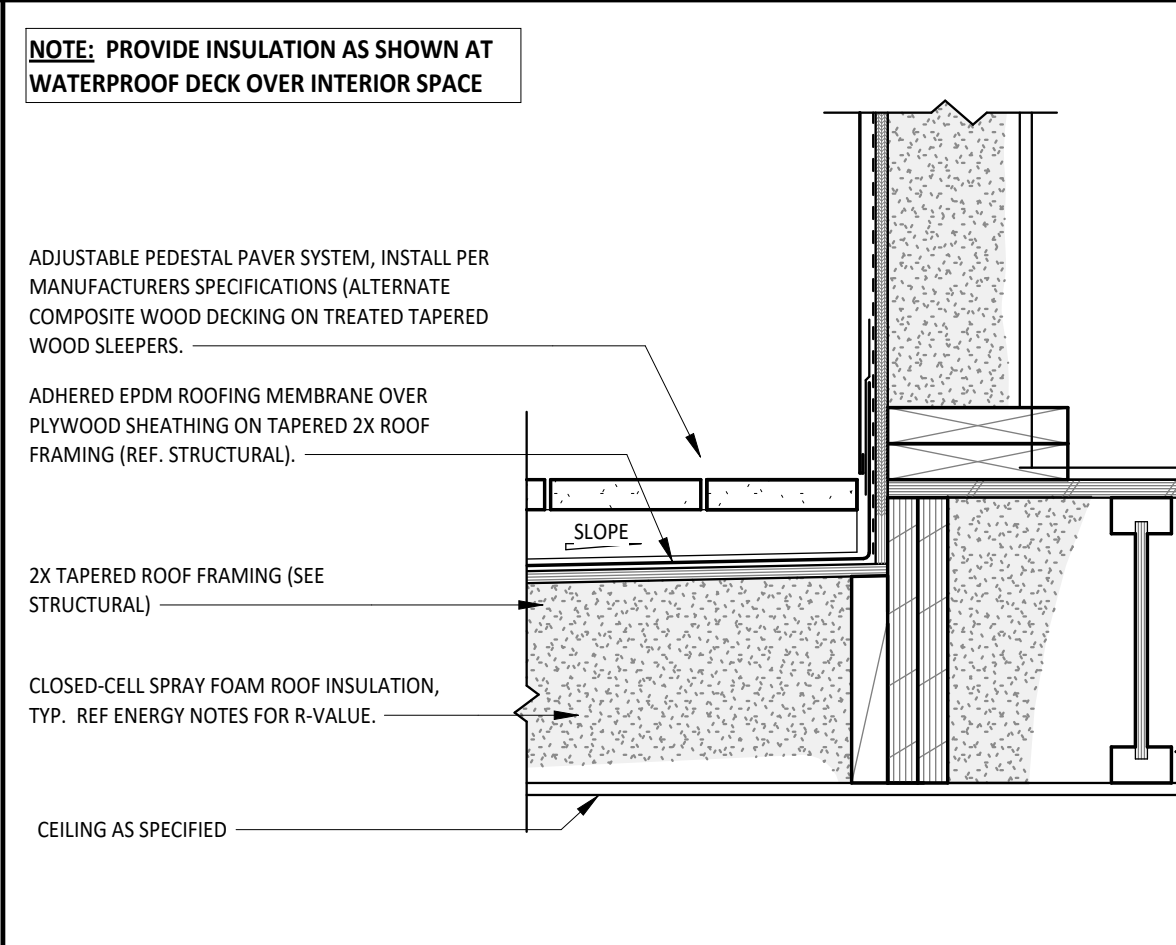

6 ROOF DECK @ WALL (INT)  
1 1/2" = 1'-0"

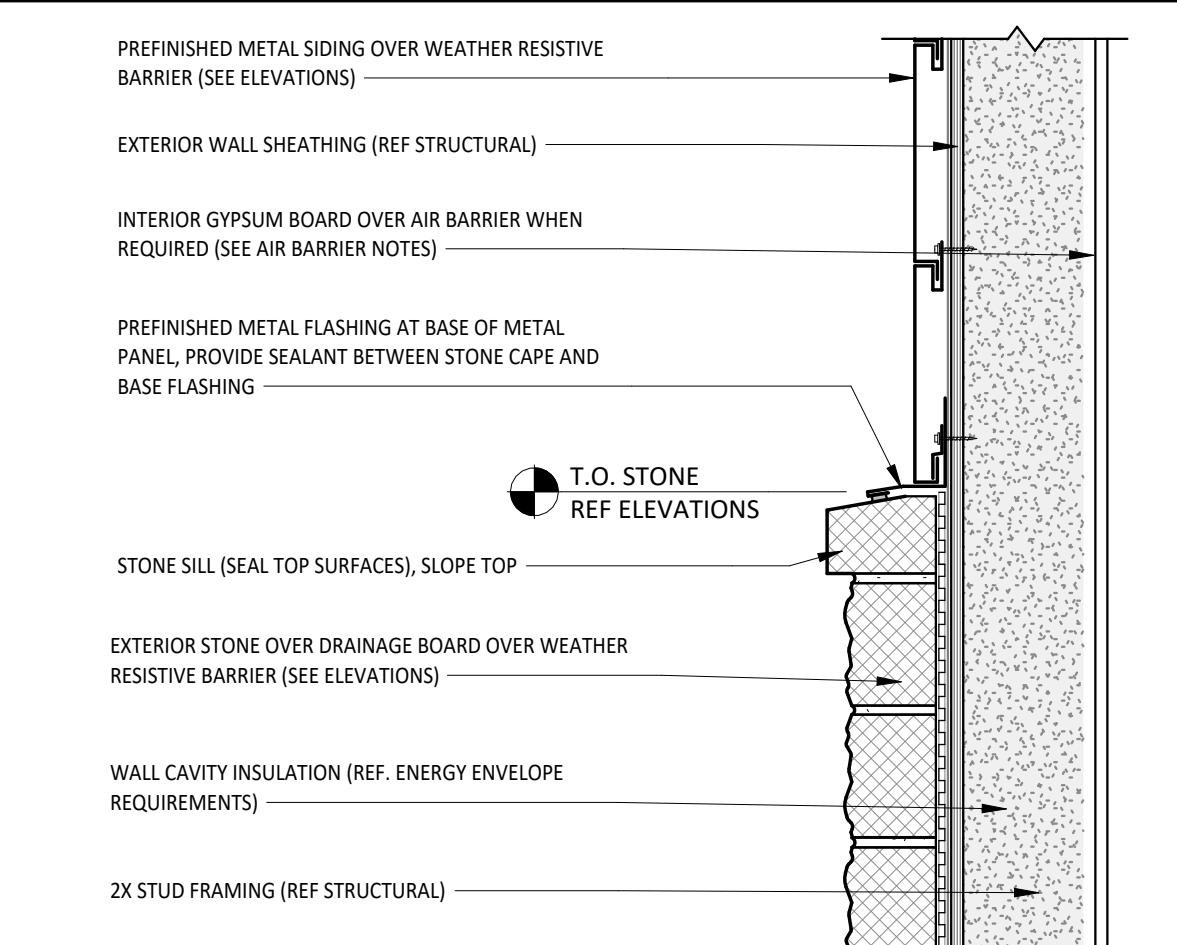

2 CAP AT STONE VENEER  
1 1/2" = 1'-0"

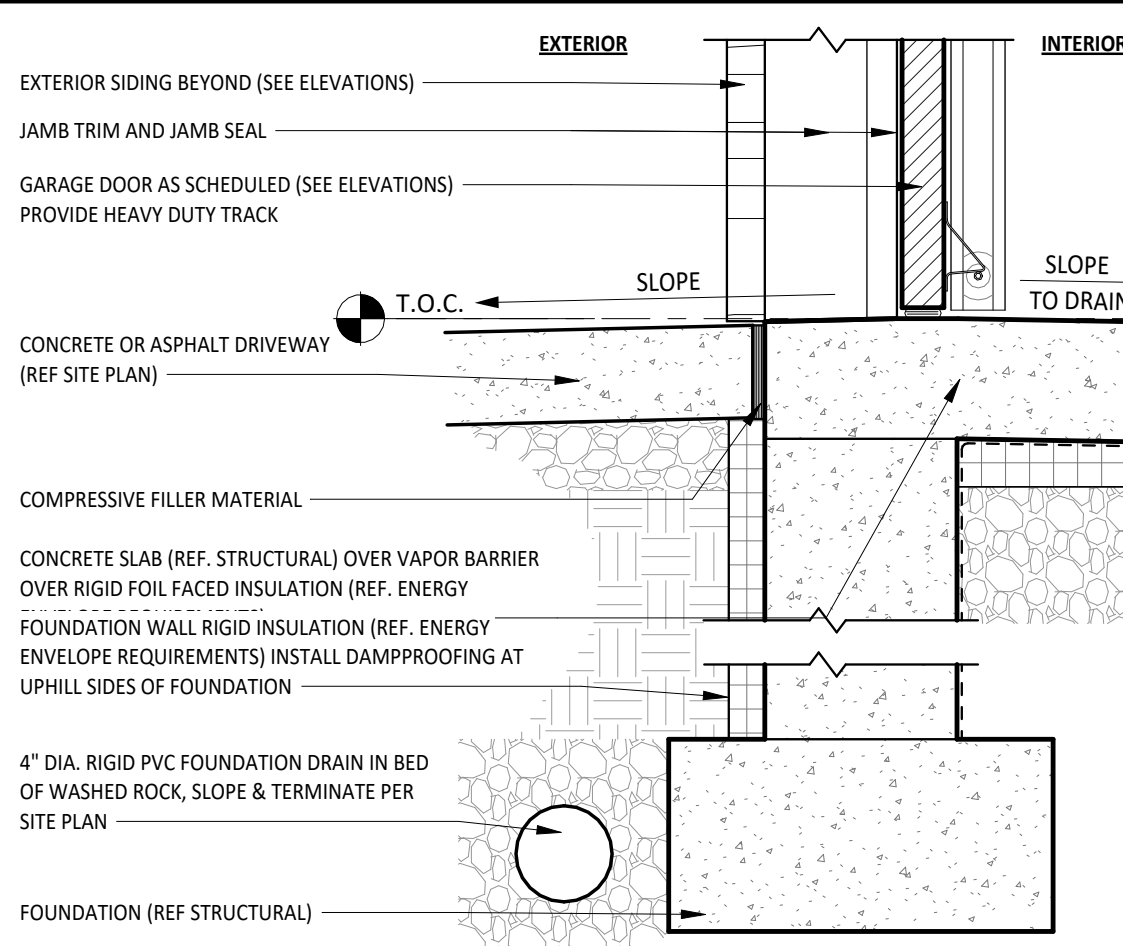

9 GARAGE DOOR THRESHOLD  
1 1/2" = 1'-0"

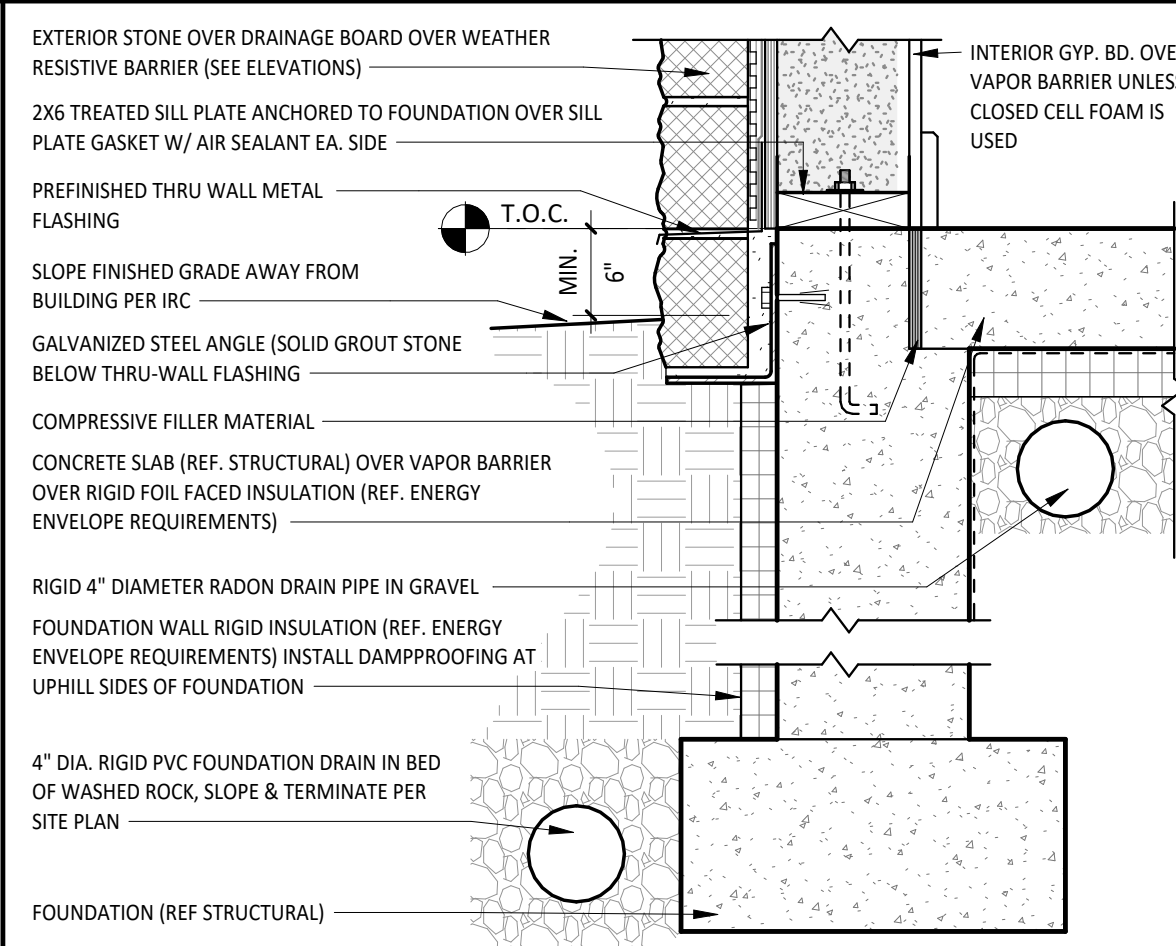

5 TYP. FOUNDATION DETAIL @ STONE  
1 1/2" = 1'-0"

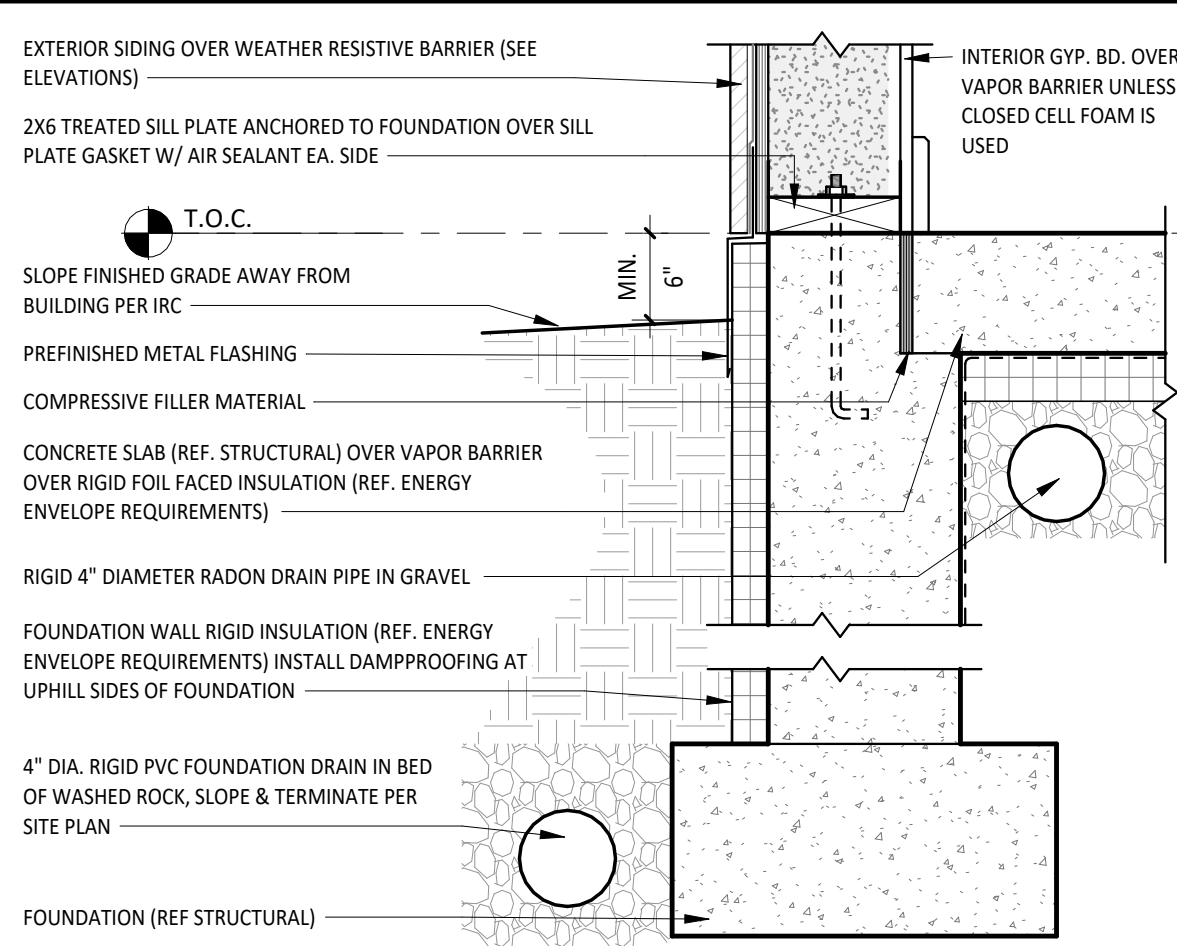

1 TYP. FOUNDATION DETAIL @ WOOD  
1 1/2" = 1'-0"

Table with 3 columns: No., Date, Revisions. It is currently empty.

Project No: 2023-16  
Stage: FINAL REVIEW SET  
Date: 05/02/2024  
Scale: As indicated

DRAWING TITLE:

DETAILS

DRAWING NO:

A7.1

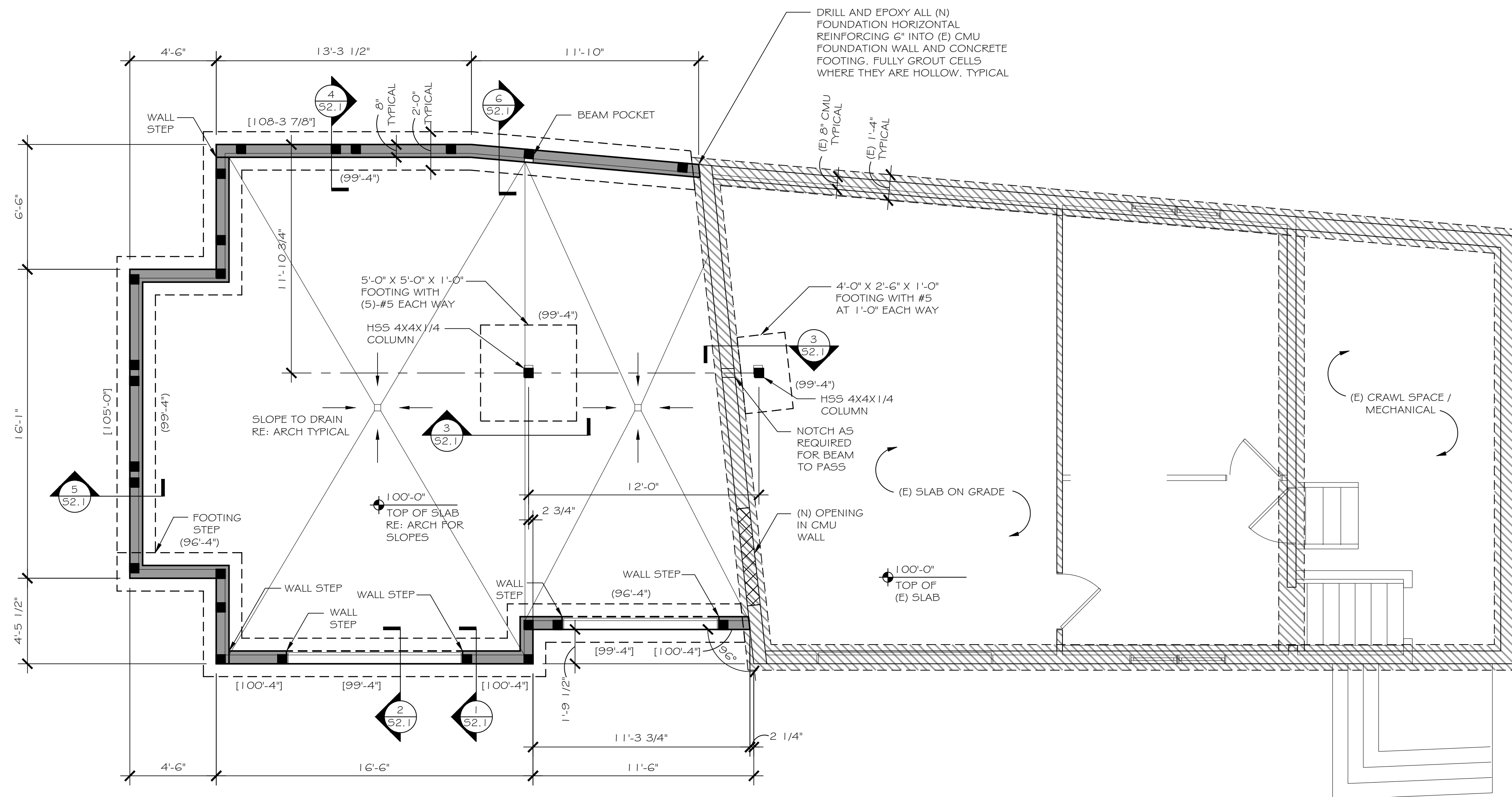

**FOUNDATION PLAN**  
 SCALE: 1/4" = 1'-0"

**FOUNDATION NOTES:**

1. DATUM ELEVATION 100'-0" EQUALS LOWER LEVEL TOP OF SLAB ELEVATION. RE: ARCH FOR USGS.
2. [XX'-XX"] INDICATES TOP OF FOUNDATION WALL ELEVATION.
3. (XX'-XX") INDICATES TOP OF FOOTING ELEVATION.
4. FLOOR ELEVATIONS SHOWN ARE AT TOP OF SLAB OR AT TOP OF PLYWOOD FLOOR SHEATHING.
5. FOOTING ELEVATIONS SHOWN ARE MAXIMUMS AND MAY NEED TO BE LOWERED DUE TO SOIL CONDITIONS. VERIFY CHANGES WITH STRUCTURAL ENGINEER.
6. ALL SLABS ON GRADE ARE 4" THICK WITH GYG W2.1XW2.1 WELDED WIRE FABRIC UNLESS NOTED OTHERWISE.
7. SITE WALLS NOT SHOWN ON THIS PLAN SHALL BE BUILT PER ARCHITECTURAL LANDSCAPE PLANS, DETAILS AND ELEVATIONS. SITE WALLS SHALL NOT BE CONNECTED TO BUILDING UNLESS NOTED OTHERWISE.
8. REFERENCE GENERAL NOTES FOR ADDITIONAL REQUIREMENTS.

**FOX STRUCTURAL ENGINEERING, LLC**  
 216 SNOWBERRY WAY  
 DILLON, COLORADO 80435  
 (970) 376-2005

**FITZGERALD ADDITION**

34 RUSTIC TERRACE  
 BLUE RIVER, COLORADO

PROJECT #2337  
 DRAWN: CM/KF  
 DATE: 04/23/2024  
 FOR PERMIT

**S1.1**

FOUNDATION PLAN

**FOX STRUCTURAL ENGINEERING, LLC**  
 216 SNOWBERRY WAY  
 DILLON, COLORADO 80435  
 (970) 376-2005

**FITZGERALD ADDITION**  
 34 RUSTIC TERRACE  
 BLUE RIVER, COLORADO

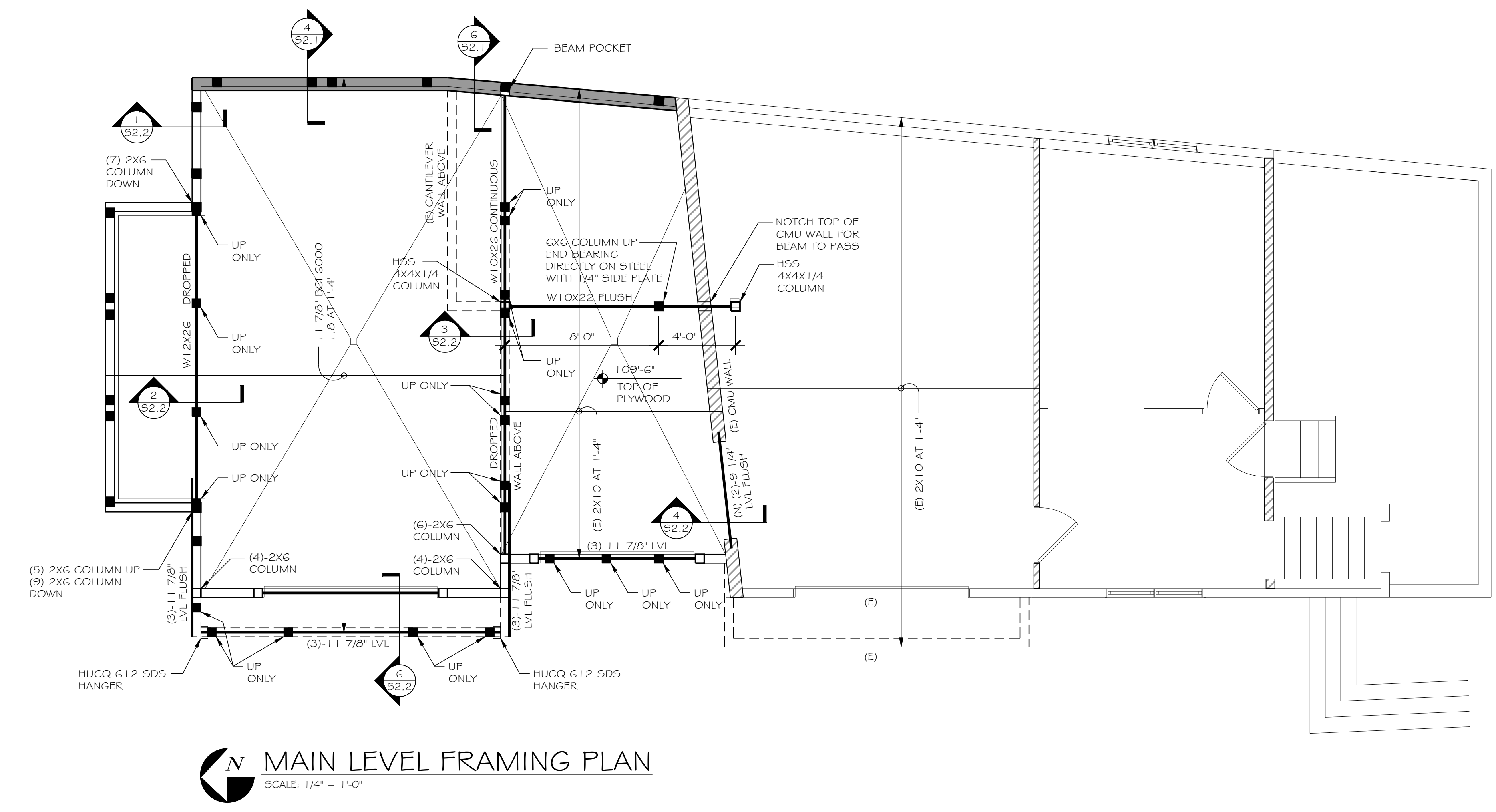

**MAIN LEVEL FRAMING PLAN**  
 SCALE: 1/4" = 1'-0"

**FRAMING NOTES:**

- INDICATES COLUMN DOWN ONLY.
- INDICATES COLUMN UP AND DOWN UNLESS IT BEARS ON CONCRETE BELOW, OR IT IS LABELED UP ONLY OR SUB COLUMN.
- ▨▨▨▨ INDICATES INTERIOR BEARING WALLS, JOISTS BEARING LOCATIONS SHALL LINE UP WITH STUDS BELOW.
- ALL COLUMNS SHALL BE (3)-2X6 MINIMUM UNLESS NOTED OTHERWISE. COLUMNS AND STUDS SHALL BE CONTINUOUS FLOOR TO FLOOR OR FLOOR TO ROOF.
- <XX-XX> INDICATES TOP OF BEAM ELEVATION OR PLATE HEIGHT ELEVATION.
- HEADERS SHALL BE (2)-9 1/4" LVL UNLESS NOTED OTHERWISE. ALL HEADERS SHALL BE BUILT OUT TO 5 1/2" WIDTH BY ADDING RIGID INSULATION RE: ARCH.
- ALL HEADERS 6'-0" AND LONGER SHALL REQUIRE TWO TRIM STUDS AND TWO KING STUDS EACH SIDE. HEADERS SHORTER THAN 6'-0" REQUIRE ONE TRIM STUD AND ONE KING STUD EACH SIDE UNLESS NOTED OTHERWISE.
- ROOF JOIST HANGERS SHALL BE SIMPSON LSSR OR LRUZ TYPE UNLESS NOTED OTHERWISE. FLOOR JOIST HANGERS SHALL BE SIMPSON IUS TYPE UNLESS NOTED OTHERWISE.
- ALL EXTERIOR WALLS SHALL BE CONSTRUCTED USING 2X6 STUDS. REFER TO EXTERIOR WALL DETAILS FOR MORE INFORMATION. STUDS CAN BE SPACED AT 2'-0" FOR WALLS SHORTER THAN 10'-0" UNLESS NOTED OTHERWISE. STUDS SHALL BE SPACED 1'-0" FOR WALLS SHORTER THAN 14'-0" AND TALLER THAN 10'-0" UNLESS NOTED OTHERWISE.
- REFERENCE ARCHITECTURAL DRAWINGS FOR LOCATION AND SIZE OF ROUGH OPENINGS IN WOOD STUD WALLS.
1. REFERENCE GENERAL NOTES FOR ADDITIONAL REQUIREMENTS.
2. BCI 6000 1.8 JOISTS MAY BE REPLACED WITH TJI 210 JOISTS EQUAL DEPTH AND SPACING RE: GENERAL NOTES.
3. FLOOR FRAMING IS NOT SIZED FOR GYPCRETE TOPPING.

PROJECT #2337  
 DRAWN: CM/KF  
 DATE: 04/23/2024  
 FOR PERMIT

**S1.2**  
 MAIN LEVEL FRAMING PLAN

**FITZGERALD ADDITION**  
34 RUSTIC TERRACE  
BLUE RIVER, COLORADO

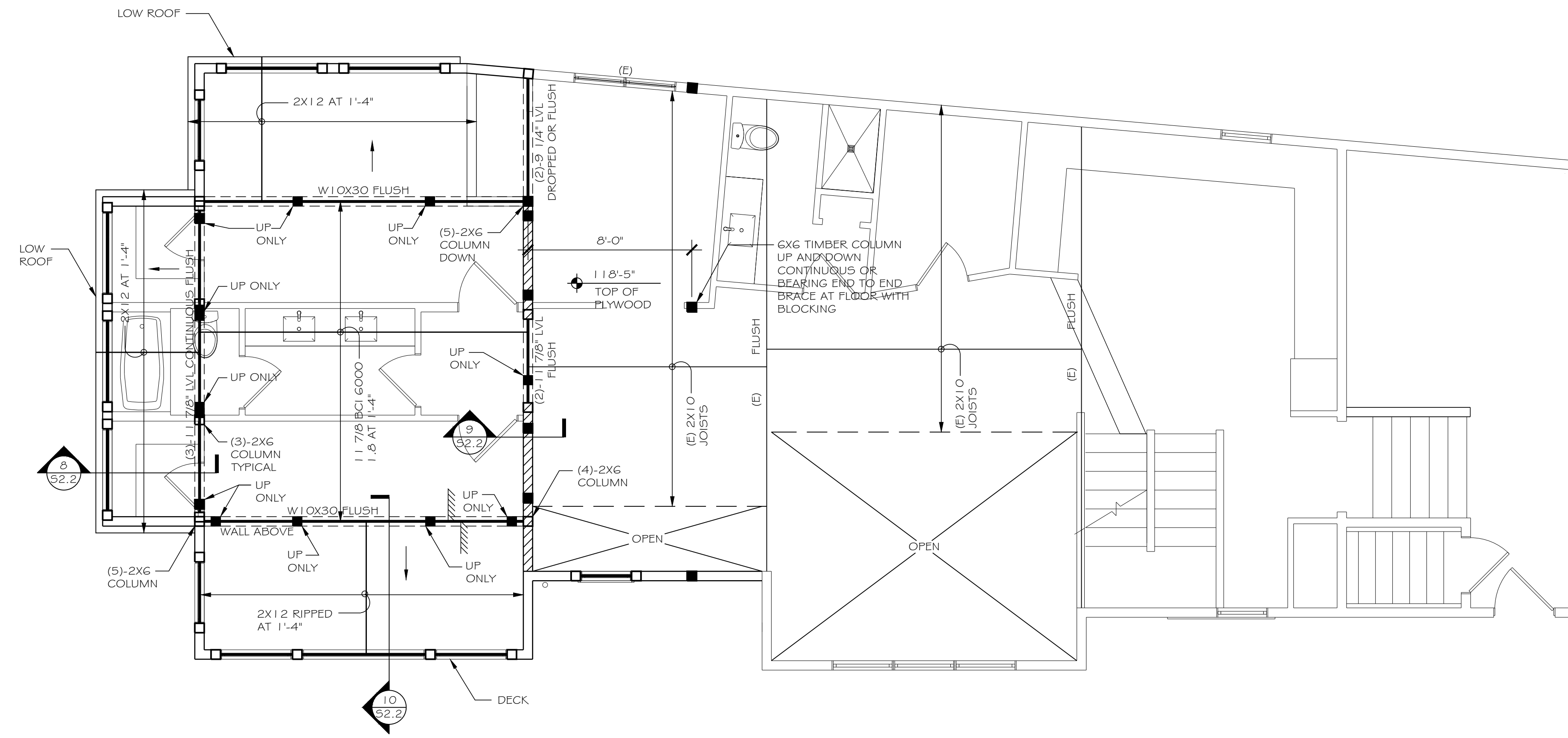

**UPPER LEVEL FRAMING PLAN**  
SCALE: 1/4" = 1'-0"

**FRAMING NOTES:**

1. □ INDICATES COLUMN DOWN ONLY.
2. ■ INDICATES COLUMN UP AND DOWN UNLESS IT BEARS ON CONCRETE BELOW, OR IT IS LABELED UP ONLY OR SUB COLUMN.
3. ▨▨▨ INDICATES INTERIOR BEARING WALLS, JOISTS BEARING LOCATIONS SHALL LINE UP WITH STUDS BELOW.
4. ALL COLUMNS SHALL BE (3)-2X6 MINIMUM UNLESS NOTED OTHERWISE. COLUMNS AND STUDS SHALL BE CONTINUOUS FLOOR TO FLOOR OR FLOOR TO ROOF.
5. <XX'-XX"> INDICATES TOP OF BEAM ELEVATION OR PLATE HEIGHT ELEVATION.
6. HEADERS SHALL BE (2)-9 1/4" LVL UNLESS NOTED OTHERWISE. ALL HEADERS SHALL BE BUILT OUT TO 5 1/2" WIDTH BY ADDING RIGID INSULATION RE: ARCH.
7. ALL HEADERS 6'-0" AND LONGER SHALL REQUIRE TWO TRIM STUDS AND TWO KING STUDS EACH SIDE. HEADERS SHORTER THAN 6'-0" REQUIRE ONE TRIM STUD AND ONE KING STUD EACH SIDE UNLESS NOTED OTHERWISE.
8. ROOF JOIST HANGERS SHALL BE SIMPSON LSSR OR LRUZ TYPE UNLESS NOTED OTHERWISE. FLOOR JOIST HANGERS SHALL BE SIMPSON IUS TYPE UNLESS NOTED OTHERWISE.
9. ALL EXTERIOR WALLS SHALL BE CONSTRUCTED USING 2X6 STUDS. REFER TO EXTERIOR WALL DETAILS FOR MORE INFORMATION. STUDS CAN BE SPACED AT 2'-0" FOR WALLS SHORTER THAN 10'-0" UNLESS NOTED OTHERWISE. STUDS SHALL BE SPACED 1'-0" FOR WALLS SHORTER THAN 14'-0" AND TALLER THAN 10'-0" UNLESS NOTED OTHERWISE.
10. REFERENCE ARCHITECTURAL DRAWINGS FOR LOCATION AND SIZE OF ROUGH OPENINGS IN WOOD STUD WALLS.
11. REFERENCE GENERAL NOTES FOR ADDITIONAL REQUIREMENTS.
12. BCI 6000 1.8 JOISTS MAY BE REPLACED WITH TJI 210 JOISTS EQUAL DEPTH AND SPACING RE: GENERAL NOTES.
13. FLOOR FRAMING IS NOT SIZED FOR GYPCRETE TOPPING.

PROJECT #2337  
DRAWN: CM/KF  
DATE: 04/23/2024  
FOR PERMIT

**S1.3**  
UPPER LEVEL FRAMING  
PLAN

**FOX STRUCTURAL ENGINEERING, LLC**  
 216 SNOWBERRY WAY  
 DILLON, COLORADO 80435  
 (970) 376-2005

**FITZGERALD ADDITION**  
 34 RUSTIC TERRACE  
 BLUE RIVER, COLORADO

PROJECT #2337  
 DRAWN: CM/KF  
 DATE: 04/23/2024  
 FOR PERMIT

**S1.4**  
 ROOF FRAMING PLAN

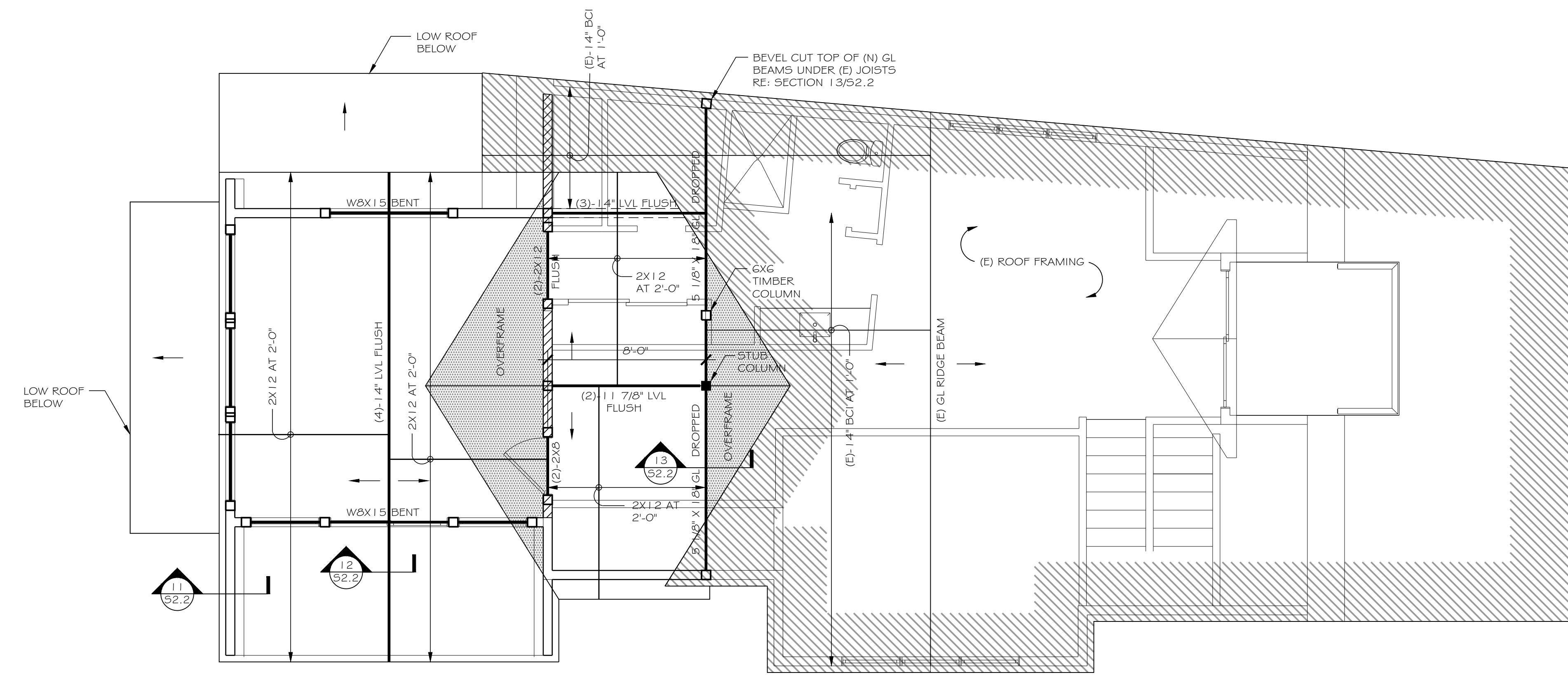

**ROOF FRAMING PLAN**  
 SCALE: 1/4" = 1'-0"

**FRAMING NOTES:**

1. □ INDICATES COLUMN DOWN ONLY.
2. ■ INDICATES COLUMN UP AND DOWN UNLESS IT BEARS ON CONCRETE BELOW, OR IT IS LABELED UP ONLY OR STUB COLUMN.
3. ▨▨▨▨ INDICATES INTERIOR BEARING WALLS, JOISTS BEARING LOCATIONS SHALL LINE UP WITH STUDS BELOW.
4. ALL COLUMNS SHALL BE (3)-2X6 MINIMUM UNLESS NOTED OTHERWISE. COLUMNS AND STUDS SHALL BE CONTINUOUS FLOOR TO FLOOR OR FLOOR TO ROOF.
5. <XX-XX> INDICATES TOP OF BEAM ELEVATION OR PLATE HEIGHT ELEVATION.
6. HEADERS SHALL BE (2)-9 1/4" LVL UNLESS NOTED OTHERWISE. ALL HEADERS SHALL BE BUILT OUT TO 5 1/2" WIDTH BY ADDING RIGID INSULATION RE: ARCH.
7. ALL HEADERS 6'-0" AND LONGER SHALL REQUIRE TWO TRIM STUDS AND TWO KING STUDS EACH SIDE. HEADERS SHORTER THAN 6'-0" REQUIRE ONE TRIM STUD AND ONE KING STUD EACH SIDE UNLESS NOTED OTHERWISE.
8. ROOF JOIST HANGERS SHALL BE SIMPSON LSSR OR LRJZ TYPE UNLESS NOTED OTHERWISE. FLOOR JOIST HANGERS SHALL BE SIMPSON IUS TYPE UNLESS NOTED OTHERWISE.
9. ALL EXTERIOR WALLS SHALL BE CONSTRUCTED USING 2X6 STUDS. REFER TO EXTERIOR WALL DETAILS FOR MORE INFORMATION. STUDS CAN BE SPACED AT 2'-0" FOR WALLS SHORTER THAN 10'-0" UNLESS NOTED OTHERWISE. STUDS SHALL BE SPACED 1'-0" FOR WALLS SHORTER THAN 14'-0" AND TALLER THAN 10'-0" UNLESS NOTED OTHERWISE.
10. REFERENCE ARCHITECTURAL DRAWINGS FOR LOCATION AND SIZE OF ROUGH OPENINGS IN WOOD STUD WALLS.
11. REFERENCE GENERAL NOTES FOR ADDITIONAL REQUIREMENTS.

**GENERAL NOTES:**

1. LIVE LOADS USED IN DESIGN

- A. ROOF SNOW 1 00 PSF
- B. DECK LIVE LOAD 1 25 PSF
- C. INTERIOR FLOOR 40 PSF
- D. ULTIMATE DESIGN WIND 1 15 MPH EXPOSURE B
- E. SEISMIC SITE CLASS D, DESIGN CATEGORY B

2. TESTING, INSPECTIONS AND OBSERVATIONS

- A. THE STRUCTURAL ENGINEER DOES NOT PROVIDE INSPECTIONS OF CONSTRUCTION. STRUCTURAL ENGINEER MAY MAKE PERIODIC OBSERVATIONS OF THE CONSTRUCTION. SUCH OBSERVATIONS SHALL NOT REPLACE REQUIRED INSPECTIONS BY THE GOVERNING AUTHORITIES OR SERVE AS "SPECIAL INSPECTIONS" AS MAY BE REQUIRED BY CHAPTER 17 OF THE INTERNATIONAL BUILDING CODE.

3. FOUNDATIONS

- A. ALLOWABLE SOIL BEARING PRESSURE ASSUMED IN DESIGN IS 2000 PSF.
- B. CONTRACTOR SHALL RETAIN A LICENSED SOILS ENGINEER TO INSPECT THE FOUNDATION EXCAVATION. SOILS ENGINEER SHALL VERIFY IN WRITING THE ACTUAL SOILS CAPACITY IS EQUAL TO OR GREATER THAN ASSUMED.
- C. THE PREPARATION OF THE SUBGRADE SHALL BE IN STRICT ACCORDANCE WITH THE SOILS ENGINEER. QUESTIONS REGARDING THE SUBGRADE PREPARATION SHALL BE DIRECTED TO THE GEOTECHNICAL ENGINEER.
- D. NOTIFY SOILS ENGINEER WHEN EXCAVATION IS COMPLETE SO THAT CONDITIONS MAY BE INSPECTED PRIOR TO PLACEMENT OF ANY FILL OR CONCRETE.
- E. CONTRACTOR TO PROVIDE, AT HIS EXPENSE, FIELD DENSITY TESTS ON COMPACTED FILL UNDER FOOTINGS AND INTERIOR SLABS ON GRADE.
- F. ALL FOOTING BEARING ELEVATIONS SHOWN ARE ASSUMED. EXACT BEARING ELEVATIONS SHALL BE VERIFIED IN THE FIELD WITH ACTUAL CONDITIONS BY CONTRACTOR WITH APPROVAL OF SOILS ENGINEER. ALL BOTTOMS OF FOOTINGS SHALL BE A MINIMUM OF 40" BELOW EXTERIOR GRADE.
- G. ALL FOOTINGS SHALL BE PLACED ON FIRM, UNDISTURBED NATIVE SOIL OR PROPERLY COMPACTED STRUCTURAL BACKFILL, APPROVED BY THE SOILS ENGINEER.
- H. CONTRACTOR SHALL BACKFILL EQUALLY ON EACH SIDE OF FOUNDATION WALLS IN 1 2 INCH MAXIMUM VERTICAL LIFTS OR AS RECOMMENDED BY THE SOILS ENGINEER. REFER TO SOILS ENGINEER FOR BACKFILL MATERIAL.
- I. CENTER ALL FOOTINGS UNDER WALLS OR COLUMNS UNLESS DIMENSIONED OTHERWISE.
- J. REFERENCE THE SOILS ENGINEER AND GRADING DRAWINGS FOR SOIL DRAINAGE REQUIREMENTS.

4. CONCRETE AND REINFORCEMENT

- A. CAST-IN-PLACE CONCRETE SHALL BE MADE WITH TYPE I/II PORTLAND CEMENT AND SHALL SATISFY 3000 PSI MINIMUM. GARAGE FLOOR SLAB SHALL SATISFY 4000 PSI MINIMUM. CONCRETE WITH EXPOSURE TO WEATHER, INCLUDING GARAGE FLOOR SLABS, SHALL BE AIR ENTRAINED AND MEET ALL REQUIREMENTS IN TABLE R402.2 FOR SEVERE WEATHERING POTENTIAL.
- B. ALL CONCRETE AND REINFORCEMENT WORK SHALL BE IN ACCORDANCE WITH ACI BUILDING CODE 318 LATEST EDITION.
- C. CONTRACTOR SHALL SAWCUT OR TROWELCUT JOINTS IN SLABS ON GRADE. JOINTS SHALL BE SPACED 12 FEET MAXIMUM AND CUT 1/4 OF SLAB DEPTH X 3/16" WIDE WITHIN 12 HOURS AFTER POURING. AREA BETWEEN JOINTS SHALL NOT EXCEED 100 SQUARE FEET. CARRY ALL SLAB REINFORCEMENT THROUGH JOINT.
- D. ALL REINFORCING SHALL BE HIGH-STRENGTH DEFORMED BARS CONFORMING TO ASTM A615, GRADE 60, EXCEPT TIES, STIRRUPS AND PLATE ANCHORS WHICH SHALL BE DEFORMED BARS, ASTM DESIGNATION A615, GRADE 40 OR A706 GRADE 60.
- E. WELDED WIRE FABRIC SHALL CONFORM TO ASTM A185 GRADE 65 AND SHALL BE LAPPED ONE FULL MESH AT SIDE AND END SPLICES AND WIRED TOGETHER.
- F. NO SPLICES OF REINFORCEMENT SHALL BE MADE EXCEPT AS DETAILED OR AUTHORIZED BY THE STRUCTURAL ENGINEER. LAP SPLICES, WHERE PERMITTED, SHALL BE A MINIMUM OF 48 BAR DIAMETERS. MAKE ALL BARS CONTINUOUS AROUND CORNERS. USE STANDARD HOOKS FOR DOWELS UNLESS NOTED OTHERWISE.

5. STRUCTURAL STEEL

- A. STRUCTURAL STEEL WIDE FLANGE BEAMS SHALL CONFORM TO ASTM 992, 50 KSI; TUBES SHALL CONFORM TO ASTM A500, GRADE B; PIPES SHALL CONFORM TO ASTM A53, GRADE B. MISCELLANEOUS ITEMS SHALL BE A36 STEEL.
- B. ALL STRUCTURAL BOLTS SHALL BE A325N INSTALLED TO A MINIMUM SHUG TIGHT CONDITION. ALL ANCHOR BOLTS SHALL CONFORM TO ASTM A307.
- C. STRUCTURAL STEEL SHALL BE DETAILED AND FABRICATED IN ACCORDANCE WITH THE LATEST PROVISIONS OF AISC "MANUAL OF STEEL CONSTRUCTION".
- D. ALL WELDERS SHALL HAVE EVIDENCE OF PASSING THE AMERICAN WELDING SOCIETY STANDARD QUALIFICATIONS TESTS AS OUTLINED IN AWS-D1.1.
- E. MINIMUM WELDS TO BE PER AISC TABLE J2.4 BUT NOT LESS THAN 3/16" CONTINUOUS FILLET UNLESS NOTED OTHERWISE.
- F. SUBMIT SHOP AND ERECTION DRAWINGS TO ENGINEER FOR REVIEW OF ALL STRUCTURAL STEEL MEMBERS. THE MANUFACTURING OR FABRICATION OF ANY ITEMS PRIOR TO WRITTEN REVIEW OF SHOP DRAWINGS WILL BE ENTIRELY AT RISK OF THE CONTRACTOR.

6. WOOD

- A. ALL FRAMING LUMBER SHALL BE DRY HEM-FIR, GRADED BY WESTERN WOOD PRODUCTS ASSOCIATION AND CONFORMING TO NO. 2 GRADE (F<sub>b</sub> = 850 PSI). WALL STUDS ONLY MAY CONFORM TO STUD GRADE (F<sub>b</sub> = 675 PSI).
- B. ALL FRAMING TIMBERS (5"X5" AND LARGER) SHALL BE DRY DOUGLAS FIR LARCH, GRADED BY WESTERN WOOD PRODUCTS ASSOCIATION AND CONFORMING TO NO. 1 GRADE (F<sub>b</sub> = 1350 PSI).
- C. PREFABRICATED WOOD MEMBERS SHALL BE "BCI" JOIST AS MANUFACTURED BY BOISE CASCADE OR "TJI" JOIST AS MANUFACTURED BY TRUS JOIST WEYERHAEUSER, TYPES AS NOTED ON THE DRAWINGS. THE BCI JOISTS SPECIFIED HAVE SLIGHTLY HIGHER CAPACITIES THAN THE TJI JOISTS SPECIFIED. ALTERNATES SHALL BE REVIEWED BY THE ENGINEER. TO BE CONSIDERED, ALTERNATES SHALL HAVE A LOAD CAPACITY IN BENDING, SHEAR AND DEFLECTION EQUAL TO OR GREATER THAN THE SIZES SHOWN ON THE DRAWINGS. WEB BLOCKING AND BRIDGING TO BE AS REQUIRED BY THE JOIST MANUFACTURER.
- D. "LVL" INDICATES 1 3/4" WIDE LAMINATED VENEER LUMBER MEMBERS, WHICH SHALL HAVE THE FOLLOWING MINIMUM STRESS CAPACITIES: F<sub>b</sub> = 2600 PSI, F<sub>v</sub> = 285 PSI, E = 2,000,000 PSI. BUILT UP MEMBERS SHALL BE CONNECTED IN ACCORDANCE WITH MANUFACTURER'S RECOMMENDATIONS.
- E. "GL" INDICATES GLULAM MEMBERS, WHICH SHALL BE FABRICATED OF DOUGLAS FIR LARCH AT 12 PERCENT MOISTURE CONTENT IN ACCORDANCE WITH WCLUB. PROVIDE MEMBERS CONFORMING WITH AITC 117, 24F-V4 DF/DF UNLESS NOTED OTHERWISE.
- F. PROVIDE SOLID BLOCKING BETWEEN ALL JOISTS AT ALL SUPPORTS AND ENDS OF CANTILEVERS.
- G. WHEN PRESERVATIVE TREATED LUMBER IS USED ALL CONNECTIONS AND NAILING SHALL BE ADEQUATELY GALVANIZED.
- H. ALL BEAM/BEAM AND BEAM/COLUMN CONNECTIONS SHALL BE MADE WITH SIMPSON STEEL PLATE CONNECTORS UNLESS NOTED OTHERWISE.
- I. FASTEN ALL WOOD MEMBERS WITH COMMON NAILS ACCORDING TO THE IRC TABLE R602.3(1) UNLESS NOTED OTHERWISE.
- J. ALL EXTERIOR WALLS SHALL HAVE CONTINUOUS STUDS FROM FLOOR TO FLOOR OR FLOOR TO ROOF (INCLUDING RAKE WALLS).
- K. OVERFRAMING SHALL BE 2X6 MINIMUM POSTED DOWN TO MAIN JOISTS ON A GRID NOT TO EXCEED 2'-0" X 2'-0".
- L. PLYWOOD DECK AND/OR ORIENTED STRAND BOARD
  - 1. APPLICATION SHALL BE IN ACCORDANCE WITH RECOMMENDATIONS OF THE AMERICAN PLYWOOD ASSOCIATION.
  - 2. EACH PANEL SHALL BE IDENTIFIED WITH THE GRADE-TRADEMARK OF THE AMERICAN PLYWOOD ASSOCIATION AND SHALL MEET THE REQUIREMENTS OF U.S. PRODUCTS STANDARD PSI, LATEST EDITION FOR PLYWOOD.
  - 3. FOR FLOORING USE 3/4" T&G STURD-I-FLOOR SHEATHING GLUED AND NAILED WITH 1 0D NAILS AT 6" ON CENTER ALONG PANEL EDGES AND AT 12" ALONG INTERMEDIATE SUPPORTS.
  - 4. FOR ROOF USE 5/8" (40/20 SPAN RATING) EXPOSURE 1 SHEATHING NAILED WITH 1 0D NAILS AT 6" ON CENTER ALONG PANEL EDGES AND AT 12" ALONG INTERMEDIATE SUPPORTS.
  - 5. EXTERIOR WALLS SHALL HAVE ONE LAYER 7/16" EXPOSURE 1 SHEATHING NAILED WITH 8D NAILS AT 6" ON CENTER ALONG PANEL EDGES AND AT 12" ALONG INTERMEDIATE SUPPORTS UNLESS NOTED OTHERWISE. ALL PANEL EDGES SHALL BE BLOCKED.
  - 6. FLOOR AND ROOF SHEATHING SHALL BE INSTALLED WITH THE FACE GRAIN PERPENDICULAR TO SUPPORTS WITH END JOINTS STAGGERED.
  - 7. INSTALL SUITABLE EDGE SUPPORT BY USE OF PLYCLIPS, TONGUE AND GROOVE PANELS OR SOLID WOOD BLOCKING SUPPORTS.

7. GENERAL

- A. ENGINEER'S ACCEPTANCE MUST BE SECURED FOR ALL STRUCTURAL SUBSTITUTIONS.
- B. ALL DIMENSIONS AND DETAILS ON STRUCTURAL DRAWINGS SHALL BE FIELD VERIFIED AND CHECKED AGAINST ARCHITECTURAL DRAWINGS.
- C. WATERPROOFING, VAPOR BARRIERS, WATERSTOP, ETC., SHALL BE AS SHOWN IN ARCHITECTURAL DRAWINGS AND DETAILS.
- D. ELEMENTS SUCH AS NON-BEARING PARTITIONS ATTACHED TO AND/OR SUPPORTED BY THE STRUCTURE SHALL TAKE INTO ACCOUNT DEFLECTIONS AND OTHER STRUCTURAL MOVEMENTS.
- E. VERIFY ALL OPENINGS THROUGH FLOORS, ROOF AND WALLS WITH MECHANICAL AND ELECTRICAL CONTRACTORS. VERIFICATION OF LOCATIONS, SIZES AND REQUIRED CONNECTIONS ARE CONTRACTOR'S RESPONSIBILITY. ENGINEER'S APPROVAL OF CONNECTIONS AND SUPPORTS SHALL BE OBTAINED PRIOR TO INSTALLATION OF MECHANICAL AND ELECTRICAL EQUIPMENT OR OTHER ITEMS TO BE ATTACHED TO THE STRUCTURE.
- F. REFER TO ARCHITECTURAL DRAWINGS FOR STAIR FRAMING DETAILS AND LANDING SLAB ELEVATIONS.
- G. ALL STONE VENEERS SHALL BE THIN ADHERED TYPE AND SHALL BE ATTACHED TO INTERIOR AND EXTERIOR WALLS AS SPECIFIED IN SECTION R703.8 OF THE INTERNATIONAL RESIDENTIAL CODE.
- H. (E) INDICATES EXISTING, (N) INDICATES NEW.

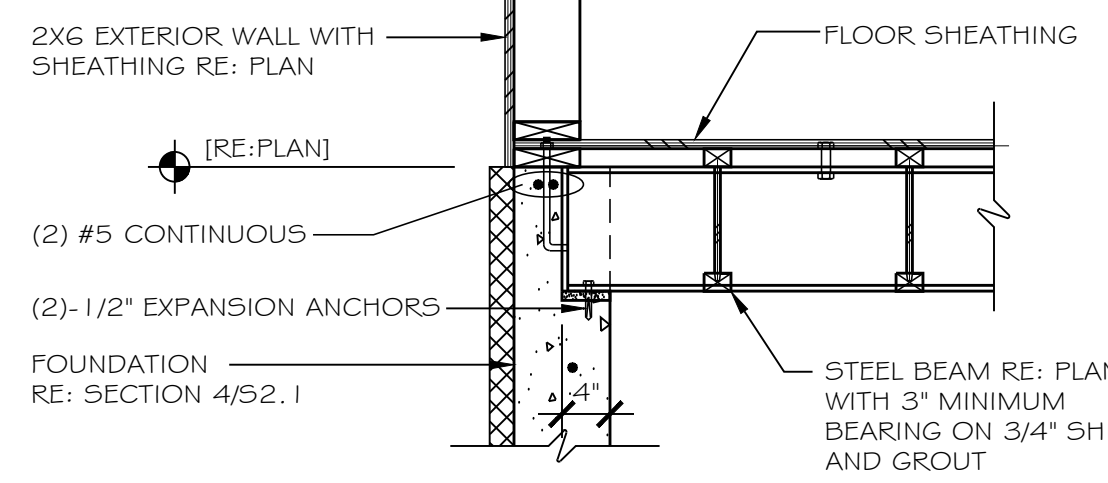

6 BEAM POCKET SCALE: 3/4" = 1'-0"

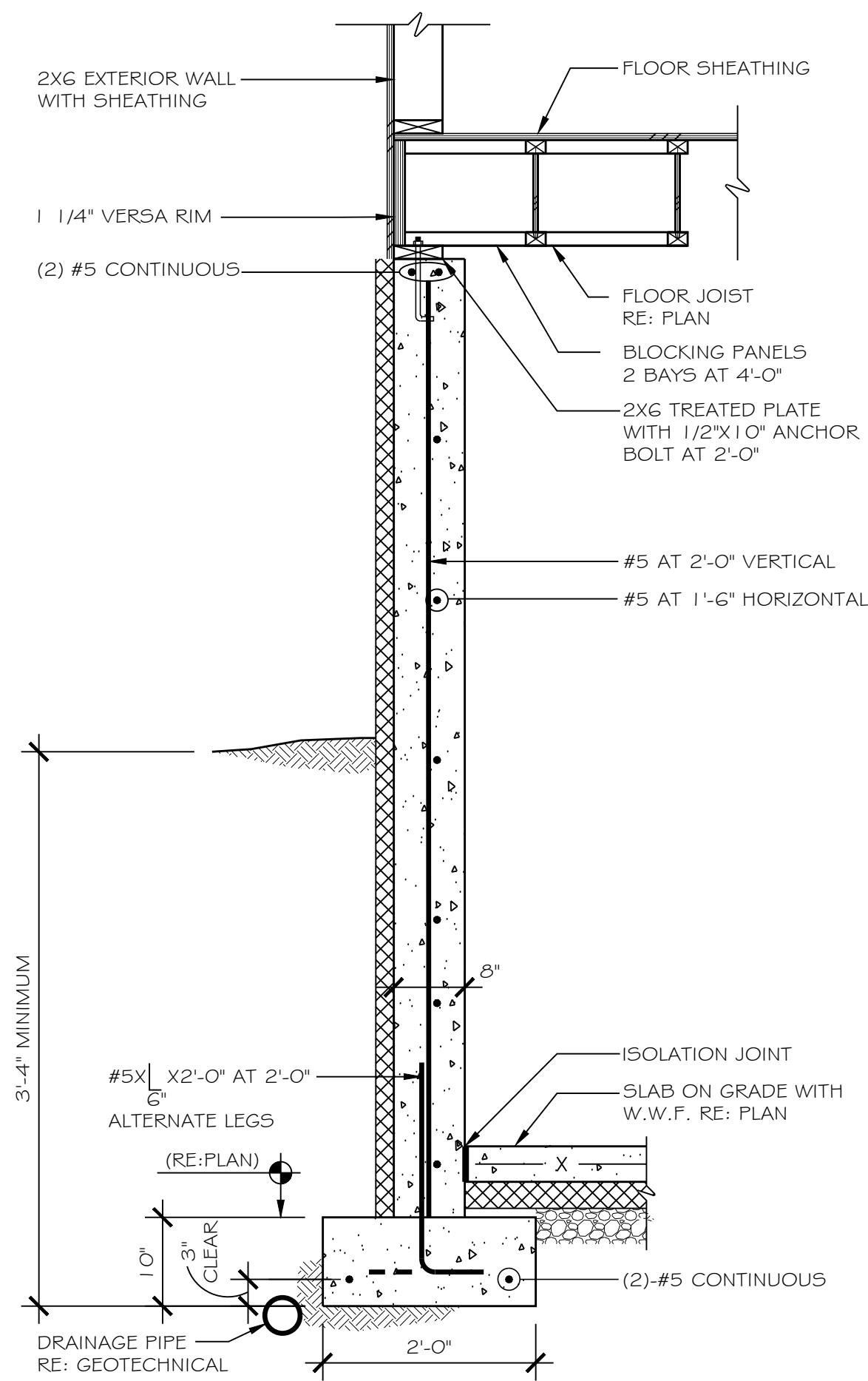

4 GARAGE BACK WALL SCALE: 3/4" = 1'-0"

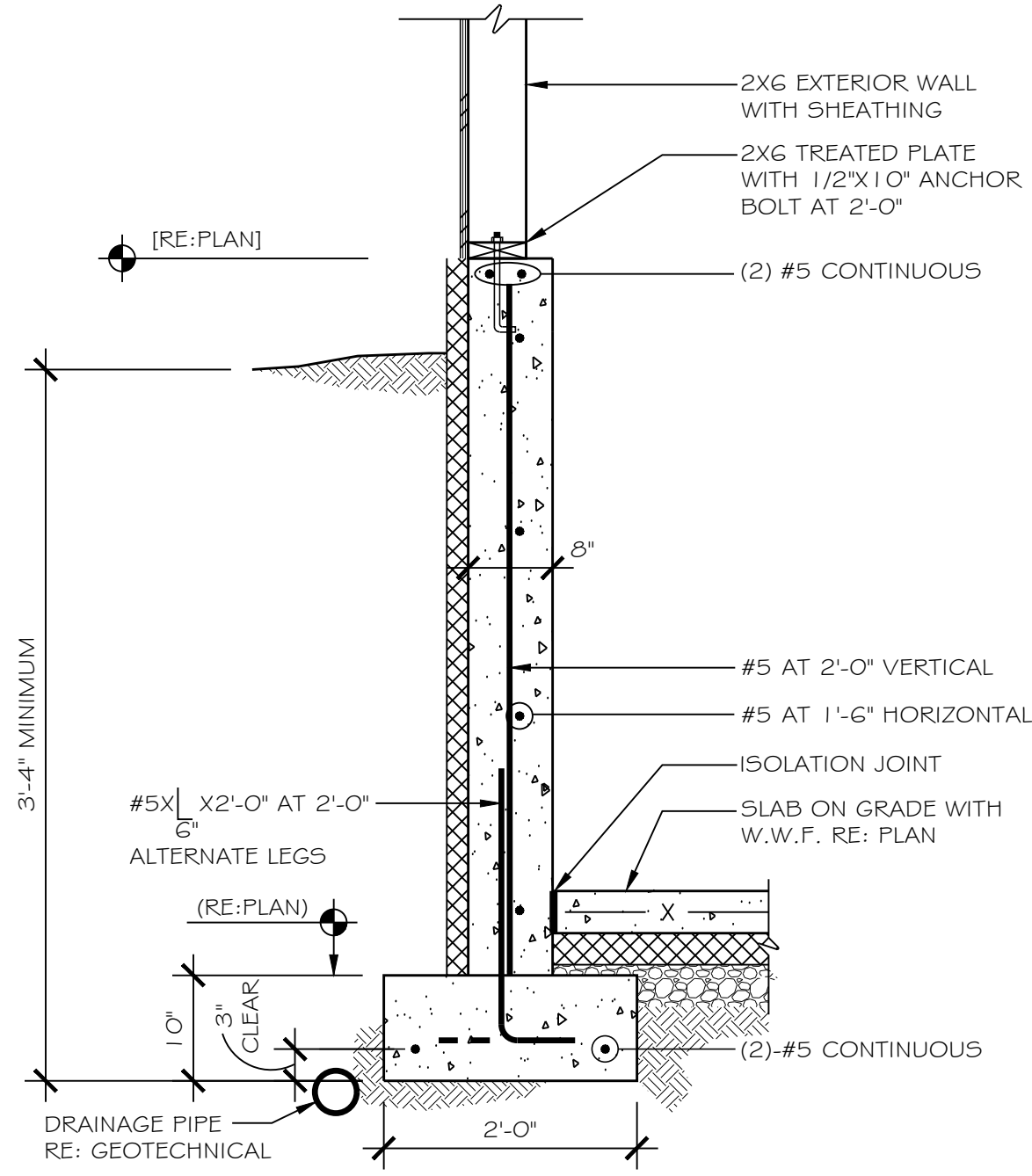

5 GARAGE SIDE WALL SCALE: 3/4" = 1'-0"

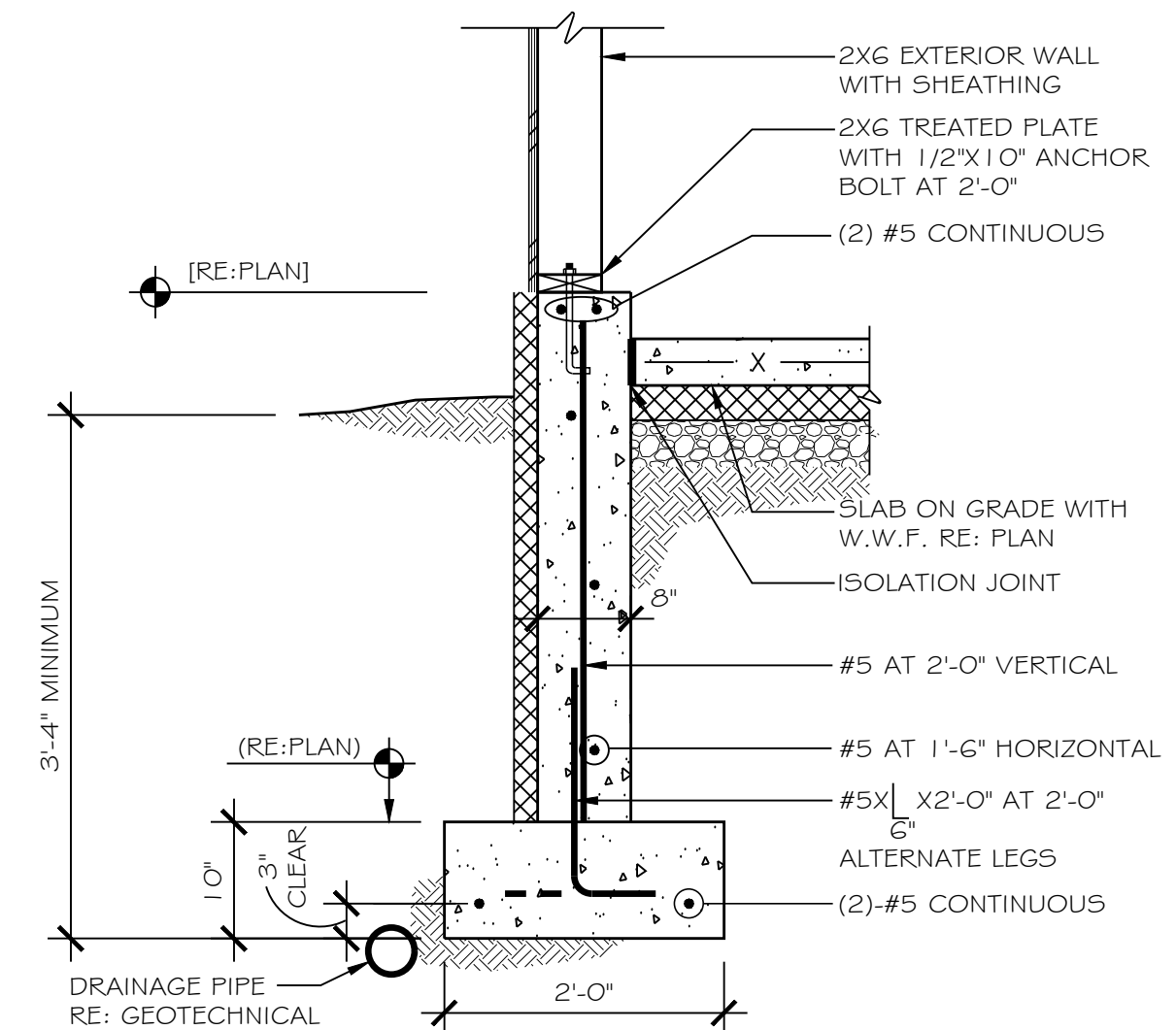

1 LOWER FOUNDATION SCALE: 3/4" = 1'-0"

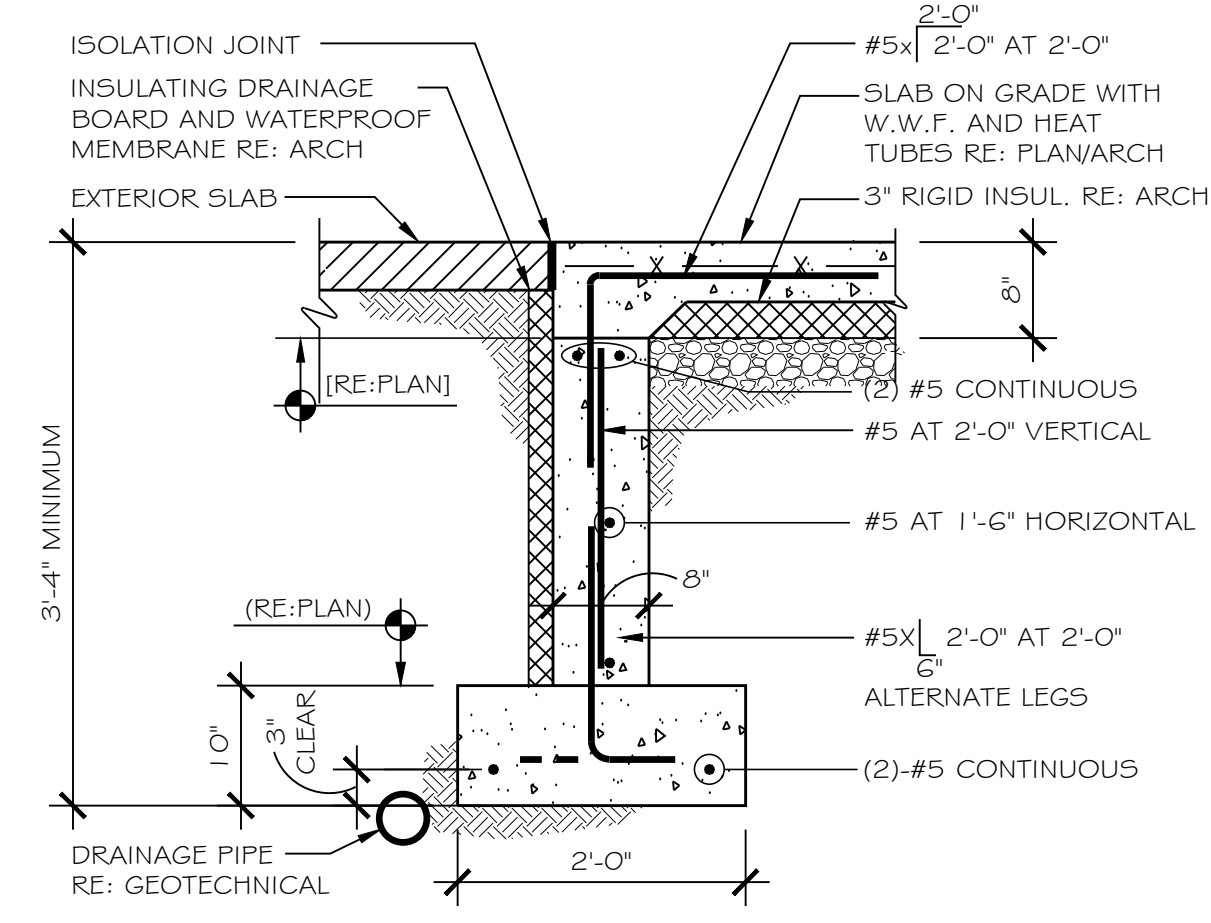

2 FOUNDATION AT DOOR SCALE: 3/4" = 1'-0"

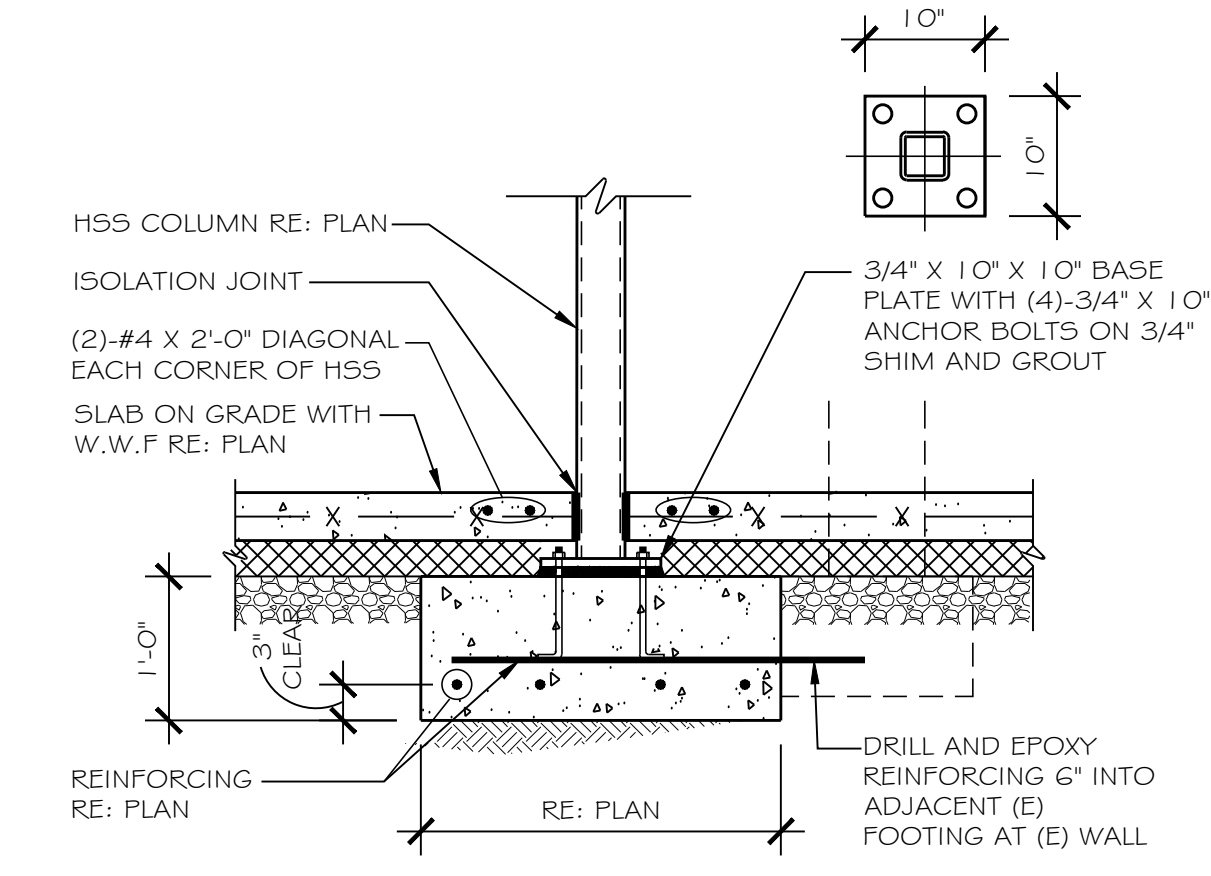

3 HSS COLUMN FOOTING SCALE: 3/4" = 1'-0"

**FOX STRUCTURAL ENGINEERING, LLC**  
 216 SNOWBERRY WAY  
 DILLON, COLORADO 80435  
 (970) 376-2005

**FITZGERALD ADDITION**  
 34 RUSTIC TERRACE  
 BLUE RIVER, COLORADO

PROJECT #2337  
 DRAWN: CM/KF  
 DATE: 04/23/2024  
 FOR PERMIT

**S2.1**  
 NOTES & DETAILS

**FITZGERALD ADDITION**  
34 RUSTIC TERRACE  
BLUE RIVER, COLORADO

PROJECT #2337  
DRAWN: CM/KF  
DATE: 04/23/2024  
FOR PERMIT

**S2.2**  
FRAMING DETAILS

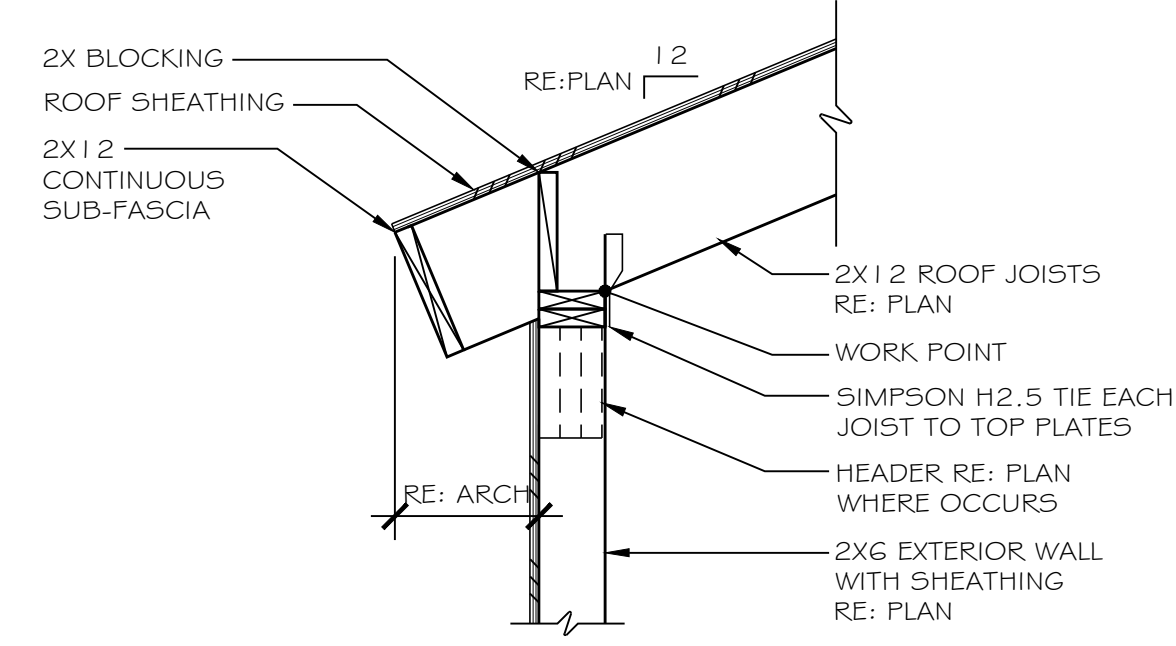

**11 EAVE SECTION**  
SCALE: 3/4" = 1'-0"

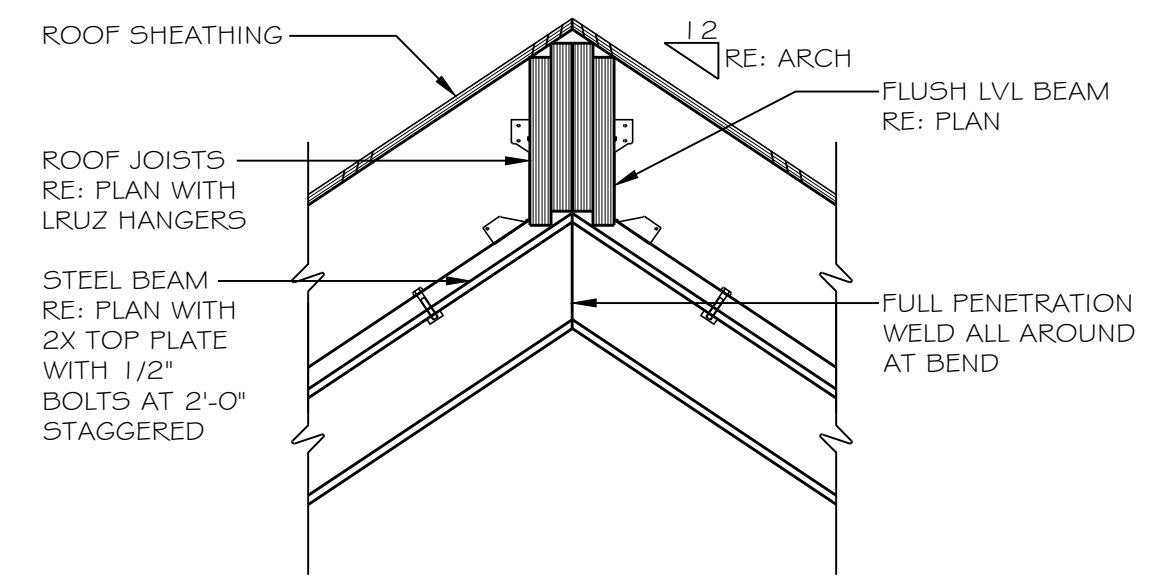

**12 FLUSH LVL RIDGE**  
SCALE: 3/4" = 1'-0"

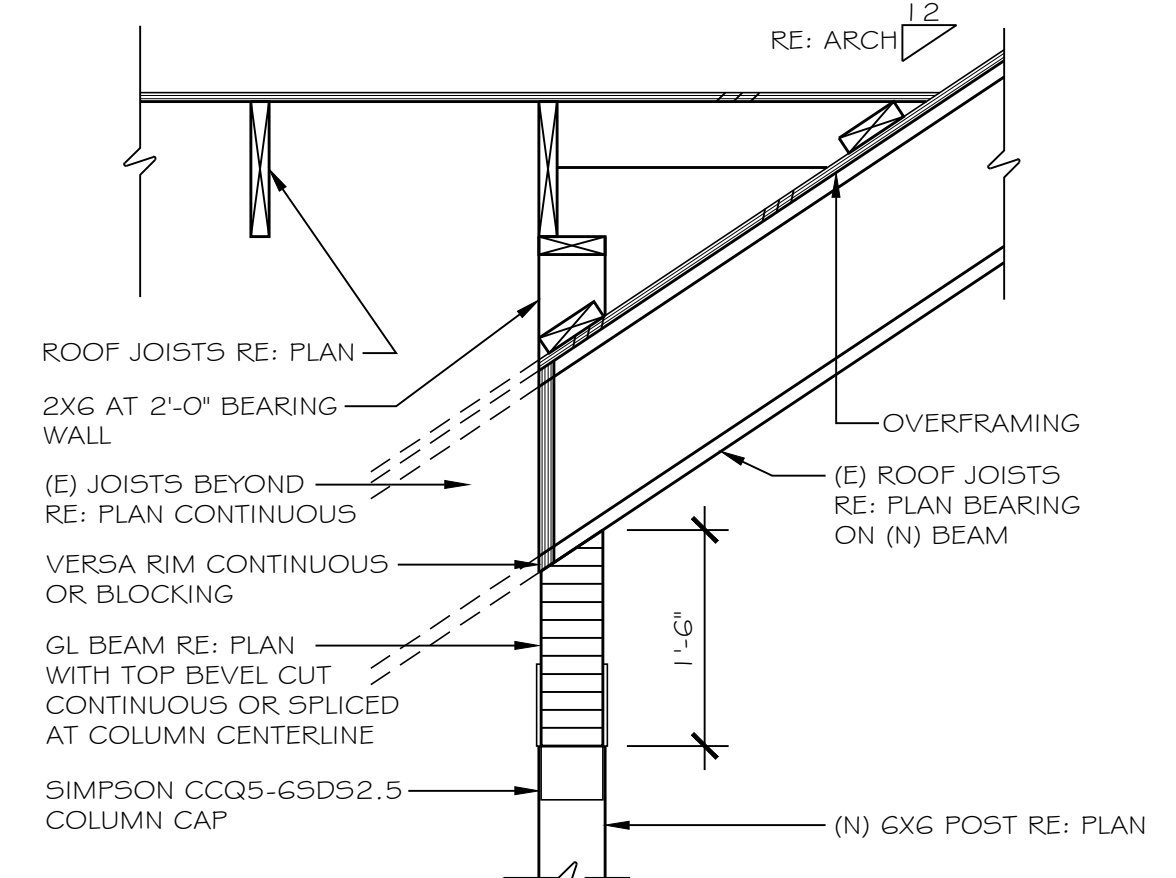

**13 (N) ROOF BEAM AT (E)**  
SCALE: 3/4" = 1'-0"

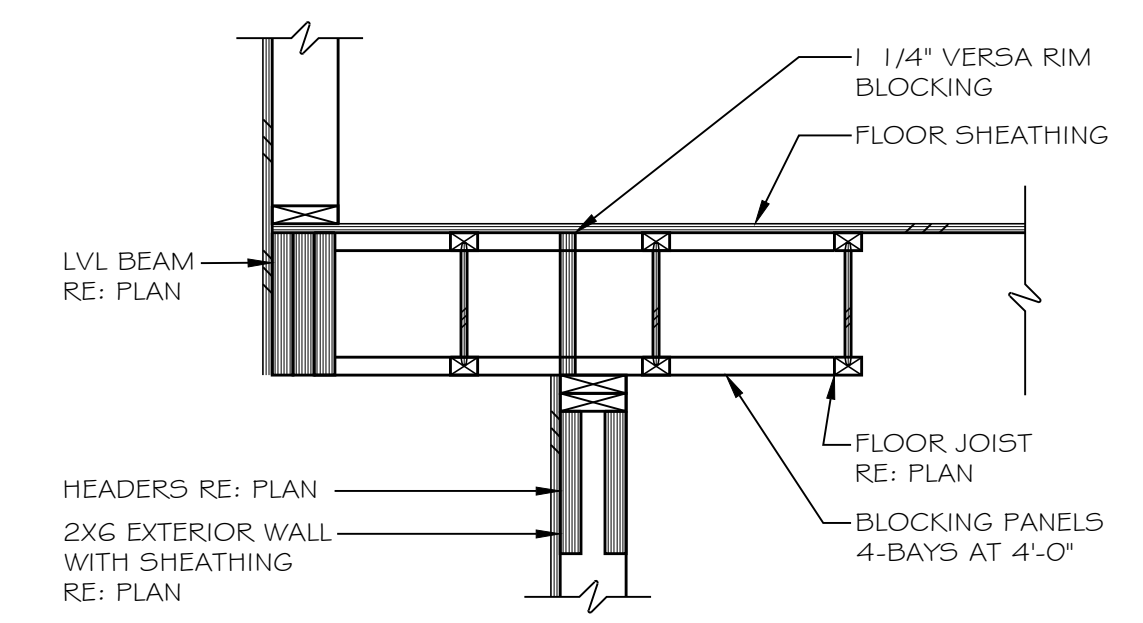

**6 FLOOR SECTION**  
SCALE: 3/4" = 1'-0"

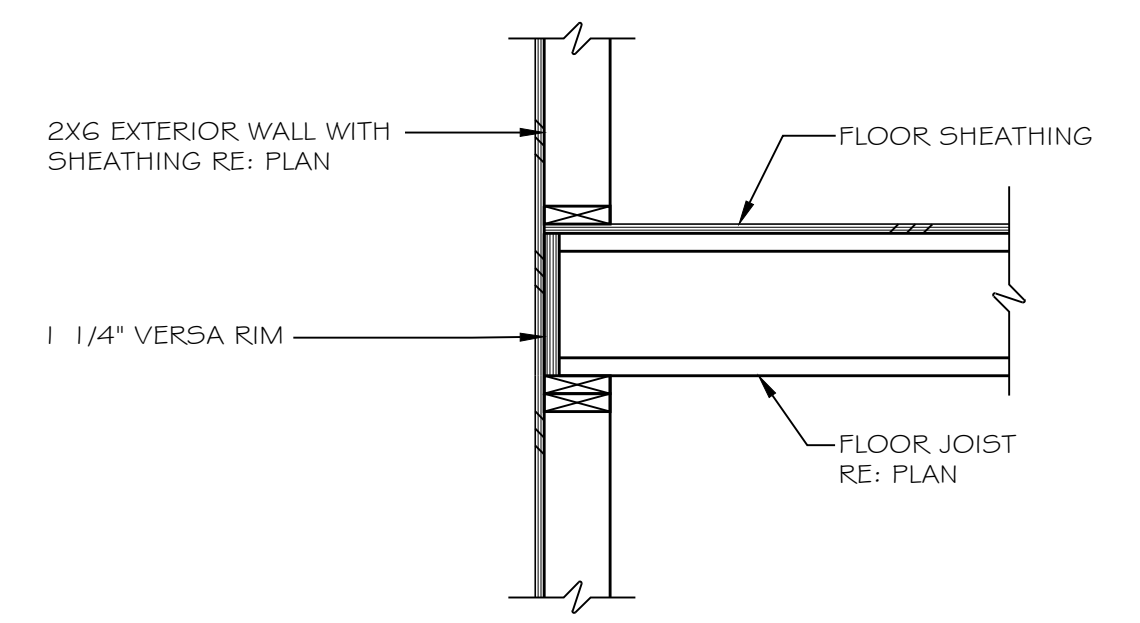

**1 FLOOR SECTION**  
SCALE: 3/4" = 1'-0"

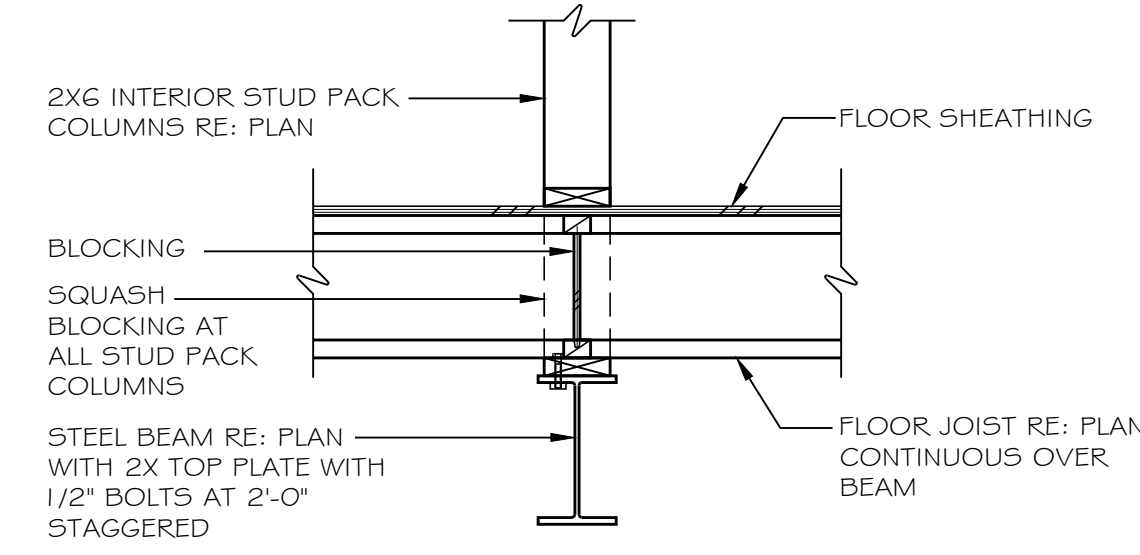

**2 DROPPED STEEL BEAM**  
SCALE: 3/4" = 1'-0"

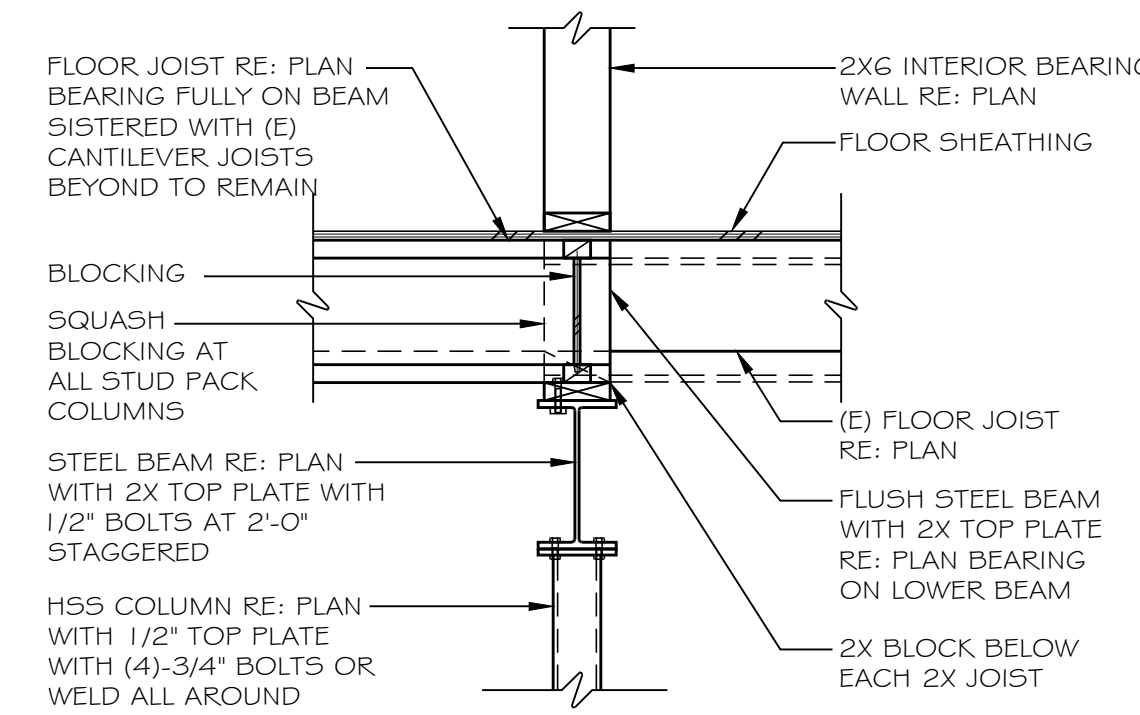

**3 DROPPED STEEL BEAM**  
SCALE: 3/4" = 1'-0"

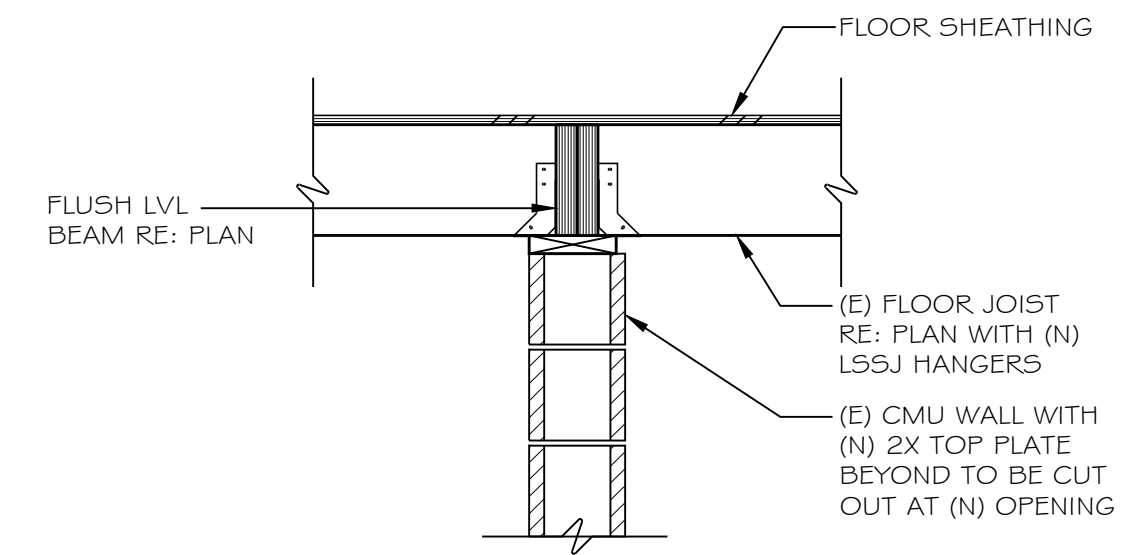

**4 FLUSH BEAM AT CMU**  
SCALE: 3/4" = 1'-0"



**7 NOT USED**  
SCALE: 3/4" = 1'-0"

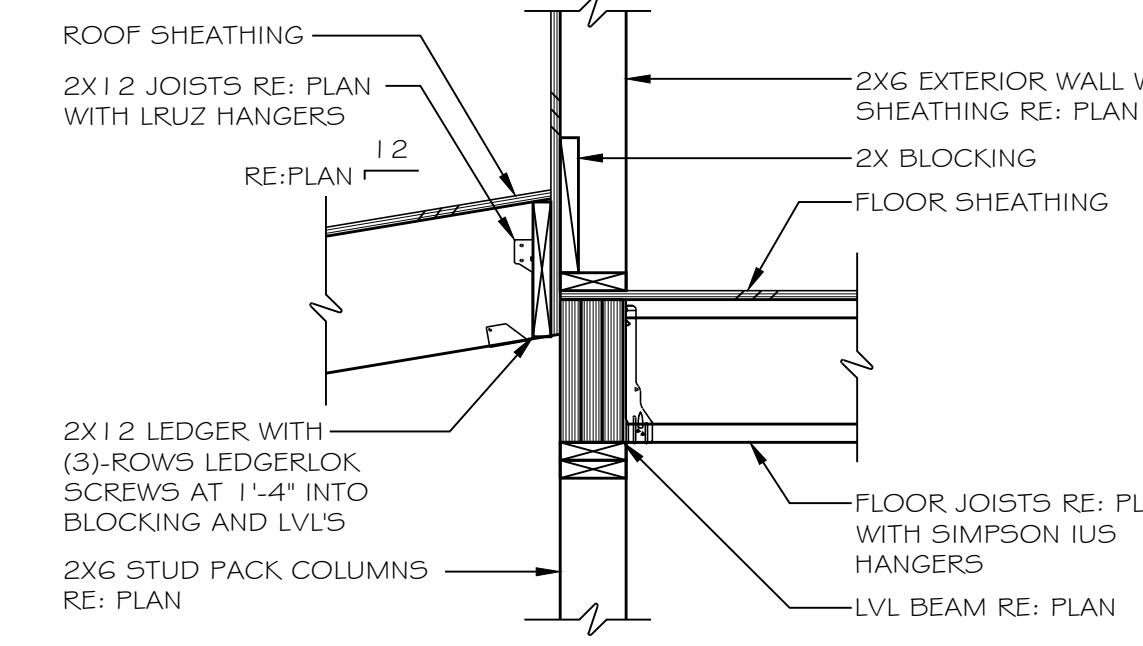

**8 FLUSH LVL BEAM / LOW ROOF**  
SCALE: 3/4" = 1'-0"

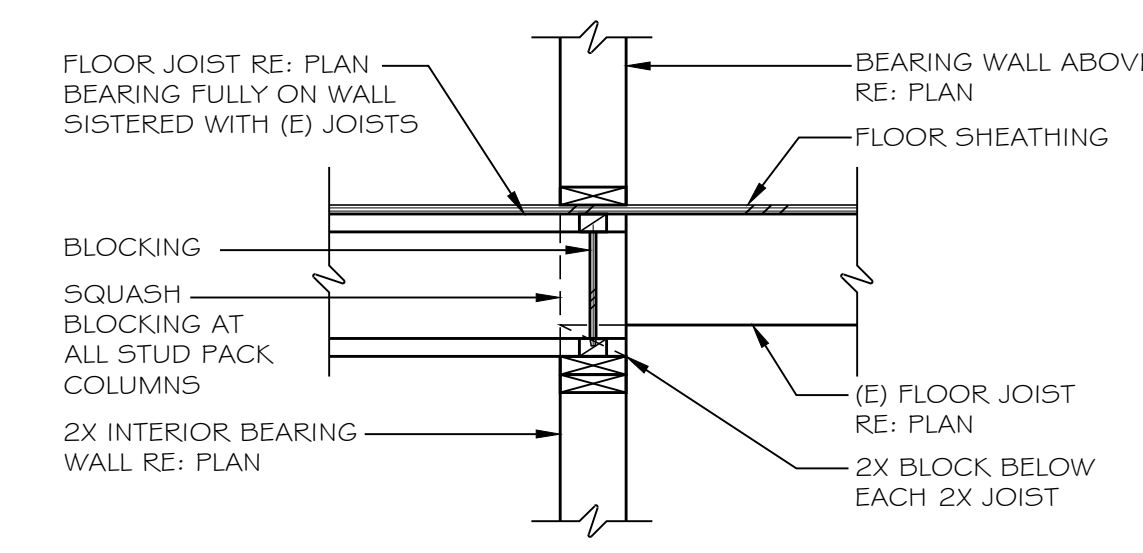

**9 BEARING WALL SECTION**  
SCALE: 3/4" = 1'-0"

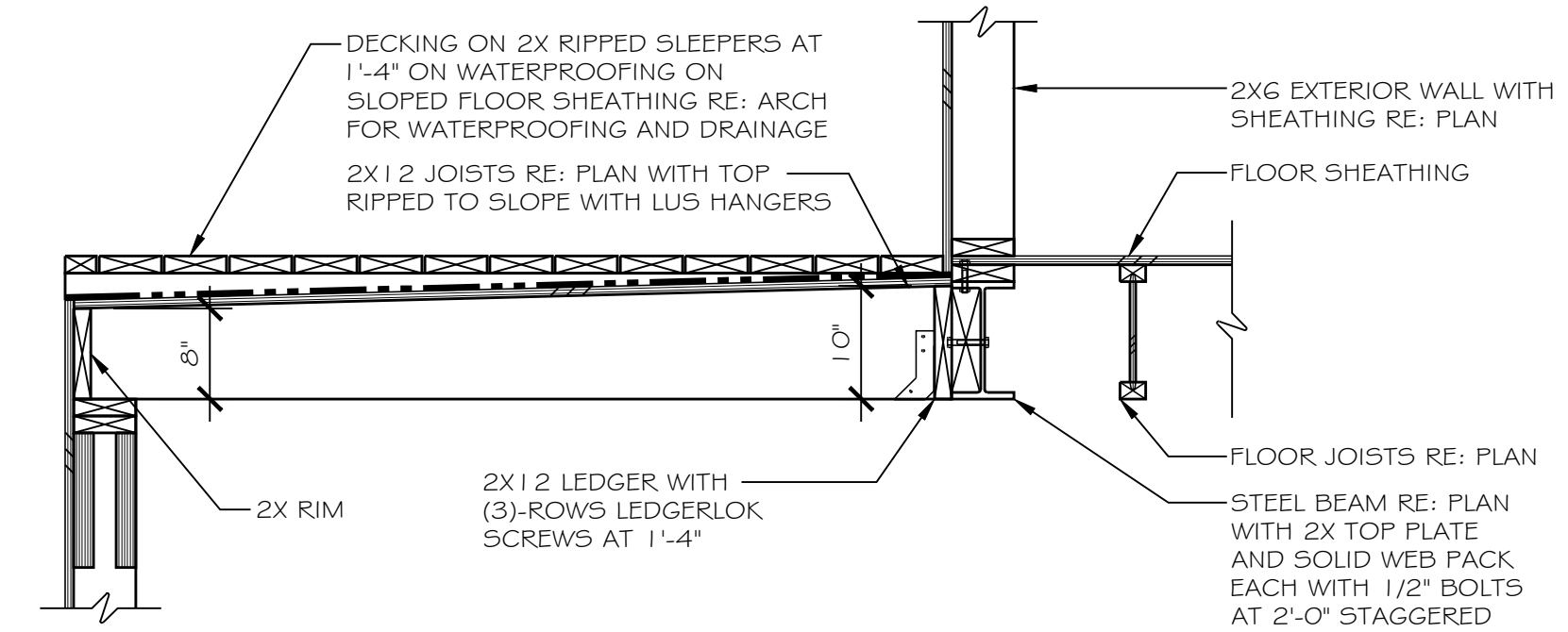

**10 UPPER LEVEL DECK**  
SCALE: 3/4" = 1'-0"

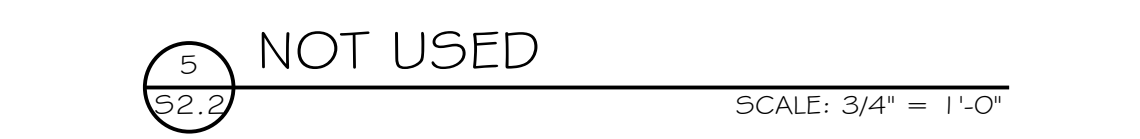

**5 NOT USED**  
SCALE: 3/4" = 1'-0"

# A PARTIAL TOPOGRAPHIC MAP OF LOT 8, BLUE RIVER ESTATES INC, BLUE ROCK SPRINGS SUBDIVISION TOWN OF BLUE RIVER, SUMMIT COUNTY, COLORADO

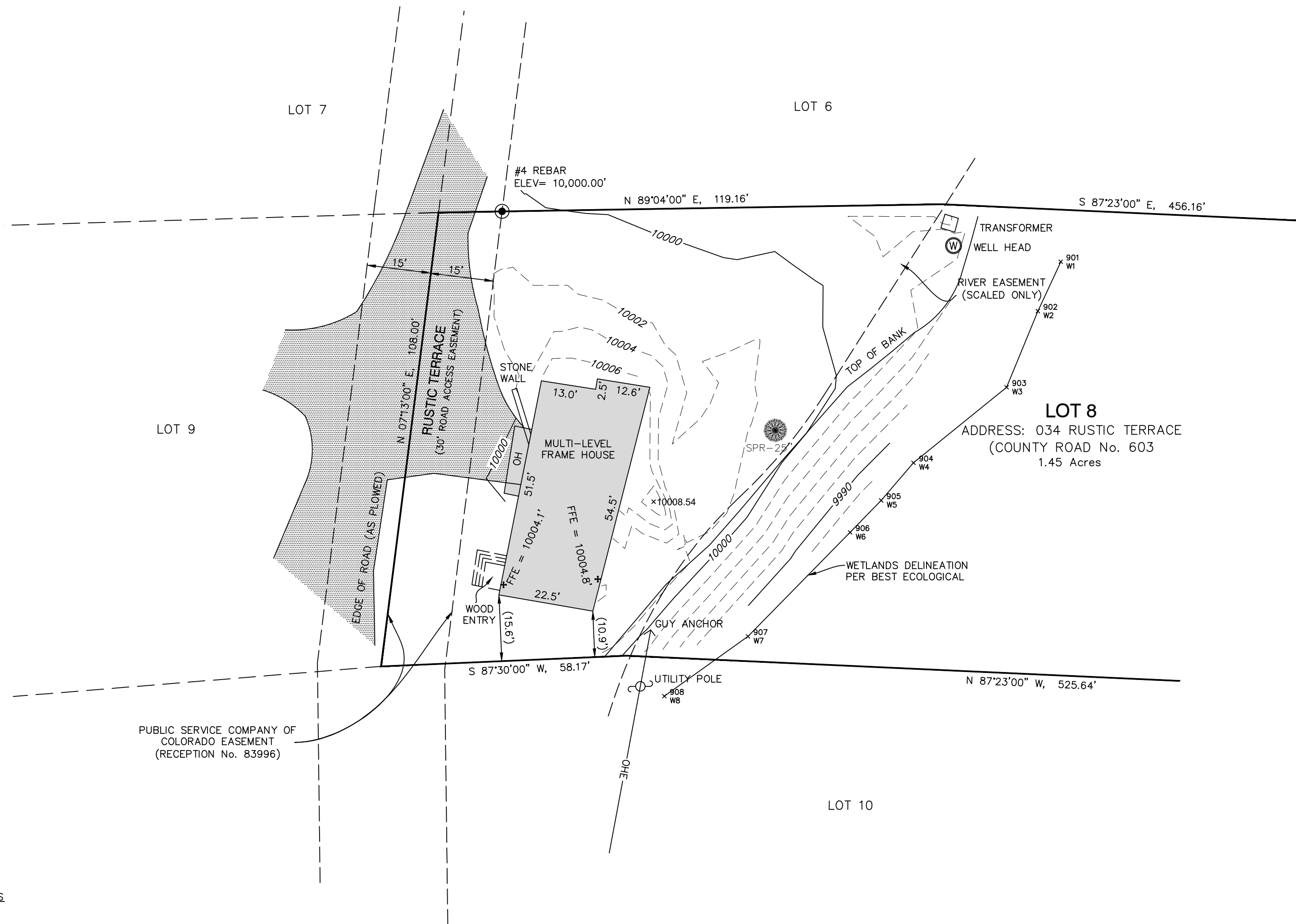
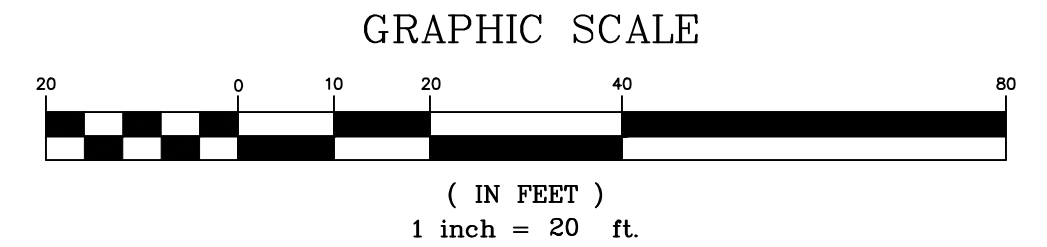

**LEGEND**

	#4 REBAR
	UTILITY POLE
	WELL HEAD
	WETLANDS FLAGGING WITH NUMBER
	SPRUCE TREE WITH TRUNK DIAMETER
	OHE OVERHEAD ELECTRIC LINE

**SURVEYOR'S CERTIFICATE**

I, ELIZABETH K. SCHMIDT, A PROFESSIONAL LAND SURVEYOR REGISTERED UNDER THE LAWS OF THE STATE OF COLORADO, DO HEREBY CERTIFY THAT THIS TOPOGRAPHIC MAP WAS MADE BY ME AND UNDER MY SUPERVISION, AND THAT THE MAP IS ACCURATE AND CORRECT TO THE BEST OF MY KNOWLEDGE.

DATE: \_\_\_\_\_

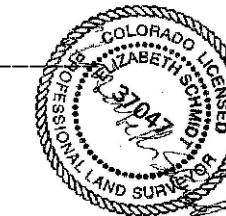

*Elizabeth Schmidt*  
ELIZABETH K. SCHMIDT  
COLORADO P.L.S. 37047

**GENERAL NOTES**

1. DATE OF SURVEY: MARCH 11, 2022. ADD WETLANDS JUNE 13, 2023.
2. CONTOUR INTERVAL = TWO FEET.
3. PROJECT BENCHMARK: HELD ELEVATION 10,000.0' AT NORTHWEST CORNER LOT 8, INTERPOLATED FROM SUMMIT COUNTY GIS WEBSITE.
4. THE PLAT FOR LOT 8, BLUE RIVER ESTATES INC, BLUE ROCK SPRINGS SUBDIVISION, WAS RECORDED AUGUST 7, 1961 AT RECEPTION No. 93729 IN THE SUMMIT COUNTY CLERK AND RECORDER'S OFFICE.
5. TWO TO FOUR FEET OF SNOW ON SITE AT TIME OF SURVEY. OTHER FEATURES MAY EXIST THAT WERE NOT VISIBLE NOR SHOWN HERON.
6. SCHMIDT LAND SURVEYING, INC. DID NOT PERFORM A TITLE SEARCH OF THE SUBJECT PROPERTY TO ESTABLISH OWNERSHIP, EASEMENTS OR RIGHTS-OF-WAY OF RECORD.

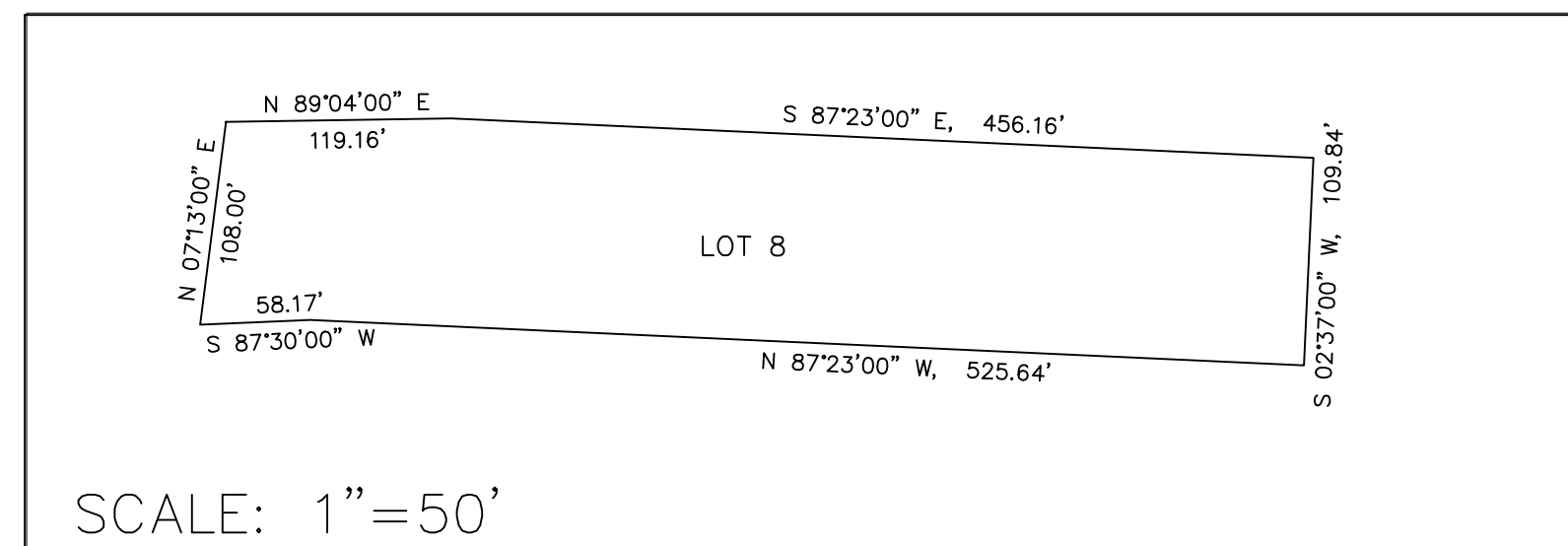

**NOTICE:**  
ACCORDING TO COLORADO LAW YOU MUST COMMENCE ANY LEGAL ACTION BASED UPON ANY DEFECT IN THIS SURVEY WITHIN THREE YEARS AFTER YOU FIRST DISCOVER SUCH DEFECT. IN NO EVENT, MAY ANY ACTION BASED UPON ANY DEFECT IN THIS SURVEY BE COMMENCED MORE THAN TEN YEARS FROM THE DATE OF CERTIFICATION SHOWN HEREON.

Drawn TMB	Dwg 2724 TP.dwg	Project 2724
Date 6/13/23	Scale 1" = 20'	Sheet 1 of 1

SCHMIDT

LAND SURVEYING, INC.  
P.O. Box 5761  
FRISCO, CO 80443 970-409-9963



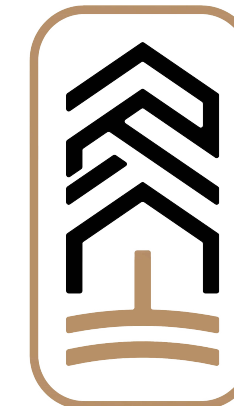

**ROOTED**  
ARCHITECTURE

SEAL:

NOT FOR CONSTRUCTION

DRAWINGS AND SPECIFICATIONS AS INSTRUMENTS OF SERVICE ARE THE PROPERTY OF THE ARCHITECT. THEY SHALL NOT BE USED, TRANSFERRED, OR SOLD FOR USE EXCEPT BY AN AGREEMENT IN WRITING FROM THE ARCHITECT.

**FITZGERALD ADDITION**

34 RUSTIC TERRACE  
BLUE RIVER, CO

No.	Date	Revisions

**Project No:** 2023-16  
**Stage:** FINAL REVIEW SET  
**Date:** 05/02/2024  
**Scale:** 12" = 1'-0"

DRAWING TITLE:

**COVER SHEET**

DRAWING NO:

**A0.1**

# Fitzgerald Addition

0034 RUSTIC TERRACE - BLUE RIVER, COLORADO

## GENERAL NOTES

**1) COPYRIGHT:**  
ALL PLANS, DESIGNS, AND CONCEPTS SHOWN IN THESE DRAWINGS ARE THE EXCLUSIVE PROPERTY OF ROOTED ARCHITECTURE, LLC. AND SHALL NOT BE USED, DISCLOSED, OR REPRODUCED FOR OR ANY PURPOSE WHATSOEVER WITHOUT THE ARCHITECT'S WRITTEN PERMISSION.

**2) CODES:**  
THIS PROJECT IS GOVERNED BY THE INTERNATIONAL RESIDENTIAL CODE, 2018 EDITION AS ADOPTED BY BLUE RIVER, COLORADO. CODE COMPLIANCE IS MANDATORY. THE DRAWINGS AND SPECIFICATIONS SHALL NOT PERMIT WORK THAT DOES NOT CONFORM TO THESE CODES. THE GENERAL CONTRACTOR AND SUBCONTRACTORS SHALL BE RESPONSIBLE FOR SATISFYING ALL APPLICABLE CODES AND OBTAINING ALL PERMITS AND REQUIRED APPROVALS. BUILDING AREAS ARE SHOWN FOR CODE PURPOSES ONLY AND SHALL BE RECALCULATED FOR ANY OTHER PURPOSES.

**3) FIELD VERIFICATION:**  
VERIFY ALL DIMENSIONS, CONDITIONS, AND UTILITY LOCATIONS ON THE JOB SITE PRIOR TO BEGINNING ANY WORK OR ORDERING ANY MATERIALS. NOTIFY ARCHITECT OF ANY CONFLICTS OR DISCREPANCIES IN THE DRAWINGS IMMEDIATELY.

**4) DIMENSIONS:**  
WRITTEN DIMENSIONS ALWAYS TAKE PRECEDENCE OVER SCALED DIMENSIONS. DO NOT SCALE DRAWINGS. VERIFY ALL DIMENSIONS SHOWN PRIOR TO BEGINNING ANY WORK AND NOTIFY ARCHITECT OF ANY CONFLICTS OR DISCREPANCIES FOR INTERPRETATION OR CLARIFICATION. PLAN DIMENSIONS ARE TO THE FACE OF FRAMING MEMBERS, FACE OF WOOD FURRING OR FACE OF CONCRETE WALLS UNLESS OTHERWISE NOTED. SECTION OR ELEVATION DIMENSIONS ARE TO TOP OF CONCRETE, TOP OF PLYWOOD, OR OP OF WALL PLATES OR BEAMS UNLESS OTHERWISE NOTED.

**5) DISCREPANCIES:**  
THE OWNER HAS REQUESTED THE ARCHITECT TO PROVIDE LIMITED ARCHITECTURAL AND ENGINEERING SERVICES. IN THE EVENT ADDITIONAL DETAILS OR GUIDANCE IS NEEDED BY THE CONTRACTOR FOR CONSTRUCTION OF ANY ASPECT OF THIS PROJECT, HE SHALL IMMEDIATELY NOTIFY THE ARCHITECT. FAILURE TO GIVE SIMPLE NOTICE SHALL RELIEVE THE ARCHITECT OF RESPONSIBILITY. DO NOT PROCEED IN AREAS OF DISCREPANCY UNTIL ALL SUCH DISCREPANCIES HAVE BEEN FULLY RESOLVED WITH WRITTEN DIRECTION FROM THE ARCHITECT.

**6) DUTY OF COOPERATION:**  
RELEASE OF THESE PLANS CONTEMPLATES FURTHER COOPERATION AMONG THE OWNER, CONTRACTOR, AND THE ARCHITECT. DESIGN AND CONSTRUCTION ARE COMPLEX. ALTHOUGH THE ARCHITECT AND HIS CONSULTANTS HAVE PERFORMED THEIR SERVICES WITH DUE CARE AND DILIGENCE, THEY CANNOT GUARANTEE PERFECTION. COMMUNICATION IS IMPERFECT, AND EVERY CONTINGENCY CANNOT BE ANTICIPATED. ANY AMBIGUITY OR DISCREPANCY DISCOVERED BY THE USE OF THESE PLANS SHALL BE REPORTED IMMEDIATELY TO THE ARCHITECT. FAILURE TO NOTIFY THE ARCHITECT COMPOUNDS MISUNDERSTANDING AND INCREASES CONSTRUCTION COSTS. A FAILURE TO COOPERATE BY A SIMPLE NOTICE TO THE ARCHITECT SHALL RELIEVE THE ARCHITECT FROM RESPONSIBILITY FOR ALL CONSEQUENCES.

**7) CHANGES TO THE WORK:**  
ANY ITEMS DESCRIBED HEREIN THAT IMPACT PROJECT BUDGET OR TIME SHALL BE REQUESTED FROM THE CONTRACTOR VIA A WRITTEN CHANGE ORDER REQUEST PRIOR TO SUCH WORK. PERFORMANCE OF SUCH WORK WITHOUT APPROVAL BY CHANGE ORDER INDICATES GENERAL CONTRACTOR'S ACKNOWLEDGMENT OF NO INCREASE IN CONTRACT SUM OR TIME. CHANGES FROM THE PLANS OR SPECIFICATIONS MADE WITHOUT CONSENT OF THE ARCHITECT ARE UNAUTHORIZED AND SHALL RELIEVE THE ARCHITECT OF RESPONSIBILITY FOR ANY AND ALL CONSEQUENCES RESULTING FROM SUCH CHANGES.

**8) WORKMANSHIP:**  
IT IS THE INTENT AND MEANING OF THESE DRAWINGS THAT THE CONTRACTOR AND EACH SUBCONTRACTOR PROVIDE ALL LABOR, MATERIALS, TRANSPORTATION, SUPPLIES, EQUIPMENT, ETC., TO OBTAIN A COMPLETE JOB WITHIN THE RECOGNIZED STANDARDS OF THE INDUSTRY.

**9) SUBSTITUTIONS:**  
SUBSTITUTION OF "EQUAL" PRODUCTS WILL BE ACCEPTABLE WITH ARCHITECT'S WRITTEN APPROVAL.

**10) CONSTRUCTION SAFETY:**  
THESE DRAWINGS DO NOT INCLUDE THE NECESSARY COMPONENTS FOR CONSTRUCTION SAFETY. THE GENERAL CONTRACTOR SHALL PROVIDE FOR THE SAFETY, CARE OF UTILITIES AND ADJACENT PROPERTIES DURING CONSTRUCTION, AND SHALL COMPLY WITH STATE AND FEDERAL SAFETY REGULATIONS.

**11) EXCAVATION PROCEDURES:**  
UPON COMPLETION OF ANY EXCAVATION, THE OWNER SHALL RETAIN A SOILS ENGINEER TO INSPECT THE SUBSURFACE CONDITIONS IN ORDER TO DETERMINE THE ADEQUACY OF FOUNDATION DESIGN. CONTRACTOR SHALL NOT POUR ANY CONCRETE UNTIL APPROVAL IS OBTAINED FROM SOILS ENGINEER.

**12) FIELD CUTTING OF STRUCTURAL MEMBERS:**  
THE GENERAL CONTRACTOR AND SUBCONTRACTORS SHALL FIELD COORDINATE AND OBTAIN APPROVAL FROM ENGINEER BEFORE ANY CUTTING, NOTCHING OR DRILLING OF ANY CAST-IN-PLACE CONCRETE, STEEL FRAMING, OR ANY OTHER STRUCTURAL ELEMENTS WHICH MAY AFFECT THE STRUCTURAL INTEGRITY OF THE BUILDING. REFER TO CURRENT INTERNATIONAL BUILDING CODE, MANUFACTURER'S OR SUPPLIER'S INSTRUCTIONS, AND STRUCTURAL DRAWINGS FOR ADDITIONAL REQUIREMENTS.

**13) EXTERIOR MATERIAL MOCK UP:**  
THE GENERAL CONTRACTOR SHALL PROVIDE A MOCK UP OF ALL EXTERIOR MATERIALS FOR REVIEW BY THE OWNER, ARCHITECT AND INTERIOR DESIGNER. THIS MOCK UP SHALL BE PROVIDED AND SIGNED OF IN WRITING PRIOR TO ANY EXTERIOR FINISH WORK. THE SAMPLE SHALL INCLUDE FASCIA, TRIM WINDOW CLADDING, AND ALL OTHER EXTERIOR FINISHES INCLUDING 3'X3' SAMPLE OF EXTERIOR STONE WORK. THIS SHALL BE RETAINED ON SITE UNTIL THE FINAL PUNCH LIST IS COMPLETE.

**14) WEATHER CONDITIONS:**  
THE OWNER HAS BEEN ADVISED THAT DUE TO HARSH WINTER CONDITIONS, ROOF AND DECK SURFACES MUST BE MAINTAINED REASONABLY FREE OF ICE AND SNOW TO ENSURE MINIMAL PROBLEMS WITH THESE SURFACES. ALL ROOFING, ROOFING MEMBRANES, AND WATERPROOFING SHALL BE APPROVED IN WRITING BY PRODUCT MANUFACTURER (W.R. GRACE FOR BITUTHENE, ETC.) PRIOR TO PROCEEDING WITH ANY WORK. FAILURE TO PROVIDE THESE WRITTEN APPROVALS REMOVES ALL RESPONSIBILITY FOR THE WORK FROM THE ARCHITECT.

**15) BUILDING AREA**  
BUILDING AREAS ARE SHOWN FOR CODE PURPOSES ONLY AND SHALL BE RECALCULATED FOR ANY OTHER USE.

**16) PROJECT STAKING**  
THE GENERAL CONTRACTOR SHALL VERIFY ALL EXISTING GRADES AND STAKE ALL BUILDING CORNERS AND DRIVEWAY LOCATION FOR OWNER/ARCHITECT AND DESIGN REVIEW BOARD APPROVAL PRIOR TO BEGINNING ANY SITE CLEARING.

**17) SITE DISTURBANCE**  
IT IS THE RESPONSIBILITY OF THE CONTRACTOR TO PROTECT THE EXISTING TREES TO REMAIN AND ADJACENT PROPERTIES FROM DAMAGE DURING CONSTRUCTION. PROVIDE PROTECTIVE FENCING THROUGHOUT CONSTRUCTION.

**18) PROJECT GRADES**  
THE GENERAL CONTRACTOR SHALL CHECK AND VERIFY ALL GRADES INCLUDING PAVED AREA SLOPES PRIOR TO POURING ANY FOUNDATIONS. SURVEY WORK SHOULD BE VERIFIED IN DETAIL.

**19) EXISTING CONDITIONS**  
THE PLANNED MODIFICATIONS AND ADDITIONS INCLUDED IN THESE DOCUMENTS DO NOT REQUIRE CHANGES OR MODIFICATIONS TO THE EXISTING STRUCTURAL COMPONENTS OF THIS BUILDING. THE GENERAL CONTRACTOR IS TO FIELD VERIFY ALL STRUCTURAL CONDITIONS ARE UNCHANGED DURING DEMOLITION AND CONSTRUCTION. ANY AND ALL STRUCTURAL COMPONENTS DISCOVERED TO REQUIRE MODIFICATION SHALL BE REPORTED TO THE ARCHITECT AND IF REQUIRED, REFERRED TO A STRUCTURAL ENGINEER FOR EVALUATION AND RECOMMENDATION BEFORE WORK PROCEEDS IN AFFECTED AREA.

**20) 3D MODELING**  
THIS PROJECT HAS BEEN DIGITALLY MODELED IN 3D SOFTWARE. THE DIGITAL MODEL IS PROVIDED FOR REFERENCE PURPOSES ONLY. TRANSMISSION OF DIGITAL MODEL FILES CONSTITUTES A WARRANTY BY THE PARTY TRANSMITTING FILES TO THE PARTY RECEIVING FILES THAT THE TRANSMITTING PARTY IS THE COPYRIGHT OWNER OF THE DIGITAL DATA. UNLESS OTHERWISE AGREED IN WRITING, ANY USE OF TRANSMISSION OF, OR RELIANCE ON THE MODEL IS AT THE RECEIVING PARTY'S RISK. THE CONTRACTOR SHALL NOTIFY THE ARCHITECT OF QUESTIONS OR COORDINATION ISSUES BETWEEN THE CONTRACT DOCUMENTS AND DIGITAL MODEL.

## PROJECT DATA

**LEGAL DESCRIPTION:**  
0034 RUSTIC TER (CR 603) BLUE RIVER, COLORADO 80461  
LOT 8 BLUE ROCK SPRINGS SUBDIVISION

## USGS DATUMS

**EXISTING GARAGE:** 100'-0" = 10,000.1' USGS  
**MAIN LEVEL:** 109'-6" = 10,009.6' USGS  
**LOFT LEVEL:** 118'-5" = 10,018.4' USGS

**NOTE: CONTRACTOR TO VERIFY ALL EXISTING DATUMS PRIOR TO CONSTRUCTION**

## AREAS CALCULATIONS

	FINISHED (EXIST)	UNFINISHED (EXIST)	FINISHED (NEW)	UNFINISHED (NEW)	TOTAL
LOWER LEVEL	298 SF	434 SF	0 SF	767 SF	1,499 SF
MAIN LEVEL	1,277 SF	0 SF	506 SF	0 SF	1,783 SF
LOFT LEVEL	532 SF	0 SF	271 SF	0 SF	803 SF
<b>TOTAL:</b>	<b>2,107 SF</b>	<b>434 SF</b>	<b>777 SF</b>	<b>767 SF</b>	<b>4,085 SF</b>

NOTE: SQUARE FOOTAGE CALCULATIONS ARE FOR CODE PURPOSES ONLY AND SHOULD BE RECALCULATED FOR ANY OTHER PURPOSES

## CODE INFORMATION

### ADOPTED CODES:

2018 International Residential Code with Blue River Amendments  
2018 International Energy Conservation Code with Blue River Amendments  
Blue River Development Code

## ENERGY REQUIREMENTS

### ENERGY EFFICIENT DESIGN FEATURES:

- RADIANT HEATING SYSTEM, MINIMUM 95% AFUE.
- HIGH-EFFICACY LED LIGHTING
- ENERGY EFFICIENT WATER HEATER. ELECTRIC MINIMUM 0.95 ENERGY FACTOR /GAS, MINIMUM 0.76 ENERGY FACTOR.
- PROVIDE AN ELECTRICAL CAR CHARGING ROUGH IN, INCLUDING A BLANKED ELECTRICAL BOX, AND A RACEWAY TERMINATING IN THE ELECTRICAL PANEL.
- PROVIDE PV READY CONSTRUCTION INCLUDING A METAL RACEWAY FROM THE ELECTRICAL PANEL TO THE ROOF LOCATION WHERE THE PANELS WILL BE INSTALLED, INCLUDING A ROOF JACK, A #8 COPPER GROUND, A 2 PULL BLANK IN THE ELECTRICAL PANEL AND AN ELECTRICAL CONDUIT FROM THE ELECTRICAL PANEL OUT TO THE ELECTRIC METER.
- WATERSENSE FIXTURES THROUGHOUT.
- (OPTIONAL) HRV/ ERV, 65% SENSIBLE HEAT RECOVERY EFFICIENCY, MEETING MINIMUM AIRFLOW RATES PER IRC INSTALLED.
- PROGRAMMABLE THERMOSTATS.

### THERMAL ENVELOPE REQUIREMENTS (2018 IRC CH. 11 - SUMMIT COUNTY ZONE 7):

**ROOF/ CEILING:** R49 CLOSED-CELL SPRAY FOAM  
**ABOVE GRADE WALLS:** R23 CAVITY CLOSED-CELL SPRAY FOAM PER AMENDMENT TO TABLE N1102.1.2 (IECC R402.1.2)  
R10 /4'  
MAX U 0.30 / SHGC N/A  
**SLABS, INCLUDING SLAB EDGE:** R38  
**FENESTRATIONS:** R15 CI OR R19 CAVITY  
**FLOOR R-VALUE:** R15 CI OR R19 CAVITY  
**BASEMENT WALL:** R15 CI OR R19 CAVITY  
**BLOWER DOOR:** ACH 2.7 AT A PRESSURE 0.2 INCHES W.G. (50 PASCALS)

THESE SPECIFICATIONS ARE BASED OFF OF THE 2018 IECC RESIDENTIAL THERMAL ENVELOPE REQUIREMENTS AS DESCRIBED IN TABLE R402.1.3, WHICH SHOULD BE REFERRED TO FOR INTERPRETATION REASONS. SEE PLANS AND DETAILS RELATED TO SPECIFIC INSULATION REQUIREMENTS FOR EXTERIOR BUILDING ENVELOPE.

THERMAL AND VAPOR CONTROL DESIGN BASED ON CLOSED-CELL FOAM INSULATION AND AIR SEALING THROUGHOUT.

## SHEET INDEX

SHEET NUMBER	SHEET NAME	SHEET ISSUE DATE
A0.1	COVER SHEET	05.01.2023
A0.2	ENLARGED SITE PLAN	05.01.2023
A1.1	FLOOR PLAN - LOWER	05.01.2023
A1.2	FLOOR PLAN - MAIN	05.01.2023
A1.3	FLOOR PLAN - UPPER	05.01.2023
A1.4	ROOF PLAN	05.01.2023
A2.1	CEILING PLANS	05.01.2023
A4.1	EXTERIOR ELEVATIONS	05.01.2023
A5.1	BUILDING SECTIONS	05.01.2023
A6.1	POWER PLANS	05.01.2023
A7.1	DETAILS	05.01.2023
S1.1	FOUNDATION PLAN	05.01.2023
S1.2	MAIN LEVEL FRAMING PLAN	05.01.2023
S1.3	UPPER LEVEL FRAMING PLAN	05.01.2023
S1.4	ROOF FRAMING PLAN	05.01.2023
S2.1	NOTES AND DETAILS	05.01.2023
S2.2	FRAMING DETAILS	05.01.2023

## LOCATION MAP

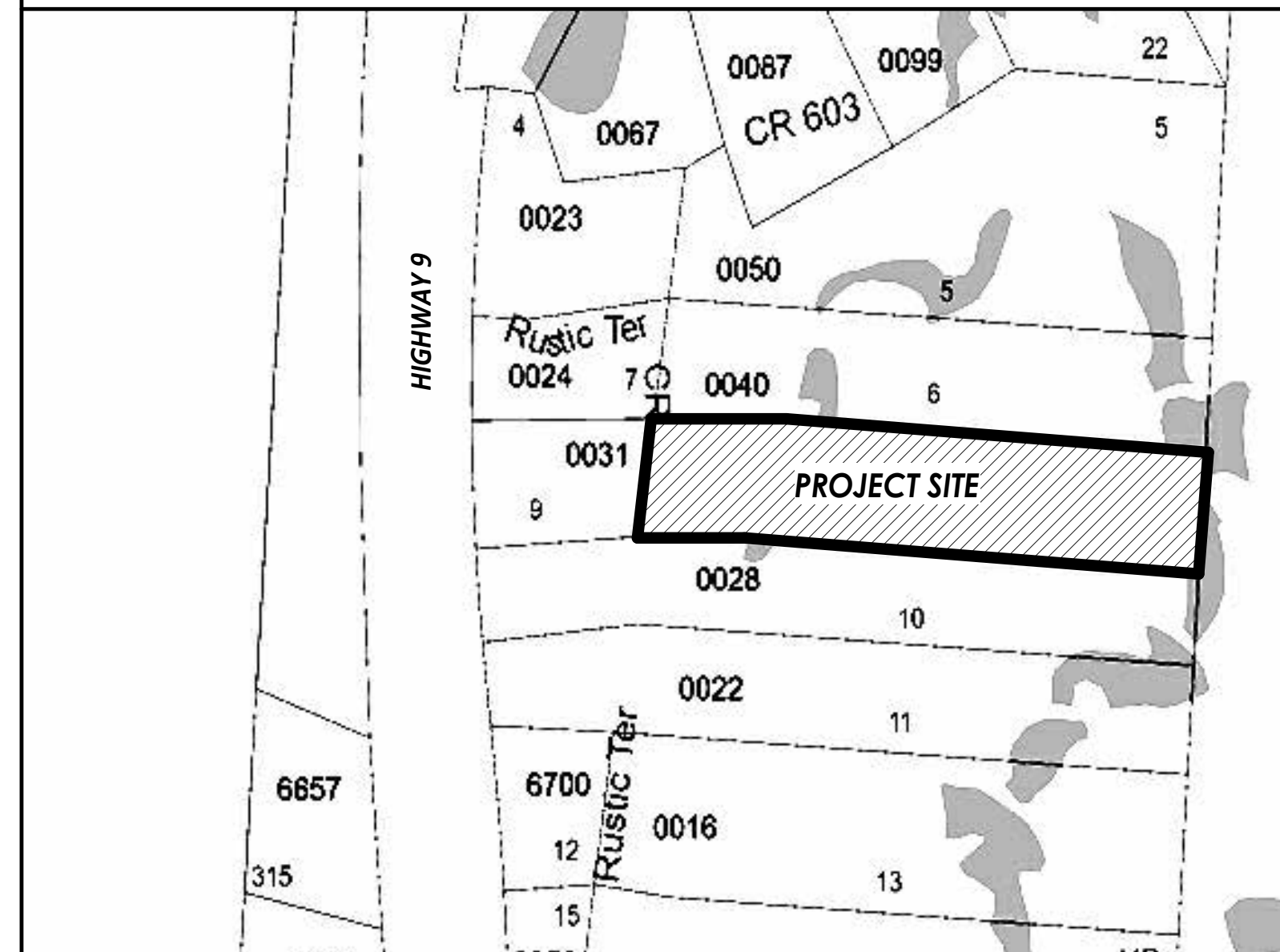

## SURVEYOR

SCHMIDT LAND SURVEYING, INC.  
LIZ SCHMIDT  
970 409-9963

## INTERIOR DESIGN

## STRUCTURAL ENG.

FOX STRUCTURAL ENGINEERING, LLC  
KRISTEN E. FOX, P.E.  
(970)376-2005

## CONTRACTOR

THE ASHLAN GROUP  
MATT KRIGMAN  
970-333-8624

## ARCHITECT

ROOTED ARCHITECTURE, LLC  
BRANDON SMITH  
BRANDON@ROOTEDARCH.COM  
469.363.2821

## OWNER

TOM AND ALEX FITZGERALD  
ATAYLORFITZ@GMAIL.COM  
TMFITZGERALD@GMAIL.COM



ROOTED ARCHITECTURE

SEAL:

NOT FOR CONSTRUCTION

DRAWINGS AND SPECIFICATIONS AS INSTRUMENTS OF SERVICE ARE THE PROPERTY OF THE ARCHITECT. THEY SHALL NOT BE USED, TRANSFERRED, OR SOLD FOR USE EXCEPT BY AN AGREEMENT IN WRITING FROM THE ARCHITECT.

FITZGERALD ADDITION

34 RUSTIC TERRACE BLUE RIVER, CO

No. Date Revisions

Project No: 2023-16  
Stage: FINAL REVIEW SET  
Date: 05/02/2024  
Scale: As indicated

DRAWING TITLE:

ENLARGED SITE PLAN

DRAWING NO:

A0.2

NOTES: SITE PLAN

- 1. VERIFY ALL UTILITY LOCATIONS PRIOR TO ANY WORK. COORDINATE UTILITY ROUTING WITH APPLICABLE UTILITY COMPANY. ALL UTILITIES TO BE UNDERGROUND.
2. SURFACE DRAINAGE SHALL BE DIVERTED TO A STORM SEWER CONVEYANCE OR OTHER APPROVED POINT OF COLLECTION THAT DOES NOT CREATE A HAZARD. LOTS SHALL BE GRADED TO DRAIN SURFACE WATER AWAY FROM FOUNDATION WALLS. THE GRADE SHALL FALL NOT FEWER THAN 6 INCHES WITHIN THE FIRST 10 FEET.
3. REFER TO FOUNDATION PLAN FOR FOUNDATION DRAIN LOCATION AND SLOPE.
4. FLAG ALL TREES FOR OWNER PRIOR TO THINNING OR REMOVAL.
5. PROTECT REMAINING TREES WITH APPROVED BARRIER DURING CONSTRUCTION.
6. GENERAL CONTRACTOR SHALL REVIEW AND COMPLY WITH ALL ZONING AND SUBDIVISION CONDITIONS.
7. FINISHED GRADING SHALL BE A MINIMUM OF 6" BELOW FOUNDATION REFERENCE ADOPTED IRC.
8. CONTRACTOR TO TRIM OR REMOVE ANY TREES ADJACENT TO BUILDING FOUNDATION AS REQUIRED, VERIFY WITH OWNER PRIOR TO REMOVAL.

NOTES: SITE CONTOUR LEGEND

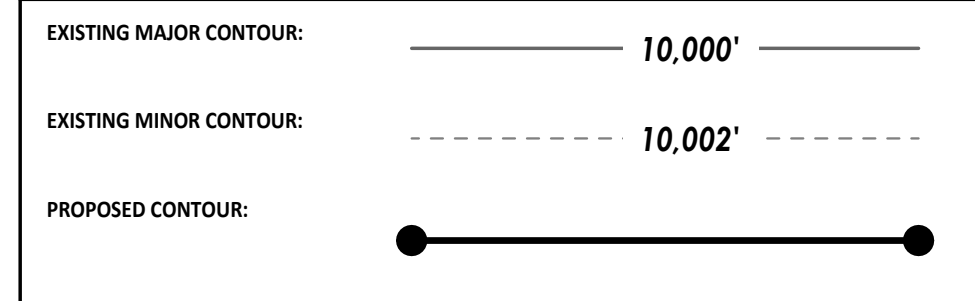

NOTES: SITE DRAINAGE

- 1. CONTRACTOR SHALL PROVIDE PROPER SITE GRADING THAT DIRECTS SURFACE WATER AWAY FROM BUILDING FOUNDATIONS, WALLS AND NEIGHBORING PROPERTIES.
2. GRADING AND LANDSCAPING SHOULD BE PLANNED WITH A SURFACE GRADE OF AT LEAST 1/4" AROUND AND AWAY FROM THE ENTIRE STRUCTURE. REFER TO LAKE COUNTY DEVELOPMENT CODE FOR SITE DRAINAGE REQUIREMENTS.
3. PROPOSED SITE DRAINAGE INDICATED ON SITE PLAN WITH FLOW ARROWS.

NOTES: FOUNDATION DRAIN

- INSTALL DRAIN TILE (PERFORATED PLASTIC DRAINAGE PIPE) ALONG THE EXTERIOR OF THE FOOTINGS OF BASEMENT OR CRAWLSPACE WALLS TO PROVIDE DRAINAGE AROUND FOUNDATION PERIMETER.
1. INSTALL DRAIN PIPE TO SIT OUTSIDE OF, NOT ON TOP OF, THE FOOTINGS AND BELOW THE BOTTOM OF THE CONCRETE SLAB OR CRAWLSPACE FLOOR.
2. LAY THE PIPE WITH ENOUGH SLOPE TO DRAIN TO A NON-PERFORATED PIPE THAT CARRIES THE COLLECTED WATER TO DAYLIGHT, TO A DRYWELL, TO A STORM SEWER IF APPROVED BY THE LOCAL MUNICIPALITY, OR TO A SUMP PUMP THAT WILL TRANSPORT IT TO DAYLIGHT, A STORM SEWER, OR A DRYWELL.
3. LAY THE DRAIN PIPE, PERFORATIONS DOWN, IN A GRAVEL TRENCH WITH AT LEAST 6 INCHES OF 3/4-INCH TO 1-INCH WASHED GRAVEL OR STONE ABOVE THE PIPE AND AT LEAST 2 INCHES BELOW (IRC).
4. INSTALL LANDSCAPE FABRIC UNDER, AROUND, AND OVER THE WASHED GRAVEL (IRC) ALTERNATELY, USE DRAIN PIPE ENCASED IN A FILTER-FABRIC SOCK AND SURROUND THE CLOTH-COVERED PIPE WITH GRAVEL. OR, INSTALL A CODE-APPROVED COMPOSITE FOUNDATION DRAINAGE SYSTEM (CFDS) (IRC).

SNOWSTACK CALCULATIONS

Table with 3 columns: Item, Square Footage, Percentage. Rows include Existing Driveway (998 SF), New Driveway (317 SF), Decks and Hardscape (NA), Total Coverage (1,315 SF, 100%), Snowstack Required (329 SF, 25%), Snowstack Provided (605 SF, 46%), and Total Lot Area (1.45 Acres).

NOTES: LANDSCAPE

- 1. VERIFY ALL UTILITY LOCATIONS PRIOR TO ANY WORK. COORDINATE UTILITY ROUTING WITH APPLICABLE UTILITY COMPANY. ALL UTILITIES TO BE UNDERGROUND. PROVIDE 2"-3" (MIN.) CLAY FREE TOPSOIL AND SEED ALL DISTURBED AREAS WITH SUMMIT CO. SHORT SEED MIX (AS APPROVED BY STRIP AND STOCKPILE EXISTING TOPSOIL IN CONSTRUCTION AREA. SCREEN TOPSOIL PRIOR TO INSTALLATION.
2. KEEP EXISTING TREES WHERE POSSIBLE, TAKING INTO CONSIDERATION DRIP LINES AND ROOT STRUCTURE. PROTECT EXISTING TREES WITH FENCING LOCATED AT OR OUTSIDE DRIP LINE OF TREE. STOCKPILE AND REUSE EXISTING TREES WHERE POSSIBLE.
3. GENERAL CONTRACTOR SHALL PROVIDE POSITIVE DRAINAGE AWAY FROM ALL BUILDING FOUNDATIONS PER SPECIFICATIONS AND CODE REQUIREMENTS.
4. PRIOR TO ANY LANDSCAPE WORK, REMOVE ALL DEBRIS, PAINT, CONCRETE, STUMPS, SLASH, ETC. FROM LANDSCAPE AREA.
5. LOCATE ALL PLANTINGS TO AVOID SNOW STACKING & SNOW SLIDE AREAS FROM ABOVE.
6. SHRUBS ARE TO BE FIELD LOCATED AS APPROVED BY OWNER AND ARCHITECT.
7. ALL NEW LANDSCAPING TO BE IRRIGATED WITH DRIP IRRIGATION SYSTEM. PROVIDE SUBMITTAL.
8. ALL NEW PLANTINGS SHOULD BE HIGH ALTITUDE GROWN AND OR COLLECTED TO ENSURE BETTER SURVIVAL.
9. NATURALIZE GROUPING OF TREES BY VARYING HEIGHT & LOCATION WHEREVER POSSIBLE.
10. SCREEN ALL UTILITY PEDESTALS WITH LANDSCAPE MATERIAL.
11. PROVIDE 3" TO 4" DIAMETER STONE RIPRAP OVER WEED BARRIER FABRIC AT BUILDING DRIP LINES. UNDULATE EDGES AND PROVIDE LANDSCAPE EDGING AT RIPRAP TO TOPSOIL JUNCTURE.
12. INSTALL & BACKFILL ALL PLANTINGS WITH SOIL MIX INCLUDING ORGANIC SOIL AMENDMENTS PER SPECIES REQUIREMENTS AND LANDSCAPE DETAILS.
13. ROOT FEED ALL NEWLY PLANTED TREES DURING INSTALLATION. PROVIDE LIQUID GROWTH TREE STIMULATOR AND SOLUBLE FERTILIZER AT RECOMMENDED RATE FOR EACH TREE SPECIES.
14. PROVIDE 3" OF SHREDDED BARK MULCH AT ALL SHRUB AND TREE WELLS.
15. LANDSCAPE BOULDERS OF 2' OR LARGER SHALL BE RETAINED ON SITE FOR USE IN LANDSCAPE WORK. BURY DECORATIVE BOULDERS ONE-HALF OF DIAMETER.
16. ADDITIONAL CONSULTATION WITH A QUALIFIED LANDSCAPE PROFESSIONAL AT OWNER OPTION IS RECOMMENDED.
17. REVEGETATE ALL DISTURBED SITE AREAS WITH APPROVED SEED MIX.

NOTE: ALL LANDSCAPING SHALL BE INSTALLED IN STRICT ACCORDANCE WITH TOWN OF BLUE RIVER GUIDELINES.

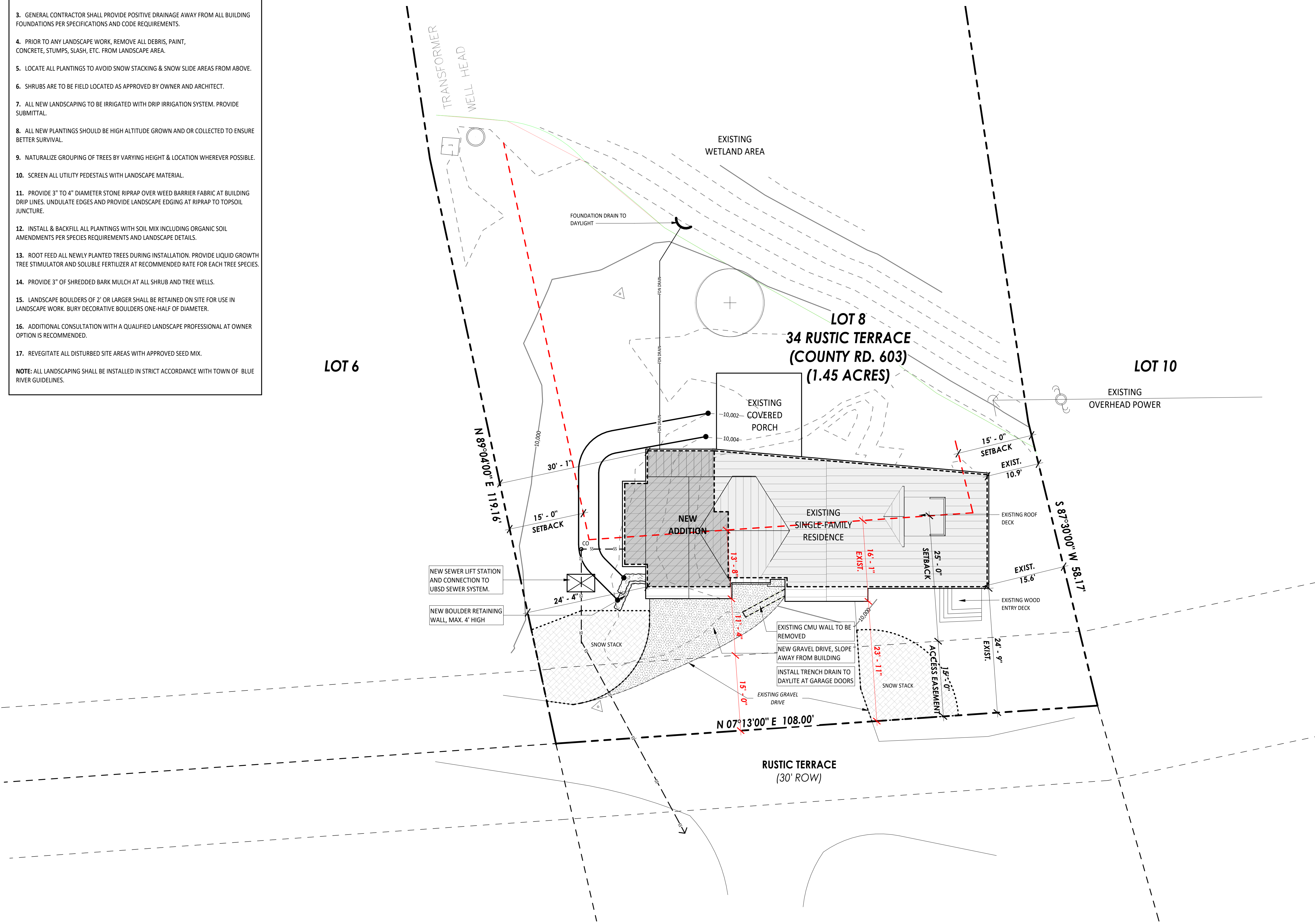

1 SITE PLAN - ENLARGED 1" = 10'-0"





**ROOTED**  
ARCHITECTURE

SEAL:

NOT FOR CONSTRUCTION

DRAWINGS AND SPECIFICATIONS AS INSTRUMENTS OF SERVICE ARE THE PROPERTY OF THE ARCHITECT. THEY SHALL NOT BE USED, TRANSFERRED, OR SOLD FOR USE EXCEPT BY AN AGREEMENT IN WRITING FROM THE ARCHITECT.

**FITZGERALD ADDITION**  
34 RUSTIC TERRACE  
BLUE RIVER, CO

No. Date Revisions

Project No: 2023-16  
Stage: FINAL REVIEW SET  
Date: 05/02/2024  
Scale: As indicated

DRAWING TITLE:

**FLOOR PLAN - LOWER**

DRAWING NO:

**A1.1**

**NOTES: FLOOR PLAN**

1. ALL INFORMATION MUST BE CONFIRMED PRIOR TO COMMENCEMENT OF CONSTRUCTION. ANY ERRORS OR DISCREPANCIES MUST BE BROUGHT TO THE ATTENTION OF THE ARCHITECT PRIOR TO PROCEEDING WITH WORK.
2. IT SHALL BE THE RESPONSIBILITY OF THE CONTRACTOR AND/OR INDIVIDUAL CONTRACTORS TO SEE THAT ALL ITEMS MEET OR EXCEED CODE REQUIREMENTS.
3. BUILDING SHALL VERIFY ALL DIMENSIONS, INTERIOR & EXTERIOR FINISHES, CONSTRUCTION & FRAMING METHODS PRIOR TO CONSTRUCTION.
4. ALL MATERIALS & WORKMANSHIP INVOLVED IN THE CONSTRUCTION OF THIS PROJECT ARE TO CONFORM WITH ALL LOCAL, STATE, NATIONAL, & INTERNATIONAL BUILDING CODES AS DESCRIBED IN THE INTERNATIONAL ONE & TWO FAMILY DWELLING CODE.
5. DRAWINGS ARE NOT TO BE SCALED. ALL DIMENSIONS ARE FROM FACE OF STUD TO FACE OF STUD, U.N.O. ALL DIMENSIONS LABELED "CLEAR" ARE TO FACE OF FINISH MATERIAL.
6. ALL INTERIOR GYPSUM BOARD TO BE 1/2" MINIMUM. USE WATER-RESISTANT GYPSUM BOARD AT ALL WET WALL LOCATIONS. USE 5/8" TYPE "X" DRYWALL SEPARATIONS BETWEEN LIVING SPACES AND GARAGES AS REQUIRED BY CODE.
7. ALL TUB & SHOWER UNITS TO HAVE ANTI-SCALDING DEVICES INSTALLED.
8. GARAGE DOORS TO BE CERTIFIED BY MANUFACTURER FOR LOCAL WIND REQUIREMENTS
9. CONTRACTOR TO COORDINATE ELECTRICAL, PLUMBING AND HEATING WORK WITH SUBCONTRACTORS PRIOR TO STARTING WORK. PROVIDE ARCHITECT AND OWNER WITH SUBMITTALS WHERE APPLICABLE.
10. ALL ANGLED WALLS TO BE 45° UNLESS NOTED OTHERWISE.
11. MILLWORK SUBCONTRACTOR TO PROVIDE MILLWORK SHOP DRAWINGS TO THE ARCHITECTS, OWNER, AND CONTRACTOR FOR APPROVAL PRIOR TO COMMENCING FABRICATION.
12. CONTRACTOR TO COORDINATE BASEBOARD RADIANT HEAT LOCATIONS WITH OWNER AND MECHANICAL DESIGNER PRIOR TO INSTALLATION.

**NOTES: DOOR AND WINDOW**

1. ALL WINDOWS ARE DIMENSIONED TO THE CENTERLINE OF WINDOW; CONTRACTOR TO COORDINATE ACTUAL REQUIRED ROUGH OPENING WITH WINDOW MANUFACTURER. PRIOR TO ANY FRAMING WORK, VERIFY ROUGH OPENING DIMENSIONS WITH WINDOW MANUFACTURER. NOTIFY ARCHITECT OF ANY DISCREPANCIES.
2. SEE PLANS / DOOR AND WINDOW SCHEDULES FOR WINDOW / DOOR OPERATION, SIZES AND TYPES. VERIFY JAMB WIDTHS WITH WALL THICKNESS PRIOR TO INSTALLATION
3. PROVIDE WEATHER STRIPPING AND ALUMINUM THRESHOLD SET IN SEALANT AT ALL EXTERIOR DOORS.
4. PROVIDE SAFETY GLASS TO COMPLY WITH CODE REQUIREMENTS (SEE CURRENT I.R.C.). WINDOWS LOCATED MORE THAN 72" ABOVE FINISHED GRADE AND LESS THAN 24" ABOVE THE FINISHED FLOOR OF THE ROOM IN WHICH THE WINDOW IS LOCATED SHALL HAVE OPENING CONTROL DEVICES IN ACCORDANCE WITH IRC R310.2.2. WINDOWS / DOORS LOCATED IN SLEEPING ROOMS SHALL ACT AS EMERGENCY ESCAPE AND RESCUE OPENINGS PER IRC R310.1
5. ALL GLAZING SYSTEMS SHALL BE RATED FOR USE AT HIGH ALTITUDES PER MANUFACTURER'S REQUIREMENTS. GLAZED FENESTRATION SHALL COMPLY WITH THE MINIMUM REQUIREMENTS OF IRC AND SUMMIT COUNTY SUSTAINABILITY CODE.
6. WRAP ALL EXTERIOR OPENINGS WITH WEATHER RESISTIVE BARRIER PER MANUFACTURERS SPECIFICATIONS. PROVIDE 1-1/2" X 1-1/2" HEAD FLASHING AT ALL EXTERIOR OPENINGS (PRIME AND PAINT OR COLOR CLAD). INSULATE ALL EXTERIOR SHIM SPACES AT WINDOWS AND DOORS.
7. PROVIDE SHOP DRAWINGS FOR ALL SPECIAL/CUSTOM DOORS AND WINDOWS PRIOR TO FABRICATION. FIELD MEASURE TO VERIFY ALL CUSTOM UNIT SIZES.
8. WINDOWS AND PATIO DOORS REFER TO 'JELD-WEN' BRAND OR COMPARABLE
9. INTERIOR DOORS TO BE CENTERED ON SPACES OR INSTALLED W/ 4 1/2" OFFSET TO NEAREST WALL (U.N.O.). ALL WINDOW OPENINGS TO HAVE PAINTED GYPSUM BOARD RETURNS ON INTERIOR SIDE UNLESS NOTED OTHERWISE, REF. INTERIORS.
10. ALL WINDOW OPENINGS TO HAVE PAINTED GYPSUM BOARD RETURNS ON INTERIOR SIDE UNLESS NOTED OTHERWISE, REF. INTERIORS.
11. WINDOWS LOCATED IN SLEEPING ROOMS SHALL ACT AS EMERGENCY ESCAPE AND RESCUE OPENINGS PER IRC R310.1
12. COORDINATE WINDOW SILL HEIGHT WITH GYPCRETE AND FLOOR FINISH THICKNESS WHERE REQUIRED. VERIFY AT LOCATIONS WHERE WINDOW SILLS TERMINATE AT FLOOR LEVEL OR AT TOP OF MILLWORK.
13. VERIFY WINDOW STYLE, OPERATION, FINISH AND HARDWARE WITH OWNER PRIOR TO PLACING ORDER.
14. WINDOW SUPPLIER TO PROVIDE TEMPERED GLAZING WHERE REQUIRED BY CODE.

**WALL LEGEND**

- NEW 2X4 / 2X6 WOOD STUD WALL
- EXISTING 2X4 / 2X6 WOOD STUD WALL
- EXISTING WALL TO BE REMOVED

**NOTES: REMODEL**

1. **PROTECTION OF EXISTING TO REMAIN:** THE CONTRACTOR SHALL PROVIDE PROTECTIVE COVERING FOR CARPET, FURNISHINGS, AND FINISHES IN EXISTING AREAS NOT DESIGNATED FOR DEMOLITION OR NEW CONSTRUCTION. THE CONTRACTOR SHALL BE RESPONSIBLE FOR THE REPAIR OF ANY DAMAGE CAUSED BY HIS WORK OR ANY SUBCONTRACTOR. IN PARTICULAR, THE CONTRACTOR SHALL MAINTAIN A DUST-FREE ENVIRONMENT WITHIN THE MAGNET VAULT.
2. **SCHEDULING:** THE CONTRACTOR SHALL MEET WITH THE OWNER IN ADVANCE OF CONSTRUCTION COMMENCEMENT TO:
  - A. SCHEDULE, SEQUENCE AND COORDINATE ALL WORK
  - B. MAINTAIN EXITS AND EGRESS WIDTHS REQUIRED BY CODES DURING ALL PHASES OF CONSTRUCTION
3. **CLEARANCES:** THE CONTRACTOR SHALL VERIFY THAT NEW CEILINGS CAN BE INSTALLED IN EXISTING SPACES TO CLEAR DUCTWORK AND OTHER CONSTRUCTED ITEMS AND MAINTAIN FLOOR TO CEILING HEIGHTS INDICATED ON DRAWINGS. IF DISCREPANCIES OCCUR DUE TO EXISTING CONDITIONS, CONSULT WITH THE ARCHITECT BEFORE PROCEEDING.
4. **MATERIAL ALIGNMENT:** THE FINISH FACE OF MATERIAL OF NEW PARTITIONS SHALL ALIGN ON BOTH SIDES OF THE PARTITION WITH THE FACE OF THE MATERIALS ON EXISTING COLUMNS, WALLS, OR PARTITIONS, UNLESS NOTED OTHERWISE.
5. **AS BUILT VERIFICATION:** THE CONTRACTOR SHALL VERIFY DIMENSIONS OF AS-BUILT CONDITIONS, AND NOTIFY THE ARCHITECT IN WRITING OF ANY DISCREPANCIES. ALL INFORMATION SHOWN ON THE CONSTRUCTION DOCUMENTS IS BASED ON FIELD OBSERVATIONS AND/OR THE ORIGINAL CONSTRUCTION DOCUMENTS OF THE FACILITY.
6. **REMOVAL SURVEY:** THE CONTRACTOR SHALL SURVEY AND DETERMINE THE REMOVAL OF EXISTING CONSTRUCTION, EITHER WHOLE OR IN PART, AS REQUIRED FOR THE INSTALLATION OF THE NEW MECHANICAL, PLUMBING AND ELECTRICAL WORK.
7. **CONSTRUCTION DEFECTS:** THE CONTRACTOR SHALL NOTIFY THE ARCHITECT IN WRITING OF ANY CONSTRUCTION DEFECTS FOUND IN UNCOVERING WORK IN THE EXISTING CONSTRUCTION.
8. **CORRECTING DEFECTIVE WORK:** THE CONTRACTOR SHALL BE RESPONSIBLE FOR CORRECTING DEFECTIVE WORK IN EXISTING CONSTRUCTION WITHIN THE LIMITS OF THE CONSTRUCTION AREA. THIS INCLUDES, BUT IS NOT LIMITED TO, UNEVEN SURFACES AND FINISHES AT PLASTER OR GYPSUM BOARD. THE CONTRACTOR SHALL PATCH AND REPAIR SURFACES TO MATCH NEW ADJACENT SURFACES.
9. **PIPING:** ALL PIPING ABOVE GRADE AND INSIDE THE BUILDING REQUIRED BY THE CONSTRUCTION DOCUMENTS SHALL BE INSTALLED IN AREAS WHERE IT WILL BE CONCEALED. THE CONTRACTOR SHALL CONSULT WITH THE ARCHITECT AND COORDINATE WITH OTHER TRADES TO PROVIDE FURRING FOR PIPING INSTALLED IN FINISH AREAS.
10. **FIXTURE REMOVAL:** REMOVE MECHANICAL AND ELECTRICAL FIXTURES AND CAP OR REMOVE EXISTING BRANCH LINES AS INDICATED IN THE MECHANICAL AND ELECTRICAL DOCUMENTS.
11. **COORDINATION:** COORDINATE PLANS FOR NEW CONSTRUCTION WITH DEMOLITION PLANS FOR EXTENT OF REMOVAL. REMOVE ONLY THOSE PORTIONS OF WALLS, FLOORS, CEILINGS, ETC. NECESSARY TO ACCOMMODATE NEW CONSTRUCTION.

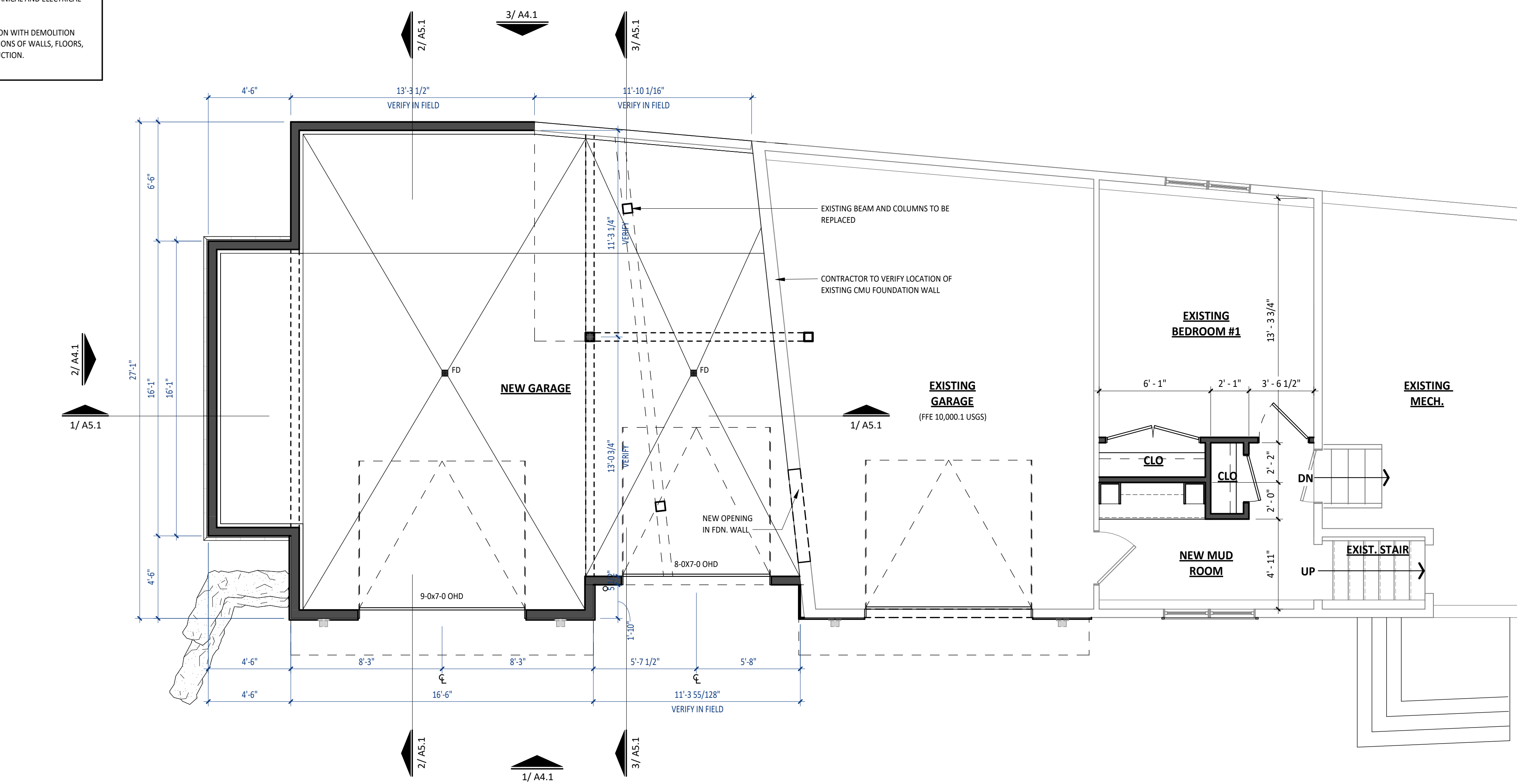

**1 FLOOR PLAN - LOWER LEVEL**  
1/4" = 1'-0"





ROOTED ARCHITECTURE

SEAL:

NOT FOR CONSTRUCTION

DRAWINGS AND SPECIFICATIONS AS INSTRUMENTS OF SERVICE ARE THE PROPERTY OF THE ARCHITECT. THEY SHALL NOT BE USED, TRANSFERRED, OR SOLD FOR USE EXCEPT BY AN AGREEMENT IN WRITING FROM THE ARCHITECT.

FITZGERALD ADDITION  
34 RUSTIC TERRACE  
BLUE RIVER, CO

No. Date Revisions

Project No: 2023-16  
Stage: FINAL REVIEW SET  
Date: 05/02/2024  
Scale: As indicated

DRAWING TITLE:

FLOOR PLAN - MAIN

DRAWING NO:

A1.2

NOTES: FLOOR PLAN

- 1. ALL INFORMATION MUST BE CONFIRMED PRIOR TO COMMENCEMENT OF CONSTRUCTION. ANY ERRORS OR DISCREPANCIES MUST BE BROUGHT TO THE ATTENTION OF THE ARCHITECT PRIOR TO PROCEEDING WITH WORK.
2. IT SHALL BE THE RESPONSIBILITY OF THE CONTRACTOR AND/OR INDIVIDUAL CONTRACTORS TO SEE THAT ALL ITEMS MEET OR EXCEED CODE REQUIREMENTS.
3. BUILDING SHALL VERIFY ALL DIMENSIONS, INTERIOR & EXTERIOR FINISHES, CONSTRUCTION & FRAMING METHODS PRIOR TO CONSTRUCTION.
4. ALL MATERIALS & WORKMANSHIP INVOLVED IN THE CONSTRUCTION OF THIS PROJECT ARE TO CONFORM WITH ALL LOCAL, STATE, NATIONAL, & INTERNATIONAL BUILDING CODES AS DESCRIBED IN THE INTERNATIONAL ONE & TWO FAMILY DWELLING CODE.
5. DRAWINGS ARE NOT TO BE SCALED. ALL DIMENSIONS ARE FROM FACE OF STUD TO FACE OF STUD, U.N.O. ALL DIMENSIONS LABELED "CLEAR" ARE TO FACE OF FINISH MATERIAL.
6. ALL INTERIOR GYPSUM BOARD TO BE 1/2" MINIMUM. USE WATER-RESISTANT GYPSUM BOARD AT ALL WET WALL LOCATIONS. USE 5/8" TYPE "X" DRYWALL SEPARATIONS BETWEEN LIVING SPACES AND GARAGES AS REQUIRED BY CODE.
7. ALL TUB & SHOWER UNITS TO HAVE ANTI-SCALDING DEVICES INSTALLED.
8. GARAGE DOORS TO BE CERTIFIED BY MANUFACTURER FOR LOCAL WIND REQUIREMENTS
9. CONTRACTOR TO COORDINATE ELECTRICAL, PLUMBING AND HEATING WORK WITH SUBCONTRACTORS PRIOR TO STARTING WORK. PROVIDE ARCHITECT AND OWNER WITH SUBMITTALS WHERE APPLICABLE.
10. ALL ANGLED WALLS TO BE 45° UNLESS NOTED OTHERWISE.
11. MILLWORK SUBCONTRACTOR TO PROVIDE MILLWORK SHOP DRAWINGS TO THE ARCHITECTS, OWNER, AND CONTRACTOR FOR APPROVAL PRIOR TO COMMENCING FABRICATION.
12. CONTRACTOR TO COORDINATE BASEBOARD RADIANT HEAT LOCATIONS WITH OWNER AND MECHANICAL DESIGNER PRIOR TO INSTALLATION.

NOTES: DOOR AND WINDOW

- 1. ALL WINDOWS ARE DIMENSIONED TO THE CENTERLINE OF WINDOW; CONTRACTOR TO COORDINATE ACTUAL REQUIRED ROUGH OPENING WITH WINDOW MANUFACTURER. PRIOR TO ANY FRAMING WORK, VERIFY ROUGH OPENING DIMENSIONS WITH WINDOW MANUFACTURER. NOTIFY ARCHITECT OF ANY DISCREPANCIES.
2. SEE PLANS / DOOR AND WINDOW SCHEDULES FOR WINDOW / DOOR OPERATION, SIZES AND TYPES. VERIFY JAMB WIDTHS WITH WALL THICKNESS PRIOR TO INSTALLATION
3. PROVIDE WEATHER STRIPPING AND ALUMINUM THRESHOLD SET IN SEALANT AT ALL EXTERIOR DOORS.
4. PROVIDE SAFETY GLASS TO COMPLY WITH CODE REQUIREMENTS (SEE CURRENT I.R.C.). WINDOWS LOCATED MORE THAN 72" ABOVE FINISHED GRADE AND LESS THAN 24" ABOVE THE FINISHED FLOOR OF THE ROOM IN WHICH THE WINDOW IS LOCATED SHALL HAVE OPENING CONTROL DEVICES IN ACCORDANCE WITH IRC R310.2.2. WINDOWS / DOORS LOCATED IN SLEEPING ROOMS SHALL ACT AS EMERGENCY ESCAPE AND RESCUE OPENINGS PER IRC R310.1
5. ALL GLAZING SYSTEMS SHALL BE RATED FOR USE AT HIGH ALTITUDES PER MANUFACTURER'S REQUIREMENTS. GLAZED FENESTRATION SHALL COMPLY WITH THE MINIMUM REQUIREMENTS OF IRC AND SUMMIT COUNTY SUSTAINABILITY CODE.
6. WRAP ALL EXTERIOR OPENINGS WITH WEATHER RESISTIVE BARRIER PER MANUFACTURERS SPECIFICATIONS. PROVIDE 1-1/2" X 1-1/2" HEAD FLASHING AT ALL EXTERIOR OPENINGS (PRIME AND PAINT OR COLOR CLAD). INSULATE ALL EXTERIOR SHIM SPACES AT WINDOWS AND DOORS.
7. PROVIDE SHOP DRAWINGS FOR ALL SPECIAL/CUSTOM DOORS AND WINDOWS PRIOR TO FABRICATION. FIELD MEASURE TO VERIFY ALL CUSTOM UNIT SIZES.
8. WINDOWS AND PATIO DOORS REFER TO 'JELD-WEN' BRAND OR COMPARABLE
9. INTERIOR DOORS TO BE CENTERED ON SPACES OR INSTALLED W/ 4 1/2" OFFSET TO NEAREST WALL (U.N.O.). ALL WINDOW OPENINGS TO HAVE PAINTED GYPSUM BOARD RETURNS ON INTERIOR SIDE UNLESS NOTED OTHERWISE, REF. INTERIORS.
10. ALL WINDOW OPENINGS TO HAVE PAINTED GYPSUM BOARD RETURNS ON INTERIOR SIDE UNLESS NOTED OTHERWISE, REF. INTERIORS.
11. WINDOWS LOCATED IN SLEEPING ROOMS SHALL ACT AS EMERGENCY ESCAPE AND RESCUE OPENINGS PER IRC R310.1
12. COORDINATE WINDOW SILL HEIGHT WITH GYPCRETE AND FLOOR FINISH THICKNESS WHERE REQUIRED. VERIFY AT LOCATIONS WHERE WINDOW SILLS TERMINATE AT FLOOR LEVEL OR AT TOP OF MILLWORK.
13. VERIFY WINDOW STYLE, OPERATION, FINISH AND HARDWARE WITH OWNER PRIOR TO PLACING ORDER.
14. WINDOW SUPPLIER TO PROVIDE TEMPERED GLAZING WHERE REQUIRED BY CODE.

WALL LEGEND

- NEW 2X4 / 2X6 WOOD STUD WALL
EXISTING 2X4 / 2X6 WOOD STUD WALL
EXISTING WALL TO BE REMOVED

NOTES: REMODEL

- 1. PROTECTION OF EXISTING TO REMAIN: THE CONTRACTOR SHALL PROVIDE PROTECTIVE COVERING FOR CARPET, FURNISHINGS, AND FINISHES IN EXISTING AREAS NOT DESIGNATED FOR DEMOLITION OR NEW CONSTRUCTION. THE CONTRACTOR SHALL BE RESPONSIBLE FOR THE REPAIR OF ANY DAMAGE CAUSED BY HIS WORK OR ANY SUBCONTRACTOR. IN PARTICULAR, THE CONTRACTOR SHALL MAINTAIN A DUST-FREE ENVIRONMENT WITHIN THE MAGNET VAULT.
2. SCHEDULING: THE CONTRACTOR SHALL MEET WITH THE OWNER IN ADVANCE OF CONSTRUCTION COMMENCEMENT TO:
A. SCHEDULE, SEQUENCE AND COORDINATE ALL WORK
B. MAINTAIN EXITS AND EGRESS WIDTHS REQUIRED BY CODES DURING ALL PHASES OF CONSTRUCTION
3. CLEARANCES: THE CONTRACTOR SHALL VERIFY THAT NEW CEILINGS CAN BE INSTALLED IN EXISTING SPACES TO CLEAR DUCTWORK AND OTHER CONSTRUCTED ITEMS AND MAINTAIN FLOOR TO CEILING HEIGHTS INDICATED ON DRAWINGS. IF DISCREPANCIES OCCUR DUE TO EXISTING CONDITIONS, CONSULT WITH THE ARCHITECT BEFORE PROCEEDING.
4. MATERIAL ALIGNMENT: THE FINISH FACE OF MATERIAL OF NEW PARTITIONS SHALL ALIGN ON BOTH SIDES OF THE PARTITION WITH THE FACE OF THE MATERIALS ON EXISTING COLUMNS, WALLS, OR PARTITIONS, UNLESS NOTED OTHERWISE.
5. AS BUILT VERIFICATION: THE CONTRACTOR SHALL VERIFY DIMENSIONS OF AS-BUILT CONDITIONS, AND NOTIFY THE ARCHITECT IN WRITING OF ANY DISCREPANCIES. ALL INFORMATION SHOWN ON THE CONSTRUCTION DOCUMENTS IS BASED ON FIELD OBSERVATIONS AND/OR THE ORIGINAL CONSTRUCTION DOCUMENTS OF THE FACILITY.
6. REMOVAL SURVEY: THE CONTRACTOR SHALL SURVEY AND DETERMINE THE REMOVAL OF EXISTING CONSTRUCTION, EITHER WHOLE OR IN PART, AS REQUIRED FOR THE INSTALLATION OF THE NEW MECHANICAL, PLUMBING AND ELECTRICAL WORK.
7. CONSTRUCTION DEFECTS: THE CONTRACTOR SHALL NOTIFY THE ARCHITECT IN WRITING OF ANY CONSTRUCTION DEFECTS FOUND IN UNCOVERING WORK IN THE EXISTING CONSTRUCTION.
8. CORRECTING DEFECTIVE WORK: THE CONTRACTOR SHALL BE RESPONSIBLE FOR CORRECTING DEFECTIVE WORK IN EXISTING CONSTRUCTION WITHIN THE LIMITS OF THE CONSTRUCTION AREA. THIS INCLUDES, BUT IS NOT LIMITED TO, UNEVEN SURFACES AND FINISHES AT PLASTER OR GYPSUM BOARD. THE CONTRACTOR SHALL PATCH AND REPAIR SURFACES TO MATCH NEW ADJACENT SURFACES.
9. PIPING: ALL PIPING ABOVE GRADE AND INSIDE THE BUILDING REQUIRED BY THE CONSTRUCTION DOCUMENTS SHALL BE INSTALLED IN AREAS WHERE IT WILL BE CONCEALED. THE CONTRACTOR SHALL CONSULT WITH THE ARCHITECT AND COORDINATE WITH OTHER TRADES TO PROVIDE FURRING FOR PIPING INSTALLED IN FINISH AREAS.
10. FIXTURE REMOVAL: REMOVE MECHANICAL AND ELECTRICAL FIXTURES AND CAP OR REMOVE EXISTING BRANCH LINES AS INDICATED IN THE MECHANICAL AND ELECTRICAL DOCUMENTS.
11. COORDINATION: COORDINATE PLANS FOR NEW CONSTRUCTION WITH DEMOLITION PLANS FOR EXTENT OF REMOVAL. REMOVE ONLY THOSE PORTIONS OF WALLS, FLOORS, CEILINGS, ETC. NECESSARY TO ACCOMMODATE NEW CONSTRUCTION.

1 FLOOR PLAN - MAIN LEVEL
1/4" = 1'-0"

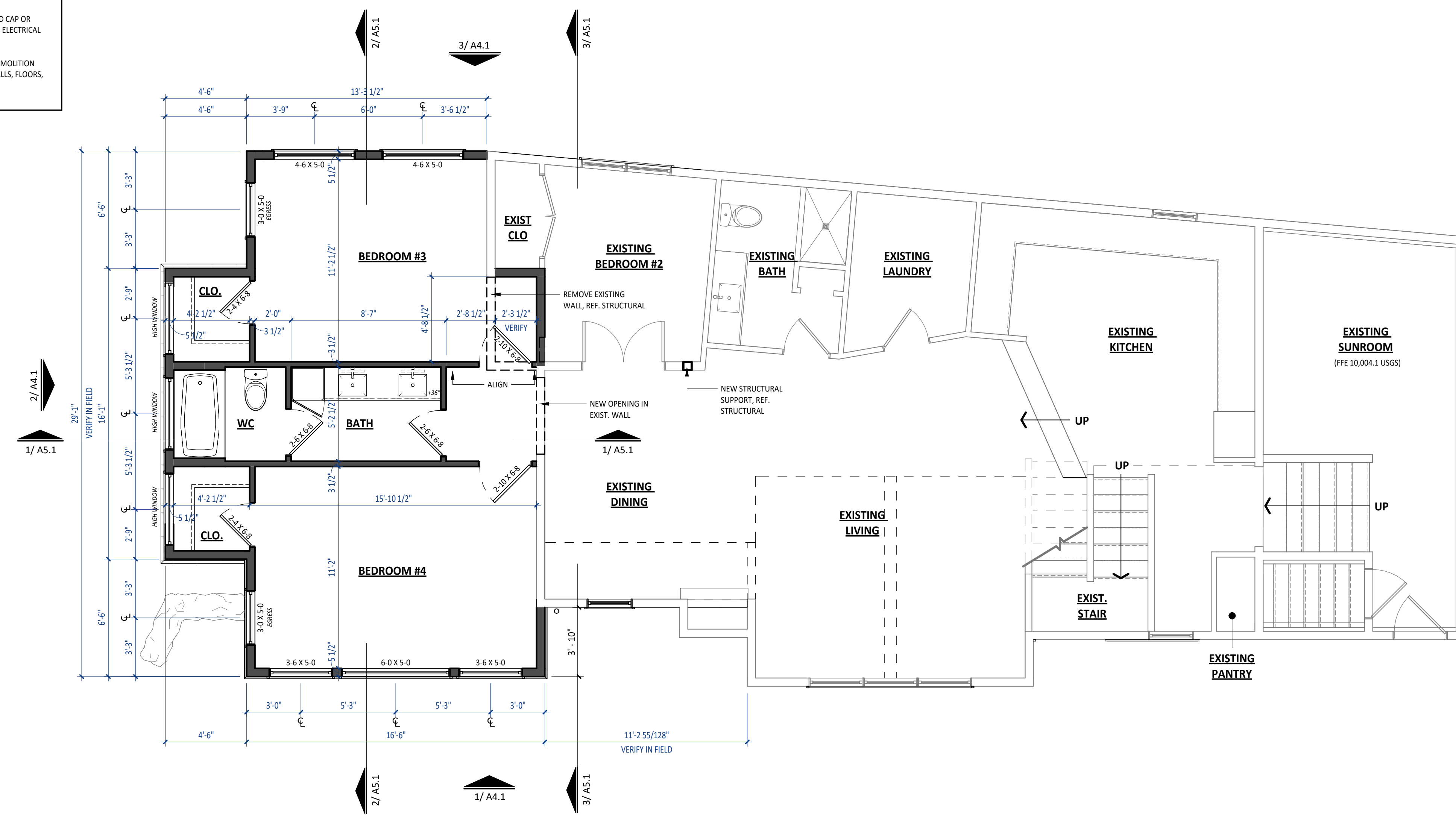



ROOTED ARCHITECTURE

SEAL:

NOT FOR CONSTRUCTION

DRAWINGS AND SPECIFICATIONS AS INSTRUMENTS OF SERVICE ARE THE PROPERTY OF THE ARCHITECT. THEY SHALL NOT BE USED, TRANSFERRED, OR SOLD FOR USE EXCEPT BY AN AGREEMENT IN WRITING FROM THE ARCHITECT.

FITZGERALD ADDITION

34 RUSTIC TERRACE  
BLUE RIVER, CO

No. Date Revisions

Project No: 2023-16  
Stage: FINAL REVIEW SET  
Date: 05/02/2024  
Scale: As indicated

DRAWING TITLE:

FLOOR PLAN - UPPER

DRAWING NO:

A1.3

NOTES: FLOOR PLAN

- 1. ALL INFORMATION MUST BE CONFIRMED PRIOR TO COMMENCEMENT OF CONSTRUCTION. ANY ERRORS OR DISCREPANCIES MUST BE BROUGHT TO THE ATTENTION OF THE ARCHITECT PRIOR TO PROCEEDING WITH WORK.
2. IT SHALL BE THE RESPONSIBILITY OF THE CONTRACTOR AND/OR INDIVIDUAL CONTRACTORS TO SEE THAT ALL ITEMS MEET OR EXCEED CODE REQUIREMENTS.
3. BUILDING SHALL VERIFY ALL DIMENSIONS, INTERIOR & EXTERIOR FINISHES, CONSTRUCTION & FRAMING METHODS PRIOR TO CONSTRUCTION.
4. ALL MATERIALS & WORKMANSHIP INVOLVED IN THE CONSTRUCTION OF THIS PROJECT ARE TO CONFORM WITH ALL LOCAL, STATE, NATIONAL, & INTERNATIONAL BUILDING CODES AS DESCRIBED IN THE INTERNATIONAL ONE & TWO FAMILY DWELLING CODE.
5. DRAWINGS ARE NOT TO BE SCALED. ALL DIMENSIONS ARE FROM FACE OF STUD TO FACE OF STUD, U.N.O. ALL DIMENSIONS LABELED "CLEAR" ARE TO FACE OF FINISH MATERIAL.
6. ALL INTERIOR GYPSUM BOARD TO BE 1/2" MINIMUM. USE WATER-RESISTANT GYPSUM BOARD AT ALL WET WALL LOCATIONS. USE 5/8" TYPE "X" DRYWALL SEPARATIONS BETWEEN LIVING SPACES AND GARAGES AS REQUIRED BY CODE.
7. ALL TUB & SHOWER UNITS TO HAVE ANTI-SCALDING DEVICES INSTALLED.
8. GARAGE DOORS TO BE CERTIFIED BY MANUFACTURER FOR LOCAL WIND REQUIREMENTS
9. CONTRACTOR TO COORDINATE ELECTRICAL, PLUMBING AND HEATING WORK WITH SUBCONTRACTORS PRIOR TO STARTING WORK. PROVIDE ARCHITECT AND OWNER WITH SUBMITTALS WHERE APPLICABLE.
10. ALL ANGLED WALLS TO BE 45° UNLESS NOTED OTHERWISE.
11. MILLWORK SUBCONTRACTOR TO PROVIDE MILLWORK SHOP DRAWINGS TO THE ARCHITECTS, OWNER, AND CONTRACTOR FOR APPROVAL PRIOR TO COMMENCING FABRICATION.
12. CONTRACTOR TO COORDINATE BASEBOARD RADIANT HEAT LOCATIONS WITH OWNER AND MECHANICAL DESIGNER PRIOR TO INSTALLATION.

NOTES: DOOR AND WINDOW

- 1. ALL WINDOWS ARE DIMENSIONED TO THE CENTERLINE OF WINDOW; CONTRACTOR TO COORDINATE ACTUAL REQUIRED ROUGH OPENING WITH WINDOW MANUFACTURER. PRIOR TO ANY FRAMING WORK, VERIFY ROUGH OPENING DIMENSIONS WITH WINDOW MANUFACTURER. NOTIFY ARCHITECT OF ANY DISCREPANCIES.
2. SEE PLANS / DOOR AND WINDOW SCHEDULES FOR WINDOW / DOOR OPERATION, SIZES AND TYPES. VERIFY JAMB WIDTHS WITH WALL THICKNESS PRIOR TO INSTALLATION
3. PROVIDE WEATHER STRIPPING AND ALUMINUM THRESHOLD SET IN SEALANT AT ALL EXTERIOR DOORS.
4. PROVIDE SAFETY GLASS TO COMPLY WITH CODE REQUIREMENTS (SEE CURRENT I.R.C.). WINDOWS LOCATED MORE THAN 72" ABOVE FINISHED GRADE AND LESS THAN 24" ABOVE THE FINISHED FLOOR OF THE ROOM IN WHICH THE WINDOW IS LOCATED SHALL HAVE OPENING CONTROL DEVICES IN ACCORDANCE WITH IRC R310.2.2. WINDOWS / DOORS LOCATED IN SLEEPING ROOMS SHALL ACT AS EMERGENCY ESCAPE AND RESCUE OPENINGS PER IRC R310.1
5. ALL GLAZING SYSTEMS SHALL BE RATED FOR USE AT HIGH ALTITUDES PER MANUFACTURER'S REQUIREMENTS. GLAZED FENESTRATION SHALL COMPLY WITH THE MINIMUM REQUIREMENTS OF IRC AND SUMMIT COUNTY SUSTAINABILITY CODE.
6. WRAP ALL EXTERIOR OPENINGS WITH WEATHER RESISTIVE BARRIER PER MANUFACTURERS SPECIFICATIONS. PROVIDE 1-1/2" X 1-1/2" HEAD FLASHING AT ALL EXTERIOR OPENINGS (PRIME AND PAINT OR COLOR CLAD). INSULATE ALL EXTERIOR SHIM SPACES AT WINDOWS AND DOORS.
7. PROVIDE SHOP DRAWINGS FOR ALL SPECIAL/CUSTOM DOORS AND WINDOWS PRIOR TO FABRICATION. FIELD MEASURE TO VERIFY ALL CUSTOM UNIT SIZES.
8. WINDOWS AND PATIO DOORS REFER TO 'JELD-WEN' BRAND OR COMPARABLE
9. INTERIOR DOORS TO BE CENTERED ON SPACES OR INSTALLED W/ 4 1/2" OFFSET TO NEAREST WALL (U.N.O.). ALL WINDOW OPENINGS TO HAVE PAINTED GYPSUM BOARD RETURNS ON INTERIOR SIDE UNLESS NOTED OTHERWISE, REF. INTERIORS.
10. ALL WINDOW OPENINGS TO HAVE PAINTED GYPSUM BOARD RETURNS ON INTERIOR SIDE UNLESS NOTED OTHERWISE, REF. INTERIORS.
11. WINDOWS LOCATED IN SLEEPING ROOMS SHALL ACT AS EMERGENCY ESCAPE AND RESCUE OPENINGS PER IRC R310.1
12. COORDINATE WINDOW SILL HEIGHT WITH GYPCRETE AND FLOOR FINISH THICKNESS WHERE REQUIRED. VERIFY AT LOCATIONS WHERE WINDOW SILLS TERMINATE AT FLOOR LEVEL OR AT TOP OF MILLWORK.
13. VERIFY WINDOW STYLE, OPERATION, FINISH AND HARDWARE WITH OWNER PRIOR TO PLACING ORDER.
14. WINDOW SUPPLIER TO PROVIDE TEMPERED GLAZING WHERE REQUIRED BY CODE.

WALL LEGEND

- NEW 2X4 / 2X6 WOOD STUD WALL
EXISTING 2X4 / 2X6 WOOD STUD WALL
EXISTING WALL TO BE REMOVED

NOTES: REMODEL

- 1. PROTECTION OF EXISTING TO REMAIN: THE CONTRACTOR SHALL PROVIDE PROTECTIVE COVERING FOR CARPET, FURNISHINGS, AND FINISHES IN EXISTING AREAS NOT DESIGNATED FOR DEMOLITION OR NEW CONSTRUCTION. THE CONTRACTOR SHALL BE RESPONSIBLE FOR THE REPAIR OF ANY DAMAGE CAUSED BY HIS WORK OR ANY SUBCONTRACTOR. IN PARTICULAR, THE CONTRACTOR SHALL MAINTAIN A DUST-FREE ENVIRONMENT WITHIN THE MAGNET VAULT.
2. SCHEDULING: THE CONTRACTOR SHALL MEET WITH THE OWNER IN ADVANCE OF CONSTRUCTION COMMENCEMENT TO:
A. SCHEDULE, SEQUENCE AND COORDINATE ALL WORK
B. MAINTAIN EXITS AND EGRESS WIDTHS REQUIRED BY CODES DURING ALL PHASES OF CONSTRUCTION
3. CLEARANCES: THE CONTRACTOR SHALL VERIFY THAT NEW CEILINGS CAN BE INSTALLED IN EXISTING SPACES TO CLEAR DUCTWORK AND OTHER CONSTRUCTED ITEMS AND MAINTAIN FLOOR TO CEILING HEIGHTS INDICATED ON DRAWINGS. IF DISCREPANCIES OCCUR DUE TO EXISTING CONDITIONS, CONSULT WITH THE ARCHITECT BEFORE PROCEEDING.
4. MATERIAL ALIGNMENT: THE FINISH FACE OF MATERIAL OF NEW PARTITIONS SHALL ALIGN ON BOTH SIDES OF THE PARTITION WITH THE FACE OF THE MATERIALS ON EXISTING COLUMNS, WALLS, OR PARTITIONS, UNLESS NOTED OTHERWISE.
5. AS BUILT VERIFICATION: THE CONTRACTOR SHALL VERIFY DIMENSIONS OF AS-BUILT CONDITIONS, AND NOTIFY THE ARCHITECT IN WRITING OF ANY DISCREPANCIES. ALL INFORMATION SHOWN ON THE CONSTRUCTION DOCUMENTS IS BASED ON FIELD OBSERVATIONS AND/OR THE ORIGINAL CONSTRUCTION DOCUMENTS OF THE FACILITY.
6. REMOVAL SURVEY: THE CONTRACTOR SHALL SURVEY AND DETERMINE THE REMOVAL OF EXISTING CONSTRUCTION, EITHER WHOLE OR IN PART, AS REQUIRED FOR THE INSTALLATION OF THE NEW MECHANICAL, PLUMBING AND ELECTRICAL WORK.
7. CONSTRUCTION DEFECTS: THE CONTRACTOR SHALL NOTIFY THE ARCHITECT IN WRITING OF ANY CONSTRUCTION DEFECTS FOUND IN UNCOVERING WORK IN THE EXISTING CONSTRUCTION.
8. CORRECTING DEFECTIVE WORK: THE CONTRACTOR SHALL BE RESPONSIBLE FOR CORRECTING DEFECTIVE WORK IN EXISTING CONSTRUCTION WITHIN THE LIMITS OF THE CONSTRUCTION AREA. THIS INCLUDES, BUT IS NOT LIMITED TO, UNEVEN SURFACES AND FINISHES AT PLASTER OR GYPSUM BOARD. THE CONTRACTOR SHALL PATCH AND REPAIR SURFACES TO MATCH NEW ADJACENT SURFACES.
9. PIPING: ALL PIPING ABOVE GRADE AND INSIDE THE BUILDING REQUIRED BY THE CONSTRUCTION DOCUMENTS SHALL BE INSTALLED IN AREAS WHERE IT WILL BE CONCEALED. THE CONTRACTOR SHALL CONSULT WITH THE ARCHITECT AND COORDINATE WITH OTHER TRADES TO PROVIDE FURRING FOR PIPING INSTALLED IN FINISH AREAS.
10. FIXTURE REMOVAL: REMOVE MECHANICAL AND ELECTRICAL FIXTURES AND CAP OR REMOVE EXISTING BRANCH LINES AS INDICATED IN THE MECHANICAL AND ELECTRICAL DOCUMENTS.
11. COORDINATION: COORDINATE PLANS FOR NEW CONSTRUCTION WITH DEMOLITION PLANS FOR EXTENT OF REMOVAL. REMOVE ONLY THOSE PORTIONS OF WALLS, FLOORS, CEILINGS, ETC. NECESSARY TO ACCOMMODATE NEW CONSTRUCTION.

1 FLOOR PLAN - UPPER LEVEL
1/4" = 1'-0"

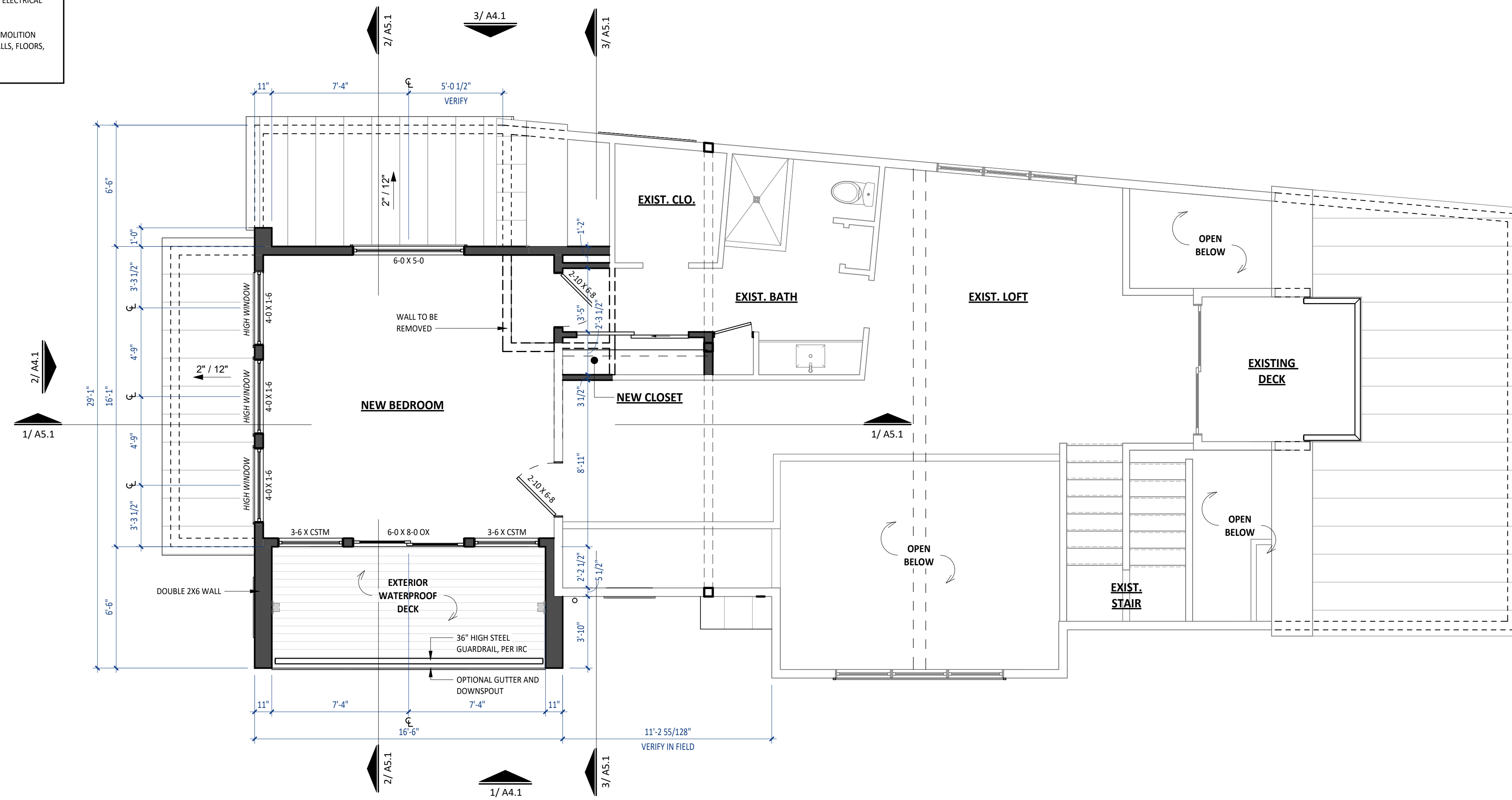



**ROOTED**  
ARCHITECTURE

SEAL:

NOT FOR CONSTRUCTION

DRAWINGS AND SPECIFICATIONS AS INSTRUMENTS OF SERVICE ARE THE PROPERTY OF THE ARCHITECT. THEY SHALL NOT BE USED, TRANSFERRED, OR SOLD FOR USE EXCEPT BY AN AGREEMENT IN WRITING FROM THE ARCHITECT.

**NOTES: ROOF PLAN**

- COORDINATE INSTALLATION OF NEW ROOFING WITH OTHER TRADES. REPORT ANY CONFLICTS WITH ITEMS INSTALLED BY OTHER TRADES TO DESIGNER.
- REFER TO SPECIFICATIONS. PROVIDE ROOF PRIMER, ROOF MEMBRANE AND ALL ROOFING PER SPECIFICATION REQUIREMENTS. PROVIDE "W.R. GRACE" MANUFACTURER CERTIFICATION LETTER STATING THAT ALL MEMBRANES HAVE BEEN INSTALLED IN COMPLETE COMPLIANCE WITH ALL MANUFACTURER'S REQUIREMENTS.
- ALL PLUMBING VENTS SHALL EXTEND ABOVE THE FINISHED SURFACE OF THE ROOF SYSTEM AS REQUIRED TO PROVIDE FOR A MINIMUM OF 8" BASE FLASHING.
- ALL EXPOSED METAL FLASHING/ TRIM PIECES TO BE PRE-FINISHED 24 GA. STL. U.N.O.. PROVIDE PRE-FINISHED OR FIELD PAINT FLASHING ONLY AS NOTED.
- GUTTERS - ALL GUTTERS TO BE PRE-FINISHED. PROVIDE PRE-FINISHED SUPPORTS AND SPACERS @ 36" O.C. MAX. MATCH EXISTING GUTTER PROFILE AND FINISH.
- ALL DOWNSPOUTS TO BE PRE-FINISHED, REFERENCE ELEVATIONS FOR LOCATIONS.
- PROVIDE HEAT TAPE AT GUTTERS AND DOWNSPOUTS. REFER TO ROOF PLAN FOR ADDITIONAL FUTURE HEAT TAPE OUTLETS. SEE ROOF PLAN FOR WATERPROOF OUTLETS AT SIDEWALL AREAS. ALL GUTTERS AND DOWNSPOUTS TO BE HEATED. REFER TO PLAN FOR ALL SOLAR AND HEAT TAPE.
- PAINT ALL EXPOSED PIPING EXTENDING THROUGH ROOF TO MATCH ROOF
- PROVIDE VALLEY FLASHING AT ALL VALLEYS AS INDICATED ON PLANS.
- OVERHANG DIMENSIONS ARE TO END OF RAFTER OR TRUSS AS INDICATED ON PLANS.
- PROVIDE KICK-OUT FLASHING AT ALL EAVE/WALL JUNCTURES.
- PROVIDE ILC AS REQUIRED.
- CONTRACTOR TO COORDINATE HEATED GUTTER AND DOWNSPOUT LOCATIONS WITH ARCHITECT.
- DOWNSPOUTS SHALL NOT DISCHARGE ONTO FLATWORK OR DECKS BELOW. CONTRACTOR TO ROUTE DISCHARGE BELOW SURFACE OR PROVIDE CHANNEL DRAIN IN FLATWORK WITH HEAT TAPE.
- REFER TO SPECIFICATIONS. PROVIDE ROOF PRIMER, ROOF MEMBRANE AND ALL ROOFING PER SPECIFICATION REQUIREMENTS. PROVIDE "W.R. GRACE" MANUFACTURER CERTIFICATION LETTER STATING THAT ALL MEMBRANES HAVE BEEN INSTALLED IN COMPLETE COMPLIANCE WITH ALL MANUFACTURER'S REQUIREMENTS.
- UNVENTED ROOFS SHALL HAVE A MINIMUM 60% AIR IMPERMEABLE CLOSED CELL INSULATION AT UNDERSIDE OF DECK.

**NOTES: ROOF MAINTENANCE**

THE OWNER HAS BEEN ADVISED THAT ALL ROOF AND DECK SURFACES MUST BE MAINTAINED RELATIVELY FREE OF SNOW & ICE.

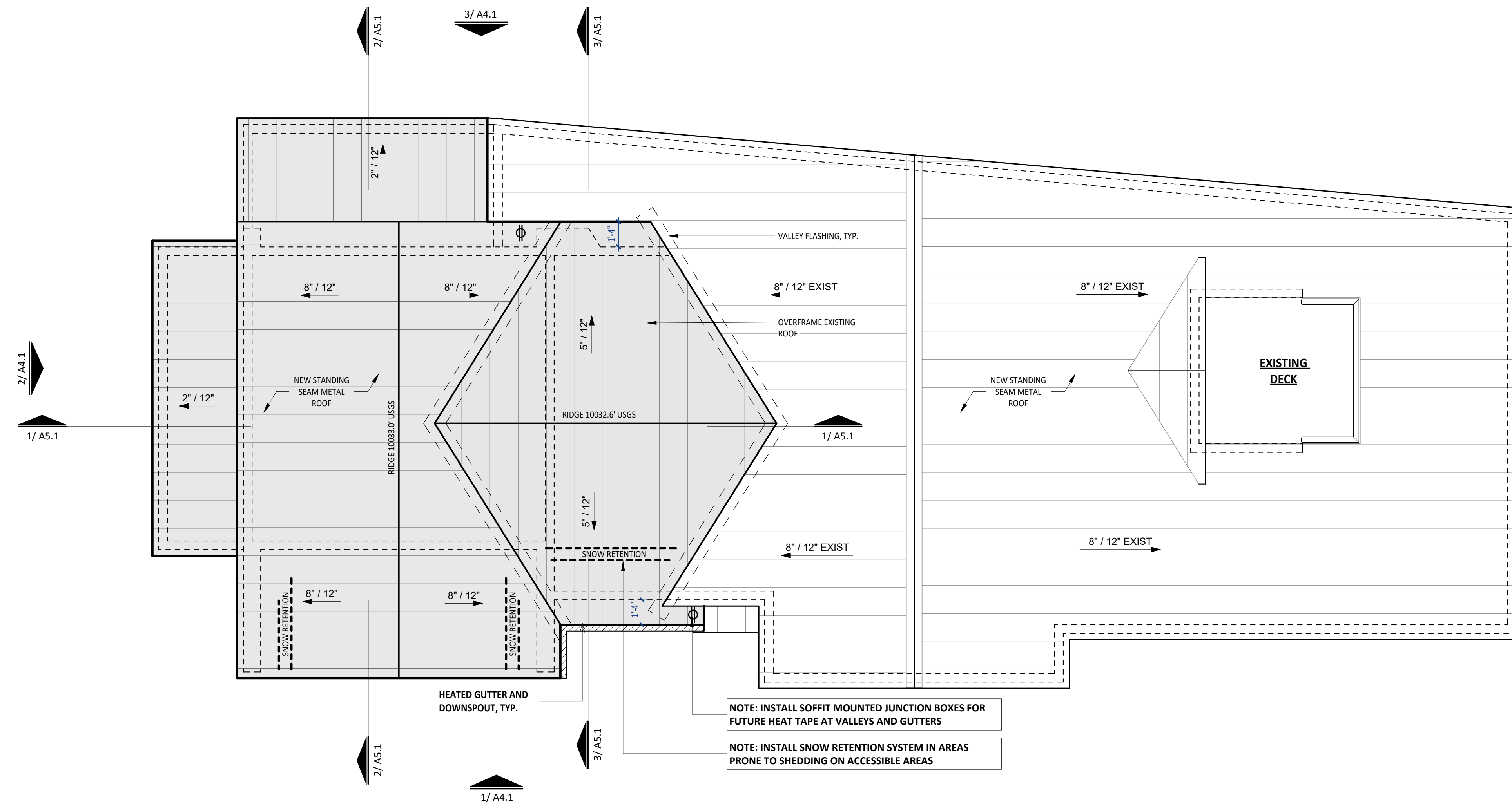

NOTE: INSTALL SOFFIT MOUNTED JUNCTION BOXES FOR FUTURE HEAT TAPE AT VALLEYS AND GUTTERS

NOTE: INSTALL SNOW RETENTION SYSTEM IN AREAS PRONE TO SHEDDING ON ACCESSIBLE AREAS

**1 ROOF PLAN**  
1/4" = 1'-0"

**FITZGERALD ADDITION**  
34 RUSTIC TERRACE  
BLUE RIVER, CO

No.	Date	Revisions

Project No: 2023-16  
 Stage: FINAL REVIEW SET  
 Date: 05/02/2024  
 Scale: As indicated

DRAWING TITLE:  
**ROOF PLAN**

DRAWING NO:

**A1.4**

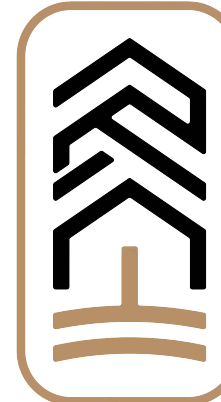

**ROOTED**  
ARCHITECTURE

SEAL:

NOT FOR CONSTRUCTION

DRAWINGS AND SPECIFICATIONS AS INSTRUMENTS OF SERVICE ARE THE PROPERTY OF THE ARCHITECT. THEY SHALL NOT BE USED, TRANSFERRED, OR SOLD FOR USE EXCEPT BY AN AGREEMENT IN WRITING FROM THE ARCHITECT.

**FITZGERALD ADDITION**

34 RUSTIC TERRACE  
BLUE RIVER, CO

No. Date Revisions

Project No: 2023-16  
Stage: FINAL REVIEW SET  
Date: 05/02/2024  
Scale: As indicated

DRAWING TITLE:

**CEILING PLANS**

DRAWING NO:

**A2.1**

FIXTURE / DEVICE LEGEND	
	A 6" RECESSED CAN LIGHT FIXTURE TO BE SELECTED - FLUORESCENT OR LED LIGHT SOURCE
	A1 6" RECESSED CAN LIGHT (MOISTURE RESISTANT) FIXTURE TO BE SELECTED - FLUORESCENT OR LED LIGHT SOURCE
	B 4" RECESSED CAN LIGHT FIXTURE TO BE SELECTED - FLUORESCENT OR LED LIGHT SOURCE
	B1 4" RECESSED CAN LIGHT (MOISTURE RESISTANT) FIXTURE TO BE SELECTED - FLUORESCENT OR LED LIGHT SOURCE
	B2 4" RECESSED CAN LIGHT (WALL WASHER) FIXTURE TO BE SELECTED - FLUORESCENT OR LED LIGHT SOURCE
	C DECORATIVE PENDANT FIXTURE FIXTURE TO BE SELECTED
	D 4" SURFACE MOUNT FLUORESCENT FIXTURE FIXTURE TO BE SELECTED
	E LINEAR LED UNDERCABINET TASK LIGHTING FIXTURE TO BE SELECTED
	F SURFACE MOUNT FIXTURE FIXTURE TO BE SELECTED
	WS WALL MOUNTED SCONCE FIXTURE FIXTURE TO BE SELECTED
	EX WALL MOUNTED EXTERIOR FIXTURE FIXTURE TO BE SELECTED
	FL WALL MOUNTED EXTERIOR FLOOD LIGHT FIXTURE FIXTURE TO BE SELECTED
	SD CEILING MOUNTED COMBINATION SMOKE AND CARBON MONOXIDE DETECTOR
	FAN CEILING MOUNTED CEILING FAN (WITH OPTIONAL LIGHT KIT) FIXTURE TO BE SELECTED

DEVICE CONTROL LEGEND	
	S SINGLE POLE SWITCH LEGRAND "RADIANT" OR SIMILAR - WHITE
	S <sup>D</sup> SINGLE POLE DIMMER SWITCH LEGRAND "RADIANT" OR SIMILAR - WHITE
	S <sup>3</sup> SINGLE POLE 3 WAY SWITCH LEGRAND "RADIANT" OR SIMILAR - WHITE
	S <sup>3/D</sup> SINGLE POLE 3 WAY DIMMER SWITCH LEGRAND "RADIANT" OR SIMILAR - WHITE
	S <sup>4/D</sup> SINGLE POLE 4 WAY DIMMER SWITCH LEGRAND "RADIANT" OR SIMILAR - WHITE
	S <sup>5</sup> SINGLE POLE DOOR JAMB SWITCH LEVITON 1865 OR SIMILAR

**NOTES: REFLECTED CEILING PLAN**

- ALL RCP DIMENSIONS ARE TO FACE OF FINISH OR FIXTURE CENTERLINE U.N.O.
- ALL CEILINGS ARE PAINTED GYPSUM BOARD U.N.O.
- REFERENCE FIXTURE LEGEND FOR FIXTURE TYPES AND DESIGNATIONS.
- LOCATE PAINTED METAL CEILING ACCESS PANELS BENEATH:
  - MECHANICAL EQUIPMENT PER MANUFACTURER'S RECOMMENDATIONS.
  - VALVES, BALANCING DEVICES, ELECTRICAL JUNCTIONS, F/S DAMPERS AND ALL OTHER ITEMS REQUIRING MAINTENANCE.
- COORDINATE LOCATION OF ALL MECHANICAL EQUIPMENT AND DUCTWORK WITH STRUCTURAL, AS WELL AS, WITH CEILING HEIGHTS SHOWN. NOTIFY ARCHITECT IMMEDIATELY OF CONFLICTS BEFORE PROCEEDING.
- IF ANY LIGHTING ITEMS OR CEILING FIXTURES CANNOT BE INSTALLED AT LOCATIONS SHOWN DUE TO FIELD CONDITIONS, NOTIFY ARCHITECT IMMEDIATELY FOR ALTERNATE LOCATIONS BEFORE PROCEEDING.

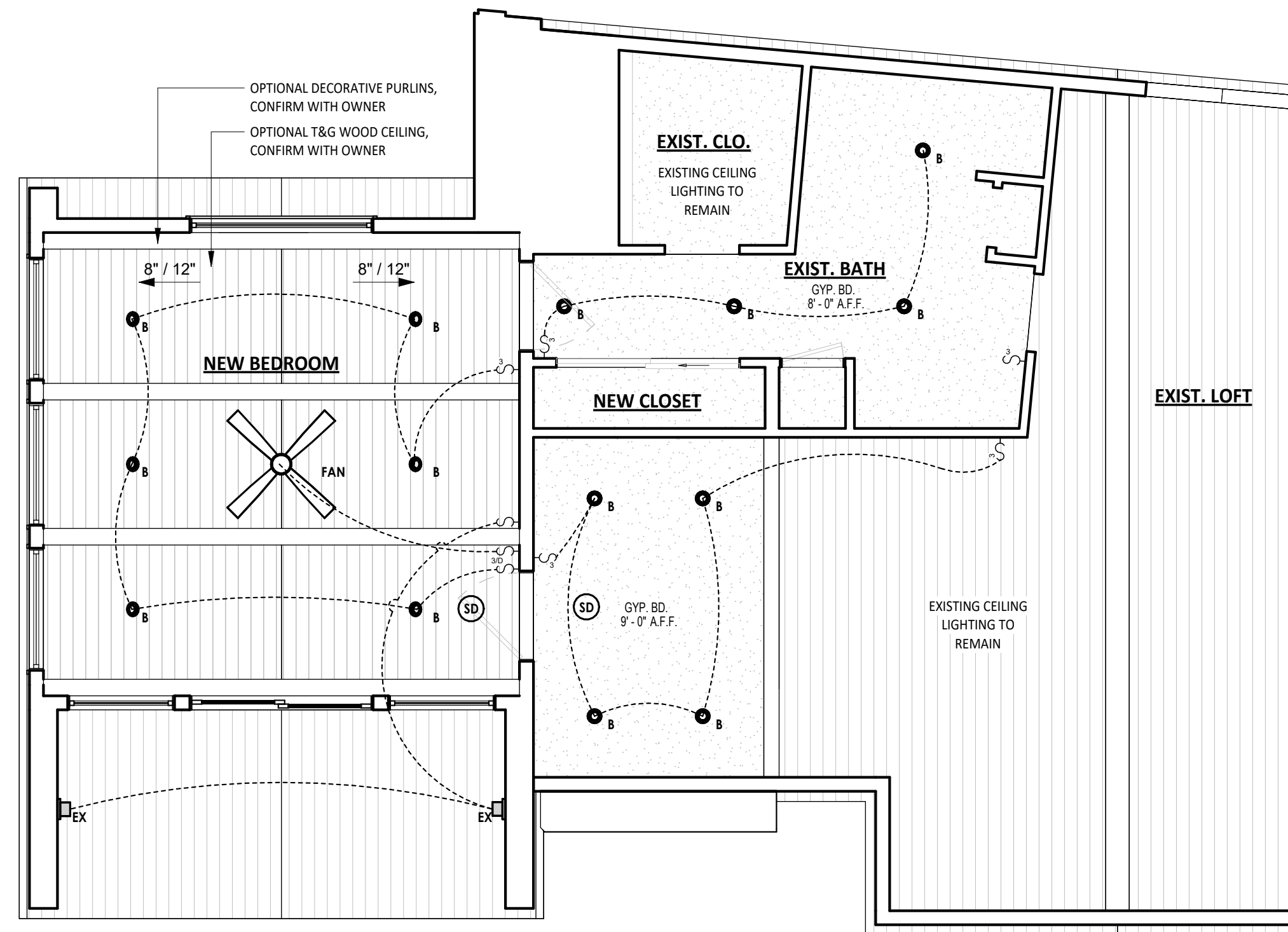

**3 CEILING PLAN - LOFT LEVEL**  
1/4" = 1'-0"

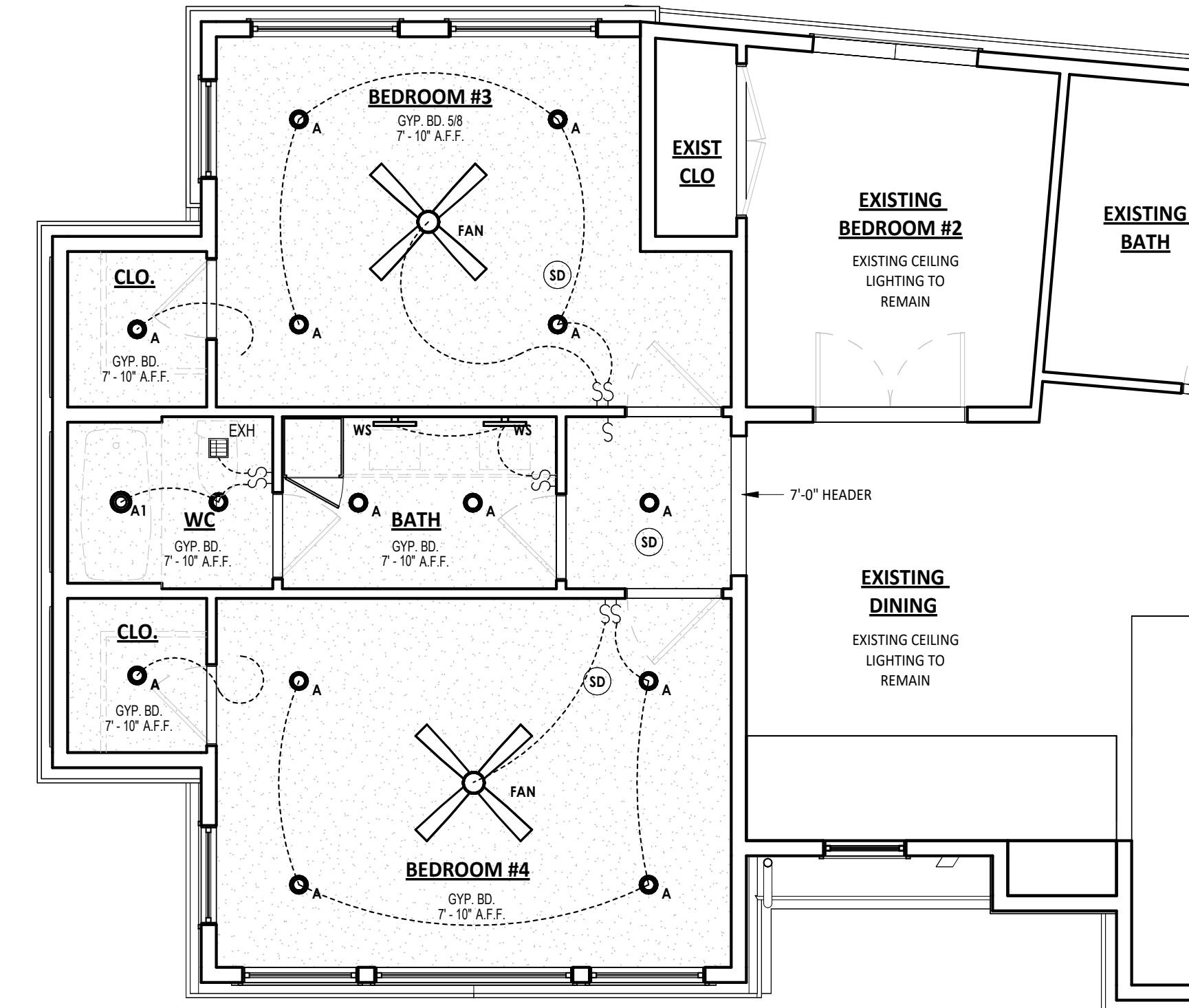

**2 CEILING PLAN - MAIN LEVEL**  
1/4" = 1'-0"

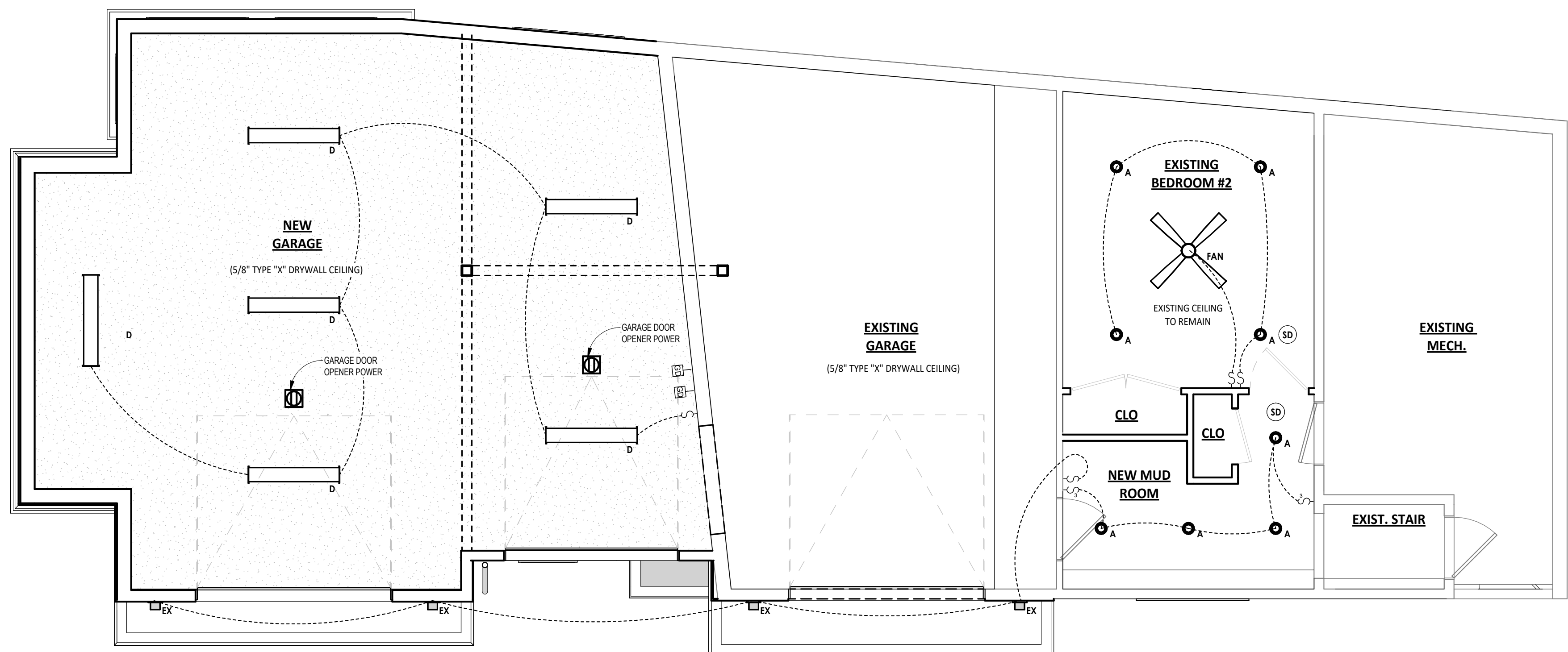

**1 CEILING PLAN - LOWER LEVEL**  
1/4" = 1'-0"



**ROOTED**  
ARCHITECTURE

SEAL:

NOT FOR CONSTRUCTION

DRAWINGS AND SPECIFICATIONS AS INSTRUMENTS OF SERVICE ARE THE PROPERTY OF THE ARCHITECT. THEY SHALL NOT BE USED, TRANSFERRED, OR SOLD FOR USE EXCEPT BY AN AGREEMENT IN WRITING FROM THE ARCHITECT.

**FITZGERALD ADDITION**

34 RUSTIC TERRACE  
BLUE RIVER, CO

No. Date Revisions

Project No: 2023-16  
Stage: FINAL REVIEW SET  
Date: 05/02/2024  
Scale: As indicated

DRAWING TITLE:

**EXTERIOR ELEVATIONS**

DRAWING NO:

**A4.1**

**NOTES: AIR BARRIER / VAPOR BARRIER**

IN COMPLIANCE WITH ENERGY CODE REQUIREMENTS, PROVIDE CONTINUOUS, SOLID AIR BARRIERS OVER ALL INSULATION SURFACES. PROVIDE AIR BARRIERS BEHIND ALL CONCEALED AREAS, SUCH AS TUBS, DROPPED CEILING AREAS, SOFFITS DECORATIVE BEAMS AND STRUCTURAL BEAMS ADJACENT TO THERMAL ENVELOPE WALLS. THESE BARRIERS SHOULD BE COORDINATED AND INSTALLED AT THE TIME OF FRAMING AND MUST BE CONTINUOUS AND UNBROKEN. PROVIDE AIR BARRIERS AND INSULATION AT THE THERMAL ENVELOPE LINE OF ALL CHIMNEYS. AIR BARRIERS CAN BE 6 MIL POLYFILM PLASTIC, DRYWALL OR SOLID SHEATHING. COORDINATE ALL AIR BARRIERS WITH VAPOR BARRIERS AND INSULATION REQUIREMENTS AS OUTLINED IN DIVISION VII. PROVIDE AND SCHEDULE A PRE-MEETING WITH THE ARCHITECT AND FRAMER TO REVIEW THESE REQUIREMENTS PRIOR TO ANY FRAMING WORK.

**NOTES: WEATHER RESISTIVE BARRIER**

1. INSTALL WEATHER RESISTIVE BARRIER IN STRICT COMPLIANCE WITH MANUFACTURERS RECOMMENDATIONS AND DETAILS. USE ONLY APPROVED PRODUCTS AND FASTENING METHODS.
2. REFERENCE LOCAL AND NATIONAL BUILDING CODES AND REGULATIONS PRIOR TO INSTALLATION. INSTALL PER GOVERNING CODE REQUIREMENTS. NOTIFY ARCHITECT IF ANY CONFLICT ARISES.

**EXTERIOR FINISH LEGEND**

MATERIAL SYMBOL	TYPE	NOTES:
(WD1)	T&G WOOD VENEER	HORIZONTAL T&G THERMALLY MODIFIED PRE-FINISHED WOOD SIDING (OWNER TO VERIFY COLOR)
(WD2)	WOOD TRIM	1X OR 2X THERMALLY MODIFIED PRE-FINISHED WOOD TRIM (MATCH SIDING) (OWNER TO VERIFY COLOR)
(MP1)	PREFINISHED METAL PANEL VENEER	METAL BOARD AND BATTEN SIDING FLATIRON STEEL "BOARD AND BATTEN" COLOR: BLACK OR MIDNIGHT BRONZE (CONFIRM WITH OWNER)
(M1)	PREFINISHED METAL FASCIA	PREFINISHED METAL TO MATCH SIDING
(ST1)	STONE VENEER	TELLURIDE STONE OPTIONAL STONE VENEER (CONFIRM WITH OWNER) COLOR: SILVERLEAF
(R1)	METAL ROOFING	STANDING SEAM METAL ROOFING COLOR: BLACK (CONFIRM WITH OWNER)

NOTE: CONTRACTOR TO PROVIDE PHYSICAL MATERIAL SAMPLE BOARD FOR OWNER / ARCHITECT APPROVAL  
NOTE: ALL EXTERIOR MATERIALS TO BE NON-REFLECTIVE



**1 WEST ELEVATION**  
1/4" = 1'-0"

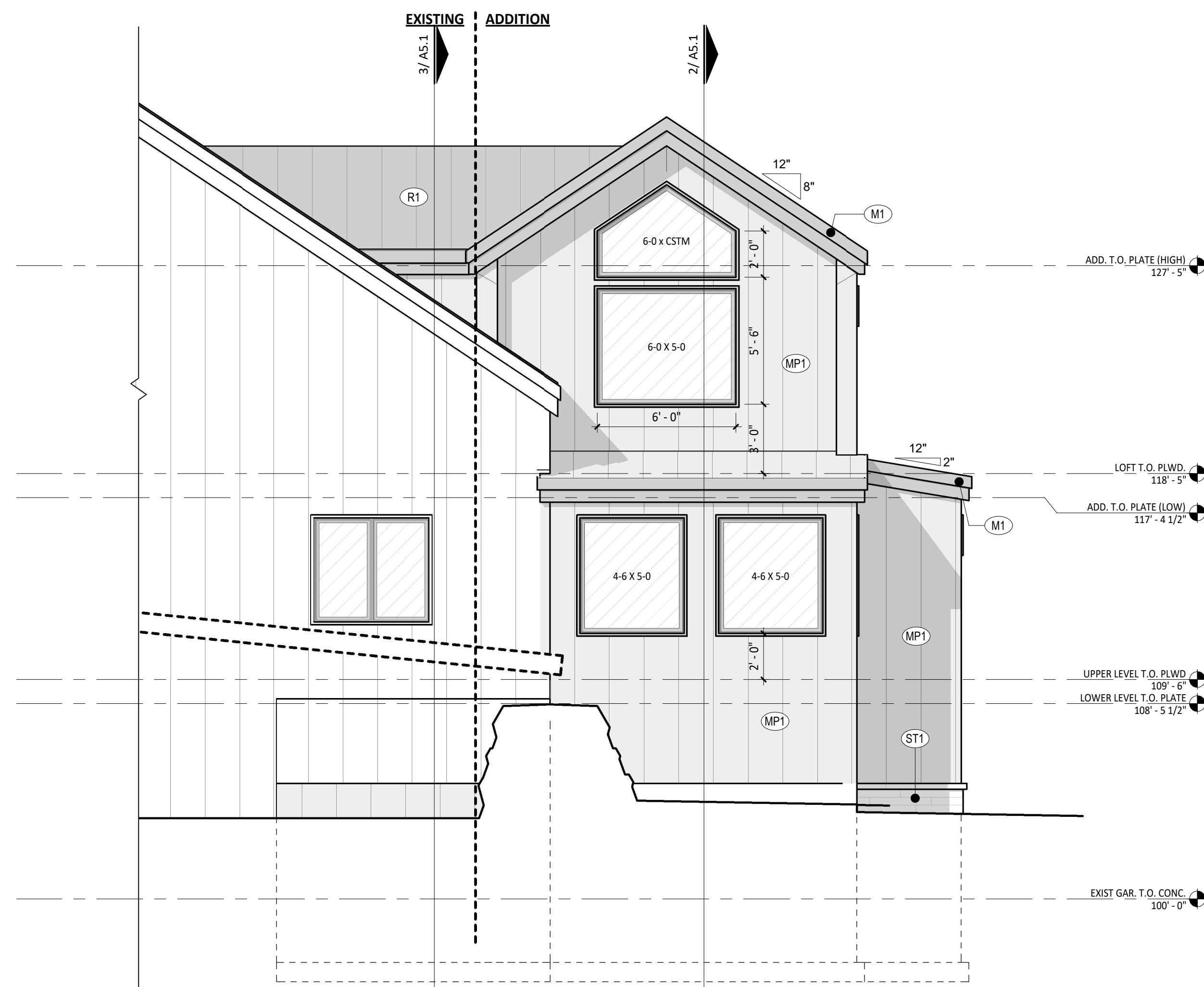

**3 EAST ELEVATION**  
1/4" = 1'-0"

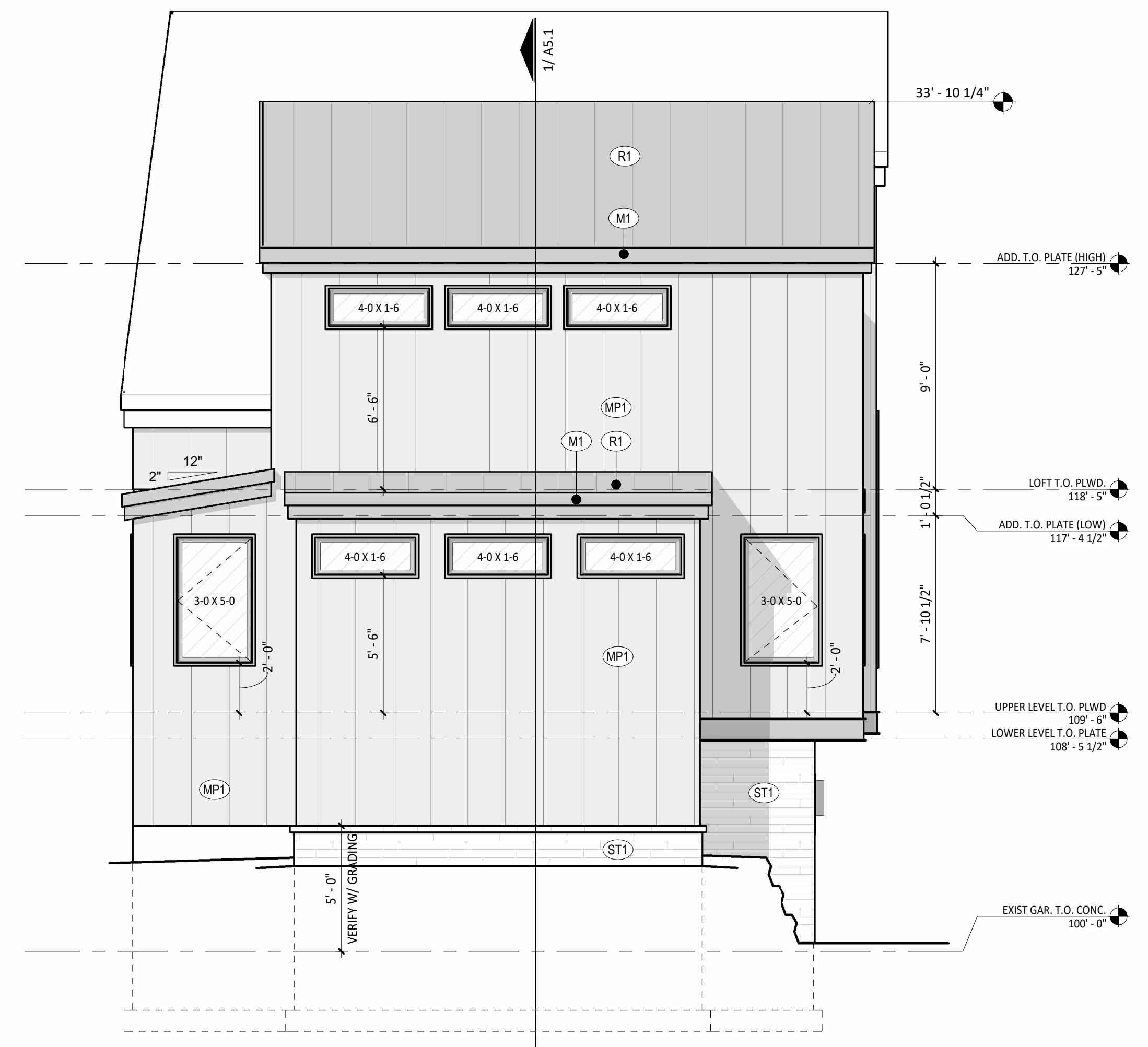

**2 NORTH ELEVATION**  
1/4" = 1'-0"





**ROOTED**  
ARCHITECTURE

SEAL:

NOT FOR CONSTRUCTION

DRAWINGS AND SPECIFICATIONS AS INSTRUMENTS OF SERVICE ARE THE PROPERTY OF THE ARCHITECT. THEY SHALL NOT BE USED, TRANSFERRED, OR SOLD FOR USE EXCEPT BY AN AGREEMENT IN WRITING FROM THE ARCHITECT.

**FITZGERALD ADDITION**

34 RUSTIC TERRACE  
BLUE RIVER, CO

No. Date Revisions

Project No: 2023-16  
Stage: FINAL REVIEW SET  
Date: 05/02/2024  
Scale: As indicated

DRAWING TITLE:

**BUILDING SECTIONS**

DRAWING NO:

**A5.1**

**NOTES: FRAMING**

1. ALL FRAMING SHOWN IS DIAGRAMMATIC AND SHALL BE STRUCTURALLY ENGINEERED WHERE APPLICABLE. CONTRACTOR TO CONFIRM COMPLIANCE WITH LOCAL CODES AND AUTHORITIES HAVING JURISDICTION.
2. ALL ROOF AND FLOOR TRUSSES SHALL BE PRE-ENGINEERED IN COMPLIANCE WITH LOCAL CODES AND AUTHORITIES HAVING JURISDICTION.
3. CONTRACTOR SHALL USE PRESSURE TREATED LUMBER WHERE REQUIRED IN COMPLIANCE WITH LOCAL CODES AND AUTHORITIES HAVING JURISDICTION.

**NOTES: WEATHER RESISTIVE BARRIER**

1. INSTALL WEATHER RESISTIVE BARRIER IN STRICT COMPLIANCE WITH MANUFACTURERS RECOMMENDATIONS AND DETAILS. USE ONLY APPROVED PRODUCTS AND FASTENING METHODS.
2. REFERENCE LOCAL AND NATIONAL BUILDING CODES AND REGULATIONS PRIOR TO INSTALLATION. INSTALL PER GOVERNING CODE REQUIREMENTS. NOTIFY ARCHITECT IF ANY CONFLICT ARISES.

**NOTES: AIR BARRIER / VAPOR BARRIER**

IN COMPLIANCE WITH ENERGY CODE REQUIREMENTS, PROVIDE CONTINUOUS, SOLID AIR BARRIERS OVER ALL INSULATION SURFACES. PROVIDE AIR BARRIERS BEHIND ALL CONCEALED AREAS, SUCH AS TUBS, DROPPED CEILING AREAS, SOFFITS DECORATIVE BEAMS AND STRUCTURAL BEAMS ADJACENT TO THERMAL ENVELOPE WALLS. THESE BARRIERS SHOULD BE COORDINATED AND INSTALLED AT THE TIME OF FRAMING AND MUST BE CONTINUOUS AND UNBROKEN. PROVIDE AIR BARRIERS AND INSULATION AT THE THERMAL ENVELOPE LINE OF ALL CHIMNEYS. AIR BARRIERS CAN BE 6 MIL POLYFILM PLASTIC, DRYWALL OR SOLID SHEATHING. COORDINATE ALL AIR BARRIERS WITH VAPOR BARRIERS AND INSULATION REQUIREMENTS AS OUTLINED IN DIVISION VII. PROVIDE AND SCHEDULE A PRE-MEETING WITH THE ARCHITECT AND FRAMER TO REVIEW THESE REQUIREMENTS PRIOR TO ANY FRAMING WORK.

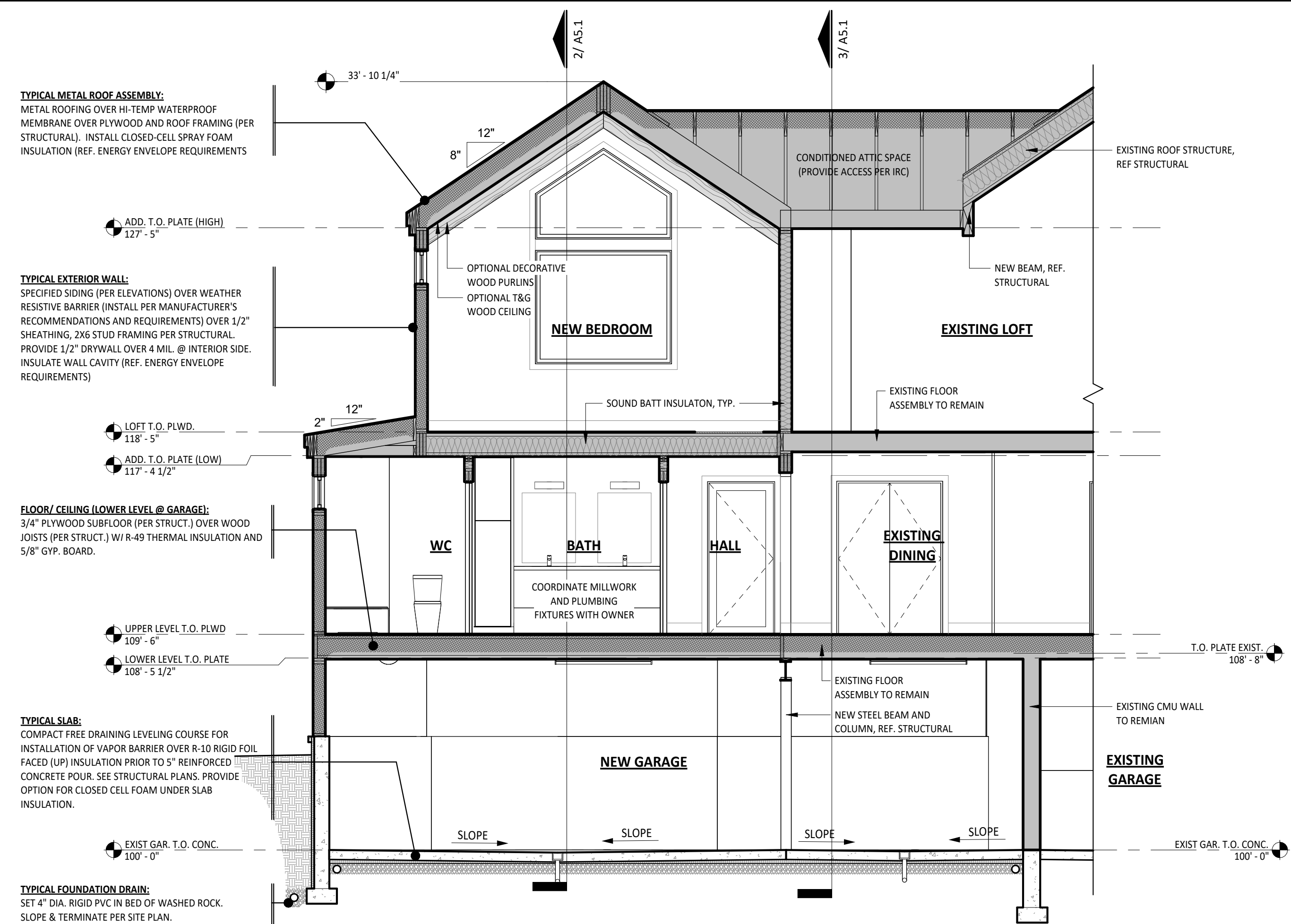

**1 SECTION A**  
1/4" = 1'-0"

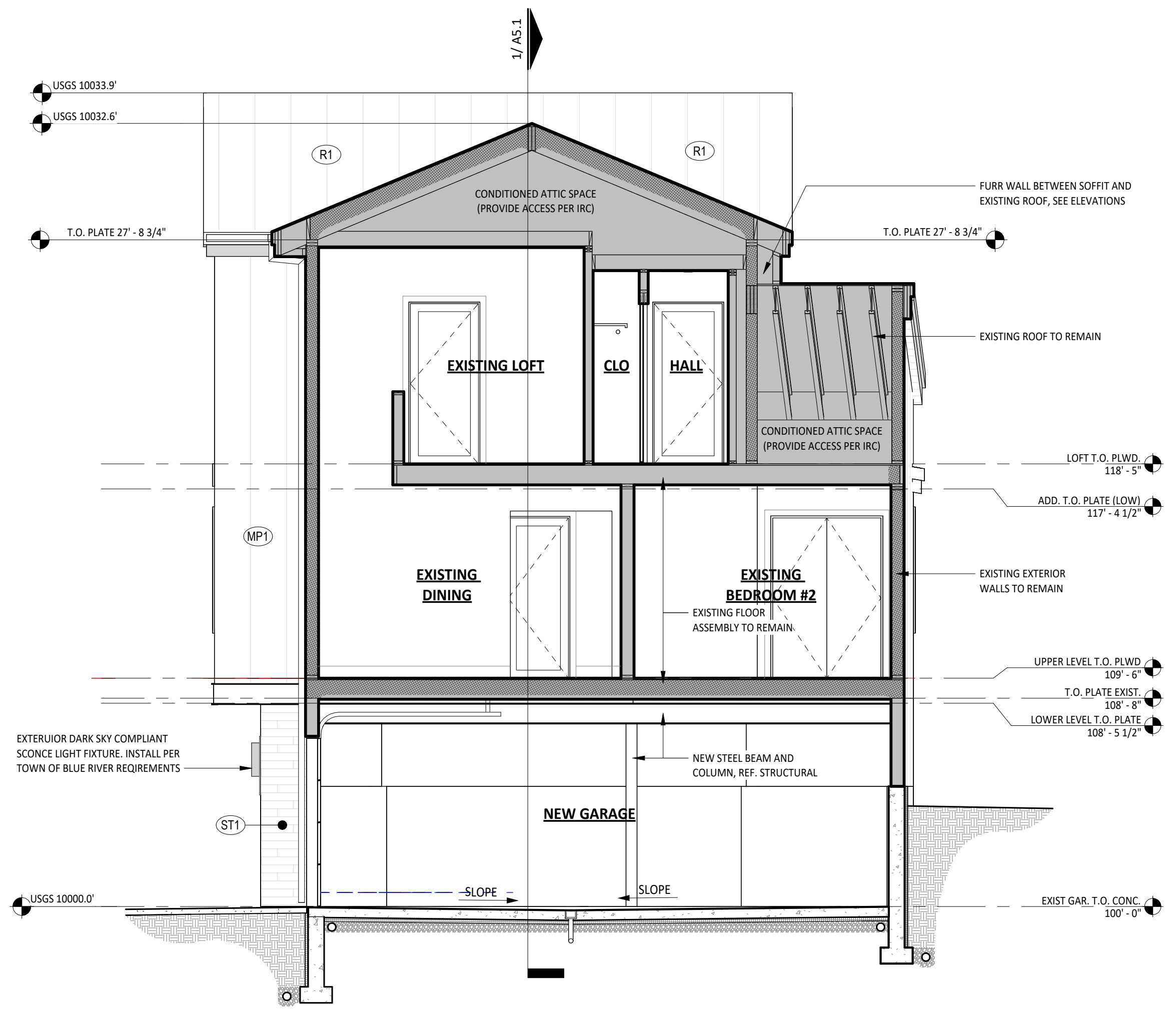

**3 SECTION C**  
1/4" = 1'-0"

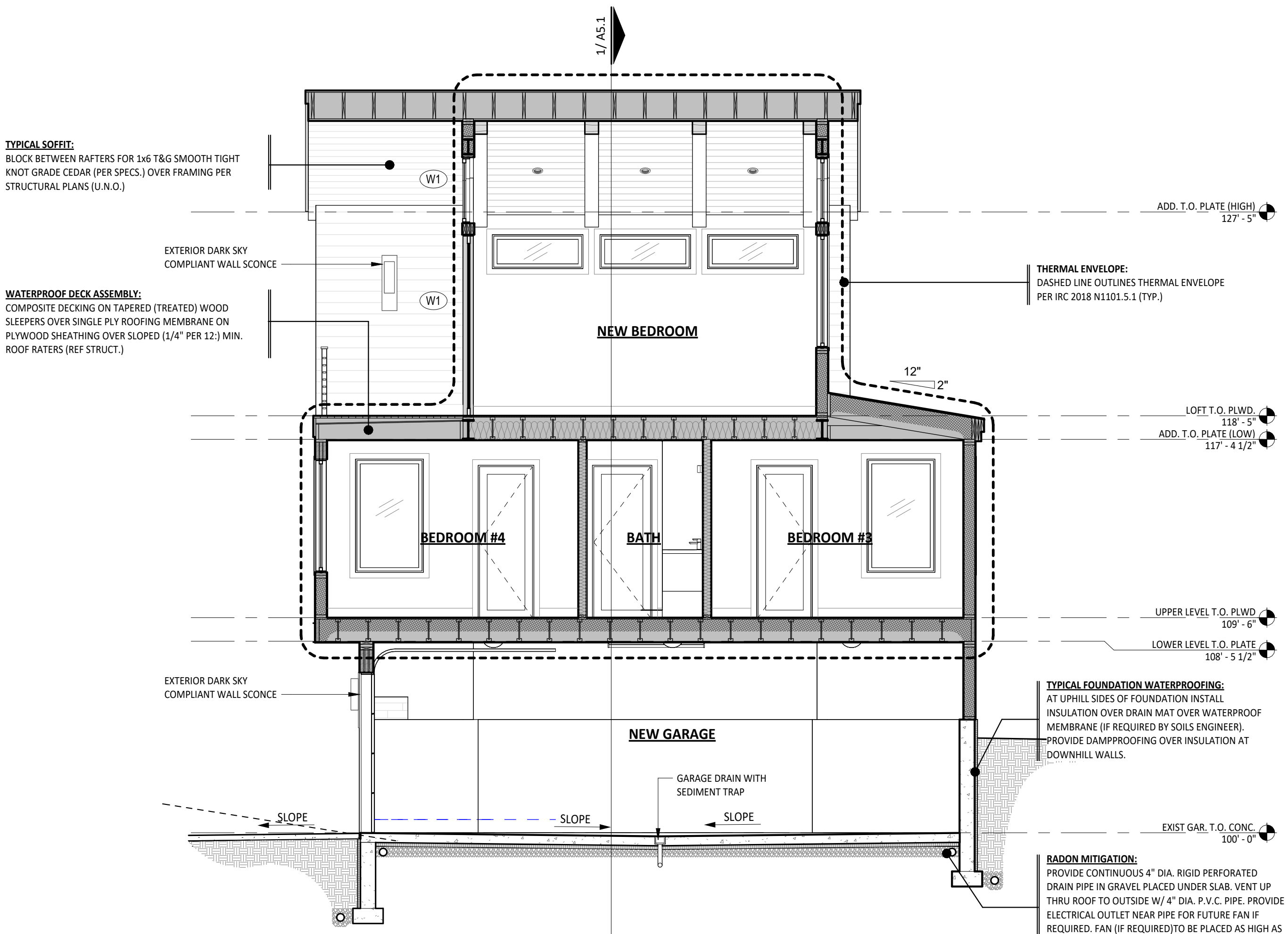

**2 SECTION B**  
1/4" = 1'-0"



**ROOTED**  
ARCHITECTURE

SEAL:

NOT FOR CONSTRUCTION

DRAWINGS AND SPECIFICATIONS AS INSTRUMENTS OF SERVICE ARE THE PROPERTY OF THE ARCHITECT. THEY SHALL NOT BE USED, TRANSFERRED, OR SOLD FOR USE EXCEPT BY AN AGREEMENT IN WRITING FROM THE ARCHITECT.

**FITZGERALD ADDITION**

34 RUSTIC TERRACE  
BLUE RIVER, CO

No.	Date	Revisions

Project No: 2023-16  
Stage: FINAL REVIEW SET  
Date: 05/02/2024  
Scale: As indicated

DRAWING TITLE:

**POWER PLANS**

DRAWING NO:

**A6.1**

- NOTES: LOW VOLTAGE**
- ROUGH-IN PHONE, INTERNET, AND CATV FROM SITE UTILITY LOCATION TO MECHANICAL / AV ROOM.
  - PROVIDE PHONE, SECURITY, AND DATA BOARDS IN MECHANICAL / AV ROOM.
  - PROVIDE CONDUIT OR STRUCTURED CABLE TO SOUTH ROOF FOR SATELLITE DISH WIRING OPTION.
  - COORDINATE PHONE LINE WITH SECURITY SYSTEM REQUIREMENTS.
  - COORDINATE CATV / DATA / LIGHTING / HOME COMPUTER CONTROL REQUIREMENTS WITH OWNER.
  - COORDINATE HOME AUTOMATION / MECHANICAL CONTROLS INTERFACE AS REQUIRED BY OWNER.
  - COORDINATE SOUND SYSTEM, HOME AUTOMATION AND ALL OTHER LOW VOLTAGE SYSTEMS PER OWNER REQUIREMENTS.

- NOTES: WINDOW SHADES**
- PROVIDE OPTION FOR MOTORIZED WINDOW SHADE SYSTEMS WHERE INDICATED ON ELECTRICAL PLANS. CONFIRM SHADE LOCATIONS WITH OWNER PRIOR TO ELECTRICAL ROUGH-IN. COORDINATE WITH ELECTRICAL AND HOME AUTOMATION WORK. ALL SHADES TO BE INSTALLED IN RECESSED WINDOW POCKETS WHERE REQUIRED.

- NOTES: HOME AUTOMATION**
- PRIOR TO ANY ELECTRICAL WORK CONFIRM SCOPE OF SMART HOME CONTROL AND AUTOMATION REQUIREMENTS WITH OWNER. WORK TO INCLUDE PROCESSOR USER INTERFACE, SCOPE OF DEVICES AND/OR SYSTEMS TO BE CONTROLLED. SCOPE OF CABLE OR WIRELESS LINKS AND POSSIBLE EMERGENCES BACKUP POWER.
- SYSTEMS TO INCLUDE SECURITY, ENTERTAINMENT, BUILDING SERVICES, AND ENVIRONMENTAL COMPONENTS.

**ELECTRICAL DEVICE LEGEND**

	DOUBLE RECEPTACLE OUTLET LEGRAND "RADIANT" OR SIMILAR - WHITE
	220V RECEPTACLE OUTLET WHITE
	DOUBLE RECEPTACLE OUTLET W/ GROUND FAULT INTERRUPTER LEGRAND "RADIANT" OR SIMILAR - WHITE
	DOUBLE RECEPTACLE OUTLET W/ GROUND FAULT INTERRUPTER INSTALL WATERPROOF COVER FOR EXTERIOR USE
	FOURPLEX RECEPTACLE OUTLET LEGRAND "RADIANT" OR SIMILAR - WHITE
	DOUBLE RECEPTACLE FLOOR OUTLET INSTALL RECESSED FLOOR OUTLET COVER
	TEL / DATA FLOOR OUTLET
	RECESSED JUNCTION BOX COORDINATE LOCATION WITH EQUIPMENT MANUFACTURER
	TEL / DATA OUTLET CAT 6 OUTLET 14" AFF U.N.O.
	DATA OUTLET CAT 6 OUTLET 14" AFF U.N.O.
	TELEVISION OUTLET PROVIDE RECESSED POWER AND OUTLET FOR WALL MOUNTING WHERE REQUIRED BY OWNER

- NOTES: MECHANICAL / ELECTRICAL**
- ALL MECHANICAL AND ELECTRICAL WORK SHALL CONFORM TO CURRENT UNIFORM MECHANICAL AND NATIONAL ELECTRIC CODES AND RELATED NFPA REQUIREMENTS.
  - MECHANICAL AND ELECTRICAL INFORMATION SHOWN IS FOR DESIGN INFORMATION PURPOSES ONLY AND IT SHALL BE THE RESPONSIBILITY OF THE MECHANICAL/ELECTRICAL CONTRACTOR(S) TO PROVIDE NECESSARY INFORMATION TO LOCAL BUILDING DEPARTMENT FOR ISSUANCE OF PERMITS FOR CONSTRUCTION.
  - SUBMIT SHOP DRAWINGS AND PRODUCT DATA FOR TO ARCHITECT / OWNER FOR REVIEW.
  - CONTRACTOR SHALL VERIFY AND CONFORM TO PRODUCT INSTALLATION REQUIREMENTS AND SHALL PROVIDE ANY ADDITIONAL BLOCKING/PREP WORK NECESSARY FOR INSTALLATION PER MANUFACTURERS SPECIFICATIONS.
  - ALL RECESSED FIXTURES WITHIN INSULATED FLOOR AND OR CEILING SPACES MUST BE U.L. APPROVED FOR USE IN THESE LOCATIONS.
  - UNLESS OTHERWISE SHOWN, FIXTURES ARE TO BE PLACED CENTERED IN GIVEN SPACE. VERIFY ALL FIXTURE AND OUTLET LOCATIONS WITH DRAWINGS.
  - VERIFY ELECTRICITY, GAS, WATER, AND DRAINAGE REQUIREMENTS OF EQUIPMENT AND PROVIDE ANDY MECHANICAL SERVICE OR VENTING REQUIRED PRIOR TO OPERATION. PLUMB PRESSURE RELIEF OR OVERFLOW VALVES TO A DRAIN. COORDINATE WITH CARPENTRY CONTRACTOR TO PROVIDE PROPER ACCESS PANELS FOR ALL EQUIPMENT.
  - PROVIDE DUCTING TO EXTERIOR FOR ALL REQUIRED MECHANICAL EQUIPMENT. COORDINATE ALL EXTERIOR VENTS AND EXHAUST OUTLETS TO MINIMIZE VISIBILITY.
  - ALL PLUMBING FIXTURES SHALL HAVE WATER SAVING DEVICES AND/OR AERATORS TO COMPLY WITH LOCAL REQUIREMENTS.
  - ALL PENETRATIONS IN CEILINGS AND WALLS MUST BE DAFT STOPPED WITH APPROVED MATERIALS.
  - CHECK DOOR SWINGS BEFORE INSTALLATION OF WALL SWITCHES AND RELOCATE AS REQUIRED. LOCATE LIGHTING FIXTURES IN MECHANICAL ROOMS OR ATTIC SPACES TO CORRELATE WITH EQUIPMENT LOCATIONS AND PROVIDE ADEQUATE ILLUMINATION FOR SERVICING.
  - COORDINATE ELECTRICAL BRANCH CIRCUITS WITH FINAL MECHANICAL EQUIPMENT LOAD. ADVISE ARCHITECT/OWNER OF CHANGES FROM ANY DRAWING REQUIREMENTS PRIOR TO INSTALLATION OF ANY ELECTRICAL OR MECHANICAL WORK.
  - INSTALLATION OF ALL EQUIPMENT SHALL BE IN STRICT ACCORDANCE WITH MANUFACTURER'S INSTALLATION SPECIFICATIONS AND RECOMMENDATIONS. CONTRACTOR SHALL INCLUDE ALL NECESSARY ACCESSORIES AND PIPING FOR A COMPLETE AND OPERATIONAL SYSTEM.

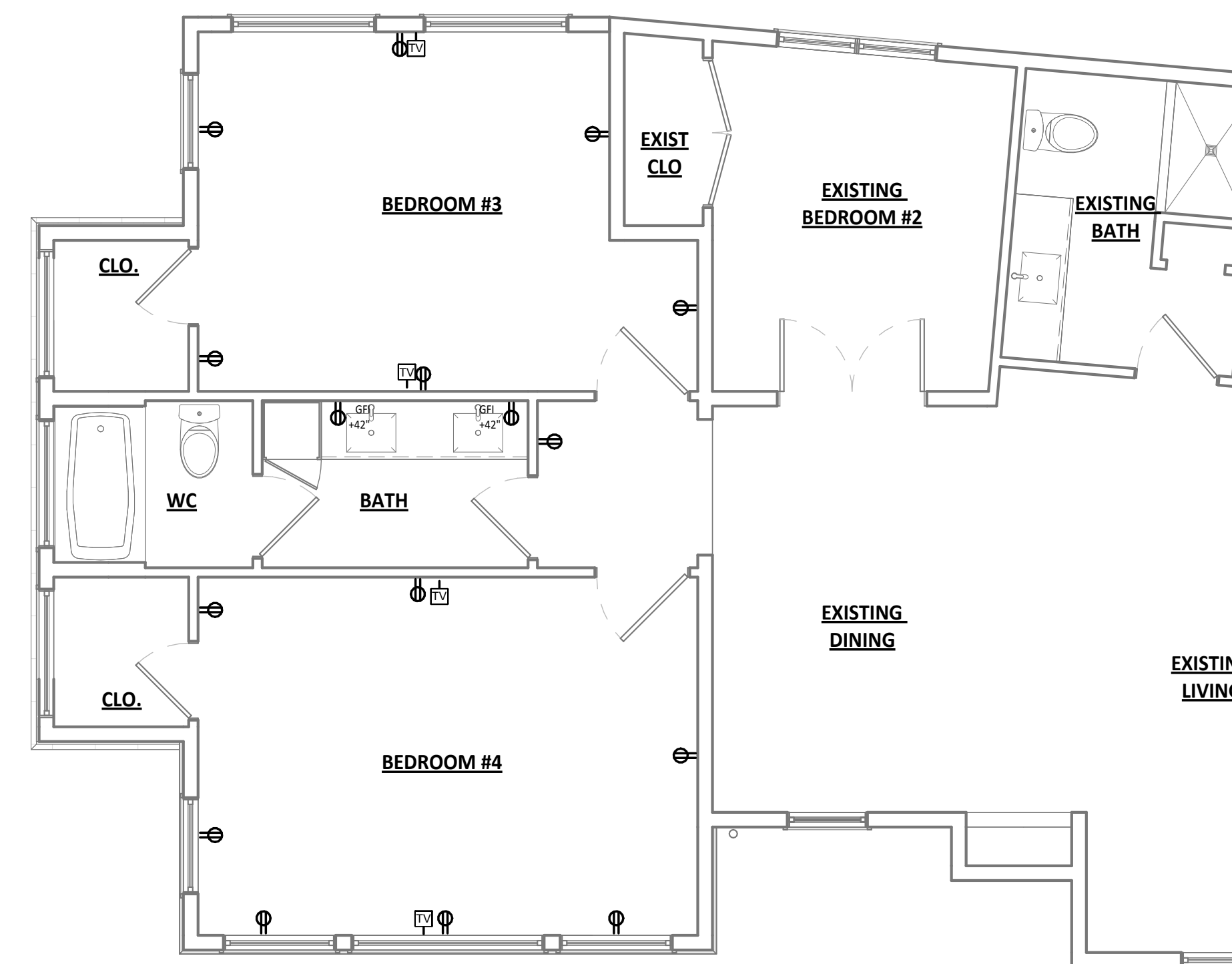

**2 POWER PLAN - MAIN LEVEL**  
1/4" = 1'-0"

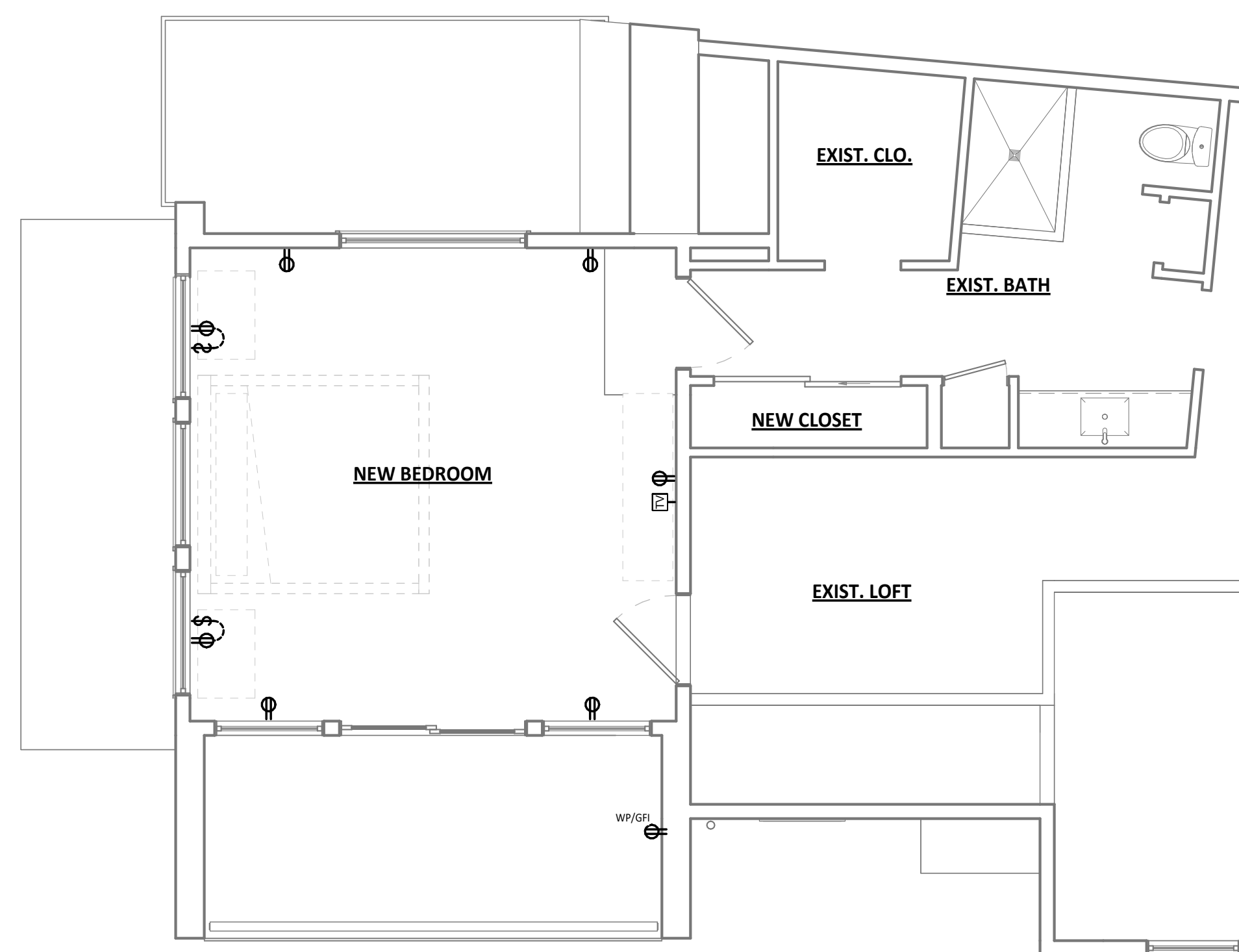

**3 POWER PLAN - LOFT LEVEL**  
1/4" = 1'-0"

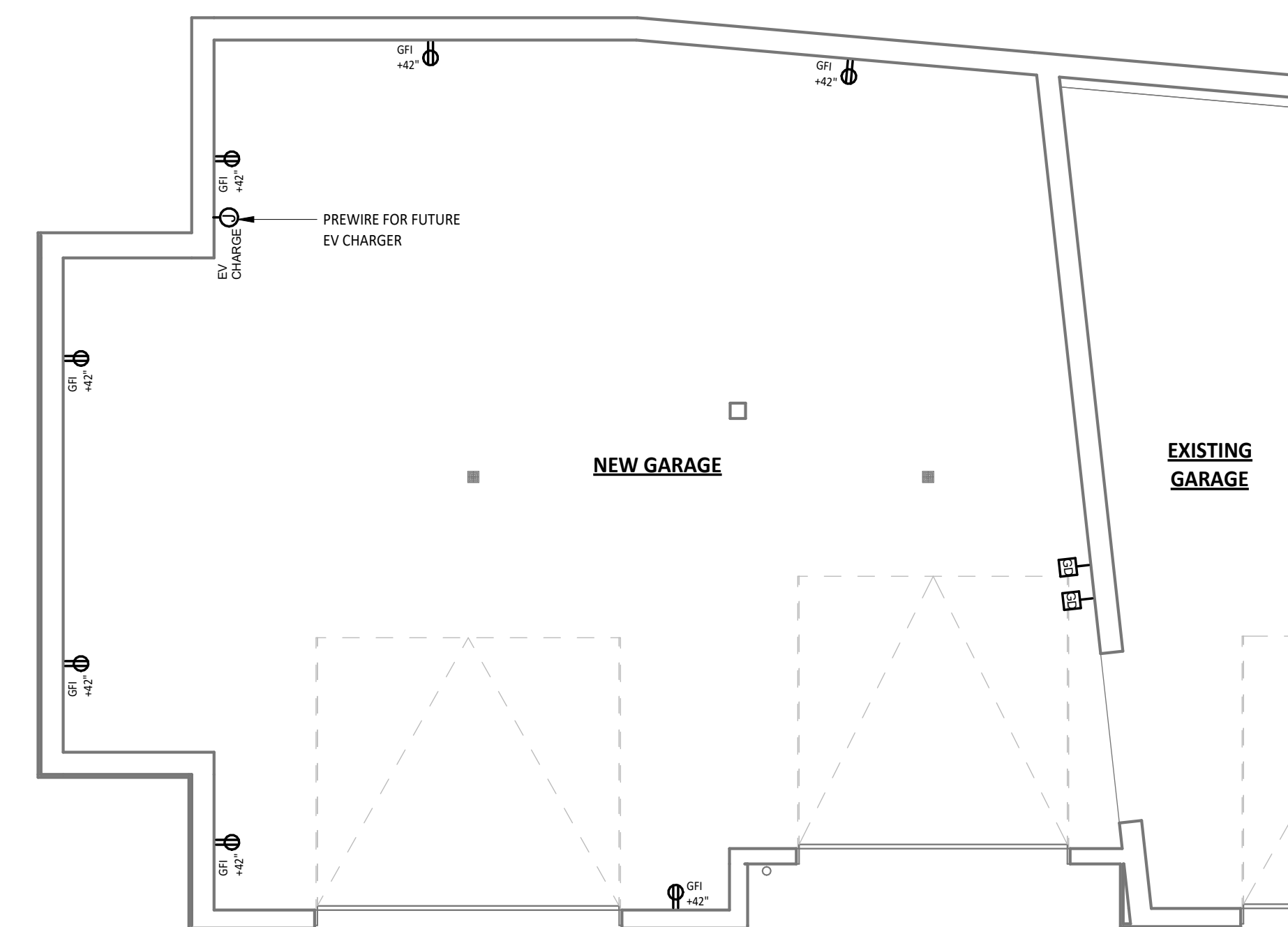

**1 POWER PLAN - LOWER LEVEL**  
1/4" = 1'-0"



ROOTED ARCHITECTURE

SEAL:

NOT FOR CONSTRUCTION

DRAWINGS AND SPECIFICATIONS AS INSTRUMENTS OF SERVICE ARE THE PROPERTY OF THE ARCHITECT. THEY SHALL NOT BE USED, TRANSFERRED, OR SOLD FOR USE EXCEPT BY AN AGREEMENT IN WRITING FROM THE ARCHITECT.

FITZGERALD ADDITION

34 RUSTIC TERRACE  
BLUE RIVER, CO

No. Date Revisions

Project No: 2023-16  
Stage: FINAL REVIEW SET  
Date: 05/02/2024  
Scale: As indicated

DRAWING TITLE:

DETAILS

DRAWING NO:

A7.1

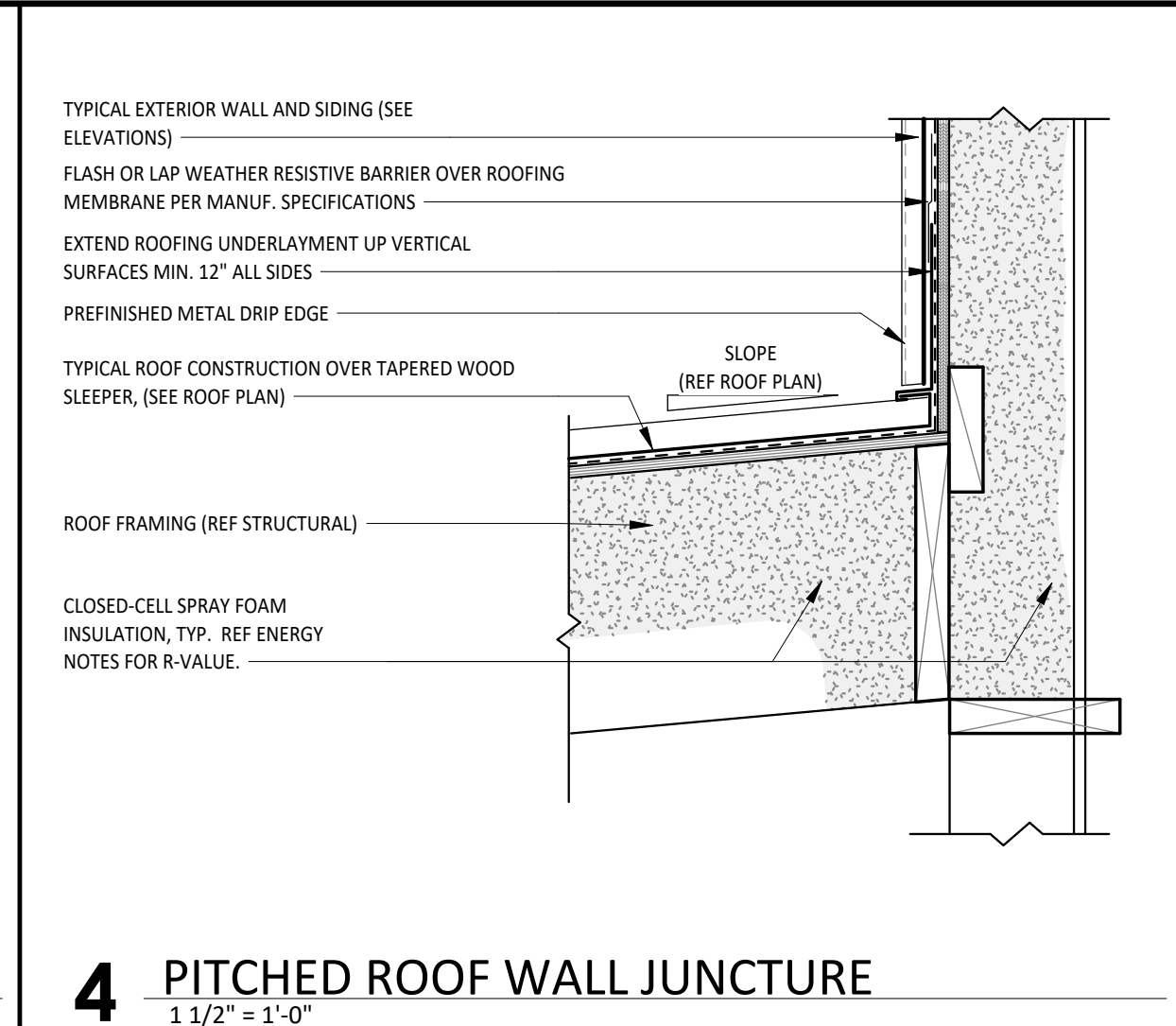

4 PITCHED ROOF WALL JUNCTURE  
1 1/2" = 1'-0"

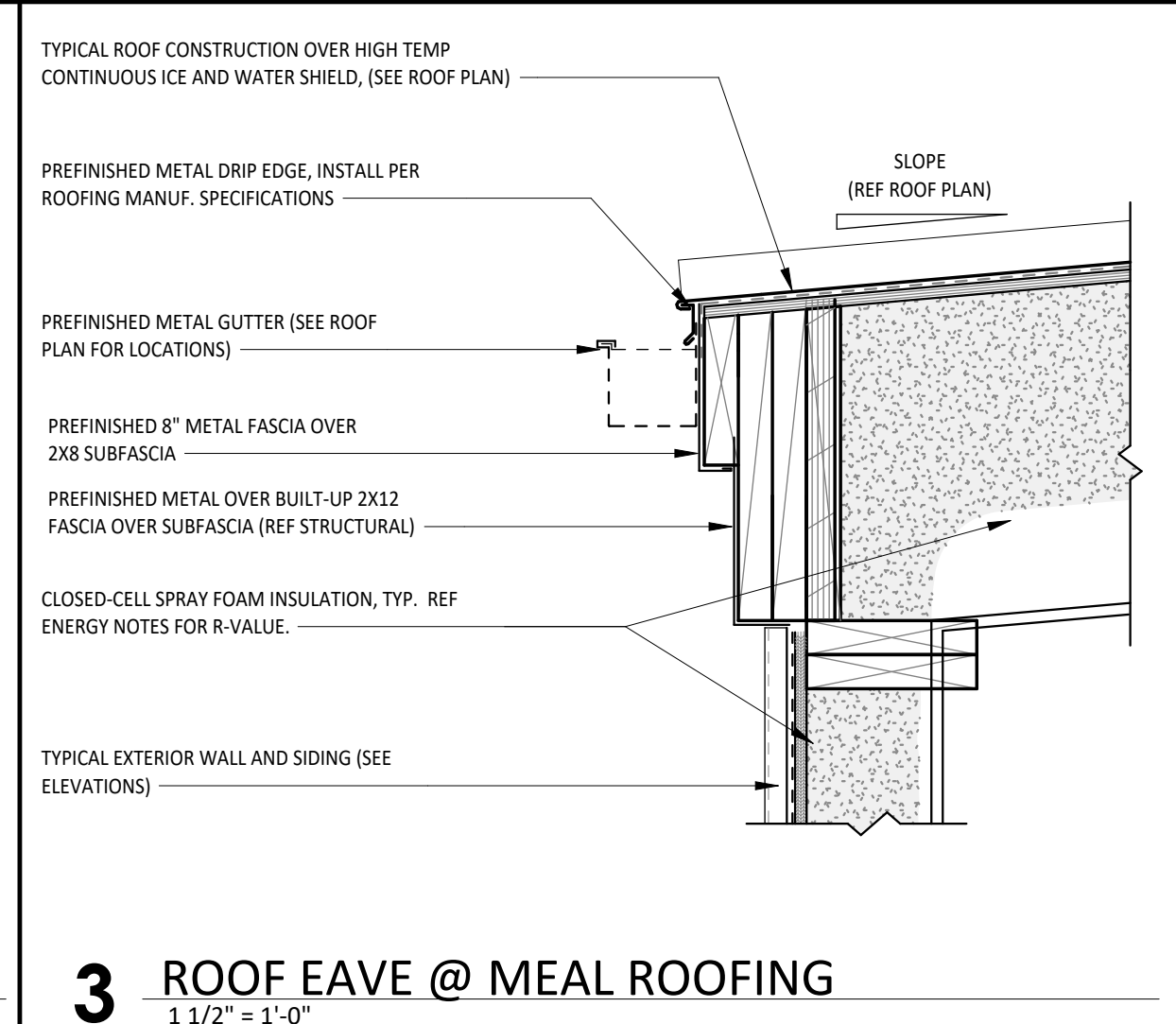

3 ROOF EAVE @ MEAL ROOFING  
1 1/2" = 1'-0"

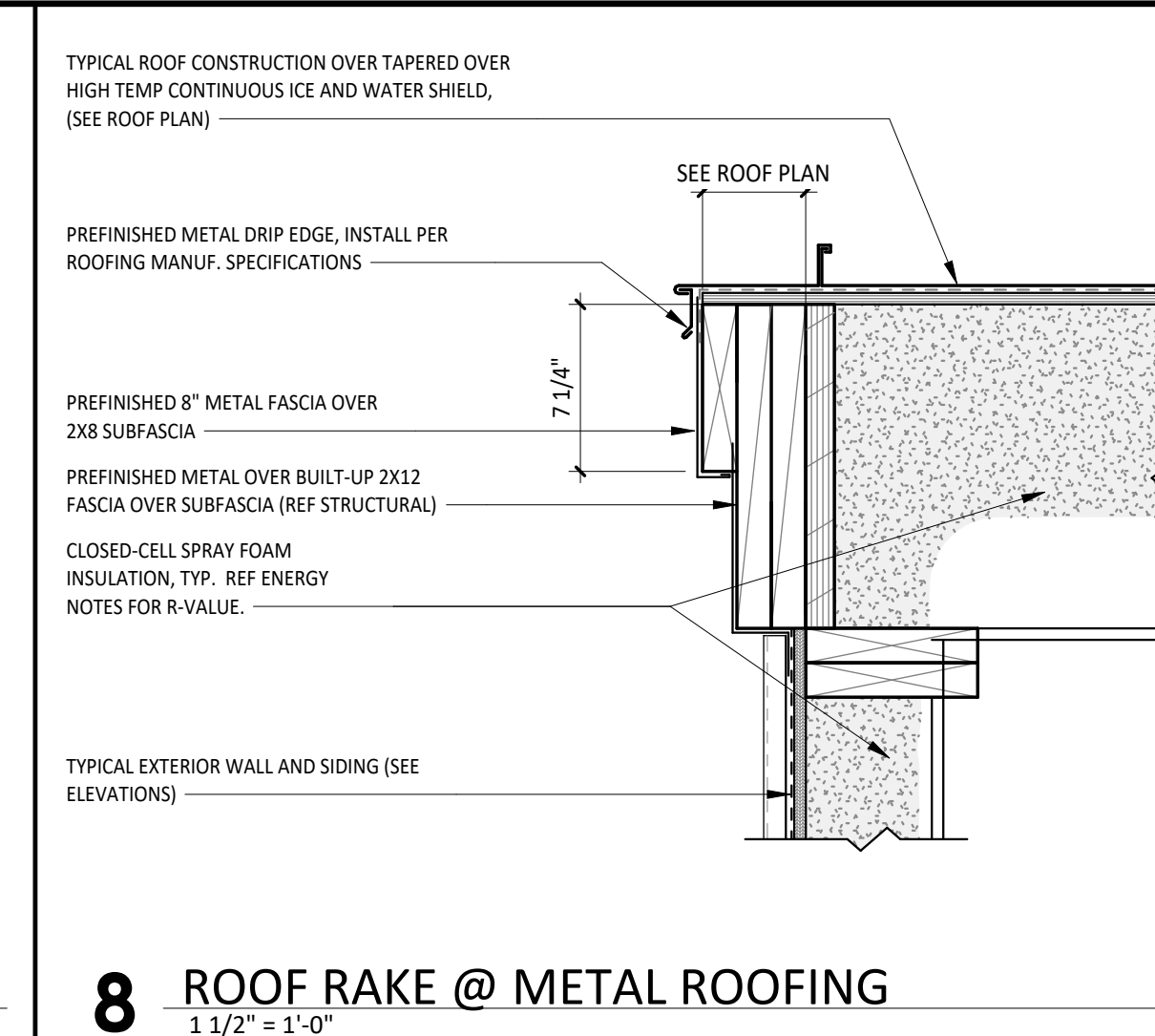

8 ROOF RAKE @ METAL ROOFING  
1 1/2" = 1'-0"

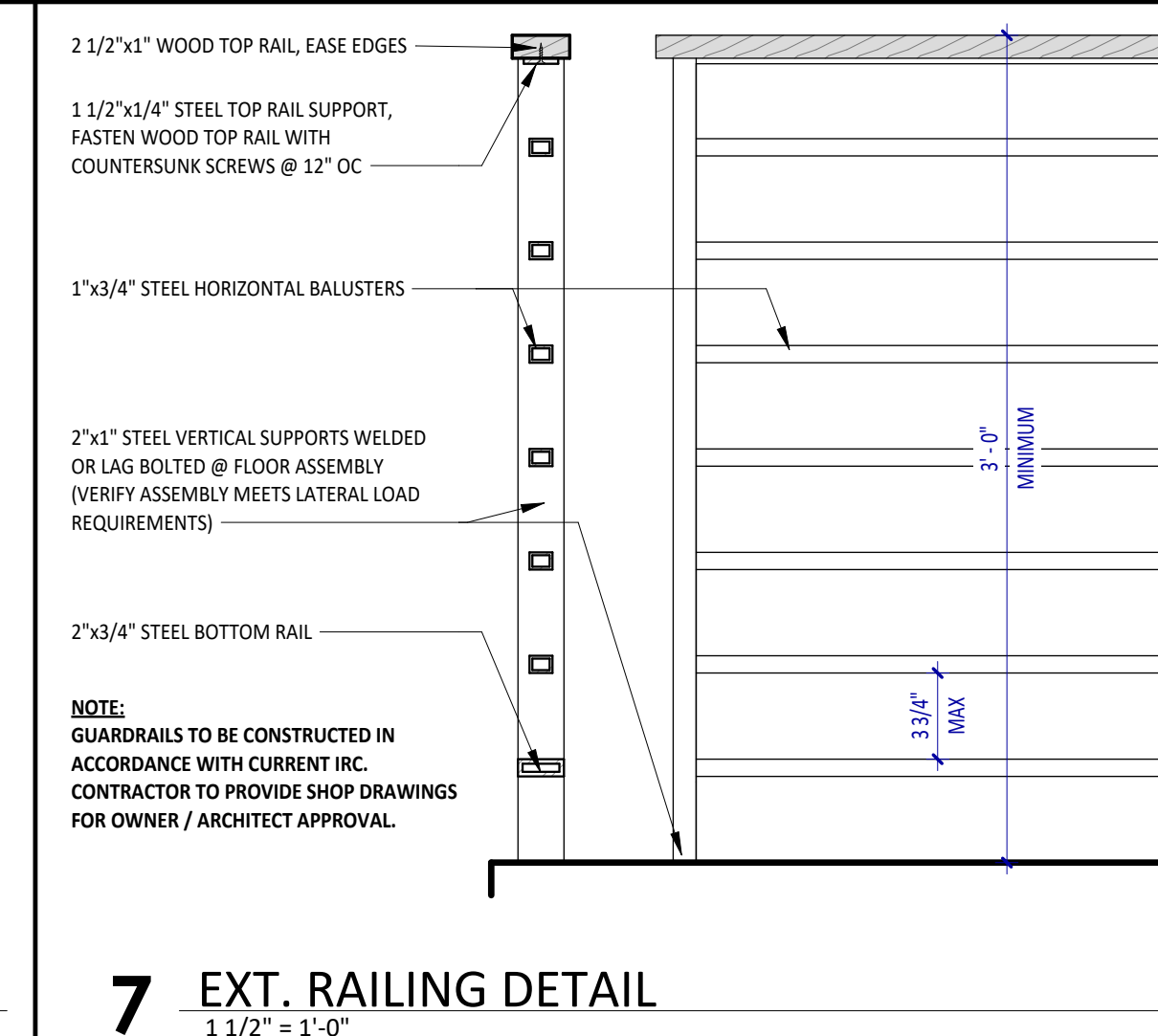

7 EXT. RAILING DETAIL  
1 1/2" = 1'-0"

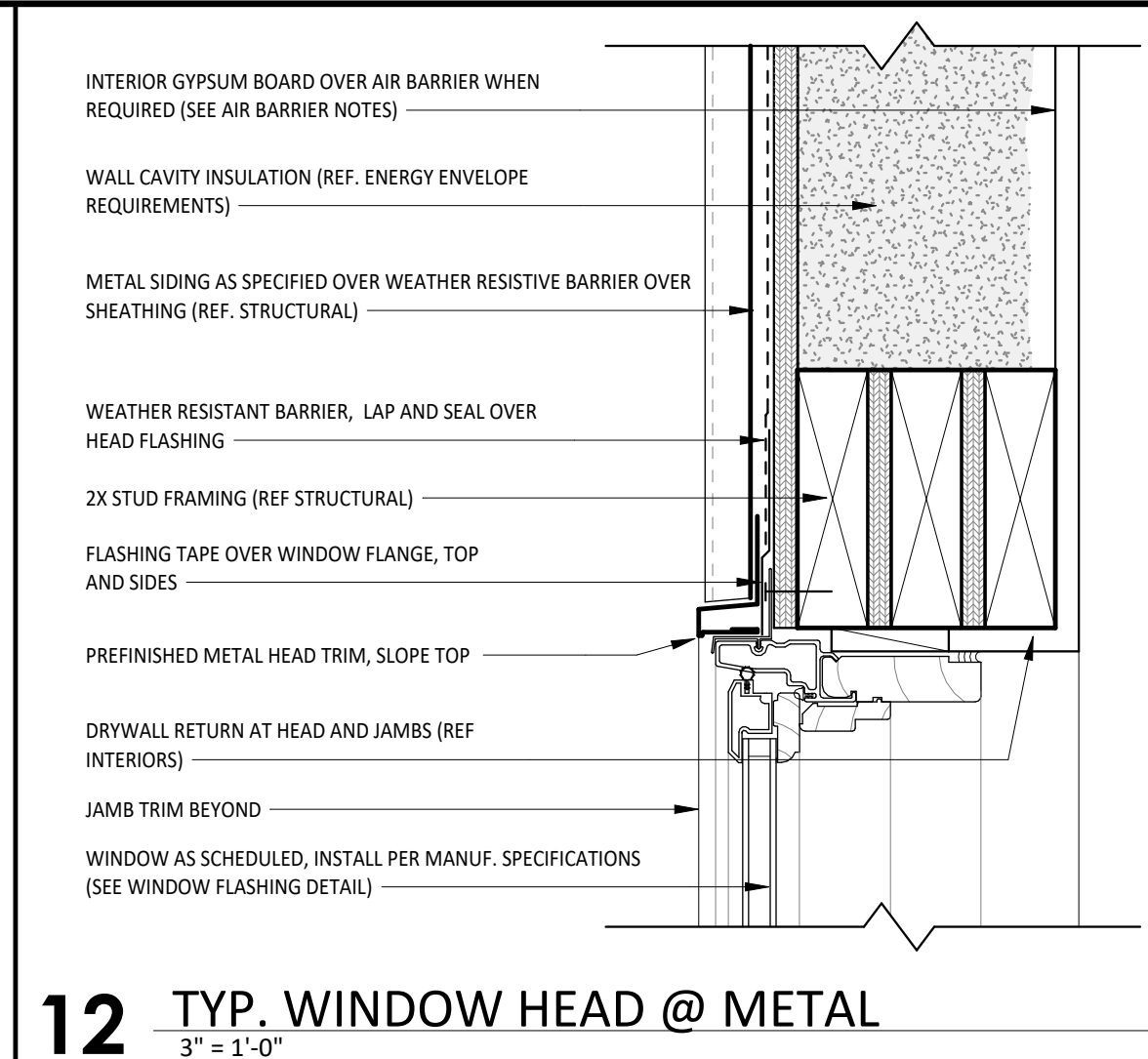

12 TYP. WINDOW HEAD @ METAL  
3" = 1'-0"

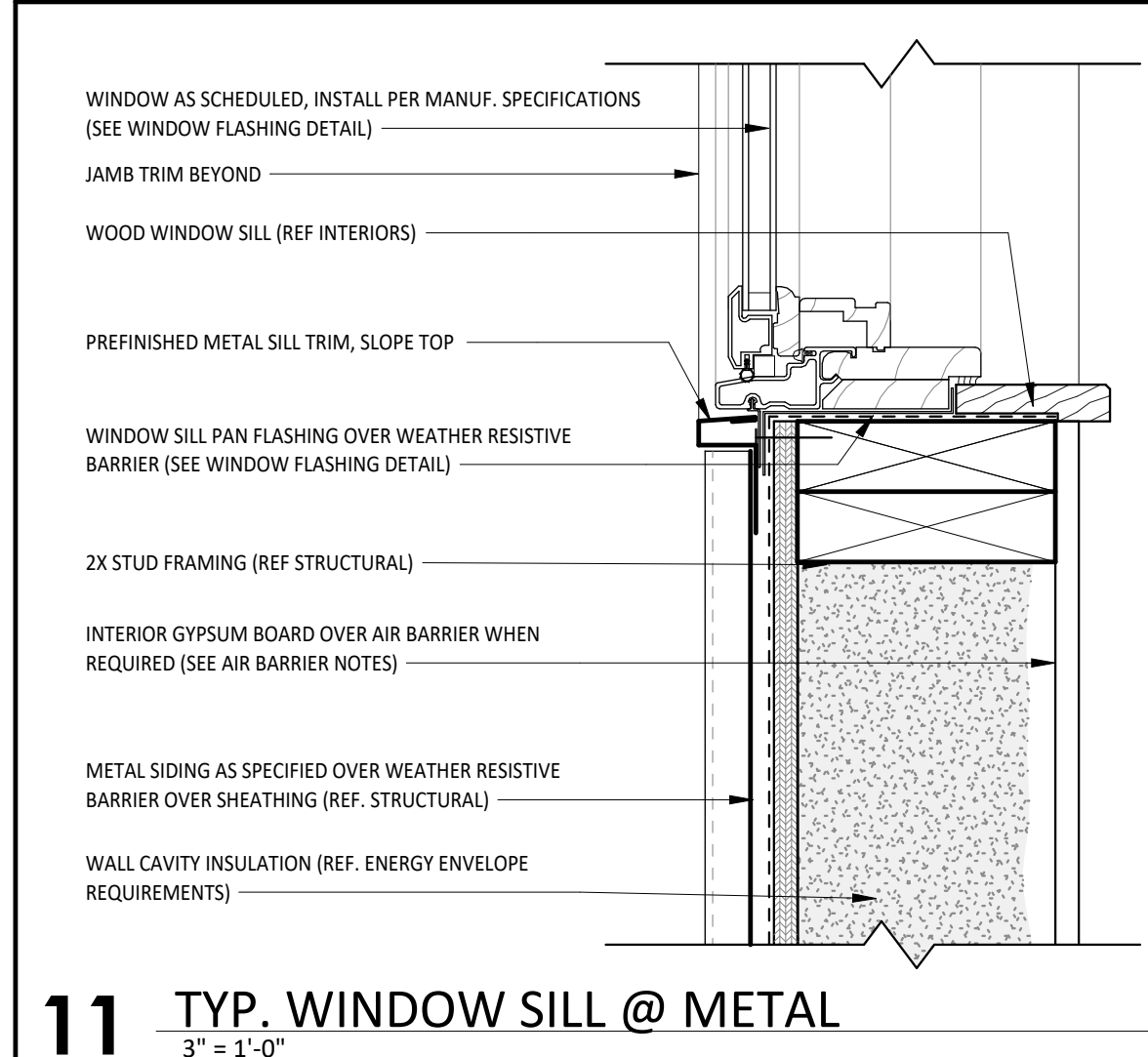

11 TYP. WINDOW SILL @ METAL  
3" = 1'-0"

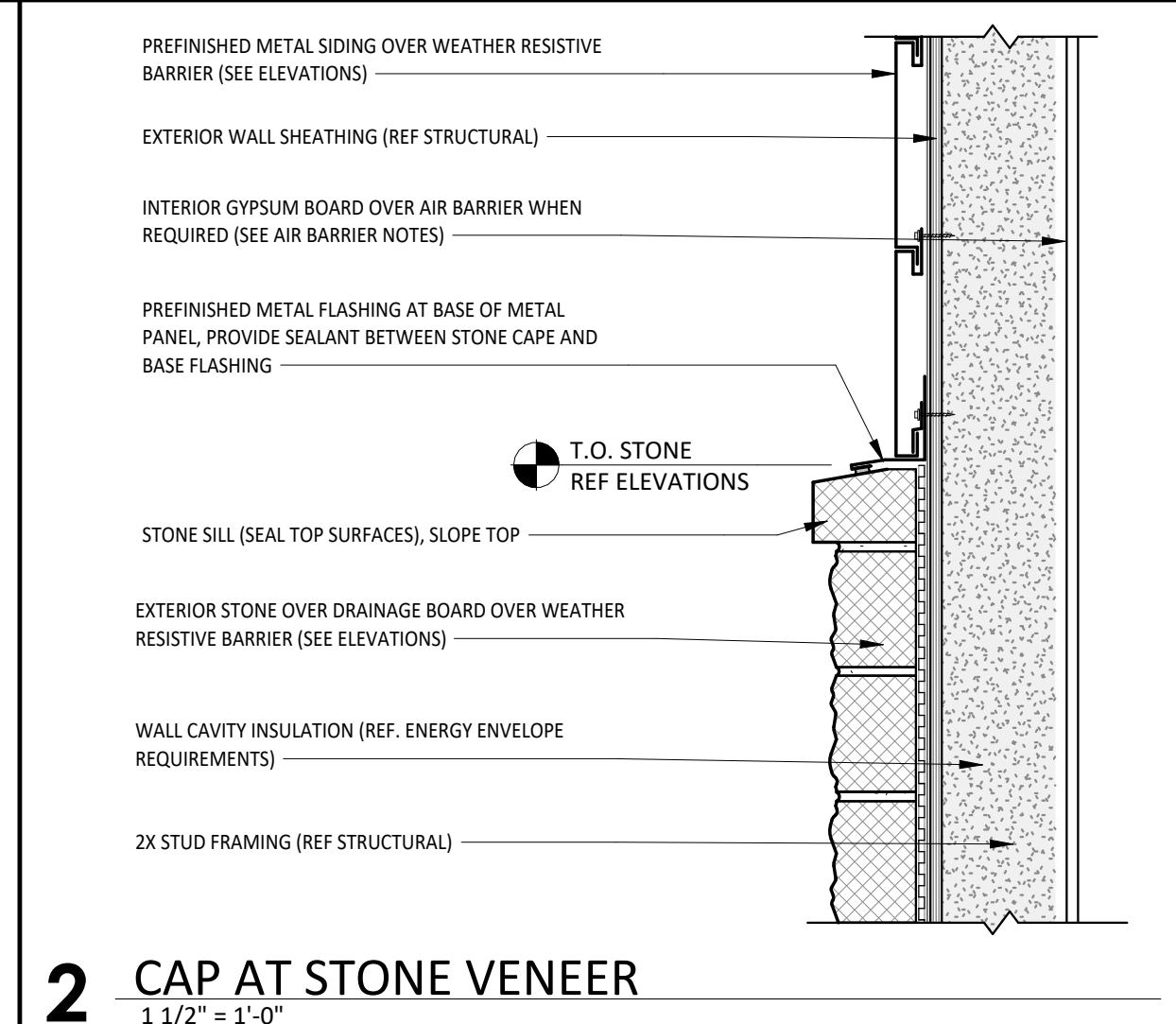

2 CAP AT STONE VENEER  
1 1/2" = 1'-0"

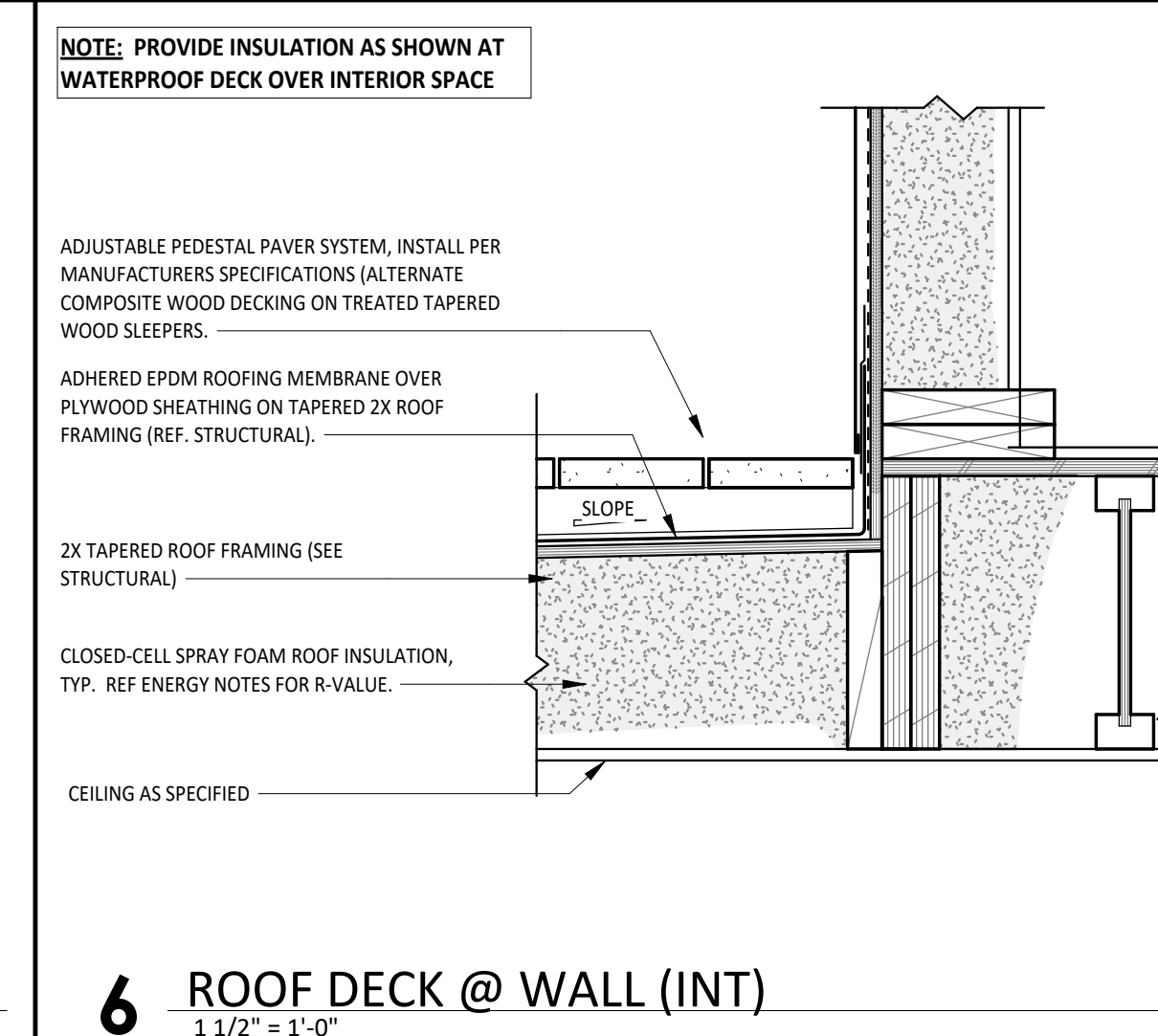

6 ROOF DECK @ WALL (INT)  
1 1/2" = 1'-0"

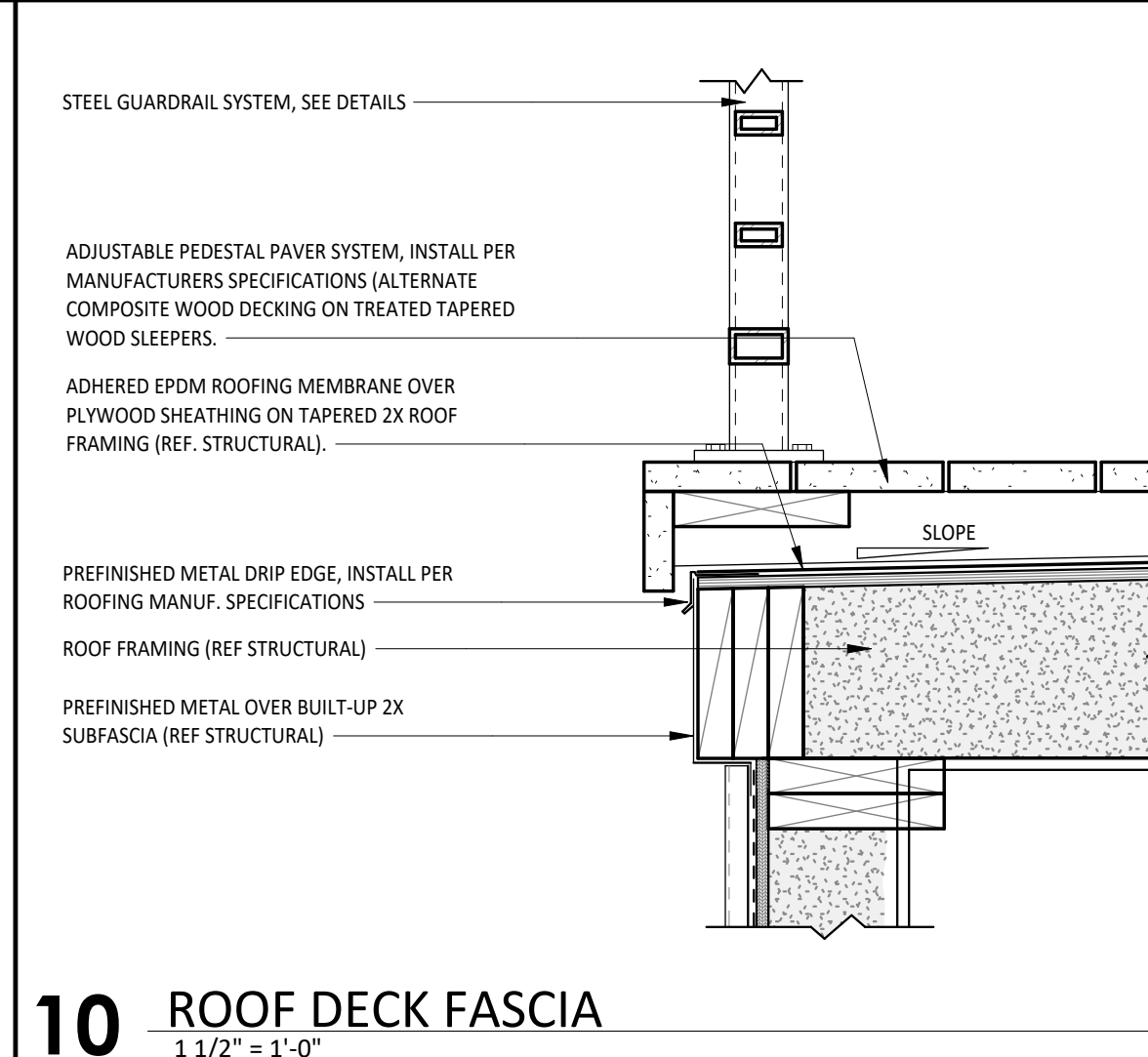

10 ROOF DECK FASCIA  
1 1/2" = 1'-0"

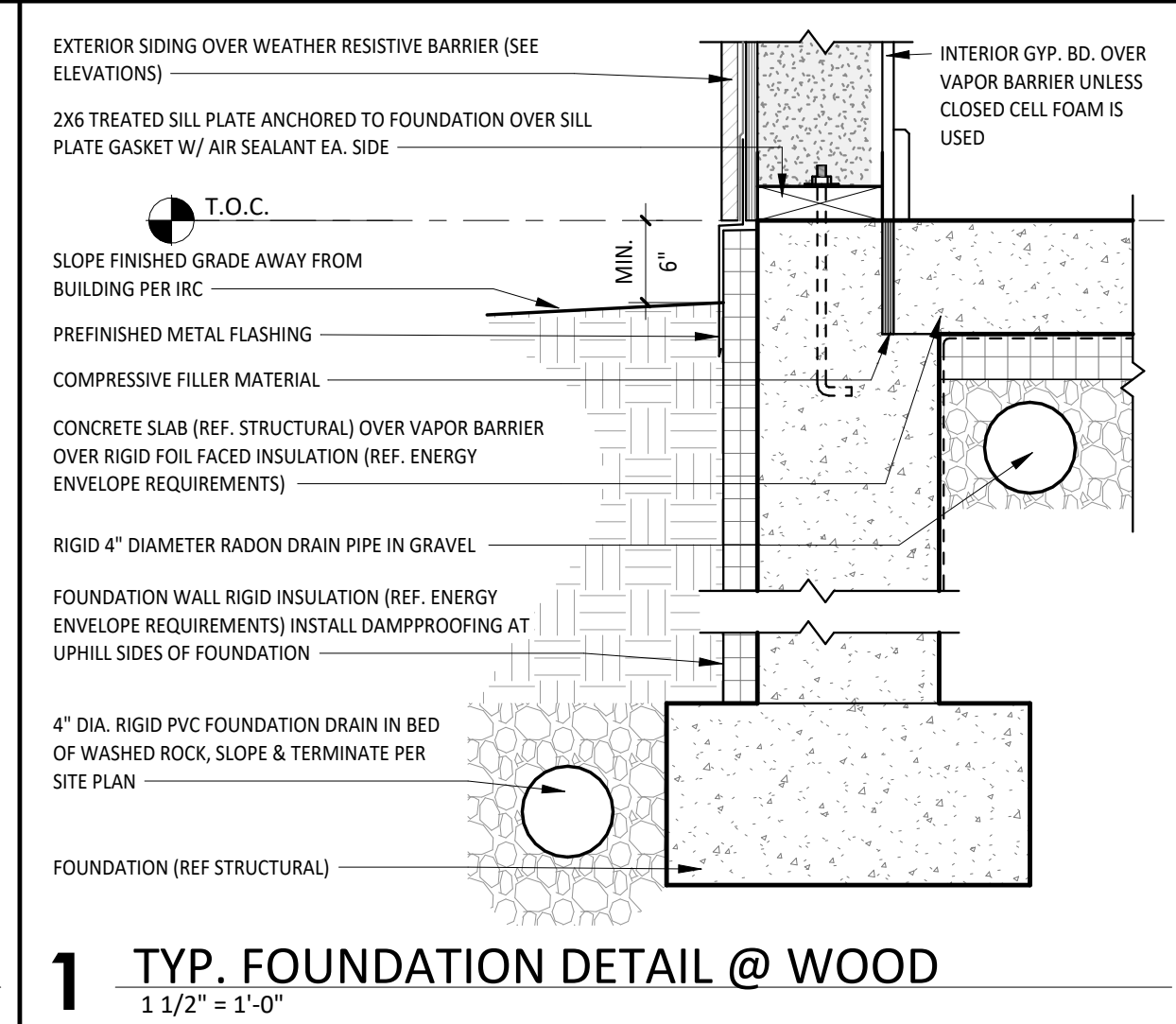

1 TYP. FOUNDATION DETAIL @ WOOD  
1 1/2" = 1'-0"

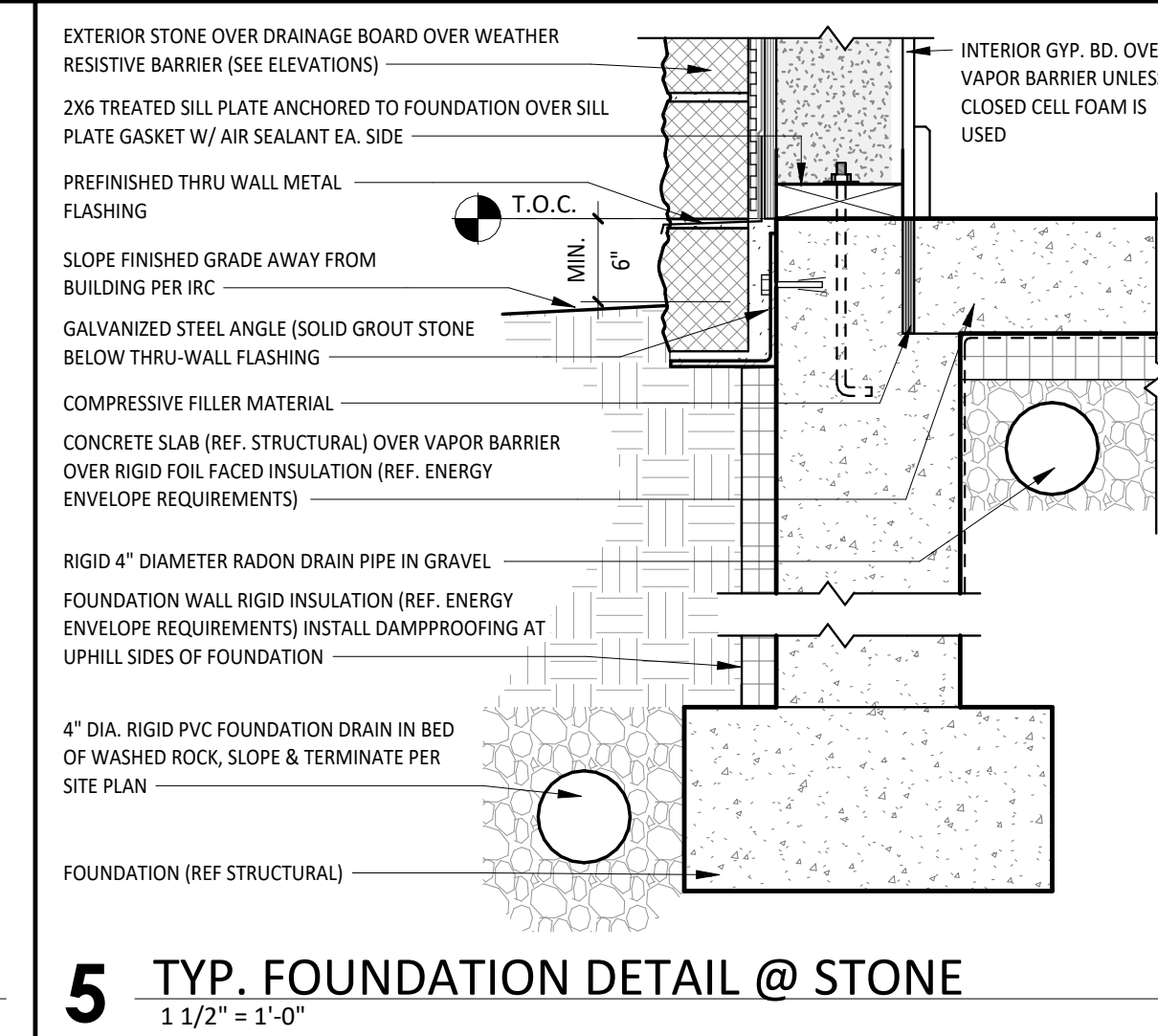

5 TYP. FOUNDATION DETAIL @ STONE  
1 1/2" = 1'-0"

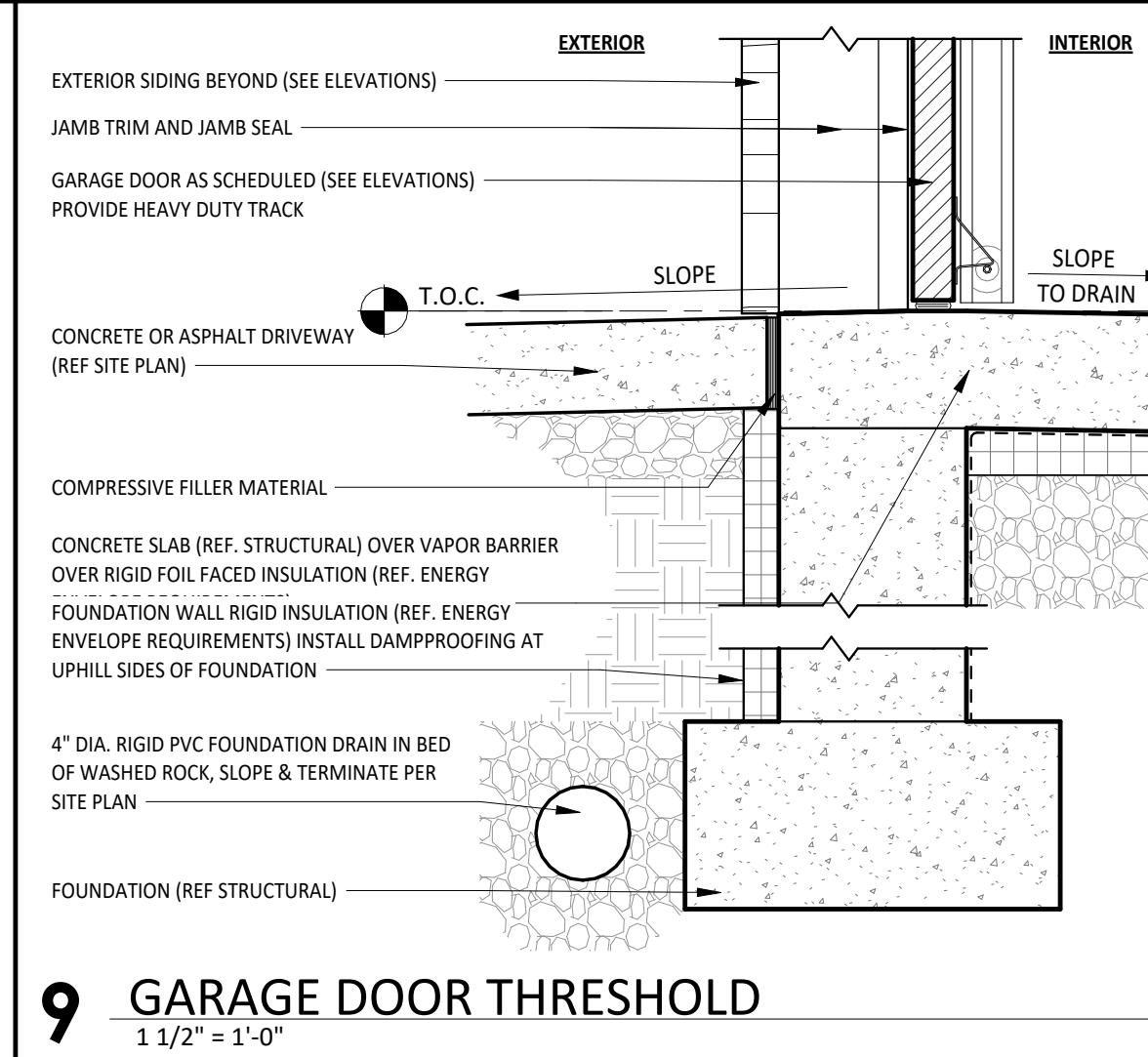

9 GARAGE DOOR THRESHOLD  
1 1/2" = 1'-0"

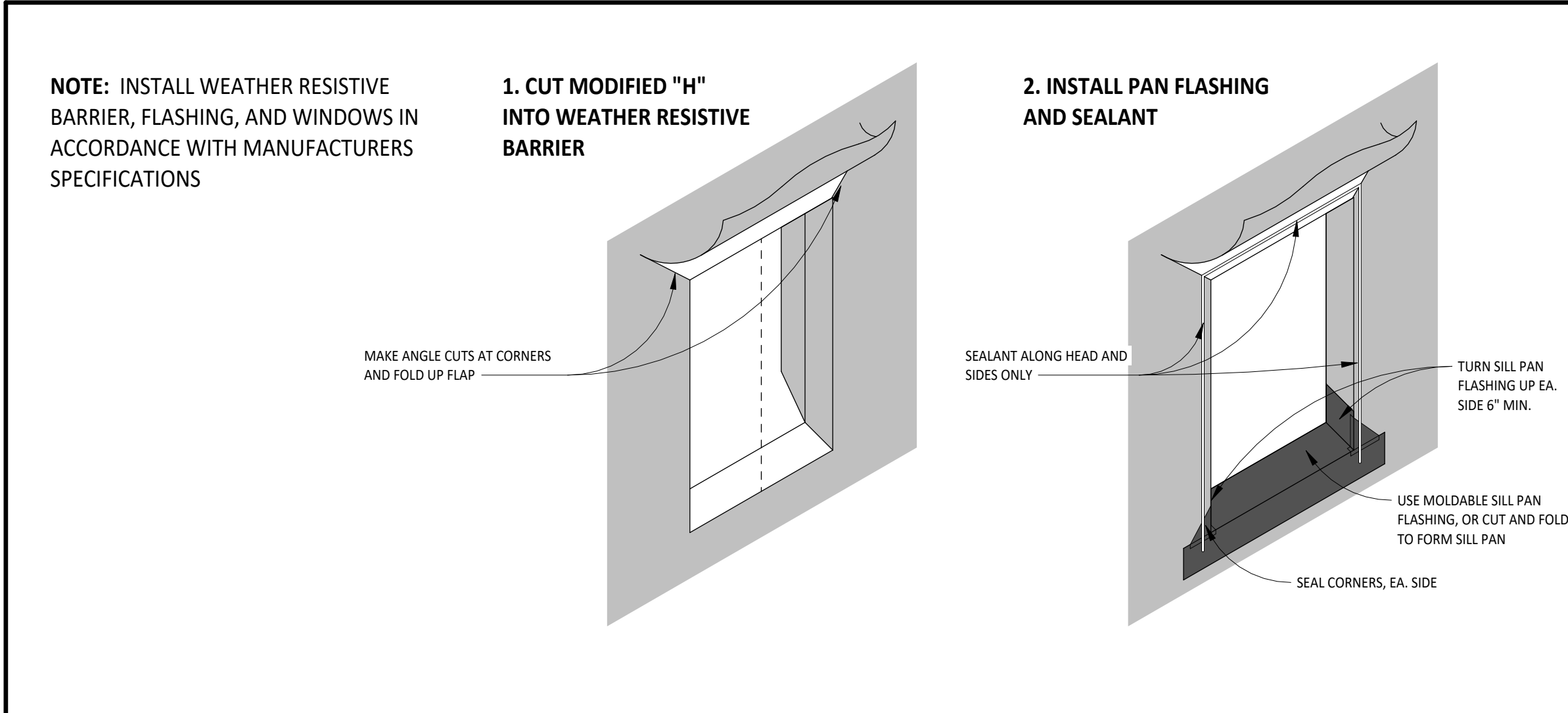

1. CUT MODIFIED "H" INTO WEATHER RESISTIVE BARRIER

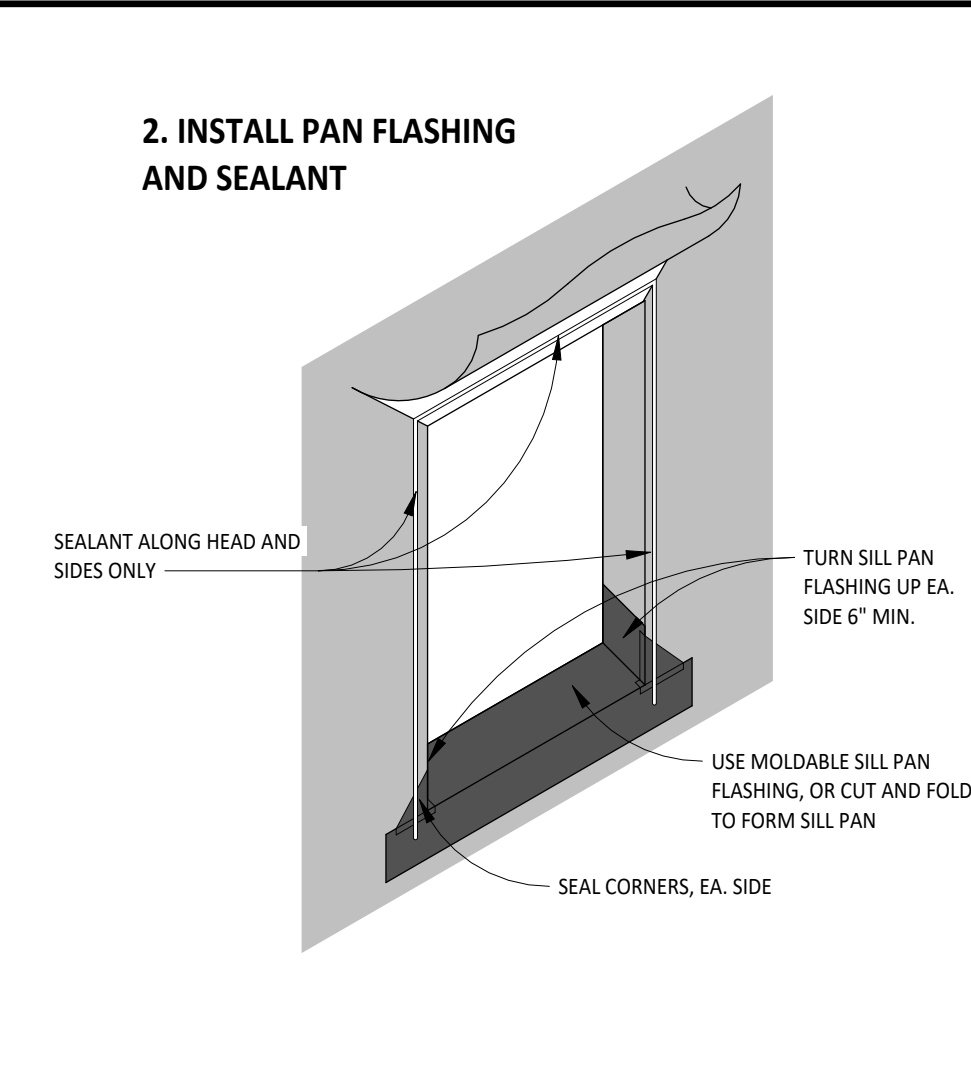

2. INSTALL PAN FLASHING AND SEALANT

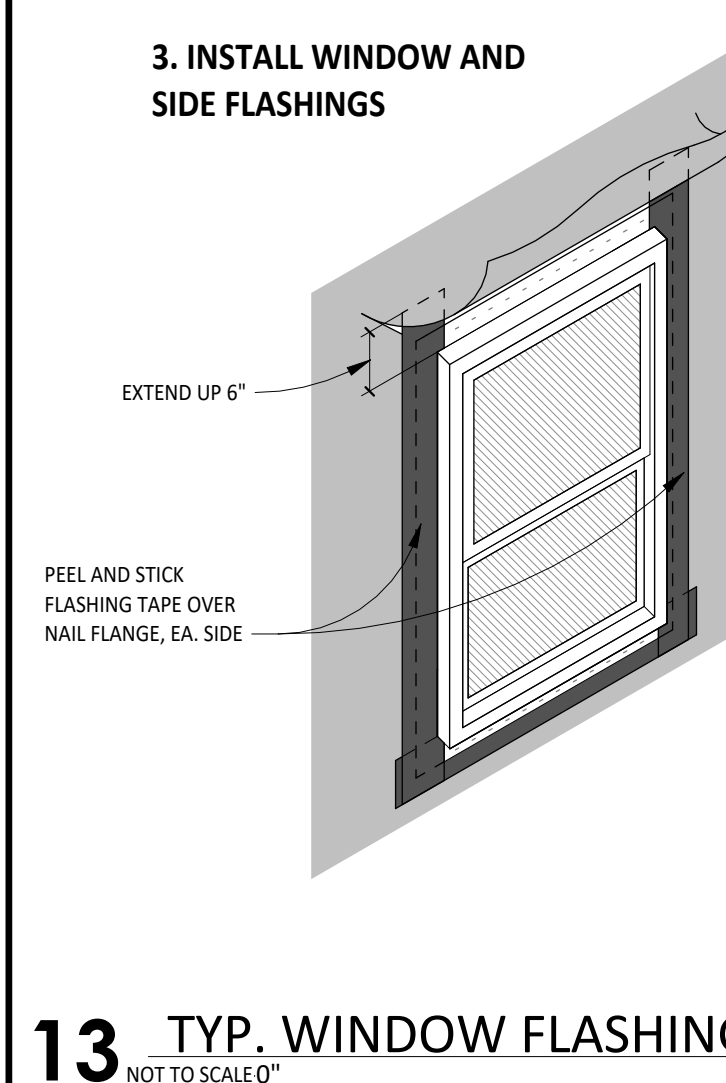

3. INSTALL WINDOW AND SIDE FLASHINGS

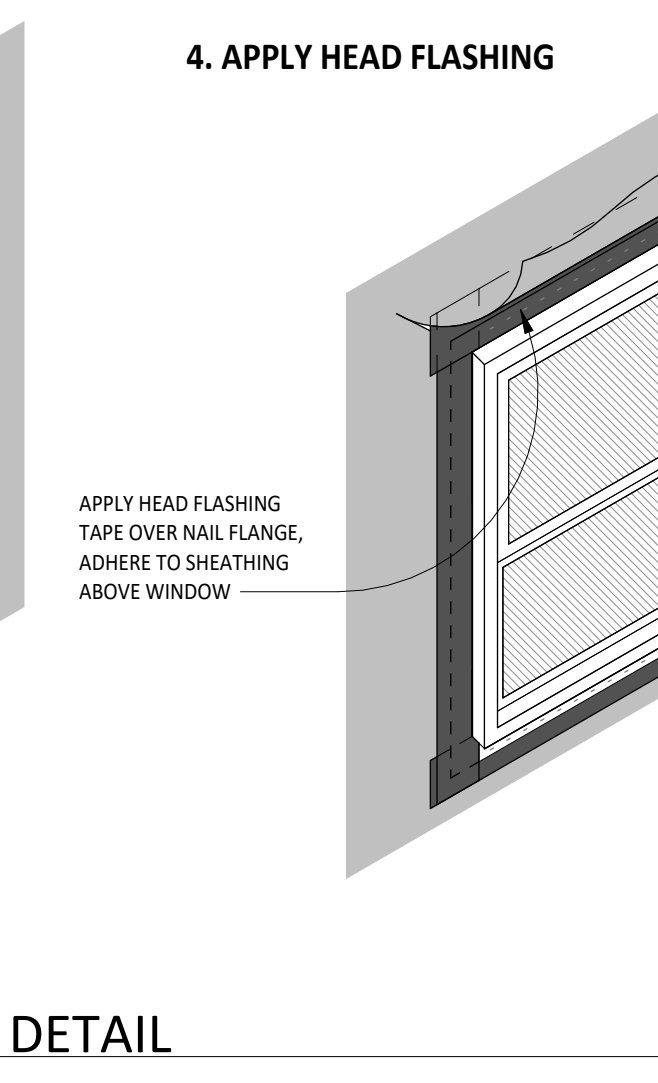

4. APPLY HEAD FLASHING

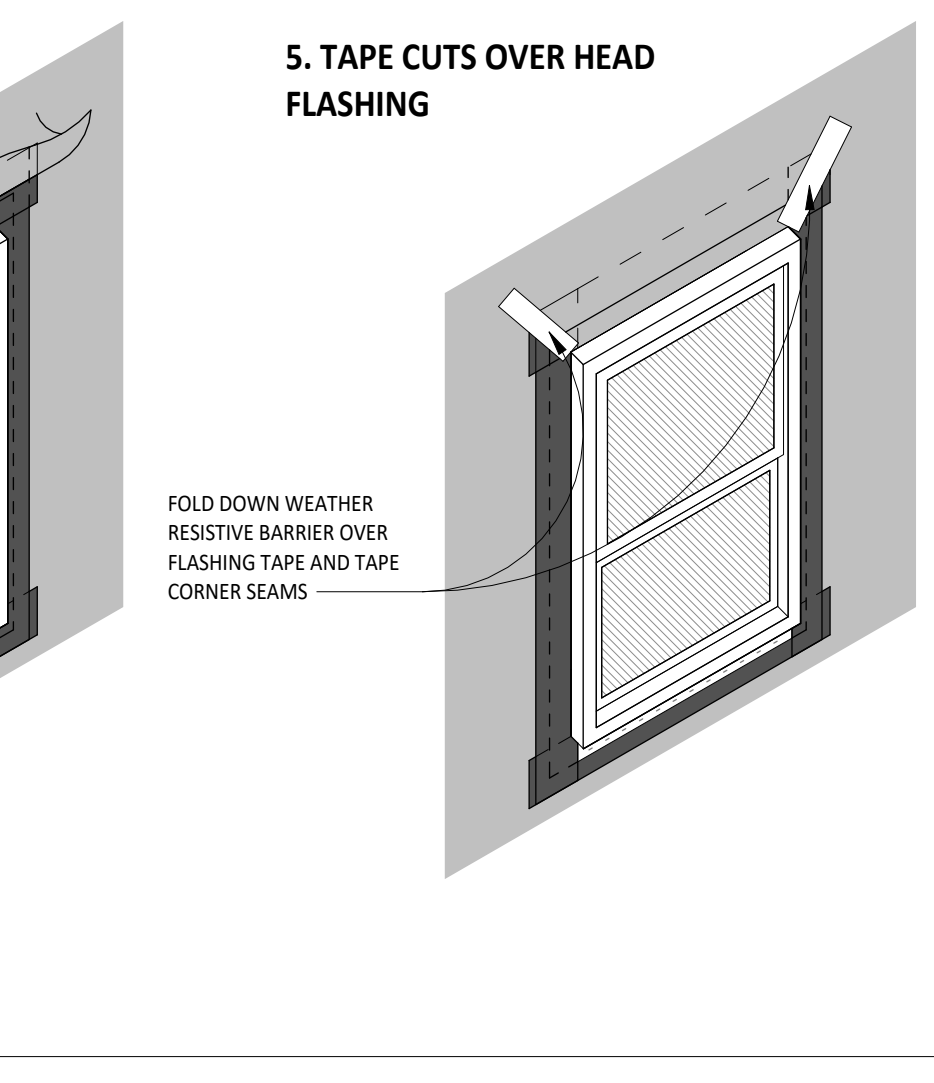

5. TAPE CUTS OVER HEAD FLASHING

13 TYP. WINDOW FLASHING DETAIL  
NOT TO SCALE



**FITZGERALD ADDITION**  
 34 RUSTIC TERRACE  
 BLUE RIVER, COLORADO

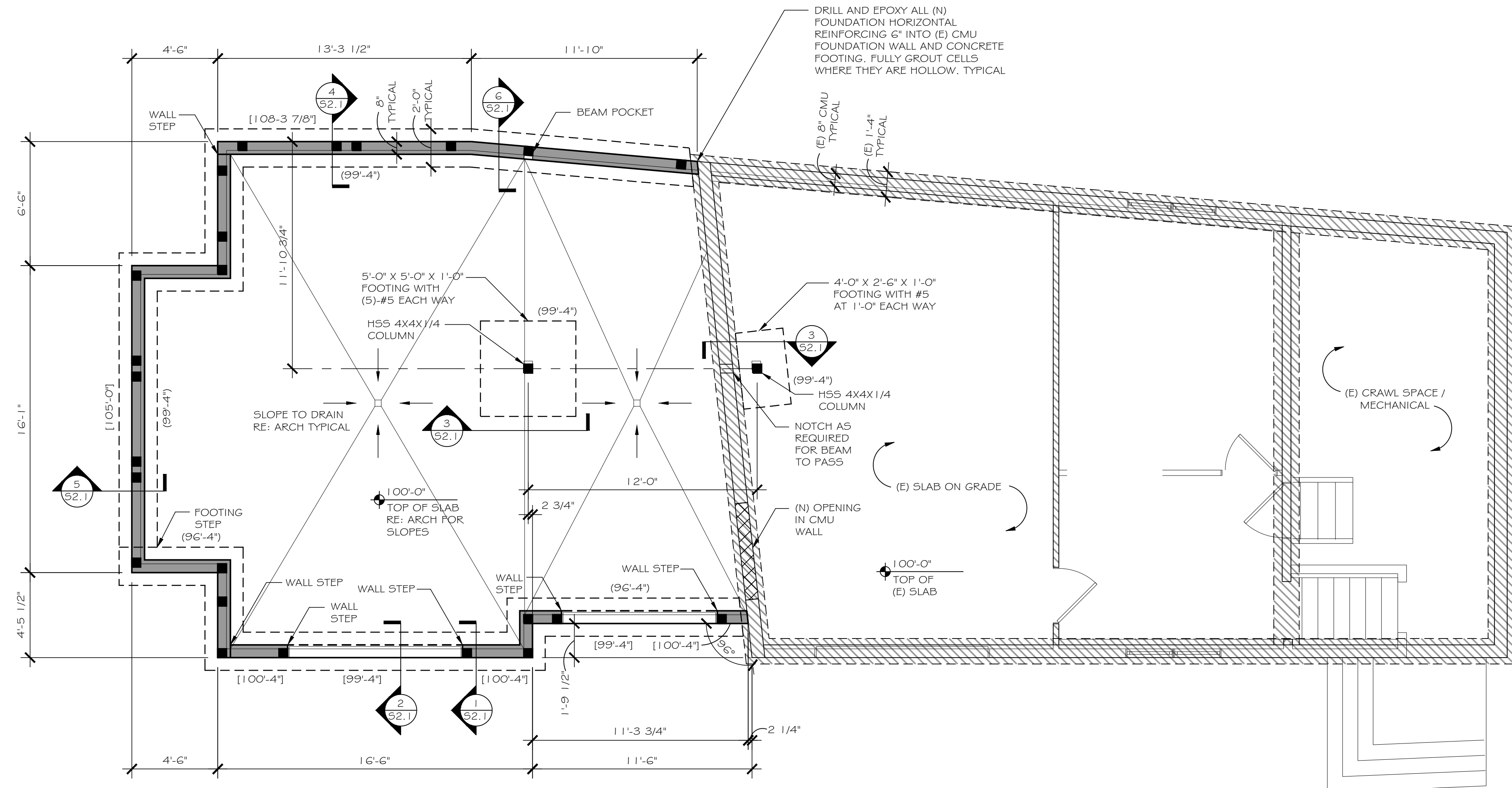

**FOUNDATION PLAN**  
 SCALE: 1/4" = 1'-0"

**FOUNDATION NOTES:**

1. DATUM ELEVATION 100'-0" EQUALS LOWER LEVEL TOP OF SLAB ELEVATION. RE: ARCH FOR USGS.
2. [XX-XX"] INDICATES TOP OF FOUNDATION WALL ELEVATION.
3. (XX-XX") INDICATES TOP OF FOOTING ELEVATION.
4. FLOOR ELEVATIONS SHOWN ARE AT TOP OF SLAB OR AT TOP OF PLYWOOD FLOOR SHEATHING.
5. FOOTING ELEVATIONS SHOWN ARE MAXIMUMS AND MAY NEED TO BE LOWERED DUE TO SOIL CONDITIONS. VERIFY CHANGES WITH STRUCTURAL ENGINEER.
6. ALL SLABS ON GRADE ARE 4" THICK WITH GXG W2.1XW2.1 WELDED WIRE FABRIC UNLESS NOTED OTHERWISE.
7. SITE WALLS NOT SHOWN ON THIS PLAN SHALL BE BUILT PER ARCHITECTURAL LANDSCAPE PLANS, DETAILS AND ELEVATIONS. SITE WALLS SHALL NOT BE CONNECTED TO BUILDING UNLESS NOTED OTHERWISE.
8. REFERENCE GENERAL NOTES FOR ADDITIONAL REQUIREMENTS.

PROJECT #2337  
 DRAWN: CM/KF  
 DATE: 04/23/2024  
 FOR PERMIT

**S1.1**  
 FOUNDATION PLAN

**FITZGERALD ADDITION**  
 34 RUSTIC TERRACE  
 BLUE RIVER, COLORADO

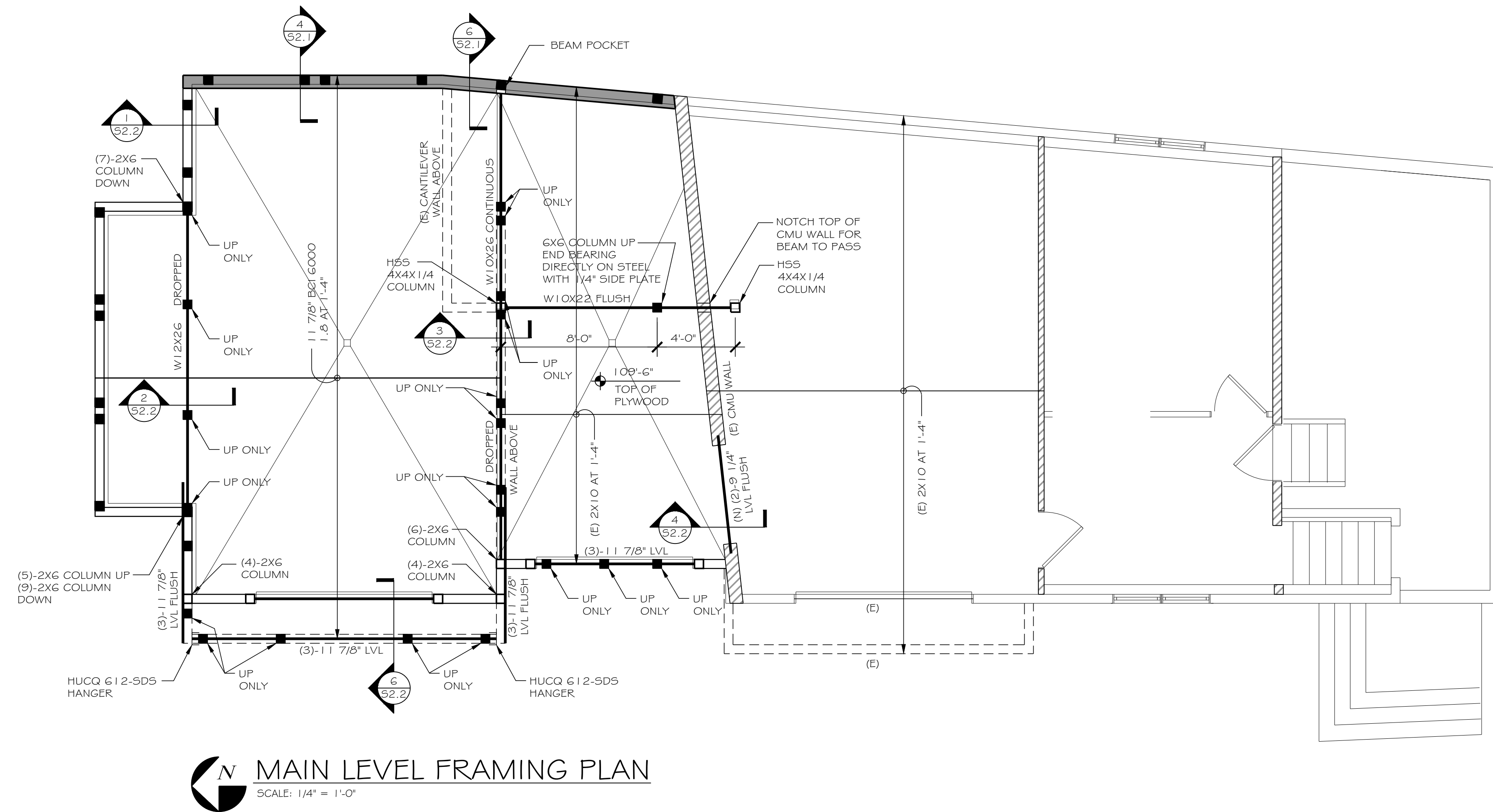

**FRAMING NOTES:**

1. □ INDICATES COLUMN DOWN ONLY.
2. ■ INDICATES COLUMN UP AND DOWN UNLESS IT BEARS ON CONCRETE BELOW, OR IT IS LABELED UP ONLY OR SUB COLUMN.
3. ▨▨▨▨ INDICATES INTERIOR BEARING WALLS, JOISTS BEARING LOCATIONS SHALL LINE UP WITH STUDS BELOW.
4. ALL COLUMNS SHALL BE (3)-2X6 MINIMUM UNLESS NOTED OTHERWISE. COLUMNS AND STUDS SHALL BE CONTINUOUS FLOOR TO FLOOR OR FLOOR TO ROOF.
5. <XX-XX> INDICATES TOP OF BEAM ELEVATION OR PLATE HEIGHT ELEVATION.
6. HEADERS SHALL BE (2)-9 1/4" LVL UNLESS NOTED OTHERWISE. ALL HEADERS SHALL BE BUILT OUT TO 5 1/2" WIDTH BY ADDING RIGID INSULATION RE: ARCH.
7. ALL HEADERS 6'-0" AND LONGER SHALL REQUIRE TWO TRIM STUDS AND TWO KING STUDS EACH SIDE. HEADERS SHORTER THAN 6'-0" REQUIRE ONE TRIM STUD AND ONE KING STUD EACH SIDE UNLESS NOTED OTHERWISE.
8. ROOF JOIST HANGERS SHALL BE SIMPSON LSSR OR LRUZ TYPE UNLESS NOTED OTHERWISE. FLOOR JOIST HANGERS SHALL BE SIMPSON IUS TYPE UNLESS NOTED OTHERWISE.
9. ALL EXTERIOR WALLS SHALL BE CONSTRUCTED USING 2X6 STUDS. REFER TO EXTERIOR WALL DETAILS FOR MORE INFORMATION. STUDS CAN BE SPACED AT 2'-0" FOR WALLS SHORTER THAN 10'-0" UNLESS NOTED OTHERWISE. STUDS SHALL BE SPACED 1'-0" FOR WALLS SHORTER THAN 14'-0" AND TALLER THAN 10'-0" UNLESS NOTED OTHERWISE.
10. REFERENCE ARCHITECTURAL DRAWINGS FOR LOCATION AND SIZE OF ROUGH OPENINGS IN WOOD STUD WALLS.
11. REFERENCE GENERAL NOTES FOR ADDITIONAL REQUIREMENTS.
12. BCI 6000 1.8 JOISTS MAY BE REPLACED WITH TJI 210 JOISTS EQUAL DEPTH AND SPACING RE: GENERAL NOTES.
13. FLOOR FRAMING IS NOT SIZED FOR GYPCRETE TOPPING.

PROJECT #2337  
 DRAWN: CM/KF  
 DATE: 04/23/2024  
 FOR PERMIT

**S1.2**  
 MAIN LEVEL FRAMING PLAN

**FITZGERALD ADDITION**  
 34 RUSTIC TERRACE  
 BLUE RIVER, COLORADO

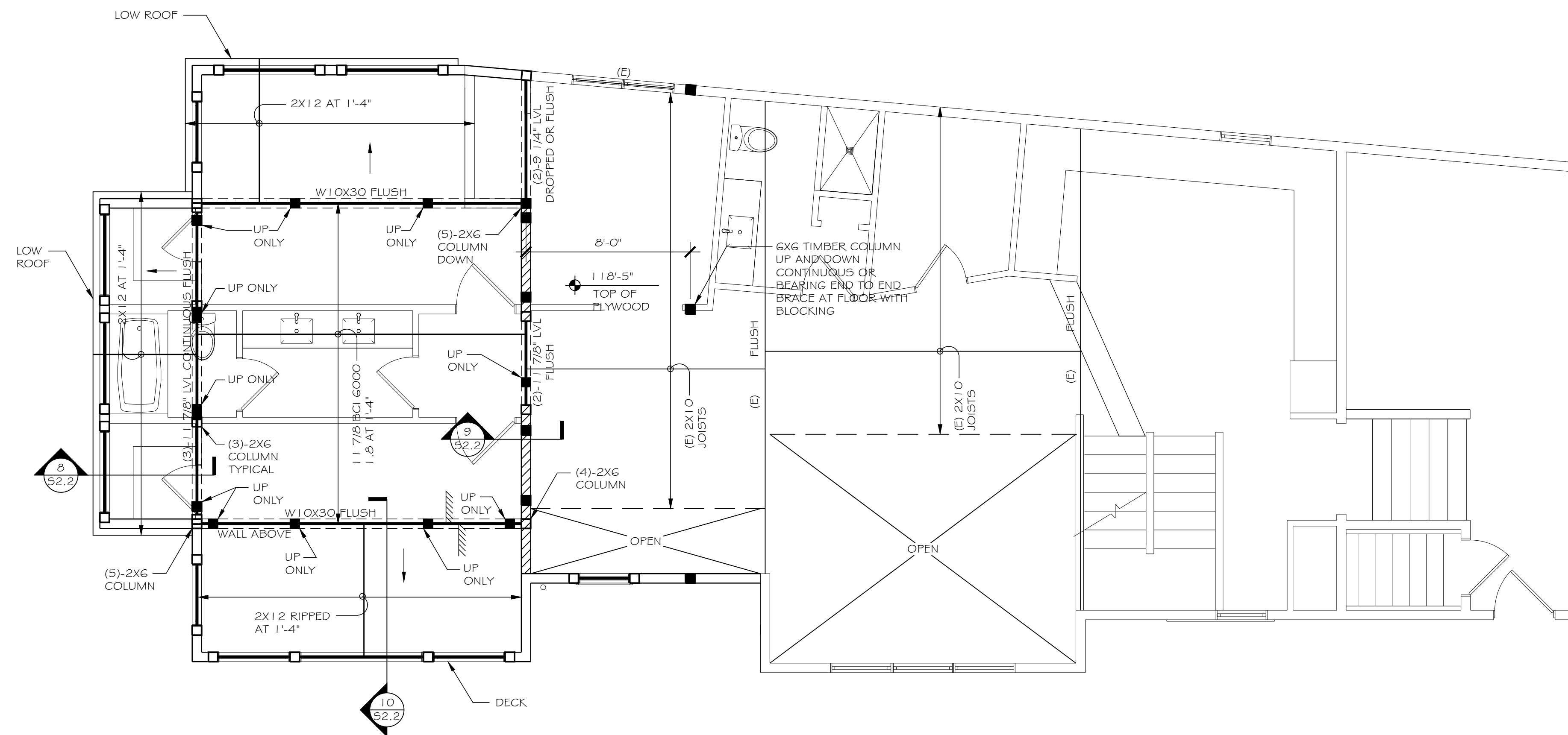

**UPPER LEVEL FRAMING PLAN**  
 SCALE: 1/4" = 1'-0"

**FRAMING NOTES:**

1. □ INDICATES COLUMN DOWN ONLY.
2. ■ INDICATES COLUMN UP AND DOWN UNLESS IT BEARS ON CONCRETE BELOW, OR IT IS LABELED UP ONLY OR SUB COLUMN.
3. ▨▨▨ INDICATES INTERIOR BEARING WALLS, JOISTS BEARING LOCATIONS SHALL LINE UP WITH STUDS BELOW.
4. ALL COLUMNS SHALL BE (3)-2X6 MINIMUM UNLESS NOTED OTHERWISE. COLUMNS AND STUDS SHALL BE CONTINUOUS FLOOR TO FLOOR OR FLOOR TO ROOF.
5. <XX-XX> INDICATES TOP OF BEAM ELEVATION OR PLATE HEIGHT ELEVATION.
6. HEADERS SHALL BE (2)-9 1/4" LVL UNLESS NOTED OTHERWISE. ALL HEADERS SHALL BE BUILT OUT TO 5 1/2" WIDTH BY ADDING RIGID INSULATION RE: ARCH.
7. ALL HEADERS 6'-0" AND LONGER SHALL REQUIRE TWO TRIM STUDS AND TWO KING STUDS EACH SIDE. HEADERS SHORTER THAN 6'-0" REQUIRE ONE TRIM STUD AND ONE KING STUD EACH SIDE UNLESS NOTED OTHERWISE.
8. ROOF JOIST HANGERS SHALL BE SIMPSON LSSR OR LRUZ TYPE UNLESS NOTED OTHERWISE. FLOOR JOIST HANGERS SHALL BE SIMPSON IUS TYPE UNLESS NOTED OTHERWISE.
9. ALL EXTERIOR WALLS SHALL BE CONSTRUCTED USING 2X6 STUDS. REFER TO EXTERIOR WALL DETAILS FOR MORE INFORMATION. STUDS CAN BE SPACED AT 2'-0" FOR WALLS SHORTER THAN 10'-0" UNLESS NOTED OTHERWISE. STUDS SHALL BE SPACED 1'-0" FOR WALLS SHORTER THAN 14'-0" AND TALLER THAN 10'-0" UNLESS NOTED OTHERWISE.
10. REFERENCE ARCHITECTURAL DRAWINGS FOR LOCATION AND SIZE OF ROUGH OPENINGS IN WOOD STUD WALLS.
11. REFERENCE GENERAL NOTES FOR ADDITIONAL REQUIREMENTS.
12. BCI 6000 1.8 JOISTS MAY BE REPLACED WITH TJI 210 JOISTS EQUAL DEPTH AND SPACING RE: GENERAL NOTES.
13. FLOOR FRAMING IS NOT SIZED FOR GYPCRETE TOPPING.

PROJECT #2337  
 DRAWN: CM/KF  
 DATE: 04/23/2024  
 FOR PERMIT

**S1.3**  
 UPPER LEVEL FRAMING PLAN

**FITZGERALD ADDITION**  
 34 RUSTIC TERRACE  
 BLUE RIVER, COLORADO

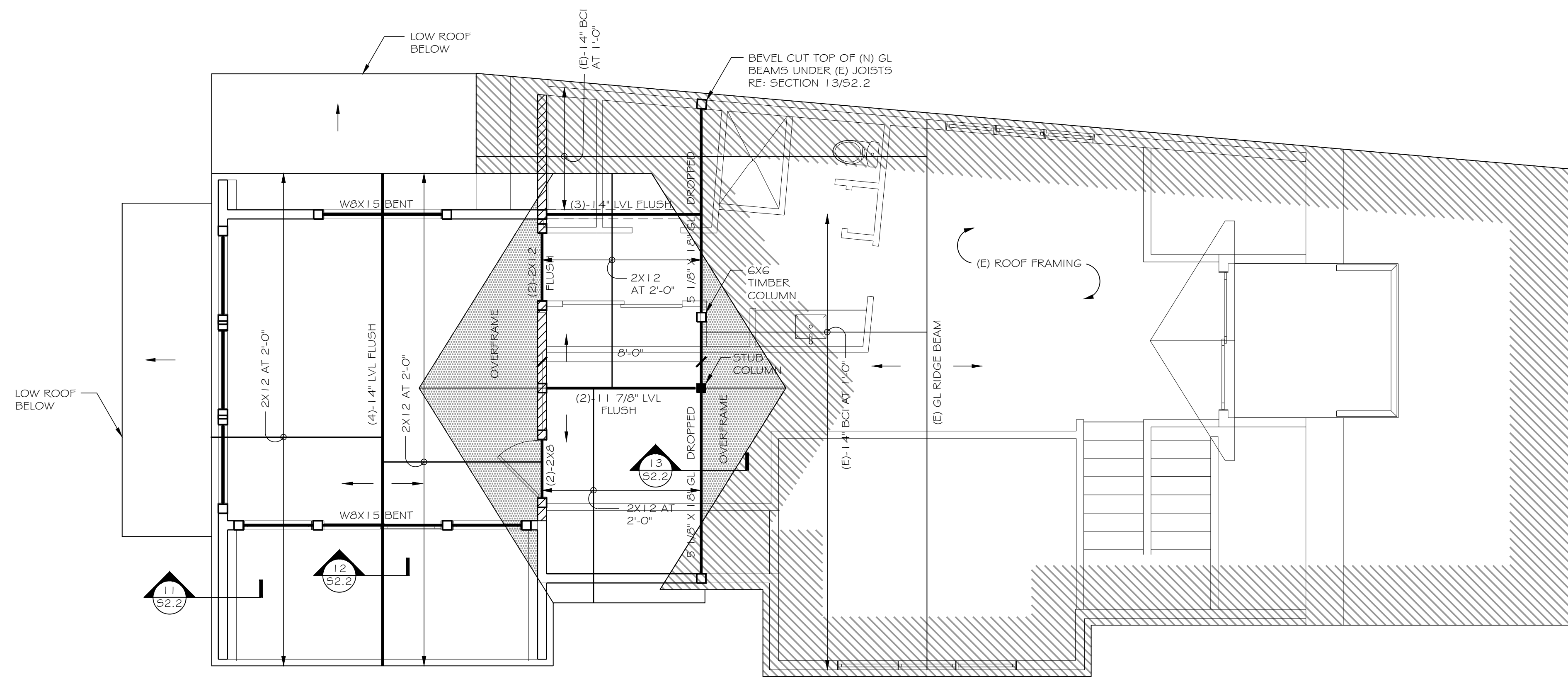

**ROOF FRAMING PLAN**  
 SCALE: 1/4" = 1'-0"

**FRAMING NOTES:**

1. □ INDICATES COLUMN DOWN ONLY.
2. ■ INDICATES COLUMN UP AND DOWN UNLESS IT BEARS ON CONCRETE BELOW, OR IT IS LABELED UP ONLY OR STUB COLUMN.
3. ▨▨▨▨ INDICATES INTERIOR BEARING WALLS, JOISTS BEARING LOCATIONS SHALL LINE UP WITH STUDS BELOW.
4. ALL COLUMNS SHALL BE (3)-2X6 MINIMUM UNLESS NOTED OTHERWISE. COLUMNS AND STUDS SHALL BE CONTINUOUS FLOOR TO FLOOR OR FLOOR TO ROOF.
5. <XX-XX> INDICATES TOP OF BEAM ELEVATION OR PLATE HEIGHT ELEVATION.
6. HEADERS SHALL BE (2)-9 1/4" LVL UNLESS NOTED OTHERWISE. ALL HEADERS SHALL BE BUILT OUT TO 5 1/2" WIDTH BY ADDING RIGID INSULATION RE: ARCH.
7. ALL HEADERS 6'-0" AND LONGER SHALL REQUIRE TWO TRIM STUDS AND TWO KING STUDS EACH SIDE. HEADERS SHORTER THAN 6'-0" REQUIRE ONE TRIM STUD AND ONE KING STUD EACH SIDE UNLESS NOTED OTHERWISE.
8. ROOF JOIST HANGERS SHALL BE SIMPSON LSSR OR LRJZ TYPE UNLESS NOTED OTHERWISE. FLOOR JOIST HANGERS SHALL BE SIMPSON IUS TYPE UNLESS NOTED OTHERWISE.
9. ALL EXTERIOR WALLS SHALL BE CONSTRUCTED USING 2X6 STUDS. REFER TO EXTERIOR WALL DETAILS FOR MORE INFORMATION. STUDS CAN BE SPACED AT 2'-0" FOR WALLS SHORTER THAN 10'-0" UNLESS NOTED OTHERWISE. STUDS SHALL BE SPACED 1'-0" FOR WALLS SHORTER THAN 14'-0" AND TALLER THAN 10'-0" UNLESS NOTED OTHERWISE.
10. REFERENCE ARCHITECTURAL DRAWINGS FOR LOCATION AND SIZE OF ROUGH OPENINGS IN WOOD STUD WALLS.
11. REFERENCE GENERAL NOTES FOR ADDITIONAL REQUIREMENTS.

PROJECT #2337  
 DRAWN: CM/KF  
 DATE: 04/23/2024  
 FOR PERMIT

**S1.4**  
 ROOF FRAMING PLAN

**GENERAL NOTES:**

1. LIVE LOADS USED IN DESIGN

- A. ROOF SNOW 1 00 PSF
- B. DECK LIVE LOAD 1 25 PSF
- C. INTERIOR FLOOR 40 PSF
- D. ULTIMATE DESIGN WIND 1 15 MPH EXPOSURE B
- E. SEISMIC SITE CLASS D, DESIGN CATEGORY B

2. TESTING, INSPECTIONS AND OBSERVATIONS

- A. THE STRUCTURAL ENGINEER DOES NOT PROVIDE INSPECTIONS OF CONSTRUCTION. STRUCTURAL ENGINEER MAY MAKE PERIODIC OBSERVATIONS OF THE CONSTRUCTION. SUCH OBSERVATIONS SHALL NOT REPLACE REQUIRED INSPECTIONS BY THE GOVERNING AUTHORITIES OR SERVE AS "SPECIAL INSPECTIONS" AS MAY BE REQUIRED BY CHAPTER 17 OF THE INTERNATIONAL BUILDING CODE.

3. FOUNDATIONS

- A. ALLOWABLE SOIL BEARING PRESSURE ASSUMED IN DESIGN IS 2000 PSF.
- B. CONTRACTOR SHALL RETAIN A LICENSED SOILS ENGINEER TO INSPECT THE FOUNDATION EXCAVATION. SOILS ENGINEER SHALL VERIFY IN WRITING THE ACTUAL SOILS CAPACITY IS EQUAL TO OR GREATER THAN ASSUMED.
- C. THE PREPARATION OF THE SUBGRADE SHALL BE IN STRICT ACCORDANCE WITH THE SOILS ENGINEER. QUESTIONS REGARDING THE SUBGRADE PREPARATION SHALL BE DIRECTED TO THE GEOTECHNICAL ENGINEER.
- D. NOTIFY SOILS ENGINEER WHEN EXCAVATION IS COMPLETE SO THAT CONDITIONS MAY BE INSPECTED PRIOR TO PLACEMENT OF ANY FILL OR CONCRETE.
- E. CONTRACTOR TO PROVIDE, AT HIS EXPENSE, FIELD DENSITY TESTS ON COMPACTED FILL UNDER FOOTINGS AND INTERIOR SLABS ON GRADE.
- F. ALL FOOTING BEARING ELEVATIONS SHOWN ARE ASSUMED. EXACT BEARING ELEVATIONS SHALL BE VERIFIED IN THE FIELD WITH ACTUAL CONDITIONS BY CONTRACTOR WITH APPROVAL OF SOILS ENGINEER. ALL BOTTOMS OF FOOTINGS SHALL BE A MINIMUM OF 40" BELOW EXTERIOR GRADE.
- G. ALL FOOTINGS SHALL BE PLACED ON FIRM, UNDISTURBED NATIVE SOIL OR PROPERLY COMPACTED STRUCTURAL BACKFILL, APPROVED BY THE SOILS ENGINEER.
- H. CONTRACTOR SHALL BACKFILL EQUALLY ON EACH SIDE OF FOUNDATION WALLS IN 1 2 INCH MAXIMUM VERTICAL LIFTS OR AS RECOMMENDED BY THE SOILS ENGINEER. REFER TO SOILS ENGINEER FOR BACKFILL MATERIAL.
- I. CENTER ALL FOOTINGS UNDER WALLS OR COLUMNS UNLESS DIMENSIONED OTHERWISE.
- J. REFERENCE THE SOILS ENGINEER AND GRADING DRAWINGS FOR SOIL DRAINAGE REQUIREMENTS.

4. CONCRETE AND REINFORCEMENT

- A. CAST-IN-PLACE CONCRETE SHALL BE MADE WITH TYPE I/II PORTLAND CEMENT AND SHALL SATISFY 3000 PSI MINIMUM. GARAGE FLOOR SLAB SHALL SATISFY 4000 PSI MINIMUM. CONCRETE WITH EXPOSURE TO WEATHER, INCLUDING GARAGE FLOOR SLABS, SHALL BE AIR ENTRAINED AND MEET ALL REQUIREMENTS IN TABLE R402.2 FOR SEVERE WEATHERING POTENTIAL.
- B. ALL CONCRETE AND REINFORCEMENT WORK SHALL BE IN ACCORDANCE WITH ACI BUILDING CODE 318 LATEST EDITION.
- C. CONTRACTOR SHALL SAWCUT OR TROWELCUT JOINTS IN SLABS ON GRADE. JOINTS SHALL BE SPACED 12 FEET MAXIMUM AND CUT 1/4 OF SLAB DEPTH X 3/16" WIDE WITHIN 12 HOURS AFTER POURING. AREA BETWEEN JOINTS SHALL NOT EXCEED 100 SQUARE FEET. CARRY ALL SLAB REINFORCEMENT THROUGH JOINT.
- D. ALL REINFORCING SHALL BE HIGH-STRENGTH DEFORMED BARS CONFORMING TO ASTM A615, GRADE 60, EXCEPT TIES, STIRRUPS AND PLATE ANCHORS WHICH SHALL BE DEFORMED BARS, ASTM DESIGNATION A615, GRADE 40 OR A706 GRADE 60.
- E. WELDED WIRE FABRIC SHALL CONFORM TO ASTM A185 GRADE 65 AND SHALL BE LAPPED ONE FULL MESH AT SIDE AND END SPLICES AND WIRED TOGETHER.
- F. NO SPLICES OF REINFORCEMENT SHALL BE MADE EXCEPT AS DETAILED OR AUTHORIZED BY THE STRUCTURAL ENGINEER. LAP SPLICES, WHERE PERMITTED, SHALL BE A MINIMUM OF 48 BAR DIAMETERS. MAKE ALL BARS CONTINUOUS AROUND CORNERS. USE STANDARD HOOKS FOR DOWELS UNLESS NOTED OTHERWISE.

5. STRUCTURAL STEEL

- A. STRUCTURAL STEEL WIDE FLANGE BEAMS SHALL CONFORM TO ASTM 992, 50 KSI; TUBES SHALL CONFORM TO ASTM A500, GRADE B; PIPES SHALL CONFORM TO ASTM A53, GRADE B. MISCELLANEOUS ITEMS SHALL BE A36 STEEL.
- B. ALL STRUCTURAL BOLTS SHALL BE A325N INSTALLED TO A MINIMUM SHUG TIGHT CONDITION. ALL ANCHOR BOLTS SHALL CONFORM TO ASTM A307.
- C. STRUCTURAL STEEL SHALL BE DETAILED AND FABRICATED IN ACCORDANCE WITH THE LATEST PROVISIONS OF AISC "MANUAL OF STEEL CONSTRUCTION".
- D. ALL WELDERS SHALL HAVE EVIDENCE OF PASSING THE AMERICAN WELDING SOCIETY STANDARD QUALIFICATIONS TESTS AS OUTLINED IN AWS-D1.1.
- E. MINIMUM WELDS TO BE PER AISC TABLE J2.4 BUT NOT LESS THAN 3/16" CONTINUOUS FILLET UNLESS NOTED OTHERWISE.
- F. SUBMIT SHOP AND ERECTION DRAWINGS TO ENGINEER FOR REVIEW OF ALL STRUCTURAL STEEL MEMBERS. THE MANUFACTURING OR FABRICATION OF ANY ITEMS PRIOR TO WRITTEN REVIEW OF SHOP DRAWINGS WILL BE ENTIRELY AT RISK OF THE CONTRACTOR.

6. WOOD

- A. ALL FRAMING LUMBER SHALL BE DRY HEM-FIR, GRADED BY WESTERN WOOD PRODUCTS ASSOCIATION AND CONFORMING TO NO. 2 GRADE (F<sub>b</sub> = 850 PSI). WALL STUDS ONLY MAY CONFORM TO STUD GRADE (F<sub>b</sub> = 675 PSI).
- B. ALL FRAMING TIMBERS (5"X5" AND LARGER) SHALL BE DRY DOUGLAS FIR LARCH, GRADED BY WESTERN WOOD PRODUCTS ASSOCIATION AND CONFORMING TO NO. 1 GRADE (F<sub>b</sub> = 1350 PSI).
- C. PREFABRICATED WOOD MEMBERS SHALL BE "BCI" JOIST AS MANUFACTURED BY BOISE CASCADE OR "TJI" JOIST AS MANUFACTURED BY TRUS JOIST WEYERHAEUSER, TYPES AS NOTED ON THE DRAWINGS. THE BCI JOISTS SPECIFIED HAVE SLIGHTLY HIGHER CAPACITIES THAN THE TJI JOISTS SPECIFIED. ALTERNATES SHALL BE REVIEWED BY THE ENGINEER. TO BE CONSIDERED, ALTERNATES SHALL HAVE A LOAD CAPACITY IN BENDING, SHEAR AND DEFLECTION EQUAL TO OR GREATER THAN THE SIZES SHOWN ON THE DRAWINGS. WEB BLOCKING AND BRIDGING TO BE AS REQUIRED BY THE JOIST MANUFACTURER.
- D. "LVL" INDICATES 1 3/4" WIDE LAMINATED VENEER LUMBER MEMBERS, WHICH SHALL HAVE THE FOLLOWING MINIMUM STRESS CAPACITIES: F<sub>b</sub> = 2600 PSI, F<sub>v</sub> = 285 PSI, E = 2,000,000 PSI. BUILT UP MEMBERS SHALL BE CONNECTED IN ACCORDANCE WITH MANUFACTURER'S RECOMMENDATIONS.
- E. "GL" INDICATES GLULAM MEMBERS, WHICH SHALL BE FABRICATED OF DOUGLAS FIR LARCH AT 12 PERCENT MOISTURE CONTENT IN ACCORDANCE WITH WCLUB. PROVIDE MEMBERS CONFORMING WITH AITC 117, 24F-V4 DF/DF UNLESS NOTED OTHERWISE.
- F. PROVIDE SOLID BLOCKING BETWEEN ALL JOISTS AT ALL SUPPORTS AND ENDS OF CANTILEVERS.
- G. WHEN PRESERVATIVE TREATED LUMBER IS USED ALL CONNECTIONS AND NAILING SHALL BE ADEQUATELY GALVANIZED.
- H. ALL BEAM/BEAM AND BEAM/COLUMN CONNECTIONS SHALL BE MADE WITH SIMPSON STEEL PLATE CONNECTORS UNLESS NOTED OTHERWISE.
- I. FASTEN ALL WOOD MEMBERS WITH COMMON NAILS ACCORDING TO THE IRC TABLE R602.3(1) UNLESS NOTED OTHERWISE.
- J. ALL EXTERIOR WALLS SHALL HAVE CONTINUOUS STUDS FROM FLOOR TO FLOOR OR FLOOR TO ROOF (INCLUDING RAKE WALLS).
- K. OVERFRAMING SHALL BE 2X6 MINIMUM POSTED DOWN TO MAIN JOISTS ON A GRID NOT TO EXCEED 2'-0" X 2'-0".
- L. PLYWOOD DECK AND/OR ORIENTED STRAND BOARD
  - 1. APPLICATION SHALL BE IN ACCORDANCE WITH RECOMMENDATIONS OF THE AMERICAN PLYWOOD ASSOCIATION.
  - 2. EACH PANEL SHALL BE IDENTIFIED WITH THE GRADE-TRADEMARK OF THE AMERICAN PLYWOOD ASSOCIATION AND SHALL MEET THE REQUIREMENTS OF U.S. PRODUCTS STANDARD PSI, LATEST EDITION FOR PLYWOOD.
  - 3. FOR FLOORING USE 3/4" T&G STURD-I-FLOOR SHEATHING GLUED AND NAILED WITH 1 0D NAILS AT 6" ON CENTER ALONG PANEL EDGES AND AT 12" ALONG INTERMEDIATE SUPPORTS.
  - 4. FOR ROOF USE 5/8" (40/20 SPAN RATING) EXPOSURE 1 SHEATHING NAILED WITH 1 0D NAILS AT 6" ON CENTER ALONG PANEL EDGES AND AT 12" ALONG INTERMEDIATE SUPPORTS.
  - 5. EXTERIOR WALLS SHALL HAVE ONE LAYER 7/16" EXPOSURE 1 SHEATHING NAILED WITH 8D NAILS AT 6" ON CENTER ALONG PANEL EDGES AND AT 12" ALONG INTERMEDIATE SUPPORTS UNLESS NOTED OTHERWISE. ALL PANEL EDGES SHALL BE BLOCKED.
  - 6. FLOOR AND ROOF SHEATHING SHALL BE INSTALLED WITH THE FACE GRAIN PERPENDICULAR TO SUPPORTS WITH END JOINTS STAGGERED.
  - 7. INSTALL SUITABLE EDGE SUPPORT BY USE OF PLYCLIPS, TONGUE AND GROOVE PANELS OR SOLID WOOD BLOCKING SUPPORTS.

7. GENERAL

- A. ENGINEER'S ACCEPTANCE MUST BE SECURED FOR ALL STRUCTURAL SUBSTITUTIONS.
- B. ALL DIMENSIONS AND DETAILS ON STRUCTURAL DRAWINGS SHALL BE FIELD VERIFIED AND CHECKED AGAINST ARCHITECTURAL DRAWINGS.
- C. WATERPROOFING, VAPOR BARRIERS, WATERSTOP, ETC., SHALL BE AS SHOWN IN ARCHITECTURAL DRAWINGS AND DETAILS.
- D. ELEMENTS SUCH AS NON-BEARING PARTITIONS ATTACHED TO AND/OR SUPPORTED BY THE STRUCTURE SHALL TAKE INTO ACCOUNT DEFLECTIONS AND OTHER STRUCTURAL MOVEMENTS.
- E. VERIFY ALL OPENINGS THROUGH FLOORS, ROOF AND WALLS WITH MECHANICAL AND ELECTRICAL CONTRACTORS. VERIFICATION OF LOCATIONS, SIZES AND REQUIRED CONNECTIONS ARE CONTRACTOR'S RESPONSIBILITY. ENGINEER'S APPROVAL OF CONNECTIONS AND SUPPORTS SHALL BE OBTAINED PRIOR TO INSTALLATION OF MECHANICAL AND ELECTRICAL EQUIPMENT OR OTHER ITEMS TO BE ATTACHED TO THE STRUCTURE.
- F. REFER TO ARCHITECTURAL DRAWINGS FOR STAIR FRAMING DETAILS AND LANDING SLAB ELEVATIONS.
- G. ALL STONE VENEERS SHALL BE THIN ADHERED TYPE AND SHALL BE ATTACHED TO INTERIOR AND EXTERIOR WALLS AS SPECIFIED IN SECTION R703.8 OF THE INTERNATIONAL RESIDENTIAL CODE.
- H. (E) INDICATES EXISTING, (N) INDICATES NEW.

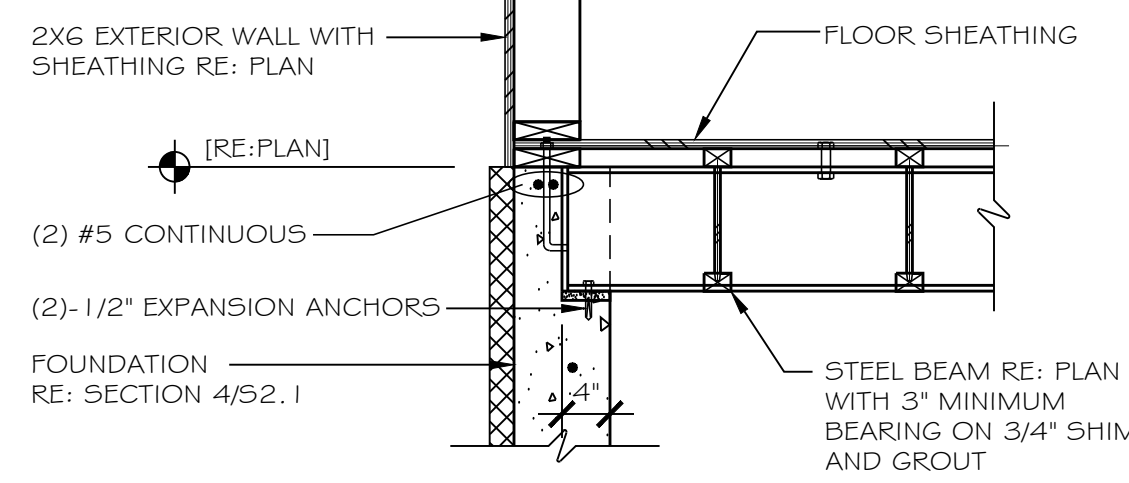

**BEAM POCKET**  
SCALE: 3/4" = 1'-0"

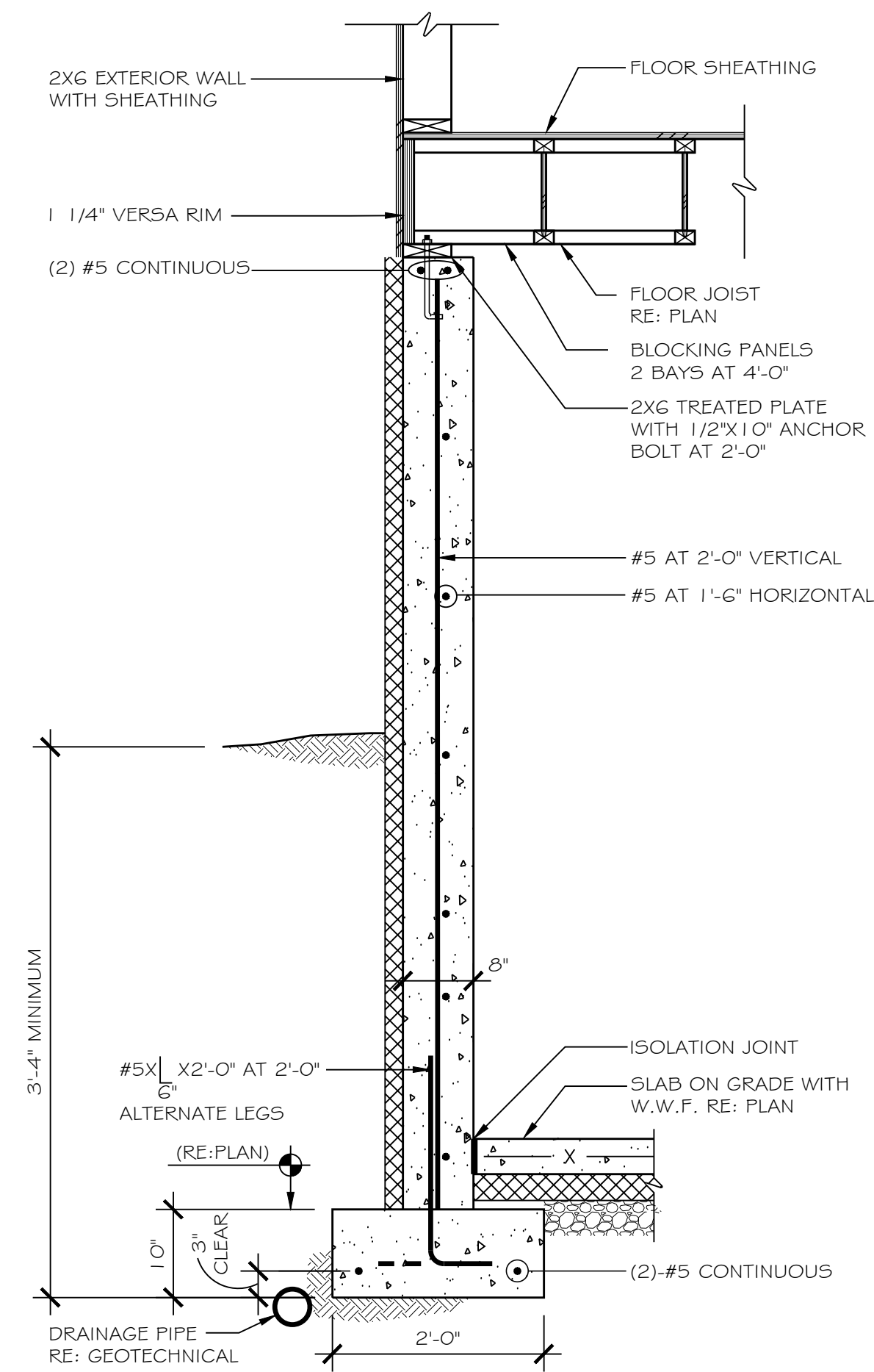

**GARAGE BACK WALL**  
SCALE: 3/4" = 1'-0"

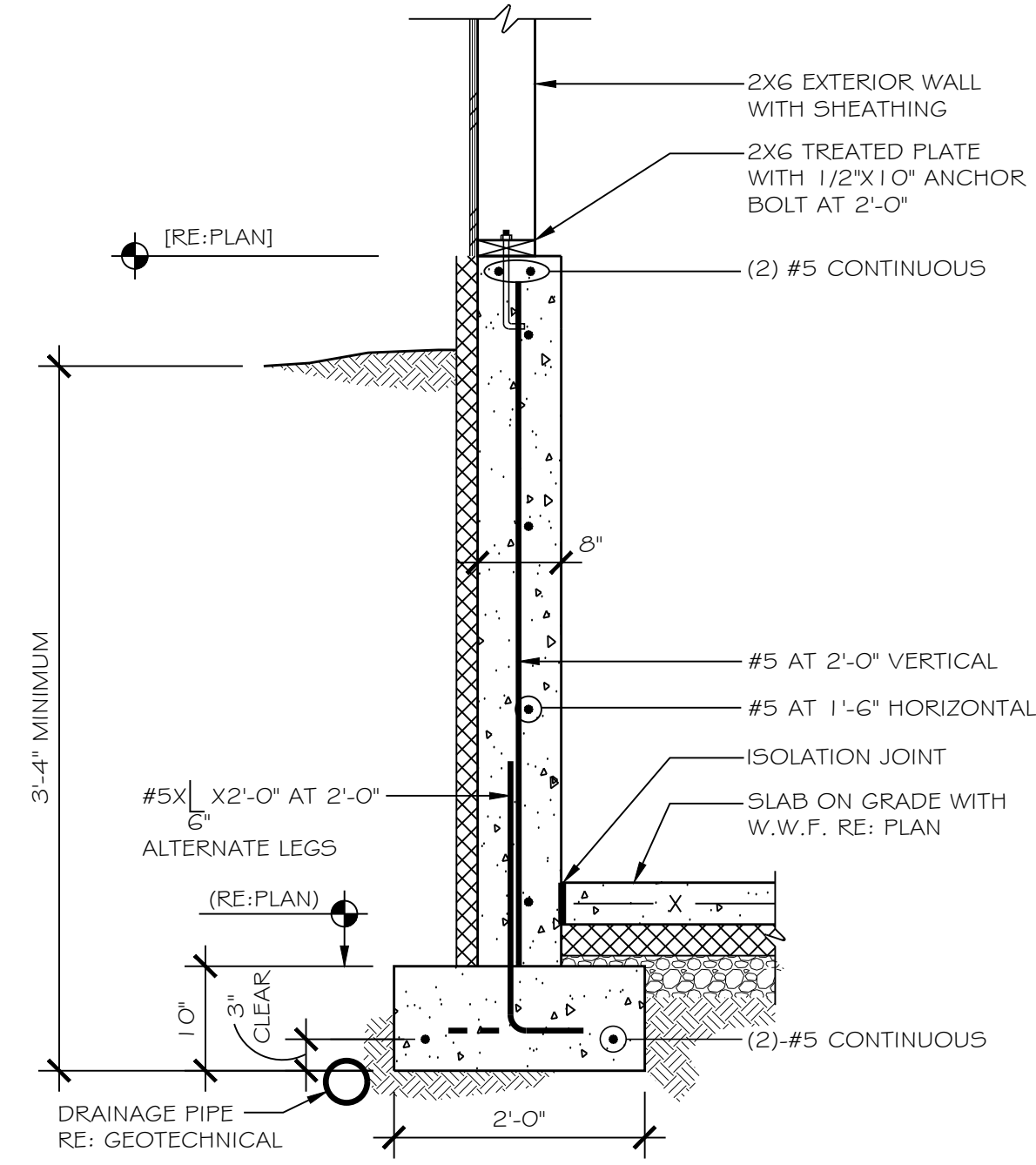

**GARAGE SIDE WALL**  
SCALE: 3/4" = 1'-0"

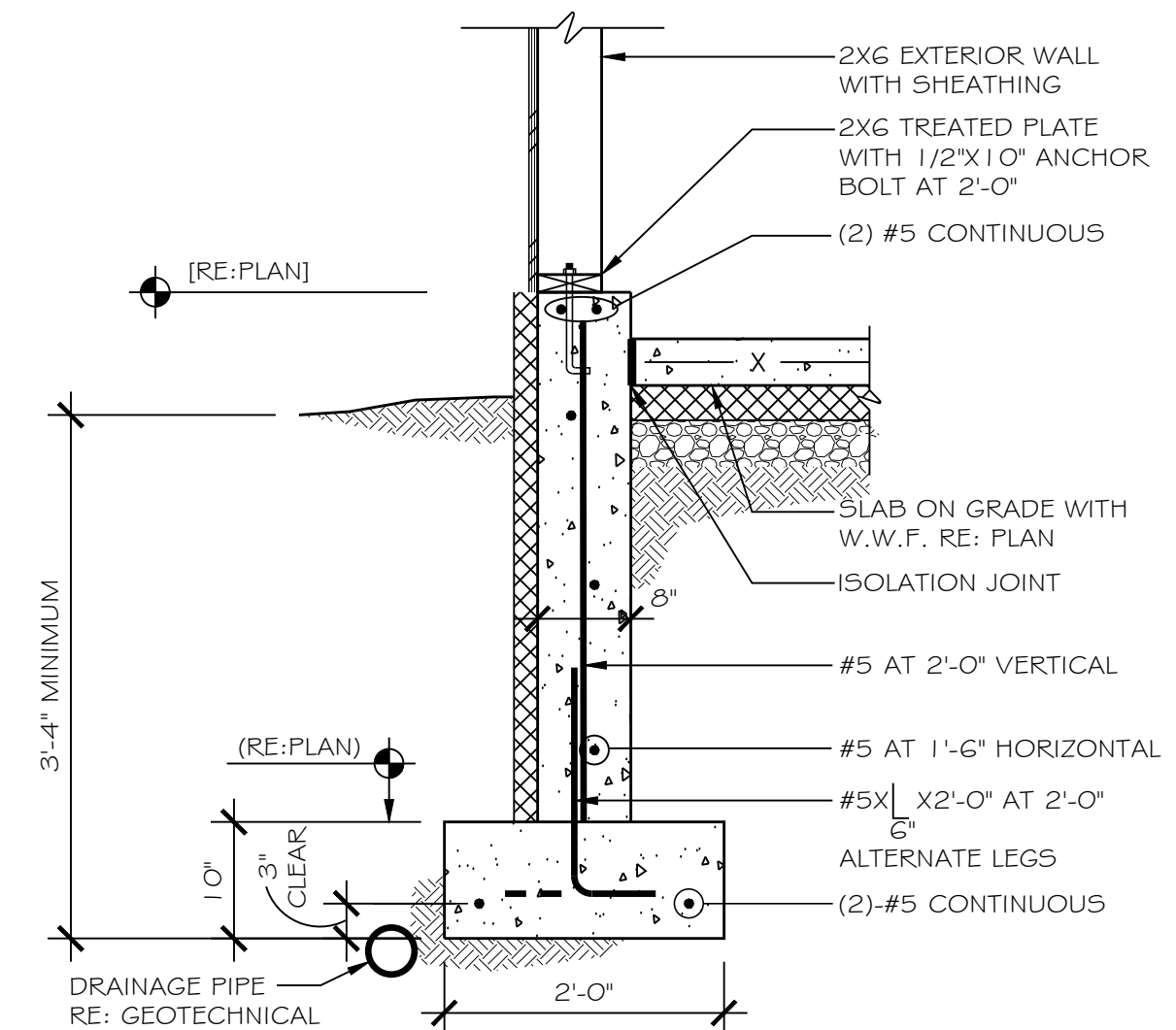

**LOWER FOUNDATION**  
SCALE: 3/4" = 1'-0"

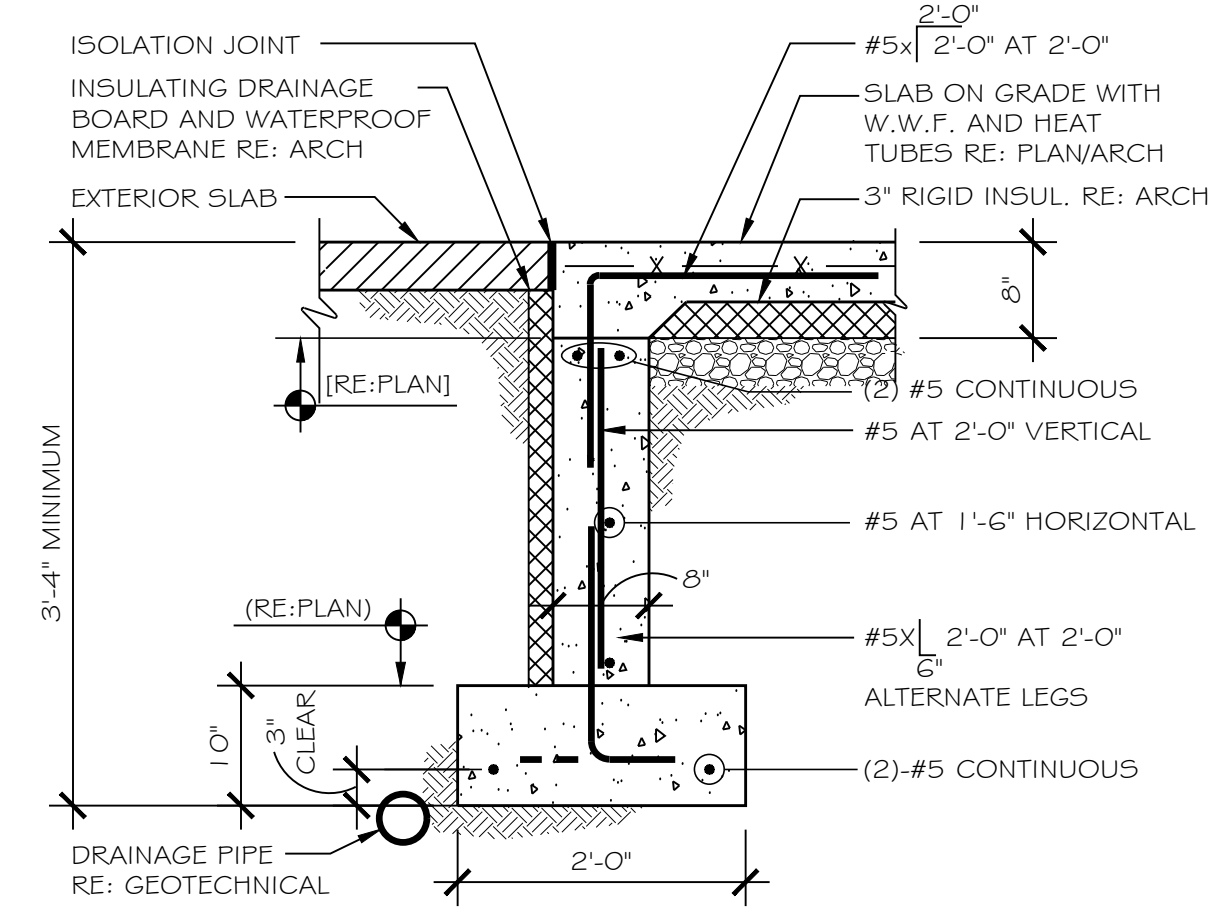

**FOUNDATION AT DOOR**  
SCALE: 3/4" = 1'-0"

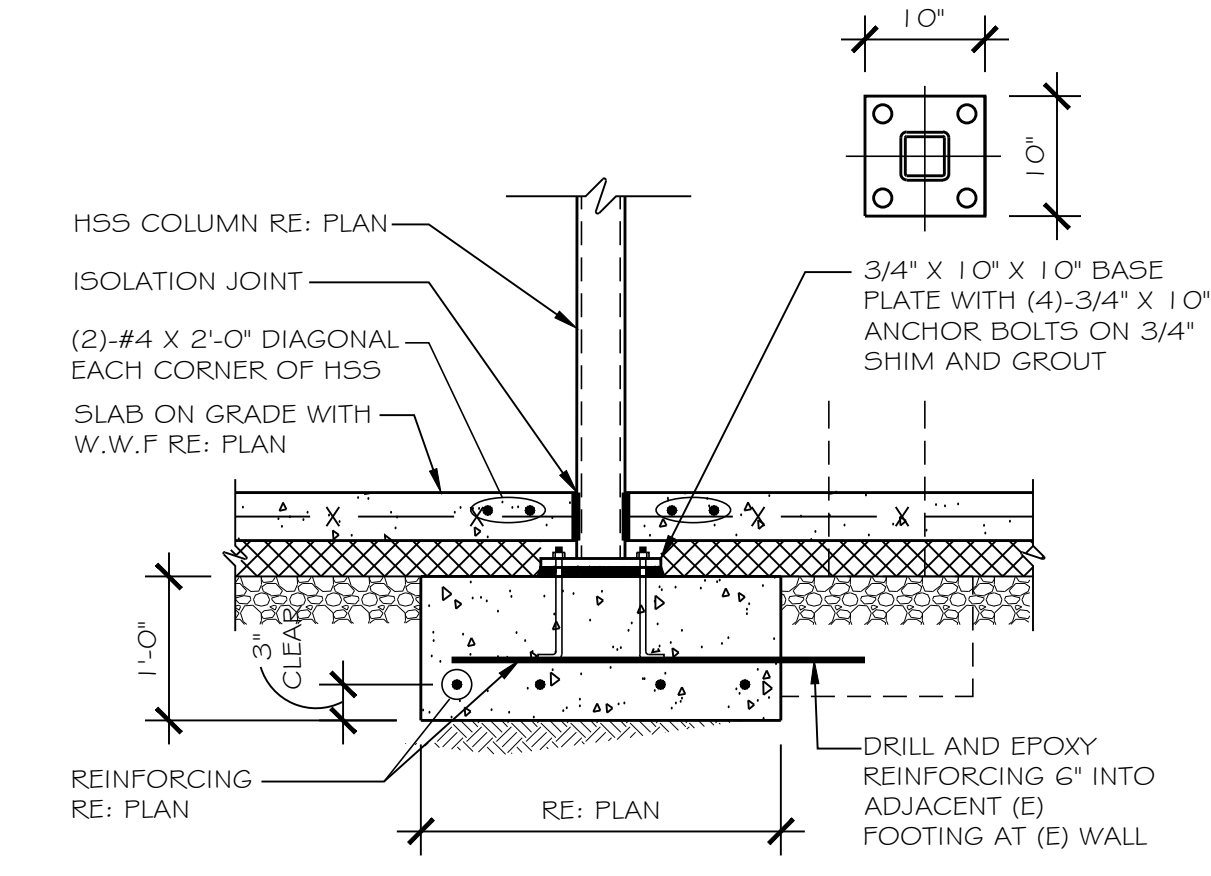

**HSS COLUMN FOOTING**  
SCALE: 3/4" = 1'-0"

**FOX STRUCTURAL ENGINEERING, LLC**  
216 SNOWBERRY WAY  
DILLON, COLORADO 80435  
(970) 376-2005

**FITZGERALD ADDITION**  
34 RUSTIC TERRACE  
BLUE RIVER, COLORADO

PROJECT #2337  
DRAWN: CM/KF  
DATE: 04/23/2024  
FOR PERMIT

**S2.1**  
NOTES & DETAILS



**FITZGERALD ADDITION**  
34 RUSTIC TERRACE  
BLUE RIVER, COLORADO

PROJECT #2337  
DRAWN: CM/KF  
DATE: 04/23/2024  
FOR PERMIT

**S2.2**  
FRAMING DETAILS

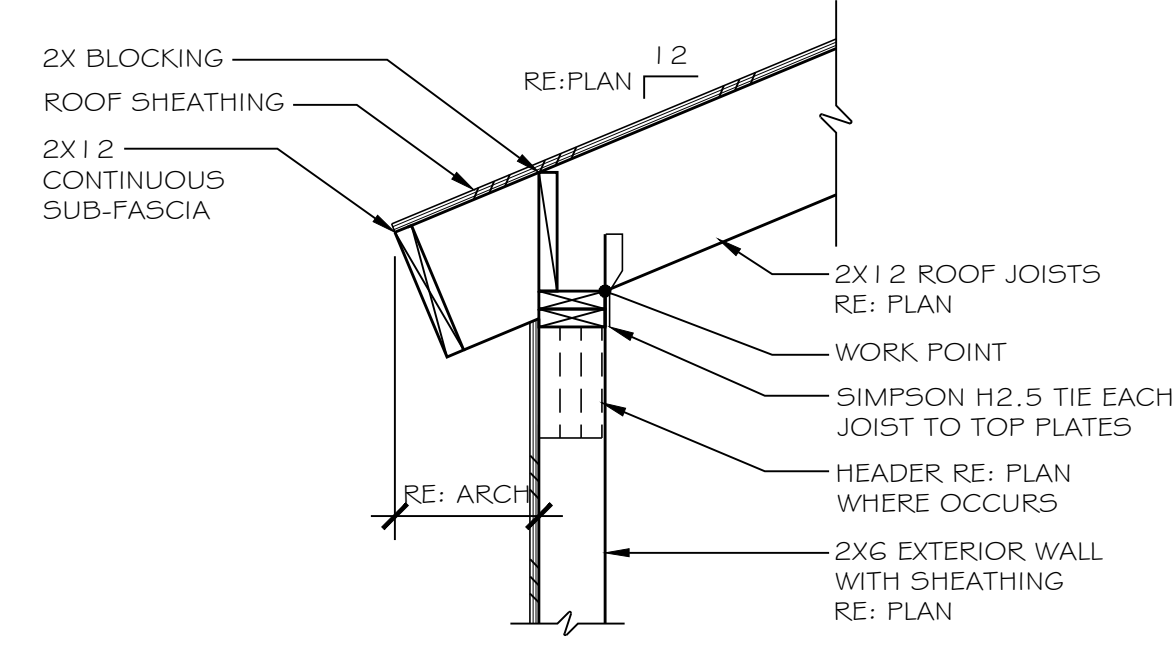

**11 EAVE SECTION**  
SCALE: 3/4" = 1'-0"

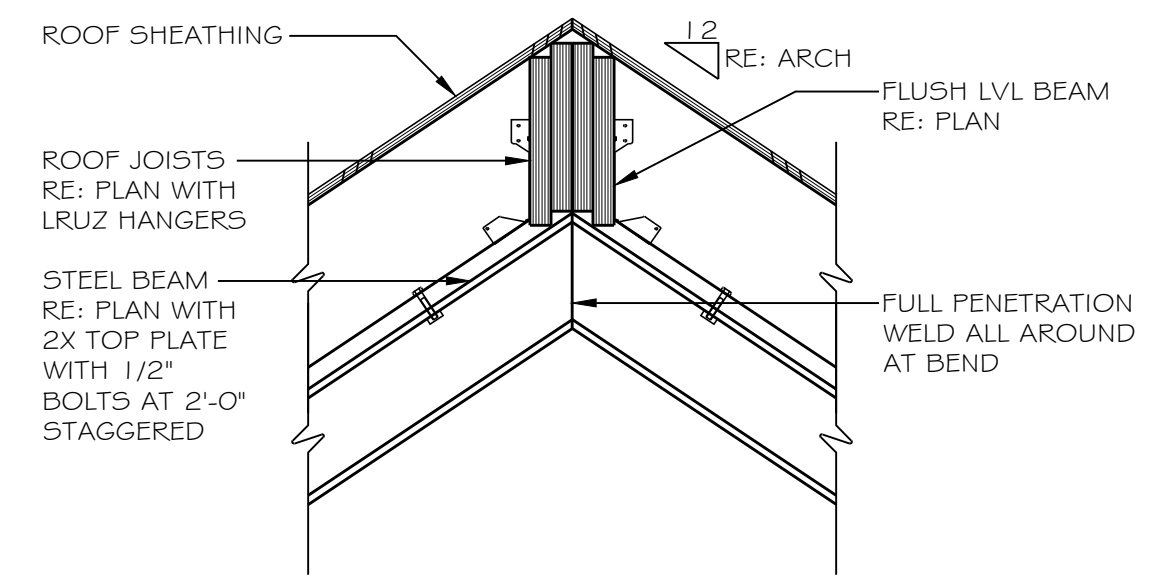

**12 FLUSH LVL RIDGE**  
SCALE: 3/4" = 1'-0"

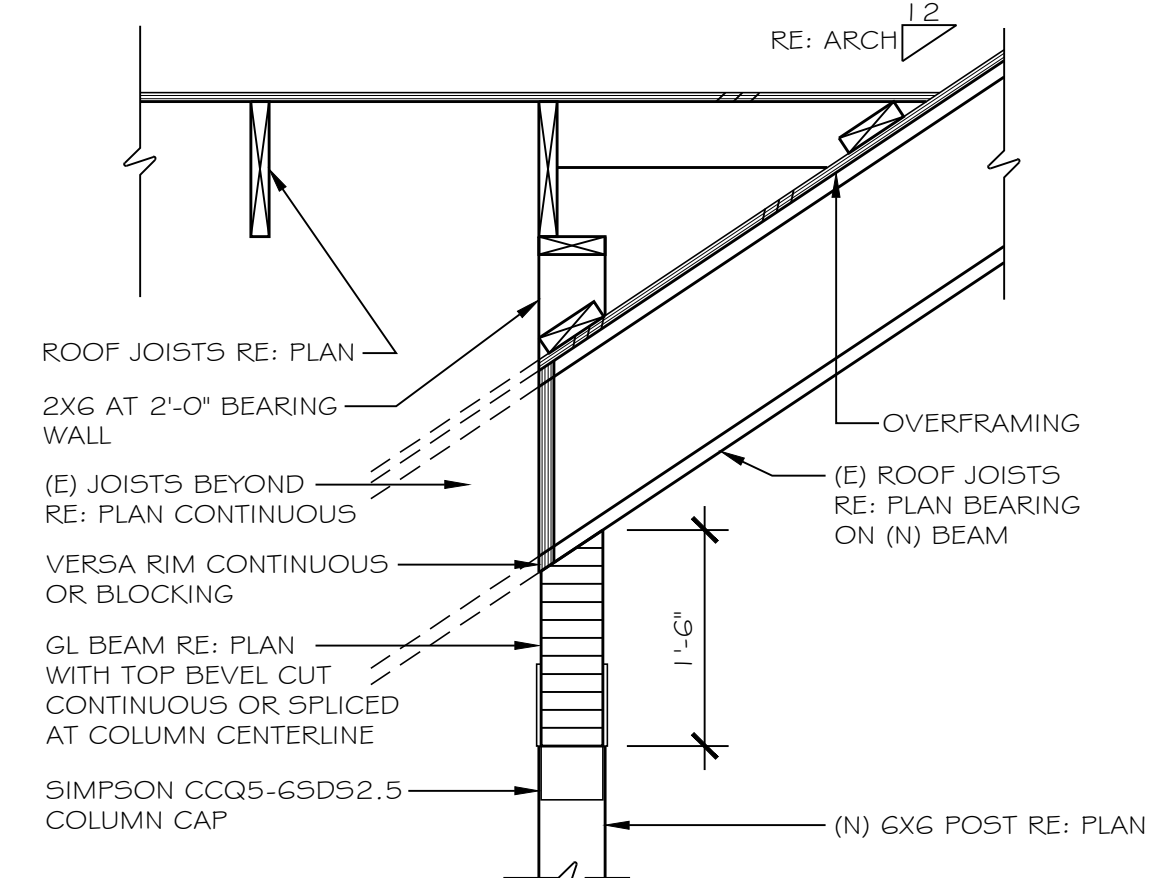

**13 (N) ROOF BEAM AT (E)**  
SCALE: 3/4" = 1'-0"

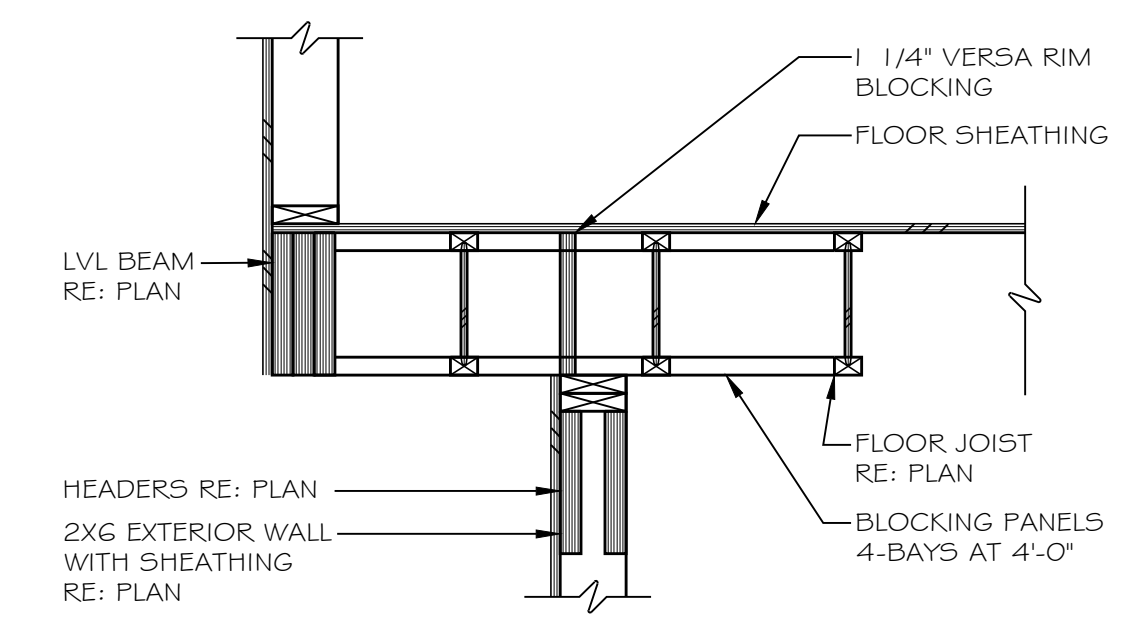

**6 FLOOR SECTION**  
SCALE: 3/4" = 1'-0"

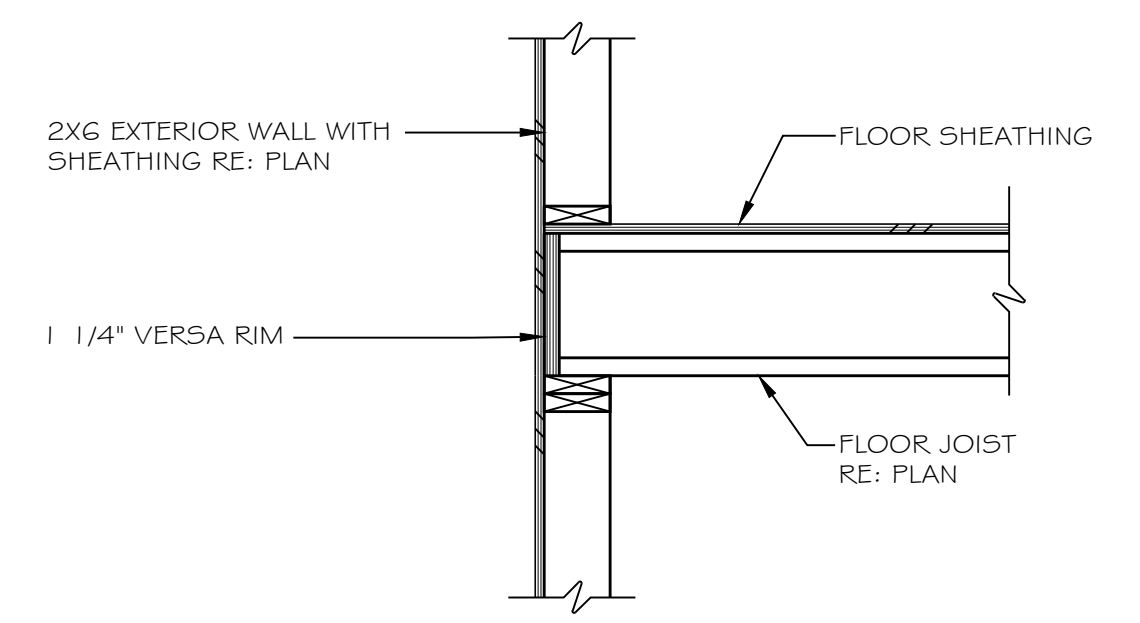

**1 FLOOR SECTION**  
SCALE: 3/4" = 1'-0"

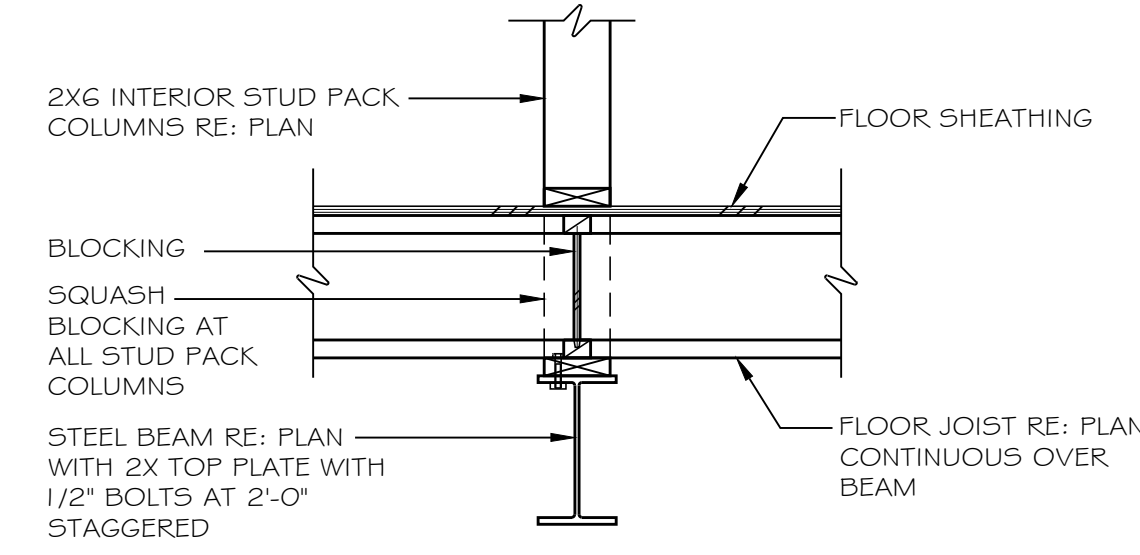

**2 DROPPED STEEL BEAM**  
SCALE: 3/4" = 1'-0"

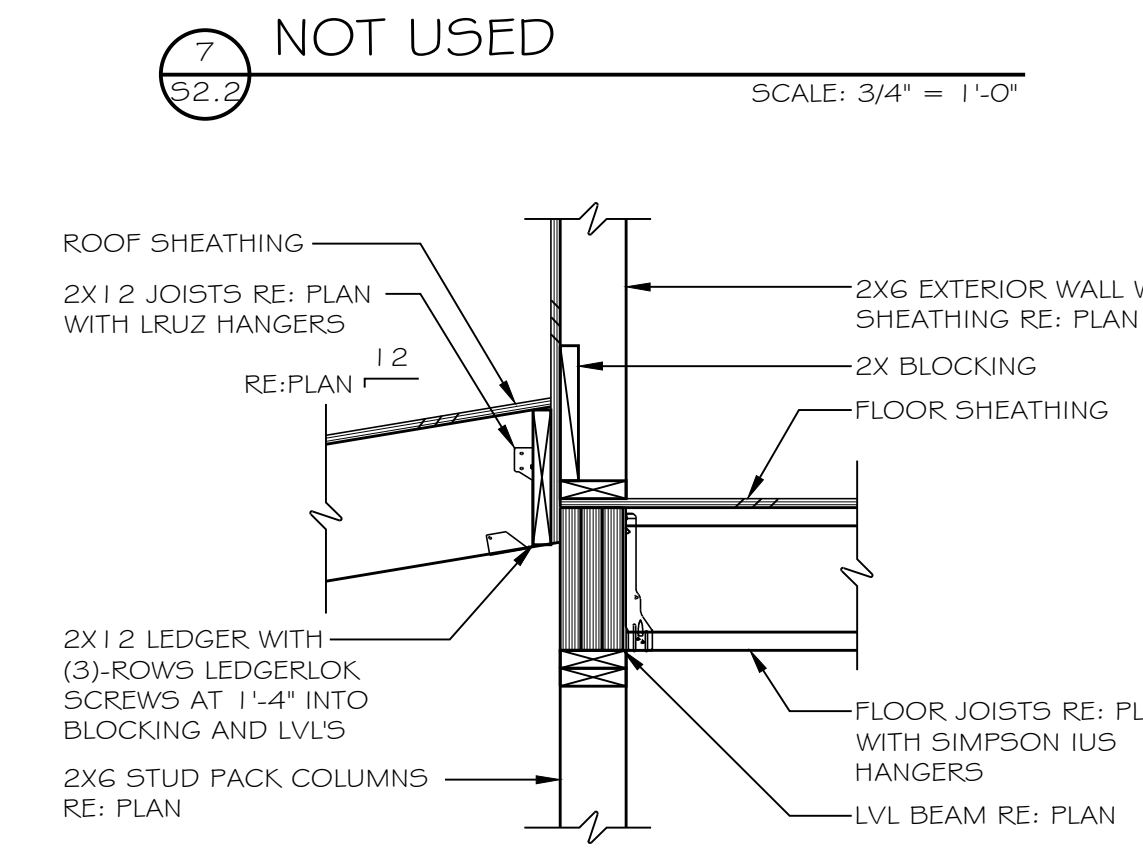

**8 FLUSH LVL BEAM / LOW ROOF**  
SCALE: 3/4" = 1'-0"

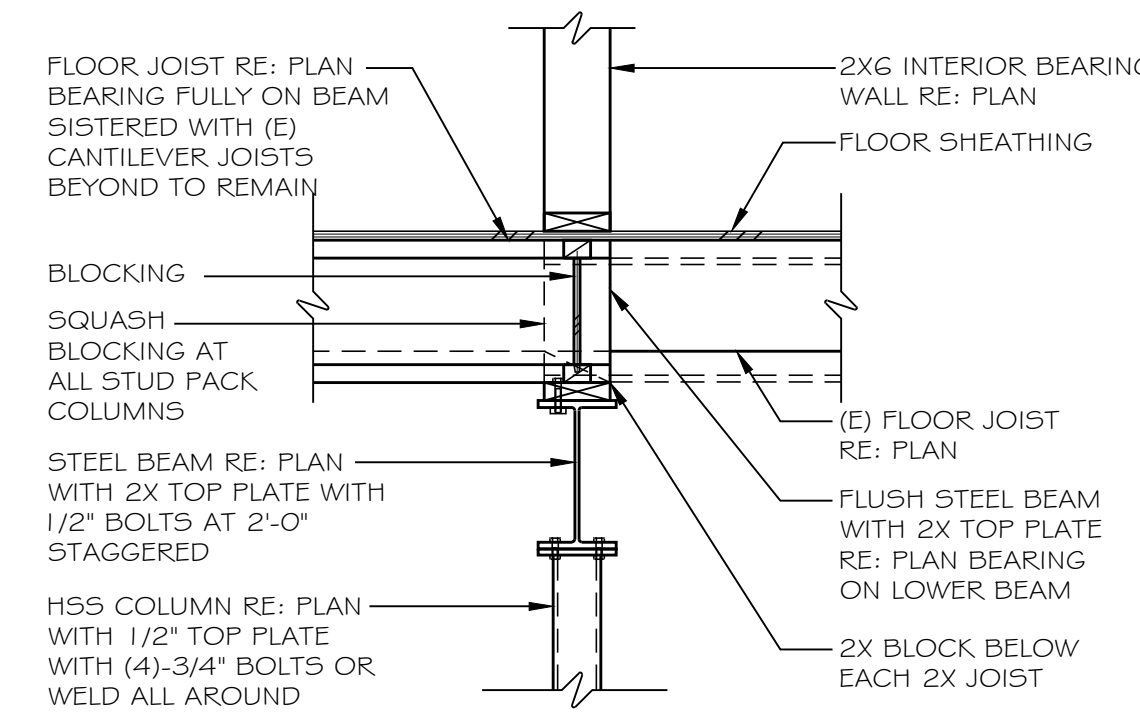

**3 DROPPED STEEL BEAM**  
SCALE: 3/4" = 1'-0"

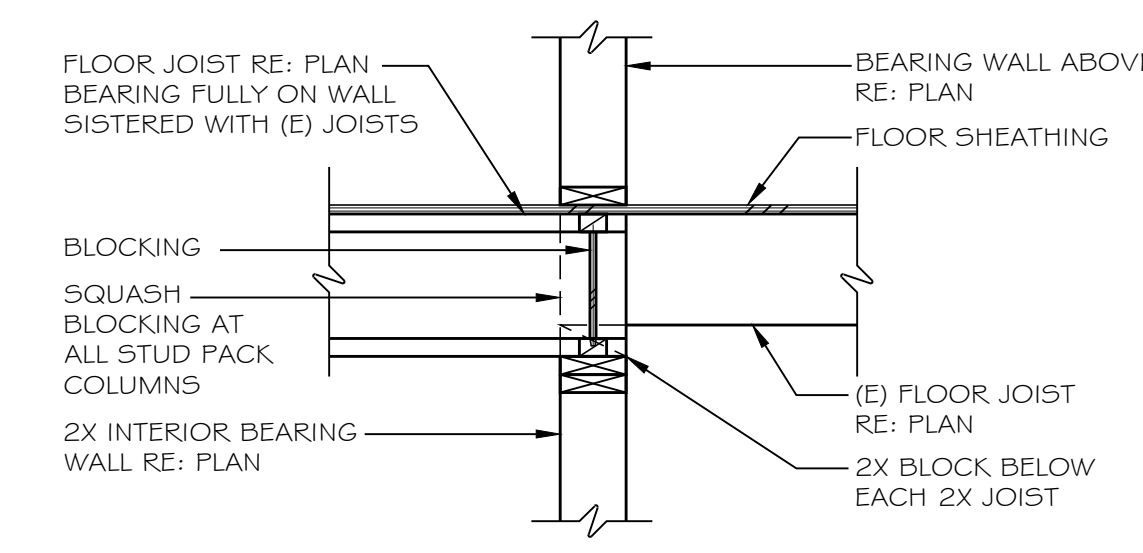

**9 BEARING WALL SECTION**  
SCALE: 3/4" = 1'-0"

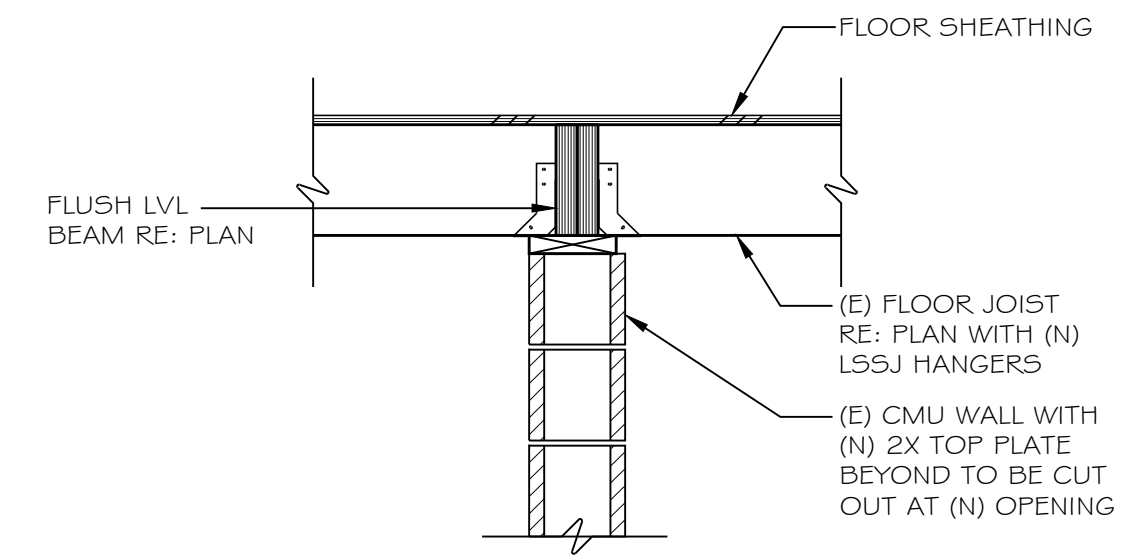

**4 FLUSH BEAM AT CMU**  
SCALE: 3/4" = 1'-0"

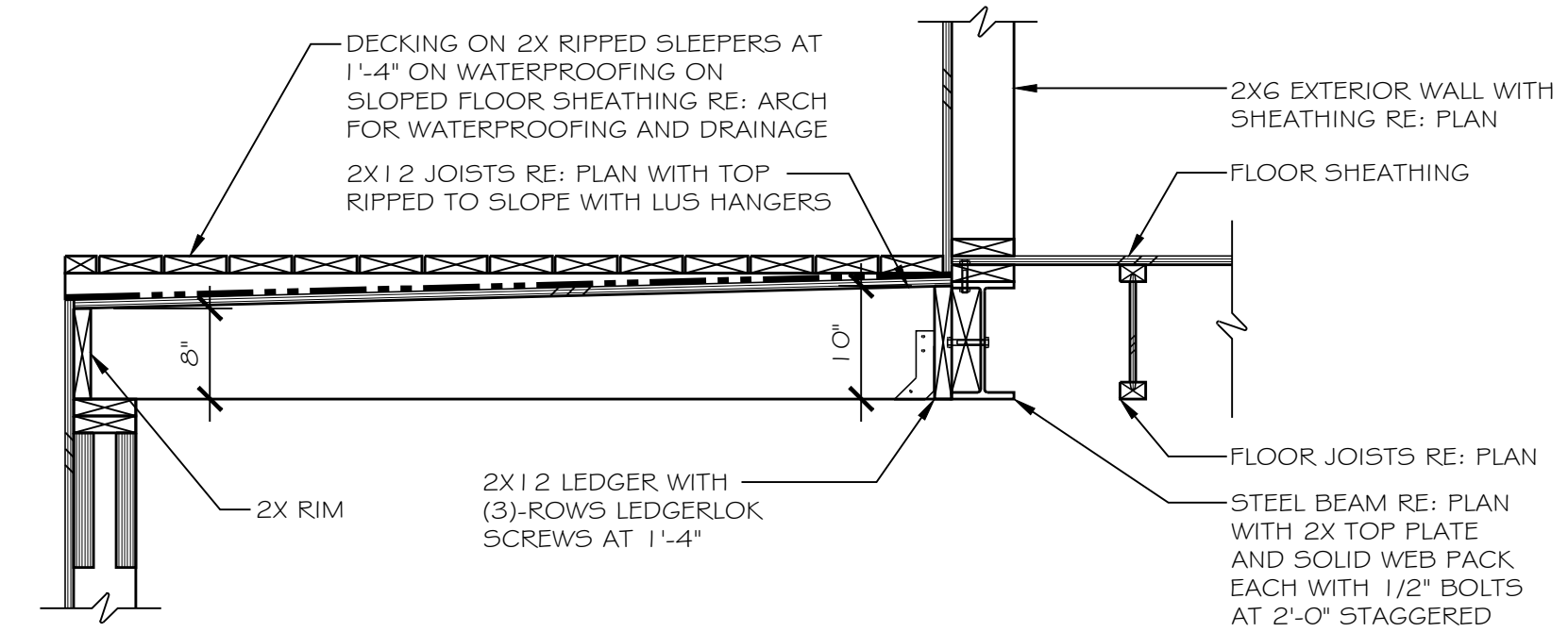

**10 UPPER LEVEL DECK**  
SCALE: 3/4" = 1'-0"

**5 NOT USED**  
SCALE: 3/4" = 1'-0"

TO: Michelle Eddy, CMC/CPM - Town Manager/Clerk  
FROM: Kyle Parag, Plan Reviewer - CAA  
DATE: September 27<sup>th</sup>, 2023  
RE: Planning/Zoning/Architectural Guidelines review – 0034 Rustic Terrace addition

Below please find staff’s analysis that outlines the review with the Town’s Zoning regulations and adopted Architectural Design Guidelines for the structure proposed

**Zoning Regulation analysis –**

Proposal: An existing 1 bedroom single family 2,107 Sqft home is proposed to have a 777 Sqft addition to increase the total Sqft to 4,085. The drawings have limited elevation information.

Zoning district: R

Lot Size: ~ Unkown  
80,000 sq. ft. Required– Existing Non-Conforming

Lot Width: ~ 107’  
100 ft. Required - Complies

Setbacks: Existing home and proposed addition do not comply with front setbacks. See Variance approval.

Height: Complies with required height limitations. The height at the highest roof ridge is proposed at 31’ 10”

Garage Stds: The proposed garage is ~774 sq. ft. and complies with the standards for structures less than 5,000 sq. ft. in habitable size.

Parking Stds: Parking requirements will be met through the proposed garage

**Architectural Design Guideline analysis -**

Please note the following key to the interpretation of the analysis table:

Y	Element is in substantial compliance with the design guidelines
N	Does not comply with the design guidelines
PC	Subject to Planning Commission Specific approval
	Requires additional information from applicant
N/A	Not Applicable to the application

STANDARD	NOTES/REMARKS	SUBSTANTIAL COMPLIANCE
<b>DEVELOPMENT STANDARD</b>		
Article 3: Easements	Road access easement is indicated, no other easements are indicated	Y
Article 4: Buildable Area/setbacks	Property ha received a Variance for the front setback encroachment	Y
<b>Article 5 Building Design Standards</b>		
Article 5-20 Building Height	Height is measured at 33’ 10” and shows general compliance	Y
Article 5-60 Foundation	Exposed Foundation is unclear, and appears to be exposed concrete which is prohibited Materials sheet not provided.	PC
Article 5-70 Roofs	Roof shows general conformance	Y
Article 5-80 Garages	Garage is scaled to 1120 sqft, which shows general conformance with requirements for homes under 5000 sqft and under. 1200 sqft is permitted for this home of a habitable size of 2,884	Y
Article 5-90 Easements and	Indicated easements and utilities show general conformance	Y

Utilities		
Article 5-100 Balconies and railings	Railing is indicated on the upper level, steel horizontal railing is indicated, but unable to be confirmed due to lack of materials sheet.	PC
Article 5-110 Chimney and Roof Penetrations	None indicated	Y
<b>Article 6 Building Materials and Colors</b>		
Article 6-20 Materials	Materials sheets location is indicated as <b>TBD</b> , but elevations show consistency with existing structure.	PC
Article 6-30 Colors	Materials sheets is indicated as TBD, but elevations show consistency with existing structure. <b>Colors are not indicated</b>	N
<b>Article 7 Accessory Improvements</b>		
Article 7-(20-40, 110) Berms, Garages, sheds and Gazebos	None indicated	Y
Article 7-50 Driveways	Driveway is indicated at 42' wide, which does not comply with the maximum allowed of 12'. Unique conditions exist.	PC
Article 7-60 Parking Areas	Parking is provided with attached garage	Y
Article 7-100 Decks	Shows general conformance	Y
Article 7-120 Hot Tubs	None indicated	Y
Article 7-140 Fences	None indicated	Y
Article 7-150 Retaining walls	None indicated	Y

<b>Article 8 Signs</b>		
Article 8 Signs	None indicated	Y
<b>Article 9 Lighting</b>		
Article 9 Lighting	Drawings indicate compliance	Y
<b>Article 13 Environmental Regulations</b>		
Article 13-20 Wetlands	Study provided, project does not encroach on designated areas.	Y

# TOWN OF BLUE RIVER, COLORADO MEMORANDUM

**NOT CONFIDENTIAL - AVAILABLE FOR PUBLIC DISTRIBUTION ON REQUEST**

TO: Michelle Eddy  
THROUGH: Bob Widner, Town Attorney  
FROM: Keith Martin, Deputy Town Attorney  
DATE: May 1, 2024  
SUBJECT: Zoning Methods to Control Housing Size and Bulk

---

This memorandum provides a brief overview of some of the various land-use controls commonly employed to limit the size and bulk of residential homes. Size and bulk controls are often used to limit the new development and redevelopment of lots and prevent what has been colloquially referred to as “McMansions” or larger homes which can be inconsistent with the character of the existing developed neighborhood.

### **Authority**

Colorado’s Zoning Enabling Act provides that a community may enact “bulk” regulations for buildings.<sup>1</sup> “Bulk” regulations are a combination of controls (lot size, floor area ratio, lot coverage, open space, yards, height, and setback) that determine the maximum size and placement of a building on a zoning lot.

### **Types of Bulk Controls**

#### *Minimum Lot Size*

Nearly all land use and zoning codes include minimum lot size requirements for zone districts. For example, the Town of Blue River’s Land Use Code (LUC) sets a minimum lot size of 80,000 square feet in the R-1 Zone District. This standard prevents lots larger than 80,000 square feet from being subdivided into smaller lots and prevents existing lots that are smaller than 80,000 square feet from being further subdivided into smaller lots.

---

<sup>1</sup> “. . . [F]or the purpose of promoting health, safety, morals, or the general welfare of the community, including energy conservation and the promotion of solar energy utilization, the governing body of each municipality is empowered to regulate and restrict the height, number of stories, and size of buildings and other structures, the percentage of lot that may be occupied, the size of yards, courts, and other open spaces, the density of population, the height and location of trees and other vegetation, and the location and use of buildings, structures, and land for trade, industry, residence, or other purposes.” C.R.S. § 31-23-301.

Minimum lot size requirements help control the density of housing in a neighborhood and preserve view and open space. Reasonable minimum lot size requirements are valid.<sup>2</sup>

### Setbacks

An ordinance may mandate building location by requiring minimum front, side and rear yards in residential districts.<sup>3</sup> Setbacks are universally common in land use codes in order to prevent certain areas of a lot from development and, in turn, limiting the area of a lot that can be developed.

**IMPORTANT NOTE:** Blue River’s LUC uses both *minimum lot size* and *setbacks* to define the “Buildable Area” of a lot. However, where a lot is larger in size and the setbacks are relatively short, the Buildable Area can potentially accommodate a significantly large residential structure. For example, a 40,000 square foot lot that is accompanied by front and rear yard setbacks of 25 feet and side yard setbacks of 15 feet, creates a potential Buildable Area as great as **25,500** square feet (assuming the lot is relatively flat and not encumbered by undevelopable slopes or easements). Even where the owner limits the footprint of the structure to 10,000 square feet, a one-, two-, or three-story residence will dwarf most homes in the neighborhood. Granted, not all owners will construct a residence of such size, but the potential will remain.

### Maximum Lot Coverage

A zoning ordinance can specify a percent of lot coverage in a residential zone to prevent building to the maximum bulk permitted by lot area, setback and height dimensions alone. For example:

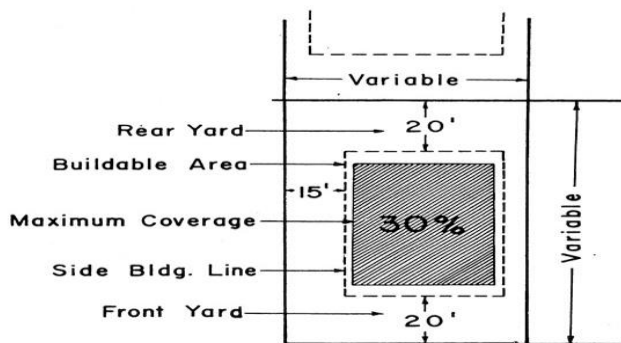

<sup>2</sup> *Di Salle v Giggall*, 128 Colo 208, 261 P2d 499 (1953)

<sup>3</sup> In *Gorieb v. Fox*, 274 U.S. 603, 47 S. Ct. 675, 71 L. Ed. 1228, 53 A.L.R. 1210 (1927), the United States Supreme Court upheld the general validity of setbacks to further the general goals of open space, light and air, and safety from fire; see also *Flinn v Treadwell*, 120 Colo 117, 207 P2d 967 (1949).

### *Maximum Building Size*

The Town could set minimum and maximum size for residential buildings, generally based on aesthetic and community character concerns. Limits on the size of residential structures have been upheld by many courts. As an example, the Town can limit all homes in the R-1 Zone District to a maximum of 4,500 square feet (regardless of the size of the lot).

### *Maximum Building Footprint (First Story)*

The Town could set a maximum building footprint (or the maximum size of the first story of the residential structure on a lot). Such a limitation, together with the zone district's maximum building *height*, will effectively limit the total size or bulk of the lot's residential structure. For example, a maximum first story building footprint of 2,000 square feet (regardless of the size of the lot) will limit the lot to a one-story residential home to 2,000 square feet and, depending on the maximum building height allowed, a two-story home of 4,000 square feet or three-story home of 6,000 square feet could theoretically be constructed (assuming no overhang of higher floors).

### *Floor Area Ratio (FAR)*

Floor area ratio or "FAR" is a metric used to measure how large a building on a lot is relative to the lot's size and is another device that permits variable dimensions within an over-all volume limit. Most of the ordinances that employ it also retain some if not all of the ordinary size limiting controls (e.g., minimum lot size, setbacks, and height). However, it does not in any way control the placement of that volume on the land. Therefore, if placement is a factor to be regulated, other bulk controls are required.

In nearly every ordinance in which it is used, a floor area ratio is obtained by the following simple formula:

$$\text{FAR} = \text{floor area} / \text{lot area}$$

In practice, this ratio is constant for a zone. For example, on a 10,000 square foot lot, a FAR of 0.5, allows a maximum 5,000 square foot building. A floor area ratio of 1.0 means that floor area may equal the lot area (10,000 square feet).

Although setting a floor area ratio affects volume, shape, and spacing of buildings on the lot, it does not determine a particular shape or spacing. Rather, it permits a choice. The following diagram (Figure 1) shows three of many possibilities under FAR 1.0, 4.0, and 9.0 and demonstrates that shape, height, and arrangement on a lot may vary widely.



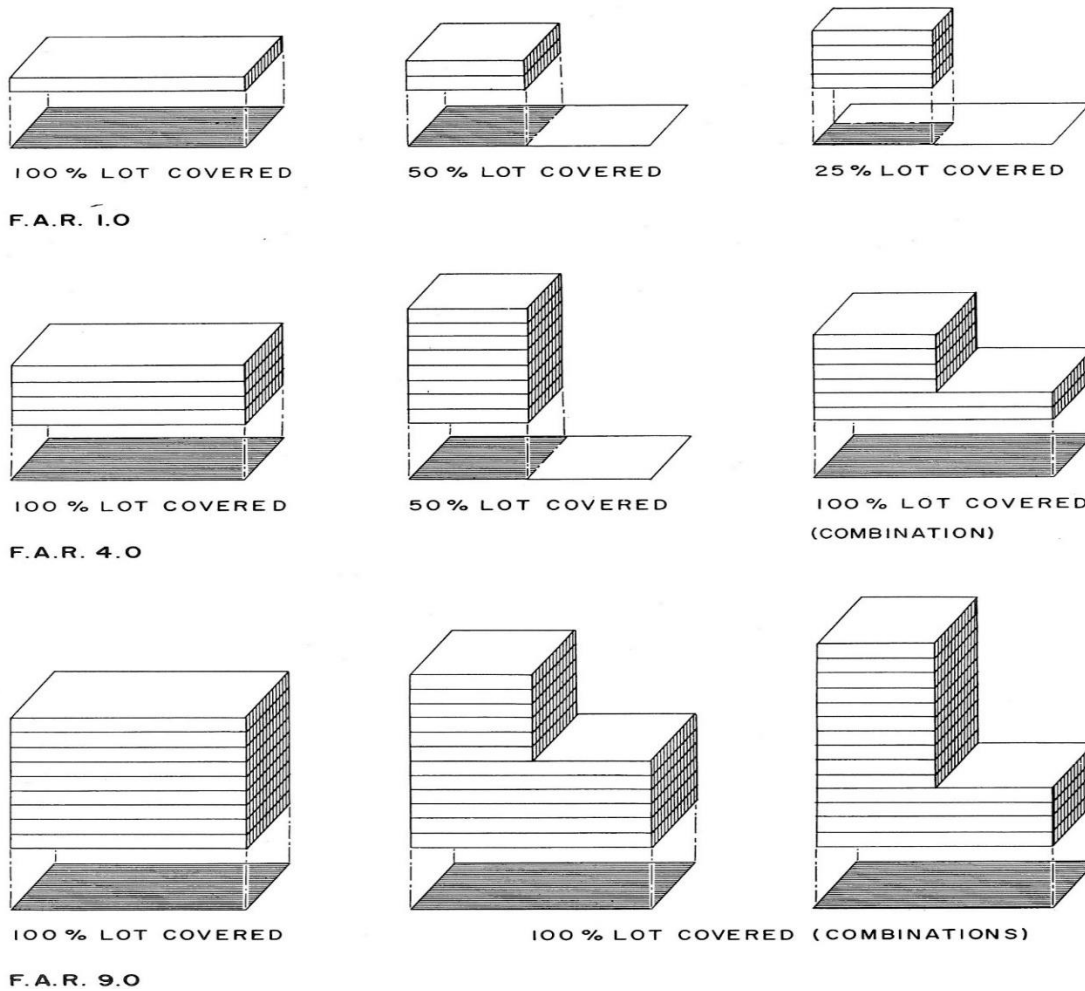

Illustrations of Floor Area Ratios. Source: *A New Zoning Plan for the District of Columbia*. Harold M. Lewis, 1956.

### ***Bulk Plane Requirements***

Bulk plane standards lower the permitted height of development near front, side and/or rear property lines by establishing an inclined plane over which buildings may not protrude. By pushing taller building elements towards the center of a lot, a bulk plane may be used to reduce looming impacts on neighboring properties and promote access to light and air.

Bulk plane standards are best suited to larger municipalities with planning staff due to the complexity of the tool and its application. If more information is desired about this method of controlling building size, bulk, and mass, please contact me.

As always, please let us know of any questions or concerns.