



## MEETING PARTICIPATION NOTICE

This meeting will be conducted utilizing teleconference communications and will be recorded for live streaming. In accordance with the State of California Executive Order N-29-20 dated March 17, 2020, all City of Beaumont public meetings will be solely available via live streaming and made available on the City's official YouTube webpage. Please use the following link during the meeting for live stream access:

### **BeaumontCa.gov/Livestream**

Public comments will be accepted using the following options:

1. Written comments will be accepted via email and will be read aloud during the corresponding item of the meeting. Public comments shall not exceed three (3) minutes unless otherwise authorized by City Council. Comments can be submitted anytime prior to the meeting as well as during the meeting up until the end of the corresponding item. Please submit your comments to: [NicoleW@BeaumontCa.gov](mailto:NicoleW@BeaumontCa.gov)
2. Teleconferenced comments will be accepted by joining the Zoom webinar during the corresponding item of the meeting. Public comments shall not exceed three (3) minutes unless otherwise authorized by City Council. Please use the following link to join the webinar at the time of the meeting: <https://us02web.zoom.us/j/86328066894>
3. Phone-in comments will be accepted by joining the Zoom webinar by calling during the corresponding item of the meeting. Public comments shall not exceed three (3) minutes unless otherwise authorized by City Council. Please use the following phone number to join the webinar: **(888) 788 0099 (Toll Free) Webinar ID: 863 2806 6894**

In compliance with the American Disabilities Act, if you require special assistance to participate in this meeting, please contact the City Clerk's office using the above email or call (951) 572-3196. Notification 48 hours prior to a meeting will ensure the best reasonable accommodation arrangements.



## CITY COUNCIL CLOSED & REGULAR SESSION

550 E. 6th Street, Beaumont, CA

Tuesday, June 02, 2020

Closed Session: 5:00 PM | Regular Meeting: 6:00 PM

### AGENDA

---

Materials related to an item on this agenda submitted to the City Council after distribution of the agenda packets are available for public inspection in the City Clerk's office at 550 E. 6th Street during normal business hours

Any person with a disability who requires accommodations in order to participate in this meeting should telephone the City Clerk's office at (951)769-8520, at least 48 hours prior to the meeting in order to make a request for a disability related modification or accommodation

Any one person may address the City Council on any matter not on this agenda. If you wish to speak, please fill out a "Public Comment Form" provided at the back table and give it to the City Clerk. There is a three (3) minute limit on public comments. There will be no sharing or passing of time to another person. State law prohibits the City Council from discussing or taking actions brought up by your comments.

---

#### CLOSED SESSION - 5:00 PM

*A Closed Session of the City Council / Beaumont Financing Authority / Beaumont Utility Authority / Beaumont Successor Agency (formerly RDA)/Beaumont Parking Authority / Beaumont Public Improvement Authority may be held in accordance with state law which may include, but is not limited to, the following types of items: personnel matters, labor negotiations, security matters, providing instructions to real property negotiators and conference with legal counsel regarding pending litigation. Any public comment on Closed Session items will be taken prior to the Closed Session. Any required announcements or discussion of Closed Session items or actions following the Closed Session will be made in the City Council Chambers.*

#### CALL TO ORDER

Mayor Santos, Mayor Pro Tem Lara, Council Member Carroll, Council Member Martinez, Council Member White

Public Comments Regarding Closed Session

- 1. Conference with Legal Counsel Regarding Anticipated/Existing Litigation - Pursuant to Government Code Section Page 1 of 271 54956.9(d)(1)and/or(2) and/or (3). (Worker's Compensation Case No. COBM-0054; COBM-0023; COBT-002879, and COBM-0070)**
- 2. Conference with Labor Negotiators - Pursuant to Government Code Section 54957.6 City Designated Representatives City Manager Todd Parton and Administrative Services Director Kari Mendoza. Employee Organizations: Beaumont Police Officers Association**

- 3. Conference with Legal Counsel - Anticipated Litigation:  
Significant exposure to liability pursuant to Government Code section 54956.9(d)(2)  
One (1) matter**

Adjourn to Regular Session

## **REGULAR SESSION - 6:00 PM**

### **CALL TO ORDER**

Mayor Santos, Mayor Pro Tem Lara, Council Member Carroll, Council Member Martinez, Council Member White

Report Out from Closed Session:

Action on Any Closed Session Items:

Action on Any Closed Session Items:

Pledge of Allegiance:

Approval / Adjustments to the Agenda:

Conflict of Interest Disclosure:

### **ANNOUNCEMENTS/ RECOGNITION / PROCLAMATIONS / CORRESPONDENCE**

#### **PUBLIC COMMENT PERIOD (ITEMS NOT ON THE AGENDA)**

*Any one person may address the City Council on any matter not on this agenda. If you wish to speak, please fill out a "Public Comment Form" provided at the back table and give it to the City Clerk. There is a three (3) minute time limit on public comments. There will be no sharing or passing of time to another person. State Law prohibits the City Council from discussing or taking actions brought up by your comments.*

#### **CONSENT CALENDAR**

*Items on the consent calendar are taken as one action item unless an item is pulled for further discussion here or at the end of action items.*

*Approval of all Ordinances and Resolutions to be read by title only.*

##### **1. Approval of Minutes**

###### **Recommended Action:**

Approve minutes dated May 19, 2020.

##### **2. A Request for Consideration of the Final, One-Year Extension of Time for Tentative Tract Map 29267**

###### **Recommended Action:**

Approve the final one-year extension of time for Tentative Map 29267.

**3. Request for Consideration of the Final, One-Year Extension of Time for Tentative Tract Map 33680 (APN 414-142-038)**

**Recommended Action:**

Approve the final, one-year extension of time for the approval of Tentative Tract Map 33680.

**4. Performance Bonds Acceptance and Security Agreement for Pardee Homes. Tract 37298-1 Traffic Signal Installation and Modifications**

**Recommended Action:**

Accept the following bonds and security agreements:  
Performance bond No. CMS331857 for traffic signal installation,  
Performance bond No. CMS331855 for traffic signal installation,  
Performance bond No. CMS331856 for traffic signal installation, and  
Performance bond No. CMS331858 for traffic signal installation.

**PUBLIC HEARINGS**

*Approval of all Ordinances and Resolutions to be read by title only.*

**5. Amendment to City of Beaumont Municipal Code Chapter 10 Section 12 – Parking Commercial Vehicles**

**Recommended Action:**

Hold a Public Hearing, and  
Waive the full first reading and approve by title only. “An Ordinance of the City of Beaumont Amending and Restating Chapter 10.12 of the Beaumont Municipal Code Entitled ‘Parking Commercial Vehicles’ and Making Findings Pursuant to the California Environmental Quality Act.”

**6. Conduct a Public Hearing and Consider a Resolution Adopting the Capital Improvement Plan (CIP) for FY 2021-2025 and Prior Year Project List**

**Recommended Action:**

Conduct a Public Hearing, and  
Waive the full reading and adopt by title only, “A Resolution of the City Council of the City of Beaumont Adopting a Five-Year Capital Improvement Plan for Fiscal Years 2021/2022 – 2024/2025 and Related Prior Year CIP Project List.”

**ACTION ITEMS**

*Approval of all Ordinances and Resolutions to be read by title only.*

**7. Consideration of a Contract for City Attorney Services between the City of Beaumont and Slovak Baron Empey Murphy & Pinkney LLP**

**Recommended Action:**

Approval of the attached contract for City Attorney Services between the City of Beaumont and Slovak Baron Empey Murphy & Pinkney LLP.

**8. Resolution of Intent – Transitioning from At-Large to By-District Elections**

**Recommended Action:**

If desired by Council, motion to pass the resolution of intent and begin the districting process by waiving the full reading, and adopting by title only, “ A Resolution of the City Council of the City of Beaumont, California, Declaring Its Intention to Transition from At-Large Elections to District-Based Elections Pursuant to Elections Code Section 10010.

**9. FY 2020-21 City-Wide Budget Review and Approval**

**Recommended Action:**

Adopt the City-Wide Budget for FY 2020-21.

**10. Approval of Contract for Auditing Services**

**Recommended Action:**

Approve a three-year contract with Rogers, Anderson, Malody and Scott, LLP to perform audit services with options for 2 one-year extensions.

**11. Ratification of Emergency Repair Costs to the City’s Wastewater System**

**Recommended Action:**

Ratify the cost of emergency repairs completed and paid to T.E. Roberts, Inc., in the amount of \$343,027.28.

**12. Facility Generators – Ratification of Emergency Repairs**

**Recommended Action:**

Ratify the costs associated with the emergency repairs to the City’s generators in an amount not to exceed \$50,000.

**13. Approval of Invoice from Riverside County Fire Department for 3rd Quarter Fire Services**

**Recommended Action:**

Approve payment of the FY 2020 3rd Quarter Fire Services invoice from Riverside County Fire Department in the amount of \$1,006,268.61.

**14. Approval of the FY 2020/21 Local Responsibility Area Wildland Protection Reimbursement Agreement**

**Recommended Action:**

Waive the full reading and approve by title only, “A Resolution of the City Council of the City of Beaumont, California, approving an Agreement with the California Department of Forestry and Fire Protection for Services from July 1, 2020 Through June 30, 2021 for Fire Protection Services within the Local Responsibility Areas within the City,” and  
Authorize the Mayor to sign the FY 2020/21 agreement with Cal-Fire for fire protection services within the Local Responsibility Areas within the City.

**15. Approval of MDC and Vehicle Functionality Equipment**

**Recommended Action:**

Approve the purchase of sixteen Panasonic Toughbooks with outfitted accessories and installation from CDCE Mobile in the amount of \$133,825.78.

**16. Police Department Air Conditioning Units – Emergency Repairs**

**Recommended Action:**

Ratify the costs associated with the emergency repairs to the Police Department air conditioning units in the amount of \$42,000.

**17. Pennsylvania Widening Project Update**

**Recommended Action:**

Receive and file the Pennsylvania Widening Project Update.

**LEGISLATIVE UPDATES AND DISCUSSION**

**COUNCIL REPORTS**

- Carroll
- Lara
- Martinez
- Santos
- White

**ECONOMIC DEVELOPMENT UPDATE**

Economic Development Committee Report Out and City Council Direction

**CITY TREASURER REPORT**

Finance and Audit Committee Report Out and City Council Direction

**CITY CLERK REPORT**

**CITY ATTORNEY REPORT**

**18. Status of Litigation Report**

**CITY MANAGER REPORT**

**FUTURE AGENDA ITEMS**

**ADJOURNMENT**

The next regular meeting of the Beaumont City Council, Beaumont Financing Authority, the Beaumont Successor Agency (formerly RDA), the Beaumont Utility Authority, the Beaumont Parking Authority and the Beaumont Public Improvement Agency is scheduled for Tuesday, June 16 2020, at 5:00 p.m. or thereafter as noted on the posted Agenda for Closed Session items in the City Council Board Room No. 5, followed by the regular meeting at 6:00 p.m. or thereafter as noted on the posted Agenda at City Hall.

Beaumont City Hall – Online [www.BeaumontCa.gov](http://www.BeaumontCa.gov)

# CITY COUNCIL CLOSED & REGULAR SESSION

550 E. 6th Street, Beaumont, CA  
 Tuesday, May 19, 2020 - 6:00 PM

## MINUTES

### REGULAR SESSION

6:00 PM

### CLOSED SESSION - 5:00 PM

*A Closed Session of the City Council / Beaumont Financing Authority / Beaumont Utility Authority / Beaumont Successor Agency (formerly RDA)/Beaumont Parking Authority / Beaumont Public Improvement Authority may be held in accordance with state law which may include, but is not limited to, the following types of items: personnel matters, labor negotiations, security matters, providing instructions to real property negotiators and conference with legal counsel regarding pending litigation. Any public comment on Closed Session items will be taken prior to the Closed Session. Any required announcements or discussion of Closed Session items or actions following the Closed Session will be made in the City Council Chambers.*

#### **CALL TO ORDER at 5:02 p.m.**

**Present:** Mayor Santos, Mayor Pro Tem Lara, Council Member Carroll, Council Member Martinez, Council Member White

Public Comments Regarding Closed Session

#### **No speakers**

1. Conference with Labor Negotiators - Pursuant to Government Code Section 54957.6 City Designated Representatives City Manager Todd Parton and Administrative Services Director Kari Mendoza. Employee Organizations: Beaumont Police Officers Association

**No reportable action.**

2. Conference with Legal Counsel Existing Litigation-Pursuant to Government Code Section 54956.9(d)(1): Urban Logic v. City of Beaumont et. al. Case No. RIC 1797201

**No reportable action.**

Adjourn to Regular Session



**REGULAR SESSION - 6:00 PM****CALL TO ORDER at 6:02 p.m.**

**Present:** Mayor Santos, Mayor Pro Tem Lara, Council Member Carroll, Council Member Martinez, Council Member White

Report out from Closed Session: *see above*

Action on any Closed Session items: **None**

Action of any requests for Excused Absence: **None**

Pledge of Allegiance

Approval / Adjustments to the Agenda: **None**

Conflict of Interest Disclosure: **None**

**ANNOUNCEMENTS/ RECOGNITION / PROCLAMATIONS / CORRESPONDENCE****PUBLIC COMMENT PERIOD (ITEMS NOT ON THE AGENDA)**

*Any one person may address the City Council on any matter not on this agenda. If you wish to speak, please fill out a "Public Comment Form" provided at the back table and give it to the City Clerk. There is a three (3) minute time limit on public comments. There will be no sharing or passing of time to another person. State Law prohibits the City Council from discussing or taking actions brought up by your comments.*

**No speakers.**

**CONSENT CALENDAR**

*Items on the consent calendar are taken as one action item unless an item is pulled for further discussion here or at the end of action items.*

*Approval of all Ordinances and Resolutions to be read by title only.*

1. Approval of Minutes

Recommended Action:

**Approve Minutes dated May 5, 2020.**

2. Approve a Park Dedication Agreement between the City of Beaumont and SDC Fairway Canyon, LLC for Trevino Park, Palmer Park, and Nicklaus Park (APNs 413-790-047, 413-790-037, 413-290-026, 413-460-051, and 413-790-030)

Recommended Action:

**Approve a Park Dedication Agreement between the City of Beaumont and SDC Fairway Canyon, LLC for Trevino Park, Palmer Park, and Nicklaus Park (APNs 413-790-047, 413-790-037, 413-290-026, 413-460-051, and 413-790-030) and authorize the Mayor to execute the agreement on behalf of the City of Beaumont.**

3. General Plan Update Contract Amendment No. 4 with Raimi + Associates for an Update to the Travel Demand Model for the General Plan Update Traffic Impact Analysis to Include the Connection of Second Street to Pennsylvania Avenue

Recommended Action:

**Approve Contract Amendment No. 4 to the purchase order with Raimi + Associates for the general plan update and the environmental impact report in the amount of \$5,945 for a total contract amount not to exceed \$840,129.**

**Motion by Council Member White  
Second by Council Member Martinez**

To approve the Consent Calendar

**Ayes: Council Member White, Council Member Martinez, Council Member Carroll, Mayor Pro Tem Lara, Mayor Santos**

**Approved by a unanimous vote**

## **PUBLIC HEARINGS**

*Approval of all Ordinances and Resolutions to be read by title only.*

4. Public Hearing and Consideration of Adopting a Resolution Updating the Transportation Uniform Mitigation Fee Schedule

**Public Hearing opened at 6:11**

**Public Hearing closed at 6:12**

**Motion by Council Member White  
Second by Mayor Pro Tem Lara**

To waive the full reading and adopt by title only, "A Resolution of the City Council of the City of Beaumont Amending the Transportation Uniform Mitigation Fee (TUMF) Ordinance of 2017 (TUMF) Under Beaumont Municipal Code Section 3.39.040.A and 3.39.040.C Applicable to All Developments in the City of Beaumont."

**Ayes: Council Member White, Council Member Martinez, Council Member Carroll, Mayor Pro Tem Lara, Mayor Santos**

**Approved by a unanimous vote**

## **ACTION ITEMS**

*Approval of all Ordinances and Resolutions to be read by title only.*

5. Approval of Acquisition Agreement in connection with Community Facilities District No. 93-1 (the "District") Improvement Area No. 8F

**Motion by Council Member White  
Second by Council Member Martinez**

To waive the full reading and adopt by title only, “A Resolution of the City Council of the City of Beaumont, Authorizing the Execution and Delivery of an Acquisition Agreement Relating to Improvement Area No. 8F of Community Facilities District No. 93-1 of the City of Beaumont and Approving Certain Documents and Taking Certain Other Actions in Connection Therewith.”

**Ayes: Council Member White, Council Member Martinez, Council Member Carroll, Mayor Pro Tem Lara, Mayor Santos**

**Approved by a unanimous vote**

6. Approval of Resolution authorizing the issuance of 2020 Special Tax Bonds in Conjunction with Community Facilities District 93-1 Improvement Area 8F

**Motion by Council Member Martinez**

**Second by Mayor Santos**

To waive the full reading and adopt by title only, “A Resolution of the City Council of the City of Beaumont, Acting as the Legislative Body of the City of Beaumont Community Facilities District No. 93-1, Authorizing the Issuance of Its (Improvement Area No. 8F) 2020 Special Tax Bonds in an Aggregate Principal Amount Not to Exceed \$15,000,000 and Approving Certain Documents and Taking Certain Other Actions in Connection Therewith.”

**Ayes: Council Member White, Council Member Martinez, Council Member Carroll, Mayor Pro Tem Lara, Mayor Santos**

**Approved by a unanimous vote**

7. Phase I Findings of the Comprehensive Operations Analysis

**Motion by Council Member White**

**Second by Mayor Santos**

To receive and file.

**Ayes: Council Member White, Council Member Martinez, Council Member Carroll, Mayor Pro Tem Lara, Mayor Santos**

**Approved by a unanimous vote**

8. Award a Professional Services Agreement to Cozad & Fox, Inc., for the Feasibility and Design of the Second Street Extension Project in an Amount Not to Exceed \$199,915

**Motion by Council Member White**

**Second by Council Member Martinez**

To award a Professional Services Agreement to Cozad & Fox, Inc., for the feasibility and design of the Second Street Extension Project in an amount not to exceed \$199,915.

**Ayes: Council Member White, Council Member Martinez, Council Member Carroll, Mayor Pro Tem Lara, Mayor Santos**

**Approved by a unanimous vote**

9. City Council Annual Review of Contracts

**John Pinkney recused himself from this item.**

**Discussion of specific contracts including the current City Attorney contract and other legal services.**

10. City Attorney Invoices for the Month of April 2020

**Motion by Council Member White  
Second by Mayor Pro Tem Lara**

Approve invoices in the amount of \$95,367.15.

**Ayes: Council Member White, Council Member Martinez, Council Member Carroll, Mayor Pro Tem Lara, Mayor Santos**

**Approved by a unanimous vote**

## **LEGISLATIVE UPDATES AND DISCUSSION**

### **11. Townsend Legislative Report**

#### **COUNCIL REPORTS**

- Carroll - Spoke regarding the Riverside County Board of Supervisor meeting and the Cherry Valley warehouse project being approved.
- Lara - No report.
- Martinez - Gave a report out from the Finance and Audit Committee.
- Santos - Gave an update to regarding the projects happening throughout the City and the need to support small businesses.
- White - No report.

#### **CITY TREASURER REPORT**

**Gave a report out from the Finance and Audit Committee meeting.**

#### **CITY CLERK REPORT**

**Gave a report of the Public Records Requests for the month of April.**

#### **CITY ATTORNEY REPORT**

**No report.**

**CITY MANAGER REPORT**

**Gave an update as to the orders from the State and how the City is maintaining levels of operations.**

**FUTURE AGENDA ITEMS**

**Proposal of adding a future item of an Emergency Economic Relief Program**

**Motion by Mayor Santos  
Second by Council Member  
Approved by a unanimous vote.**

**Proposal of adding a future item of creating a committee for support of small businesses to be able to open safely and hold a special meeting to do so.**

**Motion by Council Member White  
Second by Mayor Pro Tem Lara  
Approved by a unanimous vote.**

**ADJOURNMENT at 8:48 p.m.**



## Staff Report

**TO:** Mayor and City Council Members  
**FROM:** Christina Taylor, Community Development Director  
**DATE:** June 2, 2020  
**SUBJECT:** **A Request for Consideration of the Final, One-Year Extension of Time for Tentative Tract Map 29267**

---

### Background and Analysis:

The Noble Creek Specific Plan was approved for a maximum of 648 homes with lot sizes ranging from 6,000 square feet to 15,000 square feet and 4 neighborhood parks. Tentative Map 29267 proposes 274 single-family homes. The property is located on the north side of Oak Valley Parkway and south of Brookside Avenue, west of Beaumont Avenue adjacent the Noble Creek park area. The property is zoned Specific Plan Area (SPA) Noble Creek Specific Plan. The property to the north is zoned Public Facilities (PF) and is occupied by Beaumont High School. The property to the south is zoned Residential Single Family (RSF) and Specific Plan Area (SPA) Kirkwood Ranch. To the west, the properties are zoned Recreation and Conservation (RC) occupied by the Noble Creek park and Specific Plan Area (SPA) Oak Valley Greens. Properties to the east are zoned Residential Multi-Family (RMF) and Residential Single Family (RSF).

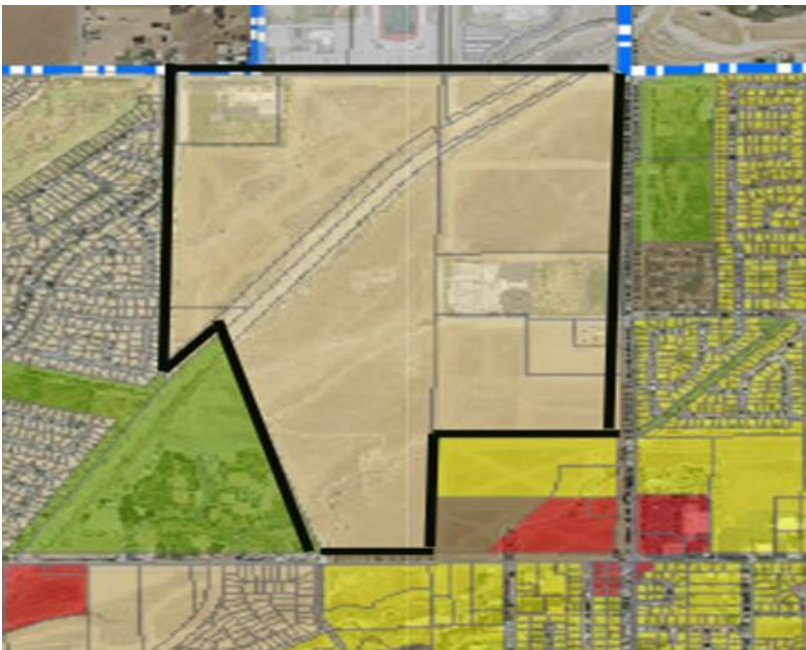

Tentative Tract Map 29267 (99-TM-02) was approved by City Council on December 16, 1999, and was subsequently litigated. Upon execution of a settlement agreement the effective approval date became May 25, 2006, for a two-year period. Additionally, the City Council approved a one-year extension until May 25, 2009.

The following California bills also extended the map for seven (7) years in California:

SB 1185 – Automatic on-year extension. Extension until May 25, 2010,

AB 333 – Automatic two-year extension. Extension until May 25, 2012,

AB 208 – Automatic two-year extension. Extension until May 25, 2014, and

AB 116 – Automatic two-year extension. Extension until May 25, 2016.

The City Council has approved four additional one-year extensions for the map resulting in an expiration of May 25, 2020.

The Subdivision Map Act (66463.5(c)) allows the applicant to apply for a maximum of six (6) additional one-year extensions. The applicant is currently requesting their sixth and final one-year extension as the map has not been finalized. If approved, the map will expire on May 25, 2021, with no additional extensions remaining.

The applicants have been working diligently with the required environmental and wildlife agencies to address issues on the site. There are no unusual or changed circumstances which affect this map or the consideration of a time extension. On May 12, 2020, the City's Planning Commission conducted a public hearing and recommended approval of the final, one-year extension.

**Fiscal Impact:**

None.

**Recommended Action:**

Approve the final one-year extension for Tentative Map 29267.

**Attachments:**

- A. TTM 29267
- B. Conditions of Approval
- C. 2017 Additional Conditions of Approval

APPROVAL OF REVISION NO. 1

PLANNING DIRECTOR, CITY OF BEAUMONT

DATE

CITY OF BEAUMONT  
REVISION NO. 1  
TENTATIVE TRACT NO. 29267

PREPARED FOR: NOBEL CREEK MEADOWS LLC

JULY 23, 2014

SHEET 2 OF 2

GABEL, COOK & ASSOCIATES INC.

LAND SURVEYORS

1777 E. IRLAND AVE. # 200, BEAUMONT, TX 77705

TELEPHONE (409) 796-4127 FAX (409) 796-0194

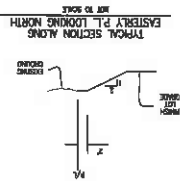

- NOTES FOR REVISION NO. 1
1. REFER TO THE APPROVALS THROUGH MAP FOR GENERAL NOTES.
  2. PLACE THE PROPOSED TRACT IN LOTS.
  3. THE PROPOSED LOT COUNT IS 12 LOTS.
  4. THE PROPOSED LOT SIZE IS 100 SQ. FT.
  5. THE PROPOSED LOT SIZE IS 100 SQ. FT.
  6. THE PROPOSED LOT SIZE IS 100 SQ. FT.
  7. THE PROPOSED LOT SIZE IS 100 SQ. FT.
  8. THE PROPOSED LOT SIZE IS 100 SQ. FT.
  9. THE PROPOSED LOT SIZE IS 100 SQ. FT.
  10. THE PROPOSED LOT SIZE IS 100 SQ. FT.
  11. THE PROPOSED LOT SIZE IS 100 SQ. FT.
  12. THE PROPOSED LOT SIZE IS 100 SQ. FT.
  13. THE PROPOSED LOT SIZE IS 100 SQ. FT.
  14. THE PROPOSED LOT SIZE IS 100 SQ. FT.
  15. THE PROPOSED LOT SIZE IS 100 SQ. FT.
  16. THE PROPOSED LOT SIZE IS 100 SQ. FT.
  17. THE PROPOSED LOT SIZE IS 100 SQ. FT.
  18. THE PROPOSED LOT SIZE IS 100 SQ. FT.
  19. THE PROPOSED LOT SIZE IS 100 SQ. FT.
  20. THE PROPOSED LOT SIZE IS 100 SQ. FT.
  21. THE PROPOSED LOT SIZE IS 100 SQ. FT.
  22. THE PROPOSED LOT SIZE IS 100 SQ. FT.
  23. THE PROPOSED LOT SIZE IS 100 SQ. FT.
  24. THE PROPOSED LOT SIZE IS 100 SQ. FT.
  25. THE PROPOSED LOT SIZE IS 100 SQ. FT.
  26. THE PROPOSED LOT SIZE IS 100 SQ. FT.
  27. THE PROPOSED LOT SIZE IS 100 SQ. FT.
  28. THE PROPOSED LOT SIZE IS 100 SQ. FT.
  29. THE PROPOSED LOT SIZE IS 100 SQ. FT.
  30. THE PROPOSED LOT SIZE IS 100 SQ. FT.
  31. THE PROPOSED LOT SIZE IS 100 SQ. FT.
  32. THE PROPOSED LOT SIZE IS 100 SQ. FT.
  33. THE PROPOSED LOT SIZE IS 100 SQ. FT.
  34. THE PROPOSED LOT SIZE IS 100 SQ. FT.
  35. THE PROPOSED LOT SIZE IS 100 SQ. FT.
  36. THE PROPOSED LOT SIZE IS 100 SQ. FT.
  37. THE PROPOSED LOT SIZE IS 100 SQ. FT.
  38. THE PROPOSED LOT SIZE IS 100 SQ. FT.
  39. THE PROPOSED LOT SIZE IS 100 SQ. FT.
  40. THE PROPOSED LOT SIZE IS 100 SQ. FT.
  41. THE PROPOSED LOT SIZE IS 100 SQ. FT.
  42. THE PROPOSED LOT SIZE IS 100 SQ. FT.
  43. THE PROPOSED LOT SIZE IS 100 SQ. FT.
  44. THE PROPOSED LOT SIZE IS 100 SQ. FT.
  45. THE PROPOSED LOT SIZE IS 100 SQ. FT.
  46. THE PROPOSED LOT SIZE IS 100 SQ. FT.
  47. THE PROPOSED LOT SIZE IS 100 SQ. FT.
  48. THE PROPOSED LOT SIZE IS 100 SQ. FT.
  49. THE PROPOSED LOT SIZE IS 100 SQ. FT.
  50. THE PROPOSED LOT SIZE IS 100 SQ. FT.
  51. THE PROPOSED LOT SIZE IS 100 SQ. FT.
  52. THE PROPOSED LOT SIZE IS 100 SQ. FT.
  53. THE PROPOSED LOT SIZE IS 100 SQ. FT.
  54. THE PROPOSED LOT SIZE IS 100 SQ. FT.
  55. THE PROPOSED LOT SIZE IS 100 SQ. FT.
  56. THE PROPOSED LOT SIZE IS 100 SQ. FT.
  57. THE PROPOSED LOT SIZE IS 100 SQ. FT.
  58. THE PROPOSED LOT SIZE IS 100 SQ. FT.
  59. THE PROPOSED LOT SIZE IS 100 SQ. FT.
  60. THE PROPOSED LOT SIZE IS 100 SQ. FT.
  61. THE PROPOSED LOT SIZE IS 100 SQ. FT.
  62. THE PROPOSED LOT SIZE IS 100 SQ. FT.
  63. THE PROPOSED LOT SIZE IS 100 SQ. FT.
  64. THE PROPOSED LOT SIZE IS 100 SQ. FT.
  65. THE PROPOSED LOT SIZE IS 100 SQ. FT.
  66. THE PROPOSED LOT SIZE IS 100 SQ. FT.
  67. THE PROPOSED LOT SIZE IS 100 SQ. FT.
  68. THE PROPOSED LOT SIZE IS 100 SQ. FT.
  69. THE PROPOSED LOT SIZE IS 100 SQ. FT.
  70. THE PROPOSED LOT SIZE IS 100 SQ. FT.
  71. THE PROPOSED LOT SIZE IS 100 SQ. FT.
  72. THE PROPOSED LOT SIZE IS 100 SQ. FT.
  73. THE PROPOSED LOT SIZE IS 100 SQ. FT.
  74. THE PROPOSED LOT SIZE IS 100 SQ. FT.
  75. THE PROPOSED LOT SIZE IS 100 SQ. FT.
  76. THE PROPOSED LOT SIZE IS 100 SQ. FT.
  77. THE PROPOSED LOT SIZE IS 100 SQ. FT.
  78. THE PROPOSED LOT SIZE IS 100 SQ. FT.
  79. THE PROPOSED LOT SIZE IS 100 SQ. FT.
  80. THE PROPOSED LOT SIZE IS 100 SQ. FT.
  81. THE PROPOSED LOT SIZE IS 100 SQ. FT.
  82. THE PROPOSED LOT SIZE IS 100 SQ. FT.
  83. THE PROPOSED LOT SIZE IS 100 SQ. FT.
  84. THE PROPOSED LOT SIZE IS 100 SQ. FT.
  85. THE PROPOSED LOT SIZE IS 100 SQ. FT.
  86. THE PROPOSED LOT SIZE IS 100 SQ. FT.
  87. THE PROPOSED LOT SIZE IS 100 SQ. FT.
  88. THE PROPOSED LOT SIZE IS 100 SQ. FT.
  89. THE PROPOSED LOT SIZE IS 100 SQ. FT.
  90. THE PROPOSED LOT SIZE IS 100 SQ. FT.
  91. THE PROPOSED LOT SIZE IS 100 SQ. FT.
  92. THE PROPOSED LOT SIZE IS 100 SQ. FT.
  93. THE PROPOSED LOT SIZE IS 100 SQ. FT.
  94. THE PROPOSED LOT SIZE IS 100 SQ. FT.
  95. THE PROPOSED LOT SIZE IS 100 SQ. FT.
  96. THE PROPOSED LOT SIZE IS 100 SQ. FT.
  97. THE PROPOSED LOT SIZE IS 100 SQ. FT.
  98. THE PROPOSED LOT SIZE IS 100 SQ. FT.
  99. THE PROPOSED LOT SIZE IS 100 SQ. FT.
  100. THE PROPOSED LOT SIZE IS 100 SQ. FT.



REVISION NO. 1  
TENTATIVE TRACT NO. 29267  
CITY OF BEAUMONT



**CITY OF BEAUMONT  
SUBDIVISION  
CONDITIONS OF APPROVAL**

**AMENDMENT #1 - TENTATIVE TRACT MAP NO. 29267  
EIR NO. 97-1  
APN: 400-250-008  
APPLICANT: NOBLE CREEK MEADOWS, LLC.**

**CITY COUNCIL  
APPROVAL DATE:  
February 15, 2005**

---

**AMENDMENT #1  
COUNCIL APPROVAL DATE:  
December 16, 2014**

**1.0 STANDARD CONDITIONS**

- 1.1 The following conditions of approval are for **AMENDMENT #1 TENTATIVE TRACT NO. 29267**, and consist of Conditions 1.1 through 1.17, Conditions 2.1 through 2.7, Conditions 3.1 through 3.26, Conditions 4.1 through 4.23, Conditions 5.1 through 5.13, Conditions 6.1 through 6.11; and pages 1 through 14, inclusive.
- 1.2 The subdivider shall defend, indemnify, and hold harmless the City of Beaumont, its agents, officers, and employees from any claim, action, or proceeding against the City of Beaumont, its agents, officers, or employees to attack, set aside, void, or annul an approval of the City of Beaumont, its advisory agencies, appeal boards, or legislative body concerning **TENTATIVE TRACT NO. 29267 and Environmental Impact Report 97-1** which action is brought within the time period provided for in California Government Code, Section 66499.37. The City of Beaumont will promptly notify the subdivider of any such claim, action, or proceeding against the City of Beaumont and will cooperate fully in the defense. If the City fails to promptly notify the subdivider of any such claim, action, or proceeding or fails to cooperate fully in the defense, the subdivider shall not, thereafter, be responsible to defend, indemnify, or hold harmless the City of Beaumont.
- 1.3 The subdivision shall comply with the State of California Subdivision Map Act and to all the pertinent requirements of The Beaumont Municipal Code, unless modified by the conditions listed below.
- 1.4 This conditionally approved tentative map will expire two (2) years after the original approval date, unless extended as provided by the Beaumont Municipal Code, the State Subdivision Map Act or by a development agreement. Action on a minor change and/or revised map request will not extend the time limits of the tentative map. Approval of the tentative map by the City Council occurred May 25, 1999; per settlement February 15, 2005; Amendment #1 approval occurred on December 16, 2014.
- 1.5 The final map shall be prepared by a licensed land surveyor or registered civil engineer subject to all the requirements of the State of California Subdivision Map Act and The Beaumont Municipal Code.

**TENTATIVE TRACT MAP NO. 29267 – Amendment #1**  
**Conditions of Approval**  
**Page 2 of 14**

- 1.6 Within ten (10) days of approval by the City Council ten (10) copies of an Amended Per Final Conditions map shall be submitted to and approved by the Planning Director, if determined to be necessary, prior to release of the final conditions of approval. The amended map shall be in substantial conformance with Exhibit B.
- 1.7 Any subsequent review/approvals required by the conditions of approval, including but not limited to grading, landscaping, plot plan and/or building plan review, shall be reviewed on an hourly basis based on, or such fee as may be in effect at the time of submittal, listed in Ordinance No. 506.
- 1.8 The subdivider shall be fully responsible for maintenance and upkeep of any and all slopes, landscaped areas, open space areas, future development areas and irrigation systems until such time as maintenance responsibilities are assumed by other as approved by the Planning Director.
- 1.9 If human remains are encountered during grading and other construction excavation, work in the immediate vicinity shall cease and the County Coroner shall be contacted pursuant to State Health and Safety Code Section 7070.5.
- 1.10 In the event that significant Native American cultural resources are discovered during project development/construction, all work in the immediate vicinity shall cease and a qualified archaeologist meeting Secretary of Interior standards shall be retained to assess the find. Work on the overall project may continue during this assessment period. If a Treatment Plan or cultural resources management plan is required, the developer shall be required to have the archaeologist consult with the relevant Native American authority regarding the disposition of any found artifacts.
- 1.11 The development and uses entitled pursuant to the permit shall comply with the Beaumont Municipal Code and all other applicable City of Beaumont ordinances and state and federal codes. The development of the premises shall conform substantially with that as shown on the plot plan, unless otherwise amended by these conditions of approval.
- 1.12 All subsequent submittals required by these conditions of approval, including but not limited to landscape plans, grading plans, building plans, improvement plans or mitigation monitoring plans, shall be subject to the payment of review fees by the permittee as set forth herein.
- 1.13 If deemed necessary by the Director of Planning, within thirty (30) days of approval by the Planning Commission ten (10) copies of an Amended Per Final Conditions set of the following Exhibits shall be submitted to the Planning Director and Public Works Department for review approval.

**TENTATIVE TRACT MAP NO. 29267 – Amendment #1**  
**Conditions of Approval**  
**Page 3 of 14**

- Exhibit "B" - Grading and Erosion Control Plan  
 Exhibit "C" - Landscape and Irrigation Plan
- 1.14 The properties contained within the Tentative Tract No. 29267 are part of the Noble Creek Vistas Specific Plan & EIR, approved by the Beaumont City Council on in 2005. The provisions and criteria of the Noble Creek Vistas Specific Plan shall control and guide the development of Tentative Tract No. 29267.
- 1.15 An Environmental Impact Report was prepared and certified for the Noble Creek Vistas Specific Plan and a series of mitigation measures were adopted by the City Council to mitigate the potential environmental impacts of the project. All of the mitigation measures set forth in the subject environmental document are conditions of approval for Tentative Tract No. 29267.
- 1.16 Tentative Tract No. 29267 has been found to be substantially in conformance with the Noble Creek Vistas Specific Plan & EIR.
- 1.17 If there are any conflicts between the Conditions of Approval as set forth under this application, the original Conditions of Approvals, or the Specific Plan, the higher standard shall prevail or otherwise be reviewed by the Planning Director.

**2.0 AGENCY CONDITIONS**

- 2.1 The subdivider shall comply with the requirements set forth in the City Public Works Department conditions, a copy of which is attached hereto.
- 2.2 The subdivider shall comply with the requirements of the Beaumont Police Department.
- 2.3 The subdivider shall comply with the requirements set forth by the Beaumont Fire Department.
- 2.4 The subdivider shall comply with the requirements as set forth by the Beaumont-Cherry Valley Water District.
- 2.5 The subdivider shall comply with the requirements as set forth by the Southern California Gas Company.
- 2.6 The subdivider shall comply with the requirement as set forth by the Beaumont Unified School District.
- 2.7 The subdivider shall comply with the requirement as set forth by the Riverside County Flood Control District.

**3.0 RECORDATION CONDITIONS**

**TENTATIVE TRACT MAP NO. 29267 – Amendment #1**  
**Conditions of Approval**  
**Page 4 of 14**

Prior to the RECORDATION of any final map, all the following conditions shall be satisfied:

- 3.1 The subdivider shall submit written clearances to the Public Works Department that all pertinent requirements from the following agencies have been met:
- City Fire Department
  - City Police Department
  - City Community and Economic Development Department
  - Beaumont Cherry Valley Water District
  - Beaumont Unified School District
- 3.2 All road easements shall be offered for dedication to the public and shall continue in force until the governing body accepts or abandons such offers. All dedications shall be free from all encumbrances as approved by the Public Works Department. Street names shall be subject to the approval of the Public Works Department. Secondary access shall be offered for dedication and improved from the tract map boundary to a City maintained road as approved by the Public Works Department prior to recordation. The final street sections, configurations and improvements shall be subject to the approval of the Public Works Department.
- 3.3 All delinquent property taxes, special taxes and assessments shall be paid to the Riverside County Tax Collectors Office.
- 3.4 Easements, when required for roadway slopes, drainage facilities, utilities, etc., shall be shown on the final map if they are located within the land division boundary. All offers of dedication and conveyances shall be submitted and recorded as directed by the Public Works Department.
- 3.5 Utilities shall be installed underground as approved by the Public Works Department.
- 3.6 No lots fronting on knuckles, or cul-de-sacs shall have less than thirty-five (25) feet of frontage measured at the property line, with the exception of flag lots as approved by the Director of Planning.
- 3.7 This subdivision may be recorded in phases subject to the following:
- a. Phasing, including phase boundaries and sequencing, shall be subject to Planning Director approval.
  - b. Common open space area improvement phasing, as applicable, shall be required subject to Planning Director approval.
- 3.8 The subdivider is obligated to provide fully improved park space at a ratio of number of lots x 3.2 persons per household x 5 acres per 1,000 population. Said conditions of approval

**TENTATIVE TRACT MAP NO. 29267 – Amendment #1**  
**Conditions of Approval**  
**Page 5 of 14**

require park improvements and/or fees (\$4 per square foot of required park area), and these requirements shall be applicable on a pro-rata basis for this subdivision.

- 3.9 The subdivider shall convey to the approved landscape maintenance entity fee simple title at no cost to the entity all park and open space areas, free and clear of all liens, taxes, assessment, leases (recorded and unrecorded) and easements, except those easements which in the sole discretion of the entity are acceptable.
- 3.10 The maintenance and management of common open space areas and common facilities shall be conducted as set forth herein and approved by the Director of Planning. All provisions of said condition shall be satisfied prior to map recordation.
- 3.11 A hydrology study, to the satisfaction of the Public Works Department, shall be prepared and approved prior to recordation. Said hydrology study shall be based upon methodology which is acceptable to the Riverside County Flood Control and Water Conservation District, and shall address the potential impacts of the project, as well as downstream impacts resulting from the project, and shall identify the level of responsibility of the project in correcting any downstream problems.
- 3.12 Prior to recordation, the subdivider shall work with the City and the Public Works Department to establish the necessary financing and implementation measures to ensure the provision of a fair share of such necessary facilities.
- 3.13 A total of 20 final, blue-line, final maps shall be submitted to the Public Works Department for final distribution to the agencies.
- 3.14 All perimeter walls and/or walls that front streets must be block wall. No wood fencing shall be permitted in this project.
- 3.15 Conditions, Covenants, and Restrictions (CC&R's) may be recorded for this tract by the Subdivider. A note shall be placed on the cover page of said CC&R's which states as follows: "The City of Beaumont shall not be responsible for the enforcement of the CC&R's for Tract No. 29267."
- 3.16 Lots created by this subdivision shall comply with the following:
- a. Lots created by this subdivision shall be in conformance with the development standards of the Noble Creek Vistas Specific Plan & Settlement in conjunction with this subdivision map.
  - b. All sewer, storm drain and other public utility crossings in side and rear yards to be located in fee title lots and not easements.
- 3.17 The open space areas described in Condition 3.15 and otherwise set forth in the Noble Creek Vistas Specific Plan, shall, as applicable, be shown as numbered lots on the final map, shall

**TENTATIVE TRACT MAP NO. 29267 – Amendment #1**  
**Conditions of Approval**  
**Page 6 of 14**

- be improved and offered for dedication to the City/CFD, Homeowner's Association or other maintenance entity approved by the Planning Director.
- 3.18 The subdivider shall comply with the following park, open space and parkway landscaping conditions for open-space areas described in Condition No. 3.9.
- a. The subdivider shall post a landscape performance bond or other acceptable security approved by the Planning Director which shall be released concurrently with the assumption of the maintenance responsibility by the City, Homeowners' Association or other entity approved pursuant to Condition 3.9. The bond or security shall include ninety (90) days of landscape maintenance costs.
  - b. The subdivider shall file a Landscaping application including detailed landscaping and irrigation plans for the subject area. The Minor Plot Plan shall require all improvements to be constructed concurrently with the development of the residential lots are part of this tract. The areas identified for park facilities shall be completed prior to completion of any one phase or 25% of the lots, whichever comes first.
- 3.19 The subdivider shall be responsible for the provision of a fair share of the necessary roadway, water, sewer and drainage facilities for the orderly implementation of the Noble Creek Vistas Specific Plan and the existing master plans for these facilities. Prior to recordation, the subdivider shall work with the City and the Public Works Department to establish the necessary financing and implementation measures to ensure the provision of a fair share of such necessary facilities.
- 3.20 A total of 20 final, blue-line, final maps shall be submitted to the Public Works Department for final distribution to the agencies.
- 3.21 All perimeter walls and/or walls that front streets must be block wall. No wood fencing shall be permitted in this project. All walls along the perimeter shall be designed to eliminate any potential gap between the new walls and any existing walls.
- 3.22 The developer shall participate in the Beaumont implementation of the transportation improvement program of the City; and Developer, as a condition of approval, shall enter into an Improvement Credit Agreement with the City of Beaumont.
- 3.23 Prior to map recordation the Public Works Department shall approved final plans for the improvements required for the Noble Creek Channel.
- 3.24 The final map shall provide for the establishment of Project and neighborhood Entry Feature(s), as set forth in the design details contained in the Noble Creek Vistas Specific Plan. The final map shall reflect the appropriate corner cut-offs to accommodate the required entry treatments.

**TENTATIVE TRACT MAP NO. 29267 – Amendment #1**  
**Conditions of Approval**  
**Page 7 of 14**

- 3.25 The maintenance and management of common open-space areas shall be conducted as set forth herein and approved by the Director of Planning and by a Homeowners' Association (HOA) or some other entity. All provisions of the said condition shall be satisfied prior to map recordation
- 3.26 An additional "Open Space" designated lot shall be incorporated into the Final Map Design between Lots 217 and 218 for additional pedestrian walkway access, to the satisfaction of the Director of Planning.

**4.0 GRADING & LANDSCAPING CONDITIONS**

- 4.1 Prior to the issuance of GRADING PERMITS, the subdivider shall comply with all the following grading conditions:
- a. The land divider or developer shall submit five (5) prints of a comprehensive grading plan to the Public Works Department which complies with the Uniform Building Code, the Beaumont Municipal Code and as may be additionally provided for in these conditions.
  - b. A grading permit shall be obtained from the City Public Works Department prior to commencement of any grading.
  - c. Graded land shall be provided with erosion control measures as approved by the Public Works Department.
- 4.2 Detailed landscaping and irrigation plans shall be submitted to and approved by the Planning Director for the phase of development in process. The plans shall address all areas and aspects of the tract requiring landscaping and irrigation to be installed including, but not limited to, front yards, parkway planting, recreation trail, street trees, slope planting, common area and/or park landscaping. The plans shall be certified by a landscape architect, and shall provide for the following:
- a. Permanent automatic irrigation systems shall be installed on all landscaped areas requiring irrigation. Low water use systems shall be specified.
  - b. Landscape screening where required shall be designed to be opaque up to a minimum height of six (6) feet at maturity.
  - c. All utility service areas and enclosures shall be screened from view with landscaping and decorative barriers or baffle treatments, as approved by the Planning Director. Utilities shall be placed underground wherever feasible.
  - d. Landscaping plans shall incorporate the use of specimen accent trees (24" box minimum) at key visual focal points within the project.

**TENTATIVE TRACT MAP NO. 29267 – Amendment #1**  
**Conditions of Approval**  
**Page 8 of 14**

- e. Where street trees cannot be planted within the right-of-way of interior streets and project parkways due to insufficient road right-of-way, they shall be planted outside of the road right-of-way.
  - f. Landscaping plans shall incorporate native, low water using and drought tolerant plants.
  - g. All specimen trees on the subject property shall be shown on grading plans. Trees intended for retention and/or removal shall be so noted on the project grading plans. Replacement trees for those to be removed shall also be shown on the project grading plans.
  - h. All trees shall be minimum double-staked. Weaker and/or slow-growing trees shall be steel-staked.
  - i. All proposed landscaping shall adhere to the standards set forth under the Beaumont Municipal Code 17.06.
  - j. All trees proposed within 10 feet of any Right-of-Way shall provide for a 36” deep root barrier.
  - k. The 12 foot trail proposed along the Noble Creek channel shall connect to the Park immediately to the north and east.
  - l. Park & Open Space areas shall be provided as noted on Tentative Tract 29267, Amendment #1.
  - m. All landscape materials and irrigation improvements shall be installed and fully operational prior to final inspection and occupancy.
- 4.3 Three (3) sets of detailed landscaping and irrigation plans shall be submitted pursuant to the Conditions of Approval with a processing fee as stated on the current Schedule of Development Fees to the Planning & Neighborhood Services Department.
- 4.4 No grading permits shall be issued for any proposed new structures outside the areas shown on the approved tentative map unless otherwise approved by the Planning Director and the Public Works Department.
- 4.5 If grading is proposed for five (5) or more acres or is part of a larger project that will disturb five (5) or more acres it shall require a National Pollutant Discharge Elimination System (NPDES) Construction General Permit from the State Water Resources Control Board. Grading permits shall not be issued until the Public Works Department has determined that the project has complied with the current City requirements for compliance with the NPDES Construction General Permit.



**TENTATIVE TRACT MAP NO. 29267 – Amendment #1**  
**Conditions of Approval**  
**Page 9 of 14**

- 4.6 If the project grading is to be phased, prior to issuance of a grading permit, an overall conceptual grading plan shall be submitted to the Public Works Department and Planning Director for approval. The plan shall be used as a guideline for subsequent detailed grading plans for individual phases of development and shall include the following:
- a. Techniques which will be utilized to prevent erosion and sedimentation during and after the grading process.
  - b. Approximate time frames for grading and identification of areas which may be graded during the higher probability rain months of December through March.
  - c. Preliminary pad and roadway elevations.
  - d. Areas of temporary grading outside of a particular phase.
- 4.7 Driveways shall be designed so as not to exceed a fifteen (15) percent grade.
- 4.8 The subdivider shall provide evidence to the Public Works Department that all off-site grading areas have recorded grading and drainage easements and that maintenance responsibilities have been assigned as approved by the Public Works Department.
- 4.9 A qualified paleontologist shall be retained by the subdivider for consultation and comment on the proposed grading with respect to potential paleontological impacts. Should the paleontologist find the potential is high for impact to significant resources, a pre-grade meeting between the paleontologist, the City Public Works Department and the grading contractor shall be arranged. When necessary, the paleontologist or representative shall have the authority to temporarily divert, redirect, or halt grading activity to allow recovery of fossils. The paleontologist shall submit in writing to the Planning Director the results of the initial consultation and details of the fossil recovery plan if recovery was deemed necessary.
- 4.10 The subdivider shall pay at his or her sole expense and shall notify the Public Works Department in writing that the appropriate California Department of Fish and Game notification pursuant to Sections 1601/1603 of the California Fish and Game Code has taken place, or obtain an "Agreement Regarding Proposed Stream or Lake Alteration" (Section 1601/1603 Permit) should any grading be proposed within or along the banks of any natural watercourse. Copies of any agreement shall be submitted to the Public Works Department with the notification.
- 4.11 The subdivider shall pay at his or her sole expense and shall notify the Public Works Department in writing that the alteration of any watercourse or wetland complies with the U.S. Army Corps of Engineers (Corps) Nationwide Permit Conditions, or obtain a permit under Section 404 of the Clean Water Act should any grading or construction be proposed within or alongside the banks of the any watercourse or wetland where the Corps has jurisdiction. Copies of any agreements shall be submitted to the Public Works Department

**TENTATIVE TRACT MAP NO. 29267 – Amendment #1****Conditions of Approval****Page 10 of 14**

- along with the notification.
- 4.12 Grading plans shall be submitted to the Public Works Department for review and approval. The plans shall include an erosion and siltation control element, as necessary, to prevent graded and cleared areas from being eroded, resulting in the transport of sediment into the watercourses and downstream where it may affect downstream properties and habitat. Approval of the grading plans is required to fulfill monitoring requirements of the California Environmental Quality Act (CEQA).
  - 4.13 Any grading plans proposing grading adjacent to or within the open space lots shall be submitted to the Planning Director for review and approval.
  - 4.14 Lots shall be graded to drain to the street with no cross lot drainage permitted. Lot drainage shall be indicated on all grading plans. All street improvement plans and lot grading for residential lots shall indicate and install under sidewalk/curb core draining with a minimum of 2 outlets per lot unless otherwise approved by the Planning Director and Public Works Department.
  - 4.15 The subdivider shall submit two (2) copies of a soils report to the Public Works Department. The report shall address the soils stability and geologic conditions of the site as approved by the Public Works Department.
  - 4.16 Prior to the issuance of a grading permit, the developer shall cause to be prepared Conditions, Covenants and Restrictions (CC&R's) for the review and approval of the Planning Director, which shall include provisions requiring formation of a homeowners' association or delegated to a CFD/LMD, or other City entity, which shall be responsible for the ownership and maintenance of any water quality basin, conservation area, open space or other facility required to be constructed, set aside or improved for purposes set forth in any regulatory permit, including but not limited to those issued by the State of California or the U.S. Army Corps of Engineers. The CC&R's shall be recorded and in force prior to the issuance of any occupancy permit or final building inspection.
  - 4.17 Detailed grading plans shall fully implement the conceptual details submitted for the treatment of significant slope areas ( in excess of 20 feet vertical height) and shall implement techniques regarding contour and landform grading, landscaping and the creation of organic pockets of landscaping which emulates natural conditions.
  - 4.18 The subdivider shall submit two (2) copies of a soils report to the Public Works Department. The report shall address the soils stability and geologic conditions of the site as approved by the Public Works Department.
  - 4.19 The developer shall get a 404 permit with U.S. Army Corps of Engineers.
  - 4.20 All residential units shall be served by a minimum of two access points at all times, for proper circulation and emergency vehicle ingress and egress, as approved by the Fire

**TENTATIVE TRACT MAP NO. 29267 – Amendment #1**  
**Conditions of Approval**  
**Page 11 of 14**

- Department. Said access improvements shall be initiated prior to building permit issuance and completed prior to occupancy of residential building.
- 4.21 Street Improvement Plans shall be prepared to the satisfaction of the Public Works Department. Additionally Street Lighting in accordance with the City of Beaumont Outdoor Lighting ordinance shall be submitted in conjunction with the Street Improvement Plans. Street Lights shall also be reviewed and approved by the planning and Building Department with appropriate fees paid. All Mailbox clusters shall have appropriate lighting as approved by the City.
- 4.22 All relevant conditions of approval for the Noble Creek Specific Plan shall be adhered to.
- 4.23 Offsite Improvements shall be provided (namely the southern road-section of Cougar Way) subject to review and approval by the P. Works Department. A Reimbursement Agreement shall be established to determine, fair share costs, subject to approval by the City Council.

**5.0 BUILDING CONDITIONS**

Prior to the issuance of BUILDING PERMITS, all the following conditions shall be satisfied:

- 5.1 The subdivider shall submit written clearances to the Planning Director that all pertinent requirements from the following agencies have been met:
- City Fire Department
  - City Police Department
  - City Public Works Department
  - Beaumont Unified School District
  - Beaumont-Cherry Valley Water District
  - Riverside County Flood Control District
- 5.2 A detailed wall and fencing plan shall be submitted to and approved by the Planning Director and shall show all project walls and fencing including, but not limited to, perimeter fencing, side and rear yard fencing, and open space or park fencing. A typical elevation of all walls and fences shall be shown on the wall and fencing plan. Decorative block walls shall be constructed along all side yards adjacent to streets and in locations as approved by the Planning Director. The wall plan shall be consistent with the acoustical report and recommendations prepared for the project.
- 5.3 Roof-mounted mechanical equipment shall not be permitted within the subdivision, however, solar equipment or any other energy saving devices shall be permitted with Planning Director approval.
- 5.4 Building separation between all buildings shall not be less than ten (10) feet. Fireplaces and media niches when connected to fire places may encroach two (2) feet into the side yard setback. Additional encroachments are allowed as approved by the Planning Director

**TENTATIVE TRACT MAP NO. 29267 – Amendment #1**  
**Conditions of Approval**  
**Page 12 of 14**

pursuant to an application for a setback adjustment.

- 5.5 All street side yard setbacks shall be a minimum of ten (10) feet.
- 5.6 All front yards shall be provided with landscaping and automatic irrigation systems, as approved by the Planning Director.
- 5.7 Wood fencing shall not be permitted in this subdivision. Acceptable materials include masonry, vinyl, and tubular steel as approved by the Planning Director.
- 5.8 All utility connections and easements shall be placed underground and shall not encroach into the driveway area unless otherwise approved by the Public Works Department.
- 5.9 A minor plot plan for all residential buildings, garages and accessory buildings shall be submitted to the Planning Director accompanied by applicable filing fees for a plot plan not subject to the California Environmental Quality Act and not subject to review by any governmental agency other than the City of Beaumont. The minor plot plan shall contain the following elements:
- a. A final site plan (1"=30' minimum scale precise grading plan) showing all lots, building footprints, setbacks, walls, fencing, the floor plan and elevations of individual lots.
  - b. One (1) color and materials sample containing precise color texture and material swatches or photographs (which may be from supplier's brochures). Indicate on the sample board the name, address and phone number of the preparer and the project applicant, the tract number, and the manufacturer and product numbers when feasible (trade names also acceptable).
  - c. One (1) set of architectural elevations colored to represent the selected color combinations, with symbols keyed to the color and materials sample board. Brief written color and material descriptions shall be located on the colored elevations. No landscaping or other enhancements shall be shown on the elevations. Enhanced or upgraded rear and side facing architectural features shall be included for dwelling units adjacent to and visible from public roadways.
  - d. Three (3) sets of photographic or color laser prints (8 X 10 in.) of the sample board and colored elevations shall be submitted for permanent filing.

The Minor Plot Plan shall require the approval of the Director of Planning prior to issuance of building permits for lots included within the plot plan, including permits for model home complexes. The submittal and approval of plot plans may be phased provided:

- a. A subdivision phasing plan has been submitted to and approved by the Planning Director and Public Works Department.

**TENTATIVE TRACT MAP NO. 29267 – Amendment #1**  
**Conditions of Approval**  
**Page 13 of 14**

- b. A separate plot plan shall be submitted to the Planning Director for each approved tract phase accompanied by the appropriate filing fees.
- 5.10 All residential units shall be served by a minimum of two access points at all times, for proper circulation and emergency vehicle ingress and egress, as approved by the Fire Department.
- 5.11 All residential and commercial structures shall be provided with “four-sided” architectural features. With respect to residential structures, this may take the form of edge trim on all exterior doors or windows, or other methods as approved by the Planning Director. Additional Building Enhancements (false shutters, etc.) shall be provided on the second floors of all homes backing up to major roadways, open space areas or tract boundaries, as approved by the Director of Planning.
- 5.12 All residences must have illuminated address numbers.
- 5.13 Prior to the issuance of any building permits within the subdivision boundary, the applicant or successor shall provide traffic signalizing to the intersection of Elm Avenue/Noble Creek Pkwy. & Oak Valley Pkwy subject to approval by the City’s Traffic Engineer.

**6.0 FINAL INSPECTION/OCCUPANCY CONDITIONS**

Prior to the FINAL BUILDING INSPECTION or issuance of OCCUPANCY PERMITS, which ever occurs first, all the following conditions shall be satisfied:

- 6.1 Decorative block and sound walls shall be constructed along all external tract boundaries subject to the approval of the Public Works Department and Planning Director. A graffiti resistant coating or landscaping shall be provided on all block walls.
- 6.2 Wall and fence locations shall conform to the approved wall fencing plan and approved landscape and irrigation plans. All walls and fences shall be constructed subject to the approval of the Planning Director.
- 6.3 All lighting shall be in compliance with the City's Outdoor Lighting Ordinance. The Ordinance governs all outdoor lighting, pole mount, wall or building mount, landscape lighting and Parks. Front and rear porch lighting are included on Residential Standards.
- 6.4 All landscaping and irrigation shall be installed in accordance with approved plans. If the seasonal conditions do not permit planting, interim landscaping, and erosion control measures shall be utilized as approved by the Planning Director and the Public Works Department.
- 6.5 A licensed landscape architect shall provide a Compliance Letter to the Planning Director and the Public Works Department stating that the landscape and irrigation system has been

**TENTATIVE TRACT MAP NO. 29267 – Amendment #1**  
**Conditions of Approval**  
**Page 14 of 14**

- installed in compliance with the approved landscaping and irrigation plans and conditions of approval. The Compliance Letter shall be submitted at least three (3) working days prior to any final building inspection or issuance of any occupancy permits, whichever occurs first.
- 6.6 All landscaping and irrigation shall be installed in accordance with approved plans and shall be verified by a City field inspection at the direction of the Planning Director.
- 6.7 All driveways shall be concrete paved.
- 6.8 The required park facilities shall be completed and issued a final building permit inspection consistent with the phasing schedule to be developed in the implementation of the Recordation Conditions set forth herein.
- 6.9 The subdivider shall submit to the Planning Director a duly and completely executed agreement with a CFD or other maintenance entity approved by the Planning Director which demonstrates to the satisfaction of the City Attorney, Planning Director and Public Works Department that the subdivider has provided for the dedication and maintenance of landscaping, irrigation and open space areas. Model homes shall be exempt from this condition.
- 6.10 Access roads, street improvements, all agency requirements, parking areas and security lighting shall be constructed in accordance with approved improvement plans and specifications.
- 6.11 Clearance shall be obtained from the Beaumont Fire Department, and all fire protection improvements shall be in place as approved by the Fire Chief.

# City of Beaumont Fire Department

## Fire Protection / Planning Department

550 E. 6<sup>TH</sup> Street, Beaumont CA 92223

### FIRE REVIEW PLANNING CASE CONDITIONS OF APPROVAL

**CASE# 13-TM-03, Revision #3, Tentative Tract Map 29267**

**APN # 400-250-008**

**SUBJECT: Tentative Tract Map 29267**

**DATE: 1/13/14 & 3/18/14 & 6/18/14 & 8/6/14**

**CONTACT: Gable, Cook, and Associates Inc.**

**PHONE # 951-788-8092**

**SITE ADDRESS: NE corner of Oak Valley Parkway and Noble Creek Parkway**

#### **Specific Condition:**

1. A 13-D fire sprinkler system shall be installed in each home. Plans shall be submitted by a licensed C-16 contractor to the Fire Prevention Bureau for review and approval.
2. Underground fire line plans shall be submitted to the Fire Prevention Bureau for review and approval, prior to Mylar's being printed.
3. Provide a title block on the Mylar's saying, "City of Beaumont Fire Division".
4. Fire department access and water is required up to the models, and before lumber can be dropped. Provide a phasing plan (homes, streets) for approval, prior to be able to pull building permits.
5. Fire department access from Cougar Way to Cougar Way shall be connected prior to phase finals. Phasing map will help determine construction.
6. Standard Conditions below apply.

#### **Standard Conditions:**

With respect to the conditions of approval for the referenced project, the Fire Department recommends the following fire protection measures be provided in accordance with City of Beaumont/Riverside County Ordinances and/or recognize fire protection standards:

**F1. FIRE FINAL** - and life safety conditions will be addressed when the Fire Prevention Bureau reviews building plans. These conditions will be based on occupancy, use, California Building Code, California Fire Code, and other related codes which are in force at the time of building plan submittal.

**F2. FIRE FLOW REQUIREMENTS** - The Fire Prevention Bureau is required to set a minimum fire flow for the remodel or construction of all commercial buildings per CFC Appendix B, Table B105.1. The applicant/developer shall provide documentation to show that a water system exists, and is capable of delivering 1,000 GPM for 2 hour(s) for duration at 20-PSI residual operating pressure must be available before any combustible material is placed on the job site. The required fire flow may be adjusted during the approval process to reflect changes in design, construction type, or automatic fire protection measures as approved by the Fire Prevention Bureau. Specific requirements for the project will be determined at time of submittal. California Fire Code 2010.

**F3. SUPER FIRE HYDRANTS** - Industrial, Commercial, Multi-family, Apartment, Condominium, Townhouse or Mobile Home Parks. A combination of on-site and off-site super fire hydrants (6" x 4" x 2 – 2 1/2") shall be located be located not less than 25 feet or more than 200 feet from any portion of the building as measured along approved emergency vehicular travel ways, and spaced no more than the required spacing per Appendix C, table C105.1 in feet apart in any direction. The fire flow shall be available from any adjacent fire hydrant(s) in the system. CFC Chapter 5, section 503.1.1 and Appendix B table – B105.1

**F4. ALL WEATHER ACCESS ROAD** - Prior to construction and issuance of building permits, all locations where structures are to be built shall have an approved fire department emergency vehicular access road (all weather surface) capable of sustaining an imposed load of 80,000 lbs. Road shall be provided prior to construction, based on street standards approved by the public works director and the Fire Prevention Bureau. CFC Chapter 5, section 503.2.3

**F5. 15 % GRADE** - Prior to construction, all roads, driveways and private roads shall not exceed 15 percent grade. Add: Grade transitions shall not exceed Riverside County Fire Department apparatus maximum approach and departure angles as determined by the Fire Chief. RVC Fire Ordinance # 787.6 CFC Chapter 5, section 503.2.7

**F6. PHASING** - If construction is phased, each phase shall provide an approved emergency vehicular access for fire protection prior to any building construction. CFC Chapter 5, section 501.4

**F7. DEAD ENDS** - Prior to building construction, dead end roadways and streets which have not been completed shall have a turnaround capable of accommodating fire apparatus. CFC Chapter 5, section 503.2.5

**F8. U/G WATER PLANS** - Prior to issuance of permits, the applicant/developer shall furnish (3) copies of the water system plans to the Fire Prevention Bureau for review. Plans shall be in accordance with Appendix B and Appendix C and section 508.1 of the CFC 2010:



- \* Signed by a registered civil engineer or certified fire protection engineer.
- \* Contain a Fire Prevention Bureau approval signature block.
- \* Conform to hydrant type, location, spacing of new and existing hydrants, and a minimum fire flow required as determined by the Fire Prevention Bureau.
- \* The post indicator valve and fire department connection shall be located to the front access side of buildings, fully visible and recognizable from the street or nearest point of fire department vehicle access, and within 200 feet of an approved fire hydrant, and within 50 of an approved roadway or driveway or otherwise approved by the Fire Chief.
- \* Guard posts or other approved means may be required to protect fire department inlet connections from vehicular damage. RVC Fire Ordinance 787.6 section 912.2.1
- \* After the local water company signs the plans, the originals shall be presented to the Fire Prevention Bureau for signatures. The required water system, including fire hydrants shall be installed, and made serviceable prior to and during the time of construction, and accepted by the City of Beaumont Fire Prevention Bureau. CFC Chapter 5, 508, and the National Fire Protection Association 24 sec 1-4.1
- \* Existing fire hydrants on public streets are allowed to be available. Existing fire hydrants on adjacent properties shall not be considered available unless fire apparatus access roads extend between properties and easements are established to prevent obstruction of such roads. CFC, Appendix A, & B and NFPA 24 section 1-4.1

**F9. BLUE DOT REFLECTOR** - Prior to issuance of Certificate of Occupancy or building final, "Blue Reflective Markers" shall be installed on private streets, public streets, and driveways to identify fire hydrant locations in accordance with City & RVC Fire Ordinance 787.6 specifications.

**F10. RESIDENTIAL NUMBERS** - Prior to issuance of Certificate of Occupancy or building final, all residential dwellings shall display street numbers in a prominent location on the street side of the residence in such a position that the numbers are easily visible to approaching emergency vehicles. The numerals shall be not less than four (4) inches in height. CFC Chapter 5, section 505.1

**F11. ROOFING** - Prior to Certificate of Occupancy or building final, all structures shall have fire retardant roofing materials (Class A & B roofs) as described in section 1504 of the CBC.

**F12. FUEL MOD PLANS** - Prior to issuance of building permits, fuel modification plans "Hazardous Fire Area" shall be submitted to the Fire Prevention Bureau for review and approval for all open space areas adjacent to the Wildland vegetation interface. Any building constructed on lots

created by this land division shall comply with the special construction provision. RVC Ordinance 787.6

**F13. PAVED ACCESS-** - Prior to issuance of the building permit for development, independent paved access to the nearest paved road, maintained by the City shall be designed and constructed by the developer within the public right of way in accordance with City Standards.

**F14. FIRE SPRINKLERS** - Prior to issuance of Certificate of Occupancy or building final, the applicant/developer shall install a fire sprinkler system based on square footage and type of construction, occupancy or use. Fire sprinkler plans (3) sets shall be submitted to the Fire Prevention Bureau for approval prior to installation. No person shall remove or modify any fire protection system installed or maintained under the provisions of the California Fire Code without the approval by the Fire Chief. A Licensed C-16 contractor shall do all the work and/or certification. CFC Chapter 9, section 901.3.1, 903.1 & CBC Chapter 9, section 903.1.1

**F15. SAFETY PRECAUTIONS** - Approval of the safety precautions for buildings being constructed, altered or demolished shall be required by the Fire Chief in addition to other approvals for specific operations or processes associated with such construction, alteration or demolition. Structure, facilities and conditions which in the opinion of the fire code official, constitute a distinct hazard to life or property. The fire code official is authorized to order the posting of signs in a conspicuous location in each structure. The posting of signs shall not be obscured, removed, defaced, mutilated, or destroyed.

**F16. FIRE DEPARTMENT INSPECTION APPROVAL** - Construction or work for which the Fire Prevention Bureau's approval is required shall be subject to inspection by the Fire Chief and such construction or work shall remain accessible and exposed for inspection purposes until approved.

**F17. AUTHORITY TO INSPECT** - The Fire Prevention Bureau shall maintain the authority to inspect as often as necessary for buildings and premises, including such other hazards or appliances designated by the Fire Chief for the purpose of ascertaining and causing to be corrected any conditions which would reasonably tend to cause fire or contribute to its spread, or any violation of the purpose or provisions of this code and of any other law or standard affecting fire safety.

**F18. ALTERATIONS** - Any alterations, demolitions, or change in design, occupancy and use of buildings or site will require plan submittal to the Fire Prevention Bureau with review and approval prior to installation.

**F19. MEDIAN CROSSOVERS** - Prior to Certificate of Occupancy all locations where medians are constructed and prohibit vehicular ingress/egress into or away from the site, provisions must be

made to construct a median-crossover at all locations determined by the Fire Chief and the City Engineer. Prior to the construction, design plans will be submitted for review and approval by the City Engineer.

**F20. SINGLE FAMILY DWELLINGS** - Approved fire prevention standard fire hydrants (6" x 4" x 2 – 2 1/2") shall be located at each intersection of all residential streets and spaced no more than 500 feet apart in any direction, with no portion of any lot frontage more than 250 feet from a fire hydrant. Minimum fire flow shall be **1,000 GPM** for 2 hours at 20 PSI. Fire flow and flow duration for dwellings in excess of 3,600 square feet shall not be less than that specified in Appendix B, Table B 105.1, RVC 787.6 & CFC Chapter 5, and Appendix C, Table C 105.1

**F21. ACCESS/ROAD LENGTH** - No cul-de-sac or dead end road length shall exceed one thousand three hundred-twenty (**1,320**) feet in length. In any hazard fire area of Riverside County, no dead-end or cul-de-sac road shall exceed six hundred-sixty (**660**) feet in length. The Fire Chief, based on city street standards shall determine minimum turning radius for fire apparatus based upon fire apparatus manufacture specifications. Riverside County Ordinance 787.6, CFC Chapter 5, section 503.2.5

**F22. BUILDING OPENINGS** - Access to building openings and roofs shall be maintained readily accessible for emergency access by the fire department. Finished grade to be flat and accessible on all sides of the building where ground ladder access is the only means to reach the highest point on the building from the exterior. Obstructions will not be placed as to interfere with ground ladder placement. CFC Chapter 5, section 504.1 & RVC Ordinance 787.6

**Please call if you have questions: (951)-572-3225**

**Thank you,  
Richard Horner  
Assistant Fire Marshal  
City of Beaumont Fire Services**

**CITY OF BEAUMONT POLICE DEPARTMENT**  
**CONDITIONS OF APPROVAL**

**PLANNING APPLICATION NO#:** 13-TM-03

**SUBJECT:** NE Corner of Oak Valley Pkwy and Noble Creek Pkwy

**DATE:** 01/14/14

**CONTACT:**

**PHONE#:**

**SITE ADDRESS:** Parcel 400-250-008

1. Prior to issuance of a building permit, the applicant shall be required to obtain approval of a construction site safety plan by the Beaumont Police Department providing adequate security measures such as lights, video cameras, locks, alarms trained security personnel, fencing etc. The nature of the measures will depend on the specific requirements of the site, and may vary with the different stages of construction. The applicant shall be responsible for the compliance of all sub-contractors working on the site.
2. Applicant shall be required to conduct a traffic survey on Noble Creek Parkway and Cougar Way, per California Vehicle Code 40802.
3. It is the recommendation of the Beaumont Police Department that stop signs be installed at all intersections leading from streets "A", "B", "F", and "O", onto Noble Creek Parkway. It is also recommended that stop signs be installed at the intersections leading from streets "P" and "I" onto Cougar Way. It is recommended to install a stop sign leading from "P" street onto "Q" street and a stop sign leading from "W" street onto Mt. View.
4. It is the recommendation of the Beaumont Police Department that three stop signs be installed at Cougar Way and Mountain View in order to establish a three way stop intersection.
5. It is recommended that a traffic signal be installed at Noble Creek Parkway and Oak Valley Parkway.

6. In the event the applicant chooses to install a locking gate, it shall contact the Beaumont Police Department to obtain the necessary information in reference to a “Knox” brand lock. This is to ensure public safety access to areas that are otherwise restricted to the public.

**CITY OF BEAUMONT POLICE DEPARTMENT**  
**CONDITIONS OF APPROVAL**

**PLANNING APPLICATION NO#:** 13-TM-03

**SUBJECT:** TTM 29267

**DATE:** 03/14/14

**SITE ADDRESS:** NE Corner of Oak Valley Pkwy and Noble Creek Pkwy

1. Prior to issuance of a building permit, the applicant shall be required to obtain approval of a construction site safety plan by the Beaumont Police Department providing adequate security measures such as lights, video cameras, locks, alarms, trained security personnel, fencing, etc. The nature of the measures will depend on the specific requirements of the site, and may vary with the different stages of construction. The applicant shall be responsible for the compliance of all sub-contractor working on site.
2. The applicant shall provide an afterhours emergency contact that is available to respond to the construction site. This should be current at all stages of construction.
3. At the time the Street Improvement and Striping Plans are submitted to the City of Beaumont, the Beaumont Police Department shall have the opportunity to review these plans prior to approval.

CITY OF BEAUMONT  
550 EAST 6<sup>TH</sup> STREET  
BEAUMONT CALIFORNIA 92223  
(951) 769-8518  
(951) 769-8526 FAX

PLANNING DEPARTMENT  
TRANSMITTAL SHEET

ASSESSOR PARCEL NO.:  
400-250-008

BEAUMONT CASE NO. DATE: RETURN COMMENTS BY:  
13-TM-03, - **Revision #1** – Existing Approved 12/12/2013 1/6/2014  
Tentative Tract Map 29267

LOCATION:  
NE Corner of Oak Valley Pkwy and Noble Creek Parkway

TRANSMITTED TO:  
Beaumont Building and Safety  
Economic Development  
Beaumont Transit Department  
Beaumont Public Works  
Beaumont Fire Department  
Beaumont Police Department

**Resubmittal**

BRIEF DESCRIPTION OF PROJECT:  
Tentative Tract Map 29267 is a proposal for the land division of 274 residential and open-space lots ranging from 6,000 SF to 10.70 Acres totaling 82.84 Acres. It will transfer 24 single-family residential lots into this Planning Area/Tentative Tract Map boundary from other Planning Areas within the same Noble Creek Vistas Specific Plan. The total lot count will not change for the Noble Creek Vistas Project. The Specific Plan and Associated Environmental Impact Report (EIR) remain current for this application.

Please review the attached tentative map/documents and return your comments or Conditions of Approval NO LATER THAN the date noted above. If additional time is needed, please so state in your recommendations or contact the Planning Director by telephone. There is no need to return the exhibit, you may keep it in your files. Should you have any questions, please do not hesitate to contact this department (951) 769-8518. Mailing Address: City of Beaumont, Planning Department, 550 E. 6<sup>th</sup> Street, Beaumont, Ca 92223

COMMENTS/RECOMMENDED CONDITIONS OF APPROVAL: (COMMENTS MAY BE ATTACHED)  
ALSO PLEASE PROVIDE IN A TEXT FORMAT ALL COMMENTS DENOTED DIRECTLY ON THE ATTACHED PLANS - THANKS

*PLEASE SUBMIT (2) FULL SIZE MAPS FOR ADDRESSING*

Submitted by: *KEITH ARNTSON*, Title: *CSU* Date: *2-4-14*  
Signature: *[Handwritten Signature]*

CITY OF BEAUMONT  
550 EAST 6<sup>TH</sup> STREET  
BEAUMONT CALIFORNIA 92223  
(951) 769-8518  
(951) 769-8526 FAX

PLANNING DEPARTMENT  
TRANSMITTAL SHEET

ASSESSOR PARCEL NO.:  
400-250-008

BEAUMONT CASE NO. DATE: RETURN COMMENTS BY:  
13-TM-03, - **Revision #1** - Existing Approved 12/12/2013 1/6/2014  
Tentative Tract Map 29267

LOCATION:  
NE Corner of Oak Valley Pkwy and Noble Creek Parkway

- TRANSMITTED TO:
- Beaumont Building and Safety
  - Economic Development
  - Beaumont Transit Department
  - Beaumont Public Works
  - Beaumont Fire Department
  - Beaumont Police Department

**Resubmittal**

BRIEF DESCRIPTION OF PROJECT:  
Tentative Tract Map 29267 is a proposal for the land division of 274 residential and open-space lots ranging from 5,000 SF to 10.70 Acres totaling 82.84 Acres. It will transfer 24 single-family residential lots into this Planning Area/Tentative Tract Map boundary from other Planning Areas within the same Noble Creek Vistas Specific Plan. The total lot count will not change for the Noble Creek Vistas Project. The Specific Plan and Associated Environmental Impact Report (EIR) remain current for this application.

Please review the attached tentative map/documents and return your comments or Conditions of Approval NO LATER THAN the date noted above. If additional time is needed, please so state in your recommendations or contact the Planning Director by telephone. There is no need to return the exhibit, you may keep it in your files. Should you have any questions, please do not hesitate to contact this department (951) 769-8518. Mailing Address: City of Beaumont, Planning Department, 550 E. 6<sup>th</sup> Street, Beaumont, Ca 92223

COMMENTS/RECOMMENDED CONDITIONS OF APPROVAL: (COMMENTS MAY BE ATTACHED)  
ALSO PLEASE PROVIDE IN A TEXT FORMAT ALL COMMENTS DENOTED DIRECTLY ON THE ATTACHED PLANS - THANKS

Please submit a list of proposed street names and (2) 24x30 tract map sheets for addressing.

Submitted by: Keith Hightower Title: CSU Date: 12-17-13

Signature: [Handwritten Signature]



TTM 29267  
 Public Works Conditions of Approval  
 NOBEL CREEK MEADOWS  
 THE TAHITI GROUP  
 Page 1 of 12

**CONDITIONS OF APPROVAL  
 NOBEL CREEK MEADOWS TTM 29267  
 AUGUST 01, 2014**

- 1.0** **GENERAL** – The tentative tract map for this project has been reviewed based on latest codes, standards, design guidelines and policies and ordinance. In the event of any change in the above rendering any feature of this project nonconforming, substandard or obsolete, the owner/developer of his/her successor in interests (Developer) shall make all changes as required by the City of Beaumont.
- 1.1** The design of the public infrastructure elements shall conform to the requirements of the City General Plan, Master Plans, Caltrans Standard Specifications and the Standard Specifications for Public Works Construction, current edition, as required and approved by the City Consulting Engineer.
- 1.2** The following plans and reports shall be prepared by a competent California licensed civil engineer prior to any site development. All required plans shall be drawn in ink at appropriate scales on mylar sheets as approved by the City Consulting Engineer. Electronic file (AutoCAD file) of the approved plans and PDF copy of the signed plans shall be submitted to the City of Beaumont after plans are approved.
- 1.21** Plans Required:
- A. Street Plans - Plan/Profile at 1" = 40' (Hor.), 1" = 4' (Vert.), plus Title/Index and Detail Sheets
  - B. Mass Grading Plan - Plan at 1" = 100', Rough grading 1"=40' and Precise grading plan 1"=30'
  - C. Master Water, Sewer, Storm Drain and Utility Plan - Plan at 1" - 100'
  - D. Landscape/Irrigation – Plan at 1"=40'
  - E. Electrical and Street Lighting Plan 1"=40'
  - F. Composite underground Utility Plan at 1"=40' showing all curbs, sewer, water, and storm drain with valves, utility valves, manholes and service connections. Gas, electric, telephone and CATV shall be shown schematically based on plans prepared by utility agencies.
- 1.22** Final maps shall meet all requirements of the Beaumont Municipal Code, and shall include the following:
- A. All easements within the City of Beaumont's rights of way shall be subordinate to the City of Beaumont.

TTM 29267  
 Public Works Conditions of Approval  
 NOBEL CREEK MEADOWS  
 THE TAHITI GROUP  
 Page 2 of 12

- B. The Developer shall acquire/dedicate off-site right-of-way/s that is/are required pursuant to the Subdivision Map Act and the Beaumont Municipal Code.

#### 1.23 Reports Required:

- A. A preliminary title report accompanied by copies of all recorded documents cited therein shall be submitted to the City Consulting Engineer for review along with the first submittal of the final map for checking.
- B. A preliminary soils report was prepared for this project and shall be submitted for review by the City Consulting Engineer along with the first submittal of grading plans, street plans and/or other improvement plans for review. Within the required soils report special attention shall be directed to the rip-ability of the proposed cuts and stability of manufactured slopes. All slopes shall be protected from erosion. The civil/geotechnical engineer shall determine the setback requirements to support loading without failures in the soil mass.
- C. Any grading and/or utility excavations and backfilling, both on and off site, shall be done under the continuous direction of a licensed geotechnical/civil engineer who shall obtain all required permits and submit reports on progress and test results to the City Consulting Engineer for review and approval as determined by the City. Upon completion of all soils related work, the civil/geotechnical engineer shall submit a final report to the City Consulting Engineer for review and approval, which may require additional tests at the expense of the Developer.  
 Permits to build structures will not be issued until a report has been submitted by a civil/geotechnical engineer and approved by the City Consulting Engineer attesting to the sufficiency of all building pads to sustain proposed foundation loading.  
 The developer is required to submit soils compaction report before any excavation for utilities or building foundation can commence. The engineer shall use the latest edition of the California Building Code (CBC) as basis of design compliance.

#### 1.3 Fees Required:

- A. At the time of first submittal of Final Map and improvement plans, the Developer shall pay to the City of Beaumont all applicable fees. An Engineer's estimate of construction shall be prepared by the developer and approved by the City Consulting Engineer.

TTM 29267  
 Public Works Conditions of Approval  
 NOBEL CREEK MEADOWS  
 THE TAHITI GROUP  
 Page 3 of 12

- B. At the time of requesting recordation of Final Map, the Developer shall provide cash deposit to the City. This deposit shall guarantee setting of final survey monumentation within the Tract. Said deposit will be refunded after the City Consulting Engineer verifies that said monumentation has been set in accordance with the Final Map and that any required amended maps and/or certificates of correction have been recorded.
- C. Prior to issuance of any permits to construct any public improvements, the Developer shall pay to the City of Beaumont all applicable fees.
- D. Prior to issuance of any permits to construct any improvements, securities to guarantee completion of construction and payment of labor and materials shall be provided by the developers and all assignees and successors to the City in accordance with Chapter 16.36 of the Beaumont Municipal Code.

### **SECTION TWO – STREET IMPROVEMENTS**

2.10 Off-site street improvement requirements shall be constructed based on the alignment shown on the TTM and based on the typical street sections included herein. The developer shall be directly and solely responsible for the mitigation of impacts related to existing traffic levels plus project traffic plus background traffic increases prior to recordation of the final map or issuance of building occupancy whichever comes first. The developer shall obtain all required right-of-ways, construct all street improvements at the times required by and approved by the City Consulting Engineer.

Prior to issuance of occupancy to any structure on this project, the Developer shall construct/install traffic signal at Oak Valley Parkway / Elm Avenue Intersection and two points of access is required at all times.

- 2.20 On-site street improvements shall be constructed as follows. Prior to or at the time of approval of plans for public facilities, subdivision agreement shall be executed and bonds to guarantee construction/execution of the proposed improvements shall be in place.
- 2.21 Oak Valley Parkway (OVP) is classified as Arterial Highway with a traffic index (TI) of 9.50 and shall be constructed per attached typical section and alignment shown on the tentative map. In addition, the developer is required to submit an alignment study for the intersection of OVP/ Elm Avenue/ Noble Creek Parkway (NCP) intersection. Said alignment study shall address the provision/ installation of a traffic signal

TTM 29267  
Public Works Conditions of Approval  
NOBEL CREEK MEADOWS  
THE TAHITI GROUP  
Page 4 of 12

required to be built by the developer. This study shall also analyze the ultimate alignment of OVP. Intersection offset will not be allowed. Developer shall be responsible for additional right of way that might be needed for this specific section.

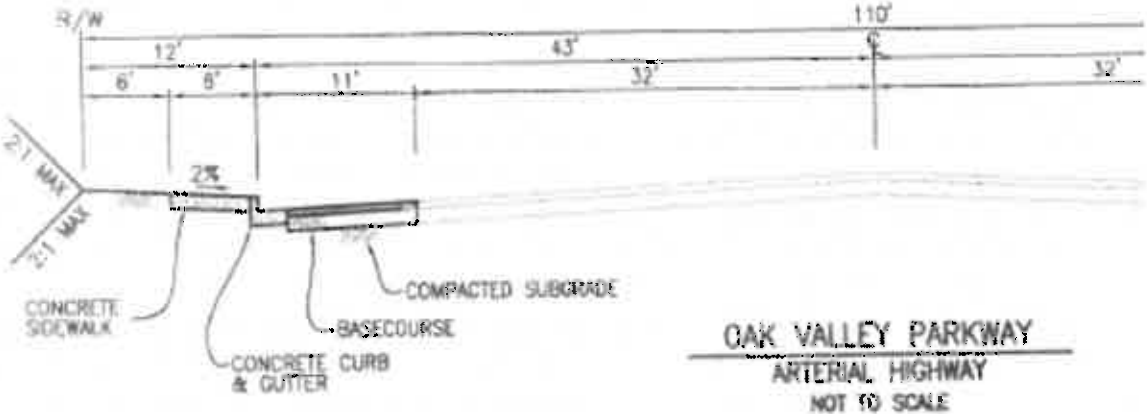

2.22 Cougar Way is a Divided Collector having a TI=8.0. It shall be constructed according to the alignment shown on the map and typical section shown herein. A safe transition to existing Cougar Way shall be constructed as it joined with the existing Cougar Way to the east.

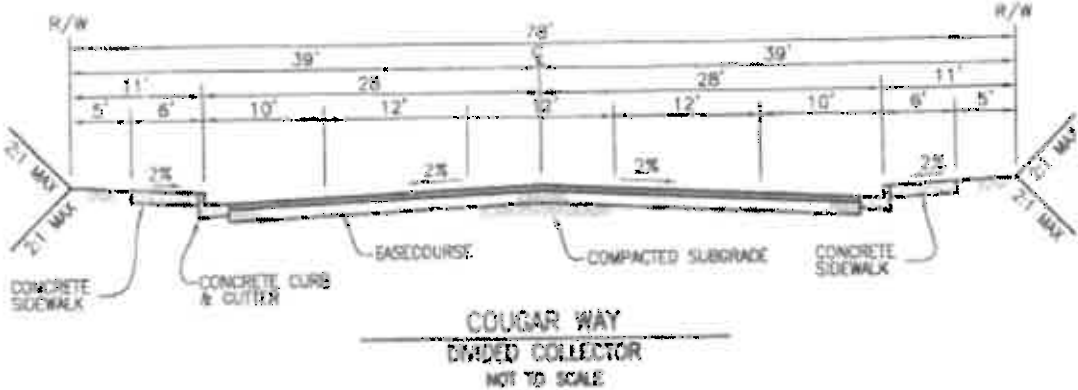

2.23 Noble Creek Parkway is a modified divided collector with TI=8.0. It shall be constructed per alignment on the map and per the following typical section.

TTM 29267  
Public Works Conditions of Approval  
NOBEL CREEK MEADOWS  
THE TAHITI GROUP  
Page 5 of 12

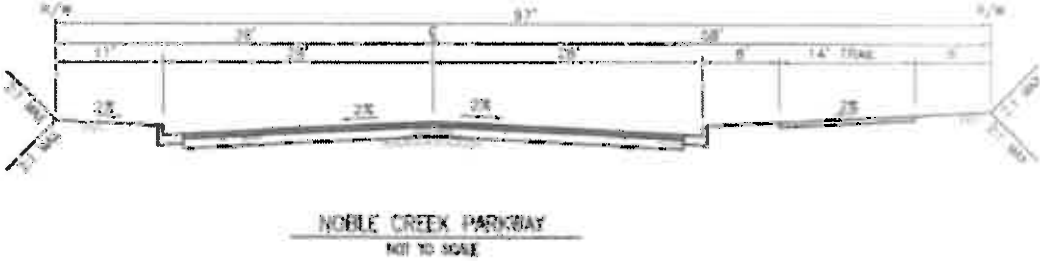

2.24 Mountain View and Interior streets having TI=5.5 shall be constructed as shown per attached typical sections and per alignment shown on the tentative map.

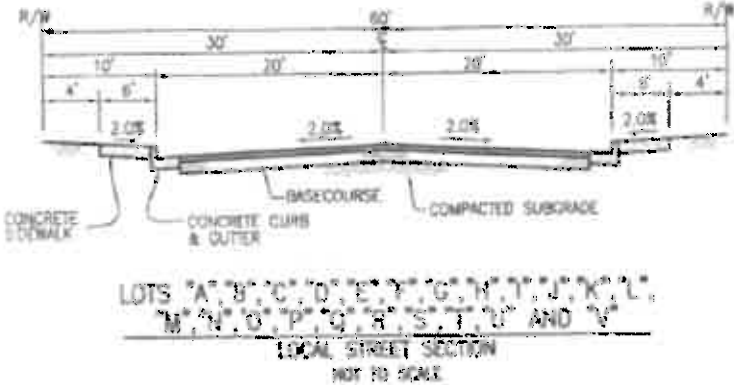
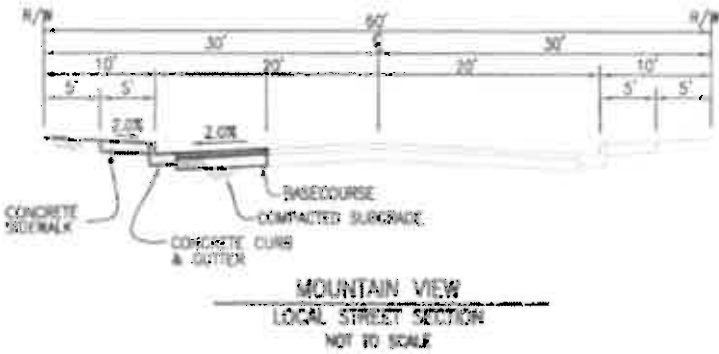

2.25 Landscaping and Irrigation plans for streets with raised median shall be submitted and approved by the City.

*TTM 29267*  
*Public Works Conditions of Approval*  
**NOBEL CREEK MEADOWS**  
**THE TAHITI GROUP**  
*Page 6 of 12*

- 2.26 Pavement structural section shall be designed based on soils tests (R-Value Tests) conducted by an acceptable soils testing laboratory and submitted by a California licensed geotechnical/civil engineer for the traffic index as approved by the City Consulting Engineer.
- 2.27 All sidewalks shall have a minimum unobstructed width of six feet in conformance to Std. 401, and the location of pedestrian ramps shall be based on approved standards in accordance with federal and state laws at the time of construction and shall conform to Std. 403.
- 2.28 All curb heights and gutter widths shall be based on Standard 200/201. Actual curb height will be determined by the Hydrology/Hydraulics Report and approved by the City Consulting Engineer. Raised median curb shall be 8-inch high per Std. 204. Driveways shall be constructed per Std. 207.
- 2.29 Cross gutters are strictly prohibited as drainage conveyance at OVP, Noble Creek parkway and Cougar Way. Where proposed and allowed, cross gutters shall be constructed per Std. 209.
- 2.30 All covers for utility manholes, valves, and vaults shall be adjusted to final grade after final paving. Street asphalt concrete pavement may be placed in multiple lifts depending on design asphalt thickness with the final lift (AC cap) placed prior to the first occupancy within that phase of development.
- Where tract phasing is proposed, streets that have been AC capped shall be free of construction traffic. Each phase that has been release for occupancy shall also be free of construction traffic unless otherwise approved by the City Engineer.
- 2.31 Prior to the time that lumber is deposited on the site for approved construction in a specific phase, all curbs and gutters and pavement shall be completed within that phase area and compaction reports for utility trenches and street base shall be approved.
- 2.32 Streets shall not be paved until all underground utilities are installed. There shall be no intersecting street centerlines less than 90° unless otherwise approved by the City Consulting Engineer.
- 2.33 Prior to issuance of buildings permits, two points of ingress and egress shall be constructed as approved by the City Consulting Engineer.

TTM 29267  
 Public Works Conditions of Approval  
 NOBEL CREEK MEADOWS  
 THE TAHITI GROUP  
 Page 7 of 12

- 2.34 Street lights shall conform to the City of Beaumont Approved Street Lighting Specifications unless otherwise approved by the City Consulting Engineer.
- 2.35 Existing power lines within project boundaries shall be placed underground and must be coordinated with utility purveyors.
- 2.36 Upon or prior to approval of all improvement plans, the developer shall submit to the City electronic drawing of such improvement and a pdf copy of the signed plans on CD.
- 2.37 Should the developer decide to build this project in phases, phasing map and unitization map shall be submitted to the City for review and approval. Each phase of the project shall have at least two points of ingress and egress.
- 2.38 Centerline profile of Cul-de-sacs bulbs shall be designed using a minimum of one-percent (1.0%) grade.

### **SECTION THREE – SEWER IMPROVEMENTS**

- 3.10 The sanitary sewer system shall be designed and constructed to collect and convey sewage to the City's Wastewater Treatment Plant on Fourth Street or a designated lift station in accordance with the Master Sewer Plan.
- 3.20 Sewer mains shall be a minimum diameter of 8" with PVC pipe and fittings unless otherwise approved by the City Consulting Engineer. Service laterals shall be constructed with PVC. No structure shall be occupied until the collection system has been thoroughly cleaned, inspected, tested, and accepted for maintenance by the City.  
 All manhole and cleanout covers within paved areas shall be adjusted to finish grade after paving is completed; and such adjustment shall be done in a manner as to prevent entry of silt and/or debris into the sewer system. A concrete collar around sewer manholes 12" thick and 12" wide must be provided.

### **SECTION FOUR - WATER IMPROVEMENTS**

- 4.10 The developer shall comply with the requirements of the Beaumont-Cherry Valley Water District and City of Beaumont Standards 817 and 818.
- 4.11 All water valves and vault covers within paved areas shall be raised to finish surfaces and painted after paving is completed.

TTM 29267  
 Public Works Conditions of Approval  
 NOBEL CREEK MEADOWS  
 THE TAHITI GROUP  
 Page 8 of 12

- 4.12 All fire hydrants, air vacs and other above ground water facilities shall be placed outside of sidewalk areas. Water meter boxes and vaults, valve covers, etc. may be placed within sidewalks or paved areas provided such devices are set flush with finished surfaces as approved by the City Consulting Engineer.

**SECTION FIVE - STORM DRAIN IMPROVEMENTS**

- 5.10 The Developer shall demonstrate by hydraulic calculations that developed flows proposed to be discharged into and through existing or any other storm drain facilities shall not exceed the maximum flows for which said facilities are presently capable of handling. In calculating drainage of proposed improvements, the engineer shall use 'Soil Type D'. Drainage easement shall be provided by the developer where required.
- 5.11 Public Works will require approval of a hydrological study prior to recordation of the final map. The study must determine the existing and proposed water surface elevation, scour, erosion and sediment transport. The finished pad elevations must be designed a minimum of 18" above the 100 year flood water surface elevation. The lots must be protected from scour and erosion. The water surface elevation in the developed condition must not exceed 1' above the existing water surface elevation on any adjacent property in a 100-year flood. The "developed condition" means raising this project, Olinger property and the Pass Agency's project out of the 100-year flood plane. The study must include a plan to stabilize sediment transport in the developed condition, if necessary. Stabilization of sediment transport benefits a large area and may require construction of regional facilities.

The exhibit shows a section detail titled 'Noble Creek Wash and Levee' with a concrete lined levee. The developer is required to propose different lining for city approval.

Prior to final map recordation, the developer shall have the storm drain improvement plans approved and bonded or constructed.

- 5.11 Storm flows may be conveyed in street sections to the extent that tops of curbs shall accommodate a 10-year storm and that right-of-way limits shall accommodate a 100-year storm. Where street sections cannot adequately handle the storm flow, underground storm drains shall be provided as recommended in the Hydrology/Hydraulics report and approved by the City Consulting Engineer.
- 5.12 Prior to the recordation of final map, the developer shall construct temporary drainage facilities and erosion control as necessary to provide for storm runoff



*TTM 29267*  
*Public Works Conditions of Approval*  
*NOBEL CREEK MEADOWS*  
*THE TAHITI GROUP*  
*Page 9 of 12*

and minimize erosion and silt deposition. The developer shall obtain a National Pollutant Discharge Elimination System (NPDES) General Permit for storm water discharges associated with construction activities as directed by the California Water Resources Control Board (RWQCB) and approved by the City Consulting Engineer. No activity involving grading will be allowed until a WDID number is issued by the RWQCB.

- 5.13 All catch basins shall be provided with fossil filters and shall be replaced and maintained by the Home Owners' Association (HOA)
- 5.14 All drainage pipes must meet the minimum D-Loading required for type of installation. Under no circumstance will the depth of cover be less than 36" unless other wise approved by the City Consulting Engineer

#### **SECTION SIX - TRAFFIC SAFETY**

- 6.10 Prior to the recordation of the final map, the Developer shall design and construct a street lighting system to the requirements of the City of Beaumont Approved Street Lighting Specifications and AMERICAN NATIONAL STANDARD PRACTICE FOR ROADWAY LIGHTING. This lighting system shall utilize Light Emitting Diode (LED) lamps.
- 6.11 Street name signs, and traffic control devices shall be constructed in accordance with approved plans. Traffic control devices shall be required for construction work for on-site and off-site locations. Street names for this Tract shall be submitted to the City Consulting Engineer for approval.
- 6.12 During construction, temporary traffic control devices shall be constructed as deemed necessary by the City Consulting Engineer. Such measures and devices shall include but not limited to: flagmen, barricades, portable electric traffic signals and street sweeping.

#### **SECTION SEVEN – Water Quality Management Plan (WQMP)**

- 7.10 At the time that grading plans are submitted or prior to recordation, whichever comes first, the Developer shall submit project specific WQMP which will establish the storm water basin design standards and include an operation manual for the basins to assure compliance with Regional Water Quality Control Board requirements. The basins will be required to detain storm flows to prevent increased storm flows onto adjacent properties following development of this property. In addition, the basins will include dry wells and a low flow conveyance and monitoring system to maximize infiltration of storm flows and urban runoff into the Beaumont Basin.

*TTM 29267*  
*Public Works Conditions of Approval*  
*NOBEL CREEK MEADOWS*  
*THE TAHITI GROUP*  
*Page 10 of 12*

All water retention/detention basins created by this project shall be owned and maintained by the HOA. Said basins shall be on lettered lots.  
The developer is required to provide easements the City over said basins and access roads.

- 7.11 All lots shall be designed and graded to drain to the approved conveyance system. The hydrology/hydraulic report shall demonstrate that developed flows for both 10-yr and 100-yr event will not inundate to any individual lot within this project.  
Special attention shall be given to the design and construction of the levee and maintenance road in order to protect the whole tract from flood inundation and erosion.

Typical lot grading is as shown below in conformance to California Building Code 2013 and shall be strictly complied with.

TTM 29267  
Public Works Conditions of Approval  
NOBEL CREEK MEADOWS  
THE TAHITI GROUP  
Page 11 of 12

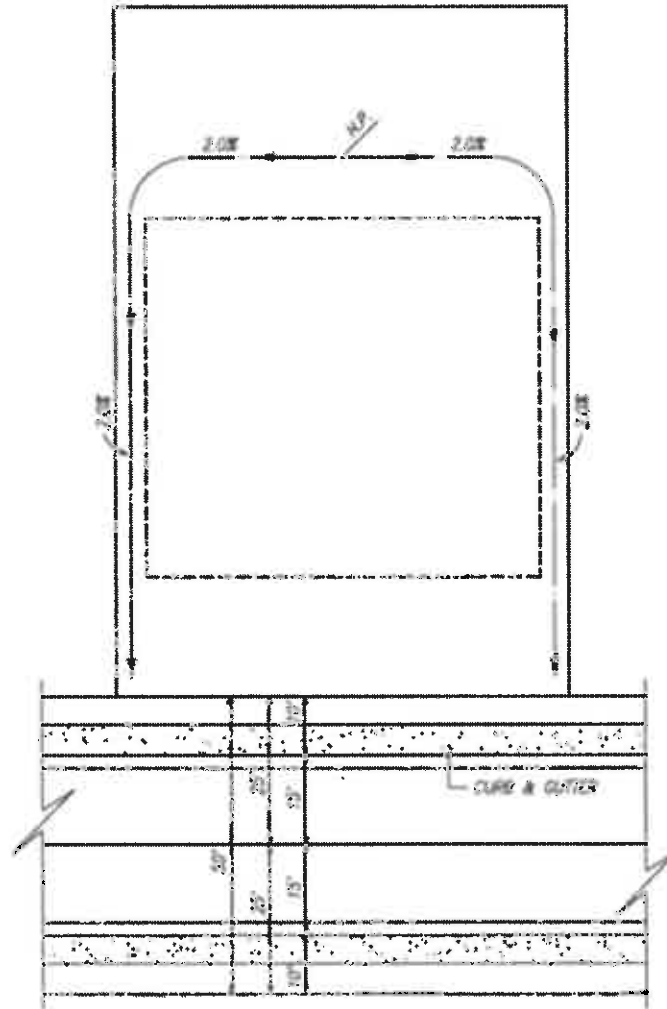

**TYPICAL LOT GRADING DETAIL**

- 7.11 All lots shall be provided with sufficient drainage per City requirements. In addition to the plans for approval by the City, the developer is required to submit project specific final WQMP which addresses how onsite drainage is handled and maintained post project completion.
  
- 7.12 The tops of all cut slopes shall be located at least two feet from rear yard property lines. Retaining walls shall be utilized where required by City Consulting Engineer to ensure that unusable and non-visible slopes are not

TTM 29267  
Public Works Conditions of Approval  
NOBEL CREEK MEADOWS  
THE TAHITI GROUP  
Page 12 of 12

created at the sides or rear of any lot, and that there is a minimum “flat” area of five feet width in all side yards.

**SECTION EIGHT - PARK AND LANDSCAPING**

8.10 Prior to the recordation of the final map for any phase of development or prior to building occupancy, whichever comes first, the Developer shall prepare landscaping and irrigation plans for landscaped areas, and all open spaces. Said plans be prepared by a California licensed landscape architect and shall be subject to the review and approval of the City Consulting Engineer and Planning Director.

**SECTION NINE – UTILITIES**

9.10 All existing and proposed utilities shall be underground. The Developer at its’ own expense shall have existing overhead power, telephone and other utilities along its’ project frontage be relocated underground before a grading permit is issued unless otherwise approved by the City Consulting Engineer .

**SECTION TEN – BASIS OF CONDITIONS OF APPROVAL (COA)**

10.0 Conditions of approval contained herein were based on the Developer’s submittal dated July 23, 2014 Sheets 1 of 2 and 2 of 2.

Sincerely,  
City of Beaumont

Ponce Yambot  

CITY OF BEAUMONT  
550 EAST 6<sup>TH</sup> STREET  
BEAUMONT CALIFORNIA 92223  
(951) 769-8518  
(951) 769-8526 FAX

PLANNING DEPARTMENT  
TRANSMITTAL SHEET

ASSESSOR PARCEL NO  
400-250-008

BEAUMONT CASE NO DATE RETURN COMMENTS BY  
13-TM-03, - **Revision #1** - Existing Approved 7/24/2014  
Tentative Tract Map 29267

8/7/2014

LOCATION:

NE Corner of Oak Valley Pkwy and Noble Creek Parkway

TRANSMITTED TO:

- Southern California Edison
- Southern California Gas Company
- Cal Trans
- Verizon
- Beaumont Building and Safety
- Economic Development
- RC Waste Management (no plans)
- Regional Water Quality Control Board
- South Coast Air Quality District

- Beaumont Transit Department
- Beaumont Unified School Dist.
- Beaumont Cherry Valley Water Dist.
- Beaumont Cherry Valley Recreation & Parks Dist.
- Beaumont Library
- Beaumont Public Works
- Beaumont Fire Department
- Beaumont Police Department
- State Dept. of Fish & Game

BRIEF DESCRIPTION OF PROJECT

Tentative Tract Map 29267 is a proposal for the land division of 274 residential and open-space lots ranging from 6,000 SF to 10,70 Acres totaling 82.84 Acres. It will transfer 24 single-family residential lots into this Planning Area/Tentative Tract Map boundary from other Planning Areas within the same Noble Creek Vistas Specific Plan. The total lot count will not change for the Noble Creek Vistas Project. The Specific Plan and Associated Environmental Impact Report (EIR) remain current for this application.

Please review the attached tentative map/documents and return your comments or Conditions of Approval NO LATER THAN the date noted above. If additional time is needed, please so state in your recommendations or contact the Planning Director by telephone. There is no need to return the exhibit, you may keep it in your files. Should you have any questions, please do not hesitate to contact this department (951) 769-8518. Mailing Address: City of Beaumont, Planning Department, 550 E. 6<sup>th</sup> Street, Beaumont, CA 92223

COMMENTS, RECOMMENDED CONDITIONS OF APPROVAL (COMMENTS MAY BE ATTACHED)  
ALSO PLEASE PROVIDE IN A TEXT FORMAT ALL COMMENTS DENOTED DIRECTLY ON THE ATTACHED PLANS. THANKS

The Beaumont Unified School District does not object to this project, but would like to remind the builder that the project is subject to school facility fees—the current rate for residential building is \$3.40 per square foot. However, this rate is subject to annual changes, so please check with District for current rates.

Staff also encourages the developer to continue to work closely with the District to ensure that future facility needs are met.

Submitted by: June Lindsey Title: Dir. of Facilities Planning Date: Aug 6, 2014

Signature: *June Lindsey*

---

**BEAUMONT-CHERRY VALLEY RECREATION & PARK DISTRICT**

---

Noble Creek Community Center  
390 W. Oak Valley Parkway

[www.bcvparks.com](http://www.bcvparks.com)



951)845-9555 Fax (951)845-9557  
Beaumont, CA 92223

e-mail: [gabe@bcvparks.com](mailto:gabe@bcvparks.com)

March 24, 2014

Rebecca Deming  
Director of Planning  
City of Beaumont  
550 E. 6<sup>th</sup> Street  
Beaumont, CA 92223

**RE: Case No. 13-TM-03– Tentative Tract Map 29267, NE Corner of Oak Valley Parkway and Proposed Noble Creek Parkway**

Dear Ms. Deming,

The Park District is in receipt of Revision #1, Resubmittal #2 for Case No. 13-TM-03– Tentative Tract Map 29267; NE Corner of Oak Valley Parkway and Proposed Noble Creek Parkway, AKA Noble Creek Meadows. We appreciate the opportunity to comment on this project and provide you with the Park District's requested Conditions of Approval. We have found the location of this project falls within the boundaries of the Beaumont-Cherry Valley Recreation and Park District (Park District) and as such represents an impact to District facilities and services.

As a matter of record, I would like to bring to your attention the attached correspondence dated November 8, 2013, which is a result of a meeting held on November 5, 2013 between the property owner, the Director of Economic Development for the City of Beaumont and BCVRPD. As this meeting was not by way of any formal procedure or process, the Park District requests that the items discussed be included as a matter of record for this project as memorialized by way of the November 8, 2013 letter and the items contained therein are considered in regards to the City of Beaumont Planning Department's Conditions of Approval.

Items of concern specific to resubmittal #2 of Revision #1 of the subject Tentative Tract Map, is it appears that the northern portion of the Park District Property will be encumbered by a newly proposed rip-rap levee at the southern end of a newly proposed concrete trapezoidal channel. In addition, Note 5 on plan sheet 2 of 2 allows for park acreage in-lieu fees via a Development Agreement between the developer, the City of Beaumont and BCVRPD. Both of these items would warrant further discussion.

At this stage in the project I believe it would be worthwhile to meet in person with the developer and the City of Beaumont to discuss the various items contained in this correspondence as well as the letter of November 8, 2013.

That being said, I am available for meetings most Tuesdays and Thursdays after 1:00 pm and would welcome the opportunity to further discuss this project. Please do not hesitate to contact me if you should have any questions or comments regarding this correspondence or if I may be of assistance in coordinating the requested meeting.

Regards,

  
**Gabriel M. Salinas**

Facilities Manager  
Beaumont-Cherry Valley  
Recreation & Parks District

**CITY OF BEAUMONT  
SUBDIVISION  
ADDITIONAL  
CONDITIONS OF APPROVAL**

**TENTATIVE TRACT MAP NO. 29267  
Nobel Creek Meadows, LLC**

**CITY COUNCIL  
APPROVAL:**

**February 7, 2017**

The City of Beaumont hereby approves your request for a one year extension subject to the previously approved conditions and the following added/amended Conditions for **TENTATIVE TRACT NO. 29267**.

1. All mailbox clusters shall be illuminated per Planning Director approval.
2. All street improvement plans and lot grading for residential lots shall indicate and install under sidewalk/curb core draining with a minimum of 2 outlets per lot unless otherwise approved by the Planning Director and Public Works Director.
3. All Community Mailboxes shall be maintained by the Homeowners or by a Homeowners Association for that area.
4. All plans prepared for City of Beaumont approval shall include, once approved, a pdf scan of the approved plans and a GIS/CAD file in the standards as forth by the City.
5. The project shall participate in the Beaumont Community Facilities District program to provide for maintenance services (if deemed required by the City of Beaumont) and public safety services. This requirement is not contingent on the project seeking public facilities financing.
6. All parks, trails and open space shall be completed/improved at a time as required by the City of Beaumont, but no later than 75% of the buildable lots within the final map/planning area/ project.

If there are any conflicting Conditions between these conditions and the prior conditions, the greater of the two standards shall prevail as determined by the Planning Department.

**REVISION NO. 1**  
**TENTATIVE TRACT NO. 29287**  
**CITY OF BEAUMONT**



- LEGEND**
- CENTERLINE
  - PROPERTY LINE (EXISTING ONLY)
  - LOT SIZE IN SQUARE FEET
  - SLOPE INDICATION & PERCENT
  - PROPOSED CHANGE & DIMENSION
  - PROPOSED CHANGE & FOOT NOTE

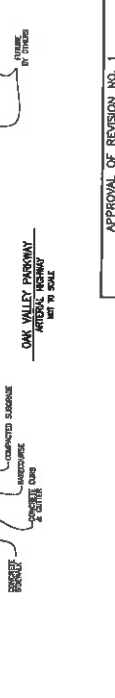
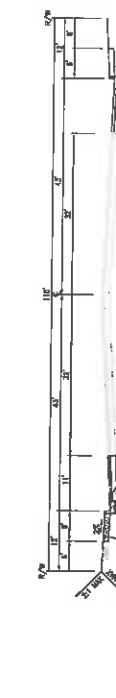
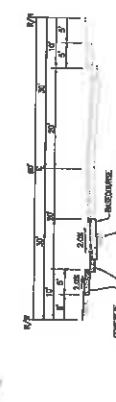
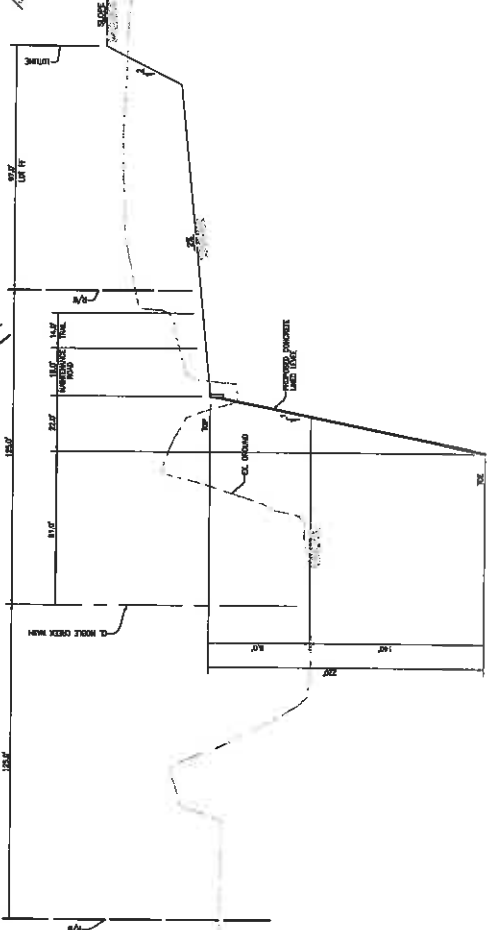
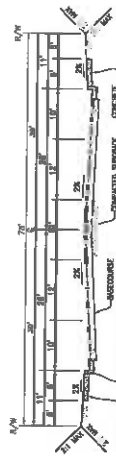
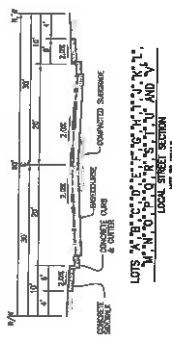
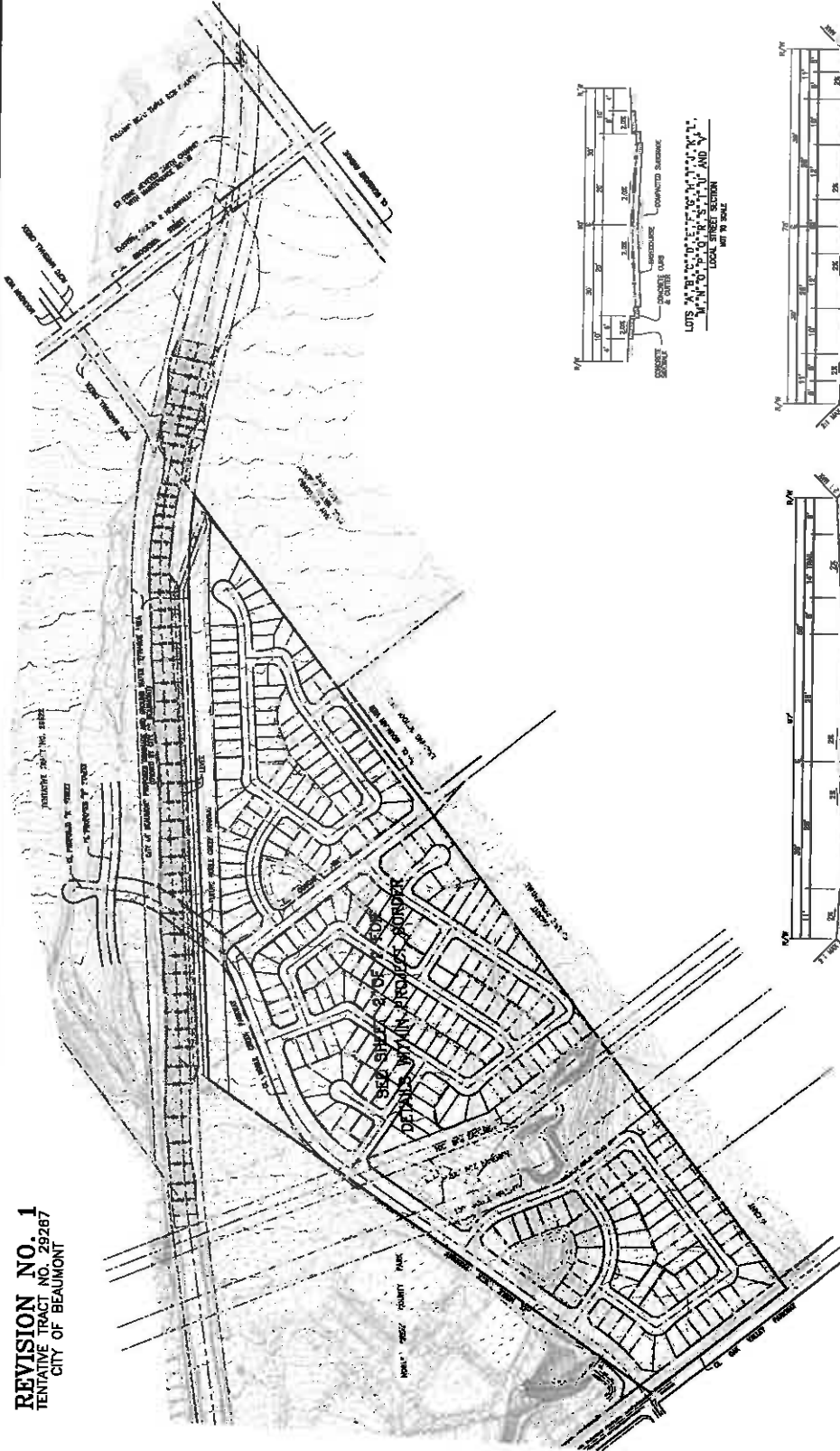

APPROVAL OF REVISION NO. 1

PLANNING DIRECTOR, CITY OF BEAUMONT \_\_\_\_\_ DATE \_\_\_\_\_

CITY OF BEAUMONT  
 TENTATIVE TRACT NO. \_\_\_\_\_  
 REVISION NO. \_\_\_\_\_

PREPARED FOR: NISPER, CREEK  
 JULY 25, 2011



**GABRIEL COOK & ASSOCIATES INC.**  
 2172 Broadway Avenue  
 Beaumont, TX 77705  
 (409) 833-1111



**REVISION NO. 1**  
**TENTATIVE TRACT NO. 29267**  
**CITY OF BEAUMONT**

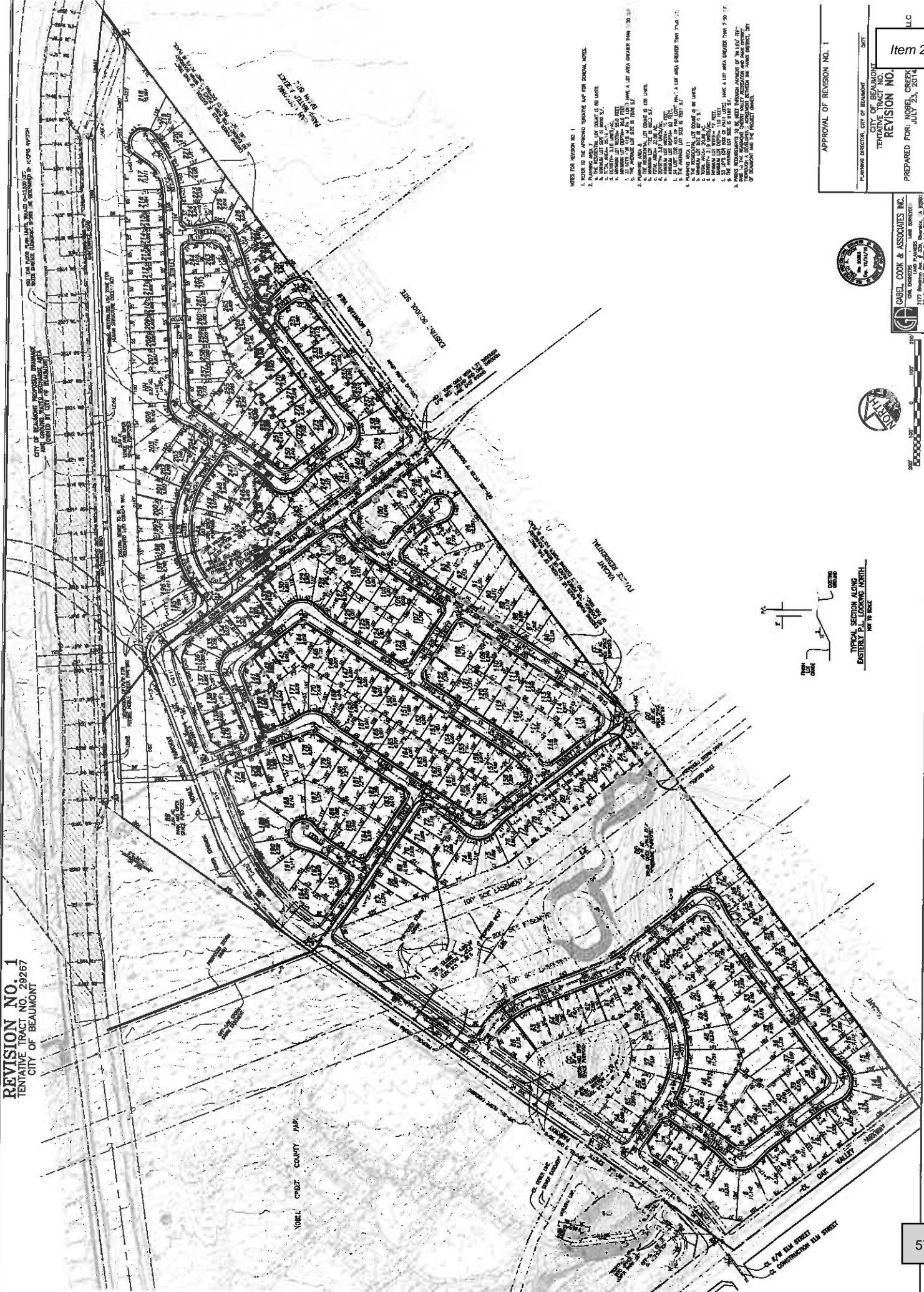

- NOTES FOR REVISION NO. 1
1. REFER TO THE APPROVED TRACTING MAP FOR GENERAL NOTES
  2. PLANNING AREA 7, LOT AREA IS 60 ACRES
  3. REMAINS LOT AREA IS 60 ACRES
  4. LOT AREA IS 60 ACRES
  5. LOT AREA IS 60 ACRES
  6. LOT AREA IS 60 ACRES
  7. LOT AREA IS 60 ACRES
  8. LOT AREA IS 60 ACRES
  9. LOT AREA IS 60 ACRES
  10. LOT AREA IS 60 ACRES
  11. LOT AREA IS 60 ACRES
  12. LOT AREA IS 60 ACRES
  13. LOT AREA IS 60 ACRES
  14. LOT AREA IS 60 ACRES
  15. LOT AREA IS 60 ACRES
  16. LOT AREA IS 60 ACRES
  17. LOT AREA IS 60 ACRES
  18. LOT AREA IS 60 ACRES
  19. LOT AREA IS 60 ACRES
  20. LOT AREA IS 60 ACRES
  21. LOT AREA IS 60 ACRES
  22. LOT AREA IS 60 ACRES
  23. LOT AREA IS 60 ACRES
  24. LOT AREA IS 60 ACRES
  25. LOT AREA IS 60 ACRES
  26. LOT AREA IS 60 ACRES
  27. LOT AREA IS 60 ACRES
  28. LOT AREA IS 60 ACRES
  29. LOT AREA IS 60 ACRES
  30. LOT AREA IS 60 ACRES
  31. LOT AREA IS 60 ACRES
  32. LOT AREA IS 60 ACRES
  33. LOT AREA IS 60 ACRES
  34. LOT AREA IS 60 ACRES
  35. LOT AREA IS 60 ACRES
  36. LOT AREA IS 60 ACRES
  37. LOT AREA IS 60 ACRES
  38. LOT AREA IS 60 ACRES
  39. LOT AREA IS 60 ACRES
  40. LOT AREA IS 60 ACRES
  41. LOT AREA IS 60 ACRES
  42. LOT AREA IS 60 ACRES
  43. LOT AREA IS 60 ACRES
  44. LOT AREA IS 60 ACRES
  45. LOT AREA IS 60 ACRES
  46. LOT AREA IS 60 ACRES
  47. LOT AREA IS 60 ACRES
  48. LOT AREA IS 60 ACRES
  49. LOT AREA IS 60 ACRES
  50. LOT AREA IS 60 ACRES
  51. LOT AREA IS 60 ACRES
  52. LOT AREA IS 60 ACRES
  53. LOT AREA IS 60 ACRES
  54. LOT AREA IS 60 ACRES
  55. LOT AREA IS 60 ACRES
  56. LOT AREA IS 60 ACRES
  57. LOT AREA IS 60 ACRES
  58. LOT AREA IS 60 ACRES
  59. LOT AREA IS 60 ACRES
  60. LOT AREA IS 60 ACRES
  61. LOT AREA IS 60 ACRES
  62. LOT AREA IS 60 ACRES
  63. LOT AREA IS 60 ACRES
  64. LOT AREA IS 60 ACRES
  65. LOT AREA IS 60 ACRES
  66. LOT AREA IS 60 ACRES
  67. LOT AREA IS 60 ACRES
  68. LOT AREA IS 60 ACRES
  69. LOT AREA IS 60 ACRES
  70. LOT AREA IS 60 ACRES
  71. LOT AREA IS 60 ACRES
  72. LOT AREA IS 60 ACRES
  73. LOT AREA IS 60 ACRES
  74. LOT AREA IS 60 ACRES
  75. LOT AREA IS 60 ACRES
  76. LOT AREA IS 60 ACRES
  77. LOT AREA IS 60 ACRES
  78. LOT AREA IS 60 ACRES
  79. LOT AREA IS 60 ACRES
  80. LOT AREA IS 60 ACRES
  81. LOT AREA IS 60 ACRES
  82. LOT AREA IS 60 ACRES
  83. LOT AREA IS 60 ACRES
  84. LOT AREA IS 60 ACRES
  85. LOT AREA IS 60 ACRES
  86. LOT AREA IS 60 ACRES
  87. LOT AREA IS 60 ACRES
  88. LOT AREA IS 60 ACRES
  89. LOT AREA IS 60 ACRES
  90. LOT AREA IS 60 ACRES
  91. LOT AREA IS 60 ACRES
  92. LOT AREA IS 60 ACRES
  93. LOT AREA IS 60 ACRES
  94. LOT AREA IS 60 ACRES
  95. LOT AREA IS 60 ACRES
  96. LOT AREA IS 60 ACRES
  97. LOT AREA IS 60 ACRES
  98. LOT AREA IS 60 ACRES
  99. LOT AREA IS 60 ACRES
  100. LOT AREA IS 60 ACRES

APPROVAL OF REVISION NO. 1

PLANNING DIRECTOR, CITY OF BEAUMONT

CITY OF BEAUMONT  
 TENTATIVE TRACT NO.  
 REVISION NO.

PREPARED FOR: NABEL CREEK  
 JULY 25, 2014

LLC



**CABEL COOK & ASSOCIATES INC.**  
 CIVIL ENGINEER  
 1112 Broadway Ave., Suite 1000, Beaumont, TX 77705  
 (409) 833-1111

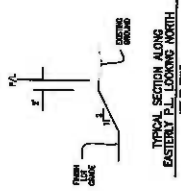



## Staff Report

**TO:** Mayor and City Council Members

**FROM:** Christina Taylor, Community Development Director

**DATE:** June 2, 2020

**SUBJECT:** Request for Consideration of the Final, One-Year Extension of Time for Tentative Tract Map 33680 (APN 414-142-038)

### Background and Analysis:

The Tentative Tract Map 33680 was originally approved by City Council on May 2, 2006 for a two-year period. The proposal provides for the division of a 6.33 acre parcel into 24 residential lots, ranging in size from 7,000 square feet to 10,806 square feet located at the terminus of Olive Avenue, west of Elm Avenue and south of Lana Way in the Residential Single Family (RSF) zone. The properties to the North, South and East are zoned Residential Single Family (RSF) and the property to the west is zoned Specific Plan Area (SPA) Three Rings Ranch.



After their initial approval, the City Council approved a one-year extension until May 2, 2009. Additionally, the following California bills also extended the map for seven (7) years in California:

SB 1185 – Automatic one-year extension. Extension until May 2, 2010,

AB 333 – Automatic two-year extension. Extension until May 2, 2012,

AB 208 – Automatic two-year extension. Extension until May 2, 2014, and

AB 116 – Automatic two-year extension. Extension until May 2, 2016.

The City Council then approved four additional one-year extensions for the map resulting in an expiration of May 2, 2020.

The Subdivision Map Act (66463.5(c)) allows the subdivider to apply for a maximum of six (6) additional one-year extensions. The applicant is currently requesting their sixth one-year extension as the map has not been finalized and construction has not commenced. If approved, the map will expire on May 2, 2021, with no additional extensions available.

The applicant did submit their extension request letter as required. There are no unusual or changed circumstances which affect this map or the consideration of a time extension. On May 12, 2020, the City's Planning Commission conducted a public hearing and recommended approval of the request for the final, one-year extension.

**Fiscal Impact:**

None.

**Recommended Action:**

Approve the final, one-year extension of time for the approval of Tentative Tract Map 33680.

**Attachments:**

- A. TTM33680
- B. Conditions of Approval

# TENTATIVE TRACT MAP NO. 33680

(IN THE CITY OF BEAUMONT, CA)

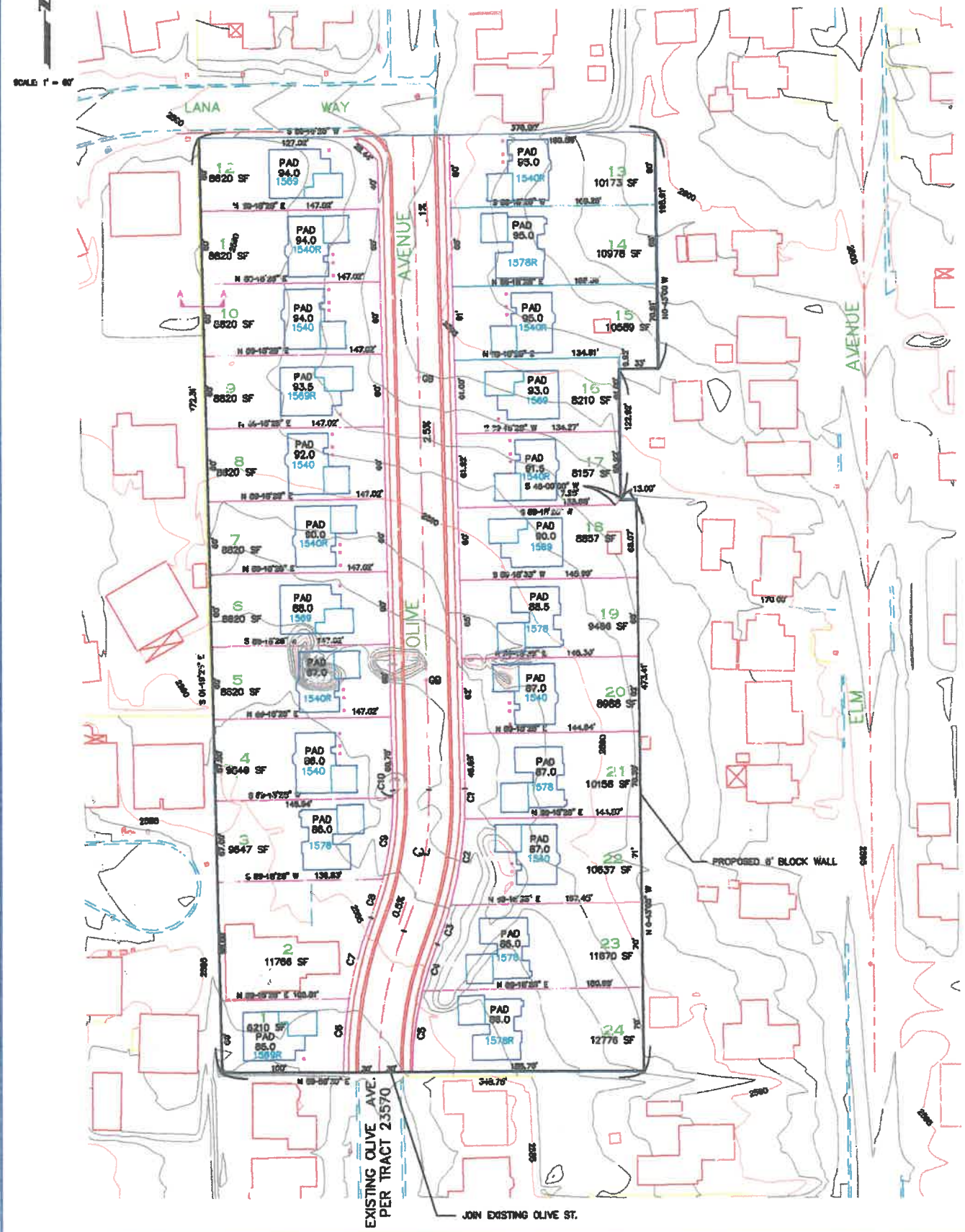

**SITE INFORMATION:**  
 SITE ADDRESS:  
 OLIVE STREET  
 BEAUMONT, CA 92223  
 6.33 ACRES  
 TAX ASSESSOR'S PARCEL NUMBER:  
 XXX-XXX-XX  
 GENERAL PLAN DESIGNATION:  
 SFR (SINGLE FAMILY RESIDENCE)  
 EXISTING ZONING:  
 SFR (SINGLE FAMILY RESIDENCE)  
 EXISTING USE:  
 SINGLE FAMILY RESIDENCE  
 PROPOSED ZONING:  
 NO CHANGE  
 PROPOSED USE:  
 SINGLE FAMILY RESIDENCE  
 BUILDING SETBACKS:  
 20' - FRONT  
 20' - REAR  
 5' - SIDE  
 PROPOSED SEWER SERVICE:  
 PUBLIC SEWER MAIN  
 PROPOSED WATER SERVICE:  
 PUBLIC WATER SYSTEM  
 SOURCE OF TOPOGRAPHY:  
 PRIVATE AERIAL TOPO 2004  
 EXISTING TERRAIN:  
 FLAT (UNDER 3%)

**OWNER/APPLICANT:**  
 ROBERT and ALICE ZARATZIAN  
 4197 BROOKTON AVE.  
 RIVERSIDE, CA 92501  
 (951) 784-9446

**SURVEYOR:**  
 HERALD LANTIS, RCE 33220  
 H.L. LAND DEVELOPMENT  
 ENGINEERING & SURVEYING  
 3890 DUTTON STREET  
 CHERRY VALLEY, CA 92223  
 (760) 802-7730

**ENGINEER:**  
 HERALD LANTIS, RCE 33220  
 H.L. LAND DEVELOPMENT  
 ENGINEERING & SURVEYING  
 3890 DUTTON STREET  
 CHERRY VALLEY, CA 92223  
 (760) 802-7730

**SITE LOCATION:**  
 OLIVE STREET BETWEEN  
 LANA WAY & REHA WAY  
 BEAUMONT, CA 92223  
**THOMAS BROS. PAGE:**  
 PAGE NO. 720, GRID H-2

**UTILITIES/SERVICES:**  
**SEWER:**  
 CITY OF BEAUMONT  
 530 E. 8TH STREET  
 BEAUMONT, CA 92223  
 (909) 846-8661  
**GAS:**  
 THE GAS COMPANY  
 1981 W. LUGONIA AVENUE  
 REDLANDS, CA 92373  
 (909) 793-2686  
**TELEPHONE:**  
 VERIZON  
 1900 CRAFTON AVENUE, BLDG. 120  
 MENTONE CA 92388  
 (909) 794-8277  
**FIRE PROTECTION:**  
 RIVERSIDE COUNTY FIRE DEPARTMENT  
 210 W. SAN JACINTO AVENUE  
 PERRIS, CA 92570  
 (909) 940-8900

**WATER:**  
 BEAUMONT-CHERRY VALLEY WATER DISTRICT  
 560 MARGOLIA  
 BEAUMONT, CA 92223  
 (909) 846-8661  
**ELECTRIC:**  
 SOUTHERN CALIFORNIA EDISON  
 287 TENNESSEE STREET  
 REDLANDS, CA 92373  
 (909) 336-7191  
**CABLE TELEVISION:**  
 ADELPHA  
 1722 ORANGE TREE LANE  
 REDLANDS, CA 92373  
 (800) 686-1400  
**FLOOD CONTROL:**  
 RIVERSIDE COUNTY FLOOD CONTROL DISTRICT  
 1906 MARKET STREET  
 RIVERSIDE, CA 92501  
 (909) 956-1200

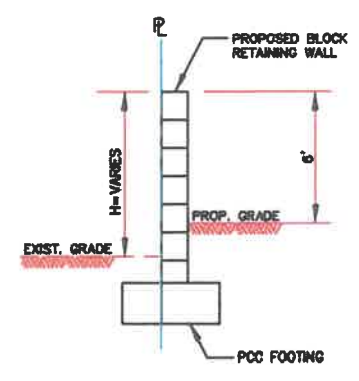

**SECTION A - A**  
 NOT TO SCALE

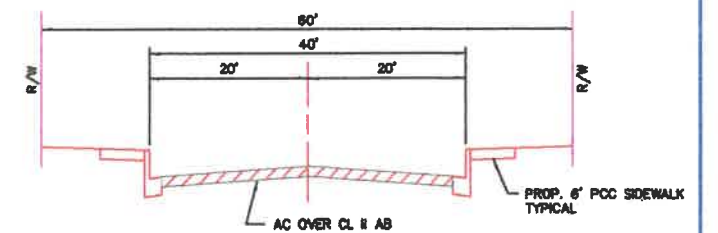

**TYPICAL SECTION OLIVE STREET**  
 NOT TO SCALE

SYM.	DETA	RADIUS	LENGTH
01	2'48"	330.00	25.28
02	14'06.30"	330.00	72.23
03	5'54.21"	330.00	34.02
04	8'77.48"	270.00	39.85
05	14'22.31"	270.00	67.74
06	10'37.74"	330.00	62.15
07	1'02.85"	330.00	89.40
08	7'03.18"	270.00	33.24
09	14'27.32"	270.00	88.14
10	1'19.32"	270.00	6.25

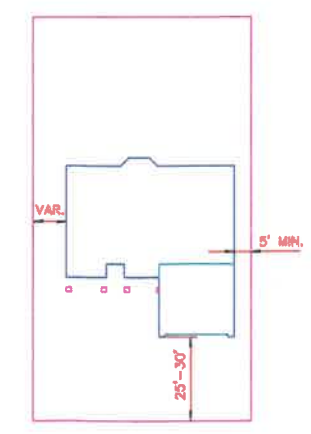

**TYPICAL PLOT PLAN**  
 NOT TO SCALE

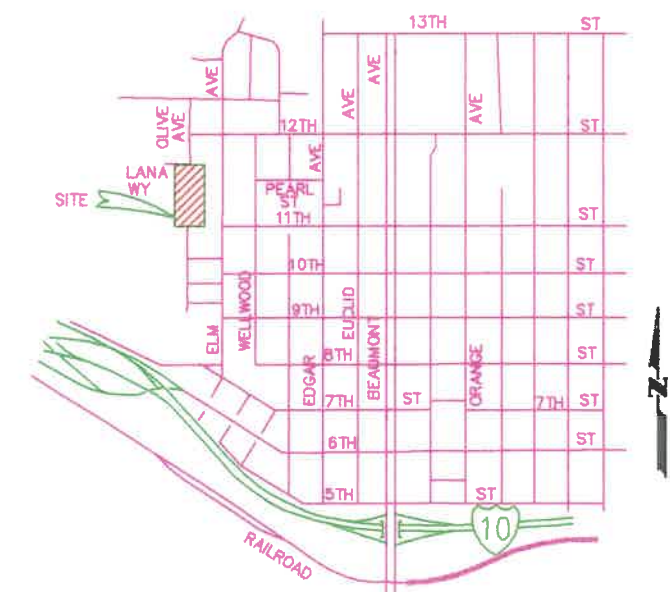

**VICINITY MAP**  
 NOT TO SCALE

**PREPARED BY:**  
 HERALD R. LANTIS  
 L.S. 4586  
 JULY 2005

**LAND DEVELOPMENT**  
 ENGINEERING AND SURVEYING  
 3890 DUTTON STREET  
 CHERRY VALLEY, CA 92223  
 (951) XXX-XXXX

**CITY OF BEAUMONT  
SUBDIVISION  
CONDITIONS OF APPROVAL**

**TENTATIVE TRACT MAP NO. 33680  
NEGATIVE DECLARATION NO. 05-ND-22  
APN: 414-182-003, 414-142-015, 019 & 023  
ROBERT & ALICE ZARATZIAN**

**CITY COUNCIL  
APPROVAL DATE:**

**May 2, 2006**

**1.0 STANDARD CONDITIONS**

- 1.1 The following conditions of approval are for **TENTATIVE TRACT NO. 33680**, and consist of Conditions 1.1 through 1.10, Conditions 2.1 through 2.6, Conditions 3.1 through 3.14, Conditions 4.1 through 4.15, Conditions 5.1 through 5.13, Conditions 6.1 through 6.9; and pages 1 through 10, inclusive.
- 1.2 The subdivider shall defend, indemnify, and hold harmless the City of Beaumont, its agents, officers, and employees from any claim, action, or proceeding against the City of Beaumont, its agents, officers, or employees to attack, set aside, void, or annul an approval of the City of Beaumont, its advisory agencies, appeal boards, or legislative body concerning **TENTATIVE TRACT NO. 33680 and Negative Declaration 05-ND-22** which action is brought within the time period provided for in California Government Code, Section 66499.37. The City of Beaumont will promptly notify the subdivider of any such claim, action, or proceeding against the City of Beaumont and will cooperate fully in the defense. If the City fails to promptly notify the subdivider of any such claim, action, or proceeding or fails to cooperate fully in the defense, the subdivider shall not, thereafter, be responsible to defend, indemnify, or hold harmless the City of Beaumont.
- 1.3 The subdivision shall comply with the State of California Subdivision Map Act and to all the pertinent requirements of The Beaumont Municipal Code, unless modified by the conditions listed below.
- 1.4 This conditionally approved tentative map will expire two (2) years after the original approval date, unless extended as provided by the Beaumont Municipal Code, the State Subdivision Map Act or by a development agreement. Action on a minor change and/or revised map request will not extend the time limits of the tentative map. Approval of the tentative map by the City Council will occur on May 2, 2006.

**TENTATIVE TRACT MAP NO. 33680**  
**Conditions of Approval**  
**Page 2 of 10**

- 1.5 The final map shall be prepared by a licensed land surveyor or registered civil engineer subject to all the requirements of the State of California Subdivision Map Act and The Beaumont Municipal Code.
- 1.6 Within ten (10) days of approval by the City Council ten (10) copies of an Amended Per Final Conditions map shall be submitted to and approved by the Planning Director, if determined to be necessary, prior to release of the final conditions of approval. The amended map shall be in substantial conformance with Exhibit B.
- 1.7 Any subsequent review/approvals required by the conditions of approval, including but not limited to grading, landscaping, plot plan and/or building plan review, shall be reviewed on an hourly basis based on, or such fee as may be in effect at the time of submittal, listed in Ordinance No. 506.
- 1.8 The subdivider shall be fully responsible for maintenance and upkeep of any and all slopes, landscaped areas, open space areas, future development areas and irrigation systems until such time as maintenance responsibilities are assumed by other as approved by the Planning Director.
- 1.9 If human remains are encountered during grading and other construction excavation, work in the immediate vicinity shall cease and the County Coroner shall be contacted pursuant to State Health and Safety Code Section 7070.5.
- 1.10 In the event that significant Native American cultural resources are discovered during project development/construction, all work in the immediate vicinity shall cease and a qualified archaeologist meeting Secretary of Interior standards shall be retained to assess the find. Work on the overall project may continue during this assessment period. If a Treatment Plan or cultural resources management plan is required, the developer shall be required to have the archaeologist consult with the relevant Native American authority regarding the disposition of any found artifacts.

**2.0 AGENCY CONDITIONS**

- 2.1 The subdivider shall comply with the requirements set forth in the City Public Works Director conditions, a copy of which is attached hereto.
- 2.2 The subdivider shall comply with the requirements of the Beaumont Police Department.

**TENTATIVE TRACT MAP NO. 33680****Conditions of Approval****Page 3 of 10**

- 2.3 The subdivider shall comply with the requirements set forth by the Riverside County Fire Department.
- 2.4 The subdivider shall comply with the requirements as set forth by the Beaumont-Cherry Valley Water District.
- 2.5 The subdivider shall comply with the requirements as set forth by the Southern California Gas Company.
- 2.6 The subdivider shall comply with the requirement as set forth by the Beaumont Unified School District, a copy of which is attached.

**3.0 RECORDATION CONDITIONS**

Prior to the RECORDATION of any final map, all the following conditions shall be satisfied:

- 3.1 The subdivider shall submit written clearances to the Public Works Director that all pertinent requirements from the following agencies have been met:
  - County Fire Department
  - City Police Department
  - City Community and Economic Development Department
  - Beaumont Cherry Valley Water District
  - Beaumont Unified School District
- 3.2 All road easements shall be offered for dedication to the public and shall continue in force until the governing body accepts or abandons such offers. All dedications shall be free from all encumbrances as approved by the Public Works Director. Street names shall be subject to the approval of the Public Works Director. Secondary access shall be offered for dedication and improved from the tract map boundary to a City maintained road as approved by the Public Works Director prior to recordation. The final street sections, configurations and improvements shall be subject to the approval of the Public Works Director.
- 3.3 All delinquent property taxes, special taxes and assessments shall be paid to the Riverside County Tax Collectors Office.
- 3.4 Easements, when required for roadway slopes, drainage facilities, utilities, etc., shall be shown on the final map if they are located within the land division boundary. All offers

**TENTATIVE TRACT MAP NO. 33680**  
**Conditions of Approval**  
**Page 4 of 10**

- of dedication and conveyances shall be submitted and recorded as directed by the Public Works Director.
- 3.5 Utilities shall be installed underground as approved by the Public Works Director.
- 3.6 No lots fronting on knuckles, or cul-de-sacs shall have less than thirty-five (35) feet of frontage measured at the property line, with the exception of flag lots as approved by the Director of Planning.
- 3.7 This subdivision may be recorded in phases subject to the following:
- a. Phasing, including phase boundaries and sequencing, shall be subject to Planning Director approval.
  - b. Common open space area improvement phasing, as applicable, shall be required subject to Planning Director approval.
- 3.7 The subdivider is obligated to provide fully improved park space at a ratio of number of lots x 3.2 persons per household x 5 acres per 1,000 population. Said conditions of approval require park improvements and/or fees (\$4 per square foot of required park area), and these requirements shall be applicable on a pro-rata basis for this subdivision.
- 3.8 The subdivider shall convey to the approved landscape maintenance entity fee simple title at no cost to the entity all park and open space areas, free and clear of all liens, taxes, assessment, leases (recorded and unrecorded) and easements, except those easements which in the sole discretion of the entity are acceptable.
- 3.9 The maintenance and management of common open space areas and common facilities shall be conducted as set forth herein and approved by the Director of Planning. All provisions of said condition shall be satisfied prior to map recordation.
- 3.10 A hydrology study, to the satisfaction of the Public Works Director, shall be prepared and approved prior to recordation. Said hydrology study shall be based upon methodology which is acceptable to the Riverside County Flood Control and Water Conservation District, and shall address the potential impacts of the project, as well as downstream impacts resulting from the project, and shall identify the level of responsibility of the project in correcting any downstream problems.
- 3.11 Prior to recordation, the subdivider shall work with the City and the Public Works Director to establish the necessary financing and implementation measures to ensure the provision of a fair share of such necessary facilities.



**TENTATIVE TRACT MAP NO. 33680****Conditions of Approval****Page 5 of 10**

- 3.12 A total of 20 final, blue-line, final maps shall be submitted to the Public Works Department for final distribution to the agencies.
- 3.13 All perimeter walls and/or walls that front streets must be block wall. No wood fencing shall be permitted in this project.
- 3.14 Conditions, Covenants, and Restrictions (CC&R's) may be recorded for this tract by the Subdivider. A note shall be placed on the cover page of said CC&R's which states as follows: "The City of Beaumont shall not be responsible for the enforcement of the CC&R's for Tract No. 33680."

**4.0 GRADING CONDITIONS**

- 4.1 Prior to the issuance of GRADING PERMITS, the subdivider shall comply with all the following grading conditions:
  - a. The land divider or developer shall submit five (5) prints of a comprehensive grading plan to the Public Works Director which complies with the Uniform Building Code, Chapter 70, the Beaumont Municipal Code and as may be additionally provided for in these conditions.
  - b. A grading permit shall be obtained from the City Public Works Department prior to commencement of any grading.
  - c. Graded land shall be provided with erosion control measures as approved by the Public Works Director.
  - d. All residential building pads shall have a minimum depth of 90 feet and pad width of 60 feet exclusive of any slope in excess of two feet in vertical height.
- 4.2 Detailed landscaping and irrigation plans shall be submitted to and approved by the Planning Director for the phase of development in process. The plans shall address all areas and aspects of the tract requiring landscaping and irrigation to be installed including, but not limited to, parkway planting, recreation trail, street trees, slope planting, common area and/or park landscaping. The plans shall be certified by a landscape architect, and shall provide for the following:
  - a. Permanent automatic irrigation systems shall be installed on all landscaped areas requiring irrigation. Low water use systems shall be specified.

**TENTATIVE TRACT MAP NO. 33680**  
**Conditions of Approval**  
**Page 6 of 10**

- b. Landscape screening where required shall be designed to be opaque up to a minimum height of six (6) feet at maturity.
  - c. All utility service areas and enclosures shall be screened from view with landscaping and decorative barriers or baffle treatments, as approved by the Planning Director. Utilities shall be placed underground wherever feasible.
  - d. Landscaping plans shall incorporate the use of specimen accent trees (24" box minimum) at key visual focal points within the project.
  - e. Where street trees cannot be planted within the right-of-way of interior streets and project parkways due to insufficient road right-of-way, they shall be planted outside of the road right-of-way.
  - f. Landscaping plans shall incorporate native, low water using and drought tolerant plants where appropriate.
  - g. All specimen trees on the subject property shall be shown on grading plans. Trees intended for retention and/or removal shall be so noted on the project grading plans. Replacement trees for those to be removed shall also be shown on the project grading plans.
  - h. All trees shall be minimum double-staked. Weaker and/or slow-growing trees shall be steel-staked.
- 4.3 Three (3) sets of detailed landscaping and irrigation plans shall be submitted pursuant to the Conditions of Approval with a processing fee as stated on the current Schedule of Development Fees to the Community and Economic Development Department.
- 4.4 No grading permits shall be issued for any proposed new structures outside the areas shown on the approved tentative map unless otherwise approved by the Planning Director and the Public Works Director.
- 4.5 If grading is proposed for five (5) or more acres or is part of a larger project that will disturb five (5) or more acres it shall require a National Pollutant Discharge Elimination System (NPDES) Construction General Permit from the State Water Resources Control Board. Grading permits shall not be issued until the Public Works Director has determined that the project has complied with the current City requirements for compliance with the NPDES Construction General Permit.

**TENTATIVE TRACT MAP NO. 33680**  
**Conditions of Approval**  
**Page 7 of 10**

- 4.6 If the project grading is to be phased, prior to issuance of a grading permit, an overall conceptual grading plan shall be submitted to the Public Works Director and Planning Director for approval. The plan shall be used as a guideline for subsequent detailed grading plans for individual phases of development and shall include the following:
- a. Techniques which will be utilized to prevent erosion and sedimentation during and after the grading process.
  - b. Approximate time frames for grading and identification of areas which may be graded during the higher probability rain months of December through March.
  - c. Preliminary pad and roadway elevations.
  - d. Areas of temporary grading outside of a particular phase.
- 4.7 Driveways shall be designed so as not to exceed a fifteen (15) percent grade.
- 4.8 The subdivider shall provide evidence to the Public Works Director that all off-site grading areas have recorded grading and drainage easements and that maintenance responsibilities have been assigned as approved by the Public Works Director.
- 4.9 A qualified paleontologist shall be retained by the subdivider for consultation and comment on the proposed grading with respect to potential paleontological impacts. Should the paleontologist find the potential is high for impact to significant resources, a pre-grade meeting between the paleontologist, the City Public Works Director and the grading contractor shall be arranged. When necessary, the paleontologist or representative shall have the authority to temporarily divert, redirect, or halt grading activity to allow recovery of fossils. The paleontologist shall submit in writing to the Planning Director the results of the initial consultation and details of the fossil recovery plan if recovery was deemed necessary.
- 4.10 The subdivider shall pay at his or her sole expense and shall notify the Public Works Director in writing that the appropriate California Department of Fish and Game notification pursuant to Sections 1601/1603 of the California Fish and Game Code has taken place, or obtain an "Agreement Regarding Proposed Stream or Lake Alteration" (Section 1601/1603 Permit) should any grading be proposed within or along the banks of any natural watercourse. Copies of any agreement shall be submitted to the Public Works Director with the notification.

**TENTATIVE TRACT MAP NO. 33680**  
**Conditions of Approval**  
**Page 8 of 10**

- 4.11 The subdivider shall pay at his or her sole expense and shall notify the Public Works Director in writing that the alteration of any watercourse or wetland complies with the U.S. Army Corps of Engineers (Corps) Nationwide Permit Conditions, or obtain a permit under Section 404 of the Clean Water Act should any grading or construction be proposed within or alongside the banks of the any watercourse or wetland where the Corps has jurisdiction. Copies of any agreements shall be submitted to the Public Works Director along with the notification.
- 4.12 Grading plans shall be submitted to the Public Works Director for review and approval. The plans shall include an erosion and siltation control element, as necessary, to prevent graded and cleared areas from being eroded, resulting in the transport of sediment into the watercourses and downstream where it may affect downstream properties and habitat. Approval of the grading plans is required to fulfill monitoring requirements of the California Environmental Quality Act (CEQA).
- 4.13 Any grading plans proposing grading adjacent to or within the open space lots shall be submitted to the Planning Director for review and approval.
- 4.14 Lots shall be graded to drain to the street with no cross lot drainage permitted. Lot drainage shall be indicated on all grading plans.
- 4.15 The subdivider shall submit two (2) copies of a soils report to the Public Works Director. The report shall address the soils stability and geologic conditions of the site as approved by the Public Works Director.

**5.0 BUILDING CONDITIONS**

Prior to the issuance of BUILDING PERMITS, all the following conditions shall be satisfied:

- 5.1 The subdivider shall submit written clearances to the Planning Director that all pertinent requirements from the following agencies have been met:
- City Public Works Department  
 Beaumont Unified School District  
 Beaumont-Cherry Valley Water District
- 5.2 A detailed wall and fencing plan shall be submitted to and approved by the Planning Director and shall show all project walls and fencing including, but not limited to, perimeter fencing,

**TENTATIVE TRACT MAP NO. 33680**  
**Conditions of Approval**  
**Page 9 of 10**

side and rear yard fencing, and open space or park fencing. A typical elevation of all walls and fences shall be shown on the wall and fencing plan. Decorative block walls shall be constructed along all side yards adjacent to streets and in locations as approved by the Planning Director. The wall plan shall be consistent with the acoustical report and recommendations prepared for the project.

- 5.3 Roof-mounted mechanical equipment shall not be permitted within the subdivision, however, solar equipment or any other energy saving devices shall be permitted with Planning Director approval.
- 5.4 Building separation between all buildings shall not be less than ten (10) feet. Fireplaces and media niches when connected to fire places may encroach one (1) foot into the side yard setback. Additional encroachments are allowed as approved by the Planning Director pursuant to an application for a setback adjustment.
- 5.5 All street side yard setbacks shall be a minimum of ten (10) feet.
- 5.6 All front yards shall be provided with landscaping and automatic irrigation systems, as approved by the Planning Director.
- 5.7 Wood fencing shall not be permitted in this subdivision. Acceptable materials include masonry, stucco or vinyl, as approved by the Planning Director.
- 5.8 All utility connections and easements shall be placed underground and shall not encroach into the driveway area unless otherwise approved by the Public Works Director.
- 5.9 A minor plot plan for all residential buildings, garages and accessory buildings shall be submitted to the Planning Director accompanied by applicable filing fees for a plot plan not subject to the California Environmental Quality Act and not subject to review by any governmental agency other than the City of Beaumont. The minor plot plan shall contain the following elements:
  - a. A final site plan (1"=30' minimum scale precise grading plan) showing all lots, building footprints, setbacks, walls, fencing, the floor plan and elevations of individual lots.
  - b. One (1) color and materials sample containing precise color texture and material swatches or photographs (which may be from supplier's brochures). Indicate on the sample board the name, address and phone number of the preparer and the

**TENTATIVE TRACT MAP NO. 33680**  
**Conditions of Approval**  
**Page 10 of 10**

project applicant, the tract number, and the manufacturer and product numbers when feasible (trade names also acceptable).

- c. One (1) set of architectural elevations colored to represent the selected color combinations, with symbols keyed to the color and materials sample board. Brief written color and material descriptions shall be located on the colored elevations. No landscaping or other enhancements shall be shown on the elevations. Enhanced or upgraded rear and side facing architectural features shall be included for dwelling units adjacent to and visible from public roadways.
- d. Five (5) sets of photographic or color laser prints (8 X 10 in.) of the sample board and colored elevations shall be submitted for permanent filing.

The Minor Plot Plan shall require the approval of the Director of Planning prior to issuance of building permits for lots included within the plot plan, including permits for model home complexes. The submittal and approval of plot plans may be phased provided:

- a. A subdivision phasing plan has been submitted to and approved by the Planning Director and Public Works Director.
- b. A separate plot plan shall be submitted to the planning Director for each approved tract phase accompanied by the appropriate filing fees.

- 5.10 All residential units shall be served by a minimum of two access points at all times, for proper circulation and emergency vehicle ingress and egress, as approved by the Fire Department.
- 5.11 All residential and commercial structures shall be provided with “four-sided” architectural features. With respect to residential structures, this may take the form of edge trim on all exterior doors or windows, or other methods as approved by the Planning Director.
- 5.12 All residences must have illuminated address numbers.
- 5.13 The existing residence’s façade shall be modified to be architecturally compatible with the proposed new residences to the satisfaction of the Planning Director.

**6.0 FINAL INSPECTION/OCCUPANCY CONDITIONS**

**TENTATIVE TRACT MAP NO. 33680**  
**Conditions of Approval**  
**Page 11 of 10**

Prior to the FINAL BUILDING INSPECTION or issuance of OCCUPANCY PERMITS, which ever occurs first, all the following conditions shall be satisfied:

- 6.1 Decorative block and sound walls shall be constructed along all external tract boundaries subject to the approval of the Public Works Director and Planning Director. A graffiti resistant coating or landscaping shall be provided on all block walls.
- 6.2 Wall and fence locations shall conform to the approved wall fencing plan and approved landscape and irrigation plans. All walls and fences shall be constructed subject to the approval of the Planning Director.
- 6.3 All lighting shall be in compliance with the City's Outdoor Lighting Ordinance. The Ordinance governs all outdoor lighting, pole mount, wall or building mount, landscape lighting and Parks. Front and rear porch lighting are included on Residential Standards.
- 6.4 All landscaping and irrigation shall be installed in accordance with approved plans. If the seasonal conditions do not permit planting, interim landscaping, and erosion control measures shall be utilized as approved by the Planning Director and the Public Works Director.
- 6.5 A licensed landscape architect shall provide a Compliance Letter to the Planning Director and the Public Works Director stating that the landscape and irrigation system has been installed in compliance with the approved landscaping and irrigation plans and conditions of approval. The Compliance Letter shall be submitted at least three (3) working days prior to any final building inspection or issuance of any occupancy permits, whichever occurs first.
- 6.6 All landscaping and irrigation shall be installed in accordance with approved plans and shall be verified by a City field inspection at the direction of the Planning Director.
- 6.7 All driveways shall be concrete paved.
- 6.8 The required park facilities shall be completed and issued a final building permit inspection consistent with the phasing schedule to be developed in the implementation of the Recordation Conditions set forth herein.
- 6.9 The subdivider shall submit to the Planning Director a duly and completely executed agreement with a CFD or other maintenance entity approved by the Planning Director which demonstrates to the satisfaction of the City Attorney, Planning Director and Public Works Director that the subdivider has provided for the dedication and maintenance of landscaping, irrigation and open space areas. Model homes shall be

**TENTATIVE TRACT MAP NO. 33680**  
**Conditions of Approval**  
**Page 12 of 10**

exempt from this condition.





## Staff Report

**TO:** Mayor, and City Council Members  
**FROM:** Jeff Hart, Public Works Director  
**DATE:** June 02, 2020  
**SUBJECT:** Performance Bonds Acceptance and Security Agreement for Pardee Homes. Tract 37298-1 Traffic Signal Installation and Modifications

---

### Background and Analysis:

The City requires all developers to provide security for public improvements consisting of, but not limited to, sewer improvements, street improvements, storm drain improvements, utility improvements, and monument improvements. The bonded improvements listed in Table 1 will be constructed by Pardee Homes.

### Pardee Homes:

Highland Springs Avenue is the main north to south arterial in the cities of Banning and Beaumont. Due to ongoing and future development Pardee Homes will install and modify existing traffic signals in the locations mentioned below. The traffic signal improvements are associated with Tract 37298-1, which is part of the Pardee Homes development and the ongoing Highland Springs street improvements. These public improvements will be constructed within the specific plan commonly referred to as Sundance and within the City of Beaumont and Banning right of ways. The contractor will provide all necessary equipment to accommodate the operation of these traffic signals which will consist of poles, mast arms, controllers, detection equipment, luminaires, and signage. Signalization will occur at the following locations:

- Highland Springs Avenue and 8th Street,
- Highland Springs Avenue and Starlight Avenue,
- Highland Springs Avenue and Sundance Drive, and
- Highland Springs Ave and Oak Valley Parkway.

The following table includes the development name, bond number, type of improvement, and the developer submitting the security agreement:

Table 1. Developer, Bond Number, Bond Type, and Type of Improvement				
Bond #	Bond Type	Type of Improvement	Development/Tract #	Developer
CMS331857	Performance	Traffic Signal Installation	37298-1 8 <sup>th</sup> Street	Pardee Homes
CMS331855	Performance	Traffic Signal Installation	37298-1 Starlight Avenue	Pardee Homes
CMS331856	Performance	Traffic Signal Installation	37298-1 Sundance Drive	Pardee Homes
CMS33858	Performance	Traffic Signal Installation	37298-1 Oak Valley Parkway	Pardee Homes

**Fiscal Impact:**

The cost of preparing the staff report is estimated to be \$350.

**Recommended Action:**

Accept the following bonds and security agreements:  
 Performance bond No. CMS331857 for traffic signal installation,  
 Performance bond No. CMS331855 for traffic signal installation,  
 Performance bond No. CMS331856 for traffic signal installation, and  
 Performance bond No. CMS331858 for traffic signal installation.

**Attachments:**

- A. Bond No. CMS331857 and security agreement for traffic signal installation Tract 37298-1 and associated improvement plan
- B. Bond No. CMS331855 and security agreement for traffic signal installation Tract 37298-1 and associated improvement plan
- C. Bond No. CMS331856 and security agreement for traffic signal installation Tract 37298-1 and associated improvement plan
- D. Bond No. CMS331858 and security agreement for traffic signal installation Tract 37298-1 and associated improvement plan

**AGREEMENT TO PROVIDE SECURITY FOR IMPROVEMENTS  
FOR TRACT MAP OR PARCEL MAP OR PLOT PLAN  
(Tract Map/Parcel Map/Plot Plan No. 37298-1)**

THIS SECURITY AGREEMENT is made by and between CITY OF BEAUMONT (“CITY”) and Pardee Homes, a California company (“DEVELOPER”).

**RECITALS**

A. DEVELOPER has applied to the CITY for permission to develop certain real property, pursuant to Tract Map/Parcel Map/Plot Plan #TR37298-1, (“Map”). DEVELOPER has also asked the CITY to accept the dedication of the street or streets and other proposed public rights-of-way, parks and recreation facilities, and easements as depicted on the Map and to otherwise approve the Map so that it may be recorded as required by law; and Atwell-Traffic Signal:Highland Spring Ave & Wilson Street

B. The CITY requires, as a condition precedent to the acceptance and approval of the Map and the dedication of the public rights-of-way and easements depicted thereon, that such rights-of-way be improved with (for example) grading, paving, curbs, gutters, sidewalks, street lights, stormdrains, sanitary sewers and appurtenances thereto, street name signs, survey monuments, electrical and telecommunications, water pipes, water mains, fire hydrants and appurtenances thereto, and landscaping, including any warranty work for all such improvements (collectively, “Improvements”); and

C. The Improvements have not yet been constructed and completed and it is the purpose of this Security Agreement to set forth the terms and conditions by which the DEVELOPER shall guarantee that such Improvements shall be constructed and completed within the time set forth herein.

**AGREEMENT**

NOW, THEREFORE, in consideration of the acceptance of the DEVELOPER’s offer of dedication and the approval of the Map for filing and recording as provided and required by law, the CITY and the DEVELOPER hereby agree as follows:

1. Provision of Improvements. DEVELOPER shall provide, at the DEVELOPER’s sole cost and expense, all necessary labor and materials to complete the construction of the Improvements depicted on the Map and described in the conditions of approval of the Map within one (1) year of the date of this Security Agreement.

2. Inspection by the CITY. The CITY shall inspect, at the DEVELOPER’s sole cost and expense, all of the work, labor and materials performed and provided by the DEVELOPER in connection with the Improvements.

3. Compliance with Plans and Specifications. The Improvements shall be constructed and installed in strict accordance with the CITY-approved plans and specifications.

4. Security for Performance. Concurrently with the execution of this Security Agreement by DEVELOPER, DEVELOPER shall deliver to the CITY a performance bond issued by a corporate surety in substantially the form attached hereto as **Exhibit "A"**, in an amount that is not less than 100% of the total estimated cost of the Improvements and any warranty therefor. The performance bond shall be issued by an "admitted" corporate surety insurer authorized to do business in the State of California and the surety insurer shall have an A.M. Best rating of at least "A, XV". The surety insurer shall have assets exceeding its liabilities in the amount equal to or in excess of the amount of the bond, and the bond shall not be in excess of 10% of the surety insurer's assets. The security or bond shall also insure against any and all defects in the Improvements for a period of not less than one full year after the date of acceptance thereof by the CITY. The bond shall be duly executed and shall meet all the requirements of Section 995.660 of the California Code of Civil Procedure.

5. Security for Contractors, Subcontractors, Laborers and Materialmen. The DEVELOPER shall also provide a payment bond issued by a corporate surety for the security of laborers and materialmen, which bond or bonds shall be in substantially the form attached hereto as **Exhibit "B"** and made a part hereof. The amount of the bond(s) shall be no less than 100% of the total estimated amount needed to secure payment to the contractor, to the subcontractors, and to the persons furnishing labor, materials, or equipment to them for the Improvements. The laborers and materialmen bond shall be provided by an "admitted" corporate surety insurer authorized to transact surety insurance in the State of California with an A.M. Best rating of "A, XV", and with assets exceeding its liabilities in the amount equal to or in excess of the amount of the bond, and the bond shall not be in excess of 10% of the surety insurer's assets. The bond shall be duly executed and shall meet all the requirements of Section 995.660 of the California Code of Civil Procedure.

6. General Liability and Worker's Compensation Insurance. The DEVELOPER shall, before commencing any work, obtain commercial general liability insurance (primary) of not less than \$2,000,000.00 per occurrence for all coverages and \$2,000,000.00 general aggregate. The CITY and its employees and agents shall be added as additional insureds. Coverage shall apply on a primary non-contributing basis in relation to any other insurance or self-insurance, primary or excess, available to the CITY or any employee or agent of the CITY. Coverage shall not be limited to the vicarious liability or supervisory role of any additional insured. Coverage shall contain no contractors' limitation endorsement. There shall be no endorsement or modification limiting the scope of coverage for liability arising from pollution, explosion, collapse, underground property damage or employment-related practices. Such insurance shall not prohibit the DEVELOPER, and its employees or agents, from waiving the right of subrogation prior to a loss. The DEVELOPER waives its right of subrogation against the CITY. Unless otherwise approved by the CITY, the DEVELOPER's insurance shall be written by insurers authorized to do business in the State of California and with a minimum A.M. Best rating of "A, XV." Self-insurance shall not be considered to comply with these insurance specifications. The DEVELOPER agrees to require all contractors, subcontractors and other parties hired for the Improvements to purchase and maintain insurance of the types specified

herein, naming as additional insureds all of the parties to this Security Agreement. The DEVELOPER shall, before commencing any work, obtain Worker's Compensation Insurance in an amount required by law and, failing to do so, the CITY may procure such insurance at the cost of the DEVELOPER.

7. Comprehensive Commercial General and Automobile Liability Insurance. The DEVELOPER, before commencing any work shall, at its own expense, maintain comprehensive commercial general and automobile liability insurance issued by a California-admitted surety company with an A.M. Best rating of no less than "A, XV" for \$2,000,000 per occurrence. Coverage shall be for the entire duration of the permitted activities. Such liability insurance policy shall name, by endorsement, the City as an additional insured.

8. Indemnification. Notwithstanding the provisions of Government Code, Section 66474.9 or any other statutes of similar import, and to the full extent permitted by law, the DEVELOPER shall defend, indemnify and hold harmless the CITY, its employees, agents, officials and attorneys, from and against any liability, claims, suits, actions, arbitration proceedings, administrative proceedings, regulatory proceedings, losses, expenses or costs of any kind or nature, whether actual, alleged or threatened, reasonable attorneys' fees, court costs, interest, expert witness fees and any other costs or expenses of any kind whatsoever, without restriction or limitation, incurred in relation to, as a consequence of, or arising out of or in any way attributable actually, allegedly or impliedly, in whole or in part, to the Map, the Improvements, this Agreement, or any matter related to the same; provided, however, that the indemnification to be provided by DEVELOPER to the CITY pursuant to the terms of this paragraph shall not be applicable where the aforementioned liability, claim, suit, action, etcetera, is the result of the sole negligence or sole willful misconduct of the CITY.

9. Procedure for Release of Performance Bond Security. The security furnished by the DEVELOPER shall be released in whole or in part in the following manner:

a. Security shall be released upon final completion and acceptance of the Improvements. If the security furnished by the DEVELOPER is a documentary evidence of security, such as a surety bond, the CITY shall release the documentary evidence and return the original to the Surety upon final completion and acceptance of the Improvements. In the event the CITY is unable to return the original documentary evidence to the Surety, the security shall be released by written notice sent by certified mail to the DEVELOPER and to the Surety within 30 days of the City's acceptance of the Improvements. The written notice shall contain a statement that the work for which security was furnished has been completed and accepted, a description of the Improvements, and the notarized signature of an authorized CITY official.

b. At such time as the DEVELOPER believes that the work for which the security was required is complete and makes payment of a partial exoneration fee of \$350 to the CITY, the DEVELOPER shall notify the CITY in writing of the completed work, including a list of work completed. Upon receipt of the written notice, the CITY shall have 45 days to review and comment or approve the completion of the Improvements. If the CITY does not agree that all work has been completed in accordance with the plans

and specifications for the Improvements, it shall supply a list of all remaining work to be completed.

c. Within 45 days of receipt of the CITY's list of remaining work, the DEVELOPER may then provide cost estimates for all remaining work for review and approval by the CITY.

d. Upon receipt of the cost estimates, the CITY shall then have 45 days to review, comment, and approve, modify or disapprove those cost estimates. The CITY shall not be required to engage in this process of partial release more than once between the start of work and the completion and acceptance of all work.

e. The DEVELOPER shall complete the works of Improvement until all remaining items are accepted by the CITY. Upon completion of the Improvements, the DEVELOPER shall be notified in writing by the CITY within 45 days and, within 45 days of the date of the CITY's notice, the release of any remaining performance security shall be made within 60 days of the recording of the Notice of Completion.

10. Procedure for Release of Payment Bond Security. Security securing the payment to the contractor, his or her subcontractors and persons furnishing labor, materials or equipment may, after passage of the time within which mechanic's liens and stop notices are required to be recorded and after acceptance of the Improvements, be reduced by Surety to an amount equal to the total claimed by all claimants for whom mechanic's liens and stop notices have been recorded and notice thereof given in writing to the CITY, and if no claims have been recorded, the security may be released in full.

11. Security for One-Year Warranty Period. The release procedures described in paragraphs 9 and 10 above shall not apply to any required guarantee and warranty period nor to the amount of the performance bond security deemed necessary by the CITY for the guarantee and warranty period nor to costs and reasonable expenses and fees, including reasonable attorneys' fees.

12. Binding Effect. This Security Agreement shall be binding upon and shall inure to the benefit of the parties hereto, their legal representatives and their successors and assigns.

13. Authority to Execute. The DEVELOPER hereby warrants and represents to the CITY that the individual signing this Security Agreement on behalf of the DEVELOPER is vested with the unconditional authority to do so pursuant to, and in accordance with, all applicable legal requirements, and has the authority bind the DEVELOPER hereto.

14. No Assignment. The DEVELOPER may not assign this Security Agreement, or any part thereof, to another without the prior written consent of the CITY.

15. Attorneys' Fees. In the event of legal action to enforce or interpret this Agreement or any of its provisions, the prevailing party shall be entitled, in addition to any other form of relief, to recover its reasonable attorneys' fees and costs of suit.

16. Execution in Counterparts. This Agreement may be executed in counterparts, each of which shall be deemed an original, but which together shall constitute a single agreement.

IN WITNESS WHEREOF, the parties have caused this Agreement to be executed on the dates listed below.

CITY OF BEAUMONT

By \_\_\_\_\_  
Mayor

\_\_\_\_\_  
Date

DEVELOPER

By  \_\_\_\_\_  
Jeff Chambers

2-18-2020  
Date

Title: VP of Community Development

Address: Pardee Homes

1250 Corona Pointe Court,

Suite 600

Corona, CA 92879

Basic Gov (Sales Force) # \_\_\_\_\_  
File # \_\_\_\_\_

Bond No: CMS331857  
Premium: \$217.00

**EXHIBIT "A"**

**PERFORMANCE BOND**

WHEREAS, the City Council of the City of Beaumont, State of California, and Pardee Homes (hereinafter designated as "Principal") have entered into Agreement To Provide Security For Improvements For Tract Map Or Parcel Map Or Plot Plan, dated \_\_\_\_\_, 20\_\_, whereby Principal agrees to install and complete certain designated public improvements itemized and described on Tract Map, Parcel Map or Plot Plan No. 37298-1, which is hereby incorporated herein and made a part hereof; and **Atwell-Traffic Signal: Highland Springs Ave & Willson Street**

WHEREAS, Principal is required under the terms of the said agreement to furnish a bond for the faithful performance of said agreement.

NOW, THEREFORE, we, the Principal and RLI Insurance Company, as Surety, are held and firmly bound unto the City of Beaumont (hereinafter called "City"), in the penal sum of Fifty Four Thousand Two Hundred Ninety Six\* dollars (\$ 54,296.00 ) lawful money of the United States, for the payment of which sum well and truly to be made, we bind ourselves, our heirs, successors, executors and administrators, jointly and severally, firmly by these presents. &00/100

The condition of this obligation is such that if the Principal, his or its heirs, executors, administrators, successors or assigns, shall in all things stand to and abide by, and well and truly keep and perform the covenants, conditions and provisions in the said agreement and any alteration thereof made as therein provided, on his or their part to be kept and performed at the time and in the manner therein specified, and in all respects according to their true intent and meaning, and shall indemnify and save harmless the City, its officers, agents and employees as therein stipulated, then this obligation shall become null and void; otherwise it shall be and remain in full force and effect.

As part of the obligation secured hereby and in addition to the face amount specified therefor, there shall be included costs and reasonable expenses and fees, including reasonable attorney's fees, incurred by the City in successfully enforcing such obligation, all to be taxed as costs and included in any judgment therein rendered.

The Surety hereby stipulates and agrees that no change, extension of time, alteration or addition to the terms of the agreement or to the work to be performed thereunder or the specifications accompanying the same shall in any way affect its obligations on this bond, and it does hereby waive notice of any such change, extension of time, alteration or addition to the terms of the agreement or to the work or to the specifications.

IN WITNESS WHEREOF, this instrument has been duly executed by the Principal and Surety above named, on February 12, 2020.

PRINCIPAL:

SURETY:

Pardee Homes

RLI Insurance Company

By 

By 

Title Jeff Chambers, VP Community Development

Title Janina Monroe, Attorney-In-Fact



# ALL-PURPOSE CERTIFICATE OF ACKNOWLEDGMENT

A notary public or other officer completing this certificate verifies only the identity of the individual who signed the document to which this certificate is attached, and not the truthfulness, accuracy, or validity of that document.

State of California }

County of Orange }

On FEB 12 2020 before me, Brianne Davis, Notary Public  
(here insert name and title of the officer)

personally appeared Janina Monroe,  
who proved to me on the basis of satisfactory evidence to be the person(s) whose  
name(s) is/~~are~~ subscribed to the within instrument and acknowledged to me that  
~~he/she/they~~ executed the same in ~~his/her/their~~ authorized capacity(~~ies~~), and that by  
~~his/her/their~~ signature(s) on the instrument the person(s), or the entity upon behalf of  
which the person(s) acted, executed the instrument.

I certify under PENALTY OF PERJURY under the laws of the State of California that  
the foregoing paragraph is true and correct.

WITNESS my hand and official seal.

*Brianne Davis*  
Notary Public Signature (Notary Public Seal)



### ADDITIONAL OPTIONAL INFORMATION

DESCRIPTION OF THE ATTACHED DOCUMENT  
\_\_\_\_\_  
(Title or description of attached document)  
\_\_\_\_\_  
(Title or description of attached document continued)  
Number of Pages \_\_\_\_\_ Document Date \_\_\_\_\_

CAPACITY CLAIMED BY THE SIGNER  
 Individual (s)  
 Corporate Officer  
\_\_\_\_\_  
(Title)  
 Partner(s)  
 Attorney-in-Fact  
 Trustee(s)  
 Other \_\_\_\_\_

### INSTRUCTIONS FOR COMPLETING THIS FORM

*This form complies with current California statutes regarding notary wording and, if needed, should be completed and attached to the document. Acknowledgments from other states may be completed for documents being sent to that state so long as the wording does not require the California notary to violate California notary law.*

- State and County information must be the State and County where the document signer(s) personally appeared before the notary public for acknowledgment.
- Date of notarization must be the date that the signer(s) personally appeared which must also be the same date the acknowledgment is completed.
- The notary public must print his or her name as it appears within his or her commission followed by a comma and then your title (notary public).
- Print the name(s) of document signer(s) who personally appear at the time of notarization.
- Indicate the correct singular or plural forms by crossing off incorrect forms (i.e. ~~he/she/they~~, is /are) or circling the correct forms. Failure to correctly indicate this information may lead to rejection of document recording.
- The notary seal impression must be clear and photographically reproducible. Impression must not cover text or lines. If seal impression smudges, re-seal if a sufficient area permits, otherwise complete a different acknowledgment form.
- Signature of the notary public must match the signature on file with the office of the county clerk.
  - ❖ Additional information is not required but could help to ensure this acknowledgment is not misused or attached to a different document.
  - ❖ Indicate title or type of attached document, number of pages and date.
  - ❖ Indicate the capacity claimed by the signer. If the claimed capacity is a corporate officer, indicate the title (i.e. CEO, CFO, Secretary).
- Securely attach this document to the signed document with a staple.

# POWER OF ATTORNEY

Item 4.

## RLI Insurance Company Contractors Bonding and Insurance Company

9025 N. Lindbergh Dr. Peoria, IL 61615  
Phone: 800-645-2402

### Know All Men by These Presents:

That this Power of Attorney is not valid or in effect unless attached to the bond which it authorizes executed, but may be detached by the approving officer if desired.

That **RLI Insurance Company and/or Contractors Bonding and Insurance Company**, each an Illinois corporation, (separately and together, the "Company") do hereby make, constitute and appoint:

Paul Boucher, Janina Monroe, Dennis Langer, Michelle Haase, Timothy Noonan, jointly or severally

in the City of Irvine, State of California its true and lawful Agent(s) and Attorney(s) in Fact, with full power and authority hereby conferred, to sign, execute, acknowledge and deliver for and on its behalf as Surety, in general, any and all bonds and undertakings in an amount not to exceed Twenty Five Million Dollars (\$25,000,000.00) for any single obligation.

The acknowledgment and execution of such bond by the said Attorney in Fact shall be as binding upon the Company as if such bond had been executed and acknowledged by the regularly elected officers of the Company.

**RLI Insurance Company and/or Contractors Bonding and Insurance Company**, as applicable, have each further certified that the following is a true and exact copy of a Resolution adopted by the Board of Directors of each such corporation, and is now in force, to-wit:

"All bonds, policies, undertakings, Powers of Attorney or other obligations of the corporation shall be executed in the corporate name of the Company by the President, Secretary, any Assistant Secretary, Treasurer, or any Vice President, or by such other officers as the Board of Directors may authorize. The President, any Vice President, Secretary, any Assistant Secretary, or the Treasurer may appoint Attorneys in Fact or Agents who shall have authority to issue bonds, policies or undertakings in the name of the Company. The corporate seal is not necessary for the validity of any bonds, policies, undertakings, Powers of Attorney or other obligations of the corporation. The signature of any such officer and the corporate seal may be printed by facsimile."

IN WITNESS WHEREOF, the **RLI Insurance Company and/or Contractors Bonding and Insurance Company**, as applicable, have caused these presents to be executed by its respective Vice President with its corporate seal affixed this 30th day of September, 2019.



**RLI Insurance Company  
Contractors Bonding and Insurance Company**

By: B. W. Davis  
Barton W. Davis Vice President

State of Illinois }  
County of Peoria } SS

### CERTIFICATE

On this 30th day of September, 2019, before me, a Notary Public, personally appeared Barton W. Davis, who being by me duly sworn, acknowledged that he signed the above Power of Attorney as the aforesaid officer of the **RLI Insurance Company and/or Contractors Bonding and Insurance Company** and acknowledged said instrument to be the voluntary act and deed of said corporation.

I, the undersigned officer of **RLI Insurance Company and/or Contractors Bonding and Insurance Company**, do hereby certify that the attached Power of Attorney is in full force and effect and is irrevocable; and furthermore, that the Resolution of the Company as set forth in the Power of Attorney, is now in force. In testimony whereof, I have hereunto set my hand and the seal of the **RLI Insurance Company and/or Contractors Bonding and Insurance Company** this \_\_\_\_\_ day of FEB 12 2020.

By: Gretchen L. Johnnigk  
Gretchen L. Johnnigk Notary Public

**RLI Insurance Company  
Contractors Bonding and Insurance Company**

By: Jean M. Stephenson  
Jean M. Stephenson Corporate Secretary



# California All-Purpose Certificate of Acknowledgment

A notary public or other officer completing this certificate verifies only the identity of the individual who signed the document to which this certificate is attached, and not the truthfulness, accuracy, or validity of that document.

State of California }  
County of Riverside } s.s.

On February 19, 2020 before me, Ana E. Chavez Perez, Notary Public,  
Name of Notary Public, Title

personally appeared Jeff Chambers  
Name of Signer (1)

\_\_\_\_\_  
Name of Signer (2)

who proved to me on the basis of satisfactory evidence to be the person(s) whose name(s) is/are subscribed to the within instrument and acknowledged to me that he/she/they executed the same in his/her/their authorized capacity(ies), and that by his/her/their signature(s) on the instrument the person(s), or the entity upon behalf of which the person(s) acted, executed the instrument.

I certify under PENALTY OF PERJURY under the laws of the State of California that the foregoing paragraph is true and correct.

WITNESS my hand and official seal.

  
Signature of Notary Public

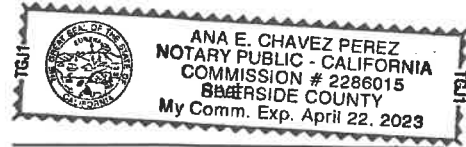

### OPTIONAL INFORMATION

Although the information in this section is not required by law, it could prevent fraudulent removal and reattachment of this acknowledgment to an unauthorized document and may prove useful to persons relying on the attached document.

### Description of Attached Document

The preceding Certificate of Acknowledgment is attached to a document titled/for the purpose of \_\_\_\_\_

containing \_\_\_\_\_ pages, and dated \_\_\_\_\_

The signer(s) capacity or authority is/are as:

- Individual(s)
- Attorney-in-fact
- Corporate Officer(s) \_\_\_\_\_  
Title(s)

- Guardian/Conservator
- Partner - Limited/General
- Trustee(s)
- Other: \_\_\_\_\_

representing: \_\_\_\_\_  
Name(s) of Person(s) Entity(ies) Signer is Representing

Additional Information
<b>Method of Signer Identification</b>
Proved to me on the basis of satisfactory evidence: <input type="checkbox"/> form(s) of identification <input type="checkbox"/> credible witness(es)
Notarial event is detailed in notary journal on: Page # _____ Entry # _____
Notary contact: _____
Other
<input type="checkbox"/> Additional Signer <input type="checkbox"/> Signer(s) Thumbprints(s)
<input type="checkbox"/> _____

**EXHIBIT "B"**

**PAYMENT BOND**

WHEREAS, the City Council of the City of Beaumont, State of California, and Pardee Homes (hereafter designated as "the Principal") have entered into Agreement To Provide Security For Improvements For Tract Map Or Parcel Map Or Plot Plan, dated \_\_\_\_\_, 20\_\_\_\_, whereby Principal agrees to install and complete certain designated public improvements itemized and described on Tract Map, Parcel Map or Plot Plan No. 37298-1, which is hereby incorporated herein and made a part hereof; and Atwell-Traffic Signal: Highland Springs Ave & Willson Street

WHEREAS, under the terms of the said agreement, the Principal is required before entering upon the performance of the work, to file a good and sufficient payment bond with the City of Beaumont to secure the claims to which reference is made in Section 8000, et seq., of the Civil Code of the State of California.

NOW, THEREFORE, the Principal and the undersigned as corporate surety, are held firmly bound unto the City of Beaumont and all contractors, subcontractors, laborers, materialmen, and other persons employed in the performance of the said agreement and referred to at Section 8000, et seq., of the Civil Code in the sum of Fifty Four Thousand Two Hundred \* dollars (\$ 54,296.00), for materials furnished or labor thereon of any kind, or for amounts due under the Unemployment Insurance Act with respect to this work or labor, that the Surety will pay the same in an amount not exceeding the amount hereinabove set forth, and also in case suit is brought upon this bond, will pay, in addition to the face amount thereof, costs and reasonable expenses and fees, including reasonable attorney's fees, incurred by the City in successfully enforcing this obligation, to be awarded and fixed by the court, and to be taxed as costs and to be included in the judgment therein rendered.

\*Ninety Six & 00/100

It is hereby expressly stipulated and agreed that this bond shall inure to the benefit of any and all persons, companies, and corporations entitled to file claims under Section 8000, et seq., of the Civil Code, so as to give a right of action to them or their assigns in any suit brought upon this bond.

Should the condition of this bond be fully performed, then this obligation shall become null and void, otherwise it shall be and remain in full force and effect.

The Surety hereby stipulates and agrees that no change, extension of time, alteration, or addition to the terms of the agreement or the specifications accompanying the same shall in any manner affect its obligations on this bond, and it does hereby waive notice of any such change, extension, alteration, or addition.

IN WITNESS WHEREOF, this instrument has been duly executed by the Principal and Surety above named, on February 12, 2020.

PRINCIPAL:

SURETY:

Pardee Homes

RLI Insurance Company

By 

By 

Title Jeff Chambers, VP Community Development

Title Janina Monroe, Attorney-In-Fact

# ALL- PURPOSE CERTIFICATE OF ACKNOWLEDGMENT

A notary public or other officer completing this certificate verifies only the identity of the individual who signed the document to which this certificate is attached, and not the truthfulness, accuracy, or validity of that document.

State of California }

County of Orange }

On FEB 12 2020 before me, Brianne Davis, Notary Public  
(Here insert name and title of the officer)

personally appeared Janina Monroe  
who proved to me on the basis of satisfactory evidence to be the person(s) whose name(s) is/are subscribed to the within instrument and acknowledged to me that he/she/they executed the same in his/her/their authorized capacity(ies), and that by his/her/their signature(s) on the instrument the person(s), or the entity upon behalf of which the person(s) acted, executed the instrument.

I certify under PENALTY OF PERJURY under the laws of the State of California that the foregoing paragraph is true and correct.

WITNESS my hand and official seal.

*Brianne Davis*

Notary Public Signature

(Notary Public Seal)



### ADDITIONAL OPTIONAL INFORMATION

DESCRIPTION OF THE ATTACHED DOCUMENT  
  
(Title or description of attached document)  
  
(Title or description of attached document continued)  
  
Number of Pages \_\_\_\_\_ Document Date \_\_\_\_\_

### CAPACITY CLAIMED BY THE SIGNER

- Individual (s)
- Corporate Officer  
\_\_\_\_\_  
(Title)
- Partner(s)
- Attorney-in-Fact
- Trustee(s)
- Other \_\_\_\_\_

### INSTRUCTIONS FOR COMPLETING THIS FORM

*This form complies with current California statutes regarding notary wording and, if needed, should be completed and attached to the document. Acknowledgments from other states may be completed for documents being sent to that state so long as the wording does not require the California notary to violate California notary law.*

- State and County information must be the State and County where the document signer(s) personally appeared before the notary public for acknowledgment.
- Date of notarization must be the date that the signer(s) personally appeared which must also be the same date the acknowledgment is completed.
- The notary public must print his or her name as it appears within his or her commission followed by a comma and then your title (notary public).
- Print the name(s) of document signer(s) who personally appear at the time of notarization.
- Indicate the correct singular or plural forms by crossing off incorrect forms (i.e. ~~he/she/they~~, is /are ) or circling the correct forms. Failure to correctly indicate this information may lead to rejection of document recording.
- The notary seal impression must be clear and photographically reproducible. Impression must not cover text or lines. If seal impression smudges, re-seal if a sufficient area permits, otherwise complete a different acknowledgment form.
- Signature of the notary public must match the signature on file with the office of the county clerk.
  - ❖ Additional information is not required but could help to ensure this acknowledgment is not misused or attached to a different document.
  - ❖ Indicate title or type of attached document, number of pages and date.
  - ❖ Indicate the capacity claimed by the signer. If the claimed capacity is a corporate officer, indicate the title (i.e. CEO, CFO, Secretary).
- Securely attach this document to the signed document with a staple.

# POWER OF ATTORNEY

Item 4.

## RLI Insurance Company Contractors Bonding and Insurance Company

9025 N. Lindbergh Dr. Peoria, IL 61615  
Phone: 800-645-2402

### Know All Men by These Presents:

That this Power of Attorney is not valid or in effect unless attached to the bond which it authorizes executed, but may be detached by the approving officer if desired.

That RLI Insurance Company and/or Contractors Bonding and Insurance Company, each an Illinois corporation, (separately and together, the "Company") do hereby make, constitute and appoint:

Paul Boucher, Janina Monroe, Dennis Langer, Michelle Haase, Timothy Noonan, jointly or severally

in the City of Irvine, State of California its true and lawful Agent(s) and Attorney(s) in Fact, with full power and authority hereby conferred, to sign, execute, acknowledge and deliver for and on its behalf as Surety, in general, any and all bonds and undertakings in an amount not to exceed Twenty Five Million Dollars (\$25,000,000.00) for any single obligation.

The acknowledgment and execution of such bond by the said Attorney in Fact shall be as binding upon the Company as if such bond had been executed and acknowledged by the regularly elected officers of the Company.

RLI Insurance Company and/or Contractors Bonding and Insurance Company, as applicable, have each further certified that the following is a true and exact copy of a Resolution adopted by the Board of Directors of each such corporation, and is now in force, to-wit:

"All bonds, policies, undertakings, Powers of Attorney or other obligations of the corporation shall be executed in the corporate name of the Company by the President, Secretary, any Assistant Secretary, Treasurer, or any Vice President, or by such other officers as the Board of Directors may authorize. The President, any Vice President, Secretary, any Assistant Secretary, or the Treasurer may appoint Attorneys in Fact or Agents who shall have authority to issue bonds, policies or undertakings in the name of the Company. The corporate seal is not necessary for the validity of any bonds, policies, undertakings, Powers of Attorney or other obligations of the corporation. The signature of any such officer and the corporate seal may be printed by facsimile."

IN WITNESS WHEREOF, the RLI Insurance Company and/or Contractors Bonding and Insurance Company, as applicable, have caused these presents to be executed by its respective Vice President with its corporate seal affixed this 30th day of September, 2019.



RLI Insurance Company  
Contractors Bonding and Insurance Company  
By: B. W. Davis  
Barton W. Davis Vice President

State of Illinois }  
County of Peoria } SS

### CERTIFICATE

On this 30th day of September, 2019, before me, a Notary Public, personally appeared Barton W. Davis, who being by me duly sworn, acknowledged that he signed the above Power of Attorney as the aforesaid officer of the RLI Insurance Company and/or Contractors Bonding and Insurance Company and acknowledged said instrument to be the voluntary act and deed of said corporation.

I, the undersigned officer of RLI Insurance Company and/or Contractors Bonding and Insurance Company, do hereby certify that the attached Power of Attorney is in full force and effect and is irrevocable; and furthermore, that the Resolution of the Company as set forth in the Power of Attorney, is now in force. In testimony whereof, I have hereunto set my hand and the seal of the RLI Insurance Company and/or Contractors Bonding and Insurance Company this \_\_\_\_\_ day of FEB 12 2020.

By: Gretchen L. Johnik  
Gretchen L. Johnik Notary Public

RLI Insurance Company  
Contractors Bonding and Insurance Company  
By: Jean M. Stephenson  
Jean M. Stephenson Corporate Secretary



# California All-Purpose Certificate of Acknowledgment

A notary public or other officer completing this certificate verifies only the identity of the individual who signed the document to which this certificate is attached, and not the truthfulness, accuracy, or validity of that document.

State of California }  
County of Riverside } s.s.

On February 19, 2020 before me, Ana E. Chavez Perez, Notary Public  
Name of Notary Public, Title

personally appeared Jeff Chambers  
Name of Signer (1)

\_\_\_\_\_  
Name of Signer (2)

who proved to me on the basis of satisfactory evidence to be the person(s) whose name(s) is/are subscribed to the within instrument and acknowledged to me that he/she/they executed the same in his/her/their authorized capacity(ies), and that by his/her/their signature(s) on the instrument the person(s), or the entity upon behalf of which the person(s) acted, executed the instrument.

I certify under PENALTY OF PERJURY under the laws of the State of California that the foregoing paragraph is true and correct.

WITNESS my hand and official seal.

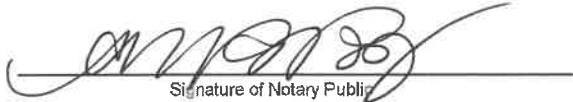
  
Signature of Notary Public

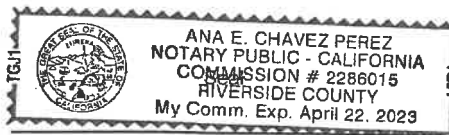

### OPTIONAL INFORMATION

Although the information in this section is not required by law, it could prevent fraudulent removal and reattachment of this acknowledgment to an unauthorized document and may prove useful to persons relying on the attached document.

### Description of Attached Document

The preceding Certificate of Acknowledgment is attached to a document titled/for the purpose of \_\_\_\_\_

containing \_\_\_\_\_ pages, and dated \_\_\_\_\_

The signer(s) capacity or authority is/are as:

- Individual(s)
- Attorney-in-fact
- Corporate Officer(s) \_\_\_\_\_  
Title(s)

- Guardian/Conservator
- Partner - Limited/General
- Trustee(s)
- Other: \_\_\_\_\_

representing: \_\_\_\_\_  
Name(s) of Person(s) Entity(ies) Signer is Representing

### Additional Information

#### Method of Signer Identification

Proved to me on the basis of satisfactory evidence:  
 form(s) of identification  credible witness(es)

Notarial event is detailed in notary journal on:

Page # \_\_\_\_\_ Entry # \_\_\_\_\_

Notary contact: \_\_\_\_\_

#### Other

Additional Signer  Signer(s) Thumbprints(s)

\_\_\_\_\_





### Traffic Signal Cost Estimate

<b>Date:</b> January 31, 2020		<b>Location:</b> Highland Springs Ave. & Wilson/8th St. City of Beaumont			
<b>Job Number:</b> 2467-18-01		<b>Prepared for:</b>			
<b>By:</b> RK Engineering Group, Inc.					
Item No.	Description	Qty.	Unit	Unit Cost	Item Cost
<b>SUBTOTAL</b>					<b>\$47,214</b>
<i>Engineering/Mobilization</i>				0.00%	\$0
<i>Fees, Permits, Supervision</i>				0.00%	\$0
<i>Contingencies</i>				15.00%	\$7,082
<b>TOTAL</b>					<b>\$54,296</b>

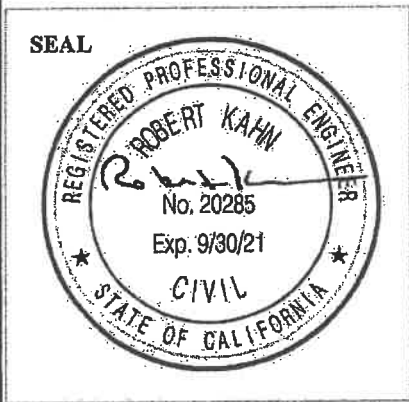

4000 Westerly Place, Suite 280 · Newport Beach, CA 92660  
 Phone: (949) 474-0809 · Fax (949) 474-0902

Reviewed By:

*Robert Kahn*

Robert Kahn

R.C.E. No. 20285

Date:

01/31/20

Exp. 09/30/21





Item 4.

**POLE AND EQUIPMENT SCHEDULE**

SYMBOLS	SIGNAL LUMIN.	VEH. SIGNAL INT.	POLE SEC.	P2P	POLE DIA.	LED	STANDARD HAST. ARM	COMMENTS
1	26'-1-00	30'	45'	15'	2-4MS	SR-1-7	SR-1-7	TO BE PAID FOR BY USER
2	30'	30'	45'	15'	2-4MS	SR-1-7	SR-1-7	TO BE PAID FOR BY USER
3	30'	30'	45'	15'	2-4MS	SR-1-7	SR-1-7	TO BE PAID FOR BY USER
4	30'	30'	45'	15'	2-4MS	SR-1-7	SR-1-7	TO BE PAID FOR BY USER
5	30'	30'	45'	15'	2-4MS	SR-1-7	SR-1-7	TO BE PAID FOR BY USER
6	30'	30'	45'	15'	2-4MS	SR-1-7	SR-1-7	TO BE PAID FOR BY USER
7	30'	30'	45'	15'	2-4MS	SR-1-7	SR-1-7	TO BE PAID FOR BY USER
8	30'	30'	45'	15'	2-4MS	SR-1-7	SR-1-7	TO BE PAID FOR BY USER
9	30'	30'	45'	15'	2-4MS	SR-1-7	SR-1-7	TO BE PAID FOR BY USER
10	30'	30'	45'	15'	2-4MS	SR-1-7	SR-1-7	TO BE PAID FOR BY USER
11	30'	30'	45'	15'	2-4MS	SR-1-7	SR-1-7	TO BE PAID FOR BY USER
12	30'	30'	45'	15'	2-4MS	SR-1-7	SR-1-7	TO BE PAID FOR BY USER
13	30'	30'	45'	15'	2-4MS	SR-1-7	SR-1-7	TO BE PAID FOR BY USER
14	30'	30'	45'	15'	2-4MS	SR-1-7	SR-1-7	TO BE PAID FOR BY USER
15	30'	30'	45'	15'	2-4MS	SR-1-7	SR-1-7	TO BE PAID FOR BY USER
16	30'	30'	45'	15'	2-4MS	SR-1-7	SR-1-7	TO BE PAID FOR BY USER
17	30'	30'	45'	15'	2-4MS	SR-1-7	SR-1-7	TO BE PAID FOR BY USER
18	30'	30'	45'	15'	2-4MS	SR-1-7	SR-1-7	TO BE PAID FOR BY USER
19	30'	30'	45'	15'	2-4MS	SR-1-7	SR-1-7	TO BE PAID FOR BY USER
20	30'	30'	45'	15'	2-4MS	SR-1-7	SR-1-7	TO BE PAID FOR BY USER

**SIGNAL STANDARD DIMENSIONS AND EQUIPMENT LOCATIONS**

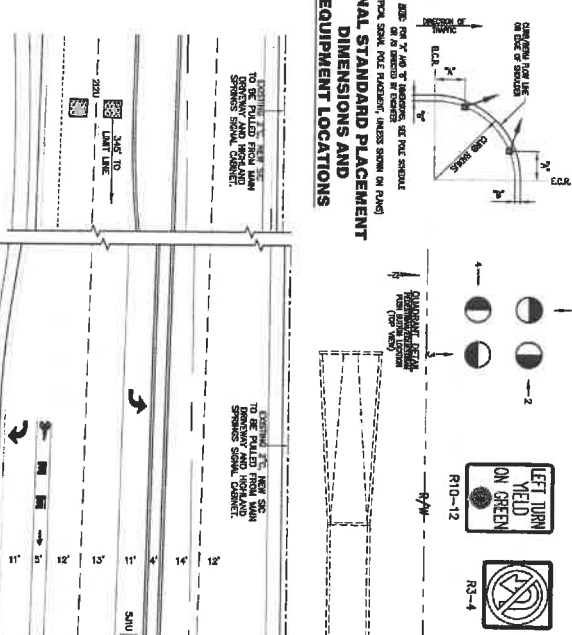

**STARLIGHT AVENUE (35 MPH)**

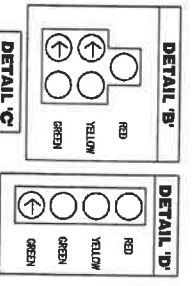
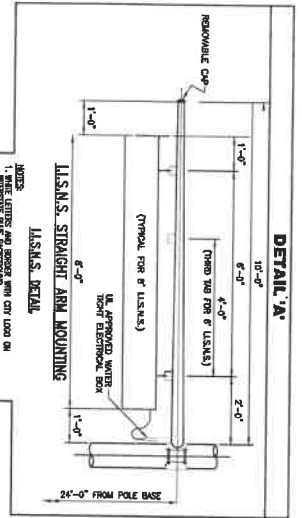
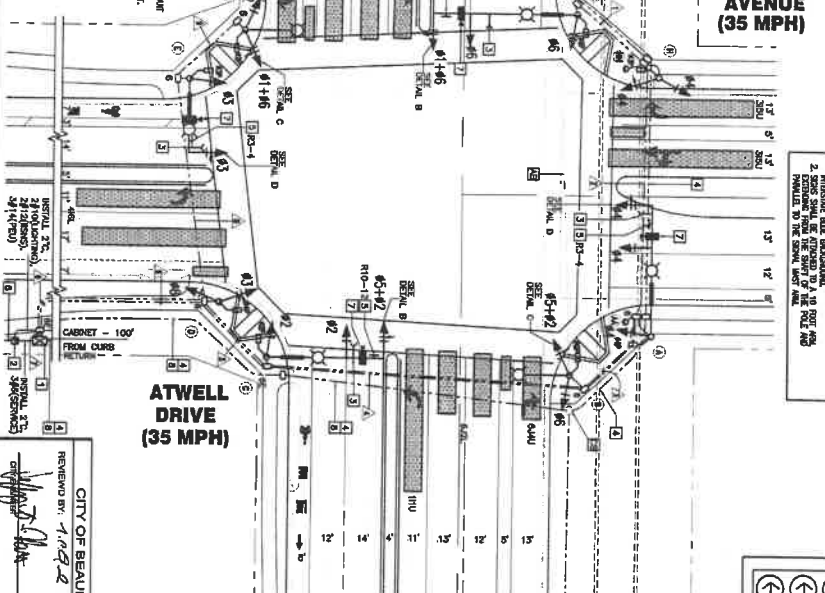

**VIDEO DETECTION ZONE**

CONDUCTOR SCHEDULE	VEH. SIGNAL INT.		POLE SEC.	P2P	POLE DIA.	LED	STANDARD HAST. ARM	COMMENTS
	TYPE	HEIGHT						
1	30'	30'	45'	15'	2-4MS	SR-1-7	SR-1-7	TO BE PAID FOR BY USER
2	30'	30'	45'	15'	2-4MS	SR-1-7	SR-1-7	TO BE PAID FOR BY USER
3	30'	30'	45'	15'	2-4MS	SR-1-7	SR-1-7	TO BE PAID FOR BY USER
4	30'	30'	45'	15'	2-4MS	SR-1-7	SR-1-7	TO BE PAID FOR BY USER
5	30'	30'	45'	15'	2-4MS	SR-1-7	SR-1-7	TO BE PAID FOR BY USER
6	30'	30'	45'	15'	2-4MS	SR-1-7	SR-1-7	TO BE PAID FOR BY USER
7	30'	30'	45'	15'	2-4MS	SR-1-7	SR-1-7	TO BE PAID FOR BY USER
8	30'	30'	45'	15'	2-4MS	SR-1-7	SR-1-7	TO BE PAID FOR BY USER
9	30'	30'	45'	15'	2-4MS	SR-1-7	SR-1-7	TO BE PAID FOR BY USER
10	30'	30'	45'	15'	2-4MS	SR-1-7	SR-1-7	TO BE PAID FOR BY USER
11	30'	30'	45'	15'	2-4MS	SR-1-7	SR-1-7	TO BE PAID FOR BY USER
12	30'	30'	45'	15'	2-4MS	SR-1-7	SR-1-7	TO BE PAID FOR BY USER
13	30'	30'	45'	15'	2-4MS	SR-1-7	SR-1-7	TO BE PAID FOR BY USER
14	30'	30'	45'	15'	2-4MS	SR-1-7	SR-1-7	TO BE PAID FOR BY USER
15	30'	30'	45'	15'	2-4MS	SR-1-7	SR-1-7	TO BE PAID FOR BY USER
16	30'	30'	45'	15'	2-4MS	SR-1-7	SR-1-7	TO BE PAID FOR BY USER
17	30'	30'	45'	15'	2-4MS	SR-1-7	SR-1-7	TO BE PAID FOR BY USER
18	30'	30'	45'	15'	2-4MS	SR-1-7	SR-1-7	TO BE PAID FOR BY USER
19	30'	30'	45'	15'	2-4MS	SR-1-7	SR-1-7	TO BE PAID FOR BY USER
20	30'	30'	45'	15'	2-4MS	SR-1-7	SR-1-7	TO BE PAID FOR BY USER



- CONSTRUCTION NOTES (THIS SHEET):**
- INSTALL TYPE 300 CONDUITS WITH SLOTTED CONDUIT JOINTS. THE JOINTS MUST BE PROTECTED BY A MINIMUM OF 3\"/>

**REVISIONS**

NO.	DESCRIPTION
1	...
2	...
3	...
4	...
5	...

**PLANS PREPARED BY:** RIK CONSULTING SIGNAL, INC.

**APPROVED BY:** [Signature]

**CITY OF BEAUMONT**

**CITY OF BANNING**

**Traffic Signal Plan**

**SHEET 3 OF 7**

**POLE AND EQUIPMENT SCHEDULE**

STANDARD	TYPE	SIGNAL	H.A.	U.A.	W.H.T.	W.H.T.	POLE	FRD. SCS.	P.P.S.	FRD. LOC.	LE.D.	STANDARD	COMMENTS
(1)	18300	30"	-	-	-	-	SP-2-100	-	-	-	-	AS SHOWN (41800)	Standard D(N)
(2)	26-4-10000	30"	40'	25'	15'	-	SP-1-100	-	-	-	-	4-1/2" High Speed (41800)	F-15'
(3)	18-4-10000	30"	25'	25'	15'	-	SP-1-100	-	-	-	-	High Speed (41800)	Standard D(N)
(4)	26-4-10000	30"	25'	25'	15'	-	SP-1-100	-	-	-	-	High Speed (41800)	Standard D(N)
(5)	26-4-10000	30"	25'	25'	15'	-	SP-1-100	-	-	-	-	High Speed (41800)	Standard D(N)
(6)	26-4-10000	30"	25'	25'	15'	-	SP-1-100	-	-	-	-	High Speed (41800)	Standard D(N)
(7)	26-4-10000	30"	25'	25'	15'	-	SP-1-100	-	-	-	-	High Speed (41800)	Standard D(N)
(8)	26-4-10000	30"	25'	25'	15'	-	SP-1-100	-	-	-	-	High Speed (41800)	Standard D(N)

INDICATE POLE LOCATIONS DETERMINED BY FIELD ENGINEER. PROVIDE POLE FOUNDATIONS PRIOR TO ORDERING POLES.  
ALL EQUIPMENT IS EXISTING EXCEPT AS NOTED.  
(N) = NEW  
\* = INACTIVE LUMINAIRE SO DEGRESS AS SHOWN ON PLAN.

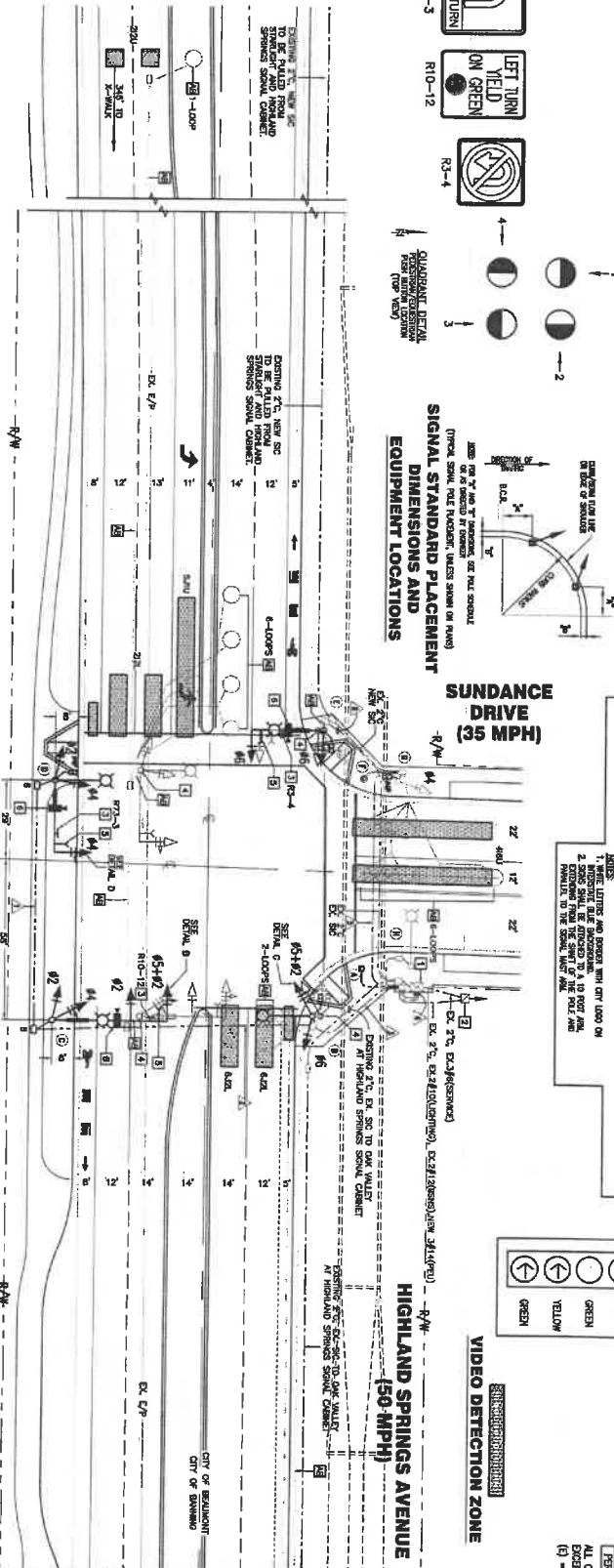

**CONSTRUCTION NOTES (THIS SHEET):**

- 1 REMOVE AND SALVAGE EXISTING SIGN CONTROLS, SIGNAL AND SIGNAL STANDS, AND REMOVE EXISTING MOUNTING STRUCTURES AND FOUNDATION. REMOVE EXISTING MOUNTING STRUCTURES AND FOUNDATION. REMOVE EXISTING MOUNTING STRUCTURES AND FOUNDATION. REMOVE EXISTING MOUNTING STRUCTURES AND FOUNDATION.
- 2 REMOVE AND RETAIL OPTION WORK. 270 DEGREE. REMOVE AND RETAIL OPTION WORK. 270 DEGREE. REMOVE AND RETAIL OPTION WORK. 270 DEGREE. REMOVE AND RETAIL OPTION WORK. 270 DEGREE.
- 3 REMOVE AND RETAIL OPTION WORK. 270 DEGREE. REMOVE AND RETAIL OPTION WORK. 270 DEGREE. REMOVE AND RETAIL OPTION WORK. 270 DEGREE. REMOVE AND RETAIL OPTION WORK. 270 DEGREE.
- 4 REMOVE AND RETAIL OPTION WORK. 270 DEGREE. REMOVE AND RETAIL OPTION WORK. 270 DEGREE. REMOVE AND RETAIL OPTION WORK. 270 DEGREE. REMOVE AND RETAIL OPTION WORK. 270 DEGREE.
- 5 REMOVE AND RETAIL OPTION WORK. 270 DEGREE. REMOVE AND RETAIL OPTION WORK. 270 DEGREE. REMOVE AND RETAIL OPTION WORK. 270 DEGREE. REMOVE AND RETAIL OPTION WORK. 270 DEGREE.

**REVISIONS**

NO.	DATE	DESCRIPTION

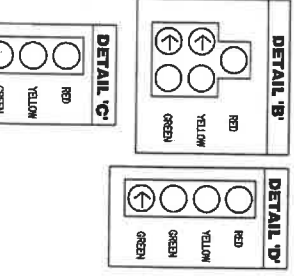
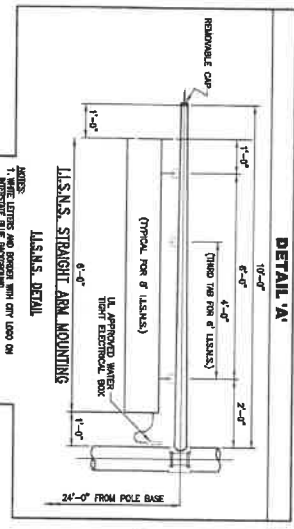

**CONDUCTOR SCHEDULE**

NO.	TYPE	FRD.	CONDUCTOR	CONDUCTOR	CONDUCTOR	CONDUCTOR	CONDUCTOR
12	POLE - A		2	2	2	2	2
10	POLE - B		2	2	2	2	2
9	POLE - C		2	2	2	2	2
8	POLE - D		2	2	2	2	2
7	POLE - E		2	2	2	2	2
6	POLE - F		2	2	2	2	2
5	POLE - G		2	2	2	2	2
4	POLE - H		2	2	2	2	2
3	POLE - I		2	2	2	2	2
2	POLE - J		2	2	2	2	2
1	POLE - K		2	2	2	2	2

**CITY OF BEAUMONT**  
TRAFFIC SIGNAL MODIFICATION PLAN  
ISLAND SPRINGS AND SUNDANCE DRIVE

**CITY OF BANNING**  
TRAFFIC SIGNAL MODIFICATION PLAN

**PLANS PREPARED BY:**  
R.K. Engineering Group, Inc.

**DATE:** 12/11/19

**PROPOSED PHASE DIAGRAM**

1	NOT USED	2	NOT USED
3	NOT USED	4	NOT USED
5	NOT USED	6	NOT USED
7	NOT USED	8	NOT USED

**POLE AND EQUIPMENT SCHEDULE**

STANDARD	TYPE	HEIGHT	SPAN	LUMIN.	VBL. SPAN	MFG.	POLE SEC.			POLE LOC.	LEIN.	STANDARD USED FOR IDENTIFIED LISTS (SEE SHEET A)	COMMENTS
							NO.	A	B				
1	26-1-161	30'	40'(0)	12	2-445(0)	SR-1-100	1	2	3	41(N)	Highland Springs Hwy(0)	F-15	
2	PR-10	31'0"	30'	15(N)	2-445(0)	SR-1-100	1	2	3	41(N)	Highland Springs Hwy(0)	F-15	
3	157(N)	30'	30'	15(N)	2-445(0)	SR-1-100	1	2	3	41(N)	Highland Springs Hwy(0)	F-15	
4	26-5-100(N)	30'	30'	15(N)	2-445(0)	SR-1-100	1	2	3	41(N)	Highland Springs Hwy(0)	F-15	
5	14(N)	10'	30'	15(N)	2-445(0)	SR-1-100	1	2	3	41(N)	Highland Springs Hwy(0)	F-15	
6	18-4-101(N)	30'	30'	15(N)	2-445(0)	SR-1-100	1	2	3	41(N)	Highland Springs Hwy(0)	F-15	
7	157(N)	30'	30'	15(N)	2-445(0)	SR-1-100	1	2	3	41(N)	Highland Springs Hwy(0)	F-15	
8	26-1-161	30'	40'(0)	12	2-445(0)	SR-1-100	1	2	3	41(N)	Highland Springs Hwy(0)	F-15	
9	PR-10	31'0"	30'	15(N)	2-445(0)	SR-1-100	1	2	3	41(N)	Highland Springs Hwy(0)	F-15	
10	1A	10'	30'	15(N)	2-445(0)	SR-1-100	1	2	3	41(N)	Highland Springs Hwy(0)	F-15	

IMPACT POLE LOCATIONS DETERMINED BY FIELD ENGINEER. REMOVE POLE FOUNDATIONS PRIOR TO IMPACT POLES.  
ALL EQUIPMENT IS EXISTING EXCEPT AS NOTED.  
(N) = NEW

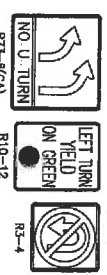

**SIGNAL STANDARD PLACEMENT**  
(TYPICAL SIGNAL POLE LOCATION, UNLESS SHOWN OTHERWISE)  
**EQUIPMENT LOCATIONS**

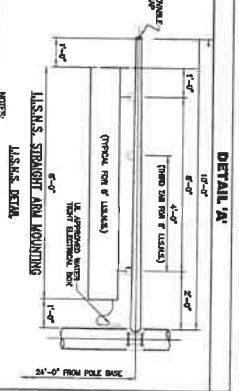
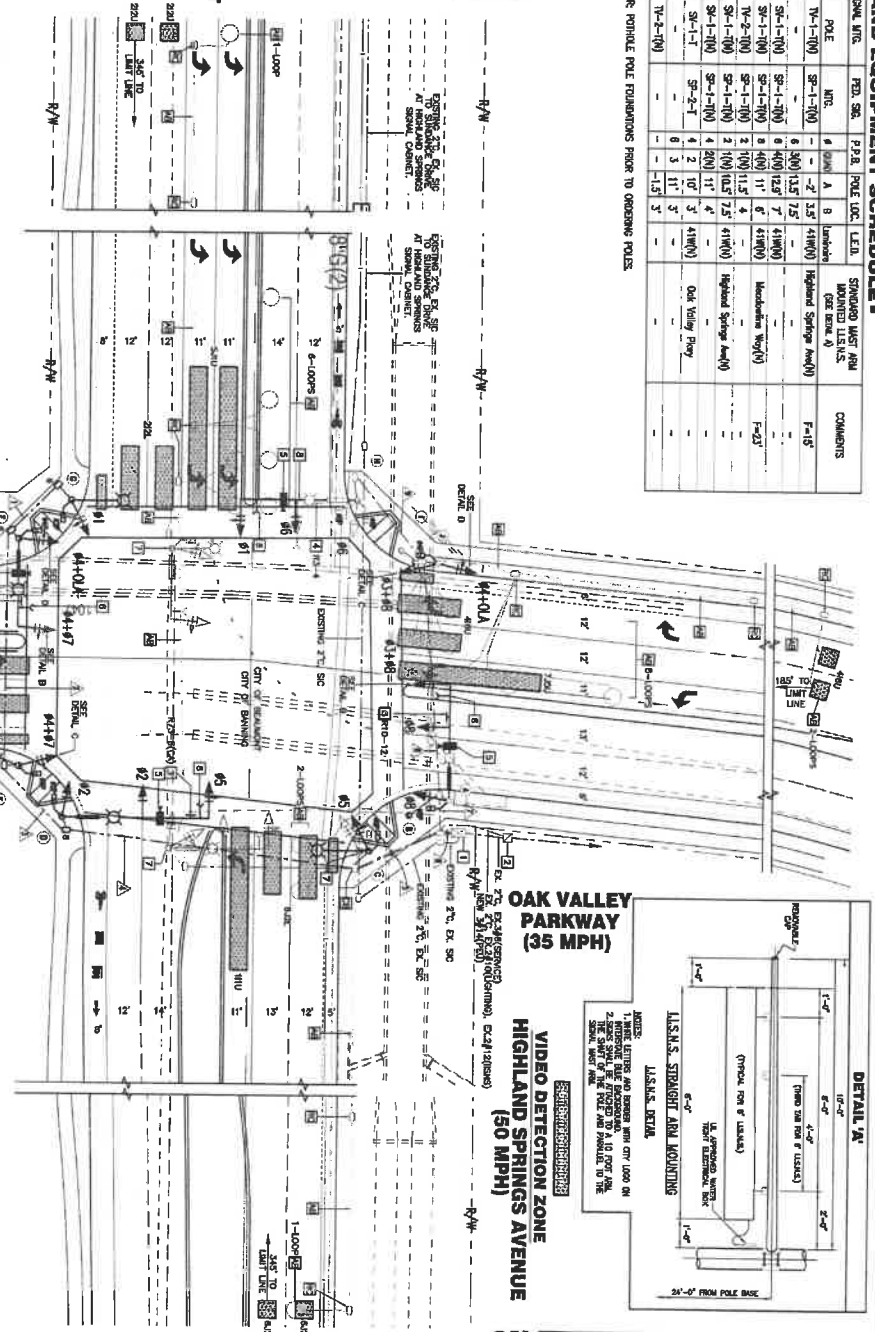
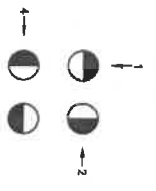

**CONDUCTOR SCHEDULE**

LINE SIZE	CONDUCTOR	POLE OR CEMENT	TYPE	1	2	3	4	5	6	7	8	9	10	11	12	13	14	15	16	17	18	19	20	21	22	23	24	
14	PHOTODUPLICATION UNIT	2	2	2	2	2	2	2	2	2	2	2	2	2	2	2	2	2	2	2	2	2	2	2	2	2	2	2
12	U.S.S.	2	2	2	2	2	2	2	2	2	2	2	2	2	2	2	2	2	2	2	2	2	2	2	2	2	2	2
10	LANEWAYS	2	2	2	2	2	2	2	2	2	2	2	2	2	2	2	2	2	2	2	2	2	2	2	2	2	2	2
8	VIDEO DETECTION	1	1	1	1	1	1	1	1	1	1	1	1	1	1	1	1	1	1	1	1	1	1	1	1	1	1	1
6	VIDEO DETECTION	1	1	1	1	1	1	1	1	1	1	1	1	1	1	1	1	1	1	1	1	1	1	1	1	1	1	1
4	VIDEO DETECTION	1	1	1	1	1	1	1	1	1	1	1	1	1	1	1	1	1	1	1	1	1	1	1	1	1	1	1
3	VIDEO DETECTION	1	1	1	1	1	1	1	1	1	1	1	1	1	1	1	1	1	1	1	1	1	1	1	1	1	1	1
2	VIDEO DETECTION	1	1	1	1	1	1	1	1	1	1	1	1	1	1	1	1	1	1	1	1	1	1	1	1	1	1	1
1	VIDEO DETECTION	1	1	1	1	1	1	1	1	1	1	1	1	1	1	1	1	1	1	1	1	1	1	1	1	1	1	1

ALL CONDUCTORS AND CONDUITS SHALL BE NEW.  
(N) = EXISTING

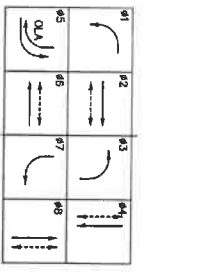
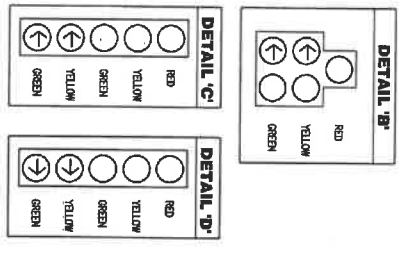

**REVISIONS**

NO.	DATE	DESCRIPTION

PLANNED PREPARED BY: **RK** ENGINEERING GROUP, INC.

SUBMITTED BY: \_\_\_\_\_

REVIEWED BY: \_\_\_\_\_

DATE: \_\_\_\_\_

CITY OF BEAUMONT

CITY OF BANNING

CITY OF BANNING TRAFFIC SIGNAL MODIFICATION PLAN

HIGHLAND SPRINGS AVE & MEADOWLINE WY @ OAK VALLEY PARKWAY

SHEET 5 OF 7

Scale: 1" = 30'

10 & Oak Valley Ave, Sheet 5

Plotted by: \_\_\_\_\_ Date Plotted: 12/05/18



**SPECIAL PROVISIONS TO STANDARD SPECIFICATIONS FOR TRAFFIC SIGNAL PROJECTS**

**A. DESCRIPTION:**

Installation, including, but not limited to, lighting, mounting and electrical wiring of traffic signals and accessories for the intersection of \_\_\_\_\_ and \_\_\_\_\_ in \_\_\_\_\_ City of Beaufort.

**B. EQUIPMENT LIST AND DRAWINGS:**

The Contractor shall submit a complete equipment list and drawings for all traffic signal equipment, including but not limited to signal heads, controllers, cabinets, and mounting hardware. All equipment shall be approved by the City Engineer and the State Engineer before procurement. Drawings shall show the exact location and orientation of all equipment on site.

**C. FOUNDATIONS:**

Foundations for all traffic signal equipment shall be constructed in accordance with the standard specifications. Foundations shall be reinforced with rebar and shall be tested to a minimum of 5000 psi. Foundations shall be approved by the City Engineer and the State Engineer before construction.

**D. STANDARDS STEEL, PEDESTALS AND POSTS:**

Standards, steel, pedestals, and posts shall be fabricated in accordance with the standard specifications. All steel shall be hot-dipped galvanized and shall be tested for corrosion resistance. Pedestals shall be tested to a minimum of 5000 psi. Posts shall be tested to a minimum of 5000 psi.

**E. CONDUIT:**

Conduit shall be installed in accordance with the standard specifications. Conduit shall be installed in a trench and shall be protected with a cover. Conduit shall be tested to a minimum of 5000 psi. Conduit shall be approved by the City Engineer and the State Engineer before procurement.

**F. PULL BOXES:**

Pull boxes shall be installed in accordance with the standard specifications. Pull boxes shall be tested to a minimum of 5000 psi. Pull boxes shall be approved by the City Engineer and the State Engineer before procurement.

**G. LEAD DRIVERS:**

Lead drivers shall be installed in accordance with the standard specifications. Lead drivers shall be tested to a minimum of 5000 psi. Lead drivers shall be approved by the City Engineer and the State Engineer before procurement.

**H. L.E.D. DRIVER:**

L.E.D. drivers shall be installed in accordance with the standard specifications. L.E.D. drivers shall be tested to a minimum of 5000 psi. L.E.D. drivers shall be approved by the City Engineer and the State Engineer before procurement.

**I. BONDING AND GROUNDING:**

Bonding and grounding shall be installed in accordance with the standard specifications. Bonding and grounding shall be tested to a minimum of 5000 psi. Bonding and grounding shall be approved by the City Engineer and the State Engineer before procurement.

**J. VEHICLE SIGNAL PAGES AND SIGNAL HEADS:**

Vehicle signal pages and signal heads shall be installed in accordance with the standard specifications. Signal heads shall be tested to a minimum of 5000 psi. Signal heads shall be approved by the City Engineer and the State Engineer before procurement.

**K. SERVICES:**

Services shall be installed in accordance with the standard specifications. Services shall be tested to a minimum of 5000 psi. Services shall be approved by the City Engineer and the State Engineer before procurement.

**P. INTERNALLY ILLUMINATED STREET NAME SIGNS:**

Internally illuminated street name signs shall be installed in accordance with the standard specifications. Street name signs shall be tested to a minimum of 5000 psi. Street name signs shall be approved by the City Engineer and the State Engineer before procurement.

**Q. EMERGENCY VEHICLE PRIORITY:**

Emergency vehicle priority shall be installed in accordance with the standard specifications. Emergency vehicle priority shall be tested to a minimum of 5000 psi. Emergency vehicle priority shall be approved by the City Engineer and the State Engineer before procurement.

**R. MODEL SCENE CONTROLLER ASSEMBLIES:**

Model scene controller assemblies shall be installed in accordance with the standard specifications. Model scene controller assemblies shall be tested to a minimum of 5000 psi. Model scene controller assemblies shall be approved by the City Engineer and the State Engineer before procurement.

Table with 4 columns: No., Description, Date, Initials. The table is currently blank.

Revision and approval section. Includes fields for "REVISIONS", "SUBMITTED BY:", "CITY OF BEANNING", "SPECIAL PROVISIONS", and "SHEET 7 OF 7".

Administrative information section. Includes the City of Beaufort seal, project name, revision history, and signatures of the City Engineer and the State Engineer.



Basic Gov (Sales Force) # RW2019-0363  
 File # 3300

**AGREEMENT TO PROVIDE SECURITY FOR IMPROVEMENTS  
 FOR TRACT MAP OR PARCEL MAP OR PLOT PLAN  
 (Tract Map/Parcel Map/Plot Plan No. 37298-1)**

THIS SECURITY AGREEMENT is made by and between CITY OF BEAUMONT ("CITY") and Pardee Homes, a California company ("DEVELOPER").

**RECITALS**

A. DEVELOPER has applied to the CITY for permission to develop certain real property, pursuant to Tract Map/Parcel Map/Plot Plan #TR37298-1, ("Map"). DEVELOPER has also asked the CITY to accept the dedication of the street or streets and other proposed public rights-of-way, parks and recreation facilities, and easements as depicted on the Map and to otherwise approve the Map so that it may be recorded as required by law; and Atwell-Traffic Signal: Highland Springs Ave & Starlight Ave

B. The CITY requires, as a condition precedent to the acceptance and approval of the Map and the dedication of the public rights-of-way and easements depicted thereon, that such rights-of-way be improved with (for example) grading, paving, curbs, gutters, sidewalks, street lights, stormdrains, sanitary sewers and appurtenances thereto, street name signs, survey monuments, electrical and telecommunications, water pipes, water mains, fire hydrants and appurtenances thereto, and landscaping, including any warranty work for all such improvements (collectively, "Improvements"); and

C. The Improvements have not yet been constructed and completed and it is the purpose of this Security Agreement to set forth the terms and conditions by which the DEVELOPER shall guarantee that such Improvements shall be constructed and completed within the time set forth herein.

**AGREEMENT**

NOW, THEREFORE, in consideration of the acceptance of the DEVELOPER's offer of dedication and the approval of the Map for filing and recording as provided and required by law, the CITY and the DEVELOPER hereby agree as follows:

1. Provision of Improvements. DEVELOPER shall provide, at the DEVELOPER's sole cost and expense, all necessary labor and materials to complete the construction of the Improvements depicted on the Map and described in the conditions of approval of the Map within one (1) year of the date of this Security Agreement.

2. Inspection by the CITY. The CITY shall inspect, at the DEVELOPER's sole cost and expense, all of the work, labor and materials performed and provided by the DEVELOPER in connection with the Improvements.

3. Compliance with Plans and Specifications. The Improvements shall be constructed and installed in strict accordance with the CITY-approved plans and specifications.

4. Security for Performance. Concurrently with the execution of this Security Agreement by DEVELOPER, DEVELOPER shall deliver to the CITY a performance bond issued by a corporate surety in substantially the form attached hereto as **Exhibit "A"**, in an amount that is not less than 100% of the total estimated cost of the Improvements and any warranty therefor. The performance bond shall be issued by an "admitted" corporate surety insurer authorized to do business in the State of California and the surety insurer shall have an A.M. Best rating of at least "A, XV". The surety insurer shall have assets exceeding its liabilities in the amount equal to or in excess of the amount of the bond, and the bond shall not be in excess of 10% of the surety insurer's assets. The security or bond shall also insure against any and all defects in the Improvements for a period of not less than one full year after the date of acceptance thereof by the CITY. The bond shall be duly executed and shall meet all the requirements of Section 995.660 of the California Code of Civil Procedure.

5. Security for Contractors, Subcontractors, Laborers and Materialmen. The DEVELOPER shall also provide a payment bond issued by a corporate surety for the security of laborers and materialmen, which bond or bonds shall be in substantially the form attached hereto as **Exhibit "B"** and made a part hereof. The amount of the bond(s) shall be no less than 100% of the total estimated amount needed to secure payment to the contractor, to the subcontractors, and to the persons furnishing labor, materials, or equipment to them for the Improvements. The laborers and materialmen bond shall be provided by an "admitted" corporate surety insurer authorized to transact surety insurance in the State of California with an A.M. Best rating of "A, XV", and with assets exceeding its liabilities in the amount equal to or in excess of the amount of the bond, and the bond shall not be in excess of 10% of the surety insurer's assets. The bond shall be duly executed and shall meet all the requirements of Section 995.660 of the California Code of Civil Procedure.

6. General Liability and Worker's Compensation Insurance. The DEVELOPER shall, before commencing any work, obtain commercial general liability insurance (primary) of not less than \$2,000,000.00 per occurrence for all coverages and \$2,000,000.00 general aggregate. The CITY and its employees and agents shall be added as additional insureds. Coverage shall apply on a primary non-contributing basis in relation to any other insurance or self-insurance, primary or excess, available to the CITY or any employee or agent of the CITY. Coverage shall not be limited to the vicarious liability or supervisory role of any additional insured. Coverage shall contain no contractors' limitation endorsement. There shall be no endorsement or modification limiting the scope of coverage for liability arising from pollution, explosion, collapse, underground property damage or employment-related practices. Such insurance shall not prohibit the DEVELOPER, and its employees or agents, from waiving the right of subrogation prior to a loss. The DEVELOPER waives its right of subrogation against the CITY. Unless otherwise approved by the CITY, the DEVELOPER's insurance shall be written by insurers authorized to do business in the State of California and with a minimum A.M. Best rating of "A, XV." Self-insurance shall not be considered to comply with these insurance specifications. The DEVELOPER agrees to require all contractors, subcontractors and other parties hired for the Improvements to purchase and maintain insurance of the types specified

herein, naming as additional insureds all of the parties to this Security Agreement. The DEVELOPER shall, before commencing any work, obtain Worker's Compensation Insurance in an amount required by law and, failing to do so, the CITY may procure such insurance at the cost of the DEVELOPER.

7. Comprehensive Commercial General and Automobile Liability Insurance. The DEVELOPER, before commencing any work shall, at its own expense, maintain comprehensive commercial general and automobile liability insurance issued by a California-admitted surety company with an A.M. Best rating of no less than "A, XV" for \$2,000,000 per occurrence. Coverage shall be for the entire duration of the permitted activities. Such liability insurance policy shall name, by endorsement, the City as an additional insured.

8. Indemnification. Notwithstanding the provisions of Government Code, Section 66474.9 or any other statutes of similar import, and to the full extent permitted by law, the DEVELOPER shall defend, indemnify and hold harmless the CITY, its employees, agents, officials and attorneys, from and against any liability, claims, suits, actions, arbitration proceedings, administrative proceedings, regulatory proceedings, losses, expenses or costs of any kind or nature, whether actual, alleged or threatened, reasonable attorneys' fees, court costs, interest, expert witness fees and any other costs or expenses of any kind whatsoever, without restriction or limitation, incurred in relation to, as a consequence of, or arising out of or in any way attributable actually, allegedly or impliedly, in whole or in part, to the Map, the Improvements, this Agreement, or any matter related to the same; provided, however, that the indemnification to be provided by DEVELOPER to the CITY pursuant to the terms of this paragraph shall not be applicable where the aforementioned liability, claim, suit, action, etcetera, is the result of the sole negligence or sole willful misconduct of the CITY.

9. Procedure for Release of Performance Bond Security. The security furnished by the DEVELOPER shall be released in whole or in part in the following manner:

a. Security shall be released upon final completion and acceptance of the Improvements. If the security furnished by the DEVELOPER is a documentary evidence of security, such as a surety bond, the CITY shall release the documentary evidence and return the original to the Surety upon final completion and acceptance of the Improvements. In the event the CITY is unable to return the original documentary evidence to the Surety, the security shall be released by written notice sent by certified mail to the DEVELOPER and to the Surety within 30 days of the City's acceptance of the Improvements. The written notice shall contain a statement that the work for which security was furnished has been completed and accepted, a description of the Improvements, and the notarized signature of an authorized CITY official.

b. At such time as the DEVELOPER believes that the work for which the security was required is complete and makes payment of a partial exoneration fee of \$350 to the CITY, the DEVELOPER shall notify the CITY in writing of the completed work, including a list of work completed. Upon receipt of the written notice, the CITY shall have 45 days to review and comment or approve the completion of the Improvements. If the CITY does not agree that all work has been completed in accordance with the plans

and specifications for the Improvements, it shall supply a list of all remaining work to be completed.

c. Within 45 days of receipt of the CITY's list of remaining work, the DEVELOPER may then provide cost estimates for all remaining work for review and approval by the CITY.

d. Upon receipt of the cost estimates, the CITY shall then have 45 days to review, comment, and approve, modify or disapprove those cost estimates. The CITY shall not be required to engage in this process of partial release more than once between the start of work and the completion and acceptance of all work.

e. The DEVELOPER shall complete the works of Improvement until all remaining items are accepted by the CITY. Upon completion of the Improvements, the DEVELOPER shall be notified in writing by the CITY within 45 days and, within 45 days of the date of the CITY's notice, the release of any remaining performance security shall be made within 60 days of the recording of the Notice of Completion.

10. Procedure for Release of Payment Bond Security. Security securing the payment to the contractor, his or her subcontractors and persons furnishing labor, materials or equipment may, after passage of the time within which mechanic's liens and stop notices are required to be recorded and after acceptance of the Improvements, be reduced by Surety to an amount equal to the total claimed by all claimants for whom mechanic's liens and stop notices have been recorded and notice thereof given in writing to the CITY, and if no claims have been recorded, the security may be released in full.

11. Security for One-Year Warranty Period. The release procedures described in paragraphs 9 and 10 above shall not apply to any required guarantee and warranty period nor to the amount of the performance bond security deemed necessary by the CITY for the guarantee and warranty period nor to costs and reasonable expenses and fees, including reasonable attorneys' fees.

12. Binding Effect. This Security Agreement shall be binding upon and shall inure to the benefit of the parties hereto, their legal representatives and their successors and assigns.

13. Authority to Execute. The DEVELOPER hereby warrants and represents to the CITY that the individual signing this Security Agreement on behalf of the DEVELOPER is vested with the unconditional authority to do so pursuant to, and in accordance with, all applicable legal requirements, and has the authority bind the DEVELOPER hereto.

14. No Assignment. The DEVELOPER may not assign this Security Agreement, or any part thereof, to another without the prior written consent of the CITY.

15. Attorneys' Fees. In the event of legal action to enforce or interpret this Agreement or any of its provisions, the prevailing party shall be entitled, in addition to any other form of relief, to recover its reasonable attorneys' fees and costs of suit.

16. Execution in Counterparts. This Agreement may be executed in counterparts, each of which shall be deemed an original, but which together shall constitute a single agreement.

IN WITNESS WHEREOF, the parties have caused this Agreement to be executed on the dates listed below.

CITY OF BEAUMONT

By \_\_\_\_\_  
Mayor

\_\_\_\_\_  
Date

DEVELOPER

By Jeff Chambers  
Jeff Chambers

2-18-2020  
Date

Title: VP of Community Development

Address: Pardee Homes  
1250 Corona Pointe Court,  
Suite 600  
Corona, CA 92879

Basic Gov (Sales Force) # \_\_\_\_\_  
File # \_\_\_\_\_

**EXHIBIT "A"**

Bond No: CMS331855  
Premium: \$536.00

**PERFORMANCE BOND**

WHEREAS, the City Council of the City of Beaumont, State of California, and Pardee Homes (hereinafter designated as "Principal") have entered into Agreement To Provide Security For Improvements For Tract Map Or Parcel Map Or Plot Plan, dated \_\_\_\_\_, 20\_\_\_\_, whereby Principal agrees to install and complete certain designated public improvements itemized and described on Tract Map, Parcel Map or Plot Plan No. 37298-1, which is hereby incorporated herein and made a part hereof; and **Atwell-Traffic Signal: Highland Springs Ave & Starlight Ave**

WHEREAS, Principal is required under the terms of the said agreement to furnish a bond for the faithful performance of said agreement.

NOW, THEREFORE, we, the Principal and RLI Insurance Company, as Surety, are held and firmly bound unto the City of Beaumont (hereinafter called "City"), in the penal sum of One Hundred Thirty Three Thousand Nine Hundred\* dollars (\$ 133,999.00 ) lawful money of the United States, for the payment of which sum well and truly to be made, we bind ourselves, our heirs, successors, executors and administrators, jointly and severally, firmly by these presents. \*Ninety Nine & 00/100

The condition of this obligation is such that if the Principal, his or its heirs, executors, administrators, successors or assigns, shall in all things stand to and abide by, and well and truly keep and perform the covenants, conditions and provisions in the said agreement and any alteration thereof made as therein provided, on his or their part to be kept and performed at the time and in the manner therein specified, and in all respects according to their true intent and meaning, and shall indemnify and save harmless the City, its officers, agents and employees as therein stipulated, then this obligation shall become null and void; otherwise it shall be and remain in full force and effect.

As part of the obligation secured hereby and in addition to the face amount specified therefor, there shall be included costs and reasonable expenses and fees, including reasonable attorney's fees, incurred by the City in successfully enforcing such obligation, all to be taxed as costs and included in any judgment therein rendered.

The Surety hereby stipulates and agrees that no change, extension of time, alteration or addition to the terms of the agreement or to the work to be performed thereunder or the specifications accompanying the same shall in any way affect its obligations on this bond, and it does hereby waive notice of any such change, extension of time, alteration or addition to the terms of the agreement or to the work or to the specifications.

IN WITNESS WHEREOF, this instrument has been duly executed by the Principal and Surety above named, on February 12, 2020.

PRINCIPAL:

SURETY:

Pardee Homes

RLI Insurance Company

By 

By 

Title Jeff Chambers, VP Community Development

Title Janina Monroe, Attorney-In-Fact

# ALL-PURPOSE CERTIFICATE OF ACKNOWLEDGMENT

A notary public or other officer completing this certificate verifies only the identity of the individual who signed the document to which this certificate is attached, and not the truthfulness, accuracy, or validity of that document.

State of California }

County of Orange }

On FEB 12 2020 before me, Brianne Davis, Notary Public  
(Here insert name and title of the officer)

personally appeared Janina Monroe,  
who proved to me on the basis of satisfactory evidence to be the person(s) whose  
name(s) is/are subscribed to the within instrument and acknowledged to me that  
~~he/she/they~~ executed the same in ~~his/her/their~~ authorized capacity(ies), and that by  
~~his/her/their~~ signature(s) on the instrument the person(s), or the entity upon behalf of  
which the person(s) acted, executed the instrument.

I certify under PENALTY OF PERJURY under the laws of the State of California that  
the foregoing paragraph is true and correct.

WITNESS my hand and official seal.

Brianne Davis  
Notary Public Signature

(Notary Public Seal)



### ADDITIONAL OPTIONAL INFORMATION

DESCRIPTION OF THE ATTACHED DOCUMENT  
  
(Title or description of attached document)  
  
(Title or description of attached document continued)  
  
Number of Pages \_\_\_\_\_ Document Date \_\_\_\_\_

CAPACITY CLAIMED BY THE SIGNER  
 Individual (s)  
 Corporate Officer  
  
\_\_\_\_\_  
(Title)  
 Partner(s)  
 Attorney-in-Fact  
 Trustee(s)  
 Other \_\_\_\_\_

### INSTRUCTIONS FOR COMPLETING THIS FORM

*This form complies with current California statutes regarding notary wording and, if needed, should be completed and attached to the document. Acknowledgments from other states may be completed for documents being sent to that state so long as the wording does not require the California notary to violate California notary law.*

- State and County information must be the State and County where the document signer(s) personally appeared before the notary public for acknowledgment.
- Date of notarization must be the date that the signer(s) personally appeared which must also be the same date the acknowledgment is completed.
- The notary public must print his or her name as it appears within his or her commission followed by a comma and then your title (notary public).
- Print the name(s) of document signi(s) who personally appear at the time of notarization.
- Indicate the correct singular or plural forms by crossing off incorrect forms (i.e. ~~he/she/they~~, is /~~are~~ ) or circling the correct forms. Failure to correctly indicate this information may lead to rejection of document recording.
- The notary seal impression must be clear and photographically reproducible. Impression must not cover text or lines. If seal impression smudges, re-seal if a sufficient area permits, otherwise complete a different acknowledgment form.
- Signature of the notary public must match the signature on file with the office of the county clerk.
  - Additional information is not required but could help to ensure this acknowledgment is not misused or attached to a different document.
  - Indicate title or type of attached document, number of pages and date.
  - Indicate the capacity claimed by the signer. If the claimed capacity is a corporate officer, indicate the title (i.e. CEO, CFO, Secretary).
- Securely attach this document to the signed document with a staple.

# POWER OF ATTORNEY

Item 4.

## RLI Insurance Company Contractors Bonding and Insurance Company

9025 N. Lindbergh Dr. Peoria, IL 61615  
Phone: 800-645-2402

### Know All Men by These Presents:

That this Power of Attorney is not valid or in effect unless attached to the bond which it authorizes executed, but may be detached by the approving officer if desired.

That RLI Insurance Company and/or Contractors Bonding and Insurance Company, each an Illinois corporation, (separately and together, the "Company") do hereby make, constitute and appoint:

Paul Boucher, Janina Monroe, Dennis Langer, Michelle Haase, Timothy Noonan, jointly or severally  
\_\_\_\_\_  
\_\_\_\_\_

in the City of Irvine, State of California its true and lawful Agent(s) and Attorney(s) in Fact, with full power and authority hereby conferred, to sign, execute, acknowledge and deliver for and on its behalf as Surety, in general, any and all bonds and undertakings in an amount not to exceed Twenty Five Million Dollars (\$25,000,000.00) for any single obligation.

The acknowledgment and execution of such bond by the said Attorney in Fact shall be as binding upon the Company as if such bond had been executed and acknowledged by the regularly elected officers of the Company.

RLI Insurance Company and/or Contractors Bonding and Insurance Company, as applicable, have each further certified that the following is a true and exact copy of a Resolution adopted by the Board of Directors of each such corporation, and is now in force, to-wit:

"All bonds, policies, undertakings, Powers of Attorney or other obligations of the corporation shall be executed in the corporate name of the Company by the President, Secretary, any Assistant Secretary, Treasurer, or any Vice President, or by such other officers as the Board of Directors may authorize. The President, any Vice President, Secretary, any Assistant Secretary, or the Treasurer may appoint Attorneys in Fact or Agents who shall have authority to issue bonds, policies or undertakings in the name of the Company. The corporate seal is not necessary for the validity of any bonds, policies, undertakings, Powers of Attorney or other obligations of the corporation. The signature of any such officer and the corporate seal may be printed by facsimile."

IN WITNESS WHEREOF, the RLI Insurance Company and/or Contractors Bonding and Insurance Company, as applicable, have caused these presents to be executed by its respective Vice President with its corporate seal affixed this 30th day of September, 2019.



RLI Insurance Company  
Contractors Bonding and Insurance Company

By: B. W. Davis  
Barton W. Davis Vice President

State of Illinois }  
County of Peoria } SS

### CERTIFICATE

On this 30th day of September, 2019, before me, a Notary Public, personally appeared Barton W. Davis, who being by me duly sworn, acknowledged that he signed the above Power of Attorney as the aforesaid officer of the RLI Insurance Company and/or Contractors Bonding and Insurance Company and acknowledged said instrument to be the voluntary act and deed of said corporation.

I, the undersigned officer of RLI Insurance Company and/or Contractors Bonding and Insurance Company, do hereby certify that the attached Power of Attorney is in full force and effect and is irrevocable; and furthermore, that the Resolution of the Company as set forth in the Power of Attorney, is now in force. In testimony whereof, I have hereunto set my hand and the seal of the RLI Insurance Company and/or Contractors Bonding and Insurance Company this \_\_\_\_\_ day of \_\_\_\_\_.

FEB 12 2020

By: Gretchen L. Johnigk  
Gretchen L. Johnigk Notary Public

RLI Insurance Company  
Contractors Bonding and Insurance Company

By: Jean M. Stephenson  
Jean M. Stephenson Corporate Secretary





# California All-Purpose Certificate of Acknowledgment

A notary public or other officer completing this certificate verifies only the identity of the individual who signed the document to which this certificate is attached, and not the truthfulness, accuracy, or validity of that document.

State of California }  
County of Riverside } s.s.

On February 19, 2020 before me, Ana E. Chavez Perez, Notary Public,  
Name of Notary Public, Title

personally appeared Jeff Chambers  
Name of Signer (1)

\_\_\_\_\_  
Name of Signer (2)

who proved to me on the basis of satisfactory evidence to be the person(s) whose name(s) is/are subscribed to the within instrument and acknowledged to me that he/she/they executed the same in his/her/their authorized capacity(ies), and that by his/her/their signature(s) on the instrument the person(s), or the entity upon behalf of which the person(s) acted, executed the instrument.

I certify under PENALTY OF PERJURY under the laws of the State of California that the foregoing paragraph is true and correct.

WITNESS my hand and official seal.

  
Signature of Notary Public

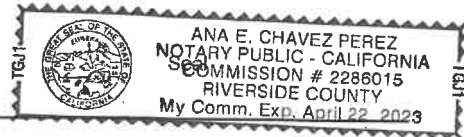

### OPTIONAL INFORMATION

Although the information in this section is not required by law, it could prevent fraudulent removal and reattachment of this acknowledgment to an unauthorized document and may prove useful to persons relying on the attached document.

### Description of Attached Document

The preceding Certificate of Acknowledgment is attached to a document titled/for the purpose of \_\_\_\_\_

containing \_\_\_\_\_ pages, and dated \_\_\_\_\_

The signer(s) capacity or authority is/are as:

- Individual(s)
- Attorney-in-fact
- Corporate Officer(s) \_\_\_\_\_  
Title(s)

- Guardian/Conservator
- Partner - Limited/General
- Trustee(s)
- Other: \_\_\_\_\_

representing: \_\_\_\_\_  
Name(s) of Person(s) Entity(ies) Signer is Representing

Additional Information	
<b>Method of Signer Identification</b>	
Proved to me on the basis of satisfactory evidence:	
<input type="checkbox"/> form(s) of identification	<input type="checkbox"/> credible witness(es)
Notarial event is detailed in notary journal on:	
Page # _____	Entry # _____
Notary contact: _____	
Other	
<input type="checkbox"/> Additional Signer	<input type="checkbox"/> Signer(s) Thumbprints(s)
<input type="checkbox"/> _____	

**EXHIBIT "B"**

**PAYMENT BOND**

WHEREAS, the City Council of the City of Beaumont, State of California, and Pardee Homes (hereafter designated as "the Principal") have entered into Agreement To Provide Security For Improvements For Tract Map Or Parcel Map Or Plot Plan, dated \_\_\_\_\_, 20\_\_\_\_, whereby Principal agrees to install and complete certain designated public improvements itemized and described on Tract Map, Parcel Map or Plot Plan No. 37298-1, which is hereby incorporated herein and made a part hereof; and **Atwell-Traffic Signal: Highland Springs Ave & Starlight Ave**

WHEREAS, under the terms of the said agreement, the Principal is required before entering upon the performance of the work, to file a good and sufficient payment bond with the City of Beaumont to secure the claims to which reference is made in Section 8000, et seq., of the Civil Code of the State of California.

NOW, THEREFORE, the Principal and the undersigned as corporate surety, are held firmly bound unto the City of Beaumont and all contractors, subcontractors, laborers, materialmen, and other persons employed in the performance of the said agreement and referred to at Section 8000, et seq., of the Civil Code in the sum of One Hundred Thirty Three Thousand \* dollars (\$ 133,999.00 ), for materials furnished or labor thereon of any kind, or for amounts due under the Unemployment Insurance Act with respect to this work or labor, that the Surety will pay the same in an amount not exceeding the amount hereinabove set forth, and also in case suit is brought upon this bond, will pay, in addition to the face amount thereof, costs and reasonable expenses and fees, including reasonable attorney's fees, incurred by the City in successfully enforcing this obligation, to be awarded and fixed by the court, and to be taxed as costs and to be included in the judgment therein rendered. \*Nine Hundred Ninety Nine & 00/100

It is hereby expressly stipulated and agreed that this bond shall inure to the benefit of any and all persons, companies, and corporations entitled to file claims under Section 8000, et seq., of the Civil Code, so as to give a right of action to them or their assigns in any suit brought upon this bond.

Should the condition of this bond be fully performed, then this obligation shall become null and void, otherwise it shall be and remain in full force and effect.

The Surety hereby stipulates and agrees that no change, extension of time, alteration, or addition to the terms of the agreement or the specifications accompanying the same shall in any manner affect its obligations on this bond, and it does hereby waive notice of any such change, extension, alteration, or addition.

IN WITNESS WHEREOF, this instrument has been duly executed by the Principal and Surety above named, on February 12, 2020.

PRINCIPAL:

Pardee Homes

By 

Title Jeff Chambers, VP Community Development

SURETY:

RLI Insurance Company

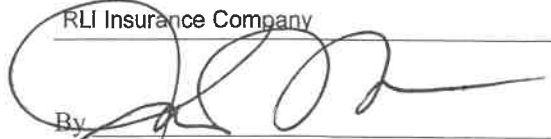
By 

Title Janina Monroe, Attorney-In-Fact

# ALL- PURPOSE CERTIFICATE OF ACKNOWLEDGMENT

A notary public or other officer completing this certificate verifies only the identity of the individual who signed the document to which this certificate is attached, and not the truthfulness, accuracy, or validity of that document.

State of California }

County of Orange }

On FEB 12 2020 before me, Brianne Davis, Notary Public  
(Here insert name and title of the officer)

personally appeared Janina Monroe,  
who proved to me on the basis of satisfactory evidence to be the person(s) whose  
name(s) is/~~are~~ subscribed to the within instrument and acknowledged to me that  
~~he/she/they~~ executed the same in ~~his/her/their~~ authorized capacity(~~ies~~), and that by  
~~his/her/their~~ signature(~~s~~) on the instrument the person(s), or the entity upon behalf of  
which the person(s) acted, executed the instrument.

I certify under PENALTY OF PERJURY under the laws of the State of California that  
the foregoing paragraph is true and correct.

WITNESS my hand and official seal.

*Brianne Davis*  
Notary Public Signature (Notary Public Seal)



### ADDITIONAL OPTIONAL INFORMATION

DESCRIPTION OF THE ATTACHED DOCUMENT  
  
(Title or description of attached document)  
  
(Title or description of attached document continued)  
  
Number of Pages \_\_\_\_\_ Document Date \_\_\_\_\_

CAPACITY CLAIMED BY THE SIGNER  
 Individual (s)  
 Corporate Officer  
\_\_\_\_\_  
(Title)  
 Partner(s)  
 Attorney-in-Fact  
 Trustee(s)  
 Other \_\_\_\_\_

### INSTRUCTIONS FOR COMPLETING THIS FORM

*This form complies with current California statutes regarding notary wording and, if needed, should be completed and attached to the document. Acknowledgments from other states may be completed for documents being sent to that state so long as the wording does not require the California notary to violate California notary law.*

- State and County information must be the State and County where the document signer(s) personally appeared before the notary public for acknowledgment.
- Date of notarization must be the date that the signer(s) personally appeared which must also be the same date the acknowledgment is completed.
- The notary public must print his or her name as it appears within his or her commission followed by a comma and then your title (notary public).
- Print the name(s) of document signer(s) who personally appear at the time of notarization.
- Indicate the correct singular or plural forms by crossing off incorrect forms (i.e. ~~he/she/they~~, is /are ) or circling the correct forms. Failure to correctly indicate this information may lead to rejection of document recording.
- The notary seal impression must be clear and photographically reproducible. Impression must not cover text or lines. If seal impression smudges, re-seal if a sufficient area permits, otherwise complete a different acknowledgment form.
- Signature of the notary public must match the signature on file with the office of the county clerk.
  - ❖ Additional information is not required but could help to ensure this acknowledgment is not misused or attached to a different document.
  - ❖ Indicate title or type of attached document, number of pages and date.
  - ❖ Indicate the capacity claimed by the signer. If the claimed capacity is a corporate officer, indicate the title (i.e. CEO, CFO, Secretary).
- Securely attach this document to the signed document with a staple.

# POWER OF ATTORNEY

Item 4.

## RLI Insurance Company Contractors Bonding and Insurance Company

9025 N. Lindbergh Dr. Peoria, IL 61615  
Phone: 800-645-2402

### Know All Men by These Presents:

That this Power of Attorney is not valid or in effect unless attached to the bond which it authorizes executed, but may be detached by the approving officer if desired.

That **RLI Insurance Company and/or Contractors Bonding and Insurance Company**, each an Illinois corporation, (separately and together, the "Company") do hereby make, constitute and appoint:

Paul Boucher, Janina Monroe, Dennis Langer, Michelle Haase, Timothy Noonan, jointly or severally

in the City of Irvine, State of California its true and lawful Agent(s) and Attorney(s) in Fact, with full power and authority hereby conferred, to sign, execute, acknowledge and deliver for and on its behalf as Surety, in general, any and all bonds and undertakings in an amount not to exceed Twenty Five Million Dollars (\$25,000,000.00) for any single obligation.

The acknowledgment and execution of such bond by the said Attorney in Fact shall be as binding upon the Company as if such bond had been executed and acknowledged by the regularly elected officers of the Company.

**RLI Insurance Company and/or Contractors Bonding and Insurance Company**, as applicable, have each further certified that the following is a true and exact copy of a Resolution adopted by the Board of Directors of each such corporation, and is now in force, to-wit:

"All bonds, policies, undertakings, Powers of Attorney or other obligations of the corporation shall be executed in the corporate name of the Company by the President, Secretary, any Assistant Secretary, Treasurer, or any Vice President, or by such other officers as the Board of Directors may authorize. The President, any Vice President, Secretary, any Assistant Secretary, or the Treasurer may appoint Attorneys in Fact or Agents who shall have authority to issue bonds, policies or undertakings in the name of the Company. The corporate seal is not necessary for the validity of any bonds, policies, undertakings, Powers of Attorney or other obligations of the corporation. The signature of any such officer and the corporate seal may be printed by facsimile."

IN WITNESS WHEREOF, the **RLI Insurance Company and/or Contractors Bonding and Insurance Company**, as applicable, have caused these presents to be executed by its respective Vice President with its corporate seal affixed this 30th day of September, 2019.



**RLI Insurance Company  
Contractors Bonding and Insurance Company**  
By: B. W. Davis  
Barton W. Davis Vice President

State of Illinois }  
County of Peoria } SS

### CERTIFICATE

On this 30th day of September, 2019, before me, a Notary Public, personally appeared Barton W. Davis, who being by me duly sworn, acknowledged that he signed the above Power of Attorney as the aforesaid officer of the **RLI Insurance Company and/or Contractors Bonding and Insurance Company** and acknowledged said instrument to be the voluntary act and deed of said corporation.

I, the undersigned officer of **RLI Insurance Company and/or Contractors Bonding and Insurance Company**, do hereby certify that the attached Power of Attorney is in full force and effect and is irrevocable; and furthermore, that the Resolution of the Company as set forth in the Power of Attorney, is now in force. In testimony whereof, I have hereunto set my hand and the seal of the **RLI Insurance Company and/or Contractors Bonding and Insurance Company** this \_\_\_\_\_ day of FEB 19 2020.

By: Gretchen L. Johnnigk  
Gretchen L. Johnnigk Notary Public

**RLI Insurance Company  
Contractors Bonding and Insurance Company**  
By: Jean M. Stephenson  
Jean M. Stephenson Corporate Secretary



# California All-Purpose Certificate of Acknowledgment

A notary public or other officer completing this certificate verifies only the identity of the individual who signed the document to which this certificate is attached, and not the truthfulness, accuracy, or validity of that document.

State of California }  
County of Riverside } s.s.

On February 19, 2020 before me, Ana E. Chavez Perez, Notary Public  
Name of Notary Public, Title

personally appeared Jeff Chambers  
Name of Signer (1)

-----  
Name of Signer (2)

who proved to me on the basis of satisfactory evidence to be the person(s) whose name(s) is/are subscribed to the within instrument and acknowledged to me that he/she/they executed the same in his/her/their authorized capacity(ies), and that by his/her/their signature(s) on the instrument the person(s), or the entity upon behalf of which the person(s) acted, executed the instrument.

I certify under PENALTY OF PERJURY under the laws of the State of California that the foregoing paragraph is true and correct.

WITNESS my hand and official seal.

  
Signature of Notary Public

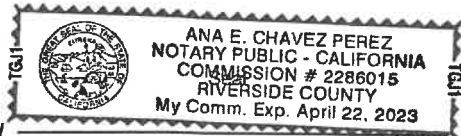

### OPTIONAL INFORMATION

Although the information in this section is not required by law, it could prevent fraudulent removal and reattachment of this acknowledgment to an unauthorized document and may prove useful to persons relying on the attached document.

### Description of Attached Document

The preceding Certificate of Acknowledgment is attached to a document titled/for the purpose of \_\_\_\_\_

containing \_\_\_\_\_ pages, and dated \_\_\_\_\_

The signer(s) capacity or authority is/are as:

- Individual(s)
- Attorney-in-fact
- Corporate Officer(s) \_\_\_\_\_  
Title(s)
- Guardian/Conservator
- Partner - Limited/General
- Trustee(s)
- Other: \_\_\_\_\_

representing: \_\_\_\_\_  
Name(s) of Person(s) Entity(ies) Signer is Representing

Additional Information	
<b>Method of Signer Identification</b>	
Proved to me on the basis of satisfactory evidence:	
<input type="checkbox"/> form(s) of identification	<input type="checkbox"/> credible witness(es)
Notarial event is detailed in notary journal on:	
Page # _____	Entry # _____
Notary contact: _____	
Other	
<input type="checkbox"/> Additional Signer	<input type="checkbox"/> Signer(s) Thumbprints(s)
<input type="checkbox"/> _____	

**Traffic Signal Cost Estimate**

<b>Date:</b>	January 31, 2020	<b>Location:</b>	Highland Springs Ave. & Starlighi/Atwell Dr. City of Beaumont		
<b>Job Number:</b>	2467-18-01	<b>Prepared for:</b>			
<b>By:</b>	RK Engineering Group, Inc.				
Item No.	Description	Qty.	Unit	Unit Cost	Item Cost
14	P.P.B. Pole (4'h), incl. Foundation	2	Ea.	\$960.00	\$1,920
15	Type 1A Pole (10'h)	1	Ea.	\$960.00	\$960
16	Type 15 Pole (30'h)	1	Ea.	\$4,080.00	\$4,080
26	Type 26 Pole (30'h) - 45' Mast Arm	1	Ea.	\$9,120.00	\$9,120
31	Type 29 Pole (30'h) - 50' Mast Arm	1	Ea.	\$9,504.00	\$9,504
39	Foundation, 24" x 3'd (No Re-bar) <Type 1A>	1	Ea.	\$720.00	\$720
40	Foundation, 30" x 5'd (Re-bar) <Type 15>	1	Ea.	\$864.00	\$864
43	Foundation, 36" x 9'd (Re-bar) <Type 18-27(c4),28,29>	2	Ea.	\$2,640.00	\$5,280
46	Signal Head, 12"Ø 3-section LED	6	Ea.	\$1,200.00	\$7,200
47	Signal Head, 12"Ø 4-section LED	2	Ea.	\$1,560.00	\$3,120
48	Signal Head, 12"Ø 5-section LED	2	Ea.	\$1,800.00	\$3,600
50	LED Module, Signal (Arrow: R, Y or G)	6	Ea.	\$300.00	\$1,800
51	LED Module, Signal (Ball: R, Y or G)	30	Ea.	\$384.00	\$11,520
52	Ped Signal Head, LED	4	Ea.	\$1,440.00	\$5,760
54	Ped Push Button (P.P.B.), ADA Compliant	2	Ea.	\$240.00	\$480
55	Illuminated Street Name Sign (I.I.S.N.S.)	2	Ea.	\$1,560.00	\$3,120
56	Luminaires	2	Ea.	\$1,440.00	\$2,880
59	Pull Box #6	7	Ea.	\$900.00	\$6,300
65	2" Conduit (Trenched)	244	LF	\$28.20	\$6,881
69	3" Conduit (Trenched)	203	LF	\$28.20	\$5,725
86	Opticom Detector	2	Ea.	\$792.00	\$1,584
73	4" Conduit (Trenched)	30	LF	\$36.00	\$1,080
83	Video Detection System (Iteris)	0.5	LS	\$35,000.00	\$17,500
137	Furnish & Install Mast Arm Mounted Sign	2	Ea.	\$288.00	\$576
161	SIC 12-pair #19 Cable	1139	LF	\$4.34	\$4,948

### Traffic Signal Cost Estimate

<b>Date:</b> January 31, 2020		<b>Location:</b> Highland Springs Ave. & Starlight/Atwell Dr. City of Beaumont			
<b>Job Number:</b> 2467-18-01		<b>Prepared for:</b>			
<b>By:</b> RK Engineering Group, Inc.					
Item No.	Description	Qty.	Unit	Unit Cost	Item Cost
<b>SUBTOTAL</b>					<b>\$116,521</b>
<i>Engineering/Mobilization</i>				0.00%	\$0
<i>Fees, Permits, Supervision</i>				0.00%	\$0
<i>Contingencies</i>				15.00%	\$17,478
<b>TOTAL</b>					<b>\$133,999</b>

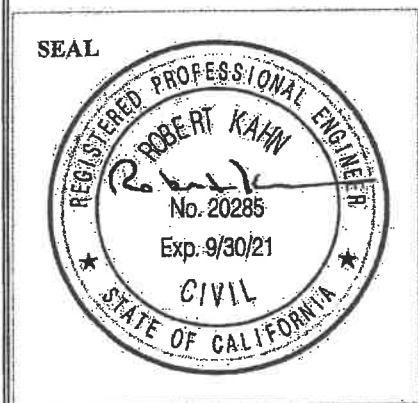

4000 Westerly Place, Suite 280 · Newport Beach, CA 92660  
 Phone: (949) 474-0809 · Fax (949) 474-0902

Reviewed By: Robert Kahn Date: 01/31/20  
 Robert Kahn R.C.E. No. 20285 Exp. 09/30/21

CITY OF BANNING GENERAL NOTES:

- 1. THE CITY OF BANNING HAS ADOPTED THE CITY OF BANNING GENERAL PLAN, THE CITY OF BANNING ZONING ORDINANCE AND THE CITY OF BANNING SUBDIVISION MAP ACT. THE CITY OF BANNING HAS ADOPTED THE CITY OF BANNING GENERAL PLAN, THE CITY OF BANNING ZONING ORDINANCE AND THE CITY OF BANNING SUBDIVISION MAP ACT. THE CITY OF BANNING HAS ADOPTED THE CITY OF BANNING GENERAL PLAN, THE CITY OF BANNING ZONING ORDINANCE AND THE CITY OF BANNING SUBDIVISION MAP ACT.

CITY OF BEAUMONT GENERAL NOTES:

- 1. THE CITY OF BEAUMONT HAS ADOPTED THE CITY OF BEAUMONT GENERAL PLAN, THE CITY OF BEAUMONT ZONING ORDINANCE AND THE CITY OF BEAUMONT SUBDIVISION MAP ACT. THE CITY OF BEAUMONT HAS ADOPTED THE CITY OF BEAUMONT GENERAL PLAN, THE CITY OF BEAUMONT ZONING ORDINANCE AND THE CITY OF BEAUMONT SUBDIVISION MAP ACT.

IN THE CITY OF BANNING, STATE OF CALIFORNIA TRACT NO. 37298-1, ATWELL TRAFFIC SIGNAL INSTALLATION AND MODIFICATION PLANS

LEGAL DESCRIPTION

LOT 11, 12 AND PORTIONS OF LOTS 1, 2, 3, 4, 5, 6, 7, 8, 9, 10, 11, 12, 13, 14, 15, 16, 17, 18, 19, 20, 21, 22, 23, 24, 25, 26, 27, 28, 29, 30, 31, 32, 33, 34, 35, 36, 37, 38, 39, 40, 41, 42, 43, 44, 45, 46, 47, 48, 49, 50, 51, 52, 53, 54, 55, 56, 57, 58, 59, 60, 61, 62, 63, 64, 65, 66, 67, 68, 69, 70, 71, 72, 73, 74, 75, 76, 77, 78, 79, 80, 81, 82, 83, 84, 85, 86, 87, 88, 89, 90, 91, 92, 93, 94, 95, 96, 97, 98, 99, 100, 101, 102, 103, 104, 105, 106, 107, 108, 109, 110, 111, 112, 113, 114, 115, 116, 117, 118, 119, 120, 121, 122, 123, 124, 125, 126, 127, 128, 129, 130, 131, 132, 133, 134, 135, 136, 137, 138, 139, 140, 141, 142, 143, 144, 145, 146, 147, 148, 149, 150, 151, 152, 153, 154, 155, 156, 157, 158, 159, 160, 161, 162, 163, 164, 165, 166, 167, 168, 169, 170, 171, 172, 173, 174, 175, 176, 177, 178, 179, 180, 181, 182, 183, 184, 185, 186, 187, 188, 189, 190, 191, 192, 193, 194, 195, 196, 197, 198, 199, 200, 201, 202, 203, 204, 205, 206, 207, 208, 209, 210, 211, 212, 213, 214, 215, 216, 217, 218, 219, 220, 221, 222, 223, 224, 225, 226, 227, 228, 229, 230, 231, 232, 233, 234, 235, 236, 237, 238, 239, 240, 241, 242, 243, 244, 245, 246, 247, 248, 249, 250, 251, 252, 253, 254, 255, 256, 257, 258, 259, 260, 261, 262, 263, 264, 265, 266, 267, 268, 269, 270, 271, 272, 273, 274, 275, 276, 277, 278, 279, 280, 281, 282, 283, 284, 285, 286, 287, 288, 289, 290, 291, 292, 293, 294, 295, 296, 297, 298, 299, 300, 301, 302, 303, 304, 305, 306, 307, 308, 309, 310, 311, 312, 313, 314, 315, 316, 317, 318, 319, 320, 321, 322, 323, 324, 325, 326, 327, 328, 329, 330, 331, 332, 333, 334, 335, 336, 337, 338, 339, 340, 341, 342, 343, 344, 345, 346, 347, 348, 349, 350, 351, 352, 353, 354, 355, 356, 357, 358, 359, 360, 361, 362, 363, 364, 365, 366, 367, 368, 369, 370, 371, 372, 373, 374, 375, 376, 377, 378, 379, 380, 381, 382, 383, 384, 385, 386, 387, 388, 389, 390, 391, 392, 393, 394, 395, 396, 397, 398, 399, 400, 401, 402, 403, 404, 405, 406, 407, 408, 409, 410, 411, 412, 413, 414, 415, 416, 417, 418, 419, 420, 421, 422, 423, 424, 425, 426, 427, 428, 429, 430, 431, 432, 433, 434, 435, 436, 437, 438, 439, 440, 441, 442, 443, 444, 445, 446, 447, 448, 449, 450, 451, 452, 453, 454, 455, 456, 457, 458, 459, 460, 461, 462, 463, 464, 465, 466, 467, 468, 469, 470, 471, 472, 473, 474, 475, 476, 477, 478, 479, 480, 481, 482, 483, 484, 485, 486, 487, 488, 489, 490, 491, 492, 493, 494, 495, 496, 497, 498, 499, 500, 501, 502, 503, 504, 505, 506, 507, 508, 509, 510, 511, 512, 513, 514, 515, 516, 517, 518, 519, 520, 521, 522, 523, 524, 525, 526, 527, 528, 529, 530, 531, 532, 533, 534, 535, 536, 537, 538, 539, 540, 541, 542, 543, 544, 545, 546, 547, 548, 549, 550, 551, 552, 553, 554, 555, 556, 557, 558, 559, 560, 561, 562, 563, 564, 565, 566, 567, 568, 569, 570, 571, 572, 573, 574, 575, 576, 577, 578, 579, 580, 581, 582, 583, 584, 585, 586, 587, 588, 589, 590, 591, 592, 593, 594, 595, 596, 597, 598, 599, 600, 601, 602, 603, 604, 605, 606, 607, 608, 609, 610, 611, 612, 613, 614, 615, 616, 617, 618, 619, 620, 621, 622, 623, 624, 625, 626, 627, 628, 629, 630, 631, 632, 633, 634, 635, 636, 637, 638, 639, 640, 641, 642, 643, 644, 645, 646, 647, 648, 649, 650, 651, 652, 653, 654, 655, 656, 657, 658, 659, 660, 661, 662, 663, 664, 665, 666, 667, 668, 669, 670, 671, 672, 673, 674, 675, 676, 677, 678, 679, 680, 681, 682, 683, 684, 685, 686, 687, 688, 689, 690, 691, 692, 693, 694, 695, 696, 697, 698, 699, 700, 701, 702, 703, 704, 705, 706, 707, 708, 709, 710, 711, 712, 713, 714, 715, 716, 717, 718, 719, 720, 721, 722, 723, 724, 725, 726, 727, 728, 729, 730, 731, 732, 733, 734, 735, 736, 737, 738, 739, 740, 741, 742, 743, 744, 745, 746, 747, 748, 749, 750, 751, 752, 753, 754, 755, 756, 757, 758, 759, 760, 761, 762, 763, 764, 765, 766, 767, 768, 769, 770, 771, 772, 773, 774, 775, 776, 777, 778, 779, 780, 781, 782, 783, 784, 785, 786, 787, 788, 789, 790, 791, 792, 793, 794, 795, 796, 797, 798, 799, 800, 801, 802, 803, 804, 805, 806, 807, 808, 809, 810, 811, 812, 813, 814, 815, 816, 817, 818, 819, 820, 821, 822, 823, 824, 825, 826, 827, 828, 829, 830, 831, 832, 833, 834, 835, 836, 837, 838, 839, 840, 841, 842, 843, 844, 845, 846, 847, 848, 849, 850, 851, 852, 853, 854, 855, 856, 857, 858, 859, 860, 861, 862, 863, 864, 865, 866, 867, 868, 869, 870, 871, 872, 873, 874, 875, 876, 877, 878, 879, 880, 881, 882, 883, 884, 885, 886, 887, 888, 889, 890, 891, 892, 893, 894, 895, 896, 897, 898, 899, 900, 901, 902, 903, 904, 905, 906, 907, 908, 909, 910, 911, 912, 913, 914, 915, 916, 917, 918, 919, 920, 921, 922, 923, 924, 925, 926, 927, 928, 929, 930, 931, 932, 933, 934, 935, 936, 937, 938, 939, 940, 941, 942, 943, 944, 945, 946, 947, 948, 949, 950, 951, 952, 953, 954, 955, 956, 957, 958, 959, 960, 961, 962, 963, 964, 965, 966, 967, 968, 969, 970, 971, 972, 973, 974, 975, 976, 977, 978, 979, 980, 981, 982, 983, 984, 985, 986, 987, 988, 989, 990, 991, 992, 993, 994, 995, 996, 997, 998, 999, 1000.

ABBREVIATIONS table with columns for symbol and description.

LEGEND table with columns for symbol and description.

VICINITY MAP showing the project location relative to surrounding streets and landmarks.

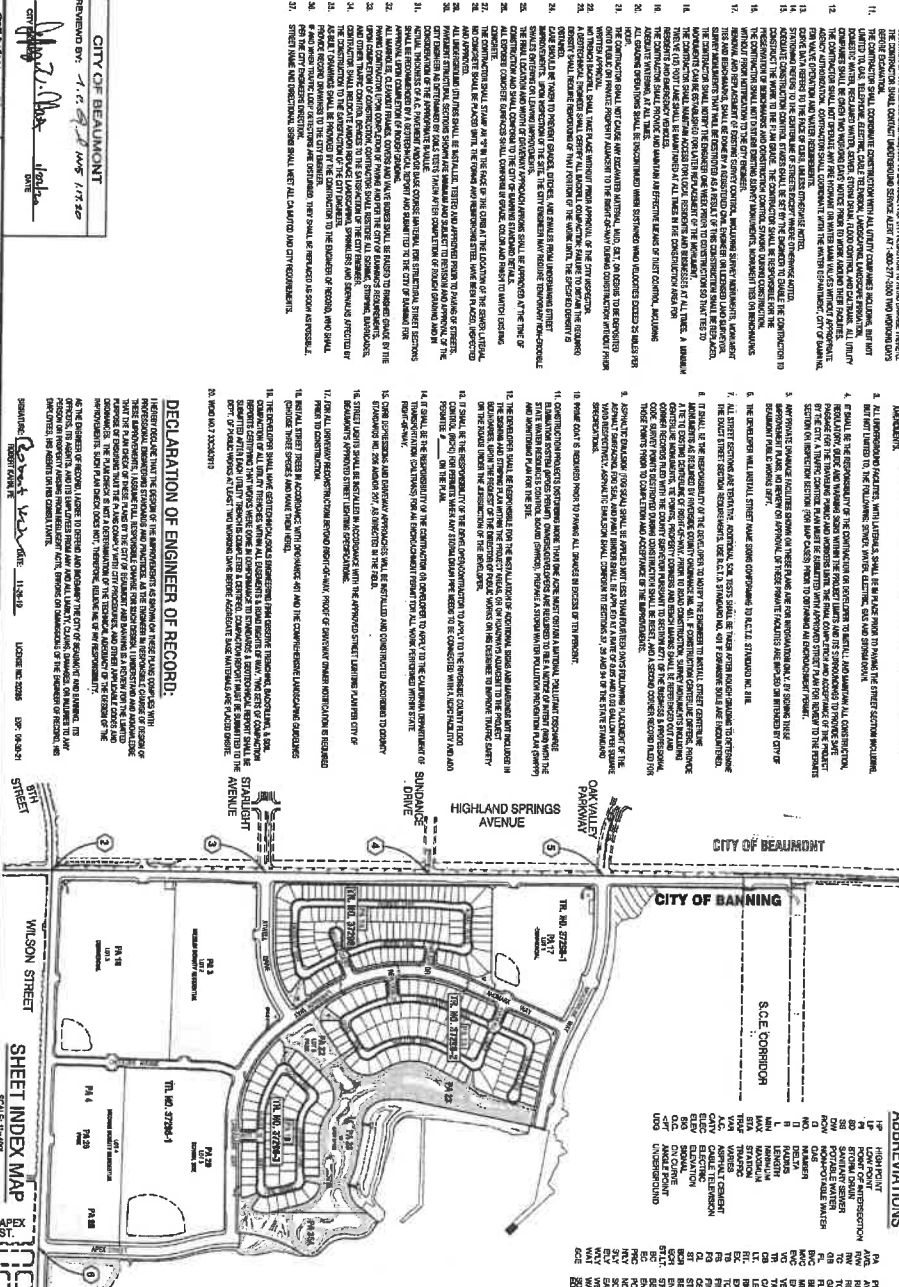

DECLARATION OF ENGINEER OF RECORD:

I, the undersigned, a duly licensed Professional Engineer in the State of California, do hereby certify that I am the Engineer of Record for the above described project and that I have prepared the plans and specifications therefor.

CITY OF BEAUMONT logo and contact information.

REVISIONS table with columns for revision number and description.

PLANS PREPARED BY: RK Engineering Group, Inc.

APPROVED BY: [Signature]

CITY OF BANNING logo and contact information.

TRAFFIC SIGNAL PLANS TITLE SHEET logo.

TRAFFIC SIGNAL PLANS TITLE SHEET logo.

TRAFFIC SIGNAL PLANS TITLE SHEET logo.

TRAFFIC SIGNAL PLANS TITLE SHEET logo.

TRAFFIC SIGNAL PLANS TITLE SHEET logo.

BENCHMARK

BENCHMARK IS A POINT OF REFERENCE FOR THE SURVEY AND SHALL BE A PERMANENT MARKER OF KNOWN LOCATION AND CHARACTER.

ASSESSORS PARCEL NUMBERS

ASSESSORS PARCEL NUMBERS ARE LISTED ON THE ASSessor'S MAP AND SHALL BE A REFERENCE FOR THE SURVEY.

ENGINEER'S NOTE TO CONTRACTORS:

THE CONTRACTOR SHALL BE RESPONSIBLE FOR OBTAINING ALL NECESSARY PERMITS AND APPROVALS FOR THE PROJECT.

WORK TO BE DONE:

THE CONTRACTOR SHALL BE RESPONSIBLE FOR OBTAINING ALL NECESSARY PERMITS AND APPROVALS FOR THE PROJECT.

SHEET INDEX

SHEET INDEX TABLE listing sheet numbers and descriptions.







**POLE AND EQUIPMENT SCHEDULE**

SIGNALS	VEH. SIGNAL, WTC.	POL. SR.	POLE LOC.	LEO.	STANDARD WGT. AND MOUNTED USAS	COMMENTS						
①	TYPE	HEIGHT	M.A.	WEST SIDE	POLE	WTC.	#	QTY	A	B		
②	18" (N)	30'	15" (N)	-	SR-2-100	SR-1-100	1	1	10.5'	4'	-	-
③	26-4-100(N)	30'	40" (N)	15" (N)	SR-2-100	SR-1-100	1	1	AS SHOWN	41" (N)	16"	15"
④	19-4-100(N)	30'	25" (N)	15" (N)	SR-2-100	SR-1-100	1	1	41" (N)	16"	15"	15"
⑤	19-4-100(N)	30'	25" (N)	15" (N)	SR-2-100	SR-1-100	1	1	41" (N)	16"	15"	15"
⑥	19-4-100(N)	30'	25" (N)	15" (N)	SR-2-100	SR-1-100	1	1	41" (N)	16"	15"	15"
⑦	19-4-100(N)	30'	25" (N)	15" (N)	SR-2-100	SR-1-100	1	1	41" (N)	16"	15"	15"
⑧	26-4-120	30'	15" (N)	-	SR-2-100	SR-1-100	1	1	10.5'	4'	-	-

REJECT POLE LOCATIONS DETERMINED BY FIELD ENGINEERS. POINTE POLE FOUNDATIONS PRIOR TO ORDERING POLES.  
 ALL EQUIPMENT IS LISTED EXCEPT AS NOTED.  
 (N) = NEW  
 \* = ROTATE CUMMINGS 90 DEGREES AS SHOWN ON PLAN.

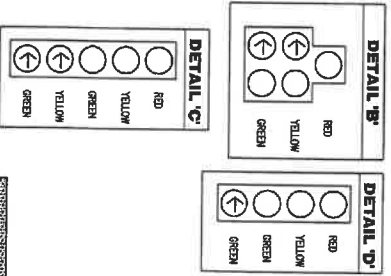
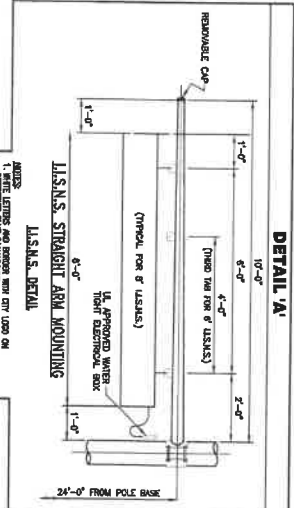
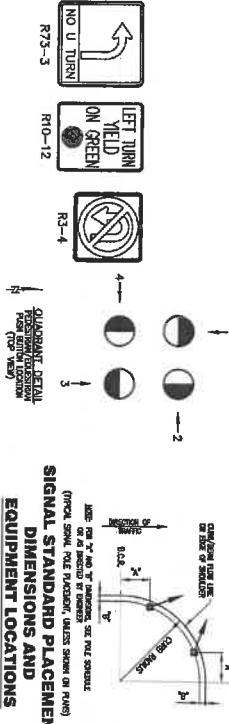

**CONDUCTOR SCHEDULE**

NO.	TYPE	SIZE	LENGTH	WEIGHT	CONDUCTOR
1	1/2"	1/2"	100'	1.5	1
2	1/2"	1/2"	100'	1.5	2
3	1/2"	1/2"	100'	1.5	3
4	1/2"	1/2"	100'	1.5	4
5	1/2"	1/2"	100'	1.5	5
6	1/2"	1/2"	100'	1.5	6
7	1/2"	1/2"	100'	1.5	7
8	1/2"	1/2"	100'	1.5	8
9	1/2"	1/2"	100'	1.5	9
10	1/2"	1/2"	100'	1.5	10
11	1/2"	1/2"	100'	1.5	11
12	1/2"	1/2"	100'	1.5	12
13	1/2"	1/2"	100'	1.5	13
14	1/2"	1/2"	100'	1.5	14
15	1/2"	1/2"	100'	1.5	15
16	1/2"	1/2"	100'	1.5	16
17	1/2"	1/2"	100'	1.5	17
18	1/2"	1/2"	100'	1.5	18
19	1/2"	1/2"	100'	1.5	19
20	1/2"	1/2"	100'	1.5	20
21	1/2"	1/2"	100'	1.5	21
22	1/2"	1/2"	100'	1.5	22
23	1/2"	1/2"	100'	1.5	23
24	1/2"	1/2"	100'	1.5	24
25	1/2"	1/2"	100'	1.5	25
26	1/2"	1/2"	100'	1.5	26
27	1/2"	1/2"	100'	1.5	27
28	1/2"	1/2"	100'	1.5	28
29	1/2"	1/2"	100'	1.5	29
30	1/2"	1/2"	100'	1.5	30
31	1/2"	1/2"	100'	1.5	31
32	1/2"	1/2"	100'	1.5	32
33	1/2"	1/2"	100'	1.5	33
34	1/2"	1/2"	100'	1.5	34
35	1/2"	1/2"	100'	1.5	35
36	1/2"	1/2"	100'	1.5	36
37	1/2"	1/2"	100'	1.5	37
38	1/2"	1/2"	100'	1.5	38
39	1/2"	1/2"	100'	1.5	39
40	1/2"	1/2"	100'	1.5	40
41	1/2"	1/2"	100'	1.5	41
42	1/2"	1/2"	100'	1.5	42
43	1/2"	1/2"	100'	1.5	43
44	1/2"	1/2"	100'	1.5	44
45	1/2"	1/2"	100'	1.5	45
46	1/2"	1/2"	100'	1.5	46
47	1/2"	1/2"	100'	1.5	47
48	1/2"	1/2"	100'	1.5	48
49	1/2"	1/2"	100'	1.5	49
50	1/2"	1/2"	100'	1.5	50

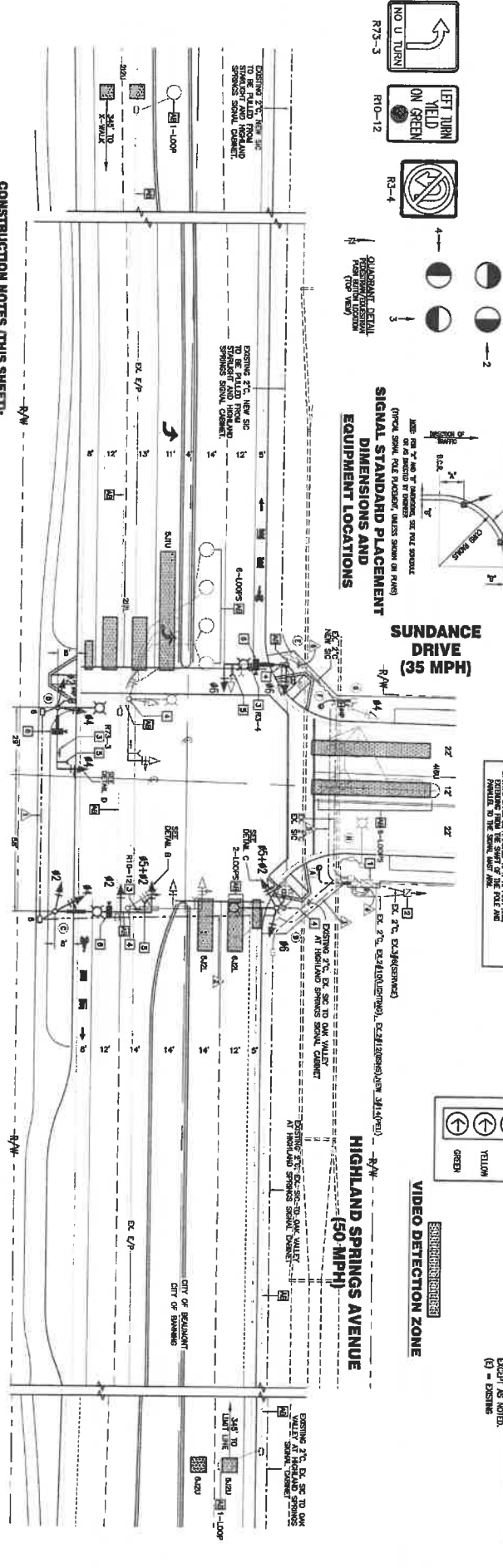

**CONSTRUCTION NOTES (THIS SHEET):**

- REMOVE AND SALVAGE EXISTING THE TYPE CONTRACTOR, FINISHES AND SIGNAL HEADS AND INSTALL THE TYPE CONTRACTOR, FINISHES AND SIGNAL HEADS AS SHOWN ON THIS SHEET. EXISTING CONTRACTOR, FINISHES AND SIGNAL HEADS SHALL BE REMOVED AND SALVAGED BY THE CONTRACTOR. CONTRACTOR TO PROVIDE ALL NECESSARY MATERIALS AND LABOR FOR THIS WORK.
- REMOVE THE POLE, WITH THE SIGNAL HEADS AND SIGNAL HEADS, AND INSTALL THE TYPE CONTRACTOR, FINISHES AND SIGNAL HEADS AS SHOWN ON THIS SHEET. EXISTING CONTRACTOR, FINISHES AND SIGNAL HEADS SHALL BE REMOVED AND SALVAGED BY THE CONTRACTOR. CONTRACTOR TO PROVIDE ALL NECESSARY MATERIALS AND LABOR FOR THIS WORK.
- REMOVE THE POLE, WITH THE SIGNAL HEADS AND SIGNAL HEADS, AND INSTALL THE TYPE CONTRACTOR, FINISHES AND SIGNAL HEADS AS SHOWN ON THIS SHEET. EXISTING CONTRACTOR, FINISHES AND SIGNAL HEADS SHALL BE REMOVED AND SALVAGED BY THE CONTRACTOR. CONTRACTOR TO PROVIDE ALL NECESSARY MATERIALS AND LABOR FOR THIS WORK.
- REMOVE THE POLE, WITH THE SIGNAL HEADS AND SIGNAL HEADS, AND INSTALL THE TYPE CONTRACTOR, FINISHES AND SIGNAL HEADS AS SHOWN ON THIS SHEET. EXISTING CONTRACTOR, FINISHES AND SIGNAL HEADS SHALL BE REMOVED AND SALVAGED BY THE CONTRACTOR. CONTRACTOR TO PROVIDE ALL NECESSARY MATERIALS AND LABOR FOR THIS WORK.
- REMOVE THE POLE, WITH THE SIGNAL HEADS AND SIGNAL HEADS, AND INSTALL THE TYPE CONTRACTOR, FINISHES AND SIGNAL HEADS AS SHOWN ON THIS SHEET. EXISTING CONTRACTOR, FINISHES AND SIGNAL HEADS SHALL BE REMOVED AND SALVAGED BY THE CONTRACTOR. CONTRACTOR TO PROVIDE ALL NECESSARY MATERIALS AND LABOR FOR THIS WORK.
- REMOVE THE POLE, WITH THE SIGNAL HEADS AND SIGNAL HEADS, AND INSTALL THE TYPE CONTRACTOR, FINISHES AND SIGNAL HEADS AS SHOWN ON THIS SHEET. EXISTING CONTRACTOR, FINISHES AND SIGNAL HEADS SHALL BE REMOVED AND SALVAGED BY THE CONTRACTOR. CONTRACTOR TO PROVIDE ALL NECESSARY MATERIALS AND LABOR FOR THIS WORK.
- REMOVE THE POLE, WITH THE SIGNAL HEADS AND SIGNAL HEADS, AND INSTALL THE TYPE CONTRACTOR, FINISHES AND SIGNAL HEADS AS SHOWN ON THIS SHEET. EXISTING CONTRACTOR, FINISHES AND SIGNAL HEADS SHALL BE REMOVED AND SALVAGED BY THE CONTRACTOR. CONTRACTOR TO PROVIDE ALL NECESSARY MATERIALS AND LABOR FOR THIS WORK.
- REMOVE THE POLE, WITH THE SIGNAL HEADS AND SIGNAL HEADS, AND INSTALL THE TYPE CONTRACTOR, FINISHES AND SIGNAL HEADS AS SHOWN ON THIS SHEET. EXISTING CONTRACTOR, FINISHES AND SIGNAL HEADS SHALL BE REMOVED AND SALVAGED BY THE CONTRACTOR. CONTRACTOR TO PROVIDE ALL NECESSARY MATERIALS AND LABOR FOR THIS WORK.
- REMOVE THE POLE, WITH THE SIGNAL HEADS AND SIGNAL HEADS, AND INSTALL THE TYPE CONTRACTOR, FINISHES AND SIGNAL HEADS AS SHOWN ON THIS SHEET. EXISTING CONTRACTOR, FINISHES AND SIGNAL HEADS SHALL BE REMOVED AND SALVAGED BY THE CONTRACTOR. CONTRACTOR TO PROVIDE ALL NECESSARY MATERIALS AND LABOR FOR THIS WORK.
- REMOVE THE POLE, WITH THE SIGNAL HEADS AND SIGNAL HEADS, AND INSTALL THE TYPE CONTRACTOR, FINISHES AND SIGNAL HEADS AS SHOWN ON THIS SHEET. EXISTING CONTRACTOR, FINISHES AND SIGNAL HEADS SHALL BE REMOVED AND SALVAGED BY THE CONTRACTOR. CONTRACTOR TO PROVIDE ALL NECESSARY MATERIALS AND LABOR FOR THIS WORK.

**REVISIONS**

NO.	DATE	DESCRIPTION
1		
2		
3		
4		
5		
6		
7		
8		
9		
10		

**PLANS PREPARED BY:** RK engineering green, inc.

**APPROVED FOR SUBMITTAL:** [Signature]

**CITY OF BEAUMONT**

**TRAFFIC SIGNAL MODIFICATION PLAN**

**HIGHLAND SPRINGS AVE & SUNDANCE DRIVE**

**SHEET 4 OF 7**





**SPECIAL PROVISIONS TO STANDARD SPECIFICATIONS FOR TRAFFIC SIGNAL PROJECTS**

**A. DESCRIPTION:**

The project consists of the installation of traffic signals at the intersection of [location] and [location]. The project includes the installation of traffic signals, pedestrian signals, and street lighting. The project also includes the installation of traffic signs, street lighting, and pedestrian signals. The project is to be completed by [date].

**B. EQUIPMENT LIST AND DRAWINGS:**

The equipment list and drawings are attached to this specification. The equipment list includes the following items: traffic signals, pedestrian signals, street lighting, traffic signs, and pedestrian signals. The drawings include the following items: traffic signal layout, pedestrian signal layout, street lighting layout, traffic sign layout, and pedestrian signal layout.

**C. FOUNDATIONS:**

The foundations for the traffic signals, pedestrian signals, and street lighting shall be constructed in accordance with the standard specifications. The foundations shall be constructed of concrete and shall be reinforced with steel reinforcement bars.

**D. STANDARDS, STEEL, PEDESTALS AND POSTS:**

The standards, steel, pedestals, and posts for the traffic signals, pedestrian signals, and street lighting shall be constructed in accordance with the standard specifications. The standards, steel, pedestals, and posts shall be constructed of steel and shall be painted with a protective paint.

**E. CONDUIT:**

The conduit for the traffic signals, pedestrian signals, and street lighting shall be constructed in accordance with the standard specifications. The conduit shall be constructed of steel and shall be painted with a protective paint.

**F. PULL BOXES:**

The pull boxes for the traffic signals, pedestrian signals, and street lighting shall be constructed in accordance with the standard specifications. The pull boxes shall be constructed of steel and shall be painted with a protective paint.

**G. LUMINAIRES:**

The luminaires for the street lighting shall be constructed in accordance with the standard specifications. The luminaires shall be constructed of steel and shall be painted with a protective paint.

**H. L.E.D. DRIVER:**

The L.E.D. driver for the street lighting shall be constructed in accordance with the standard specifications. The L.E.D. driver shall be constructed of steel and shall be painted with a protective paint.

**I. BONDING AND GROUNDING:**

The bonding and grounding for the traffic signals, pedestrian signals, and street lighting shall be constructed in accordance with the standard specifications. The bonding and grounding shall be constructed of steel and shall be painted with a protective paint.

**J. SERVICES:**

The services for the traffic signals, pedestrian signals, and street lighting shall be constructed in accordance with the standard specifications. The services shall be constructed of steel and shall be painted with a protective paint.

**K. SIGNAL HEADS:**

The signal heads for the traffic signals, pedestrian signals, and street lighting shall be constructed in accordance with the standard specifications. The signal heads shall be constructed of steel and shall be painted with a protective paint.

**L. VEHICLE SIGNAL, FACES AND SIGNAL HEADS:**

The vehicle signal, faces, and signal heads for the traffic signals, pedestrian signals, and street lighting shall be constructed in accordance with the standard specifications. The vehicle signal, faces, and signal heads shall be constructed of steel and shall be painted with a protective paint.

**M. PEDESTRIAN SIGNALS:**

The pedestrian signals for the traffic signals, pedestrian signals, and street lighting shall be constructed in accordance with the standard specifications. The pedestrian signals shall be constructed of steel and shall be painted with a protective paint.

**N. BATTERY BACK-UP SYSTEM:**

The battery back-up system for the traffic signals, pedestrian signals, and street lighting shall be constructed in accordance with the standard specifications. The battery back-up system shall be constructed of steel and shall be painted with a protective paint.

**O. EMERGENCY VEHICLE PRIORITY:**

The emergency vehicle priority for the traffic signals, pedestrian signals, and street lighting shall be constructed in accordance with the standard specifications. The emergency vehicle priority shall be constructed of steel and shall be painted with a protective paint.

**P. INTERNALLY ILLUMINATED STREET MARK SIGNS:**

The internally illuminated street mark signs for the traffic signals, pedestrian signals, and street lighting shall be constructed in accordance with the standard specifications. The internally illuminated street mark signs shall be constructed of steel and shall be painted with a protective paint.

**Q. MODEL 2070E CONTROLLER ASSEMBLIES:**

The model 2070e controller assemblies for the traffic signals, pedestrian signals, and street lighting shall be constructed in accordance with the standard specifications. The model 2070e controller assemblies shall be constructed of steel and shall be painted with a protective paint.

CITY OF BEAUMONT  
Reviewed By: [Signature]  
Date: [Date]  
City of Beaumont Logo

PLANNED PREPARED BY:  
RJK Engineering  
Submitted By: [Signature]  
Date: [Date]

CITY OF BEAUMONT  
City of Beaumont Logo  
City of Beaumont Logo

CITY OF BEAUMONT  
SPECIAL PROVISIONS  
SHEET 7 OF 7

Basic Gov (Sales Force) # PW2019-0363  
File # 3300

**AGREEMENT TO PROVIDE SECURITY FOR IMPROVEMENTS  
FOR TRACT MAP OR PARCEL MAP OR PLOT PLAN  
(Tract Map/Parcel Map/Plot Plan No. 37298-1)**

THIS SECURITY AGREEMENT is made by and between CITY OF BEAUMONT (“CITY”) and Pardee Homes, a California company (“DEVELOPER”).

**RECITALS**

A. DEVELOPER has applied to the CITY for permission to develop certain real property, pursuant to Tract Map/Parcel Map/Plot Plan #TR37298-1, (“Map”). DEVELOPER has also asked the CITY to accept the dedication of the street or streets and other proposed public rights-of-way, parks and recreation facilities, and easements as depicted on the Map and to otherwise approve the Map so that it may be recorded as required by law; and Atwell-Traffic Signal: Highland Springs Ave & Sundance Drive

B. The CITY requires, as a condition precedent to the acceptance and approval of the Map and the dedication of the public rights-of-way and easements depicted thereon, that such rights-of-way be improved with (for example) grading, paving, curbs, gutters, sidewalks, street lights, stormdrains, sanitary sewers and appurtenances thereto, street name signs, survey monuments, electrical and telecommunications, water pipes, water mains, fire hydrants and appurtenances thereto, and landscaping, including any warranty work for all such improvements (collectively, “Improvements”); and

C. The Improvements have not yet been constructed and completed and it is the purpose of this Security Agreement to set forth the terms and conditions by which the DEVELOPER shall guarantee that such Improvements shall be constructed and completed within the time set forth herein.

**AGREEMENT**

NOW, THEREFORE, in consideration of the acceptance of the DEVELOPER’s offer of dedication and the approval of the Map for filing and recording as provided and required by law, the CITY and the DEVELOPER hereby agree as follows:

1. Provision of Improvements. DEVELOPER shall provide, at the DEVELOPER’s sole cost and expense, all necessary labor and materials to complete the construction of the Improvements depicted on the Map and described in the conditions of approval of the Map within one (1) year of the date of this Security Agreement.

2. Inspection by the CITY. The CITY shall inspect, at the DEVELOPER’s sole cost and expense, all of the work, labor and materials performed and provided by the DEVELOPER in connection with the Improvements.

3. Compliance with Plans and Specifications. The Improvements shall be constructed and installed in strict accordance with the CITY-approved plans and specifications.

4. Security for Performance. Concurrently with the execution of this Security Agreement by DEVELOPER, DEVELOPER shall deliver to the CITY a performance bond issued by a corporate surety in substantially the form attached hereto as **Exhibit "A"**, in an amount that is not less than 100% of the total estimated cost of the Improvements and any warranty therefor. The performance bond shall be issued by an "admitted" corporate surety insurer authorized to do business in the State of California and the surety insurer shall have an A.M. Best rating of at least "A, XV". The surety insurer shall have assets exceeding its liabilities in the amount equal to or in excess of the amount of the bond, and the bond shall not be in excess of 10% of the surety insurer's assets. The security or bond shall also insure against any and all defects in the Improvements for a period of not less than one full year after the date of acceptance thereof by the CITY. The bond shall be duly executed and shall meet all the requirements of Section 995.660 of the California Code of Civil Procedure.

5. Security for Contractors, Subcontractors, Laborers and Materialmen. The DEVELOPER shall also provide a payment bond issued by a corporate surety for the security of laborers and materialmen, which bond or bonds shall be in substantially the form attached hereto as **Exhibit "B"** and made a part hereof. The amount of the bond(s) shall be no less than 100% of the total estimated amount needed to secure payment to the contractor, to the subcontractors, and to the persons furnishing labor, materials, or equipment to them for the Improvements. The laborers and materialmen bond shall be provided by an "admitted" corporate surety insurer authorized to transact surety insurance in the State of California with an A.M. Best rating of "A, XV", and with assets exceeding its liabilities in the amount equal to or in excess of the amount of the bond, and the bond shall not be in excess of 10% of the surety insurer's assets. The bond shall be duly executed and shall meet all the requirements of Section 995.660 of the California Code of Civil Procedure.

6. General Liability and Worker's Compensation Insurance. The DEVELOPER shall, before commencing any work, obtain commercial general liability insurance (primary) of not less than \$2,000,000.00 per occurrence for all coverages and \$2,000,000.00 general aggregate. The CITY and its employees and agents shall be added as additional insureds. Coverage shall apply on a primary non-contributing basis in relation to any other insurance or self-insurance, primary or excess, available to the CITY or any employee or agent of the CITY. Coverage shall not be limited to the vicarious liability or supervisory role of any additional insured. Coverage shall contain no contractors' limitation endorsement. There shall be no endorsement or modification limiting the scope of coverage for liability arising from pollution, explosion, collapse, underground property damage or employment-related practices. Such insurance shall not prohibit the DEVELOPER, and its employees or agents, from waiving the right of subrogation prior to a loss. The DEVELOPER waives its right of subrogation against the CITY. Unless otherwise approved by the CITY, the DEVELOPER's insurance shall be written by insurers authorized to do business in the State of California and with a minimum A.M. Best rating of "A, XV." Self-insurance shall not be considered to comply with these insurance specifications. The DEVELOPER agrees to require all contractors, subcontractors and other parties hired for the Improvements to purchase and maintain insurance of the types specified



herein, naming as additional insureds all of the parties to this Security Agreement. The DEVELOPER shall, before commencing any work, obtain Worker's Compensation Insurance in an amount required by law and, failing to do so, the CITY may procure such insurance at the cost of the DEVELOPER.

7. Comprehensive Commercial General and Automobile Liability Insurance. The DEVELOPER, before commencing any work shall, at its own expense, maintain comprehensive commercial general and automobile liability insurance issued by a California-admitted surety company with an A.M. Best rating of no less than "A, XV" for \$2,000,000 per occurrence. Coverage shall be for the entire duration of the permitted activities. Such liability insurance policy shall name, by endorsement, the City as an additional insured.

8. Indemnification. Notwithstanding the provisions of Government Code, Section 66474.9 or any other statutes of similar import, and to the full extent permitted by law, the DEVELOPER shall defend, indemnify and hold harmless the CITY, its employees, agents, officials and attorneys, from and against any liability, claims, suits, actions, arbitration proceedings, administrative proceedings, regulatory proceedings, losses, expenses or costs of any kind or nature, whether actual, alleged or threatened, reasonable attorneys' fees, court costs, interest, expert witness fees and any other costs or expenses of any kind whatsoever, without restriction or limitation, incurred in relation to, as a consequence of, or arising out of or in any way attributable actually, allegedly or impliedly, in whole or in part, to the Map, the Improvements, this Agreement, or any matter related to the same; provided, however, that the indemnification to be provided by DEVELOPER to the CITY pursuant to the terms of this paragraph shall not be applicable where the aforementioned liability, claim, suit, action, etcetera, is the result of the sole negligence or sole willful misconduct of the CITY.

9. Procedure for Release of Performance Bond Security. The security furnished by the DEVELOPER shall be released in whole or in part in the following manner:

a. Security shall be released upon final completion and acceptance of the Improvements. If the security furnished by the DEVELOPER is a documentary evidence of security, such as a surety bond, the CITY shall release the documentary evidence and return the original to the Surety upon final completion and acceptance of the Improvements. In the event the CITY is unable to return the original documentary evidence to the Surety, the security shall be released by written notice sent by certified mail to the DEVELOPER and to the Surety within 30 days of the City's acceptance of the Improvements. The written notice shall contain a statement that the work for which security was furnished has been completed and accepted, a description of the Improvements, and the notarized signature of an authorized CITY official.

b. At such time as the DEVELOPER believes that the work for which the security was required is complete and makes payment of a partial exoneration fee of \$350 to the CITY, the DEVELOPER shall notify the CITY in writing of the completed work, including a list of work completed. Upon receipt of the written notice, the CITY shall have 45 days to review and comment or approve the completion of the Improvements. If the CITY does not agree that all work has been completed in accordance with the plans

and specifications for the Improvements, it shall supply a list of all remaining work to be completed.

c. Within 45 days of receipt of the CITY's list of remaining work, the DEVELOPER may then provide cost estimates for all remaining work for review and approval by the CITY.

d. Upon receipt of the cost estimates, the CITY shall then have 45 days to review, comment, and approve, modify or disapprove those cost estimates. The CITY shall not be required to engage in this process of partial release more than once between the start of work and the completion and acceptance of all work.

e. The DEVELOPER shall complete the works of Improvement until all remaining items are accepted by the CITY. Upon completion of the Improvements, the DEVELOPER shall be notified in writing by the CITY within 45 days and, within 45 days of the date of the CITY's notice, the release of any remaining performance security shall be made within 60 days of the recording of the Notice of Completion.

10. Procedure for Release of Payment Bond Security. Security securing the payment to the contractor, his or her subcontractors and persons furnishing labor, materials or equipment may, after passage of the time within which mechanic's liens and stop notices are required to be recorded and after acceptance of the Improvements, be reduced by Surety to an amount equal to the total claimed by all claimants for whom mechanic's liens and stop notices have been recorded and notice thereof given in writing to the CITY, and if no claims have been recorded, the security may be released in full.

11. Security for One-Year Warranty Period. The release procedures described in paragraphs 9 and 10 above shall not apply to any required guarantee and warranty period nor to the amount of the performance bond security deemed necessary by the CITY for the guarantee and warranty period nor to costs and reasonable expenses and fees, including reasonable attorneys' fees.

12. Binding Effect. This Security Agreement shall be binding upon and shall inure to the benefit of the parties hereto, their legal representatives and their successors and assigns.

13. Authority to Execute. The DEVELOPER hereby warrants and represents to the CITY that the individual signing this Security Agreement on behalf of the DEVELOPER is vested with the unconditional authority to do so pursuant to, and in accordance with, all applicable legal requirements, and has the authority bind the DEVELOPER hereto.

14. No Assignment. The DEVELOPER may not assign this Security Agreement, or any part thereof, to another without the prior written consent of the CITY.

15. Attorneys' Fees. In the event of legal action to enforce or interpret this Agreement or any of its provisions, the prevailing party shall be entitled, in addition to any other form of relief, to recover its reasonable attorneys' fees and costs of suit.

16. Execution in Counterparts. This Agreement may be executed in counterparts, each of which shall be deemed an original, but which together shall constitute a single agreement.

IN WITNESS WHEREOF, the parties have caused this Agreement to be executed on the dates listed below.

CITY OF BEAUMONT

By \_\_\_\_\_  
Mayor

\_\_\_\_\_  
Date

DEVELOPER

By  \_\_\_\_\_  
Jeff Chambers

2-18-2026  
Date

Title: VP of Community Development

Address: Pardee Homes  
1250 Corona Pointe Court,  
Suite 600  
Corona, CA 92879

Basic Gov (Sales Force) # \_\_\_\_\_  
File # \_\_\_\_\_

Bond No: CMS331856  
Premium: \$507.00

**EXHIBIT "A"**

**PERFORMANCE BOND**

WHEREAS, the City Council of the City of Beaumont, State of California, and Pardee Homes (hereinafter designated as "Principal") have entered into Agreement To Provide Security For Improvements For Tract Map Or Parcel Map Or Plot Plan, dated \_\_\_\_\_, 20\_\_, whereby Principal agrees to install and complete certain designated public improvements itemized and described on Tract Map, Parcel Map or Plot Plan No. 37298-1, which is hereby incorporated herein and made a part hereof; and **Atwell-Traffic Signal: Highland Springs Ave & Sundance Drive**

WHEREAS, Principal is required under the terms of the said agreement to furnish a bond for the faithful performance of said agreement.

NOW, THEREFORE, we, the Principal and RLI Insurance Company, as Surety, are held and firmly bound unto the City of Beaumont (hereinafter called "City"), in the penal sum of One Hundred Twenty Six Thousand Eight Hundred\* dollars (\$ 126,850.00 ) lawful money of the United States, for the payment of which sum well and truly to be made, we bind ourselves, our heirs, successors, executors and administrators, jointly and severally, firmly by these presents. \*Fifty & 00/100

The condition of this obligation is such that if the Principal, his or its heirs, executors, administrators, successors or assigns, shall in all things stand to and abide by, and well and truly keep and perform the covenants, conditions and provisions in the said agreement and any alteration thereof made as therein provided, on his or their part to be kept and performed at the time and in the manner therein specified, and in all respects according to their true intent and meaning, and shall indemnify and save harmless the City, its officers, agents and employees as therein stipulated, then this obligation shall become null and void; otherwise it shall be and remain in full force and effect.

As part of the obligation secured hereby and in addition to the face amount specified therefor, there shall be included costs and reasonable expenses and fees, including reasonable attorney's fees, incurred by the City in successfully enforcing such obligation, all to be taxed as costs and included in any judgment therein rendered.

The Surety hereby stipulates and agrees that no change, extension of time, alteration or addition to the terms of the agreement or to the work to be performed thereunder or the specifications accompanying the same shall in any way affect its obligations on this bond, and it does hereby waive notice of any such change, extension of time, alteration or addition to the terms of the agreement or to the work or to the specifications.

IN WITNESS WHEREOF, this instrument has been duly executed by the Principal and Surety above named, on February 12, 2020.

PRINCIPAL:

Pardee Homes

By

Title Jeff Chambers, VP Community Development

SURETY:

RLI Insurance Company

By

Title Janina Monroe, Attorney-In-Fact

# ALL- PURPOSE CERTIFICATE OF ACKNOWLEDGMENT

A notary public or other officer completing this certificate verifies only the identity of the individual who signed the document to which this certificate is attached, and not the truthfulness, accuracy, or validity of that document.

State of California }

County of Orange }

On FEB 12 2020 before me, Brianne Davis, Notary Public  
(Here insert name and title of the officer)

personally appeared Janina Monroe  
who proved to me on the basis of satisfactory evidence to be the person(s) whose name(s) is/~~are~~ subscribed to the within instrument and acknowledged to me that he/~~she/they~~ executed the same in his/~~her/their~~ authorized capacity(~~ies~~), and that by his/~~her/their~~ signature(~~s~~) on the instrument the person(s), or the entity upon behalf of which the person(s) acted, executed the instrument.

I certify under PENALTY OF PERJURY under the laws of the State of California that the foregoing paragraph is true and correct.

WITNESS my hand and official seal.

Brianne Davis  
Notary Public Signature (Notary Public Seal)



### ADDITIONAL OPTIONAL INFORMATION

DESCRIPTION OF THE ATTACHED DOCUMENT  
  
(Title or description of attached document)  
  
(Title or description of attached document continued)  
Number of Pages \_\_\_\_\_ Document Date \_\_\_\_\_

CAPACITY CLAIMED BY THE SIGNER  
 Individual (s)  
 Corporate Officer  
\_\_\_\_\_  
(Title)  
 Partner(s)  
 Attorney-in-Fact  
 Trustee(s)  
 Other \_\_\_\_\_

### INSTRUCTIONS FOR COMPLETING THIS FORM

*This form complies with current California statutes regarding notary wording and, if needed, should be completed and attached to the document. Acknowledgments from other states may be completed for documents being sent to that state so long as the wording does not require the California notary to violate California notary law.*

- State and County information must be the State and County where the document signer(s) personally appeared before the notary public for acknowledgment.
- Date of notarization must be the date that the signer(s) personally appeared which must also be the same date the acknowledgment is completed.
- The notary public must print his or her name as it appears within his or her commission followed by a comma and then your title (notary public).
- Print the name(s) of document signer(s) who personally appear at the time of notarization.
- Indicate the correct singular or plural forms by crossing off incorrect forms (i.e. he/she/they, is /are) or circling the correct forms. Failure to correctly indicate this information may lead to rejection of document recording.
- The notary seal impression must be clear and photographically reproducible. Impression must not cover text or lines. If seal impression smudges, re-seal if a sufficient area permits, otherwise complete a different acknowledgment form.
- Signature of the notary public must match the signature on file with the office of the county clerk.
  - ❖ Additional information is not required but could help to ensure this acknowledgment is not misused or attached to a different document.
  - ❖ Indicate title or type of attached document, number of pages and date.
  - ❖ Indicate the capacity claimed by the signer. If the claimed capacity is a corporate officer, indicate the title (i.e. CEO, CFO, Secretary).
- Securely attach this document to the signed document with a staple.

# POWER OF ATTORNEY

Item 4.

## RLI Insurance Company Contractors Bonding and Insurance Company

9025 N. Lindbergh Dr. Peoria, IL 61615  
Phone: 800-645-2402

### Know All Men by These Presents:

That this Power of Attorney is not valid or in effect unless attached to the bond which it authorizes executed, but may be detached by the approving officer if desired.

That **RLI Insurance Company and/or Contractors Bonding and Insurance Company**, each an Illinois corporation, (separately and together, the "Company") do hereby make, constitute and appoint:

Paul Boucher, Janina Monroe, Dennis Langer, Michelle Haase, Timothy Noonan, jointly or severally

in the City of Irvine, State of California its true and lawful Agent(s) and Attorney(s) in Fact, with full power and authority hereby conferred, to sign, execute, acknowledge and deliver for and on its behalf as Surety, in general, any and all bonds and undertakings in an amount not to exceed Twenty Five Million Dollars (\$25,000,000.00) for any single obligation.

The acknowledgment and execution of such bond by the said Attorney in Fact shall be as binding upon the Company as if such bond had been executed and acknowledged by the regularly elected officers of the Company.

**RLI Insurance Company and/or Contractors Bonding and Insurance Company**, as applicable, have each further certified that the following is a true and exact copy of a Resolution adopted by the Board of Directors of each such corporation, and is now in force, to-wit:

"All bonds, policies, undertakings, Powers of Attorney or other obligations of the corporation shall be executed in the corporate name of the Company by the President, Secretary, any Assistant Secretary, Treasurer, or any Vice President, or by such other officers as the Board of Directors may authorize. The President, any Vice President, Secretary, any Assistant Secretary, or the Treasurer may appoint Attorneys in Fact or Agents who shall have authority to issue bonds, policies or undertakings in the name of the Company. The corporate seal is not necessary for the validity of any bonds, policies, undertakings, Powers of Attorney or other obligations of the corporation. The signature of any such officer and the corporate seal may be printed by facsimile."

IN WITNESS WHEREOF, the **RLI Insurance Company and/or Contractors Bonding and Insurance Company**, as applicable, have caused these presents to be executed by its respective Vice President with its corporate seal affixed this 30th day of September, 2019.



**RLI Insurance Company  
Contractors Bonding and Insurance Company**

By: B. W. Davis  
Barton W. Davis Vice President

State of Illinois }  
County of Peoria } SS

### CERTIFICATE

On this 30th day of September, 2019, before me, a Notary Public, personally appeared Barton W. Davis, who being by me duly sworn, acknowledged that he signed the above Power of Attorney as the aforesaid officer of the **RLI Insurance Company and/or Contractors Bonding and Insurance Company** and acknowledged said instrument to be the voluntary act and deed of said corporation.

I, the undersigned officer of **RLI Insurance Company and/or Contractors Bonding and Insurance Company**, do hereby certify that the attached Power of Attorney is in full force and effect and is irrevocable; and furthermore, that the Resolution of the Company as set forth in the Power of Attorney, is now in force. In testimony whereof, I have hereunto set my hand and the seal of the **RLI Insurance Company and/or Contractors Bonding and Insurance Company** this \_\_\_\_\_ day of FEB 12 2020.

By: Gretchen L. Johnnigk  
Gretchen L. Johnnigk Notary Public

**RLI Insurance Company  
Contractors Bonding and Insurance Company**

By: Jean M. Stephenson  
Jean M. Stephenson Corporate Secretary



# California All-Purpose Certificate of Acknowledgment

A notary public or other officer completing this certificate verifies only the identity of the individual who signed the document to which this certificate is attached, and not the truthfulness, accuracy, or validity of that document.

State of California }  
County of Riverside } s.s.

On February 19, 2020 before me, Ana E. Chavez Perez, Notary Public  
Name of Notary Public, Title

personally appeared Jeff Chambers  
Name of Signer (1)

\_\_\_\_\_  
Name of Signer (2)

who proved to me on the basis of satisfactory evidence to be the person(s) whose name(s) is/are subscribed to the within instrument and acknowledged to me that he/she/they executed the same in his/her/their authorized capacity(ies), and that by his/her/their signature(s) on the instrument the person(s), or the entity upon behalf of which the person(s) acted, executed the instrument.

I certify under PENALTY OF PERJURY under the laws of the State of California that the foregoing paragraph is true and correct.

WITNESS my hand and official seal.

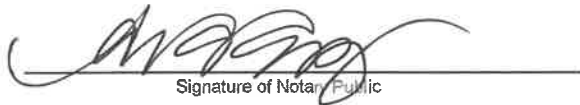
  
Signature of Notary Public



### OPTIONAL INFORMATION

Although the information in this section is not required by law, it could prevent fraudulent removal and reattachment of this acknowledgment to an unauthorized document and may prove useful to persons relying on the attached document.

### Description of Attached Document

The preceding Certificate of Acknowledgment is attached to a document titled/for the purpose of \_\_\_\_\_  
containing \_\_\_\_\_ pages, and dated \_\_\_\_\_

The signer(s) capacity or authority is/are as:

- Individual(s)
- Attorney-in-fact
- Corporate Officer(s) \_\_\_\_\_  
Title(s)
- Guardian/Conservator
- Partner - Limited/General
- Trustee(s)
- Other: \_\_\_\_\_

representing: \_\_\_\_\_  
Name(s) of Person(s) Entity(ies) Signer is Representing

Additional Information	
<b>Method of Signer Identification</b>	
Proved to me on the basis of satisfactory evidence:	
<input type="checkbox"/> form(s) of identification	<input type="checkbox"/> credible witness(es)
Notarial event is detailed in notary journal on:	
Page # _____	Entry # _____
Notary contact: _____	
Other	
<input type="checkbox"/> Additional Signer	<input type="checkbox"/> Signer(s) Thumbprints(s)
<input type="checkbox"/> _____	

**EXHIBIT "B"**

**PAYMENT BOND**

WHEREAS, the City Council of the City of Beaumont, State of California, and Pardee Homes (hereafter designated as "the Principal") have entered into Agreement To Provide Security For Improvements For Tract Map Or Parcel Map Or Plot Plan, dated \_\_\_\_\_, 20\_\_\_\_, whereby Principal agrees to install and complete certain designated public improvements itemized and described on Tract Map, Parcel Map or Plot Plan No. 37298-1, which is hereby incorporated herein and made a part hereof; and **Atwell-Traffic Signal: Highland Springs Ave & Sundance Drive**

WHEREAS, under the terms of the said agreement, the Principal is required before entering upon the performance of the work, to file a good and sufficient payment bond with the City of Beaumont to secure the claims to which reference is made in Section 8000, et seq., of the Civil Code of the State of California.

NOW, THEREFORE, the Principal and the undersigned as corporate surety, are held firmly bound unto the City of Beaumont and all contractors, subcontractors, laborers, materialmen, and other persons employed in the performance of the said agreement and referred to at Section 8000, et seq., of the Civil Code in the sum of One Hundred Twenty Six Thousand\* dollars (\$ 126,850.00), for materials furnished or labor thereon of any kind, or for amounts due under the Unemployment Insurance Act with respect to this work or labor, that the Surety will pay the same in an amount not exceeding the amount hereinabove set forth, and also in case suit is brought upon this bond, will pay, in addition to the face amount thereof, costs and reasonable expenses and fees, including reasonable attorney's fees, incurred by the City in successfully enforcing this obligation, to be awarded and fixed by the court, and to be taxed as costs and to be included in the judgment therein rendered. \*Eight Hundred Fifty & 00/100

It is hereby expressly stipulated and agreed that this bond shall inure to the benefit of any and all persons, companies, and corporations entitled to file claims under Section 8000, et seq., of the Civil Code, so as to give a right of action to them or their assigns in any suit brought upon this bond.

Should the condition of this bond be fully performed, then this obligation shall become null and void, otherwise it shall be and remain in full force and effect.

The Surety hereby stipulates and agrees that no change, extension of time, alteration, or addition to the terms of the agreement or the specifications accompanying the same shall in any manner affect its obligations on this bond, and it does hereby waive notice of any such change, extension, alteration, or addition.

IN WITNESS WHEREOF, this instrument has been duly executed by the Principal and Surety above named, on February 12, 2020.

PRINCIPAL:

SURETY:

Pardee Homes

RLI Insurance Company

By 

By 

Title Jeff Chambers, VP Community Development

Title Janina Monroe, Attorney-In-Fact



# ALL- PURPOSE CERTIFICATE OF ACKNOWLEDGMENT

A notary public or other officer completing this certificate verifies only the identity of the individual who signed the document to which this certificate is attached, and not the truthfulness, accuracy, or validity of that document.

State of California }

County of Orange }

On FEB 12 2020 before me, Brianne Davis, Notary Public  
(Here insert name and title of the officer)

personally appeared Janina Monroe,  
who proved to me on the basis of satisfactory evidence to be the person(s) whose  
name(s) is/are subscribed to the within instrument and acknowledged to me that  
~~he/she/they~~ executed the same in ~~his/her/their~~ authorized capacity(ies), and that by  
~~his/her/their~~ signature(s) on the instrument the person(s), or the entity upon behalf of  
which the person(s) acted, executed the instrument.

I certify under PENALTY OF PERJURY under the laws of the State of California that  
the foregoing paragraph is true and correct.

WITNESS my hand and official seal.

Brianne Davis  
Notary Public Signature

(Notary Public Seal)



### ADDITIONAL OPTIONAL INFORMATION

DESCRIPTION OF THE ATTACHED DOCUMENT

(Title or description of attached document)

(Title or description of attached document continued)

Number of Pages \_\_\_\_\_ Document Date \_\_\_\_\_

CAPACITY CLAIMED BY THE SIGNER

Individual (s)

Corporate Officer

\_\_\_\_\_ (Title)

Partner(s)

Attorney-in-Fact

Trustee(s)

Other \_\_\_\_\_

### INSTRUCTIONS FOR COMPLETING THIS FORM

*This form complies with current California statutes regarding notary wording and, if needed, should be completed and attached to the document. Acknowledgments from other states may be completed for documents being sent to that state so long as the wording does not require the California notary to violate California notary law.*

- State and County information must be the State and County where the document signer(s) personally appeared before the notary public for acknowledgment.
- Date of notarization must be the date that the signer(s) personally appeared which must also be the same date the acknowledgment is completed.
- The notary public must print his or her name as it appears within his or her commission followed by a comma and then your title (notary public).
- Print the name(s) of document signer(s) who personally appear at the time of notarization.
- Indicate the correct singular or plural forms by crossing off incorrect forms (i.e. ~~he/she/they~~, is /ere) or circling the correct forms. Failure to correctly indicate this information may lead to rejection of document recording.
- The notary seal impression must be clear and photographically reproducible. Impression must not cover text or lines. If seal impression smudges, re-seal if a sufficient area permits, otherwise complete a different acknowledgment form.
- Signature of the notary public must match the signature on file with the office of the county clerk.
  - ❖ Additional information is not required but could help to ensure this acknowledgment is not misused or attached to a different document.
  - ❖ Indicate title or type of attached document, number of pages and date.
  - ❖ Indicate the capacity claimed by the signer. If the claimed capacity is a corporate officer, indicate the title (i.e. CEO, CFO, Secretary).
- Securely attach this document to the signed document with a staple.

# POWER OF ATTORNEY

## RLI Insurance Company Contractors Bonding and Insurance Company

9025 N. Lindbergh Dr. Peoria, IL 61615  
Phone: 800-645-2402

### Know All Men by These Presents:

That this Power of Attorney is not valid or in effect unless attached to the bond which it authorizes executed, but may be detached by the approving officer if desired.

That **RLI Insurance Company** and/or **Contractors Bonding and Insurance Company**, each an Illinois corporation, (separately and together, the "Company") do hereby make, constitute and appoint:

Paul Boucher, Janina Monroe, Dennis Langer, Michelle Haase, Timothy Noonan, jointly or severally

in the City of Irvine, State of California its true and lawful Agent(s) and Attorney(s) in Fact, with full power and authority hereby conferred, to sign, execute, acknowledge and deliver for and on its behalf as Surety, in general, any and all bonds and undertakings in an amount not to exceed Twenty Five Million Dollars (\$25,000,000.00) for any single obligation.

The acknowledgment and execution of such bond by the said Attorney in Fact shall be as binding upon the Company as if such bond had been executed and acknowledged by the regularly elected officers of the Company.

**RLI Insurance Company** and/or **Contractors Bonding and Insurance Company**, as applicable, have each further certified that the following is a true and exact copy of a Resolution adopted by the Board of Directors of each such corporation, and is now in force, to-wit:

"All bonds, policies, undertakings, Powers of Attorney or other obligations of the corporation shall be executed in the corporate name of the Company by the President, Secretary, any Assistant Secretary, Treasurer, or any Vice President, or by such other officers as the Board of Directors may authorize. The President, any Vice President, Secretary, any Assistant Secretary, or the Treasurer may appoint Attorneys in Fact or Agents who shall have authority to issue bonds, policies or undertakings in the name of the Company. The corporate seal is not necessary for the validity of any bonds, policies, undertakings, Powers of Attorney or other obligations of the corporation. The signature of any such officer and the corporate seal may be printed by facsimile."

IN WITNESS WHEREOF, the **RLI Insurance Company** and/or **Contractors Bonding and Insurance Company**, as applicable, have caused these presents to be executed by its respective Vice President with its corporate seal affixed this 30th day of September, 2019.

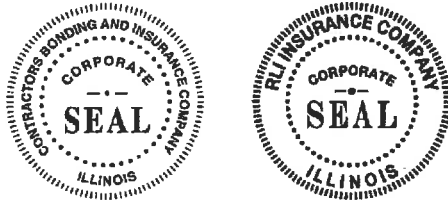

**RLI Insurance Company**  
**Contractors Bonding and Insurance Company**

By: B. W. Davis  
Barton W. Davis Vice President

State of Illinois }  
County of Peoria } SS

### CERTIFICATE

On this 30th day of September, 2019, before me, a Notary Public, personally appeared Barton W. Davis, who being by me duly sworn, acknowledged that he signed the above Power of Attorney as the aforesaid officer of the **RLI Insurance Company** and/or **Contractors Bonding and Insurance Company** and acknowledged said instrument to be the voluntary act and deed of said corporation.

I, the undersigned officer of **RLI Insurance Company** and/or **Contractors Bonding and Insurance Company**, do hereby certify that the attached Power of Attorney is in full force and effect and is irrevocable; and furthermore, that the Resolution of the Company as set forth in the Power of Attorney, is now in force. In testimony whereof, I have hereunto set my hand and the seal of the **RLI Insurance Company** and/or **Contractors Bonding and Insurance Company** this \_\_\_\_\_ day of \_\_\_\_\_

**FEB 12 2020**

By: Gretchen L. Johnnigk  
Gretchen L. Johnnigk Notary Public

**RLI Insurance Company**  
**Contractors Bonding and Insurance Company**

By: Jean M. Stephenson  
Jean M. Stephenson Corporate Secretary



# California All-Purpose Certificate of Acknowledgment

A notary public or other officer completing this certificate verifies only the identity of the individual who signed the document to which this certificate is attached, and not the truthfulness, accuracy, or validity of that document.

State of California }  
County of Riverside } s.s.

On February 19, 2020 before me, Ana E. Chavez Perez, Notary Public  
Name of Notary Public, Title

personally appeared Jeff Chambers  
Name of Signer (1)

\_\_\_\_\_  
Name of Signer (2)

who proved to me on the basis of satisfactory evidence to be the person(s) whose name(s) is/are subscribed to the within instrument and acknowledged to me that he/she/they executed the same in his/her/their authorized capacity(ies), and that by his/her/their signature(s) on the instrument the person(s), or the entity upon behalf of which the person(s) acted, executed the instrument.

I certify under PENALTY OF PERJURY under the laws of the State of California that the foregoing paragraph is true and correct.

WITNESS my hand and official seal.

  
Signature of Notary Public



### OPTIONAL INFORMATION

Although the information in this section is not required by law, it could prevent fraudulent removal and reattachment of this acknowledgment to an unauthorized document and may prove useful to persons relying on the attached document.

### Description of Attached Document

The preceding Certificate of Acknowledgment is attached to a document titled/for the purpose of \_\_\_\_\_  
containing \_\_\_\_\_ pages, and dated \_\_\_\_\_

The signer(s) capacity or authority is/are as:  
 Individual(s)  
 Attorney-in-fact  
 Corporate Officer(s) \_\_\_\_\_ Title(s)  
  
 Guardian/Conservator  
 Partner - Limited/General  
 Trustee(s)  
 Other: \_\_\_\_\_  
representing: \_\_\_\_\_  
Name(s) of Person(s) Entity(ies) Signer is Representing

Additional Information
<b>Method of Signer Identification</b>
Proved to me on the basis of satisfactory evidence: <input type="checkbox"/> form(s) of identification <input type="checkbox"/> credible witness(es)
Notarial event is detailed in notary journal on: Page # _____ Entry # _____
Notary contact: _____
Other
<input type="checkbox"/> Additional Signer <input type="checkbox"/> Signer(s) Thumbprints(s)
<input type="checkbox"/> _____

**Traffic Signal Cost Estimate**

<b>Date:</b> January 31, 2020		<b>Location:</b> Highland Springs Ave./Sundance Dr. City of Beaumont	
<b>Job Number:</b> 2467-18-01		<b>Prepared for:</b>	
<b>By:</b> RK Engineering Group, Inc.			

Item No.	Description	Qty.	Unit	Unit Cost	Item Cost
2	Controller w/Cabinet (Type 2070E)	1	Ea.	\$22,800.00	\$22,800
7	Install Controller/Cabinet	1	Ea.	\$2,520.00	\$2,520
10	2-Channel Detector w/Rack	1	Ea.	\$900.00	\$900
11	Detector Rack And Power	1	Ea.	\$3,000.00	\$3,000
14	P.P.B. Pole (4'h), incl. Foundation	2	Ea.	\$960.00	\$1,920
16	Type 15 Pole (30'h)	1	Ea.	\$4,080.00	\$4,080
22	Type 19 Pole (30'h) - 30' Mast Arm	1	Ea.	\$7,800.00	\$7,800
40	Foundation, 30" x 5'd (Re-bar) <Type 15>	1	Ea.	\$864.00	\$864
43	Foundation, 36" x 9'd (Re-bar) <Type 18-27(c4),28,29>	1	Ea.	\$2,640.00	\$2,640
46	Signal Head, 12"Ø 3-section LED	3	Ea.	\$1,200.00	\$3,600
48	Signal Head, 12"Ø 5-section LED	1	Ea.	\$1,800.00	\$1,800
50	LED Module, Signal (Arrow: R, Y or G)	2	Ea.	\$300.00	\$600
51	LED Module, Signal (Ball: R, Y or G)	12	Ea.	\$384.00	\$4,608
52	Ped Signal Head, LED	3	Ea.	\$1,440.00	\$4,320
54	Ped Push Button (P.P.B.), ADA Compliant	1	Ea.	\$240.00	\$240
55	Illuminated Street Name Sign (I.I.S.N.S.)	1	Ea.	\$1,560.00	\$1,560
56	Luminaires	1	Ea.	\$1,440.00	\$1,440
73	4" Conduit (Trenched)	38	LF	\$36.00	\$1,368
83	Video Detection System (Iteris)	0.5	LS	\$35,000.00	\$17,500
84	Opticom Discriminator	1	Ea.	\$2,538.00	\$2,538
86	Opticom Detector	1	Ea.	\$792.00	\$792
88	Wiring, Signal (TS Mod.)	1	LS	\$8,400.00	\$8,400
96	Remove Exist. Signal Pole/Equipment	2	Ea.	\$792.00	\$1,584
128	Furnish & Install Caltrans Approved Battery Backup System	1	LS	\$7,920.00	\$7,920
129	Remove and Salvage Existing Controller and Cabinet	1	Ea.	\$396.00	\$396
137	Furnish & Install Mast Arm Mounted Sign	1	Ea.	\$288.00	\$288
161	SIC 12-pair #19 Cable	1111	LF	\$4.34	\$4,826

### Traffic Signal Cost Estimate

<b>Date:</b> January 31, 2020		<b>Location:</b> Highland Springs Ave./Sundance Dr. City of Beaumont				
<b>Job Number:</b> 2467-18-01		<b>Prepared for:</b>				
<b>By:</b> RK Engineering Group, Inc.						
Item No.	Description	Qty.	Unit	Unit Cost	Item Cost	
<b>SUBTOTAL</b>					<b>\$110,304</b>	
				<i>Engineering/Mobilization</i>	0.00%	\$0
				<i>Fees, Permits, Supervision</i>	0.00%	\$0
				<i>Contingencies</i>	15.00%	\$16,546
<b>TOTAL</b>					<b>\$126,850</b>	

SEAL



4000 Westerly Place, Suite 280 · Newport Beach, CA 92660  
Phone: (949) 474-0809 · Fax (949) 474-0902

Reviewed By:

*Robert Kahn*

Robert Kahn

R.C.E. No. 20285

Date:

01/31/20

Exp. 09/30/21



**POLE AND EQUIPMENT SCHEDULE**

STANDARDS	VEH. SIGNAL LENS.	PER. SIG.	PER. LOC.	LE.D.	STANDARD MOUNT HEIGHT (SEE SPEC.)	COMMENTS
A	25'-5-10(N)	30'	50'(N)	2-4(S/N)	SP-1-1(N)	
B	1A	10'	30'	2-4(S/N)	SP-1-1(N)	F-155
C	*20'-4-16	30'	40'	2-4(S)	SP-1-1(N)	
D	1A	10'	30'	2-4(S)	SP-1-1(N)	Highland Springs Ave
E	P19	31'	-	-	SP-1-1(N)	
F	20'-5-16	30'	55A	15'	SP-1-1(N)	
G	1A	10'	30'	2-4(S)	SP-1-1(N)	
H	20'-4-16	30'	40A	15'	SP-1-1(N)	
I	1A(N)	10'	-	-	SP-1-1(N)	

INDICATE POLE LOCATIONS PREPARED BY FIELD ENGINEER. PROVIDE POLE FOUNDATIONS PRIOR TO ORDERING POLES.  
 ALL EQUIPMENT IS EXISTING EXCEPT AS NOTED.  
 (N) = NEW  
 \* = MANUAL TYPE V PHOTOELECTRIC CONTROL UNIT ON TRAFFIC SIGNAL POLE  
 ▲ = SIGNAL MOUNT AND TO BE REMOVED.

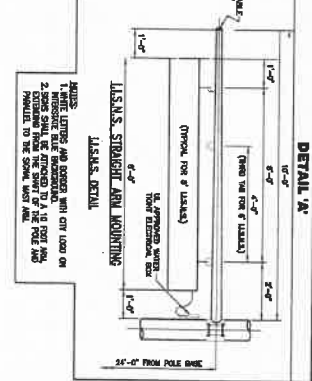
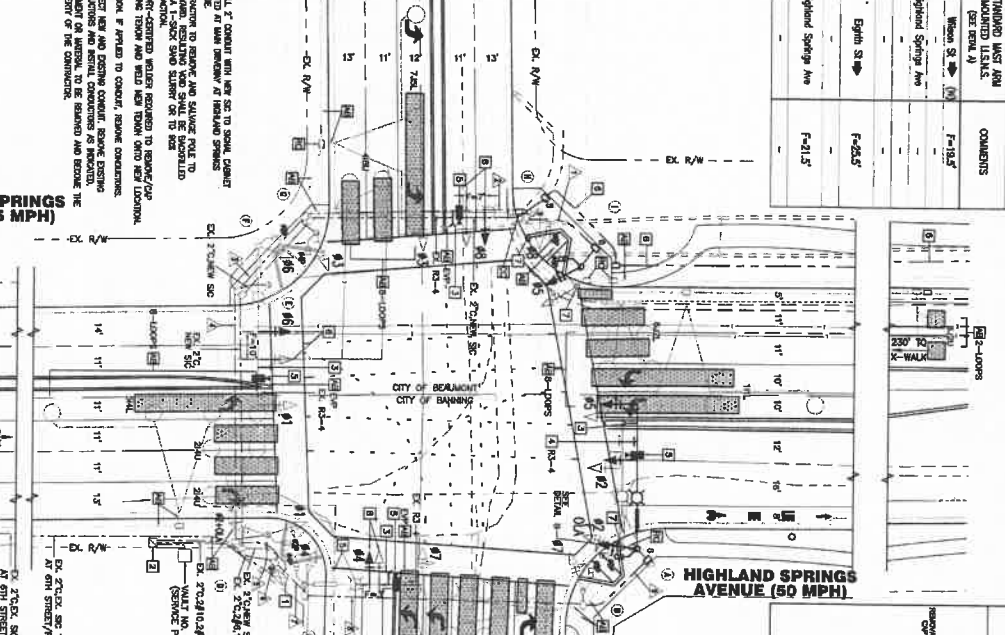
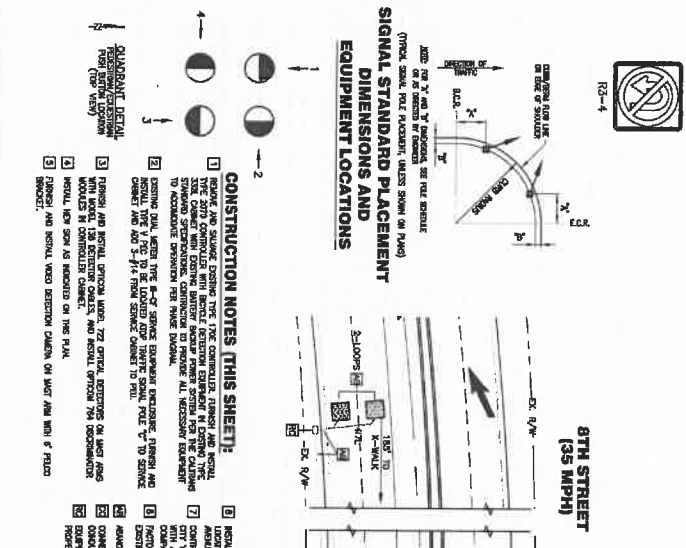

**CONDUCTOR SCHEDULE**

NO.	TYPE	SIZE	PHASE	INSULATION	NOTES
1	P	2	R	10	
2	P	2	Y	10	
3	P	2	G	10	
4	N	3	W	10	
5	N	3	B	10	
6	N	3	R	10	
7	N	3	Y	10	
8	N	3	G	10	
9	N	3	B	10	
10	N	3	R	10	
11	N	3	Y	10	
12	N	3	G	10	
13	N	3	B	10	
14	N	3	R	10	
15	N	3	Y	10	
16	N	3	G	10	
17	N	3	B	10	
18	N	3	R	10	
19	N	3	Y	10	
20	N	3	G	10	
21	N	3	B	10	
22	N	3	R	10	
23	N	3	Y	10	
24	N	3	G	10	
25	N	3	B	10	
26	N	3	R	10	
27	N	3	Y	10	
28	N	3	G	10	
29	N	3	B	10	
30	N	3	R	10	
31	N	3	Y	10	
32	N	3	G	10	
33	N	3	B	10	
34	N	3	R	10	
35	N	3	Y	10	
36	N	3	G	10	
37	N	3	B	10	
38	N	3	R	10	
39	N	3	Y	10	
40	N	3	G	10	
41	N	3	B	10	
42	N	3	R	10	
43	N	3	Y	10	
44	N	3	G	10	
45	N	3	B	10	
46	N	3	R	10	
47	N	3	Y	10	
48	N	3	G	10	
49	N	3	B	10	
50	N	3	R	10	

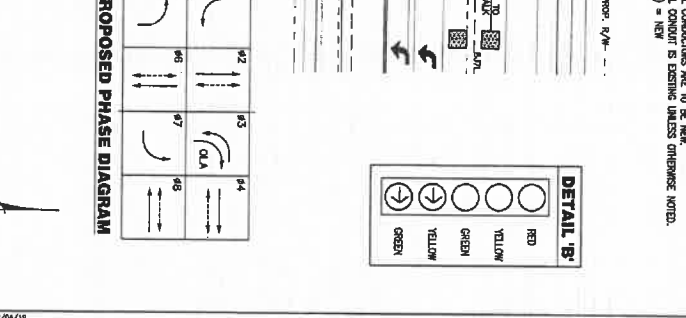
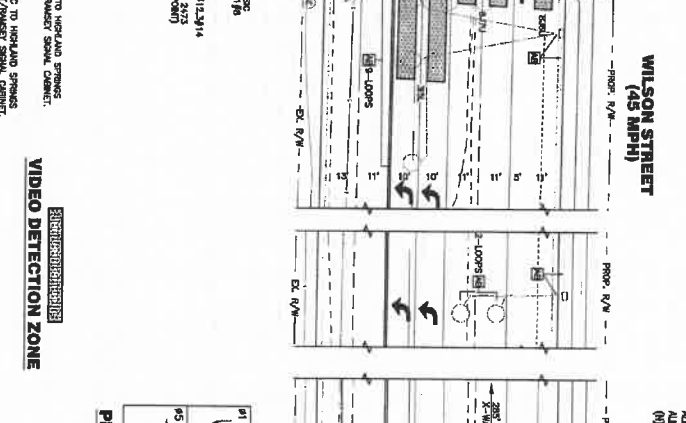

**CITY OF BEAUMONT**  
 REVISED BY: 1/6, 7/20 AMF, 1/7, 2/20  
 1-888-381-8888  
 CREDIT: BEAUMONT POLICE DEPARTMENT  
 10/11/20  
 1-888-381-8888  
 PLAN PREPARED BY: **RK**  
 SUBMITTED BY: **RK**  
 CITY OF BEAUMONT  
 CITY OF BANNING  
 TRAFFIC SIGNAL MODIFICATION PLAN  
 HIGHLAND SPRINGS AVE & 8TH STREET / WILSON STREET  
 SHEET 2 OF 7  
 SCALE: 1" = 30'





**POLE AND EQUIPMENT SCHEDULE**

STANDARDS	SIGNAL LIGHT	VER. SIGNAL HGT.	RED. SR.	P.P.R.	POLE LOC.	LED.	STANDARD LIGHT ARM HANGING (SEE DETAIL A)	COMMENTS
1	REAR M.A. U.A.	15'-0"	SR-1-100	12'	A	12'	Standard 1200	
2	31"	15'-0"	SR-2-100	12'	B	12'	Standard 1200	
3	31"	15'-0"	SR-1-100	12'	A	12'	Standard 1200	
4	31"	15'-0"	SR-2-100	12'	B	12'	Standard 1200	
5	31"	15'-0"	SR-1-100	12'	A	12'	Standard 1200	
6	31"	15'-0"	SR-2-100	12'	B	12'	Standard 1200	
7	31"	15'-0"	SR-1-100	12'	A	12'	Standard 1200	
8	31"	15'-0"	SR-2-100	12'	B	12'	Standard 1200	
9	31"	15'-0"	SR-1-100	12'	A	12'	Standard 1200	
10	31"	15'-0"	SR-2-100	12'	B	12'	Standard 1200	

EXACT POLE LOCATIONS DETERMINED BY FIELD ENGINEER. PROVIDE POLE FOUNDATIONS PRIOR TO ORDERING POLES.  
 ALL EQUIPMENT IS EXCEPT AS NOTED.  
 (N) = NEW  
 \* = ROTARY LUMINAIRE 90 DEGREES AS SHOWN ON PLAN.

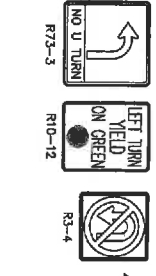

**SIGNAL STANDARD PLACEMENT DIMENSIONS AND EQUIPMENT LOCATIONS**  
 (TYPICAL SPACING BETWEEN SIGNALS SHOWN ON PLAN)  
 SEE DETAIL A FOR SIGNAL PLACEMENT ON CURVE  
 SEE DETAIL B FOR SIGNAL PLACEMENT AT CORNER  
 SEE DETAIL C FOR SIGNAL PLACEMENT AT INTERSECTION

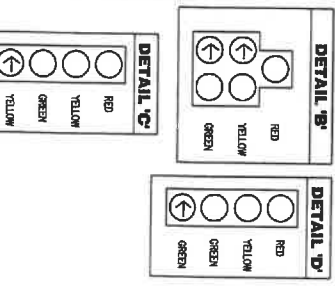
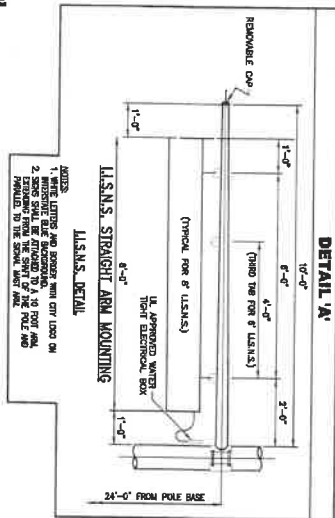

**CONDUCTOR SCHEDULE**

NO.	SIZE	TYPE	CONDUCTOR	CONDUCTOR	CONDUCTOR	CONDUCTOR	CONDUCTOR	CONDUCTOR	CONDUCTOR
1	12	AL	1	1	1	1	1	1	1
2	12	AL	1	1	1	1	1	1	1
3	12	AL	1	1	1	1	1	1	1
4	12	AL	1	1	1	1	1	1	1
5	12	AL	1	1	1	1	1	1	1
6	12	AL	1	1	1	1	1	1	1
7	12	AL	1	1	1	1	1	1	1
8	12	AL	1	1	1	1	1	1	1
9	12	AL	1	1	1	1	1	1	1
10	12	AL	1	1	1	1	1	1	1

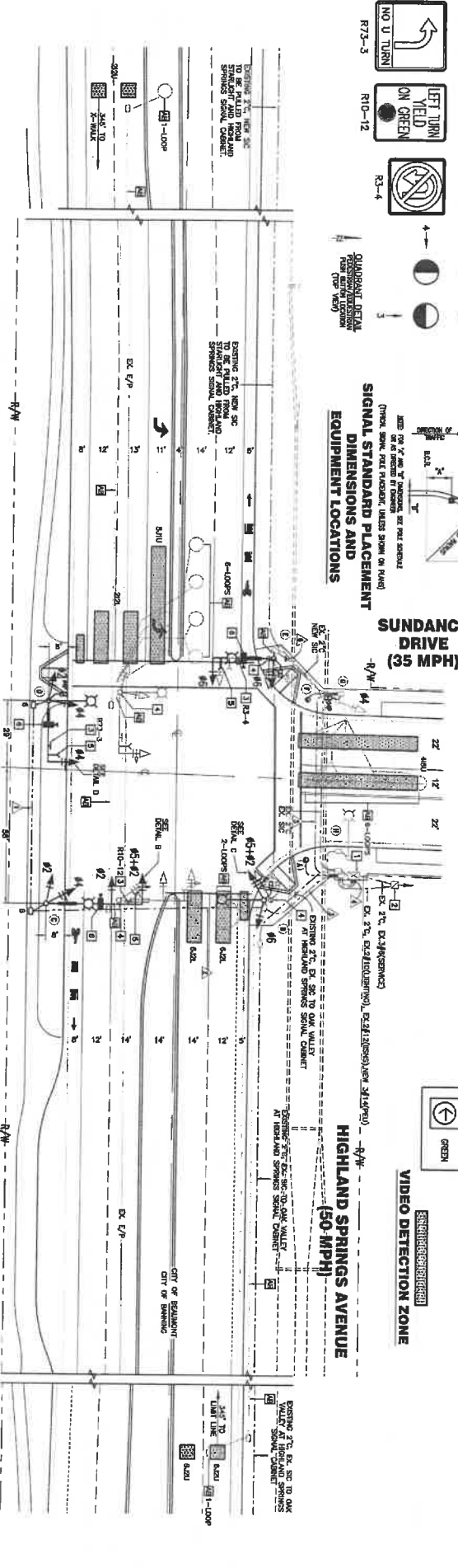

**CONSTRUCTION NOTES (THIS SHEET):**

- REMOVE AND SHAVE EXISTING TYPE TYPE CONDUIT, HANGERS AND RETAIL THE CONDUIT WITH BRUTE EXISTING EQUIPMENT IN EXISTING THE EXISTING STANDARD SPECIFICATION, CONDUIT TO PROVIDE ALL NECESSARY SUPPORT TO ACCOMMODATE OVERHEAD FOR PHASE OVERHEAD.
- REMOVE AND SHAVE EXISTING TYPE TYPE CONDUIT, HANGERS AND RETAIL THE CONDUIT WITH BRUTE EXISTING EQUIPMENT IN EXISTING THE EXISTING STANDARD SPECIFICATION, CONDUIT TO PROVIDE ALL NECESSARY SUPPORT TO ACCOMMODATE OVERHEAD FOR PHASE OVERHEAD.
- REMOVE AND SHAVE EXISTING TYPE TYPE CONDUIT, HANGERS AND RETAIL THE CONDUIT WITH BRUTE EXISTING EQUIPMENT IN EXISTING THE EXISTING STANDARD SPECIFICATION, CONDUIT TO PROVIDE ALL NECESSARY SUPPORT TO ACCOMMODATE OVERHEAD FOR PHASE OVERHEAD.
- REMOVE AND SHAVE EXISTING TYPE TYPE CONDUIT, HANGERS AND RETAIL THE CONDUIT WITH BRUTE EXISTING EQUIPMENT IN EXISTING THE EXISTING STANDARD SPECIFICATION, CONDUIT TO PROVIDE ALL NECESSARY SUPPORT TO ACCOMMODATE OVERHEAD FOR PHASE OVERHEAD.

**REVISIONS**

NO.	DATE	DESCRIPTION
1		
2		
3		
4		

PLANNED BY: **RK** CONSULTING GROUP, INC.  
 SUBMITTED BY: **RK** CONSULTING GROUP, INC.  
 CITY OF BANNING  
 CITY OF BEAUMONT  
 TRAFFIC SIGNAL MODIFICATION PLAN  
 HIGHLAND SPRINGS AND SUNDANCE DRIVE  
 SHEET 4 OF 7

**POLE AND EQUIPMENT SCHEDULE**

SYMBOLOGY	TYPE	HEIGHT	VERT. SPAN. LMR.		POLE LOC. L.E.D.	SYMBOLOGY		COMMENTS
			MAX. U.A.	MAX. L.A.		MAX. SPAN. LMR.	MAX. U.A.	
1	28-4-181 30' x 30' 30'	42' 0"	2-4-181(2)	11-1-100	6' Quad A	B	Highland Springs Area	
2	28-5-10000 30' x 30' 30'	57' 0"	2-4-181(2)	11-1-100	6' Quad A	B	Highland Springs Area	
3	19-4-181(2)	30'	19-4-181(2)	11-1-100	6' Quad A	B	Highland Springs Area	
4	19-4-181(2)	30'	19-4-181(2)	11-1-100	6' Quad A	B	Highland Springs Area	
5	19-4-181(2)	30'	19-4-181(2)	11-1-100	6' Quad A	B	Highland Springs Area	
6	19-4-181(2)	30'	19-4-181(2)	11-1-100	6' Quad A	B	Highland Springs Area	
7	19-4-181(2)	30'	19-4-181(2)	11-1-100	6' Quad A	B	Highland Springs Area	
8	19-4-181(2)	30'	19-4-181(2)	11-1-100	6' Quad A	B	Highland Springs Area	
9	19-4-181(2)	30'	19-4-181(2)	11-1-100	6' Quad A	B	Highland Springs Area	
10	19-4-181(2)	30'	19-4-181(2)	11-1-100	6' Quad A	B	Highland Springs Area	

INDICATE POLE LOCATIONS DETERMINED BY FIELD ENGINEER. PROVIDE POLE FOUNDATIONS PRIOR TO OPERATING POLES.  
ALL EQUIPMENT IS EXISTING EXCEPT AS NOTED  
(N) = NEW

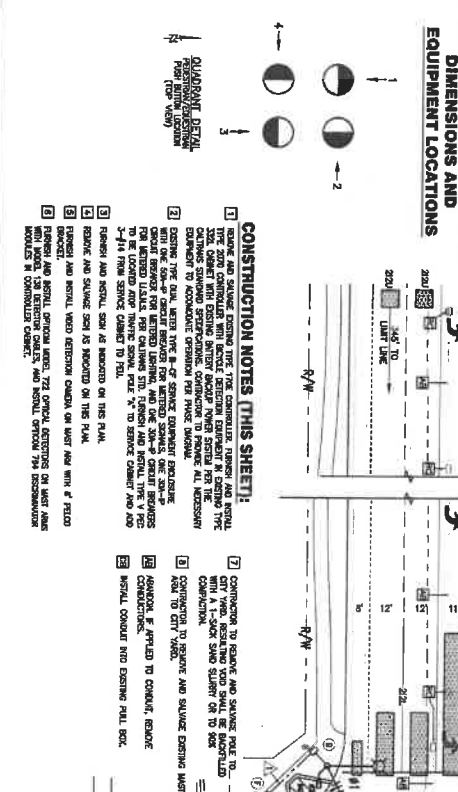
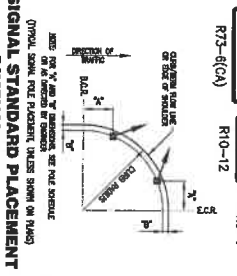

**DETAIL 'A'**

1LS&S, STRAIGHT ARM MOUNTING  
1LS&S, STRAIGHT ARM MOUNTING  
1LS&S, STRAIGHT ARM MOUNTING  
2'-0" FROM POLE BOLE

NOTES: LAMPING AND SPACING PER CITY 1500 OR PER CITY RECORDS.  
2" MINIMUM CLEARANCE FROM 12" O.D. RADIUS.  
2" MINIMUM CLEARANCE FROM 12" O.D. RADIUS.  
SPACING PER CITY RECORDS.

**CONDUCTOR SCHEDULE**

NO.	TYPE	COND.	COND. SCHED.	COND. SCHED.	COND. SCHED.	COND. SCHED.
1/4	PHOSPHOR BR.					
1/2	PHOSPHOR BR.					
1/0	PHOSPHOR BR.					
3/0	PHOSPHOR BR.					
2# OPTICAL CABLE FIB						
VIDEO DETECTION						
TOTAL						
17	24	21	23	23	27	23

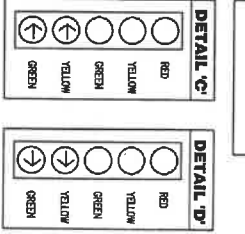

- CONSTRUCTION NOTES (THIS SHEET):**
1. REMOVE AND REPLACE EXISTING TRAFFIC SIGNALS, MOUNTING AND HOLES. THE SIGNAL STANDARD PLACEMENT SHALL BE MAINTAINED. THE EXISTING SIGNALS SHALL BE MAINTAINED. THE EXISTING SIGNALS SHALL BE MAINTAINED.
  2. EXISTING TRAFFIC SIGNALS SHALL BE MAINTAINED. THE EXISTING TRAFFIC SIGNALS SHALL BE MAINTAINED.
  3. REMOVE AND REPLACE EXISTING TRAFFIC SIGNALS, MOUNTING AND HOLES. THE SIGNAL STANDARD PLACEMENT SHALL BE MAINTAINED. THE EXISTING SIGNALS SHALL BE MAINTAINED.
  4. REMOVE AND REPLACE EXISTING TRAFFIC SIGNALS, MOUNTING AND HOLES. THE SIGNAL STANDARD PLACEMENT SHALL BE MAINTAINED. THE EXISTING SIGNALS SHALL BE MAINTAINED.
  5. REMOVE AND REPLACE EXISTING TRAFFIC SIGNALS, MOUNTING AND HOLES. THE SIGNAL STANDARD PLACEMENT SHALL BE MAINTAINED. THE EXISTING SIGNALS SHALL BE MAINTAINED.
  6. REMOVE AND REPLACE EXISTING TRAFFIC SIGNALS, MOUNTING AND HOLES. THE SIGNAL STANDARD PLACEMENT SHALL BE MAINTAINED. THE EXISTING SIGNALS SHALL BE MAINTAINED.
  7. REMOVE AND REPLACE EXISTING TRAFFIC SIGNALS, MOUNTING AND HOLES. THE SIGNAL STANDARD PLACEMENT SHALL BE MAINTAINED. THE EXISTING SIGNALS SHALL BE MAINTAINED.
  8. REMOVE AND REPLACE EXISTING TRAFFIC SIGNALS, MOUNTING AND HOLES. THE SIGNAL STANDARD PLACEMENT SHALL BE MAINTAINED. THE EXISTING SIGNALS SHALL BE MAINTAINED.
  9. REMOVE AND REPLACE EXISTING TRAFFIC SIGNALS, MOUNTING AND HOLES. THE SIGNAL STANDARD PLACEMENT SHALL BE MAINTAINED. THE EXISTING SIGNALS SHALL BE MAINTAINED.
  10. REMOVE AND REPLACE EXISTING TRAFFIC SIGNALS, MOUNTING AND HOLES. THE SIGNAL STANDARD PLACEMENT SHALL BE MAINTAINED. THE EXISTING SIGNALS SHALL BE MAINTAINED.

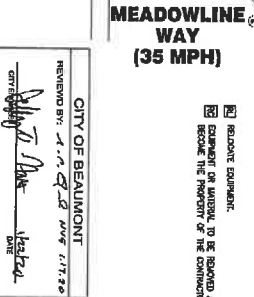

**REVISIONS**

NO.	DATE	DESCRIPTION

DESIGNED BY: [Signature]

CHECKED BY: [Signature]

APPROVED BY: [Signature]

CITY OF BEAUMONT

CITY OF BANNING

TRAFFIC SIGNAL MODIFICATION PLAN

HIGHLAND SPRINGS AVE & MEADOWLINE WAY/OAK VALLEY PARKWAY

SHEET 5 OF 7

POLE AND EQUIPMENT SCHEDULE

Table with columns: STANCHIONS (TYPE, HEIGHT, W/L, L/W, W/LAST, H/W), VEH. SIGNALS, LED, PAPER, POLE LOC., L.E.D., STANCHION, WET AND MOUNTED LISTS, COMMENTS.

ALL EQUIPMENT IS NEW. ALL SIGNALS SHALL BE EDGE LIT LED. \* = INSTALLED TYPE V PHOTOELECTRIC CONTROL UNIT ON TRAFFIC SIGNAL POLE.



RT10-12

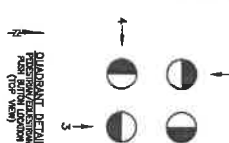

CONSTRUCTION NOTES (THIS SHEET):

- 1. INSTALL THE ZONE CONTROLLER WITH SERVICE METERBOX IN A TYPE 2X...
2. OBTAIN THE SERVICE FEED FROM THE CITY...
3. OBTAIN THE SIGNAL FROM THE SIGNAL MOUNTING...
4. PROVIDE AND INSTALL...
5. PROVIDE AND INSTALL...
6. OBTAIN THE SERVICE FEED FROM THE CITY...
7. OBTAIN THE SIGNAL FROM THE SIGNAL MOUNTING...
8. PROVIDE AND INSTALL...
9. PROVIDE AND INSTALL...

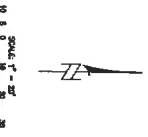
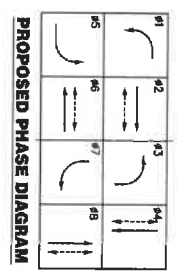

VIDEO DETECTION ZONE

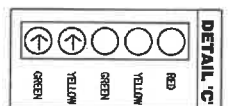

Project information including City of Banning logo, title 'TRAFFIC SIGNAL PLAN WILSON STREET & APEX STREET', author 'C. Banning', date '12/11/19', and sheet number '6 OF 7'.

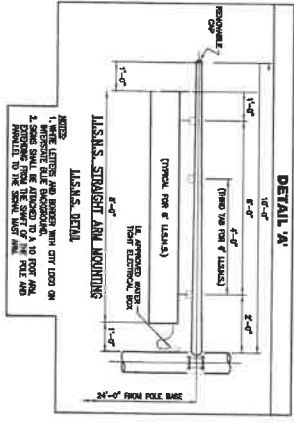

CONDUCTOR SCHEDULE table showing timing for phases 1 through 8 (e.g., PHOTOMATIC, LISTS, LAMBERS, CHANG, 3rd OPTICAL, VARIO DETECTION).

**SPECIAL PROVISIONS TO STANDARD SPECIFICATIONS FOR TRAFFIC SIGNAL PROJECTS**

**A. DESCRIPTION:**

The project consists of the installation of traffic signals at the intersection of [Location] and [Location] in the City of Beaumont, Texas. The project includes the installation of traffic signals, pedestrian signals, and related equipment. The project is to be completed by [Date].

**B. EQUIPMENT LIST AND DRAWINGS:**

The Contractor shall submit a detailed equipment list and drawings for the traffic signals, pedestrian signals, and related equipment. The equipment list shall include the make, model, and quantity of each item. The drawings shall show the location and orientation of each item. The Contractor shall also provide a list of the drawings to be used for the project.

**C. FOUNDATIONS:**

The Contractor shall provide foundations for the traffic signals, pedestrian signals, and related equipment. The foundations shall be constructed in accordance with the standard specifications and the project specifications. The Contractor shall also provide a list of the drawings to be used for the project.

**D. STANDARDS, STEEL, PEDESTALS AND POSTS:**

The Contractor shall provide standards, steel, pedestals, and posts for the traffic signals, pedestrian signals, and related equipment. The standards, steel, pedestals, and posts shall be constructed in accordance with the standard specifications and the project specifications. The Contractor shall also provide a list of the drawings to be used for the project.

**E. CONDUIT:**

The Contractor shall provide conduit for the traffic signals, pedestrian signals, and related equipment. The conduit shall be constructed in accordance with the standard specifications and the project specifications. The Contractor shall also provide a list of the drawings to be used for the project.

**F. PULL BOXES:**

The Contractor shall provide pull boxes for the traffic signals, pedestrian signals, and related equipment. The pull boxes shall be constructed in accordance with the standard specifications and the project specifications. The Contractor shall also provide a list of the drawings to be used for the project.

**G. LUMINAIRES:**

The Contractor shall provide luminaires for the traffic signals, pedestrian signals, and related equipment. The luminaires shall be constructed in accordance with the standard specifications and the project specifications. The Contractor shall also provide a list of the drawings to be used for the project.

**H. L.E.D. DRIVER:**

The Contractor shall provide L.E.D. drivers for the traffic signals, pedestrian signals, and related equipment. The L.E.D. drivers shall be constructed in accordance with the standard specifications and the project specifications. The Contractor shall also provide a list of the drawings to be used for the project.

**I. BONDING AND GUARANTEE:**

The Contractor shall provide bonding and guarantee for the traffic signals, pedestrian signals, and related equipment. The bonding and guarantee shall be constructed in accordance with the standard specifications and the project specifications. The Contractor shall also provide a list of the drawings to be used for the project.

**J. VEHICLE SIGNAL PAGES AND SIGNAL HEADS:**

The Contractor shall provide vehicle signal pages and signal heads for the traffic signals, pedestrian signals, and related equipment. The vehicle signal pages and signal heads shall be constructed in accordance with the standard specifications and the project specifications. The Contractor shall also provide a list of the drawings to be used for the project.

**K. SERVICE:**

The Contractor shall provide service for the traffic signals, pedestrian signals, and related equipment. The service shall be constructed in accordance with the standard specifications and the project specifications. The Contractor shall also provide a list of the drawings to be used for the project.

**L. DETECTION:**

The Contractor shall provide detection for the traffic signals, pedestrian signals, and related equipment. The detection shall be constructed in accordance with the standard specifications and the project specifications. The Contractor shall also provide a list of the drawings to be used for the project.

**M. REDISTRIBUTE SIGNALS:**

The Contractor shall provide redistribution of signals for the traffic signals, pedestrian signals, and related equipment. The redistribution of signals shall be constructed in accordance with the standard specifications and the project specifications. The Contractor shall also provide a list of the drawings to be used for the project.

**P. INTERNALLY ILLUMINATED STREET NAME SIGNS:**

The Contractor shall provide internally illuminated street name signs for the project. The signs shall be constructed in accordance with the standard specifications and the project specifications. The Contractor shall also provide a list of the drawings to be used for the project.

**Q. EMERGENCY VEHICLE PRE-EMPTION:**

The Contractor shall provide emergency vehicle pre-emption for the project. The pre-emption shall be constructed in accordance with the standard specifications and the project specifications. The Contractor shall also provide a list of the drawings to be used for the project.

**R. MODEL SIGNAL CONTROLLER ASSEMBLIES:**

The Contractor shall provide model signal controller assemblies for the project. The assemblies shall be constructed in accordance with the standard specifications and the project specifications. The Contractor shall also provide a list of the drawings to be used for the project.

**S. BATTERY BACK-UP SYSTEM:**

The Contractor shall provide a battery back-up system for the project. The system shall be constructed in accordance with the standard specifications and the project specifications. The Contractor shall also provide a list of the drawings to be used for the project.

**T. BATTERY BACK-UP SYSTEM:**

The Contractor shall provide a battery back-up system for the project. The system shall be constructed in accordance with the standard specifications and the project specifications. The Contractor shall also provide a list of the drawings to be used for the project.

**U. BATTERY BACK-UP SYSTEM:**

The Contractor shall provide a battery back-up system for the project. The system shall be constructed in accordance with the standard specifications and the project specifications. The Contractor shall also provide a list of the drawings to be used for the project.

CITY OF BEAUMONT  
REVISIONS  
APPROVED BY: [Signature]  
DATE: 1/17/20

PLANS PREPARED BY:  
RIK Engineering  
10000 Highway 101, Suite 100  
Beaumont, TX 77705

SUBMITTED BY:  
[Signature]  
DATE: 1/17/20

CITY OF BEAUMONT  
SEAL  
OFFICIAL SEAL

CITY OF BANNING  
APPROVED BY:  
[Signature]  
DATE: 1/17/20

CITY OF BANNING  
SPECIAL PROVISIONS  
SHEET 7 OF 7

Basic Gov (Sales Force) # PW2019-0363  
File # 3300 Springs Ave & Oak Valley Pkwy

**AGREEMENT TO PROVIDE SECURITY FOR IMPROVEMENTS  
FOR TRACT MAP OR PARCEL MAP OR PLOT PLAN  
(Tract Map/Parcel Map/Plot Plan No. 37298-1)**

THIS SECURITY AGREEMENT is made by and between CITY OF BEAUMONT (“CITY”) and Pardee Homes, a California company (“DEVELOPER”).

**RECITALS**

A. DEVELOPER has applied to the CITY for permission to develop certain real property, pursuant to Tract Map/Parcel Map/Plot Plan #TR37298-1 (“Map”). DEVELOPER has also asked the CITY to accept the dedication of the street or streets and other proposed public rights-of-way, parks and recreation facilities, and easements as depicted on the Map and to otherwise approve the Map so that it may be recorded as required by law; and Atwell-Traffic Signal: Highland Springs Ave & Oak Valley Pkwy

B. The CITY requires, as a condition precedent to the acceptance and approval of the Map and the dedication of the public rights-of-way and easements depicted thereon, that such rights-of-way be improved with (for example) grading, paving, curbs, gutters, sidewalks, street lights, stormdrains, sanitary sewers and appurtenances thereto, street name signs, survey monuments, electrical and telecommunications, water pipes, water mains, fire hydrants and appurtenances thereto, and landscaping, including any warranty work for all such improvements (collectively, “Improvements”); and

C. The Improvements have not yet been constructed and completed and it is the purpose of this Security Agreement to set forth the terms and conditions by which the DEVELOPER shall guarantee that such Improvements shall be constructed and completed within the time set forth herein.

**AGREEMENT**

NOW, THEREFORE, in consideration of the acceptance of the DEVELOPER’s offer of dedication and the approval of the Map for filing and recording as provided and required by law, the CITY and the DEVELOPER hereby agree as follows:

1. Provision of Improvements. DEVELOPER shall provide, at the DEVELOPER’s sole cost and expense, all necessary labor and materials to complete the construction of the Improvements depicted on the Map and described in the conditions of approval of the Map within one (1) year of the date of this Security Agreement.

2. Inspection by the CITY. The CITY shall inspect, at the DEVELOPER’s sole cost and expense, all of the work, labor and materials performed and provided by the DEVELOPER in connection with the Improvements.

3. Compliance with Plans and Specifications. The Improvements shall be constructed and installed in strict accordance with the CITY-approved plans and specifications.

4. Security for Performance. Concurrently with the execution of this Security Agreement by DEVELOPER, DEVELOPER shall deliver to the CITY a performance bond issued by a corporate surety in substantially the form attached hereto as **Exhibit "A"**, in an amount that is not less than 100% of the total estimated cost of the Improvements and any warranty therefor. The performance bond shall be issued by an "admitted" corporate surety insurer authorized to do business in the State of California and the surety insurer shall have an A.M. Best rating of at least "A, XV". The surety insurer shall have assets exceeding its liabilities in the amount equal to or in excess of the amount of the bond, and the bond shall not be in excess of 10% of the surety insurer's assets. The security or bond shall also insure against any and all defects in the Improvements for a period of not less than one full year after the date of acceptance thereof by the CITY. The bond shall be duly executed and shall meet all the requirements of Section 995.660 of the California Code of Civil Procedure.

5. Security for Contractors, Subcontractors, Laborers and Materialmen. The DEVELOPER shall also provide a payment bond issued by a corporate surety for the security of laborers and materialmen, which bond or bonds shall be in substantially the form attached hereto as **Exhibit "B"** and made a part hereof. The amount of the bond(s) shall be no less than 100% of the total estimated amount needed to secure payment to the contractor, to the subcontractors, and to the persons furnishing labor, materials, or equipment to them for the Improvements. The laborers and materialmen bond shall be provided by an "admitted" corporate surety insurer authorized to transact surety insurance in the State of California with an A.M. Best rating of "A, XV", and with assets exceeding its liabilities in the amount equal to or in excess of the amount of the bond, and the bond shall not be in excess of 10% of the surety insurer's assets. The bond shall be duly executed and shall meet all the requirements of Section 995.660 of the California Code of Civil Procedure.

6. General Liability and Worker's Compensation Insurance. The DEVELOPER shall, before commencing any work, obtain commercial general liability insurance (primary) of not less than \$2,000,000.00 per occurrence for all coverages and \$2,000,000.00 general aggregate. The CITY and its employees and agents shall be added as additional insureds. Coverage shall apply on a primary non-contributing basis in relation to any other insurance or self-insurance, primary or excess, available to the CITY or any employee or agent of the CITY. Coverage shall not be limited to the vicarious liability or supervisory role of any additional insured. Coverage shall contain no contractors' limitation endorsement. There shall be no endorsement or modification limiting the scope of coverage for liability arising from pollution, explosion, collapse, underground property damage or employment-related practices. Such insurance shall not prohibit the DEVELOPER, and its employees or agents, from waiving the right of subrogation prior to a loss. The DEVELOPER waives its right of subrogation against the CITY. Unless otherwise approved by the CITY, the DEVELOPER's insurance shall be written by insurers authorized to do business in the State of California and with a minimum A.M. Best rating of "A, XV." Self-insurance shall not be considered to comply with these insurance specifications. The DEVELOPER agrees to require all contractors, subcontractors and other parties hired for the Improvements to purchase and maintain insurance of the types specified

herein, naming as additional insureds all of the parties to this Security Agreement. The DEVELOPER shall, before commencing any work, obtain Worker's Compensation Insurance in an amount required by law and, failing to do so, the CITY may procure such insurance at the cost of the DEVELOPER.

7. Comprehensive Commercial General and Automobile Liability Insurance. The DEVELOPER, before commencing any work shall, at its own expense, maintain comprehensive commercial general and automobile liability insurance issued by a California-admitted surety company with an A.M. Best rating of no less than "A, XV" for \$2,000,000 per occurrence. Coverage shall be for the entire duration of the permitted activities. Such liability insurance policy shall name, by endorsement, the City as an additional insured.

8. Indemnification. Notwithstanding the provisions of Government Code, Section 66474.9 or any other statutes of similar import, and to the full extent permitted by law, the DEVELOPER shall defend, indemnify and hold harmless the CITY, its employees, agents, officials and attorneys, from and against any liability, claims, suits, actions, arbitration proceedings, administrative proceedings, regulatory proceedings, losses, expenses or costs of any kind or nature, whether actual, alleged or threatened, reasonable attorneys' fees, court costs, interest, expert witness fees and any other costs or expenses of any kind whatsoever, without restriction or limitation, incurred in relation to, as a consequence of, or arising out of or in any way attributable actually, allegedly or impliedly, in whole or in part, to the Map, the Improvements, this Agreement, or any matter related to the same; provided, however, that the indemnification to be provided by DEVELOPER to the CITY pursuant to the terms of this paragraph shall not be applicable where the aforementioned liability, claim, suit, action, etcetera, is the result of the sole negligence or sole willful misconduct of the CITY.

9. Procedure for Release of Performance Bond Security. The security furnished by the DEVELOPER shall be released in whole or in part in the following manner:

a. Security shall be released upon final completion and acceptance of the Improvements. If the security furnished by the DEVELOPER is a documentary evidence of security, such as a surety bond, the CITY shall release the documentary evidence and return the original to the Surety upon final completion and acceptance of the Improvements. In the event the CITY is unable to return the original documentary evidence to the Surety, the security shall be released by written notice sent by certified mail to the DEVELOPER and to the Surety within 30 days of the City's acceptance of the Improvements. The written notice shall contain a statement that the work for which security was furnished has been completed and accepted, a description of the Improvements, and the notarized signature of an authorized CITY official.

b. At such time as the DEVELOPER believes that the work for which the security was required is complete and makes payment of a partial exoneration fee of \$350 to the CITY, the DEVELOPER shall notify the CITY in writing of the completed work, including a list of work completed. Upon receipt of the written notice, the CITY shall have 45 days to review and comment or approve the completion of the Improvements. If the CITY does not agree that all work has been completed in accordance with the plans

and specifications for the Improvements, it shall supply a list of all remaining work to be completed.

c. Within 45 days of receipt of the CITY's list of remaining work, the DEVELOPER may then provide cost estimates for all remaining work for review and approval by the CITY.

d. Upon receipt of the cost estimates, the CITY shall then have 45 days to review, comment, and approve, modify or disapprove those cost estimates. The CITY shall not be required to engage in this process of partial release more than once between the start of work and the completion and acceptance of all work.

e. The DEVELOPER shall complete the works of Improvement until all remaining items are accepted by the CITY. Upon completion of the Improvements, the DEVELOPER shall be notified in writing by the CITY within 45 days and, within 45 days of the date of the CITY's notice, the release of any remaining performance security shall be made within 60 days of the recording of the Notice of Completion.

10. Procedure for Release of Payment Bond Security. Security securing the payment to the contractor, his or her subcontractors and persons furnishing labor, materials or equipment may, after passage of the time within which mechanic's liens and stop notices are required to be recorded and after acceptance of the Improvements, be reduced by Surety to an amount equal to the total claimed by all claimants for whom mechanic's liens and stop notices have been recorded and notice thereof given in writing to the CITY, and if no claims have been recorded, the security may be released in full.

11. Security for One-Year Warranty Period. The release procedures described in paragraphs 9 and 10 above shall not apply to any required guarantee and warranty period nor to the amount of the performance bond security deemed necessary by the CITY for the guarantee and warranty period nor to costs and reasonable expenses and fees, including reasonable attorneys' fees.

12. Binding Effect. This Security Agreement shall be binding upon and shall inure to the benefit of the parties hereto, their legal representatives and their successors and assigns.

13. Authority to Execute. The DEVELOPER hereby warrants and represents to the CITY that the individual signing this Security Agreement on behalf of the DEVELOPER is vested with the unconditional authority to do so pursuant to, and in accordance with, all applicable legal requirements, and has the authority bind the DEVELOPER hereto.

14. No Assignment. The DEVELOPER may not assign this Security Agreement, or any part thereof, to another without the prior written consent of the CITY.

15. Attorneys' Fees. In the event of legal action to enforce or interpret this Agreement or any of its provisions, the prevailing party shall be entitled, in addition to any other form of relief, to recover its reasonable attorneys' fees and costs of suit.



16. Execution in Counterparts. This Agreement may be executed in counterparts, each of which shall be deemed an original, but which together shall constitute a single agreement.

IN WITNESS WHEREOF, the parties have caused this Agreement to be executed on the dates listed below.

CITY OF BEAUMONT

By \_\_\_\_\_  
Mayor

\_\_\_\_\_  
Date

DEVELOPER

By  \_\_\_\_\_  
Jeff Chambers

2-18-2020  
Date

Title: VP of Community Development

Address: Pardee Homes  
1250 Corona Pointe Court,  
Suite 600  
Corona, CA 92879

Basic Gov (Sales Force) # \_\_\_\_\_  
File # \_\_\_\_\_

**EXHIBIT "A"**

Bond No: CMS331858  
Premium: \$469.00

**PERFORMANCE BOND**

WHEREAS, the City Council of the City of Beaumont, State of California, and Pardee Homes (hereinafter designated as "Principal") have entered into Agreement To Provide Security For Improvements For Tract Map Or Parcel Map Or Plot Plan, dated \_\_\_\_\_, 20\_\_\_\_, whereby Principal agrees to install and complete certain designated public improvements itemized and described on Tract Map, Parcel Map or Plot Plan No. 37298-1, which is hereby incorporated herein and made a part hereof; and **Atwell-Traffic Signal: Highland Springs Ave & Oak Valley Parkway**

WHEREAS, Principal is required under the terms of the said agreement to furnish a bond for the faithful performance of said agreement.

NOW, THEREFORE, we, the Principal and RLI Insurance Company, as Surety, are held and firmly bound unto the City of Beaumont (hereinafter called "City"), in the penal sum of One Hundred Seventeen Thousand Three \* dollars (\$ 117,362.00 ) lawful money of the United States, for the payment of which sum well and truly to be made, we bind ourselves, our heirs, successors, executors and administrators, jointly and severally, firmly by these presents. \*Hundred Sixty Two & 00/100

The condition of this obligation is such that if the Principal, his or its heirs, executors, administrators, successors or assigns, shall in all things stand to and abide by, and well and truly keep and perform the covenants, conditions and provisions in the said agreement and any alteration thereof made as therein provided, on his or their part to be kept and performed at the time and in the manner therein specified, and in all respects according to their true intent and meaning, and shall indemnify and save harmless the City, its officers, agents and employees as therein stipulated, then this obligation shall become null and void; otherwise it shall be and remain in full force and effect.

As part of the obligation secured hereby and in addition to the face amount specified therefor, there shall be included costs and reasonable expenses and fees, including reasonable attorney's fees, incurred by the City in successfully enforcing such obligation, all to be taxed as costs and included in any judgment therein rendered.

The Surety hereby stipulates and agrees that no change, extension of time, alteration or addition to the terms of the agreement or to the work to be performed thereunder or the specifications accompanying the same shall in any way affect its obligations on this bond, and it does hereby waive notice of any such change, extension of time, alteration or addition to the terms of the agreement or to the work or to the specifications.

IN WITNESS WHEREOF, this instrument has been duly executed by the Principal and Surety above named, on February 12, 2020.

PRINCIPAL:

SURETY:

Pardee Homes

RLI Insurance Company

By 

By 

Title Jeff Chambers, VP Community Development

Title Janina Monroe, Attorney-In-Fact

# ALL- PURPOSE CERTIFICATE OF ACKNOWLEDGMENT

A notary public or other officer completing this certificate verifies only the identity of the individual who signed the document to which this certificate is attached, and not the truthfulness, accuracy, or validity of that document.

State of California }

County of Orange }

On FEB 12 2020 before me, Brianne Davis, Notary Public  
(Here insert name and title of the officer)

personally appeared Janina Monroe  
who proved to me on the basis of satisfactory evidence to be the person(s) whose name(s) is/are subscribed to the within instrument and acknowledged to me that he/she/they executed the same in his/her/their authorized capacity(ies), and that by his/her/their signature(s) on the instrument the person(s), or the entity upon behalf of which the person(s) acted, executed the instrument.

I certify under PENALTY OF PERJURY under the laws of the State of California that the foregoing paragraph is true and correct.

WITNESS my hand and official seal.

Brianne Davis  
Notary Public Signature (Notary Public Seal)



### ADDITIONAL OPTIONAL INFORMATION

DESCRIPTION OF THE ATTACHED DOCUMENT  
  
(Title or description of attached document)  
  
(Title or description of attached document continued)  
  
Number of Pages \_\_\_\_\_ Document Date \_\_\_\_\_

CAPACITY CLAIMED BY THE SIGNER  
 Individual (s)  
 Corporate Officer  
  
\_\_\_\_\_  
(Title)  
 Partner(s)  
 Attorney-in-Fact  
 Trustee(s)  
 Other \_\_\_\_\_

### INSTRUCTIONS FOR COMPLETING THIS FORM

*This form complies with current California statutes regarding notary wording and, if needed, should be completed and attached to the document. Acknowledgments from other states may be completed for documents being sent to that state so long as the wording does not require the California notary to violate California notary law.*

- State and County information must be the State and County where the document signer(s) personally appeared before the notary public for acknowledgment.
- Date of notarization must be the date that the signer(s) personally appeared which must also be the same date the acknowledgment is completed.
- The notary public must print his or her name as it appears within his or her commission followed by a comma and then your title (notary public).
- Print the name(s) of document signer(s) who personally appear at the time of notarization.
- Indicate the correct singular or plural forms by crossing off incorrect forms (i.e. he/she/they, is /are) or circling the correct forms. Failure to correctly indicate this information may lead to rejection of document recording.
- The notary seal impression must be clear and photographically reproducible. Impression must not cover text or lines. If seal impression smudges, re-seal if a sufficient area permits, otherwise complete a different acknowledgment form.
- Signature of the notary public must match the signature on file with the office of the county clerk.
  - ❖ Additional information is not required but could help to ensure this acknowledgment is not misused or attached to a different document.
  - ❖ Indicate title or type of attached document, number of pages and date.
  - ❖ Indicate the capacity claimed by the signer. If the claimed capacity is a corporate officer, indicate the title (i.e. CEO, CFO, Secretary).
- Securely attach this document to the signed document with a staple.

# POWER OF ATTORNEY

Item 4.

## RLI Insurance Company Contractors Bonding and Insurance Company

9025 N. Lindbergh Dr. Peoria, IL 61615  
Phone: 800-645-2402

### Know All Men by These Presents:

That this Power of Attorney is not valid or in effect unless attached to the bond which it authorizes executed, but may be detached by the approving officer if desired.

That **RLI Insurance Company** and/or **Contractors Bonding and Insurance Company**, each an Illinois corporation, (separately and together, the "Company") do hereby make, constitute and appoint:

Paul Boucher, Janina Monroe, Dennis Langer, Michelle Haase, Timothy Noonan, jointly or severally

in the City of Irvine, State of California its true and lawful Agent(s) and Attorney(s) in Fact, with full power and authority hereby conferred, to sign, execute, acknowledge and deliver for and on its behalf as Surety, in general, any and all bonds and undertakings in an amount not to exceed Twenty Five Million Dollars (\$25,000,000.00) for any single obligation.

The acknowledgment and execution of such bond by the said Attorney in Fact shall be as binding upon the Company as if such bond had been executed and acknowledged by the regularly elected officers of the Company.

**RLI Insurance Company** and/or **Contractors Bonding and Insurance Company**, as applicable, have each further certified that the following is a true and exact copy of a Resolution adopted by the Board of Directors of each such corporation, and is now in force, to-wit:

"All bonds, policies, undertakings, Powers of Attorney or other obligations of the corporation shall be executed in the corporate name of the Company by the President, Secretary, any Assistant Secretary, Treasurer, or any Vice President, or by such other officers as the Board of Directors may authorize. The President, any Vice President, Secretary, any Assistant Secretary, or the Treasurer may appoint Attorneys in Fact or Agents who shall have authority to issue bonds, policies or undertakings in the name of the Company. The corporate seal is not necessary for the validity of any bonds, policies, undertakings, Powers of Attorney or other obligations of the corporation. The signature of any such officer and the corporate seal may be printed by facsimile."

IN WITNESS WHEREOF, the **RLI Insurance Company** and/or **Contractors Bonding and Insurance Company**, as applicable, have caused these presents to be executed by its respective Vice President with its corporate seal affixed this 30th day of September, 2019.



**RLI Insurance Company  
Contractors Bonding and Insurance Company**

By: B. W. Davis  
Barton W. Davis Vice President

State of Illinois }  
County of Peoria } SS

### CERTIFICATE

On this 30th day of September, 2019, before me, a Notary Public, personally appeared Barton W. Davis, who being by me duly sworn, acknowledged that he signed the above Power of Attorney as the aforesaid officer of the **RLI Insurance Company** and/or **Contractors Bonding and Insurance Company** and acknowledged said instrument to be the voluntary act and deed of said corporation.

I, the undersigned officer of **RLI Insurance Company** and/or **Contractors Bonding and Insurance Company**, do hereby certify that the attached Power of Attorney is in full force and effect and is irrevocable; and furthermore, that the Resolution of the Company as set forth in the Power of Attorney, is now in force. In testimony whereof, I have hereunto set my hand and the seal of the **RLI Insurance Company** and/or **Contractors Bonding and Insurance Company** this \_\_\_\_\_ day of \_\_\_\_\_

By: Gretchen L. Johnigk  
Gretchen L. Johnigk Notary Public

**RLI Insurance Company  
Contractors Bonding and Insurance Company**  
FEB 12 2020

By: Jean M. Stephenson  
Jean M. Stephenson Corporate Secretary



# California All-Purpose Certificate of Acknowledgment

A notary public or other officer completing this certificate verifies only the identity of the individual who signed the document to which this certificate is attached, and not the truthfulness, accuracy, or validity of that document.

State of California }  
County of Riverside } s.s.

On February 19, 2020 before me, Ana E. Chavez Perez, Notary Public  
Name of Notary Public, Title

personally appeared Jeff Chambers  
Name of Signer (1)

\_\_\_\_\_  
Name of Signer (2)

who proved to me on the basis of satisfactory evidence to be the person(s) whose name(s) is/are subscribed to the within instrument and acknowledged to me that he/she/they executed the same in his/her/their authorized capacity(ies), and that by his/her/their signature(s) on the instrument the person(s), or the entity upon behalf of which the person(s) acted, executed the instrument.

I certify under PENALTY OF PERJURY under the laws of the State of California that the foregoing paragraph is true and correct.

WITNESS my hand and official seal.

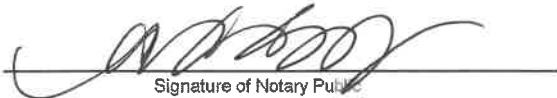
  
Signature of Notary Public

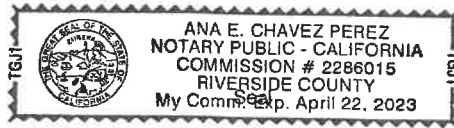

### OPTIONAL INFORMATION

Although the information in this section is not required by law, it could prevent fraudulent removal and reattachment of this acknowledgment to an unauthorized document and may prove useful to persons relying on the attached document.

### Description of Attached Document

The preceding Certificate of Acknowledgment is attached to a document titled/for the purpose of \_\_\_\_\_  
containing \_\_\_\_\_ pages, and dated \_\_\_\_\_.

The signer(s) capacity or authority is/are as:

- Individual(s)
- Attorney-in-fact
- Corporate Officer(s) \_\_\_\_\_  
Title(s)
- Guardian/Conservator
- Partner - Limited/General
- Trustee(s)
- Other: \_\_\_\_\_

representing: \_\_\_\_\_  
Name(s) of Person(s) Entity(ies) Signer is Representing

### Additional Information

#### Method of Signer Identification

Proved to me on the basis of satisfactory evidence:  
 form(s) of identification  credible witness(es)

Notarial event is detailed in notary journal on:

Page # \_\_\_\_\_ Entry # \_\_\_\_\_

Notary contact: \_\_\_\_\_

#### Other

- Additional Signer  Signer(s) Thumbprints(s)
- \_\_\_\_\_

**EXHIBIT "B"**

**PAYMENT BOND**

WHEREAS, the City Council of the City of Beaumont, State of California, and Pardee Homes (hereafter designated as "the Principal") have entered into Agreement To Provide Security For Improvements For Tract Map Or Parcel Map Or Plot Plan, dated \_\_\_\_\_, 20\_\_\_\_, whereby Principal agrees to install and complete certain designated public improvements itemized and described on Tract Map, Parcel Map or Plot Plan No. 37298-1, which is hereby incorporated herein and made a part hereof; and Atwell-Traffic Signal: Highland Springs Ave & Oak Valley Parkway

WHEREAS, under the terms of the said agreement, the Principal is required before entering upon the performance of the work, to file a good and sufficient payment bond with the City of Beaumont to secure the claims to which reference is made in Section 8000, et seq., of the Civil Code of the State of California.

NOW, THEREFORE, the Principal and the undersigned as corporate surety, are held firmly bound unto the City of Beaumont and all contractors, subcontractors, laborers, materialmen, and other persons employed in the performance of the said agreement and referred to at Section 8000, et seq., of the Civil Code in the sum of One Hundred Seventeen Thousand \* dollars (\$ 117,362.00 ), for materials furnished or labor thereon of any kind, or for amounts due under the Unemployment Insurance Act with respect to this work or labor, that the Surety will pay the same in an amount not exceeding the amount hereinabove set forth, and also in case suit is brought upon this bond, will pay, in addition to the face amount thereof, costs and reasonable expenses and fees, including reasonable attorney's fees, incurred by the City in successfully enforcing this obligation, to be awarded and fixed by the court, and to be taxed as costs and to be included in the judgment therein rendered. \*Three Hundred Sixty Two & 00/100

It is hereby expressly stipulated and agreed that this bond shall inure to the benefit of any and all persons, companies, and corporations entitled to file claims under Section 8000, et seq., of the Civil Code, so as to give a right of action to them or their assigns in any suit brought upon this bond.

Should the condition of this bond be fully performed, then this obligation shall become null and void, otherwise it shall be and remain in full force and effect.

The Surety hereby stipulates and agrees that no change, extension of time, alteration, or addition to the terms of the agreement or the specifications accompanying the same shall in any manner affect its obligations on this bond, and it does hereby waive notice of any such change, extension, alteration, or addition.

IN WITNESS WHEREOF, this instrument has been duly executed by the Principal and Surety above named, on February 12, 2020.

PRINCIPAL:

SURETY:

Pardee Homes

RLI Insurance Company

By 

By 

Title Jeff Chambers, VP Community Development

Title Janina Monroe, Attorney-In-Fact

# ALL- PURPOSE CERTIFICATE OF ACKNOWLEDGMENT

A notary public or other officer completing this certificate verifies only the identity of the individual who signed the document to which this certificate is attached, and not the truthfulness, accuracy, or validity of that document.

State of California }

County of Orange }

On FEB 12 2020 before me, Brianne Davis, Notary Public  
(Here insert name and title of the officer)

personally appeared Janina Monroe  
who proved to me on the basis of satisfactory evidence to be the person(s) whose name(s) is/are ~~was~~ subscribed to the within instrument and acknowledged to me that he/she/they executed the same in his/her/their authorized capacity(ies), and that by his/her/their signature(s) on the instrument the person(s), or the entity upon behalf of which the person(s) acted, executed the instrument.

I certify under PENALTY OF PERJURY under the laws of the State of California that the foregoing paragraph is true and correct.

WITNESS my hand and official seal.

*Brianne Davis*

Notary Public Signature

(Notary Public Seal)



### ADDITIONAL OPTIONAL INFORMATION

DESCRIPTION OF THE ATTACHED DOCUMENT  
  
(Title or description of attached document)  
  
(Title or description of attached document continued)  
Number of Pages \_\_\_\_\_ Document Date \_\_\_\_\_

CAPACITY CLAIMED BY THE SIGNER  
 Individual (s)  
 Corporate Officer  
\_\_\_\_\_  
(Title)  
 Partner(s)  
 Attorney-in-Fact  
 Trustee(s)  
 Other \_\_\_\_\_

### INSTRUCTIONS FOR COMPLETING THIS FORM

*This form complies with current California statutes regarding notary wording and, if needed, should be completed and attached to the document. Acknowledgments from other states may be completed for documents being sent to that state so long as the wording does not require the California notary to violate California notary law.*

- State and County information must be the State and County where the document signer(s) personally appeared before the notary public for acknowledgment.
- Date of notarization must be the date that the signer(s) personally appeared which must also be the same date the acknowledgment is completed.
- The notary public must print his or her name as it appears within his or her commission followed by a comma and then your title (notary public).
- Print the name(s) of document signer(s) who personally appear at the time of notarization.
- Indicate the correct singular or plural forms by crossing off incorrect forms (i.e. he/she/they- is /are ) or circling the correct forms. Failure to correctly indicate this information may lead to rejection of document recording.
- The notary seal impression must be clear and photographically reproducible. Impression must not cover text or lines. If seal impression smudges, re-seal if a sufficient area permits, otherwise complete a different acknowledgment form.
- Signature of the notary public must match the signature on file with the office of the county clerk.
  - ❖ Additional information is not required but could help to ensure this acknowledgment is not misused or attached to a different document.
  - ❖ Indicate title or type of attached document, number of pages and date.
  - ❖ Indicate the capacity claimed by the signer. If the claimed capacity is a corporate officer, indicate the title (i.e. CEO, CFO, Secretary).
- Securely attach this document to the signed document with a staple.

# POWER OF ATTORNEY

Item 4.

## RLI Insurance Company Contractors Bonding and Insurance Company

9025 N. Lindbergh Dr. Peoria, IL 61615  
Phone: 800-645-2402

### Know All Men by These Presents:

That this Power of Attorney is not valid or in effect unless attached to the bond which it authorizes executed, but may be detached by the approving officer if desired.

That **RLI Insurance Company** and/or **Contractors Bonding and Insurance Company**, each an Illinois corporation, (separately and together, the "Company") do hereby make, constitute and appoint:

Paul Boucher, Janina Monroe, Dennis Langer, Michelle Haase, Timothy Noonan, jointly or severally

in the City of Irvine, State of California its true and lawful Agent(s) and Attorney(s) in Fact, with full power and authority hereby conferred, to sign, execute, acknowledge and deliver for and on its behalf as Surety, in general, any and all bonds and undertakings in an amount not to exceed Twenty Five Million Dollars (\$25,000,000.00) for any single obligation.

The acknowledgment and execution of such bond by the said Attorney in Fact shall be as binding upon the Company as if such bond had been executed and acknowledged by the regularly elected officers of the Company.

**RLI Insurance Company** and/or **Contractors Bonding and Insurance Company**, as applicable, have each further certified that the following is a true and exact copy of a Resolution adopted by the Board of Directors of each such corporation, and is now in force, to-wit:

"All bonds, policies, undertakings, Powers of Attorney or other obligations of the corporation shall be executed in the corporate name of the Company by the President, Secretary, any Assistant Secretary, Treasurer, or any Vice President, or by such other officers as the Board of Directors may authorize. The President, any Vice President, Secretary, any Assistant Secretary, or the Treasurer may appoint Attorneys in Fact or Agents who shall have authority to issue bonds, policies or undertakings in the name of the Company. The corporate seal is not necessary for the validity of any bonds, policies, undertakings, Powers of Attorney or other obligations of the corporation. The signature of any such officer and the corporate seal may be printed by facsimile."

IN WITNESS WHEREOF, the **RLI Insurance Company** and/or **Contractors Bonding and Insurance Company**, as applicable, have caused these presents to be executed by its respective Vice President with its corporate seal affixed this 30th day of September, 2019.



**RLI Insurance Company**  
**Contractors Bonding and Insurance Company**

By: Barton W. Davis  
Barton W. Davis Vice President

State of Illinois }  
County of Peoria } SS

### CERTIFICATE

On this 30th day of September, 2019, before me, a Notary Public, personally appeared Barton W. Davis, who being by me duly sworn, acknowledged that he signed the above Power of Attorney as the aforesaid officer of the **RLI Insurance Company** and/or **Contractors Bonding and Insurance Company** and acknowledged said instrument to be the voluntary act and deed of said corporation.

I, the undersigned officer of **RLI Insurance Company** and/or **Contractors Bonding and Insurance Company**, do hereby certify that the attached Power of Attorney is in full force and effect and is irrevocable; and furthermore, that the Resolution of the Company as set forth in the Power of Attorney, is now in force. In testimony whereof, I have hereunto set my hand and the seal of the **RLI Insurance Company** and/or **Contractors Bonding and Insurance Company** this \_\_\_\_\_ day of FEB 12 2020.

By: Gretchen L. Johnnigk  
Gretchen L. Johnnigk Notary Public

**RLI Insurance Company**  
**Contractors Bonding and Insurance Company**

By: Jean M. Stephenson  
Jean M. Stephenson Corporate Secretary





# California All-Purpose Certificate of Acknowledgment

A notary public or other officer completing this certificate verifies only the identity of the individual who signed the document to which this certificate is attached, and not the truthfulness, accuracy, or validity of that document.

State of California }  
County of Riverside } s.s.

On February 19, 2020 before me, Ana E. Chavez Perez, Notary Public,  
Name of Notary Public, Title

personally appeared Jeff Chambers  
Name of Signer (1)

\_\_\_\_\_  
Name of Signer (2)

who proved to me on the basis of satisfactory evidence to be the person(s) whose name(s) is/are subscribed to the within instrument and acknowledged to me that he/she/they executed the same in his/her/their authorized capacity(ies), and that by his/her/their signature(s) on the instrument the person(s), or the entity upon behalf of which the person(s) acted, executed the instrument.

I certify under PENALTY OF PERJURY under the laws of the State of California that the foregoing paragraph is true and correct.

WITNESS my hand and official seal.

  
Signature of Notary Public

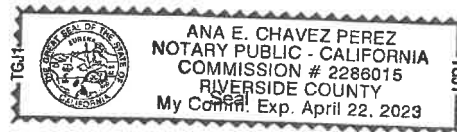

### OPTIONAL INFORMATION

Although the information in this section is not required by law, it could prevent fraudulent removal and reattachment of this acknowledgment to an unauthorized document and may prove useful to persons relying on the attached document.

### Description of Attached Document

The preceding Certificate of Acknowledgment is attached to a document titled/for the purpose of \_\_\_\_\_

containing \_\_\_\_\_ pages, and dated \_\_\_\_\_

The signer(s) capacity or authority is/are as:

- Individual(s)
- Attorney-in-fact
- Corporate Officer(s) \_\_\_\_\_  
Title(s)

- Guardian/Conservator
- Partner - Limited/General
- Trustee(s)
- Other: \_\_\_\_\_

representing: \_\_\_\_\_  
Name(s) of Person(s) Entity(ies) Signer is Representing

### Additional Information

#### Method of Signer Identification

Proved to me on the basis of satisfactory evidence:  
 form(s) of identification  credible witness(es)

Notarial event is detailed in notary journal on:

Page # \_\_\_\_\_ Entry # \_\_\_\_\_

Notary contact: \_\_\_\_\_

#### Other

Additional Signer  Signer(s) Thumbprints(s)

\_\_\_\_\_

**Traffic Signal Cost Estimate**

<b>Date:</b> January 31, 2020		<b>Location:</b> Highland Springs Ave. & Oak Valley Pkwy/ Meadowline Way, City of Beaumont			
<b>Job Number:</b> 2467-18-01		<b>Prepared for:</b>			
<b>By:</b> RK Engineering Group, Inc.					
Item No.	Description	Qty.	Unit	Unit Cost	Item Cost
2	Controller w/Cabinet (Type 2070E)	1	Ea.	\$22,800.00	\$22,800
7	Install Controller/Cabinet	1	Ea.	\$2,520.00	\$2,520
10	2-Channel Detector w/Rack	1	Ea.	\$900.00	\$900
11	Detector Rack And Power	1	Ea.	\$3,000.00	\$3,000
14	P.P.B. Pole (4'h), incl. Foundation	1	Ea.	\$960.00	\$960
16	Type 15 Pole (30'h)	1	Ea.	\$4,080.00	\$4,080
40	Foundation, 30" x 5'd (Re-bar) <Type 15>	1	Ea.	\$864.00	\$864
46	Signal Head, 12"Ø 3-section LED	5	Ea.	\$1,200.00	\$6,000
48	Signal Head, 12"Ø 5-section LED	3	Ea.	\$1,800.00	\$5,400
50	LED Module, Signal (Arrow: R,Y or G)	12	Ea.	\$300.00	\$3,600
51	LED Module, Signal (Ball: R,Y or G)	18	Ea.	\$384.00	\$6,912
52	Ped Signal Head, LED	3	Ea.	\$1,440.00	\$4,320
54	Ped Push Button (P.P.B.), ADA Compliant	1	Ea.	\$240.00	\$240
55	Illuminated Street Name Sign (I.I.S.N.S.)	1	Ea.	\$1,560.00	\$1,560
69	3" Conduit (Trenched)	62	LF	\$28.20	\$1,748
73	4" Conduit (Trenched)	37	LF	\$36.00	\$1,332
83	Video Detection System (Iteris)	0.5	LS	\$35,000.00	\$17,500
84	Opticom Discriminator	1	Ea.	\$2,538.00	\$2,538
86	Opticom Detector	2	Ea.	\$792.00	\$1,584
88	Wiring, Signal (TS Mod.)	1	LS	\$8,400.00	\$8,400
96	Remove Exist. Signal Pole/Equipment	1	Ea.	\$792.00	\$792
129	Remove and Salvage Existing Controller and Cabinet	1	Ea.	\$396.00	\$396
136	Remove & Salvage Mast Arm Mounted Sign	1	Ea.	\$126.00	\$126
137	Furnish & Install Mast Arm Mounted Sign	1	Ea.	\$288.00	\$288
138	Remove & Salvage Mast Arm	1	Ea.	\$636.00	\$636
140	Furnish & Install 45' Mast Arm	2	Ea.	\$1,440.00	\$2,880
161	SIC 12-pair #19 Cable	156	LF	\$4.34	\$678

### Traffic Signal Cost Estimate

<b>Date:</b> January 31, 2020		<b>Location:</b> Highland Springs Ave. & Oak Valley Pkwy./ Meadowline Way, City of Beaumont			
<b>Job Number:</b> 2467-18-01		<b>Prepared for:</b>			
<b>By:</b> RK Engineering Group, Inc.					
Item No.	Description	Qty.	Unit	Unit Cost	Item Cost
<b>SUBTOTAL</b>					<b>\$102,054</b>
<i>Engineering/Mobilization:</i>				0.00%	\$0
<i>Fees, Permits, Supervision</i>				0.00%	\$0
<i>Contingencies</i>				15.00%	\$15,308
<b>TOTAL</b>					<b>\$117,362</b>

SEAL



4000 Westerly Place, Suite 280 · Newport Beach, CA 92660  
 Phone: (949) 474-0809 · Fax (949) 474-0902

Reviewed By:

Robert Kahn

R.C.E. No. 20285

Date:

01/31/20

Exp. 09/30/21



### POLE AND EQUIPMENT SCHEDULE

STANDARD	TYPE	HEIGHT	TYPE	VEH. SIGNAL	POLE	P.O.L. NO.	P.O.L. COC.	LEAD	STANDARD	COMMENTS
1	28-4-1000	30'	50(W)	SP-1-100	0	3000	A	8	Standard	
2	1A	10'	10'	SP-1-1	2	17'	17'	5.5'	41W	F-105'
3	28-4-161	30'	40'	SP-1-1	4	17'	17'	5.5'	41W	Highland Springs Ave.
4	1A	10'	10'	SP-1-1	4	17'	17'	5.5'	41W	
5	1A	10'	10'	SP-1-1	4	17'	17'	5.5'	41W	
6	1A	10'	10'	SP-1-1	4	17'	17'	5.5'	41W	
7	28-5-161	30'	55(A)	SP-1-1	9	2	3.8'	3.1'	41W	F-205'
8	1A	10'	10'	SP-1-1	9	10'	17.5'	41W		
9	1A	10'	40(A)	SP-1-1	9	30(W)	11'	5'		Highland Springs Ave
10	1A	10'	10'	SP-1-1	9	30(W)	11'	5'		F-41.5'

ALL EQUIPMENT IS EXISTING EXCEPT AS NOTED.  
 ALL CONNECTIONS ARE TO BE NEW.  
 ALL CONDUIT IS EXISTING UNLESS OTHERWISE NOTED.  
 (N) = NEW  
 (R) = REPAIR  
 (S) = SIGNAL (W) = WALK TO BE REPAIRED.



### SIGNAL STANDARD PLACEMENT AND EQUIPMENT LOCATIONS

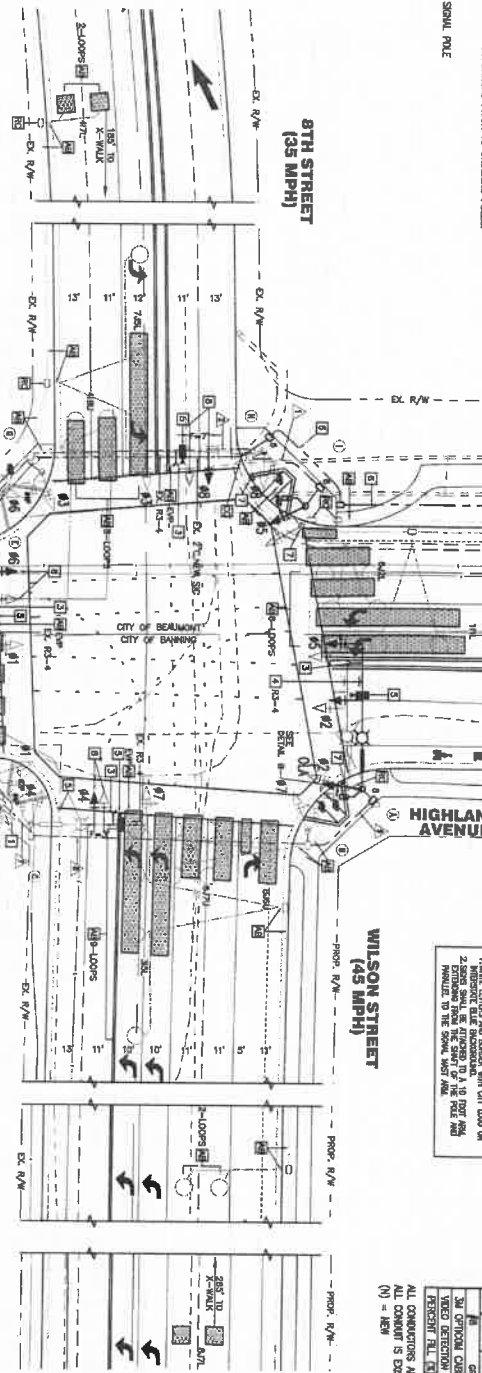

### CONSTRUCTION NOTES (THIS SHEET)

- REMOVE EXISTING SIGNAL HEAD AND EQUIPMENT FROM THE EXISTING POLE TO BE REPLACED WITH THE NEW SIGNAL HEAD AND EQUIPMENT.
- REMOVE EXISTING SIGNAL HEAD AND EQUIPMENT FROM THE EXISTING POLE TO BE REPLACED WITH THE NEW SIGNAL HEAD AND EQUIPMENT.
- REMOVE EXISTING SIGNAL HEAD AND EQUIPMENT FROM THE EXISTING POLE TO BE REPLACED WITH THE NEW SIGNAL HEAD AND EQUIPMENT.
- REMOVE EXISTING SIGNAL HEAD AND EQUIPMENT FROM THE EXISTING POLE TO BE REPLACED WITH THE NEW SIGNAL HEAD AND EQUIPMENT.
- REMOVE EXISTING SIGNAL HEAD AND EQUIPMENT FROM THE EXISTING POLE TO BE REPLACED WITH THE NEW SIGNAL HEAD AND EQUIPMENT.
- REMOVE EXISTING SIGNAL HEAD AND EQUIPMENT FROM THE EXISTING POLE TO BE REPLACED WITH THE NEW SIGNAL HEAD AND EQUIPMENT.
- REMOVE EXISTING SIGNAL HEAD AND EQUIPMENT FROM THE EXISTING POLE TO BE REPLACED WITH THE NEW SIGNAL HEAD AND EQUIPMENT.
- REMOVE EXISTING SIGNAL HEAD AND EQUIPMENT FROM THE EXISTING POLE TO BE REPLACED WITH THE NEW SIGNAL HEAD AND EQUIPMENT.
- REMOVE EXISTING SIGNAL HEAD AND EQUIPMENT FROM THE EXISTING POLE TO BE REPLACED WITH THE NEW SIGNAL HEAD AND EQUIPMENT.
- REMOVE EXISTING SIGNAL HEAD AND EQUIPMENT FROM THE EXISTING POLE TO BE REPLACED WITH THE NEW SIGNAL HEAD AND EQUIPMENT.

### VIDEO DETECTION ZONE

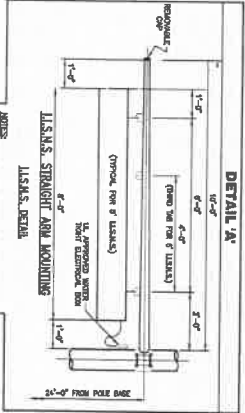
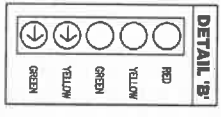
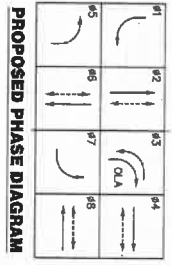
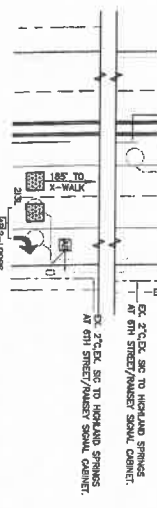

ALL CONDUITS ARE TO BE NEW.  
 ALL CONDUIT IS EXISTING UNLESS OTHERWISE NOTED.  
 (N) = NEW

### CONDUCTOR SCHEDULE

TYPE	CONDUCTORS	SIZE	LENGTH	WEIGHT	RESISTANCE	INDUCTIVE REACTANCE	WAVELENGTH
1	1	1/2"	100'	1.2	0.01	0.00	100'
2	2	1/2"	100'	2.4	0.02	0.00	100'
3	3	1/2"	100'	3.6	0.03	0.00	100'
4	4	1/2"	100'	4.8	0.04	0.00	100'
5	5	1/2"	100'	6.0	0.05	0.00	100'
6	6	1/2"	100'	7.2	0.06	0.00	100'
7	7	1/2"	100'	8.4	0.07	0.00	100'
8	8	1/2"	100'	9.6	0.08	0.00	100'
9	9	1/2"	100'	10.8	0.09	0.00	100'
10	10	1/2"	100'	12.0	0.10	0.00	100'
11	11	1/2"	100'	13.2	0.11	0.00	100'
12	12	1/2"	100'	14.4	0.12	0.00	100'
13	13	1/2"	100'	15.6	0.13	0.00	100'
14	14	1/2"	100'	16.8	0.14	0.00	100'
15	15	1/2"	100'	18.0	0.15	0.00	100'
16	16	1/2"	100'	19.2	0.16	0.00	100'
17	17	1/2"	100'	20.4	0.17	0.00	100'
18	18	1/2"	100'	21.6	0.18	0.00	100'
19	19	1/2"	100'	22.8	0.19	0.00	100'
20	20	1/2"	100'	24.0	0.20	0.00	100'
21	21	1/2"	100'	25.2	0.21	0.00	100'
22	22	1/2"	100'	26.4	0.22	0.00	100'
23	23	1/2"	100'	27.6	0.23	0.00	100'
24	24	1/2"	100'	28.8	0.24	0.00	100'
25	25	1/2"	100'	30.0	0.25	0.00	100'

CITY OF BEAUMONT  
 REVISIONS  
 1. 11/15/19  
 2. 11/15/19  
 3. 11/15/19  
 4. 11/15/19  
 5. 11/15/19  
 6. 11/15/19  
 7. 11/15/19  
 8. 11/15/19  
 9. 11/15/19  
 10. 11/15/19

CITY OF BEAUMONT  
 CITY OF BANNING  
 TRAFFIC SIGNAL MODIFICATION PLAN  
 HIGHLAND SPRINGS AVE & 8TH STREET/WILSON STREET  
 SHEET 2 OF 7





### POLE AND EQUIPMENT SCHEDULE

STANDARD	YAL SIGNAL NOS.	REQ. SIG.	POLE LOC.	LEL	STANDARD LIGHT ARM MOUNTED ISSUES	COMMENTS
TYPE	HEIGHT H.A.	WGT. H.W.	POLE	WT.	TYPE A B	
1	25-4-161	30'	TN-1-100	8 3000 13.5' 7.5'	Highland Springs Arm (1) (See Item A)	F-15
2	25-4-161	30'	TN-1-100	8 3000 13.5' 7.5'	Highland Springs Arm (1)	
3	25-4-161	30'	TN-2-100	8 400 12.5' 7'	Highland Springs Arm (1)	
4	25-4-161	30'	TN-2-100	8 400 12.5' 7'	Highland Springs Arm (1)	
5	25-4-161	30'	TN-2-100	8 400 12.5' 7'	Highland Springs Arm (1)	
6	25-4-161	30'	TN-2-100	8 400 12.5' 7'	Highland Springs Arm (1)	
7	25-4-161	30'	TN-2-100	8 400 12.5' 7'	Highland Springs Arm (1)	
8	25-4-161	30'	TN-2-100	8 400 12.5' 7'	Highland Springs Arm (1)	
9	25-4-161	30'	TN-2-100	8 400 12.5' 7'	Highland Springs Arm (1)	
10	25-4-161	30'	TN-2-100	8 400 12.5' 7'	Highland Springs Arm (1)	
11	25-4-161	30'	TN-2-100	8 400 12.5' 7'	Highland Springs Arm (1)	
12	25-4-161	30'	TN-2-100	8 400 12.5' 7'	Highland Springs Arm (1)	
13	25-4-161	30'	TN-2-100	8 400 12.5' 7'	Highland Springs Arm (1)	
14	25-4-161	30'	TN-2-100	8 400 12.5' 7'	Highland Springs Arm (1)	
15	25-4-161	30'	TN-2-100	8 400 12.5' 7'	Highland Springs Arm (1)	
16	25-4-161	30'	TN-2-100	8 400 12.5' 7'	Highland Springs Arm (1)	
17	25-4-161	30'	TN-2-100	8 400 12.5' 7'	Highland Springs Arm (1)	
18	25-4-161	30'	TN-2-100	8 400 12.5' 7'	Highland Springs Arm (1)	
19	25-4-161	30'	TN-2-100	8 400 12.5' 7'	Highland Springs Arm (1)	
20	25-4-161	30'	TN-2-100	8 400 12.5' 7'	Highland Springs Arm (1)	
21	25-4-161	30'	TN-2-100	8 400 12.5' 7'	Highland Springs Arm (1)	
22	25-4-161	30'	TN-2-100	8 400 12.5' 7'	Highland Springs Arm (1)	
23	25-4-161	30'	TN-2-100	8 400 12.5' 7'	Highland Springs Arm (1)	
24	25-4-161	30'	TN-2-100	8 400 12.5' 7'	Highland Springs Arm (1)	
25	25-4-161	30'	TN-2-100	8 400 12.5' 7'	Highland Springs Arm (1)	

EXACT POLE LOCATIONS DETERMINED BY FIELD ENGINEER. POLE FOUNDATIONS FROM TO ORDINATE POLES.  
 ALL EQUIPMENT IS EXISTING EXCEPT AS NOTED  
 (N) = NEW

**NO U TURN** (R3-6(GA))

**LEFT TURN ON GREEN** (R10-12)

**NO U TURN** (R3-4)

### SIGNAL STANDARD PLACEMENT AND EQUIPMENT LOCATIONS

(TYPICAL SIGNAL POLE LOCATION, (SEE SIGN OF PLAN))

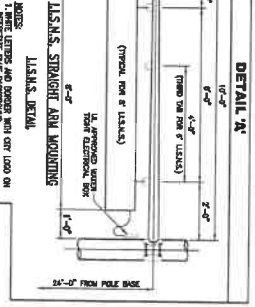
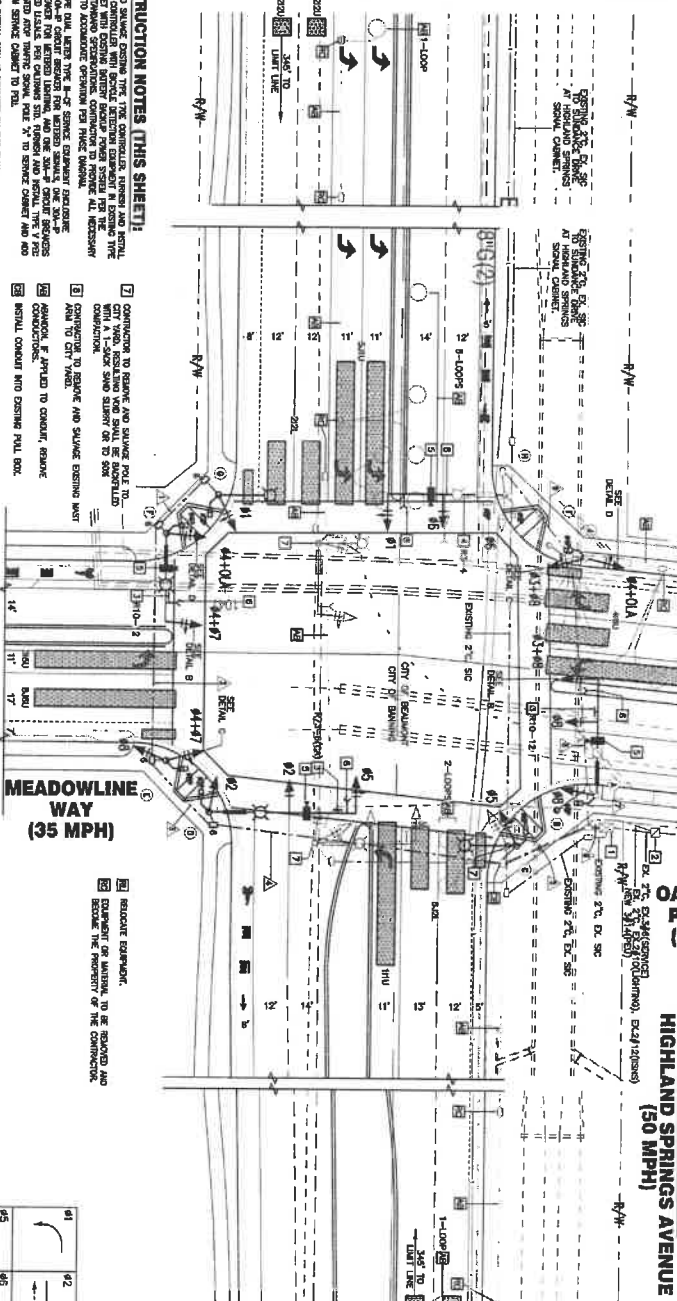

### CONDUCTOR SCHEDULE

NO. OF POLES	TYPE OF CONDUCTOR	NO. OF CONDUCTORS	NO. OF POLES	TYPE OF CONDUCTOR	NO. OF CONDUCTORS
12	POLE A	12	12	POLE A	12
12	C	12	12	C	12
12	E	12	12	E	12
12	F	12	12	F	12
12	G	12	12	G	12
12	H	12	12	H	12
12	I	12	12	I	12
12	J	12	12	J	12
12	K	12	12	K	12
12	L	12	12	L	12
12	M	12	12	M	12
12	N	12	12	N	12
12	O	12	12	O	12
12	P	12	12	P	12
12	Q	12	12	Q	12
12	R	12	12	R	12
12	S	12	12	S	12
12	T	12	12	T	12
12	U	12	12	U	12
12	V	12	12	V	12
12	W	12	12	W	12
12	X	12	12	X	12
12	Y	12	12	Y	12
12	Z	12	12	Z	12

ALL CONDUCTORS AND CONDUITS SHALL BE NEW  
 (D) = EXISTING

**DETAIL 'B'**

**DETAIL 'C'**

**DETAIL 'D'**

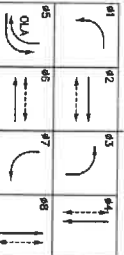

### CONSTRUCTION NOTES (THIS SHEET)

- 1. EXISTING AND PROPOSED EQUIPMENT, THE TYPE, THE COMPLETE NUMBER AND HEIGHT OF THE SIGNAL STANDARD SHALL BE SHOWN ON THE PLAN AND THE EXISTING AND PROPOSED EQUIPMENT SHALL BE SHOWN ON THE PLAN. THE EXISTING EQUIPMENT SHALL BE SHOWN ON THE PLAN AND THE PROPOSED EQUIPMENT SHALL BE SHOWN ON THE PLAN.
- 2. EXISTING EQUIPMENT SHALL BE SHOWN ON THE PLAN AND THE PROPOSED EQUIPMENT SHALL BE SHOWN ON THE PLAN.
- 3. EXISTING EQUIPMENT SHALL BE SHOWN ON THE PLAN AND THE PROPOSED EQUIPMENT SHALL BE SHOWN ON THE PLAN.
- 4. EXISTING EQUIPMENT SHALL BE SHOWN ON THE PLAN AND THE PROPOSED EQUIPMENT SHALL BE SHOWN ON THE PLAN.
- 5. EXISTING EQUIPMENT SHALL BE SHOWN ON THE PLAN AND THE PROPOSED EQUIPMENT SHALL BE SHOWN ON THE PLAN.
- 6. EXISTING EQUIPMENT SHALL BE SHOWN ON THE PLAN AND THE PROPOSED EQUIPMENT SHALL BE SHOWN ON THE PLAN.
- 7. CONDUCTOR TO REMAIN AND SIGNAL POLE TO REMAIN SHALL BE SHOWN ON THE PLAN AND THE PROPOSED CONDUCTOR TO REMAIN AND SIGNAL POLE TO REMAIN SHALL BE SHOWN ON THE PLAN.
- 8. CONDUCTOR TO REMAIN AND SIGNAL POLE TO REMAIN SHALL BE SHOWN ON THE PLAN AND THE PROPOSED CONDUCTOR TO REMAIN AND SIGNAL POLE TO REMAIN SHALL BE SHOWN ON THE PLAN.
- 9. CONDUCTOR TO REMAIN AND SIGNAL POLE TO REMAIN SHALL BE SHOWN ON THE PLAN AND THE PROPOSED CONDUCTOR TO REMAIN AND SIGNAL POLE TO REMAIN SHALL BE SHOWN ON THE PLAN.
- 10. CONDUCTOR TO REMAIN AND SIGNAL POLE TO REMAIN SHALL BE SHOWN ON THE PLAN AND THE PROPOSED CONDUCTOR TO REMAIN AND SIGNAL POLE TO REMAIN SHALL BE SHOWN ON THE PLAN.
- 11. CONDUCTOR TO REMAIN AND SIGNAL POLE TO REMAIN SHALL BE SHOWN ON THE PLAN AND THE PROPOSED CONDUCTOR TO REMAIN AND SIGNAL POLE TO REMAIN SHALL BE SHOWN ON THE PLAN.
- 12. CONDUCTOR TO REMAIN AND SIGNAL POLE TO REMAIN SHALL BE SHOWN ON THE PLAN AND THE PROPOSED CONDUCTOR TO REMAIN AND SIGNAL POLE TO REMAIN SHALL BE SHOWN ON THE PLAN.
- 13. CONDUCTOR TO REMAIN AND SIGNAL POLE TO REMAIN SHALL BE SHOWN ON THE PLAN AND THE PROPOSED CONDUCTOR TO REMAIN AND SIGNAL POLE TO REMAIN SHALL BE SHOWN ON THE PLAN.
- 14. CONDUCTOR TO REMAIN AND SIGNAL POLE TO REMAIN SHALL BE SHOWN ON THE PLAN AND THE PROPOSED CONDUCTOR TO REMAIN AND SIGNAL POLE TO REMAIN SHALL BE SHOWN ON THE PLAN.
- 15. CONDUCTOR TO REMAIN AND SIGNAL POLE TO REMAIN SHALL BE SHOWN ON THE PLAN AND THE PROPOSED CONDUCTOR TO REMAIN AND SIGNAL POLE TO REMAIN SHALL BE SHOWN ON THE PLAN.
- 16. CONDUCTOR TO REMAIN AND SIGNAL POLE TO REMAIN SHALL BE SHOWN ON THE PLAN AND THE PROPOSED CONDUCTOR TO REMAIN AND SIGNAL POLE TO REMAIN SHALL BE SHOWN ON THE PLAN.
- 17. CONDUCTOR TO REMAIN AND SIGNAL POLE TO REMAIN SHALL BE SHOWN ON THE PLAN AND THE PROPOSED CONDUCTOR TO REMAIN AND SIGNAL POLE TO REMAIN SHALL BE SHOWN ON THE PLAN.
- 18. CONDUCTOR TO REMAIN AND SIGNAL POLE TO REMAIN SHALL BE SHOWN ON THE PLAN AND THE PROPOSED CONDUCTOR TO REMAIN AND SIGNAL POLE TO REMAIN SHALL BE SHOWN ON THE PLAN.
- 19. CONDUCTOR TO REMAIN AND SIGNAL POLE TO REMAIN SHALL BE SHOWN ON THE PLAN AND THE PROPOSED CONDUCTOR TO REMAIN AND SIGNAL POLE TO REMAIN SHALL BE SHOWN ON THE PLAN.
- 20. CONDUCTOR TO REMAIN AND SIGNAL POLE TO REMAIN SHALL BE SHOWN ON THE PLAN AND THE PROPOSED CONDUCTOR TO REMAIN AND SIGNAL POLE TO REMAIN SHALL BE SHOWN ON THE PLAN.
- 21. CONDUCTOR TO REMAIN AND SIGNAL POLE TO REMAIN SHALL BE SHOWN ON THE PLAN AND THE PROPOSED CONDUCTOR TO REMAIN AND SIGNAL POLE TO REMAIN SHALL BE SHOWN ON THE PLAN.
- 22. CONDUCTOR TO REMAIN AND SIGNAL POLE TO REMAIN SHALL BE SHOWN ON THE PLAN AND THE PROPOSED CONDUCTOR TO REMAIN AND SIGNAL POLE TO REMAIN SHALL BE SHOWN ON THE PLAN.
- 23. CONDUCTOR TO REMAIN AND SIGNAL POLE TO REMAIN SHALL BE SHOWN ON THE PLAN AND THE PROPOSED CONDUCTOR TO REMAIN AND SIGNAL POLE TO REMAIN SHALL BE SHOWN ON THE PLAN.
- 24. CONDUCTOR TO REMAIN AND SIGNAL POLE TO REMAIN SHALL BE SHOWN ON THE PLAN AND THE PROPOSED CONDUCTOR TO REMAIN AND SIGNAL POLE TO REMAIN SHALL BE SHOWN ON THE PLAN.
- 25. CONDUCTOR TO REMAIN AND SIGNAL POLE TO REMAIN SHALL BE SHOWN ON THE PLAN AND THE PROPOSED CONDUCTOR TO REMAIN AND SIGNAL POLE TO REMAIN SHALL BE SHOWN ON THE PLAN.

**811** Call Center

**REVISIONS**

NO.	DESCRIPTION	DATE

PLANS PREPARED BY: **ROBERT KAY**

SUBMITTED BY: **ROBERT KAY**

**CITY OF BEAUMONT**

**CITY OF BANNING**

**TRAFFIC SIGNAL MODIFICATION PLAN**

HIGHLAND SPRINGS AVE & MEADOWLINE WAY/OAK VALLEY PARKWAY

SCALE: 1" = 30'

SHEET 5 OF 7



**POLE AND EQUIPMENT SCHEDULE**

STANDARD	VEH SIGNAL UNIT	POLE SEC.	P.P.S.	POLE LOC.	LEA.	STANDARD MOUNTING ASSEMBLY	COMMENTS
1	24-4-100	30'	45'	15'	SP-1-T	4 2 10d 7 41W	Flu17
2	24-3-100	30'	30'	15'	SP-1-T	6 3 11' 5'	
3	24-4-100	30'	30'	15'	SP-1-T	6 3 10d 7 41W	Wilson St
4	1A	30'	30'	15'	SP-1-T	6 4 4' 5'	Apex St
5	1A	30'	30'	15'	SP-1-T	6 4 4' 5'	Apex St
6	1A	30'	30'	15'	SP-1-T	6 4 4' 5'	Apex St
7	1A	30'	30'	15'	SP-1-T	6 4 4' 5'	Apex St
8	1A	30'	30'	15'	SP-1-T	6 4 4' 5'	Apex St
9	1A	30'	30'	15'	SP-1-T	6 4 4' 5'	Apex St
10	1A	30'	30'	15'	SP-1-T	6 4 4' 5'	Apex St
11	1A	30'	30'	15'	SP-1-T	6 4 4' 5'	Apex St
12	1A	30'	30'	15'	SP-1-T	6 4 4' 5'	Apex St
13	1A	30'	30'	15'	SP-1-T	6 4 4' 5'	Apex St
14	1A	30'	30'	15'	SP-1-T	6 4 4' 5'	Apex St
15	1A	30'	30'	15'	SP-1-T	6 4 4' 5'	Apex St
16	1A	30'	30'	15'	SP-1-T	6 4 4' 5'	Apex St
17	1A	30'	30'	15'	SP-1-T	6 4 4' 5'	Apex St

ALL POLE LOCATIONS DETERMINED BY FIELD ENGINEER. POLE FOUNDATIONS PRIOR TO ORDERING POLES.  
 ALL EQUIPMENT IS NEW.  
 ALL SIGNALS SHALL BE EDGE UP LED.  
 \* = SIGNAL TYPE V MANUFACTURING CONTROL UNIT ON TRAFFIC SIGNAL POLE



**SIGNAL STANDARDS PLACEMENT DIMENSIONS AND EQUIPMENT LOCATIONS**

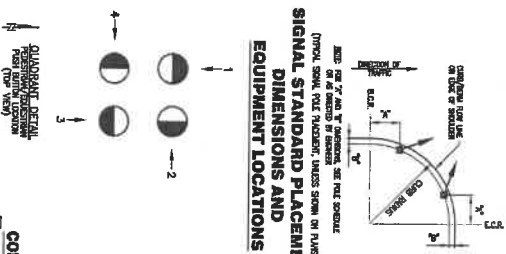

- CONSTRUCTION NOTES (THIS SHEET):**
- INSTALL THE POLE, CONDUIT AND SERVICE PERMANENTLY IN A TYPE 30L CONCRETE FOUNDATION. PROVIDE A 2" MINIMUM CLEARANCE TO ADJACENT STRUCTURES TO PREVENT ALL NECESSARY MAINTENANCE.
  - INSTALL THE SIGNAL STANDARDS PERMANENTLY IN A TYPE 30L CONCRETE FOUNDATION. PROVIDE A 2" MINIMUM CLEARANCE TO ADJACENT STRUCTURES TO PREVENT ALL NECESSARY MAINTENANCE.
  - INSTALL THE SIGNAL STANDARDS PERMANENTLY IN A TYPE 30L CONCRETE FOUNDATION. PROVIDE A 2" MINIMUM CLEARANCE TO ADJACENT STRUCTURES TO PREVENT ALL NECESSARY MAINTENANCE.
  - INSTALL THE SIGNAL STANDARDS PERMANENTLY IN A TYPE 30L CONCRETE FOUNDATION. PROVIDE A 2" MINIMUM CLEARANCE TO ADJACENT STRUCTURES TO PREVENT ALL NECESSARY MAINTENANCE.
  - INSTALL THE SIGNAL STANDARDS PERMANENTLY IN A TYPE 30L CONCRETE FOUNDATION. PROVIDE A 2" MINIMUM CLEARANCE TO ADJACENT STRUCTURES TO PREVENT ALL NECESSARY MAINTENANCE.

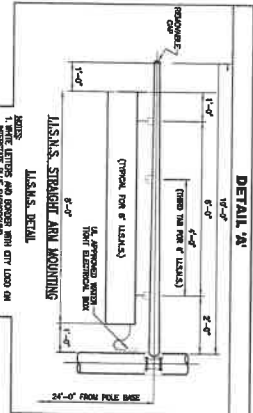
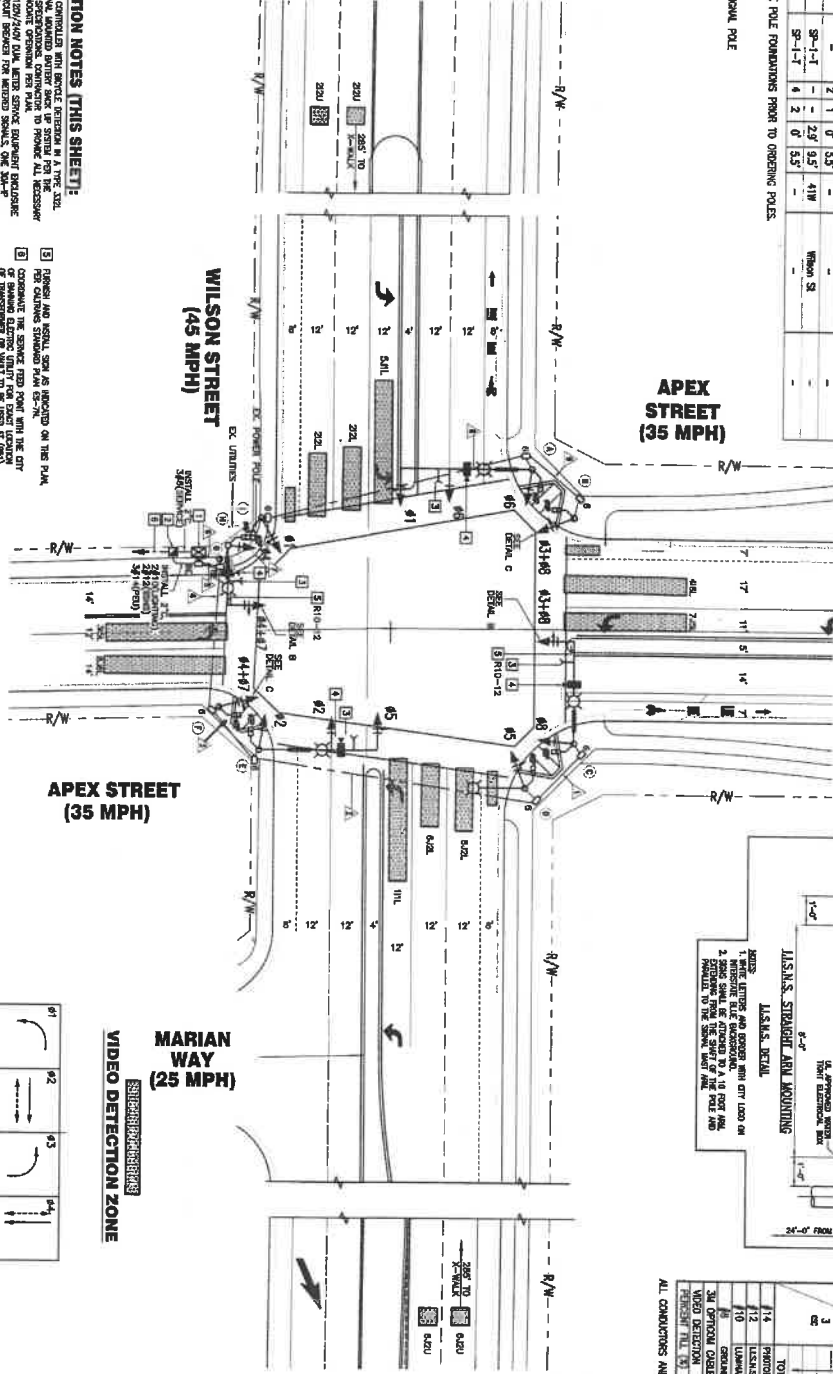

**CONDUCTOR SCHEDULE**

CONDUCTOR TYPE	POLE OR CIRCUIT	CONDUCTOR SIZE	CONDUCTOR WEIGHT
1	1	1/2"	1.1
2	2	3/8"	0.6
3	3	1/2"	1.1
4	4	3/8"	0.6
5	5	1/2"	1.1
6	6	3/8"	0.6
7	7	1/2"	1.1
8	8	3/8"	0.6
9	9	1/2"	1.1
10	10	3/8"	0.6
11	11	1/2"	1.1
12	12	3/8"	0.6
13	13	1/2"	1.1
14	14	3/8"	0.6
15	15	1/2"	1.1
16	16	3/8"	0.6
17	17	1/2"	1.1

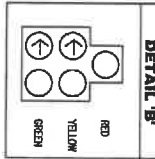
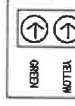
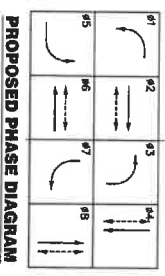

**REVISIONS**

NO.	DESCRIPTION	DATE

PLANS PREPARED BY: **RK** **ambrosio**  
**ambrosio**  
 1000 W. 10th Street, Suite 100  
 Phoenix, AZ 85003

SUBMITTED BY: **Robert J. Banning**  
 1000 W. 10th Street, Suite 100  
 Phoenix, AZ 85003

**CITY OF BANNING**  
 1000 W. 10th Street, Suite 100  
 Phoenix, AZ 85003

**CITY OF BANNING**  
 TRAFFIC SIGNAL PLAN  
 WILSON STREET & APEX STREET

SHEET **6** OF **7**

SPECIAL PROVISIONS TO STANDARD SPECIFICATIONS FOR TRAFFIC SIGNAL PROJECTS

INTERNALLY ILLUMINATED STREET NAME SIGNS

Internally illuminated street name signs shall be used on all streets within the City of Banning. The signs shall be made of aluminum and shall be illuminated by fluorescent lights. The signs shall be made of aluminum and shall be illuminated by fluorescent lights. The signs shall be made of aluminum and shall be illuminated by fluorescent lights.

CONDUCTORS AND WIRING

Conductors shall be made of copper or aluminum. The conductors shall be made of copper or aluminum. The conductors shall be made of copper or aluminum. The conductors shall be made of copper or aluminum.

BONDING AND GROUNDING

Bonding and grounding shall be done in accordance with the National Electrical Code. The bonding and grounding shall be done in accordance with the National Electrical Code. The bonding and grounding shall be done in accordance with the National Electrical Code.

EQUIPMENT LIST AND DRAWINGS

The equipment list and drawings shall be submitted with the bid. The equipment list and drawings shall be submitted with the bid. The equipment list and drawings shall be submitted with the bid.

FOUNDATION

Foundations shall be made of concrete. The foundations shall be made of concrete. The foundations shall be made of concrete. The foundations shall be made of concrete.

STANDARDS, STEEL, PEDESTALS AND POSTS

Standards, steel, pedestals and posts shall be made of steel. The standards, steel, pedestals and posts shall be made of steel. The standards, steel, pedestals and posts shall be made of steel.

CONDUIT

Conduit shall be made of steel. The conduit shall be made of steel. The conduit shall be made of steel. The conduit shall be made of steel.

LUMINAIRES

Luminaires shall be made of aluminum. The luminaires shall be made of aluminum. The luminaires shall be made of aluminum. The luminaires shall be made of aluminum.

PULL BOXES

Pull boxes shall be made of steel. The pull boxes shall be made of steel. The pull boxes shall be made of steel. The pull boxes shall be made of steel.

LEDS, DRIVERS

LEDs and drivers shall be made of aluminum. The LEDs and drivers shall be made of aluminum. The LEDs and drivers shall be made of aluminum. The LEDs and drivers shall be made of aluminum.

REVISIONS

Revisions shall be made in accordance with the standard specifications. The revisions shall be made in accordance with the standard specifications. The revisions shall be made in accordance with the standard specifications.

PLANS PREPARED BY

Plans prepared by RK Engineering Group, Inc. The plans prepared by RK Engineering Group, Inc. The plans prepared by RK Engineering Group, Inc.

SUBMITTED BY

Submitted by the City of Banning. The submitted by the City of Banning. The submitted by the City of Banning.

CITY OF BANNING

City of Banning, California. The city of Banning, California. The city of Banning, California.

SPECIAL PROVISIONS

Special provisions for traffic signal projects. The special provisions for traffic signal projects. The special provisions for traffic signal projects.

DATE

Date of the document. The date of the document. The date of the document.

PROJECT

Project name and location. The project name and location. The project name and location.

SCALE

Scale of the drawings. The scale of the drawings. The scale of the drawings.

SHEET

Sheet number and total sheets. The sheet number and total sheets. The sheet number and total sheets.

DATE

Date of the drawing. The date of the drawing. The date of the drawing.

BY

Signature of the preparer. The signature of the preparer. The signature of the preparer.

DATE

Date of the signature. The date of the signature. The date of the signature.

BY

Signature of the submitter. The signature of the submitter. The signature of the submitter.

DATE

Date of the signature. The date of the signature. The date of the signature.

BY

Signature of the official. The signature of the official. The signature of the official.

DATE

Date of the signature. The date of the signature. The date of the signature.

BY

Signature of the official. The signature of the official. The signature of the official.

DATE

Date of the signature. The date of the signature. The date of the signature.

BY

Signature of the official. The signature of the official. The signature of the official.

DATE

Date of the signature. The date of the signature. The date of the signature.

BY

Signature of the official. The signature of the official. The signature of the official.

DATE

Date of the signature. The date of the signature. The date of the signature.

BY

Signature of the official. The signature of the official. The signature of the official.

DATE

BY

DATE





## Staff Report

**TO:** Mayor and City Council Members  
**FROM:** Sean Thuilliez, Chief of Police  
**DATE:** June 2, 2020  
**SUBJECT:** Amendment to City of Beaumont Municipal Code Chapter 10 Section 12 – Parking Commercial Vehicles

---

### Background and Analysis:

In September 2009, a municipal code was enacted to govern the parking of commercial vehicles within the City of Beaumont. Chapter 10, Section 12, “Commercial Vehicles” are defined as “any dray, truck, wagon, cart, automobile or other traffic vehicle carrying or used in transporting goods, merchandise, lumber, machinery, oil, dirt or any article of trade or commerce.”

With few exceptions, parking of commercial vehicles within any school or residential district is prohibited. This is to protect roads from damage that heavy commercial vehicles cause and also to maintain the integrity of residential districts by prohibiting the use of commercial vehicles at home businesses. Commercial vehicles in residential zones also pose safety concerns with regard to road access and visibility around these vehicles for other drivers.

Exceptions include, the delivery of goods, wares, or merchandise; parking on designated truck routes up to a two-hour period; when servicing residential properties or vehicles operated by government agencies; servicing public and private utilities, or licensed contractors engaged in the installation or maintenance of any utility or roadway.

The City of Beaumont Municipal Code Section 10.12.040 - “Permits” currently allows the ability to apply for an exemption under the authority of the Chief of Police. This authority is not consistent with other cities and is not in line with current industry standards. Staff recommends that this section be removed in its entirety, and amend the remainder of the code section to remove any such exemption references.

**Fiscal Impact:**

There is no fiscal impact.

**Recommended Action:**

Hold a Public Hearing, and  
Waive the full first reading and approve by title only. "An Ordinance of the City of Beaumont Amending and Restating Chapter 10.12 of the Beaumont Municipal Code Entitled 'Parking Commercial Vehicles' and Making Findings Pursuant to the California Environmental Quality Act."

**Attachments:**

- A. Proposed Amendments to Beaumont Municipal Code 10.12

- **Chapter 10.12 - PARKING COMMERCIAL VEHICLES**
- **10.12.010 - Definition.**

For the purpose of this Chapter, the term "*commercial vehicles*" is defined to be any dray, truck, wagon, cart, automobile or other traffic vehicle carrying or used in transporting goods, merchandise, lumber, machinery, oil, dirt or any article of trade or commerce.

(Ord. 953, 9-1-09)

- **10.12.020 - Parking near schools prohibited.**

It is unlawful for any person, firm or corporation to park, stop or leave standing, whether attended or unattended, a commercial vehicle upon a public highway, street or alley within the corporate limits of the City within 500 feet of any school building, school yard or other premises used in connection with public schools, except for the purpose of delivering goods, wares or merchandise, and then only while such delivery is being made.

(Ord. 953, 9-1-09)

- **10.12.030 - Parking on public streets, highways, alleys or rights-of-ways and on residential property.**

A. Except as provided in subsections B<sup>[AY1]</sup> and C: ~~and D below, and subject to the issuance of a permit pursuant to Section 10.12.040,~~

1. It is unlawful for any person to park or leave standing, or allow to be parked or leave standing, any commercial vehicle consisting of a truck tractor, motor truck, semi-trailer or a combination thereof, exceeding a manufacturer's gross vehicle weight of 10,000 pounds, upon any street, highway, alley, public right-of-way or residential property within the City.
2. It is unlawful for the owner or operator of any commercial vehicle consisting of a truck tractor, motor truck, semi-trailer or a combination thereof, exceeding a manufacturer's gross vehicle weight of 10,000 pounds, to allow such vehicle to remain standing upon any street, highway, alley, public right-of-way or residential property within the City.
3. It is unlawful for any person to park, or allow to be parked, any trailer which has been detached from a truck tractor or truck, or which is not in itself capable of being driven, upon any street, highway, alley or public right-of-way within the City.
4. It is unlawful for any person to park or leave standing within 100 feet of any street intersection, or within 100 feet of any official traffic control device, any vehicle which is ten feet or more in height, including the height of any load thereon.
5. It is unlawful for any person to park or leave standing on any street, highway, alley, or public right-of-way within the City, any commercial vehicle consisting of a truck tractor, motor truck, trailer, semi-trailer or combination thereof, exceeding a manufacturer's gross vehicle weight of 10,000 pounds, so that any part of such vehicle is within 30 feet of any driveway opening, other than the driver's own driveway.

6. It is unlawful for any person to park or leave standing on any street, highway, alley, or public right-of-way within the City, any commercial vehicle consisting of a truck tractor, motor truck, trailer, semi-trailer or combination thereof, exceeding a manufacturer's gross vehicle weight of 10,000 pounds, so that any part of such vehicle is within 50 feet of any part of any other truck tractor, motor truck, trailer, semi-trailer or combination thereof.

B. Commercial truck tractors, motor trucks, semi-trailers or combination thereof, exceeding a manufacturer's gross vehicle weight of 10,000 pounds, may be parked on public streets, highways, alleys, public rights-of-way, or residential property as follows:

1. On designated truck routes for a period of time not exceeding two consecutive hours;
2. While making pickups or deliveries of goods, wares or merchandise from or to any property adjacent to or abutting upon streets or highways which are not designated truck routes;
3. When such vehicle is parked in connection with, and in aid of, the ongoing performance of a service to, or on, a property in the block in which such vehicle is parked or left standing;
4. ~~The restrictions and prohibitions set forth in subsection A(1), (2) and (3) of this section shall not apply to commercial vehicles which have valid and effective permits issued pursuant to section 10.12.040.~~

C. The provisions of this section shall not apply:

1. In the community industrial land use district; and
2. To commercial vehicles operated by government agencies, public and private utilities and licensed contractors engaged in the installation, maintenance or repair of any public property, utility or roadway.

(Ord. 953, 9-1-09)

### ~~10.12.040 - Permits.~~

~~A. Any owner or operator of a vehicle or property which is subject to this Chapter may apply to the Chief of Police or his/her designee for, and the Chief of Police or his/her designee may issue, a permit for an exemption from the restrictions and prohibitions of Section 10.12.030(A)(1) through (3).~~

~~B. Permits shall expire one year after the date of issuance. Applications for renewal of a permit shall be submitted at least ten days prior to the expiration date of the then-current permit.~~

~~C. Permits, if issued to nonresident visitors, shall expire three days after the date of issuance. Not more than three nonresident visitor permits may be issued to any one person in any 12-month period of time.~~

~~D. Permits shall be nontransferable and shall apply only to the particular property or location described in the application, and the privileges granted therein shall be limited to the term of the permit.~~

~~E. The Chief of Police or his/her designee may revoke any permit issued hereunder prior to the permit's expiration date upon a determination that good cause exists for such revocation. Good cause for revocation is established by a finding that the permittee, or any person operating a permitted vehicle with the permittee's consent, has violated one or more of the provisions of this Chapter or any other provision of this Code or of state law relating to the operation, licensing, maintenance or parking of vehicles.~~

~~(Ord. 953, 9-1-09)~~

- **10.12.050 - Violation—Penalty.**

In the discretion of the Enforcement Officer, any person violating the provisions of this [Chapter 10.12](#) shall be issued an administrative citation pursuant to Beaumont Municipal Code Sections 1.17.200 et seq., or shall be guilty of an infraction pursuant to Beaumont Municipal Code [Section 1.16.010](#). In either case, the amount of the fine shall be in the appropriate amount set forth in [Section 1.16.030](#) of this Code. Each such violation shall be deemed a separate offense as specified in Beaumont Municipal Code [Section 1.16.040](#).

(Ord. 953, 9-1-09)

ORDINANCE NO. \_\_  
 AN ORDINANCE OF THE CITY OF BEAUMONT AMENDING AND  
 RESTATING CHAPTER 10.12 OF THE BEAUMONT MUNICIPAL  
 CODE ENTITLED "PARKING COMMERCIAL VEHICLES" AND  
 MAKING FINDINGS PURSUANT TO THE CALIFORNIA  
 ENVIRONMENTAL QUALITY ACT

THE CITY COUNCIL OF THE CITY OF BEAUMONT HEREBY ORDAINS AS FOLLOWS:

**Section 1. Findings.**

(a) In September 2009, the City Council of the City of Beaumont enacted Beaumont Municipal Code chapter 10.12 entitled "Parking Commercial Vehicles."

(b) Beaumont Municipal Code section 10.12.010 defines commercial vehicles as "any dray, truck, wagon, cart, automobile or other traffic vehicle carrying or used in transporting goods, merchandise, lumber, machinery, oil, dirt or any article of trade or commerce."

(c) Beaumont Municipal Code chapter 10.12, among other things, prohibits the parking of commercial vehicles within any school or residential district and makes unlawful the parking of any commercial vehicle exceeding a manufacturer's gross vehicle weight of 10,000 pounds, upon any street, highway, alley, public right-of-way or residential property within the City of Beaumont.

(d) Beaumont Municipal Code chapter 10.12 currently authorizes the issuance of special permits to park commercial vehicles in residential zones. This authority is inconsistent with other cities and current, customary industry standards.

(e) The City Council desires to amend and restate chapter 10.12 of the Beaumont Municipal Code to preserve the safety, functionality and attractiveness of the City's streets for residents and businesses by amending the Beaumont Municipal Code to no longer allow the issuance of special permits to park commercial vehicles in residential zones. This amendment to the Beaumont Municipal Code will facilitate the City's ability to effectively enforce its parking restrictions in residential zones throughout the City.

**Section 2. CEQA.** The City Council hereby finds and determines that adoption of this ordinance would provide limitations on the use of public streets for parking and is therefore categorically exempt from environmental review pursuant to the California Environmental Quality Act ("CEQA") Guidelines Section 15301 concerning the operation or minor alteration of existing public facilities involving negligible or no expansion of use.

**Section 3. Amend and Restate Chapter 10.12.** The City Council hereby amends chapter 10.12 of the Beaumont Municipal Code, "Parking Commercial Vehicles," and restates it to read as follows:



## **“Chapter 10.12 - PARKING COMMERCIAL VEHICLES**

### **10.12.010 - Definition.**

For the purpose of this Chapter, the term "*commercial vehicles*" is defined to be any dray, truck, wagon, cart, automobile or other traffic vehicle carrying or used in transporting goods, merchandise, lumber, machinery, oil, dirt or any article of trade or commerce.

(Ord. 953, 9-1-09)

### **10.12.020 - Parking near schools prohibited.**

It is unlawful for any person, firm or corporation to park, stop or leave standing, whether attended or unattended, a commercial vehicle upon a public highway, street or alley within the corporate limits of the City within 500 feet of any school building, school yard or other premises used in connection with public schools, except for the purpose of delivering goods, wares or merchandise, and then only while such delivery is being made.

(Ord. 953, 9-1-09)

### **10.12.030 - Parking on public streets, highways, alleys or rights-of-ways and on residential property.**

A. Except as provided for in subsections B and C:

1. It is unlawful for any person to park or leave standing, or allow to be parked or leave standing, any commercial vehicle consisting of a truck tractor, motor truck, semi-trailer or a combination thereof, exceeding a manufacturer's gross vehicle weight of 10,000 pounds, upon any street, highway, alley, public right-of-way or residential property within the City.

2. It is unlawful for the owner or operator of any commercial vehicle consisting of a truck tractor, motor truck, semi-trailer or a combination thereof, exceeding a manufacturer's gross vehicle weight of 10,000 pounds, to allow such vehicle to remain standing upon any street, highway, alley, public right-of-way or residential property within the City.

3. It is unlawful for any person to park, or allow to be parked, any trailer which has been detached from a truck tractor or truck, or which is not in itself capable of being driven, upon any street, highway, alley or public right-of-way within the City.

4. It is unlawful for any person to park or leave standing within 100 feet of any street intersection, or within 100 feet of any official traffic control device, any vehicle which is ten feet or more in height, including the height of any load thereon.

5. It is unlawful for any person to park or leave standing on any street, highway, alley, or public right-of-way within the City, any commercial vehicle consisting of a truck tractor, motor truck, trailer, semi-trailer or combination thereof, exceeding a manufacturer's gross

vehicle weight of 10,000 pounds, so that any part of such vehicle is within 30 feet of any driveway opening, other than the driver's own driveway.

6. It is unlawful for any person to park or leave standing on any street, highway, alley, or public right-of-way within the City, any commercial vehicle consisting of a truck tractor, motor truck, trailer, semi-trailer or combination thereof, exceeding a manufacturer's gross vehicle weight of 10,000 pounds, so that any part of such vehicle is within 50 feet of any part of any other truck tractor, motor truck, trailer, semi-trailer or combination thereof.

B. Commercial truck tractors, motor trucks, semi-trailers or combination thereof, exceeding a manufacturer's gross vehicle weight of 10,000 pounds, may be parked on public streets, highways, alleys, public rights-of-way, or residential property as follows:

1. On designated truck routes for a period of time not exceeding two consecutive hours;

2. While making pickups or deliveries of goods, wares or merchandise from or to any property adjacent to or abutting upon streets or highways which are not designated truck routes;

3. When such vehicle is parked in connection with, and in aid of, the ongoing performance of a service to, or on, a property in the block in which such vehicle is parked or left standing;

C. The provisions of this section shall not apply:

1. In the community industrial land use district; and

2. To commercial vehicles operated by government agencies, public and private utilities and licensed contractors engaged in the installation, maintenance or repair of any public property, utility or roadway.

(Ord. 953, 9-1-09)

#### **10.12.050 - Violation—Penalty.**

In the discretion of the Enforcement Officer, any person violating the provisions of this Chapter 10.12 shall be issued an administrative citation pursuant to Beaumont Municipal Code Sections 1.17.200 et seq., or shall be guilty of an infraction pursuant to Beaumont Municipal Code Section 1.16.010. In either case, the amount of the fine shall be in the appropriate amount set forth in Section 1.16.030 of this Code. Each such violation shall be deemed a separate offense as specified in Beaumont Municipal Code Section 1.16.040.

(Ord. 953, 9-1-09).”

**Section 4. Severability.** If any sentence, word, phrase, section or provision of this ordinance is held invalid by a court of competent jurisdiction, such provision shall be considered a separate, distinct and independent provision and such holding shall not affect the validity and enforceability of the other provisions of this ordinance.

**Section 5. Publication and Certification.** The City Clerk shall cause this ordinance to be published at least once in a newspaper of general circulation published and circulated in the City within fifteen (15) days after its passage in accordance with Section 36933 of the Government Code, shall certify to the adoption of this ordinance, and shall cause this ordinance and certification, together with proof of publication, to be entered in the book of ordinances of the Council of this City.

**Section 6. Effective Date.** This ordinance shall take effect thirty-one days after its adoption.

NOW, THEREFORE, BE IT ORDAINED that the City Council of the City of Beaumont, California, approves an amendment to the City Code.

INTRODUCED AND READ for the first time and ordered posted at a regular meeting of the City Council of the City of Beaumont, California, held on the \_\_\_\_\_ day of June 2020, by the following roll call vote:

- AYES:
- NOES:
- ABSENT:
- ABSTAIN:

**PASSED, APPROVED AND ADOPTED** at a regular meeting of the City Council of the City of Beaumont, California, held on the \_\_\_\_\_ day of June 2020, by the following roll call vote:

- AYES:
- NOES:
- ABSENT:
- ABSTAIN:

\_\_\_\_\_  
Rey Santos, Mayor

Attest: \_\_\_\_\_  
Deputy City Clerk

Approved as to form:

\_\_\_\_\_  
John O. Pinkney, City Attorney



## Staff Report

**TO:** Mayor, and City Council Members

**FROM:** Kristine Day, Assistant City Manager

**DATE** June 2, 2020

**SUBJECT: Conduct a Public Hearing and Consider a Resolution Adopting the Capital Improvement Plan (CIP) for FY 2021-2025 and Prior Year Project List**

---

### **Background and Analysis:**

Each year as part of the budgetary process, the City Council reviews and adopts a Five-Year Capital Improvement Plan (CIP) pursuant to the California Government Code. Adoption of the CIP requires the City Council to hold a public hearing and pass a resolution. Staff has noticed for public hearing regarding this item and provided a resolution for consideration which adopts the Five-Year CIP and Prior Year Project List.

### **Prior Year CIP Project List**

This project list is a culmination of prior year CIP projects, status and funding source. Many of these projects are under design or construction, however, staff does recommend closing several projects which are now complete. Staff has recommended adjusting two project allocations including Pennsylvania Widening and the Street Rehabilitation Project for FY19/20. Pennsylvania Widening was originally intended to be constructed by the developer under the TUMF Fee Credit Agreement program which at the time prohibited the City from being the lead on the project. WRCOG has since changed their requirements and staff recommends taking the lead on this project with the developer depositing the TUMF funds. The Street Rehabilitation FY 19/20 allocation has been adjusted to reflect the funds received to date from SB1 and Measure A.

### **Five Year Capital Improvement Plan FY 2021-2025**

Attached is the CIP for City Council consideration on projects proposed for fiscal years 2021-2025. The proposed project list provides for a balance of projects City-wide including street improvements, public safety, quality of life and wastewater system improvements based on the priorities of the City Council. Projects are categorized by funding source, many of which are restricted funds which must be spent for the expansion of services within the type of impact fee. Staff provided an overview at the

May 5, 2020, City Council meeting. Below is an overview of several key project categories.

### Street Improvement Projects

Several street improvement projects are included in the CIP with a variety of funding sources such as Measure A, SB1, CDBG, Road and Bridge DIF and Traffic Signal DIF. City Council approved a list of street rehabilitation and slurry seal projects at the April 21, 2020, meeting which will be funded through Measure A and SB1. In addition, staff has added the remaining street improvement of the expansion of Oak Valley Parkway from I10 to Desert Lawn Drive for compliance with the WRCOG settlement agreement. In order to address traffic congestion and circulation capacity around the City, staff has included funds each fiscal year to perform necessary traffic studies as well as associated improvements. Lastly, beginning FY 2022, staff has programmed the CDBG funds to enhance the street rehabilitation program in the City core and other eligible segments of town. This will increase street maintenance roughly \$130,000 annually.

### Public Safety Projects

The aging facilities of the Police Department and the fire station necessitate funds be allocated to protect the core of the facility. Each facility has been allotted \$250,000 for renovations such as electrical, mechanical, carpeting, etc. In addition, to prepare for the future police station, funds have been allocated to perform a feasibility study. This study will provide facility space planning, conceptual drawings, and construction cost estimates to allow the City Council to plan for this facility in the future.

### Quality of Life Projects

With development, the City has collected Regional Park, Community Park, Neighborhood Park and Recreation Facility Impact Fees. These fees are restricted funds specifically for the expansion of park and recreation facilities in the system. Additional dollars for renovations of existing facilities are programmed from capital CFD funds. Staff is proposing a variety of projects to enhance all areas of parks and recreation in the community. Projects by park are summarized below:

Sports Park – multi-purpose field expansion, additional lighting and a support building for the leagues;

Nicklaus Park – multi-purpose field expansion, associated lighting, a support building for the leagues, skate park and splash park;

Stewart Park – large splash park, and a skate park renovation;

Rangel Park – ball field renovation, playground renovation and a splash park; and

Various Parks – shade covers for playgrounds.

### Wastewater System

The Wastewater Master Plan is currently underway and will provide a list of system improvements which will be incorporated into future CIPs. One identified need during this past year has been the need for a project to address the inflow and infiltration of storm water in the wastewater system. Staff has added funds over three fiscal years to address this issue. Additionally, once the new plant is operational and the Wastewater Master Plan is complete, a new rate study will be in order with those funds programmed for FY 2022.

### **Fiscal Impact:**

The Finance Department has reviewed both the Prior Year CIP Project List and the Five-Year Capital Improvement Plan. All projects on the Prior Year Project List are funded or awaiting grant dollars for construction. Funding for projects listed in the FY2021 column can be fully funded with the identified funding source.

### **Recommended Action:**

Conduct a Public Hearing, and  
Waive the full reading and adopt by title only, “A Resolution of the City Council of the City of Beaumont Adopting a Five-Year Capital Improvement Plan for Fiscal Years 2021/2022 – 2024/2025 and Related Prior Year CIP Project List.”

### **Attachments:**

- A. Resolution
- B. Prior Year CIP Project List
- C. Five Year Capital Improvement Plan FY 2021-2025

Five Year Capital Improvement Plan FY 21-25

**Funding Source: TUMF**

Project Name	Project Number	FY20/21	FY21/22	FY22/23	FY23/24	FY24/25	Future Funding	TOTAL
<b>TOTAL</b>		\$ -	\$ -	\$ -	\$ -	\$ -	\$ -	\$ -

**Funding Source: Basic Services DIF**

Project Name	Project Number	FY20/21	FY21/22	FY22/23	FY23/24	FY24/25	Future Funding	TOTAL
New City Hall							\$ 18,000,000	\$ 18,000,000
<b>TOTAL</b>		\$ -	\$ -	\$ -	\$ -	\$ -	\$ 18,000,000	\$ 18,000,000

**Funding Source: Road & Bridge DIF**

Project Name	Project Number	FY20/21	FY21/22	FY22/23	FY23/24	FY24/25	Future Funding	TOTAL
Oak Valley Parkway Expansion I10-Desert Lawn Phase 2		\$ 600,000						\$ 600,000
2nd Street Extension Construction							\$ 5,000,000	\$ 5,000,000
1st Street Widening Penn to Beaumont Ave Design & Construction							\$ 1,600,000	\$ 1,600,000
<b>TOTAL</b>		\$ 600,000	\$ -	\$ -	\$ -	\$ -	\$ 6,600,000	\$ 7,200,000

**Funding Source: Traffic Signal DIF**

Project Name	Project Number	FY20/21	FY21/22	FY22/23	FY23/24	FY24/25	Future Funding	TOTAL
Citywide Traffic Signal Upgrade & Capacity Improvement Phase 1		\$ 150,000						\$ 150,000
Citywide Traffic Signal Upgrade & Capacity Improvement Phase 2			\$ 150,000					\$ 150,000
Citywide Traffic Signal Upgrade & Capacity Improvement Phase 3				\$ 150,000				\$ 150,000
Citywide Traffic Signal Upgrade & Capacity Improvement Phase 4					\$ 150,000			\$ 150,000
Citywide Traffic Signal Upgrade & Capacity Improvement Phase 5						\$ 150,000		\$ 150,000
<b>TOTAL</b>		\$ 150,000	\$ 150,000	\$ 150,000	\$ 150,000	\$ 150,000	\$ -	\$ 750,000

**Funding Source: Community Park DIF**

Project Name	Project Number	FY20/21	FY21/22	FY22/23	FY23/24	FY24/25	Future Funding	TOTAL
Stewart Park Splash Park		\$ 1,145,000						\$ 1,145,000
<b>TOTAL</b>		\$ 1,145,000	\$ -	\$ -	\$ -	\$ -	\$ -	\$ 1,145,000

**Funding Source: Neighborhood Park DIF**

Project Name	Project Number	FY20/21	FY21/22	FY22/23	FY23/24	FY24/25	Future Funding	TOTAL
Rangel Park Splash Park		\$ 500,000						\$ 500,000
Nicklaus Park Splash Park		\$ 850,000						\$ 850,000

<b>TOTAL</b>		\$ 1,350,000	\$ -	\$ -	\$ -	\$ -	\$ -	\$ 1,350,000
--------------	--	--------------	------	------	------	------	------	--------------

**Funding Source: Regional Park DIF**

Project Name	Project Number	FY20/21	FY21/22	FY22/23	FY23/24	FY24/25	Future Funding	TOTAL
Sports Park Field Lighting & Field Expansion		\$ 1,000,000						\$ 1,000,000
Nicklaus Park Field Lighting & Field Expansion		\$ 900,000						\$ 900,000
<b>TOTAL</b>		\$ 1,900,000	\$ -	\$ -	\$ -	\$ -	\$ -	\$ 1,900,000

**Funding Source: Recreation Facilities DIF**

Project Name	Project Number	FY20/21	FY21/22	FY22/23	FY23/24	FY24/25	Future Funding	TOTAL
Sports Park Support Building for Leagues		\$ 300,000						\$ 300,000
Nicklaus Park Support Building for Leagues		\$ 300,000						\$ 300,000
Nicklaus Park Skate Park		\$ 300,000						\$ 300,000
<b>TOTAL</b>		\$ 900,000	\$ -	\$ -	\$ -	\$ -	\$ -	\$ 900,000

**Funding Source: Fire Station DIF**

Project Name	Project Number	FY20/21	FY21/22	FY22/23	FY23/24	FY24/25	Future Funding	TOTAL
<b>TOTAL</b>		\$ -	\$ -	\$ -	\$ -	\$ -	\$ -	\$ -

**Funding Source: Police Facilities Mitigation DIF**

Project Name	Project Number	FY20/21	FY21/22	FY22/23	FY23/24	FY24/25	Future Funding	TOTAL
New Police Station Feasibility Study		\$ 250,000						\$ 250,000
<b>TOTAL</b>		\$ 250,000	\$ -	\$ -	\$ -	\$ -	\$ -	\$ 250,000

**Funding Source: Public Safety CFD**

Project Name	Project Number	FY20/21	FY21/22	FY22/23	FY23/24	FY24/25	Future Funding	TOTAL
		\$ -	\$ -	\$ -	\$ -	\$ -	\$ -	\$ -

**Funding Source: CFD**

Project Name	Project Number	FY20/21	FY21/22	FY22/23	FY23/24	FY24/25	Future Funding	TOTAL
Police Station Renovations - Roof, HVAC, Carpet		\$ 250,000						\$ 250,000



Fire Station Rehab		\$ 250,000						\$ 250,000
Playground Shade Covers - Phase 1		\$ 250,000						\$ 250,000
Stewart Park Skate Park		\$ 250,000						\$ 250,000
Rangel Park - Ball Field Lights, Electrical and Playground		\$ 500,000						\$ 500,000
Playground Shade Covers - Phase 2			\$ 250,000					\$ 250,000
Downtown Plaza				\$ 1,500,000				\$ 1,500,000
<b>TOTAL</b>		<b>\$ 1,500,000</b>	<b>\$ 250,000</b>	<b>\$ 1,500,000</b>	<b>\$ -</b>	<b>\$ -</b>	<b>\$ -</b>	<b>\$ 3,250,000</b>

**Funding Source: Measure A**

Project Name	Project Number	FY20/21	FY21/22	FY22/23	FY23/24	FY24/25	Future Funding	TOTAL
Annual Slurry Seal 20/21		\$ 400,000						\$ 400,000
Annual Citywide Street Rehab 20/21		\$ 400,000						\$ 400,000
Annual Slurry Seal 21/22			\$ 400,000					\$ 400,000
Annual Citywide Street Rehab 21/22			\$ 400,000					\$ 400,000
Annual Slurry Seal 22/23				\$ 160,000				\$ 160,000
Annual Citywide Street Rehab 22/23				\$ 160,000				\$ 160,000
Annual Slurry Seal 23/24					\$ 160,000			\$ 160,000
Annual Citywide Street Rehab 23/24					\$ 160,000			\$ 160,000
Annual Slurry Seal 24/25						\$ 160,000		\$ 160,000
Annual Citywide Street Rehab 24/25						\$ 160,000		\$ 160,000
<b>TOTAL</b>		<b>\$ 800,000</b>	<b>\$ 800,000</b>	<b>\$ 320,000</b>	<b>\$ 320,000</b>	<b>\$ 320,000</b>	<b>\$ -</b>	<b>\$ 2,560,000</b>

**Funding Source: RMRA/SB 1**

Project Name	Project Number	FY20/21	FY21/22	FY22/23	FY23/24	FY24/25	Future Funding	TOTAL
Annual Slurry Seal 20/21		\$ 430,000						\$ 430,000
Annual Citywide Street Rehab 20/21		\$ 300,000						\$ 300,000
Annual Slurry Seal 21/22			\$ 430,000					\$ 430,000
Annual Citywide Street Rehab 21/22			\$ 300,000					\$ 300,000
Annual Slurry Seal 22/23				\$ 430,000				\$ 430,000
Annual Citywide Street Rehab 22/23				\$ 300,000				\$ 300,000
Annual Slurry Seal 23/24					\$ 430,000			\$ 430,000
Annual Citywide Street Rehab 23/24					\$ 300,000			\$ 300,000
Annual Slurry Seal 24/25						\$ 430,000		\$ 430,000
Annual Citywide Street Rehab 24/25						\$ 300,000		\$ 300,000
<b>TOTAL</b>		<b>\$ 730,000</b>	<b>\$ 730,000</b>	<b>\$ 730,000</b>	<b>\$ 730,000</b>	<b>\$ 730,000</b>	<b>\$ -</b>	<b>\$ 3,650,000</b>

**Funding Source: Grants**

Project Name	Project Number	FY20/21	FY21/22	FY22/23	FY23/24	FY24/25	Future Funding	TOTAL
SB2 Grant - Housing Code Updates		\$ 160,000						\$ 160,000
LEAP Grant - Housing Element Update		\$ 150,000						\$ 150,000
Pennsylvania Ave/UPRR Grade Separation - Construction							\$ 34,000,000	\$ 34,000,000
California Ave/UPRR Grade Separation - Construction							\$ 34,000,000	\$ 34,000,000
Oak Valley/I-10 Interchange - Construction							\$ 65,000,000	\$ 65,000,000
<b>TOTAL</b>		<b>\$ 310,000</b>	<b>\$ -</b>	<b>\$ -</b>	<b>\$ -</b>	<b>\$ -</b>	<b>\$ 133,000,000</b>	<b>\$ 133,310,000</b>

**Funding Source: Transit Grants**

Project Name	Project Number	FY20/21	FY21/22	FY22/23	FY23/24	FY24/25	Future Funding	TOTAL
Fleet Maintenance and Operations Facility- Construction							\$ 3,000,000	\$ 3,000,000
SGR- Bus Stop Rehabilitation & Passenger Amenities							\$ 150,000	\$ 150,000
2 Electric Shuttle Vehicles- STA & Volkswagen		\$ 300,000						\$ 300,000
Bus Wraps-STA			\$ 100,000					\$ 100,000
Vehicle Replacements - STA			\$ 700,000	\$ 700,000				\$ 1,400,000
Measure A- Commuter Link Farebox Recovery			\$ 16,000	\$ 41,480				\$ 57,480
<b>TOTAL</b>		<b>\$ 300,000</b>	<b>\$ 816,000</b>	<b>\$ 741,480</b>	<b>\$ -</b>	<b>\$ -</b>	<b>\$ 3,150,000</b>	<b>\$ 5,007,480</b>

**Funding Source: Asset Forfeiture**

Project Name	Project Number	FY20/21	FY21/22	FY22/23	FY23/24	FY24/25	Future Funding	TOTAL
<b>TOTAL</b>		<b>\$ -</b>	<b>\$ -</b>	<b>\$ -</b>	<b>\$ -</b>	<b>\$ -</b>	<b>\$ -</b>	<b>\$ -</b>

**Funding Source: CDBG Grants**

Project Name	Project Number	FY20/21	FY21/22	FY22/23	FY23/24	FY24/25	Future Funding	TOTAL
Rangel Park Improvement Project Phase 2		\$ 130,000						\$ 130,000
Citywide Street Improvements 21/22 - CDBG			\$ 130,000					\$ 130,000
Citywide Street Improvements 22/23 - CDBG				\$ 130,000				\$ 130,000
Citywide Street Improvements 23/24 - CDBG					\$ 130,000			\$ 130,000
Citywide Street Improvements 24/25 - CDBG						\$ 130,000		\$ 130,000
<b>TOTAL</b>		<b>\$ 130,000</b>	<b>\$ 130,000</b>	<b>\$ 130,000</b>	<b>\$ 130,000</b>	<b>\$ 130,000</b>	<b>\$ -</b>	<b>\$ 650,000</b>

**Funding Source: General Fund**

Project Name	Project Number	FY20/21	FY21/22	FY22/23	FY23/24	FY24/25	Future Funding	TOTAL
Storm Drain Facilities							\$ 1,000,000	\$ 1,000,000
Storm Drain Master Plan							\$ 500,000	\$ 500,000
<b>TOTAL</b>		<b>\$ -</b>	<b>\$ -</b>	<b>\$ -</b>	<b>\$ -</b>	<b>\$ -</b>	<b>\$ 1,500,000</b>	<b>\$ 1,500,000</b>

**Funding Source: Wastewater**

Project Name	Project Number	FY20/21	FY21/22	FY22/23	FY23/24	FY24/25	Future Funding	TOTAL
I&I Rehabilitation Project - Phase 1		\$ 200,000						\$ 200,000
I&I Rehabilitation Project - Phase 2			\$ 200,000					\$ 200,000
I&I Rehabilitation Project - Phase 3				\$ 200,000				\$ 200,000
Wastewater Rate Study			\$ 200,000					\$ 200,000
<b>TOTAL</b>		<b>\$ 200,000</b>	<b>\$ 400,000</b>	<b>\$ 200,000</b>	<b>\$ -</b>	<b>\$ -</b>	<b>\$ -</b>	<b>\$ 800,000</b>

**City of Beaumont  
Prior Year CIP Projects**

Project #	Project Name	Budget Allocation	Status	Funding Source
104	CF104 City Hall and BLDG B	\$ 1,000,000	Open	Basic Services DIF
2016-001	Oak Valley/I-10 Traffic Signals	\$ 1,490,500	Close	Road & Bridge DIF, Traffic Signal DIF, Grant
2016-003	Potrero Interchange- Phase 1 & 2	\$ 66,600,664	Phase 1 Complete, Phase 2 Seeking Funds	Grants/ Developer Contributions
2016-004	General Plan Update	\$ 763,374	In progress	General Fund/ GP DIF
2017-001	Pennsylvania Avenue/Ramp Additions	\$ 3,950,000	In design	Road & Bridge DIF
2017-002	Oak Valley Pkwy Rehab	\$ 1,191,660	close	Road & Bridge DIF
2017-005	WWTP Exp PH 1 & Advanced R	\$ 67,235,187	In construction	Bonds, WW DIF, Recycled Water DIF, CFD
2017-006	Brine Pipeline to San Bernardino	\$ 40,572,639	In construction	Bonds, WW DIF, Recycled Water DIF, CFD
2017-008	Lift Stations Assessment	\$ 250,000	Close	WW Funds
2017-009	Pennsylvania Widening	\$ 4,018,000	In Design	TUMF, Road & Bridge DIF
2017-010	6th Street Rehab & Beautification	\$ 50,000	Close	Traffic Signal DIF
2017-012	Pennsylvania Ave/UPR Grade Separation	\$ 1,500,000	In Design	Railroad DIF
2017-013	California Ave/UPR Grade Sep	\$ 1,500,000	Close	Railroad DIF
2017-014	Highland Springs/1st St Storm Dr	\$ 175,000	Close	Road & Bridge DIF
2017-016	Beaumont Ave Signalization	\$ 1,000,000	Close	Traffic Signal DIF
2017-023	Potrero Interchange PH 2	\$ 27,000,000	Close	Grants/ Developer Contributions
2017-027	Oak Valley/I-10 Interchange Design	\$ 7,000,000	Design	TUMF, Grants
2017-028	Potrero Fire Station	\$ 8,650,000	Design	Fire Station DIF, General Fund
2017-CF100	City Hall Campus Plan	\$ 200,000	Close	Basic Services DIF
2018-001	Slurry Seal 18-19	\$ 600,000	Construction	SB1, Measure A
2018-003	Street Rehab - Alley	\$ 34,476	Construction	Alley DIF
2018-004	Beaumont Ave Reconstruction	\$ 1,953,000	Construction	SB1, Measure A
2018-005	Rangel Park	\$ 521,470	Construction	CDBG
2018-006	Park and ROW Upgrades 18-19	\$ 300,000	Close	CFD
2018-007	Recycle Water Feasibility Study	\$ 100,000	Close	Recycled Water DIF
2018-008	Oak Valley Pkwy PH2	\$ 500,000	Close	Road & Bridge DIF
2018-009	Seneca Springs Lift Station- Feasibility Study	\$ 100,000	Close	Wastewater Fund
2018-010	Seneca Springs Lift Station Design & Construction	\$ 200,000	Construction	Wastewater Fund
2019-001	Slurry Seal 19-20	\$ 1,000,000	Construction	SB1, Measure A
2019-002	Street Rehab 19-20	\$ 466,647	Construction	SB1, Measure A
2019-003	Park and ROW Upgrades 19-20	\$ 300,000	Close	CFD
2019-004	CNG Station	\$ 1,941,795	Design	Grants
2019-005	Police Annex	\$ 41,300	Close	Grants, Forfiture
2019-006	City Hall Council Chambers	\$ 325,000	Close	PEG Funds
2019-007	PD Server Room	\$ 54,000	Close	General Fund/ CFD Public Safety
2019-008	Housing Element Update	\$ 90,000	RFP	Close
2019-009	2nd Street Extension Feasibility / Design	\$ 200,000	RFP	Road & Bridge
2019-010	PLC Upgrade Construction	\$ 350,000	Not Started	WW Funds
2019-011	CMOM	\$ 100,000	Close	WW Funds
2019-012	WQMP & WWTP Permit	\$ 50,000	In process	WW Funds
2019-013	Wastewater Master Plan	\$ 350,000	In process	WW Funds
2019-015	Security Infrastructure Upgrades	\$ 40,000	In process	General Funds
2019-016	EV Charging Station	\$ 371,870	Construction	Grants
2019-017	Beaumont Ave Signalization	\$ 795,000	Close	Traffic Signal DIF
2019-018	PLC Upgrade Design	\$ 50,000	Design	WW Funds
2019-019	Beaumont Master Drainage Plan - Line 2 Stage 1	\$ 5,000,000	Design	Grant

**RESOLUTION NO. \_\_\_\_\_**

**A RESOLUTION OF THE CITY COUNCIL OF THE CITY OF BEAUMONT  
ADOPTING A FIVE-YEAR CAPITAL IMPROVEMENT PLAN FOR FISCAL YEARS  
2021/2022-2024/2025 AND RELATED PRIOR YEAR CIP PROJECT LIST**

**WHEREAS**, the City Council of the City of Beaumont desires to adopt the City’s Five-Year Capital Improvement Plan for Fiscal Years 2021/2022 through 2024/2025 (“CIP”) and the Prior Year CIP Project List, as defined below;

**WHEREAS**, the Prior Year CIP Project List is a culmination of the prior year CIP projects, status and funding sources;

**WHEREAS**, the City Council received a presentation on the proposed CIP and Prior Year CIP Project List at a public meeting held on May 5, 2020 where members of the public had the opportunity to comment on the proposed CIP and Prior Year CIP Project List;

**WHEREAS**, the proposed CIP is attached hereto as **Exhibit “A”**;

**WHEREAS**, the proposed Prior Year CIP Project List is attached hereto as **Exhibit “B”**;

**WHEREAS**, pursuant to Government Code, section 66002, the City duly gave public notice of the public hearing of the proposed CIP and Prior Year CIP Project List, a copy of which has been on file with the City Clerk Board at least 10 calendar days prior to the City Council’s commencement of such public hearing; and

**WHEREAS**, the City Council desires to adopt the CIP and Prior Year CIP Project List as set forth herein;

**NOW, THEREFORE BE IT RESOLVED BY THE BEAUMONT CITY COUNCIL  
AS FOLLOWS:**

**Section 1.** The City Council hereby approves and adopts the Capital Improvement Plan for Fiscal Years 2021/2022 through 2024/2025, a copy of which is attached hereto as Exhibit “A” and made a part hereof by this reference.

**Section 2.** The City Council hereby approves and adopts the Prior Year CIP Project List, a copy of which is attached hereto as Exhibit “B” and made a part hereof by this reference.

**Section 3.** The Capital Improvement Plan may be updated by the City Council from time to time pursuant to California Government Code, section 66002, or as otherwise provided by law.

**Section 4.** This Resolution shall take effect immediately upon its passage and adoption.

**MOVED, PASSED, and ADOPTED** this 2nd day of June, 2020, by the following vote:

- AYES:**
- NOES:**
- ABSTAIN:**
- ABSENT:**

By: \_\_\_\_\_  
Rey Santos, Mayor  
City of Beaumont

**ATTEST:**

By: \_\_\_\_\_  
Steve Mehlman, City Clerk  
City of Beaumont

**EXHIBIT A**



## Staff Report

**TO:** Mayor and City Council Members  
**FROM:** Todd Parton, City Manager  
**DATE:** June 2, 2020  
**SUBJECT:** **Consideration of a Contract for City Attorney Services between the City of Beaumont and Slovak Baron Empey Murphy & Pinkney LLP**

---

### **Background and Analysis:**

Attached is a new contract for legal services with Slovak Baron Empey Murphy & Pinkney LLP (SBEMP). SBEMP has served the City since May 4, 2015, when its original contract was awarded after a competitive selection process. SBEMP's current contract term runs from May 14, 2018, through June 1, 2020, after which it continues on a month-to-month basis.

SBEMP has proposed a new contract with a term that runs from June 1, 2020, through June 1, 2023. Rates contained within the contract remain unchanged from those established via the original contract of May 4, 2015. Additionally, the contract provides for an annual evaluation of SBEMP's performance and allows the City to terminate the agreement for any purpose with a 20-day notice.

Services proposed in the attached contract are also consistent with those specified in the expiring contract.

### **Fiscal Impact:**

Legal services are budgeted to be for \$750,000 for FY2021.

### **Recommended Action:**

Approval of the attached contract for City Attorney Services between the City of Beaumont and Slovak Baron Empey Murphy & Pinkney LLP.

**Attachments:**

- A. Contract for City Attorney Services between the City of Beaumont and Slovak Baron Empey Murphy & Pinkney LLP



**CONTRACT FOR CITY ATTORNEY SERVICES**

**CITY OF BEAUMONT**

**&**

**SLOVAK BARON EMPEY MURPHY & PINKNEY LLP**

This Contract for City Attorney Services (“Agreement”) sets forth the terms under which the law firm of Slovak Baron Empey Murphy & Pinkney LLP (“SBEMP”) will be retained to represent the City of Beaumont for City Attorney services. John O. Pinkney shall serve as City Attorney and Robert L. Patterson shall serve as Deputy City Attorney. The terms of this Agreement will also govern any additional work which SBEMP may undertake on behalf of the City, as well as on behalf of the City’s related entities (i.e. Beaumont Utility Authority, Parking Authority, Public Improvement Authority, etc.) unless the parties hereto enter into a separate written engagement specifying other terms. The City and its related entities are collectively referred to herein as “City”. As City Attorney, SBEMP shall represent the City as requested in connection with all City legal matters, including but not limited to, litigation, eminent domain, labor and employment, land use, contracting/real estate, Council meetings, CEQA/environmental, utility related issues, law enforcement related issues, and other matters as requested by the City.

**IDENTITY OF CLIENT**

In the matters SBEMP handles for the City, the City, as defined above, will be SBEMP’s client, and not any other persons, entities, or affiliates. SBEMP does not by this Agreement become or take on the role as legal counsel in any capacity for the City’s member agencies or the individuals serving on the City’s council or committees.

**FEES**

SBEMP will serve as City Attorney for a fixed monthly retainer of \$7,500.00 per month for up to 50 hours per calendar month of attorney and paralegal time. This monthly retainer does not cover litigation work. To the extent we provide services exceeding 50 hours per month, said services will be billed at the rate of \$199 per hour for associate time, \$239 per hour for partner and of counsel time, and \$120 per hour for paralegal time. Litigation (including preparation, review, supervision, and counsel of record work) will be billed at an hourly rate of \$239.00 for associates, \$275 for partners and of counsel, and \$130 for paralegal time.

**AGREEMENT TERM**

The term of this Agreement shall run from June 1, 2020 through June 1, 2023 (the “*Term*”). SBEMP shall be subject to an annual evaluation by the City Council. Upon the expiration of the Term, this Agreement shall continue on a month-to-month basis, subject to renewal or extension by City.

### EXPERTS/CONSULTANTS

SBEMP may retain the services of experts/consultants in connection with the services it provides to the City under this Agreement. The City shall be responsible for all fees and costs billed to SBEMP by said experts/consultants.

### REIMBURSEMENT FOR COSTS

SBEMP does not advance costs for clients. Inevitably, however, some routine costs (photocopying, service of process fees, marshal's fees, etc.) are incurred on behalf of SBEMP's clients. Where costs are high (e.g., filing fees, court reporter's fees, expert and consultant fees and costs) and they can be anticipated, SBEMP will contact the City and request that funds be advanced to cover the estimated amount of such costs. To the extent the estimate is too low; SBEMP will then bill the City for the difference on its monthly statement. Unless an emergency occurs, or the costs are small, SBEMP does not advance costs for clients of the firm.

Reimbursement for costs advanced by SBEMP on the City's behalf and other expenses will be billed in addition to the monthly retainer fee charged. These currently include, but are not limited to, mileage for trips outside the Coachella Valley at the current Internal Revenue Service rate, actual expenses away from SBEMP's office on client's business, messenger and delivery service, computerized research, videotape recording, court costs and filing fees, faxes, long distance telephone calls, photocopy charges (\$0.15 per page), and the cost of producing or reproducing any photographs, documents or other things necessary for the preparation or presentation of the City's matters. Travel time is billed at SBEMP's regular hourly rate. All fees and costs will be itemized and billed monthly.

### BILLING

SBEMP's billing procedures are designed to be as simple and as clear as possible. The City will be billed monthly for services rendered and for costs and expenses. The City is encouraged to direct any questions it may have regarding billing to Attorney John Pinkney, as the partners at SBEMP want the City to be satisfied not only with SBEMP's services, but with the cost of services.

### INSURANCE COVERAGE

Unless specifically requested to do so, SBEMP will not provide advice on the type or amount of insurance recommendable to the City. Moreover, to the extent the City is ever named as a defendant in a lawsuit, the City will notify its insurance carrier and broker of the claim to determine whether insurance coverage is available.

SBEMP carries its own errors and omissions insurance. After a standard deductible, this insurance provides coverage in the amount of \$3 million.

### ABSENCE OF CONFLICTS

In order to avoid conflicts of interest among SBEMP's clients, SBEMP maintains a conflict of interest index. SBEMP will not represent any party with an interest that may be adverse to an indexed person without an examination to determine if a conflict of interest would be created. In connection with the City, SBEMP has indexed the following name: **CITY OF BEAUMONT**. Please review this list to determine whether any other individuals or entities should be added. Unless SBEMP hears from the City to the contrary in writing, SBEMP will assume by its signature on this Agreement that the above listing is accurate and complete.

### TERMINATION

This Agreement may be terminated by the City upon twenty (20) days written notice. SBEMP may also terminate its services upon twenty (20) written notice.

### DOCUMENT STORAGE POLICIES

SBEMP's policy with regard to documents at the conclusion of a matter is to maintain documents in storage for a period of five (5) years. At the conclusion of that period, without any further notice, all documents in a file are destroyed and discarded. Accordingly, if there are any documents or papers the City desires removed from its file at the conclusion of a matter, it will be necessary for the City to advise SBEMP of that request to ensure that the documents are not destroyed.

### NO GUARANTEE OF OUTCOME

The City acknowledges that SBEMP has made no guarantees regarding any phase of its representation of the City. Any comments SBEMP's attorneys may make regarding the outcome of a particular matter it handles for the City should be considered expressions of opinion only based on the facts and circumstances known at the time the comment is made.

### INDEPENDENT CONTRACTOR

SBEMP shall perform all legal services required under this Agreement as an independent contractor of the City, and shall remain, at all times as to the City, a wholly independent contractor with only such obligations as are required under this Agreement. Neither the City, nor any of its employees, shall have any control over the manner, mode, or means by which SBEMP, its agents or employees, render the legal services required under this Agreement, except as otherwise set forth. The City shall have no voice in the selection, discharge, supervision, or control of SBEMP employees, servants, representatives, or agents, or in fixing their number, compensation, or hours of service.

### INDEMNIFICATION

The City acknowledges SBEMP is serving as the City Attorney pursuant to the authority of Government Code Section 36505, and has the authority of that office. Accordingly, the City is responsible pursuant to Government Code Section 825 for providing a defense for the City

Attorney for actions within the scope of its engagement hereunder. Therefore, the City agrees to undertake its statutory duty and indemnify SBEMP, its officers, employees and agents against and will hold and save each of them harmless from, any and all claims or liabilities that may be asserted or claims by any person, firm or entity arising out of or in connection with the work, operations or activities of SBEMP within the course and scope of its performance hereunder, but nothing herein shall require the City to indemnify SBEMP for liability arising from its own negligence or alleged negligence. In connection herewith:

(i) The City will promptly provide a defense and pay any judgment rendered against the City, its officers, agency, or employees for any such claims or liabilities arising out of or in connection with such work, operations, or activities of the City hereunder;

(ii) In the event SBEMP, its officers, agents or employees is made a party to any action or proceeding filed or prosecuted against the City for such damages or other claims solely arising out of or in connection with the work, operation or activities of the City hereunder, the City agrees to pay to SBEMP, its officers, agents or employees any and all costs and expenses incurred by attorney, its officers, agents or employees in such action or proceeding, including, but not limited to, reasonable attorneys' fees, paralegal fees, expert witness fees, and other fees, costs, and expenses incurred in connection with such action or proceeding, through and including exhaustion of any appeals.

**NOTICES**

Notices required pursuant to this Agreement shall be given by personal service upon the party to be notified, or by delivery of same into the custody of the United States Postal Service, or its lawful successor; postage prepaid and addressed as follows:

The City: City of Beaumont  
550 E. 6<sup>th</sup> Street  
Beaumont, CA 92223  
Attn: Mayor/City Manager

SBEMP: Slovak Baron Empey Murphy & Pinkney LLP  
1800 E. Tahquitz Canyon Way  
Palm Springs, CA 92262  
Attn: John O. Pinkney, Esq.

Service of a notice by personal service shall be deemed to have been given as of the date of such personal service. Notice given by deposit with the United States Postal Service shall be deemed to have been given two (2) consecutive business days following the deposit of the same in the custody of said Postal Service. Either party hereto may, from time to time, by written notice to the other, designate a different address or person which shall be substituted for that specified above.

**NON-DISCRIMINATION**

In connection with the execution of this Agreement, SBEMP shall not discriminate

against any employee or applicant for employment because of race, religion, marital status, color, sex, handicap, sexual persuasion, or national origin. SBEMP shall take affirmative action to ensure that applicants are employed, and that employees are treated fairly during their employment, without regard to their race, religion, color, sex, marital status, handicap, sexual persuasion, or national origin. Such actions shall include, but not be limited to, the following: employment, promotion, demotion, transfer, duties assignment; recruitment or recruitment advertising; layoff or termination; rates of pay or other forms of compensation; and selection for training, including apprenticeship.

### **INTERPRETATION OF AGREEMENT AND FORUM**

This Agreement shall be construed and interpreted both as to validity and performance of the parties in accordance with the laws of the State of California. In the event of any dispute hereunder, forum shall be the Superior Court, Riverside County.

### **REPRESENTATION BY COUNSEL**

In entering into this Agreement, each party hereto acknowledges that each of them have had the opportunity to be represented by independent legal counsel of their own choice, that each Party had the opportunity to consult with legal counsel of their own selection concerning the terms set forth in this Agreement.

### **INTEGRATED AGREEMENT; AMENDMENT**

This Agreement contains all of the agreements of the parties and cannot be amended or modified except by written agreement. No prior oral or written understanding shall be of any force or effect with respect to those matters covered in this Agreement. This Agreement may be amended at any time by the mutual consent of the parties by an instrument in writing.

### **CORPORATE AUTHORITY**

The persons executing this Agreement on behalf of the parties hereto warrant that they are duly authorized to execute this Agreement on behalf of said parties and that in so executing this Agreement the parties hereto are formally bound to the provisions of this Agreement.

### **DISPUTE RESOLUTION**

The parties agree to cooperate and use all reasonable efforts to undertake the terms of this Agreement and, in good faith, to undertake the resolution of all disputes thereunder. Prior to submitting a dispute to final and binding arbitration as provided below, any party claiming a dispute must give ninety (90) days' written notice to the non-disputing party of the occurrence of the dispute, along with a detail explanation of the nature of the dispute. The parties agree that upon receipt of the notice of dispute, the parties will, in good faith, meet and confer to resolve the dispute, and if unsuccessful, submit the matter to mediation. If the matter is not resolved within ninety (90) days, the disputing party is entitled to pursue arbitration hereunder.

ARBITRATION

IN THE EVENT ANY DISPUTE IS NOT RESOLVED PURSUANT TO THE DISPUTE RESOLUTION PROVISION ABOVE OVER THE AMOUNTS DUE, ANY COLLECTION ACTION BY US, OR ANY OTHER DISPUTE OF ANY KIND WHATSOEVER BETWEEN US, INCLUDING WITHOUT LIMITATION, DISSATISFACTION WITH THE SERVICES PROVIDED TO YOU OR YOUR BELIEF THAT THE FIRM HAS ENGAGED IN MALPRACTICE, THE PARTIES HEREBY AGREE TO SUBMIT ANY AND ALL DISPUTES TO FINAL AND BINDING ARBITRATION. THE ARBITRATOR ALSO SHALL HAVE THE EXCLUSIVE AUTHORITY TO RESOLVE ANY DISPUTE RELATING TO WHAT ISSUES HEREUNDER ARE ARBITRABLE INASMUCH AS THE INTENT OF THIS AGREEMENT IS TO INVEST IN THE ARBITRATOR SUCH EXCLUSIVE AUTHORITY TO INCLUDE ANY ISSUES AS TO THE ENFORCEABILITY OF THIS AGREEMENT AND/OR ANY CLAIM THAT ALL OR PART OF THIS AGREEMENT IS OR IS NOT ENFORCEABLE, VOID, AND/OR VOIDABLE. IT IS AGREED THAT THE ARBITRATOR SHALL BE REQUIRED TO FOLLOW THE LAW.

THE PARTIES AGREE THAT THE ARBITRATOR SHALL BE SELECTED THROUGH JAMS IN ONTARIO, CALIFORNIA, WITH VENUE TO OCCUR IN PALM SPRINGS, CALIFORNIA, UNLESS OTHERWISE AGREED UPON IN WRITING BY ALL PARTIES. THE PARTIES AGREE THAT JAMS SHALL SUBMIT A PANEL OF FIVE ARBITRATORS WITH THE PARTY DEMANDING ARBITRATION REQUIRED TO STRIKE A NAME FIRST AND THEREAFTER THE OTHER PARTY TO STRIKE A NAME UNTIL SUCH TIME AS ONE NAME REMAINS WHO SHALL BE THE ARBITRATOR, UNLESS THE PARTIES STIPULATE IN UNITY TO AN ARBITRATOR.

THE PARTIES AGREE TO WAIVE DISCOVERY RIGHTS AND PROCEED TO ARBITRATION AS EXPEDITIOUSLY AS POSSIBLE WITH THE ARBITRATION TO BE SCHEDULED NOT LATER THAN NINETY (90) DAYS AFTER THE PARTY FIRST REQUESTING SAME TO HAVE MADE WRITTEN DEMAND. THE PARTIES AGREE TO EACH PAY ONE-HALF OF THE ARBITRATOR'S FEES NECESSARY TO PROCEED WITH AND HOLD THE ARBITRATION. EACH SIDE SHALL BEAR THEIR OWN COSTS AND FEES IN CONNECTION WITH THE ARBITRATION, REGARDLESS OF WHO IS CONSIDERED TO BE THE PREVAILING PARTY.

YOU ACKNOWLEDGE THAT IT HAS BEEN EXPLAINED TO YOU THAT SUCH BINDING ARBITRATION MAY DEPRIVE YOU OF VARIOUS RIGHTS THAT YOU OTHERWISE MIGHT HAVE IN A LEGAL ACTION, INCLUDING WITHOUT LIMITATION THE RIGHT TO A JURY TRIAL, THE RIGHT TO APPEAL, THE RIGHT TO PUNITIVE DAMAGES, AND FULL DISCOVERY RIGHTS. IF YOU DO NOT UNDERSTAND THIS CLAUSE, YOU SHOULD SEEK INDEPENDENT LEGAL COUNSEL.

\_\_\_\_\_  
(City's initials)

MBE  
(SBEMP's initials)

**ADDITIONAL MATTERS**

The parties agree that this Agreement shall be applicable to and shall bind the parties respecting any additional matters undertaken by SBEMP for the City in the future so that separately executed retainer agreements shall be unnecessary.

By executing this Agreement below, the parties agree to the above terms and agree that this Agreement may only be modified by mutually executed written agreement.

Thank you again.

**APPROVED AND ACCEPTED:**

Dated: 5-27-2020

Slovak Baron Empey Murphy & Pinkney LLP

BY:   
Marc E. Empey  
Its: Partner

Dated: \_\_\_\_\_

City of Beaumont

BY: \_\_\_\_\_  
Rey Santos  
Its: Mayor

Dated: \_\_\_\_\_

Attested to:

By: \_\_\_\_\_  
Steven Mehlman City Clerk



## Staff Report

**TO:** Mayor and City Council Members  
**FROM:** John Pinkney, City Attorney  
**DATE:** June 2, 2020  
**SUBJECT:** **Resolution of Intent – Transitioning from At-Large to By-District Elections**

---

### Background and Analysis:

The California Voting Rights Act of 2001 (CVRA) is a state law that was enacted to implement the California constitutional guarantees of equal protection and the right to vote. It provides a private right of action to members of a protected class whose ability to elect candidates of their choice or influence the outcome of elections is impaired due to an at-large elections system. The focus is to eliminate racially polarized voting.

In 2017, the CVRA was updated to allow cities, regardless of size, to move to a district election system by ordinance. It also capped the amount of attorney's fees recoverable by the plaintiff and included a safe harbor provision of 45-days to allow cities time to adopt a resolution of intent to create a by-district election system. As of today, no city has prevailed in a CVRA lawsuit.

In October 2019, the California legislature passed the Fair and Inclusive Redistricting for Municipalities and Political Subdivision Act (FAIR Maps Act or Act). Governor Newsom signed the bill into law and it took effect on January 1, 2020. The FAIR Maps Act requires cities to redraw district map boundaries after each census and requires additional outreach and public hearings. The act only applies to cities or special districts that move to a district election system prior to the release of the 2020 census data. Cities that are moving to district elections for the first time are still bound by Elections Code section 10010.

On May 5, 2020, a presentation was made to the City Council regarding the CVRA and the transition from at-large to by-district elections by many California cities. The Council was presented with the history of the CVRA, the legal challenges made across California, and the different options available to the Council in transitioning to by-district



elections. After questions and discussion, the Council directed City staff to prepare a Resolution of Intent to move to by-district elections.

The resolution of intent states that the Beaumont City Council intends to transition from an at-large election system to a by-district election system once 2020 census results are available. While the City could choose to transition to districts prior to receiving 2020 census results, it may not be possible due to current restrictions on public hearings due to the COVID-19 pandemic. Further, the Council was in agreement that the districting process should not be rushed and further demographic information would assist in the districting process.

Whether to district is ultimately a policy decision for the Council. The resolution of intent does not bind the Council to move to a by-district election system and may be rescinded at any time should the Council make other findings in favor of an at-large system. The passage of this resolution initiates a process for the City to explore the districting process without the threat of litigation and allows the City Attorney to retain a demographer to gather demographic data to aide the Council in its consideration of districting.

**Fiscal Impact:**

The estimated cost to the City consists of administrative costs related to holding public hearings and conducting outreach to the public and the cost of a demographer to assist in the creation of potential district maps. The City Manager estimates that costs associated with the districting process will be up to \$50,000. These costs will be split between FY2021 and FY2022.

**Recommended Action:**

If desired by Council, motion to pass the resolution of intent and begin the districting process by waiving the full reading, and adopting by title only, " A Resolution of the City Council of the City of Beaumont, California, Declaring Its Intention to Transition from At-Large Elections to District-Based Elections Pursuant to Elections Code Section 10010.

**Attachments:**

- A. Resolution of Intent
- B. May 5, 2020 CVRA Presentation

**RESOLUTION NO.**

**A RESOLUTION OF THE CITY COUNCIL OF THE CITY OF BEAUMONT,  
CALIFORNIA, DECLARING ITS INTENTION TO TRANSITION FROM AT-LARGE  
ELECTIONS TO DISTRICT-BASED ELECTIONS PURSUANT TO ELECTIONS CODE  
SECTION 10010**

**WHEREAS**, the City Council of the City of Beaumont (City) are currently elected in at-large elections, in which each member is elected by the registered voters of the entire City; and

**WHEREAS**, Government Code Section 34886 authorizes the legislative body of a city of any population to adopt an ordinance to change its method of election from an “at-large” system to a “by-district” system; and

**WHEREAS**, many cities in California and Riverside County have transitioned to a “by-district” system either on their own accord or due to the receipt of a demand letter; and

**WHEREAS**, the City has an interest in voluntarily transitioning to a “by-district” system in order to maintain control of the transition process; and

**WHEREAS**, prior to the City Council’s consideration of an ordinance to establish boundaries for a district-based electoral system, Elections Code Section 10010 requires all the following at a minimum:

1. The City shall host at least two public hearings over a period of no more than thirty days, at which the public will be invited to provide input regarding the composition of districts.
2. Draft district maps will be published and made available to the public at least seven days prior to the public hearings. Any changes to draft maps between public hearings, requires the publication of the map for at least another seven days prior to the public hearing.
3. The City shall host an additional two public hearings over a period of no more than 45 days, at which the public is invited to provide input regarding the content of the draft map(s) and the proposed sequence of elections, if applicable.

**WHEREAS**, the current COVID-19 pandemic and Governor Newsom’s Executive Order N-34-20 prevents the City from holding public hearings on the transition to districts until after the stay-at-home order has been lifted; and

**WHEREAS**, the City intends to use 2020 census data in the transition process to ensure the most current demographics of the City are used; and

**WHEREAS**, the adoption of a district-based electoral system will not affect the terms of any sitting Councilmember, each of who will serve out his or her current term.

**NOW, THEREFORE, THE CITY COUNCIL OF THE CITY OF BEAUMONT, CALIFORNIA, DOES RESOLVE, DECLARE, AND DETERMINE AND ORDER AS FOLLOWS:**

**SECTION 1.** The true and correct recitals above are incorporated herein, the City Council hereby resolves and states its intention to adopt an ordinance, pursuant to California Government Code section 34886, to transition election of its City Council members from an at-large electoral

system to a district-based electoral system, for use in the City's 2022 General Municipal Election, scheduled for November 2022.

SECTION 2. In the event that a district-based electoral system is adopted, it is the City Council's desire and intention that City resources will continue to be prioritized based on the greatest citywide need and benefit, and that the City Council will work cooperatively with one another for the benefit of the entire City.

SECTION 3. The City Council directs the City Manager and City Attorney to work with a professional demographer, and other appropriate consultants as needed, to provide a detailed analysis of Beaumont's current demographics and any other information or data necessary to prepare a draft map that divides Beaumont into voting districts in a manner consistent with the intent and purpose of the CVRA and the Federal Voting Rights Act.

SECTION 4. In adopting this Resolution, the City Council has determined that it will gather and study demographic data, solicit community input, and create CVRA-compliant districts that best serve the City as a whole.

SECTION 5. The City Council directs the City Manager to post all information regarding the proposed transition to a district-based electoral system on the City's website, including maps, notices, agendas and other information once the information becomes available.

SECTION 6. The City Council hereby declares that if any provision, section, paragraph, sentence, or word of this Ordinance is rendered or declared to be invalid or unconstitutional by any final court action in a court of competent jurisdiction, or by reason of any preemptive legislation, such invalidity shall not affect the other provisions, sections, paragraphs, sentences or words of this Ordinance, and to this end the provisions of this Ordinance are severable. The City Council declares that it would have adopted this Ordinance irrespective of the invalidity of any particular portion thereof and intends that the invalid portions should be severed, and the balance of the Ordinance enforced.

SECTION 7. The City Council finds that the actions contemplated by this Resolution are exempt from the California Environmental Quality Act ("CEQA") pursuant to Section 15060 (c)(2) (the activity will not result in a direct or reasonably foreseeable indirect physical change in the environment) and 15060(c)(3) (the activity is not a project as defined in Section 15378) of the CEQA Guidelines, California Code of Regulations, Title 14, Chapter 3, because it has no potential for resulting in physical change to the environment, directly or indirectly.

SECTION 8. This Resolution shall take effect immediately upon adoption.

NOW, THEREFORE, BE IT RESOLVED that the City Council of the City of Beaumont, California, approves this Resolution.

**MOVED, PASSED, AND ADOPTED** at a regular meeting of the City Council of the City of Beaumont, California, held on the \_\_\_\_\_ day of \_\_\_\_\_, 2020.

AYES:

NOES:

ABSENT:

ABSTAIN:

\_\_\_\_\_

Rey Santos, Mayor

Attest: \_\_\_\_\_

Nicole Wheelwright, Deputy City Clerk

# California Voting Rights Act (CVRA)



1800 E. Tahquitz Canyon Way  
Palm Springs, California 92262  
Tel. (760) 322-2275  
Fax (760) 322-2107

650 Town Center Drive, Ste. 1400  
Costa Mesa, California 92626  
Tel. (714) 435-9592  
Fax (714) 850-9011

103 Carnegie Center Blvd., Ste. 300  
Princeton, New Jersey 08540  
Tel. (609) 955-3393  
Fax (609) 520-8731

1955 Sunset Blvd.  
San Diego, California 92103  
Tel. (619) 501-4540

# What is the California Voting Rights Act (CVRA)?

- The CVRA is a California state law that was enacted to implement the California constitutional guarantees of equal protection and the right to vote.
- Provides a private right of action to members of a protected class whose ability to elect candidates of their choice or influence the outcome of elections is impaired due to at-large elections.
- Focus is to eliminate racially polarized voting.

# What is the FAIR Maps Act?

- In October 2019, the California legislature passed the Fair and Inclusive Redistricting for Municipalities and Political Subdivision Act (FAIR Maps Act or Act).
- The FAIR Maps Act requires cities to redraw district map boundaries after each census and requires additional outreach and public hearings.
- The Act is intended to provide a more streamline and political neutral approach to redistricting efforts.

# At-Large vs. By-District Elections

- At-Large – an election system in which the voters of the entire jurisdiction elect the members to the governing body.
- By-District – an election system in which the candidate must reside within a district and is elected only by voters residing within that district.



# What is Racially Polarized Voting?

- Voting in which there is a difference, in the choice of candidates that are preferred by voters in a protected class, and in the choice of candidates that are preferred by voters in the rest of the electorate.
  - Protected class means a class of voters who are members of a race, color, or language minority group.

# Factors to Determine Racially Polarized Voting

- Examining results of elections in which at least one candidate is a member of a protected class.
- Proof of intent to discriminate against a protected class is not required.
- Probative factors:
  - History of discrimination
  - Dilutive effects of at-large elections
  - Denial of access
  - Extent of past discrimination
  - Use of overt or subtle racial appeals in political campaigns

# What Now?

- Many cities and political districts have recently been served with demand letters to force the districts to comply with the CVRA.
  - If you receive a demand letter, the potential plaintiff is entitled to \$30,000.
  - The timeline in which to implement districts is approximately 4 months from the date the demand letter is received.
- Some cities and political districts are choosing to implement district elections to avoid a demand letter and potential litigation.

# Demand Letter Timeline

- Day 1: Agency receives a demand letter
- Day 45: Agency adopts a resolution to move to district elections
  - 90 day stay on any potential litigation
- Day 46: Agency prepares at least two public hearings over no more than 30 days
- Day 76: Agency draws district maps based on feedback from hearings
- Day 80: Agency releases draft maps to the public
- Day 87: Agency holds at least two more additional hearings
- Day 90: Agency adopts a resolution creating districts
- Day 91: Agency settles with potential plaintiff for \$30k

# Demographics of Beaumont

- According to the 2010 census, Beaumont has a population of approximately 36,000 residents.
- The racial makeup up the city is 42% white, 40% Hispanic or Latino, 6.2% African American, and 1.5% Native American.
- A demographer can be hired to give a full accounting of the demographics of the city.
  - Including where there are high concentrations of certain racial groups.



## Potential for Liability

- Generally, cities with a history of racially polarized voting are being targeted to move to district elections.
- Especially those cities that do not currently have elected officials that reflect the racial diversity of the community.
- Beaumont currently has a diverse city council and may not be considered high risk for a threat of litigation.
- However, the legislature intended for all cities in California to eventually move to district elections.

## Option 1: Wait for a Demand Letter

- Wait to receive a demand letter.
  - Attempt to negotiate a more favorable timeline for implementation.
  - Proceed directly to litigation.
  - Implement district elections.

## Option 2: Move to District Elections

- Begin the process of district elections.
- Hire a demographer.
- Create an outreach plan.
- Hold public meetings.
- Implement district elections.



## Option 3: Conduct Demographic Study

- Hire a demographer to provide a detailed account of the demographics within the City.
- Based on the information provided, determine whether to move in the direction of districting as well as the risk of litigation.

# City of Banning

- In June 2016, the City of Banning, California adopted a five council district plan.
- While smaller in size, Banning’s demographic breakdown is similar to that of Beaumont.
- However, Banning did not have as diverse a city council as Beaumont.

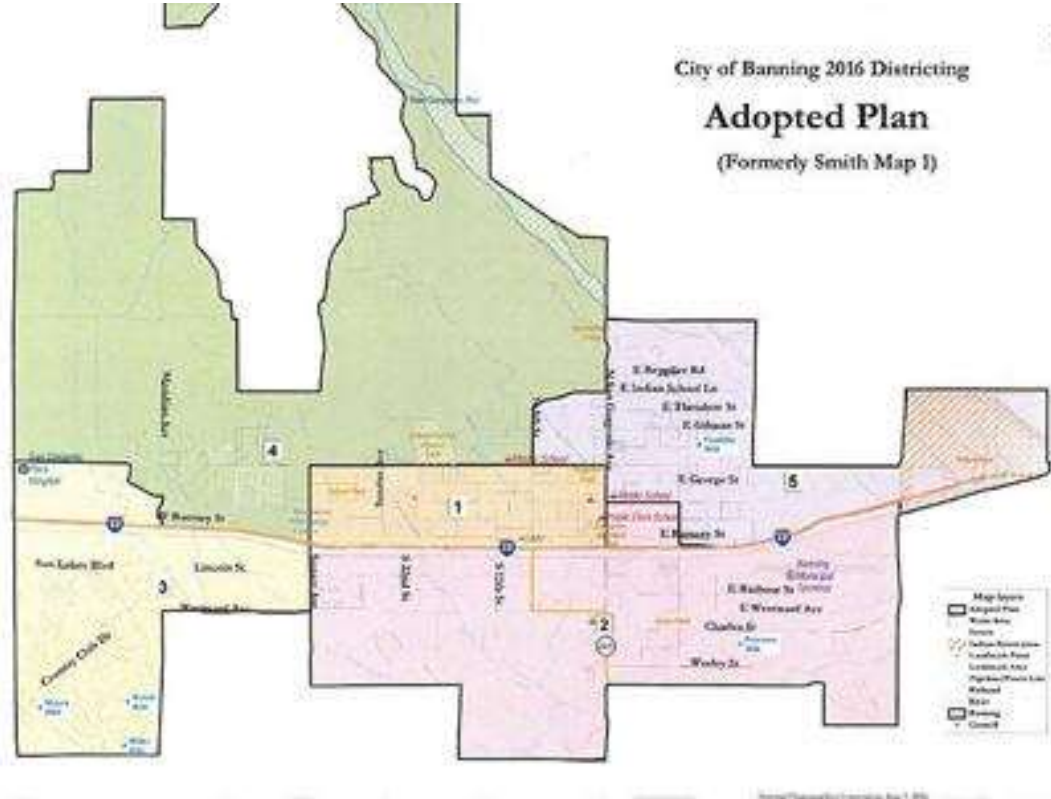

## By-District Cities in Riverside County

- Banning
- Cathedral City
- Corona
- Eastvale
- Hemet
- Indio
- Jurupa Valley
- Lake Elsinore
- Menifee
- Moreno Valley
- Palm Springs
- Palm Desert (currently in the process)
- Rancho Mirage (received a demand letter)
- Riverside
- Temecula
- Wildomar

# Summary

- No district has prevailed in a CVRA action.
- The intent of the CVRA is for all cities and political districts to eventually move to a district election system.
- Potential for costly litigation.
- Cities and political districts that move to a district election system on their own volition will save money.



## Staff Report

**TO:** Mayor, and City Council Members  
**FROM:** Jeff Mohlenkamp, Finance Director  
**DATE:** June 2, 2020  
**SUBJECT:** FY 2020-21 City-Wide Budget Review and Approval

---

### Background and Analysis:

On May 5, 2020, the City Council reviewed the General Fund and Wastewater Fund budgets for FY2020-21. Staff developed strategies with City Council review for cost reductions of both personnel and operating costs to build a balanced budget that meets the guidance provided by the City Council.

### Budget Overview

The City has three major operating funds (General Fund, Wastewater Fund and Transit Fund). Revenues and expenditures for FY 2020-21 for these three funds are as follows:

Operating Fund	Revenues	Expenditures
General Fund	\$ 33,018,793	\$ 33,018,793
Wastewater	\$ 10,892,800	\$ 10,892,800
Transit	\$ 3,084,384	\$ 3,084,384

Additionally, there are several other special funds that round out the budget. These funds are used to both support operations and make capital acquisitions. They include development impact fees, community facilities district fees, grants funds and state/county pass through funds. A summary listing of all funds and projected revenues and expenditures is included as Attachment A.

Total revenues across all funds, including transfers, is projected to be \$68.7 million. Total expenditures are budgeted at \$70.9 million. This represents the planned draw down of \$2.2 million in certain DIF balances for capital projects identified in the Five-Year Capital Improvement Project list. This reflects the programmed use of restricted funds that have accumulated for capital projects.

A detailed listing of revenues and expenditures for all funds is included as Attachment F.

## General Fund Highlights

- Revenues are projected to drop slightly from FY 2020 to FY 2021 in anticipation that property taxes and CFD revenues will increase while sales tax and development related revenues will decrease,
- Expenses are budgeted at 2% less than FY 2020. Both personnel and operating costs are decreased slightly,
- The Contingency Fund in Administration has been increased from \$50,000 to \$150,000 to assist the City in addressing unforeseen costs,
- Contractual services adjustments with more services to be conducted internally (permitting, inspections, financial reporting, etc.), and
- Close monitoring of the budget will be essential to assess whether funding can be restored or whether additional reductions may be necessary.

A summary for the General Fund is included as Attachment B. Charts demonstrating major revenue sources and expenditures categories are included as Attachments C and D.

## Wastewater Fund Highlights

- Revenues are expected to increase due to the expected growth of the number of residences and businesses and a scheduled 5% increase in rates,
- Expenses are expected to increase slightly due to the fund covering a larger share of debt service costs and a small increase in operating costs. It is offset by a reduction in planned capital costs from this operating fund, and
- Some unexpected capital costs may still occur during FY 2020-21 with the newly constructed wastewater treatment plant as needs are identified that were not previously addressed. A \$300,000 contingency is built into the budget to address these costs if necessary.

A summary for the Wastewater Fund is included as Attachment E.

The Transit Fund budget was previously approved by the City Council on April 21, 2020. It is incorporated into the overall budget and is subject to approval by the Riverside County Transit Commission.

## Fiscal Impact:

This item sets the City-wide budget for FY 2021 and provides expenditures authority for operations.

## Recommended Action:

Adopt the City-Wide Budget for FY 2020-21.

**Attachments:**

- A. FY 2020-21 Summary of All Funds Revenue and Expenditures
- B. FY 2020-21 General Fund Summary
- C. FY 2020-21 General Fund – Chart for Revenues
- D. FY 2020-21 General Fund – Chart for Expenses
- E. FY 2020-21 Wastewater Fund Summary
- F. FY 2020-21 Detailed list of All Funds Revenue and Expenditures

**City of Beaumont  
Budget Summary by Fund  
Fiscal Year 2021**

**Operating Funds**

#	Fund Name	Estimated				Estimated	
		Beginning Fund	Revenue	%	Expenditure	Net	Ending Fund
		Balance					Balance
100	GENERAL FUND	16,199,841.00	\$ 33,018,793.00	70.26%	\$ 33,018,793.00	-	16,199,841.00
700	WASTEWATER	7,613,730.00	10,892,800.00	23.18%	10,892,800.00	-	7,613,730.00
750	TRANSIT	-	3,084,384.00	6.56%	2,776,095.00	308,289.00	308,289.00
755	TRANSIT GASB		-	0.00%	308,289.00	(308,289.00)	(308,289.00)
			<u>\$ 46,995,977.00</u>	<u>100%</u>	<u>\$ 46,995,977.00</u>	<u>-</u>	

**Special Revenue Funds that Support Operating Funds and Other Funds**

120	Self Insurance	2,293,593.00					2,293,593.00
200	HIGHWAY USERS TAX	-	976,216.00	6.03%	976,216.00	-	-
201	STATE - SB1 FUNDING	188,513.00	766,244.00	4.73%	730,000.00	36,244.00	224,757.00
202	SALES TAX - MEASURE A	158,544.00	735,074.00	4.54%	800,000.00	(64,926.00)	93,618.00
205	MOTOR VEHICLE SUBVENTION (AB2766-AQMD)	482,280.00	65,520.00	0.40%	-	65,520.00	547,800.00
210	PUBLIC, EDUCATIONAL, GOVT (PEG)	9,273.00	27,807.00	0.17%	-	27,807.00	37,080.00
215	GRANTS (REIMBURSABLE)	-	440,000.00	2.72%	440,000.00	-	-
220	CITIZEN OPTION PUBLIC SAFETY (COPS)	226,737.00	102,609.00	0.63%	90,937.00	11,672.00	238,409.00
225	ASSET SEIZURES (STATE)	282,771.00	6,169.00	0.04%	-	6,169.00	288,940.00
230	ASSET SEAIZURES (FEDERAL)	10,995.00	3,028.00	0.02%		3,028.00	14,023.00
240	OTHER RESTRICTED FUNDS	89,516.00	34,546.00	0.21%	51,630.00	(17,084.00)	72,432.00
250	COMMUNITY FAC DISTRICT (CFD) - ADMIN	8,541,846.00	1,598,785.00	9.87%	1,998,052.00	(399,267.00)	8,142,579.00
255	COMMUNITY FAC DISTRICT (CFD) - MAINT SERVICES	528,439.00	3,895,009.00	24.05%	3,895,009.00	-	528,439.00
260	COMMUNITY FAC DISTRICT (CFD) - PUBLIC SAFETY	348,512.00	571,020.00	3.53%	571,020.00	-	348,512.00
265	COMMUNITY FAC DISTRICT - FACILITES	-		0.00%		-	-
850	BEAUMONT FINANCE AUTHORITY (CFD)	98,066,012.00	6,450,029.00	39.82%	6,293,649.00	156,380.00	98,222,392.00
855	BEAUMONT PUBLIC IMPROVEMENT AUTHORITY	9,625.00	526,550.00	3.25%	526,450.00	100.00	9,725.00
			<u>\$ 16,198,606.00</u>	<u>100%</u>	<u>\$ 16,372,963.00</u>	<u>\$ (174,357.00)</u>	

**Capital Project Funds**

510	COMMUNITY FACILITES DISTRICT (CFD)	12,604,132.00	710,001.00	11.82%	1,503,000.00	(792,999.00)	11,811,133.00
550	OTHER MITIGATION	7,145.00	-	0.00%	-	-	7,145.00



552 BASIC SERVICES MITIGATION	155,092.00	159,408.00	2.65%	-	159,408.00	314,500.00
554 GENERAL PLAN MITIGATION	(17,782.00)	17,782.00	0.30%	-	17,782.00	-
555 RECREATIONAL FACILITIES MITIGATION	935,947.00	266,952.00	4.45%	900,000.00	(633,048.00)	302,899.00
556 TRAFFIC SIGNAL MITIGATION	1,426,966.00	106,359.00	1.77%	150,000.00	(43,641.00)	1,383,325.00
558 RAILROAD CROSSING MITIGATION	1,559,754.00	120,518.00	2.01%	-	120,518.00	1,680,272.00
705 WASTEWATER MITIGATION	2,815,099.00	2,098,604.00	34.95%	282,000.00	1,816,604.00	4,631,703.00
559 POLICE FACILITIES MITIGATION	786,466.00	184,191.00	3.07%	250,000.00	(65,809.00)	720,657.00
560 FIRE STATION MITIGATION	232,278.00	237,204.00	3.95%	-	237,204.00	469,482.00
562 ROAD AND BRIDGE MITIGATION	2,717,352.00	990,891.00	16.50%	600,000.00	390,891.00	3,108,243.00
564 RECYCLED WATER MITIGATION	(517,867.00)	296,639.00	4.94%	-	296,639.00	(221,228.00)
566 EMERGENCY PREPAREDNESS MITIGATION	(1,124,356.00)	258,289.00	4.30%	-	258,289.00	(866,067.00)
567 COMMUNITY PARK MITIGATION	1,299,725.00	252,467.00	4.20%	1,145,000.00	(892,533.00)	407,192.00
568 REGIONAL PARK MITIGATION	1,927,025.00	-	0.00%	1,900,000.00	(1,900,000.00)	27,025.00
569 NEIGHBORHOOD PARK MITIGATION	1,572,884.00	305,529.00	5.09%	1,350,000.00	(1,044,471.00)	528,413.00
		\$ 6,004,834.00	100.00%	\$ 8,080,000.00	\$ (2,075,166.00)	

Note: Transfers between Funds are included in these totals

**FY 2020-21 GENERAL FUND BUDGET**

City of Beaumont, CA

Budget Reductions Included



	FY 2017-18 Actuals	FY 2018-19 Actuals	FY 2019-20 BUDGET	FY 2019-20 Estimated Results	FY 2020-21 Budget for Adoption
<b>REVENUES</b>					
<b>Taxes</b>					
Property Tax	\$ 5,199,098	\$ 5,656,662	\$ 5,051,562	\$ 5,849,278	\$ 6,141,742
Sales Tax	\$ 5,029,443	\$ 5,558,667	\$ 5,436,227	\$ 5,069,306	\$ 4,025,048
Motor Vehicle in Lieu	\$ 4,125,662	\$ 4,517,090	\$ 5,002,506	\$ 4,997,852	\$ 5,247,745
Utility Users Tax	\$ 1,524,158	\$ 1,584,224	\$ 1,604,250	\$ 1,895,581	\$ 1,600,000
Franchise Fees	\$ 876,551	\$ 912,924	\$ 853,875	\$ 933,280	\$ 869,846
Franchise Fees - Waste Management	\$ -	\$ -	\$ 2,100,000	\$ 2,100,000	\$ 2,100,000
One time franchise fee	\$ -	\$ -	\$ 5,000,000	\$ 5,000,000	\$ -
Transient Occupancy Tax	\$ 363,868	\$ 335,304	\$ 268,925	\$ 250,432	\$ 196,000
Other Taxes	\$ -	\$ 23,154	\$ 20,700	\$ 38,307	\$ 40,000
<b>Total Taxes</b>	<b>\$ 17,118,780</b>	<b>\$ 18,588,024</b>	<b>\$ 25,338,045</b>	<b>\$ 26,134,036</b>	<b>\$ 20,220,381</b>
Business License	\$ 242,634	\$ 287,908	\$ 214,221	\$ 257,405	\$ 225,000
<b>Permits</b>					
Building Permits	\$ 2,076,224	\$ 3,122,755	\$ 2,324,500	\$ 1,847,635	\$ 1,800,000
Public Works Inspection	\$ 1,263,922	\$ 519,597	\$ 900,000	\$ 150,819	\$ 210,000
Develop Service Plan Check	\$ 237,744	\$ 945,230	\$ 1,025,000	\$ 435,214	\$ 400,000
All other permits	\$ 966,629	\$ 958,443	\$ 918,385	\$ 476,123	\$ 417,500
<b>Total Permits</b>	<b>\$ 4,544,519</b>	<b>\$ 5,546,026</b>	<b>\$ 5,167,885</b>	<b>\$ 2,909,791</b>	<b>\$ 2,827,500</b>
Charges for Services	\$ 8,792,761	\$ 9,160,139	\$ 877,950	\$ 880,086	\$ 1,018,400
Other Revenues	\$ 824,438	\$ 1,077,341	\$ 409,319	\$ 881,098	\$ 813,500
Transfers In (CFD and Gas)	\$ 4,299,392	\$ 5,450,787	\$ 6,121,237	\$ 6,121,237	\$ 7,164,012
Transfers In (admin coverage)					\$ 750,000
<b>Total Revenue</b>	<b>\$ 35,822,524</b>	<b>\$ 40,110,225</b>	<b>\$ 37,914,436</b>	<b>\$ 37,183,653</b>	<b>\$ 33,018,793</b>
<b>Expenses</b>					
<b>Personnel</b>					
Salaries	\$ 9,590,672	\$ 10,965,713	\$ 11,959,929	\$ 11,027,176	\$ 12,759,643
Health Insurance	\$ 1,384,031	\$ 1,585,813	\$ 2,272,646	\$ 1,890,872	\$ 2,105,708
Workers Comp/Disability/Other Compensation	\$ 1,251,663	\$ 2,230,699	\$ 2,454,417	\$ 2,513,506	\$ 1,386,878
Retirement	\$ 2,244,152	\$ 2,434,460	\$ 3,027,640	\$ 2,750,173	\$ 2,965,968
<b>Total Personnel Services</b>	<b>\$ 14,470,518</b>	<b>\$ 17,216,685</b>	<b>\$ 19,714,632</b>	<b>\$ 18,181,727</b>	<b>\$ 19,218,197</b>
<b>Operating</b>					
CONTRACTUAL SERVICES	\$ 5,283,353	\$ 6,336,492	\$ 6,534,147	\$ 6,957,330	\$ 7,305,058
UTILITIES	\$ 1,266,736	\$ 1,233,172	\$ 1,472,264	\$ 1,189,310	\$ 1,265,899
INSURANCE	\$ 745,750	\$ 894,848	\$ 1,122,602	\$ 1,111,127	\$ 1,366,566
PLAN CHECK FEES	\$ 770,716	\$ 1,008,345	\$ 750,000	\$ 469,681	\$ 355,000
INSPECTIONS	\$ 646,948	\$ 521,630	\$ 300,000	\$ 353,369	\$ 31,000
Other Operating Costs	\$ 6,650,238	\$ 8,251,324	\$ 2,536,283	\$ 2,346,121	\$ 3,105,257
<b>Total Operating Costs</b>	<b>\$ 15,363,741</b>	<b>\$ 18,245,810</b>	<b>\$ 12,715,296</b>	<b>\$ 12,426,938</b>	<b>\$ 13,428,780</b>
<b>Capital Costs</b>					
Equipment and Furniture	\$ 96,772	\$ 447,740	\$ 116,988	\$ 116,934	\$ 98,000
Vehicles	\$ 602,312	\$ 209,275	\$ 351,020	\$ 466,169	\$ 273,816
<b>Total Capital Costs</b>	<b>\$ 720,632</b>	<b>\$ 670,831</b>	<b>\$ 468,008</b>	<b>\$ 583,103</b>	<b>\$ 371,816</b>
<b>Total Expense</b>	<b>\$ 30,554,891</b>	<b>\$ 36,133,326</b>	<b>\$ 32,897,936</b>	<b>\$ 31,191,768</b>	<b>\$ 33,018,793</b>
<b>Operating Surplus/(Deficit)</b>	<b>\$ 5,267,633</b>	<b>\$ 3,976,899</b>	<b>\$ 5,016,500</b>	<b>\$ 5,991,885</b>	<b>\$ -</b>

Notes: Solid Waste revenues and expenses eliminated/ Measure A eliminated/Admin overhead converted to transfer

### FY 2020-21 General Fund Revenues and Transfers

Revenue Type	FY 2021 Budget	%
Other Taxes	4,805,836.00	15%
Transfers In	7,914,012.00	24%
Sales Tax	4,025,048.00	12%
Permits and Fees	2,827,500.00	9%
Property Tax	11,389,497.00	34%
Charges for Services	1,018,400.00	3%
Licenses	225,000.00	1%
Fines and Forfeitures	115,000.00	0%
Cost Recovery	359,000.00	1%
Miscellaneous	324,500.00	1%
Intergovernmental Revenue	-	0%
Other Financing Sources	15,000.00	0%
Proprietary	-	0%
<b>TOTAL</b>	<b>33,018,793.00</b>	<b>100%</b>

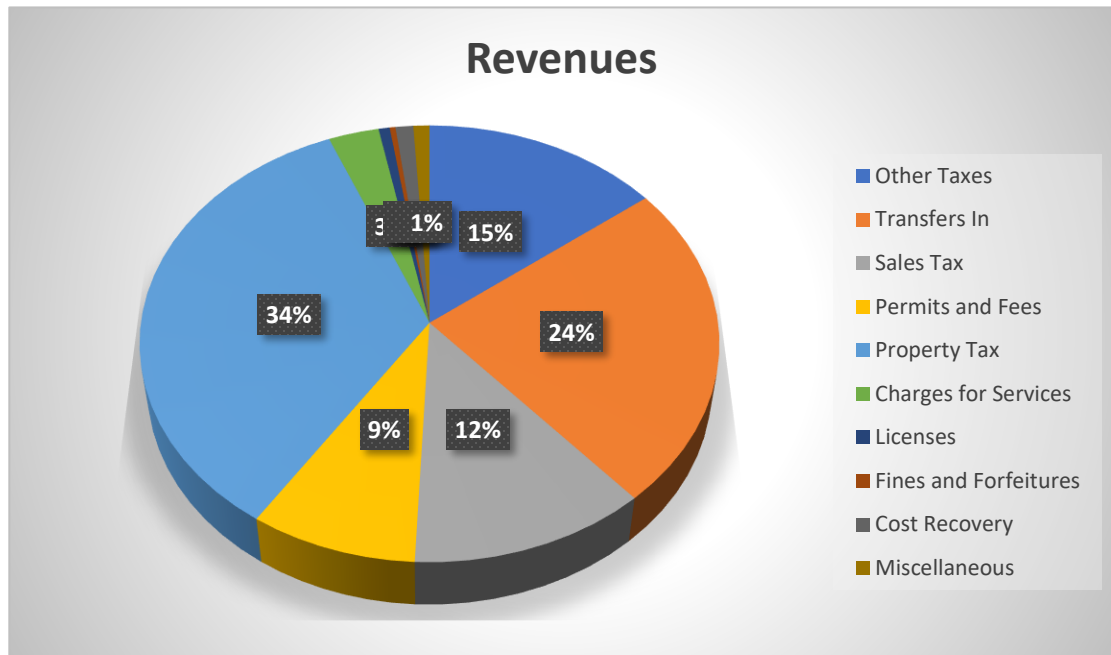

Transfers-In		%
Gas Tax	976,216.00	14%
COPS	65,770.00	1%
CFD Maint	3,895,009.00	54%
CFD Public Safety	571,020.00	8%
CFD Admin	1,655,997.00	23%
<b>Total</b>	<b>7,164,012.00</b>	<b>100%</b>

Transfers-In - Overhead		%
Wastewater	650,000.00	87%
Transit	100,000.00	13%
<b>Total</b>	<b>750,000.00</b>	<b>100%</b>

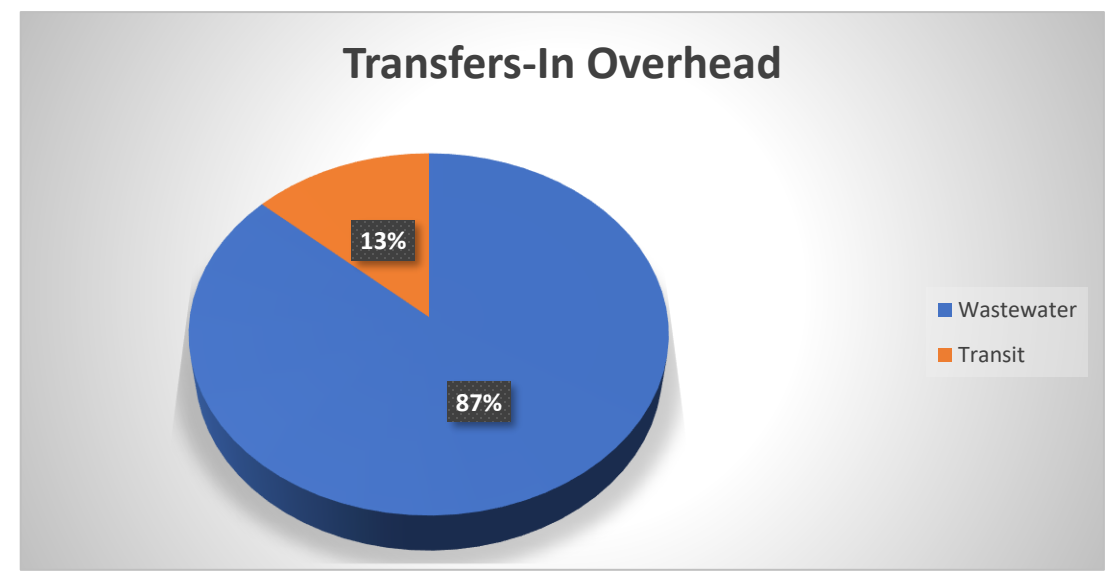
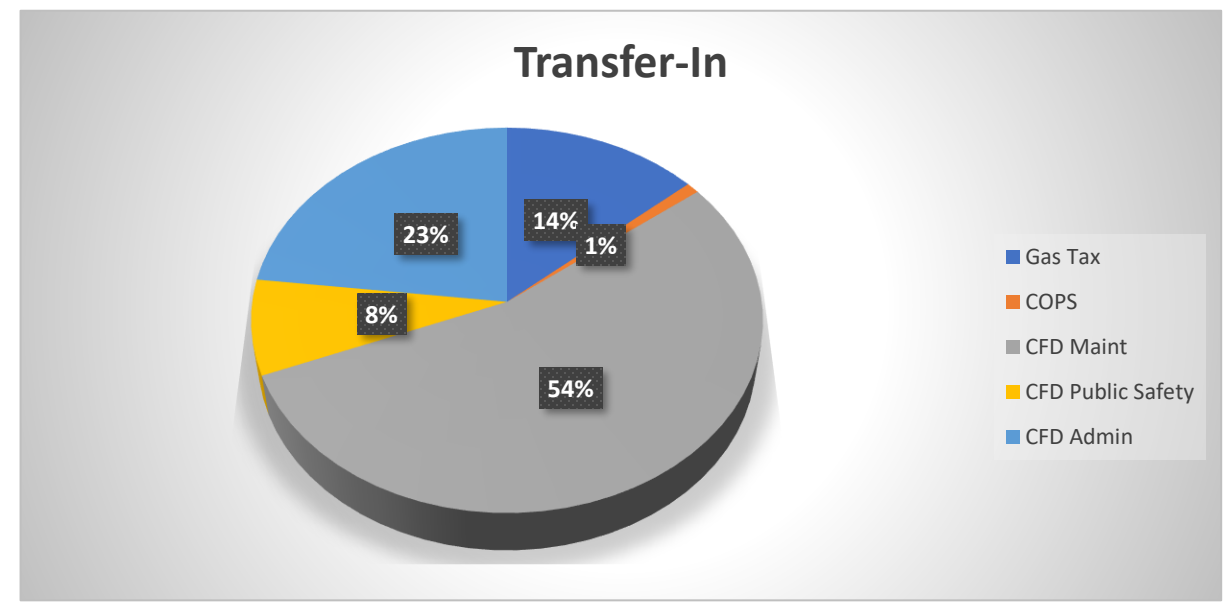

### FY 2020-21 General Fund Budgeted Expenses

By Function	Total Expenditures	%
Public Safety	16,505,120.00	50%
Parks and Grounds	3,507,815.00	11%
Streets	1,599,040.00	5%
Public Works	1,151,943.00	3%
Community Services	481,145.00	1%
Community Development	1,875,363.00	6%
General Government	7,898,367.00	24%
	<b>33,018,793.00</b>	<b>100%</b>

Expenditure Type	Total Expenditures	%
Personnel	19,218,197.00	58%
Operating Costs	13,278,779.00	40%
Capital Improvements	371,816.00	1%
Contingency	150,001.00	0%
	<b>33,018,793.00</b>	<b>100%</b>

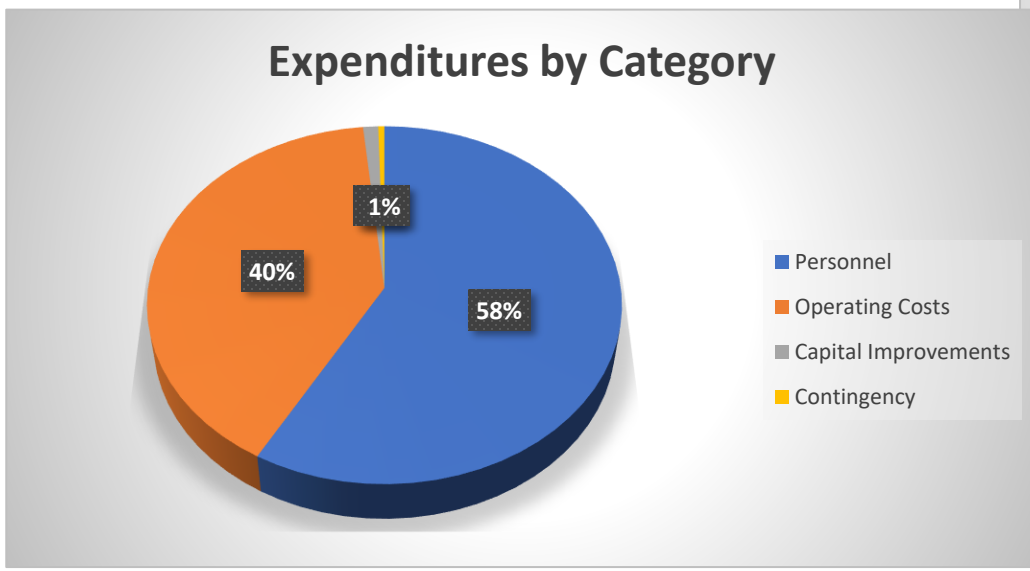
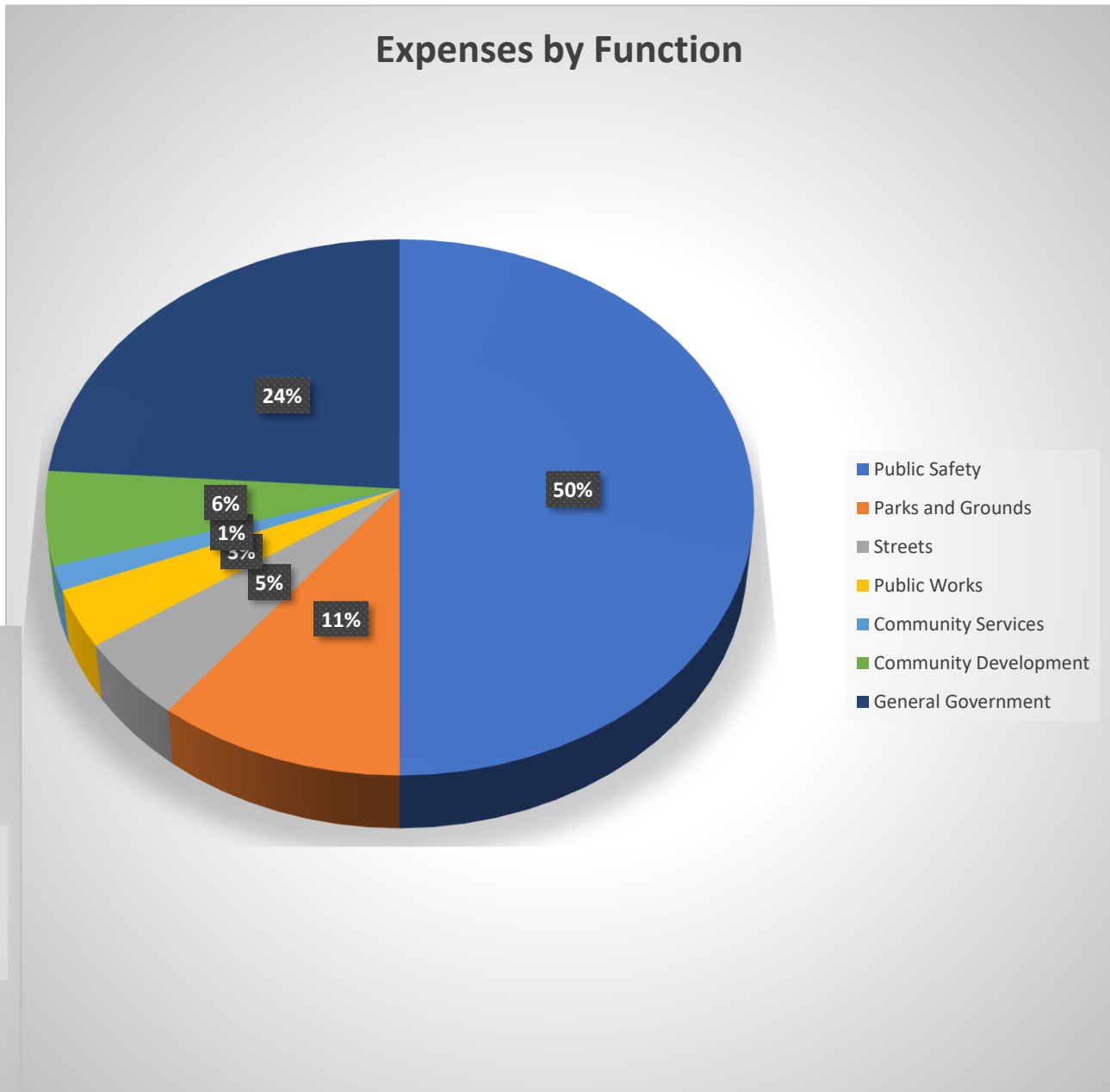

Departments	Budget	%
City Council	48,913.00	0%
City Clerk	229,694.00	1%
Administration	2,044,298.00	6%
Finance and Budget	1,034,306.00	3%
I.T.	1,347,479.00	4%
Risk and Human Resources	1,943,177.00	6%
Legal	1,250,500.00	4%
Community Development	528,994.00	2%
Community Services	466,145.00	1%
Animal Control	324,893.00	1%
Community Enhancement	307,781.00	1%
Police	9,941,711.00	30%
K-9	5,550.00	0%
Police Support	1,653,658.00	5%
Fire	4,579,308.00	14%
Building and Safety	1,038,588.00	3%
Public Works	1,151,943.00	3%
Street Maintenance	1,599,040.00	5%
Building Maintenance	434,764.00	1%
Parks and Grounds	3,073,051.00	9%
City Pool	15,000.00	0%
<b>Total</b>	<b>33,018,793.00</b>	<b>100%</b>

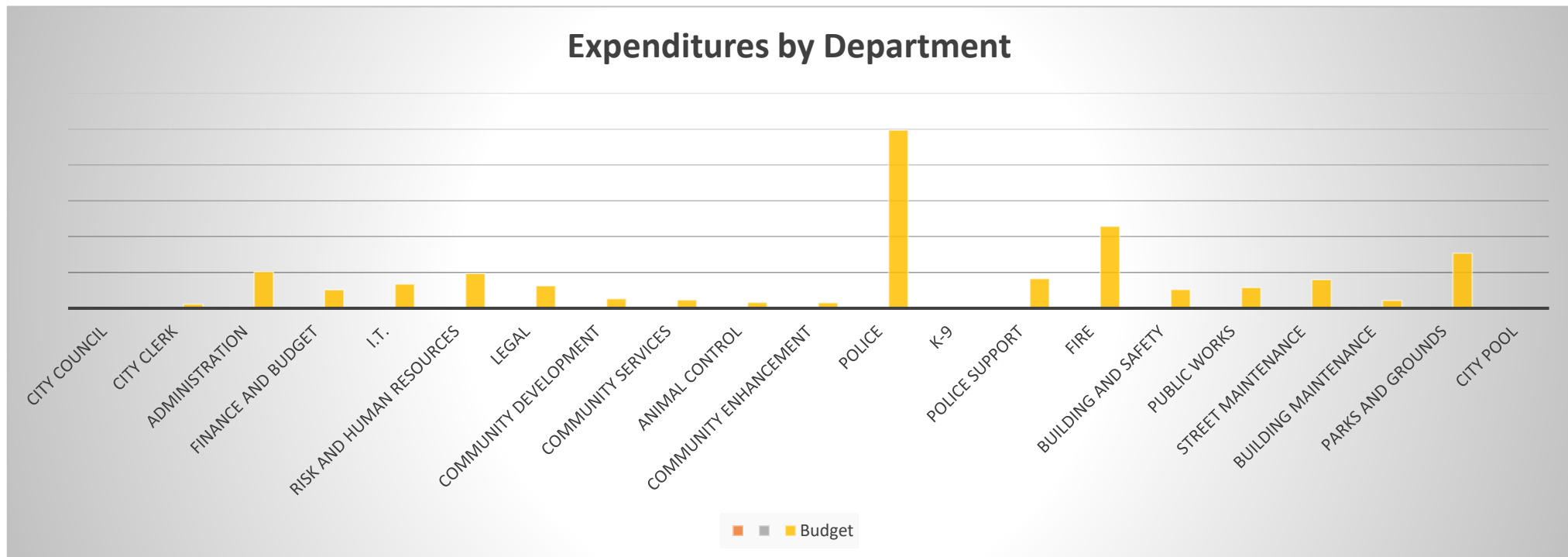

## FY 2020-21 WASTEWATER FUND BUDGET

Final Draft for Council Adoption



	FY 2017-18 Actuals	FY 2018-19 Actuals	FY 2019-20 BUDGET	FY 2019-20 Estimated Results	FY 2020-21 Draft Budget
<b>REVENUES</b>					
Sewer Service Fees	\$ 7,967,757	\$ 8,779,252	\$ 9,851,375	\$ 10,040,958	\$ 10,833,000
Interest	\$ -	\$ 118,335	\$ 75,000	\$ 86,907	\$ 37,500
Sewer Permits/ Application Fees	\$ 15,993	\$ 20,892	\$ 11,250	\$ 11,636	\$ 16,000
Cost Recovery	\$ 11,312	\$ -	\$ -	\$ 6,236	\$ 6,300
Sewer Connection/ Standby Fees	\$ 63,126	\$ 2,773	\$ -	\$ -	\$ -
Transfer In	\$ (3,855,106)	\$ 221,047	\$ -	\$ -	\$ -
Miscellaneous Revenues	\$ -	\$ 10,465	\$ -	\$ 1,780	\$ -
<b>Total Revenue</b>	<b>\$ 4,203,082</b>	<b>\$ 9,152,764</b>	<b>\$ 9,937,625</b>	<b>\$ 10,147,517</b>	<b>\$ 10,892,800</b>
<b>Expenses</b>					
<b>Personnel</b>					
Salaries	\$ 205,802	\$ 667,531	\$ 1,208,132	\$ 1,074,791	\$ 1,106,592
Health Insurance	\$ 27,771	\$ 77,053	\$ 248,100	\$ 108,357	\$ 152,199
Workers Comp/Disability/Other Compensation	\$ 8,794	\$ 39,603	\$ 97,702	\$ 90,688	\$ 99,236
Retirement	\$ 42,202	\$ 124,612	\$ 236,073	\$ 227,504	\$ 238,165
Other Personnel Costs	\$ 3,141	\$ 32,197	\$ 104,212	\$ 44,356	\$ 67,161
<b>Total Personnel Services</b>	<b>\$ 287,710</b>	<b>\$ 940,996</b>	<b>\$ 1,894,219</b>	<b>\$ 1,545,696</b>	<b>\$ 1,663,353</b>
<b>Operating</b>					
Contractual Services	\$ 1,493,716	\$ 1,376,890	\$ 1,147,140	\$ 990,178	\$ 1,062,563
Utilities	\$ 666,975	\$ 770,280	\$ 819,450	\$ 709,141	\$ 827,821
Admin Overhead	\$ 600,000	\$ 612,000	\$ 650,000	\$ 650,000	\$ 650,000
License Permits and Fees	\$ 99,600	\$ 71,726	\$ 62,474	\$ 90,917	\$ 263,018
Special Dept Supplies	\$ 292,219	\$ 276,232	\$ 316,000	\$ 237,670	\$ 374,000
Other Operating Costs	\$ 142,147	\$ 370,965	\$ 939,084	\$ 876,836	\$ 906,620
<b>Total Operating Costs</b>	<b>\$ 3,294,657</b>	<b>\$ 3,478,093</b>	<b>\$ 3,934,148</b>	<b>\$ 3,554,742</b>	<b>\$ 4,084,022</b>
<b>Capital Costs</b>					
Debt Service Payment	\$ -	\$ -	\$ 3,738,688	\$ 3,738,688	\$ 4,791,787
Wastewater Equipment			\$ 198,637	\$ 218,189	\$ 153,638
Capital Projects			\$ 795,000	\$ 795,000	\$ 200,000
<b>Total Expenses</b>	<b>\$ 3,582,367</b>	<b>\$ 4,419,089</b>	<b>\$ 10,560,692</b>	<b>\$ 9,852,315</b>	<b>\$ 10,892,800</b>
<b>Operating Surplus/(Deficit)</b>	<b>\$ 620,715</b>	<b>\$ 4,733,675</b>	<b>\$ (623,067)</b>	<b>\$ 295,202</b>	<b>\$ -</b>

The Wastewater operating fund is a relatively new operation to the City as it was contracted out in the past. Capital costs and repairs have been significant and the true costs of operating the system are still being determined. The budget and actual for FY 2020 provides that \$1 million of debt service was paid using development impact fees (DIF). This process will be followed again for FY 2021, with the transfer for debt service payments reduced to the amount of \$282,000. Without this transfer the fund would have a deficit of approximately (\$282K). The City plans to re-evaluate rates and will have a better understanding of operating costs by the end of FY 2021. This will allow the development of a plan to move away from using DIF to support debt payments, which is not sustainable in the long term.



City of Beaumont, CA

Item 9.  
**Budget Worksheet**  
**Account Summary**

For Fiscal: 2020-2021 Period Ending: 05/31/2021

		Defined Budgets					
		2018-2019	2018-2019	2019-2020	2019-2020	2020-2021	2020-2021
		Total Budget	Total Activity	Total Budget	Total Activity	Total Budget	YTD Activity
<b>Fund: 100 - GENERAL FUND</b>							
<b>Department: 0000 - NON-DEPARTMENTAL</b>							
<a href="#">100-0000-4005-0000</a>	SECURED PROPERTY TAX	3,771,115.00	4,520,152.48	4,178,562.00	3,117,918.06	4,887,655.00	0.00
<a href="#">100-0000-4008-0000</a>	UNSECURED PROPERTY TAXES	205,950.00	176,340.70	228,000.00	254,416.12	267,137.00	0.00
<a href="#">100-0000-4010-0000</a>	PROPERTY TRANSFER TAX	230,000.00	357,519.58	255,000.00	317,110.62	369,255.00	0.00
<a href="#">100-0000-4015-0000</a>	STREET LIGHT ASSESSMENT (PR...	354,320.00	602,649.00	390,000.00	394,247.73	617,695.00	0.00
<a href="#">100-0000-4050-0000</a>	SALES & USE TAXES	5,112,393.00	5,399,963.59	5,291,327.00	3,745,340.82	3,899,316.00	0.00
<a href="#">100-0000-4055-0000</a>	1/2% SALES TAX-PBLC SFTY	140,000.00	158,703.60	144,900.01	137,391.11	125,732.00	0.00
<a href="#">100-0000-4060-0000</a>	MOTOR VEH IN-LIEU TAXES	4,517,089.00	4,517,090.00	5,002,505.85	2,498,926.00	5,247,745.00	0.00
<a href="#">100-0000-4065-0000</a>	VEH.LICENSE COLLECTION	20,000.00	23,153.98	20,700.00	38,307.18	40,000.00	0.00
<a href="#">100-0000-4075-0000</a>	UTILITY USERS TAX	1,550,000.00	1,584,224.14	1,604,250.00	1,603,433.41	1,600,000.00	0.00
<a href="#">100-0000-4080-0000</a>	FRANCHISE FEES - EDISON	305,000.00	319,943.99	315,675.00	0.00	303,947.00	0.00
<a href="#">100-0000-4082-0000</a>	FRANCHISE FEES - CABLE	200,000.00	296,737.85	207,000.00	197,136.66	293,154.00	0.00
<a href="#">100-0000-4085-0000</a>	FRANCHISE FEES - VERIZON/FRO...	225,000.00	199,366.17	232,875.00	138,678.82	180,713.00	0.00
<a href="#">100-0000-4087-0000</a>	FRANCHISE FEES- GAS COMPANY	95,000.00	96,875.54	98,325.00	114,528.72	92,032.00	0.00
<a href="#">100-0000-4088-0000</a>	FRANCHISE FEE -WASTE MANAG...	0.00	0.00	2,100,000.00	2,100,000.00	2,100,000.00	0.00
<a href="#">100-0000-4089-0000</a>	ONE TIME FRANCHISE RETENTIO...	0.00	0.00	5,000,000.00	5,000,000.00	0.00	0.00
<a href="#">100-0000-4090-0000</a>	TRANSIENT OCCUPANCY TAX	255,000.00	335,303.62	268,925.01	217,247.23	196,000.00	0.00
<a href="#">100-0000-4200-0000</a>	BUSINESS LICENSES	212,100.00	287,908.45	214,221.00	174,317.54	225,000.00	0.00
<a href="#">100-0000-4210-2000</a>	ANIMAL LICENSE - BEAUMONT	90,000.00	56,628.02	76,000.00	41,499.47	60,000.00	0.00
<a href="#">100-0000-4210-2100</a>	ANIMAL LICENSE - BANNING	0.00	240.00	0.00	0.00	0.00	0.00
<a href="#">100-0000-4210-2150</a>	ANIMAL LICENSE - CALIMESA	0.00	8,510.00	0.00	5,355.00	6,600.00	0.00
<a href="#">100-0000-4211-2000</a>	ANIMAL LICENSE - LATE FEE BEA...	0.00	2,175.00	0.00	2,270.00	3,000.00	0.00
<a href="#">100-0000-4211-2150</a>	ANIMAL LICENSE - LATE FEE CAL...	0.00	535.00	0.00	300.00	500.00	0.00
<a href="#">100-0000-4212-2000</a>	ANIMAL LICENSE - REPLACEMENT..	0.00	775.00	0.00	525.00	600.00	0.00
<a href="#">100-0000-4212-2100</a>	ANIMAL LICENSE - REPLACEMENT..	0.00	25.00	0.00	0.00	0.00	0.00
<a href="#">100-0000-4212-2150</a>	ANIMAL LICENSE - REPLACEMENT..	0.00	325.00	0.00	150.00	300.00	0.00

Defined Budgets

		2018-2019 Total Budget	2018-2019 Total Activity	2019-2020 Total Budget	2019-2020 Total Activity	2020-2021 Total Budget	2020-2021 YTD Activity
<a href="#">100-0000-4310-0000</a>	BUILDING PERMITS AND INSPECT...	2,324,500.00	3,122,755.00	2,324,500.00	1,447,174.99	1,800,000.00	0.00
<a href="#">100-0000-4315-0000</a>	YARD SALE	5,000.00	6,365.00	5,000.00	3,145.00	6,000.00	0.00
<a href="#">100-0000-4318-0000</a>	TRANSPORTATION PERMITS	5,000.00	5,834.00	5,000.00	5,314.00	5,500.00	0.00
<a href="#">100-0000-4320-0000</a>	MISC PERMITS	49,000.00	5,827.89	7,715.00	14,682.16	15,000.00	0.00
<a href="#">100-0000-4325-0000</a>	ENCROACHMENT PERMITS	0.00	72,642.65	0.00	-75,974.50	0.00	0.00
<a href="#">100-0000-4330-0000</a>	BUILDING PLAN CHECK	1,025,000.00	945,230.32	1,025,000.00	408,702.23	400,000.00	0.00
<a href="#">100-0000-4450-0014</a>	COST RECOVERY	0.00	0.00	0.00	15.00	0.00	0.00
<a href="#">100-0000-4460-0000</a>	GRANTS	0.00	9,257.00	0.00	2,549.65	0.00	0.00
<a href="#">100-0000-4464-0002</a>	GRANT-CALRECYCLE	21,288.00	31,934.92	21,288.00	0.00	0.00	0.00
<a href="#">100-0000-4500-0000</a>	REFUSE COLLECTION - RESIDENT...	4,400,000.00	5,091,285.36	0.00	143,978.10	0.00	0.00
<a href="#">100-0000-4501-0000</a>	REFUSE COLLECTION - COMMERC...	2,500,000.00	2,995,607.20	0.00	0.00	0.00	0.00
<a href="#">100-0000-4505-2000</a>	ANIMAL CARE - MICRO CHIP	0.00	448.00	0.00	364.00	450.00	0.00
<a href="#">100-0000-4507-2000</a>	ANIMAL CARE - RETURN OF ANI...	0.00	2,931.00	0.00	2,775.00	3,300.00	0.00
<a href="#">100-0000-4507-2100</a>	ANIMAL CARE - RETURN OF ANI...	0.00	100.00	0.00	0.00	0.00	0.00
<a href="#">100-0000-4507-2150</a>	ANIMAL CARE - RETURN OF ANI...	0.00	420.00	0.00	80.00	100.00	0.00
<a href="#">100-0000-4513-2000</a>	ANIMAL CARE - OWNER TURN IN	0.00	1,769.00	0.00	2,387.00	2,100.00	0.00
<a href="#">100-0000-4513-2100</a>	ANIMAL CARE - OWNER TURN IN	0.00	0.00	0.00	404.00	400.00	0.00
<a href="#">100-0000-4513-2150</a>	ANIMAL CARE - OWNER TURN IN	0.00	971.00	0.00	574.00	700.00	0.00
<a href="#">100-0000-4515-2000</a>	ANIMAL CARE - EUTHANASIA FEE	0.00	468.00	0.00	202.00	200.00	0.00
<a href="#">100-0000-4515-2150</a>	ANIMAL CARE - EUTHANASIA FEE	0.00	101.00	0.00	101.00	100.00	0.00
<a href="#">100-0000-4517-2000</a>	ANIMAL CARE - TRAP RENTAL FEE	0.00	145.00	0.00	25.00	100.00	0.00
<a href="#">100-0000-4522-2150</a>	COST RECOVERY-ANIMAL CONT...	15,000.00	40,000.00	40,000.00	20,100.00	40,000.00	0.00
<a href="#">100-0000-4522-2200</a>	COST RECOVERY-ANIMAL CONT...	2,000.00	1,490.00	2,000.00	0.00	1,000.00	0.00
<a href="#">100-0000-4525-0000</a>	CODE ENFORCEMENT-WEED AB...	70,000.00	27,426.44	25,000.00	23,582.17	32,000.00	0.00
<a href="#">100-0000-4526-0000</a>	CODE ENFORCEMENT-OTHER	35,000.00	13,566.47	16,000.00	10,790.16	14,000.00	0.00
<a href="#">100-0000-4527-0000</a>	CODE ENFORCEMENT LIEN RECO...	25,000.00	1,236.48	25,000.00	6,040.00	8,500.00	0.00
<a href="#">100-0000-4528-0000</a>	PROPERTY ABATEMENT	0.00	292.24	0.00	0.00	0.00	0.00
<a href="#">100-0000-4530-0000</a>	LIVE SCAN-FINGERPRINTING	20,000.00	27,623.00	20,000.00	16,779.00	17,000.00	0.00
<a href="#">100-0000-4535-0000</a>	NOTARY FEES	500.00	270.00	500.00	495.00	500.00	0.00
<a href="#">100-0000-4540-0000</a>	PASSPORT FEES	35,000.00	38,630.00	35,000.00	20,930.00	30,000.00	0.00
<a href="#">100-0000-4550-0000</a>	SWIMMING POOL-ADMISSIONS	22,000.00	29,287.13	22,000.00	10,339.00	0.00	0.00



Budget Worksheet

Defined Budgets

		2018-2019 Total Budget	2018-2019 Total Activity	2019-2020 Total Budget	2019-2020 Total Activity	2020-2021 Total Budget	2020-2021 YTD Activity
<a href="#">100-0000-4551-0000</a>	RAILCAR FEES	5,670.00	6,489.00	5,670.00	2,961.00	3,500.00	0.00
<a href="#">100-0000-4552-0000</a>	SWIMMING POOL-FOOD SALES	4,400.00	2,281.15	4,400.00	64.00	0.00	0.00
<a href="#">100-0000-4556-0000</a>	PLANNING DEPARTMENT REVEN...	170,500.00	306,817.43	170,500.00	209,088.10	200,000.00	0.00
<a href="#">100-0000-4562-0000</a>	SPECIAL POLICE SERVICES	90,000.00	173,378.89	90,000.00	33,969.72	366,850.00	0.00
<a href="#">100-0000-4565-0000</a>	SCHOOL RESOURCE OFFICER PR...	137,000.00	142,485.03	149,460.21	149,977.75	154,000.00	0.00
<a href="#">100-0000-4566-0000</a>	PUBLIC WORKS-PERMITS	9,400.00	10,438.00	9,400.00	12,856.32	13,000.00	0.00
<a href="#">100-0000-4567-0000</a>	PUBLIC WORKS-PLAN CHECK	478,000.00	143,698.56	390,000.00	138,399.19	110,000.00	0.00
<a href="#">100-0000-4568-0000</a>	PUBLIC WORKS-INSPECTION	1,000,000.00	519,597.13	900,000.00	152,643.80	150,000.00	0.00
<a href="#">100-0000-4569-0000</a>	PUBLIC WORKS-ENGINEERING	180,100.00	133,803.87	180,100.00	22,251.83	60,000.00	0.00
<a href="#">100-0000-4570-0000</a>	COMMUNITY PROGRAMS	2,000.00	7,510.33	2,000.00	384.00	2,000.00	0.00
<a href="#">100-0000-4572-0000</a>	FIRE DEPT FEES	150,000.00	212,360.89	150,000.00	82,973.00	70,000.00	0.00
<a href="#">100-0000-4575-0000</a>	DAY CAMP PROGRAM	60,000.00	89,765.50	62,100.00	51,995.00	0.00	0.00
<a href="#">100-0000-4578-0000</a>	BOND ACCEPTANCE	5,000.00	3,348.00	5,000.00	5,301.00	4,200.00	0.00
<a href="#">100-0000-4579-0000</a>	BOND REDUCTION/EXONERATION	8,000.00	6,097.00	8,000.00	6,097.00	3,700.00	0.00
<a href="#">100-0000-4590-0000</a>	BUILDING RENTAL	125,000.00	179,469.39	125,000.00	101,948.44	125,000.00	0.00
<a href="#">100-0000-4595-1550</a>	COMMUNITY SERVICE STAFF TI...	20,000.00	22,205.00	20,000.00	15,100.00	18,000.00	0.00
<a href="#">100-0000-4599-0000</a>	SALE OF MISC COPIES	1,900.00	2,450.65	1,900.00	2,387.50	2,700.00	0.00
<a href="#">100-0000-4600-0000</a>	RELEASE OF LIEN	6,500.00	13,516.00	6,500.00	13,947.00	10,000.00	0.00
<a href="#">100-0000-4605-0000</a>	CANDIDATE REGISTRATION	0.00	933.63	0.00	-932.33	0.00	0.00
<a href="#">100-0000-4640-0000</a>	ABANDONED VEHICLE PROGRAM	5,000.00	1,473.00	5,175.00	9,430.13	12,000.00	0.00
<a href="#">100-0000-4641-0000</a>	GENERAL FINES	2,000.00	36,917.47	22,070.00	25,160.14	45,000.00	0.00
<a href="#">100-0000-4643-0000</a>	PARKING FINE REVENUE	8,000.00	17,758.50	8,280.00	15,032.00	13,000.00	0.00
<a href="#">100-0000-4647-0000</a>	CA VEHICLE CODE FINES	95,000.00	73,074.53	98,325.00	37,861.04	45,000.00	0.00
<a href="#">100-0000-4650-0000</a>	INTEREST	1,000.00	7,136.18	1,000.00	106,258.80	170,000.00	0.00
<a href="#">100-0000-4685-0000</a>	COST RECOVERY	0.00	120,691.36	0.00	81,927.78	134,000.00	0.00
<a href="#">100-0000-4685-0001</a>	COST RECOVERY - SOLID WASTE ...	0.00	0.00	125,000.00	125,000.00	127,500.00	0.00
<a href="#">100-0000-4685-00K9</a>	COST RECOVERY - K9 PROGRAM	0.00	5,185.00	0.00	0.00	0.00	0.00
<a href="#">100-0000-4689-0000</a>	COST RECOVERY-POST	0.00	8,889.40	0.00	24,870.02	25,000.00	0.00
<a href="#">100-0000-4693-0000</a>	INSURANCE RECOVERY	0.00	608,181.86	0.00	334,513.85	200,000.00	0.00
<a href="#">100-0000-4800-0000</a>	CASH OVER/SHORT	0.00	87.15	0.00	-31.75	0.00	0.00
<a href="#">100-0000-4820-0000</a>	ADMINISTRATIVE FEES	30,000.00	181,100.95	31,050.00	29,675.54	55,000.00	0.00

Budget Worksheet

Defined Budgets

		2018-2019 Total Budget	2018-2019 Total Activity	2019-2020 Total Budget	2019-2020 Total Activity	2020-2021 Total Budget	2020-2021 YTD Activity
<a href="#">100-0000-4821-0000</a>	ADMINISTRATIVE FEES - PLANNI...	0.00	0.00	0.00	0.00	10,000.00	0.00
<a href="#">100-0000-4822-0000</a>	ADMINISTRATIVE FEES - PUBLIC...	0.00	0.00	0.00	84,387.42	50,000.00	0.00
<a href="#">100-0000-4825-0000</a>	MISCELLANEOUS REVENUE	15,000.00	8,787.71	15,000.00	13,192.34	17,000.00	0.00
<a href="#">100-0000-4829-0000</a>	FIREWORKS EVENT	0.00	7,500.00	0.00	0.00	0.00	0.00
<a href="#">100-0000-4830-0000</a>	LEASE REVENUE	0.00	0.00	0.00	6,103.89	0.00	0.00
<a href="#">100-0000-4850-0000</a>	SALE OF PROPERTY	0.00	19,494.04	5,000.00	27,430.98	15,000.00	0.00
<a href="#">100-0000-8976-0000</a>	OBLIGATIONS INCURRED ON CAP...	0.00	167,456.00	0.00	0.00	0.00	0.00
<a href="#">100-0000-9950-0000</a>	TRANSFERS IN	5,132,745.00	5,450,786.76	6,121,237.00	1,831,407.65	7,164,012.00	0.00
<a href="#">100-0000-9951-0000</a>	TRANSFER IN - OVERHEAD	0.00	0.00	0.00	0.00	750,000.00	0.00
<a href="#">100-0000-9960-0000</a>	TRANSFERS OUT	0.00	914,693.22	154,000.00	45,194.35	0.00	0.00
<b>Department: 0000 - NON-DEPARTMENTAL Surplus (Deficit):</b>		<b>35,579,470.00</b>	<b>39,195,531.95</b>	<b>37,760,436.08</b>	<b>25,873,091.25</b>	<b>33,018,793.00</b>	<b>0.00</b>
<b>Department: 1050 - CITY COUNCIL</b>							
<a href="#">100-1050-6010-0000</a>	SALARIES	25,200.00	25,171.18	25,200.00	21,199.20	25,200.00	0.00
<a href="#">100-1050-6022-0000</a>	WORKERS COMP	838.00	774.01	1,260.00	629.40	1,260.00	0.00
<a href="#">100-1050-6024-0000</a>	P.E.R.S./P.E.P.R.A.	0.00	2,836.17	0.00	4.90	0.00	0.00
<a href="#">100-1050-6025-0000</a>	UNEMPLOYMENT	0.00	337.68	0.00	0.00	0.00	0.00
<a href="#">100-1050-6034-0000</a>	MEDICARE	365.00	365.30	365.00	288.04	365.00	0.00
<a href="#">100-1050-6035-0000</a>	FICA/PARS	328.00	327.60	328.00	277.15	328.00	0.00
<a href="#">100-1050-7025-0000</a>	OFFICE SUPPLIES	200.00	134.54	176.00	209.52	0.00	0.00
<a href="#">100-1050-7030-0000</a>	DUES & SUBSCRIPTIONS	2,500.00	2,500.00	5,250.00	0.00	5,250.00	0.00
<a href="#">100-1050-7035-0000</a>	LOCAL MEETINGS	3,000.00	5,711.51	7,500.00	2,277.05	2,000.00	0.00
<a href="#">100-1050-7065-0000</a>	UNIFORMS	0.00	178.86	24.00	161.62	0.00	0.00
<a href="#">100-1050-7066-0000</a>	TRAVEL, EDUCATION, TRAINING	4,000.00	6,553.75	11,000.00	8,050.98	14,510.00	0.00
<a href="#">100-1050-7068-0000</a>	CONTRACTUAL SERVICES	32,400.00	0.00	48,397.00	48,397.22	0.00	0.00
<a href="#">100-1050-7070-0000</a>	SPECIAL DEPT SUPPLIES	10,500.00	3,743.63	0.00	0.00	0.00	0.00
<b>Department: 1050 - CITY COUNCIL Total:</b>		<b>79,331.00</b>	<b>48,634.23</b>	<b>99,500.00</b>	<b>81,495.08</b>	<b>48,913.00</b>	<b>0.00</b>
<b>Department: 1150 - CITY CLERK</b>							
<a href="#">100-1150-6010-0000</a>	SALARIES	91,865.00	78,356.44	103,237.00	75,293.88	106,551.00	0.00
<a href="#">100-1150-6013-0000</a>	SICK LEAVE	0.00	1,855.14	0.00	913.50	0.00	0.00
<a href="#">100-1150-6014-0000</a>	HOLIDAY PAY	0.00	4,773.69	0.00	4,864.98	0.00	0.00
<a href="#">100-1150-6015-0000</a>	VACATION	0.00	7,923.16	0.00	2,034.34	0.00	0.00

Budget Worksheet

Defined Budgets

		2018-2019 Total Budget	2018-2019 Total Activity	2019-2020 Total Budget	2019-2020 Total Activity	2020-2021 Total Budget	2020-2021 YTD Activity
<a href="#">100-1150-6016-0000</a>	ACCRUED TIME CASH OUT	1,647.00	0.00	3,637.00	0.00	7,832.00	0.00
<a href="#">100-1150-6018-0000</a>	OTHER COMPENSATION	0.00	6,152.55	1,200.00	6,084.13	1,200.00	0.00
<a href="#">100-1150-6020-0000</a>	HEALTH INSURANCE	3,000.00	1,086.98	19,200.00	703.80	9,957.00	0.00
<a href="#">100-1150-6021-0000</a>	DENTAL INSURANCE	0.00	-78.20	0.00	164.22	0.00	0.00
<a href="#">100-1150-6022-0000</a>	WORKERS COMP	3,000.00	2,568.17	5,162.00	2,248.35	5,418.00	0.00
<a href="#">100-1150-6023-0000</a>	DISABILITY	600.00	583.80	526.00	535.15	526.00	0.00
<a href="#">100-1150-6024-0000</a>	P.E.R.S./P.E.P.R.A.	17,832.00	17,942.13	22,583.00	13,211.88	26,254.00	0.00
<a href="#">100-1150-6028-0000</a>	LIFE INSURANCE	84.00	84.00	84.00	77.00	84.00	0.00
<a href="#">100-1150-6034-0000</a>	MEDICARE	1,356.00	1,423.72	1,550.00	1,279.97	1,685.00	0.00
<a href="#">100-1150-6035-0000</a>	FICA/PARS	12.00	19.88	22.00	18.48	22.00	0.00
<a href="#">100-1150-7020-0000</a>	ADVERTISING	1,300.00	989.60	800.00	1,185.40	900.00	0.00
<a href="#">100-1150-7025-0000</a>	OFFICE SUPPLIES	800.00	753.22	800.00	782.46	400.00	0.00
<a href="#">100-1150-7027-0000</a>	HEALTH/FITNESS	0.00	0.00	600.00	0.00	300.00	0.00
<a href="#">100-1150-7030-0000</a>	DUES & SUBSCRIPTIONS	670.00	395.00	855.00	302.50	250.00	0.00
<a href="#">100-1150-7035-0000</a>	LOCAL MEETINGS	1,500.00	1,558.66	1,150.00	-710.41	0.00	0.00
<a href="#">100-1150-7066-0000</a>	TRAVEL, EDUCATION, TRAINING	1,150.00	1,345.95	2,600.00	4,434.88	315.00	0.00
<a href="#">100-1150-7068-0000</a>	CONTRACTUAL SERVICES	15,250.00	9,415.50	10,500.00	5,468.51	68,000.00	0.00
<a href="#">100-1150-7070-0000</a>	SPECIAL DEPT SUPPLIES	0.00	1,951.58	0.00	0.00	0.00	0.00
<b>Department: 1150 - CITY CLERK Total:</b>		<b>140,066.00</b>	<b>139,100.97</b>	<b>174,506.00</b>	<b>118,893.02</b>	<b>229,694.00</b>	<b>0.00</b>
<b>Department: 1200 - ADMINISTRATION</b>							
<a href="#">100-1200-6010-0000</a>	SALARIES	905,156.00	793,364.14	904,947.00	688,094.28	933,430.00	0.00
<a href="#">100-1200-6011-0000</a>	ADMIN TIME	0.00	9,316.01	5,705.00	5,704.55	0.00	0.00
<a href="#">100-1200-6012-0000</a>	OVERTIME	2,500.00	430.05	2,000.00	213.28	2,000.00	0.00
<a href="#">100-1200-6013-0000</a>	SICK LEAVE	0.00	22,522.27	4,235.00	18,055.19	0.00	0.00
<a href="#">100-1200-6014-0000</a>	HOLIDAY	0.00	49,577.33	3,411.00	49,676.82	0.00	0.00
<a href="#">100-1200-6015-0000</a>	VACATION	0.00	34,554.73	18,573.00	51,179.55	0.00	0.00
<a href="#">100-1200-6016-0000</a>	ACCRUED TIME CASH OUT	24,686.00	757.82	42,142.00	890.80	57,542.00	0.00
<a href="#">100-1200-6018-0000</a>	OTHER COMPENSATION	0.00	15,990.04	2,019.00	13,873.02	3,600.00	0.00
<a href="#">100-1200-6020-0000</a>	HEALTH INSURANCE	122,000.00	101,867.02	151,454.00	96,762.77	130,749.00	0.00
<a href="#">100-1200-6021-0000</a>	DENTAL INSURANCE	0.00	779.31	845.00	1,758.28	0.00	0.00
<a href="#">100-1200-6022-0000</a>	WORKERS COMP	33,835.00	25,496.10	3,899.00	20,595.78	48,882.00	0.00

Budget Worksheet

Defined Budgets

		2018-2019 Total Budget	2018-2019 Total Activity	2019-2020 Total Budget	2019-2020 Total Activity	2020-2021 Total Budget	2020-2021 YTD Activity
<a href="#">100-1200-6023-0000</a>	DISABILITY	4,734.00	5,086.39	4,208.00	4,331.25	4,208.00	0.00
<a href="#">100-1200-6024-0000</a>	P.E.R.S./P.E.P.R.A.	170,400.00	183,981.58	106,370.00	121,708.84	124,459.00	0.00
<a href="#">100-1200-6026-0000</a>	DEFERRED COMP	24,000.00	36,665.65	3,793.00	29,004.23	23,220.00	0.00
<a href="#">100-1200-6027-0000</a>	VISION CARE	340.00	451.43	102.00	493.70	0.00	0.00
<a href="#">100-1200-6028-0000</a>	LIFE INSURANCE	714.00	701.68	672.00	624.54	672.00	0.00
<a href="#">100-1200-6030-0000</a>	CAR ALLOWANCE	0.00	15,393.75	15,420.00	12,785.75	12,600.00	0.00
<a href="#">100-1200-6034-0000</a>	MEDICARE	13,519.00	13,263.38	14,309.00	11,908.45	15,039.00	0.00
<a href="#">100-1200-6035-0000</a>	FICA/PARS	300.00	289.68	5.00	4.20	0.00	0.00
<a href="#">100-1200-7001-0000</a>	ADMIN OVERHEAD	-712,000.00	-712,000.00	-750,000.00	-562,500.00	0.00	0.00
<a href="#">100-1200-7020-0000</a>	ADVERTISING	9,710.00	6,874.19	12,500.00	6,379.18	5,000.00	0.00
<a href="#">100-1200-7025-0000</a>	OFFICE SUPPLIES	32,175.00	20,009.70	22,546.00	14,257.56	22,546.00	0.00
<a href="#">100-1200-7027-0000</a>	HEALTH/FITNESS	1,300.00	1,779.54	1,300.00	1,285.74	2,000.00	0.00
<a href="#">100-1200-7030-0000</a>	DUES & SUBSCRIPTIONS	27,620.00	31,866.21	32,740.00	43,183.52	32,000.00	0.00
<a href="#">100-1200-7035-0000</a>	LOCAL MEETINGS	3,500.00	5,624.20	3,900.00	3,751.98	3,900.00	0.00
<a href="#">100-1200-7036-0000</a>	GRANT SPECIFIC COSTS (CalRecyc..	10,500.00	10,078.23	10,500.00	6,645.72	0.00	0.00
<a href="#">100-1200-7037-0000</a>	VEHICLE MAINTENANCE	190.00	30.00	100.00	8,631.37	8,700.00	0.00
<a href="#">100-1200-7041-0000</a>	EVENTS	0.00	0.00	1,500.00	35.55	50.00	0.00
<a href="#">100-1200-7050-0000</a>	FUEL	0.00	14.19	0.00	0.00	0.00	0.00
<a href="#">100-1200-7065-0000</a>	UNIFORMS	2,040.00	3,245.79	2,000.00	1,465.35	2,000.00	0.00
<a href="#">100-1200-7066-0000</a>	TRAVEL, EDUCATION, TRAINING	12,675.00	8,292.22	12,475.00	2,751.38	3,700.00	0.00
<a href="#">100-1200-7068-0000</a>	CONTRACTUAL SERVICES	218,400.00	277,979.03	406,500.00	462,137.07	450,000.00	0.00
<a href="#">100-1200-7070-0000</a>	SPECIAL DEPT SUPPLIES	17,900.00	41,211.82	8,200.00	2,872.03	8,000.00	0.00
<a href="#">100-1200-7071-0000</a>	SOFTWARE	0.00	-238.80	0.00	1,437.80	0.00	0.00
<a href="#">100-1200-7072-0000</a>	COMPUTER SUPPLIES/MAINT	0.00	209.52	0.00	0.00	0.00	0.00
<a href="#">100-1200-7075-0000</a>	EQUIPMENT LEASING/RENTAL	0.00	-513.37	0.00	2,053.78	0.00	0.00
<a href="#">100-1200-7090-0000</a>	EQUIPMENT SUPPLIES/MAINT	400.00	402.42	0.00	0.00	0.00	0.00
<a href="#">100-1200-7096-0000</a>	COMMUNITY PROGRAM	0.00	1,541.38	0.00	0.00	0.00	0.00
<a href="#">100-1200-7900-0000</a>	CONTINGENCY	150,433.24	30,000.00	47,960.79	0.00	150,001.00	0.00
<b>Department: 1200 - ADMINISTRATION Total:</b>		<b>1,077,027.24</b>	<b>1,036,894.63</b>	<b>1,096,330.79</b>	<b>1,122,053.31</b>	<b>2,044,298.00</b>	<b>0.00</b>
<b>Department: 1225 - FINANCE AND BUDGETING</b>							
<a href="#">100-1225-6010-0000</a>	SALARIES	580,109.00	513,400.99	596,942.00	408,783.18	646,885.00	0.00

Budget Worksheet

Defined Budgets

		2018-2019 Total Budget	2018-2019 Total Activity	2019-2020 Total Budget	2019-2020 Total Activity	2020-2021 Total Budget	2020-2021 YTD Activity
<a href="#">100-1225-6011-0000</a>	ADMIN TIME	0.00	5,959.20	0.00	1,808.84	0.00	0.00
<a href="#">100-1225-6012-0000</a>	OVERTIME	1,000.00	1,086.11	1,000.00	133.36	1,000.00	0.00
<a href="#">100-1225-6013-0000</a>	SICK LEAVE	0.00	26,726.73	1,652.00	5,227.51	0.00	0.00
<a href="#">100-1225-6014-0000</a>	HOLIDAY	0.00	32,012.22	1,655.00	27,855.53	0.00	0.00
<a href="#">100-1225-6015-0000</a>	VACATION	0.00	20,993.31	7,870.00	15,339.82	0.00	0.00
<a href="#">100-1225-6016-0000</a>	ACCRUED TIME CASH OUT	13,127.00	0.00	24,880.00	10.99	17,626.00	0.00
<a href="#">100-1225-6018-0000</a>	OTHER COMPENSATION	0.00	13,064.98	2,100.00	9,512.60	2,100.00	0.00
<a href="#">100-1225-6020-0000</a>	HEALTH INSURANCE	63,000.00	50,453.43	116,972.00	50,095.54	85,304.00	0.00
<a href="#">100-1225-6021-0000</a>	DENTAL INSURANCE	0.00	-1,257.76	28.00	1,037.21	0.00	0.00
<a href="#">100-1225-6022-0000</a>	WORKERS COMP	12,708.00	16,467.34	30,406.00	11,896.65	32,689.00	0.00
<a href="#">100-1225-6023-0000</a>	DISABILITY	3,156.00	3,102.33	3,156.00	3,287.77	3,156.00	0.00
<a href="#">100-1225-6024-0000</a>	P.E.R.S./P.E.P.R.A.	86,064.00	114,618.30	66,334.00	72,902.45	81,230.00	0.00
<a href="#">100-1225-6025-0000</a>	UNEMPLOYMENT	0.00	0.00	0.00	5,400.00	0.00	0.00
<a href="#">100-1225-6026-0000</a>	DEFERRED COMP	0.00	0.00	0.00	3,868.44	0.00	0.00
<a href="#">100-1225-6027-0000</a>	VISION CARE	25.00	12.29	0.00	72.79	0.00	0.00
<a href="#">100-1225-6028-0000</a>	LIFE INSURANCE	504.00	399.00	504.00	399.93	504.00	0.00
<a href="#">100-1225-6030-0000</a>	CAR ALLOWANCE	0.00	2,012.50	0.00	1,312.50	1,200.00	0.00
<a href="#">100-1225-6034-0000</a>	MEDICARE	8,616.00	8,484.53	9,193.00	6,587.90	9,750.00	0.00
<a href="#">100-1225-6035-0000</a>	FICA/PARS	0.00	0.00	22.00	14.28	22.00	0.00
<a href="#">100-1225-6050-0000</a>	RECRUITMENT AND HIRING COS...	210.00	105.00	0.00	0.00	0.00	0.00
<a href="#">100-1225-7025-0000</a>	OFFICE SUPPLIES	2,500.00	2,807.69	2,520.00	2,251.37	2,494.00	0.00
<a href="#">100-1225-7027-0000</a>	HEALTH/FITNESS	1,660.00	1,885.30	3,600.00	2,154.67	2,300.00	0.00
<a href="#">100-1225-7030-0000</a>	DUES & SUBSCRIPTIONS	1,100.00	1,026.19	1,415.00	635.00	1,000.00	0.00
<a href="#">100-1225-7035-0000</a>	LOCAL MEETINGS	0.00	0.00	0.00	140.02	0.00	0.00
<a href="#">100-1225-7051-0000</a>	BANKING FEES	14,000.00	46,402.02	3,371.00	3,375.46	10,000.00	0.00
<a href="#">100-1225-7052-0000</a>	CREDIT CARD FEES	75,000.00	90,363.55	38,629.00	71,901.76	63,071.00	0.00
<a href="#">100-1225-7053-0000</a>	PERMITS, FEES AND LICENSES	150.00	120.00	240.00	0.00	0.00	0.00
<a href="#">100-1225-7065-0000</a>	UNIFORMS	180.00	0.00	1,500.00	805.95	500.00	0.00
<a href="#">100-1225-7066-0000</a>	TRAVEL, EDUCATION, TRAINING	2,800.00	6,391.94	2,950.00	3,999.40	3,310.00	0.00
<a href="#">100-1225-7068-0000</a>	CONTRACTUAL SERVICES	56,000.00	60,564.00	48,500.00	104,960.00	70,000.00	0.00
<a href="#">100-1225-7070-0000</a>	SPECIAL DEPT SUPPLIES	400.00	82.35	400.00	0.00	0.00	0.00

Budget Worksheet

Defined Budgets

		2018-2019 Total Budget	2018-2019 Total Activity	2019-2020 Total Budget	2019-2020 Total Activity	2020-2021 Total Budget	2020-2021 YTD Activity
<a href="#">100-1225-7090-0000</a>	EQUIPMENT SUPPLIES/MAINT	0.00	0.00	0.00	165.67	165.00	0.00
<b>Department: 1225 - FINANCE AND BUDGETING Total:</b>		<b>922,309.00</b>	<b>1,017,283.54</b>	<b>965,839.00</b>	<b>815,936.59</b>	<b>1,034,306.00</b>	<b>0.00</b>
<b>Department: 1230 - I.T.</b>							
<a href="#">100-1230-6010-0000</a>	SALARIES	122,148.00	104,701.04	245,480.00	146,782.86	257,213.00	0.00
<a href="#">100-1230-6012-0000</a>	OVERTIME	500.00	0.00	10,000.00	1,798.95	10,000.00	0.00
<a href="#">100-1230-6013-0000</a>	SICK LEAVE	0.00	779.28	484.00	2,572.73	0.00	0.00
<a href="#">100-1230-6014-0000</a>	HOLIDAY	0.00	7,154.95	484.00	9,721.29	0.00	0.00
<a href="#">100-1230-6015-0000</a>	VACATION	0.00	2,622.50	0.00	3,625.11	0.00	0.00
<a href="#">100-1230-6016-0000</a>	ACCRUED TIME CASH OUT	2,216.00	0.00	9,114.00	270.47	10,084.00	0.00
<a href="#">100-1230-6018-0000</a>	OTHER COMPENSATION	0.00	1,205.00	1,200.00	995.00	1,200.00	0.00
<a href="#">100-1230-6020-0000</a>	HEALTH INSURANCE	18,000.00	23,245.54	57,513.00	36,661.31	58,928.00	0.00
<a href="#">100-1230-6021-0000</a>	DENTAL INSURANCE	0.00	42.69	87.00	1,017.88	0.00	0.00
<a href="#">100-1230-6022-0000</a>	WORKERS COMP	3,000.00	3,125.30	12,322.00	4,256.91	13,011.00	0.00
<a href="#">100-1230-6023-0000</a>	DISABILITY	850.00	824.88	1,578.00	1,199.74	1,578.00	0.00
<a href="#">100-1230-6024-0000</a>	P.E.R.S./P.E.P.R.A.	23,944.00	23,356.26	46,602.00	27,051.38	43,940.00	0.00
<a href="#">100-1230-6027-0000</a>	VISION CARE	0.00	0.00	0.00	263.50	0.00	0.00
<a href="#">100-1230-6028-0000</a>	LIFE INSURANCE	84.00	84.00	252.00	168.00	252.00	0.00
<a href="#">100-1230-6034-0000</a>	MEDICARE	1,811.00	1,633.34	3,851.00	2,317.98	4,064.00	0.00
<a href="#">100-1230-6050-0000</a>	RECRUITMENT AND HIRING COS...	0.00	0.00	0.00	105.00	0.00	0.00
<a href="#">100-1230-7010-0000</a>	UTILITIES	0.00	0.00	32,400.00	0.00	0.00	0.00
<a href="#">100-1230-7015-0000</a>	TELEPHONE	147,910.00	52,723.97	37,900.00	58,862.77	85,550.00	0.00
<a href="#">100-1230-7015-5400</a>	TELEPHONE - SPORTS PARK	0.00	916.08	950.00	702.09	950.00	0.00
<a href="#">100-1230-7015-6025</a>	TELEPHONE (CITY HALL)	0.00	23,385.31	9,850.00	21,598.98	9,850.00	0.00
<a href="#">100-1230-7015-6026</a>	TELEPHONE (BLDG B)	0.00	76.02	1,500.00	0.00	1,500.00	0.00
<a href="#">100-1230-7015-6040</a>	TELEPHONE (POLICE DPT)	0.00	51,811.55	97,500.00	41,595.72	102,900.00	0.00
<a href="#">100-1230-7015-6041</a>	TELEPHONE (PD ANNEX)	0.00	0.00	0.00	983.90	3,500.00	0.00
<a href="#">100-1230-7015-6045</a>	TELEPHONE (COMM CTR)	0.00	8,489.14	9,000.00	7,648.14	9,000.00	0.00
<a href="#">100-1230-7015-6048</a>	TELEPHONE (POOL)	0.00	561.96	1,000.00	771.37	1,000.00	0.00
<a href="#">100-1230-7015-6055</a>	TELEPHONE (MAPLE AVE)	0.00	136.05	550.00	464.91	4,050.00	0.00
<a href="#">100-1230-7015-6060</a>	TELEPHONE (4th ST YARD)	0.00	1,696.05	4,500.00	1,793.60	4,500.00	0.00
<a href="#">100-1230-7025-0000</a>	OFFICE SUPPLIES	800.00	348.20	1,000.00	0.00	1,000.00	0.00

Budget Worksheet

Defined Budgets

		2018-2019 Total Budget	2018-2019 Total Activity	2019-2020 Total Budget	2019-2020 Total Activity	2020-2021 Total Budget	2020-2021 YTD Activity
<a href="#">100-1230-7027-0000</a>	HEALTH/FITNESS	0.00	113.70	1,800.00	600.30	1,000.00	0.00
<a href="#">100-1230-7030-0000</a>	DUES & SUBSCRIPTIONS	200.00	835.00	800.00	357.50	800.00	0.00
<a href="#">100-1230-7035-0000</a>	LOCAL MEETINGS	0.00	0.00	0.00	-1,212.00	500.00	0.00
<a href="#">100-1230-7050-0000</a>	FUEL	300.00	0.00	0.00	0.00	0.00	0.00
<a href="#">100-1230-7053-0000</a>	PERMITS, FEES AND LICENSES	10,000.00	12,678.61	0.00	4,312.56	4,300.00	0.00
<a href="#">100-1230-7065-0000</a>	UNIFORMS	0.00	0.00	0.00	642.19	650.00	0.00
<a href="#">100-1230-7066-0000</a>	TRAVEL, EDUCATION, TRAINING	2,500.00	1,212.00	2,500.00	5,001.50	0.00	0.00
<a href="#">100-1230-7068-0000</a>	CONTRACTUAL SERVICES	194,430.00	168,516.60	0.00	50.00	30,000.00	0.00
<a href="#">100-1230-7068-6025</a>	CONTRACT SVC - CITY HALL	0.00	0.00	20,000.00	19,872.50	0.00	0.00
<a href="#">100-1230-7068-6040</a>	CONTRACT SVC - P.D.	0.00	2,273.69	10,000.00	19,872.50	0.00	0.00
<a href="#">100-1230-7070-0000</a>	SPECIAL DEPT SUPPLIES	0.00	0.00	0.00	9.19	0.00	0.00
<a href="#">100-1230-7071-0000</a>	SOFTWARE	264,725.00	201,897.96	211,700.00	94,110.24	326,369.00	0.00
<a href="#">100-1230-7071-6025</a>	SOFTWARE (CITY HALL)	0.00	0.00	39,725.00	33,258.40	14,290.00	0.00
<a href="#">100-1230-7071-6026</a>	SOFTWARE (BLDG B)	0.00	0.00	54,500.00	2,392.08	6,000.00	0.00
<a href="#">100-1230-7071-6040</a>	SOFTWARE (POLICE DEPT)	0.00	78,522.10	113,800.00	81,319.61	222,000.00	0.00
<a href="#">100-1230-7071-6045</a>	SOFTWARE (COMMUNITY CENT...	0.00	0.00	2,700.00	0.00	3,500.00	0.00
<a href="#">100-1230-7072-0000</a>	COMPUTER SUPPLIES/MAINT	20,150.00	8,444.75	26,500.00	24,215.57	26,500.00	0.00
<a href="#">100-1230-7072-6025</a>	COMPUTER SUPPLIES/MAINT (CI...	0.00	2,445.85	0.00	0.00	0.00	0.00
<a href="#">100-1230-7072-6040</a>	COMPUTER SUPPLIES/MAINT (P...	0.00	10,479.71	24,500.00	11,613.53	24,500.00	0.00
<a href="#">100-1230-7072-6075</a>	COMPUTER SUPPLIES/MAINT (...	0.00	0.00	0.00	38.78	0.00	0.00
<a href="#">100-1230-7075-0000</a>	EQUIPMENT LEASING/RENTAL	51,510.00	0.00	29,350.00	397.84	41,000.00	0.00
<a href="#">100-1230-7075-6025</a>	EQUIPMENT LEASING/RENTAL (C...	0.00	5,882.19	6,000.00	4,941.75	6,000.00	0.00
<a href="#">100-1230-7075-6026</a>	EQUIPMENT LEASING/RENTAL (B...	0.00	4,920.53	5,050.00	4,890.89	0.00	0.00
<a href="#">100-1230-7075-6040</a>	EQUIPMENT LEASING/RENTAL (P...	0.00	27,875.50	6,500.00	4,109.65	2,000.00	0.00
<a href="#">100-1230-7075-6045</a>	EQUIPMENT LEASING/RENTAL (...	0.00	9,029.83	4,500.00	4,109.66	0.00	0.00
<a href="#">100-1230-7090-0000</a>	EQUIPMENT SUPPLIES/MAINT	8,930.00	2,287.57	0.00	1,318.96	12,000.00	0.00
<a href="#">100-1230-7090-6025</a>	EQUIP SUPPLIES/MAINT (CITY HA...	0.00	5,130.55	4,000.00	3,234.74	0.00	0.00
<a href="#">100-1230-7090-6026</a>	EQUIP SUPPLIES/MAINT (BLDG B)	0.00	1,017.22	2,000.00	3,191.00	2,000.00	0.00
<a href="#">100-1230-7090-6040</a>	EQUIP SUPPLIES/MAINT (P.D.)	0.00	2,607.40	4,000.00	2,333.79	0.00	0.00
<a href="#">100-1230-7090-6041</a>	EQUIP SUPPLIES/MAINT (PD AN...	0.00	0.00	0.00	1,366.97	0.00	0.00
<a href="#">100-1230-7090-6045</a>	EQUIP SUPPLIES/MAINT (COMM...	0.00	1,634.49	4,000.00	972.95	0.00	0.00

Defined Budgets

		2018-2019 Total Budget	2018-2019 Total Activity	2019-2020 Total Budget	2019-2020 Total Activity	2020-2021 Total Budget	2020-2021 YTD Activity
<a href="#">100-1230-8040-0000</a>	EQUIPMENT	287,750.00	141,138.91	0.00	0.00	0.00	0.00
	<b>Department: 1230 - I.T. Total:</b>	<b>1,161,758.00</b>	<b>997,863.27</b>	<b>1,159,042.00</b>	<b>700,552.24</b>	<b>1,347,479.00</b>	<b>0.00</b>
	<b>Department: 1240 - RISK AND HUMAN RESOURCES</b>						
<a href="#">100-1240-6010-0000</a>	SALARIES	255,057.00	221,874.78	276,952.00	206,534.77	274,707.00	0.00
<a href="#">100-1240-6011-0000</a>	ADMIN TIME	0.00	6,577.60	0.00	3,455.60	0.00	0.00
<a href="#">100-1240-6012-0000</a>	OVERTIME	500.00	0.00	0.00	0.00	0.00	0.00
<a href="#">100-1240-6013-0000</a>	SICK LEAVE	0.00	5,826.79	0.00	6,700.25	0.00	0.00
<a href="#">100-1240-6014-0000</a>	HOLIDAY	0.00	14,809.31	945.00	14,024.06	0.00	0.00
<a href="#">100-1240-6015-0000</a>	VACATION	0.00	17,136.20	692.00	19,443.43	0.00	0.00
<a href="#">100-1240-6016-0000</a>	ACCRUED TIME CASH OUT	7,681.00	0.00	13,161.00	0.00	24,374.00	0.00
<a href="#">100-1240-6018-0000</a>	OTHER COMPENSATION	0.00	6,314.77	6,600.00	7,931.51	2,400.00	0.00
<a href="#">100-1240-6019-0000</a>	FIRST AID	1,300.00	1,006.09	830.00	519.50	830.00	0.00
<a href="#">100-1240-6020-0000</a>	HEALTH INSURANCE	36,000.00	26,852.91	38,400.00	16,735.27	32,073.00	0.00
<a href="#">100-1240-6021-0000</a>	DENTAL INSURANCE	0.00	119.65	0.00	197.08	0.00	0.00
<a href="#">100-1240-6022-0000</a>	WORKERS COMP	7,800.00	7,232.94	13,929.00	59,684.79	14,125.00	0.00
<a href="#">100-1240-6023-0000</a>	DISABILITY	1,400.00	1,399.20	1,052.00	1,282.60	1,052.00	0.00
<a href="#">100-1240-6024-0000</a>	P.E.R.S./P.E.P.R.A.	49,525.00	51,243.23	61,948.00	36,073.94	69,532.00	0.00
<a href="#">100-1240-6028-0000</a>	LIFE INSURANCE	168.00	168.00	168.00	154.00	168.00	0.00
<a href="#">100-1240-6030-0000</a>	CAR ALLOWANCE	0.00	4,217.50	6,600.00	3,482.50	4,200.00	0.00
<a href="#">100-1240-6034-0000</a>	MEDICARE	3,817.00	3,952.48	4,230.00	3,744.25	4,450.00	0.00
<a href="#">100-1240-6050-0000</a>	RECRUITMENT AND HIRING COS...	6,800.00	12,642.91	23,000.00	32,257.10	12,500.00	0.00
<a href="#">100-1240-7025-0000</a>	OFFICE SUPPLIES	260.00	249.36	250.00	26.12	0.00	0.00
<a href="#">100-1240-7027-0000</a>	HEALTH/FITNESS	900.00	1,073.25	1,200.00	859.16	1,000.00	0.00
<a href="#">100-1240-7030-0000</a>	DUES & SUBSCRIPTIONS	460.00	209.00	550.00	759.00	200.00	0.00
<a href="#">100-1240-7035-0000</a>	LOCAL MEETINGS	850.00	1,668.79	2,000.00	1,378.46	2,000.00	0.00
<a href="#">100-1240-7066-0000</a>	TRAVEL, EDUCATION, TRAINING	3,700.00	7,469.52	6,000.00	2,399.26	0.00	0.00
<a href="#">100-1240-7068-0000</a>	CONTRACTUAL SERVICES	70,500.00	57,066.92	56,500.00	63,264.44	126,500.00	0.00
<a href="#">100-1240-7070-0000</a>	SPECIAL DEPT SUPPLIES	500.00	2,854.98	2,500.00	1,749.67	1,300.00	0.00
<a href="#">100-1240-7072-0000</a>	COMPUTER SUPPLIES/MAINT	800.00	426.58	0.00	0.00	0.00	0.00
<a href="#">100-1240-7080-0000</a>	INSURANCE	895,000.00	894,847.63	1,122,602.00	1,111,127.00	1,366,566.00	0.00
<a href="#">100-1240-7081-0000</a>	CLAIM COSTS	10,000.00	9,715.80	10,000.00	375.92	5,000.00	0.00



Budget Worksheet

Defined Budgets

		2018-2019 Total Budget	2018-2019 Total Activity	2019-2020 Total Budget	2019-2020 Total Activity	2020-2021 Total Budget	2020-2021 YTD Activity
<a href="#">100-1240-7090-0000</a>	EQUIPMENT SUPPLIES/MAINT	0.00	0.00	0.00	165.66	200.00	0.00
<b>Department: 1240 - RISK AND HUMAN RESOURCES Total:</b>		<b>1,353,018.00</b>	<b>1,356,956.19</b>	<b>1,650,109.00</b>	<b>1,594,325.34</b>	<b>1,943,177.00</b>	<b>0.00</b>
<b>Department: 1300 - LEGAL</b>							
<a href="#">100-1300-7025-0000</a>	OFFICE SUPPLIES	0.00	0.00	454.00	453.41	500.00	0.00
<a href="#">100-1300-7068-0000</a>	CONTRACTUAL SERVICES	750,000.00	1,509,210.63	750,000.00	997,931.74	1,250,000.00	0.00
<b>Department: 1300 - LEGAL Total:</b>		<b>750,000.00</b>	<b>1,509,210.63</b>	<b>750,454.00</b>	<b>998,385.15</b>	<b>1,250,500.00</b>	<b>0.00</b>
<b>Department: 1350 - COMMUNITY DEVELOPMENT</b>							
<a href="#">100-1350-6010-0000</a>	SALARIES	275,034.00	177,983.25	262,261.00	181,522.42	257,748.00	0.00
<a href="#">100-1350-6011-0000</a>	ADMIN TIME	0.00	7,355.92	0.00	2,344.93	0.00	0.00
<a href="#">100-1350-6013-0000</a>	SICK LEAVE	0.00	54,808.21	0.00	5,652.68	0.00	0.00
<a href="#">100-1350-6014-0000</a>	HOLIDAY	0.00	21,507.90	486.00	12,161.31	0.00	0.00
<a href="#">100-1350-6015-0000</a>	VACATION	0.00	19,467.13	2,753.00	5,090.32	0.00	0.00
<a href="#">100-1350-6016-0000</a>	ACCRUED TIME CASH OUT	7,870.00	0.00	11,919.00	0.00	12,212.00	0.00
<a href="#">100-1350-6018-0000</a>	OTHER COMPENSATION	0.00	1,595.00	5,400.00	995.00	1,200.00	0.00
<a href="#">100-1350-6020-0000</a>	HEALTH INSURANCE	20,000.00	18,071.25	38,204.00	35,729.85	37,024.00	0.00
<a href="#">100-1350-6021-0000</a>	DENTAL INSURANCE	0.00	-51.73	138.00	262.98	0.00	0.00
<a href="#">100-1350-6022-0000</a>	WORKERS COMP	13,001.00	8,459.99	13,275.00	5,362.09	13,367.00	0.00
<a href="#">100-1350-6023-0000</a>	DISABILITY	1,052.00	1,133.20	1,052.00	1,325.72	1,052.00	0.00
<a href="#">100-1350-6024-0000</a>	P.E.R.S./P.E.P.R.A.	39,387.00	41,208.07	34,388.00	32,317.06	39,450.00	0.00
<a href="#">100-1350-6026-0000</a>	DEFERRED COMP	5,210.00	2,605.40	0.00	0.00	0.00	0.00
<a href="#">100-1350-6027-0000</a>	VISION CARE	50.00	147.60	58.00	286.38	0.00	0.00
<a href="#">100-1350-6028-0000</a>	LIFE INSURANCE	168.00	122.27	168.00	154.00	168.00	0.00
<a href="#">100-1350-6030-0000</a>	CAR ALLOWANCE	0.00	2,975.00	0.00	3,482.50	4,200.00	0.00
<a href="#">100-1350-6034-0000</a>	MEDICARE	4,102.00	4,113.58	4,023.00	2,991.52	4,054.00	0.00
<a href="#">100-1350-6035-0000</a>	FICA/PARS	78.00	37.20	78.00	32.40	78.00	0.00
<a href="#">100-1350-7020-0000</a>	ADVERTISING	2,500.00	2,026.80	2,000.00	3,375.00	2,975.00	0.00
<a href="#">100-1350-7025-0000</a>	OFFICE SUPPLIES	325.00	258.74	325.00	338.23	298.00	0.00
<a href="#">100-1350-7027-0000</a>	HEALTH/FITNESS	900.00	708.06	4,200.00	616.02	1,200.00	0.00
<a href="#">100-1350-7030-0000</a>	DUES & SUBSCRIPTIONS	1,084.00	0.00	1,000.00	1,110.80	1,000.00	0.00
<a href="#">100-1350-7035-0000</a>	LOCAL MEETINGS	10,500.00	584.12	10,000.00	0.00	2,500.00	0.00
<a href="#">100-1350-7053-0000</a>	PERMITS, FEES AND LICENSES	0.00	195.00	0.00	0.00	0.00	0.00

Defined Budgets

		2018-2019 Total Budget	2018-2019 Total Activity	2019-2020 Total Budget	2019-2020 Total Activity	2020-2021 Total Budget	2020-2021 YTD Activity
<a href="#">100-1350-7063-0000</a>	PLAN CHECK FEES	12,000.00	2,640.75	0.00	0.00	0.00	0.00
<a href="#">100-1350-7065-0000</a>	UNIFORMS	550.00	323.98	500.00	271.20	0.00	0.00
<a href="#">100-1350-7066-0000</a>	TRAVEL, EDUCATION, TRAINING	0.00	4,260.48	0.00	0.00	0.00	0.00
<a href="#">100-1350-7068-0000</a>	CONTRACTUAL SERVICES	23,500.00	38,969.75	131,002.00	25,976.75	150,000.00	0.00
<a href="#">100-1350-7070-0000</a>	SPECIAL DEPT SUPPLIES	2,000.00	471.00	1,000.00	179.57	468.00	0.00
<a href="#">100-1350-7072-0000</a>	COMPUTER SUPPLIES/MAINT	200.00	95.96	0.00	0.00	0.00	0.00
<a href="#">100-1350-7075-0000</a>	EQUIPMENT LEASING/RENTAL	0.00	0.00	0.00	189.64	0.00	0.00
<a href="#">100-1350-7090-0000</a>	EQUIPMENT SUPPLIES/MAINT	800.00	242.05	380.00	172.40	0.00	0.00
<b>Department: 1350 - COMMUNITY DEVELOPMENT Total:</b>		<b>420,311.00</b>	<b>412,315.93</b>	<b>524,610.00</b>	<b>321,940.77</b>	<b>528,994.00</b>	<b>0.00</b>
<b>Department: 1550 - COMMUNITY SERVICES</b>							
<a href="#">100-1550-6010-0000</a>	SALARIES	360,834.00	232,064.15	430,911.00	251,052.16	265,071.00	0.00
<a href="#">100-1550-6011-0000</a>	ADMIN TIME	0.00	8,162.00	0.00	0.00	0.00	0.00
<a href="#">100-1550-6012-0000</a>	OVERTIME	500.00	4,820.37	1,750.00	3,284.37	1,250.00	0.00
<a href="#">100-1550-6013-0000</a>	SICK LEAVE	0.00	40,785.94	1,407.00	9,884.64	0.00	0.00
<a href="#">100-1550-6014-0000</a>	HOLIDAY	0.00	15,211.73	1,827.00	15,787.62	0.00	0.00
<a href="#">100-1550-6015-0000</a>	VACATION	0.00	38,029.86	2,041.00	16,659.15	0.00	0.00
<a href="#">100-1550-6016-0000</a>	ACCRUED TIME CASH OUT	11,616.00	3,629.58	13,952.00	3,972.70	15,614.00	0.00
<a href="#">100-1550-6018-0000</a>	OTHER COMPENSATION	0.00	10,323.68	2,700.00	12,303.14	600.00	0.00
<a href="#">100-1550-6019-0000</a>	FIRST AID	0.00	0.00	0.00	45.00	0.00	0.00
<a href="#">100-1550-6020-0000</a>	HEALTH INSURANCE	53,500.00	29,991.79	44,909.00	32,556.22	47,247.00	0.00
<a href="#">100-1550-6021-0000</a>	DENTAL INSURANCE	0.00	421.77	235.00	1,021.95	0.00	0.00
<a href="#">100-1550-6022-0000</a>	WORKERS COMP	14,454.00	9,201.11	19,652.00	5,713.87	11,370.00	0.00
<a href="#">100-1550-6023-0000</a>	DISABILITY	1,841.00	1,282.31	2,104.00	1,006.28	1,578.00	0.00
<a href="#">100-1550-6024-0000</a>	P.E.R.S./P.E.P.R.A.	50,306.00	54,583.24	62,201.00	50,953.30	66,348.00	0.00
<a href="#">100-1550-6027-0000</a>	VISION CARE	50.00	104.85	0.00	83.82	0.00	0.00
<a href="#">100-1550-6028-0000</a>	LIFE INSURANCE	294.00	273.00	336.00	231.00	252.00	0.00
<a href="#">100-1550-6030-0000</a>	CAR ALLOWANCE	0.00	0.00	0.00	962.50	2,100.00	0.00
<a href="#">100-1550-6034-0000</a>	MEDICARE	6,008.00	5,076.33	5,911.00	4,512.81	3,515.00	0.00
<a href="#">100-1550-6035-0000</a>	FICA/PARS	2,186.00	1,617.74	1,573.00	1,007.75	0.00	0.00
<a href="#">100-1550-6050-0000</a>	RECRUITMENT AND HIRING COS...	950.00	1,135.00	0.00	0.00	0.00	0.00
<a href="#">100-1550-7025-0000</a>	OFFICE SUPPLIES	1,000.00	1,293.50	1,000.00	197.02	500.00	0.00

Budget Worksheet

Defined Budgets

		2018-2019 Total Budget	2018-2019 Total Activity	2019-2020 Total Budget	2019-2020 Total Activity	2020-2021 Total Budget	2020-2021 YTD Activity
<a href="#">100-1550-7027-0000</a>	HEALTH/FITNESS	200.00	259.00	7,800.00	230.97	1,000.00	0.00
<a href="#">100-1550-7030-0000</a>	DUES & SUBSCRIPTIONS	170.00	0.00	170.00	0.00	0.00	0.00
<a href="#">100-1550-7037-0000</a>	VEHICLE MAINTENANCE	226.00	42.00	0.00	0.00	0.00	0.00
<a href="#">100-1550-7040-0000</a>	RECREATION PROGRAMS	47,200.00	120,581.05	145,000.00	142,761.21	47,500.00	0.00
<a href="#">100-1550-7046-0000</a>	SPECIAL COMMUNITY PROGRAMS	0.00	0.00	0.00	38.79	0.00	0.00
<a href="#">100-1550-7049-0000</a>	SPECIAL COMMUNITY EVENTS	0.00	0.00	0.00	785.47	0.00	0.00
<a href="#">100-1550-7050-0000</a>	FUEL	2,000.00	6,820.06	0.00	0.00	0.00	0.00
<a href="#">100-1550-7053-0000</a>	PERMITS, FEES AND LICENSES	1,020.00	0.00	1,020.00	1,078.72	700.00	0.00
<a href="#">100-1550-7065-0000</a>	UNIFORMS	1,320.00	1,028.43	1,320.00	1,934.00	1,500.00	0.00
<a href="#">100-1550-7066-0000</a>	TRAVEL, EDUCATION, TRAINING	1,140.00	760.00	500.00	0.00	0.00	0.00
<a href="#">100-1550-7068-0000</a>	CONTRACTUAL SERVICES	0.00	1,155.46	0.00	0.00	0.00	0.00
<a href="#">100-1550-7070-0000</a>	SPECIAL DEPT SUPPLIES	1,500.00	1,447.67	1,500.00	5,215.05	0.00	0.00
<a href="#">100-1550-7072-0000</a>	COMPUTER SUPPLIES/MAINT	0.00	59.97	0.00	0.00	0.00	0.00
<a href="#">100-1550-7075-0000</a>	EQUIPMENT LEASING/RENTAL	0.00	1,568.40	0.00	0.00	0.00	0.00
<a href="#">100-1550-7085-0000</a>	BUILDING SUPPLIES/MAINT	0.00	0.00	600.00	0.00	0.00	0.00
<a href="#">100-1550-7090-0000</a>	EQUIPMENT SUPPLIES/MAINT	500.00	0.00	0.00	39.44	0.00	0.00
<a href="#">100-1550-8040-0000</a>	EQUIPMENT	0.00	0.00	12,000.00	0.00	0.00	0.00
<b>Department: 1550 - COMMUNITY SERVICES Total:</b>		<b>558,815.00</b>	<b>591,729.99</b>	<b>762,419.00</b>	<b>563,318.95</b>	<b>466,145.00</b>	<b>0.00</b>
<b>Department: 2000 - ANIMAL CONTROL</b>							
<a href="#">100-2000-6010-0000</a>	SALARIES	140,773.00	120,141.27	140,133.00	104,709.45	147,748.00	0.00
<a href="#">100-2000-6012-0000</a>	OVERTIME	2,000.00	2,588.59	4,000.00	1,791.07	4,000.00	0.00
<a href="#">100-2000-6013-0000</a>	SICK LEAVE	0.00	4,584.80	278.00	2,477.48	0.00	0.00
<a href="#">100-2000-6014-0000</a>	HOLIDAY	0.00	10,948.54	1,403.00	11,633.11	0.00	0.00
<a href="#">100-2000-6015-0000</a>	VACATION	0.00	11,635.21	2,413.00	7,988.93	0.00	0.00
<a href="#">100-2000-6016-0000</a>	ACCRUED TIME CASH OUT	2,574.00	0.00	5,277.00	1,039.50	11,088.00	0.00
<a href="#">100-2000-6020-0000</a>	HEALTH INSURANCE	53,000.00	52,756.68	40,200.00	35,602.00	40,200.00	0.00
<a href="#">100-2000-6021-0000</a>	DENTAL INSURANCE	0.00	520.86	0.00	0.00	0.00	0.00
<a href="#">100-2000-6022-0000</a>	WORKERS COMP	6,150.00	4,072.89	7,226.00	3,101.06	7,582.00	0.00
<a href="#">100-2000-6023-0000</a>	DISABILITY	1,352.00	1,162.70	1,052.00	900.24	1,052.00	0.00
<a href="#">100-2000-6024-0000</a>	P.E.R.S./P.E.P.R.A.	27,595.00	27,574.74	32,137.00	18,874.24	37,324.00	0.00
<a href="#">100-2000-6027-0000</a>	VISION CARE	50.00	23.62	0.00	0.00	0.00	0.00

Budget Worksheet

Defined Budgets

		2018-2019 Total Budget	2018-2019 Total Activity	2019-2020 Total Budget	2019-2020 Total Activity	2020-2021 Total Budget	2020-2021 YTD Activity
<a href="#">100-2000-6028-0000</a>	LIFE INSURANCE	250.00	196.00	168.00	154.00	168.00	0.00
<a href="#">100-2000-6034-0000</a>	MEDICARE	2,108.00	2,156.60	2,201.00	1,853.42	2,418.00	0.00
<a href="#">100-2000-6036-0000</a>	UNIFORMS	1,135.00	2,544.95	2,400.00	2,045.05	2,400.00	0.00
<a href="#">100-2000-7025-0000</a>	OFFICE SUPPLIES	633.00	32.28	1,080.00	621.35	650.00	0.00
<a href="#">100-2000-7027-0000</a>	HEALTH/FITNESS	800.00	1,054.00	1,500.00	1,170.00	1,200.00	0.00
<a href="#">100-2000-7030-0000</a>	DUES & SUBSCRIPTIONS	100.00	0.00	100.00	0.00	75.00	0.00
<a href="#">100-2000-7037-0000</a>	VEHICLE MAINTENANCE	800.00	55.14	2,136.00	1,634.46	2,636.00	0.00
<a href="#">100-2000-7050-0000</a>	FUEL	10,400.00	10,339.06	10,500.00	5,777.33	8,000.00	0.00
<a href="#">100-2000-7066-0000</a>	TRAVEL, EDUCATION, TRAINING	1,945.00	0.00	1,500.00	0.00	0.00	0.00
<a href="#">100-2000-7068-0000</a>	CONTRACTUAL SERVICES	50,000.00	56,739.91	61,000.00	42,463.96	53,500.00	0.00
<a href="#">100-2000-7070-0000</a>	SPECIAL DEPT SUPPLIES	1,345.00	815.77	1,500.00	2,061.92	4,852.00	0.00
<a href="#">100-2000-8040-0000</a>	EQUIPMENT	8,800.00	8,744.76	0.00	0.00	0.00	0.00
<a href="#">100-2000-8060-0000</a>	VEHICLES	0.00	0.00	0.00	-6,000.00	0.00	0.00
<b>Department: 2000 - ANIMAL CONTROL Total:</b>		<b>311,810.00</b>	<b>318,688.37</b>	<b>318,204.00</b>	<b>239,898.57</b>	<b>324,893.00</b>	<b>0.00</b>
<b>Department: 2030 - COMMUNITY ENHANCEMENT</b>							
<a href="#">100-2030-6010-0000</a>	SALARIES	136,153.00	119,758.24	147,387.00	109,742.83	155,210.00	0.00
<a href="#">100-2030-6012-0000</a>	OVERTIME	2,000.00	844.46	2,000.00	136.50	2,000.00	0.00
<a href="#">100-2030-6013-0000</a>	SICK LEAVE	0.00	4,271.07	347.00	4,501.31	0.00	0.00
<a href="#">100-2030-6014-0000</a>	HOLIDAY	0.00	9,761.97	609.00	9,438.06	0.00	0.00
<a href="#">100-2030-6015-0000</a>	VACATION	0.00	5,778.91	0.00	8,664.53	0.00	0.00
<a href="#">100-2030-6016-0000</a>	ACCRUED TIME CASH OUT	2,453.00	1,319.20	2,638.00	0.00	11,648.00	0.00
<a href="#">100-2030-6020-0000</a>	HEALTH INSURANCE	26,000.00	16,974.17	35,793.00	27,983.88	27,056.00	0.00
<a href="#">100-2030-6021-0000</a>	DENTAL INSURANCE	0.00	239.47	159.00	786.67	0.00	0.00
<a href="#">100-2030-6022-0000</a>	WORKERS COMP	4,350.00	4,339.45	7,432.00	3,938.45	7,955.00	0.00
<a href="#">100-2030-6023-0000</a>	DISABILITY	1,052.00	844.04	1,052.00	838.42	1,052.00	0.00
<a href="#">100-2030-6024-0000</a>	P.E.R.S./P.E.P.R.A.	26,690.00	26,698.78	33,053.00	19,361.95	39,161.00	0.00
<a href="#">100-2030-6027-0000</a>	VISION CARE	0.00	131.60	48.00	260.59	0.00	0.00
<a href="#">100-2030-6028-0000</a>	LIFE INSURANCE	168.00	154.00	168.00	154.00	168.00	0.00
<a href="#">100-2030-6034-0000</a>	MEDICARE	2,039.00	2,071.57	2,223.00	1,948.81	2,505.00	0.00
<a href="#">100-2030-6036-0000</a>	UNIFORMS	1,045.00	2,484.39	2,400.00	1,990.00	2,400.00	0.00
<a href="#">100-2030-7025-0000</a>	OFFICE SUPPLIES	2,038.00	0.00	1,580.00	254.37	298.00	0.00

Defined Budgets

		2018-2019 Total Budget	2018-2019 Total Activity	2019-2020 Total Budget	2019-2020 Total Activity	2020-2021 Total Budget	2020-2021 YTD Activity
<a href="#">100-2030-7027-0000</a>	HEALTH/FITNESS	100.00	139.93	1,500.00	169.94	1,000.00	0.00
<a href="#">100-2030-7030-0000</a>	DUES & SUBSCRIPTIONS	190.00	190.00	190.00	190.00	190.00	0.00
<a href="#">100-2030-7035-0000</a>	LOCAL MEETINGS	600.00	101.47	100.00	205.14	170.00	0.00
<a href="#">100-2030-7037-0000</a>	VEHICLE MAINTENANCE	500.00	166.16	1,352.00	1,422.44	1,403.00	0.00
<a href="#">100-2030-7039-0000</a>	CODE ENFORCEMENT	37,500.00	42,120.38	11,000.00	9,487.06	40,000.00	0.00
<a href="#">100-2030-7050-0000</a>	FUEL	1,240.00	994.17	1,600.00	1,469.27	1,615.00	0.00
<a href="#">100-2030-7065-0000</a>	UNIFORMS	0.00	0.00	0.00	224.12	0.00	0.00
<a href="#">100-2030-7066-0000</a>	TRAVEL, EDUCATION, TRAINING	1,180.00	860.00	2,775.00	1,555.74	1,200.00	0.00
<a href="#">100-2030-7070-0000</a>	SPECIAL DEPT SUPPLIES	550.00	0.00	0.00	0.00	0.00	0.00
<a href="#">100-2030-7155-0000</a>	WEED ABATEMENT/VECTOR CO...	0.00	0.00	40,000.00	32,546.25	12,750.00	0.00
<b>Department: 2030 - COMMUNITY ENHANCEMENT Total:</b>		<b>245,848.00</b>	<b>240,243.43</b>	<b>295,406.00</b>	<b>237,270.33</b>	<b>307,781.00</b>	<b>0.00</b>
<b>Department: 2040 - PUBLIC SAFETY - OES</b>							
<a href="#">100-2040-7036-0000</a>	GRANT SPECIFIC COSTS (OES)	6,000.00	2,803.25	6,000.00	0.00	0.00	0.00
<a href="#">100-2040-7070-0000</a>	SPECIAL DEPT SUPPLIES	1,000.00	0.00	0.00	0.00	0.00	0.00
<b>Department: 2040 - PUBLIC SAFETY - OES Total:</b>		<b>7,000.00</b>	<b>2,803.25</b>	<b>6,000.00</b>	<b>0.00</b>	<b>0.00</b>	<b>0.00</b>
<b>Department: 2050 - POLICE</b>							
<a href="#">100-2050-6010-0000</a>	SALARIES	4,618,328.00	3,671,631.13	4,717,361.00	3,209,449.65	4,705,629.00	0.00
<a href="#">100-2050-6011-0000</a>	ADMIN TIME	0.00	7,382.92	6,923.00	12,167.73	0.00	0.00
<a href="#">100-2050-6012-0000</a>	OVERTIME	200,897.00	369,252.12	223,254.00	229,270.57	276,507.00	0.00
<a href="#">100-2050-6013-0000</a>	SICK LEAVE	0.00	161,622.67	61,459.00	246,029.02	0.00	0.00
<a href="#">100-2050-6014-0000</a>	HOLIDAY	0.00	237,121.36	25,269.00	250,634.81	0.00	0.00
<a href="#">100-2050-6015-0000</a>	VACATION	0.00	284,532.78	101,088.00	331,352.00	0.00	0.00
<a href="#">100-2050-6016-0000</a>	ACCRUED TIME CASH OUT	307,516.00	232,320.23	426,973.00	263,809.65	549,544.00	0.00
<a href="#">100-2050-6018-0000</a>	OTHER COMPENSATION	0.00	16,671.22	4,381.00	30,082.14	1,025.00	0.00
<a href="#">100-2050-6019-0000</a>	FIRST AID	6,500.00	4,379.24	3,023.00	6,694.60	0.00	0.00
<a href="#">100-2050-6020-0000</a>	HEALTH INSURANCE	774,000.00	621,876.45	763,077.00	565,594.01	754,878.00	0.00
<a href="#">100-2050-6021-0000</a>	DENTAL INSURANCE	0.00	713.46	2,039.00	4,961.23	0.00	0.00
<a href="#">100-2050-6022-0000</a>	WORKERS COMP	725,580.00	731,158.11	897,942.00	654,569.41	484,187.00	0.00
<a href="#">100-2050-6023-0000</a>	DISABILITY	27,618.00	27,879.20	23,144.00	25,940.94	21,566.00	0.00
<a href="#">100-2050-6024-0000</a>	P.E.R.S./P.E.P.R.A.	1,580,347.00	1,305,218.96	1,936,655.00	1,591,378.30	1,744,043.00	0.00
<a href="#">100-2050-6025-0000</a>	UNEMPLOYMENT	5,000.00	2,483.02	0.00	0.00	0.00	0.00

Budget Worksheet

Defined Budgets

		2018-2019 Total Budget	2018-2019 Total Activity	2019-2020 Total Budget	2019-2020 Total Activity	2020-2021 Total Budget	2020-2021 YTD Activity
<a href="#">100-2050-6026-0000</a>	DEFERRED COMP	5,300.00	6,379.16	974.00	5,161.96	0.00	0.00
<a href="#">100-2050-6027-0000</a>	VISION CARE	500.00	3.94	165.00	361.47	0.00	0.00
<a href="#">100-2050-6028-0000</a>	LIFE INSURANCE	4,614.00	3,448.52	3,708.00	3,198.32	3,456.00	0.00
<a href="#">100-2050-6029-0000</a>	WORKERS COMP COST	0.00	520,591.00	79,519.00	453,214.30	200,000.00	0.00
<a href="#">100-2050-6034-0000</a>	MEDICARE	74,338.00	73,170.97	81,630.00	65,984.81	81,279.00	0.00
<a href="#">100-2050-6036-0000</a>	UNIFORMS	30,000.00	48,130.00	117,916.00	41,590.00	49,200.00	0.00
<a href="#">100-2050-6050-0000</a>	RECRUITMENT AND HIRING COS...	9,000.00	4,532.50	15,000.00	0.00	2,500.00	0.00
<a href="#">100-2050-7020-0000</a>	ADVERTISING	919.45	1,681.68	1,000.00	81.60	200.00	0.00
<a href="#">100-2050-7025-0000</a>	OFFICE SUPPLIES	14,222.00	18,232.00	17,000.00	13,493.45	15,900.00	0.00
<a href="#">100-2050-7027-0000</a>	HEALTH/FITNESS	1,800.00	3,762.17	26,400.00	9,885.97	12,000.00	0.00
<a href="#">100-2050-7030-0000</a>	DUES & SUBSCRIPTIONS	26,165.00	29,304.61	27,465.00	21,493.30	27,443.00	0.00
<a href="#">100-2050-7031-0000</a>	LIVE SCAN-FINGERPRINTING	7,000.00	16,356.00	20,000.00	10,269.00	17,000.00	0.00
<a href="#">100-2050-7035-0000</a>	LOCAL MEETINGS	4,400.00	2,318.08	5,000.00	2,161.74	3,900.00	0.00
<a href="#">100-2050-7037-0000</a>	VEHICLE MAINTENANCE	64,250.00	87,780.44	56,325.00	74,433.65	73,285.00	0.00
<a href="#">100-2050-7050-0000</a>	FUEL	111,274.00	136,283.29	132,125.00	118,147.08	135,000.00	0.00
<a href="#">100-2050-7053-0000</a>	PERMITS, FEES AND LICENSES	1,900.00	9,479.22	12,000.00	8,600.08	18,000.00	0.00
<a href="#">100-2050-7055-0000</a>	INTEREST AND PENALTIES	0.00	2,474.41	0.00	0.00	0.00	0.00
<a href="#">100-2050-7056-0000</a>	GOVT FEE DISTRIBUTION	2,420.00	5,575.00	6,000.00	4,387.50	8,000.00	0.00
<a href="#">100-2050-7057-0000</a>	ERICA	226,500.00	241,205.04	230,000.00	235,290.49	260,000.00	0.00
<a href="#">100-2050-7058-0000</a>	CLETS SYSTEM	26,000.00	25,333.00	26,000.00	24,578.00	28,000.00	0.00
<a href="#">100-2050-7059-0000</a>	BOOKING FEES	0.00	0.00	5,500.00	0.00	5,500.00	0.00
<a href="#">100-2050-7065-0000</a>	UNIFORMS	10,000.00	20,166.99	28,545.00	10,215.06	19,360.00	0.00
<a href="#">100-2050-7066-0000</a>	TRAVEL, EDUCATION, TRAINING	47,650.00	37,745.48	51,700.00	40,258.23	49,478.00	0.00
<a href="#">100-2050-7068-0000</a>	CONTRACTUAL SERVICES	70,100.00	58,709.71	57,549.00	29,008.59	43,500.00	0.00
<a href="#">100-2050-7070-0000</a>	SPECIAL DEPT SUPPLIES	13,500.00	14,090.34	60,850.00	55,852.94	66,847.00	0.00
<a href="#">100-2050-7071-0000</a>	SOFTWARE	0.00	20,016.11	0.00	0.00	0.00	0.00
<a href="#">100-2050-7075-0000</a>	EQUIPMENT LEASING/RENTAL	0.00	0.00	0.00	311.34	0.00	0.00
<a href="#">100-2050-7087-0000</a>	SECURITY SERVICES	0.00	0.00	0.00	193.50	0.00	0.00
<a href="#">100-2050-7090-0000</a>	EQUIPMENT SUPPLIES/MAINT	4,000.00	1,772.49	0.00	0.00	0.00	0.00
<a href="#">100-2050-7091-0000</a>	CAL-ID FEE	46,200.00	46,179.00	48,000.00	48,237.00	49,000.00	0.00
<a href="#">100-2050-8050-0000</a>	FURNITURE & FIXTURES	0.00	13,815.54	0.00	2,616.17	0.00	0.00

Budget Worksheet

Defined Budgets

		2018-2019 Total Budget	2018-2019 Total Activity	2019-2020 Total Budget	2019-2020 Total Activity	2020-2021 Total Budget	2020-2021 YTD Activity
<a href="#">100-2050-8060-0000</a>	VEHICLES	246,688.36	89,006.48	252,688.36	135,436.53	235,484.00	0.00
	<b>Department: 2050 - POLICE Total:</b>	<b>9,294,526.81</b>	<b>9,211,786.04</b>	<b>10,555,647.36</b>	<b>8,836,396.14</b>	<b>9,941,711.00</b>	<b>0.00</b>
<b>Department: 2080 - K-9</b>							
<a href="#">100-2080-7035-0000</a>	LOCAL MEETINGS	0.00	0.00	2,400.00	0.00	1,000.00	0.00
<a href="#">100-2080-7037-0000</a>	VEHICLE MAINTENANCE	100.00	0.00	0.00	0.00	0.00	0.00
<a href="#">100-2080-7060-0000</a>	CONTRACTUAL SERVICES	500.00	0.00	1,000.00	0.00	1,000.00	0.00
<a href="#">100-2080-7066-0000</a>	TRAVEL, EDUCATION, TRAINING	1,500.00	1,656.22	1,500.00	1,375.00	1,550.00	0.00
<a href="#">100-2080-7070-0000</a>	SPECIAL DEPT SUPPLIES	1,500.00	3,377.06	1,000.00	1,773.60	2,000.00	0.00
	<b>Department: 2080 - K-9 Total:</b>	<b>3,600.00</b>	<b>5,033.28</b>	<b>5,900.00</b>	<b>3,148.60</b>	<b>5,550.00</b>	<b>0.00</b>
<b>Department: 2090 - POLICE SUPPORT</b>							
<a href="#">100-2090-6010-0000</a>	SALARIES	1,033,466.00	826,341.44	1,026,219.00	676,163.79	986,178.00	0.00
<a href="#">100-2090-6012-0000</a>	OVERTIME	80,500.00	125,875.38	21,500.00	82,852.46	21,500.00	0.00
<a href="#">100-2090-6013-0000</a>	SICK LEAVE	0.00	62,017.19	4,411.00	40,850.97	0.00	0.00
<a href="#">100-2090-6014-0000</a>	HOLIDAY	0.00	45,225.38	4,557.00	42,467.80	0.00	0.00
<a href="#">100-2090-6015-0000</a>	VACATION	0.00	75,080.20	9,477.00	38,728.32	0.00	0.00
<a href="#">100-2090-6016-0000</a>	ACCRUED TIME CASH OUT	60,223.00	9,016.92	79,036.00	7,799.90	113,164.00	0.00
<a href="#">100-2090-6018-0000</a>	OTHER COMPENSATION	0.00	8,861.15	865.00	5,941.51	0.00	0.00
<a href="#">100-2090-6020-0000</a>	HEALTH INSURANCE	234,000.00	171,849.45	267,985.00	172,234.79	247,497.00	0.00
<a href="#">100-2090-6021-0000</a>	DENTAL INSURANCE	0.00	3.20	791.00	1,161.60	0.00	0.00
<a href="#">100-2090-6022-0000</a>	WORKERS COMP	64,575.00	30,832.30	52,276.00	20,093.78	50,539.00	0.00
<a href="#">100-2090-6023-0000</a>	DISABILITY	6,838.00	5,666.44	7,364.00	5,156.94	7,364.00	0.00
<a href="#">100-2090-6024-0000</a>	P.E.R.S./P.E.P.R.A.	173,022.00	191,724.72	171,307.00	127,345.75	186,975.00	0.00
<a href="#">100-2090-6027-0000</a>	VISION CARE	5.00	-81.05	24.00	21.78	0.00	0.00
<a href="#">100-2090-6028-0000</a>	LIFE INSURANCE	1,092.00	1,063.55	1,176.00	986.10	1,176.00	0.00
<a href="#">100-2090-6034-0000</a>	MEDICARE	17,076.00	16,628.51	16,618.00	12,993.39	16,609.00	0.00
<a href="#">100-2090-6035-0000</a>	FICA/PARS	1,606.00	1,141.90	1,730.00	834.49	1,491.00	0.00
<a href="#">100-2090-6036-0000</a>	UNIFORMS	8,000.00	14,005.00	14,400.00	12,040.00	15,600.00	0.00
<a href="#">100-2090-6050-0000</a>	RECRUITMENT AND HIRING COS...	1,400.00	810.00	0.00	0.00	0.00	0.00
<a href="#">100-2090-7025-0000</a>	OFFICE SUPPLIES	0.00	0.00	0.00	196.59	0.00	0.00
<a href="#">100-2090-7027-0000</a>	HEALTH/FITNESS	800.00	2,084.74	9,000.00	3,034.17	4,000.00	0.00
<a href="#">100-2090-7030-0000</a>	DUES & SUBSCRIPTIONS	470.00	811.50	575.00	592.00	565.00	0.00

Budget Worksheet

Defined Budgets

		2018-2019 Total Budget	2018-2019 Total Activity	2019-2020 Total Budget	2019-2020 Total Activity	2020-2021 Total Budget	2020-2021 YTD Activity
<a href="#">100-2090-7035-0000</a>	LOCAL MEETINGS	0.00	35.00	240.00	0.00	0.00	0.00
<a href="#">100-2090-7066-0000</a>	TRAVEL, EDUCATION, TRAINING	3,750.00	2,323.32	7,400.00	2,615.81	0.00	0.00
<a href="#">100-2090-7070-0000</a>	SPECIAL DEPT SUPPLIES	0.00	255.40	0.00	1,830.72	1,000.00	0.00
<b>Department: 2090 - POLICE SUPPORT Total:</b>		<b>1,686,823.00</b>	<b>1,591,571.64</b>	<b>1,696,951.00</b>	<b>1,255,942.66</b>	<b>1,653,658.00</b>	<b>0.00</b>
<b>Department: 2100 - FIRE</b>							
<a href="#">100-2100-7010-0000</a>	UTILITIES	0.00	45.35	1,200.00	-45.35	0.00	0.00
<a href="#">100-2100-7025-0000</a>	OFFICE SUPPLIES	130.00	64.62	0.00	0.00	0.00	0.00
<a href="#">100-2100-7037-0000</a>	VEHICLE MAINTENANCE	2,000.00	7,836.51	12,000.00	25,105.06	10,000.00	0.00
<a href="#">100-2100-7050-0000</a>	FUEL	1,500.00	1,480.57	16,500.00	1,402.70	3,000.00	0.00
<a href="#">100-2100-7068-0000</a>	CONTRACTUAL SERVICES	4,200,000.00	3,412,575.05	4,390,200.00	2,052,423.88	4,565,808.00	0.00
<a href="#">100-2100-7070-0000</a>	SPECIAL DEPT SUPPLIES	1,000.00	98.56	0.00	980.49	0.00	0.00
<a href="#">100-2100-7073-0000</a>	MEDICAL/OEM SUPPLIES	3,000.00	382.51	500.00	-2,198.60	500.00	0.00
<a href="#">100-2100-7090-0000</a>	EQUIPMENT SUPPLIES/MAINT	500.00	5.61	0.00	0.00	0.00	0.00
<b>Department: 2100 - FIRE Total:</b>		<b>4,208,130.00</b>	<b>3,422,488.78</b>	<b>4,420,400.00</b>	<b>2,077,668.18</b>	<b>4,579,308.00</b>	<b>0.00</b>
<b>Department: 2150 - BUILDING AND SAFETY</b>							
<a href="#">100-2150-6010-0000</a>	SALARIES	307,057.00	268,648.78	391,348.00	257,253.09	467,620.00	0.00
<a href="#">100-2150-6012-0000</a>	OVERTIME	1,500.00	983.92	2,000.00	916.34	2,000.00	0.00
<a href="#">100-2150-6013-0000</a>	SICK LEAVE	0.00	66,954.78	84.00	2,897.85	0.00	0.00
<a href="#">100-2150-6014-0000</a>	HOLIDAY	0.00	29,648.33	831.00	17,706.00	0.00	0.00
<a href="#">100-2150-6015-0000</a>	VACATION	0.00	32,370.25	2,495.00	14,020.74	0.00	0.00
<a href="#">100-2150-6016-0000</a>	ACCRUED TIME CASH OUT	5,501.00	4,585.66	14,414.00	2,145.96	26,381.00	0.00
<a href="#">100-2150-6018-0000</a>	OTHER COMPENSATION	0.00	1,045.00	0.00	700.00	1,200.00	0.00
<a href="#">100-2150-6020-0000</a>	HEALTH INSURANCE	72,000.00	71,998.07	99,341.00	64,010.73	95,578.00	0.00
<a href="#">100-2150-6021-0000</a>	DENTAL INSURANCE	0.00	525.59	228.00	1,682.24	0.00	0.00
<a href="#">100-2150-6022-0000</a>	WORKERS COMP	9,959.00	8,708.91	19,738.00	7,453.34	23,741.00	0.00
<a href="#">100-2150-6023-0000</a>	DISABILITY	2,104.00	2,032.47	2,630.00	1,901.66	2,630.00	0.00
<a href="#">100-2150-6024-0000</a>	P.E.R.S./P.E.P.R.A.	60,192.00	62,063.70	76,257.00	46,432.89	106,709.00	0.00
<a href="#">100-2150-6027-0000</a>	VISION CARE	20.00	101.05	31.00	215.44	0.00	0.00
<a href="#">100-2150-6028-0000</a>	LIFE INSURANCE	336.00	329.00	420.00	287.00	420.00	0.00
<a href="#">100-2150-6034-0000</a>	MEDICARE	4,554.00	5,791.24	5,962.00	4,207.09	7,296.00	0.00
<a href="#">100-2150-6036-0000</a>	UNIFORMS	2,500.00	2,550.00	2,400.00	2,226.20	2,400.00	0.00



Budget Worksheet

Defined Budgets

		2018-2019 Total Budget	2018-2019 Total Activity	2019-2020 Total Budget	2019-2020 Total Activity	2020-2021 Total Budget	2020-2021 YTD Activity
<a href="#">100-2150-7020-0000</a>	ADVERTISING	0.00	0.00	300.00	275.40	283.00	0.00
<a href="#">100-2150-7025-0000</a>	OFFICE SUPPLIES	240.00	0.00	740.00	1,523.68	400.00	0.00
<a href="#">100-2150-7027-0000</a>	HEALTH/FITNESS	540.00	270.00	3,600.00	135.00	500.00	0.00
<a href="#">100-2150-7030-0000</a>	DUES & SUBSCRIPTIONS	970.00	615.00	445.00	815.00	500.00	0.00
<a href="#">100-2150-7035-0000</a>	LOCAL MEETINGS	2,440.00	0.00	2,440.00	0.00	380.00	0.00
<a href="#">100-2150-7037-0000</a>	VEHICLE MAINTENANCE	2,000.00	1,776.75	2,500.00	3,742.38	3,000.00	0.00
<a href="#">100-2150-7050-0000</a>	FUEL	5,300.00	5,584.20	5,300.00	3,402.09	3,750.00	0.00
<a href="#">100-2150-7063-0000</a>	PLAN CHECK FEES	710,000.00	657,658.39	500,000.00	242,930.20	255,000.00	0.00
<a href="#">100-2150-7065-0000</a>	UNIFORMS	0.00	151.93	300.00	878.07	1,300.00	0.00
<a href="#">100-2150-7066-0000</a>	TRAVEL, EDUCATION, TRAINING	8,500.00	5,908.97	5,000.00	2,653.00	4,000.00	0.00
<a href="#">100-2150-7067-0000</a>	INSPECTIONS	160,000.00	159,484.96	150,000.00	175,860.00	31,000.00	0.00
<a href="#">100-2150-7068-0000</a>	CONTRACTUAL SERVICES	120,000.00	114,988.58	0.00	0.00	0.00	0.00
<a href="#">100-2150-7070-0000</a>	SPECIAL DEPT SUPPLIES	1,730.00	1,298.11	3,930.00	2,387.15	2,500.00	0.00
<a href="#">100-2150-7090-0000</a>	EQUIPMENT SUPPLIES/MAINT	295.00	56.00	0.00	0.00	0.00	0.00
<a href="#">100-2150-8060-0000</a>	VEHICLES	30,500.00	30,470.45	0.00	24,322.54	0.00	0.00
<b>Department: 2150 - BUILDING AND SAFETY Total:</b>		<b>1,508,238.00</b>	<b>1,536,600.09</b>	<b>1,292,734.00</b>	<b>882,981.08</b>	<b>1,038,588.00</b>	<b>0.00</b>
<b>Department: 3100 - ENGINEERING AND PUBLIC WORKS</b>							
<a href="#">100-3100-6010-0000</a>	SALARIES	302,417.00	278,281.48	491,114.00	310,786.34	641,750.00	0.00
<a href="#">100-3100-6011-0000</a>	ADMIN TIME	0.00	5,715.84	0.00	1,817.28	0.00	0.00
<a href="#">100-3100-6012-0000</a>	OVERTIME	1,875.00	-54.53	3,500.00	53.10	4,647.00	0.00
<a href="#">100-3100-6013-0000</a>	SICK LEAVE	0.00	7,704.38	4,645.00	17,181.91	0.00	0.00
<a href="#">100-3100-6014-0000</a>	HOLIDAY	0.00	14,712.35	1,535.00	35,695.85	0.00	0.00
<a href="#">100-3100-6015-0000</a>	VACATION	0.00	18,062.01	2,693.00	22,718.84	0.00	0.00
<a href="#">100-3100-6016-0000</a>	ACCRUED TIME CASH OUT	5,530.00	3,527.48	7,328.00	0.00	28,893.00	0.00
<a href="#">100-3100-6018-0000</a>	OTHER COMPENSATION	0.00	4,409.58	2,700.00	6,977.75	3,600.00	0.00
<a href="#">100-3100-6020-0000</a>	HEALTH INSURANCE	49,500.00	50,002.81	99,150.00	68,299.17	128,437.00	0.00
<a href="#">100-3100-6021-0000</a>	DENTAL INSURANCE	0.00	123.94	-75.00	2,016.76	0.00	0.00
<a href="#">100-3100-6022-0000</a>	WORKERS COMP	10,182.00	8,636.91	14,187.00	14,765.78	27,529.00	0.00
<a href="#">100-3100-6023-0000</a>	DISABILITY	1,847.00	1,699.84	2,630.00	3,340.07	3,419.00	0.00
<a href="#">100-3100-6024-0000</a>	P.E.R.S./P.E.P.R.A.	56,000.00	63,526.49	88,673.00	53,496.13	124,759.00	0.00
<a href="#">100-3100-6027-0000</a>	VISION CARE	50.00	145.75	75.00	458.53	0.00	0.00

Budget Worksheet

Defined Budgets

		2018-2019 Total Budget	2018-2019 Total Activity	2019-2020 Total Budget	2019-2020 Total Activity	2020-2021 Total Budget	2020-2021 YTD Activity
<a href="#">100-3100-6028-0000</a>	LIFE INSURANCE	315.00	271.80	420.00	496.30	546.00	0.00
<a href="#">100-3100-6030-0000</a>	CAR ALLOWANCE	0.00	1,557.50	508.00	1,907.50	2,100.00	0.00
<a href="#">100-3100-6034-0000</a>	MEDICARE	5,000.00	4,988.08	4,213.00	5,544.51	7,673.00	0.00
<a href="#">100-3100-6036-0000</a>	UNIFORMS	850.00	530.00	863.00	1,065.00	0.00	0.00
<a href="#">100-3100-7020-0000</a>	ADVERTISING	500.00	159.90	600.00	1,726.20	1,200.00	0.00
<a href="#">100-3100-7025-0000</a>	OFFICE SUPPLIES	850.00	1,360.25	870.00	1,863.15	870.00	0.00
<a href="#">100-3100-7027-0000</a>	HEALTH/FITNESS	700.00	973.66	4,125.00	1,704.08	2,500.00	0.00
<a href="#">100-3100-7030-0000</a>	DUES & SUBSCRIPTIONS	0.00	0.00	0.00	65.00	0.00	0.00
<a href="#">100-3100-7037-0000</a>	VEHICLE MAINTENANCE	500.00	487.49	1,000.00	409.60	1,200.00	0.00
<a href="#">100-3100-7050-0000</a>	FUEL	700.00	0.00	7,840.00	2,677.36	6,180.00	0.00
<a href="#">100-3100-7053-0000</a>	PERMITS, FEES AND LICENSES	24,500.00	0.00	0.00	116.00	0.00	0.00
<a href="#">100-3100-7063-0000</a>	PLAN CHECK FEES	400,000.00	348,045.84	250,000.00	118,344.86	100,000.00	0.00
<a href="#">100-3100-7064-0000</a>	STORM WATER INSPECTIONS	75,000.00	18,332.32	65,000.00	26,914.58	61,700.00	0.00
<a href="#">100-3100-7065-0000</a>	UNIFORMS	900.00	1,132.85	911.00	2,341.20	1,950.00	0.00
<a href="#">100-3100-7066-0000</a>	TRAVEL, EDUCATION, TRAINING	1,180.00	0.00	3,000.00	689.00	0.00	0.00
<a href="#">100-3100-7067-0000</a>	INSPECTIONS	436,800.00	362,145.35	150,000.00	57,849.75	0.00	0.00
<a href="#">100-3100-7068-0000</a>	CONTRACTUAL SERVICES	50,000.00	47,357.51	26,000.00	39,459.00	1,000.00	0.00
<a href="#">100-3100-7070-0000</a>	SPECIAL DEPT SUPPLIES	4,870.00	1,660.61	2,500.00	4,867.66	1,990.00	0.00
<a href="#">100-3100-7090-0000</a>	EQUIPMENT SUPPLIES/MAINT	3,050.00	1,831.75	0.00	0.00	0.00	0.00
<a href="#">100-3100-8060-0000</a>	VEHICLES	500.00	0.00	60,000.00	56,149.87	0.00	0.00
<b>Department: 3100 - ENGINEERING AND PUBLIC WORKS Total:</b>		<b>1,433,616.00</b>	<b>1,247,329.24</b>	<b>1,296,005.00</b>	<b>861,798.13</b>	<b>1,151,943.00</b>	<b>0.00</b>
<b>Department: 3150 - REFUSE</b>							
<a href="#">100-3150-7060-0000</a>	REFUSE COST - RESIDENTIAL	3,000,000.00	3,137,981.99	0.00	0.00	0.00	0.00
<a href="#">100-3150-7061-0000</a>	REFUSE COST - COMMERCIAL	2,000,000.00	2,366,529.69	0.00	0.00	0.00	0.00
<b>Department: 3150 - REFUSE Total:</b>		<b>5,000,000.00</b>	<b>5,504,511.68</b>	<b>0.00</b>	<b>0.00</b>	<b>0.00</b>	<b>0.00</b>
<b>Department: 3250 - STREET MAINTENANCE</b>							
<a href="#">100-3250-6010-0000</a>	SALARIES	295,131.00	254,504.54	324,077.00	234,880.21	346,205.00	0.00
<a href="#">100-3250-6012-0000</a>	OVERTIME	10,000.00	3,711.64	10,000.00	6,724.24	14,452.00	0.00
<a href="#">100-3250-6013-0000</a>	SICK LEAVE	0.00	13,816.01	1,837.00	12,460.70	0.00	0.00
<a href="#">100-3250-6014-0000</a>	HOLIDAY	0.00	22,427.14	1,017.00	17,160.17	0.00	0.00
<a href="#">100-3250-6015-0000</a>	VACATION	0.00	13,026.01	2,046.00	10,969.78	0.00	0.00

Budget Worksheet

Defined Budgets

		2018-2019 Total Budget	2018-2019 Total Activity	2019-2020 Total Budget	2019-2020 Total Activity	2020-2021 Total Budget	2020-2021 YTD Activity
<a href="#">100-3250-6016-0000</a>	ACCRUED TIME CASH OUT	5,267.00	18,934.58	11,735.00	9,534.41	20,194.00	0.00
<a href="#">100-3250-6019-0000</a>	FIRST AID	200.00	172.00	90.00	188.00	0.00	0.00
<a href="#">100-3250-6020-0000</a>	HEALTH INSURANCE	90,000.00	89,470.90	99,031.00	86,115.10	96,306.00	0.00
<a href="#">100-3250-6021-0000</a>	DENTAL INSURANCE	0.00	1,083.29	488.00	2,352.78	0.00	0.00
<a href="#">100-3250-6022-0000</a>	WORKERS COMP	9,000.00	8,373.49	16,453.00	6,916.57	17,720.00	0.00
<a href="#">100-3250-6023-0000</a>	DISABILITY	2,630.00	1,942.32	2,630.00	1,780.46	2,630.00	0.00
<a href="#">100-3250-6024-0000</a>	P.E.R.S./P.E.P.R.A.	58,000.00	58,300.58	52,924.00	41,297.40	63,264.00	0.00
<a href="#">100-3250-6027-0000</a>	VISION CARE	30.00	249.74	81.00	441.88	0.00	0.00
<a href="#">100-3250-6028-0000</a>	LIFE INSURANCE	420.00	420.00	420.00	385.00	420.00	0.00
<a href="#">100-3250-6034-0000</a>	MEDICARE	4,501.00	4,635.60	5,087.00	4,097.16	5,577.00	0.00
<a href="#">100-3250-6036-0000</a>	UNIFORMS	550.00	417.59	4,107.00	265.59	0.00	0.00
<a href="#">100-3250-7010-0000</a>	UTILITIES	800,000.00	493,493.24	578,850.00	185,183.55	641,899.00	0.00
<a href="#">100-3250-7010-003X</a>	UTILITIES (IA 3)	0.00	27,231.69	29,020.00	23,166.00	0.00	0.00
<a href="#">100-3250-7010-004X</a>	UTILITIES (IA 4)	0.00	2,856.35	3,530.00	1,830.26	0.00	0.00
<a href="#">100-3250-7010-006B</a>	UTILITIES (IA 6B)	0.00	20,246.04	22,715.00	21,191.74	0.00	0.00
<a href="#">100-3250-7010-007A</a>	UTILITIES (IA 7A)	0.00	5,253.97	4,460.00	14,867.83	0.00	0.00
<a href="#">100-3250-7010-007B</a>	UTILITIES (IA 7B)	0.00	1,659.48	1,600.00	4,609.16	0.00	0.00
<a href="#">100-3250-7010-007D</a>	UTILITIES (IA 7D)	0.00	1,014.65	1,140.00	975.50	0.00	0.00
<a href="#">100-3250-7010-008A</a>	UTILITIES (IA 8A)	0.00	10,236.65	11,660.00	9,537.43	0.00	0.00
<a href="#">100-3250-7010-008B</a>	UTILITIES (IA 8B)	0.00	1,602.82	1,910.00	4,787.58	0.00	0.00
<a href="#">100-3250-7010-008C</a>	UTILITIES (IA 8C)	0.00	7,393.07	8,225.00	6,885.91	0.00	0.00
<a href="#">100-3250-7010-008D</a>	UTILITIES (IA 8D)	0.00	233.19	265.00	185.05	0.00	0.00
<a href="#">100-3250-7010-010A</a>	UTILITIES (IA 10)	0.00	2,449.86	2,200.00	5,912.41	0.00	0.00
<a href="#">100-3250-7010-011A</a>	UTILITIES (IA 11A)	0.00	1,796.63	1,995.00	1,460.82	0.00	0.00
<a href="#">100-3250-7010-012A</a>	UTILITIES (IA 12)	0.00	1,634.36	1,530.00	2,862.58	0.00	0.00
<a href="#">100-3250-7010-014A</a>	UTILITIES (IA 14A)	0.00	1,439.62	2,020.00	1,038.76	0.00	0.00
<a href="#">100-3250-7010-014B</a>	UTILITIES (IA 14B)	0.00	5,171.49	4,170.00	11,149.62	0.00	0.00
<a href="#">100-3250-7010-014X</a>	UTILITIES (IA 14)	0.00	28,957.21	25,450.00	57,852.28	0.00	0.00
<a href="#">100-3250-7010-015X</a>	UTILITIES (IA 15)	0.00	2,516.80	1,470.00	8,901.48	0.00	0.00
<a href="#">100-3250-7010-016X</a>	UTILITIES (IA 16)	0.00	7,704.06	6,215.00	15,372.64	0.00	0.00
<a href="#">100-3250-7010-018X</a>	UTILITIES (IA 18)	0.00	4,581.67	3,955.00	6,425.22	0.00	0.00

Budget Worksheet

Defined Budgets

		2018-2019 Total Budget	2018-2019 Total Activity	2019-2020 Total Budget	2019-2020 Total Activity	2020-2021 Total Budget	2020-2021 YTD Activity
<a href="#">100-3250-7010-019A</a>	UTILITIES (IA 19A)	0.00	3,108.51	2,290.00	11,398.20	0.00	0.00
<a href="#">100-3250-7010-019C</a>	UTILITIES (IA 19C)	0.00	31,459.46	36,290.00	26,631.36	0.00	0.00
<a href="#">100-3250-7010-06A1</a>	UTILITIES (IA 6A1)	0.00	23,375.86	22,860.00	49,443.40	0.00	0.00
<a href="#">100-3250-7012-0000</a>	STREET LIGHT MAINTENACE - 4 S...	0.00	0.00	0.00	8,175.83	75,000.00	0.00
<a href="#">100-3250-7025-0000</a>	OFFICE SUPPLIES	150.00	88.31	150.00	56.95	157.00	0.00
<a href="#">100-3250-7027-0000</a>	HEALTH/FITNESS	500.00	250.00	3,750.00	735.00	1,200.00	0.00
<a href="#">100-3250-7030-0000</a>	DUES & SUBSCRIPTIONS	0.00	45.00	0.00	0.00	0.00	0.00
<a href="#">100-3250-7037-0000</a>	VEHICLE MAINTENANCE	6,900.00	8,874.12	6,300.00	7,932.15	7,900.00	0.00
<a href="#">100-3250-7050-0000</a>	FUEL	18,000.00	14,607.50	22,740.00	18,772.53	20,000.00	0.00
<a href="#">100-3250-7053-0000</a>	PERMITS, FEES AND LICENSES	0.00	0.00	15,412.00	42,420.02	21,954.00	0.00
<a href="#">100-3250-7055-0000</a>	INTEREST AND PENALTIES	0.00	7,817.20	0.00	0.00	0.00	0.00
<a href="#">100-3250-7065-0000</a>	UNIFORMS	2,460.00	3,574.93	2,135.00	3,309.93	5,350.00	0.00
<a href="#">100-3250-7066-0000</a>	TRAVEL, EDUCATION, TRAINING	7,950.00	472.24	5,180.00	320.00	480.00	0.00
<a href="#">100-3250-7068-0000</a>	CONTRACTUAL SERVICES	509,482.00	209,425.47	225,000.00	127,908.04	150,000.00	0.00
<a href="#">100-3250-7070-0000</a>	SPECIAL DEPT SUPPLIES	127,585.00	90,643.37	60,000.00	78,095.44	60,000.00	0.00
<a href="#">100-3250-7070-5150</a>	SPEC DEPT SUPPLIES-MOUNTAI...	540.00	0.00	540.00	0.00	0.00	0.00
<a href="#">100-3250-7075-0000</a>	EQUIPMENT LEASING/RENTAL	14,910.00	4,281.23	4,280.00	5,844.36	10,000.00	0.00
<a href="#">100-3250-7090-0000</a>	EQUIPMENT SUPPLIES/MAINT	2,000.00	50.77	0.00	52.10	0.00	0.00
<a href="#">100-3250-8040-0000</a>	EQUIPMENT	70,000.00	91,067.05	0.00	0.00	0.00	0.00
<a href="#">100-3250-8060-0000</a>	VEHICLES	82,500.00	89,798.40	38,331.72	40,178.91	38,332.00	0.00
<b>Department: 3250 - STREET MAINTENANCE Total:</b>		<b>2,118,706.00</b>	<b>1,697,897.70</b>	<b>1,689,661.72</b>	<b>1,241,039.49</b>	<b>1,599,040.00</b>	<b>0.00</b>
<b>Department: 6000 - BUILDING MAINTENANCE</b>							
<a href="#">100-6000-7010-0000</a>	UTILITIES	203,725.00	0.00	0.00	0.00	179,000.00	0.00
<a href="#">100-6000-7010-6025</a>	UTILITIES - CITY HALL	0.00	45,653.01	46,624.00	40,566.05	0.00	0.00
<a href="#">100-6000-7010-6026</a>	UTILITIES - CITY HALL BLDG B	0.00	0.00	0.00	921.70	0.00	0.00
<a href="#">100-6000-7010-6031</a>	UTILITIES - CITY HALL BLDG G (C...	0.00	14,409.55	14,553.00	12,445.57	0.00	0.00
<a href="#">100-6000-7010-6032</a>	UTILITIES - CITY HALL BLDG H (AN..	0.00	14,874.29	14,553.00	13,082.17	0.00	0.00
<a href="#">100-6000-7010-6040</a>	UTILITIES - POLICE DEPT	0.00	38,142.81	39,643.00	34,954.67	0.00	0.00
<a href="#">100-6000-7010-6041</a>	UTILITIES - POLICE ANNEX	0.00	68.95	0.00	4,359.84	0.00	0.00
<a href="#">100-6000-7010-6045</a>	UTILITIES - COMMUNITY CENTER	0.00	58,597.84	58,659.00	45,335.29	0.00	0.00
<a href="#">100-6000-7010-6055</a>	UTILITIES - FIRE STATION MAPLE ...	0.00	6,621.76	5,160.00	6,439.73	0.00	0.00

Budget Worksheet

Defined Budgets

		2018-2019 Total Budget	2018-2019 Total Activity	2019-2020 Total Budget	2019-2020 Total Activity	2020-2021 Total Budget	2020-2021 YTD Activity
<a href="#">100-6000-7022-6025</a>	LICENSE, PERMITS, FEES - CITY H...	1,900.00	472.69	811.00	978.44	1,164.00	0.00
<a href="#">100-6000-7022-6040</a>	LICENSE, PERMITS, FEES - PD BL...	0.00	538.58	585.00	557.42	600.00	0.00
<a href="#">100-6000-7022-6045</a>	LICENSE, PERMITS, FEES - CRC	0.00	1,648.95	386.00	1,516.42	1,600.00	0.00
<a href="#">100-6000-7022-6048</a>	LICENSE, PERMITS, FEES - POOL	0.00	812.00	1,392.00	0.00	0.00	0.00
<a href="#">100-6000-7022-6050</a>	LICENSE, PERMTIS, FEES - VFW B...	0.00	285.76	490.00	283.64	300.00	0.00
<a href="#">100-6000-7050-0000</a>	FUEL	0.00	1,440.29	0.00	0.00	0.00	0.00
<a href="#">100-6000-7068-0000</a>	CONTRACTUAL SERVICES	4,500.00	0.00	25,000.00	0.00	133,000.00	0.00
<a href="#">100-6000-7068-6025</a>	CONTRACTUAL SVC - CITY HALL	26,180.00	48,521.10	49,880.00	72,153.06	0.00	0.00
<a href="#">100-6000-7068-6026</a>	CONTRACTUAL SVC - CITY HALL B...	0.00	4,061.88	8,160.00	7,062.30	0.00	0.00
<a href="#">100-6000-7068-6028</a>	CONTRACTUAL SVC- CITY HALL B...	0.00	1,020.00	0.00	0.00	0.00	0.00
<a href="#">100-6000-7068-6029</a>	CONTRACTUAL SVC- CITY HALL B...	0.00	0.00	0.00	325.00	0.00	0.00
<a href="#">100-6000-7068-6032</a>	CONTRACTUAL SVC- CITY HALL B...	0.00	6,685.00	0.00	3,350.60	0.00	0.00
<a href="#">100-6000-7068-6040</a>	CONTRACTUAL SVC- POLICE DEPT	10,000.00	3,942.00	45,000.00	30,628.80	0.00	0.00
<a href="#">100-6000-7068-6041</a>	CONTRACTUAL SVC- POLICE ANN...	0.00	21,966.00	20,000.00	24,508.80	0.00	0.00
<a href="#">100-6000-7068-6045</a>	CONTRACTUAL SVC- COMMUNIT...	23,800.00	50,077.51	45,128.00	30,600.00	4,500.00	0.00
<a href="#">100-6000-7068-6048</a>	CONTRACTUAL SERVICES - POOL	0.00	1,498.81	0.00	0.00	0.00	0.00
<a href="#">100-6000-7068-6055</a>	CONTRACTUAL SVC- FIRE STATI...	0.00	0.00	0.00	3,743.79	0.00	0.00
<a href="#">100-6000-7068-6060</a>	CONTRACTUAL SVC- 713 W 4TH ...	0.00	2,593.27	2,040.00	4,015.30	0.00	0.00
<a href="#">100-6000-7068-6065</a>	CONTRACTUAL SVC- 550 CALIF A...	0.00	500.00	0.00	0.00	0.00	0.00
<a href="#">100-6000-7070-0000</a>	SPECIAL DEPT SUPPLIES	1,000.00	768.43	839.00	13.57	1,100.00	0.00
<a href="#">100-6000-7070-6025</a>	SPEC DEPT EXP - CITY HALL	2,100.00	2,545.12	4,298.00	901.08	0.00	0.00
<a href="#">100-6000-7070-6026</a>	SPEC DEPT EXP - CITY HALL BLDG...	625.00	310.15	532.00	0.00	0.00	0.00
<a href="#">100-6000-7070-6040</a>	SPEC DEPT EXP- POLICE DEPT	23.00	375.33	20.00	289.83	0.00	0.00
<a href="#">100-6000-7070-6045</a>	SPEC DEPT EXP- COMMUNITY C...	215.00	427.84	187.00	9.66	0.00	0.00
<a href="#">100-6000-7070-6055</a>	SPEC DEPT EXP- FIRE STATION M...	0.00	0.00	0.00	448.96	0.00	0.00
<a href="#">100-6000-7070-6060</a>	SPEC DEPT EXP- 713 W 4TH ST	0.00	1,016.67	0.00	0.00	0.00	0.00
<a href="#">100-6000-7075-0000</a>	EQUIPMENT LEASING/RENTAL	350.00	172.16	296.00	0.00	300.00	0.00
<a href="#">100-6000-7075-6025</a>	EQUIP LEASING/RENTAL - CITY H...	0.00	100.00	0.00	0.00	0.00	0.00
<a href="#">100-6000-7075-6040</a>	EQUIPMENT LEASING/RENTAL	0.00	95.92	0.00	0.00	0.00	0.00
<a href="#">100-6000-7075-6048</a>	EQUIP LEASING - POOL	0.00	0.00	0.00	106.48	0.00	0.00
<a href="#">100-6000-7085-0000</a>	BUILDING SUPPLIES/MAINT	70,000.00	3,163.10	2,226.00	58.16	44,666.00	0.00

Budget Worksheet

Defined Budgets

		2018-2019 Total Budget	2018-2019 Total Activity	2019-2020 Total Budget	2019-2020 Total Activity	2020-2021 Total Budget	2020-2021 YTD Activity
<a href="#">100-6000-7085-5300</a>	BLDG MAINT - SENECA SPRINGS ...	0.00	76.88	0.00	0.00	0.00	0.00
<a href="#">100-6000-7085-5400</a>	BLDG MAINT - SPORTS PARK	0.00	142.87	55.00	0.00	0.00	0.00
<a href="#">100-6000-7085-5500</a>	BLDG MAINT - STEWART PARK	0.00	8.00	0.00	0.00	0.00	0.00
<a href="#">100-6000-7085-6025</a>	BLDG MAINT - CITY HALL	50,000.00	27,428.66	42,482.56	18,111.03	25,000.00	0.00
<a href="#">100-6000-7085-6026</a>	BLDG MAINT- CITY HALL BLDG B	0.00	1,054.82	1,665.00	237.12	0.00	0.00
<a href="#">100-6000-7085-6027</a>	BLDG MAINT - CITY HALL BLDG C	0.00	89.38	0.00	0.00	0.00	0.00
<a href="#">100-6000-7085-6029</a>	BLDG MAINT - CITY HALL BLDG E	0.00	1,241.47	0.00	771.59	0.00	0.00
<a href="#">100-6000-7085-6030</a>	BLDG MAINT- CITY HALL BLDG F ...	0.00	321.38	551.00	238.56	0.00	0.00
<a href="#">100-6000-7085-6031</a>	BLDG MAINT- CITY HALL BLDG G ...	0.00	119.17	205.00	0.00	0.00	0.00
<a href="#">100-6000-7085-6032</a>	BLDG MAINT- CITY HALL BLDG H ...	0.00	1,568.07	981.00	810.10	0.00	0.00
<a href="#">100-6000-7085-6040</a>	BLDG MAINT - POLICE DEPT	0.00	56,510.19	50,699.00	22,751.80	25,100.00	0.00
<a href="#">100-6000-7085-6041</a>	BLDG MAINT - POLICE ANNEX	0.00	1,869.84	0.00	1,874.95	0.00	0.00
<a href="#">100-6000-7085-6045</a>	BLDG MAINT- COMMUNITY CEN...	40,000.00	25,809.08	15,283.00	16,631.80	0.00	0.00
<a href="#">100-6000-7085-6048</a>	BLDG MAINT - POOL	0.00	10,667.01	258.00	720.78	0.00	0.00
<a href="#">100-6000-7085-6055</a>	BLDG MAINT- FIRE STATION MA...	0.00	5,643.45	12,234.00	7,187.45	5,234.00	0.00
<a href="#">100-6000-7085-6060</a>	BLDG MAINT- 713 W 4TH ST	0.00	5,426.82	484.00	1,431.01	0.00	0.00
<a href="#">100-6000-7087-0000</a>	SECURITY SERVICES	0.00	0.00	0.00	0.00	6,500.00	0.00
<a href="#">100-6000-7087-5400</a>	SECURITY - SPORTS PARK	0.00	456.00	0.00	456.00	0.00	0.00
<a href="#">100-6000-7087-6025</a>	SECURITY - CITY HALL	1,500.00	2,575.97	1,543.00	2,809.25	0.00	0.00
<a href="#">100-6000-7087-6026</a>	SECURITY- CITY HALL BLDG B	460.00	575.00	493.00	657.25	0.00	0.00
<a href="#">100-6000-7087-6030</a>	SECURITY - CITY HALL BLDG F (EV...	0.00	111.00	0.00	0.00	0.00	0.00
<a href="#">100-6000-7087-6040</a>	SECURITY - POLICE DEPT	1,741.00	1,737.50	1,772.00	1,869.50	0.00	0.00
<a href="#">100-6000-7087-6045</a>	SECURITY - COMMUNITY CENTER	1,450.00	2,287.95	1,382.00	2,014.50	0.00	0.00
<a href="#">100-6000-7087-6048</a>	SECURITY - POOL	0.00	336.00	0.00	336.00	0.00	0.00
<a href="#">100-6000-7087-6050</a>	SECURITY - 450 E 4TH ST	0.00	360.00	0.00	360.00	0.00	0.00
<a href="#">100-6000-7087-6055</a>	SECURITY - FIRE STATION MAPLE...	220.00	107.50	185.00	0.00	0.00	0.00
<a href="#">100-6000-7087-6060</a>	SECURITY - 713 W 4TH ST	0.00	1,020.00	0.00	1,020.00	0.00	0.00
<a href="#">100-6000-7090-0000</a>	EQUIPMENT SUPPLIES/MAINT	0.00	20.63	0.00	24.54	6,700.00	0.00
<a href="#">100-6000-7090-6025</a>	EQUIPMENT SUPPLIES/MAINT-Cl...	0.00	0.00	0.00	1,876.52	0.00	0.00
<a href="#">100-6000-7090-6040</a>	EQUIPMENT SUPPLIES/MAINT-P...	500.00	4,575.64	669.00	1,983.24	0.00	0.00
<a href="#">100-6000-7090-6045</a>	EQUIPMENT SUPPLIES/MAINT-C...	0.00	5,676.01	1,939.00	4,244.25	0.00	0.00

Budget Worksheet

Defined Budgets

		2018-2019 Total Budget	2018-2019 Total Activity	2019-2020 Total Budget	2019-2020 Total Activity	2020-2021 Total Budget	2020-2021 YTD Activity
<a href="#">100-6000-7090-6048</a>	EQUIPMENT SUPPLIES/MAINT - ...	0.00	5,611.35	0.00	1,448.85	0.00	0.00
<a href="#">100-6000-8014-0000</a>	BUILDING IMPROVEMENTS	100,000.00	26,269.00	0.00	0.00	0.00	0.00
<a href="#">100-6000-8050-6025</a>	FURNITURE AND FIXTURES	0.00	0.00	6,038.44	6,465.81	0.00	0.00
<b>Department: 6000 - BUILDING MAINTENANCE Total:</b>		<b>540,289.00</b>	<b>523,103.41</b>	<b>525,381.00</b>	<b>435,988.23</b>	<b>434,764.00</b>	<b>0.00</b>
<b>Department: 6050 - PARKS AND GROUNDS MAINT</b>							
<a href="#">100-6050-6010-0000</a>	SALARIES	1,164,776.00	883,941.84	1,200,932.00	765,671.54	1,126,137.00	0.00
<a href="#">100-6050-6011-0000</a>	ADMIN TIME	0.00	307.00	1,428.00	11,007.90	0.00	0.00
<a href="#">100-6050-6012-0000</a>	OVERTIME	14,400.00	44,608.61	50,000.00	33,085.87	56,406.00	0.00
<a href="#">100-6050-6013-0000</a>	SICK LEAVE	0.00	52,925.23	8,657.00	51,232.13	0.00	0.00
<a href="#">100-6050-6014-0000</a>	HOLIDAY	0.00	62,184.87	3,746.00	55,379.23	0.00	0.00
<a href="#">100-6050-6015-0000</a>	VACATION	0.00	63,744.38	11,486.00	65,912.66	0.00	0.00
<a href="#">100-6050-6016-0000</a>	ACCRUED TIME CASH OUT	23,987.00	26,370.66	44,410.00	23,065.74	69,878.00	0.00
<a href="#">100-6050-6018-0000</a>	OTHER COMPENSATION	0.00	17,783.28	1,874.00	14,672.98	0.00	0.00
<a href="#">100-6050-6019-0000</a>	FIRST AID	450.00	608.00	309.00	2,082.20	0.00	0.00
<a href="#">100-6050-6020-0000</a>	HEALTH INSURANCE	260,000.00	250,102.18	393,904.00	245,802.36	314,474.00	0.00
<a href="#">100-6050-6021-0000</a>	DENTAL INSURANCE	0.00	3,746.44	1,642.00	8,371.06	0.00	0.00
<a href="#">100-6050-6022-0000</a>	WORKERS COMP	50,710.00	32,772.56	61,481.00	52,581.60	57,580.00	0.00
<a href="#">100-6050-6023-0000</a>	DISABILITY	8,000.00	7,345.69	10,520.00	6,849.38	9,468.00	0.00
<a href="#">100-6050-6024-0000</a>	P.E.R.S./P.E.P.R.A.	190,000.00	200,857.42	236,208.00	143,036.14	212,520.00	0.00
<a href="#">100-6050-6026-0000</a>	DEFERRED COMP	6,000.00	7,007.59	1,193.00	5,970.24	0.00	0.00
<a href="#">100-6050-6027-0000</a>	VISION CARE	200.00	1,018.89	324.00	1,539.70	0.00	0.00
<a href="#">100-6050-6028-0000</a>	LIFE INSURANCE	1,680.00	1,623.53	1,680.00	1,495.75	1,512.00	0.00
<a href="#">100-6050-6029-0000</a>	WORKERS COMP COST	6,000.00	2,811.54	4,330.00	24,271.56	0.00	0.00
<a href="#">100-6050-6034-0000</a>	MEDICARE	17,446.00	16,418.88	19,198.00	14,536.12	18,356.00	0.00
<a href="#">100-6050-6036-0000</a>	UNIFORMS	1,500.00	1,465.93	12,772.00	1,505.42	0.00	0.00
<a href="#">100-6050-6050-0000</a>	RECRUITMENT AND HIRING COS...	200.00	66.00	0.00	0.00	0.00	0.00
<a href="#">100-6050-7010-0000</a>	UTILITIES	525,000.00	157,053.65	314,906.00	41,555.96	445,000.00	0.00
<a href="#">100-6050-7010-002X</a>	UTILITIES IA 2	0.00	1,113.15	895.00	1,032.29	0.00	0.00
<a href="#">100-6050-7010-003X</a>	UTILITIES IA 3	0.00	11,312.02	5,327.00	45,998.23	0.00	0.00
<a href="#">100-6050-7010-005X</a>	UTILITIES IA 5	0.00	44,239.00	35,393.00	43,824.81	0.00	0.00
<a href="#">100-6050-7010-007A</a>	UTILITIES IA 7A	0.00	1,029.64	1,060.00	4,390.99	0.00	0.00

Budget Worksheet

Defined Budgets

		2018-2019 Total Budget	2018-2019 Total Activity	2019-2020 Total Budget	2019-2020 Total Activity	2020-2021 Total Budget	2020-2021 YTD Activity
<a href="#">100-6050-7010-008A</a>	UTILITIES IA 8A (SUNDANCE)	0.00	91,142.60	86,407.00	52,123.36	0.00	0.00
<a href="#">100-6050-7010-008C</a>	UTILITIES IA 8C	0.00	304.44	103.00	392.96	0.00	0.00
<a href="#">100-6050-7010-008D</a>	UTILITIES IA 8D	0.00	624.11	0.00	1,429.73	0.00	0.00
<a href="#">100-6050-7010-008E</a>	UTILITIES IA 8E	0.00	599.21	202.00	868.31	0.00	0.00
<a href="#">100-6050-7010-014A</a>	UTILITIES IA 14A (OAK VALLEY)	0.00	2,024.38	1,284.00	4,177.01	0.00	0.00
<a href="#">100-6050-7010-014B</a>	UTILITIES IA 14B	0.00	6,936.42	772.00	13,355.04	0.00	0.00
<a href="#">100-6050-7010-014X</a>	UTILITIES IA 14	0.00	264.77	271.00	115.01	0.00	0.00
<a href="#">100-6050-7010-017A</a>	UTILITIES IA 17A (TOURNAMENT...	0.00	3,739.34	2,667.00	11,279.90	0.00	0.00
<a href="#">100-6050-7010-018X</a>	UTILITIES IA 18	0.00	155.16	45.00	261.03	0.00	0.00
<a href="#">100-6050-7010-019C</a>	UTILITIES IA 19C	0.00	2,110.36	839.00	4,387.31	0.00	0.00
<a href="#">100-6050-7010-020X</a>	UTILITIES IA 20	0.00	1,269.82	747.00	2,948.71	0.00	0.00
<a href="#">100-6050-7010-06A1</a>	UTILITIES IA 6A1	0.00	2,925.93	2,316.00	5,170.87	0.00	0.00
<a href="#">100-6050-7010-1601</a>	UTILITIES IA 1601	0.00	0.00	0.00	6,083.79	0.00	0.00
<a href="#">100-6050-7010-5050</a>	UTILITIES, PARK (DEFORGE)	0.00	895.50	389.00	5,746.53	0.00	0.00
<a href="#">100-6050-7010-5200</a>	UTILITIES, PARK (PALMER)	0.00	74.10	22.00	126.96	0.00	0.00
<a href="#">100-6050-7010-5250</a>	UTILITIES, PARK (RANGAL)	0.00	896.52	216.00	5,370.26	0.00	0.00
<a href="#">100-6050-7010-5300</a>	UTILITIES, PARK (SENECA SPRING...	0.00	3,539.72	5,069.00	0.00	0.00	0.00
<a href="#">100-6050-7010-5350</a>	UTILITIES, PARK (SHADOW HILLS)	0.00	281.94	484.00	964.57	0.00	0.00
<a href="#">100-6050-7010-5400</a>	UTILITIES, PARK (SPORTS PARK)	0.00	16,061.12	9,457.00	50,297.48	0.00	0.00
<a href="#">100-6050-7010-5450</a>	UTILITIES, PARK (STETSON)	0.00	5,310.42	2,424.00	31,811.08	0.00	0.00
<a href="#">100-6050-7010-5500</a>	UTILITIES, PARK (STEWART)	0.00	6,232.03	4,068.00	22,082.89	0.00	0.00
<a href="#">100-6050-7010-5600</a>	UTILITIES, PARK (TREVINO)	0.00	454.28	130.00	752.56	0.00	0.00
<a href="#">100-6050-7010-5650</a>	UTILITIES, PARK (VETERANS)	0.00	194.38	82.00	586.90	0.00	0.00
<a href="#">100-6050-7010-5700</a>	UTILITIES, PARK (WILD FLOWER)	0.00	2,112.98	193.00	9,904.14	0.00	0.00
<a href="#">100-6050-7010-5750</a>	UTILITIES (NICKLAUS PARK)	0.00	679.22	0.00	0.00	0.00	0.00
<a href="#">100-6050-7010-6000</a>	UTILITIES	0.00	669.62	1,148.00	0.00	0.00	0.00
<a href="#">100-6050-7010-6001</a>	UTILITIES	0.00	1,281.36	2,197.00	0.00	0.00	0.00
<a href="#">100-6050-7011-2000</a>	UTILITIES - RYLAN	0.00	3,814.36	6,539.00	0.00	0.00	0.00
<a href="#">100-6050-7022-5400</a>	LICENSE, PERMITS, FEES - SPORTS..	0.00	292.00	251.00	0.00	250.00	0.00
<a href="#">100-6050-7027-0000</a>	HEALTH/FITNESS	1,200.00	2,112.82	15,000.00	1,931.91	3,000.00	0.00
<a href="#">100-6050-7037-0000</a>	VEHICLE MAINTENANCE	41,000.00	37,725.01	31,508.00	43,891.53	25,000.00	0.00



Budget Worksheet

Defined Budgets

		2018-2019 Total Budget	2018-2019 Total Activity	2019-2020 Total Budget	2019-2020 Total Activity	2020-2021 Total Budget	2020-2021 YTD Activity
<a href="#">100-6050-7050-0000</a>	FUEL	60,000.00	56,109.65	54,236.00	47,866.25	59,000.00	0.00
<a href="#">100-6050-7055-0000</a>	INTEREST AND PENALTIES	0.00	579.38	0.00	0.00	0.00	0.00
<a href="#">100-6050-7065-0000</a>	UNIFORMS	17,100.00	19,617.08	16,850.00	9,853.55	16,850.00	0.00
<a href="#">100-6050-7066-0000</a>	TRAVEL, EDUCATION, TRAINING	395.00	3,407.51	2,000.00	277.88	2,000.00	0.00
<a href="#">100-6050-7068-0000</a>	CONTRACTUAL SERVICES	113,539.95	43,707.34	3,612.00	3,357.06	25,000.00	0.00
<a href="#">100-6050-7068-001A</a>	CONTRACTUAL SVC IA 1A	0.00	0.00	0.00	2,380.99	0.00	0.00
<a href="#">100-6050-7068-003X</a>	CONTRACTUAL SVC IA 3	0.00	1,456.93	0.00	25,025.00	0.00	0.00
<a href="#">100-6050-7068-006A</a>	CONTRACTUAL SVC IA 6A	0.00	15,850.00	16,143.00	5,750.00	0.00	0.00
<a href="#">100-6050-7068-006B</a>	CONTRACTUAL SVC IA 6B	0.00	0.00	0.00	2,700.00	0.00	0.00
<a href="#">100-6050-7068-007B</a>	CONTRACTUAL SVC IA 7B	0.00	353.00	0.00	0.00	0.00	0.00
<a href="#">100-6050-7068-008a</a>	CONTRACT SVC - IA 8A	0.00	18,605.21	8,125.00	15,234.20	0.00	0.00
<a href="#">100-6050-7068-008C</a>	CONTRACTUAL SVC IA 8C	0.00	4,800.00	0.00	0.00	0.00	0.00
<a href="#">100-6050-7068-010A</a>	CONTRACT SVC - IA 10A	0.00	0.00	0.00	1,650.28	0.00	0.00
<a href="#">100-6050-7068-011A</a>	CONTRACT SVC - IA 11A	0.00	0.00	0.00	2,294.08	0.00	0.00
<a href="#">100-6050-7068-013X</a>	CONTRACTUAL SVC IA 13	0.00	1,868.90	0.00	570.00	0.00	0.00
<a href="#">100-6050-7068-014A</a>	CONTRACTUAL SVC IA 14A (OAK ...	0.00	880.00	600.00	73,513.48	0.00	0.00
<a href="#">100-6050-7068-014B</a>	CONTRACT SVC - IA 14B	0.00	110.00	0.00	1,120.00	0.00	0.00
<a href="#">100-6050-7068-014X</a>	CONTRACTUAL SVC IA 14	0.00	5,270.00	9,035.00	0.00	0.00	0.00
<a href="#">100-6050-7068-016X</a>	CONTRACTUAL SVC IA 16	0.00	0.00	0.00	378.00	0.00	0.00
<a href="#">100-6050-7068-017A</a>	CONTRACTUAL SERVICES	0.00	2,512.40	0.00	841.23	0.00	0.00
<a href="#">100-6050-7068-017C</a>	CONTRACTUAL SVC IA 17C	0.00	0.00	0.00	40.00	0.00	0.00
<a href="#">100-6050-7068-018X</a>	CONTRACTUAL SVC IA 18	0.00	635.00	0.00	2,187.65	0.00	0.00
<a href="#">100-6050-7068-019C</a>	CONTRACTUAL SVC IA 19C	0.00	0.00	0.00	40.00	0.00	0.00
<a href="#">100-6050-7068-020X</a>	CONTRACTUAL SVC IA 20	0.00	0.00	0.00	1,958.50	0.00	0.00
<a href="#">100-6050-7068-06A1</a>	CONTRACTUAL SVC IA 6A1	0.00	37,794.69	45,172.00	7,429.19	0.00	0.00
<a href="#">100-6050-7068-1602</a>	CONTRACT SVC - IA 1602	0.00	0.00	0.00	40.00	0.00	0.00
<a href="#">100-6050-7068-5000</a>	CONTRACT SVC - THREE RINGS R...	0.00	1,300.00	2,229.00	0.00	0.00	0.00
<a href="#">100-6050-7068-5100</a>	CONTRACTUAL SVC, PARK (FALL...	0.00	23,680.65	0.00	1,246.35	0.00	0.00
<a href="#">100-6050-7068-5200</a>	CONTRACTUAL SVC, PARK (PALM...	0.00	0.00	0.00	9,190.69	0.00	0.00
<a href="#">100-6050-7068-5250</a>	CONTRACT SVC - RANGAL PARK	0.00	4,914.39	3,092.00	598.38	0.00	0.00
<a href="#">100-6050-7068-5300</a>	CONTRACT SVC - SENECA SPRIN...	0.00	1,230.00	0.00	0.00	0.00	0.00

Budget Worksheet

Defined Budgets

		2018-2019 Total Budget	2018-2019 Total Activity	2019-2020 Total Budget	2019-2020 Total Activity	2020-2021 Total Budget	2020-2021 YTD Activity
<a href="#">100-6050-7068-5400</a>	CONTRACT SVC - SPORTS PARK	0.00	386.72	2,663.00	25,574.74	0.00	0.00
<a href="#">100-6050-7068-5500</a>	CONTRACT SVC - STEWART PARK	0.00	1,527.84	2,620.00	8,224.97	0.00	0.00
<a href="#">100-6050-7068-5999</a>	CONTRACT SVC - ALL PARKS	0.00	0.00	0.00	9,239.20	0.00	0.00
<a href="#">100-6050-7068-6060</a>	CONTRACTUAL SVC- 713 W 4TH ...	0.00	257.15	0.00	0.00	0.00	0.00
<a href="#">100-6050-7070-0000</a>	SPECIAL DEPT SUPPLIES	140,400.00	35,341.44	188,286.00	14,386.40	330,000.00	0.00
<a href="#">100-6050-7070-003X</a>	SPEC DEPT EXP - IA 3	0.00	0.00	0.00	180.01	0.00	0.00
<a href="#">100-6050-7070-006A</a>	SPEC DEPT EXP - IA 6A	0.00	3,900.84	6,688.00	471.21	0.00	0.00
<a href="#">100-6050-7070-006B</a>	SPEC DEPT EXP - IA 6B	0.00	3,900.85	6,688.00	1,320.00	0.00	0.00
<a href="#">100-6050-7070-008A</a>	SPEC DEPT EXP - IA 8A	0.00	21,958.00	37,461.00	1,363.10	0.00	0.00
<a href="#">100-6050-7070-008C</a>	SPEC DEPT EXP - IA 8C	0.00	0.00	0.00	29.57	0.00	0.00
<a href="#">100-6050-7070-010A</a>	SPEC DEPT EXP - IA 10A	0.00	874.18	1,499.00	108.64	0.00	0.00
<a href="#">100-6050-7070-011A</a>	SPEC DEPT EXP - IA 11A	0.00	299.65	514.00	0.00	0.00	0.00
<a href="#">100-6050-7070-012A</a>	SPEC DEPT EXP - IA 12A	0.00	0.00	0.00	7.00	0.00	0.00
<a href="#">100-6050-7070-013X</a>	SPEC DEPT EXP - IA 13	0.00	0.00	0.00	22.34	0.00	0.00
<a href="#">100-6050-7070-014A</a>	SPEC DEPT EXP - IA 14A	0.00	303.53	521.00	2,071.03	0.00	0.00
<a href="#">100-6050-7070-014B</a>	SPEC DEPT EXP - IA 14B	0.00	290.93	0.00	506.75	0.00	0.00
<a href="#">100-6050-7070-014X</a>	SPEC DEPT EXP - IA 14	0.00	25.83	0.00	311.77	0.00	0.00
<a href="#">100-6050-7070-016X</a>	SPEC DEPT EXP - IA 16	0.00	0.00	0.00	9,207.00	0.00	0.00
<a href="#">100-6050-7070-017A</a>	SPEC DEPT EXP - IA 17A	0.00	60.08	103.00	362.47	0.00	0.00
<a href="#">100-6050-7070-018X</a>	SPEC DEPT EXP - IA 18	0.00	0.00	0.00	2,381.59	0.00	0.00
<a href="#">100-6050-7070-019A</a>	SPEC DEPT EXP - IA 19A	0.00	5,091.19	8,728.00	2,827.75	0.00	0.00
<a href="#">100-6050-7070-019F</a>	SPEC DEPT EXP - IA 19F	0.00	0.00	0.00	67.76	0.00	0.00
<a href="#">100-6050-7070-023X</a>	SPEC DEPT EXP - IA 23	0.00	0.00	0.00	80.05	0.00	0.00
<a href="#">100-6050-7070-06A1</a>	SPEC DEPT EXP - IA 6A1	0.00	541.33	462.00	2,693.28	0.00	0.00
<a href="#">100-6050-7070-5000</a>	SPEC DEPT EXP - THREE RINGS R...	0.00	276.13	166.00	3,708.81	0.00	0.00
<a href="#">100-6050-7070-5050</a>	SPEC DEPT EXP - DEFORGE PARK	0.00	741.11	882.00	3,777.09	0.00	0.00
<a href="#">100-6050-7070-5100</a>	SPEC DEPT EXP - FALLEN HEROES...	0.00	10,454.16	17,671.00	684.00	0.00	0.00
<a href="#">100-6050-7070-5150</a>	SPEC DEPT EXP - MOUNTAINVIE...	0.00	1,108.13	1,028.00	2,652.69	0.00	0.00
<a href="#">100-6050-7070-5200</a>	SPEC DEPT EXP - PALMER PARK	0.00	93.39	122.00	3,182.93	0.00	0.00
<a href="#">100-6050-7070-5250</a>	SPEC DEPT EXP - RANGAL PARK	0.00	557.54	897.00	70.92	0.00	0.00
<a href="#">100-6050-7070-5300</a>	SPEC DEPT EXP - SENECA SPRING...	0.00	1,111.37	1,765.00	688.92	0.00	0.00

Budget Worksheet

Defined Budgets

		2018-2019 Total Budget	2018-2019 Total Activity	2019-2020 Total Budget	2019-2020 Total Activity	2020-2021 Total Budget	2020-2021 YTD Activity
<a href="#">100-6050-7070-5350</a>	SPEC DEPT EXP - SHADOW HILLS ...	0.00	705.03	467.00	136.52	0.00	0.00
<a href="#">100-6050-7070-5400</a>	SPEC DEPT EXP - SPORTS PARK	0.00	20,480.33	14,611.00	10,438.68	0.00	0.00
<a href="#">100-6050-7070-5450</a>	SPEC DEPT EXP - STETSON PARK	0.00	905.89	730.00	2,323.68	0.00	0.00
<a href="#">100-6050-7070-5500</a>	SPEC DEPT EXP - STEWART PARK	0.00	7,699.76	720.00	4,033.07	0.00	0.00
<a href="#">100-6050-7070-5550</a>	SPEC DEPT EXP - SUNNY HILLS P...	0.00	0.00	0.00	2,143.88	0.00	0.00
<a href="#">100-6050-7070-5600</a>	SPEC DEPT EXP - TREVINO PARK	0.00	131.49	0.00	211.01	0.00	0.00
<a href="#">100-6050-7070-5700</a>	SPEC DEPT EXP - WILD FLOWER ...	0.00	4,058.58	6,770.00	2,101.67	0.00	0.00
<a href="#">100-6050-7070-5750</a>	SPECIAL DEPT SUPPLIES (NICKLA...	0.00	171.01	0.00	2,806.79	0.00	0.00
<a href="#">100-6050-7070-5999</a>	SPEC DEPT EXP - ALL PARKS	0.00	30,275.40	32,151.00	24,239.03	0.00	0.00
<a href="#">100-6050-7070-6025</a>	SPEC DEPT EXP - CITY HALL	0.00	402.02	565.00	0.00	0.00	0.00
<a href="#">100-6050-7070-6050</a>	SPEC DEPT EXP- 450 E 4TH ST	0.00	0.00	0.00	20.42	0.00	0.00
<a href="#">100-6050-7070-6060</a>	SPEC DEPT EXP- 713 W 4TH ST	0.00	760.79	0.00	0.00	0.00	0.00
<a href="#">100-6050-7071-0000</a>	SOFTWARE	0.00	2,620.00	2,620.00	0.00	2,620.00	0.00
<a href="#">100-6050-7072-0000</a>	COMPUTER SUPPLIES/MAINT	0.00	2,200.74	0.00	0.00	0.00	0.00
<a href="#">100-6050-7075-0000</a>	EQUIPMENT LEASING/RENTAL	4,800.00	870.00	360.00	47.26	4,000.00	0.00
<a href="#">100-6050-7075-003X</a>	EQUIPMENT LEASING/RENTAL (IA...	0.00	2,604.80	566.00	1,508.76	0.00	0.00
<a href="#">100-6050-7075-008A</a>	EQUIP LEASING/RENTAL (IA 8A)	0.00	3,181.20	0.00	0.00	0.00	0.00
<a href="#">100-6050-7075-014X</a>	EQUIPMENT LEASING/RENTAL (O...	0.00	0.00	0.00	96.80	0.00	0.00
<a href="#">100-6050-7075-016X</a>	EQUIP LEASING/RENTAL (IA 016X)	0.00	0.00	0.00	1,137.82	0.00	0.00
<a href="#">100-6050-7075-018X</a>	EQUIP LEASING/RENTAL (IA 018X)	0.00	0.00	0.00	330.00	0.00	0.00
<a href="#">100-6050-7075-06A1</a>	EQUIPMENT LEASING/RENTAL (IA...	0.00	990.00	566.00	0.00	0.00	0.00
<a href="#">100-6050-7075-5400</a>	EQUIP LEASING/RENTAL (SPORTS...	0.00	386.72	663.00	3,530.56	0.00	0.00
<a href="#">100-6050-7075-5500</a>	EQUIP LEASING/RENTAL (STEWA...	0.00	38.61	67.00	0.00	0.00	0.00
<a href="#">100-6050-7075-5750</a>	EQUIPMENT LEASING/RENTAL (N...	0.00	0.00	0.00	330.00	0.00	0.00
<a href="#">100-6050-7075-5999</a>	EQUIPMENT LEASING/RENTAL (A...	0.00	0.00	0.00	136.40	0.00	0.00
<a href="#">100-6050-7075-6025</a>	EQUIP LEASING/RENTAL (CITY H...	0.00	79.20	136.00	0.00	0.00	0.00
<a href="#">100-6050-7085-0000</a>	BUILDING SUPPLIES/MAINT	500.00	250.82	0.00	117.28	0.00	0.00
<a href="#">100-6050-7090-0000</a>	EQUIPMENT SUPPLIES/MAINT	46,000.00	36,278.07	39,422.00	16,801.20	21,000.00	0.00
<a href="#">100-6050-7090-5000</a>	SPEC DEPT EXP - THREE RINGS R...	0.00	375.79	0.00	0.00	0.00	0.00
<a href="#">100-6050-7090-5050</a>	EQUIP SUPPLIES/MAINT- DEFOR...	0.00	0.00	0.00	511.18	0.00	0.00
<a href="#">100-6050-7090-5300</a>	SPEC DEPT EXP - SENECA SPRING...	0.00	0.00	0.00	1,971.73	0.00	0.00

Budget Worksheet

Defined Budgets

		2018-2019 Total Budget	2018-2019 Total Activity	2019-2020 Total Budget	2019-2020 Total Activity	2020-2021 Total Budget	2020-2021 YTD Activity
<a href="#">100-6050-7090-5400</a>	EQUIP SUPPLIES/MAINT - SPORTS..	0.00	0.00	0.00	1,382.50	0.00	0.00
<a href="#">100-6050-7090-5500</a>	SPEC DEPT EXP - STEWART PARK	0.00	0.00	0.00	40.49	0.00	0.00
<a href="#">100-6050-7090-5550</a>	SPEC DEPT EXP - SUNNY HILLS P...	0.00	402.74	0.00	0.00	0.00	0.00
<a href="#">100-6050-7090-5600</a>	SPEC DEPT EXP - TREVINO PARK	0.00	375.80	0.00	0.00	0.00	0.00
<a href="#">100-6050-7090-5999</a>	EQUIP SUPPLIES/MAINT - ALL PA...	0.00	315.08	1,528.00	0.00	0.00	0.00
<a href="#">100-6050-7090-6055</a>	SPEC DEPT EXP- FIRE STATION M...	0.00	0.00	0.00	619.91	0.00	0.00
<a href="#">100-6050-7090-6060</a>	SPEC DEPT EXP- 713 W 4TH ST	0.00	0.00	0.00	13.11	0.00	0.00
<a href="#">100-6050-7156-0000</a>	WEED ABATEMENT/TREE TRIMM...	0.00	0.00	175,000.00	76,084.03	175,000.00	0.00
<a href="#">100-6050-8040-0000</a>	EQUIPMENT	52,200.00	191,089.64	98,950.00	47,595.49	98,000.00	0.00
<b>Department: 6050 - PARKS AND GROUNDS MAINT Total:</b>		<b>2,747,483.95</b>	<b>2,728,614.93</b>	<b>3,414,255.00</b>	<b>2,453,385.72</b>	<b>3,073,051.00</b>	<b>0.00</b>
<b>Department: 6150 - CITY POOL</b>							
<a href="#">100-6150-6010-0000</a>	SALARIES	60,051.00	39,327.60	27,512.00	27,338.96	0.00	0.00
<a href="#">100-6150-6012-0000</a>	OVERTIME	0.00	1,454.92	48.00	47.21	0.00	0.00
<a href="#">100-6150-6013-0000</a>	SICK LEAVE	0.00	238.69	111.00	225.38	0.00	0.00
<a href="#">100-6150-6014-0000</a>	HOLIDAY	0.00	199.88	1,799.00	2,869.81	0.00	0.00
<a href="#">100-6150-6015-0000</a>	VACATION	0.00	169.63	0.00	216.08	0.00	0.00
<a href="#">100-6150-6019-0000</a>	FIRST AID	0.00	429.45	495.00	821.47	0.00	0.00
<a href="#">100-6150-6020-0000</a>	HEALTH INSURANCE	0.00	-26.33	0.00	0.00	0.00	0.00
<a href="#">100-6150-6021-0000</a>	DENTAL INSURANCE	0.00	-1.87	0.00	0.00	0.00	0.00
<a href="#">100-6150-6022-0000</a>	WORKERS COMP	1,953.00	964.66	1,503.00	1,025.37	0.00	0.00
<a href="#">100-6150-6024-0000</a>	P.E.R.S./P.E.P.R.A.	13,000.00	8,725.35	0.00	4,119.46	0.00	0.00
<a href="#">100-6150-6027-0000</a>	VISION INSURANCE	0.00	-0.33	0.00	0.00	0.00	0.00
<a href="#">100-6150-6034-0000</a>	MEDICARE	700.00	599.91	436.00	445.08	0.00	0.00
<a href="#">100-6150-6035-0000</a>	FICA/PARS	600.00	345.72	477.00	504.74	0.00	0.00
<a href="#">100-6150-6050-0000</a>	RECRUITMENT AND HIRING COS...	0.00	2,035.00	0.00	0.00	0.00	0.00
<a href="#">100-6150-7020-0000</a>	ADVERTISING	0.00	31.92	0.00	8.80	0.00	0.00
<a href="#">100-6150-7025-0000</a>	OFFICE SUPPLIES	0.00	77.97	0.00	0.00	0.00	0.00
<a href="#">100-6150-7040-0000</a>	RECREATION PROGRAMS	700.00	1,306.54	700.00	1,465.00	0.00	0.00
<a href="#">100-6150-7053-0000</a>	PERMITS, FEES AND LICENSES	610.00	0.00	0.00	812.00	0.00	0.00
<a href="#">100-6150-7065-0000</a>	UNIFORMS	0.00	810.43	0.00	0.00	0.00	0.00
<a href="#">100-6150-7066-0000</a>	TRAVEL, EDUCATION, TRAINING	250.00	1,850.92	0.00	10.00	0.00	0.00

Budget Worksheet

Defined Budgets

		2018-2019 Total Budget	2018-2019 Total Activity	2019-2020 Total Budget	2019-2020 Total Activity	2020-2021 Total Budget	2020-2021 YTD Activity
<a href="#">100-6150-7068-0000</a>	CONTRACTUAL SERVICES	8,100.00	5,036.85	4,500.00	2,000.00	0.00	0.00
<a href="#">100-6150-7070-0000</a>	SPECIAL DEPT SUPPLIES	21,000.00	15,783.60	21,000.00	17,736.82	15,000.00	0.00
<a href="#">100-6150-7085-0000</a>	BUILDING SUPPLIES/MAINT	0.00	841.35	0.00	0.00	0.00	0.00
<a href="#">100-6150-7090-0000</a>	EQUIPMENT SUPPLIES/MAINT	3,800.00	3,888.38	2,500.00	546.84	0.00	0.00
<a href="#">100-6150-8040-0000</a>	EQUIPMENT	0.00	1,884.44	0.00	0.00	0.00	0.00
<b>Department: 6150 - CITY POOL Total:</b>		<b>110,764.00</b>	<b>85,974.68</b>	<b>61,081.00</b>	<b>60,193.02</b>	<b>15,000.00</b>	<b>0.00</b>
<b>Fund: 100 - GENERAL FUND Surplus (Deficit):</b>		<b>-100,000.00</b>	<b>3,968,896.05</b>	<b>5,000,000.21</b>	<b>970,480.65</b>	<b>0.00</b>	<b>0.00</b>
<b>Fund: 110 - SUCCESSOR AGENCY</b>							
<b>Department: 0000 - NON-DEPARTMENTAL</b>							
<a href="#">110-0000-4650-0000</a>	INTEREST	0.00	0.00	0.00	0.91	0.00	0.00
<a href="#">110-0000-7068-0000</a>	CONTRACTUAL SERVICE	300,000.00	300,000.00	0.00	0.00	0.00	0.00
<a href="#">110-0000-7500-0000</a>	SETTLEMENT	0.00	19,771.18	0.00	0.00	0.00	0.00
<a href="#">110-0000-9950-0000</a>	TRANSFERS IN	0.00	300,000.00	0.00	0.00	0.00	0.00
<b>Department: 0000 - NON-DEPARTMENTAL Surplus (Deficit):</b>		<b>-300,000.00</b>	<b>-19,771.18</b>	<b>0.00</b>	<b>0.91</b>	<b>0.00</b>	<b>0.00</b>
<b>Fund: 110 - SUCCESSOR AGENCY Surplus (Deficit):</b>		<b>-300,000.00</b>	<b>-19,771.18</b>	<b>0.00</b>	<b>0.91</b>	<b>0.00</b>	<b>0.00</b>
<b>Fund: 120 - SELF INSURANCE</b>							
<b>Department: 0000 - NON-DEPARTMENTAL</b>							
<a href="#">120-0000-4650-0000</a>	INTEREST	0.00	0.00	0.00	13,347.84	0.00	0.00
<a href="#">120-0000-4685-0000</a>	COST RECOVERY	0.00	694,455.30	0.00	193,259.18	0.00	0.00
<a href="#">120-0000-7060-0000</a>	CONTRACTUAL SERVICES	0.00	-1,554,282.46	0.00	-1,008,480.44	0.00	0.00
<b>Department: 0000 - NON-DEPARTMENTAL Surplus (Deficit):</b>		<b>0.00</b>	<b>2,248,737.76</b>	<b>0.00</b>	<b>1,215,087.46</b>	<b>0.00</b>	<b>0.00</b>
<b>Department: 9663 - GENERAL LIABILITY</b>							
<a href="#">120-9663-7200-0000</a>	COST REIMBURSEMENT	0.00	-106,086.59	0.00	0.00	0.00	0.00
<a href="#">120-9663-7300-0000</a>	CONTRACTUAL SERVICES	0.00	1,552,723.58	0.00	1,016,563.79	0.00	0.00
<a href="#">120-9663-7500-0000</a>	SETTLEMENTS	0.00	2,199.76	0.00	274,000.00	0.00	0.00
<b>Department: 9663 - GENERAL LIABILITY Total:</b>		<b>0.00</b>	<b>1,448,836.75</b>	<b>0.00</b>	<b>1,290,563.79</b>	<b>0.00</b>	<b>0.00</b>
<b>Fund: 120 - SELF INSURANCE Surplus (Deficit):</b>		<b>0.00</b>	<b>799,901.01</b>	<b>0.00</b>	<b>-75,476.33</b>	<b>0.00</b>	<b>0.00</b>
<b>Fund: 150 - GOVERNMENTAL CAPITAL ASSETS</b>							
<b>Department: 0000 - NON-DEPARTMENTAL</b>							
<a href="#">150-0000-4695-0000</a>	DEVELOPER CONTRIBUTIONS	0.00	8,592,122.00	0.00	0.00	0.00	0.00

Budget Worksheet

Defined Budgets

		2018-2019 Total Budget	2018-2019 Total Activity	2019-2020 Total Budget	2019-2020 Total Activity	2020-2021 Total Budget	2020-2021 YTD Activity
<a href="#">150-0000-7079-0000</a>	DEPRECIATION	0.00	5,181,712.58	5,100,000.00	0.00	0.00	0.00
<b>Department: 0000 - NON-DEPARTMENTAL Surplus (Deficit):</b>		<b>0.00</b>	<b>3,410,409.42</b>	<b>-5,100,000.00</b>	<b>0.00</b>	<b>0.00</b>	<b>0.00</b>
<b>Fund: 150 - GOVERNMENTAL CAPITAL ASSETS Surplus (Deficit):</b>		<b>0.00</b>	<b>3,410,409.42</b>	<b>-5,100,000.00</b>	<b>0.00</b>	<b>0.00</b>	<b>0.00</b>
<b>Fund: 200 - HIGHWAY USERS TAX (Gas)</b>							
<b>Department: 0000 - NON-DEPARTMENTAL</b>							
<a href="#">200-0000-4030-0000</a>	2103 GAS TAX- - -	170,000.00	161,147.31	400,000.00	313,035.40	343,273.00	0.00
<a href="#">200-0000-4032-0000</a>	2105 GAS TAX	267,500.00	264,658.27	263,500.00	217,197.43	222,555.00	0.00
<a href="#">200-0000-4035-0000</a>	2106 GAS TAX	170,000.00	170,817.63	168,000.00	135,829.25	135,013.00	0.00
<a href="#">200-0000-4037-0000</a>	2107 GAS TAX	342,000.00	332,836.82	323,000.00	270,034.53	265,700.00	0.00
<a href="#">200-0000-4040-0000</a>	2107.5 GAX TAX	6,400.00	6,000.00	6,000.00	6,000.00	4,800.00	0.00
<a href="#">200-0000-4469-0000</a>	PROPOSITION 1B FUND	360,000.00	0.00	0.00	0.00	0.00	0.00
<a href="#">200-0000-4650-0000</a>	INTEREST	26,000.00	3,265.08	11,600.00	4,887.05	4,875.00	0.00
<a href="#">200-0000-7051-0000</a>	BANKING FEES	0.00	0.00	0.00	25.00	0.00	0.00
<a href="#">200-0000-9950-0000</a>	TRANSFERS IN	-1,305,000.00	64,751.25	0.00	0.00	0.00	0.00
<a href="#">200-0000-9960-0000</a>	TRANSFERS OUT	0.00	1,163,423.43	1,172,000.00	761,737.46	976,216.00	0.00
<b>Department: 0000 - NON-DEPARTMENTAL Surplus (Deficit):</b>		<b>36,900.00</b>	<b>-159,947.07</b>	<b>100.00</b>	<b>185,221.20</b>	<b>0.00</b>	<b>0.00</b>
<b>Fund: 200 - HIGHWAY USERS TAX (Gas) Surplus (Deficit):</b>		<b>36,900.00</b>	<b>-159,947.07</b>	<b>100.00</b>	<b>185,221.20</b>	<b>0.00</b>	<b>0.00</b>
<b>Fund: 201 - STATE - SB1 FUNDING</b>							
<b>Department: 0000 - NON-DEPARTMENTAL</b>							
<a href="#">201-0000-4469-0000</a>	PROPOSITION 1B	0.00	864,034.56	845,000.00	736,598.44	731,313.00	0.00
<a href="#">201-0000-4650-0000</a>	INTEREST	0.00	18,193.04	0.00	8,238.04	34,931.00	0.00
<a href="#">201-0000-9950-0000</a>	TRANSFERS IN	0.00	263,368.43	0.00	43,535.23	0.00	0.00
<a href="#">201-0000-9960-0000</a>	TRANSFERS OUT	0.00	43,535.23	1,600,000.00	3,250.00	730,000.00	0.00
<b>Department: 0000 - NON-DEPARTMENTAL Surplus (Deficit):</b>		<b>0.00</b>	<b>1,102,060.80</b>	<b>-755,000.00</b>	<b>785,121.71</b>	<b>36,244.00</b>	<b>0.00</b>
<b>Fund: 201 - STATE - SB1 FUNDING Surplus (Deficit):</b>		<b>0.00</b>	<b>1,102,060.80</b>	<b>-755,000.00</b>	<b>785,121.71</b>	<b>36,244.00</b>	<b>0.00</b>
<b>Fund: 202 - SALES TAX - MEASURE A</b>							
<b>Department: 0000 - NON-DEPARTMENTAL</b>							
<a href="#">202-0000-4057-0000</a>	TAX - MEASURE A	0.00	1,038,267.02	1,078,700.00	674,445.79	723,205.00	0.00
<a href="#">202-0000-4650-0000</a>	INTEREST	0.00	25,896.73	0.00	10,017.06	11,869.00	0.00
<a href="#">202-0000-9950-0000</a>	TRANSFERS IN	0.00	541,888.79	0.00	0.00	0.00	0.00

Budget Worksheet

Defined Budgets

		2018-2019 Total Budget	2018-2019 Total Activity	2019-2020 Total Budget	2019-2020 Total Activity	2020-2021 Total Budget	2020-2021 YTD Activity
<a href="#">202-0000-9960-0000</a>	TRANSFERS OUT	0.00	64,035.24	1,634,000.00	117,678.27	800,000.00	0.00
<b>Department: 0000 - NON-DEPARTMENTAL Surplus (Deficit):</b>		<b>0.00</b>	<b>1,542,017.30</b>	<b>-555,300.00</b>	<b>566,784.58</b>	<b>-64,926.00</b>	<b>0.00</b>
<b>Fund: 202 - SALES TAX - MEASURE A Surplus (Deficit):</b>		<b>0.00</b>	<b>1,542,017.30</b>	<b>-555,300.00</b>	<b>566,784.58</b>	<b>-64,926.00</b>	<b>0.00</b>
<b>Fund: 205 - MOTOR VEHICLE SUBVENTION (AB2766-AQMD)</b>							
<b>Department: 0000 - NON-DEPARTMENTAL</b>							
<a href="#">205-0000-4380-0000</a>	AB2766 -DMV/AIR POLLUTION	50,000.00	62,566.23	57,000.00	30,199.65	62,500.00	0.00
<a href="#">205-0000-4650-0000</a>	INTEREST	4,000.00	11,137.14	0.00	2,382.00	3,020.00	0.00
<a href="#">205-0000-9960-0000</a>	TRANSFERS OUT	0.00	0.00	30,000.00	30,000.00	0.00	0.00
<b>Department: 0000 - NON-DEPARTMENTAL Surplus (Deficit):</b>		<b>54,000.00</b>	<b>73,703.37</b>	<b>27,000.00</b>	<b>2,581.65</b>	<b>65,520.00</b>	<b>0.00</b>
<b>Fund: 205 - MOTOR VEHICLE SUBVENTION (AB2766-AQMD) Surplus (Def.)</b>		<b>54,000.00</b>	<b>73,703.37</b>	<b>27,000.00</b>	<b>2,581.65</b>	<b>65,520.00</b>	<b>0.00</b>
<b>Fund: 210 - PUBLIC, EDUCATIONAL, GOVT (PEG)</b>							
<b>Department: 0000 - NON-DEPARTMENTAL</b>							
<a href="#">210-0000-4020-0000</a>	PEG FEES	52,520.00	39,652.25	30,000.00	25,619.11	25,800.00	0.00
<a href="#">210-0000-4650-0000</a>	INTEREST	2,000.00	7,504.57	0.00	1,273.71	2,007.00	0.00
<a href="#">210-0000-9960-0000</a>	TRANSFERS OUT	0.00	0.00	273,000.00	183,294.10	0.00	0.00
<b>Department: 0000 - NON-DEPARTMENTAL Surplus (Deficit):</b>		<b>54,520.00</b>	<b>47,156.82</b>	<b>-243,000.00</b>	<b>-156,401.28</b>	<b>27,807.00</b>	<b>0.00</b>
<b>Fund: 210 - PUBLIC, EDUCATIONAL, GOVT (PEG) Surplus (Deficit):</b>		<b>54,520.00</b>	<b>47,156.82</b>	<b>-243,000.00</b>	<b>-156,401.28</b>	<b>27,807.00</b>	<b>0.00</b>
<b>Fund: 215 - GRANTS (REIMBURSABLE)</b>							
<b>Department: 0000 - NON-DEPARTMENTAL</b>							
<a href="#">215-0000-4350-0000</a>	CDBG GRANT	190,000.00	3,601.11	175,000.00	57,000.00	130,000.00	0.00
<a href="#">215-0000-4352-0000</a>	GRANT - OTHER	10,000,000.00	0.00	0.00	0.00	150,000.00	0.00
<a href="#">215-0000-4353-0000</a>	SB2 PLANNING GRANT	0.00	0.00	0.00	0.00	160,000.00	0.00
<a href="#">215-0000-7036-0000</a>	GRANT SPECIFIC COSTS	0.00	0.00	0.00	44,501.86	0.00	0.00
<a href="#">215-0000-7068-0000</a>	CONTRACTUAL SERVICES	190,000.00	0.00	0.00	0.00	310,000.00	0.00
<a href="#">215-0000-8020-0000</a>	LAND IMPROVEMENTS	0.00	3,193.11	45,000.00	58,645.40	130,000.00	0.00
<a href="#">215-0000-9950-0000</a>	TRANSFERS IN	-10,000,000.00	0.00	0.00	0.00	0.00	0.00
<a href="#">215-0000-9960-0000</a>	TRANSFERS OUT	0.00	408.00	130,000.00	48,531.98	0.00	0.00
<b>Department: 0000 - NON-DEPARTMENTAL Surplus (Deficit):</b>		<b>0.00</b>	<b>0.00</b>	<b>0.00</b>	<b>-94,679.24</b>	<b>0.00</b>	<b>0.00</b>
<b>Fund: 215 - GRANTS (REIMBURSABLE) Surplus (Deficit):</b>		<b>0.00</b>	<b>0.00</b>	<b>0.00</b>	<b>-94,679.24</b>	<b>0.00</b>	<b>0.00</b>
<b>Fund: 220 - CITIZEN OPTION PUBLIC SAFETY (COPS)</b>							
<b>Department: 0000 - NON-DEPARTMENTAL</b>							
<a href="#">220-0000-4385-0000</a>	COPS FUNDING	100,000.00	132,079.87	100,000.00	122,614.26	100,000.00	0.00
<a href="#">220-0000-4387-0000</a>	PUBLIC SAFETY	0.00	26,670.60	0.00	0.00	0.00	0.00

Budget Worksheet

Defined Budgets

		2018-2019 Total Budget	2018-2019 Total Activity	2019-2020 Total Budget	2019-2020 Total Activity	2020-2021 Total Budget	2020-2021 YTD Activity
<a href="#">220-0000-4586-0000</a>	COPS TECHNOLOGY	110,000.00	0.00	0.00	0.00	0.00	0.00
<a href="#">220-0000-4650-0000</a>	INTEREST	2,400.00	8,816.31	0.00	2,051.06	2,609.00	0.00
<a href="#">220-0000-7065-0000</a>	UNIFORMS	0.00	122.80	0.00	0.00	0.00	0.00
<a href="#">220-0000-7068-0000</a>	CONTRACTUAL SERVICES	0.00	3,857.50	0.00	0.00	0.00	0.00
<a href="#">220-0000-7071-0000</a>	SOFTWARE	0.00	8,268.75	33,300.00	20,268.75	0.00	0.00
<a href="#">220-0000-7072-0000</a>	COMPUTER SUPPLIES/MAINT	0.00	8,186.12	200,000.00	45,454.37	0.00	0.00
<a href="#">220-0000-7090-0000</a>	EQUIPMENT SUPPLIES/MAINT	0.00	0.00	0.00	5,082.96	0.00	0.00
<a href="#">220-0000-7096-0000</a>	PROGRAM COSTS	0.00	0.00	50,000.00	0.00	0.00	0.00
<a href="#">220-0000-8040-0000</a>	EQUIPMENT	125,000.00	34,752.62	0.00	0.00	25,167.00	0.00
<a href="#">220-0000-9950-0000</a>	TRANSFERS IN	-80,000.00	21,694.91	50,000.00	0.00	0.00	0.00
<a href="#">220-0000-9960-0000</a>	TRANSFERS OUT	0.00	60,000.00	14,800.00	20,154.78	65,770.00	0.00
<b>Department: 0000 - NON-DEPARTMENTAL Surplus (Deficit):</b>		<b>7,400.00</b>	<b>74,073.90</b>	<b>-148,100.00</b>	<b>33,704.46</b>	<b>11,672.00</b>	<b>0.00</b>
<b>Fund: 220 - CITIZEN OPTION PUBLIC SAFETY (COPS) Surplus (Deficit):</b>		<b>7,400.00</b>	<b>74,073.90</b>	<b>-148,100.00</b>	<b>33,704.46</b>	<b>11,672.00</b>	<b>0.00</b>
<b>Fund: 225 - ASSET SEIZURES (STATE)</b>							
<b>Department: 0000 - NON-DEPARTMENTAL</b>							
<a href="#">225-0000-4390-0000</a>	STATE SEIZURE FUNDS	0.00	3,481.23	0.00	898.30	1,347.00	0.00
<a href="#">225-0000-4650-0000</a>	INTEREST	2,400.00	9,502.99	0.00	1,169.51	4,822.00	0.00
<a href="#">225-0000-7055-0000</a>	INTEREST AND/OR PENALTIES	0.00	54.18	0.00	105.73	0.00	0.00
<a href="#">225-0000-8040-0000</a>	EQUIPMENT	275,000.00	2,911.57	0.00	0.00	0.00	0.00
<a href="#">225-0000-9960-0000</a>	TRANSFERS OUT	0.00	0.00	26,500.00	17,411.50	0.00	0.00
<b>Department: 0000 - NON-DEPARTMENTAL Surplus (Deficit):</b>		<b>-272,600.00</b>	<b>10,018.47</b>	<b>-26,500.00</b>	<b>-15,449.42</b>	<b>6,169.00</b>	<b>0.00</b>
<b>Fund: 225 - ASSET SEIZURES (STATE) Surplus (Deficit):</b>		<b>-272,600.00</b>	<b>10,018.47</b>	<b>-26,500.00</b>	<b>-15,449.42</b>	<b>6,169.00</b>	<b>0.00</b>
<b>Fund: 230 - ASSET SEIZURES (FEDERAL)</b>							
<b>Department: 0000 - NON-DEPARTMENTAL</b>							
<a href="#">230-0000-4390-0000</a>	FEDERAL ASSET SEIZURE	0.00	3,075.00	0.00	0.00	3,028.00	0.00
<a href="#">230-0000-4650-0000</a>	INTEREST	2,000.00	5,552.14	0.00	0.00	0.00	0.00
<a href="#">230-0000-8040-0000</a>	EQUIPMENT	200,000.00	0.00	200,000.00	200,000.00	0.00	0.00
<b>Department: 0000 - NON-DEPARTMENTAL Surplus (Deficit):</b>		<b>-198,000.00</b>	<b>8,627.14</b>	<b>-200,000.00</b>	<b>-200,000.00</b>	<b>3,028.00</b>	<b>0.00</b>
<b>Fund: 230 - ASSET SEIZURES (FEDERAL) Surplus (Deficit):</b>		<b>-198,000.00</b>	<b>8,627.14</b>	<b>-200,000.00</b>	<b>-200,000.00</b>	<b>3,028.00</b>	<b>0.00</b>
<b>Fund: 240 - OTHER RESTRICTED FUNDS</b>							
<b>Department: 0000 - NON-DEPARTMENTAL</b>							
<a href="#">240-0000-4460-0000</a>	GRANTS	0.00	0.00	10,000.00	0.00	0.00	0.00



Defined Budgets

		2018-2019 Total Budget	2018-2019 Total Activity	2019-2020 Total Budget	2019-2020 Total Activity	2020-2021 Total Budget	2020-2021 YTD Activity
<a href="#">240-0000-4650-0000</a>	INTEREST	0.00	0.00	0.00	834.20	0.00	0.00
<a href="#">240-0000-7096-0000</a>	PROGRAM COSTS - OTHER	0.00	0.00	10,000.00	0.00	0.00	0.00
<a href="#">240-0000-9950-0000</a>	TRANSFERS IN	0.00	0.00	10,000.00	0.00	0.00	0.00
<a href="#">240-0000-9960-0000</a>	TRANSFERS OUT	0.00	0.00	2,000.00	0.00	0.00	0.00
<b>Department: 0000 - NON-DEPARTMENTAL Surplus (Deficit):</b>		<b>0.00</b>	<b>0.00</b>	<b>8,000.00</b>	<b>834.20</b>	<b>0.00</b>	<b>0.00</b>
<b>Department: 2080 - K-9</b>							
<a href="#">240-2080-4815-0000</a>	DONATIONS - K9 PROGRAM	7,000.00	5,575.71	7,000.00	2,604.23	3,534.00	0.00
<a href="#">240-2080-7070-0000</a>	SPEC DEPT SUPPLIES - K9	0.00	146.54	0.00	0.00	0.00	0.00
<a href="#">240-2080-7096-0000</a>	PROGRAM COSTS - K9	2,000.00	136.95	20,000.00	19,391.23	20,000.00	0.00
<a href="#">240-2080-8040-0000</a>	EQUIPMENT	30,000.00	0.00	0.00	0.00	0.00	0.00
<b>Department: 2080 - K-9 Surplus (Deficit):</b>		<b>-25,000.00</b>	<b>5,292.22</b>	<b>-13,000.00</b>	<b>-16,787.00</b>	<b>-16,466.00</b>	<b>0.00</b>
<b>Department: 2300 - SHOP WITH A COP/HERO</b>							
<a href="#">240-2300-4815-0000</a>	DONATIONS - SHOP WITH A COP	4,000.00	8,820.00	5,000.00	3,850.00	3,773.00	0.00
<a href="#">240-2300-7096-0000</a>	PROGRAM COSTS - SHOP W/ A C...	4,000.00	5,039.42	5,000.00	2,540.00	5,000.00	0.00
<b>Department: 2300 - SHOP WITH A COP/HERO Surplus (Deficit):</b>		<b>0.00</b>	<b>3,780.58</b>	<b>0.00</b>	<b>1,310.00</b>	<b>-1,227.00</b>	<b>0.00</b>
<b>Department: 2310 - EXPLORER PROGRAM</b>							
<a href="#">240-2310-4815-0000</a>	DONATIONS - EXPLORER PROGR...	500.00	700.00	500.00	440.00	647.00	0.00
<a href="#">240-2310-7070-0000</a>	SPEC DEPT SUPPLIES - EXPLORER...	0.00	183.10	0.00	0.00	0.00	0.00
<a href="#">240-2310-7096-0000</a>	PROGRAM COSTS - EXPLORER P...	500.00	460.00	500.00	921.49	500.00	0.00
<b>Department: 2310 - EXPLORER PROGRAM Surplus (Deficit):</b>		<b>0.00</b>	<b>56.90</b>	<b>0.00</b>	<b>-481.49</b>	<b>147.00</b>	<b>0.00</b>
<b>Department: 2320 - AMR EMERGENCY SUPPORT</b>							
<a href="#">240-2320-4815-0000</a>	DONATIONS - AMR PROGRAM	10,000.00	0.00	8,000.00	0.00	8,000.00	0.00
<a href="#">240-2320-7070-0000</a>	SPEC DEPT SUPPLIES - AMR PRO...	0.00	4,950.00	0.00	319.10	0.00	0.00
<a href="#">240-2320-7096-0000</a>	PROGRAM COSTS - AMR PROGR...	10,000.00	2,010.14	13,600.00	1,313.43	10,000.00	0.00
<b>Department: 2320 - AMR EMERGENCY SUPPORT Surplus (Deficit):</b>		<b>0.00</b>	<b>-6,960.14</b>	<b>-5,600.00</b>	<b>-1,632.53</b>	<b>-2,000.00</b>	<b>0.00</b>
<b>Department: 2330 - SB1186 CASP FEES (BUS LICENSE)</b>							
<a href="#">240-2330-4200-0000</a>	BUSINESS LICENSE (CASP)	0.00	7,059.60	0.00	2,772.00	3,918.00	0.00
<a href="#">240-2330-7066-0000</a>	TRAVEL, EDCUATION, TRAINING	0.00	0.00	0.00	0.00	1,000.00	0.00
<b>Department: 2330 - SB1186 CASP FEES (BUS LICENSE) Surplus (Deficit):</b>		<b>0.00</b>	<b>7,059.60</b>	<b>0.00</b>	<b>2,772.00</b>	<b>2,918.00</b>	<b>0.00</b>
<b>Department: 2350 - MILITARY BANNER PROGRAM</b>							
<a href="#">240-2350-4815-0000</a>	DONATIONS - MILITARY BANNERS	0.00	2,420.00	-1,000.00	1,300.00	1,544.00	0.00

Defined Budgets

		2018-2019 Total Budget	2018-2019 Total Activity	2019-2020 Total Budget	2019-2020 Total Activity	2020-2021 Total Budget	2020-2021 YTD Activity
<a href="#">240-2350-7070-0000</a>	SPEC DEPT SUPPLIES - MILITARY ...	0.00	0.00	0.00	3,470.96	3,500.00	0.00
<b>Department: 2350 - MILITARY BANNER PROGRAM Surplus (Deficit):</b>		<b>0.00</b>	<b>2,420.00</b>	<b>-1,000.00</b>	<b>-2,170.96</b>	<b>-1,956.00</b>	<b>0.00</b>
<b>Department: 2360 - PINK PATCHES</b>							
<a href="#">240-2360-4816-0000</a>	DONATIONS - PINK PATCHES	0.00	0.00	0.00	1,130.00	1,130.00	0.00
<a href="#">240-2360-7096-0000</a>	PINK PATCHES PROGRAM COSTS	0.00	0.00	0.00	1,777.50	1,130.00	0.00
<b>Department: 2360 - PINK PATCHES Surplus (Deficit):</b>		<b>0.00</b>	<b>0.00</b>	<b>0.00</b>	<b>-647.50</b>	<b>0.00</b>	<b>0.00</b>
<b>Department: 2370 - CAL-RECYCLE</b>							
<a href="#">240-2370-4817-0000</a>	GRANTS - CAL-RECYCLE	0.00	0.00	0.00	0.00	12,000.00	0.00
<a href="#">240-2370-7080-0000</a>	CAL-RECYCLE COSTS	0.00	0.00	0.00	513.74	10,500.00	0.00
<b>Department: 2370 - CAL-RECYCLE Surplus (Deficit):</b>		<b>0.00</b>	<b>0.00</b>	<b>0.00</b>	<b>-513.74</b>	<b>1,500.00</b>	<b>0.00</b>
<b>Department: 2390 - OTHER PUBLIC SAFETY RESTRICTED</b>							
<a href="#">240-2390-4815-0000</a>	OTHER PUBLIC SAFETY REVENUE	0.00	10.22	0.00	0.00	0.00	0.00
<b>Department: 2390 - OTHER PUBLIC SAFETY RESTRICTED Total:</b>		<b>0.00</b>	<b>10.22</b>	<b>0.00</b>	<b>0.00</b>	<b>0.00</b>	<b>0.00</b>
<b>Fund: 240 - OTHER RESTRICTED FUNDS Surplus (Deficit):</b>		<b>-25,000.00</b>	<b>11,659.38</b>	<b>-11,600.00</b>	<b>-17,317.02</b>	<b>-17,084.00</b>	<b>0.00</b>
<b>Fund: 250 - COMMUNITY FAC DISTRICT (CFD) - ADMIN</b>							
<b>Department: 0000 - NON-DEPARTMENTAL</b>							
<a href="#">250-0000-4441-0000</a>	DELINQUENCIES	0.00	0.00	26,325.00	0.00	0.00	0.00
<a href="#">250-0000-4445-001A</a>	ALLOCATED ASSESSMENTS - IA 1A	30,000.00	30,000.00	30,000.00	0.00	30,000.00	0.00
<a href="#">250-0000-4445-002X</a>	ALLOCATED ASSESSMENTS - IA 2	20,260.00	15,260.00	15,606.00	0.00	15,941.00	0.00
<a href="#">250-0000-4445-003X</a>	ALLOCATED ASSESSMENTS - IA 3	47,366.00	30,000.00	48,055.00	0.00	48,603.00	0.00
<a href="#">250-0000-4445-004X</a>	ALLOCATED ASSESSMENTS - IA 4	30,000.00	30,000.00	30,000.00	0.00	30,000.00	0.00
<a href="#">250-0000-4445-005X</a>	ALLOCATED ASSESSMENTS - IA 5	29,958.00	30,000.00	30,000.00	0.00	30,000.00	0.00
<a href="#">250-0000-4445-006A</a>	ALLOCATED ASSESSMENTS - IA 6A	3,350.00	6,850.00	6,987.00	0.00	7,127.00	0.00
<a href="#">250-0000-4445-006B</a>	ALLOCATED ASSESSMENTS - IA 6B	30,000.00	19,228.00	19,583.00	0.00	20,000.00	0.00
<a href="#">250-0000-4445-007A</a>	ALLOCATED ASSESSMENTS - IA 7A	47,502.00	30,000.00	48,196.00	0.00	48,747.00	0.00
<a href="#">250-0000-4445-007B</a>	ALLOCATED ASSESSMENTS - IA 7B	39,223.00	28,154.00	39,589.00	0.00	29,880.00	0.00
<a href="#">250-0000-4445-007C</a>	ALLOCATED ASSESSMENTS - IA 7C	42,189.00	30,000.00	43,046.00	0.00	43,441.00	0.00
<a href="#">250-0000-4445-007D</a>	ALLOCATED ASSESSMENTS - IA 7D	39,656.00	30,000.00	40,039.00	0.00	30,343.00	0.00
<a href="#">250-0000-4445-008A</a>	ALLOCATED ASSESSMENTS - IA 8A	35,970.00	30,000.00	36,207.00	0.00	36,396.00	0.00
<a href="#">250-0000-4445-008B</a>	ALLOCATED ASSESSMENTS - IA 8B	36,423.00	30,000.00	36,677.00	0.00	36,880.00	0.00
<a href="#">250-0000-4445-008C</a>	ALLOCATED ASSESSMENTS - IA 8C	53,054.00	30,000.00	53,969.00	0.00	54,695.00	0.00
<a href="#">250-0000-4445-008D</a>	ALLOCATED ASSESSMENTS - IA 8D	39,335.00	30,000.00	39,706.00	0.00	40,000.00	0.00

Defined Budgets

		2018-2019 Total Budget	2018-2019 Total Activity	2019-2020 Total Budget	2019-2020 Total Activity	2020-2021 Total Budget	2020-2021 YTD Activity
<a href="#">250-0000-4445-008E</a>	ALLOCATED ASSESSMENTS - IA 8E	41,735.00	30,000.00	43,653.00	0.00	43,918.00	0.00
<a href="#">250-0000-4445-008F</a>	ALLOCATED ASSESSMENTS - IA 8F	31,714.00	30,000.00	32,469.00	0.00	35,632.00	0.00
<a href="#">250-0000-4445-008X</a>	ALLOCATED ASSESSMENTS - IA 8	60,000.00	30,000.00	60,000.00	0.00	60,000.00	0.00
<a href="#">250-0000-4445-009X</a>	ALLOCATED ASSESSMENTS - IA 9	12,958.00	17,760.00	21,568.00	0.00	21,522.00	0.00
<a href="#">250-0000-4445-010A</a>	ALLOCATED ASSESSMENTS - IA 1...	33,027.00	30,000.00	33,147.00	0.00	33,242.00	0.00
<a href="#">250-0000-4445-011A</a>	ALLOCATED ASSESSMENTS - IA 1...	33,105.00	30,000.00	33,229.00	0.00	33,326.00	0.00
<a href="#">250-0000-4445-012A</a>	ALLOCATED ASSESSMENTS - IA 1...	33,613.00	30,000.00	33,756.00	0.00	33,870.00	0.00
<a href="#">250-0000-4445-013X</a>	ALLOCATED ASSESSMENTS - IA 13	3,902.00	0.00	4,056.00	0.00	4,179.00	0.00
<a href="#">250-0000-4445-014A</a>	ALLOCATED ASSESSMENTS - IA 1...	30,000.00	30,000.00	30,000.00	0.00	30,000.00	0.00
<a href="#">250-0000-4445-014B</a>	ALLOCATED ASSESSMENTS - IA 1...	30,000.00	30,000.00	30,000.00	0.00	30,000.00	0.00
<a href="#">250-0000-4445-014X</a>	ALLOCATED ASSESSMENTS - IA 14	60,000.00	30,000.00	60,000.00	0.00	60,000.00	0.00
<a href="#">250-0000-4445-015X</a>	ALLOCATED ASSESSMENTS - IA 15	2,512.00	0.00	2,611.00	0.00	2,691.00	0.00
<a href="#">250-0000-4445-016X</a>	ALLOCATED ASSESSMENTS - IA 16	37,855.00	30,000.00	38,166.00	0.00	38,414.00	0.00
<a href="#">250-0000-4445-017A</a>	ALLOCATED ASSESSMENTS - IA 1...	45,905.00	30,000.00	46,536.00	0.00	47,037.00	0.00
<a href="#">250-0000-4445-017B</a>	ALLOCATED ASSESSMENTS - IA 1...	42,711.00	30,000.00	43,215.00	0.00	43,616.00	0.00
<a href="#">250-0000-4445-017C</a>	ALLOCATED ASSESSMENTS - IA 1...	37,364.00	30,000.00	37,656.00	0.00	37,888.00	0.00
<a href="#">250-0000-4445-018X</a>	ALLOCATED ASSESSMENTS - IA 18	36,323.00	30,000.00	36,574.00	0.00	36,773.00	0.00
<a href="#">250-0000-4445-019A</a>	ALLOCATED ASSESSMENTS - IA 1...	47,942.00	30,000.00	49,986.00	0.00	50,592.00	0.00
<a href="#">250-0000-4445-019C</a>	ALLOCATED ASSESSMENTS - IA 1...	51,984.00	30,000.00	52,856.00	0.00	53,548.00	0.00
<a href="#">250-0000-4445-020X</a>	ALLOCATED ASSESSMENTS - IA 20	33,483.00	30,000.00	33,621.00	0.00	33,731.00	0.00
<a href="#">250-0000-4445-023X</a>	ALLOCATED ASSESSMENTS - IA 23	2,454.00	0.00	2,551.00	0.00	2,629.00	0.00
<a href="#">250-0000-4445-06A1</a>	ALLOCATED ASSESSMENTS - IA 6...	60,000.00	30,000.00	60,000.00	0.00	60,000.00	0.00
<a href="#">250-0000-4445-1601</a>	ALLOCATED ASSESSMENTS - IA 2...	31,988.00	30,000.00	41,691.00	0.00	42,255.00	0.00
<a href="#">250-0000-4445-1602</a>	ALLOCATED ASSESSMENTS - IA 2...	33,508.00	30,000.00	58,432.00	0.00	75,043.00	0.00
<a href="#">250-0000-4445-1603</a>	ALLOCATED ASSESSMENTS - IA 2...	0.00	0.00	31,527.00	0.00	34,417.00	0.00
<a href="#">250-0000-4445-1604</a>	ALLOCATED ASSESSMENTS - IA 2...	32,921.00	45,000.00	41,871.00	0.00	54,031.00	0.00
<a href="#">250-0000-4445-1801</a>	ALLOCATED ASSESSMENTS - IA 2...	0.00	0.00	6,984.00	0.00	10,395.00	0.00
<a href="#">250-0000-4445-1901</a>	ALLOCATED ASSESSMENTS - IA 2...	0.00	0.00	32,965.00	0.00	33,529.00	0.00
<a href="#">250-0000-4650-0000</a>	INTEREST	0.00	239,533.55	0.00	43,173.41	54,454.00	0.00
<a href="#">250-0000-4825-0000</a>	MISCELLANEOUS REVENUE	0.00	10,250.00	0.00	0.00	0.00	0.00
<a href="#">250-0000-7020-003X</a>	ADVERTISING	0.00	27.28	0.00	0.00	0.00	0.00

Budget Worksheet

Defined Budgets

		2018-2019 Total Budget	2018-2019 Total Activity	2019-2020 Total Budget	2019-2020 Total Activity	2020-2021 Total Budget	2020-2021 YTD Activity
<a href="#">250-0000-7020-009X</a>	ADVERTISING	0.00	27.28	0.00	0.00	0.00	0.00
<a href="#">250-0000-7020-010A</a>	ADVERTISING	0.00	27.28	0.00	0.00	0.00	0.00
<a href="#">250-0000-7020-011A</a>	ADVERTISING	0.00	27.28	0.00	0.00	0.00	0.00
<a href="#">250-0000-7020-012A</a>	ADVERTISING	0.00	27.28	0.00	0.00	0.00	0.00
<a href="#">250-0000-7051-0000</a>	TRUSTEE FEES	100,000.00	-14,000.00	35,000.00	33,800.00	111,000.00	0.00
<a href="#">250-0000-7068-0000</a>	CONTRACTUAL SERVICES	0.00	0.00	281,000.00	194,607.50	28,000.00	0.00
<a href="#">250-0000-7068-001A</a>	CONTRACTUAL SERVICE - IA 1A	4,948.00	3,857.26	0.00	0.00	3,960.00	0.00
<a href="#">250-0000-7068-002X</a>	CONTRACTUAL SERVICE - IA 2	4,948.00	3,857.26	0.00	0.00	3,960.00	0.00
<a href="#">250-0000-7068-003X</a>	CONTRACTUAL SERVICE - IA 3	6,376.00	4,972.07	0.00	0.00	5,105.00	0.00
<a href="#">250-0000-7068-004X</a>	CONTRACTUAL SERVICE - IA 4	4,948.00	3,857.26	0.00	0.00	3,960.00	0.00
<a href="#">250-0000-7068-005X</a>	CONTRACTUAL SERVICE - IA 5	4,948.00	3,857.26	0.00	0.00	3,960.00	0.00
<a href="#">250-0000-7068-006A</a>	CONTRACTUAL SERVICE - IA 6A	0.00	2,970.00	0.00	0.00	3,960.00	0.00
<a href="#">250-0000-7068-006B</a>	CONTRACTUAL SERVICE - IA 6B	4,948.00	3,857.26	0.00	0.00	3,960.00	0.00
<a href="#">250-0000-7068-007A</a>	CONTRACTUAL SERVICE - IA 7A	6,376.00	4,972.07	0.00	0.00	5,105.00	0.00
<a href="#">250-0000-7068-007B</a>	CONTRACTUAL SERVICE - IA 7B	6,376.00	9,472.07	0.00	0.00	5,105.00	0.00
<a href="#">250-0000-7068-007C</a>	CONTRACTUAL SERVICE - IA 7C	6,376.00	5,472.07	0.00	0.00	5,105.00	0.00
<a href="#">250-0000-7068-007D</a>	CONTRACTUAL SERVICE - IA 7D	6,376.00	8,472.07	0.00	0.00	5,105.00	0.00
<a href="#">250-0000-7068-008A</a>	CONTRACTUAL SERVICE - IA 8A	6,376.00	6,972.07	0.00	0.00	5,105.00	0.00
<a href="#">250-0000-7068-008B</a>	CONTRACTUAL SERVICE - IA 8B	6,376.00	4,972.07	0.00	0.00	5,105.00	0.00
<a href="#">250-0000-7068-008C</a>	CONTRACTUAL SERVICE - IA 8C	6,376.00	6,972.07	0.00	0.00	5,105.00	0.00
<a href="#">250-0000-7068-008D</a>	CONTRACTUAL SERVICE - IA 8D	6,376.00	6,972.07	0.00	0.00	5,105.00	0.00
<a href="#">250-0000-7068-008E</a>	CONTRACTUAL SERVICE - IA 8E	6,376.00	8,472.07	0.00	0.00	5,105.00	0.00
<a href="#">250-0000-7068-008F</a>	CONTRACTUAL SERVICE - IA 8F	6,376.00	4,972.07	0.00	0.00	5,105.00	0.00
<a href="#">250-0000-7068-008X</a>	CONTRACTUAL SERVICE - IA 8X	6,376.00	6,972.07	0.00	0.00	5,105.00	0.00
<a href="#">250-0000-7068-009X</a>	CONTRACTUAL SERVICE - IA 9	6,376.00	4,972.07	0.00	0.00	5,105.00	0.00
<a href="#">250-0000-7068-010A</a>	CONTRACTUAL SERVICE - IA 10A	6,376.00	4,972.07	0.00	0.00	5,105.00	0.00
<a href="#">250-0000-7068-011A</a>	CONTRACTUAL SERVICE - IA 11A	6,376.00	4,972.07	0.00	0.00	5,105.00	0.00
<a href="#">250-0000-7068-012A</a>	CONTRACTUAL SERVICE - IA 12A	6,376.00	4,972.07	0.00	0.00	5,105.00	0.00
<a href="#">250-0000-7068-013X</a>	CONTRACTUAL SERVICE - IA 13	1,428.00	1,114.81	0.00	0.00	1,145.00	0.00
<a href="#">250-0000-7068-014A</a>	CONTRACTUAL SERVICE - IA 14A	4,948.00	4,957.26	0.00	0.00	3,960.00	0.00
<a href="#">250-0000-7068-014B</a>	CONTRACTUAL SERVICE - IA 14B	4,948.00	5,857.26	0.00	0.00	3,960.00	0.00

Defined Budgets

		2018-2019 Total Budget	2018-2019 Total Activity	2019-2020 Total Budget	2019-2020 Total Activity	2020-2021 Total Budget	2020-2021 YTD Activity
<a href="#">250-0000-7068-014X</a>	CONTRACTUAL SERVICE - IA 14	6,376.00	4,972.07	0.00	0.00	5,105.00	0.00
<a href="#">250-0000-7068-015X</a>	COINTRACTUAL SERVICE - IA 15	1,428.00	1,114.81	0.00	0.00	1,145.00	0.00
<a href="#">250-0000-7068-016X</a>	CONTRACTUAL SERVICE - IA 16	6,376.00	4,972.07	0.00	0.00	5,105.00	0.00
<a href="#">250-0000-7068-017A</a>	CONTRACTUAL SERVICE - IA 17A	6,376.00	4,972.07	0.00	0.00	5,105.00	0.00
<a href="#">250-0000-7068-017B</a>	CONTRACTUAL SERVICE - IA 17B	6,376.00	4,972.07	0.00	0.00	5,105.00	0.00
<a href="#">250-0000-7068-017C</a>	CONTRACTUAL SERVICE - IA 17C	6,376.00	8,472.07	0.00	0.00	5,105.00	0.00
<a href="#">250-0000-7068-018X</a>	CONTRACTUAL SERVICE - IA 18	6,376.00	4,972.07	0.00	0.00	5,105.00	0.00
<a href="#">250-0000-7068-019A</a>	CONTRACTUAL SERVICE - IA 19A	6,376.00	4,972.07	0.00	0.00	5,105.00	0.00
<a href="#">250-0000-7068-019C</a>	CONTRACTUAL SERVICE - IA 19C	6,376.00	7,472.07	0.00	0.00	5,105.00	0.00
<a href="#">250-0000-7068-020X</a>	CONTRACTUAL SERVICE - IA 20	6,376.00	4,972.07	0.00	0.00	5,105.00	0.00
<a href="#">250-0000-7068-023X</a>	CONTRACTUAL SERVICE - IA 23	1,428.00	1,114.81	0.00	0.00	1,145.00	0.00
<a href="#">250-0000-7068-06A1</a>	CONTRACTUAL SERVICE - IA 6A1	11,324.00	7,859.30	0.00	0.00	5,105.00	0.00
<a href="#">250-0000-7068-1601</a>	CONTRACTUAL SERVICE - IA 2016..	6,376.00	4,972.07	0.00	0.00	5,105.00	0.00
<a href="#">250-0000-7068-1602</a>	CONTRACTUAL SERVICE - IA 2016..	7,804.00	6,086.88	0.00	0.00	6,250.00	0.00
<a href="#">250-0000-7068-1603</a>	CONTRACTUAL SERVICE - IA 2016..	0.00	0.00	0.00	0.00	6,250.00	0.00
<a href="#">250-0000-7068-1604</a>	CONTRACTUAL SERVICE - IA 2016..	7,804.00	6,086.88	0.00	0.00	6,250.00	0.00
<a href="#">250-0000-7068-1801</a>	CONTRACTUAL SERVICE - IA 2018..	0.00	0.00	0.00	0.00	5,105.00	0.00
<a href="#">250-0000-7068-1901</a>	CONTRACTUAL SERVICE - IA 2019..	0.00	0.00	0.00	0.00	6,250.00	0.00
<a href="#">250-0000-8920-0000</a>	CFD PREPAYMENT FEE	0.00	1,900.00	0.00	500.00	0.00	0.00
<a href="#">250-0000-8925-0000</a>	CFD PREPAYMENTS	0.00	0.00	0.00	26,229.03	0.00	0.00
<a href="#">250-0000-9950-0000</a>	TRANSFERS IN	100,000.00	0.00	0.00	0.00	0.00	0.00
<a href="#">250-0000-9950-001A</a>	TRANSFERS - IA 1A	-25,052.00	-25,052.00	0.00	0.00	0.00	0.00
<a href="#">250-0000-9950-002X</a>	TRANSFERS - IA 2	-15,312.00	-15,312.00	0.00	0.00	0.00	0.00
<a href="#">250-0000-9950-003X</a>	TRANSFERS - IA 3	-40,990.00	-40,990.00	0.00	0.00	0.00	0.00
<a href="#">250-0000-9950-004X</a>	TRANSFERS - IA 4	-25,052.00	-25,052.00	0.00	0.00	0.00	0.00
<a href="#">250-0000-9950-005X</a>	TRANSFERS - IA 5	-25,010.00	-25,010.00	0.00	0.00	0.00	0.00
<a href="#">250-0000-9950-006A</a>	TRANSFERS - IA 6A	-3,350.00	-3,350.00	0.00	0.00	0.00	0.00
<a href="#">250-0000-9950-006B</a>	TRANSFERS - IA 6B	-25,052.00	-25,052.00	0.00	0.00	0.00	0.00
<a href="#">250-0000-9950-007A</a>	TRANSFERS - IA 7A	-41,126.00	-41,126.00	0.00	0.00	0.00	0.00
<a href="#">250-0000-9950-007B</a>	TRANSFERS - IA 7B	-32,847.00	-32,847.00	0.00	0.00	0.00	0.00
<a href="#">250-0000-9950-007C</a>	TRANSFERS - IA 7C	-35,813.00	-35,813.00	0.00	0.00	0.00	0.00

Defined Budgets

		2018-2019 Total Budget	2018-2019 Total Activity	2019-2020 Total Budget	2019-2020 Total Activity	2020-2021 Total Budget	2020-2021 YTD Activity
<a href="#">250-0000-9950-007D</a>	TRANSFERS - IA 7D	-33,280.00	-33,280.00	0.00	0.00	0.00	0.00
<a href="#">250-0000-9950-008A</a>	TRANSFERS - IA 8A	-29,594.00	-29,594.00	0.00	0.00	0.00	0.00
<a href="#">250-0000-9950-008B</a>	TRANSFERS - IA 8B	-30,047.00	-30,047.00	0.00	0.00	0.00	0.00
<a href="#">250-0000-9950-008C</a>	TRANSFERS - IA 8C	-46,678.00	-46,678.00	0.00	0.00	0.00	0.00
<a href="#">250-0000-9950-008D</a>	TRANSFERS - IA 8D	-32,959.00	-32,959.00	0.00	0.00	0.00	0.00
<a href="#">250-0000-9950-008E</a>	TRANSFERS - IA 8E	-35,359.00	-35,359.00	0.00	0.00	0.00	0.00
<a href="#">250-0000-9950-008F</a>	TRANSFERS - IA 8F	-25,338.00	-25,338.00	0.00	0.00	0.00	0.00
<a href="#">250-0000-9950-008X</a>	TRANSFERS - IA 8	-53,624.00	-53,624.00	0.00	0.00	0.00	0.00
<a href="#">250-0000-9950-009X</a>	TRANSFERS - IA 9	-6,582.00	-6,582.00	0.00	0.00	0.00	0.00
<a href="#">250-0000-9950-010A</a>	TRANSFERS - IA 10A	-26,651.00	-26,651.00	0.00	0.00	0.00	0.00
<a href="#">250-0000-9950-011A</a>	TRANSFERS - IA 11A	-26,729.00	-26,729.00	0.00	0.00	0.00	0.00
<a href="#">250-0000-9950-012A</a>	TRANSFERS - IA 12A	-27,237.00	-27,237.00	0.00	0.00	0.00	0.00
<a href="#">250-0000-9950-013X</a>	TRANSFERS - IA 13	-2,474.00	-2,474.00	0.00	0.00	0.00	0.00
<a href="#">250-0000-9950-014A</a>	TRANSFERS - IA 14A	-25,052.00	-25,052.00	0.00	0.00	0.00	0.00
<a href="#">250-0000-9950-014B</a>	TRANSFERS - IA 14B	-25,052.00	-25,052.00	0.00	0.00	0.00	0.00
<a href="#">250-0000-9950-014X</a>	TRANSFERS - IA 14	-53,624.00	-53,624.00	0.00	0.00	0.00	0.00
<a href="#">250-0000-9950-015X</a>	TRANSFERS - IA 15	-1,084.00	-1,084.00	0.00	0.00	0.00	0.00
<a href="#">250-0000-9950-016X</a>	TRANSFERS - IA 16	-31,479.00	-31,479.00	0.00	0.00	0.00	0.00
<a href="#">250-0000-9950-017A</a>	TRANSFERS - IA 17A	-39,529.00	-39,529.00	0.00	0.00	0.00	0.00
<a href="#">250-0000-9950-017B</a>	TRANSFERS - IA 17B	-36,335.00	-36,335.00	0.00	0.00	0.00	0.00
<a href="#">250-0000-9950-017C</a>	TRANSFERS - IA 17C	-30,988.00	-30,988.00	0.00	0.00	0.00	0.00
<a href="#">250-0000-9950-018X</a>	TRANSFERS - IA 18	-29,947.00	-29,947.00	0.00	0.00	0.00	0.00
<a href="#">250-0000-9950-019A</a>	TRANSFERS - IA 19A	-41,566.00	-41,566.00	0.00	0.00	0.00	0.00
<a href="#">250-0000-9950-019C</a>	TRANSFERS - IA 19C	-45,608.00	-45,608.00	0.00	0.00	0.00	0.00
<a href="#">250-0000-9950-020X</a>	TRANSFERS - IA 20	-27,107.00	-27,107.00	0.00	0.00	0.00	0.00
<a href="#">250-0000-9950-023X</a>	TRANSFERS - IA 23	-1,026.00	-1,026.00	0.00	0.00	0.00	0.00
<a href="#">250-0000-9950-06A1</a>	TRANSFERS - IA 6A1	-48,676.00	-48,676.00	0.00	0.00	0.00	0.00
<a href="#">250-0000-9950-1601</a>	TRANSFERS - IA 2016-1	-25,612.00	-25,612.00	0.00	0.00	0.00	0.00
<a href="#">250-0000-9950-1602</a>	TRANSFERS - IA 2016-2	-25,704.00	-25,704.00	0.00	0.00	0.00	0.00
<a href="#">250-0000-9950-1604</a>	TRANSFERS - IA 2016-4	-25,117.00	-25,117.00	0.00	0.00	0.00	0.00

Defined Budgets

		2018-2019 Total Budget	2018-2019 Total Activity	2019-2020 Total Budget	2019-2020 Total Activity	2020-2021 Total Budget	2020-2021 YTD Activity
<a href="#">250-0000-9960-0000</a>	TRANSFERS OUT	0.00	3,500.00	1,100,402.00	649,077.78	1,655,997.00	0.00
<b>Department: 0000 - NON-DEPARTMENTAL Surplus (Deficit):</b>		<b>0.00</b>	<b>-47,084.98</b>	<b>126,703.00</b>	<b>-807,582.84</b>	<b>-399,267.00</b>	<b>0.00</b>
<b>Fund: 250 - COMMUNITY FAC DISTRICT (CFD) - ADMIN Surplus (Deficit):</b>		<b>0.00</b>	<b>-47,084.98</b>	<b>126,703.00</b>	<b>-807,582.84</b>	<b>-399,267.00</b>	<b>0.00</b>
<b>Fund: 255 - COMMUNITY FAC DISTRICT (CFD) - MAINT SERVICES</b>							
<b>Department: 0000 - NON-DEPARTMENTAL</b>							
<a href="#">255-0000-4445-001A</a>	ALLOCATED ASSESSMENTS - IA 1A	0.00	-4,544.07	0.00	0.00	0.00	0.00
<a href="#">255-0000-4445-002X</a>	ALLOCATED ASSESSMENTS - IA 2	0.00	-528.03	0.00	0.00	0.00	0.00
<a href="#">255-0000-4445-003X</a>	ALLOCATED ASSESSMENTS - IA 3	156,298.00	175,748.38	162,497.00	90,822.78	167,423.00	0.00
<a href="#">255-0000-4445-004X</a>	ALLOCATED ASSESSMENTS - IA 4	0.00	-7,677.61	0.00	0.00	0.00	0.00
<a href="#">255-0000-4445-005X</a>	ALLOCATED ASSESSMENTS - IA 5	0.00	-7,614.84	0.00	0.00	0.00	0.00
<a href="#">255-0000-4445-006B</a>	ALLOCATED ASSESSMENTS - IA 6B	0.00	-327.20	0.00	0.00	0.00	0.00
<a href="#">255-0000-4445-007A</a>	ALLOCATED ASSESSMENTS - IA 7A	157,514.00	176,061.39	163,764.00	100,465.88	168,727.00	0.00
<a href="#">255-0000-4445-007B</a>	ALLOCATED ASSESSMENTS - IA 7B	83,010.00	82,849.44	86,304.00	54,899.46	88,920.00	0.00
<a href="#">255-0000-4445-007C</a>	ALLOCATED ASSESSMENTS - IA 7C	109,702.00	124,849.10	117,410.00	70,149.91	120,969.00	0.00
<a href="#">255-0000-4445-007D</a>	ALLOCATED ASSESSMENTS - IA 7D	86,905.00	97,279.67	90,352.00	53,931.37	93,090.00	0.00
<a href="#">255-0000-4445-008A</a>	ALLOCATED ASSESSMENTS - IA 8A	53,733.00	59,152.16	55,866.00	31,928.77	57,560.00	0.00
<a href="#">255-0000-4445-008B</a>	ALLOCATED ASSESSMENTS - IA 8B	57,804.00	64,476.55	60,097.00	34,793.52	61,919.00	0.00
<a href="#">255-0000-4445-008C</a>	ALLOCATED ASSESSMENTS - IA 8C	207,482.00	231,870.96	215,720.00	121,139.78	222,259.00	0.00
<a href="#">255-0000-4445-008D</a>	ALLOCATED ASSESSMENTS - IA 8D	84,017.00	93,806.79	87,353.00	49,219.54	90,000.00	0.00
<a href="#">255-0000-4445-008E</a>	ALLOCATED ASSESSMENTS - IA 8E	105,618.00	127,214.22	122,881.00	68,312.72	125,259.00	0.00
<a href="#">255-0000-4445-008F</a>	ALLOCATED ASSESSMENTS-IA8F	15,426.00	19,810.97	22,223.00	24,632.84	50,688.00	0.00
<a href="#">255-0000-4445-008X</a>	ALLOCATED ASSESSMENTS - IA 8	284,787.00	319,154.94	298,992.00	170,256.60	308,964.00	0.00
<a href="#">255-0000-4445-009X</a>	ALLOCATED ASSESSMENTS - IA 9	12,787.00	14,235.50	13,295.00	7,612.23	13,697.00	0.00
<a href="#">255-0000-4445-010A</a>	ALLOCATED ASSESSMENTS - IA 1...	27,242.00	29,698.90	28,323.00	16,146.92	29,182.00	0.00
<a href="#">255-0000-4445-011A</a>	ALLOCATED ASSESSMENTS - IA 1...	27,948.00	29,583.87	29,057.00	16,589.86	29,938.00	0.00
<a href="#">255-0000-4445-012A</a>	ALLOCATED ASSESSMENTS - IA 1...	32,513.00	35,714.87	33,803.00	19,536.24	34,828.00	0.00
<a href="#">255-0000-4445-013X</a>	ALLOCATED ASSESSMENTS - IA 13	35,114.00	39,223.84	36,508.00	19,963.68	37,614.00	0.00
<a href="#">255-0000-4445-014X</a>	ALLOCATED ASSESSMENTS - IA 14	528,159.00	590,389.70	580,142.00	329,626.94	598,635.00	0.00
<a href="#">255-0000-4445-015X</a>	ALLOCATED ASSESSMENTS - IA 15	22,606.00	24,879.14	23,503.00	12,959.26	24,215.00	0.00
<a href="#">255-0000-4445-016X</a>	ALLOCATED ASSESSMENTS - IA 16	70,691.00	70,766.63	73,496.00	40,485.28	75,723.00	0.00
<a href="#">255-0000-4445-017A</a>	ALLOCATED ASSESSMENTS - IA 1...	143,141.00	158,803.98	148,821.00	90,076.37	153,332.00	0.00

Defined Budgets

		2018-2019 Total Budget	2018-2019 Total Activity	2019-2020 Total Budget	2019-2020 Total Activity	2020-2021 Total Budget	2020-2021 YTD Activity
<a href="#">255-0000-4445-017B</a>	ALLOCATED ASSESSMENTS - IA 1...	114,396.00	125,794.45	118,937.00	67,911.25	122,542.00	0.00
<a href="#">255-0000-4445-017C</a>	ALLOCATED ASSESSMENTS - IA 1...	66,277.00	73,199.39	68,908.00	40,583.68	70,996.00	0.00
<a href="#">255-0000-4445-018X</a>	ALLOCATED ASSESSMENTS - IA 18	56,904.00	63,015.99	59,162.00	32,577.21	60,956.00	0.00
<a href="#">255-0000-4445-019A</a>	ALLOCATED ASSESSMENTS - IA 1...	161,476.00	195,040.20	179,872.00	104,217.10	185,324.00	0.00
<a href="#">255-0000-4445-019C</a>	ALLOCATED ASSESSMENTS - IA 1...	197,852.00	222,142.60	205,700.00	120,069.86	211,934.00	0.00
<a href="#">255-0000-4445-020X</a>	ALLOCATED ASSESSMENTS - IA 20	31,349.00	34,973.86	32,592.00	18,831.64	33,580.00	0.00
<a href="#">255-0000-4445-023X</a>	ALLOCATED ASSESSMENTS - IA 23	22,084.00	24,254.64	22,961.00	13,622.88	23,657.00	0.00
<a href="#">255-0000-4445-06A1</a>	ALLOCATED ASSESSMENTS - IA 6...	279,882.00	314,915.99	293,314.00	167,107.08	303,166.00	0.00
<a href="#">255-0000-4445-1601</a>	ALLOCATED ASSESSMENTS - IA 2...	17,895.00	97,414.64	105,223.00	60,455.79	110,298.00	0.00
<a href="#">255-0000-4445-1602</a>	ALLOCATED ASSESSMENTS - IA 2...	13,756.00	94,103.94	110,794.00	86,894.43	171,111.00	0.00
<a href="#">255-0000-4445-1603</a>	ALLOCATED ASSESSMENTS - IA 2...	0.00	0.00	2,109.00	2,222.15	5,513.00	0.00
<a href="#">255-0000-4445-1604</a>	ALLOCATED ASSESSMENTS - IA 2...	3,715.00	12,387.43	14,959.00	14,015.59	29,275.00	0.00
<a href="#">255-0000-4445-1801</a>	ALLOCATED ASSESSMENTS - IA 2...	0.00	0.00	32,497.00	0.00	0.00	0.00
<a href="#">255-0000-4445-1901</a>	ALLOCATED ASSESSMENTS - IA 2...	0.00	0.00	13,800.00	0.00	10,557.00	0.00
<a href="#">255-0000-4650-0000</a>	INTEREST	0.00	0.00	0.00	6,118.66	3,158.00	0.00
<a href="#">255-0000-9950-003X</a>	TRANSFERS - IA 3	-156,298.00	-156,298.00	0.00	0.00	0.00	0.00
<a href="#">255-0000-9950-007A</a>	TRANSFERS - IA 7A	-157,514.00	-157,514.00	0.00	0.00	0.00	0.00
<a href="#">255-0000-9950-007B</a>	TRANSFERS - IA 7B	-83,010.00	-83,010.00	0.00	0.00	0.00	0.00
<a href="#">255-0000-9950-007C</a>	TRANSFERS - IA 7C	-109,702.00	-109,702.00	0.00	0.00	0.00	0.00
<a href="#">255-0000-9950-007D</a>	TRANSFERS - IA 7D	-86,905.00	-86,905.00	0.00	0.00	0.00	0.00
<a href="#">255-0000-9950-008A</a>	TRANSFERS - IA 8A	-53,733.00	-53,733.00	0.00	0.00	0.00	0.00
<a href="#">255-0000-9950-008B</a>	TRANSFERS - IA 8B	-57,804.00	-57,804.00	0.00	0.00	0.00	0.00
<a href="#">255-0000-9950-008C</a>	TRANSFERS - IA 8C	-207,482.00	-207,482.00	0.00	0.00	0.00	0.00
<a href="#">255-0000-9950-008D</a>	TRANSFERS - IA 8D	-84,017.00	-84,017.00	0.00	0.00	0.00	0.00
<a href="#">255-0000-9950-008E</a>	TRANSFERS - IA 8E	-105,618.00	-105,618.00	0.00	0.00	0.00	0.00
<a href="#">255-0000-9950-008F</a>	TRANSFERS - IA 8F	-15,426.00	-15,426.00	0.00	0.00	0.00	0.00
<a href="#">255-0000-9950-008X</a>	TRANSFERS - IA 8	-284,787.00	-284,787.00	0.00	0.00	0.00	0.00
<a href="#">255-0000-9950-009X</a>	TRANSFERS - IA 9	-12,787.00	-12,787.00	0.00	0.00	0.00	0.00
<a href="#">255-0000-9950-010A</a>	TRANSFERS - IA 10A	-27,242.00	-27,242.00	0.00	0.00	0.00	0.00
<a href="#">255-0000-9950-011A</a>	TRANSFERS - IA 11A	-27,948.00	-27,948.00	0.00	0.00	0.00	0.00
<a href="#">255-0000-9950-012A</a>	TRANSFERS - IA 12A	-32,513.00	-32,513.00	0.00	0.00	0.00	0.00



Defined Budgets

		2018-2019 Total Budget	2018-2019 Total Activity	2019-2020 Total Budget	2019-2020 Total Activity	2020-2021 Total Budget	2020-2021 YTD Activity
<a href="#">255-0000-9950-013X</a>	TRANSFERS - IA 13	-35,114.00	-35,114.00	0.00	0.00	0.00	0.00
<a href="#">255-0000-9950-014X</a>	TRANSFERS - IA 14	-528,159.00	-528,159.00	0.00	0.00	0.00	0.00
<a href="#">255-0000-9950-015X</a>	TRANSFERS - IA 15	-22,606.00	-22,606.00	0.00	0.00	0.00	0.00
<a href="#">255-0000-9950-016X</a>	TRANSFERS - IA 16	-70,691.00	-70,691.00	0.00	0.00	0.00	0.00
<a href="#">255-0000-9950-017A</a>	TRANSFERS - IA 17A	-143,141.00	-143,141.00	0.00	0.00	0.00	0.00
<a href="#">255-0000-9950-017B</a>	TRANSFERS - IA 17B	-114,396.00	-114,396.00	0.00	0.00	0.00	0.00
<a href="#">255-0000-9950-017C</a>	TRANSFERS - IA 17C	-66,277.00	-66,277.00	0.00	0.00	0.00	0.00
<a href="#">255-0000-9950-018X</a>	TRANSFERS - IA 18	-56,904.00	-56,904.00	0.00	0.00	0.00	0.00
<a href="#">255-0000-9950-019A</a>	TRANSFERS - IA 19A	-161,476.00	-161,476.00	0.00	0.00	0.00	0.00
<a href="#">255-0000-9950-019C</a>	TRANSFERS - IA 19C	-197,852.00	-197,852.00	0.00	0.00	0.00	0.00
<a href="#">255-0000-9950-020X</a>	TRANSFERS - IA 20	-31,349.00	-31,349.00	0.00	0.00	0.00	0.00
<a href="#">255-0000-9950-023X</a>	TRANSFERS - IA 23	-22,084.00	-22,084.00	0.00	0.00	0.00	0.00
<a href="#">255-0000-9950-06A1</a>	TRANSFERS - IA 6A1	-279,882.00	-279,882.00	0.00	0.00	0.00	0.00
<a href="#">255-0000-9950-1601</a>	TRANSFERS - IA 2016-1	-17,895.00	-17,895.00	0.00	0.00	0.00	0.00
<a href="#">255-0000-9950-1602</a>	TRANSFERS - IA 2016-2	-13,756.00	-13,756.00	0.00	0.00	0.00	0.00
<a href="#">255-0000-9950-1604</a>	TRANSFERS - IA 2016-4	-3,715.00	-3,715.00	0.00	0.00	0.00	0.00
<a href="#">255-0000-9960-0000</a>	TRANSFERS OUT	0.00	0.00	3,716,835.00	296,666.66	3,895,009.00	0.00
<b>Department: 0000 - NON-DEPARTMENTAL Surplus (Deficit):</b>		<b>0.00</b>	<b>534,039.38</b>	<b>-5,600.00</b>	<b>1,861,510.61</b>	<b>0.00</b>	<b>0.00</b>
<b>Fund: 255 - COMMUNITY FAC DISTRICT (CFD) - MAINT SERVICES Surplus ..</b>		<b>0.00</b>	<b>534,039.38</b>	<b>-5,600.00</b>	<b>1,861,510.61</b>	<b>0.00</b>	<b>0.00</b>
<b>Fund: 260 - COMMUNITY FAC DISTRICT (CFD) - PUBLIC SAFETY</b>							
<b>Department: 0000 - NON-DEPARTMENTAL</b>							
<a href="#">260-0000-4445-1602</a>	ALLOCATED ASSESSMENTS - IA 2...	17,818.00	121,144.24	145,098.00	113,882.69	234,277.00	0.00
<a href="#">260-0000-4445-1603</a>	ALLOCATED ASSESSMENTS - IA 2...	0.00	0.00	11,641.00	12,775.62	34,237.00	0.00
<a href="#">260-0000-4445-1604</a>	ALLOCATED ASSESSMENTS - IA 2...	22,569.00	75,504.55	91,881.00	87,186.75	187,006.00	0.00
<a href="#">260-0000-4445-1801</a>	ALLOCATED ASSESSMENTS - IA 2...	0.00	0.00	30,353.00	40,991.68	93,555.00	0.00
<a href="#">260-0000-4445-1901</a>	ALLOCATED ASSESSMENTS - IA 2...	0.00	0.00	12,890.00	0.00	21,206.00	0.00
<a href="#">260-0000-4650-0000</a>	INTEREST	0.00	0.00	0.00	965.00	739.00	0.00
<a href="#">260-0000-9960-0000</a>	TRANSFERS OUT	0.00	0.00	140,000.00	140,000.00	571,020.00	0.00
<b>Department: 0000 - NON-DEPARTMENTAL Surplus (Deficit):</b>		<b>40,387.00</b>	<b>196,648.79</b>	<b>151,863.00</b>	<b>115,801.74</b>	<b>0.00</b>	<b>0.00</b>
<b>Fund: 260 - COMMUNITY FAC DISTRICT (CFD) - PUBLIC SAFETY Surplus (...)</b>		<b>40,387.00</b>	<b>196,648.79</b>	<b>151,863.00</b>	<b>115,801.74</b>	<b>0.00</b>	<b>0.00</b>

Defined Budgets

		2018-2019 Total Budget	2018-2019 Total Activity	2019-2020 Total Budget	2019-2020 Total Activity	2020-2021 Total Budget	2020-2021 YTD Activity
<b>Fund: 265 - COMMUNITY FAC DISTRICT (CFD) - PUBLIC FACILITIES</b>							
<b>Department: 0000 - NON-DEPARTMENTAL</b>							
<a href="#">265-0000-4445-005X</a>	ALLOCATED ASSESSMENTS - IA 5	0.00	0.00	111,398.00	0.00	0.00	0.00
<a href="#">265-0000-4445-008F</a>	ALLOCATED ASSESSMENTS - IA 8F	0.00	0.00	104,645.00	0.00	0.00	0.00
<a href="#">265-0000-4445-1602</a>	ALLOCATED ASSESSMENTS - IA 2...	0.00	0.00	444,504.00	0.00	0.00	0.00
<a href="#">265-0000-4445-1603</a>	ALLOCATED ASSESSMENTS - IA 2...	0.00	0.00	24,643.00	0.00	0.00	0.00
<a href="#">265-0000-4445-1604</a>	ALLOCATED ASSESSMENTS - IA 2...	0.00	0.00	163,521.00	0.00	0.00	0.00
<a href="#">265-0000-4445-1901</a>	ALLOCATED ASSESSMENTS - IA 2...	0.00	0.00	12,070.00	0.00	0.00	0.00
<a href="#">265-0000-9960-0000</a>	TRANSFERS OUT	0.00	0.00	300,000.00	0.00	0.00	0.00
<b>Department: 0000 - NON-DEPARTMENTAL Surplus (Deficit):</b>		<b>0.00</b>	<b>0.00</b>	<b>560,781.00</b>	<b>0.00</b>	<b>0.00</b>	<b>0.00</b>
<b>Fund: 265 - COMMUNITY FAC DISTRICT (CFD) - PUBLIC FACILITIES Surplus..</b>		<b>0.00</b>	<b>0.00</b>	<b>560,781.00</b>	<b>0.00</b>	<b>0.00</b>	<b>0.00</b>
<b>Fund: 300 - DEBT SERVICE</b>							
<b>Department: 0000 - NON-DEPARTMENTAL</b>							
<a href="#">300-0000-6040-0000</a>	GASB 68 PENSION ADJMT	0.00	-3,153,312.00	0.00	0.00	0.00	0.00
<b>Department: 0000 - NON-DEPARTMENTAL Total:</b>		<b>0.00</b>	<b>-3,153,312.00</b>	<b>0.00</b>	<b>0.00</b>	<b>0.00</b>	<b>0.00</b>
<b>Fund: 300 - DEBT SERVICE Total:</b>		<b>0.00</b>	<b>-3,153,312.00</b>	<b>0.00</b>	<b>0.00</b>	<b>0.00</b>	<b>0.00</b>
<b>Fund: 500 - GENERAL CAPITAL PROJECTS</b>							
<b>Department: 0000 - NON-DEPARTMENTAL</b>							
<a href="#">500-0000-4455-0000</a>	FEDERAL GRANTS	0.00	0.00	0.00	1,412,554.53	0.00	0.00
<a href="#">500-0000-4460-0000</a>	GRANTS	12,000,000.00	4,963,592.20	0.00	970,040.93	0.00	0.00
<a href="#">500-0000-4650-0000</a>	INTEREST	0.00	220,546.89	0.00	4,215.06	0.00	0.00
<a href="#">500-0000-4695-0000</a>	DEVELOPER CONTRIBUTIONS	0.00	3,260,750.33	0.00	59,498.09	0.00	0.00
<a href="#">500-0000-7068-0000</a>	CONTRACTUAL SERVICE	0.00	2,409,261.82	0.00	595,551.98	0.00	0.00
<a href="#">500-0000-8014-0000</a>	BUILDING IMPROVEMENTS	0.00	20,476.99	0.00	0.00	0.00	0.00
<a href="#">500-0000-8030-0000</a>	INFRASTRUCTURE IMPROVEMEN...	23,014,000.00	9,600,138.29	0.00	3,564,296.43	0.00	0.00
<a href="#">500-0000-8990-0000</a>	CAPITAL OUTLAY	0.00	0.00	5,107,300.00	446,988.77	9,325,000.00	0.00
<a href="#">500-0000-9950-0000</a>	TRANSFERS IN	11,014,000.00	3,339,628.79	5,107,300.00	876,974.95	9,325,000.00	0.00
<a href="#">500-0000-9960-0000</a>	TRANSFERS OUT	0.00	108,479.14	0.00	218,521.74	0.00	0.00
<b>Department: 0000 - NON-DEPARTMENTAL Surplus (Deficit):</b>		<b>0.00</b>	<b>-353,838.03</b>	<b>0.00</b>	<b>-1,502,075.36</b>	<b>0.00</b>	<b>0.00</b>
<b>Fund: 500 - GENERAL CAPITAL PROJECTS Surplus (Deficit):</b>		<b>0.00</b>	<b>-353,838.03</b>	<b>0.00</b>	<b>-1,502,075.36</b>	<b>0.00</b>	<b>0.00</b>

Defined Budgets

		2018-2019 Total Budget	2018-2019 Total Activity	2019-2020 Total Budget	2019-2020 Total Activity	2020-2021 Total Budget	2020-2021 YTD Activity
<b>Fund: 505 - EQUIPMENT REPLACEMENT</b>							
<b>Department: 0000 - NON-DEPARTMENTAL</b>							
<a href="#">505-0000-4650-0000</a>	INTEREST	0.00	0.00	0.00	1,147.36	0.00	0.00
<b>Department: 0000 - NON-DEPARTMENTAL Total:</b>		<b>0.00</b>	<b>0.00</b>	<b>0.00</b>	<b>1,147.36</b>	<b>0.00</b>	<b>0.00</b>
<b>Fund: 505 - EQUIPMENT REPLACEMENT Total:</b>		<b>0.00</b>	<b>0.00</b>	<b>0.00</b>	<b>1,147.36</b>	<b>0.00</b>	<b>0.00</b>
<b>Fund: 510 - COMMUNITY FACILITIES DISTRICT (CFD) - CAPITAL FUND</b>							
<b>Department: 0000 - NON-DEPARTMENTAL</b>							
<a href="#">510-0000-4445-003X</a>	ALLOCATED ASSESSMENTS - IA 3	0.00	46,420.71	0.00	0.00	0.00	0.00
<a href="#">510-0000-4445-006A</a>	ALLOCATED ASSESSMENTS - IA 6A	0.00	576.83	0.00	0.00	0.00	0.00
<a href="#">510-0000-4445-007A</a>	ALLOCATED ASSESSMENTS - IA 7A	0.00	1,541.27	0.00	0.00	0.00	0.00
<a href="#">510-0000-4445-007D</a>	ALLOCATED ASSESSMENTS - IA 7D	0.00	10,247.63	0.00	0.00	0.00	0.00
<a href="#">510-0000-4445-008B</a>	ALLOCATED ASSESSMENTS - IA 8B	0.00	8,773.41	0.00	0.00	0.00	0.00
<a href="#">510-0000-4445-008C</a>	ALLOCATED ASSESSMENTS - IA 8C	0.00	142,987.06	0.00	0.00	0.00	0.00
<a href="#">510-0000-4445-008D</a>	ALLOCATED ASSESSMENTS - IA 8D	0.00	67,725.42	0.00	0.00	0.00	0.00
<a href="#">510-0000-4445-008E</a>	ALLOCATED ASSESSMENTS - IA 8E	0.00	56,445.96	0.00	0.00	0.00	0.00
<a href="#">510-0000-4445-008F</a>	ALLOCATED ASSESSMENTS-IA8F	0.00	70,264.99	0.00	0.00	310,518.00	0.00
<a href="#">510-0000-4445-008X</a>	ALLOCATED ASSESSMENTS - IA 8	0.00	2,379.02	0.00	0.00	0.00	0.00
<a href="#">510-0000-4445-009X</a>	ALLOCATED ASSESSMENTS - IA 9	0.00	11,553.13	0.00	0.00	0.00	0.00
<a href="#">510-0000-4445-014A</a>	ALLOCATED ASSESSMENTS - IA 1...	0.00	11,186.05	0.00	0.00	0.00	0.00
<a href="#">510-0000-4445-014B</a>	ALLOCATED ASSESSMENTS - IA 1...	0.00	57,544.66	0.00	0.00	0.00	0.00
<a href="#">510-0000-4445-014X</a>	ALLOCATED ASSESSMENTS - IA 14	0.00	623.72	0.00	0.00	0.00	0.00
<a href="#">510-0000-4445-017A</a>	ALLOCATED ASSESSMENTS - IA 1...	0.00	35,841.56	0.00	0.00	0.00	0.00
<a href="#">510-0000-4445-017C</a>	ALLOCATED ASSESSMENTS - IA 1...	0.00	71,215.46	0.00	0.00	0.00	0.00
<a href="#">510-0000-4445-019A</a>	ALLOCATED ASSESSMENTS - IA 1...	0.00	21,788.09	0.00	0.00	0.00	0.00
<a href="#">510-0000-4445-019C</a>	ALLOCATED ASSESSMENTS - IA 1...	0.00	18,994.58	0.00	0.00	0.00	0.00
<a href="#">510-0000-4445-06A1</a>	ALLOCATED ASSESSMENTS - IA 6...	0.00	35,821.73	0.00	0.00	0.00	0.00
<a href="#">510-0000-4445-1601</a>	ALLOCATED ASSESSMENTS - IA 2...	0.00	36,039.55	0.00	0.00	0.00	0.00
<a href="#">510-0000-4445-1602</a>	ALLOCATED ASSESSMENTS - IA 2...	0.00	334,918.80	0.00	0.00	0.00	0.00
<a href="#">510-0000-4445-1603</a>	ALLOCATED ASSESSMENTS-IA 20...	0.00	0.00	0.00	0.00	90,986.00	0.00
<a href="#">510-0000-4445-1604</a>	ALLOCATED ASSESSMENTS - IA 2...	0.00	80,089.87	0.00	0.00	0.00	0.00
<a href="#">510-0000-4445-1901</a>	ALLOCATED ASSESSMENTS-IA 20...	0.00	0.00	0.00	0.00	42,403.00	0.00
<a href="#">510-0000-4650-0000</a>	INTEREST	0.00	200,018.57	280,000.00	160,426.05	266,094.00	0.00

Budget Worksheet

Defined Budgets

		2018-2019 Total Budget	2018-2019 Total Activity	2019-2020 Total Budget	2019-2020 Total Activity	2020-2021 Total Budget	2020-2021 YTD Activity
<a href="#">510-0000-4650-007B</a>	INTEREST - IA 7B	0.00	757.36	0.00	0.00	0.00	0.00
<a href="#">510-0000-4650-007C</a>	INTEREST - IA 7C	0.00	283.82	0.00	0.00	0.00	0.00
<a href="#">510-0000-4650-007D</a>	INTEREST - IA 7D	0.00	8.16	0.00	0.00	0.00	0.00
<a href="#">510-0000-4650-008C</a>	INTEREST - IA 8C	0.00	52.82	0.00	0.00	0.00	0.00
<a href="#">510-0000-4650-008E</a>	INTEREST-IA8E	0.00	6,190.17	0.00	0.00	0.00	0.00
<a href="#">510-0000-4650-016X</a>	INTEREST - IA 16	0.00	35,820.06	34,000.00	0.00	0.00	0.00
<a href="#">510-0000-4650-017B</a>	INTEREST - IA 17B	0.00	2.02	0.00	0.00	0.00	0.00
<a href="#">510-0000-4650-018X</a>	INTEREST - IA 18	0.00	16,850.67	16,400.00	0.00	0.00	0.00
<a href="#">510-0000-4650-019C</a>	INTEREST - IA 19C	0.00	2,667.04	0.00	0.00	0.00	0.00
<a href="#">510-0000-4650-020X</a>	INTEREST - IA 20	0.00	22,170.42	0.00	0.00	0.00	0.00
<a href="#">510-0000-4650-1601</a>	INTEREST - IA 2016-1	0.00	6,852.13	0.00	0.00	0.00	0.00
<a href="#">510-0000-4695-007B</a>	DEVELOPER CONTRIB - IA 7B	0.00	779,492.13	0.00	0.00	0.00	0.00
<a href="#">510-0000-4695-007D</a>	DEVELOPER CONTRIB - IA 7D	0.00	201,512.84	0.00	0.00	0.00	0.00
<a href="#">510-0000-7068-0000</a>	CONTRACTUAL SERVICES	0.00	1,375.00	3,000.00	0.00	3,000.00	0.00
<a href="#">510-0000-7500-008C</a>	SETTLEMENT (IA 8C)	0.00	549,192.80	0.00	0.00	0.00	0.00
<a href="#">510-0000-7500-008D</a>	SETTLEMENT (IA 8D)	0.00	391,642.79	0.00	0.00	0.00	0.00
<a href="#">510-0000-7500-008E</a>	SETTLEMENT (IA 8E)	0.00	585,819.52	0.00	0.00	0.00	0.00
<a href="#">510-0000-7500-008F</a>	SETTLEMENT (IA 8F)	0.00	55,494.52	0.00	0.00	0.00	0.00
<a href="#">510-0000-7500-017C</a>	SETTLEMENT (IA 17C)	0.00	458,203.17	0.00	0.00	0.00	0.00
<a href="#">510-0000-7500-1602</a>	SETTLEMENT (2016-2)	0.00	24,292.77	0.00	0.00	0.00	0.00
<a href="#">510-0000-8030-0000</a>	INFRASTRUCTURE	0.00	3,136,047.00	2,666,100.00	142,695.76	0.00	0.00
<a href="#">510-0000-8990-0000</a>	CAPITAL OUTLAY	0.00	0.00	0.00	0.00	0.00	0.00
<a href="#">510-0000-8999-0000</a>	TRANSFER TO FIXED ASSET/DEBT...	0.00	-3,136,047.00	0.00	0.00	0.00	0.00
<a href="#">510-0000-9500-0000</a>	SPECIAL ITEMS	0.00	0.00	0.00	0.00	0.00	0.00
<a href="#">510-0000-9950-0000</a>	TRANSFERS IN	0.00	0.00	0.00	0.00	0.00	0.00
<a href="#">510-0000-9950-007B</a>	TRANSFERS	0.00	0.00	0.00	0.00	0.00	0.00
<a href="#">510-0000-9950-007D</a>	TRANSFERS - IA 7D	0.00	0.00	0.00	0.00	0.00	0.00
<a href="#">510-0000-9960-0000</a>	TRANSFERS OUT	0.00	3,136,047.00	0.00	0.00	1,500,000.00	0.00
<b>Department: 0000 - NON-DEPARTMENTAL Surplus (Deficit):</b>		<b>0.00</b>	<b>-2,806,409.86</b>	<b>-2,338,700.00</b>	<b>17,730.29</b>	<b>-792,999.00</b>	<b>0.00</b>
<b>Fund: 510 - COMMUNITY FACILITIES DISTRICT (CFD) - CAPITAL FUND Sur...</b>		<b>0.00</b>	<b>-2,806,409.86</b>	<b>-2,338,700.00</b>	<b>17,730.29</b>	<b>-792,999.00</b>	<b>0.00</b>

Defined Budgets

		2018-2019 Total Budget	2018-2019 Total Activity	2019-2020 Total Budget	2019-2020 Total Activity	2020-2021 Total Budget	2020-2021 YTD Activity
<b>Fund: 550 - DEVELOPMENT IMPACT (MITIGATION)</b>							
<b>Department: 0000 - NON-DEPARTMENTAL</b>							
<a href="#">550-0000-4650-0000</a>	INTEREST	0.00	0.00	0.00	224.90	0.00	0.00
<a href="#">550-0000-9910-0000</a>	RECOGNIZE AS DEFERRED	0.00	2,597,331.84	0.00	0.00	0.00	0.00
<a href="#">550-0000-9950-0000</a>	TRANSFERS IN	-34,000.00	0.00	0.00	0.00	0.00	0.00
<a href="#">550-0000-9960-0000</a>	TRANSFERS OUT	0.00	2,597,331.84	0.00	3,000.00	0.00	0.00
<b>Department: 0000 - NON-DEPARTMENTAL Surplus (Deficit):</b>		<b>-34,000.00</b>	<b>0.00</b>	<b>0.00</b>	<b>-2,775.10</b>	<b>0.00</b>	<b>0.00</b>
<b>Fund: 550 - DEVELOPMENT IMPACT (MITIGATION) Surplus (Deficit):</b>		<b>-34,000.00</b>	<b>0.00</b>	<b>0.00</b>	<b>-2,775.10</b>	<b>0.00</b>	<b>0.00</b>
<b>Fund: 552 - BASIC SERVICES DEVELOPMENT</b>							
<b>Department: 0000 - NON-DEPARTMENTAL</b>							
<a href="#">552-0000-4650-0000</a>	INTEREST	0.00	0.00	0.00	5,496.94	7,029.00	0.00
<a href="#">552-0000-4915-0000</a>	BASIC SERVICE MITIGATION FEES	167,448.00	381,826.69	189,873.00	129,954.75	152,379.00	0.00
<a href="#">552-0000-7900-0000</a>	MITIGATION FEE REFUNDS	0.00	50.19	0.00	0.00	0.00	0.00
<a href="#">552-0000-9910-0000</a>	RECOGNIZE AS DEFERRED	0.00	-2,576.57	0.00	0.00	0.00	0.00
<a href="#">552-0000-9950-0000</a>	TRANSFERS IN	0.00	0.07	0.00	0.00	0.00	0.00
<a href="#">552-0000-9960-0000</a>	TRANSFERS OUT	0.00	379,200.00	0.00	19,121.94	0.00	0.00
<b>Department: 0000 - NON-DEPARTMENTAL Surplus (Deficit):</b>		<b>167,448.00</b>	<b>0.00</b>	<b>189,873.00</b>	<b>116,329.75</b>	<b>159,408.00</b>	<b>0.00</b>
<b>Fund: 552 - BASIC SERVICES DEVELOPMENT Surplus (Deficit):</b>		<b>167,448.00</b>	<b>0.00</b>	<b>189,873.00</b>	<b>116,329.75</b>	<b>159,408.00</b>	<b>0.00</b>
<b>Fund: 554 - GENERAL PLAN DEVELOPMENT</b>							
<b>Department: 0000 - NON-DEPARTMENTAL</b>							
<a href="#">554-0000-4650-0000</a>	INTEREST	0.00	0.00	0.00	42.67	82.00	0.00
<a href="#">554-0000-4915-0000</a>	GENERAL PLAN MITIGATION FEES	20,000.00	172,889.85	22,500.00	16,877.54	17,700.00	0.00
<a href="#">554-0000-7900-0000</a>	MITIGATION FEE REFUNDS	0.00	32.00	0.00	0.00	0.00	0.00
<a href="#">554-0000-9910-0000</a>	RECOGNIZE AS DEFERRED	0.00	-1,242.03	0.00	0.00	0.00	0.00
<a href="#">554-0000-9950-0000</a>	TRANSFERS IN	0.00	0.00	0.00	0.00	0.00	0.00
<a href="#">554-0000-9960-0000</a>	TRANSFERS OUT	0.00	171,615.82	0.00	69,933.03	0.00	0.00
<b>Department: 0000 - NON-DEPARTMENTAL Surplus (Deficit):</b>		<b>20,000.00</b>	<b>0.00</b>	<b>22,500.00</b>	<b>-53,012.82</b>	<b>17,782.00</b>	<b>0.00</b>
<b>Fund: 554 - GENERAL PLAN DEVELOPMENT Surplus (Deficit):</b>		<b>20,000.00</b>	<b>0.00</b>	<b>22,500.00</b>	<b>-53,012.82</b>	<b>17,782.00</b>	<b>0.00</b>
<b>Fund: 555 - RECREATIONAL FACILITIES DEVELOPMENT</b>							
<b>Department: 0000 - NON-DEPARTMENTAL</b>							
<a href="#">555-0000-4650-0000</a>	INTEREST	0.00	0.00	0.00	5,144.18	6,514.00	0.00
<a href="#">555-0000-4915-0000</a>	RECREATION FACILITIES MITIGAT...	286,196.00	459,550.51	324,522.00	217,572.91	260,438.00	0.00
<a href="#">555-0000-9910-0000</a>	RECOGNIZE AS DEFERRED	0.00	-459,550.51	0.00	0.00	0.00	0.00

Defined Budgets

		2018-2019 Total Budget	2018-2019 Total Activity	2019-2020 Total Budget	2019-2020 Total Activity	2020-2021 Total Budget	2020-2021 YTD Activity
<a href="#">555-0000-9960-0000</a>	TRANSFERS OUT	0.00	0.00	0.00	0.00	900,000.00	0.00
<b>Department: 0000 - NON-DEPARTMENTAL Surplus (Deficit):</b>		<b>286,196.00</b>	<b>0.00</b>	<b>324,522.00</b>	<b>222,717.09</b>	<b>-633,048.00</b>	<b>0.00</b>
<b>Fund: 555 - RECREATIONAL FACILITIES DEVELOPMENT Surplus (Deficit):</b>		<b>286,196.00</b>	<b>0.00</b>	<b>324,522.00</b>	<b>222,717.09</b>	<b>-633,048.00</b>	<b>0.00</b>
<b>Fund: 556 - TRAFFIC IMPACT DEVELOPMENT</b>							
<b>Department: 0000 - NON-DEPARTMENTAL</b>							
<a href="#">556-0000-4650-0000</a>	INTEREST	0.00	0.00	0.00	7,789.41	9,303.00	0.00
<a href="#">556-0000-4915-0000</a>	TRAFFIC SIGNAL MITIGATION FE...	108,284.00	313,846.26	122,076.00	174,883.44	97,056.00	0.00
<a href="#">556-0000-7900-0000</a>	MITIGATION FEE REFUNDS	0.00	205.58	0.00	0.00	0.00	0.00
<a href="#">556-0000-9910-0000</a>	RECOGNIZE AS DEFERRED	0.00	-284,650.55	0.00	0.00	0.00	0.00
<a href="#">556-0000-9950-0000</a>	TRANSFERS IN	0.00	0.17	0.00	218,521.74	0.00	0.00
<a href="#">556-0000-9960-0000</a>	TRANSFERS OUT	0.00	28,990.30	795,000.00	148,837.54	150,000.00	0.00
<b>Department: 0000 - NON-DEPARTMENTAL Surplus (Deficit):</b>		<b>108,284.00</b>	<b>0.00</b>	<b>-672,924.00</b>	<b>252,357.05</b>	<b>-43,641.00</b>	<b>0.00</b>
<b>Fund: 556 - TRAFFIC IMPACT DEVELOPMENT Surplus (Deficit):</b>		<b>108,284.00</b>	<b>0.00</b>	<b>-672,924.00</b>	<b>252,357.05</b>	<b>-43,641.00</b>	<b>0.00</b>
<b>Fund: 558 - RAILROAD CROSSING DEVELOPMENT</b>							
<b>Department: 0000 - NON-DEPARTMENTAL</b>							
<a href="#">558-0000-4650-0000</a>	INTEREST	0.00	0.00	0.00	12,426.30	16,215.00	0.00
<a href="#">558-0000-4915-0000</a>	RAILROAD CROSSING MITIGATI...	116,368.00	336,358.14	131,188.00	98,441.70	104,303.00	0.00
<a href="#">558-0000-7900-0000</a>	MITIGATION FEE REFUNDS	0.00	220.83	0.00	0.00	0.00	0.00
<a href="#">558-0000-9910-0000</a>	RECOGNIZE AS DEFERRED	0.00	-336,137.13	0.00	0.00	0.00	0.00
<a href="#">558-0000-9950-0000</a>	TRANSFERS IN	0.00	-0.18	0.00	0.00	0.00	0.00
<a href="#">558-0000-9960-0000</a>	TRANSFERS OUT	0.00	0.00	0.00	160,825.73	0.00	0.00
<b>Department: 0000 - NON-DEPARTMENTAL Surplus (Deficit):</b>		<b>116,368.00</b>	<b>0.00</b>	<b>131,188.00</b>	<b>-49,957.73</b>	<b>120,518.00</b>	<b>0.00</b>
<b>Fund: 558 - RAILROAD CROSSING DEVELOPMENT Surplus (Deficit):</b>		<b>116,368.00</b>	<b>0.00</b>	<b>131,188.00</b>	<b>-49,957.73</b>	<b>120,518.00</b>	<b>0.00</b>
<b>Fund: 559 - POLICE FACILITIES DEVELOPMENT</b>							
<b>Department: 0000 - NON-DEPARTMENTAL</b>							
<a href="#">559-0000-4650-0000</a>	INTEREST	0.00	0.00	0.00	4,304.89	5,456.00	0.00
<a href="#">559-0000-4915-0000</a>	POLICE FACILITIES MITIGATION F...	196,412.00	447,718.03	222,714.00	154,716.91	178,735.00	0.00
<a href="#">559-0000-7900-0000</a>	MITIGATION FEE REFUNDS	0.00	58.85	0.00	0.00	0.00	0.00
<a href="#">559-0000-9910-0000</a>	RECOGNIZE AS DEFERRED	0.00	-447,659.18	0.00	0.00	0.00	0.00
<a href="#">559-0000-9960-0000</a>	TRANSFERS OUT	0.00	0.00	0.00	0.00	250,000.00	0.00
<b>Department: 0000 - NON-DEPARTMENTAL Surplus (Deficit):</b>		<b>196,412.00</b>	<b>0.00</b>	<b>222,714.00</b>	<b>159,021.80</b>	<b>-65,809.00</b>	<b>0.00</b>
<b>Fund: 559 - POLICE FACILITIES DEVELOPMENT Surplus (Deficit):</b>		<b>196,412.00</b>	<b>0.00</b>	<b>222,714.00</b>	<b>159,021.80</b>	<b>-65,809.00</b>	<b>0.00</b>

Defined Budgets

		2018-2019 Total Budget	2018-2019 Total Activity	2019-2020 Total Budget	2019-2020 Total Activity	2020-2021 Total Budget	2020-2021 YTD Activity
<b>Fund: 560 - FIRE STATION DEVELOPMENT</b>							
<b>Department: 0000 - NON-DEPARTMENTAL</b>							
<a href="#">560-0000-4650-0000</a>	INTEREST	0.00	0.00	0.00	23,592.91	30,206.00	0.00
<a href="#">560-0000-4915-0000</a>	FIRE STATION MITIGATION FEES	227,472.00	741,689.31	257,935.00	179,327.19	206,998.00	0.00
<a href="#">560-0000-4916-0000</a>	MITIGATION CREDITS	0.00	-25,116.63	0.00	0.00	0.00	0.00
<a href="#">560-0000-7900-0000</a>	MITIGATION FEE REFUNDS	0.00	112.71	0.00	0.00	0.00	0.00
<a href="#">560-0000-9910-0000</a>	RECOGNIZE AS DEFERRED	0.00	-716,460.06	0.00	0.00	0.00	0.00
<a href="#">560-0000-9950-0000</a>	TRANSFERS IN	0.00	0.09	0.00	0.00	0.00	0.00
<a href="#">560-0000-9960-0000</a>	TRANSFERS OUT	0.00	0.00	0.00	55,615.00	0.00	0.00
<b>Department: 0000 - NON-DEPARTMENTAL Surplus (Deficit):</b>		<b>227,472.00</b>	<b>0.00</b>	<b>257,935.00</b>	<b>147,305.10</b>	<b>237,204.00</b>	<b>0.00</b>
<b>Fund: 560 - FIRE STATION DEVELOPMENT Surplus (Deficit):</b>		<b>227,472.00</b>	<b>0.00</b>	<b>257,935.00</b>	<b>147,305.10</b>	<b>237,204.00</b>	<b>0.00</b>
<b>Fund: 562 - ROAD AND BRIDGE DEVELOPMENT</b>							
<b>Department: 0000 - NON-DEPARTMENTAL</b>							
<a href="#">562-0000-4650-0000</a>	INTEREST	0.00	0.00	0.00	84,126.06	107,236.00	0.00
<a href="#">562-0000-4915-0000</a>	ROAD AND BRIDGE MITIGATION ...	985,884.00	2,837,951.85	1,111,450.00	714,711.18	883,655.00	0.00
<a href="#">562-0000-7500-0000</a>	SETTLEMENTS	0.00	0.00	0.00	388,251.30	0.00	0.00
<a href="#">562-0000-7900-0000</a>	MITIGATION FEE REFUNDS	0.00	1,871.15	0.00	0.00	0.00	0.00
<a href="#">562-0000-7921-0000</a>	MITIGATION COST - PROJECTS	0.00	341.07	0.00	0.00	0.00	0.00
<a href="#">562-0000-9910-0000</a>	RECOGNIZE AS DEFERRED	0.00	-2,831,662.11	0.00	0.00	0.00	0.00
<a href="#">562-0000-9950-0000</a>	TRANSFERS IN	-500,000.00	-0.02	0.00	0.00	0.00	0.00
<a href="#">562-0000-9960-0000</a>	TRANSFERS OUT	0.00	4,077.50	200,000.00	56,348.72	600,000.00	0.00
<b>Department: 0000 - NON-DEPARTMENTAL Surplus (Deficit):</b>		<b>485,884.00</b>	<b>0.00</b>	<b>911,450.00</b>	<b>354,237.22</b>	<b>390,891.00</b>	<b>0.00</b>
<b>Fund: 562 - ROAD AND BRIDGE DEVELOPMENT Surplus (Deficit):</b>		<b>485,884.00</b>	<b>0.00</b>	<b>911,450.00</b>	<b>354,237.22</b>	<b>390,891.00</b>	<b>0.00</b>
<b>Fund: 564 - RECYCLED WATER DEVELOPMENT</b>							
<b>Department: 0000 - NON-DEPARTMENTAL</b>							
<a href="#">564-0000-4650-0000</a>	INTEREST	0.00	0.00	0.00	12,036.24	18,168.00	0.00
<a href="#">564-0000-4915-0000</a>	RECYCLED WATER MITIGATION F...	314,656.00	675,313.81	353,988.00	233,651.11	278,471.00	0.00
<a href="#">564-0000-9910-0000</a>	RECOGNIZE AS DEFERRED	0.00	-675,313.81	0.00	0.00	0.00	0.00
<a href="#">564-0000-9950-0000</a>	TRANSFERS IN	-50,000.00	0.00	0.00	0.00	0.00	0.00
<a href="#">564-0000-9960-0000</a>	TRANSFERS OUT	0.00	0.00	0.00	1,204,146.78	0.00	0.00
<b>Department: 0000 - NON-DEPARTMENTAL Surplus (Deficit):</b>		<b>264,656.00</b>	<b>0.00</b>	<b>353,988.00</b>	<b>-958,459.43</b>	<b>296,639.00</b>	<b>0.00</b>
<b>Fund: 564 - RECYCLED WATER DEVELOPMENT Surplus (Deficit):</b>		<b>264,656.00</b>	<b>0.00</b>	<b>353,988.00</b>	<b>-958,459.43</b>	<b>296,639.00</b>	<b>0.00</b>

Defined Budgets

		2018-2019 Total Budget	2018-2019 Total Activity	2019-2020 Total Budget	2019-2020 Total Activity	2020-2021 Total Budget	2020-2021 YTD Activity
<b>Fund: 566 - EMERGENCY PREPAREDNESS DEVELOPMENT</b>							
<b>Department: 0000 - NON-DEPARTMENTAL</b>							
<a href="#">566-0000-4915-0000</a>	EMERGENCY PREPARED MITIGAT...	291,852.00	1,056,153.34	353,988.00	231,227.21	258,289.00	0.00
<a href="#">566-0000-7900-0000</a>	MITIGATION FEE REFUNDS	0.00	140.80	0.00	0.00	0.00	0.00
<a href="#">566-0000-9910-0000</a>	RECOGNIZE AS DEFERRED	0.00	-1,056,012.54	0.00	0.00	0.00	0.00
<b>Department: 0000 - NON-DEPARTMENTAL Surplus (Deficit):</b>		<b>291,852.00</b>	<b>0.00</b>	<b>353,988.00</b>	<b>231,227.21</b>	<b>258,289.00</b>	<b>0.00</b>
<b>Fund: 566 - EMERGENCY PREPAREDNESS DEVELOPMENT Surplus (Deficit):</b>		<b>291,852.00</b>	<b>0.00</b>	<b>353,988.00</b>	<b>231,227.21</b>	<b>258,289.00</b>	<b>0.00</b>
<b>Fund: 567 - COMMUNITY PARK DEVELOPMENT</b>							
<b>Department: 0000 - NON-DEPARTMENTAL</b>							
<a href="#">567-0000-4650-0000</a>	INTEREST	0.00	0.00	0.00	3,630.49	4,481.00	0.00
<a href="#">567-0000-4915-0000</a>	COMMUNITY PARKS MITIGATION..	939,828.00	1,788,401.77	1,061,707.00	697,136.66	247,986.00	0.00
<a href="#">567-0000-4916-0000</a>	MITIGATION CREDITS	0.00	0.00	0.00	-30,998.24	0.00	0.00
<a href="#">567-0000-7900-0000</a>	MITIGATION FEE REFUNDS	0.00	197,363.88	0.00	517,629.12	0.00	0.00
<a href="#">567-0000-9910-0000</a>	RECOGNIZE AS DEFERRED	0.00	-1,591,037.89	0.00	0.00	0.00	0.00
<a href="#">567-0000-9960-0000</a>	TRANSFERS OUT	0.00	0.00	0.00	0.00	1,145,000.00	0.00
<b>Department: 0000 - NON-DEPARTMENTAL Surplus (Deficit):</b>		<b>939,828.00</b>	<b>0.00</b>	<b>1,061,707.00</b>	<b>152,139.79</b>	<b>-892,533.00</b>	<b>0.00</b>
<b>Fund: 567 - COMMUNITY PARK DEVELOPMENT Surplus (Deficit):</b>		<b>939,828.00</b>	<b>0.00</b>	<b>1,061,707.00</b>	<b>152,139.79</b>	<b>-892,533.00</b>	<b>0.00</b>
<b>Fund: 568 - REGIONAL PARK DEVELOPMENT</b>							
<b>Department: 0000 - NON-DEPARTMENTAL</b>							
<a href="#">568-0000-4650-0000</a>	INTEREST	0.00	0.00	0.00	10,412.82	0.00	0.00
<a href="#">568-0000-9960-0000</a>	TRANSFERS OUT	0.00	0.00	0.00	0.00	1,900,000.00	0.00
<b>Department: 0000 - NON-DEPARTMENTAL Surplus (Deficit):</b>		<b>0.00</b>	<b>0.00</b>	<b>0.00</b>	<b>10,412.82</b>	<b>-1,900,000.00</b>	<b>0.00</b>
<b>Fund: 568 - REGIONAL PARK DEVELOPMENT Surplus (Deficit):</b>		<b>0.00</b>	<b>0.00</b>	<b>0.00</b>	<b>10,412.82</b>	<b>-1,900,000.00</b>	<b>0.00</b>
<b>Fund: 569 - NEIGHBORHOOLD PARK DEVELOPMENT</b>							
<b>Department: 0000 - NON-DEPARTMENTAL</b>							
<a href="#">569-0000-4650-0000</a>	INTEREST	0.00	0.00	0.00	4,395.94	5,425.00	0.00
<a href="#">569-0000-4915-0000</a>	NEIGHBORHOOD PARK MITIGAT...	1,137,348.00	2,164,264.80	1,284,844.00	844,280.62	300,104.00	0.00
<a href="#">569-0000-4916-0000</a>	MITIGATION CREDITS	0.00	0.00	0.00	-37,513.06	0.00	0.00
<a href="#">569-0000-7900-0000</a>	MITIGATION FEE REFUNDS	0.00	238,843.08	0.00	626,417.56	0.00	0.00
<a href="#">569-0000-9910-0000</a>	RECOGNIZE AS DEFERRED	0.00	-1,925,421.72	0.00	0.00	0.00	0.00
<a href="#">569-0000-9960-0000</a>	TRANSFERS OUT	0.00	0.00	0.00	0.00	1,350,000.00	0.00
<b>Department: 0000 - NON-DEPARTMENTAL Surplus (Deficit):</b>		<b>1,137,348.00</b>	<b>0.00</b>	<b>1,284,844.00</b>	<b>184,745.94</b>	<b>-1,044,471.00</b>	<b>0.00</b>
<b>Fund: 569 - NEIGHBORHOOLD PARK DEVELOPMENT Surplus (Deficit):</b>		<b>1,137,348.00</b>	<b>0.00</b>	<b>1,284,844.00</b>	<b>184,745.94</b>	<b>-1,044,471.00</b>	<b>0.00</b>



Budget Worksheet

Defined Budgets

		2018-2019 Total Budget	2018-2019 Total Activity	2019-2020 Total Budget	2019-2020 Total Activity	2020-2021 Total Budget	2020-2021 YTD Activity
<b>Fund: 570 - DIF PASS THROUGH FUNDS</b>							
<b>Department: 0000 - NON-DEPARTMENTAL</b>							
<a href="#">570-0000-4650-0000</a>	INTEREST	0.00	0.00	0.00	37,762.35	0.00	0.00
<b>Department: 0000 - NON-DEPARTMENTAL Total:</b>		<b>0.00</b>	<b>0.00</b>	<b>0.00</b>	<b>37,762.35</b>	<b>0.00</b>	<b>0.00</b>
<b>Fund: 570 - DIF PASS THROUGH FUNDS Total:</b>		<b>0.00</b>	<b>0.00</b>	<b>0.00</b>	<b>37,762.35</b>	<b>0.00</b>	<b>0.00</b>
<b>Fund: 700 - WASTEWATER FUND</b>							
<b>Department: 0000 - NON-DEPARTMENTAL</b>							
<a href="#">700-0000-4641-0000</a>	GENERAL FINES	9,000.00	9,000.00	0.00	1,000.00	0.00	0.00
<a href="#">700-0000-4650-0000</a>	INTEREST	33,000.00	118,335.17	75,000.00	40,158.22	37,500.00	0.00
<a href="#">700-0000-4685-0001</a>	COST RECOVERY	0.00	0.00	0.00	6,236.10	6,300.00	0.00
<a href="#">700-0000-4750-0000</a>	SEWER SERVICE FEES	8,800,000.00	8,779,252.24	9,851,375.00	8,406,572.58	10,833,000.00	0.00
<a href="#">700-0000-4752-0000</a>	SEWER PERMITS/APPL.FEES	18,000.00	20,891.98	11,250.00	7,235.02	16,000.00	0.00
<a href="#">700-0000-4760-0000</a>	SEWER STAND-BY FEE	2,774.00	2,773.45	0.00	0.00	0.00	0.00
<a href="#">700-0000-4825-0000</a>	MISCELLANEOUS REVENUE	831.00	830.88	0.00	780.00	0.00	0.00
<a href="#">700-0000-4850-0000</a>	SALE OF PROPERTY	635.00	635.00	0.00	0.00	0.00	0.00
<a href="#">700-0000-6040-0000</a>	GASB 68 PENSION ADJMT	0.00	17,852.00	0.00	0.00	0.00	0.00
<a href="#">700-0000-9950-0000</a>	TRANSFERS IN	0.00	221,046.64	0.00	0.00	0.00	0.00
<a href="#">700-0000-9960-0000</a>	TRANSFERS OUT	0.00	100,000.00	4,732,325.64	3,858,375.12	4,991,787.00	0.00
<a href="#">700-0000-9961-0000</a>	TRANSFER OUT - OVERHEAD	0.00	0.00	0.00	0.00	650,000.00	0.00
<b>Department: 0000 - NON-DEPARTMENTAL Surplus (Deficit):</b>		<b>8,864,240.00</b>	<b>9,034,913.36</b>	<b>5,205,299.36</b>	<b>4,603,606.80</b>	<b>5,251,013.00</b>	<b>0.00</b>
<b>Department: 4050 - SEWER OPERATIONS</b>							
<a href="#">700-4050-6010-0000</a>	SALARIES	614,497.00	566,575.87	1,208,132.00	801,919.32	1,040,186.00	0.00
<a href="#">700-4050-6011-0000</a>	ADMIN TIME	0.00	2,971.11	0.00	3,644.58	0.00	0.00
<a href="#">700-4050-6012-0000</a>	OVERTIME	5,250.00	22,275.44	66,834.00	18,764.92	117,593.00	0.00
<a href="#">700-4050-6013-0000</a>	SICK LEAVE	0.00	17,953.16	0.00	9,555.04	0.00	0.00
<a href="#">700-4050-6014-0000</a>	HOLIDAY	0.00	32,851.14	0.00	57,025.38	0.00	0.00
<a href="#">700-4050-6015-0000</a>	VACATION	0.00	47,179.23	0.00	19,685.98	0.00	0.00
<a href="#">700-4050-6016-0000</a>	ACCRUED TIME CASH OUT	14,504.00	1,014.99	33,890.00	21,389.50	37,056.00	0.00
<a href="#">700-4050-6018-0000</a>	OTHER COMPENSATION	0.00	11,633.40	4,500.00	20,425.28	3,600.00	0.00
<a href="#">700-4050-6019-0000</a>	FIRST AID	0.00	169.00	0.00	534.50	0.00	0.00
<a href="#">700-4050-6020-0000</a>	HEALTH INSURANCE	83,500.00	74,643.43	248,100.00	87,265.22	152,199.00	0.00
<a href="#">700-4050-6021-0000</a>	DENTAL INSURANCE	0.00	1,697.09	0.00	2,770.94	0.00	0.00

Budget Worksheet

Defined Budgets

		2018-2019 Total Budget	2018-2019 Total Activity	2019-2020 Total Budget	2019-2020 Total Activity	2020-2021 Total Budget	2020-2021 YTD Activity
<a href="#">700-4050-6022-0000</a>	WORKERS COMP	50,300.00	17,471.18	51,687.00	18,183.00	50,075.00	0.00
<a href="#">700-4050-6023-0000</a>	DISABILITY	4,602.00	3,957.28	6,575.00	4,545.30	5,523.00	0.00
<a href="#">700-4050-6024-0000</a>	P.E.R.S./P.E.P.R.A.	148,000.00	124,611.83	236,073.00	149,022.79	238,165.00	0.00
<a href="#">700-4050-6026-0000</a>	DEFERRED COMP	0.00	4,769.28	0.00	11,940.48	0.00	0.00
<a href="#">700-4050-6027-0000</a>	VISION CARE	0.00	344.75	0.00	723.45	0.00	0.00
<a href="#">700-4050-6028-0000</a>	LIFE INSURANCE	882.00	588.00	1,050.00	607.19	882.00	0.00
<a href="#">700-4050-6030-0000</a>	CAR ALLOWANCE	0.00	367.50	0.00	1,575.00	2,100.00	0.00
<a href="#">700-4050-6034-0000</a>	MEDICARE	11,229.00	9,294.03	16,396.00	13,661.01	15,974.00	0.00
<a href="#">700-4050-6036-0000</a>	UNIFORMS	0.00	628.26	20,982.00	1,613.76	0.00	0.00
<a href="#">700-4050-6050-0000</a>	RECRUITMENT AND HIRING COS...	0.00	1,044.00	1,150.00	0.00	0.00	0.00
<a href="#">700-4050-7001-0000</a>	ADMIN OVERHEAD	612,000.00	612,000.00	650,000.00	487,500.00	0.00	0.00
<a href="#">700-4050-7010-0000</a>	UTILITIES	960,000.00	770,179.29	819,450.00	713,611.24	819,653.00	0.00
<a href="#">700-4050-7010-019C</a>	UTILITIES (IA 19C)	0.00	101.10	0.00	171.62	0.00	0.00
<a href="#">700-4050-7015-0000</a>	TELEPHONE	6,080.00	5,834.61	8,168.00	5,978.03	8,168.00	0.00
<a href="#">700-4050-7020-0000</a>	ADVERTISING	2,000.00	107.10	800.00	70.20	600.00	0.00
<a href="#">700-4050-7022-0000</a>	LICENSE, PERMITS, FEES	0.00	61,906.52	51,592.58	70,397.65	251,398.00	0.00
<a href="#">700-4050-7022-002X</a>	LICENSE, PERMITS, FEES	0.00	1,513.56	1,665.00	1,399.42	1,660.00	0.00
<a href="#">700-4050-7022-003X</a>	LICENSE, PERMITS, FEES	0.00	2,058.41	1,665.00	1,399.42	1,660.00	0.00
<a href="#">700-4050-7022-005X</a>	LICENSE, PERMITS, FEES - IA 5	0.00	1,368.23	1,665.00	1,105.00	1,660.00	0.00
<a href="#">700-4050-7022-007A</a>	LICENSE, PERMITS, FEES	0.00	1,782.83	1,680.00	1,662.42	1,660.00	0.00
<a href="#">700-4050-7022-019A</a>	FEES LICENSE PERMITS	0.00	25.08	0.00	0.00	0.00	0.00
<a href="#">700-4050-7022-019C</a>	LICENSE, PERMITS, FEES	0.00	2,222.76	2,804.00	2,526.04	3,320.00	0.00
<a href="#">700-4050-7022-06A1</a>	LICENSE, PERMITS, FEES	0.00	848.27	1,402.00	1,399.42	1,660.00	0.00
<a href="#">700-4050-7025-0000</a>	OFFICE SUPPLIES	1,080.00	607.00	5,610.00	1,328.11	5,610.00	0.00
<a href="#">700-4050-7027-0000</a>	HEALTH/FITNESS	100.00	162.48	8,775.00	1,265.36	1,500.00	0.00
<a href="#">700-4050-7030-0000</a>	DUES & SUBSCRIPTIONS	200.00	560.00	9,554.60	12,466.60	16,639.00	0.00
<a href="#">700-4050-7037-0000</a>	VEHICLE MAINTENANCE	3,000.00	1,190.37	7,700.00	8,558.64	8,200.00	0.00
<a href="#">700-4050-7050-0000</a>	FUEL	15,000.00	14,631.78	29,180.00	14,252.90	23,780.00	0.00
<a href="#">700-4050-7053-0000</a>	PERMITS, FEES AND LICENSES	107,885.00	30,274.33	0.00	0.00	0.00	0.00
<a href="#">700-4050-7065-0000</a>	UNIFORMS	6,000.00	4,823.87	2,816.00	4,038.57	4,469.00	0.00
<a href="#">700-4050-7066-0000</a>	TRAVEL, EDUCATION, TRAINING	5,500.00	5,930.67	9,800.00	1,390.25	0.00	0.00

Budget Worksheet

Defined Budgets

		2018-2019 Total Budget	2018-2019 Total Activity	2019-2020 Total Budget	2019-2020 Total Activity	2020-2021 Total Budget	2020-2021 YTD Activity
<a href="#">700-4050-7068-0000</a>	CONTRACTUAL SERVICES	1,938,000.00	1,374,155.76	1,147,140.00	691,700.78	1,062,563.00	0.00
<a href="#">700-4050-7068-002X</a>	CONTRACTUAL SERVICES - IA 2	0.00	2,833.88	0.00	0.00	0.00	0.00
<a href="#">700-4050-7070-0000</a>	SPECIAL DEPT SUPPLIES	300,000.00	275,363.58	316,000.00	159,671.01	374,000.00	0.00
<a href="#">700-4050-7070-019C</a>	SPECIAL DEPT SUPPLIES - LIFT ST...	0.00	868.24	0.00	0.00	0.00	0.00
<a href="#">700-4050-7071-0000</a>	SOFTWARE	21,200.00	2,460.65	52,500.00	0.00	6,895.00	0.00
<a href="#">700-4050-7072-0000</a>	COMPUTER SUPPLIES/MAINT	1,400.00	3,176.43	3,000.00	0.00	3,000.00	0.00
<a href="#">700-4050-7072-019C</a>	COMPUTER SUPPLIES/MAINT (IA...	0.00	161.61	0.00	0.00	0.00	0.00
<a href="#">700-4050-7075-0000</a>	EQUIPMENT LEASING/RENTAL	52,000.00	21,730.47	68,519.00	19,505.81	63,650.00	0.00
<a href="#">700-4050-7085-0000</a>	BUILDING SUPPLIES/MAINT	1,000.00	0.00	0.00	532.85	1,800.00	0.00
<a href="#">700-4050-7087-0000</a>	SECURITY SERVICES	8,000.00	171.00	0.00	454.95	718.00	0.00
<a href="#">700-4050-7087-005X</a>	SECURITY SERVICES	0.00	3,450.00	3,450.00	3,288.50	3,618.00	0.00
<a href="#">700-4050-7087-007A</a>	SECURITY SERVICES	0.00	2,052.00	2,052.00	1,957.95	2,154.00	0.00
<a href="#">700-4050-7089-0000</a>	BRINE LINE MAINTENANCE	78,570.00	78,566.40	156,010.00	82,493.40	414,987.00	0.00
<a href="#">700-4050-7090-0000</a>	EQUIPMENT SUPPLIES/MAINT	49,345.00	19,993.34	7,500.00	36,421.35	49,000.00	0.00
<a href="#">700-4050-7090-002X</a>	EQUIPMENT SUPPLIES/MAINT (IA...	0.00	8,677.95	7,500.00	2,852.76	0.00	0.00
<a href="#">700-4050-7090-003X</a>	EQUIPMENT SUPPLIES/MAINT (IA...	0.00	1,557.00	7,500.00	750.00	0.00	0.00
<a href="#">700-4050-7090-005X</a>	EQUIPMENT SUPPLIES/MAINT (IA...	0.00	32,443.63	7,500.00	0.00	0.00	0.00
<a href="#">700-4050-7090-007A</a>	EQUIPMENT SUPPLIES/MAINT (IA...	0.00	2,621.49	7,500.00	1,095.00	0.00	0.00
<a href="#">700-4050-7090-019C</a>	EQUIPMENT SUPPLIES/MAINT (IA...	0.00	2,778.45	7,500.00	1,095.00	0.00	0.00
<a href="#">700-4050-7090-06A1</a>	EQUIPMENT SUPPLIES/MAINT (IA...	0.00	1,074.88	7,500.00	750.00	0.00	0.00
<a href="#">700-4050-7090-6026</a>	EQUIPMENT SUPPLIES/MAINT	0.00	440.88	7,500.00	223.05	0.00	0.00
<a href="#">700-4050-7900-0000</a>	CONTINGENCY	0.00	0.00	500,000.00	0.00	300,000.00	0.00
<a href="#">700-4050-8040-0000</a>	EQUIPMENT	89,750.00	-4,672.14	10,000.00	363,122.70	153,638.00	0.00
<a href="#">700-4050-8040-002X</a>	EQUIPMENT - IA 2	0.00	11,163.00	0.00	0.00	0.00	0.00
<a href="#">700-4050-8040-06A1</a>	EQUIPMENT	0.00	0.00	0.00	19,522.61	0.00	0.00
<b>Department: 4050 - SEWER OPERATIONS Total:</b>		<b>5,190,874.00</b>	<b>4,301,236.73</b>	<b>5,828,367.18</b>	<b>3,960,811.25</b>	<b>5,251,013.00</b>	<b>0.00</b>
<b>Fund: 700 - WASTEWATER FUND Surplus (Deficit):</b>		<b>3,673,366.00</b>	<b>4,733,676.63</b>	<b>-623,067.82</b>	<b>642,795.55</b>	<b>0.00</b>	<b>0.00</b>
<b>Fund: 705 - WASTEWATER DEVELOPMENT</b>							
<b>Department: 0000 - NON-DEPARTMENTAL</b>							
<a href="#">705-0000-4650-0000</a>	INTEREST	0.00	0.00	15,000.00	10,432.17	102,242.00	0.00
<a href="#">705-0000-7500-0000</a>	SETTLEMENTS	0.00	0.00	0.00	63,185.00	0.00	0.00

Defined Budgets

		2018-2019 Total Budget	2018-2019 Total Activity	2019-2020 Total Budget	2019-2020 Total Activity	2020-2021 Total Budget	2020-2021 YTD Activity
<a href="#">705-0000-9910-0000</a>	RECOGNIZED FROM DEFERRED	0.00	-3,685,089.20	0.00	0.00	0.00	0.00
<a href="#">705-0000-9950-0000</a>	TRANSFERS IN	-300,000.00	119,943.12	0.00	0.00	0.00	0.00
<a href="#">705-0000-9960-0000</a>	TRANSFERS OUT	0.00	0.00	1,119,971.00	1,837,940.47	282,000.00	0.00
<b>Department: 0000 - NON-DEPARTMENTAL Surplus (Deficit):</b>		<b>-300,000.00</b>	<b>-3,565,146.08</b>	<b>-1,104,971.00</b>	<b>-1,890,693.30</b>	<b>-179,758.00</b>	<b>0.00</b>
<b>Department: 6005 - CAPACITY FEES</b>							
<a href="#">705-6005-4915-0000</a>	MITIGATION FEES (CAPACITY)	2,050,000.00	3,626,710.00	2,398,500.00	1,743,717.46	1,935,877.00	0.00
<a href="#">705-6005-4916-0000</a>	MITIGATION CREDITS (CAPACITY)	0.00	-38,611.00	0.00	0.00	0.00	0.00
<a href="#">705-6005-7900-0000</a>	MITIGATION FEE REFUNDS	0.00	140,555.82	0.00	0.00	0.00	0.00
<b>Department: 6005 - CAPACITY FEES Surplus (Deficit):</b>		<b>2,050,000.00</b>	<b>3,447,543.18</b>	<b>2,398,500.00</b>	<b>1,743,717.46</b>	<b>1,935,877.00</b>	<b>0.00</b>
<b>Department: 6015 - UPPER POTRERO</b>							
<a href="#">705-6015-4915-0000</a>	MITIGATION FEES (UPPER POTR...	0.00	85,564.40	0.00	41,775.56	0.00	0.00
<a href="#">705-6015-4916-0000</a>	MITIGATION CREDITS (UPPER PO...	0.00	-85,564.40	0.00	-41,775.56	0.00	0.00
<b>Department: 6015 - UPPER POTRERO Total:</b>		<b>0.00</b>	<b>0.00</b>	<b>0.00</b>	<b>0.00</b>	<b>0.00</b>	<b>0.00</b>
<b>Department: 6020 - LOWER POTRERO</b>							
<a href="#">705-6020-4915-0000</a>	MITIGATION FEES (LOWER POTR...	0.00	114,116.54	24,600.00	40,861.19	0.00	0.00
<a href="#">705-6020-4916-0000</a>	MITIGATION CREDITS (LOWER P...	0.00	-73,628.14	0.00	-29,037.44	0.00	0.00
<b>Department: 6020 - LOWER POTRERO Total:</b>		<b>0.00</b>	<b>40,488.40</b>	<b>24,600.00</b>	<b>11,823.75</b>	<b>0.00</b>	<b>0.00</b>
<b>Department: 6025 - SAN TIMOTEO NO-2 (LOWER OAK VALLEY)</b>							
<a href="#">705-6025-4915-0000</a>	MITIGATION FEES (SAN TIM #2 - ...	0.00	43,848.20	0.00	0.00	0.00	0.00
<a href="#">705-6025-4916-0000</a>	MITIGATION CREDITS (SAN TIM ...	0.00	-43,848.20	0.00	0.00	0.00	0.00
<b>Department: 6025 - SAN TIMOTEO NO-2 (LOWER OAK VALLEY) Total:</b>		<b>0.00</b>	<b>0.00</b>	<b>0.00</b>	<b>0.00</b>	<b>0.00</b>	<b>0.00</b>
<b>Department: 6026 - SAN TIMOTEO NO-3 (BEAUMONT MESA)</b>							
<a href="#">705-6026-4915-0000</a>	MITIGATION FEES (SAN TIM #3 - ...	0.00	24,435.94	12,097.00	16,693.86	60,485.00	0.00
<a href="#">705-6026-4916-0000</a>	MITIGATION CREDITS (SAN TIM ...	0.00	-10,645.36	0.00	0.00	0.00	0.00
<b>Department: 6026 - SAN TIMOTEO NO-3 (BEAUMONT MESA) Total:</b>		<b>0.00</b>	<b>13,790.58</b>	<b>12,097.00</b>	<b>16,693.86</b>	<b>60,485.00</b>	<b>0.00</b>
<b>Department: 6030 - SOUTHERN TRUNK MAIN</b>							
<a href="#">705-6030-4915-0000</a>	MITIGATION FEES (SOUTHERN T...	0.00	55,826.91	6,760.00	23,351.04	0.00	0.00
<a href="#">705-6030-4916-0000</a>	MITIGATION CREDITS (SO TRUNK)	0.00	-47,509.05	0.00	-21,185.25	0.00	0.00
<b>Department: 6030 - SOUTHERN TRUNK MAIN Total:</b>		<b>0.00</b>	<b>8,317.86</b>	<b>6,760.00</b>	<b>2,165.79</b>	<b>0.00</b>	<b>0.00</b>

Budget Worksheet

Defined Budgets

		2018-2019 Total Budget	2018-2019 Total Activity	2019-2020 Total Budget	2019-2020 Total Activity	2020-2021 Total Budget	2020-2021 YTD Activity
<b>Department: 6065 - WILLOW SPRINGS</b>							
<a href="#">705-6065-4915-0000</a>	MITIGATION FEES (WILLOW SPR...	0.00	55,006.06	0.00	0.00	0.00	0.00
<b>Department: 6065 - WILLOW SPRINGS Total:</b>		<b>0.00</b>	<b>55,006.06</b>	<b>0.00</b>	<b>0.00</b>	<b>0.00</b>	<b>0.00</b>
<b>Fund: 705 - WASTEWATER DEVELOPMENT Surplus (Deficit):</b>		<b>1,750,000.00</b>	<b>0.00</b>	<b>1,336,986.00</b>	<b>-116,292.44</b>	<b>1,816,604.00</b>	<b>0.00</b>
<b>Fund: 710 - WASTEWATER CAPITAL PROJECTS</b>							
<b>Department: 0000 - NON-DEPARTMENTAL</b>							
<a href="#">710-0000-4650-0000</a>	INTEREST	0.00	1,443,101.29	0.00	474,726.07	0.00	0.00
<a href="#">710-0000-4695-0000</a>	DEVELOPER CONTRIBUTIONS	0.00	731,125.00	0.00	0.00	0.00	0.00
<a href="#">710-0000-4700-0000</a>	BOND PROCEEDS	90,000,000.00	0.00	0.00	0.00	0.00	0.00
<a href="#">710-0000-4851-0000</a>	GAIN/(LOSS) ON SALE OF ASSETS	0.00	1,135.00	0.00	0.00	0.00	0.00
<a href="#">710-0000-7051-0000</a>	TRUSTEE FEES	0.00	3,500.00	0.00	2,000.00	0.00	0.00
<a href="#">710-0000-7055-0000</a>	INTEREST AND PENALTIES	0.00	2,740,829.87	0.00	2,581,160.67	3,828,788.00	0.00
<a href="#">710-0000-7068-0000</a>	CONTRACTUAL SERVICE	3,150,000.00	5,000.00	0.00	2,591,215.73	0.00	0.00
<a href="#">710-0000-7079-0000</a>	DEPRECIATION	0.00	7,005,273.20	0.00	0.00	0.00	0.00
<a href="#">710-0000-8030-0000</a>	CAPITAL IMPROVEMENT	86,655,000.00	5,289.44	790,000.00	37,952,835.15	200,000.00	0.00
<a href="#">710-0000-8035-0000</a>	SEWER LINE REPAIRS	250,000.00	0.00	0.00	0.00	0.00	0.00
<a href="#">710-0000-8040-0000</a>	EQUIPMENT	120,000.00	0.00	18,167.00	0.00	0.00	0.00
<a href="#">710-0000-8060-0000</a>	VEHICLES	175,000.00	0.00	203,637.64	112,274.10	0.00	0.00
<a href="#">710-0000-8900-0000</a>	DEBT SERVICE	0.00	0.00	4,858,659.00	0.00	1,245,000.00	0.00
<a href="#">710-0000-8950-0000</a>	COST OF ISSUANCE	0.00	794,969.15	0.00	0.00	0.00	0.00
<a href="#">710-0000-9950-0000</a>	TRANSFERS IN	350,000.00	3,239,547.00	5,870,463.64	6,900,462.37	5,273,788.00	0.00
<a href="#">710-0000-9960-0000</a>	TRANSFERS OUT	0.00	340,989.76	0.00	0.00	0.00	0.00
<b>Department: 0000 - NON-DEPARTMENTAL Surplus (Deficit):</b>		<b>0.00</b>	<b>-5,480,943.13</b>	<b>0.00</b>	<b>-35,864,297.21</b>	<b>0.00</b>	<b>0.00</b>
<b>Fund: 710 - WASTEWATER CAPITAL PROJECTS Surplus (Deficit):</b>		<b>0.00</b>	<b>-5,480,943.13</b>	<b>0.00</b>	<b>-35,864,297.21</b>	<b>0.00</b>	<b>0.00</b>
<b>Fund: 750 - TRANSIT FUND</b>							
<b>Department: 0000 - NON-DEPARTMENTAL</b>							
<a href="#">750-0000-4476-1016</a>	LCTOP GRANT	0.00	131,490.62	16,899.00	0.00	93,346.00	0.00
<a href="#">750-0000-4650-0000</a>	INTEREST	4,000.00	2,783.56	6,200.00	3,886.28	1,000.00	0.00
<a href="#">750-0000-4670-0000</a>	ARTICLE 4 - TRANSIT	2,498,881.00	2,379,982.00	2,735,230.00	2,320,802.00	2,776,096.00	0.00
<a href="#">750-0000-4671-0000</a>	ROUTE 2 FAREBOX	0.00	372.32	27,750.00	9,389.14	26,800.00	0.00
<a href="#">750-0000-4673-0000</a>	ROUTE 3 FAREBOX	0.00	41.92	40,700.00	13,082.35	28,000.00	0.00
<a href="#">750-0000-4674-0000</a>	ROUTE 4 FAREBOX	0.00	33.69	40,700.00	13,082.52	24,285.00	0.00

Budget Worksheet

Defined Budgets

		2018-2019 Total Budget	2018-2019 Total Activity	2019-2020 Total Budget	2019-2020 Total Activity	2020-2021 Total Budget	2020-2021 YTD Activity
<a href="#">750-0000-4675-0000</a>	ROUTE 3/4 FAREBOX	0.00	26.40	9,250.00	2,860.79	9,515.00	0.00
<a href="#">750-0000-4677-0000</a>	ROUTE 7 FAREBOX	0.00	6.05	40,700.00	13,017.26	33,000.00	0.00
<a href="#">750-0000-4678-0000</a>	ROUTE 9 FAREBOX	0.00	0.00	16,650.00	5,381.93	12,000.00	0.00
<a href="#">750-0000-4679-0000</a>	RTA BUS PASSES	300.00	855.00	0.00	345.00	0.00	0.00
<a href="#">750-0000-4680-0000</a>	ROUTE 120 FAREBOX	27,050.00	18,368.91	59,860.00	30,556.88	48,342.00	0.00
<a href="#">750-0000-4681-0000</a>	ROUTE 136 FAREBOX	0.00	106.84	0.00	0.00	0.00	0.00
<a href="#">750-0000-4682-0000</a>	DIAL-A-RIDE BUS PASSES	5,544.00	12,865.00	0.00	6,813.50	0.00	0.00
<a href="#">750-0000-4683-0000</a>	ROUTE 125 FAREBOX	0.00	3,197.69	13,140.00	6,608.48	12,000.00	0.00
<a href="#">750-0000-4684-0000</a>	FIXED ROUTE BUS PASSES	45,100.00	33,400.98	0.00	38,332.19	0.00	0.00
<a href="#">750-0000-4686-0000</a>	CHARGES FOR SERVICES	1,100.00	0.00	0.00	0.00	0.00	0.00
<a href="#">750-0000-4691-0000</a>	DAR - FAREBOX	8,650.00	7,295.78	23,000.00	4,293.78	20,000.00	0.00
<a href="#">750-0000-4692-0000</a>	FIXED ROUTE FAREBOX	124,525.00	93,482.13	9,250.00	3,059.59	0.00	0.00
<a href="#">750-0000-4693-0000</a>	INSURANCE RECOVERY	0.00	2,408.45	0.00	-2,408.45	0.00	0.00
<a href="#">750-0000-4698-000A</a>	CLIENT TRANSPORTATION CHAR...	6,610.00	0.00	0.00	0.00	0.00	0.00
<a href="#">750-0000-4699-0000</a>	OTHER INCOME	100.00	153.70	0.00	728.50	0.00	0.00
<a href="#">750-0000-4730-0000</a>	TOKEN - GENERAL BASE	0.00	1,190.30	0.00	2,005.80	0.00	0.00
<a href="#">750-0000-4731-0000</a>	TOKEN - DAILY	0.00	454.65	0.00	552.70	0.00	0.00
<a href="#">750-0000-4732-0000</a>	TOKEN - 10 DAY RIDE	0.00	3,157.35	0.00	5,919.40	0.00	0.00
<a href="#">750-0000-4733-0000</a>	TOKEN - MONTHLY	0.00	5,673.00	0.00	8,834.92	0.00	0.00
<a href="#">750-0000-4734-0000</a>	TOKEN - COMMUTER	0.00	1,192.00	0.00	4,598.27	0.00	0.00
<a href="#">750-0000-4850-0000</a>	SALE OF PROPERTY	0.00	4,168.75	0.00	30.00	0.00	0.00
<a href="#">750-0000-9950-0000</a>	TRANSFERS IN	0.00	321.66	0.00	0.00	0.00	0.00
<a href="#">750-0000-9960-0000</a>	TRANSFERS OUT	0.00	18,906.00	0.00	0.00	0.00	0.00
<b>Department: 0000 - NON-DEPARTMENTAL Surplus (Deficit):</b>		<b>2,721,860.00</b>	<b>2,684,122.75</b>	<b>3,039,329.00</b>	<b>2,491,772.83</b>	<b>3,084,384.00</b>	<b>0.00</b>
<b>Department: 7000 - TRANSIT ADMINISTRATION</b>							
<a href="#">750-7000-6010-0000</a>	SALARIES	343,267.00	287,734.46	224,208.00	140,122.61	112,539.00	0.00
<a href="#">750-7000-6011-0000</a>	ADMIN TIME	0.00	3,952.19	0.00	1,036.95	0.00	0.00
<a href="#">750-7000-6012-0000</a>	OVERTIME	1,000.00	1,701.22	750.00	119.45	625.00	0.00
<a href="#">750-7000-6013-0000</a>	SICK LEAVE	0.00	17,671.20	0.00	19,916.04	0.00	0.00
<a href="#">750-7000-6014-0000</a>	HOLIDAY	0.00	20,563.97	0.00	18,530.32	0.00	0.00
<a href="#">750-7000-6015-0000</a>	VACATION	0.00	22,520.52	0.00	29,738.91	0.00	0.00

Budget Worksheet

Defined Budgets

		2018-2019 Total Budget	2018-2019 Total Activity	2019-2020 Total Budget	2019-2020 Total Activity	2020-2021 Total Budget	2020-2021 YTD Activity
<a href="#">750-7000-6016-0000</a>	ACCRUED TIME CASH OUT	6,214.00	4,470.10	8,164.00	1,029.08	2,686.00	0.00
<a href="#">750-7000-6018-0000</a>	OTHER COMPENSATION	150.00	0.00	2,700.00	0.00	0.00	0.00
<a href="#">750-7000-6019-0000</a>	FIRST AID	200.00	0.00	500.00	374.50	0.00	0.00
<a href="#">750-7000-6020-0000</a>	HEALTH INSURANCE	72,000.00	56,787.87	58,950.00	36,022.20	20,469.00	0.00
<a href="#">750-7000-6021-0000</a>	DENTAL INSURANCE	0.00	487.17	0.00	1,687.88	0.00	0.00
<a href="#">750-7000-6022-0000</a>	WORKERS COMP	22,312.00	9,147.32	11,685.00	7,670.65	5,107.00	0.00
<a href="#">750-7000-6023-0000</a>	DISABILITY	2,104.00	2,105.47	1,578.00	1,767.09	658.00	0.00
<a href="#">750-7000-6024-0000</a>	P.E.R.S./P.E.P.R.A.	53,348.00	65,784.22	39,605.00	26,393.01	20,504.00	0.00
<a href="#">750-7000-6025-0000</a>	UNEMPLOYMENT	0.00	3,447.00	0.00	764.00	0.00	0.00
<a href="#">750-7000-6027-0000</a>	VISION CARE	0.00	231.31	0.00	359.75	0.00	0.00
<a href="#">750-7000-6028-0000</a>	LIFE INSURANCE	336.00	315.00	252.00	313.33	105.00	0.00
<a href="#">750-7000-6030-0000</a>	CAR ALLOWANCE	0.00	4,200.00	0.00	2,038.75	1,050.00	0.00
<a href="#">750-7000-6034-0000</a>	MEDICARE	5,082.00	5,219.47	3,502.00	3,084.24	1,520.00	0.00
<a href="#">750-7000-6050-0000</a>	RECRUITMENT AND HIRING COS...	250.00	57.00	500.00	0.00	0.00	0.00
<a href="#">750-7000-7001-0000</a>	ADMIN OVERHEAD	100,000.00	100,000.00	100,000.00	75,000.00	0.00	0.00
<a href="#">750-7000-7010-0000</a>	UTILITIES	1,750.00	3,118.86	1,750.00	1,367.65	1,000.00	0.00
<a href="#">750-7000-7015-0000</a>	TELEPHONE	7,700.00	8,191.96	6,000.00	11,216.06	6,000.00	0.00
<a href="#">750-7000-7020-0000</a>	ADVERTISING	100.00	116.80	300.00	124.10	0.00	0.00
<a href="#">750-7000-7022-0000</a>	LICENSE, PERMITS, FEES	0.00	472.68	500.00	0.00	0.00	0.00
<a href="#">750-7000-7025-0000</a>	OFFICE SUPPLIES	4,000.00	3,349.53	1,700.00	2,782.35	1,000.00	0.00
<a href="#">750-7000-7027-0000</a>	HEALTH/FITNESS	0.00	1,049.91	1,950.00	419.98	0.00	0.00
<a href="#">750-7000-7035-0000</a>	LOCAL MEETINGS	650.00	1,160.62	500.00	136.98	250.00	0.00
<a href="#">750-7000-7037-0000</a>	VEHICLE MAINTENANCE	1,600.00	1,171.82	0.00	0.00	0.00	0.00
<a href="#">750-7000-7050-0000</a>	FUEL	1,000.00	8,013.03	0.00	144.12	0.00	0.00
<a href="#">750-7000-7053-0000</a>	PERMITS, FEES AND LICENSES	0.00	991.11	1,500.00	0.00	40.00	0.00
<a href="#">750-7000-7065-0000</a>	UNIFORMS	20,000.00	9,395.82	850.00	926.60	551.00	0.00
<a href="#">750-7000-7066-0000</a>	TRAVEL, EDUCATION, TRAINING	1,000.00	1,155.00	3,000.00	1,456.15	0.00	0.00
<a href="#">750-7000-7068-0000</a>	CONTRACTUAL SERVICES	9,600.00	33,210.90	131,120.00	110,298.61	0.00	0.00
<a href="#">750-7000-7070-0000</a>	SPECIAL DEPT SUPPLIES	750.00	284.20	0.00	0.00	0.00	0.00
<a href="#">750-7000-7071-0000</a>	SOFTWARE	2,600.00	6,074.99	3,500.00	650.00	650.00	0.00
<a href="#">750-7000-7072-0000</a>	COMPUTER SUPPLIES/MAINT	7,000.00	0.00	6,000.00	0.00	0.00	0.00

Budget Worksheet

Defined Budgets

		2018-2019 Total Budget	2018-2019 Total Activity	2019-2020 Total Budget	2019-2020 Total Activity	2020-2021 Total Budget	2020-2021 YTD Activity
<a href="#">750-7000-7075-0000</a>	EQUIPMENT LEASING/RENTAL	2,900.00	3,547.08	2,900.00	4,109.68	2,900.00	0.00
<a href="#">750-7000-7085-0000</a>	BUILDING SUPPLIES/MAINT	7,620.00	5,717.63	3,000.00	1,766.31	3,000.00	0.00
<a href="#">750-7000-7087-0000</a>	SECURITY SERVICES	650.00	900.17	650.00	606.85	650.00	0.00
<a href="#">750-7000-7090-0000</a>	EQUIPMENT SUPPLIES/MAINT	4,500.00	2,243.45	3,500.00	3,403.82	5,000.00	0.00
<b>Department: 7000 - TRANSIT ADMINISTRATION Total:</b>		<b>679,683.00</b>	<b>696,561.05</b>	<b>621,114.00</b>	<b>505,378.02</b>	<b>186,304.00</b>	<b>0.00</b>
<b>Department: 7100 - DIAL-A-RIDE</b>							
<a href="#">750-7100-6010-0000</a>	SALARIES	94,660.00	68,485.00	105,058.00	82,410.95	136,701.00	0.00
<a href="#">750-7100-6012-0000</a>	OVERTIME	5,000.00	3,279.88	5,000.00	7,129.90	5,500.00	0.00
<a href="#">750-7100-6013-0000</a>	SICK LEAVE	0.00	12,746.95	0.00	2,643.93	0.00	0.00
<a href="#">750-7100-6014-0000</a>	HOLIDAY	0.00	5,238.77	0.00	4,446.28	0.00	0.00
<a href="#">750-7100-6015-0000</a>	VACATION	0.00	2,110.19	0.00	2,526.65	0.00	0.00
<a href="#">750-7100-6016-0000</a>	ACCRUED TIME CASH OUT	1,735.00	0.00	3,838.00	58.11	8,641.00	0.00
<a href="#">750-7100-6018-0000</a>	OTHER COMPENSATION	300.00	99.17	0.00	4,182.84	0.00	0.00
<a href="#">750-7100-6019-0000</a>	FIRST AID	200.00	120.00	0.00	40.00	0.00	0.00
<a href="#">750-7100-6020-0000</a>	HEALTH INSURANCE	36,000.00	63,377.46	40,200.00	34,965.57	49,522.00	0.00
<a href="#">750-7100-6021-0000</a>	DENTAL INSURANCE	0.00	1,701.67	0.00	1,791.87	0.00	0.00
<a href="#">750-7100-6022-0000</a>	WORKERS COMP	6,153.00	2,428.42	5,253.00	1,682.30	6,835.00	0.00
<a href="#">750-7100-6023-0000</a>	DISABILITY	1,052.00	698.00	1,052.00	505.53	1,710.00	0.00
<a href="#">750-7100-6024-0000</a>	P.E.R.S./P.E.P.R.A.	18,556.00	15,985.98	23,361.00	12,395.54	11,152.00	0.00
<a href="#">750-7100-6027-0000</a>	VISION CARE	0.00	-75.63	0.00	178.50	0.00	0.00
<a href="#">750-7100-6028-0000</a>	LIFE INSURANCE	168.00	175.00	168.00	115.50	273.00	0.00
<a href="#">750-7100-6034-0000</a>	MEDICARE	1,470.00	1,541.18	1,652.00	1,445.34	2,187.00	0.00
<a href="#">750-7100-6035-0000</a>	FICA/PARS	0.00	0.00	0.00	36.76	0.00	0.00
<a href="#">750-7100-6036-0000</a>	UNIFORMS	0.00	150.00	0.00	0.00	0.00	0.00
<a href="#">750-7100-7015-0000</a>	TELEPHONE	0.00	0.00	0.00	760.14	913.00	0.00
<a href="#">750-7100-7027-0000</a>	HEALTH/FITNESS	0.00	344.25	0.00	190.22	0.00	0.00
<a href="#">750-7100-7037-0000</a>	VEHICLE MAINTENANCE	7,700.00	9,957.94	5,404.00	6,864.18	6,600.00	0.00
<a href="#">750-7100-7050-0000</a>	FUEL	30,000.00	25,368.75	15,000.00	27,565.78	30,000.00	0.00
<a href="#">750-7100-7053-0000</a>	PERMITS, FEES AND LICENSES	0.00	0.00	0.00	0.00	430.00	0.00
<a href="#">750-7100-7065-0000</a>	UNIFORMS	0.00	0.00	2,200.00	944.51	915.00	0.00
<a href="#">750-7100-7068-0000</a>	CONTRACTUAL SERVICES	1,225.00	1,854.80	6,200.00	3,701.77	0.00	0.00



Budget Worksheet

Defined Budgets

		2018-2019 Total Budget	2018-2019 Total Activity	2019-2020 Total Budget	2019-2020 Total Activity	2020-2021 Total Budget	2020-2021 YTD Activity
<a href="#">750-7100-7070-0000</a>	SPECIAL DEPT SUPPLIES	0.00	0.00	0.00	63.50	0.00	0.00
<a href="#">750-7100-7071-0000</a>	SOFTWARE	0.00	319.00	0.00	2,569.54	2,408.00	0.00
<a href="#">750-7100-9961-0000</a>	TRANSFERS OUT - OVERHEAD	0.00	0.00	0.00	0.00	10,000.00	0.00
<b>Department: 7100 - DIAL-A-RIDE Total:</b>		<b>204,219.00</b>	<b>215,906.78</b>	<b>214,386.00</b>	<b>199,215.21</b>	<b>273,787.00</b>	<b>0.00</b>
<b>Department: 7200 - FIXED ROUTE</b>							
<a href="#">750-7200-6010-0000</a>	SALARIES	508,973.00	360,454.83	516,531.00	-1,254.24	0.00	0.00
<a href="#">750-7200-6012-0000</a>	OVERTIME	25,000.00	24,062.45	22,500.00	2,082.92	0.00	0.00
<a href="#">750-7200-6013-0000</a>	SICK LEAVE	0.00	29,345.15	0.00	1,889.26	0.00	0.00
<a href="#">750-7200-6014-0000</a>	HOLIDAY	0.00	34,942.93	0.00	3,799.98	0.00	0.00
<a href="#">750-7200-6015-0000</a>	VACATION	0.00	13,806.41	0.00	5,335.51	0.00	0.00
<a href="#">750-7200-6016-0000</a>	ACCRUED TIME CASH OUT	10,531.00	6,254.51	18,413.00	3,164.57	0.00	0.00
<a href="#">750-7200-6018-0000</a>	OTHER COMPENSATOIN	1,800.00	12,115.43	0.00	2,529.41	0.00	0.00
<a href="#">750-7200-6019-0000</a>	FIRST AID	1,500.00	1,599.23	0.00	590.00	0.00	0.00
<a href="#">750-7200-6020-0000</a>	HEALTH INSURANCE	216,000.00	74,413.60	200,475.00	22,376.46	0.00	0.00
<a href="#">750-7200-6021-0000</a>	DENTAL INSURANCE	0.00	1,417.13	0.00	1,833.15	0.00	0.00
<a href="#">750-7200-6022-0000</a>	WORKERS COMP	33,083.00	28,493.52	25,827.00	2,101.15	0.00	0.00
<a href="#">750-7200-6023-0000</a>	DISABILITY	5,260.00	2,687.91	4,734.00	971.21	0.00	0.00
<a href="#">750-7200-6024-0000</a>	P.E.R.S./P.E.P.R.A.	64,022.00	82,233.28	52,964.00	32,372.77	0.00	0.00
<a href="#">750-7200-6025-0000</a>	UNEMPLOYMENT	0.00	4,083.48	0.00	1,910.00	0.00	0.00
<a href="#">750-7200-6026-0000</a>	DEFERRED COMP	0.00	6,796.52	0.00	1,788.48	0.00	0.00
<a href="#">750-7200-6027-0000</a>	VISION CARE	0.00	364.76	0.00	177.13	0.00	0.00
<a href="#">750-7200-6028-0000</a>	LIFE INSURANCE	840.00	741.07	756.00	246.16	0.00	0.00
<a href="#">750-7200-6029-0000</a>	WORKERS COMP COST	0.00	0.00	0.00	96.27	0.00	0.00
<a href="#">750-7200-6034-0000</a>	MEDICARE	7,895.00	6,941.28	8,083.00	1,259.01	0.00	0.00
<a href="#">750-7200-6035-0000</a>	FICA/PARS	714.00	682.78	1,270.00	505.99	0.00	0.00
<a href="#">750-7200-6036-0000</a>	UNIFORMS	0.00	244.75	0.00	64.79	0.00	0.00
<a href="#">750-7200-6050-0000</a>	RECRUITMENT AND HIRING COS...	0.00	237.00	0.00	0.00	0.00	0.00
<a href="#">750-7200-7015-0000</a>	TELEPHONE	9,600.00	9,578.52	12,000.00	0.00	0.00	0.00
<a href="#">750-7200-7020-0000</a>	ADVERTISING	100.00	0.00	0.00	0.00	0.00	0.00
<a href="#">750-7200-7025-0000</a>	OFFICE SUPPLIES	4,300.00	2,419.77	2,000.00	0.00	0.00	0.00
<a href="#">750-7200-7027-0000</a>	HEALTH/FITNESS	0.00	769.77	9,750.00	0.00	0.00	0.00

Budget Worksheet

Defined Budgets

		2018-2019 Total Budget	2018-2019 Total Activity	2019-2020 Total Budget	2019-2020 Total Activity	2020-2021 Total Budget	2020-2021 YTD Activity
<a href="#">750-7200-7036-0000</a>	UNIFORMS	0.00	0.00	0.00	-64.79	0.00	0.00
<a href="#">750-7200-7037-0000</a>	VEHICLE MAINTENANCE	78,700.00	88,000.60	67,000.00	0.00	0.00	0.00
<a href="#">750-7200-7050-0000</a>	FUEL	150,000.00	189,469.19	184,000.00	0.00	0.00	0.00
<a href="#">750-7200-7053-0000</a>	PERMITS, FEES AND LICENSES	0.00	1,062.85	3,200.00	-4.04	0.00	0.00
<a href="#">750-7200-7065-0000</a>	UNIFORMS	0.00	3,932.02	13,100.00	0.00	0.00	0.00
<a href="#">750-7200-7068-0000</a>	CONTRACTUAL SERVICES	5,800.00	11,234.20	52,660.00	-100.80	0.00	0.00
<a href="#">750-7200-7070-0000</a>	SPECIAL DEPT SUPPLIES	0.00	26,383.81	100.00	0.00	0.00	0.00
<a href="#">750-7200-7072-0000</a>	COMPUTER SUPPLIES/MAINT	26,000.00	30.48	28,000.00	0.00	0.00	0.00
<a href="#">750-7200-7085-0000</a>	BUILDING SUPPLIES/MAINT	250.00	591.15	0.00	0.00	0.00	0.00
<b>Department: 7200 - FIXED ROUTE Total:</b>		<b>1,150,368.00</b>	<b>1,025,390.38</b>	<b>1,223,363.00</b>	<b>83,670.35</b>	<b>0.00</b>	<b>0.00</b>
<b>Department: 7300 - VEHICLE MAINTENANCE</b>							
<a href="#">750-7300-6010-0000</a>	SALARIES	314,359.00	256,551.06	333,338.00	242,795.88	348,488.00	0.00
<a href="#">750-7300-6012-0000</a>	OVERTIME	3,500.00	1,640.04	2,500.00	2,084.12	2,500.00	0.00
<a href="#">750-7300-6013-0000</a>	SICK LEAVE	0.00	28,068.29	0.00	6,925.68	0.00	0.00
<a href="#">750-7300-6014-0000</a>	HOLIDAY	0.00	16,804.67	0.00	16,685.22	0.00	0.00
<a href="#">750-7300-6015-0000</a>	VACATION	0.00	4,925.67	0.00	13,414.84	0.00	0.00
<a href="#">750-7300-6016-0000</a>	ACCRUED TIME CASH OUT	5,680.00	848.49	12,313.00	1,491.20	25,810.00	0.00
<a href="#">750-7300-6018-0000</a>	OTHER COMPENSATION	600.00	0.00	0.00	0.00	0.00	0.00
<a href="#">750-7300-6019-0000</a>	FIRST AID	250.00	227.00	0.00	264.50	0.00	0.00
<a href="#">750-7300-6020-0000</a>	HEALTH INSURANCE	90,000.00	68,689.96	99,600.00	67,766.11	79,383.00	0.00
<a href="#">750-7300-6021-0000</a>	DENTAL INSURANCE	0.00	934.83	0.00	2,199.01	0.00	0.00
<a href="#">750-7300-6022-0000</a>	WORKERS COMP	20,433.00	23,859.59	16,667.00	23,521.46	17,424.00	0.00
<a href="#">750-7300-6023-0000</a>	DISABILITY	2,630.00	2,105.76	2,630.00	1,930.28	2,630.00	0.00
<a href="#">750-7300-6024-0000</a>	P.E.R.S./P.E.P.R.A.	44,764.00	59,368.40	51,854.00	43,747.87	60,699.00	0.00
<a href="#">750-7300-6027-0000</a>	VISION CARE	0.00	143.38	0.00	364.24	0.00	0.00
<a href="#">750-7300-6028-0000</a>	LIFE INSURANCE	420.00	420.00	420.00	385.00	420.00	0.00
<a href="#">750-7300-6029-0000</a>	WORKERS COMP COST	0.00	1,093.13	0.00	0.00	0.00	0.00
<a href="#">750-7300-6034-0000</a>	MEDICARE	4,691.00	3,588.30	5,048.00	3,278.95	5,464.00	0.00
<a href="#">750-7300-6036-0000</a>	UNIFORMS	0.00	222.92	0.00	0.00	0.00	0.00
<a href="#">750-7300-7010-0000</a>	UTILITIES	4,300.00	5,374.82	5,300.00	5,354.85	4,000.00	0.00
<a href="#">750-7300-7015-0000</a>	TELEPHONE	2,200.00	658.11	582.00	633.59	723.00	0.00

Budget Worksheet

Defined Budgets

		2018-2019 Total Budget	2018-2019 Total Activity	2019-2020 Total Budget	2019-2020 Total Activity	2020-2021 Total Budget	2020-2021 YTD Activity
<a href="#">750-7300-7022-0000</a>	LICENSE, PERMITS, FEES	0.00	1,094.00	0.00	1,094.00	0.00	0.00
<a href="#">750-7300-7025-0000</a>	OFFICE SUPPLIES	500.00	278.46	500.00	836.96	500.00	0.00
<a href="#">750-7300-7027-0000</a>	HEALTH/FITNESS	0.00	0.00	3,750.00	0.00	0.00	0.00
<a href="#">750-7300-7037-0000</a>	VEHICLE MAINTENANCE	20,100.00	22,338.24	20,100.00	15,362.80	14,538.00	0.00
<a href="#">750-7300-7038-0000</a>	ALLOC VEHICLE MAINTENANCE	-100,000.00	-52,563.74	-45,000.00	-61,546.91	-56,556.00	0.00
<a href="#">750-7300-7050-0000</a>	FUEL	1,000.00	5,513.96	5,000.00	6,728.33	6,000.00	0.00
<a href="#">750-7300-7053-0000</a>	PERMITS, FEES AND LICENSES	1,200.00	665.00	1,865.00	0.00	2,095.00	0.00
<a href="#">750-7300-7065-0000</a>	UNIFORMS	100.00	0.00	4,500.00	3,246.91	2,819.00	0.00
<a href="#">750-7300-7066-0000</a>	TRAVEL, EDUCATION, TRAINING	4,500.00	1,700.00	3,400.00	570.15	0.00	0.00
<a href="#">750-7300-7068-0000</a>	CONTRACTUAL SERVICES	3,200.00	2,166.00	3,180.00	3,500.00	0.00	0.00
<a href="#">750-7300-7070-0000</a>	SPECIAL DEPT SUPPLIES	500.00	279.94	700.00	30.18	1,084.00	0.00
<a href="#">750-7300-7071-0000</a>	SOFTWARE	0.00	972.00	13,197.00	10,278.00	7,365.00	0.00
<a href="#">750-7300-7072-0000</a>	COMPUTER SUPPLIES/MAINT	999.00	1,996.84	1,000.00	0.00	0.00	0.00
<a href="#">750-7300-7075-0000</a>	EQUIPMENT LEASING/RENTAL	0.00	0.00	0.00	319.93	549.00	0.00
<a href="#">750-7300-7085-0000</a>	BUILDING SUPPLIES/MAINT	2,100.00	2,410.48	2,100.00	3,088.83	1,000.00	0.00
<a href="#">750-7300-7087-0000</a>	SECURITY SERVICES	750.00	702.00	800.00	670.50	412.00	0.00
<a href="#">750-7300-7090-0000</a>	EQUIPMENT SUPPLIES/MAINT	0.00	0.00	0.00	324.83	494.00	0.00
<a href="#">750-7300-9961-0000</a>	TRANSFER OUT - OVERHEAD	0.00	0.00	0.00	0.00	10,000.00	0.00
<b>Department: 7300 - VEHICLE MAINTENANCE Total:</b>		<b>428,776.00</b>	<b>463,077.60</b>	<b>545,344.00</b>	<b>417,347.31</b>	<b>537,841.00</b>	<b>0.00</b>
<b>Department: 7400 - ROUTE 120</b>							
<a href="#">750-7400-6010-0000</a>	SALARIES	54,177.00	91,445.49	106,893.00	148,360.36	247,420.00	0.00
<a href="#">750-7400-6011-0000</a>	ADMIN TIME	0.00	156.40	0.00	0.00	0.00	0.00
<a href="#">750-7400-6012-0000</a>	OVERTIME	2,500.00	5,806.08	5,000.00	5,540.86	10,025.00	0.00
<a href="#">750-7400-6013-0000</a>	SICK LEAVE	0.00	4,515.99	0.00	6,452.98	0.00	0.00
<a href="#">750-7400-6014-0000</a>	HOLIDAY	0.00	4,825.76	0.00	19,404.28	0.00	0.00
<a href="#">750-7400-6015-0000</a>	VACATION	0.00	2,317.56	0.00	8,635.28	0.00	0.00
<a href="#">750-7400-6016-0000</a>	ACCRUED TIME CASH OUT	1,005.00	113.67	3,958.00	1,086.61	16,825.00	0.00
<a href="#">750-7400-6018-0000</a>	OTHER COMPENSATION	150.00	0.00	0.00	0.00	0.00	0.00
<a href="#">750-7400-6019-0000</a>	FIRST AID	100.00	0.00	0.00	287.00	0.00	0.00
<a href="#">750-7400-6020-0000</a>	HEALTH INSURANCE	18,000.00	420.55	40,200.00	22,271.69	54,230.00	0.00
<a href="#">750-7400-6021-0000</a>	DENTAL INSURANCE	0.00	-458.34	0.00	281.85	0.00	0.00

Budget Worksheet

Defined Budgets

		2018-2019 Total Budget	2018-2019 Total Activity	2019-2020 Total Budget	2019-2020 Total Activity	2020-2021 Total Budget	2020-2021 YTD Activity
<a href="#">750-7400-6022-0000</a>	WORKERS COMP	3,522.00	3,012.44	5,345.00	3,872.97	12,371.00	0.00
<a href="#">750-7400-6023-0000</a>	DISABILITY	526.00	383.52	1,052.00	996.40	2,209.00	0.00
<a href="#">750-7400-6024-0000</a>	P.E.R.S./P.E.P.R.A.	10,620.00	21,465.57	23,769.00	21,893.25	59,351.00	0.00
<a href="#">750-7400-6026-0000</a>	DEFERRED COMP	0.00	0.00	0.00	4,181.76	0.00	0.00
<a href="#">750-7400-6027-0000</a>	VISION CARE	0.00	134.05	0.00	245.89	0.00	0.00
<a href="#">750-7400-6028-0000</a>	LIFE INSURANCE	84.00	84.00	168.00	224.00	353.00	0.00
<a href="#">750-7400-6030-0000</a>	CAR ALLOWANCE	0.00	0.00	0.00	96.25	0.00	0.00
<a href="#">750-7400-6034-0000</a>	MEDICARE	836.00	1,472.27	1,680.00	2,687.74	3,977.00	0.00
<a href="#">750-7400-6036-0000</a>	UNIFORMS	0.00	129.99	0.00	81.49	0.00	0.00
<a href="#">750-7400-6050-0000</a>	RECRUITMENT AND HIRING COS...	0.00	40.00	0.00	0.00	0.00	0.00
<a href="#">750-7400-7015-0000</a>	TELEPHONE	0.00	0.00	0.00	2,280.20	2,737.00	0.00
<a href="#">750-7400-7025-0000</a>	OFFICE SUPPLIES	0.00	0.00	0.00	13.70	0.00	0.00
<a href="#">750-7400-7027-0000</a>	HEALTH/FITNESS	0.00	89.97	1,500.00	15.00	0.00	0.00
<a href="#">750-7400-7036-0000</a>	UNIFORMS	0.00	0.00	0.00	64.79	0.00	0.00
<a href="#">750-7400-7037-0000</a>	VEHICLE MAINTENANCE	5,600.00	25,620.87	10,000.00	27,301.87	20,900.00	0.00
<a href="#">750-7400-7050-0000</a>	FUEL	17,500.00	58,871.30	42,000.00	96,251.33	100,000.00	0.00
<a href="#">750-7400-7053-0000</a>	PERMITS, FEES AND LICENSES	0.00	136.31	0.00	45.91	1,994.00	0.00
<a href="#">750-7400-7065-0000</a>	UNIFORMS	0.00	1,990.79	2,200.00	2,592.24	1,795.00	0.00
<a href="#">750-7400-7068-0000</a>	CONTRACTUAL EXPENSES	125.00	1,566.00	3,100.00	10,320.96	0.00	0.00
<a href="#">750-7400-7070-0000</a>	SPECIAL DEPT SUPPLIES	0.00	0.00	0.00	485.85	547.00	0.00
<a href="#">750-7400-7071-0000</a>	SOFTWARE	0.00	0.00	0.00	7,192.38	8,635.00	0.00
<a href="#">750-7400-9961-0000</a>	TRANSFER OUT - OVERHEAD	0.00	0.00	0.00	0.00	10,000.00	0.00
<b>Department: 7400 - ROUTE 120 Total:</b>		<b>114,745.00</b>	<b>224,140.24</b>	<b>246,865.00</b>	<b>393,164.89</b>	<b>553,369.00</b>	<b>0.00</b>
<b>Department: 7500 - ROUTE 136</b>							
<a href="#">750-7500-6010-0000</a>	SALARIES	70,687.00	4,961.73	0.00	284.26	0.00	0.00
<a href="#">750-7500-6011-0000</a>	ADMIN TIME	0.00	92.62	0.00	0.00	0.00	0.00
<a href="#">750-7500-6012-0000</a>	OVERTIME	5,000.00	275.63	0.00	0.00	0.00	0.00
<a href="#">750-7500-6013-0000</a>	SICK LEAVE	0.00	1,923.31	0.00	590.21	0.00	0.00
<a href="#">750-7500-6014-0000</a>	HOLIDAY	0.00	231.70	0.00	708.16	0.00	0.00
<a href="#">750-7500-6015-0000</a>	VACATION	0.00	-1,373.82	0.00	0.00	0.00	0.00
<a href="#">750-7500-6016-0000</a>	ACCRUED TIME CASH OUT	1,287.00	0.00	0.00	0.00	0.00	0.00

Budget Worksheet

Defined Budgets

		2018-2019 Total Budget	2018-2019 Total Activity	2019-2020 Total Budget	2019-2020 Total Activity	2020-2021 Total Budget	2020-2021 YTD Activity
<a href="#">750-7500-6018-0000</a>	OTHER COMPENSATION	0.00	0.00	0.00	2,277.73	0.00	0.00
<a href="#">750-7500-6019-0000</a>	FIRST AID	0.00	40.00	0.00	0.00	0.00	0.00
<a href="#">750-7500-6020-0000</a>	HEALTH INSURANCE	36,000.00	3,264.05	0.00	16.99	0.00	0.00
<a href="#">750-7500-6021-0000</a>	DENTAL INSURANCE	0.00	171.91	0.00	-39.71	0.00	0.00
<a href="#">750-7500-6022-0000</a>	WORKERS COMP	4,595.00	233.94	0.00	6.65	0.00	0.00
<a href="#">750-7500-6023-0000</a>	DISABILITY	1,052.00	122.73	0.00	0.00	0.00	0.00
<a href="#">750-7500-6024-0000</a>	P.E.R.S./P.E.P.R.A.	4,904.00	1,417.54	0.00	4,741.20	0.00	0.00
<a href="#">750-7500-6027-0000</a>	VISION CARE	0.00	-5.02	0.00	14.92	0.00	0.00
<a href="#">750-7500-6028-0000</a>	LIFE INSURANCE	168.00	42.00	0.00	0.00	0.00	0.00
<a href="#">750-7500-6029-0000</a>	WORKER'S COMP COST	0.00	0.00	0.00	5,310.97	0.00	0.00
<a href="#">750-7500-6034-0000</a>	MEDICARE	1,116.00	109.97	0.00	53.09	0.00	0.00
<a href="#">750-7500-7037-0000</a>	VEHICLE MAINTENANCE	500.00	726.54	0.00	0.00	0.00	0.00
<a href="#">750-7500-7050-0000</a>	FUEL	1,000.00	1,882.71	0.00	0.00	0.00	0.00
<a href="#">750-7500-7070-0000</a>	SPECIAL DEPT SUPPLIES	0.00	87.33	0.00	0.00	0.00	0.00
<b>Department: 7500 - ROUTE 136 Total:</b>		<b>126,309.00</b>	<b>14,204.87</b>	<b>0.00</b>	<b>13,964.47</b>	<b>0.00</b>	<b>0.00</b>
<b>Department: 7600 - ROUTE 125</b>							
<a href="#">750-7600-6010-0000</a>	SALARIES	0.00	60,457.01	88,709.00	74,492.18	129,583.00	0.00
<a href="#">750-7600-6012-0000</a>	OVERTIME	0.00	3,861.83	5,000.00	3,592.53	5,025.00	0.00
<a href="#">750-7600-6013-0000</a>	SICK LEAVE	0.00	4,082.91	0.00	1,306.34	0.00	0.00
<a href="#">750-7600-6014-0000</a>	HOLIDAY	0.00	6,481.98	0.00	3,961.55	0.00	0.00
<a href="#">750-7600-6015-0000</a>	VACATION	0.00	7,229.15	0.00	1,403.61	0.00	0.00
<a href="#">750-7600-6016-0000</a>	ACCRUED TIME CASH OUT	0.00	619.13	3,186.00	2,104.36	7,711.00	0.00
<a href="#">750-7600-6018-0000</a>	OTHER COMPENSATION	300.00	0.00	0.00	1,794.96	0.00	0.00
<a href="#">750-7600-6019-0000</a>	FIRST AID	100.00	45.00	0.00	85.00	0.00	0.00
<a href="#">750-7600-6020-0000</a>	HEALTH INSURANCE	0.00	11,187.56	40,200.00	19,481.14	29,104.00	0.00
<a href="#">750-7600-6021-0000</a>	DENTAL INSURANCE	0.00	426.88	0.00	1,251.62	0.00	0.00
<a href="#">750-7600-6022-0000</a>	WORKERS COMP	0.00	2,042.26	4,435.00	1,549.96	6,479.00	0.00
<a href="#">750-7600-6023-0000</a>	DISABILITY	0.00	368.19	1,052.00	471.22	1,157.00	0.00
<a href="#">750-7600-6024-0000</a>	P.E.R.S./P.E.P.R.A.	0.00	14,486.43	6,302.00	6,783.37	12,818.00	0.00
<a href="#">750-7600-6027-0000</a>	VISION CARE	0.00	-37.78	0.00	45.10	0.00	0.00
<a href="#">750-7600-6028-0000</a>	LIFE INSURANCE	0.00	126.00	168.00	154.00	185.00	0.00

Budget Worksheet

Defined Budgets

		2018-2019 Total Budget	2018-2019 Total Activity	2019-2020 Total Budget	2019-2020 Total Activity	2020-2021 Total Budget	2020-2021 YTD Activity
<a href="#">750-7600-6029-0000</a>	WORKERS COMP COST	0.00	0.00	0.00	7,054.45	0.00	0.00
<a href="#">750-7600-6030-0000</a>	CAR ALLOWANCE	0.00	0.00	0.00	96.25	0.00	0.00
<a href="#">750-7600-6034-0000</a>	MEDICARE	0.00	1,115.11	1,405.00	1,120.31	2,064.00	0.00
<a href="#">750-7600-7015-0000</a>	TELEPHONE	0.00	0.00	0.00	1,863.21	2,281.00	0.00
<a href="#">750-7600-7020-0000</a>	ADVERTISING	0.00	20,412.86	0.00	0.00	0.00	0.00
<a href="#">750-7600-7025-0000</a>	OFFICE SUPPLIES	0.00	0.00	0.00	4.17	0.00	0.00
<a href="#">750-7600-7027-0000</a>	HEALTH/FITNESS	0.00	0.00	1,500.00	15.00	0.00	0.00
<a href="#">750-7600-7037-0000</a>	VEHICLE MAINTENANCE	4,200.00	3,463.88	11,000.00	10,192.70	11,148.00	0.00
<a href="#">750-7600-7050-0000</a>	FUEL	13,100.00	16,939.81	20,000.00	23,058.44	20,000.00	0.00
<a href="#">750-7600-7053-0000</a>	PERMITS, FEES AND LICENSES	0.00	0.00	0.00	97.20	155.00	0.00
<a href="#">750-7600-7065-0000</a>	UNIFORMS	0.00	2,130.73	2,200.00	2,211.70	1,516.00	0.00
<a href="#">750-7600-7068-0000</a>	CONTRACTUAL SERVICES	60.00	1,598.00	3,100.00	7,068.21	0.00	0.00
<a href="#">750-7600-7070-0000</a>	SPECIAL DEPT SUPPLIES	0.00	0.00	0.00	202.60	0.00	0.00
<a href="#">750-7600-7071-0000</a>	SOFTWARE	0.00	0.00	0.00	6,992.64	7,921.00	0.00
<a href="#">750-7600-7090-0000</a>	EQUIPMENT SUPPLIES/MAINT	0.00	0.00	0.00	34.88	0.00	0.00
<a href="#">750-7600-9961-0000</a>	TRANSFER OUT - OVERHEAD	0.00	0.00	0.00	0.00	10,000.00	0.00
<b>Department: 7600 - ROUTE 125 Total:</b>		<b>17,760.00</b>	<b>157,036.94</b>	<b>188,257.00</b>	<b>178,488.70</b>	<b>247,147.00</b>	<b>0.00</b>
<b>Department: 7700 - ROUTE 2</b>							
<a href="#">750-7700-6010-0000</a>	SALARIES	0.00	0.00	0.00	59,561.38	126,437.00	0.00
<a href="#">750-7700-6012-0000</a>	OVERTIME	0.00	0.00	0.00	4,309.32	5,025.00	0.00
<a href="#">750-7700-6013-0000</a>	SICK LEAVE	0.00	0.00	0.00	3,081.63	0.00	0.00
<a href="#">750-7700-6014-0000</a>	SICK LEAVE	0.00	0.00	0.00	3,634.44	0.00	0.00
<a href="#">750-7700-6015-0000</a>	HOLIDAY	0.00	0.00	0.00	3,274.04	0.00	0.00
<a href="#">750-7700-6016-0000</a>	ACCRUED TIME CASH OUT	0.00	0.00	0.00	1,167.43	7,830.00	0.00
<a href="#">750-7700-6020-0000</a>	HEALTH INSURANCE	0.00	0.00	0.00	19,952.54	31,176.00	0.00
<a href="#">750-7700-6021-0000</a>	DENTAL INSURANCE	0.00	0.00	0.00	560.16	0.00	0.00
<a href="#">750-7700-6022-0000</a>	WORKERS COMP	0.00	0.00	0.00	1,258.69	6,322.00	0.00
<a href="#">750-7700-6023-0000</a>	DISABILITY	0.00	0.00	0.00	372.89	1,157.00	0.00
<a href="#">750-7700-6024-0000</a>	P.E.R.S./P.E.P.R.A.	0.00	0.00	0.00	5,868.40	29,614.00	0.00
<a href="#">750-7700-6027-0000</a>	VISION CARE	0.00	0.00	0.00	57.93	0.00	0.00
<a href="#">750-7700-6028-0000</a>	LIFE INSURANCE	0.00	0.00	0.00	98.00	185.00	0.00

Budget Worksheet

Defined Budgets

		2018-2019 Total Budget	2018-2019 Total Activity	2019-2020 Total Budget	2019-2020 Total Activity	2020-2021 Total Budget	2020-2021 YTD Activity
<a href="#">750-7700-6030-0000</a>	CAR ALLOWANCE	0.00	0.00	0.00	96.25	0.00	0.00
<a href="#">750-7700-6034-0000</a>	MEDICARE	0.00	0.00	0.00	982.01	2,020.00	0.00
<a href="#">750-7700-6036-0000</a>	UNIFORMS	0.00	0.00	0.00	165.29	0.00	0.00
<a href="#">750-7700-7015-0000</a>	TELEPHONE	0.00	0.00	0.00	798.15	913.00	0.00
<a href="#">750-7700-7025-0000</a>	OFFICE SUPPLIES	0.00	0.00	0.00	125.42	0.00	0.00
<a href="#">750-7700-7027-0000</a>	HEALTH/FITNESS	0.00	0.00	0.00	336.30	0.00	0.00
<a href="#">750-7700-7037-0000</a>	VEHICLE MAINTENANCE	0.00	0.00	0.00	17,264.83	22,455.00	0.00
<a href="#">750-7700-7050-0000</a>	FUEL	0.00	0.00	0.00	31,828.40	38,241.00	0.00
<a href="#">750-7700-7053-0000</a>	PERMITS, FEES AND LICENSES	0.00	0.00	0.00	63.27	173.00	0.00
<a href="#">750-7700-7065-0000</a>	UNIFORMS	0.00	0.00	0.00	1,176.61	1,080.00	0.00
<a href="#">750-7700-7068-0000</a>	CONTRACTUAL SERVICES	0.00	0.00	0.00	5,750.80	0.00	0.00
<a href="#">750-7700-7070-0000</a>	SPECIAL DEPT SUPPLIES	0.00	0.00	0.00	95.24	164.00	0.00
<a href="#">750-7700-7071-0000</a>	SOFTWARE	0.00	0.00	0.00	2,173.82	3,968.00	0.00
<a href="#">750-7700-9961-0000</a>	TRANSFER OUT - OVERHEAD	0.00	0.00	0.00	0.00	10,000.00	0.00
<b>Department: 7700 - ROUTE 2 Total:</b>		<b>0.00</b>	<b>0.00</b>	<b>0.00</b>	<b>164,053.24</b>	<b>286,760.00</b>	<b>0.00</b>
<b>Department: 7800 - ROUTE 3</b>							
<a href="#">750-7800-6010-0000</a>	SALARIES	0.00	0.00	0.00	57,414.86	118,221.00	0.00
<a href="#">750-7800-6012-0000</a>	OVERTIME	0.00	0.00	0.00	2,499.13	5,025.00	0.00
<a href="#">750-7800-6013-0000</a>	SICK LEAVE	0.00	0.00	0.00	2,255.27	0.00	0.00
<a href="#">750-7800-6014-0000</a>	HOLIDAY	0.00	0.00	0.00	2,100.65	0.00	0.00
<a href="#">750-7800-6015-0000</a>	VACATION	0.00	0.00	0.00	1,095.44	0.00	0.00
<a href="#">750-7800-6016-0000</a>	ACCRUED TIME CASH OUT	0.00	0.00	0.00	1,328.02	6,881.00	0.00
<a href="#">750-7800-6020-0000</a>	HEALTH INSURANCE	0.00	0.00	0.00	7,738.80	39,508.00	0.00
<a href="#">750-7800-6021-0000</a>	DENTAL INSURANCE	0.00	0.00	0.00	344.46	0.00	0.00
<a href="#">750-7800-6022-0000</a>	WORKERS COMP	0.00	0.00	0.00	1,217.39	5,911.00	0.00
<a href="#">750-7800-6023-0000</a>	DISABILITY	0.00	0.00	0.00	149.87	1,157.00	0.00
<a href="#">750-7800-6024-0000</a>	P.E.R.S./P.E.P.R.A.	0.00	0.00	0.00	5,968.77	19,549.00	0.00
<a href="#">750-7800-6027-0000</a>	VISION CARE	0.00	0.00	0.00	-56.25	0.00	0.00
<a href="#">750-7800-6028-0000</a>	LIFE INSURANCE	0.00	0.00	0.00	49.00	185.00	0.00
<a href="#">750-7800-6030-0000</a>	CAR ALLOWANCE	0.00	0.00	0.00	96.25	0.00	0.00
<a href="#">750-7800-6034-0000</a>	MEDICARE	0.00	0.00	0.00	832.20	1,887.00	0.00

Budget Worksheet

Defined Budgets

		2018-2019 Total Budget	2018-2019 Total Activity	2019-2020 Total Budget	2019-2020 Total Activity	2020-2021 Total Budget	2020-2021 YTD Activity
<a href="#">750-7800-6036-0000</a>	UNIFORMS	0.00	0.00	0.00	139.50	0.00	0.00
<a href="#">750-7800-7015-0000</a>	TELEPHONE	0.00	0.00	0.00	380.06	457.00	0.00
<a href="#">750-7800-7025-0000</a>	OFFICE SUPPLIES	0.00	0.00	0.00	252.32	0.00	0.00
<a href="#">750-7800-7027-0000</a>	HEALTH/FITNESS	0.00	0.00	0.00	15.00	0.00	0.00
<a href="#">750-7800-7037-0000</a>	VEHICLE MAINTENANCE	0.00	110.48	0.00	4,808.18	5,735.00	0.00
<a href="#">750-7800-7050-0000</a>	FUEL	0.00	0.00	0.00	11,041.04	13,605.00	0.00
<a href="#">750-7800-7053-0000</a>	PERMITS, FEES AND LICENSES	0.00	0.00	0.00	292.21	418.00	0.00
<a href="#">750-7800-7065-0000</a>	UNIFORMS	0.00	0.00	0.00	1,147.27	1,080.00	0.00
<a href="#">750-7800-7068-0000</a>	CONTRACTUAL SERVICES	0.00	0.00	0.00	2,241.76	0.00	0.00
<a href="#">750-7800-7070-0000</a>	SPECIAL DEPT SUPPLIES	0.00	0.00	0.00	31.75	55.00	0.00
<a href="#">750-7800-7071-0000</a>	SOFTWARE	0.00	0.00	0.00	1,973.96	2,130.00	0.00
<a href="#">750-7800-9961-0000</a>	TRANSFER OUT - OVERHEAD	0.00	0.00	0.00	0.00	10,000.00	0.00
<b>Department: 7800 - ROUTE 3 Total:</b>		<b>0.00</b>	<b>110.48</b>	<b>0.00</b>	<b>105,356.91</b>	<b>231,804.00</b>	<b>0.00</b>
<b>Department: 7900 - ROUTE 4</b>							
<a href="#">750-7900-6010-0000</a>	SALARIES	0.00	0.00	0.00	44,419.76	115,262.00	0.00
<a href="#">750-7900-6012-0000</a>	OVERTIME	0.00	0.00	0.00	4,116.70	5,025.00	0.00
<a href="#">750-7900-6013-0000</a>	SICK LEAVE	0.00	0.00	0.00	1,889.29	0.00	0.00
<a href="#">750-7900-6014-0000</a>	HOLIDAY	0.00	0.00	0.00	3,954.08	0.00	0.00
<a href="#">750-7900-6015-0000</a>	VACATION	0.00	0.00	0.00	2,135.09	0.00	0.00
<a href="#">750-7900-6016-0000</a>	ACCRUED TIME CASH OUT	0.00	0.00	0.00	2,017.27	5,132.00	0.00
<a href="#">750-7900-6019-0000</a>	FIRST AID	0.00	0.00	0.00	144.50	0.00	0.00
<a href="#">750-7900-6020-0000</a>	HEALTH INSURANCE	0.00	0.00	0.00	10,084.09	19,215.00	0.00
<a href="#">750-7900-6021-0000</a>	DENTAL INSURANCE	0.00	0.00	0.00	760.21	0.00	0.00
<a href="#">750-7900-6022-0000</a>	WORKERS COMP	0.00	0.00	0.00	1,077.18	5,763.00	0.00
<a href="#">750-7900-6023-0000</a>	DISABILITY	0.00	0.00	0.00	286.37	1,157.00	0.00
<a href="#">750-7900-6024-0000</a>	P.E.R.S./P.E.P.R.A.	0.00	0.00	0.00	5,468.85	11,650.00	0.00
<a href="#">750-7900-6027-0000</a>	VISION CARE	0.00	0.00	0.00	-0.54	0.00	0.00
<a href="#">750-7900-6028-0000</a>	LIFE INSURANCE	0.00	0.00	0.00	98.00	185.00	0.00
<a href="#">750-7900-6030-0000</a>	CAR ALLOWANCE	0.00	0.00	0.00	96.25	0.00	0.00
<a href="#">750-7900-6034-0000</a>	MEDICARE	0.00	0.00	0.00	855.89	1,819.00	0.00
<a href="#">750-7900-7015-0000</a>	TELEPHONE	0.00	0.00	0.00	380.06	457.00	0.00



Budget Worksheet

Defined Budgets

		2018-2019 Total Budget	2018-2019 Total Activity	2019-2020 Total Budget	2019-2020 Total Activity	2020-2021 Total Budget	2020-2021 YTD Activity
<a href="#">750-7900-7025-0000</a>	OFFICE SUPPLIES	0.00	0.00	0.00	238.29	0.00	0.00
<a href="#">750-7900-7027-0000</a>	HEALTH/FITNESS	0.00	0.00	0.00	209.39	0.00	0.00
<a href="#">750-7900-7037-0000</a>	VEHICLE MAINTENANCE	0.00	0.00	0.00	4,334.76	3,832.00	0.00
<a href="#">750-7900-7050-0000</a>	FUEL	0.00	0.00	0.00	13,344.49	17,956.00	0.00
<a href="#">750-7900-7053-0000</a>	PERMITS, FEES AND LICENSES	0.00	0.00	0.00	174.56	274.00	0.00
<a href="#">750-7900-7065-0000</a>	UNIFORMS	0.00	0.00	0.00	1,111.81	827.00	0.00
<a href="#">750-7900-7068-0000</a>	CONTRACTUAL SERVICES	0.00	0.00	0.00	2,271.84	0.00	0.00
<a href="#">750-7900-7070-0000</a>	SPECIAL DEPT SUPPLIES	0.00	0.00	0.00	31.75	55.00	0.00
<a href="#">750-7900-7071-0000</a>	SOFTWARE	0.00	0.00	0.00	1,974.02	2,130.00	0.00
<a href="#">750-7900-9961-0000</a>	TRANSFER OUT - OVERHEAD	0.00	0.00	0.00	0.00	10,000.00	0.00
<b>Department: 7900 - ROUTE 4 Total:</b>		<b>0.00</b>	<b>0.00</b>	<b>0.00</b>	<b>101,473.96</b>	<b>200,739.00</b>	<b>0.00</b>
<b>Department: 8000 - ROUTE 3/4</b>							
<a href="#">750-8000-6010-0000</a>	SALARIES	0.00	0.00	0.00	23,797.64	42,645.00	0.00
<a href="#">750-8000-6012-0000</a>	OVERTIME	0.00	0.00	0.00	8.37	2,500.00	0.00
<a href="#">750-8000-6013-0000</a>	SICK LEAVE	0.00	0.00	0.00	1,272.05	0.00	0.00
<a href="#">750-8000-6014-0000</a>	HOLIDAY	0.00	0.00	0.00	4,340.33	0.00	0.00
<a href="#">750-8000-6015-0000</a>	VACATION	0.00	0.00	0.00	326.44	0.00	0.00
<a href="#">750-8000-6016-0000</a>	ACCRUED TIME CASH OUT	0.00	0.00	0.00	5,152.28	2,299.00	0.00
<a href="#">750-8000-6019-0000</a>	FIRST AID	0.00	0.00	0.00	189.00	0.00	0.00
<a href="#">750-8000-6020-0000</a>	HEALTH INSURANCE	0.00	0.00	0.00	-1,596.75	7,180.00	0.00
<a href="#">750-8000-6021-0000</a>	DENTAL INSURANCE	0.00	0.00	0.00	-103.02	0.00	0.00
<a href="#">750-8000-6022-0000</a>	WORKERS COMP	0.00	0.00	0.00	477.31	2,132.00	0.00
<a href="#">750-8000-6023-0000</a>	DISABILITY	0.00	0.00	0.00	154.35	526.00	0.00
<a href="#">750-8000-6024-0000</a>	P.E.R.S./P.E.P.R.A.	0.00	0.00	0.00	1,784.63	3,479.00	0.00
<a href="#">750-8000-6027-0000</a>	VISION CARE	0.00	0.00	0.00	-6.92	0.00	0.00
<a href="#">750-8000-6028-0000</a>	LIFE INSURANCE	0.00	0.00	0.00	49.00	84.00	0.00
<a href="#">750-8000-6034-0000</a>	MEDICARE	0.00	0.00	0.00	444.19	688.00	0.00
<a href="#">750-8000-6035-0000</a>	FICA/PARS	0.00	0.00	0.00	0.00	617.00	0.00
<a href="#">750-8000-6036-0000</a>	UNIFORMS	0.00	0.00	0.00	150.00	0.00	0.00
<a href="#">750-8000-7015-0000</a>	TELEPHONE	0.00	0.00	0.00	380.06	457.00	0.00
<a href="#">750-8000-7025-0000</a>	OFFICE SUPPLIES	0.00	0.00	0.00	107.18	0.00	0.00

Budget Worksheet

Defined Budgets

		2018-2019 Total Budget	2018-2019 Total Activity	2019-2020 Total Budget	2019-2020 Total Activity	2020-2021 Total Budget	2020-2021 YTD Activity
<a href="#">750-8000-7037-0000</a>	VEHICLE MAINTENANCE	0.00	0.00	0.00	1,501.88	2,101.00	0.00
<a href="#">750-8000-7050-0000</a>	FUEL	0.00	0.00	0.00	1,186.50	1,844.00	0.00
<a href="#">750-8000-7053-0000</a>	PERMITS, FEES AND LICENSES	0.00	0.00	0.00	40.61	94.00	0.00
<a href="#">750-8000-7065-0000</a>	UNIFORMS	0.00	0.00	0.00	75.77	0.00	0.00
<a href="#">750-8000-7068-0000</a>	CONTRACTUAL SERVICES	0.00	0.00	0.00	2,116.92	0.00	0.00
<a href="#">750-8000-7070-0000</a>	SPECIAL DEPT SUPPLIES	0.00	0.00	0.00	153.79	55.00	0.00
<a href="#">750-8000-7071-0000</a>	SOFTWARE	0.00	0.00	0.00	1,974.02	1,984.00	0.00
<a href="#">750-8000-9961-0000</a>	TRANSFER OUT - OVERHEAD	0.00	0.00	0.00	0.00	10,000.00	0.00
<b>Department: 8000 - ROUTE 3/4 Total:</b>		<b>0.00</b>	<b>0.00</b>	<b>0.00</b>	<b>43,975.63</b>	<b>78,685.00</b>	<b>0.00</b>
<b>Department: 8100 - ROUTE 7</b>							
<a href="#">750-8100-6010-0000</a>	SALARIES	0.00	0.00	0.00	27,805.25	49,799.00	0.00
<a href="#">750-8100-6012-0000</a>	OVERTIME	0.00	0.00	0.00	1,738.60	0.00	0.00
<a href="#">750-8100-6013-0000</a>	SICK LEAVE	0.00	0.00	0.00	4,218.81	0.00	0.00
<a href="#">750-8100-6014-0000</a>	HOLIDAY	0.00	0.00	0.00	3,611.48	0.00	0.00
<a href="#">750-8100-6015-0000</a>	VACATION	0.00	0.00	0.00	6,048.75	0.00	0.00
<a href="#">750-8100-6016-0000</a>	ACCRUED TIME CASH OUT	0.00	0.00	0.00	332.80	3,343.00	0.00
<a href="#">750-8100-6019-0000</a>	FIRST AID	0.00	0.00	0.00	119.50	0.00	0.00
<a href="#">750-8100-6020-0000</a>	HEALTH INSURANCE	0.00	0.00	0.00	-3,207.23	10,050.00	0.00
<a href="#">750-8100-6021-0000</a>	DENTAL INSURANCE	0.00	0.00	0.00	-255.59	0.00	0.00
<a href="#">750-8100-6022-0000</a>	WORKERS COMP	0.00	0.00	0.00	686.20	2,490.00	0.00
<a href="#">750-8100-6024-0000</a>	P.E.R.S./P.E.P.R.A.	0.00	0.00	0.00	2,785.79	0.00	0.00
<a href="#">750-8100-6027-0000</a>	VISION CARE	0.00	0.00	0.00	-12.69	0.00	0.00
<a href="#">750-8100-6034-0000</a>	MEDICARE	0.00	0.00	0.00	540.05	771.00	0.00
<a href="#">750-8100-6035-0000</a>	FICA/PARS	0.00	0.00	0.00	177.08	691.00	0.00
<a href="#">750-8100-7015-0000</a>	TELEPHONE	0.00	0.00	0.00	760.14	913.00	0.00
<a href="#">750-8100-7025-0000</a>	OFFICE SUPPLIES	0.00	0.00	0.00	233.44	0.00	0.00
<a href="#">750-8100-7037-0000</a>	VEHICLE MAINTENANCE	0.00	0.00	0.00	14,818.83	2,237.00	0.00
<a href="#">750-8100-7050-0000</a>	FUEL	0.00	0.00	0.00	9,317.63	9,809.00	0.00
<a href="#">750-8100-7053-0000</a>	PERMITS, FEES AND LICENSES	0.00	0.00	0.00	790.20	1,032.00	0.00
<a href="#">750-8100-7065-0000</a>	UNIFORMS	0.00	0.00	0.00	6.00	0.00	0.00
<a href="#">750-8100-7068-0000</a>	CONTRACTUAL SERVICES	0.00	0.00	0.00	5,458.30	0.00	0.00

Budget Worksheet

Defined Budgets

		2018-2019 Total Budget	2018-2019 Total Activity	2019-2020 Total Budget	2019-2020 Total Activity	2020-2021 Total Budget	2020-2021 YTD Activity
<a href="#">750-8100-7070-0000</a>	SPECIAL DEPT SUPPLIES	0.00	0.00	0.00	63.50	109.00	0.00
<a href="#">750-8100-7071-0000</a>	SOFTWARE	0.00	0.00	0.00	3,610.78	3,822.00	0.00
<a href="#">750-8100-9961-0000</a>	TRANSFER OUT - OVERHEAD	0.00	0.00	0.00	0.00	10,000.00	0.00
<b>Department: 8100 - ROUTE 7 Total:</b>		<b>0.00</b>	<b>0.00</b>	<b>0.00</b>	<b>79,647.62</b>	<b>95,066.00</b>	<b>0.00</b>
<b>Department: 8200 - ROUTE 9</b>							
<a href="#">750-8200-6010-0000</a>	SALARIES	0.00	0.00	0.00	10,326.28	47,766.00	0.00
<a href="#">750-8200-6012-0000</a>	OVERTIME	0.00	0.00	0.00	1,224.58	0.00	0.00
<a href="#">750-8200-6013-0000</a>	SICK LEAVE	0.00	0.00	0.00	414.20	0.00	0.00
<a href="#">750-8200-6016-0000</a>	ACCRUED TIME CASH OUT	0.00	0.00	0.00	0.00	3,355.00	0.00
<a href="#">750-8200-6020-0000</a>	HEALTH INSURANCE	0.00	0.00	0.00	-1,697.54	10,050.00	0.00
<a href="#">750-8200-6021-0000</a>	DENTAL INSURANCE	0.00	0.00	0.00	-110.48	0.00	0.00
<a href="#">750-8200-6022-0000</a>	WORKERS COMP	0.00	0.00	0.00	318.64	2,388.00	0.00
<a href="#">750-8200-6024-0000</a>	P.E.R.S./P.E.P.R.A.	0.00	0.00	0.00	1,273.57	0.00	0.00
<a href="#">750-8200-6027-0000</a>	VISION CARE	0.00	0.00	0.00	-6.93	0.00	0.00
<a href="#">750-8200-6034-0000</a>	MEDICARE	0.00	0.00	0.00	135.26	741.00	0.00
<a href="#">750-8200-6035-0000</a>	FICA/PARS	0.00	0.00	0.00	0.00	665.00	0.00
<a href="#">750-8200-7015-0000</a>	TELEPHONE	0.00	0.00	0.00	380.08	457.00	0.00
<a href="#">750-8200-7025-0000</a>	OFFICE SUPPLIES	0.00	0.00	0.00	164.28	0.00	0.00
<a href="#">750-8200-7037-0000</a>	VEHICLE MAINTENANCE	0.00	0.00	0.00	1,124.75	572.00	0.00
<a href="#">750-8200-7050-0000</a>	FUEL	0.00	0.00	0.00	7,397.85	6,018.00	0.00
<a href="#">750-8200-7053-0000</a>	PERMITS, FEES, AND LICENSES	0.00	0.00	0.00	402.68	542.00	0.00
<a href="#">750-8200-7068-0000</a>	CONTRACTUAL SERVICES	0.00	0.00	0.00	3,076.44	0.00	0.00
<a href="#">750-8200-7070-0000</a>	SPECIAL DEPT SUPPLIES	0.00	0.00	0.00	31.75	55.00	0.00
<a href="#">750-8200-7071-0000</a>	SOFTWARE	0.00	0.00	0.00	1,975.02	1,984.00	0.00
<a href="#">750-8200-9961-0000</a>	TRANSFER OUT - OVERHEAD	0.00	0.00	0.00	0.00	10,000.00	0.00
<b>Department: 8200 - ROUTE 9 Total:</b>		<b>0.00</b>	<b>0.00</b>	<b>0.00</b>	<b>26,430.43</b>	<b>84,593.00</b>	<b>0.00</b>
<b>Fund: 750 - TRANSIT FUND Surplus (Deficit):</b>		<b>0.00</b>	<b>-112,305.59</b>	<b>0.00</b>	<b>179,606.09</b>	<b>308,289.00</b>	<b>0.00</b>
<b>Fund: 755 - TRANSIT GASB68 FUND</b>							
<b>Department: 0000 - NON-DEPARTMENTAL</b>							
<a href="#">755-0000-4670-0000</a>	ARTICLE 4 - TRANSIT	0.00	0.00	100,000.00	0.00	0.00	0.00

Defined Budgets

		2018-2019 Total Budget	2018-2019 Total Activity	2019-2020 Total Budget	2019-2020 Total Activity	2020-2021 Total Budget	2020-2021 YTD Activity
<a href="#">755-0000-6040-0000</a>	GASB 68 PENSION ADJMT	0.00	37,489.00	100,000.00	0.00	308,289.00	0.00
<b>Department: 0000 - NON-DEPARTMENTAL Surplus (Deficit):</b>		<b>0.00</b>	<b>-37,489.00</b>	<b>0.00</b>	<b>0.00</b>	<b>-308,289.00</b>	<b>0.00</b>
<b>Fund: 755 - TRANSIT GASB68 FUND Surplus (Deficit):</b>		<b>0.00</b>	<b>-37,489.00</b>	<b>0.00</b>	<b>0.00</b>	<b>-308,289.00</b>	<b>0.00</b>
<b>Fund: 760 - TRANSIT CAPITAL PROJECTS</b>							
<b>Department: 0000 - NON-DEPARTMENTAL</b>							
<a href="#">760-0000-4352-0000</a>	GRANT - OTHER	0.00	25,000.00	0.00	0.00	0.00	0.00
<a href="#">760-0000-4468-1113</a>	PROP 1B GRANT-PY	0.00	20,938.83	0.00	0.00	0.00	0.00
<a href="#">760-0000-4476-1016</a>	LCTOP Revenue	0.00	0.00	129,943.00	2,499.00	0.00	0.00
<a href="#">760-0000-4480-0000</a>	STATE OF CALIFORNIA - SGR	0.00	0.00	0.00	0.00	155,431.00	0.00
<a href="#">760-0000-4672-0000</a>	ARTICLE 4 - CAPITAL	0.00	1,575,040.55	2,840,000.00	10,260.00	1,166,463.00	0.00
<a href="#">760-0000-7068-0000</a>	CONTRACTUAL SERVICE	0.00	12,327.84	100,000.00	0.00	0.00	0.00
<a href="#">760-0000-7079-0000</a>	DEPRECIATION	0.00	507,921.35	0.00	0.00	0.00	0.00
<a href="#">760-0000-8014-0000</a>	BUILDING IMPROVEMENTS	0.00	960.49	0.00	-7,980.00	0.00	0.00
<a href="#">760-0000-8030-0000</a>	INFRASTRUCTURE IMPROVEMEN...	0.00	13,289.00	2,129,943.00	249,958.97	551,999.00	0.00
<a href="#">760-0000-8040-0000</a>	EQUIPMENT	0.00	18,031.64	0.00	22,800.00	57,498.00	0.00
<a href="#">760-0000-8044-0000</a>	BUS LIFT/JACKSTAND/TOOLS	0.00	0.00	40,000.00	16,135.55	0.00	0.00
<a href="#">760-0000-8045-0000</a>	TRANSIT YARD IMPROVEMENTS	0.00	0.00	0.00	412.66	492,397.00	0.00
<a href="#">760-0000-8062-0000</a>	BUS PURCHASES	0.00	516,264.84	700,000.00	0.00	220,000.00	0.00
<a href="#">760-0000-8999-0000</a>	TRANSFER TO FIXED ASSET/DEBT...	0.00	-530,203.29	0.00	0.00	0.00	0.00
<a href="#">760-0000-9960-0000</a>	TRANSFERS OUT	0.00	0.00	0.00	0.00	0.00	0.00
<b>Department: 0000 - NON-DEPARTMENTAL Surplus (Deficit):</b>		<b>0.00</b>	<b>1,082,387.51</b>	<b>0.00</b>	<b>-268,568.18</b>	<b>0.00</b>	<b>0.00</b>
<b>Fund: 760 - TRANSIT CAPITAL PROJECTS Surplus (Deficit):</b>		<b>0.00</b>	<b>1,082,387.51</b>	<b>0.00</b>	<b>-268,568.18</b>	<b>0.00</b>	<b>0.00</b>
<b>Fund: 840 - COMMUNITY FACILITIES DISTRICT (CFD) - BOND MGMT</b>							
<b>Department: 0000 - NON-DEPARTMENTAL</b>							
<a href="#">840-0000-4441-0000</a>	DELINQUENCIES	0.00	0.00	114,389.56	0.00	0.00	0.00
<a href="#">840-0000-4445-001A</a>	ALLOCATED ASSESSMENTS - IA 1A	159,491.00	163,909.41	162,274.00	96,017.73	165,279.00	0.00
<a href="#">840-0000-4445-002X</a>	ALLOCATED ASSESSMENTS - IA 2	15,758.00	16,194.19	16,033.00	15,727.54	16,330.00	0.00
<a href="#">840-0000-4445-003X</a>	ALLOCATED ASSESSMENTS - IA 3	274,538.00	236,508.76	273,338.00	119,140.34	212,400.00	0.00
<a href="#">840-0000-4445-004X</a>	ALLOCATED ASSESSMENTS - IA 4	275,970.00	283,556.71	282,716.00	156,266.04	288,023.00	0.00
<a href="#">840-0000-4445-005X</a>	ALLOCATED ASSESSMENTS - IA 5	247,747.00	254,610.62	252,070.00	140,352.80	256,738.00	0.00
<a href="#">840-0000-4445-006A</a>	ALLOCATED ASSESSMENTS - IA 6A	2,339,708.00	0.00	0.00	3,401.63	0.00	0.00
<a href="#">840-0000-4445-006B</a>	ALLOCATED ASSESSMENTS - IA 6B	18,759.00	19,080.31	19,163.00	21,712.00	8,735.00	0.00

Defined Budgets

		2018-2019 Total Budget	2018-2019 Total Activity	2019-2020 Total Budget	2019-2020 Total Activity	2020-2021 Total Budget	2020-2021 YTD Activity
<a href="#">840-0000-4445-007A</a>	ALLOCATED ASSESSMENTS - IA 7A	675,125.00	688,446.54	674,375.00	388,459.73	674,200.00	0.00
<a href="#">840-0000-4445-007B</a>	ALLOCATED ASSESSMENTS - IA 7B	120,844.00	312,437.42	309,188.00	194,227.07	309,150.00	0.00
<a href="#">840-0000-4445-007C</a>	ALLOCATED ASSESSMENTS - IA 7C	106,850.00	108,672.77	110,975.00	74,933.60	108,800.00	0.00
<a href="#">840-0000-4445-007D</a>	ALLOCATED ASSESSMENTS - IA 7D	0.00	216,273.31	211,100.00	128,886.46	214,000.00	0.00
<a href="#">840-0000-4445-008A</a>	ALLOCATED ASSESSMENTS - IA 8A	484,639.00	489,504.67	481,889.00	267,187.38	483,308.00	0.00
<a href="#">840-0000-4445-008B</a>	ALLOCATED ASSESSMENTS - IA 8B	418,867.00	417,342.20	420,987.00	236,258.70	422,713.00	0.00
<a href="#">840-0000-4445-008C</a>	ALLOCATED ASSESSMENTS - IA 8C	694,310.00	1,351,444.54	1,526,969.00	787,378.11	1,557,409.00	0.00
<a href="#">840-0000-4445-008D</a>	ALLOCATED ASSESSMENTS - IA 8D	46,766.00	342,722.81	415,891.00	226,872.78	424,166.00	0.00
<a href="#">840-0000-4445-008E</a>	ALLOCATED ASSESSMENTS - IA 8E	0.00	591,594.33	616,600.00	337,609.28	629,950.00	0.00
<a href="#">840-0000-4445-008F</a>	ALLOCATED ASSESSMENTS-IA8F	0.00	4,282.00	0.00	149,984.52	0.00	0.00
<a href="#">840-0000-4445-008X</a>	ALLOCATED ASSESSMENTS - IA 8	636,339.00	642,167.22	637,632.00	346,463.27	633,405.00	0.00
<a href="#">840-0000-4445-009X</a>	ALLOCATED ASSESSMENTS - IA 9	53,340.00	36,493.75	47,038.00	30,318.53	41,200.00	0.00
<a href="#">840-0000-4445-010A</a>	ALLOCATED ASSESSMENTS - IA 1...	182,058.00	159,712.50	159,563.00	87,068.26	137,200.00	0.00
<a href="#">840-0000-4445-011A</a>	ALLOCATED ASSESSMENTS - IA 1...	103,163.00	103,162.50	105,963.00	56,356.35	85,650.00	0.00
<a href="#">840-0000-4445-012A</a>	ALLOCATED ASSESSMENTS - IA 1...	107,248.00	101,750.00	99,500.00	59,952.18	85,650.00	0.00
<a href="#">840-0000-4445-014A</a>	ALLOCATED ASSESSMENTS - IA 1...	1,067,040.00	1,068,041.74	1,095,040.00	619,859.48	1,096,104.00	0.00
<a href="#">840-0000-4445-014B</a>	ALLOCATED ASSESSMENTS - IA 1...	276,553.00	220,078.67	276,353.00	164,493.28	275,785.00	0.00
<a href="#">840-0000-4445-014X</a>	ALLOCATED ASSESSMENTS - IA 14	602,528.00	608,772.57	604,418.00	339,406.86	605,790.00	0.00
<a href="#">840-0000-4445-016X</a>	ALLOCATED ASSESSMENTS - IA 16	567,994.00	576,379.08	565,569.00	296,152.03	562,194.00	0.00
<a href="#">840-0000-4445-017A</a>	ALLOCATED ASSESSMENTS - IA 1...	802,269.00	759,337.39	815,113.00	482,930.29	832,925.00	0.00
<a href="#">840-0000-4445-017B</a>	ALLOCATED ASSESSMENTS - IA 1...	825,788.00	835,915.38	842,188.00	449,762.92	857,188.00	0.00
<a href="#">840-0000-4445-017C</a>	ALLOCATED ASSESSMENTS - IA 1...	0.00	352,777.36	432,225.00	246,205.34	441,025.00	0.00
<a href="#">840-0000-4445-018X</a>	ALLOCATED ASSESSMENTS - IA 18	380,744.00	385,248.74	380,519.00	204,260.11	384,613.00	0.00
<a href="#">840-0000-4445-019A</a>	ALLOCATED ASSESSMENTS - IA 1...	1,502,425.00	1,528,234.00	1,500,250.00	800,908.96	1,497,475.00	0.00
<a href="#">840-0000-4445-019C</a>	ALLOCATED ASSESSMENTS - IA 1...	1,827,488.00	1,851,476.85	1,802,300.00	972,452.75	1,775,084.00	0.00
<a href="#">840-0000-4445-020X</a>	ALLOCATED ASSESSMENTS - IA 20	246,740.00	246,630.08	253,459.00	148,285.39	259,634.00	0.00
<a href="#">840-0000-4445-06A1</a>	ALLOCATED ASSESSMENTS - IA 6...	0.00	2,355,178.69	2,339,708.00	1,228,302.54	2,339,707.00	0.00
<a href="#">840-0000-4445-1601</a>	ALLOCATED ASSESSMENTS - IA 2...	0.00	440,978.72	546,388.00	293,601.01	546,588.00	0.00
<a href="#">840-0000-4445-1602</a>	ALLOCATED ASSESSMENTS - IA 2...	0.00	0.00	0.00	333,677.28	639,500.00	0.00
<a href="#">840-0000-4445-1603</a>	ALLOCATED ASSESSMENTS - IA 2...	0.00	0.00	0.00	46,256.08	0.00	0.00
<a href="#">840-0000-4445-1604</a>	ALLOCATED ASSESSMENTS - IA 2...	0.00	901.00	0.00	163,849.18	242,925.00	0.00

Budget Worksheet

Defined Budgets

		2018-2019 Total Budget	2018-2019 Total Activity	2019-2020 Total Budget	2019-2020 Total Activity	2020-2021 Total Budget	2020-2021 YTD Activity
<a href="#">840-0000-4650-0000</a>	INTEREST	0.00	0.00	0.00	-5,293.98	10,376.00	0.00
<a href="#">840-0000-4650-001A</a>	INTEREST - IA 1A	0.00	72.90	100.00	214.66	274.00	0.00
<a href="#">840-0000-4650-002X</a>	INTEREST - IA 2	0.00	47.06	50.00	97.23	137.00	0.00
<a href="#">840-0000-4650-003X</a>	INTEREST - IA 3	0.00	501.02	600.00	1,651.99	50.00	0.00
<a href="#">840-0000-4650-004X</a>	INTEREST - IA 4	0.00	94.70	100.00	368.16	507.00	0.00
<a href="#">840-0000-4650-005X</a>	INTEREST - IA 5	0.00	88.21	100.00	340.12	468.00	0.00
<a href="#">840-0000-4650-006B</a>	INTEREST - IA 6B	0.00	46.33	50.00	101.50	142.00	0.00
<a href="#">840-0000-4650-007A</a>	INTEREST - IA 7A	0.00	597.40	600.00	808.16	971.00	0.00
<a href="#">840-0000-4650-007B</a>	INTEREST - IA 7B	0.00	2,623.38	2,000.00	3,442.10	4,421.00	0.00
<a href="#">840-0000-4650-007C</a>	INTEREST - IA 7C	0.00	446.24	400.00	280.38	322.00	0.00
<a href="#">840-0000-4650-007D</a>	INTEREST - IA 7D	0.00	1,067.87	350.00	2,990.65	3,854.00	0.00
<a href="#">840-0000-4650-008A</a>	INTEREST - IA 8A	0.00	2,538.26	2,500.00	2,187.16	2,800.00	0.00
<a href="#">840-0000-4650-008B</a>	INTEREST - IA 8B	0.00	2,119.60	1,800.00	1,837.52	2,341.00	0.00
<a href="#">840-0000-4650-008C</a>	INTEREST - IA 8C	0.00	8,776.96	7,800.00	18,593.95	22,686.00	0.00
<a href="#">840-0000-4650-008D</a>	INTEREST - IA 8D	0.00	395.96	400.00	6,301.23	7,614.00	0.00
<a href="#">840-0000-4650-008E</a>	INTEREST - IA 8E	0.00	10,572.59	1,200.00	13,817.96	17,787.00	0.00
<a href="#">840-0000-4650-008X</a>	INTEREST - IA 8	0.00	3,429.71	2,900.00	2,922.78	3,767.00	0.00
<a href="#">840-0000-4650-009X</a>	INTEREST - IA 9	0.00	109.28	150.00	940.14	10.00	0.00
<a href="#">840-0000-4650-010A</a>	INTEREST - IA 10A	0.00	487.70	550.00	957.66	10.00	0.00
<a href="#">840-0000-4650-011A</a>	INTEREST - IA 11A	0.00	239.85	275.00	1,627.93	10.00	0.00
<a href="#">840-0000-4650-012A</a>	INTEREST - IA 12A	0.00	211.38	250.00	953.84	10.00	0.00
<a href="#">840-0000-4650-014A</a>	INTEREST - IA 14A	0.00	5,634.71	4,700.00	4,866.67	6,253.00	0.00
<a href="#">840-0000-4650-014B</a>	INTEREST - IA 14B	0.00	7,619.76	6,600.00	5,428.08	6,961.00	0.00
<a href="#">840-0000-4650-014X</a>	INTEREST - IA 14	0.00	3,206.65	2,750.00	2,789.05	3,594.00	0.00
<a href="#">840-0000-4650-016X</a>	INTEREST - IA 16	0.00	4,539.77	1,150.00	23,024.98	28,956.00	0.00
<a href="#">840-0000-4650-017A</a>	INTEREST - IA 17A	0.00	1,129.32	1,200.00	978.59	1,233.00	0.00
<a href="#">840-0000-4650-017B</a>	INTEREST - IA 17B	0.00	513.15	550.00	923.76	1,002.00	0.00
<a href="#">840-0000-4650-017C</a>	INTEREST - IA 17C	0.00	0.02	0.00	6,626.35	8,015.00	0.00
<a href="#">840-0000-4650-018X</a>	INTEREST - IA 18	0.00	1,710.78	200.00	10,643.42	13,384.00	0.00
<a href="#">840-0000-4650-019A</a>	INTEREST - IA 19A	0.00	822.99	900.00	1,927.73	2,481.00	0.00
<a href="#">840-0000-4650-019C</a>	INTEREST - IA 19C	0.00	8,526.34	7,500.00	7,651.71	9,872.00	0.00

Defined Budgets

		2018-2019 Total Budget	2018-2019 Total Activity	2019-2020 Total Budget	2019-2020 Total Activity	2020-2021 Total Budget	2020-2021 YTD Activity
<a href="#">840-0000-4650-020X</a>	INTEREST - IA 20	0.00	2,251.20	250.00	13,723.60	17,203.00	0.00
<a href="#">840-0000-4650-06A1</a>	INTEREST - IA 6A1	0.00	16,487.43	15,000.00	13,400.53	17,169.00	0.00
<a href="#">840-0000-4650-1601</a>	INTEREST - IA 2016-1	0.00	2,562.23	350.00	12,867.36	17,534.00	0.00
<a href="#">840-0000-4650-1602</a>	INTEREST - IA 2016-2	0.00	0.00	0.00	44,881.34	64,284.00	0.00
<a href="#">840-0000-4650-1604</a>	INTEREST - IA 2016-4	0.00	0.00	0.00	16,231.80	100.00	0.00
<a href="#">840-0000-4705-0000</a>	PREMIUM ON BOND PROCEEDS	0.00	0.00	0.00	1,367,061.75	0.00	0.00
<a href="#">840-0000-4710-0000</a>	DISCOUNT ON BOND PROCEEDS	0.00	0.00	0.00	0.00	0.00	0.00
<a href="#">840-0000-7051-0000</a>	TRUSTEE FEES	0.00	10,500.00	0.00	7,000.00	0.00	0.00
<a href="#">840-0000-7055-0000</a>	INTEREST	0.00	0.00	0.00	2,354.30	0.00	0.00
<a href="#">840-0000-7055-001A</a>	INTEREST - IA 1A	60,334.18	73,982.71	48,550.00	30,957.76	39,442.00	0.00
<a href="#">840-0000-7055-002X</a>	INTEREST - IA 2	5,961.00	7,309.47	4,800.00	3,058.61	3,897.00	0.00
<a href="#">840-0000-7055-003X</a>	INTEREST - IA 3	134,709.38	162,166.78	120,680.00	20,988.74	89,050.00	0.00
<a href="#">840-0000-7055-004X</a>	INTEREST - IA 4	108,454.82	132,978.57	82,401.00	55,742.03	71,091.00	0.00
<a href="#">840-0000-7055-005X</a>	INTEREST - IA 5	93,720.82	114,921.93	75,415.00	48,088.59	61,267.00	0.00
<a href="#">840-0000-7055-006B</a>	INTEREST - IA 6B	4,382.18	4,888.88	7,048.00	1,556.59	1,331.00	0.00
<a href="#">840-0000-7055-007A</a>	INTEREST - IA 7A	454,525.00	600,511.82	446,625.00	297,813.18	441,788.00	0.00
<a href="#">840-0000-7055-007B</a>	INTEREST - IA 7B	91,818.77	183,578.96	215,461.00	152,395.85	171,569.00	0.00
<a href="#">840-0000-7055-007C</a>	INTEREST - IA 7C	83,087.51	108,927.60	85,735.00	18,069.30	79,363.00	0.00
<a href="#">840-0000-7055-007D</a>	INTEREST - IA 7D	0.00	92,245.64	51,890.00	94,802.49	0.00	0.00
<a href="#">840-0000-7055-008A</a>	INTEREST - IA 8A	446,864.26	311,367.21	218,146.00	146,320.38	211,406.00	0.00
<a href="#">840-0000-7055-008B</a>	INTEREST - IA 8B	404,819.02	300,518.86	168,814.00	142,367.83	206,850.00	0.00
<a href="#">840-0000-7055-008C</a>	INTEREST - IA 8C	761,939.71	1,180,535.58	1,028,000.00	1,134,967.99	987,085.00	0.00
<a href="#">840-0000-7055-008D</a>	INTEREST - IA 8D	61,195.60	242,445.39	509,553.00	436,139.91	375,635.00	0.00
<a href="#">840-0000-7055-008E</a>	INTEREST - IA 8E	0.00	326,144.02	155,671.00	375,990.26	560,775.00	0.00
<a href="#">840-0000-7055-008X</a>	INTEREST - IA 8	270,232.03	335,102.21	333,408.00	154,476.29	220,519.00	0.00
<a href="#">840-0000-7055-009X</a>	INTEREST - IA 9	25,353.75	31,321.45	24,716.00	-7,663.95	16,500.00	0.00
<a href="#">840-0000-7055-010A</a>	INTEREST - IA 10A	97,125.00	112,023.00	78,268.00	6,012.68	58,325.00	0.00
<a href="#">840-0000-7055-011A</a>	INTEREST - IA 11A	54,106.25	65,229.42	42,821.00	2,458.08	36,250.00	0.00
<a href="#">840-0000-7055-012A</a>	INTEREST - IA 12A	55,771.25	69,986.25	51,492.00	3,707.63	36,325.00	0.00
<a href="#">840-0000-7055-014A</a>	INTEREST - IA 14A	858,052.25	612,180.30	523,323.00	287,630.87	413,424.00	0.00
<a href="#">840-0000-7055-014B</a>	INTEREST - IA 14B	249,053.49	271,664.51	113,771.00	-51,488.94	133,988.00	0.00

Defined Budgets

		2018-2019 Total Budget	2018-2019 Total Activity	2019-2020 Total Budget	2019-2020 Total Activity	2020-2021 Total Budget	2020-2021 YTD Activity
<a href="#">840-0000-7055-014X</a>	INTEREST - IA 14	457,154.64	240,894.58	316,526.00	220,800.00	207,863.00	0.00
<a href="#">840-0000-7055-016X</a>	INTEREST - IA 16	244,393.78	320,093.89	234,281.00	155,381.17	226,381.00	0.00
<a href="#">840-0000-7055-017A</a>	INTEREST - IA 17A	446,618.78	586,284.22	0.00	286,100.17	419,019.00	0.00
<a href="#">840-0000-7055-017B</a>	INTEREST - IA 17B	748,487.56	994,382.34	743,988.00	496,742.78	739,688.00	0.00
<a href="#">840-0000-7055-017C</a>	INTEREST - IA 17C	0.00	224,485.22	882,135.00	392,525.04	391,625.00	0.00
<a href="#">840-0000-7055-018X</a>	INTEREST - IA 18	165,043.76	216,183.83	158,131.00	104,841.23	152,566.00	0.00
<a href="#">840-0000-7055-019A</a>	INTEREST - IA 19A	742,525.00	974,739.42	718,000.00	477,398.12	701,363.00	0.00
<a href="#">840-0000-7055-019C</a>	INTEREST - IA 19C	1,391,973.61	1,125,018.03	1,184,260.00	535,120.99	498,911.00	0.00
<a href="#">840-0000-7055-020X</a>	INTEREST - IA 20	174,802.50	230,206.83	170,100.00	113,163.87	166,546.00	0.00
<a href="#">840-0000-7055-06A1</a>	INTEREST - IA 6A1	2,146,743.32	1,492,413.04	1,045,861.00	712,149.09	1,028,927.00	0.00
<a href="#">840-0000-7055-1601</a>	INTEREST - IA 2016-1	0.00	127,350.20	633,172.00	255,523.52	383,988.00	0.00
<a href="#">840-0000-7055-1602</a>	INTEREST - IA 2016-2	0.00	0.00	0.00	256,851.40	452,500.00	0.00
<a href="#">840-0000-7055-1604</a>	INTEREST	0.00	0.00	0.00	54,173.75	169,500.00	0.00
<a href="#">840-0000-8030-0000</a>	INFRASTRUCTURE	0.00	14,729,560.29	0.00	14,487,719.34	0.00	0.00
<a href="#">840-0000-8900-001A</a>	DEBT SERVICE - IA 1A	95,630.54	95,630.54	106,800.00	106,797.83	118,114.00	0.00
<a href="#">840-0000-8900-002X</a>	DEBT SERVICE - IA 2	9,448.27	9,448.27	10,550.00	10,551.59	11,670.00	0.00
<a href="#">840-0000-8900-003X</a>	DEBT SERVICE - IA 3	150,000.00	150,000.00	155,000.00	0.00	110,000.00	0.00
<a href="#">840-0000-8900-004X</a>	DEBT SERVICE - IA 4	164,641.00	164,641.00	181,265.00	181,263.00	203,144.00	0.00
<a href="#">840-0000-8900-005X</a>	DEBT SERVICE - IA 5	148,548.83	148,548.83	165,895.00	165,895.68	183,474.00	0.00
<a href="#">840-0000-8900-006B</a>	DEBT SERVICE - IA 6B	13,882.91	13,882.91	15,505.00	15,504.09	17,147.00	0.00
<a href="#">840-0000-8900-007A</a>	DEBT SERVICE - IA 7A	220,000.00	245,750.00	225,000.00	225,000.00	230,000.00	0.00
<a href="#">840-0000-8900-007B</a>	DEBT SERVICE - IA 7B	25,000.00	40,450.00	55,000.00	145,000.00	135,000.00	0.00
<a href="#">840-0000-8900-007C</a>	DEBT SERVICE - IA 7C	25,000.00	30,150.00	25,000.00	25,000.00	30,000.00	0.00
<a href="#">840-0000-8900-007D</a>	DEBT SERVICE - IA 7D	0.00	0.00	10,000.00	95,000.00	0.00	0.00
<a href="#">840-0000-8900-008A</a>	DEBT SERVICE - IA 8A	34,774.62	224,784.00	258,500.00	258,446.00	265,465.00	0.00
<a href="#">840-0000-8900-008B</a>	DEBT SERVICE - IA 8B	15,576.25	180,000.00	200,000.00	200,000.00	210,000.00	0.00
<a href="#">840-0000-8900-008C</a>	DEBT SERVICE - IA 8C	110,259.00	120,559.00	265,700.00	175,689.00	185,313.00	0.00
<a href="#">840-0000-8900-008D</a>	DEBT SERVICE - IA 8D	-13,579.00	17,231.00	114,700.00	29,661.00	39,562.00	0.00
<a href="#">840-0000-8900-008E</a>	DEBT SERVICE - IA 8E	0.00	0.00	30,000.00	170,000.00	55,000.00	0.00
<a href="#">840-0000-8900-008X</a>	DEBT SERVICE - IA 8	365,000.00	365,000.00	395,000.00	395,000.00	410,000.00	0.00
<a href="#">840-0000-8900-009X</a>	DEBT SERVICE - IA 9	24,000.00	24,000.00	24,000.00	0.00	20,000.00	0.00



Budget Worksheet

Defined Budgets

		2018-2019 Total Budget	2018-2019 Total Activity	2019-2020 Total Budget	2019-2020 Total Activity	2020-2021 Total Budget	2020-2021 YTD Activity
<a href="#">840-0000-8900-010A</a>	DEBT SERVICE - IA 10A	68,000.00	68,000.00	76,000.00	0.00	75,000.00	0.00
<a href="#">840-0000-8900-011A</a>	DEBT SERVICE - IA 11A	55,000.00	55,000.00	55,000.00	0.00	40,000.00	0.00
<a href="#">840-0000-8900-012A</a>	DEBT SERVICE - IA 12A	48,000.00	48,000.00	50,000.00	0.00	45,000.00	0.00
<a href="#">840-0000-8900-014A</a>	DEBT SERVICE - IA 14A	213,993.75	575,000.00	620,000.00	630,000.00	670,000.00	0.00
<a href="#">840-0000-8900-014B</a>	DEBT SERVICE - IA 14B	27,499.87	116,553.00	134,800.00	134,789.00	139,711.00	0.00
<a href="#">840-0000-8900-014X</a>	DEBT SERVICE - IA 14	152,853.12	355,000.00	375,000.00	380,000.00	390,000.00	0.00
<a href="#">840-0000-8900-016X</a>	DEBT SERVICE - IA 16	320,000.00	320,000.00	330,000.00	330,000.00	335,000.00	0.00
<a href="#">840-0000-8900-017A</a>	DEBT SERVICE - IA 17A	340,000.00	355,450.00	0.00	365,000.00	390,000.00	0.00
<a href="#">840-0000-8900-017B</a>	DEBT SERVICE - IA 17B	60,000.00	60,000.00	80,000.00	80,000.00	100,000.00	0.00
<a href="#">840-0000-8900-017C</a>	DEBT SERVICE - IA 17C	0.00	0.00	170,000.00	30,000.00	40,000.00	0.00
<a href="#">840-0000-8900-018X</a>	DEBT SERVICE - IA 18	215,000.00	215,000.00	220,000.00	220,000.00	225,000.00	0.00
<a href="#">840-0000-8900-019A</a>	DEBT SERVICE - IA 19A	755,000.00	791,050.00	775,000.00	775,000.00	790,000.00	0.00
<a href="#">840-0000-8900-019C</a>	DEBT SERVICE - IA 19C	459,314.75	938,746.00	1,364,000.00	1,029,849.00	569,974.00	0.00
<a href="#">840-0000-8900-020X</a>	DEBT SERVICE - IA 20	70,000.00	70,000.00	75,000.00	75,000.00	85,000.00	0.00
<a href="#">840-0000-8900-06A1</a>	DEBT SERVICE - IA 6A1	192,962.00	1,089,682.00	1,239,000.00	1,239,069.00	1,286,277.00	0.00
<a href="#">840-0000-8900-1601</a>	DEBT SERVICE - IA 2016-1	0.00	0.00	0.00	255,000.00	160,000.00	0.00
<a href="#">840-0000-8900-1602</a>	DEBT SERVICE - IA 2016-2	0.00	0.00	0.00	0.00	150,000.00	0.00
<a href="#">840-0000-8900-1604</a>	DEBT SERVICE - IA 2016-4	0.00	0.00	0.00	0.00	105,000.00	0.00
<a href="#">840-0000-8910-0000</a>	DEBT SERVICE - REFUNDINGS	0.00	0.00	0.00	75,993.85	0.00	0.00
<a href="#">840-0000-8925-0000</a>	CFD PREPAYMENTS	0.00	107,343.18	0.00	0.00	0.00	0.00
<a href="#">840-0000-8950-0000</a>	COST OF ISSUANCE	0.00	1,099,277.45	0.00	448,623.96	0.00	0.00
<a href="#">840-0000-8970-0000</a>	OTHER FINANCING SOURCES - B...	0.00	0.00	0.00	20,796,696.23	0.00	0.00
<a href="#">840-0000-8975-0000</a>	OTHER FINANCING USES - BOND...	0.00	0.00	0.00	7,130,589.17	0.00	0.00
<a href="#">840-0000-8990-0000</a>	CAPITAL OUTLAY	0.00	2,154,738.65	0.00	0.00	0.00	0.00
<a href="#">840-0000-9500-0000</a>	SPECIAL ITEMS	0.00	8,637,028.95	0.00	0.00	0.00	0.00
<a href="#">840-0000-9950-0000</a>	TRANSFERS IN	0.00	0.01	0.00	380,604.20	0.00	0.00
<a href="#">840-0000-9960-0000</a>	TRANSFERS OUT	0.00	0.00	0.00	0.00	1,812,833.00	0.00
<b>Department: 0000 - NON-DEPARTMENTAL Surplus (Deficit):</b>		<b>-143,966.13</b>	<b>-27,424,113.28</b>	<b>179,751.56</b>	<b>-3,829,513.02</b>	<b>0.00</b>	<b>0.00</b>
<b>Fund: 840 - COMMUNITY FACILITIES DISTRICT (CFD) - BOND MGMT Surp..</b>		<b>-143,966.13</b>	<b>-27,424,113.28</b>	<b>179,751.56</b>	<b>-3,829,513.02</b>	<b>0.00</b>	<b>0.00</b>

Defined Budgets

		2018-2019 Total Budget	2018-2019 Total Activity	2019-2020 Total Budget	2019-2020 Total Activity	2020-2021 Total Budget	2020-2021 YTD Activity
<b>Fund: 850 - BEAUMONT FINANCING AUTHORITY (CFD)</b>							
<b>Department: 0000 - NON-DEPARTMENTAL</b>							
<a href="#">850-0000-4650-0000</a>	INTEREST - TRUSTEE	0.00	236,291.71	225,000.00	147,279.23	156,380.00	0.00
<a href="#">850-0000-4655-0000</a>	INTEREST - CFD PYMTS	4,302,380.80	4,302,166.25	4,220,638.00	3,911,926.03	3,493,649.00	0.00
<a href="#">850-0000-4660-0000</a>	PRINCIPAL RECD - CFD	3,325,980.63	2,999.55	3,435,012.00	3,075,012.19	2,800,000.00	0.00
<a href="#">850-0000-7055-0000</a>	INTEREST	0.00	4,312,611.86	4,220,638.00	2,458,671.37	3,493,649.00	0.00
<a href="#">850-0000-8900-0000</a>	DEBT SERVICE PAYMENTS	7,628,361.43	3,403,000.00	3,600,000.00	3,105,300.00	2,800,000.00	0.00
<a href="#">850-0000-8975-0000</a>	OTHER FINANCING USES - BOND...	0.00	0.00	0.00	266,317.48	0.00	0.00
<a href="#">850-0000-9950-0000</a>	TRANSFERS IN	0.00	0.00	0.00	0.00	0.00	0.00
<a href="#">850-0000-9960-0000</a>	TRANSFERS OUT	0.00	0.01	0.00	354,375.17	0.00	0.00
<b>Department: 0000 - NON-DEPARTMENTAL Surplus (Deficit):</b>		<b>0.00</b>	<b>-3,174,154.36</b>	<b>60,012.00</b>	<b>949,553.43</b>	<b>156,380.00</b>	<b>0.00</b>
<b>Fund: 850 - BEAUMONT FINANCING AUTHORITY (CFD) Surplus (Deficit):</b>		<b>0.00</b>	<b>-3,174,154.36</b>	<b>60,012.00</b>	<b>949,553.43</b>	<b>156,380.00</b>	<b>0.00</b>
<b>Fund: 855 - BEAUMONT PUBLIC IMPROVEMENT AUTHORITY</b>							
<b>Department: 0000 - NON-DEPARTMENTAL</b>							
<a href="#">855-0000-4650-0000</a>	INTEREST	0.00	-18,997.49	0.00	333.63	100.00	0.00
<a href="#">855-0000-4655-0000</a>	INTEREST - CFD BONDS	0.00	0.00	0.00	135,784.38	236,450.00	0.00
<a href="#">855-0000-4660-0000</a>	CFD PRINCIPAL RECEIVED	0.00	0.00	0.00	0.00	290,000.00	0.00
<a href="#">855-0000-4705-0000</a>	PREMIUM ON BOND PROCEEDS	0.00	-803,951.95	0.00	1,014,919.00	0.00	0.00
<a href="#">855-0000-7051-0000</a>	TRUSTEE FEES	0.00	0.00	0.00	15,000.00	0.00	0.00
<a href="#">855-0000-7055-0000</a>	INTEREST	0.00	-0.01	0.00	135,784.43	236,450.00	0.00
<a href="#">855-0000-8900-0000</a>	DEBT SERVICE PAYMENTS	0.00	0.00	0.00	0.00	290,000.00	0.00
<a href="#">855-0000-8950-0000</a>	COST OF ISSUANCE	0.00	-794,969.15	0.00	305,234.87	0.00	0.00
<a href="#">855-0000-8970-0000</a>	OTHER FINANCING SOURCES - B...	0.00	0.00	0.00	5,375,000.00	0.00	0.00
<a href="#">855-0000-8975-0000</a>	OTHER FINANCING USES - BOND...	0.00	0.00	0.00	6,060,378.75	0.00	0.00
<a href="#">855-0000-9950-0000</a>	TRANSFERS IN	0.00	0.00	0.00	0.00	0.00	0.00
<b>Department: 0000 - NON-DEPARTMENTAL Surplus (Deficit):</b>		<b>0.00</b>	<b>-27,980.28</b>	<b>0.00</b>	<b>9,638.96</b>	<b>100.00</b>	<b>0.00</b>
<b>Fund: 855 - BEAUMONT PUBLIC IMPROVEMENT AUTHORITY Surplus (De..</b>		<b>0.00</b>	<b>-27,980.28</b>	<b>0.00</b>	<b>9,638.96</b>	<b>100.00</b>	<b>0.00</b>
<b>Report Surplus (Deficit):</b>		<b>8,784,754.87</b>	<b>-18,895,448.79</b>	<b>1,878,113.95</b>	<b>-35,821,922.11</b>	<b>-2,249,523.00</b>	<b>0.00</b>

**Group Summary**

Defined Budgets

Departmen...	2018-2019 Total Budget	2018-2019 Total Activity	2019-2020 Total Budget	2019-2020 Total Activity	2020-2021 Total Budget	2020-2021 YTD Activity
<b>Fund: 100 - GENERAL FUND</b>						
0000 - NON-DEPARTMENTAL	35,579,470.00	39,195,531.95	37,760,436.08	25,873,091.25	33,018,793.00	0.00
1050 - CITY COUNCIL	79,331.00	48,634.23	99,500.00	81,495.08	48,913.00	0.00
1150 - CITY CLERK	140,066.00	139,100.97	174,506.00	118,893.02	229,694.00	0.00
1200 - ADMINISTRATION	1,077,027.24	1,036,894.63	1,096,330.79	1,122,053.31	2,044,298.00	0.00
1225 - FINANCE AND BUDGETING	922,309.00	1,017,283.54	965,839.00	815,936.59	1,034,306.00	0.00
1230 - I.T.	1,161,758.00	997,863.27	1,159,042.00	700,552.24	1,347,479.00	0.00
1240 - RISK AND HUMAN RESOURCES	1,353,018.00	1,356,956.19	1,650,109.00	1,594,325.34	1,943,177.00	0.00
1300 - LEGAL	750,000.00	1,509,210.63	750,454.00	998,385.15	1,250,500.00	0.00
1350 - COMMUNITY DEVELOPMENT	420,311.00	412,315.93	524,610.00	321,940.77	528,994.00	0.00
1550 - COMMUNITY SERVICES	558,815.00	591,729.99	762,419.00	563,318.95	466,145.00	0.00
2000 - ANIMAL CONTROL	311,810.00	318,688.37	318,204.00	239,898.57	324,893.00	0.00
2030 - COMMUNITY ENHANCEMENT	245,848.00	240,243.43	295,406.00	237,270.33	307,781.00	0.00
2040 - PUBLIC SAFETY - OES	7,000.00	2,803.25	6,000.00	0.00	0.00	0.00
2050 - POLICE	9,294,526.81	9,211,786.04	10,555,647.36	8,836,396.14	9,941,711.00	0.00
2080 - K-9	3,600.00	5,033.28	5,900.00	3,148.60	5,550.00	0.00
2090 - POLICE SUPPORT	1,686,823.00	1,591,571.64	1,696,951.00	1,255,942.66	1,653,658.00	0.00
2100 - FIRE	4,208,130.00	3,422,488.78	4,420,400.00	2,077,668.18	4,579,308.00	0.00
2150 - BUILDING AND SAFETY	1,508,238.00	1,536,600.09	1,292,734.00	882,981.08	1,038,588.00	0.00
3100 - ENGINEERING AND PUBLIC WORKS	1,433,616.00	1,247,329.24	1,296,005.00	861,798.13	1,151,943.00	0.00
3150 - REFUSE	5,000,000.00	5,504,511.68	0.00	0.00	0.00	0.00
3250 - STREET MAINTENANCE	2,118,706.00	1,697,897.70	1,689,661.72	1,241,039.49	1,599,040.00	0.00
6000 - BUILDING MAINTENANCE	540,289.00	523,103.41	525,381.00	435,988.23	434,764.00	0.00
6050 - PARKS AND GROUNDS MAINT	2,747,483.95	2,728,614.93	3,414,255.00	2,453,385.72	3,073,051.00	0.00
6150 - CITY POOL	110,764.00	85,974.68	61,081.00	60,193.02	15,000.00	0.00
<b>Fund: 100 - GENERAL FUND Surplus (Deficit):</b>	<b>-100,000.00</b>	<b>3,968,896.05</b>	<b>5,000,000.21</b>	<b>970,480.65</b>	<b>0.00</b>	<b>0.00</b>
<b>Fund: 110 - SUCCESSOR AGENCY</b>						
0000 - NON-DEPARTMENTAL	-300,000.00	-19,771.18	0.00	0.91	0.00	0.00
<b>Fund: 110 - SUCCESSOR AGENCY Surplus (Deficit):</b>	<b>-300,000.00</b>	<b>-19,771.18</b>	<b>0.00</b>	<b>0.91</b>	<b>0.00</b>	<b>0.00</b>
<b>Fund: 120 - SELF INSURANCE</b>						
0000 - NON-DEPARTMENTAL	0.00	2,248,737.76	0.00	1,215,087.46	0.00	0.00
9663 - GENERAL LIABILITY	0.00	1,448,836.75	0.00	1,290,563.79	0.00	0.00
<b>Fund: 120 - SELF INSURANCE Surplus (Deficit):</b>	<b>0.00</b>	<b>799,901.01</b>	<b>0.00</b>	<b>-75,476.33</b>	<b>0.00</b>	<b>0.00</b>
<b>Fund: 150 - GOVERNMENTAL CAPITAL ASSETS</b>						
0000 - NON-DEPARTMENTAL	0.00	3,410,409.42	-5,100,000.00	0.00	0.00	0.00
<b>Fund: 150 - GOVERNMENTAL CAPITAL ASSETS Surplus (Deficit):</b>	<b>0.00</b>	<b>3,410,409.42</b>	<b>-5,100,000.00</b>	<b>0.00</b>	<b>0.00</b>	<b>0.00</b>
<b>Fund: 200 - HIGHWAY USERS TAX (Gas)</b>						
0000 - NON-DEPARTMENTAL	36,900.00	-159,947.07	100.00	185,221.20	0.00	0.00

Budget Worksheet

Defined Budgets

Departmen...	2018-2019 Total Budget	2018-2019 Total Activity	2019-2020 Total Budget	2019-2020 Total Activity	2020-2021 Total Budget	2020-2021 YTD Activity
<b>Fund: 200 - HIGHWAY USERS TAX (Gas) Surplus (Deficit):</b>	<b>36,900.00</b>	<b>-159,947.07</b>	<b>100.00</b>	<b>185,221.20</b>	<b>0.00</b>	<b>0.00</b>
<b>Fund: 201 - STATE - SB1 FUNDING</b>						
0000 - NON-DEPARTMENTAL	0.00	1,102,060.80	-755,000.00	785,121.71	36,244.00	0.00
<b>Fund: 201 - STATE - SB1 FUNDING Surplus (Deficit):</b>	<b>0.00</b>	<b>1,102,060.80</b>	<b>-755,000.00</b>	<b>785,121.71</b>	<b>36,244.00</b>	<b>0.00</b>
<b>Fund: 202 - SALES TAX - MEASURE A</b>						
0000 - NON-DEPARTMENTAL	0.00	1,542,017.30	-555,300.00	566,784.58	-64,926.00	0.00
<b>Fund: 202 - SALES TAX - MEASURE A Surplus (Deficit):</b>	<b>0.00</b>	<b>1,542,017.30</b>	<b>-555,300.00</b>	<b>566,784.58</b>	<b>-64,926.00</b>	<b>0.00</b>
<b>Fund: 205 - MOTOR VEHICLE SUBVENTION (AB2766-AQMD)</b>						
0000 - NON-DEPARTMENTAL	54,000.00	73,703.37	27,000.00	2,581.65	65,520.00	0.00
<b>Fund: 205 - MOTOR VEHICLE SUBVENTION (AB2766-AQMD) Surplus (Def..)</b>	<b>54,000.00</b>	<b>73,703.37</b>	<b>27,000.00</b>	<b>2,581.65</b>	<b>65,520.00</b>	<b>0.00</b>
<b>Fund: 210 - PUBLIC, EDUCATIONAL, GOVT (PEG)</b>						
0000 - NON-DEPARTMENTAL	54,520.00	47,156.82	-243,000.00	-156,401.28	27,807.00	0.00
<b>Fund: 210 - PUBLIC, EDUCATIONAL, GOVT (PEG) Surplus (Deficit):</b>	<b>54,520.00</b>	<b>47,156.82</b>	<b>-243,000.00</b>	<b>-156,401.28</b>	<b>27,807.00</b>	<b>0.00</b>
<b>Fund: 215 - GRANTS (REIMBURSABLE)</b>						
0000 - NON-DEPARTMENTAL	0.00	0.00	0.00	-94,679.24	0.00	0.00
<b>Fund: 215 - GRANTS (REIMBURSABLE) Surplus (Deficit):</b>	<b>0.00</b>	<b>0.00</b>	<b>0.00</b>	<b>-94,679.24</b>	<b>0.00</b>	<b>0.00</b>
<b>Fund: 220 - CITIZEN OPTION PUBLIC SAFETY (COPS)</b>						
0000 - NON-DEPARTMENTAL	7,400.00	74,073.90	-148,100.00	33,704.46	11,672.00	0.00
<b>Fund: 220 - CITIZEN OPTION PUBLIC SAFETY (COPS) Surplus (Deficit):</b>	<b>7,400.00</b>	<b>74,073.90</b>	<b>-148,100.00</b>	<b>33,704.46</b>	<b>11,672.00</b>	<b>0.00</b>
<b>Fund: 225 - ASSET SEIZURES (STATE)</b>						
0000 - NON-DEPARTMENTAL	-272,600.00	10,018.47	-26,500.00	-15,449.42	6,169.00	0.00
<b>Fund: 225 - ASSET SEIZURES (STATE) Surplus (Deficit):</b>	<b>-272,600.00</b>	<b>10,018.47</b>	<b>-26,500.00</b>	<b>-15,449.42</b>	<b>6,169.00</b>	<b>0.00</b>
<b>Fund: 230 - ASSET SEIZURES (FEDERAL)</b>						
0000 - NON-DEPARTMENTAL	-198,000.00	8,627.14	-200,000.00	-200,000.00	3,028.00	0.00
<b>Fund: 230 - ASSET SEIZURES (FEDERAL) Surplus (Deficit):</b>	<b>-198,000.00</b>	<b>8,627.14</b>	<b>-200,000.00</b>	<b>-200,000.00</b>	<b>3,028.00</b>	<b>0.00</b>
<b>Fund: 240 - OTHER RESTRICTED FUNDS</b>						
0000 - NON-DEPARTMENTAL	0.00	0.00	8,000.00	834.20	0.00	0.00
2080 - K-9	-25,000.00	5,292.22	-13,000.00	-16,787.00	-16,466.00	0.00
2300 - SHOP WITH A COP/HERO	0.00	3,780.58	0.00	1,310.00	-1,227.00	0.00
2310 - EXPLORER PROGRAM	0.00	56.90	0.00	-481.49	147.00	0.00
2320 - AMR EMERGENCY SUPPORT	0.00	-6,960.14	-5,600.00	-1,632.53	-2,000.00	0.00
2330 - SB1186 CASP FEES (BUS LICENSE)	0.00	7,059.60	0.00	2,772.00	2,918.00	0.00
2350 - MILITARY BANNER PROGRAM	0.00	2,420.00	-1,000.00	-2,170.96	-1,956.00	0.00
2360 - PINK PATCHES	0.00	0.00	0.00	-647.50	0.00	0.00
2370 - CAL-RECYCLE	0.00	0.00	0.00	-513.74	1,500.00	0.00
2390 - OTHER PUBLIC SAFETY RESTRICTED	0.00	10.22	0.00	0.00	0.00	0.00
<b>Fund: 240 - OTHER RESTRICTED FUNDS Surplus (Deficit):</b>	<b>-25,000.00</b>	<b>11,659.38</b>	<b>-11,600.00</b>	<b>-17,317.02</b>	<b>-17,084.00</b>	<b>0.00</b>

Budget Worksheet

Defined Budgets

Departmen...	2018-2019 Total Budget	2018-2019 Total Activity	2019-2020 Total Budget	2019-2020 Total Activity	2020-2021 Total Budget	2020-2021 YTD Activity
<b>Fund: 250 - COMMUNITY FAC DISTRICT (CFD) - ADMIN</b>						
0000 - NON-DEPARTMENTAL	0.00	-47,084.98	126,703.00	-807,582.84	-399,267.00	0.00
<b>Fund: 250 - COMMUNITY FAC DISTRICT (CFD) - ADMIN Surplus (Deficit):</b>	<b>0.00</b>	<b>-47,084.98</b>	<b>126,703.00</b>	<b>-807,582.84</b>	<b>-399,267.00</b>	<b>0.00</b>
<b>Fund: 255 - COMMUNITY FAC DISTRICT (CFD) - MAINT SERVICES</b>						
0000 - NON-DEPARTMENTAL	0.00	534,039.38	-5,600.00	1,861,510.61	0.00	0.00
<b>Fund: 255 - COMMUNITY FAC DISTRICT (CFD) - MAINT SERVICES Surplus ..</b>	<b>0.00</b>	<b>534,039.38</b>	<b>-5,600.00</b>	<b>1,861,510.61</b>	<b>0.00</b>	<b>0.00</b>
<b>Fund: 260 - COMMUNITY FAC DISTRICT (CFD) - PUBLIC SAFETY</b>						
0000 - NON-DEPARTMENTAL	40,387.00	196,648.79	151,863.00	115,801.74	0.00	0.00
<b>Fund: 260 - COMMUNITY FAC DISTRICT (CFD) - PUBLIC SAFETY Surplus (...)</b>	<b>40,387.00</b>	<b>196,648.79</b>	<b>151,863.00</b>	<b>115,801.74</b>	<b>0.00</b>	<b>0.00</b>
<b>Fund: 265 - COMMUNITY FAC DISTRICT (CFD) - PUBLIC FACILITIES</b>						
0000 - NON-DEPARTMENTAL	0.00	0.00	560,781.00	0.00	0.00	0.00
<b>Fund: 265 - COMMUNITY FAC DISTRICT (CFD) - PUBLIC FACILITIES Surplus..</b>	<b>0.00</b>	<b>0.00</b>	<b>560,781.00</b>	<b>0.00</b>	<b>0.00</b>	<b>0.00</b>
<b>Fund: 300 - DEBT SERVICE</b>						
0000 - NON-DEPARTMENTAL	0.00	-3,153,312.00	0.00	0.00	0.00	0.00
<b>Fund: 300 - DEBT SERVICE Total:</b>	<b>0.00</b>	<b>-3,153,312.00</b>	<b>0.00</b>	<b>0.00</b>	<b>0.00</b>	<b>0.00</b>
<b>Fund: 500 - GENERAL CAPITAL PROJECTS</b>						
0000 - NON-DEPARTMENTAL	0.00	-353,838.03	0.00	-1,502,075.36	0.00	0.00
<b>Fund: 500 - GENERAL CAPITAL PROJECTS Surplus (Deficit):</b>	<b>0.00</b>	<b>-353,838.03</b>	<b>0.00</b>	<b>-1,502,075.36</b>	<b>0.00</b>	<b>0.00</b>
<b>Fund: 505 - EQUIPMENT REPLACEMENT</b>						
0000 - NON-DEPARTMENTAL	0.00	0.00	0.00	1,147.36	0.00	0.00
<b>Fund: 505 - EQUIPMENT REPLACEMENT Total:</b>	<b>0.00</b>	<b>0.00</b>	<b>0.00</b>	<b>1,147.36</b>	<b>0.00</b>	<b>0.00</b>
<b>Fund: 510 - COMMUNITY FACILITIES DISTRICT (CFD) - CAPITAL FUND</b>						
0000 - NON-DEPARTMENTAL	0.00	-2,806,409.86	-2,338,700.00	17,730.29	-792,999.00	0.00
<b>Fund: 510 - COMMUNITY FACILITIES DISTRICT (CFD) - CAPITAL FUND Sur...</b>	<b>0.00</b>	<b>-2,806,409.86</b>	<b>-2,338,700.00</b>	<b>17,730.29</b>	<b>-792,999.00</b>	<b>0.00</b>
<b>Fund: 550 - DEVELOPMENT IMPACT (MITIGATION)</b>						
0000 - NON-DEPARTMENTAL	-34,000.00	0.00	0.00	-2,775.10	0.00	0.00
<b>Fund: 550 - DEVELOPMENT IMPACT (MITIGATION) Surplus (Deficit):</b>	<b>-34,000.00</b>	<b>0.00</b>	<b>0.00</b>	<b>-2,775.10</b>	<b>0.00</b>	<b>0.00</b>
<b>Fund: 552 - BASIC SERVICES DEVELOPMENT</b>						
0000 - NON-DEPARTMENTAL	167,448.00	0.00	189,873.00	116,329.75	159,408.00	0.00
<b>Fund: 552 - BASIC SERVICES DEVELOPMENT Surplus (Deficit):</b>	<b>167,448.00</b>	<b>0.00</b>	<b>189,873.00</b>	<b>116,329.75</b>	<b>159,408.00</b>	<b>0.00</b>
<b>Fund: 554 - GENERAL PLAN DEVELOPMENT</b>						
0000 - NON-DEPARTMENTAL	20,000.00	0.00	22,500.00	-53,012.82	17,782.00	0.00
<b>Fund: 554 - GENERAL PLAN DEVELOPMENT Surplus (Deficit):</b>	<b>20,000.00</b>	<b>0.00</b>	<b>22,500.00</b>	<b>-53,012.82</b>	<b>17,782.00</b>	<b>0.00</b>
<b>Fund: 555 - RECREATIONAL FACILITIES DEVELOPMENT</b>						
0000 - NON-DEPARTMENTAL	286,196.00	0.00	324,522.00	222,717.09	-633,048.00	0.00
<b>Fund: 555 - RECREATIONAL FACILITIES DEVELOPMENT Surplus (Deficit):</b>	<b>286,196.00</b>	<b>0.00</b>	<b>324,522.00</b>	<b>222,717.09</b>	<b>-633,048.00</b>	<b>0.00</b>
<b>Fund: 556 - TRAFFIC IMPACT DEVELOPMENT</b>						
0000 - NON-DEPARTMENTAL	108,284.00	0.00	-672,924.00	252,357.05	-43,641.00	0.00

Budget Worksheet

Defined Budgets

Departmen...	2018-2019 Total Budget	2018-2019 Total Activity	2019-2020 Total Budget	2019-2020 Total Activity	2020-2021 Total Budget	2020-2021 YTD Activity
<b>Fund: 556 - TRAFFIC IMPACT DEVELOPMENT Surplus (Deficit):</b>	<b>108,284.00</b>	<b>0.00</b>	<b>-672,924.00</b>	<b>252,357.05</b>	<b>-43,641.00</b>	<b>0.00</b>
<b>Fund: 558 - RAILROAD CROSSING DEVELOPMENT</b>						
0000 - NON-DEPARTMENTAL	116,368.00	0.00	131,188.00	-49,957.73	120,518.00	0.00
<b>Fund: 558 - RAILROAD CROSSING DEVELOPMENT Surplus (Deficit):</b>	<b>116,368.00</b>	<b>0.00</b>	<b>131,188.00</b>	<b>-49,957.73</b>	<b>120,518.00</b>	<b>0.00</b>
<b>Fund: 559 - POLICE FACILITIES DEVELOPMENT</b>						
0000 - NON-DEPARTMENTAL	196,412.00	0.00	222,714.00	159,021.80	-65,809.00	0.00
<b>Fund: 559 - POLICE FACILITIES DEVELOPMENT Surplus (Deficit):</b>	<b>196,412.00</b>	<b>0.00</b>	<b>222,714.00</b>	<b>159,021.80</b>	<b>-65,809.00</b>	<b>0.00</b>
<b>Fund: 560 - FIRE STATION DEVELOPMENT</b>						
0000 - NON-DEPARTMENTAL	227,472.00	0.00	257,935.00	147,305.10	237,204.00	0.00
<b>Fund: 560 - FIRE STATION DEVELOPMENT Surplus (Deficit):</b>	<b>227,472.00</b>	<b>0.00</b>	<b>257,935.00</b>	<b>147,305.10</b>	<b>237,204.00</b>	<b>0.00</b>
<b>Fund: 562 - ROAD AND BRIDGE DEVELOPMENT</b>						
0000 - NON-DEPARTMENTAL	485,884.00	0.00	911,450.00	354,237.22	390,891.00	0.00
<b>Fund: 562 - ROAD AND BRIDGE DEVELOPMENT Surplus (Deficit):</b>	<b>485,884.00</b>	<b>0.00</b>	<b>911,450.00</b>	<b>354,237.22</b>	<b>390,891.00</b>	<b>0.00</b>
<b>Fund: 564 - RECYCLED WATER DEVELOPMENT</b>						
0000 - NON-DEPARTMENTAL	264,656.00	0.00	353,988.00	-958,459.43	296,639.00	0.00
<b>Fund: 564 - RECYCLED WATER DEVELOPMENT Surplus (Deficit):</b>	<b>264,656.00</b>	<b>0.00</b>	<b>353,988.00</b>	<b>-958,459.43</b>	<b>296,639.00</b>	<b>0.00</b>
<b>Fund: 566 - EMERGENCY PREPAREDNESS DEVELOPMENT</b>						
0000 - NON-DEPARTMENTAL	291,852.00	0.00	353,988.00	231,227.21	258,289.00	0.00
<b>Fund: 566 - EMERGENCY PREPAREDNESS DEVELOPMENT Surplus (Deficit):</b>	<b>291,852.00</b>	<b>0.00</b>	<b>353,988.00</b>	<b>231,227.21</b>	<b>258,289.00</b>	<b>0.00</b>
<b>Fund: 567 - COMMUNITY PARK DEVELOPMENT</b>						
0000 - NON-DEPARTMENTAL	939,828.00	0.00	1,061,707.00	152,139.79	-892,533.00	0.00
<b>Fund: 567 - COMMUNITY PARK DEVELOPMENT Surplus (Deficit):</b>	<b>939,828.00</b>	<b>0.00</b>	<b>1,061,707.00</b>	<b>152,139.79</b>	<b>-892,533.00</b>	<b>0.00</b>
<b>Fund: 568 - REGIONAL PARK DEVELOPMENT</b>						
0000 - NON-DEPARTMENTAL	0.00	0.00	0.00	10,412.82	-1,900,000.00	0.00
<b>Fund: 568 - REGIONAL PARK DEVELOPMENT Surplus (Deficit):</b>	<b>0.00</b>	<b>0.00</b>	<b>0.00</b>	<b>10,412.82</b>	<b>-1,900,000.00</b>	<b>0.00</b>
<b>Fund: 569 - NEIGHBORHOOLD PARK DEVELOPMENT</b>						
0000 - NON-DEPARTMENTAL	1,137,348.00	0.00	1,284,844.00	184,745.94	-1,044,471.00	0.00
<b>Fund: 569 - NEIGHBORHOOLD PARK DEVELOPMENT Surplus (Deficit):</b>	<b>1,137,348.00</b>	<b>0.00</b>	<b>1,284,844.00</b>	<b>184,745.94</b>	<b>-1,044,471.00</b>	<b>0.00</b>
<b>Fund: 570 - DIF PASS THROUGH FUNDS</b>						
0000 - NON-DEPARTMENTAL	0.00	0.00	0.00	37,762.35	0.00	0.00
<b>Fund: 570 - DIF PASS THROUGH FUNDS Total:</b>	<b>0.00</b>	<b>0.00</b>	<b>0.00</b>	<b>37,762.35</b>	<b>0.00</b>	<b>0.00</b>
<b>Fund: 700 - WASTEWATER FUND</b>						
0000 - NON-DEPARTMENTAL	8,864,240.00	9,034,913.36	5,205,299.36	4,603,606.80	5,251,013.00	0.00
4050 - SEWER OPERATIONS	5,190,874.00	4,301,236.73	5,828,367.18	3,960,811.25	5,251,013.00	0.00
<b>Fund: 700 - WASTEWATER FUND Surplus (Deficit):</b>	<b>3,673,366.00</b>	<b>4,733,676.63</b>	<b>-623,067.82</b>	<b>642,795.55</b>	<b>0.00</b>	<b>0.00</b>
<b>Fund: 705 - WASTEWATER DEVELOPMENT</b>						
0000 - NON-DEPARTMENTAL	-300,000.00	-3,565,146.08	-1,104,971.00	-1,890,693.30	-179,758.00	0.00
6005 - CAPACITY FEES	2,050,000.00	3,447,543.18	2,398,500.00	1,743,717.46	1,935,877.00	0.00

Budget Worksheet

Defined Budgets

Departmen...	2018-2019 Total Budget	2018-2019 Total Activity	2019-2020 Total Budget	2019-2020 Total Activity	2020-2021 Total Budget	2020-2021 YTD Activity
6015 - UPPER POTRERO	0.00	0.00	0.00	0.00	0.00	0.00
6020 - LOWER POTRERO	0.00	40,488.40	24,600.00	11,823.75	0.00	0.00
6025 - SAN TIMOTEO NO-2 (LOWER OAK VALLEY)	0.00	0.00	0.00	0.00	0.00	0.00
6026 - SAN TIMOTEO NO-3 (BEAUMONT MESA)	0.00	13,790.58	12,097.00	16,693.86	60,485.00	0.00
6030 - SOUTHERN TRUNK MAIN	0.00	8,317.86	6,760.00	2,165.79	0.00	0.00
6065 - WILLOW SPRINGS	0.00	55,006.06	0.00	0.00	0.00	0.00
<b>Fund: 705 - WASTEWATER DEVELOPMENT Surplus (Deficit):</b>	<b>1,750,000.00</b>	<b>0.00</b>	<b>1,336,986.00</b>	<b>-116,292.44</b>	<b>1,816,604.00</b>	<b>0.00</b>
<b>Fund: 710 - WASTEWATER CAPITAL PROJECTS</b>						
0000 - NON-DEPARTMENTAL	0.00	-5,480,943.13	0.00	-35,864,297.21	0.00	0.00
<b>Fund: 710 - WASTEWATER CAPITAL PROJECTS Surplus (Deficit):</b>	<b>0.00</b>	<b>-5,480,943.13</b>	<b>0.00</b>	<b>-35,864,297.21</b>	<b>0.00</b>	<b>0.00</b>
<b>Fund: 750 - TRANSIT FUND</b>						
0000 - NON-DEPARTMENTAL	2,721,860.00	2,684,122.75	3,039,329.00	2,491,772.83	3,084,384.00	0.00
7000 - TRANSIT ADMINISTRATION	679,683.00	696,561.05	621,114.00	505,378.02	186,304.00	0.00
7100 - DIAL-A-RIDE	204,219.00	215,906.78	214,386.00	199,215.21	273,787.00	0.00
7200 - FIXED ROUTE	1,150,368.00	1,025,390.38	1,223,363.00	83,670.35	0.00	0.00
7300 - VEHICLE MAINTENANCE	428,776.00	463,077.60	545,344.00	417,347.31	537,841.00	0.00
7400 - ROUTE 120	114,745.00	224,140.24	246,865.00	393,164.89	553,369.00	0.00
7500 - ROUTE 136	126,309.00	14,204.87	0.00	13,964.47	0.00	0.00
7600 - ROUTE 125	17,760.00	157,036.94	188,257.00	178,488.70	247,147.00	0.00
7700 - ROUTE 2	0.00	0.00	0.00	164,053.24	286,760.00	0.00
7800 - ROUTE 3	0.00	110.48	0.00	105,356.91	231,804.00	0.00
7900 - ROUTE 4	0.00	0.00	0.00	101,473.96	200,739.00	0.00
8000 - ROUTE 3/4	0.00	0.00	0.00	43,975.63	78,685.00	0.00
8100 - ROUTE 7	0.00	0.00	0.00	79,647.62	95,066.00	0.00
8200 - ROUTE 9	0.00	0.00	0.00	26,430.43	84,593.00	0.00
<b>Fund: 750 - TRANSIT FUND Surplus (Deficit):</b>	<b>0.00</b>	<b>-112,305.59</b>	<b>0.00</b>	<b>179,606.09</b>	<b>308,289.00</b>	<b>0.00</b>
<b>Fund: 755 - TRANSIT GASB68 FUND</b>						
0000 - NON-DEPARTMENTAL	0.00	-37,489.00	0.00	0.00	-308,289.00	0.00
<b>Fund: 755 - TRANSIT GASB68 FUND Surplus (Deficit):</b>	<b>0.00</b>	<b>-37,489.00</b>	<b>0.00</b>	<b>0.00</b>	<b>-308,289.00</b>	<b>0.00</b>
<b>Fund: 760 - TRANSIT CAPITAL PROJECTS</b>						
0000 - NON-DEPARTMENTAL	0.00	1,082,387.51	0.00	-268,568.18	0.00	0.00
<b>Fund: 760 - TRANSIT CAPITAL PROJECTS Surplus (Deficit):</b>	<b>0.00</b>	<b>1,082,387.51</b>	<b>0.00</b>	<b>-268,568.18</b>	<b>0.00</b>	<b>0.00</b>
<b>Fund: 840 - COMMUNITY FACILITIES DISTRICT (CFD) - BOND MGMT</b>						
0000 - NON-DEPARTMENTAL	-143,966.13	-27,424,113.28	179,751.56	-3,829,513.02	0.00	0.00
<b>Fund: 840 - COMMUNITY FACILITIES DISTRICT (CFD) - BOND MGMT Surp..</b>	<b>-143,966.13</b>	<b>-27,424,113.28</b>	<b>179,751.56</b>	<b>-3,829,513.02</b>	<b>0.00</b>	<b>0.00</b>
<b>Fund: 850 - BEAUMONT FINANCING AUTHORITY (CFD)</b>						
0000 - NON-DEPARTMENTAL	0.00	-3,174,154.36	60,012.00	949,553.43	156,380.00	0.00
<b>Fund: 850 - BEAUMONT FINANCING AUTHORITY (CFD) Surplus (Deficit):</b>	<b>0.00</b>	<b>-3,174,154.36</b>	<b>60,012.00</b>	<b>949,553.43</b>	<b>156,380.00</b>	<b>0.00</b>

Budget Worksheet

For Fiscal: 2020-2021 Period Ending Item 9. 1  
 Defined Budgets

Departmen...	2018-2019 Total Budget	2018-2019 Total Activity	2019-2020 Total Budget	2019-2020 Total Activity	2020-2021 Total Budget	2020-2021 YTD Activity
<b>Fund: 855 - BEAUMONT PUBLIC IMPROVEMENT AUTHORITY</b>						
0000 - NON-DEPARTMENTAL	0.00	-27,980.28	0.00	9,638.96	100.00	0.00
<b>Fund: 855 - BEAUMONT PUBLIC IMPROVEMENT AUTHORITY Surplus (De..</b>	<b>0.00</b>	<b>-27,980.28</b>	<b>0.00</b>	<b>9,638.96</b>	<b>100.00</b>	<b>0.00</b>
<b>Report Surplus (Deficit):</b>	<b>8,784,754.87</b>	<b>-18,895,448.79</b>	<b>1,878,113.95</b>	<b>-35,821,922.11</b>	<b>-2,249,523.00</b>	<b>0.00</b>



**Fund Summary**

Fund	Defined Budgets					
	2018-2019 Total Budget	2018-2019 Total Activity	2019-2020 Total Budget	2019-2020 Total Activity	2020-2021 Total Budget	2020-2021 YTD Activity
100 - GENERAL FUND	-100,000.00	3,968,896.05	5,000,000.21	970,480.65	0.00	0.00
110 - SUCCESSOR AGENCY	-300,000.00	-19,771.18	0.00	0.91	0.00	0.00
120 - SELF INSURANCE	0.00	799,901.01	0.00	-75,476.33	0.00	0.00
150 - GOVERNMENTAL CAPITAL ASSETS	0.00	3,410,409.42	-5,100,000.00	0.00	0.00	0.00
200 - HIGHWAY USERS TAX (Gas)	36,900.00	-159,947.07	100.00	185,221.20	0.00	0.00
201 - STATE - SB1 FUNDING	0.00	1,102,060.80	-755,000.00	785,121.71	36,244.00	0.00
202 - SALES TAX - MEASURE A	0.00	1,542,017.30	-555,300.00	566,784.58	-64,926.00	0.00
205 - MOTOR VEHICLE SUBVENTION (AB2766-AQMD)	54,000.00	73,703.37	27,000.00	2,581.65	65,520.00	0.00
210 - PUBLIC, EDUCATIONAL, GOVT (PEG)	54,520.00	47,156.82	-243,000.00	-156,401.28	27,807.00	0.00
215 - GRANTS (REIMBURSABLE)	0.00	0.00	0.00	-94,679.24	0.00	0.00
220 - CITIZEN OPTION PUBLIC SAFETY (COPS)	7,400.00	74,073.90	-148,100.00	33,704.46	11,672.00	0.00
225 - ASSET SEIZURES (STATE)	-272,600.00	10,018.47	-26,500.00	-15,449.42	6,169.00	0.00
230 - ASSET SEIZURES (FEDERAL)	-198,000.00	8,627.14	-200,000.00	-200,000.00	3,028.00	0.00
240 - OTHER RESTRICTED FUNDS	-25,000.00	11,659.38	-11,600.00	-17,317.02	-17,084.00	0.00
250 - COMMUNITY FAC DISTRICT (CFD) - ADMIN	0.00	-47,084.98	126,703.00	-807,582.84	-399,267.00	0.00
255 - COMMUNITY FAC DISTRICT (CFD) - MAINT SERVICES	0.00	534,039.38	-5,600.00	1,861,510.61	0.00	0.00
260 - COMMUNITY FAC DISTRICT (CFD) - PUBLIC SAFETY	40,387.00	196,648.79	151,863.00	115,801.74	0.00	0.00
265 - COMMUNITY FAC DISTRICT (CFD) - PUBLIC FACILITIES	0.00	0.00	560,781.00	0.00	0.00	0.00
300 - DEBT SERVICE	0.00	3,153,312.00	0.00	0.00	0.00	0.00
500 - GENERAL CAPITAL PROJECTS	0.00	-353,838.03	0.00	-1,502,075.36	0.00	0.00
505 - EQUIPMENT REPLACEMENT	0.00	0.00	0.00	1,147.36	0.00	0.00
510 - COMMUNITY FACILITIES DISTRICT (CFD) - CAPITAL FUND	0.00	-2,806,409.86	-2,338,700.00	17,730.29	-792,999.00	0.00
550 - DEVELOPMENT IMPACT (MITIGATION)	-34,000.00	0.00	0.00	-2,775.10	0.00	0.00
552 - BASIC SERVICES DEVELOPMENT	167,448.00	0.00	189,873.00	116,329.75	159,408.00	0.00
554 - GENERAL PLAN DEVELOPMENT	20,000.00	0.00	22,500.00	-53,012.82	17,782.00	0.00
555 - RECREATIONAL FACILITIES DEVELOPMENT	286,196.00	0.00	324,522.00	222,717.09	-633,048.00	0.00
556 - TRAFFIC IMPACT DEVELOPMENT	108,284.00	0.00	-672,924.00	252,357.05	-43,641.00	0.00
558 - RAILROAD CROSSING DEVELOPMENT	116,368.00	0.00	131,188.00	-49,957.73	120,518.00	0.00
559 - POLICE FACILITIES DEVELOPMENT	196,412.00	0.00	222,714.00	159,021.80	-65,809.00	0.00
560 - FIRE STATION DEVELOPMENT	227,472.00	0.00	257,935.00	147,305.10	237,204.00	0.00
562 - ROAD AND BRIDGE DEVELOPMENT	485,884.00	0.00	911,450.00	354,237.22	390,891.00	0.00
564 - RECYCLED WATER DEVELOPMENT	264,656.00	0.00	353,988.00	-958,459.43	296,639.00	0.00
566 - EMERGENCY PREPAREDNESS DEVELOPMENT	291,852.00	0.00	353,988.00	231,227.21	258,289.00	0.00
567 - COMMUNITY PARK DEVELOPMENT	939,828.00	0.00	1,061,707.00	152,139.79	-892,533.00	0.00
568 - REGIONAL PARK DEVELOPMENT	0.00	0.00	0.00	10,412.82	-1,900,000.00	0.00
569 - NEIGHBORHOOD PARK DEVELOPMENT	1,137,348.00	0.00	1,284,844.00	184,745.94	-1,044,471.00	0.00
570 - DIF PASS THROUGH FUNDS	0.00	0.00	0.00	37,762.35	0.00	0.00
700 - WASTEWATER FUND	3,673,366.00	4,733,676.63	-623,067.82	642,795.55	0.00	0.00
705 - WASTEWATER DEVELOPMENT	1,750,000.00	0.00	1,336,986.00	-116,292.44	1,816,604.00	0.00
710 - WASTEWATER CAPITAL PROJECTS	0.00	-5,480,943.13	0.00	-35,864,297.21	0.00	0.00

**Budget Worksheet**

For Fiscal: 2020-2021 Period Ending Item 9. 1

750 - TRANSIT FUND	0.00	-112,305.59	0.00	179,606.09	308,289.00	0.00
755 - TRANSIT GASB68 FUND	0.00	-37,489.00	0.00	0.00	-308,289.00	0.00
760 - TRANSIT CAPITAL PROJECTS	0.00	1,082,387.51	0.00	-268,568.18	0.00	0.00
840 - COMMUNITY FACILITIES DISTRICT (CFD) - BOND MGMT	-143,966.13	-27,424,113.28	179,751.56	-3,829,513.02	0.00	0.00
850 - BEAUMONT FINANCING AUTHORITY (CFD)	0.00	-3,174,154.36	60,012.00	949,553.43	156,380.00	0.00
855 - BEAUMONT PUBLIC IMPROVEMENT AUTHORITY	0.00	-27,980.28	0.00	9,638.96	100.00	0.00
<b>Report Surplus (Deficit):</b>	<b>8,784,754.87</b>	<b>-18,895,448.79</b>	<b>1,878,113.95</b>	<b>-35,821,922.11</b>	<b>-2,249,523.00</b>	<b>0.00</b>



## Staff Report

**TO:** Mayor, and City Council Members  
**FROM:** Jeff Mohlenkamp, Finance Director  
**DATE** June 2, 2020  
**SUBJECT: Approval of Contract for Auditing Services**

---

### Background and Analysis:

The City Council has assigned the Finance and Audit Committee the responsibility to prepare a request for proposal (RFP) and to recommend an auditor for the City's financial statements.

For the past three years, the City has contracted with the Pun Group, LLP to perform both the independent audit of the City's financial statements and to complete the review of internal controls and a single audit report. While the contract provides the option for two one-year extensions, best practice for governmental entities is to secure competitive bids.

The Finance and Audit Committee assigned two members, Baron Ginnetti (Chair) and Steve Cooley (member) to work with staff on the preparation of an RFP and evaluation of responses. The other two members of the RFP committee were Jeff Mohlenkamp, Finance Director, and Lisa Leach, Senior Accountant. The City issued an RFP on March 6, 2020. The RFP is included as Attachment A. Three CPA firms responded to the RFP as follows:

- Rogers, Anderson, Malody and Scott, LLP (RAMS),
- Eadie and Payne, LLP (Eadie and Payne), and
- The PUN Group, LLP.

After review and scoring of the RFP submissions, RAMS and Eadie and Payne were selected to move forward to an interview. Interviews were conducted on May 7, 2020. After deliberation, the RFP committee recommended RAMS as the respondent to present to the Finance and Audit Committee.

Contributing factors to the recommendation that RAMS be selected include the following:

- RAMS has direct expertise with many cities that are similar in size to Beaumont;
- RAMS has strong local connections with headquarters in San Bernardino and many clients in the Inland Empire and surrounding areas;
- RAMS has a clear focus on governmental auditing and consulting with this constituting over 80% of their business activity;
- RAMS was able to demonstrate a strong background in community financing districts, development impact fees and other areas very important to our City; and
- RAMS provided the lowest bid price.

The Finance committee met on May 11, 2020, and unanimously recommended that the contract for audit services be negotiated with RAMS and taken before the City Council for consideration.

A contract has been negotiated for audit services beginning with the audit of FY 2020 for three years with options for two additional one-year extensions (see Attachment B.)

**Fiscal Impact:**

The contract amount (not to exceed) for the three-year period is as follows:

FY 2020	\$46,200
FY 2021	\$46,200
FY 2022	\$47,350

This planned expenditure is within the budgeted allocation for the upcoming FY 2021 and is contemplated to be an ongoing expenditure of the City as we are required to have an independent audit of our financial statements.

**Recommended Action:**

Approve a three-year contract with Rogers, Anderson, Malody and Scott, LLP to perform audit services with options for 2 one-year extensions.

**Attachments:**

- A. RFP for City Audit Services issued on March 6, 2020.

- B. Contract with Rogers, Anderson, Malody and Scott, LLP to perform audit services
- C. Contract Exhibit A – RAMS RFP proposal
- D. Contract Exhibit B – Audit Engagement Letter
- E. Contract Exhibit C – Certificates of Insurance



## **CITY OF BEAUMONT**

550 E. Sixth Street, Beaumont, CA 92223  
Phone: (951) 572-3236 Fax: (951) 769-8526

# **REQUEST FOR PROPOSAL**

## **PROFESSIONAL AUDITING SERVICES**

### **CITY OF BEAUMONT FINANCE DEPARTMENT**

Jeff Mohlenkamp, Director of Finance  
550 E. 6th Street - Beaumont, California 92223

(951) 572-3236  
e-mail address: [jmohlenkamp@beaumontca.gov](mailto:jmohlenkamp@beaumontca.gov)

**Proposals Due By:**

12:00 Noon  
Friday, April 3, 2020

RFP Available online at:  
Public Purchase, CSMFO, GFOA and  
[www.ci.beaumont.ca.us](http://www.ci.beaumont.ca.us)

# Table of Contents

## Request for Proposal

Introduction.....2

Background.....2

Project Schedule.....2

Response Submittal.....4

General Requirements.....4

Proposal Requirements.....5

Overview and Scope of Services.....6

Selection Process.....6

### Attachment I

Contract Services Agreement.....8-16

### Attachment II

Contract Services Agreement.....17-20

### Attachment III

Cost Summary.....21

# CITY OF BEAUMONT REQUEST FOR PROPOSAL PROFESSIONAL AUDITING SERVICES

## INTRODUCTION

The City of Beaumont is requesting qualified public accounting firms to submit proposals to audit the City's financial statements for the three (3) fiscal years beginning with the year ending June 30, 2020, with the option of extending the contract for two (2) additional one-year periods, at the City's sole discretion. These audits are to be performed in accordance with generally accepted auditing standards, *Governmental Auditing Standards* issued by the Comptroller General of the United States, and U.S. Office of Management and Budget (OMB) Circular A-133 *Audits of States, Local Governments, and Non-Profit Organizations*. Additional information is found in the Scopes of Services (Attachment II).

### Background Information

The City of Beaumont is a general law city incorporated in 1912 currently serving a population of approximately 49,000, located in Western Riverside County. The City operates under a council-manager format of government which consists of a Mayor, Mayor Pro-Tem, three Councilmembers and the City Manager. The positions of Mayor and Mayor Pro-Tem are rotated among the elected Councilmembers. A City Clerk and Treasurer are elected positions, each for a four-year term.

In addition to its function as the governing body of the City, the City Council acts as the governing body for other separate entities: Beaumont Financing Authority, Beaumont Transit System, and Beaumont Utility Authority. The City's management also has custodial, accounting and financial reporting responsibilities for the Successor Agency to the City of Beaumont Redevelopment Agency. There is no requirement for separate financial reporting for these separate entities with one exception (Beaumont Transit System).

Official accounting records are on-site in the Finance Department, while some supporting information may be located in other departments within the City. Beaumont uses the Tyler Incode 10 accounting software and Tyler Incode 9 centralized cashiering system for receipts and sewer utility billing. Payroll is processed through Paychex. We are in the process of upgrading the cashiering system to Incode 10 and should be complete by June 30, 2020.

Relevant operational detail for conducting the independent financial audit is provided as follows:

1. The Finance Department consists of the Finance Director, and five (5) staff members responsible for accounting and financial reporting, budgeting, payroll, accounts payable, revenue recording, banking and treasury investment, purchase order and project accounting tracking. Revenues are collected at various locations throughout the City and recorded into Tyler Incode 9 by non-finance department personnel.



2. City Funds and Account Groups are as follows:
  - a. General Fund (1)
  - b. Internal Service Funds (2)
  - c. Special Revenue Funds (9)
  - d. Debt Service Fund (1)
  - e. Capital Project Funds (17)
  - f. Enterprise Funds (7)
  - g. Agency Funds (4)
  
3. The City, organized into eight departments (Administration, Finance and Budget, IT, Risk and Human Resources, Community Development, Community Services, Public Safety, Public Works), provides a full range of municipal services. In addition, the City has component units including the Successor Agency, Beaumont Utility Authority, Beaumont Financing Authority, and Beaumont Transit System. Public Safety Fire services are contracted with Cal Fire, but Animal Control, Code Enforcement, Police and Dispatch are performed by City employees.
  
4. The City's total expected payroll for the year ended June 30, 2020 is approximately \$18 million, covering 143 budgeted full-time and part-time positions. The total municipal budget for the 2019-20 fiscal year is approximately \$60 million.

For further information, City's past two years AFRs' and current and last year adopted budget are located on the City's website at: <https://beaumontca.gov/921/Audits-and-Reports>

The PUN Group, LLC served as the City's auditor in the past years.

### Project Schedule

RFP Issued	Friday, March 6, 2020
Questions Due	Friday, March 20, 2020
Responses to questions provided by	Friday, March 27, 2020
Submittals Due	Friday, April 3, 2020, 12:00 p.m.
Staff Review	April 6, 2020 to April 10, 2020
Presentations/Interview	Week of April 20,2020
City Council review/approval	Tuesday, May 19, 2020
Implementation begins	Monday, July 06, 2020

## Response Submittal

Interested firms shall submit three (3) copies of the proposal **no later than April 3, 2020 at 12:00p.m.** No late submittals will be accepted. “City of Beaumont 2020 Professional Auditing Services RFP” must be clearly marked on the outside of the envelope:

**Submit Proposal to:**

City of Beaumont  
550 E. 6<sup>th</sup> Street  
Beaumont, CA 92223

Additionally, one electronic copy of the proposal shall be sent to [finance@beaumontca.gov](mailto:finance@beaumontca.gov) by 12:00p.m. on April 3, 2020 for a proposal to be considered.

Any requests for clarification or other questions concerning this RFP must be submitted via email to Lisa Leach (as shown below) no later than March 20, 2020. Responses to all questions will be provided to all know interested parties by March 27, 2020.

Lisa Leach, CPA, Senior Accountant  
Email:lleach@beaumontca.gov

## General Requirements

The City of Beaumont reserves the right to reject any or all responses, to waive any informality in any responses, and to select the vendor that best meets the City’s needs.

There is no expressed or implied obligation for the City to reimburse responding firms for any expenses incurred in preparing proposals in response to this request. Materials submitted by respondents are subject to public inspection under the California Public Records Act (Government Code Sec. 6250 et seq.) unless exempt. Any language purporting to render the entire proposal confidential or proprietary will be ineffective and will be disregarded.

All property rights, including publication rights of all reports produced by respondents in connection with services performed under this agreement will be vested in the City. In addition, respondents will not publish or release any of the results of its examination without the express written permission of the City.

Responses must be submitted no later than the date and time stated on this RFP. Responses shall be reviewed and rated as set forth in the Selection Process section of this RFP. The City will then determine which firm best meets the City’s requirements.

During the evaluation process, the City reserves the right (where it may serve the City’s best interest) to request additional information or clarification from respondents. At the discretion of the City, firms submitting proposals may be requested to make oral presentations as part of the evaluation process.

The City reserves the right to retain all proposals submitted and to use any ideas in a proposal regardless of whether the proposal was selected. Submission of a proposal indicates acceptance by the firm of the conditions contained in this Request for Proposals, unless clearly and specifically noted in the proposal as submitted and confirmed in the contract between the City and the firm selected.

The City reserves the right to negotiate final pricing with the most qualified firm. The City may invite selected firms to meet with the evaluation team on or around the week of April 20, 2020, at no additional cost to the City.

The City's standard Contract Services Agreement is included as Attachment I. Upon award of the contract, it is expected that the successful proposer will accept the Agreement terms and conditions "as is" without modification. Any contract modifications are to be stated upfront, at the time of submittal.

Any costs incurred in the preparation of the response, presentation to the City, travel in conjunction with such presentations, or samples of items shall be the responsibility of the respondent. The City assumes no responsibility and no liability for costs incurred by respondents prior to issuance of a contract.

The proposer shall furnish the City with such additional information as the City may reasonably require.

## **PROPOSAL REQUIREMENTS**

The City requests responses be organized in a logical format that is relevant to these services. The responses shall also be concise, excluding excessive or irrelevant material.

*Personnel* - This section shall identify the Partner, Manager, and other key personnel and any subconsultants assigned to the services. Provide information on the training, government auditing experience, and specialized skills of each person.

*Company Background* - Firms must provide the following information regarding the organization:

- Name
- Street Address
- City, State, Zip Code
- Corporate Structure
- State/Country of Incorporation
- Website
- License #
- Contact Information

In addition, please include the size of the firm, the size of the firm's governmental audit staff, and the location of the office from which the work on this engagement will be performed.

Firms should provide an affirmative statement that it is independent of the City as defined by generally accepted auditing standards and the U.S. General Accounting Office's Government Auditing Standards. Firms should provide an affirmative statement that the firm and all assigned key professional staff are properly licensed to practice in California.

Firms shall provide information on the circumstances and status of any disciplinary action taken or pending against the firm with state regulatory bodies or professional organizations, as well as any pending or settled litigation, during the past three years.

Peer Review - Firms shall submit a copy of its most recent quality control review. Quality control reviews older than 3 years will not be considered.

Audit Approach - The proposal should set forth a detailed work plan, including an explanation of the audit methodology for providing the services required in this RFP. Include a proposed timeline for the fiscal year 2019-20 audit.

Specific Expertise Desired –The City has extensive use of Community Facility Districts (CFDs), Development Impact Fees (DIFs) and land secured bond issuances. Direct expertise in these areas is desired. Please provide your experience and knowledge in these areas.

References - For the firm’s office that will be assigned responsibility for the audit, provide a list of the most significant engagements performed in the last five years that are similar to the engagement described in this Request for Proposal. Indicate the scope of work, dates, engagement partners, total hours and contact information for the client.

Cost Summary - The Cost Summary should contain, itemized pricing for each of the five potential fiscal years. The total maximum annual price should contain all direct and indirect costs, including out-of-pocket expenses. Please use the Cost Summary (Attachment III) to submit pricing. In your proposal, please indicate any specific costing elements such as footnote disclosures that impact the overall cost, such as preparation of GASB 68 reporting.

The proposal should include the anticipated number of hours and distribution by staff classification. The proposal should also include a schedule of rates by professional staff classifications for audit services and consulting services. Please indicate if your proposal includes a “not to exceed” quote.

Signature - The response shall be signed by an official authorized to bind the firm and shall contain a statement to the effect that the proposal is valid for ninety (90) days.

### **Overview and Scope of Services**

The request for Proposals is for Professional Auditing Services as set forth in Attachment II – Scope of Services.

### **Selection Process**

Staff will review the proposals and make a recommendation to the City Council for review (tentatively scheduled for May 19, 2020). The City intends to evaluate the proposals based upon the data presented in response to the RFP. The following general selection criteria will be used to evaluate each proposal:

1. Ability to meet service requirements; understanding the needs and requirements of the City; scope and services offered.
2. Experience, qualifications and knowledge of key personnel; references for similar work completed within the last three years. (Particular emphasis will be placed in the area of customer support.)
3. Proposed pricing.
4. Completeness of responses to the Request for Proposals

**Attachment I**

**AGREEMENT FOR PROFESSIONAL SERVICES BY INDEPENDENT CONTRACTOR**Error!  
Bookmark not defined.

THIS AGREEMENT FOR PROFESSIONAL SERVICES BY INDEPENDENT CONTRACTOR is made and effective as of the \_\_\_\_\_ day of \_\_\_\_\_, 2019, by and between the CITY OF BEAUMONT (“CITY”) whose address is 550 E. 6<sup>th</sup> Street, Beaumont, California 92223 and \_\_\_\_\_ whose address is \_\_\_\_\_ (“CONTRACTOR”).

**RECITALS**

This Agreement is entered into on the basis of the following facts, understandings and intentions of the parties to this Agreement:

A. CITY desires to engage CONTRACTOR to provide \_\_\_\_\_; and

B. CONTRACTOR has made a proposal (“Proposal”) to the CITY to provide such professional services, which Proposal is attached hereto as Exhibit “A”; and

C. CONTRACTOR agrees to provide such services pursuant to, and in accordance with, the terms and conditions of this Agreement, and represents and warrants to CITY that CONTRACTOR possesses the necessary skills, licenses, certifications, qualifications, personnel and equipment to provide such services.

**AGREEMENT**

NOW, THEREFORE, in consideration of the foregoing Recitals and mutual covenants contained herein, CITY and CONTRACTOR agree as follows:

1. Term of Agreement. This Agreement is effective as of the date first above written and shall continue until terminated as provided for herein. Notwithstanding anything in this Agreement to the contrary, this Agreement shall automatically terminate after three (3) years unless extended by the parties with the approval of the City Council of the CITY up to an additional two (2) years.

2. Services to be Performed. CONTRACTOR agrees to provide the services (“Services”) as follows: \_\_\_\_\_ per Exhibit “A” and any other services which the City may request in writing. All Services shall be performed in the manner and according to the timeframe set forth in the Proposal. CONTRACTOR designates Ming Guan as CONTRACTOR’S professional responsible for overseeing the Services provided by CONTRACTOR.

3. Associates and Subcontractors. CONTRACTOR may, at CONTRACTOR's sole cost and expense, employ such competent and qualified independent associates, subcontractors and consultants as CONTRACTOR deems necessary to perform the Services; provided, however, that CONTRACTOR shall not subcontract any of the Services without the written consent of CITY.

4. Compensation.

4.01 CONTRACTOR shall be paid at the rates set forth in the Proposal and shall not increase any rate without the prior written consent of the CITY. Notwithstanding anything in this Agreement to the contrary, total fees and charges paid by CITY to CONTRACTOR under this Agreement shall not exceed \_\_\_\_\_.

4.02 CONTRACTOR shall not be compensated for any Services rendered nor reimbursed for any expenses incurred in excess of those authorized unless approved in advance by the CITY, in writing.

4.03 CONTRACTOR shall submit to CITY, on or before the fifteenth (15<sup>th</sup>) of each month, itemized invoices for the Services rendered in the previous month. The CITY shall not be obligated to pay any invoice that is submitted more than sixty (60) days after the due date of such invoice. CITY shall have the right to review and audit all invoices prior to or after payment to CONTRACTOR. This review and audit may include, but not be limited to CITY's:

- a. Determination that any hourly fee charged is consistent with this Agreement's approved hourly rate schedule;
- b. Determination that the multiplication of the hours billed times the approved rate schedule dollars is correct;
- c. Determination that each item charged is the usual, customary, and reasonable charge for the particular item. If CITY determines an item charged is greater than usual, customary, or reasonable, or is duplicative, ambiguous, excessive, or inappropriate, CITY shall either return the bill to CONTRACTOR with a request for explanation or adjust the payment accordingly, and give notice to CONTRACTOR of the adjustment.

4.04 If the work is satisfactorily completed, CITY shall pay such invoice within thirty (30) days of its receipt. Should CITY dispute any portion of any invoice, CITY shall pay the undisputed portion within the time stated above, and at the same time advise CONTRACTOR in writing of the disputed portion.

5. Obligations of CONTRACTOR.

5.01 CONTRACTOR agrees to perform all Services in accordance with the terms and conditions of this Agreement and the Proposal. In the event that the terms of the Proposal shall conflict with the terms of this Agreement, or contain additional terms other than the Services to be rendered and the price for the Services, the terms of this Agreement shall govern and said additional or conflicting terms shall be of no force or effect.

5.02 Except as otherwise agreed by the parties, CONTRACTOR will supply all personnel, materials and equipment required to perform the Services. CONTRACTOR shall provide its own offices, telephones, vehicles and computers and set its own work hours. CONTRACTOR will determine the method, details, and means of performing the Services under this Agreement.

5.03 CONTRACTOR shall keep CITY informed as to the progress of the Services by means of regular and frequent consultations. Additionally, when requested by CITY, CONTRACTOR shall prepare written status reports.

5.04 CONTRACTOR is responsible for paying, when due, all income and other taxes, fees and withholding, including withholding state and federal taxes, social security, unemployment and worker's compensation, incurred as a result of the compensation paid under this Agreement. CONTRACTOR agrees to indemnify, defend and hold harmless CITY for any claims, costs, losses, fees, penalties, interest, or damages suffered by CITY resulting from CONTRACTOR's failure to comply with this provision.

5.05 In the event CONTRACTOR is required to prepare plans, drawings, specifications and/or estimates, the same shall be furnished in conformance with local, state and federal laws, rules and regulations.

5.06 CONTRACTOR represents that it possesses all required licenses necessary or applicable to the performance of Services under this Agreement and the Proposal and shall obtain and keep in full force and effect all permits and approvals required to perform the Services herein. In the event CITY is required to obtain an approval or permit from another governmental entity, CONTRACTOR shall provide all necessary supporting documents to be filed with such entity.

5.07 CONTRACTOR shall be solely responsible for obtaining Employment Eligibility Verification information from CONTRACTOR's employees, in compliance with the Immigration Reform and Control Act of 1986, Pub. L. 99-603 (8 U.S.C. 1324a), and shall ensure that CONTRACTOR's employees are eligible to work in the United States.

5.08 In the event that CONTRACTOR employs, contracts with, or otherwise utilizes any CalPers retirees in completing any of the Services performed hereunder, such instances shall be disclosed in advance to the CITY and shall be subject to the CITY's advance written approval.

5.09 Drug-free Workplace Certification. By signing this Agreement, the CONTRACTOR hereby certifies under penalty of perjury under the laws of the State of California that the CONTRACTOR will comply with the requirements of the Drug-Free Workplace Act of 1990 (Government Code, Section 8350 et seq.) and will provide a drug-free workplace.

5.10 CONTRACTOR shall comply with all applicable local, state and federal laws, rules, regulations, entitlements and/or permits applicable to, or governing the Services authorized hereunder.



6. Insurance. CONTRACTOR hereby agrees to be solely responsible for the health and safety of its employees and agents in performing the Services under this Agreement and shall comply with all laws applicable to worker safety including but not limited to Cal-OSHA. Therefore, throughout the duration of this Agreement, CONTRACTOR hereby covenants and agrees to maintain insurance in conformance with the requirements set forth below. Attached hereto as **Exhibit "B"** are copies of Certificates of Insurance and endorsements as required by Section 7.02. If existing coverage does not meet the requirements set forth herein, CONTRACTOR agrees to amend, supplement or endorse the existing coverage to do so. CONTRACTOR shall provide the following types and amounts of insurance:

6.01 Commercial general liability insurance in an amount of not less than \$1,000,000 per occurrence and \$2,000,000 in the aggregate; CONTRACTOR agrees to have its insurer endorse the general liability coverage required herein to include as additional insured's CITY, its officials, employees and agents. CONTRACTOR also agrees to require all contractors and subcontractors to provide the same coverage required under this Section 6.

6.02 Business Auto Coverage in an amount no less than \$1 million per accident. If CONTRACTOR or CONTRACTOR's employees will use personal autos in performance of the Services hereunder, CONTRACTOR shall provide evidence of personal auto liability coverage for each such person.

6.03 Workers' Compensation coverage for any of CONTRACTOR's employees that will be providing any Services hereunder. CONTRACTOR will have a state-approved policy form providing statutory benefits as required by California law. The provisions of any workers' compensation will not limit the obligations of CONTRACTOR under this Agreement. CONTRACTOR expressly agrees not to use any statutory immunity defenses under such laws with respect to CITY, its employees, officials and agents.

6.04 Optional Insurance Coverage. Choose and check one: Required X /Not Required   ; Errors and omissions insurance in a minimum amount of \$2 million per occurrence to cover any negligent acts or omissions committed by CONTRACTOR, its employees and/or agents in the performance of any Services for CITY.

7. General Conditions pertaining to Insurance Coverage

7.01 No liability insurance coverage provided shall prohibit CONTRACTOR from waiving the right of subrogation prior to a loss. CONTRACTOR waives all rights of subrogation against CITY regardless of the applicability of insurance proceeds and shall require all contractors and subcontractors to do likewise.

7.02. Prior to beginning the Services under this Agreement, CONTRACTOR shall furnish CITY with certificates of insurance, endorsements, and upon request, complete copies of all policies, including complete copies of all endorsements. All copies of policies and endorsements shall show the signature of a person authorized by that insurer to bind coverage on its behalf.

7.03. All required policies shall be issued by a highly rated insurer with a minimum A.M.

Best rating of “A:VII”). The insurer(s) shall be admitted and licensed to do business in California. The certificates of insurance hereunder shall state that coverage shall not be suspended, voided, canceled by either party, or reduced in coverage or in limits, except after thirty (30) days' prior written notice has been given to CITY.

7.04 Self-insurance does not comply with these insurance specifications. CONTRACTOR acknowledges and agrees that that all insurance coverage required to be provided by CONTRACTOR or any subcontractor, shall apply first and on a primary, non-contributing basis in relation to any other insurance, indemnity or self-insurance available to CITY.

7.05 All coverage types and limits required are subject to approval, modification and additional requirements by CITY, as the need arises. CONTRACTOR shall not make any reductions in scope of coverage (e.g. elimination of contractual liability or reduction of discovery period) that may affect CITY’s protection without CITY’s prior written consent.

7.06 CONTRACTOR agrees to provide immediate notice to CITY of any claim or loss against CONTRACTOR or arising out of the Services performed under this Agreement. CITY assumes no obligation or liability by such notice, but has the right (but not the duty) to monitor the handling of any such claim or claims if they are likely to involve CITY.

## 8. Indemnification.

8.01 CONTRACTOR and CITY agree that CITY, its employees, agents and officials should, to the extent permitted by law, be fully protected from any loss, injury, damage, claim, lawsuit, cost, expense, attorneys’ fees, litigation costs, defense costs, court costs or any other costs arising out of or in any way related to the performance of this Agreement by CONTRACTOR or any subcontractor or agent of either as set forth herein. Accordingly, the provisions of this indemnity are intended by the parties to be interpreted and construed to provide the fullest protection possible under the law to CITY. CONTRACTOR acknowledges that CITY would not enter into this Agreement in the absence of the commitment of CONTRACTOR to indemnify and protect CITY as set forth herein.

a. To the fullest extent permitted by law, CONTRACTOR shall defend, indemnify and hold harmless CITY, its employees, agents and officials, from any liability, claims, suits, actions, arbitration proceedings, administrative proceedings, regulatory proceedings, losses, expenses, damages or costs of any kind, whether actual, alleged or threatened, actual attorneys’ fees incurred by CITY, court costs, interest, defense costs, including expert witness fees and any other costs or expenses of any kind whatsoever without restriction or limitation incurred in relation to, as a consequence of or arising out of, or in any way attributable actually, allegedly or impliedly, in whole or in part to the performance of this Agreement. CONTRACTOR’s obligation to defend, indemnify and hold harmless shall include any and all claims, suits and proceedings in which CONTRACTOR (and/or CONTRACTOR’s agents and/or employees) is alleged to be an employee of CITY. All obligations under this provision are to be paid by CONTRACTOR as they are incurred by CITY.

b. Without affecting the rights of CITY under any provision of this Agreement or this Section, CONTRACTOR shall not be required to indemnify and hold harmless CITY as set forth above for liability attributable solely to the fault of CITY, provided such fault is determined by agreement between the parties or the findings of a court of competent jurisdiction.

9. Additional Services, Changes and Deletions.

9.01 In the event CONTRACTOR performs additional or different services than those described herein without the prior written approval of the City Manager and/or City Council of CITY, CONTRACTOR shall not be compensated for such services. CONTRACTOR expressly waives any right to be compensated for services and materials not covered by the scope of this Agreement or authorized by the CITY in writing.

9.02 CONTRACTOR shall promptly advise the City Manager and Finance Director of CITY as soon as reasonably practicable upon gaining knowledge of a condition, event or accumulation of events which may affect the scope and/or cost of Services. All proposed changes, modifications, deletions and/or requests for additional services shall be reduced to writing for review and approval by the CITY and/or City Council.

10. Termination of Agreement.

10.01 Notwithstanding any other provision of this Agreement, CITY, at its sole option, may terminate this Agreement with or without cause, or for no cause, at any time by giving twenty (20) days' written notice to CONTRACTOR.

10.02 In the event of termination, the payment of monies due CONTRACTOR for undisputed Services performed prior to the effective date of such termination shall be paid within thirty (30) business days after receipt of an invoice as provided in this Agreement. Immediately upon termination, CONTRACTOR agrees to promptly provide and deliver to CITY all original documents, reports, studies, plans, specifications and the like which are in the possession or control of CONTRACTOR and pertain to CITY.

11. Status of CONTRACTOR.

11.01 CONTRACTOR shall perform the Services in CONTRACTOR's own way as an independent contractor, and in pursuit of CONTRACTOR's independent calling, and not as an employee of CITY. However, CONTRACTOR shall regularly confer with CITY's City Manager as provided for in this Agreement.

11.02 CONTRACTOR agrees that it is not entitled to the rights and benefits afforded to CITY's employees, including disability or unemployment insurance, workers' compensation, retirement, CalPers, medical insurance, sick leave, or any other employment benefit. CONTRACTOR is responsible for providing, at its own expense, disability, unemployment, workers' compensation and other insurance, training, permits, and licenses for itself and its

employees and subcontractors.

11.03 CONTRACTOR hereby specifically represents and warrants to CITY that it possesses the qualifications and skills necessary to perform the Services under this Agreement in a competent, professional manner, without the advice or direction of CITY and that the Services to be rendered pursuant to this Agreement shall be performed in accordance with the standards customarily applicable to an experienced and competent professional rendering the same or similar services in the same geographic area where the CITY is located. Further, CONTRACTOR represents and warrants that the individual signing this Agreement on behalf of CONTRACTOR has the full authority to bind CONTRACTOR to this Agreement.

12. Ownership of Documents; Audit.

12.01 All draft and final reports, plans, drawings, studies, maps, photographs, specifications, data, notes, manuals, warranties and all other documents of any kind or nature prepared, developed or obtained by CONTRACTOR in connection with the performance of Services performed for the CITY shall become the sole property of CITY, and CONTRACTOR shall promptly deliver all such materials to CITY upon request. At the CITY's sole discretion, CONTRACTOR may be permitted to retain original documents, and furnish reproductions to CITY upon request, at no cost to CITY.

12.02 Subject to applicable federal and state laws, rules and regulations, CITY shall hold all intellectual property rights to any materials developed pursuant to this Agreement. CONTRACTOR shall not such use data or documents for purposes other than the performance of this Agreement, nor shall CONTRACTOR release, reproduce, distribute, publish, adapt for future use or any other purposes, or otherwise use, any data or other materials first produced in the performance of this Agreement, nor authorize others to do so, without the prior written consent of CITY.

12.03 CONTRACTOR shall retain and maintain, for a period not less than four years following termination of this Agreement, all time records, accounting records and vouchers and all other records with respect to all matters concerning Services performed, compensation paid and expenses reimbursed. At any time during normal business hours and as often as CITY may deem necessary, CONTRACTOR shall make available to CITY's agents for examination all of such records and shall permit CITY's agents to audit, examine and reproduce such records.

13. Miscellaneous Provisions.

13.01 This Agreement, which includes all attached exhibits, supersedes any and all previous agreements, either oral or written, between the parties hereto with respect to the rendering of Services by CONTRACTOR for CITY and contains all of the covenants and agreements between the parties with respect to the rendering of such Services in any manner whatsoever. Any modification of this Agreement will be effective only if it is in writing signed by both parties.

13.02 CONTRACTOR shall not assign or otherwise transfer any rights or interest in this

Agreement without the prior written consent of CITY. Unless specifically stated to the contrary in any written consent to an assignment, no assignment will release or discharge the assignor from any duty or responsibility under this Agreement.

13.03 CONTRACTOR shall timely file FPPC Form 700 Conflict of Interest Statements with CITY if required by California law and/or the CITY's conflict of interest policy.

13.04 If any legal action or proceeding, including an action for declaratory relief, is brought to enforce or interpret the provisions of this Agreement, the prevailing party will be entitled to reasonable attorneys' fees and costs, in addition to any other relief to which that party may be entitled.

13.05 This Agreement is made, entered into and shall be performed in the County of Riverside in the State of California and shall in all respects be interpreted, enforced and governed under the laws of the State of California.

13.06 CONTRACTOR covenants that neither it nor any officer or principal of its firm has any interest, nor shall they acquire any interest, either directly or indirectly, which will conflict in any manner or degree with the performance of their Services hereunder. CONTRACTOR further covenants that in the performance of this Agreement, no person having such interest shall be employed by it as an officer, employee, agent, or subcontractor.

13.07 CONTRACTOR has read and is aware of the provisions of Section 1090 et seq. and Section 87100 et seq. of the Government Code relating to conflicts of interest of public officers and employees. CONTRACTOR agrees that they are unaware of any financial or economic interest of any public officer or employee of the CITY relating to this Agreement. It is further understood and agreed that if such a financial interest does exist at the inception of this Agreement, the CITY may immediately terminate this Agreement by giving notice thereof. CONTRACTOR shall comply with the requirements of Government Code section 87100 et seq. and section 1090 in the performance of and during the term of this Agreement.

13.08 Improper Consideration. CONTRACTOR shall not offer (either directly or through an intermediary) any improper consideration such as, but not limited to, cash, discounts, services, the provision of travel or entertainment, or any items of value to any officer, employee or agent of the CITY in an attempt to secure favorable treatment regarding this Agreement or any contract awarded by CITY. The CITY, by notice, may immediately terminate this Agreement if it determines that any improper consideration as described in the preceding sentence was offered to any officer, employee or agent of the CITY with respect to the proposal and award process of this Agreement or any CITY contract. This prohibition shall apply to any amendment, extension or evaluation process once this Agreement or any CITY contract has been awarded. CONTRACTOR shall immediately report any attempt by any CITY officer, employee or agent to solicit (either directly or through an intermediary) improper consideration from CONTRACTOR.

13.09 Severability. If any portion of this Agreement is declared invalid, illegal or otherwise unenforceable by a court of competent jurisdiction, the entire balance of this

Agreement not so affected shall remain in full force and effect.

IN WITNESS WHEREOF, the parties hereby have made and executed this Agreement to be effective as of the day and year first above-written.

**CITY:**

CITY OF BEAUMONT

By: \_\_\_\_\_  
Rey Santos, Mayor

**CONTRACTOR:**

\_\_\_\_\_

By: \_\_\_\_\_

Print Name: \_\_\_\_\_

Title: \_\_\_\_\_

## Attachment II

### Scope of Services

The City's goal is to provide the public and its constituents with a financial statement that gives complete, accurate and understandable information about the City's financial condition. The selected independent auditor will be required to perform the following tasks:

1. Annual Financial Report - Audit the Basic Financial Statements of the City to obtain reasonable assurance about whether the financial statements are free from material misstatement. Express an opinion on the fair presentation of the City's governmental activities, business-type activities, each major fund, and the aggregate remaining fund information in conformity with generally accepted accounting principles. The Auditor shall also be responsible for performing certain limited procedures involving management's discussion and analysis (MD&A) and the required supplementary information (RSI) required by the Governmental Accounting Standards Board as mandated by generally accepted auditing standards.
2. Single Audit Act Report (if required) – The audit firm will perform a single audit on the expenditures of federal grants in accordance with the provisions of the Single Audit Act Amendments of 1996 and the provisions of U.S. Office of Management and Budget (OMB) Circular A-133, Audits of States, Local Governments, and Non-Profit Organizations and render the appropriate audit reports on Internal Control over Finance Reporting based upon the audit of the City's financial statements in accordance with Government Auditing Standards and the appropriate reports on compliance with Requirements Applicable to each Major Program, and internal Control over Compliance. The single audit report prepared and publish by the audit firm will include appropriate schedule of expenditures and material weaknesses and follow up on prior audit findings where required. If the City does not meet the minimum requirements to necessitate a single audit, the fees shall be adjusted accordingly. Additionally, the audit firm will submit the required information to the Federal Audit Clearinghouse.
3. GASB 68 – The firm selected is expected to provide templates and/or journal entries required to comply with Governmental Accounting Standards Board Statement No. 68.
4. Management Letter – The firm will issue a separate “management letter” that includes recommendations for improvement in internal control, accounting procedures and other significant observations that are considered to be non-reportable conditions. The management letter shall be addressed to the City Manager. Prior to its release, City staff shall be given an opportunity to review and comment.
5. Updates – The firm selected is expected to keep the City abreast of new developments affecting municipal finance and reporting, Government Accounting Standards Board pronouncements, procedural changes for grants, etc. The firm is also expected to provide advice to City staff related to the proper accounting treatment for transactions as needed and without additional costs.

6. Other – The firm selected will prepare the Comprehensive Annual Financial Report (CAFR) and the statistical sections as well as the Single Audit Report (if needed). The firm will also be asked to prepare the Cities State Controller’s Office Financial Transaction Report (FTR). The firm selected may also be asked to examine other reports or perform other services as required. The scope and compensation for any such request would be negotiated between the City and the Auditor.

### **Auditing Standards to be Followed**

To meet the requirements of this Request for Proposal, the audit shall be performed in accordance with:

- Generally accepted auditing standards as set forth by the American Institute of Certified Public Accountants
- The standards applicable to financial audits contained in Government Auditing Standards, issued by the Comptroller General of the United States
- The provisions of the Federal Single Audit Act
- The provisions of the U.S. Office of Management and Budget (OMB) Circular A-133, Audits of States, Local Governments, and Non-Profit Organizations

### **Reports to be Issued**

Following completion of the audit and preparation of the fiscal year’s financial statements and special purpose audits, the Auditor shall issue:

1. Reports on the fair presentation of the financial statements in accordance with auditing standards generally accepted in the United States of America as listed below: a. Basic Financial Statements for the City; b. Single Audit Report
2. A report based on the internal control over financial reporting and on compliance and other matters based on an audit of financial statements performed in accordance with Government Auditing Standards.
3. A report on the compliance with requirements that could have a direct and material effect on each major program and internal control over compliance in accordance with OMB Circular A-133 and on the schedule of expenditures of federal awards. Also included would be a schedule of findings and questioned costs associated with federal awards.
4. A Management Letter setting forth recommendations (as applicable) for improvements in the City’s internal control, accounting procedures, and any other significant observations.
5. Reports to and communication with those charged with governance, as required by auditing standards.



6. Auditors shall be required to make immediate, written notification to the City Council, City Manager, and City Attorney of all irregularities and illegal acts or indications of illegal acts of which they become aware.

7. Any other reports that may become required as a result of a change in accounting standards or new pronouncements that become effective during the term of the engagement.

### **Other Communications**

The Auditor shall make all communications to the City required by the audit standards under which the engagement is performed. Those communications include, but are not limited to:

- The Auditor's responsibility under generally accepted auditing standards.
- Significant accounting policies.
- Management judgment and accounting estimates.
- Significant audit adjustments.
- Other information in documents containing audited financial statements.
- Disagreements with management.
- Management consultation with other accountants.
- Major issues discussed with management prior to retention.
- Difficulties encountered in performing the audit.
- Errors, irregularities, and illegal acts.

The Auditor must be available to present the audit plan prior to beginning field work. In addition, the Auditor must be available to present all final reports to City management, Audit and Finance Committee and the City Council as requested at no additional costs.

### **Working Paper Retention and Access to Working Papers**

All work papers and reports must be retained, at the auditor's expense, for a minimum of five years (or the retention timeframe established by the professional standards, whichever is longer) unless the firm is notified in writing by the City of the need to extend the retention period. The work papers are subject to review by Federal and state agencies and other individuals designated by the City. Accordingly, the work papers will be made available upon request.

In addition, the firm will respond to the reasonable inquiries of successor auditors and allow successor auditors to review work papers.

#### Journal Entries

All adjusting journal entries made by the independent auditors must be discussed and explained to the designated Finance Department personnel prior to recording. They should be in a format that shows the lowest level of posting detail needed for data entry in the general ledger system.

Attachment III

**Cost Summary**

**NOT TO EXCEED PRICE FOR PROPOSED SERVICES SCHEDULE**

In accordance with the Request for Proposal for Audit Services issued by City of Beaumont, the firm referenced below hereby submits the following cost proposal:

		<u>Year Ended June 30th</u>				
		2020	2021	2022	2023	2024
<b>Basic Reports to Be Issued</b>						
	City Audit, including AFR and Related Reports					
	<b>Total</b>	<hr/> <hr/>				
<b>Additional Audit Reports To Be Requested At City Option</b>						
	Single Audit and Related Reports					
	Annual Report of City Financial Transactions to State Controller					
	<b>Total</b>	<hr/> <hr/>				

Please include an hourly fee quotation and hours proposed for all positions to be assigned to the audit:

	<b>Hours Billing Rate</b>	<b>Estimated Number of Hours</b>	<b>Estimated Charges</b>
Partners			
Mangers			
Senior Accountant			
Staff Accountant			
Clerical/Support Staff			
Other			

I hereby certify that the undersigned is authorized to represent the firm stated above, and empowered to submit this bid, and if selected, authorized to sign a contract with the City, for the services identified in the Request for Proposals.

Firm Name: \_\_\_\_\_

Signature: \_\_\_\_\_

Printed Name: \_\_\_\_\_

Title: \_\_\_\_\_

Date: \_\_\_\_\_

## AGREEMENT FOR PROFESSIONAL SERVICES BY INDEPENDENT CONTRACTOR

THIS AGREEMENT FOR PROFESSIONAL SERVICES BY INDEPENDENT CONTRACTOR is made and effective as of the 3<sup>rd</sup> day of June, 2020, by and between the CITY OF BEAUMONT (“CITY”) whose address is 550 E. 6<sup>th</sup> Street, Beaumont, California 92223 and Rogers, Anderson, Malody & Scott, LLP whose address is 735 E. Carnegie Drive, Suite 100 San Bernardino, CA 92408 (“CONTRACTOR”).

### RECITALS

This Agreement is entered into on the basis of the following facts, understandings and intentions of the parties to this Agreement:

- A. CITY desires to engage CONTRACTOR to provide independent audit services; and
- B. CONTRACTOR has made a proposal (“Proposal”) to the CITY to provide such professional services, which Proposal is attached hereto as Exhibit “A”; and
- C. CONTRACTOR agrees to provide such services pursuant to, and in accordance with, the terms and conditions of this Agreement, and represents and warrants to CITY that CONTRACTOR possesses the necessary skills, licenses, certifications, qualifications, personnel and equipment to provide such services.

### AGREEMENT

NOW, THEREFORE, in consideration of the foregoing Recitals and mutual covenants contained herein, CITY and CONTRACTOR agree as follows:

1. Term of Agreement. This Agreement is effective as of the date first above written and shall continue until terminated as provided for herein. Notwithstanding anything in this Agreement to the contrary, this Agreement shall continue for (3) one-year periods, with an option to extended for (2) one year periods by the parties with the approval of the City Council of the CITY.
2. Services to be Performed. CONTRACTOR agrees to provide the services (“Services”) as set forth in Exhibit “B” hereto (“Engagement Letter”) and any other services which the City may request in writing. All Services shall be performed in the manner and according to the timeframe set forth in the Proposal. CONTRACTOR designates Scott W. Manno, CPA, CGMA as CONTRACTOR’S professional responsible for overseeing the Services provided by CONTRACTOR.
3. Associates and Subcontractors. CONTRACTOR may, at CONTRACTOR’s sole cost and expense, employ such competent and qualified independent associates, subcontractors and consultants as CONTRACTOR deems necessary to perform the Services; provided, however, that CONTRACTOR shall not subcontract any of the Services without the written consent of CITY.

4. Compensation.

4.01 CONTRACTOR shall be paid at the rates set forth in the Engagement Letter in an amount not to exceed \$46,200 for the year ending June 30, 2020 and does not include work to be performed under a Single Audit pursuant to the Federal Single Audit Act, which would be subject to a separate engagement letter if required and as addressed more fully in Exhibit "B" hereto.

4.02 CONTRACTOR shall not be compensated for any Services rendered nor reimbursed for any expenses incurred in excess of those authorized unless approved in advance by the CITY, in writing.

4.03 CONTRACTOR shall submit to CITY, on or before the fifteenth (15<sup>th</sup>) of each month, itemized invoices for the Services rendered in the previous month. The CITY shall not be obligated to pay any invoice that is submitted more than sixty (60) days after the due date of such invoice. CITY shall have the right to review and audit all invoices prior to or after payment to CONTRACTOR. This review and audit may include, but not be limited to CITY's:

- a. Determination that any hourly fee charged is consistent with this Agreement's approved hourly rate schedule;
- b. Determination that the multiplication of the hours billed times the approved rate schedule dollars is correct;
- c. Determination that each item charged is the usual, customary, and reasonable charge for the particular item. If CITY determines an item charged is greater than usual, customary, or reasonable, or is duplicative, ambiguous, excessive, or inappropriate, CITY shall either return the bill to CONTRACTOR with a request for explanation or adjust the payment accordingly and give notice to CONTRACTOR of the adjustment.

4.04 If the work is satisfactorily completed, CITY shall pay such invoice within thirty (30) days of its receipt. Should CITY dispute any portion of any invoice, CITY shall pay the undisputed portion within the time stated above, and at the same time advise CONTRACTOR in writing of the disputed portion.

5. Obligations of CONTRACTOR.

5.01 CONTRACTOR agrees to perform all Services in accordance with the terms and conditions of this Agreement (including the Proposal and the Engagement Letter). In the event that the terms of the Proposal shall conflict with the terms of this Agreement, or contain additional terms other than the Services to be rendered and the price for the Services, the terms of the Engagement Letter shall govern and said additional or conflicting terms shall be of no force or effect.

5.02 Except as otherwise agreed by the parties, CONTRACTOR will supply all personnel, materials and equipment required to perform the Services. CONTRACTOR

shall provide its own offices, telephones, vehicles and computers and set its own work hours. CONTRACTOR will determine the method, details, and means of performing the Services under this Agreement.

5.03 CONTRACTOR shall keep CITY informed as to the progress of the Services by means of regular and frequent consultations. Additionally, when requested by CITY, CONTRACTOR shall prepare written status reports.

5.04 CONTRACTOR is responsible for paying, when due, all income and other taxes, fees and withholding, including withholding state and federal taxes, social security, unemployment and worker's compensation, incurred as a result of the compensation paid under this Agreement. CONTRACTOR agrees to indemnify, defend and hold harmless CITY for any claims, costs, losses, fees, penalties, interest, or damages suffered by CITY resulting from CONTRACTOR's failure to comply with this provision.

5.05 In the event CONTRACTOR is required to prepare plans, drawings, specifications and/or estimates, the same shall be furnished in conformance with local, state and federal laws, rules and regulations.

5.06 CONTRACTOR represents that it possesses all required licenses necessary or applicable to the performance of Services under this Agreement and the Proposal and shall obtain and keep in full force and effect all permits and approvals required to perform the Services herein. In the event CITY is required to obtain an approval or permit from another governmental entity, CONTRACTOR shall provide all necessary supporting documents to be filed with such entity.

5.07 CONTRACTOR shall be solely responsible for obtaining Employment Eligibility Verification information from CONTRACTOR's employees, in compliance with the Immigration Reform and Control Act of 1986, Pub. L. 99-603 (8 U.S.C. 1324a), and shall ensure that CONTRACTOR's employees are eligible to work in the United States.

5.08 In the event that CONTRACTOR employs, contracts with, or otherwise utilizes any CalPers retirees in completing any of the Services performed hereunder, such instances shall be disclosed in advance to the CITY and shall be subject to the CITY's advance written approval.

5.09 Drug-free Workplace Certification. By signing this Agreement, the CONTRACTOR hereby certifies under penalty of perjury under the laws of the State of California that the CONTRACTOR will comply with the requirements of the Drug-Free Workplace Act of 1990 (Government Code, Section 8350 et seq.) and will provide a drug-free workplace.

5.10 CONTRACTOR shall comply with all applicable local, state and federal laws, rules, regulations, entitlements and/or permits applicable to, or governing the Services authorized hereunder.

6. Insurance. CONTRACTOR hereby agrees to be solely responsible for the health

and safety of its employees and agents in performing the Services under this Agreement and shall comply with all laws applicable to worker safety including but not limited to Cal-OSHA. Therefore, throughout the duration of this Agreement, CONTRACTOR hereby covenants and agrees to maintain insurance in conformance with the requirements set forth below. Attached hereto as **Exhibit “C”** are copies of Certificates of Insurance and endorsements as required by Section 7.02. If existing coverage does not meet the requirements set forth herein, CONTRACTOR agrees to amend, supplement or endorse the existing coverage to do so. CONTRACTOR shall provide the following types and amounts of insurance:

6.01 Commercial general liability insurance in an amount of not less than \$1,000,000 per occurrence and \$2,000,000 in the aggregate; CONTRACTOR agrees to have its insurer endorse the general liability coverage required herein to include as additional insured’s CITY, its officials, employees and agents. CONTRACTOR also agrees to require all contractors and subcontractors to provide the same coverage required under this Section 6.

6.02 Business Auto Coverage in an amount no less than \$1 million per accident. If CONTRACTOR or CONTRACTOR’s employees will use personal autos in performance of the Services hereunder, CONTRACTOR shall provide evidence of personal auto liability coverage for each such person.

6.03 Workers’ Compensation coverage for any of CONTRACTOR’s employees that will be providing any Services hereunder. CONTRACTOR will have a state-approved policy form providing statutory benefits as required by California law. The provisions of any workers’ compensation will not limit the obligations of CONTRACTOR under this Agreement. CONTRACTOR expressly agrees not to use any statutory immunity defenses under such laws with respect to CITY, its employees, officials and agents.

6.04 Optional Insurance Coverage. Choose and check one: Required  /Not Required ; Errors and omissions insurance in a minimum amount of \$2 million per occurrence to cover any negligent acts or omissions committed by CONTRACTOR, its employees and/or agents in the performance of any Services for CITY.

## 7. General Conditions pertaining to Insurance Coverage

7.01 No liability insurance coverage provided shall prohibit CONTRACTOR from waiving the right of subrogation prior to a loss. CONTRACTOR waives all rights of subrogation against CITY regardless of the applicability of insurance proceeds and shall require all contractors and subcontractors to do likewise.

7.02. Prior to beginning the Services under this Agreement, CONTRACTOR shall furnish CITY with certificates of insurance, endorsements, and upon request, complete copies of all policies, including complete copies of all endorsements. All copies of policies and endorsements shall show the signature of a person authorized by that insurer to bind coverage on its behalf.

7.03. All required policies shall be issued by a highly rated insurer with a minimum A.M. Best rating of “A:VII”). The insurer(s) shall be admitted and licensed to do business

in California. The certificates of insurance hereunder shall state that coverage shall not be suspended, voided, canceled by either party, or reduced in coverage or in limits, except after thirty (30) days' prior written notice has been given to CITY.

7.04 Self-insurance does not comply with these insurance specifications. CONTRACTOR acknowledges and agrees that that all insurance coverage required to be provided by CONTRACTOR or any subcontractor, shall apply first and on a primary, non-contributing basis in relation to any other insurance, indemnity or self-insurance available to CITY.

7.05 All coverage types and limits required are subject to approval, modification and additional requirements by CITY, as the need arises. CONTRACTOR shall not make any reductions in scope of coverage (e.g. elimination of contractual liability or reduction of discovery period) that may affect CITY's protection without CITY's prior written consent.

7.06 CONTRACTOR agrees to provide immediate notice to CITY of any claim or loss against CONTRACTOR or arising out of the Services performed under this Agreement. CITY assumes no obligation or liability by such notice but has the right (but not the duty) to monitor the handling of any such claim or claims if they are likely to involve CITY.

## 8. Indemnification.

8.01 CONTRACTOR and CITY agree that CITY, its employees, agents and officials should, to the extent permitted by law, be fully protected from any loss, injury, damage, claim, lawsuit, cost, expense, attorneys' fees, litigation costs, defense costs, court costs or any other costs arising out of or in any way related to the performance of this Agreement by CONTRACTOR or any subcontractor or agent of either as set forth herein. Accordingly, the provisions of this indemnity are intended by the parties to be interpreted and construed to provide the fullest protection possible under the law to CITY. CONTRACTOR acknowledges that CITY would not enter into this Agreement in the absence of the commitment of CONTRACTOR to indemnify and protect CITY as set forth herein.

a. To the fullest extent permitted by law, CONTRACTOR shall defend, indemnify and hold harmless CITY, its employees, agents and officials, from any liability, claims, suits, actions, arbitration proceedings, administrative proceedings, regulatory proceedings, losses, expenses, damages or costs of any kind, whether actual, alleged or threatened, actual attorneys' fees incurred by CITY, court costs, interest, defense costs, including expert witness fees and any other costs or expenses of any kind whatsoever without restriction or limitation incurred in relation to, as a consequence of or arising out of, or in any way attributable actually, allegedly or impliedly, in whole or in part to the performance of this Agreement. CONTRACTOR's obligation to defend, indemnify and hold harmless shall include any and all claims, suits and proceedings in which CONTRACTOR (and/or CONTRACTOR's agents and/or employees) is alleged to be an employee of CITY. All obligations under this provision are to be paid by CONTRACTOR as they are



incurred by CITY.

b. Without affecting the rights of CITY under any provision of this Agreement or this Section, CONTRACTOR shall not be required to indemnify and hold harmless CITY as set forth above for liability attributable solely to the fault of CITY, provided such fault is determined by agreement between the parties or the findings of a court of competent jurisdiction.

9. Additional Services, Changes and Deletions.

9.01 In the event CONTRACTOR performs additional or different services than those described herein without the prior written approval of the City Manager and/or City Council of CITY, CONTRACTOR shall not be compensated for such services. CONTRACTOR expressly waives any right to be compensated for services and materials not covered by the scope of this Agreement or authorized by the CITY in writing.

9.02 CONTRACTOR shall promptly advise the City Manager and Finance Director of CITY as soon as reasonably practicable upon gaining knowledge of a condition, event or accumulation of events which may affect the scope and/or cost of Services. All proposed changes, modifications, deletions and/or requests for additional services shall be reduced to writing for review and approval by the CITY and/or City Council.

10. Termination of Agreement.

10.01 Notwithstanding any other provision of this Agreement, CITY, at its sole option, may terminate this Agreement with or without cause, or for no cause, at any time by giving twenty (20) days' written notice to CONTRACTOR.

10.02 In the event of termination, the payment of monies due CONTRACTOR for undisputed Services performed prior to the effective date of such termination shall be paid within thirty (30) business days after receipt of an invoice as provided in this Agreement. Immediately upon termination, CONTRACTOR agrees to promptly provide and deliver to CITY all original documents, reports, studies, plans, specifications and the like which are in the possession or control of CONTRACTOR and pertain to CITY.

11. Status of CONTRACTOR.

11.01 CONTRACTOR shall perform the Services in CONTRACTOR's own way as an independent contractor, and in pursuit of CONTRACTOR's independent calling, and not as an employee of CITY. However, CONTRACTOR shall regularly confer with CITY's City Manager as provided for in this Agreement.

11.02 CONTRACTOR agrees that it is not entitled to the rights and benefits afforded to CITY's employees, including disability or unemployment insurance, workers' compensation, retirement, CalPers, medical insurance, sick leave, or any other employment benefit. CONTRACTOR is responsible for providing, at its own expense, disability, unemployment, workers' compensation and other insurance, training, permits, and licenses for itself and its employees and subcontractors.

11.03 CONTRACTOR hereby specifically represents and warrants to CITY that it possesses the qualifications and skills necessary to perform the Services under this Agreement in a competent, professional manner, without the advice or direction of CITY and that the Services to be rendered pursuant to this Agreement shall be performed in accordance with the standards customarily applicable to an experienced and competent professional rendering the same or similar services in the same geographic area where the CITY is located. Further, CONTRACTOR represents and warrants that the individual signing this Agreement on behalf of CONTRACTOR has the full authority to bind CONTRACTOR to this Agreement.

12. Ownership of Documents; Audit.

12.01 All draft and final reports, plans, drawings, studies, maps, photographs, specifications, data, notes, manuals, warranties and all other documents of any kind or nature prepared, developed or obtained by CONTRACTOR in connection with the performance of Services performed for the CITY shall become the sole property of CITY, ***except those items defined as audit documentation under professional standards promulgated by the American Institute of Certified Public Accountants (AICPA), which will be the property of CONSULTANT*** and CONTRACTOR shall promptly deliver all such materials to CITY upon request. At the CITY's sole discretion, CONTRACTOR may be permitted to retain original documents, and furnish reproductions to CITY upon request, at no cost to CITY.

12.02 Subject to applicable federal and state laws, rules and regulations, CITY shall hold all intellectual property rights to any materials developed pursuant to this Agreement, ***except those items defined as audit documentation under professional standards promulgated by the American Institute of Certified Public Accountants (AICPA), which will be the property of CONSULTANT***. CONTRACTOR shall not such use data or documents for purposes other than the performance of this Agreement, nor shall CONTRACTOR release, reproduce, distribute, publish, adapt for future use or any other purposes, or otherwise use, any data or other materials first produced in the performance of this Agreement, nor authorize others to do so, without the prior written consent of CITY.

12.03 CONTRACTOR shall retain and maintain, for a period not less than four years following termination of this Agreement, all-time records, accounting records and vouchers and all other records with respect to all matters concerning Services performed, compensation paid and expenses reimbursed. At any time during normal business hours and as often as CITY may deem necessary, CONTRACTOR shall make available to CITY's agents for examination all of such records and shall permit CITY's agents to audit, examine and reproduce such records.

13. Miscellaneous Provisions.

13.01 This Agreement, which includes all attached exhibits, supersedes any and all previous agreements, either oral or written, between the parties hereto with respect to the rendering of Services by CONTRACTOR for CITY and contains all of the covenants and agreements between the parties with respect to the rendering of such Services in any

manner whatsoever. Any modification of this Agreement will be effective only if it is in writing signed by both parties.

13.02 CONTRACTOR shall not assign or otherwise transfer any rights or interest in this Agreement without the prior written consent of CITY. Unless specifically stated to the contrary in any written consent to an assignment, no assignment will release or discharge the assignor from any duty or responsibility under this Agreement.

13.03 CONTRACTOR shall timely file FPPC Form 700 Conflict of Interest Statements with CITY if required by California law and/or the CITY's conflict of interest policy.

13.04 If any legal action or proceeding, including an action for declaratory relief, is brought to enforce or interpret the provisions of this Agreement, the prevailing party will be entitled to reasonable attorneys' fees and costs, in addition to any other relief to which that party may be entitled.

13.05 This Agreement is made, entered into and shall be performed in the County of Riverside in the State of California and shall in all respects be interpreted, enforced and governed under the laws of the State of California.

13.06 CONTRACTOR covenants that neither it nor any officer or principal of its firm has any interest, nor shall they acquire any interest, either directly or indirectly, which will conflict in any manner or degree with the performance of their Services hereunder. CONTRACTOR further covenants that in the performance of this Agreement, no person having such interest shall be employed by it as an officer, employee, agent, or subcontractor.

13.07 CONTRACTOR has read and is aware of the provisions of Section 1090 et seq. and Section 87100 et seq. of the Government Code relating to conflicts of interest of public officers and employees. CONTRACTOR agrees that they are unaware of any financial or economic interest of any public officer or employee of the CITY relating to this Agreement. It is further understood and agreed that if such a financial interest does exist at the inception of this Agreement, the CITY may immediately terminate this Agreement by giving notice thereof. CONTRACTOR shall comply with the requirements of Government Code section 87100 et seq. and section 1090 in the performance of and during the term of this Agreement.

13.08 Improper Consideration. CONTRACTOR shall not offer (either directly or through an intermediary) any improper consideration such as, but not limited to, cash, discounts, services, the provision of travel or entertainment, or any items of value to any officer, employee or agent of the CITY in an attempt to secure favorable treatment regarding this Agreement or any contract awarded by CITY. The CITY, by notice, may immediately terminate this Agreement if it determines that any improper consideration as described in the preceding sentence was offered to any officer, employee or agent of the CITY with respect to the proposal and award process of this Agreement or any CITY contract. This prohibition shall apply to any amendment, extension or evaluation process once this Agreement or any CITY contract has been awarded. CONTRACTOR shall

immediately report any attempt by any CITY officer, employee or agent to solicit (either directly or through an intermediary) improper consideration from CONTRACTOR.

13.09 Severability. If any portion of this Agreement is declared invalid, illegal or otherwise unenforceable by a court of competent jurisdiction, the entire balance of this Agreement not so affected shall remain in full force and effect.

IN WITNESS WHEREOF, the parties hereby have made and executed this Agreement to be effective as of the day and year first above-written.

**CITY:**

**CONTRACTOR:**

CITY OF BEAUMONT

\_\_\_\_\_

By: \_\_\_\_\_  
Rey Santos,, Mayor

By: \_\_\_\_\_

Print Name: \_\_\_\_\_

Title: \_\_\_\_\_

**EXHIBIT "A"**

**PROPOSAL**

**(insert behind this page)**

**EXHIBIT "B"**

**ENGAGEMENT LETTER**

**(insert behind this page)**

**EXHIBIT "C"**

**CERTIFICATES OF INSURANCE AND ENDORSEMENTS A**

**(insert behind this page)**



ROGERS, ANDERSON, MALODY & SCOTT, LLP  
CERTIFIED PUBLIC ACCOUNTANTS, SINCE 1948

Item 10.

APRIL 3, 2020

# CITY OF BEAUMONT

PROPOSAL FOR PROFESSIONAL AUDITING SERVICES  
FOR THE FISCAL YEARS ENDING JUNE 30, 2020, 2021 AND 2022  
(WITH THE OPTION OF TWO ADDITIONAL FISCAL YEARS)

CONTACT PERSONS:  
SCOTT W. MANNO, CPA, CGMA  
smanno@ramsca.net

BRAD WELEBIR, CPA, CGMA, MBA  
bwelebir@ramscpa.net

909.889.0871

PREPARED BY  
ROGERS ANDERSON MALODY & SCOTT, LLP  
735 E Carnegie Drive, Suite 100  
San Bernardino, CA 92408

LICENSE #2596  
FEIN 95-2662063



# CITY OF BEAUMONT

## PROPOSAL FOR PROFESSIONAL AUDITING SERVICES

### Table of Contents

	<u>Page</u>
<b>Transmittal Letter</b> .....	i
<b>Technical Proposal</b>	
Personnel .....	1
<i>Partner and supervisory staff involvement</i>	
<i>Staff continuity</i>	
<i>Continuing professional education</i>	
<i>Assigned personnel</i>	
<i>Engagement team resumes</i>	
Company background .....	10
<i>License to practice</i>	
<i>Independence</i>	
<i>About our firm</i>	
<i>Governmental Audit Quality Center</i>	
<i>Engagement quality control</i>	
<i>Disciplinary action</i>	
<i>Equal Opportunity Employer</i>	
Peer review .....	12
<i>External quality control review</i>	
Audit approach .....	13
<i>Services to be provided</i>	
<i>Engagement approach</i>	
<i>Audit approach and proposed audit segmentation</i>	
<i>Level of staff and approximate number of hours assigned to each segment</i>	
<i>Sample sizes</i>	
<i>Audit technology</i>	
<i>Analytical procedures</i>	
<i>Understanding of internal control over financial reporting</i>	
<i>Approach in determining applicable laws and regulations</i>	
<i>Approach in drawing samples for compliance testing</i>	
<i>Proposed audit timing</i>	
Specific expertise desired .....	21
References .....	22
Contract terms .....	24
Cost summary .....	25

### Attachment A: Government Clients Served



April 3, 2020

735 E. Carnegie Dr. Suite 100  
San Bernardino, CA 92408  
909 889 0871 T  
909 889 5361 F  
ramscca.net

City of Beaumont  
550 E. 6<sup>th</sup> Street  
Beaumont, CA 92223

**PARTNERS**

Brenda L. Odle, CPA, MST  
Terry P. Shea, CPA  
Scott W. Manno, CPA, CGMA  
Leena Shanbhag, CPA, MST, CGMA  
Bradferd A. Welebir, CPA, MBA, CGMA  
Jenny W. Liu, CPA, MST  
Jay H. Zercher, CPA (Partner Emeritus)  
Phillip H. Waller, CPA (Partner Emeritus)  
Kirk A. Franks, CPA (Partner Emeritus)

**MANAGERS / STAFF**

Charles De Simoni, CPA  
Gardenya Duran, CPA  
Brianna Schultz, CPA  
Jingjie Wu, CPA  
Evelyn Morentin-Barcena, CPA  
Veronica Hernandez, CPA  
Tara R. Thorp, CPA, MSA  
Laura Arvizu, CPA  
Ye Ying Stella Xia, CPA, MSBA  
Louis Fernandez, CPA  
Abigail O. Hernandez Conde, CPA, MSA  
Zoe Xinlu Zhang, CPA, MSA

**MEMBERS**

American Institute of  
Certified Public Accountants

*PCPS The AICPA Alliance  
for CPA Firms*

*Governmental Audit  
Quality Center*

*Employee Benefit Plan  
Audit Quality Center*

California Society of  
Certified Public Accountants



A Worldwide Alliance of Independent  
Accounting, Law and Consulting Firms

Dear Evaluation Committee:

I am pleased to respond, on behalf of Rogers, Anderson, Malody & Scott, LLP, (RAMS) to your request for a proposal regarding professional auditing services. As a recognized industry leader and innovator, our goal for the past 72 years has been to provide honest, objective and high quality results to all of our clients, including governmental organizations such as yours. Our success in these efforts is witnessed by both the growth of our firm and the list of long-term clients who trust us.

At RAMS, we are committed to achieving the highest quality audit possible. We understand the complexity of performing governmental audits and that's why we have a *dedicated team of auditors* that possess the specialized knowledge and experience to help ensure compliance with changes in regulations that may impact your organization. We plan and execute our audits in a way that maximizes audit efficiency and effectiveness and provides you the highest quality services.

We are aware that the City of Beaumont (the City) will be reviewing other proposals during this process, but we believe that RAMS would be an exceptional choice for the audit for the following reasons; which are provided in more detail in our proposal. Our firm:

- Utilizes *Teammate Analytics*, a suite of more than 150 Computer Aided Audit Tools (CAATs). This software empowers our audit teams with the ability to perform powerful, meaningful data analysis which builds upon our other value added services. *Teammate Analytics* also helps to identify specific transactions or amounts which may be indicative of fraud.
- Using our CAAT, performs an intelligent, risk based audit which enables us to focus on key audit areas allowing us to become more efficient resulting in lower audit fees.
- Provides auditing services to over 50 governmental agencies and not-for-profit organizations, including over 20 cities, most of which have enterprise activities.
- Understands the audit process, as a whole, can be a stressful experience for you and your staff; we understand that you will have other commitments and your regular workloads during the audit. We make every effort to ensure the audit process, from the interim fieldwork to the preparation of any required financial reports, will be as trouble-free as possible for you and your staff. We accomplish this by comprehensively planning the audit and utilizing our staff in the most efficient and effective manner while keeping disruptions and miscommunications to a minimum.

- Has an established reputation in the governmental and not-for-profit accounting and auditing community for providing excellent, timely service with high quality reporting to our clients.
- Has audit team members that are personable and easy to work with, yet still focused on the audit. Through open and responsive communication with all parties involved in the audit process, we work to have the most efficient audit possible by minimizing operational distractions of your staff, while maximizing quality service and products.
- Provides extensive training and continuing education to all of our audit staff through a combined use of in-house instruction and third-party providers. Our audit team members are experienced with and receive regular training in performing Single Audits in accordance with Federal OMB Uniform Guidance.
- Is committed to helping you meet all reporting/auditing deadlines, resolving any issues encountered during your audit (e.g. accounting or auditing, new pronouncements, etc.), and providing you with quality audit services.
- Has an extensive internal quality control review process to ensure your financial reports meet the highest standards. In addition to the preparation of financial reports by the engagement team and review by the engagement manager, *each report is also examined by 2 partners and 1 professional proofreader.*
- Has assisted many of our clients with the preparation of their Comprehensive Annual Financial Reports, and all of our clients that have submitted their reports for the Government Finance Officers Association (GFOA) or California Society of Municipal Finance Officers (CSMFO) awards have received the awards. Our participation as a GFOA reviewer also indirectly benefits our clients in the quality review process.
- Is a full service firm, with specialists in auditing, reviews and compilations, tax planning and preparation, as well as business consulting. The diverse experience and accessibility of the professionals in these areas help us to provide a comprehensive approach to a wide variety of needs.
- Believes that our fee estimate and arrangement provides a fair and reasonable cost, commensurate with the experience of the audit team members, to perform the requested audit services.
- We are a local Inland Empire firm. All of our employees live, work and shop in the region, allowing our local cities to benefit from our sales and property taxes.

Rogers, Anderson, Malody & Scott, LLP is properly licensed to practice in California, including all of the assigned professional staff to the engagement. Mr. Welebir, Partner and Mr. Manno, Partner are authorized to represent the firm, are empowered to submit the bid and authorized to sign a contract with the City. We understand the work to be done as listed in the section of this proposal titled *Services to be provided*. In addition, we will be committed to meeting any agreed upon time frames. This proposal is valid for ninety (90) days.

We can be reached at: 735 E. Carnegie Drive, Suite 100, San Bernardino, CA 92408, (909) 889-0871, [Bwelebir@ramscpa.net](mailto:Bwelebir@ramscpa.net) or [smanno@ramscpa.net](mailto:smanno@ramscpa.net).

Thank you for the opportunity to present our proposal to the City. We will be committed to exceeding your expectations of an auditor and believe this proposal provides you with information about our firm, the service team members and our customized audit approach. We look forward to having a long and mutually beneficial relationship with the City. Please contact us if you have any questions regarding this proposal.

Respectfully yours,

**ROGERS, ANDERSON, MALODY & SCOTT, LLP**

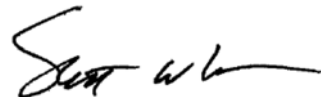

---

Scott W. Manno, CPA, CGMA  
Partner

# CITY OF BEAUMONT

## PROPOSAL FOR PROFESSIONAL AUDITING SERVICES

### Personnel

The quality of service you receive is dependent on the capabilities of the individuals assigned to the engagement, and the manner in which those personnel resources are organized to efficiently focus their abilities on providing you with the requested audit services. These professionals are highly trained and knowledgeable and have a thorough understanding of the environment in which governmental and not-for-profit entities operate. This experience is a critical component in providing the City with an effective and efficient audit.

Our engagement team will provide significant experience coupled with an extensive, practical understanding of governmental and not-for-profit accounting and auditing along with a broad business perspective. Each member will have access to a wide range of technical resources and knowledge bases which will enable them to provide the City with practical observations and effective solutions.

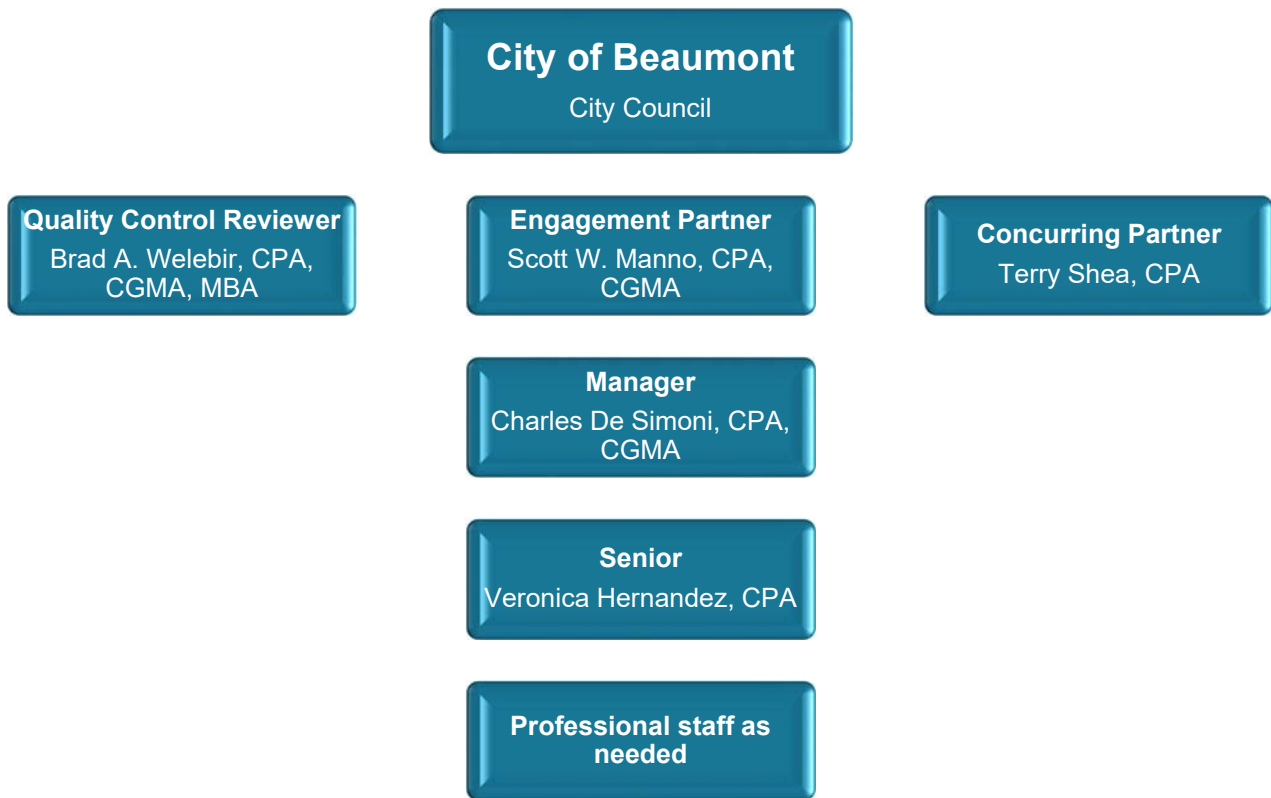

# CITY OF BEAUMONT

## PROPOSAL FOR PROFESSIONAL AUDITING SERVICES

### Personnel (continued)

#### *Partner and supervisory staff involvement*

All partners and supervisory staff are working professionals and are actively and continually involved in all aspects of their engagements. We believe that partner and supervisory staff involvement in all areas of the audit is a key aspect of the overall audit process. This involvement includes being on-site for interim and year-end fieldwork, thus facilitating a proper, efficient and effective audit, with minimal disruption of your staff. In addition, the time spent on-site by the partners and supervisory staff ensures they gain an understanding of the entire City's accounting processes and procedures. This understanding will enable them to evaluate and develop opportunities for efficiency as well as offer practical and functional advice for improving your accounting processes and procedures.

All professionals on this engagement have worked on audits similar in nature to the City's, therefore, the City will not have to train our engagement team.

#### *Staff continuity*

Continuity of audit staff is a principal concern with our firm. In order to retain our staff, we offer extremely competitive wages, opportunities for advancement, generous medical packages, a retirement plan, bonus opportunities, as well as educational benefits. Even with the benefits we provide, we realize we may lose staff at any given time. Knowing this, we plan to provide staff continuity from year to year, which is in the best interest of the City and our firm. Continuity ensures an orderly, efficient, and less disruptive audit experience. Since we cannot guarantee staff will remain with us, principal supervisory and management staff, including engagement partners, managers, other supervisory staff, and specialists, may be changed if those personnel leave the firm or are promoted. **However, the City reserves the right to accept or reject replacements.**

We believe that due to the significant involvement of the partners on all of our engagements, any staff transition would have a minimal effect on the audit efficiency and effectiveness of subsequent years.

#### *Continuing professional education*

Our team of auditor specialists stays current in this highly technical practice area by adhering to, and typically exceeding, the continuing professional education requirements of *Government Auditing Standards* as well as the State Board of Accountancy guidelines. All professionals at our firm participate in continuing professional education (CPE) programs, which are sponsored by various organizations including the Government Finance Officers Association, the American Institute of Certified Public Accountants, the California State Society of Certified Public Accountants, the California Society of Municipal Finance Officers and the Association of Government Accountants. Participation in these programs helps us to ensure that our clients are serviced with the best trained and most proficient government and not-for-profit auditors and accountants available. In addition, we periodically provide in-house training taught by our partners and senior level staff using published resources. All staff are required to attend fraud and ethics training. It is our goal to provide our professional staff continuing education which exceeds the minimum standard of 80 hours over two years.

In accordance with our firm's Quality Control document and *Government Auditing Standards (GAS)*, all staff members who work on audits subject to GAS are required to complete CPE in accordance with GAS standards which require 24 hours directly related to governmental accounting and auditing.

In addition to the required CPE, we also use the following to increase our technical knowledge: view the Governmental Audit Quality Center Annual Webcast Update and other relevant seminars and review monthly publications from the AICPA, the GFOA, and various other resources. We also attend conferences and seminars sponsored by the GFOA, California Society of Municipal Finance Officers and the California Special District Association.

# CITY OF BEAUMONT

## PROPOSAL FOR PROFESSIONAL AUDITING SERVICES

### Personnel (continued)

#### *Assigned personnel*

It is our goal to provide you with capable, competent, and personable individuals who offer an extensive background, not only in governmental and not-for-profit accounting and auditing, but also in general business practices. We offer practical solutions, as well as provide technical support. This enables you to stay at the forefront of governmental and not-for-profit accounting and provides you with the support you need in dealing with the complex issues confronting entities such as yours.

In addition, our engagement team has the managerial and supervisory experience to provide the City with a comprehensive audit of the highest quality, while still focusing on personal service. The resumes of the key engagement personnel assigned to the audit are presented near the end of this proposal. The following individuals will be assigned to the engagement for the entire contract period:

*Scott W. Manno, CPA, CGMA - Partner, Engagement Partner*

Scott is a municipal audit partner with the firm and will be the engagement partner. He is licensed to practice as a certified public accountant in the State of California. He has been in public accounting for 25 years specializing in serving local governments such as yours. As the engagement partner, he will be responsible for overall engagement quality, as well as ensuring that the engagement is performed in the most effective and efficient manner. Scott will directly oversee all engagement staff while assisting in planning and performing the engagement as well as reviewing all work-papers prepared during the engagement, in addition to all required reports. Scott is a working partner and will be actively and continually involved in all aspects of the engagement.

*Terry Shea, CPA - Partner, Concurring Partner*

Terry is also a municipal audit partner with the firm. He is licensed to practice as a certified public accountant in the State of California. Terry has over 39 years of public accounting experience and has provided accounting, auditing, and consulting services for municipalities, special districts, water agencies, and various not-for-profit organizations. As the concurring partner, Terry will work directly with Scott in planning and performing the engagement. In addition, he will provide technical consultation for the engagement team.

*Brad A. Welebir, CPA, CGMA, MBA - Partner, Quality Control Reviewer*

Brad will be the Quality Control Reviewer. He is licensed to practice as a certified public accountant in the State of California. He has over 16 years of practical, governmental accounting and auditing experience. Brad will be responsible for the final quality control review of all released reports.

*Charles De Simoni, CPA, CGMA - Engagement Manager*

Charles is an audit manager with the firm. He is licensed to practice as a certified public accountant in the State of California. Charles has over 10 years of public accounting experience and has provided accounting, auditing, and consulting services for municipalities, special districts, water agencies, and various not-for-profit organizations. He will work directly with Scott and Terry while supervising the engagement team during all phases of the engagement. In addition, he will oversee the preparation of any required reports.

# CITY OF BEAUMONT

## PROPOSAL FOR PROFESSIONAL AUDITING SERVICES

### Personnel (continued)

*Veronica Hernandez, CPA - Audit Senior*

Veronica is an Audit Senior with the firm. She is licensed to practice as a certified public accountant in the State of California. She has over 4 years' experience in providing accounting and auditing services for municipalities, special districts and various not-for-profit organizations. As an audit senior, Veronica will work closely with the engagement partner and manager and be responsible for planning the audit, supervising the staff assigned to the engagement, and performing reviews of all work-papers prepared for the engagement. In addition, she will also be responsible for the preparation of any required reports.

*Senior and staff level accountants*

All staff employed by us and working on governmental audits are qualified to perform governmental audits. Each staff member is encouraged to take on increased responsibility for engagements previously worked on. This enables our staff to grow on each engagement and allows them to continue to gain the skills and knowledge required to perform the audits.

In summary, we want to emphasize the credentials of the above professionals who will be directly responsible for the quality of service that you will receive. Additionally, our audit team has another attribute that is very important, even though it is intangible -- the professionals assigned to the audits have previously worked together as a multi-disciplined team, thus ensuring a smooth, efficient and effective audit. We are committed to allocating the necessary resources to ensure that we provide continuity of personnel throughout the term of our relationship with the City.

Full engagement team resumes are provided as follows.

# CITY OF BEAUMONT

## PROPOSAL FOR PROFESSIONAL AUDITING SERVICES

### Personnel (continued)

Engagement team resumes

**Scott W. Manno, CPA, CGMA**  
**Engagement Partner**



*Professional experience*

Mr. Manno began his career with Thomas, Bigbie and Smith in 1995 after serving in the United States Army. He spent six years with the firm primarily working on audits of municipalities, special districts and redevelopment agencies as well as various not-for-profit organizations. He joined Rogers, Anderson, Malody & Scott, LLP in July 2001. Currently, Mr. Manno serves as a technical reviewer for the GFOA CAFR Award program. Since 2010, Mr. Manno has been serving as a technical volunteer on the California Special Districts Association Audit Committee and is also on the Association's fiscal committee providing accounting and fiscal program guidance. Also, Mr. Manno has done presentations on fraud.

In addition, he is part of the California State Society of Certified Public Accountants Governmental Accounting and Auditing Committee which meets periodically to discuss current events, pronouncements, etc., including the implementation of GASBS 68/75.

*Education/licenses*

Bachelor of Science degree from California State University, San Bernardino  
 Certified Public Accountant - State of California  
 Chartered Global Management Accountant - American Institute of Certified Public Accountants

*Related professional experience*

Partial listing of relevant governmental agencies served (\*includes enterprise fund accounting):

City of El Cajon*	Town of Yucca Valley	City of La Mesa*	City of La Verna
City of Sierra Madre*	City of Fillmore*	City of Chino*	City of 29 Palms
City of Claremont	City of Perris*	City of Exeter*	City of Woodlake*
City of San Jacinto*	City of Menifee	City of Aliso Viejo	City of Poway*

Mr. Manno has completed over 200 hours of continuing professional education courses over the past three years of which the following select courses are relevant to this engagement:

- ◆ Association of Certified Fraud Examiners, *Fraud Related Internal Controls*
- ◆ American Institute of Certified Public Accountants, *Governmental Accounting and Auditing Update*
- ◆ Checkpoint Learning, *GASB Pension Standards Overview*

*Professional affiliations*

Mr. Manno is a member of the following organizations:

- ◆ American Institute of Certified Public Accountants (AICPA)
- ◆ California Society of Certified Public Accountants (CalCPA)
- ◆ Association of Government Accountants (AGA)
- ◆ Association of Certified Fraud Examiners (ACFE)
- ◆ Government Finance Officers Association (GFOA)
- ◆ California Special Districts Association (CSDA)
- ◆ California Society of Municipal Finance Officers (CSMFO)



# CITY OF BEAUMONT

## PROPOSAL FOR PROFESSIONAL AUDITING SERVICES

### Personnel (continued)



**Terry P. Shea, CPA**  
**Concurring Partner**

*Professional experience*

Mr. Shea began his career with Thomas, Byrne and Smith in 1981. He spent five years with the firm primarily working on audits of municipalities, special districts, redevelopment and other governmental agencies. He joined Rogers, Anderson, Malody & Scott, LLP in 1987 where he has completed governmental audits including municipalities and provided financial consulting services for various cities.

*Education/licenses*

Bachelor of Arts degree from California State University, Fullerton  
Certified Public Accountant - State of California

*Related professional experience*

Partial listing of relevant governmental agencies served (\*includes enterprise fund accounting):

- |                          |                        |                        |
|--------------------------|------------------------|------------------------|
| City of La Mesa*         | City of Loma Linda*    | City of Riverside*     |
| City of Grand Terrace*   | City of San Jacinto*   | City of El Cajon*      |
| City of Twentynine Palms | City of Palm Desert*   | City of Indian Wells   |
| City of Corona*          | City of Coachella      | City of Fillmore       |
| City of Norco*           | City of Goleta         | City of Redondo Beach* |
| City of Indio*           | City of Mission Viejo* | City of Poway          |
| City of Fontana*         |                        | City of San Marcos     |

Mr. Shea served as the Interim Finance Director for the City of Perris from July 1998 to October 2001. He currently serves as the Contract Finance Director for one Riverside County city and one Los Angeles County city.

*Continuing professional education*

Mr. Shea has completed over 120 hours of continuing professional education courses in the past three years, of which, the following select courses are relevant to this engagement:

- ◆ American Institute of Certified Public Accountants, *Foundations in Governmental Accounting*
- ◆ American Institute of Certified Public Accountants, *Governmental and Not-for-Profit Conference*
- ◆ California Society of CPAs Education Foundation, *Governmental Auditing Skills*
- ◆ Thomson Reuters, *Audits of State and Local Governments*

*Professional affiliations*

Mr. Shea is a member of the following professional organizations:

- ◆ American Institute of Certified Public Accountants (AICPA)
- ◆ California Society of Certified Public Accountants (CalCPA)
- ◆ Government Finance Officers Association (GFOA)
- ◆ California Society of Municipal Finance Officers (CSMFO)

# CITY OF BEAUMONT

## PROPOSAL FOR PROFESSIONAL AUDITING SERVICES

### Personnel (continued)



**Brad A. Welebir, CPA, CGMA, MBA**  
**Quality Control Partner**

#### *Professional experience*

Mr. Welebir joined Rogers, Anderson, Malody & Scott, LLP in January 2004. He works primarily on audits of governmental agencies, small to mid-sized businesses, and not-for-profit organizations. Mr. Welebir serves as a technical reviewer for the GFOA CAFR Award program.

#### *Education/licenses*

Masters of Business Administration - Accounting Emphasis from California State University, Fullerton  
Bachelor of Arts in Business Administration from La Sierra University  
Certified Public Accountant - State of California  
Chartered Global Management Accountant - American Institute of Certified Public Accountants

#### *Related professional experience*

Partial listing of relevant governmental agencies served (\*includes enterprise fund accounting):

San Bernardino International Airport Authority*	Inland Valley Development Agency*
City of Twentynine Palms	City of San Juan Capistrano
City of Loma Linda*	City of La Verne
City of San Bernardino*	City of Mission Viejo*
City of Sierra Madre*	City of Rosemead
City of San Jacinto*	City of Redondo Beach*
City of Moorpark*	City of Claremont
City of Fillmore*	City of San Marcos

#### *Continuing professional education*

Mr. Welebir has completed over 120 hours of continuing professional education courses in the past three years of which the following select courses are relevant to this engagement:

- ◆ California Society of CPAs Education Foundation, *Governmental Accounting and Auditing Update*
- ◆ American Institute of Certified Public Accountants, *OMB A-133 Single Audit Update*
- ◆ California Society of Municipal Finance Officers, *Annual Conference Sessions*
- ◆ Government Finance Officers Association, *GAAP Update*
- ◆ Thomson Reuters, *Yellow Book Update*

#### *Professional affiliations*

Mr. Welebir is a member of the following professional organizations:

- ◆ American Institute of Certified Public Accountants (AICPA)
- ◆ California Society of Certified Public Accountants (CalCPA)
- ◆ Government Finance Officers Association (GFOA)
- ◆ California Society of Municipal Finance Officers (CSMFO)
- ◆ California Special Districts Association (CSDA)

# CITY OF BEAUMONT

## PROPOSAL FOR PROFESSIONAL AUDITING SERVICES

### Personnel (continued)



**Charles De Simoni, CPA, CGMA**  
**Audit Manager**

#### *Professional experience*

Mr. De Simoni joined Rogers, Anderson, Malody & Scott, LLP in January 2009. He works primarily on audits of governmental agencies, small to mid-sized businesses, and nonprofit organizations. Prior to joining our firm, he worked at Jasper Engines, where he was assistant branch operations manager.

#### *Education/licenses*

Bachelor of Science in Business Administration from CSUSB  
Certified Public Accountant – State of California  
Chartered Global Management Accountant – American Institute of Certified Public Accountants

#### *Related professional experience*

Partial listing of relevant governmental agencies served (\*includes enterprise fund accounting):

City of Fillmore*	City of Twentynine Palms
Town of Yucca Valley	City of Hawthorne*
City of Rosemead	Elsinore Valley Municipal Water District
City of Moorpark*	City of Menifee
City of San Bernardino*	City of Loma Linda*
City of Redondo Beach*	City of La Verne
City of West Covina*	City of Aliso Viejo

#### *Continuing professional education*

Mr. De Simoni has completed over 120 hours of continuing professional education courses in the past three years of which the following select courses are relevant to this engagement:

- ◆ California Society of Municipal Finance Officers, *GASB Update*
- ◆ California Society of Municipal Finance Officers, *GASB 75 Case Study*
- ◆ California Society of Municipal Finance Officers, *OPEB*
- ◆ California Society of Municipal Finance Officers, *GASB 87: Lease Accounting*
- ◆ Wolters Kluwer CCH CPE Link, *Governmental Accounting and Auditing Update*
- ◆ Wolters Kluwer CCH CPE Link, *Government Auditing: Current Developments*
- ◆ Wolters Kluwer CCH CPE Link, *Sub-recipient Monitoring Under Uniform Guidance*

#### *Professional affiliations*

Mr. De Simoni is a member of the following professional organizations:

- ◆ American Institute of Certified Public Accountants (AICPA)
- ◆ California Society of Certified Public Accountants (CalCPA)
- ◆ Government Finance Officers Association (GFOA)
- ◆ California Society of Municipal Finance Officers (CSMFO)

# CITY OF BEAUMONT

## PROPOSAL FOR PROFESSIONAL AUDITING SERVICES

### Personnel (continued)



**Veronica Hernandez, CPA**  
**Audit Senior**

*Professional Experience*

Ms. Hernandez is an Audit Senior with the firm. She has over 4 years' experience in providing accounting and auditing services for municipalities, special districts and various nonprofit organizations. As an audit senior, she will work closely with the engagement partner and manager and be responsible for planning the audit, supervising the staff assigned to the engagement, and performing reviews of all workpapers prepared for the engagement. In addition, she will also be responsible for the preparation of any required reports.

*Education*

Bachelor of Science degree from California State University, San Bernardino  
Certified Public Accountant – State of California

*Related professional experience*

Partial listing of relevant governmental agencies served (\*includes enterprise fund accounting):

- |                     |                      |
|---------------------|----------------------|
| City of Loma Linda* | City of La Verne*    |
| City of Aliso Viejo | City of Claremont    |
| City of Hawthorne   | City of El Cajon     |
| City of West Covina | City of Poway*       |
| City of Moorpark*   | City of San Marcos   |
| City of San Jacinto | Town of Yucca Valley |

*Continuing Professional Education*

Ms. Hernandez has completed over 100 hours of continuing professional education courses over the past two years of which the following select courses are relevant to this engagement:

- ◆ California Society of Municipal Finance Officers, *Lease Accounting*
- ◆ California Society of Municipal Finance Officers, *Fiduciary Activities*
- ◆ California Society of Municipal Finance Officers, *Blue Book has been updated*
- ◆ California Society of Municipal Finance Officers, *Lease Accounting of tomorrow*
- ◆ California Society of Municipal Finance Officers, *GASB Update*
- ◆ American Institute of Certified Public Accountants, *Governmental Accounting and Auditing Update*

*Professional affiliations*

Ms. Hernandez is a member of the following professional organizations:

- ◆ American Institute of Certified Public Accountants (AICPA)
- ◆ California Society of Certified Public Accountants (CaCPA)
- ◆ California Society of Municipal Finance Officers (CSMFO)

# CITY OF BEAUMONT

## PROPOSAL FOR PROFESSIONAL AUDITING SERVICES

### Company background

Name:	Rogers, Anderson, Malody & Scott, LLP
Street Address:	735 E. Carnegie Drive, Suite 100
City, State, Zip Code:	San Bernardino, CA 92408
Corporate structure:	Limited liability partnership
State/County of incorporation:	California/San Bernardino
Website:	www.ramscpa.net
License #:	2596
Contact information:	Scott W. Manno, CPA, CGMA 909.889.0871 smanno@ramscpa.net

#### *License to practice*

Rogers, Anderson, Malody & Scott, LLP is licensed to practice in the State of California. The key professional staff, which includes the partners, managers, and supervisors, are all certified public accountants licensed to practice in the State of California and are in compliance with all applicable Board of Accountancy standards.

#### *Independence*

Rogers, Anderson, Malody & Scott, LLP is independent of the City and any component units, as defined by general standard number two of the generally accepted auditing standards, and by the second general standard for government auditing in the U.S. Government Accountability Office's *Government Auditing Standards*.

#### *About our firm*



Our firm was founded in 1948 and is located at 735 E. Carnegie Drive, Suite 100, San Bernardino, California and provides the full range of services expected of a full service accounting firm. We are one of the oldest, most trusted and respected CPA firms in Southern California, with over 72 years of public practice experience, specializing in governmental agency and not-for-profit organization auditing, accounting and management advisory services. Over *nineteen thousand hours per year* are devoted to this area of our practice, which includes cities, redevelopment successor agencies, water districts, other special districts, not-for-profit corporations and joint power authorities. We do not use our government accounting

and auditing practice as "fill work" for the firm, it is one of our primary focuses.

We understand your desire engage auditors that have a thorough understanding of the ever changing complex accounting and compliance issues confronting governments today. Our firm has an extensive history of governmental accounting and auditing. During that time we have gained valuable experience, acquired an in-depth knowledge of, and obtained the technical expertise needed to perform high quality governmental audits. This expertise has enabled us to provide exceptional, high quality service and to provide solutions at fees we feel represent our value to our clients. In addition, we use our participation in various industry associations to continuously update our knowledge with respect to issues relating to governmental accounting, auditing and operations. Any insight we gain is immediately passed on to our clients if we feel they will benefit from it.

# CITY OF BEAUMONT

## PROPOSAL FOR PROFESSIONAL AUDITING SERVICES

### Company background (continued)

Our firm has a total staff of thirty-two people, which includes sixteen certified public accountants. The staff consists of six partners, three managers, seven supervisors/senior accountants, eleven staff accountants and five support staff. The audit staff consists of twenty members who devote over 80% of their time to municipal engagements. The engagement team assigned to the City's engagement will consist of the following full-time staff: one audit partner, one audit manager, one audit supervisor/senior and two to three staff auditors. All personnel are located in our San Bernardino office.

#### *Governmental Audit Quality Center*

As a member of the American Institute of CPAs *Governmental Audit Quality Center* (Center), we are committed to adhering to the highest quality standards by voluntarily agreeing to the Center membership requirements, which include designating a partner responsible for the quality of our governmental and not-for-profit audit practice, establishing quality control programs, performing annual internal inspection procedures, and making our peer review report findings publicly available. At RAMS, our goal is to continue to enhance our quality initiatives within our governmental and not-for-profit audit practice to deliver the highest quality audit services possible.

In addition, the *Governmental Audit Quality Center* provides access to comprehensive resources that will assist us in further enhancing the quality of your audit. The Center membership provides us with timely information on a variety of technical, legislative and regulatory subjects that we can in turn apply to your audit to help ensure compliance with the appropriate standards and changes in regulations which we pass on to our clients.

#### *Engagement quality control*

We have an extensive internal quality control review process to ensure your audit meets the highest standards. In addition to the preparation of financial reports by a senior member of the engagement team, each report is reviewed by the engagement manager/supervisor and then is examined by the engagement partner. Subsequently, a technical review is then performed by the Quality Control partner along with being proofread by a professional staff. In addition, all audit workpapers are reviewed by the in-charge auditor and the partner in-charge of the engagement.

#### *Disciplinary action*

The firm **has never** had any disciplinary action taken or pending against it with state regulatory bodies or professional organizations, nor has it ever had any pending or settled litigation, civil or criminal investigations.

**Our firm does not have a record of substandard work.**

In addition to the external quality control review, our firm performs in-house peer reviews over our audit and attest engagements annually.

#### *Equal Opportunity Employer*

Our firm is an equal opportunity employer and is committed to providing employment opportunities to all qualified persons regardless of race, color, sex, religion, national origin or handicap. Our staff represents a wide range of cultures and ethnic backgrounds. We provide opportunities for advancement for all staff based on ability, skill and desire to advance.

# CITY OF BEAUMONT

## PROPOSAL FOR PROFESSIONAL AUDITING SERVICES

### Peer review

#### External quality control review

As a member of the AICPA Private Companies Practice Section, our firm has participated in the "Peer Review" program since 1993 and has been examined every three years since that date by an outside, independent firm of certified public accountants. Participation in this program ensures that our engagements, firm policies, and audit procedures meet the standards of the AICPA, the Yellow Book and the California State Board of Accountancy. Throughout our participation in this program, the firm has received pass ratings from the peer reviewers. The latest review below included reviews of specific governmental entities.

During the latest review, an independent firm reviewed our policies and procedures and then inspected a representative sample of engagement workpapers and reports, including governmental entities and engagements subject to the *Uniform Guidance*. For the year ended November 30, 2017, our firm received a rating of *pass* which indicates our auditing practice is suitably designed and complied with to provide reasonable assurance of performing and reporting in conformity with applicable standards. The results provide confirmation that the custom audit approach and procedures we use are technically sound and in compliance with applicable standards.

The firm is not aware of any federal or state desk reviews or field reviews of its audits during the last three years.

### Grant Bennett Associates

A PROFESSIONAL CORPORATION

#### Report on the Firm's System of Quality Control

May 15, 2018

To the Partners of Rogers, Anderson, Malody & Scott, LLP and the Peer Review Committee of the California Society of CPAs:

We have reviewed the system of quality control for the accounting and auditing practice of Rogers, Anderson, Malody & Scott, LLP (the firm) in effect for the year ended November 30, 2017. Our peer review was conducted in accordance with the Standards for Performing and Reporting on Peer Reviews established by the Peer Review Board of the American Institute of Certified Public Accountants (Standards).

A summary of the nature, objectives, scope, limitations of, and the procedures performed in a System Review as described in the Standards may be found at [www.aicpa.org/prsummary](http://www.aicpa.org/prsummary). The summary also includes an explanation of how engagements identified as not performed or reported in conformity with applicable professional standards, if any, are evaluated by a peer reviewer to determine a peer review rating.

#### Firm's Responsibility

The firm is responsible for designing a system of quality control and complying with it to provide the firm with reasonable assurance of performing and reporting in conformity with applicable professional standards in all material respects. The firm is also responsible for evaluating actions to promptly remediate engagements deemed as not performed or reported in conformity with professional standards, when appropriate, and for remediating weaknesses in its system of quality control, if any.

#### Peer Reviewer's Responsibility

Our responsibility is to express an opinion on the design of the system of quality control and the firm's compliance therewith based on our review.

#### Required Selections and Considerations

Engagements selected for review included engagements performed under *Government Auditing Standards*, including a compliance audit under the Single Audit Act and an audit of an employee benefit plan.

As a part of our peer review, we considered reviews by regulatory entities as communicated by the firm, if applicable, in determining the nature and extent of our procedures.

#### Opinion

In our opinion, the system of quality control for the accounting and auditing practice of Rogers, Anderson, Malody & Scott, LLP in effect for the year ended November 30, 2017, has been suitably designed and complied with to provide the firm with reasonable assurance of performing and reporting in conformity with applicable professional standards in all material respects. Firms can receive a rating of *pass*, *pass with deficiency(ies)* or *fail*. Rogers, Anderson, Malody & Scott, LLP has received a peer review rating of *pass*.

*Grant Bennett Associates*

GRANT BENNETT ASSOCIATES  
A PROFESSIONAL CORPORATION  
Certified Public Accountants



1375 Exposition Boulevard, Suite 230  
Sacramento, CA 95815  
916/922-5109 FAX 916/641-5200

P.O. Box 223096  
Princeville, HI 96722  
888/769-7323

# CITY OF BEAUMONT

## PROPOSAL FOR PROFESSIONAL AUDITING SERVICES

### Audit approach

#### *Services to be provided*

The City desires the auditor to express an opinion on the fair presentation of the financial statements for the following: the City of Beaumont in accordance with generally accepted accounting principles.

In addition, we shall:

- Preparation of the financial statements.
- Apply certain limited procedures related to Management's Discussion and Analysis and Required Supplementary Information and provide an "in-relation-to" report on the combining and individual fund financial statements and supporting schedules, if applicable.
- Provide opinions as to the compliance with the *Uniform Administrative Requirements, Cost Principles and Audit Requirements for Federal Awards* (OMB Uniform Guidance). RAMS is to provide an "in-relation-to" report on the Schedule of Expenditures of Federal Awards based on the auditing procedures applied during the audit of the financial statements.
- Determine compliance with bond covenants.
- GASB 68 assistance.
- Prepare the Annual Transaction Report to the State Controllers Office.
- Test compliance with Article XIII B pertaining to the City's appropriation limit, and prepare an Agreed-Upon Procedures report to the City Council regarding compliance.
- Provide updates on recent GASB pronouncements as needed.

Our audit(s) will be in accordance with:

- Generally Accepted Auditing Standards as promulgated by the American Institute of Certified Public Accountants, including requirements found in the new AICPA audit guide "Audits of State and Local Governments".
- *Government Auditing Standards* issued by the Comptroller of the United States of America.
- Uniform Administrative Requirements, Cost Principles and Audit Requirements for Federal Awards (OMB Uniform Guidance).
- Any other applicable standards for conducting the examinations of items outlined in the Scope of Work to be performed and/or reports to be issued.

Reports to be issued:

- A report on the fair presentation of the financial statements in conformity with GAAP.
- A report on internal control over financial reporting and on compliance and other matters based on an audit of financial statements performed in accordance with *Government Auditing Standards*.
- A report in compliance with requirements applicable to each major federal program and internal control over compliance in accordance with the *Uniform Guidance*.
- Prepare Management Letter that includes significant and less significant (i.e. reportable and non-reportable) recommendations for improvements to internal control.
- We will issue reports to those charged with governance (SAS 114 letters) as required by auditing standards.

RAMS will also perform the following:

- We shall communicate to management any reportable conditions found during the audit, including significant deficiencies and material weaknesses, nonreportable conditions will be reported in a separate letter to management.
- Make an immediate, written notification of all irregularities and illegal acts or indication of illegal acts of which we become aware to the following: City Manager and the Director of Finance.



# CITY OF BEAUMONT

## PROPOSAL FOR PROFESSIONAL AUDITING SERVICES

### Audit approach (continued)

#### *Engagement approach*

Our engagement approach for your audit will be developed using established goals which will enable measurement of the audit process by the engagement partner and lead auditor. Our approach involves frequent communication between the partner and the engagement team to ensure that all audit objectives are achieved in accordance with our goals and that any issues which may arise are communicated and dealt with on a timely basis. Our overall knowledge and expertise in governmental accounting and auditing has allowed us to identify key audit and accounting risks in the government environment. More importantly, the approach provides for a complete reassessment of the management and control environment in each year's audit and thus is capable of responding to changes and will ensure that deadlines are met in issuing the annual financial statements.

Our engagement approach has been developed and refined over many years. The backbone of our approach revolves around the following six constants:

- **Knowledge and experience.** We have been auditing governmental entities like the City, both large and small, for over 72 years. This experience has allowed us to gain in-depth knowledge of the governmental environment which in turn allows us to perform a more efficient and effective audit and enables us to perform detailed risk assessment procedures. These risk assessment procedures allow us to identify significant audit risk areas within the City.
- **Oversight.** Professional judgment is not developed overnight. Our partners, managers and supervisors have been deeply involved in governmental audits on a continuous basis for most of their professional careers. By having direct partner and manager oversight, we are able to design audit strategies that result in effective and efficient audits.
- **Timeliness.** Deadlines are not just "dates" to us, they are professional commitments. All required deadlines will be met.
- **Open communication.** Open lines of communication with all parties (the engagement team members and City Management and staff) throughout the audit process helps to eliminate "surprises." Proper planning and proper use of experienced engagement personnel tend to provide for an effective and efficient audit process. Consequently, inefficiencies, disruptions, and lack of understanding are kept to a minimum.
- **Availability.** All engagement team members are available throughout the year for any questions or additional consultation. City staff will have direct access to the partner, manager and other supervisory staff at all times during the engagement, as well as subsequent to.
- **Cost effectiveness.** Our customized audit approach and procedures and our experienced auditors help to reduce your overall audit costs while still providing an effective audit and high quality reports.
- **Intelligent design:** As discussed later in our proposal, all of our audits are designed to be intelligent using our powerful audit software tools (Engagement and Teammate Analytics). This allows us to analyze large amounts of data in seconds increasing both efficiency and effectiveness on all engagements.

# CITY OF BEAUMONT

## PROPOSAL FOR PROFESSIONAL AUDITING SERVICES

### Audit approach (continued)

As indicated in the next section of the proposal, the overall objective of the engagement with the City is to conduct an audit of the financial statements in accordance with required auditing standards and the expression of an opinion on those financial statements. Beyond that initial objective, we believe that our engagement approach provides certain other value added characteristics, at no additional cost, that will benefit the City over the long-term:

- All of our audits are designed to be performed in an efficient and effective way to minimize disruption to the office operations.
- We offer practical observations and recommendations relating to internal control issues, implementation of accounting standards and the policies and procedures regarding both.
- We identify opportunities for operating efficiencies which can be used to decrease operating costs of the City.

#### *Audit approach and proposed audit segmentation*

The following is a summary of the audit team's audit approach for the City's engagement. The audit will be divided into the following segments:

#### Segment 1 - Interim testing - planning, pre-audit administration and internal control testing

During this phase of the audit, our principal objectives will be to gather information about the City and its environment, including its internal control over financial reporting.

In order to achieve the desired objectives of this phase of the audit, we will:

- Meet with the City's staff in order to determine convenient dates in which we can begin our audit, and to discuss the assistance to be provided by the City's staff.
- Hold brainstorming sessions with engagement team members to discuss the susceptibility of the City's financial statements to material misstatement and fraud.
- Review and evaluate the City's accounting and reporting processes by reviewing the prior year's audit workpapers, any City-prepared documents such as budgets, in-house financial reports, policies and procedures manuals, minutes of council meetings, etc., and by using various analytical procedures. Analytical procedures will enhance our understanding of the City and will help us identify areas that may need further assessment and additional testing.
- Review and retain copies of any pertinent local, state and federal statutes, regulations, or charters that apply to the City.
- Evaluate the design of controls that are relevant to the audit by obtaining a thorough understanding of the City's internal controls over financial reporting and compliance by documenting key internal control components, utilizing questionnaires, walkthroughs, inquiring of the City's personnel, and observing and reviewing key supporting documentation (a more thorough explanation of this process is discussed later in the technical proposal).
- Test controls, if control risk is assessed below the maximum, by selecting a sample of transactions within the audit area being tested and reviewing supporting documentation, and evaluating the completeness of the documentation tested, as well as the adequacy of support and approvals as they appear on the support.
- Document and review with management, any findings noted during the testing of internal controls and provide a preliminary management letter that will include our recommendations for improving any weaknesses in operations. The letter will also include suggestions for improving the efficiency of the City's operations.

# CITY OF BEAUMONT

## PROPOSAL FOR PROFESSIONAL AUDITING SERVICES

### Audit approach (continued)

In addition, we will perform the following procedures related to IT General Controls that “touch” financial data:

- *Security access (including physical) controls:* evaluate the general system security settings and password parameters; evaluate the process for adding, deleting and changing security access; and evaluate the access capabilities of various types of users; evaluate access controls to networks and financial applications; evaluate access controls related to data files; and evaluate physical access to networks, servers, etc.
- *Computer operations:* Evaluate backup and recovery processes; and review processes of identifying and handling operational problems.
- *System development and system changes:* Evaluate processes related to system development and system changes (if applicable).
- *Application testing:* We will determine if the testing of application controls is deemed necessary based on our professional judgment in the planning stages of the engagement. If deemed appropriate, application control testing might consist of the following:
  - Interview key personnel, inquire of testing processes (quality assurance and end user testing) for application changes, review the chain of relevant documents (end user acceptance report);
  - Observe attempts to input incorrect data, determine who can override controls;
  - If table driven, determine who can change edits and tolerance levels;
  - Conduct tests based on user access rights;
  - Test access privileges for each sensitive function or transaction;
  - Review access rights that set and amend configurable approval and authorization limits;
  - Observe transmission reports and error reports;
  - Observe validity and completeness parameters and settings;
  - Review access to set and amend configurable parameters on file transfers; and
  - Review process for validation and test operation.

This phase of the engagement for the audit will be performed by the audit senior and two staff accountants with direct supervision by the audit manager and partner.

### Segment 2 - Year-end testing - substantive testing

During this phase of the audit, our principal objectives will be to assess the risk of material misstatement at the financial statement level and specific assertions, design overall responses to assessed risks and further audit procedures, perform substantive tests, as needed, and complete the audit and evaluate audit findings, if applicable.

In order to achieve the desired objectives of this phase of the audit, we will:

- Determine whether our testing supports the assessed level of risk initially assigned at the financial statement level and at the assertion level.
- Identify significant risks.
- Develop a detailed audit plan.

# CITY OF BEAUMONT

## PROPOSAL FOR PROFESSIONAL AUDITING SERVICES

### Audit approach (continued)

- Design substantive tests of account balances, designed and modified specifically for the City's operations and assessed level of risk. Substantive procedures will consist of testing balance sheet accounts, revenues and expenditures accounts along with various analytical procedures as deemed necessary. In addition, various accounts made be confirmed with outside parties (cash, investments, etc.).

This phase of the engagement for the audit will be performed by the senior accountant and two/three staff accountants with direct supervision by the audit manager and partner.

### Segment 3 - Reporting - report preparation/audit conclusion (workpaper review)

During this phase of the audit, our principal objectives will be to evaluate whether the financial statements, taken as a whole, are free from material misstatement and form an opinion(s) and issue our report.

In order to achieve the desired objectives of this phase of the audit, we will:

- Determine whether, based on our substantive testing and other procedures, the financial statements, taken as a whole, are free of material misstatement. This will provide the basis for our opinion(s).
- Review all audit workpapers to ensure that the audit was performed in accordance with the required standards (GAAS, GAGAS, etc.).
- Prepare drafts of all required reports by the agreed-upon dates.
- Conduct an independent review of the financial statement draft by the engagement's quality control partner.
- Issue all reports by the agreed-upon dates.

This phase of the engagement will be performed by the audit senior and one staff accountant with direct supervision by the audit manager and partner. In addition, the engagement's quality control partner will perform a detailed quality control review of the financial statements.

The above procedures are a general list of procedures to be performed. After our initial review of the City and our detailed risk assessment, we will customize the engagement and gear it towards the needs of the City and the audit itself. In doing so, we will determine which procedures to perform relative to our risk assessment. All of our audits are customized to each entity, helping to ensure a complete, effective, and efficient audit. The foundation of the above approach is based on open communication coupled with a strong knowledge of the City's operations and detailed planning at the initial stages of the audit.

Our firm is dedicated to performing a timely audit engagement. Prior to the start of the audit, we will meet with City staff and decide on adequate timeframes, agreed upon by both the City and us, for the performance of the audit and the release of the financial statements. *We will dedicate the necessary resources to meet any agree upon time frames.*

# CITY OF BEAUMONT

## PROPOSAL FOR PROFESSIONAL AUDITING SERVICES

### Audit approach (continued)

Level of staff and approximate number of hours assigned to each segment:

Segment	Partner	Manager	Senior	Staff	Total
Segment 1	6	8	30	65	109
Segment 2	10	12	48	85	155
Segment 3	14	10	42	20	86
Totals*	30	30	120	170	350

\* = excludes Single Audit hours

### Sample sizes

Our sample sizes will be determined in accordance with the AICPA's *Audit and Accounting Guide, Audit Sampling*, and will be selected using professional judgment as permitted by Statement on Auditing Standards. Our methods are designed to provide the most audit coverage without expending excess time. Our sample sizes will depend upon our preliminary assessment of control risk, our planned substantive testing and analytical procedures as well as our professional judgement.

We utilize our Computer Aided Audit Tools (CAAT) software, Teammate Analytics, to draw our audit samples. The software allows us to generate random samples, systematic samples, stratified samples, attributes samples as well as monetary unit samples (also called probability-proportional-to-size or dollar unit sampling).

### Audit technology

We design our audits to be intelligent using our powerful audit software tools (Engagement and Teammate Analytics). This allows us to analyze large amounts of data in seconds. In addition, all audit team members are linked to each other using wireless connections (or a local router) which enables them to share information at an almost real-time speed. Below are benefits of our audit software:

- **We utilize Teammate Analytics, a suite of more than 150 dynamic Computer Aided Audit Tools (CAATs). Using data received directly from the Department, we can perform the following: search for duplicate checks, detect transactions occurring on holidays/weekends or during unusual hours, perform Benford's Law analysis, and identify instances when a vendor has issued multiple invoices with sequential references along with many other tests. The software empowers our audit teams with the ability to perform powerful, meaningful data analysis which will build upon our other value added services.**
- We can create our own analytical schedules allowing for easy analysis of current balances to prior year balance, current vs budget balance, thus reducing significant City staff time.
- Once your trial balances and financial statements are entered into our software, we are able to observe your statements in the field allowing us to notice any variances and address them at your office.
- We link the financial statement schedules directly to our audit software trial balances, and as a result, we can provide the City with fund financial statements almost immediately after importing the trial balances.
- We can provide the City with our audited trial balances which show the coding of the financial statement schedules for ease of review for City staff. These reports show each account coded to a specific financial statement line item/function as well as journal entries posted during the audit.

# CITY OF BEAUMONT

## PROPOSAL FOR PROFESSIONAL AUDITING SERVICES

### Audit approach (continued)

#### *Analytical procedures*

In order to properly utilize analytical procedures, industry background and knowledge are needed. With our firm's long history and qualified staff, we believe we have the necessary knowledge and experience to effectively apply analytical procedures. We will utilize analytical review procedures throughout our audit of the City. During the *interim* phase of our audit, we will compare current and prior year unadjusted balances to determine areas that may need additional analysis; we will also compare current year actual amounts to the City's annual budget. During the *final* phase of our audit, we will perform procedures similar to those mentioned above, as well as compare certain financial ratios for current and prior years. We will also conduct certain "reasonableness" tests. Any significant variances are investigated further through inquiry and other substantive testing as deemed necessary until resolved to our satisfaction. Finally, after we have completed our fieldwork, we will compare current and prior year audited balances, keeping in mind expected relationships obtained from our knowledge of the City and various other entities. In addition, we may choose to use various other analytical techniques such as trend analysis, etc.

***Unlike other audit firms, we use analytical procedures to supplement our substantive testing, not supplant them.***

#### *Understanding of internal control over financial reporting*

Our approach to obtaining an understanding of the City's internal control over financial reporting will be performed in accordance with professional standards as promulgated by the American Institute of Certified Public Accountants -- our understanding will include the *Control Environment, Risk Assessment, Control Activities, Information and Communication, and Monitoring*. We will use customized procedures which we have developed internally to evaluate your internal control systems. By combining our customized procedures and our detailed knowledge of the City and its environment, we will be able to provide constructive feedback in areas we feel need improvement. In addition to our customized procedures, we will also perform the following:

***Control Environment.*** Through inquiry of the City's personnel, prompted by questionnaires, personal knowledge, and review of the minutes of the City's Council meetings, we will obtain an understanding of management's and the City Council's attitudes, awareness and actions concerning the control environment, focusing on the substance of the controls rather than their form.

***Risk Assessment.*** Through inquiry of the City's personnel and the use of questionnaires, we will obtain sufficient knowledge of the City's risk assessment process to understand how management considers risks relevant to financial reporting objectives and decides upon actions to address those risks. This will include understanding how management identifies risks, estimates the significance of these risks, assesses the likelihood of their occurrence, and relates them to financial reporting.

***Control Activities.*** Certain control procedures will be documented during our analysis of the control environment and the accounting system. However, many specific control procedures will still need to be documented that will focus primarily on the City's major transaction cycles. As mentioned above, we will test the City's control procedures on which we intend to rely on for safeguarding assets from unauthorized use or disposition and detecting/preventing unauthorized transactions. Any flow charts, organizational charts and any other manuals, programs, and financial and management information systems will be analyzed during this process.

# CITY OF BEAUMONT

## PROPOSAL FOR PROFESSIONAL AUDITING SERVICES

### Audit approach (continued)

**Information and Communication.** Through inquiry of the City's personnel, we will identify the major types of transactions engaged in by the City. We will become familiar with the treatment of those transactions, including how the transactions are initiated, the related accounting records, and the manner of processing the transactions. Finally, we will obtain an understanding of the City's financial reporting process used to prepare financial reports, including the approaches used in making accounting estimates and disclosures.

**Monitoring.** Through inquiry of the City's personnel and the use of questionnaires, we will obtain sufficient knowledge of the major types of activities the City uses to monitor internal control over financial reporting. We will also determine how those activities are used to initiate corrective actions.

#### *Approach in determining applicable laws and regulations*

We understand the importance of laws and regulations in planning an audit of a local government or not-for-profit entity and design all of our audits to ensure we test transactions for compliance. As part of our audit process, our audit team will obtain an understanding of the laws and regulations that will have a direct and material effect on the City's financial statements. In determining which laws and regulations are applicable to the City's financial statement audit, we will consult the following sources:

- AICPA Audit and Accounting Guide, *Audits of State and Local Governments*
- California Government Code (investments, GANN limit requirements, etc.)
- U.S. Government Accountability Office's *Government Auditing Standards* (The Yellow Book), 2018 Revision
- Applicable contracts/grants of the City
- *Uniform Administrative Requirements, Cost Principles and Audit Requirements for Federal Awards* (OMB Uniform Guidance)

After consulting the applicable sources, we will design our audit to provide reasonable assurance of detecting material instances of noncompliance while continuing to refer back to the applicable compliance guideline to ensure changes in compliance are not missed.

#### *Approach in drawing samples for compliance testing*

Our approach to be taken in drawing audit samples for purposes of tests of compliance will depend on the number of transactions, the amounts of financial assistance provided (as applicable), and the City's internal controls over the respective programs. Our audits are designed to ensure we will select samples that will provide sufficient evidence of the City's compliance with the laws and regulations that will have a material effect on compliance with laws and regulations.

As previously mentioned, we utilize our CAAT software, *Teammate Analytics*, to draw our audit samples. The software allows us to pull random samples, systematic samples, stratified samples as well as monetary unit samples (also called probability-proportional-to-size or dollar unit sampling).

# CITY OF BEAUMONT

## PROPOSAL FOR PROFESSIONAL AUDITING SERVICES

### Audit approach (continued)

#### Proposed audit timing

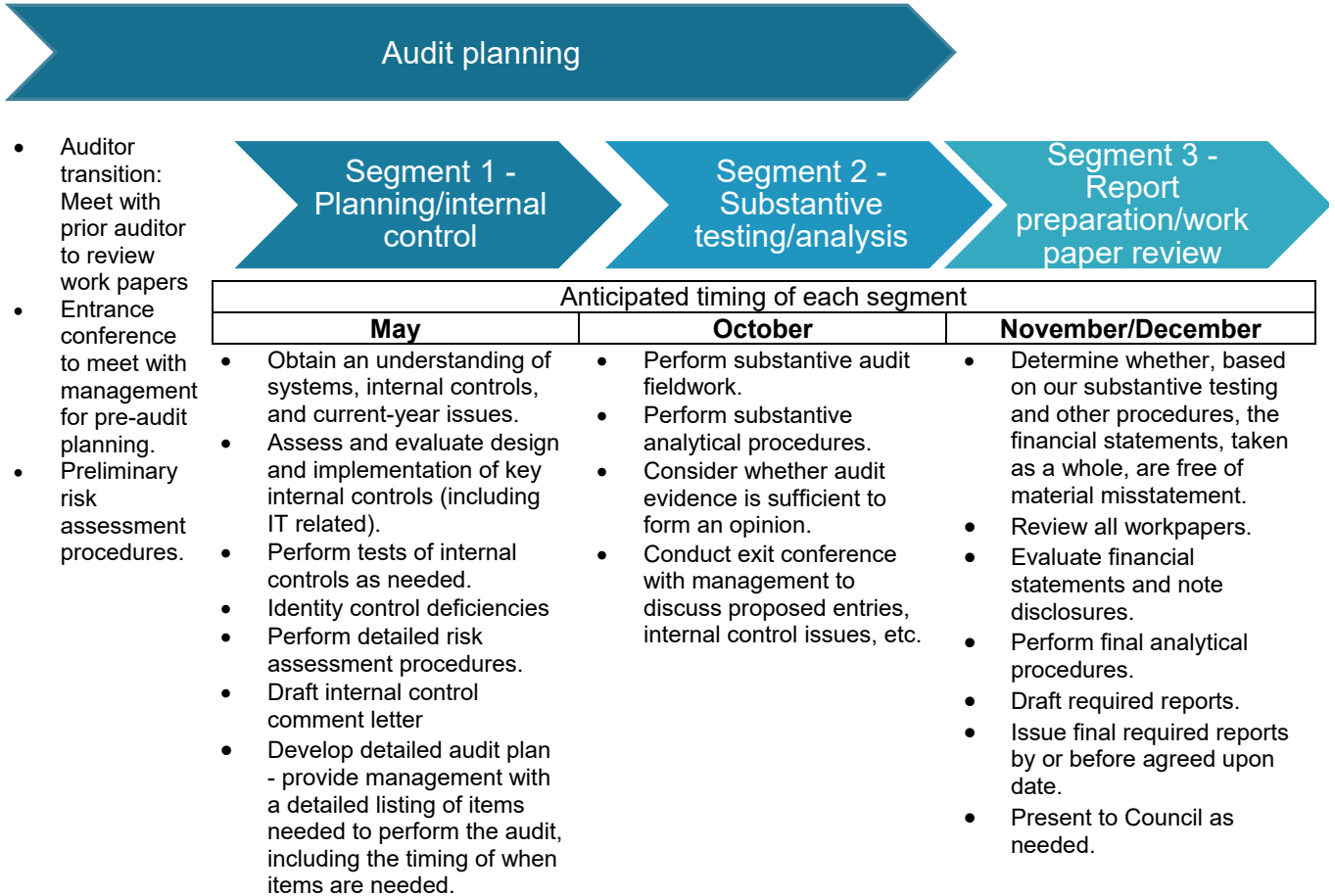

### Specific expertise desired

Almost all of our City clients have development impact fees, we are very familiar with the required accounting, reporting and financial reporting for those funds.

Also, our partners have seen and dealt with a variety of debt issuances throughout the years, including Community Facilities Bonds, Certificates of Participation, Revenue Bonds, Variable Rate Bonds, Tax Anticipation Notes, to name a few.



# CITY OF BEAUMONT

## PROPOSAL FOR PROFESSIONAL AUDITING SERVICES

### References

<b>Entity:</b>	<b>City of Claremont</b>
Scope of work:	Financial Audit/CAFR*/Successor Agency
Date:	Year ending June 30, 2016 - present
Engagement partner:	Mr. Brad Welebir
Total hours:	Approximately 400 hours
Contact person:	Mr. Adam Pirrie, Finance Director, (909) 399-5328, apirrie@ci.claremont.ca.us
<b>Entity:</b>	<b>City of Thousand Oaks</b>
Scope of work:	Financial Audit/CAFR*/Successor Agency/Single Audit
Date:	Year ending June 30, 2018 - present
Engagement partner:	Mr. Terry Shea
Total hours:	Approximately 440 hours
Contact person:	Ms. Elisa Magana, Accounting Manager, (805) 449-2216, emagana@toaks.org
<b>Entity:</b>	<b>City of San Marcos</b>
Scope of work:	City CAFR/Single Audit
Date:	Year ending June 30, 2014 - present
Engagement partner:	Mr. Scott Manno
Total hours:	Approximately 600 hours
Contact person:	Lisa Fowler, Finance Director, (760) 744-1050, Lfowler@san-marcos.net
<b>Entity:</b>	<b>City of La Mesa</b>
Scope of work:	Financial Audit/Single Audit
Date:	Year ending June 30, 2011 - present
Engagement partner:	Mr. Scott Manno
Total hours:	Approximately 325 hours each year
Contact person:	Mrs. Sarah Waller-Bullock, Director of Finance, (619) 667-1125, sbullock@cityoflamesa
<b>Entity:</b>	<b>City of Loma Linda</b>
Scope of work:	Financial Audit/RDA/Successor Agency
Date:	Years ending June 30, 2013 - present
Engagement partner:	Mr. Terry Shea
Total hours:	Approximately 225 hours each year
Contact person:	Ms. Diana DeAnda, Finance Director/Treasurer, (909) 799-2840, ddeanda@lomalinda-ca.gov

\* = received GFOA/CSMFO award.

See Attachment A for a listing of current and recent government clients served.

# CITY OF BEAUMONT

## PROPOSAL FOR PROFESSIONAL AUDITING SERVICES

### References (continued)

<b>Entity:</b>	<b>City of El Cajon</b>
Scope of work:	City CAFR*/Successor Agency/Public Financing Authority/Single Audit/GANN limit/Measure O
Date:	Years ending June 30, 2008 - present
Engagement partner:	Mr. Scott Manno
Total hours:	Approximately 500 hours each year
Contact person:	Ms. Victoria Danganan, Finance Manager, (619) 441-1763

<b>Entity:</b>	<b>Town of Yucca Valley</b>
Scope of work:	Financial Audit/CAFR*/Successor Agency
Date:	Years ending June 30, 2008 - present
Engagement partner:	Mr. Scott Manno
Total hours:	Approximately 350 hours each year
Contact person:	Mr. Curtis Yakimow, Town Manager (760) 369-7207

<b>Entity:</b>	<b>City of Exeter</b>
Scope of Work:	Financial Audit/Transportation Fund Audit
Date:	Years ending June 30, 2018 - present
Engagement partner:	Mr. Scott Manno
Total hours:	Approximately 200 hours each year
Contact Person:	Mr. Chris Tavaréz, Finance Director, (559) 592-2755

<b>Entity:</b>	<b>City of San Jacinto</b>
Scope of work:	Financial Audit/ Single Audit/Successor Agency
Date:	Years ending June 30, 2011 - present
Engagement partner:	Mr. Scott Manno
Total hours:	Approximately 300 hours each year
Contact Person:	Mr. Tom Prill, Finance Manager, (951) 487-7330

<b>Entity:</b>	<b>City of Sierra Madre</b>
Scope of work:	Financial Audit/CAFR*
Date:	Year ending June 30, 2012 - present
Engagement partner:	Mr. Scott Manno
Total hours:	Approximately 300 hours each year
Contact person:	Mr. Colby Konisek, Finance Director (626) 355-7135

# CITY OF BEAUMONT

## PROPOSAL FOR PROFESSIONAL AUDITING SERVICES

### Contract terms

We have read the terms and conditions of the provided contract and have an issue with the following:

*12. Ownership of Documents; Audit.*

*All draft and final reports, plans, drawings, studies, maps, photographs, specifications, data, notes, manuals, warranties and all other documents of any kind or nature prepared, developed or obtained by CONTRACTOR in connection with the performance of Services performed for the CITY shall become the sole property of CITY, and CONTRACTOR shall promptly deliver all such materials to CITY upon request. At the CITY's sole discretion, CONTRACTOR may be permitted to retain original documents, and furnish reproductions to CITY upon request, at no cost to CITY.*

*Subject to applicable federal and state laws, rules and regulations, CITY shall hold all intellectual property rights to any materials developed pursuant to this Agreement. CONTRACTOR shall not such use data or documents for purposes other than the performance of this Agreement, nor shall CONTRACTOR release, reproduce, distribute, publish, adapt for future use or any other purposes, or otherwise use, any data or other materials first produced in performance of this Agreement, nor authorize others to do so, without the prior written consent of CITY.*

Per professional standards, audit documentation is the property of the auditor. Audit documentation is the auditor's evidence of the procedures performed, evidence obtained, and conclusions reached. However, the auditor may make available to the City, at the auditor's discretion, copies of the audit documentation, provided such disclosure does not undermine the effectiveness and integrity of the audit process. If the language that is currently in the contract is included, that opens our workpapers to a possible FOA request since they are the "property of the City".

# CITY OF BEAUMONT

## PROPOSAL FOR PROFESSIONAL AUDITING SERVICES

### Cost summary

#### Cost Summary

#### Not to exceed price for proposed services schedule

In accordance with the Request for Proposal for Audit Services issued by the City of Beaumont, the firm referenced below hereby submits the following cost proposal:

	Fiscal years ending June 30,				
			Option years		
	2020	2021	2022	2023	2024
<b>Basic report to be issued</b>					
City audit, including CAFR and related reports	\$ 46,200	\$ 46,200	\$ 47,350	\$ 48,200	\$ 48,200
<b>Total</b>	<u>\$ 46,200</u>	<u>\$ 46,200</u>	<u>\$ 47,350</u>	<u>\$ 48,200</u>	<u>\$ 48,200</u>
<b>Additional Audit Reports to be Requested at City Option:</b>					
Single Audit* and related reports	\$ 4,910	\$ 4,910	\$ 5,025	\$ 5,100	\$ 5,100
Annual Report of City Financial Transactions to SCR	2,580	2,580	2,635	2,685	2,685
<b>Total</b>	<u>\$ 7,490</u>	<u>\$ 7,490</u>	<u>\$ 7,660</u>	<u>\$ 7,785</u>	<u>\$ 7,785</u>

\* = for the first major program, each additional major program \$3,250.

Rates for additional professional services:

Position	Hourly rate	Estimated hours*	Estimated charges
Partner	\$ 280	30	\$ 8,400
Manager	190	30	5,700
Senior accountant	140	120	16,800
Staff accountant	90	170	15,300

\* = excludes Single audit and SCR

I hereby certify that the undersigned is authorized to represent the firm stated above, and empowered to submit this bid, and if selected, is authorized to sign a contract with the City, for the services identified in the Request for Proposals.

Firm name: Rogers Anderson Malody & Scott, LLP

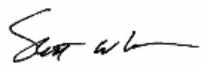
Signature: 

Printed name: Scott W. Manno, CPA, CGMA

Title: Partner

Date: April 3, 2020

We have no specific, separate cost elements.

GOVERNMENT CLIENTS SERVED

<u>Government Client</u>	<u>Years Served</u>	<u>CSMFO/ GFOA Awards</u>	<u>Successor Agency</u>	<u>Housing Authority</u>
City of El Cajon	06/30/07 to 06/30/19	Yes	Yes	Yes
City of Exeter	06/30/17 to 06/30/19			
City of Woodlake	06/30/17 to 06/30/19			
Town of Yucca Valley	06/30/08 to 06/30/19	Yes	Yes	Yes
City of La Verne	06/30/11 to 06/30/19	Yes	Yes	Yes
City of San Jacinto	06/30/11 to 06/30/19		Yes	Yes
City of Twentynine Palms	06/30/11 to 06/30/19	Yes	Yes	Yes
City of La Mesa	06/30/11 to 06/30/19		Yes	Yes
City of Menifee	06/30/14 to 06/30/19	Yes		
City of San Marcos	06/30/14 to 06/30/19	Yes	Yes	Yes
City of Redondo Beach	06/30/12 to 06/30/16	Yes	Yes	Yes
City of Loma Linda	06/30/13 to 06/30/19	Yes	Yes	Yes
City of Sierra Madre	06/30/12 to 06/30/19	Yes	Yes	Yes
Successor Agency to the County of SB	06/30/14 to 06/30/19			
City of Hawthorne	06/30/16 to 06/30/19	Yes	Yes	Yes
City of West Covina	06/30/16 to 06/30/19	Yes	Yes	Yes
City of Aliso Viejo	06/30/16 to 06/30/19	Yes	No	No
City of Claremont	06/30/16 to 06/30/19	Yes	Yes	Yes
City of Thousand Oaks	06/30/18 to 06/30/19	Yes	Yes	Yes
City of South Pasadena	06/30/18 to 06/30/19		Yes	Yes
City of Rolling Hills Estates	06/30/19			
City of Poway	06/30/14 to 06/30/19	Yes	Yes	Yes
City of Capitola	06/30/12 to 06/30/18	Yes	Yes	Yes
City of Fillmore	06/30/08 to 06/30/18	Yes	Yes	Yes
City of San Juan Capistrano	06/30/11 to 06/30/15	Yes	Yes	Yes
City of Chino	06/30/11 to 06/30/16	Yes	Yes	Yes
City of Rosemead	06/30/11 to 06/30/17	Yes	Yes	Yes
City of Moorpark	06/30/12 to 06/30/17	Yes	Yes	Yes
City of Mission Viejo	06/30/12 to 06/30/15	Yes	Yes	Yes
Crestline Village Water District	04/30/96 to 04/30/19			
Crestline-Lake Arrowhead Water	06/30/98 to 06/30/19			
San Bernardino Valley Muni Water District	06/30/04 to 06/30/19			
Elsinore Valley Municipal Water District	06/30/15 to 06/30/19	Yes		
Ventura Regional Sanitation District	06/30/07 to 06/30/19	Yes		
Saticoy Sanitary District	06/30/07 to 06/30/19			
Pine Cove Water District	06/30/10 to 06/30/19			
Western Municipal Water District	06/30/11 to 06/30/16	Yes		
WRCRWA	06/30/11 to 06/30/16			
Vista Irrigation District	06/30/11 to 06/30/16	Yes		
Idyllwild Water District	06/30/11 to 06/30/19			
Vallecitos Water District	06/30/15 to 06/30/18	Yes		
29 Palms Water District	06/30/12 to 06/30/15			
Big Bear Area Regional Wastewater	06/30/12 to 06/30/19	Yes		
Beaumont Basin Watermaster	06/30/13 to 06/30/19			
Mojave Water Agency	6/30/2019			

GOVERNMENT CLIENTS SERVED (continued)

<u>Government Client</u>	<u>Years Served</u>		<u>CSMFO/ GFOA Awards</u>	<u>Successor Agency</u>	<u>Housing Authority</u>
Costa Mesa Sanitary District	06/30/15	to 06/30/17	Yes		
Beaumont Cherry Valley Water District	12/31/17	to 12/31/18	Yes		
United Water Conservation Agency	06/30/15	to 06/30/19	Yes		
Inland Empire Resource Cons. District	06/30/04	to 06/30/16			
Rosamond Community Services District	06/30/15	to 06/30/19			
Rossmoor Community Services District	06/30/05	to 06/30/19			
Rim of the World Park & Rec. District	06/30/06	to 06/30/19			
Ventura County Regional Energy	06/30/07	to 06/30/19			
Heartlands Communications Fac Auth	06/30/07	to 06/30/19			
Heartlands Fire Training Authority	06/30/07	to 06/30/19			
Consolidated Fire Agencies	06/30/14	to 06/30/19			
Riverside County Habitat Con. Agency	06/30/15	to 06/30/19			
Santa Ana Watershed Association	12/31/09	to 12/31/18			
SB Fire Training Authority	06/30/10	to 06/30/15			
Capistrano Bay Community Services District	06/30/13	to 06/30/19			
Ventura County Public Fin Authority	06/30/12	to 06/30/19			
Nipomo Community Services District	06/30/16	to 06/30/19	Yes		
SBIAA	06/30/17	to 06/30/19			
West Valley San Bernardino Water District	06/30/17	to 06/30/19			
WRCOG	06/30/17	to 06/30/19	Yes		
San Diego Workforce Partnership	06/30/16	to 06/30/19			
Rubidoux Community Services District	06/30/16	to 06/30/19			
CSUSB - Student Union	06/30/05	to 06/30/19			
CSUSB - Associated Students Inc.	06/30/10	to 06/30/19			
CSUSB - Philanthropic Foundation	06/30/11	to 06/30/19			
CSUSB - University Enterprise Corp.	06/30/11	to 06/30/19			
Helendale Community Services District	06/30/10	to 06/30/18			
Conejo Recreation and Park District		06/30/19			
Upper San Gabriel Valley MWD		06/30/19			
March Joint Powers Authority		06/30/19			
Chino Basin Desalter Authority		06/30/19			
Mountains Recreation and Conservation		06/30/19			
Running Springs Water District	Accounting support				
Phelan Pinon Hills Community Services District	Accounting support				



May 20, 2020

735 E. Carnegie Dr. Suite 100  
San Bernardino, CA 92408  
909 889 0871 T  
909 889 5361 F  
ramscpa.net

To the Honorable City Council  
City of Beaumont  
Beaumont, California

**PARTNERS**

Brenda L. Odle, CPA, MST  
Terry P. Shea, CPA  
Scott W. Manno, CPA, CGMA  
Leena Shanbhag, CPA, MST, CGMA  
Bradferd A. Welebir, CPA, MBA, CGMA  
Jenny W. Liu, CPA, MST  
Jay H. Zercher, CPA (Partner Emeritus)  
Phillip H. Waller, CPA (Partner Emeritus)  
Kirk A. Franks, CPA (Partner Emeritus)

**MANAGERS / STAFF**

Charles De Simoni, CPA  
Gardenya Duran, CPA  
Brianna Schultz, CPA  
Jingjie Wu, CPA  
Evelyn Morentin-Barcena, CPA  
Veronica Hernandez, CPA  
Tara R. Thorp, CPA, MSA  
Laura Arvizu, CPA  
Ye Ying Stella Xia, CPA, MSBA  
Louis Fernandez, CPA  
Abigail O. Hernandez Conde, CPA, MSA  
Zoe Xinlu Zhang, CPA, MSA

**MEMBERS**

American Institute of  
Certified Public Accountants

*PCPS The AICPA Alliance  
for CPA Firms*

*Governmental Audit  
Quality Center*

*Employee Benefit Plan  
Audit Quality Center*

California Society of  
Certified Public Accountants



A Worldwide Alliance of Independent  
Accounting, Law and Consulting Firms

The following represents our understanding of the services we will provide the City of Beaumont.

You have requested that we audit the governmental activities, business-type activities, each major fund, and the aggregate remaining fund information of the City of Beaumont (the City), as of June 30, 2020, and for the year then ended and the related notes, which collectively comprise the City's basic financial statements as listed in the table of contents. We are pleased to confirm our acceptance and our understanding of this audit engagement by means of this letter. Our audit will be conducted with the objective of our expressing an opinion on each opinion unit applicable to those basic financial statements.

Accounting principles generally accepted in the United States of America (U.S. GAAP), as promulgated by the Governmental Accounting Standards Board (GASB) require that supplementary information, such as management's discussion and analysis (MD&A) and budgetary comparison information be presented to supplement the basic financial statements. Such information, although not a part of the basic financial statements, is required by the GASB, who considers it to be an essential part of financial reporting for placing the basic financial statements in an appropriate operational, economic, or historical context. As part of our engagement, we will apply certain limited procedures to the required supplementary information (RSI) in accordance with auditing standards generally accepted in the United States of America (U.S. GAAS). These limited procedures will consist primarily of inquiries of management regarding their methods of measurement and presentation, and comparing the information for consistency with management's responses to our inquiries. We will not express an opinion or provide any form of assurance on the RSI. The following RSI is required by U.S. GAAP. This RSI will be subjected to certain limited procedures but will not be audited:

1. Management's Discussion and Analysis
2. General and Major Fund Budgetary Comparison Schedules
3. Pension Related Schedules

Supplementary information other than RSI will accompany the City's basic financial statements. We will subject the following supplementary information to the auditing procedures applied in the audit of the basic financial statements and certain additional procedures, including comparing and reconciling such information directly to the underlying accounting and other records used to prepare the basic financial statements themselves, and additional procedures in accordance with U.S. GAAS. We intend to provide an opinion on the supplementary information in relation to the basic financial statements as a whole:

1. Non-major Combined Schedules

**Auditor Responsibilities**

We will conduct our audit in accordance with U.S. GAAS, and the standards applicable to financial audits contained in *Government Auditing Standards*, issued by the Comptroller General of the United States of America. Those standards require that we plan and perform the audit to obtain reasonable assurance about whether the basic financial statements are free from material misstatement. An audit involves performing procedures to obtain audit evidence about the amounts and disclosures in the basic financial statements. The procedures selected depend on the auditor's judgment, including the assessment of the risks of material misstatement of the basic financial statements, whether due to fraud or error, misappropriation of assets, or violations of laws, governmental regulations, grant agreements, or contractual agreements.

An audit also includes evaluating the appropriateness of accounting policies used, and the reasonableness of significant accounting estimates made by management, as well as evaluating the overall presentation of the basic financial statements. If appropriate, our procedures will therefore include tests of documentary evidence that support the transactions recorded in the accounts, tests of the physical existence of inventories, and direct confirmation of cash, investments, and certain other assets and liabilities by correspondence with creditors and financial institutions. As part of our audit process, we will request written representations from your attorneys, and they may bill you for responding. At the conclusion of our audit, we will also request certain written representations from you about the basic financial statements and related matters.

Because of the inherent limitations of an audit, together with the inherent limitations of internal control, an unavoidable risk that some material misstatements (whether caused by errors, fraudulent financial reporting, misappropriation of assets, or violations of laws or governmental regulations) may not be detected exists, even though the audit is properly planned and performed in accordance with U.S. GAAS and *Government Auditing Standards*.

In making our risk assessments, we consider internal control relevant to the entity's preparation and fair presentation of the basic financial statements in order to design audit procedures that are appropriate in the circumstances but not for the purpose of expressing an opinion on the effectiveness of the entity's internal control. However, we will communicate to you in writing concerning any significant deficiencies or material weaknesses in internal control relevant to the audit of the basic financial statements that we have identified during the audit. Our responsibility as auditors is, of course, limited to the period covered by our audit and does not extend to any other periods.

We cannot provide assurance that unmodified opinions will be expressed. Circumstances may arise in which it is necessary for us to modify our opinions or add emphasis-of-matter or other-matter paragraphs. If our opinions on the basic financial statements are other than unmodified, we will discuss the reasons with you in advance. If, for any reason, we are unable to complete the audit or are unable to form or have not formed opinions, we may decline to express opinions or to issue a report as a result of this engagement.



### **Compliance with Laws and Regulations**

As previously discussed, as part of obtaining reasonable assurance about whether the basic financial statements are free of material misstatement, we will perform tests of the City's compliance with the provisions of applicable laws, regulations, contracts, and agreements. However, the objective of our audit will not be to provide an opinion on overall compliance and we will not express such an opinion.

### **Management's Responsibilities**

Our audit will be conducted on the basis that management acknowledge and understand that they have responsibility:

1. For the preparation and fair presentation of the basic financial statements in accordance with accounting principles generally accepted in the United States of America;
2. For the design, implementation, and maintenance of internal control relevant to the preparation and fair presentation of basic financial statements that are free from material misstatement, whether due to error, fraudulent financial reporting, misappropriation of assets, or violations of laws, governmental regulations, grant agreements, or contractual agreements; and
3. To provide us with:
  - a. Access to all information of which management is aware that is relevant to the preparation and fair presentation of the basic financial statements such as records, documentation, and other matters;
  - b. Additional information that we may request from management for the purpose of the audit; and
  - c. Unrestricted access to persons within the entity from whom we determine it necessary to obtain audit evidence.
4. For including the auditor's report in any document containing basic financial statements that indicates that such basic financial statements have been audited by the entity's auditor;
5. For identifying and ensuring that the entity complies with the laws and regulations applicable to its activities;
6. For adjusting the basic financial statements to correct material misstatements and confirming to us in the management representation letter that the effects of any uncorrected misstatements aggregated by us during the current engagement and pertaining to the current year period(s) under audit are immaterial, both individually and in the aggregate, to the basic financial statements as a whole; and
7. For acceptance of nonattest services, including identifying the proper party to oversee nonattest work;
8. For maintaining adequate records, selecting and applying accounting principles, and safeguarding assets;
9. For informing us of any known or suspected fraud affecting the entity involving management, employees with significant role in internal control and others where fraud could have a material effect on the financials; and
10. For the accuracy and completeness of all information provided.

With regard to the supplementary information referred to above, you acknowledge and understand your responsibility: (a) for the preparation of the supplementary information in accordance with the applicable criteria; (b) to provide us with the appropriate written representations regarding supplementary information; (c) to include our report on the supplementary information in any document that contains the supplementary information and that indicates that we have reported on such supplementary information; and (d) to present the supplementary information with the audited basic financial statements, or if the supplementary information will not be presented with the audited basic financial statements, to make the audited basic financial statements readily available to the intended users of the supplementary information no later than the date of issuance by you of the supplementary information and our report thereon.

As part of our audit process, we will request from management written confirmation concerning representations made to us in connection with the audit.

### **Reporting**

We will issue a written report upon completion of our audit of the City's basic financial statements. Our report will be addressed to the City Council. We cannot provide assurance that unmodified opinions will be expressed. Circumstances may arise in which it is necessary for us to modify our opinions, add an emphasis-of-matter or other-matter paragraph(s), or withdraw from the engagement.

We also will issue a written report on the Appropriations Limit upon completion of our audit.

In accordance with the requirements of *Government Auditing Standards*, we will also issue a written report describing the scope of our testing over internal control over financial reporting and over compliance with laws, regulations, and provisions of grants and contracts, including the results of that testing. However, providing an opinion on internal control and compliance will not be an objective of the audit and, therefore, no such opinion will be expressed.

### **Other**

We understand that your employees will prepare all confirmations we request and will locate any documents or support for any other transactions we select for testing.

If you intend to publish or otherwise reproduce the financial statements in a format other than that provided by us, and make reference to our firm, you agree to provide us with printers' proofs or masters for our review and approval before printing. You also agree to provide us with a copy of the final reproduced material for our approval before it is distributed. Regarding the electronic dissemination of audited financial statements, including financial statements published electronically on your Internet website, you understand that electronic sites are a means to distribute information and, therefore, we are not required to read the information contained in these sites or to consider the consistency of other information in the electronic site with the original document.

We will assist management with drafting the financial statements based on the City's trial balances and preparing the State Controller's Annual Financial Transactions Report. With respect to this or any nonattest services we perform, the City's management is responsible for (a) making all management decisions and performing all management functions; (b) assigning a competent individual to oversee the services; (c) evaluating the adequacy of the services performed; (d) evaluating and accepting responsibility for the results of the services performed; and (e) establishing and maintaining internal controls, including monitoring ongoing activities. We will not assume management responsibilities on behalf of the City.

*Government Auditing Standards* require that we document an assessment of the skills, knowledge, and experience of management, should we participate in any form of preparation of the basic financial statements and related schedules or disclosures as these actions are deemed a non-audit service.

In addition, we will perform an agreed upon procedures engagement related to City's Appropriations Limit. The procedures have been agreed to by the City and the League of California Cities (as presented in the publication entitled *Agreed-upon Procedures Applied to the Appropriations Limitation Prescribed by Article XIII B of the California Constitution*) and will be performed solely to assist the City in meeting the requirements of Section 1.5 of Article XIII B of the California Constitution. The City's management will be responsible for the Appropriations Limit worksheet.

If it is determined a Single Audit is needed subsequent to this engagement letter, we will provide the City with another engagement letter covering the terms and conditions related to a Single Audit and the Uniform Guidance.

**Provisions of Engagement Administration, Timing and Fees**

During the course of the engagement, we may communicate with you or your personnel via fax or e-mail, and you should be aware that communication in those mediums contains a risk of misdirected or intercepted communications.

Our firm may transmit confidential information that you provided us to third parties in order to facilitate delivering our services to you. We have obtained confidentiality agreements with all our service providers to maintain the confidentiality of your information and we will take reasonable precautions to determine that they have the appropriate procedures in place to prevent the unauthorized release of confidential information to others. We will remain responsible for the work provided by any third-party service providers used under this agreement. By your signature below, you consent to having confidential information transmitted to entities outside the firm. Please feel free to inquire if you would like additional information regarding the transmission of confidential information to entities outside the firm.

Scott Manno, CPA, CGMA is the engagement partner for the audit services specified in this letter. His responsibilities include supervising Rogers, Anderson, Malody & Scott, LLP's services performed as part of this engagement and signing or authorizing another qualified firm representative to sign the audit report.

Our fee for the audit will be \$46,200 for the audit and \$2,580 for the financial transactions report to the State Controller's Office. We will notify you immediately of any circumstances we encounter that could significantly affect this initial fee estimate. Whenever possible, we will attempt to use the City's personnel to assist in the preparation of schedules and analyses of accounts. This effort could substantially reduce our time requirements and facilitate the timely conclusion of the audit. Further, we will be available during the year to consult with you on financial management and accounting matters of a routine nature.

If during the engagement, the City desires an expanded scope of testing related to any audit area, we will meet with City staff and come to a mutually agree upon fee prior to any additional procedures being performed (including a separate engagement letter).

During the course of the audit we may observe opportunities for economy in, or improved controls over, your operations. We will bring such matters to the attention of the appropriate level of management, either orally or in writing.

You agree to inform us of facts that may affect the basic financial statements of which you may become aware during the period from the date of the auditor's report to the date the financial statements are issued.

To ensure that Rogers, Anderson, Malody & Scott, LLP's independence is not impaired under the AICPA *Code of Professional Conduct*, you agree to inform the engagement partner before entering into any substantive employment discussions with any of our personnel.

We agree to retain our audit documentation or work papers for a period of at least seven years from the date of our report. Upon expiration of this period, we will be free to destroy our records related to the engagement. However, we do not keep original client documents, so we will return those as they are used during each engagement. It is management's responsibility to retain and protect the records for possible future use, including examination by regulators and federal agencies.

We require that a copy of the final trial balance (i.e., a trial balance ready to audit) be delivered to us at least 10 business days prior to the start of the audit, otherwise we may reschedule the start of the audit.

At the conclusion of our audit engagement, we will communicate to the City Council the following significant findings from the audit:

- Our view about the qualitative aspects of the entity’s significant accounting practices;
- Significant difficulties, if any, encountered during the audit;
- Uncorrected misstatements, other than those we believe are trivial, if any;
- Disagreements with management, if any;
- Other findings or issues, if any, arising from the audit that are, in our professional judgment, significant and relevant to those charged with governance regarding their oversight of the financial reporting process;
- Material, corrected misstatements that were brought to the attention of management as a result of our audit procedures;
- Representations we requested from management;
- Management’s consultations with other accountants, if any; and
- Significant issues, if any, arising from the audit that were discussed, or the subject of correspondence, with management

The audit documentation for this engagement is the property of Rogers, Anderson, Malody & Scott, LLP and constitutes confidential information. However, we may be requested to make certain audit documentation available to regulators and federal agencies and to the U.S. Government Accountability Office pursuant to authority given to it by law or regulation, or to peer reviewers. If requested, access to such audit documentation will be provided under the supervision of Rogers, Anderson, Malody & Scott, LLP’s personnel. Furthermore, upon request, we may provide copies of selected audit documentation to the regulators. The regulators may intend, or decide, to distribute the copies of information contained therein to others, including other governmental agencies.

In accordance with the requirements of *Government Auditing Standards*, we have attached a copy of our latest external peer review report of our firm for your consideration and files.

Please sign and return this letter to indicate your acknowledgment of, and agreement with, the arrangements for our audit of the financial statements including our respective responsibilities. Keep a copy for your records.

We appreciate the opportunity to be your financial statement auditors and look forward to working with you and your staff.

Respectfully,

**ROGERS, ANDERSON, MALODY & SCOTT, LLP**

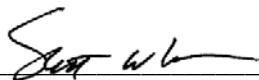
  
\_\_\_\_\_  
Scott Manno, CPA, CGMA  
Partner

**RESPONSE:**

This letter correctly sets forth our understanding.

Acknowledged and agreed on behalf of City of Beaumont by:

Name: \_\_\_\_\_

Title: \_\_\_\_\_

Date: \_\_\_\_\_

# Grant Bennett Associates

A PROFESSIONAL CORPORATION

## Report on the Firm's System of Quality Control

May 15, 2018

To the Partners of Rogers, Anderson, Malody & Scott, LLP and the Peer Review Committee of the California Society of CPAs:

We have reviewed the system of quality control for the accounting and auditing practice of Rogers, Anderson, Malody & Scott, LLP (the firm) in effect for the year ended November 30, 2017. Our peer review was conducted in accordance with the Standards for Performing and Reporting on Peer Reviews established by the Peer Review Board of the American Institute of Certified Public Accountants (Standards).

A summary of the nature, objectives, scope, limitations of, and the procedures performed in a System Review as described in the Standards may be found at [www.aicpa.org/prsummary](http://www.aicpa.org/prsummary). The summary also includes an explanation of how engagements identified as not performed or reported in conformity with applicable professional standards, if any, are evaluated by a peer reviewer to determine a peer review rating.

### Firm's Responsibility

The firm is responsible for designing a system of quality control and complying with it to provide the firm with reasonable assurance of performing and reporting in conformity with applicable professional standards in all material respects. The firm is also responsible for evaluating actions to promptly remediate engagements deemed as not performed or reported in conformity with professional standards, when appropriate, and for remediating weaknesses in its system of quality control, if any.

### Peer Reviewer's Responsibility

Our responsibility is to express an opinion on the design of the system of quality control and the firm's compliance therewith based on our review.

### Required Selections and Considerations

Engagements selected for review included engagements performed under *Government Auditing Standards*, including a compliance audit under the Single Audit Act and an audit of an employee benefit plan.

As a part of our peer review, we considered reviews by regulatory entities as communicated by the firm, if applicable, in determining the nature and extent of our procedures.

### Opinion

In our opinion, the system of quality control for the accounting and auditing practice of Rogers, Anderson, Malody & Scott, LLP in effect for the year ended November 30, 2017, has been suitably designed and complied with to provide the firm with reasonable assurance of performing and reporting in conformity with applicable professional standards in all material respects. Firms can receive a rating of *pass*, *pass with deficiency(ies)* or *fail*. Rogers, Anderson, Malody & Scott, LLP has received a peer review rating of *pass*.



GRANT BENNETT ASSOCIATES  
A PROFESSIONAL CORPORATION  
Certified Public Accountants



[www.gbacpa.com](http://www.gbacpa.com)

1375 Exposition Boulevard, Suite 230  
Sacramento, CA 95815  
916/922-5109 FAX 916/641-5200

P.O. Box 223096  
Princeville, HI 96722  
888/769-7323



CERTIFICATE OF LIABILITY INSURANCE

DATE (Item 10) 5/16/2020

THIS CERTIFICATE IS ISSUED AS A MATTER OF INFORMATION ONLY AND CONFERS NO RIGHTS UPON THE CERTIFICATE HOLDER. THIS CERTIFICATE DOES NOT AFFIRMATIVELY OR NEGATIVELY AMEND, EXTEND OR ALTER THE COVERAGE AFFORDED BY THE POLICIES BELOW.

IMPORTANT: If the certificate holder is an ADDITIONAL INSURED, the policy(ies) must have ADDITIONAL INSURED provisions or be endorsed. If SUBROGATION IS WAIVED, subject to the terms and conditions of the policy, certain policies may require an endorsement.

Table with 2 main columns: PRODUCER (Orion Business Insurance and Risk Management Services, Inc.) and CONTACT INFORMATION (Sentinel Insurance Company, Insurance Company of the West, Travelers Indemnity Company).

COVERAGES CERTIFICATE NUMBER: REVISION NUMBER:

THIS IS TO CERTIFY THAT THE POLICIES OF INSURANCE LISTED BELOW HAVE BEEN ISSUED TO THE INSURED NAMED ABOVE FOR THE POLICY PERIOD INDICATED. NOTWITHSTANDING ANY REQUIREMENT, TERM OR CONDITION OF ANY CONTRACT OR OTHER DOCUMENT WITH RESPECT TO WHICH THIS CERTIFICATE MAY BE ISSUED OR MAY PERTAIN, THE INSURANCE AFFORDED BY THE POLICIES DESCRIBED HEREIN IS SUBJECT TO ALL THE TERMS, EXCLUSIONS AND CONDITIONS OF SUCH POLICIES.

Main table listing coverages: COMMERCIAL GENERAL LIABILITY, AUTOMOBILE LIABILITY, UMBRELLA LIAB, WORKERS COMPENSATION AND EMPLOYERS' LIABILITY, and Errors & Omissions.

DESCRIPTION OF OPERATIONS / LOCATIONS / VEHICLES (ACORD 101, Additional Remarks Schedule, may be attached if more space is required) Evidence of Insurance

CERTIFICATE HOLDER CANCELLATION

Table with 2 columns: CERTIFICATE HOLDER (City Of Beaumont) and CANCELLATION (Should any of the above described policies be cancelled before the expiration date thereof, notice will be delivered in accordance with the policy provisions).



## Staff Report

**TO:** Mayor and City Council Members  
**FROM:** Jeff Mohlenkamp, Finance Director  
**DATE:** June 2, 2020  
**SUBJECT:** **Ratification of Emergency Repair Costs to the City's Wastewater System**

---

### **Background and Analysis:**

This report seeks City Council ratification of the costs of emergency repairs to the City's wastewater system that were undertaken in February and March 2020 at a total cost of \$343,027.28. These repairs were funded using the contingency funds within the Wastewater Fund and were fully budgeted with an adjustment that was authorized by the City Council on March 17, 2020.

In early February, City staff became aware of an escalating erosion concern along a tributary drainage channel to the San Timoteo Wash, which parallels Oak Valley Parkway, from Potrero Boulevard to Apron Lane.

Within this drainage channel exists two parallel 12" sewer force mains as well as a 12" gravity sewer main. Several portions of the 12" force mains had become exposed due to continual runoff, its proximity to the drainage channel bottom and a lack of protection from the original installation. In more than one instance, the pipe had become deflected beyond its tolerances, triggering an immediate operational, health and safety, and environmental concern. The condition appeared to be worsening with each storm event and staff determined that it was prudent to repair as soon as possible to mitigate further damage and line failure.

The City hired T.E Roberts, Inc., to complete the repairs and install appropriate protection measures. The repairs are intended to permanently stabilize both the force and gravity sewer mains, as well as manhole structures within the flow path which addresses the imminent hazard to the integrity of the sewer mains.



**Fiscal Impact:**

The costs of these emergency repairs was \$343,027.28. A summary of repairs and a detailed listing of costs is included as Attachment A.

**Recommended Action:**

Ratify the cost of emergency repairs completed and paid to T.E. Roberts, Inc., in the amount of \$343,027.28.

**Attachments:**

A. Invoice for services from T.E Roberts, Inc.



**T. E. Roberts, Inc.**  
 306 W. Katella Ave  
 Unit B  
 Orange CA 92867  
 714 669-0072

# Invoice

Invoice#: 3616  
 Date: 03/31/2020  
 Job #: 5943

License: 603008  
 DIR# 1000000280  
 SBE#: 1766256

**Billed To:** City Of Beaumont  
 Attn: Accounts Payable  
 550 E. 6th st.  
 Beaumont CA 92223

**Project:** Beaumont Oak Valley On-Call  
 Oak Valley Parkway @ Linksman  
 .  
 Beaumont CA 92223

**Due Date:** 04/10/2020

**Terms:** 10DY

**PO#** Kristine Day

Description	Amount
Force Main Stabilization - Oak Valley Parkway	
02/10/2020 - (Monday) Mobilized to job site. Arrived on site. Excavated to install (2) sewer lines at (3) locations on Oak Valley Parkway. Installed joints. Cleaned up and secured site.	9,823.66
02/11/2020 - (Tuesday) Arrived on site. Backfilled and compacted exposed pipes. Imported dirt to backfill from Redlands. (6) loads with 10-Wheel dump and (6) loads with the end dump. Cleaned up sand secured site.	8,806.23
02/24/2020 - (Monday) Mobilized to job site. Arrived on site and set up traffic control. Foreman had a meeting with Jeff from Beaumont. Went over the scope of work. Imported dirt loads from Redlands. Moved rip rap (rock) from the flowline to the wash start. Compacted slope. Cleaned up and secured site. Took down traffic control.	9,726.54
02/25/2020 - (Tuesday) Arrived on site. Hauled (36) loads of dirt from Redlands and compacted slope. Moved rip rap (rock) to the grade wash. Wet dirt at fill site and wet dirt at loading site. Cleaned up and secured work site.	10,286.37
02/26/2020 - (Wednesday) Arrived on site. Hauled (25) loads from Redlands to the job site and compacted slope. Moved rip rap (rock) from the flowline to the other side. Cleaned up and secured site.	11,479.66
02/27/2020 - (Thursday) Arrived on site and set up traffic control on Oak Valley Parkway. Hauled (10) loads of dirt from Redlands. Graded the top of the wash and compacted slopes. Dug around manhole cone to raise. Moved	

700-4050-8040-0000

**Invoice Total:** 343,027.28  
**Retention:** 0.00  
**Amount Due:** 343,027.28

*Thank you for your prompt payment!*

## Contract Invoice

Invoice#: 3616

Continued...

Date: 03/31/2020

Description	Amount
rip rap (rock) from the flowline. Cleaned up and secured site. Took down traffic control.	9,014.41
02/28/2020 - (Friday) Arrived on site and set up traffic control on Oak Valley Parkway, (1) lane closed. Loaded pre-wet dirt and hauled to Beaumont from Redlands. Graded and compacted slopes. Unloaded Gabion material from United Water Works. Moved rip rap (rock) from the flowline. Cleaned up and secured site. Took down traffic control.	13,056.89
03/02/2020 - (Monday) Arrived on site and set up traffic control. Started to dig for Gabion walls. Raised manhole, 24-inch tie and set 6-12-foot walls. Raised manhole. Cleaned up and secured site. Took down traffic control.	9,821.83
03/03/2020 - (Tuesday) Arrived on site and set up traffic control. Dug and set Gabions. Compacted and graded slopes. Cleaned up and secured site. Took down traffic control.	10,851.19
03/04/2020 - (Wednesday) Arrived on site and set up traffic control, closed (1) lane. Compacted and graded slopes, 600-feet graded. Cleaned curb and gutter. Compacted dirt behind the Gabions. Cleaned up and secured site. Took down traffic control.	6,887.32
03/05/2020 - (Thursday) Arrived on site and set up traffic control, closed (1) lane. Graded and compacted slopes. Wacked and compacted behind the Gabions. Dug out last Gabion. Geo Labs came out and ran field density test. Tested Gabions and slopes. Cleaned up and secured site. Took down traffic control.	8,293.80
03/06/2020 - (Friday) Arrived on site and set up traffic control, closed (1) lane. Tied Gabions and set. Filled with rip rap (rock). Compacted behind manhole. Cleaned up and secured site. Took down traffic control.	8,353.03
03/09/2020 - (Monday) Arrived on site and set up traffic control, closed (1) lane. Compacted slopes and finished last manhole Gabion. Poured slurry around (4) manholes, 18-yards of slurry. Cleaned up and secured site. Took down traffic control.	9,286.14
03/11/2020 - (Wednesday) Arrived on site. Checked on job and met with Jeff from Beaumont. Backfilled around 1st manhole. Placed rip rap (rock) in flowline to slow water between manhole #1 & #4. Cleaned up and secured site.	2,808.34
03/23/2020 - (Monday) Arrived on site and set up traffic control, closed (1) lane. Walked job slopes, looked good. One location had the force main700-4050-80 exposed. Began to rain, to wet to work. Cleaned up and secured site. Took	

## Contract Invoice

Invoice#: 3616

Continued...

Date: 03/31/2020

Description	Amount
down traffic control.	1,131.04
03/24/2020 - (Tuesday) Arrived on site and set up traffic control, closed (1) lane. Moved rip rap (rock). Imported dirt from Redlands to re-compact slopes. Covered and compacted location where the force main was exposed. Cleaned up and secured site. Took down traffic control.	9,559.90
03/25/2020 - (Wednesday) Arrived on site and set up traffic control, closed (1) lane. Hauled dirt from Redlands. Placed imported dirt and compacted slopes. Clean up and secured site. Took down traffic control.	9,450.61
03/26/2020 - (Thursday) Arrived on site and set up traffic control, closed (1) lane. Compacted and graded slopes. Cleaned up and secured site. Took down traffic control.	5,652.85
03/27/2020 - (Friday) Arrived on site and set up traffic control, closed (1) lane. Compacted and graded slopes. Cleaned up and secured site. Took down traffic control. Sub (V-Ditch Solutions) 6-inch slope paving and welded wire mesh.	188,737.47



306 W. Katella Ave., Unit B  
Orange, CA 92867

DATE: 2/10/2020

LOCATION: Oak Valley Parkway

DETAILS:

**Force Main Stabilization (Monday)** - Mobilized to job site. Arrived on site. Excavated to install (2) sewer lines at (3) locations on Oak Valley. Installed (8) joints. Cleaned up site.

Job#	Beaumont
5943	
Name:	

TYPE	RATE/HR	QTY	REG AMT	OT RATE	QTY	OT AMT	DT RATE	DT HRS	DT AMT	TOTAL			
<b>LABOR</b>													
LABOR FOREMAN	8.00	6.50	666.25	153.75	1.50	230.63	205.00	-	-	896.88			
PIPELAYER/Asphalt wkr	8.00	6.50	603.79	139.34	1.50	209.00	185.78	-	-	812.79			
LABORER ( )	8.00	6.50	572.91	132.21	1.50	198.32	176.28	-	-	771.23			
TRUCK DRIVER ( )	3.00	1.50	141.12	141.12	1.50	211.68	188.16	-	-	352.80			
EQPT OPERATOR ( )	4.00	4.00	469.88	176.21		-	234.94	-	-	469.88			
	<b>31.00</b>	<b>25.00</b>			<b>6.00</b>								
<b>LABOR</b>										<b>\$3,303.57</b>			
<b>LABOR TOTAL</b>										<b>\$3,303.57</b>			
<b>EQUIPMENT</b>													
SERVICE TRUCK F550	55.10	8.00	440.80							440.80			
BACKHOE	91.18	8.00	729.44							729.44			
LOWBED	86.51	3.00	259.53							259.53			
WATER TRUCK	55.10	8.00	440.80							440.80			
<b>EQPT TOTAL</b>										<b>\$1,870.57</b>			
<b>SUBCONTRACTOR</b>													
<b>Sub Total</b>										<b>Tax</b>	<b>Total</b>		
<b>Sub Total</b>										<b>SUBCONTRACTOR TOTAL</b>			
<b>\$0.00</b>													
<b>MATERIAL</b>													
<b>United Water Works - Inv# S100084848.001 &amp; S100084864.001 (Items Below)</b>										<b>TOTAL</b>			
12-inch Joint Restraints										4,552.26			
										593.77			
										3,958.49			
										255.95			
										3,302.54			
										400.00			
										<b>MATERIAL TOTAL</b>			
										<b>\$4,552.26</b>			
<b>EQUIPMENT RENT</b>													
<b>Sub Total</b>										<b>Tax</b>	<b>AMOUNT</b>	<b>15%</b>	<b>TOTAL</b>
<b>Sub Total</b>										<b>EQ RENT TOTAL</b>			
										<b>\$0.00</b>			
<b>DUMP FEES</b>													
<b>Sub Total</b>										<b>Tax</b>	<b>AMOUNT</b>	<b>10%</b>	<b>TOTAL</b>
<b>Sub Total</b>										<b>DUMP FEE TOTAL</b>			
										<b>\$0.00</b>			

Item 11.



306 W. Katella Ave., Unit B  
Orange, CA 92867

Job#	Beaumont
5943	
Name:	

DATE: 2/10/2020

LOCATION: Oak Valley Parkway

DETAILS: **Force Main Stabilization (Monday)** - Mobilized to job site. Arrived on site. Excavated to install (2) sewer lines at (3) locations on Oak Valley. Installed (8) joints. Cleaned up site.

TYPE	RATE/HR	QTY	REG AMT	OT RATE	QTY	OT AMT	DT RATE	DT HRS	DT AMT	TOTAL
SUB TOTAL										\$9,726.40
1% - Bond										\$97.26
GRAND TOTAL										\$9,823.66

Item 11.



306 W. Katella Avenue  
Unit B  
Orange, CA 92867

T. 714.669.0072  
F. 714.200.0241

tr Roberts@teroberts.com  
License #603008  
www.teroberts.com

NO: \_\_\_\_\_ Item 11.

# DAILY WORK REPORT/CHANGE ORDER

DATE: 02-10-2020 (MONDAY)  
 JOB TITLE: Forse main Stabilization Exhibit  
 JOB NUMBER: 5830 5943  
 CUST. PO#: \_\_\_\_\_

TO: Beaumont 1169  
 \_\_\_\_\_  
 \_\_\_\_\_  
 ATTN: \_\_\_\_\_

QUANT.	LABOR (CLASSIFY)	ST	OT	TOTAL HRS.	RATE	TOTAL
	Javier Magana - L/FM	6.5	1.5	8 ✓		<del>8</del>
	Jose Rodriguez - PL	6.5	1.5	8 ✓		
	Manuel Infante - LI	6.5	1.5	8 ✓		
	Steve Mcarty - DE	4	0	4 ✓		<del>4</del>
	DOUG SAGE - T	1.5	1.5	3 ✓		
	TOTAL	25	6	31 ✓		
EQUIPMENT						
1	Water truck			8		
1	Service truck			8		
1	710 Backhoe			8		
MATERIAL AND OTHER ITEMS				UNIT PRICE		
8	12" Joint restraints (United Water Works)					

COMMENTS: On Monday 02-10-2020 T.E Roberts put back to grade 2 Sewer lines on 3 locations on Oak Valley. Installed 8 Joint restraints

TAX
SUB-TOTAL
%OHP
TOTAL

CONTRACT TIME EXT. \_\_\_\_\_ CAL. DAYS  
 SIGNED \_\_\_\_\_  
 BY \_\_\_\_\_

T.E. ROBERTS, INC.  
 BY Javier Magana



Serving Southern California

Orange County / San Diego  
 Riverside / San Bernardino  
 Los Angeles / Ventura

1-888-4-UNITED



# Invoice

Item 11.

INVOICE DATE	INVOICE NUMBER
02/10/2020	S100084848.001
DUE DATE	PAGE NUMBER
03/11/2020	1 of 1

BILL TO:

T.E. ROBERTS INC.  
 306 W KATELLA AVE  
 UNIT B  
 ORANGE, CA 92867

SHIP TO:

5830 CITY OF BEAUMONT  
 550 E 6TH STREET  
 BEAUMONT, CA 92223

PO NUMBER		JOB NAME		SALESPERSON		
				Steve Hagman		
WRITER		SHIP VIA	TERMS		SHIP DATE	ORDER DATE
Jerry Canada		OT OUR TRUCK	NET 30 DAYS PRELIM		02/10/2020	02/10/2020
ORDER QTY	SHIP QTY	ITEM NUMBER	DESCRIPTION		UNIT PRICE	EXT PRICE
6ea	6ea	191200	<b>JAVIER 714-322-8027</b> FULL PRESS SPLIT RSTR HARNESS FOR AWWA C900		220.169/ea	1321.02
		<small>02-10-2020 12:06:08 PM            S100084848.001</small>  Javier Magana				

**Past Due invoices may be subject to 1.50% late charge.**

Remit To: UNITED WATER WORKS, INC, PO BOX 150122 , OGDEN, UT 84415

Subtotal	1321.02
S&H Charges	200.00
Tax	102.38
Payments	0.00
Amount Due	1623.40

392





Serving Southern California

Orange County / San Diego  
Riverside / San Bernardino  
Los Angeles / Ventura

1-888-4-UNITED



**Invoice**

Item 11.

INVOICE DATE	INVOICE NUMBER
02/10/2020	S100084864.001
DUE DATE	PAGE NUMBER
03/11/2020	1 of 1

BILL TO:

T.E. ROBERTS INC.  
306 W KATELLA AVE  
UNIT B  
ORANGE, CA 92867

SHIP TO:

5830 CITY OF BEAUMONT  
550 E 6TH STREET  
BEAUMONT, CA 92223

PO NUMBER		JOB NAME		SALESPERSON	
				Steve Hagman	
WRITER	SHIP VIA	TERMS	SHIP DATE	ORDER DATE	
Jerry Canada	OT OUR TRUCK	NET 30 DAYS PRELIM	02/10/2020	02/10/2020	
ORDER QTY	SHIP QTY	ITEM NUMBER	DESCRIPTION	UNIT PRICE	EXT PRICE
9ea	9ea	191200	<b>JAVIER714-322-8027</b> FULL PRESS SPLIT RSTR HARNESS FOR AWWA C900  <small>02-10-2020 02:28:46 PM S100084864.001</small>  <small>© Hartwell</small>	220.169/ea	1981.52

**Past Due invoices may be subject to 1.50% late charge.**

Remit To: UNITED WATER WORKS, INC, PO BOX 150122 , OGDEN, UT 84415

Subtotal	1981.52
S&H Charges	200.00
Tax	153.57
Payments	0.00
Amount Due	2335.09

393



306 W. Katella Ave., Unit B  
Orange, CA 92867

Job#	Beaumont
5943	
Name:	

DATE: 2/11/2020

LOCATION: Oak Valley Parkway

DETAILS:

**Force Main Stabilization (Tuesday)** - Arrived on site. Backfilled and compacted exposed pipes. Import all material to backfill. Cleaned up site. (6) Loads of dirt with 10-wheel dump and (6) loads of dirt with End Dump.

TYPE	RATE/HR	QTY	REG AMT	OT RATE	QTY	OT AMT	DT RATE	DT HRS	DT AMT	TOTAL
<b>LABOR</b>										
LABOR FOREMAN	8.00	8.00	820.00	153.75	-	-	205.00	-	-	820.00
PIPELAYER/Asphalt wkr	8.00	8.00	743.12	139.34	-	-	185.78	-	-	743.12
LABORER	8.00	8.00	705.12	132.21	-	-	176.28	-	-	705.12
EQPT OPERATOR (2)	16.00	16.00	1,879.52	176.21	-	-	234.94	-	-	1,879.52
	40.00	40.00								
										<b>LABOR TOTAL \$4,147.76</b>
<b>EQUIPMENT</b>										
SERVICE TRUCK F450	46.18	8.00	369.44							369.44
SERVICE TRUCK F550	55.10	8.00	440.80							440.80
EXCAVATOR	166.46	8.00	1,331.68							1331.68
BACKHOE	91.18	8.00	729.44							729.44
DUMP TRUCK, End Dump	62.89	8.00	503.12							503.12
WATER TRUCK	55.10	8.00	440.80							440.80
										<b>EQPT TOTAL \$3,815.28</b>

SUBCONTRACTOR	Sub Total	Tax	Total	5%	TOTAL
Collins Trucking - Inv# 3559 (8hrs) - 10-wheel Dump & Driver (12) loads	720.00	0.00	720.00	36.00	756.00
	<b>SUBCONTRACTOR TOTAL</b>				<b>\$756.00</b>

MATERIAL	Sub Total	Tax	AMOUNT	15%	TOTAL
	<b>MATERIAL TOTAL</b>				<b>\$0.00</b>

EQUIPMENT RENT	Sub Total	Tax	AMOUNT	15%	TOTAL
	<b>EQ RENT TOTAL</b>				<b>\$0.00</b>

DUMP FEES	Sub Total	Tax	AMOUNT	10%	TOTAL

Item 11.



306 W. Katella Ave., Unit B  
Orange, CA 92867

Job#	Beaumont
5943	
Name:	

DATE: 2/11/2020

LOCATION: Oak Valley Parkway

DETAILS: **Force Main Stabilization (Tuesday)** - Arrived on site. Backfilled and compacted exposed pipes. Import all material to backfill. Cleaned up site. (6) Loads of dirt with 10-wheel dump and (6) loads of dirt with End Dump.

TYPE	RATE/HR	QTY	REG AMT	OT RATE	QTY	OT AMT	DT RATE	DT HRS	DT AMT	TOTAL
DUMP FEE TOTAL										\$0.00
SUB TOTAL										\$8,719.04
1% - Bond										\$87.19
GRAND TOTAL										\$8,806.23

Item 11.



306 W. Katella Avenue  
Unit B  
Orange, CA 92867

T. 714.669.0072  
F. 714.200.0241

troberts@teroberts.com  
License #603008  
www.teroberts.com

NO: \_\_\_\_\_ Item 11.

# DAILY WORK REPORT/CHANGE ORDER

TO: Beaumont 1169

DATE: 02-11-2020 (TUESDAY)

JOB TITLE: Forse Main Stabilization Exhibit

JOB NUMBER: ~~5830~~ 5943

CUST. PO#: \_\_\_\_\_

ATTN: \_\_\_\_\_

QUANT.	LABOR (CLASSIFY)	ST	OT	TOTAL HRS.	RATE	TOTAL
	Javier Magana - L/FM	8	0	8 ✓		
	Mario Mancha - OE	8	0	8 ✓		
	Jose Rodriguez - PL	8	0	8 ✓		
	Manuel Infante - LI	8	0	8 ✓		
	Ruben Aldama - OE	8	0	8 ✓		
	TOTAL	40	0	40 ✓		
EQUIPMENT						
1	Water truck			8		
2	Service trucks			8		
1	End dump truck			8		
1	710 backhoe			8		
1	Excavator			8		
MATERIAL AND OTHER ITEMS				UNIT PRICE		
1	10 wheel dump truck (Phill Collings)			8		
6	loads of dirt with the Super 10					
6	loads of dirt with a End dump truck.					

COMMENTS: On Tuesday 02-11-2020 T.E Roberts Cover and compact the exposed pipes. T.E Roberts import all the material to backfill.

CONTRACT TIME EXT. \_\_\_\_\_ CAL. DAYS

SIGNED \_\_\_\_\_

BY \_\_\_\_\_

**T.E. ROBERTS, INC.**

BY Javier Magana

TAX	_____
SUB-TOTAL	_____
%OHP	_____
TOTAL	_____

# Collins Trucking

P.O. Box 5082  
 Inglewood, CA 90310  
 BUS.323-327-6060  
 FAX 323-756-2667

#5830 ✓

# Invoice

DATE	INVOICE #
2/11/2020	3559

BILL TO

T.E.Roberts Inc  
 306 w.katella ave  
 unit B  
 orange.ca 92867

POSTED  
 MAR 09 2020  
 PRISCILLA

RECEIVED  
 MAR 06 2020  
 EV.

P.O. NO.	TERMS	PROJECT

DATE	TICKET	ITEM	HOURS	CONTRACTOR	LOCATION	RATE	AMOUNT
<del>2/6/2020</del>	<del>898290</del>	<del>Construction</del>	<del>8</del>	<del>same</del>	<del>redlands</del>	<del>90.00</del>	<del>720.00</del>
2/11/2020	898293	Construction	8	same	redlands	90.00	720.00
<del>2/11/2020</del>	<del>5693035</del>	<del>Construction</del>	<del>8</del>	<del>same</del>	<del>redlands</del>	<del>90.00</del>	<del>720.00</del>
<del>2/12/2020</del>	<del>898294</del>	<del>Construction</del>	<del>8</del>	<del>same</del>	<del>redlands</del>	<del>90.00</del>	<del>720.00</del>
<del>2/24/2020</del>	<del>236902</del>	<del>Construction</del>	<del>9</del>	<del>same (NITE)</del>	<del>redlands</del>	<del>90.00</del>	<del>810.00</del>
<del>2/25/2020</del>	<del>236903</del>	<del>Construction</del>	<del>8</del>	<del>same (NITE)</del>	<del>redlands</del>	<del>90.00</del>	<del>720.00</del>
2/26/2020	236904	Construction	9	same (NITE)	redlands	90.00	810.00
<del>2/26/2020</del>	<del>5693065</del>	<del>Construction</del>	<del>7.5</del>	<del>same (NITE)</del>	<del>redlands</del>	<del>90.00</del>	<del>675.00</del>
<del>2/27/2020</del>	<del>5693066</del>	<del>Construction</del>	<del>6.5</del>	<del>same (NITE)</del>	<del>redlands</del>	<del>90.00</del>	<del>585.00</del>
2/27/2020	236905	Construction	8	same (NITE) mailed 3/3/2020	redlands	90.00	720.00
<b>Total</b>							<b>\$720.00</b>

Item 11.

NON-NEGOTIABLE BILL-OF-LADING AND TRANSPORTATION AGREEMENT

PRINCIPAL CARRIER: *COLEMAN TRUCKING*

DATE: *02-11-20*

BILL NO. **A- 898293**

ADDRESS: \_\_\_\_\_  
 CITY/STATE/ZIP: \_\_\_\_\_  
 PH: \_\_\_\_\_

UNDERLYING CARRIER (IF ANY): *ARMA TRUCKING*  
 ADDRESS: \_\_\_\_\_  
 PH: \_\_\_\_\_

SHIPPER: *T.E. ROBERTS*  
 ADDRESS: \_\_\_\_\_  
 CITY/STATE/ZIP: \_\_\_\_\_

RECEIVER: \_\_\_\_\_  
 ADDRESS: \_\_\_\_\_  
 CITY/STATE/ZIP: \_\_\_\_\_

POINT OF ORIGIN: *MEDLANDS*  
 POINT OF DESTINATION: \_\_\_\_\_

EQUIPMENT TYPE:  10-WHEELER  SUPER TAG  END DUMP  FLAT BED  
 SUPER-10  TRANSFER  SIDE DUMP  MIXER  
 STRONG ARM  DBL BOTTOMS  TRUCK & PUP  OTHER  
 WATER TRUCK

HOURLY  TONNAGE  PER LOAD  
 RATE @ \$ \_\_\_\_\_

TAG NO.	WEIGHT	COMMODITY	LOADING ARRIVE	LOADING DEPART	UNLOADING ARRIVE	UNLOADING DEPART	STANDBY TIME	BREAKDOWN OR REASON FOR DELAY
1								
2								
3								
4								
5								
6								
7								
8								
9								
10								
11								
12								
13								
14								
15								

REPORTING TIME: *7:00* ENDING TIME: *3:00* TOTAL TIME: *8:0* DEDUCTIBLE TIME: \_\_\_\_\_ NET TIME: \_\_\_\_\_ TOTAL TONS: \_\_\_\_\_ ACCESSORIAL OTHER: \_\_\_\_\_

START DRIVING TIME: \_\_\_\_\_ ARRIVAL TIME AT DUMP LAST TRIP: \_\_\_\_\_ END LOADING LAST TRIP: \_\_\_\_\_ RUNNING TIME LAST TRIP: \_\_\_\_\_

398

**SUBJECT TO TERMS AND CONDITIONS OF REVERSE SIDE**

**TOTAL CHARGES**

ORIGINAL

SHIPPER/RECEIVER (AGENT OR DEBITOR) SIGNATURE

DRIVER SIGNATURE



306 W. Katella Ave., Unit B  
Orange, CA 92867

**DATE:** 2/24/2020

**LOCATION:** Oak Valley Parkway

**DETAILS:**

**Force Main Stabilization (Monday)** - Mobilized to job site. Arrived on site and set up traffic control. Foreman had a meeting with Jeff from Beaumont. Went over the scope of work. Imported dirt loads from Redlands Blvd. Moved Rip Rap from the flow line to the wash start. Compacted slope. Cleaned up site.

<b>Job#</b>	<b>Beaumont</b>
5943	
<b>Name: Jeff</b>	

TYPE	RATE/HR	QTY	REG AMT	OT RATE	QTY	OT AMT	DT RATE	DT HRS	DT AMT	TOTAL
<b>LABOR</b>										
OE FOREMAN	9.00	8.00	978.96	183.56	1.00	183.56	244.74	-	-	1,162.52
PIPELAYER/Asphalt wkr	8.50	8.00	743.12	139.34	0.50	69.67	185.78	-	-	812.79
LABORER	8.00	8.00	705.12	132.21	-	-	176.28	-	-	705.12
EQPT OPERATOR	8.50	8.00	939.76	176.21	0.50	88.10	234.94	-	-	1,027.86
	34.00	32.00			2.00					
<b>LABOR TOTAL</b>										<b>\$3,708.29</b>
<b>LABOR TOTAL</b>										<b>\$3,708.29</b>
<b>EQUIPMENT</b>										
SERVICE TRUCK F450 ( )	T51	8.50	392.53							392.53
SERVICE TRUCK F550		9.00	495.90							495.90
EXCAVATOR		8.00	1,331.68							1331.68
WHEEL LOADER 544K		8.00	993.20							993.20
WHEEL LOADER 644K		8.00	1,194.24							1194.24
DELINEATORS/ SIGNS (1)		8.00	2.40							2.40
<b>EQPT TOTAL</b>										<b>\$4,409.95</b>

SUBCONTRACTOR	Sub Total	Tax	Total	5%	TOTAL
D M Courville Trucking - Inv# 2788 - Truck#1458 (8 Hrs)	720.00	-	720.00	36.00	756.00
D M Courville Trucking - Inv# 2796 - Truck#1304 (8 Hrs)	720.00	-	720.00	36.00	756.00
			<b>SUBCONTRACTOR TOTAL</b>		<b>\$1,512.00</b>

MATERIAL	Sub Total	Tax	AMOUNT	15%	TOTAL
			<b>MATERIAL TOTAL</b>		<b>\$0.00</b>

EQUIPMENT RENT	Sub Total	Tax	AMOUNT	15%	TOTAL
			<b>EQ RENT TOTAL</b>		<b>\$0.00</b>

Item 11.



306 W. Katella Ave., Unit B  
Orange, CA 92867

**DATE:** 2/24/2020

**LOCATION:** Oak Valley Parkway

**DETAILS:**

**Force Main Stabilization (Monday)** - Mobilized to job site. Arrived on site and set up traffic control. Foreman had a meeting with Jeff from Beaumont. Went over the scope of work. Imported dirt loads from Redlands Blvd. Moved Rip Rap from the flow line to the wash start. Compacted slope. Cleaned up site.

Job#	Beaumont
5943	
Name: Jeff	

TYPE	RATE/HR	QTY	REG AMT	OT RATE	QTY	OT AMT	DT RATE	DT HRS	DT AMT	TOTAL
<b>DUMP FEES</b>										
				Sub Total	Tax	AMOUNT	10%			TOTAL
				DUMP FEE TOTAL						\$0.00

SUB TOTAL	\$9,630.24
1% - Bond	\$96.30
<b>GRAND TOTAL</b>	<b>\$9,726.54</b>





306 W. Katella Avenue, Unit B  
 Orange, CA 92867  
 T: 714-669-007  
 F: 714-200-0241  
 LICENSE# 603008  
 www.teroberts.com

No. Item 11.

### FIELD CHANGE ORDER

TO: City of Beaumont

DATE: 2-24-2020 (MONDAY)  
 JOB TITLE: Force Main Stabilization  
 JOB NUMBER: 5943  
 LOCATION: OAK Valley Parkway

ATTN: Jeff

LABOR:	RT	OT	TOTAL		RT	OT	TOTAL
Robert Hartwell III OF	8	1	9	✓			
Robert Hartwell IV OF	8	.5	8.5	✓			
Jose Magana PLO	8	.5	8.5	✓			
Anthony Hartwell LAB	8	0	8	✓			
TOTALS	32	2	34	✓			

EQUIPMENT:	DESCRIPTION	HOURS
T-36	Crew Truck	9
T-51	Flat bed	8.5
	328 Dcat Exc	8
WL-7	544K Deer (506)	8
WL-13	644K Deer (Loading)	8

MATERIALS and RENTAL EQUIPMENT:	QTY	DESCRIPTION	VENDOR
	2	Super 10s	8
		Dan Corville TRUCKING	
		10 Loads	
	1	Restroom From United	
	1	Roadwork sign	

DESCRIPTION OF WORK, CHANGES, AND COMMENTS:  
met with JEFF went over scope of work  
import dirt from Redlands build down paper job  
move Rip Rap from flow line of wash start  
compacting slope.

Contract Time Extension: \_\_\_\_\_ Calendar Days

Signed: \_\_\_\_\_  
 Printed Name: \_\_\_\_\_  
 Company: \_\_\_\_\_

Signed: \_\_\_\_\_  
 Printed Name: \_\_\_\_\_  
 T.E. Roberts, Inc.

**D M COURVILLE TRUCKING, INC.**

313 CODY ROAD  
SAN DIMAS CA 91773  
Office: 909 455-8322 Fax: 909 599-1939  
Lic#: CA28653

INVOICE: 2788

Date: 03/01/2020

Item 11.

#5943

Customer No: 1159 ✓

T. E. ROBERTS  
306 W. KATELLA AVENUE UNIT B  
ORANGE CA 92867

**RECEIVED**  
MAR 04 2020  
BY: \_\_\_\_\_

Date	Ft Bill	Truck	Description	Qty	Rate	Amount
02/24/20	3771636	1458	REDLANDS	8.00	90.00	720.00
02/26/20	3771638	1458	REDLANDS	7.00	90.00	630.00
02/27/20	3771639	1345	REDLANDS	8.00	90.00	720.00
02/28/20	3771640	1458	REDLANDS	6.00	90.00	540.00
<b>Amount:</b>						<del>2,610.00</del>

Item	Qty	Amount
HOURS	29.00	2,610.00

**Total \$720.00**

**Please Pay This Amount:** ~~2,610.00~~

**THANK YOU FOR YOUR BUSINESS**

Net 30 Days. Unpaid balance is subject to 1 1/2% service charge per month and any and all cost of collections.

**NON-NEGOTIABLE BILL-OF-LADING AND TRANSPORTATION AGREEMENT**

BILL NO.

PRINCIPAL CARRIER D & M Courville Trucking DATE 2-27-20  
 ADDRESS \_\_\_\_\_  
 CITY/STATE/ZIP \_\_\_\_\_ PH. \_\_\_\_\_

**A- 3771636**  
 JOB # \_\_\_\_\_  
 BROKER # \_\_\_\_\_  
 TRUCK # C70  
 TRAILER # \_\_\_\_\_  
 CA# 28653

Item 11.

UNDERLYING CARRIER (IF ANY) \_\_\_\_\_  
 ADDRESS \_\_\_\_\_ PH. \_\_\_\_\_

SHIPPER T. E. ROBERTS  
 ADDRESS \_\_\_\_\_  
 CITY/STATE/ZIP \_\_\_\_\_

RECEIVER \_\_\_\_\_  
 ADDRESS OAK VALLEY PARKWAY  
 CITY/STATE/ZIP \_\_\_\_\_

POINT OF ORIGIN REDLANDS

POINT OF DESTINATION BEAUMONT

EQUIPMENT TYPE  
 10 WHEELER  SUPER TAG  END DUMP  FLAT BED  
 SUPER-10  TRANSFER  SIDE DUMP  MIXER  
 STRONG ARM  DBL BOTTOMS  TRUCK & PUP  SWEEPER  
 SEMI-BOTTOM  WATER TRUCK  OTHER \_\_\_\_\_  
 HOURLY  TONNAGE  PER LOAD  
 RATE @ \$ 90.00

TAG NO.	WEIGHT	COMMODITY	LOADING		UNLOADING		STANDBY TIME	BREAKDOWN OR REASON FOR DELAY
			ARRIVE	DEPART	ARRIVE	DEPART		
1			700	820				
2			110	120				
3								
4								
5								
6								
7								
8								
9								
10								
11								
12								
13								
14								
15								

REPORTING TIME 700 ENDING TIME 330 TOTAL TIME 8 hrs DEDUCTIBLE TIME 30 mins NET TIME 8 hrs TOTAL TONS \_\_\_\_\_ ACCESSORIAL OTHER \_\_\_\_\_  
 START DRIVING TIME LAST TRIP ARRIVAL TIME AT DUMP LAST TRIP END LOADING LAST TRIP RUNNING TIME LAST TRIP  
**SUBJECT TO TERMS AND CONDITIONS ON REVERSE SIDE** TOTAL CHARGES 720.00

*[Signature]* DRIVER SIGNATURE *[Signature]* SHIPPER/RECEIVER (AGENT OR DEBITOR) SIGNATURE  
**ORIGINAL**

**D M COURVILLE TRUCKING, INC.**

313 CODY ROAD  
SAN DIMAS CA 91773  
Office: 909 455-8322 Fax: 909 599-1939  
Lic#: CA28653

INVOICE: 2796

Date: 02/29/20

Item 11.

✓ #5943  
GH

Customer No: 1159

T. E. ROBERTS  
306 W. KATELLA AVENUE UNIT B  
ORANGE CA 92867

**RECEIVED**  
MAR 05 2020  
BY: \_\_\_\_\_

Date	Ft Bill	Truck	Description	Qty	Rate	Amount
02/24/20	3771631	1304	REDLANDS			
<del>02/25/20</del>	<del>3771632</del>	<del>1304</del>	<del>REDLANDS</del>	8.00	90.00	720.00
<del>02/26/20</del>	<del>3771633</del>	<del>1304</del>	<del>REDLANDS</del>	8.00	90.00	720.00
<del>02/27/20</del>	<del>3771634</del>	<del>1304</del>	<del>REDLANDS</del>	7.00	90.00	630.00
<del>02/28/20</del>	<del>3771635</del>	<del>1304</del>	<del>REDLANDS</del>	8.40	90.00	756.00
				6.00	90.00	540.00
<b>Amount:</b>						<del>3,366.00</del>

Item	Qty	Amount
HOURS	37.40	3,366.00

**Total \$720.00**

**Please Pay This Amount: 3,366.00**

**THANK YOU FOR YOUR BUSINESS**

Net 30 Days. Unpaid balance is subject to 1 1/2% service charge per month and any and all cost of collections.

**NON-NEGOTIABLE BILL-OF-LADING AND TRANSPORTATION AGREEMENT**

DATE **2-24-20**

**A-3771651**

Item 11.

PRINCIPAL CARRIER **DM Crown**  
 ADDRESS  
 CITY/STATE/ZIP

JOB #  
 BROKER #  
 TRUCK # **C-00**  
 TRAILER #  
 CA #

UNDERLYING CARRIER (IF ANY)  
 ADDRESS  
 SHIPPER **J E Roberts**  
 ADDRESS  
 CITY/STATE/ZIP

RECEIVER  
 ADDRESS  
 CITY/STATE/ZIP  
 POINT OF DESTINATION **OAK Valley Hwy Beaumont**

POINT OF ORIGIN **Roadlands Blvd. Rob**

EQUIPMENT TYPE  
 10-WHEELER  
 SUPER-10  
 STRONG ARM  
 SUPER TAG  
 TRANSFER  
 DBL BOTTOMS  
 SEMI-BOTTOM  
 END DUMP  
 SIDE DUMP  
 TRUCK & PUP  
 WATER TRUCK  
 FLAT BED  
 MIXER  
 SWEEPER  
 OTHER

HOURLY  TONNAGE  PER LOAD  
 RATE @ \$

TAG NO.	WEIGHT	COMMODITY	LOADING		UNLOADING		STANDBY TIME	BREAKDOWN OR REASON FOR DELAY
			ARRIVE	DEPART	ARRIVE	DEPART		
1		Dirt	7:00					
2		u						
3		u						
4		u						
5		u						
6								
7								
8								
9								
10								
11								
12								
13								
14								
15								

**LOADS**

**GAES**

REPORTING TIME **7:00** ENDING TIME **7:00** TOTAL TIME **98** DEDUCTIBLE TIME **0** NET TIME **98** TOTAL TONS **58** ACCESSORIAL OTHER

START DRIVING TIME LAST TRIP **7:00** ARRIVAL TIME AT DUMP LAST TRIP **7:00** END LOADING LAST TRIP **7:00** RUNNING TIME LAST TRIP **98**

**SUBJECT TO TERMS AND CONDITIONS ON REVERSE SIDE**

TOTAL CHARGES

**DM Crown**  
 SIGNATURE

**ORIGINAL**  
 SHIPPER/RECEIVER (AGENT OR DEBITOR) SIGNATURE



306 W. Katella Ave., Unit B  
Orange, CA 92867

**DATE:** 2/25/2020

**LOCATION:** Oak Valley Parkway

**DETAILS:** Force Main Stabilization (Tuesday) - Hauled in (36) Loads of dirt and compacted slope. Moved Rip Rap grade wash. Wet dirt at fill site and wet dirt at loading site. Cleaned up site.

Job#	Beaumont
5943	
Name: Jeff	

TYPE	RATE/HR	QTY	REG AMT	OT RATE	QTY	OT AMT	DT RATE	DT HRS	DT AMT	TOTAL
<b>LABOR</b>										
OE FOREMAN	8.50	8.00	978.96	183.56	0.50	91.78	244.74	-	-	1,070.74
EQPT OPERATOR (2)	16.00	16.00	1,879.52	176.21		-	234.94	-	-	1,879.52
	24.50	24.00			0.50			-		
<b>EQUIPMENT</b>										
SERVICE TRUCK F550 (1)		8.50	468.35							468.35
EXCAVATOR		8.00	1,331.68							1331.68
WHEEL LOADER 544K		8.00	993.20							993.20
WHEEL LOADER 644K		8.00	1,194.24							1194.24
WATER TRUCK		4.00	220.40							220.40
DELINEATORS/ SIGNS (1)		8.00	2.40							2.40
									<b>LABOR</b>	<b>\$2,950.26</b>
									<b>LABOR TOTAL</b>	<b>\$2,950.26</b>
									<b>EQPT TOTAL</b>	<b>\$4,210.27</b>

	Sub Total	Tax	Total	5%	TOTAL
D M Courville Trucking - Inv# 2796 - Truck#1304 (8 Hrs)	720.00	-	720.00	36.00	756.00
D M Courville Trucking - Inv# 2803 - Truck#1298 (8 Hrs)	720.00	-	720.00	36.00	756.00
D M Courville Trucking - Inv# 2808 - Truck#1382 (8 Hrs)	720.00	-	720.00	36.00	756.00
D M Courville Trucking - Inv# 2817 - Truck#1446 (8 Hrs)	720.00	-	720.00	36.00	756.00
D M Courville Trucking - Inv# 2839 - Truck#1368 (1&2) (16 Hrs)	1,440.00	-	1,440.00	72.00	1,512.00
				<b>SUBCONTRACTOR TOTAL</b>	<b>\$3,024.00</b>

	Sub Total	Tax	AMOUNT	15%	TOTAL	
					<b>MATERIAL TOTAL</b>	<b>\$0.00</b>

	Sub Total	Tax	AMOUNT	15%	TOTAL	
					<b>EQ RENT TOTAL</b>	<b>\$0.00</b>

Item 11.



306 W. Katella Ave., Unit B  
Orange, CA 92867

**DATE:** 2/25/2020

**LOCATION:** Oak Valley Parkway

**DETAILS:** **Force Main Stabilization (Tuesday)** - Hauled in (36) Loads of dirt and compacted slope. Moved Rip Rap grade wash. Wet dirt at fill site and wet dirt at loading site. Cleaned up site.

Job#	Beaumont
5943	
Name: Jeff	

TYPE	RATE/HR	QTY	REG AMT	OT RATE	QTY	OT AMT	DT RATE	DT HRS	DT AMT	TOTAL
<b>DUMP FEES</b>										
										\$0.00

<b>SUB TOTAL</b>	<b>\$10,184.53</b>
1% - Bond	\$101.85
<b>GRAND TOTAL</b>	<b>\$10,286.37</b>



306 W. Katella Avenue, Unit B  
 Orange, CA 92867  
 T: 714-669-007  
 F: 714-200-0241  
 LICENSE# 603008  
 www.teroberts.com

No. \_\_\_\_\_

Item 11.

FIELD CHANGE ORDER

TO: City of Beaumont

DATE: 2-25-2020 (TUESDAY)  
 JOB TITLE: Force Main Stabilization  
 JOB NUMBER: 5943  
 LOCATION: OAK Valley Parkway

ATTN: Jeff

LABOR:	RT	OT	TOTAL		RT	OT	TOTAL
Robert Hartwell III OF	8	.5	8.5	✓			
Robert Hartwell IV OF	8	.5	8.5	✓			
Jose Magana	8	.5	8.5	✓			
TOTALS	24	.5	24.5	✓			

EQUIPMENT:

EQPT NO.	DESCRIPTION	HOURS
F-36	CREW TRUCK	8.5
	328 cat Exc	8
WL-7	544K Deer (Job)	8
WL-13	644K Deer (Loading)	8
WT-07	Water truck	4

MATERIALS and RENTAL EQUIPMENT:

QTY	DESCRIPTION	VENDOR
6	Super 10s From Dan Courville	8 hrs
	36 Loads	
1	Restroom From United	
1	Road work Sign	

DESCRIPTION OF WORK, CHANGES, AND COMMENTS:

Haul dirt from Redlands 36 Loads  
compact slope and move Rip Rap grade wash  
wet dirt at Full Sight  
wet dirt at Loading site

Contract Time Extension: \_\_\_\_\_ Calendar Days

Signed: \_\_\_\_\_  
 Printed Name: \_\_\_\_\_  
 Company: \_\_\_\_\_

Signed: \_\_\_\_\_  
 Printed Name: \_\_\_\_\_  
 T.E. Roberts, Inc.



**D M COURVILLE TRUCKING, INC.**

313 CODY ROAD  
SAN DIMAS CA 91773  
Office: 909 455-8322 Fax: 909 599-1939  
Lic#: CA28653

INVOICE: 2796

Date: 02/29/20

Item 11.

✓ #5943  
GH

Customer No: 1159

T. E. ROBERTS  
306 W. KATELLA AVENUE UNIT B  
ORANGE CA 92867

**RECEIVED**  
MAR 05 2020  
BY: \_\_\_\_\_

Date	Ft Bill	Truck	Description	Qty	Rate	Amount
<del>02/24/20</del>	<del>3771631</del>	<del>1304</del>	<del>REDLANDS</del>	<del>8.00</del>	<del>90.00</del>	<del>720.00</del>
<del>02/25/20</del>	<del>3771632</del>	<del>1304</del>	<del>REDLANDS</del>	<del>8.00</del>	<del>90.00</del>	<del>720.00</del>
<del>02/26/20</del>	<del>3771633</del>	<del>1304</del>	<del>REDLANDS</del>	<del>7.00</del>	<del>90.00</del>	<del>630.00</del>
<del>02/27/20</del>	<del>3771634</del>	<del>1304</del>	<del>REDLANDS</del>	<del>8.40</del>	<del>90.00</del>	<del>756.00</del>
<del>02/28/20</del>	<del>3771635</del>	<del>1304</del>	<del>REDLANDS</del>	<del>6.00</del>	<del>90.00</del>	<del>540.00</del>
<b>Amount:</b>						<del>3,366.00</del>

Item	Qty	Amount
HOURS	37.40	3,366.00

**Total \$720.00**

**Please Pay This Amount: 3,366.00**

**THANK YOU FOR YOUR BUSINESS**

Net 30 Days. Unpaid balance is subject to 1 1/2% service charge per month and any and all cost of collections.

**NON-NEGOTIABLE BILL-OF-LADING AND TRANSPORTATION AGREEMENT**

CARRIER **DM Lewis**  
 ADDRESS  
 CITY/STATE/ZIP

DATE **2-25-20**

**A- 3771632**  
 JOB #  
 BROKER #  
 TRUCK # **000**  
 TRAILER #  
 CA #

Item 11.

UNDERLYING CARRIER (IF ANY)  
 ADDRESS  
 SHIPPER **JR Roberts**  
 ADDRESS  
 CITY/STATE/ZIP

PH.  
 RECEIVER  
 ADDRESS  
 CITY/STATE/ZIP  
 POINT OF DESTINATION **OKLAHOMA**

POINT OF ORIGIN **Richards**  
 EQUIPMENT TYPE  
 10-WHEELER  
 SUPER-10  
 STRONG ARM  
 SUPER TAG  
 TRANSFER  
 DBL BOTTOMS  
 SEMI-BOTTOM  
 END DUMP  
 SIDE DUMP  
 TRUCK & PUP  
 WATER TRUCK  
 FLAT BED  
 MIXER  
 SWEEPER  
 OTHER  
 HOURLY  TONNAGE  PER LOAD  
 RATE @ \$ **95.00**

TAG NO.	WEIGHT	COMMODITY	LOADING		UNLOADING		STANDBY TIME	BREAKDOWN OR REASON FOR DELAY
			ARRIVE	DEPART	ARRIVE	DEPART		
1		Oil	7:00					
2		Oil	9:14	9:10	9:10	10:05		
3		Oil	10:10			11:10		
4		Oil						
5		Oil						
6		Oil						
7								
8								
9								
10								
11								
12								
13								
14								
15								

**Oil Loads**

REPORTING TIME **9:01** ENDING TIME **2:13** TOTAL TIME **8** DEDUCTIBLE TIME **0** NET TIME **8** TOTAL TONS  
 START DRIVING TIME LAST TRIP ARRIVAL TIME AT DUMP LAST TRIP END LOADING LAST TRIP RUNNING TIME LAST TRIP  
**SUBJECT TO TERMS AND CONDITIONS ON REVERSE SIDE**  
**ORIGINAL**  
 SHIPPER/RECEIVER (AGENT OR DEBITOR) SIGNATURE **DM Lewis**

**D M COURVILLE TRUCKING, INC.**

313 CODY ROAD  
SAN DIMAS CA 91773  
Office: 909 455-8322 Fax: 909 599-1939  
Lic#: CA28653

INVOICE: 2803

Date: 03/03/2020

Item 11.

#159422  
✓ GH

Customer No: 1159

**RECEIVED**  
MAR 05 2020  
BY: \_\_\_\_\_

T. E. ROBERTS  
306 W. KATELLA AVENUE UNIT B  
ORANGE CA 92867

Date	Ft Bill	Truck	Description	Qty	Rate	Amount
02/25/20	5813521	1298	REDLANDS	8.00	90.00	720.00
<del>02/26/20</del>	<del>5731932</del>	<del>1137</del>	<del>REDLANDS</del>	<del>7.00</del>	<del>90.00</del>	<del>630.00</del>
<del>02/26/20</del>	<del>5813522</del>	<del>1298</del>	<del>REDLANDS</del>	<del>7.00</del>	<del>90.00</del>	<del>630.00</del>
<del>02/28/20</del>	<del>5731934</del>	<del>1137</del>	<del>REDLANDS</del>	<del>6.00</del>	<del>90.00</del>	<del>540.00</del>
<b>Amount:</b>						<del>2,520.00</del>

**Total \$720.00**

Item	Qty	Amount
HOURS	28.00	2,520.00

**Please Pay This Amount: 2,520.00**

**THANK YOU FOR YOUR BUSINESS**

Net 30 Days. Unpaid balance is subject to 1 1/2% service charge per month and any and all cost of collections.

**NON-NEGOTIABLE BILL-OF-LADING AND TRANSPORTATION AGREEMENT**

DATE **2-25-20**

**A-5813521**

Item 11.

PRINCIPAL CARRIER **Dan Courville**

ADDRESS \_\_\_\_\_ PH. \_\_\_\_\_

CITY/STATE/ZIP \_\_\_\_\_

UNDERLYING CARRIER (IF ANY) **Jonathan Beers**

ADDRESS \_\_\_\_\_ PH. \_\_\_\_\_

SHIPPER **TE Roberts**

ADDRESS \_\_\_\_\_

CITY/STATE/ZIP \_\_\_\_\_

POINT OF ORIGIN **Redlands Blvd between Mountain View + California**

EQUIPMENT TYPE

- 10-WHEELER
- SUPER-10
- STRONG ARM

- SUPER TAG
- TRANSFER
- DBL BOTTOMS
- SEMI-BOTTOM

- END DUMP
- SIDE DUMP
- TRUCK & PUP
- WATER TRUCK

- FLAT BED
- MIXER
- SWEEPER
- OTHER

HOURLY  TONNAGE  PER LOAD  
RATE @ \$ **90<sup>00</sup>**

TAG NO.	WEIGHT	COMMODITY	LOADING		UNLOADING		STANDBY TIME	BREAKDOWN OR REASON FOR DELAY
			ARRIVE	DEPART	ARRIVE	DEPART		
1			700					
2			841					
3			944					
4			1100					
5			1204					
6			110					
7								
8								
9								
10								
11								
12								
13								
14								
15								

MUST BE PAID IN WITHIN 3 DAYS  
THANK YOU  
SURE PAYMENT

REPORTING TIME <b>700</b>	ENDING TIME <b>300</b>	TOTAL TIME <b>8</b>	DEDUCTIBLE TIME <b>0</b>	NET TIME <b>8</b>	TOTAL TONS	ACCESSORIAL OTHER
START DRIVING TIME LAST TRIP	ARRIVAL TIME AT DUMP LAST TRIP	END LOADING LAST TRIP	RUNNING TIME LAST TRIP	<b>SUBJECT TO TERMS AND CONDITIONS ON REVERSE SIDE</b>		TOTAL CHARGES <b>720.<sup>00</sup></b>

*A Beers*  
SHIPPER SIGNATURE

*[Signature]*  
SHIPPER/RECEIVER (AGENT OR DEBITOR) SIGNATURE

**ORIGINAL**

**D M COURVILLE TRUCKING, INC.**

313 CODY ROAD  
SAN DIMAS CA 91773  
Office: 909 455-8322 Fax: 909 599-1939  
Lic#: CA28653

INVOICE: 2808

Date: 02/29/2020

Item 11.

#5947  
G-H  
✓

Customer No: 1159

**RECEIVED**  
MAR 05 2020  
BY: \_\_\_\_\_

T. E. ROBERTS  
306 W. KATELLA AVENUE UNIT B  
ORANGE CA 92867

Date	Ft Bill	Truck	Description	Qty	Rate	Amount
02/25/20	2667453	1382	REDLANDS	8.00	90.00	720.00
<del>02/28/20</del>	<del>2667456</del>	<del>1382</del>	<del>REDLANDS</del>	<del>6.00</del>	<del>90.00</del>	<del>540.00</del>
<b>Amount:</b>						<del>1,260.00</del>

Total \$720.00

Item	Qty	Amount
HOURS	14.00	1,260.00

Please Pay This Amount: 1,260.00

**THANK YOU FOR YOUR BUSINESS**

Net 30 Days. Unpaid balance is subject to 1 1/2% service charge per month and any and all cost of collections.

**NON-NEGOTIABLE BILL-OF-LADING AND TRANSPORTATION AGREEMENT**

BILL NO.

PRINCIPAL CARRIER

DAN COURVILLE TRKG 2-25-20

**A-2667453**

Item 11.

ADDRESS

CITY/STATE/ZIP

PH.

JOB #

BROKER #

TRUCK #

TRAILER #

CA #

LT2

529464

UNDERLYING CARRIER (IF ANY)

DOZANP TRKG  
2485 MADRONA FOUNTAIN CA 92335

SHIPPER T.E ROBERTS CONST INC

RECEIVER OAK VALLEY PKWY

ADDRESS

ADDRESS

CITY/STATE/ZIP

MT VIEW & Redland

CITY/STATE/ZIP

POINT OF ORIGIN

Redlands

POINT OF DESTINATION

BEAUMONT

EQUIPMENT TYPE

- 10-WHEELER
- SUPER-10
- STRONG ARM

- SUPER TAG
- TRANSFER
- DBL BOTTOMS
- SEMI-BOTTOM
- END DUMP
- SIDE DUMP
- TRUCK & PUP
- WATER TRUCK
- FLAT BED
- MIXER
- OTHER

HOURLY  TONNAGE  PER LOAD

RATE @ \$ 90

TAG NO.	WEIGHT	COMMODITY	LOADING		UNLOADING		STANDBY TIME	BREAKDOWN OR REASON FOR DELAY
			ARRIVE	DEPART	ARRIVE	DEPART		
<del>1</del>		DIRT	7:00	7:15	7:48	8:06		
2		DIRT	8:35	8:42				
3		DIRT	9:45	9:49				
4		DIRT	10:50	11:30				
5		DIRT	11:57	12:00				
6		DIRT	1:13	1:18				
7								
8								
9								
10								
11								
12								
13								
14								
15								

PAID WITHIN 30 DAYS OF THE PAYMENT DATE  
THANK YOU FOR YOUR BUSINESS  
4 LOADS

8 HR

REPORTING TIME <u>7:00</u>	ENDING TIME <u>3:00</u>	TOTAL TIME <u>8 HR</u>	DEDUCTIBLE TIME	NET TIME	TOTAL TONS	ACCESSORIAL OTHER
START DRIVING TIME LAST TRIP	ARRIVAL TIME AT DUMP LAST TRIP	END LOADING LAST TRIP	RUNNING TIME LAST TRIP	<b>SUBJECT TO TERMS AND CONDITIONS ON REVERSE SIDE</b>		TOTAL CHARGES <u>720.00</u>

Richard Lopez

[Signature]

ORIGINAL

SHIPPER/RECEIVER (AGENT OR DEBITOR) SIGNATURE

**D M COURVILLE TRUCKING, INC.**

313 CODY ROAD  
SAN DIMAS CA 91773  
Office: 909 455-8322 Fax: 909 599-1939  
Lic#: CA28653

INVOICE: 2817

Date: 03/01/2020

Item 11.

#5943



Customer No: 1159

T. E. ROBERTS  
306 W. KATELLA AVENUE UNIT B  
ORANGE CA 92867

**RECEIVED**  
MAR 10 2020  
BY: \_\_\_\_\_

Date	Ft Bill	Truck	Description	Qty	Rate	Amount
02/25/20	3771559	1446	REDLANDS	8.00	90.00	720.00
<b>Amount:</b>						<b>720.00</b>

Item	Qty	Amount
HOURS	8.00	720.00

**Please Pay This Amount: 720.00**

**THANK YOU FOR YOUR BUSINESS**

Net 30 Days. Unpaid balance is subject to 1 1/2% service charge per month and any and all cost of collections.

**NON-NEGOTIABLE BILL-OF-LADING AND TRANSPORTATION AGREEMENT**

BILL NO.

DATE **2-25-20** **A- 3771559**

PRINCIPAL CARRIER **Te Roberts** JOB #

ADDRESS \_\_\_\_\_ BROKER #

CITY/STATE/ZIP \_\_\_\_\_ PH. TRUCK # **567502**

UNDERLYING CARRIER **D-courville/savage Trucking** TRAILER #

(IF ANY) \_\_\_\_\_ CA #

ADDRESS \_\_\_\_\_ PH. \_\_\_\_\_

Item 11.

SHIPPER **Te Roberts** RECEIVER

ADDRESS **Redlands Blvd** ADDRESS **Oak Valley Pkway**

CITY/STATE/ZIP **Redlands** CITY/STATE/ZIP **At BOUNT**

POINT OF ORIGIN \_\_\_\_\_ POINT OF DESTINATION \_\_\_\_\_

EQUIPMENT TYPE

10-WHEELER  SUPER TAG  END DUMP  FLAT BED  HOURLY  TONNAGE  PER LOAD

SUPER-10  TRANSFER  SIDE DUMP  MIXER

STRONG ARM  DBL BOTTOMS  TRUCK & PUP  SWEEPER

SEMI-BOTTOM  WATER TRUCK  OTHER

RATE @ \$ **90.00**

TAG NO.	WEIGHT	COMMODITY	LOADING		UNLOADING		STANDBY TIME	BREAKDOWN OR REASON FOR DELAY
			ARRIVE	DEPART	ARRIVE	DEPART		
1 ✓		DIRT	7:00	7:14	7:45	7:53		
2 ✓			8:35					
3 ✓								
4 ✓								
5 ✓								
6 ✓								
7								
8								
9								
10								
11								
12								
13								
14								
15								

REPORTING TIME **7:00** ENDING TIME **3:00** TOTAL TIME **8** DEDUCTIBLE TIME **0** NET TIME **8** TOTAL TONS \_\_\_\_\_ ACCESSORIAL OTHER \_\_\_\_\_

START DRIVING TIME LAST TRIP \_\_\_\_\_ ARRIVAL TIME AT DUMP LAST TRIP \_\_\_\_\_ END LOADING LAST TRIP \_\_\_\_\_ RUNNING TIME LAST TRIP \_\_\_\_\_

**SUBJECT TO TERMS AND CONDITIONS ON REVERSE SIDE** TOTAL CHARGES **720.00**

**ORIGINAL**

**Rene Iraeta** DRIVER SIGNATURE

**[Signature]** SHIPPER/RECEIVER (AGENT OR DEBITOR) SIGNATURE



**D M COURVILLE TRUCKING, INC.**

313 CODY ROAD  
SAN DIMAS CA 91773  
Office: 909 455-8322 Fax: 909 599-1939  
Lic#: CA28653

INVOICE: 2839

Date: 03/16/2020

Item 11.

#5943



**RECEIVED**  
MAR 19 2020  
BY: \_\_\_\_\_

Customer No: 1159

T. E. ROBERTS  
306 W. KATELLA AVENUE UNIT B  
ORANGE CA 92867

Date	Ft Bill	Truck	Description	Qty	Rate	Amount
02/25/20	4052341	1368	REDLANDS	8.00	90.00	720.00
02/25/20	4052875	1368	REDLANDS	8.00	90.00	720.00
<b>Amount:</b>						<b>1,440.00</b>

Item	Qty	Amount
HOURS	16.00	1,440.00

**Please Pay This Amount: 1,440.00**

**THANK YOU FOR YOUR BUSINESS**

Net 30 Days. Unpaid balance is subject to 1 1/2% service charge per month and any and all cost of collections.

**NON-NEGOTIABLE BILL-OF-LADING AND TRANSPORTATION AGREEMENT**

BILL NO.

**A-4052875**

Item 11.

PRINCIPAL CARRIER Dam Courville Trucking DATE 2/25/20

ADDRESS \_\_\_\_\_ PH. \_\_\_\_\_

CITY/STATE/ZIP \_\_\_\_\_

JOB # \_\_\_\_\_  
 BROKER # \_\_\_\_\_  
 TRUCK # 01  
 TRAILER # \_\_\_\_\_  
 CA# 526279

SHIPPER TE Roberts  
 ADDRESS Redlands & California  
 CITY/STATE/ZIP Redlands  
 POINT OF ORIGIN \_\_\_\_\_

RECEIVER TE Roberts  
 ADDRESS Oak Valley Pkwy  
 CITY/STATE/ZIP Beaumont  
 POINT OF DESTINATION \_\_\_\_\_

EQUIPMENT TYPE  
 10-WHEELER  
 SUPER-10  
 STRONG ARM  
 SUPER TAG  
 TRANSFER  
 DBL BOTTOMS  
 SEMI-BOTTOM  
 END DUMP  
 SIDE DUMP  
 TRUCK & PUP  
 WATER TRUCK  
 FLAT BED  
 MIXER  
 SWEEPER  
 OTHER \_\_\_\_\_

HOURLY  TONNAGE  PER LOAD  
 RATE @ \$ 90.00

TAG NO.	WEIGHT	COMMODITY	LOADING		UNLOADING		STANDBY TIME	BREAKDOWN OR REASON FOR DELAY
			ARRIVE	DEPART	ARRIVE	DEPART		
1		DIRT						
2		DIRT						
3		DIRT						
4		DIRT						
5		DIRT						
6		DIRT						
7								
8								
9								720.00
10								
11								
12								
13								
14								
15								

REPORTING TIME 7:00 ENDING TIME 3:00 TOTAL TIME 8 DEDUCTIBLE TIME 0 NET TIME 8 TOTAL TONS \_\_\_\_\_ ACCESSORIAL OTHER \_\_\_\_\_  
 START DRIVING TIME LAST TRIP ARRIVAL TIME AT DUMP LAST TRIP END LOADING LAST TRIP RUNNING TIME LAST TRIP  
**SUBJECT TO TERMS AND CONDITIONS ON REVERSE SIDE** TOTAL CHARGES 720.00

I Yines  
 DRIVER SIGNATURE

[Signature]  
 SHIPPER/RECEIVER (AGENT OR DEBITOR) SIGNATURE

ORIGINAL

**NON-NEGOTIABLE BILL-OF-LADING  
AND TRANSPORTATION AGREEMENT**

BILL NO.

**A-4052341**

DATE 2-25-20

Item 11.

PRINCIPAL CARRIER DM Courville Trucking

ADDRESS \_\_\_\_\_  
CITY/STATE/ZIP \_\_\_\_\_ PH. \_\_\_\_\_

UNDERLYING CARRIER (IF ANY) Casillas Trucking

ADDRESS \_\_\_\_\_ PH. \_\_\_\_\_

JOB # \_\_\_\_\_  
BROKER # \_\_\_\_\_  
TRUCK # 02  
TRAILER # 044818N2  
CA# 526279

SHIPPER TE Roberts

ADDRESS Redlands Blvd and cati

CITY/STATE/ZIP Redlands

POINT OF ORIGIN \_\_\_\_\_

RECEIVER Oak Valley

ADDRESS \_\_\_\_\_

CITY/STATE/ZIP \_\_\_\_\_

POINT OF DESTINATION \_\_\_\_\_

- EQUIPMENT TYPE
- SUPER TAG
  - END DUMP
  - FLAT BED
  - 10-WHEELER
  - TRANSFER
  - SIDE DUMP
  - MIXER
  - SUPER-10
  - DBL BOTTOMS
  - TRUCK & PUP
  - SWEEPER
  - STRONG ARM
  - SEMI-BOTTOM
  - WATER TRUCK
  - OTHER \_\_\_\_\_

HOURLY  TONNAGE  PER LOAD  
RATE @ \$ 900

	TAG NO.	WEIGHT	COMMODITY	LOADING		UNLOADING		STANDBY TIME	BREAKDOWN OR REASON FOR DELAY
				ARRIVE	DEPART	ARRIVE	DEPART		
1			Dirt						
2			Dirt						
3			Dirt						
4			Dirt						
5			Dirt						
6			Dirt						
7			Dirt						
8									
9									
10									
11									
12									
13									
14									
15									

REPORTING TIME 7:05 ENDING TIME 3:55 TOTAL TIME 8:50 DEDUCTIBLE TIME 8 NET TIME 8 TOTAL TONS \_\_\_\_\_ ACCESSORIAL OTHER \_\_\_\_\_

START DRIVING TIME LAST TRIP \_\_\_\_\_ ARRIVAL TIME AT DUMP LAST TRIP \_\_\_\_\_ END LOADING LAST TRIP \_\_\_\_\_ RUNNING TIME LAST TRIP \_\_\_\_\_

**SUBJECT TO TERMS AND CONDITIONS ON REVERSE SIDE**

**TOTAL CHARGES**  
720.00

Robert C. Gu  
DRIVER SIGNATURE

Robert C. Gu ORIGINAL  
SHIPPER/RECEIVER (AGENT OR DEBITOR) SIGNATURE



306 W. Katella Ave., Unit B  
Orange, CA 92867

Job#	Beaumont
5943	
Name: Jeff	

DATE: 2/26/2020

LOCATION: Oak Valley Parkway

DETAILS: **Force Main Stabilization (Weekday)** - Hauled (25) loads from Redlands to compact slope. Moved rip rap from the flow line to the other side. Cleaned and secured site.

TYPE	REG AMT	QTY	RATE/HR	QTY	OT RATE	OT RATE	QTY	OT AMT	DT RATE	DT HRS	DT AMT	TOTAL
<b>LABOR</b>												
OE FOREMAN	8.50	8.00	122.37	8.00	183.56	183.56	0.50	91.78	244.74	-	-	1,070.74
LABORER	8.00	8.00	88.14	8.00	132.21	132.21	-	-	176.28	-	-	705.12
EQPT OPERATOR (2)	16.00	16.00	117.47	16.00	176.21	176.21	-	-	234.94	-	-	1,879.52
	32.50	32.00		32.00			0.50					
<b>EQUIPMENT</b>												
SERVICE TRUCK F50		8.00	55.10	8.00	440.80	440.80						440.80
EXCAVATOR		8.00	166.46	8.00	1,331.68	1,331.68						1331.68
WHEEL LOADER 544K		8.00	124.15	8.00	993.20	993.20						993.20
WHEEL LOADER 644K		8.00	149.28	8.00	1,194.24	1,194.24						1194.24
WATER TRUCK		8.00	55.10	8.00	440.80	440.80						440.80
DELINEATORS/ SIGNS (1)		8.00	0.30	8.00	2.40	2.40						2.40
<b>LABOR TOTAL</b>												
<b>LABOR TOTAL</b>												
<b>EQPT TOTAL</b>												
<b>EQPT TOTAL</b>												

SUBCONTRACTOR	Sub Total	Tax	Total	5%	TOTAL
D M Courville Trucking - Inv# 2788 - Truck#1458 (7 Hrs)	630.00	-	630.00	31.50	661.50
D M Courville Trucking - Inv# 2796 - Truck#1304 (7 Hrs)	630.00	-	630.00	31.50	661.50
D M Courville Trucking - Inv# 2799 - Truck#1404 (7 Hrs)	630.00	-	630.00	31.50	661.50
D M Courville Trucking - Inv# 2803-Truck#1137 & #1298 (2 Trucks[7hrs ea])(14 Hrs)	1,260.00	-	1,260.00	63.00	1,323.00
<b>SUBCONTRACTOR TOTAL</b>					<b>\$3,307.50</b>

MATERIAL	Sub Total	Tax	AMOUNT	15%	TOTAL
<b>MATERIAL TOTAL</b>					<b>\$0.00</b>

EQUIPMENT RENT	Sub Total	Tax	AMOUNT	15%	TOTAL
<b>EQ RENT TOTAL</b>					<b>\$0.00</b>

Item 11.



306 W. Katella Ave., Unit B  
Orange, CA 92867

Job#	Beaumont
5943	
Name: Jeff	

DATE: 2/26/2020

LOCATION: Oak Valley Parkway

DETAILS: **Force Main Stabilization (Weekday)** - Hauled (25) loads from Redlands to compact slope. Moved rip rap from the flow line to the other side. Cleaned and secured site.

TYPE	RATE/HR	QTY	REG AMT	OT RATE	QTY	OT AMT	DT RATE	DT HRS	DT AMT	TOTAL
<b>DUMP FEES</b>										
				Sub Total	Tax	AMOUNT	10%			TOTAL
				DUMP FEE TOTAL						\$0.00

SUB TOTAL	\$11,366.00
1% - Bond	\$113.66
<b>GRAND TOTAL</b>	<b>\$11,479.66</b>



306 W. Katella Avenue  
Unit B  
Orange, CA 92867

T. 714.669.0072  
F. 714.200.0241

troberts@teroberts.com  
License #603008  
www.teroberts.com

NO: \_\_\_\_\_ Item 11.

# DAILY WORK REPORT/CHANGE ORDER

TO: City of Beaumont

DATE: 2-26-2020 (WEDNESDAY)

JOB TITLE: Face main stabilization

JOB NUMBER: 5943

CUST. PO#: \_\_\_\_\_

ATTN: Jeff

QUANT.	LABOR (CLASSIFY)	ST	OT	TOTAL HRS.	RATE	TOTAL
	Robert Hartwell IAT operator/Foreman	8	.5	8.5 ✓		
	Robert Hartwell IV operator	8	0	8 ✓		
	Jose Magana operator	8	0	8 ✓		
	Anthony Hartwell Labor APP 3	8	0	8 ✓		
	TOTAL	32	.5	32.5 ✓		
5	Super 10s From Dan Courville 25 Loads					
EQUIPMENT						
T-36	CREW TRUCK			8		
	328 Cat Excavator			8		
WL-7	S44K DEER			8		
WL-13	644K			8		
WT-01	water truck			8		
MATERIAL AND OTHER ITEMS				UNIT PRICE		
	Haul dirt from Redlands to compact slope move Rip Rap From Flow Line to other side					
	1 Restroom From United					
	1 Roadwork Sign					

COMMENTS: \_\_\_\_\_  
 \_\_\_\_\_  
 \_\_\_\_\_

TAX
SUB-TOTAL
%OHP
TOTAL

CONTRACT TIME EXT. \_\_\_\_\_ CAL. DAYS

SIGNED \_\_\_\_\_

BY \_\_\_\_\_

**T.E. ROBERTS, INC.**

BY \_\_\_\_\_ 422

**D M COURVILLE TRUCKING, INC.**

313 CODY ROAD  
SAN DIMAS CA 91773  
Office: 909 455-8322 Fax: 909 599-1939  
Lic#: CA28653

INVOICE: 2788

Date: 03/01/2020

Item 11.

#5943

Customer No: 1159 ✓

T. E. ROBERTS  
306 W. KATELLA AVENUE UNIT B  
ORANGE CA 92867

**RECEIVED**  
MAR 04 2020  
BY: \_\_\_\_\_

Date	Ft Bill	Truck	Description	Qty	Rate	Amount
<del>02/24/20</del>	<del>3771636</del>	<del>1458</del>	<del>REDLANDS</del>	<del>8.00</del>	<del>90.00</del>	<del>720.00</del>
<del>02/26/20</del>	<del>3771638</del>	<del>1458</del>	<del>REDLANDS</del>	<del>7.00</del>	<del>90.00</del>	<del>630.00</del>
<del>02/27/20</del>	<del>3771639</del>	<del>1345</del>	<del>REDLANDS</del>	<del>8.00</del>	<del>90.00</del>	<del>720.00</del>
<del>02/28/20</del>	<del>3771640</del>	<del>1458</del>	<del>REDLANDS</del>	<del>6.00</del>	<del>90.00</del>	<del>540.00</del>
<b>Amount:</b>						<del>2,610.00</del>

Item	Qty	Amount
HOURS	29.00	2,610.00

**Total \$630.00**

**Please Pay This Amount:** ~~2,610.00~~

**THANK YOU FOR YOUR BUSINESS**

Net 30 Days. Unpaid balance is subject to 1 1/2% service charge per month and any and all cost of collections.

**NON-NEGOTIABLE BILL-OF-LADING AND TRANSPORTATION AGREEMENT**

BILL NO.

PRINCIPAL CARRIER D3M Courville Trucking DATE 2-26-20

**A- 3771638**

Item 11.

ADDRESS \_\_\_\_\_ PH. \_\_\_\_\_  
CITY/STATE/ZIP \_\_\_\_\_

JOB # \_\_\_\_\_  
BROKER # \_\_\_\_\_  
TRUCK # C70  
TRAILER # \_\_\_\_\_  
CA# 28653

UNDERLYING CARRIER (IF ANY) \_\_\_\_\_  
ADDRESS \_\_\_\_\_ PH. \_\_\_\_\_

SHIPPER T.E. ROBERTS  
ADDRESS \_\_\_\_\_  
CITY/STATE/ZIP \_\_\_\_\_

RECEIVER DUMP  
ADDRESS \_\_\_\_\_  
CITY/STATE/ZIP \_\_\_\_\_

POINT OF ORIGIN REPLANDS

POINT OF DESTINATION BEAUMONT

- EQUIPMENT TYPE
- 10 WHEELER
  - SUPER-10
  - STRONG ARM
  - SUPER TAG
  - TRANSFER
  - DBL BOTTOMS
  - SEMI-BOTTOM
  - END DUMP
  - SIDE DUMP
  - TRUCK & PUP
  - WATER TRUCK
  - FLAT BED
  - MIXER
  - SWEEPER
  - OTHER \_\_\_\_\_
  - HOURLY
  - TONNAGE
  - PER LOAD
- RATE @ \$ 90.00

TAG NO.	WEIGHT	COMMODITY	LOADING		UNLOADING		STANDBY TIME	BREAKDOWN OR REASON FOR DELAY
			ARRIVE	DEPART	ARRIVE	DEPART		
1			700					
2								
3								
4								
5								
6								
7								
8								
9								
10								
11								
12								
13								
14								
15								

REPORTING TIME 700 ENDING TIME 200 TOTAL TIME 7hrs DEDUCTIBLE TIME \_\_\_\_\_ NET TIME 7hrs TOTAL TONS \_\_\_\_\_ ACCESSORIAL OTHER \_\_\_\_\_

START DRIVING TIME LAST TRIP \_\_\_\_\_ ARRIVAL TIME AT DUMP LAST TRIP \_\_\_\_\_ END LOADING LAST TRIP \_\_\_\_\_ RUNNING TIME LAST TRIP \_\_\_\_\_

**SUBJECT TO TERMS AND CONDITIONS ON REVERSE SIDE** TOTAL CHARGES 636.00

[Signature] DRIVER SIGNATURE [Signature] SHIPPER/RECEIVER (AGENT OR DEBITOR) SIGNATURE

**ORIGINAL**



**D M COURVILLE TRUCKING, INC.**

313 CODY ROAD  
SAN DIMAS CA 91773  
Office: 909 455-8322 Fax: 909 599-1939  
Lic#: CA28653

INVOICE: 2796

Date: 02/29/20

Item 11.

✓ #5943  
GH

Customer No: 1159

T. E. ROBERTS  
306 W. KATELLA AVENUE UNIT B  
ORANGE CA 92867

**RECEIVED**  
MAR 05 2020  
BY: \_\_\_\_\_

Date	Ft Bill	Truck	Description	Qty	Rate	Amount
<del>02/24/20</del>	<del>3771631</del>	<del>1304</del>	<del>REDLANDS</del>	<del>8.00</del>	<del>90.00</del>	<del>720.00</del>
<del>02/25/20</del>	<del>3771632</del>	<del>1304</del>	<del>REDLANDS</del>	<del>8.00</del>	<del>90.00</del>	<del>720.00</del>
<del>02/26/20</del>	<del>3771633</del>	<del>1304</del>	<del>REDLANDS</del>	<del>7.00</del>	<del>90.00</del>	<del>630.00</del>
<del>02/27/20</del>	<del>3771634</del>	<del>1304</del>	<del>REDLANDS</del>	<del>8.40</del>	<del>90.00</del>	<del>756.00</del>
<del>02/28/20</del>	<del>3771635</del>	<del>1304</del>	<del>REDLANDS</del>	<del>6.00</del>	<del>90.00</del>	<del>540.00</del>
<b>Amount:</b>						<del>3,366.00</del>

Item	Qty	Amount
HOURS	37.40	3,366.00

**Total \$630.00**

**Please Pay This Amount: 3,366.00**

**THANK YOU FOR YOUR BUSINESS**

Net 30 Days. Unpaid balance is subject to 1 1/2% service charge per month and any and all cost of collections.

**NON-NEGOTIABLE BILL-OF-LADING AND TRANSPORTATION AGREEMENT**

BILL NO.

DATE 2-28-20

**A- 3771633**

Item 11.

PRINCIPAL CARRIER DM Car-Vm  
 ADDRESS \_\_\_\_\_  
 CITY/STATE/ZIP \_\_\_\_\_

JOB # \_\_\_\_\_  
 BROKER # \_\_\_\_\_  
 TRUCK # C-60  
 TRAILER # \_\_\_\_\_  
 CA # \_\_\_\_\_

UNDERLYING CARRIER (IF ANY) \_\_\_\_\_  
 ADDRESS \_\_\_\_\_

SHIPPER H.R. Rob  
 ADDRESS \_\_\_\_\_  
 CITY/STATE/ZIP \_\_\_\_\_  
 POINT OF ORIGIN Rd 1000, Gwa

RECEIVER \_\_\_\_\_  
 ADDRESS \_\_\_\_\_  
 CITY/STATE/ZIP \_\_\_\_\_  
 POINT OF DESTINATION Corral Valley Park

EQUIPMENT TYPE  
 10-WHEELER  
 SUPER-10  
 STRONG ARM  
 SUPER TAG  
 TRANSFER  
 DBL BOTTOMS  
 SEMI-BOTTOM  
 END DUMP  
 SIDE DUMP  
 TRUCK & PUP  
 WATER TRUCK  
 FLAT BED  
 MIXER  
 SWEEPER  
 OTHER  
 HOURLY  
 TONNAGE  
 PER LOAD  
 RATE @ \$ 950

TAG NO.	WEIGHT	COMMODITY	LOADING		UNLOADING		STANDBY TIME	BREAKDOWN OR REASON FOR DELAY
			ARRIVE	DEPART	ARRIVE	DEPART		
1		Dirt	7:00	7:06	7:40	7:45		
2		"	8:35					
3		"	9:50					
4		"	10:53					
5		"	12:05					
6								
7								
8								
9								
10								
11								
12								
13								
14								
15								

*STORAGED*

REPORTING TIME 7:00 ENDING TIME 7:06 TOTAL TIME 7 DEDUCTIBLE TIME 0 NET TIME 7 TOTAL TONS \_\_\_\_\_ ACCESSORIAL OTHER \_\_\_\_\_  
 START DRIVING TIME LAST TRIP \_\_\_\_\_ ARRIVAL TIME AT DUMP LAST TRIP \_\_\_\_\_ END LOADING LAST TRIP \_\_\_\_\_ RUNNING TIME LAST TRIP \_\_\_\_\_  
**SUBJECT TO TERMS AND CONDITIONS ON REVERSE SIDE** **TOTAL CHARGES**

Mik Coan Coan  
 DRIVER SIGNATURE SHIPPER/RECEIVER (AGENT OR DEBITOR) SIGNATURE

**ORIGINAL**

**D M COURVILLE TRUCKING, INC.**

313 CODY ROAD  
SAN DIMAS CA 91773  
Office: 909 455-8322 Fax: 909 599-1939  
Lic#: CA28653

INVOICE: 2799

Date: 02/29/2020

Item 11.

#5943

Customer No: 1159

T. E. ROBERTS  
306 W. KATELLA AVENUE UNIT B  
ORANGE CA 92867

**RECEIVED**  
MAR 04 2020  
BY: \_\_\_\_\_

Date	Ft Bill	Truck	Description	Qty	Rate	Amount
02/26/20	3771560	1404	REDLANDS	7.00	90.00	630.00
<b>Amount:</b>						<b>630.00</b>

Item	Qty	Amount
HOURS	7.00	630.00

**Please Pay This Amount: 630.00**

**THANK YOU FOR YOUR BUSINESS**

Net 30 Days. Unpaid balance is subject to 1 1/2% service charge per month and any and all cost of collections.

**NON-NEGOTIABLE BILL-OF-LADING AND TRANSPORTATION AGREEMENT**

PRINCIPAL CARRIER Te Roberts  
 ADDRESS \_\_\_\_\_  
 CITY/STATE/ZIP \_\_\_\_\_

DATE 2-26-20

**A- 3771560**  
 JOB # \_\_\_\_\_  
 BROKER # \_\_\_\_\_  
 TRUCK # 2295572  
 TRAILER # \_\_\_\_\_  
 CA # \_\_\_\_\_

Item 11.

UNDERLYING CARRIER (IF ANY) D-courville  
 ADDRESS \_\_\_\_\_

PH. \_\_\_\_\_

SHIPPER Te Roberts  
 ADDRESS 26235 Redlands Blvd  
 CITY/STATE/ZIP Redlands

RECEIVER  
 ADDRESS Oak valley prkway  
 CITY/STATE/ZIP ROUENOT

POINT OF ORIGIN \_\_\_\_\_

POINT OF DESTINATION \_\_\_\_\_

EQUIPMENT TYPE  
 10-WHEELER  
 SUPER-10  
 STRONG ARM  
 SUPER TAG  
 TRANSFER  
 DBL BOTTOMS  
 SEMI-BOTTOM  
 END DUMP  
 SIDE DUMP  
 TRUCK & PUP  
 WATER TRUCK  
 FLAT BED  
 MIXER  
 SWEEPER  
 OTHER \_\_\_\_\_  
 HOURLY  TONNAGE  PER LOAD  
 RATE @ \$ 90.00

TAG NO.	WEIGHT	COMMODITY	LOADING		UNLOADING		STANDBY TIME	BREAKDOWN OR REASON FOR DELAY
			ARRIVE	DEPART	ARRIVE	DEPART		
1	✓		7:00					
2	✓							
3	✓							
4	✓							
5	✓							
6								
7								
8								
9			7	4:55				
10								
11								
12								
13								
14								
15								

REPORTING TIME <u>7:00</u>	ENDING TIME <u>2:00</u>	TOTAL TIME <u>7 Hrs</u>	DEDUCTIBLE TIME <u>0</u>	NET TIME <u>7:14:55</u>	TOTAL TONS	ACCESSORIAL OTHER
START DRIVING TIME LAST TRIP	ARRIVAL TIME AT DUMP LAST TRIP	END LOADING LAST TRIP	RUNNING TIME LAST TRIP	<b>SUBJECT TO TERMS AND CONDITIONS ON REVERSE SIDE</b>		<b>TOTAL CHARGES</b>

Jose G. Gonzalez  
 DRIVER SIGNATURE

[Signature]  
 SHIPPER/RECEIVER (AGENT OR DEBITOR) SIGNATURE

**ORIGINAL**

**D M COURVILLE TRUCKING, INC.**

313 CODY ROAD  
SAN DIMAS CA 91773  
Office: 909 455-8322 Fax: 909 599-1939  
Lic#: CA28653

INVOICE: 2803

Date: 03/03/2020

Item 11.

#159422  
✓ GH

Customer No: 1159

**RECEIVED**  
MAR 05 2020  
BY: \_\_\_\_\_

T. E. ROBERTS  
306 W. KATELLA AVENUE UNIT B  
ORANGE CA 92867

Date	Ft Bill	Truck	Description	Qty	Rate	Amount
<del>02/25/20</del>	<del>5813521</del>	<del>1298</del>	<del>REDLANDS</del>	<del>8.00</del>	<del>90.00</del>	<del>720.00</del>
02/26/20	5731932	1137	REDLANDS	7.00	90.00	630.00
02/26/20	5813522	1298	REDLANDS	7.00	90.00	630.00
<del>02/28/20</del>	<del>5731934</del>	<del>1137</del>	<del>REDLANDS</del>	<del>6.00</del>	<del>90.00</del>	<del>540.00</del>
<b>Amount:</b>						<del>2,520.00</del>

Item	Qty	Amount
HOURS	28.00	2,520.00

**Total \$1,260.00**

**Please Pay This Amount: 2,520.00**

**THANK YOU FOR YOUR BUSINESS**

Net 30 Days. Unpaid balance is subject to 1 1/2% service charge per month and any and all cost of collections.

**NON-NEGOTIABLE BILL-OF-LADING AND TRANSPORTATION AGREEMENT**

DATE / 2-26-2020

**A - 5731932**

Item 11.

PRINCIPAL CARRIER DM Courville

ADDRESS \_\_\_\_\_ PH. \_\_\_\_\_  
CITY/STATE/ZIP \_\_\_\_\_

JOB # \_\_\_\_\_  
BROKER # \_\_\_\_\_  
TRUCK # K-10  
TRAILER # \_\_\_\_\_  
CA # 403298

UNDERLYING CARRIER (IF ANY) KLK Trucking PH. \_\_\_\_\_  
ADDRESS \_\_\_\_\_

SHIPPER T.E. Roberts

RECEIVER \_\_\_\_\_  
ADDRESS \_\_\_\_\_  
CITY/STATE/ZIP \_\_\_\_\_

ADDRESS \_\_\_\_\_  
CITY/STATE/ZIP \_\_\_\_\_

POINT OF DESTINATION Oak Valley, Beaumont

POINT OF ORIGIN Redlands Blvd

- EQUIPMENT TYPE
- 10-WHEELER
  - SUPER-10
  - STRONG ARM
  - SUPER TAG
  - TRANSFER
  - DBL BOTTOMS
  - SEMI-BOTTOM
  - END DUMP
  - SIDE DUMP
  - TRUCK & PUP
  - WATER TRUCK
  - FLAT BED
  - MIXER
  - SWEEPER
  - OTHER

HOURLY  TONNAGE  PER LOAD  
RATE @ \$ 90

TAG NO.	WEIGHT	COMMODITY	LOADING		UNLOADING		STANDBY TIME	BREAKDOWN OR REASON FOR DELAY
			ARRIVE	DEPART	ARRIVE	DEPART		
1		Dirt	7:00AM					
2		Dirt	8:30					
3		Dirt						
4		Dirt						
5		Dirt						
6								
7								
8								
9								
10								
11								
12								
13								
14								
15								

5 loads  
7.0 hours

REPORTING TIME	ENDING TIME	TOTAL TIME	DEDUCTIBLE TIME	NET TIME	TOTAL TONS	ACCESSORIAL OTHER
<u>7:00AM</u>	<u>2:00PM</u>	<u>7.0</u>		<u>7.0</u>		
START DRIVING TIME LAST TRIP	ARRIVAL TIME AT DUMP LAST TRIP	END LOADING LAST TRIP	RUNNING TIME LAST TRIP	<b>SUBJECT TO TERMS AND CONDITIONS ON REVERSE SIDE</b>		TOTAL CHARGES
						<u>630.00</u>

Kevin Taylor  
SIGNATURE

[Signature]  
SHIPPER/RECEIVER (AGENT OR DEBITOR) SIGNATURE

ORIGINAL

**NON-NEGOTIABLE BILL-OF-LADING AND TRANSPORTATION AGREEMENT**

BILL NO.

**A-5813522**

DATE  
**2-26-20**

PRINCIPAL CARRIER **Dan Courville**

ADDRESS \_\_\_\_\_ PH. \_\_\_\_\_

CITY/STATE/ZIP \_\_\_\_\_

UNDERLYING CARRIER (IF ANY) **Jonathan Boeng** PH. \_\_\_\_\_

SHIPPER **TE Roberts** ADDRESS \_\_\_\_\_

ADDRESS \_\_\_\_\_ CITY/STATE/ZIP \_\_\_\_\_

POINT OF ORIGIN **Redlands between Mountain View +**

EQUIPMENT TYPE  10-WHEELER  SUPER-10  STRONG ARM

SUPER TAG  TRANSFER  DBL BOTTOMS  SEMI-BOTTOM

END DUMP  SIDE DUMP  TRUCK & PUP  WATER TRUCK

FLAT BED  MIXER  SWEEPER  OTHER \_\_\_\_\_

RECEIVER **TE Roberts** ADDRESS \_\_\_\_\_

CITY/STATE/ZIP \_\_\_\_\_ POINT OF DESTINATION **California**

POINT OF DESTINATION **California**

HOURLY  TONNAGE  PER LOAD  
RATE @ \$ **70<sup>00</sup>**

	TAG NO.	WEIGHT	COMMODITY	LOADING		UNLOADING		STANDBY TIME	BREAKDOWN OR REASON FOR DELAY
				ARRIVE	DEPART	ARRIVE	DEPART		
1				700					
2				830					
3				948					
4				1086					
5				1206					
6									
7									
8									
9									
10									
11									
12									
13									
14									
15									

REPORTING TIME <b>200</b>	ENDING TIME <b>200</b>	TOTAL TIME <b>7</b>	DEDUCTIBLE TIME <b>0</b>	NET TIME <b>7</b>	TOTAL TONS	ACCESSORIAL OTHER
START DRIVING TIME LAST TRIP	ARRIVAL TIME AT DUMP LAST TRIP	END LOADING LAST TRIP	RUNNING TIME LAST TRIP	<b>SUBJECT TO TERMS AND CONDITIONS ON REVERSE SIDE</b>		TOTAL CHARGES <b>630<sup>00</sup></b>

*A. B. W.*  
SIGNATURE

*[Signature]*  
SHIPPER/RECEIVER (AGENT OR DEBITOR) SIGNATURE

**ORIGINAL**

Item 11.



306 W. Katella Ave., Unit B  
Orange, CA 92867

**DATE:** 2/27/2020

**LOCATION:** Oak Valley Parkway

**DETAILS:** **Force Main Stabilization (Thursday)** - Arrived on site and set up traffic control on Oak Valley Parkway. Hauled (10) loads of dirt from Redlands. Graded the top of the wash and compacted slopes. Dug around manhole cone to raise. Moved rip rap from flow line. Cleaned up and secured site. Took down traffic control.

<b>Job#</b>	<b>Beaumont</b>
5943	
<b>Name: Jeff</b>	

TYPE	RATE/HR	QTY	REG AMT	OT RATE	QTY	OT AMT	DT RATE	DT HRS	DT AMT	TOTAL
<b>LABOR</b>										
OE FOREMAN	9.00	8.00	978.96	183.56	1.00	183.56	244.74	-	-	1,162.52
LABORER	8.00	8.00	705.12	132.21	-	-	176.28	-	-	705.12
EQPT OPERATOR	9.00	8.00	939.76	176.21	1.00	176.21	234.94	-	-	1,115.97
	<b>26.00</b>	<b>24.00</b>			<b>2.00</b>					
<b>LABOR</b>										<b>\$2,983.60</b>
<b>LABOR TOTAL</b>										<b>\$2,983.60</b>
<b>EQUIPMENT</b>										
SERVICE TRUCK F450	T51	46.18	8.00	369.44						369.44
EXCAVATOR	WL7	166.46	8.00	1,331.68						1331.68
WHEEL LOADER 544K	WL13	124.15	8.00	993.20						993.20
WHEEL LOADER 644K	WT1	149.28	8.00	1,194.24						1194.24
WATER TRUCK		55.10	8.00	440.80						440.80
DELINEATORS/ SIGNS (1)		0.30	8.00	2.40						2.40
TRAFFIC CONES (25)		0.30	200.00	60.00						60.00
<b>EQPT TOTAL</b>										<b>\$4,391.76</b>

SUBCONTRACTOR	Sub Total	Tax	Total	5%	TOTAL
D M Courville Trucking - Inv# 2788 - Truck#1345 (8 Hrs)	720.00		720.00	36.00	756.00
D M Courville Trucking - Inv# 2796 - Truck#1305 (8.4 Hrs)	756.00		756.00	37.80	793.80
<b>SUBCONTRACTOR TOTAL</b>			<b>1,476.00</b>	<b>73.80</b>	<b>\$1,549.80</b>

MATERIAL	Sub Total	Tax	AMOUNT	15%	TOTAL
<b>MATERIAL TOTAL</b>					<b>\$0.00</b>

EQUIPMENT RENT	Sub Total	Tax	AMOUNT	15%	TOTAL
<b>EQ RENT TOTAL</b>					<b>\$0.00</b>

Item 11.





306 W. Katella Ave., Unit B  
Orange, CA 92867

Job#	Beaumont
5943	
Name: Jeff	

**DATE:** 2/27/2020

**LOCATION:** Oak Valley Parkway

**DETAILS:** **Force Main Stabilization (Thursday)** - Arrived on site and set up traffic control on Oak Valley Parkway. Hauled (10) loads of dirt from Redlands. Graded the top of the wash and compacted slopes. Dug around manhole cone to raise. Moved rip rap from flow line. Cleaned up and secured site. Took down traffic control.

TYPE	RATE/HR	QTY	REG AMT	OT RATE	QTY	OT AMT	DT RATE	DT HRS	DT AMT	TOTAL
<b>DUMP FEES</b>										
						Sub Total	Tax	AMOUNT	10%	TOTAL
								DUMP FEE TOTAL		\$0.00

SUB TOTAL	\$8,925.16
1% - Bond	\$89.25
<b>GRAND TOTAL</b>	<b>\$9,014.41</b>



306 W. Katella Avenue, Unit B  
 Orange, CA 92867  
 T: 714-669-007  
 F: 714-200-0241  
 LICENSE# 603008  
 www.teroberts.com

No. \_\_\_\_\_

Item 11.

### FIELD CHANGE ORDER

TO: City of Beaumont  
 \_\_\_\_\_  
 \_\_\_\_\_  
 ATTN: Jeff

DATE: 2-27-2020 (THURSDAY)  
 JOB TITLE: Force main Stabilization  
 JOB NUMBER: 5943  
 LOCATION: OAK valley Parkway

LABOR:	RT	OT	TOTAL		RT	OT	TOTAL
Robert Hartwell III DEFM	8	1	9	✓			
Robert Hartwell IV DE	8	1	9	✓			
Anthony Hartwell	<del>8</del>	<del>0</del>	<del>8</del>	✓			
TOTALS	24	2	26		TOTALS		

EQPT NO.	DESCRIPTION	HOURS
FS1	Flat bed	8
	326 Cat Excavator	8
WL-7	544k Deer Job	8
WL-13	644k Deer Loading	8
WT-01	Water truck wet at Loading Site	8

QTY	DESCRIPTION	VENDOR
2	Super 10's	8 hours
	Don Courville Trucking	
	10 Loads	
1	Restroom From United	
1	Road work sign	

DESCRIPTION OF WORK, CHANGES, AND COMMENTS:  
Set up traffic control on OAK valley Parkway  
Haul dirt From Redlands Grade top of wash and compact  
Slopes Dig around MH cone to raise move Rip Rap  
From FinLine

Contract Time Extension: \_\_\_\_\_ Calendar Days  
 Signed: \_\_\_\_\_  
 Printed Name: \_\_\_\_\_  
 Company: \_\_\_\_\_

Signed: \_\_\_\_\_  
 Printed Name: \_\_\_\_\_  
 T.E. Roberts, Inc.

**D M COURVILLE TRUCKING, INC.**

313 CODY ROAD  
SAN DIMAS CA 91773  
Office: 909 455-8322 Fax: 909 599-1939  
Lic#: CA28653

INVOICE: 2788

Date: 03/01/2020

Item 11.

#5943

Customer No: 1159 ✓

T. E. ROBERTS  
306 W. KATELLA AVENUE UNIT B  
ORANGE CA 92867

**RECEIVED**  
MAR 04 2020  
BY: \_\_\_\_\_

Date	Ft Bill	Truck	Description	Qty	Rate	Amount
<del>02/24/20</del>	<del>3771636</del>	<del>1458</del>	<del>REDLANDS</del>	<del>8.00</del>	<del>90.00</del>	<del>720.00</del>
<del>02/26/20</del>	<del>3771638</del>	<del>1458</del>	<del>REDLANDS</del>	<del>7.00</del>	<del>90.00</del>	<del>630.00</del>
<del>02/27/20</del>	<del>3771639</del>	<del>1345</del>	<del>REDLANDS</del>	<del>8.00</del>	<del>90.00</del>	<del>720.00</del>
<del>02/28/20</del>	<del>3771640</del>	<del>1458</del>	<del>REDLANDS</del>	<del>6.00</del>	<del>90.00</del>	<del>540.00</del>
<b>Amount:</b>						<del>2,610.00</del>

Item	Qty	Amount
HOURS	29.00	2,610.00

**Total \$720.00**

Please Pay This Amount: ~~2,610.00~~

**THANK YOU FOR YOUR BUSINESS**

Net 30 Days. Unpaid balance is subject to 1 1/2% service charge per month and any and all cost of collections.

**NON-NEGOTIABLE BILL-OF-LADING AND TRANSPORTATION AGREEMENT**

BILL NO.

PRINCIPAL CARRIER D3M Courville Trucking DATE 2-27-20

**A- 3771639**

Item 11.

ADDRESS \_\_\_\_\_  
CITY/STATE/ZIP \_\_\_\_\_

JOB # \_\_\_\_\_  
BROKER # \_\_\_\_\_  
TRUCK # C70  
TRAILER # \_\_\_\_\_  
CA# 28653

UNDERLYING CARRIER (IF ANY) \_\_\_\_\_  
ADDRESS \_\_\_\_\_

PH. \_\_\_\_\_

SHIPPER T. E. ROBERTS  
ADDRESS \_\_\_\_\_  
CITY/STATE/ZIP \_\_\_\_\_

RECEIVER DUMP  
ADDRESS \_\_\_\_\_  
CITY/STATE/ZIP \_\_\_\_\_

POINT OF ORIGIN REPLANDS

POINT OF DESTINATION BEAUMONT

EQUIPMENT TYPE  
 10 WHEELER  
 SUPER-10  
 STRONG ARM  
 SUPER TAG  
 TRANSFER  
 DBL BOTTOMS  
 SEMI-BOTTOM  
 END DUMP  
 SIDE DUMP  
 TRUCK & PUP  
 WATER TRUCK  
 FLAT BED  
 MIXER  
 SWEEPER  
 OTHER \_\_\_\_\_  
 HOURLY  TONNAGE  PER LOAD  
 RATE @ \$ 90

TAG NO.	WEIGHT	COMMODITY	LOADING		UNLOADING		STANDBY TIME	BREAKDOWN OR REASON FOR DELAY
			ARRIVE	DEPART	ARRIVE	DEPART		
1								
2								
3								
4								
5								
6								
7								
8								
9								
10								
11								
12								
13								
14								
15								

REPORTING TIME 700 ENDING TIME 300 TOTAL TIME 8hrs DEDUCTIBLE TIME \_\_\_\_\_ NET TIME 8hrs TOTAL TONS \_\_\_\_\_ ACCESSORIAL OTHER \_\_\_\_\_  
 START DRIVING TIME LAST TRIP \_\_\_\_\_ ARRIVAL TIME AT DUMP LAST TRIP \_\_\_\_\_ END LOADING LAST TRIP \_\_\_\_\_ RUNNING TIME LAST TRIP \_\_\_\_\_  
**SUBJECT TO TERMS AND CONDITIONS ON REVERSE SIDE** TOTAL CHARGES 720.00

[Signature] DRIVER SIGNATURE [Signature] SHIPPER/RECEIVER (AGENT OR DEBITOR) SIGNATURE ORIGINAL

**D M COURVILLE TRUCKING, INC.**

313 CODY ROAD  
SAN DIMAS CA 91773  
Office: 909 455-8322 Fax: 909 599-1939  
Lic#: CA28653

INVOICE: 2796

Date: 02/29/20

Item 11.

✓ #5943  
GH

Customer No: 1159

T. E. ROBERTS  
306 W. KATELLA AVENUE UNIT B  
ORANGE CA 92867

**RECEIVED**  
MAR 05 2020  
BY: \_\_\_\_\_

Date	Ft Bill	Truck	Description	Qty	Rate	Amount
<del>02/24/20</del>	<del>3771631</del>	<del>1304</del>	<del>REDLANDS</del>	<del>8.00</del>	<del>90.00</del>	<del>720.00</del>
<del>02/25/20</del>	<del>3771632</del>	<del>1304</del>	<del>REDLANDS</del>	<del>8.00</del>	<del>90.00</del>	<del>720.00</del>
<del>02/26/20</del>	<del>3771633</del>	<del>1304</del>	<del>REDLANDS</del>	<del>7.00</del>	<del>90.00</del>	<del>630.00</del>
<del>02/27/20</del>	<del>3771634</del>	<del>1304</del>	<del>REDLANDS</del>	<del>8.40</del>	<del>90.00</del>	<del>756.00</del>
<del>02/28/20</del>	<del>3771635</del>	<del>1304</del>	<del>REDLANDS</del>	<del>6.00</del>	<del>90.00</del>	<del>540.00</del>
<b>Amount:</b>						<del>3,366.00</del>

Item	Qty	Amount
HOURS	37.40	3,366.00

**Total \$756.00**

**Please Pay This Amount: 3,366.00**

**THANK YOU FOR YOUR BUSINESS**

Net 30 Days. Unpaid balance is subject to 1 1/2% service charge per month and any and all cost of collections.

**NON-NEGOTIABLE BILL-OF-LADING AND TRANSPORTATION AGREEMENT**

DATE 2 27

**A-3771634**

Item 11.

PRINCIPAL CARRIER DM Leovik  
 ADDRESS \_\_\_\_\_  
 CITY/STATE/ZIP \_\_\_\_\_

JOB # \_\_\_\_\_  
 BROKER # \_\_\_\_\_  
 TRUCK # C 60  
 TRAILER # \_\_\_\_\_  
 CA # \_\_\_\_\_

UNDERLYING CARRIER (IF ANY) \_\_\_\_\_  
 ADDRESS \_\_\_\_\_

RECEIVER  
 ADDRESS \_\_\_\_\_  
 CITY/STATE/ZIP \_\_\_\_\_

SHIPPER F E Roberts  
 ADDRESS \_\_\_\_\_  
 CITY/STATE/ZIP \_\_\_\_\_

POINT OF ORIGIN Road Works

POINT OF DESTINATION OAK VALLEY AVE Bell

EQUIPMENT TYPE  
 10-WHEELER  
 SUPER-10  
 STRONG ARM  
 SUPER TAG  
 TRANSFER  
 DBL BOTTOMS  
 SEMI-BOTTOM  
 END DUMP  
 SIDE DUMP  
 TRUCK & PUP  
 WATER TRUCK  
 FLAT BED  
 MIXER  
 SWEEPER  
 OTHER \_\_\_\_\_

HOURLY  TONNAGE  PER LOAD   
 RATE @ \$9500

TAG NO.	WEIGHT	COMMODITY	LOADING		UNLOADING		STANDBY TIME	BREAKDOWN OR REASON FOR DELAY
			ARRIVE	DEPART	ARRIVE	DEPART		
1		<u>Gravel</u>	<u>7:00</u>					
2		<u>Gravel</u>						
3		<u>Gravel</u>						
4		<u>Gravel</u>						
5		<u>Gravel</u>						
6		<u>Gravel</u>						
7		<u>Gravel</u>						
8		<u>Gravel</u>						
9		<u>Gravel</u>						
10		<u>Gravel</u>						
11		<u>Gravel</u>						
12		<u>Gravel</u>						
13		<u>Gravel</u>						
14		<u>Gravel</u>						
15		<u>Gravel</u>						

0 Loads

8 hrs

REPORTING TIME 7:00  
 ENDING TIME 3:30  
 TOTAL TIME 8:4  
 DEDUCTIBLE TIME 0.5  
 NET TIME 8.4  
 RUNNING TIME LAST TRIP \_\_\_\_\_

TOTAL TONS \_\_\_\_\_  
 ACCESSORIAL OTHER \_\_\_\_\_  
**SUBJECT TO TERMS AND CONDITIONS ON REVERSE SIDE**

START DRIVING TIME LAST TRIP \_\_\_\_\_  
 ARRIVAL TIME AT DUMP LAST TRIP \_\_\_\_\_  
 END LOADING LAST TRIP \_\_\_\_\_  
 SIGNATURE Samou

SIGNATURE Samou  
 SHIPPER/RECEIVER (AGENT OR DEBITOR) SIGNATURE



306 W. Katella Ave., Unit B  
Orange, CA 92867

**DATE:** 2/28/2020

**LOCATION:** Oak Valley Parkway

**DETAILS:** **Force Main Stabilization (Friday)** - Arrived on site and set up traffic control on Oak Valley Parkway, 1 lane closure. Loaded prewet dirt and hauled to Beaumont. Grade and compacted slopes. Unloaded Gabion material from United. Moved rip rap from the flow line. Cleaned and secured site. Took down traffic control.

Job#	Beaumont
5943	
Name: Jeff	

TYPE	RATE/HR	QTY	REG AMT	OT RATE	QTY	OT AMT	DT RATE	DT HRS	DT AMT	TOTAL
<b>LABOR</b>										
OE FOREMAN	7.50	7.50	917.78	183.56	-	-	244.74	-	-	917.78
LABORER	7.00	7.00	616.98	132.21	-	-	176.28	-	-	616.98
EQPT OPERATOR (2)	15.00	15.00	1,762.05	176.21	-	-	234.94	-	-	1,762.05
	29.50	29.50								
<b>LABOR</b>										<b>\$3,296.81</b>
<b>LABOR TOTAL</b>										<b>\$3,296.81</b>
<b>EQUIPMENT</b>										
SERVICE TRUCK F450		7.50	346.35							346.35
SERVICE TRUCK F550		7.50	413.25							413.25
EXCAVATOR		7.50	1,248.45							1,248.45
WHEEL LOADER 544K		7.50	931.13							931.13
WHEEL LOADER 644K		7.50	1,119.60							1,119.60
WATER TRUCK		7.50	413.25							413.25
DELINEATORS/ SIGNS (1)		7.50	2.25							2.25
TRAFFIC CONES (25)		187.50	56.25							56.25
<b>EQPT TOTAL</b>										<b>\$4,530.53</b>

SUBCONTRACTOR	Sub Total	Tax	Total	5%	TOTAL
D M Courville Trucking - Inv# 2788 - Truck#1458 (6 Hrs)	540.00	-	540.00	27.00	567.00
D M Courville Trucking - Inv# 2796 - Truck#1304 (6 Hrs)	540.00	-	540.00	27.00	567.00
D M Courville Trucking - Inv# 2803 - Truck#1137 (6 Hrs)	540.00	-	540.00	27.00	567.00
D M Courville Trucking - Inv# 2808 - Truck#1382 (6 Hrs)	540.00	-	540.00	27.00	567.00
<b>SUBCONTRACTOR TOTAL</b>					<b>\$2,268.00</b>

MATERIAL	Sub Total	Tax	AMOUNT	15%	TOTAL
United Water Works- Inv# S100085297.001 (Items Below)	2,000.00	155.00	2,155.00	323.25	2,478.25
(10) 12' X 3' X 3' Gabion Basket Valve	285.71	22.14	307.85	46.18	354.13

Item 11.



306 W. Katella Ave., Unit B  
Orange, CA 92867

**DATE:** 2/28/2020

**LOCATION:** Oak Valley Parkway

**DETAILS:** **Force Main Stabilization (Friday)** - Arrived on site and set up traffic control on Oak Valley Parkway, 1 lane closure. Loaded prewet dirt and hauled to Beaumont. Grade and compacted slopes. Unloaded Gabion material from United. Moved rip rap from the flow line. Cleaned and secured site. Took down traffic control.

Job#	Beaumont
5943	
Name: Jeff	

TYPE	RATE/HR	QTY	REG AMT	OT RATE	QTY	OT AMT	DT RATE	DT HRS	DT AMT	TOTAL
<b>EQUIPMENT RENT</b>										
				Tax		Sub Total		AMOUNT	15%	TOTAL
								EQ RENT TOTAL		\$0.00
<b>DUMP FEES</b>										
				Tax		Sub Total		AMOUNT	10%	TOTAL
								DUMP FEE TOTAL		\$0.00
<b>MATERIAL TOTAL</b>										
<b>MATERIAL TOTAL</b>										
<b>\$2,832.28</b>										

<b>SUB TOTAL</b>	<b>\$12,927.61</b>
1% - Bond	\$129.28
<b>GRAND TOTAL</b>	<b>\$13,056.89</b>

Item 11.





**D M COURVILLE TRUCKING, INC.**

313 CODY ROAD  
SAN DIMAS CA 91773  
Office: 909 455-8322 Fax: 909 599-1939  
Lic#: CA28653

INVOICE: 2788

Date: 03/01/2020

Item 11.

#5943

Customer No: 1159 ✓

T. E. ROBERTS  
306 W. KATELLA AVENUE UNIT B  
ORANGE CA 92867

**RECEIVED**  
MAR 04 2020  
BY: \_\_\_\_\_

Date	Ft Bill	Truck	Description	Qty	Rate	Amount
<del>02/24/20</del>	<del>3771636</del>	<del>1458</del>	<del>REDLANDS</del>	<del>8.00</del>	<del>90.00</del>	<del>720.00</del>
<del>02/26/20</del>	<del>3771638</del>	<del>1458</del>	<del>REDLANDS</del>	<del>7.00</del>	<del>90.00</del>	<del>630.00</del>
<del>02/27/20</del>	<del>3771639</del>	<del>1345</del>	<del>REDLANDS</del>	<del>8.00</del>	<del>90.00</del>	<del>720.00</del>
02/28/20	3771640	1458	REDLANDS	6.00	90.00	540.00
<b>Amount:</b>						<del>2,610.00</del>

Item	Qty	Amount
HOURS	29.00	2,610.00

**Total \$540.00**

**Please Pay This Amount:** ~~2,610.00~~

**THANK YOU FOR YOUR BUSINESS**

Net 30 Days. Unpaid balance is subject to 1 1/2% service charge per month and any and all cost of collections.

**NON-NEGOTIABLE BILL-OF-LADING AND TRANSPORTATION AGREEMENT**

BILL NO.

PRINCIPAL CARRIER **D3 M Courville Trucking**

DATE **2-28-20**

**A- 3771640**

Item 11.

ADDRESS  
CITY/STATE/ZIP

PH.

JOB #  
BROKER #  
TRUCK # **C70**  
TRAILER #  
CA# **28653**

UNDERLYING CARRIER (IF ANY)  
ADDRESS

PH.

SHIPPER **T.E. ROBERTS**

RECEIVER

**DUMP**

ADDRESS  
CITY/STATE/ZIP

ADDRESS  
CITY/STATE/ZIP

POINT OF ORIGIN **REDLANDS**

POINT OF DESTINATION **BEAUMONT**

EQUIPMENT TYPE  
 10 WHEELER  
 SUPER-10  
 STRONG ARM  
 SUPER TAG  
 END DUMP  
 SIDE DUMP  
 TRUCK & PUP  
 WATER TRUCK  
 TRANSFER  
 DBL BOTTOMS  
 SEMI-BOTTOM  
 FLAT BED  
 MIXER  
 SWEEPER  
 OTHER  
 HOURLY  
 TONNAGE  
 PER LOAD  
 RATE @ \$ **90.00**

TAG NO.	WEIGHT	COMMODITY	LOADING		UNLOADING		STANDBY TIME	BREAKDOWN OR REASON FOR DELAY
			ARRIVE	DEPART	ARRIVE	DEPART		
1			700					
2								
3								
4			1111					
5								
6								
7								
8								
9								
10								
11								
12								
13								
14								
15								

REPORTING TIME <b>700</b>	ENDING TIME <b>100</b>	TOTAL TIME <b>6hr</b>	DEDUCTIBLE TIME —	NET TIME	TOTAL TONS	ACCESSORIAL OTHER <b>540.00</b>
START DRIVING TIME LAST TRIP	ARRIVAL TIME AT DUMP LAST TRIP	END LOADING LAST TRIP	RUNNING TIME LAST TRIP			TOTAL CHARGES

**SUBJECT TO TERMS AND CONDITIONS ON REVERSE SIDE**

*[Signature]*  
DRIVER SIGNATURE

*[Signature]*  
SHIPPER/RECEIVER (AGENT OR DEBITOR) SIGNATURE

ORIGINAL

**D M COURVILLE TRUCKING, INC.**

313 CODY ROAD  
SAN DIMAS CA 91773  
Office: 909 455-8322 Fax: 909 599-1939  
Lic#: CA28653

INVOICE: 2796

Date: 02/29/20

Item 11.

✓ #5943  
GH

Customer No: 1159

T. E. ROBERTS  
306 W. KATELLA AVENUE UNIT B  
ORANGE CA 92867

**RECEIVED**  
MAR 05 2020  
BY: \_\_\_\_\_

Date	Ft Bill	Truck	Description	Qty	Rate	Amount
<del>02/24/20</del>	<del>3771631</del>	<del>1304</del>	<del>REDLANDS</del>	<del>8.00</del>	<del>90.00</del>	<del>720.00</del>
<del>02/25/20</del>	<del>3771632</del>	<del>1304</del>	<del>REDLANDS</del>	<del>8.00</del>	<del>90.00</del>	<del>720.00</del>
<del>02/26/20</del>	<del>3771633</del>	<del>1304</del>	<del>REDLANDS</del>	<del>7.00</del>	<del>90.00</del>	<del>630.00</del>
<del>02/27/20</del>	<del>3771634</del>	<del>1304</del>	<del>REDLANDS</del>	<del>8.40</del>	<del>90.00</del>	<del>756.00</del>
02/28/20	3771635	1304	REDLANDS	6.00	90.00	540.00

Amount: ~~3,366.00~~

Item	Qty	Amount
HOURS	37.40	3,366.00

**Total \$540.00**

Please Pay This Amount: **3,366.00**

**THANK YOU FOR YOUR BUSINESS**

Net 30 Days. Unpaid balance is subject to 1 1/2% service charge per month and any and all cost of collections.

**NON-NEGOTIABLE BILL-OF-LADING AND TRANSPORTATION AGREEMENT**

DATE 2-28

**A- 3771635**

Item 11.

PRINCIPAL CARRIER DM Clark  
 ADDRESS \_\_\_\_\_  
 CITY/STATE/ZIP \_\_\_\_\_

JOB # \_\_\_\_\_  
 BROKER # \_\_\_\_\_  
 TRUCK # CC  
 TRAILER # \_\_\_\_\_  
 CA # \_\_\_\_\_

UNDERLYING CARRIER (IF ANY) \_\_\_\_\_  
 ADDRESS \_\_\_\_\_

SHIPPER F E Roberts  
 ADDRESS \_\_\_\_\_  
 CITY/STATE/ZIP \_\_\_\_\_  
 POINT OF ORIGIN Redlands

RECEIVER \_\_\_\_\_  
 ADDRESS \_\_\_\_\_  
 CITY/STATE/ZIP \_\_\_\_\_  
 POINT OF DESTINATION ONE VALLEY PLAZA

EQUIPMENT TYPE  
 10-WHEELER  
 SUPER-10  
 STRONG ARM  
 SUPER TAG  
 TRANSFER  
 DBL BOTTOMS  
 SEMI-BOTTOM  
 END DUMP  
 SIDE DUMP  
 TRUCK & PUP  
 WATER TRUCK  
 FLAT BED  
 MIXER  
 SWEEPER  
 OTHER \_\_\_\_\_  
 HOURLY  TONNAGE  PER LOAD  
 RATE @ \$ 95

TAG NO.	WEIGHT	COMMODITY	LOADING ARRIVE	LOADING DEPART	UNLOADING ARRIVE	UNLOADING DEPART	STANDBY TIME	BREAKDOWN OR REASON FOR DELAY
1								
2								
3								
4								
5								
6								
7								
8								
9								
10								
11								
12								
13								
14								
15								

REPORTING TIME 7:00 ENDING TIME 1:30 TOTAL TIME 6:30 DEDUCTIBLE TIME 0:00 NET TIME 6 TOTAL TONS \_\_\_\_\_ ACCESSORIAL OTHER \_\_\_\_\_  
 START DRIVING TIME LAST TRIP ARRIVAL TIME AT DUMP LAST TRIP END LOADING LAST TRIP RUNNING TIME LAST TRIP

**SUBJECT TO TERMS AND CONDITIONS ON REVERSE SIDE**

**TOTAL CHARGES**

M. Clark SHIPPER SIGNATURE [Signature] SHIPPER/RECEIVER (AGENT OR DEBITOR) SIGNATURE  
 ORIGINAL

**D M COURVILLE TRUCKING, INC.**

313 CODY ROAD  
SAN DIMAS CA 91773  
Office: 909 455-8322 Fax: 909 599-1939  
Lic#: CA28653

INVOICE: 2803

Date: 03/03/2020

Item 11.

#159422  
✓ GH

Customer No: 1159

**RECEIVED**  
MAR 05 2020  
BY: \_\_\_\_\_

T. E. ROBERTS  
306 W. KATELLA AVENUE UNIT B  
ORANGE CA 92867

Date	Ft Bill	Truck	Description	Qty	Rate	Amount
<del>02/25/20</del>	<del>5813521</del>	<del>1298</del>	<del>REDLANDS</del>	<del>8.00</del>	<del>90.00</del>	<del>720.00</del>
<del>02/26/20</del>	<del>5731932</del>	<del>1137</del>	<del>REDLANDS</del>	<del>7.00</del>	<del>90.00</del>	<del>630.00</del>
<del>02/26/20</del>	<del>5813522</del>	<del>1298</del>	<del>REDLANDS</del>	<del>7.00</del>	<del>90.00</del>	<del>630.00</del>
02/28/20	5731934	1137	REDLANDS	6.00	90.00	540.00
<b>Amount:</b>						<del>2,520.00</del>

Item	Qty	Amount
HOURS	28.00	2,520.00

**Total \$540.00**

**Please Pay This Amount: 2,520.00**

**THANK YOU FOR YOUR BUSINESS**

Net 30 Days. Unpaid balance is subject to 1 1/2% service charge per month and any and all cost of collections.

**NON-NEGOTIABLE BILL-OF-LADING AND TRANSPORTATION AGREEMENT**

BILL NO.

DATE **2-28-2020**

**A- 5731934**

Item 11.

PRINCIPAL CARRIER **DM Courville**  
 ADDRESS \_\_\_\_\_  
 CITY/STATE/ZIP \_\_\_\_\_

JOB # \_\_\_\_\_  
 BROKER # \_\_\_\_\_  
 TRUCK # **K-10**  
 TRAILER # \_\_\_\_\_  
 CA# **403298**

UNDERLYING CARRIER (IF ANY) **KLK Trucking**  
 ADDRESS \_\_\_\_\_

RECEIVER  
 ADDRESS \_\_\_\_\_  
 CITY/STATE/ZIP \_\_\_\_\_  
 POINT OF DESTINATION **Oak Valley Rd. Beaumont**

SHIPPER **T. E. Roberts**  
 ADDRESS \_\_\_\_\_  
 CITY/STATE/ZIP \_\_\_\_\_

POINT OF ORIGIN **Redlands Blvd, Redlands, CA**  
 EQUIPMENT TYPE  
 10-WHEELER  
 SUPER-10  
 STRONG ARM  
 SUPER TAG  
 TRANSFER  
 DBL BOTTOMS  
 SEMI-BOTTOM  
 END DUMP  
 SIDE DUMP  
 TRUCK & PUP  
 WATER TRUCK  
 FLAT BED  
 MIXER  
 SWEEPER  
 OTHER

HOURLY  TONNAGE  PER LOAD  
 RATE @ **\$ 90.<sup>00</sup>**

TAG NO.	WEIGHT	COMMODITY	LOADING ARRIVE	LOADING DEPART	UNLOADING ARRIVE	UNLOADING DEPART	STANDBY TIME	BREAKDOWN OR REASON FOR DELAY
1		Dirt	7:00am					
2		"						
3		"						
4		"						
5								
6								
7								
8								
9								
10								
11								
12								
13								
14								
15								

**MUST RETURN IN WITHIN 3 DAYS TO ENSURE PAYMENT**

**4 loads**  
**6 hours**

REPORTING TIME **7:00AM**  
 ENDING TIME **1:00pm**  
 TOTAL TIME **60**  
 DEDUCTIBLE TIME \_\_\_\_\_  
 NET TIME **60**  
 TOTAL TONS \_\_\_\_\_  
 ACCESSORIAL OTHER \_\_\_\_\_

**SUBJECT TO TERMS AND CONDITIONS ON REVERSE SIDE**

TOTAL CHARGES **540<sup>00</sup>**

*Kevin [Signature]*  
 SHIPPER/RECEIVER (AGENT OR DEBITOR) SIGNATURE

*[Signature]*  
 SHIPPER/RECEIVER (AGENT OR DEBITOR) SIGNATURE

**ORIGINAL**

**D M COURVILLE TRUCKING, INC.**

313 CODY ROAD  
SAN DIMAS CA 91773  
Office: 909 455-8322 Fax: 909 599-1939  
Lic#: CA28653

INVOICE: 2808

Date: 02/29/2020

Item 11.

#5947  
✓ G-H

Customer No: 1159

**RECEIVED**  
MAR 05 2020  
BY: \_\_\_\_\_

T. E. ROBERTS  
306 W. KATELLA AVENUE UNIT B  
ORANGE CA 92867

Date	Ft Bill	Truck	Description	Qty	Rate	Amount
<del>02/25/20</del>	<del>2667453</del>	<del>1382</del>	<del>REDLANDS</del>	<del>8.00</del>	<del>90.00</del>	<del>720.00</del>
02/28/20	2667456	1382	REDLANDS	6.00	90.00	540.00

Amount: ~~1,260.00~~

**Total \$540.00**

Item	Qty	Amount
HOURS	14.00	1,260.00

**Please Pay This Amount: 1,260.00**

**THANK YOU FOR YOUR BUSINESS**

Net 30 Days. Unpaid balance is subject to 1 1/2% service charge per month and any and all cost of collections.



**NON-NEGOTIABLE BILL-OF-LADING  
AND TRANSPORTATION AGREEMENT**

BILL NO.

DATE 2-28-20 **A-2667456**

PRINCIPAL CARRIER

DAN COURVILLE TRK

JOB #

BROKER #

TRUCK #

CT 2

TRAILER #

CA #

529464

ADDRESS

PH.

CITY/STATE/ZIP

UNDERLYING CARRIER (IF ANY)

COZANO TRK CA

ADDRESS

9485 MADRONA FONTANA PH. 92335

SHIPPER

T.E ROBERTS CONST RECEIVER

ADDRESS

ADDRESS

CITY/STATE/ZIP

Redlands BIV Y MT. VIEW

POINT OF ORIGIN

Redlands

POINT OF DESTINATION

EQUIPMENT TYPE

- 10-WHEELER
- SUPER-10
- STRONG ARM

- SUPER TAG
- TRANSFER
- DBL BOTTOMS
- SEMI-BOTTOM
- END DUMP
- SIDE DUMP
- TRUCK & PUP
- WATER TRUCK

- FLAT BED
- MIXER
- OTHER

- HOURLY
- TONNAGE
- PER LOAD

RATE @ \$ 90

TAG NO.	WEIGHT	COMMODITY	LOADING		UNLOADING		STANDBY TIME	BREAKDOWN OR REASON FOR DELAY
			ARRIVE	DEPART	ARRIVE	DEPART		
1	<u>1111</u>	<u>DIRT</u>						
2								
3								
4								
5								
6								
7								
8								
9								
10								
11								
12								
13								
14								
15								

MUST BE TURNED IN WITHIN  
3 DAYS TO ENSURE PAYMENT  
THANK YOU

6 HR

REPORTING TIME 7.00 ENDING TIME 1.00 TOTAL TIME 6 HR DEDUCTIBLE TIME NET TIME TOTAL TONS ACCESSORIAL OTHER

START DRIVING TIME LAST TRIP ARRIVAL TIME AT DUMP LAST TRIP END LOADING LAST TRIP RUNNING TIME LAST TRIP **SUBJECT TO TERMS AND CONDITIONS ON REVERSE SIDE** TOTAL CHARGES

Richard Fogo  
DRIVER SIGNATURE

[Signature]  
SHIPPER/RECEIVER (AGENT OR DEBITOR) SIGNATURE

ORIGINAL

Item 11.



Serving Southern California

Orange County / San Diego  
 Riverside / San Bernardino  
 Los Angeles / Ventura

1-888-4-UNITED



Invoice

Item 11.

INVOICE DATE	INVOICE NUMBER
02/28/2020	S100085297.001
DUE DATE	PAGE NUMBER
03/29/2020	1 of 1

BILL TO:

T.E. ROBERTS INC.  
 306 W KATELLA AVE  
 UNIT B  
 ORANGE, CA 92867

SHIP TO:

5830 CITY OF BEAUMONT  
 550 E 6TH STREET  
 BEAUMONT, CA 92223

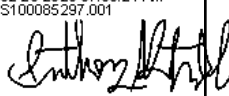
PO NUMBER		JOB NAME		SALESPERSON		
				Steve Hagman		
WRITER		SHIP VIA		TERMS	SHIP DATE	ORDER DATE
Jerry Canada		OT OUR TRUCK		NET 30 DAYS PRELIM	02/28/2020	02/24/2020
ORDER QTY	SHIP QTY	ITEM NUMBER	DESCRIPTION		UNIT PRICE	EXT PRICE
10ea	10ea	GBG	<b>ROBERT HARTWELL 760-995-7955</b> GABION BASKET GALV 12' X 3' X 3' *** Special Order Item ***		200.000/ea	2000.00
1ea	1ea	S48X24PS	<b>P000035758</b> 48" X 24" MANHOLE SHAFT W/ PLASTIC STEPS *** Special Order Item ***		285.714/ea	285.71
		02-28-2020 07:35:21 AM S100085297.001  Anthony				

**Past Due invoices may be subject to 1.50% late charge.**  
 Remit To: UNITED WATER WORKS, INC, PO BOX 150122 , OGDEN, UT 84415

Subtotal	2285.71
S&H Charges	0.00
Tax	177.14
Payments	0.00
Amount Due	2462.85

450



306 W. Katella Ave., Unit B  
Orange, CA 92867

**DATE:** 3/2/2020

**LOCATION:** Oak Valley Parkway

**DETAILS:**

**Force Main Stabilization (Monday)** - Arrived on site and set up traffic control. Started to dig for Gabion walls. Raise manhole 24-inch tie and set 6-12-foot walls. Raised manhole. Cleaned up and secured site. Took down traffic control.

<b>Job#</b>	<b>Beaumont</b>
5943	
<b>Name: Jeff</b>	

TYPE	RATE/HR	QTY	REG AMT	OT RATE	QTY	OT AMT	DT RATE	DT HRS	DT AMT	TOTAL
<b>LABOR</b>										
OE FOREMAN	9.50	8.00	978.96	183.56	1.50	275.33	244.74	-	-	1,254.29
PIPELAYER/Asphalt wkr	9.50	8.00	743.12	139.34	1.50	209.00	185.78	-	-	952.12
LABORER	9.00	8.00	705.12	132.21	1.00	132.21	176.28	-	-	837.33
EQPT OPERATOR	9.50	8.00	939.76	176.21	1.50	264.31	234.94	-	-	1,204.07
	<b>37.50</b>	<b>32.00</b>			<b>5.50</b>					
<b>LABOR</b>										<b>\$4,247.81</b>
<b>LABOR TOTAL</b>										<b>\$4,247.81</b>
<b>EQUIPMENT</b>										
SERVICE TRUCK ( )	46.18	9.50	438.71							438.71
FLATBED TRUCK F550	55.10	9.50	523.45							523.45
EXCAVATOR	119.93	9.50	1,139.34							1,139.34
WHEEL LOADER 544K	124.15	8.00	993.20							993.20
WATER TRUCK	55.10	4.00	220.40							220.40
DELINEATORS/ SIGNS (2)	0.30	19.00	5.70							5.70
<b>EQPT TOTAL</b>										<b>\$3,320.80</b>

SUBCONTRACTOR	Sub Total	Tax	Total	5%	TOTAL
<b>SUBCONTRACTOR TOTAL</b>					<b>\$0.00</b>

MATERIAL	Sub Total	Tax	AMOUNT	15%	TOTAL
John Green Trucking - Inv# 4371 (54 tons 4-inch/6-inch rock)	1,874.76		1,874.76	281.21	2,155.97
<b>MATERIAL TOTAL</b>					<b>\$2,155.97</b>

EQUIPMENT RENT	Sub Total	Tax	AMOUNT	15%	TOTAL
<b>EQ RENT TOTAL</b>					<b>\$0.00</b>

DUMP FEES	Sub Total	Tax	AMOUNT	10%	TOTAL
<b>TOTAL</b>					<b>Item 11.</b>



306 W. Katella Ave., Unit B  
Orange, CA 92867

**DATE:** 3/2/2020

**LOCATION:** Oak Valley Parkway

**DETAILS:**

**Force Main Stabilization (Monday)** - Arrived on site and set up traffic control. Started to dig for Gabion walls. Raise manhole 24-inch tie and set 6-12-foot walls. Raised manhole. Cleaned up and secured site. Took down traffic control.

<b>Job#</b>	<b>Beaumont</b>
5943	
<b>Name: Jeff</b>	

TYPE	RATE/HR	QTY	REG AMT	OT RATE	QTY	OT AMT	DT RATE	DT HRS	DT AMT	TOTAL
<b>DUMP FEE TOTAL</b>										<b>\$0.00</b>

<b>SUB TOTAL</b>	<b>\$9,724.58</b>
1% - Bond	\$97.25
<b>GRAND TOTAL</b>	<b>\$9,821.83</b>



306 W. Kotella Avenue  
Unit B  
Orange, CA 92867

T. 714.669.0072  
F. 714.200.0241

troberts@teroberts.com  
License #603008  
www.teroberts.com

NO: \_\_\_\_\_ Item 11.

# DAILY WORK REPORT/CHANGE ORDER

TO: City of Beaumont

DATE: 3-2-2010

JOB TITLE: Force Main Stabilization

JOB NUMBER: 5943

ATTN: Jeff

CUST. PO#: \_\_\_\_\_

QUANT.	LABOR (CLASSIFY)	TOTAL HRS.	RATE	TOTAL
	Robert Hartwell 3 o/f	9.5		
	Robert Hartwell 4 0	9.5		
	Nick Peterson PL	9.5		
	Anthony Hartwell A	9		
EQUIPMENT				
T-36	Crew truck	9.5		
F-51	Flatbed	9.5		
WL-7	544K Deer	8		
WT-01	water truck	4		
328	Cat Excavator	9.5		
	<del>1 Rest room unit</del>			
MATERIAL AND OTHER ITEMS				
		UNIT PRICE		
54	Tons of 4" x 6" Rock for Gabion Walls (John Green trucking)			
2	Road work signs cones			
1	Restroom on wheels			

COMMENTS: Took 1 lane on Oak Valley Park way start digging  
Gabion Walls Raise MH 24" tie and set 6-12' walls  
Raised MH 24"

TAX
SUB-TOTAL
%OHP
TOTAL

CONTRACT TIME EXT. \_\_\_\_\_ CAL. DAYS

SIGNED \_\_\_\_\_

BY \_\_\_\_\_

T.E. ROBERTS, INC.

BY \_\_\_\_\_

John Green Trucking  
 354 S First Ave  
 Upland, CA 91786

951-377-6396

JohnGreenTrucking@gmail.com

Inv **Item 11.**

Date
03/06/20

Invoice No.
4371

Bill To
TE ROBERTS, INC 306 W KATELLA AVE #B ORANGE, CA 92867

Ship To
LIVE OAK BEAUMONT JOB#5943

P.O. Number

Terms
Net 30

Due Date
04/11/20

Quantity	Item	Description	Rate	Amount
54.09	RIP RAP	MATERIAL & DELIVERY 3/2 - A3246742	34.66	1,874.76
<del>74.59</del>	<del>RIP RAP</del>	<del>MATERIAL &amp; DELIVERY 3/3 - A5873643</del>	<del>34.66</del>	<del>2,585.29</del>
		<b>Total \$1,874.76</b>		
			Subtotal	<del>\$4,460.05</del>

Total	<del>\$4,460.05</del>
-------	-----------------------

**NON-NEGOTIABLE BILL-OF-LADING AND TRANSPORTATION AGREEMENT**

PRINCIPAL CARRIER JOHN O'ROAN TRUCKING

DATE 3-2-20

**A-3240142**

Item 11.

ADDRESS \_\_\_\_\_  
CITY/STATE/ZIP \_\_\_\_\_ PH. \_\_\_\_\_

JOB # \_\_\_\_\_  
BROKER # \_\_\_\_\_  
TRUCK # \_\_\_\_\_  
TRAILER # \_\_\_\_\_  
CA# \_\_\_\_\_

UNDERLYING CARRIER (IF ANY) CP TRACTOR SERVICE  
ADDRESS \_\_\_\_\_ PH. \_\_\_\_\_

SHIPPER FEST  
ADDRESS FEST  
CITY/STATE/ZIP \_\_\_\_\_  
POINT OF ORIGIN CORON A.

RECEIVER T.E. Roberts  
ADDRESS BOB  
CITY/STATE/ZIP WINDOAK  
POINT OF DESTINATION \_\_\_\_\_

- EQUIPMENT TYPE
- 10-WHEELER
  - SUPER-10
  - STRONG ARM
  - SUPER TAG
  - TRANSFER
  - DBL BOTTOMS
  - SEMI-BOTTOM
  - END DUMP
  - SIDE DUMP
  - TRUCK & PUP
  - WATER TRUCK
  - FLAT BED
  - MIXER
  - OTHER

HOURLY  TONNAGE  PER LOAD  
RATE @ \$34.60

	TAG NO.	WEIGHT	COMMODITY	LOADING		UNLOADING		STANDBY TIME	BREAKDOWN OR REASON FOR DELAY
				ARRIVE	DEPART	ARRIVE	DEPART		
1	61597	18.35	3-6 inch						
2	645461	17.23	3-6 inch						
3	645462	16.01	3-6 inch						
4									
5									
6									
7									
8									
9									
10									
11									
12									
13									
14									
15									

MUST BE TURNED IN WITHIN 3 DAYS TO ENSURE PAYMENT  
THANK YOU

REPORTING TIME	ENDING TIME	TOTAL TIME	DEDUCTIBLE TIME	NET TIME	TOTAL TONS <u>54.09</u>	ACCESSORIAL OTHER
START DRIVING TIME LAST TRIP	ARRIVAL TIME AT DUMP LAST TRIP	END LOADING LAST TRIP	RUNNING TIME LAST TRIP	<b>SUBJECT TO TERMS AND CONDITIONS ON REVERSE SIDE</b>		TOTAL CHARGES <u>1874.76</u>

DRIVER SIGNATURE \_\_\_\_\_ SHIPPER/RECEIVER (AGENT OR DEBITOR) SIGNATURE \_\_\_\_\_ ORIGINAL



306 W. Katella Ave., Unit B  
Orange, CA 92867

Job#	Beaumont
5943	
Name: Jeff	

DATE: 3/3/2020

LOCATION: Oak Valley Parkway

DETAILS: **Force Main Stabilization** (Tuesday) Arrived on site and set up traffic control. Dug and set Gabions. Compact and graded slopes. Cleaned up and secured site. Took down traffic control.

TYPE	RATE/HR	QTY	REG AMT	OT RATE	QTY	OT AMT	DT RATE	DT HRS	DT AMT	TOTAL
<b>LABOR</b>										
OE FOREMAN	9.50	8.00	978.96	183.56	1.50	275.33	244.74	-	-	1,254.29
PIPELAYER/Asphalt wkr	9.00	8.00	743.12	139.34	1.00	139.34	185.78	-	-	882.46
LABORER	9.00	8.00	705.12	132.21	1.00	132.21	176.28	-	-	837.33
EQPT OPERATOR	9.50	8.00	939.76	176.21	1.50	264.31	234.94	-	-	1,204.07
	<b>37.00</b>	<b>32.00</b>			<b>5.00</b>					
										<b>LABOR TOTAL \$4,178.15</b>
										<b>LABOR TOTAL \$4,178.15</b>
<b>EQUIPMENT</b>										
SERVICE TRUCK		9.50	438.71							438.71
FLATBED TRUCK F550		9.50	523.45							523.45
EXCAVATOR		9.50	1,139.34							1,139.34
WHEEL LOADER 544K		9.50	1,179.43							1,179.43
WATER TRUCK		4.00	220.40							220.40
DELINEATORS/ SIGNS (2)		19.00	5.70							5.70
TRAFFIC CONES (30)		285.00	85.50							85.50
										<b>EOPT TOTAL \$3,592.52</b>

SUBCONTRACTOR	Sub Total	Tax	Total	5%	TOTAL
					<b>\$0.00</b>

MATERIAL	Sub Total	Tax	AMOUNT	15%	TOTAL
John Green Trucking - Inv# 4371 (73.54 tons 4-inch/6-inch rock)	2,585.29	-	2,585.29	387.79	2,973.08
			<b>MATERIAL TOTAL</b>		<b>\$2,973.08</b>

EQUIPMENT RENT	Sub Total	Tax	AMOUNT	15%	TOTAL
					<b>\$0.00</b>
			<b>EQ RENT TOTAL</b>		<b>\$0.00</b>

DUMP FEES	Sub Total	Tax	AMOUNT	10%	TOTAL

Item 11.





306 W. Katella Ave., Unit B  
Orange, CA 92867

Job#	Beaumont
5943	
Name: Jeff	

**DATE:** 3/3/2020

**LOCATION:** Oak Valley Parkway

**DETAILS:** **Force Main Stabilization** (Tuesday) Arrived on site and set up traffic control. Dug and set Gabions. Compact and graded slopes. Cleaned up and secured site. Took down traffic control.

TYPE	RATE/HR	QTY	REG AMT	OT RATE	QTY	OT AMT	DT RATE	DT HRS	DT AMT	TOTAL
DUMP FEE TOTAL										\$0.00

SUB TOTAL	\$10,743.75
1% - Bond	\$107.44
<b>GRAND TOTAL</b>	<b>\$10,851.19</b>

Item 11.



306 W. Katella Avenue  
Unit B  
Orange, CA 92867

T: 714.669.0072  
F: 714.200.0241

troberts@teroberts.com  
License #603008  
www.teroberts.com

NO: Item 11.

# DAILY WORK REPORT/CHANGE ORDER

DATE: 3-3-2020  
 JOB TITLE: Force Main Stabilization  
 JOB NUMBER: 5943  
 CUST. PO#: \_\_\_\_\_

TO: City of Beaumont  
 \_\_\_\_\_  
 ATTN: Jeff

QUANT.	LABOR (CLASSIFY)	TOTAL HRS.	RATE	TOTAL
	Robert Hartwell III o/f	9.5		
	Robert Hartwell IV o	9.5		
	Nick Peterson pl	9		
	Anthony Hartwell A	9		
EQUIPMENT				
F-36	crew truck	9.5		
T-51	Flat bed	9.5		
WL-7	544K Deere	9.5		
328	cat Excavator	9.5		
WT-01	water truck	4		
MATERIAL AND OTHER ITEMS				
73.54	TONS OF 4'x6" ROCK (John Green trucking)		UNIT PRICE	
1	Rest room united			
2	Road Work Signs			
30	cones			

COMMENTS: Dis and set Gabions compact and grade slopes

TAX
SUB-TOTAL
%OHP
TOTAL

CONTRACT TIME EXT. \_\_\_\_\_ CAL. DAYS  
 SIGNED \_\_\_\_\_  
 BY \_\_\_\_\_

T.E. ROBERTS, INC.  
 BY \_\_\_\_\_

John Green Trucking  
 354 S First Ave  
 Upland, CA 91786

951-377-6396

JohnGreenTrucking@gmail.com

Inv Item 11.

Date
03/06/20

Invoice No.
4371

Bill To
TE ROBERTS, INC 306 W KATELLA AVE #B ORANGE, CA 92867

Ship To
LIVE OAK BEAUMONT JOB#5943

P.O. Number

Terms
Net 30

Due Date
04/11/20

Quantity	Item	Description	Rate	Amount
<del>54.09</del>	<del>RIP RAP</del>	<del>MATERIAL &amp; DELIVERY 3/2 - A3246742</del>	<del>34.66</del>	<del>1,874.76</del>
74.59	RIP RAP	MATERIAL & DELIVERY 3/3 - A5873643	34.66	2,585.29
		<b>Total \$2,585.29</b>		
			Subtotal	<del>\$4,460.05</del>

Total	<del>\$4,460.05</del>
-------	-----------------------

**NON-NEGOTIABLE BILL-OF-LADING AND TRANSPORTATION AGREEMENT**

BILL NO.

PRINCIPAL CARRIER JGT

DATE 3/3/20

**A-5873643**

Item 11.

ADDRESS \_\_\_\_\_  
CITY/STATE/ZIP \_\_\_\_\_ PH. \_\_\_\_\_

JOB # \_\_\_\_\_  
BROKER # \_\_\_\_\_  
TRUCK # \_\_\_\_\_  
TRAILER # \_\_\_\_\_  
CA # \_\_\_\_\_

UNDERLYING CARRIER (IF ANY) BNI  
ADDRESS \_\_\_\_\_ PH. \_\_\_\_\_

SHIPPER \_\_\_\_\_  
ADDRESS \_\_\_\_\_  
CITY/STATE/ZIP \_\_\_\_\_  
POINT OF ORIGIN \_\_\_\_\_

RECEIVER TE Roberts  
ADDRESS \_\_\_\_\_  
CITY/STATE/ZIP Beaumont  
POINT OF DESTINATION \_\_\_\_\_

EQUIPMENT TYPE  
 10-WHEELER  
 SUPER-10  
 STRONG ARM  
 SUPER TAG  
 TRANSFER  
 DBL BOTTOMS  
 SEMI-BOTTOM  
 END DUMP  
 SIDE DUMP  
 TRUCK & PUP  
 WATER TRUCK  
 FLAT BED  
 MIXER  
 SWEEPER  
 OTHER \_\_\_\_\_

HOURLY  TONNAGE  PER LOAD  
 RATE @ \$ 34.66

	TAG NO.	WEIGHT	COMMODITY	LOADING		UNLOADING		STANDBY TIME	BREAKDOWN OR REASON FOR DELAY
				ARRIVE	DEPART	ARRIVE	DEPART		
1	61612	24.15	Rip Rap						
2	64623	25.22	I						
3	64615	25.20	I						
4									
5									
6									
7									
8									
9									
10									
11									
12									
13									
14									
15									

REPORTING TIME	ENDING TIME	TOTAL TIME	DEDUCTIBLE TIME	NET TIME	TOTAL TONS <u>74.59</u>	ACCESSORIAL OTHER
START DRIVING TIME LAST TRIP	ARRIVAL TIME AT DUMP LAST TRIP	END LOADING LAST TRIP	RUNNING TIME LAST TRIP	<b>SUBJECT TO TERMS AND CONDITIONS ON REVERSE SIDE</b>		TOTAL CHARGES <u>2585.29</u>

DRIVER SIGNATURE \_\_\_\_\_ SHIPPER/RECEIVER (AGENT OR DEBITOR) SIGNATURE \_\_\_\_\_ ORIGINAL



306 W. Katella Ave., Unit B  
Orange, CA 92867

DATE: 3/4/2020

LOCATION: Oak Valley Parkway

DETAILS:

**Force Main Stabilization (Wednesday)** - Arrived on site and set up traffic control, closed (1) lane. Compacted and graded slopes, 600-foot graded. Cleaned curb and gutter. Compacted behind gabions. Cleaned up and secured site. Took down traffic control.

Job#	Beaumont
5943	
Name: Jeff	

TYPE	RATE/HR	QTY	REG AMT	OT RATE	QTY	OT AMT	DT RATE	DT HRS	DT AMT	TOTAL
<b>LABOR</b>										
OE FOREMAN	7.50	7.50	917.78	183.56	-	-	244.74	-	-	917.78
PIPELAYER/Asphalt wkr	8.00	8.00	743.12	139.34	-	-	185.78	-	-	743.12
LABORER	7.50	7.50	661.05	132.21	-	-	176.28	-	-	661.05
EQPT OPERATOR	8.00	8.00	939.76	176.21	-	-	234.94	-	-	939.76
	31.00	31.00								

										LABOR	\$3,261.71
										LABOR TOTAL	\$3,261.71

**EQUIPMENT**

SERVICE TRUCK	T51	46.18	8.00	369.44						369.44
FLATBED TRUCK F550	T36	55.10	9.50	523.45						523.45
EXCAVATOR	328	119.93	9.50	1,139.34						1,139.34
WHEEL LOADER 544K	WL7	124.15	8.00	993.20						993.20
WATER TRUCK	WT1	55.10	8.00	440.80						440.80
DELINEATORS/ SIGNS (2)		0.30	19.00	5.70						5.70
TRAFFIC CONES (30)		0.30	285.00	85.50						85.50

										EQPT TOTAL	\$3,557.43
--	--	--	--	--	--	--	--	--	--	------------	------------

**SUBCONTRACTOR**

Sub Total	Tax	Total	5%	TOTAL
		SUBCONTRACTOR TOTAL		\$0.00

**MATERIAL**

Sub Total	Tax	AMOUNT	15%	TOTAL
		MATERIAL TOTAL		\$0.00

**EQUIPMENT RENT**

Sub Total	Tax	AMOUNT	15%	TOTAL
		EQ RENT TOTAL		\$0.00

Item 11.



306 W. Katella Ave., Unit B  
Orange, CA 92867

**DATE:** 3/4/2020

**LOCATION:** Oak Valley Parkway

**DETAILS:**

**Force Main Stabilization (Wednesday)** - Arrived on site and set up traffic control, closed (1) lane. Compacted and graded slopes, 600-foot graded. Cleaned curb and gutter. Compacted behind gabions. Cleaned up and secured site. Took down traffic control.

<b>Job#</b>	<b>Beaumont</b>
5943	
<b>Name: Jeff</b>	

TYPE	RATE/HR	QTY	REG AMT	OT RATE	QTY	OT AMT	DT RATE	DT HRS	DT AMT	TOTAL
DUMP FEES										\$0.00
<b>SUB TOTAL</b>										<b>\$6,819.13</b>
1% - Bond										\$68.19
<b>GRAND TOTAL</b>										<b>\$6,887.32</b>

Item 11.





306 W. Katella Ave., Unit B  
Orange, CA 92867

Job#	Beaumont
5943	
Name: Jeff	

DATE: 3/5/2020

LOCATION: Oak Valley Parkway

DETAILS: **Force Main Stabilization (Thursday)** - Arrived on site and set up traffic control, closed (1) lane. Graded and compacted slopes. Wacked and compacted behind Gabions. Dug out last Gabion. Geo Labs came out and tested the Gabions and slopes.

TYPE	RATE/HR	QTY	REG AMT	OT RATE	QTY	OT AMT	DT RATE	DT HRS	DT AMT	TOTAL
<b>LABOR</b>										
OE FOREMAN	8.00	8.00	978.96	183.56	-	-	244.74	-	-	978.96
PIPELAYER/Asphalt wkr	8.50	8.00	743.12	139.34	0.50	69.67	185.78	-	-	812.79
LABORER	8.00	8.00	705.12	132.21	-	-	176.28	-	-	705.12
EQPT OPERATOR	8.50	8.00	939.76	176.21	0.50	88.10	234.94	-	-	1,027.86
	<b>33.00</b>	<b>32.00</b>			<b>1.00</b>					
										<b>LABOR</b>
										<b>LABOR TOTAL</b>
										<b>\$3,524.73</b>
										<b>\$3,524.73</b>
<b>EQUIPMENT</b>										
SERVICE TRUCK	T51	46.18	8.00	369.44						369.44
FLATBED TRUCK F550	T36	55.10	8.00	440.80						440.80
EXCAVATOR	328	119.93	8.00	959.44						959.44
WHEEL LOADER 544K	WL7	124.15	8.00	993.20						993.20
WATER TRUCK	WT1	55.10	8.00	440.80						440.80
DELINEATORS/ SIGNS (2)		0.30	16.00	4.80						4.80
TRAFFIC CONES (30)		0.30	240.00	72.00						72.00
										<b>EQPT TOTAL</b>
										<b>\$3,280.48</b>

SUBCONTRACTOR	Sub Total	Tax	Total	5%	TOTAL
Geo Labs - Inv# 30152464 (Field Density Test)	1,339.50		1,339.50	66.98	1,406.48
			<b>SUBCONTRACTOR TOTAL</b>		<b>\$1,406.48</b>

MATERIAL	Sub Total	Tax	AMOUNT	15%	TOTAL
			<b>MATERIAL TOTAL</b>		<b>\$0.00</b>

EQUIPMENT RENT	Sub Total	Tax	AMOUNT	15%	TOTAL
			<b>EQ RENT TOTAL</b>		<b>\$0.00</b>

Item 11.





306 W. Katella Ave., Unit B  
Orange, CA 92867

**DATE:** 3/5/2020

**LOCATION:** Oak Valley Parkway

**DETAILS:** **Force Main Stabilization (Thursday)** - Arrived on site and set up traffic control, closed (1) lane. Graded and compacted slopes. Wacked and compacted behind Gabions. Dug out last Gabion. Geo Labs came out and tested the Gabions and slopes.

<b>Job#</b>	<b>Beaumont</b>
5943	
<b>Name: Jeff</b>	

TYPE	RATE/HR	QTY	REG AMT	OT RATE	QTY	OT AMT	DT RATE	DT HRS	DT AMT	TOTAL
<b>DUMP FEES</b>										
				Tax		<u>Sub Total</u>		<u>AMOUNT</u>	10%	<u>TOTAL</u>
								<b>DUMP FEE TOTAL</b>		<b>\$0.00</b>

<b>SUB TOTAL</b>	<b>\$8,211.69</b>
1% - Bond	\$82.12
<b>GRAND TOTAL</b>	<b>\$8,293.80</b>



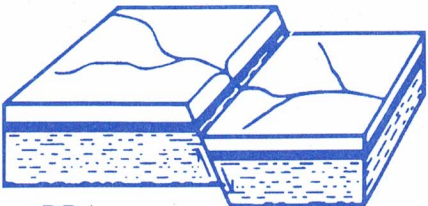

# GEOLABS - WESTLAKE VILLAGE

Foundation and Soils Engineering Geotechnical

Item 11.

31119 Via Colinas, Suite 502 • Westlake Village, CA 91362

VOICE: (818) 889-2562 (805) 495-2197

FAX: (818) 889-2995 (805) 379-2603

#5943



a DBA  
of R&R Services  
Corporation

## INVOICE

SOLD TO  
T.E. Roberts, Inc.  
306 W. Katella Ave. Unit B  
Orange, CA 92867

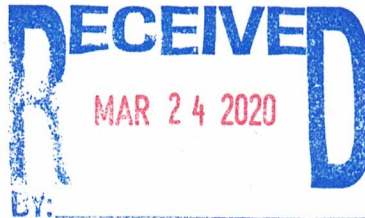

INVOICE NO. 30152464  
W.O. NUMBER 9242.999.015  
PURCHASE ORDER DIR 265381  
DATE OF INVOICE 3/20/2020  
PROJECT Beaumomy

PROGRESSIVE BILLING: thru March 17, 2020

DATE OF WORK	DESCRIPTION	HOURS	UNIT	PER HOUR OR UNIT	AMOUNT
	CITY OF BEAUMONT JOB #5830 DIR 265381 - Oak Valley Parkway ✓				
	Prevailing Wage Field Soils Group 1	8		111.50	892.00
	Max. Density & Optimum Moisture, ASTM D-698	1		169.50	169.50
	Rock Correction	1		113.00	113.00
	March 17, 2020 Report - Field Density	1		165.00	165.00

THANK YOU

TOTAL AMOUNT DUE →

\$1,339.50

PLEASE PAY FROM INVOICE -- THIS IS A PROFESSIONAL SERVICE BILLING AND IS DUE AND PAYABLE ON RECEIPT.  
1½% INTEREST CHARGE APPLIED AFTER 30 DAYS.



306 W. Katella Ave., Unit B  
Orange, CA 92867

Job#	Beaumont
5943	
Name: Jeff	

DATE: 3/6/2020

LOCATION: Oak Valley Parkway

DETAILS: **Force Main Stabilization (Friday)** - Arrived on site and set up traffic control, closed (1) lane. Tie Gabions and set. Filled with 4-inch/9-inch crushed rock (Rip Rap). Compacted behind manhole. Cleaned up sand secured site. Took down traffic control.

TYPE	RATE/HR	QTY	REG AMT	OT RATE	QTY	OT AMT	DT RATE	DT HRS	DT AMT	TOTAL
<b>LABOR</b>										
OE FOREMAN	9.50	8.00	978.96	183.56	1.50	275.33	244.74	-	-	1,254.29
LABORER	9.00	8.00	705.12	132.21	1.00	132.21	176.28	-	-	837.33
EQPT OPERATOR	9.50	8.00	939.76	176.21	1.50	264.31	234.94	-	-	1,204.07
	<b>28.00</b>	<b>24.00</b>			<b>4.00</b>					
<b>LABOR</b>										<b>\$3,295.69</b>
<b>LABOR TOTAL</b>										<b>\$3,295.69</b>
<b>EQUIPMENT</b>										
SERVICE TRUCK		9.50	438.71							438.71
FLATBED TRUCK F550		9.50	523.45							523.45
EXCAVATOR		8.00	959.44							959.44
WHEEL LOADER 544K		8.00	993.20							993.20
DELINEATORS/ SIGNS (2)		19.00	5.70							5.70
TRAFFIC CONES (30)		285.00	85.50							85.50
<b>EQPT TOTAL</b>										<b>\$3,006.00</b>

SUBCONTRACTOR	Sub Total	Tax	Total	5%	TOTAL
					<b>\$0.00</b>

MATERIAL	Sub Total	Tax	AMOUNT	15%	TOTAL
John Green Trucking - Inv# 4381 (49.39 tons 4-inch/6-inch rock) - (2) Loads	1,711.86	-	1,711.86	256.78	1,968.64
			<b>MATERIAL TOTAL</b>		<b>\$1,968.64</b>

EQUIPMENT RENT	Sub Total	Tax	AMOUNT	15%	TOTAL
					<b>\$0.00</b>

DUMP FEES	Sub Total	Tax	AMOUNT	10%	TOTAL
					<b>\$0.00</b>

Item 11.



306 W. Katella Ave., Unit B  
Orange, CA 92867

**DATE:** 3/6/2020

**LOCATION:** Oak Valley Parkway

**DETAILS:** **Force Main Stabilization (Friday)** - Arrived on site and set up traffic control, closed (1) lane. Tie Gabions and set. Filled with 4-inch/9-inch crushed rock (Rip Rap). Compacted behind manhole. Cleaned up sand secured site. Took down traffic control.

<b>Job#</b>	<b>Beaumont</b>
5943	
<b>Name: Jeff</b>	

TYPE	RATE/HR	QTY	REG AMT	OT RATE	QTY	OT AMT	DT RATE	DT HRS	DT AMT	TOTAL																																
<table border="1"> <tr> <td><b>SUB TOTAL</b></td> <td><b>\$8,270.33</b></td> <td colspan="9"></td> </tr> <tr> <td>1% - Bond</td> <td>\$82.70</td> <td colspan="9"></td> </tr> <tr> <td><b>GRAND TOTAL</b></td> <td><b>\$8,353.03</b></td> <td colspan="9"></td> </tr> </table>										<b>SUB TOTAL</b>	<b>\$8,270.33</b>										1% - Bond	\$82.70										<b>GRAND TOTAL</b>	<b>\$8,353.03</b>									
<b>SUB TOTAL</b>	<b>\$8,270.33</b>																																									
1% - Bond	\$82.70																																									
<b>GRAND TOTAL</b>	<b>\$8,353.03</b>																																									

Item 11.



John Green Trucking  
354 S First Ave  
Upland, CA 91786

*CS*

951-377-6396

JohnGreenTrucking@gmail.com

#5943

Inv Item 11.

Date
03/13/20

Invoice No.
4381

Bill To
TE ROBERTS, INC 306 W KATELLA AVE #B ORANGE, CA 92867

Ship To
LIVE OAK BEAUMONT JOB#5943

P.O. Number

Terms
Net 30

Due Date
04/12/20

Quantity	Item	Description	Rate	Amount
49.39	RIP RAP	MATERIAL & DELIVERY 3/3 - A5873644	34.66	1,711.86
			Subtotal	\$1,711.86

*URGENT*  
URGENT MAR 24 2020

Total	\$1,711.86
-------	------------

**NON-NEGOTIABLE BILL-OF-LADING AND TRANSPORTATION AGREEMENT**

BILL NO.

PRINCIPAL CARRIER

BT

DATE

3-3-80

**A-5873644**

Item 11.

ADDRESS

CITY/STATE/ZIP

PH.

JOB #

BROKER #

TRUCK #

TRAILER #

CA #

UNDERLYING CARRIER (IF ANY)

BT

ADDRESS

PH.

SHIPPER

ADDRESS

CITY/STATE/ZIP

POINT OF ORIGIN

RECEIVER

ADDRESS

CITY/STATE/ZIP

POINT OF DESTINATION

TE Roberts  
Live Oak  
Beaumont

EQUIPMENT TYPE

- 10-WHEELER
- SUPER-10
- STRONG ARM

- SUPER TAG
- TRANSFER
- DBL BOTTOMS
- SEMI-BOTTOM

- END DUMP
- SIDE DUMP
- TRUCK & PUP
- WATER TRUCK

- FLAT BED
- MIXER
- SWEEPER
- OTHER

HOURLY  TONNAGE  PER LOAD

RATE @ \$ 34.66

	TAG NO.	WEIGHT	COMMODITY	LOADING		UNLOADING		STANDBY TIME	BREAKDOWN OR REASON FOR DELAY
				ARRIVE	DEPART	ARRIVE	DEPART		
1	<u>5742</u>	<u>2445</u>	<u>Kup Kelp</u>						
2	<u>5167</u>	<u>2494</u>	<u>L</u>						
3									
4									
5									
6									
7									
8									
9									
10									
11									
12									
13									
14									
15									

REPORTING TIME	ENDING TIME	TOTAL TIME	DEDUCTIBLE TIME	NET TIME	TOTAL TONS <u>49.38</u>	ACCESSORIAL OTHER
START DRIVING TIME LAST TRIP	ARRIVAL TIME AT DUMP LAST TRIP	END LOADING LAST TRIP	RUNNING TIME LAST TRIP	<b>SUBJECT TO TERMS AND CONDITIONS ON REVERSE SIDE</b>		TOTAL CHARGES <u>1711.80</u>

ORIGINAL

DRIVER SIGNATURE

SHIPPER/RECEIVER (AGENT OR DEBITOR) SIGNATURE





306 W. Katella Ave., Unit B  
Orange, CA 92867

Job#	Beaumont
5943	
Name: Jeff	

DATE: 3/9/2020

LOCATION: Oak Valley Parkway

DETAILS: **Force Main Stabilization (Monday)** - Arrived on site and set up traffic control, closed (1) lane. Compacted slopes and finished last manhole Gabion. Poured slurry around (4) manholes, 18-yards of slurry. Cleaned up and secured site. Took down traffic control.

TYPE	REG AMT	QTY	RATE/HR	QTY	OT RATE	QTY	OT AMT	DT RATE	DT HRS	DT AMT	TOTAL
<b>LABOR</b>											
OE FOREMAN	8.00	8.00	122.37	8.00	183.56		978.96	244.74	-	-	978.96
PIPELAYER/Asphalt wkr	8.00	8.00	92.89	8.00	139.34		743.12	185.78	-	-	743.12
LABORER	7.50	7.50	88.14	7.50	132.21		661.05	176.28	-	-	661.05
EQPT OPERATOR	8.00	8.00	117.47	8.00	176.21		939.76	234.94	-	-	939.76
	<b>31.50</b>	<b>31.50</b>									
<b>LABOR</b>											<b>\$3,322.89</b>
<b>LABOR TOTAL</b>											<b>\$3,322.89</b>
<b>EQUIPMENT</b>											
SERVICE TRUCK		8.00	46.18	8.00			369.44				369.44
FLATBED TRUCK F550		8.00	55.10	8.00			440.80				440.80
EXCAVATOR		8.00	119.93	8.00			959.44				959.44
WHEEL LOADER 544K		8.00	124.15	8.00			993.20				993.20
WATER TRUCK		8.00	55.10	8.00			440.80				440.80
DELINEATORS/ SIGNS (2)		16.00	0.30	16.00			4.80				4.80
TRAFFIC CONES (30)		240.00	0.30	240.00			72.00				72.00
<b>EQPT TOTAL</b>											<b>\$3,280.48</b>

SUBCONTRACTOR	Sub Total	Tax	Total	5%	TOTAL
<b>SUBCONTRACTOR TOTAL</b>					<b>\$0.00</b>

MATERIAL	Fee	Sub Total	Tax	AMOUNT	15%	TOTAL
Robertson's - Inv# 658355 (18-yards of Slurry)	16.00	2,076.00	160.89	2,252.89	337.93	2,590.82
<b>MATERIAL TOTAL</b>						<b>\$2,590.82</b>

EQUIPMENT RENT	Sub Total	Tax	AMOUNT	15%	TOTAL
<b>EQ RENT TOTAL</b>					<b>\$0.00</b>

DUMP FEES	Sub Total	Tax	AMOUNT	10%	TOTAL
<b>DUMP FEE TOTAL</b>					<b>\$0.00</b>

Item 11.



306 W. Katella Ave., Unit B  
Orange, CA 92867

**DATE:** 3/9/2020

**LOCATION:** Oak Valley Parkway

**DETAILS:** **Force Main Stabilization (Monday)** - Arrived on site and set up traffic control, closed (1) lane. Compacted slopes and finished last manhole Gabion. Poured slurry around (4) manholes, 18-yards of slurry. Cleaned up and secured site. Took down traffic control.

Job#	Beaumont
5943	
Name: Jeff	

TYPE	RATE/HR	QTY	REG AMT	OT RATE	QTY	OT AMT	DT RATE	DT HRS	DT AMT	TOTAL
<b>SUB TOTAL</b>										<b>\$9,194.19</b>
1% - Bond										\$91.94
<b>GRAND TOTAL</b>										<b>\$9,286.14</b>





306 W. Katella Ave., Unit B  
Orange, CA 92867

DATE: 3/11/2020

LOCATION: Oak Valley Parkway

DETAILS:

**Force Main Stabilization (Wednesday)** - Arrived on site. Checked on job and met with Jeff from Beaumont. Backfilled around 1st manhole. Placed Rip rap in flow line to slow water between manhole #1 - #4. Cleaned up site.

Job#	Beaumont
5943	
Name: Jeff	

TYPE	RATE/HR	QTY	REG AMT	OT RATE	QTY	OT AMT	DT RATE	DT HRS	DT AMT	TOTAL			
<b>LABOR</b>													
OE FOREMAN	6.50	6.50	795.41	183.56	-	-	244.74	-	-	795.41			
EQPT OPERATOR	4.50	4.50	528.62	176.21	-	-	234.94	-	-	528.62			
	11.00	11.00											
LABOR TOTAL										\$1,324.02			
LABOR TOTAL										\$1,324.02			
<b>EQUIPMENT</b>													
TRUCK F550		6.50	358.15							358.15			
EXCAVATOR		4.50	539.69							539.69			
WHEEL LOADER 544K		4.50	558.68							558.68			
EQPT TOTAL										\$1,456.51			
<b>SUBCONTRACTOR</b>													
Sub Total										Tax	Total	5%	TOTAL
SUBCONTRACTOR TOTAL													\$0.00
<b>MATERIAL</b>													
Sub Total										Tax	AMOUNT	15%	TOTAL
MATERIAL TOTAL													\$0.00
<b>EQUIPMENT RENT</b>													
Sub Total										Tax	AMOUNT	15%	TOTAL
EQ RENT TOTAL													\$0.00
<b>DUMP FEES</b>													
Sub Total										Tax	AMOUNT	10%	TOTAL
DUMP FEE TOTAL													\$0.00

SUB TOTAL	\$2,780.53
1% - Bond	\$27.81
<b>GRAND TOTAL</b>	<b>\$2,808.34</b>

Item 11.





306 W. Katella Ave., Unit B  
Orange, CA 92867

DATE: 3/23/2020

LOCATION: Oak Valley Parkway

DETAILS:

**Force Main Stabilization (Monday)** - Arrived on site and set up traffic control, closed (1) lane. Walked job slopes, looked good. One location had the force main exposed. Began to rain, to wet to work. Cleaned and secured site. Took down traffic control.

Job#	Beaumont
5943	
Name: Jeff	

TYPE	RATE/HR	QTY	REG AMT	OT RATE	QTY	OT AMT	DT RATE	DT HRS	DT AMT	TOTAL					
<b>LABOR</b>															
OE FOREMAN	4.00	122.37	4.00	489.48	183.56	-	244.74	-	-	489.48					
PIPELAYER/Asphalt wkr (2)	4.00	92.89	4.00	371.56	139.34	-	185.78	-	-	371.56					
	8.00		8.00												
<b>EQUIPMENT</b>															
TRUCK F550		55.10	4.00	220.40						220.40					
DELINEATORS/ SIGNS (2)		0.30	8.00	2.40						2.40					
TRAFFIC CONES (30)		0.30	120.00	36.00						36.00					
										<b>EQPT TOTAL</b>	<b>\$258.80</b>				
<b>SUBCONTRACTOR</b>															
										Sub Total	Tax	Total	5%	TOTAL	
										SUBCONTRACTOR TOTAL					\$0.00
<b>MATERIAL</b>															
										Sub Total	Tax	AMOUNT	15%	TOTAL	
										MATERIAL TOTAL					\$0.00
<b>EQUIPMENT RENT</b>															
										Sub Total	Tax	AMOUNT	15%	TOTAL	
										EQ RENT TOTAL					\$0.00
<b>DUMP FEES</b>															
										Sub Total	Tax	AMOUNT	10%	TOTAL	
										DUMP FEE TOTAL					\$0.00

SUB TOTAL	\$1,119.84
1% - Bond	\$11.20
<b>GRAND TOTAL</b>	<b>\$1,131.04</b>

Item 11.





306 W. Katella Ave., Unit B  
Orange, CA 92867

DATE: 3/24/2020

LOCATION: Oak Valley Parkway

DETAILS:

**Force Main Stabilization (Tuesday)** - Arrived on site and set up traffic control, closed (1) lane. Moved Rip Rap (4-inch/6-inch rock). Imported dirt from Redlands to re-compact slope. Cover and compacted location where force main was exposed. Cleaned up and secured site. Took down traffic control.

Job#	Beaumont
5943	
Name: Jeff	

TYPE	RATE/HR	QTY	REG AMT	OT RATE	QTY	OT AMT	DT RATE	DT HRS	DT AMT	TOTAL
<b>LABOR</b>										
OE FOREMAN	8.50	8.00	978.96	183.56	0.50	91.78	244.74	-	-	1,070.74
EQPT OPERATOR (2)	16.00	16.00	1,879.52	176.21	-	-	234.94	-	-	1,879.52
	24.50	24.00			0.50					
<b>EQUIPMENT</b>										
TRUCK F550	55.10	8.50	468.35							468.35
EXCAVATOR	119.93	8.00	959.44							959.44
WHEEL LOADER 544K (2)	124.15	16.00	1,986.40							1,986.40
WHEEL LOADER 644K	149.28									0.00
DELINEATORS/ SIGNS (2)	0.30	16.00	4.80							4.80
TRAFFIC CONES (30)	0.30	240.00	72.00							72.00
										<b>EQPT TOTAL \$3,490.99</b>

SUBCONTRACTOR	Sub Total	Tax	Total	5%	TOTAL
D M Courville Trucking - Inv#2872, Truck#1304 (8 Hrs [6 loads])	720.00	-	720.00	36.00	756.00
D M Courville Trucking - Inv#2883, Truck#1404 (8 Hrs [6 loads])	720.00	-	720.00	36.00	756.00
Collins Trucking - (2) Trucks (8 Hrs each) @ \$90 Per Hr.	1,440.00		1,440.00	72.00	1,512.00
					<b>SUBCONTRACTOR TOTAL \$3,024.00</b>

MATERIAL	Sub Total	Tax	AMOUNT	15%	TOTAL
<b>EQUIPMENT RENT</b>					
	Sub Total	Tax	AMOUNT	15%	TOTAL
			EQ RENT TOTAL		\$0.00

DUMP FEES	Sub Total	Tax	AMOUNT	10%	TOTAL

Item 11.





306 W. Katella Ave., Unit B  
Orange, CA 92867

**DATE:** 3/24/2020

**LOCATION:** Oak Valley Parkway

**DETAILS:**

**Force Main Stabilization (Tuesday)** - Arrived on site and set up traffic control, closed (1) lane. Moved Rip Rap (4-inch/6-inch rock). Imported dirt from Redlands to re-compact slope. Cover and compacted location where force main was exposed. Cleaned up and secured site. Took down traffic control.

<b>Job#</b>	<b>Beaumont</b>
5943	
<b>Name: Jeff</b>	

TYPE	RATE/HR	QTY	REG AMT	OT RATE	QTY	OT AMT	DT RATE	DT HRS	DT AMT	TOTAL
<b>DUMP FEE TOTAL</b>										<b>\$0.00</b>

<b>SUB TOTAL</b>	<b>\$9,465.25</b>
1% - Bond	\$94.65
<b>GRAND TOTAL</b>	<b>\$9,559.90</b>

Item 11.



**D M COURVILLE TRUCKING, INC.**

313 CODY ROAD  
SAN DIMAS CA 91773  
Office: 909 455-8322 Fax: 909 599-1939  
Lic#: CA28653

INVOICE: 2872

Date: 03/26/2020

Item 11.

#594

Customer No: 1159

T. E. ROBERTS  
306 W. KATELLA AVENUE UNIT B  
ORANGE CA 92867

**RECEIVED**  
MAR 30 2020  
BY: \_\_\_\_\_

Date	Ft Bill	Truck	Description	Qty	Rate	Amount
03/24/20	3771930	1304	REDLANDS	8.00	90.00	720.00
<del>03/25/20</del>	<del>3771931</del>	<del>1459</del>	<del>REDLANDS</del>	<del>8.00</del>	<del>90.00</del>	<del>720.00</del>

Amount: ~~1,440.00~~

**Total \$720.00**

Item	Qty	Amount
HOURS	16.00	1,440.00

**Please Pay This Amount: ~~1,440.00~~**

**THANK YOU FOR YOUR BUSINESS**

Net 30 Days. Unpaid balance is subject to 1 1/2% service charge per month and any and all cost of collections.

NON-NEGOTIABLE BILL-OF-LADING AND TRANSPORTATION AGREEMENT

BILL NO.

PRINCIPAL CARRIER DM Court Vln  
 ADDRESS \_\_\_\_\_  
 CITY/STATE/ZIP \_\_\_\_\_

DATE 3-24-70

**A- 3771930**

Item 11.

UNDERLYING CARRIER (IF ANY) \_\_\_\_\_  
 ADDRESS \_\_\_\_\_  
 PH. \_\_\_\_\_

JOB # \_\_\_\_\_  
 BROKER # \_\_\_\_\_  
 TRUCK # 4-60  
 TRAILER # \_\_\_\_\_  
 CA # \_\_\_\_\_

SHIPPER PK Roberts  
 ADDRESS \_\_\_\_\_  
 CITY/STATE/ZIP \_\_\_\_\_

RECEIVER \_\_\_\_\_  
 ADDRESS \_\_\_\_\_  
 CITY/STATE/ZIP \_\_\_\_\_

POINT OF ORIGIN 26000 Fremont Blvd

POINT OF DESTINATION Berkeley

EQUIPMENT TYPE  
 10-WHEELER  SUPER TAG  END DUMP  FLAT BED  
 SUPER-10  TRANSFER  SIDE DUMP  MIXER  
 STRONG ARM  DBL BOTTOMS  TRUCK & PUP  SWEEPER  
 OTHER \_\_\_\_\_  
 HOURLY  TONNAGE  PER LOAD  
 RATE @ \$ 90.00

TAG NO.	WEIGHT	COMMODITY	LOADING		UNLOADING		STANDBY TIME	BREAKDOWN OR REASON FOR DELAY
			ARRIVE	DEPART	ARRIVE	DEPART		
1		<u>SH</u>	<u>7:45</u>	<u>7:57</u>				
2								
3		<u>U</u>	<u>9:45</u>					
4								
5		<u>U</u>	<u>10:40</u>					
6								
7		<u>U</u>	<u>12:10</u>					
8								
9		<u>U</u>	<u>1:25</u>					
10								
11		<u>U</u>	<u>2:30</u>					
12								
13								
14								
15								

REPORTING TIME 7:45 ENDING TIME 3:45 TOTAL TIME 8 DEDUCTIBLE TIME 0 NET TIME 8 TOTAL TONS \_\_\_\_\_ ACCESSORIAL OTHER \_\_\_\_\_

START DRIVING TIME LAST TRIP \_\_\_\_\_ ARRIVAL TIME AT DUMP LAST TRIP \_\_\_\_\_ END LOADING LAST TRIP \_\_\_\_\_ RUNNING TIME LAST TRIP \_\_\_\_\_

**SUBJECT TO TERMS AND CONDITIONS ON REVERSE SIDE**

TOTAL CHARGES \_\_\_\_\_

MMK DRIVER SIGNATURE

[Signature] SHIPPER/RECEIVER (AGENT OR DEBITOR) SIGNATURE

ORIGINAL

**D M COURVILLE TRUCKING, INC.**

313 CODY ROAD  
SAN DIMAS CA 91773  
Office: 909 455-8322 Fax: 909 599-1939  
Lic#: CA28653

INVOICE: 2883

Date: 03/30/2020

Item 11.

#5943

Customer No: 1159

T. E. ROBERTS  
306 W. KATELLA AVENUE UNIT B  
ORANGE CA 92867

**RECEIVED**  
APR 02 2020  
BY: \_\_\_\_\_

Date	Ft Bill	Truck	Description	Qty	Rate	Amount
03/24/20	3771573	1404	✓ REDLANDS	8.00	90.00	720.00
<del>03/25/20</del>	<del>3771005</del>	<del>1458</del>	<del>REDLANDS</del>	<del>8.00</del>	<del>90.00</del>	<del>720.00</del>
<del>03/25/20</del>	<del>3771574</del>	<del>1404</del>	<del>REDLANDS</del>	<del>8.00</del>	<del>90.00</del>	<del>720.00</del>
<b>Amount:</b>						<del>2,160.00</del>

**Total \$720.00**

Item	Qty	Amount
HOURS	24.00	2,160.00

**Please Pay This Amount:** ~~2,160.00~~

**THANK YOU FOR YOUR BUSINESS**

Net 30 Days. Unpaid balance is subject to 1 1/2% service charge per month and any and all cost of collections.

**NON-NEGOTIABLE BILL-OF-LADING AND TRANSPORTATION AGREEMENT**

DATE 3-24-20 **A- 3771573**

JOB # \_\_\_\_\_

BROKER # \_\_\_\_\_

TRUCK # C-100

TRAILER # \_\_\_\_\_

CA # \_\_\_\_\_

Item 11.

PRINCIPAL CARRIER Te Roberts

ADDRESS \_\_\_\_\_

CITY/STATE/ZIP \_\_\_\_\_

PH. \_\_\_\_\_

UNDERLYING CARRIER (IF ANY) D-courville

ADDRESS \_\_\_\_\_

SHIPPER Te Roberts

ADDRESS Redland & California

CITY/STATE/ZIP Redlands

POINT OF ORIGIN \_\_\_\_\_

RECEIVER \_\_\_\_\_

ADDRESS oak valley wy

CITY/STATE/ZIP Beemont

POINT OF DESTINATION \_\_\_\_\_

EQUIPMENT TYPE

10-WHEELER  SUPER TAG  END DUMP  FLAT BED  HOURLY  TONNAGE  PER LOAD

SUPER-10  TRANSFER  SIDE DUMP  MIXER

STRONG ARM  DBL BOTTOMS  TRUCK & PUP  SWEEPER

SEMI-BOTTOM  WATER TRUCK  OTHER

RATE @ \$ 90.00

TAG NO.	WEIGHT	COMMODITY	LOADING		UNLOADING		STANDBY TIME	BREAKDOWN OR REASON FOR DELAY
			ARRIVE	DEPART	ARRIVE	DEPART		
1	✓	<u>DIRT</u>	<u>8:00</u>					
2	✓							
3	✓							
4	✓							
5	✓							
6	✓	<u>G-Lands</u>						
7								
8								
9								
10			<u>8:45</u>					
11								
12								
13								
14								
15								

REPORTING TIME <u>8:00</u>	ENDING TIME <u>4:00</u>	TOTAL TIME <u>8</u>	DEDUCTIBLE TIME <u>0</u>	NET TIME <u>8</u>	TOTAL TONS _____	ACCESSORIAL OTHER _____
START DRIVING TIME LAST TRIP	ARRIVAL TIME AT DUMP LAST TRIP	END LOADING LAST TRIP	RUNNING TIME LAST TRIP	<b>SUBJECT TO TERMS AND CONDITIONS ON REVERSE SIDE</b>		TOTAL CHARGES <u>720.00</u>

Jose Gutierrez DRIVER SIGNATURE

[Signature] SHIPPER/RECEIVER (AGENT OR DEBITOR) SIGNATURE

**ORIGINAL**





306 W. Katella Ave., Unit B  
Orange, CA 92867

Job#	Beaumont
5943	
Name: Jeff	

**DATE:** 3/25/2020

**LOCATION:** Oak Valley Parkway

**DETAILS:** Force Main Stabilization (Wednesday) - Arrived on site and set up traffic control, closed (1) lane. Imported dirt from Redlands. Placed dirt and compacted dirt on slopes. Cleaned up and secured site. Took down traffic control.

TYPE	RATE/HR	QTY	REG AMT	OT RATE	QTY	OT AMT	DT RATE	DT HRS	DT AMT	TOTAL
<b>DUMP FEE TOTAL</b>										<b>\$0.00</b>

<b>SUB TOTAL</b>	<b>\$9,357.04</b>
1% - Bond	\$93.57
<b>GRAND TOTAL</b>	<b>\$9,450.61</b>





306 W. Katella Avenue, Unit B  
Orange, CA 92867  
T: 714-669-007  
F: 714-200-0241  
LICENSE# 603008  
www.teroberts.com

No. \_\_\_\_\_

### FIELD CHANGE ORDER

TO: City of Beaumont  
\_\_\_\_\_  
ATTN: Jeff  
\_\_\_\_\_

DATE: 3-25-2020  
JOB TITLE: Force main stabilization  
JOB NUMBER: 5943  
LOCATION: OAK Valley Park Way

LABOR:	RT	OT	TOTAL
Robert Hartwell 3 O/E	8		
Robert Hartwell 4 O	8		
Jose Magana PL	8		
Cameron Wmsford O	8		
TOTALS			

	RT	OT	TOTAL
TOTALS			

#### EQUIPMENT:

EQPT NO.	DESCRIPTION	HOURS
F-36	Crew TRUCK	8
WL16	544 Loader	8
WL7	544 Loader	8
328	Cat Excavator	8

#### MATERIALS and RENTAL EQUIPMENT:

QTY	DESCRIPTION	VENDOR
4	Super 10 FROM Dan Courville TRUCKING	8
2		7.5
2	Road work signs	
40	cones	
1	Restroom	

#### DESCRIPTION OF WORK, CHANGES, AND COMMENTS:

Set up traffic control and take 1 lane  
import dirt FROM Redlands place and compact  
dirt on slopes

Contract Time Extension: \_\_\_\_\_ Calendar Days

Signed: \_\_\_\_\_  
Printed Name: \_\_\_\_\_  
Company: \_\_\_\_\_

Signed: \_\_\_\_\_  
Printed Name: \_\_\_\_\_  
T.E. Roberts, Inc.

**D M COURVILLE TRUCKING, INC.**

313 CODY ROAD  
SAN DIMAS CA 91773  
Office: 909 455-8322 Fax: 909 599-1939  
Lic#: CA28653

INVOICE: 2872

Date: 03/26/2020

Item 11.

#594

Customer No: 1159

T. E. ROBERTS  
306 W. KATELLA AVENUE UNIT B  
ORANGE CA 92867

**RECEIVED**  
MAR 30 2020

BY: \_\_\_\_\_

Date	Ft Bill	Truck	Description	Qty	Rate	Amount
<del>03/24/20</del>	<del>3771930</del>	<del>1304</del>	<del>REDLANDS</del>	<del>8.00</del>	<del>90.00</del>	<del>720.00</del>
03/25/20	3771931	1459	REDLANDS	8.00	90.00	720.00

Amount: ~~1,440.00~~

**Total \$720.00**

Item	Qty	Amount
HOURS	16.00	1,440.00

**Please Pay This Amount: 1,440.00**

**THANK YOU FOR YOUR BUSINESS**

Net 30 Days. Unpaid balance is subject to 1 1/2% service charge per month and any and all cost of collections.

**NON-NEGOTIABLE BILL-OF-LADING AND TRANSPORTATION AGREEMENT**

BILL NO.

PRINCIPAL CARRIER: DMCOW

DATE: 3-25

**A-3771931**

Item 11.

ADDRESS: \_\_\_\_\_  
CITY/STATE/ZIP: \_\_\_\_\_

JOB # \_\_\_\_\_  
BROKER # \_\_\_\_\_  
TRUCK # C-10  
TRAILER # \_\_\_\_\_  
CA # \_\_\_\_\_

UNDERLYING CARRIER (IF ANY): \_\_\_\_\_  
ADDRESS: \_\_\_\_\_

SHIPPER: TK Roberts

RECEIVER: \_\_\_\_\_

ADDRESS: \_\_\_\_\_  
CITY/STATE/ZIP: \_\_\_\_\_

ADDRESS: \_\_\_\_\_  
CITY/STATE/ZIP: \_\_\_\_\_

POINT OF ORIGIN: Redlands, CA

POINT OF DESTINATION: San Mateo, CA

EQUIPMENT TYPE:  SUPER TAG  END DUMP  FLAT BED  
 10-WHEELER  TRANSFER  SIDE DUMP  MIXER  
 SUPER-10  DBL BOTTOMS  TRUCK & PUP  SWEEPER  
 STRONG ARM  SEMI-BOTTOM  WATER TRUCK  OTHER \_\_\_\_\_  
 HOURLY  TONNAGE  PER LOAD  
 RATE @ \$ 90.00

TAG NO.	WEIGHT	COMMODITY	LOADING		UNLOADING		STANDBY TIME	BREAKDOWN OR REASON FOR DELAY
			ARRIVE	DEPART	ARRIVE	DEPART		
1		<u>Sub</u>	<u>6:30</u>					
2								
3		<u>11</u>	<u>7:30</u>					
4		<u>11</u>	<u>9:10</u>					
5		<u>11</u>	<u>10:30</u>					
6		<u>11</u>	<u>11:50</u>					
7		<u>11</u>	<u>1:12</u>					
8								
9								
10								
11								
12								
13								
14								
15								

*Le hold AS*

REPORTING TIME: 6:35 ENDING TIME: 2:35 TOTAL TIME: 8 DEDUCTIBLE TIME: 2 NET TIME: 8 TOTAL TONS: \_\_\_\_\_ ACCESSORIAL OTHER: \_\_\_\_\_

START DRIVING TIME LAST TRIP: \_\_\_\_\_ ARRIVAL TIME AT DUMP LAST TRIP: \_\_\_\_\_ END LOADING LAST TRIP: \_\_\_\_\_ RUNNING TIME LAST TRIP: \_\_\_\_\_

**SUBJECT TO TERMS AND CONDITIONS ON REVERSE SIDE**

TOTAL CHARGES

DRIVER SIGNATURE: Mick GAMBLE

SHIPPER/RECEIVER SIGNATURE: \_\_\_\_\_

ORIGINAL

**D M COURVILLE TRUCKING, INC.**

313 CODY ROAD  
SAN DIMAS CA 91773  
Office: 909 455-8322 Fax: 909 599-1939  
Lic#: CA28653

INVOICE: 2883

Date: 03/30/2020

Item 11.

✓ #5943

Customer No: 1159

T. E. ROBERTS  
306 W. KATELLA AVENUE UNIT B  
ORANGE CA 92867

**RECEIVED**  
APR 02 2020  
BY: \_\_\_\_\_

Date	Ft Bill	Truck	Description	Qty	Rate	Amount
<del>03/24/20</del>	<del>3771573</del>	<del>1404</del>	<del>✓ REDLANDS</del>	<del>8.00</del>	<del>90.00</del>	<del>720.00</del>
03/25/20	3771005	1458	REDLANDS	8.00	90.00	720.00
03/25/20	3771574	1404	REDLANDS	8.00	90.00	720.00
<b>Amount:</b>						<del>2,160.00</del>

**Total \$1,440.00**

Item	Qty	Amount
HOURS	24.00	2,160.00

**Please Pay This Amount:** ~~2,160.00~~

**THANK YOU FOR YOUR BUSINESS**

Net 30 Days. Unpaid balance is subject to 1 1/2% service charge per month and any and all cost of collections.

**NON-NEGOTIABLE BILL-OF-LADING AND TRANSPORTATION AGREEMENT**

DATE **3-25-20** BILL NO. **A-3771005**

JOB # \_\_\_\_\_  
 BROKER # \_\_\_\_\_  
 TRUCK # **C70**  
 TRAILER # \_\_\_\_\_  
 CA # **28653**

Item 11.

PRINCIPAL CARRIER **D3M Courville Trucking**

ADDRESS \_\_\_\_\_  
 CITY/STATE/ZIP \_\_\_\_\_

UNDERLYING CARRIER (IF ANY) \_\_\_\_\_  
 ADDRESS \_\_\_\_\_

SHIPPER **T. E. ROBERTS**

ADDRESS \_\_\_\_\_  
 CITY/STATE/ZIP \_\_\_\_\_

POINT OF ORIGIN **REDCAMP**

RECEIVER **DUMP**

ADDRESS **OAK VALLEY PKWY**  
 CITY/STATE/ZIP \_\_\_\_\_

POINT OF DESTINATION **BEAUMONT**

EQUIPMENT TYPE

SUPER TAG  END DUMP  FLAT BED  HOURLY  TONNAGE  PER LOAD

WHEELER  TRANSFER  SIDE DUMP  MIXER

SUPER-10  DBL BOTTOMS  TRUCK & PUP  SWEEPER

STRONG ARM  SEMI-BOTTOM  WATER TRUCK  OTHER

RATE @ **\$ 90<sup>00</sup>**

TAG NO.	WEIGHT	COMMODITY	LOADING		UNLOADING		STANDBY TIME	BREAKDOWN OR REASON FOR DELAY
			ARRIVE	DEPART	ARRIVE	DEPART		
1			700					
2								
3								
4								
5								
6								
7								
8								
9								
10								
11								
12								
13								
14								
15								

REPORTING TIME	ENDING TIME	TOTAL TIME	DEDUCTIBLE TIME	NET TIME	TOTAL TONS	ACCESSORIAL OTHER
700	300	8hrs		8hrs		
START DRIVING TIME LAST TRIP	ARRIVAL TIME AT DUMP LAST TRIP	END LOADING LAST TRIP	RUNNING TIME LAST TRIP	<b>SUBJECT TO TERMS AND CONDITIONS ON REVERSE SIDE</b>		<b>TOTAL CHARGES 720<sup>00</sup></b>

*[Signature]* DRIVER SIGNATURE *[Signature]* SHIPPER/RECEIVER (AGENT OR DEBITOR) SIGNATURE

**ORIGINAL**

**NON-NEGOTIABLE BILL-OF-LADING AND TRANSPORTATION AGREEMENT**

DATE **3-25-20** BILL NO. **A-3771574**

Item 11.

PRINCIPAL CARRIER **Te Roberts** ADDRESS **Redlands** CITY/STATE/ZIP **Redlands**

UNDERLYING CARRIER (IF ANY) **D-courville** ADDRESS **Redlands** CITY/STATE/ZIP **Redlands**

SHIPPER **Te Roberts** ADDRESS **Redlands** CITY/STATE/ZIP **Redlands**

RECEIVER **Te Roberts** ADDRESS **oak valley park wy** CITY/STATE/ZIP **Beaumont**

POINT OF ORIGIN **Redlands** POINT OF DESTINATION **Beaumont**

EQUIPMENT TYPE

10-WHEELER  SUPER TAG  END DUMP  FLAT BED  HOURLY  TONNAGE  PER LOAD

SUPER-10  TRANSFER  SIDE DUMP  MIXER

STRONG ARM  DBL BOTTOMS  TRUCK & PUP  SWEEPER

SEMI-BOTTOM  WATER TRUCK  OTHER

RATE @ \$ **90.00**

TAG NO.	WEIGHT	COMMODITY	LOADING ARRIVE	LOADING DEPART	UNLOADING ARRIVE	UNLOADING DEPART	STANDBY TIME	BREAKDOWN OR REASON FOR DELAY
1		Dirt	7:30					
2								
3								
4								
5								
6								
7		6-Load						
8								
9								
10								
11								
12								
13								
14								
15								

REPORTING TIME **7:30** ENDING TIME **3:30** TOTAL TIME **8** DEDUCTIBLE TIME **0** NET TIME **8** TOTAL TONS **8** ACCESSORIAL OTHER **720.00**

START DRIVING TIME LAST TRIP **7:30** ARRIVAL TIME AT DUMP LAST TRIP **3:30** END LOADING LAST TRIP **8** RUNNING TIME LAST TRIP **8**

**SUBJECT TO TERMS AND CONDITIONS ON REVERSE SIDE**

**TOTAL CHARGES**

**Te Gutierrez** DRIVER SIGNATURE

**[Signature]** SHIPPER/RECEIVER (AGENT OR DEBITOR) SIGNATURE

**ORIGINAL**



306 W. Katella Ave., Unit B  
Orange, CA 92867

Job#	Beaumont
5943	
Name: Jeff	

DATE: 3/26/2020

LOCATION: Oak Valley Parkway

DETAILS:

**Force Main Stabilization (Thursday)** - Arrived on site and set up traffic control, closed (1) lane. Compacted and graded slopes. Cleaned up and secured site. Took down traffic control.

TYPE	RATE/HR	QTY	REG AMT	OT RATE	QTY	OT AMT	DT RATE	DT HRS	DT AMT	TOTAL
<b>LABOR</b>										
OE FOREMAN	8.00	8.00	978.96	183.56	-	-	244.74	-	-	978.96
PIPELAYER/Asphalt wkr	8.00	8.00	743.12	139.34	-	-	185.78	-	-	743.12
EQPT OPERATOR	8.00	8.00	939.76	176.21	-	-	234.94	-	-	939.76
	<b>24.00</b>	<b>24.00</b>								
<b>LABOR TOTAL</b>										<b>\$2,661.84</b>
<b>LABOR TOTAL</b>										<b>\$2,661.84</b>
<b>EQUIPMENT</b>										
TRUCK F550		8.00	440.80							440.80
EXCAVATOR		8.00	959.44							959.44
WHEEL LOADER 544K		8.00	993.20							993.20
WATER TRUCK		8.00	440.80							440.80
DELINEATORS/ SIGNS (2)		16.00	4.80							4.80
TRAFFIC CONES (40)		320.00	96.00							96.00
<b>EQPT TOTAL</b>										<b>\$2,935.04</b>

SUBCONTRACTOR	Sub Total	Tax	Total	5%	TOTAL
<b>SUBCONTRACTOR TOTAL</b>					<b>\$0.00</b>

MATERIAL	Sub Total	Tax	AMOUNT	15%	TOTAL
<b>MATERIAL TOTAL</b>					<b>\$0.00</b>

EQUIPMENT RENT	Sub Total	Tax	AMOUNT	15%	TOTAL
<b>EQ RENT TOTAL</b>					<b>\$0.00</b>

DUMP FEES	Sub Total	Tax	AMOUNT	10%	TOTAL
<b>DUMP FEE TOTAL</b>					<b>\$0.00</b>

Item 11.



306 W. Katella Ave., Unit B  
Orange, CA 92867

**DATE:** 3/26/2020

**LOCATION:** Oak Valley Parkway

**DETAILS:**

**Force Main Stabilization (Thursday)** - Arrived on site and set up traffic control, closed (1) lane. Compacted and graded slopes. Cleaned up and secured site. Took down traffic control.

<b>Job#</b>	<b>Beaumont</b>
5943	
<b>Name: Jeff</b>	

TYPE	RATE/HR	QTY	REG AMT	OT RATE	QTY	OT AMT	DT RATE	DT HRS	DT AMT	TOTAL
<b>SUB TOTAL</b>										<b>\$5,596.88</b>
1% - Bond										\$55.97
<b>GRAND TOTAL</b>										<b>\$5,652.85</b>





306 W. Katella Avenue, Unit B  
Orange, CA 92867  
T: 714-669-007  
F: 714-200-0241  
LICENSE# 603008  
www.teroberts.com

No. \_\_\_\_\_

### FIELD CHANGE ORDER

TO: City of Beaumont

DATE: 3-26-2020

ATTN: JEFF

JOB TITLE: Force main stabilization

JOB NUMBER: 5943

LOCATION: OAK Valley park way

LABOR:

	RT	OT	TOTAL
Robert Hartwell 3 off	8		
Robert Hartwell 4 O	8		
Jose Magana PL	8		
TOTALS			

	RT	OT	TOTAL
TOTALS			

EQUIPMENT:

EQPT NO.	DESCRIPTION	HOURS
F-36	Crew truck	8
WL-7	544 Peer loader	8
328	Cat Excavator	8
WT-10	Water truck	8

MATERIALS and RENTAL EQUIPMENT:

QTY	DESCRIPTION	VENDOR
2	Road work signs	
40	cones	
1	Rest room	

DESCRIPTION OF WORK, CHANGES, AND COMMENTS:

Setup and take 1 Lane compact and grade slopes

Contract Time Extension: \_\_\_\_\_ Calendar Days

Signed: \_\_\_\_\_  
Printed Name: \_\_\_\_\_  
Company: \_\_\_\_\_

Signed: \_\_\_\_\_  
Printed Name: \_\_\_\_\_  
T.E. Roberts, Inc.



306 W. Katella Ave., Unit B  
Orange, CA 92867

Job#	Beaumont
5943	
Name: Jeff	

DATE: 3/27/2020

LOCATION: Oak Valley Parkway

DETAILS: Force Main Stabilization (Friday) - Arrived on site and set up traffic control, closed (1) lane. Compacted and graded slopes. Cleaned up and secured site. Took down traffic control.

TYPE	RATE/HR	QTY	REG AMT	OT RATE	QTY	OT AMT	DT RATE	DT HRS	DT AMT	TOTAL
<b>LABOR</b>										
OE FOREMAN	6.00	6.00	734.22	183.56		-	244.74	-	-	734.22
PIPELAYER/Asphalt wkr	6.00	6.00	557.34	139.34		-	185.78	-	-	557.34
EQPT OPERATOR	6.00	6.00	704.82	176.21		-	234.94	-	-	704.82
	18.00	18.00				-		-	-	
										<b>LABOR TOTAL</b>
										<b>\$1,996.38</b>
<b>EQUIPMENT</b>										
TRUCK F550		6.00	330.60							330.60
EXCAVATOR		6.00	719.58							719.58
WHEEL LOADER 544K		6.00	744.90							744.90
WATER TRUCK		6.00	330.60							330.60
DELINEATORS/ SIGNS (2)		12.00	3.60							3.60
TRAFFIC CONES (40)		240.00	72.00							72.00
										<b>EQPT TOTAL</b>
										<b>\$2,201.28</b>

SUBCONTRACTOR	Sub Total	Tax	Total	5%	TOTAL
V Ditch Solutions - Inv# 10086 6-inch Slope Paving & welded wire mesh	173,972.50	-	173,972.50	8,698.63	182,671.13
					<b>SUBCONTRACTOR TOTAL</b>
					<b>\$182,671.13</b>

MATERIAL	Sub Total	Tax	AMOUNT	15%	TOTAL
					<b>MATERIAL TOTAL</b>
					<b>\$0.00</b>

EQUIPMENT RENT	Sub Total	Tax	AMOUNT	15%	TOTAL
					<b>EQ RENT TOTAL</b>
					<b>\$0.00</b>

DUMP FEES	Sub Total	Tax	AMOUNT	10%	TOTAL
					<b>DUMP FEE TOTAL</b>
					<b>\$0.00</b>

**SUB TOTAL** \$186,868.73

Item 11.



306 W. Katella Ave., Unit B  
Orange, CA 92867

<b>Job#</b>	<b>Beaumont</b>
5943	
<b>Name: Jeff</b>	

**DATE:** 3/27/2020

**LOCATION:** Oak Valley Parkway

**DETAILS:** **Force Main Stabilization (Friday)** - Arrived on site and set up traffic control, closed (1) lane. Compacted and graded slopes. Cleaned up and secured site. Took down traffic control.

TYPE	RATE/HR	QTY	REG AMT	OT RATE	QTY	OT AMT	DT RATE	DT HRS	DT AMT	TOTAL
										\$1,868.69
										<b>\$188,737.47</b>

Item 11.





6879 Palm Ave.  
San Bernardino, CA 92407  
Fax: 909-887-4650  
Lic. No. 1010578

## INVOICE 10086

---

April 04, 2020

T E Roberts

Project : Beaumont

Attention: Gilbert Hartwell

We are proposing to install the following

1).- Construct 6" thick slope paving with 6-6-10-10 welded wire mesh

17,225 S.F. x \$ 10.10 = \$ 173,972.50

Price based on 4 move ins. Price includes 5000 psi pea gravel mix  
Price includes Machine excavation for 1'x2' footing at toe of slope, wire mesh, concrete ( 5000 psi pea gravel mix), and concrete placement.

**Exclusions:**

Fine grade on slope, Color, rock removal, inspections, rip rap, water source, staking, and any forming all by others.

If you have any questions please call me at 818-458-5102

Manuel Hernandez



## Staff Report

**TO:** Mayor and City Council Members  
**FROM:** Elizabeth Gibbs, Community Services Director  
**DATE:** June 2, 2020  
**SUBJECT:** Facility Generators – Ratification of Emergency Repairs

---

### Background and Analysis:

The City of Beaumont owns eighteen generators that are located throughout the City and serve multiple facilities, including sewer lift stations. Staff recently awarded a bid to The Pape Group, Inc., (formerly known as Yale Chase Equipment and Service, Inc.) to perform maintenance on all City owned generators, in an approximate amount of \$20,000.

During the maintenance, it was determined that several of the generators needed additional work, including new parts. The additional repairs and parts have been contracted on an emergency basis due to the generators providing backup power to critical public safety facilities and sewer lift stations.

### Fiscal Impact:

The costs to repair the generators will not exceed \$50,000.

### Recommended Action:

Ratify the costs associated with the emergency repairs to the City's generators in an amount not to exceed \$50,000.

### Attachments:

- A. Estimates from The Pape Group, Inc.



**SERVICE ESTIMATE**

Quote Number SVQ49149  
 Quote Date March 18, 2020  
 Order Time 10:23:36 AM  
 Contract Number  
 Payment Terms Net 10 Days  
 PO Number

Fontana Service Department  
 8089 Cherry Aveune  
 Fontana, CA 92336  
 Phone No.. (909) 428-3400 Fax No.. (909) 428-9620  
 C08726

Page 1

Bill CITY OF BEAUMONT - WATER DEPT  
 To 550 E 6TH ST  
 THAXTON VAN BELL CA  
 Beaumont, CA 92223  
 USA

C08726  
 Ship CITY OF BEAUMONT - LOWER OAKS  
 To 11246 PALMER  
 Beaumont, CA 92223  
 USA

Contact THAXTON VAN BELL  
 E-Mail TVANBELLE@BEAUMONTCA.GOV

Phone No. (909) 496-5689  
 FAX No.

**Job Description: OM REPAIRS**

Comments: PERFORM REPAIRS AS NOTED ON WORK ORDER SVO673791  
 UPPER AND LOWER RAD HOSES AND CLAMPS  
 RAD CAP  
 HEATER HOSES AND CLAMPS  
 BATTERY 4D  
 COOLANT

Manufacturer Code: KAT Model: D200FRJ4T2 Serial No.: 123485-0406 Cust. Fleet No.: LOWER OAKS  
 Y/C Fleet No.: EQ99742 Equipment Type: 200kW Diesel Powered Stb Hr. Meter Reading:0

**Description of Work Performed OM REPAIRS**

Line No.	Description	Quantity	Unit Price Exc	Amount
10000	Quoted Field Labor and Travel	8.00	155.00	1,240.00
10000	CUS - Travel	60.00	2.25	135.00
10000	CUS - Inbound Freight	1.00	50.00	50.00
10000	COOLING PARTS	1.00	380.00	380.00
10000	COOLANT 50-50	16.00	17.08	273.28
10000	5/8 HEATER HOSE	8.00	4.83	38.64
10000	HOSE CLAMP 5/8 NO 10	4.00	3.63	14.52
10000	4D BATTERY	1.00	322.00	322.00
<b>Total</b>				<b>2,453.44</b>

**Service Order Total 2,453.44 2,637.02**

Approved By \_\_\_\_\_ PO # \_\_\_\_\_

Signature \_\_\_\_\_ Date \_\_\_\_\_

This estimate is based on operational and visual inspections, upon disassembly of components additional parts and labor may be required to complete the necessary repairs. If the necessary additional repairs are within 10% of the quoted amount customer authorizes the dealer to proceed with the repairs. In the event that the necessary repairs exceed the 10% of the quoted amount then an additional quotation will be required prior to completing the necessary repairs. All quoted repairs are plus applicable sales tax and shipping of non-stock parts.



**SERVICE ESTIMATE**

Quote Number SVQ49150  
 Quote Date March 18, 2020  
 Order Time 10:31:55 AM  
 Contract Number  
 Payment Terms Net 10 Days  
 PO Number

Fontana Service Department  
 8089 Cherry Aveune  
 Fontana, CA 92336  
 Phone No.. (909) 428-3400 Fax No.. (909) 428-9620  
 C08726

Page 1

Bill To CITY OF BEAUMONT - WATER DEPT  
 550 E 6TH ST  
 THAXTON VAN BELL CA  
 Beaumont, CA 92223  
 USA

Ship To C08726  
 CITY OF BEAUMONT - WWTP BLDG 8  
 715 W 4TH ST  
 Beaumont, CA 92223  
 USA

Contact THAXTON VAN BELL  
 E-Mail TVANBELLE@BEAUMONTCA.GOV

Phone No. (909) 496-5689  
 FAX No.

**Job Description: OM REPAIRS**

Comments: PERFORM REPAIRS AS NOTED ON WORK ORDER SVO673788  
 REPLACE THE FOLLOWING:  
 COOLANT  
 UPPER AND LOWER HOSES AND CLAMPS  
 AIR FILTERS  
 HEATER HOSES

Manufacturer Code: CATP Model: SR-4 Serial No.: AFK00541 Cust. Fleet No.: WWTP BLDG 8  
 Y/C Fleet No.: EQ99738 Equipment Type: 750kW Diesel Powered Stb Hr. Meter Reading:0

**Description of Work Performed OM REPAIRS**

Line No.	Description	Quantity	Unit Price Exc	Amount
10000	Quoted Field Labor and Travel	8.00	155.00	1,240.00
10000	CUS - Travel	60.00	2.25	135.00
10000	CUS - Inbound Freight	1.00	68.00	68.00
10000	COOLANT HOSES/CLAMPS/AIR FILTERS	1.00	552.30	552.30
10000	COOLANT FLEET CHRGS50/50 DRUM	1.00	661.71	661.71
10000	HOSE, 3/4" PURSIL	30.00	7.00	210.00
10000	CLAMP 13/16 - 1-1/2 SILICON	4.00	3.25	13.00
10000	CUS - Miscellaneous Hardware	1.00	250.00	250.00
10000	Quoted Field Labor -OT	2.00	232.50	465.00
<b>Total</b>				<b>3,595.01</b>

**Service Order Total 3,595.01 3,731.02**

Approved By \_\_\_\_\_ PO # \_\_\_\_\_

Signature \_\_\_\_\_ Date \_\_\_\_\_

This estimate is based on operational and visual inspections, upon disassembly of components additional parts and labor may be required to complete the necessary repairs. If the necessary additional repairs are within 10% of the quoted amount customer authorizes the dealer to proceed with the repairs. In the event that the necessary repairs exceed the 10% of the quoted amount then an additional quotation will be required prior to completing the necessary repairs. All quoted repairs are plus applicable sales tax and shipping of non-stock parts.





### SERVICE ESTIMATE

Quote Number SVQ49154  
 Quote Date March 18, 2020  
 Order Time 10:57:28 AM  
 Contract Number  
 Payment Terms Net 10 Days  
 PO Number

Fontana Service Department  
 8089 Cherry Aveune  
 Fontana, CA 92336  
 Phone No.. (909) 428-3400 Fax No.. (909) 428-9620  
 C08726

Page 1

Bill CITY OF BEAUMONT - WATER DEPT  
 To 550 E 6TH ST  
 THAXTON VAN BELL CA  
 Beaumont, CA 92223  
 USA

C08726  
 Ship CITY OF BEAUMONT - MESA  
 To 12940 POTRERO BLVD  
 Beaumont, CA 92223  
 USA

Contact THAXTON VAN BELL  
 E-Mail TVANBELLE@BEAUMONTCA.GOV

Phone No. (909) 496-5689  
 FAX No.

#### Job Description: OM REPAIRS

Comments: PERFORM REPAIRS AS NOTED ON WORK ORDER SVO673793  
 UPPER AND LOWERRAD HOSES AND CLAMPS  
 COOLANT

Manufacturer Code: CATP Model: SR-4 Serial No.: AFN04519 Cust. Fleet No.: MESA  
 Y/C Fleet No.: EQ99744 Equipment Type: 700kW Diesel Powered Stb Hr. Meter Reading:0

#### Description of Work Performed OM REPIARS

Line No.	Description	Quantity	Unit Price Exc	Amount
10000	Quoted Field Labor and Travel	8.00	155.00	1,240.00
10000	CUS - Travel	60.00	2.25	135.00
10000	CUS - Inbound Freight	1.00	68.00	68.00
10000	COOLANT FLEET CHRGS50/50 DRUM	1.00	661.71	661.71
10000	COOLANT HOSES/CLAMPS	1.00	575.00	575.00
<b>Total</b>				<b>2,679.71</b>

Service Order Total 2,679.71 2,780.83

Approved By \_\_\_\_\_ PO # \_\_\_\_\_

Signature \_\_\_\_\_ Date \_\_\_\_\_

This estimate is based on operational and visual inspections, upon disassembly of components additional parts and labor may be required to complete the necessary repairs. If the necessary additional repairs are within 10% of the quoted amount customer authorizes the dealer to proceed with the repairs. In the event that the necessary repairs exceed the 10% of the quoted amount then an additional quotation will be required prior to completing the necessary repairs. All quoted repairs are plus applicable sales tax and shipping of non-stock parts.



**SERVICE ESTIMATE**

Quote Number SVQ49156  
 Quote Date March 18, 2020  
 Order Time 11:04:29 AM  
 Contract Number  
 Payment Terms Net 10 Days  
 PO Number

Fontana Service Department  
 8089 Cherry Aveune  
 Fontana, CA 92336  
 Phone No.. .(909) 428-3400 Fax No.. .(909) 428-9620  
 C08726

Page 1

Bill CITY OF BEAUMONT - WATER DEPT  
 To 550 E 6TH ST  
 THAXTON VAN BELL CA  
 Beaumont, CA 92223  
 USA

Ship C08726 CITY OF BEAUMONT - WWTP BLDG 8  
 To 715 W 4TH ST  
 Beaumont, CA 92223  
 USA

Contact THAXTON VAN BELL  
 E-Mail TVANBELLE@BEAUMONTCA.GOV

Phone No. (909) 496-5689  
 FAX No.

**Job Description: OM REPAIRS**

Comments: PERFORM REPAIRS AS NOTED ON WORK ORDER SVO673787  
 REPLACE THE FOLLOWING  
 UPPER AND LOWER RAD HOSES AND CLAMPS  
 RAD CAP  
 HEATER HOSES AND CLAMPS  
 AIR FILTER  
 BATTERIES

Manufacturer Code: CATP Model: SR-4 Serial No.: 5NJ00512 Cust. Fleet No.: WWTP HW ST  
 Y/C Fleet No.: EQ99739 Equipment Type: 700kW Diesel Powered Stb Hr. Meter Reading:0

**Description of Work Performed OM REPAIRS**

Line No.	Description	Quantity	Unit Price Exc	Amount
10000	Quoted Field Laborand Travel	8.00	155.00	1,240.00
10000	CUS - Travel	60.00	2.25	135.00
10000	CUS - Inbound Freight	1.00	68.00	68.00
10000	COOLING PARTS	1.00	300.00	300.00
10000	8D BATTERY	2.00	322.00	644.00
10000	HOSE, 3/4" PURSIL	30.00	7.00	210.00
10000	CLAMP 13/16 - 1-1/2 SILICON	4.00	3.25	13.00
10000	ENGINE HEATER- 2500W/120V	1.00	430.20	430.20
10000	AIR FILTER	2.00	121.39	242.78
10000	COOLANT FLEET CHR50/50 DRUM	1.00	661.71	661.71
<b>Total</b>				<b>3,944.69</b>

Service Order Total 3,944.69 4,143.84

Approved By \_\_\_\_\_ PO # \_\_\_\_\_

Signature \_\_\_\_\_ Date \_\_\_\_\_

This estimate is based on operational and visual inspections, upon disassembly of components additional parts and labor may be required to complete the necessary repairs. If the necessary additional repairs are within 10% of the quoted amount customer authorizes the dealer to proceed with the repairs. In the event that the necessary repairs exceed the10% of the quoted amount then an additional quotation will be required prior to completing the necessary repairs. All quoted repairs are plus applicable sales tax and shipping of non-stock parts.



### SERVICE ESTIMATE

Quote Number SVQ49157  
 Quote Date March 18, 2020  
 Order Time 11:29:00 AM  
 Contract Number  
 Payment Terms Net 10 Days  
 PO Number

Fontana Service Department  
 8089 Cherry Aveune  
 Fontana, CA 92336  
 Phone No.. (909) 428-3400 Fax No.. (909) 428-9620  
 C08726

Page 1

Bill CITY OF BEAUMONT - WATER DEPT  
 To 550 E 6TH ST  
 THAXTON VAN BELL CA  
 Beaumont, CA 92223  
 USA

Ship C08726  
 To CITY OF BEAUMONT - UPPER OAK  
 35980 OAK VALLEY PKWY  
 Beaumont, CA 92223  
 USA

Contact THAXTON VAN BELL  
 E-Mail TVANBELLE@BEAUMONTCA.GOV

Phone No. (909) 496-5689  
 FAX No.

#### Job Description: OM REPAIRS

Comments: PERFORM REPAIRS AS NOTED ON WORK ORDER SVO673796  
 REPLACE COOLANT AND AIR FILTER

Manufacturer Code: CATP Model: LC6 Serial No.: G6B00815 Cust. Fleet No.: UPPER OAK  
 Y/C Fleet No.: EQ99747 Equipment Type: 550kW Diesel Powered Stb Hr. Meter Reading:0

#### Description of Work Performed OM REPAIRS

Line No.	Description	Quantity	Unit Price Exc	Amount
10000	Quoted Field Labor and Travel	8.00	155.00	1,240.00
10000	CUS - Travel	60.00	2.25	135.00
10000	COOLANT FLEET CHR50/50 DRUM	1.00	661.71	661.71
10000	FILTER - AIR	1.00	218.90	218.90
10000	CUS - Inbound Freight	1.00	25.00	25.00
<b>Total</b>				<b>2,280.61</b>

Service Order Total 2,280.61 2,360.80

Approved By \_\_\_\_\_ PO # \_\_\_\_\_

Signature \_\_\_\_\_ Date \_\_\_\_\_

This estimate is based on operational and visual inspections, upon disassembly of components additional parts and labor may be required to complete the necessary repairs. If the necessary additional repairs are within 10% of the quoted amount customer authorizes the dealer to proceed with the repairs. In the event that the necessary repairs exceed the 10% of the quoted amount then an additional quotation will be required prior to completing the necessary repairs. All quoted repairs are plus applicable sales tax and shipping of non-stock parts.



**SERVICE ESTIMATE**

Quote Number SVQ49158  
 Quote Date March 18, 2020  
 Order Time 11:45:41 AM  
 Contract Number  
 Payment Terms Net 10 Days  
 PO Number

Fontana Service Department  
 8089 Cherry Aveune  
 Fontana, CA 92336  
 Phone No.. (909) 428-3400 Fax No.. (909) 428-9620  
 C08726

Page 1

Bill CITY OF BEAUMONT - WATER DEPT  
 To 550 E 6TH ST  
 THAXTON VAN BELL CA  
 Beaumont, CA 92223  
 USA

C08726  
 Ship CITY OF BEAUMONT - LITTLE LOWER OAKS  
 To 34003 CRENSHAW ST  
 Beaumont, CA 92223  
 USA

Contact THAXTON VAN BELL  
 E-Mail TVANBELLE@BEAUMONTCA.GOV

Phone No. (909) 496-5689  
 FAX No.

**Job Description: OM REPAIRS**

**Comments:** PERFORM REPAIRS AS NOTED ON WORK ORDER SVO673790  
 REPLEACE THE FOLLOWING  
 UPPER AND LOWER HOSES AND CLAMPS  
 HEATER HOSE AND CLAMPS AND 1 " PURSIL X 4 FT  
 ENGINE BELT  
 NOTE: THE CUSTOMER WILL NEED TO HAVE THE UNIT CLEANED  
 AND DISINFECTED BEFORE WORK CAN BE DONE

Manufacturer Code: GEN Model: SD100 Serial No.: 2086451 Cust. Fleet No.: LITTLE LOWER  
 Y/C Fleet No.: EQ99741 Equipment Type: 100kW Diesel Powered Stb Hr. Meter Reading:0

**Description of Work Performed OM REPAIRS**

Line No.	Description	Quantity	Unit Price Exc	Amount
10000	Quoted Field Labor and Travel	8.00	155.00	1,240.00
10000	CUS - Travel	60.00	2.25	135.00
10000	CUS - Inbound Freight	1.00	68.00	68.00
10000	COOLING PARTS	1.00	350.00	350.00
10000	COOLANT 50-50	6.00	17.08	102.48
10000	5/8 HEATER HOSE	10.00	4.83	48.30
10000	HOSE CLAMP 5/8 NO 10	4.00	3.63	14.52
10000	1" PURSIL HOSE	5.00	11.70	58.50
10000	CLAMP 13/16 - 1-1/2 SILICON	4.00	3.25	13.00
<b>Total</b>				<b>2,029.80</b>

Service Order Total 2,029.80 2,080.55

Approved By \_\_\_\_\_ PO # \_\_\_\_\_

Signature \_\_\_\_\_ Date \_\_\_\_\_

This estimate is based on operational and visual inspections, upon disassembly of components additional parts and labor may be required to complete the necessary repairs. If the necessary additional repairs are within 10% of the quoted amount customer authorizes the dealer to proceed with the repairs. In the event that the necessary repairs exceed the 10% of the quoted amount then an additional quotation will be required prior to completing the necessary repairs. All quoted repairs are plus applicable sales tax and shipping of non-stock parts.



**SERVICE ESTIMATE**

Quote Number SVQ49159  
Quote Date March 18, 2020  
Order Time 11:58:06 AM  
Contract Number  
Payment Terms Net 10 Days  
PO Number

Fontana Service Department  
8089 Cherry Aveune  
Fontana, CA 92336  
Phone No.. (909) 428-3400 Fax No.. (909) 428-9620  
C08726

Page 1

Bill CITY OF BEAUMONT - WATER DEPT  
To 550 E 6TH ST  
THAXTON VAN BELL CA  
Beaumont, CA 92223  
USA

C08726  
Ship CITY OF BEAUMONT - FOUR SEASONS  
To 1075 S HIGHLAND SPRING AVE  
Beaumont, CA 92223  
USA

Contact THAXTON VAN BELL  
E-Mail TVANBELLE@BEAUMONTCA.GOV

Phone No. (909) 496-5689  
FAX No.

**Job Description: OM REPAIRS**

Comments: PERFORM REPAIRS AS NOTED ON WORK ORDER SVO673786  
REPLACE 8D BATTERIES

Manufacturer Code: KAT Model: D300FRJ4T2 Serial No.: 123489-0306 Cust. Fleet No.: FOUR SEASON  
Y/C Fleet No.: EQ99737 Equipment Type: 300kW Diesel Powered Stb Hr. Meter Reading:0

**Description of Work Performed OM REPAIRS**

Line No.	Description	Quantity	Unit Price Exc	Amount
10000	Quoted Field Labor and Travel	4.00	155.00	620.00
10000	CUS - Travel	60.00	2.25	135.00
10000	8D BATTERY	2.00	322.00	644.00
<b>Total</b>				<b>1,399.00</b>

Service Order Total 1,399.00 1,448.91

Approved By \_\_\_\_\_ PO # \_\_\_\_\_

Signature \_\_\_\_\_ Date \_\_\_\_\_

This estimate is based on operational and visual inspections, upon disassembly of components additional parts and labor may be required to complete the necessary repairs. If the necessary additional repairs are within 10% of the quoted amount customer authorizes the dealer to proceed with the repairs. In the event that the necessary repairs exceed the 10% of the quoted amount then an additional quotation will be required prior to completing the necessary repairs. All quoted repairs are plus applicable sales tax and shipping of non-stock parts.



**SERVICE ESTIMATE**

Quote Number SVQ49161  
 Quote Date March 18, 2020  
 Order Time 12:01:48 PM  
 Contract Number  
 Payment Terms Net 10 Days  
 PO Number

Fontana Service Department  
 8089 Cherry Aveune  
 Fontana, CA 92336  
 Phone No.. (909) 428-3400 Fax No.. (909) 428-9620  
 C08726

Page 1

Bill CITY OF BEAUMONT - WATER DEPT  
 To 550 E 6TH ST  
 THAXTON VAN BELL CA  
 Beaumont, CA 92223  
 USA

Ship C08726  
 To CITY OF BEAUMONT - WWTP BLDG 8  
 715 W 4TH ST  
 Beaumont, CA 92223  
 USA

Contact THAXTON VAN BELL  
 E-Mail TVANBELLE@BEAUMONTCA.GOV

Phone No. (909) 496-5689  
 FAX No.

**Job Description: OM REPAIRS-DAIGNOSTIC**

Comments: PERFORM REPAIRS AS NOTED ON WORK ORDER SVO679636  
 LOW VOLTAGE OUTPUT- NEEDS DIAGNOSTIC TRIP

Manufacturer Code: GEN Model: SD100 Serial No.: 2095846 Cust. Fleet No.: WWTP HD POR  
 Y/C Fleet No.: EQ99740 Equipment Type: 100kW Diesel Powered Stb Hr. Meter Reading:0

**Description of Work Performed OM REPAIRS-DAIGNOSTIC**

Line No.	Description	Quantity	Unit Price Exc	Amount
10000	Quoted Field Labor and Travel	8.00	155.00	1,240.00
10000	CUS - Travel	60.00	2.25	135.00
<b>Total</b>				<b>1,375.00</b>

**Service Order Total 1,375.00 1,375.00**

Approved By \_\_\_\_\_ PO # \_\_\_\_\_

Signature \_\_\_\_\_ Date \_\_\_\_\_

This estimate is based on operational and visual inspections, upon disassembly of components additional parts and labor may be required to complete the necessary repairs. If the necessary additional repairs are within 10% of the quoted amount customer authorizes the dealer to proceed with the repairs. In the event that the necessary repairs exceed the 10% of the quoted amount then an additional quotation will be required prior to completing the necessary repairs. All quoted repairs are plus applicable sales tax and shipping of non-stock parts.



**SERVICE ESTIMATE**

Quote Number SVQ49162  
 Quote Date March 18, 2020  
 Order Time 12:06:19 PM  
 Contract Number  
 Payment Terms Net 10 Days  
 PO Number

Fontana Service Department  
 8089 Cherry Aveune  
 Fontana, CA 92336  
 Phone No.. (909) 428-3400 Fax No.. (909) 428-9620  
 C08726

Page 1

Bill CITY OF BEAUMONT - WATER DEPT  
 To 550 E 6TH ST  
 THAXTON VAN BELL CA  
 Beaumont, CA 92223  
 USA

C08726  
 Ship CITY OF BEAUMONT - SENECA  
 To 1390 POTRERO BLVD  
 Beaumont, CA 92223  
 USA

Contact THAXTON VAN BELL  
 E-Mail TVANBELLE@BEAUMONTCA.GOV

Phone No. (909) 496-5689  
 FAX No.

**Job Description:**

Comments: PERFORM REPAIRS AS NOTED ON WORK ORDER SVO673795  
 REPLACE THE FOLLOWING  
 UPPER AND LOWER HOSES AND CLAMPS  
 RAD CAP  
 HEATER HOSE AND CLAMPS  
 COOLANT  
 BELT

Manufacturer Code: GEN Model: SD050 Serial No.: 2087696 Cust. Fleet No.: SENECA  
 Y/C Fleet No.: EQ99746 Equipment Type: 50kW Diesel Powered Stby Hr. Meter Reading:0

**Description of Work Performed OM REPAIRS**

Line No.	Description	Quantity	Unit Price Exc	Amount
10000	Quoted Field Labor and Travel	8.00	155.00	1,240.00
10000	CUS - Travel	60.00	2.25	135.00
10000	CUS - Inbound Freight	1.00	68.00	68.00
10000	BELT	1.00	114.18	114.18
10000	COOLANT 50-50	5.00	17.08	85.40
10000	5/8 HEATER HOSE	8.00	4.83	38.64
10000	HOSE CLAMP 5/8 NO 10	4.00	3.63	14.52
10000	HOSES,CAP,CLAMPS	1.00	350.00	350.00
<b>Total</b>				<b>2,045.74</b>

**Service Order Total 2,045.74 2,097.72**

Approved By \_\_\_\_\_ PO # \_\_\_\_\_

Signature \_\_\_\_\_ Date \_\_\_\_\_

This estimate is based on operational and visual inspections, upon disassembly of components additional parts and labor may be required to complete the necessary repairs. If the necessary additional repairs are within 10% of the quoted amount customer authorizes the dealer to proceed with the repairs. In the event that the necessary repairs exceed the 10% of the quoted amount then an additional quotation will be required prior to completing the necessary repairs. All quoted repairs are plus applicable sales tax and shipping of non-stock parts.



**SERVICE ESTIMATE**

Quote Number SVQ49164  
 Quote Date March 18, 2020  
 Order Time 12:32:35 PM  
 Contract Number  
 Payment Terms Net 10 Days  
 PO Number

Fontana Service Department  
 8089 Cherry Aveune  
 Fontana, CA 92336  
 Phone No.. .(909) 428-3400 Fax No.. .(909) 428-9620  
 C08726

Page 1

Bill CITY OF BEAUMONT - WATER DEPT  
 To 550 E 6TH ST  
 THAXTON VAN BELL CA  
 Beaumont, CA 92223  
 USA

C08726  
 Ship CITY OF BEAUMONT - NOBLE CREEK  
 To 33.944968/117.001317  
 Beaumont, CA 92223  
 USA

Contact THAXTON VAN BELL  
 E-Mail TVANBELLE@BEAUMONTCA.GOV

Phone No. (909) 496-5689  
 FAX No.

**Job Description: OM REPAIRS**

**Comments:** PERFORM SOME OF THE REPAIRS NOTED ON WORK ORDER SVO673794  
 THE UPPER AND LOWER HOSES CLAMPS AND RAD CAP ARE  
 BEING RESEARCHED. THE MANUFACTURER DOESNT HAVE AVAILABILITY  
 OR PRICING AT THE MOMENT  
 REPLACE ALL PARTS:  
 COOLANT  
 BATTERIES  
 HEATER HOSE AND CLAMPS  
 BLOCK HEATER

Manufacturer Code: MUQ Model: 431FSL6206 Serial No.: LM-238700-0201 Cust. Fleet No.: NOBLE CREEK  
 Y/C Fleet No.: EQ99745 Equipment Type: 175kW Diesel Powered Stb Hr. Meter Reading:0

**Description of Work Performed OM REPAIRS**

Line No.	Description	Quantity	Unit Price Exc	Amount
10000	Quoted Field Labor and Travel	8.00	155.00	1,240.00
10000	CUS - Travel	60.00	2.25	135.00
10000	CUS - Inbound Freight	1.00	45.00	45.00
10000	4D BATTERY	2.00	322.00	644.00
10000	COOLANT 50-50	12.00	17.08	204.96
10000	HOSE CLAMP 5/8 NO 10	4.00	3.63	14.52
10000	5/8 HEATER HOSE	6.00	4.83	28.98
10000	1" PURSIL HOSE	6.00	11.70	70.20
10000	CLAMP 13/16 - 1-1/2 SILICON	4.00	3.25	13.00
10000	HEATER BLOCK 1800W 120V	1.00	259.48	259.48
<b>Total</b>				<b>2,655.14</b>

**Service Order Total 2,655.14 2,754.35**

Approved By \_\_\_\_\_ PO # \_\_\_\_\_

Signature \_\_\_\_\_ Date \_\_\_\_\_

This estimate is based on operational and visual inspections, upon disassembly of components additional parts and labor may be required to complete the necessary repairs. If the necessary additional repairs are within 10% of the quoted amount customer authorizes the dealer to proceed with the repairs. In the event that the necessary repairs exceed the 10% of the quoted amount then an additional quotation will be required prior to completing the necessary repairs. All quoted repairs are plus applicable sales tax and shipping of non-stock parts.





**SERVICE ESTIMATE**

Quote Number SVQ49155  
 Quote Date March 18, 2020  
 Order Time 11:02:11 AM  
 Contract Number  
 Payment Terms Net 10 Days  
 PO Number

Fontana Service Department  
 8089 Cherry Aveune  
 Fontana, CA 92336  
 Phone No.. (909) 428-3400 Fax No.. (909) 428-9620  
 C08726

Page 1

Bill CITY OF BEAUMONT - WATER DEPT  
 To 550 E 6TH ST  
 THAXTON VAN BELL CA  
 Beaumont, CA 92223  
 USA

C08726  
 Ship CITY OF BEAUMONT - MARSHALL  
 To 990 RING RANCH RD  
 Beaumont, CA 92223  
 USA

Contact THAXTON VAN BELL  
 E-Mail TVANBELLE@BEAUMONTCA.GOV

Phone No. (909) 496-5689  
 FAX No.

**Job Description: OM REPAIRS**

Comments: PERFORM REPAIRS AS NOTED ON WORK ORDER SVO673792

Manufacturer Code: MUQ Model: 432RSL4017 Serial No.: LM-240057-0901 Cust. Fleet No.: MARSHALL  
 Y/C Fleet No.: EQ99743 Equipment Type: 292kW Diesel Powered Stb Hr. Meter Reading:0

**Description of Work Performed OM REPAIRS**

Line No.	Description	Quantity	Unit Price Exc	Amount
10000	Quoted Field Labor and Travel	8.00	155.00	1,240.00
10000	CUS - Travel	60.00	2.25	135.00
10000	CUS - Inbound Freight	1.00	68.00	68.00
10000	COOLANT 50-50	12.00	17.08	204.96
10000	4D BATTERY	2.00	322.00	644.00
10000	5/8 HEATER HOSE	6.00	4.83	28.98
10000	HOSE CLAMP 5/8 NO 10	4.00	3.63	14.52
10000	1" PURSIL HOSE	4.00	11.70	46.80
10000	CLAMP 13/16 - 1-1/2 SILICON	4.00	3.25	13.00
10000	ENGINE HEATER- 2500W/120V	1.00	430.20	430.20
<b>Total</b>				<b>2,825.46</b>

Service Order Total 2,825.46 2,937.87

Approved By \_\_\_\_\_ PO # \_\_\_\_\_

Signature \_\_\_\_\_ Date \_\_\_\_\_

This estimate is based on operational and visual inspections, upon disassembly of components additional parts and labor may be required to complete the necessary repairs. If the necessary additional repairs are within 10% of the quoted amount customer authorizes the dealer to proceed with the repairs. In the event that the necessary repairs exceed the 10% of the quoted amount then an additional quotation will be required prior to completing the necessary repairs. All quoted repairs are plus applicable sales tax and shipping of non-stock parts.



EQUIPMENT AND SERVICES, INC.

Fontana Service Department  
 8089 Cherry Aveune  
 Fontana, CA 92336

Phone No.. (909) 428-3400 Fax No.. (909) 428-9620  
 C08756

Bill CITY OF BEAUMONT - PUBLIC WORKS  
 To 550 E 6TH ST  
 EILEEN RODRIGUEZ CA  
 Beaumont, CA 92223  
 USA

C08756  
 Ship CITY OF BEAUMONT - PUBLIC WORKS  
 To 550 E 6TH ST  
 Beaumont, CA 92223  
 USA

**SERVICE ESTIMATE**

Item 12.

Quote Number SVQ49137  
 Quote Date March 18, 2020  
 Order Time 8:58:35 AM  
 Contract Number  
 Payment Terms Cash on Delivery  
 PO Number

Page 1

Contact EILEEN RODRIGUEZ Phone No. (951) 769-8524  
 E-Mail ERodriguez@beaumontca.gov; jmiranda@beaumontca.g FAX No.

**Job Description: OM REPAIRS**

Comments: Customer COD Call A/R EXT 2299 BEFORE Dispatching Technician  
 REPLACE THE FUEL LINES AS NOTED ON WORK ORDER SVO676756

Manufacturer Code: CUM Model: DSGAE Serial No.: 73206103 Cust. Fleet No.: TRANSIT BLDG  
 Y/C Fleet No.: EQ99893 Equipment Type: 200kW Diesel Powered Stb Hr. Meter Reading:0

Description of Work Performed	Generator	Quantity	Unit Price Exc	Amount
Line No. Description				
10000 Quoted Field Labor and Travel		4.00	155.00	620.00
10000 CUS - Travel		60.00	2.25	135.00
10000 FUEL HOSE		12.00	7.98	95.76
<b>Total</b>				<b>850.76</b>

Service Order Total 850.76 858.18

Approved By \_\_\_\_\_ PO # \_\_\_\_\_

Signature \_\_\_\_\_ Date \_\_\_\_\_

This estimate is based on operational and visual inspections, upon disassembly of components additional parts and labor may be required to complete the necessary repairs. If the necessary additional repairs are within 10% of the quoted amount customer authorizes the dealer to proceed with the repairs. In the event that the necessary repairs exceed the 10% of the quoted amount then an additional quotation will be required prior to completing the necessary repairs. All quoted repairs are plus applicable sales tax and shipping of non-stock parts.



**SERVICE ESTIMATE**

Item 12.

Quote Number SVQ49138  
 Quote Date March 18, 2020  
 Order Time 9:16:45 AM  
 Contract Number  
 Payment Terms Cash on Delivery  
 PO Number

Fontana Service Department  
 8089 Cherry Aveune  
 Fontana, CA 92336

Phone No.. (909) 428-3400 Fax No.. (909) 428-9620  
 C08756

Page 1

Bill CITY OF BEAUMONT - PUBLIC WORKS  
 To 550 E 6TH ST  
 EILEEN RODRIGUEZ  
 Beaumont, CA 92223  
 USA

C08756  
 Ship CITY OF BEAUMONT - PUBLIC WORKS  
 To 550 E 6TH ST  
 Beaumont, CA 92223  
 USA

Contact EILEEN RODRIGUEZ Phone No. (951) 769-8524  
 E-Mail ERodriguez@beaumontca.gov; jmiranda@beaumontca.g FAX No.

**Job Description: OM REPAIRS**

Comments: Customer COD Call A/R EXT 2299 BEFORE Dispatching Technician  
 PERFORM THE REPAIRS AS NOTED ON WORK ORDER SVO676757  
 REPLACE THE FOLLOWING:  
 FUEL HOSES  
 RAD CAP- 211-6574  
 GR 31 BATTERY  
 REMOVE THE INJECTION PUMP FOR INSPECTION/REPAIR  
 NOTE: ADDITIONAL CHARGES WILL APPLY ONCE THE PUMP HAS BEEN  
 DIAGNOSED IN ORDER TO COMPLETE THE REPAIR  
 THE GENERATOR WILL BE DOWN WHILE THE REPAIR IS BEING MADE

Manufacturer Code: OLY Model: D100P4 Serial No.: CAT00C44ANCE0029 Cust. Fleet No.: CITY HALL  
 Y/C Fleet No.: EQ99890 Equipment Type: 100kW Standby Generator Hr. Meter Reading:0

Description of Work Performed	Generator	Quantity	Unit Price Exc	Amount
Line No. 10000	Quoted Field Labor and Travel	6.00	155.00	930.00
10000	CUS - Travel	60.00	2.25	135.00
10000	FUEL HOSE 3/8	10.00	1.78	17.80
10000	GRP 31 BATT 1000CCA CNTR PST	1.00	156.40	156.40
10000	RAD CAP	1.00	32.00	32.00
10000	INJ PUMP DIAGNOSTIC	1.00	350.00	350.00
<b>Total</b>				<b>1,621.20</b>

Service Order Total 1,621.20 1,637.18

Approved By \_\_\_\_\_ PO # \_\_\_\_\_

Signature \_\_\_\_\_ Date \_\_\_\_\_

This estimate is based on operational and visual inspections, upon disassembly of components additional parts and labor may be required to complete the necessary repairs. If the necessary additional repairs are within 10% of the quoted amount customer authorizes the dealer to proceed with the repairs. In the event that the necessary repairs exceed the 10% of the quoted amount then an additional quotation will be required prior to completing the necessary repairs. All quoted repairs are plus applicable sales tax and shipping of non-stock parts.



**SERVICE ESTIMATE**

Item 12.

Quote Number SVQ49141  
 Quote Date March 18, 2020  
 Order Time 9:26:15 AM  
 Contract Number  
 Payment Terms Cash on Delivery  
 PO Number

Fontana Service Department  
 8089 Cherry Aveune  
 Fontana, CA 92336  
 Phone No.. (909) 428-3400 Fax No.. (909) 428-9620  
 C08756

Page 1

Bill CITY OF BEAUMONT - PUBLIC WORKS  
 To 550 E 6TH ST  
 EILEEN RODRIGUEZ  
 Beaumont, CA 92223  
 USA

Ship C08756  
 To CITY OF BEAUMONT - COMM/REC CENTER  
 To 1310 OAK VALLEY PKWY  
 Beaumont, CA 92223  
 USA

Contact EILEEN RODRIGUEZ Phone No. (951) 769-8524  
 E-Mail ERodriguez@beaumontca.gov; jmiranda@beaumontca.g FAX No.

**Job Description: OM REPAIRS**

Comments: Customer COD Call A/R EXT 2299 BEFORE Dispatching Technician  
 PERFORM REPAIRS AS NOTED ON WORK ORDER SVO676658  
 REPLACE THE FOLLOWING:  
 UPPER AND LOWER RAD HOSES AND CLAMPS  
 RAD CAP  
 AIR FILTER  
 GR31 BATTERY X2  
 FUEL LINES  
 HEATER HOSE AND CLAMPS

Manufacturer Code: GEN Model: SD500 Serial No.: 10290350100-2100662 Cust. Fleet No.: COMMUNITY C  
 Y/C Fleet No.: EQ44232 Equipment Type: 500kW Diesel Powered Stb Hr. Meter Reading:0

Description of Work Performed	Generator	Quantity	Unit Price Exc	Amount
10000 Quoted Field Labor and Travel		8.00	155.00	1,240.00
10000 CUS - Travel		60.00	2.25	135.00
10000 CUS - Inbound Freight		1.00	68.00	68.00
10000 COOLING PARTS		1.00	450.00	450.00
10000 COOLANT 50-50		16.00	17.08	273.28
10000 AIRCLNR ECO-II 13.5 X 18LG		1.00	242.30	242.30
10000 GRP 31 BATT 1000CCA CNTR PST		2.00	156.40	312.80
10000 5/8 HEATER HOSE		12.00	4.83	57.96
10000 HOSE CLAMP 5/8 NO 10		4.00	3.63	14.52
10000 FUEL HOSE 3/8		24.00	1.78	42.72
<b>Total</b>				<b>2,836.58</b>

Service Order Total 2,836.58 2,949.85

Approved By \_\_\_\_\_ PO # \_\_\_\_\_

Signature \_\_\_\_\_ Date \_\_\_\_\_

This estimate is based on operational and visual inspections, upon disassembly of components additional parts and labor may be required to complete the necessary repairs. If the necessary additional repairs are within 10% of the quoted amount customer authorizes the dealer to proceed with the repairs. In the event that the necessary repairs exceed the 10% of the quoted amount then an additional quotation will be required prior to completing the necessary repairs. All quoted repairs are plus applicable sales tax and shipping of non-stock parts.



**SERVICE ESTIMATE**

Item 12.

**Quote Number** SVQ49146  
**Quote Date** March 18, 2020  
**Order Time** 9:34:23 AM  
**Contract Number**  
**Payment Terms** Cash on Delivery  
**PO Number**

Fontana Service Department  
 8089 Cherry Aveune  
 Fontana, CA 92336  
 Phone No.. (909) 428-3400 Fax No.. (909) 428-9620  
 C08756

Page 1

**Bill** CITY OF BEAUMONT - PUBLIC WORKS  
**To** 550 E 6TH ST  
 EILEEN RODRIGUEZ  
 Beaumont, CA 92223  
 USA

**Ship** C08756  
**To** CITY OF BEAUMONT - FIRE ST 66  
 628 MAPLE ST  
 Beaumont, CA 92223  
 USA

**Contact** EILEEN RODRIGUEZ  
**E-Mail** ERodriguez@beaumontca.gov; jmiranda@beaumontca.g  
**Phone No.** (951) 769-8524  
**FAX No.**

**Job Description: OM REPAIRS**

**Comments:** Customer COD Call A/R EXT 2299 BEFORE Dispatching Technician  
 PERFORM REPAIRS AS NOTED ON WORK ORDER SVO676760  
 UPPER AND LOWER HOSES AND CLAMPS  
 RAD CAP  
 COOLANT LEVEL SENSOR  
 COOLANT

**Manufacturer Code:** GEN **Model:** QT025 **Serial No.:** 0 **Cust. Fleet No.:** FIRE STATION  
**Y/C Fleet No.:** EQ99895 **Equipment Type:** 25KW Gas Powered Stby G **Hr. Meter Reading:**0

Description of Work Performed		Generator	Quantity	Unit Price Exc	Amount
10000	Quoted Field Labor and Travl		8.00	155.00	1,240.00
10000	CUS - Travel		60.00	2.25	135.00
10000	COOLANT PARTS		1.00	350.00	350.00
10000	COOLANT 50-50		3.00	17.08	51.24
10000	COOLLANT SENSOR KIT		1.00	125.17	125.17
10000	CUS - Inbound Freight		1.00	25.00	25.00
			<b>Total</b>		<b>1,926.41</b>

Serial No. **Service Order Total** 1,926.41 1,969.15  
 25KW Gas Powered Stby G

Approved By \_\_\_\_\_ PO # \_\_\_\_\_

Signature \_\_\_\_\_ Date \_\_\_\_\_

This estimate is based on operational and visual inspections, upon disassembly of components additional parts and labor may be required to complete the necessary repairs. If the necessary additional repairs are within 10% of the quoted amount customer authorizes the dealer to proceed with the repairs. In the event that the necessary repairs exceed the 10% of the quoted amount then an additional quotation will be required prior to completing the necessary repairs. All quoted repairs are plus applicable sales tax and shipping of non-stock parts.



## Staff Report

**TO:** Mayor, and City Council Members  
**FROM:** Jeff Mohlenkamp, Finance Director  
**DATE:** June 2, 2020  
**SUBJECT:** **Approval of Invoice from Riverside County Fire Department for 3rd Quarter Fire Services**

---

### Background and Analysis:

The City of Beaumont maintains a contract with Riverside County Fire Department for applicable fire protection services that are provided by The California Department of Forestry and Fire Protection ("Cal Fire"). Cal Fire provides an estimate of costs for the year during the budgeting process, which is evaluated against the actual invoices as they are received. Invoices are presented to the City on a quarterly basis and are based on actual costs except for support services which follow the budgeted cost estimate.

The City has received the invoice for January 1, 2020, through March 31, 2020, for \$1,006,268.61. The invoice has been reviewed by staff and is in compliance with our contract. The invoice summary has been included as Attachment A.

The budget for this contract for FY 2020 is \$4,390,200. The invoices for the first two quarters are as follows:

1<sup>st</sup> Quarter - \$ 952,444.77 – approved by the City Council  
 2<sup>nd</sup> Quarter - \$1,099,979.11 – approved by the City Council  
 3<sup>rd</sup> Quarter - \$1,006,268.61 – **pending approval**

Total - \$3,058,692.49 – 69.8% of budget expended  $\frac{3}{4}$  of the way through the fiscal year

**Fiscal Impact:**

The cost for this contract is included in the budget and the expenditures are tracking under budget through March of the fiscal year.

**Recommended Action:**

Approve payment of the FY 2020 3rd Quarter Fire Services invoice from Riverside County Fire Department in the amount of \$1,006,268.61.

**Attachments:**

- A. FY 2020 Fire Services Invoice from Riverside County Fire Department



# RIVERSIDE COUNTY FIRE DEPARTMENT

IN COOPERATION WITH  
THE CALIFORNIA DEPARTMENT OF FORESTRY AND FIRE PROTECTION

Item 13.

**Shawn C. Newman ~ Fire Chief**

210 West San Jacinto Avenue • Perris, California 92570 • (951) 940-6900  
• Fax (951) 657-2662 • www.rvcfire.org

PROUDLY SERVING THE  
UNINCORPORATED AREAS  
OF RIVERSIDE COUNTY  
AND THE CITIES OF:

April 30, 2020

- BANNING
- BEAUMONT
- CANYON LAKE
- COACHELLA
- DESERT HOT SPRINGS

City of Beaumont  
Attn: City Manager  
550 E. Sixth Street  
Beaumont, CA 92223

- EASTVALE
- INDIAN WELLS
- INDIO
- JURUPA VALLEY

RE: Fire Protection Services  
3<sup>rd</sup> Qtr. FY 19/20

Please find enclosed invoice #233579 in the amount of \$1,006,268.61 for fire protection services provided for the period of January 1, through March 31, 2020. There are no estimated costs in this invoice for Safety Staffing Personnel. All costs are actual or based on your Exhibit "A".

- LAKE ELSINORE
- LA QUINTA
- MENIFEE
- MORENO VALLEY
- NORCO

Payments can also be made via Wire Transfer or ACH, information as follows:

Union Bank  
1980 Saturn Street  
Monterey Park, CA 91755  
Account Name: Riverside County Treasurer  
ABA #: 122000496  
Account #: 0050173925

- PALM DESERT
- PERRIS
- RANCHO MIRAGE
- RUBIDOUX CSD
- SAN JACINTO
- TEMECULA
- WILDOMAR

Reference information to be included on check, wire transfer or ACH :

**FPARC – City abbreviation, Invoice #, FY, Q# (ie: FPARC-BM,233579,19/20,Q3)**

If you have any questions regarding this billing, please contact Karen Gipson at (951) 940-6333.

Sincerely,  
Shawn C. Newman  
Riverside County Fire Chief

*Karen Gipson*

by:  
Karen Gipson  
Administrative Services Officer

- BOARD OF SUPERVISORS:
- KEVIN JEFFRIES  
DISTRICT 1
- KAREN SPIEGEL  
DISTRICT 2
- CHARLES WASHINGTON  
DISTRICT 3
- V. MANUEL PEREZ  
DISTRICT 4
- JEFF HEWITT  
DISTRICT 5

KG: mrm  
Enclosures

cc: DC Todd Hopkins  
Chief Smith  
Chief Otterman





# Riverside County Fire Department

210 West San Jacinto Avenue  
 Perris, CA 92570  
 Ph: (951) 940-6900  
 Fx: (951) 657-2662

# Invoice

Item 13.

FIRE PROTECTION SERVICES

Date	Invoice #
4/30/2020	233579
<b>Make Remittance Payable to:</b>	
County of Riverside Fire Department 210 W. San Jacinto Ave. Perris, CA 92570	

City of Beaumont  
 Attn: City Manager  
 550 E. Sixth Street  
 Beaumont, CA 92223

**FIRE PROTECTION SERVICES FURNISHED FOR THE PERIOD OF: JAN- MAR FY 19/20 Q3**

Description	Amount
***** ACTUAL BILLING *****	
SAFETY STAFFING COST INCLUDING BENEFITS (CAL-Fire Employees): PCA # 37101	
AO17 for the month of: JANUARY 2020	185,571.15
AO17 for the month of: FEBRUARY 2020	183,753.74
AO17 for the month of: MARCH 2020	182,202.65
Subtotal	551,527.54
State's Administrative Charge Pass Thru: 0.1169	64,473.57
Total Safety Staffing Cost	616,001.11
NON-SAFETY STAFFING COSTS (County Employees):	
For the 3rd Qtr	30,882.57
HR Overhead Charges - Qtr 3	328.05
Subtotal	31,210.62
SUPPORT SERVICES (Cooperative Agreement):	
Quarterly Service Delivery Costs (\$780,744.00 Yearly)	195,186.00
Subtotal	195,186.00
FIRE ENGINE USE AGREEMENT:	
Fire Engine - 2 (\$25,800.00 each = \$51,600.00 Yearly)	12,900.00
Subtotal	12,900.00
TAX CREDIT:	
NOT APPLICABLE	0.00
Subtotal	0.00
MISCELLANEOUS COSTS & DIRECT CHARGES:	
Banning - Sta # 20 Cooperative Agreement PCA # 37129	147,934.03
3rd Qtr Direct Charges	8,161.90
3rd Qtr Direct Journals	0.00
AMR Transport Costs Reimb.: FY 19/20 Q3	-5,125.05
Subtotal	150,970.88
INVOICE SUBTOTAL	1,006,268.61

**Please Pay this Amount \$1,006,268.61**

FOR INTERNAL USE ONLY:

27002- \_\_\_\_\_ - \$ \_\_\_\_\_  
 27004- \_\_\_\_\_ - \$ \_\_\_\_\_  
 2700200000-230100- \$ \_\_\_\_\_ FP\_HAZMAT\_VEH

AO17

California Department of Forestry and Fire Protection



Billing Period: 1/1/2020

RRU	SOUTHERN REGION	INDEX 3100	PCA 37101	RIVERSIDE COUNTY-BEAUMONT
-----	-----------------	------------	-----------	---------------------------

Gross Expenditures: \$185,571.15

Administrative Charge: .0647 12,006.45

Statewide Pro Rata: .0522 9,686.81

GRAND TOTAL: \$207,264.41

Prepared by: <i>Maria Silva</i>	Date Sent to Accounting: <i>2-20-20</i>
Approved by: <i>[Signature]</i>	Date: <i>2-20-20</i>

Print Date: 02/19/2020 2:59PM Ver 1.8

Prepared by: <i>Maria Silva</i>	Date Sent to Accounting:
Approved by: <i>[Signature]</i>	Date: <i>2-20-20</i>

Print Date: 02/19/2020 2:59PM Ver 1.8

RRU	SOUTHERN REGION	INDEX 3100	PCA 37101	RIVERSIDE COUNTY-BEAUMONT
-----	-----------------	------------	-----------	---------------------------

**Safety - BU (08)  
PERSONNEL SALARIES**

<u>CLASS</u>	<u>SERIAL</u>	<u>NAME</u>	<u>%</u>	<u>SALARY</u>	<u>DAYS</u>	<u>HOURS</u>	<u>AMOUNT</u>
FIRE APPARATUS ENGINEER	201	BALESTRACCI, PIETRO D	100.00	4,342.00	22.00	0.00	4,342.00
FIRE APPARATUS ENGINEER	200	ROHRABAUGH, JOHN R	100.00	4,597.00	22.00	0.00	4,597.00
FIRE APPARATUS ENGINEER (PARAME	642	DUTTON, RYAN	100.00	5,325.00	22.00	0.00	5,325.00
FIRE APPARATUS ENGINEER (PARAME	646	JUAREZ II, GUADALUPE	100.00	5,325.00	22.00	0.00	5,325.00
FIRE CAPTAIN	624	GHILONI, RICHARD M	100.00	5,822.40	22.00	0.00	5,822.40
FIRE FIGHTER II	739	BRENNAN, NICHOLAS L	100.00	3,789.00	22.00	0.00	3,789.00
FIRE FIGHTER II	762	CLIFFORD, EDDIE D	100.00	4,872.88	22.00	0.00	4,872.88
FIRE FIGHTER II	758	HOLMES, JACOB B	100.00	4,484.00	22.00	0.00	4,484.00
FIRE FIGHTER II (PARAMEDIC)	638	HAYS, DEVON D	100.00	4,872.00	22.00	0.00	4,872.00
FIRE FIGHTER II (PARAMEDIC)	710	MEZA, RENEE	100.00	4,396.00	22.00	0.00	4,396.00
FIRE FIGHTER II (PARAMEDIC)	203	OCONNOR, CHRISTOPHER J	100.00	4,797.00	22.00	0.00	4,797.00
FIRE FIGHTER II (PARAMEDIC)	739	WADLUND, JAMES E	100.00	3,798.00	22.00	0.00	3,798.00
Total:							56,420.28
Staff Benefits 0.9160:							51,680.98
Total with Benefits:							\$108,101.26

RRU	SOUTHERN REGION	INDEX 3100	PCA 37101	RIVERSIDE COUNTY-BEAUMONT
-----	-----------------	------------	-----------	---------------------------

**UNIFORM - SAFETY**

<u>CLASS</u>	<u>NAME</u>	<u>DESCRIPTION</u>	<u>RATE</u>	<u>%</u>	<u>AMOUNT</u>
FIRE APPARATUS ENGINEER	BALESTRACCI, PIETRO D	Permanent Fulltime Wearer	177.50	100.00	177.50
FIRE APPARATUS ENGINEER	ROHRABAUGH, JOHN R	Permanent Fulltime Wearer	177.50	100.00	177.50
FIRE APPARATUS ENGINEER (PARAM	DUTTON, RYAN	Permanent Fulltime Wearer	177.50	100.00	177.50
FIRE APPARATUS ENGINEER (PARAM	JUAREZ II, GUADALUPE	Permanent Fulltime Wearer	177.50	100.00	177.50
FIRE CAPTAIN	GHILONI, RICHARD M	Permanent Fulltime Wearer	177.50	100.00	177.50
FIRE FIGHTER II	BRENNAN, NICHOLAS L	Permanent Fulltime Wearer	177.50	100.00	177.50
FIRE FIGHTER II	CLIFFORD, EDDIE D	Permanent Fulltime Wearer	177.50	100.00	177.50
FIRE FIGHTER II	HOLMES, JACOB B	Permanent Fulltime Wearer	177.50	100.00	177.50
FIRE FIGHTER II (PARAMEDIC)	HAYS, DEVON D	Permanent Fulltime Wearer	177.50	100.00	177.50
FIRE FIGHTER II (PARAMEDIC)	MEZA, RENEE	Permanent Fulltime Wearer	177.50	100.00	177.50
FIRE FIGHTER II (PARAMEDIC)	OCONNOR, CHRISTOPHER J	Permanent Fulltime Wearer	177.50	100.00	177.50
FIRE FIGHTER II (PARAMEDIC)	WADLUND, JAMES E	Permanent Fulltime Wearer	177.50	100.00	177.50
Total:					2,130.00
Staff Benefits :0.0145					30.89
Total with Benefits:					\$2,160.89

RRU	SOUTHERN REGION	INDEX 3100	PCA 37101	RIVERSIDE COUNTY-BEAUMONT
-----	-----------------	------------	-----------	---------------------------

**EXTENDED DUTY WEEK COMP - SAFETY**

<u>CLASS</u>	<u>SERIAL</u>	<u>NAME</u>	<u>WP</u>	<u>SALARY</u>	<u>HOURS</u>	<u>RATE</u>	<u>AMOUNT</u>
FIRE APPARATUS ENGINEER	201	BALESTRACCI, PIETRO D	414	4,342.00	76.00	26.87	2,042.12
FIRE APPARATUS ENGINEER	200	ROHRABAUGH, JOHN R	414	4,597.00	76.00	28.44	2,161.44
FIRE APPARATUS ENGINEER (PAF)	642	DUTTON, RYAN	414	5,825.00	76.00	36.03	2,738.28
FIRE APPARATUS ENGINEER (PAF)	646	JUAREZ II, GUADALUPE	414	5,825.00	76.00	36.03	2,738.28
FIRE CAPTAIN	624	GHILONI, RICHARD M	414	5,822.40	76.00	36.02	2,737.52
FIRE FIGHTER II	739	BRENNAN, NICHOLAS L	414	3,789.00	76.00	23.45	1,782.20
FIRE FIGHTER II	762	CLIFFORD, EDDIE D	414	4,872.88	76.00	30.15	2,291.40
FIRE FIGHTER II	758	HOLMES, JACOB B	414	4,484.00	76.00	27.74	2,108.24
FIRE FIGHTER II (PARAMEDIC)	638	HAYS, DEVON D	414	5,372.00	76.00	33.23	2,525.48
FIRE FIGHTER II (PARAMEDIC)	710	MEZA, RENEE	414	5,051.00	76.00	31.25	2,375.00
FIRE FIGHTER II (PARAMEDIC)	203	OCONNOR, CHRISTOPHER J	414	5,147.00	76.00	31.85	2,420.60
FIRE FIGHTER II (PARAMEDIC)	739	WADLUND, JAMES E	414	4,203.00	76.00	26.00	1,976.00
<b>Total:</b>							<b>27,896.56</b>
Staff Benefits .5504:							15,354.27
<b>Total with Benefits:</b>							<b>\$43,250.83</b>

**OVERTIME - SAFETY**

<u>CLASS</u>	<u>SERIAL</u>	<u>NAME</u>	<u>WP</u>	<u>SALARY</u>	<u>HOURS</u>	<u>RATE</u>	<u>AMOUNT</u>
FIRE APPARATUS ENGINEER	510	ESPARZA, MICHAEL A	414	5,348.22	24.00	33.09	794.16
FIRE APPARATUS ENGINEER	509	GRINSTEAD, TRENTON R	414	4,463.00	24.00	27.62	662.88
FIRE APPARATUS ENGINEER	607	LACBAIN, BRIAN	414	4,974.00	24.00	30.77	738.48
FIRE APPARATUS ENGINEER	618	LEMUS, TOMMY V	414	5,198.74	24.00	32.16	771.84
FIRE APPARATUS ENGINEER	200	ROHRABAUGH, JOHN R	414	4,597.00	60.00	28.44	1,706.40
FIRE APPARATUS ENGINEER	658	RUTZINGER, JASON D	414	4,974.00	24.00	30.77	738.48
FIRE APPARATUS ENGINEER	624	RYE, TRAVIS J	414	5,351.68	48.00	33.11	1,589.28
FIRE APPARATUS ENGINEER (PAF)	642	DUTTON, RYAN	414	5,825.00	1.50	36.03	54.05
FIRE APPARATUS ENGINEER (PAF)	636	GEBHARDT, JACOB E	414	5,590.00	50.00	34.58	1,729.00
FIRE APPARATUS ENGINEER (PAF)	646	JUAREZ II, GUADALUPE	414	5,825.00	48.00	36.03	1,729.44
FIRE APPARATUS ENGINEER (PAF)	662	MUSSELMAN, ROBERT A	414	6,050.00	46.00	37.43	1,721.78
FIRE APPARATUS ENGINEER (PAF)	631	WIER, JEREMY C	414	5,825.00	96.00	36.03	3,458.88
FIRE CAPTAIN	507	BERNARDO, EVAN C	414	5,965.63	48.00	36.90	1,771.20
FIRE CAPTAIN	508	BRYANT, WILLIAM K	414	5,822.40	48.00	36.02	1,728.96
FIRE CAPTAIN	624	GHILONI, RICHARD M	414	5,822.40	2.00	36.02	72.04
FIRE CAPTAIN	627	LOPEZ, JAMES F	414	5,822.40	24.00	36.02	864.48
FIRE CAPTAIN (PARAMEDIC)	625	DAVIS, KRISTOFER L	414	6,512.00	24.00	40.29	966.96
FIRE CAPTAIN (PARAMEDIC)	630	LINNEMANN, CHRISTIAN R	414	6,698.00	24.00	41.43	994.32
FIRE FIGHTER II	739	BRENNAN, NICHOLAS L	414	3,789.00	6.00	23.45	140.70

RRU	SOUTHERN REGION	INDEX 3100	PCA 37101	RIVERSIDE COUNTY-BEAUMONT
-----	-----------------	------------	-----------	---------------------------

**OVERTIME - SAFETY**

<u>CLASS</u>	<u>SERIAL</u>	<u>NAME</u>	<u>WP</u>	<u>SALARY</u>	<u>HOURS</u>	<u>RATE</u>	<u>AMOUNT</u>
FIRE FIGHTER II	758	HOLMES, JACOB B	414	4,484.00	6.00	27.74	166.44
FIRE FIGHTER II	202	WEIDEMANN, KRISTOFER T	414	4,484.00	24.00	27.74	665.76
FIRE FIGHTER II (PARAMEDIC)	725	DYER, CHRISTOPHER B	414	4,048.00	25.00	25.04	626.00
FIRE FIGHTER II (PARAMEDIC)	776	GARRETT III, CREAVONE L	414	5,297.00	5.50	32.78	180.29
FIRE FIGHTER II (PARAMEDIC)	241	GENTRY-COTTRELL, AUSTIN	414	5,288.66	24.00	32.72	785.28
FIRE FIGHTER II (PARAMEDIC)	638	HAYS, DEVON D	414	5,372.00	1.00	33.23	33.23
FIRE FIGHTER II (PARAMEDIC)	235	KING, SPENCER J	414	4,537.00	24.00	28.07	673.68
FIRE FIGHTER II (PARAMEDIC)	659	LABELLA, KORY N	414	4,048.00	24.00	25.04	600.96
FIRE FIGHTER II (PARAMEDIC)	686	MILLEMANN, BENJAMIN G	414	4,203.00	24.00	26.00	624.00
FIRE FIGHTER II (PARAMEDIC)	203	OCONNOR, CHRISTOPHER J	414	5,147.00	68.00	31.85	2,165.80
FIRE FIGHTER II (PARAMEDIC)	221	VOTAW, ADAM M	414	5,419.03	24.00	33.53	804.72
FIRE FIGHTER II (PARAMEDIC)	739	WADLUND, JAMES E	414	4,203.00	54.00	26.00	1,404.00
FIRE FIGHTER II (PARAMEDIC)	657	WILLIMAN, BRIAN D	414	4,288.00	24.00	26.52	636.48
Total:							31,599.97
Staff Benefits .0145:							458.20
Total with Benefits:							\$32,058.17

AO17

California Department of Forestry and Fire Protection



Billing Period: 2/1/2020

RRU	SOUTHERN REGION	INDEX 3100	PCA 37101	RIVERSIDE COUNTY-BEAUMONT
-----	-----------------	------------	-----------	---------------------------

<b>Gross Expenditures:</b>		\$183,753.74
<b>Administrative Charge:</b>	.0647	11,888.87
<b>Statewide Pro Rata:</b>	.0522	9,591.95

**GRAND TOTAL: \$205,234.56**

Prepared by: *Ustena Lopez*  
 Approved by: *Benny L. Aron*

Print Date: 03/16/2020 1:23 PM Ver 1.6

Prepared by: <i>Ustena Lopez</i>	Date Sent to Accounting:
Approved by: <i>Benny L. Aron</i>	Date: <i>3/17/2020</i>

Print Date: 03/16/2020 1:23PM Ver 1.8

Billing Period:

RRU	SOUTHERN REGION	INDEX 3100	PCA 37101	RIVERSIDE COUNTY-BEAUMONT
-----	-----------------	------------	-----------	---------------------------

**Safety - BU (08)  
PERSONNEL SALARIES**

<u>CLASS</u>	<u>SERIAL</u>	<u>NAME</u>	<u>%</u>	<u>SALARY</u>	<u>DAYS</u>	<u>HOURS</u>	<u>AMOUNT</u>
FIRE APPARATUS ENGINEER	201	BALESTRACCI, PIETRO D	100.00	4,342.00	21.00	0.00	4,342.00
FIRE APPARATUS ENGINEER	200	ROHRABAUGH, JOHN R	100.00	4,827.00	21.00	0.00	4,827.00
FIRE APPARATUS ENGINEER (PARAMEDIC)	642	DUTTON, RYAN	100.00	5,325.00	21.00	0.00	5,325.00
FIRE APPARATUS ENGINEER (PARAMEDIC)	646	JUAREZ II, GUADALUPE	100.00	5,325.00	21.00	0.00	5,325.00
FIRE CAPTAIN	624	GHILONI, RICHARD M	100.00	5,822.40	21.00	0.00	5,822.40
FIRE FIGHTER II	739	BRENNAN, NICHOLAS L	100.00	3,789.00	21.00	0.00	3,789.00
FIRE FIGHTER II	762	CLIFFORD, EDDIE D	100.00	4,872.88	21.00	0.00	4,872.88
FIRE FIGHTER II	758	HOLMES, JACOB B	100.00	4,484.00	21.00	0.00	4,484.00
FIRE FIGHTER II (PARAMEDIC)	638	HAYS, DEVON D	100.00	4,872.00	21.00	0.00	4,872.00
FIRE FIGHTER II (PARAMEDIC)	710	MEZA, RENEE	100.00	4,396.00	21.00	0.00	4,396.00
FIRE FIGHTER II (PARAMEDIC)	203	OCONNOR, CHRISTOPHER J	100.00	4,797.00	21.00	0.00	4,797.00
FIRE FIGHTER II (PARAMEDIC)	739	WADLUND, JAMES E	100.00	3,798.00	21.00	0.00	3,798.00
Total:							56,650.28
Staff Benefits 0.9160:							51,891.66
Total with Benefits:							\$108,541.94



RRU	SOUTHERN REGION	INDEX 3100	PCA 37101	RIVERSIDE COUNTY-BEAUMONT
-----	-----------------	------------	-----------	---------------------------

**UNIFORM - SAFETY**

<u>CLASS</u>	<u>NAME</u>	<u>DESCRIPTION</u>	<u>RATE</u>	<u>%</u>	<u>AMOUNT</u>
FIRE APPARATUS ENGINEER	BALESTRACCI, PIETRO D	Permanent Fulltime Wearer	177.50	100.00	177.50
FIRE APPARATUS ENGINEER	ROHRABAUGH, JOHN R	Permanent Fulltime Wearer	177.50	100.00	177.50
FIRE APPARATUS ENGINEER (PARAM	DUTTON, RYAN	Permanent Fulltime Wearer	177.50	100.00	177.50
FIRE APPARATUS ENGINEER (PARAM	JUAREZ II, GUADALUPE	Permanent Fulltime Wearer	177.50	100.00	177.50
FIRE CAPTAIN	GHILONI, RICHARD M	Permanent Fulltime Wearer	177.50	100.00	177.50
FIRE FIGHTER II	BRENNAN, NICHOLAS L	Permanent Fulltime Wearer	177.50	100.00	177.50
FIRE FIGHTER II	CLIFFORD, EDDIE D	Permanent Fulltime Wearer	177.50	100.00	177.50
FIRE FIGHTER II	HOLMES, JACOB B	Permanent Fulltime Wearer	177.50	100.00	177.50
FIRE FIGHTER II (PARAMEDIC)	HAYS, DEVON D	Permanent Fulltime Wearer	177.50	100.00	177.50
FIRE FIGHTER II (PARAMEDIC)	MEZA, RENEE	Permanent Fulltime Wearer	177.50	100.00	177.50
FIRE FIGHTER II (PARAMEDIC)	OCONNOR, CHRISTOPHER J	Permanent Fulltime Wearer	177.50	100.00	177.50
FIRE FIGHTER II (PARAMEDIC)	WADLUND, JAMES E	Permanent Fulltime Wearer	177.50	100.00	177.50
Total:					2,130.00
Staff Benefits :0.0145					30.89
Total with Benefits:					\$2,160.89

Billing Period:

RRU	SOUTHERN REGION	INDEX 3100	PCA 37101	RIVERSIDE COUNTY-BEAUMONT
-----	-----------------	------------	-----------	---------------------------

**OVERTIME - SAFETY**

<u>CLASS</u>	<u>SERIAL</u>	<u>NAME</u>	<u>WP</u>	<u>SALARY</u>	<u>HOURS</u>	<u>RATE</u>	<u>AMOUNT</u>
FIRE CAPTAIN	711	AYERS, DONALD R	415	5,934.00	24.00	36.71	881.04
FIRE CAPTAIN	624	GHILONI, RICHARD M	415	5,822.40	5.00	36.02	180.10
FIRE CAPTAIN	202	KOLODZIK, KARL F	415	5,718.00	12.00	35.37	424.44
FIRE CAPTAIN	677	WHITAKER, MICHAEL R	415	5,298.00	24.00	32.78	786.72
FIRE CAPTAIN	742	WINANS, THOMAS	415	5,655.00	24.00	34.98	839.52
FIRE FIGHTER II	654	BENNETT, EVAN A	415	3,893.00	48.00	24.09	1,156.32
FIRE FIGHTER II	739	BRENNAN, NICHOLAS L	415	3,789.00	12.00	23.45	281.40
FIRE FIGHTER II	739	BRENNAN, NICHOLAS L	415	3,789.00	8.00	23.45	187.60
FIRE FIGHTER II	866	CLASS, TAYLOR M	415	4,485.66	24.00	27.75	666.00
FIRE FIGHTER II	758	HOLMES, JACOB B	415	4,484.00	5.00	27.74	138.70
FIRE FIGHTER II	209	WALDRON, THOMAS R	415	4,484.00	24.00	27.74	665.76
FIRE FIGHTER II (PARAMEDIC)	733	GOODBAN, DALE J	415	5,447.00	24.00	33.69	808.56
FIRE FIGHTER II (PARAMEDIC)	203	OCONNOR, CHRISTOPHER J	415	5,147.00	48.00	31.85	1,528.80
FIRE FIGHTER II (PARAMEDIC)	739	WADLUND, JAMES E	415	4,203.00	102.00	26.00	2,652.00

Total: 29,109.68

Staff Benefits .0145: 422.09

Total with Benefits: \$29,531.77

AO17

California Department of Forestry and Fire Protection



Billing Period: 3/1/2020

RRU	SOUTHERN REGION	INDEX 3100	PCA 37101	RIVERSIDE COUNTY-BEAUMONT
-----	-----------------	------------	-----------	---------------------------

<b>Gross Expenditures:</b>		\$182,202.65
<b>Administrative Charge:</b>	.0647	11,788.51
<b>Statewide Pro Rata:</b>	.0522	9,510.98
		<hr/>
<b>GRAND TOTAL:</b>		<b>\$203,502.14</b>

Prepared by: <i>Maria Silva</i>	Date Sent to Accounting:
Approved by:	Date:

Print Date: 04/15/2020 5:52PM Ver 1.8

Billing Period:

RRU	SOUTHERN REGION	INDEX 3100	PCA 37101	RIVERSIDE COUNTY-BEAUMONT
-----	-----------------	------------	-----------	---------------------------

## Safety - BU (08)

## PERSONNEL SALARIES

<u>CLASS</u>	<u>SERIAL</u>	<u>NAME</u>	<u>%</u>	<u>SALARY</u>	<u>DAYS</u>	<u>HOURS</u>	<u>AMOUNT</u>
FIRE APPARATUS ENGINEER	201	BALESTRACCI, PIETRO D	100.00	4,342.00	10.00	0.00	1,973.64
FIRE APPARATUS ENGINEER	200	ROHRABAUGH, JOHN R	100.00	4,827.00	22.00	0.00	4,827.00
FIRE APPARATUS ENGINEER (PARAME	642	DUTTON, RYAN	100.00	5,325.00	22.00	0.00	5,325.00
FIRE APPARATUS ENGINEER (PARAME	646	JUAREZ II, GUADALUPE	100.00	5,325.00	22.00	0.00	5,325.00
FIRE CAPTAIN	624	GHILONI, RICHARD M	100.00	5,822.40	22.00	0.00	5,822.40
FIRE FIGHTER II	739	BRENNAN, NICHOLAS L	100.00	3,789.00	22.00	0.00	3,789.00
FIRE FIGHTER II	762	CLIFFORD, EDDIE D	100.00	4,872.88	22.00	0.00	4,872.88
FIRE FIGHTER II	758	HOLMES, JACOB B	100.00	4,484.00	22.00	0.00	4,484.00
FIRE FIGHTER II (PARAMEDIC)	638	HAYS, DEVON D	100.00	4,872.00	22.00	0.00	4,872.00
FIRE FIGHTER II (PARAMEDIC)	710	MEZA, RENEE	100.00	4,616.00	22.00	0.00	4,616.00
FIRE FIGHTER II (PARAMEDIC)	203	OCONNOR, CHRISTOPHER J	100.00	4,797.00	22.00	0.00	4,797.00
FIRE FIGHTER II (PARAMEDIC)	739	WADLUND, JAMES E	100.00	3,798.00	22.00	0.00	3,798.00
Total:							54,501.92
Staff Benefits 0.9160:							49,923.76
Total with Benefits:							\$104,425.68

RRU	SOUTHERN REGION	INDEX 3100	PCA 37101	RIVERSIDE COUNTY-BEAUMONT
-----	-----------------	------------	-----------	---------------------------

**UNIFORM - SAFETY**

<u>CLASS</u>	<u>NAME</u>	<u>DESCRIPTION</u>	<u>RATE</u>	<u>%</u>	<u>AMOUNT</u>
FIRE APPARATUS ENGINEER	ROHRABAUGH, JOHN R	Permanent Fulltime Wearer	177.50	100.00	177.50
FIRE APPARATUS ENGINEER (PARAM	DUTTON, RYAN	Permanent Fulltime Wearer	177.50	100.00	177.50
FIRE APPARATUS ENGINEER (PARAM	JUAREZ II, GUADALUPE	Permanent Fulltime Wearer	177.50	100.00	177.50
FIRE CAPTAIN	GHILONI, RICHARD M	Permanent Fulltime Wearer	177.50	100.00	177.50
FIRE FIGHTER II	BRENNAN, NICHOLAS L	Permanent Fulltime Wearer	177.50	100.00	177.50
FIRE FIGHTER II	CLIFFORD, EDDIE D	Permanent Fulltime Wearer	177.50	100.00	177.50
FIRE FIGHTER II	HOLMES, JACOB B	Permanent Fulltime Wearer	177.50	100.00	177.50
FIRE FIGHTER II (PARAMEDIC)	HAYS, DEVON D	Permanent Fulltime Wearer	177.50	100.00	177.50
FIRE FIGHTER II (PARAMEDIC)	MEZA, RENEE	Permanent Fulltime Wearer	177.50	100.00	177.50
FIRE FIGHTER II (PARAMEDIC)	OCONNOR, CHRISTOPHER J	Permanent Fulltime Wearer	177.50	100.00	177.50
FIRE FIGHTER II (PARAMEDIC)	WADLUND, JAMES E	Permanent Fulltime Wearer	177.50	100.00	177.50
Total:					1,952.50
Staff Benefits :0.0145					28.31
Total with Benefits:					\$1,980.81

RRU	SOUTHERN REGION	INDEX 3100	PCA 37101	RIVERSIDE COUNTY-BEAUMONT
-----	-----------------	------------	-----------	---------------------------

**EXTENDED DUTY WEEK COMP - SAFETY**

<u>CLASS</u>	<u>SERIAL</u>	<u>NAME</u>	<u>WP</u>	<u>SALARY</u>	<u>HOURS</u>	<u>RATE</u>	<u>AMOUNT</u>
FIRE APPARATUS ENGINEER	201	BALESTRACCI, PIETRO D	416	4,342.00	57.00	26.87	1,531.59
FIRE APPARATUS ENGINEER	200	ROHRABAUGH, JOHN R	416	4,982.00	76.00	30.83	2,343.08
FIRE APPARATUS ENGINEER (PAF)	642	DUTTON, RYAN	416	5,825.00	76.00	36.03	2,738.28
FIRE APPARATUS ENGINEER (PAF)	646	JUAREZ II, GUADALUPE	416	5,825.00	76.00	36.03	2,738.28
FIRE CAPTAIN	624	GHILONI, RICHARD M	416	5,822.40	76.00	36.02	2,737.52
FIRE FIGHTER II	739	BRENNAN, NICHOLAS L	416	3,789.00	76.00	23.45	1,782.20
FIRE FIGHTER II	762	CLIFFORD, EDDIE D	416	4,872.88	76.00	30.15	2,291.40
FIRE FIGHTER II	758	HOLMES, JACOB B	416	4,484.00	76.00	27.74	2,108.24
FIRE FIGHTER II (PARAMEDIC)	638	HAYS, DEVON D	416	5,372.00	76.00	33.23	2,525.48
FIRE FIGHTER II (PARAMEDIC)	710	MEZA, RENEE	416	5,271.00	57.00	32.61	1,858.77
FIRE FIGHTER II (PARAMEDIC)	710	MEZA, RENEE	416	5,051.00	19.00	31.25	593.75
FIRE FIGHTER II (PARAMEDIC)	203	OCONNOR, CHRISTOPHER J	416	5,297.00	63.00	32.78	2,065.14
FIRE FIGHTER II (PARAMEDIC)	203	OCONNOR, CHRISTOPHER J	416	5,147.00	13.00	31.85	414.05
FIRE FIGHTER II (PARAMEDIC)	739	WADLUND, JAMES E	416	4,203.00	76.00	26.00	1,976.00
Total:							27,703.78
Staff Benefits .5504:							15,248.16
Total with Benefits:							\$42,951.94

**OVERTIME - SAFETY**

<u>CLASS</u>	<u>SERIAL</u>	<u>NAME</u>	<u>WP</u>	<u>SALARY</u>	<u>HOURS</u>	<u>RATE</u>	<u>AMOUNT</u>
FIRE APPARATUS ENGINEER	201	BALESTRACCI, PIETRO D	416	4,342.00	12.00	26.87	322.44
FIRE APPARATUS ENGINEER	661	EGAN, MICHAEL E	416	4,974.00	24.00	30.77	738.48
FIRE APPARATUS ENGINEER	510	ESPARZA, MICHAEL A	416	5,348.22	48.00	33.09	1,588.32
FIRE APPARATUS ENGINEER	768	HERNANDEZ, LUIS A	416	4,273.66	24.00	26.43	634.32
FIRE APPARATUS ENGINEER	745	JOHNSON, LAWRENCE C	416	5,049.00	133.00	31.23	4,153.59
FIRE APPARATUS ENGINEER	720	MCGOWAN, KENNETH J	416	4,132.00	24.00	25.56	613.44
FIRE APPARATUS ENGINEER	746	VASQUEZ, CARLOS A	416	4,974.00	24.00	30.77	738.48
FIRE APPARATUS ENGINEER (PAF)	642	DUTTON, RYAN	416	5,825.00	20.00	36.03	720.60
FIRE APPARATUS ENGINEER (PAF)	646	JUAREZ II, GUADALUPE	416	5,825.00	48.00	36.03	1,729.44
FIRE APPARATUS ENGINEER (PAF)	633	KATULS, JUSTIN A	416	5,825.00	24.00	36.03	864.72
FIRE APPARATUS ENGINEER (PAF)	650	MURRAY, STEVEN D	416	5,464.00	24.00	33.80	811.20
FIRE APPARATUS ENGINEER (PAF)	631	WIER, JEREMY C	416	5,825.00	120.00	36.03	4,323.60
FIRE CAPTAIN	508	BRYANT, WILLIAM K	416	5,822.40	24.00	36.02	864.48
FIRE CAPTAIN	767	CAMP JR, DON L	416	5,710.80	24.00	35.33	847.92
FIRE CAPTAIN	218	DELEON, JUAN R	416	5,389.00	24.00	33.33	799.92
FIRE CAPTAIN	624	GHILONI, RICHARD M	416	5,822.40	44.00	36.02	1,584.88
FIRE CAPTAIN	702	MCNALLY, KEVIN J	416	5,878.20	24.00	36.36	872.64

RRU	SOUTHERN REGION	INDEX 3100	PCA 37101	RIVERSIDE COUNTY-BEAUMONT
-----	-----------------	------------	-----------	---------------------------

**OVERTIME - SAFETY**

<u>CLASS</u>	<u>SERIAL</u>	<u>NAME</u>	<u>WP</u>	<u>SALARY</u>	<u>HOURS</u>	<u>RATE</u>	<u>AMOUNT</u>
FIRE CAPTAIN	750	SPERLICH, ALEXANDER	416	5,655.00	24.00	34.98	839.52
FIRE CAPTAIN	685	VOIGT, TIMOTHY L	416	5,655.00	24.00	34.98	839.52
FIRE CAPTAIN (PARAMEDIC)	625	DAVIS, KRISTOFER L	416	6,512.00	12.00	40.29	483.48
FIRE FIGHTER II	654	BENNETT, EVAN A	416	4,088.00	24.00	25.29	606.96
FIRE FIGHTER II	866	CLASS, TAYLOR M	416	4,485.66	38.00	27.75	1,054.50
FIRE FIGHTER II	762	CLIFFORD, EDDIE D	416	4,872.88	24.00	30.15	723.60
FIRE FIGHTER II	758	HOLMES, JACOB B	416	4,484.00	48.00	27.74	1,331.52
FIRE FIGHTER II	202	WEIDEMANN, KRISTOFER T	416	4,484.00	24.00	27.74	665.76
FIRE FIGHTER II (PARAMEDIC)	638	HAYS, DEVON D	416	5,372.00	58.00	33.23	1,927.34
FIRE FIGHTER II (PARAMEDIC)	659	LABELLA, KORY N	416	4,048.00	14.00	25.04	350.56
FIRE FIGHTER II (PARAMEDIC)	710	MEZA, RENEE	416	5,271.00	12.00	32.61	391.32
FIRE FIGHTER II (PARAMEDIC)	203	OCONNOR, CHRISTOPHER J	416	5,297.00	24.00	32.78	786.72
FIRE FIGHTER II (PARAMEDIC)	221	VOTAW, ADAM M	416	5,494.03	24.00	33.53	804.72
Total:							33,013.99
Staff Benefits .0145:							478.70
Total with Benefits:							\$33,492.69

Billing Period:

RRU	SOUTHERN REGION	INDEX 3100	PCA 37101	RIVERSIDE COUNTY-BEAUMONT
-----	-----------------	------------	-----------	---------------------------

**OPERATING EXPENSES AND EQUIPMENT**

	<u>CATEGORY</u>	<u>REMARKS</u>	<u>RATE</u>	<u>%</u>	<u>AMOUNT</u>
ADMIN	MISCELLANEOUS	SEE EXPENDITURE REPORT	1197.51	100.00	1,197.51
				Total:	<u>\$1,197.51</u>



Billing Period:

RRU	SOUTHERN REGION	INDEX 3100	PCA 37101	RIVERSIDE COUNTY-BEAUMONT
-----	-----------------	------------	-----------	---------------------------

**RETROACTIVE CHARGES**

Safety - 08

**PERSONNEL SALARIES**

<u>CLASS</u>	<u>SERIAL</u>	<u>NAME</u>		<u>%</u>	<u>SALARY</u>	<u>DAYS</u>	<u>HOURS</u>	<u>AMOUNT</u>
FIRE FIGHTER II (PARAMEDIC)	710	MEZA, RENEE	01/01/2020	100.00	4,396.00	0.00	0.00	-1,598.55
							Total:	-1,598.55
							Staff Benefits .9160:	-1,464.27
							Total with Benefits:	\$-3,062.82

Billing Period:

RRU	SOUTHERN REGION	INDEX 3100	PCA 37101	RIVERSIDE COUNTY-BEAUMONT
-----	-----------------	------------	-----------	---------------------------

**RETROACTIVE CHARGES**

**EXTENDED DUTY WEEK COMP - SAFETY**

<u>CLASS</u>	<u>SERIAL</u>	<u>NAME</u>	<u>WP</u>	<u>SALARY</u>	<u>HOURS</u>	<u>RATE</u>	<u>AMOUNT</u>
FIRE APPARATUS ENGINEER	200	ROHRABAUGH, JOHN R	407	4,752.00	38.00	0.96	36.48
FIRE APPARATUS ENGINEER	200	ROHRABAUGH, JOHN R	407	4,629.00	38.00	0.96	36.48
FIRE APPARATUS ENGINEER	200	ROHRABAUGH, JOHN R	408	4,752.00	76.00	0.96	72.96
FIRE APPARATUS ENGINEER	200	ROHRABAUGH, JOHN R	409	4,752.00	76.00	0.96	72.96
FIRE APPARATUS ENGINEER	200	ROHRABAUGH, JOHN R	410	4,752.00	76.00	0.96	72.96
FIRE APPARATUS ENGINEER	200	ROHRABAUGH, JOHN R	411	4,752.00	76.00	0.96	72.96
FIRE APPARATUS ENGINEER	200	ROHRABAUGH, JOHN R	412	4,752.00	76.00	0.96	72.96
FIRE APPARATUS ENGINEER	200	ROHRABAUGH, JOHN R	414	4,752.00	76.00	0.96	72.96
FIRE APPARATUS ENGINEER	200	ROHRABAUGH, JOHN R	413	4,752.00	76.00	0.96	72.96
Total:							583.68
Staff Benefits .5504:							321.26
Total with Benefits:							\$904.94

**OVERTIME - SAFETY**

<u>CLASS</u>	<u>SERIAL</u>	<u>NAME</u>	<u>WP</u>	<u>SALARY</u>	<u>HOURS</u>	<u>RATE</u>	<u>AMOUNT</u>
FIRE APPARATUS ENGINEER	200	ROHRABAUGH, JOHN R	407	4,629.00	2.25	0.96	2.16
FIRE APPARATUS ENGINEER	200	ROHRABAUGH, JOHN R	407	4,752.00	24.00	0.96	23.04
FIRE APPARATUS ENGINEER	200	ROHRABAUGH, JOHN R	408	4,752.00	48.00	0.96	46.08
FIRE APPARATUS ENGINEER	200	ROHRABAUGH, JOHN R	409	4,752.00	48.00	0.96	46.08
FIRE APPARATUS ENGINEER	200	ROHRABAUGH, JOHN R	410	4,752.00	36.00	0.96	34.56
FIRE APPARATUS ENGINEER	200	ROHRABAUGH, JOHN R	412	4,752.00	24.00	0.96	23.04
FIRE APPARATUS ENGINEER	200	ROHRABAUGH, JOHN R	414	4,752.00	60.00	0.96	57.60
FIRE APPARATUS ENGINEER	200	ROHRABAUGH, JOHN R	413	4,752.00	78.00	0.96	74.88
Total:							307.44
Staff Benefits .0145:							4.46
Total with Benefits:							\$311.90



**FY 19/20 OVERHEAD FOR COUNTY PERSONNEL AND WARRANT SERVICES - BEAUMONT**

	Per Warrant	
ACO Payroll Fee Per Warrant	4.49	
x Total Qtr Warrants	6	
<b>Total Per Warrant</b>	<b>26.94</b>	
Annual Personnel Cost	1,204.42	
÷ Total Personnel	1.00	
<b>Per Personnel Cost</b>	<b>1,204.42</b>	

	No. of Pay Periods	Annual Personnel Count	New Hire Physical
Richard Horner	0	0.00	0
Shawn Branaugh	6	0.23	\$
<b>TOTALS</b>	<b>6</b>	<b>0.23</b>	<b>-</b>

Warrant Costs	Cost / Warrant	4.49	# of Warrants Issued	6	26.94
	\$				

Personnel Costs	Yrly Cost / Per Personnel	1,204.42	# of Personnel	1.00	Quarterly	301.11
	\$					

New Hire Physical Costs	Cost / For Physical	215.71	0	-
	\$			

**TOTAL PERSONNEL COSTS 328.05**

**ENGINE 20 STAFFING - PCA# 37129**

Qtr 3

<b>FY 19/20 Banning</b>		
Banning - Sta# 20		
Support Services FY 19/20		
Exh. "A" Administrative Operational	163,208.00	
Medic Program	23,355.00	
Support Services Annual Costs	186,563.00	
Support Services - Quarterly Costs	186,563.00	\$ 46,640.75
Retroactive Charges	\$0.00	\$0.00
JANUARY 2020 AO-17 PCA37129	130,416.29	
FEBRUARY 2020 AO-17 PCA37129	133,497.88	
MARCH 2020 AO-17 PCA37129	133,247.17	
Subtotal 3rd Qtr (AO-17)		\$ 397,161.34
Subtotal 3rd Qtr		\$ 443,802.09
<b>Breakdown by City</b>		
City of Banning - 1/3rd		\$ 147,934.03
City of Beaumont 1/3rd		\$ 147,934.03
County of Riverside 1/3rd		\$ 147,934.03
Balance		\$ 443,802.09

yellow = input

AO17

California Department of Forestry and Fire Protection



Billing Period: 1/1/2020

RRU	SOUTHERN REGION	INDEX 3100	PCA 37129	BANNING WEST STATION 20
-----	-----------------	------------	-----------	-------------------------

Gross Expenditures: \$116,766.31

Administrative Charge: .0647 7,554.78

Statewide Pro Rata: .0522 6,095.20

GRAND TOTAL: \$130,416.29

Prepared by: <i>Maria Silva</i>	Date Sent to Accounting:
Approved by: <i>[Signature]</i>	Date: <i>2-20-20</i>

Print Date: 02/19/2020 3:51PM Ver 1.8

RRU	SOUTHERN REGION	INDEX 3100	PCA 37129	BANNING WEST STATION 20
-----	-----------------	------------	-----------	-------------------------

**Safety - BU (08)**  
**PERSONNEL SALARIES**

<u>CLASS</u>	<u>SERIAL</u>	<u>NAME</u>	<u>%</u>	<u>SALARY</u>	<u>DAYS</u>	<u>HOURS</u>	<u>AMOUNT</u>
FIRE APPARATUS ENGINEER	693	OCONNELL, DAVID A	100.00	5,049.00	22.00	0.00	5,049.00
FIRE APPARATUS ENGINEER (PARAME	631	WIER, JEREMY C	100.00	5,325.00	22.00	0.00	5,325.00
FIRE CAPTAIN	603	ARIZAGA, MICHAEL L	100.00	5,934.00	22.00	0.00	5,934.00
FIRE FIGHTER II	281	ALVAREZ, PABLO	100.00	4,484.00	22.00	0.00	4,484.00
FIRE FIGHTER II	866	CLASS, TAYLOR M	100.00	4,344.00	22.00	0.00	4,344.00
FIRE FIGHTER II	761	MORGAN, ALADDIN K	100.00	4,484.00	22.00	0.00	4,484.00
FIRE FIGHTER II (PARAMEDIC)	722	CORLETT, DAVID T	100.00	4,187.00	22.00	0.00	4,187.00
FIRE FIGHTER II (PARAMEDIC)	281	MORRIS, JUSTIN L	100.00	4,872.00	22.00	0.00	4,872.00
Total:							38,679.00
Staff Benefits 0.9160:							35,429.96
Total with Benefits:							\$74,108.96

RRU	SOUTHERN REGION	INDEX 3100	PCA 37129	BANNING WEST STATION 20
-----	-----------------	------------	-----------	-------------------------

**UNIFORM - SAFETY**

<u>CLASS</u>	<u>NAME</u>	<u>DESCRIPTION</u>	<u>RATE</u>	<u>%</u>	<u>AMOUNT</u>
FIRE APPARATUS ENGINEER	OCONNELL, DAVID A	Permanent Fulltime Wearer	177.50	100.00	177.50
FIRE APPARATUS ENGINEER (PARAM	WIER, JEREMY C	Permanent Fulltime Wearer	177.50	100.00	177.50
FIRE CAPTAIN	ARIZAGA, MICHAEL L	Permanent Fulltime Wearer	177.50	100.00	177.50
FIRE FIGHTER II	ALVAREZ, PABLO	Permanent Fulltime Wearer	177.50	100.00	177.50
FIRE FIGHTER II	CLASS, TAYLOR M	Permanent Fulltime Wearer	177.50	100.00	177.50
FIRE FIGHTER II	MORGAN, ALADDIN K	Permanent Fulltime Wearer	177.50	100.00	177.50
FIRE FIGHTER II (PARAMEDIC)	CORLETT, DAVID T	Permanent Fulltime Wearer	177.50	100.00	177.50
FIRE FIGHTER II (PARAMEDIC)	MORRIS, JUSTIN L	Permanent Fulltime Wearer	177.50	100.00	177.50
Total:					1,420.00
Staff Benefits :0.0145					20.59
Total with Benefits:					\$1,440.59



RRU	SOUTHERN REGION	INDEX 3100	PCA 37129	BANNING WEST STATION 20
-----	-----------------	------------	-----------	-------------------------

**EXTENDED DUTY WEEK COMP - SAFETY**

<u>CLASS</u>	<u>SERIAL</u>	<u>NAME</u>	<u>WP</u>	<u>SALARY</u>	<u>HOURS</u>	<u>RATE</u>	<u>AMOUNT</u>
FIRE APPARATUS ENGINEER	693	OCONNELL, DAVID A	414	5,049.00	76.00	31.23	2,373.48
FIRE APPARATUS ENGINEER (PAF)	631	WIER, JEREMY C	414	5,825.00	76.00	36.03	2,738.28
FIRE CAPTAIN	603	ARIZAGA, MICHAEL L	414	5,934.00	76.00	36.71	2,789.96
FIRE FIGHTER II	281	ALVAREZ, PABLO	414	4,484.00	76.00	27.74	2,108.24
FIRE FIGHTER II	866	CLASS, TAYLOR M	414	4,485.66	76.00	27.75	2,109.00
FIRE FIGHTER II	761	MORGAN, ALADDIN K	414	4,484.00	76.00	27.74	2,108.24
FIRE FIGHTER II (PARAMEDIC)	722	CORLETT, DAVID T	414	5,191.02	76.00	32.12	2,441.12
FIRE FIGHTER II (PARAMEDIC)	281	MORRIS, JUSTIN L	414	5,372.00	76.00	33.23	2,525.48
Total:							19,193.80
Staff Benefits .5504:							10,564.27
Total with Benefits:							\$29,758.07

**OVERTIME - SAFETY**

<u>CLASS</u>	<u>SERIAL</u>	<u>NAME</u>	<u>WP</u>	<u>SALARY</u>	<u>HOURS</u>	<u>RATE</u>	<u>AMOUNT</u>
FIRE APPARATUS ENGINEER	745	JOHNSON, LAWRENCE C	414	5,049.00	24.00	31.23	749.52
FIRE APPARATUS ENGINEER	626	MINOR, BRETT L	414	5,049.00	48.00	31.23	1,499.04
FIRE APPARATUS ENGINEER (PAF)	631	WIER, JEREMY C	414	5,825.00	48.00	36.03	1,729.44
FIRE CAPTAIN	507	BERNARDO, EVAN C	414	5,965.63	24.00	36.90	885.60
FIRE CAPTAIN	508	BRYANT, WILLIAM K	414	5,822.40	24.00	36.02	864.48
FIRE FIGHTER II	866	CLASS, TAYLOR M	414	4,485.66	5.00	27.75	138.75
FIRE FIGHTER II	852	GOODE, RYAN M	414	4,137.00	24.00	25.59	614.16
FIRE FIGHTER II	701	POSEY, BRETT C	414	4,559.00	24.00	28.20	676.80
FIRE FIGHTER II	209	WALDRON, THOMAS R	414	4,484.00	48.00	27.74	1,331.52
FIRE FIGHTER II	202	WEIDEMANN, KRISTOFER T	414	4,484.00	24.00	27.74	665.76
FIRE FIGHTER II (PARAMEDIC)	740	DORMAN, GREGORY M	414	4,896.00	24.00	30.29	726.96
FIRE FIGHTER II (PARAMEDIC)	281	MORRIS, JUSTIN L	414	5,372.00	24.00	33.23	797.52
FIRE FIGHTER II (PARAMEDIC)	623	STEARNS, COREY R	414	4,143.00	24.00	25.64	615.36
Total:							11,294.91
Staff Benefits .0145:							163.78
Total with Benefits:							\$11,458.69

AO17

California Department of Forestry and Fire Protection



Billing Period: 2/1/2020

RRU	SOUTHERN REGION	INDEX 3100	PCA 37129	BANNING WEST STATION 20
-----	-----------------	------------	-----------	-------------------------

<b>Gross Expenditures:</b>		\$119,525.37
<b>Administrative Charge:</b>	.0647	7,733.29
<b>Statewide Pro Rata:</b>	.0522	6,239.22
		<hr/>
<b>GRAND TOTAL:</b>		<b>\$133,497.88</b>

Prepared by: <i>Astena Lopez</i>	Date Sent to Accounting:
Approved by: <i>Ray E. Quinn</i>	Date: <i>3/17/2020</i>

Print Date: 03/16/2020 2:10PM Ver 1.8

RRU	SOUTHERN REGION	INDEX 3100	PCA 37129	BANNING WEST STATION 20
-----	-----------------	------------	-----------	-------------------------

**Safety - BU (08)**  
**PERSONNEL SALARIES**

<u>CLASS</u>	<u>SERIAL</u>	<u>NAME</u>	<u>%</u>	<u>SALARY</u>	<u>DAYS</u>	<u>HOURS</u>	<u>AMOUNT</u>
FIRE APPARATUS ENGINEER	693	OCONELL, DAVID A	100.00	5,049.00	21.00	0.00	5,049.00
FIRE APPARATUS ENGINEER (PARAMEDIC)	631	WIER, JEREMY C	100.00	5,325.00	21.00	0.00	5,325.00
FIRE CAPTAIN	603	ARIZAGA, MICHAEL L	100.00	5,934.00	21.00	0.00	5,934.00
FIRE FIGHTER II	281	ALVAREZ, PABLO	100.00	4,484.00	21.00	0.00	4,484.00
FIRE FIGHTER II	866	CLASS, TAYLOR M	100.00	4,344.00	21.00	0.00	4,344.00
FIRE FIGHTER II	761	MORGAN, ALADDIN K	100.00	4,484.00	21.00	0.00	4,484.00
FIRE FIGHTER II (PARAMEDIC)	722	CORLETT, DAVID T	100.00	4,187.00	21.00	0.00	4,187.00
FIRE FIGHTER II (PARAMEDIC)	281	MORRIS, JUSTIN L	100.00	4,872.00	21.00	0.00	4,872.00
Total:							38,679.00
Staff Benefits 0.9160:							35,429.96
Total with Benefits:							\$74,108.96

RRU	SOUTHERN REGION	INDEX 3100	PCA 37129	BANNING WEST STATION 20
-----	-----------------	------------	-----------	-------------------------

**UNIFORM - SAFETY**

<u>CLASS</u>	<u>NAME</u>	<u>DESCRIPTION</u>	<u>RATE</u>	<u>%</u>	<u>AMOUNT</u>
FIRE APPARATUS ENGINEER	OCONNELL, DAVID A	Permanent Fulltime Wearer	177.50	100.00	177.50
FIRE APPARATUS ENGINEER (PARAM	WIER, JEREMY C	Permanent Fulltime Wearer	177.50	100.00	177.50
FIRE CAPTAIN	ARIZAGA, MICHAEL L	Permanent Fulltime Wearer	177.50	100.00	177.50
FIRE FIGHTER II	ALVAREZ, PABLO	Permanent Fulltime Wearer	177.50	100.00	177.50
FIRE FIGHTER II	CLASS, TAYLOR M	Permanent Fulltime Wearer	177.50	100.00	177.50
FIRE FIGHTER II	MORGAN, ALADDIN K	Permanent Fulltime Wearer	177.50	100.00	177.50
FIRE FIGHTER II (PARAMEDIC)	CORLETT, DAVID T	Permanent Fulltime Wearer	177.50	100.00	177.50
FIRE FIGHTER II (PARAMEDIC)	MORRIS, JUSTIN L	Permanent Fulltime Wearer	177.50	100.00	177.50
Total:					1,420.00
Staff Benefits :0.0145					20.59
Total with Benefits:					\$1,440.59

RRU	SOUTHERN REGION	INDEX 3100	PCA 37129	BANNING WEST STATION 20
-----	-----------------	------------	-----------	-------------------------

**EXTENDED DUTY WEEK COMP - SAFETY**

<u>CLASS</u>	<u>SERIAL</u>	<u>NAME</u>	<u>WP</u>	<u>SALARY</u>	<u>HOURS</u>	<u>RATE</u>	<u>AMOUNT</u>
FIRE APPARATUS ENGINEER	693	OCONNELL, DAVID A	415	5,049.00	76.00	31.23	2,373.48
FIRE APPARATUS ENGINEER (PAF)	631	WIER, JEREMY C	415	5,825.00	76.00	36.03	2,738.28
FIRE CAPTAIN	603	ARIZAGA, MICHAEL L	415	5,934.00	76.00	36.71	2,789.96
FIRE FIGHTER II	281	ALVAREZ, PABLO	415	4,484.00	76.00	27.74	2,108.24
FIRE FIGHTER II	866	CLASS, TAYLOR M	415	4,485.66	76.00	27.75	2,109.00
FIRE FIGHTER II	761	MORGAN, ALADDIN K	415	4,484.00	76.00	27.74	2,108.24
FIRE FIGHTER II (PARAMEDIC)	722	CORLETT, DAVID T	415	5,191.02	76.00	32.12	2,441.12
FIRE FIGHTER II (PARAMEDIC)	281	MORRIS, JUSTIN L	415	5,372.00	76.00	33.23	2,525.48
Total:							19,193.80
Staff Benefits .5504:							10,564.27
Total with Benefits:							\$29,758.07

**OVERTIME - SAFETY**

<u>CLASS</u>	<u>SERIAL</u>	<u>NAME</u>	<u>WP</u>	<u>SALARY</u>	<u>HOURS</u>	<u>RATE</u>	<u>AMOUNT</u>
FIRE APPARATUS ENGINEER	510	ESPARZA, MICHAEL A	415	5,348.22	48.00	33.09	1,588.32
FIRE APPARATUS ENGINEER	693	OCONNELL, DAVID A	415	5,049.00	3.50	31.23	109.31
FIRE APPARATUS ENGINEER	651	VITALE, KEITH P	415	4,920.00	24.00	30.44	730.56
FIRE APPARATUS ENGINEER (PAF)	633	KATULS, JUSTIN A	415	5,825.00	13.00	36.03	468.39
FIRE APPARATUS ENGINEER (PAF)	631	WIER, JEREMY C	415	5,825.00	40.00	36.03	1,441.20
FIRE CAPTAIN	539	GORDON, TIMOTHY J	415	5,655.00	24.00	34.98	839.52
FIRE FIGHTER II	281	ALVAREZ, PABLO	415	4,484.00	4.00	27.74	110.96
FIRE FIGHTER II	762	CLIFFORD, EDDIE D	415	4,872.88	48.00	30.15	1,447.20
FIRE FIGHTER II	726	REYES CANCINO, DAVID J	415	4,484.00	51.50	27.74	1,428.61
FIRE FIGHTER II	251	WALLACE, KYLE M	415	4,484.00	24.00	27.74	665.76
FIRE FIGHTER II (PARAMEDIC)	703	CADENA, MATTHEW G	415	4,048.00	24.00	25.04	600.96
FIRE FIGHTER II (PARAMEDIC)	650	CARR, JEREMY K	415	4,288.00	24.00	26.52	636.48
FIRE FIGHTER II (PARAMEDIC)	638	HAYS, DEVON D	415	5,372.00	11.00	33.23	365.53
FIRE FIGHTER II (PARAMEDIC)	710	MEZA, RENEE	415	5,051.00	24.00	31.25	750.00
FIRE FIGHTER II (PARAMEDIC)	281	MORRIS, JUSTIN L	415	5,372.00	2.50	33.23	83.08
FIRE FIGHTER II (PARAMEDIC)	203	OCONNOR, CHRISTOPHER J	415	5,147.00	18.00	31.85	573.30
FIRE FIGHTER II (PARAMEDIC)	661	PATLAN, ANDREW D	415	5,208.00	24.00	32.22	773.28
FIRE FIGHTER II (PARAMEDIC)	623	STEARNS, COREY R	415	4,143.00	24.00	25.64	615.36
FIRE FIGHTER II (PARAMEDIC)	257	VALENZUELA, CHRISTOPHER	415	5,297.00	24.00	32.78	786.72
Total:							14,014.54
Staff Benefits .0145:							203.21
Total with Benefits:							\$14,217.75



AO17

California Department of Forestry and Fire Protection

Billing Period: 3/1/2020

RRU	SOUTHERN REGION	INDEX 3100	PCA 37129	BANNING WEST STATION 20
-----	-----------------	------------	-----------	-------------------------

<b>Gross Expenditures:</b>		\$119,300.89
<b>Administrative Charge:</b>	.0647	7,718.77
<b>Statewide Pro Rata:</b>	.0522	6,227.51
		<hr/>
<b>GRAND TOTAL:</b>		<b>\$133,247.17</b>

Prepared by: <i>Maria Silva</i>	Date Sent to Accounting:
Approved by:	Date:

Print Date: 04/15/2020 6:06PM Ver 1.8

Billing Period:

RRU	SOUTHERN REGION	INDEX 3100	PCA 37129	BANNING WEST STATION 20
-----	-----------------	------------	-----------	-------------------------

**Safety - BU (08)**  
**PERSONNEL SALARIES**

<u>CLASS</u>	<u>SERIAL</u>	<u>NAME</u>	<u>%</u>	<u>SALARY</u>	<u>DAYS</u>	<u>HOURS</u>	<u>AMOUNT</u>
FIRE APPARATUS ENGINEER	693	OCONELL, DAVID A	100.00	5,049.00	22.00	0.00	5,049.00
FIRE APPARATUS ENGINEER (PARAMEDIC)	631	WIER, JEREMY C	100.00	5,325.00	22.00	0.00	5,325.00
FIRE CAPTAIN	603	ARIZAGA, MICHAEL L	100.00	5,934.00	22.00	0.00	5,934.00
FIRE FIGHTER II	281	ALVAREZ, PABLO	100.00	4,484.00	22.00	0.00	4,484.00
FIRE FIGHTER II	866	CLASS, TAYLOR M	100.00	4,344.00	22.00	0.00	4,344.00
FIRE FIGHTER II	761	MORGAN, ALADDIN K	100.00	4,484.00	22.00	0.00	4,484.00
FIRE FIGHTER II (PARAMEDIC)	722	CORLETT, DAVID T	100.00	4,187.00	22.00	0.00	4,187.00
FIRE FIGHTER II (PARAMEDIC)	281	MORRIS, JUSTIN L	100.00	4,872.00	22.00	0.00	4,872.00
Total:							38,679.00
Staff Benefits 0.9160:							35,429.96
Total with Benefits:							\$74,108.96

RRU	SOUTHERN REGION	INDEX 3100	PCA 37129	BANNING WEST STATION 20
-----	-----------------	------------	-----------	-------------------------

**UNIFORM - SAFETY**

<u>CLASS</u>	<u>NAME</u>	<u>DESCRIPTION</u>	<u>RATE</u>	<u>%</u>	<u>AMOUNT</u>
FIRE APPARATUS ENGINEER	OCONNELL, DAVID A	Permanent Fulltime Wearer	177.50	100.00	177.50
FIRE APPARATUS ENGINEER (PARAM	WIER, JEREMY C	Permanent Fulltime Wearer	177.50	100.00	177.50
FIRE CAPTAIN	ARIZAGA, MICHAEL L	Permanent Fulltime Wearer	177.50	100.00	177.50
FIRE FIGHTER II	ALVAREZ, PABLO	Permanent Fulltime Wearer	177.50	100.00	177.50
FIRE FIGHTER II	CLASS, TAYLOR M	Permanent Fulltime Wearer	177.50	100.00	177.50
FIRE FIGHTER II	MORGAN, ALADDIN K	Permanent Fulltime Wearer	177.50	100.00	177.50
FIRE FIGHTER II (PARAMEDIC)	CORLETT, DAVID T	Permanent Fulltime Wearer	177.50	100.00	177.50
FIRE FIGHTER II (PARAMEDIC)	MORRIS, JUSTIN L	Permanent Fulltime Wearer	177.50	100.00	177.50
Total:					1,420.00
Staff Benefits :0.0145					20.59
Total with Benefits:					\$1,440.59



RRU	SOUTHERN REGION	INDEX 3100	PCA 37129	BANNING WEST STATION 20
-----	-----------------	------------	-----------	-------------------------

**EXTENDED DUTY WEEK COMP - SAFETY**

<u>CLASS</u>	<u>SERIAL</u>	<u>NAME</u>	<u>WP</u>	<u>SALARY</u>	<u>HOURS</u>	<u>RATE</u>	<u>AMOUNT</u>
FIRE APPARATUS ENGINEER	693	OCONELL, DAVID A	416	5,049.00	76.00	31.23	2,373.48
FIRE APPARATUS ENGINEER (PAF)	631	WIER, JEREMY C	416	5,825.00	76.00	36.03	2,738.28
FIRE CAPTAIN	603	ARIZAGA, MICHAEL L	416	5,934.00	76.00	36.71	2,789.96
FIRE FIGHTER II	281	ALVAREZ, PABLO	416	4,484.00	76.00	27.74	2,108.24
FIRE FIGHTER II	866	CLASS, TAYLOR M	416	4,485.66	76.00	27.75	2,109.00
FIRE FIGHTER II	761	MORGAN, ALADDIN K	416	4,484.00	76.00	27.74	2,108.24
FIRE FIGHTER II (PARAMEDIC)	722	CORLETT, DAVID T	416	5,191.02	76.00	32.12	2,441.12
FIRE FIGHTER II (PARAMEDIC)	281	MORRIS, JUSTIN L	416	5,372.00	76.00	33.23	2,525.48
Total:							19,193.80
Staff Benefits .5504:							10,564.27
Total with Benefits:							\$29,758.07

**OVERTIME - SAFETY**

<u>CLASS</u>	<u>SERIAL</u>	<u>NAME</u>	<u>WP</u>	<u>SALARY</u>	<u>HOURS</u>	<u>RATE</u>	<u>AMOUNT</u>
FIRE APPARATUS ENGINEER	516	BRUNS, MARK C	416	4,920.00	24.00	30.44	730.56
FIRE APPARATUS ENGINEER	768	HERNANDEZ, LUIS A	416	4,273.66	24.00	26.43	634.32
FIRE APPARATUS ENGINEER	745	JOHNSON, LAWRENCE C	416	5,049.00	24.00	31.23	749.52
FIRE APPARATUS ENGINEER	712	LIEBERUM, CHASE P	416	4,854.04	30.00	30.03	900.90
FIRE APPARATUS ENGINEER	626	MINOR, BRETT L	416	5,049.00	24.00	31.23	749.52
FIRE APPARATUS ENGINEER	693	OCONELL, DAVID A	416	5,049.00	20.00	31.23	624.60
FIRE APPARATUS ENGINEER	200	ROHRABAUGH, JOHN R	416	4,982.00	24.00	30.83	739.92
FIRE APPARATUS ENGINEER	746	VASQUEZ, CARLOS A	416	4,974.00	24.00	30.77	738.48
FIRE APPARATUS ENGINEER	699	WILLIAMS, TYLER L	416	5,199.00	26.00	32.16	836.16
FIRE APPARATUS ENGINEER (PAF)	658	SHEARER, MARK T	416	4,939.00	24.00	30.56	733.44
FIRE CAPTAIN	138	MORRISON II, DAVID H	416	6,289.53	12.00	38.91	466.92
FIRE CAPTAIN	129	ROSARIO, ALEXY	416	6,228.00	24.00	38.52	924.48
FIRE CAPTAIN (PARAMEDIC)	625	DAVIS, KRISTOFER L	416	6,512.00	12.00	40.29	483.48
FIRE FIGHTER II	281	ALVAREZ, PABLO	416	4,484.00	6.00	27.74	166.44
FIRE FIGHTER II (PARAMEDIC)	650	CARR, JEREMY K	416	4,288.00	48.00	26.52	1,272.96
FIRE FIGHTER II (PARAMEDIC)	722	CORLETT, DAVID T	416	5,191.02	27.00	32.12	867.24
FIRE FIGHTER II (PARAMEDIC)	281	MORRIS, JUSTIN L	416	5,372.00	34.00	33.23	1,129.82
FIRE FIGHTER II (PARAMEDIC)	657	WILLIMAN, BRIAN D	416	4,288.00	26.00	26.52	689.52
Total:							13,438.28
Staff Benefits .0145:							194.86
Total with Benefits:							\$13,633.14



## Staff Report

**TO:** Mayor and City Council Members  
**FROM:** Sean Thuilliez, Chief of Police  
**DATE:** June 2, 2020  
**SUBJECT:** **Approval of the FY 2020/21 Local Responsibility Area Wildland Protection Reimbursement Agreement**

---

### Background and Analysis:

The City currently contracts with the California Department of Forestry and Fire Protection (CalFIRE) for fire protection of 1,173 acres of designated wildland area that is within the boundaries of the City. Wildland areas that are within incorporated cities, fire protection districts, and special districts with fire suppression responsibility are referred to as Local Responsibility Areas (LRA). All fire suppression activities and responsibilities within LRA wildland areas are the responsibility of the local agency. The current contract with CalFIRE expires on June 30, 2020.

Wildland fires within the areas incorporated within the City are frequent. Wildland fires are considered one of the highest natural disaster risks that the City faces. The City is in an extremely wind prone area and it is not uncommon for fires to grow beyond the local capability of the resources assigned to protect the City. When a wildland fire grows beyond the ability and capability of local resources, assistance is requested from CalFIRE to provide wildland engine companies, inmate hand crews, bulldozers and aircraft.

Without an agreement for protection of wildlands within an LRA between the City and the State of California, these resources are then considered assistance-by-hire and the City is liable for the cost from the time of dispatch.

Within the City there are 1,173 acres designated as wildlands subject to the LRA designation. In an effort to reduce the City's liability for the cost of wildland fire suppression in the LRA area, the City can enter into a Local Responsibility Area Wildland Fire Protection Agreement (Agreement) with CalFIRE, for protection of wildlands within the City. The Agreement will provide state resources to control a wildland fire at no additional cost to the City. CalFIRE will provide fire protection to the

LRA as if they were still the sole agency with fire suppression responsibility. This Agreement will provide unlimited use of state engine companies, inmate hand crews, bulldozers and aircraft to supplement the daily level of fire protection provided to the City by the County of Riverside.

**Fiscal Impact:**

The cost to enter into the Agreement with CalFIRE is \$32.85 per acre plus a 12.47% administrative charge. The total annual cost for the 1,173 acres being covered is \$43,338.12.

**Recommended Action:**

Waive the full reading and approve by title only, "A Resolution of the City Council of the City of Beaumont, California, approving an Agreement with the California Department of Forestry and Fire Protection for Services from July 1, 2020 Through June 30, 2021 for Fire Protection Services within the Local Responsibility Areas within the City," and  
Authorize the Mayor to sign the FY 2020/21 agreement with Cal-Fire for fire protection services within the Local Responsibility Areas within the City.

**Attachments:**

- A. LRS Wildland Protection Agreement
- B. Resolution for Wildland Protection Services from Cal Fire

**DEPARTMENT OF FORESTRY AND FIRE PROTECTION**

P.O. Box 944246  
SACRAMENTO, CA 94244-2460  
(916) 653-7772  
Website: [www.fire.ca.gov](http://www.fire.ca.gov)



April 22, 2020

Todd Parton  
City of Beaumont  
550 East 6<sup>th</sup> Street  
Beaumont, Ca. 92223

Dear Mr. Parton,

Enclosed is the new contract for the Wildland Agreement for fiscal year 2020/2021.

The following items are needed to complete the new contract:

- 1) Sign all five copies of the amendment.
- 2) Include Two Original Signed Board Resolutions accepting the Agreement for FY 20/21.
- 3) Return to CAL FIRE / Riverside County Fire Attention: Chief Scott Lane.

If you have any questions please feel free to contact Scott Lane  
951-940-6903.

Shawn C. Newman  
Unit Chief

  
By: Scott Lane  
Battalion Chief

STATE OF CALIFORNIA  
COOPERATIVE FIRE PROGRAMS  
LOCAL RESPONSIBILITY AREA WILDLAND PROTECTION  
REIMBURSEMENT AGREEMENT  
LG-W REV 01/2017

AGREEMENT NUMBER	<b>3CA04805</b>
REGISTRATION NUMBER:	

1. This Agreement is entered into between the State Agency and the Local Agency named below:

STATE AGENCY'S NAME  
 California Department of Forestry and Fire Protection – (CAL FIRE)

LOCAL AGENCY'S NAME  
 City of Beaumont

2. The term of this Agreement is: July 1, 2020 through June 30, 2021

3. The maximum amount of this Agreement is: \$ 43,338.12

4. The parties agree to comply with the terms and conditions of the following exhibits which are by this reference made a part of the Agreement.

Exhibit A – Scope of Work – Includes page 2 (contact page) in count for Exhibit A	2 pages
Exhibit B – Budget Detail and Payment Provisions	2 pages
Exhibit C* – General Terms and Conditions; DGS GTC Version: 04/2017	0 pages
Exhibit D – Special Terms and Conditions (Attached hereto as part of this Agreement)	1 pages
Exhibit E – Additional Provisions	11 pages

\*Items shown with an Asterisk (\*), are hereby incorporated by reference and made part of this Agreement as if attached hereto.  
*General Terms and Conditions can be viewed at: <http://www.dgs.ca.gov/ols>*

IN WITNESS WHEREOF, this Agreement has been executed by the parties hereto.

**LOCAL AGENCY**

LOCAL AGENCY'S NAME  
 City of Beaumont

BY (Authorized Signature)  

DATE SIGNED(Do not type)

PRINTED NAME AND TITLE OF PERSON SIGNING  
 Todd Parton - City Manager

ADDRESS  
 550 East 6<sup>th</sup> St. Beaumont, CA 92223

**California Department of General Services Use Only**

**STATE OF CALIFORNIA**

AGENCY NAME  
 California Department of Forestry and Fire Protection

BY (Authorized Signature)  

DATE SIGNED(Do not type)

PRINTED NAME AND TITLE OF PERSON SIGNING  
 Don Gordon, Assistant Deputy Director, Cooperative Fire Protection, Training & Safety

ADDRESS P.O. Box 944246, Sacramento, CA 94244-2460

**EXHIBIT A**

**COOPERATIVE FIRE PROGRAMS**

**AGREEMENT FOR PROTECTION OF WILDLANDS WITHIN LOCAL AGENCY RESPONSIBILITY AREA**

1. The project representatives during the term of this Agreement will be:

CAL FIRE Unit Chief:	Riverside Unit	Local Agency:	City of Beaumont
Name:	Shawn C. Newman	Name:	Todd Parton
Phone:	951-940-6900	Phone:	951-769-8520
Fax:	951-940-6910	Fax:	951-769-8526

All required correspondence shall be sent through U.S. Postal Service by certified mail and directed to:

CAL FIRE Unit Chief:	Shawn C. Newman	Local Agency:	City of Beaumont
Section/Unit:	Riverside Unit	Section/Unit:	City Manager
Attention:	Scott Lane	Attention:	Todd Parton
Address:	210 W. San Jacinto St. Perris, CA 92570	Address:	550 East 6 <sup>th</sup> St. Beaumont, CA 92223
Phone:	951-940-6900	Phone:	951-769-8526
Fax:	951-940-6910	Fax:	951-769-8526

Send an additional copy of all correspondence to:

**CAL FIRE  
Cooperative Fire Services  
P.O. Box 944246  
Sacramento, CA 94244-2460**

**2. AUTHORIZATION**

This Agreement is entered into this 1st day of July, 2020, by and between the State of California, hereinafter called STATE and City of Beaumont, County of Riverside, State of California, hereinafter called Local Agency through its duly authorized officers. As used herein, Director shall mean Director of the California Department of Forestry and Fire Protection (CAL FIRE). Where the standard clauses for example in Exhibit C, use the word "Contractor" that word shall mean LOCAL AGENCY as LOCAL AGENCY is used in this Agreement.

Section 4142 of the Public Resources Code provides that the Director may enter into cooperative Agreements with local jurisdictions for the purpose of providing wildland fire protection.

**3. SCOPE OF WORK**

LOCAL AGENCY has the responsibility for protection of life, property, and wildland areas comprising 1173 acres of land as indicated on the map included under Exhibit E and desires to contract with the STATE to provide wildland fire protection to said area.

STATE has the ability to provide wildland fire protection for said area, of the type and degree, which it now provides on adjacent State Responsibility Areas.

**4. SERVICES BY STATE**

- A. STATE shall provide wildland fire protection for the areas defined in the above section.
- B. For those areas, which are adjacent to State Responsibility Area, STATE will provide wildland fire protection at the same level of service it now provides on adjacent State Responsibility Area.
- C. For those areas (islands), which are not adjacent to State Responsibility Area, the wildland fire protection provided by the STATE will be limited to those resources identified in the preplanned wildland response for the respective area. Any resources beyond those specified in the preplanned wildland response are assistance by hire and the financial responsibility of the LOCAL AGENCY.

**5. ADMINISTRATION**

- A. LOCAL AGENCY agrees that STATE may dispatch fire protection resources available under this Agreement to other areas of the state when needed at the sole discretion of STATE.
- B. STATE response will be subject to availability of resources.
- C. Incident Management within the contract area shall conform to current Incident Command System criteria for Unified Command.
- D. STATE and LOCAL AGENCY shall, through established dispatch procedures, immediately notify each other of any fire incident within the contract area.

**6. MUTUAL AID**

LOCAL AGENCY shall provide mutual aid response into the contract area for wildfires. Structural fire protection remains the jurisdictional and financial responsibility of LOCAL AGENCY.

**7. ENTIRE AGREEMENT**

This Agreement contains the whole Agreement between the parties. It cancels and supersedes any previous Agreement for the same or similar services.



## EXHIBIT B

### BUDGET DETAIL, INVOICING, PAYMENT AND RECONCILIATION

#### 1. Invoicing and Payment:

- A. LOCAL AGENCY shall pay STATE for providing said protection at the rate of \$32.85 per acre, plus an 12.47% administrative charge for a total of \$43,338.12 upon presentation of an invoice by STATE. The rate per acre and administrative charge will be calculated by STATE prior to January 1, of each year and annually thereafter, for the succeeding fiscal year subject to approval by LOCAL AGENCY. This Agreement shall be amended each fiscal year to reflect new rates.
- B. STATE shall provide thirty (30) day written notice to LOCAL AGENCY of the cost per acre and the administrative charge to be assessed for each subsequent fiscal year during the term of this Agreement; LOCAL AGENCY shall have thirty (30) days to approve said rate; if written approval is not received by STATE within said period, STATE's obligations hereunder shall terminate; LOCAL AGENCY shall be liable for all amounts due up to and including the date of such termination.
- C. To minimize the need for reconciliation payment is expected in full after the LOCAL AGENCY receives the STATE invoice. Payments made by the LOCAL AGENCY will cover the protection rate per acre and the administrative charge for the protection services rendered by STATE and including any other costs as provided herein, giving credit for all payments made by LOCAL AGENCY and claiming the balance due to STATE, if any, or refunding to LOCAL AGENCY the amount of any overpayment.

#### 2. Budget Contingency Clause

- A. If the LOCAL AGENCY's governing authority does not appropriate sufficient funds for the current year or any subsequent years covered under this Agreement, which results in an inability to pay the STATE for the services specified in this Agreement, the LOCAL AGENCY shall promptly notify the STATE and this Agreement will terminate pursuant to the notice periods required herein.
- B. If funding for any fiscal year is reduced or deleted by the LOCAL AGENCY for purposes of this program, the LOCAL AGENCY shall promptly notify the STATE, and the STATE shall have the option to either cancel this Agreement with no liability occurring to the STATE, or offer an agreement amendment to LOCAL AGENCY to reflect the reduced amount, pursuant to the notice terms herein
- C. If the STATE Budget Act does not appropriate sufficient funds to provide the services for the current year or any subsequent years covered under this Agreement, which results in an inability to provide the services specified in this Agreement to the LOCAL AGENCY, the STATE shall promptly notify the LOCAL AGENCY, and this Agreement will terminate pursuant to the notice periods required herein.

- D. If funding for any fiscal year is reduced or deleted by the STATE Budget Act for purposes of this program, the STATE shall promptly notify the LOCAL AGENCY, and the LOCAL AGENCY shall have the option to either cancel this Agreement with no liability occurring to the LOCAL AGENCY, or offer an agreement amendment to LOCAL AGENCY to reflect the reduced services, pursuant to the notice terms herein.
- E. Notwithstanding the foregoing provisions in paragraphs A and B above, the LOCAL AGENCY shall remain responsible for payment for all services actually rendered by the STATE under this Agreement regardless of LOCAL AGENCY funding being reduced, deleted or not otherwise appropriated for this program. The LOCAL AGENCY shall promptly notify the STATE in writing of any budgetary changes that would impact this Agreement.
- F. LOCAL AGENCY and STATE agree that this Budget Contingency Clause shall not relieve or excuse either party from its obligation(s) to provide timely notice as may be required elsewhere in this Agreement.

**EXHIBIT D**

**SPECIAL TERMS AND CONDITIONS**

**1. Cancellation**

Failure of either party to meet any of the terms and conditions of this Agreement, including non-payment of monies due hereunder, shall be cause for the termination of this Agreement; such termination shall become effective upon written receipt of 30 day notice of cancellation.

**2. Audit**

If the Agreement is over \$10,000, the parties shall, in accordance with Government Code Section 10532, be subject to examination and audit of the State Auditor General for a period of three (3) years after final payment under the Agreement. Examination and audit shall be confined to those matters connected with performance of the Agreement including, but not limited to, cost of administering the Agreement. The Contractor warrants by execution of this Agreement, that no person or selling agency has been employed or retained to solicit or secure this Agreement upon Agreement or understanding.

**3. Operating Plan**

Prior to April 1 of each year, STATE and LOCAL AGENCY shall establish a joint Operating Plan for the contract area, which shall be attached after Exhibit E. If LOCAL AGENCY received its structural fire protection from another local agency, the local agency providing the structural fire protection must be party to the Operating Plan.

**4. Extension of Agreement**

Unless there is written notice by LOCAL AGENCY to terminate this Agreement STATE shall extend this Agreement for a single one-year period from the original termination date. The cost of services provided by STATE during the extended period shall be based upon the rates published for the fiscal year in which the extended period falls had a new Agreement been entered into.

**5. Modification**

This Agreement may be amended at any time by written mutual consent of the parties hereto.

**6. Indemnification**

Each party, to the extent permitted by law, agrees to indemnify and hold harmless the other party, its officers, agents, and employees from any and all claims and losses accruing or resulting to any person, firm or corporation who may be injured or damaged by the indemnifying party.

**EXHIBIT E**  
**ADDITIONAL PROVISIONS**

Attachments

- Budget Plan
- Topographic Map
- Operating Plan
- Annual Report

### LOCAL RESPONSIBILITY AREA (LRA) WILDLAND PROTECTION REIMBURSEMENT AGREEMENT

Program Cost Account (PCA #) 39016

THIS IS THE BUDGET PLAN FOR THE LOCAL RESPONSIBILITY AREA (LRA)  
WILDLAND FIRE PROTECTION REIMBURSEMENT AGREEMENT BETWEEN THE  
STATE OF CALIFORNIA, DEPARTMENT OF FORESTRY & FIRE PROTECTION (CAL FIRE)  
AND THE CITY/TOWN OF Beaumont A LOCAL AGENCY  
FOR THE 2020/2021 FISCAL YEAR

#### AGREEMENT COST CALCULATIONS:

Number of Acres 1173

General Fund Reimbursement	\$ 12.30	\$ 14,427.90
Unit Budget	\$ 20.55	\$ 24,105.15
Sub-Total		\$ 38,533.05
Admin Rate	12.47%	\$ 4,805.07
<b>Total Protection Cost</b>		<b>\$ 43,338.12</b>

Comments Section:

# Beaumont Wildland and SRA (1 Mile Buffer) Area Map

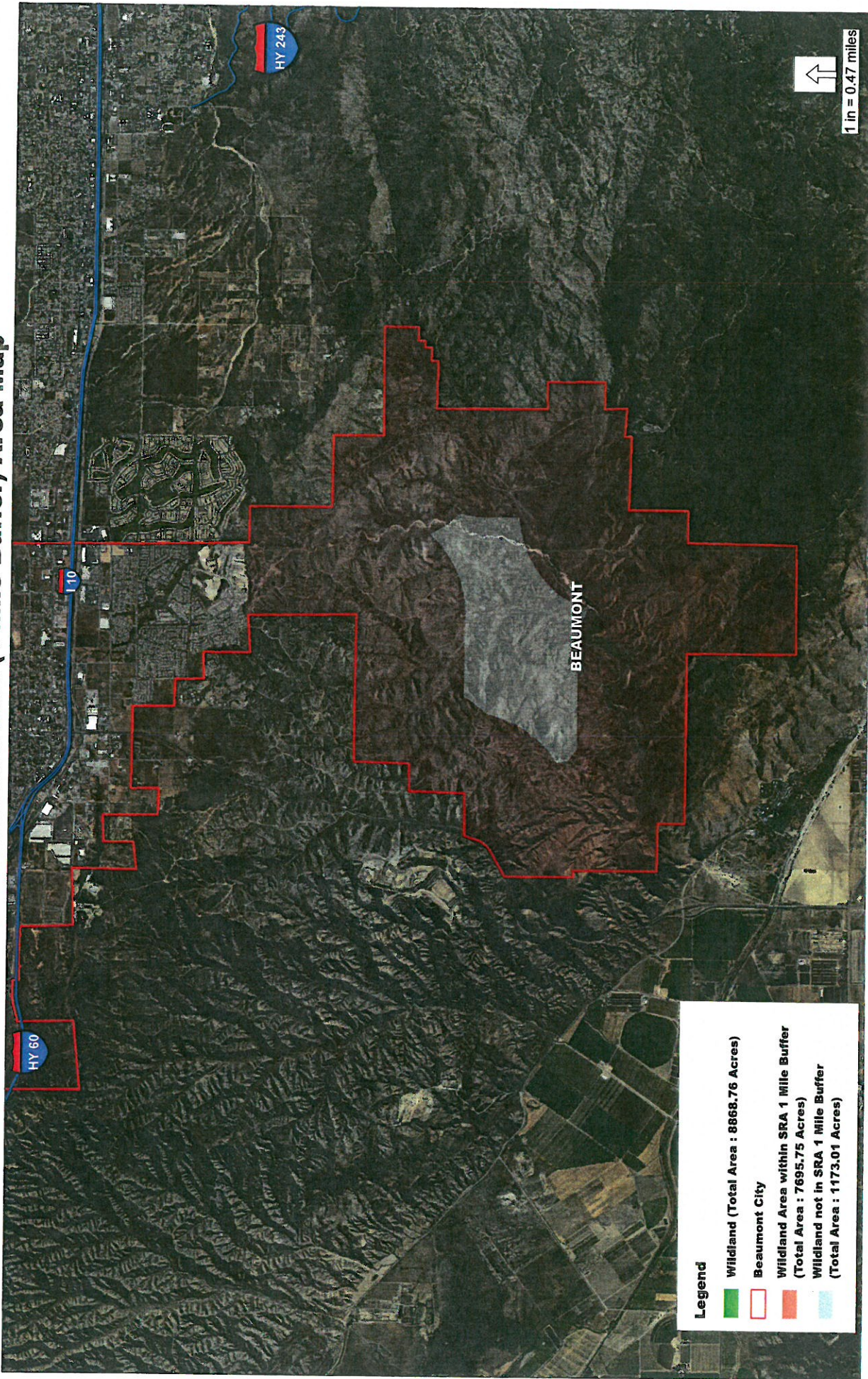



---

Wildland Operating Plan  
Between  
The City of Beaumont  
and  
CAL FIRE/Riverside Unit.

OPERATING PLAN

Table of Contents

	<u>Page</u>
1. Overview.....	02
2. Authority.....	02
3. Purpose.....	02
4. Definitions & Restrictions.....	02
5. Procedures.....	02
6. Administration.....	04
7. Fire Prevention.....	04
8. Approval.....	07

APPENDIX

Preplanned Initial Attack Response – Riverside Ranger Unit.....	E-1
---	-----



## OPERATING PLAN

### 1. OVERVIEW

This Operating Plan, hereinafter referred to as PLAN, is between the California Department of Forestry & Fire Protection, Riverside Unit, hereinafter referred to as CAL FIRE and the City of Beaumont, Beaumont Fire Department, hereinafter referred to as CITY. It has been developed to specifically address the Agreement for Protection of Wildlands within a Local Agency, hereinafter referred to as AGREEMENT, between CAL FIRE and CITY for wildland fire protection within the city limits.

### 2. AUTHORITY

The PLAN is required of both CAL FIRE and CITY as part of the AGREEMENT dated July 1, 2018.

### 3. PURPOSE

This PLAN will provide the Unit Chief of CAL FIRE and the CITY a means for executing the AGREEMENT and is hereby attached as Exhibit E with appendices E-1 to that AGREEMENT.

### 4. DEFINITIONS AND RESTRICTIONS

See AGREEMENT for definitions and descriptions of general terms. This PLAN does not allow either agency to operate outside the limitations in the AGREEMENT.

### 5. PROCEDURES

- A. Fire Reporting/Reports-When CITY receives a report of a wildfire within the area of the AGREEMENT, it shall promptly notify the Riverside Unit Emergency Command Center (ECC). Each agency will process their appropriate reports and make the information available, upon request of the other agency, in no more than 60 days.
- B. Incident Management-The Incident Command System (ICS) will be used to manage wildfires within the area of the AGREEMENT. Unified Command will be implemented with a CAL FIRE representative and a CITY representative.

- C. Fires within the area of the AGREEMENT-Each agency will maintain a preplanned initial attack response (PIAR) for fires within the area of the AGREEMENT. See Appendices E-1. Immediate cooperation between agency dispatch centers will occur to ensure prompt response of appropriate resources into the area of the fire. CAL FIRE resources will be ordered according to the terms of the AGREEMENT through the ECC. Any augmentation of the preplanned response, with CAL FIRE resources, shall be authorized by a CAL FIRE Incident Commander or Agency Representative. Augmentation of the preplanned response may require a post incident audit. The audit will seek to demonstrate that adjacent CAL FIRE Direct Protection Areas (DPA's) were threatened, or that the augmentation was justified on a cost efficiency basis. Local government and private resources will be ordered through the CITY dispatch center (DISPATCH) to ensure proper utilization of the Master Mutual Aid Agreement.
- D. Mutual Aid-All initial attack resources will be considered mutual aid for the purpose of this AGREEMENT.
- E. Initial Attack-Initial attack resources will always be based on the closest resources concept identified in the PIAR. See Appendices E-1.
- F. Move-Up & Cover-Station coverage will be exchanged between both agencies when appropriate. To prevent long-term coverage problems to either agency, the covering agency's engines will be replaced with the covered agency's resources as soon as it is practical to do so.
- G. Fire Information: Unified Command-
  - 1. Both agencies will enter into a unified command structure to manage the incident by establishing a common set of incident objectives and strategies. This will be accomplished without losing or abdicating agency authority, responsibility or accountability. A Unified Ordering Point will be identified and established.
  - 2. Representatives of both agencies will meet as needed to discuss procedures governing and locations of potential Information Centers. Both agencies will strive to maintain a roster of certified Public Information Officers for use during emergencies.
  - 3. The Unified Command will determine which agency will provide the Lead Information Officer. Normally, it will be the agency with the greatest commitment of resources on the incident.

- H. Representatives of CAL FIRE and CITY, of the rank of Battalion Chief or higher, may order resources directly from the ECC or DISPATCH when an immediate need arises. These resources may include engines, fire crews and bulldozers in accordance with the AGREEMENT. Resources sent in response to these requests will conform to the closet resources concept

## 6. ADMINISTRATION

The CAL FIRE Unit Chief and the CITY Fire Chief, or their designees, along with representatives from the CAL FIRE ECC and CITY DISPATCH will meet annually to discuss, review, and update the following items; procedures for reporting fires, procedures to dispatch resources to fires within the area of the AGREEMENT, procedures to dispatch resources to fires along the boundaries of the area of the AGREEMENT, and exchange general or specific information which may affect the other agency.

## 7. FIRE PREVENTION

### A. POLICY

All fire prevention activities conducted on lands within the area of the AGREEMENT will be consistent with both agencies guidelines. CAL FIRE and CITY will be expected to conduct a year-round, aggressive fire prevention program using guidelines within CAL FIRE Handbook 9000 and CITY Fire Prevention Guidelines. This will include, but is not limited to, annual analysis and planning sessions to generate an active fire prevention plan.

1. Public Information Program-This will include all types of fire prevention news releases through the available media. Other methods will include public meetings, fairs, rodeos, parades, services clubs and a regular schedule of school programs for all grades.
2. Protection/Planning Issues-Although the responsibility for enforcing fire safe ordinances pertaining to improvements in wildland areas within the city limits is the responsibility of CITY, a CAL FIRE representative will be available upon request to comment on these issues and assist in the enforcement of related ordinances.
3. Hazard Reduction Inspections
  - a. Home Inspection – CAL FIRE will work directly with CITY to enforce Public Resources Code (PRC) Sections 4291, 4446, 4442, 4123, or the Uniform Fire Code sections when applicable.
  - b. Power line Inspections – CAL FIRE will work directly with CITY inspecting power lines over 750 volts, using PRC 4292 and 4293 as a guide.

B. RESPONSIBILITY

CAL FIRE and CITY personnel will, in the performance of their duties, give full consideration to the prevention of fires and public education. Both agencies will allow staff to establish attainable fire prevention goals.

C. EXISTING AND PROJECTED DEMAND

Fire Prevention and suppression are the primary roles for both agencies. If the demand for services increases in the future, both agencies will develop more intensive programs. Fire protection and prevention will be influenced by the following factors:

1. Increased recreational use.
2. Increased residential and commercial development.
3. Increased utilization of vacation residences.
4. Industrial activity.

D. OBJECTIVES

The primary objective of the fire prevention plan is the reduction of fire suppression expenditures and damages from human-caused fires. The secondary objective is a current and comprehensive public education program for fire safety awareness and code enforcement.

E. RECOMMENDED ACTIONS

Both agencies will actively pursue public awareness programs through the following:

1. Public Education
  - a. School programs, ages K-12
  - b. Roadside sign program
  - c. Timely newspaper articles concerning fire awareness
  - d. Attendance at various local events which lend themselves to fire prevention displays.

2. Code Enforcement
  - a. Active PRC 4291 home inspection program in target areas.
  - b. Enforcement of the Fire Safe Ordinances as they apply to construction in watershed areas. CAL FIRE will take an advisory role with the CITY Fire Marshal within the areas of the AGREEMENT.

F. FUEL MODIFICATION

Both agencies will continue to encourage individual property owners and property owner associations to establish and maintain a healthy fuel complex through the following:

1. Prescribed burning through available programs.
2. Forest practice inspections.
3. Fuel modification using mechanized systems, fire crews, and local resources.
4. Biomass programs to control stems per acre, and remove dead and down materials.

G. BURNING PERMITS

Burning permits will be required in the city limits consistent with those guidelines established in adjacent areas. This will provide consistency in the burn hours and any controls needed for the overall program.

1. Burning Permit Issuance

The CITY has the responsibility of issuing burn permits within the city limits and the area of the AGREEMENT. Both agencies will agree to and establish burn permit guidelines by April 1 of each year. The guidelines will follow those established by CAL FIRE to ensure consistency in the burn programs in both the CITY and areas adjacent to CAL FIRE.

2. Suspension of Permit Procedures

The suspension of burning permits in the area of the AGREEMENT will be directly related to the burning permit suspension procedures outside the area of the AGREEMENT to ensure area-wide consistency. Suspensions will be based on input from CAL FIRE and CITY.

H. MONITORING AND EVALUATION

Periodic monitoring and evaluation of the PLAN will provide the opportunity to make orderly and timely amendments and revisions of the PLAN. Monitoring will determine if the:

1. PLAN is being followed.
2. PLAN objectives are being met.
3. PLAN is achieving desired results.

8. APPROVAL:

This PLAN is approved and authorized as Exhibit B Attachment 3 of the AGREEMENT between CAL FIRE and CITY:

FOR CAL FIRE:

California Department of Forestry  
& Fire Protection  
Riverside Unit  
210 W. San Jacinto Ave  
Perris, CA 92570

FOR CITY:

City of Beaumont  
550 East 6<sup>th</sup> Street  
Beaumont CA. 92223

---

Shawn C. Newman, Unit Chief

---

Todd Parton, City Manager

**STANDARD RESPONSE PLAN FOR VEGETATION FIRES  
CALFIRE RRU AND CITY OF BEAUMONT**

**E-1**

CALFIRE WPA VEGETATION RESPONSE	BC	E	AA	AT	COP	DOZ	CREW	WT
LOW	1	3						
MED	2	5%	1	2	1	2	2	1
HIGH	2	10%	1	2	1	2	4	1
<b>CITY OF BEAUMONT VEGETATION RESPONSE</b>								
LOW	1	3						
MED	1	3						
HIGH	1	3						

% ~ MUST include 3 type 3 engines on a MED and 4 type 3 engines on a HIGH

**RESOLUTION NO. 2020-**

**A RESOLUTION OF THE CITY COUNCIL OF THE CITY OF BEAUMONT, CALIFORNIA, APPROVING AN AGREEMENT WITH THE CALIFORNIA DEPARTMENT OF FORESTRY AND FIRE PROTECTION FOR SERVICES FROM JULY 1, 2020 THROUGH JUNE 30, 2021 FOR FIRE PROTECTION SERVICES WITHIN THE LOCAL RESPONSIBILITY AREAS WITHIN THE CITY.**

**WHEREAS**, City of Beaumont was incorporated in 1912, as a general law City of the State of California; and

**WHEREAS**, the City has fire protection responsibility for certain wildlands areas within the city designated as Local Responsibility Areas (LRA); and

**WHEREAS**, the City Council desires to enter into an agreement with the State of California for fire protection services within the LRA.

**NOW, THEREFORE, BE IT RESOLVED** by the City Council of the City of Beaumont that:

Section 1. that the City Council of the City of Beaumont does hereby approve the agreement with the California Department of Forestry and Fire Protection (CAL FIRE) from July 1, 2020 to June 30, 2021;

Section 2. that the City Manager of the City of Beaumont is hereby authorized to sign and execute said agreement on behalf of the City of Beaumont

Section 3. If any section, subsection, subdivision, sentence, clause, phrase, word, or portion of this resolution is, for any reason, held to be invalid by the decision of any court of competent jurisdiction, such decision shall not affect the validity of the remaining portions of this resolution and each section, subsection, subdivision, sentence, clause, phrase, word or portion thereof, irrespective of the fact that any one or more sections, subsections, subdivision, sentences, clauses, phrases, words, or portions thereof be declared invalid.

**PASSED, APPROVED AND ADOPTED** at a regular meeting of the City Council of the City of Beaumont, California, held on the 2<sup>nd</sup> day of June, 2020, by the following roll call vote:



AYES  
NOES  
ABSENT  
ABSTAIN

---

Rey Santos, Mayor

ATTEST:  
(SEAL)

---

Nicole Wheelwright, Deputy City Clerk

APPROVED AS TO FORM:

---

John Pinkney, City Attorney



## Staff Report

**TO:** Mayor and City Council Members  
**FROM:** Sean Thuilliez, Police Chief  
**DATE:** June 2, 2020  
**SUBJECT:** Approval of MDC and Vehicle Functionality Equipment

---

### Background and Analysis:

The Beaumont Police Department's current mobile data computer (MDC) solution is the L3 V-One by Mobile Vision. Originally designed in 2012, Mobile Vision made minor performance and storage enhancements but the unit itself remained unchanged. Mobile Vision no longer offers an MDC solution and the V-One platform has become obsolete. The Police Department has reached a critical point where the inability to outfit newly built or retrofit existing dedicated patrol vehicles is affecting the service delivery.

Having recognized the need to replace the existing MDC solution, the department has been vetting and beta-testing replacement MDC platforms. Based on this research, the department concluded the Panasonic 33-LE-02VM Toughbook as the best replacement model.

CDCE Mobile lot Integration of Yorba Linda was identified as the lowest-priced local distributor/installer of the MDC solution. The total per unit cost is approximately \$133,825.78, which includes Toughbook, keyboard, port replicator, mounting kit, additional warranty, Cradlepoint IBR900 first net routers with Wi-Fi, low profile shark fin 2G/3G/4G LTE antenna, cables, and installation.

In addition, two subscriber identity module (SIM) cards per MDC are required; one from Verizon (or similar wireless carrier) and one from AT&T (or similar wireless carrier), to provide secure Wi-Fi connectivity and redundancy. Each SIM card is projected to cost approximately \$40.00 per card (law enforcement rate), per month for a total annual per MDC cost of \$1,280.00.

The Police Department requests purchasing this equipment through the Supplemental Law Enforcement Services Account which provides money to support front line law enforcement services. In April 2002, Senate Bill 823 amended the Government Code

Sections 30061 and 30063 to require that City Council appropriate existing and anticipated monies exclusively to fund frontline municipal police services, in accordance with written request submitted by the Chief of Police of that City or the Chief Administrator of the enforcement agency that provides police services to that City.

**Fiscal Impact:**

There is no anticipated direct fiscal impact to the general fund for the initial purchase of sixteen MDC's and vehicle functionality equipment. Funding would come from the Supplemental Law Enforcement Services Account (SLESA) grant funds pursuant to Government Code Sections 30061 to 30063. The fiscal impact to the SLESA grant fund budget (Account 220-0000-8040) is \$133,825.78.

**Recommended Action:**

Approve the purchase of sixteen Panasonic Toughbooks with outfitted accessories and installation from CDCE Mobile in the amount of \$133,825.78.

**Attachments:**

- A. CDCE quote

# Sales Quote

CDCE, Inc.  
22641 Old Canal Road  
Yorba Linda, CA 92887



<b>Sales Quote No.</b>	114996
<b>Customer No.</b>	CIBEAUMOPD
<b>Customer PO #</b>	

**Telephone:** 800-373-5353

**Bill To**

**Ship To**

City of Beaumont Police Department  
Financing Authority  
660 Orange Ave.  
Beaumont, CA 92223

City of Beaumont Police Department  
Financing Authority  
660 Orange Ave.  
Beaumont, CA 92223

**Contact:** Greg Fagan  
**Telephone:** 951-769-8500

**Contact:** Greg Fagan  
**Telephone:** 951-769-8500

Order Date	Ship Via	F.O.B.	Customer PO Number	Payment Method
04/21/20	Installation	Destination		NET 30
Entered By		Salesperson	Ordered By	Resale Number
Casey Leff		Casey Leff	Greg Fagan	
Order Quantity	Approve Quantity	Item Number / Description	Unit Price	Extended Price
16	16	<a href="#">33-LE-02VM</a> Panasonic CF-33 Tablet Only  Public Sector Specific - STD 3, Win10 Pro, Intel Core i5-7300U 2.60GHz, vPro, 12.0" QHD Gloved Multi Touch+Digitizer, 8GB, 256GB SSD, Intel WiFi a/b/g/n/ac, TPM 2.0, Bluetooth, Dual Pass (Upper:WWAN/Lower:dGPS), 4G LTE Multi Carrier (EM7455), dGPS, Infrared Webcam, 8MP Cam, Contactless SmartCard, Toughbook Preferred, 3 Year ProService Premier Deployment Service, TabletPC ProPlus Warranty, 256 SSD no return service, and Custom BIOS.	2,921.000	46,736.00
16	16	<a href="#">FEE-100001</a> Recycle Fee for Monitors 4"-15"	4.000	64.00
16	16	<a href="#">WR-105014</a> PANASONIC: 4th and 5th years Public Safety Service  Bundle Add on (Year 4 & 5 only). Must be purchased in conjunction with PS bundle base unit. Includes Premier, Protection Plus, Customer Portal, Disk Image Management.	555.000	8,880.00
17	17	<a href="#">NA-210048</a> Premium Keyboard for CF-33. Emissive Red Backlit  (4 levels).Handle/kickstand - display can be opened to any angle.Compatible with Tablet, 33 Laptop Vehicle Dock, and 33 Desktop Dock.Ethernet, SDXC (full-size), HDMI, VGA, USB 2.0, USB 3.0 (2), Serial (USB)	500.000	8,500.00
17	17	<a href="#">PR-320088</a> Havis CF-33 Laptop 2-in-1 Dock, Dual RF	730.000	12,410.00

<b>Print Date</b>	04/21/20
<b>Print Time</b>	02:47:19 PM
<b>Page No.</b>	1 of 4

Printed By: Casey Leff

# Sales Quote

CDCE, Inc.  
22641 Old Canal Road  
Yorba Linda, CA 92887



<b>Sales Quote No.</b>	114996
<b>Customer No.</b>	CIBEAUMOPD
<b>Customer PO #</b>	

**Telephone:** 800-373-5353

**Bill To**

**Ship To**

City of Beaumont Police Department  
Financing Authority  
660 Orange Ave.  
Beaumont, CA 92223

City of Beaumont Police Department  
Financing Authority  
660 Orange Ave.  
Beaumont, CA 92223

**Contact:** Greg Fagan  
**Telephone:** 951-769-8500

**Contact:** Greg Fagan  
**Telephone:** 951-769-8500

Order Date	Ship Via	F.O.B.	Customer PO Number	Payment Method
04/21/20	Installation	Destination		NET 30
Entered By		Salesperson	Ordered By	Resale Number
Casey Leff		Casey Leff	Greg Fagan	
Order Quantity	Approve Quantity	Item Number / Description	Unit Price	Extended Price
17	17	PS-202013 Lind 120 Watt CF-33 DC Cig Adapter	110.000	1,870.00
6	6	VK-421036 2011+ Ford Interceptor Utility Pole Mnt Kit Beaumont P	500.000	3,000.00
1	1	VK-121015 2019 Chevy Tahoe Pole Mount Kit - Beaumont PD	500.000	500.00
5	5	VK-421045 2020 Ford Interceptor Utility Pole Mnt Kit GJ Beaumont	500.000	2,500.00
1	1	VK-411102 2017 Ford F350 Pole Mnt Kit Beaumont PD	500.000	500.00
3	3	VK-411042 07-08 Chevy Tahoe Pole Mnt Kit Beaumont PD	485.000	1,455.00
1	1	VK-411049 06 Ford F250 Pole Mnt Kit Beaumont PD	485.000	485.00

<b>Print Date</b>	04/21/20
<b>Print Time</b>	02:47:19 PM
<b>Page No.</b>	2 of 4

Printed By: Casey Leff

Continued on Next Page

# Sales Quote

CDCE, Inc.  
22641 Old Canal Road  
Yorba Linda, CA 92887



<b>Sales Quote No.</b>	114996
<b>Customer No.</b>	CIBEAUMOPD
<b>Customer PO #</b>	

**Telephone:** 800-373-5353

**Bill To**

**Ship To**

City of Beaumont Police Department  
Financing Authority  
660 Orange Ave.  
Beaumont, CA 92223

City of Beaumont Police Department  
Financing Authority  
660 Orange Ave.  
Beaumont, CA 92223

**Contact:** Greg Fagan  
**Telephone:** 951-769-8500

**Contact:** Greg Fagan  
**Telephone:** 951-769-8500

Order Date	Ship Via	F.O.B.	Customer PO Number	Payment Method
04/21/20	Installation	Destination		NET 30
Entered By		Salesperson	Ordered By	Resale Number
Casey Leff		Casey Leff	Greg Fagan	
Order Quantity	Approve Quantity	Item Number / Description	Unit Price	Extended Price
17	17	<a href="#">DM-400104</a> IBR900 router with WiFi (1000Mbps modem) 5-yr NetCloud Mobile Essentials Plan, no AC power supply or antennas, North America	1,235.000	20,995.00
17	17	<a href="#">ANT-841044</a> Low profile Sharkfin, 5 in 1 Antenna Black: MiMo 2G/3G/4G LTE, MiMo 2.4/5GHz Wi-Fi, GPS/GNSS, 5m/16 cables for use with IBR600, IBR900, IBR1100. FirstNet compatible.	250.000	4,250.00
17	17	<a href="#">CA-700008</a> 25' Cat5e Cable	10.000	170.00
17.0000	17.0000	<a href="#">LAB-320001</a> De-Install old; Installation New Customer Site Pedestal Mount, power, Cradlepoint IBR900 External Roof Antenna Run power and cabling	745.000	12,665.00
17	17	<a href="#">EE-900068</a> Magnetic Mic Clip	30.000	510.00

<b>Print Date</b>	04/21/20
<b>Print Time</b>	02:47:19 PM
<b>Page No.</b>	3 of 4

Printed By: Casey Leff

Continued on Next Page

# Sales Quote

CDCE, Inc.  
22641 Old Canal Road  
Yorba Linda, CA 92887



<b>Sales Quote No.</b>	114996
<b>Customer No.</b>	CIBEAUMOPD
<b>Customer PO #</b>	

**Telephone:** 800-373-5353

**Bill To**

**Ship To**

City of Beaumont Police Department  
Financing Authority  
660 Orange Ave.  
Beaumont, CA 92223

City of Beaumont Police Department  
Financing Authority  
660 Orange Ave.  
Beaumont, CA 92223

**Contact:** Greg Fagan  
**Telephone:** 951-769-8500

**Contact:** Greg Fagan  
**Telephone:** 951-769-8500

Order Date	Ship Via	F.O.B.	Customer PO Number	Payment Method
04/21/20	Installation	Destination		NET 30
Entered By		Salesperson	Ordered By	Resale Number
Casey Leff		Casey Leff	Greg Fagan	

Order Quantity	Approve Quantity	Item Number / Description	Unit Price	Extended Price
		<p>----- Estimated delivery 6-8 weeks ARO</p> <p>Panasonic &amp; Cradlepoint Entitlements Greg Fagan 951-769-8500 gfagan@beaumontpd.org</p> <p>By Signing, you are confirming not only your request to purchase, but also your authority to purchase the goods and services on this quote on behalf of the organization you represent. Signed quotes are de facto purchase orders and fall under the same terms and conditions of a sale. If you choose to pay by credit card, then you approve an additional 3% processing fee on the total order.</p> <p>Signature _____</p> <p>Printed Name _____</p> <p>Date _____</p> <p><b>Approved By:</b> _____</p> <p><input type="checkbox"/> <b>Approve All Items &amp; Quantities</b></p>		

<b>Print Date</b>	04/21/20
<b>Print Time</b>	02:47:19 PM
<b>Page No.</b>	4 of 4

<b>Subtotal</b>	125,490.00
<b>Freight</b>	285.00
<b>7.750 % Sales Tax</b>	8,050.78
<b>Order Total</b>	133,825.78

Printed By: Casey Leff



## Staff Report

**TO:** Mayor and City Council Members  
**FROM:** Elizabeth Gibbs, Community Services Director  
**DATE:** June 2, 2020  
**SUBJECT:** Police Department Air Conditioning Units – Emergency Repairs

---

### Background and Analysis:

The Police Department facility has three roof mounted air conditioning units that have well surpassed their life expectancy. One or more of the units were last replaced approximately 32 years ago. The replacement of the units has been contracted on an emergency basis due to their continual failure, causing extreme high temperatures within the facility. One unit recently had an electrical shortage and no longer operates. As a short-term solution to keep the facility's temperatures at a reasonable level and allow occupants to maintain productivity, portable air conditioning units have been purchased for use throughout the facility.

The costs to replace the three units is \$42,000 and includes all necessary permits, rental of a crane, and all new disconnects.

### Fiscal Impact:

The cost of the emergency repair is \$42,000.

### Recommended Action:

Ratify the costs associated with the emergency repairs to the Police Department air conditioning units in the amount of \$42,000.

### Attachments:

- A. Estimate from All A/C and Heating, Inc.



ESTIMATE	#	Item 16.
TOTAL		<b>\$42,000.00</b>

City Of Beaumont  
 660 Orange Ave  
 Beaumont, CA 92223

☎ (951) 390-0062  
 ✉ dstory@beaumontca.gov

CONTACT US  
 705 Beaumont Ave.  
 Beaumont, CA 92223

☎ (909) 557-3023  
 ✉ drew@allacandheatinginc.com

ESTIMATE

Services	qty	unit price	amount
Custom Job	1.0	\$42,000.00	\$42,000.00
Hvac change out on the buildings rear units. Install two new daikin eight ton and one 4 ton gas/electric package units on the roof top. includes curbs and econ valve title 24 compliant units. new quick disconnects and whips with permits and crane service. fifty percent parts deposit required at start of repairs and final payment when job is completed.			
<b>Total</b>			<b>\$42,000.00</b>

License # 989172



### Staff Report

**TO:** Mayor, and City Council Members  
**FROM:** Jeff Hart, Director of Public Works  
**DATE:** June 2, 2020  
**SUBJECT:** Pennsylvania Widening Project Update

#### Background and Analysis:

On September 19, 2017, the City Council approved a professional services agreement with Kimley Horn, Inc. (Consultant), for the engineering design of the Pennsylvania Avenue widening project (Project). The proposed Project is intended to widen Pennsylvania Avenue from First Street to Sixth Street, changing Pennsylvania from two lanes to four lanes.

Due to escalating construction costs and environmental constraints, staff directed the consultant to explore the possibility of revising the project to fit within the footprint of the existing right-of-way. For the portion of the improvements that lie between First Street and Third Street, the proposed street section would be revised to look as follows:

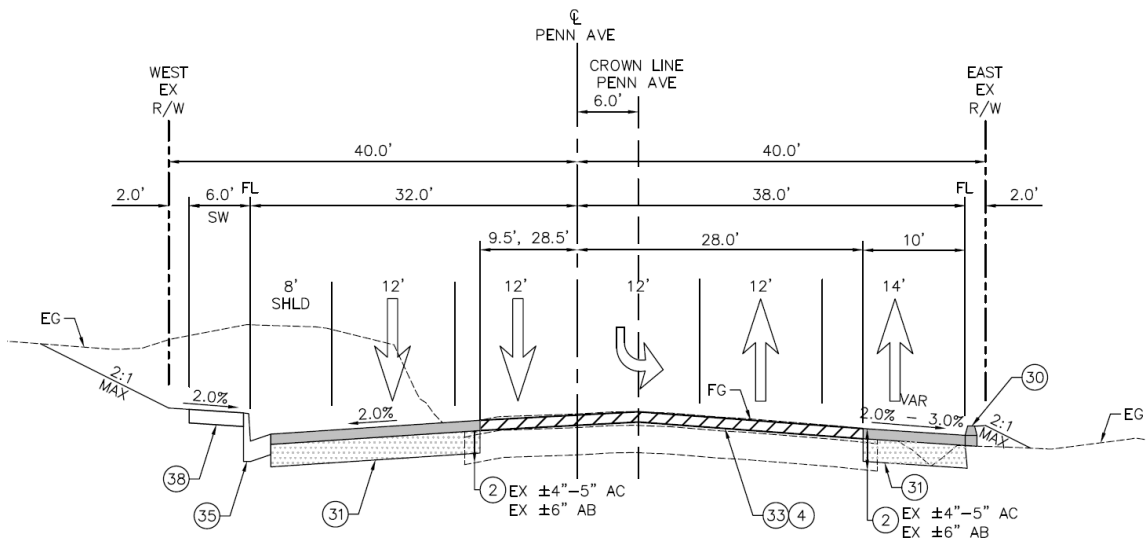

**PENNSYLVANIA AVENUE**  
 STA 20+00 TO STA 31+00  
 NOT TO SCALE

This configuration would allow the City to take full advantage of the additional vehicle capacity yet reduce some of the additional costs of additional paving, curb, gutter, sidewalk, and drainage appurtenances. Pedestrian access along Pennsylvania Avenue would be maintained though only on the westerly side via an additional-width sidewalk of six feet. Staff is comfortable with the limitation of pedestrian access to one side at this time as the easterly side of Pennsylvania Avenue in this stretch is vacant. Upon future development, projects would be conditioned to complete the widening which would include curb, gutter, and sidewalk.

From Third Street to just southerly of the Union Pacific Railroad the street would transition from the previous depicted section to the following:

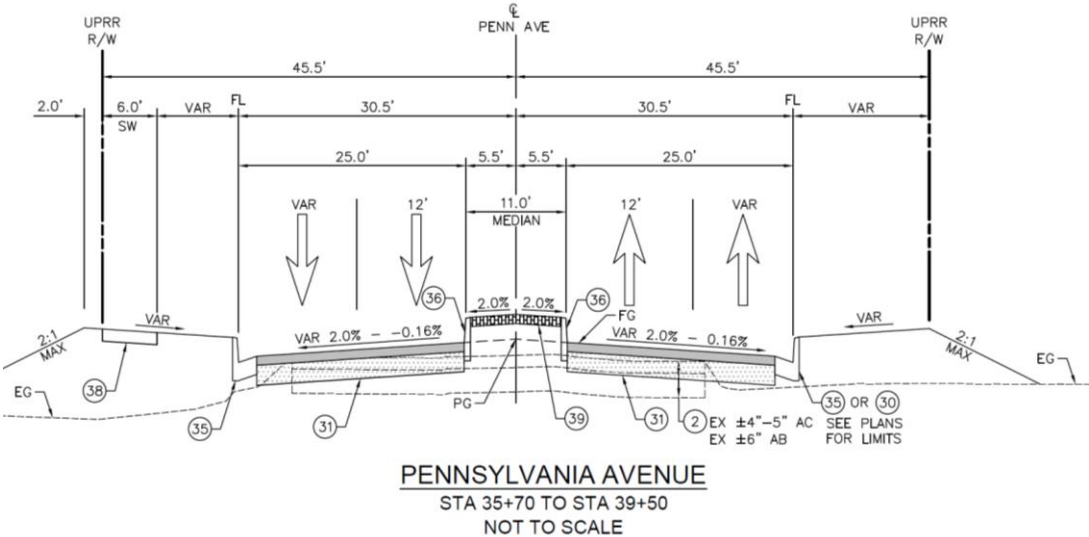

This section will still allow for four lanes of traffic and will also include a raised median which is a requirement for the proposed “quiet zone” at grade rail crossing. In order to comply with California Public Utility Commission (CPUC) requirements for the quiet zone crossing, a raised median needs to be constructed in order to deter cross over traffic and to allow for railroad crossing arms on both sides of the street. Once the project is complete and compliant with CPUC requirements trains will only need to blow their horn for any perceived dangers, not every time they cross.

As the improvements continue to the north they will transition from the previous section to the following, just north of the Interstate 10 under crossing:

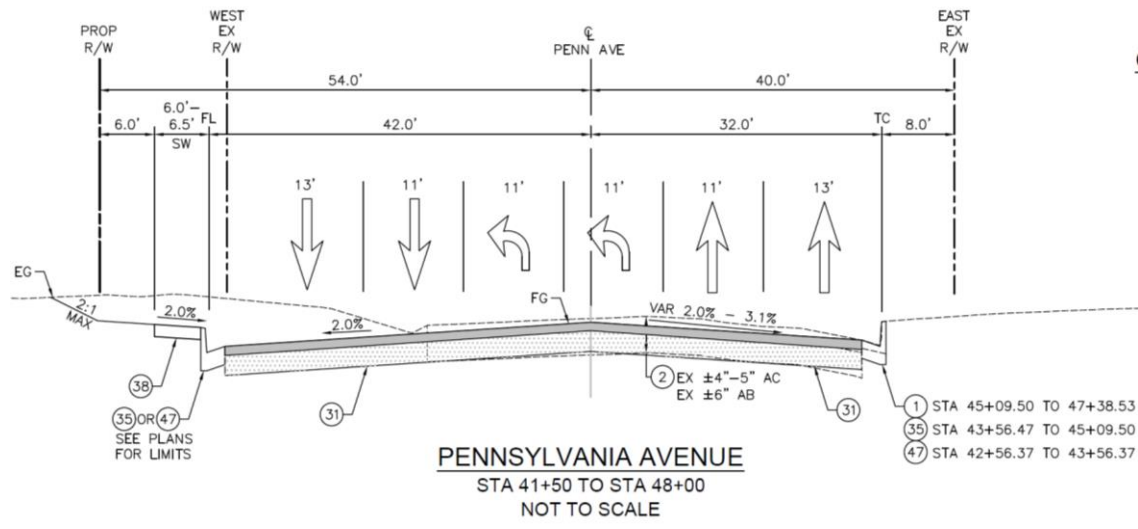

This section will allow for four through lanes of traffic as well as dual left turns from northbound Pennsylvania Avenue to westbound Sixth Street. Improvements will also be inclusive of a new signalized intersection, including protected turns which currently do not exist. The implementation of protected left turns will help decongest the intersection, particularly at peak commute times.

Staff has recently initiated the environmental stage of this project, as well as submitted updated packages to both Caltrans and the Union Pacific Railroad. The targeted advertisement of this project for construction at the end of 2020. The following table provides an estimated schedule from recent milestones to construction commencement:

Task	Description	Estimated Completion Date
Kick-Off	Council Approval of PSA and project commencement	09/2017
Drawing Development	Development of 90% design drawings based upon full width improvements and need for right-of-way acquisition. Authorize technical studies (traffic, geotechnical, water quality)	02/2019
UPRR Review	Submittal of 90% drawings to UPRR for review	05/2019
Caltrans Review	Submittal of 90% drawing to Caltrans for review	05/2019
Revised Drawings	Consultant delivery of 95% drawings based upon improvements entirely within existing r/w	04/2020
Updated UPRR Plans	Submit Revised 95% drawings to UPRR for review	05/2020

Updated Caltrans Plans	Submit Revised 95% drawings to Caltrans for review	05/2020
Environmental	Initiate CEQA compliance document	05/2020
Environmental	Completion of CEQA compliance	11/2020
Final Drawings	Approval of final engineering drawings and specifications	11/2020
Advertise	Advertise project for construction	11/2020
Award	Award construction contract	12/2020

**Fiscal Impact:**

The cost to prepare this staff report is estimated to be \$350.

**Recommended Action:**

Receive and file the Pennsylvania Widening Project Update.



To: City Council  
From: John O. Pinkney, City Attorney  
Date: May 26, 2020  
Re: List of Pending Litigation Against City of Beaumont

---

**Pending Litigation Against the City (does not include litigation initiated by the City)**

1. ***Urban Logic v. City of Beaumont et al.***, Case No. RIC 1707201 (Pre-Trial)
2. ***Aguirre et al. v. City of Beaumont et al.***, Case No. RIC 1810937 (Pre-Trial)
3. ***Serrato v. City of Beaumont***, Case No. RIC 1820593 (Pre-Trial)
4. ***Charles Peters dba Pioneer Mobile Village v. City of Beaumont, et. al.***, Case No. RIC 1707116 (Pleading)
5. ***Pucio, et. al. v. Cal. Dept. of Transp. et. al.***, Case No. RIC 1905672 (Pleading)
6. ***Loandepot.com, LLC, dba Imortgage v. Penman et. al.***, Case No. RIC 1722842 (Pleading)